

# 35DT

## *Mini-Skid Loader*



## **Owner's, Operator's and Parts Manual**

Publication Number - 52597  
July, 2005

## **THOMAS EQUIPMENT LIABILITY WARRANTY**

**THE WARRANTY IS THE ONLY OBLIGATION OF THOMAS OR A THOMAS DEALER TO THE PURCHASER OR ANYONE ELSE CONCERNING A PRODUCT, IT'S SERVICE, IT'S USE OR PERFORMANCE OR IT'S LOSS OF USE OR FAILURE TO PERFORM. NEITHER THOMAS NOR A THOMAS DEALER HAVE MADE AND NEITHER WILL MAKE ANY OTHER EXPRESSED OR IMPLIED REPRESENTATION, WARRANTY OR AGREEMENT CONCERNING A PRODUCT, NEITHER THOMAS NOR A THOMAS DEALER HAVE MADE OR WILL MAKE ANY REPRESENTATION, WARRANTY OR AGREEMENT CONCERNING A PRODUCT'S MERCHANTABILITY OR OTHER QUALITY, IT'S SUITABILITY FOR PURCHASER'S PURPOSE (EVEN IF A PURCHASER HAS INFORMED THOMAS OR A THOMAS DEALER OF THAT PURPOSE), IT'S DURABILITY, PERFORMANCE OR OTHER CONDITION.**

**EVEN IF THOMAS OR A THOMAS DEALER WAS ADVISED OF THE POSSIBILITY OF SUCH LOSS, NEITHER THOMAS NOR A THOMAS DEALER WILL BE LIABLE TO PURCHASER OR ANYONE ELSE FOR ANY INDIRECT, INCIDENTAL CONSEQUENTIAL, PUNITIVE, ECONOMIC, COMMERCIAL, OR SPECIAL LOSS WHICH IN ANY WAY ASSOCIATED WITH A PRODUCT. THIS INCLUDES ANY LOSS OF USE OR NON-PERFORMANCE OF A PRODUCT, ANY REPLACEMENT RENTAL OR ACQUISITION COST, ANY LOSS OF REVENUE OR PROFITS, ANY FAILURE TO REALIZE EXPECTED SAVINGS, ANY INTEREST COSTS, ANY IMPAIRMENT OF OTHER GOODS, ANY INCONVENIENCE OR ANY LIABILITY OF THE PURCHASER TO ANY OTHER PERSON.**

**PURCHASER MAY NOT ATTEMPT TO ENLARGE ITS RIGHTS UNDER THE WARRANTY BY MAKING CLAIM, FOR INDEMNITY, FOR BREACH OF CONTRACT, FOR BREACH OF COLLATERAL WARRANTY, FOR A TORT (INCLUDING NEGLIGENCE, MISREPRESENTATION OR STRICT LIABILITY) OR BY CLAIMING ANY OTHER CAUSE OF ACTION.**

**THE WARRANTY IS A CONDITION OF SALE OF THE PRODUCT TO THE PURCHASER AND WILL THEREFORE APPLY EVEN IF THE PURCHASER ALLEGES THAT THERE IS A TOTAL FAILURE OF THE PRODUCT.**

*N.B. Read and practice your Thomas operating and servicing instructions. Failure to do this may void the warranty.*

**PUBLICATION NUMBER 52597**

© Thomas Equipment 2004 Inc.

Printed in Canada

## FOREWORD

This book has been written to give the Owner / Operator necessary operating, servicing and preventative maintenance instructions on the Mini-Skid Loader.

Read this manual completely and know the Mini-Skid Loader before operation or servicing it.

Do not perform any service procedures that are not in this manual.

Only service personnel that have had training in the service of this Mini-Skid Loader can perform these service procedures.

## Reference Information

Write the correct information for your Mini-Skid Loader in the spaces below. Always use these numbers when referring to your machine.

**Model No.** \_\_\_\_\_

**Serial No.** \_\_\_\_\_

**Dealer Name** \_\_\_\_\_

**Address** \_\_\_\_\_

**Phone** \_\_\_\_\_

Throughout this manual the terms DANGER, WARNING and CAUTION are used to indicate the degree of hazard in terms of personal safety. These words will be used in conjunction with the Safety - Alert symbol, a triangle with an exclamation mark.

Throughout this manual, the term IMPORTANT is used:

- \* To indicate that instructions are necessary before operating or servicing the Mini-Skid Loader.
- \* To show important procedures which must be followed to prevent damage to the Mini-Skid Loader attachment.

 <b>DANGER</b>	<b>This warning indicates an immediate hazard which WILL result in severe personal injury or death.</b>
---	---

 <b>WARNING</b>	<b>This warning indicates hazard or unsafe practices which COULD result in severe personal injury or death.</b>
--	---

 <b>CAUTION</b>	<b>This warning indicates hazards or unsafe practices which COULD result in minor personal injury or product or property damage.</b>
--	--

<b>IMPORTANT</b>	<b>Instructions are necessary before operation or servicing this machine. Read the operators manual and service decals on the Mini-Skid Loader. Follow warnings and instructions in this manual when making repairs, adjustments or servicing. Check for correct operation after adjustments and repairs.</b>
------------------	---

<b>IMPORTANT</b>	<b>This notice shows important procedures which must be followed to prevent damage to the Mini-Skid Loader or attachment.</b>
------------------	---

# **INDEX**

## **1. SAFETY PRECAUTIONS**

## **2. CONTROLS**

- 2.1 Instrument Panel
- 2.2 Control Panel
- 2.3 Safety Interlock System
- 2.4 Speed/Flow Regulation
- 2.5 Attachment Lock Pins

## **3. OPERATION**

- 3.1 Starting Instructions
- 3.2 Mounting Attachments
- 3.3 Operational Procedure
- 3.4 Filling From a Pile
- 3.5 Digging with a Bucket
- 3.6 Levelling and Backfilling
- 3.7 Securing and Transporting
- 3.8 Lifting the Mini-Skid Loader

## **4. MAINTENANCE**

- 4.1 Parts Ordering
- 4.2 Fuels, Lubricants and Capacities
- 4.3 Lift Arm Support
- 4.4 Engine Maintenance
- 4.5 Battery Maintenance
- 4.6 Hydraulic/Hydrostatic System Maintenance
- 4.7 Fuel Shutoff Valve
- 4.8 Engine Cooling System
- 4.9 Tracks
- 4.10 Electrical
- 4.11 Periodic Maintenance and Service Schedule
- 4.12 Trouble Shooting
- 4.13 Hydraulic Circuit
- 4.14 Electrical Circuit
- 4.15 Special Tools

## **5. SPECIFICATIONS**

- 5.1 Specifications
- 5.2 Decals

## **6. PARTS CATALOGUE**

- 6.1 Mainframe
- 6.2 Operator's Platform
- 6.3 Lift Arms
- 6.4 Tracks
- 6.5 Hydraulic Schematic
- 6.6 Control Levers/Dash Panel
- 6.7 Electrical Schematic
- 6.8 Engine Spare Parts

---

# 1. SAFETY PRECAUTIONS

---

## The following precautions are suggested to help prevent accidents

A careful operator is the best operator. Most accidents can be avoided by observing certain precautions. Read and take the following precautions before operating the Mini-Skid Loader to help prevent accidents. Equipment should be operated only by those who are responsible and are instructed to do so.

1. Read this manual carefully before using the Mini-Skid Loader. Working with unfamiliar equipment can lead to accidents.
2. Do not allow any passengers on the Mini-Skid Loader while being operated.
3. Never run the engine in a closed building without adequate ventilation as exhaust fumes can cause death.
4. Do not operate the Mini-Skid Loader unless all safety equipment, shields, the parking brake, liftarm support and hydraulic controls are working properly, as well as all safety and instruction decals are in place.
5. Wear close fitting clothing and safety equipment appropriate for the job.
6. Loud noise can cause impairment or loss of hearing. Wear a suitable protective device such as earplugs.
7. Do not wear radio or music headphones while operating the machine. Safe operation requires your full attention.
6. Be careful when driving through door openings or under overhead objects. Always make sure there is enough clearance.
7. Always be sure of water, gas, sewage and electrical line locations before you start to dig.
8. Watch out for overhead and underground high-voltage electrical lines when operating the Mini-Skid Loader.
9. Always park the Mini-Skid Loader on level ground. If the Mini-Skid Loader is to be parked on an incline, always lower the attachment so it contacts the ground and block the tracks.
10. Do not leave the Mini-Skid Loader while it is in motion.
11. Do not dismount from the Mini-Skid Loader and leave the lift arms raised unless following specific service procedures. Always lower the lift arms down and drop the attachment down to contact the ground.
12. Always be watchful of bystanders when operating the Mini-Skid Loader.

## OPERATING THE MINI-LOADER

1. Inspect the machine before you operate it. Be sure hardware is tight. Repair or replace damaged, badly worn or missing parts. Be sure guards and shields are in good condition and fastened in place. Make any necessary adjustment before you operate.
2. Avoid jerky turns, starts, stops, or reverses.
3. Use care when operating on steep grades to maintain proper stability.
4. Carry load low while turning.
5. Exercise extreme caution when operating the Mini-Skid Loader with a raised attachment.
13. Always carry the attachment low for maximum stability and visibility.
14. Never attempt to lift loads in excess of the Mini-Skid Loader's capacity.
15. Keep hands on the control levers and grab handle while Mini-Skid Loader is in motion.
16. Do not operate Mini-Skid Loader unless standing on operator's platform.
17. Always drive the Mini-Skid Loader at speeds compatible with safety, especially when operating over rough ground, unfamiliar terrain, when crossing ditches or when turning

# 1. SAFETY PRECAUTIONS

## MAINTENANCE

1. Stop the engine before performing any service on the Mini-Skid Loader.
2. Never refuel the Mini-Skid Loader while smoking or with the engine hot or running.
3. Replace all missing, illegible or damaged safety and warning decals.
4. Do not modify or alter, or permit anyone to modify or alter this Mini-Skid Loader or any of its components or any Mini-Skid Loader functions.
5. Do not make mechanical adjustments while the Mini-Skid Loader is in motion or when the engine is running. However, if minor engine adjustments must be made, ensure safety system is active by shutting off the engine and restarting the Mini-Skid Loader without depressing the system unlock button.
6. Do not by pass the safety interlock system. Consult your Thomas Dealer if your safety interlock system is malfunctioning.
7. Do not attempt to repair or tighten hydraulic hoses when the system is under pressure, when the engine is running or when the lift arms are raised.
8. Do not get under the lift arms or reach through the lift arms while they are raised.
9. **If service is required with the lift arms in the raised position, the lift arm support must be engaged.**

To engage the lift arm support, remove any attachment and raise the lift arm to its maximum height. Remove hitch pin while holding the lift arm support with your other hand. Slowly allow the lift arm support down into position against the cylinder shaft, taking care not to damage the cylinder shaft. (See Fig. 1)

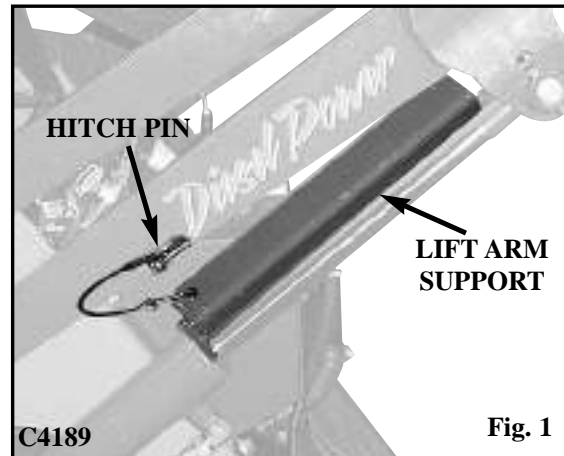

Ensure nylon lanyard does not get pinched or broken. If it does, replace immediately.

10. Whenever servicing or replacing pins in the cylinder ends, buckets, etc., always use a brass drift and a hammer. Failure to do so could result in injury from flying metal fragments.
11. Keep the operator area free from debris.
12. When lifting or towing/transporting is required, please refer to instructions in section 3.7 of this manual.
13. The cooling system operates under pressure which is controlled by the radiator cap. It is dangerous to remove the cap while system is hot. Always turn the cap slowly to the first stop and allow the pressure to escape before removing the cap entirely.

# 1. SAFETY PRECAUTIONS

## SAFETY DECAL EXPLANATIONS

### CAUTION:

#### MISUSE HAZARD

Read the Operator's Manual before operating the machine to avoid risk of injury.



TH46301

### WARNING:

#### CUTTING HAZARD

Make sure the engine is stopped before working on any part of the engine compartment.



TH41064

### WARNING:

#### STAY CLEAR OF FRONT OF MINI-LOADER

To avoid personal injury, stay clear of the front of the Mini-Loader during operation. Stay clear of raised lift arms, unless the proper safety procedures have been followed. See Section 4.3.



TH47781

### WARNING:

#### BYSTANDERS BEWARE

To avoid personal injury, all bystanders should keep a safe distance from the Mini-Loader during operation. This includes, but is not exclusive to the lift arms, turning radius, bucket and any other working equipment attached to the Mini-Loader.



TH41065

#### AUXILIARY CONNECTOR (CYLINDER)

These couplers are for use with cylinder operated attachments only. For example, a 4-in-1 bucket.



TH49710

#### AUXILIARY CONNECTOR (MOTOR)

These couplers are for use with motor driven attachments only. For example, a sweeper attachment.



TH49709

## CHECK THE CONDITIONS OF THE SAFETY AND WARNING LABELS

1. Keep the safety and warning labels clean and legible.
2. Wash the labels with soap and water. Dry with a soft cloth.
3. Replace all damaged and lost labels.
4. If a part with a safety or warning label affixed to it needs replacing, ensure the new part also has the warning or safety label.
5. When replacing labels, ensure that the surface beneath is clean, dry and free from oil and grease.
6. Press air bubbles towards the outside edges.





---

## SECTION 2

---

### 2. CONTROLS

- 2.1 Instrument Panel
- 2.2 Control Panel
- 2.3 Safety Interlock System
- 2.4 Speed/Flow Regulation
- 2.5 Attachment Lock Pins

## 2. CONTROLS

### 2.1 INSTRUMENT PANEL

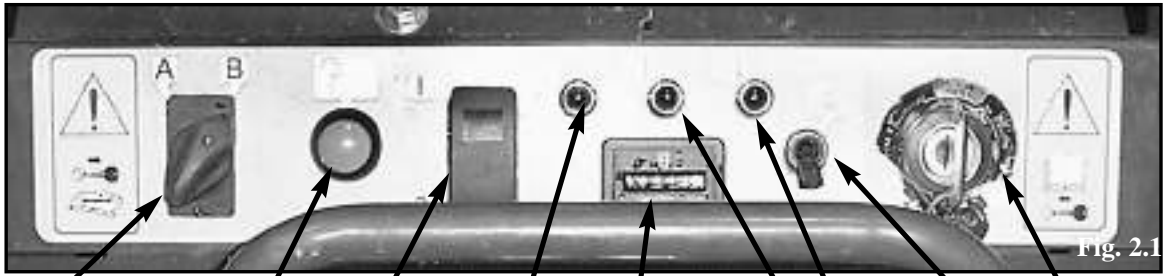

Fig. 2.1

It is necessary to become familiar with the location and purpose of each control before operating the Mini-Skid Loader.

- 1. Pump Selector Switch:** Selects either primary or secondary circuit.
- 2. Safety Interlock Pushbutton:** Activates Hydraulic flow to the Mini-Skid Loader.
- 3. Speed Regulation Switch:** Controls the diverting of oil from one circuit into the other. Toggle upwards to activate. Toggle downwards to deactivate.
- 4. Low Engine Oil Pressure Light:** This light illuminates if the engine oil pressure is low. Stop the engine immediately and determine the cause.
- 5. Hourmeter:** The hourmeter records the number of engine operating hours and has a total of 9999.9 hours.
- 6. High Engine Coolant Temperature Light:** This light will illuminate if the coolant temperature has exceeded recommended levels. If this occurs, shut off the engine immediately following proper shutdown procedures and determine the cause.

- 7. High Hydraulic Oil Temperature Light:** This light will illuminate when the oil temperature has exceeded recommended levels. Shut off the engine immediately and determine the cause.
- 8. Light Switch:** Turns working light on and off.
- 9. Ignition Switch:** The ignition switch is a four position switch. Clockwise from the OFF position are the ON, and START positions. Counter-Clockwise is the GLOW position.

**IMPORTANT**

Remove key when not in operation.



**WARNING**

To prevent personal injury, do not start the engine unless you are on the Operator's Platform.

**IMPORTANT**

This engine is equipped with glow plugs. Do not use ether or any high energy fuels to assist starting.



**WARNING**

To prevent personal injury, never add fuel to the Mini-Skid Loader when the engine is running or is hot. NO SMOKING.

## 2. CONTROLS

### 2.2 CONTROL PANEL

The THOMAS Mini-Skid Loader features two independent hydraulic systems for the Mini-Skid Loader and attachment operation.

Each of these systems is powered by either or both hydraulic pumps. The primary pump provides larger oil flow, while the secondary pump produces lower flow.

One system is dedicated to hydraulic motor driven attachments only, while the second system controls all other Mini-Skid Loader functions. The pumps can be switched back and forth between the two systems or diverted as the need arises.

For example, for normal operation, one would have the large displacement pump operating the Mini-Skid Loader functions. However, if one was operating an attachment with a hydraulic motor, one would switch the circuits so that the large displacement pump was operating the attachment, while the smaller pump was operating the Mini-Skid Loader, thus allowing the operator to drive slowly while providing maximum power to the attachment.

All functions are controlled from the top console of the mini-skid as shown in Fig. 2.2.

### OPERATOR AREA CONTROLS (Fig. 2.2)

1. Throttle
2. LH Drive Lever
3. RH Drive Lever
4. Auxiliary Lever, Cylinder Driven Attach.
5. Lift & Tilt Joystick
6. Handle Grip

### DASH PANEL CONTROLS (Fig. 2.2)

7. Pump Selector Switch
8. Auxiliary Lever, Motor Driven Attach.
9. Key Switch
10. Speed Regulation Switch

### Throttle Control

The throttle control is on the right hand side of the operator area controls (Item #1 in Fig. 2.2). When the throttle control is set fully back the engine is at idle speed. Moving the throttle control forward increases the engine speed. The machine should always be operated with the throttle fully open.

Before shutting off the engine, return the throttle control to the idle position and allow the engine to cool for at least 2 minutes.

### Steering Controls

The THOMAS Mini-Skid Loader features single-hand steering. For normal operation, the most comfortable hand position is to operate the steering levers with the palm of the left hand, with the fingers gripping the grip handle. This position will allow for better control of the unit. At the same time, the right hand should grip the grip handle for operator stability, but can also be used to operate the lift and tilt joystick as required.

Flexing the fingers will allow forward travel, and simply rotating the palm will allow normal steering.

(Steering Controls continued on page 6)

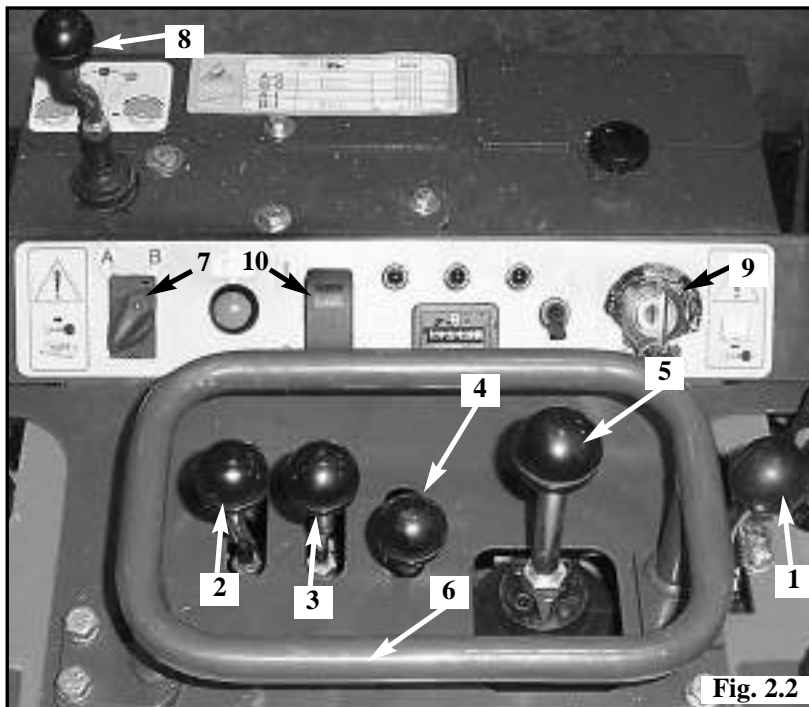

Fig. 2.2

## 2. CONTROLS

### Steering Controls (continued)

To reverse, slip the palm back to the rear of the grip handle, and use the tips of the fingers to pull the steering levers backwards.

The Mini-Skid Loader is turned by moving one lever further forward than the other. To turn right, move the LH Drive Lever further than the RH Drive Lever. To turn left, move the RH Drive lever further than the LH Drive Lever.

For the Mini-Skid Loader to turn or “skid steer” within its own length, one lever is moved forward and the other back. This causes the tracks on one side to turn forward and the tracks on the other side to reverse.

### Lift and Tilt Joystick

The Joystick located on the right hand side controls the lift and tilt. Pushing the joystick forward lowers the lift arm and pulling the joystick back raises the lift arm. In these two positions, the joystick is spring centered to neutral upon release of the joystick.

Moving the joystick left tilts the attachment back. Moving the joystick to the right tilts the attachment ahead. The joystick is spring centered to neutral upon release.

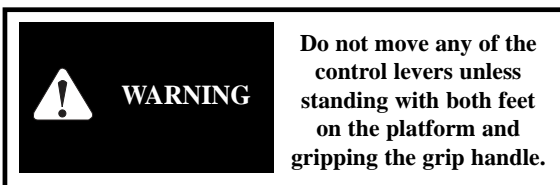

### Auxiliary Control Lever-Cylinder Operation

The THOMAS Mini-Skid Loader features two separate auxiliary systems. The auxiliary lever (Shown as item #4 in Fig. 2.2) is part of the primary controls, and is located between the main levers. This control is connected to the pair of quick connect couplings located on the right side of the Mini-Skid Loader arms. Pushing this lever forward extends the attachment hydraulic cylinder, while pulling it back reverses the motion.

This lever is mainly intended to operate attachment hydraulic cylinders. This would include such attachments as angling dozer blades, grapple forks, and 4 in 1 bucket, which must operate from this control only.

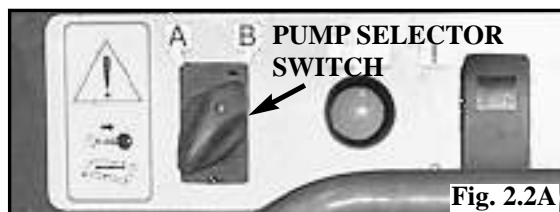
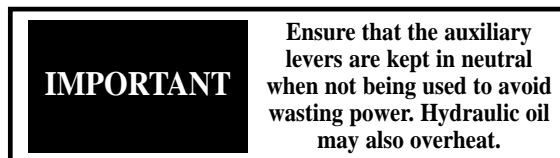
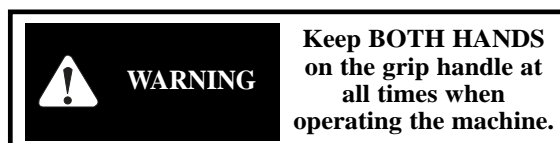

SECONDARY CONTROLS:

### Pump Selector Switch

The Pump Selector Switch is located on the left hand side of the dash panel (See Fig. 2.2A). This switch selects which pump is connected to the primary and the secondary circuits. This is a rotary electrical switch which is lit green when the hydraulic system is active, and is labeled A for left and B for right.

When the rotary knob is turned to the left (A), the smaller secondary pump is connected to the Mini-Skid Loader drive and the larger primary pump is connected to the auxiliary circuit.

This would be the position used when operating attachments such as trenchers, sweepers, roto-tillers, snowblowers, and post hole augers, as it provides for increased flow to the attachment while allowing a reduced flow for Mini-Skid Loader functions.

When the knob is turned to the right (B), the large primary pump is connected to the Mini-Skid Loader drive circuit and the smaller secondary pump is connected to the auxiliary valve. This would be the normal position for operations not requiring a powered attachment.

It is advised that any new or inexperienced operators use the A position to become familiar with operating the Mini-Skid Loader.



## 2. CONTROLS



### AUXILIARY LEVER-HYDRAULIC MOTOR DRIVES

This lever is located to the left and forward of the operator area controls (See Fig. 2.2, page 5, item 8), and operates the set of quick connect couplings located on the left hand side of the Mini-Skid Loader arms.

This is a dedicated hydraulic motor control valve, to be used to operate such attachments as trenchers, post hole augers, sweepers, hammers, and similar units. **Do not connect hydraulic cylinders to this control.** When this control is in the neutral position, the auxiliary couplers are connected together, which provides a “free-wheeling” or “slowdown” position for hydraulic motors, preventing attachment damage and internal pressure buildup.

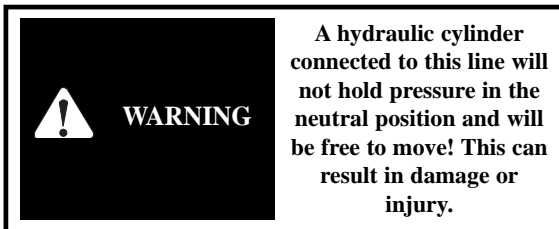

This lever operates side to side, moving the lever to the left provides oil flow to the female coupler, while moving it to the right to provide oil flow to the male coupler. Centering the lever provides a neutral, off position.

**Always use the auxiliary couplers located on the right hand side of the Mini-Skid Loader lift arms for hydraulic cylinder use!**

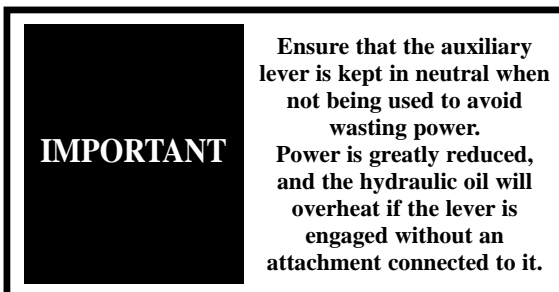

### 2.3 SAFETY INTERLOCK SYSTEM

The Mini-Skid Loader is equipped with a hydraulic safety interlock system.

When the Mini-Skid Loader is started, all hydraulic flow is directed away from the loader controls and into the hydraulic tank until the operator depresses the safety interlock pushbutton (See Fig 2.3).

To direct flow to the main control valve (which includes drive control, lift and tilt control, and primary auxiliary control) and the second auxiliary valve, there is an electric Safety Interlock Pushbutton (See Fig 2.3) located on the left hand side of the instrument panel. This switch must be depressed momentarily to activate the hydraulic circuits. The Mini-Skid Loader engages the Safety Interlock System by turning the ignition key to the off position (See Section 3.1 for proper Shutdown procedures).



### PARKING BRAKE

The Mini-Skid Loader is equipped with an electrically actuated parking brake. The brake is automatically engaged when the key is turned to the OFF position.

To disengage the parking brake, depress the safety interlock pushbutton (located on the left hand side of the dashpanel) and jogging the RH drive lever forward and rearward slightly to ensure the brake pin is fully disengaged.

## 2. CONTROLS

### 2.4 SPEED/FLOW REGULATION

The loader is equipped with a two-pump system, which supplies hydraulic power to operate the drive as well as all hydraulic functions. The output of the two pumps is 8.5 gpm (32.2 l/m) and 3 gpm (11.4 l/m).

The direction and flow from these pumps can be controlled by a pump selector switch (fig. 2.4A), a combiner switch (Fig. 2.4A), both of which are located on the dash, and a flow control knob (Fig. 2.4B), located on the service access panel.

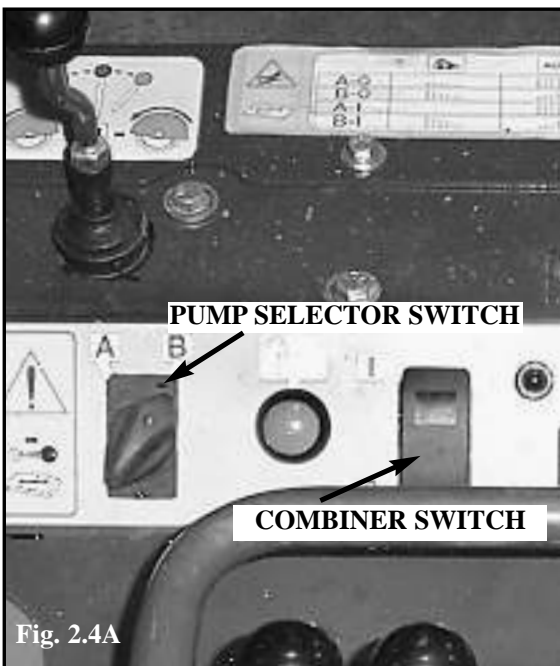

#### Pump Selector Switch:

The pump selector switch, (Fig. 2.4A), controls which pump, either the 3 gpm (11.4 l/m) or 8.5 gpm (32.2 l/m), provides flow to either the motor spool auxiliary hydraulic circuit or the res of the loader funtions.

#### Combiner Switch:

The combiner switch, (Fig. 2.4A), can be used to combine the flow of both pumps.

#### Flow Control Knob:

The flow control knob, (Fig. 2.4B), allows metering the amount of oil flow between the drive system and the motor spool auxiliary circuit.



Turning the flow control knob clockwise will divert oil from the loaders drive system to the motor spool auxiliary circuit slowing the loaders travel speed. When fully turned in, approximately 1 gpm (3.8 l/m) of oil will still flow to the loaders drive system. This is the loaders slowest travel speed setting.

When fully turned out, no oil flow is diverted to the loaders motor spool auxiliary circuit.

The flow control knob will function in all mode settings except A/1.

**Before making any adjustments to the selector valve, combiner valve or flow control knob, return the steering control levers as well as all auxiliary hydraulic controls to the neutral position. Do not adjust these controls while the loader is in motion or during attachment operation.**

## 2. CONTROLS

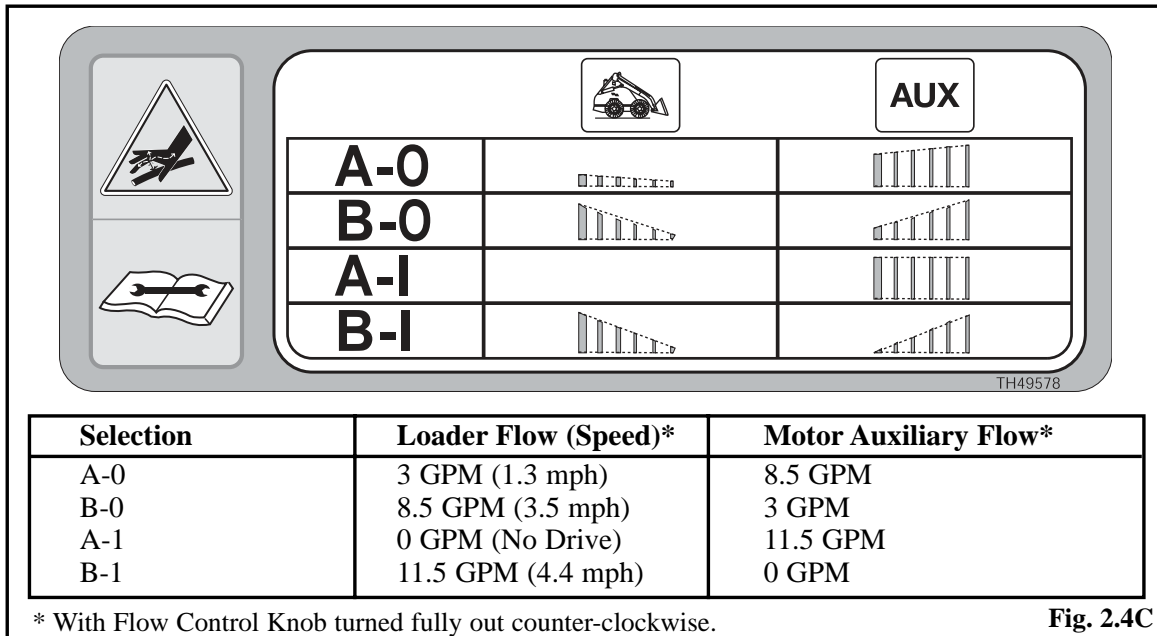

**Fig. 2.4C**

**OPERATING MODES (See Fig. 2.4C):**

**A/0 - Trencher Operation, New Operators**

This mode is used for operating motorized hydraulic attachments such as trenchers, sweepers, augers, snow blowers etc. This position provides a slow travel speed as well as reduced oil flow to the loaders boom and bucket and the cylinder spool auxiliary hydraulic circuit while providing increased oil flow to the motor spool auxiliary hydraulic circuit. With the attachment connected to the loaders motor spool auxiliary hydraulic circuit, set the controls as follows.

**Pump Selector Switch** - Set switch to "A" position.

**Combiner Switch** - Set the switch to "0" position.

**Flow Control Knob** - Turn clockwise to reduce the loaders drive speed and increase the amount of flow to the motor spool auxiliary circuit.

With the flow control knob turned fully out (counter clockwise), approximately 3 gpm (11.4 l/m) flows to the loaders drive and 8.5 gpm (32.2 l/m) flows to the motor spool auxiliary hydraulic circuit. This provides a travel speed of 1.3 mph (2.1 km/hr).

With the flow control knob turned fully in (clockwise) approximately 1 gpm (3.8 l/m) flows to

the loaders drive system and 10.5 gpm (39.8 l/m) flows to the motor spool auxiliary hydraulic circuit. This provides a travel or "inching" speed of 0.3 mph (0.5 km/hr). NOTE: While this is the recommended trenching mode, trenching can be performed in any mode by using the flow control knob to divert oil.

**B/0 - Bucket Operation**

This mode is used for normal bucket and travel operation as well as for operating cylinder equipped hydraulic attachments such as grapples. This position provides a fast travel speed as well as quick boom and bucket operation and a higher flow to the loaders cylinder spool auxiliary hydraulic circuit. Attach the hydraulic powered attachment to the cylinder spool auxiliary hydraulic circuit or mount a bucket or other attachment and set the controls as follows.

**Pump Selector Switch** - Set switch to "B" position.

**Combiner Switch** - Set the switch to "0" position.

**Flow Control Knob** - Turn clockwise to reduce the loaders drive speed and increase the amount of oil flow to the motor spool auxiliary circuit.

With the flow control knob turned fully out (counter clockwise), approximately 8.5 gpm (32.2 l/m)

---

## 2. CONTROLS

---

flows to the loaders drive and cylinder spool auxiliary hydraulic circuit. 3 gpm (11.4 l/m) flows to the motor spool auxiliary hydraulic circuit. This setting provides a travel speed of 3.5 mph (5.6 km/hr).

With the flow control knob turned fully in (clockwise) approximately 1 gpm (3.8 l/m) flows to the loaders drive system and 10.5 gpm (39.8 l/m) flows to the motor spool auxiliary hydraulic circuit. This provides a travel or "inching" speed of 0.3 mph (0.5 km/hr).

### **A/1 - Stationary Power Source**

This mode is used to provide full hydraulic power to the motor spool auxiliary hydraulic circuit to power attachments such as water pumps where no travel speed or boom and bucket operation is required.

In this position the loaders travel speed, boom and bucket circuits as well as the cylinder spool auxiliary hydraulic circuits do not function.

**Pump Selector Switch** - Set switch to "A" position.

**Combiner Switch** - Set the switch to "1" position.

**Flow Control Knob** - The flow control knob does not function in this mode.

In this mode the drive system receives 0 gpm (0 l/m) while the motor spool auxiliary hydraulic circuit receives 11.5 gpm (43.5 l/m).

### **B/1 - High Speed Travel**

This mode is used when long travel distances are encountered. This position provides the fastest maximum travel speed as well as increased oil flow to the loaders boom and bucket and cylinder spool auxiliary hydraulic circuit while providing reduced oil flow to the motor spool auxiliary hydraulic circuit. Attach the hydraulic powered attachment to the cylinder spool auxiliary hydraulic circuit or mount a bucket or other attachment and set the controls as follows.

**Pump Selector Switch** - Set switch to "B" position.

**Combiner Switch** - Set the switch to "1" position.

**Flow Control Knob** - Turning clockwise will reduce the loaders drive speed and increase the amount of flow to the motor spool auxiliary circuit.

With the flow control knob turned fully out (counter clockwise), approximately 11.5 gpm (43.5 l/m) flows to the loaders drive and cylinder spool auxiliary hydraulic circuit. 0 gpm (0 l/m) flows to the motor spool auxiliary hydraulic circuit. This setting provides a travel speed of 4.4 mph (7.1 km/hr).

With the flow control knob turned fully in (clockwise) approximately 1 gpm (3.8 l/m) flows to the loaders drive system and 10.5 gpm (39.8 l/m) flows to the motor spool auxiliary hydraulic circuit. This provides a travel or "inching" speed of 0.3 mph (0.5 km/hr).



## 2. CONTROLS

### 2.5 ATTACHMENT LOCK PINS

The quick-tach design allows changing from one attachment to another quickly and easily by disengaging pins.

Attachments are secured on the unit with two spring loaded cam action locking pins. Rotating the handles on the pins one half turn moves the pins from the locked to the unlocked position.

To **unlock** attachments, rotate both pins so that their handles are both pointing to the **outside** of the quick-tach. (Figs. 2.5)

To **lock** attachments, rotate both pins inwards so that both handles are pointing towards the **center** of the machine. This will allow the springs to push the pins downwards through the mounting holes in the attachment and secure it to the unit. (Figs. 2.5A)

 <b>WARNING</b>	<b>After hook-up to attachment, check to be sure pins are fully engaged, and locked into position.</b>
--	--

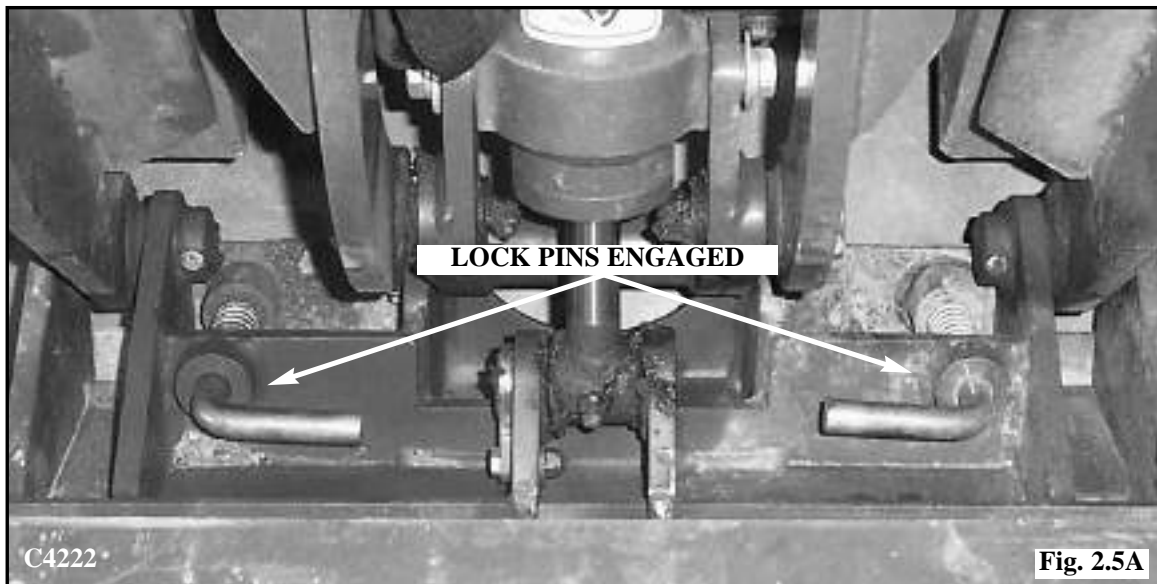
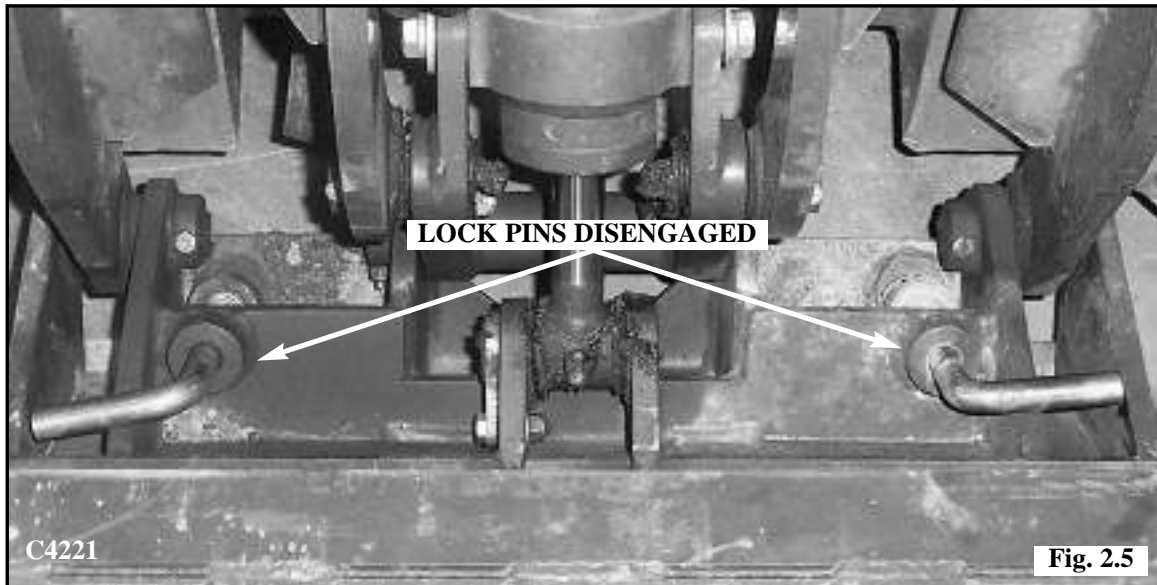



---

## SECTION 3

---

### 3. OPERATION

- 3.1 Starting Instructions
- 3.2 Mounting Attachments
- 3.3 Operational Procedure
- 3.4 Filling From a Pile
- 3.5 Digging with a Bucket
- 3.6 Levelling and Backfilling
- 3.7 Securing and Transporting
- 3.8 Lifting the Mini-Skid Loader

## 3. OPERATION

### 3.1 STARTING INSTRUCTIONS

#### 1. Pre-Starting Inspection

Before starting the Mini-Skid Loader complete the following inspection:

- (1) Check the hydraulic oil level, engine oil level, engine coolant level and fuel supply.
- (2) Check for fuel, oil and hydraulic lines for leaks.
- (3) Check lights, battery level and cables.
- (4) Inspect tracks, pivot points, mounting pins, nuts and bolts for possible failure or looseness.
- (5) Check all controls are in the neutral position.
- (6) Check the condition and operation of all safety decals and equipment – Ensure all shields and safety screens are in place. If necessary repair or replace before starting.

For complete daily servicing refer to Section 4.9.

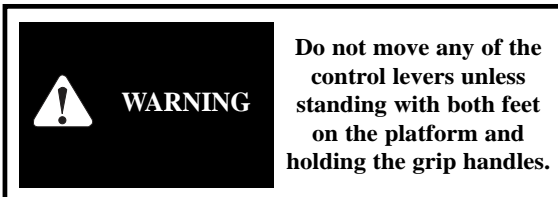

#### 2. Starting Procedure

- (1) Set the throttle for idling speed. Avoid excessive engine speed during warm-up.
- (2) Turn the ignition key counter clockwise to activate the glow plugs. Hold approximately 6 seconds.
- (3) Turn the key clockwise to the start position to engage the starter. Do not crank the starter for more than 15 seconds. If the engine fails to start turn the key counter clockwise and pre-heat again.
- (4) Allow the engine to warm up for 5 minutes before operating. Keep the operator's area free of debris. Always drive the loader at speeds compatible with safety, especially when operating over rough ground, unfamiliar terrain, when crossing ditches or when turning.
- (5) To restart a warm engine, move throttle control slightly ahead of idle position and turn ignition key to "START".

#### IMPORTANT

This engine is equipped with glow plugs. Do not use ether or any high energy fuels to assist starting.

#### IMPORTANT

Ensure that the auxiliary lever is kept in neutral when not being used to avoid power loss and overheating of hydraulic oil.

#### IMPORTANT

Do not crank engine with starter for more than 15 seconds at a time, as this will overheat the starter.

#### 3. Shut-Off Procedure

- (1) Select level ground whenever possible. If you must park on a slope or incline, position the machine at right angles to the slope. Lower the attachment to the ground and block the tracks.
- (2) Lower the lift arms and ground the attachment.
- (3) Return auxiliary hydraulics to the neutral position.
- (4) Return the throttle control to the idle position. If the engine is hot, allow it to idle for at least 2 minutes.
- (5) Turn the ignition switch to the OFF position and remove the key.

#### IMPORTANT

Always let the engine warm completely before you begin operation each day.

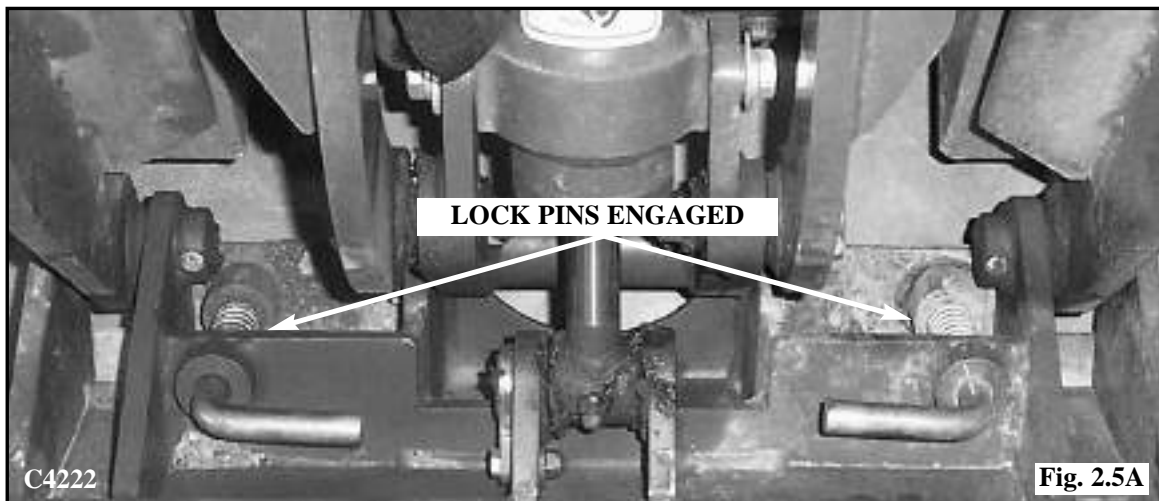
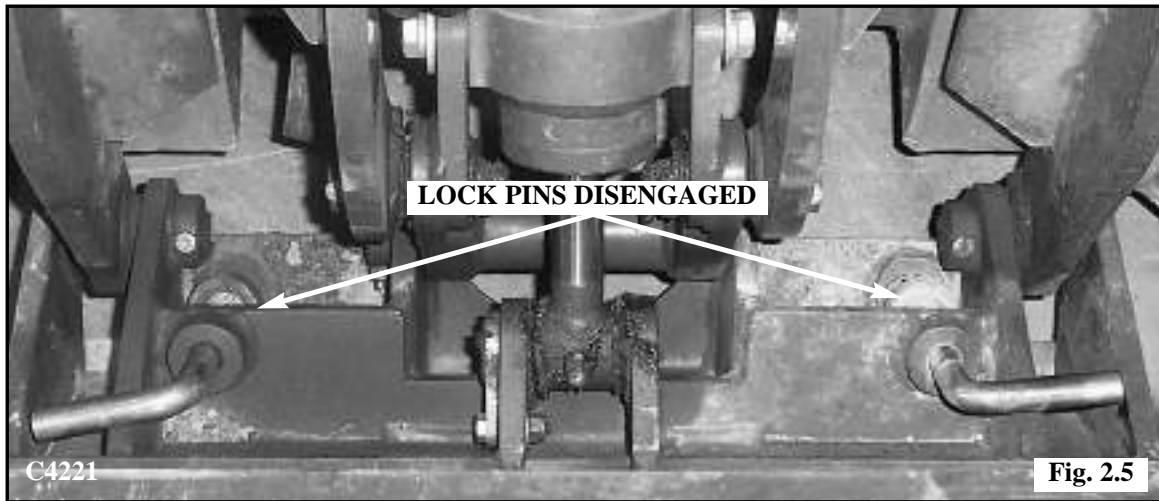

## 3. OPERATION



### 3.2 MOUNTING ATTACHMENTS

The quick-tach, which is standard equipment, allows changing from one attachment to another quickly without having to remove bolts or pins.

#### INSTALLATION OF ATTACHMENT

1. Rotate lock pins to the unlock position (handle pointing outward). (Figs. 3.2)
2. Tilt the attachment frame forward so that the top round edge of the attachment frame will fit under the lip on the attachment. (Fig. 3.2B)
3. Drive into the attachment, raising the arms so that the top of the attachment frame slips under the lip on the attachment, and the attachment lifts slightly.
4. Using the tilt cylinder, roll back the attachment so that it drops into place.
5. Rotate the lock pins to the locked position (handles facing inwards) (Figs. 3.2A), and check that the lock pins are fully inserted through the lock holes in the attachment.
6. Connect attachment hydraulic hoses (if required) to the quick couplers. (Fig. 3.2C)
7. Using the couplers on RH side of the Mini-Skid Loader (marked ) are for cylinder operated attachments and the couplers on the LH side of the Mini-Skid Loader are for motor-driven attachments (marked )

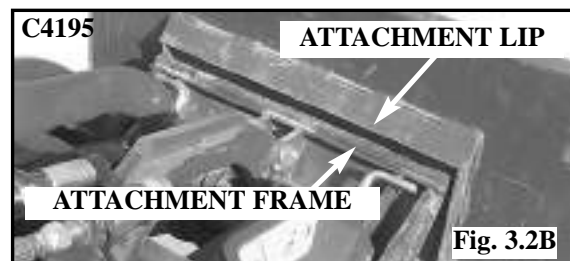

## 3. OPERATION

### REMOVAL OF ATTACHMENTS

1. Lower lift arms and tilt forward on the attachment so that the attachment is resting on the ground.
2. If the attachment is hydraulically equipped, stop the engine, relieve hydraulic pressure in the attachment lines by partially shifting the auxiliary lever back and forth and disconnecting the attachment hydraulic hoses.
3. Rotate the lock pins to the unlocked (handles pointing outwards) position. See Figs. 3.2 & 3.2A.
4. Start engine, activate the hydraulic safety interlock switch, tilt the attachment forward (dump) until the top edge of the attachment mount frame clears the lip on the attachment. Back the Mini-Skid Loader away from the attachment. See Fig. 3.2B.

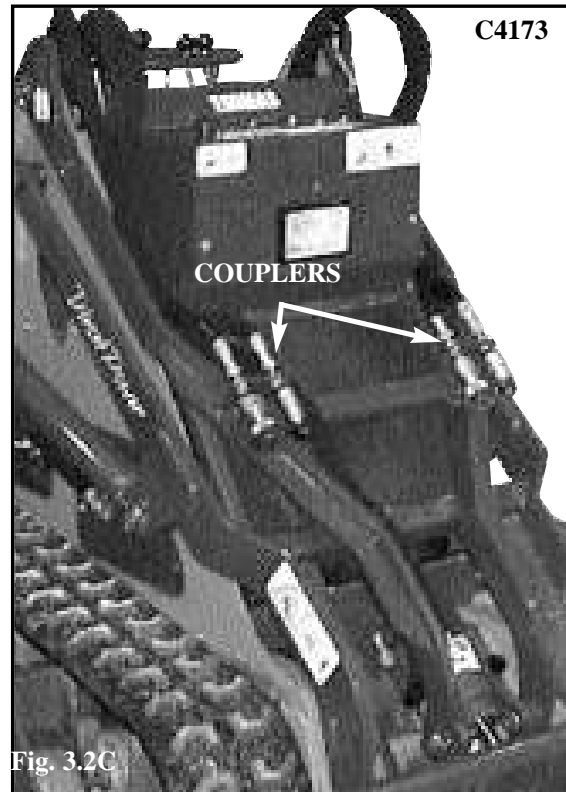

## 3. OPERATION

### 3.3 OPERATIONAL PROCEDURE

Mini-Skid Loader operational procedure and suggestions in this manual are based on the use of a bucket.

1. When learning to use the Mini-Skid Loader operate at a slow rate.
2. Take advantage of the efficient operation of the Mini-Skid Loader. Keep the travel distance as short as possible. Keep the work area small so the cycle time is short and keep the work area as level as possible.
3. Decrease cycle time by “skid” turning rather than a go backward-go forward turn. (See Section 2.2)
4. Fill the bucket to rated capacity. Turning is easier with a full load than with a partial load. Keep the loaded bucket close to the ground when transporting.
5. When driving on slopes, keep the heaviest end of the Mini-Skid Loader upward. When driving on a slope with an empty bucket, back up the slope in reverse, and drive down a slope forward (Fig. 3.3). When driving on a slope with a load, drive up the slope forward and back down the slope in reverse. (Fig. 3.3A)
6. Do not drive across a slope. Always go up or down a slope with the heavy end of the Mini-Skid Loader pointing up towards the top of the slope.
7. To increase machine life, let the engine warm completely before starting operations each day. Avoid “overloading” or “lugging” the Mini-Skid Loader.
8. Hydraulic power transmission is instantaneous. When using the drive levers, sudden movement will result in jerky operation. Easing the levers either forward or reverse will result in a smoother operation.
9. When approaching the heap or pile, always have the bucket level. To achieve this, lower the Mini-Skid Loader arm and activate the bucket level with the ground.
10. Towards the end of the run, when the bucket is nearly full, gently roll the bucket backwards. This decreases the lifting resistance when the arms are raised and promotes an efficient tear out.
11. When transporting material in the bucket on hillsides or rough ground, keep the bucket as close to ground level as possible. This lowers the center of gravity of the Mini-Skid Loader and maximizes stability.
12. When scooping, leveling and surface stripping, lower the bucket to ground level, tilt it downward. The bucket will bite into the soil as you move forward.
13. The material may then be dumped into a trailer or utility truck for removal or repositioning on the site. Do not step off the operator platform with the load raised.

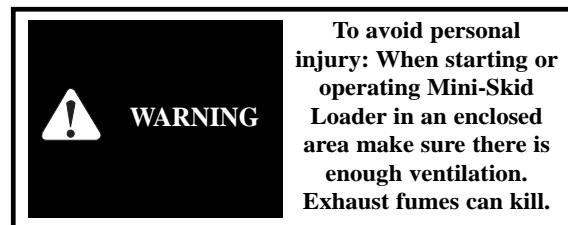
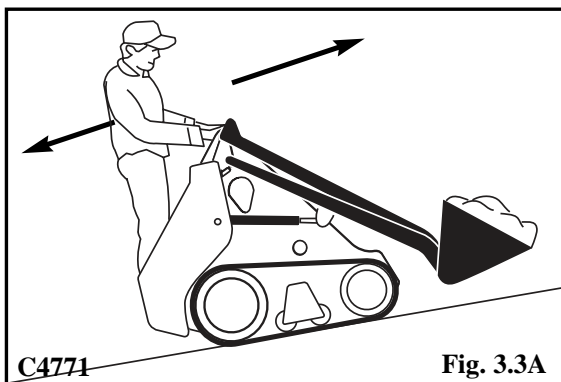
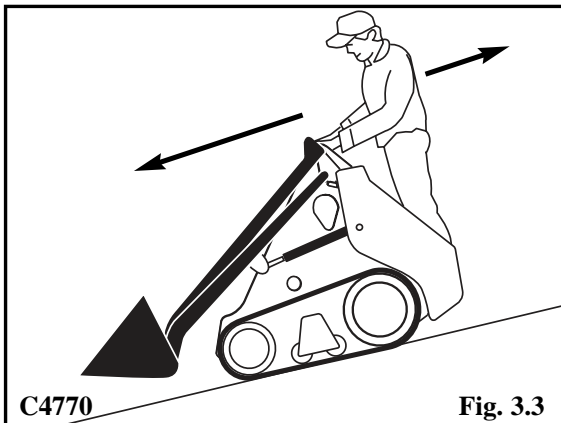

## 3. OPERATION

### 3.4 FILLING FROM A PILE

1. Push the Lift and Tilt Joystick forward and lower the lift arms completely down. Push the Lift and Tilt Joystick right and place the cutting edge of the bucket on the ground. See Fig.3.4.
2. Drive the loader forward slowly. See Fig. 3.4A. As the bucket begins to fill push the Lift and Tilt Joystick to the left to raise the front of the bucket and pull back on the Lift and Tilt Joystick to raise the lift arms. When the bucket is full back away from the pile. See Fig 3.4B.
3. To dump the bucket pull back on the Lift and Tilt Joystick to raise the lift arms. Push the Lift and Tilt Joystick left small amounts as the lift arms are raising to stop material from falling off the back of the bucket. When the bucket is at the correct height for dumping, push the Lift and Tilt Joystick to the right to empty the bucket.

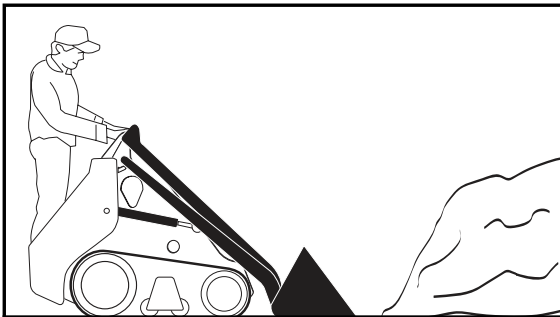

C4196

Fig. 3.4

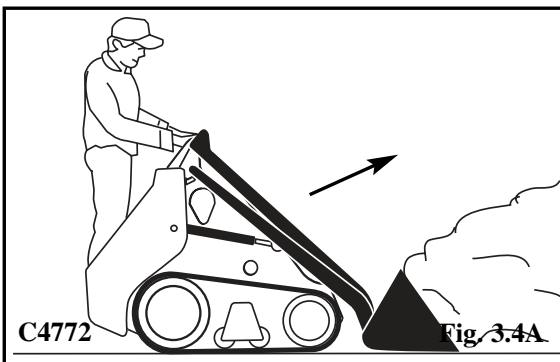

C4772

Fig. 3.4A

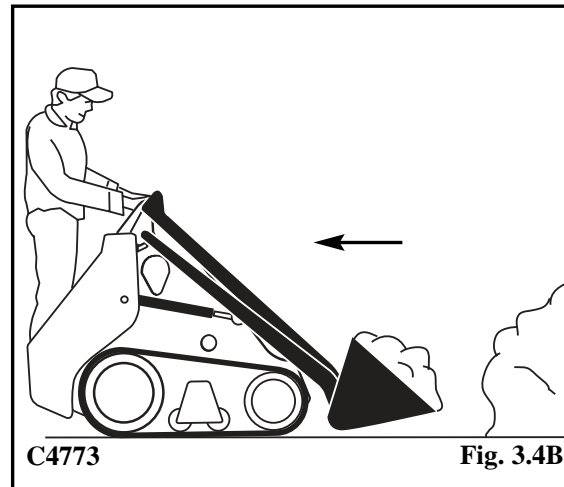
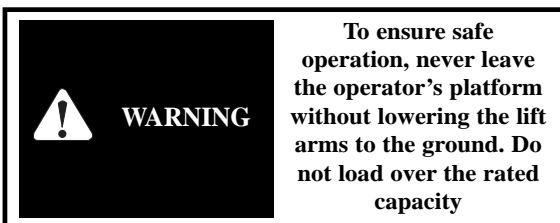

C4773

Fig. 3.4B

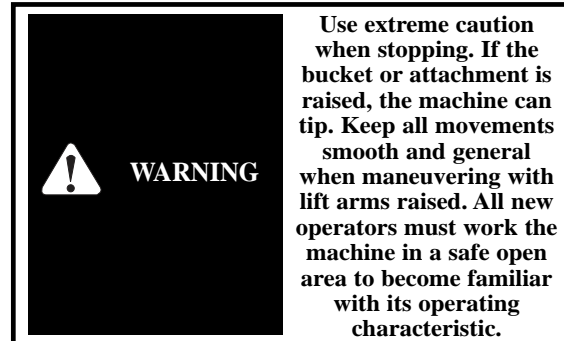

### 3.5 DIGGING WITH A BUCKET

1. Lower lift arms fully and tilt bucket forward until cutting edge is on the ground.
2. Drive machine forward slowly and continue to tilt bucket forward until it enters the ground to desired depth and then tilt it back a small amount to keep an even depth (Fig. 3.5).
3. Continue driving forward until bucket is full and then tilt bucket fully back while driving slowly forward or stopping the machine.

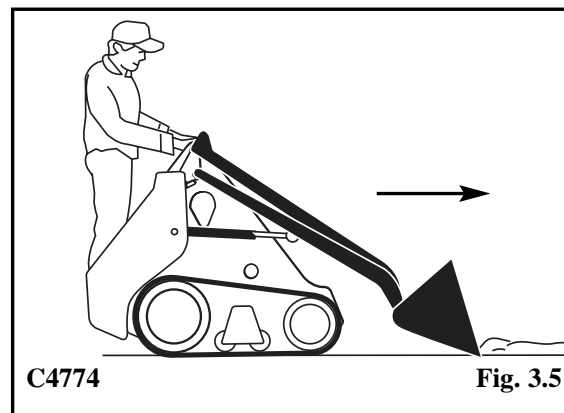

C4774

Fig. 3.5



## 3. OPERATION

### 3.6 LEVELLING AND BACKFILLING

1. To spread material on uneven ground, raise lift arms and tilt bucket forward while driving slowly forward (Fig. 3.6).

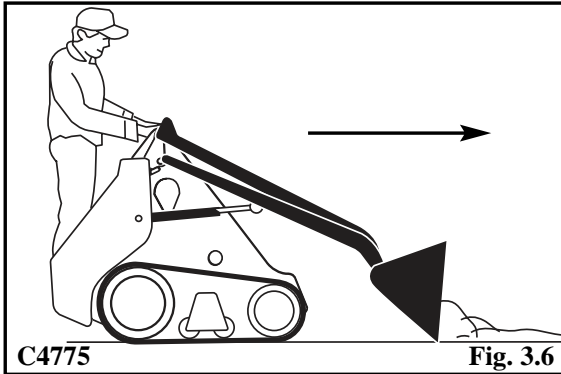

2. To level a filled area, tilt bucket forward and drive machine backwards to drag bucket and spread material (Fig. 3.6A).

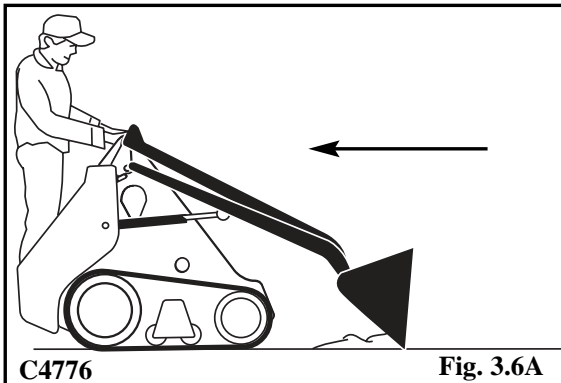

3. Another method of levelling is to travel forward with bucket down and level, full of material and pushing excess into low areas. Depth is controlled by tilting the bucket slightly up or down. (Fig. 3.6B).

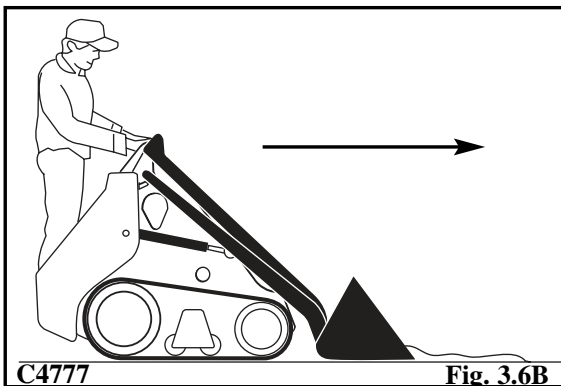

4. When filling a trench or a hole, drive up to the hole with bucket low to push material up to the edge. (Fig. 3.6C).

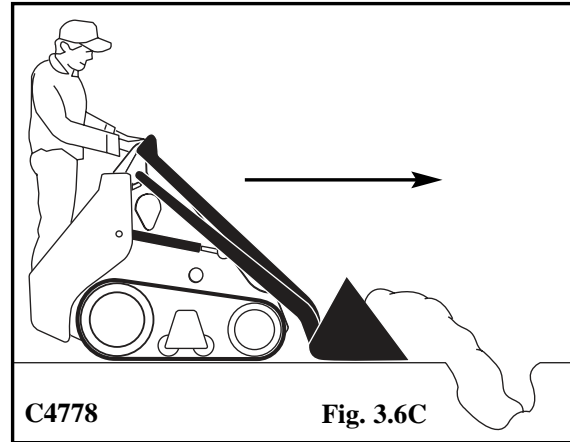

5. Tilt bucket forward as soon as it reaches the edge of the hole and when necessary raise the arms to empty the bucket. (Fig. 3.6D).

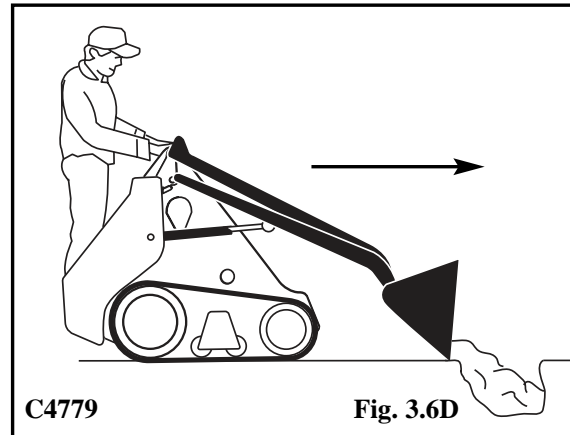

## 3. OPERATION

### 3.7 SECURING AND TRANSPORTING

There are three tie down points provided for securing the Mini-Skid Loader while transporting. One at the lower front and two at the rear. See Figs. 3.7A & 3.7B.

Be sure the trailer and/or truck is of adequate size and capacity to safely transport your Mini-Skid Loader.

Measure the clearance height of the Mini-Skid Loader and trailer or truck, and post it in the cab of the truck.

Before loading the Mini-Skid Loader make sure the ramps and parking surface are free of all oil, grease, ice, etc. and of sufficient strength to support the load.

Know the local rules and regulations, and make sure your truck and trailer is equipped with the correct safety equipment.

When loading a Mini-Skid Loader with an attachment, always load the heavy end first.

Once the Mini-Skid Loader has been loaded, lower the attachment to the floor and stop the engine.

Install chains at the front and rear tie down locations, and securely attach to the transport vehicle.

**Note:** Minimum 3/8 in. grade 40 chain is required.

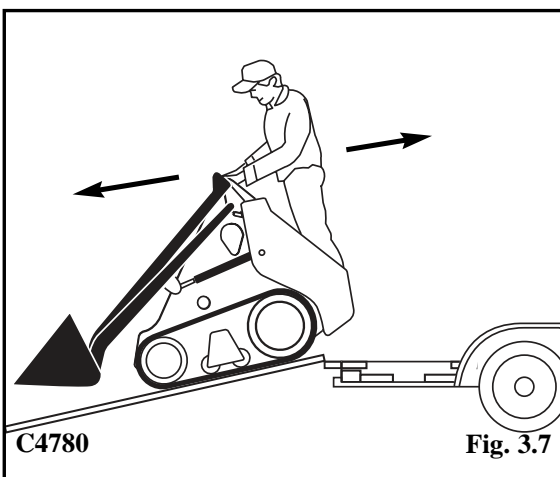

**IMPORTANT**

Never tow the Mini-Skid Loader! Damage may result.

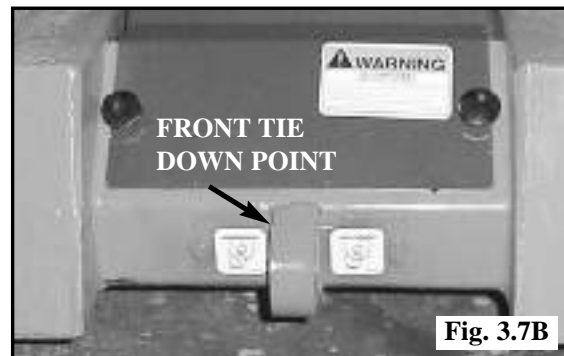
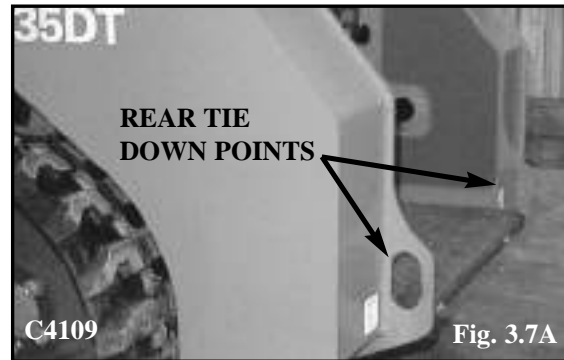

When transporting on a road or highway during the day or at night, be sure that the trailer is equipped with lights and signs as required by law.

### 3.8 LIFTING THE MINI-LOADER

Attach properly rated cables, chains or straps to the lift points. See Fig. 3.8



---

## SECTION 4

---

### 4. MAINTENANCE

- 4.1 Parts Ordering
- 4.2 Fuels, Lubricants and Capacities
- 4.3 Lift Arm Support
- 4.4 Engine Maintenance
- 4.5 Battery Maintenance
- 4.6 Hydraulic/Hydrostatic System Maintenance
- 4.7 Fuel Shutoff Valve
- 4.8 Engine Cooling System
- 4.9 Tracks
- 4.10 Electrical
- 4.11 Periodic Maintenance and Service Schedule
- 4.12 Trouble Shooting
- 4.13 Hydraulic Circuit
- 4.14 Electrical Circuit
- 4.15 Special Tools

---

## 4. MAINTENANCE

---

### 4.1 PARTS ORDERING

Maintenance and service intervals recommended in this manual are based on operation under average conditions. When operating the Mini-Skid Loader in severe conditions of heat, cold, dust, humidity or other extremes, service the Mini-Skid Loader at more frequent intervals.

Failure to perform regular maintenance will result in damage to the Mini-Skid Loader. Periodic maintenance and service is the key to trouble free operation.

### 4.2 FUELS, LUBRICANTS AND CAPACITIES

The service obtained from your Mini-Skid is greatly affected by the quality of the petroleum products used in it. It requires only common products which are commercially available through the outlets of major refineries. The following chart shows which lubricant to use in the various components of the Mini-Skid.

<b>COMPONENT</b>	<b>TYPE OF LUBRICANT/FLUID</b>	<b>CAPACITY Litre (Imp. Gals.)</b>
Engine Oil	SAE 10W30 API Classification CF	5.1 Litres (1.35US Gal.)
Fuel Tank (Fig 4.2)	Diesel	30.6 Litres (8.1 US Gal.)
Hydraulic Oil Reservoir	SAE 10W30 API Classification SJ	40 Litres (10.6 US Gal.)
Grease	Good quality lithium based grease	

## 4. MAINTENANCE

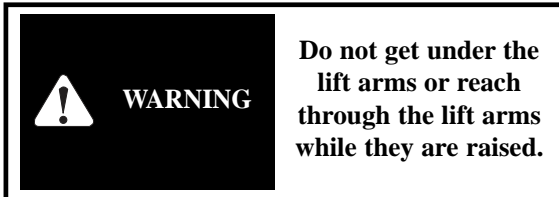

### 4.3 LIFT ARM SUPPORT

To engage the lift arm support, remove any attachment and raise the lift arm to its maximum height. Remove hitch pin while holding the lift arm support with your other hand. Slowly allow the lift arm support down into position against the cylinder shaft, taking care not to damage the cylinder shaft. See Fig. 4.3.

Ensure nylon lanyard does not get pinched or broken. If it does, replace immediately.

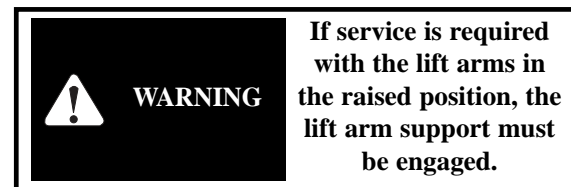
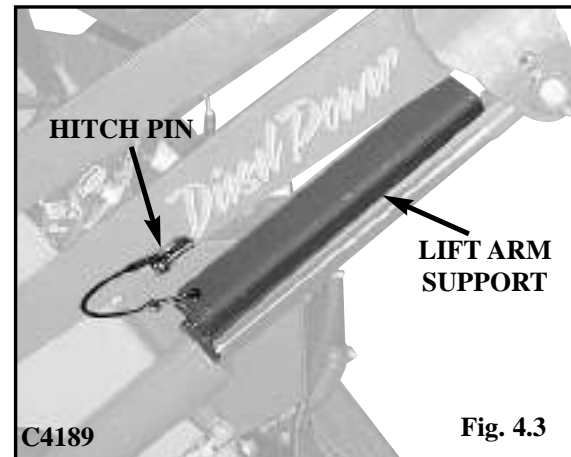

## 4. MAINTENANCE

### 4.4 ENGINE MAINTENANCE

#### OIL LEVEL CHECK

1. Ensure that the Mini-Skid is standing level.
2. Open the Service Access Cover (See Fig. 4.4) to access dipstick (See Fig 4.4A).
3. Remove dipstick on the right hand side of the engine and visibly check the level. Top up with recommended oil (See Fig 4.4B). See the chart if required.

For proper engine maintenance, refer to your Engine Owner's Manual. This pertains to all applicable maintenance on your engine.

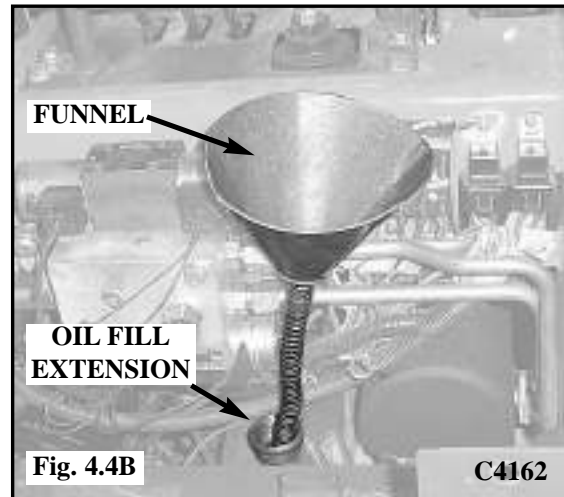
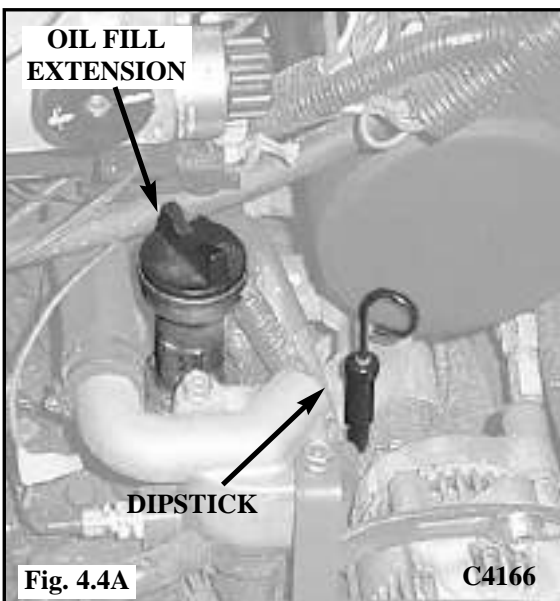

#### AIR FILTER MAINTENANCE

The air cleaner is located behind the service access cover and on the left hand side of the engine compartment.

Daily service can be performed by reviewing the air restriction indicator through the access hole provided on the left hand side of the machine. (Fig. 4.4C) If red indicator is visible perform air filter cartridge replacement by removing clips on air cleaner cover and removing both the primary and secondary cartridges. Replace with new filters. Ensure cartridges and cover are securely seated prior to operating the Mini-Skid Loader.

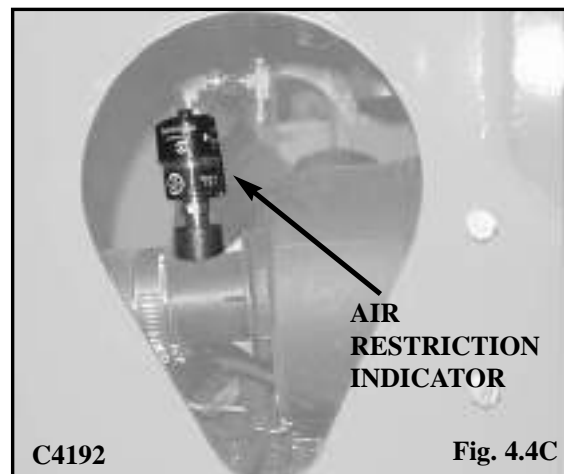

## 4. MAINTENANCE

### 4.5 BATTERY MAINTENANCE

**NOTE:** Raise lift arms and apply lift arm support device. See section 4.4.

1. Remove the access panel by removing the two black knobs (See Figs. 4.5 & 4.5A).
2. Check the battery hold down bracket for tightness. Do not overtighten.
3. Remove any acid corrosion from the battery terminals and cables with baking soda and water solution. Coat the terminals with a dielectric grease.
4. Ensure boot is securely in place over positive (+) terminal.

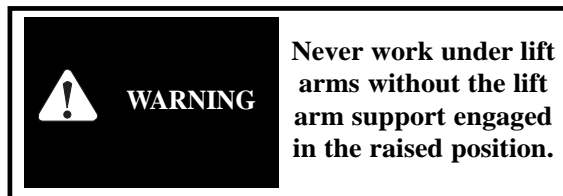
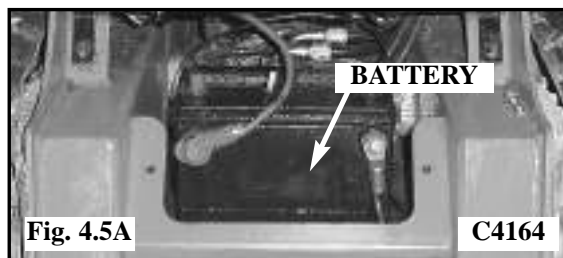
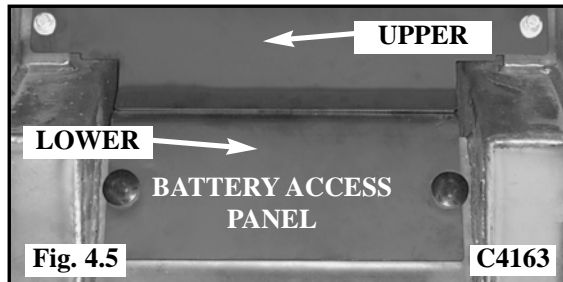

### 4.6 HYDRAULIC/HYDROSTATIC SYSTEM MAINTENANCE

#### HYDRAULIC OIL LEVEL CHECK

1. Ensure that the Mini-Skid is standing level, the lift arms are down and the tilt cylinder is closed.
2. Check visible oil level in sight glass, located on the left hand side of the operator's area. A dark color indicates oil presence (See Figs. 4.6 & 4.6A).
3. If it's necessary to add oil, remove the reservoir cap (See Fig. 4.6B) and add oil until it appears approximately half full in the sight glass. Use a good quality 10W30 oil which meets the API classification SE/CD.

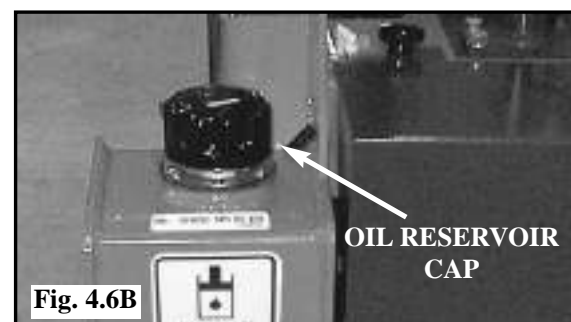
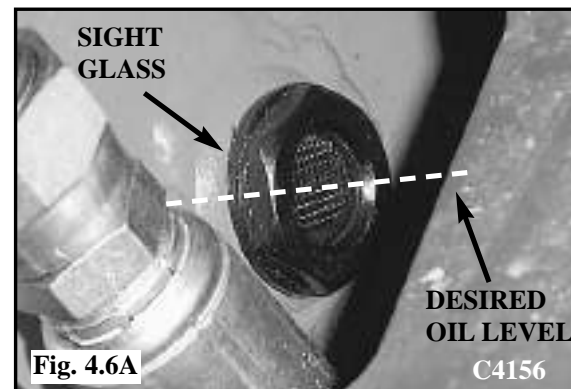
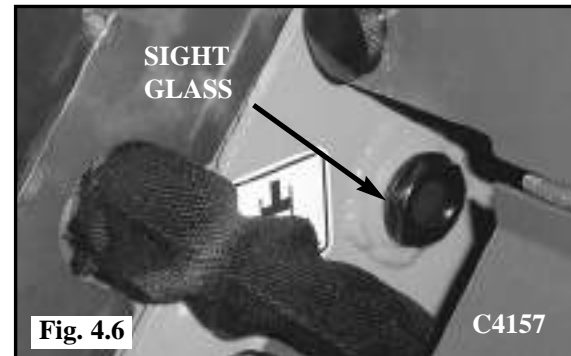



## 4. MAINTENANCE

### CHANGING HYDRAULIC OIL FILTER

1. With the engine stopped, remove bolts from the filter cover and remove the oil filter cartridge and bypass valve. See Fig 4.6C.
2. Remove bypass valve from used cartridge and install the bypass valve on new cartridge and install in filter housing. See Fig. 4.6D
3. Replace cover and tighten bolts.
4. Start the engine and check for leaks.
5. Stop the engine and check the hydraulic oil levels.

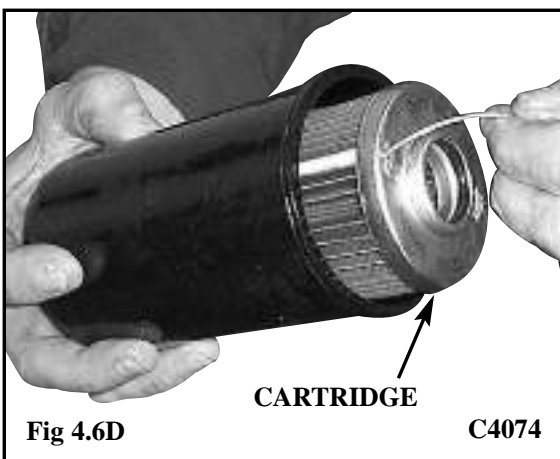
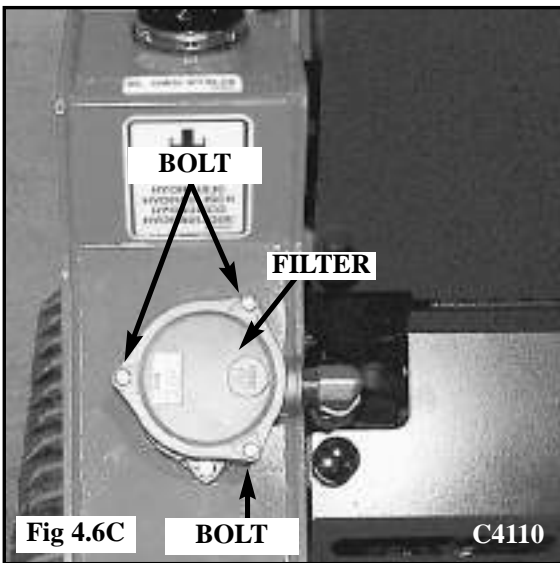

**IMPORTANT**

Do not allow dirt to enter the hydraulic/hydrostatic system

### CHANGING HYDRAULIC OIL

The hydraulic oil normally needs to be changed after 1000 operating hours or annually. However, if the oil becomes contaminated, or a major repair has been done to the hydrostatic transmission, it should be changed at once.

1. Remove the oil drain plugs located on the bottom of the oil tank (See Fig. 4.6E) as well as the bottom of the Mini-Skid Loader in the center.
2. Replace the oil drain plug, and refill the reservoir with clean oil of proper grade and type.
3. Start engine and check for leaks. Stop the engine and recheck the oil level.

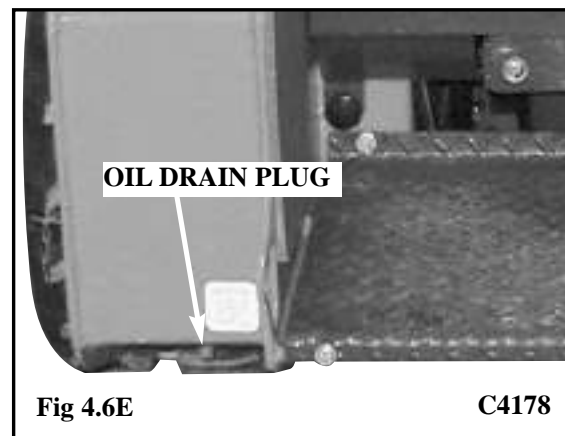

**WARNING**

Escaping hydraulic fluid under pressure can penetrate the skin causing serious injury.

- **DO NOT** use your hand to check for leaks. Use a piece of cardboard or paper to search for leaks.
  - Stop engine and relieve pressure before connecting or disconnecting lines.
  - Tighten all connections before starting engine or pressurizing lines.
- If any fluid is injected into the skin obtain medical attention immediately or gangrene may result.



## 4. MAINTENANCE

### 4.7 FUEL SHUTOFF VALVE

The fuel shutoff valve is located under the step plate of the Mini-Skid Loader (See Fig 4.7). Remove the four bolts in the step plate to gain access to the fuel shutoff valve.

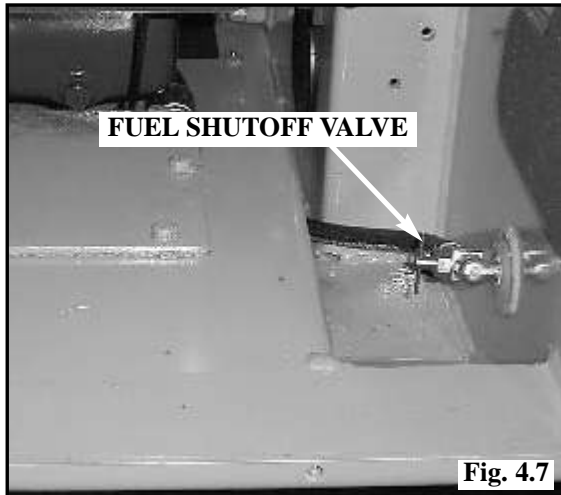

### FUEL FILTER REPLACEMENT

The fuel filter is located in the engine compartment on the left hand side (See Fig. 4.7A). The fuel filter should be replaced every 300 hours. To replace the filter, close the fuel shutoff valve, located below the operator's step plate (See Fig. 4.7). Replace the filter and ensure the clamps are secure. Open the fuel shutoff valve. It is not a requirement to bleed air from the fuel system. Follow Section 3.1 for starting instructions.

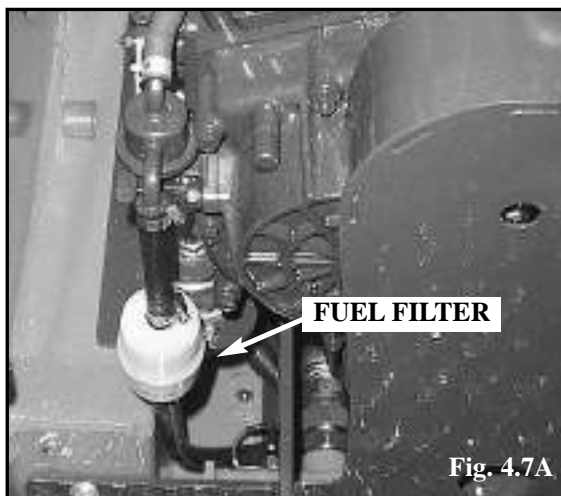

### 4.8 ENGINE COOLING SYSTEM

#### CHECKING COOLANT LEVEL (Fig. 4.8)

1. With the Mini-Loader shutdown and the engine cool, remove the black knob.
2. Swing the lid open.
3. Slowly remove radiator cap.
4. Check to see if coolant is visible in the bottom of the neck. If not add but do not fill beyond the bottom of the filler neck tube. If adding coolant is required, fill with a 50% mixture of ethylene glycol and water for cold weather protection.

The radiator cooling fins (See Fig. 4.8) must be kept free of debris otherwise overheating of the engine will occur. Inspect the radiator cooling fins for damage or buildup of debris. Repair any damage and, if necessary, flush the radiator with compressed air to remove debris.

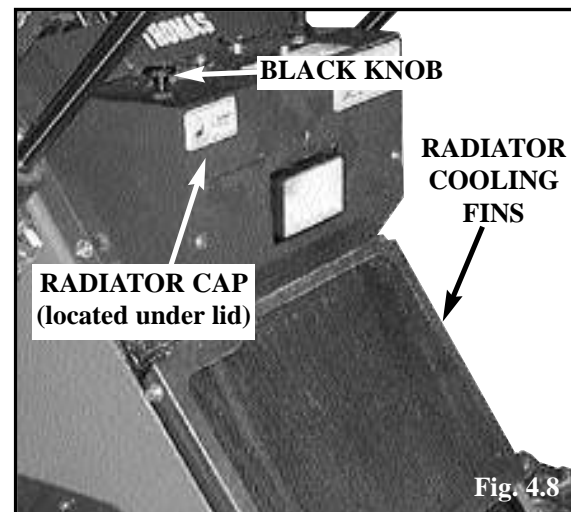

## 4. MAINTENANCE

### 4.9 TRACKS

Every 8 hours:

To perform this check, raise and block the front of Mini-Skid Loader using the bucket tilt function, and the rear of the Mini-Skid Loader with a suitable lifting device. (See Fig. 4.9)

Check The Following Items (See Fig. 4.9A):

- Torques on 5/8" idler mount bolts (80 ft. lbs.)
- Idler wheels are unbroken and rotating freely. Check idler wheel bolts to ensure tightness.
- For sprocket wear.
- Inspect tracks and springs for cracks and premature failure.
- Sprocket bolt torque (80 ft. lbs.)
- Wheel nuts (80-90 ft. lbs.)

Ratcheting is the term given to sprocket/track slippage. (When the sprocket spins inside the track). This is a symptom of component failure and must be diagnosed and corrected immediately.

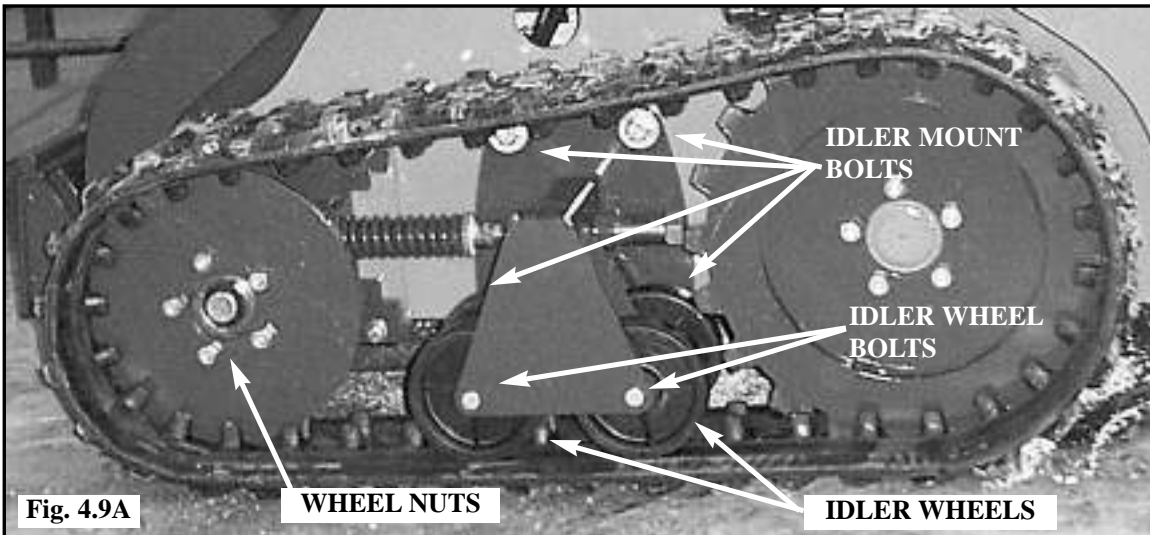
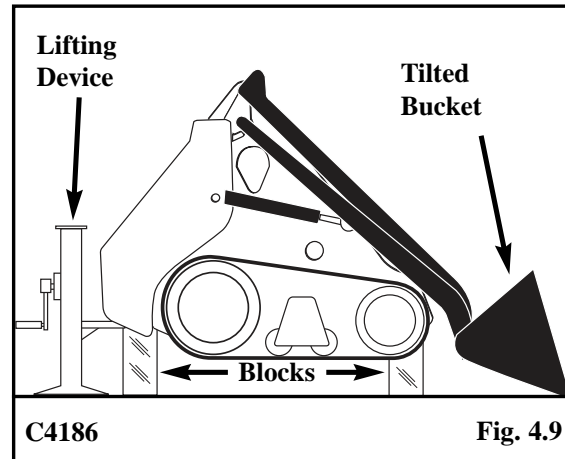

## 4. MAINTENANCE

### 4.10 ELECTRICAL

The Mini-Skid Loader is equipped with a 12 volt, negative ground electrical system. All electrical service items can be accessed through the service access panel on rear of machine. See Fig 4.10A.

All fuses, relays and circuit breakers terminate to this point.

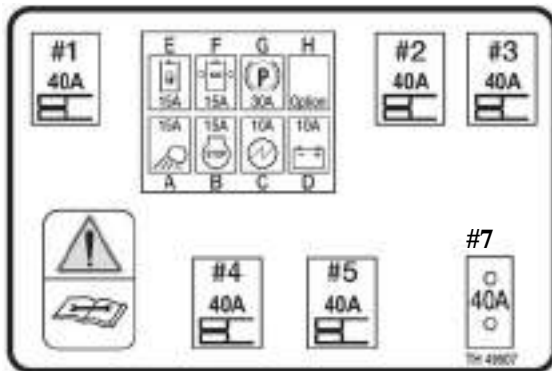
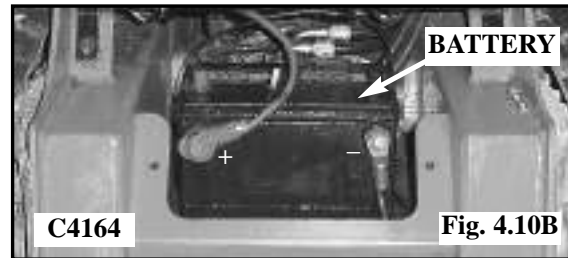
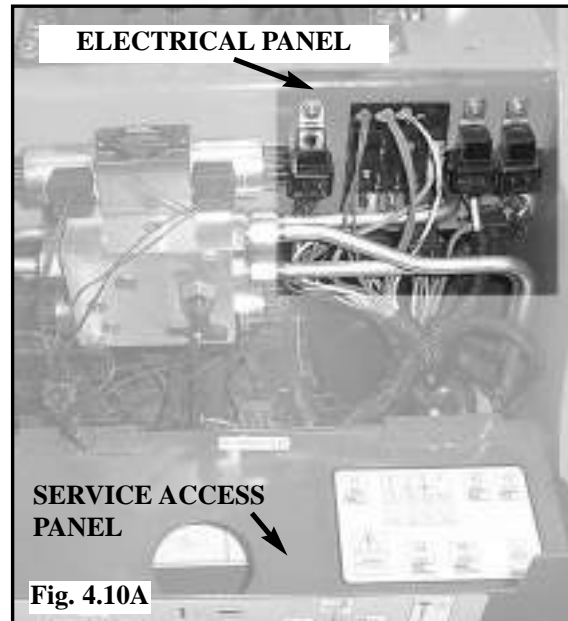

Fig. 4.10

#### RELAYS AND FUSES (Fig. 4.10)

1. Safety Latching Relay
2. Alternate Latching Relay
3. First Alternating Relay
4. Second Alternating Relay
5. Glow Plug Relay
6. Fuse Panel
  - A. Work Lamp, Access. Plug, Tilt Plug
  - B. Hourmeter, Fuel Solenoid
  - C. Low Oil Pressure Lamp
  - D. Alternator "IGN"
  - E. Safety Interlock
  - F. Combiner Valves
  - G. Brake
  - H. Option
7. 40 Amp Circuit Breaker



#### BOOSTING PROCEDURES

The ignition must be in the OFF position. The booster battery to be used must be 12 volt. Connect the end of the first cable to the positive (+) terminal of the booster battery. Connect the other end of the same cable to the Mini-Skid Loader battery positive (+) terminal (See fig. 4.10B). Connect the end of the second cable to the negative (-) terminal of the booster battery. Connect the other end of the same cable to a ground. Keep cables away from moving parts. Start the engine. After the engine has started, disconnect the end of the second cable from the negative (-) terminal of the booster battery. Disconnect the other end of the same cable from the ground. Disconnect the end of the first cable from the positive (+) terminal of the booster battery. Disconnect the other end of the same cable from the Mini-Skid Loader battery positive (+) terminal.

## 4. MAINTENANCE

### 4.11 PERIODIC MAINTENANCE AND SERVICE SCHEDULE

ITEM	SERVICE REQUIRED	8 HOURS	50 HOURS	150 HOURS	300 HOURS	1000 HOURS
Engine Oil	Check level of engine oil and top up if necessary. Use 10W30 API Classification CF oil.					
Engine Fuel	Check level and top up if necessary.					
Hydraulic System	Check level and top up if necessary. Use 10W30 API Classification SJ oil. Check hoses, fittings, etc.					
Cooler	Check level and add if necessary. Fill with 50% mixture of ethylene glycol and water. Check cooling fins for dirt.					
Air Cleaner	Check indicator.					
Tracks and Wheel Nuts	Check tracks for damage and check wheel nut torque. 80 ft. lbs.					
Safety System	Verify Safety System is functional. See Section 2.3 .					
Decals	Check for damaged safety or instruction decals (See Section 5.3). If necessary replace.					
Lubrication	Grease all hinge pin fittings and pivot bearings until excess shows.					
Hydraulic Oil Filter	Replace hydraulic oil filter element. Initial change only.					
Engine Oil	Replace engine oil. Use API Classification CF oil. Initial change only.					
Engine Oil Filter	Replace engine oil filter. Initial change only.					
Final Drive	Check chain, sprocket and bearing conditions..					
Hydraulic Oil Filter	Replace hydraulic oil filter.					
Axle Lubrication	Grease rear axle and pack front.					
Engine Oil	Replace engine oil. Use API Classification CF oil.					
Battery	Clean and protect battery terminals.					
Fuel Filter	Replace fuel filter.					
Engine Oil Filter	Replace engine oil filter.					
Hydraulic Oil	Change hydraulic oil. Use 10W30 API Classification SJ oil. Replace inlet strainers in the oil reservoir.					
Engine Cooling System	Drain, flush and refill. Use 50% mixture of ethylene glycol and water. Inspect coolant hoses.					

## 4. MAINTENANCE

### 4.12 TROUBLE SHOOTING

The following chart is intended to help isolate troubles and list possible remedies.

Problem	Cause	Remedy
Starter does not crank engine.	Low battery output.	Recharge or replace battery.
	Loose or disconnected battery cable.	Check and tighten all connections.
Engine turns over, but does not start.	No fuel in tank.	Fill tank with clean fuel.
	Fuel shut-off valve closed.	Open shut-off valve.
	Improper starting procedure.	Refer to starting procedure.
	Glow plug burnt out.	Replace glow plug.
Noisy hydraulic system.	Air in system.	Check oil level, add if necessary.
	Loose suction line and/or fittings.	Tighten all fittings and connections.
	Clogged oil filter.	Replace oil filter.
	Hydraulic oil too heavy.	Warm up hydraulic oil when too cold.
	Internal pump or motor damage.	Contact dealer.
Erratic or no output on drive.	Hydraulic oil too heavy.	Use proper viscosity oil.
	Hydraulic oil level too low.	Check oil level. Add if necessary.
	Drive couplings between engine and pump broken.	Check couplings, replace if necessary.
Loss of hydraulic oil flow from gear pump.	Reservoir low on oil.	Check oil level. Add if necessary.
	Drive couplings between engine and pump broken.	Check couplings, replace if necessary.
	Hydraulic gear pump not functioning.	Inspect and repair if necessary.
Hydraulic cylinders do not function properly.	Loss of hydraulic flow from gear pump.	See above.
	Safety system not releasing.	Troubleshoot system operations.
Oil overheating.	Reservoir low on oil.	Check oil level. Add if necessary.
	Auxiliary control lever engaged.	Return auxiliary lever to neutral.
	Setting of relief valve too high or too low.	Check relief pressure.
Engine overheating.	Cooling water insufficient.	Replenish.
	Radiator clogged with dust.	Clean.
	Auxiliary valve engaged.	Return to neutral position.
Noisy drive operation.	Chains too loose.	Tighten chain.
No electrical functions.	Fuse blown.	Check fuses.
Brake on RH drive will not release.	Fuse blown.	Check fuses.
	Defective solenoid.	Diagnose and replace if necessary.
	Corroded brake pin.	Clean or replace as necessary.
	Tension on brake pin.	Jog loader forward and rearward slightly to relieve tension.

# 4. MAINTENANCE

## 4.13 HYDRAULIC CIRCUIT

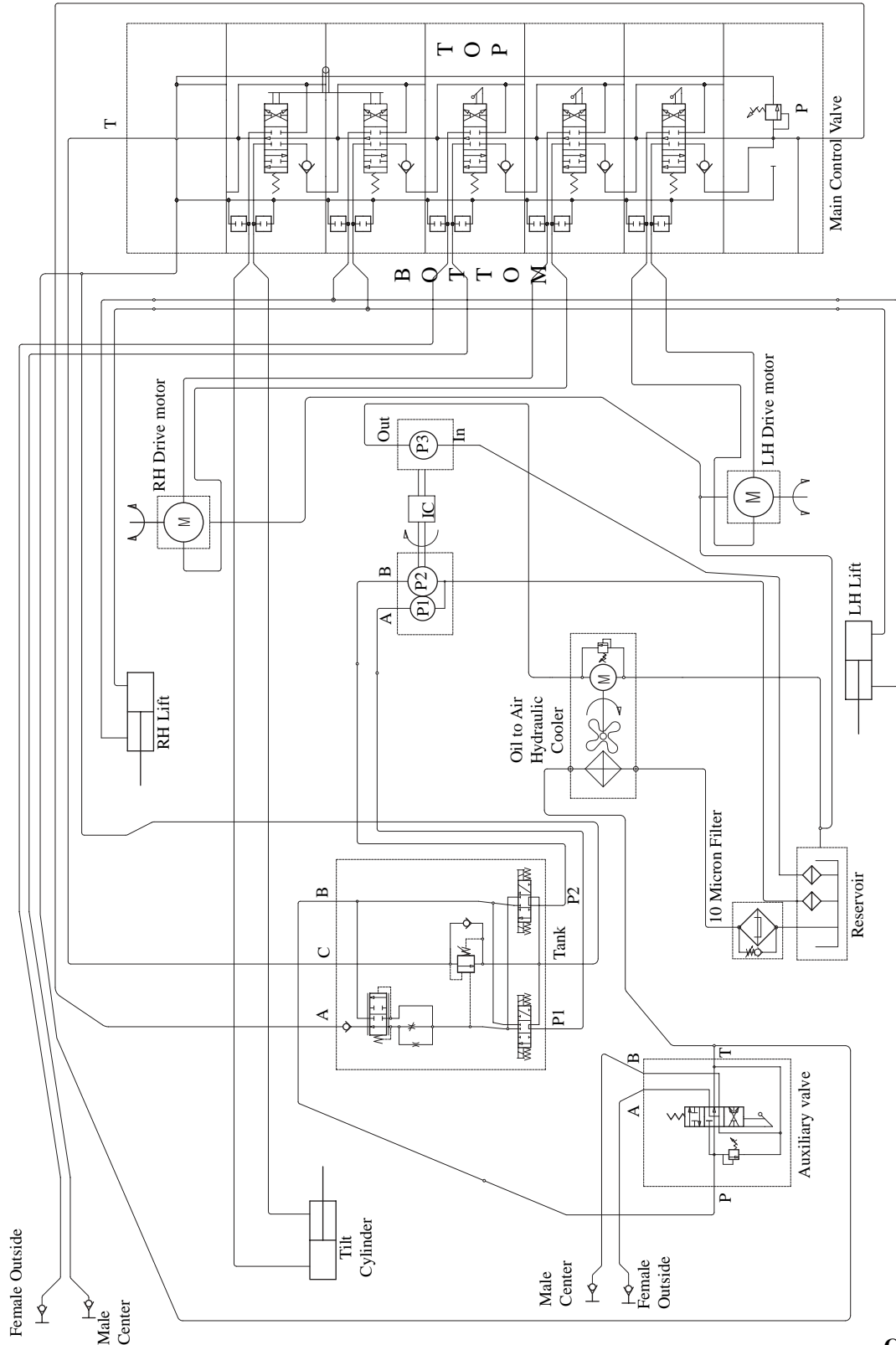

C4717

# 4. MAINTENANCE

## 4.14 ELECTRICAL CIRCUIT

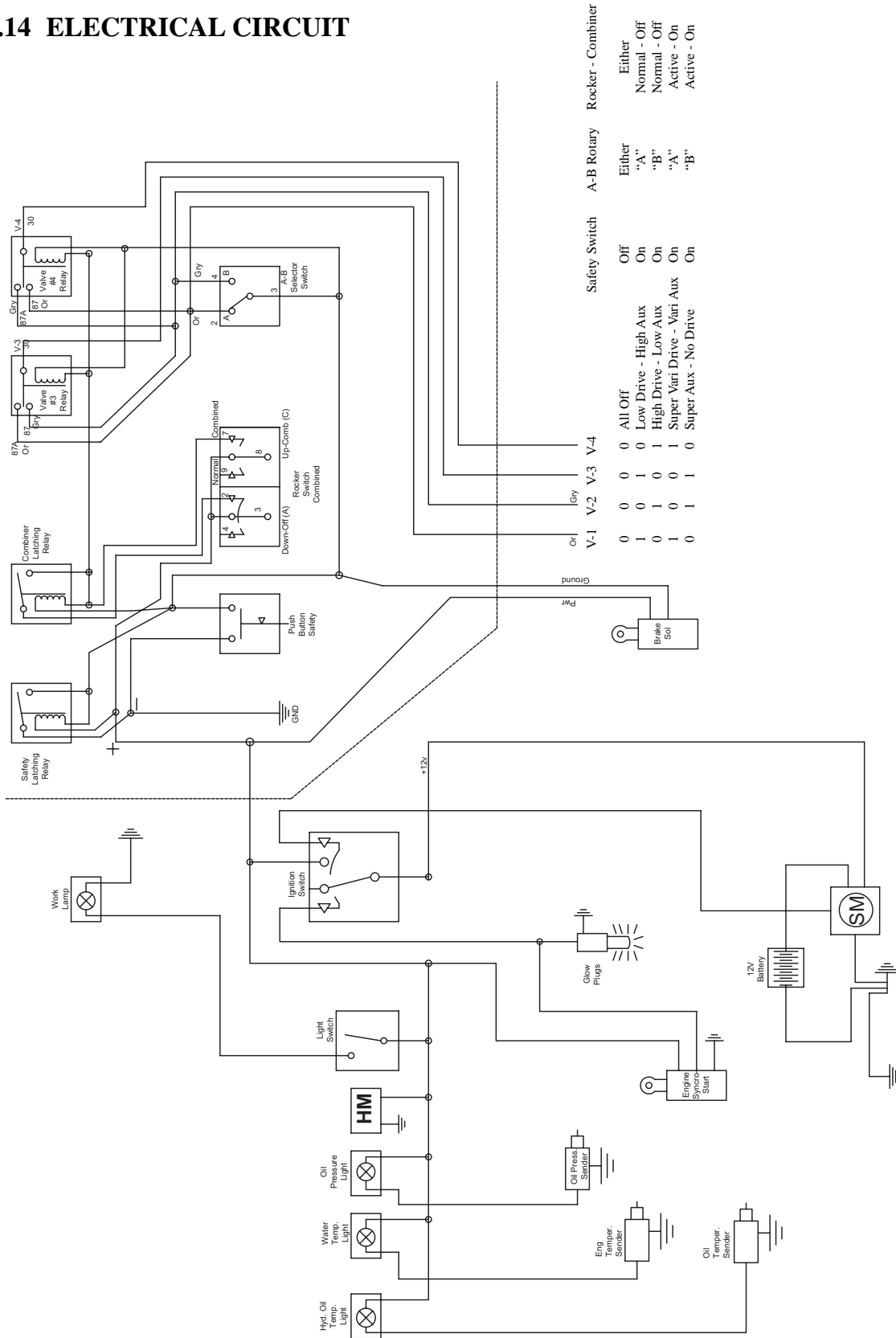

C4131

## 4. MAINTENANCE

### 4.15 SPECIAL TOOLS

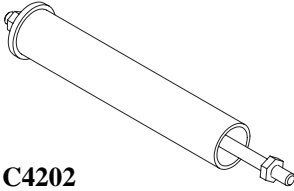
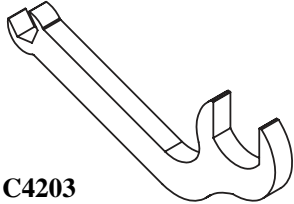
PART #	ILLUSTRATION	DESCRIPTION	MODEL
960456	 C500	Hydraulic Flow and Pressure gauge assembly	ALL MODELS
964976	 C4202	Pin Removal Tool	35DT
51661	 C4203	Plate, Filter Assembly Tool	35DT



---

## **SECTION 5**

---

### **5. SPECIFICATIONS**

- 5.1 Specifications
- 5.2 Decals

# 5. SPECIFICATIONS

## 5.1 SPECIFICATIONS

### 35DT Mini-Skid Loader

Tipping Load .....1200 lbs. (544.3 kg)  
 Rated Operating Capacity (35%)  
 .....420 lbs. (190.5 kg)  
 Shipping Weight:w/o bucket  
 .....2050 lbs. (929.86 kg)  
 Operating Weight w/ bucket  
 .....2350 lbs. (1065.92 kg)  
 Travel Speed.....1.3 mph (2.1 km/hr) (low)  
 .....3.5 mph (5.6 km/hr) (high)  
 .....4.4 mph (7.1 km/hr) (combined flow)

### DIMENSIONS

A. Overall Operating Height, in. (mm)  
 .....85 (2158)  
 B. Height To Hinge Pin .....68.75 (1746.25)  
 C. Overall Height Of Mini-Skid  
 .....51.25 (1301.75)  
 D. Overall Length With 42" Bucket  
 .....79.75 (2025.65)

E. Dump Angle.....72°  
 F. Dump Height .....46 (1168.4)  
 G. Reach-Fully Raised .....10 (254)  
 H. Height @ 45° Dump Angle  
 .....48.75 (1238)  
 I. Reach @ 45° Dump Angle  
 .....18.75 (464)  
 J. Maximum Roll Back @ Ground .....35°  
 K. Maximum Roll Back - Fully Raised .....34°  
 M. Wheelbase .....30.25 (768.35)  
 N. Overall Length, Less Bucket  
 .....63.25 (1606.55)  
 O. Ground Clearance .....6 (152.4)  
 P. Maximum Grading Angle - Bucket .....70°  
 Q. Angle of Departure .....30°  
 R. Bucket Width .....42 (1066.8)  
 S. Clearance Circle, Front - Less Bucket  
 .....30.63 (778)  
 T. Clearance Circle, Front - with Bucket  
 .....50.3 (1277)  
 U. Clearance Circle, Rear .....38.3 (973)  
 V. Over-all Width - Less Bucket  
 .....42 (1066.8)  
 W. Tread .....33 (838.2)

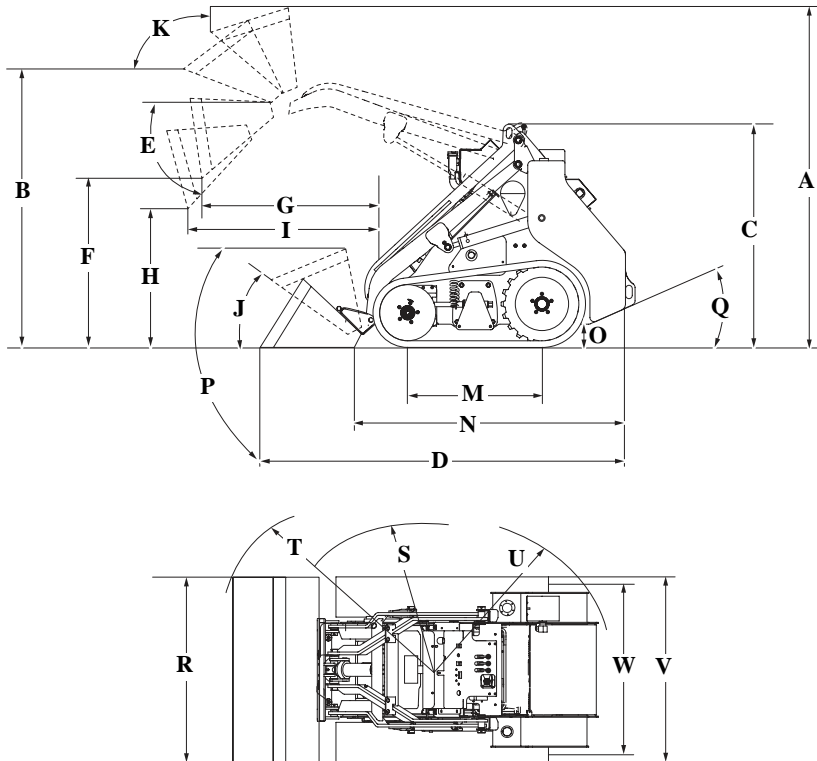

## 5. SPECIFICATIONS

### ENGINE - DIESEL

Make and Model .....Kubota D1105  
Type.....Three cylinder, liquid cooled diesel  
Displacement.....1.1 L  
Output Horsepower.....25 HP net @ 3000 RPM (ISO 9249 Net Power)  
Output Torque .....50.5 ft.lb @ 2100 RPM

### FLUID CAPACITIES

Fuel Tank .....30.6 L (8.1 US gal.)  
Engine Oil with Filter Change .....5.1 L (1.35 US gal.)  
Hydraulic Oil Reservoir .....40 L (10.6 US gal.)

### TRACK AND BUCKET

#### TRACK

Imbedded steel rubber track

BUCKET	Struck Capacity	Rated Capacity	Weight
42" General Purpose	3.8 ft. <sup>3</sup> (0.101 m <sup>3</sup> )	4.70 ft. <sup>3</sup> (0.133 m <sup>3</sup> )	120 lbs. (54.5 kg.)

# 5. SPECIFICATIONS

## 5.2 DECALS

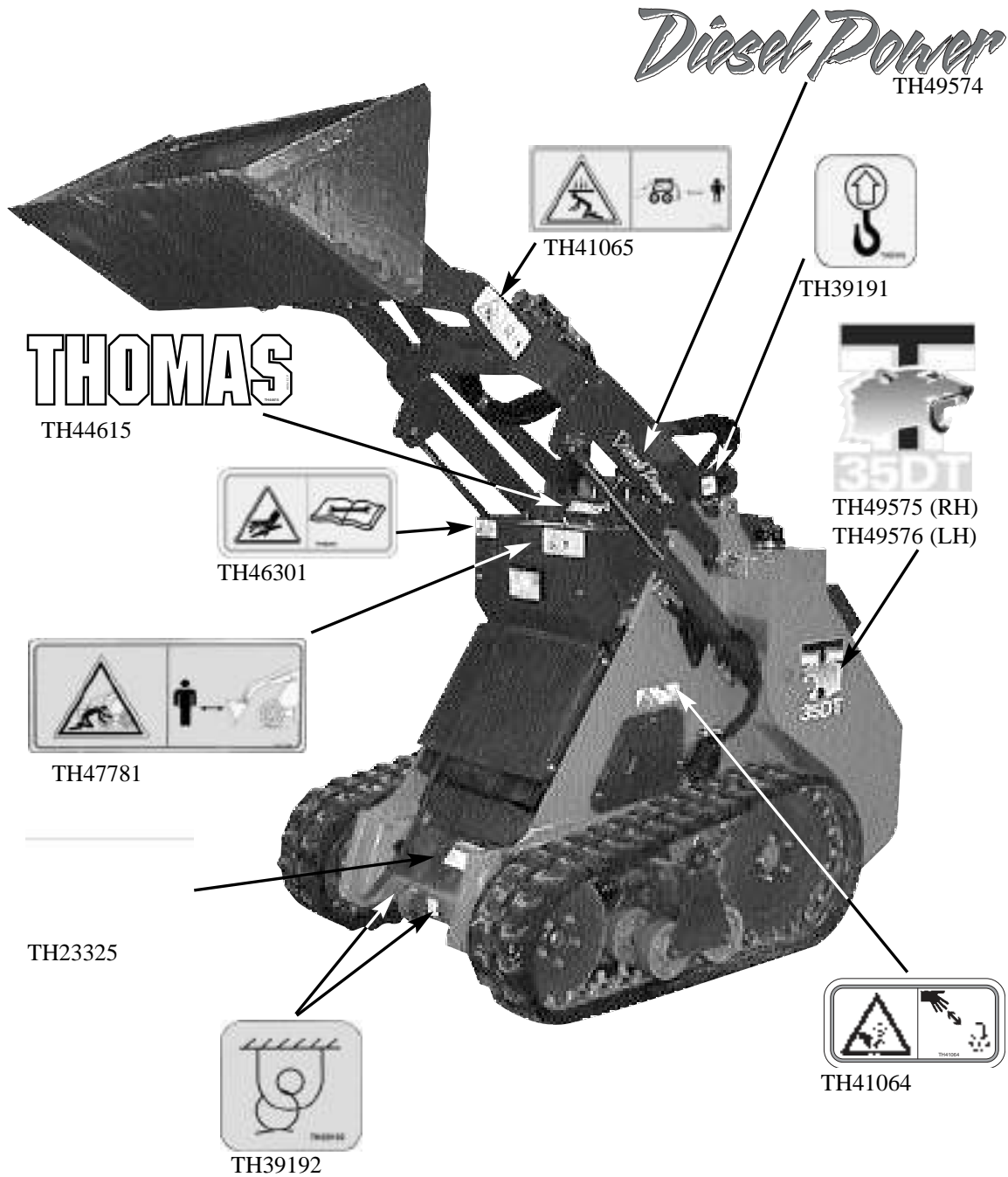

# 5. SPECIFICATIONS

## 5.2 DECALS

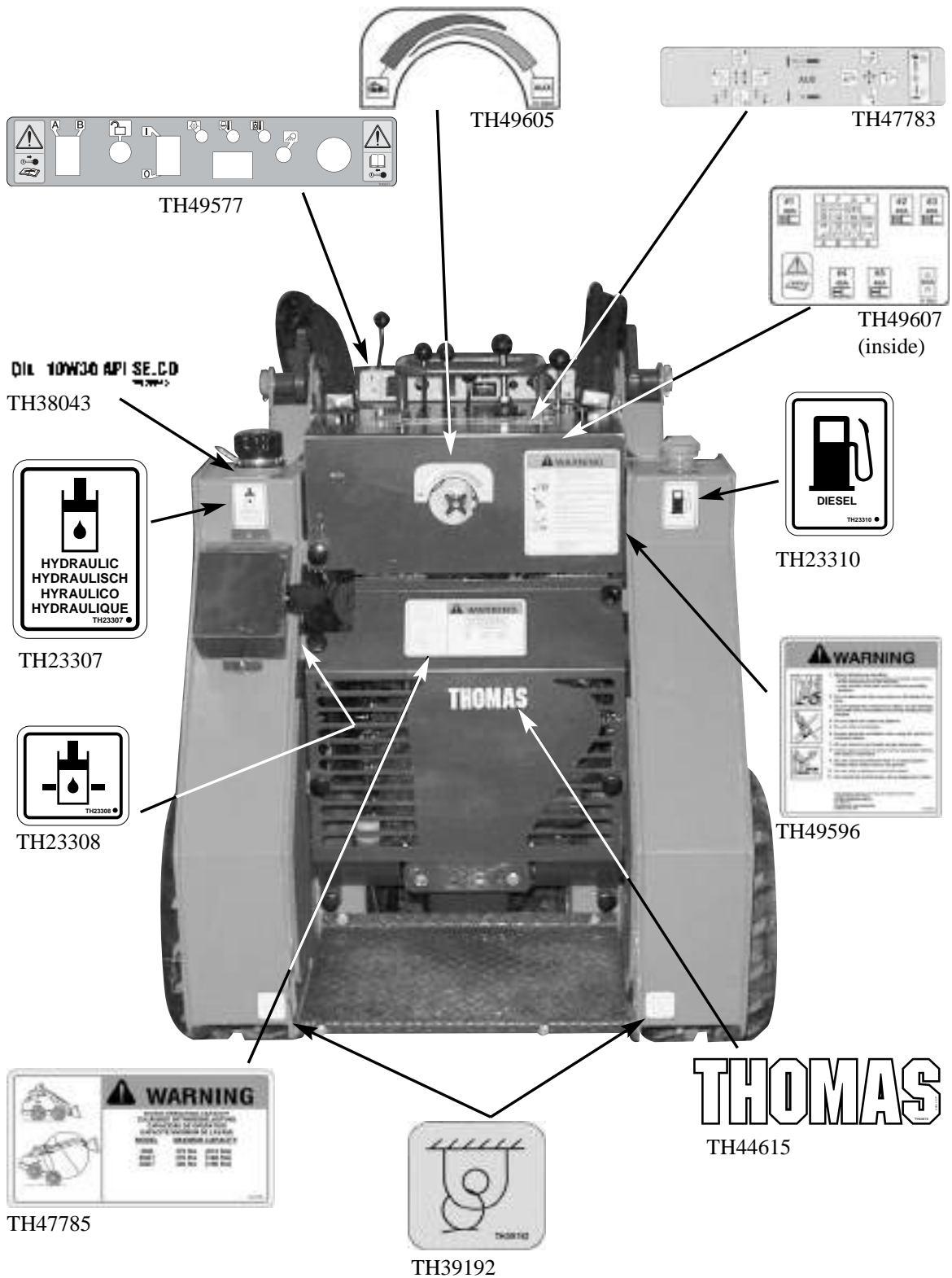

# 5. SPECIFICATIONS

## 5.2 DECALS

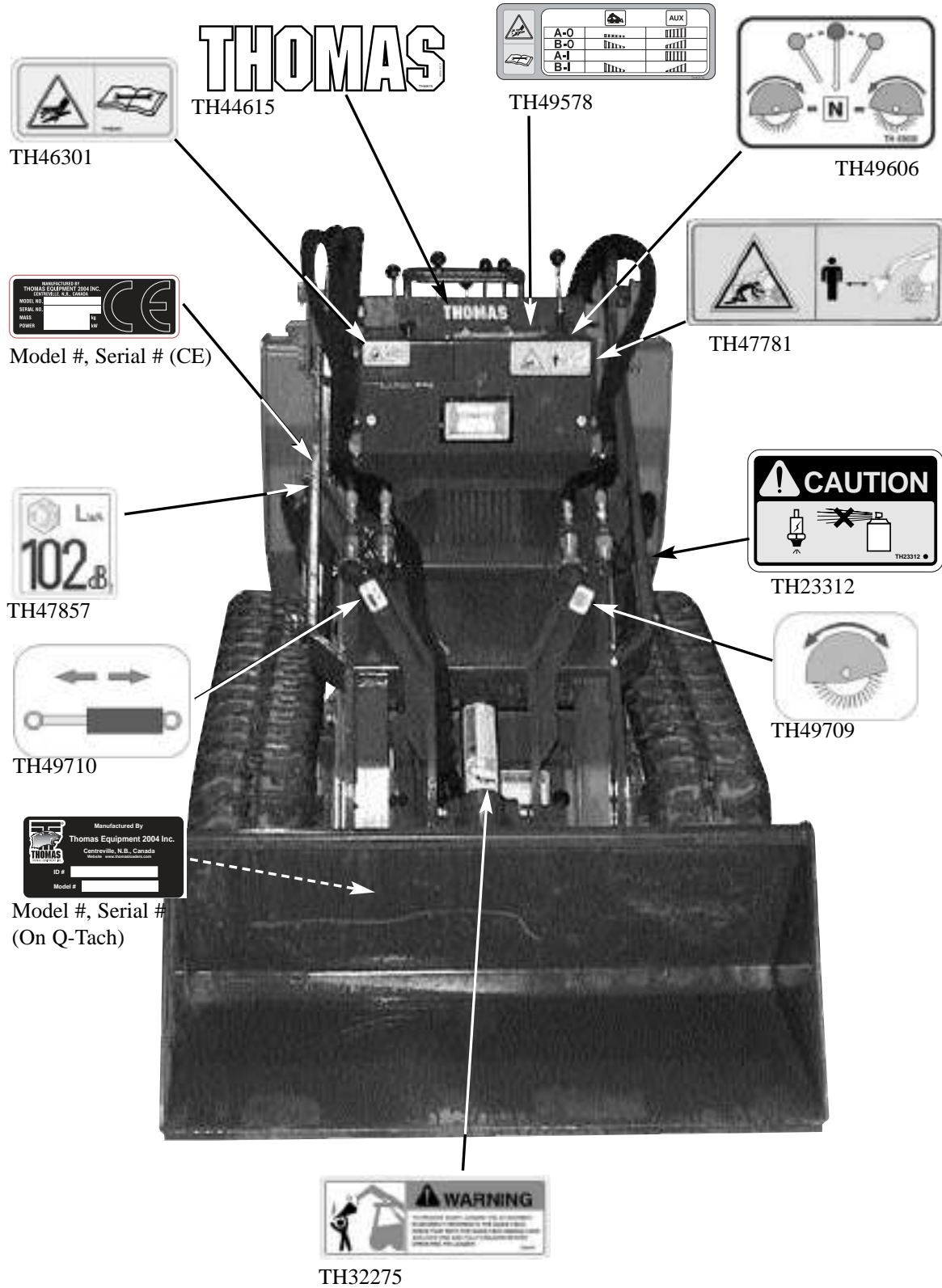

---

## SECTION 5

---

### 6. PARTS CATALOGUE

- 6.1 Mainframe
- 6.2 Operator's Platform
- 6.3 Lift Arms
- 6.4 Tracks
- 6.5 Hydraulic Schematic
- 6.6 Control Levers/Dash Panel
- 6.7 Electrical Schematic
- 6.8 Engine Spare Parts

# 6. PARTS BREAKDOWN

## 6.1 MAINFRAME

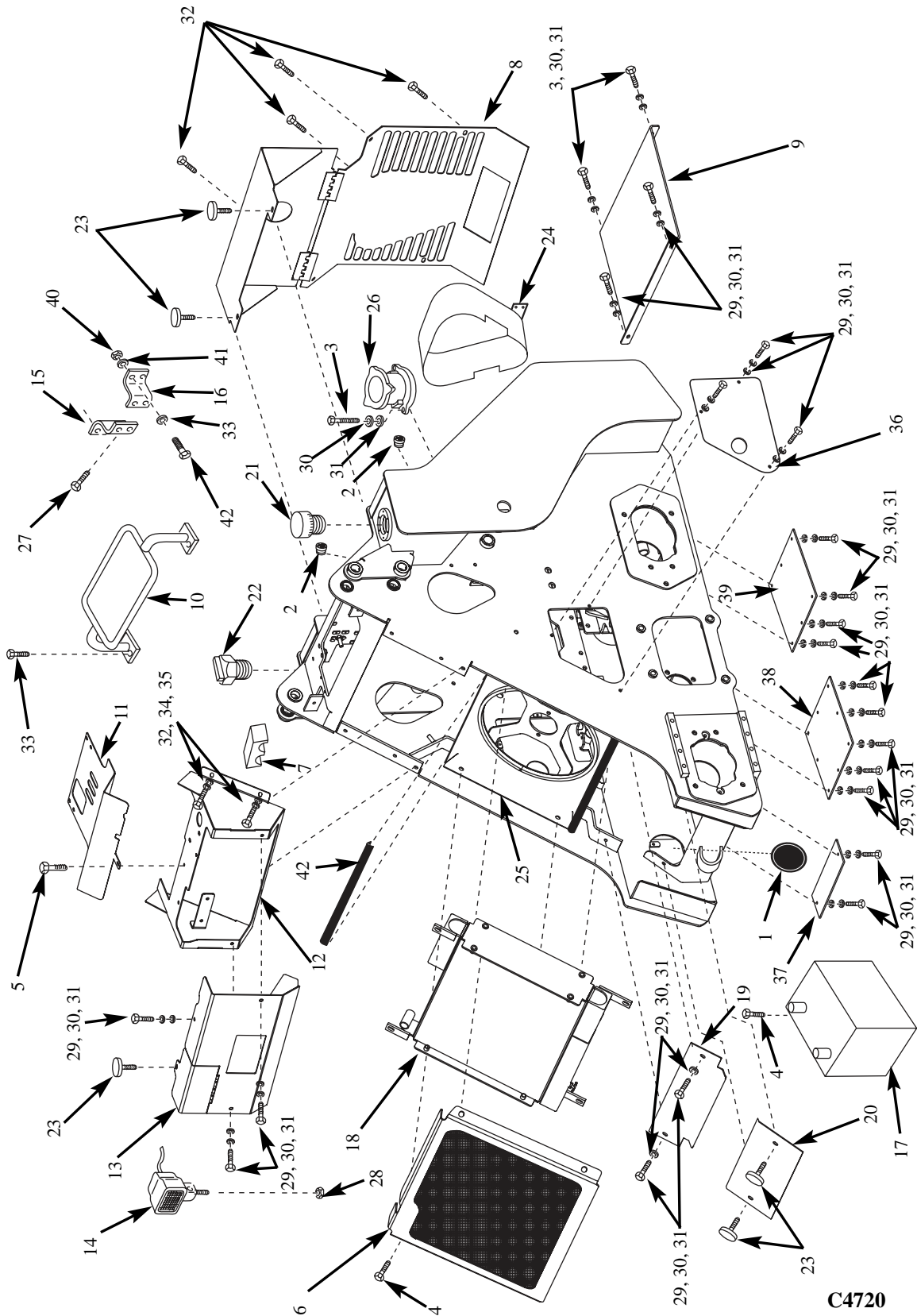



## 6. PARTS BREAKDOWN

<b>6.1 MAINFRAME</b>			
ITEM	PART NO.	DESCRIPTION	QTY.
1.	38789	Plug, Snap-In 4"	4
2.	48090	Sight Glass 1" NPT	2
3.	5170	Bolt, Hex 1/4" x 1" UNC GR5 PL	4
4.	1193	Bolt, Hex 3/8 x 1/2 PC	9
5.	2338	Bolt, 1/4" x 1/2"	1
6.	964975	Cooler Cover	1
7.	38303	Clamp, Tube Twin	7
8.	964796	Combiner Cover Assembly	1
9.	48902	Step Plate	1
10.	964132	Handle, Welded Assembly	1
11.	51073	Dash Panel	1
12.	965592	Valve Mount Ass'y	1
13.	965216	Valve Mount Cover Welded Ass'y	1
14.	47468	Lamp, Halogen Complete	1
*	47861	Bulb, Halogen (Not shown)	1
15.	47766	R.H. Valve Mount	1
16.	47767	L.H. Valve Mount	1
17.	38870	Battery, 12 V	1
18.	49237	Cooler	1
19.	51379	Upper Front Shield	1
20.	51380	Lower Front Shield	1
21.	36733	Breather, Oil Filler Locking	1
22.	40922	Fuel Cap, Locking	1
23.	42070	Knob	5
24.	964797	Belt Guard Assembly	1
25.	964667	Cooler Fan Shroud	1
26.	47838	In-Tank Oil Filter	1
27.	23459	Bolt, Hex 8 mm x 15 mm x 1.25 mm	3
28.	47470	Nut, 3/8" Hex Flanged	1
29.	2663	Bolt, 1/4" x 3/4"	28
30.	2279	Washer, Lock 1/4"	34
31.	1650	Washer, 1/4"	36
32.	6081	Bolt, 5/16" x 3/4"	4
33.	21029	Washer, Lock 8 mm	4
34.	1870	Washer, Lock 5/16"	16
35.	1651	Washer, 5/16"	12
36.	51384	LH Shield, RH Shield	2
37.	51349	Front Bottom Shield	1
38.	51204	Middle Bottom Shield	1
39.	51205	Back Bottom Shield	1
40.	7465	Nut, Nylok 3/8" UNC	1
41.	1643	Washer, Flat 3/8"	3
42.	920	Trim Lock, Molded, 1/8"	3.27 ft.

# 6. PARTS BREAKDOWN

## 6.2 OPERATOR'S PLATFORM

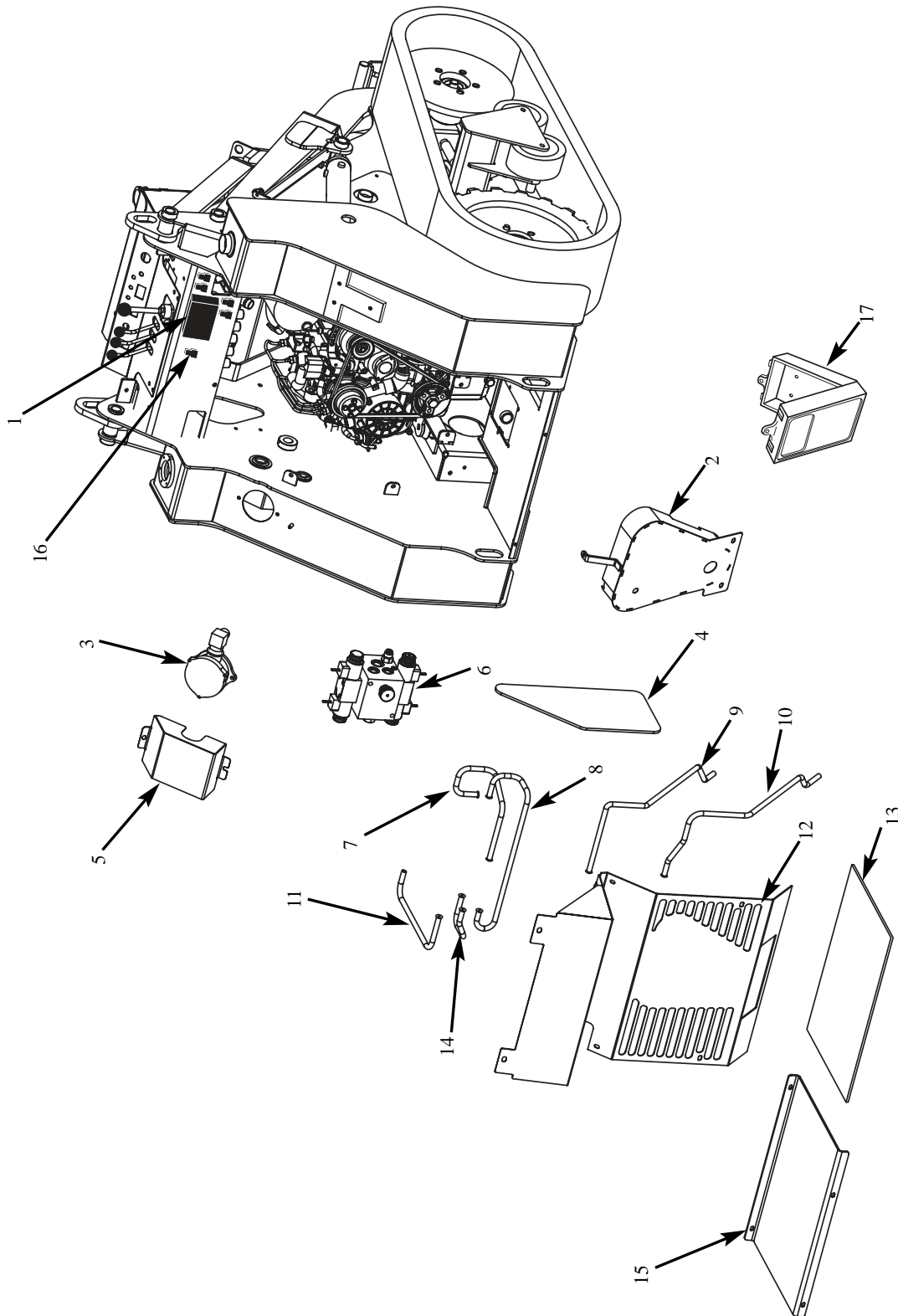

C4723

## 6. PARTS BREAKDOWN

### 6.2 OPERATOR'S PLATFORM

ITEM	PART NO.	DESCRIPTION	QTY.
1.	39540	Panel, Fuse & Circuit	1
2.	964797	Belt Guard Assembly	1
3.	47838	In-tank Oil Filter	1
4.	48906	Tank Insulation Left Hand Side	1
5.	964988	Filter Shield Welded Assembly	1
6.	49236	Valve, Hydraulic Combiner	1
7.	49362	Tube, Hydraulic 1/2" x 20"	1
8.	49364	Tube, Hydraulic 1/2" x 29"	1
9.	49361	Tube, Hydraulic 1/2" x 28"	1
10.	49360	Tube, Hydraulic 1/2" x 30"	1
11.	49365	Tube, Hydraulic 1/2" x 20"	1
12.	964796	Combiner Cover Assembly	1
13.	49570	Insulation, Heat Barrier	1
14.	49363	Tube, Hydraulic 1/2" x 12"	1
15.	48902	Step Plate	1
16.	39840	Relays	5
17.	40737	Manual Holder	1
*	39840	Relays	5
*	39121	Fuse, 15 Amp	4
*	39122	Fuse, 10 Amp	3
*	39119	Fuse, 30 Amp	1
*	21927	40 Amp Circuit Breaker	1
*	48025	Cap, Circuit Breaker	1

\* - Item not shown.

# 6. PARTS BREAKDOWN

## 6.3 LIFT ARMS

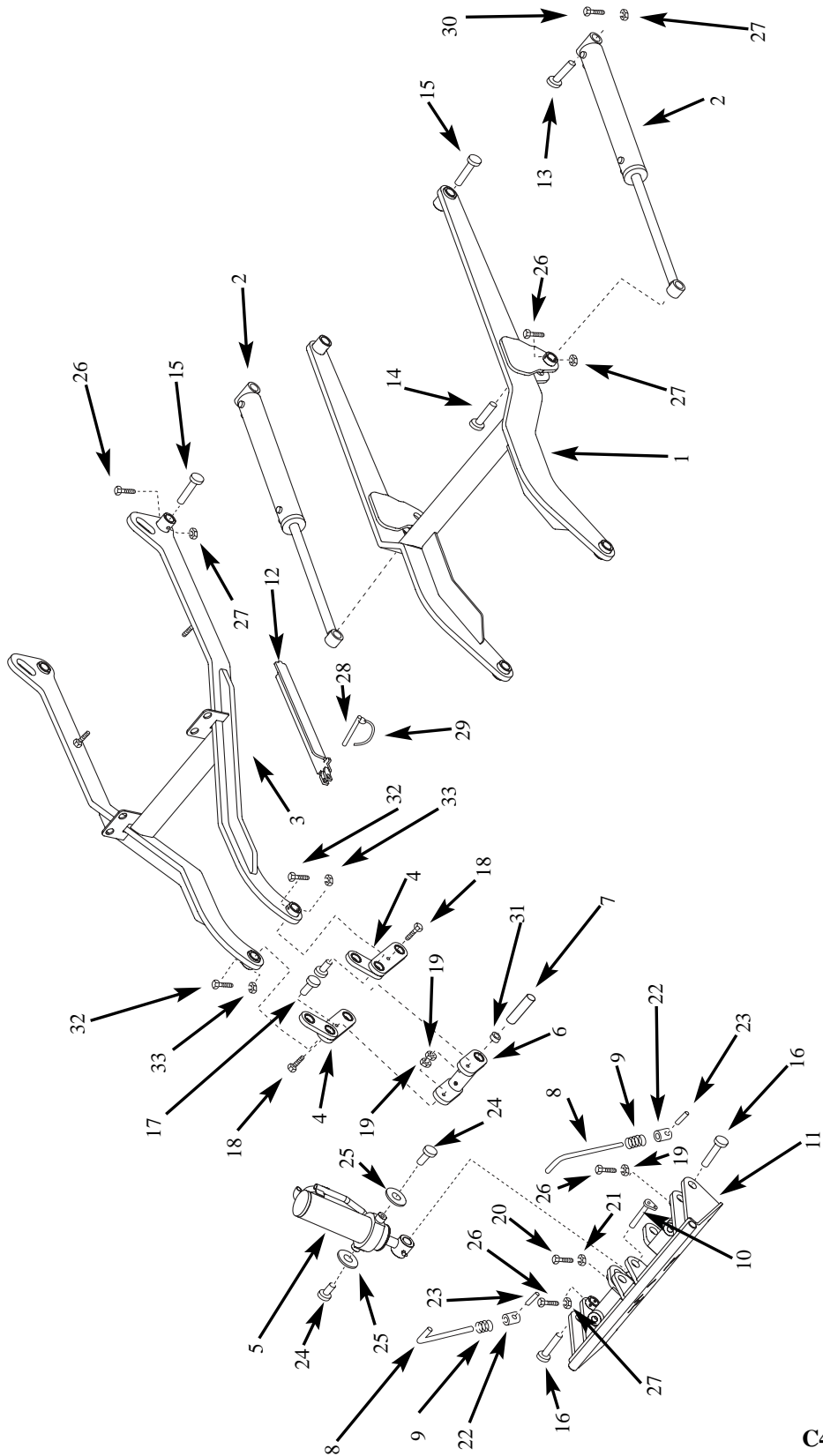

C4133

## 6. PARTS BREAKDOWN

### 6.3 LIFT ARMS

ITEM	PART NO.	DESCRIPTION	QTY.
1.	964509	Lift Arm Welded Assembly (To S/N MD000192)	1
1.	965365	Lift Arm Welded Assembly (S/N MD000193 Onward)	1
2.	49334	Cylinder, 2 x 14 x 22	2
3.	964510	Parallel Arm Welded Assembly (To S/N MD000192)	1
3.	965649	Parallel Arm Welded Assembly (S/N MD000193 Onward)	1
4.	963987	Tilt Support (L.H.)	1
4.	963988	Tilt Support (R.H.)	1
5.	47463	Cylinder Assembly, 2.5" x 6.5" x 3.75"	1
6.	963989	Tilt Support Center Assembly	1
7.	47698	Pin, Q-Tach Pivot	1
8.	47691	Bar, Q-Tach Handle	2
9.	47613	Spring, Compression	2
10.	49298	Pin, Tilt Assembly	1
11.	964511	Q-Tach Welded Assembly	1
12.	49749	Lift Arm Support	1
*	15931	Weather Strip Foam	1.5"
13.	51052	Pin, Lift Cylinder Base	2
14.	51019	Pin, Lift Cylinder Rod End	2
15.	51018	Pin, Lift Arm Pivot	4
16.	51020	Pin, Liftarm to Q-Tach	2
17.	49958	Parallel arm to Q-Tach	2
18.	1672	3/8" x 1 1/2" Bolt	2
19.	7465	3/8" Nylok Nut	2
20.	2580	5/16" x 1 1/4" Bolt	1
21.	16771	5/16" Nylok Nut	1
22.	47832	Angle Bushing	2
23.	1386	Pin, Cotter 3/16" x 2"	2
24.	47693	1/2" x 3/4" Cap Screw	2
25.	23385	1/2" Flat Washer	2
26.	3313	1/4" x 2" Bolt	9
27.	6645	1/4" Nylok Nut	11
28.	49610	Lock Pin 1/4" x 1 3/8"	1
29.	48086	Lanyard	1
30.	3237	1/4" x 2 1/2" Bolt	2
31.	47788	Bushing	10
32.	1677	Bolt, 7/16" x 2 1/2"	2
33.	16771	Nut, 7/16" Nylok	2

# 6. PARTS BREAKDOWN

## 6.4 TRACKS

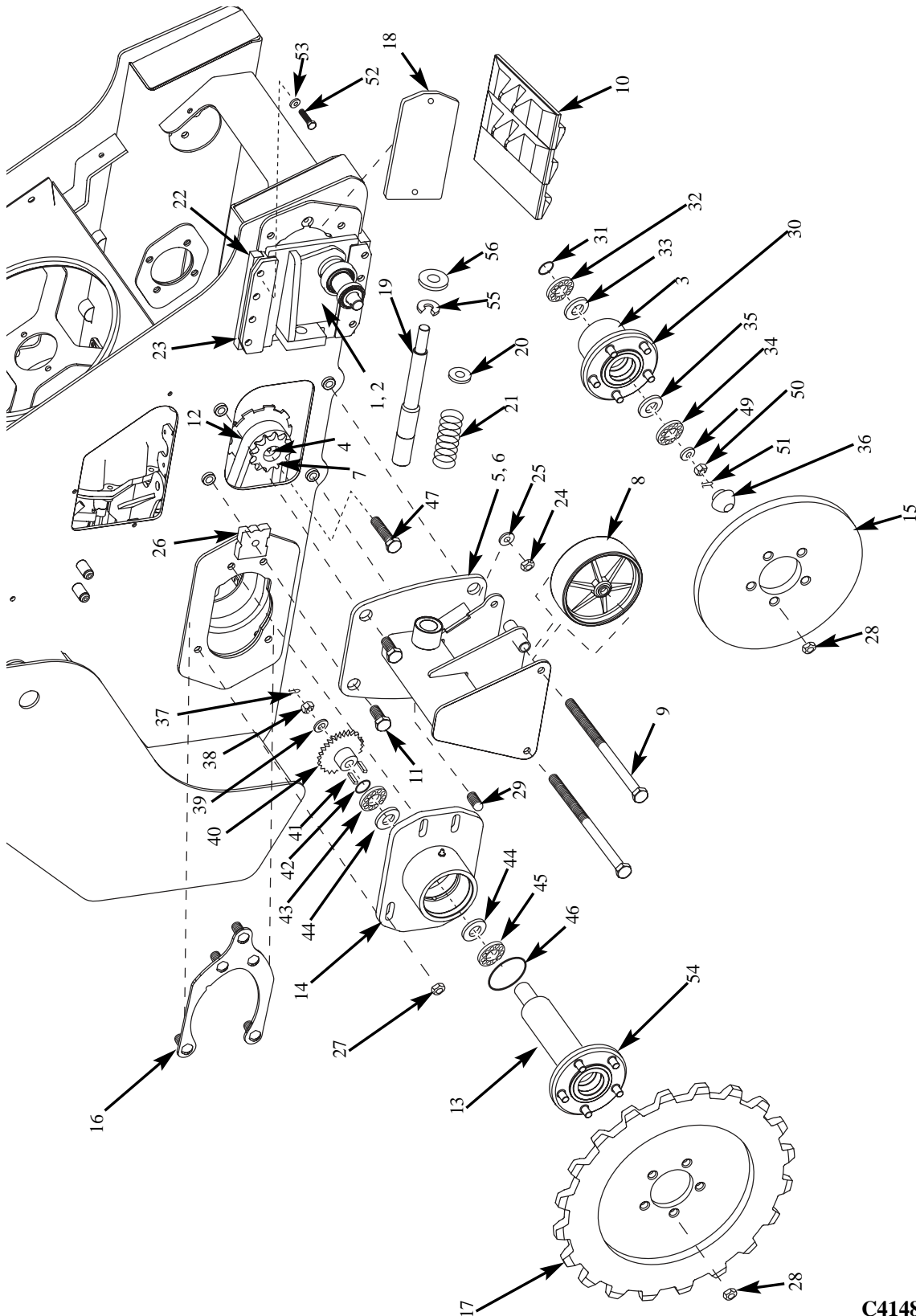

C4148

## 6. PARTS BREAKDOWN

### 6.4 TRACKS

ITEM	PART NO.	DESCRIPTION	QTY.
1.	965277	Axle Weld Assembly R.H.	1
2.	965278	Axle Weld Assembly L.H.	1
3.	964861	Front Hub Welded Assembly	2
4.	51200	Bar, Drive Sprocket Washer	2
5.	964859	Idler Mount Assembly, L.H.	1
6.	964860	Idler Mount Assembly, R.H.	1
7.	51193	Drive Sprocket	2
8.	49339	Wheel, Polyolefin	8
9.	1474	1/2" x 9" Bolt, Hex UNC	4
10.	49953	Conventional Rubber Track, Type G	2
11.	49492	Flange Bolt, 5/8" x 1 1/4"	8
12.	49955	Chain # 60H 62 Pitches, LH	1
12.	49954	Chain # 60H 50 Pitches, RH	1
13.	964548	Axle Welded Assembly	2
14.	964541	Axle Tower Welded Assembly	2
15.	51153	Plate, Front Idler	2
16.	964913	Bolt Cage Welded Assembly	2
17.	964952	Drive Sprocket	2
18.	964863	Plate	2
19.	51340	Bar, Spring Puller	2
20.	51339	Washer	2
21.	49407	Compression Spring	2
22.	49408	Nyloil Wear Pad	4
23.	51367	Wear Guide Support	4
24.	8613	1/2" Nylok Nut	4
25.	23385	1/2" Washer	8
26.	52035	Tensioner Block	2
27.	43559	1/2" Flange Nut	10
28.	3093	Nut, Wheel	20
29.	49501	1 1/2 "Set Screw	2
30.	49342	Wheel Stud, 1 7/8"	10

\* - Item not shown.

# 6. PARTS BREAKDOWN

## 6.4 TRACKS (Continued)

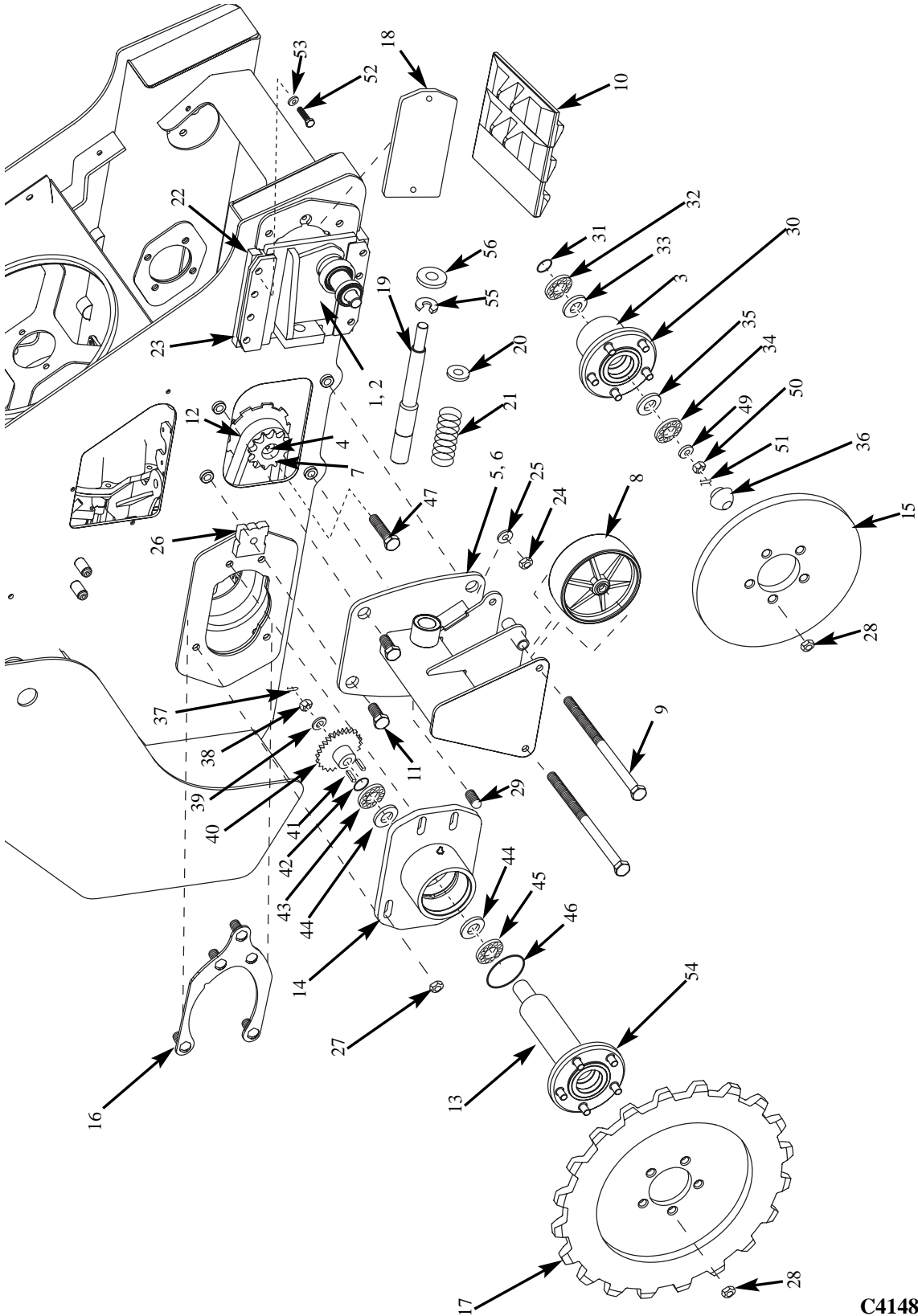

C4148



## 6. PARTS BREAKDOWN

### 6.4 TRACKS (Continued)

ITEM	PART NO.	DESCRIPTION	QTY.
31.	49435	Seal	2
32.	16071	Bearing	2
33.	16072	Race	2
34.	26722	Bearing	2
35.	26723	Race	2
36.	47534	Dust Cap	2
37.	1632	Cotter Pin	2
38.	5914	Nut, Cotter	2
39.	8675	Axle Spacer	2
40.	51338	Rear Sprocket	2
41.	20200	1/2" x 1 1/4" Keystock	4
42.	49306	Inner Seal	2
43.	49437	Inner Bearing	2
44.	5968	Race	4
45.	3665	Outer Bearing	2
46.	3667	Outer Seal	2
47.	49581	Bolt, 8 mm x 35 mm	2
49.	7729	15/16" Washer	2
50.	3668	Nut, Castle 7/8"	2
51.	1632	Cotter Pin	4
52.	49471	1/2" x 1 1/4" Bolt, Hex Socket Head	16
53.	20861	1/2" Washer, Lock	16
54.	49341	Wheel Stud, 1 5/8"	10
55.	51332	Plate, Locking Clip	2
56.	51339	Plate, Washer	4

# 6. PARTS BREAKDOWN

## 6.5 HYDRAULIC SCHEMATIC (TO S/N MD000239)

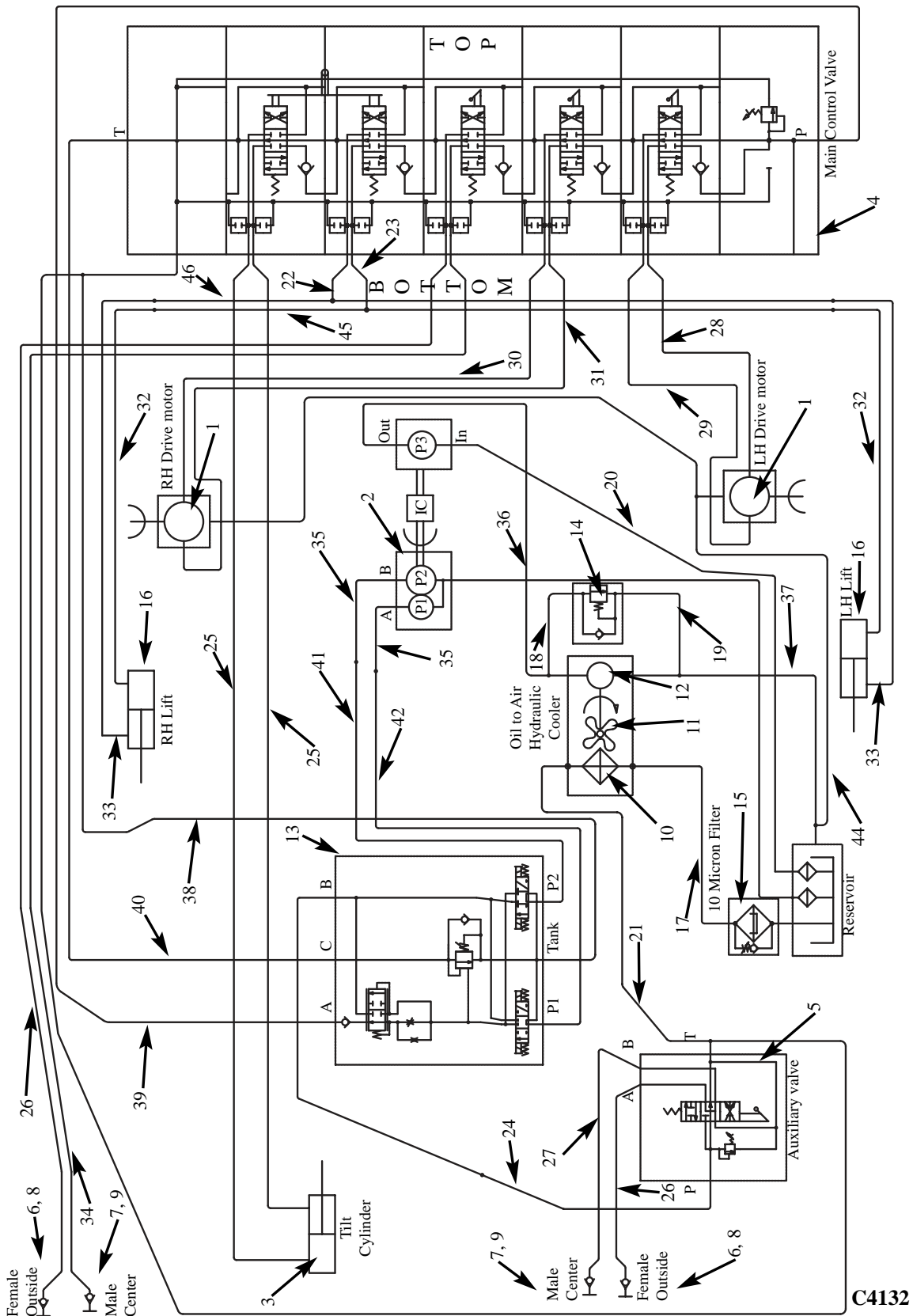

## 6. PARTS BREAKDOWN

### 6.5 HYDRAULIC SCHEMATIC (TO S/N MD000239)

ITEM	PART NO.	DESCRIPTION	QTY.
1.	49015	315 cc Hydraulic Motor	2
2.	49016	Pump, Hydraulic Dual	1
3.	47463	Tilt Cylinder	1
4.	49373	Valve, Hyd SD6/5/AC (JG3) S-1C-SAE-CVN-Q38	1
5.	47461	Valve, Hyd. SD4/1 (JG3) /11L-SAE	1
6.	48592	Cplg, QU DIS 8 F 8 1/2 NPT Flush face body 1/2	2
7.	48593	Cplg, QU DIS 8 M 8 1/2 NPT Flush face body 1/2	2
8.	48594	Cap, Dust for 8 F Flush Face Cplg.	2
9.	48595	Cap, Dust for 8 M Flush Face Cplg.	2
*	38303	Clamp, Tube Twin 5/8"	10
*	38472	Plate, Cover Twin	7
10.	49237	Cooler, Oil/Rad Combo	1
11.	49238	Fan, Multiwing 6 Blade 13" Dia.	1
12.	49357	Motor, Hyd. Fan 4.95 cc/Rev SAE "A"	1
13.	49236	Valve, Hyd. Combiner	1
14.	49431	Valve, Relief	1
*	18767	Plug, Hex Head 6 9/16 ORB M	1
15.	47838	Intank Oil Filter	1
16.	49334	Cylinder, 2 x 14 x 22	2
17.	964811	Hose, Hyd 3/4" x 38 9/16"	1
18.	964822	Hose, Hyd 3/8" x 13"	1
19.	964813	Hose, Hyd 1/2" x 18 3/4"	1
*	964815	Hose, Hyd 3/8" x 27 5/16"	1
20.	965235	Hose, Hyd 5/8" x 28 1/2"	1
21.	965232	Hose, Hyd 1/2" x 15 1/8"	1
22.	964821	Hose, Hyd 3/8" x 15 1/2"	1
23.	964822	Hose, Hyd 3/8" x 13"	1
24.	964823	Hose, Hyd 3/8" x 15 1/8"	1
25.	964824	Hose, Hyd 3/8" x 80 7/8"	2
26.	964826	Hose, Hyd 3/8" x 47 3/16"	2
27.	964825	Hose, Hyd 3/8" x 50"	1
28.	964827	Hose, Hyd 3/8" x 42"	1
29.	964828	Hose, Hyd 3/8" x 40"	1
30.	964830	Hose, Hyd 3/8" x 51"	1
31.	964829	Hose, Hyd 3/8" x 54"	1
32.	964831	Hose, Hyd 3/8" x 20 13/16"	2
33.	964832	Hose, Hyd 3/8" x 23"	2
34.	964833	Hose, Hyd 3/8" x 51"	1
35.	964834	Hose, Hyd 3/8" x 12 3/4"	2
36.	964865	Hose, Hyd 3/8" x 11 5/8"	1
37.	964866	Hose, Hyd 1/2" x 37 1/8"	1
*	964867	Hose, Hyd 1/4" x 10 1/8"	1
38.	49362	Tube, Hyd 1/2" x 20" LOA T to T	1
39.	49363	Tube, Hyd 1/2" x 12" LOA IN to A	1

\* - Item not shown.

# 6. PARTS BREAKDOWN

## 6.5 HYDRAULIC SCHEMATIC (Continued)

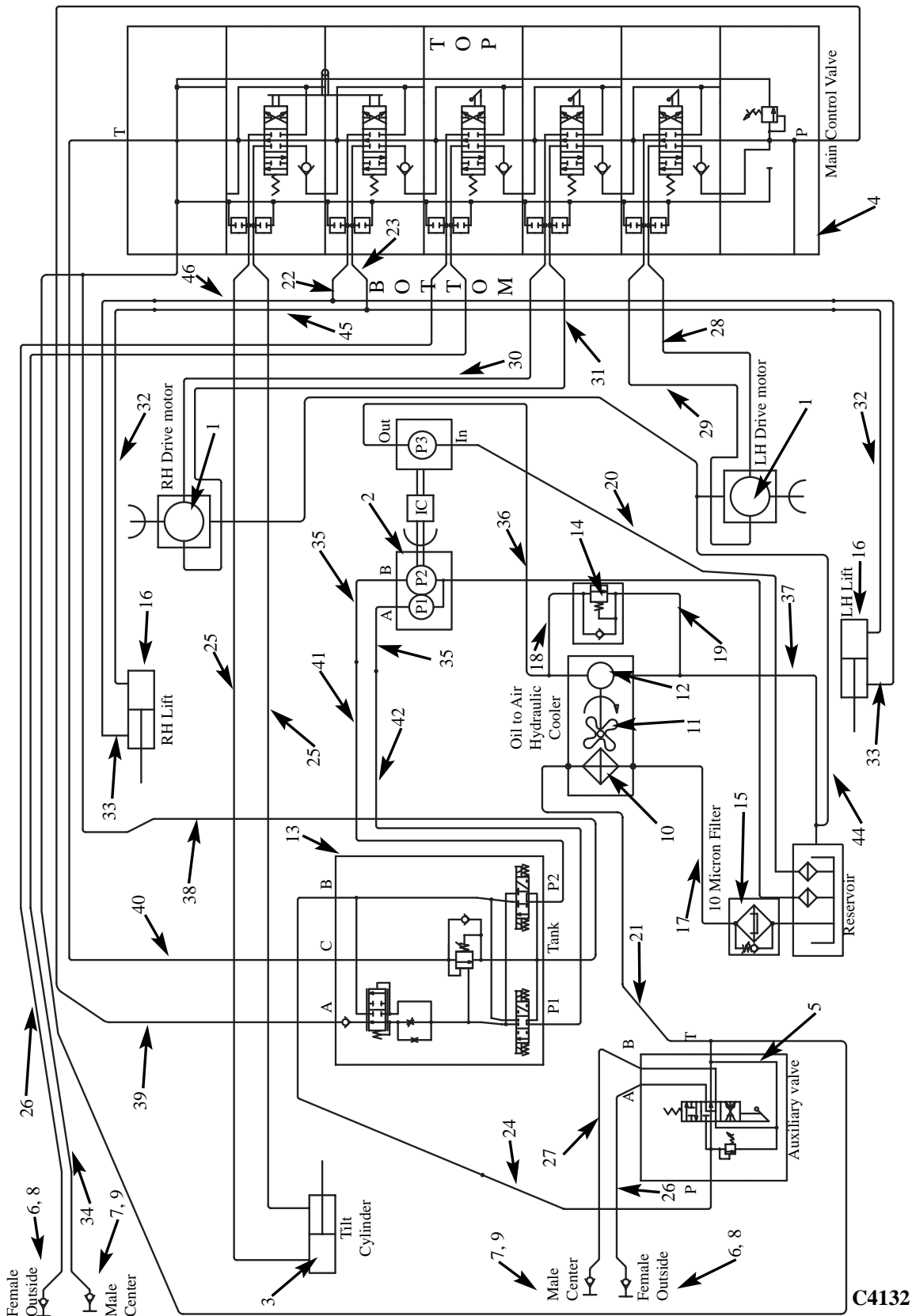

---

## 6. PARTS BREAKDOWN

---

### 6.5 HYDRAULIC SCHEMATIC (Continued)

ITEM	PART NO.	DESCRIPTION	QTY.
40.	49364	Tube, Hyd 1/2" x 29" LOA T to C	1
41.	49360	Tube, Hyd 1/2" x 30" LOA P2 to P2	1
42.	49361	Tube, Hyd 1/2" x 28" LOA P1 to P1	1
43.	965233	Hose, Hyd 1/2" x 16 11/16"	1
44.	965234	Hose, Hyd 3/8" x 40 3/16"	1
45.	49366	Tube, Hyd 1/2" x 25" LOA Front Lift	1
46.	49367	Tube, Hyd 1/2" x 28" LOA Rear Lift	1
47.	49365	Tube, Hyd 1/2" x 20" LOA	1

\* - Item not shown.

# 6. PARTS BREAKDOWN

## 6.5 HYDRAULIC SCHEMATIC (S/N MD000240 Onward)

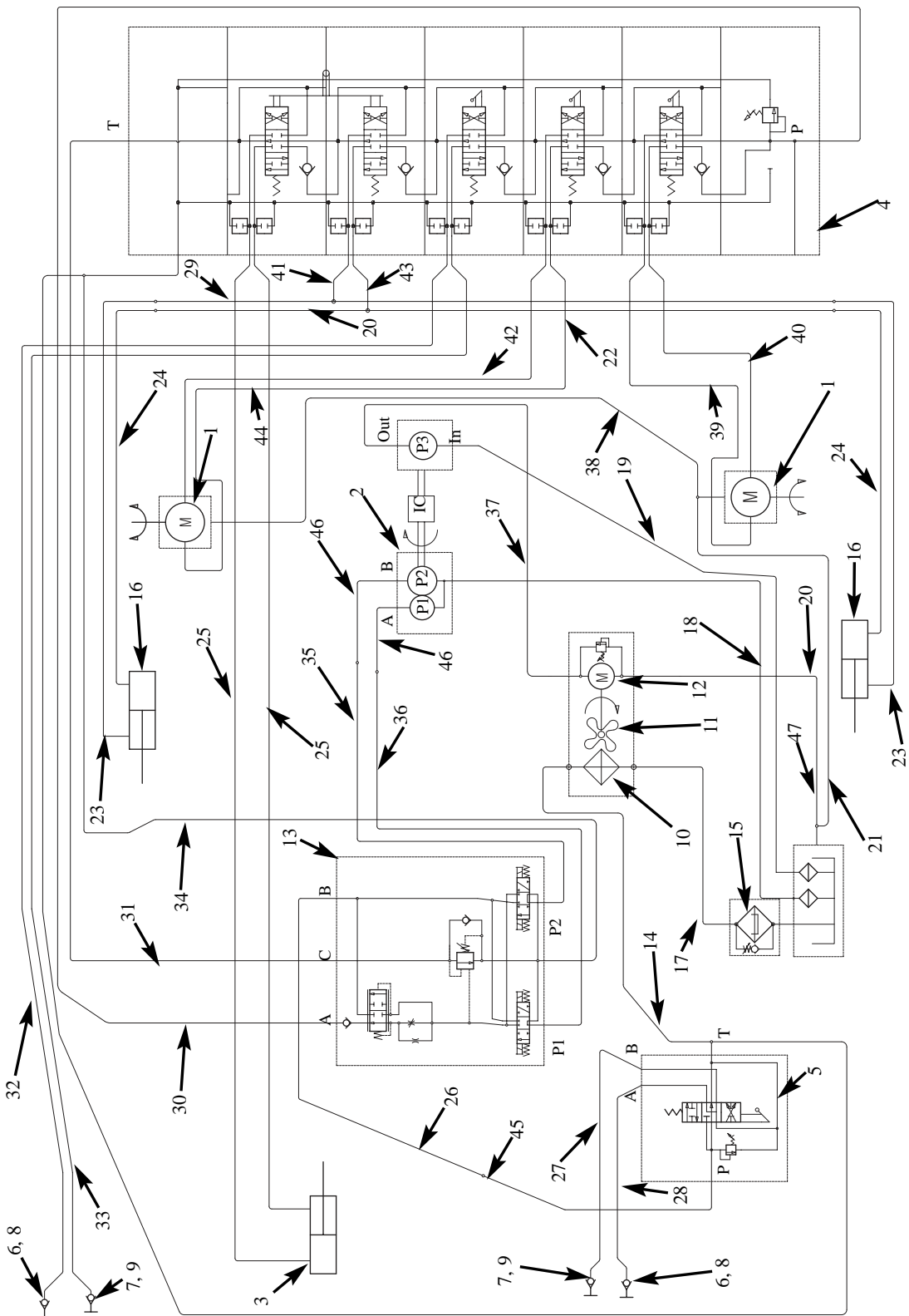

C4717

## 6. PARTS BREAKDOWN

### 6.5 HYDRAULIC SCHEMATIC (S/N MD000240 Onward)

ITEM	PART NO.	DESCRIPTION	QTY.
1.	49015	315 cc Hydraulic Motor	2
2.	49016	Pump, Hydraulic Dual	1
3.	47463	Tilt Cylinder	1
4.	49373	Valve, Hyd.	1
5.	47461	Valve, Hyd.	1
6.	48592	Female Coupling, 1/2"	2
7.	48593	Male Coupling, 1/2"	2
8.	48594	Dust Cap For Female Flush Faced Coupling	2
9.	48595	Dust Cap For Male Flush Faced Coupling	2
*	38303	Clamp, Tube Twin 5/8"	10
*	38472	Plate, Cover Twin	7
10.	49237	Cooler, Oil/Rad Combo	1
11.	49238	Fan, Multiwing 6 Blade 13" Dia.	1
*	49890	Bushing, Fan	1
12.	49357	Motor, Hyd. Fan 4.95 cc/Rev SAE "A"	1
13.	965333	Combiner Valve Ass'y	1
14.	965538	Hose, Hydraulic	1
15.	47838	Intank Oil Filter	1
16.	49334	Lift Cylinder, 2" x 14" x 22"	2
17.	964811	Hose, Hyd 3/4" x 38 9/16"	1
18.	964819	Hose, Hydraulic	1
19.	965235	Hose, Hydraulic	1
20.	49366	Tube, Hyd. 1/2" x 25" Front Lift	1
21.	965234	Hose, Hyd. 3/8" x 40 3/16"	1
22.	964829	Hose, Hyd. 3/8" x 54"	1
23.	964832	Hose, Hyd. 3/8" x 23"	2
24.	964831	Hose, Hyd. 3/8" x 20 13/16"	2
25.	964824	Hose, Hyd. 3/8" x 80 7/8"	2
26.	49365	Tube, Hyd. 1/2" x 20"	1
27.	964825	Hose, Hyd. 3/8" x 50"	1
28.	964826	Hose, Hyd. 3/8" x 47 3/16"	1
29.	49367	Tube, Hyd. 1/2" x 28" Rear Lift	1
30.	49363	Tube, Hyd. 1/2" x 12" (In to A)	1
31.	49364	Tube, Hyd. 1/2" x 29" (T to C)	1
32.	964826	Hose, Hyd. 3/8" x 47 3/16"	1
33.	964833	Hose, Hyd. 3/8" x 51"	1
34.	49362	Tube, Hyd. 1/2" x 20" (T to T)	1
35.	49360	Tube, Hyd. 1/2" x 30" (P2 to P2)	1
36.	49361	Tube, Hyd. 1/2" x 28" (P1 to P1)	1
37.	964865	Hose, Hyd. 3/8" x 11 5/8"	1
38.	964867	Hose, Hyd. 1/4" x 10 1/8"	1
39.	964828	Hose, Hyd. 3/8" x 40"	1
40.	964827	Hose, Hyd. 3/8" x 42"	1

# 6. PARTS BREAKDOWN

## 6.5 HYDRAULIC SCHEMATIC (Continued)

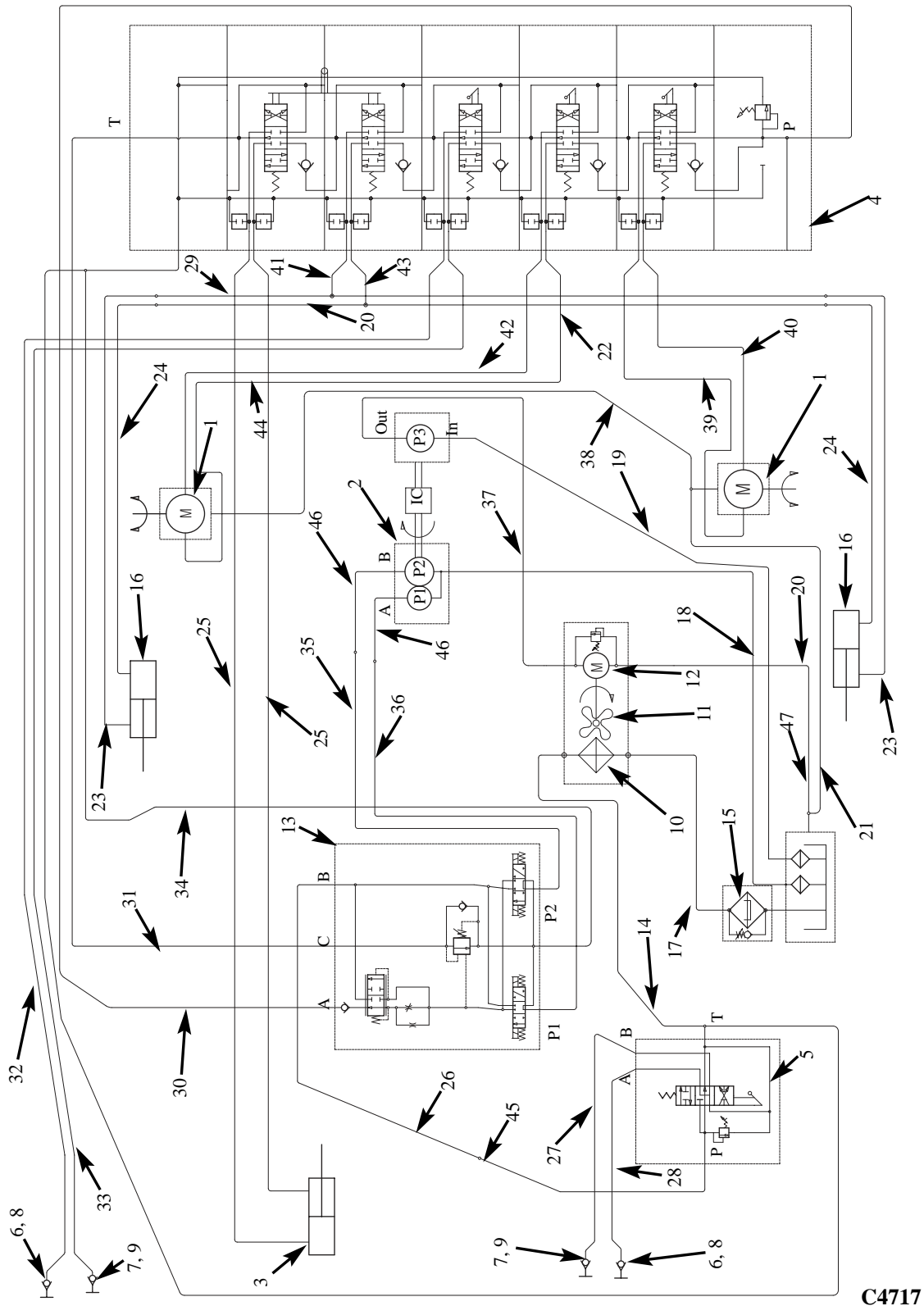

C4717



## 6. PARTS BREAKDOWN

### 6.5 HYDRAULIC SCHEMATIC (Continued)

ITEM	PART NO.	DESCRIPTION	QTY.
41.	964821	Hose, Hyd. 3/8" x 15 1/2"	1
42.	964830	Hose, Hyd. 3/8" x 51"	1
43.	964822	Hose, Hyd. 3/8" x 13"	1
44.	964829	Hose, Hyd. 3/8" x 54"	1
45.	964823	Hose, Hyd. 3/8" x 15 1/8"	1
46.	964834	Hose, Hyd. 3/8" x 12 3/4"	2
47.	964866	Hose, Hyd. 1/2" x 37 1/8"	1

# 6. PARTS BREAKDOWN

## 6.6 CONTROL LEVERS/DASH

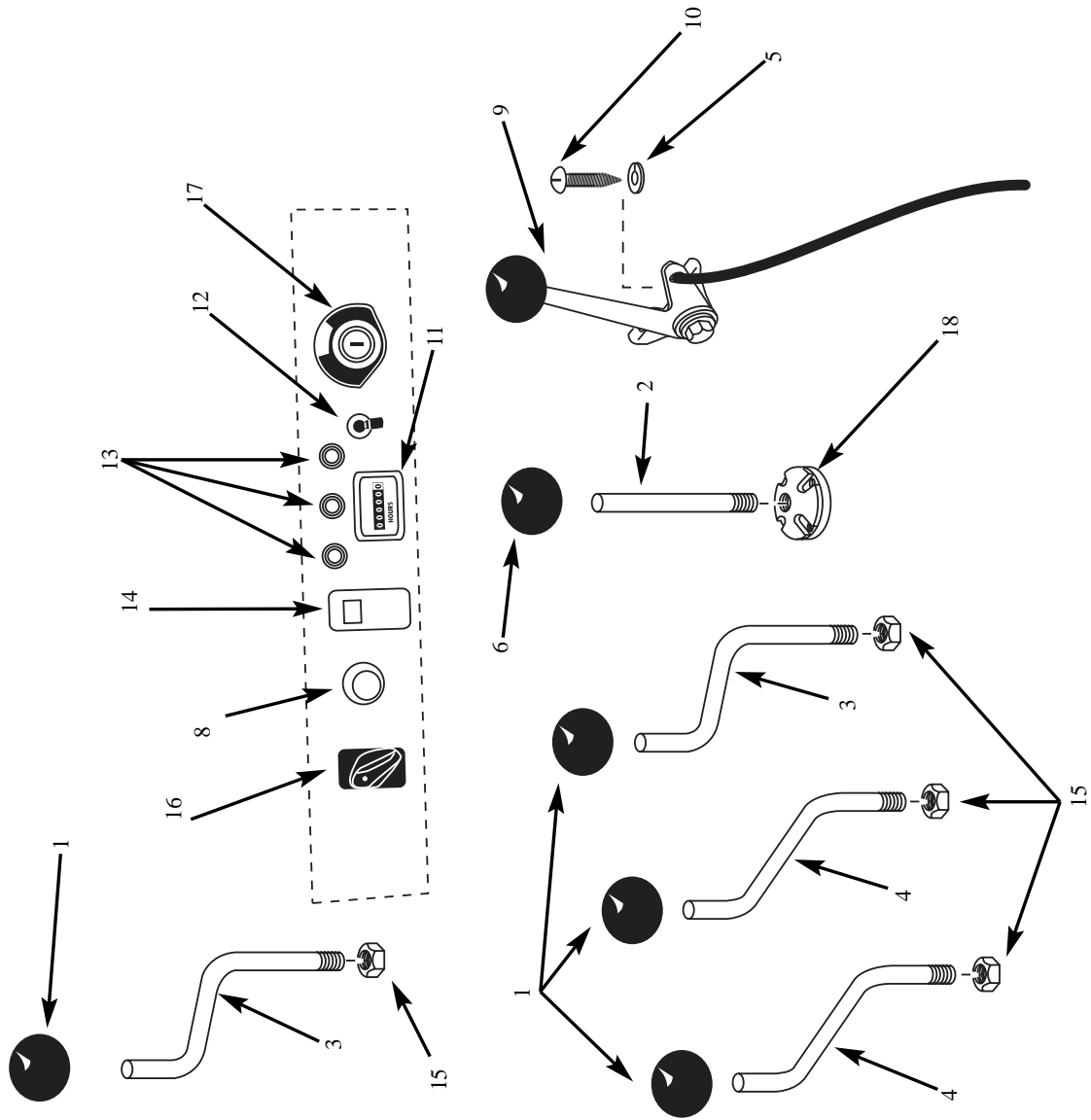

C4146

## 6. PARTS BREAKDOWN

### 6.6 CONTROL LEVERS/DASH

ITEM	PART NO.	DESCRIPTION	QTY.
1.	48012	Knob, Black Ball	4
2.	47864	Handle, Joystick	1
3.	47862	Lever, Auxiliary	2
4.	47863	Lever, Handle, Drive	2
5.	2811	3/16" Washer, Lock PL	2
6.	48013	Black Knob, Press On	1
8.	48041	Switch, Green Pushbutton	1
9.	49424	Throttle Control Assembly	1
10.	49598	10-32 x 5/8" Machine Screw	2
11.	38761	Hourmeter	1
12.	39123	Switch, Toggle	1
13.	49434	Lamp, Indicator Red	3
14.	49432	Switch, Rocker (I-O)	1
15.	23250	Nut, Hex 8mm P1.25 PL	4
16.	49433	Switch, Rotary (A-B)	1
17.	44961	Key Switch	1
18.	52401	Base, Mechanical Joystick	1
*	44960	Key, Replacement	1
*	49662	Gasket, Panel Seal	2

\* - Item not shown.

# 6. PARTS BREAKDOWN

## 6.7 ELECTRICAL SCHEMATIC

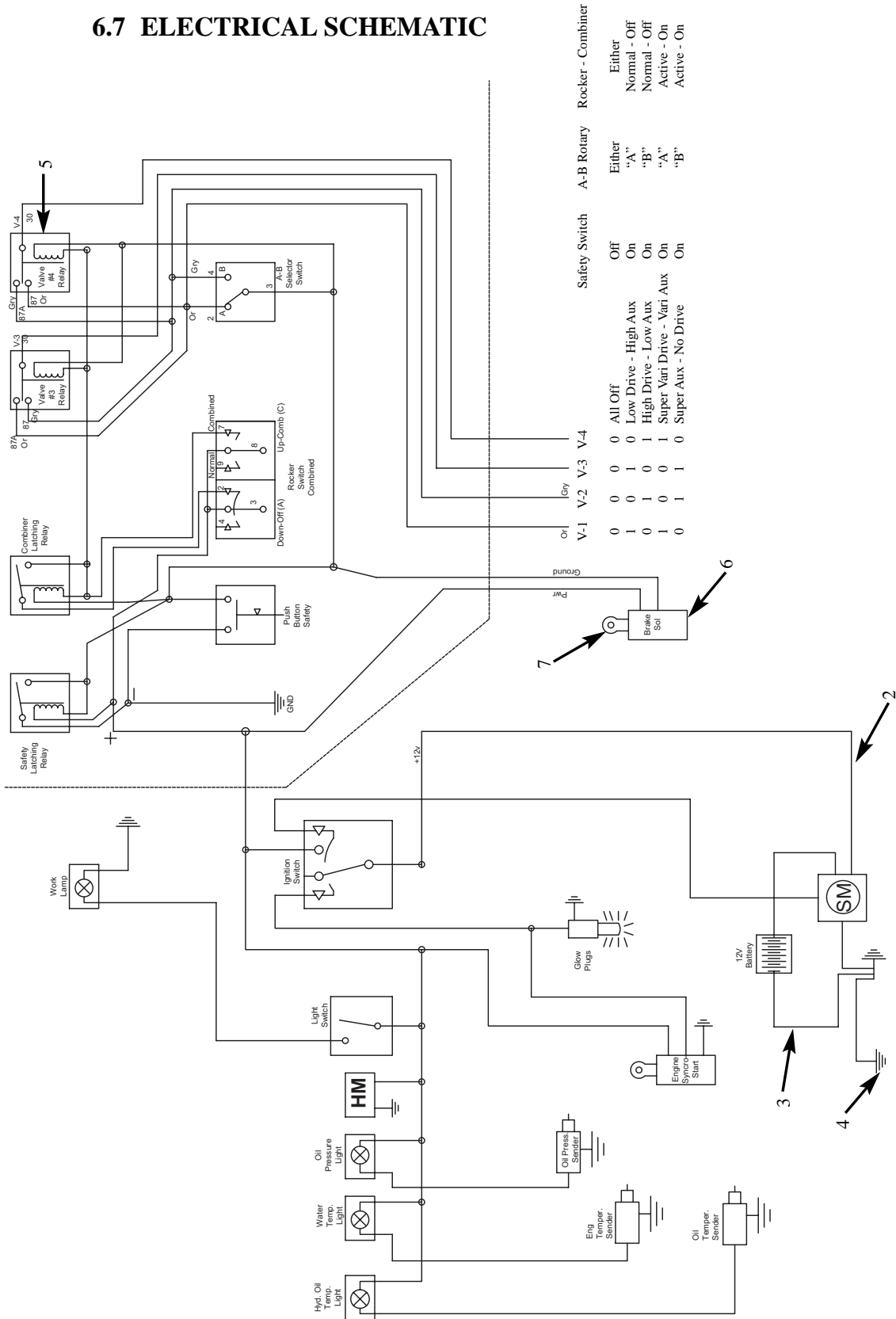

1

C4131

## 6. PARTS BREAKDOWN

### 6.7 ELECTRICAL SCHEMATIC

ITEM	PART NO.	DESCRIPTION	QTY.
1.	49591	Electrical Harness	1
2.	45589	Battery Cable, to Starter	1
3.	45590	Battery Cable, to Engine	1
4.	22819	Battery Cable, to Frame	1
5.	39840	Relay	5
6.	49487	Brake Solenoid	1
7.	51363	Brake Solenoid Extension	1

## 6. PARTS BREAKDOWN

### 6.8 ENGINE SPARE PARTS

ITEM	PART NO.	DESCRIPTION	QTY.
1.	261	Hose, Fuel 5 5/16	4 ft.
2.	407	Hose, Fuel 3 3/16	5 ft.
3.	6268	Clamp, Hose #32	6
4.	11141	Clamp, Hose #16	4
5.	12052	Clamp, Hose 0.75	2
6.	14797	Cock, Shut off 1/4 NPT MX 1/4 F	1
7.	19949	Clamp, Fuel Line	4
8.	26737	Clamp, Wire Hose 3/16	2
9.	38558	Isolator, Engine	4
10.	49235	Engine, Assembly V1105	1
11.	49283	Clamp, Muffler 1 3/8" PL	1
12.	49424	Throttle, Control Assembly	1
13.	49478	Cleaner, Air Assembly 4" with Safety Filter	1
14.	49454	Hose, Air Cleaner	1
15.	49463	Muffler, Mini Skid 1105	1
16.	49464	Pipe, Exhaust	1
17.	49016	Pump, Hyd. Assy. PLP 20/10 11.2CC/4.0CC	1
18.	49465	Tube, Filler Neck	1
19.	49468	Hose, Filler Neck	1
20.	964648	Motor Mount, LH	1
21.	964632	Motor Mount, RH	1
22.	964664	Frame Adapter, LH	1
23.	964663	Frame Adapter, RH	1
24.	49616	Starter	1
25.	39185	Alternator	1
26.	39186	Glow Plug	3
27.	43333	Air Cleaner, Primary	1
28.	49477	Air Cleaner, Safety	1
29.	43350	Engine Oil Filter	1
30.	49617	Fuel Filter	1
31.	964894	Throttle Cable Bracket	1
32.	38558	Isolator, Engine Mount	4
33.	49618	Stop Solenoid	1
34.	43345	Fan Belt	1
35.	49811	Hyd. Seal Kit, Tilt	1
36.	49875	Hyd. Seal Kit, Lift	1