

Farmall JX70
Farmall JX75
Farmall JX80
Farmall JX90
Farmall JX100
Farmall JX110
Tractors

Parts Catalog

Print No. MOD-T-TJ62IR-C-AN
Issued 1/2014

<https://www.tractormanualpdf.info/>



GENERAL INFORMATION

1. Whenever the terms left and right are used, it should be understood to mean from a position facing in direction of travel.
2. Throughout this manual you may find common hardware not illustrated, but listed in the description column. The service part immediately preceding a hardware listing is the part using these particular items for mounting purposes. This hardware is not included with the service part or assembly when ordered as a replacement.
3. The illustrations show typical assemblies plus individual parts but in all cases may not show the exact shape or detail of parts required. However, the purpose for the illustrations is to identify parts performing like functions. Whenever possible illustrations are located at the beginning of each section or immediately adjacent to the applicable text.
4. CNH America LLC is continually striving to improve its products. We must, therefore, reserve the right to make improvements or changes when it becomes practical and possible to do so, without incurring any obligation to make changes or additions to the equipment sold previously.

CNH America LLC, Racine, WI 53404 U.S.A.

How to Use Your Parts Catalog

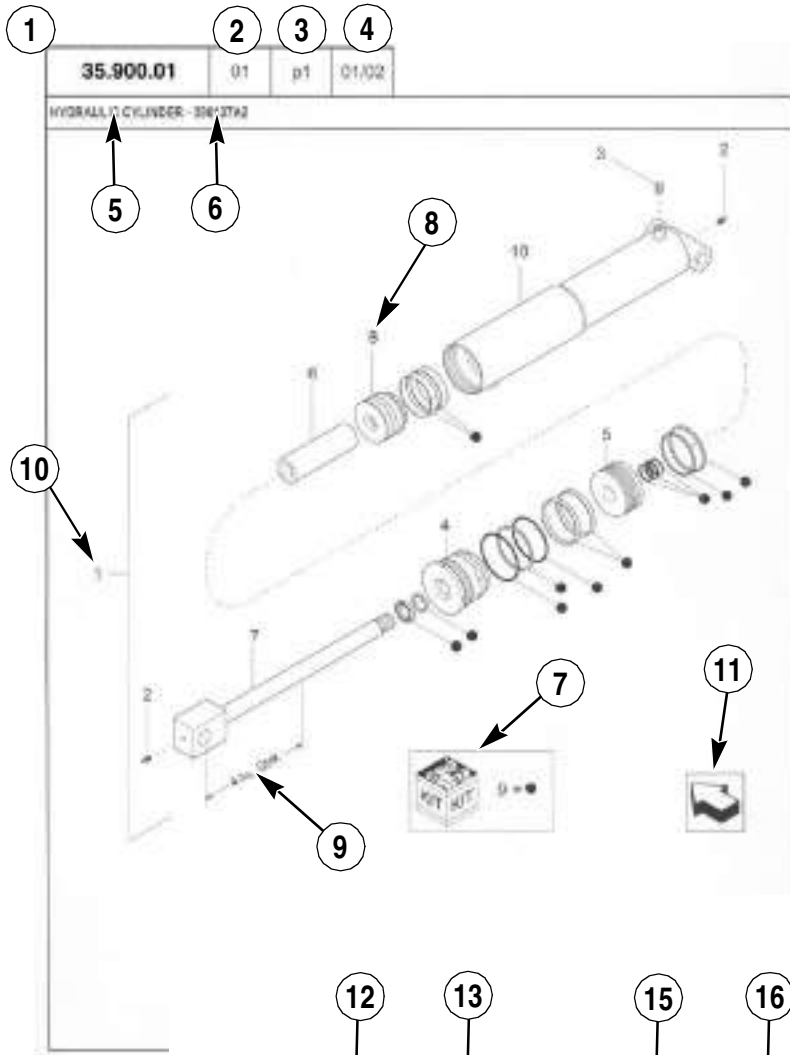

35.900.01					
01					
p1					
01/02					
HYDRAULIC CYLINDER - 359137A2					
REF	FN	PART NUMBER	YR/MS	QTY	DESCRIPTION
1	1	359137A2	01/05 & 02/02	1	CYLINDER ASSY 4.0M in.stk. Inc 2-10
2		31-95	Before 01/05	2	FITTING
2		219-0	From 01/05	2	NIPPLE, LUBE Grease, 1/4" Ipr x 1/2" 22
3		(402476A2)		1	BREATHER
4		402476A1		1	CAP CYLINDER END
5		402468A1	BSN JJC0189200	1	PISTON ROD/CLAND
5		402471C3	ASN JJC0189200	1	PISTON
6		402471A1		1	SPACER
7		402473A1		1	ROD, PISTON
8		402469A1		1	PISTON ROD/CLAND
9		402476A1		1	PACKAGE, SEALS
10		MSS		1	MOT SERVICED SEPARAT CASE ASSEMBLY
11		08-20			
STANDARD			MODELS		

How to Use Your Parts Catalog

1. Figure Number
2. Sequence code within the Figure Number
3. Page number within the Sequence Code
4. Date of Printing (month / year)
5. Figure Description
6. General information regarding the figure
7. Parts supplied in repair kits per symbol reference
8. Figure call-out of the part number (REF)
9. Technical Specifications relating to the part indicated
10. Figure call-out includes bracketed items, the included items may also be listed in the additional description area
11. Orientation - Arrow indicates front of the machine
12. Footnote - Additional information relating to the part number. In this example, 08-20 equals another figure that this part is shown on.
13. Part Number
NSS = Non-serviced parts
Bracketed numbers = not available as service parts in this market
14. Not Available as service part in this market
15. YR/SN
Year
Before 01/85 = Part valid for production January 1985 and before
From 01/85 = Part valid for production from January 1985 and after
BTW 01/85 & 02/02 = Part valid for machines produced between January 1985 and February 2002.

Serial Number (P.I.N.)
BSN JJC0268800 = Part valid for serial number JJC0268800 and below
ASN JJC0268800 = Part valid for serial number JJC0268800 and above
BTW JJC0178000 & JJC0179000 = Part valid for serial numbers between JJC0178000 & JJC0179000
16. Total Quantity of the Part referred to in the page. The quantity can be replaced by the following indications:
AR = quantity as required
X = as required
17. Part Description
18. Additional description of the part to help confirm identification
19. Figure Notes
20. Model Number(s)

Explanation of Abbreviations

Abbreviation	Meaning
adj	adjustable
amp	ampere
AR	As required
ASN	Serial number and after / P.I.N. and after
barb	barb
blkhd	bulkhead
boss	boss
BSN	before serial number / before P.I.N
BTW	between
cc	cubic centimetre
chain	chain
cl	class
cp pt	cup point
CRS	Chrome Alloy Steel
CST	Carbon Steel
cu yd	cubic yard
deg	degree
dia	diameter
dr type	drive type
dry	dry
fc	face
fc sl	face seal
fem	female
fem PT	female pipe thread
fl	flare
ft	feet (or foot)
gal	gallon(s)
gr	grade
hd	head
hp	horsepower
ID	inside diameter

Abbreviation	Meaning
in	inch(es)
Inc.	includes
inv fl	inverted flare
K	kilo
kg	kilogram
L	litre
lb	pound(s)
lg	long
LH	left hand
LH thd	left hand thread
links	links
M	(prefix) metric thread size
m	metre
male	male
mm	millimetre
NF	National Fine
No.	number
NS	National Super Fine
OD	outside diameter
ohm	electrical unit of resistance
Or	O-ring
orifice	orifice
P	pitch
piece	piece
psi	pounds per square inch
PT	pipe thread
rd	round
rd holes	round holes
RH	right hand
RH thd	right hand thread
rpm	revolutions per minute

Explanation of Abbreviations

Abbreviation	Meaning
sl	self locking
slat	slat
spool	spool
sq	square
SST	Stainless Steel
st	self tapping
stem	stem
strk	stroke
sw	swivel
T	teeth
Teflon	Teflon
thin	thin
thk	thick
tpr	taper

Abbreviation	Meaning
tube	tube
type	type
V	volt(s)
W	watt(s)
way	way
wide	wide
X	as required
yd	yard

Dimensions

Metric and U.S. hardware dimensions do not show the numeric designations of standard coarse threads. A number following a semi colon (;) is the class or grade of hardware. A comma (,) represents the decimal point (.) used in U.S. dimensions.



TABLE OF CONTENTS

00.000.00	01	PICTORIAL INDEX - MAIN SECTIONS
00.000.00	02	PICTORIAL INDEX - MAIN SECTIONS
00.000.10	03	PICTORIAL INDEX - ENGINE
00.000.18	01	PICTORIAL INDEX - CLUTCH
00.000.21	01	PICTORIAL INDEX - TRANSMISSION
00.000.21	02	PICTORIAL INDEX - TRANSMISSION
00.000.23	01	PICTORIAL INDEX - 4WD LINES
00.000.25	01	PICTORIAL INDEX - FRONT MECHANICAL DRIVE
00.000.27	01	PICTORIAL INDEX - REAR DRIVE AXLE
00.000.31	01	PICTORIAL INDEX - IMPLEMENT POWER TAKE-OFF
00.000.33	01	PICTORIAL INDEX - BRAKES & CONTROLS
00.000.35	01	PICTORIAL INDEX - HYDRAULIC SYSTEMS
00.000.35	02	PICTORIAL INDEX - HYDRAULIC SYSTEMS
00.000.37	01	PICTORIAL INDEX - HITCHES, DRAWBARS AND IMPLEMENT COUPLINGS
00.000.39	01	PICTORIAL INDEX - FRAMES AND BALLASTINGS
00.000.41	01	PICTORIAL INDEX - STEERING
00.000.44	01	PICTORIAL INDEX - WHEELS
00.000.44	02	PICTORIAL INDEX - WHEELS
00.000.50	01	PICTORIAL INDEX - CAB CLIMATE CONTROL
00.000.55	02	PICTORIAL INDEX - ELECTRICAL SYSTEMS
00.000.55	03	PICTORIAL INDEX - ELECTRICAL SYSTEMS
00.000.55	04	PICTORIAL INDEX - ELECTRICAL SYSTEMS
00.000.82	01	PICTORIAL INDEX - FRONT LOADER
00.000.88	01	PICTORIAL INDEX - ACCESSORIES
00.000.90	01	PICTORIAL INDEX - PLATFORM, CAB, BODYWORK AND DECALS
00.000.90	02	PICTORIAL INDEX - PLATFORM, CAB, BODYWORK AND DECALS
00.000.90	03	PICTORIAL INDEX - PLATFORM, CAB, BODYWORK AND DECALS
00.000.90	04	PICTORIAL INDEX - PLATFORM, CAB, BODYWORK AND DECALS
00.001.00	01	OPTIONAL EQUIPMENT
00.001.00	02	OPTIONAL EQUIPMENT
00.100.01	01	IDENTIFICATION PLATE AND VERSION LIST
00.100.01	02	IDENTIFICATION PLATE AND VERSION LIST
00.100.01	03	IDENTIFICATION PLATE AND VERSION LIST
00.500.01		DIA KITS

TABLE OF CONTENTS

05.100.01		INITIAL STOCKING LIST (LIST A)
05.100.02		INITIAL STOCKING LIST (LIST B)
05.100.03	01	FILTERS & CAPACITIES
05.100.03	02	FILTERS & CAPACITIES
10.000.00	03	SECTION INDEX, ENGINE
10.001.AD	01	VAR - 390002, 744731 - ENGINE, ASSY
10.001.AD	01	VAR - 390002, 744731 - ENGINE, ASSY
10.001.AD	01	VAR - 390002, 744731 - ENGINE, ASSY
10.001.AD	01	VAR - 390002, 744731 - ENGINE, ASSY
10.001.AD	01	VAR - 390002, 744731 - ENGINE, ASSY
10.001.AD	01	VAR - 390002, 744731 - ENGINE, ASSY
10.001.AD	03	VAR - 334300, 744731 - ENGINE, ASSY, W/ POWER SHUTTLE
10.001.AD	03	VAR - 334300, 744731 - ENGINE, ASSY, W/ POWER SHUTTLE
10.202.AB	01	VAR - 330200, 390227 - DRY AIR CLEANER & RELATED PARTS
10.202.AB	02	VAR - 330200, 390227 - DRY AIR CLEANER, BREAKDOWN
10.202.AB	03	VAR - 330200 - DRY AIR CLEANER WITH DUST EJECTOR
10.202.AD	01	VAR - 330200, 390227 - AIR FILTER, PIPES
10.202.AD	02	VAR - 390971 - AIR FILTER, PIPES
10.202.AH	01	VAR - 330200, 390227, 390971, 743852 - AIR CLEANER, SUPPORT
10.206.AF	01	VAR - 334296 - WATER SEPARATOR
10.216.AI	01	VAR - 334296, 390246 - FUEL TANK
10.216.AI	02	VAR - 334296, 390246 - FUEL TANK, SUPPORT
10.220.AA	01	VAR - 334299, 334300, 334301, 390002, 744731 - THROTTLE CONTROL LINKAGE
10.220.AA	02	VAR - 334299, 334300, 334301, 390002, 744731 - THROTTLE CONTROL LINKAGE
10.254.AI	01	VAR - 333153, 391151, 744733 - MUFFLER, VERTICAL EXHAUST
10.254.AI	02	VAR - 330153, 391151, 744733 - MUFFLER, VERTICAL EXHAUST
10.254.AI	03	VAR - 391151, 744733 - VERTICAL EXHAUST, SHIELD
10.254.AI	04	VAR - 391151, 744733 - VERTICAL EXHAUST, SHIELD
10.254.AI	05	VAR - 330150, 744734 - HORIZONTAL EXHAUST SHIELD
10.254.AI	06	VAR - 330150, 744734 - HORIZONTAL EXHAUST SHIELD
10.254.AI	07	VAR - 330153 - VERTICAL EXHAUST, SHIELD
10.254.AI	08	VAR - 330153 - VERTICAL EXHAUST, SHIELD
10.310.AA	01	VAR - 334299, 334300, 334301, 390002, 744731 - INTERCOOLER

TABLE OF CONTENTS

10.310.AB	01	VAR - 334299, 390002, 744731 - INTERCOOLER LINE
10.310.AB	02	VAR - 334299, 334300, 334301, 390002, 744731 - INTERCOOLER LINE
10.400.AY	01	VAR - 330641, 390641 - RADIATOR HOSE
10.400.BE	01	VAR - 334299, 334300, 334301, 390002, 744731 - RADIATOR
10.400.BE	02	VAR - 330641, 390249, 390641, 744731 - RADIATOR, SEAL
10.400.BH	01	VAR - 330641, 390641 - COOLING, EXPANSION TANK
10.414.AC	01	VAR - 390018 - FAN
10.414.AC	02	VAR - 334299, 334300, 334301, 390002, 744731 - RADIATOR FAN SHROUD
10.414.AC	03	VAR - 330009 - VISCOUS JOINT FAN
10.414.AC	04	VAR - 330009 - VISCOUS JOINT FAN
18.000.00	01	SECTION INDEX, CLUTCH
18.100.AA	01	VAR - 390249 - CLUTCH, CABLE
18.100.AF	01	VAR - 390249 - CLUTCH, PEDAL
18.100.AF	02	VAR - 330120, 331120, 743846 - CLUTCH, PEDAL
18.100.AJ	01	VAR - 335113, 335116, 390249, 744735, 744738, 744739, 744744 - CLUTCH LEVERS LINKS
18.104.AM	01	VAR - 330120, 331120, 743846 - PTO ENGAGEMENT CLUTCH, SERVOCONTROL - CONTROL VALVE - BREAKDOWN
18.104.AS	01	VAR - 330120, 331120, 743846 - PTO ENGAGEMENT CLUTCH, SERVOCONTROL - CYLINDER AND RELEVANT PARTS
18.104.AS	02	VAR - 330120, 331120, 743846 - POWER SHUTTLE SERVO PTO FOR DIFF. LOCK - PTO CLUTCH CONTROL ACTUATOR CYLINDER - BREAKDOWN
18.110.AB	01	VAR - 395250 - CLUTCH & DISC ASSY
18.110.AB	02	VAR - 390815, 720248 - CLUTCH & DISC ASSY
18.110.AB	03	VAR - 390815, 720248 - CLUTCH & DISC ASSY
18.110.AB	04	VAR - 390816, 744743 - CLUTCH & DISC ASSY
18.110.AB	05	VAR - 390816, 744743 - CLUTCH & DISC ASSY
18.110.AB	06	VAR - 335248 - CLUTCH & DISC ASSY
18.110.AB	07	VAR - 334409, 334410, 720248, 720514 - CLUTCH & DISC ASSY
18.110.AB	08	VAR - 335814, 744743 - CLUTCH & DISC ASSY
18.110.AB	09	VAR - 334298, 720514 - CLUTCH & DISC ASSY
18.110.AB	10	VAR - 335814, 744743 - CLUTCH & DISC ASSY
21.000.00	01	SECTION INDEX, TRANSMISSION
21.000.00	02	SECTION INDEX, TRANSMISSION
21.104.AR	01	VAR - 330120, 331120, 743846 - TRANSMISSION LUBRICATION LINE

TABLE OF CONTENTS

21.109.AK	01	VAR - 330120, 331120, 743846 - TRASMISSION OIL COOLER
21.112.AB	01	VAR - 335116, 390110, 744735 - TRACTOR BODY, GEARBOX HOUSING
21.112.AB	03	VAR - 335113 - 20X12 TRANSMISSION WITH SYNCHRO SHUTTLE AND CREEPER - TRACTOR BODY
21.112.AB	04	VAR - 330120, 331120, 743846 - POWER SHUTTLE AND SERVO PTO FOR MECH. DIFF. LOCK - TRACTOR BODY
21.118.AF	01	VAR - 334303, 335116, 390110, 744735 - TRACTOR BODY, REAR TRANSMISSION HOUSING
21.118.AF	02	VAR - 335113 - 20X12 TRANSMISSION WITH SYNCHRO SHUTTLE AND CREEPER, HOUSING
21.118.AG	01	VAR - 334303, 335113, 335116, 390110, 744735 - TRACTOR BODY - REAR TRANSMISSION HOUSING COVER
21.130.AZ	01	VAR - 335113, 335116, 743846, 744735 - REVERSE CONTROL
21.130.AZ	02	VAR - 335113, 390110, 744735 - REVERSER INTERLOCK MECHANISM
21.130.AZ	03	VAR - 335113 - REVERSER INTERLOCK MECHANISM
21.130.BC	01	VAR - 744738, 744739, 744744 - GEARSHIFT CONTROL
21.130.BC	02	VAR - 335113, 743846, 744735 - GEAR SPLITTER CONTROL
21.134.AM	01	VAR - 330120, 331120, 743846 - POWER SHUTTLE E SERVO PTO FOR DIFF. LOCK, POWER SHUTTLE VALVE
21.134.AM	02	VAR - 330120, 331120, 743846 - POWER SHUTTLE E SERVO PTO FOR DIFF. LOCK, POWER SHUTTLE VALVE, BREAKDOWN
21.134.AM	03	VAR - 330120, 331120, 743846 - POWER SHUTTLE E SERVO PTO FOR DIFF. LOCK, POWER SHUTTLE VALVE, BREAKDOWN
21.134.AM	04	VAR - 330120, 331120, 743846 - POWER SHUTTLE E SERVO PTO FOR DIFF. LOCK, POWER SHUTTLE VALVE, BREAKDOWN
21.134.AM	05	VAR - 330120, 331120, 743846 - POWER SHUTTLE E SERVO PTO FOR DIFF. LOCK, POWER SHUTTLE VALVE, BREAKDOWN
21.148.AA	01	VAR - 335113, 335116, 390110, 744735 - TRANSMISSION GEARS, 1ST - 2ND SPEED SYNCRONIZER - BREAKDOWN
21.148.AA	02	VAR - 335113, 335116, 390110, 744735 - TRANSMISSION GEARS, 3RD - 4TH SPEED SYNCRONIZER - BREAKDOWN
21.148.AC	01	VAR - 335113, 335116, 390249, 743846, 744735 - BEVEL GEAR
21.148.AC	02	VAR - 335113, 335116, 390249, 743846, 744735 - BEVEL GEAR, SHIM
21.148.AC	03	VAR - 335113, 335116, 390249, 743846, 744735 - CENTRAL REDUCTION GEARS - MEDIUM RANGE GEARS
21.148.AC	04	VAR - 335116 - 12+4 SYNCHRO AND SHAFT
21.148.AC	05	VAR - 330120, 331120, 390249, 743846 - BEVEL GEAR
21.148.AC	06	VAR - 330120, 331120, 390249, 743846 - BEVEL GEAR, SHIM
21.148.AK	01	VAR - 334303, 335113, 335116, 390110, 744735 - INNER CONTROLS - ROD AND FORK
21.148.AK	02	VAR - 335113 - INNER CONTROLS - ROD AND FORK
21.148.AK	03	VAR - 335113, 744735 - INNER CONTROLS - ROD AND FORK
21.148.AK	04	VAR - 743846, 744735 - INNER CONTROLS - ROD AND FORK

TABLE OF CONTENTS

21.148.AL	01	VAR - 335116, 390110, 744735 - TRANSMISSION GEARS - SHAFT
21.148.AL	02	VAR - 390110, 744735 - TRANSMISSION GEARS - SHAFT
21.148.AL	03	VAR - 335113 - TRANSMISSION GEARS - SHAFT
21.148.AQ	01	VAR - 390110, 744735 - TRANSMISSION, GEAR SHAFT
21.148.AQ	02	VAR - 330120, 331120, 743846 - TRANSMISSION GEARS
21.148.AQ	03	VAR - 330120, 331120, 743846 - TRANSMISSION, GEAR SHAFT
21.148.AQ	04	VAR - 335116 - TRANSMISSION, GEAR SHAFT
21.148.AQ	05	VAR - 335113 - TRANSMISSION, GEAR SHAFT
21.148.AQ	06	VAR - 335113 - TRANSMISSION GEARS
21.148.AQ	07	VAR - 335113 - TRANSMISSION GEARS
21.148.AQ	08	VAR - 335113 - TRANSMISSION GEARS
21.154.AA	01	VAR - 330120, 331120, 743846 - CLUTCH
21.154.AA	02	VAR - 330120, 331120, 743846 - CLUTCH DISK
21.154.AJ	01	VAR - 330120, 331120, 743846 - DRIVE GEAR SHAFT
21.154.AO	01	VAR - 330120, 331120, 743846 - TRANSMISSION, GEAR
21.160.AI	01	VAR - 335113 - 20X12 TRANSMISSION WITH SYNCHRO SHUTTLE - CREEPER CONTROL LEVER
21.162.AF	01	VAR - 390110, 744735 - REVERSER
23.000.00	01	SECTION INDEX - 4WD LINES
23.101.AK	01	VAR - 334321, 390268, 744738 - 4WD IDLER CONTROL LEVER
23.202.AD	01	VAR - 334321, 390268, 744738 - TRANSMISSION BOXES AND COVERS - 4WD
23.202.AD	02	VAR - 330384, 334322, 744739 - ELECTROHYDRAULIC DIFFERENTIAL LOCK CONTROL, 4WD IDLER CASE
23.202.AD	03	VAR - 330384, 334322, 744739 - 4WD TRANSMISSION SHAFT
23.202.AD	04	VAR - 330384, 334322, 744739 - 4WD TRANSMISSION GEARINGS
23.202.AD	05	VAR - 330384, 334322, 390895, 720450, 744739 - 4WD TRANSMISSION SHAFT
23.202.AI	02	VAR - 334315, 390258, 390895, 720450, 744745 - 4WD TRANSMISSION GEARINGS
23.202.AI	03	VAR - 334396, 334397 - 4WD TRANSMISSION GEARINGS
23.202.AI	04	VAR - 334397, 390895, 720450 - 4WD TRANSMISSION GEARINGS
23.314.AH	01	VAR - 334396, 334397, 720450, 744745 - 4WD PROPELLER SHAFT
23.314.AH	02	VAR - 334315, 390258, 390895, 720450, 744745 - 4WD PROPELLER SHAFT, GUARD
23.314.AH	03	VAR - 330384, 334322, 744739 - 4WD PROPELLER SHAFT
23.314.AH	04	VAR - 330384, 334322, 744739 - 4WD PROPELLER SHAFT, GUARD

TABLE OF CONTENTS

23.314.AH	05	VAR - 334396, 334397 - 4WD WATER PROOF PROPELLER SHAFT
23.314.AH	06	VAR - 334396, 334397 - 4WD WATER PROOF PROPELLER SHAFT, GUARD
25.000.00	01	SECTION INDEX - FRONT MECHANICAL DRIVE
25.100.AD	01	VAR - 390250 - 4WD FRONT AXLE, AXLE HOUSING
25.100.AD	02	VAR - 335325 - 4WD FRONT AXLE, AXLE HOUSING
25.100.AD	03	VAR - 335539 - 4WD FRONT AXLE - AXLE HOUSING
25.100.AV	01	VAR - 334396, 334397, 720450, 744745 - FRONT AXLE SUPPORT
25.102.AB	01	VAR - 390250 - 4WD FRONT AXLE, BEVEL GEAR
25.102.AB	02	VAR - 390250 - 4WD FRONT AXLE, BEVEL GEAR, SHIM
25.102.AB	03	VAR - 390250 - 4WD FRONT AXLE, BEVEL GEAR, SHIM
25.102.AB	04	VAR - 335325, 335539 - 4WD FRONT AXLE, BEVEL GEAR
25.102.AB	05	VAR - 335325, 335539 - 4WD FRONT AXLE, BEVEL GEAR, SHIM
25.102.AB	06	VAR - 335325, 335539 - 4WD FRONT AXLE, BEVEL GEAR, SHIM
25.102.AC	01	VAR - 390250 - 4WD FRONT AXLE, SUPPORT
25.102.AC	02	VAR - 335539 - 4WD FRONT AXLE, SUPPORT
25.102.AC	03	VAR - 335325 - 4WD FRONT AXLE, SUPPORT
25.102.AD	01	4WD FRONT AXLE - DIFFERENTIAL
25.102.AE	01	4WD FRONT AXLE - DIFFERENTIAL
25.102.AE	02	VAR - 335539 - 4WD FRONT AXLE - DIFFERENTIAL - W/LIMITED SLIP DIFFERENTIAL
25.102.AE	03	VAR - 335325 - 4WD FRONT AXLE, DIFFERENTIAL W/ LIMITED SLIP
25.108.AA	01	4WD FRONT AXLE - AXLE-SHAFT ARTICULATED - BREAKDOWN
25.108.AA	02	4WD FRONT AXLE - AXLE-SHAFT ARTICULATED - BREAKDOWN
25.108.AB	01	4WD FRONT AXLE - DIFFERENTIAL GEARS AND DIFFERENTIAL SHAFT
25.108.AB	02	VAR - 335325, 335539 - 4WD FRONT AXLE - DIFFERENTIAL GEARS AND DIFFERENTIAL SHAFT
25.108.AG	01	4WD FRONT AXLE - STEERING KNUCKLES
25.108.AG	02	VAR - 335325, 335539 - 4WD FRONT AXLE, STEERING KNUCKLE
25.108.AN	01	VAR - 390250 - 4WD FRONT AXLE, HUB
25.108.AN	02	VAR - 335325, 335539 - 4WD FRONT AXLE, HUB
25.400.AH	01	VAR - 338860, 390860 - 2WD FRONT AXLE - HUB
25.400.AM	01	VAR - 334413, 390338, 743515 - 2WD FRONT AXLE
25.400.AQ	01	VAR - 334413, 390860, 743515 - 2WD FRONT AXLE, STEERING KNUCKLE
25.400.AQ	02	VAR - 334413, 390860, 743515 - 2WD FRONT AXLE, STEERING KNUCKLE

TABLE OF CONTENTS

27.000.00	01	SECTION INDEX - REAR DRIVE AXLE
27.106.AB	01	VAR - 744738, 744739, 744744 - DIFFERENTIAL GEARS
27.106.AB	02	VAR - 744738, 744739, 744744 - DIFFERENTIAL GEARS
27.106.AB	03	VAR - 744738, 744739, 744744 - DIFFERENTIAL GEARS
27.106.AK	01	VAR - 744738, 744744 - DIFFERENTIAL LOCK CONTROL - ROD AND FORK
27.106.AK	02	VAR - 330384, 334322, 744739 - ROD & FORKS - 4WD
27.106.AL	01	VAR - 744738, 744744 - DIFFERENTIAL LOCK CONTROL - LEVER
27.106.AP	01	VAR - 330384, 334322, 744739 - ELECTROHYDRAULIC DIFFERENTIAL LOCK CONTROL, CONTROL VALVE, 4WD
27.106.AP	02	VAR - 330384, 334322, 744739 - ELECTROHYDRAULIC DIFFERENTIAL LOCK CONTROL - CONTROL VALVE - BREAKDOWN - 4WD
27.106.AR	01	VAR - 744738, 744739, 744744 - DIFFERENTIAL GEAR, SUPPORT
27.106.AR	02	VAR - 744738, 744739, 744744 - DIFFERENTIAL GEAR, SUPPORT
27.120.AD	01	VAR - 334396, 334397, 720450, 744745 - SIDE REDUCER GEARINGS, SHAFT AND BEARINGS
27.120.AD	02	VAR - 334397, 334416, 390895, 720450 - REDUCER, SHAFT, BEARING
27.120.AI	01	VAR - 720450, 744745 - SIDE REDUCER BOX AND COVERS
27.120.AI	02	VAR - 334396, 334397 - SIDE REDUCER BOX AND COVERS
27.120.AR	01	VAR - 334396, 334397, 720450, 744745 - SHAFT & GEAR
27.120.AR	02	VAR - 334397, 334416, 390895, 720450 - SHAFT & GEAR
31.000.00	01	SECTION INDEX - IMPLEMENT POWER TAKE-OFF
31.101.AB	01	VAR - 334394, 335805, 335818, 390813 - PTO CONTROLS
31.101.AB	02	VAR - 334394, 335805, 335818 - PTO, CONTROLS
31.101.AC	01	VAR - 390249 - PTO CONTROLS
31.101.AC	02	VAR - 390249 - PTO CONTROLS, BREAKDOWN
31.101.AC	03	VAR - 330120, 331120, 743846 - PTO CONTROLS
31.101.AC	04	VAR - 330120, 331120, 743846 - PTO CONTROLS
31.110.AB	01	VAR - 390813 - PTO SHAFT, GEAR
31.110.AB	02	VAR - 335818 - SHAFT & GEAR
31.110.AB	03	VAR - 334394, 335805, 335818 - FORK, ROD
31.110.AB	04	VAR - 334394, 335805 - PTO 540/1000 RPM - SHAFT AND GEARS
31.110.AI	01	VAR - 390813 - PTO, COVER
31.110.AI	02	VAR - 334394, 335805, 335818 - PTO, COVER
31.110.AI	03	VAR - 334394, 335805, 335818, 390813, 744751 - PTO, SHIELD
31.110.AO	01	VAR - 330120, 331120, 743846 - POWER SHUTTLE AND SERVO PTO FOR DIFF. LOCK, PTO CLUTCH CONTROL SAND LEVER LINK

TABLE OF CONTENTS

31.201.AG	01	VAR - 390249 - PTO SHAFT
31.201.AG	02	VAR - 330120, 331120, 743846 - PTO SHAFT
33.000.00	01	SECTION INDEX - BRAKES & CONTROLS
33.110.AJ	01	VAR - 744738, 744739, 744744 - HAND BRAKE CONTROL
33.110.AJ	02	VAR - 744738, 744739, 744744 - HAND BRAKE, BREAKDOWN
33.120.AD	01	VAR - 744738, 744739, 744744 - BRAKE CONTROLS
33.120.AD	02	VAR - 335113, 390110, 390249, 744735 - BRAKE CONTROLS
33.202.AJ	01	VAR - 335113, 390110, 390249, 744735 - HYDRAULIC BRAKE, BRAKE CYLINDER
33.202.AK	01	VAR - 744738, 744739, 744744 - BRAKE DISCS
33.202.AN	01	VAR - 744738, 744739, 744744 - BRAKE RESERVOIR
33.202.AP	01	VAR - 335113, 390110, 390249, 744735 - BRAKE PIPING
33.202.AR	01	VAR - 333606, 334318, 334319, 391606, 392315 - BRAKE CYLINDER
33.202.BE	01	VAR - 744738, 744739, 744744 - BRAKE CYLINDER PIPING
33.202.BE	02	VAR - 330120, 331120, 335116, 743846 - BRAKE CYLINDER PIPING
33.202.BN	01	VAR - 333606, 334318, 334319, 391606, 392315 - BRAKE, PEDAL
33.220.AK	01	VAR - 334336, 334337, 744751, 744752, 744753, 744754, 744755 - TRAILER BRAKE LEVER SUPPORT
33.220.AM	01	VAR - 335370, 336370, 337370, 720396 - TRAILER BRAKE VALVE (FRANCE)
35.000.00	01	SECTION INDEX, HYDRAULIC SYSTEMS
35.000.00	02	SECTION INDEX, HYDRAULIC SYSTEMS
35.100.AR	01	HYDRAULIC LIFT, LINE, PRESSURE RELIEF VALVE
35.104.AA	01	VAR - 334314, 390257 - LIFTER PUMP
35.104.AA	02	VAR - 334314, 390257 - LIFTER PUMP, BREAKDOWN
35.104.AF	01	VAR - 334395, 390814 - HYDRAULIC LIFT PIPES, OIL FILTER
35.104.AF	05	STD, VAR - 334395, 390814 - HYDRAULIC LIFT PIPES
35.104.AF	07	VAR - 728054, 728366, 728368, 729103, 729412, 729413, 729417 - HYDRAULIC LIFT PIPES
35.114.AA	01	VAR - 334395, 390814 - LIFTER DISTRIBUTOR AND VALVES
35.114.AA	02	VAR - 334395, 390814 - LIFTER DISTRIBUTOR AND VALVES, BREAKDOWN
35.114.AA	03	VAR - 334395, 390814 - LIFTER DISTRIBUTOR AND VALVES, BREAKDOWN
35.204.BB	01	VAR - 728054, 728366, 728368, 729103, 729412, 729413, 729417 - QUICK COUPLER, COMPONENTS
35.204.BE	01	VAR - 334332, 335103, 729103 - 3 CONTROL VALVES (2 S/D W/FLOAT W/KICK OUT + 1 S/D W/KICK OUT)
35.204.BE	02	VAR - 334332, 335103, 729103 - 3 CONTROL VALVES (2 S/D W/FLOAT W/KICK OUT + 1 S/D W/KICK OUT) - BREAKDOWN

TABLE OF CONTENTS

35.204.BE	03	VAR - 334331, 335054, 728054 - 3 CONTROL VALVES (2S/D + 1S/D W/KICK OUT)
35.204.BE	04	VAR - 334331, 335054, 728054 - 3 CONTROL VALVES (2 S/D W/FLOAT W/KICK OUT + 1 S/D W/KICK OUT), BREAKDOWN
35.204.BE	05	VAR - 334328, 335368, 728368 - 2 CONTROL VALVE (1 S/D + 1 DOUBLE ACTING)
35.204.BE	06	VAR - 334328, 335368, 728368 - 2 CONTROL VALVE (1 S/D W/KICK OUT + 1 DOUBLE ACTING) - BREAKDOWN
35.204.BE	07	VAR - 334329, 335413, 729413 - 2 CONTROL VALVE (1 S/D + 1 DOUBLE ACTING WITH FLOAT AND KICK OUT)
35.204.BE	08	VAR - 334329, 335413, 729413 - 2 CONTROL VALVES (1 S/D W/KICK OUT + 1 DOUBLE ACTING W/FLOAT W/KICK OUT), BREAKDOWN
35.204.BE	09	VAR - 334330, 335417, 729417 - 2 CONTROL VALVE (1 S/D W/KICK OUT + 1 DOUBLE ACTING WITH FLOAT AND KICK OUT)
35.204.BE	10	VAR - 334330, 335417, 729417 - 2 CONTROL VALVES (1 S/D W/KICK OUT + 1 DOUBLE ACTING W/FLOAT W/KICK OUT) - BREAKDOWN
35.204.BE	11	VAR - 728366, 729412 - 1 CONTROL VALVE (1 S/D)
35.204.BE	12	VAR - 334325, 335366, 728366 - 1 CONTROL VALVE (1 S/D), BREAKDOWN
35.204.BE	13	VAR - 334326, 334327, 729412 - 1 CONTROL VALVE, BREAKDOWN
35.204.BJ	01	VAR - 728054, 729103 - PIPES
35.204.BJ	02	VAR - 728368, 729413, 729417 - PIPES
35.204.BJ	03	VAR - 728366, 729412 - PIPES
35.204.BJ	04	VAR - 334326, 335366, 728366, 729412 - 1 CONTROL VALVE, PIPES
35.204.BJ	05	VAR - 728368, 729413, 729417 - 2 CONTROL VALVE, PIPES
35.204.BJ	06	VAR - 728054, 729103 - 3 CONTROL VALVE, PIPES
35.204.BL	01	VAR - 728054, 729103 - CONTROL LEVER
35.204.BL	02	VAR - 728054, 729103 - 3 CONTROL VALVES, LEVER AND KNOB, ROPS
35.204.BL	03	VAR - 728366, 729413, 729417 - 2 CONTROL VALVES, LEVER AND KNOB, ROPS
35.204.BL	04	VAR - 728366, 729412 - 1 CONTROL VALVE, LEVER AND KNOB, ROPS
35.204.BL	05	VAR - 728054, 729103 - 3 CONTROL VALVES, LEVER AND KNOB, CAB
35.204.BL	06	VAR - 728368, 729413, 729417 - 2 CONTROL VALVES, LEVER AND KNOB, CAB
35.204.BL	07	VAR - 728366, 729412 - 1 CONTROL VALVE, LEVER AND KNOB, CAB
35.204.BL	08	VAR - 728366, 728368, 729412, 729413, 729417 - CONTROL LEVER
35.359.AB	01	VAR - 336125 - 2 MID MOUNT VALVES WITH JOYSTICK, VALVES AND PIPES
35.359.AB	02	VAR - 336125 - TWO FRONT CONTROL VALVES, BREAKDOWN
35.701.AX	01	VAR - 344351 - FRONT LOADER HYDRAULIC SYSTEM
35.701.AX	02	VAR - 330489, 334351, 334352 - 4 MULTIFASTER COUPLERS

TABLE OF CONTENTS

35.701.AX	03	VAR - 334351, 334352 - FRONT LOADER WITH 4 COUPLERS, FRONT QUICK COUPLINGS
35.701.AX	04	VAR - 334352 - FRONT LOADER HYDRAULIC SYSTEM (SELF LEVELLING)
35.701.CB	01	VAR - 334351, 334352 - LIFT ARM, CYLINDER, COMPONENTS
35.723.AA	01	VAR - 334351 - BUCKET CYLINDER, COMPONENTS
35.723.AA	02	VAR - 334352 - BUCKET CYLINDER, COMPONENTS
35.724.AE	01	VAR - 336125 - 2 MID MOUNTS VALVES WITH JOYSTICK, JOYSTICK AND SUPPORT
35.724.AE	02	VAR - 336125 - JOYSTICK FOR MID MOUNT, BREAKDOWN
37.000.00	01	SECTION INDEX - HITCHES, DRAWBARS AND IMPLEMENT COUPLINGS
37.100.AA	01	VAR - 334340, 334424, 744755 - DRAWBAR AND SUPPORT WITH PIN (HOLE DIAMETER 33MM)
37.100.AA	02	VAR - 744752, 744754 - TRAILER HITCH FRAME WITH HIGH POINT HITCH AND SWINGING DRAWBAR
37.100.AA	03	VAR - 330899 - LINKAGE DRAWBAR
37.100.AA	04	VAR - 335893, 744753 - DRAWBAR AND SUPPORT WITH PIN (FRANCE)
37.100.AB	02	VAR - 334334, 334421, 744751 - TRAILER HITCH FRAME WITH HIGH POINT HITCH AND SWINGING DRAWBAR - BREAKDOWN
37.100.AB	03	VAR - 334335, 334422, 744752 - TRAILER HITCH FRAME WITH HIGH POINT HITCH AND SWINGING DRAWBAR - BREAKDOWN
37.100.AB	04	VAR - 334338, 334423, 744754 - TRAILER HITCH FRAME LESS HIGH POINT HITCH, BREAKDOWN
37.100.AB	05	VAR - 334336, 334337 - SWIVEL TRAILER HITCH WITH SLIDER SUPPORT
37.100.AC	01	VAR - 335892 - FRONT TOW HOOK
37.100.AF	01	VAR - 334336, 334337 - TOW HOOK
37.100.AF	02	VAR - 335893, 744753 - TOW HOOK (FRANCE)
37.108.AD	01	VAR - 334395, 390814 - HYDRAULIC LIFT, CONTROL, KNOB
37.108.AD	02	VAR - 334395, 390814 - LIFT CONTROLS - HANDLE AND LEVERS - CAB
37.108.AD	03	VAR - 334395, 390814 - HYDRAULIC LIFT, CONTROL, KNOB, ROPS
37.108.AE	01	VAR - 334395 - LIFT CONTROLS - CABLE
37.108.AE	02	VAR - 334395 - CONTROL LEVER, BREAKDOWN
37.108.AL	01	VAR - 334395, 390814 - LIFTOMATIC RANGE LIMITER DEVICE
37.110.AK	01	VAR - 744738, 744739, 744744 - HYDRAULIC LIFT, CONTROL SHAFT
37.110.AM	01	VAR - 744738, 744739, 744744 - HYDRAULIC LIFT, HYDRAULIC LIFT, TIE-ROD, LEVER
37.110.AM	02	VAR - 744738, 744739, 744744 - HYDRAULIC LIFT, CONTROL, TIE-ROD, LEVER, BEARING
37.110.AM	03	VAR - 744738, 744739, 744744 - HYDRAULIC LIFT, CONTROL, TIE-ROD, LEVER, BEARING

TABLE OF CONTENTS

37.110.AP	01	VAR - 334395, 390814 - HYDRAULIC LIFT, COVER
37.110.AP	02	VAR - 334395, 390814 - LIFTER OIL PAN AND RELATED PARTS
37.110.AQ	01	VAR - 334395, 390814 - LIFT - LIFT ARMS AND ROCKSHAFT
37.110.AQ	02	VAR - 334395, 390814 - LIFT CYLINDER, PISTON
37.120.AA	01	VAR - 334316, 334317, 390259 - IMPLEMENT CARRIER, LINK AND ARM
37.120.AA	02	VAR - 334316, 334317, 390259 - IMPLEMENT CARRIER, SWING CARRIAGE
37.120.AA	03	VAR - 334316, 334317, 390259 - IMPLEMENT CARRIER, UPPER LINK, BREAKDOWN
37.120.AA	04	VAR - 334317 - THREE POINT HITCH WITH QUICK ATTACH ENDS, THIRD-LINK SPRAG, BREAKDOWN
37.120.AF	01	VAR - 330899, 390269 - 2 PIN TYPE TELESCOPIC STABILIZERS
37.120.AO	01	VAR - 334316 - THREE POINT LINKAGE WITH CAT.2 FLEXIBLE ENDS
37.120.AO	02	VAR - 334317 - THREE POINT HITCH WITH CAT2 QUICK ATTACH
37.120.AO	03	VAR - 334316 - TELESCOPIC LINK ENDS - BREAKDOWN
37.120.AV	01	VAR - 334316, 334317, 390259 - RH SIDE ADJUSTABLE TIE-ROD, BREAKDOWN
37.120.AV	02	VAR - 334316, 390259 - RH SIDE ADJUSTABLE TIE-ROD, BREAKDOWN
39.000.00	01	SECTION INDEX - FRAMES AND BALLASTINGS
39.140.AF	01	VAR - 335240, 335241 - FRONT SUPPORT AND WEIGHTS WITH HOOK
39.140.AF	02	VAR - 335397 - FRONT SUPPORT AND WEIGHT WITH HOOK
39.140.AL	01	VAR - 330470, 330471 - REAR BALLAST
41.000.00	01	SECTION INDEX - STEERING
41.101.AA	01	VAR - 333606, 334318, 334319, 391606, 392315 - STEERING WHEEL
41.101.AB	01	VAR - 333606, 334318, 334319, 391606, 392315 - STEERING COLUMN
41.106.AB	01	VAR - 338860, 390860 - 2WD, FRONT AXLE, LEVER
41.106.AC	01	VAR - 334413, 390338, 743515 - 2WD, FRONT AXLE
41.106.AD	01	VAR - 390250 - 4WD FRONT AXLE, TIE-ROD
41.106.AD	02	VAR - 335325 - 4WD FRONT AXLE, TIE-ROD
41.106.AD	03	VAR - 335539 - CLASS 2 FRONT AXLE WITH 2ND STEERING CYLINDER & LIMITED SLIP (30KM/H) - TIE ROD
41.200.AL	01	VAR - 330120, 331120, 743846 - STEERING ASSY, FILTER, COMPONENTS
41.200.AO	01	VAR - 390249, 743846, 744738, 744739, 744744 - HYDRAULIC STEERING HOSE
41.200.AO	02	VAR - 744738, 744739, 744744 - HYDRAULIC STEERING HOSE RETURN
41.200.AO	03	VAR - 330384, 744739 - HYDRAULIC STEERING HOSE RETURN
41.200.AO	04	VAR - 330120, 331120, 743846 - HYDRAULIC STEERING HOSE

TABLE OF CONTENTS

41.200.CA	01	VAR - 333606, 334318, 334319, 391606, 392315 - STEERING CONTROL VALVE
41.206.AA	01	VAR - 330120, 331120, 390249, 743846 - HYDRAULIC STEERING PUMP
41.206.AA	02	VAR - 330120, 331120, 390249, 743846 - POWER STEERING PUMP, BREAKDOWN
41.206.AJ	01	VAR - 330120, 331120, 390249, 743846 - HYDRAULIC STEERING, PUMP, LINE
41.216.AN	01	VAR - 334413, 390338, 743515 - 2WD FRONT AXLE, HYDRAULIC STEERING CYLINDER HOSES
41.216.AN	02	VAR - 334413, 390338, 743515 - 2WD FRONT AXLE, HYDRAULIC STEERING CYLINDER, BREAKDOWN
41.216.AN	05	VAR - 390250 - 4WD FRONT AXLE - HYDRAULIC STEERING CYLINDER
41.216.AN	06	VAR - 390250 - HYDRAULIC STEERING, CYLINDER, COMPONENTS
41.216.AN	07	VAR - 335325 - 4WD FRONT AXLE - HYDRAULIC STEERING CYL
41.216.AN	08	VAR - 335325 - 4WD, FRONT AXLE, HYDRAULIC STEERING, CYLINDER, COMPONENTS
41.216.AN	10	VAR - 335539 - FRONT AXLE - HYDRAULIC STEERING CYLINDER - BREAKDOWN
41.216.AV	01	VAR - 335539 - HYDRAULIC STEERING CYLINDER LINES
44.000.00	01	SECTION INDEX - WHEELS
44.000.00	02	SECTION INDEX - WHEELS
44.511.AE	01	WHEEL, FRONT, 4WD
44.511.AE	02	WHEEL, FRONT, 4WD
44.511.AE	03	WHEEL, FRONT, 4WD
44.511.AE	04	WHEEL, FRONT, 4WD
44.511.AE	05	WHEEL, FRONT, 4WD
44.511.AE	06	WHEEL, FRONT, 4WD
44.511.AE	07	WHEEL, FRONT, 4WD
44.511.AE	08	WHEEL, FRONT, 4WD
44.511.AE	09	WHEEL, FRONT, 2WD
44.511.AE	10	WHEEL, FRONT, 2WD
44.511.AE	11	WHEEL, FRONT, 2WD
44.511.AE	12	WHEEL, FRONT, 2WD
44.520.AB	01	WHEEL, REAR
44.520.AB	02	WHEEL, REAR
44.520.AB	03	WHEEL, REAR
44.520.AB	04	WHEEL, REAR
44.520.AB	05	WHEEL, REAR

TABLE OF CONTENTS

44.520.AB	06	WHEEL, REAR
44.520.AB	07	WHEEL, REAR
44.520.AB	07	WHEEL, REAR
44.520.AB	08	WHEEL, REAR
50.000.00	01	SECTION INDEX - CAB CLIMATE CONTROL
50.100.AC	01	VAR - 330641, 390641 - HEATER, HOSE
50.100.AP	01	VAR - 390641 - HEATER
50.100.AP	02	VAR - 390641 - HEATER, COMPONENT
50.104.AO	01	VAR - 330641, 390641 - AIR DUCT, GRILLE
50.104.AQ	01	VAR - 330641, 390641 - AIR FILTER, CAB
50.200.AK	01	VAR - 330641 - AIR CONDITIONER, CONDENSER
50.200.BB	01	VAR - 330641 - CONDENSER RECEIVER-DRYER HOSES
50.200.BY	01	VAR - 330641 - AIR CONDITIONER, LINE
50.200.CA	01	VAR - 330641 - AIR CONDITIONER
50.200.CA	02	VAR - 330641 - AIR CONDITIONER, COMPONENT
55.000.00	02	SECTION INDEX - ELECTRICAL SYSTEMS
55.000.00	03	SECTION INDEX - ELECTRICAL SYSTEMS
55.000.00	04	SECTION INDEX - ELECTRICAL SYSTEMS
55.010.AP	01	VAR - 333606, 334318, 334319, 391606, 392315 - ENGINE FUEL SENSOR
55.010.AQ	02	VAR - 334296 - WATER SEPARATOR, SENSOR
55.014.AC	01	VAR - 330200, 390227 - AIR CLEANER, RESTRICTION SWITCH, INDICATOR
55.015.AB	01	VAR - 333606, 334318, 334319, 391606, 392315 - ENGINE HARNESS
55.023.AA	01	VAR - 330120, 331120, 743846 - HYDRAULIC GEARBOX CONTROLS (POWER SHUTTLE) - SENSOR
55.030.AB	01	VAR - 744738, 744739, 744744 - BRAKE, SENSOR
55.031.AE	01	VAR - 333606, 334318, 334319, 391606, 392315 - PARKING BRAKE, SWITCH
55.046.AH	01	VAR - 743846, 744739 - DIFFERENTIAL LOCK, CONTROL, SWITCH
55.047.AD	01	VAR - 330120, 331120, 390249, 743846 - POWER STEERING KIT, PRESSURE SWITCH
55.048.AB	01	VAR - 333606, 334318, 334319, 391606, 392315 - PTO, CONTROL LEVER, SWITCH
55.051.AA	01	VAR - 330641 - AIR CONDITIONER, CONTROL PANEL, BREAKDOWN
55.051.AB	01	VAR - 390641 - HEATING SYSTEM, CONTROL PANEL, BREAKDOWN
55.100.DO	01	VAR - 333606, 391606 - FUSE BOX, CAB

TABLE OF CONTENTS

55.100.DO	02	VAR - 334318, 334319, 392315 - FUSE BOX, ROPS
55.201.AH	01	VAR - 333606, 334318, 334319, 391606, 392315 - ENGINE STARTER SAFETY SWITCH
55.202.AY	01	VAR - 330203 - THERMOSTART
55.302.AG	01	VAR - 330740, 335210 - BATTERY MOUNTING
55.404.AC	01	VAR - 334343, 335914 - ROTARY BEACON, CAB
55.404.AC	02	VAR - 334343, 335914 - ROTARY BEACON, ROPS
55.404.BA	01	VAR - 334342, 334343 - NUMBER PLATE LIGHT
55.404.BH	01	VAR - 334344, 334345, 334346, 334347, 334348, 334349, 334350, 335914 - REFLECTOR, REAR
55.404.BS	01	VAR - 335767 - WORK LIGHT, ROPS
55.404.CA	01	VAR - 334344, 334345, 334346, 334347, 334348, 334339, 334350, 335914 - FRONT TURN INDICATORS
55.404.CL	01	VAR - 334344, 334345, 334346, 334347, 334348, 334349, 334950, 335914 - REAR TURN INDICATORS
55.404.CY	01	VAR - 334342, 334343, 334344, 334345, 334346, 334347, 334348, 334349, 334950, 335914 - ROAD LIGHTS - FRONT HEADLAMPS
55.404.CY	02	VAR - 334342, 334343, 334344, 334345, 334346, 334347, 334348, 334349, 334950, 335914 - FRONT HEADLAMPS - BREAKDOWN
55.405.CH	01	VAR - 334343, 335914 - ROTARY BEACON, SWITCH, CAB
55.405.CH	02	VAR - 334343, 335914 - ROTARY BEACON, SWITCH, ROPS
55.408.AG	01	VAR - 333606, 334318, 334319, 391606, 392315 - SIGNAL HORN AND RELATED PARTS
55.408.BE	01	VAR - 334353, 335001, 336001, 744258 - REVERSE SPEED ALARM
55.408.CA	01	VAR - 333606, 334318, 334319, 391606, 392315 - INSTRUMENT CLUSTER
55.510.AF	01	VAR - 333606, 334318, 334319, 391606, 392315 - MAIN HARNESS
55.510.AF	02	VAR - 333606, 334318, 334319, 391606, 392315 - MAIN HARNESS
55.510.BM	01	VAR - 334342, 334344, 334345, 334346, 334347, 334348, 334349, 334350 - AUXILIARY POWER SOCKET
55.510.BM	02	VAR - 335394 - INSIDE CAB POWER SOCKET
55.512.AA	01	VAR - 390777 - LESS RADIO READY, CAB
55.512.AA	02	VAR - 333777 - CAB, RADIO
55.512.AA	03	VAR - 330777 - CAB, 2 SPEAKERS AND ANTENNA
55.512.BG	01	VAR - 333606, 334318, 334319, 391606, 392315 - ELECTRIC CONTROLS, SWITCHES
55.512.BG	02	VAR - 333606, 334318, 334319, 391606, 392315 - ELECTRIC SYSTEM CONTROL, SWITCH
55.514.AA	01	VAR - 334344, 334345, 334346, 334347, 334348, 334349, 334950, 335914 - CAB LIGHTING
55.514.AB	01	VAR - 335709, 335769 - CAB WORK LIGHT

TABLE OF CONTENTS

55.518.AH	01	VAR - 334339, 334402, 334403, 334404 - REAR WINDSHIELD WIPER
55.518.AT	01	VAR - 334399, 334402, 334403, 334404 - WINDSHIELD WIPER TANK
55.518.AW	01	VAR - 334399, 334402 - FRONT WINDSHIELD WIPER
55.518.AW	02	VAR - 334403, 334404 - PARALLEL FRONT WINDSHIELD WIPER
82.000.00	01	PICTORIAL INDEX - FRONT LOADER
82.100.AF	01	VAR - 334351 - FRONT LOADER WITH 4 COUPLERS AND GRILL GUARDS
82.100.AF	02	VAR - 334351 - LOADER ARM, BREAKDOWN
82.100.AF	03	VAR - 334351 - FRONT LOADER, BREAKDOWN, LOADER ARM AND LEVER
82.100.AF	04	VAR - 334351, 334352 - FRONT LOADER, BREAKDOWN, PARKING LEG AND PIPE PROTECTION
82.100.AF	05	VAR - 334351, 334352 - LOADER, FRONT, LINK
82.100.AF	06	VAR - 334352 - FRONT LOADER WITH 4 COUPLERS AND GRILL GUARDS (SELF LEVELLING)
82.100.AF	07	VAR - 334352 - LOADER ARM (SELF LEVELLING), BREAKDOWN
82.100.AF	08	VAR - 334352 - FRONT LOADER (SELF LEVELLING), BREAKDOWN, LOADER ARM LEVER
82.100.AI	01	VAR - 330489, 334351, 334352 - FRONT LOADER WITH 4 COUPLERS, REAR BRACKETS
82.100.BG	01	VAR - 334351 - FRONT LOADER, BREAKDOWN, PINS ARM AND LEVER
82.100.BG	02	VAR - 334352 - FRONT LOADER, BREAKDOWN, PINS ARM AND LEVER
82.300.AN	01	VAR - 334351, 334352 - FRONT LOADER WITH 4 COUPLERS AND GRILL GUARDS, LOADER BUCKET
82.300.AX	01	VAR - 334351, 334352 - FRONT LOADER, BREAKDOWN, QUICK COUPLER BUCKET
88.000.00	01	SECTION INDEX, ACCESSORIES
88.100.AC	01	VAR - 334342, 334343, 334344, 334345, 334346, 334347, 334348, 334349, 334350, 335914 - LICENSE PLATE LAMP & SUPPORT, CAB
88.100.AC	02	VAR - 334342, 334343, 334344, 334345, 334346, 334347, 334348, 334349, 334350, 335914 - LICENSE PLATE LAMP & SUPPORT, ROPS
88.100.AG	01	VAR - 334408 - SET OF TOOLS
88.100.AH	01	VAR - 332998, 334408 - TOOL BOX
90.000.00	01	SECTION INDEX - PLATFORM, CAB, BODYWORK AND DECALS
90.000.00	02	SECTION INDEX - PLATFORM, CAB, BODYWORK AND DECALS
90.000.00	03	SECTION INDEX - PLATFORM, CAB, BODYWORK AND DECALS
90.000.00	04	SECTION INDEX - PLATFORM, CAB, BODYWORK AND DECALS
90.100.AC	01	VAR - 333606, 334318, 334319, 391606, 392315 - SIDE PANELS
90.100.AC	02	VAR - 333606, 334318, 334319, 391606, 392315 - SIDE PANELS

TABLE OF CONTENTS

90.100.AU	01	VAR - 333606, 334318, 334319, 391606, 392315 - ENGINE HOOD
90.100.AU	02	VAR - 333606, 334318, 334319, 391606, 392315 - ENGINE HOOD, SEALS
90.102.AU	01	VAR - 333606, 334318, 334319, 391606, 392315 - ENGINE HOOD
90.102.AW	01	VAR - 333606, 334318, 334319, 391606, 392315 - HOOD CLOSING SUPPORT
90.102.AW	02	VAR - 333606, 334318, 334319, 391606, 392315 - HOOD CLOSING SUPPORT
90.105.CQ	01	VAR - 333606, 334318, 334319, 391606, 392315 - BULKHEAD
90.108.AA	01	VAR - 330641, 390641 - DECALS, CONTROLS
90.108.AB	01	VAR - 334342, 334343, 334344, 334345, 334346, 334347 - DECALS, MODEL IDENTIFICATION
90.108.AB	02	VAR - 334351, 334352 - MODEL IDENTIFICATION DECALS, LOADER ARM
90.108.AC	01	VAR - 333606, 334318, 334319, 391606, 392315 - DECALS, WARNING, ISO
90.108.AC	02	VAR - 334395 - DECALS, WARNING, ISO
90.108.AC	03	VAR - 333606, 334318, 334319, 391606, 392315 - DECALS, WARNING, ISO
90.108.AC	04	VAR - 334351, 334352 - SAFETY DECALS, LOADER ARM
90.108.AD	01	VAR - 333606, 334318, 334319, 391606, 392315 - DECALS - TRADEMARK EMBLEM
90.110.AH	01	VAR - 333606, 334318, 334319, 391606, 392315 - INSTRUMENT PANEL, ROPS
90.110.AV	01	VAR - 334318, 334319, 392315 - PASSENGER SEAT, SIDE PANEL, ROPS
90.114.AQ	01	VAR - 334318, 334319, 392315 - ROPS, FRAME
90.114.AR	01	VAR - 334318, 334319 - ROPS, ROPS FRAME CANOPY
90.116.AC	01	VAR - 335928, 391460, 744756 - REAR FENDER
90.116.AC	02	VAR - 335897 - REAR FENDER EXTENSION
90.116.AC	04	VAR - 339860 - 4WD FRONT FENDERS, 340 MM
90.116.AC	05	VAR - 339860 - 4WD FRONT FENDERS, 340 MM
90.116.AC	06	VAR - 335495 - 4WD WIDE FRONT FENDERS, 400 MM
90.116.AC	07	VAR - 338860 - 2WD FRONT FENDERS, 240 MM.
90.118.BM	01	VAR - 390879 - REAR VIEW MIRROR, CAB
90.118.BM	02	VAR - 330879 - EXTENDABLE MIRROR, CAB
90.118.BM	03	VAR - 337652, 337653, 337654 - REAR MIRROR, ROPS
90.118.BX	01	VAR - 335928, 391460, 744756 - LADDER
90.120.AD	01	VAR - 744746, 744748 - SEAT AND SUPPORT
90.120.AD	02	VAR - 744747, 744749 - SEAT AND SUPPORT

TABLE OF CONTENTS

90.120.AD	03	VAR - 744746, 744748 - SEAT, COMPONENTS
90.120.AD	04	VAR - 744746, 744748 - SEAT, COMPONENTS
90.120.AD	05	VAR - 744747, 744749 - SEAT, COMPONENTS
90.120.AD	06	VAR - 744747, 744749 - SEAT, COMPONENTS
90.120.AD	07	VAR - 744747, 744749 - SEAT, COMPONENTS
90.150.AC	01	VAR - 333606, 391606 - CAB, FRAME
90.150.AE	01	VAR - 333606, 334318, 334319, 391606, 392315 - CAB & ROPS FRONT SUPPORT
90.150.AG	01	VAR - 333606, 334318, 334319, 391606, 392315 - CAB & ROPS REAR SUPPORT
90.150.BC	01	VAR - 333606 - HIGH VISIBILITY ROOF FOR CAB
90.150.BG	01	VAR - 391606 - CAB ROOF
90.150.BG	02	VAR - 333606, 391606 - CAB ROOF
90.151.AC	01	VAR - 334418, 334420, 744748, 744749 - PASSENGER SEAT
90.151.AE	01	VAR - 333606, 391606 - CAB, SUNVISOR
90.151.AF	01	VAR - 333606, 391606 - INSTRUMENT PANEL, CAB
90.151.AK	01	VAR - 330879, 390879 - REAR VIEW MIRROR, CAB
90.154.AC	01	VAR - 334342, 334343, 334344, 334345, 334346, 334347, 334348, 334349, 334350, 335914 - CAB DOOR, LEFT, HANDLE
90.154.AC	02	VAR - 334342, 334343, 334344, 334345, 334346, 334347, 334348, 334349, 334350, 335914 - CAB DOOR, RIGHT, HANDLE
90.154.AV	01	VAR - 334342, 334343, 334344, 334345, 334346, 334347, 334348, 334349, 334350, 335914 - CAB DOOR, LEFT, GLASS
90.154.AV	02	VAR - 334342, 334343, 334344, 334345, 334346, 334347, 334348, 334349, 334350, 335914 - CAB DOOR, RIGHT, GLASS
90.156.AB	01	VAR - 333606, 334318, 334319, 391606, 392315 - REAR WINDOW GLASS
90.156.AD	01	VAR - 333606, 391606 - CAB REAR WINDOW
90.156.AG	01	VAR - 334318, 334319, 392315 - GLASS, FRONT, ROPS
90.156.AL	01	VAR - 333606, 392606 - CAB WINDSHIELD GLASS
90.156.AZ	01	VAR - 333606, 391606 - WINDOW, LEFT
90.156.AZ	02	VAR - 333606, 391606 - CAB WINDOW GLASS, RIGHT SIDE
90.160.AM	01	VAR - 744746, 744747, 744748, 744749 - CAB SIDE PANEL (LH)
90.160.AR	01	VAR - 744738, 744744 - CAB FLOOR, MAT
90.160.AR	02	VAR - 330384, 334322, 744739 - CAB FLOOR, MAT
90.160.AR	03	VAR - 330120, 331120, 390249, 743846 - FLOOR MAT, ROPS
90.160.AX	01	VAR - 391606 - CAB HEADLINER
90.160.AX	02	VAR - 333606 - HIGH VISIBILITY ROOF FOR CAB - HEADLINER

TABLE OF CONTENTS

90.160.BI	01	VAR - 744746, 744747, 744748, 744749 - PILLAR, RIGHT, TRIM, CAB
90.160.BL	01	VAR - 336125, 390124 - CONTROL PANEL, RIGHT, CAB
90.160.CK	01	VAR - 333606, 391606 - CAB, INSULATION

SECTION INDEX

TOP LEVEL

00.000.00	01	PICTORIAL INDEX - MAIN SECTIONS
00.000.00	02	PICTORIAL INDEX - MAIN SECTIONS
00.000.10	03	PICTORIAL INDEX - ENGINE
00.000.18	01	PICTORIAL INDEX - CLUTCH
00.000.21	01	PICTORIAL INDEX - TRANSMISSION
00.000.21	02	PICTORIAL INDEX - TRANSMISSION
00.000.23	01	PICTORIAL INDEX - 4WD LINES
00.000.25	01	PICTORIAL INDEX - FRONT MECHANICAL DRIVE
00.000.27	01	PICTORIAL INDEX - REAR DRIVE AXLE
00.000.31	01	PICTORIAL INDEX - IMPLEMENT POWER TAKE-OFF
00.000.33	01	PICTORIAL INDEX - BRAKES & CONTROLS
00.000.35	01	PICTORIAL INDEX - HYDRAULIC SYSTEMS
00.000.35	02	PICTORIAL INDEX - HYDRAULIC SYSTEMS
00.000.37	01	PICTORIAL INDEX - HITCHES, DRAWBARS AND IMPLEMENT COUPLINGS
00.000.39	01	PICTORIAL INDEX - FRAMES AND BALLASTINGS
00.000.41	01	PICTORIAL INDEX - STEERING
00.000.44	01	PICTORIAL INDEX - WHEELS
00.000.44	02	PICTORIAL INDEX - WHEELS
00.000.50	01	PICTORIAL INDEX - CAB CLIMATE CONTROL
00.000.55	02	PICTORIAL INDEX - ELECTRICAL SYSTEMS
00.000.55	03	PICTORIAL INDEX - ELECTRICAL SYSTEMS
00.000.55	04	PICTORIAL INDEX - ELECTRICAL SYSTEMS
00.000.82	01	PICTORIAL INDEX - FRONT LOADER
00.000.88	01	PICTORIAL INDEX - ACCESSORIES
00.000.90	01	PICTORIAL INDEX - PLATFORM, CAB, BODYWORK AND DECALS
00.000.90	02	PICTORIAL INDEX - PLATFORM, CAB, BODYWORK AND DECALS
00.000.90	03	PICTORIAL INDEX - PLATFORM, CAB, BODYWORK AND DECALS
00.000.90	04	PICTORIAL INDEX - PLATFORM, CAB, BODYWORK AND DECALS
00.001.00	01	OPTIONAL EQUIPMENT
00.001.00	02	OPTIONAL EQUIPMENT
00.100.01	01	IDENTIFICATION PLATE AND VERSION LIST
00.100.01	02	IDENTIFICATION PLATE AND VERSION LIST
00.100.01	03	IDENTIFICATION PLATE AND VERSION LIST
00.500.01		DIA KITS

PICTORIAL INDEX - MAIN SECTIONS

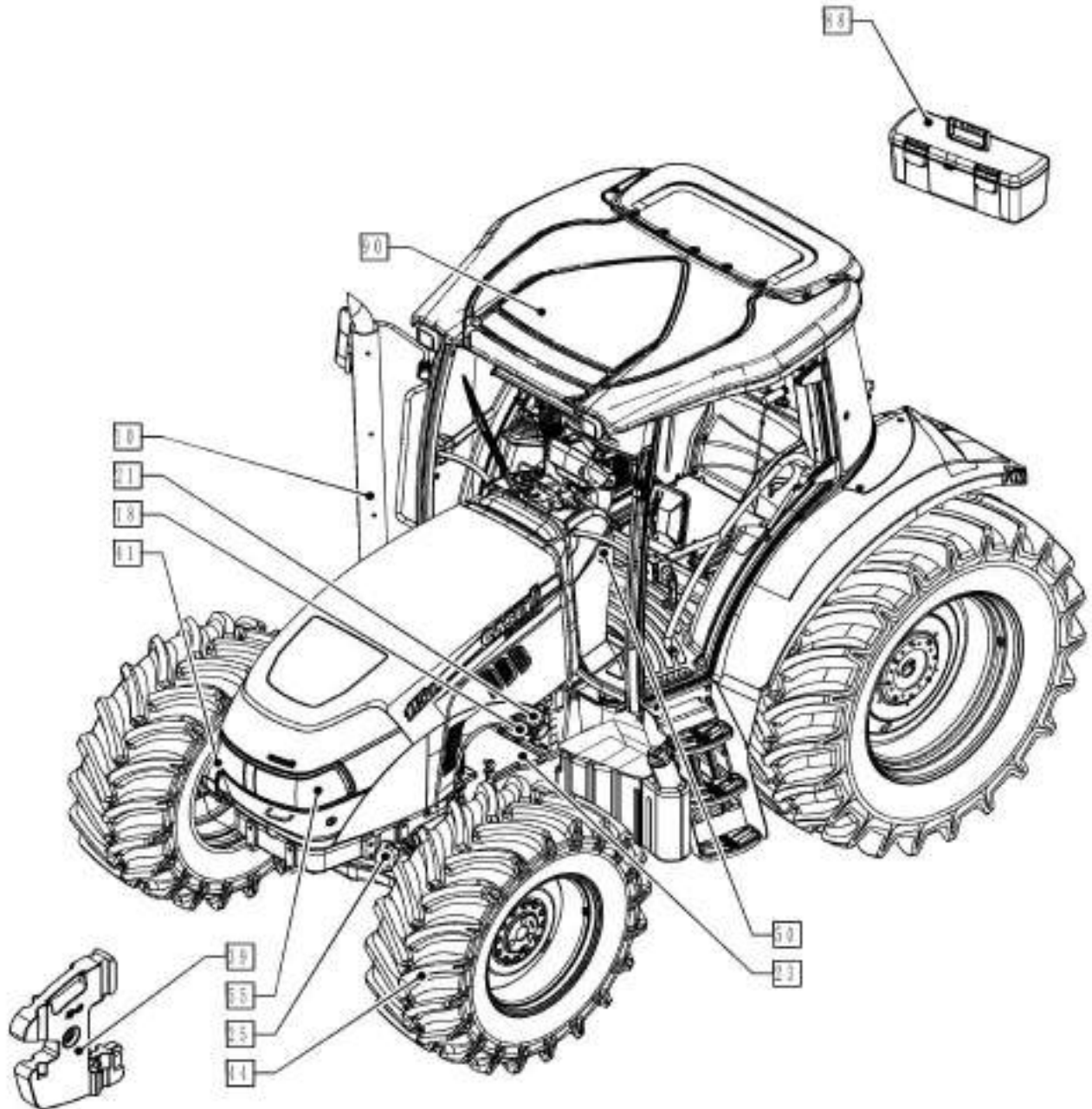

00.000.00

01

p1

1/2014

PICTORIAL INDEX - MAIN SECTIONS

REF FN	PART NUMBER	YR/SN	QTY	DESCRIPTION
---------------	--------------------	--------------	------------	--------------------

				FARMALL JX100 FARMALL JX110 FARMALL JX70 FARMALL JX75 FARMALL JX80 FARMALL JX90
--	--	--	--	--

PICTORIAL INDEX - MAIN SECTIONS

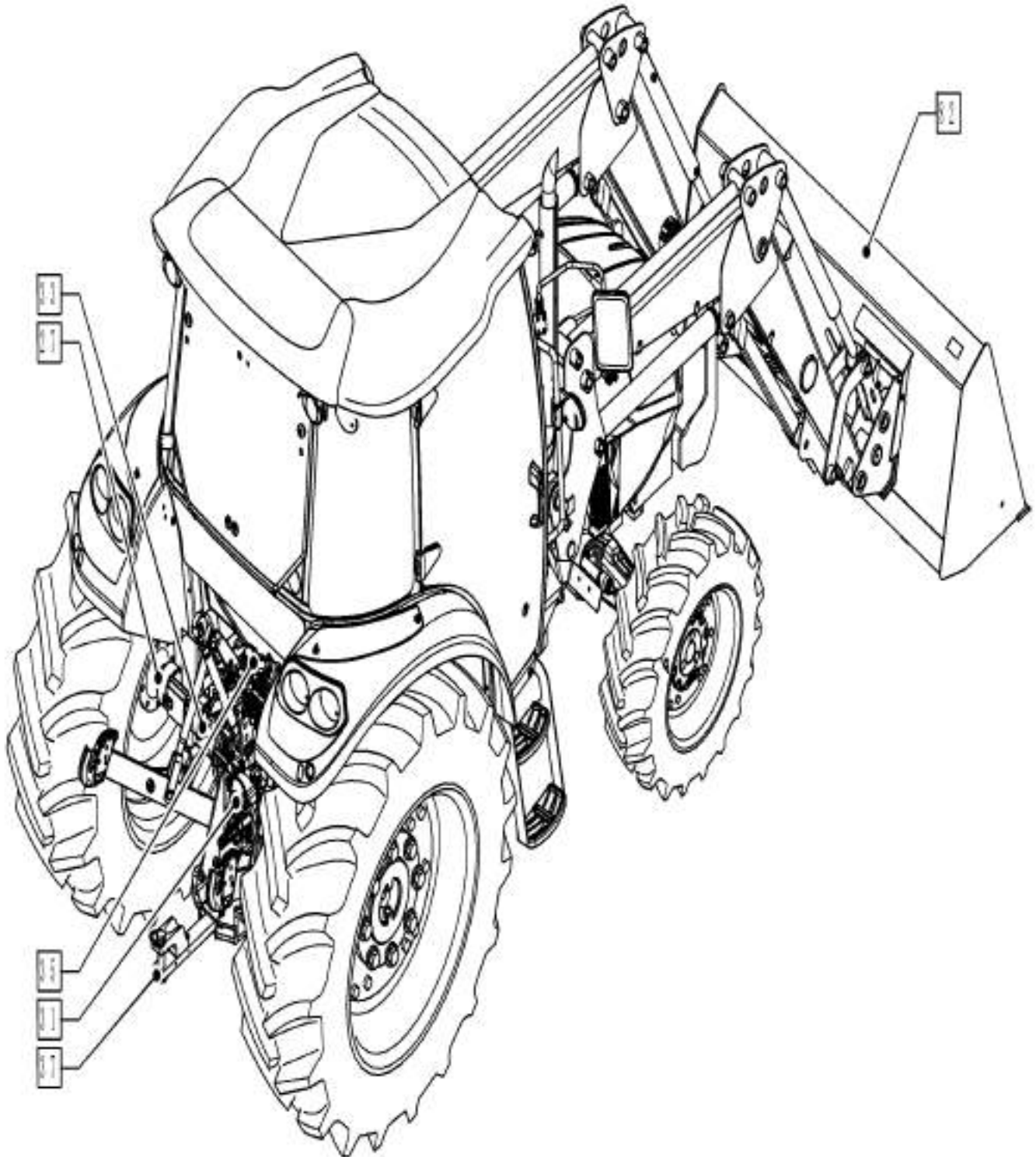

00.000.00

02

p1

1/2014

PICTORIAL INDEX - MAIN SECTIONS

REF FN	PART NUMBER	YR/SN	QTY	DESCRIPTION
---------------	--------------------	--------------	------------	--------------------

				FARMALL JX100 FARMALL JX110 FARMALL JX70 FARMALL JX75 FARMALL JX80 FARMALL JX90
--	--	--	--	--

PICTORIAL INDEX - ENGINE

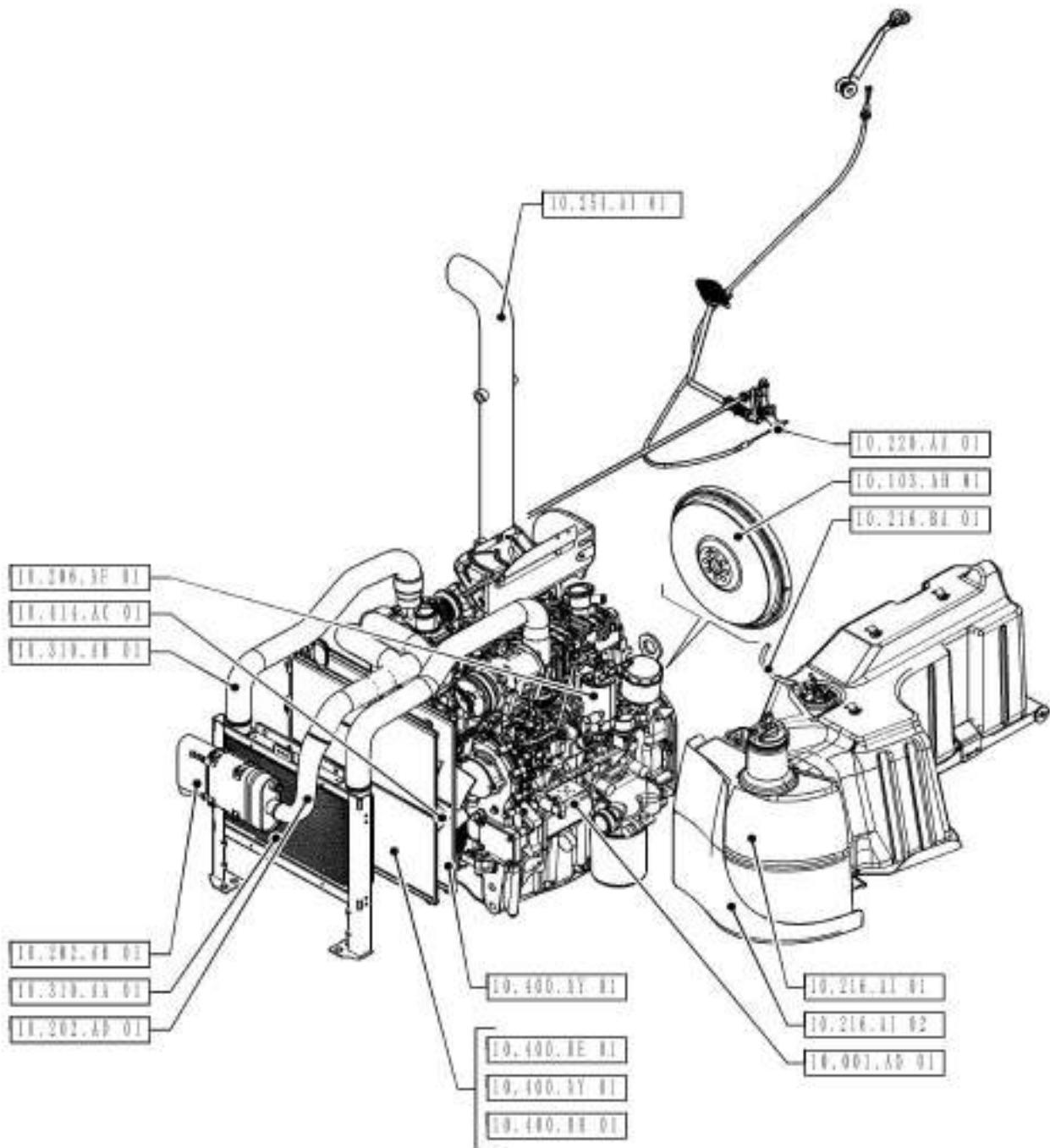

00.000.10

03

p1

1/2014

PICTORIAL INDEX - ENGINE

REF FN	PART NUMBER	YR/SN	QTY	DESCRIPTION
---------------	--------------------	--------------	------------	--------------------

				FARMALL JX100 FARMALL JX110 FARMALL JX70 FARMALL JX75 FARMALL JX80 FARMALL JX90
--	--	--	--	--

PICTORIAL INDEX - CLUTCH

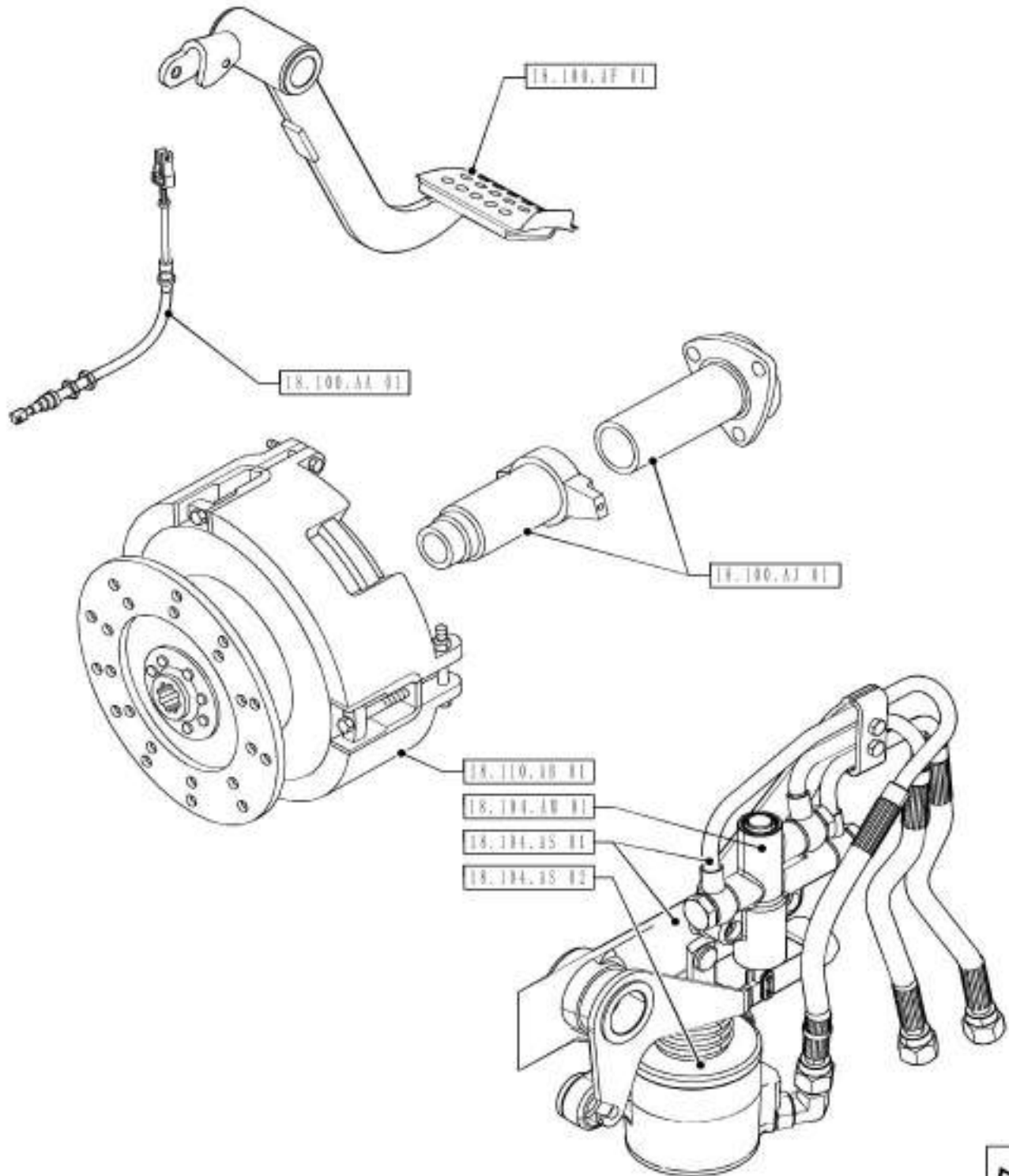

00.000.18

01

p1

1/2014

PICTORIAL INDEX - CLUTCH

REF FN	PART NUMBER	YR/SN	QTY	DESCRIPTION
---------------	--------------------	--------------	------------	--------------------

				FARMALL JX100 FARMALL JX110 FARMALL JX70 FARMALL JX75 FARMALL JX80 FARMALL JX90
--	--	--	--	--

PICTORIAL INDEX - TRANSMISSION

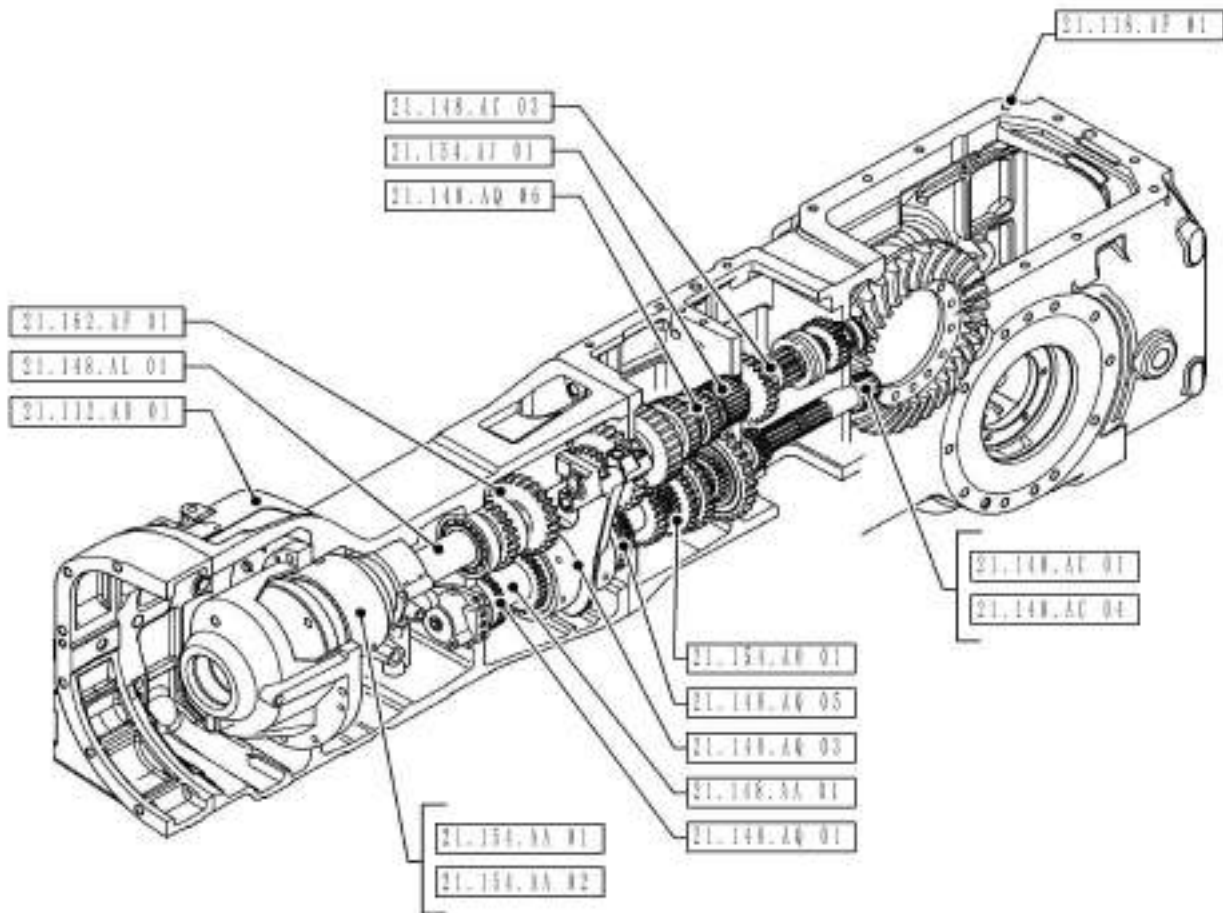

00.000.21

01

p1

1/2014

PICTORIAL INDEX - TRANSMISSION

REF FN	PART NUMBER	YR/SN	QTY	DESCRIPTION
---------------	--------------------	--------------	------------	--------------------

				FARMALL JX100 FARMALL JX70 FARMALL JX75 FARMALL JX80
--	--	--	--	---

PICTORIAL INDEX - TRANSMISSION

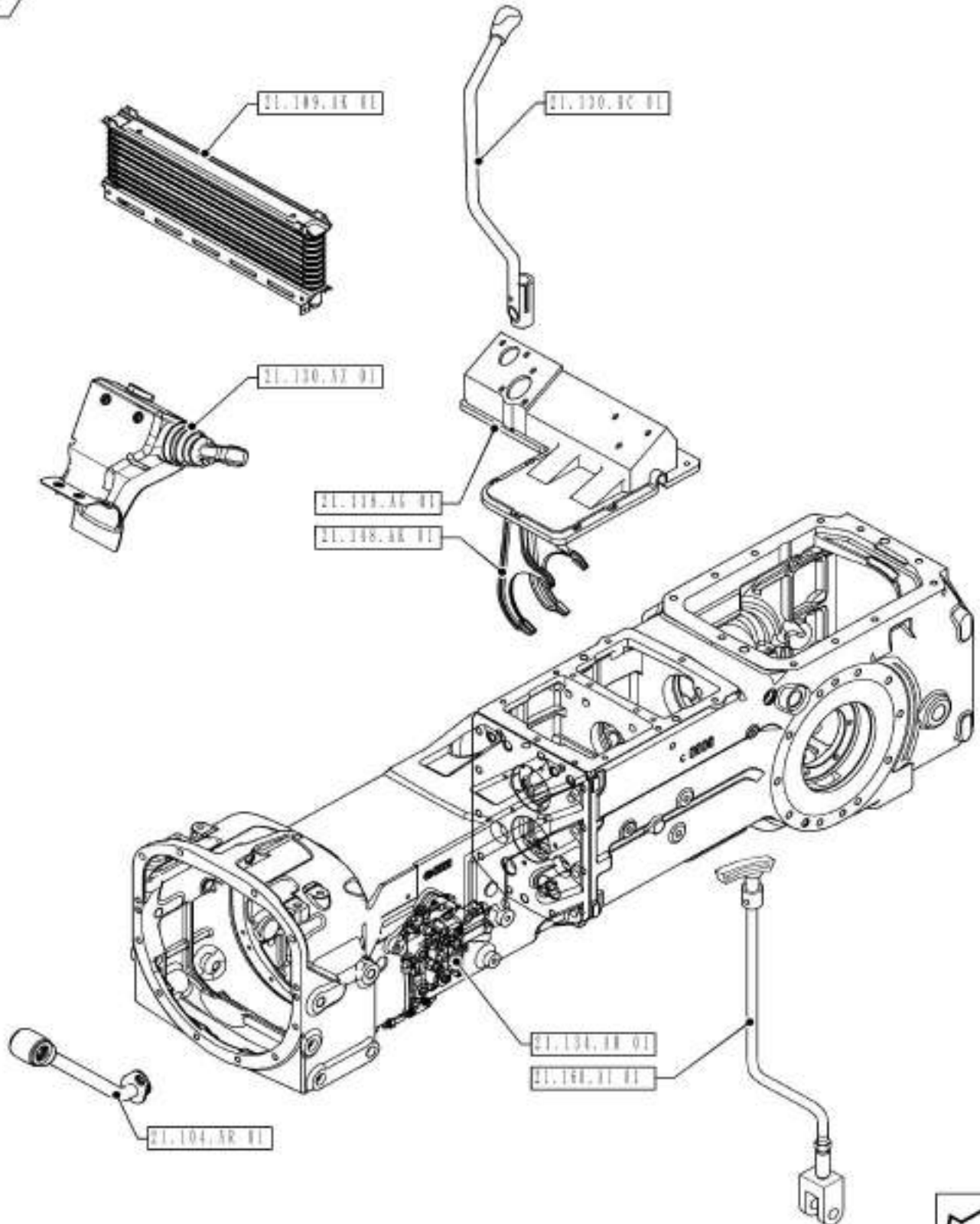

00.000.21

02

p1

1/2014

PICTORIAL INDEX - TRANSMISSION

REF FN	PART NUMBER	YR/SN	QTY	DESCRIPTION
---------------	--------------------	--------------	------------	--------------------

				FARMALL JX100 FARMALL JX110 FARMALL JX70 FARMALL JX75 FARMALL JX80 FARMALL JX90
--	--	--	--	--

PICTORIAL INDEX - 4WD LINES

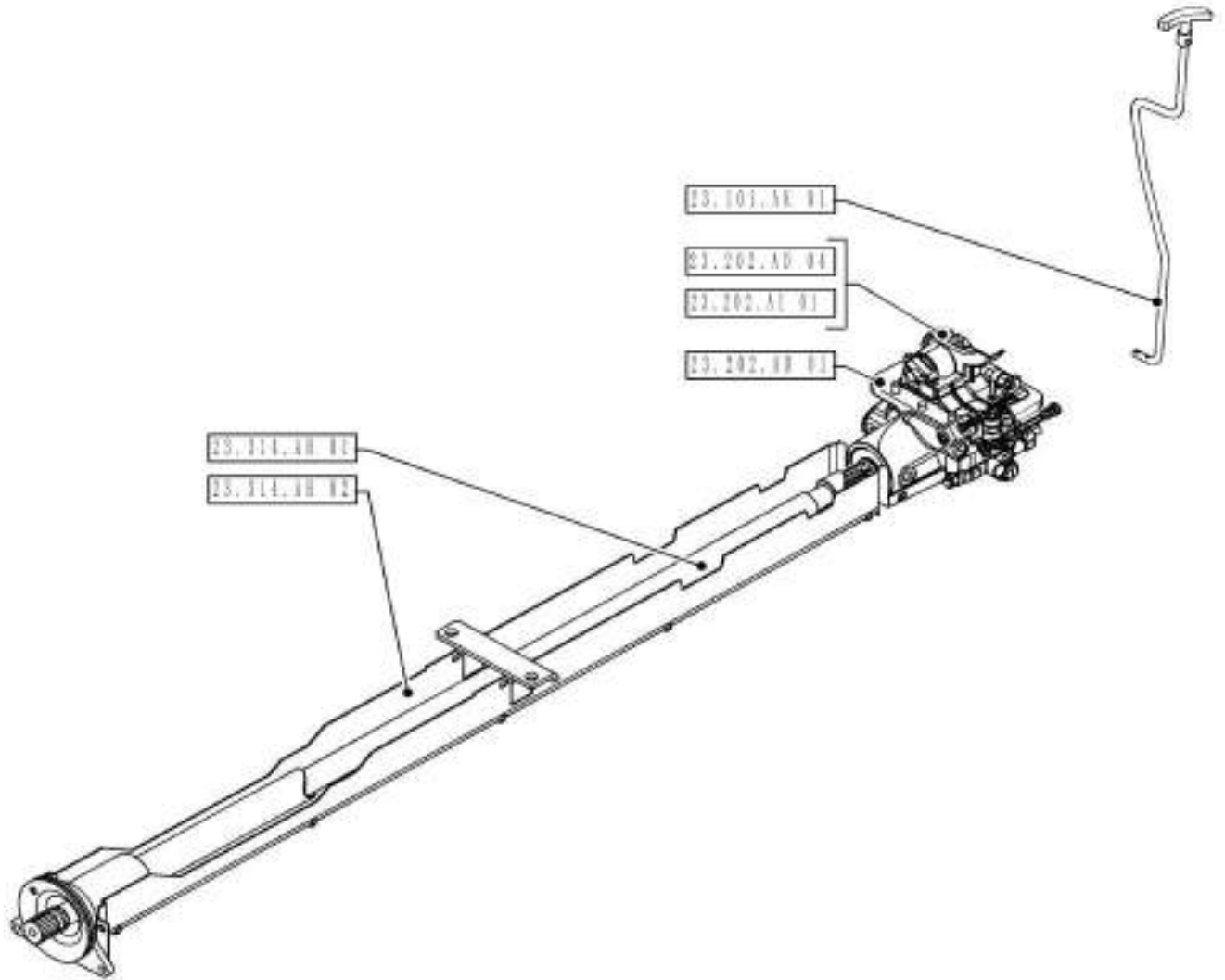

00.000.23

01

p1

1/2014

PICTORIAL INDEX - 4WD LINES

REF FN	PART NUMBER	YR/SN	QTY	DESCRIPTION
---------------	--------------------	--------------	------------	--------------------

				FARMALL JX100 FARMALL JX110 FARMALL JX70 FARMALL JX75 FARMALL JX80 FARMALL JX90
--	--	--	--	--

PICTORIAL INDEX - FRONT MECHANICAL DRIVE

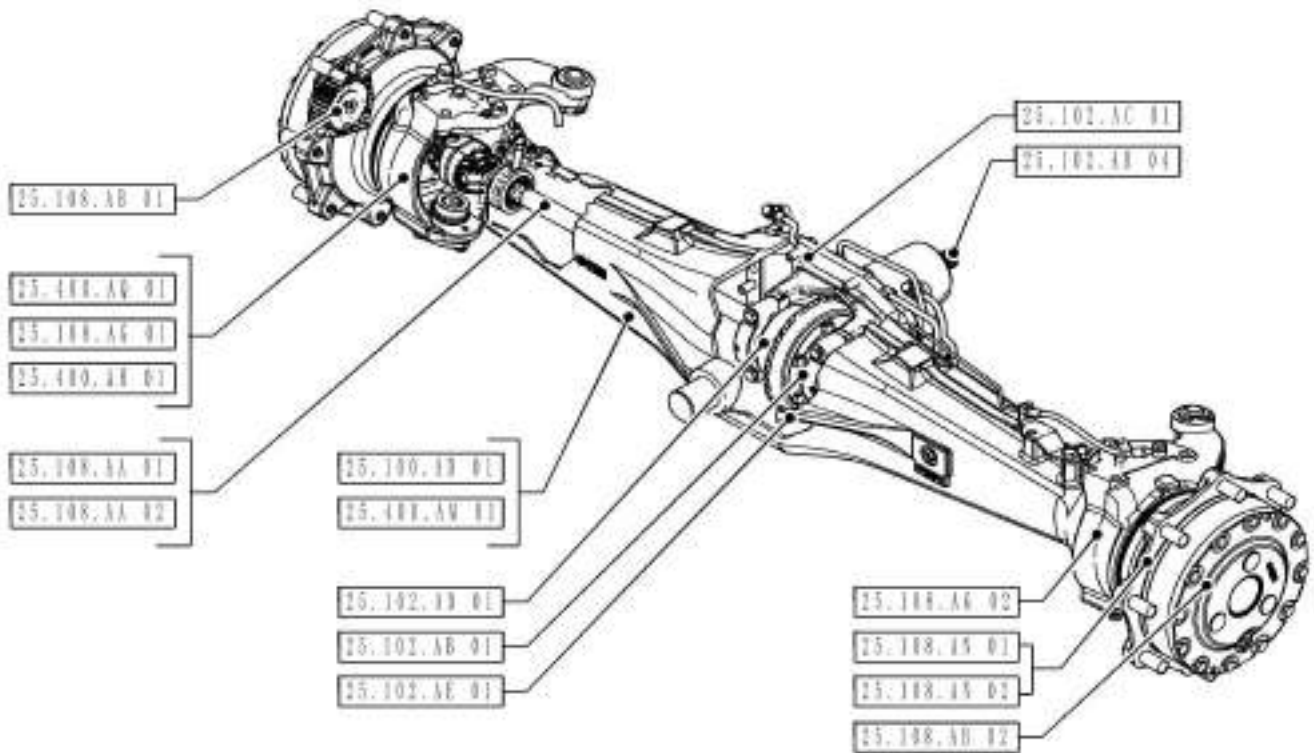
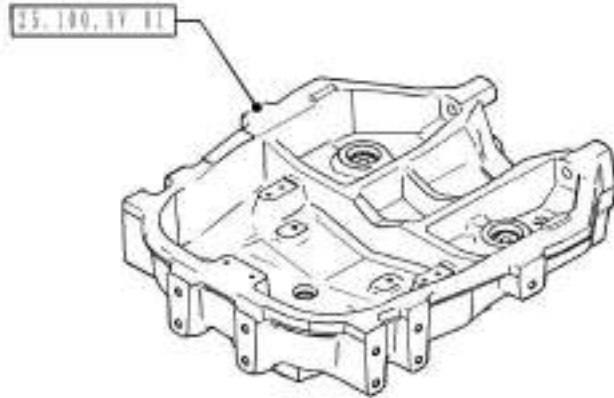

00.000.25

01

p1

1/2014

PICTORIAL INDEX - FRONT MECHANICAL DRIVE

REF FN	PART NUMBER	YR/SN	QTY	DESCRIPTION
---------------	--------------------	--------------	------------	--------------------

				FARMALL JX100 FARMALL JX110 FARMALL JX70 FARMALL JX75 FARMALL JX80 FARMALL JX90
--	--	--	--	--

PICTORIAL INDEX - REAR DRIVE AXLE

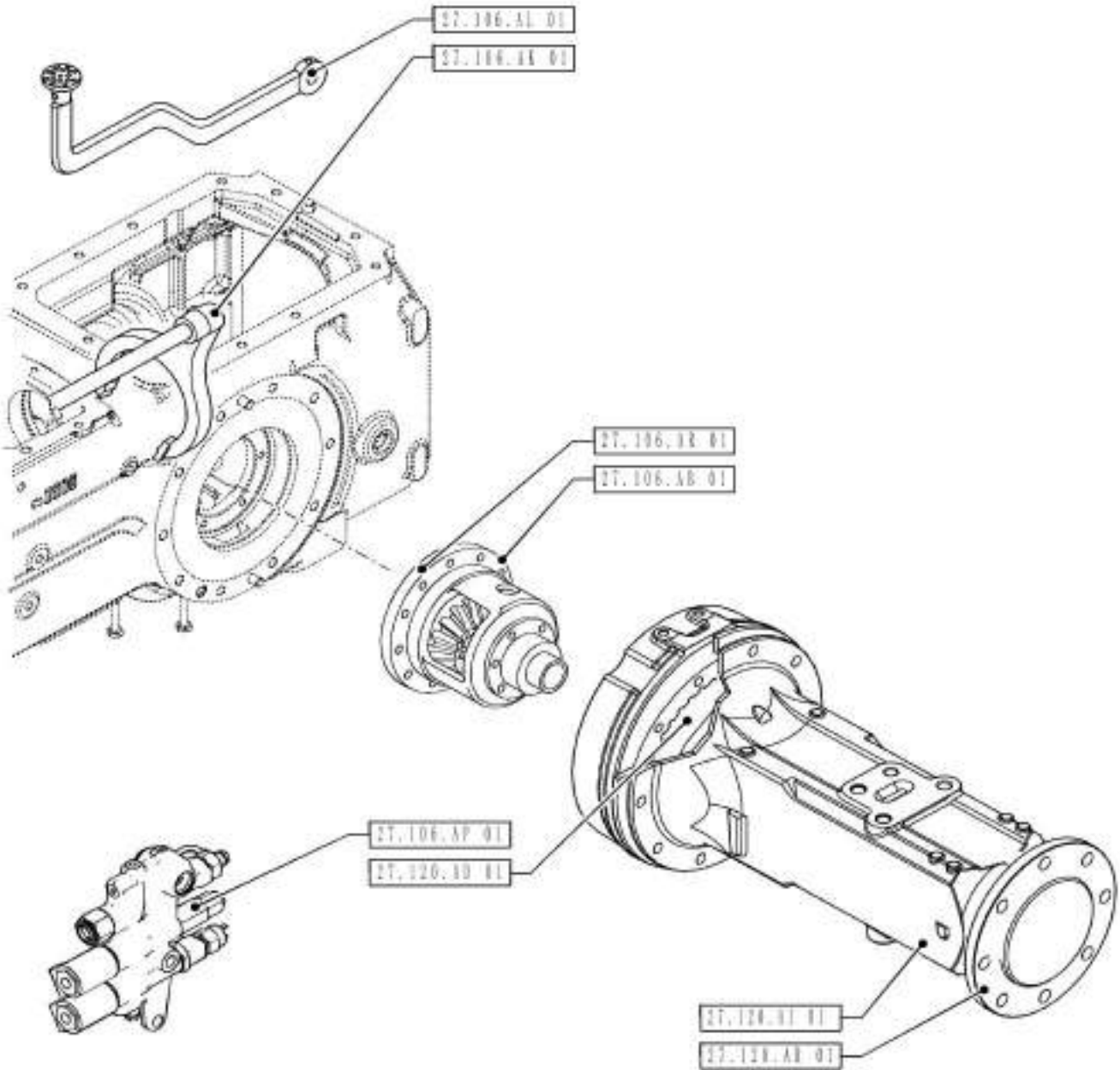

PICTORIAL INDEX - REAR DRIVE AXLE

REF FN	PART NUMBER	YR/SN	QTY	DESCRIPTION
--------	-------------	-------	-----	-------------

				FARMALL JX100 FARMALL JX110 FARMALL JX70 FARMALL JX75 FARMALL JX80 FARMALL JX90
--	--	--	--	--

PICTORIAL INDEX - IMPLEMENT POWER TAKE-OFF

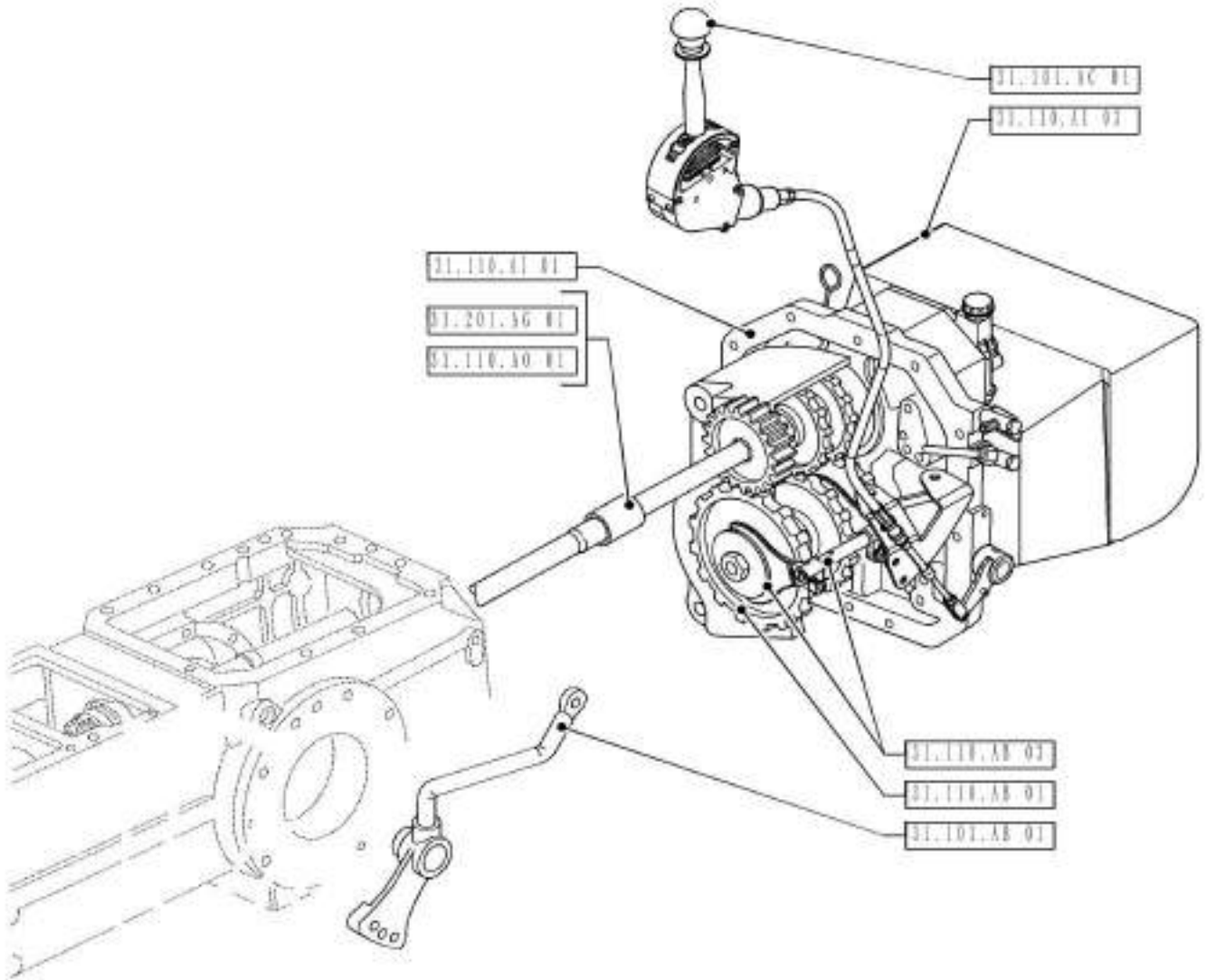

00.000.31

01

p1

1/2014

PICTORIAL INDEX - IMPLEMENT POWER TAKE-OFF

REF FN	PART NUMBER	YR/SN	QTY	DESCRIPTION
---------------	--------------------	--------------	------------	--------------------

				FARMALL JX100 FARMALL JX110 FARMALL JX70 FARMALL JX75 FARMALL JX80 FARMALL JX90
--	--	--	--	--

PICTORIAL INDEX - BRAKES & CONTROLS

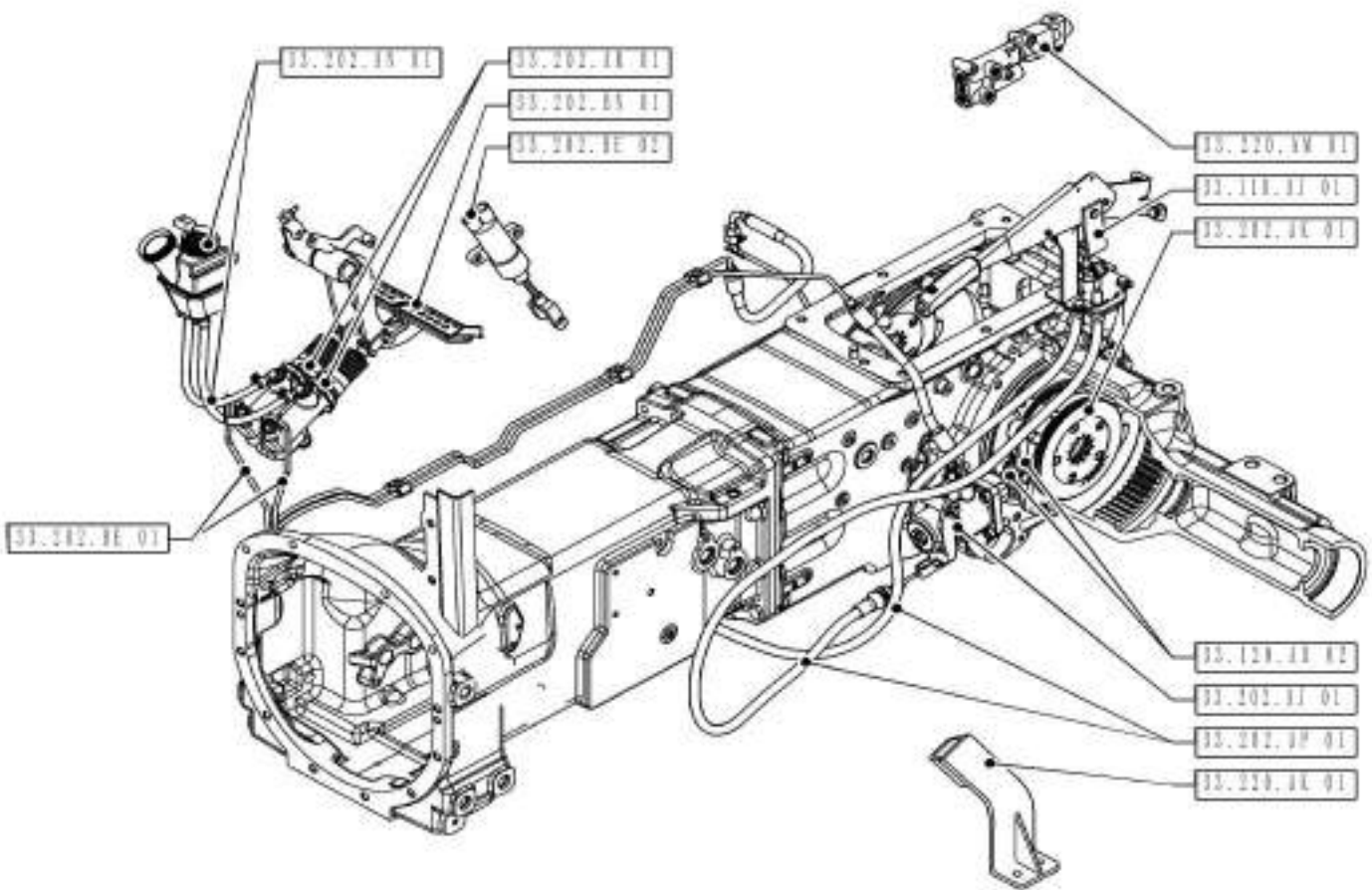

00.000.33

01

p1

1/2014

PICTORIAL INDEX - BRAKES & CONTROLS

REF FN	PART NUMBER	YR/SN	QTY	DESCRIPTION
---------------	--------------------	--------------	------------	--------------------

				FARMALL JX100 FARMALL JX110 FARMALL JX70 FARMALL JX75 FARMALL JX80 FARMALL JX90
--	--	--	--	--

PICTORIAL INDEX - HYDRAULIC SYSTEMS

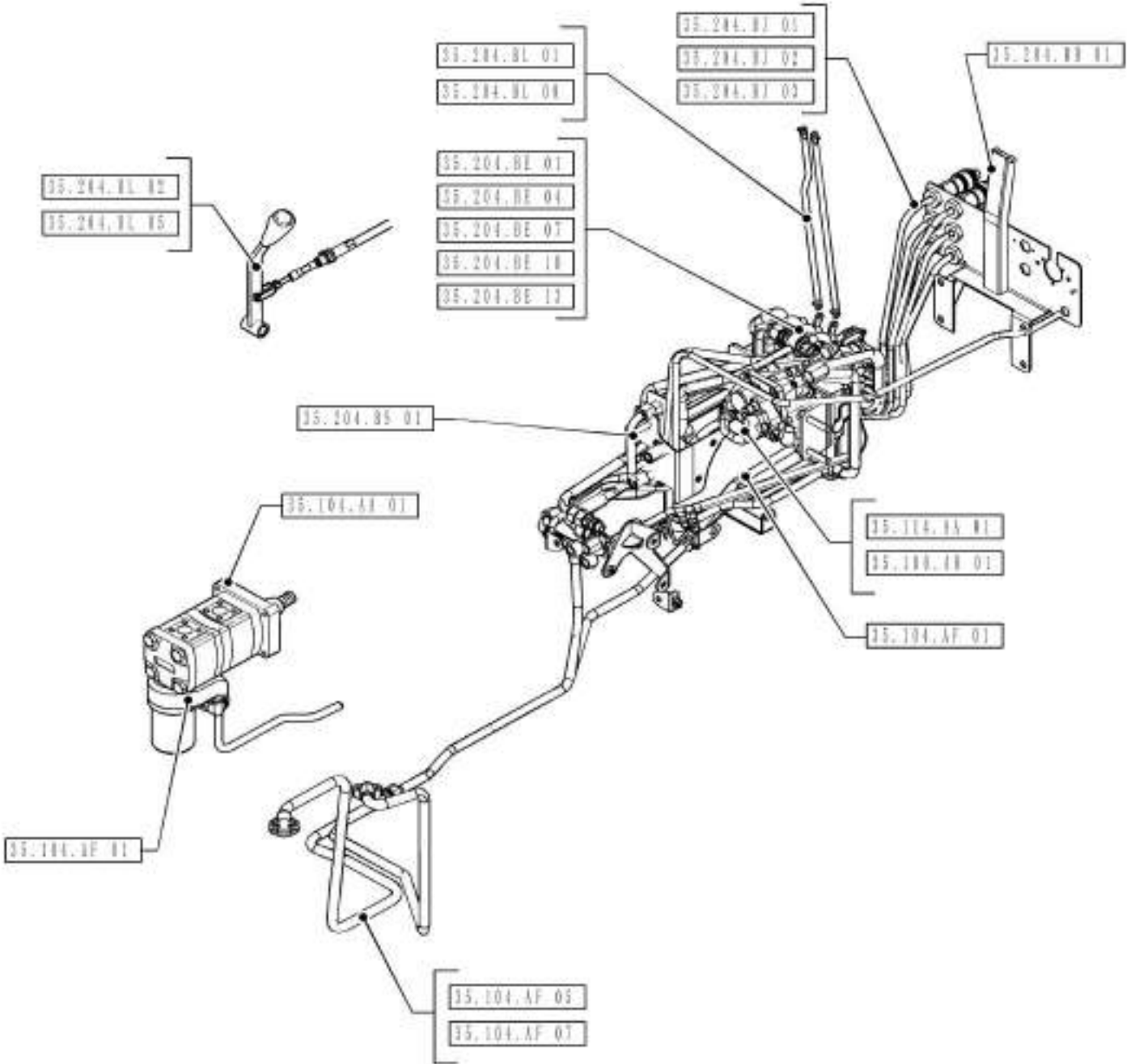

00.000.35

01

p1

1/2014

PICTORIAL INDEX - HYDRAULIC SYSTEMS

REF FN	PART NUMBER	YR/SN	QTY	DESCRIPTION
---------------	--------------------	--------------	------------	--------------------

				FARMALL JX100 FARMALL JX110 FARMALL JX70 FARMALL JX75 FARMALL JX80 FARMALL JX90
--	--	--	--	--

PICTORIAL INDEX - HYDRAULIC SYSTEMS

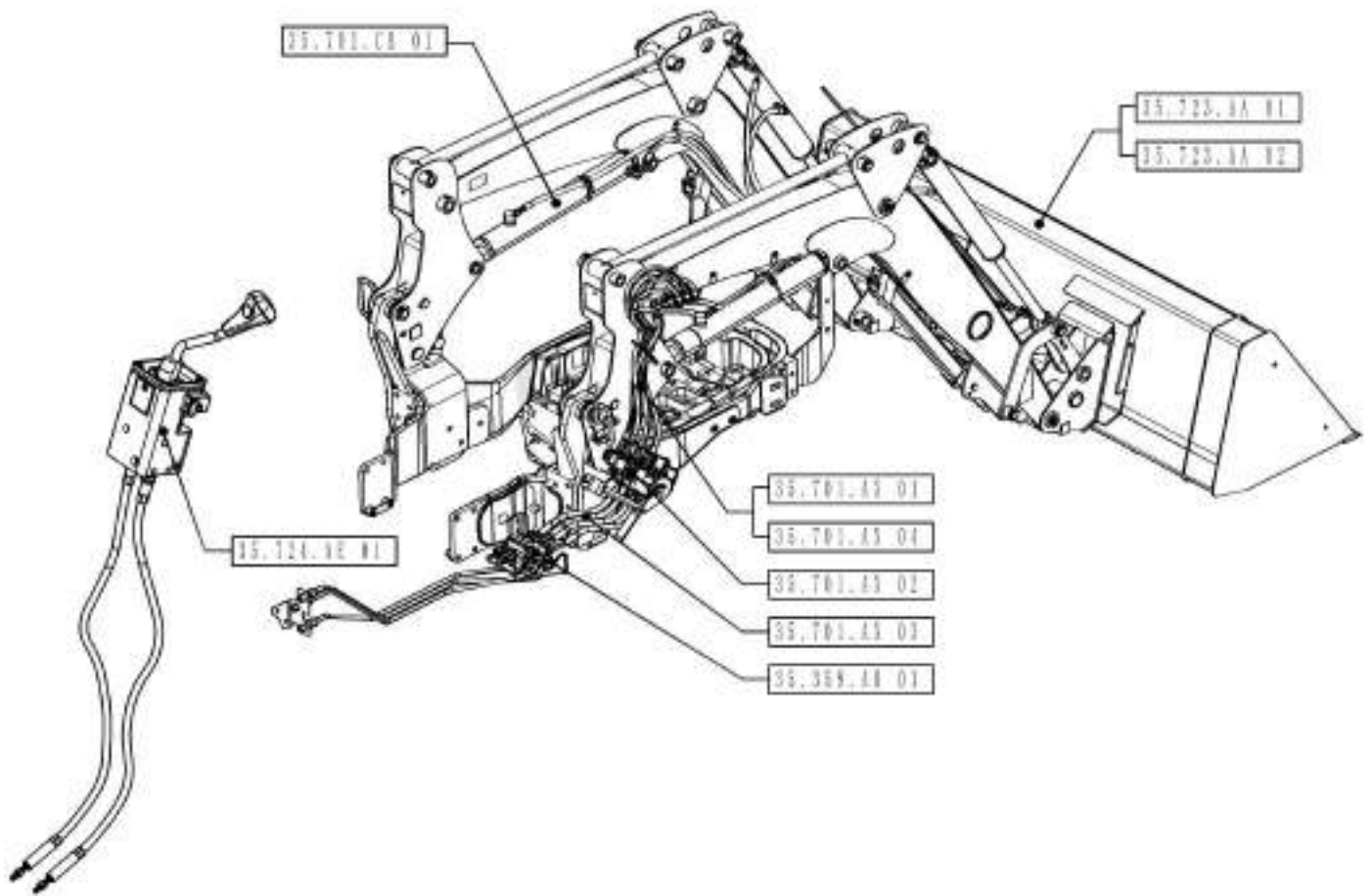

00.000.35

02

p1

1/2014

PICTORIAL INDEX - HYDRAULIC SYSTEMS

REF FN	PART NUMBER	YR/SN	QTY	DESCRIPTION
---------------	--------------------	--------------	------------	--------------------

				FARMALL JX100 FARMALL JX110 FARMALL JX70 FARMALL JX75 FARMALL JX80 FARMALL JX90
--	--	--	--	--

PICTORIAL INDEX - HITCHES, DRAWBARS AND IMPLEMENT COUPLINGS

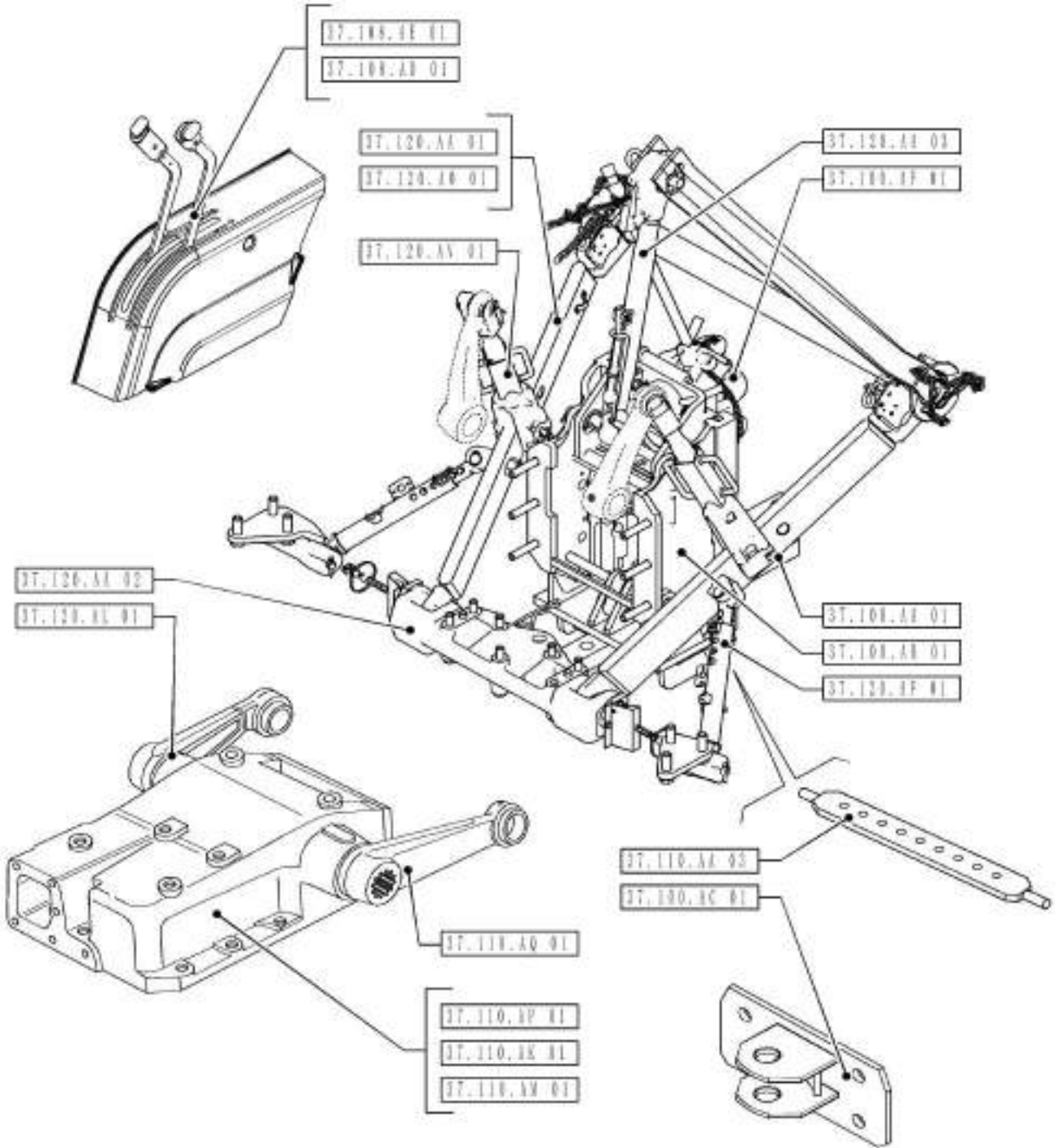

00.000.37

01

p1

1/2014

PICTORIAL INDEX - HITCHES, DRAWBARS AND IMPLEMENT COUPLINGS

REF FN	PART NUMBER	YR/SN	QTY	DESCRIPTION
---------------	--------------------	--------------	------------	--------------------

				FARMALL JX100 FARMALL JX110 FARMALL JX70 FARMALL JX75 FARMALL JX80 FARMALL JX90
--	--	--	--	--

PICTORIAL INDEX - FRAMES AND BALLASTINGS

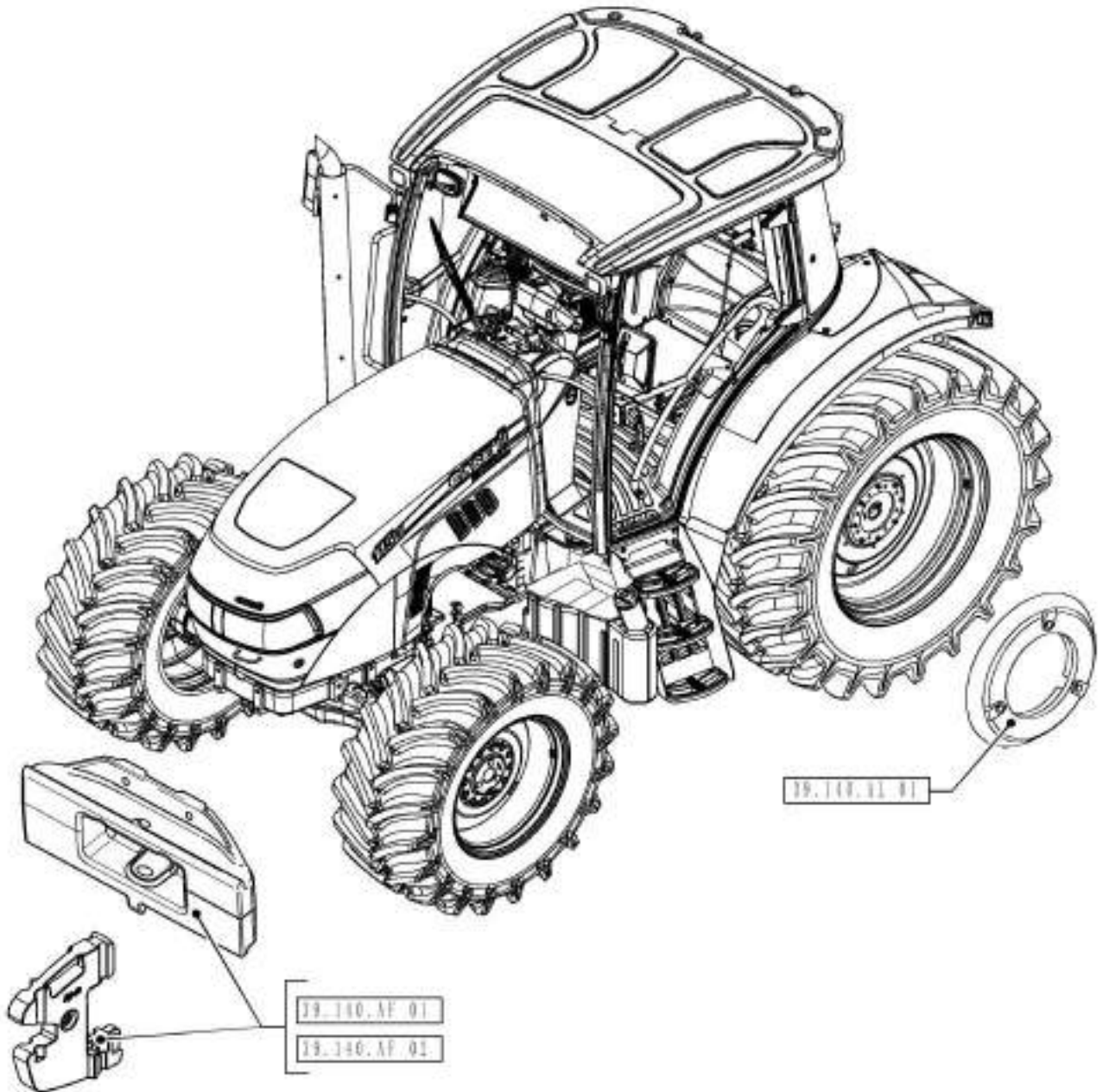

00.000.39

01

p1

1/2014

PICTORIAL INDEX - FRAMES AND BALLASTINGS

REF FN	PART NUMBER	YR/SN	QTY	DESCRIPTION
---------------	--------------------	--------------	------------	--------------------

				FARMALL JX100 FARMALL JX110 FARMALL JX70 FARMALL JX75 FARMALL JX80 FARMALL JX90
--	--	--	--	--

PICTORIAL INDEX - STEERING

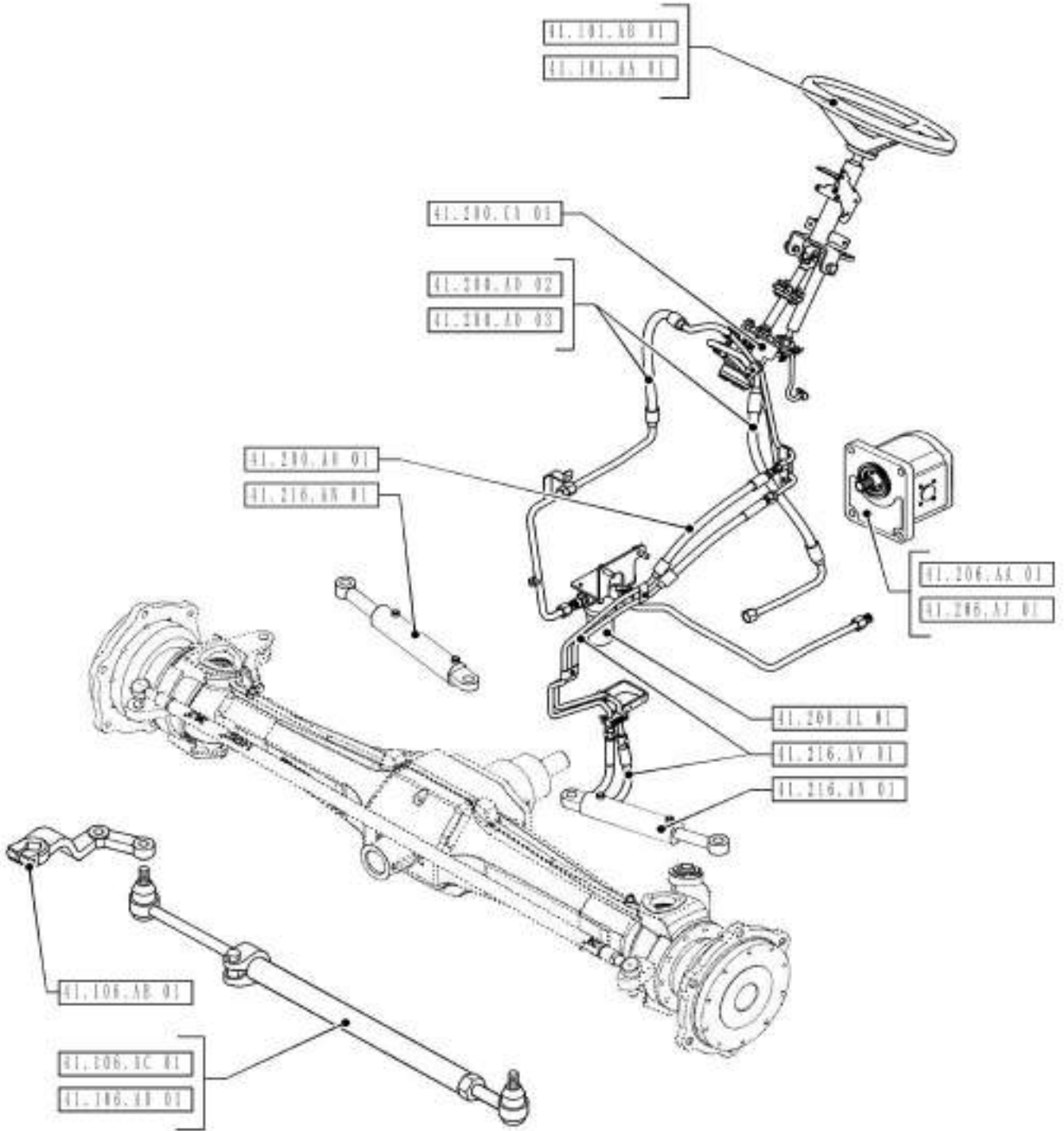

00.000.41

01

p1

1/2014

PICTORIAL INDEX - STEERING

REF FN PART NUMBER

YR/SN

QTY DESCRIPTION

FARMALL JX100 FARMALL
JX110 FARMALL JX70
FARMALL JX75 FARMALL
JX80 FARMALL JX90

PICTORIAL INDEX - WHEELS

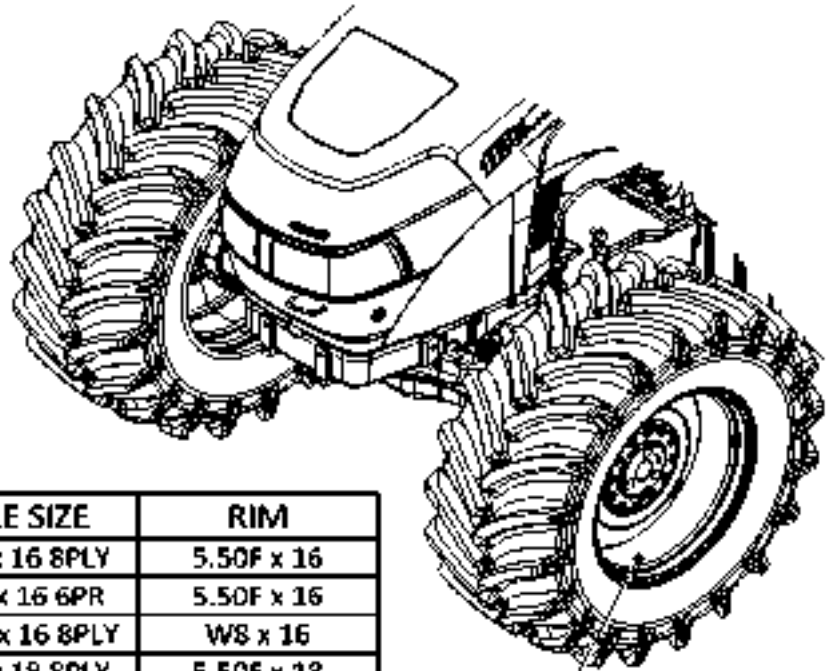

GROUP	EQUIP.	TYRE SIZE	RIM
44.511.AE	81.11	7.50 x 16 8PLY	5.50F x 16
	81.11	7.50 x 16 6PR	5.50F x 16
	81.14	10.00 x 16 8PLY	W8 x 16
	81.18	7.50 x 18 8PLY	5.50F x 18
	81.18	7.50 x 18 6PR	5.50F x 18
	81.18	7.50 x 18 8PR	5.50F x 18
	81.25	9.00 x 16 8PLY	W8 x 16
	81.26	7.50 x 20 8PLY	5.50F x 20
	82.03	12.4 R20	W11 x 20
	82.03	320/85 R20	W11 x 20
	82.32	11.2 R24	W10 x 24
	82.32	280/85 R24	W10 x 24
	82.32	11.2 R24	W10 x 24
	82.32	280/85 R24	W10 x 24
	82.33	9.5 R24 A8	W8 x 24
	82.35	12.4 R24	W10 x 24
	82.35	320/85 R24	W10 x 24
	82.35	12.4 R24	W10 x 24
	82.35	320/85 R24	W10 x 24
	82.36	13.6 R24	W12 x 24
	82.36	340/85 R24	W12 x 24
	82.47	11.2 R28	W10 x 28
	82.47	280/85 R28	W10 x 28
	88.29	360/70 R20	W11 x 20
	88.33	230/95 R32	W8 x 32
	88.38	13.6 R28	W12 x 28
	88.42	320/70 R24	W10 x 24
	88.83	14.9 R24	W12 x 24

00.000.44

01

p1

1/2014

PICTORIAL INDEX - WHEELS

REF FN	PART NUMBER	YR/SN	QTY	DESCRIPTION
---------------	--------------------	--------------	------------	--------------------

				FARMALL JX100 FARMALL JX110 FARMALL JX70 FARMALL JX75 FARMALL JX80 FARMALL JX90
--	--	--	--	--

PICTORIAL INDEX - WHEELS

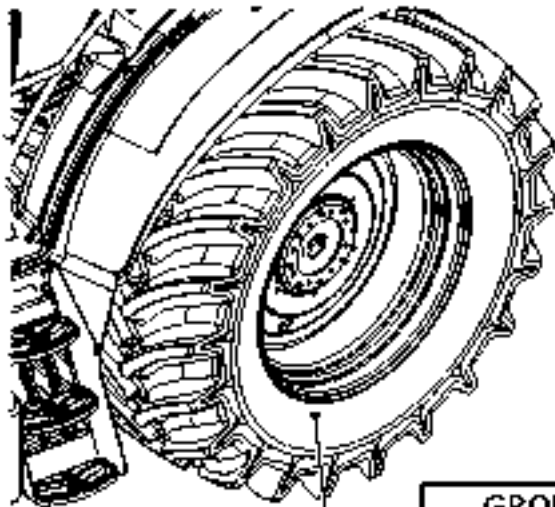

GROUP	EQUIP.	TYRE SIZE	RIM
44.520.AB	83.16	14.9 R38	DWW12 x 38
	83.22	9.5 R48 A8	W8 x 48
	83.22	230/95 R48 A8	W8 x 48
	83.54	14.9 R30 6PR	W13 x 30
	83.55	16.9 R30 6PR	W14L x 30
	83.55	16.9 R30	DWW15L x 30
	83.55	420/85 R30	DWW15L x 30
	83.57	18.4 R30	DWW15L x 30
	83.57	460/85 R30	DWW15L x 30
	83.57	18.4 R30 A8	W15L x 30
	83.57	460/85 R30 A8	W15L x 30
	83.64	16.9 R34	DWW15L x 34
	83.64	420/85 R34	DWW15L x 34
	83.65	18.4 R34	DWW15L x 34
	83.65	460/85 R34	DWW15L x 34
	83.69	12.4 R36	W11 x 36
	83.69	320/85 R36	W11 x 36
	83.71	13.6 R36	W11 x 36
	83.71	340/85 R36	W11 x 36
	83.72	13.6 R38	DWW12 x 38
	83.72	340/85 R38	DWW12 x 38
	89.38	420/70 R30	W13 x 30
	89.54	480/70 R30	DWW15L x 30
89.55	420/70 R30	W13 x 30	
89.64	480/70 R34	DWW15L x 34	



00.000.44

02

p1

1/2014

PICTORIAL INDEX - WHEELS

REF FN	PART NUMBER	YR/SN	QTY	DESCRIPTION
---------------	--------------------	--------------	------------	--------------------

				FARMALL JX100 FARMALL JX110 FARMALL JX70 FARMALL JX75 FARMALL JX80 FARMALL JX90
--	--	--	--	--

PICTORIAL INDEX - CAB CLIMATE CONTROL

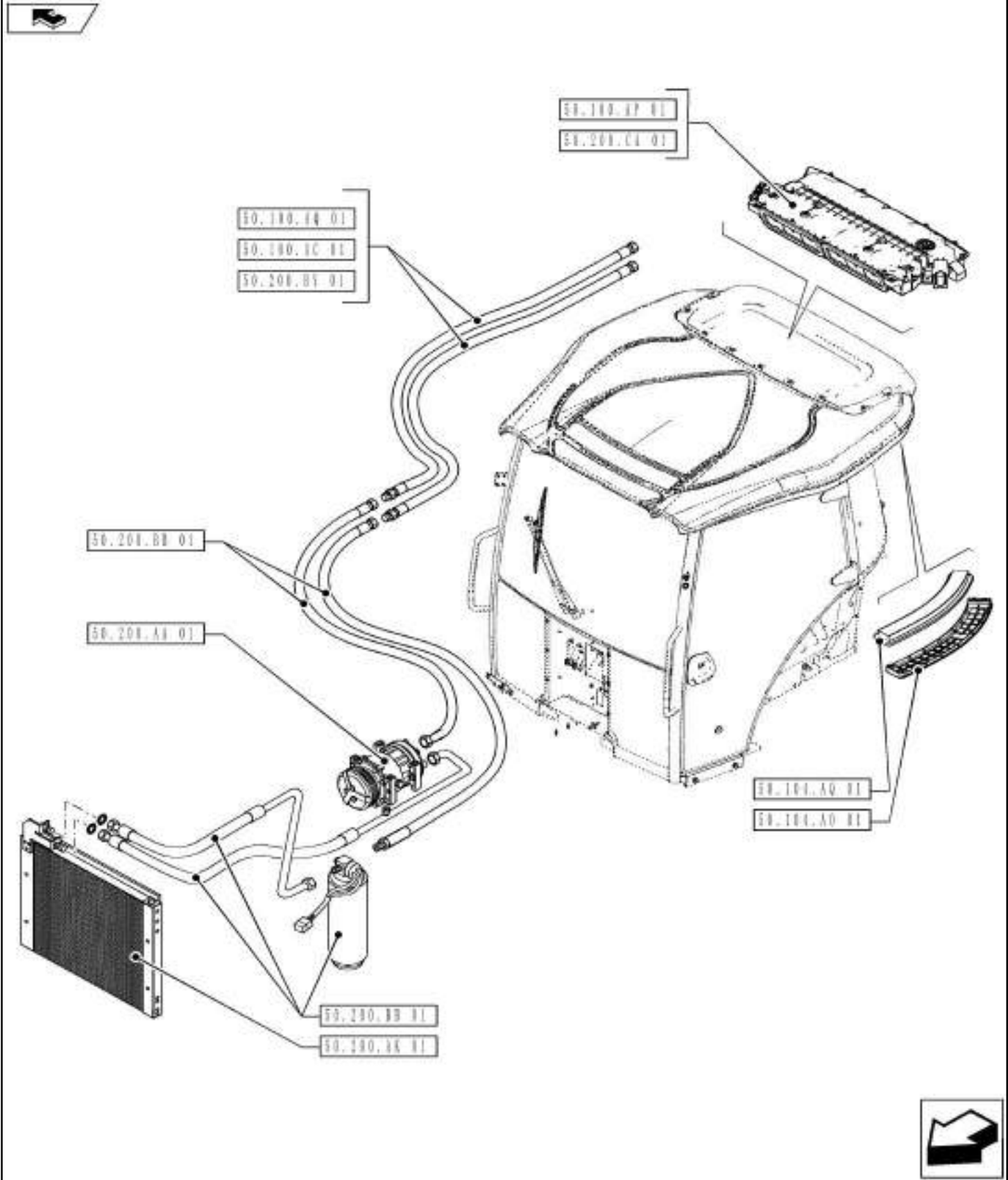

00.000.50

01

p1

1/2014

PICTORIAL INDEX - CAB CLIMATE CONTROL

REF FN	PART NUMBER	YR/SN	QTY	DESCRIPTION
---------------	--------------------	--------------	------------	--------------------

				FARMALL JX100 FARMALL JX110 FARMALL JX70 FARMALL JX75 FARMALL JX80 FARMALL JX90
--	--	--	--	--

PICTORIAL INDEX - ELECTRICAL SYSTEMS

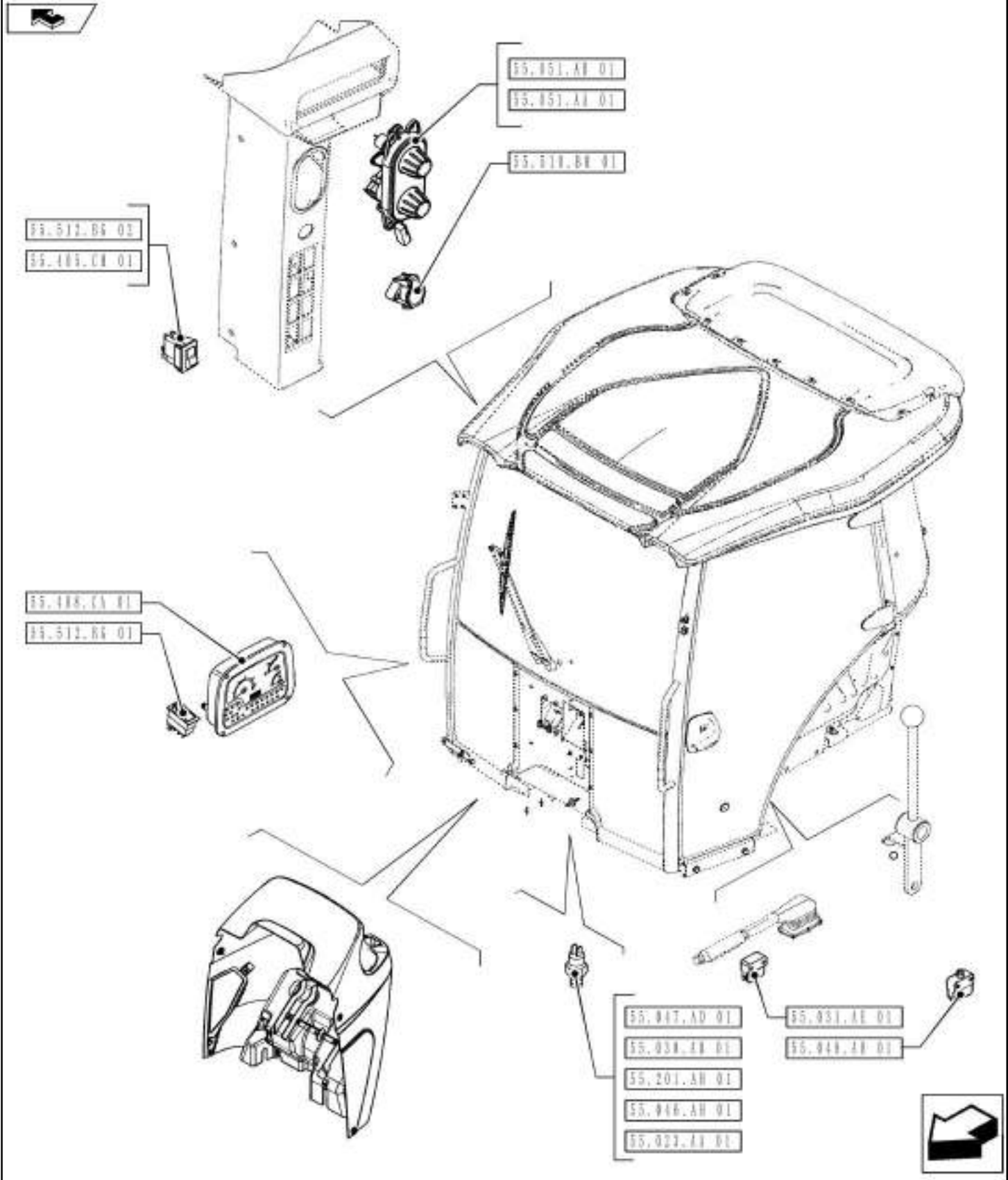

00.000.55

02

p1

1/2014

PICTORIAL INDEX - ELECTRICAL SYSTEMS

REF FN	PART NUMBER	YR/SN	QTY	DESCRIPTION
---------------	--------------------	--------------	------------	--------------------

				FARMALL JX100 FARMALL JX110 FARMALL JX70 FARMALL JX75 FARMALL JX80 FARMALL JX90
--	--	--	--	--

PICTORIAL INDEX - ELECTRICAL SYSTEMS

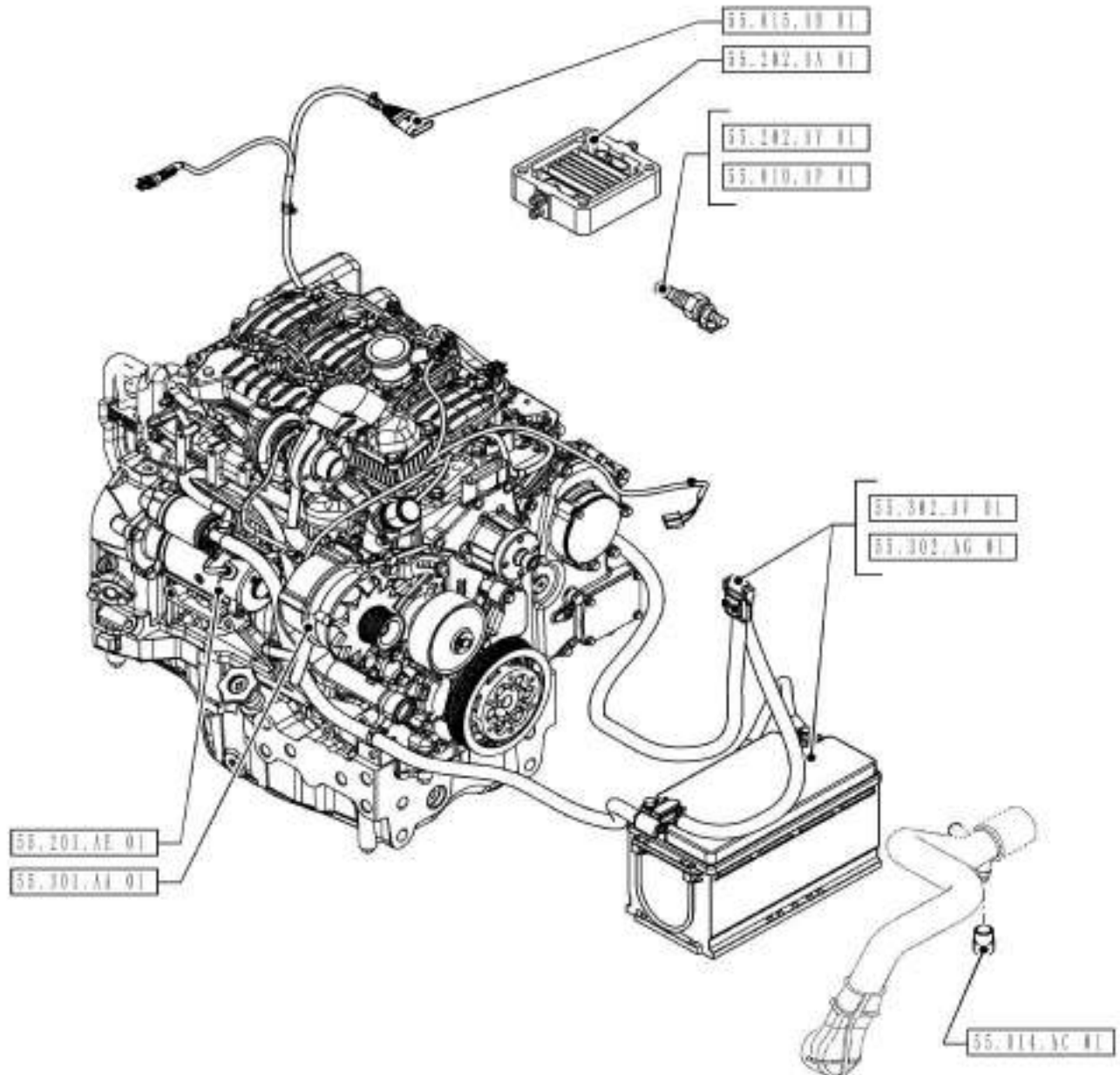

00.000.55

03

p1

1/2014

PICTORIAL INDEX - ELECTRICAL SYSTEMS

REF FN	PART NUMBER	YR/SN	QTY	DESCRIPTION
---------------	--------------------	--------------	------------	--------------------

				FARMALL JX100 FARMALL JX110 FARMALL JX70 FARMALL JX75 FARMALL JX80 FARMALL JX90
--	--	--	--	--

PICTORIAL INDEX - ELECTRICAL SYSTEMS

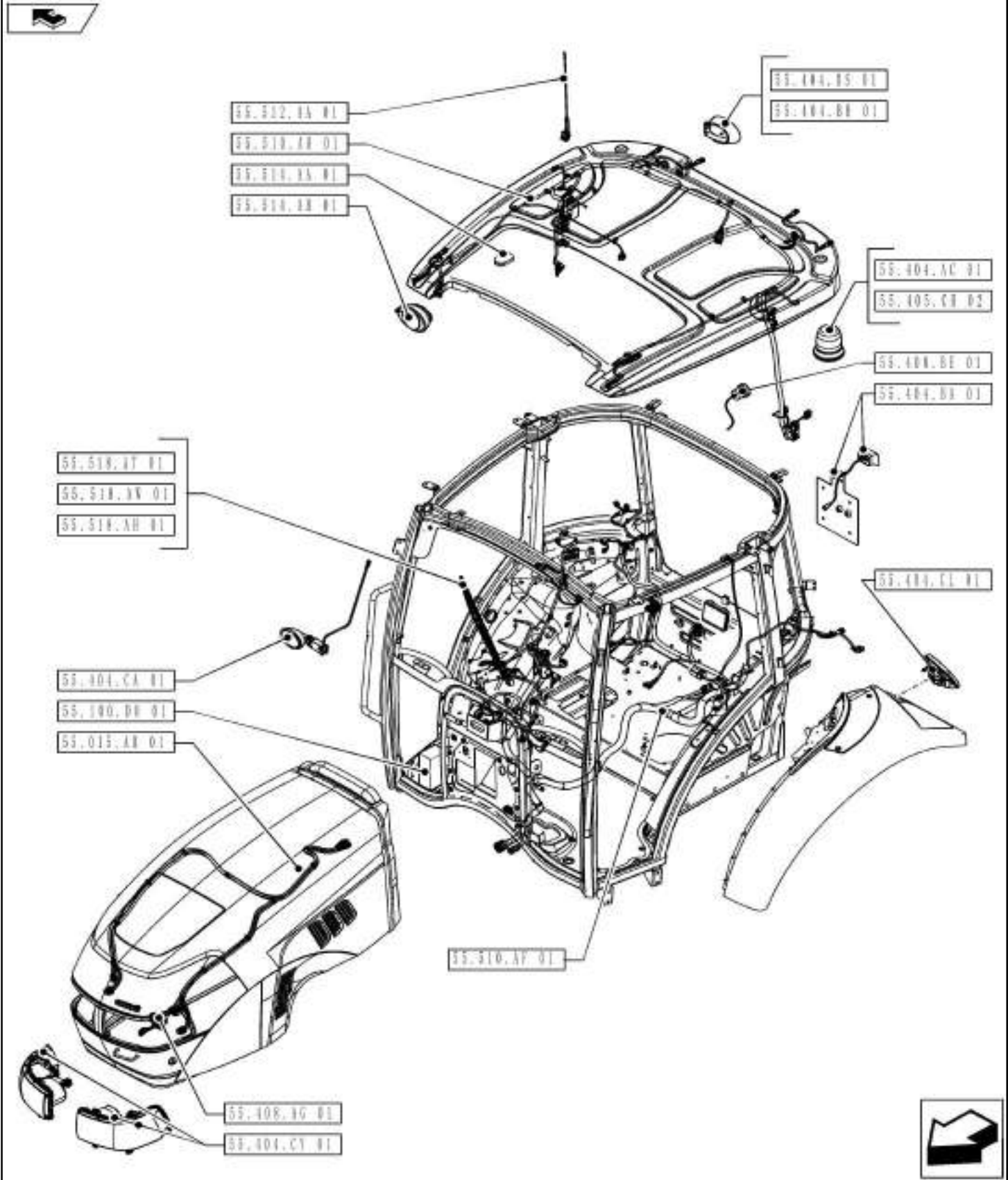

00.000.55

04

p1

1/2014

PICTORIAL INDEX - ELECTRICAL SYSTEMS

REF FN	PART NUMBER	YR/SN	QTY	DESCRIPTION
---------------	--------------------	--------------	------------	--------------------

				FARMALL JX100 FARMALL JX110 FARMALL JX70 FARMALL JX75 FARMALL JX80 FARMALL JX90
--	--	--	--	--

PICTORIAL INDEX - FRONT LOADER

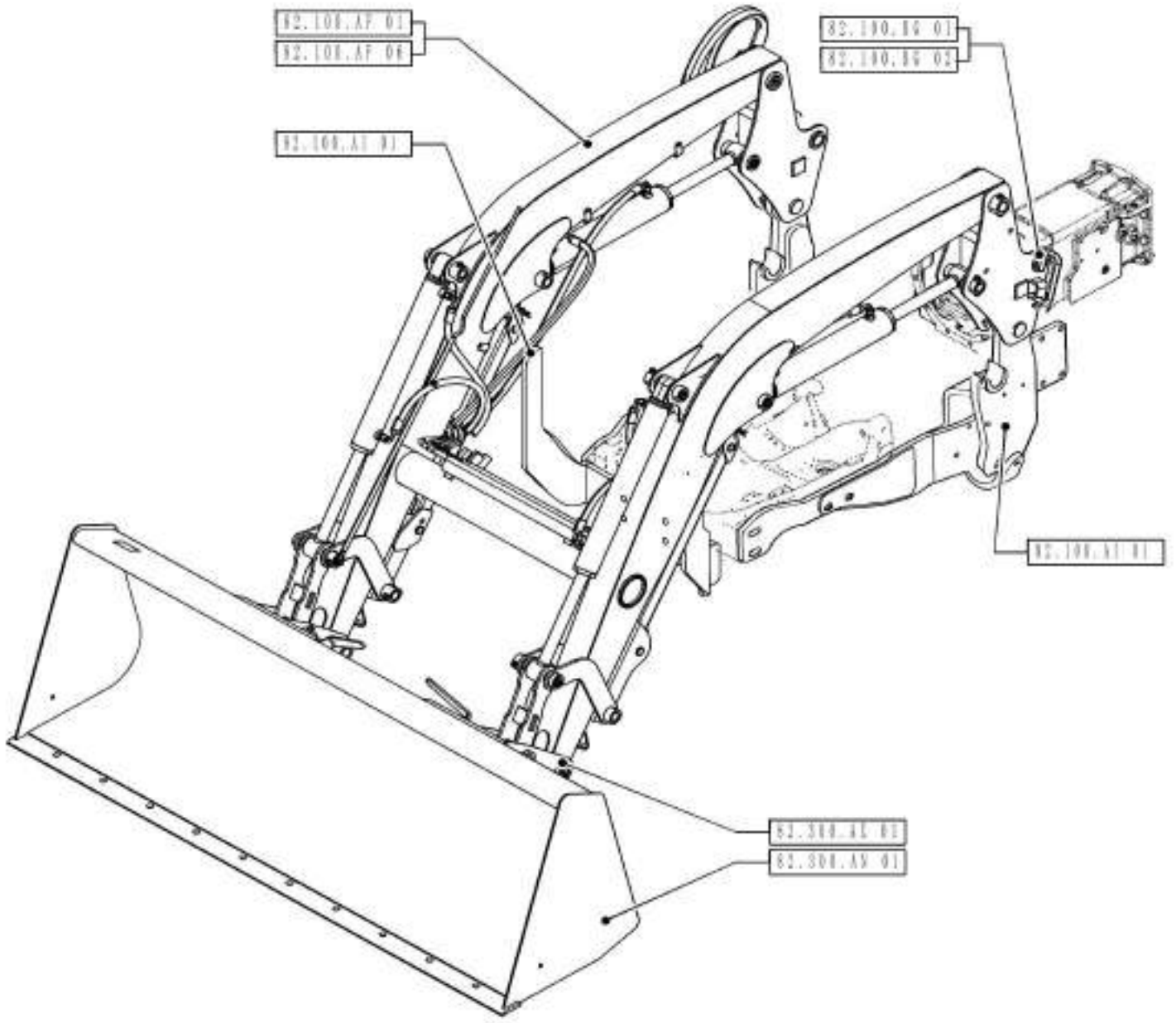

00.000.82

01

p1

1/2014

PICTORIAL INDEX - FRONT LOADER

REF FN	PART NUMBER	YR/SN	QTY	DESCRIPTION
---------------	--------------------	--------------	------------	--------------------

				FARMALL JX100 FARMALL JX110 FARMALL JX70 FARMALL JX75 FARMALL JX80 FARMALL JX90
--	--	--	--	--

PICTORIAL INDEX - ACCESSORIES

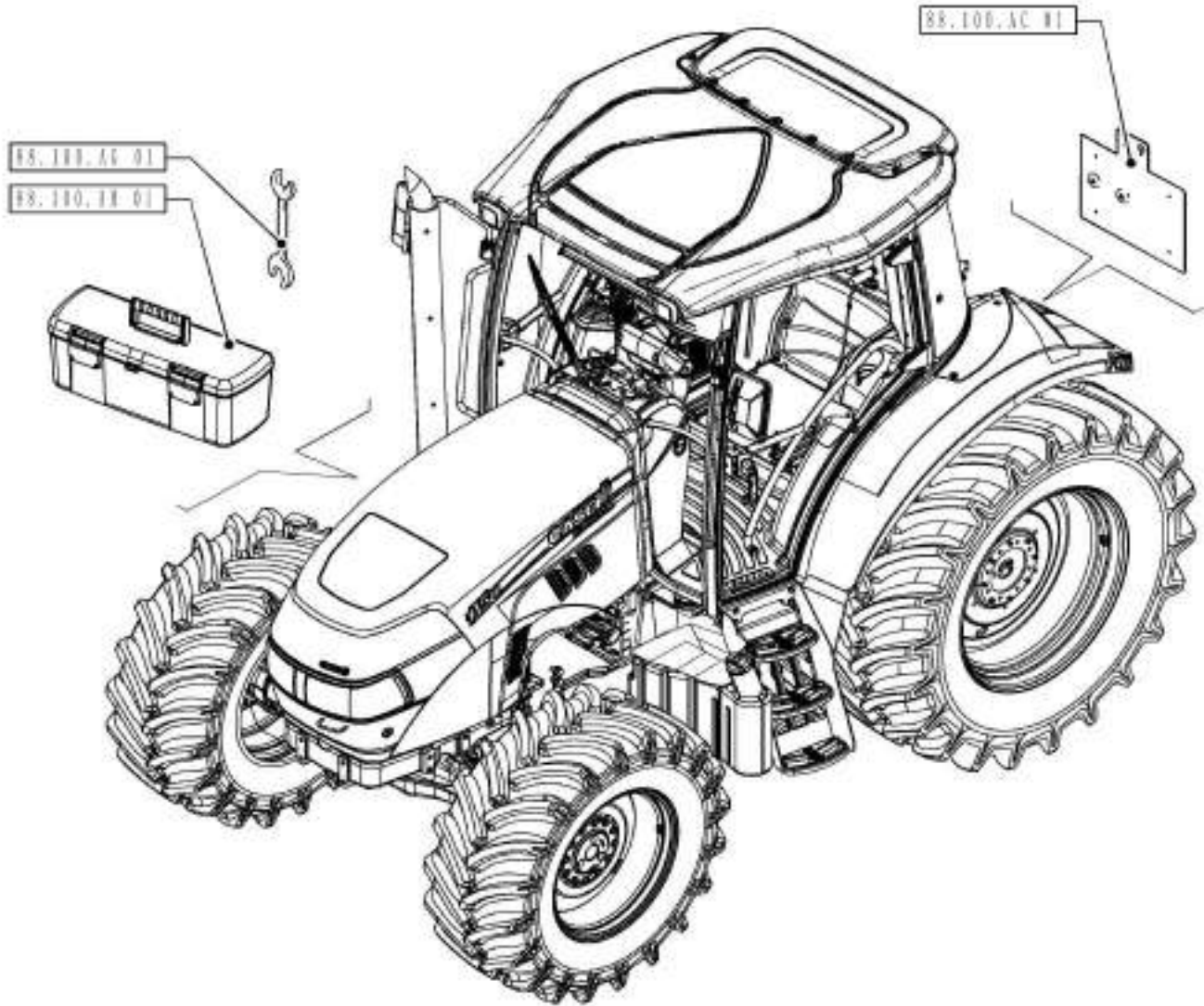

00.000.88

01

p1

1/2014

PICTORIAL INDEX - ACCESSORIES

REF FN	PART NUMBER	YR/SN	QTY	DESCRIPTION
---------------	--------------------	--------------	------------	--------------------

				FARMALL JX100 FARMALL JX110 FARMALL JX70 FARMALL JX75 FARMALL JX80 FARMALL JX90
--	--	--	--	--

PICTORIAL INDEX - PLATFORM, CAB, BODYWORK AND DECALS

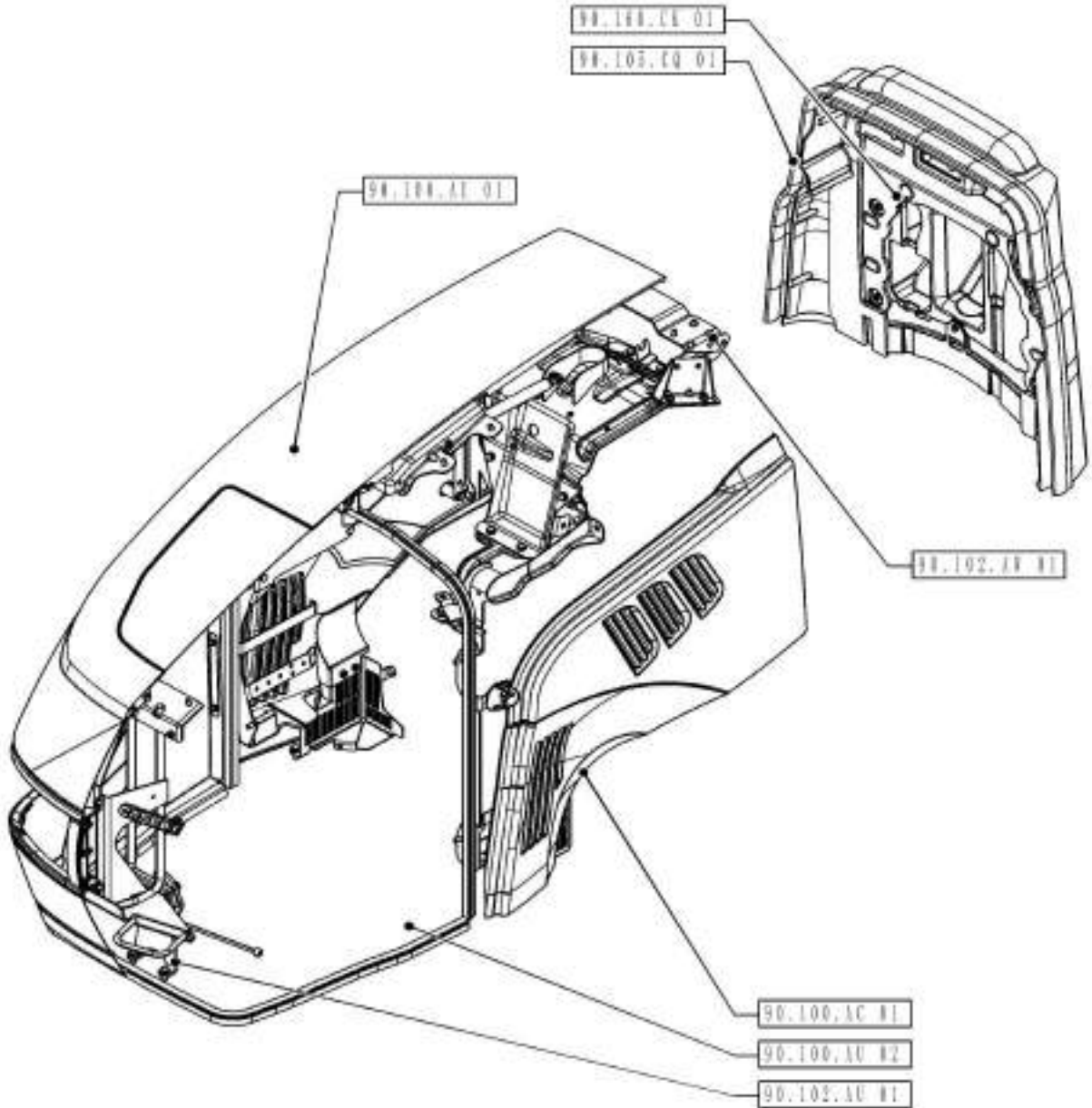

00.000.90

01

p1

1/2014

PICTORIAL INDEX - PLATFORM, CAB, BODYWORK AND DECALS

REF FN	PART NUMBER	YR/SN	QTY	DESCRIPTION
---------------	--------------------	--------------	------------	--------------------

				FARMALL JX100 FARMALL JX110 FARMALL JX70 FARMALL JX75 FARMALL JX80 FARMALL JX90
--	--	--	--	--

PICTORIAL INDEX - PLATFORM, CAB, BODYWORK AND DECALS

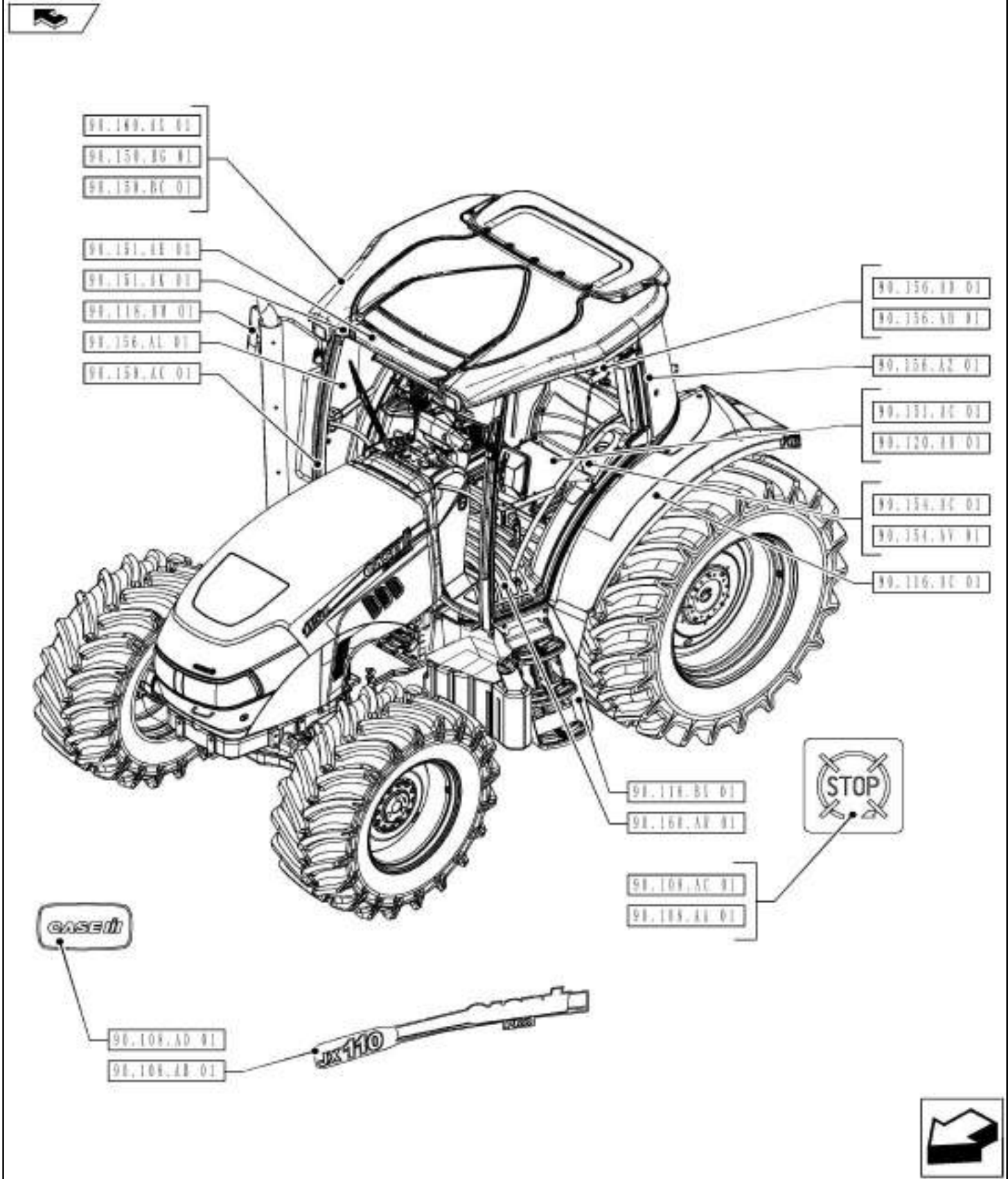

00.000.90

02

p1

1/2014

PICTORIAL INDEX - PLATFORM, CAB, BODYWORK AND DECALS

REF FN	PART NUMBER	YR/SN	QTY	DESCRIPTION
---------------	--------------------	--------------	------------	--------------------

				FARMALL JX100 FARMALL JX110 FARMALL JX70 FARMALL JX75 FARMALL JX80 FARMALL JX90
--	--	--	--	--

PICTORIAL INDEX - PLATFORM, CAB, BODYWORK AND DECALS

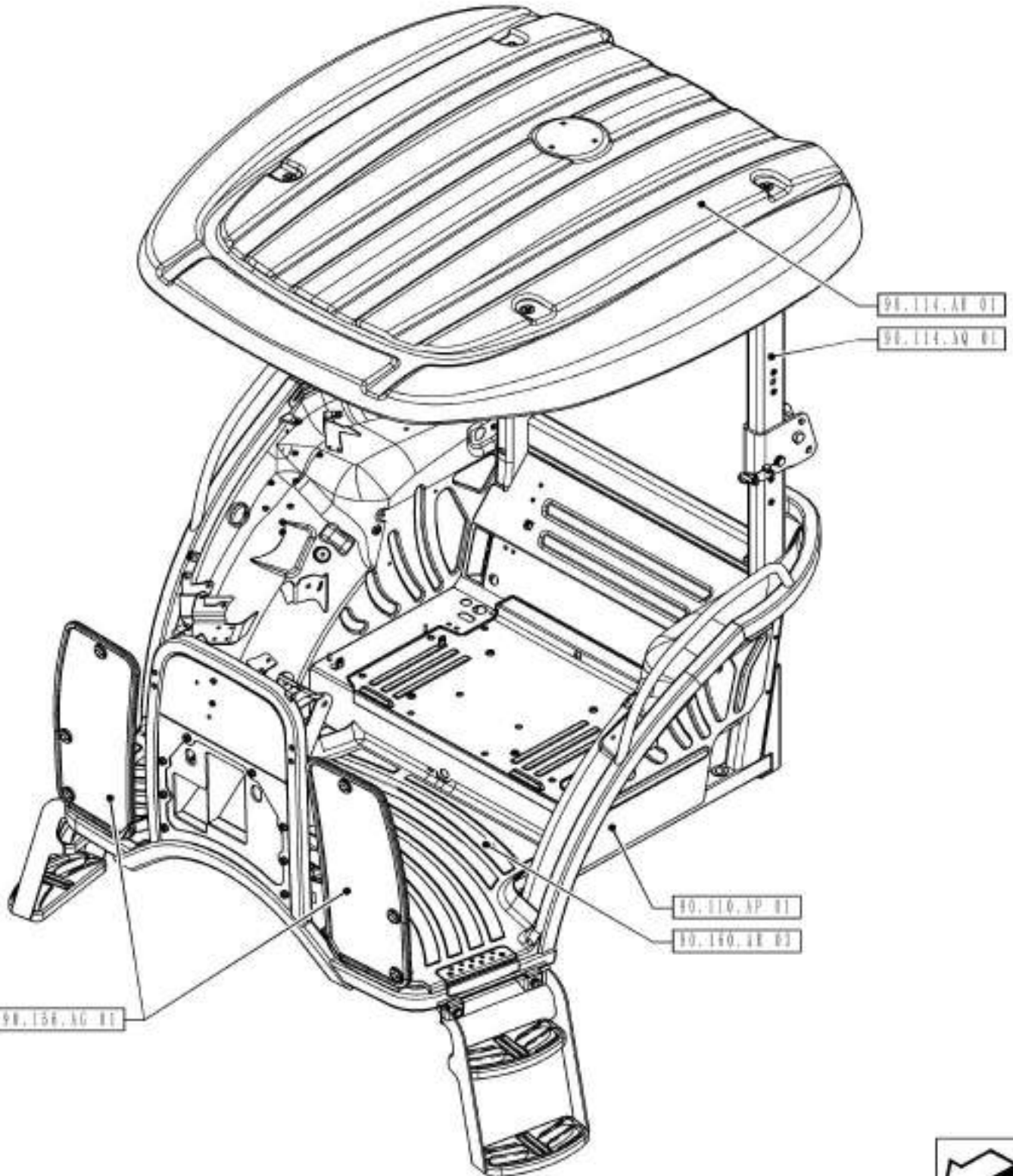

00.000.90

03

p1

1/2014

PICTORIAL INDEX - PLATFORM, CAB, BODYWORK AND DECALS

REF FN	PART NUMBER	YR/SN	QTY	DESCRIPTION
---------------	--------------------	--------------	------------	--------------------

				FARMALL JX100 FARMALL JX110 FARMALL JX70 FARMALL JX75 FARMALL JX80 FARMALL JX90
--	--	--	--	--

PICTORIAL INDEX - PLATFORM, CAB, BODYWORK AND DECALS

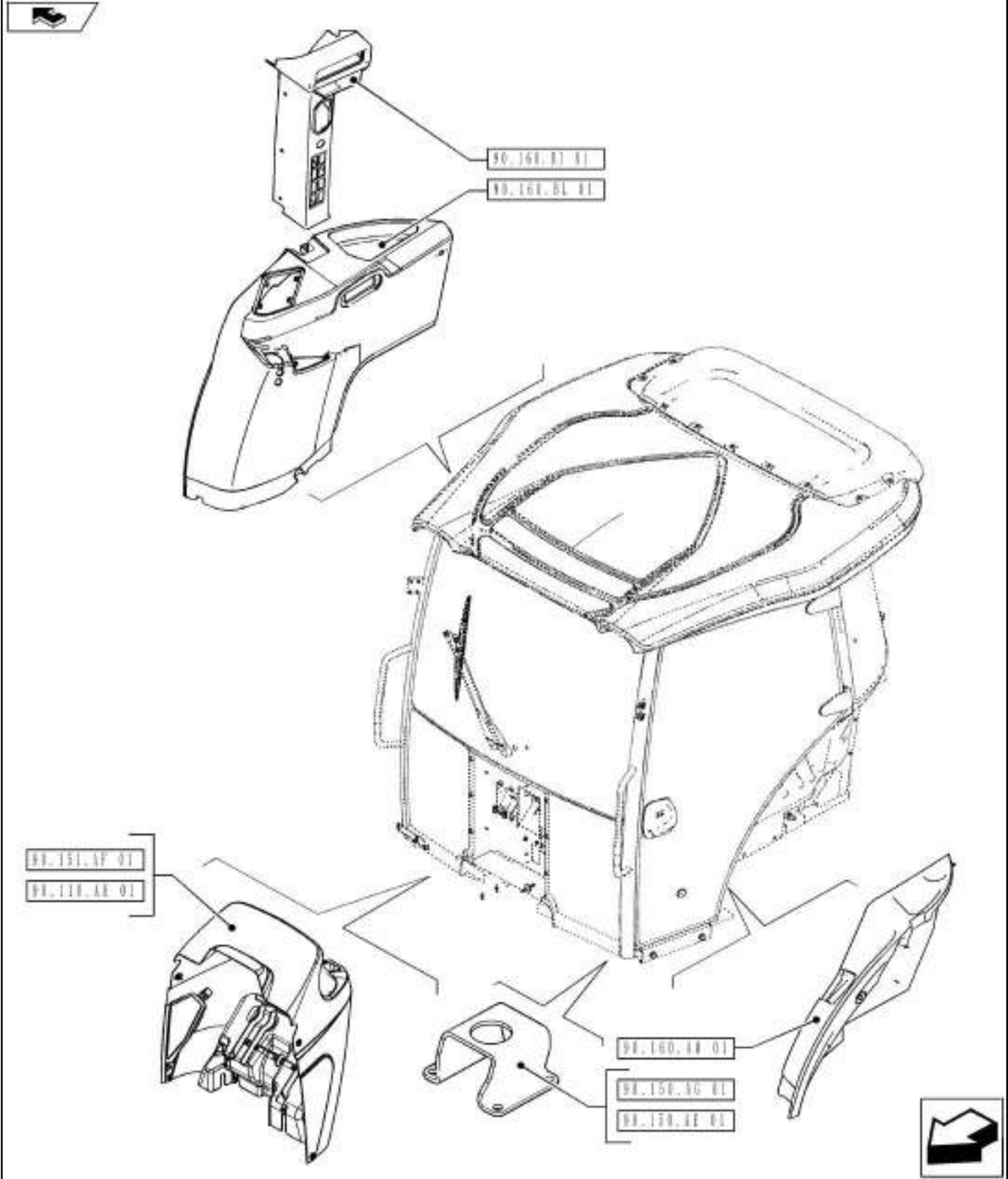

00.000.90

04

p1

1/2014

PICTORIAL INDEX - PLATFORM, CAB, BODYWORK AND DECALS

REF FN	PART NUMBER	YR/SN	QTY	DESCRIPTION
---------------	--------------------	--------------	------------	--------------------

				FARMALL JX100 FARMALL JX110 FARMALL JX70 FARMALL JX75 FARMALL JX80 FARMALL JX90
--	--	--	--	--

OPTIONAL EQUIPMENT

VARIANT CODE	DESCRIPTION	APPLICATION											
		JX116 P110		JX116 P110		JX85 P110		JX85 P110		JX116 P110		JX116 P110	
		2WD	4WD	2WD	4WD	2WD	4WD	2WD	4WD	2WD	4WD	2WD	4WD
33009	VISCOUS FAN	*	*	*	*	*	*	*	*	*	*	*	*
334296	FUEL DOCUMENTING DEVICE	*	*	*	*	*	*	*	*	*	*	*	*
330203	THERMOSTARTER	*	*	*	*	*	*	*	*	*	*	*	*
744734	HORIZONTAL EXHAUST	*	*	*	*	*	*	*	*	*	*	*	*
330200	DRY AIR FILTER DUST SEPARATOR	*	*	*	*	*	*	*	*	*	*	*	*
335248	CERAMETALLIC DISC 11"	*	*	*	*	*	*	*	*	*	*	*	*
720514	CERAMETALLIC DISC 11" - LUK CLUTCH	*	*	*	*	*	*	*	*	*	*	*	*
331118	13-8 SYNCHROMESH GEARBOX	*	*	*	*	*	*	*	*	*	*	*	*
331113	20-12 SYNCHROMESH GEARBOX + CREEPER	*	*	*	*	*	*	*	*	*	*	*	*
335005	540/1000 RPM WITH GROUND SPEED PTO	*	*	*	*	*	*	*	*	*	*	*	*
335018	540/540 RPM WITH GROUND SPEED PTO	*	*	*	*	*	*	*	*	*	*	*	*
334264	540/1000 RPM WITH GROUND SPEED PTO - 1 3/8 - 21 SPLINE SHAFT	*	*	*	*	*	*	*	*	*	*	*	*
742946	POWER SHUTTLE & SERVO PTO	*	*	*	*	*	*	*	*	*	*	*	*
333305	CLASS 2 FRONT AXLE, LESS 2nd STEERING CYLINDER, WITH LIM, SLIP AND LESS BRAKES	*	*	*	*	*	*	*	*	*	*	*	*
335324	CLASS 2 FRONT AXLE, LESS 2nd STEERING CYLINDER WITH LIM,SLIP AND FRONT BRAKE	*	*	*	*	*	*	*	*	*	*	*	*
333039	CLASS 2 FRONT AXLE, WITH 2nd STEERING CYLINDER, WITH LIM,SLIP, LESS BRAKES	*	*	*	*	*	*	*	*	*	*	*	*
334212	CLASS 2 FRONT AXLE, LESS 2nd STEERING CYLINDER, WITH LIM, SLIP, LESS BRAKES HEAVY DUTY	*	*	*	*	*	*	*	*	*	*	*	*
334213	CLASS 2 FRONT AXLE, WITH 2nd STEERING CYLINDER, WITH LIM, SLIP, LESS BRAKES HEAVY DUTY	*	*	*	*	*	*	*	*	*	*	*	*
744739	ELECTROHYDRAULIC DIFFLOCK & ELECTROHYDRAULIC 4WD ENGAGEMENT	*	*	*	*	*	*	*	*	*	*	*	*
334265	LIFTMATIC WITH RANGE LIMITER WITH EXTERNAL HPL CONTROL LEVER	*	*	*	*	*	*	*	*	*	*	*	*
334214	HYDRAULIC PUMP (51.7 LBMN, 13.8 GPM)	*	*	*	*	*	*	*	*	*	*	*	*
334266	STANDARD TRANSMISSION - RICE VERSION	*	*	*	*	*	*	*	*	*	*	*	*
720400	HEAVY DUTY TRANSMISSION (30 RPH)	*	*	*	*	*	*	*	*	*	*	*	*
334267	HEAVY DUTY TRANSMISSION (30 RPH) - RICE VERSION	*	*	*	*	*	*	*	*	*	*	*	*
720368	1 REMOTE VALVE (SINGLE DOUBLE ACTING)	*	*	*	*	*	*	*	*	*	*	*	*
720412	1 REMOTE VALVE (S/D ACTING WITH KICK OUT)	*	*	*	*	*	*	*	*	*	*	*	*
735308	2 REMOTE VALVES (1 S/D ACTING + 1 DOUBLE ACTING)	*	*	*	*	*	*	*	*	*	*	*	*
720413	2 REMOTE VALVES (1 S/D ACTING + 1 DOUBLE ACTING WITH FLOAT & KICK OUT)	*	*	*	*	*	*	*	*	*	*	*	*
720417	2 REMOTE VALVES (1 S/D ACTING WITH KICK OUT + 1 DOUBLE ACTING WITH FLOAT & KICK OUT)	*	*	*	*	*	*	*	*	*	*	*	*
720054	3 REMOTE VALVES (2 S/D ACTING + 1 SINGLE DOUBLE ACTING WITH KICK OUT)	*	*	*	*	*	*	*	*	*	*	*	*
720102	3 REMOTE VALVES (2 S/D ACTING WITH KICK OUT AND FLOAT + 1 S/D ACTING WITH KICK OUT)	*	*	*	*	*	*	*	*	*	*	*	*
336125	MECHANICAL JOYSTICK WITH MID MOUNT VALVES (INCL. HYDRAULIC CONNECTIONS)	*	*	*	*	*	*	*	*	*	*	*	*
720386	TRAILER BRAKE VALVE	*	*	*	*	*	*	*	*	*	*	*	*
334701	CAT 1-2, 3 POINT LINKAGE, PIN TYPE STABILIZERS FOR BALL ENDS, RIVALH TURN BUCKLE - 65MM LONGER	*	*	*	*	*	*	*	*	*	*	*	*
334316	3-POINT LINKAGE WITH CAT 2 FLEXIBLE ENDS	*	*	*	*	*	*	*	*	*	*	*	*
334077	3-POINT LINKAGE WITH CAT 2 FLEXIBLE ENDS - 65MM LONGER	*	*	*	*	*	*	*	*	*	*	*	*
334317	CAT 2 QUICK ATTACH HOOK LINK ENDS	*	*	*	*	*	*	*	*	*	*	*	*
334061	CAT 2 QUICK ATTACH HOOK LINK ENDS - 65MM LONGER	*	*	*	*	*	*	*	*	*	*	*	*
337934	CAT 2 QUICK ATTACH HOOK LINK ENDS, HYD. TOP LINK	*	*	*	*	*	*	*	*	*	*	*	*
334934	CAT 2 QUICK ATTACH HOOK LINK ENDS, 95MM LONGER, HYD. TOP LINK	*	*	*	*	*	*	*	*	*	*	*	*
333606	HIGH VISIBILITY CAB	*	*	*	*	*	*	*	*	*	*	*	*
334318	STANDARD POSITIONED CANDY	*	*	*	*	*	*	*	*	*	*	*	*
334319	LOW POSITIONED CANDY	*	*	*	*	*	*	*	*	*	*	*	*
744747	DELUXE SEAT	*	*	*	*	*	*	*	*	*	*	*	*
744748	STANDARD SEAT + PASSENGER SEAT	*	*	*	*	*	*	*	*	*	*	*	*
744749	DELUXE SEAT + PASSENGER SEAT	*	*	*	*	*	*	*	*	*	*	*	*
330641	AIR CONDITION	*	*	*	*	*	*	*	*	*	*	*	*
333700	2 REAR & 2 FRONT WORK LIGHTS	*	*	*	*	*	*	*	*	*	*	*	*

00.001.00

01

p1

1/2014

OPTIONAL EQUIPMENT

REF FN	PART NUMBER	YR/SN	QTY	DESCRIPTION
---------------	--------------------	--------------	------------	--------------------

				FARMALL JX100 FARMALL JX110 FARMALL JX70 FARMALL JX75 FARMALL JX80 FARMALL JX90
--	--	--	--	--

OPTIONAL EQUIPMENT

VARIANT CODE	DESCRIPTION	APPLICATION											
		J303 PRO		J305 PRO		J309 PRO		J310 PRO		J310E PRO		J311E PRO	
		2WD	4WD	2WD	4WD	2WD	4WD	2WD	4WD	2WD	4WD	2WD	4WD
335769	4 REAR & 2 FRONT WORK LIGHTS	*	*	*	*	*	*	*	*	*	*	*	*
335767	FENDER REAR WORK LIGHT	*	*	*	*	*	*	*	*	*	*	*	*
330777	RADIO READY (2 SPEAKERS AND ANTENNA)	*	*	*	*	*	*	*	*	*	*	*	*
333777	RADIO	*	*	*	*	*	*	*	*	*	*	*	*
334482	FRONT WIPER - REAR WIPER	*	*	*	*	*	*	*	*	*	*	*	*
334681	PARALLEL FRONT WIPER - LESS REAR WIPER	*	*	*	*	*	*	*	*	*	*	*	*
334684	PARALLEL FRONT WIPER - WITH REAR WIPER	*	*	*	*	*	*	*	*	*	*	*	*
330879	TELESCOPIC MIRRORS	*	*	*	*	*	*	*	*	*	*	*	*
337662	LH MIRROR	*	*	*	*	*	*	*	*	*	*	*	*
337663	RH MIRROR	*	*	*	*	*	*	*	*	*	*	*	*
337684	MIRRORS	*	*	*	*	*	*	*	*	*	*	*	*
744791	TRAILER HITCH (C) (25MM HOLE) + PTO GUARD	*	*	*	*	*	*	*	*	*	*	*	*
744792	TRAILER HITCH (C) + SWINGING DRAWBAR (C) (20 MM PIN HOLE) + PTO GUARD	*	*	*	*	*	*	*	*	*	*	*	*
744753	FRENCH TRAILER HITCH + FITON + SWINGING DRAWBAR (20 MM PIN HOLE) & PTO GUARD	*	*	*	*	*	*	*	*	*	*	*	*
334338	SLIDER TYPE TRAILER HITCH	*	*	*	*	*	*	*	*	*	*	*	*
334337	SLIDER TYPE TRAILER HITCH WITH SWINGING DRAWBAR	*	*	*	*	*	*	*	*	*	*	*	*
744794	SWINGING DRAWBAR CAT. A (20 MM HOLE) + PTO GUARD	*	*	*	*	*	*	*	*	*	*	*	*
744795	INDEPENDENT H/D. DRAWBAR WITH GLOVES (32 MM PIN HOLE) + FLIP UP PTO GUARD	*	*	*	*	*	*	*	*	*	*	*	*
330889	LINKAGE DRAWBAR	*	*	*	*	*	*	*	*	*	*	*	*
330226	75 KG FRONT CARRIER WITH HOOK	*	*	*	*	*	*	*	*	*	*	*	*
335019	FRONT CARRIER AND 4 X 40 KG WEIGHTS, WITH HOOK (254 KG)	*	*	*	*	*	*	*	*	*	*	*	*
335019	FRONT CARRIER AND 4 X 40 KG WEIGHTS, WITH HOOK (314 KG)	*	*	*	*	*	*	*	*	*	*	*	*
335023	FRONT CARRIER AND 4 X 40 KG WEIGHTS, WITH HOOK (284 KG)	*	*	*	*	*	*	*	*	*	*	*	*
335024	FRONT CARRIER AND 10 X 40 KG WEIGHTS, WITH HOOK (674 KG)	*	*	*	*	*	*	*	*	*	*	*	*
335287	70 KG FRONT CARRIER WITH 100 KG CENTER WEIGHT	*	*	*	*	*	*	*	*	*	*	*	*
330340	FRONT CARRIER WITH 2 X 40 KG WEIGHTS AND 100 KG CENTER WEIGHT (272 KG)	*	*	*	*	*	*	*	*	*	*	*	*
334486	FRONT CARRIER WITH 4 X 40 KG WEIGHTS AND 100 KG CENTER WEIGHT (352 KG)	*	*	*	*	*	*	*	*	*	*	*	*
335241	FRONT CARRIER WITH 4 X 40 KG WEIGHTS AND 100 KG CENTER WEIGHT (482 KG)	*	*	*	*	*	*	*	*	*	*	*	*
335882	FRONT HOOK 33 MM PIN HOLE	*	*	*	*	*	*	*	*	*	*	*	*
330470	4 RING WEIGHTS (300KG)	*	*	*	*	*	*	*	*	*	*	*	*
330471	8 RING WEIGHTS (300KG)	*	*	*	*	*	*	*	*	*	*	*	*
330860	2WD FRONT FENDERS (240 MM)	*	*	*	*	*	*	*	*	*	*	*	*
330863	4WD FRONT FENDERS (240 MM)	*	*	*	*	*	*	*	*	*	*	*	*
335485	4WD WIDE FRONT FENDERS (400 MM)	*	*	*	*	*	*	*	*	*	*	*	*
744256	REVERSE SPEED ALARM	*	*	*	*	*	*	*	*	*	*	*	*
330384	4 PIN (6A) ELECTRICAL STANDARD SOCKET	*	*	*	*	*	*	*	*	*	*	*	*
744750	STEPS	*	*	*	*	*	*	*	*	*	*	*	*
334342	SOUTH AFRICA MARKET (ENGLISH OMI) LH DIP	*	*	*	*	*	*	*	*	*	*	*	*
334343	AUSTRALIA MARKET (ENGLISH OMI) LH DIP	*	*	*	*	*	*	*	*	*	*	*	*
334344	INTERNATIONAL MARKET (ENGLISH OMI)	*	*	*	*	*	*	*	*	*	*	*	*
334345	INTERNATIONAL MARKET (FRENCH OMI)	*	*	*	*	*	*	*	*	*	*	*	*
334346	INTERNATIONAL MARKET (CHINA (CHINESE OMI)	*	*	*	*	*	*	*	*	*	*	*	*
334347	INTERNATIONAL MARKET (RUSSIA (RUSSIAN OMI)	*	*	*	*	*	*	*	*	*	*	*	*
334348	LAR MARKET - SPANISH OMI	*	*	*	*	*	*	*	*	*	*	*	*
334349	LAR MARKET - PORTUGUESE OMI	*	*	*	*	*	*	*	*	*	*	*	*
334350	LAR MARKET - BRAZIL (BRAZILIAN OMI)	*	*	*	*	*	*	*	*	*	*	*	*
332890	TOOLBOX	*	*	*	*	*	*	*	*	*	*	*	*
334488	TOOLBOX WITH SET OF TOOLS	*	*	*	*	*	*	*	*	*	*	*	*
330489	LOADER READY	*	*	*	*	*	*	*	*	*	*	*	*
334351	COMPLETE LOADER, WITH RAPID COUPLER	*	*	*	*	*	*	*	*	*	*	*	*
334352	COMPLETE LOADER, DELUXE WITH SELF LEVELING AND RAPID COUPLER	*	*	*	*	*	*	*	*	*	*	*	*

00.001.00

02

p1

1/2014

OPTIONAL EQUIPMENT

REF FN	PART NUMBER	YR/SN	QTY	DESCRIPTION
---------------	--------------------	--------------	------------	--------------------

				FARMALL JX100 FARMALL JX110 FARMALL JX70 FARMALL JX75 FARMALL JX80 FARMALL JX90
--	--	--	--	--

00.100.01

01

p1

1/2014

IDENTIFICATION PLATE AND VERSION LIST

MODELS MODELLI MODELLS MODELLE MODELOS MODELLER MODELLER	ENGINE/ENGINE CODE DENOMINAZIONE TECNICA DÉNOMINATION TECHNIQUE TECHNISCHE BEZEICHNUNG DENOMINACIÓN TÉCNICA TECHNISCHE BEZEICHNUNG TECHNISCHE BEZEICHNUNG	ENGINE MODEL MODELLO DEL MOTORE MODELE DU MOTEUR MOTORBAUMUSTER MODELO DEL MOTOR MODELO DO MOTOR MODEL VAN MOTOR MOTOR-MODEL
JX 70 PRO	695065215 695065216 695065217 695065218 695065225 695065226 695065227 695065228	64527381 (3 Cyl / 56HP) Tier 3
JX 75 PRO		64527376 (4 Cyl / 72HP) Tier 3
MODELS MODELLI MODELLS MODELLE MODELOS MODELLER MODELLER	MACHINE SERIAL NUMBER - NUMERO DI MATRICOLA DELLA MACCHINA NUMERO DE SERIE DE LA MACHINE - SERIENNUMMER DER MASCHINE NUMERO DE SERIE DE LA MAQUINA - MATRICULA DA MAQUINA SERIENNUMMER VAN DE MACHINE - MASHINENS MATRIKEL	
JX 70 PRO JX 75 PRO	Zxxxxxxx ← []	



Machine identification code, useful in case of Dealer assistance.

Codice identificativo specifico della macchina, da riportare nelle comunicazioni con la Rete Assistenza.

Code d'identification spécifique du véhicule, à reporter dans les communications avec le Réseau d'Assistance.

Spezielles Kenn-Code der Maschine, der in den Mitteilungen an das Kundendienstnetz anzugeben ist.

Código de identificación específico de la máquina, a incluir en las comunicaciones con la Red Asistencial.

Código identificativo específico de máquina, que deve ser indicado nas comunicações com a Rede de Assistência.

Specificke identifikaatscode van de machine, te vermelden bij communicatie met het Servicenetwerk.

Spezifika identifikaats-kode for maskinen som skal anføres i kommunikationerne med Service-nettet.

RECORD YOUR SERIAL NUMBERS BELOW - REGISTRATE I VOSTRI NUMERI DI MATRICOLA QUI SOTTO
ENREGISTREZ VOS NUMEROS DE SERIE CI-DESSOUS - UNTEREN SERIENNUMMER VIERMERKEN
ANOTE AQUI LOS NUMEROS DE SERIE - REGISTRAR OS NUMEROS DE MATRICULA ABAIXO
NOTEER HIERONDER DE SERIENNUMMERS - REGISTRER DERES MATRIKEL-NUMRE FOR NEDEN

MACHINE SERIAL NUMBER - NUMERO DI MATRICOLA DELLA MACCHINA
NUMERO DE SERIE DE LA MACHINE - SERIENNUMMER DER MASCHINE
NUMERO DE SERIE DE LA MAQUINA - MATRICULA DA MAQUINA
SERIENNUMMER VAN DE MACHINE - MASHINENS MATRIKEL

ENGINE SERIAL NUMBER - MATRICOLA DEL MOTORE
NUMERO DE SERIE DU MOTEUR - SERIENNUMMER DES MOTORS
NUMERO DE SERIE DEL MOTOR - MATRICULA DO MOTOR
SERIENNUMMER VAN DE MOTOR - MOTORENS MATRIKEL

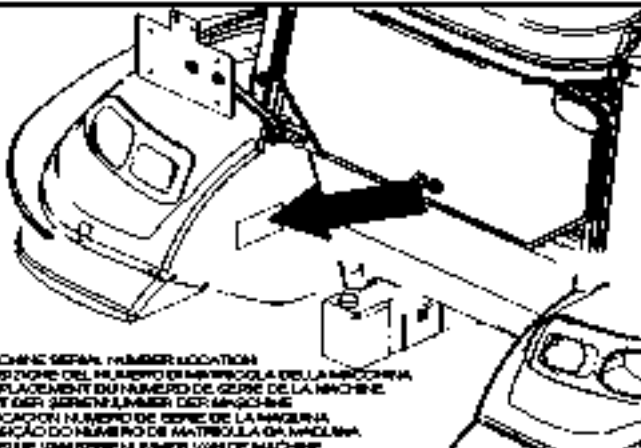

MACHINE SERIAL NUMBER LOCATION
POSIZIONE DEL NUMERO DI MATRICOLA DELLA MACCHINA
EMPLACEMENT DU NUMERO DE SERIE DE LA MACHINE
ORT DER SERIENNUMMER DER MASCHINE
UBACAOIN NUMERO DE SERIE DE LA MAQUINA
POSICAO DO NUMERO DE MATRICULA DA MAQUINA
POSITIE VAN SERIENNUMMER VAN DE MACHINE
POSITION PA MASHINENS MATRIKEL-NUMMER

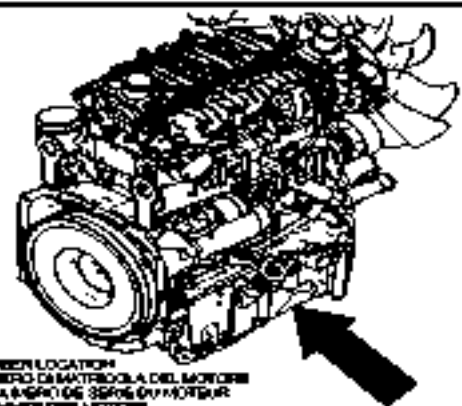

ENGINE SERIAL NUMBER LOCATION
POSIZIONE DEL NUMERO DI MATRICOLA DEL MOTORE
EMPLACEMENT DU LA SERIE DE SERIE DU MOTEUR
ORT DER SERIENNUMMER DES MOTORS
UBACAOIN DEL NUMERO DE SERIE DO MOTOR
POSICAO DO NUMERO DE MATRICULA DO MOTOR
POSITIE VAN SERIENNUMMER VAN DE MOTOR
POSITION PA MOTORENS MATRIKEL-NUMMER

00.100.01

01

p1

1/2014

IDENTIFICATION PLATE AND VERSION LIST

REF FN	PART NUMBER	YR/SN	QTY	DESCRIPTION
---------------	--------------------	--------------	------------	--------------------

				FARMALL JX70 FARMALL JX75
--	--	--	--	------------------------------

00.100.01

02

p1

1/2014

IDENTIFICATION PLATE AND VERSION LIST

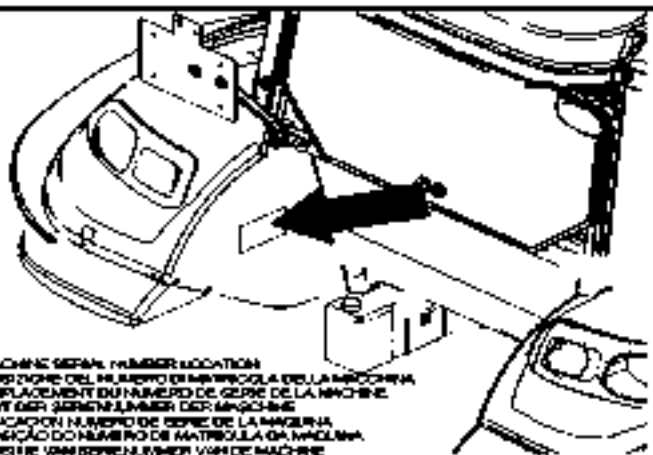
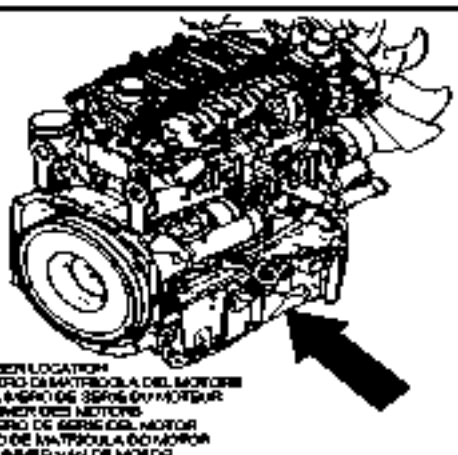
MODELS MODELLI MODELLS MODELLE MODELOS MODELOS MODELLER MODELLER	ENGLISHING CODE DENOMINAZIONE TECNICA DÉSIGNATION TECHNIQUE TECHNISCHE BEZEICHNUNG DENOMINACIÓN TÉCNICA TECHNISCHE BEZEICHNUNG TECHNISCHE BEZEICHNUNG	ENGINE MODEL MODELLO DEL MOTORE MODELE DU MOTEUR MOTORBAUMUSTER MODELO DEL MOTOR MODELO DO MOTOR MOTOR-MODEL
JX60 PRO	698095235 698095236 698095237 698095239	E4927383 (3 Cyl / 80HP) Type 3
MODELS MODELLI MODELOS MODELLE MODELOS MODELOS MODELLER MODELLER	MACHINE SERIAL NUMBER - NUMERO DI MATRICOLA DELLA MACCHINA NUMERO DE SERIE DE LA MACHINE - SERIENNUMMER DER MASCHINE NUMERO DE SERIE DE LA MAQUINA - MATRICULA DA MAQUINA SERIENNUMMER VAN DE MACHINE - MASJINENS MATRIKEL	
JX60 PRO	ZXXXXXXXX ← []	
 <p>Machine identification code, useful in case of Dealer assistance. Codice identificativo specifico della macchina, da riportare nelle comunicazioni con la Rete Assistenza. Code d'identification spécifique du véhicule, à reporter dans les communications avec le Réseau d'Assistance. Spezifischer Kenn-Code der Maschine, der in den Mitteilungen an das Kundendienstnetz anzugeben ist. Código de identificación específico de la máquina, a incluir en las comunicaciones con la Red Asistencial. Código identificativo específico de máquina, que deve ser indicado nas comunicações com a Rede de Assistência. Specificke identifikačioný kód pro mašiny, je uvést v komunikaci s servisní sítí. Specificke identifikačioný kód pro mašiny, je uvést v komunikaci s servisní sítí.</p>		
RECORD YOUR SERIAL NUMBERS BELOW - REGISTRATE I VOSTRI NUMERI DI MATRICOLA QUI SOTTO ENREGISTREZ VOS NUMEROS DE SERIE CI-DESSOUS - UNTER SERIENNUMMER VIERMERKEN ANOTE AQUI LOS NUMEROS DE SERIE - REGISTRAR OS NUMEROS DE MATRICULA ABAIXO NOTEER HIERONDER DE SERIENNUMMERS - REGISTRER DIERES MATRIKEL-NUMRE FOR NEDEN		
MACHINE SERIAL NUMBER - NUMERO DI MATRICOLA DELLA MACCHINA NUMERO DE SERIE DE LA MACHINE - SERIENNUMMER DER MASCHINE NUMERO DE SERIE DE LA MAQUINA - MATRICULA DA MAQUINA SERIENNUMMER VAN DE MACHINE - MASJINENS MATRIKEL	ENGINE SERIAL NUMBER - MATRICOLA DEL MOTORE NUMERO DE SERIE DU MOTEUR - SERIENNUMMER DES MOTORS NUMERO DE SERIE DEL MOTOR - MATRICULA DO MOTOR SERIENNUMMER VAN DE MOTOR - MOTORENS MATRIKEL	
 <p>MACHINE SERIAL NUMBER LOCATION POSIZIONE DEL NUMERO DI MATRICOLA DELLA MACCHINA EMPLACEMENT DU NUMERO DE SERIE DE LA MACHINE ORT DER SERIENNUMMER DER MASCHINE UBACAO DO NUMERO DE SERIE DE LA MAQUINA POSICAO DO NUMERO DE MATRICULA DA MAQUINA POSITIE VAN SERIENNUMMER VAN DE MACHINE POSITION PA MASJINENS MATRIKEL-NUMMER</p>	 <p>ENGINE SERIAL NUMBER LOCATION POSIZIONE DEL NUMERO DI MATRICOLA DEL MOTORE EMPLACEMENT DU NUMERO DE SERIE DU MOTEUR ORT DER SERIENNUMMER DES MOTORS UBACAO DO NUMERO DE SERIE DO MOTOR POSITIE VAN SERIENNUMMER VAN DE MOTOR POSITION PA MOTORENS MATRIKEL-NUMMER</p>	

00.100.01

02

p1

1/2014

IDENTIFICATION PLATE AND VERSION LIST

REF FN	PART NUMBER	YR/SN	QTY	DESCRIPTION
---------------	--------------------	--------------	------------	--------------------

	FARMALL JX80
--	---------------------

00.100.01

03

p1

1/2014

IDENTIFICATION PLATE AND VERSION LIST

MODELS MODELLI MODELLS MODELLE MODELOS MODELLER MODELLER	ENGINE/SPRING CODE DENOMINAZIONE TECNICA DÉNOMINATION TECHNIQUE TECHNISCHE BEZEICHNUNG DENOMINAÇÃO TÉCNICA TECHNISCHE BEZEMMING TECHNISCH BENENNUNGE	ENGINE MODEL MODELLO DEL MOTORE MODELE DU MOTEUR MOTORBAUMUSTER MODELO DO MOTOR MODEL DO MOTOR MOTOR-MODEL
JX90 PRO	090005245 090005246 090005247 090005248 090005275 090005276 090005277 090005278 090005285	04527377 (4 Cyl / 88HP) Tier 3 04527379 (4 Cyl / 98HP) Tier 3 04554842 (4 Cyl / 108HP) Tier 3
JX100 PRO		
JX110 PRO		
MODELS MODELLI MODELLS MODELLE MODELOS MODELLER MODELLER	MACHINE SERIAL NUMBER - NUMERO DI MATRICOLA DELLA MACCHINA NUMERO DE SERIE DE LA MACHINE - SERIENUMMER DER MASCHINE NUMERO DE SERIE DE LA MAQUINA - MATRICULA DA MAQUINA SERIENUMMER VAN DE MACHINE - MASHINENS MATRIKEL	
JX90 PRO JX100 PRO JX110 PRO	ZXXXXXXXX ← []	



Machine identification code, useful in case of Dealer assistance.

Codice identificativo specifico della macchina, da riportare nelle comunicazioni con la Rete Assistenza.

Code d'identification spécifique du véhicule, à reporter dans les communications avec le Réseau d'Assistance.

Spezifischer Kenn-Code der Maschine, der in den Mitteilungen an das Kundendienstnetz anzugeben ist.

Código de identificación específico de la máquina, a incluir en las comunicaciones con la Red Asistencial.

Código identificativo específico de máquina, que deve ser indicado nas comunicações com a Rede de Assistência.

Specificke identifikaatcode van de machine, te vermelden bij communicatie met het Service-netwerk.

Specificke identifikaatcode for maskinen som skal anføres i kommunikationerne med Service-nettet.

RECORD YOUR SERIAL NUMBERS BELOW - REGISTRATE I VOSTRI NUMERI DI MATRICOLA QUI SOTTO
ENREGISTREZ VOS NUMEROS DE SERIE CI-DESSOUS - UNTER SERIENUMMER VIERWERKEN
ANOTE AQUI LOS NUMEROS DE SERIE - REGISTRAR OS NUMEROS DE MATRICULA ABAIXO
NOTEER HIERONDER DE SERIENUMMERS - REGISTRER DERES MATRIKEL-NUMRE FOR NEDEN

MACHINE SERIAL NUMBER - NUMERO DI MATRICOLA DELLA MACCHINA
NUMERO DE SERIE DE LA MACHINE - SERIENUMMER DER MASCHINE
NUMERO DE SERIE DE LA MAQUINA - MATRICULA DA MAQUINA
SERIENUMMER VAN DE MACHINE - MASHINENS MATRIKEL

ENGINE SERIAL NUMBER - MATRICOLA DEL MOTORE
NUMERO DE SERIE DU MOTEUR - SERIENUMMER DES MOTORS
NUMERO DE SERIE DEL MOTOR - MATRICULA DO MOTOR
SERIENUMMER VAN DE MOTOR - MOTORENS MATRIKEL

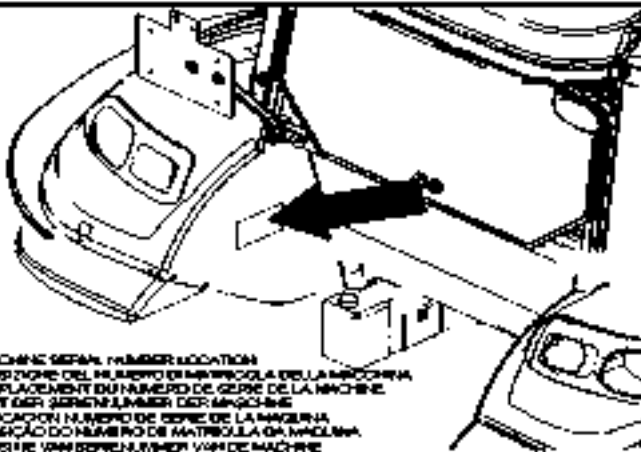

MACHINE SERIAL NUMBER LOCATION
POSIZIONE DEL NUMERO DI MATRICOLA DELLA MACCHINA
EMPLACEMENT DU NUMERO DE SERIE DE LA MACHINE
ORT DER SERIENUMMER DER MASCHINE
UBACAOIN NUMERO DE SERIE DE LA MAQUINA
POSICAO DO NUMERO DE MATRICULA DA MAQUINA
POSITIE VAN SERIENUMMER VAN DE MACHINE
POSITION PA MASHINENS MATRIKEL-NUMER

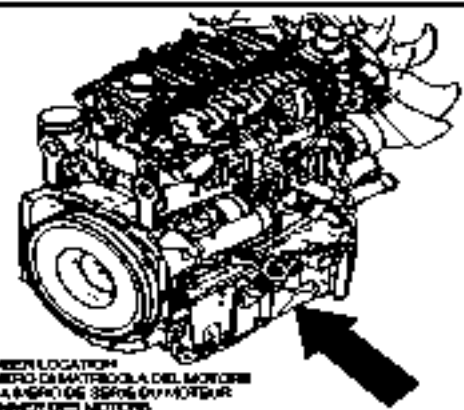

ENGINE SERIAL NUMBER LOCATION
POSIZIONE DEL NUMERO DI MATRICOLA DEL MOTORE
EMPLACEMENT DU NUMERO DE SERIE DU MOTEUR
ORT DER SERIENUMMER DES MOTORS
UBACAOIN DEL NUMERO DE SERIE DO MOTOR
POSICAO DO NUMERO DE MATRICULA DO MOTOR
POSITIE VAN SERIENUMMER VAN DE MOTOR
POSITION PA MOTORENS MATRIKEL-NUMER

00.100.01

03

p1

1/2014

IDENTIFICATION PLATE AND VERSION LIST

REF FN	PART NUMBER	YR/SN	QTY	DESCRIPTION
---------------	--------------------	--------------	------------	--------------------

				FARMALL JX100 FARMALL JX110 FARMALL JX90
--	--	--	--	--

DIA KITS

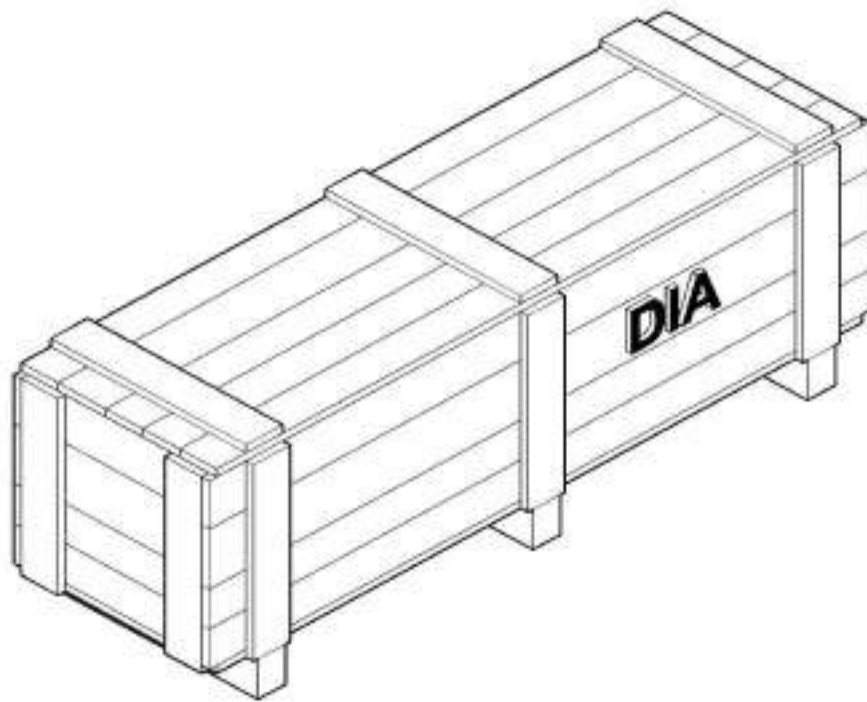

DIA KITS

REF FN	PART NUMBER	YR/SN	QTY	DESCRIPTION
1	719347675			DIA KIT, TRACTOR 1 Rear Remote S/D W/Kick-out and Quick Couplers
2	719347685			DIA KIT, TRACTOR 1 Rear Remote S/D W/Kick-out and Quick Couplers
3	719055645			DIA KIT, TRACTOR 1 Rear Remote S/D W/Kick-out and Quick Couplers
4	719055655			DIA KIT, TRACTOR 1 Rear Remote S/D W/Kick-out and Quick Couplers
5	719357695			DIA KIT, TRACTOR 1 Rear Remote S/D W/Kick-out and Quick Couplers
6	719357745			DIA KIT, TRACTOR 1 Rear Remote S/D W/Kick-out and Quick Couplers
7	710860565			DIA KIT, TRACTOR 2WD Front Fenders (240mm Width)
8	710860575			DIA KIT, TRACTOR 2WD Front Fenders (240mm Width)
7	710860595			DIA KIT, TRACTOR 4WD Front Fenders (340mm Width)
9	710860585			DIA KIT, TRACTOR 4WD Front Fenders (340mm Width)
	710495515			DIA KIT, TRACTOR 4WD Wide Front Fenders (400mm Width)
¹⁰	719158615			DIA KIT, TRACTOR Horizontal Exhaust for Underhood Muffler

- (1) For Models W/CAB, W/O Remotes to go to 1
(2) For Models W/O CAB, W/O Remotes to go to 1
(3) For Models W/CAB, W/ 1 Remote to go to 2
(4) For Models W/O CAB, W/ 1 Remote to go to 2
(5) For Models W/CAB, W/ 2 Remotes to go to 3
(6) For Models W/O CAB, W/ 2 Remotes to go to 3
(7) For Model FARMALL JX70
(8) For Models FARMALL JX75, 80, 90, 100
(9) For Models FARMALL JX75, 80, 90, 100, 110
(10) For Models FARMALL JX70, 80

FARMALL JX100 FARMALL
JX110 FARMALL JX70
FARMALL JX75 FARMALL
JX80 FARMALL JX90

DIA KITS

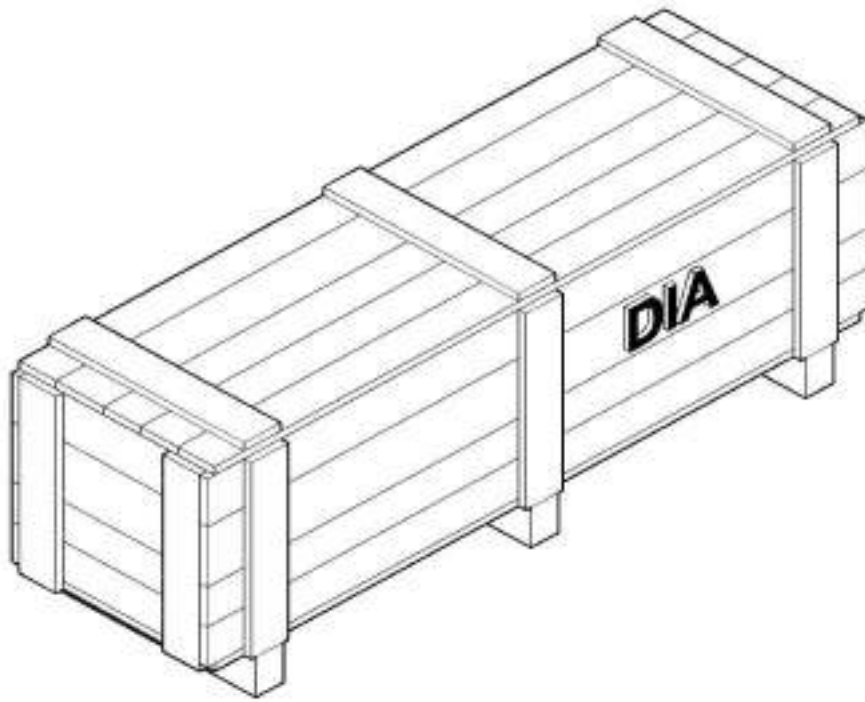

DIA KITS

REF FN	PART NUMBER	YR/SN	QTY DESCRIPTION
1	719158625		DIA KIT, TRACTOR Horizontal Exhaust for Underhood Muffler
2	710642565		DIA KIT, TRACTOR Rear Wiper and Washer
3	719614535		DIA KIT, TRACTOR LH Side Mirror
3	719613535		DIA KIT, TRACTOR RH Side Mirror
2	719879515		DIA KIT, TRACTOR 2 External Mirrors
(1)	For Models FARMALL JX75, 90, 100, 110		
(2)	For Models W/ CAB		
(3)	For Models W/O CAB		
			FARMALL JX100 FARMALL JX110 FARMALL JX70 FARMALL JX75 FARMALL JX80 FARMALL JX90

SECTION INDEX

MACHINE COMPLETION & EQUIPMENT

05.100.01		INITIAL STOCKING LIST (LIST A)
05.100.02		INITIAL STOCKING LIST (LIST B)
05.100.03	01	FILTERS & CAPACITIES
05.100.03	02	FILTERS & CAPACITIES

INITIAL STOCKING LIST (LIST A)

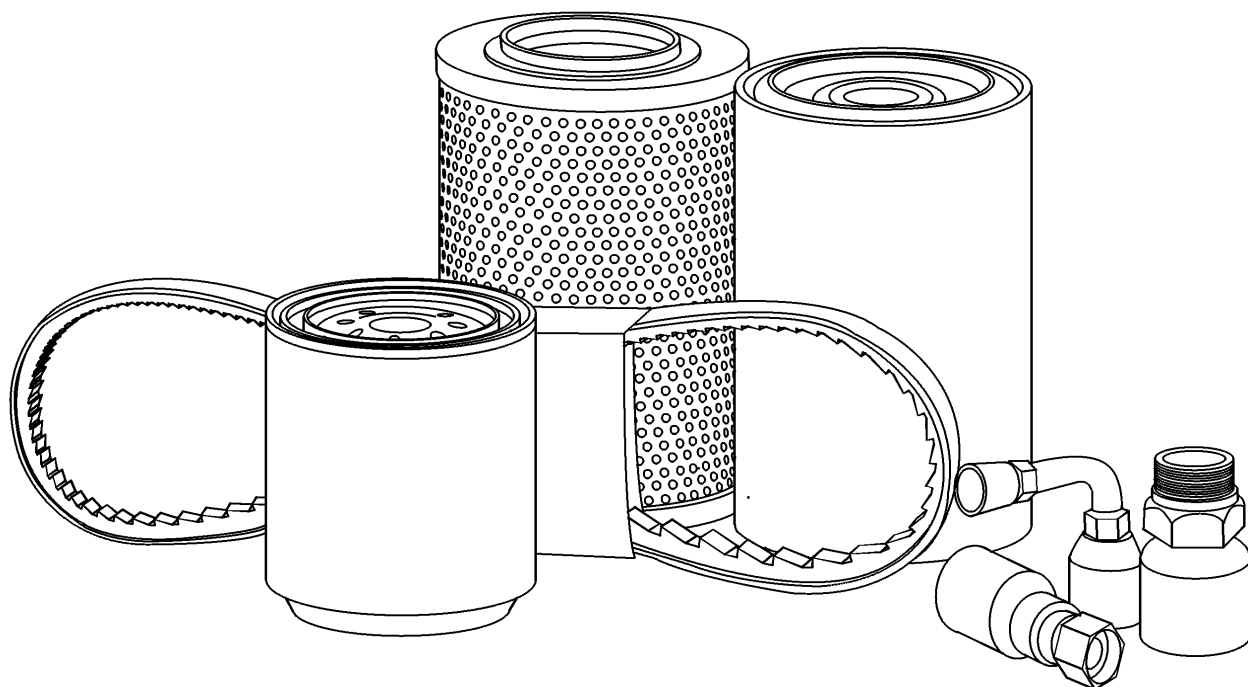

INITIAL STOCKING LIST (LIST A)

REF FN	PART NUMBER	YR/SN	QTY DESCRIPTION
1	84214564		1 FUEL FILTER Engine Fuel Filter
2	1 84217953		1 FUEL FILTER Water Separator
3	5096729		1 ENGINE OIL FILTER
4	87037984		1 ELEMENT Air Filter, Primary
5	87037985		1 ELEMENT Air Filter, Secondary
6	84257511		1 HYDRAULIC OIL FILTER
7	84524359		1 CAB FILTER Outer RH
8	84524358		1 CAB FILTER Outer LH
9	84524327		1 CAB FILTER Outer Rear
10	5165615		1 RECEIVER-DRYER
11	2 84395801		1 BELT Main, 9.5mm x 1125mm
12	3 84370635		1 BELT Main, 9.5mm x 1100mm
13	^{4,5} 47364506		1 BELT Main, 8PK, 1170mm
14	^{6,5} 84370634		1 BELT A/C Compressor, 9.5mm x 1000 mm
15	^{5,4} 84395802		1 BELT A/C Compressor, 9.5mm x 985 mm
(1)	for Fuel Sedimenting Device (Var. 334296)		
(2)	Valid for TD5.65, TD5.80, TD5.100, TD5.110, FARMALL JX70, 80, 100, 110		
(3)	Valid for TD5.75, TD5.90, FARMALL JX75, 90		
(4)	Valid for TD5.75, TD5.90, TD5.100, TD5.110, FARMALL JX75, 90, 100, 110		
(5)	for Engine with A/C (Var. 334299-334301), W/ CAB Models only		
(6)	Valid for TD5.65, TD5.80, FARMALL JX70, 80		
			FARMALL JX100 FARMALL JX110 FARMALL JX70 FARMALL JX75 FARMALL JX80 FARMALL JX90

INITIAL STOCKING LIST (LIST B)

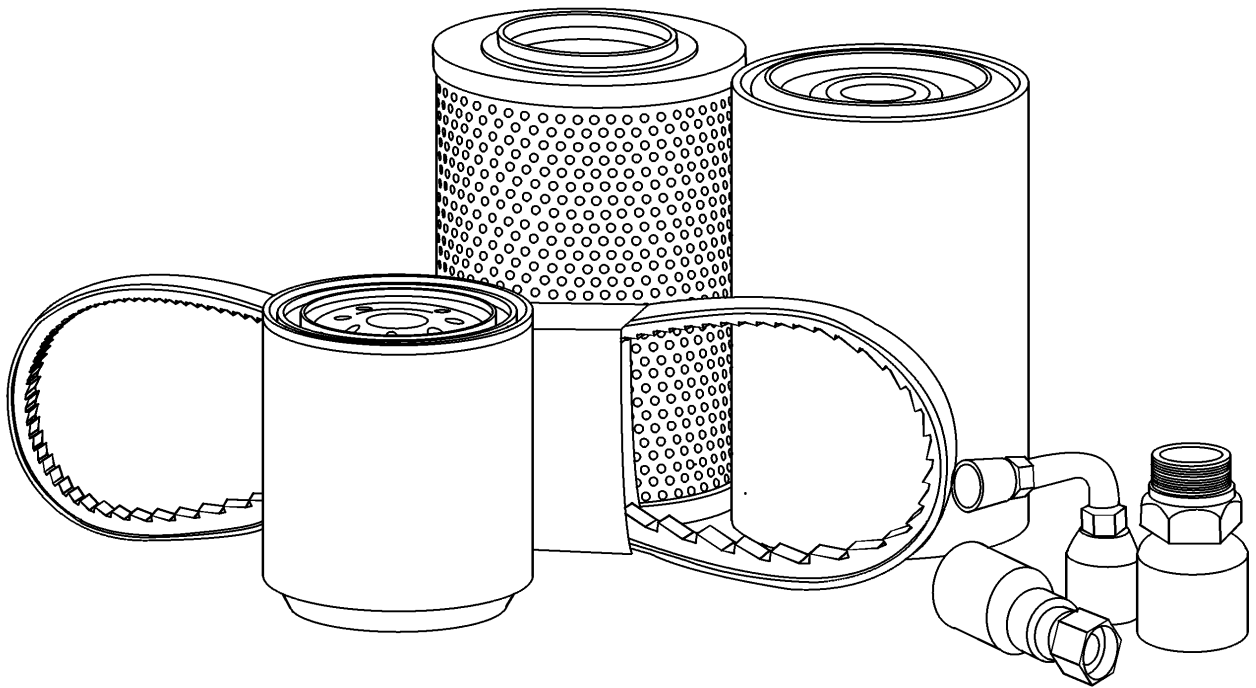

INITIAL STOCKING LIST (LIST B)

REF FN	PART NUMBER	YR/SN	QTY DESCRIPTION
1	84381139		1 STARTER MOTOR
2	1 84232230		1 DIPSTICK Engine Oil
3	2 84232231		1 DIPSTICK Engine Oil
4	84511173		1 SENDER UNIT Fuel Tank
5	47357568		1 LOCKABLE FUEL CAP
6	9971771		1 INDICATOR Water Separator
7	82036587		1 PRESSURE SWITCH Engine Oil
8	5099414		1 PRESSURE SWITCH Power Steering
9	504062682		1 SENDER UNIT Coolant Temperature on Engine Water Pump
10	5161845		1 THERMOSTART
11	5138821		1 INDICATOR Dust Indicator on Air Cleaner
12	84219064		1 NEUTRAL START SWITCH 35A
13	5089430		1 WINDSHIELD WASHER SWITCH
14	87376568		1 BEACON SWITCH
15	84560042		1 SWITCH Windshield Wiper
16	87472544		1 SWITCH ASSY Front Work Lamp
17	87551489		1 LIGHT SWITCH Rear Work Lamp
18	5086006		1 SWITCH Thermostarter
19	87584696		1 PRESSURE SWITCH Brake Oil
20	5093820		1 BEACON SWITCH Beacon Lamp
21	83961521		1 SWITCH ASSY Interior Lamp
22	84370675		1 SWITCH Differential Lock Control Valve
23	5184399		1 DIFF LOCK SWITCH
24	47128548		1 TOGGLE SWITCH 4wd
25	87702928		1 PARK BRAKE SWITCH
26	84209856		1 SWITCH ASSY Multifunction
27	84155394		1 FLASHER SWITCH
28	5146155		1 IGNITION SWITCH
29	5170782		1 IGNITION KEY Black
(1)	Valid for TD5.65, TD5.80, FARMALL JX70, 80		
(2)	Valid for TD5.75, TD5.90, TD5.100, TD5.110, FARMALL JX75, 90, 100, 110		

FARMALL JX100 FARMALL
JX110 FARMALL JX70
FARMALL JX75 FARMALL
JX80 FARMALL JX90

INITIAL STOCKING LIST (LIST B)

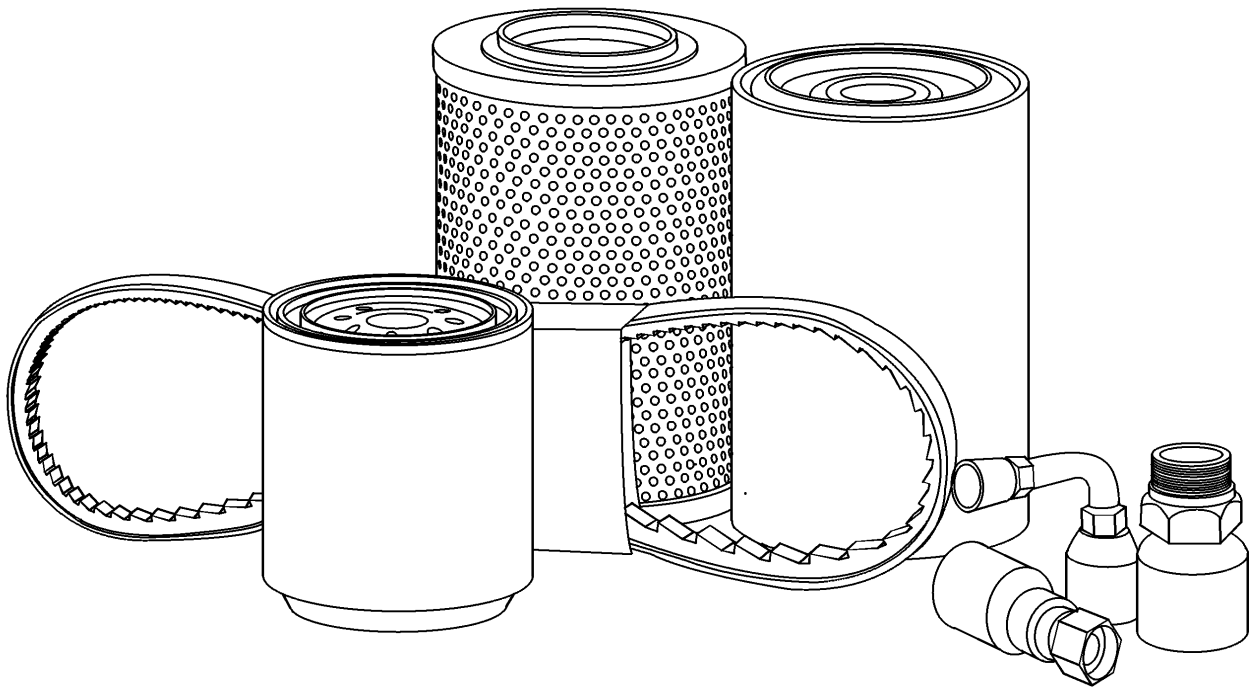

INITIAL STOCKING LIST (LIST B)

REF FN	PART NUMBER	YR/SN	QTY DESCRIPTION
30	5080358		1 SEAL KIT
31	5083055		1 SEAL KIT Steering Cylinder
32	5083051		1 SEAL KIT Remote Valve, for p/n 5099440
33	87341173		1 SEAL KIT Remote Valve, for p/n 5099332
34	84392603		1 SEAL KIT Brake Master Cylinder
35	84407173		1 WIPER BLADE Single, 400MM
36	84407170		1 WIPER ARM Single
37	87319297		1 WIPER BLADE Parallel, 500MM
38	84346681		1 WINDSHIELD WIPER Parallel
39	5089603		1 MIRROR L/CAB
40	5091914		1 REAR VIEW MIRROR W/CAB
41	14457681		1 O-RING 21.89mm ID x 2.62" Width Oil Sump
42	2852318		1 PLUG Rd Hd, Int Hex, M22 x 1.5 x 16mm, ORB Oil Sump
43	84153830		AR FUSE 5A Beige
44	84152583		AR FUSE 7.5A Brown
45	84127702		AR FUSE 10A Red
46	84127703		AR FUSE 15A Blue
47	84127704		AR FUSE 20A Yellow
48	84127705		AR FUSE 25A Natural
49	84127708		AR FUSE 30A Green
50	5190333		AR FUSE 40A Orange
51	10404290		AR FUSE 80A White
52	84157161		AR RELAY 12V - 10/20A
53	84157157		AR RELAY 12V - 20A
54	5080366		AR RELAY 12V - 40A
55	87341931		AR RELAY 12V - 70A
56	87617349		AR BULB H3 12V-55W, Worklamp on Fender, L/CAB
57	84135750		AR BULB 12V-55W, Worklamp, W/CAB
			FARMALL JX100 FARMALL JX110 FARMALL JX70 FARMALL JX75 FARMALL JX80 FARMALL JX90

INITIAL STOCKING LIST (LIST B)

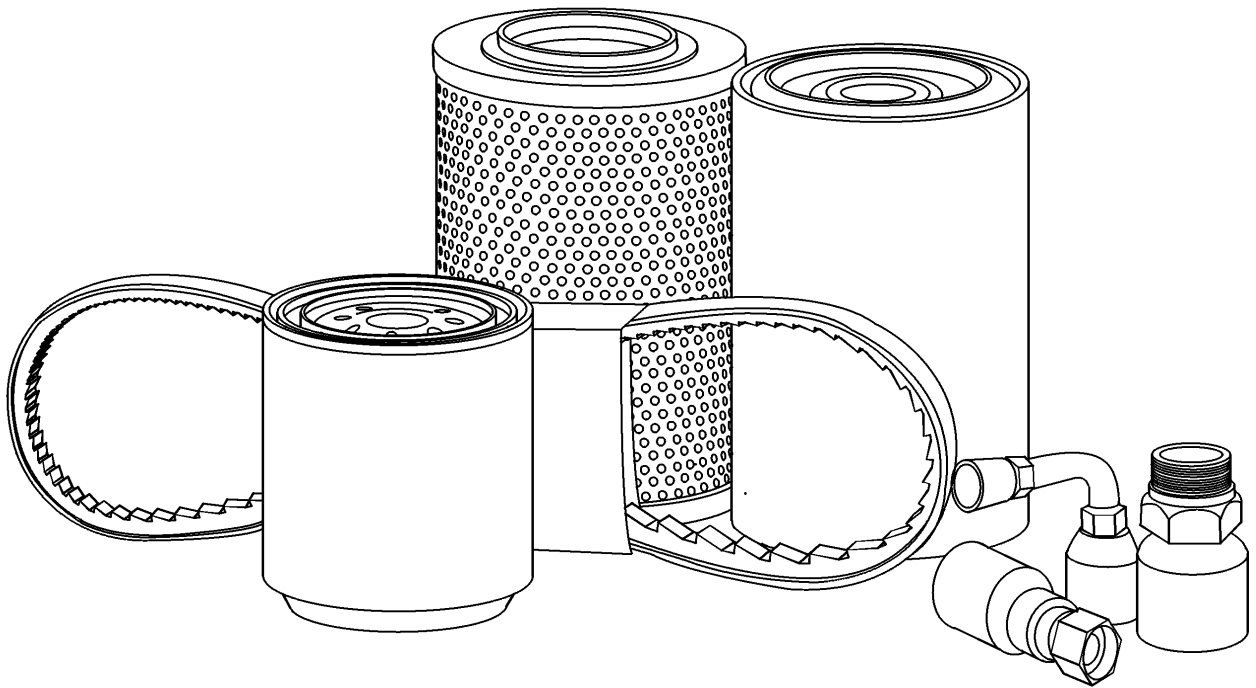

INITIAL STOCKING LIST (LIST B)

REF FN	PART NUMBER	YR/SN	QTY DESCRIPTION
58	86616248		AR BULB #HI, 55w 12V-55W, Rotary Beacon, W/CAB
59	5080613		AR BULB 21W, Directional Signal Lamp
60	5080705		AR BULB 5W, Directional Signal Lamp
61	5091860		1 QUICK FEMALE COUPLING Green
62	5092198		1 QUICK FEMALE COUPLING Blue
63	5092199		1 QUICK FEMALE COUPLING Brown
64	5093853		1 QUICK FEMALE COUPLING Black
65	84188027		1 WET BATTERY 100AH
66	84247250		1 WET BATTERY 120AH
			FARMALL JX100 FARMALL JX110 FARMALL JX70 FARMALL JX75 FARMALL JX80 FARMALL JX90

FILTERS & CAPACITIES

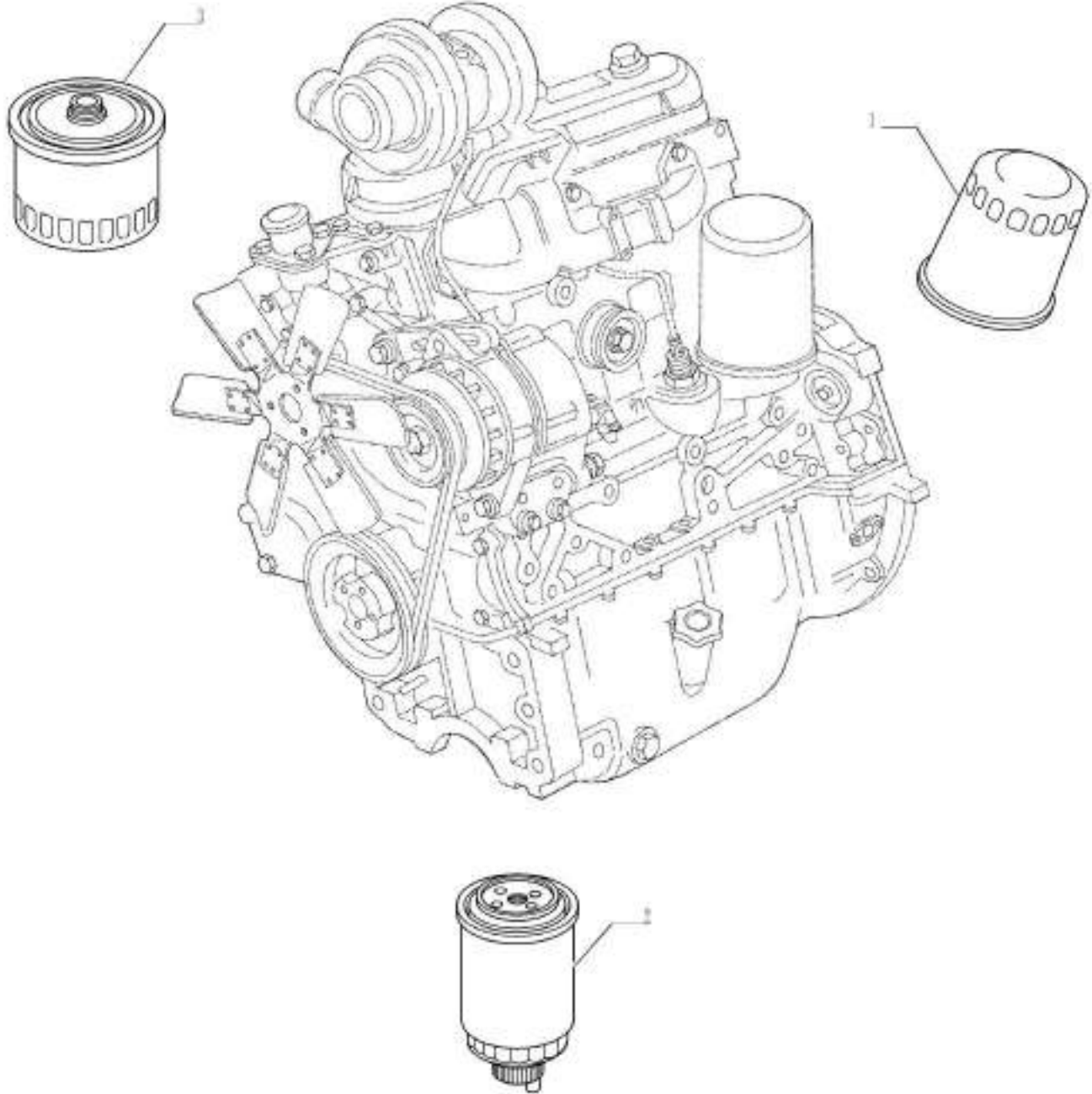

FILTERS & CAPACITIES

REF FN	PART NUMBER	YR/SN	QTY DESCRIPTION
1	5096729		1 ENGINE OIL FILTER
2	5088079		1 ELEMENT
3	1 84217953		1 FUEL FILTER
(1)	VAR - 334296		

FARMALL JX100 FARMALL
JX110 FARMALL JX70
FARMALL JX75 FARMALL
JX80 FARMALL JX90

FILTERS & CAPACITIES

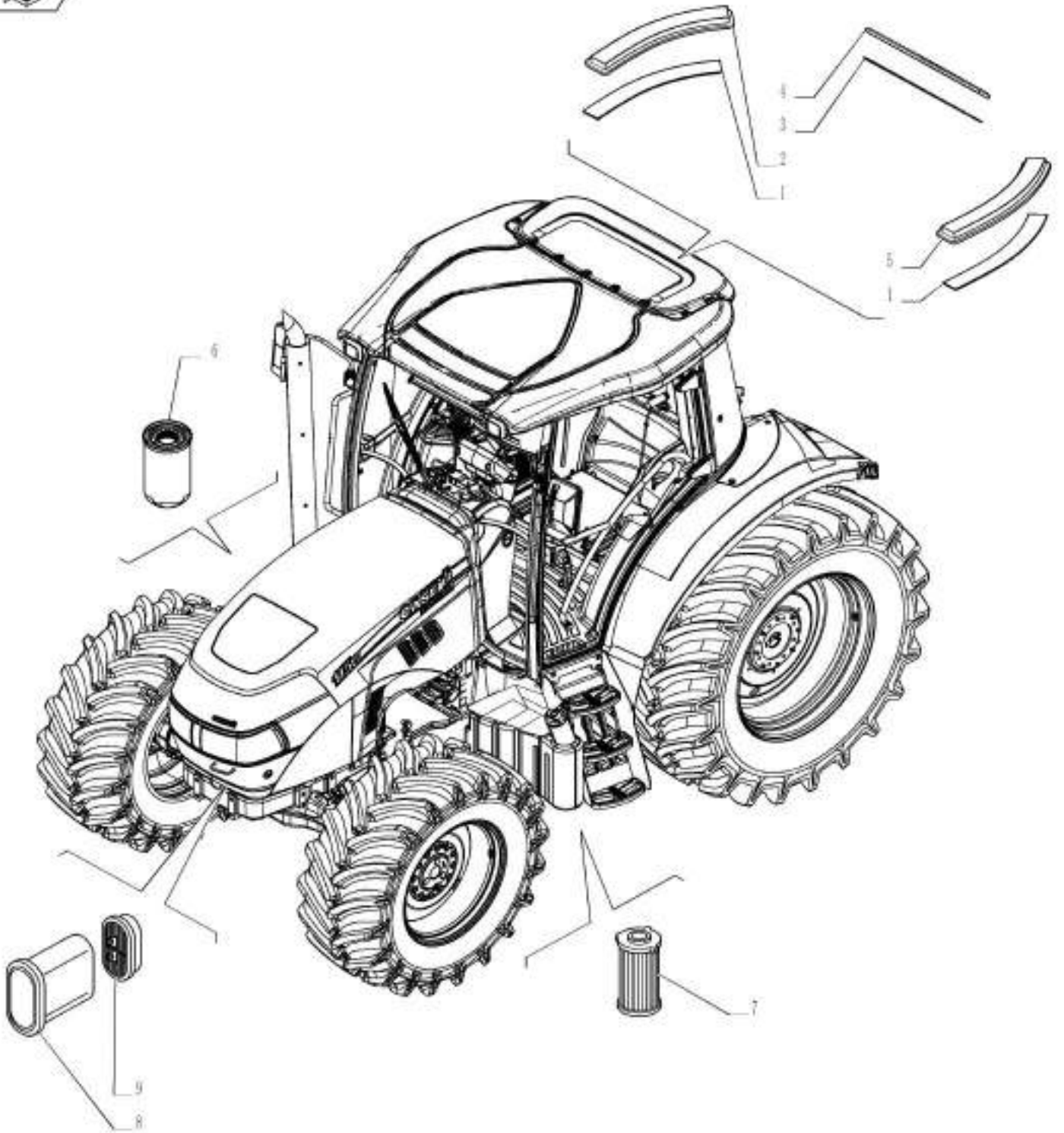

FILTERS & CAPACITIES

REF FN	PART NUMBER	YR/SN	QTY DESCRIPTION
1	84554028		2 FILTER
2	84524359		1 CAB FILTER
3	84554034		1 FILTER
4	84524327		1 CAB FILTER
5	84524358		1 CAB FILTER
6	84123428		1 HYDRAULIC OIL FILTER
7 1	5178100		1 ELEMENT
8	87356351		1 AIR FILTER
9	87356353		1 AIR FILTER

(1) Valid for FARMALL JX80, 90, 100, 110 Models Only

FARMALL JX100 FARMALL
 JX110 FARMALL JX70
 FARMALL JX75 FARMALL
 JX80 FARMALL JX90

SECTION INDEX

ENGINE

10.000.00	03	SECTION INDEX, ENGINE
10.001.AD	01	VAR - 390002, 744731 - ENGINE, ASSY
10.001.AD	01	VAR - 390002, 744731 - ENGINE, ASSY
10.001.AD	01	VAR - 390002, 744731 - ENGINE, ASSY
10.001.AD	01	VAR - 390002, 744731 - ENGINE, ASSY
10.001.AD	01	VAR - 390002, 744731 - ENGINE, ASSY
10.001.AD	01	VAR - 390002, 744731 - ENGINE, ASSY
10.001.AD	03	VAR - 334300, 744731 - ENGINE, ASSY, W/ POWER SHUTTLE
10.001.AD	03	VAR - 334300, 744731 - ENGINE, ASSY, W/ POWER SHUTTLE
10.202.AB	01	VAR - 330200, 390227 - DRY AIR CLEANER & RELATED PARTS
10.202.AB	02	VAR - 330200, 390227 - DRY AIR CLEANER, BREAKDOWN
10.202.AB	03	VAR - 330200 - DRY AIR CLEANER WITH DUST EJECTOR
10.202.AD	01	VAR - 330200, 390227 - AIR FILTER, PIPES
10.202.AD	02	VAR - 390971 - AIR FILTER, PIPES
10.202.AH	01	VAR - 330200, 390227, 390971, 743852 - AIR CLEANER, SUPPORT
10.206.AF	01	VAR - 334296 - WATER SEPARATOR
10.216.AI	01	VAR - 334296, 390246 - FUEL TANK
10.216.AI	02	VAR - 334296, 390246 - FUEL TANK, SUPPORT
10.220.AA	01	VAR - 334299, 334300, 334301, 390002, 744731 - THROTTLE CONTROL LINKAGE
10.220.AA	02	VAR - 334299, 334300, 334301, 390002, 744731 - THROTTLE CONTROL LINKAGE
10.254.AI	01	VAR - 333153, 391151, 744733 - MUFFLER, VERTICAL EXHAUST
10.254.AI	02	VAR - 330153, 391151, 744733 - MUFFLER, VERTICAL EXHAUST
10.254.AI	03	VAR - 391151, 744733 - VERTICAL EXHAUST, SHIELD
10.254.AI	04	VAR - 391151, 744733 - VERTICAL EXHAUST, SHIELD
10.254.AI	05	VAR - 330150, 744734 - HORIZONTAL EXHAUST SHIELD
10.254.AI	06	VAR - 330150, 744734 - HORIZONTAL EXHAUST SHIELD
10.254.AI	07	VAR - 330153 - VERTICAL EXHAUST, SHIELD
10.254.AI	08	VAR - 330153 - VERTICAL EXHAUST, SHIELD
10.310.AA	01	VAR - 334299, 334300, 334301, 390002, 744731 - INTERCOOLER
10.310.AB	01	VAR - 334299, 390002, 744731 - INTERCOOLER LINE
10.310.AB	02	VAR - 334299, 334300, 334301, 390002, 744731 - INTERCOOLER LINE
10.400.AY	01	VAR - 330641, 390641 - RADIATOR HOSE
10.400.BE	01	VAR - 334299, 334300, 334301, 390002, 744731 - RADIATOR
10.400.BE	02	VAR - 330641, 390641, 390641, 744731 - RADIATOR, SEAL
10.400.BH	01	VAR - 330641, 390641 - COOLING. EXPANSION TANK

SECTION INDEX

ENGINE

10.414.AC	01	VAR - 390018 - FAN
10.414.AC	02	VAR - 334299, 334300, 334301, 390002, 744731 - RADIATOR FAN SHROUD
10.414.AC	03	VAR - 330009 - VISCOUS JOINT FAN
10.414.AC	04	VAR - 330009 - VISCOUS JOINT FAN

SECTION INDEX, ENGINE

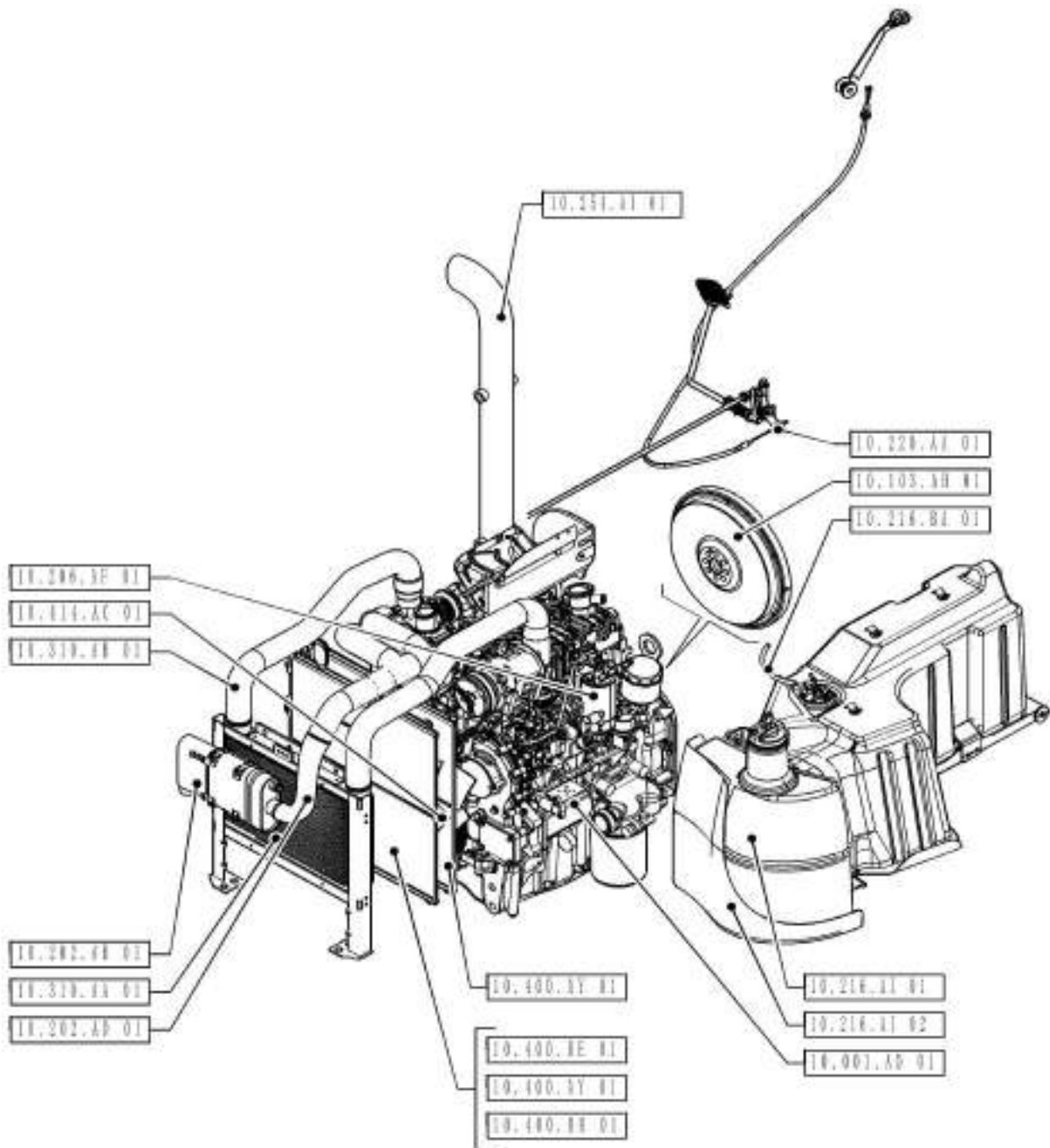

10.000.00

03

p1

1/2014

SECTION INDEX, ENGINE

REF FN	PART NUMBER	YR/SN	QTY	DESCRIPTION
---------------	--------------------	--------------	------------	--------------------

				FARMALL JX100 FARMALL JX110 FARMALL JX70 FARMALL JX75 FARMALL JX80 FARMALL JX90
--	--	--	--	--

10.001.AD

01

p1

1/2014

VAR - 390002, 744731 - ENGINE, ASSY

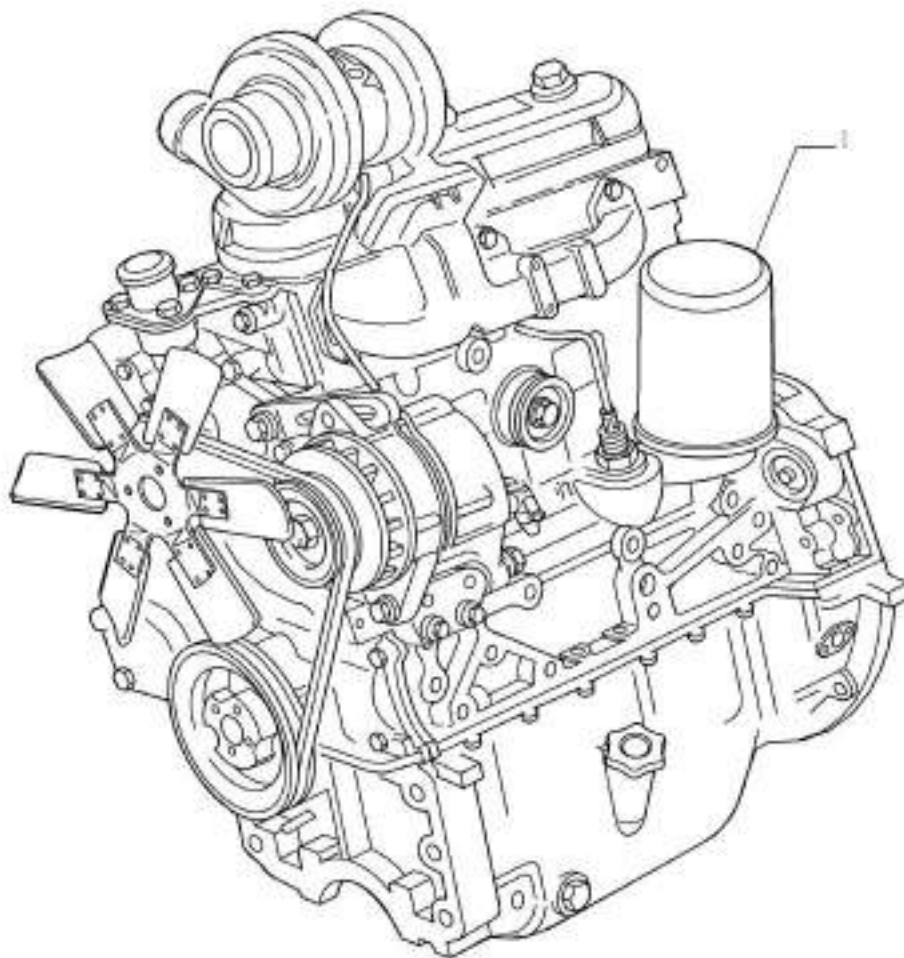

10.001.AD

01

p1

1/2014

VAR - 390002, 744731 - ENGINE, ASSY

REF FN PART NUMBER

YR/SN

QTY DESCRIPTION

1

84527381

1 ENGINE ASSY, 3 Cylinders, 65HP

Valid for Industrial Var. 390002 (744731); Incompatible with Var. 330641 (Air Conditioning); Incompatible with Var. 330120, 331120 (743846) (Power Shuttle Transm.)

FARMALL JX70

10.001.AD

01

p1

1/2014

VAR - 390002, 744731 - ENGINE, ASSY

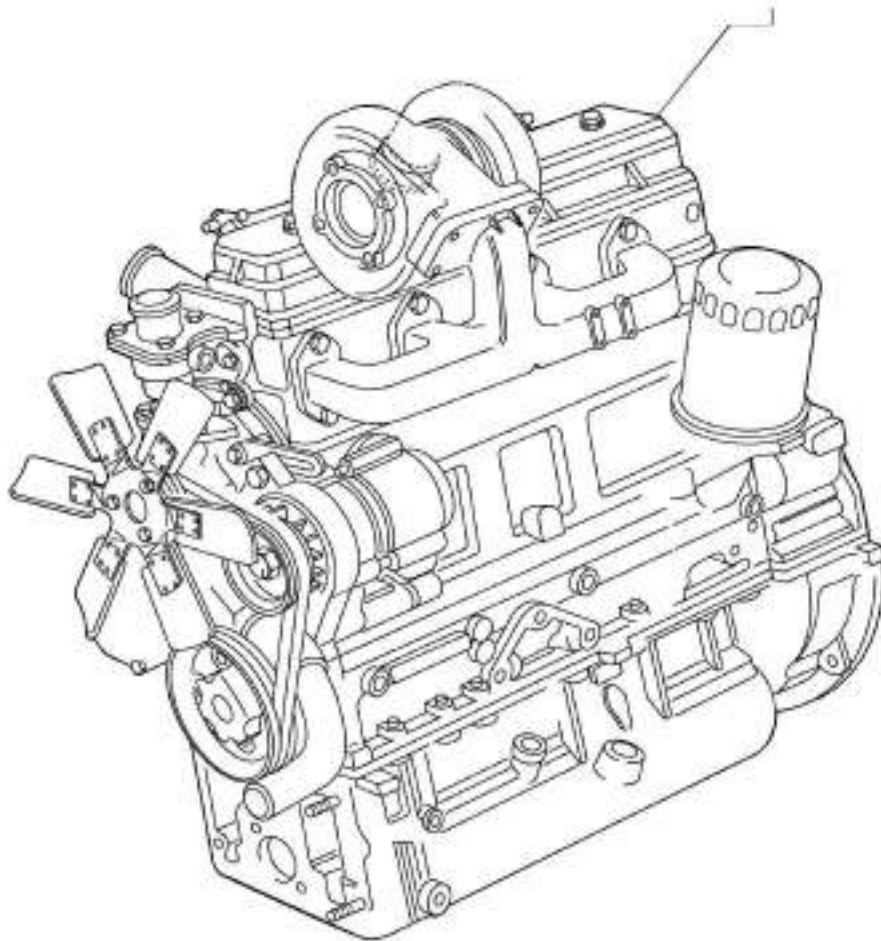

10.001.AD

01

p1

1/2014

VAR - 390002, 744731 - ENGINE, ASSY

REF FN PART NUMBER

YR/SN

QTY DESCRIPTION

1 84527379

1 ENGINE ASSY, 4 Cylinders, 98HP

Valid for Industrial Var. 390002 (744731); Incompatible with Var. 330641 (Air Conditioning); Incompatible with Var. 330120, 331120 (743846) (Power Shuttle Transm.)

FARMALL JX100

10.001.AD

01

p1

1/2014

VAR - 390002, 744731 - ENGINE, ASSY

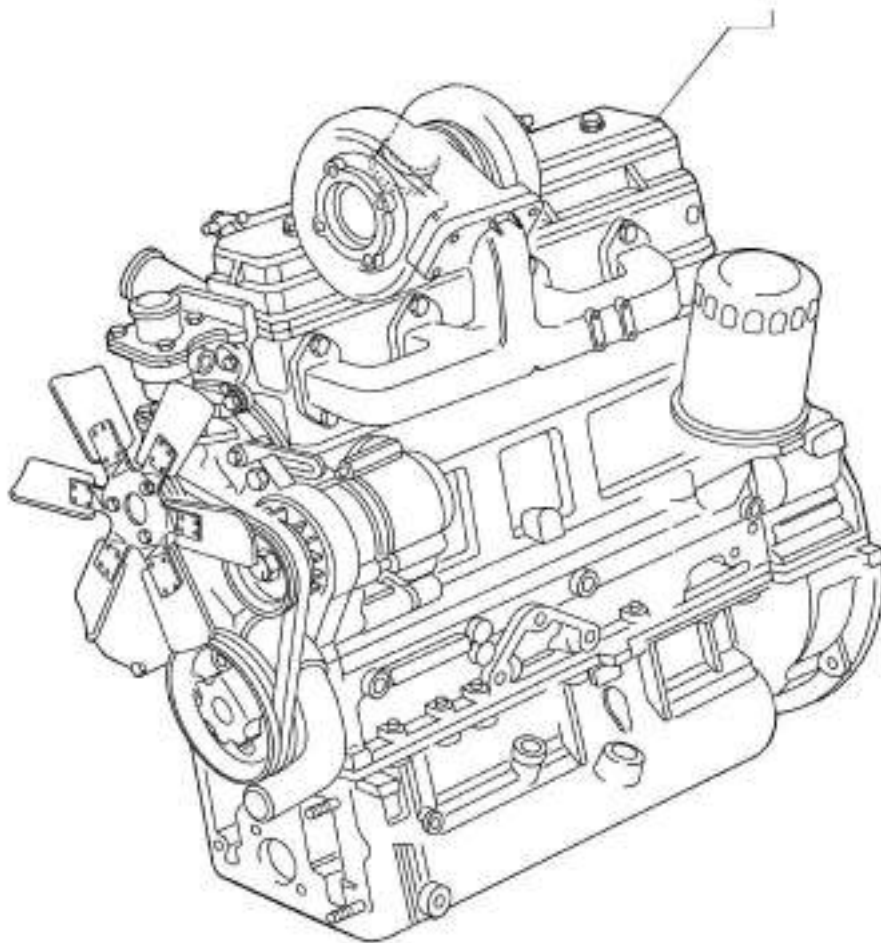

10.001.AD

01

p1

1/2014

VAR - 390002, 744731 - ENGINE, ASSY

REF FN PART NUMBER

YR/SN

QTY DESCRIPTION

1

84527375

1 ENGINE ASSY, 4 Cylinders, 75HP

Valid for Industrial Var. 390002 (744731); Incompatible with Var. 330641 (Air Conditioning); Incompatible with Var. 330120, 331120 (743846) (Power Shuttle Transm.)

FARMALL JX75

10.001.AD

01

p1

1/2014

VAR - 390002, 744731 - ENGINE, ASSY

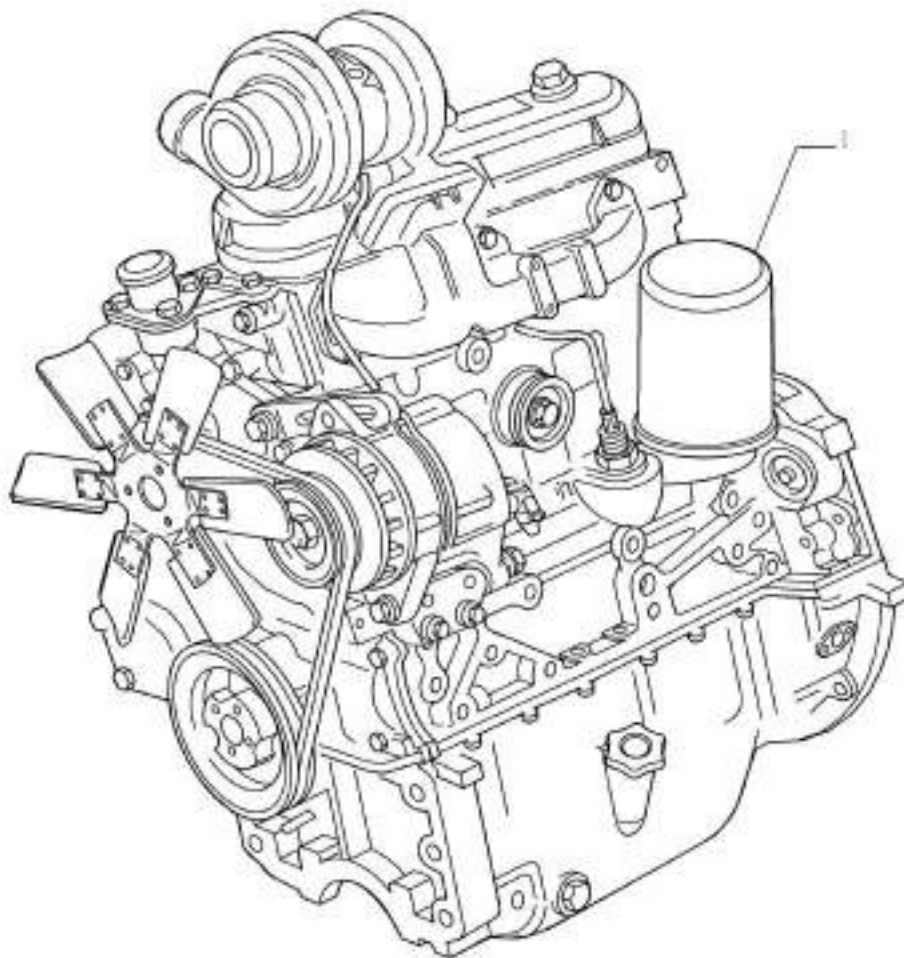

10.001.AD

01

p1

1/2014

VAR - 390002, 744731 - ENGINE, ASSY

REF FN PART NUMBER

YR/SN

QTY DESCRIPTION

1

84527383

1 ENGINE ASSY, 3 Cylinders, 80HP

Valid for Industrial Var. 390002 (744731); Incompatible with Var. 330641 (Air Conditioning); Incompatible with Var. 330120, 331120 (743846) (Power Shuttle Transm.)

FARMALL JX80

10.001.AD

01

p1

1/2014

VAR - 390002, 744731 - ENGINE, ASSY

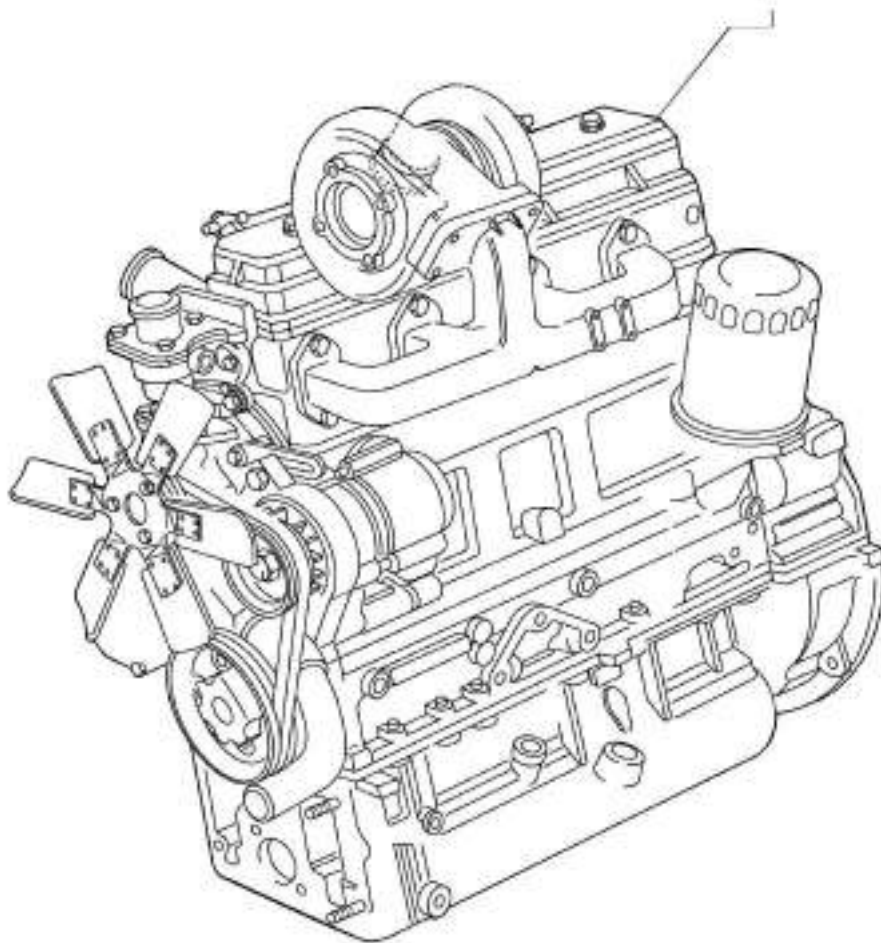

10.001.AD

01

p1

1/2014

VAR - 390002, 744731 - ENGINE, ASSY

REF FN PART NUMBER

YR/SN

QTY DESCRIPTION

1

84534642

1 ENGINE ASSY, 4 Cylinders, 108HP

Valid for Industrial Var. 390002 (744731); Incompatible with Var. 330641 (Air Conditioning); Incompatible with Var. 330120, 331120 (743846) (Power Shuttle Transm.)

FARMALL JX110

10.001.AD

01

p1

1/2014

VAR - 390002, 744731 - ENGINE, ASSY

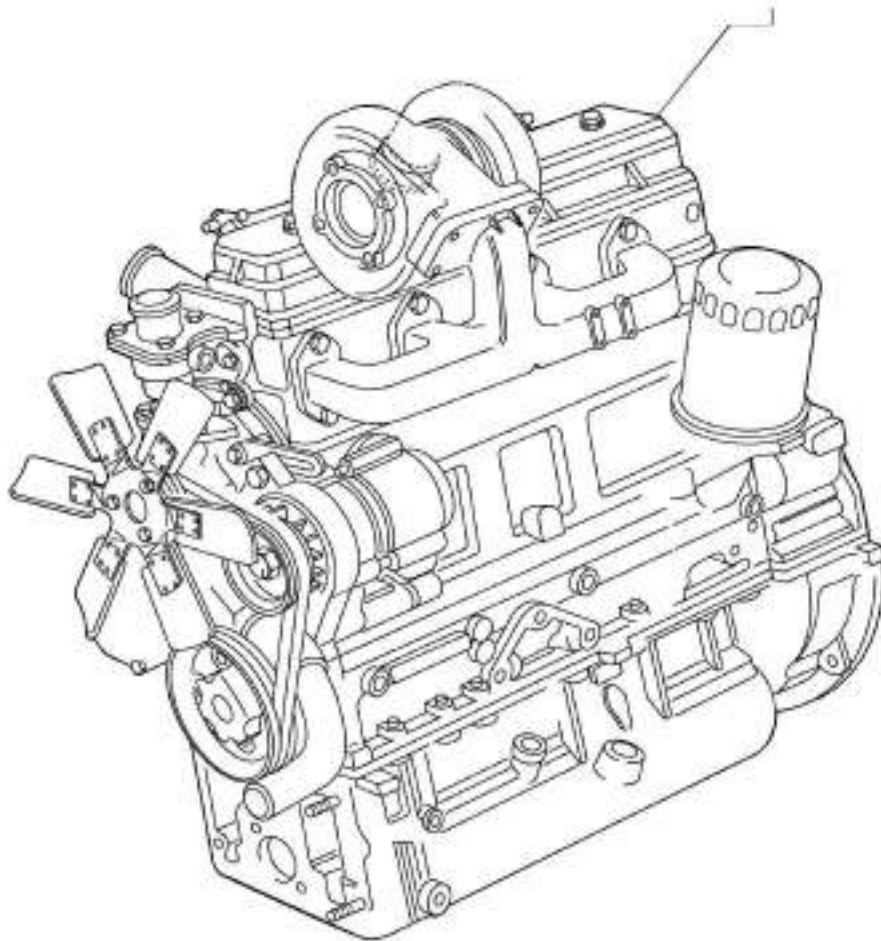

10.001.AD

01

p1

1/2014

VAR - 390002, 744731 - ENGINE, ASSY

REF FN PART NUMBER

YR/SN

QTY DESCRIPTION

1

84527377

1 ENGINE ASSY, 4 Cylinders, 88HP

Valid for Industrial Var. 390002 (744731); Incompatible with Var. 330641 (Air Conditioning); Incompatible with Var. 330120, 331120 (743846) (Power Shuttle Transm.)

FARMALL JX90

10.001.AD

03

p1

1/2014

VAR - 334300, 744731 - ENGINE, ASSY, W/ POWER SHUTTLE

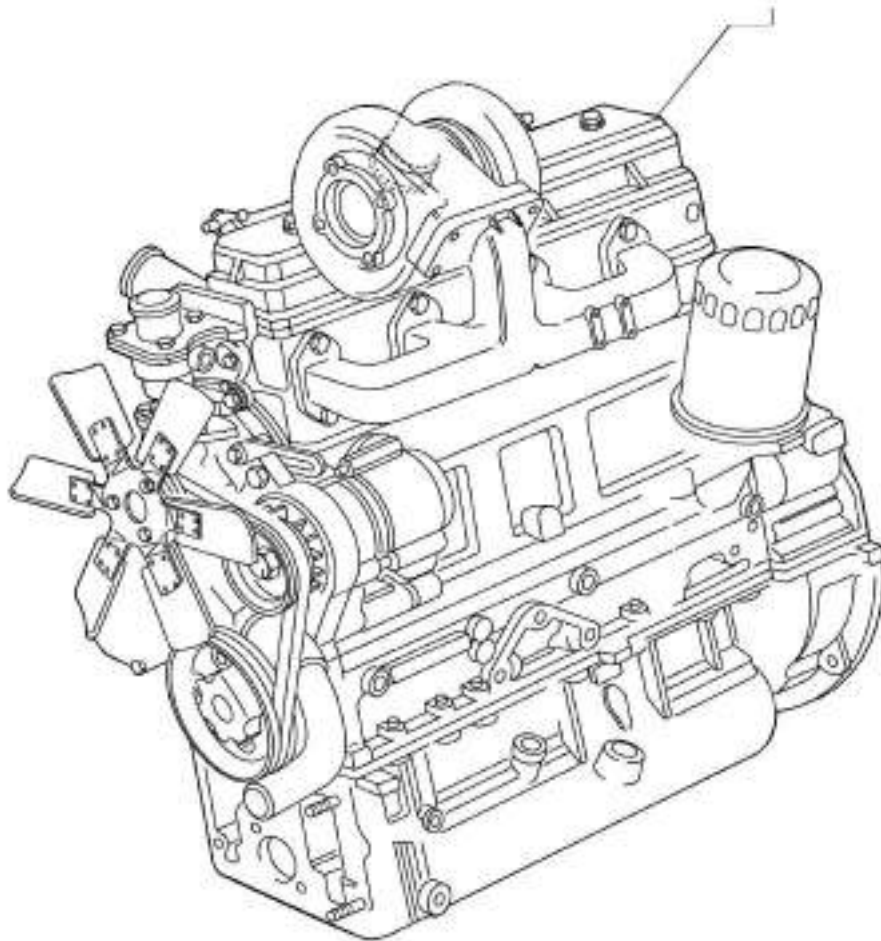

10.001.AD

03

p1

1/2014

VAR - 334300, 744731 - ENGINE, ASSY, W/ POWER SHUTTLE

REF	FN	PART NUMBER	YR/SN	QTY	DESCRIPTION
1	1	{84527385}		1	ASSY, 4 Cylinders, 98HP
(1)		W/ Power Shuttle Transmission			

Valid for Industrial Var. 334300 (744731); Requires Var. 330120, 331120 (743846) (Power Shuttle Transm.); Incompatible with Var. 330641 (Air Conditioning)

FARMALL JX100

10.001.AD

03

p1

1/2014

VAR - 334300, 744731 - ENGINE, ASSY, W/ POWER SHUTTLE

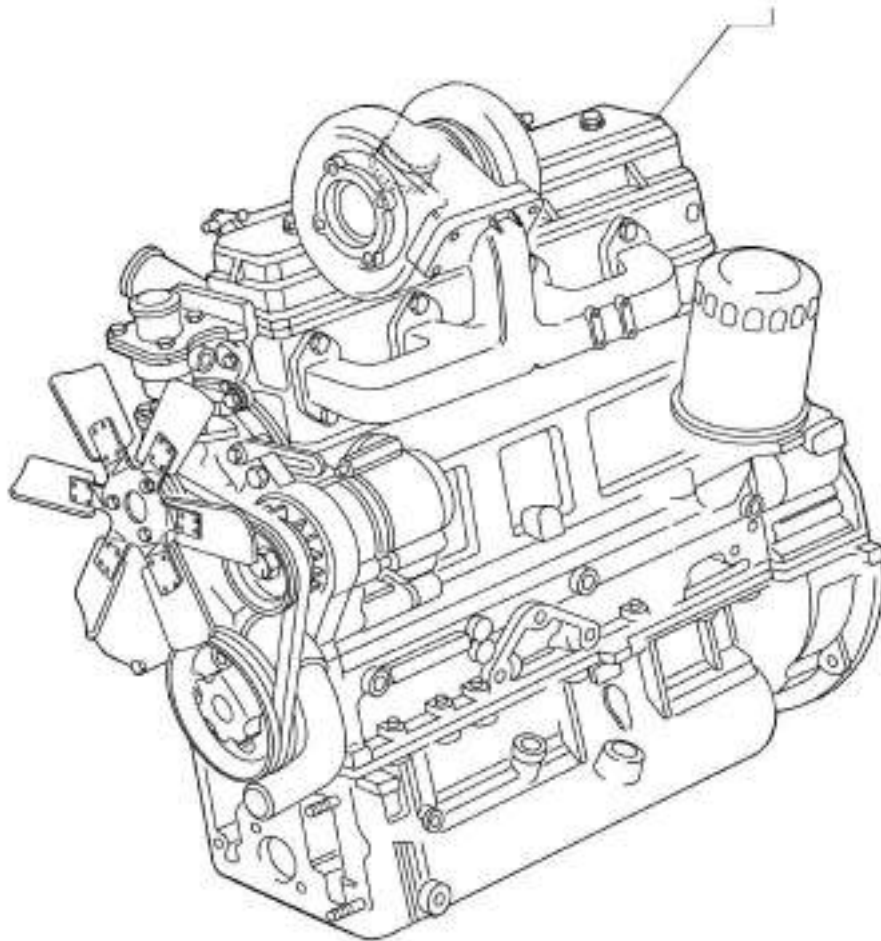

10.001.AD

03

p1

1/2014

VAR - 334300, 744731 - ENGINE, ASSY, W/ POWER SHUTTLE

REF	FN	PART NUMBER	YR/SN	QTY	DESCRIPTION
1	1	{84534644}		1	ASSY, 4 Cylinders, 108HP
(1)		W/ Power Shuttle Transmission			

Valid for Industrial Var. 334300 (744731); Requires Var. 330120, 331120 (743846) (Power Shuttle Transm.); Incompatible with Var. 330641 (Air Conditioning)

FARMALL JX110

10.202.AB

01

p1

1/2014

VAR - 330200, 390227 - DRY AIR CLEANER & RELATED PARTS

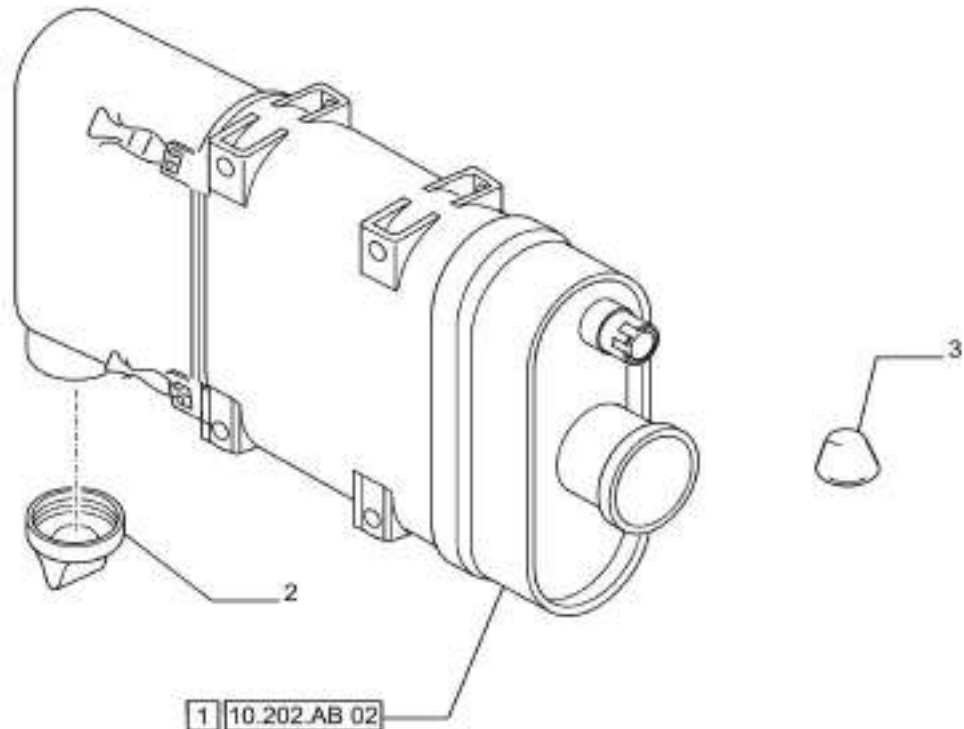

VAR - 330200, 390227 - DRY AIR CLEANER, BREAKDOWN

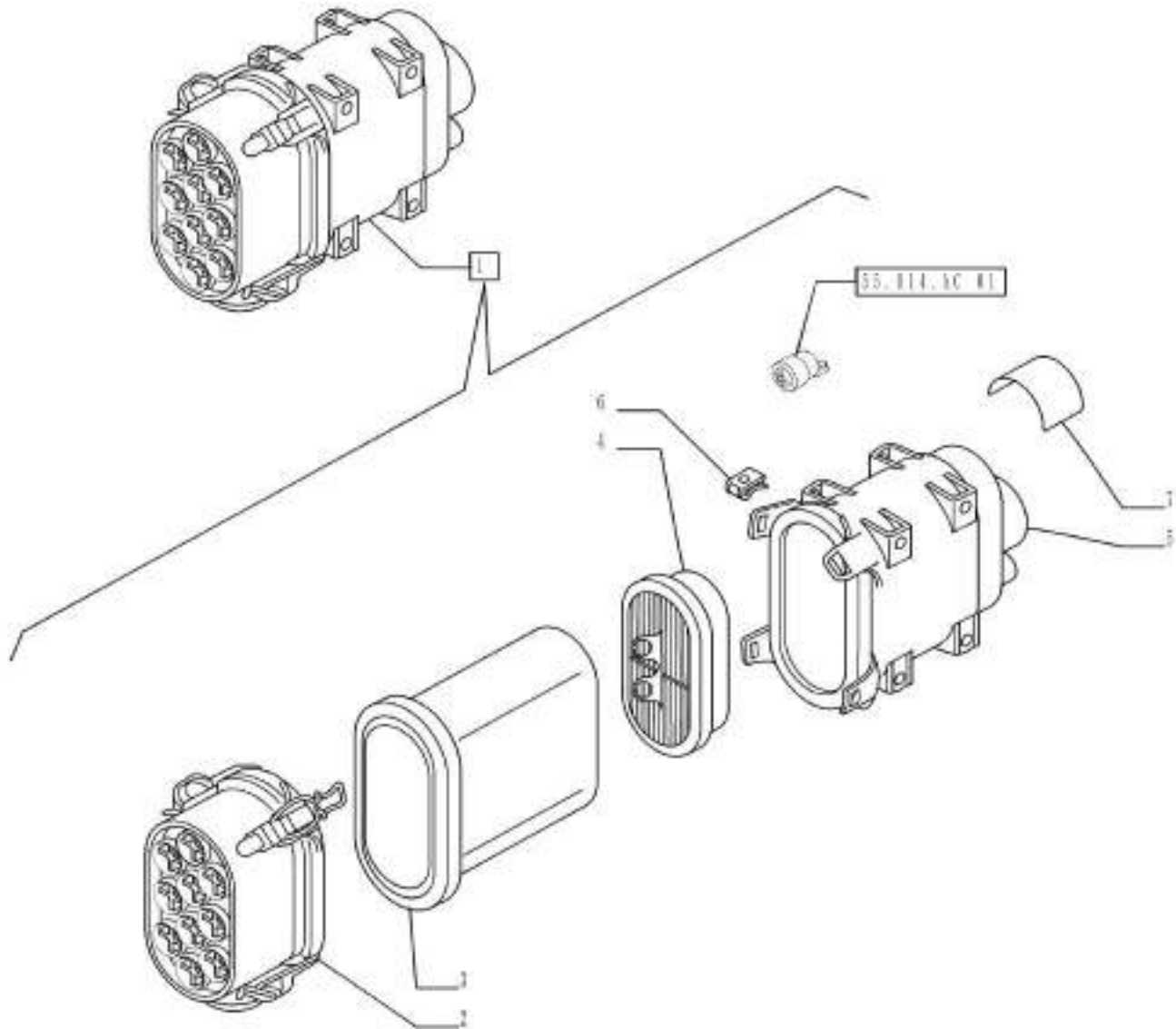

10.202.AB

02

p1

1/2014

VAR - 330200, 390227 - DRY AIR CLEANER, BREAKDOWN

REF FN	PART NUMBER	YR/SN	QTY DESCRIPTION
1	84497470		1 AIR CLEANER ASSY Incl 2 - 7
2	84513807		1 COVER
3	87356351		1 AIR FILTER
4	87356353		1 AIR FILTER
5	84513760		1 BODY
6	84513804		8 CLIP
7	84513751		2 DECAL

Valid for Var. 330200 or Var. 390227

FARMALL JX100 FARMALL
JX110 FARMALL JX70
FARMALL JX75 FARMALL
JX80 FARMALL JX90

VAR - 330200 - DRY AIR CLEANER WITH DUST EJECTOR

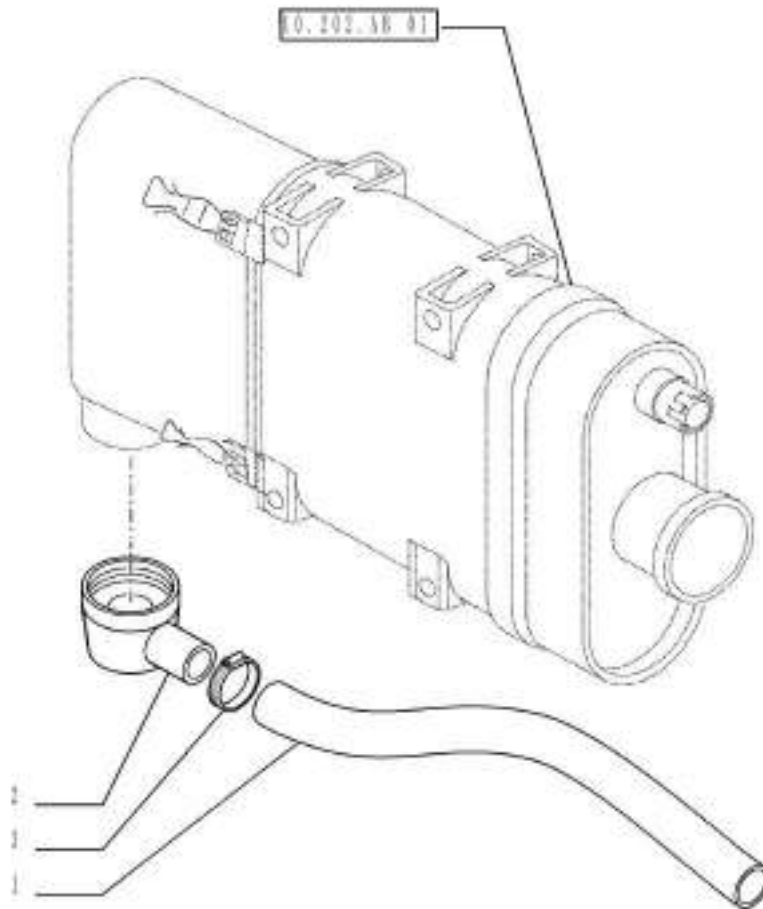

10.202.AB

03

p1

1/2014

VAR - 330200 - DRY AIR CLEANER WITH DUST EJECTOR

REF FN	PART NUMBER	YR/SN	QTY DESCRIPTION
1	5083428		1 HOSE
2	87546353		1 ADAPTER
3	5085778		1 CLAMP

Valid for Var. 330200

FARMALL JX100 FARMALL
JX110 FARMALL JX70
FARMALL JX75 FARMALL
JX80 FARMALL JX90

10.202.AD

01

p1

1/2014

VAR - 330200, 390227 - AIR FILTER, PIPES

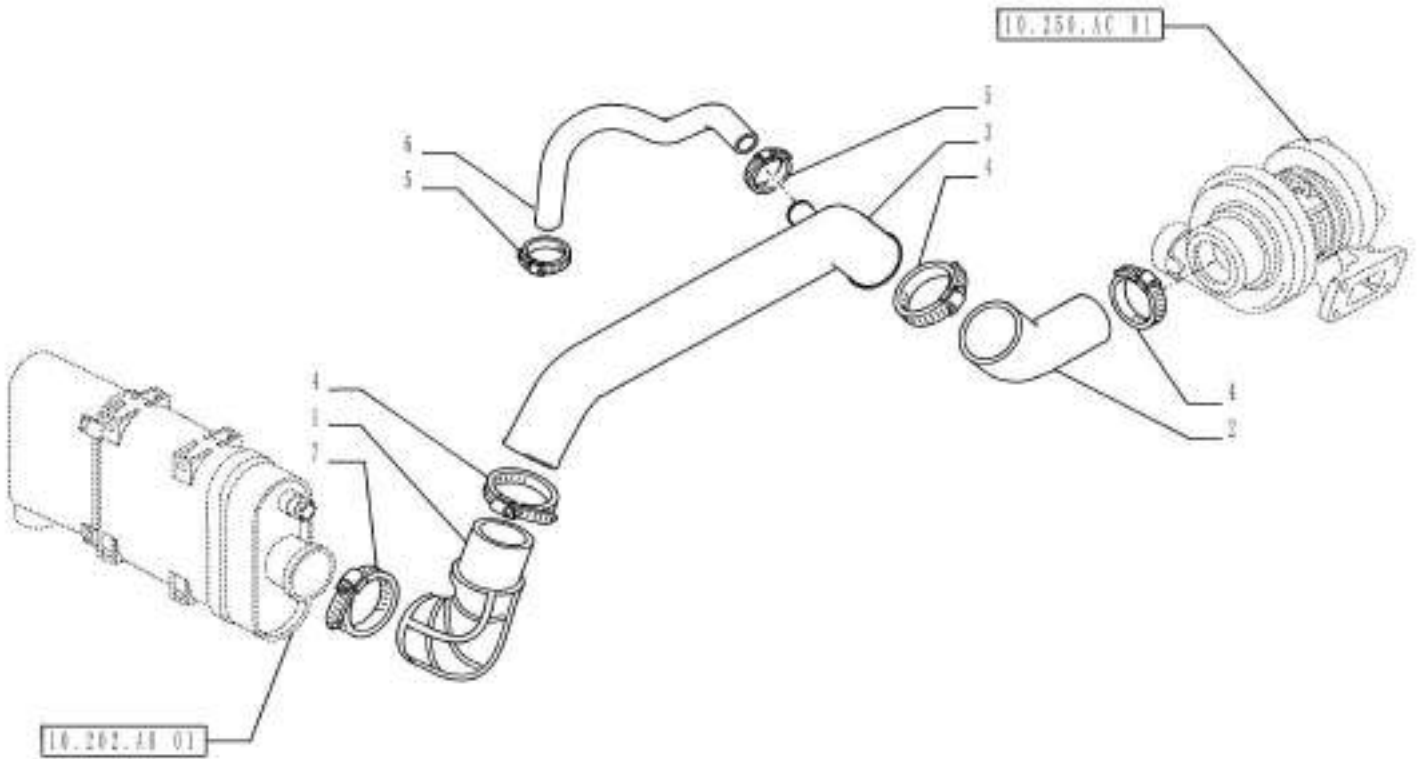

VAR - 330200, 390227 - AIR FILTER, PIPES

REF FN	PART NUMBER	YR/SN	QTY DESCRIPTION
1	{84357640}		1
2	84512632		1 PIPE
3	84511778		1 PIPE
4	84518709		3 COLLAR
5	5085776		2 HOSE CLAMP
6	5094791		1 HOSE 21.00 mm ID x 88.50 mm, SAE 100RG, SAE J517
7	84518710		1 COLLAR

Valid for Var. 330200 or Var. 390227

FARMALL JX70
FARMALL JX80

VAR - 390971 - AIR FILTER, PIPES

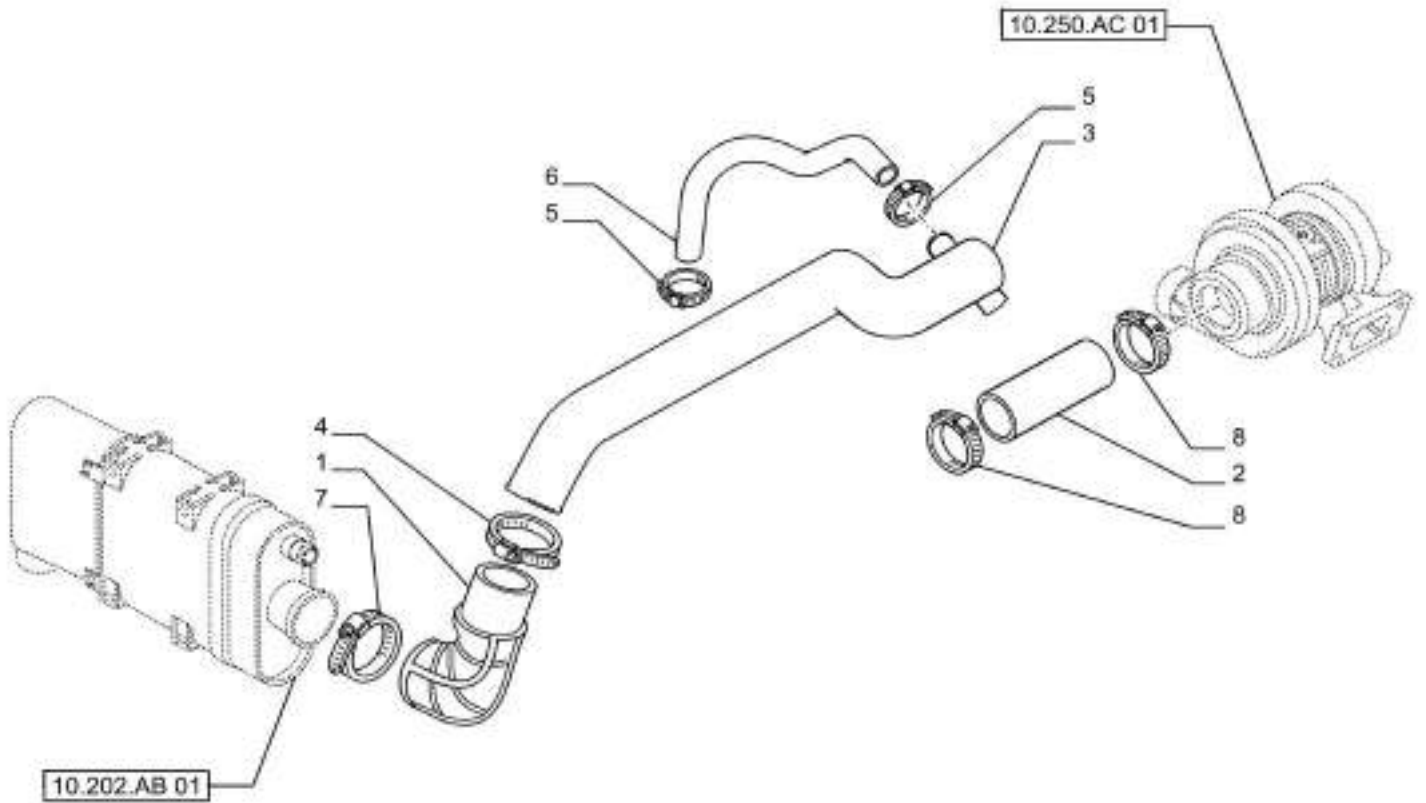

VAR - 390971 - AIR FILTER, PIPES

REF FN	PART NUMBER	YR/SN	QTY DESCRIPTION
1	84487281		1 ELBOW
2	5117303		1 HOSE 60.00 mm ID x 80.00 mm
3	84511778		1 PIPE
4	84518709		1 COLLAR
5	5085776		2 HOSE CLAMP
6	5094791		1 HOSE 21.00 mm ID x 88.50 mm, SAE 100RG, SAE J517
7	84518710		1 COLLAR
8	84518708		2 COLLAR

Valid for Var. 390971

FARMALL JX100
FARMALL JX110
FARMALL JX75
FARMALL JX90

10.202.AH

01

p1

1/2014

VAR - 330200, 390227, 390971, 743852 - AIR CLEANER, SUPPORT

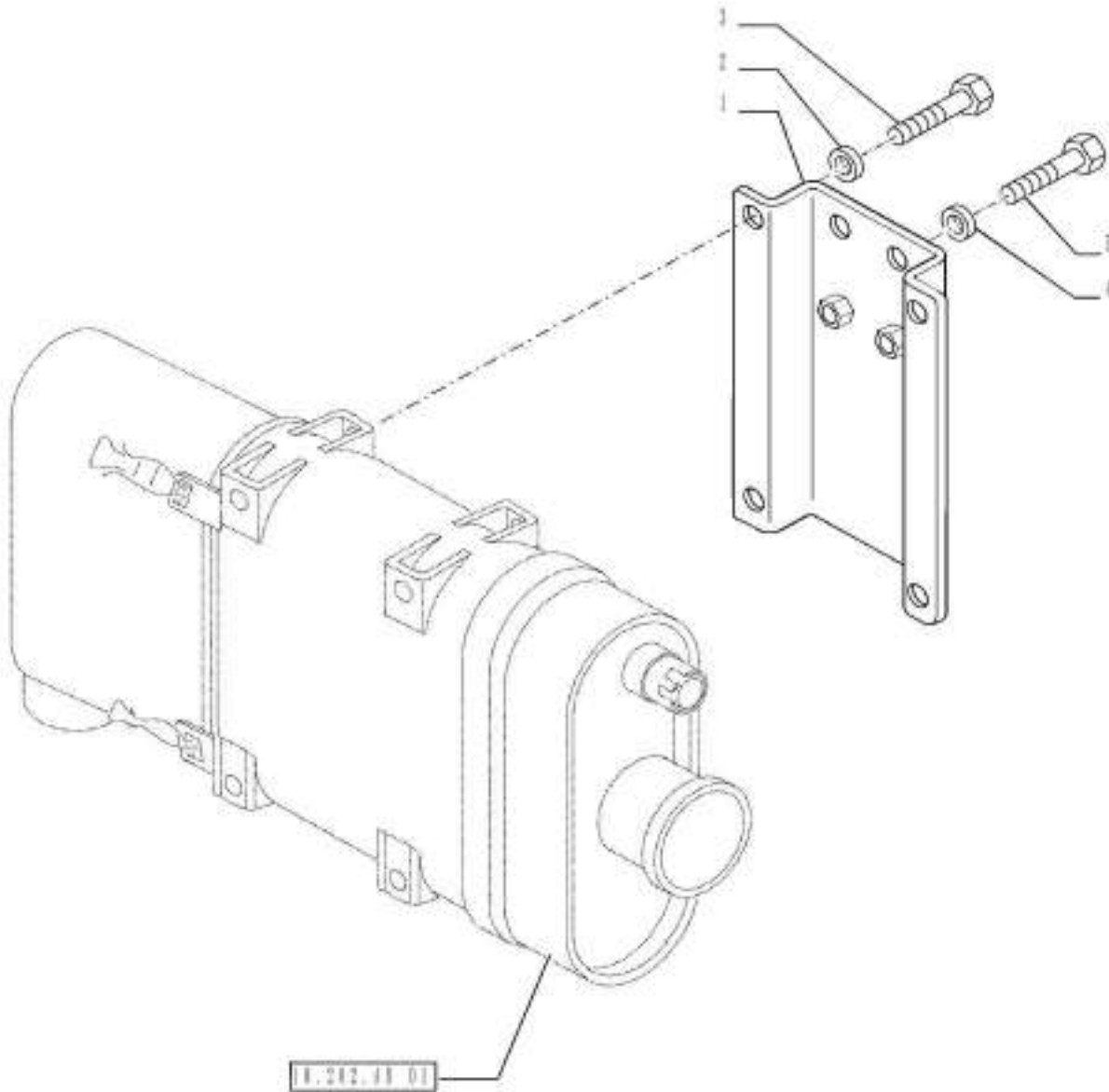

10.202.AH

01

p1

1/2014

VAR - 330200, 390227, 390971, 743852 - AIR CLEANER, SUPPORT

REF FN	PART NUMBER	YR/SN	QTY DESCRIPTION
1	84514808		1 SUPPORT
2	10519401		4 WASHER M6 x 11.95 x 1.6
3	86508568		4 BOLT Hex, M6 x 16mm, Cl 8.8, Full Thd
4	12601374		2 WAVE WASHER Wave, 8.40mm ID x 15.00mm OD x 0.80mm, 3.00mm, CST, DAC
5	120104		2 BOLT Hex, M8 x 1.25 x 20mm, Cl 8.8, Full Thd

Valid for Var. 330200 or Var. 390227 or Var. 390971 or Industrial Var.
332208, 335399 (743852)FARMALL JX100 FARMALL
JX110 FARMALL JX70
FARMALL JX75 FARMALL
JX80 FARMALL JX90

VAR - 334296 - WATER SEPARATOR

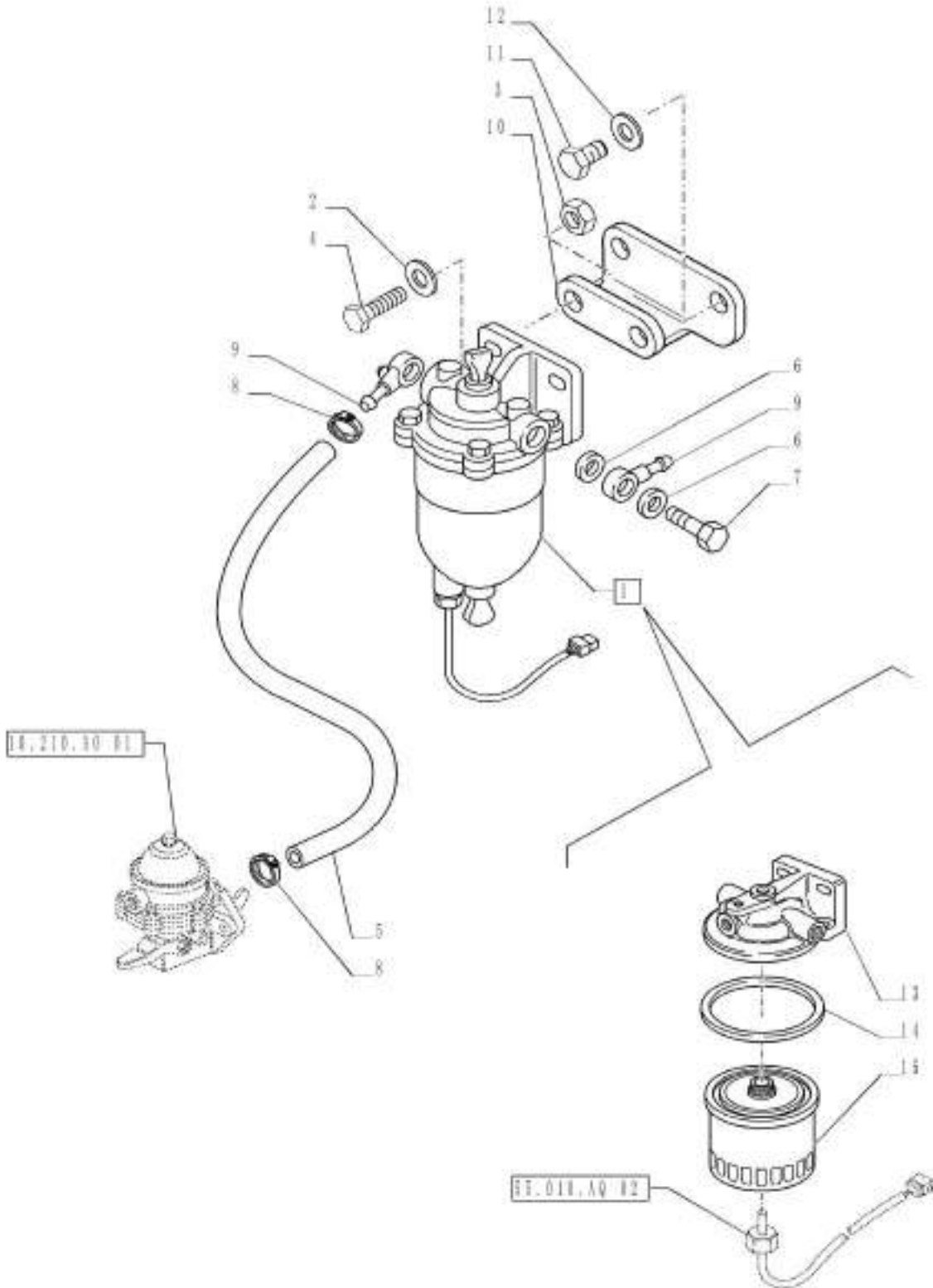

VAR - 334296 - WATER SEPARATOR

REF FN	PART NUMBER	YR/SN	QTY DESCRIPTION
1	84349380		1 FUEL FILTER Incl 13 - 15
2	12601474		2 WAVE WASHER Wave, 10.50mm ID x 21.00mm OD x 0.80mm, 3.00mm, CST, DAC
3	12164711		2 NUT M10 x 1.25, Cl 8
4	15970721		2 SCREW Hex, M10 x 1.25 x 25mm, Cl 8.8, Full Thd
5	1 5094401		1 HOSE
5	2 5090195		1 FUEL HOSE
6	5169544		4 SEAL 14.70mm ID x 22mm OD, 1.50mm Thk
7	10184311		2 BANJO BOLT M14-1.5 x 27
8	10186590		2 COLLAR M11-13, Worm
9	5150924		2 HYD CONNECTOR
10	1 84512382		1 SUPPORT
10	2 84592858		1 SUPPORT
11	11112121		2 SCREW Hex, M12 x 20, 8.8, Full Thd
12	13507401		2 WASHER M12 x 20 x 2
13	NSS		1 NOT SERVICED SEPARATELY Body Incl in 1
14	NSS		1 NOT SERVICED SEPARATELY Seal Incl in 1
15	84217953		1 FUEL FILTER Filter Incl in 1

(1) Valid for FARMALL JX75, 80, 90, 100, 110 Models Only

(2) Valid for FARMALL JX70 Model Only

Valid for Var. 334296

FARMALL JX100 FARMALL
 JX110 FARMALL JX70
 FARMALL JX75 FARMALL
 JX80 FARMALL JX90

VAR - 334296, 390246 - FUEL TANK

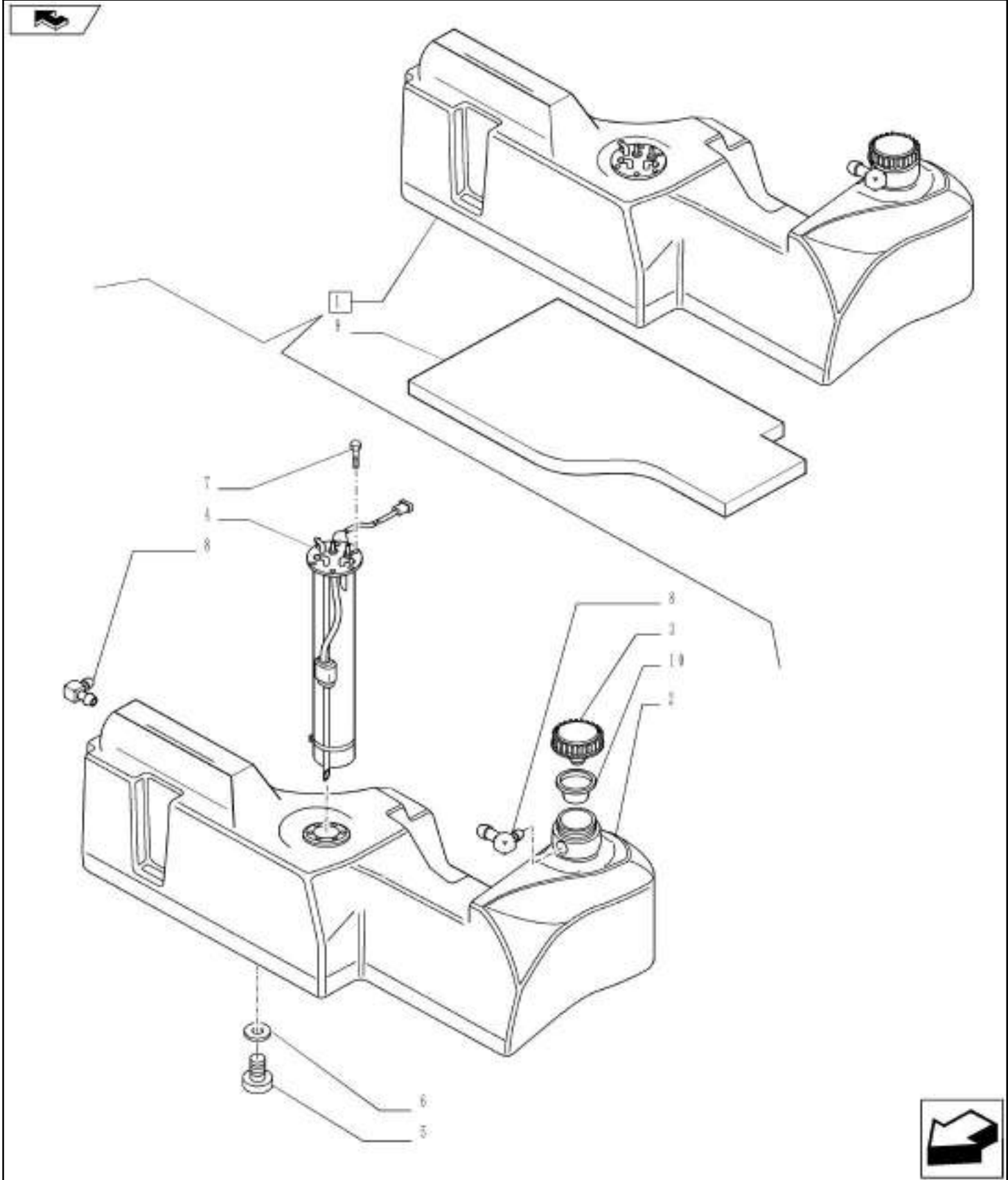

VAR - 334296, 390246 - FUEL TANK

REF FN	PART NUMBER	YR/SN	QTY DESCRIPTION
1	84511164		1 FUEL TANK Incl 2 - 8
2	84511171		1 FUEL TANK
3	47357568		1 LOCKABLE FUEL CAP
4	84511173		1 SENDER UNIT
5	5094121		1 PLUG
6	5093981		1 SEAL
7	13833824		6 BOLT M15 x 18mm
8	5091906		2 HYD CONNECTOR
9	84559265		1 INSULATION
10	47357536		1 NECK FILLER

Valid for Var. 334296 or Var. 390246	FARMALL JX100 FARMALL JX110 FARMALL JX70 FARMALL JX75 FARMALL JX80 FARMALL JX90
--------------------------------------	--

VAR - 334296, 390246 - FUEL TANK, SUPPORT

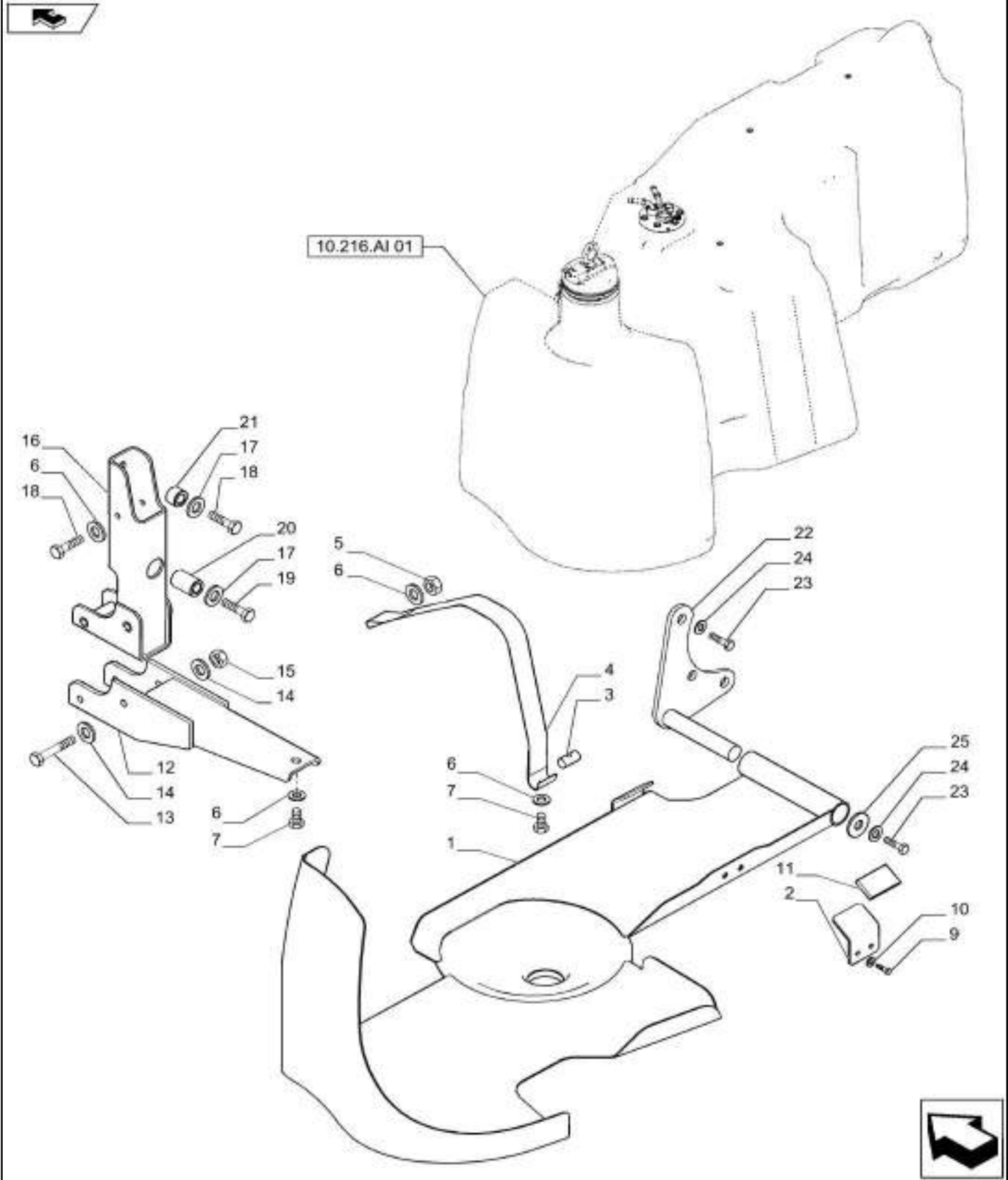

VAR - 334296, 390246 - FUEL TANK, SUPPORT

REF FN	PART NUMBER	YR/SN	QTY DESCRIPTION
1	84511216		1 SUPPORT
2	5089670		1 PLATE
3	5184438		1 PIN
4	84525635		1 BAND
5	12574511		1 LOCK NUT M10 x 1.25, CI 8
6	12601474		3 WAVE WASHER Wave, 10.50mm ID x 21.00mm OD x 0.80mm, 3.00mm, CST, DAC
7	15888721		1 BOLT Hex, M10 x 1.25 x 55, 8.8
8	15971321		1 SCREW Hex, M10 x 1.25 x 75mm, CI 8.8
9	86625000		2 BOLT Hex, M8 x 18mm, CI 8.8, Full Thd
10	12646204		2 WASHER M8 x 35 x 3
11	5092858		2 RUBBER PAD
12	84581995		1 SUPPORT
13	15541721		2 SCREW Hex, M12 x 1.25 x 110mm, CI 8.8
14	11198674		4 BELLEVILLE WASHER Belleville, M13
15	379752		2 NUT M12 x 1.25, CI 10
16	84525475		1 SUPPORT
17	11194279		2 BELLEVILLE WASHER Belleville, M17
18	15981421		1 SCREW
19	15835221		1 BOLT Hex, M16 x 1.5 x 70, 8.8
20	84525688		1 BUSHING
21	84525631		1 SPACER
22	5089671		1 PIN
23	16043821		3 SCREW Hex, M8 x 1.25 x 30mm, CI 8.8, Full Thd
24	12601374		3 WAVE WASHER Wave, 8.40mm ID x 15.00mm OD x 0.80mm, 3.00mm, CST, DAC
25	5090428		1 WASHER

Valid for Var. 334296 or Var. 390246

FARMALL JX100 FARMALL
JX110 FARMALL JX70
FARMALL JX75 FARMALL
JX80 FARMALL JX90

10.220.AA

01

p1

1/2014

VAR - 334299, 334300, 334301, 390002, 744731 - THROTTLE CONTROL LINKAGE

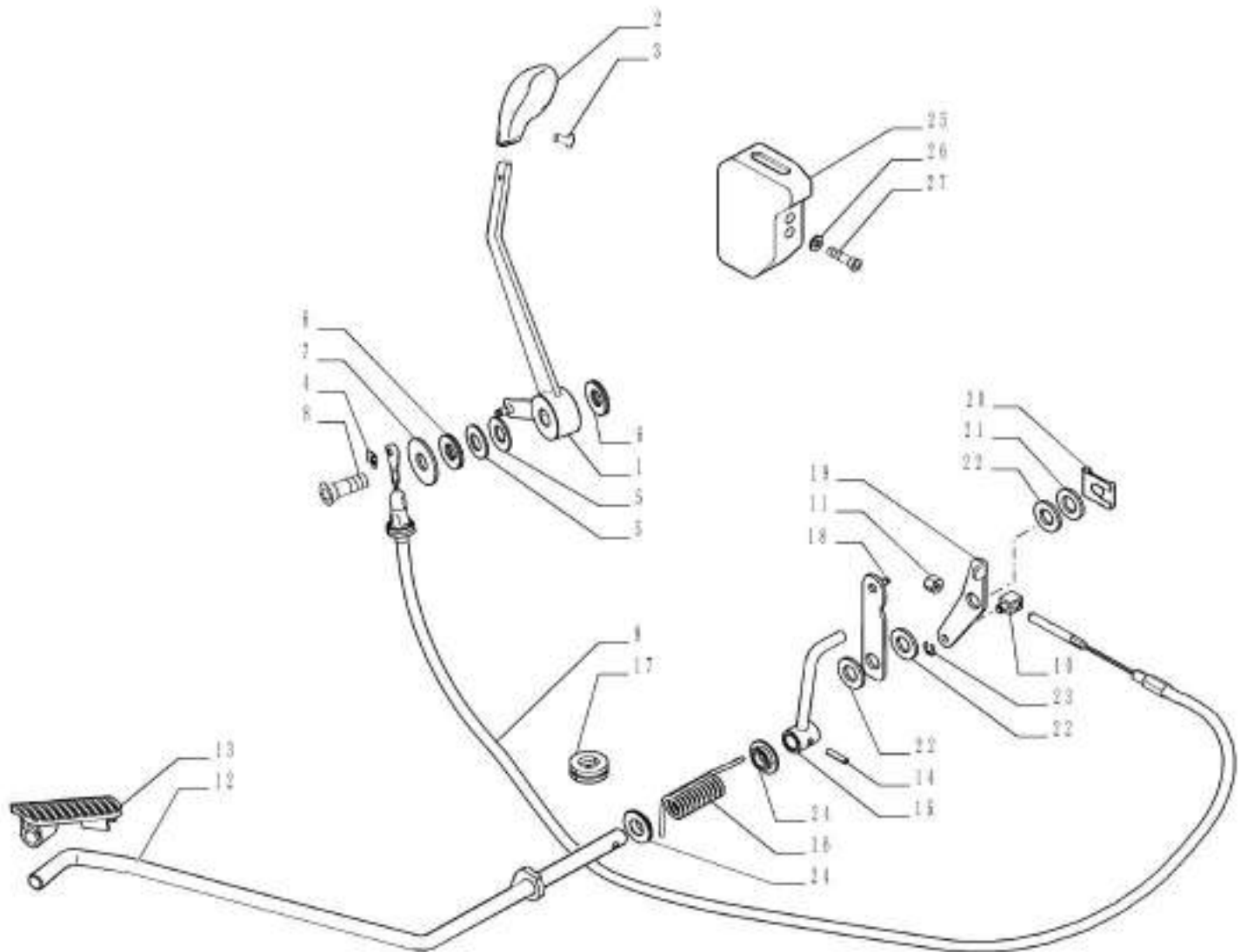

VAR - 334299, 334300, 334301, 390002, 744731 - THROTTLE CONTROL LINKAGE

REF FN	PART NUMBER	YR/SN	QTY DESCRIPTION
1	84399884		1 LEVER
2	82034589		1 KNOB
3	13308714		1 SCREW Cross Oval Hd, M4 x 8
4	11063876		1 CLIP
5	5083084		4 SPRING
6	5152998		2 WASHER
7	5096559		1 WASHER
8	13301411		1 BOLT
9	84487146		1 CABLE
10	84399889		1 PIN
11	12574211		1 NUT M6 x 1, CI 8
12	84388779		1 ARM
13	84250071		1 PEDAL
14	13904570		1 ROLL PIN M4 x 18, Coiled
15	84424563		1 SUPPORT
16	5097692		1 SPRING
17	10397480		1 GROMMET
18	84424571		1 ARM
19	84424572		1 ARM
20	11064276		1 CLIP
21	14496701		1 WASHER 13.00mm ID x 24.00mm OD x 2.50mm, CST, ZND
22	84424573		3 WASHER
23	11087776		1 CIRCLIP Ext., M6, BLO
24	87679075		2 BUSHING
25	1 84548149		1 COVER
26	1 84524958		3 WASHER
27	1 13301511		3 SCREW Phil Flat Hd, M6 x 20, 5.8

(1) VAR - 334299, 390002 (744731); Only ROPS Models

Valid for Industrial Var. 334299, 334300, 334301, 390002 (744731)

FARMALL JX100 FARMALL
JX110 FARMALL JX70
FARMALL JX75 FARMALL
JX80 FARMALL JX90

10.220.AA

02

p1

1/2014

VAR - 334299, 334300, 334301, 390002, 744731 - THROTTLE CONTROL LINKAGE

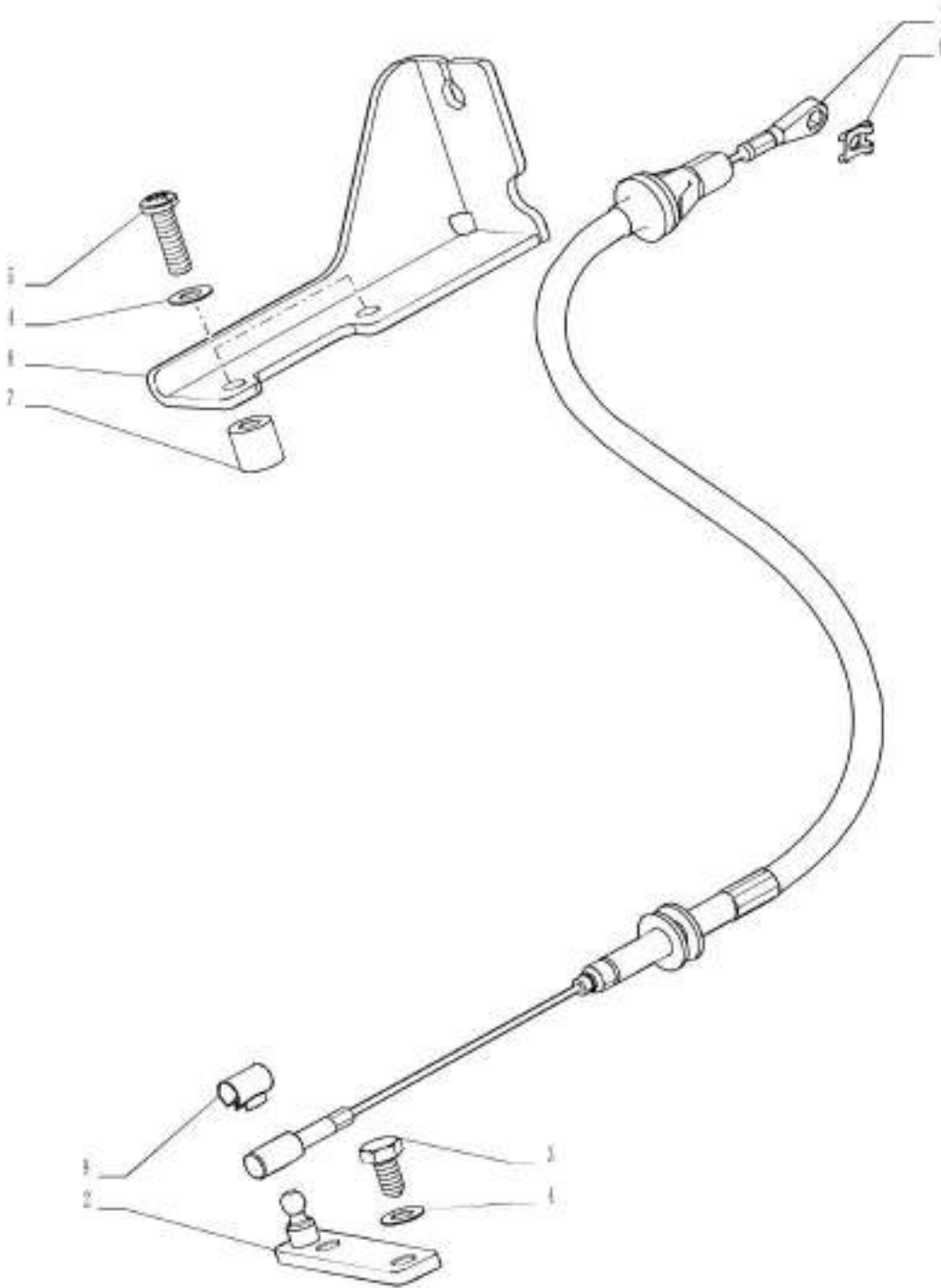

VAR - 334299, 334300, 334301, 390002, 744731 - THROTTLE CONTROL LINKAGE

REF	FN	PART NUMBER	YR/SN	QTY	DESCRIPTION
1	1	84487344		1	CABLE
1	2	84487346		1	CABLE
1	3	84487147		1	CABLE
2		84424577		1	SUPPORT
3		84513712		2	SCREW
4		12601274		4	WAVE WASHER Wave, M6.4
5		86977726		2	BOLT Hex, M6 x 12mm, Cl 8.8, Full Thd
6		84424580		1	SUPPORT
7		5092579		1	SPACER
8		11063876		1	CLIP
9		47134319		1	CLIP
(1)	VAR - 334299, 390002 (744731); Valid for FARMALL JX70 Model Only				
(2)	Valid for FARMALL JX75, 90, 100, 110 Models Only				
(3)	VAR - 334299, 390002 (744731); Valid for FARMALL JX80 Model Only				
Valid for Industrial Var. 334299, 334300, 334301, 390002 (744731)					FARMALL JX100 FARMALL JX110 FARMALL JX70 FARMALL JX75 FARMALL JX80 FARMALL JX90

10.254.AI

01

p1

1/2014

VAR - 333153, 391151, 744733 - MUFFLER, VERTICAL EXHAUST

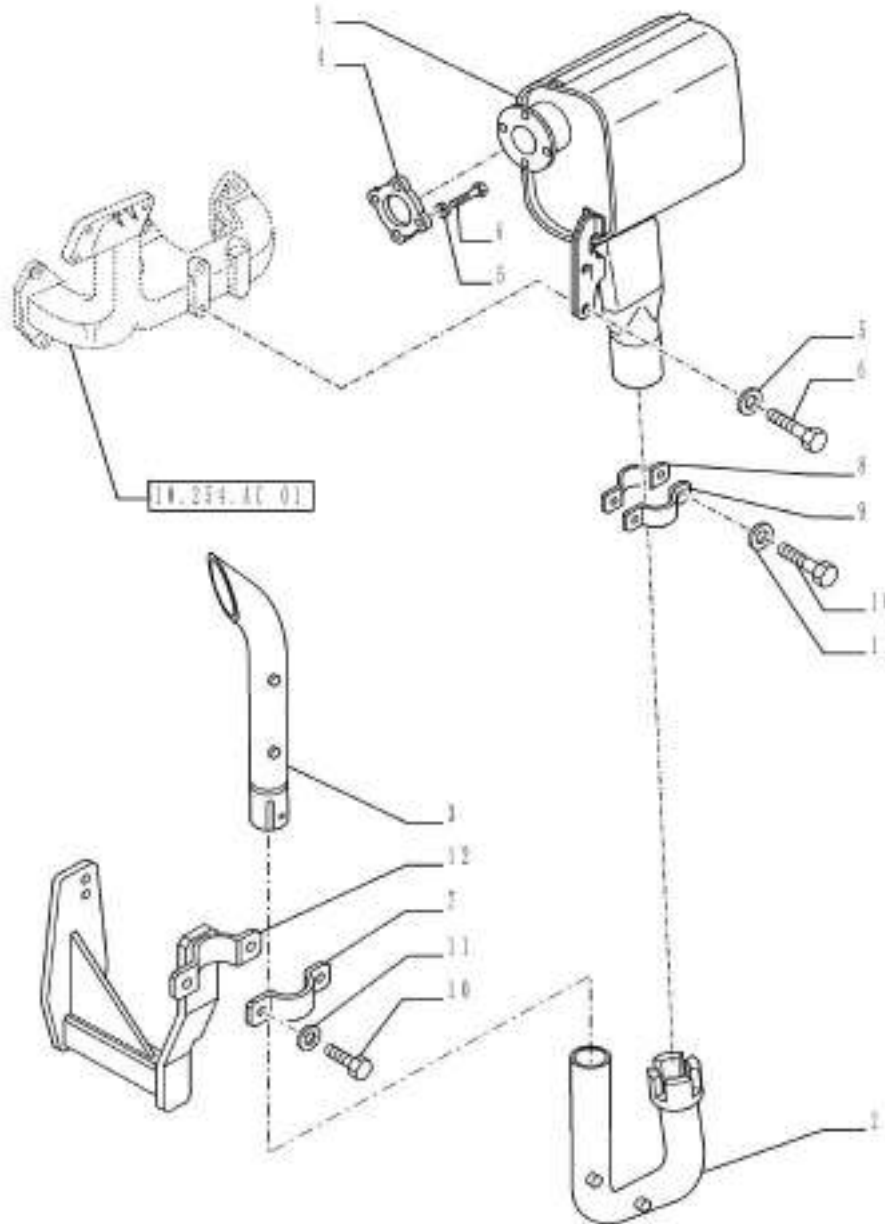

VAR - 333153, 391151, 744733 - MUFFLER, VERTICAL EXHAUST

REF	FN	PART NUMBER	YR/SN	QTY	DESCRIPTION
1	1	84358641		1	MUFFLER
2		47402637		1	ELBOW
3	2	5091091		1	EXHAUST SYSTEM PIPE
4	1	84360502		1	GASKET
5		11193874		6	BELLEVILLE WASHER 8.4mm ID x 16.00mm OD x 1.4mm, 1.85mm, CI 8.8
6		86625001		6	BOLT Hex, M8 x 22mm, CI 8.8, Full Thd D=60
7		84409237		1	COLLAR
8		84224426		1	COLLAR
9		84224416		1	COLLAR
10		86625000		4	BOLT Hex, M8 x 18mm, CI 8.8, Full Thd
11		12601374		5	WAVE WASHER Wave, 8.40mm ID x 15.00mm OD x 0.80mm, 3.00mm, CST, DAC
12		84512753		1	SUPPORT

(1) VAR - 330153, 391151 (744733), 330150 (744734)

(2) VAR - 391151 (744733)

Valid for Var. 330153 or Industrial Var. 391151 (744733)

FARMALL JX70
FARMALL JX80

VAR - 330153, 391151, 744733 - MUFFLER, VERTICAL EXHAUST

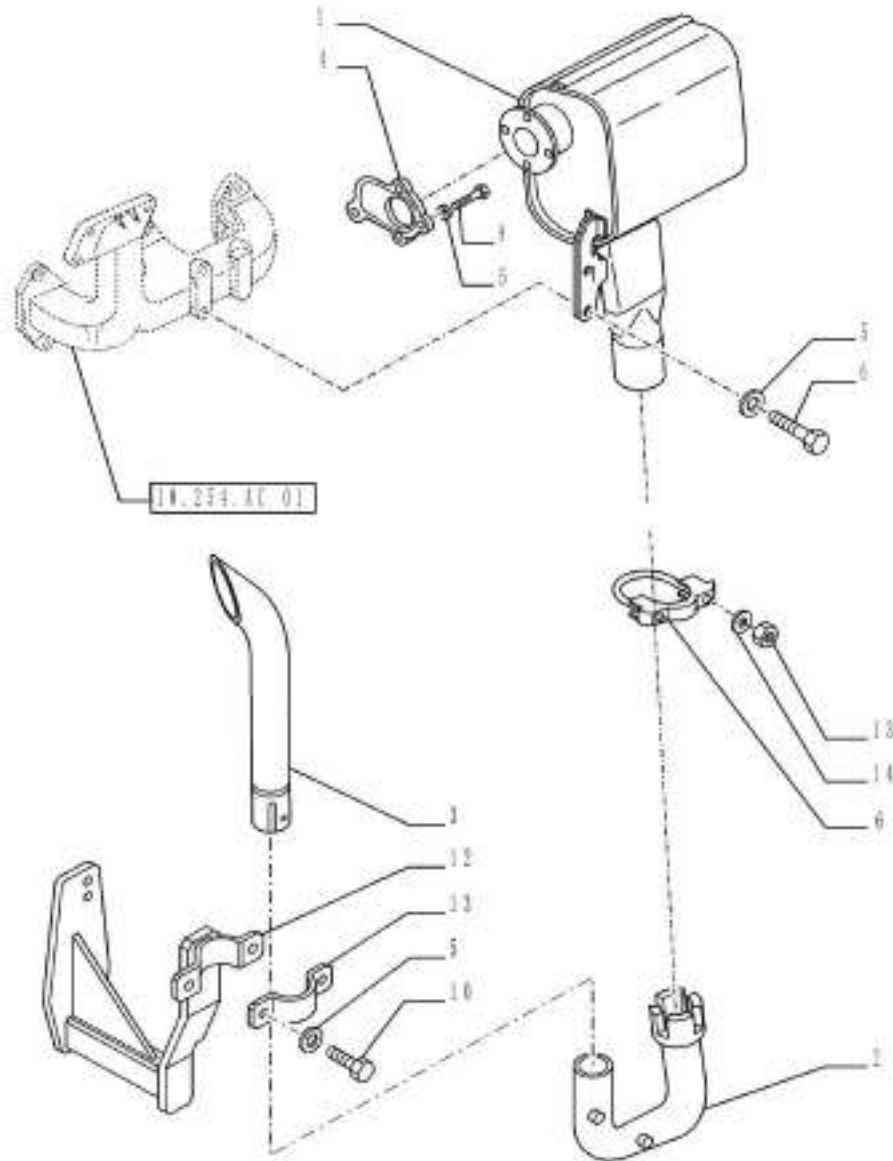

VAR - 330153, 391151, 744733 - MUFFLER, VERTICAL EXHAUST

REF	FN	PART NUMBER	YR/SN	QTY	DESCRIPTION
1	1	84511895		1	MUFFLER
2		47402625		1	ELBOW
3	2	84368631		1	EXHAUST SYSTEM PIPE
4	1	84360486		1	GASKET
5		11193874		6	BELLEVILLE WASHER 8.4mm ID x 16.00mm OD x 1.4mm, 1.85mm, CI 8.8
6		84368639		1	COLLAR
7		84368633		1	COLLAR
8		16043821		2	SCREW Hex, M8 x 1.25 x 30mm, CI 8.8, Full Thd
9		86625000		4	BOLT Hex, M8 x 18mm, CI 8.8, Full Thd
10		120104		2	BOLT Hex, M8 x 1.25 x 20mm, CI 8.8, Full Thd
11		12601374		2	WAVE WASHER Wave, 8.40mm ID x 15.00mm OD x 0.80mm, 3.00mm, CST, DAC
12		84512381		1	SUPPORT
13		12164711		2	NUT M10 x 1.25, CI 8
14		12601474		2	WAVE WASHER Wave, 10.50mm ID x 21.00mm OD x 0.80mm, 3.00mm, CST, DAC

(1) VAR - 330153, 391151 (744733), 330150 (744734)

(2) VAR - 391151 (744733)

Valid for Var. 330153 or Industrial Var. 391151 (744733)

FARMALL JX100
 FARMALL JX110
 FARMALL JX75
 FARMALL JX90

VAR - 391151, 744733 - VERTICAL EXHAUST, SHIELD

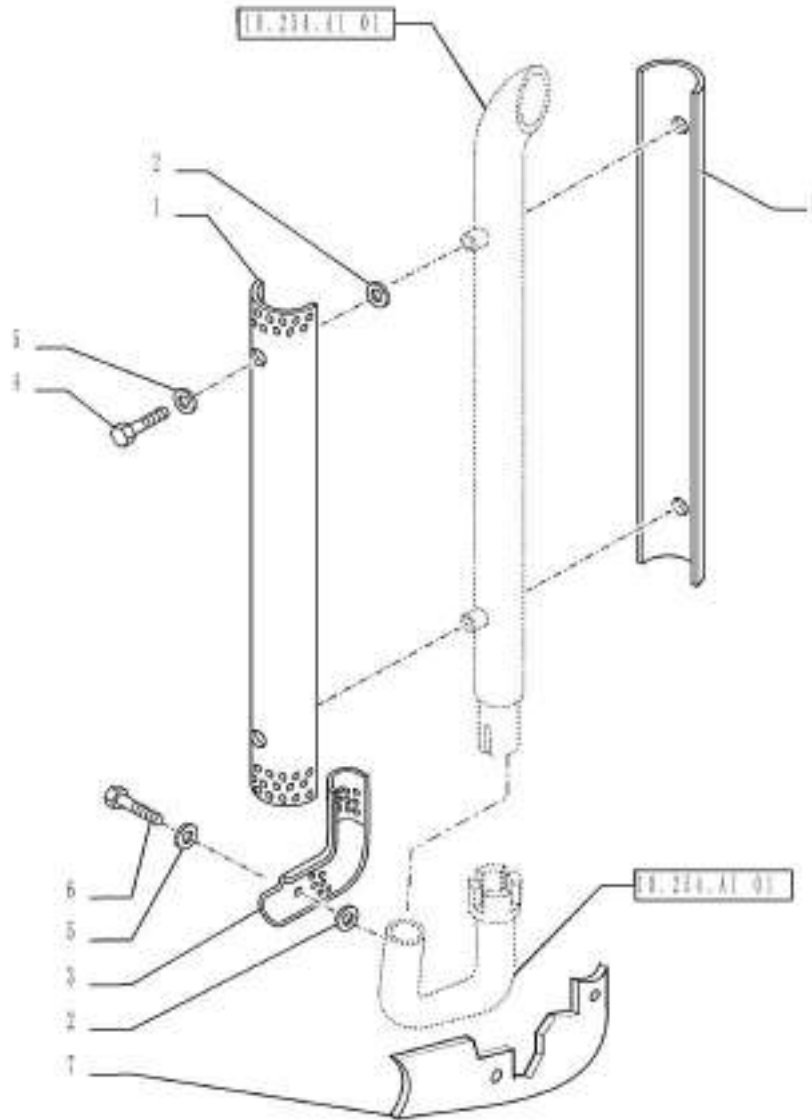

10.254.AI

03

p1

1/2014

VAR - 391151, 744733 - VERTICAL EXHAUST, SHIELD

REF FN	PART NUMBER	YR/SN	QTY DESCRIPTION
1	5091586		2 GUARD 1100 mm
2	12640601		8 WASHER M6 x 25 x 2
3	47402631		1 GUARD
4	10902321		4 SCREW Hex, M6 x 18, 8.8, Full Thd
5	10571579		8 LOCK WASHER M6
6	43117		4 SCREW Hex, M6 x 1 x 30mm, Cl 8.8
7	47402630		1 GUARD

Valid for Industrial Var. 391151 (744733)

**FARMALL JX70
FARMALL JX80**

VAR - 391151, 744733 - VERTICAL EXHAUST, SHIELD

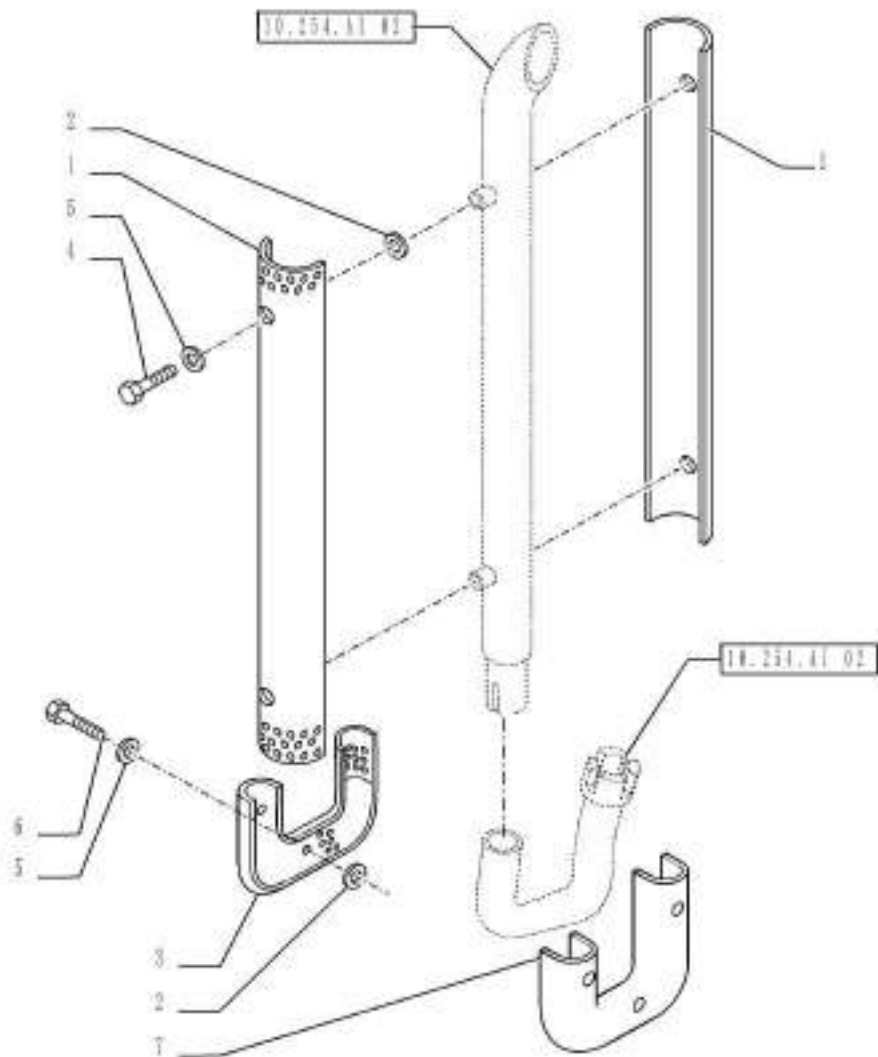

10.254.AI

04

p1

1/2014

VAR - 391151, 744733 - VERTICAL EXHAUST, SHIELD

REF FN	PART NUMBER	YR/SN	QTY DESCRIPTION
1	84368629		2 GUARD
2	14499301		10 WASHER M6 x 12.00mm OD x 1.60mm Overwrite
3	47402627		1 GUARD
4	10902321		4 SCREW Hex, M6 x 18, 8.8, Full Thd
5	12601274		10 WAVE WASHER Wave, M6.4
6	43117		6 SCREW Hex, M6 x 1 x 30mm, Cl 8.8
7	47402629		1 GUARD

Valid for Industrial Var. 391151 (744733)

**FARMALL JX100
FARMALL JX110
FARMALL JX75
FARMALL JX90**

VAR - 330150, 744734 - HORIZONTAL EXHAUST SHIELD

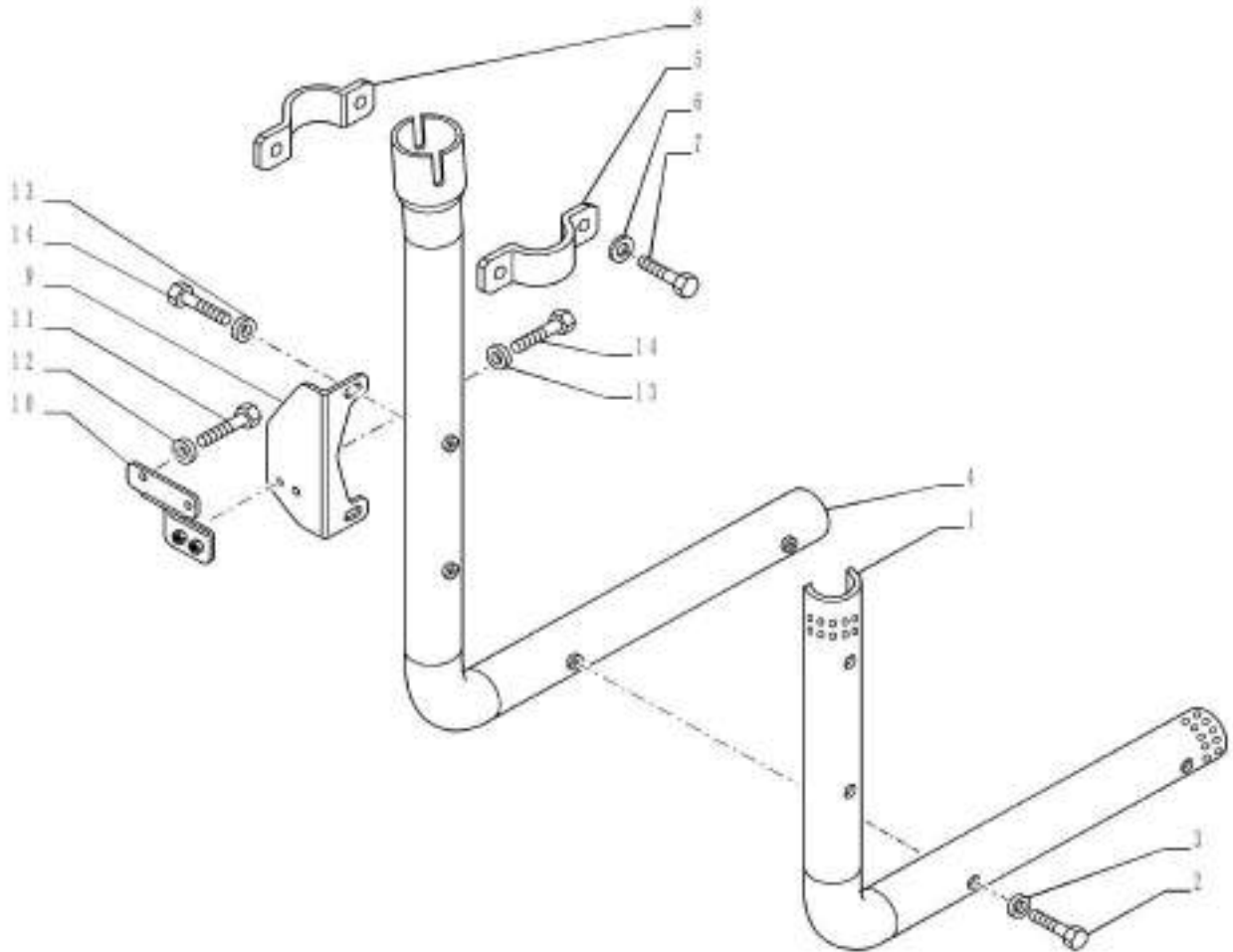

10.254.AI

05

p1

1/2014

VAR - 330150, 744734 - HORIZONTAL EXHAUST SHIELD

REF FN	PART NUMBER	YR/SN	QTY DESCRIPTION
1	84517389		1 GUARD
2	86977726		4 BOLT Hex, M6 x 12mm, Cl 8.8, Full Thd
3	12601274		4 WAVE WASHER Wave, M6.4
4	84514307		1 EXHAUST SYSTEM PIPE
5	84224416		1 COLLAR
6	12601374		2 WAVE WASHER Wave, 8.40mm ID x 15.00mm OD x 0.80mm, 3.00mm, CST, DAC
7	86625001		2 BOLT Hex, M8 x 22mm, Cl 8.8, Full Thd
8	84224426		1 COLLAR
9	84520494		1 SUPPORT
10	84520493		1 SUPPORT
11	11112121		2 SCREW Hex, M12 x 20, 8.8, Full Thd
12	14496721		2 WASHER Flat, 13.00mm ID x 24.00mm OD x 2.50mm, R80, ZND
13	10519601		4 WASHER M8 x 17 x 2
14	86625000		4 BOLT Hex, M8 x 18mm, Cl 8.8, Full Thd

Valid for Industrial Var. 330150 (744734)

**FARMALL JX70
FARMALL JX80**

VAR - 330150, 744734 - HORIZONTAL EXHAUST SHIELD

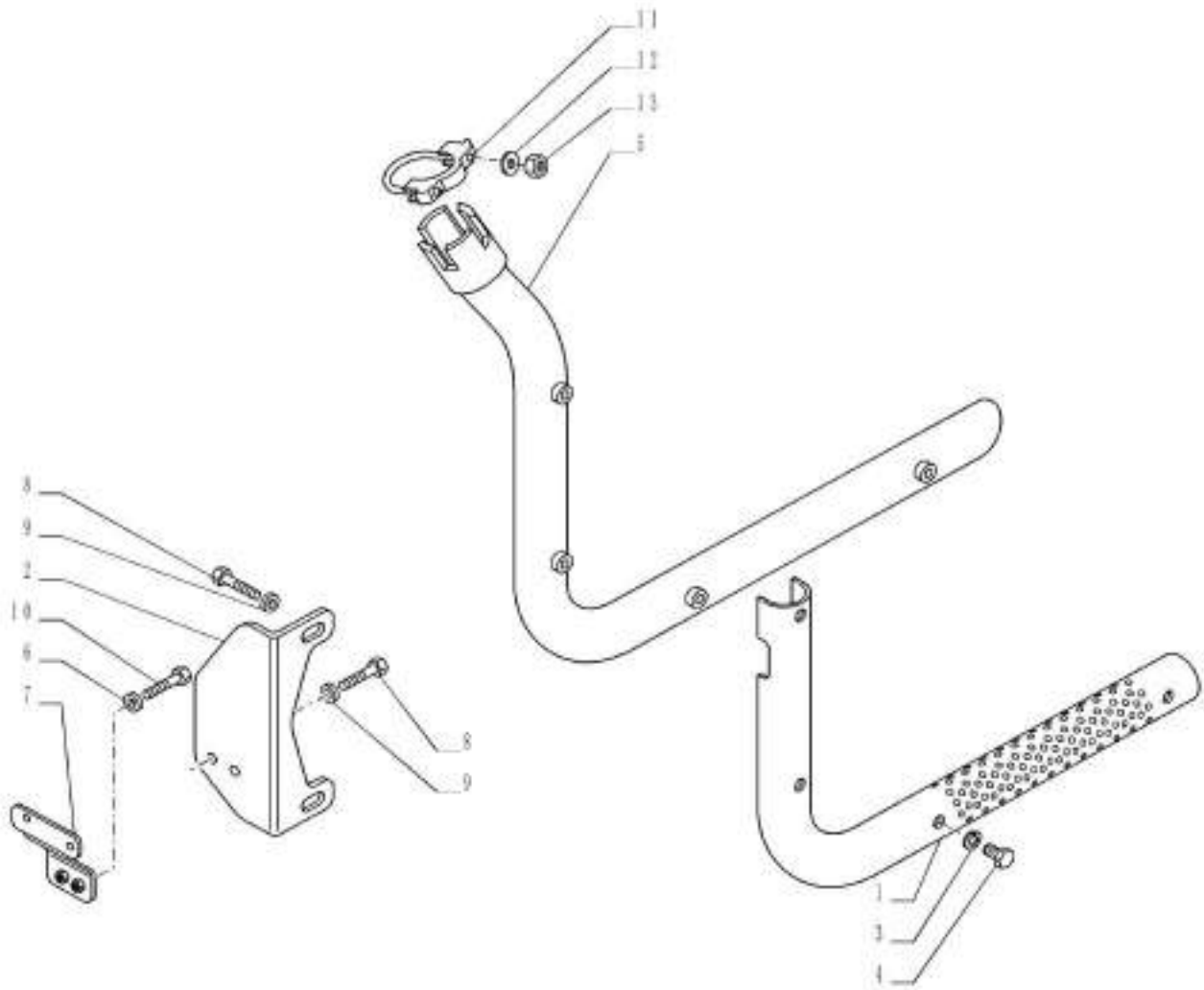

10.254.AI

06

p1

1/2014

VAR - 330150, 744734 - HORIZONTAL EXHAUST SHIELD

REF FN	PART NUMBER	YR/SN	QTY DESCRIPTION
1	84512578		1 GUARD
2	84520492		1 SUPPORT
3	12601274		4 WAVE WASHER Wave, M6.4
4	86977726		4 BOLT Hex, M6 x 12mm, Cl 8.8, Full Thd
5	84512576		1 EXHAUST SYSTEM PIPE
6	14496721		2 WASHER Flat, 13.00mm ID x 24.00mm OD x 2.50mm, R80, ZND
7	84520493		1 SUPPORT
8	86625000		4 BOLT Hex, M8 x 18mm, Cl 8.8, Full Thd
9	10519601		4 WASHER M8 x 17 x 2
10	11112121		2 SCREW Hex, M12 x 20, 8.8, Full Thd
11	84368639		1 COLLAR
12	12601474		2 WAVE WASHER Wave, 10.50mm ID x 21.00mm OD x 0.80mm, 3.00mm, CST, DAC
13	12164711		2 NUT M10 x 1.25, Cl 8

Valid for Industrial Var. 330150 (744734)

**FARMALL JX100
FARMALL JX110
FARMALL JX75
FARMALL JX90**

VAR - 330153 - VERTICAL EXHAUST, SHIELD

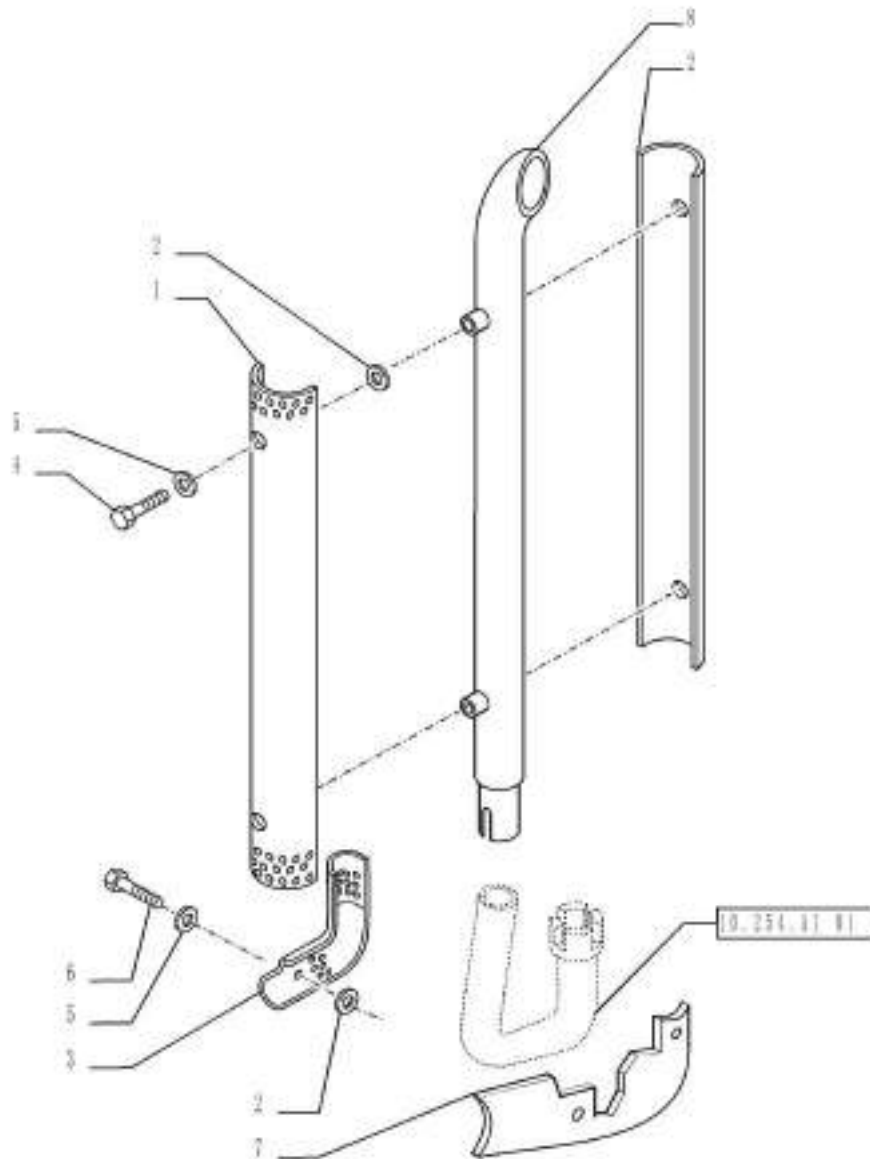

VAR - 330153 - VERTICAL EXHAUST, SHIELD

REF FN	PART NUMBER	YR/SN	QTY DESCRIPTION
1	5091586		1 GUARD 1100 mm
2	5091489		1 GUARD 1000 mm
3	47402631		1 GUARD
4	86625000		4 BOLT Hex, M8 x 18mm, Cl 8.8, Full Thd
5	10519601		8 WASHER M8 x 17 x 2
6	16043821		4 SCREW Hex, M8 x 1.25 x 30mm, Cl 8.8, Full Thd
7	47402630		1 GUARD
8	5091485		1 EXHAUST SYSTEM PIPE

Valid for Var. 330153

FARMALL JX70
FARMALL JX80

VAR - 330153 - VERTICAL EXHAUST, SHIELD

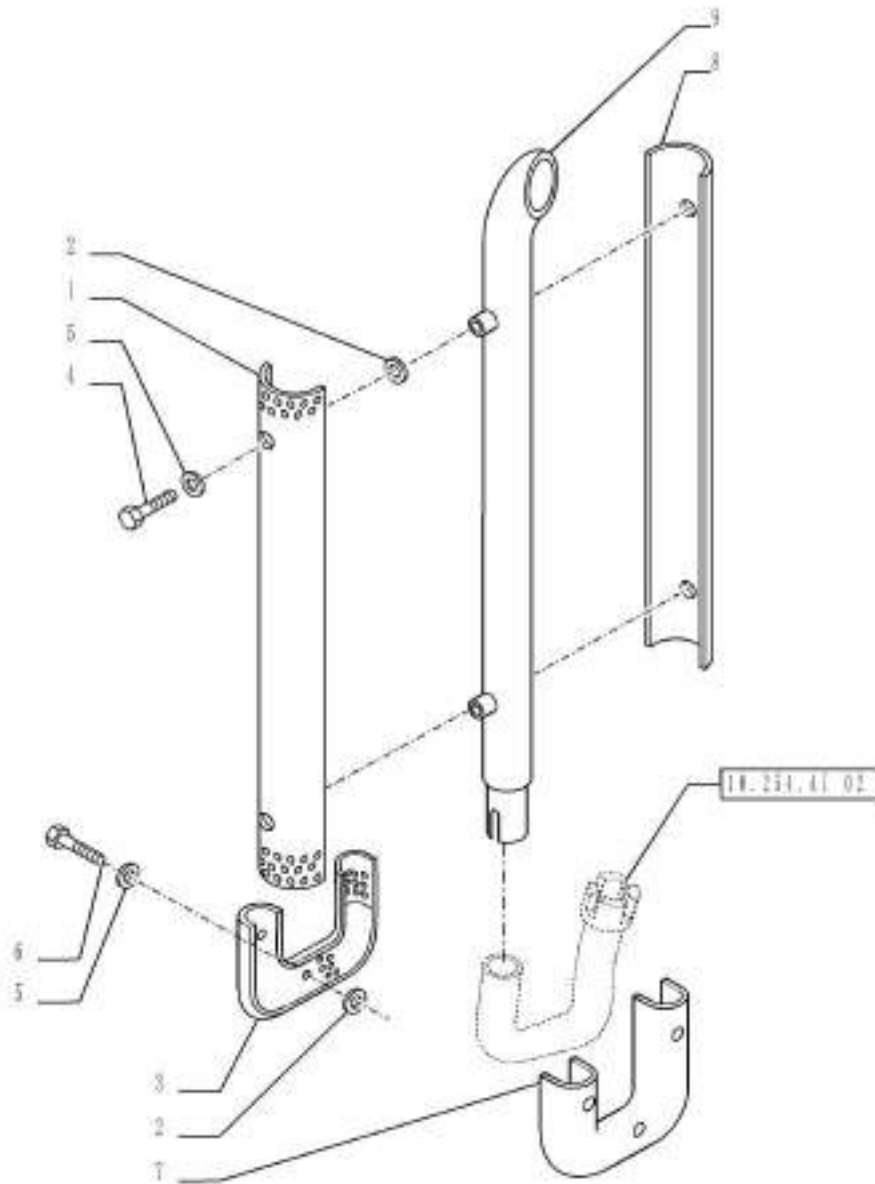

VAR - 330153 - VERTICAL EXHAUST, SHIELD

REF FN	PART NUMBER	YR/SN	QTY DESCRIPTION
1	84368629		1 GUARD
2	10519601		10 WASHER M8 x 17 x 2
3	47402627		1 GUARD
4	86625000		4 BOLT Hex, M8 x 18mm, Cl 8.8, Full Thd
5	14499407		10 WASHER M8 x 14 x 1.6
6	16043821		6 SCREW Hex, M8 x 1.25 x 30mm, Cl 8.8, Full Thd
7	47402629		1 GUARD
8	5091489		1 GUARD 1000 mm
9	84368666		1 EXHAUST SYSTEM PIPE

Valid for Var. 330153

FARMALL JX100
FARMALL JX110
FARMALL JX75
FARMALL JX90

10.310.AA

01

p1

1/2014

VAR - 334299, 334300, 334301, 390002, 744731 - INTERCOOLER

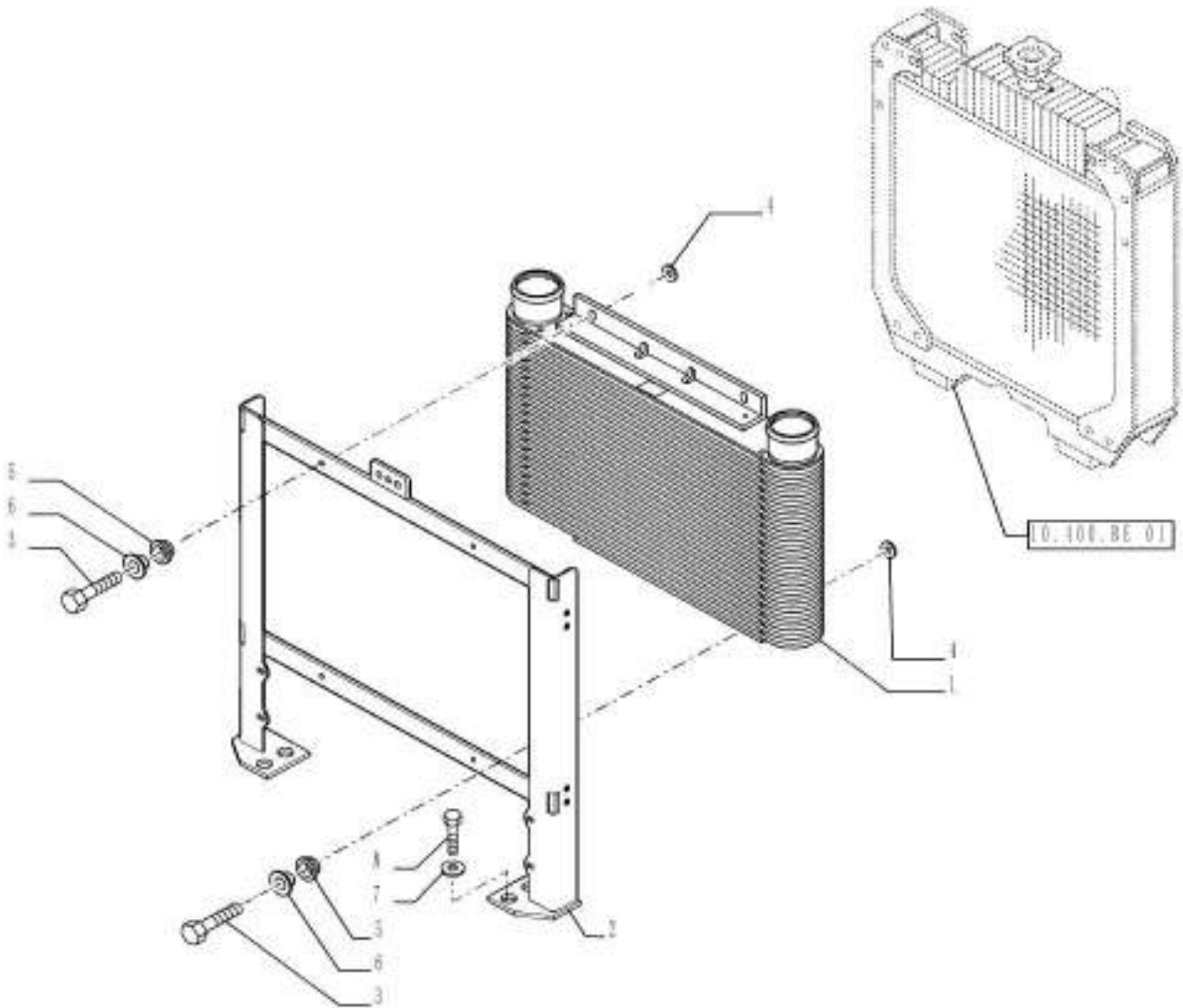

VAR - 334299, 334300, 334301, 390002, 744731 - INTERCOOLER

REF	FN	PART NUMBER	YR/SN	QTY	DESCRIPTION
1	1	84408677		1	INTERCOOLER
1	2	84408680		1	INTERCOOLER
2		84563205		1	SUPPORT
3		43127		4	BOLT Hex, M8 x 1.25 x 25mm, CI 8.8, Full Thd
4		11193974		4	BELLEVILLE WASHER Belleville, M8.4
5		47131603		4	PAD
6		47131590		4	SPACER
7		11193874		4	BELLEVILLE WASHER 8.4mm ID x 16.00mm OD x 1.4mm, 1.85mm, CI 8.8
8		86624003		4	BOLT Hex, M8 x 14mm, CI 8.8, Full Thd
(1)	VAR - 334299, 390002 (744731); Valid for FARMALL JX70, 80 Models Only				
(2)	Valid for FARMALL JX75, 90, 100, 110 Models Only				

Valid for Industrial Var. 334299, 334300, 334301, 390002 (744731)

FARMALL JX100 FARMALL
 JX110 FARMALL JX70
 FARMALL JX75 FARMALL
 JX80 FARMALL JX90

10.310.AB

01

p1

1/2014

VAR - 334299, 390002, 744731 - INTERCOOLER LINE

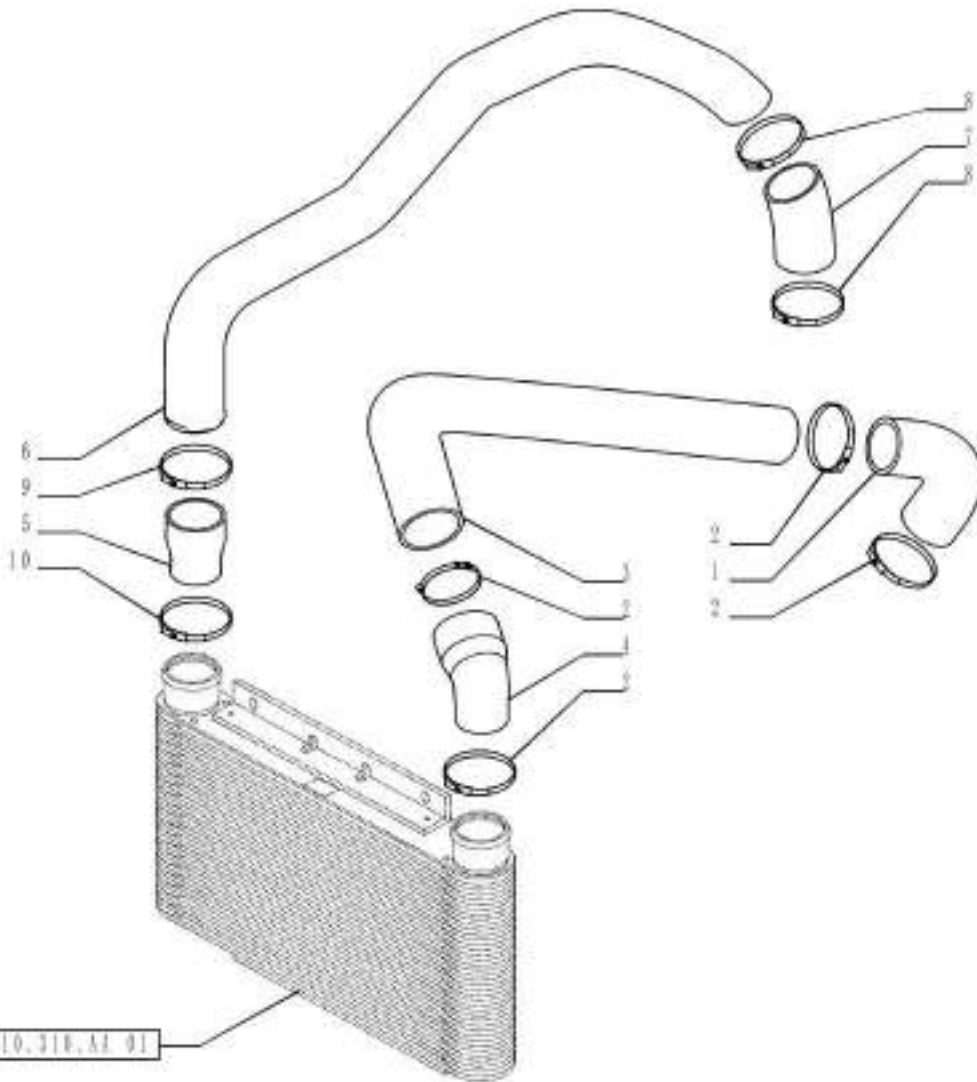

10.310.AB

01

p1

1/2014

VAR - 334299, 390002, 744731 - INTERCOOLER LINE

REF FN	PART NUMBER	YR/SN	QTY DESCRIPTION
1	84512590		1 LARGE HOSE Outlet
2	84518706		4 COLLAR
3	84512629		1 PIPE Inlet
4	84512579		1 LARGE HOSE Inlet
5	84408681		1 LARGE HOSE
6	84512615		1 PIPE Outlet
7	47363088		1 LARGE HOSE
8	84518708		2 COLLAR
9	84518709		1 COLLAR
10	84518705		1 COLLAR

Valid for Industrial Var. 334299, 390002 (744731)

**FARMALL JX70
FARMALL JX80**

VAR - 334299, 334300, 334301, 390002, 744731 - INTERCOOLER LINE

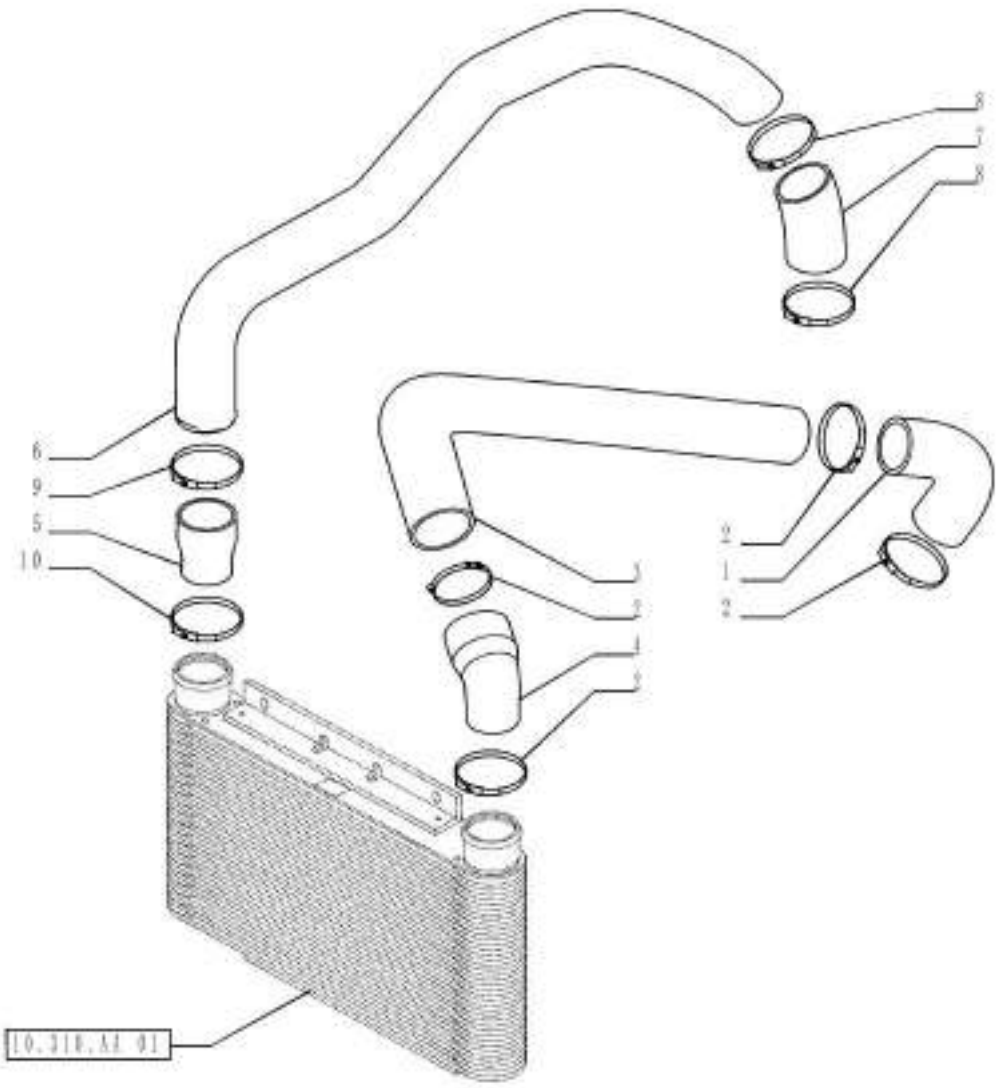

VAR - 334299, 334300, 334301, 390002, 744731 - INTERCOOLER LINE

REF FN	PART NUMBER	YR/SN	QTY DESCRIPTION
1	84511807		1 LARGE HOSE Outlet
2	84518706		4 COLLAR
3	84511764		1 PIPE Inlet
4	84511804		1 LARGE HOSE Inlet
5	84408681		1 LARGE HOSE
6	84511761		1 PIPE Outlet
7	47363088		1 LARGE HOSE
8	84518708		2 COLLAR
9	84518709		1 COLLAR
10	84518705		1 COLLAR

Valid for Industrial Var. 334299, 334300, 334301, 390002 (744731)	FARMALL JX100 FARMALL JX110 FARMALL JX75 FARMALL JX90
---	--

10.400.AY

01

p1

1/2014

VAR - 330641, 390641 - RADIATOR HOSE

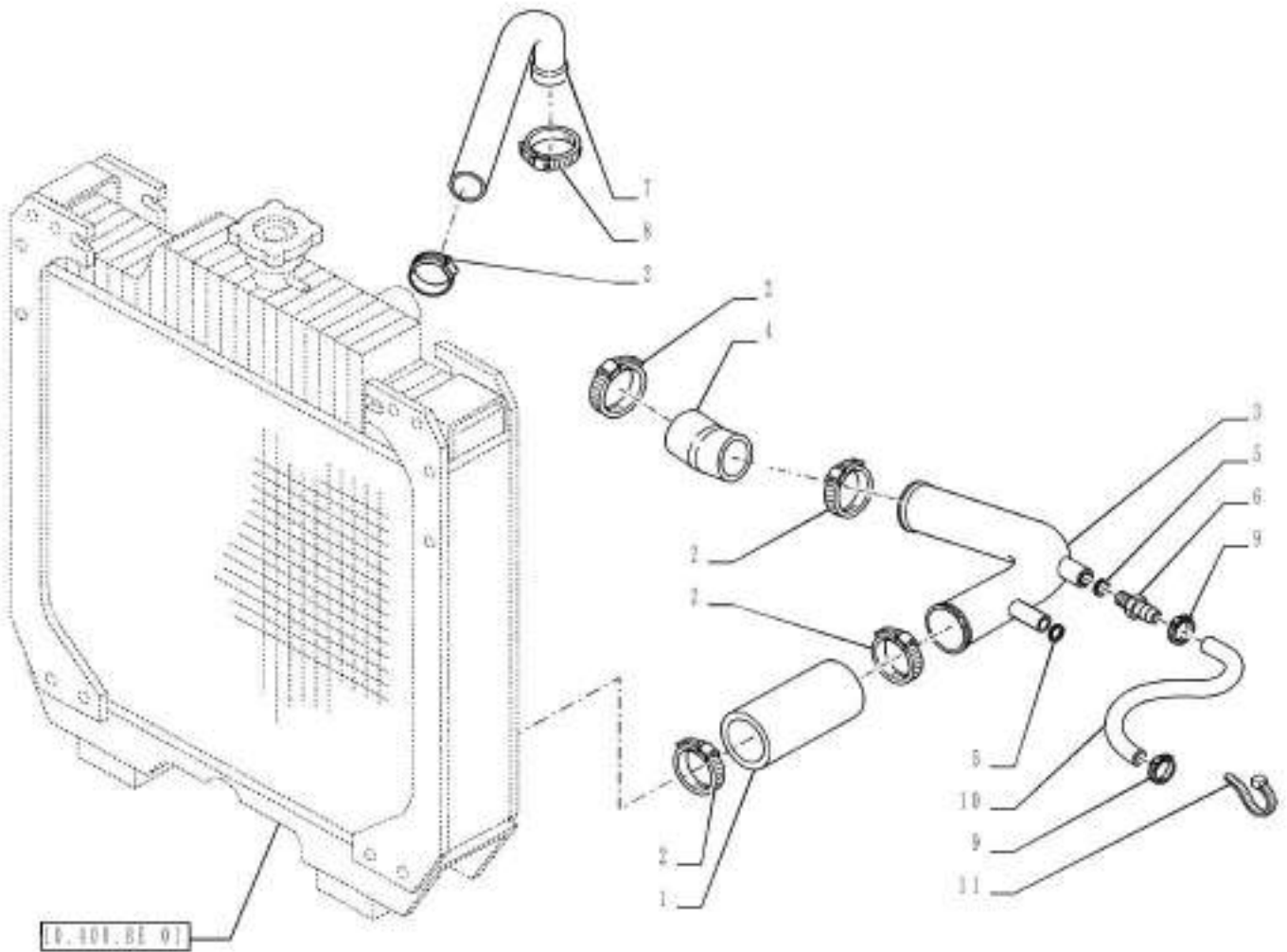

10.400.AY

01

p1

1/2014

VAR - 330641, 390641 - RADIATOR HOSE

REF FN	PART NUMBER	YR/SN	QTY DESCRIPTION
1	5083101		1 RADIATOR HOSE
2	5097539		5 COLLAR
3	84511885		1 LARGE HOSE Outlet
4	5083099		1 RADIATOR HOSE
5	10278660		1 COPPER WASHER M16.3 x 22 x 1.5
6	5094423		1 HYD CONNECTOR
7	84511799		1 RADIATOR HOSE Inlet
8	5097540		1 COLLAR
9	87557209		2 CLAMP Adj Hose, M16-27
10	5098180		1 HOSE 16 x 23/ l=530mm
11	5112712		1 COLLAR M4.8 x 283

Valid for Var. 330641 or Var. 390641	FARMALL JX100 FARMALL JX110 FARMALL JX70 FARMALL JX75 FARMALL JX80 FARMALL JX90
---	--

10.400.BE

01

p1

1/2014

VAR - 334299, 334300, 334301, 390002, 744731 - RADIATOR

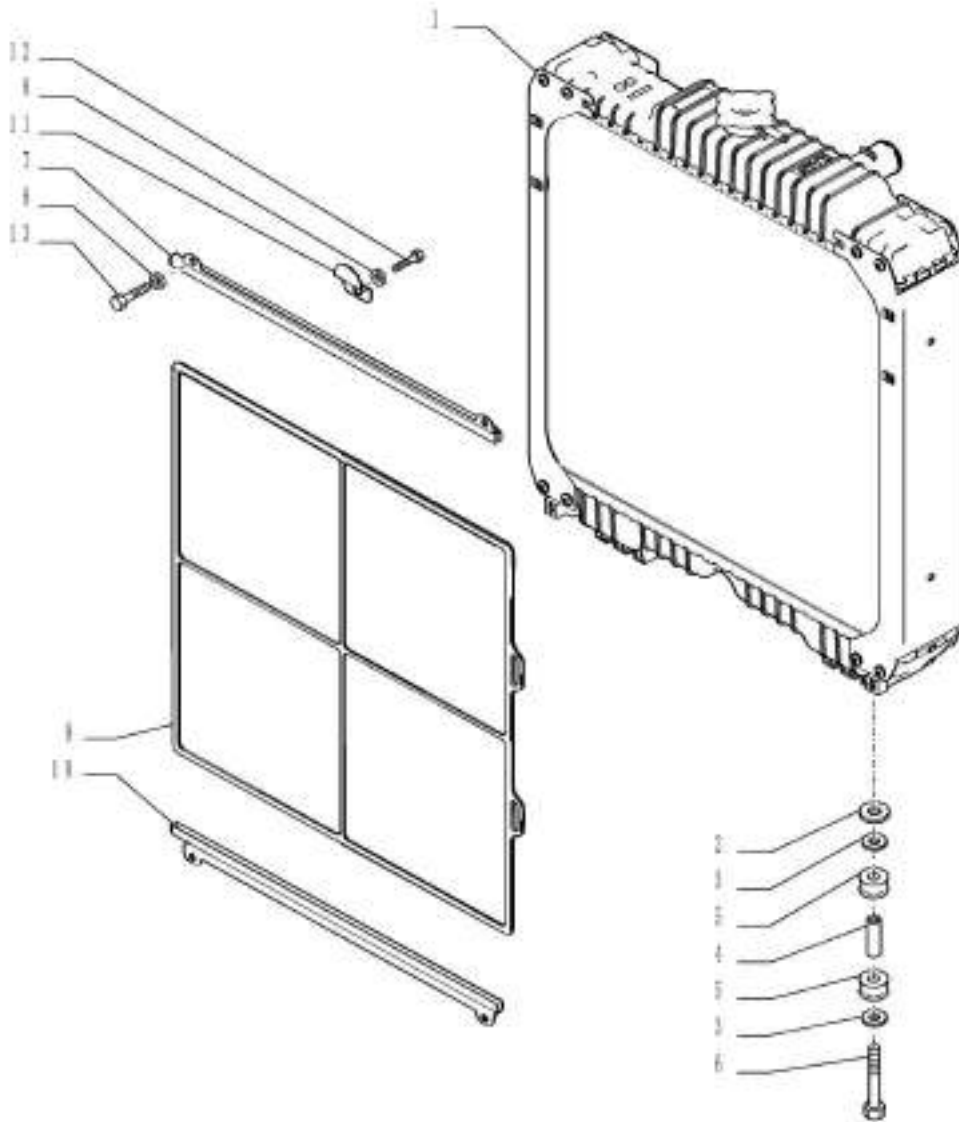

VAR - 334299, 334300, 334301, 390002, 744731 - RADIATOR

REF	FN	PART NUMBER	YR/SN	QTY	DESCRIPTION
1	1	84519000		1	RADIATOR
1	2	84516461		1	RADIATOR
2		11198379		2	SPRING WASHER Belleville, M10.5
3		5102702		4	WASHER M10 x 45 x 3 Thk
4		5102703		2	SPACER
5		5108225		4	RUBBER MOUNTING
6		15971621		2	SCREW Hex, M10 x 1.25 x 90mm, Cl 8.8
7		84491093		1	SUPPORT
8		12601374		5	WAVE WASHER Wave, 8.40mm ID x 15.00mm OD x 0.80mm, 3.00mm, CST, DAC
9		84511098		1	GUARD
10		84491107		1	SUPPORT
11		84491078		1	CLIP
12		86624003		1	BOLT Hex, M8 x 14mm, Cl 8.8, Full Thd
13		15697804		1	SELF-TAP SCREW Hex Wash Hd, M6 x 20

(1) VAR - 334299, 390002 (744731); Valid for FARMALL JX70, 75, 80, 90 Models Only

(2) Valid for FARMALL JX100, 110 Models Only

Valid for Industrial Var. 334299, 334300, 334301, 390002 (744731)

FARMALL JX100 FARMALL
 JX110 FARMALL JX70
 FARMALL JX75 FARMALL
 JX80 FARMALL JX90

10.400.BE

02

p1

1/2014

VAR - 330641, 390249, 390641, 744731 - RADIATOR, SEAL

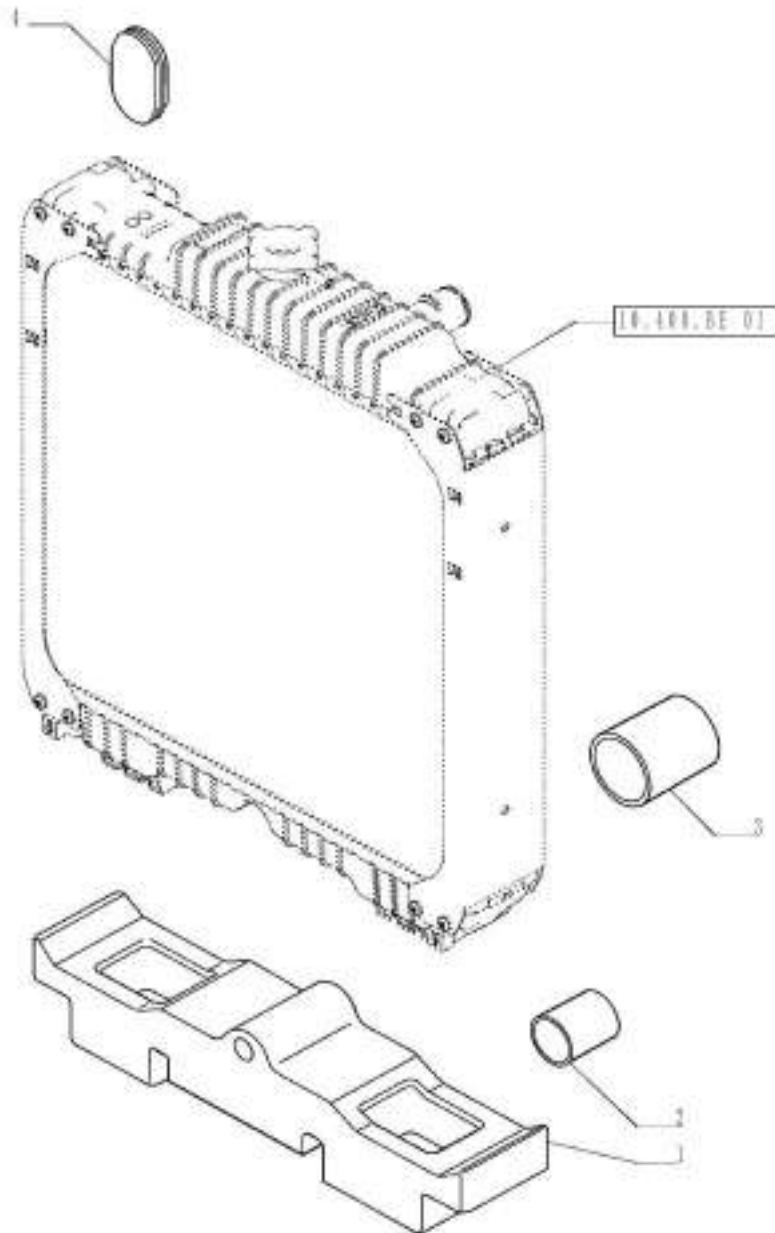

VAR - 330641, 390249, 390641, 744731 - RADIATOR, SEAL

REF	FN	PART NUMBER	YR/SN	QTY	DESCRIPTION
1	1	84481223		1	FOAM
2	2	84511894		1	RUBBER SEAL
3	3	84511893		1	RUBBER SEAL
4	4	84515006		1	RUBBER SEAL

(1) VAR - 334299, 334300, 334301, 390002 (744731)

(2) VAR - 334299, 334300, 334301, 390002 (744731) or 390249

(3) VAR - 390227

(4) VAR - 330641, 390641

Valid for Var. 330641 or Var. 390249 or Var. 390641 or Industrial Var.
334299, 334300, 334301, 390002 (744731)FARMALL JX100 FARMALL
JX110 FARMALL JX70
FARMALL JX75 FARMALL
JX80 FARMALL JX90

10.400.BH

01

p1

1/2014

VAR - 330641, 390641 - COOLING, EXPANSION TANK

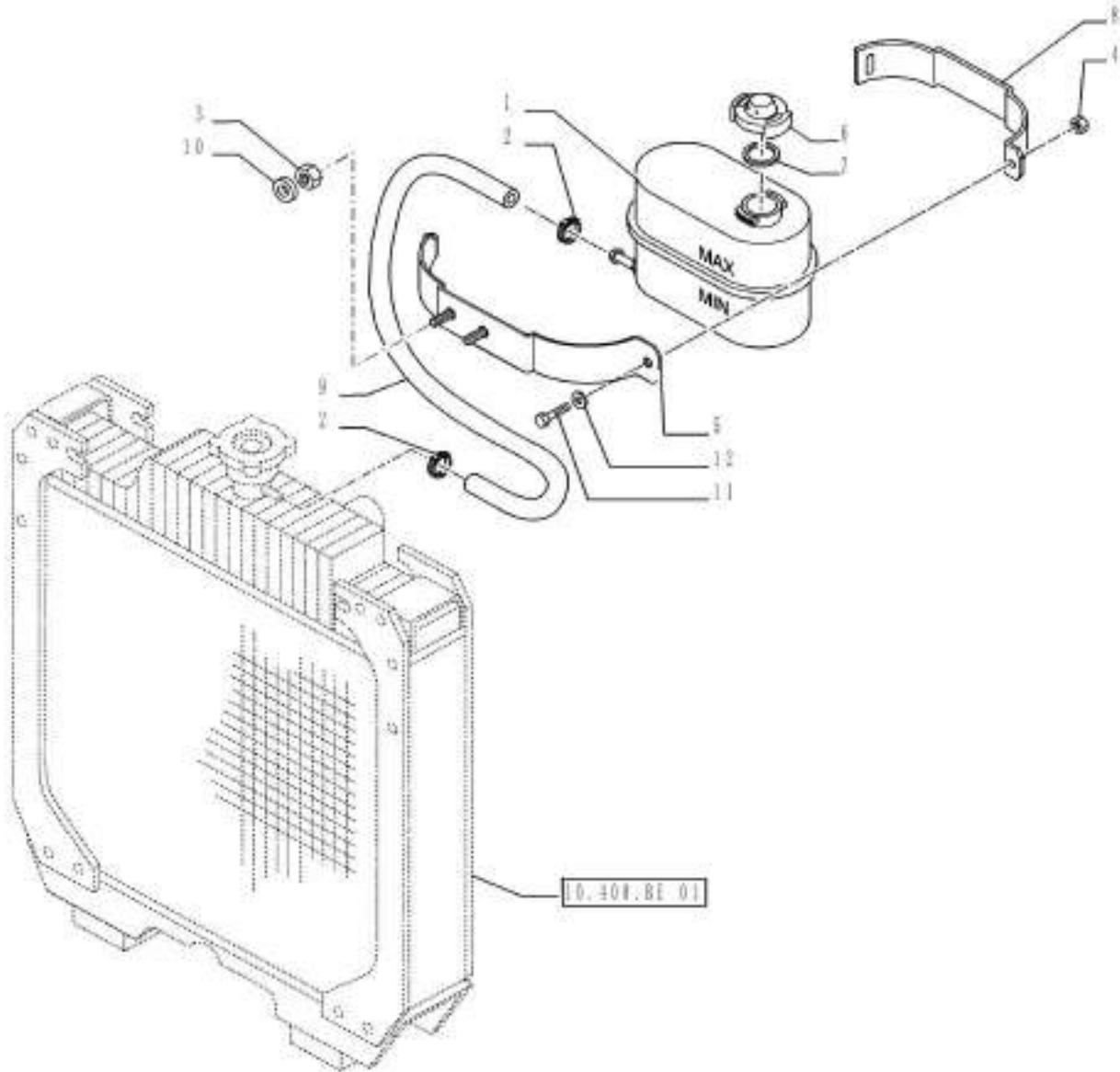

VAR - 330641, 390641 - COOLING, EXPANSION TANK

REF FN	PART NUMBER	YR/SN	QTY DESCRIPTION
1	5097071		1 TANK Outlet
2	10186590		2 COLLAR M11-13, Worm
3	12601374		2 WAVE WASHER Wave, 8.40mm ID x 15.00mm OD x 0.80mm, 3.00mm, CST, DAC Inlet
4	15896211		1 NUT M6, CI 8
5	84515347		1 CLAMP BRACKET
6	4274034		1 PLUG
7	4153008		1 SEAL
8	5097262		1 CLAMP
9	5092725		1 HOSE 7.00 mm ID x 340.00 mm
10	16100811		2 NUT Hex, M8, 6.80mm, CI 8, ZND
11	120100		1 BOLT Hex, M6 x 1 x 20mm, CI 8.8
12	12601274		1 WAVE WASHER Wave, M6.4

Valid for Var. 330641 or Var. 390641

FARMALL JX100 FARMALL
 JX110 FARMALL JX70
 FARMALL JX75 FARMALL
 JX80 FARMALL JX90

10.414.AC

01

p1

1/2014

VAR - 390018 - FAN

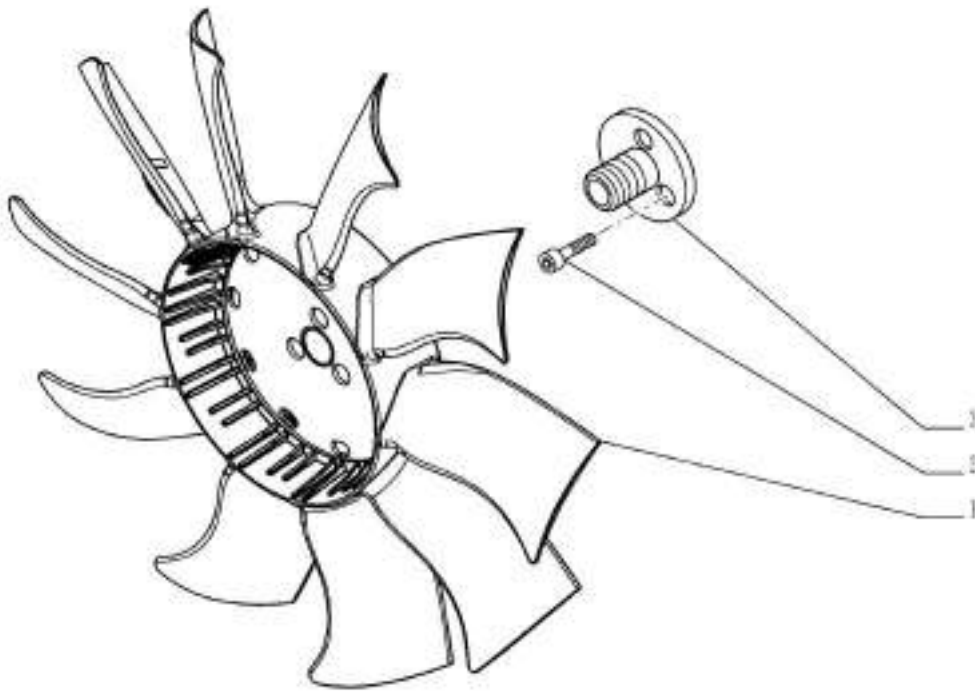

VAR - 390018 - FAN

REF	FN	PART NUMBER	YR/SN	QTY	DESCRIPTION
1	1	87542809		1	FAN
1	2	84526921		1	FAN
2		14306421		3	HEX SOC SCREW M8 x 1.25 x 25mm, CI 8.8
3		84490409		1	SPACER
(1)	Valid for FARMALL JX70, 75, 80, 90 Models Only				
(2)	Valid for FARMALL JX100, 110 Models Only				

Valid for Var. 390018

FARMALL JX100 FARMALL
 JX110 FARMALL JX70
 FARMALL JX75 FARMALL
 JX80 FARMALL JX90

VAR - 334299, 334300, 334301, 390002, 744731 - RADIATOR FAN SHROUD

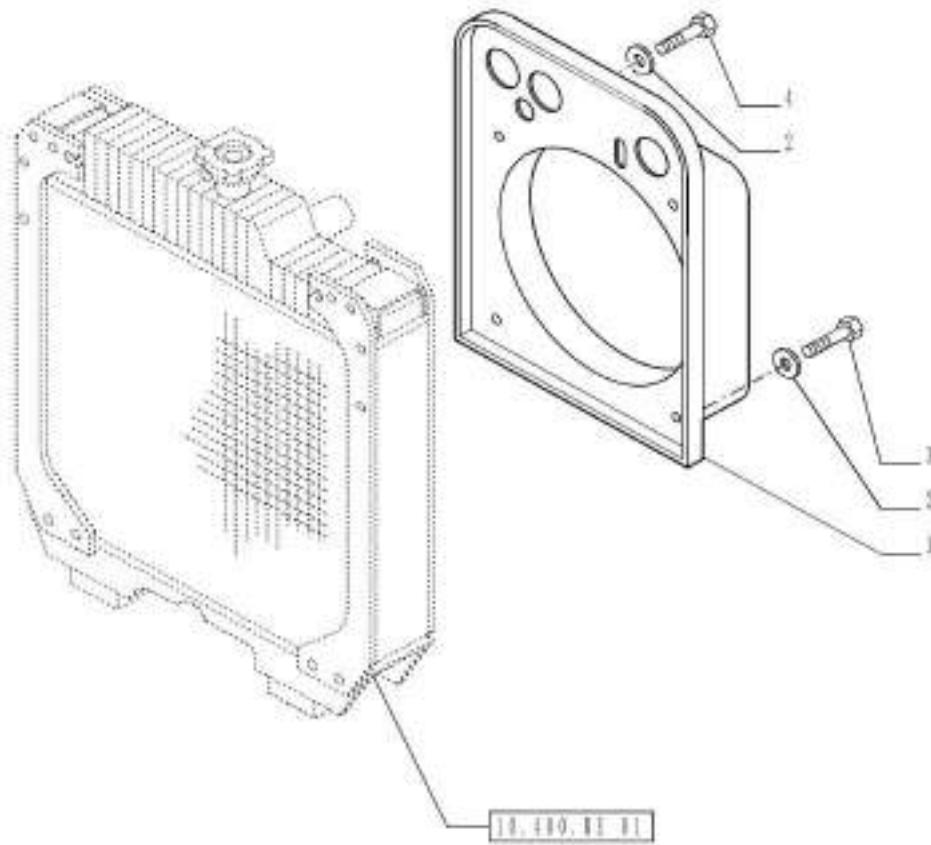

VAR - 334299, 334300, 334301, 390002, 744731 - RADIATOR FAN SHROUD

REF	FN	PART NUMBER	YR/SN	QTY DESCRIPTION
1	1	84511812		1 GUARD
1	2	84511873		1 GUARD
2		12601374		6 WAVE WASHER Wave, 8.40mm ID x 15.00mm OD x 0.80mm, 3.00mm, CST, DAC
3		16043221		2 BOLT Hex, M8 x 16.00mm, Cl 8.8, ZND
4		86625000		4 BOLT Hex, M8 x 18mm, Cl 8.8, Full Thd
(1)	Valid for FARMALL JX100, 110 Models Only			
(2)	VAR - 334299, 390002 (744731); Valid for FARMALL JX70, 75, 80, 90 Models Only			

Valid for Industrial Var. 334299, 334300, 334301, 390002 (744731)

FARMALL JX100 FARMALL
 JX110 FARMALL JX70
 FARMALL JX75 FARMALL
 JX80 FARMALL JX90

VAR - 330009 - VISCOUS JOINT FAN

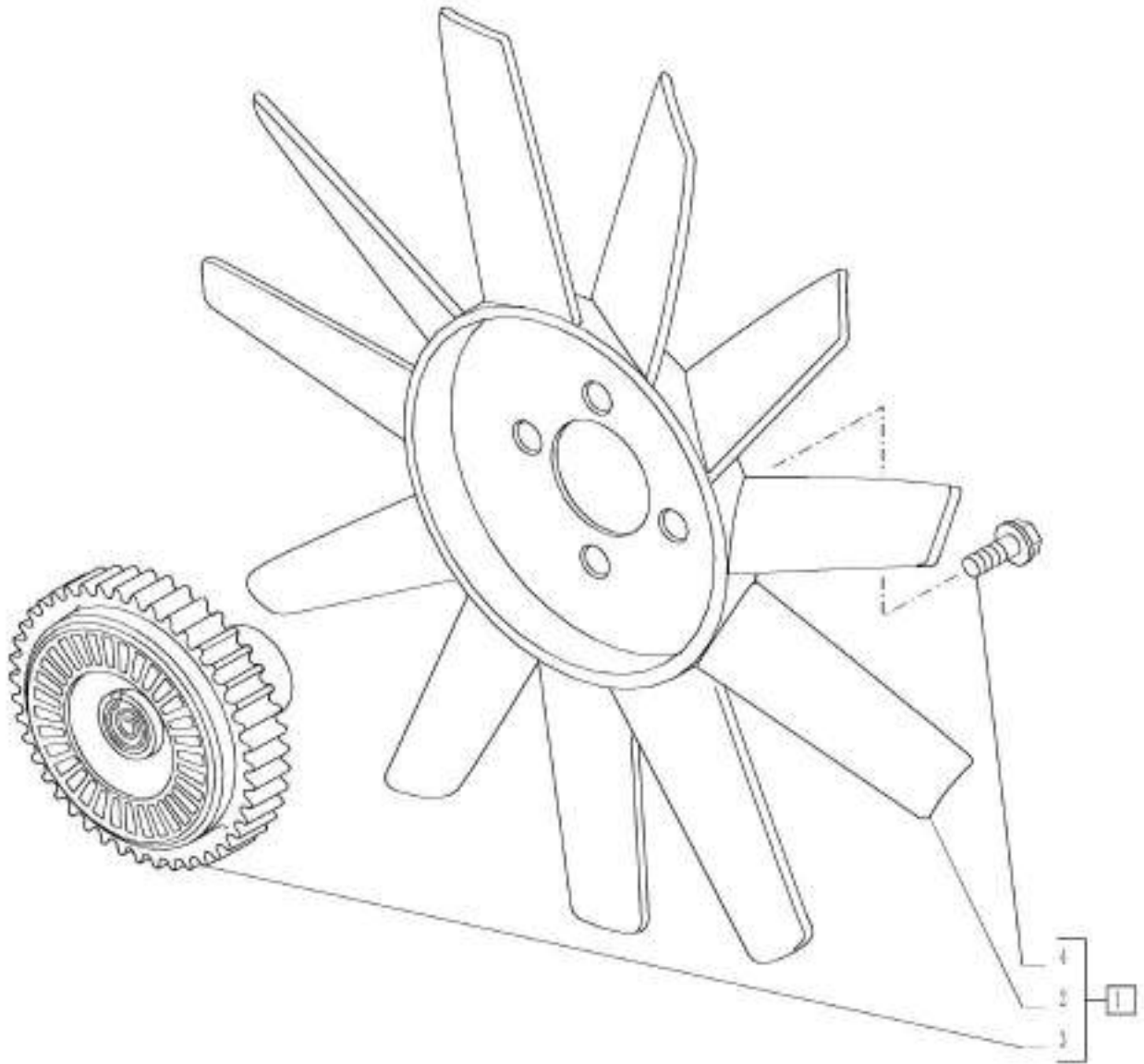

10.414.AC

03

p1

1/2014

VAR - 330009 - VISCOUS JOINT FAN

REF FN	PART NUMBER	YR/SN	QTY DESCRIPTION
1	87623308		1 FAN Incl 2 - 4
2	87624549		1 FAN
3	47135805		1 UNIVERSAL JOINT
4	13838421		4 SCREW M8 x 1.25 x 12mm

Valid for Var. 330009

**FARMALL JX70
FARMALL JX75
FARMALL JX80
FARMALL JX90**

VAR - 330009 - VISCOUS JOINT FAN

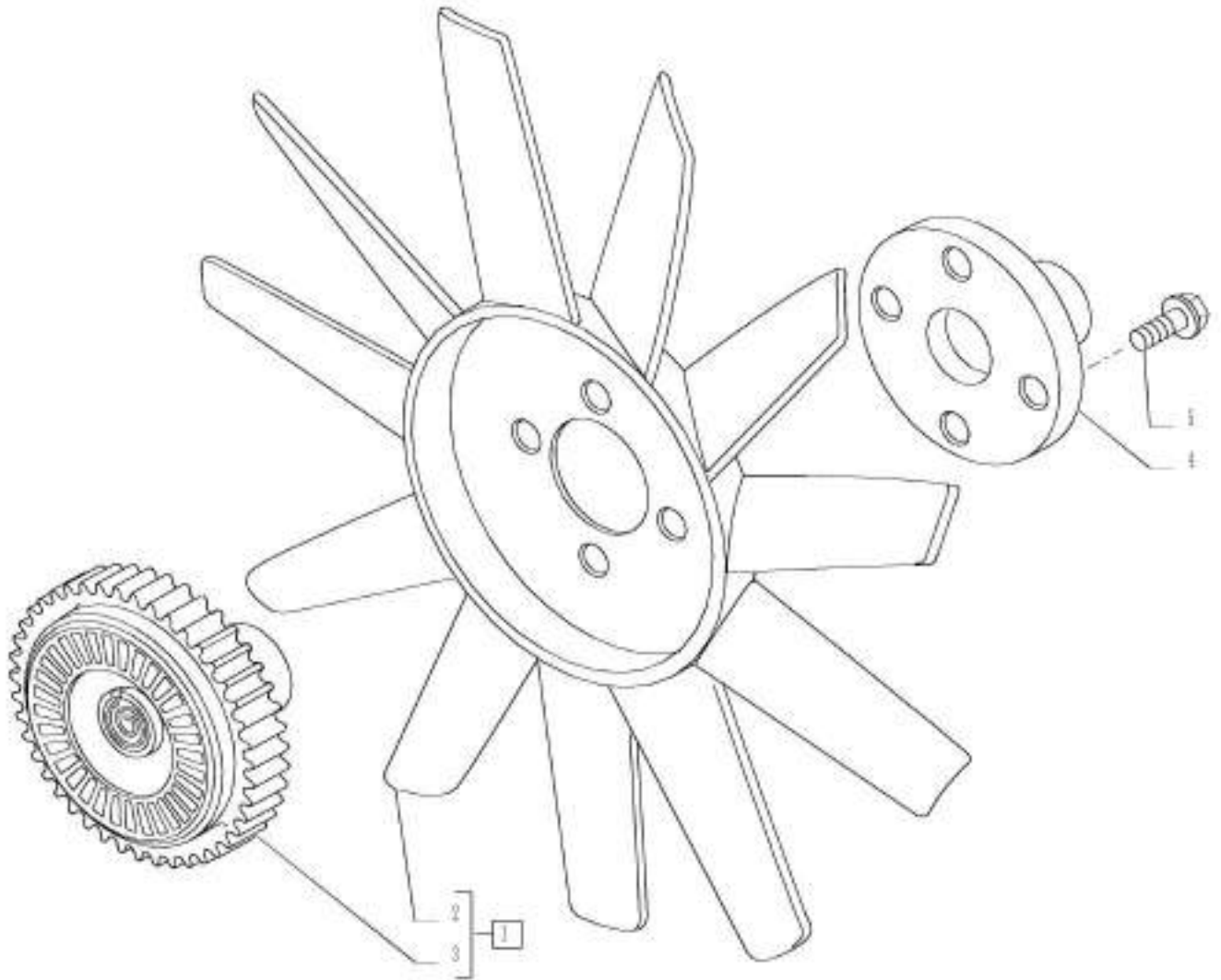

10.414.AC

04

p1

1/2014

VAR - 330009 - VISCOUS JOINT FAN

REF FN	PART NUMBER	YR/SN	QTY DESCRIPTION
1	84587514		1 FAN
2	NSS		1 NOT SERVICED SEPARATELY Fan Incl in 1
3	NSS		1 NOT SERVICED SEPARATELY Drive Incl in 1
4	84490409		1 SPACER
5	14306421		3 HEX SOC SCREW M8 x 1.25 x 25mm, CI 8.8

Valid for Var. 330009

FARMALL JX100
FARMALL JX110

SECTION INDEX

CLUTCH

18.000.00	01	SECTION INDEX, CLUTCH
18.100.AA	01	VAR - 390249 - CLUTCH, CABLE
18.100.AF	01	VAR - 390249 - CLUTCH, PEDAL
18.100.AF	02	VAR - 330120, 331120, 743846 - CLUTCH, PEDAL
18.100.AJ	01	VAR - 335113, 335116, 390249, 744735, 744738, 744739, 744744 - CLUTCH LEVERS LINKS
18.104.AM	01	VAR - 330120, 331120, 743846 - PTO ENGAGEMENT CLUTCH, SERVOCONTROL - CONTROL VALVE - BREAKDOWN
18.104.AS	01	VAR - 330120, 331120, 743846 - PTO ENGAGEMENT CLUTCH, SERVOCONTROL - CYLINDER AND RELEVANT PARTS
18.104.AS	02	VAR - 330120, 331120, 743846 - POWER SHUTTLE SERVO PTO FOR DIFF. LOCK - PTO CLUTCH CONTROL ACTUATOR CYLINDER - BREAKDOWN
18.110.AB	01	VAR - 395250 - CLUTCH & DISC ASSY
18.110.AB	02	VAR - 390815, 720248 - CLUTCH & DISC ASSY
18.110.AB	03	VAR - 390815, 720248 - CLUTCH & DISC ASSY
18.110.AB	04	VAR - 390816, 744743 - CLUTCH & DISC ASSY
18.110.AB	05	VAR - 390816, 744743 - CLUTCH & DISC ASSY
18.110.AB	06	VAR - 335248 - CLUTCH & DISC ASSY
18.110.AB	07	VAR - 334409, 334410, 720248, 720514 - CLUTCH & DISC ASSY
18.110.AB	08	VAR - 335814, 744743 - CLUTCH & DISC ASSY
18.110.AB	09	VAR - 334298, 720514 - CLUTCH & DISC ASSY
18.110.AB	10	VAR - 335814, 744743 - CLUTCH & DISC ASSY

SECTION INDEX, CLUTCH

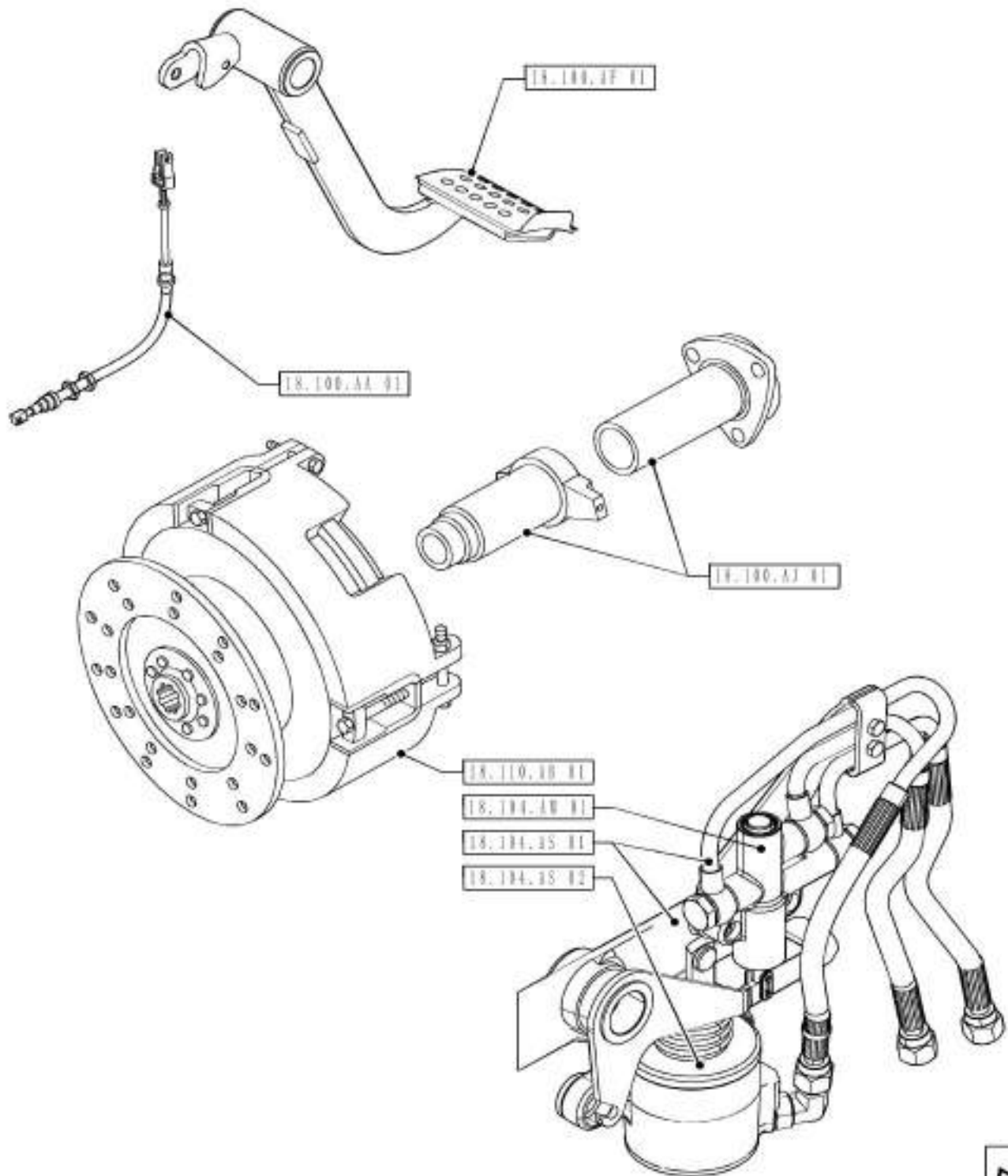

18.000.00

01

p1

1/2014

SECTION INDEX, CLUTCH

REF FN	PART NUMBER	YR/SN	QTY	DESCRIPTION
---------------	--------------------	--------------	------------	--------------------

FARMALL JX100 FARMALL JX110 FARMALL JX70 FARMALL JX75 FARMALL JX80 FARMALL JX90
--

18.100.AA

01

p1

1/2014

VAR - 390249 - CLUTCH, CABLE

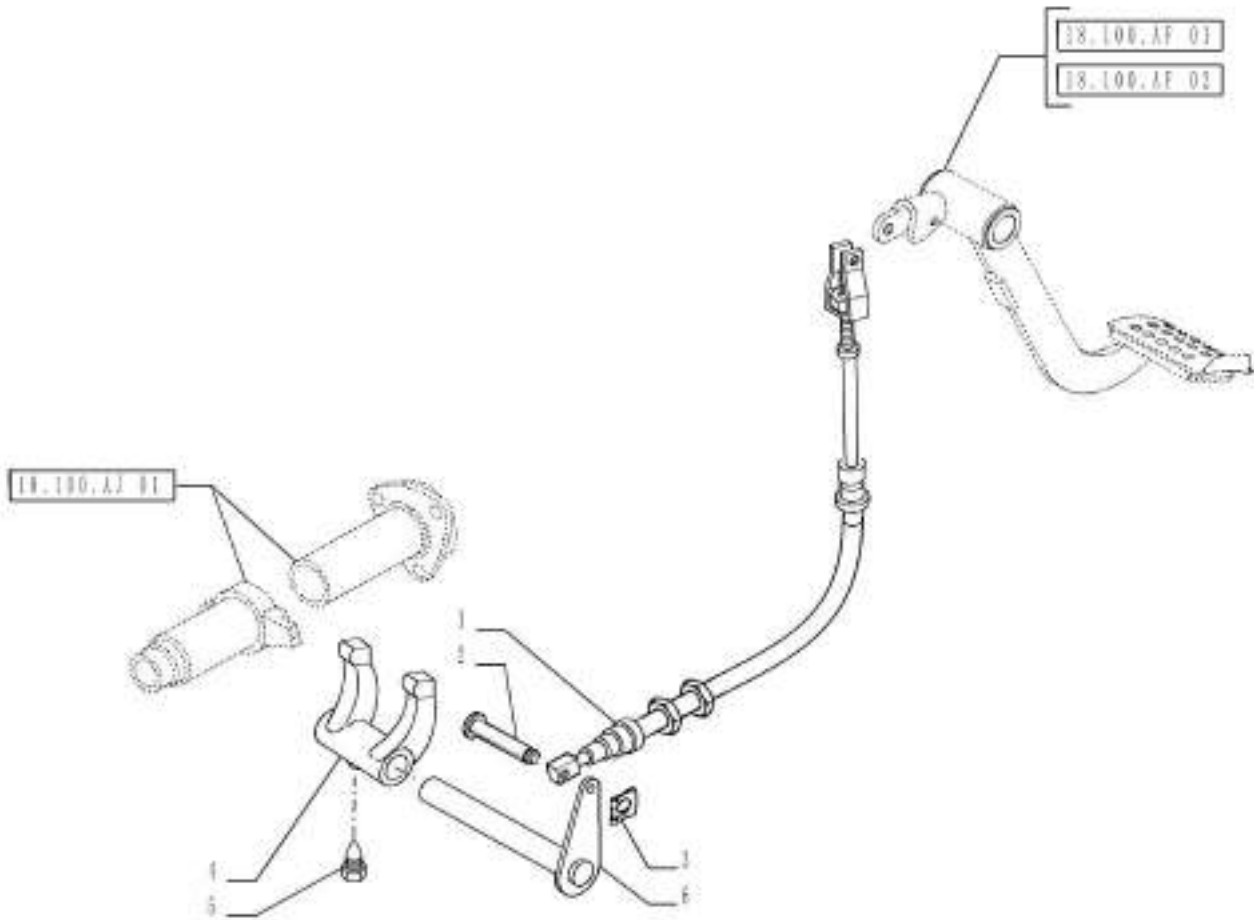

18.100.AA

01

p1

1/2014

VAR - 390249 - CLUTCH, CABLE

REF FN	PART NUMBER	YR/SN	QTY DESCRIPTION
1	84193546		1 CABLE
2	84195822		1 PIN
3	11063971		1 CLIP M6
4	4993814		1 SHIFTER FORK
5	4968813		1 SCREW Hex, M16 x 1.5 x 32mm
6	84603884		1 PIN

Valid for Var. 390249

FARMALL JX100 FARMALL
JX110 FARMALL JX70
FARMALL JX75 FARMALL
JX80 FARMALL JX90

18.100.AF

01

p1

1/2014

VAR - 390249 - CLUTCH, PEDAL

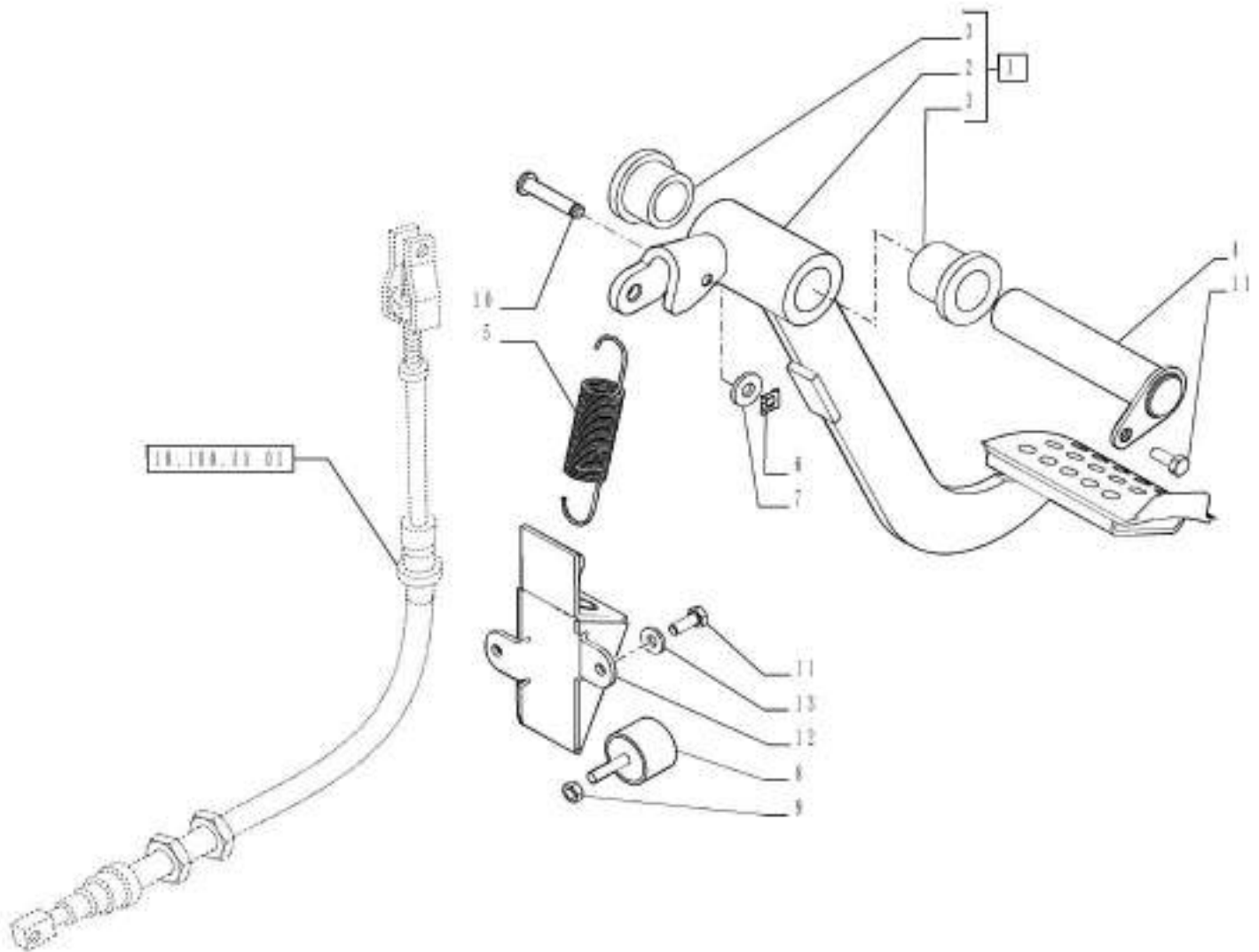

VAR - 390249 - CLUTCH, PEDAL

REF FN	PART NUMBER	YR/SN	QTY DESCRIPTION
1	84573973		1 PEDAL Incl 2, 3
2	NSS		1 NOT SERVICED SEPARATELY Pedal Incl in 1
3	5097550		2 BUSHING
4	5097582		1 SHAFT
5	84527897		1 SPRING
6	11063971		1 CLIP M6
7	12601274		1 WAVE WASHER Wave, M6.4
8	5097046		1 INSULATOR BLOCK
9	15896221		1 NUT M6, CI 10 M6
10	84193023		1 PIN
11	86508568		3 BOLT Hex, M6 x 16mm, CI 8.8, Full Thd
12	84540031		1 SUPPORT
13	12601279		2 WAVE WASHER Wave, M6.4
Valid for Var. 390249			FARMALL JX100 FARMALL JX110 FARMALL JX70 FARMALL JX75 FARMALL JX80 FARMALL JX90

18.100.AF

02

p1

1/2014

VAR - 330120, 331120, 743846 - CLUTCH, PEDAL

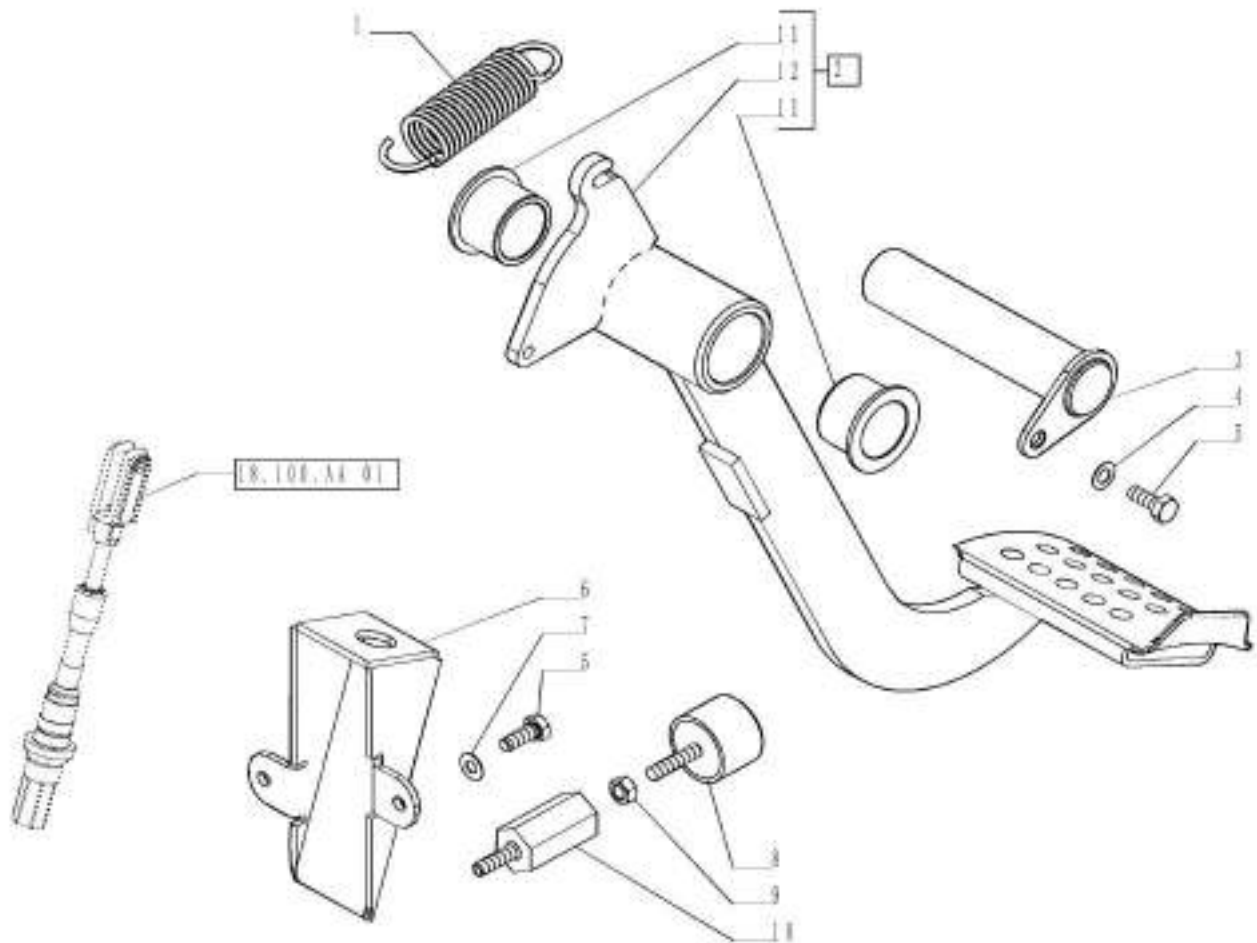

VAR - 330120, 331120, 743846 - CLUTCH, PEDAL

REF FN	PART NUMBER	YR/SN	QTY DESCRIPTION
1	84527899		1 SPRING
2	84519372		1 PEDAL Incl 11 - 12
3	5097582		1 SHAFT
4	12601274		1 WAVE WASHER Wave, M6.4
5	86508568		3 BOLT Hex, M6 x 16mm, CI 8.8, Full Thd
6	84519370		1 SUPPORT
7	12601279		2 WAVE WASHER Wave, M6.4
8	5097046		1 INSULATOR BLOCK
9	15896221		1 NUT M6, CI 10
10	84519369		1 PIN
11	5097550		2 BUSHING Incl in 2
12	NSS		1 NOT SERVICED SEPARATELY Pedal Incl in 2

Valid for Industrial Var. 330120, 331120 (743846)

FARMALL JX100
 FARMALL JX110
 FARMALL JX75
 FARMALL JX90

18.100.AJ

01

p1

1/2014

VAR - 335113, 335116, 390249, 744735, 744738, 744739, 744744 - CLUTCH LEVERS LINKS

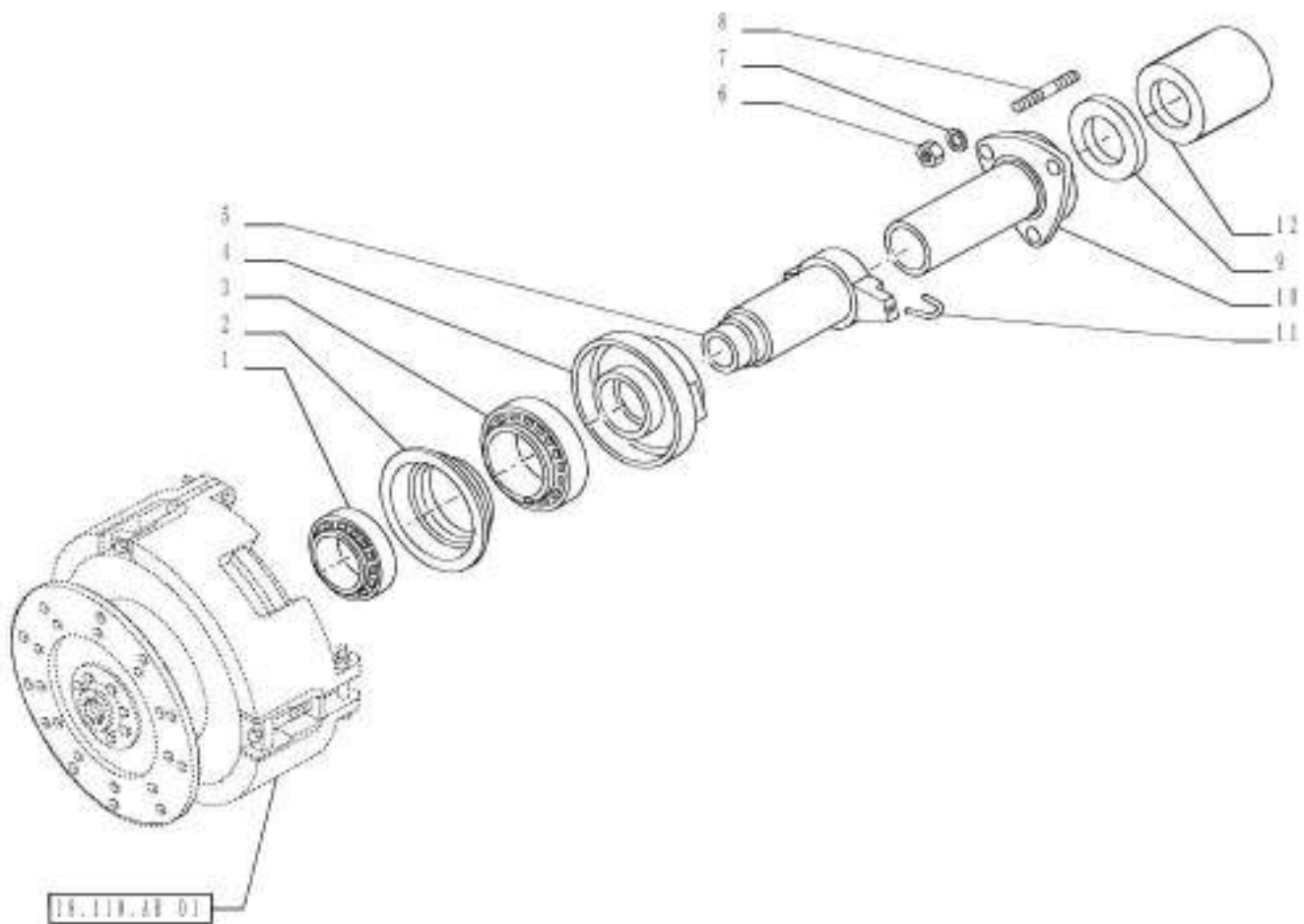

VAR - 335113, 335116, 390249, 744735, 744738, 744739, 744744 - CLUTCH LEVERS LINKS

REF FN	PART NUMBER	YR/SN	QTY DESCRIPTION
1	^{1,2} 87541562		1 THRUST BEARING 50 mm ID x 90.5 mm OD x 22 mm
2	3 5087034		1 COLLAR
2	4 84180006		1 SLEEVE
2	5 5089370		1 COLLAR
2	6 5097678		1 COLLAR
3	7 24905360		1 BALL BEARING 70 mm ID x 110 mm OD x 20 mm
4	7 84524919		1 SLEEVE
5	2 5147787		1 SLEEVE
5	4 84179988		1 SLEEVE
5	8 5089355		1 SLEEVE CYLINDER
6	^{1,2} 16100811		3 NUT Hex, M8, 6.80mm, CI 8, ZND
7	^{1,2} 12601374		3 WAVE WASHER Wave, 8.40mm ID x 15.00mm OD x 0.80mm, 3.00mm, CST, DAC
8	^{1,2} 13517111		3 STUD M8 x 12mm, CI 5.8
9	5144380		1 SEAL
10	9 5128070		1 COVER
10	¹⁰ 5097579		1 SLIPPER
10	¹¹ 84179991		1 COVER
10	¹² 84184490		1 SLEEVE

(1) VAR - 390249; FARMALL JX75, 80, 90, 100, 110 Models Only

(2) VAR - 390268 (744738) or 330384 (744739) or 390267 (744744); FARMALL JX70 Model Only

(3) VAR - 390249; FARMALL JX70 Model Only

(4) VAR - 390249; FARMALL JX75, 80, 90 Models Only

(5) VAR - 390249; FARMALL JX100 Model Only

(6) VAR - 390249; FARMALL JX110 Model Only

(7) VAR - 390249

(8) VAR - 390249; FARMALL JX100, 110 Models Only

(9) VAR - 335116 or 390110 (744735); FARMALL JX70 Model Only

(10) VAR - 335113; FARMALL JX70 Models Only

(11) VAR - 335116 or 390110 (744735); FARMALL JX75, 80, 90 Models Only

(12) VAR - 335113; FARMALL JX75, 80, 90 Models Only

Valid for Var. 335113 or Var. 335116 or Var. 390249 or Industrial Var. 390110 (744735) or Industrial Var. 390268 (744738) or Industrial Var. 330384 (744739) or Industrial Var. 390267 (744744)

FARMALL JX100
FARMALL JX110
FARMALL JX75
FARMALL JX80

VAR - 335113, 335116, 390249, 744735, 744738, 744739, 744744 - CLUTCH LEVERS LINKS

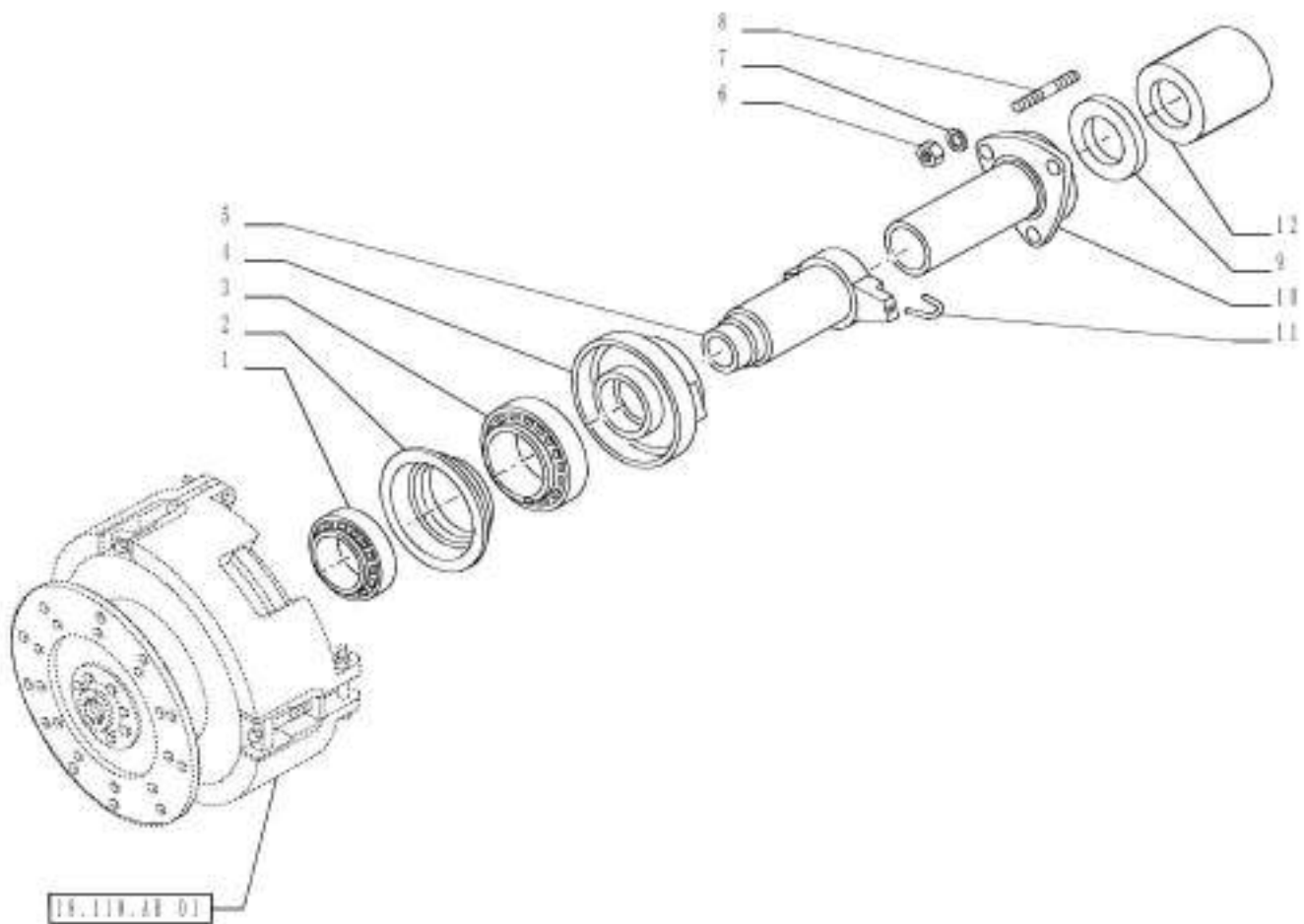

VAR - 335113, 335116, 390249, 744735, 744738, 744739, 744744 - CLUTCH LEVERS LINKS

REF	FN	PART NUMBER	YR/SN	QTY	DESCRIPTION
10	1	5089356		1	SUPPORT
10	2	5097574		1	SLIPPER
11	^{3,4}	44011615		2	SPRING
12	5	87660491		1	SEAL
(1)		VAR - 390110 (744735); FARMALL JX100, 110 Models Only			
(2)		VAR - 335113; FARMALL JX100, 110 Models Only			
(3)		VAR - 390249			
(4)		VAR - 390268 (744738) or 330384 (744739) or 390267 (744744); FARMALL JX70 Model Only			
(5)		VAR - 335113			

Valid for Var. 335113 or Var. 335116 or Var. 390249 or Industrial Var. 390110 (744735) or Industrial Var. 390268 (744738) or Industrial Var. 330384 (744739) or Industrial Var. 390267 (744744)

FARMALL JX100
FARMALL JX110
FARMALL JX75
FARMALL JX80

18.104.AM

01

p1

1/2014

VAR - 330120, 331120, 743846 - PTO ENGAGEMENT CLUTCH, SERVOCONTROL - CONTROL VALVE - BREAKDOWN

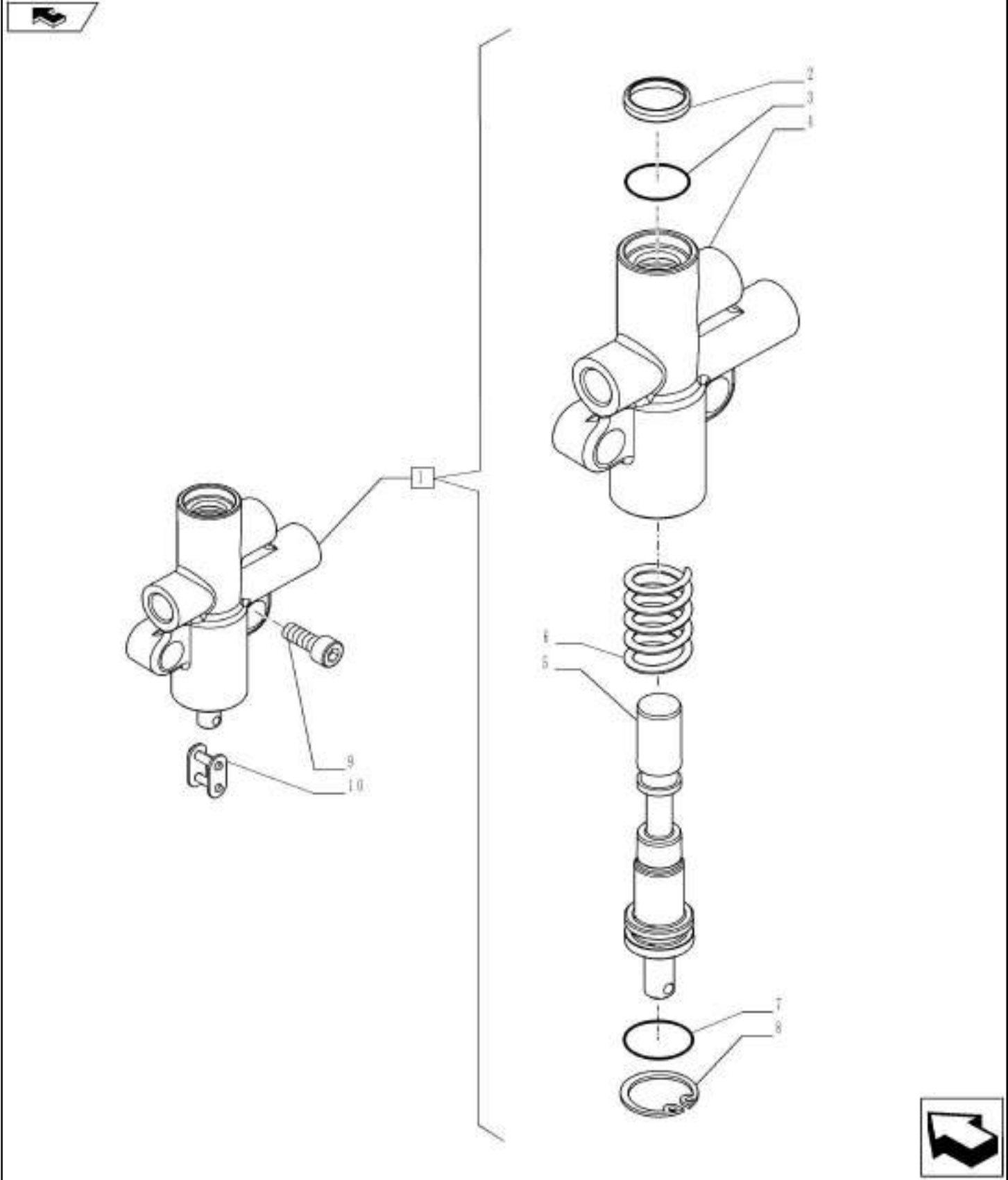

VAR - 330120, 331120, 743846 - PTO ENGAGEMENT CLUTCH, SERVOCONTROL - CONTROL VALVE - BREAKDOWN

REF FN	PART NUMBER	YR/SN	QTY DESCRIPTION
1	5185025		1 HYDRAULIC VALVE ASSY, Incl 2 - 8
2	5114359		1 SCRAPER RING
3	5192732		1 RUBBER RING
4	NSS		1 NOT SERVICED SEPARATELY Body, Incl in 1
5	NSS		1 NOT SERVICED SEPARATELY Spool, Incl in 1
6	5188876		1 SPRING
7	14457180		1 O-RING 13.94mm ID x 2.62" Width
8	11057876		1 SNAP RING M20, Int
9	14305224		2 HEX SOC SCREW M6 x 16mm, Cl 8.8, Full Thd
10	5185788		1 CONNECTING LINK

Valid for Industrial Var. 330120, 331120 (743846)

**FARMALL JX100
FARMALL JX110
FARMALL JX75
FARMALL JX90**

18.104.AS

01

p1

1/2014

VAR - 330120, 331120, 743846 - PTO ENGAGEMENT CLUTCH, SERVOCONTROL - CYLINDER AND RELEVANT PARTS

REF FN	PART NUMBER	YR/SN	QTY DESCRIPTION
1	84527853		1 CONTROL VALVE
2	14331121		2 HEX SOC SCREW M12 x 1.25 x 30mm, CI 8.8, Full Thd
3	87616449		1 HYD CONNECTOR
4	5183637		1 LEVER
5	10734201		1 COTTER PIN M2 x 12
6	13550301		1 WASHER
7	84547803		1 PIPE
8	84481040		1 FLEXIBLE HOSE
9	84481039		1 FLEXIBLE HOSE
10	5185806		1 LEVER Assy Incl 11, 12
11	NSS		1 NOT SERVICED SEPARATELY Lever, Incl in 10
12	5185794		1 BUSHING
13	10050814		1 PIN
14	84481042		1 SUPPORT
15	10185011		3 BANJO BOLT M12 x 1.25 x 23
16	5183780		6 SEALING WASHER 14.40mm ID x 18.00mm OD x 1.50mm, Steel, Zinc
17	10977821		2 BOLT Hex, M5 x 0.8 x 16.00mm, CI 8.8, ZND
18	5184304		1 BRACKET

Valid for Industrial Var. 330120, 331120 (743846)

FARMALL JX100
FARMALL JX110
FARMALL JX75
FARMALL JX90

18.104.AS

02

p1

1/2014

VAR - 330120, 331120, 743846 - POWER SHUTTLE SERVO PTO FOR DIFF. LOCK - PTO CLUTCH CONTROL ACTUATOR CYLINDER - BREAKDOWN

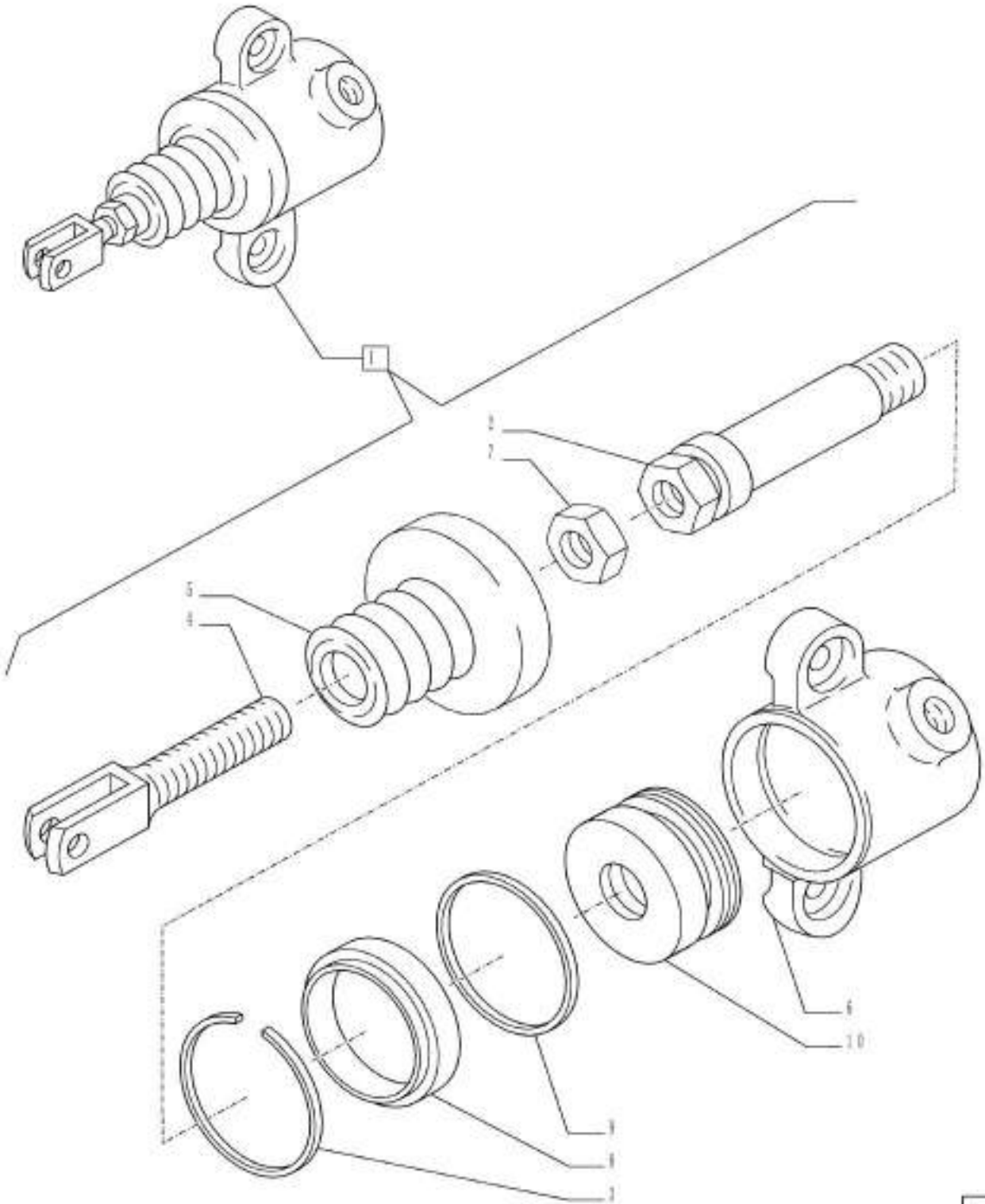

18.104.AS

02

p1

1/2014

VAR - 330120, 331120, 743846 - POWER SHUTTLE SERVO PTO FOR DIFF. LOCK - PTO CLUTCH CONTROL ACTUATOR CYLINDER - BREAKDOWN

REF FN	PART NUMBER	YR/SN	QTY DESCRIPTION
1	84527853		1 CONTROL VALVE ASSY, Incl 2 - 10
2	84515276		1 STUD
3	84163829		1 RING
4	5183675		1 CLEVIS
5	5183723		1 BELLOWS
6	NSS		1 NOT SERVICED SEPARATELY Pipe Incl in 1
7	10791014		1 NUT M10 x 1.25, CI 04
8	5185834		1 SEAL
9	5185835		1 RING
10	84342331		1 PISTON

Valid for Industrial Var. 330120, 331120 (743846)	FARMALL JX100 FARMALL JX110 FARMALL JX75 FARMALL JX90
---	--

VAR - 395250 - CLUTCH & DISC ASSY

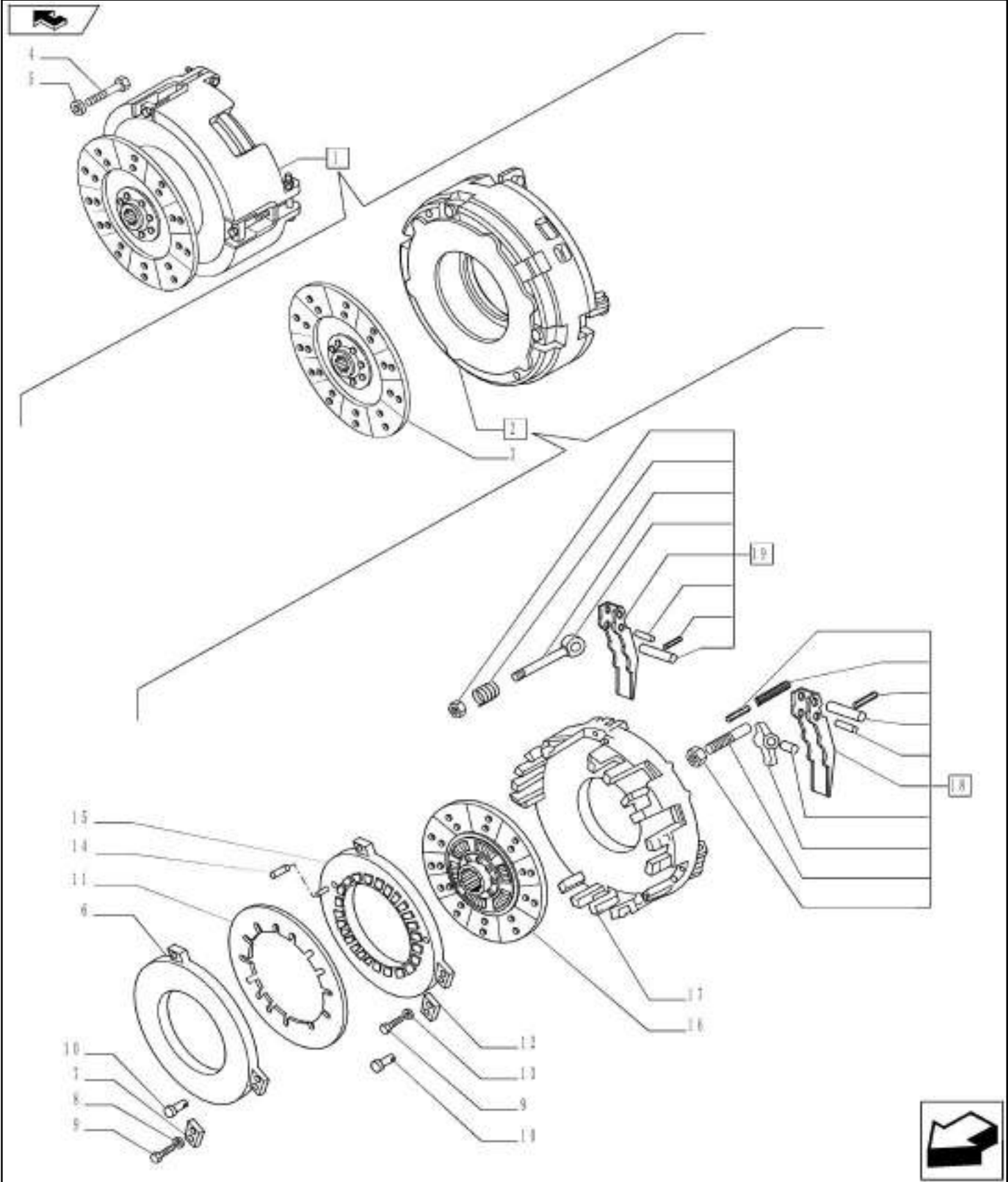

18.110.AB

01

p1

1/2014

VAR - 395250 - CLUTCH & DISC ASSY

REF FN	PART NUMBER	YR/SN	QTY DESCRIPTION
1	84328831		1 CLUTCH Incl 2, 3
2	84328832		1 CLUTCH Incl 6 - 19
3	5092788		1 CLUTCH PLATE
4	16045121		6 BOLT Hex, M8 x 95, 8.8
5	11193874		6 BELLEVILLE WASHER 8.4mm ID x 16.00mm OD x 1.4mm, 1.85mm, Cl 8.8
6	C1009837		1 PRESSURE RING
7	25221058		9 PLATE
8	25274715		6 WASHER
9	25286430		6 BOLT
10	25276324		6 RIVET
11	25174661		1 BELLEVILLE SPRING
12	25220538		12 PLATE
13	25742115		3 WASHER
14	25173704		3 PIN
15	25174761		1 CLUTCH PLATE
16	5092790		1 DISC
17	C1009881		1 CLUTCH MECHANISM
18	5080820		1 FINGER Big
19	5080821		1 FINGER Small

Valid for Var. 395250

FARMALL JX70

VAR - 390815, 720248 - CLUTCH & DISC ASSY

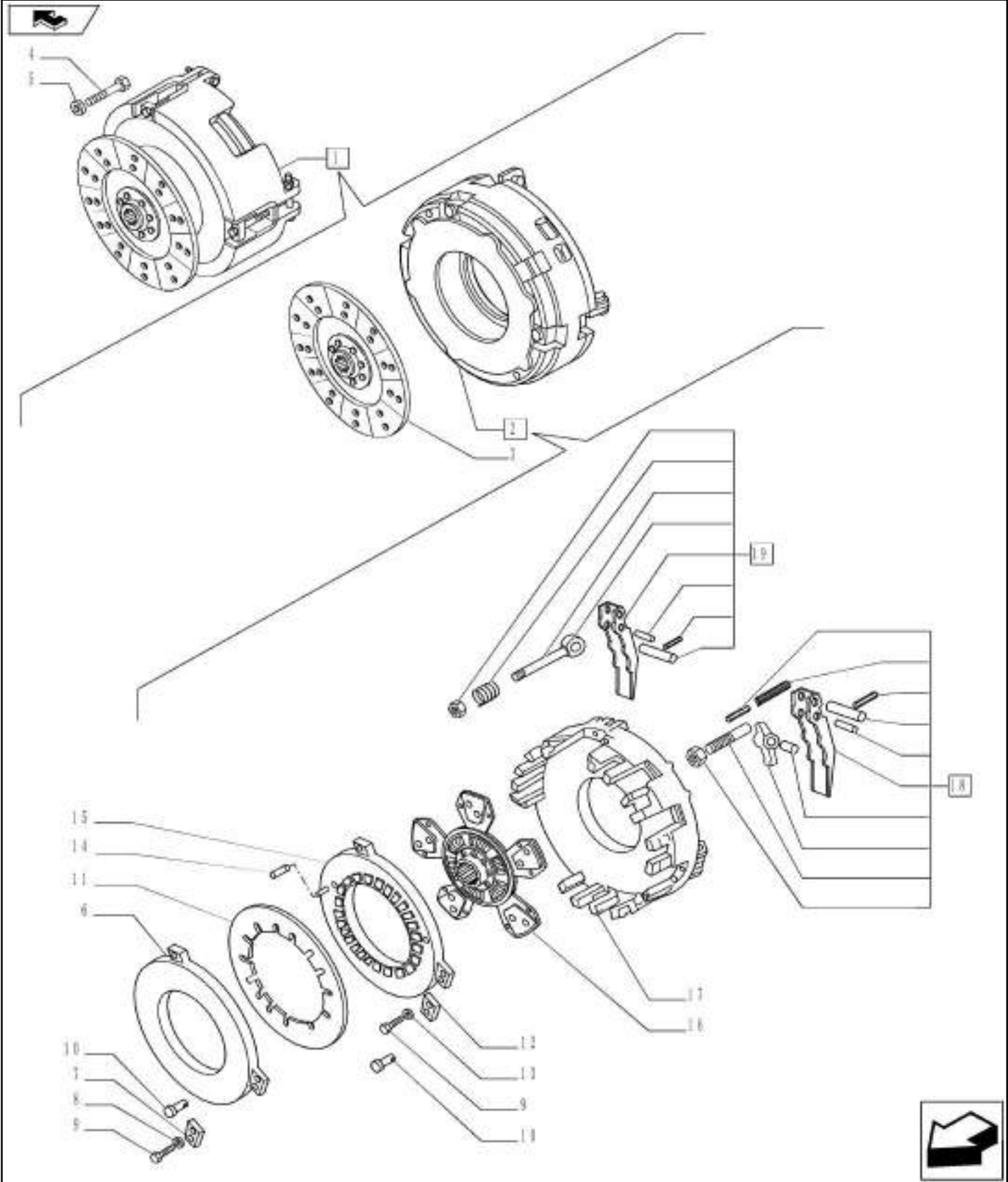

18.110.AB

02

p1

1/2014

VAR - 390815, 720248 - CLUTCH & DISC ASSY

REF FN	PART NUMBER	YR/SN	QTY DESCRIPTION
1	84328833		1 CLUTCH Incl 2, 3
2	84328834		1 CLUTCH Incl 6 - 19
3	5092788		1 CLUTCH PLATE
4	16045121		6 BOLT Hex, M8 x 95, 8.8
5	11193874		6 BELLEVILLE WASHER 8.4mm ID x 16.00mm OD x 1.4mm, 1.85mm, CI 8.8
6	C1009837		1 PRESSURE RING
7	25221058		9 PLATE
8	25274715		6 WASHER
9	25286430		6 BOLT
10	25276324		6 RIVET
11	25174661		1 BELLEVILLE SPRING
12	25220538		12 PLATE
13	25742115		3 WASHER
14	25173704		3 PIN
15	25174761		1 CLUTCH PLATE
16	5092794		1 DISC
17	C1009881		1 CLUTCH MECHANISM
18	5080820		1 FINGER Big
19	5080821		1 FINGER Small

Valid for Industrial Var. 390815 (720248)

FARMALL JX75

18.110.AB

03

p1

1/2014

VAR - 390815, 720248 - CLUTCH & DISC ASSY

REF FN	PART NUMBER	YR/SN	QTY DESCRIPTION
1	84328434		1 CLUTCH Incl 2, 3
2	84328836		1 CLUTCH Incl 6 - 19
3	84328451		1 CLUTCH PLATE
4	16045121		6 BOLT Hex, M8 x 95, 8.8
5	11193874		6 BELLEVILLE WASHER 8.4mm ID x 16.00mm OD x 1.4mm, 1.85mm, CI 8.8
6	C1010031		1 CLUTCH PRESSURE PLATE
7	25221058		9 PLATE
8	25274715		6 WASHER
9	25286430		6 BOLT
10	25276324		6 RIVET
11	25174661		1 BELLEVILLE SPRING
12	25220538		12 PLATE
13	25742115		3 WASHER
14	25173704		3 PIN
15	25174761		1 CLUTCH PLATE
16	84328362		1 CLUTCH PLATE
17	C1009881		1 CLUTCH MECHANISM
18	5080820		1 FINGER Big
19	5080821		1 FINGER Small

Valid for Industrial Var. 390815 (720248)

**FARMALL JX80
FARMALL JX90**

18.110.AB

04

p1

1/2014

VAR - 390816, 744743 - CLUTCH & DISC ASSY

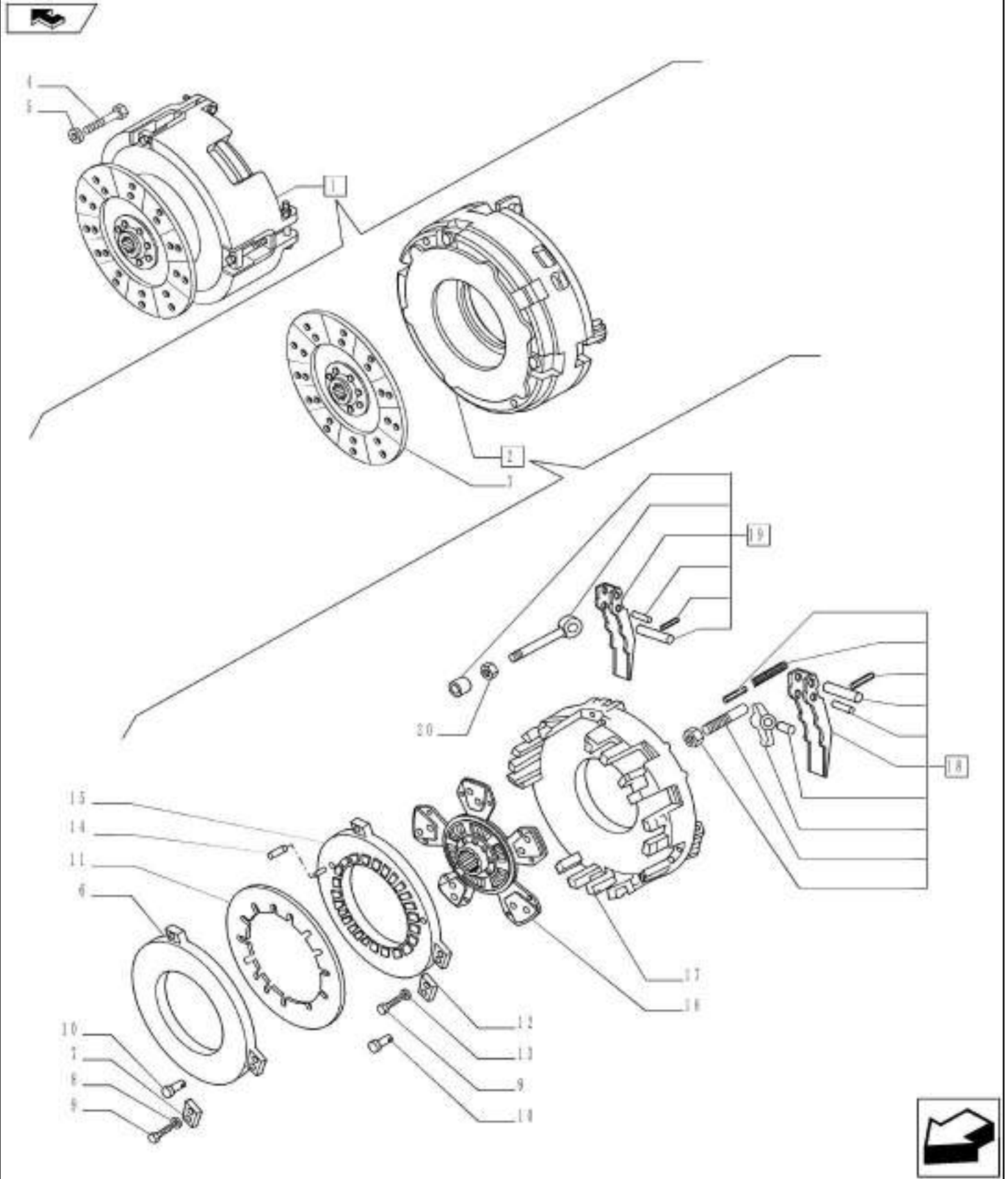

18.110.AB

04

p1

1/2014

VAR - 390816, 744743 - CLUTCH & DISC ASSY

REF FN	PART NUMBER	YR/SN	QTY DESCRIPTION
1	84328437		1 CLUTCH & DISC ASSY Incl 2, 3
2	84328448		1 CLUTCH Incl 6 - 19
3	5089337		1 CLUTCH PLATE
4	15971824		6 SCREW Hex, M10 x 1.25 x 100mm, CI 8.8
5	11190574		6 BELLEVILLE WASHER Belleville, M10.5
6	25280501		1 CLUTCH PLATE
7	25583743		9 SPRING
8	25274715		6 WASHER
9	25286430		6 BOLT
10	25276324		6 RIVET
11	C0174657		1 BELLEVILLE SPRING
12	25220538		12 PLATE
13	25742115		3 WASHER
14	25173704		3 PIN
15	25174666		1 CLUTCH PLATE
16	5092805		1 CLUTCH PLATE
17	25583031		1 CLUTCH MECHANISM
18	84361145		1 CLUTCH PACK
19	84361152		1 CLUTCH PACK

Valid for Industrial Var. 390816 (744743)	FARMALL JX100
--	----------------------

18.110.AB

05

p1

1/2014

VAR - 390816, 744743 - CLUTCH & DISC ASSY

REF FN	PART NUMBER	YR/SN	QTY DESCRIPTION
1	84478094		1 CLUTCH Incl 2, 3
2	84478095		1 CLUTCH Incl 6, 7
3	84146735		1 CLUTCH PLATE
4	11234721		6 BOLT Hex, M10 x 1.25 x 45, 8.8
5	11190574		6 BELLEVILLE WASHER Belleville, M10.5
6	NSS		1 NOT SERVICED SEPARATELY Housing Incl in 2
7	84478096		1 CLUTCH DISC

Valid for Industrial Var. 390816 (744743)

FARMALL JX110

VAR - 335248 - CLUTCH & DISC ASSY

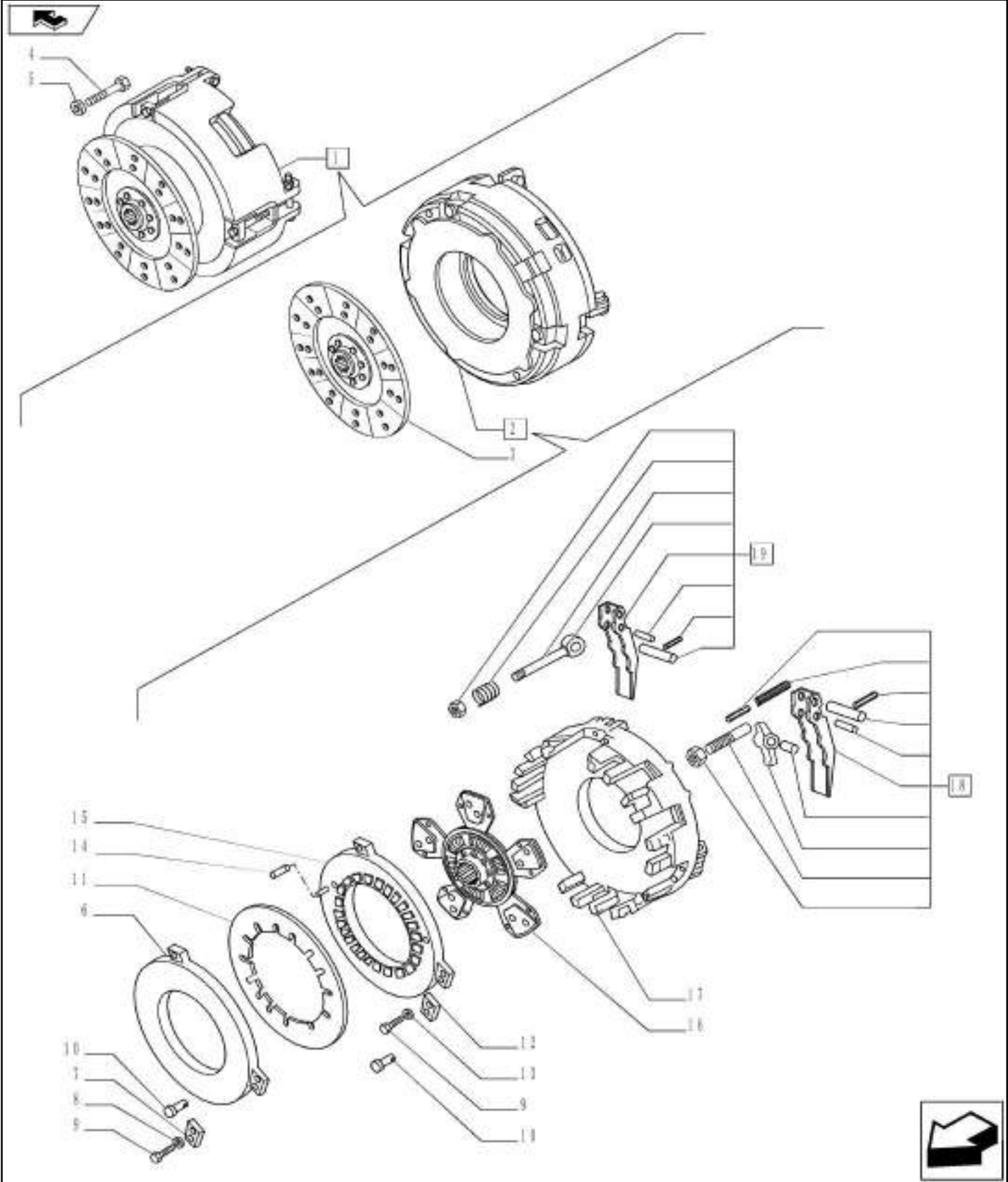

18.110.AB

06

p1

1/2014

VAR - 335248 - CLUTCH & DISC ASSY

REF FN	PART NUMBER	YR/SN	QTY DESCRIPTION
1	84328833		1 CLUTCH Incl 2, 3
2	84328834		1 CLUTCH Incl 6 - 19
3	5092788		1 CLUTCH PLATE
4	16045121		6 BOLT Hex, M8 x 95, 8.8
5	11193874		6 BELLEVILLE WASHER 8.4mm ID x 16.00mm OD x 1.4mm, 1.85mm, Cl 8.8
6	C1009837		1 PRESSURE RING
7	25221058		9 PLATE
8	25274715		6 WASHER
9	25286430		6 BOLT
10	25276324		6 RIVET
11	25174661		1 BELLEVILLE SPRING
12	25220538		12 PLATE
13	25742115		3 WASHER
14	25173704		3 PIN
15	25174761		1 CLUTCH PLATE
16	5092794		1 DISC
17	C1009881		1 CLUTCH MECHANISM
18	5080820		1 FINGER Big
19	5080821		1 FINGER Small

Valid for Var. 335248

FARMALL JX70

18.110.AB

07

p1

1/2014

VAR - 334409, 334410, 720248, 720514 - CLUTCH & DISC ASSY

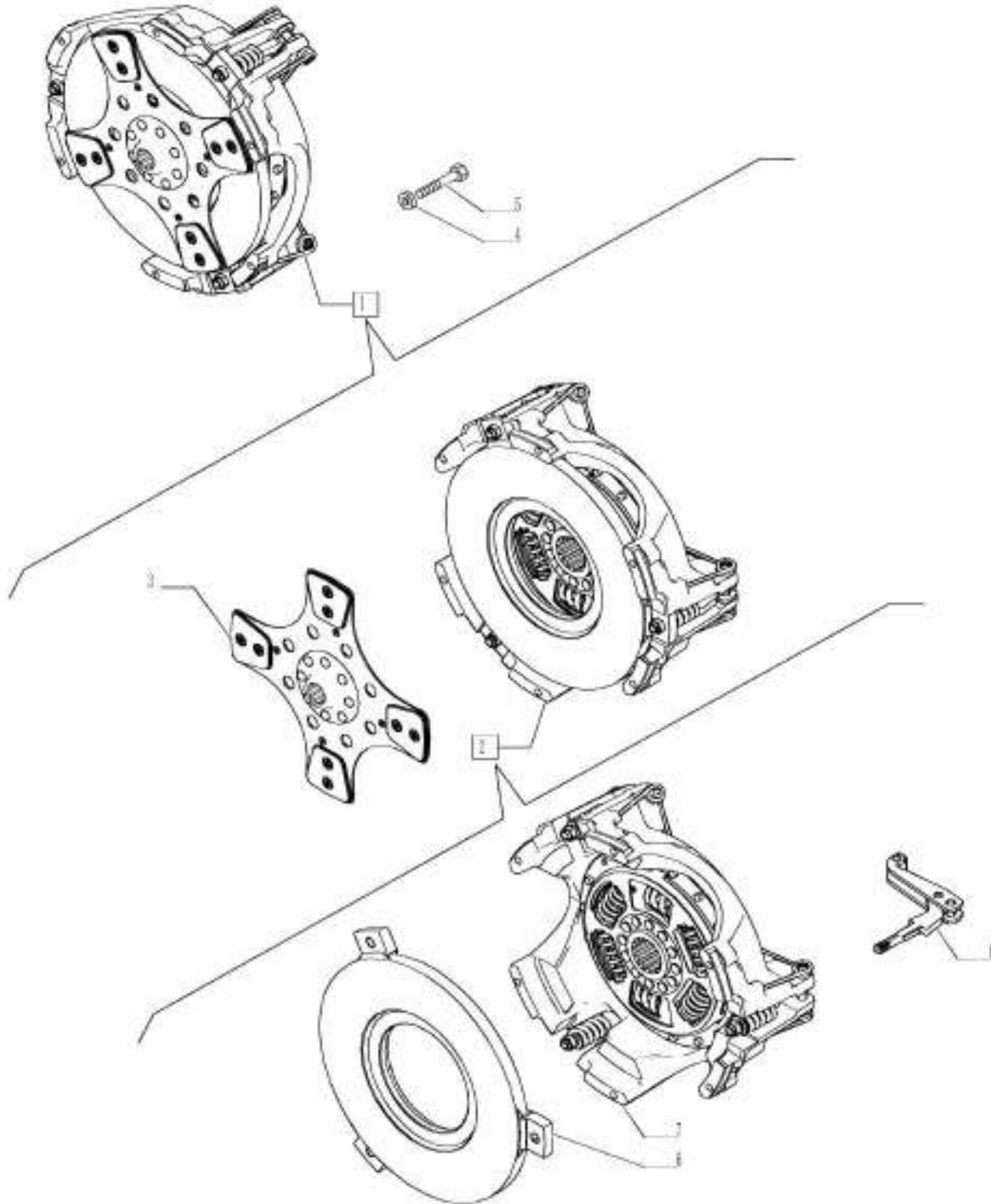

18.110.AB

07

p1

1/2014

VAR - 334409, 334410, 720248, 720514 - CLUTCH & DISC ASSY

REF FN	PART NUMBER	YR/SN	QTY DESCRIPTION
1	87732485		1 CLUTCH Incl 2, 3
2	87732490		1 CLUTCH Incl 6 - 8
3	47134874		1 CLUTCH PLATE
4	386045		6 BOLT Hex, M8 x 45, 8.8
5	11193874		6 BELLEVILLE WASHER 8.4mm ID x 16.00mm OD x 1.4mm, 1.85mm, Cl 8.8
6	87594144		1 PRESSURE RING
7	NSS		1 NOT SERVICED SEPARATELY Housing Incl in 1
8	87741845		1 KIT

Valid for Industrial Var. 334409 (720248) or Industrial Var. 334410 (720514)

FARMALL JX75
FARMALL JX90

18.110.AB

08

p1

1/2014

VAR - 335814, 744743 - CLUTCH & DISC ASSY

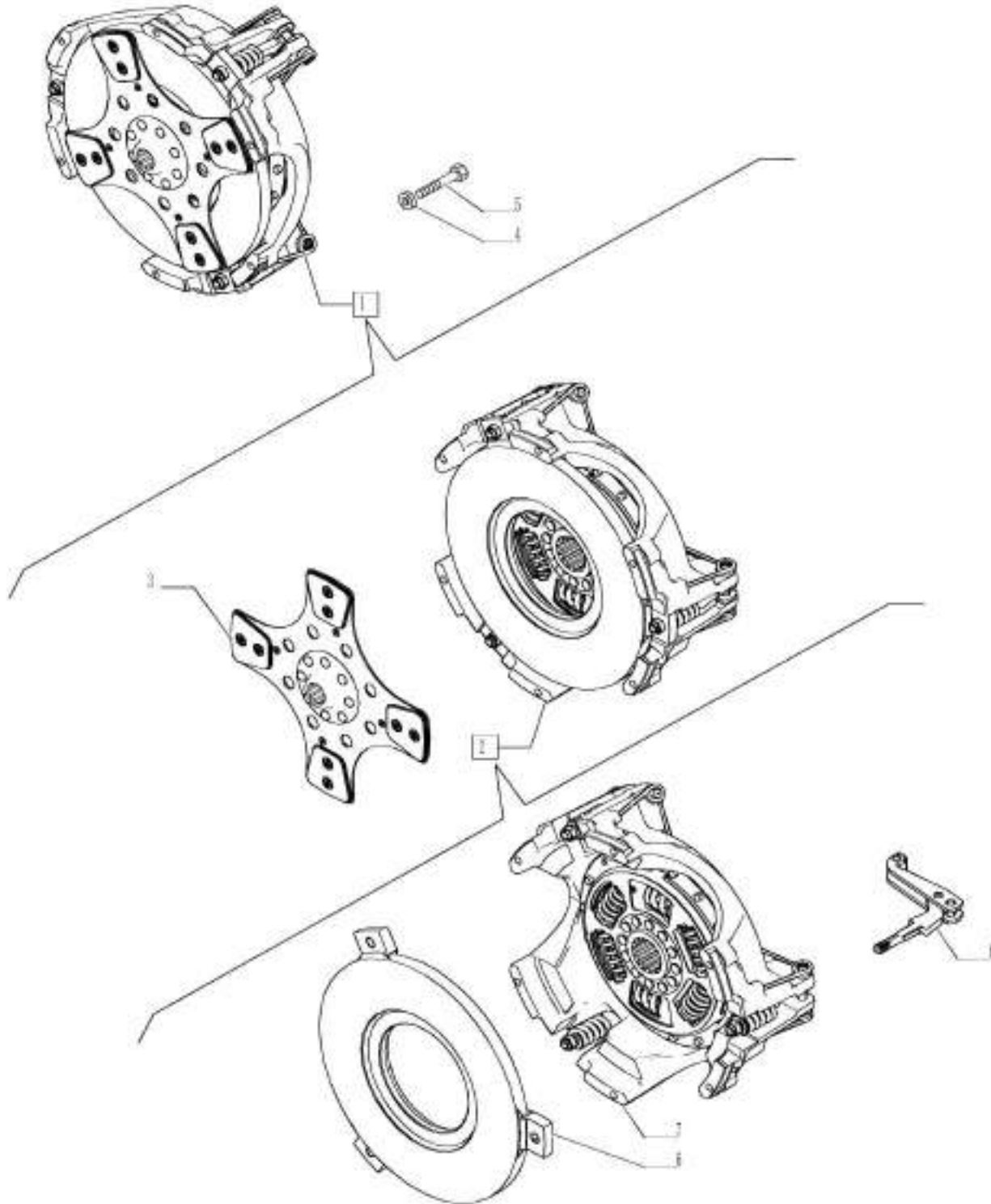

18.110.AB

08

p1

1/2014

VAR - 335814, 744743 - CLUTCH & DISC ASSY

REF FN	PART NUMBER	YR/SN	QTY DESCRIPTION
1	87732485		1 CLUTCH Incl 2, 3
2	87732490		1 CLUTCH Incl 6 - 8
3	47134874		1 CLUTCH PLATE
4	386045		6 BOLT Hex, M8 x 45, 8.8
5	11193874		6 BELLEVILLE WASHER 8.4mm ID x 16.00mm OD x 1.4mm, 1.85mm, Cl 8.8
6	87594144		1 PRESSURE RING
7	NSS		1 NOT SERVICED SEPARATELY Housing Incl in 1
8	87741845		1 KIT

Valid for Industrial Var. 335814 (744743)

FARMALL JX100

VAR - 334298, 720514 - CLUTCH & DISC ASSY

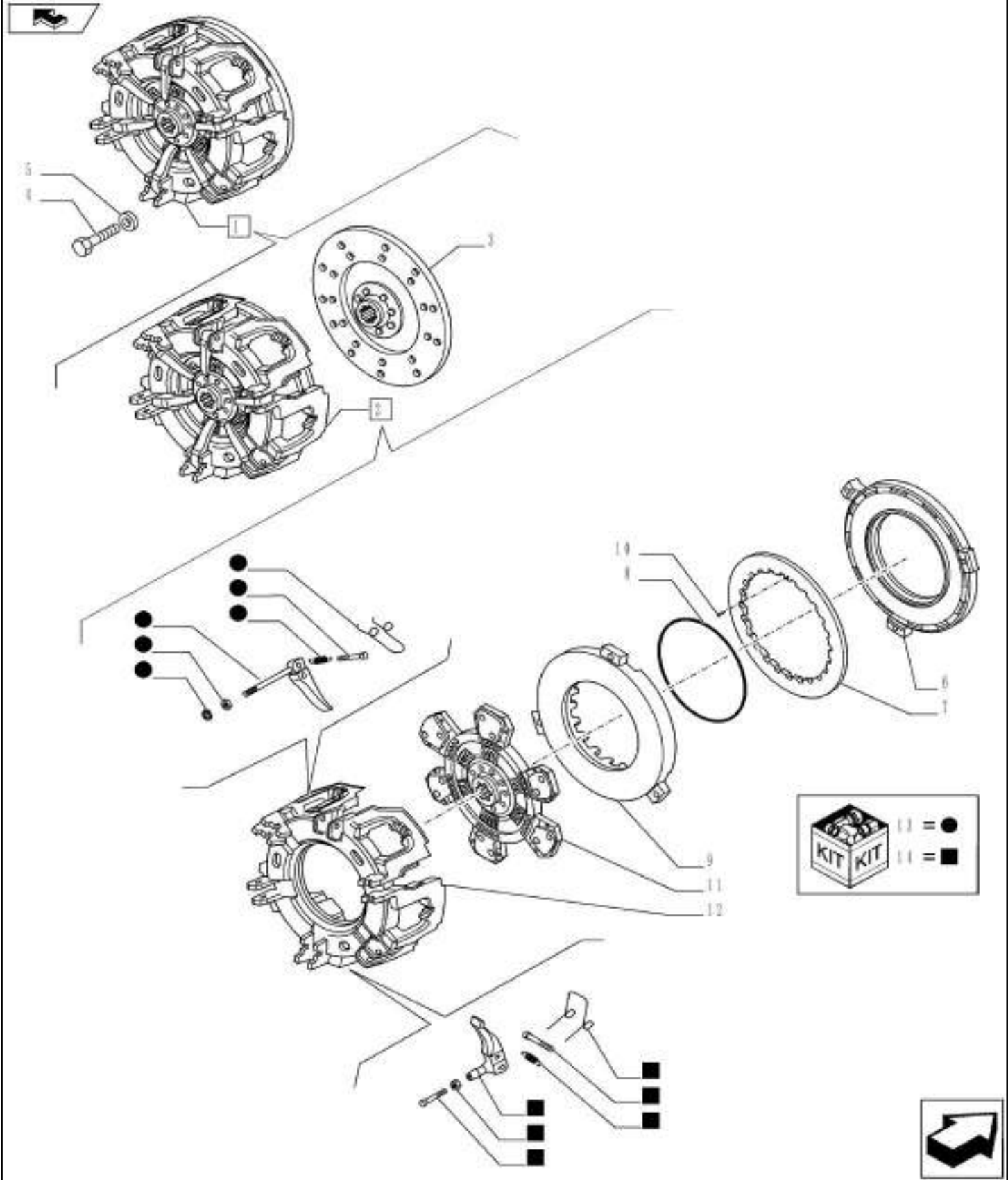

18.110.AB

09

p1

1/2014

VAR - 334298, 720514 - CLUTCH & DISC ASSY

REF FN	PART NUMBER	YR/SN	QTY DESCRIPTION
1	84177325		1 CLUTCH Incl 2, 3
2	84177326		1 CLUTCH Incl 4 - 14
3	5154703		1 CLUTCH PLATE
4	43129		6 BOLT Hex, M8 x 1.25 x 40mm, Cl 8.8
5	11193879		6 BELLEVILLE WASHER Belleville, M8.4
6	84420865		1 PRESSURE RING
7	84420864		1 DIAPHRAGM
8	84420863		1 RING
9	84420862		1 PRESSURE RING
10	84420610		1 PIN
11	84177329		1 CLUTCH PLATE
12	84420860		1 CLUTCH HOUSING
13	84420878		1 KIT
14	84420877		1 KIT

Valid for Industrial Var. 334298 (720514)	FARMALL JX75 FARMALL JX80 FARMALL JX90
--	---

18.110.AB

10

p1

1/2014

VAR - 335814, 744743 - CLUTCH & DISC ASSY

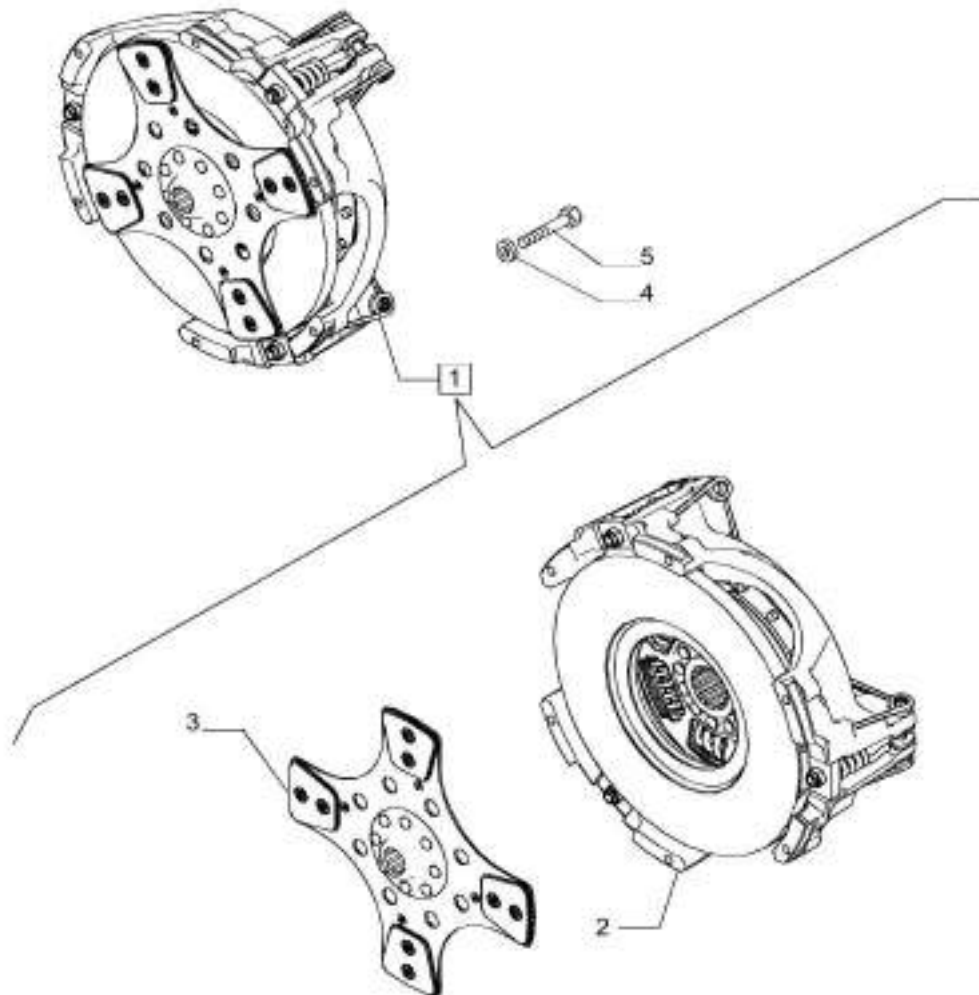

18.110.AB

10

p1

1/2014

VAR - 335814, 744743 - CLUTCH & DISC ASSY

REF FN	PART NUMBER	YR/SN	QTY DESCRIPTION
1	84427005		1 CLUTCH Incl 2, 3
2	84427009		1 CLUTCH
3	84146735		1 CLUTCH PLATE
4	11193874		6 BELLEVILLE WASHER 8.4mm ID x 16.00mm OD x 1.4mm, 1.85mm, CI 8.8
5	16044121		6 BOLT Hex, M8 x 45, 8.8

Valid for Industrial Var. 335814 (744743)

FARMALL JX110

SECTION INDEX

TRANSMISSION

21.000.00	01	SECTION INDEX, TRANSMISSION
21.000.00	02	SECTION INDEX, TRANSMISSION
21.104.AR	01	VAR - 330120, 331120, 743846 - TRANSMISSION LUBRICATION LINE
21.109.AK	01	VAR - 330120, 331120, 743846 - TRANSMISSION OIL COOLER
21.112.AB	01	VAR - 335116, 390110, 744735 - TRACTOR BODY, GEARBOX HOUSING
21.112.AB	03	VAR - 335113 - 20X12 TRANSMISSION WITH SYNCHRO SHUTTLE AND CREEPER - TRACTOR BODY
21.112.AB	04	VAR - 330120, 331120, 743846 - POWER SHUTTLE AND SERVO PTO FOR MECH. DIFF. LOCK - TRACTOR BODY
21.118.AF	01	VAR - 334303, 335116, 390110, 744735 - TRACTOR BODY, REAR TRANSMISSION HOUSING
21.118.AF	02	VAR - 335113 - 20X12 TRANSMISSION WITH SYNCHRO SHUTTLE AND CREEPER, HOUSING
21.118.AG	01	VAR - 334303, 335113, 335116, 390110, 744735 - TRACTOR BODY - REAR TRANSMISSION HOUSING COVER
21.130.AZ	01	VAR - 335113, 335116, 743846, 744735 - REVERSE CONTROL
21.130.AZ	02	VAR - 335113, 390110, 744735 - REVERSER INTERLOCK MECHANISM
21.130.AZ	03	VAR - 335113 - REVERSER INTERLOCK MECHANISM
21.130.BC	01	VAR - 744738, 744739, 744744 - GEARSHIFT CONTROL
21.130.BC	02	VAR - 335113, 743846, 744735 - GEAR SPLITTER CONTROL
21.134.AM	01	VAR - 330120, 331120, 743846 - POWER SHUTTLE E SERVO PTO FOR DIFF. LOCK, POWER SHUTTLE VALVE
21.134.AM	02	VAR - 330120, 331120, 743846 - POWER SHUTTLE E SERVO PTO FOR DIFF. LOCK, POWER SHUTTLE VALVE, BREAKDOWN
21.134.AM	03	VAR - 330120, 331120, 743846 - POWER SHUTTLE E SERVO PTO FOR DIFF. LOCK, POWER SHUTTLE VALVE, BREAKDOWN
21.134.AM	04	VAR - 330120, 331120, 743846 - POWER SHUTTLE E SERVO PTO FOR DIFF. LOCK, POWER SHUTTLE VALVE, BREAKDOWN
21.134.AM	05	VAR - 330120, 331120, 743846 - POWER SHUTTLE E SERVO PTO FOR DIFF. LOCK, POWER SHUTTLE VALVE, BREAKDOWN
21.148.AA	01	VAR - 335113, 335116, 390110, 744735 - TRANSMISSION GEARS, 1ST - 2ND SPEED SYNCHRONIZER - BREAKDOWN
21.148.AA	02	VAR - 335113, 335116, 390110, 744735 - TRANSMISSION GEARS, 3RD - 4TH SPEED SYNCHRONIZER - BREAKDOWN
21.148.AC	01	VAR - 335113, 335116, 390249, 743846, 744735 - BEVEL GEAR
21.148.AC	02	VAR - 335113, 335116, 390249, 743846, 744735 - BEVEL GEAR, SHIM
21.148.AC	03	VAR - 335113, 335116, 390249, 743846, 744735 - CENTRAL REDUCTION GEARS - MEDIUM RANGE GEARS
21.148.AC	04	VAR - 335116 - 12+4 SYNCHRO AND SHAFT
21.148.AC	05	VAR - 330120, 331120, 390249, 743846 - BEVEL GEAR
21.148.AC	06	VAR - 330120, 331120, 390249, 743846 - BEVEL GEAR, SHIM
21.148.AK	01	VAR - 334303, 335113, 335116, 390110, 744735 - INNER CONTROLS - ROD AND FORK
21.148.AK	02	VAR - 335113 - INNER CONTROLS - ROD AND FORK

SECTION INDEX

TRANSMISSION

21.148.AQ	01	VAR - 390110, 744735 - TRANSMISSION, GEAR SHAFT
21.148.AQ	02	VAR - 330120, 331120, 743846 - TRANSMISSION GEARS
21.148.AQ	03	VAR - 330120, 331120, 743846 - TRANSMISSION, GEAR SHAFT
21.148.AQ	04	VAR - 335116 - TRANSMISSION, GEAR SHAFT
21.148.AQ	05	VAR - 335113 - TRANSMISSION, GEAR SHAFT
21.148.AQ	06	VAR - 335113 - TRANSMISSION GEARS
21.148.AQ	07	VAR - 335113 - TRANSMISSION GEARS
21.148.AQ	08	VAR - 335113 - TRANSMISSION GEARS
21.154.AA	01	VAR - 330120, 331120, 743846 - CLUTCH
21.154.AA	02	VAR - 330120, 331120, 743846 - CLUTCH DISK
21.154.AJ	01	VAR - 330120, 331120, 743846 - DRIVE GEAR SHAFT
21.154.AO	01	VAR - 330120, 331120, 743846 - TRANSMISSION, GEAR
21.160.AI	01	VAR - 335113 - 20X12 TRANSMISSION WITH SYNCHRO SHUTTLE - CREEPER CONTROL LEVER
21.162.AF	01	VAR - 390110, 744735 - REVERSER

SECTION INDEX, TRANSMISSION

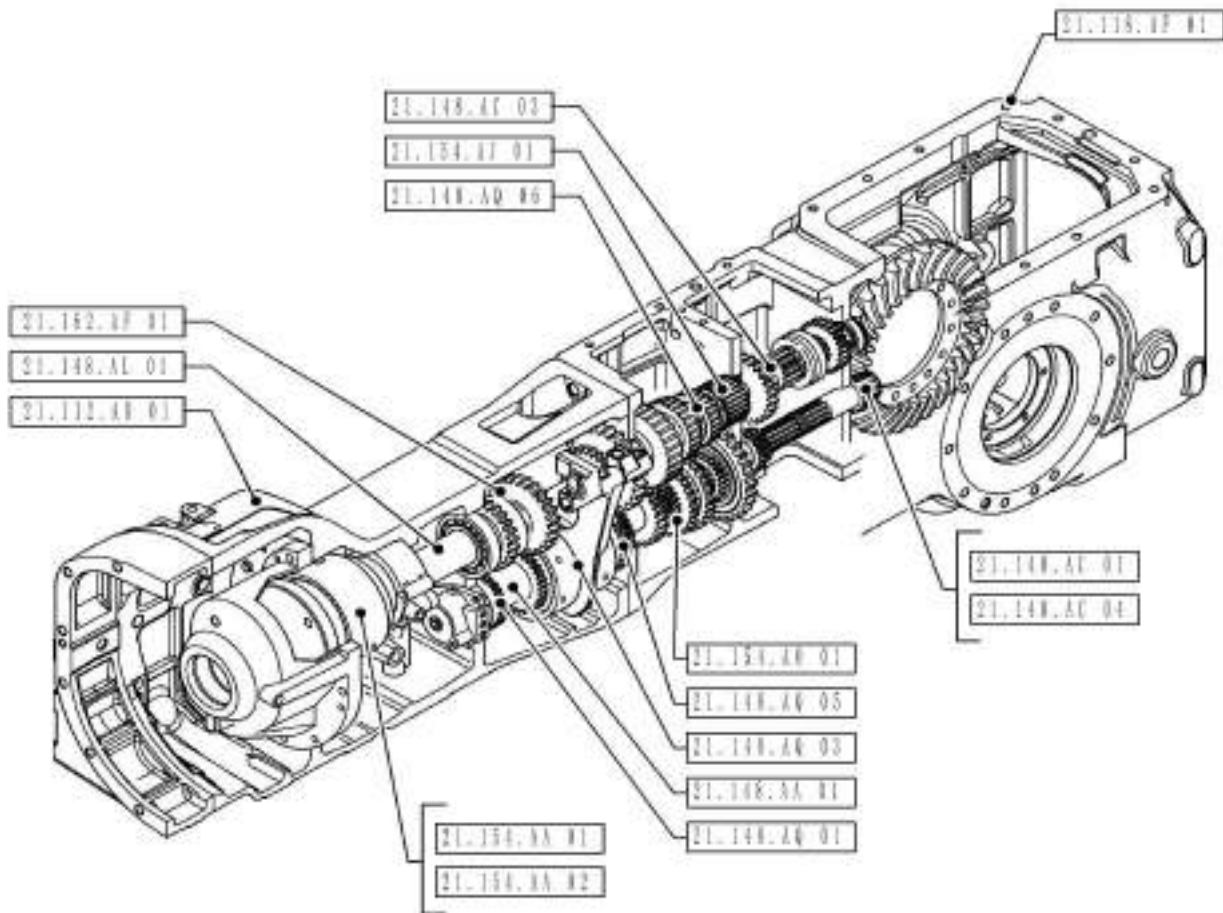

21.000.00

01

p1

1/2014

SECTION INDEX, TRANSMISSION

REF FN	PART NUMBER	YR/SN	QTY	DESCRIPTION
---------------	--------------------	--------------	------------	--------------------

				FARMALL JX100 FARMALL JX110 FARMALL JX70 FARMALL JX75 FARMALL JX80 FARMALL JX90
--	--	--	--	--

SECTION INDEX, TRANSMISSION

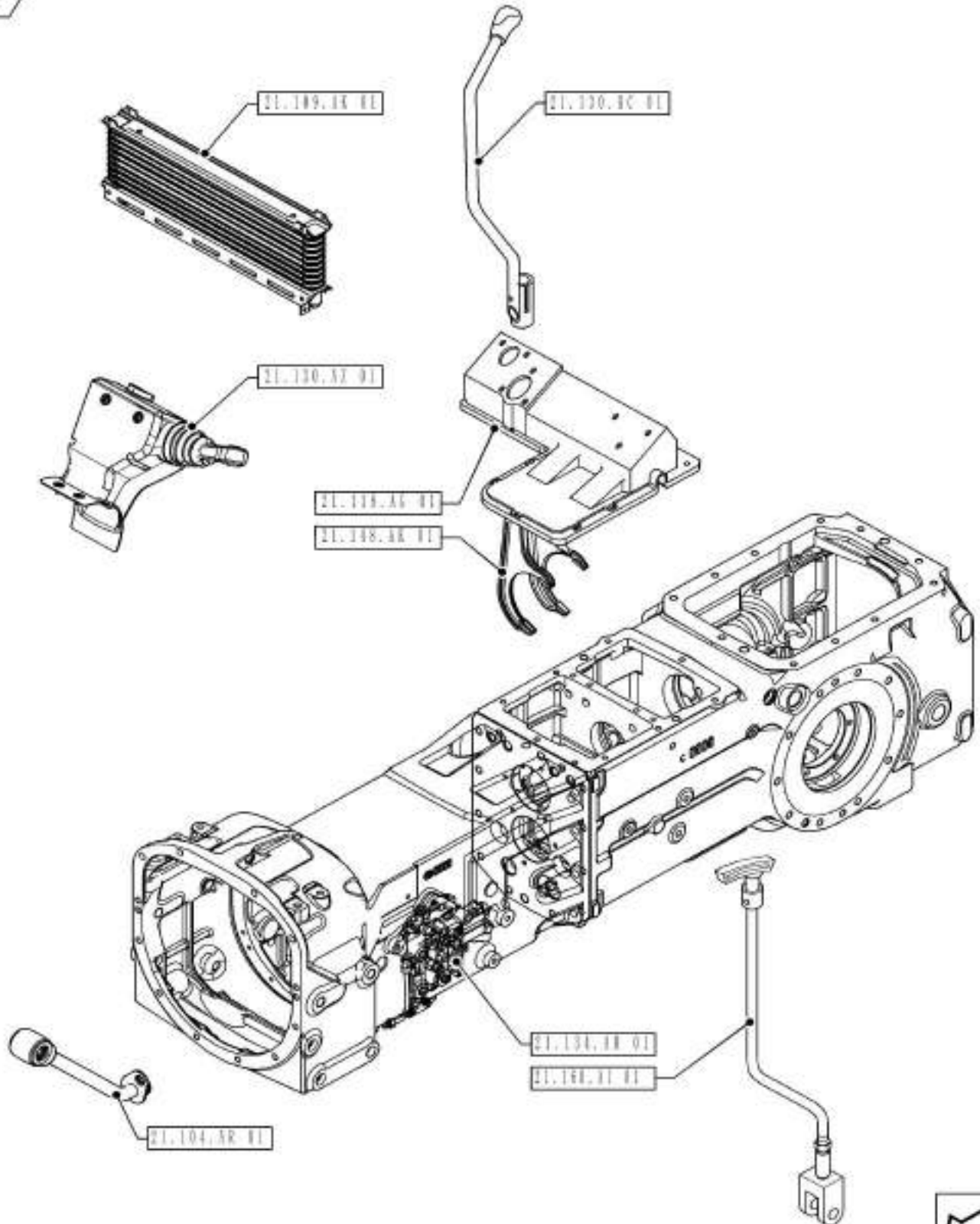

21.000.00

02

p1

1/2014

SECTION INDEX, TRANSMISSION

REF FN	PART NUMBER	YR/SN	QTY	DESCRIPTION
---------------	--------------------	--------------	------------	--------------------

				FARMALL JX100 FARMALL JX110 FARMALL JX70 FARMALL JX75 FARMALL JX80 FARMALL JX90
--	--	--	--	--

VAR - 330120, 331120, 743846 - TRANSMISSION LUBRICATION LINE

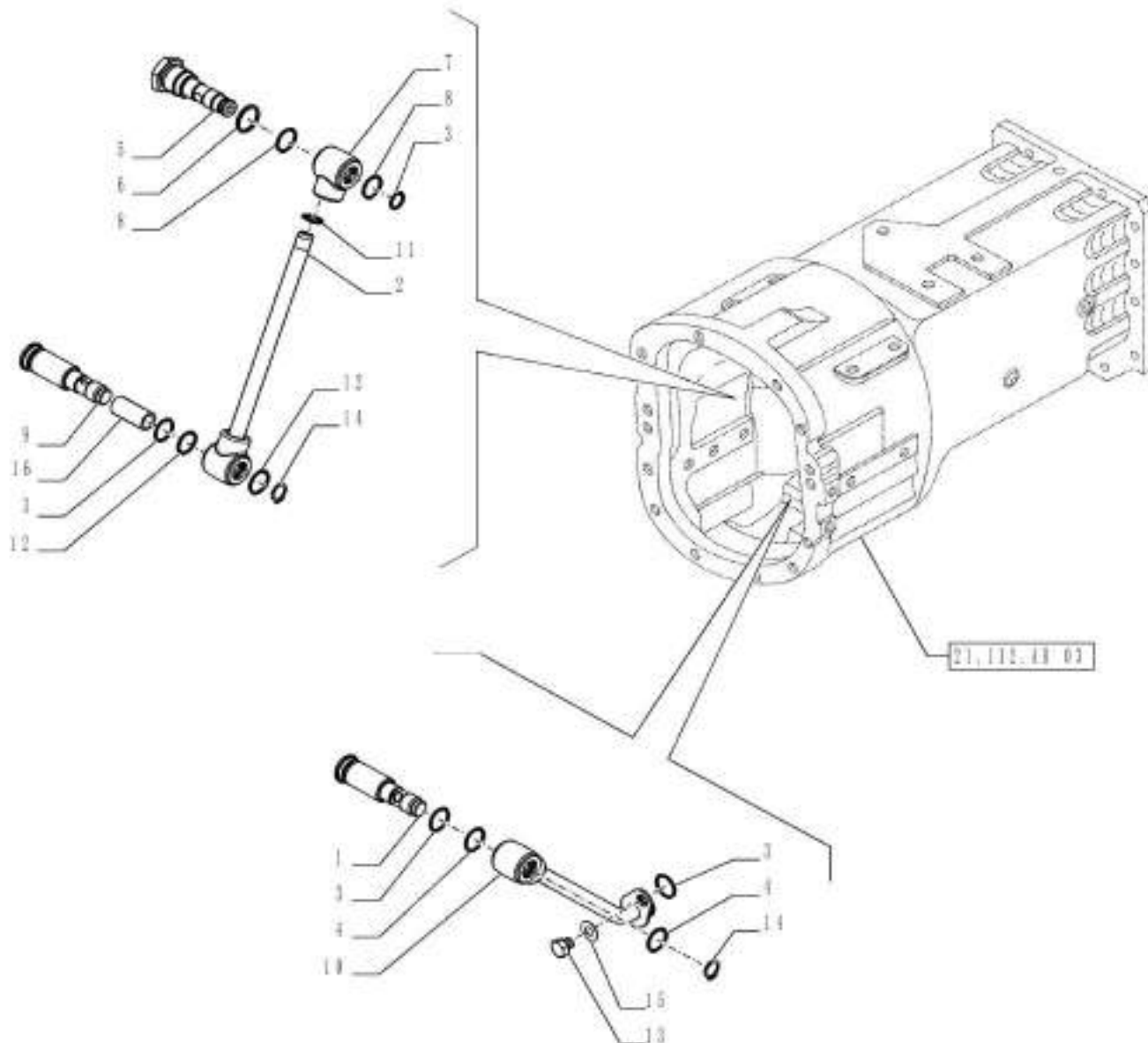

VAR - 330120, 331120, 743846 - TRANSMISSION LUBRICATION LINE

REF FN	PART NUMBER	YR/SN	QTY DESCRIPTION
1	84516898		1 HYD CONNECTOR
2	84286490		1 PIPE
3	14456881		3 O-RING 0.362" ID x 0.103" Width
4	14457180		2 O-RING 13.94mm ID x 2.62" Width
5	84286481		1 HYD CONNECTOR
6	14438085		1 O-RING 19.3mm ID x 2.4mm
7	5177779		1 HYD CONNECTOR
8	14457181		2 O-RING 13.94mm ID x 2.62" Width
9	84516901		1 HYD CONNECTOR
10	84573290		1 PIPE
11	5103230		1 O-RING 11.91mm ID x 2.62mm Width
12	14457280		4 O-RING 0.612" ID x 0.103"
13	15857624		1 SCREW Hex, M8 x 8mm, Cl 8.8, Full Thd
14	11066176		2 SNAP RING M13, Ext
15	12601374		1 WAVE WASHER Wave, 8.40mm ID x 15.00mm OD x 0.80mm, 3.00mm, CST, DAC
16	84527851		1 SPACER

Valid for Industrial Var. 330120, 331120 (743846)

FARMALL JX100
 FARMALL JX110
 FARMALL JX75
 FARMALL JX90

21.109.AK

01

p1

1/2014

VAR - 330120, 331120, 743846 - TRASMISSION OIL COOLER

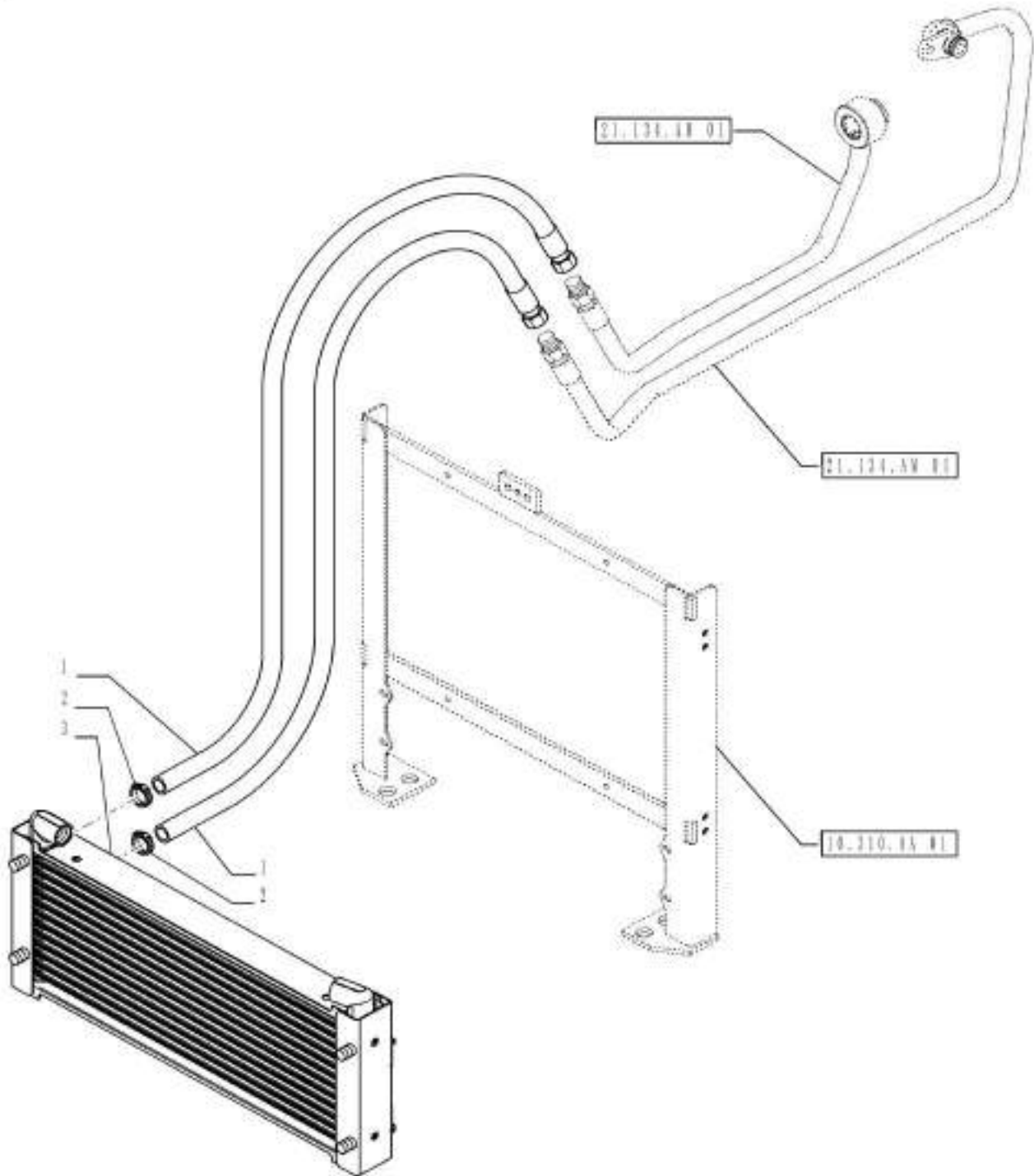

21.112.AB

01

p1

1/2014

VAR - 335116, 390110, 744735 - TRACTOR BODY, GEARBOX HOUSING

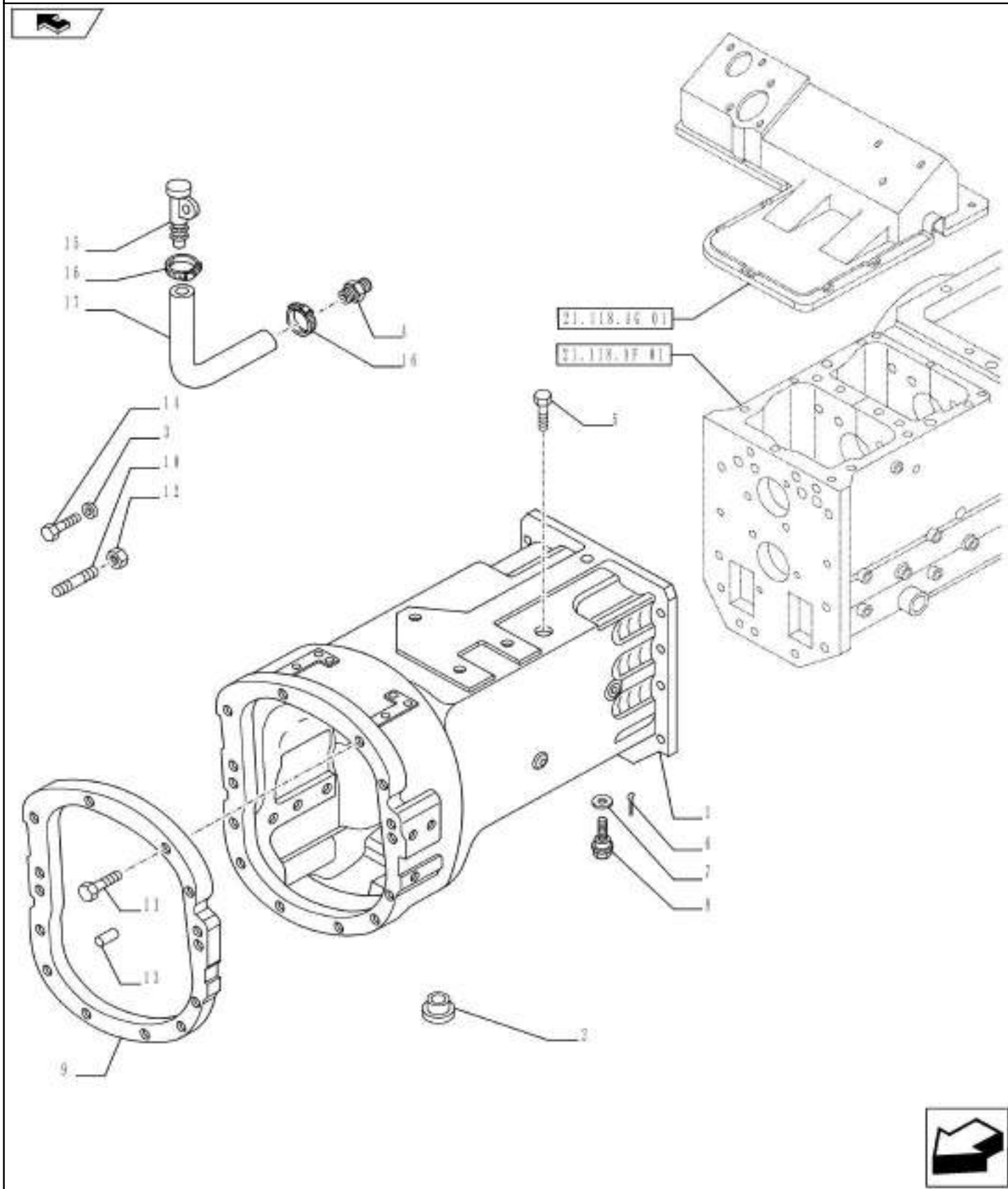

VAR - 335116, 390110, 744735 - TRACTOR BODY, GEARBOX HOUSING

REF FN	PART NUMBER	YR/SN	QTY DESCRIPTION
1	84585525		1 HOUSING
2	87529026		AR PLUG
3	11198674		AR BELLEVILLE WASHER Belleville, M13
4	5157395		1 FITTING
5	13305311		1 SCREW Phil Flat Hd, M10 x 20, 4.8
6	10798201		1 COTTER PIN M6.3 x 32
7	10263460		1 SEAL 22.30mm ID x 28.00mm OD, 1.50mm, Copper
8	5118991		1 PLUG M22 x 1.50 x 23.00mm
9	5166241		1 SPACER
10	13972434		AR SCREW M12 x 1.25 x 105mm, CI 10.9 M12x1.25x125
11	47132053		AR SCREW M12x1;25x105
12	16105021		AR LOCK NUT M12 x 1.25, CI 10
13	1 4658441		6 DOWEL M10 x 20mm
14	1 15540634		12 BOLT Hex, M12 x 1.25 x 40, 10.9, Full Thd
15	1 5153270		1 BREATHER
16	1 5085797		2 COLLAR
17	1 84236795		1 HOSE 1000MM

(1) VAR - 330120, 331120 (743846) or 390249

Valid for Var. 335116 or Industrial Var. 390110 (744735)

FARMALL JX100 FARMALL
JX110 FARMALL JX70
FARMALL JX75 FARMALL
JX80 FARMALL JX90

VAR - 335113 - 20X12 TRANSMISSION WITH SYNCHRO SHUTTLE AND CREEPER - TRACTOR BODY

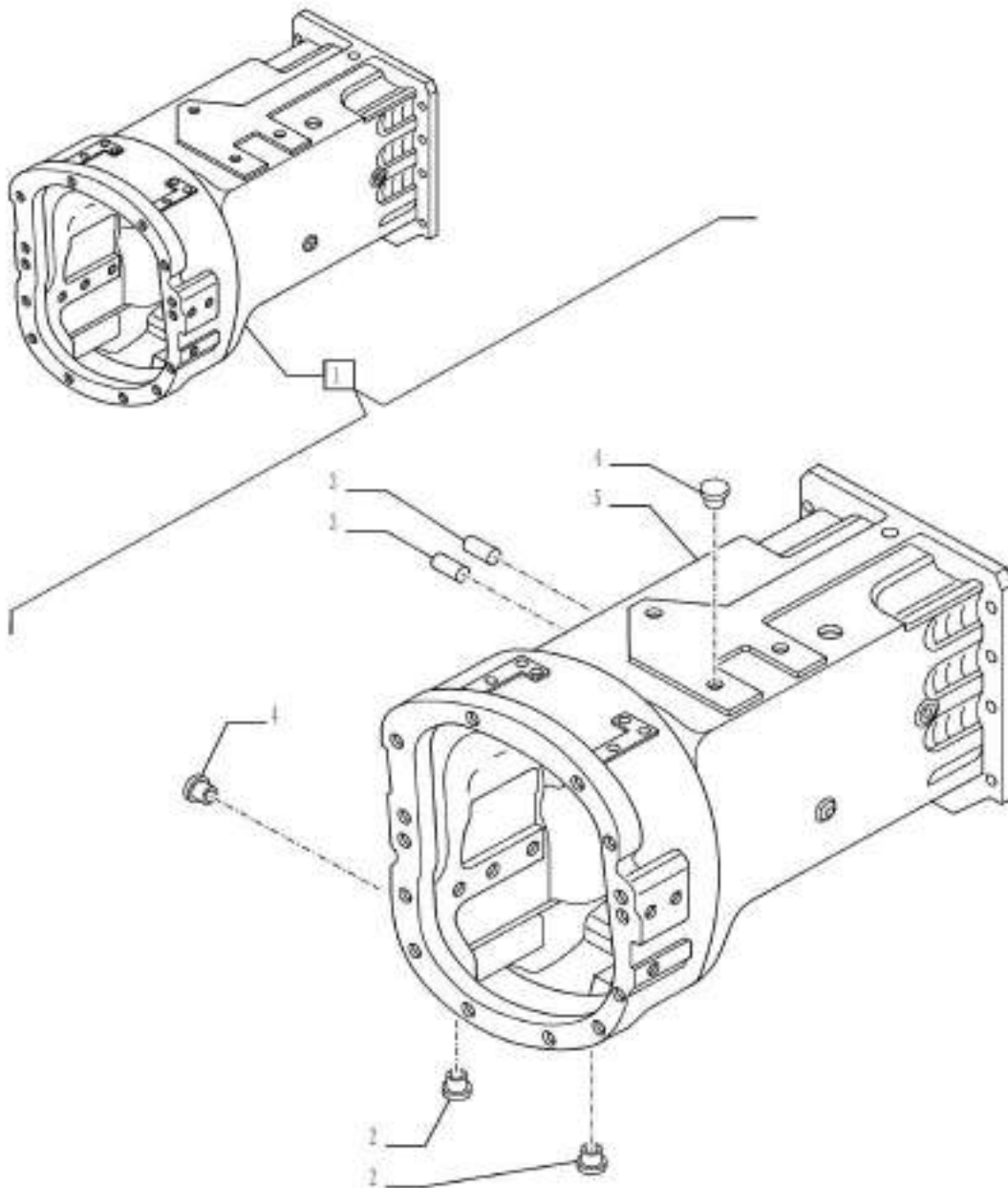

21.112.AB

03

p1

1/2014

VAR - 335113 - 20X12 TRANSMISSION WITH SYNCHRO SHUTTLE AND CREEPER - TRACTOR BODY

REF FN	PART NUMBER	YR/SN	QTY DESCRIPTION
1	84585803		1 HOUSING ASSY Incl 2 - 5
2	4998275		2 PLUG D=10.8-11
3	5133142		2 BUSHING
4	590353		2 PLUG 15mm OD x 10mm High, Plastic D=14.8-15
5	NSS		1 NOT SERVICED SEPARATELY Housing Incl in 1

Valid for Var. 335113

FARMALL JX100 FARMALL
JX110 FARMALL JX70
FARMALL JX75 FARMALL
JX80 FARMALL JX90

VAR - 330120, 331120, 743846 - POWER SHUTTLE AND SERVO PTO FOR MECH. DIFF. LOCK - TRACTOR BODY

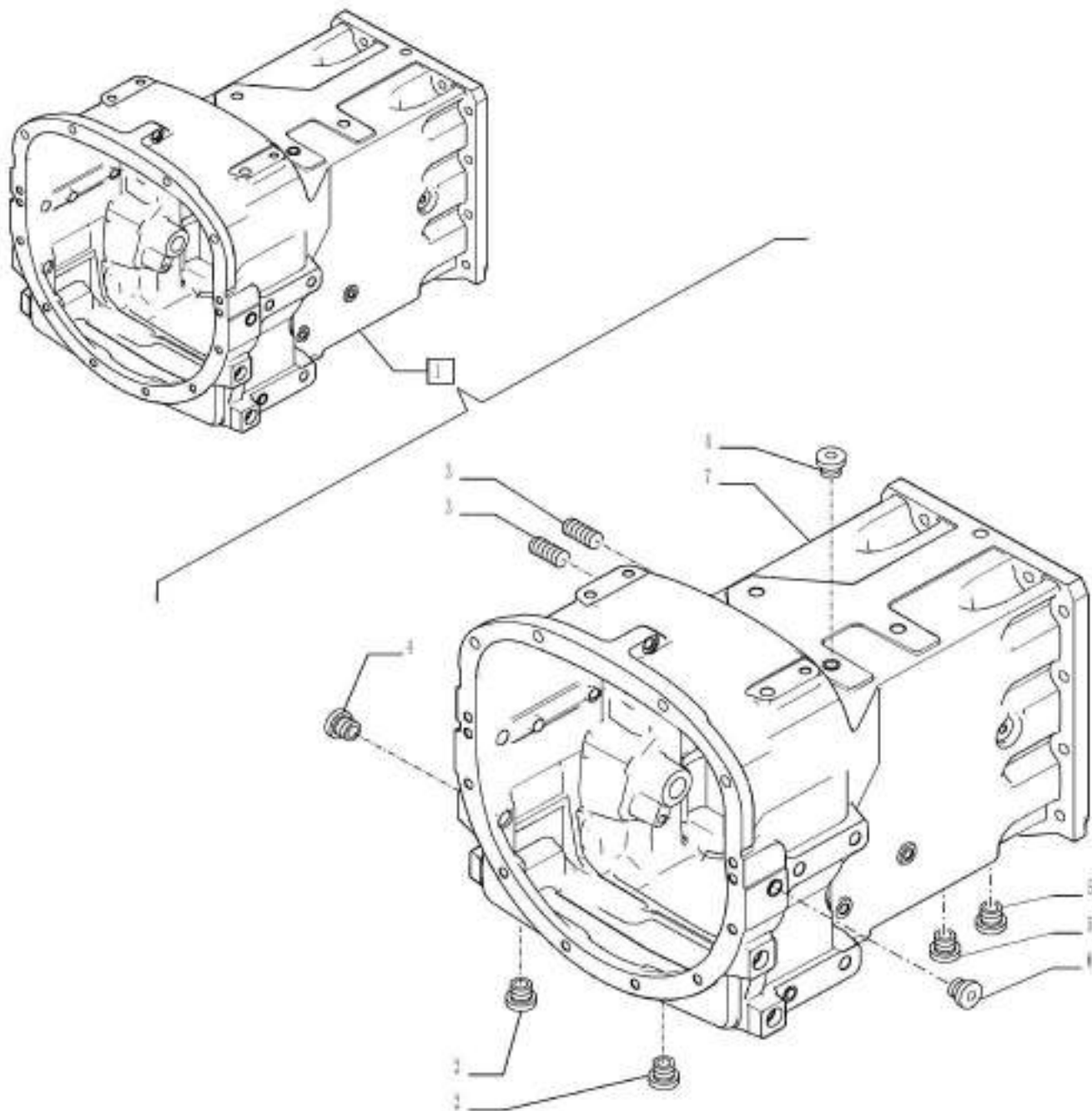

21.112.AB

04

p1

1/2014

VAR - 330120, 331120, 743846 - POWER SHUTTLE AND SERVO PTO FOR MECH. DIFF. LOCK - TRACTOR BODY

REF FN	PART NUMBER	YR/SN	QTY DESCRIPTION
1	84286478		1 HOUSING ASSY, Incl 2 - 7
2	4998275		2 PLUG D=10.8-11
3	14327401		2 PLUG M13, Tapered
4	590353		2 PLUG 15mm OD x 10mm High, Plastic D=14.8-15
5	10275501		2 PLUG Pipe, Hex Skt, M12 x 1.25 x 11mm, Cl 4.8
6	87529026		6 PLUG
7	NSS		1 NOT SERVICED SEPARATELY Housing Incl in 1

Valid for Industrial Var. 330120, 331120 (743846)

**FARMALL JX100
FARMALL JX110
FARMALL JX75
FARMALL JX90**

VAR - 334303, 335116, 390110, 744735 - TRACTOR BODY, REAR TRANSMISSION HOUSING

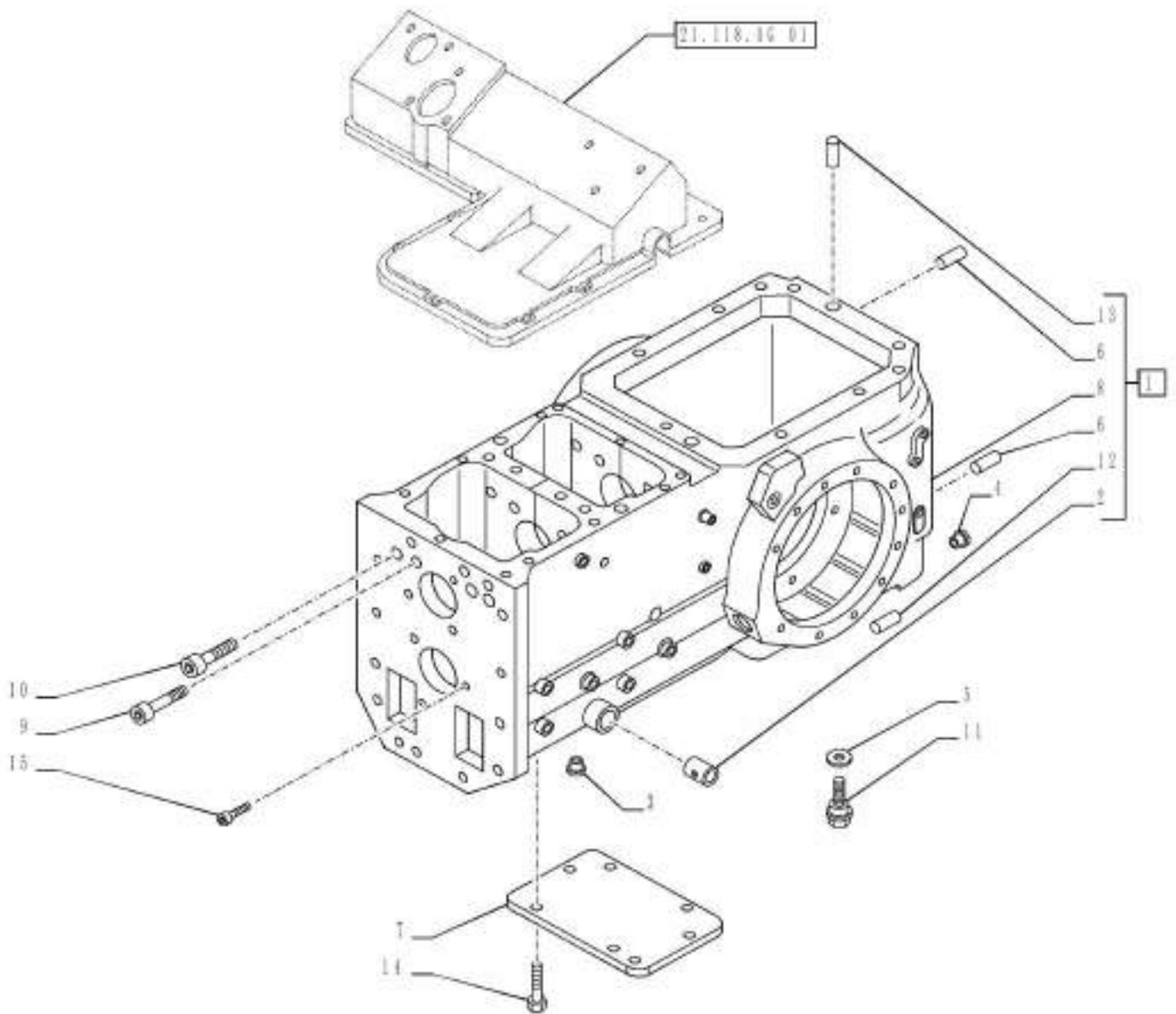

VAR - 334303, 335116, 390110, 744735 - TRACTOR BODY, REAR TRANSMISSION HOUSING

REF FN	PART NUMBER	YR/SN	QTY DESCRIPTION
1	^{1,2} 84424254		1 TRANSMISSION HOUSING ASSY Incl 2, 6, 8, 12, 13
2	^{1,2} 5118942		1 BUSHING
3	10275501		1 PLUG Pipe, Hex Skt, M12 x 1.25 x 11mm, Cl 4.8
4	10159004		2 PLUG M25, Tapered
5	10263460		2 SEAL 22.30mm ID x 28.00mm OD, 1.50mm, Copper
6	^{1,2} 10839810		2 DOWEL
7	3 5195411		1 COVER
8	^{1,2} NSS		1 NOT SERVICED SEPARATELY Housing Incl in 1
9	15540734		2 BOLT Hex, M12 x 1.25 x 45, 10.9
10	15540634		8 BOLT Hex, M12 x 1.25 x 40, 10.9, Full Thd
11	5118991		2 PLUG M22 x 1.50 x 23.00mm
12	^{1,4} 10839910		2 DOWEL
13	^{1,2} 5119529		2 DOWEL
14	3 15540421		6 SCREW Hex, M12 x 1.25 x 30mm, Cl 8.8, Full Thd
15	15970921		8 SCREW Hex, M10 x 1.25 x 35mm, Cl 8.8, Full Thd

(1) VAR - 334303 (744735) - Valid for FARMALL JX75, 90, 100, 110 Models Only

(2) VAR - 335116 - Valid for FARMALL JX70, 75, 80 Models Only

(3) VAR - 334303, 390110 (744735), 334320, 390267 (744744), 334414, 390258 (744745), 334315, 334416, 390895

(4) VAR - 335116 - Valid for FARMALL JX70, 75, 80 PRO Models Only

Valid for Var. 335116 or Industrial Var. 334303, 390110 (744735)

FARMALL JX100 FARMALL
JX110 FARMALL JX70
FARMALL JX75 FARMALL
JX80 FARMALL JX90

VAR - 335113 - 20X12 TRANSMISSION WITH SYNCHRO SHUTTLE AND CREEPER, HOUSING

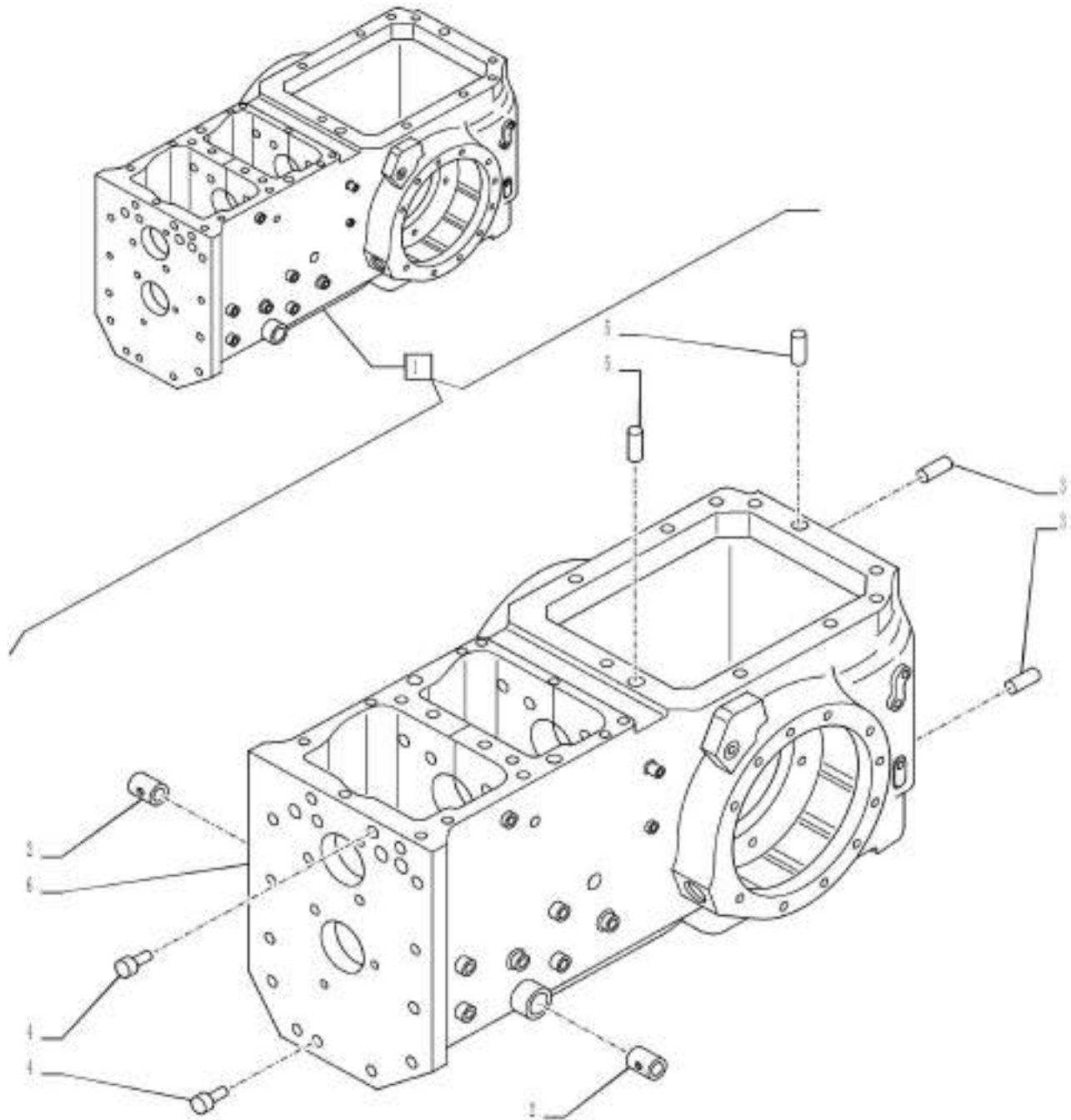

21.118.AF

02

p1

1/2014

VAR - 335113 - 20X12 TRANSMISSION WITH SYNCHRO SHUTTLE AND CREEPER, HOUSING

REF FN	PART NUMBER	YR/SN	QTY DESCRIPTION
1	84424274		1 TRANSMISSION HOUSING ASSY Incl 2 - 6
2	5118942		1 BUSHING D=10.8-11
3	10839810		2 DOWEL
4	5163325		2 DOWEL D=14.8-15
5	5119529		2 DOWEL
6	NSS		1 NOT SERVICED SEPARATELY Housing Incl in 1

Valid for Var. 335113

FARMALL JX100 FARMALL
JX110 FARMALL JX70
FARMALL JX75 FARMALL
JX80 FARMALL JX90

VAR - 334303, 335113, 335116, 390110, 744735 - TRACTOR BODY - REAR TRANSMISSION HOUSING COVER

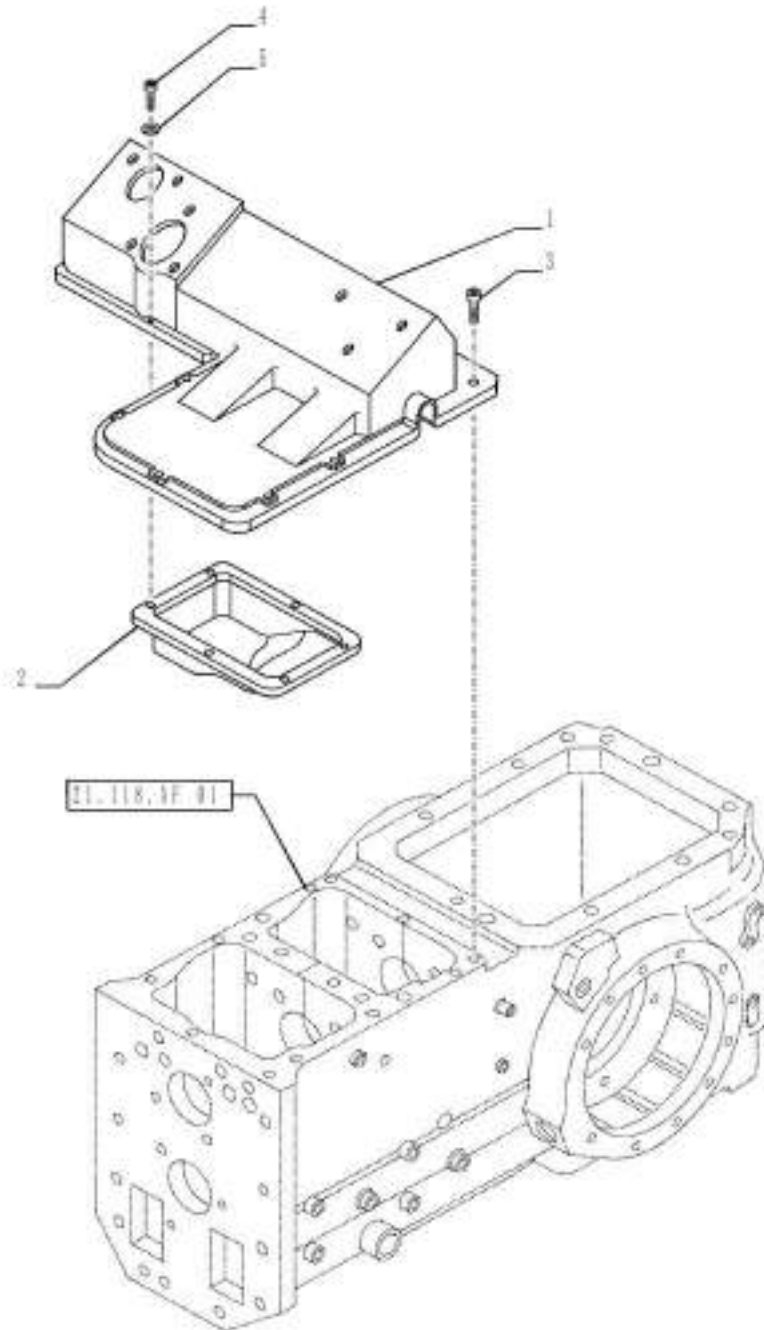

21.118.AG

01

p1

1/2014

VAR - 334303, 335113, 335116, 390110, 744735 - TRACTOR BODY - REAR TRANSMISSION HOUSING COVER

REF FN	PART NUMBER	YR/SN	QTY DESCRIPTION
1	5089402		1 COVER
2	5089709		1 GUARD
3	15970921		8 SCREW Hex, M10 x 1.25 x 35mm, Cl 8.8, Full Thd
4	14305121		6 HEX SOC SCREW M6 x 12mm, Cl 8.8
5	11197779		6 BELLEVILLE WASHER 6.40mm ID x 12.00mm OD x 1.20mm, 1.63mm, Cl 8.8, ZNM

Valid for Var. 335113 or Var. 335116 or Industrial Var. 334303, 390110 (744735)

FARMALL JX100 FARMALL
JX110 FARMALL JX70
FARMALL JX75 FARMALL
JX80 FARMALL JX90

21.130.AZ

01

p1

1/2014

VAR - 335113, 335116, 743846, 744735 - REVERSE CONTROL

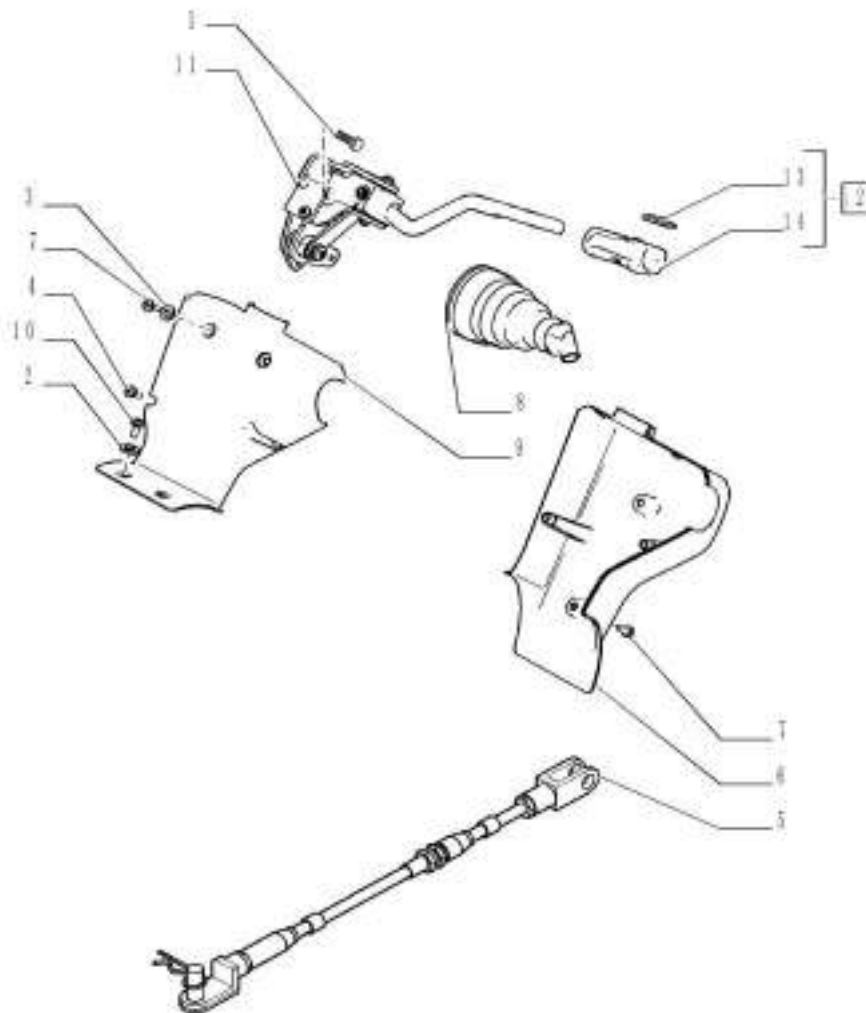

VAR - 335113, 335116, 743846, 744735 - REVERSE CONTROL

REF FN	PART NUMBER	YR/SN	QTY DESCRIPTION
1	13276211		5 SCREW Cross Pan, M6 x 14.00mm, CI 5.8, ZND
2	10519401		2 WASHER M6 x 11.95 x 1.6
3	14499301		4 WASHER M6 x 12.00mm OD x 1.60mm Overwrite
4	13272011		2 SCREW Cross Pan Hd, M4 x 12
5 1	84600229		1 CABLE
5 2	84520316		1 CABLE
5 3	84600228		1 CABLE
6	84520313		1 COVER
7	13276217		4 SCREW Cross Pan Hd, M6 x 16
8	84520314		1 COVER
9	84520311		1 COVER
10	13297614		2 SCREW
11 ^{4,3}	84589694		1 LEVER
11 2	84487160		1 LEVER
12	84552494		1 KNOB Incl 13 - 14
13	84552496		1 SYMBOL
14	NSS		1 NOT SERVICED SEPARATELY Incl in 12

(1) VAR - 335113

(2) VAR - 330120, 331120 (743846)

(3) VAR - 390110 (744735)

(4) VAR - 335113

Valid for Var. 335113 or Var. 335116 or Industrial Var. 330120, 331120 (743846) or Industrial Var. 390110 (744735)

FARMALL JX100 FARMALL
JX110 FARMALL JX70
FARMALL JX75 FARMALL
JX80 FARMALL JX90

21.130.AZ

02

p1

1/2014

VAR - 335113, 390110, 744735 - REVERSER INTERLOCK MECHANISM

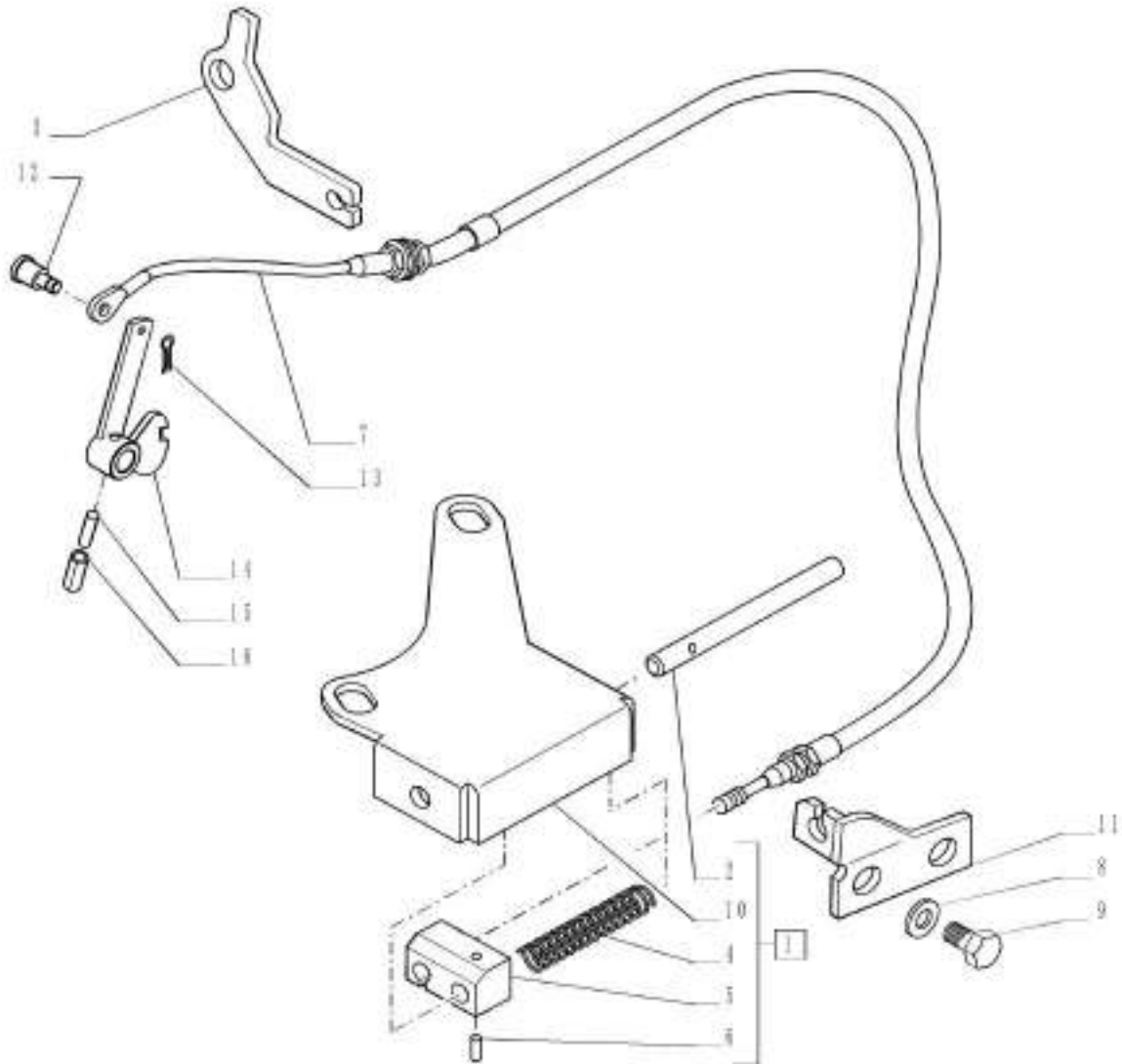

VAR - 335113, 390110, 744735 - REVERSER INTERLOCK MECHANISM

REF FN	PART NUMBER	YR/SN	QTY DESCRIPTION
1	84197393		1 TRIGGER ASSY Incl 2, 4 - 6, 10
2	87342321		1 PIN
3	84590211		1 SUPPORT
4	87363968		1 SPRING
5	87342320		1 BLOCK
6	14162074		1 LOCK PIN M3 x 22, Slotted
7	84193546		1 CABLE 661MM, Interlock
8	12601774		2 WAVE WASHER 17mm ID x 30mm OD x 1.60mm, 6.30mm Max, CST, DAC
9	15980324		2 BOLT Hex, M16 x 1.5 x 25, 8.8, Full Thd
10	NSS		1 NOT SERVICED SEPARATELY Box Incl in 1
11	84590474		1 SUPPORT
12	84195822		1 PIN
13	11063971		1 CLIP M6
14	84589227		1 LEVER
15	14607074		1 ROLL PIN
16	14601479		1 ROLL PIN M5 x 32, Slotted

Valid for Var. 335113 or Industrial Var. 390110 (744735)

FARMALL JX100 FARMALL
 JX110 FARMALL JX70
 FARMALL JX75 FARMALL
 JX80 FARMALL JX90

VAR - 335113 - REVERSER INTERLOCK MECHANISM

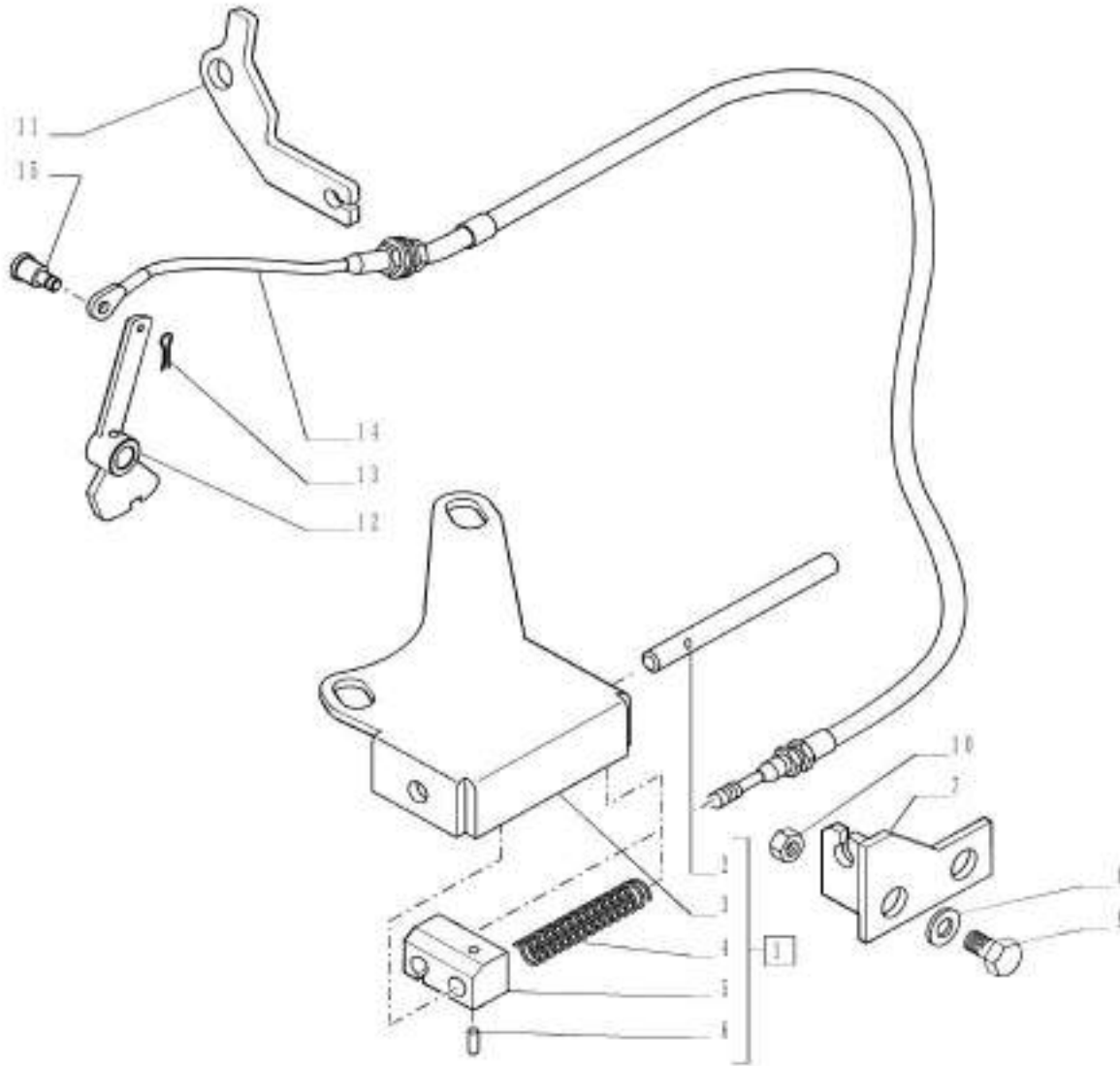

VAR - 335113 - REVERSER INTERLOCK MECHANISM

REF FN	PART NUMBER	YR/SN	QTY DESCRIPTION
1	84197393		1 TRIGGER ASSY Incl 2 - 6
2	87342321		1 PIN
3	NSS		1 NOT SERVICED SEPARATELY Box Incl in 1
4	87363968		1 SPRING
5	87342320		1 BLOCK
6	14162074		1 LOCK PIN M3 x 22, Slotted
7	84590477		1 SUPPORT
8	12601474		2 WAVE WASHER Wave, 10.50mm ID x 21.00mm OD x 0.80mm, 3.00mm, CST, DAC
9	15970421		2 SCREW Hex, M10 x 1.25 x 18mm, Cl 8.8, Full Thd
10	10791011		2 THIN NUT Thin, M10 x 1.25, Cl 04
11	84590211		1 SUPPORT
12	84589228		1 LEVER
13	11063971		1 CLIP M6
14	84193546		1 CABLE 661MM, Interlock
15	84195822		1 PIN

Valid for Var. 335113

FARMALL JX100 FARMALL
 JX110 FARMALL JX70
 FARMALL JX75 FARMALL
 JX80 FARMALL JX90

VAR - 744738, 744739, 744744 - GEARSHIFT CONTROL

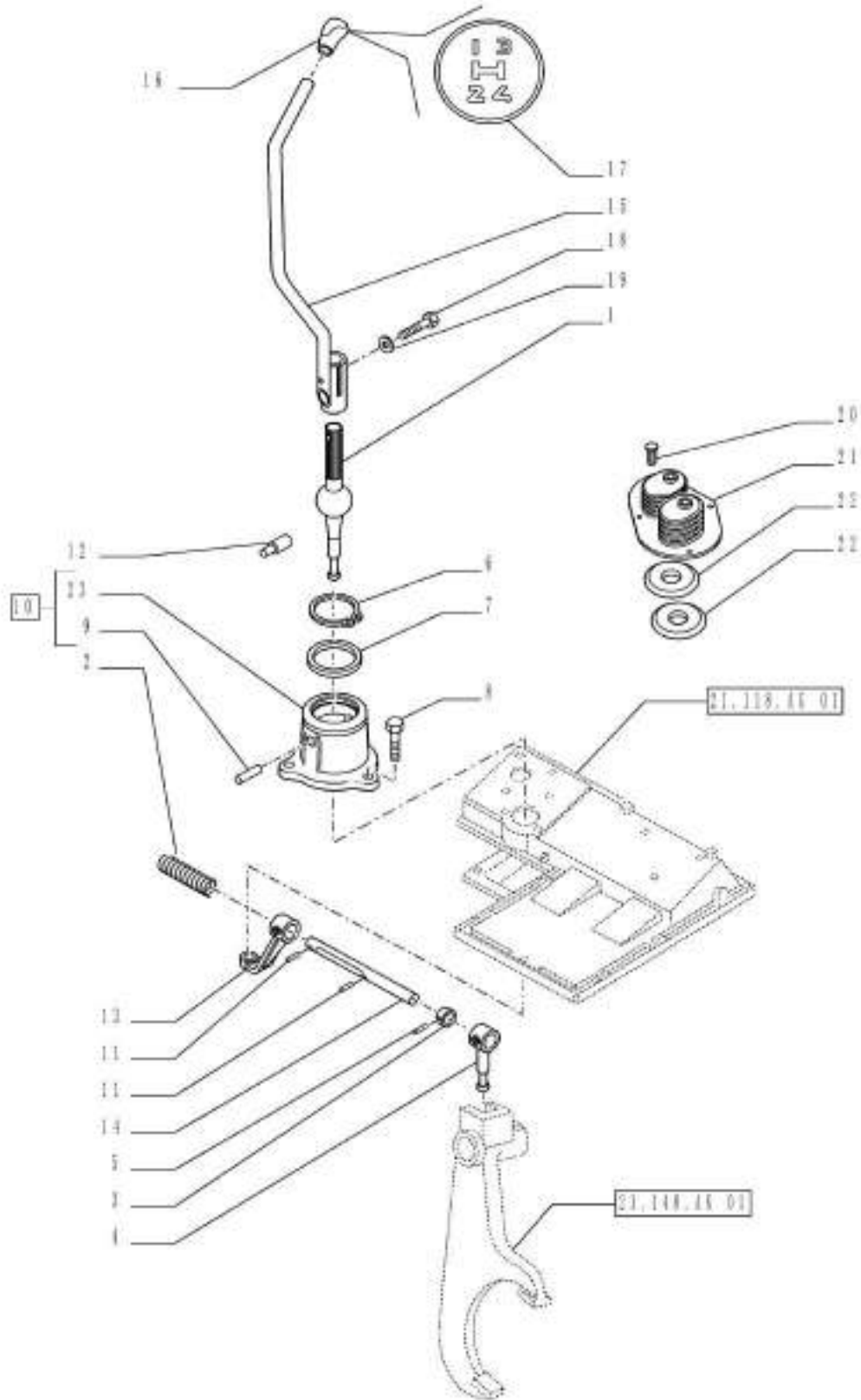

VAR - 744738, 744739, 744744 - GEARSHIFT CONTROL

REF FN	PART NUMBER	YR/SN	QTY DESCRIPTION
1	84523654		1 LEVER
2	5127962		1 SPRING
3	5132334		1 SPACER
4	5127965		1 LEVER
5	13907670		1 ROLL PIN M5 x 30, Coiled
6	11059976		1 SNAP RING M40, Int
7	4984223		1 SEAL
8	86625001		3 BOLT Hex, M8 x 22mm, Cl 8.8, Full Thd
9	5125535		2 DOWEL
10	84525663		1 SUPPORT Incl 9, 23
11	14607270		2 LOCK PIN M8 x 40, Slotted
12	14601670		2 LOCK PIN M5 x 40, Slotted
13	5175998		1 LEVER
14	5089404		1 ROD
15	47389056		1 LEVER
16	84210474		1 KNOB
17	84210476		1 SYMBOL
18	386045		1 BOLT Hex, M8 x 45, 8.8
19	10569374		1 LOCK WASHER M8
20	14591987		7 BUTTON
21	5093583		1 BELLOWS
22	5129575		2 BOOT
23	NSS		1 NOT SERVICED SEPARATELY Support Incl in 10

Valid for Industrial Var. 334321, 390268 (744738) or Industrial Var. 330384, 334322 (744739) or Industrial Var. 334320, 390267 (744744)

FARMALL JX100 FARMALL
JX110 FARMALL JX70
FARMALL JX75 FARMALL
JX80 FARMALL JX90

VAR - 335113, 743846, 744735 - GEAR SPLITTER CONTROL

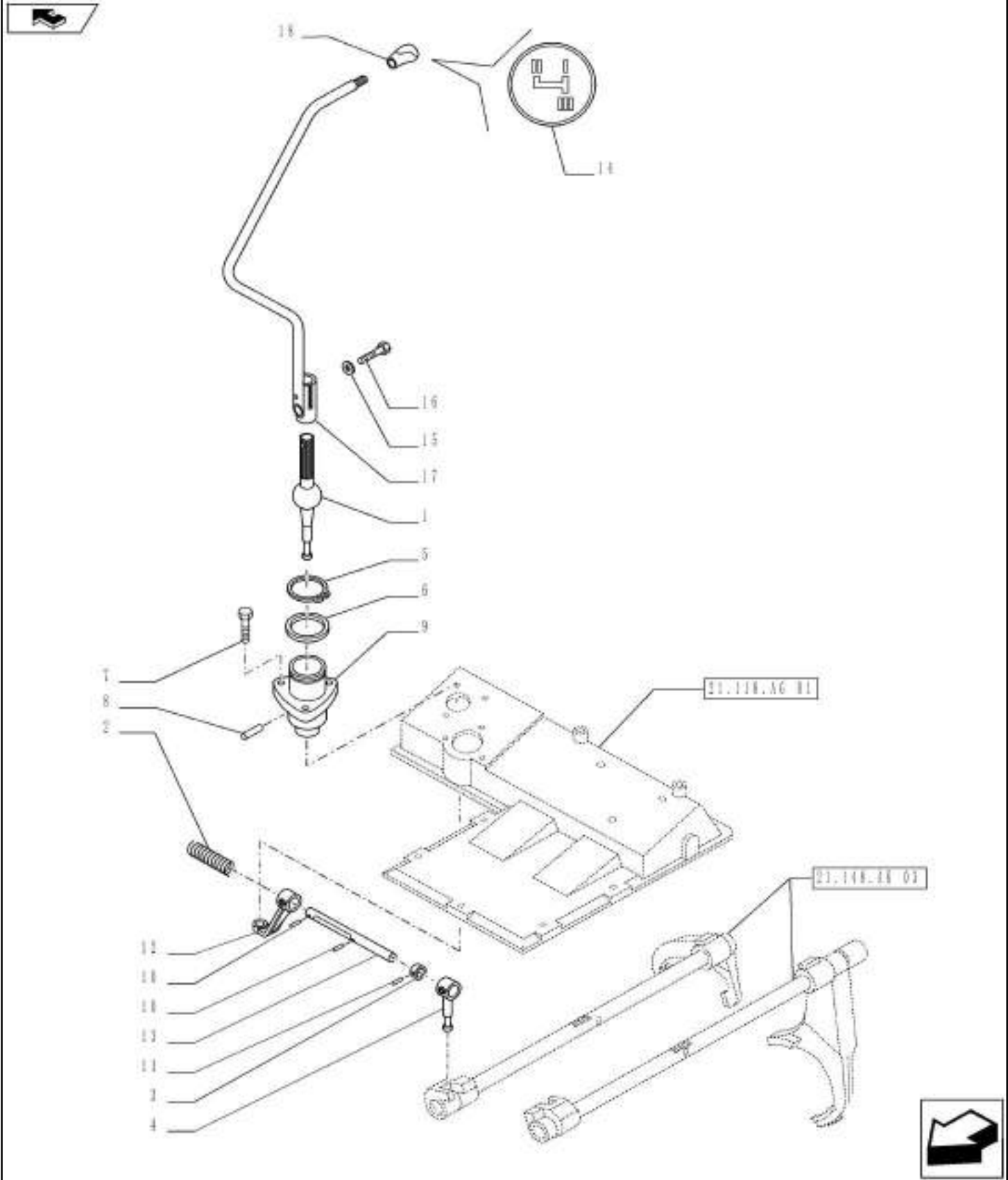

VAR - 335113, 743846, 744735 - GEAR SPLITTER CONTROL

REF FN	PART NUMBER	YR/SN	QTY DESCRIPTION
1	5127966		1 LEVER
2	5127962		1 SPRING
3	5132334		1 SPACER
4	5127970		1 LEVER
5	11059976		1 SNAP RING M40, Int
6	4984223		1 SEAL
7	86625001		3 BOLT Hex, M8 x 22mm, Cl 8.8, Full Thd
8	5125535		2 DOWEL
9	5127967		1 SUPPORT
10	14607270		2 LOCK PIN M8 x 40, Slotted
11	14601670		2 LOCK PIN M5 x 40, Slotted
12	5127971		1 LEVER
13	5089411		1 ROD
14	84210478		1 SYMBOL
15	10569374		1 LOCK WASHER M8
16	386045		1 BOLT Hex, M8 x 45, 8.8
17	47389053		1 LEVER
18	84210474		1 KNOB

4WD; Valid for Var. 335113 or Industrial Var. 330120, 331120 (743846) or Industrial Var. 334303, 390110 (744735)

FARMALL JX100 FARMALL
JX110 FARMALL JX70
FARMALL JX75 FARMALL
JX80 FARMALL JX90

21.134.AM

01

p1

1/2014

VAR - 330120, 331120, 743846 - POWER SHUTTLE E SERVO PTO FOR DIFF. LOCK, POWER SHUTTLE VALVE

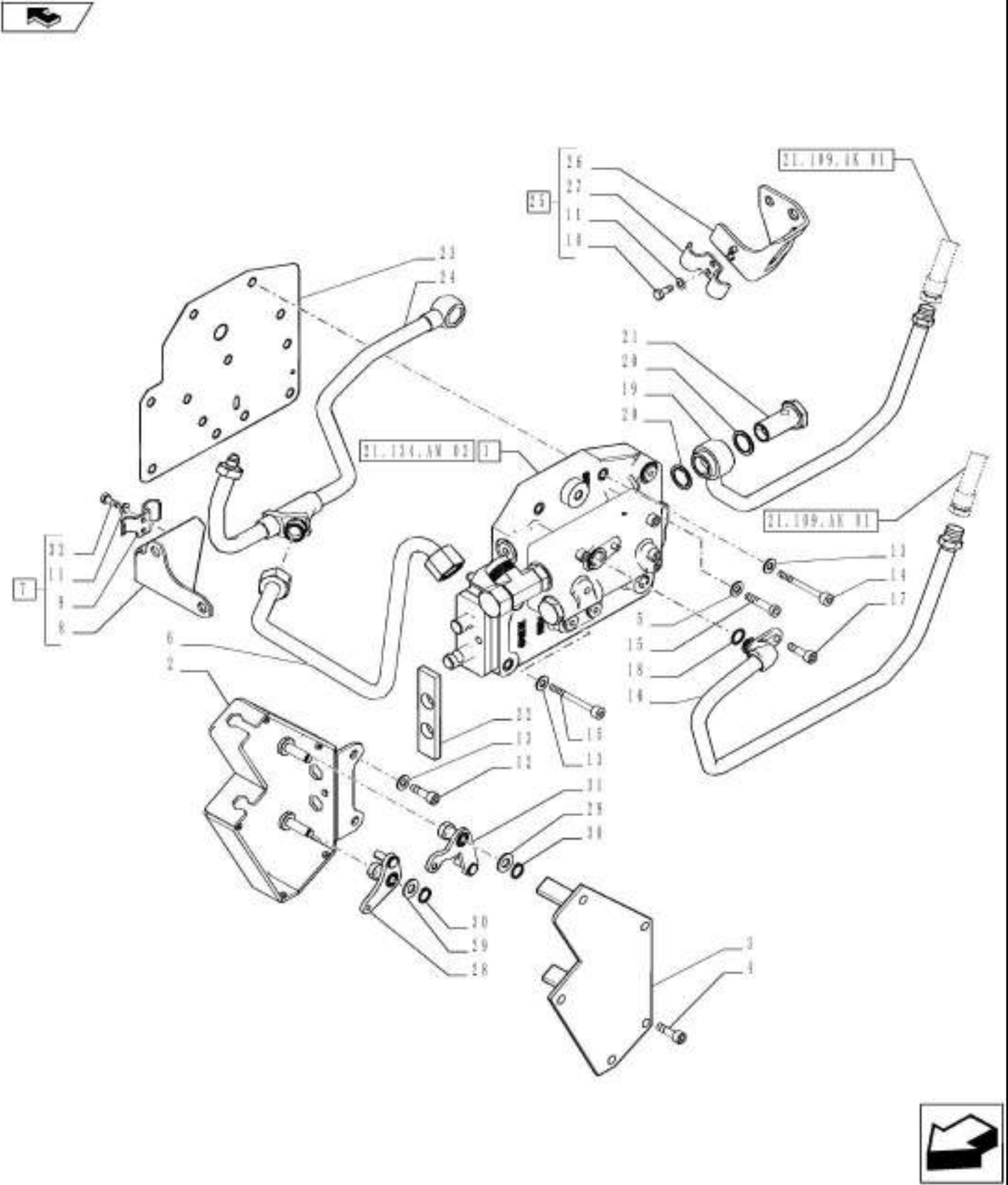

21.134.AM

01

p1

1/2014

VAR - 330120, 331120, 743846 - POWER SHUTTLE E SERVO PTO FOR DIFF. LOCK, POWER SHUTTLE VALVE

REF FN	PART NUMBER	YR/SN	QTY DESCRIPTION
1	47412490		1 CONTROL VALVE
2	84404362		1 SUPPORT
3	84404369		1 COVER
4	10445821		5 SCREW Hex, M4 x 8, 8.8, Full Thd
5	12626001		1 WASHER M10 x 22 x 3
6	84328436		1 PIPE
7	84327445		1 SUPPORT ASSY, Incl 8, 9, 11, 32
8	NSS		1 NOT SERVICED SEPARATELY Support, Incl in 7
9	84341939		1 COLLAR
10	86508568		1 BOLT Hex, M6 x 16mm, Cl 8.8, Full Thd
11	12601274		2 WAVE WASHER Wave, M6.4
12	15888731		1 SCREW Hex, M10 x 1.25 x 55mm, Cl 10.9
13	11198374		7 BELLEVILLE WASHER Belleville, M10.5
14	11234731		2 SCREW Hex, M10 x 1.25 x 45, 10.9
15	11343731		3 SCREW Hex, M10 x 1.25 x 65, 10.9
16	47359272		1 PIPE
17	14306321		1 HEX SOC SCREW M8 x 20mm, Cl 8.8
18	14457080		1 O-RING 0.487" ID x 0.103"
19	47359271		1 PIPE
20	10263460		2 SEAL 22.30mm ID x 28.00mm OD, 1.50mm, Copper
21	84391031		1 HYD CONNECTOR
22	84590032		1 FOAM INSULATION
23	84558621		1 GASKET
24	84526752		1 PIPE
25	84240021		1 SUPPORT ASSY, Incl 10, 11, 26, 27
26	NSS		1 NOT SERVICED SEPARATELY Support, Incl in 25
27	84327447		1 COLLAR
28	84413950		1 LEVER
29	86624176		2 WASHER M10 x 20 x 2

Valid for Industrial Var. 330120, 331120 (743846)

FARMALL JX100
FARMALL JX75
FARMALL JX90

21.134.AM

01

p2

1/2014

VAR - 330120, 331120, 743846 - POWER SHUTTLE E SERVO PTO FOR DIFF. LOCK, POWER SHUTTLE VALVE

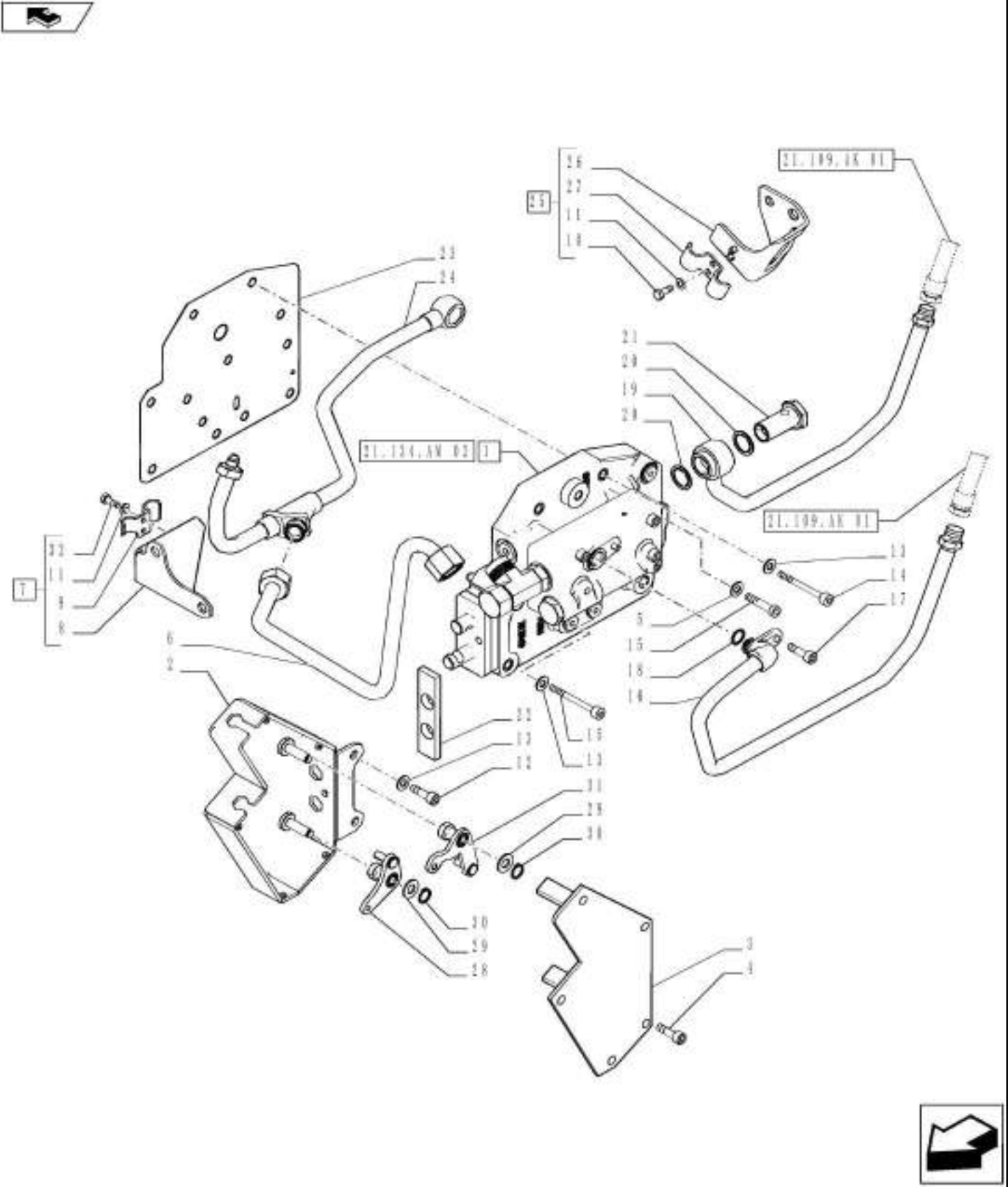

21.134.AM

01

p2

1/2014

VAR - 330120, 331120, 743846 - POWER SHUTTLE E SERVO PTO FOR DIFF. LOCK, POWER SHUTTLE VALVE

REF FN	PART NUMBER	YR/SN	QTY DESCRIPTION
30	11065971		2 LOCKING RING
31	84414804		1 LEVER
32	10902224		1 SCREW Hex, M6 x 16, 8.8, Full Thd

Valid for Industrial Var. 330120, 331120 (743846)

**FARMALL JX100
FARMALL JX75
FARMALL JX90**

21.134.AM

02

p1

1/2014

VAR - 330120, 331120, 743846 - POWER SHUTTLE E SERVO PTO FOR DIFF. LOCK, POWER SHUTTLE VALVE, BREAKDOWN

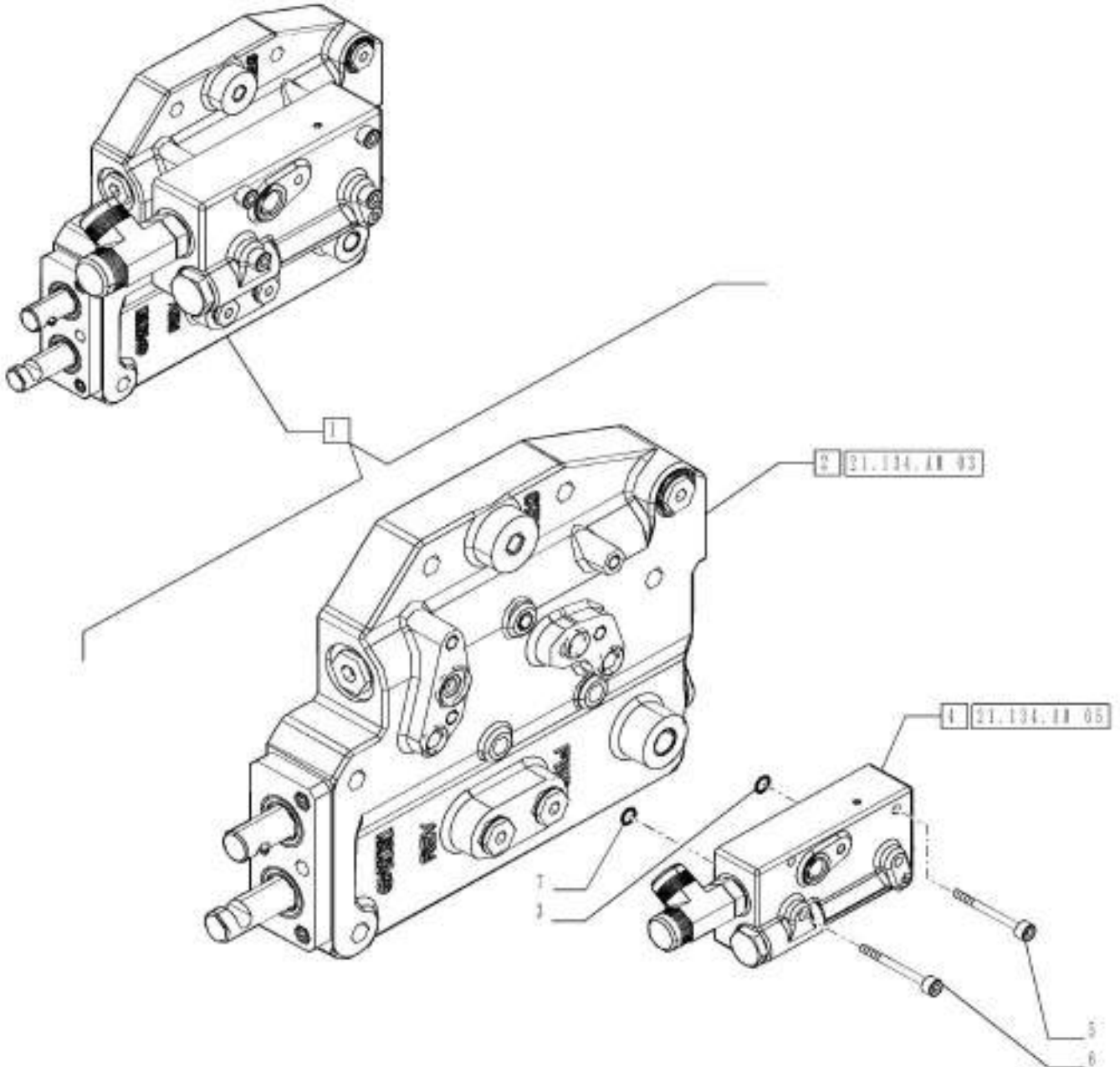

21.134.AM

02

p1

1/2014

VAR - 330120, 331120, 743846 - POWER SHUTTLE E SERVO PTO FOR DIFF. LOCK, POWER SHUTTLE VALVE, BREAKDOWN

REF FN	PART NUMBER	YR/SN	QTY DESCRIPTION
1	47412490		1 CONTROL VALVE ASSY, Incl 2 - 7
2	NSS		1 NOT SERVICED SEPARATELY Valve, Incl in 1
3	14456980		3 O-RING 10.77mm ID x 2.62mm
4	NSS		1 NOT SERVICED SEPARATELY Valve, Pressure Control, Incl in 1
5	14302221		2 HEX SOC SCREW M8 x 55mm, Cl 8.8
6	2900720		2 HEX SOC SCREW Hex Soc Hd, M8 x 65, 10.9
7	14457381		1 O-RING 17.12mm ID x 2.62" Width

Valid for Industrial Var. 330120, 331120 (743846)

FARMALL JX100
FARMALL JX75
FARMALL JX90

VAR - 330120, 331120, 743846 - POWER SHUTTLE E SERVO PTO FOR DIFF. LOCK, POWER SHUTTLE VALVE, BREAKDOWN

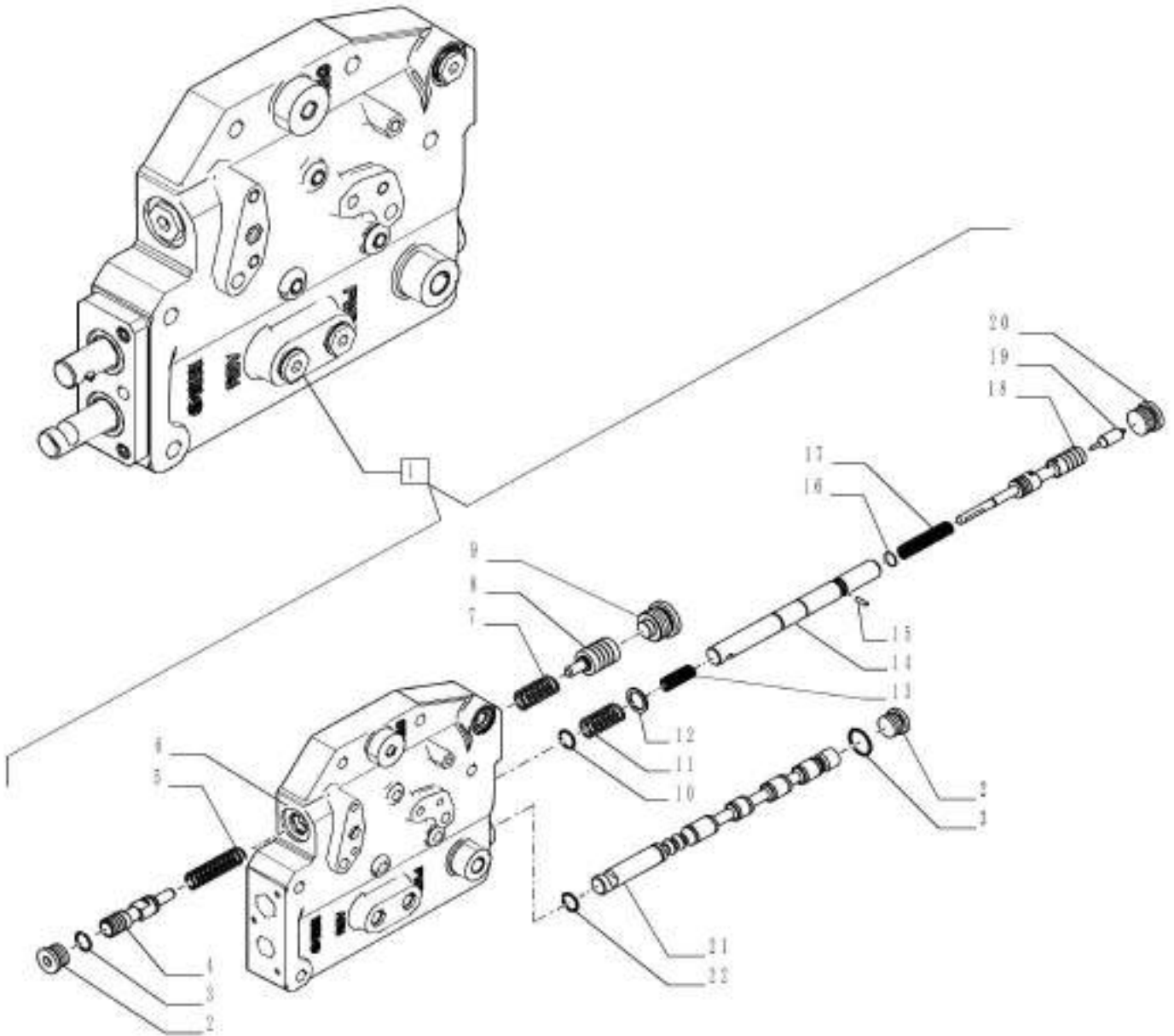

VAR - 330120, 331120, 743846 - POWER SHUTTLE E SERVO PTO FOR DIFF. LOCK, POWER SHUTTLE VALVE, BREAKDOWN

REF FN	PART NUMBER	YR/SN	QTY DESCRIPTION
1	1	NSS	1 NOT SERVICED SEPARATELY Valve, ASSY, Incl in 47412490, Incl 2 - 22
2	86590562		2 PLUG Hex Soc, 3/4"-16 ORB
3	128825		2 O-RING 0.644" ID x 0.087" Width
4	84289760		1 SPOOL
5	84414724		1 SPRING
6	NSS		1 NOT SERVICED SEPARATELY Valve, Incl in 1
7	84289764		1 SPRING
8	47397119		1 PISTON
9	47423396		1 PLUG
10	11066476		1 SNAP RING M16, Ext
11	84289745		1 SPRING Return Inching
12	84275592		1 RING
13	5120761		1 SPRING
14	47405331		1 ROD Inching
15	84289761		1 PIN
16	84289763		1 CIRCLIP
17	84412795		1 SPRING
18	84413934		1 ROD
19	84411956		1 PIN
20	86625138		1 PLUG Hex Soc, 7/8"-14 ORB
21	47408519		1 ROD Forward/Reverse
22	13397776		1 SNAP RING M16, Int

(1) See also figure 21.134.AM 04

Valid for Industrial Var. 330120, 331120 (743846)

FARMALL JX100
FARMALL JX75
FARMALL JX90

21.134.AM

04

p1

1/2014

VAR - 330120, 331120, 743846 - POWER SHUTTLE E SERVO PTO FOR DIFF. LOCK, POWER SHUTTLE VALVE, BREAKDOWN

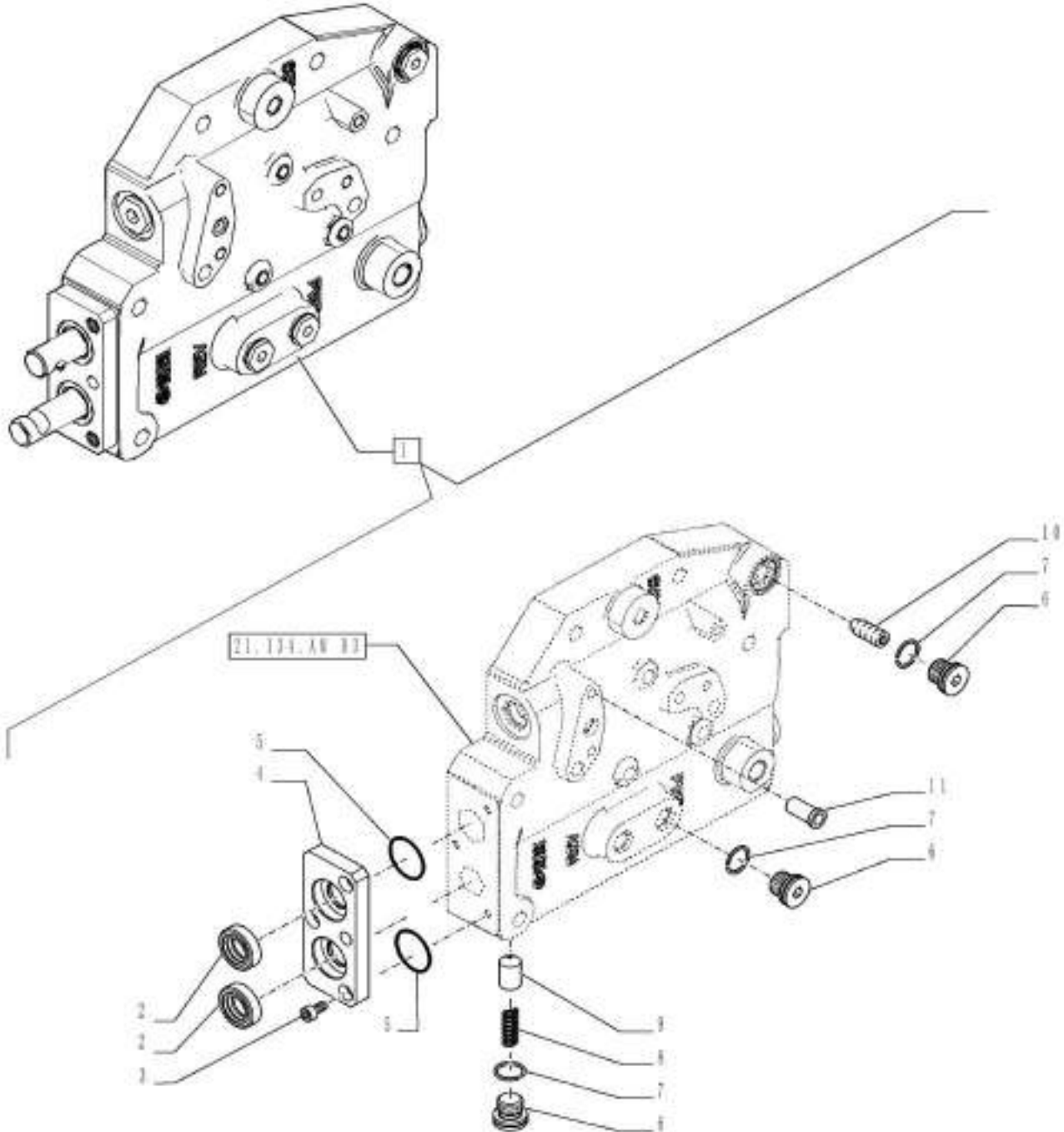

VAR - 330120, 331120, 743846 - POWER SHUTTLE E SERVO PTO FOR DIFF. LOCK, POWER SHUTTLE VALVE, BREAKDOWN

REF	FN	PART NUMBER	YR/SN	QTY	DESCRIPTION
1	1	NSS		1	NOT SERVICED SEPARATELY Valve, ASSY, Incl in 47412490, Incl 2 - 11
2		84273378		2	SEAL
3		14304021		3	HEX SOC SCREW M5 x 10mm, Cl 8.8, Full Thd
4		47396563		1	COVER ASSY
5		9626940		2	O-RING 1.114" ID x 1.254" OD x 0.07"
6		86598044		4	PLUG Hex Soc, M14 x 1.5, ORB ASSY
7		86598099		4	O-RING 11.30mm ID x 2.20mm
8		84408628		1	SPRING
9		84594366		1	DETENT
10		47400499		1	BLEEDER
11		84413706		1	FILTER

(1) See also Figure 21.134.AM 03

Valid for Industrial Var. 330120, 331120 (743846)

FARMALL JX100
FARMALL JX75
FARMALL JX90

21.134.AM

05

p1

1/2014

VAR - 330120, 331120, 743846 - POWER SHUTTLE E SERVO PTO FOR DIFF. LOCK, POWER SHUTTLE VALVE, BREAKDOWN

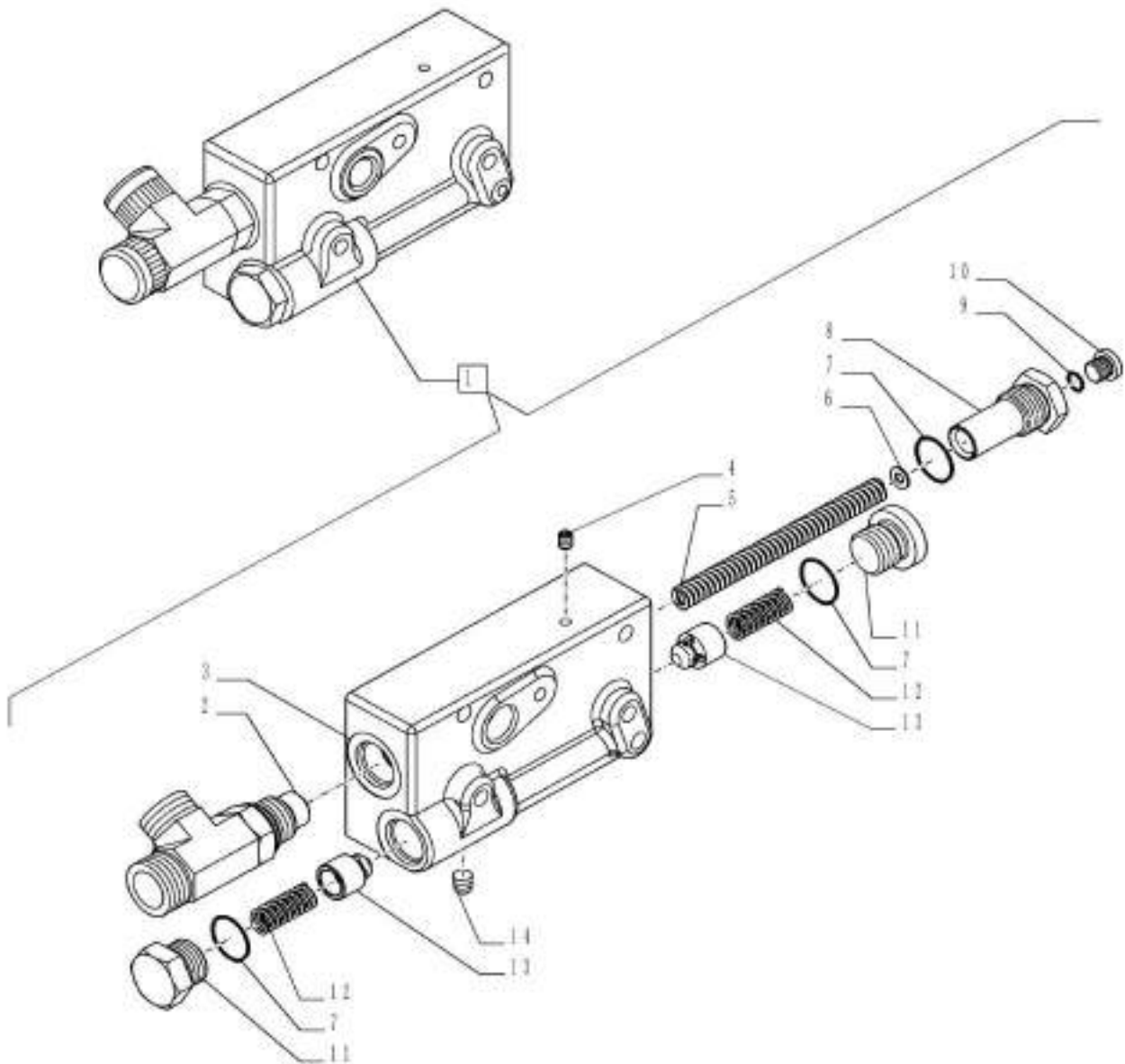

21.134.AM

05

p1

1/2014

VAR - 330120, 331120, 743846 - POWER SHUTTLE E SERVO PTO FOR DIFF. LOCK, POWER SHUTTLE VALVE, BREAKDOWN

REF FN	PART NUMBER	YR/SN	QTY DESCRIPTION
1	NSS		1 NOT SERVICED SEPARATELY Valve, Pressure Control, ASSY, Incl in 47412490, Incl 2 - 14
2	84329041		1 HYD CONNECTOR
3	NSS		1 NOT SERVICED SEPARATELY Valve Incl in 1
4	47137823		1 HYD CONNECTOR
5	5157119		1 SPRING
6	12637804		1 WASHER M5 x 11 x 1
7	14438085		3 O-RING 19.3mm ID x 2.4mm
8	84332904		1 PLUG M22 x 1/5
9	14437585		1 O-RING 8.00mm ID x 1.50mm
10	10118540		1 PLUG M10 x 1 x 11, Brass
11	84332901		2 PLUG
12	5159185		2 SPRING
13	5169565		2 BY-PASS VALVE
14	10269704		1 PLUG

Valid for Industrial Var. 330120, 331120 (743846)

FARMALL JX100
FARMALL JX75
FARMALL JX90

VAR - 335113, 335116, 390110, 744735 - TRANSMISSION GEARS, 1ST - 2ND SPEED SYNCRONIZER - BREAKDOWN

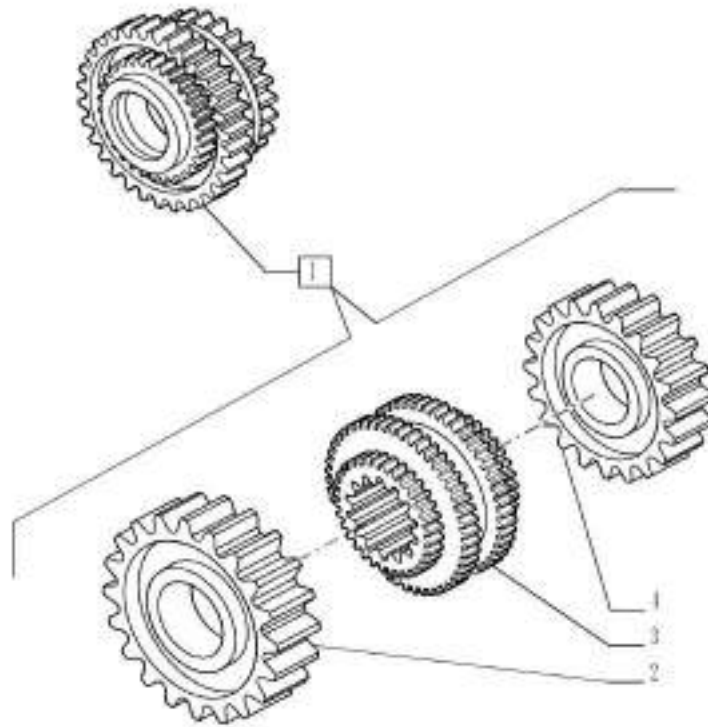

21.148.AA

01

p1

1/2014

**VAR - 335113, 335116, 390110, 744735 - TRANSMISSION GEARS, 1ST - 2ND SPEED SYNCRONIZER -
BREAKDOWN**

REF FN	PART NUMBER	YR/SN	QTY DESCRIPTION
1	84222590		1 SYNCHRONIZER 1st - 2nd SPEED, ASSY Incl 2 - 4
2	5172047		1 DRIVEN GEAR 1st SPEED
3	84254475		1 SYNCHRONIZER
4	5172048		1 DRIVEN GEAR 2nd SPEED

Valid for Var. 335113 or Var. 335116 or Industrial Var. 390110 (744735)

FARMALL JX100 FARMALL
JX110 FARMALL JX70
FARMALL JX75 FARMALL
JX80 FARMALL JX90

VAR - 335113, 335116, 390110, 744735 - TRANSMISSION GEARS, 3RD - 4TH SPEED SYNCHRONIZER - BREAKDOWN

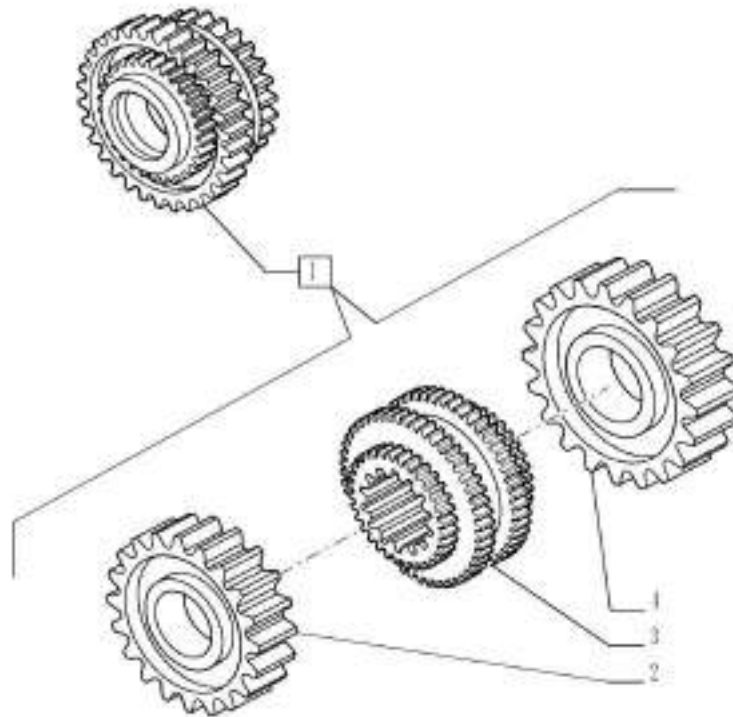

21.148.AA

02

p1

1/2014

**VAR - 335113, 335116, 390110, 744735 - TRANSMISSION GEARS, 3RD - 4TH SPEED SYNCRONIZER -
BREAKDOWN**

REF FN	PART NUMBER	YR/SN	QTY DESCRIPTION
1	84222592		1 SYNCHRONIZER 3rd - 4th SPEED, ASSY Incl 2 - 4
2	5179673		1 DRIVEN GEAR 4th SPEED
3	84254475		1 SYNCHRONIZER
4	5172050		1 DRIVEN GEAR 3rd SPEED

Valid for Var. 335113 or Var. 335116 or Industrial Var. 390110 (744735)

FARMALL JX100 FARMALL
JX110 FARMALL JX70
FARMALL JX75 FARMALL
JX80 FARMALL JX90

VAR - 335113, 335116, 390249, 743846, 744735 - BEVEL GEAR

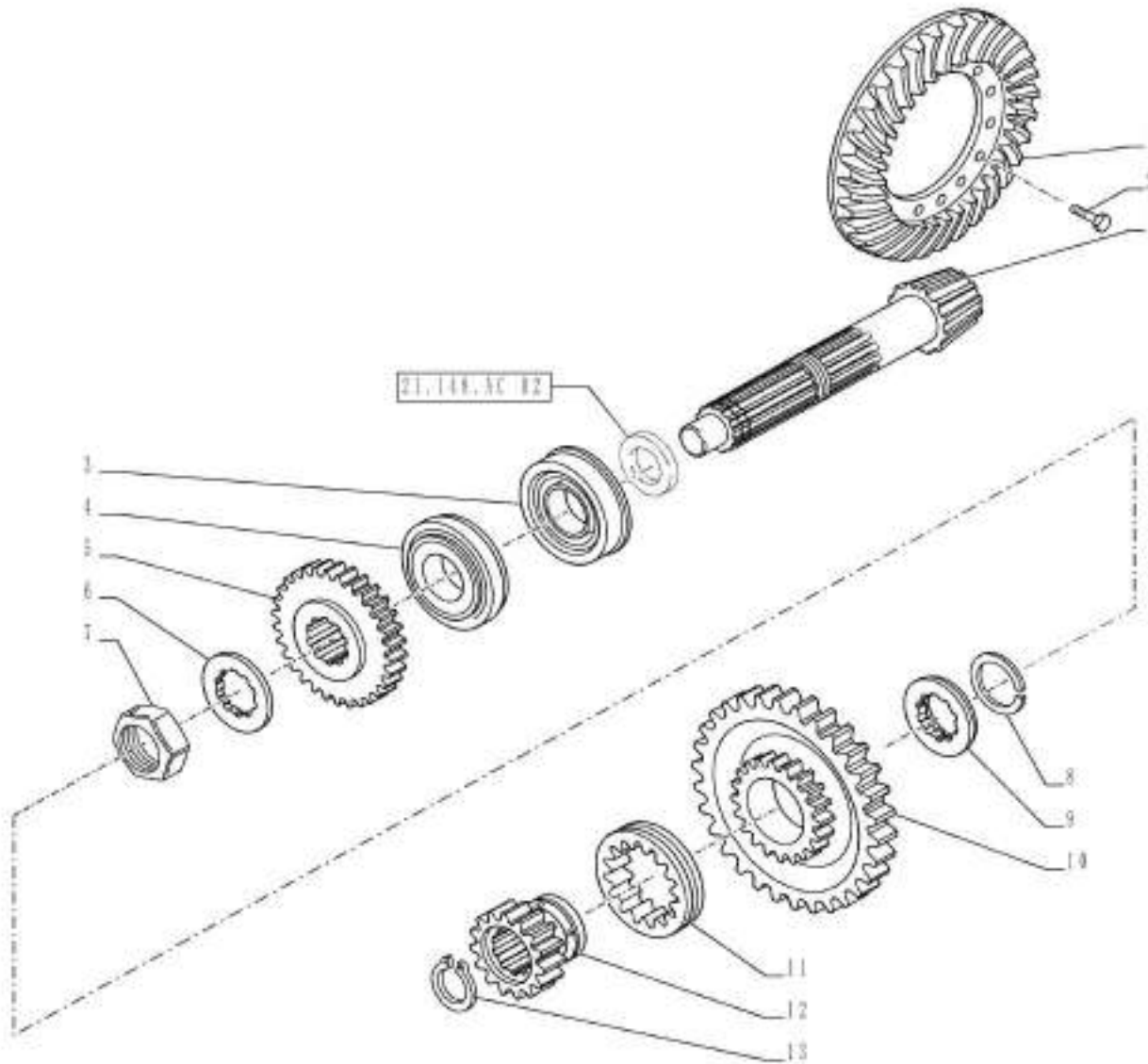

VAR - 335113, 335116, 390249, 743846, 744735 - BEVEL GEAR

REF	FN	PART NUMBER	YR/SN	QTY	DESCRIPTION
1	1	5094910		1	BEVEL GEAR (10/43)
1	2,3,4,5	5094909		1	BEVEL GEAR
2	2,3	14274631		12	LOCK BOLT Hex, M12 x 1.25 x 35mm, CI 10.9
2	1	14274534		8	LOCK BOLT Hex, M12 x 1.25 x 30mm, CI 10.9, Full Thd
3		5138664		1	TAPERED ROLLER BEARING
4		5130990		1	TAPERED ROLLER BEARING
5	3,4	5131674		1	DRIVEN GEAR
5	1,2,5	5125005		1	DRIVEN GEAR
6		5119261		1	LOCK WASHER
7		5117744		1	NUT
8		5127762		1	HALF-RING
9	6	5128016		1	SPACER
9	3,4	5160748		1	SPACER
10	1,2,5	5125007		1	DRIVEN GEAR
10	3,4	5160747		1	GEAR
11		5125010		1	SLEEVE
12	3,4	5160749		1	DRIVE BUSHING
12	1,2,5	5125009		1	SLEEVE
13		11068976		1	SNAP RING M42, Ext

(1) Valid for FARMALL JX70 Model Only

(2) Valid for Var. 335113, 390110 (744735) FARMALL JX75, 80, 90 Models Only

(3) Valid for FARMALL JX100 Model Only

(4) Valid for Var. 330120, 331120 (744735) FARMALL JX75, 90 Models Only

(5) Valid for Var. 335116 FARMALL JX75, 80 Models Only

(6) Valid for Var. 335113, 390110 (744735) FARMALL JX70, 75, 80, 90 Models Only

Valid for Var. 335113 or Var. 335116 or Var. 390249 or Industrial Var. 330120, 331120 (743846) or Industrial Var. 390110 (744735)

FARMALL JX100
 FARMALL JX70
 FARMALL JX75
 FARMALL JX80

21.148.AC

02

p1

1/2014

VAR - 335113, 335116, 390249, 743846, 744735 - BEVEL GEAR, SHIM

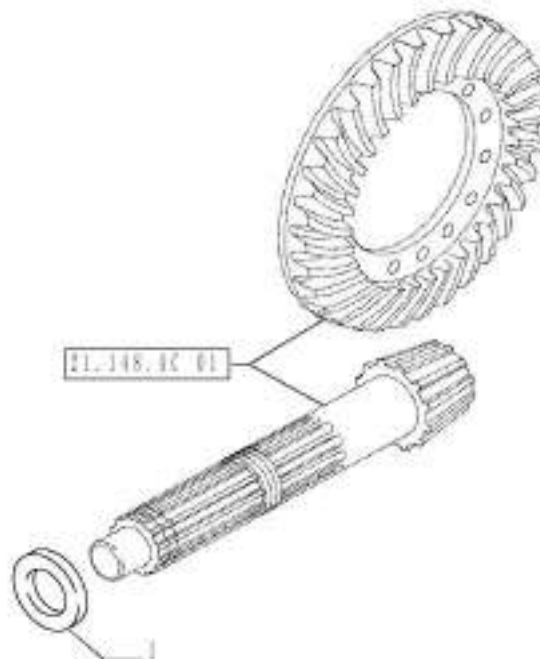

VAR - 335113, 335116, 390249, 743846, 744735 - BEVEL GEAR, SHIM

REF FN	PART NUMBER	YR/SN	QTY DESCRIPTION
1	5111859		AR SHIM 1.90mm Thk
1	5111860		AR SHIM 1.95mm Thk
1	5111861		AR SHIM 2.00mm Thk
1	5111862		AR SHIM 2.05mm Thk
1	5111863		AR SHIM 2.10mm Thk
1	5111864		AR SHIM 2.15mm Thk
1	5111865		AR SHIM 2.20mm Thk
1	5111866		AR SHIM 2.25mm Thk
1	5111867		AR SHIM 2.30mm Thk
1	5111868		AR SHIM 2.35mm Thk
1	5111869		AR SHIM 2.40mm Thk
1	5111870		AR SHIM 2.45mm Thk
1	5111871		AR SHIM 2.50mm Thk
1	5125098		AR SHIM 1.85mm Thk
1	5125099		AR SHIM 2.55mm Thk
1	5125100		AR SHIM 2.60mm Thk
1	5125101		AR SHIM 2.65mm Thk
1	5125102		AR SHIM 2.70mm Thk

Valid for Var. 335113 or Var. 335116 or Var. 390249 or Industrial Var. 330120, 331120 (743846) or Industrial Var. 390110 (744735)

FARMALL JX100
 FARMALL JX70
 FARMALL JX75
 FARMALL JX80

VAR - 335113, 335116, 390249, 743846, 744735 - CENTRAL REDUCTION GEARS - MEDIUM RANGE GEARS

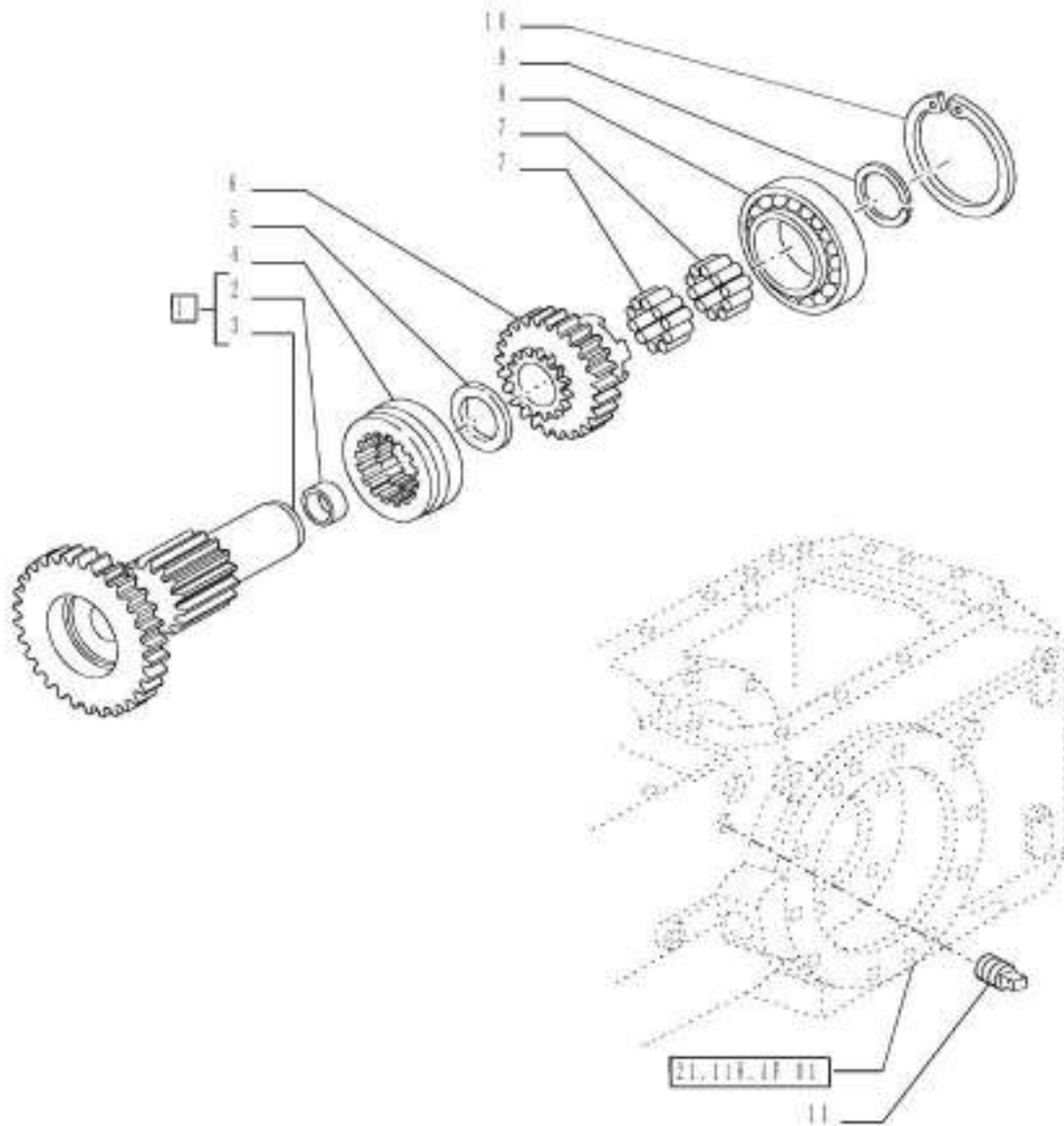

VAR - 335113, 335116, 390249, 743846, 744735 - CENTRAL REDUCTION GEARS - MEDIUM RANGE GEARS

REF FN	PART NUMBER	YR/SN	QTY DESCRIPTION
1	^{1,2} 5176776		1 SHAFT ASSY, Incl 2 - 3
1	3 5176751		1 MAIN SHAFT ASSY, Incl 2 - 3
2	4950081		1 BUSHING 25 x 28.53 x 18
3	NSS		1 NOT SERVICED SEPARATELY Shaft Incl in 1
4	5125880		1 COUPLING
5	5109683		1 THRUST WASHER
6	^{1,2} 5125013		1 GEAR
6	3 5131169		1 GEAR
7	5109747		2 NEEDLE BEARING 42 x 47 x 27
8	20141040		1 BALL BEARING 60.00mm x 110.00mm x 22.00mm 60 x 110 x 22
9	5117076		1 CIRCLIP D=47
10	11075476		1 SNAP RING M110, Int
11	14323914		2 PLUG M10

(1) VAR - 335113 or 390110 (744735); FARMALL JX70, 75, 80, 90 Models Only

(2) VAR - 335116; FARMALL JX70, 75, 80 Models Only

(3) VAR - 390249 or 330120, 331120 (743846); ; FARMALL JX75, 90, 100 Models Only

Valid for Var. 335113 or Var. 335116 or Var. 390249 or Industrial Var.
330120, 331120 (743846) or Industrial Var. 390110 (744735)

FARMALL JX100
FARMALL JX70
FARMALL JX75
FARMALL JX80

VAR - 335116 - 12+4 SYNCHRO AND SHAFT

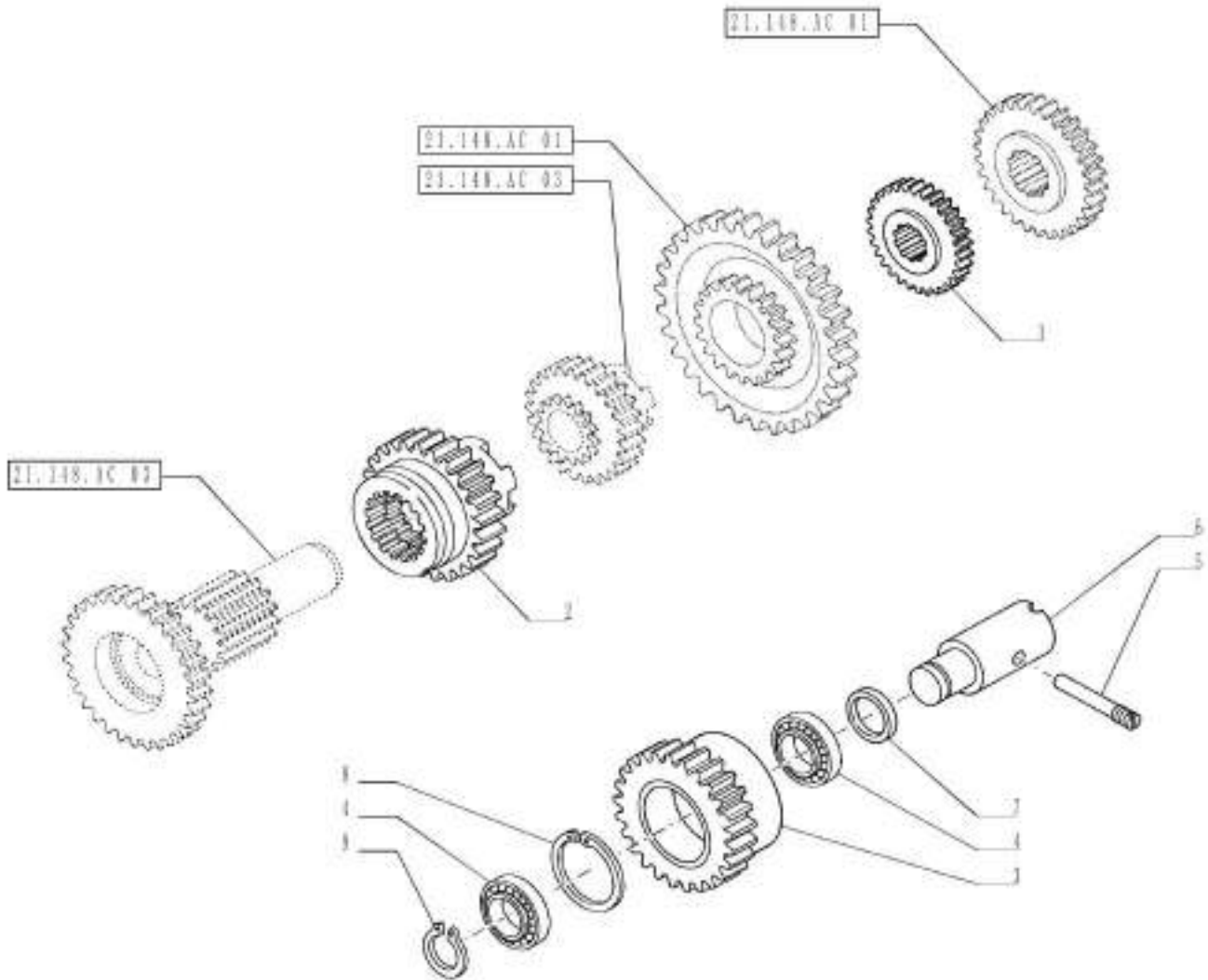

VAR - 335116 - 12+4 SYNCHRO AND SHAFT

REF FN	PART NUMBER	YR/SN	QTY DESCRIPTION
1	44033197		1 GEAR
2	47033202		1 GEAR
3	47033203		1 GEAR
4	20715580		2 BALL BEARING 25 mm ID x 52 mm OD x 15 mm
5	5152965		1 CLUTCH CENTRALIZER
6	5153087		1 PIN
7	5153088		1 THRUST WASHER
8	5117075		1 SNAP RING
9	11060576		1 SNAP RING M52, Int

Valid for Var. 335116

FARMALL JX70
FARMALL JX75
FARMALL JX80

21.148.AC

05

p1

1/2014

VAR - 330120, 331120, 390249, 743846 - BEVEL GEAR

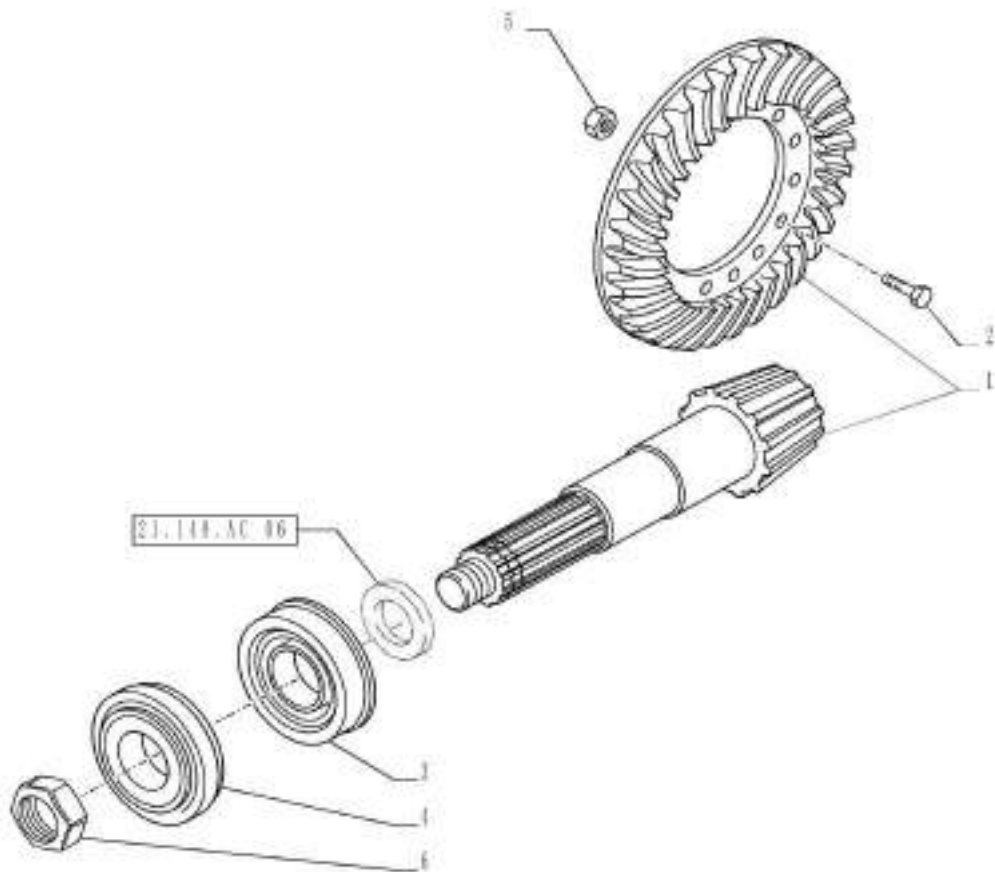

21.148.AC

05

p1

1/2014

VAR - 330120, 331120, 390249, 743846 - BEVEL GEAR

REF FN	PART NUMBER	YR/SN	QTY DESCRIPTION
1	82824504		1 BEVEL GEAR Set Crown Wheel Pinion, Ratio 14:47
2	4964930		8 SCREW M12 x 1.25 x 45
3	551170		1 TAPERED ROLLER BEARING
4	5117713		1 TAPERED ROLLER BEARING
5	5115377		8 LOCK NUT M12 x 1.25
6	5123113		1 RING NUT

Valid for Var. 390249 or Industrial Var. 330120, 331120 (743846)

FARMALL JX110

21.148.AC

06

p1

1/2014

VAR - 330120, 331120, 390249, 743846 - BEVEL GEAR, SHIM

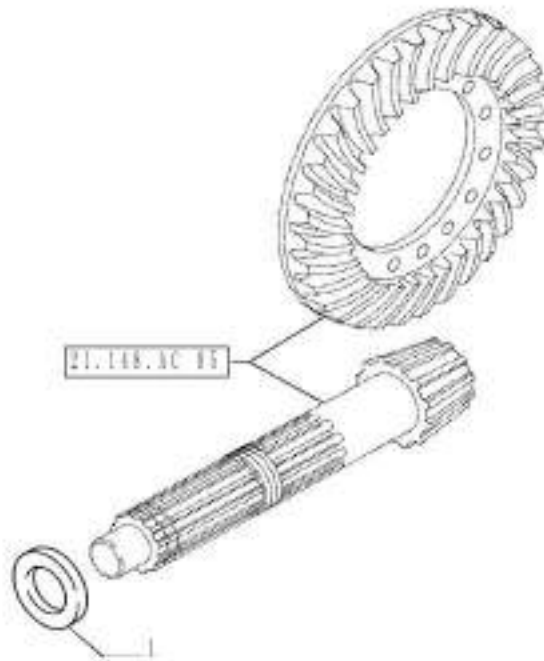

VAR - 330120, 331120, 390249, 743846 - BEVEL GEAR, SHIM

REF FN	PART NUMBER	YR/SN	QTY DESCRIPTION
1	562057		AR SHIM 3.8mm Thk
1	562058		AR SHIM 4mm Thk
1	562059		AR SHIM 4.2mm Thk
1	562060		AR SHIM 4.4mm Thk
1	569185		AR SHIM 3.9mm Thk
1	569186		AR SHIM 4.1mm Thk
1	569187		AR SHIM 4.3mm Thk
1	569188		AR SHIM 4.5mm Thk
1	569189		AR SHIM 4.6mm Thk
1	569190		AR SHIM 4.7mm Thk
1	569191		AR SHIM 4.8mm Thk
1	4997923		AR SHIM 1mm Thk
1	4997924		AR SHIM 1.5mm Thk
1	4997925		AR SHIM 1.70mm Thk
1	4997926		AR SHIM 1.75mm Thk
1	4997928		AR SHIM 1.90mm Thk
1	4997929		AR SHIM
1	4997930		AR SHIM
1	4997931		AR SHIM
1	4997932		AR SHIM
1	5106249		AR SHIM 1.40mm Thk
1	5106250		AR SHIM 1.05mm Thk
1	5106514		AR SHIM 1.10mm Thk
1	5106515		AR SHIM 1.15mm Thk
1	5106516		AR SHIM 1.20mm Thk
1	5106517		AR SHIM 1.85mm Thk
1	5106518		AR SHIM 1.95mm Thk
1	5106519		AR RING
1	5106520		AR RING
1	4997933		AR SHIM
1	1 5137140		1 SHIM KIT
1	2 5137139		1 SHIM

(1) With 2 Shiim from 1 to 2.30 MM

(2) With 1 Shiim from 2.50 to 3.50 MM

Valid for Var. 390249 or Industrial Var. 330120, 331120 (743846)

FARMALL JX110

21.148.AK

01

p1

1/2014

VAR - 334303, 335113, 335116, 390110, 744735 - INNER CONTROLS - ROD AND FORK

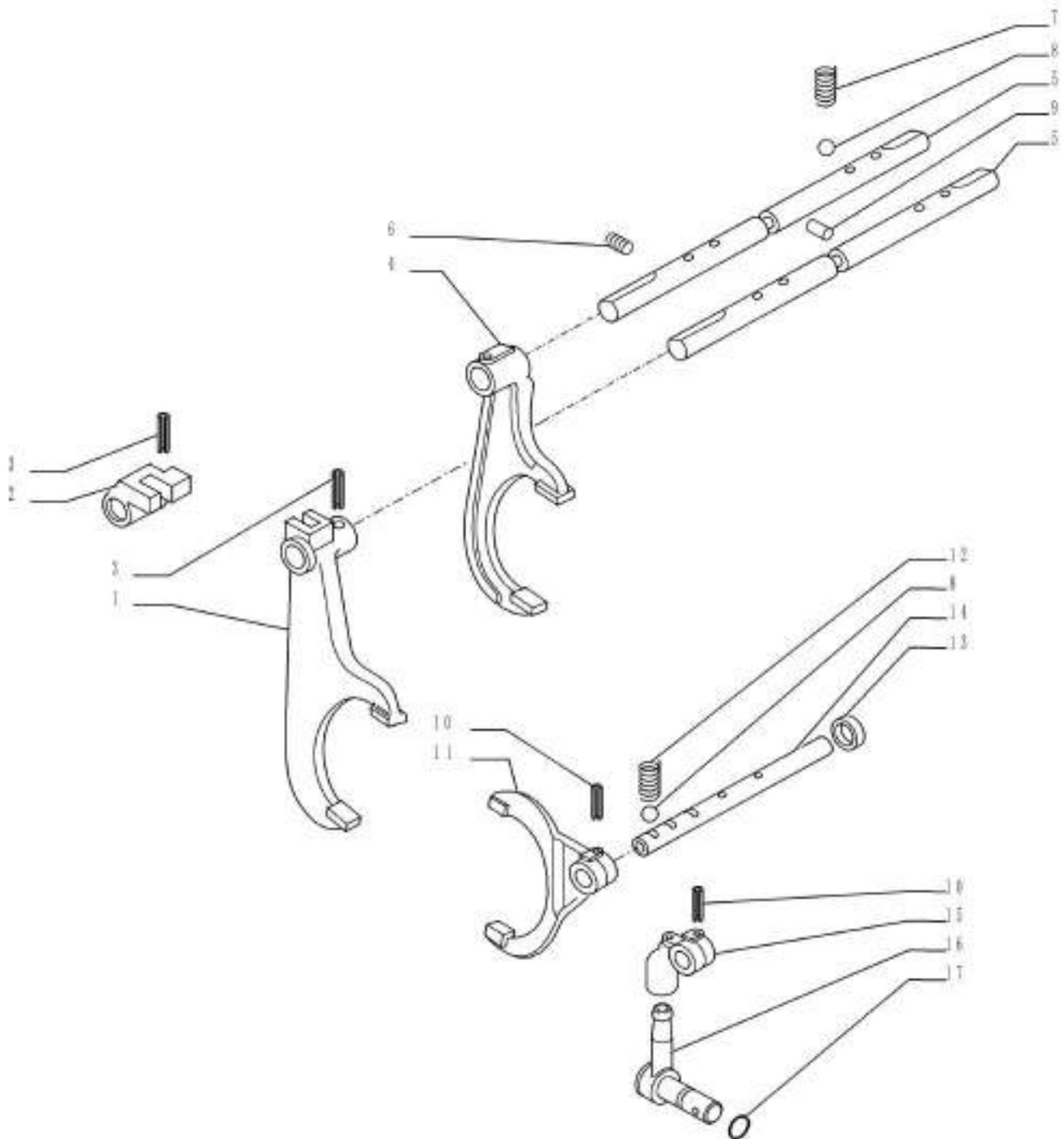

VAR - 334303, 335113, 335116, 390110, 744735 - INNER CONTROLS - ROD AND FORK

REF	FN	PART NUMBER	YR/SN	QTY	DESCRIPTION
1	1	5174202		1	SHIFTER FORK
2		5174201		1	DOG
3		13907770		3	ROLL PIN M5 x 32, Coiled
4	2	5127387		1	SHIFTER FORK
5		84291900		2	SHIFT RAIL
6		10275501		1	PLUG Pipe, Hex Skt, M12 x 1.25 x 11mm, CI 4.8
7		4994342		2	SPRING
8		20063390		2	BALL
9		5110264		1	PAWL
10	3	13907670		2	ROLL PIN M5 x 30, Coiled
11	3	5143463		1	SHIFTER FORK
12	3	84526761		1	SPRING
13	3	5161859		1	SPACER
14	3	5161826		1	SHIFT RAIL
15	3	5162090		1	HUB
16	3	84587991		1	PIN
17	3	14457280		1	O-RING 0.612" ID x 0.103"
18	4	5089403		1	SHAFT 1st-2nd-3rd-4th Speed Shifter Rod: Not Shown

- (1) Third and Forth Gear Selector Fork
(2) First and Second Gear Selector Fork
(3) VAR - 334303, 390110 (744735)
(4) VAR - 335113; Valid for FARMALL JX65, 75, 80, 90 Models Only

Valid for Var. 335113 or Var. 335116 or Industrial Var. 334303, 390110 (744735)

FARMALL JX100 FARMALL
JX110 FARMALL JX70
FARMALL JX75 FARMALL
JX80 FARMALL JX90

VAR - 335113 - INNER CONTROLS - ROD AND FORK

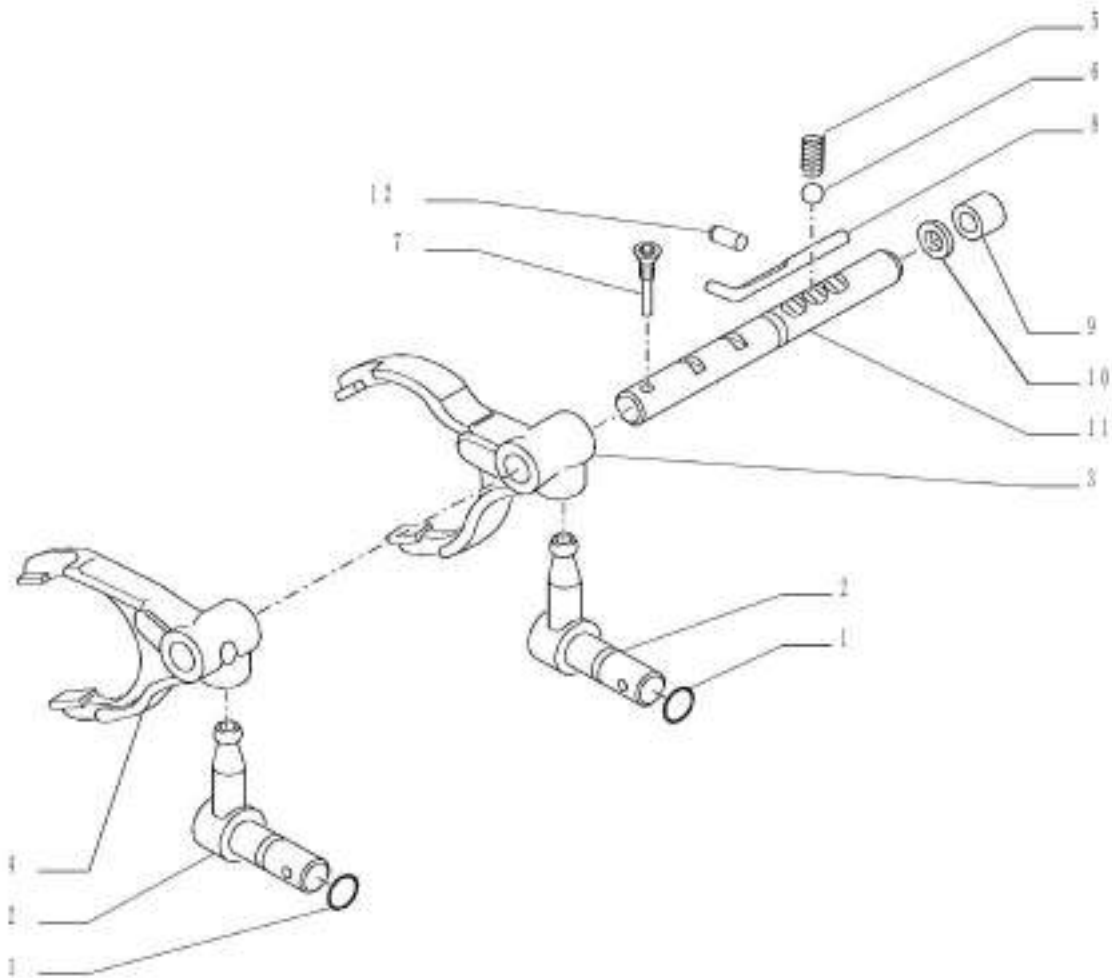

VAR - 335113 - INNER CONTROLS - ROD AND FORK

REF FN	PART NUMBER	YR/SN	QTY DESCRIPTION
1	5089407		1 DETENT
2	13907770		1 ROLL PIN M5 x 32, Coiled
2	84591959		1 PIN
3	5110264		1 PAWL
4	20063390		2 BALL
5	4994342		2 SPRING
6	5131682		1 SHIFT RAIL
7	10152311		1 PLUG
8	5089466		1 SHIFT RAIL
9	5125823		1 SHIFTER FORK Slow/Fast
10	5092219		1 SHIFTER FORK
11	13604211		1 SPACER
12	5095312		1 DOG

Valid for Var. 335113

FARMALL JX100 FARMALL
 JX110 FARMALL JX70
 FARMALL JX75 FARMALL
 JX80 FARMALL JX90

VAR - 335113, 744735 - INNER CONTROLS - ROD AND FORK

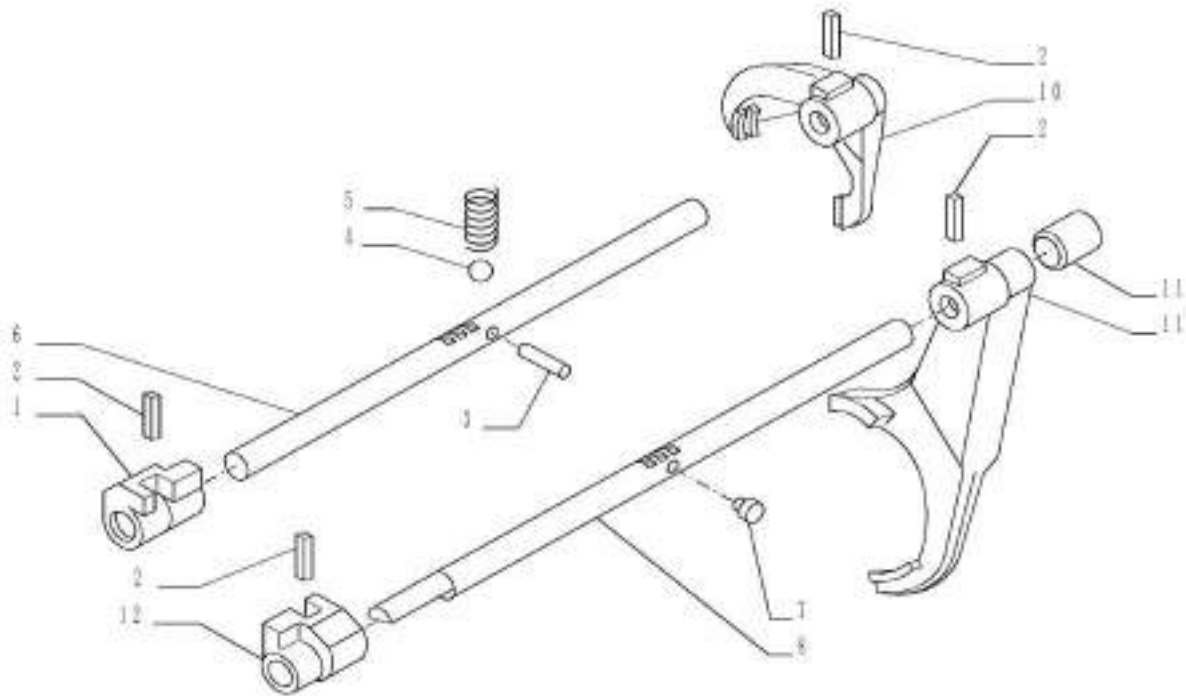

21.148.AK

03

p1

1/2014

VAR - 335113, 744735 - INNER CONTROLS - ROD AND FORK

REF FN	PART NUMBER	YR/SN	QTY DESCRIPTION
1	5089407		1 DETENT
2	13907770		AR ROLL PIN M5 x 32, Coiled
3	5110264		1 PAWL
4	20063390		2 BALL
5	4994342		2 SPRING
6	5131682		1 SHIFT RAIL
7	10152311		1 PLUG
8	5089466		1 SHIFT RAIL
9	5125823		1 SHIFTER FORK Slow/Fast
10	5092219		1 SHIFTER FORK
11	13604211		1 SPACER
12	5095312		1 DOG

4WD; Valid for Var. 335113 or Industrial Var. 334303, 390110 (744735)

FARMALL JX100
FARMALL JX110

VAR - 743846, 744735 - INNER CONTROLS - ROD AND FORK

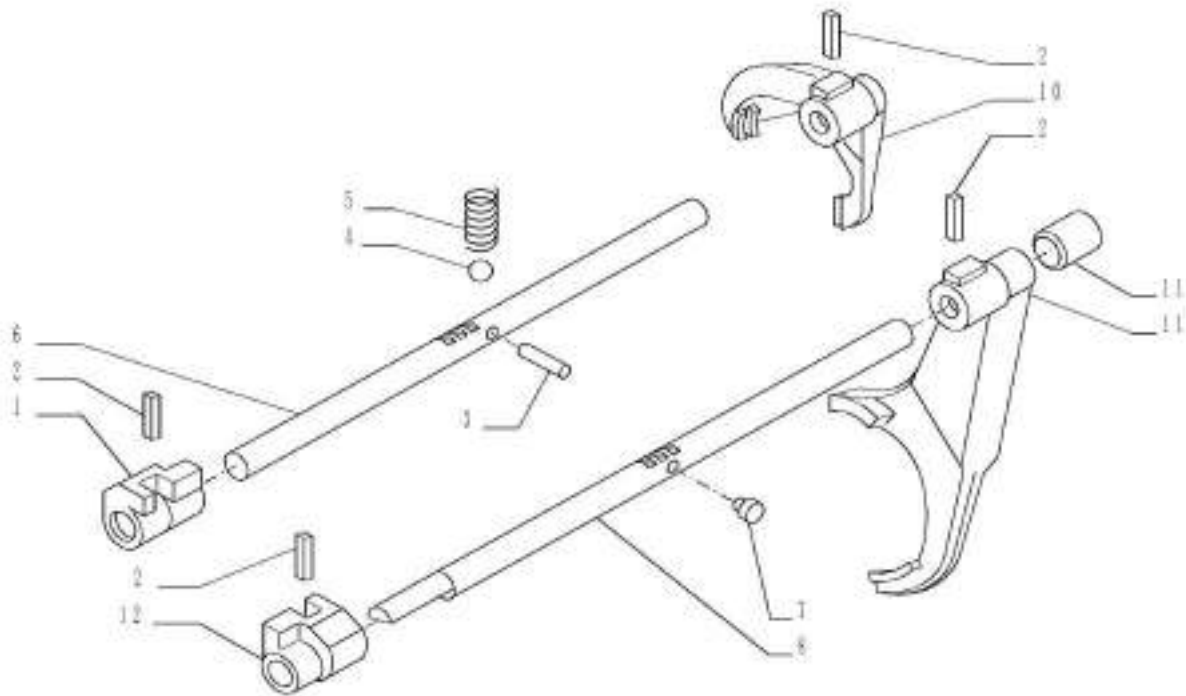

VAR - 743846, 744735 - INNER CONTROLS - ROD AND FORK

REF FN	PART NUMBER	YR/SN	QTY DESCRIPTION
1	5089407		1 DETENT
2	13907770		AR ROLL PIN M5 x 32, Coiled
3	5110264		1 PAWL
4	20063390		2 BALL
5	4994342		2 SPRING
6 1	5127897		1 SHIFT RAIL
6 2	5131682		1 SHIFT RAIL
7 1	10275501		1 PLUG Pipe, Hex Skt, M12 x 1.25 x 11mm, Cl 4.8
7 2	10152311		1 PLUG
8 1	5089410		1 ROD
8 2	5089466		1 SHIFT RAIL
9	5125823		1 SHIFTER FORK Slow/Fast
10 1	5089406		1 FORK
10 2	5092219		1 SHIFTER FORK
11	13604211		1 SPACER
12	5095312		1 DOG

(1) VAR - 390110 (744735)

(2) VAR - 330120, 331120 (743846), 334303 (744735)

Valid for Industrial Var. 330120, 331120 (743846) or Industrial Var. 334303, 390110 (744735)

FARMALL JX70
 FARMALL JX75
 FARMALL JX80
 FARMALL JX90

21.148.AL

01

p1

1/2014

VAR - 335116, 390110, 744735 - TRANSMISSION GEARS - SHAFT

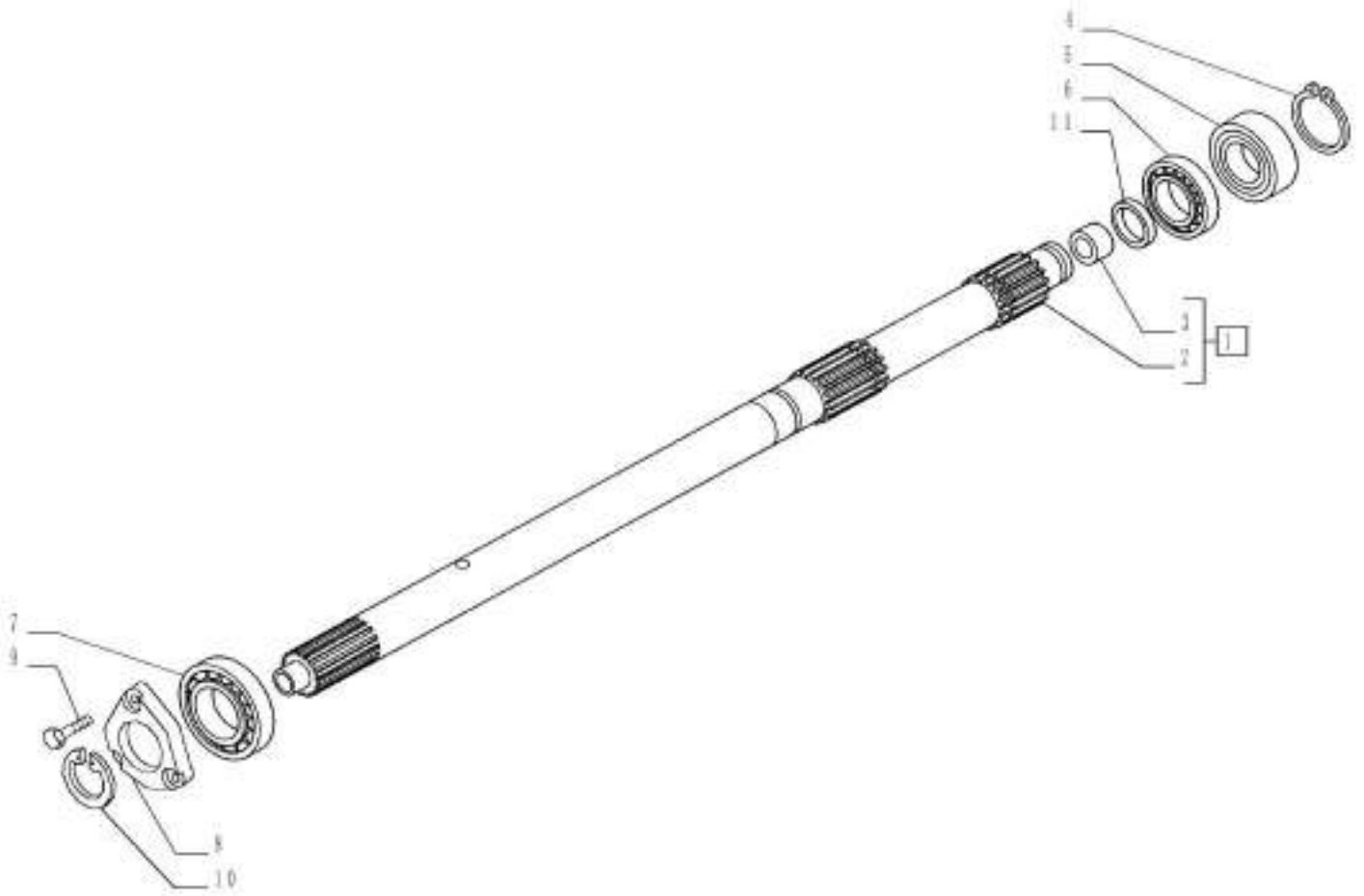

VAR - 335116, 390110, 744735 - TRANSMISSION GEARS - SHAFT

REF	FN	PART NUMBER	YR/SN	QTY	DESCRIPTION
1	1	84206608		1	SHAFT ASSY Incl 2 - 3
1	2	5161816		1	CLUTCH INPUT SHAFT ASSY Incl 2 - 3
1	3	5089358		1	CLUTCH INPUT SHAFT
1	4	47033199		1	SHAFT
2		NSS		1	NOT SERVICED SEPARATELY Shaft Incl in 1
3		4950081		1	BUSHING
4		11068876		1	SNAP RING M40, Ext
5		47134157		1	BALL BEARING 40 mm ID x 68 mm OD x 15 mm
6		87302536		1	BALL BEARING 45 mm ID x 85 mm OD x 19 mm
7		28996330		1	BALL BEARING
8		5162671		1	COVER
9		14238121		3	BOLT Hex, M8 x 1.25 x 25mm, Cl 8.8, Full Thd
10		5135061		1	CIRCLIP M45, Ext
11	5	84226406		1	OIL SEAL
11	4	11069076		1	SNAP RING M45, Ext

(1) VAR - 390110 (744735); Valid for FARMALL JX70 Model Only

(2) VAR - 390110 (744735); Valid for FARMALL JX75, 80, 90 Models Only

(3) VAR - 390110 (744735); Valid for FARMALL JX100, 110 Models Only

(4) VAR - 335116

(5) VAR - 390110 (744735)

Valid for Var. 335116 or Industrial Var. 390110 (744735)

FARMALL JX100 FARMALL
JX110 FARMALL JX70
FARMALL JX75 FARMALL
JX80 FARMALL JX90

VAR - 390110, 744735 - TRANSMISSION GEARS - SHAFT

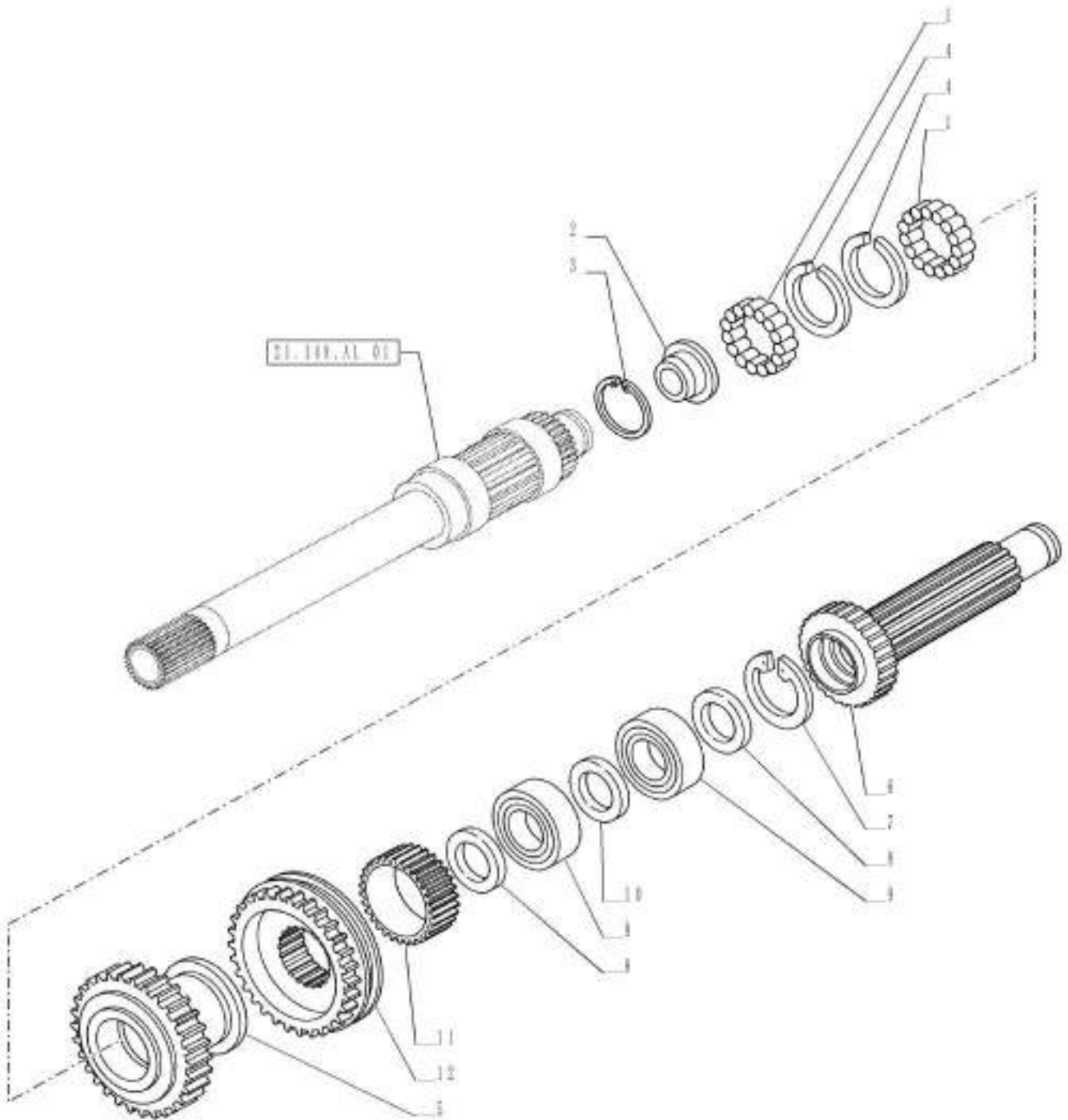

VAR - 390110, 744735 - TRANSMISSION GEARS - SHAFT

REF FN	PART NUMBER	YR/SN	QTY DESCRIPTION
1	5137225		2 NEEDLE BEARING CAGE
2	5137222		1 SPACER
3	11062176		1 CIRCLIP M85, Int
4	5137224		2 WASHER
5	5164583		1 DRIVEN GEAR
6	5161817		1 MAIN SHAFT
7	11070876		1 CIRCLIP M80, Ext
8	5143461		2 WASHER
9	28042480		2 BALL BEARING 40.00mm x 68.00mm x 15.00mm
10	5086496		1 SPACER
10	5109669		1 WASHER 3mm Thk
10	5118937		1 WASHER 3.25mm Thk
10	5118938		1 WASHER 3.50mm Thk
10	5118939		1 WASHER 3.75mm Thk
10	5118940		1 THRUST WASHER 4.00mm Thk
10	5088424		1 SHIM KIT
11	5143460		1 SLEEVE
12	5186629		1 SYNCHRONIZER

Valid for Industrial Var. 390110 (744735)

FARMALL JX100 FARMALL
 JX110 FARMALL JX70
 FARMALL JX75 FARMALL
 JX80 FARMALL JX90

21.148.AL

03

p1

1/2014

VAR - 335113 - TRANSMISSION GEARS - SHAFT

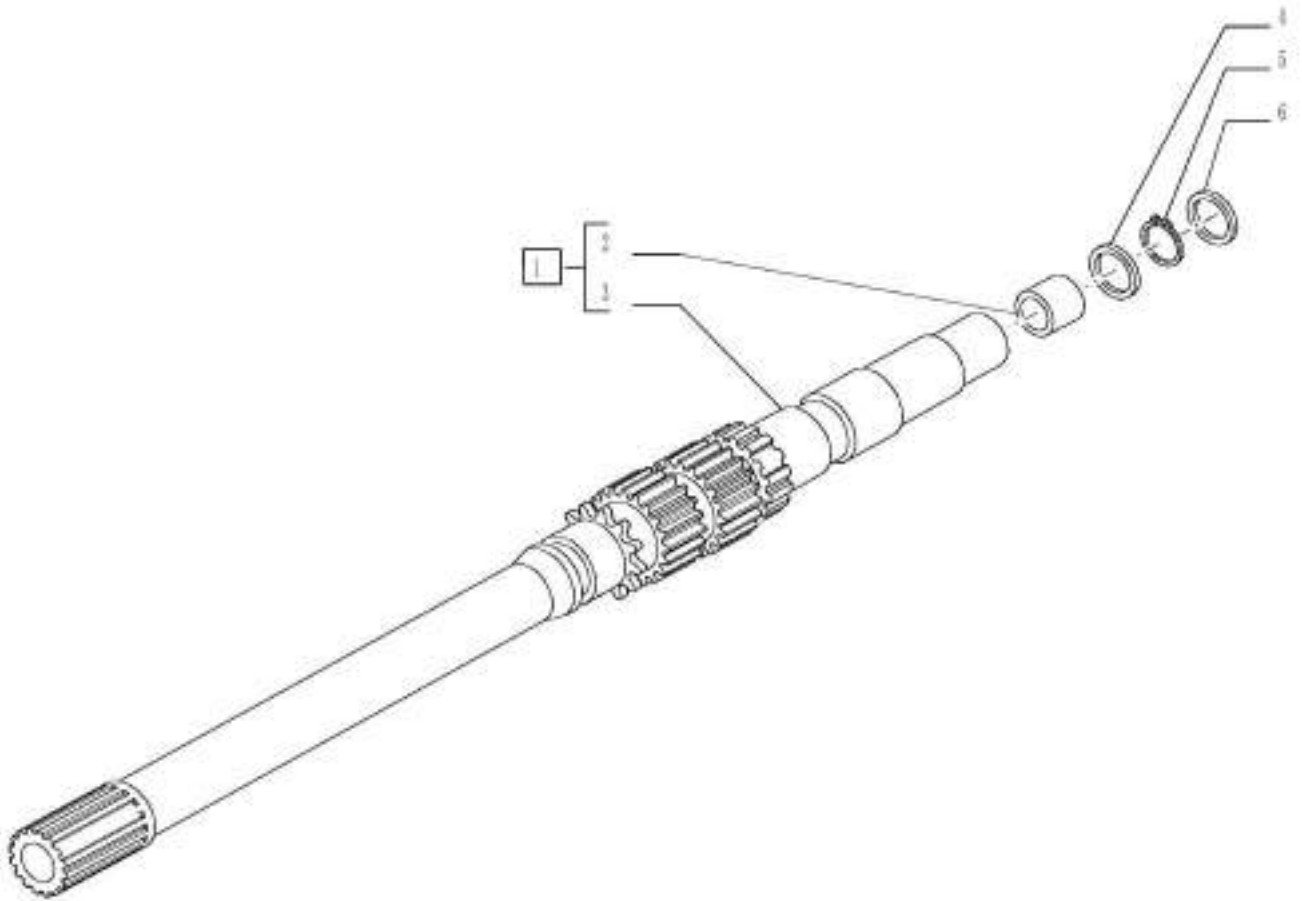

VAR - 335113 - TRANSMISSION GEARS - SHAFT

REF	FN	PART NUMBER	YR/SN	QTY	DESCRIPTION
1	1	5097581		1	SHAFT ASSY, Incl 2 - 3
1	2	84209504		1	SHAFT ASSY, Incl 2 - 3
1	3	5097576		1	SHAFT ASSY, Incl 2 - 3
2		4950081		1	BUSHING
3		NSS		1	NOT SERVICED SEPARATELY Shaft Incl in 1
4		84226406		1	OIL SEAL
5		11069376		1	SNAP RING M50, Ext
6		5175959		1	HALF-RING

- (1) Valid for FARMALL JX70 Model Only
 (2) Valid for FARMALL JX75, 80, 90 Models Only
 (3) Valid for FARMALL JX100, 110 Models Only

Valid for Var. 335113

FARMALL JX100 FARMALL
 JX110 FARMALL JX70
 FARMALL JX75 FARMALL
 JX80 FARMALL JX90

VAR - 390110, 744735 - TRANSMISSION, GEAR SHAFT

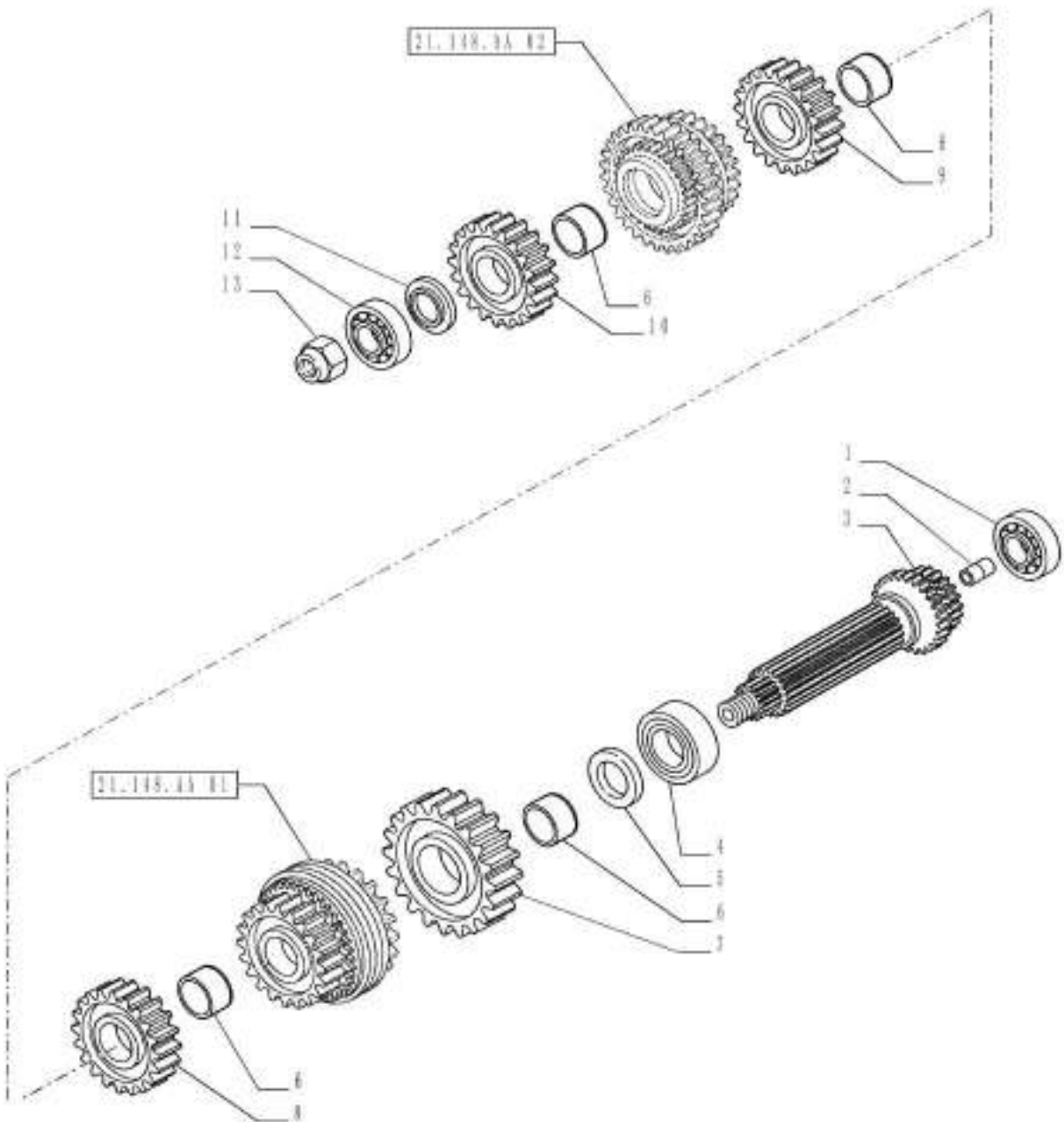

VAR - 390110, 744735 - TRANSMISSION, GEAR SHAFT

REF FN	PART NUMBER	YR/SN	QTY DESCRIPTION
1	5126458		1 CYLINDRICAL ROLLER BEARING 27.5 mm ID x 52 mm OD x 21 mm
2	5145131		1 RIGID TUBE
3	1 5127958		1 DRIVEN SHAFT
3	2 5001132		1 CONTROL SHAFT
4	84204873		1 ROLLER BEARING
5	5109656		1 THRUST WASHER
6	5101537		4 BUSHING
7	5118912		1 DRIVING GEAR
8	5169606		1 DRIVING GEAR
9	5179672		1 DRIVING GEAR
10	5123982		1 DRIVING GEAR
11	5122797		1 THRUST WASHER
12	28995880		1 BALL BEARING
13	5122985		1 NUT Ring, M32, 1.5 Pitch

(1) Valid for FARMALL JX70, 75, 80, 90 Models Only

(2) Valid for FARMALL JX100, 110 Models Only

Valid for Industrial Var. 390110 (744735)

FARMALL JX100 FARMALL
 JX110 FARMALL JX70
 FARMALL JX75 FARMALL
 JX80 FARMALL JX90

VAR - 330120, 331120, 743846 - TRANSMISSION GEARS

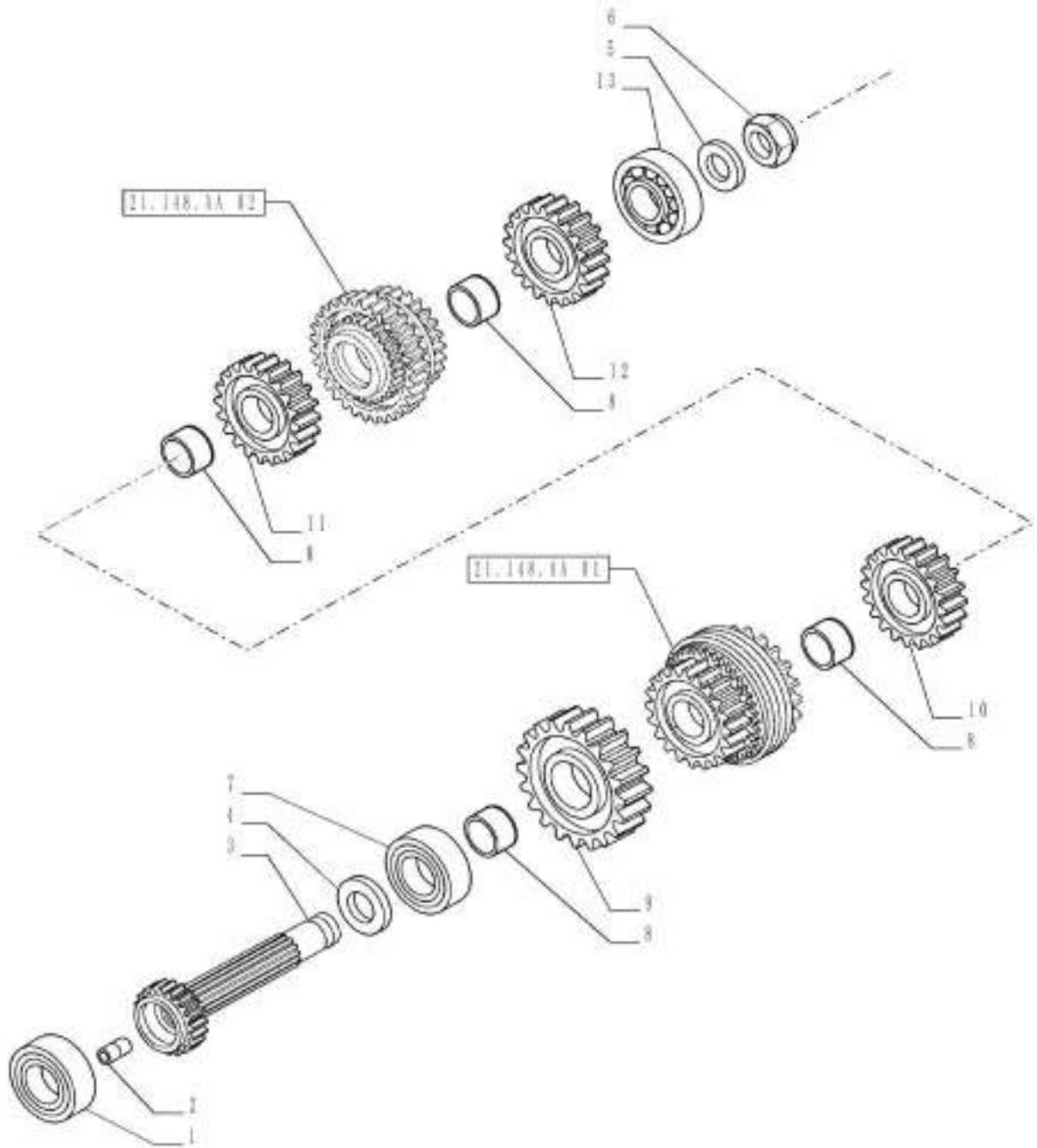

VAR - 330120, 331120, 743846 - TRANSMISSION GEARS

REF FN	PART NUMBER	YR/SN	QTY DESCRIPTION
1	5126458		1 CYLINDRICAL ROLLER BEARING 27.5 mm ID x 52 mm OD x 21 mm
2	5145131		1 RIGID TUBE
3	5160028		1 SHAFT
4	5109669		AR WASHER 3mm Thk
4	5118937		AR WASHER 3.25mm Thk
4	5118938		AR WASHER 3.50mm Thk
4	5118939		AR WASHER 3.75mm Thk
4	5118940		AR THRUST WASHER 4.00mm Thk
5	5137678		1 RING NUT
6	5122797		1 THRUST WASHER
7	84204873		1 ROLLER BEARING
8	5101537		4 BUSHING
9	5118912		1 DRIVING GEAR 1st SPEED
10	5169606		1 DRIVING GEAR 2nd SPEED
11	5179672		1 DRIVING GEAR 3rd SPEED
12	5123982		1 DRIVING GEAR 4th SPEED
13	28995880		1 BALL BEARING

Valid for Industrial Var. 330120, 331120 (743846)

FARMALL JX100
 FARMALL JX110
 FARMALL JX75
 FARMALL JX90

21.148.AQ

03

p1

1/2014

VAR - 330120, 331120, 743846 - TRANSMISSION, GEAR SHAFT

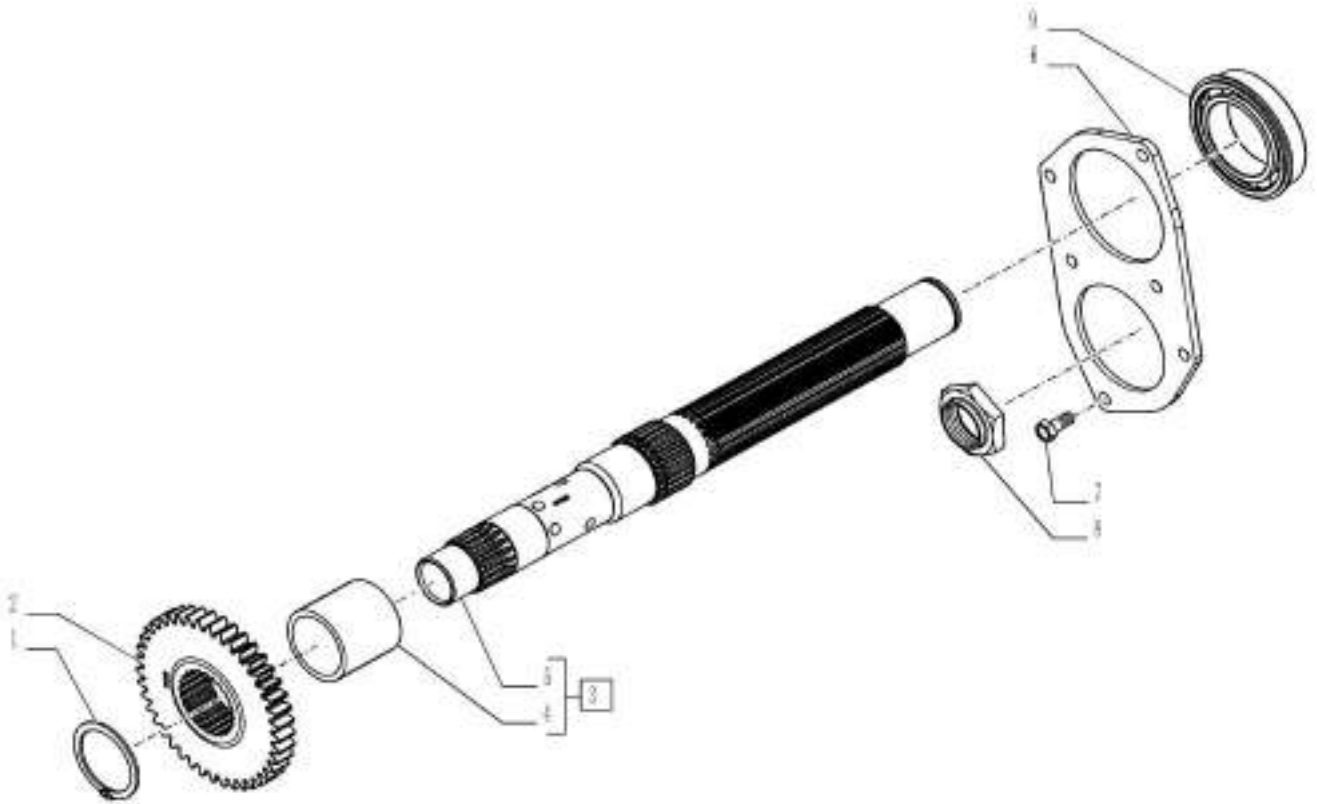

VAR - 330120, 331120, 743846 - TRANSMISSION, GEAR SHAFT

REF FN	PART NUMBER	YR/SN	QTY DESCRIPTION
1	11069376		1 SNAP RING M50, Ext
2	84396952		1 GEAR
3	84286501		1 SHAFT ASSY Incl 4 - 5
4	4950081		1 BUSHING
5	NSS		1 NOT SERVICED SEPARATELY Shaft Incl in 1
6	5137550		1 COVER
7	14238021		6 LOCK BOLT Hex, M8 x 1.25 x 20mm, Cl 8.8, Full Thd
8	5137678		4 RING NUT
9	28996330		1 BALL BEARING

Valid for Industrial Var. 330120, 331120 (743846)

FARMALL JX100
FARMALL JX110
FARMALL JX75
FARMALL JX90

VAR - 335116 - TRANSMISSION, GEAR SHAFT

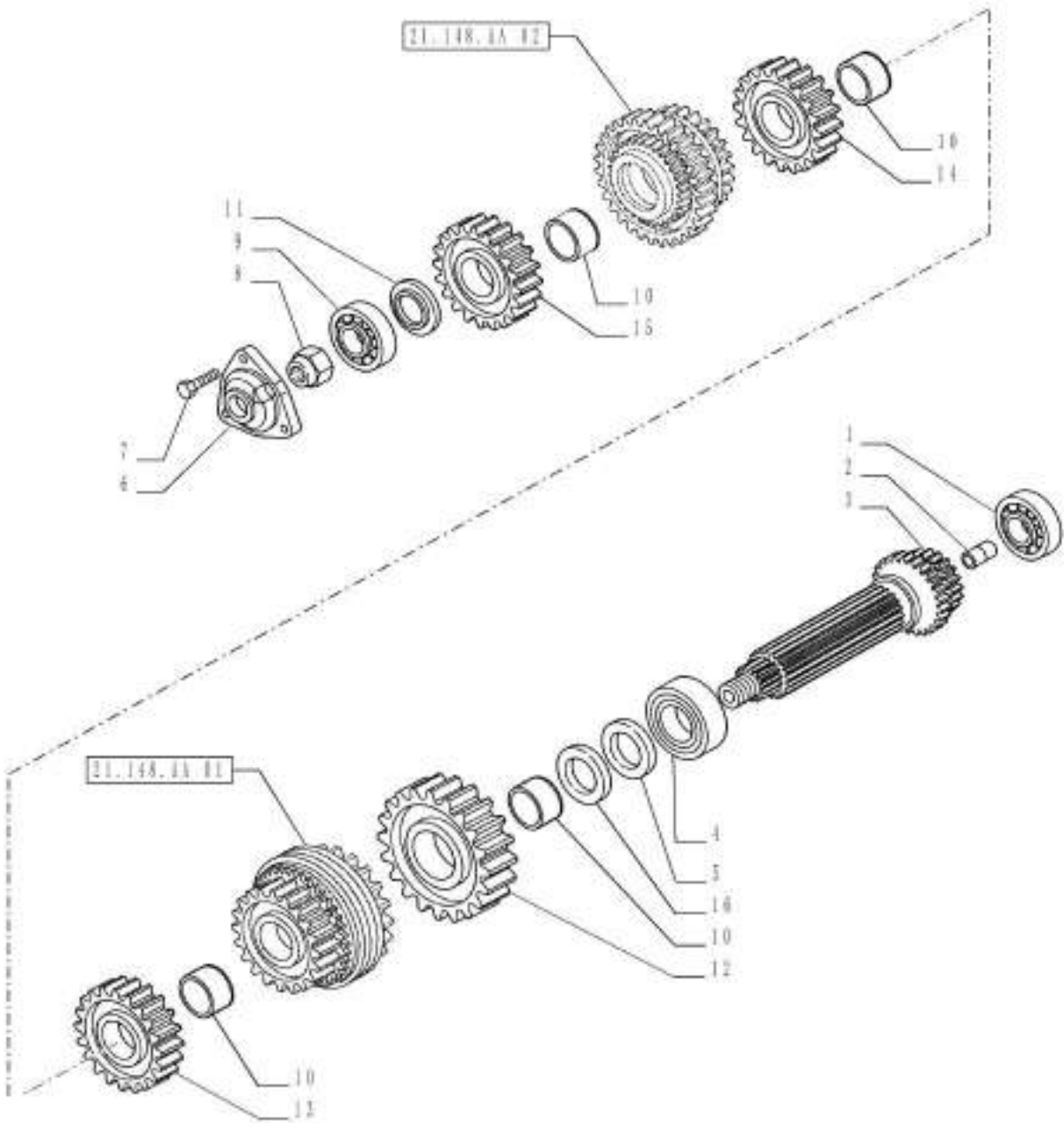

VAR - 335116 - TRANSMISSION, GEAR SHAFT

REF FN	PART NUMBER	YR/SN	QTY DESCRIPTION
1	5126458		1 CYLINDRICAL ROLLER BEARING 27.5 mm ID x 52 mm OD x 21 mm
2	5145131		1 RIGID TUBE
3	5127958		1 DRIVEN SHAFT
4	20943310		1 BALL BEARING 40.00mm x 90.00mm x 23.00mm
5	5109656		1 THRUST WASHER
6	5117552		1 COVER
7	14302821		3 HEX SOC SCREW M8 x 1.25 x 18mm, Cl 8.8, Full Thd
8	5122985		1 NUT Ring, M32, 1.5 Pitch
9	28995880		1 BALL BEARING
10	5101537		4 BUSHING
11	5122797		1 THRUST WASHER
12	5118912		1 DRIVING GEAR 1st SPEED
13	5169606		1 DRIVING GEAR 2nd SPEED
14	5179672		1 DRIVING GEAR 3rd SPEED
15	5123982		1 DRIVING GEAR 4th SPEED
16	5109669		AR WASHER 3mm Thk
16	5118937		AR WASHER 3.25mm Thk
16	5118938		AR WASHER 3.50mm Thk
16	5118939		AR WASHER 3.75mm Thk
16	5118940		AR THRUST WASHER 4.00mm Thk

Valid for Var. 335116

FARMALL JX70
 FARMALL JX75
 FARMALL JX80

VAR - 335113 - TRANSMISSION, GEAR SHAFT

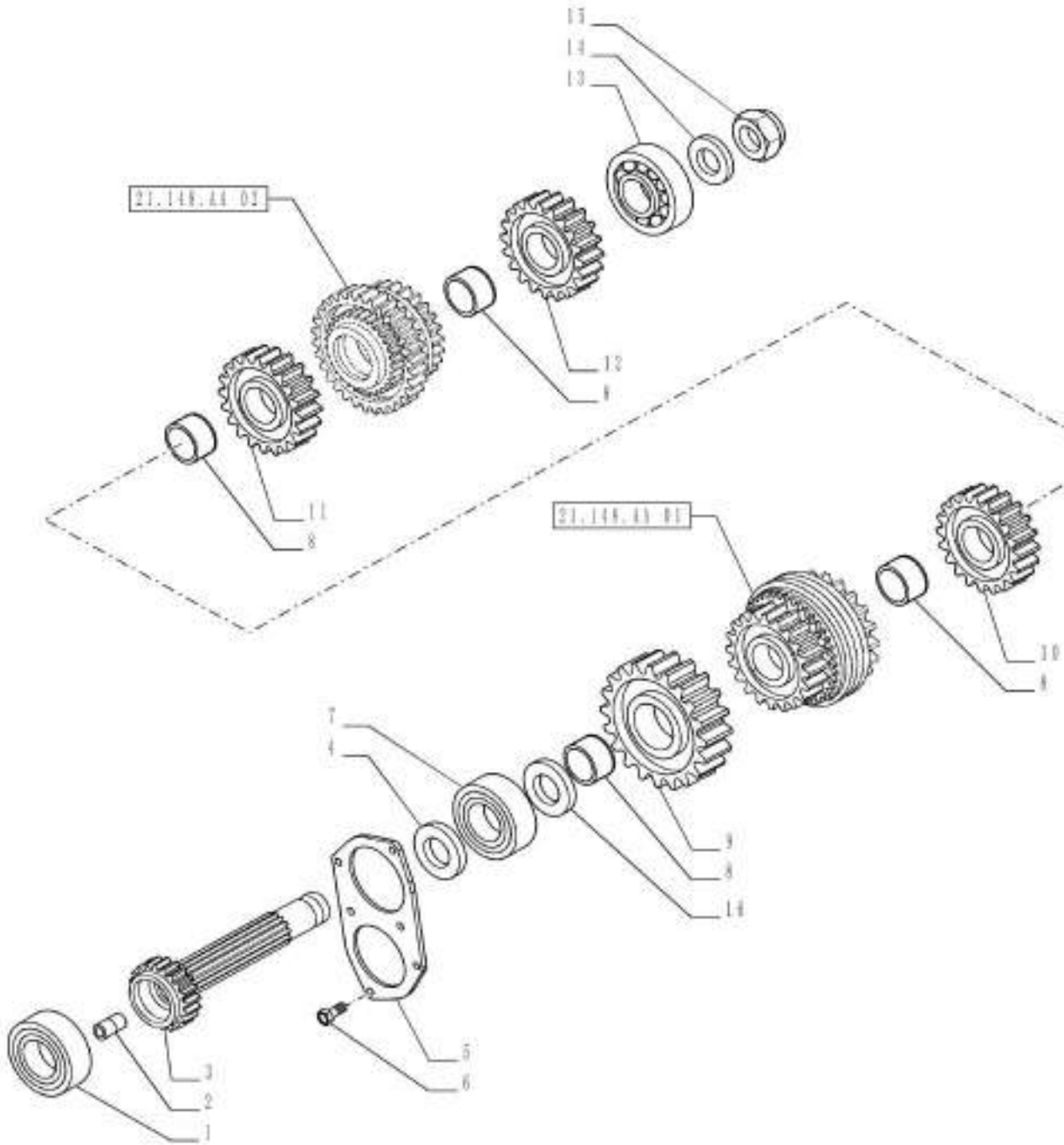

VAR - 335113 - TRANSMISSION, GEAR SHAFT

REF FN	PART NUMBER	YR/SN	QTY DESCRIPTION
1	5126458		1 CYLINDRICAL ROLLER BEARING 27.5 mm ID x 52 mm OD x 21 mm
2	5145131		1 RIGID TUBE
3	1 5125045		1 SHAFT
3	2 5160028		1 SHAFT
4	5109669		AR WASHER 3mm Thk
4	5118937		AR WASHER 3.25mm Thk
4	5118938		AR WASHER 3.50mm Thk
4	5118939		AR WASHER 3.75mm Thk
4	5118940		AR THRUST WASHER 4.00mm Thk
5	5137550		1 COVER
6	14238024		6 BOLT Hex, M8 x 1.25 x 20mm, Cl 8.8, Full Thd
7	1 20943310		1 BALL BEARING 40.00mm x 90.00mm x 23.00mm
7	2 84204873		1 ROLLER BEARING
8	5101537		4 BUSHING
9	5118912		1 DRIVING GEAR 1st SPEED
10	5169606		1 DRIVING GEAR 2nd SPEED
11	5179672		1 DRIVING GEAR 3rd SPEED
12	5123982		1 DRIVING GEAR 4th SPEED
13	28995880		1 BALL BEARING
14	5122797		1 THRUST WASHER
15	5137678		1 RING NUT
16	5109656		1 THRUST WASHER

(1) Valid for FARMALL JX70, 75, 80, 90 Models Only

(2) Valid for FARMALL 100, 110 Models Only

Valid for Var. 335113

FARMALL JX100 FARMALL
 JX110 FARMALL JX70
 FARMALL JX75 FARMALL
 JX80 FARMALL JX90

VAR - 335113 - TRANSMISSION GEARS

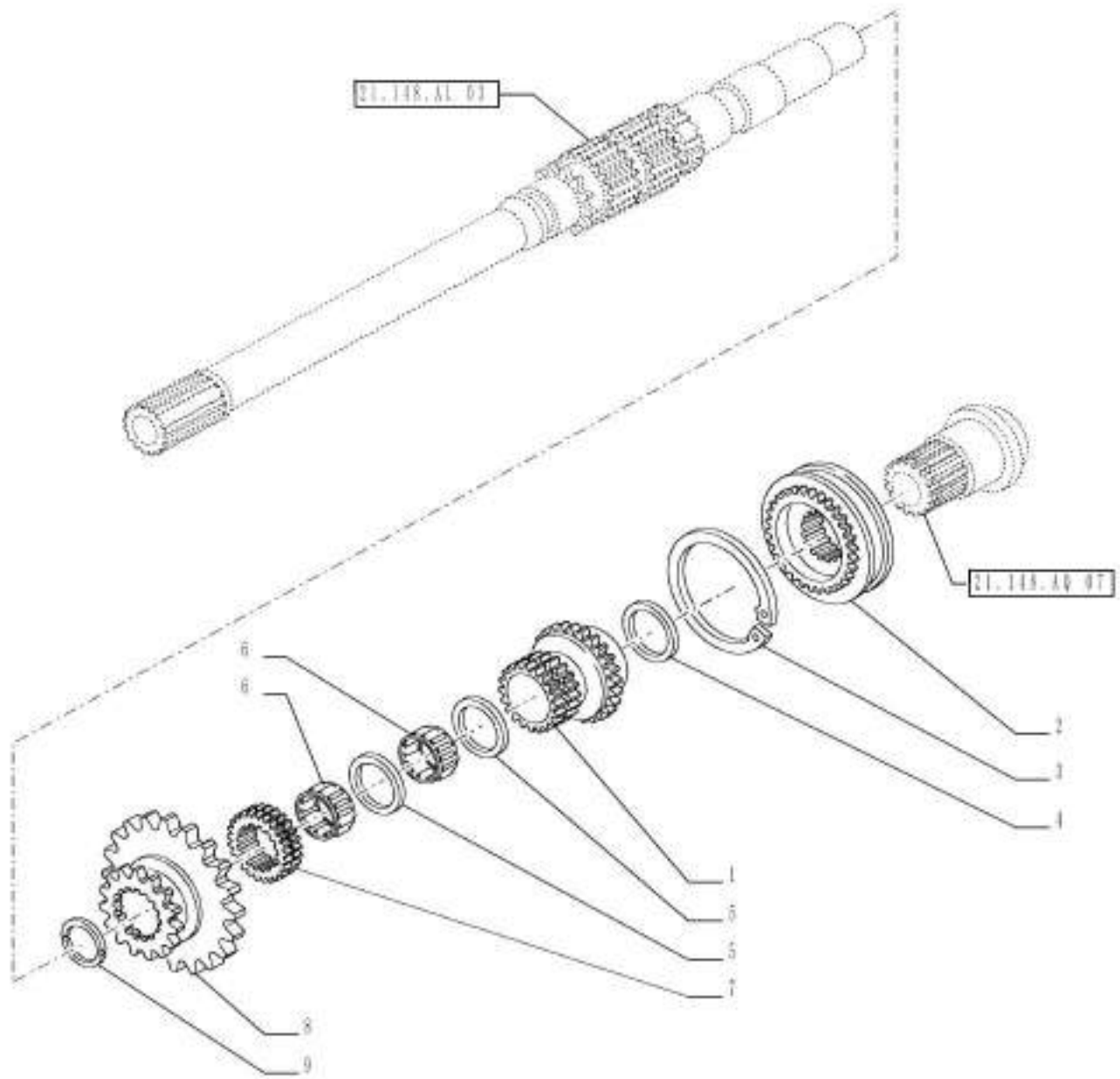

VAR - 335113 - TRANSMISSION GEARS

REF FN	PART NUMBER	YR/SN	QTY DESCRIPTION
1	5175962		1 SLEEVE
2	5186638		1 SYNCHRONIZER
3	11070076		1 SNAP RING M65, Ext
4	5182075		1 WASHER
5	5160929		2 SNAP RING 55.3mm OD x 1.5mm Width D=53
6	5160928		2 NEEDLE BEARING
7	5175960		1 SLEEVE
8	5175967		1 GEAR
9	5141500		1 RING

Valid for Var. 335113	FARMALL JX100 FARMALL JX110 FARMALL JX70 FARMALL JX75 FARMALL JX80 FARMALL JX90
-----------------------	--

VAR - 335113 - TRANSMISSION GEARS

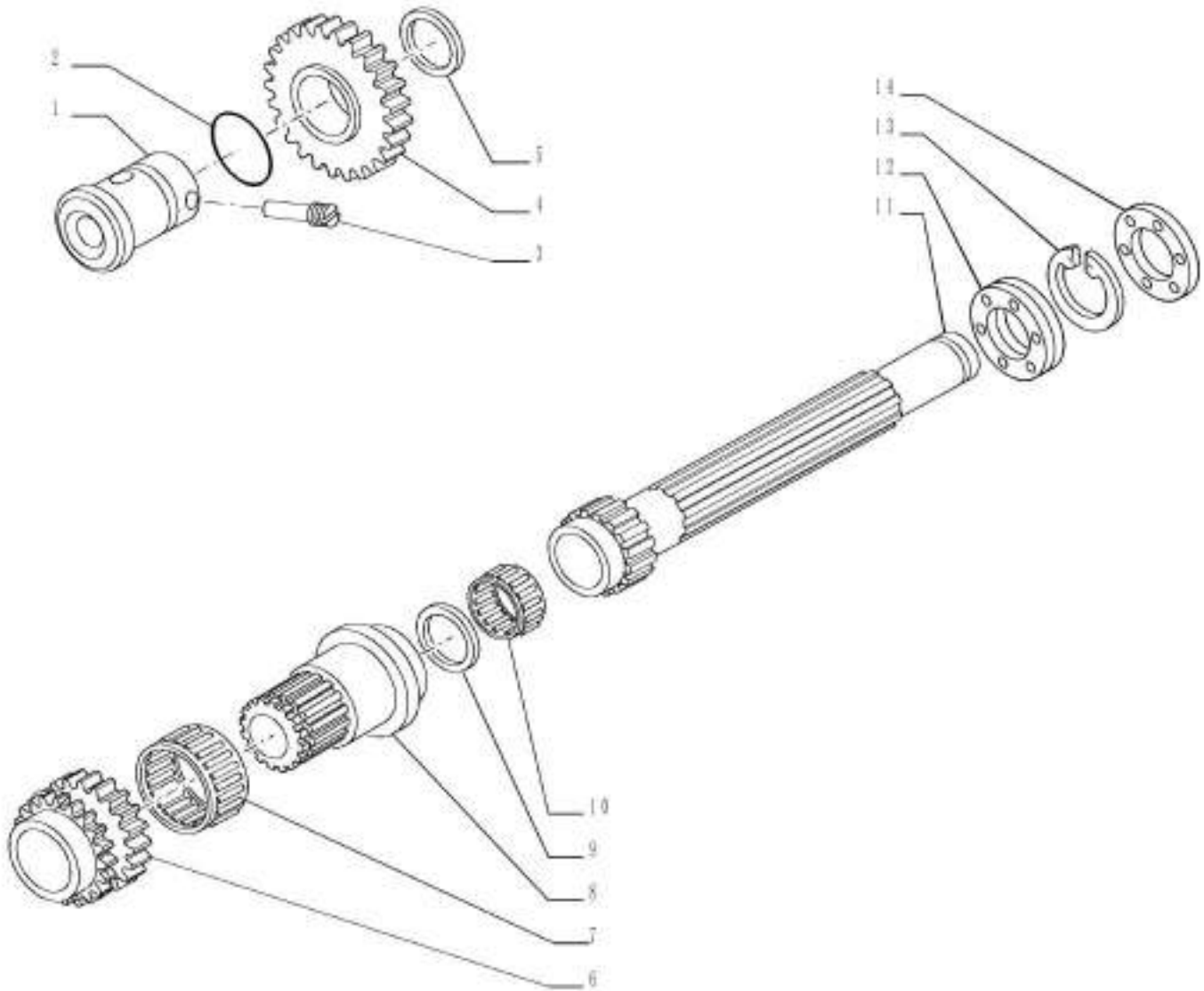

VAR - 335113 - TRANSMISSION GEARS

REF FN	PART NUMBER	YR/SN	QTY DESCRIPTION
1	5161821		1 PIN
2	14457980		1 O-RING 26.64mm ID x 2.62" Width
3	5161823		1 ROLL PIN
4	5175975		1 GEAR
5	5117570		1 THRUST WASHER
6	5160664		1 DRIVEN GEAR
7	5149885		1 ROLLER CAGE BEARING 75 mm ID x 81 mm OD x 30 mm
8	5160665		1 COUPLING
9	5160672		AR O-RING 51mm ID x 58.5mm OD x 2.7mm Width
9	84490418		AR SHIM 1.5mm Thk
9	84490419		AR SHIM 1.7mm Thk
9	84490420		AR SHIM 1.9mm Thk
9	84490421		AR SHIM 2.1mm Thk
9	5160673		AR SHIM 2.9mm Thk
9	5160674		AR SHIM 3.1mm Thk
9	5160675		AR SHIM 3.3mm Thk
9	5162094		AR SHIM 3.5mm Thk
9	5162095		AR SHIM 3.7mm Thk
9	84490422		AR SHIM
9	84490423		AR SHIM
10	5128943		1 NEEDLE BEARING
11	5160658		1 MAIN SHAFT
12	5097663		1 BALL BEARING 50mm ID x 90mm OD x 20mm
13	11068876		1 SNAP RING M40, Ext
14	28996330		1 BALL BEARING

Valid for Var. 335113

FARMALL JX100 FARMALL
 JX110 FARMALL JX70
 FARMALL JX75 FARMALL
 JX80 FARMALL JX90

VAR - 335113 - TRANSMISSION GEARS

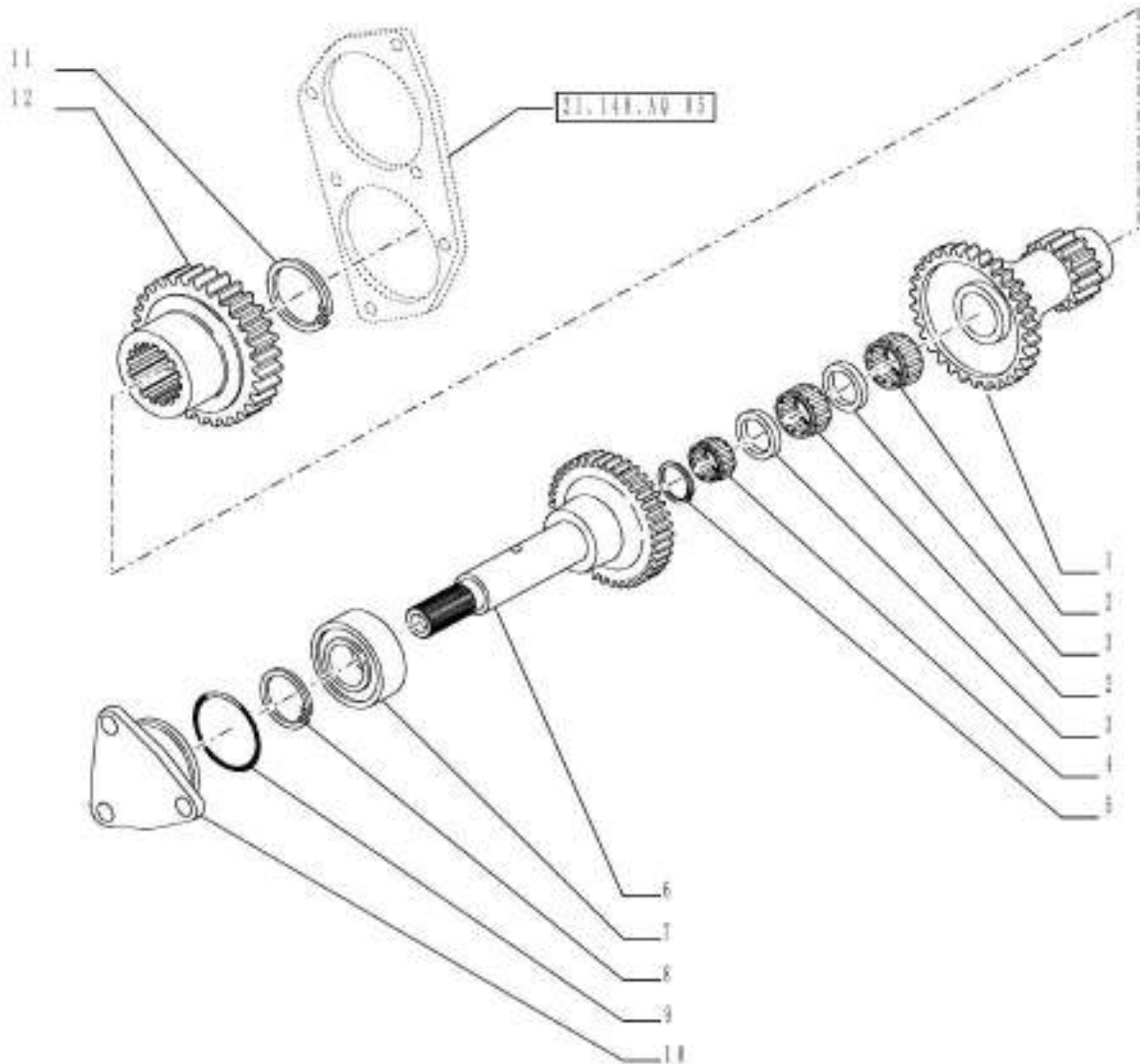

VAR - 335113 - TRANSMISSION GEARS

REF FN	PART NUMBER	YR/SN	QTY DESCRIPTION
1	5175974		1 GEAR
2	5109747		2 NEEDLE BEARING
3	5175973		2 THRUST WASHER
4	5107311		1 NEEDLE BEARING
5	5116573		1 CIRCLIP D=35
6	5175970		1 SHAFT
7	28996320		1 BALL BEARING 40 x 80 x 18
8	11068876		1 SNAP RING M40, Ext
9	14461080		1 O-RING 3.237" ID x 3.442" OD x 0.103"
10	5161822		1 COVER
11	11069576		1 SNAP RING M55, Ext
12	5175972		1 GEAR

Valid for Var. 335113

FARMALL JX100 FARMALL
 JX110 FARMALL JX70
 FARMALL JX75 FARMALL
 JX80 FARMALL JX90

21.154.AA

01

p1

1/2014

VAR - 330120, 331120, 743846 - CLUTCH

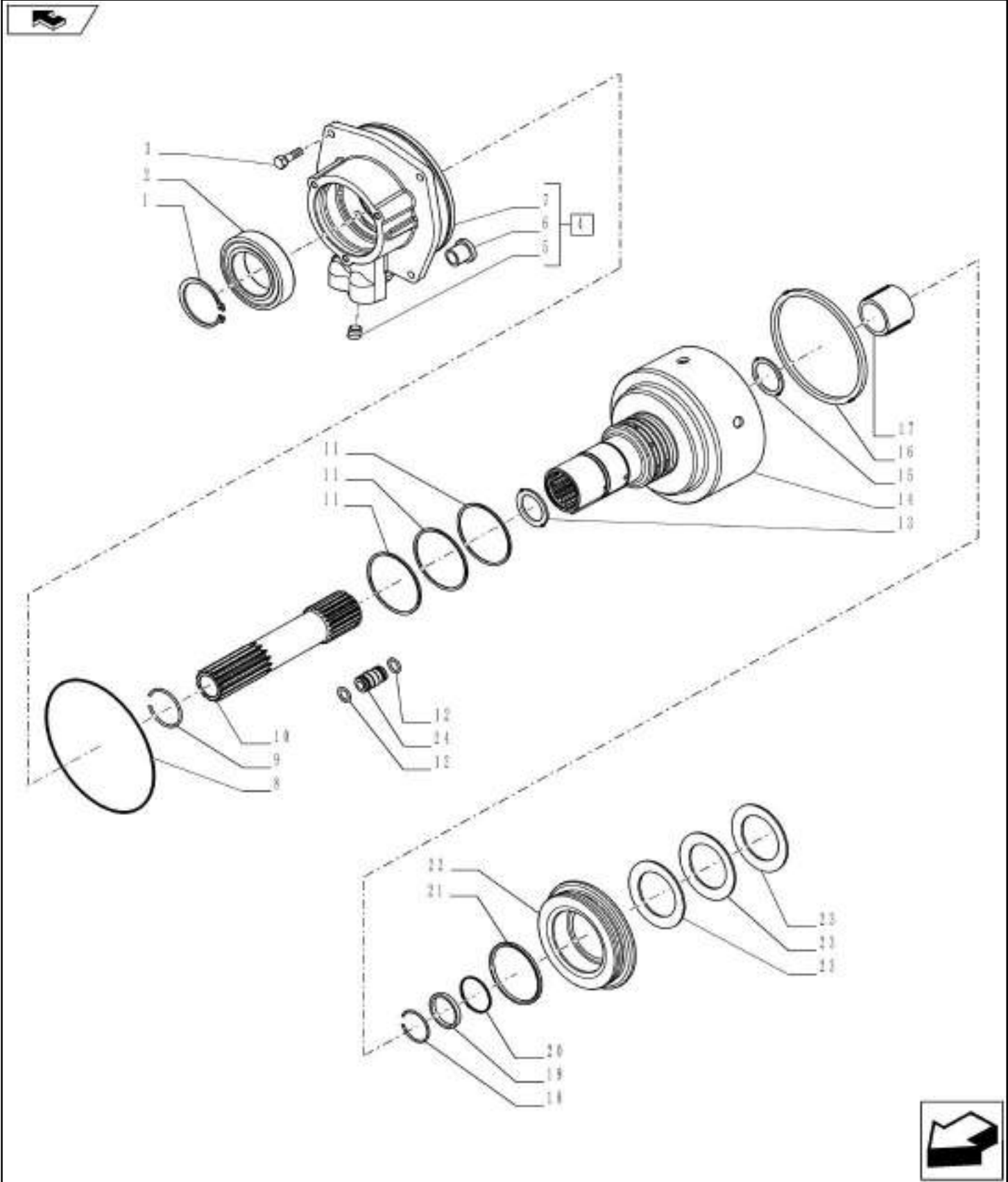

VAR - 330120, 331120, 743846 - CLUTCH

REF FN	PART NUMBER	YR/SN	QTY DESCRIPTION
1	11069576		1 SNAP RING M55, Ext
2	5122846		1 BALL BEARING 55 mm ID x 90 mm OD x 18 mm
3	43127		4 BOLT Hex, M8 x 1.25 x 25mm, Cl 8.8, Full Thd
4	5177559		1 COVER ASSY Incl 5 - 7
5	10269404		2 PLUG
6	5168157		2 BUSHING
7	NSS		1 NOT SERVICED SEPARATELY Cover Incl in 1
8	14462180		1 O-RING 152.1mm ID x 2.62" Width
9	13421976		1 SNAP RING M45, Int
10	84335414		1 SHAFT
11	83911795		3 SEAL 3" ID x .105" Thk
12	5174041		4 O-RING 13.1mm ID x 2.62mm
13	5181057		1 THRUST WASHER
14	1 84490739		1 PISTON
14	2 87558415		1 HOUSING
15	5180152		1 THRUST WASHER
16	87528273		1 OIL SEAL
17	5181211		1 BEARING ASSY
18	5124473		1 CIRCLIP
19	5173674		1 GASKET
20	5168345		1 GASKET
21	1 5182703		1 GASKET
21	2 5172413		1 SLIPPER
22	1 84490736		1 PISTON
22	2 5179794		1 PLUNGER
23	5168346		7 BELLEVILLE WASHER
24	84286494		2 HYD CONNECTOR

(1) Valid for FARMALL JX110 Models Only

(2) Valid for FARMALL JX75, 90, 100 Models Only

Valid for Industrial Var. 330120, 331120 (743846)

FARMALL JX100
 FARMALL JX110
 FARMALL JX75
 FARMALL JX90

21.154.AA

02

p1

1/2014

VAR - 330120, 331120, 743846 - CLUTCH DISK

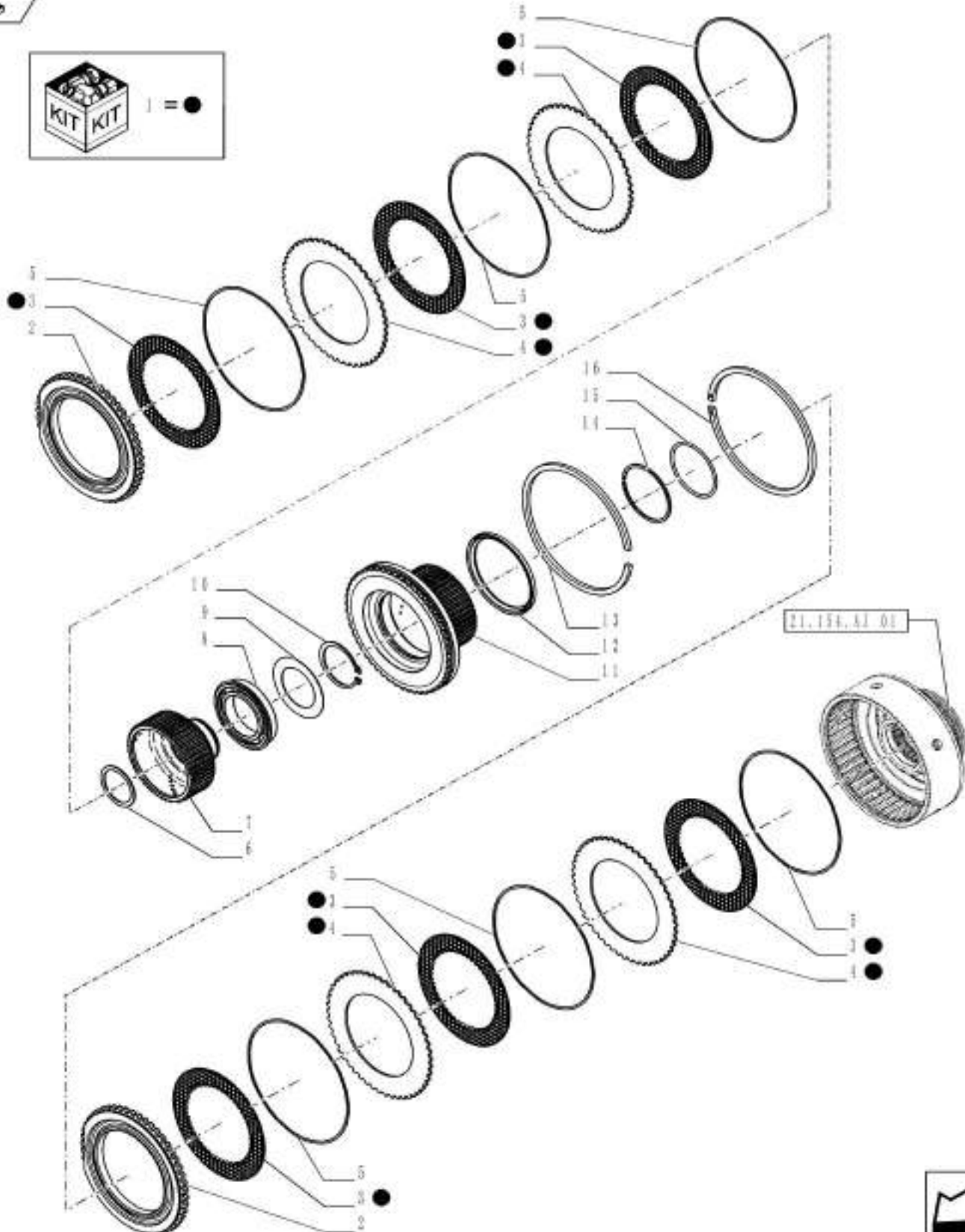

VAR - 330120, 331120, 743846 - CLUTCH DISK

REF FN	PART NUMBER	YR/SN	QTY DESCRIPTION
1	84286493		2 CLUTCH PLATE
2	5171657		2 DISC
3	84286489		12 CLUTCH PLATE
4	5173295		AR CLUTCH DISC 99.00mm ID x 152.60mm OD x 2.20mm THICK 2,2 MM
4	5173294		AR CLUTCH DISC THICK 2,0 MM
5	81864341		12 SPRING
6	14463880		1 O-RING 34.52mm ID x 3.53" Width
7	5171654		1 HUB
8	5168354		1 BALL BEARING 50 mm ID x 80 mm OD x 16 mm
9	5171655		1 THRUST WASHER
10	11069376		1 SNAP RING M50, Ext
11	5171664		1 HUB
12	5177500		1 SEAL
13	5173675		1 SNAP RING
14	5168348		1 CIRCLIP
15	5168347		1 CUP
16	5162251		1 CIRCLIP

Valid for Industrial Var. 330120, 331120 (743846)

FARMALL JX100
 FARMALL JX110
 FARMALL JX75
 FARMALL JX90

VAR - 330120, 331120, 743846 - DRIVE GEAR SHAFT

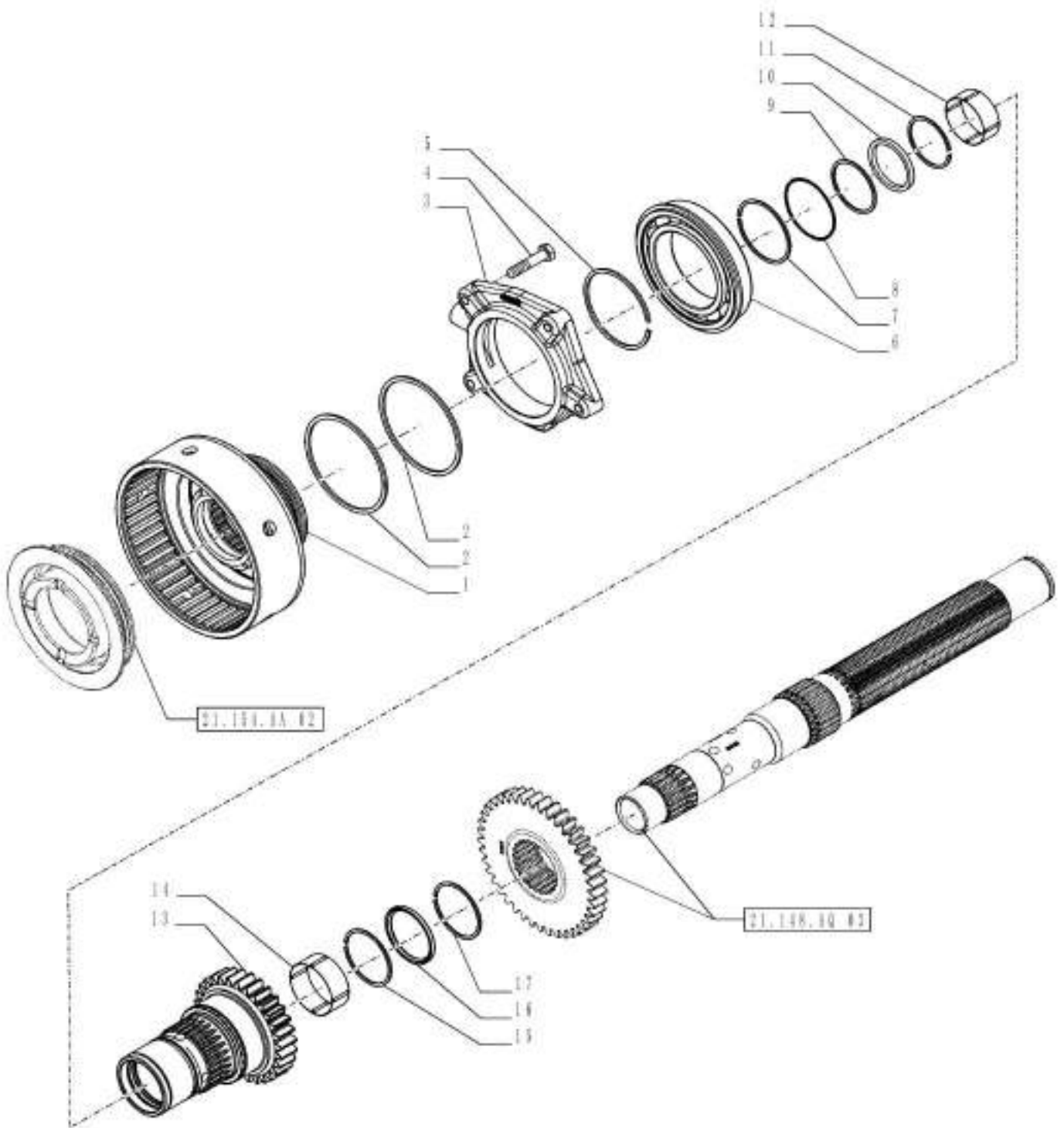

VAR - 330120, 331120, 743846 - DRIVE GEAR SHAFT

REF	FN	PART NUMBER	YR/SN	QTY	DESCRIPTION
1	1	5177478		1	BELL HOUSING
1	2	84490737		1	PISTON
2		5131232		2	SEALING RING 82mm ID x 90mm OD, 3.45mm Thk
3		84286486		1	CLUTCH
4		43129		4	BOLT Hex, M8 x 1.25 x 40mm, Cl 8.8
5		5177510		1	CIRCLIP
6		5168366		1	BALL BEARING 70 mm ID x 110 mm OD x 20 mm
7		5168348		1	CIRCLIP
8		14455080		1	O-RING 50.52mm ID x 1.78mm
9		5117076		1	CIRCLIP
10		5168364		1	SEAL
11		5139494		1	CIRCLIP
12		5168362		1	ROLLER CAGE BEARING 40 mm ID x 45 mm OD x 17 mm
13		84602951		1	SHAFT
14		5161805		1	NEEDLE BEARING
15		5139492		1	RING
16		87564297		1	OIL SEAL
17		87617914		1	SNAP RING

(1) Valid for FARMALL JX75, 90, 100 Models Only

(2) Valid for FARMALL JX110 Model Only

Valid for Industrial Var. 330120, 331120 (743846)

FARMALL JX100
 FARMALL JX110
 FARMALL JX75
 FARMALL JX90

21.154.AO

01

p1

1/2014

VAR - 330120, 331120, 743846 - TRANSMISSION, GEAR

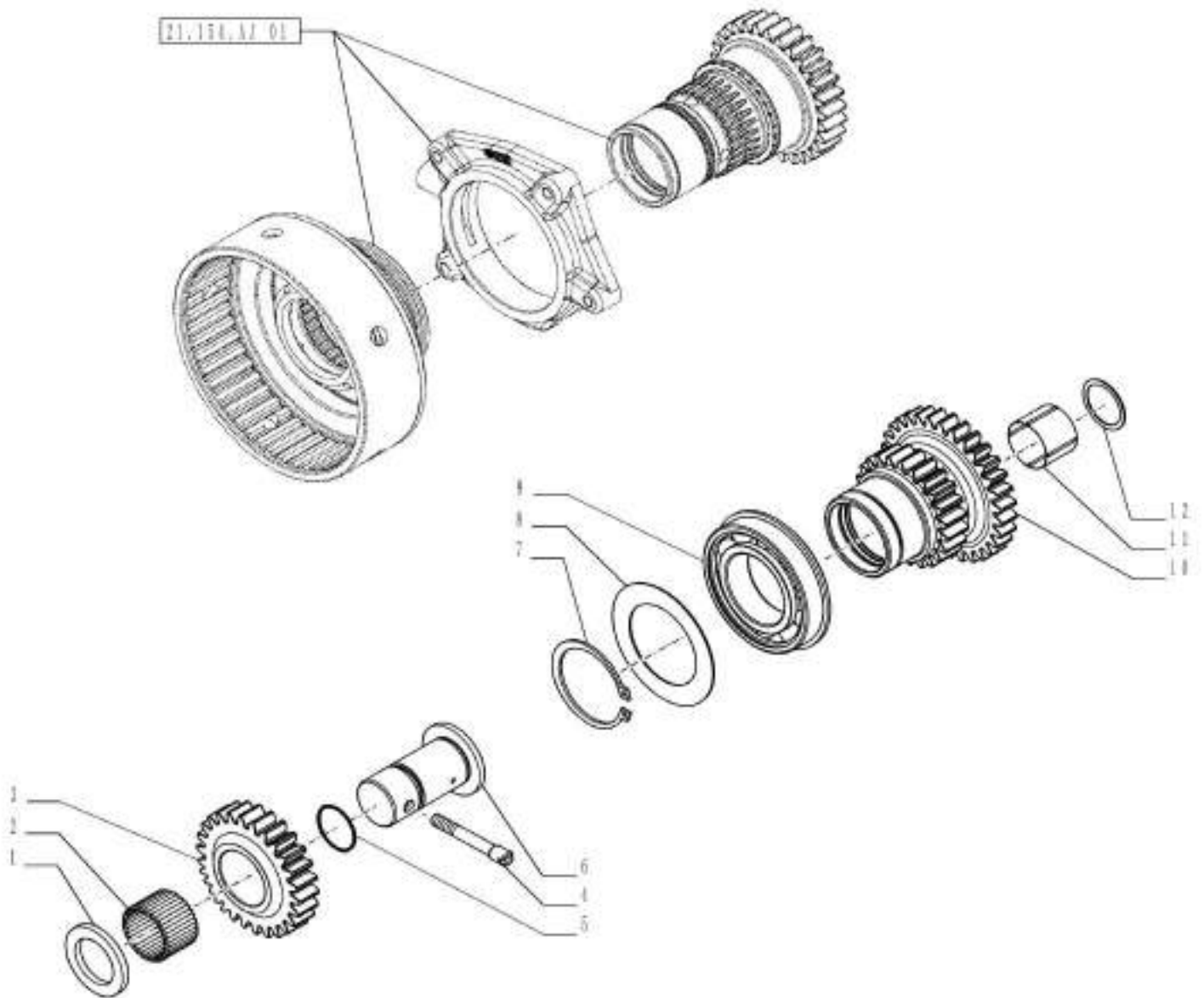

VAR - 330120, 331120, 743846 - TRANSMISSION, GEAR

REF FN	PART NUMBER	YR/SN	QTY DESCRIPTION
1	5117560		1 THRUST WASHER
2	5117559		1 NEEDLE BEARING CAGE
3	84286506		1 GEAR
4	84424141		1 THREADED ROD
5	14457980		1 O-RING 26.64mm ID x 2.62" Width
6	5137525		1 PIN
7	11069576		1 SNAP RING M55, Ext
8	84286507		1 GUARD
9	5149909		1 BALL BEARING 55 mm ID x 90 mm OD x 18 mm
10	84396955		1 GEAR
11	5107311		1 NEEDLE BEARING
12	5141500		1 RING

Valid for Industrial Var. 330120, 331120 (743846)

FARMALL JX100
 FARMALL JX110
 FARMALL JX75
 FARMALL JX90

VAR - 335113 - 20X12 TRANSMISSION WITH SYNCHRO SHUTTLE - CREEPER CONTROL LEVER

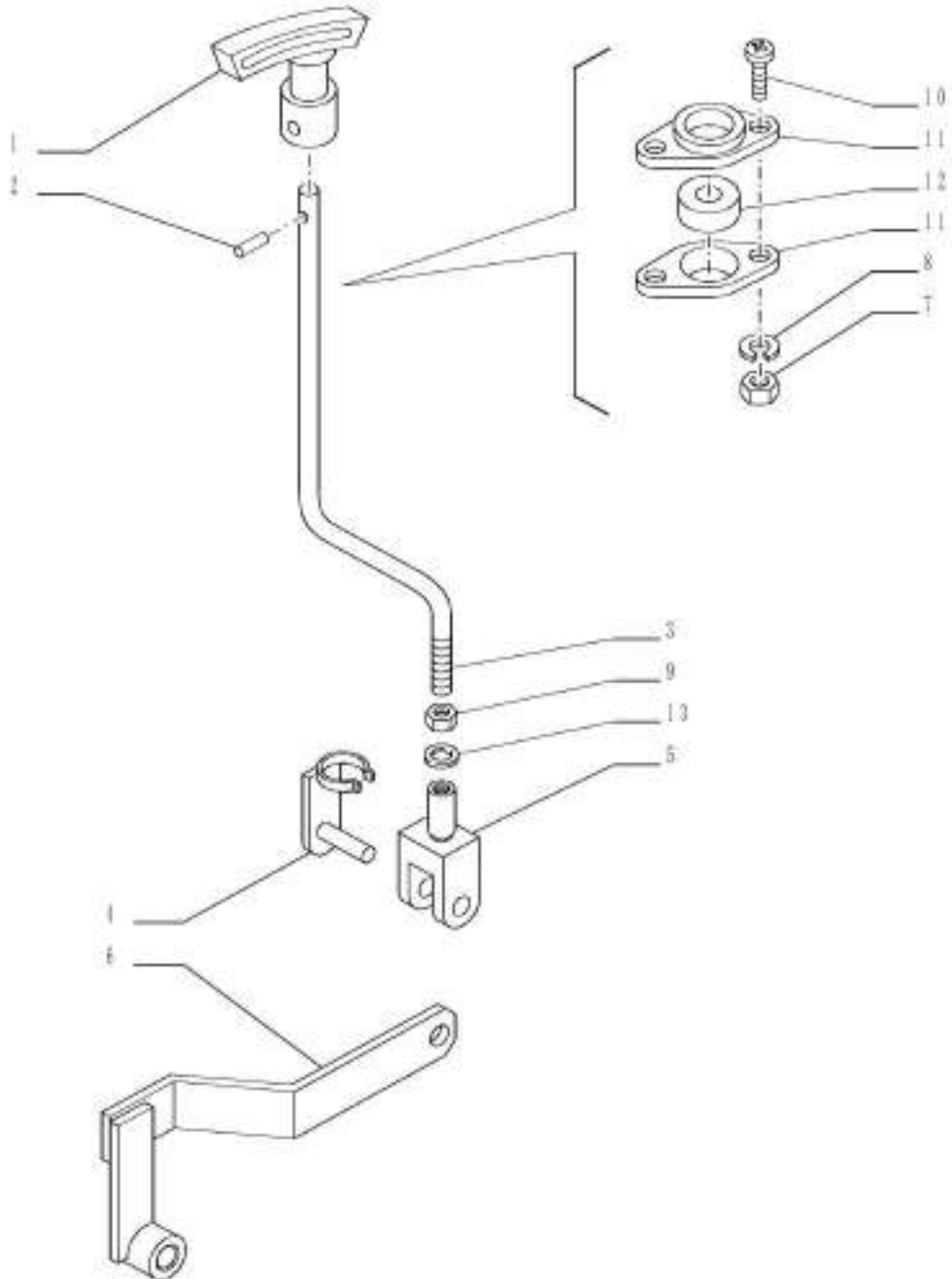

VAR - 335113 - 20X12 TRANSMISSION WITH SYNCHRO SHUTTLE - CREEPER CONTROL LEVER

REF FN	PART NUMBER	YR/SN	QTY DESCRIPTION
1	5112229		1 HANDLE GRIP
2	14163970		1 COTTER PIN M4 x 20, Slotted
3	84527848		1 ARM
4	5111594		1 PIN
5	5148659		1 CLEVIS
6	5092888		1 LEVER
7	15896221		2 NUT M6, CI 10
8	5089035		2 WASHER
9	10791011		1 THIN NUT Thin, M10 x 1.25, CI 04
10	13276114		2 SCREW Cross Pan Hd, M6 x 14
11	5156494		2 FLANGE
12	5109058		1 BUSHING
13	12626001		1 WASHER M10 x 22 x 3
Valid for Var. 335113			FARMALL JX100 FARMALL JX110 FARMALL JX70 FARMALL JX75 FARMALL JX80 FARMALL JX90

VAR - 390110, 744735 - REVERSER

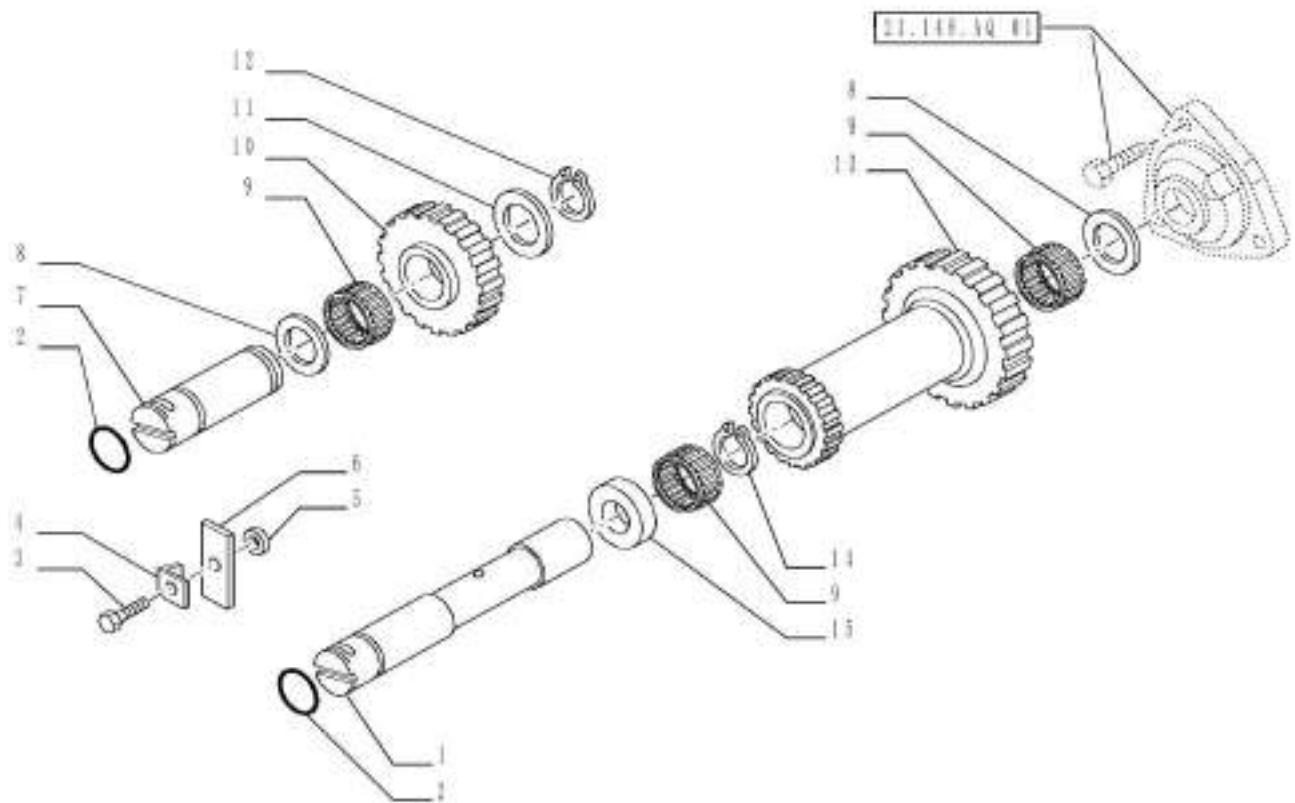

VAR - 390110, 744735 - REVERSER

REF FN	PART NUMBER	YR/SN	QTY DESCRIPTION
1	5117557		1 PIN
2	14457980		2 O-RING 26.64mm ID x 2.62" Width
3	15540321		1 SCREW Hex, M12 x 1.25 x 25mm, Cl 8.8, Full Thd
4	14198901		1 LOCKING PLATE
5	5117562		1 SPACER
6	5117561		1 PLATE
7	5117567		1 PIN
8	5117560		2 THRUST WASHER
9	5117559		3 NEEDLE BEARING CAGE
10	5160492		1 DRIVING GEAR
11	5117570		1 THRUST WASHER
12	11068076		1 SNAP RING M32, Ext
13	5160495		1 IDLER GEAR
14	5137228		2 CIRCLIP
15	5117563		1 THRUST WASHER

Valid for Industrial Var. 390110 (744735)

FARMALL JX100 FARMALL
 JX110 FARMALL JX70
 FARMALL JX75 FARMALL
 JX80 FARMALL JX90

SECTION INDEX

FOUR WHEEL DRIVE SYSTEM

23.000.00	01	SECTION INDEX - 4WD LINES
23.101.AK	01	VAR - 334321, 390268, 744738 - 4WD IDLER CONTROL LEVER
23.202.AD	01	VAR - 334321, 390268, 744738 - TRANSMISSION BOXES AND COVERS - 4WD
23.202.AD	02	VAR - 330384, 334322, 744739 - ELECTROHYDRAULIC DIFFERENTIAL LOCK CONTROL, 4WD IDLER CASE
23.202.AD	03	VAR - 330384, 334322, 744739 - 4WD TRANSMISSION SHAFT
23.202.AD	04	VAR - 330384, 334322, 744739 - 4WD TRANSMISSION GEARINGS
23.202.AD	05	VAR - 330384, 334322, 390895, 720450, 744739 - 4WD TRANSMISSION SHAFT
23.202.AI	02	VAR - 334315, 390258, 390895, 720450, 744745 - 4WD TRANSMISSION GEARINGS
23.202.AI	03	VAR - 334396, 334397 - 4WD TRANSMISSION GEARINGS
23.202.AI	04	VAR - 334397, 390895, 720450 - 4WD TRANSMISSION GEARINGS
23.314.AH	01	VAR - 334396, 334397, 720450, 744745 - 4WD PROPELLER SHAFT
23.314.AH	02	VAR - 334315, 390258, 390895, 720450, 744745 - 4WD PROPELLER SHAFT, GUARD
23.314.AH	03	VAR - 330384, 334322, 744739 - 4WD PROPELLER SHAFT
23.314.AH	04	VAR - 330384, 334322, 744739 - 4WD PROPELLER SHAFT, GUARD
23.314.AH	05	VAR - 334396, 334397 - 4WD WATER PROOF PROPELLER SHAFT
23.314.AH	06	VAR - 334396, 334397 - 4WD WATER PROOF PROPELLER SHAFT, GUARD

23.000.00

01

p1

1/2014

SECTION INDEX - 4WD LINES

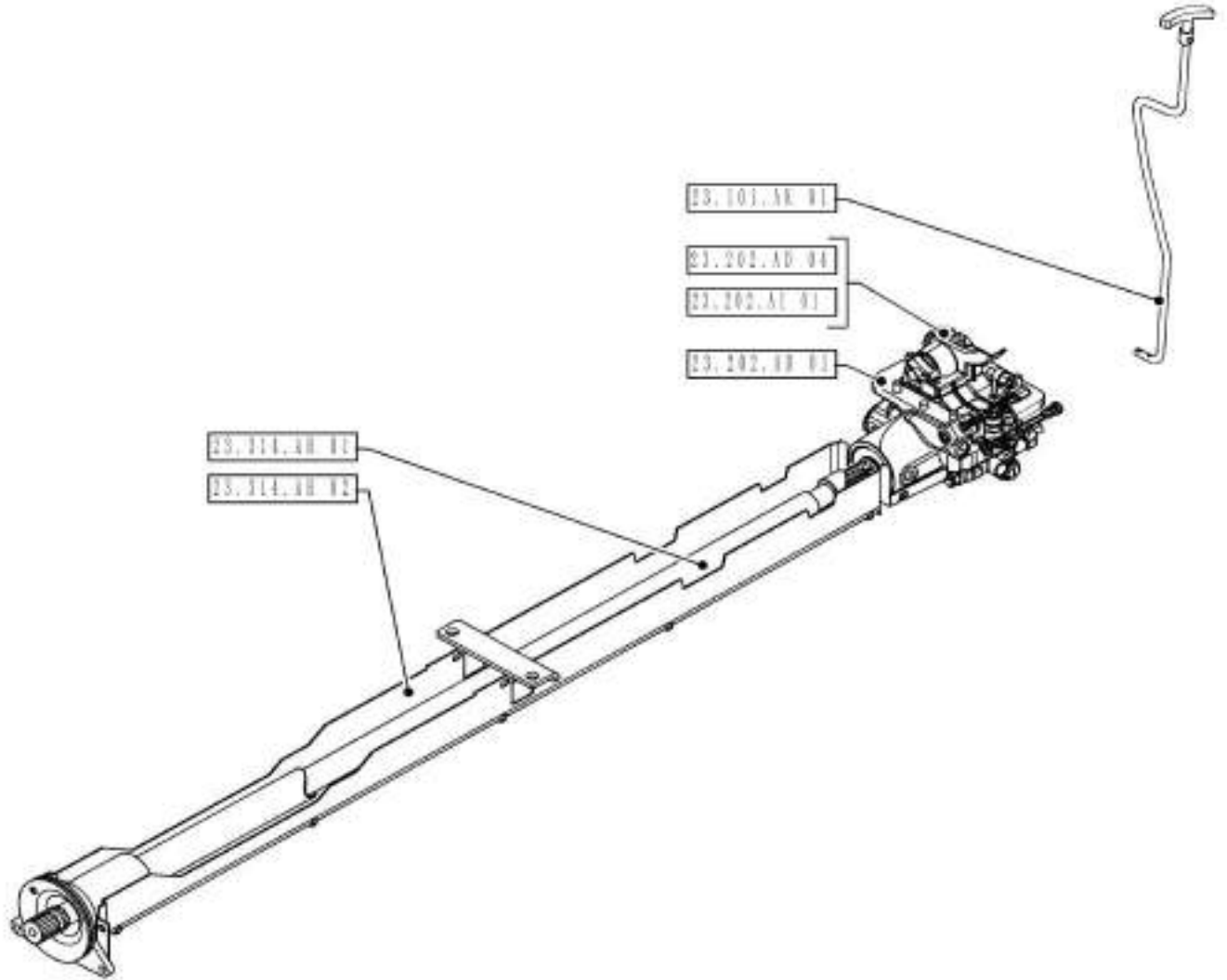

23.000.00

01

p1

1/2014

SECTION INDEX - 4WD LINES

REF FN	PART NUMBER	YR/SN	QTY	DESCRIPTION
---------------	--------------------	--------------	------------	--------------------

FARMALL JX100 FARMALL JX110 FARMALL JX70 FARMALL JX75 FARMALL JX80 FARMALL JX90
--

23.101.AK

01

p1

1/2014

VAR - 334321, 390268, 744738 - 4WD IDLER CONTROL LEVER

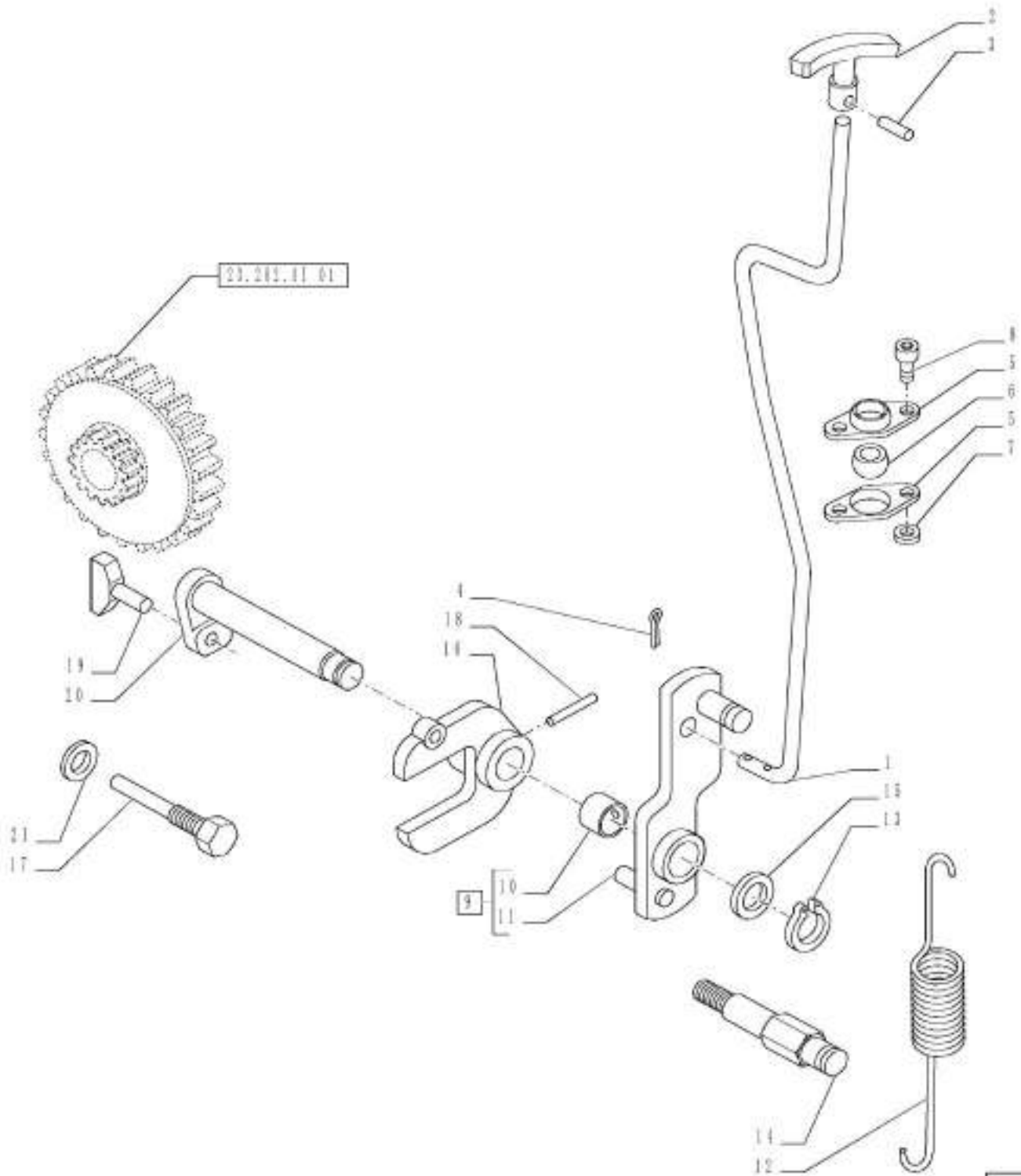

VAR - 334321, 390268, 744738 - 4WD IDLER CONTROL LEVER

REF FN	PART NUMBER	YR/SN	QTY DESCRIPTION
1	84527846		1 LEVER
2	5112229		1 HANDLE GRIP
3	14163970		1 COTTER PIN M4 x 20, Slotted
4	10734401		1 COTTER PIN M2 x 22
5	5156494		2 FLANGE
6	5109058		1 BUSHING
7	12601274		2 WAVE WASHER Wave, M6.4
8	13276114		2 SCREW Cross Pan Hd, M6 x 14
9	5129028		1 LEVER ASSY Incl 10 - 11
10	5129030		1 BUSHING
11	NSS		1 NOT SERVICED SEPARATELY Lever Incl in 1
12	5129033		1 SPRING
13	11066276		1 SNAP RING M14, Ext
14	5129031		1 SCREW
15	5129024		1 WASHER
16	5129032		1 YOKE
17	5129023		1 SCREW
18	13940470		1 ROLL PIN
19	5095899		1 SLIDING PAD
20	5157597		1 LEVER
21	10280060		1 SEAL M14.2 x 20 x 1.5

Valid for Industrial Var. 334321, 390268 (744738)

FARMALL JX100 FARMALL
 JX110 FARMALL JX70
 FARMALL JX75 FARMALL
 JX80 FARMALL JX90

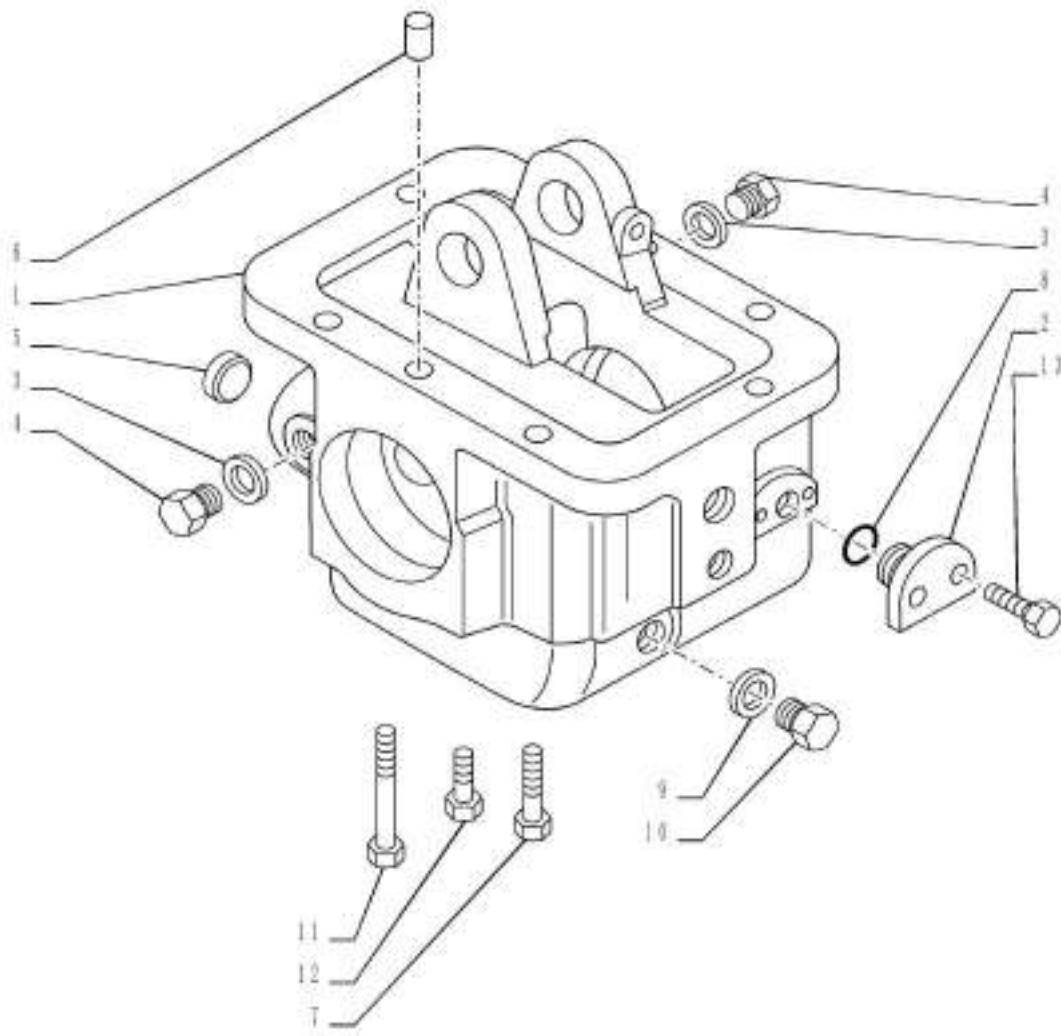

VAR - 334321, 390268, 744738 - TRANSMISSION BOXES AND COVERS - 4WD

REF	FN	PART NUMBER	YR/SN	QTY	DESCRIPTION
1	1	5091160		1	TRANSFER UNIT
1	2	84361546		1	HOUSING
2		5171837		1	PLUG
3		10298460		3	SEALING WASHER M12.2 x 18 x 1.5
4		11903214		3	PLUG M12 x 1.25 x 12
5		14329001		1	PLUG M28, Tapered
6		10839810		2	DOWEL
7		15540921		1	SCREW Hex, M12 x 1.25 x 55mm, Cl 8.8
8		14453280		1	O-RING 0.551" ID x 0.07"
9		10263460		1	SEAL 22.30mm ID x 28.00mm OD, 1.50mm, Copper
10		10305111		1	PLUG M22 x 1.5 x 21, Cl5.8
11		15541721		1	SCREW Hex, M12 x 1.25 x 110mm, Cl 8.8
12		15540521		4	SCREW Hex, M12 x 1.25 x 35mm, Cl 8.8, Full Thd
13		10977711		2	BOLT

(1) Valid for FARMALL JX110 Model Only

(2) Valid for FARMALL JX70, 75, 80, 90, 100 Models Only

Valid for Industrial Var. 334321, 390268 (744738)

FARMALL JX100 FARMALL
 JX110 FARMALL JX70
 FARMALL JX75 FARMALL
 JX80 FARMALL JX90

VAR - 330384, 334322, 744739 - ELECTROHYDRAULIC DIFFERENTIAL LOCK CONTROL, 4WD IDLER CASE

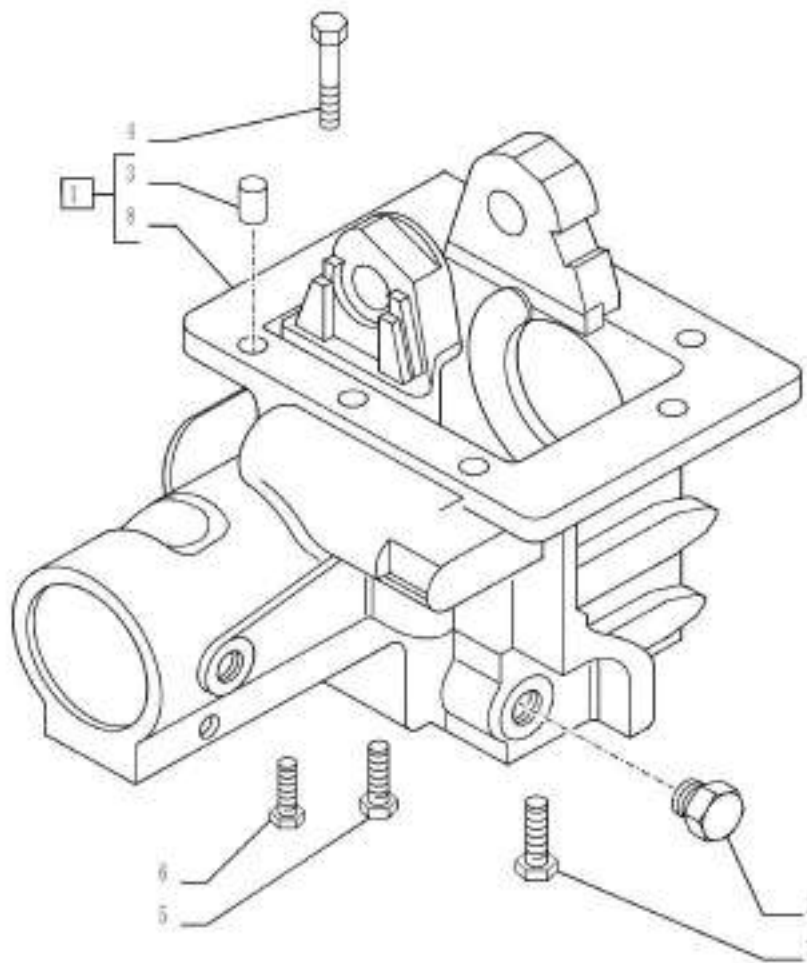

VAR - 330384, 334322, 744739 - ELECTROHYDRAULIC DIFFERENTIAL LOCK CONTROL, 4WD IDLER CASE

REF	FN	PART NUMBER	YR/SN	QTY	DESCRIPTION
1	1	84151179		1	HOUSING Incl 3, 8
1	2	84361545		1	HOUSING Incl 3, 8
2	1	86598047		1	PLUG Hex Soc, M22 x 1.5, ORB
3		10839810		2	DOWEL
4		15541721		1	SCREW Hex, M12 x 1.25 x 110mm, CI 8.8
5		15540521		3	SCREW Hex, M12 x 1.25 x 35mm, CI 8.8, Full Thd
6		15540921		1	SCREW Hex, M12 x 1.25 x 55mm, CI 8.8
7		15542021		1	SCREW Hex, M12 x 1.25 x 140mm, CI 8.8
8		NSS		1	NOT SERVICED SEPARATELY Housing Incl in 1
(1)	Valid for FARMALL JX110 Model Only				
(2)	Valid for FARMALL JX70, 75, 80, 90, 100 Models Only				

Valid for Industrial Var. 330384, 334322 (744739)

FARMALL JX100 FARMALL
 JX110 FARMALL JX70
 FARMALL JX75 FARMALL
 JX80 FARMALL JX90

VAR - 330384, 334322, 744739 - 4WD TRANSMISSION SHAFT

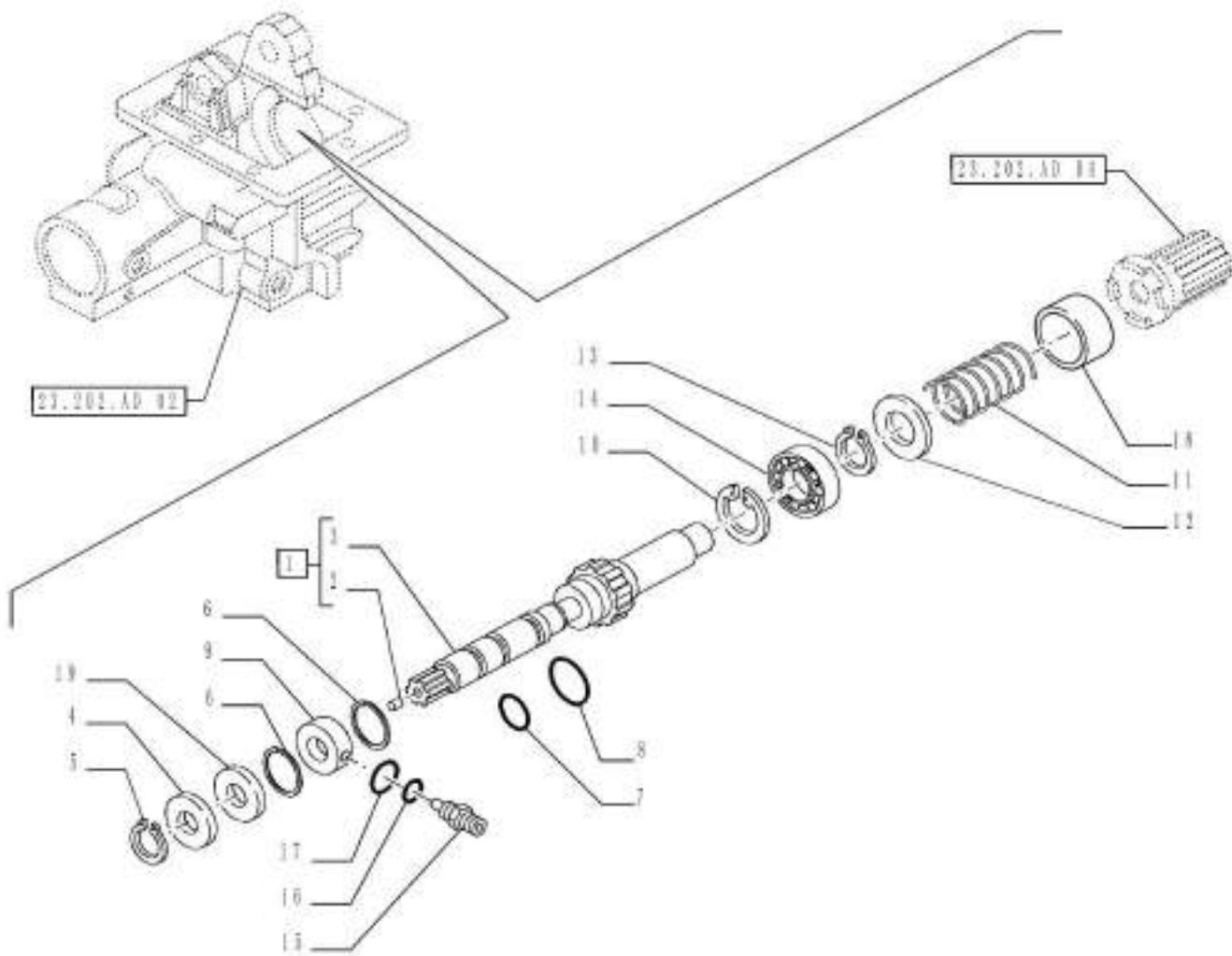

23.202.AD

03

p1

1/2014

VAR - 330384, 334322, 744739 - 4WD TRANSMISSION SHAFT

REF FN	PART NUMBER	YR/SN	QTY DESCRIPTION
1	47130811		1 SHAFT ASSY Incl 2 - 3
2	13789720		1 SET SCREW Hex Soc, M8 x 12mm, Flat Pt
3	NSS		1 NOT SERVICED SEPARATELY Shaft Incl in 1
4	5150371		1 DISC
5	11067776		1 SNAP RING M29, Ext
6	5195944		2 CIRCLIP
7	5160580		1 GASKET D=35
8	5152665		1 SEAL 42.6 x 50 x 3.2
9	5197419		1 MANIFOLD
10	11061976		1 SNAP RING M80, Int D=80
11	87704329		1 SPRING
12	5176902		1 RING
13	11068376		1 SNAP RING M35, Ext x 1.5 Thk
14	20045200		1 BALL BEARING 35 mm ID x 80 mm OD x 21 mm 35 x 80 x 21
15	5181968		1 HYD CONNECTOR
16	14453080		1 O-RING 0.426" ID x 0.07"
17	14437985		1 O-RING 15.3mm ID x 2.4mm
18	84151182		1 SPACER
19	84482082		1 SEAL 35 x 80 x 10

Valid for Industrial Var. 330384, 334322 (744739)

**FARMALL JX100
FARMALL JX70
FARMALL JX75
FARMALL JX80**

VAR - 330384, 334322, 744739 - 4WD TRANSMISSION GEARINGS

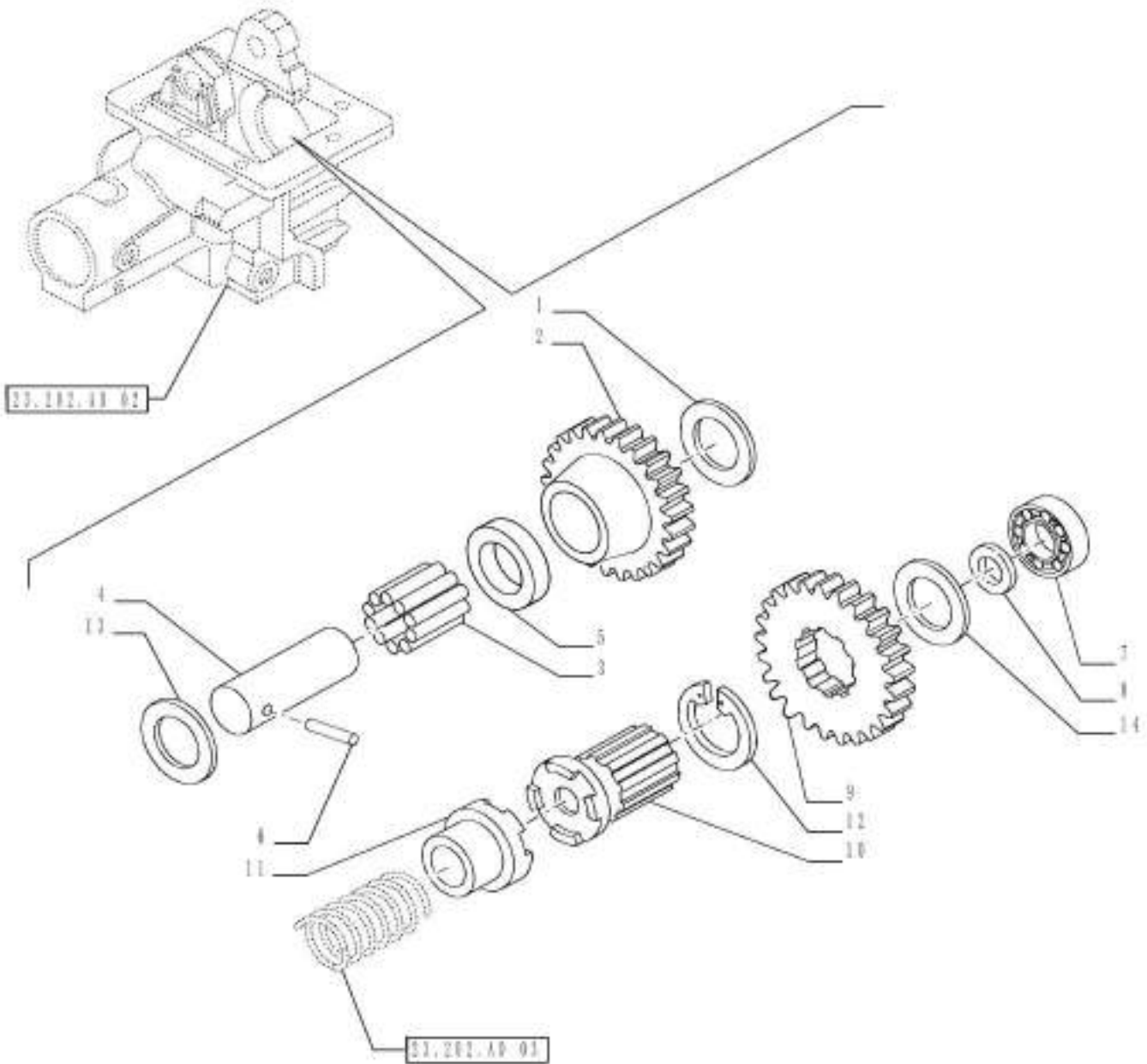

VAR - 330384, 334322, 744739 - 4WD TRANSMISSION GEARINGS

REF FN	PART NUMBER	YR/SN	QTY DESCRIPTION
1	47133292		1 THRUST WASHER
2	1 84321801		1 GEAR
2	2 84336754		1 GEAR
3	5115937		1 NEEDLE BEARING
4	47133291		1 PIN
5	1 87315062		1 SPACER
5	2 84354605		1 SPACER
6	13942970		1 ROLL PIN M6 x 45, Coiled
7	23111990		1 BALL BEARING 30 mm ID x 72 mm OD x 19 mm
8	5160571		1 THRUST WASHER
9	1 87388610		1 GEAR
9	2 84312678		1 GEAR
10	47130409		1 SLEEVE
11	5176903		1 SLEEVE
12	11069776		1 SNAP RING M58, Ext
13	1 87314981		1 THRUST WASHER
13	2 87612253		1 THRUST WASHER
14	84151183		1 SPACER

(1) Valid for FARMALL JX110 Model Only

(2) Valid for FARMALL JX70, 75, 80, 90, 100 Models Only

Valid for Industrial Var. 330384, 334322 (744739)

FARMALL JX100
 FARMALL JX70
 FARMALL JX75
 FARMALL JX80

VAR- 330384, 334322, 390895, 720450, 744739 - 4WD TRANSMISSION SHAFT

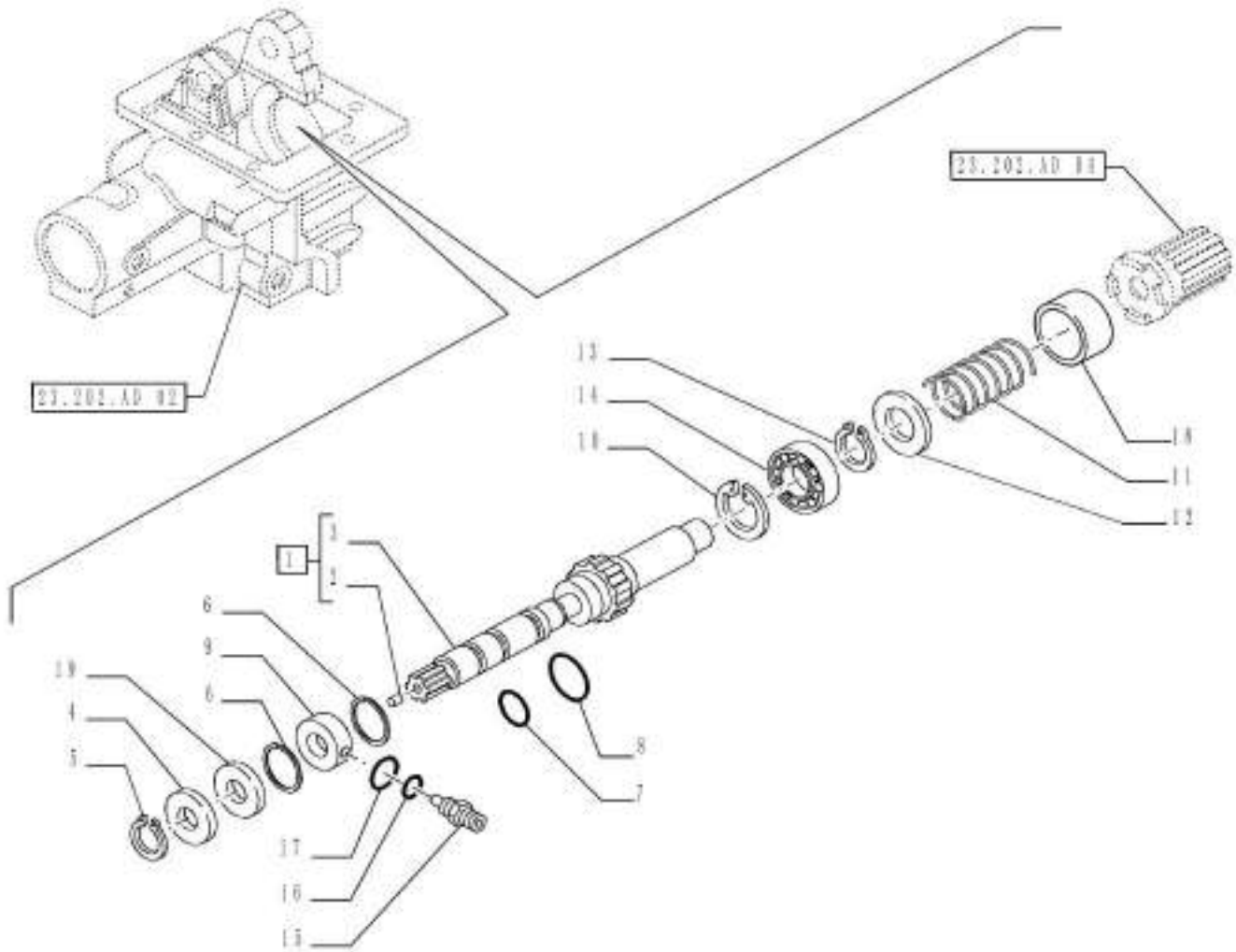

VAR- 330384, 334322, 390895, 720450, 744739 - 4WD TRANSMISSION SHAFT

REF FN	PART NUMBER	YR/SN	QTY DESCRIPTION
1	47130811		1 SHAFT ASSY Incl 2 - 3
2	13789720		1 SET SCREW Hex Soc, M8 x 12mm, Flat Pt
3	NSS		1 NOT SERVICED SEPARATELY Shaft Incl in 1
4	5150371		1 DISC
5	11067776		1 SNAP RING M29, Ext
6	5195944		2 CIRCLIP
7	5160580		1 GASKET D=35
8	5152665		1 SEAL 42.6 x 50 x 3.2
9	5197419		1 MANIFOLD
10	11061976		1 SNAP RING M80, Int D=80
11	87704329		1 SPRING
12	5176902		1 RING
13	11068376		1 SNAP RING M35, Ext x 1.5 Thk
14	20045200		1 BALL BEARING 35 mm ID x 80 mm OD x 21 mm 35 x 80 x 21
15	5181968		1 HYD CONNECTOR
16	14453080		1 O-RING 0.426" ID x 0.07"
17	14437985		1 O-RING 15.3mm ID x 2.4mm
18	84151182		1 SPACER
19	84482082		1 SEAL 35 x 80 x 10

Valid for Industrial Var. 390895 (720450) or Industrial Var. 330384,
334322 (744739)

FARMALL JX100
FARMALL JX110
FARMALL JX75
FARMALL JX90

VAR - 334315, 390258, 390895, 720450, 744745 - 4WD TRANSMISSION GEARINGS

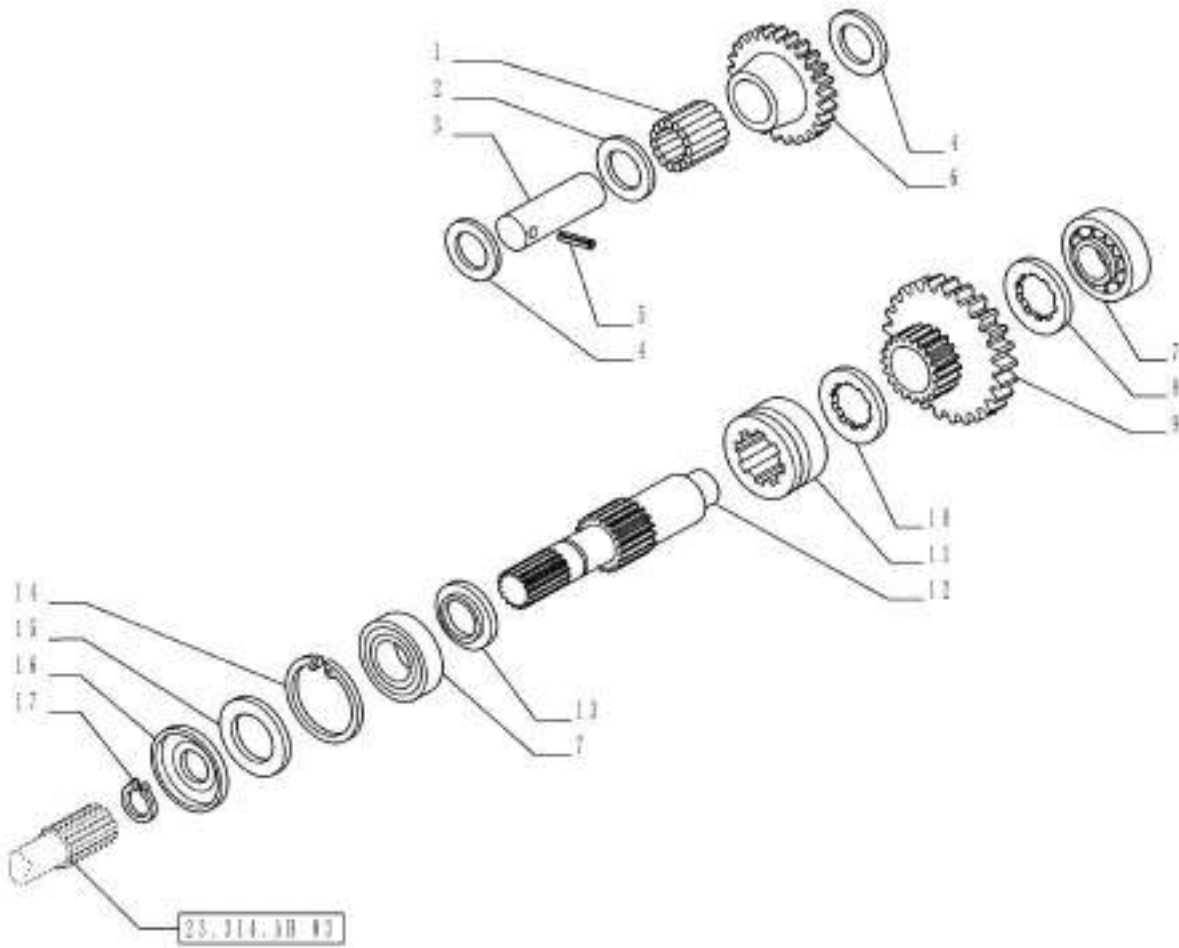

VAR - 334315, 390258, 390895, 720450, 744745 - 4WD TRANSMISSION GEARINGS

REF FN	PART NUMBER	YR/SN	QTY DESCRIPTION
1	5115937		15 NEEDLE BEARING
2	5123389		1 SPACER
3	5123387		1 PIN
4	5115930		2 THRUST WASHER
5	13943070		1 ROLL PIN M6 x 50, Coiled
6	84336754		1 GEAR
7	23111990		2 BALL BEARING 30 mm ID x 72 mm OD x 19 mm
8	5121807		1 THRUST WASHER
9	84359382		1 GEAR
10	5124122		1 THRUST WASHER
11	5123388		1 SLEEVE
12	5123391		1 CONTROL SHAFT
13	584132		1 DISC
14	11061576		1 SNAP RING M72, Int
15	5119206		1 SEAL
16	5109919		1 DISC
17	11067776		1 SNAP RING M29, Ext

Valid for Industrial Var. 334315, 390895 (720450) or Industrial Var. 390258 (744745)

FARMALL JX100
 FARMALL JX70
 FARMALL JX75
 FARMALL JX80

VAR - 334396, 334397 - 4WD TRANSMISSION GEARINGS

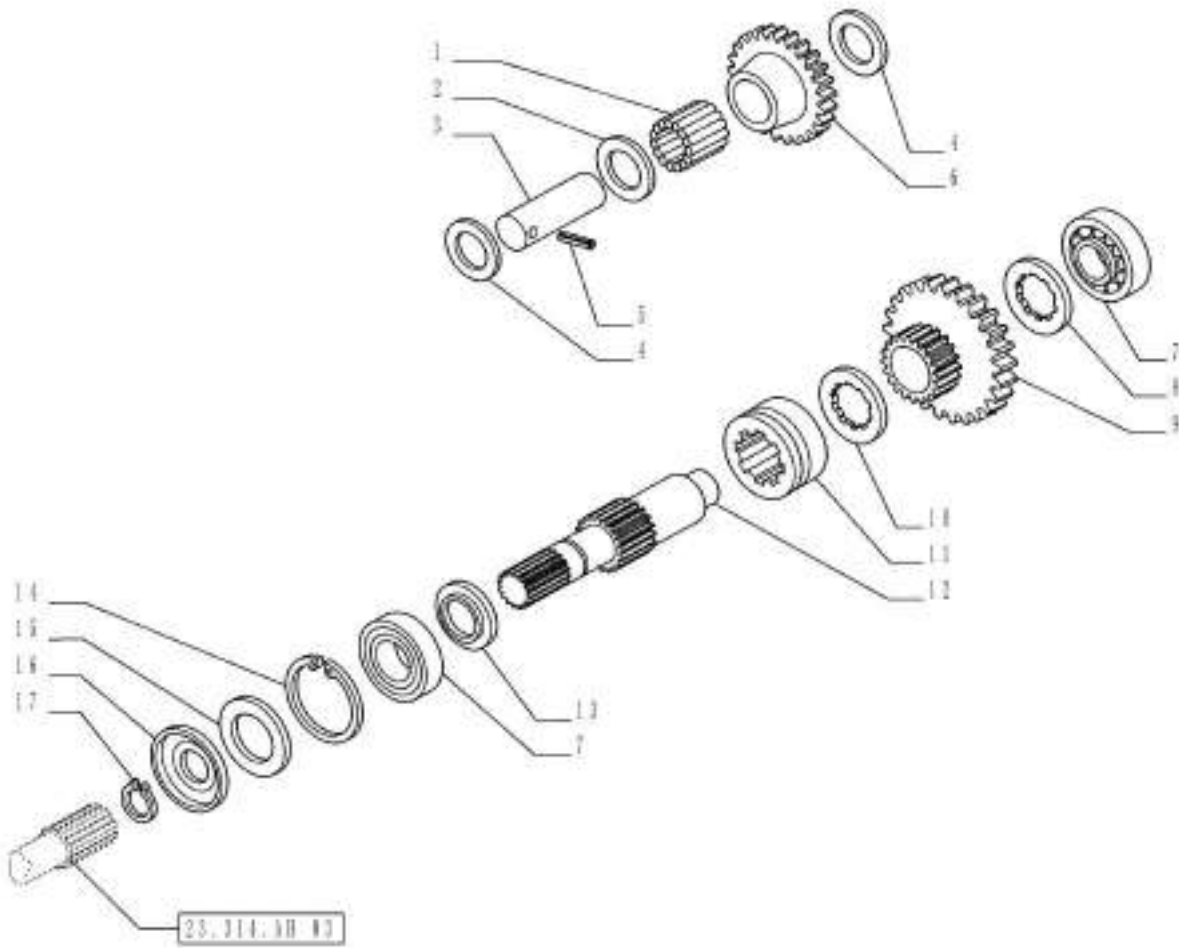

VAR - 334396, 334397 - 4WD TRANSMISSION GEARINGS

REF FN	PART NUMBER	YR/SN	QTY DESCRIPTION
1	5115937		15 NEEDLE BEARING
2	5123389		1 SPACER
3	5123387		1 PIN
4	5115930		2 THRUST WASHER
5	13943070		1 ROLL PIN M6 x 50, Coiled
6	84336754		1 GEAR
7	23111990		2 BALL BEARING 30 mm ID x 72 mm OD x 19 mm
8	5121807		1 THRUST WASHER
9	84359382		1 GEAR
10	5124122		1 THRUST WASHER
11	5123388		1 SLEEVE
12	5123391		1 CONTROL SHAFT
13	584132		1 DISC
14	11061576		1 SNAP RING M72, Int
15	5119206		1 SEAL
16	5109919		1 DISC
17	11067776		1 SNAP RING M29, Ext

Valid for Var. 334396 or Var. 334397

FARMALL JX100
 FARMALL JX70
 FARMALL JX75
 FARMALL JX80

VAR - 334397, 390895, 720450 - 4WD TRANSMISSION GEARINGS

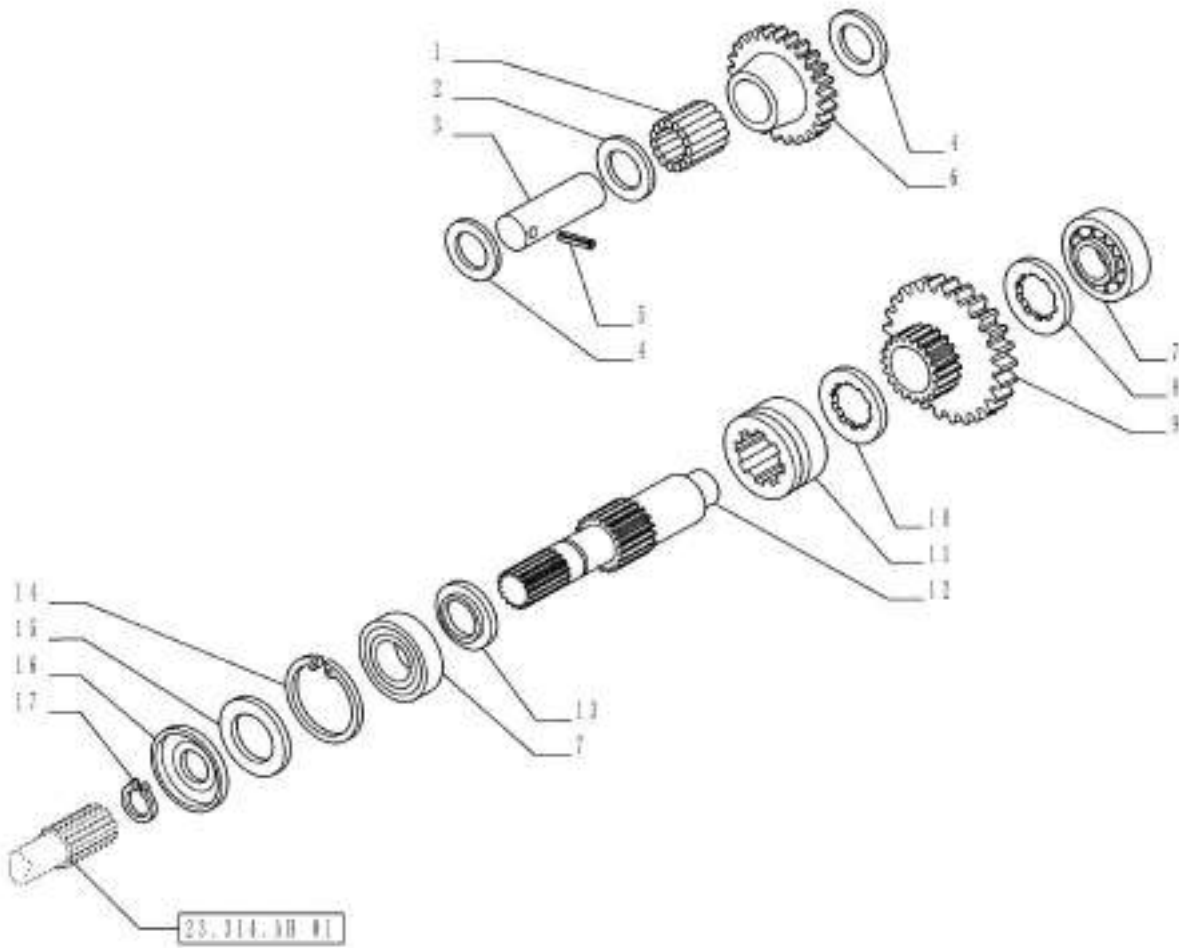

VAR - 334397, 390895, 720450 - 4WD TRANSMISSION GEARINGS

REF FN	PART NUMBER	YR/SN	QTY DESCRIPTION
1	5115937		15 NEEDLE BEARING
2	5123389		1 SPACER
3	5123387		1 PIN
4	5115930		2 THRUST WASHER
5	13943070		1 ROLL PIN M6 x 50, Coiled
6 1	5125011		1 IDLER GEAR
6 2	5123391		1 CONTROL SHAFT
7	23111990		2 BALL BEARING 30 mm ID x 72 mm OD x 19 mm
8	5121807		1 THRUST WASHER
9	5125012		1 IDLER GEAR
10	5124122		1 THRUST WASHER
11	5123388		1 SLEEVE
12	5123391		1 CONTROL SHAFT
13	584132		1 DISC
14	11061576		1 SNAP RING M72, Int
15	5119206		1 SEAL
16	5109919		1 DISC
17	11067776		1 SNAP RING M29, Ext

(1) VAR - 390895 (720450)

(2) VAR - 334397

Valid for Var. 334397 or Industrial Var. 390895 (720450)

FARMALL JX110

23.314.AH

01

p1

1/2014

VAR - 334396, 334397, 720450, 744745 - 4WD PROPELLER SHAFT

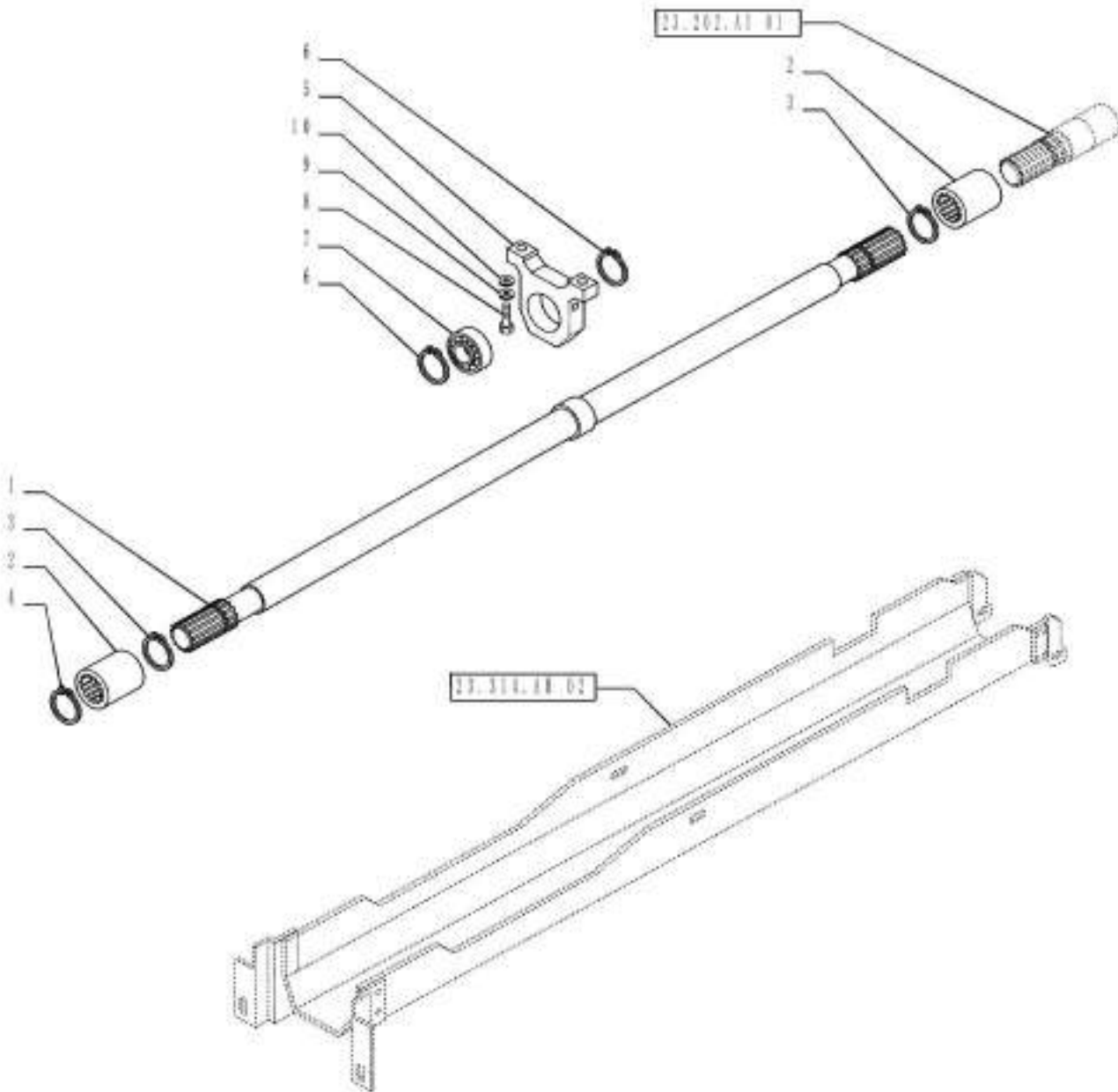

VAR - 334396, 334397, 720450, 744745 - 4WD PROPELLER SHAFT

REF	FN	PART NUMBER	YR/SN	QTY	DESCRIPTION
1	1	84537449		1	SHAFT
1	2	84537437		1	PROPELLER SHAFT
1	3	84536564		1	PROPELLER SHAFT
2		5199243		2	SPLINED COUPLING
3		11067776		2	SNAP RING M29, Ext
4		5085566		2	SHIM KIT
4		4997301		AR	SHIM 2.2mm Thk
4		4997302		AR	SHIM 2.5mm Thk
4		4997303		AR	SHIM 2.8mm Thk
4		4997304		AR	SHIM 3.0mm Thk
4		4997305		AR	SHIM 3.3mm Thk
4		4997306		AR	SHIM 3.7mm Thk
4		4997307		AR	SHIM 4.0mm Thk
4		4997308		AR	SHIM 4.3mm Thk
4		5158051		AR	SHIM 1.5mm Thk
4		5158052		AR	SHIM 1.9mm Thk
4		4997302		AR	SHIM 2.5mm Thk
4		4997303		AR	SHIM 2.8mm Thk
4		4997304		AR	SHIM 3.0mm Thk
4		4997305		AR	SHIM 3.3mm Thk
4		4997306		AR	SHIM 3.7mm Thk
4		4997307		AR	SHIM 4.0mm Thk
4		4997308		AR	SHIM 4.3mm Thk
4		5158051		AR	SHIM 1.5mm Thk
4		5158052		AR	SHIM 1.9mm Thk
5		5156553		1	SUPPORT
6		11061576		2	SNAP RING M72, Int
7		28996680		1	BALL BEARING
8		15540634		2	BOLT Hex, M12 x 1.25 x 40, 10.9, Full Thd
9		12601574		2	WAVE WASHER Wave, M13
(1)	Valid for FARMALL JX75, 90, 100, 110 Models Only				
(2)	Valid for FARMALL JX70 Model Only				
(3)	Valid for FARMALL JX80 Model Only				
Valid for Var. 334396 or Var. 334397 or Industrial Var. 334315, 390895 (720450) or Industrial Var. 390258 (744745)					FARMALL JX100 FARMALL JX110 FARMALL JX70 FARMALL JX75 FARMALL JX80 FARMALL JX90

23.314.AH

01

p2

1/2014

VAR - 334396, 334397, 720450, 744745 - 4WD PROPELLER SHAFT

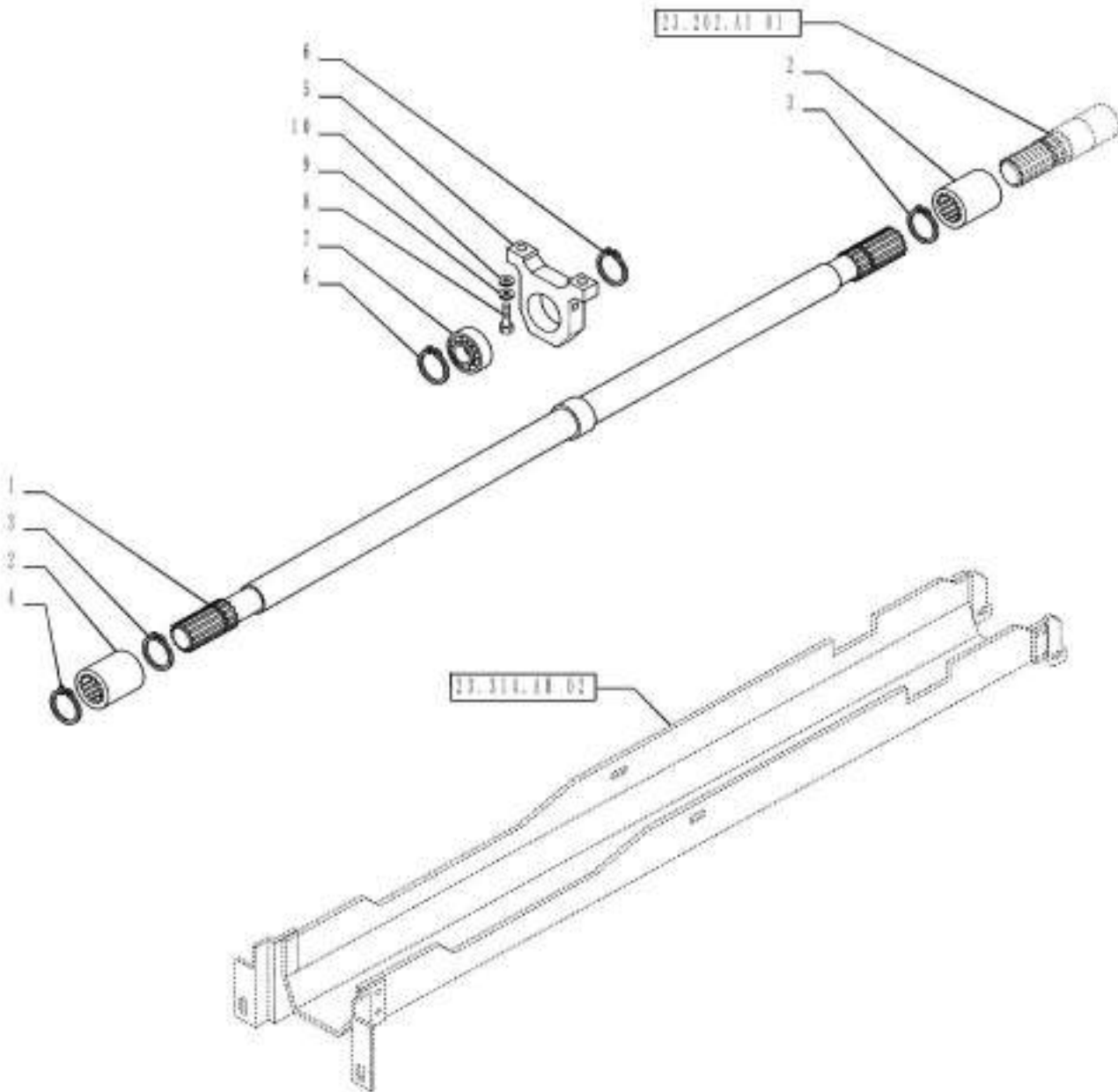

23.314.AH

01

p2

1/2014

VAR - 334396, 334397, 720450, 744745 - 4WD PROPELLER SHAFT

REF FN	PART NUMBER	YR/SN	QTY DESCRIPTION
10	14496701		2 WASHER 13.00mm ID x 24.00mm OD x 2.50mm, CST, ZND
Valid for Var. 334396 or Var. 334397 or Industrial Var. 334315, 390895 (720450) or Industrial Var. 390258 (744745)			FARMALL JX100 FARMALL JX110 FARMALL JX70 FARMALL JX75 FARMALL JX80 FARMALL JX90

23.314.AH

02

p1

1/2014

VAR - 334315, 390258, 390895, 720450, 744745 - 4WD PROPELLER SHAFT, GUARD

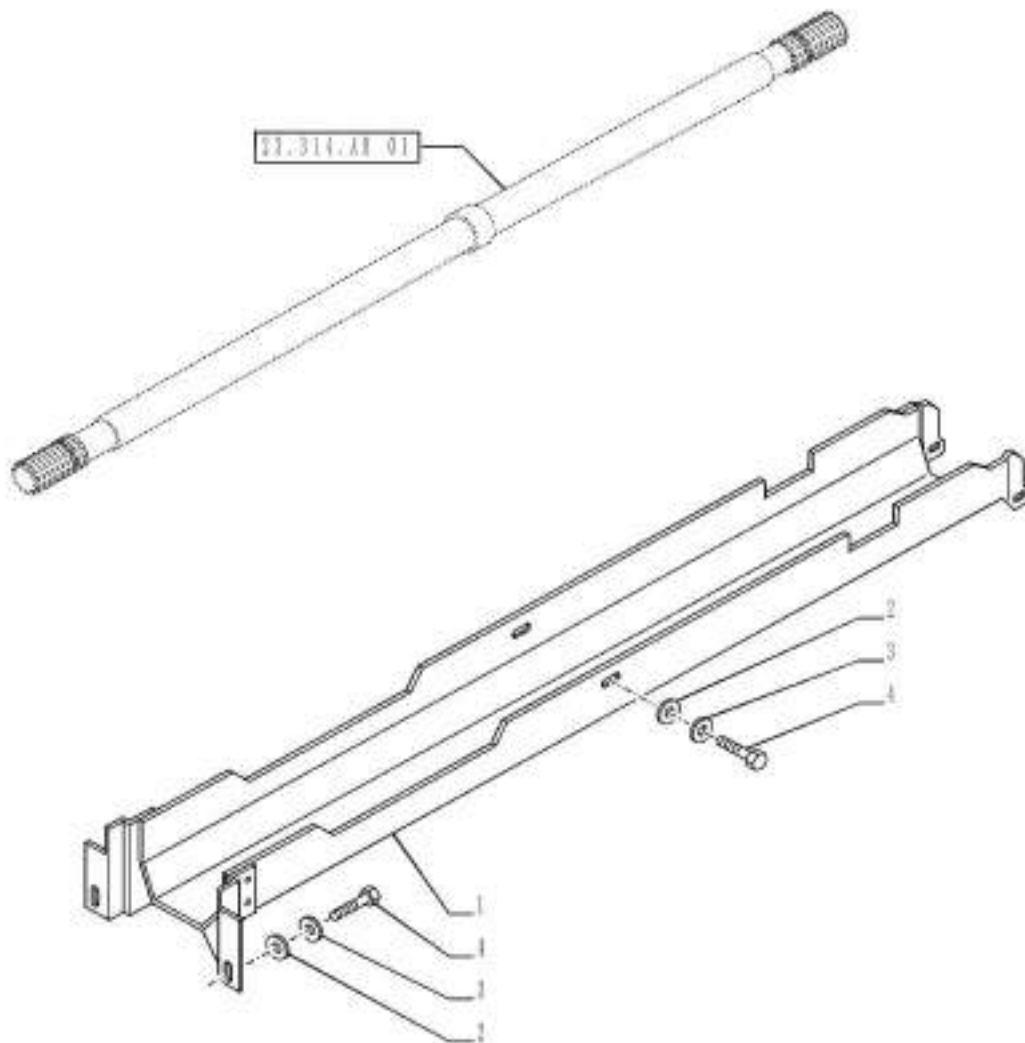

VAR - 334315, 390258, 390895, 720450, 744745 - 4WD PROPELLER SHAFT, GUARD

REF	FN	PART NUMBER	YR/SN	QTY	DESCRIPTION
1	1	84536577		1	GUARD
1	2	84537451		1	GUARD
1	3	84537444		1	GUARD
2		10519601		6	WASHER M8 x 17 x 2
3		12601374		6	WAVE WASHER Wave, 8.40mm ID x 15.00mm OD x 0.80mm, 3.00mm, CST, DAC
4		86624003		6	BOLT Hex, M8 x 14mm, Cl 8.8, Full Thd
(1)	Valid for FARMALL JX70 Model Only				
(2)	Valid for FARMALL JX75, 90, 100, 110 Models Only				
(3)	Valid for FARMALL JX80 Model Only				

Valid for Industrial Var. 334315, 390895 (720450) or Industrial Var. 390258 (744745)

FARMALL JX100 FARMALL
JX110 FARMALL JX70
FARMALL JX75 FARMALL
JX80 FARMALL JX90

23.314.AH

03

p1

1/2014

VAR - 330384, 334322, 744739 - 4WD PROPELLER SHAFT

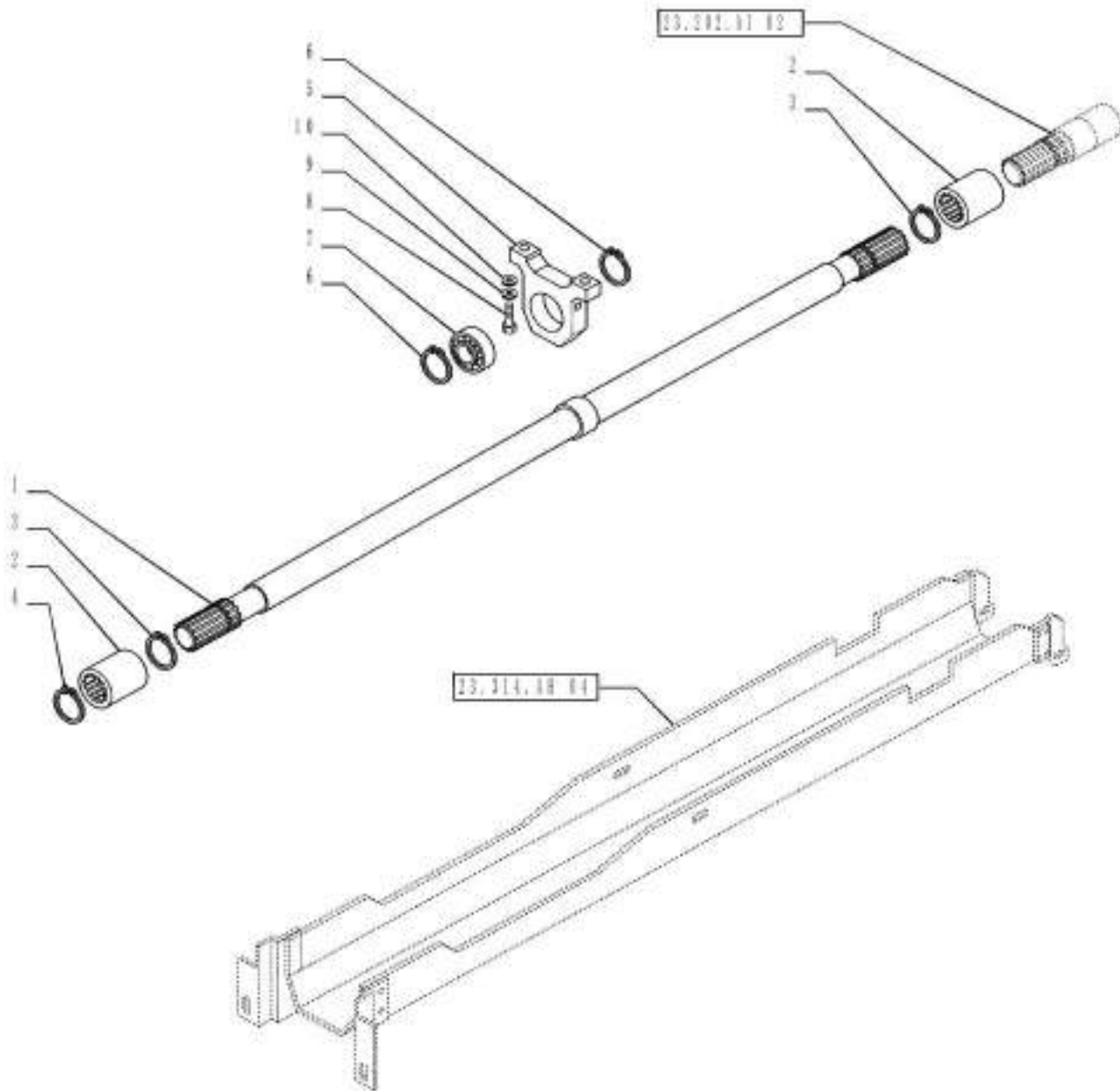

VAR - 330384, 334322, 744739 - 4WD PROPELLER SHAFT

REF	FN	PART NUMBER	YR/SN	QTY	DESCRIPTION
1	1	84537450		1	SHAFT
1	2	84536575		1	PROPELLER SHAFT
1	3	84537436		1	PROPELLER SHAFT
2		5199243		2	SPLINED COUPLING
3		11067776		2	SNAP RING M29, Ext
4		5085566		2	SHIM KIT
4		4997301		AR	SHIM 2.2mm Thk
4		4997302		AR	SHIM 2.5mm Thk
4		4997303		AR	SHIM 2.8mm Thk
4		4997304		AR	SHIM 3.0mm Thk
4		4997305		AR	SHIM 3.3mm Thk
4		4997306		AR	SHIM 3.7mm Thk
4		4997307		AR	SHIM 4.0mm Thk
4		4997308		AR	SHIM 4.3mm Thk
4		5158051		AR	SHIM 1.5mm Thk
4		5158052		AR	SHIM 1.9mm Thk
4		4997302		AR	SHIM 2.5mm Thk
4		4997303		AR	SHIM 2.8mm Thk
4		4997304		AR	SHIM 3.0mm Thk
4		4997305		AR	SHIM 3.3mm Thk
4		4997306		AR	SHIM 3.7mm Thk
4		4997307		AR	SHIM 4.0mm Thk
4		4997308		AR	SHIM 4.3mm Thk
4		5158051		AR	SHIM 1.5mm Thk
4		5158052		AR	SHIM 1.9mm Thk
5		5156553		1	SUPPORT
6		11061576		2	SNAP RING M72, Int
7		28996680		1	BALL BEARING
8		15540634		2	BOLT Hex, M12 x 1.25 x 40, 10.9, Full Thd
9		12601574		2	WAVE WASHER Wave, M13
(1)	Valid for FARMALL JX75, 90, 100, 110 Models Only				
(2)	Valid for FARMALL JX70 Model Only				
(3)	Valid for FARMALL JX80 Model Only				
Valid for Industrial Var. 330384, 334322 (744739)					FARMALL JX100 FARMALL JX110 FARMALL JX70 FARMALL JX75 FARMALL JX80 FARMALL JX90

23.314.AH

03

p2

1/2014

VAR - 330384, 334322, 744739 - 4WD PROPELLER SHAFT

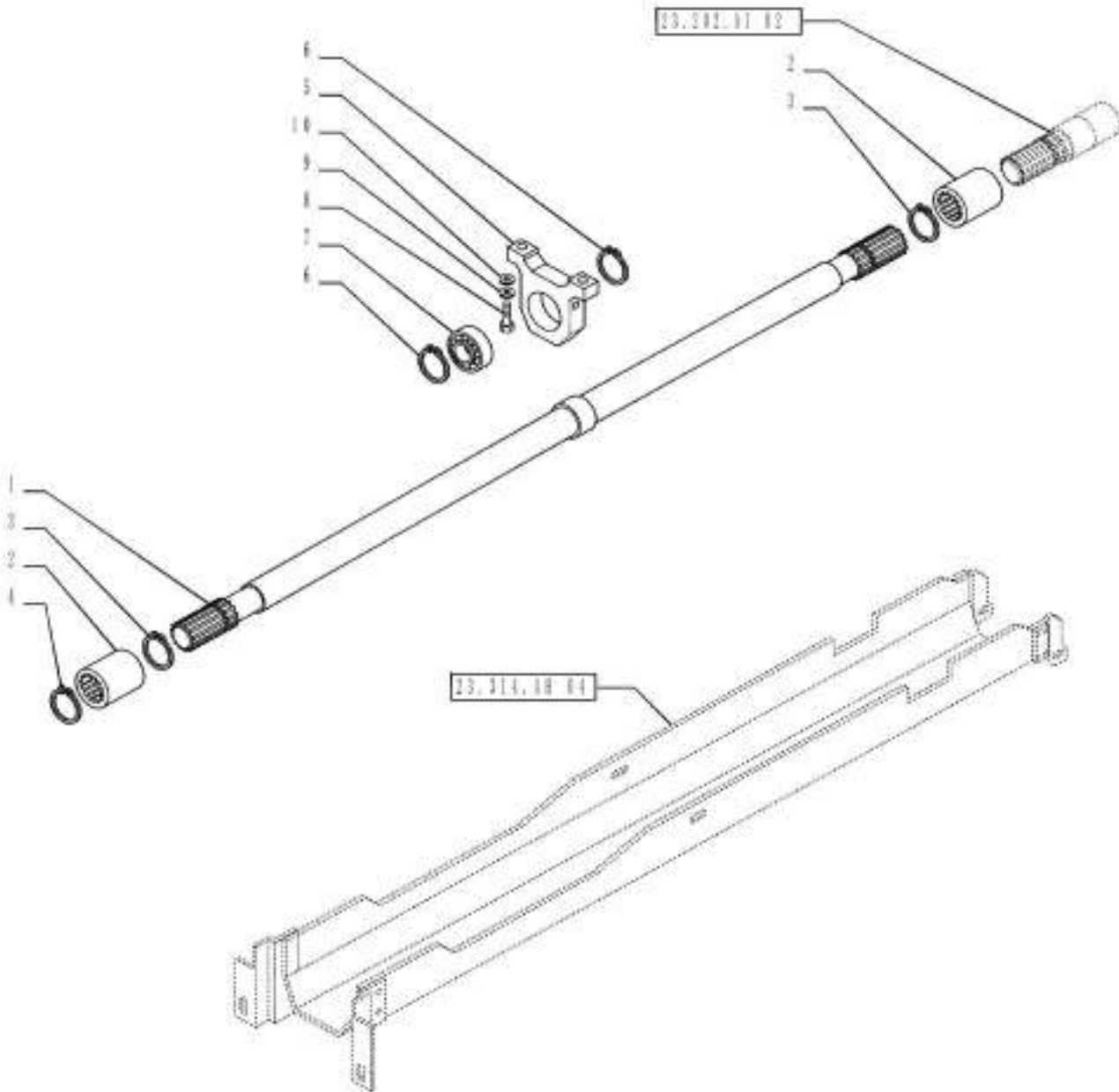

23.314.AH

03

p2

1/2014

VAR - 330384, 334322, 744739 - 4WD PROPELLER SHAFT

REF FN	PART NUMBER	YR/SN	QTY DESCRIPTION
10	14496701		2 WASHER 13.00mm ID x 24.00mm OD x 2.50mm, CST, ZND
Valid for Industrial Var. 330384, 334322 (744739)			FARMALL JX100 FARMALL JX110 FARMALL JX70 FARMALL JX75 FARMALL JX80 FARMALL JX90

23.314.AH

04

p1

1/2014

VAR - 330384, 334322, 744739 - 4WD PROPELLER SHAFT, GUARD

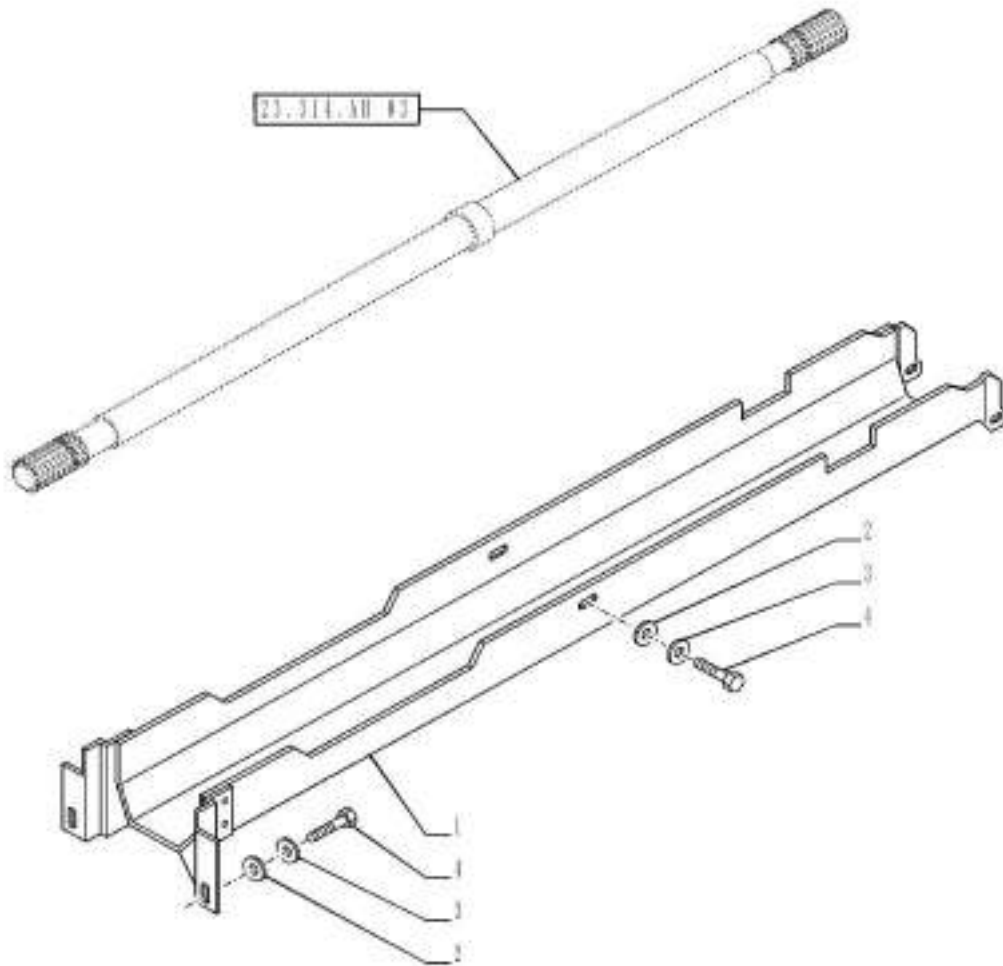

VAR - 330384, 334322, 744739 - 4WD PROPELLER SHAFT, GUARD

REF	FN	PART NUMBER	YR/SN	QTY	DESCRIPTION
1	1	84537441		1	GUARD
1	2	84537452		1	GUARD
1	3	84536579		1	GUARD
2		10519601		6	WASHER M8 x 17 x 2
3		12601374		6	WAVE WASHER Wave, 8.40mm ID x 15.00mm OD x 0.80mm, 3.00mm, CST, DAC
4		86624003		6	BOLT Hex, M8 x 14mm, Cl 8.8, Full Thd
(1)	Valid for FARMALL JX80 Model Only				
(2)	Valid for FARMALL JX75, 90, 100, 110 Models Only				
(3)	Valid for FARMALL JX70 Model Only				

Valid for Industrial Var. 330384, 334322 (744739)

FARMALL JX100 FARMALL
 JX110 FARMALL JX70
 FARMALL JX75 FARMALL
 JX80 FARMALL JX90

VAR - 334396, 334397 - 4WD WATER PROOF PROPELLER SHAFT

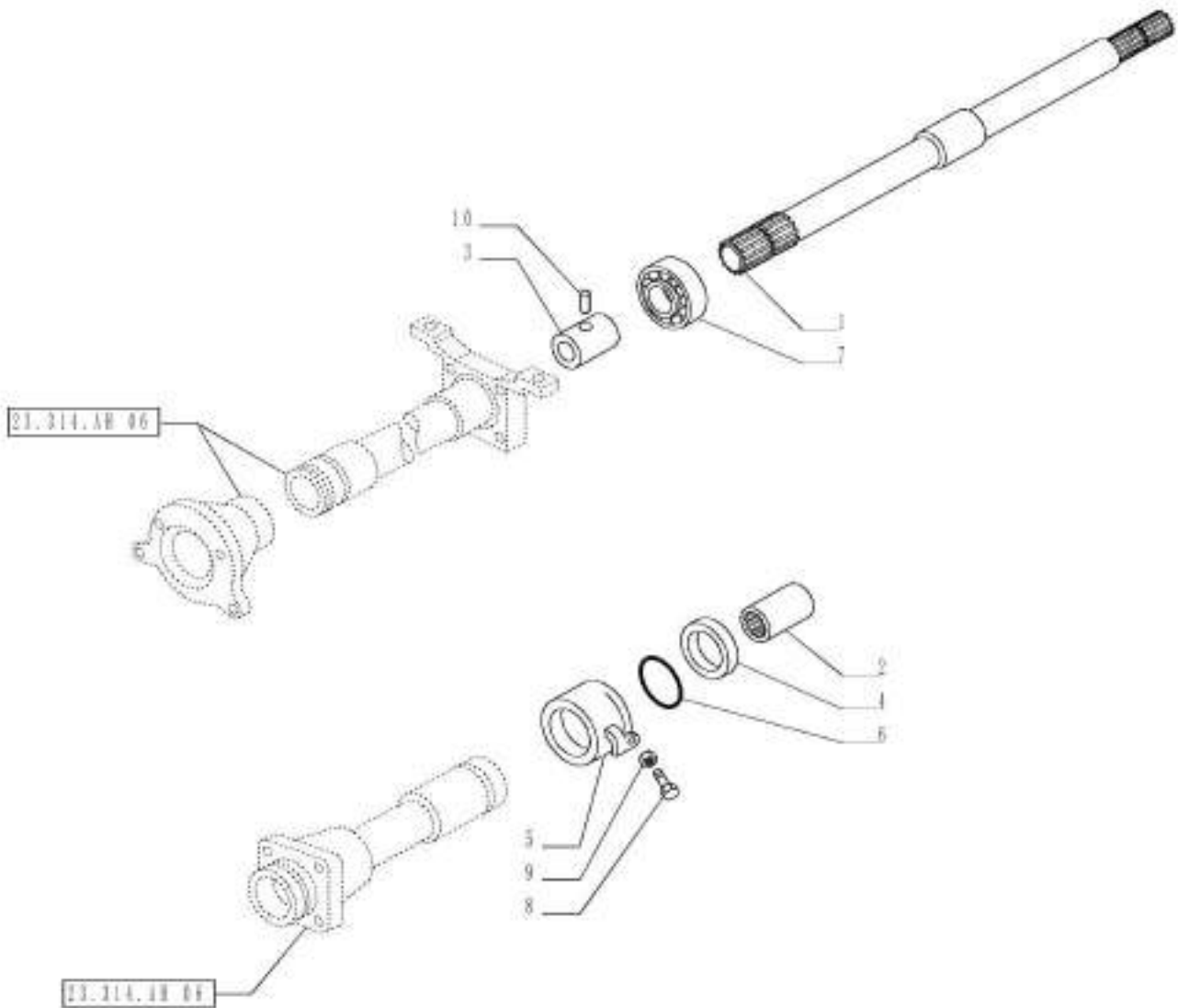

VAR - 334396, 334397 - 4WD WATER PROOF PROPELLER SHAFT

REF	FN	PART NUMBER	YR/SN	QTY	DESCRIPTION
1	1	84536564		1	PROPELLER SHAFT
1	2	84537437		1	PROPELLER SHAFT
1	3	84537449		1	SHAFT
2		5199243		1	SPLINED COUPLING
3		5146936		1	BUSHING
4		5105989		1	SEAL
5		5146948		1	BUSHING
6		14460480		2	O-RING 2.612" ID x 2.818" OD x .103"
7		28996680		1	BALL BEARING
8		86624003		2	BOLT Hex, M8 x 14mm, Cl 8.8, Full Thd
9		11193879		2	BELLEVILLE WASHER Belleville, M8.4
10		13905470		1	COTTER PIN
(1)	Valid for FARMALL JX70 Model Only				
(2)	Valid for FARMALL JX80 Model Only				
(3)	Valid for FARMALL JX75, 90, 100, 110 Models Only				
Valid for Var. 334396 or Var. 334397					FARMALL JX100 FARMALL JX110 FARMALL JX70 FARMALL JX75 FARMALL JX80 FARMALL JX90

VAR - 334396, 334397 - 4WD WATER PROOF PROPELLER SHAFT, GUARD

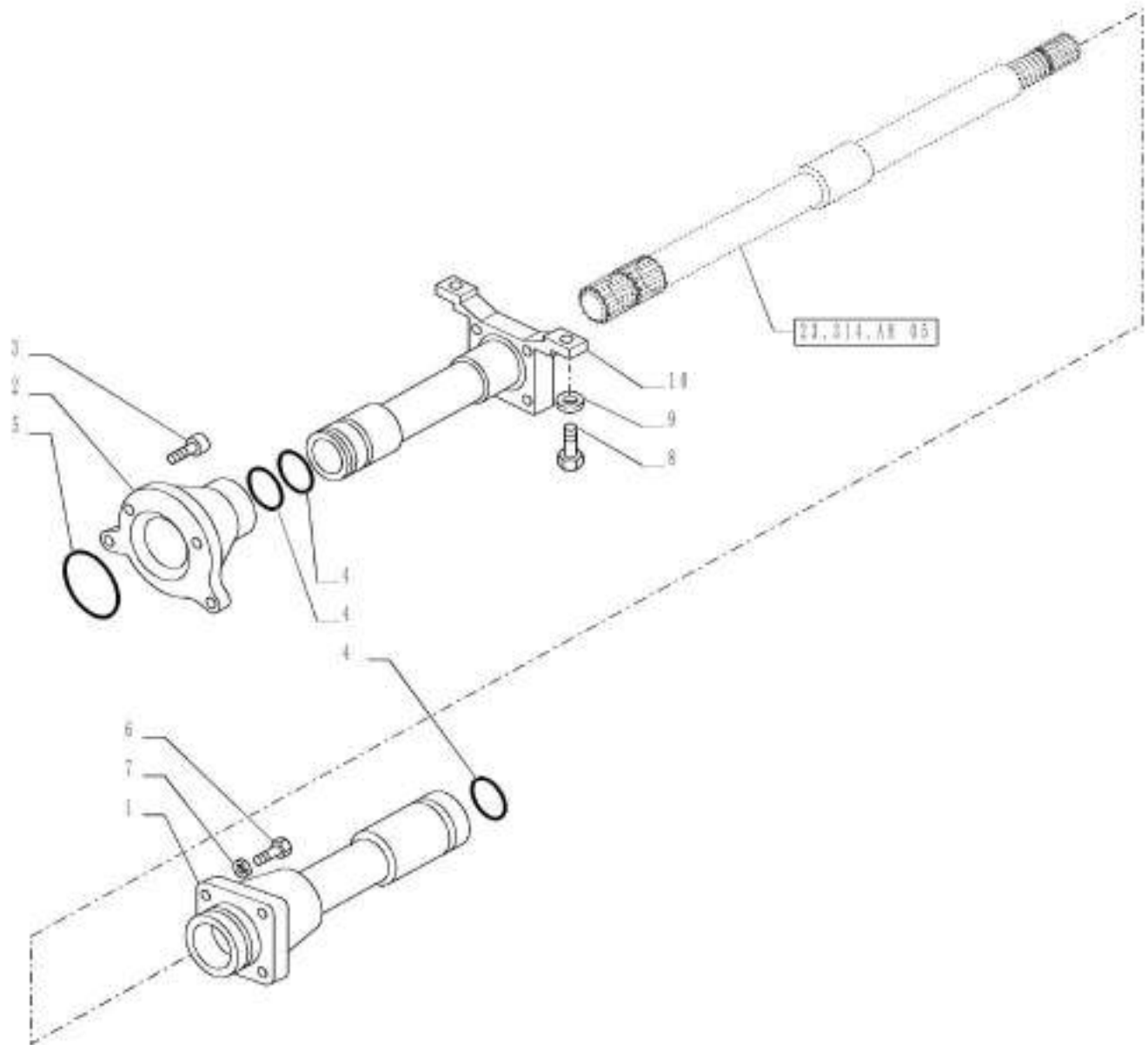

VAR - 334396, 334397 - 4WD WATER PROOF PROPELLER SHAFT, GUARD

REF FN	PART NUMBER	YR/SN	QTY DESCRIPTION
1	5146945		1 SHIELD
2	1 5149419		1 SLEEVE
2	^{2,3} 5146937		1 SLEEVE
3	1 14359221		4 HEX SOC SCREW M8 x 22mm, Cl 8.8, Full Thd
3	^{2,3} 43127		4 BOLT Hex, M8 x 1.25 x 25mm, Cl 8.8, Full Thd
4	14459480		3 O-RING 50.47mm ID x 2.62mm
5	1 70923855		1 O-RING -340, 70 Duro, 3.35" ID x .210" Thk
5	^{2,3} 14461480		1 O-RING 4.237" ID x 0.103"
6	86625001		4 BOLT Hex, M8 x 22mm, Cl 8.8, Full Thd
7	1 12601374		4 WAVE WASHER Wave, 8.40mm ID x 15.00mm OD x 0.80mm, 3.00mm, CST, DAC
8	15540634		2 BOLT Hex, M12 x 1.25 x 40, 10.9, Full Thd
9	11198674		2 BELLEVILLE WASHER Belleville, M13
10	1 84537934		1 GUARD
10	2 84537943		1 GUARD
10	3 84537941		1 GUARD

(1) Valid for FARMALL JX70 Model Only

(2) Valid for FARMALL JX80 Model Only

(3) Valid for FARMALL JX75, 90, 100, 110 Models Only

Valid for Var. 334396 or Var. 334397

FARMALL JX100 FARMALL
 JX110 FARMALL JX70
 FARMALL JX75 FARMALL
 JX80 FARMALL JX90

SECTION INDEX

FRONT AXLE SYSTEM

25.000.00	01	SECTION INDEX - FRONT MECHANICAL DRIVE
25.100.AD	01	VAR - 390250 - 4WD FRONT AXLE, AXLE HOUSING
25.100.AD	02	VAR - 335325 - 4WD FRONT AXLE, AXLE HOUSING
25.100.AD	03	VAR - 335539 - 4WD FRONT AXLE - AXLE HOUSING
25.100.AV	01	VAR - 334396, 334397, 720450, 744745 - FRONT AXLE SUPPORT
25.102.AB	01	VAR - 390250 - 4WD FRONT AXLE, BEVEL GEAR
25.102.AB	02	VAR - 390250 - 4WD FRONT AXLE, BEVEL GEAR, SHIM
25.102.AB	03	VAR - 390250 - 4WD FRONT AXLE, BEVEL GEAR, SHIM
25.102.AB	04	VAR - 335325, 335539 - 4WD FRONT AXLE, BEVEL GEAR
25.102.AB	05	VAR - 335325, 335539 - 4WD FRONT AXLE, BEVEL GEAR, SHIM
25.102.AB	06	VAR - 335325, 335539 - 4WD FRONT AXLE, BEVEL GEAR, SHIM
25.102.AC	01	VAR - 390250 - 4WD FRONT AXLE, SUPPORT
25.102.AC	02	VAR - 335539 - 4WD FRONT AXLE, SUPPORT
25.102.AC	03	VAR - 335325 - 4WD FRONT AXLE, SUPPORT
25.102.AD	01	4WD FRONT AXLE - DIFFERENTIAL
25.102.AE	01	4WD FRONT AXLE - DIFFERENTIAL
25.102.AE	02	VAR - 335539 - 4WD FRONT AXLE - DIFFERENTIAL - W/LIMITED SLIP DIFFERENTIAL
25.102.AE	03	VAR - 335325 - 4WD FRONT AXLE, DIFFERENTIAL W/ LIMITED SLIP
25.108.AA	01	4WD FRONT AXLE - AXLE-SHAFT ARTICULATED - BREAKDOWN
25.108.AA	02	4WD FRONT AXLE - AXLE-SHAFT ARTICULATED - BREAKDOWN
25.108.AB	01	4WD FRONT AXLE - DIFFERENTIAL GEARS AND DIFFERENTIAL SHAFT
25.108.AB	02	VAR - 335325, 335539 - 4WD FRONT AXLE - DIFFERENTIAL GEARS AND DIFFERENTIAL SHAFT
25.108.AG	01	4WD FRONT AXLE - STEERING KNUCKLES
25.108.AG	02	VAR - 335325, 335539 - 4WD FRONT AXLE, STEERING KNUCKLE
25.108.AN	01	VAR - 390250 - 4WD FRONT AXLE, HUB
25.108.AN	02	VAR - 335325, 335539 - 4WD FRONT AXLE, HUB
25.400.AH	01	VAR - 338860, 390860 - 2WD FRONT AXLE - HUB
25.400.AM	01	VAR - 334413, 390338, 743515 - 2WD FRONT AXLE
25.400.AQ	01	VAR - 334413, 390860, 743515 - 2WD FRONT AXLE, STEERING KNUCKLE
25.400.AQ	02	VAR - 334413, 390860, 743515 - 2WD FRONT AXLE, STEERING KNUCKLE

SECTION INDEX - FRONT MECHANICAL DRIVE

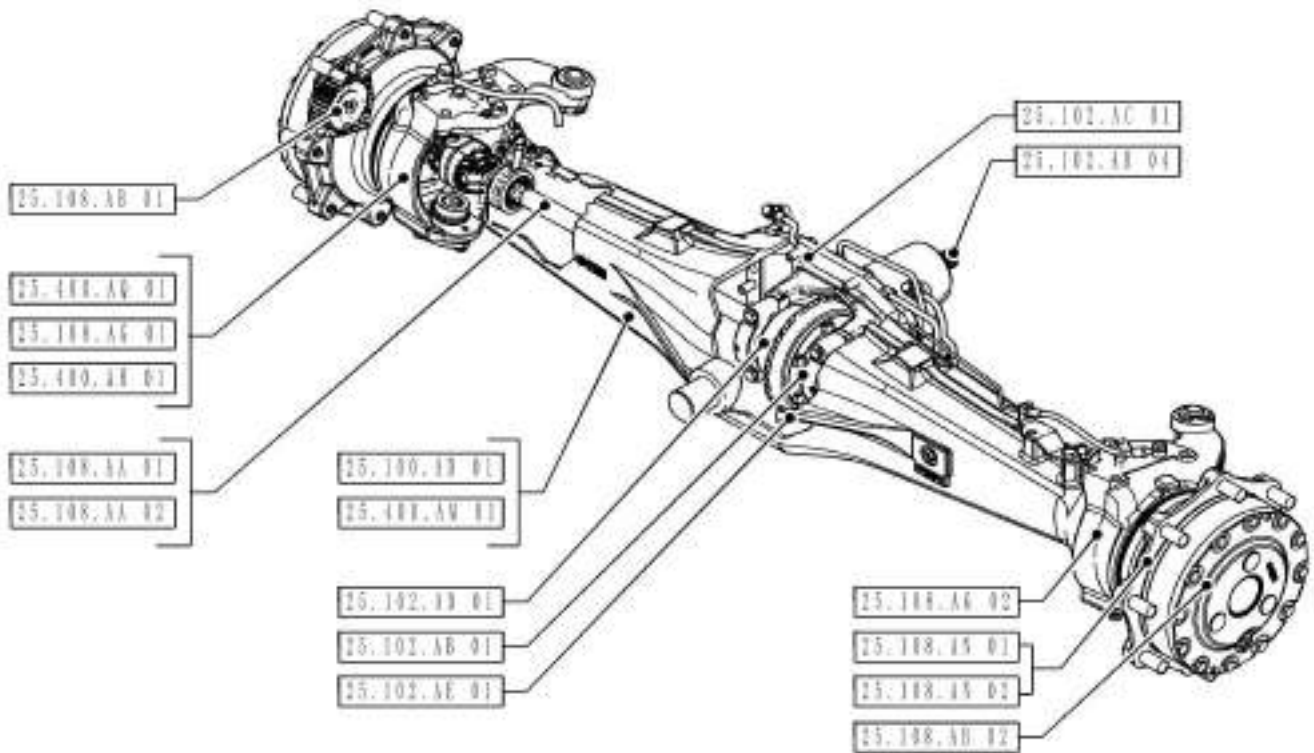
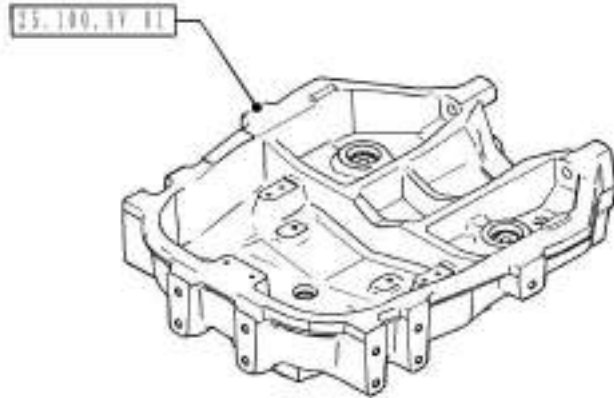

25.000.00

01

p1

1/2014

SECTION INDEX - FRONT MECHANICAL DRIVE

REF FN	PART NUMBER	YR/SN	QTY	DESCRIPTION
---------------	--------------------	--------------	------------	--------------------

				FARMALL JX100 FARMALL JX110 FARMALL JX70 FARMALL JX75 FARMALL JX80 FARMALL JX90
--	--	--	--	--

25.100.AD

01

p1

1/2014

VAR - 390250 - 4WD FRONT AXLE, AXLE HOUSING

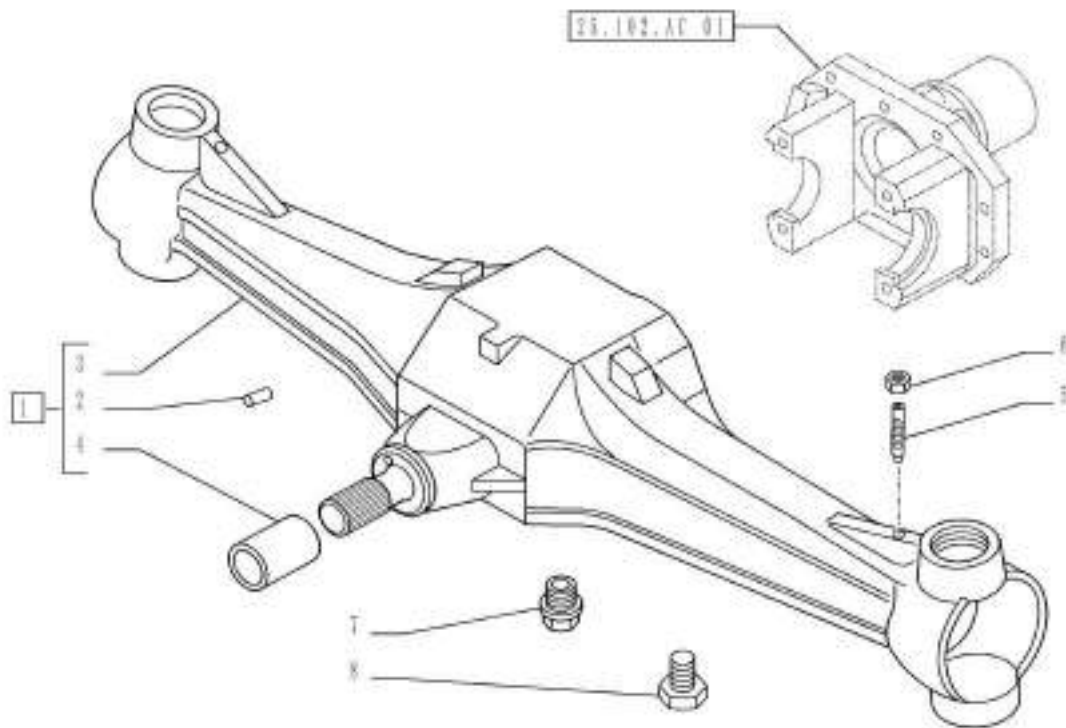

25.100.AD

01

p1

1/2014

VAR - 390250 - 4WD FRONT AXLE, AXLE HOUSING

REF FN	PART NUMBER	YR/SN	QTY DESCRIPTION
1	5135077		1 AXLE HOUSING Incl 2 - 4
2	4988170		2 DOWEL
3	NSS		1 NOT SERVICED SEPARATELY Housing Incl in 1
4	4996836		1 PIN
5	87316865		2 SET SCREW M12 x 1.25 x 53.00mm, Carbon Steel
6	16105021		2 LOCK NUT M12 x 1.25, CI 10
7	14324411		1 MAGNETIC PLUG M22 x 1.50, CI 5.8, ZND
8	14326211		1 PLUG M22 x 1.50, R50, ZND

Valid for Var. 390250

FARMALL JX70

VAR - 335325 - 4WD FRONT AXLE, AXLE HOUSING

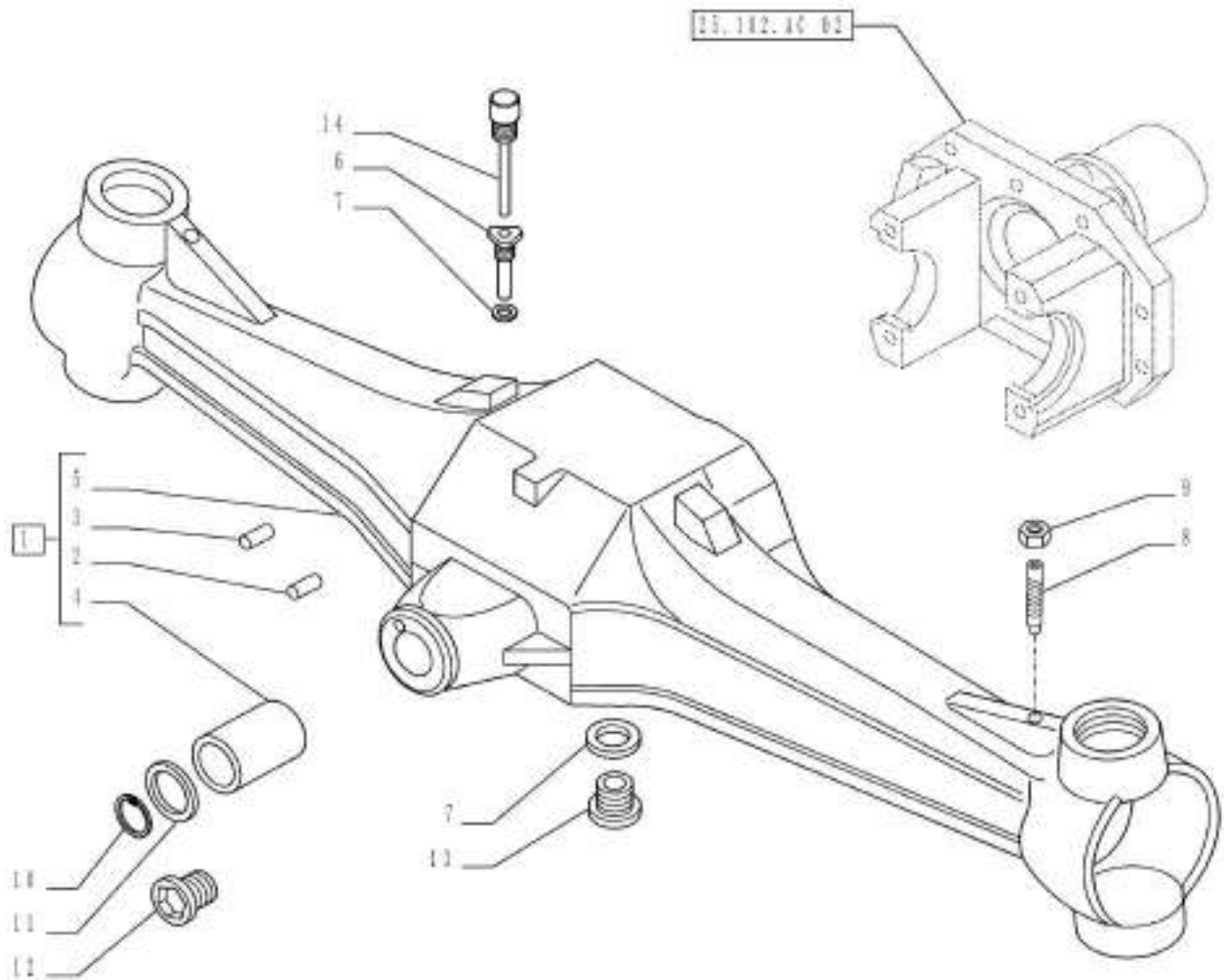

25.100.AD

02

p1

1/2014

VAR - 335325 - 4WD FRONT AXLE, AXLE HOUSING

REF FN	PART NUMBER	YR/SN	QTY DESCRIPTION
1	5156389		1 FRONT AXLE Incl 2 - 5
2	4988170		2 DOWEL
3	4966244		1 DOWEL M5 x 15
4	5140017		1 PIN 52.65mm OD x 153.00mm
5	NSS		1 NOT SERVICED SEPARATELY Body Incl in 1
6	5153744		1 BODY
7	10263460		3 SEAL 22.30mm ID x 28.00mm OD, 1.50mm, Copper
8	87309002		2 SET SCREW
9	16105021		2 LOCK NUT M12 x 1.25, CI 10
10	11067776		1 SNAP RING M29, Ext
11	5140456		1 RING
12	14324411		1 MAGNETIC PLUG M22 x 1.50, CI 5.8, ZND
13	14326211		1 PLUG M22 x 1.50, R50, ZND
14	5101814		1 BREATHER

Valid for Var. 335325

FARMALL JX100
FARMALL JX110
FARMALL JX75
FARMALL JX80

VAR - 335539 - 4WD FRONT AXLE - AXLE HOUSING

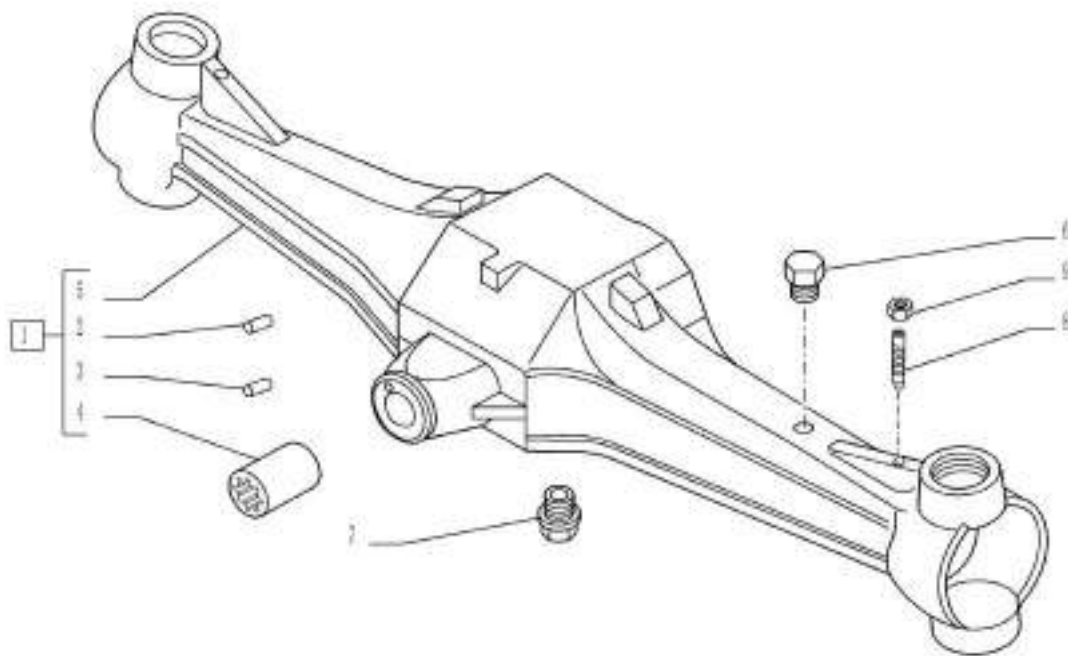

25.100.AD

03

p1

1/2014

VAR - 335539 - 4WD FRONT AXLE - AXLE HOUSING

REF FN	PART NUMBER	YR/SN	QTY DESCRIPTION
1	87309861		1 AXLE HOUSING Incl 2 - 5
2	4988170		2 DOWEL M10 x 20
3	4966244		1 DOWEL M5 x 15
4	5140017		1 PIN 52.65mm OD x 153.00mm
5	NSS		1 NOT SERVICED SEPARATELY Housing Incl in 1
6	14326211		1 PLUG M22 x 1.50, R50, ZND
7	14324411		1 MAGNETIC PLUG M22 x 1.50, CI 5.8, ZND
8	87309002		2 SET SCREW
9	16101511		2 NUT M12 x 1.25, CI 8

Valid for Var. 335539

FARMALL JX100
FARMALL JX110
FARMALL JX75
FARMALL JX80

VAR - 334396, 334397, 720450, 744745 - FRONT AXLE SUPPORT

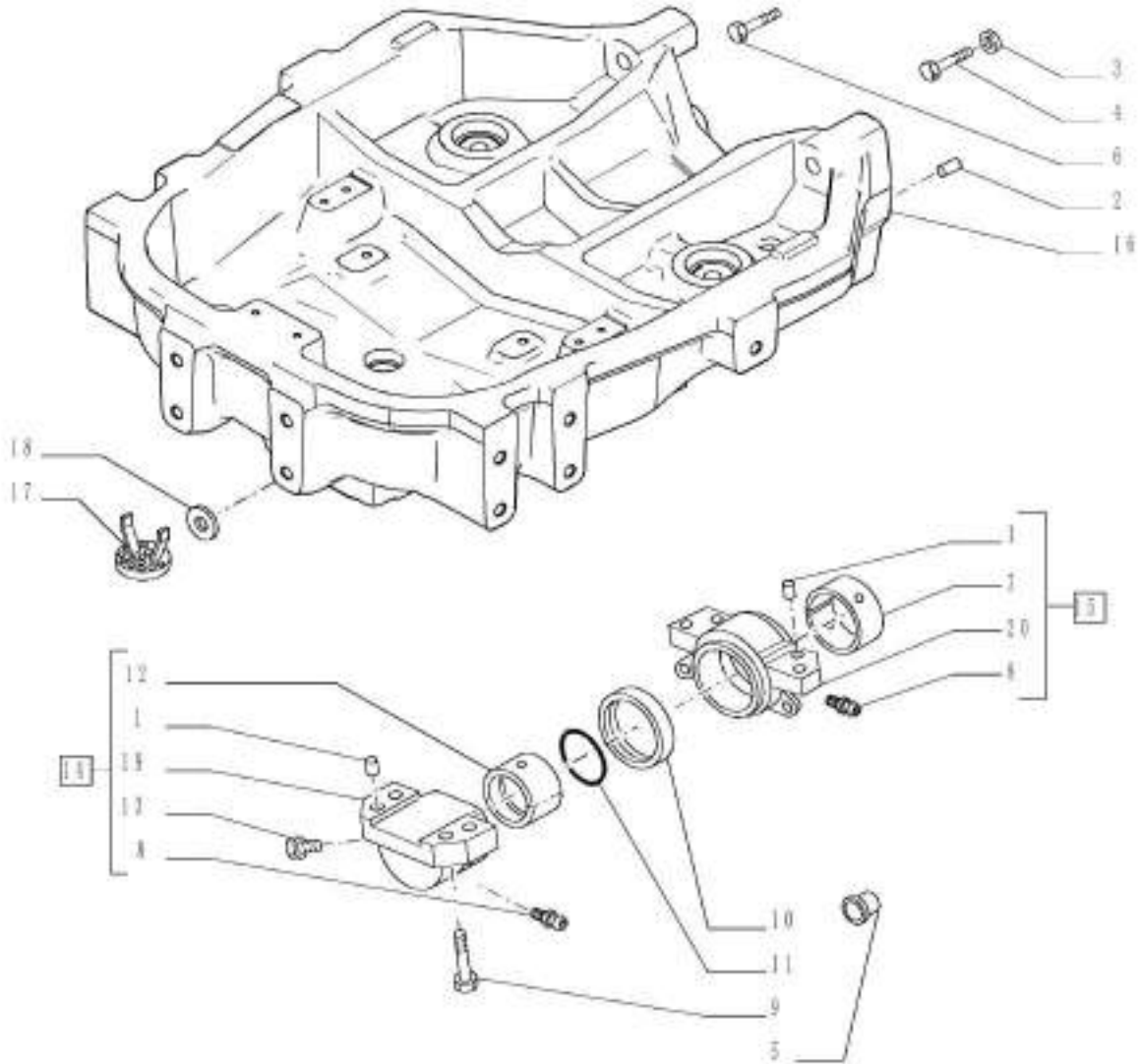

VAR - 334396, 334397, 720450, 744745 - FRONT AXLE SUPPORT

REF FN	PART NUMBER	YR/SN	QTY DESCRIPTION
1	10837710		2 DOWEL M10 x 25
2	4668595		2 DOWEL
3	11191879		4 BELLEVILLE WASHER
4	84515089		2 SCREW M18
5	590353		AR PLUG 15mm OD x 10mm High, Plastic
6	84515067		2 SCREW M18 x 150
7	5129385		1 BUSHING 99.00mm ID x 103.70mm OD x 52.00mm
8	13407211		2 LUBE NIPPLE M10 x 1
9	14272034		2 LOCK BOLT Hex, M18 x 1.5 x 65mm, CI 10.9
10	1 5140455		2 SEALING RING
11	1 14471380		1 O-RING 53.34mm ID x 5.33mm
12	5101112		1 BUSHING 52.00mm ID x 57.00mm OD x 42.00mm
13	13411117		2 PRESSURE RELIEF VALVE
14	1 5140452		1 SUPPORT ASSY Incl 1, 8, 12, 13, 19
14	2 5111886		1 SUPPORT ASSY Incl 1, 8, 12, 13, 19
15	3 5140454		1 SUPPORT ASSY Incl 1, 7, 8, 20
15	4 5111887		1 SUPPORT ASSY Incl 1, 7, 8, 20
15	5 5147613		1 SUPPORT
16	6 84539324		1 AXLE SUPPORT
16	84539327		1 AXLE SUPPORT
17	5120218		1 GRILLE
18	7 47128135		AR SHIM 1.8mm Thk Yellow
18	7 47128136		AR SHIM 2.0mm Thk Red
18	7 47128137		AR SHIM 2.2mm Thk Green
(1)	VAR - 334396 or 334397 or 334315, 334416, 390895 (720450) or 334414, 390258 (744745); FARMALL JX75, 80, 90,		
(2)	VAR - 334396 or 334414, 390258 (744745); FARMALL JX70 Model Only		
(3)	VAR - 334315, 334416, 390895 (720450) or 334414, 390258 (744745); FARMALL JX75, 80, 90, 100, 110 Models Only		
(4)	VAR - 334414, 390258 (744745); FARMALL JX70 Model Only		
(5)	VAR - 334396 or 334397; FARMALL JX75, 80, 90, 100, 110 Models Only		
(6)	VAR - 334396 or 334397 or 334315, 390895 (720450) or 390258 (744745)		
(7)	Valid for FARMALL JX75, 80, 90, 100, 110 Models Only, 4WD		

Valid for Var. 334396 or Var. 334397 or Industrial Var. 334315, 334416, 390895 (720450) or Industrial Var. 334414, 390258 (744745)

FARMALL JX100 FARMALL
JX110 FARMALL JX70
FARMALL JX75 FARMALL
JX80 FARMALL JX90

VAR - 334396, 334397, 720450, 744745 - FRONT AXLE SUPPORT

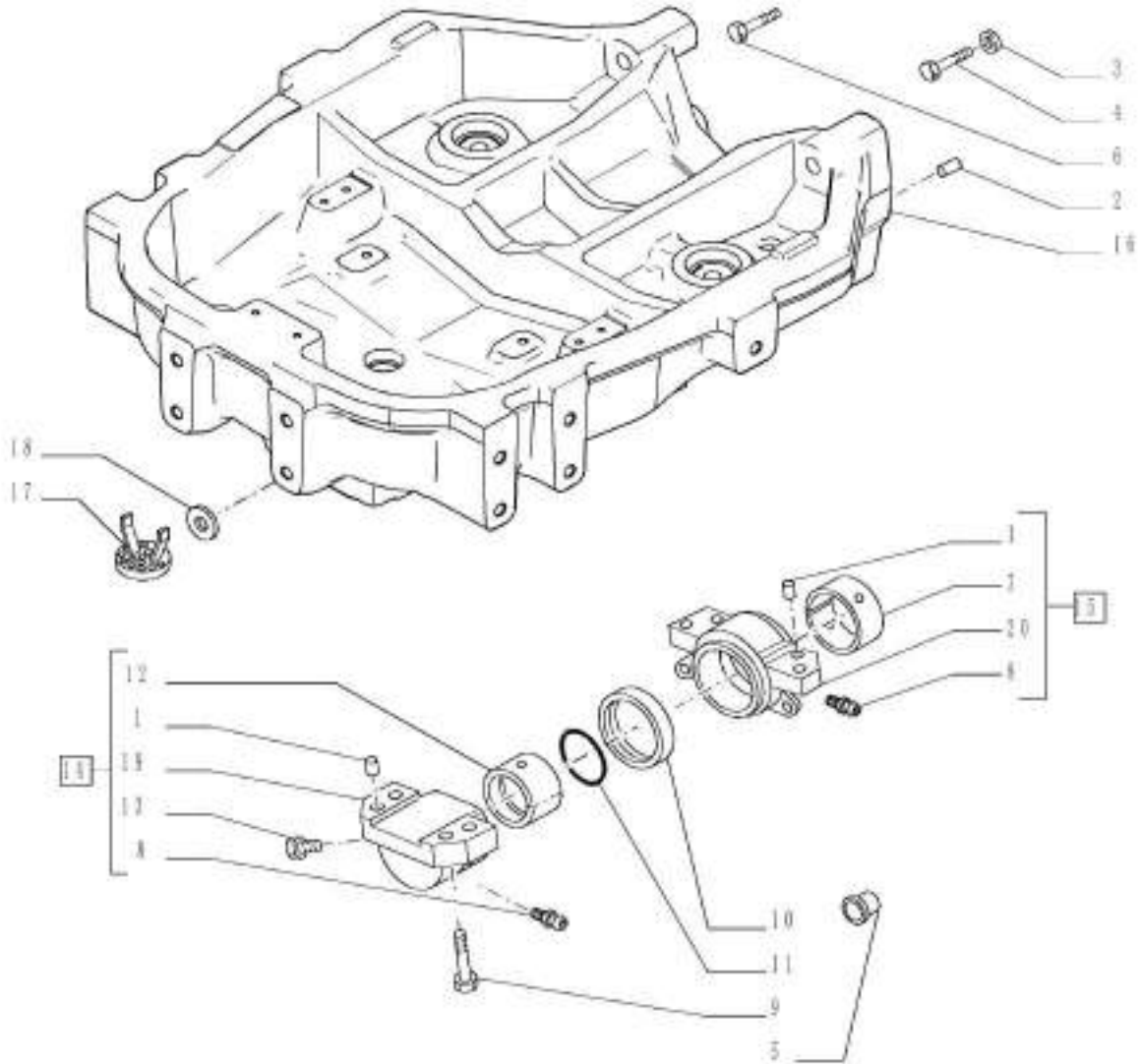

VAR - 334396, 334397, 720450, 744745 - FRONT AXLE SUPPORT

REF	FN	PART NUMBER	YR/SN	QTY	DESCRIPTION
18	1	47128138			AR SHIM 2.4mm Thk Blue
18	1	47136468			AR SHIM 1.6mm Thk Black
19		NSS		1	NOT SERVICED SEPARATELY Support Incl in 14
20	^{2,3}	NSS		1	NOT SERVICED SEPARATELY Support Incl in 15
20	4	5001104		1	SUPPORT
(1)		Valid for FARMALL JX75, 80, 90, 100, 110 Models Only, 4WD			
(2)		VAR - 334396 or 334397 or 334315, 334416, 390895 (720450) or 334414, 390258 (744745); FARMALL JX75, 80, 90,			
(3)		VAR - 334414, 390258 (744745); FARMALL JX70 Model Only			
(4)		VAR - 334396; FARMALL JX70 Model Only, 4WD			

Valid for Var. 334396 or Var. 334397 or Industrial Var. 334315, 334416, 390895 (720450) or Industrial Var. 334414, 390258 (744745)

FARMALL JX100 FARMALL
JX110 FARMALL JX70
FARMALL JX75 FARMALL
JX80 FARMALL JX90

25.102.AB

01

p1

1/2014

VAR - 390250 - 4WD FRONT AXLE, BEVEL GEAR

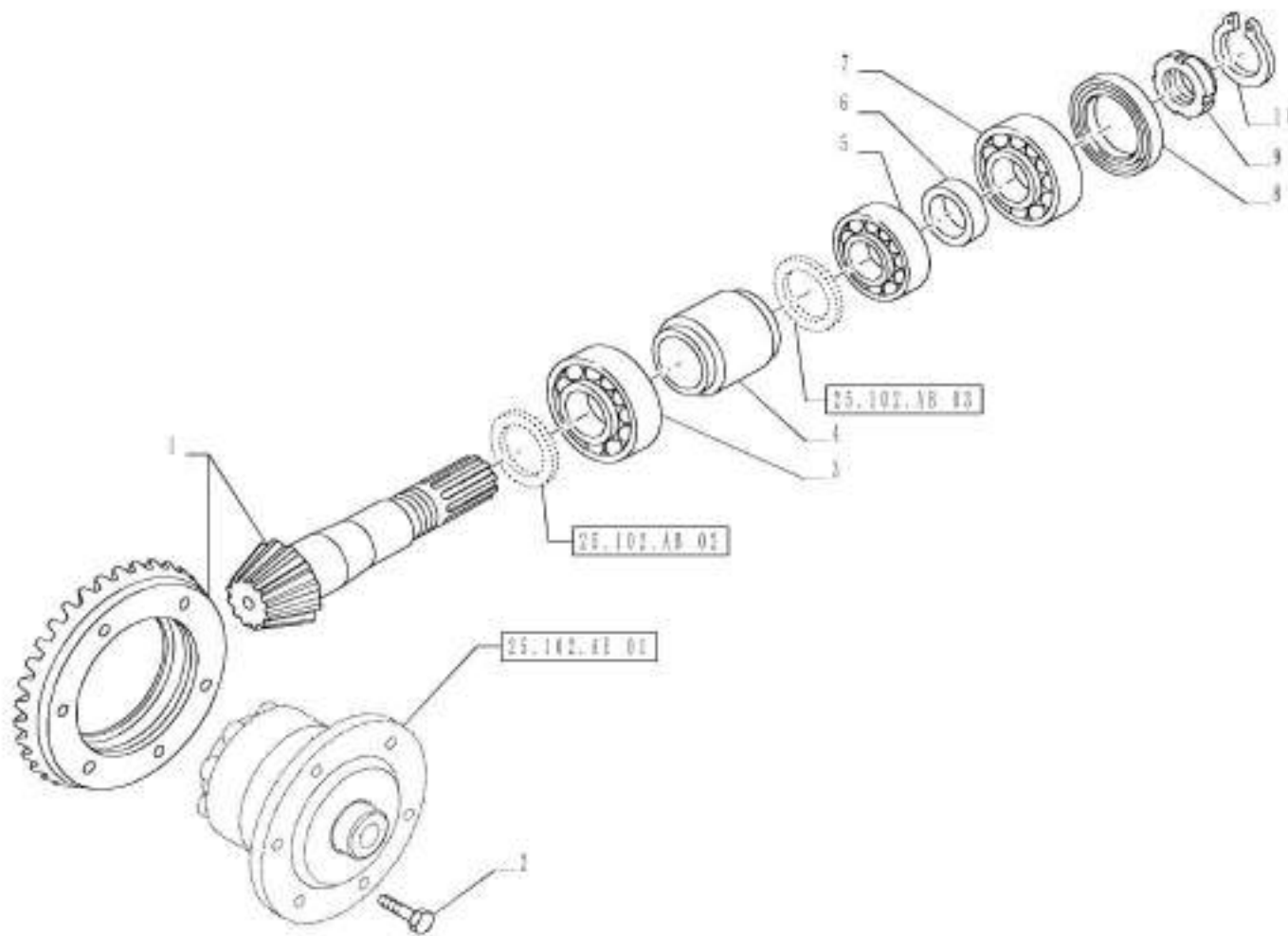

25.102.AB

01

p1

1/2014

VAR - 390250 - 4WD FRONT AXLE, BEVEL GEAR

REF FN	PART NUMBER	YR/SN	QTY DESCRIPTION
1	5119221		1 BEVEL GEAR
2	14274434		6 LOCK BOLT Hex, M12 x 1.25 x 25mm, CI 10.9, Full Thd
3	28042230		1 TAPERED ROLLER BEARING
4	4997452		1 SPACER
5	26799950		1 TAPERED ROLLER BEARING 35.00mm x 72.00mm x 18.25mm
6	5149764		1 RING
7	5135294		1 SEAL
8	4997451		1 SEAL PROTECTION
9	4997450		1 RING NUT
10	11067776		1 SNAP RING M29, Ext

Valid for Var. 390250

FARMALL JX70

25.102.AB

02

p1

1/2014

VAR - 390250 - 4WD FRONT AXLE, BEVEL GEAR, SHIM

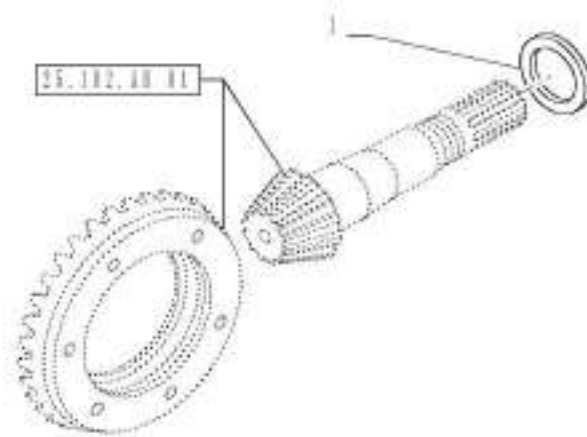

25.102.AB

02

p1

1/2014

VAR - 390250 - 4WD FRONT AXLE, BEVEL GEAR, SHIM

REF FN	PART NUMBER	YR/SN	QTY DESCRIPTION
1	4998754		AR RING
1	4998742		AR SHIM 2.5mm Thk
1	4998743		AR SHIM 2.6mm Thk
1	4998744		AR SHIM 2.7mm Thk
1	4998745		AR SHIM 2.8mm Thk
1	4998746		AR SHIM 2.9mm Thk
1	4998747		AR SHIM 3.0mm Thk
1	4998748		AR SHIM 3.1mm Thk
1	4998749		AR SHIM 3.2mm Thk
1	4998750		AR SHIM 3.3mm Thk
1	4998751		AR SHIM 3.4mm Thk
1	4998752		AR SHIM 3.5mm Thk
1	4998753		AR SHIM 3.6mm Thk

Valid for Var. 390250

FARMALL JX70

25.102.AB

03

p1

1/2014

VAR - 390250 - 4WD FRONT AXLE, BEVEL GEAR, SHIM

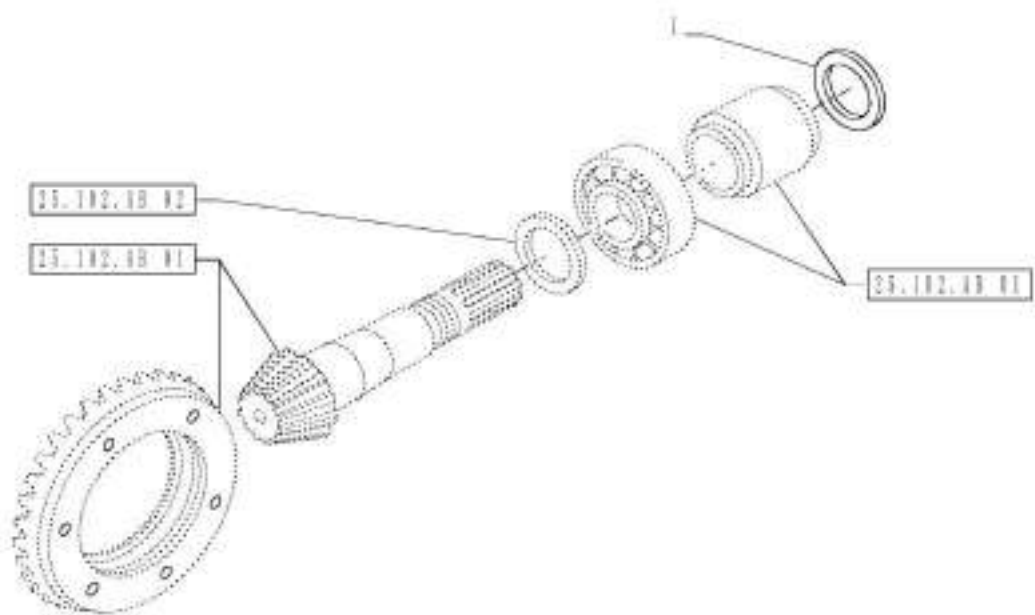

VAR - 390250 - 4WD FRONT AXLE, BEVEL GEAR, SHIM

REF FN	PART NUMBER	YR/SN	QTY DESCRIPTION
1	5101236		AR SHIM 35.00mm ID x 43.00mm OD x 3.50mm T
1	5101237		AR SHIM 35.00mm ID x 43.00mm OD x 3.60mm T
1	5101238		AR SHIM 35.00mm ID x 43.00mm OD x 3.70mm T
1	5129151		AR SHIM 35.00mm ID x 43.00mm OD x 2.55mm T
1	5129152		AR SHIM 35.00mm ID x 43.00mm OD x 2.65mm T
1	5129153		AR SHIM 35.00mm ID x 43.00mm OD x 2.75mm T
1	5129154		AR SHIM 35.00mm ID x 43.00mm OD x 2.85mm T
1	5129155		AR SHIM 35.00mm ID x 43.00mm OD x 2.95mm T
1	5129156		AR SHIM 35.00mm ID x 43.00mm OD x 3.05mm T
1	4997456		AR SHIM 35.00mm ID x 43.00mm OD x 2.50mm T
1	4997457		AR SHIM 35.00mm ID x 43.00mm OD x 2.60mm T
1	4997458		AR SHIM 35.00mm ID x 43.00mm OD x 2.70mm T
1	4997459		AR SHIM 35.00mm ID x 43.00mm OD x 2.80mm T
1	4997460		AR SHIM 35.00mm ID x 43.00mm OD x 2.90mm T
1	4997461		AR SHIM 35.00mm ID x 43.00mm OD x 3.00mm T
1	4997462		AR SHIM 35.00mm ID x 43.00mm OD x 3.10mm T
1	5129157		AR SHIM 35.00mm ID x 43.00mm OD x 3.15mm T

Valid for Var. 390250

FARMALL JX70

VAR - 390250 - 4WD FRONT AXLE, BEVEL GEAR, SHIM

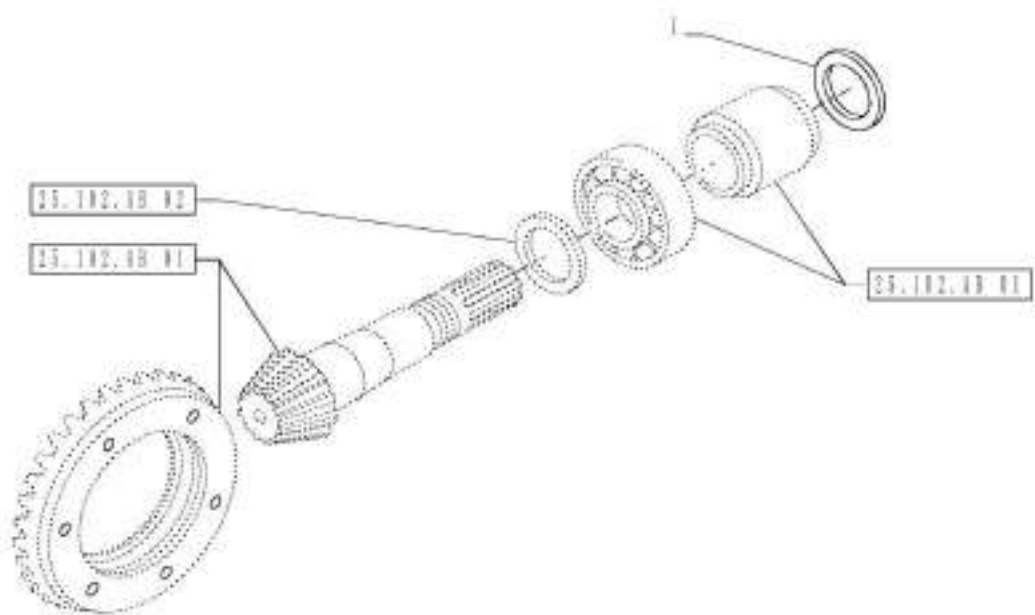

VAR - 390250 - 4WD FRONT AXLE, BEVEL GEAR, SHIM

REF FN	PART NUMBER	YR/SN	QTY DESCRIPTION
1	4997463		AR SHIM 35.00mm ID x 43.00mm OD x 3.20mm T
1	5101234		AR SHIM 35.00mm ID x 43.00mm OD x 3.30mm T
1	5129158		AR SHIM 35.00mm ID x 43.00mm OD x 3.25mm T
1	5129159		AR SHIM 35.00mm ID x 43.00mm OD x 3.35mm T
1	5101235		AR SHIM 35.00mm ID x 43.00mm OD x 3.40mm T
1	5129160		AR SHIM 35.00mm ID x 43.00mm OD x 3.45mm T
1	5129161		AR SHIM 35.00mm ID x 43.00mm OD x 3.55mm T
1	5129162		AR SHIM 35.00mm ID x 43.00mm OD x 3.65mm T
1	5169313		AR SHIM 35.10 - 35.40mm ID x 43mm OD x 3.75mm Thk
1	5169314		AR SHIM 35.10 - 35.40mm ID x 43mm OD x 3.80mm Thk
1	5169315		AR SHIM 35.10 - 35.40mm ID x 43mm OD x 3.85mm Thk
1	5169316		AR SHIM 35.10 - 35.40mm ID x 43mm OD x 3.90mm Thk
1	5169317		AR SHIM 35.10 - 35.40mm ID x 43mm OD x 3.95mm Thk
1	5169318		AR SHIM 35.10 - 35.40mm ID x 43mm OD x 4mm Thk
1	5169319		AR SHIM 35.10 - 35.40mm ID x 43mm OD x 4.05mm Thk
1	5169320		AR SHIM 35.10 - 35.40mm ID x 43mm OD x 4.10mm Thk
1	5169321		AR SHIM 35.10 - 35.40mm ID x 43mm OD x 4.15mm Thk

Valid for Var. 390250

FARMALL JX70

VAR - 390250 - 4WD FRONT AXLE, BEVEL GEAR, SHIM

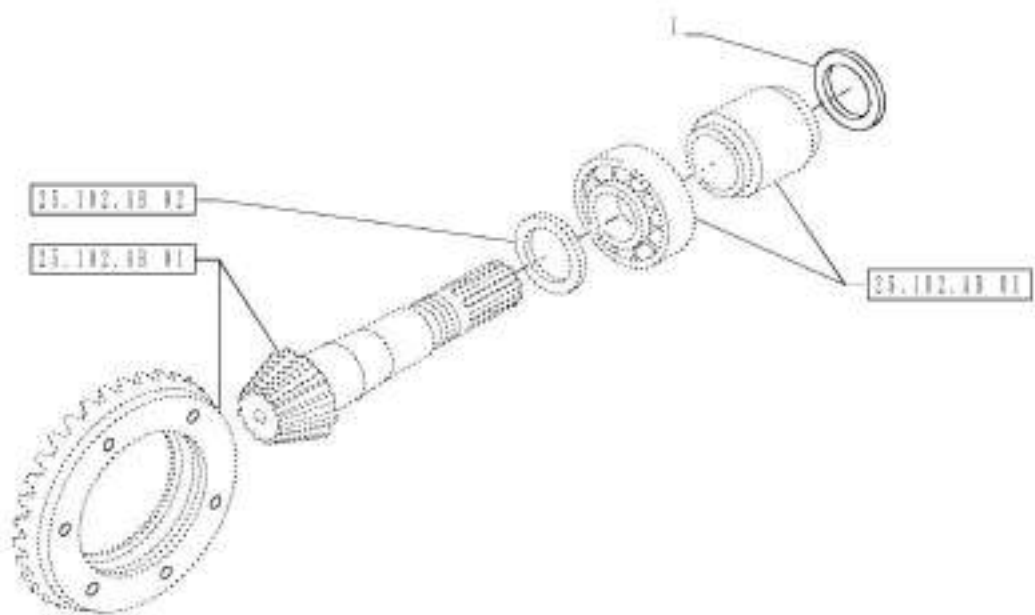

VAR - 390250 - 4WD FRONT AXLE, BEVEL GEAR, SHIM

REF FN	PART NUMBER	YR/SN	QTY DESCRIPTION
1	5169322		AR SHIM 35.10 - 35.40mm ID x 43mm OD x 4.20mm Thk
1	5169323		AR SHIM 35.10 - 35.40mm ID x 43mm OD x 4.25mm Thk
1	5169324		AR SHIM 35.10 - 35.40mm ID x 43mm OD x 4.30mm Thk
1	5169325		AR SHIM 35.10 - 35.40mm ID x 43mm OD x 4.35mm Thk
1	5169326		AR SHIM 35.10 - 35.40mm ID x 43mm OD x 4.40mm Thk
1	5169327		AR SHIM 35.10 - 35.40mm ID x 43mm OD x 4.45mm Thk
1	5169328		AR SHIM 35.10 - 35.40mm ID x 43mm OD x 4.50mm Thk
1	5169329		AR SHIM 35.10 - 35.40mm ID x 43mm OD x 4.55mm Thk
1	5169330		AR SHIM 35.10 - 35.40mm ID x 43mm OD x 4.60mm Thk
1	5169331		AR SHIM 35.10 - 35.40mm ID x 43mm OD x 4.65mm Thk
1	5169332		AR SHIM 35.10 - 35.40mm ID x 43mm OD x 4.70mm Thk
1	5169333		AR SHIM 35.10 - 35.40mm ID x 43mm OD x 4.75mm Thk
1	5169334		AR SHIM 35.10 - 35.40mm ID x 43mm OD x 4.80mm Thk

Valid for Var. 390250

FARMALL JX70

25.102.AB

04

p1

1/2014

VAR - 335325, 335539 - 4WD FRONT AXLE, BEVEL GEAR

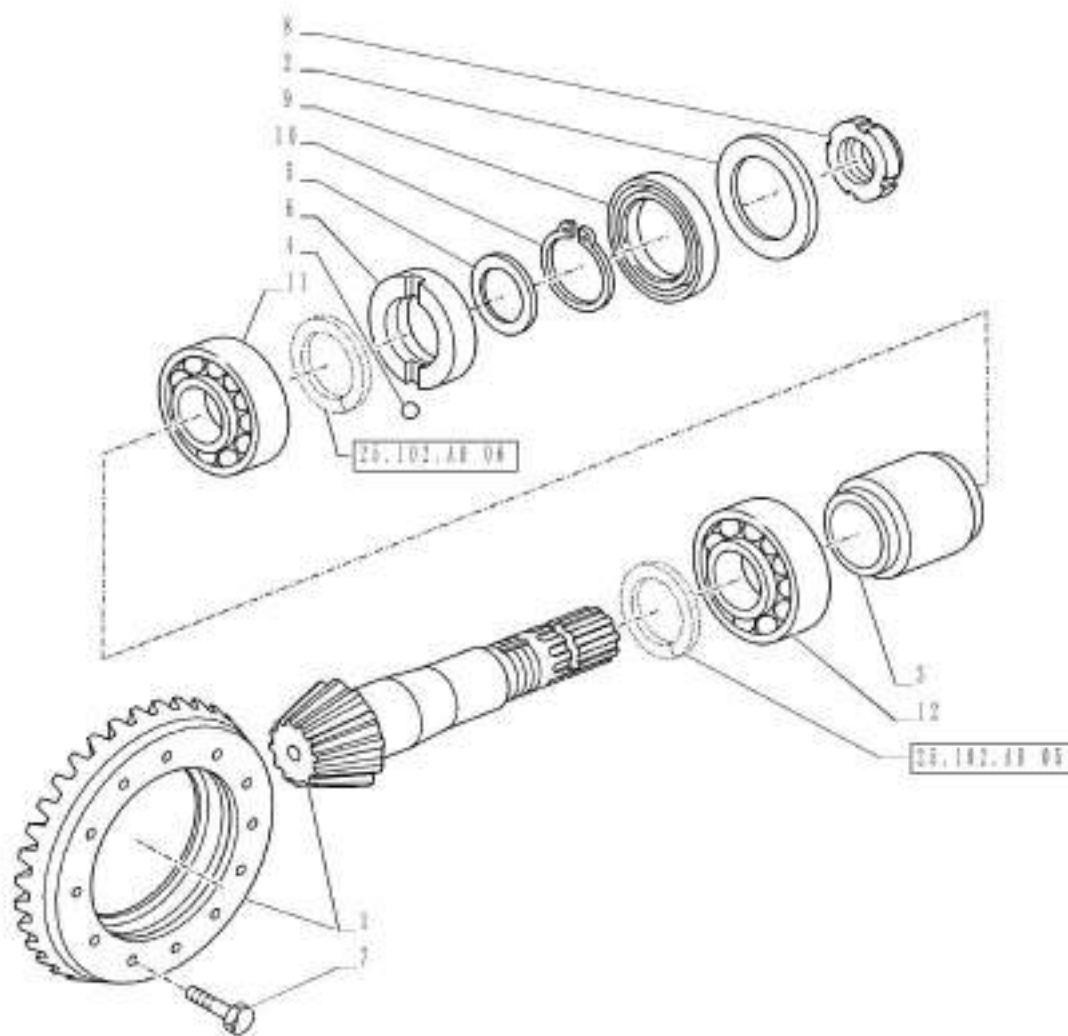

25.102.AB

04

p1

1/2014

VAR - 335325, 335539 - 4WD FRONT AXLE, BEVEL GEAR

REF FN	PART NUMBER	YR/SN	QTY DESCRIPTION
1	5142023		1 GEAR SET 9/39
2	4997451		1 SEAL PROTECTION
3	5169235		1 SPACER
4	20419320		1 BALL
5	14454380		1 O-RING 31.47mm ID x 1.78" Width
6	5142026		1 RING
7	14274434		8 LOCK BOLT Hex, M12 x 1.25 x 25mm, CI 10.9, Full Thd
8	5143242		1 RING NUT M35 x 1.5
9	5135294		1 SEAL
10	11067776		1 SNAP RING M29, Ext
11	5133776		1 TAPERED ROLLER BEARING 35.00mm x 72.00mm x 28.00mm
12	5143109		1 TAPERED ROLLER BEARING 41.27mm x 82.55mm x 26.54mm

Valid for Var. 353325 or Var. 335539

FARMALL JX100
FARMALL JX110
FARMALL JX75
FARMALL JX80

25.102.AB

05

p1

1/2014

VAR - 335325, 335539 - 4WD FRONT AXLE, BEVEL GEAR, SHIM

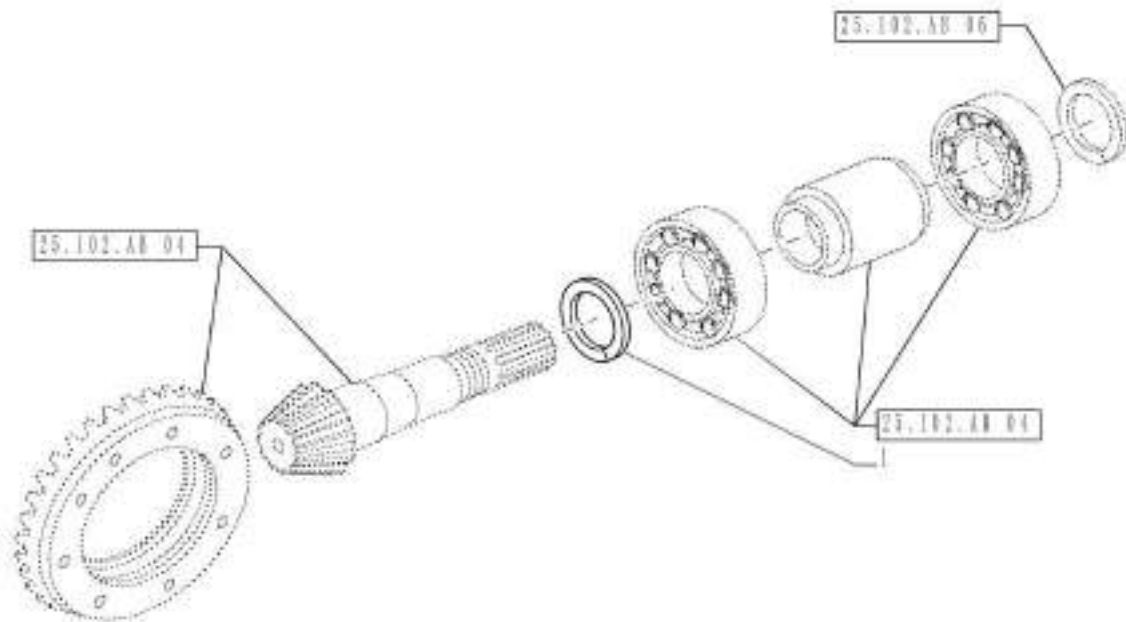

25.102.AB

05

p1

1/2014

VAR - 335325, 335539 - 4WD FRONT AXLE, BEVEL GEAR, SHIM

REF FN	PART NUMBER	YR/SN	QTY DESCRIPTION
1	5142027		AR SHIM 41.40mm ID x 58.00mm OD x 2.50mm T
1	5142028		AR SHIM 41.40mm ID x 58.00mm OD x 2.60mm T
1	5142029		AR SHIM 41.40mm ID x 58.00mm OD x 2.70mm T
1	5142030		AR SHIM 41.40mm ID x 58.00mm OD x 2.80mm T
1	5142031		AR SHIM 41.40mm ID x 58.00mm OD x 2.90mm T
1	5142032		AR SHIM 41.40mm ID x 58.00mm OD x 3.00mm T
1	5142033		AR SHIM 41.40mm ID x 58.00mm OD x 3.10mm T
1	5142034		AR SHIM 41.40mm ID x 58.00mm OD x 3.20mm T
1	5142035		AR SHIM 47.40mm ID x 58.00mm OD x 3.30mm T
1	5142036		AR SHIM 41.40mm ID x 58.00mm OD x 3.40mm T
1	5142037		AR SHIM 41.40mm ID x 58.00mm OD x 3.50mm T
1	5142038		AR SHIM 41.40mm ID x 58.00mm OD x 3.60mm T
1	5142039		AR SHIM 41.40mm ID x 58.00mm OD x 3.70mm T
1	5087435		1 SHIM KIT

Valid for Var. 335325 or Var. 335539	FARMALL JX100 FARMALL JX110 FARMALL JX75 FARMALL JX80
---	--

25.102.AB

06

p1

1/2014

VAR - 335325, 335539 - 4WD FRONT AXLE, BEVEL GEAR, SHIM

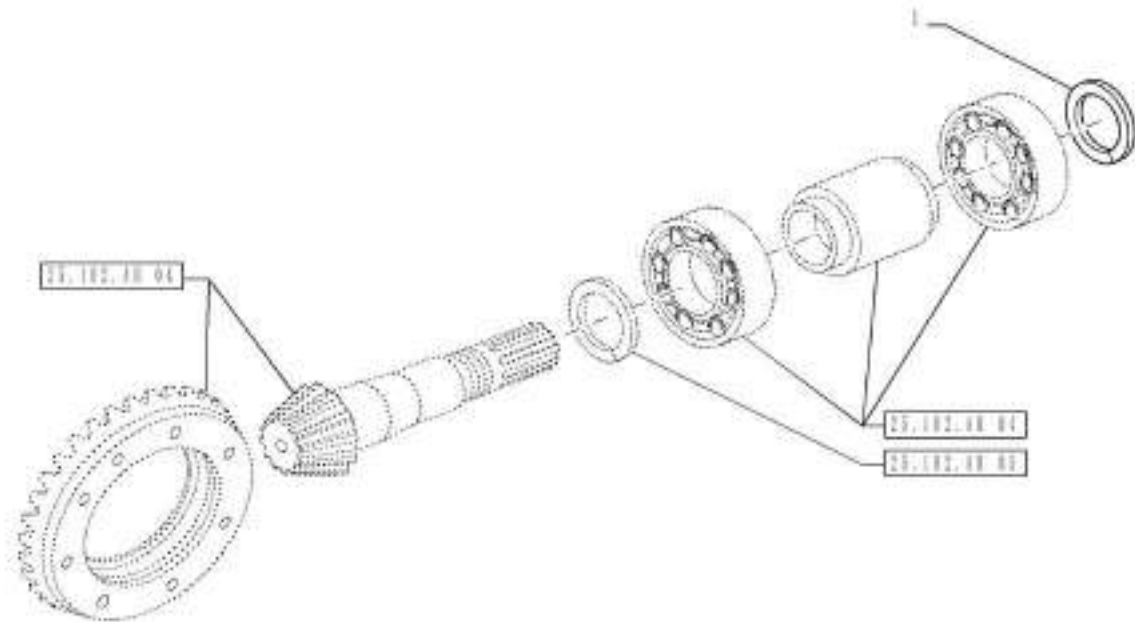

VAR - 335325, 335539 - 4WD FRONT AXLE, BEVEL GEAR, SHIM

REF FN	PART NUMBER	YR/SN	QTY DESCRIPTION
1	4997456		1 SHIM 35.00mm ID x 43.00mm OD x 2.50mm T
1	4997457		AR SHIM 35.00mm ID x 43.00mm OD x 2.60mm T
1	4997458		AR SHIM 35.00mm ID x 43.00mm OD x 2.70mm T
1	4997459		AR SHIM 35.00mm ID x 43.00mm OD x 2.80mm T
1	4997460		AR SHIM 35.00mm ID x 43.00mm OD x 2.90mm T
1	4997461		AR SHIM 35.00mm ID x 43.00mm OD x 3.00mm T
1	4997462		AR SHIM 35.00mm ID x 43.00mm OD x 3.10mm T
1	4997463		AR SHIM 35.00mm ID x 43.00mm OD x 3.20mm T
1	5101234		AR SHIM 35.00mm ID x 43.00mm OD x 3.30mm T
1	5101235		AR SHIM 35.00mm ID x 43.00mm OD x 3.40mm T
1	5101236		AR SHIM 35.00mm ID x 43.00mm OD x 3.50mm T
1	5101237		AR SHIM 35.00mm ID x 43.00mm OD x 3.60mm T
1	5101238		AR SHIM 35.00mm ID x 43.00mm OD x 3.70mm T
1	5129151		AR SHIM 35.00mm ID x 43.00mm OD x 2.55mm T
1	5129152		AR SHIM 35.00mm ID x 43.00mm OD x 2.65mm T
1	5129153		AR SHIM 35.00mm ID x 43.00mm OD x 2.75mm T
1	5129154		AR SHIM 35.00mm ID x 43.00mm OD x 2.85mm T
Valid for Var. 335325 or Var. 335539			FARMALL JX100 FARMALL JX110 FARMALL JX75 FARMALL JX80

VAR - 335325, 335539 - 4WD FRONT AXLE, BEVEL GEAR, SHIM

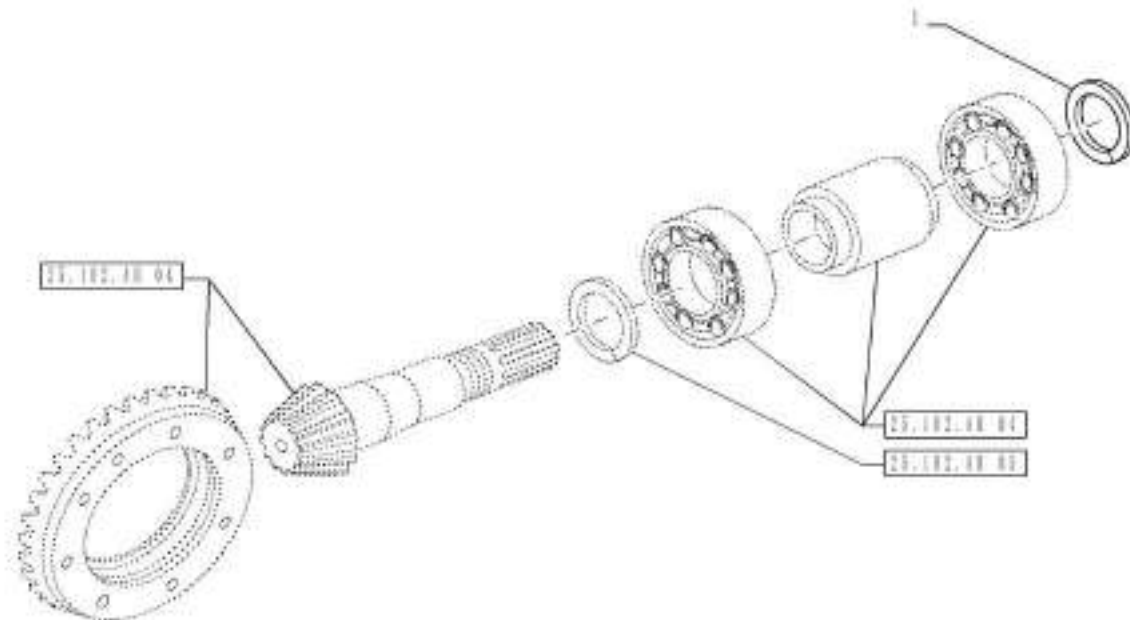

VAR - 335325, 335539 - 4WD FRONT AXLE, BEVEL GEAR, SHIM

REF FN	PART NUMBER	YR/SN	QTY DESCRIPTION
1	5129155		AR SHIM 35.00mm ID x 43.00mm OD x 2.95mm T
1	5129156		AR SHIM 35.00mm ID x 43.00mm OD x 3.05mm T
1	5129157		AR SHIM 35.00mm ID x 43.00mm OD x 3.15mm T
1	5129158		AR SHIM 35.00mm ID x 43.00mm OD x 3.25mm T
1	5129159		AR SHIM 35.00mm ID x 43.00mm OD x 3.35mm T
1	5129160		AR SHIM 35.00mm ID x 43.00mm OD x 3.45mm T
1	5129161		AR SHIM 35.00mm ID x 43.00mm OD x 3.55mm T
1	5129162		AR SHIM 35.00mm ID x 43.00mm OD x 3.65mm T
1	5169313		AR SHIM 35.10 - 35.40mm ID x 43mm OD x 3.75mm Thk
1	5169314		AR SHIM 35.10 - 35.40mm ID x 43mm OD x 3.80mm Thk
1	5169315		AR SHIM 35.10 - 35.40mm ID x 43mm OD x 3.85mm Thk
1	5169316		AR SHIM 35.10 - 35.40mm ID x 43mm OD x 3.90mm Thk
1	5169317		AR SHIM 35.10 - 35.40mm ID x 43mm OD x 3.95mm Thk
1	5169318		AR SHIM 35.10 - 35.40mm ID x 43mm OD x 4mm Thk
1	5169319		AR SHIM 35.10 - 35.40mm ID x 43mm OD x 4.05mm Thk
1	5169320		AR SHIM 35.10 - 35.40mm ID x 43mm OD x 4.10mm Thk
1	5169321		AR SHIM 35.10 - 35.40mm ID x 43mm OD x 4.15mm Thk
Valid for Var. 335325 or Var. 335539			FARMALL JX100 FARMALL JX110 FARMALL JX75 FARMALL JX80

25.102.AB

06

p3

1/2014

VAR - 335325, 335539 - 4WD FRONT AXLE, BEVEL GEAR, SHIM

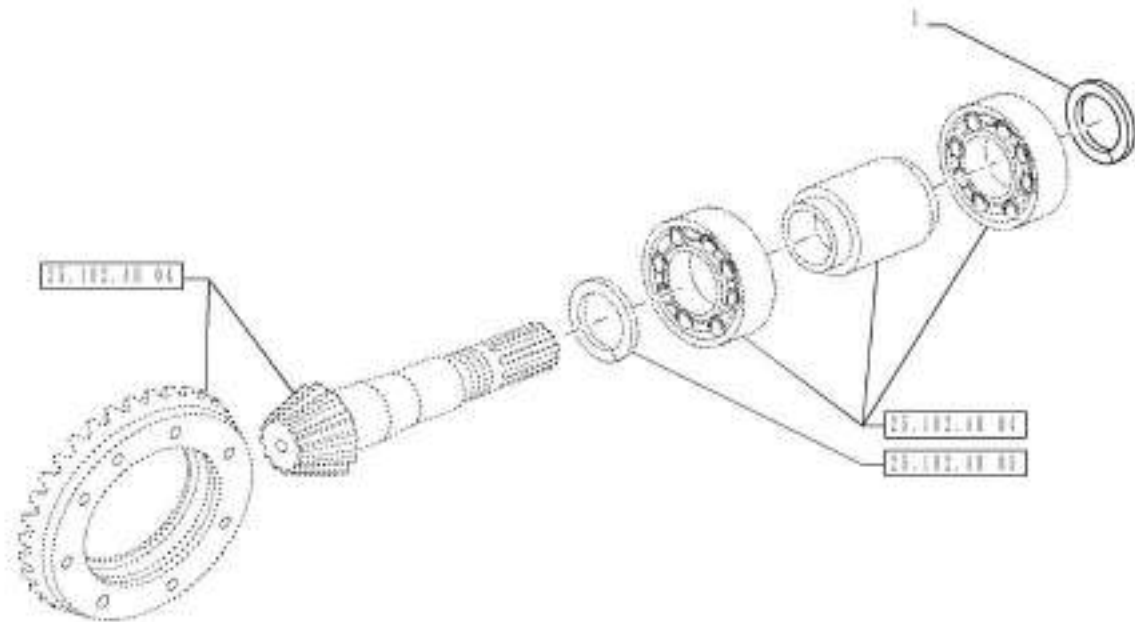

VAR - 335325, 335539 - 4WD FRONT AXLE, BEVEL GEAR, SHIM

REF FN	PART NUMBER	YR/SN	QTY DESCRIPTION
1	5169322		AR SHIM 35.10 - 35.40mm ID x 43mm OD x 4.20mm Thk
1	5169323		AR SHIM 35.10 - 35.40mm ID x 43mm OD x 4.25mm Thk
1	5169324		AR SHIM 35.10 - 35.40mm ID x 43mm OD x 4.30mm Thk
1	5169325		AR SHIM 35.10 - 35.40mm ID x 43mm OD x 4.35mm Thk
1	5169326		AR SHIM 35.10 - 35.40mm ID x 43mm OD x 4.40mm Thk
1	5169327		AR SHIM 35.10 - 35.40mm ID x 43mm OD x 4.45mm Thk
1	5169328		AR SHIM 35.10 - 35.40mm ID x 43mm OD x 4.50mm Thk
1	5169329		AR SHIM 35.10 - 35.40mm ID x 43mm OD x 4.55mm Thk
1	5169330		AR SHIM 35.10 - 35.40mm ID x 43mm OD x 4.60mm Thk
1	5169331		AR SHIM 35.10 - 35.40mm ID x 43mm OD x 4.65mm Thk
1	5169332		AR SHIM 35.10 - 35.40mm ID x 43mm OD x 4.70mm Thk
1	5169333		AR SHIM 35.10 - 35.40mm ID x 43mm OD x 4.75mm Thk
1	5169334		AR SHIM 35.10 - 35.40mm ID x 43mm OD x 4.80mm Thk
Valid for Var. 335325 or Var. 335539			FARMALL JX100 FARMALL JX110 FARMALL JX75 FARMALL JX80

VAR - 390250 - 4WD FRONT AXLE, SUPPORT

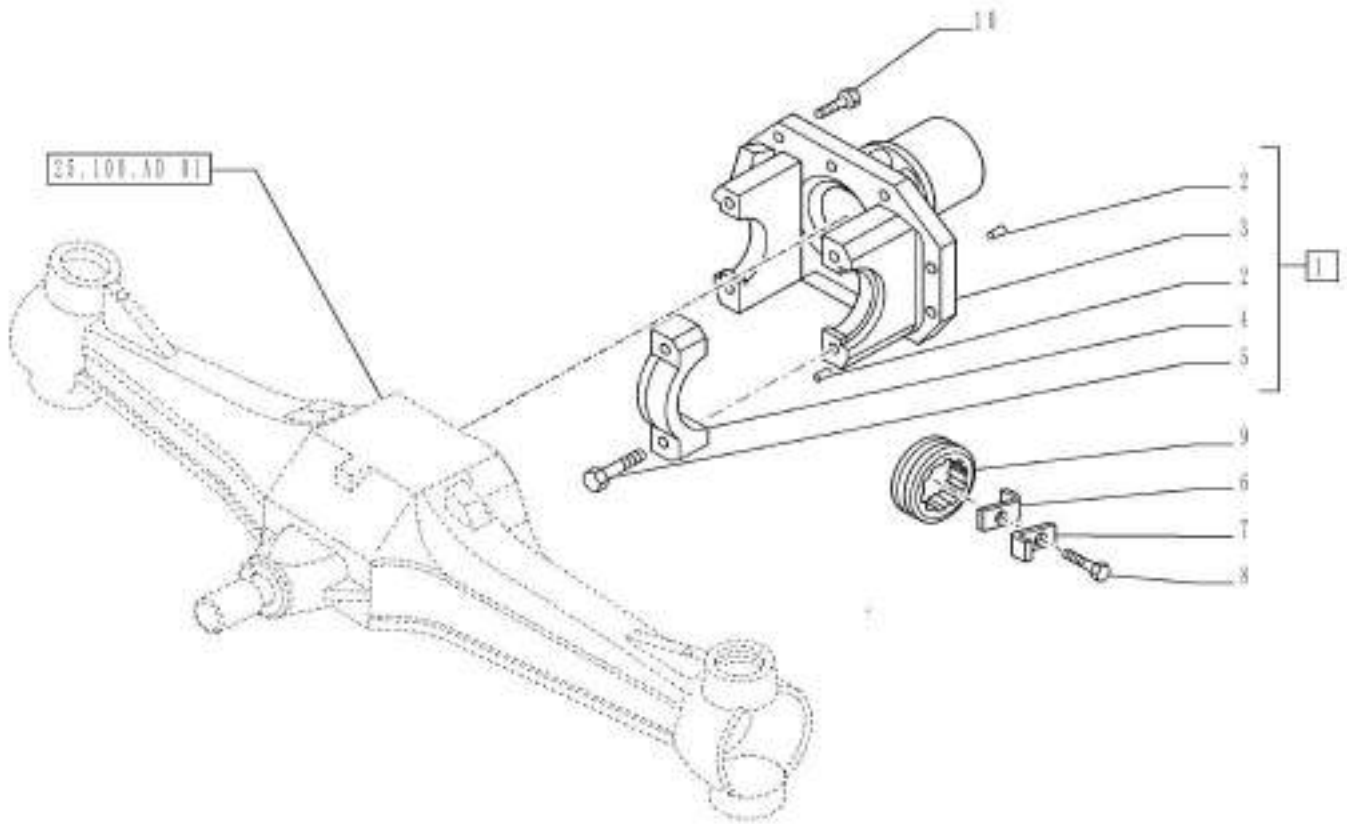

VAR - 390250 - 4WD FRONT AXLE, SUPPORT

REF FN	PART NUMBER	YR/SN	QTY DESCRIPTION
1	4998735		1 DIFFERENTIAL ASSY Incl 2 - 5
2	4966244		3 DOWEL M5 x 15
3	NSS		1 NOT SERVICED SEPARATELY Housing Incl in 1
4	NSS		2 NOT SERVICED SEPARATELY Support Incl in 1
5	14275334		4 BOLT Lock, Hex, M12 x 1.25 x 70mm, CI 10.9 M95
6	4966243		2 ADJUSTING PLATE
7	562659		2 PLATE
8	15970521		2 BOLT Hex, M10 x 1.25 x 20, 8.8, Full Thd
9	4966240		2 BEARING LOCK NUT Support Incl in 4
10	14274631		10 LOCK BOLT Hex, M12 x 1.25 x 35mm, CI 10.9 Housing Incl in 4

Valid for Var. 390250

FARMALL JX70

VAR - 335539 - 4WD FRONT AXLE, SUPPORT

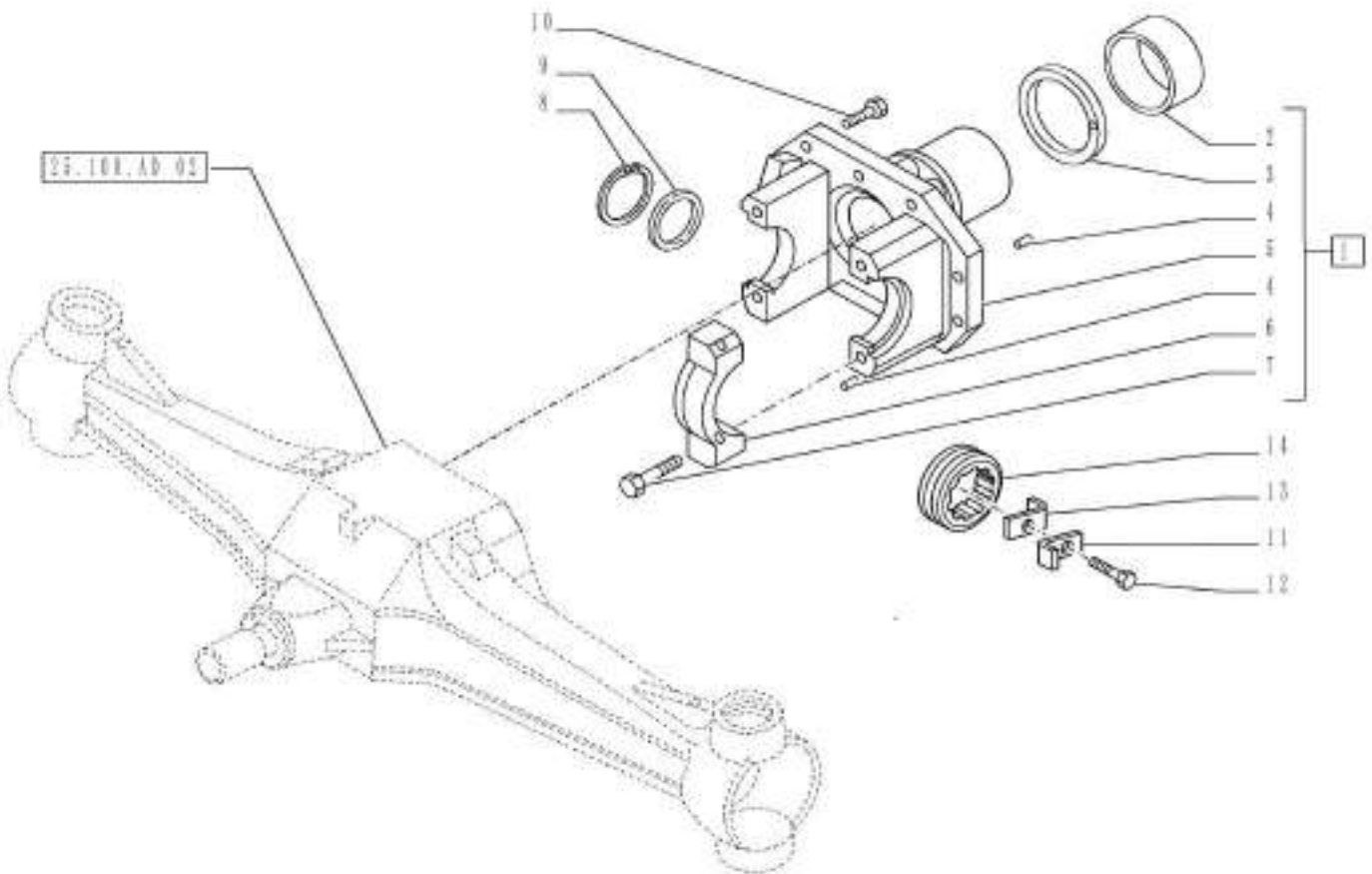

VAR - 335539 - 4WD FRONT AXLE, SUPPORT

REF FN	PART NUMBER	YR/SN	QTY DESCRIPTION
1	5153612		1 SUPPORT Incl 2 - 7
2	5136120		1 BUSHING 90.00mm x 99.00mm x 72.00mm
3	5136119		1 RING 90.0mm x 136.00mm x 5.00mm
4	4966244		3 DOWEL M5 x 15
5	5153611		1 PLATE
6	4996749		1 SUPPORT
7	14275334		2 BOLT Lock, Hex, M12 x 1.25 x 70mm, Cl 10.9
8	11062676		1 SNAP RING M95, Int
9	5141460		1 SHIM 83.00mm ID x 94.50mm OD x 0.90mm T
9	5141461		1 SHIM 83.00mm ID x 94.50mm OD x 1.00mm T
9	5141462		1 SHIM 83.00mm ID x 94.50mm OD x 1.10mm T
9	5141463		1 SHIM 83.00mm ID x 94.50mm OD x 1.20mm T
9	5141464		1 SHIM 83.00mm ID x 94.50mm OD x 1.30mm T
9	5141465		1 SHIM 83.00mm ID x 94.50mm OD x 1.40mm T
9	5141466		1 SHIM 83.00mm ID x 94.50mm OD x 1.50mm T
9	5141467		1 SHIM 83.00mm ID x 94.50mm OD x 1.60mm T
9	5141468		1 SHIM 83.00mm ID x 94.50mm OD x 1.70mm T
9	5141469		1 SHIM 83.00mm ID x 94.50mm OD x 1.80mm T M5x15
9	5141470		1 SHIM 83.00mm ID x 94.50mm OD x 1.90mm T 90x99x72
9	5141471		1 SHIM 83.00mm ID x 94.50mm OD x 2.00mm T 90x136x5
Valid for Var. 335539			FARMALL JX100 FARMALL JX110 FARMALL JX75 FARMALL JX80

VAR - 335539 - 4WD FRONT AXLE, SUPPORT

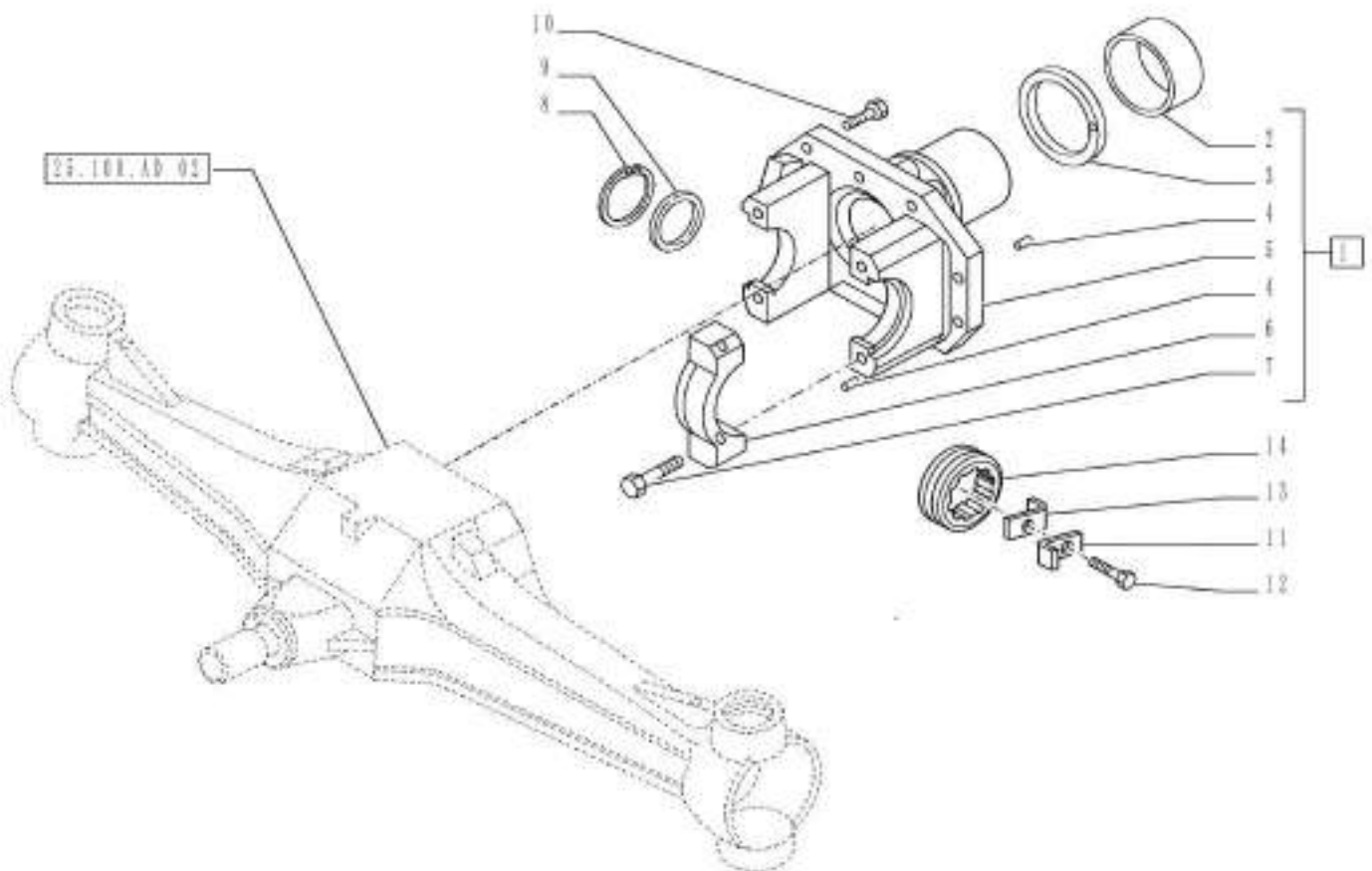

VAR - 335325 - 4WD FRONT AXLE, SUPPORT

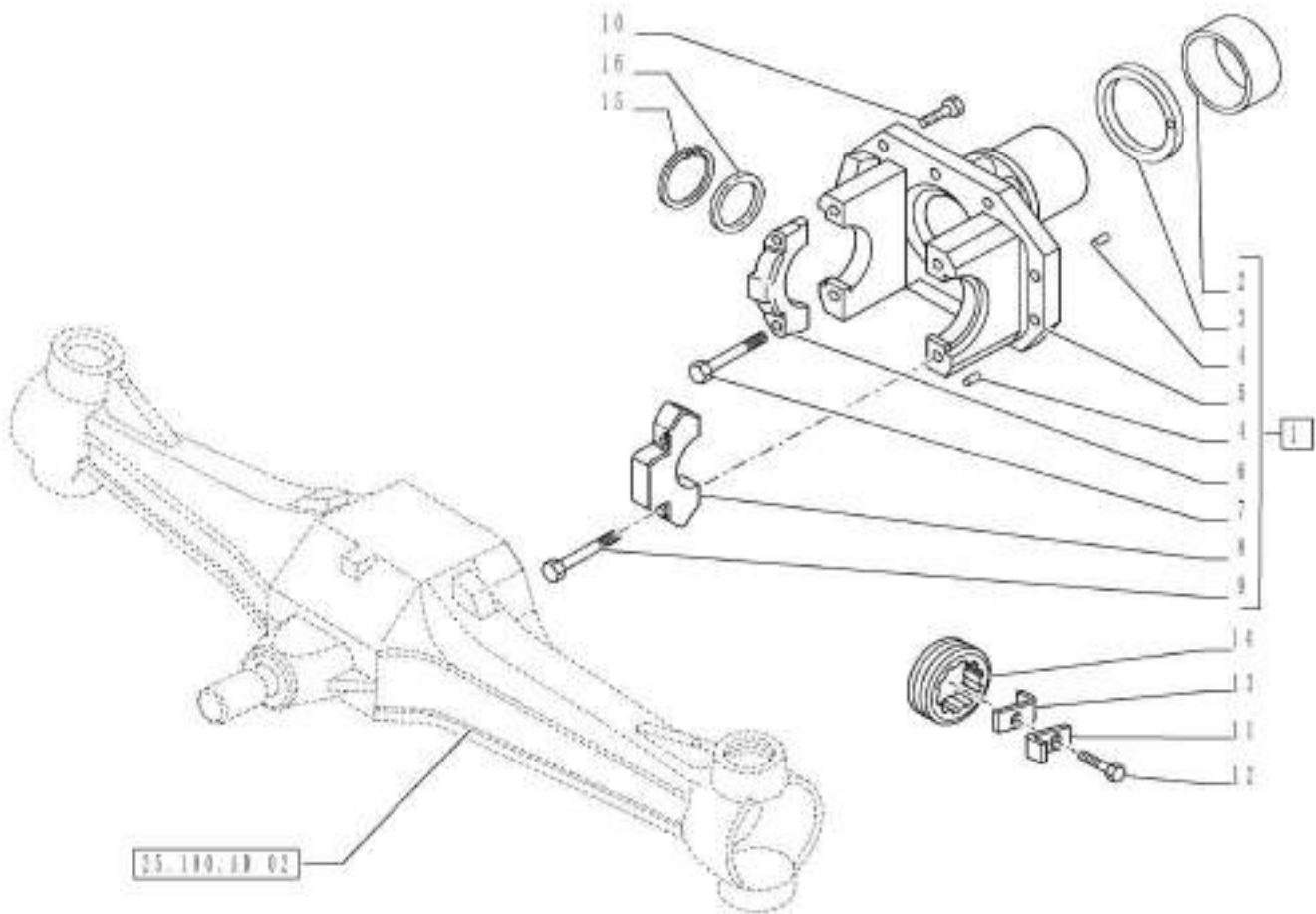

VAR - 335325 - 4WD FRONT AXLE, SUPPORT

REF FN	PART NUMBER	YR/SN	QTY DESCRIPTION
1	5153613		1 SUPPORT Incl 2 - 9
2	5136120		1 BUSHING 90.00mm x 99.00mm x 72.00mm 90x99x72
3	5136119		1 RING 90.0mm x 136.00mm x 5.00mm 90x136x5
4	4966244		3 DOWEL M5 x 15 M5x15
5	NSS		1 NOT SERVICED SEPARATELY Support, Incl in 1
6	NSS		1 NOT SERVICED SEPARATELY Keep, Incl in 1
7	14275334		2 BOLT Lock, Hex, M12 x 1.25 x 70mm, CI 10.9
8	NSS		1 NOT SERVICED SEPARATELY Keep, Incl in 1
9	14276934		2 BOLT Hex, M12 x 1.25 x 78mm, CI 10.9
10	14274631		10 LOCK BOLT Hex, M12 x 1.25 x 35mm, CI 10.9
11	562659		1 PLATE
12	15970521		1 BOLT Hex, M10 x 1.25 x 20, 8.8, Full Thd
13	4996751		1 CLIP
14	4996750		1 RING NUT
15	11062676		1 SNAP RING M95, Int
16	5141460		1 SHIM 83.00mm ID x 94.50mm OD x 0.90mm T
16	5141461		1 SHIM 83.00mm ID x 94.50mm OD x 1.00mm T
16	5141462		1 SHIM 83.00mm ID x 94.50mm OD x 1.10mm T
16	5141463		1 SHIM 83.00mm ID x 94.50mm OD x 1.20mm T
16	5141464		1 SHIM 83.00mm ID x 94.50mm OD x 1.30mm T

Valid for Var. 335325

FARMALL JX100
 FARMALL JX110
 FARMALL JX75
 FARMALL JX80

VAR - 335325 - 4WD FRONT AXLE, SUPPORT

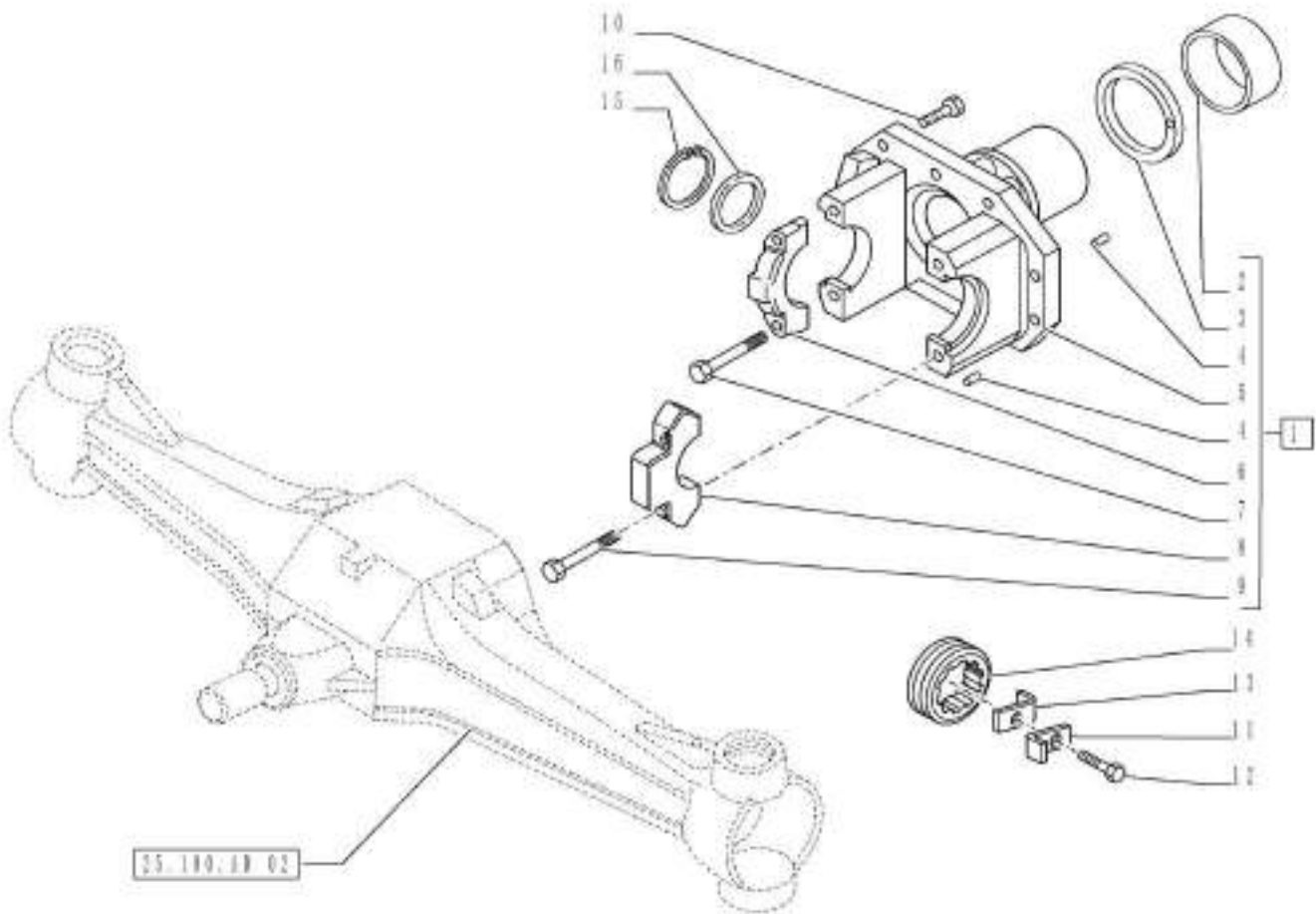

4WD FRONT AXLE - DIFFERENTIAL

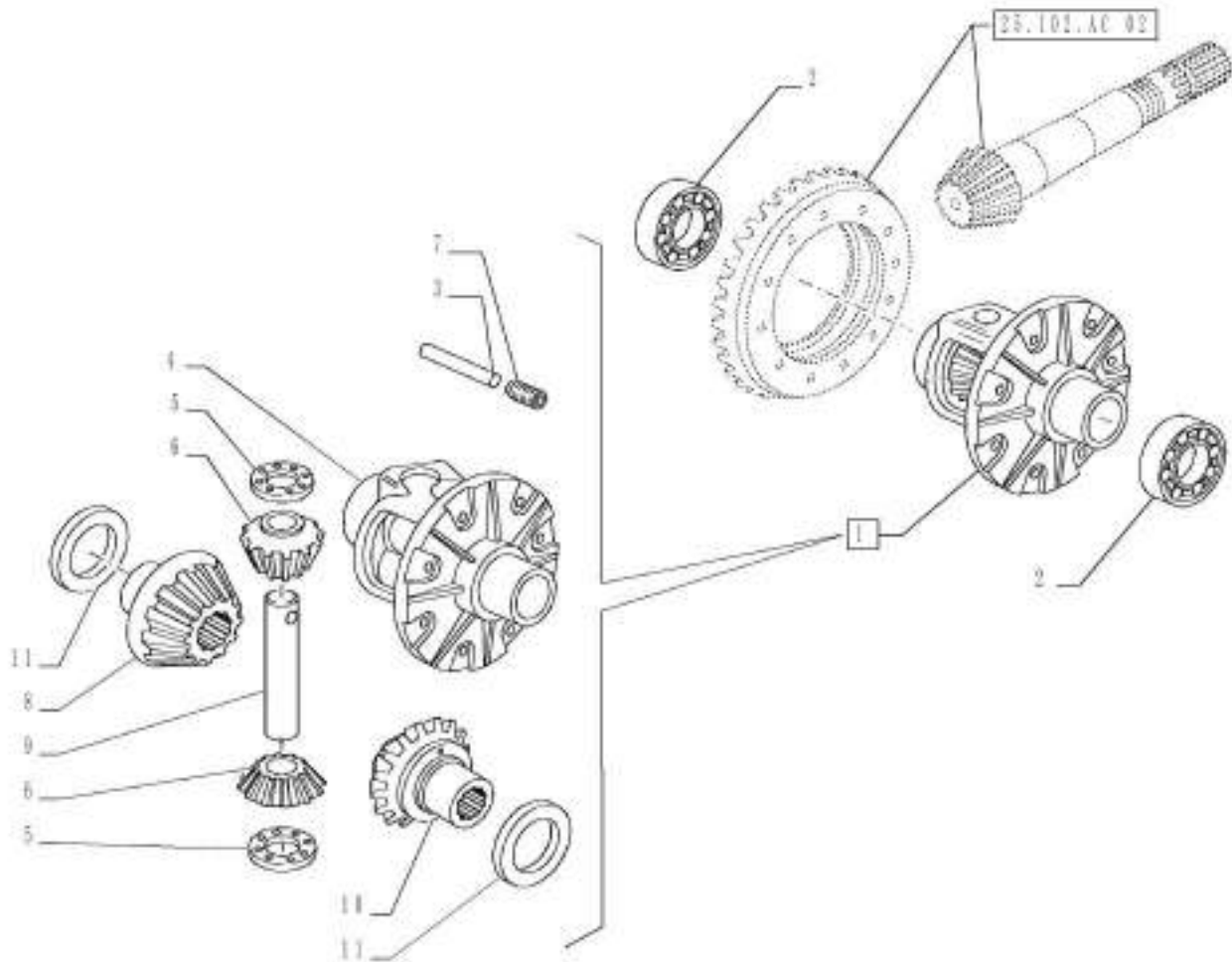

4WD FRONT AXLE - DIFFERENTIAL

REF FN	PART NUMBER	YR/SN	QTY DESCRIPTION
1	5117219		1 HOUSING ASSY, Incl 3 -11
2	24903450		2 TAPERED ROLLER BEARING 60.00mm x 95.00mm x 23.00mm
3	5173242		1 ROLL PIN
4	5174844		1 HOUSING
5	4987975		2 THRUST WASHER
6	5103870		2 PINION
7	13807870		1 SET SCREW Hex Soc, M8 x 14, Flat Pt
8	5110716		1 PLANETARY GEAR
9	5148935		1 PIN
10	5103868		1 PINION
11	5148936		AR THRUST WASHER 44.00mm ID x 66.00mm OD x 1.6mm T
11	5148937		AR THRUST WASHER 44.00mm ID x 66.00mm OD x 1.8mm T
11	5148938		AR THRUST WASHER 44.00mm ID x 66.00mm OD x 1.7mm T
11	5148939		AR THRUST WASHER 44.00mm ID x 66.00mm OD x 1.5mm T
11	5148940		AR THRUST WASHER 44.00mm ID x 66.00mm OD x 1.4mm T
11	5167387		AR THRUST WASHER 44.00mm ID x 66.00mm OD x 1.9mm T
11	5167388		AR THRUST WASHER 44.00mm ID x 66.00mm OD x 2.0mm T
11	5181356		1 THRUST WASHER 44.00mm ID x 66.00mm OD x 2.1mm T
11	5181357		1 THRUST WASHER 44.00mm ID x 66.00mm OD x 2.2mm T
11	5087993		AR SHIM 2.3mm Thk
11	5087994		AR SHIM 2.4mm Thk
11	5087995		AR SHIM 2.5mm Thk
11	5087991		AR SHIM 2.1mm Thk
11	5087992		AR SHIM 2.2mm Thk

FARMALL JX100
 FARMALL JX110
 FARMALL JX75
 FARMALL JX80

4WD FRONT AXLE - DIFFERENTIAL

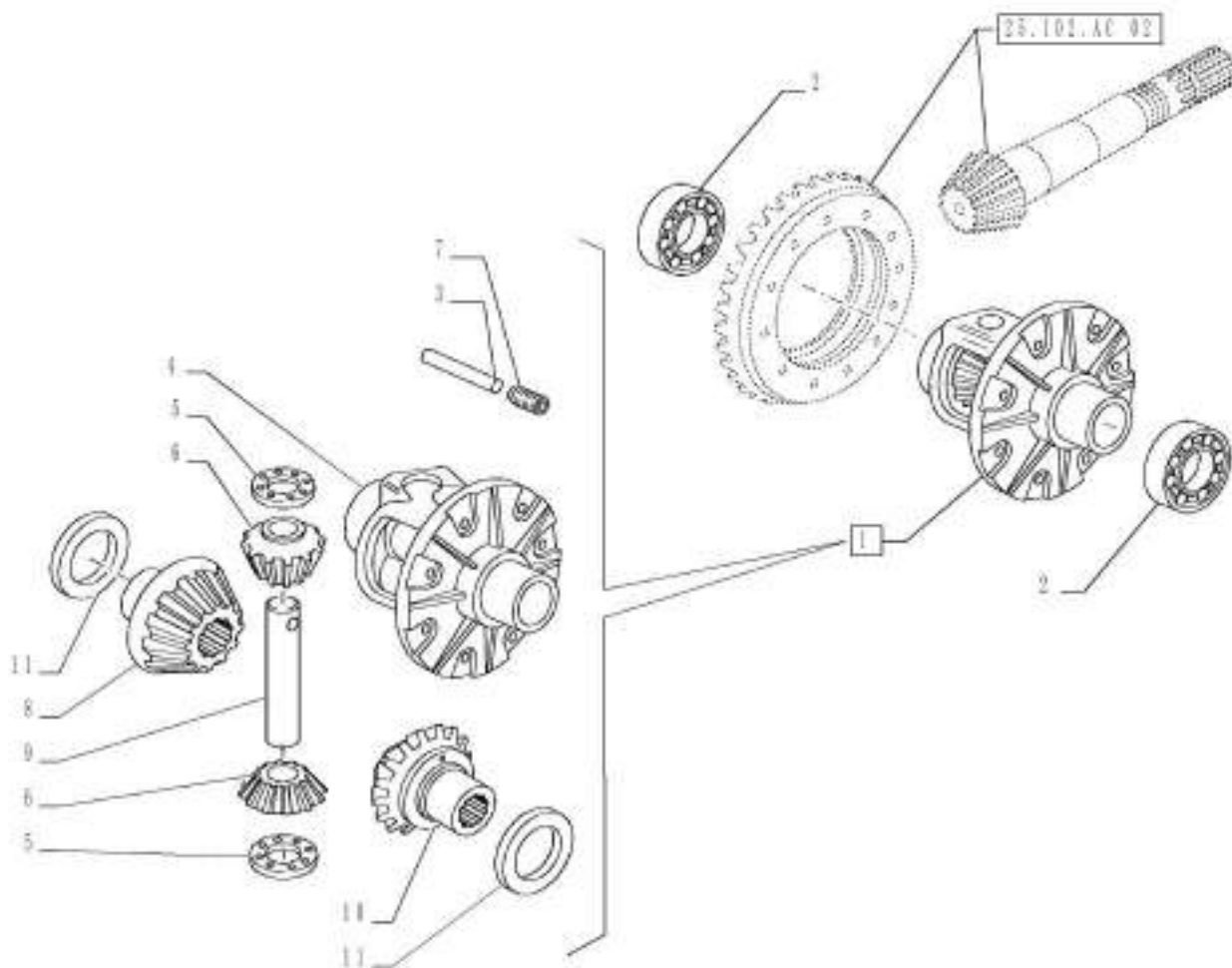

4WD FRONT AXLE - DIFFERENTIAL

REF FN	PART NUMBER	YR/SN	QTY DESCRIPTION
11	5088603		AR SHIM 1.9mm Thk
11	5088604		AR SHIM 2.0mm Thk
11	5086488		AR THRUST WASHER
			FARMALL JX100
			FARMALL JX110
			FARMALL JX75
			FARMALL JX80

4WD FRONT AXLE - DIFFERENTIAL

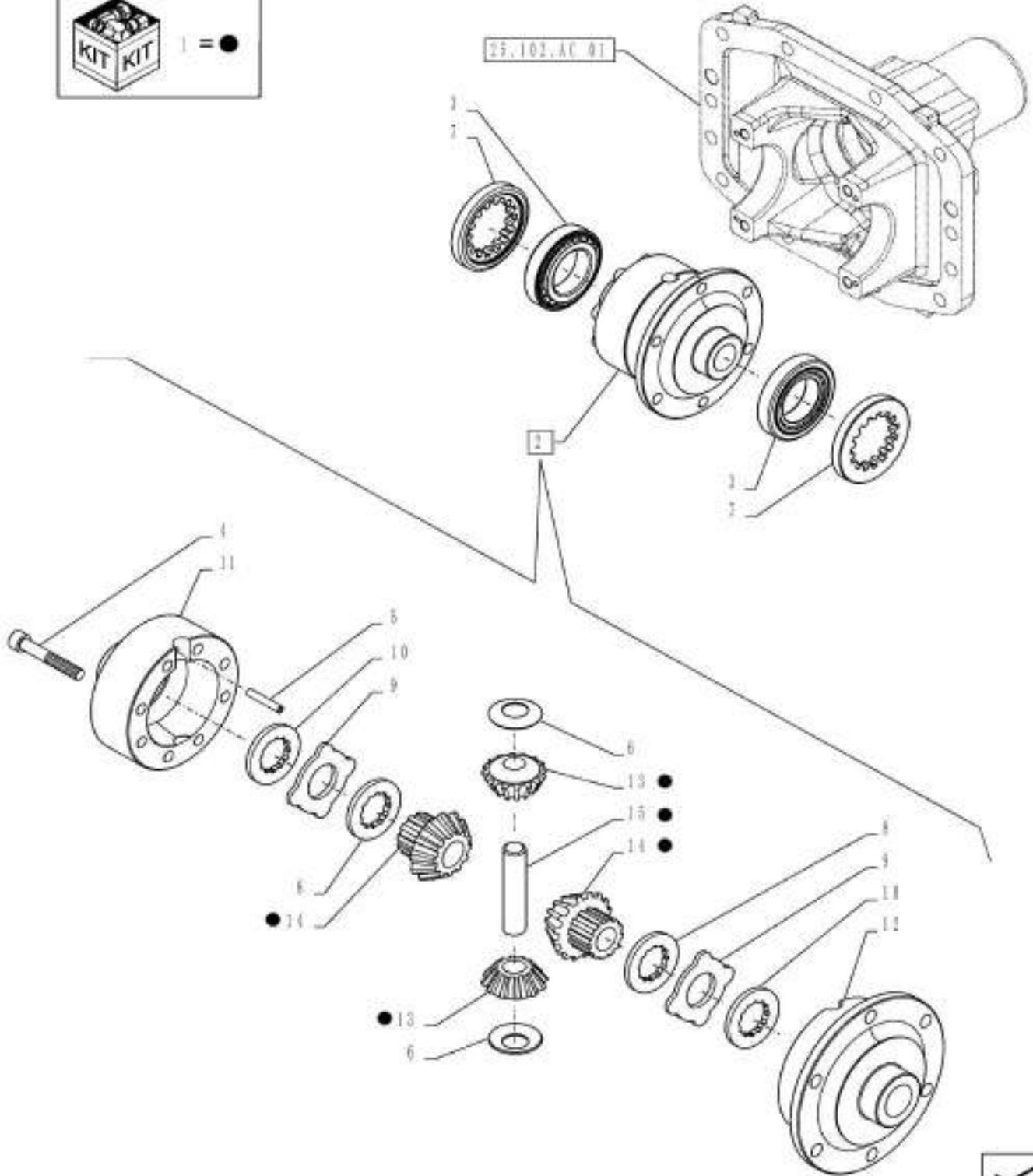

4WD FRONT AXLE - DIFFERENTIAL

REF FN	PART NUMBER	YR/SN	QTY DESCRIPTION
1	9970166		1 KIT
2	5162456		1 DIFFERENTIAL ASSY, Incl 4 - 6, 8 - 15
3	26799980		2 BEARING ASSY
4	14308221		1 HEX SOC SCREW M10 x 1.25 x 65mm, Cl 8.8
5	9966303		1 ROLL PIN
6	9966306		2 WASHER
7	4966240		2 BEARING LOCK NUT
8	9966308		2 PLATE
9	9966309		10 DRIVEN PLATE
10	9966310		8 PLATE
11	NSS		1 NOT SERVICED SEPARATELY Differential Housing, Incl in 2
12	NSS		1 NOT SERVICED SEPARATELY Differential Housing, Incl in 2
13	NSS		2 NOT SERVICED SEPARATELY Gear, Incl in 1
14	NSS		2 NOT SERVICED SEPARATELY Gear, Incl in 1
15	NSS		1 NOT SERVICED SEPARATELY Pin, Incl in 1
			FARMALL JX70

VAR - 335539 - 4WD FRONT AXLE - DIFFERENTIAL - W/LIMITED SLIP DIFFERENTIAL

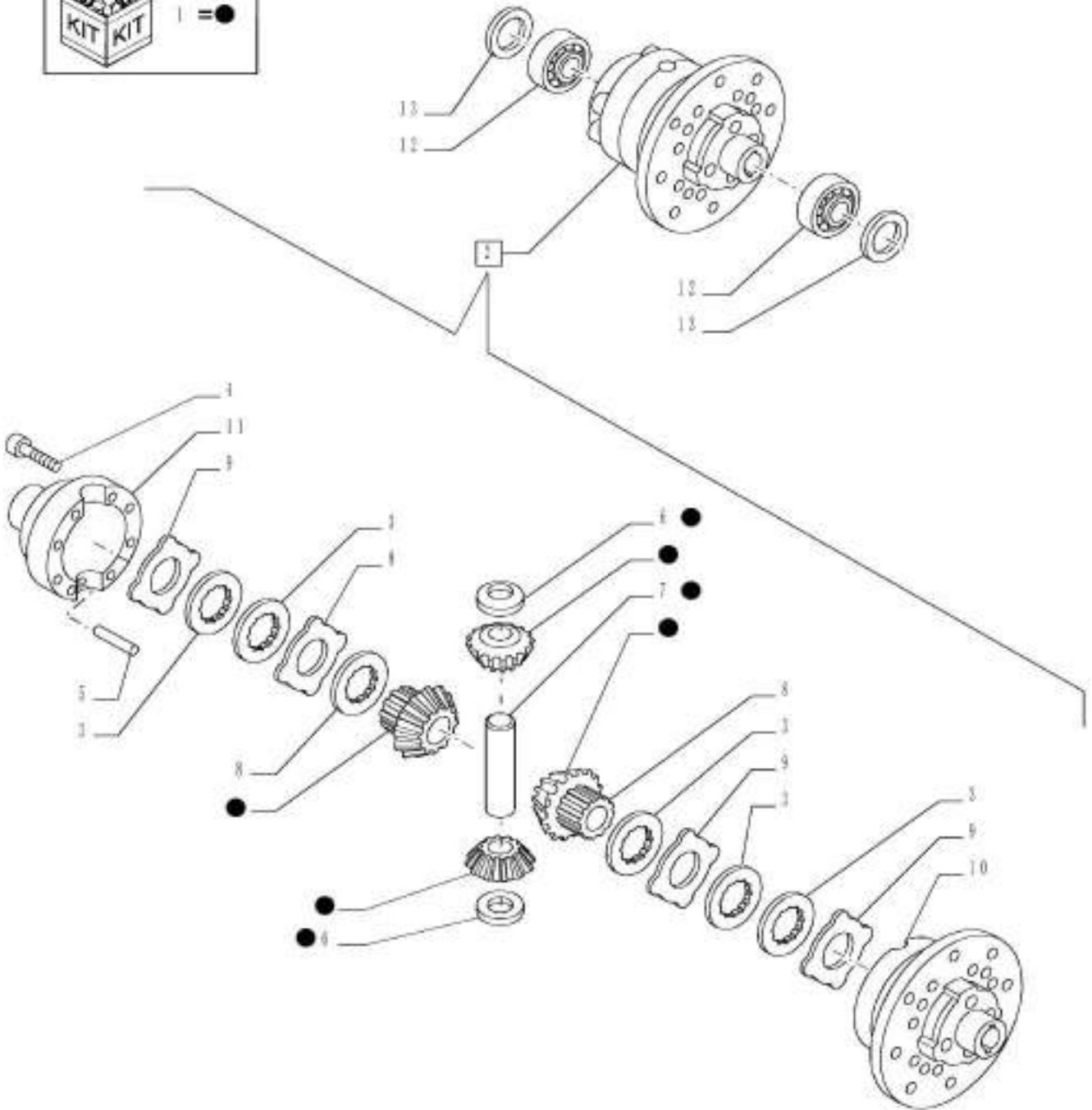
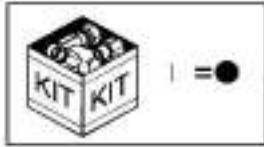

VAR - 335539 - 4WD FRONT AXLE - DIFFERENTIAL - W/LIMITED SLIP DIFFERENTIAL

REF FN	PART NUMBER	YR/SN	QTY DESCRIPTION
1	1930983		1 KIT Incl 6 - 7
2	5162583		1 DIFFERENTIAL GEAR Incl 3 - 11
3	9966310		8 PLATE
4	14421034		12 HEX SOC SCREW M10 x 70mm, Cl 10.9
5	9966356		1 ROLL PIN
6	9966352		2 THRUST WASHER
7	9966354		1 SHAFT
8	9966308		2 PLATE
9	9966309		10 DRIVEN PLATE
10	NSS		1 NOT SERVICED SEPARATELY Differential Housing Incl in 2
11	NSS		1 NOT SERVICED SEPARATELY Differential Housing Incl in 2
12	24903450		2 TAPERED ROLLER BEARING 60.00mm x 95.00mm x 23.00mm
13	5133799		2 SEAL 62 x 42 x 17

Valid for Var. 335539

FARMALL JX100
 FARMALL JX110
 FARMALL JX75
 FARMALL JX80

VAR - 335325 - 4WD FRONT AXLE, DIFFERENTIAL W/ LIMITED SLIP

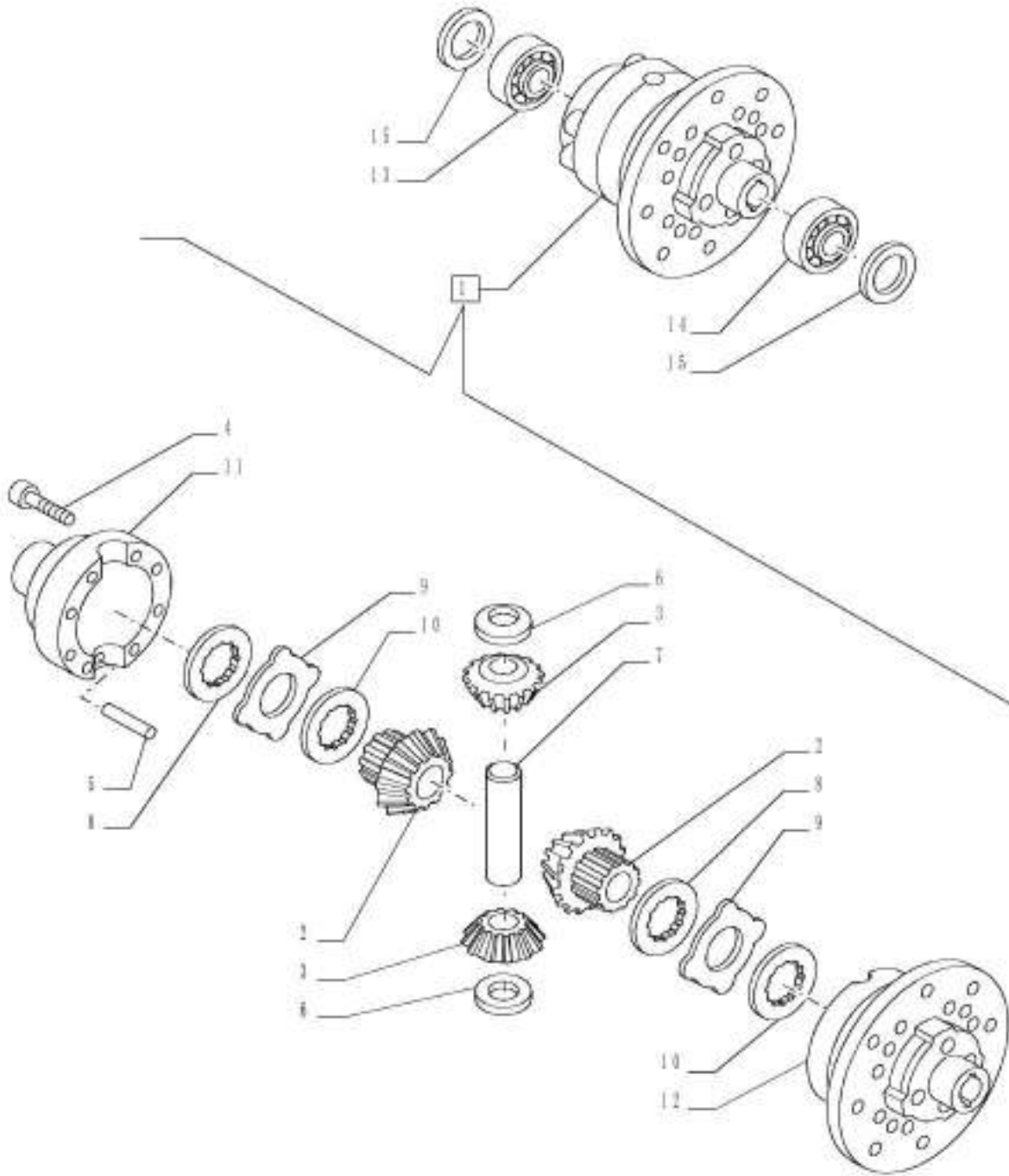

VAR - 335325 - 4WD FRONT AXLE, DIFFERENTIAL W/ LIMITED SLIP

REF FN	PART NUMBER	YR/SN	QTY DESCRIPTION
1	5163496		1 DIFFERENTIAL Incl 2 - 12
2	9966355		2 PLANETARY GEAR
3	9966353		2 IDLER PINION
4	14308124		12 HEX SOC SCREW M10 x 1.25 x 60mm, CI 8.8
5	9966356		1 ROLL PIN
6	9966352		2 THRUST WASHER
7	9966354		1 SHAFT
8	9966308		2 PLATE
9	9966309		10 DRIVEN PLATE
10	9966310		8 PLATE
11	NSS		1 NOT SERVICED SEPARATELY Differential Housing, Incl in 1
12	NSS		1 NOT SERVICED SEPARATELY Differential Housing, Incl in 1
13	24903450		1 TAPERED ROLLER BEARING 60.00mm x 95.00mm x 23.00mm 60 x 95 x 2
14	5163500		1 ROLLER BEARING 63.485 mm ID x 94.975 mm OD x 17 mm
15	5133799		2 SEAL 62 x 42 x 17
Valid for Var. 335325			FARMALL JX100 FARMALL JX110 FARMALL JX75 FARMALL JX80

4WD FRONT AXLE - AXLE-SHAFT ARTICULATED - BREAKDOWN

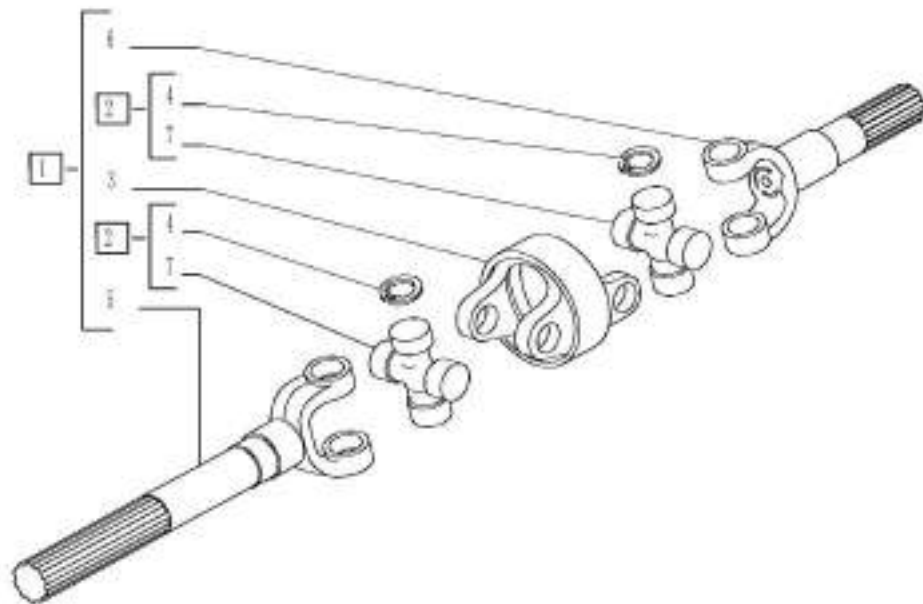

4WD FRONT AXLE - AXLE-SHAFT ARTICULATED - BREAKDOWN

REF FN	PART NUMBER	YR/SN	QTY DESCRIPTION
1	5186865		1 ARTICULATED AXLE SHAFT RH, ASSY Incl 2 - 7
1	5186867		1 ARTICULATED AXLE SHAFT LH, ASSY Incl 2 - 7
2	5191457		2 SPIDER ASSY, Incl 4, 7
3	5191460		1 YOKE
4	5191458		8 LOCKING RING
5	47131307		1 SHAFT 413 mm
5	47131305		1 SHAFT 359 mm
6	5191459		1 SHORT SHAFT 175 mm
7	NSS		1 NOT SERVICED SEPARATELY Spider Incl in 2

FARMALL JX70

4WD FRONT AXLE - AXLE-SHAFT ARTICULATED - BREAKDOWN

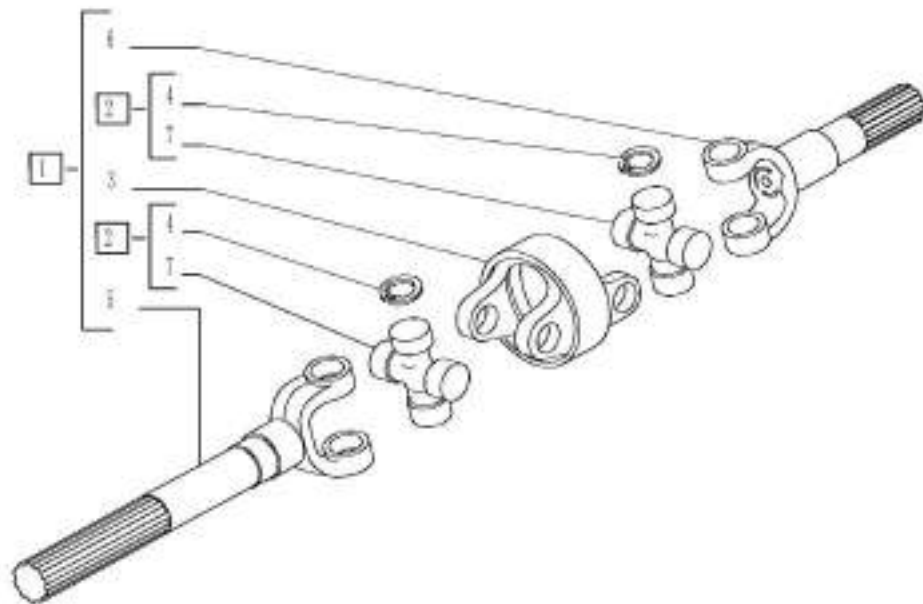

4WD FRONT AXLE - AXLE-SHAFT ARTICULATED - BREAKDOWN

REF FN	PART NUMBER	YR/SN	QTY DESCRIPTION
1	5166549		1 ARTICULATED AXLE SHAFT RH, Incl 2 - 7
1	5166562		1 ARTICULATED AXLE SHAFT LH, Incl 2 - 7
2	5191547		4 U-JOINT SPIDER Incl 4, 7
3	87361042		2 YOKE
4	5191548		16 CIRCLIP
5	5191589		1 SHAFT
5	5191562		1 SHAFT
6	5191561		1 SHAFT
6	5191559		1 SHAFT
7	NSS		1 NOT SERVICED SEPARATELY Spider Incl in 2
			FARMALL JX100 FARMALL JX110 FARMALL JX75 FARMALL JX80

4WD FRONT AXLE - DIFFERENTIAL GEARS AND DIFFERENTIAL SHAFT

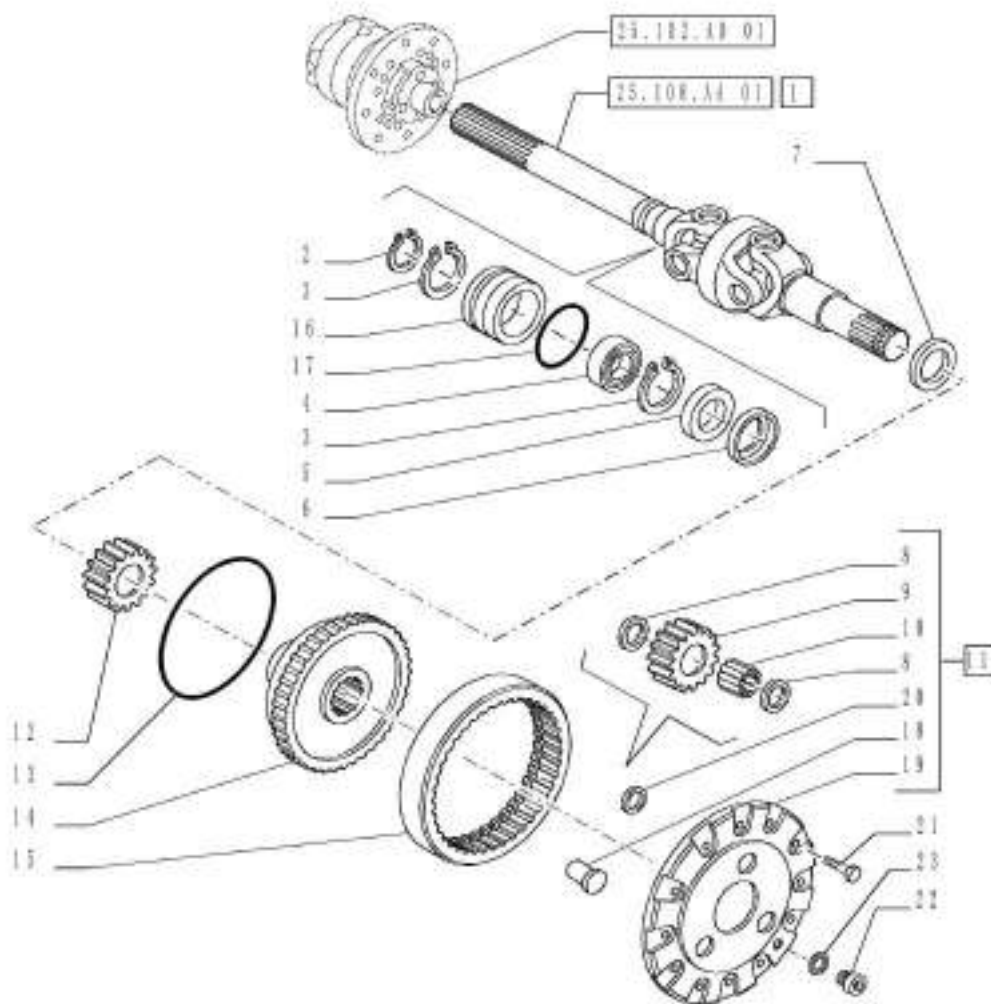

4WD FRONT AXLE - DIFFERENTIAL GEARS AND DIFFERENTIAL SHAFT

REF FN	PART NUMBER	YR/SN	QTY DESCRIPTION
1	5186865		1 ARTICULATED AXLE SHAFT RH
1	5186867		1 ARTICULATED AXLE SHAFT LH
2	11067876		2 SNAP RING M30, Ext
3	11060676		4 CIRCLIP M55, Int
4	28042460		2 BALL BEARING
5	5116701		2 SEAL M35 x 55 x 11 Thk
6	4997436		2 RETAINER
7	5135386		2 SEAL
8	5100513		6 WASHER
9	5100509		3 PLANETARY GEAR
10	5103755		3 ROLLER BEARING 22.4 mm ID x 32.4 mm OD x 25.8 mm
11	5143847		2 SUPPORT ASSY, Incl 8 - 10, 18 - 20
12	5116664		2 GEAR
13	5100512		2 CIRCLIP
14	5132810		2 GEAR
15	5100507		2 RING GEAR
16	87371275		2 HOUSING
17	84480076		1 O-RING
18	5100511		3 PIN
19	NSS		2 NOT SERVICED SEPARATELY Plate Incl in 11
20	5143849		1 BUSHING
21	14233634		20 LOCK BOLT Hex, M10 x 1.25 x 30mm, CI 10.9, Full Thd
22	10305111		2 PLUG M22 x 1.5 x 21, CI5.8
23	10263460		2 SEAL 22.30mm ID x 28.00mm OD, 1.50mm, Copper

FARMALL JX70

VAR - 335325, 335539 - 4WD FRONT AXLE - DIFFERENTIAL GEARS AND DIFFERENTIAL SHAFT

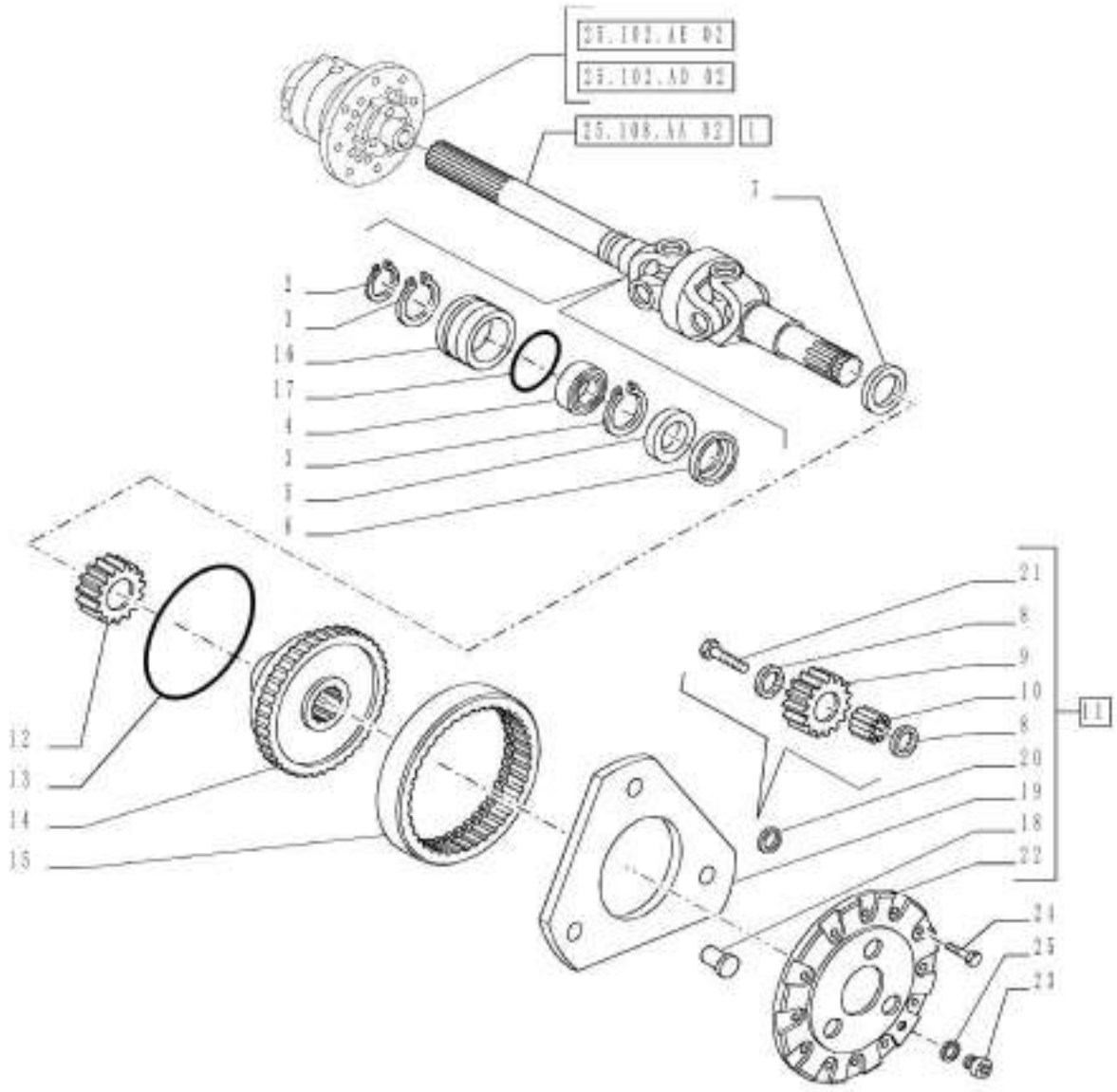

25.108.AB

02

p1

1/2014

VAR - 335325, 335539 - 4WD FRONT AXLE - DIFFERENTIAL GEARS AND DIFFERENTIAL SHAFT

REF	FN	PART NUMBER	YR/SN	QTY	DESCRIPTION
1	1	5164345		1	ARTICULATED AXLE SHAFT RH, ASSY
1	1	5164342		1	ARTICULATED AXLE SHAFT LH, ASSY
1		5166549		1	ARTICULATED AXLE SHAFT
1		5166562		1	ARTICULATED AXLE SHAFT
2		11068376		2	SNAP RING M35, Ext x 1.5 Thk
3		11061076		4	SNAP RING M62, Int
4		28042470		2	BALL BEARING 35 x 62 x 14
5		87350856		2	SEAL 40.00mm ID x 62.00mm OD x 10.00mm 40x62x10
6		4996762		2	RETAINER
7		5133799		2	SEAL 62x42x17
8		5145499		12	THRUST WASHER
9		87303252		6	PLANETARY GEAR
10		5145492		6	ROLLER BEARING 30.30mm x 40.30mm x 29.80mm
11		87303291		2	CARRIER ASSY Incl 8 - 10, 18 - 22
12		5137107		2	PLANETARY GEAR
13		4997571		2	CIRCLIP
14		5142047		2	SUPPORT
15		5108749		2	RING GEAR
16		87371268		1	BUSHING
17		4966231		1	O-RING 80mm ID x 2.62mm Width
18		87304540		6	PIN 30.30mm, 31.00mm OD x 68.00mm 68mm l.
19		47137794		2	RING
20		5140018		4	SNAP RING M30, Ext
21		14274424		3	LOCK BOLT Hex, M12 x 1.25 x 25mm, Cl 8.8, Full Thd
22		87312520		2	SUPPORT
23		10305111		2	PLUG M22 x 1.5 x 21, Cl 5.8
24		14233734		24	BOLT Hex, M10 x 1.25 x 35mm, Cl 10.9, Full Thd

(1) VAR - 335325, 335539

Valid for Var. 335325 or Var. 335539

FARMALL JX100
 FARMALL JX110
 FARMALL JX75
 FARMALL JX80

VAR - 335325, 335539 - 4WD FRONT AXLE - DIFFERENTIAL GEARS AND DIFFERENTIAL SHAFT

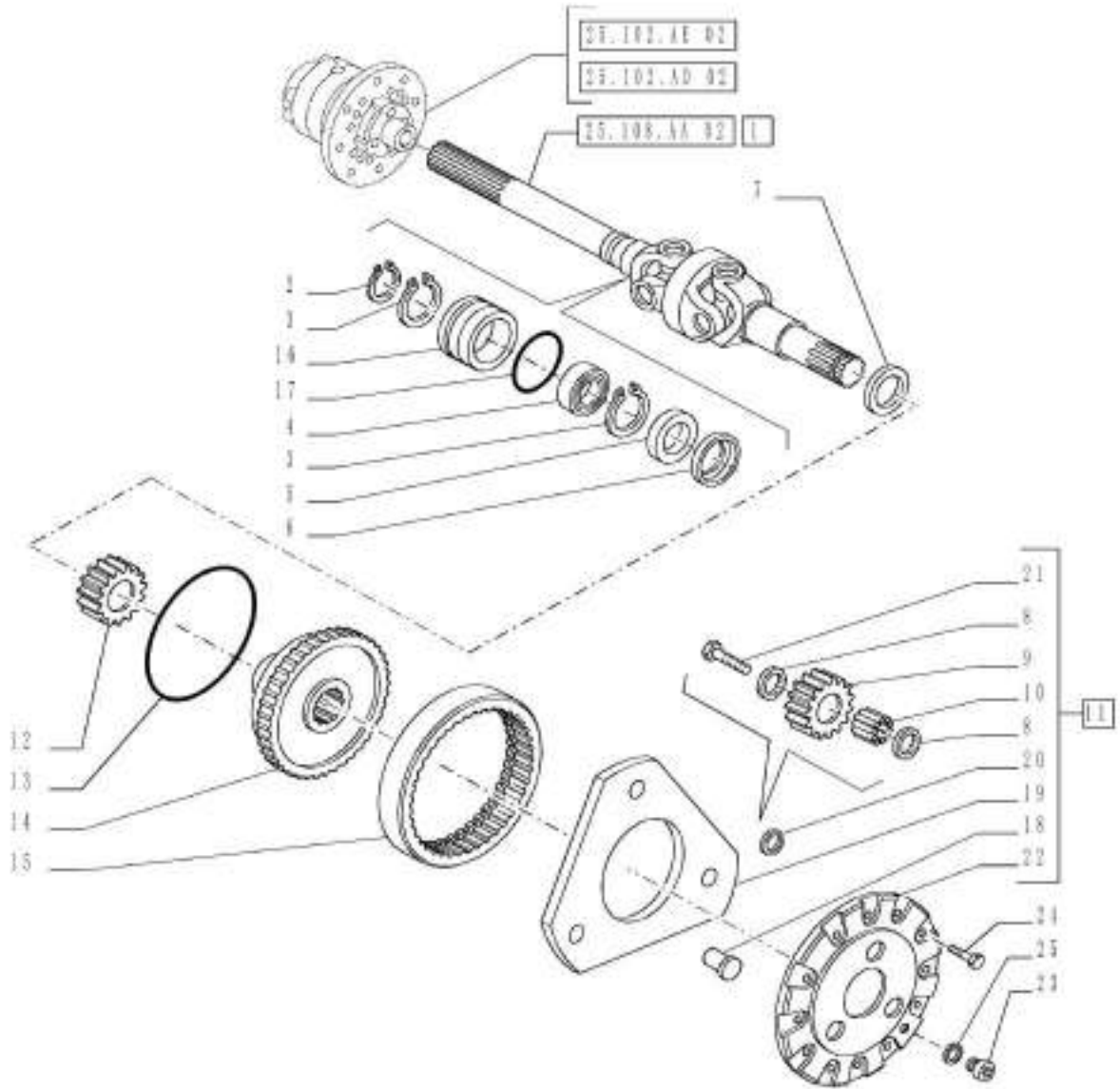

25.108.AB

02

p2

1/2014

VAR - 335325, 335539 - 4WD FRONT AXLE - DIFFERENTIAL GEARS AND DIFFERENTIAL SHAFT

REF FN	PART NUMBER	YR/SN	QTY DESCRIPTION
25	10263460		2 SEAL 22.30mm ID x 28.00mm OD, 1.50mm, Copper

Valid for Var. 335325 or Var. 335539

FARMALL JX100
FARMALL JX110
FARMALL JX75
FARMALL JX80

4WD FRONT AXLE - STEERING KNUCKLES

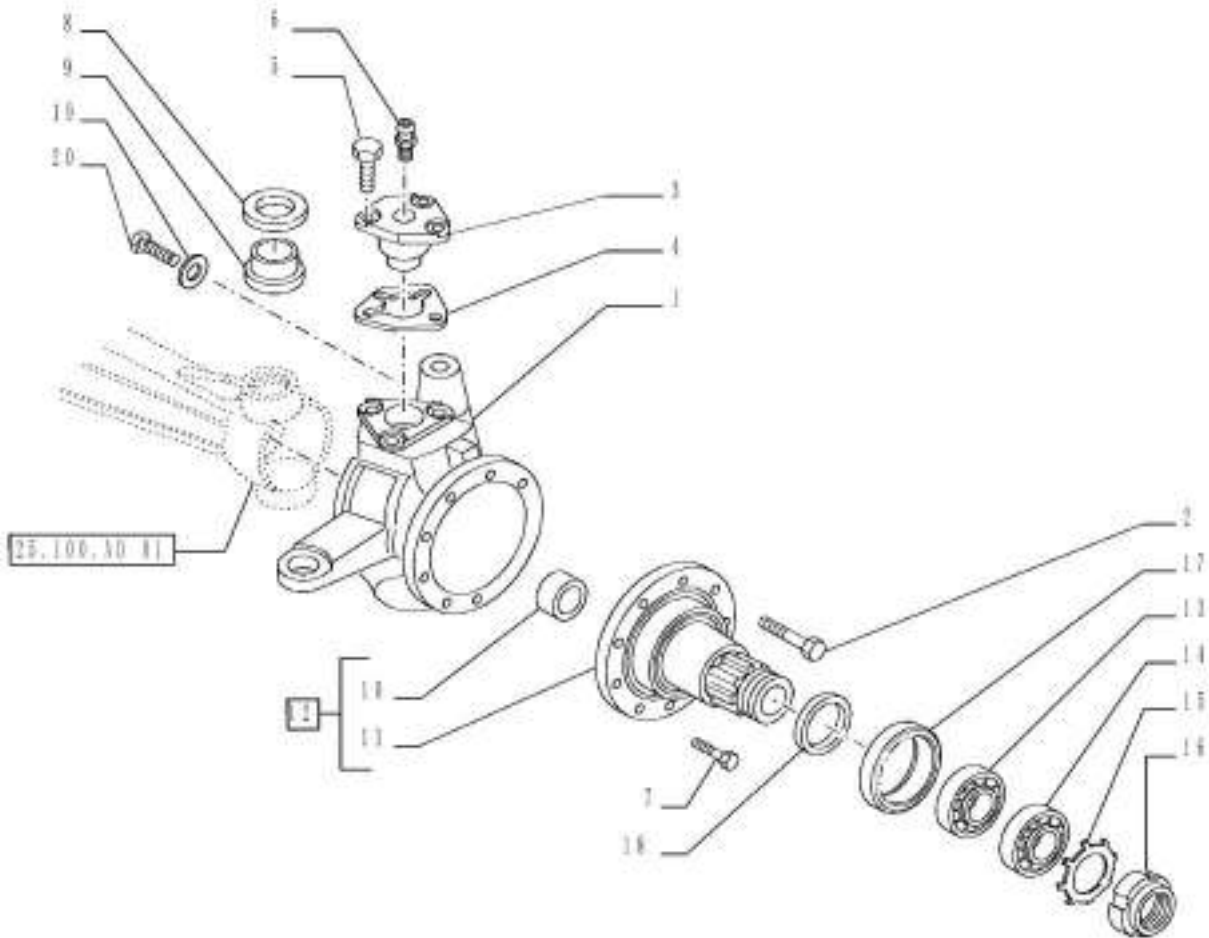

4WD FRONT AXLE - STEERING KNUCKLES

REF FN	PART NUMBER	YR/SN	QTY DESCRIPTION
1	5126626		1 STEERING KNUCKLE LH
1	5126627		1 STEERING KNUCKLE RH
2	14274434		8 LOCK BOLT Hex, M12 x 1.25 x 25mm, CI 10.9, Full Thd LH Incl 12, 16
3	5122540		4 PIN
4	5100793		AR SHIM .30mm Thk
4	5100789		AR SHIM .10mm Thk
4	5100790		AR SHIM .15mm Thk
4	5100792		AR SHIM .25mm Thk
4	5100791		AR SHIM .20mm Thk
5	14233431		12 BOLT Hex, M10 x 1.25 x 25mm, CI 10.9, Full Thd
6	5120532		4 LUBE NIPPLE Straight, M14 x 1.5 x 6.50mm
7	14274534		12 LOCK BOLT Hex, M12 x 1.25 x 30mm, CI 10.9, Full Thd
8	5122548		4 SEAL 0.20MM
9	24903780		4 TAPERED ROLLER BEARING 30 mm ID x 55 mm OD x 17 mm 0.30MM
10	5135385		2 BUSHING
11	NSS		1 NOT SERVICED SEPARATELY Shaft Incl in 12
12	5126631		2 SHAFT ASSY Incl 10, 11
13	24903450		2 TAPERED ROLLER BEARING 60.00mm x 95.00mm x 23.00mm
14	24903460		2 TAPERED ROLLER BEARING 65 mm ID x 100 mm OD x 23 mm
15	5116725		2 LOCK WASHER 42x46x28
16	5124794		2 RING NUT 165 x 190 x 15.5-17
17	5135387		2 OIL SEAL 95 x 135 x 20
18	5119545		2 WASHER Incl in 1
19	5166180		2 SPACER
20	5126628		2 SCREW

FARMALL JX70

VAR - 335325, 335539 - 4WD FRONT AXLE, STEERING KNUCKLE

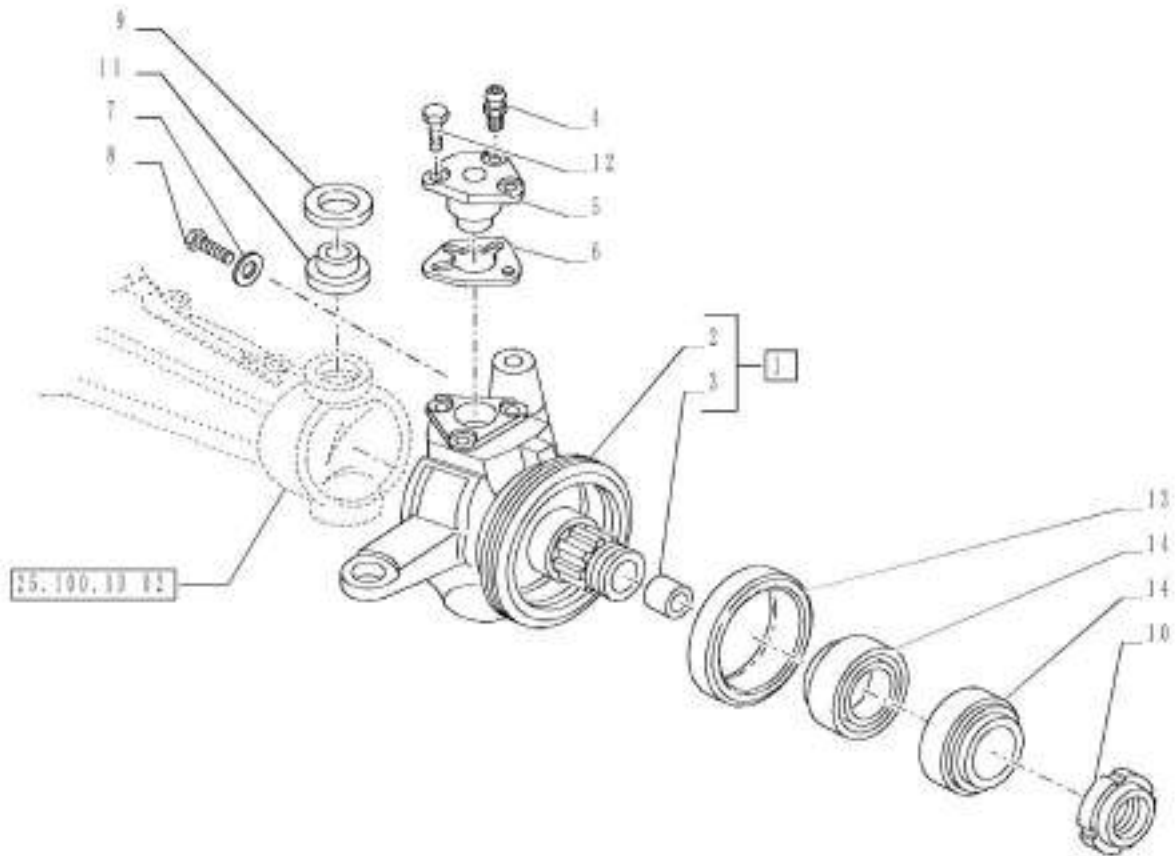

VAR - 335325, 335539 - 4WD FRONT AXLE, STEERING KNUCKLE

REF	FN	PART NUMBER	YR/SN	QTY	DESCRIPTION
1	1	5171553		1	KNUCKLE RH Incl 2 - 3
1	1	5171552		1	STUB AXLE/STRG. SPINDLE LH Incl 2 - 3
1	2	5142231		1	STUB AXLE/STRG. SPINDLE RH Incl 2 - 3
1	2	5142229		1	STUB AXLE/STRG. SPINDLE LH Incl 2 - 3
2		NSS		1	NOT SERVICED SEPARATELY Knuckle Incl in 1
3		87525550		2	BUSHING 42.00mm x 46.00mm x 28.00mm
4		5120532		4	LUBE NIPPLE Straight, M14 x 1.5 x 6.50mm
5		5137239		4	BALL STUD
6		5137456		1	SHIM 0.10mm T
6		5137457		1	SHIM 0.15mm T
6		5137458		1	SHIM 0.20mm T 0.20MM
6		5137460		1	SHIM 0.30mm T 0.30MM
6		5137459		1	SHIM 0.25mm T
7	2	5148495		2	SPACER
7	1	10717624		2	THIN NUT Thin, M18 x 2.5, CI 05
8	1	5126628		2	SCREW
8	2	84357510		2	SCREW
9		5121471		4	SEAL 70x56x7.5
10		5142020		2	NUT
11		5119699		4	BALL JOINT
12		14274531		12	BOLT Hex, M12 x 1.25 x 30mm, CI 10.9 42x46x28
13		87309584		2	OIL SEAL 165.00mm x 190.00mm x 15.50 - 16.50mm T 165 x 190 x 15.5-17
14		5136951		4	TAPERED ROLLER BEARING 95.00mm x 135.00mm x 20.00mm 95 x 135 x 20
(1)		VAR - 335539			
(2)		VAR - 335325			

Valid for Var. 335325 or Var. 335539

FARMALL JX100
 FARMALL JX110
 FARMALL JX75
 FARMALL JX80

25.108.AN

01

p1

1/2014

VAR - 390250 - 4WD FRONT AXLE, HUB

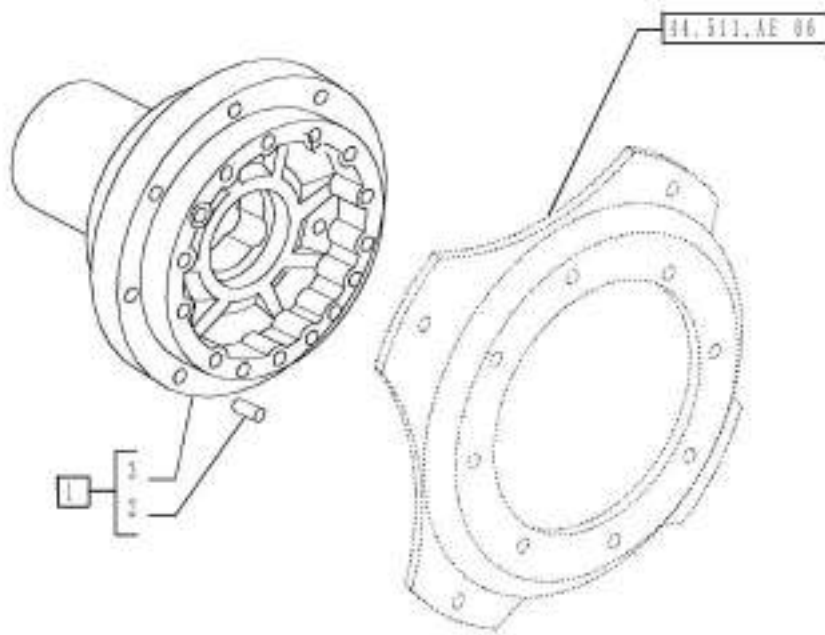

25.108.AN

01

p1

1/2014

VAR - 390250 - 4WD FRONT AXLE, HUB

REF FN	PART NUMBER	YR/SN	QTY DESCRIPTION
1	5181488		2 HUB Incl 2 - 3
2	4988170		4 DOWEL
3	NSS		1 NOT SERVICED SEPARATELY Hub Incl in 1

Valid for Var. 390250

FARMALL JX70

VAR - 335325, 335539 - 4WD FRONT AXLE, HUB

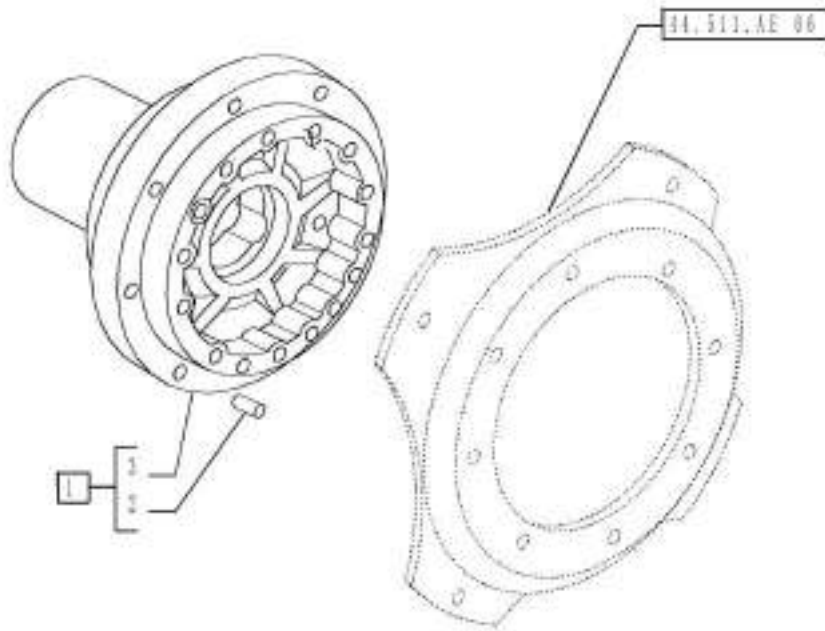

25.108.AN

02

p1

1/2014

VAR - 335325, 335539 - 4WD FRONT AXLE, HUB

REF FN	PART NUMBER	YR/SN	QTY DESCRIPTION
1	87341361		2 HUB Incl 2 - 3
2	4985063		2 DOWEL
3	NSS		1 NOT SERVICED SEPARATELY Hub Incl in 1

Valid for Var. 335325 or Var. 335539

FARMALL JX100
FARMALL JX110
FARMALL JX75
FARMALL JX80

25.400.AH

01

p1

1/2014

VAR - 338860, 390860 - 2WD FRONT AXLE - HUB

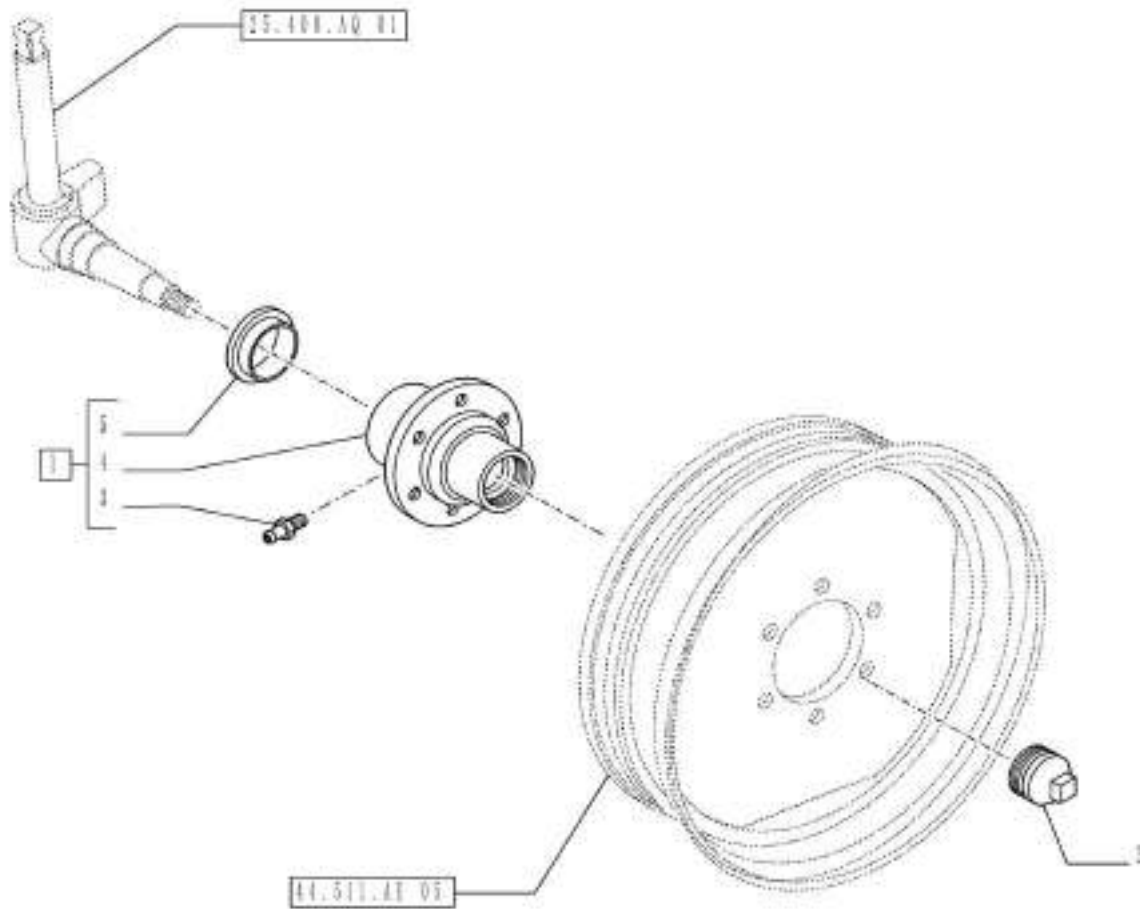

25.400.AH

01

p1

1/2014

VAR - 338860, 390860 - 2WD FRONT AXLE - HUB

REF FN	PART NUMBER	YR/SN	QTY DESCRIPTION
1	5090496		2 HUB ASSY Incl 3 - 5
2	4957312		2 HUB CAP
3	13407211		2 LUBE NIPPLE M10 x 1
4	5090500		2 HUB
5	5090134		2 SLEEVE

Valid for Var. 338860 or Var. 390860

FARMALL JX100
FARMALL JX70
FARMALL JX75
FARMALL JX80

VAR - 334413, 390338, 743515 - 2WD FRONT AXLE

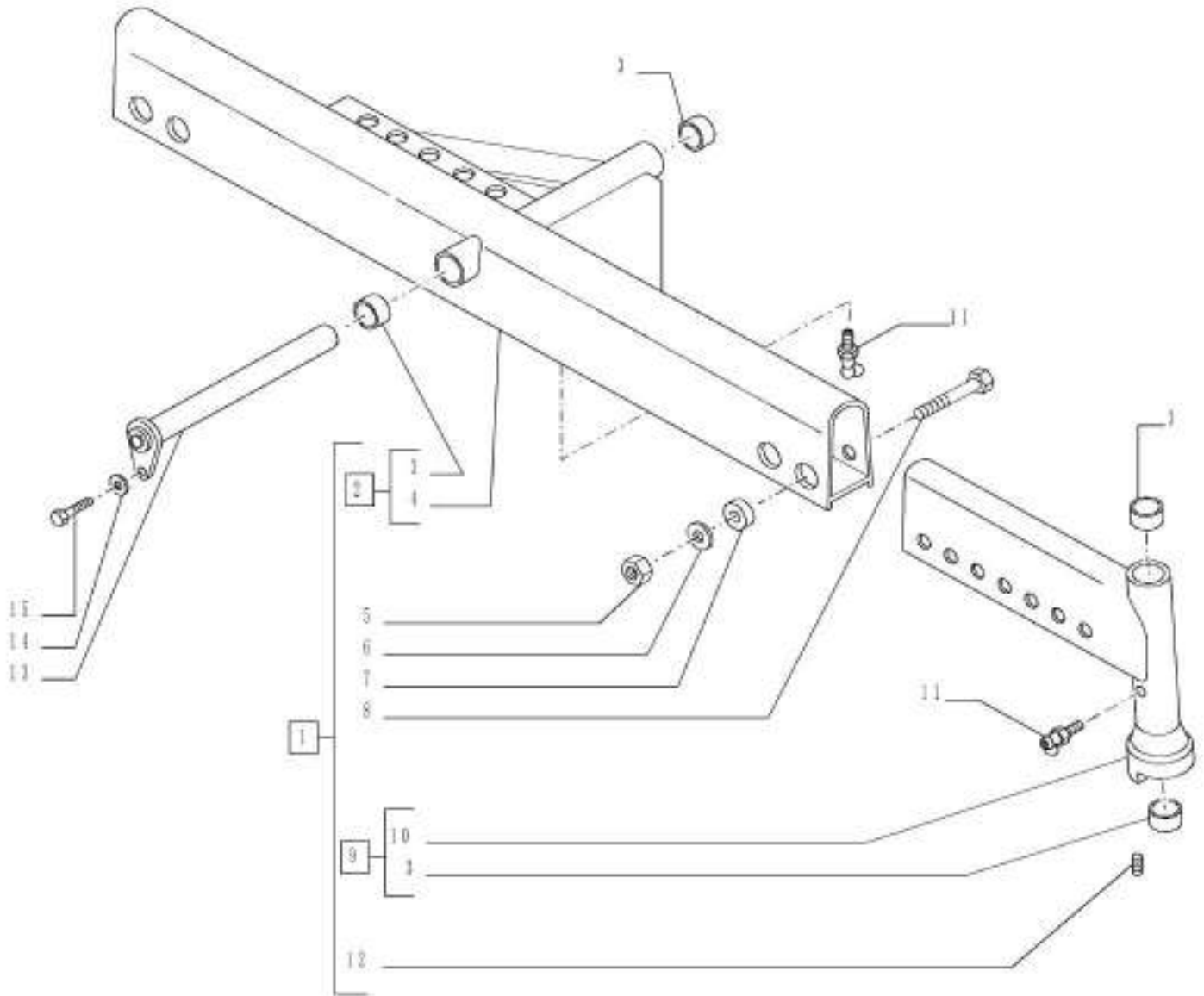

VAR - 334413, 390338, 743515 - 2WD FRONT AXLE

REF	FN	PART NUMBER	YR/SN	QTY	DESCRIPTION
1	1	5087803		1	FRONT AXLE ASSY Incl 2 - 10, 12
1	2	5086618		1	FRONT AXLE ASSY Incl 2 - 10, 12
2		5086777		1	FRONT AXLE
3		5115850		6	BUSHING
4		5086616		1	FRONT AXLE
5		12164121		4	NUT M16 x 1.5, CI 10
6		12601774		4	WAVE WASHER 17mm ID x 30mm OD x 1.60mm, 6.30mm Max, CST, DAC M16
7		5104245		4	SPACER
8		15981821		4	SCREW Hex, M16 x 1.5 x 120mm, CI 8.8
9	1	5085384		2	END Incl 3, 10
9	2	5085387		2	AXLE Incl 3, 10
10	1	5085262		2	TRACK ROD END ASSY
10	2	5085273		2	AXLE
11		13408411		3	LUBE NIPPLE 90°, M10 x1
12		10839510		2	DOWEL M6 x 9
13		5110400		1	PIVOT PIN
14		12601474		1	WAVE WASHER Wave, 10.50mm ID x 21.00mm OD x 0.80mm, 3.00mm, CST, DAC
15		15970521		1	BOLT Hex, M10 x 1.25 x 20, 8.8, Full Thd

(1) Valid for FARMALL JX70 Model Only

(2) Valid for FARMALL JX75, 80, 90,100 Models Only

Valid for Industrial Var. 334413, 390338 (743515)

FARMALL JX100
 FARMALL JX70
 FARMALL JX75
 FARMALL JX80

VAR - 334413, 390860, 743515 - 2WD FRONT AXLE, STEERING KNUCKLE

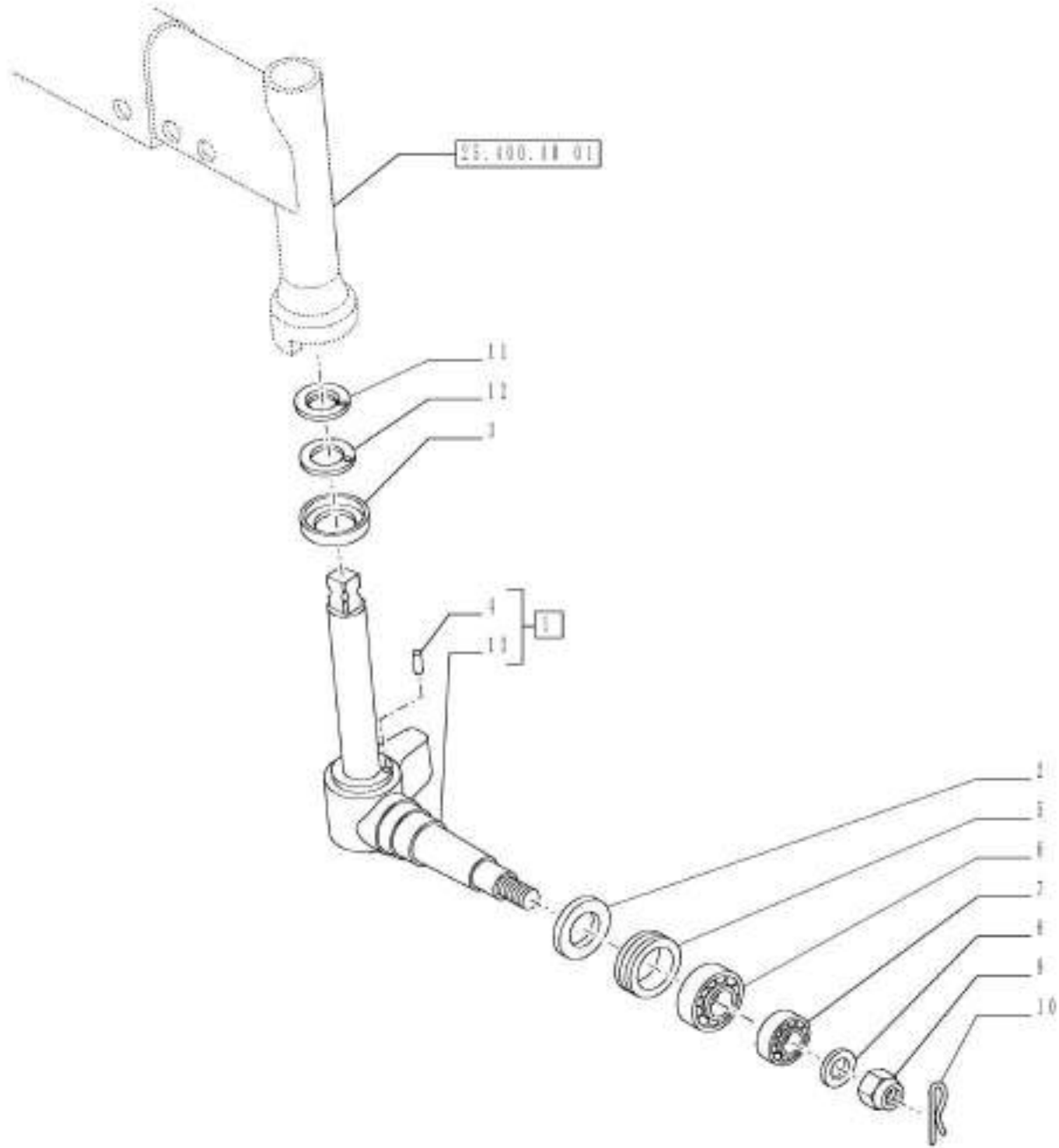

VAR - 334413, 390860, 743515 - 2WD FRONT AXLE, STEERING KNUCKLE

REF	FN	PART NUMBER	YR/SN	QTY	DESCRIPTION
1	1	5090324		1	STUB AXLE/STRG. SPINDLE RH, ASSY Incl 4, 13
1	1	5090325		1	STUB AXLE/STRG. SPINDLE LH, ASSY Incl 4, 13
1	2	5090851		1	STUB AXLE/STRG. SPINDLE
1	2	5090850		1	STUB AXLE/STRG. SPINDLE
2		5090133		2	SEALING RING
3		566125		2	CUP
4		10839510		2	DOWEL M6 x 9
5		5090135		2	SEAL
6		5132342		2	TAPERED ROLLER BEARING 41.275 x 73.431 x 19.558
7		5132343		2	TAPERED ROLLER BEARING 25.4 x 57.15 x 19.4
8		5086901		2	WASHER
9		10724720		2	SLOTTED NUT M20 x 1.5
10		10733801		2	COTTER PIN M4 x 36
11		561953		2	RING
12		5144475		2	THRUST WASHER
13		NSS		1	NOT SERVICED SEPARATELY Spindle Incl in 1

(1) VAR - 390860

(2) VAR - 334413 (743515)

Valid for Var. 390860 or Industrial Var. 334413 (743515)

FARMALL JX100
 FARMALL JX75
 FARMALL JX80
 FARMALL JX90

VAR - 334413, 390860, 743515 - 2WD FRONT AXLE, STEERING KNUCKLE

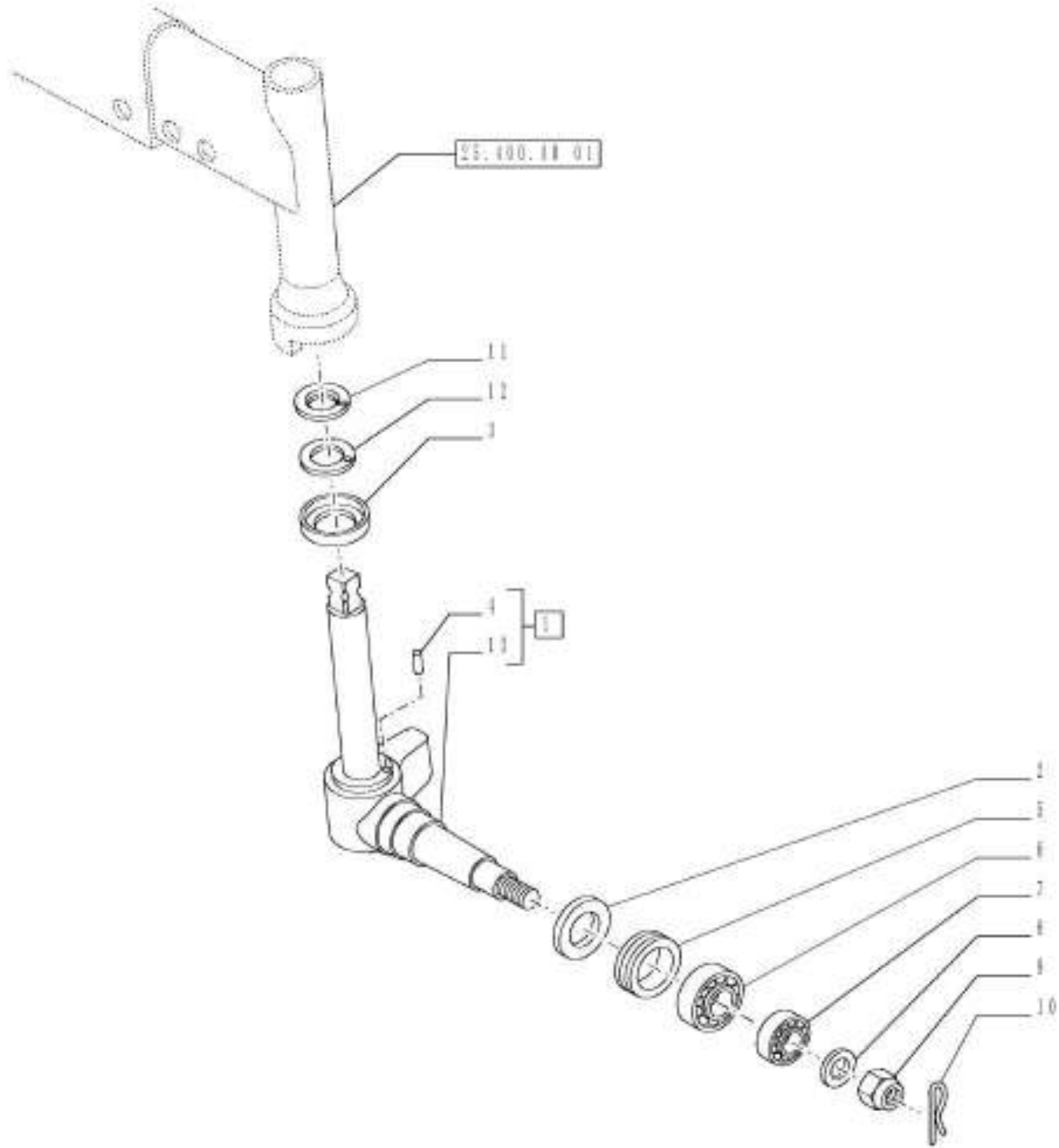

VAR - 334413, 390860, 743515 - 2WD FRONT AXLE, STEERING KNUCKLE

REF	FN	PART NUMBER	YR/SN	QTY	DESCRIPTION
1	1	5090334		1	STUB AXLE/STRG. SPINDLE LH, ASSY Incl 4, 13
1	1	5090332		1	STUB AXLE/STRG. SPINDLE RH, ASSY Incl 4, 13
1	2	5090481		1	STUB AXLE/STRG. SPINDLE RH, ASSY Incl 4, 13
1	2	5090482		1	STUB AXLE/STRG. SPINDLE LH, ASSY Incl 4,13
2		5090133		2	SEALING RING
3		566125		2	CUP
4		10839510		2	DOWEL M6 x 9
5		5090135		2	SEAL
6		5132342		2	TAPERED ROLLER BEARING 41.275 x 73.431 x 19.558
7		5132343		2	TAPERED ROLLER BEARING 25.4 x 57.15 x 19.4
8		5086901		2	WASHER
9		10724720		2	SLOTTED NUT M20 x 1.5
10		10733801		2	COTTER PIN M4 x 36
11		561953		2	RING
12		5144475		2	THRUST WASHER
13		NSS		1	NOT SERVICED SEPARATELY Spindle Incl in 1

(1) VAR - 390860

(2) VAR - 334413 (743515)

Valid for Industrial Var. 334413, 390338 (743515)

FARMALL JX70

SECTION INDEX

REAR AXLE SYSTEM

27.000.00	01	SECTION INDEX - REAR DRIVE AXLE
27.106.AB	01	VAR - 744738, 744739, 744744 - DIFFERENTIAL GEARS
27.106.AB	02	VAR - 744738, 744739, 744744 - DIFFERENTIAL GEARS
27.106.AB	03	VAR - 744738, 744739, 744744 - DIFFERENTIAL GEARS
27.106.AK	01	VAR - 744738, 744744 - DIFFERENTIAL LOCK CONTROL - ROD AND FORK
27.106.AK	02	VAR - 330384, 334322, 744739 - ROD & FORKS - 4WD
27.106.AL	01	VAR - 744738, 744744 - DIFFERENTIAL LOCK CONTROL - LEVER
27.106.AP	01	VAR - 330384, 334322, 744739 - ELECTROHYDRAULIC DIFFERENTIAL LOCK CONTROL, CONTROL VALVE, 4WD
27.106.AP	02	VAR - 330384, 334322, 744739 - ELECTROHYDRAULIC DIFFERENTIAL LOCK CONTROL - CONTROL VALVE - BREAKDOWN - 4WD
27.106.AR	01	VAR - 744738, 744739, 744744 - DIFFERENTIAL GEAR, SUPPORT
27.106.AR	02	VAR - 744738, 744739, 744744 - DIFFERENTIAL GEAR, SUPPORT
27.120.AD	01	VAR - 334396, 334397, 720450, 744745 - SIDE REDUCER GEARINGS, SHAFT AND BEARINGS
27.120.AD	02	VAR - 334397, 334416, 390895, 720450 - REDUCER, SHAFT, BEARING
27.120.AI	01	VAR - 720450, 744745 - SIDE REDUCER BOX AND COVERS
27.120.AI	02	VAR - 334396, 334397 - SIDE REDUCER BOX AND COVERS
27.120.AR	01	VAR - 334396, 334397, 720450, 744745 - SHAFT & GEAR
27.120.AR	02	VAR - 334397, 334416, 390895, 720450 - SHAFT & GEAR

SECTION INDEX - REAR DRIVE AXLE

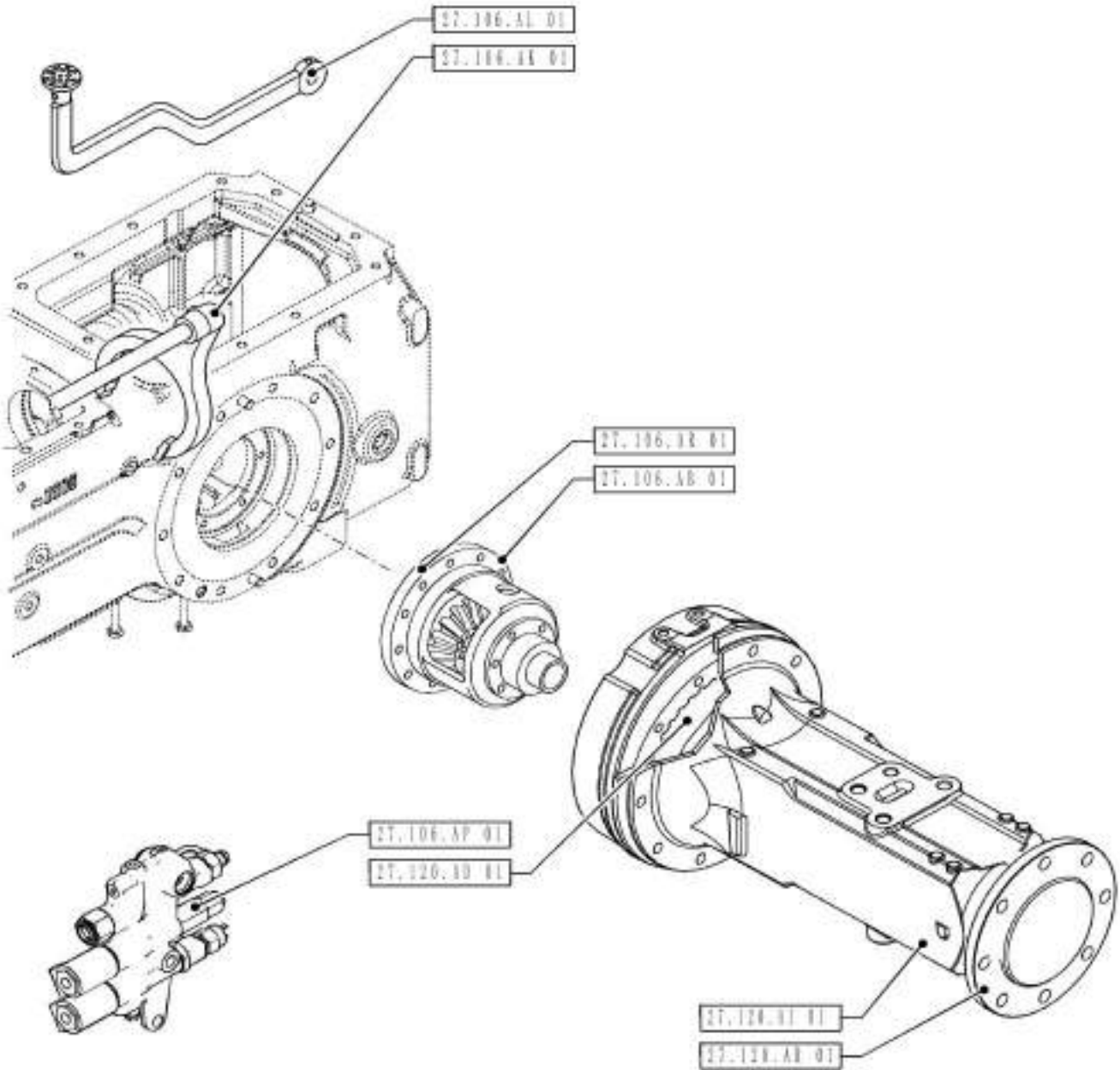

27.000.00

01

p1

1/2014

SECTION INDEX - REAR DRIVE AXLE

REF FN	PART NUMBER	YR/SN	QTY	DESCRIPTION
---------------	--------------------	--------------	------------	--------------------

FARMALL JX100 FARMALL JX110 FARMALL JX70 FARMALL JX75 FARMALL JX80 FARMALL JX90
--

VAR - 744738, 744739, 744744 - DIFFERENTIAL GEARS

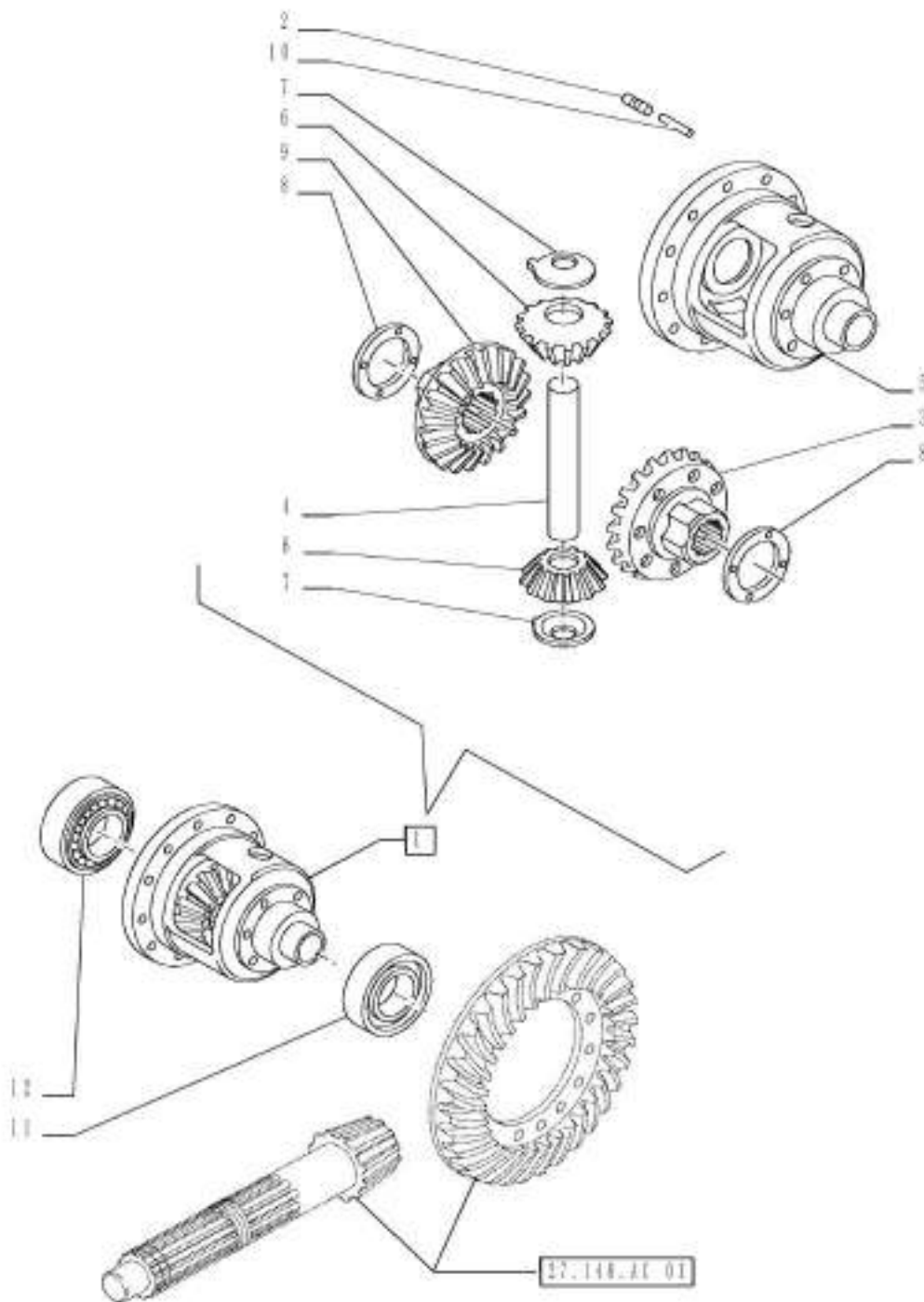

VAR - 744738, 744739, 744744 - DIFFERENTIAL GEARS

REF FN	PART NUMBER	YR/SN	QTY DESCRIPTION
1	5106314		1 DIFF CARRIER & GEARS Incl 2 - 10
2	13807870		1 SET SCREW Hex Soc, M8 x 14, Flat Pt
3	5103868		1 PINION LH
4	5094840		1 PINION CARRIER
5	NSS		1 NOT SERVICED SEPARATELY Housing Incl in 1
6	5103870		2 PINION
7	4987975		2 THRUST WASHER
8	5087992		AR SHIM 2.2mm Thk
8	5087994		AR SHIM 2.4mm Thk
8	5087995		AR SHIM 2.5mm Thk
8	5087993		AR SHIM 2.3mm Thk
8	5087991		AR SHIM 2.1mm Thk
8	5088329		AR SHIM 1.3mm Thk
8	5088328		AR SHIM 1.2mm Thk
8	5088604		AR SHIM 2.0mm Thk
8	5088603		AR SHIM 1.9mm Thk
8	5148936		AR THRUST WASHER 44.00mm ID x 66.00mm OD x 1.6mm T
8	5148937		AR THRUST WASHER 44.00mm ID x 66.00mm OD x 1.8mm T
8	5148938		AR THRUST WASHER 44.00mm ID x 66.00mm OD x 1.7mm T
8	5148940		AR THRUST WASHER 44.00mm ID x 66.00mm OD x 1.4mm T
8	5148939		AR THRUST WASHER 44.00mm ID x 66.00mm OD x 1.5mm T
8	5167387		AR THRUST WASHER 44.00mm ID x 66.00mm OD x 1.9mm T
8	5167388		AR THRUST WASHER 44.00mm ID x 66.00mm OD x 2.0mm T
8	5181357		AR THRUST WASHER 44.00mm ID x 66.00mm OD x 2.2mm T

Valid for Industrial Var. 334321, 390268 (744738) or Industrial Var. 330384, 334322 (744739) or Industrial Var. 334320, 390267 (744744)

FARMALL JX70

27.106.AB

01

p2

1/2014

VAR - 744738, 744739, 744744 - DIFFERENTIAL GEARS

REF FN	PART NUMBER	YR/SN	QTY DESCRIPTION
8	5181356		AR THRUST WASHER 44.00mm ID x 66.00mm OD x 2.1mm T
9	5103869		1 PLANETARY GEAR RH
10	5173242		1 ROLL PIN
11	26799980		1 BEARING ASSY
12	24903450		1 TAPERED ROLLER BEARING 60.00mm x 95.00mm x 23.00mm Incl 1 - 9

Valid for Industrial Var. 334321, 390268 (744738) or Industrial Var. 330384, 334322 (744739) or Industrial Var. 334320, 390267 (744744)

FARMALL JX70

VAR - 744738, 744739, 744744 - DIFFERENTIAL GEARS

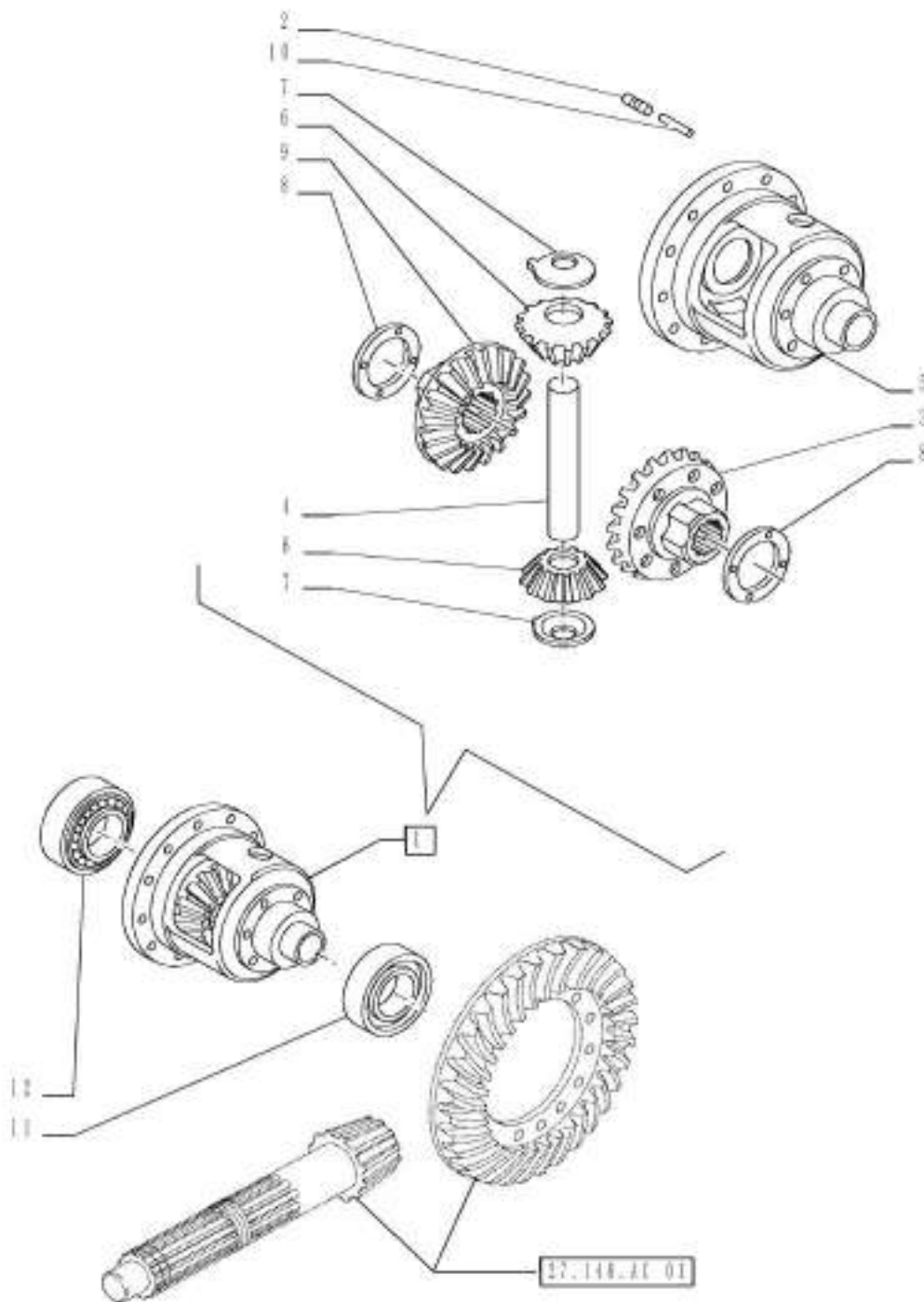

VAR - 744738, 744739, 744744 - DIFFERENTIAL GEARS

REF FN	PART NUMBER	YR/SN	QTY DESCRIPTION
1	5117236		1 DIFFERENTIAL GEAR ASSY Incl 2 - 10
2	13807870		1 SET SCREW Hex Soc, M8 x 14, Flat Pt
3	5149551		1 PLANETARY GEAR RH
4	4991652		1 PIN
5	5173246		1 HOUSING
6	4991695		2 IDLER PINION
7	4991658		2 THRUST WASHER 1.5MM
8	5144801		AR THRUST WASHER 1.4mm Thk
8	4997235		AR THRUST WASHER 1.5mm Thk
8	4997236		AR THRUST WASHER 1.6mm Thk
8	5138267		AR THRUST WASHER 1.7mm Thk
8	5144802		AR THRUST WASHER 1.8mm Thk
8	5170588		AR THRUST WASHER 1.9mm Thk
8	5170589		AR THRUST WASHER 2.0mm Thk
8	5182769		AR THRUST WASHER 2.1mm Thk
8	5182770		AR THRUST WASHER 2.2mm Thk
9	4997230		1 PLANETARY GEAR LH
10	5173242		1 ROLL PIN 65 x 100 x 23
11	26799990		1 TAPERED ROLLER BEARING
12	24903460		1 TAPERED ROLLER BEARING 65 mm ID x 100 mm OD x 23 mm ASSY, Contains Ref. 1-9

Valid for Industrial Var. 334321, 390268 (744738) or Industrial Var.
330384, 334322 (744739) or Industrial Var. 334320, 390267 (744744)

FARMALL JX75
FARMALL JX80
FARMALL JX90

VAR - 744738, 744739, 744744 - DIFFERENTIAL GEARS

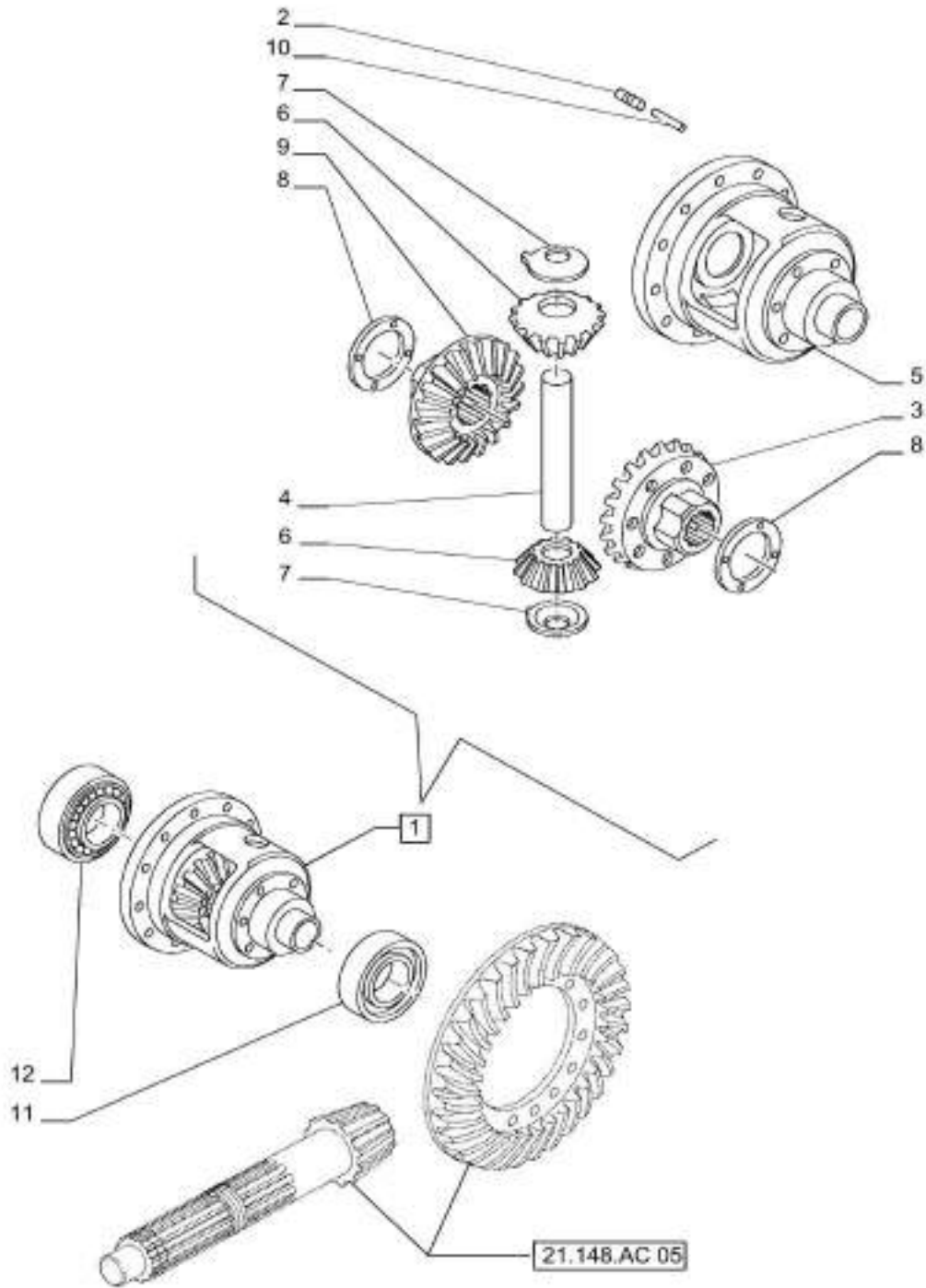

VAR - 744738, 744739, 744744 - DIFFERENTIAL GEARS

REF FN	PART NUMBER	YR/SN	QTY DESCRIPTION
1	84345898		1 DIFFERENTIAL Gear ASSY, Incl 2 - 10
2	13807870		1 SET SCREW Hex Soc, M8 x 14, Flat Pt
3	5149551		1 PLANETARY GEAR RH
4	84474220		1 PIN
5	5090264		1 CASE
6	84343773		2 GEAR
7	5089372		2 THRUST WASHER
8	5144801		AR THRUST WASHER 1.4mm Thk
8	4997235		AR THRUST WASHER 1.5mm Thk
8	4997236		AR THRUST WASHER 1.6mm Thk
8	5138267		AR THRUST WASHER 1.7mm Thk
8	5144802		AR THRUST WASHER 1.8mm Thk
8	5170588		AR THRUST WASHER 1.9mm Thk
8	5170589		AR THRUST WASHER 2.0mm Thk
8	5182769		AR THRUST WASHER 2.1mm Thk
8	5182770		AR THRUST WASHER 2.2mm Thk
9	4997230		1 PLANETARY GEAR LH
10	5173242		1 ROLL PIN 65 x 100 x 23
11	26799990		1 TAPERED ROLLER BEARING
12	24903460		1 TAPERED ROLLER BEARING 65 mm ID x 100 mm OD x 23 mm Gear ASSY, Incl 1 - 9

Valid for Industrial Var. 334321, 390268 (744738) or Industrial Var.
330384, 334322 (744739) or Industrial Var. 334320, 390267 (744744)

FARMALL JX100
FARMALL JX110

VAR - 744738, 744744 - DIFFERENTIAL LOCK CONTROL - ROD AND FORK

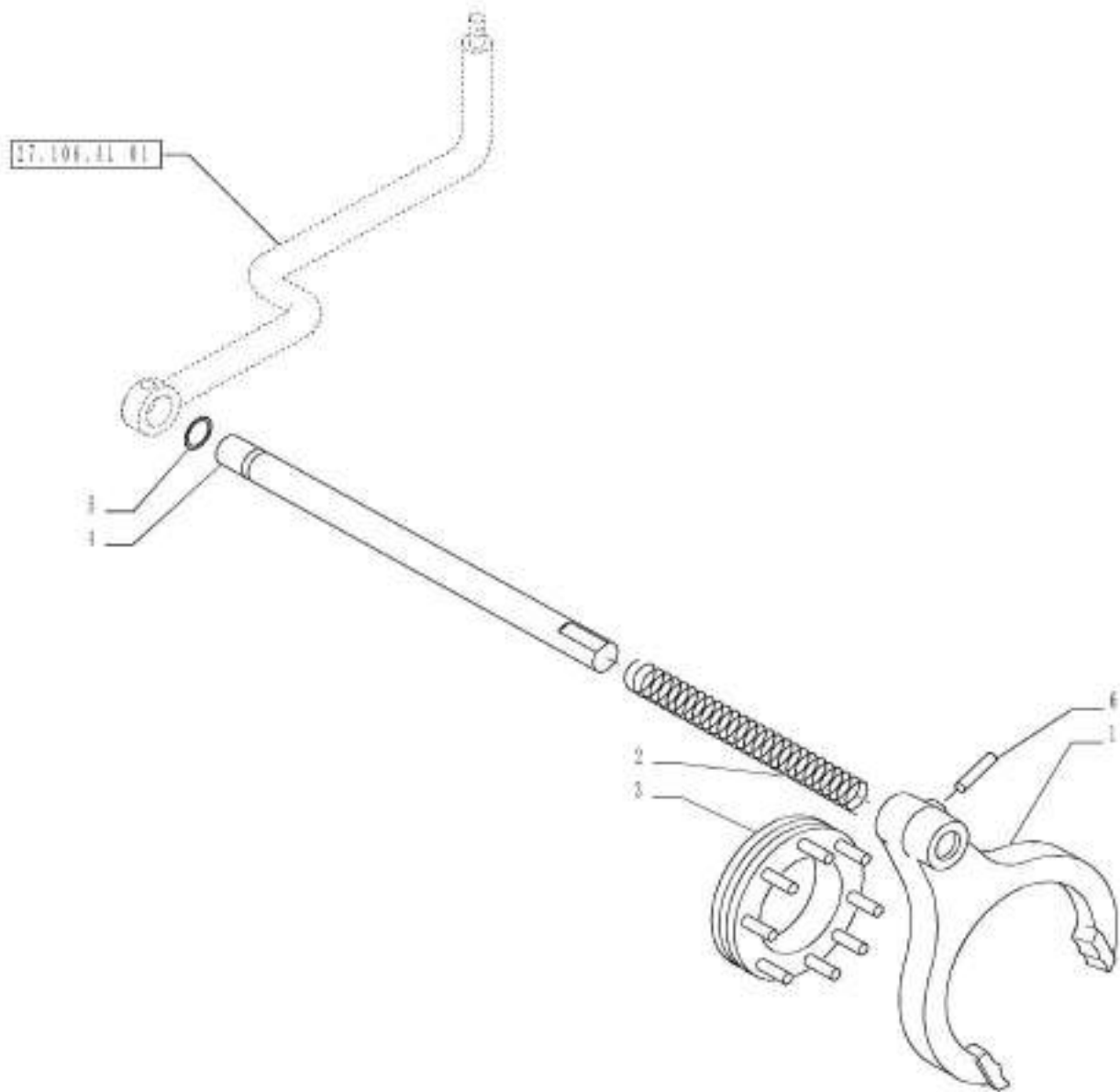

VAR - 744738, 744744 - DIFFERENTIAL LOCK CONTROL - ROD AND FORK

REF	FN	PART NUMBER	YR/SN	QTY	DESCRIPTION
1	1	5114583		1	YOKE
1	2	5113659		1	SHIFTER FORK
2		5094199		1	SPRING
3	1	5195412		1	COLLAR
3	2	5195413		1	COLLAR
4		84129925		1	SHAFT
5		14457280		1	O-RING 0.612" ID x 0.103"
6		13910670		1	ROLL PIN M6 x 40, Coiled

(1) Valid for FARMALL JX70 Model Only

(2) Valid for FARMALL JX75, 80, 90, 100, 110 Models Only

Valid for Industrial Var. 334321, 390268 (744738) or Industrial Var. 334320, 390267 (744744)

FARMALL JX100 FARMALL
JX110 FARMALL JX70
FARMALL JX75 FARMALL
JX80 FARMALL JX90

27.106.AK

02

p1

1/2014

VAR - 330384, 334322, 744739 - ROD & FORKS - 4WD

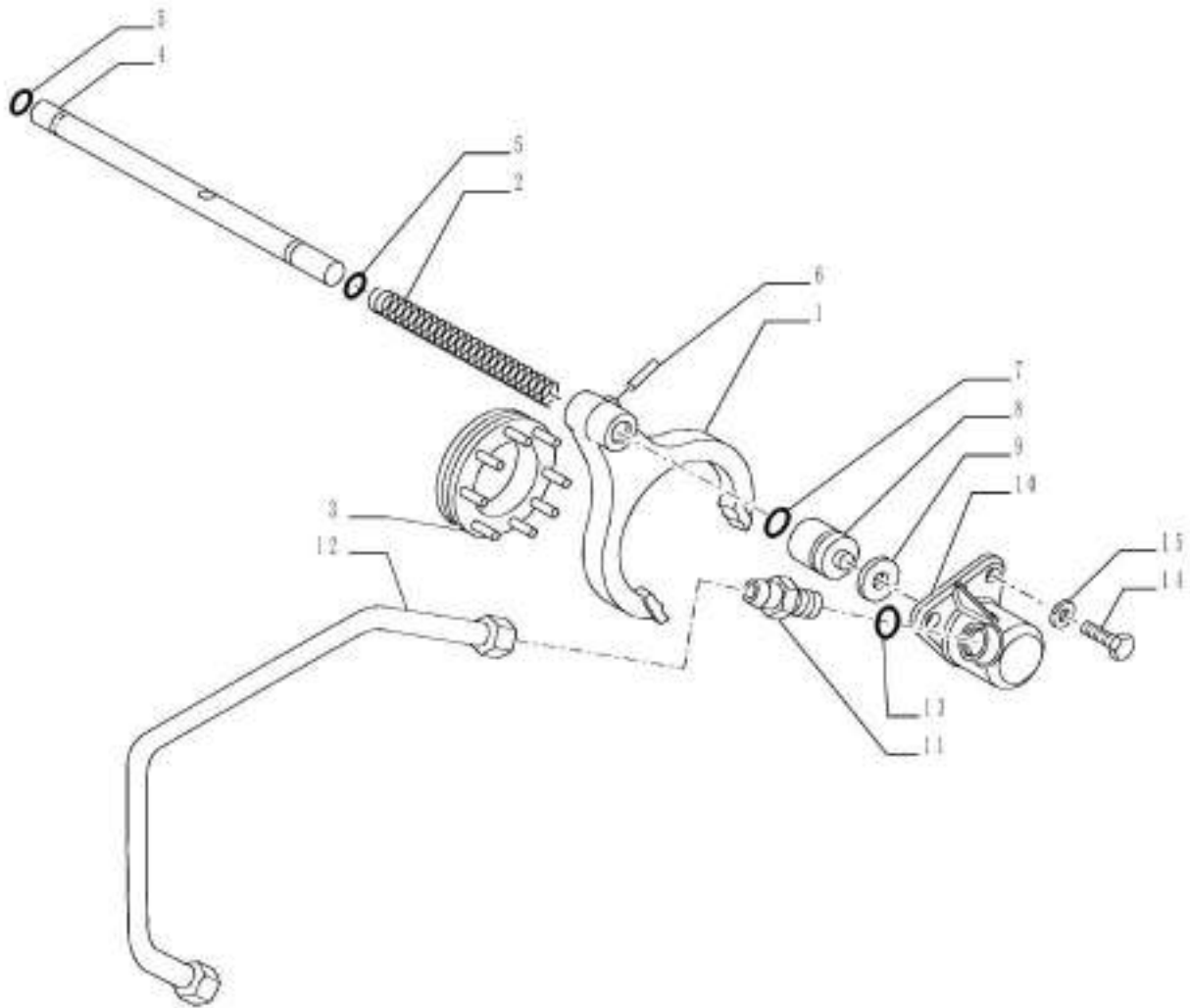

VAR - 330384, 334322, 744739 - ROD & FORKS - 4WD

REF	FN	PART NUMBER	YR/SN	QTY	DESCRIPTION
1	1	5113659		1	SHIFTER FORK
1	2	5114583		1	YOKE
2		5094199		1	SPRING
3	1	5195413		1	COLLAR
3	2	5195412		1	COLLAR
4		84129925		1	SHAFT
5		14457280		2	O-RING 0.612" ID x 0.103"
6		13910670		1	ROLL PIN M6 x 40, Coiled
7		5160827		1	GASKET 22.55mm ID x 30mm OD, 3.20mm Thk
8		84129783		1	PISTON
9		84129792		3	SPACER
10		84129572		1	LINER
11	1	5158800		1	HYD CONNECTOR
12	1	84139250		1	PIPE
13		84480071		1	SEAL
14		10923221		2	SCREW
15		12601474		2	WAVE WASHER Wave, 10.50mm ID x 21.00mm OD x 0.80mm, 3.00mm, CST, DAC

(1) VAR - 330384, 334322 (744739) Valid for FARMALL JX75, 80, 90, 100, 110 Models Only

(2) VAR - 330384 (744739) Valid for FARMALL JX70 Model Only

Valid for Industrial Var. 330384, 334322 (744739)

FARMALL JX100 FARMALL
JX110 FARMALL JX70
FARMALL JX75 FARMALL
JX80 FARMALL JX90

27.106.AL

01

p1

1/2014

VAR - 744738, 744744 - DIFFERENTIAL LOCK CONTROL - LEVER

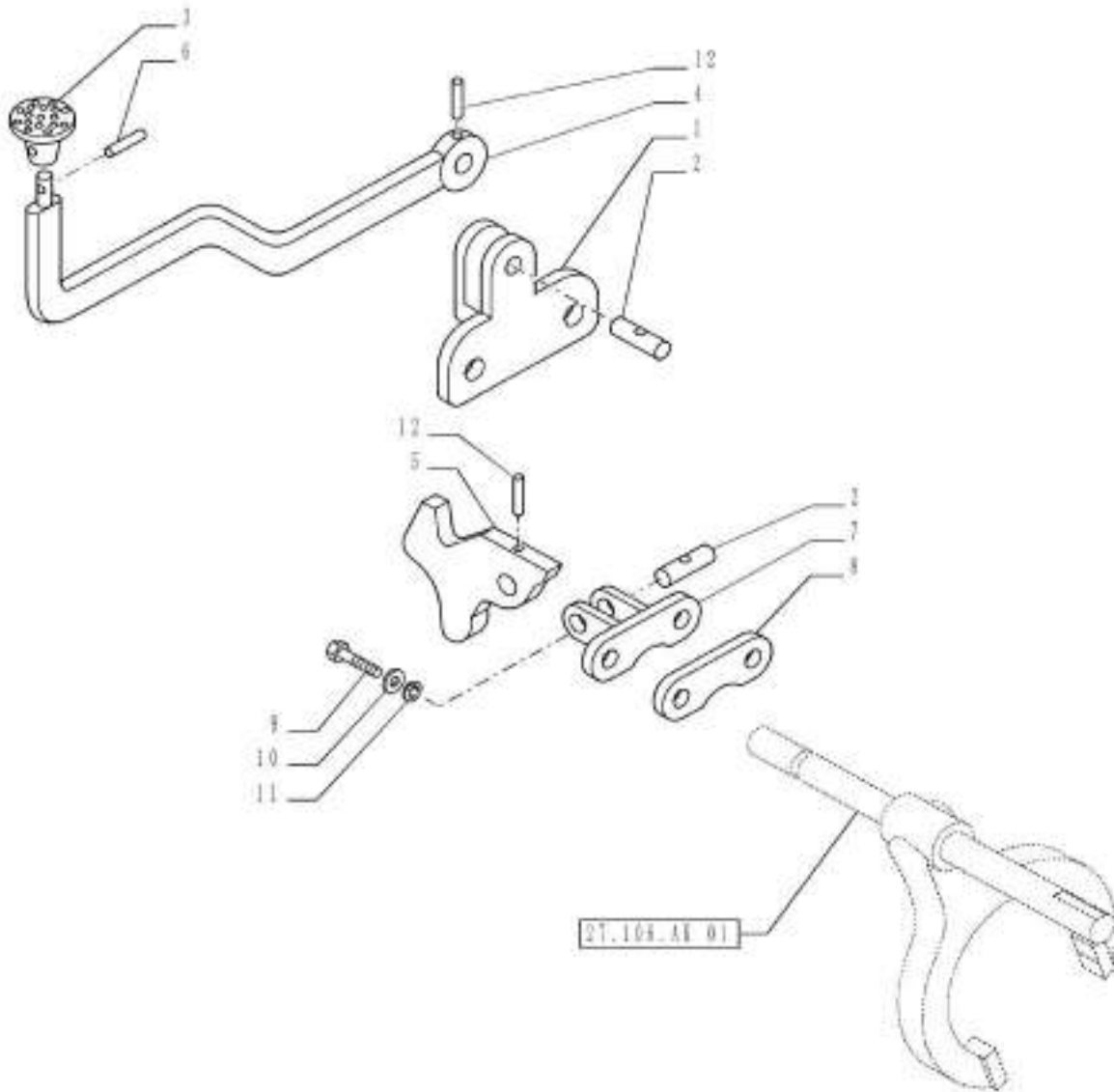

27.106.AL

01

p1

1/2014

VAR - 744738, 744744 - DIFFERENTIAL LOCK CONTROL - LEVER

REF FN	PART NUMBER	YR/SN	QTY DESCRIPTION
1	5089683		1 SUPPORT
2	567360		2 PIN
3	87395998		1 RUBBER PAD
4	84526198		1 ARM
5	5089682		1 SPACER
6	13904570		1 ROLL PIN M4 x 18, Coiled
7	5085538		1 SUPPORT
8	5114582		6 SPACER
9	10923221		2 SCREW
10	14496701		1 WASHER 13.00mm ID x 24.00mm OD x 2.50mm, CST, ZND
11	12601474		2 WAVE WASHER Wave, 10.50mm ID x 21.00mm OD x 0.80mm, 3.00mm, CST, DAC
12	13900070		1 ROLL PIN M3 x 26, Coiled

Valid for Industrial Var. 334321, 390268 (744738) or Industrial Var. 334320, 390267 (744744)

FARMALL JX100 FARMALL
JX110 FARMALL JX70
FARMALL JX75 FARMALL
JX80 FARMALL JX90

27.106.AP

01

p1

1/2014

VAR - 330384, 334322, 744739 - ELECTROHYDRAULIC DIFFERENTIAL LOCK CONTROL, CONTROL VALVE, 4WD

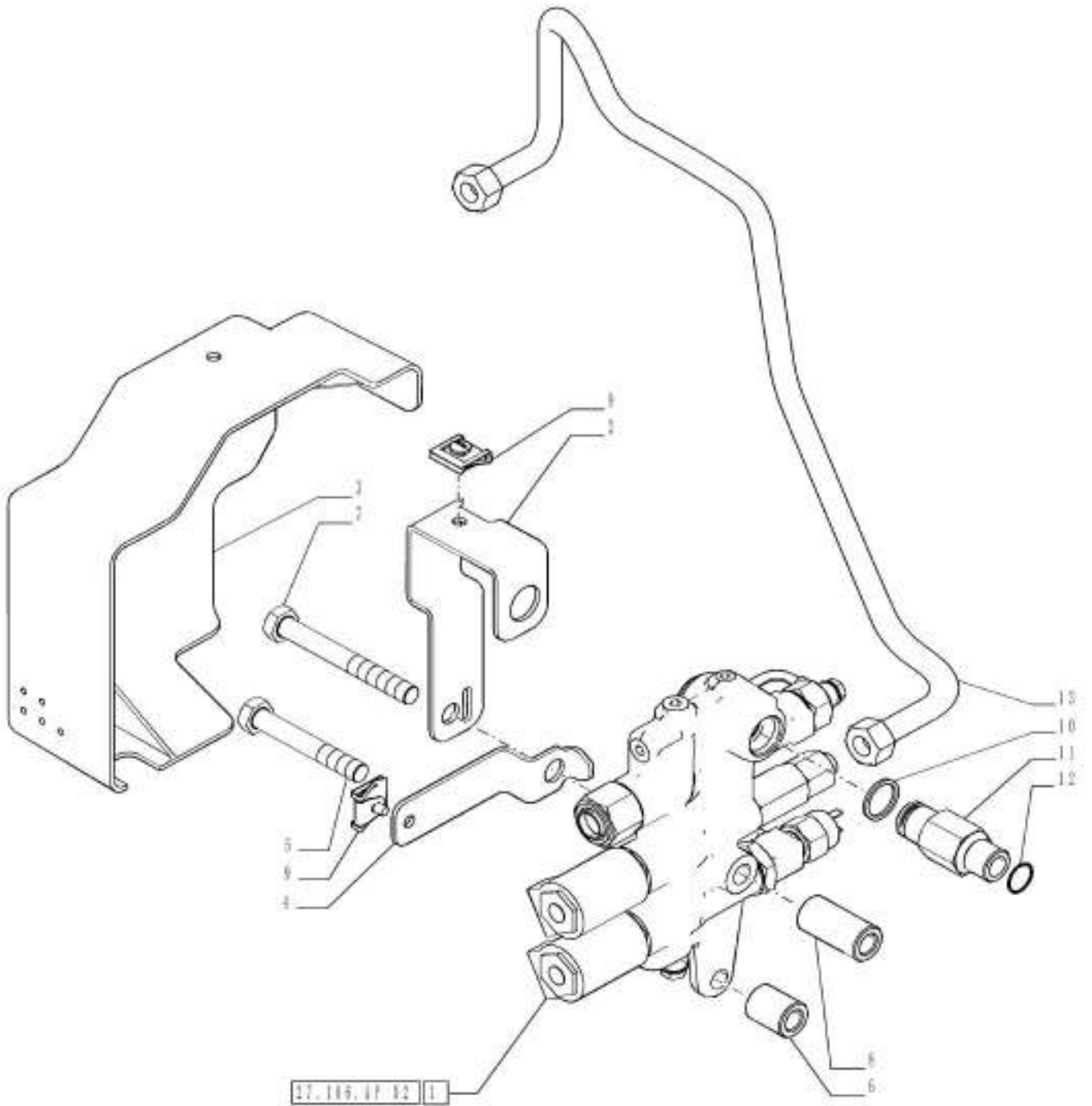

VAR - 330384, 334322, 744739 - ELECTROHYDRAULIC DIFFERENTIAL LOCK CONTROL, CONTROL VALVE, 4WD

REF FN	PART NUMBER	YR/SN	QTY DESCRIPTION
1	84361102		1 CONTROL VALVE ASSY
2	84426449		1 SUPPORT
3	84323590		1 SUPPORT
4	84323575		1 SUPPORT
5	15541421		1 SCREW Hex, M12 x 1.25 x 80mm, Cl 8.8
6	84144850		1 SPACER
7	15541621		1 SCREW Hex, M12 x 1.25 x 100mm, Cl 8.8
8	84144851		1 SPACER
9	5174673		2 KIT
10	44019496		1 GASKET
11 1	84144852		1 HYD CONNECTOR
11 2	84341938		1 HYD CONNECTOR
12	129979		1 O-RING 0.674" ID x 0.88" OD x 0.103"
13 1	84243491		1 PIPE
(1)	VAR - 330384 (744739)		
(2)	VAR - 334322 (744739)		

Valid for Industrial Var. 330384, 334322 (744739)

FARMALL JX100 FARMALL
 JX110 FARMALL JX70
 FARMALL JX75 FARMALL
 JX80 FARMALL JX90

VAR - 330384, 334322, 744739 - ELECTROHYDRAULIC DIFFERENTIAL LOCK CONTROL - CONTROL VALVE - BREAKDOWN - 4WD

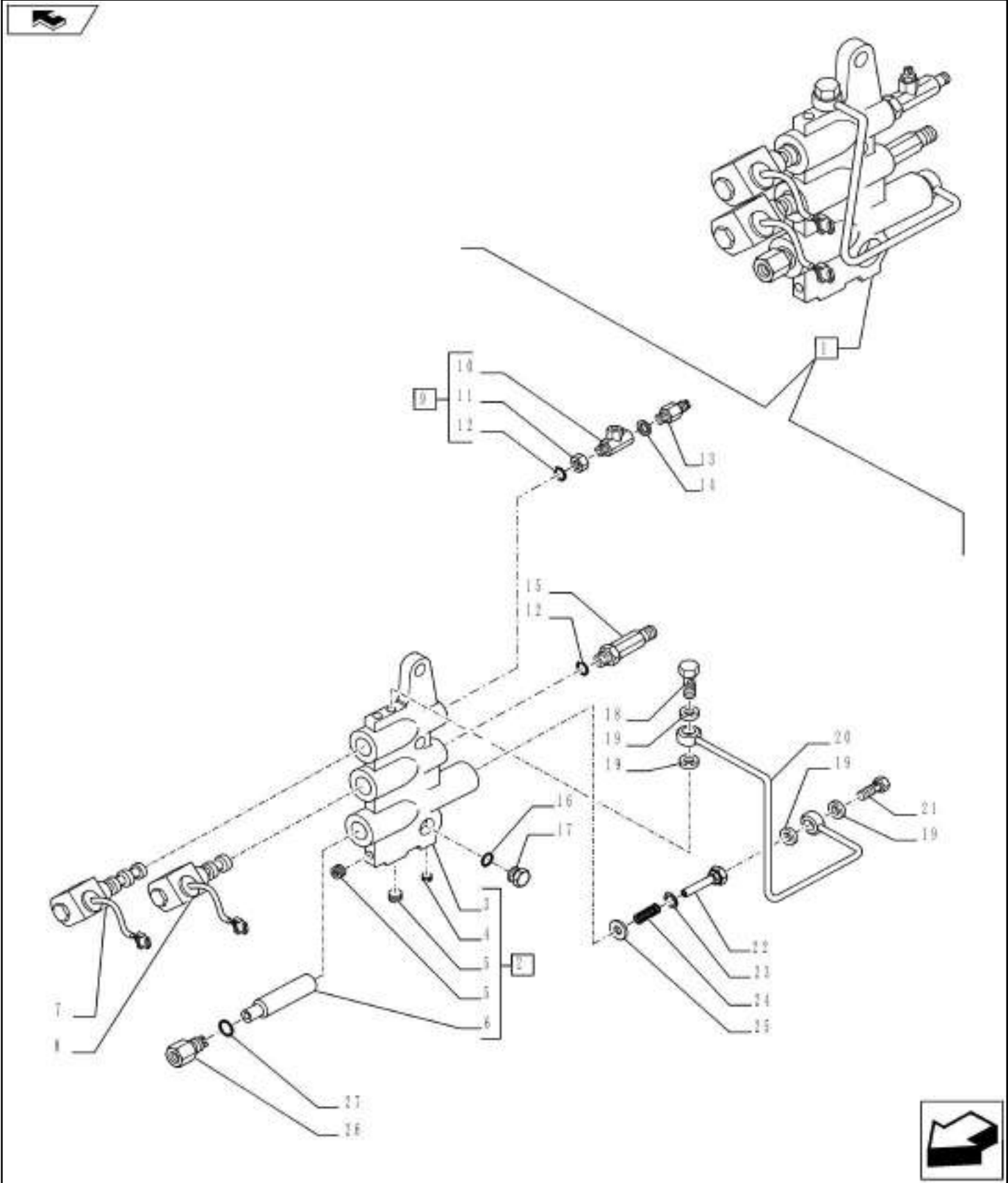

VAR - 330384, 334322, 744739 - ELECTROHYDRAULIC DIFFERENTIAL LOCK CONTROL - CONTROL VALVE - BREAKDOWN - 4WD

REF FN	PART NUMBER	YR/SN	QTY DESCRIPTION
1	84361102		1 CONTROL VALVE ASSY, Incl 2 - 27
2	5174901		1 SUPPORT ASSY, Incl 3 - 6
3	NSS		1 NOT SERVICED SEPARATELY Support, Incl in 2
4	14326004		3 PLUG Hex Socket, M10 x 1.25 x 11.00mm, STL, DAC M10 x 1.25
5	10269501		2 PLUG 14 x 1.5
6	5169220		1 HYDRAULIC VALVE
7	5164628		1 SOLENOID VALVE 4WD
8	5164627		1 SOLENOID VALVE Diff. Lock
9	84186994		1 HYD CONNECTOR ASSY, Incl 10 - 12
10	NSS		1 NOT SERVICED SEPARATELY Connector, Incl in 9
11	10717624		1 THIN NUT Thin, M18 x 2.5, CI 05
12	14437985		2 O-RING 15.3mm ID x 2.4mm
13	84370675		1 SWITCH
14	10298460		1 SEALING WASHER M12.2 x 18 x 1.5
15	5162919		1 EXTENSION
16	14438185		1 O-RING 24mm ID x 3mm
17	5174927		1 PLUG
18	11903814		1 BANJO BOLT M10 x 1.25 x 19
19	10298360		4 SEALING WASHER M10.2 x 16 x 1, Copper
20	5169701		1 TUBE
21	5169835		1 BANJO BOLT
22	5196410		1 PLUG
23	10257460		1 SEAL M20.3 x 26 x 1.5
24	84370678		1 SPRING
25	13550124		1 WASHER 5 x 11
26	84139506		1 HYD CONNECTOR
27	14438085		1 O-RING 19.3mm ID x 2.4mm

Valid for Industrial Var. 330384, 334322 (744739)

 FARMALL JX100 FARMALL
 JX110 FARMALL JX70
 FARMALL JX75 FARMALL
 JX80 FARMALL JX90

VAR - 744738, 744739, 744744 - DIFFERENTIAL GEAR, SUPPORT

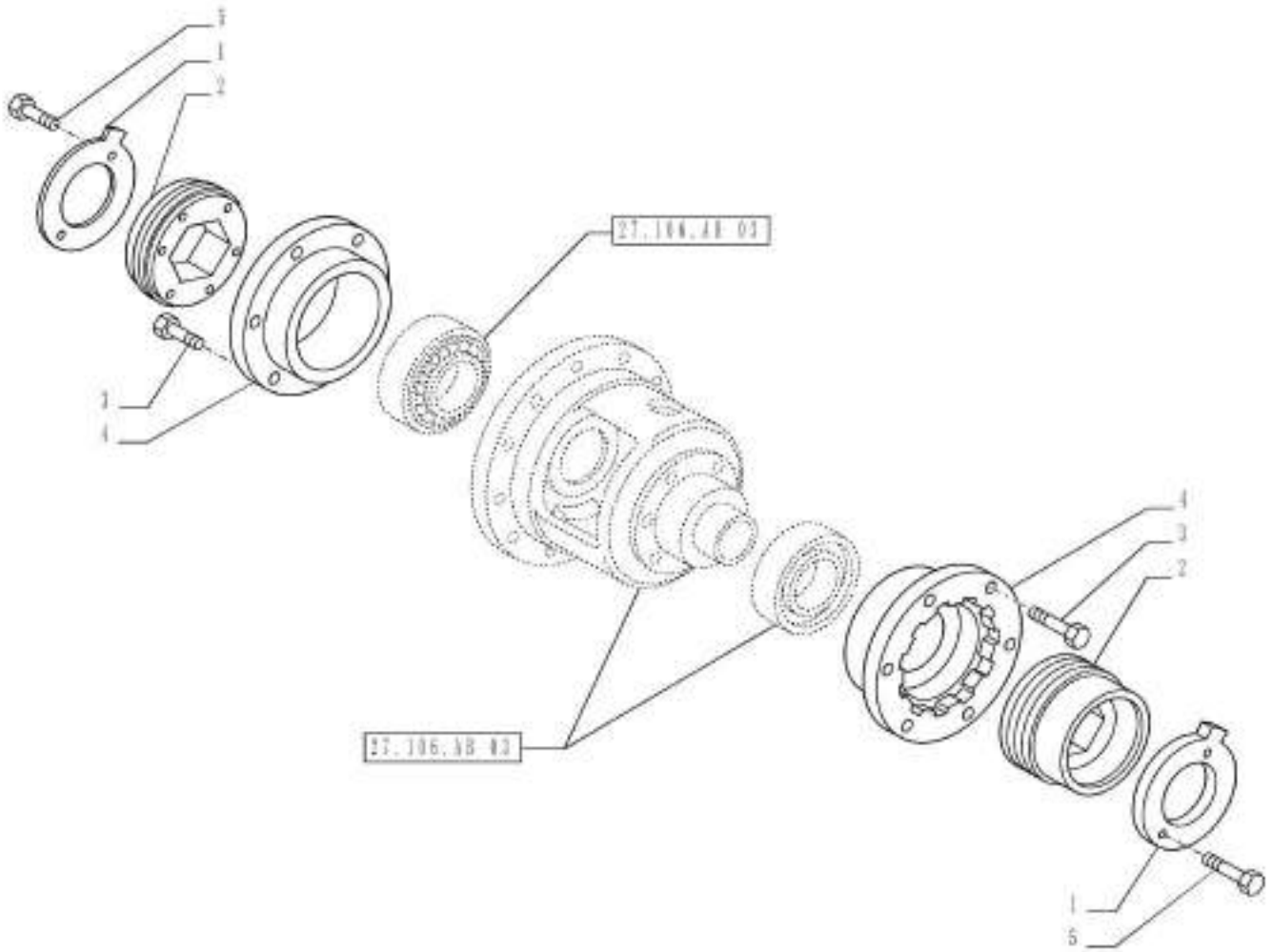

27.106.AR

01

p1

1/2014

VAR - 744738, 744739, 744744 - DIFFERENTIAL GEAR, SUPPORT

REF FN	PART NUMBER	YR/SN	QTY DESCRIPTION
1	5087672		2 LOCK WASHER
2	5087671		2 LOCK NUT
3	11306921		12 SCREW Hex, M10 x 1.25 x 30, 8.8, Full Thd
4	5127162		2 SUPPORT
5	14238021		4 LOCK BOLT Hex, M8 x 1.25 x 20mm, Cl 8.8, Full Thd

Valid for Industrial Var. 334321, 390268 (744738) or Industrial Var. 330384, 334322 (744739) or Industrial Var. 334329, 390267 (744744)

**FARMALL JX75
FARMALL JX80
FARMALL JX90**

VAR - 744738, 744739, 744744 - DIFFERENTIAL GEAR, SUPPORT

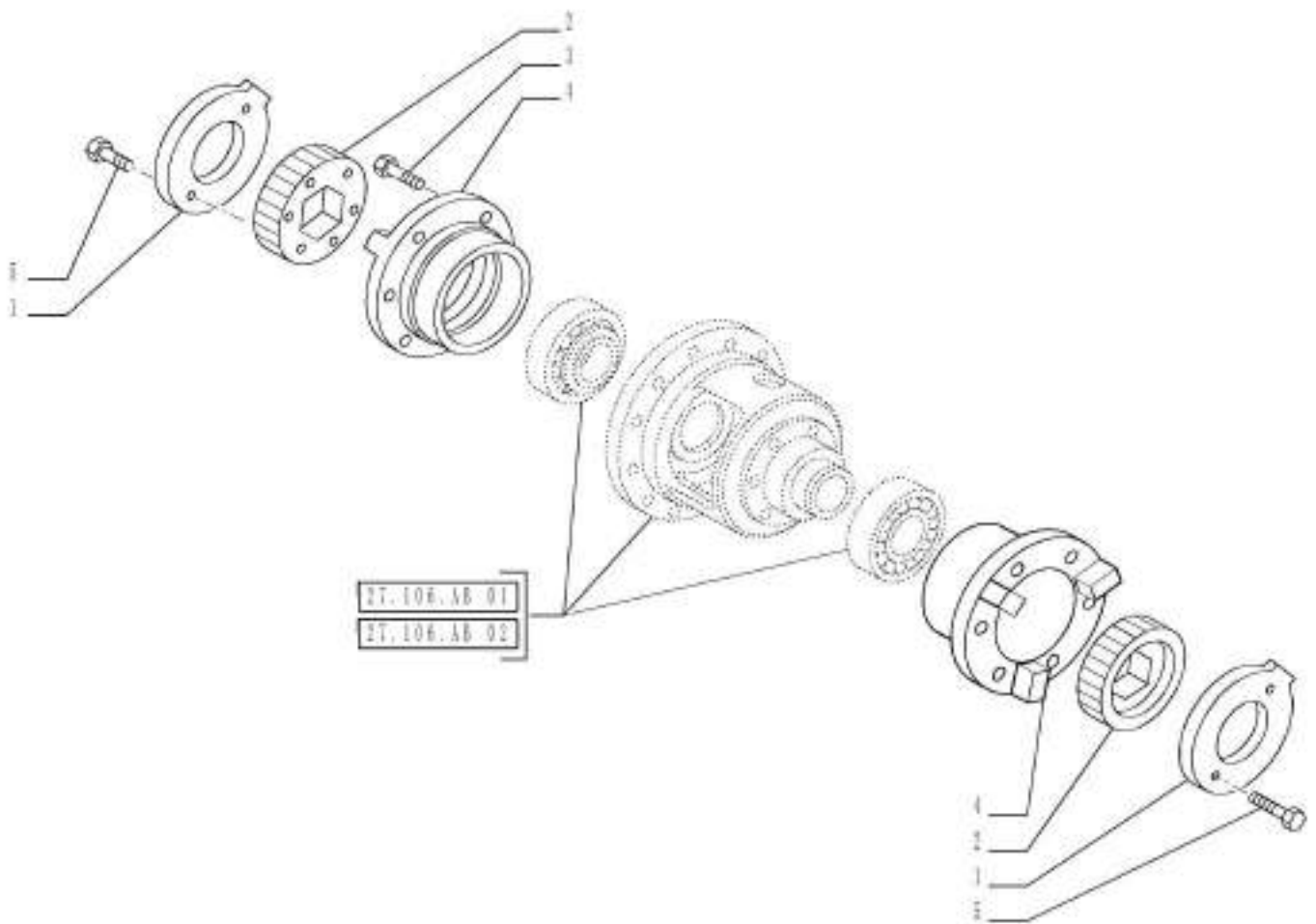

VAR - 744738, 744739, 744744 - DIFFERENTIAL GEAR, SUPPORT

REF FN	PART NUMBER	YR/SN	QTY DESCRIPTION
1	5087672		2 LOCK WASHER
2	1 5087671		2 LOCK NUT
2	2 5087673		2 NUT
3	11306921		12 SCREW Hex, M10 x 1.25 x 30, 8.8, Full Thd
4	2 5127166		2 SUPPORT LH
4	2 5127165		1 SUPPORT RH
4	1 84481227		2 SUPPORT
5	14238021		4 LOCK BOLT Hex, M8 x 1.25 x 20mm, Cl 8.8, Full Thd

(1) Valid for FARMALL JX100.110 Models Only

(2) Valid for FARMALL JX70 Model Only

Valid for Industrial Var. 334321, 390268 (744738) or 330384, 334322 (744739) or 334320, 390267 (744744)

FARMALL JX100
FARMALL JX110
FARMALL JX70

VAR - 334396, 334397, 720450, 744745 - SIDE REDUCER GEARINGS, SHAFT AND BEARINGS

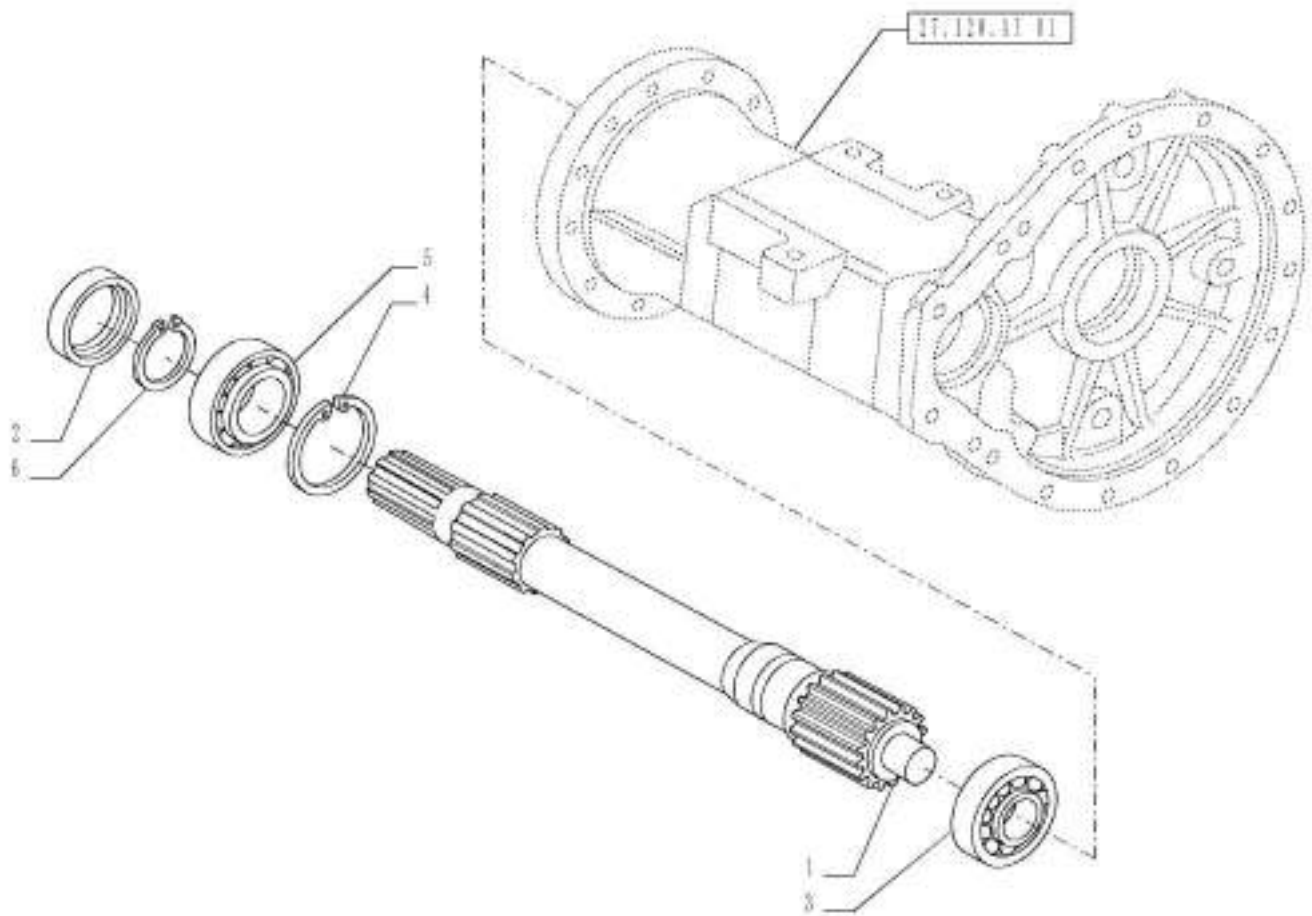

VAR - 334396, 334397, 720450, 744745 - SIDE REDUCER GEARINGS, SHAFT AND BEARINGS

REF	FN	PART NUMBER	YR/SN	QTY DESCRIPTION
1	1	5119240		1 HALF SHAFT RH
1	2	5141650		1 HALF SHAFT RH
1	3	5089365		1 HALF SHAFT RH
1	1	5119241		1 HALF SHAFT LH
1	2	5141651		1 HALF SHAFT LH
1	3	5089366		1 HALF SHAFT LH
1	4	5161808		1 DRIVEN SPROCKET RH
1	4	5161801		1 DRIVEN SPROCKET LH
2	1	5119249		4 SEAL
2	5	5119215		4 GASKET
3	1	5125824		2 ROLLER BEARING 35 mm ID x 72 mm OD x 23 mm
3	5	5140199		2 CYLINDRICAL ROLLER BEARING 35 mm ID x 80 mm OD x 31 mm
4	1	11062976		2 SNAP RING Int, M100 x 3
4	5	11075476		2 SNAP RING M110, Int
5	1	20033750		2 BALL BEARING 45 mm ID x 100 mm OD x 25 mm 45 x 100 x 25
5	5	20229990		2 BALL BEARING 50.00mm ID x 110.00mm OD x 27.00mm
6	1	11069076		2 SNAP RING M45, Ext
6	5	11069376		2 SNAP RING M50, Ext

(1) Valid for FARMALL JX70 Model Only

(2) Valid for Var. 334396 or 334414, 390258 (744745) FARMALL JX75, 90 Models Only

(3) Valid for FARMALL JX100 Model Only

(4) Valid for Var. 334397 or Var. 334315, 334416 (720450) FARMALL JX75, 90 Models Only

(5) Valid for FARMALL JX75, 90, 100 Models Only

Valid for Industrial Var. 334396 or Var. 334397 or Industrial Var. 334315, 334416 (720450) or Industrial Var. 344414, 390258 (744745)

FARMALL JX100
 FARMALL JX70
 FARMALL JX75
 FARMALL JX80

VAR - 334397, 334416, 390895, 720450 - REDUCER, SHAFT, BEARING

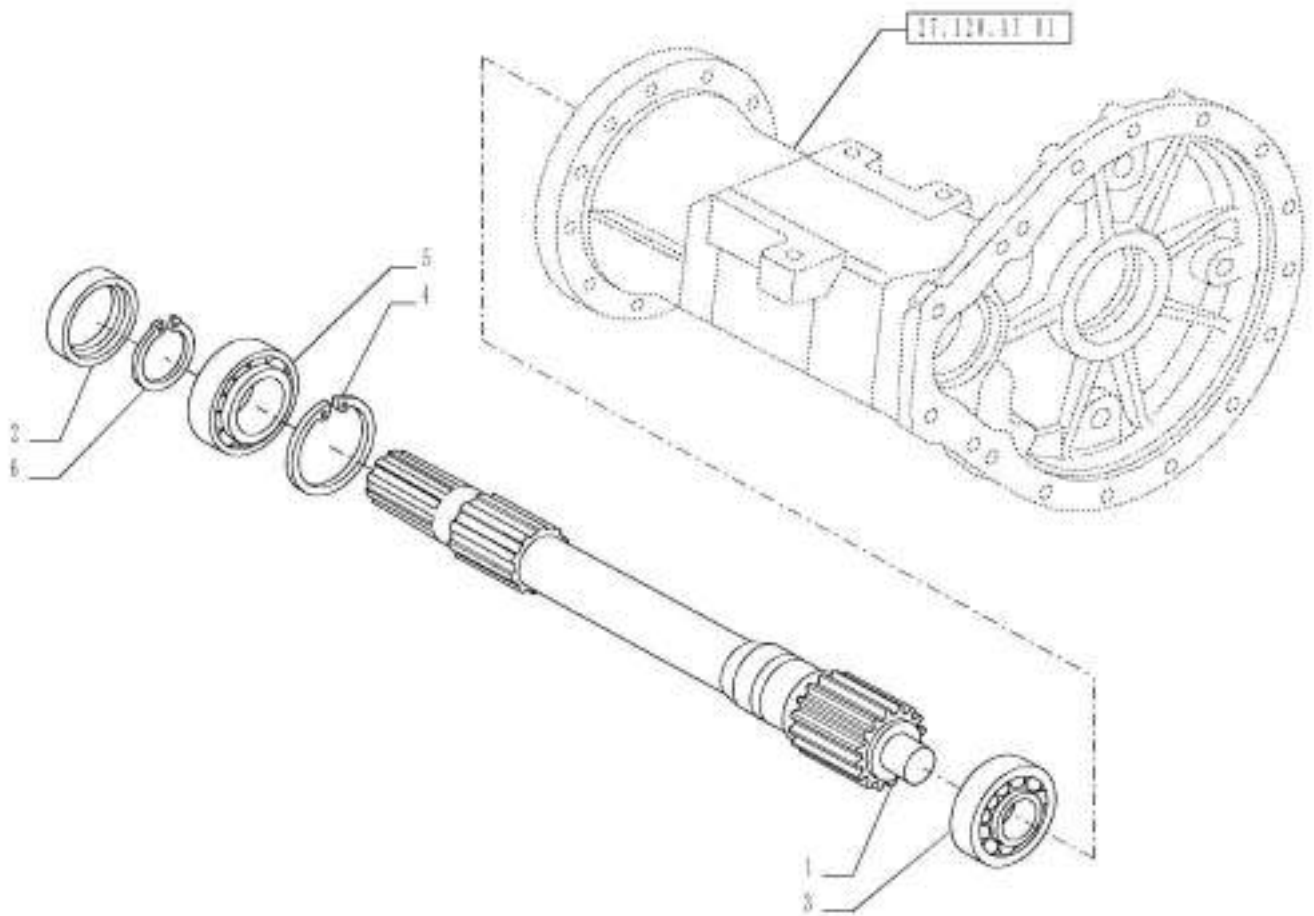

27.120.AD

02

p1

1/2014

VAR - 334397, 334416, 390895, 720450 - REDUCER, SHAFT, BEARING

REF FN	PART NUMBER	YR/SN	QTY DESCRIPTION
1	84401115		1 SHAFT RH
1	84401116		1 SHAFT LH
2	5119215		4 GASKET
3	47364507		2 ROLLER BEARING
4	11075476		2 SNAP RING M110, Int
5	20229990		2 BALL BEARING 50.00mm ID x 110.00mm OD x 27.00mm
6	11069376		2 SNAP RING M50, Ext

Valid for Var. 334397 or Industrial Var. 334416, 390895 (720450)

FARMALL JX110

VAR - 720450, 744745 - SIDE REDUCER BOX AND COVERS

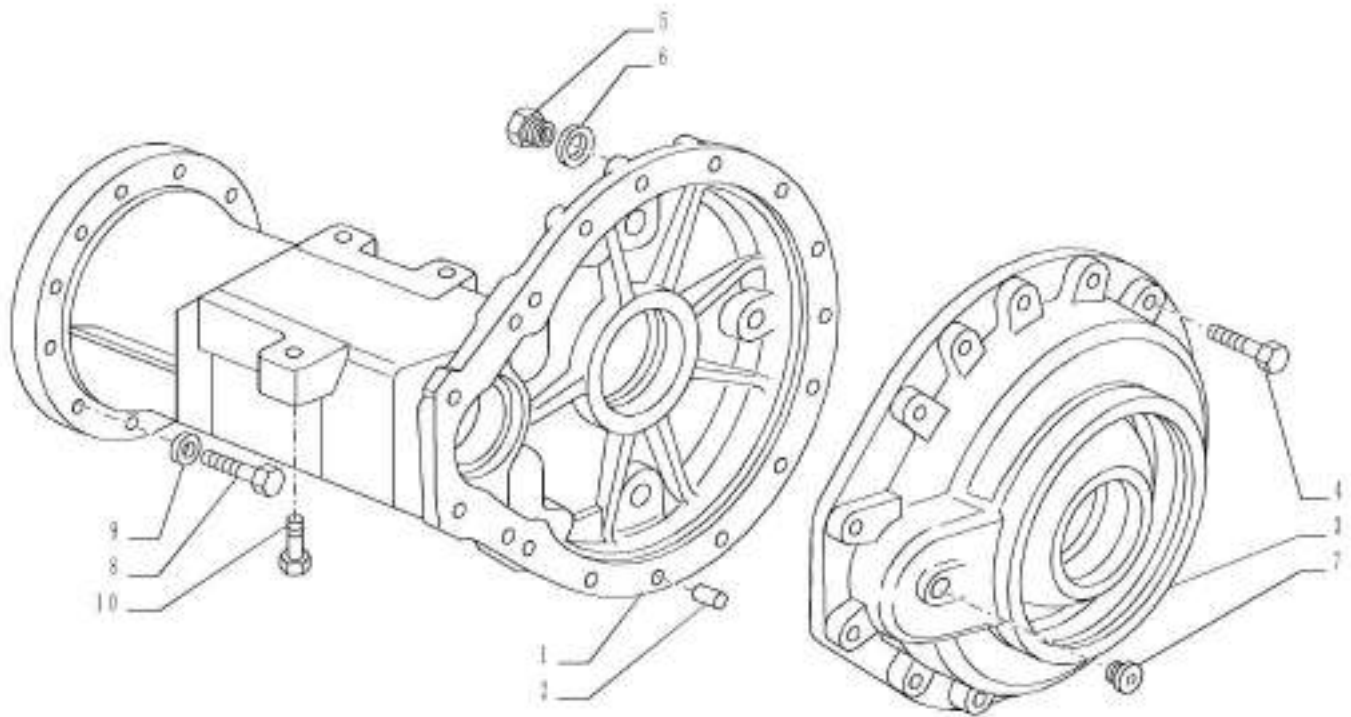

VAR - 720450, 744745 - SIDE REDUCER BOX AND COVERS

REF	FN	PART NUMBER	YR/SN	QTY DESCRIPTION
1	1	84480380		1 FINAL DRIVE HOUSING RH
1	1	84480378		1 FINAL DRIVE HOUSING LH
1	2	5098564		1 FINAL DRIVE HOUSING RH
1	2	5098575		1 FINAL DRIVE HOUSING LH
1	3	5098560		1 FINAL DRIVE HOUSING RH
1	3	5098572		1 FINAL DRIVE HOUSING LH
2		10839910		2 DOWEL
3	4	84480588		2 HOUSING
3	2	47411355		2 COVER
3	5	5089364		2 COVER
3	3	5116343		2 COVER
4		11307021		AR BOLT Hex, M10 x 1.25 x 40, 10.9, Full Thd
4	3	11306921		4 SCREW Hex, M10 x 1.25 x 30, 8.8, Full Thd
5		10305111		2 PLUG M22 x 1.5 x 21, CI5.8
6		10263460		2 SEAL 22.30mm ID x 28.00mm OD, 1.50mm, Copper
7		84209347		2 PLUG
8		15540831		AR BOLT Hex, M12 x 1.25 x 50, 10.9
8		15541031		AR BOLT Hex, M12 x 1.25 x 60mm, CI 10.9
9		11198679		AR BELLEVILLE WASHER Belleville, M13
10		15540931		AR BOLT Hex, M12 x 1.25 x 55, 10.9
10		15540831		AR BOLT Hex, M12 x 1.25 x 50, 10.9
(1)		Valid for FARMALL JX100, 110 Models Only		
(2)		Valid for FARMALL JX75, 80, 90 Models Only		
(3)		Valid for FARMALL JX70 Model Only		
(4)		Valid for FARMALL JX110 Model Only		
(5)		Valid for FARMALL JX100 Model Only		

Valid for Industrial Var. 334316, 390895 (720450) or Industrial Var. 344414, 390258 (744745)

FARMALL JX100 FARMALL
JX110 FARMALL JX70
FARMALL JX75 FARMALL
JX80 FARMALL JX90

VAR - 334396, 334397 - SIDE REDUCER BOX AND COVERS

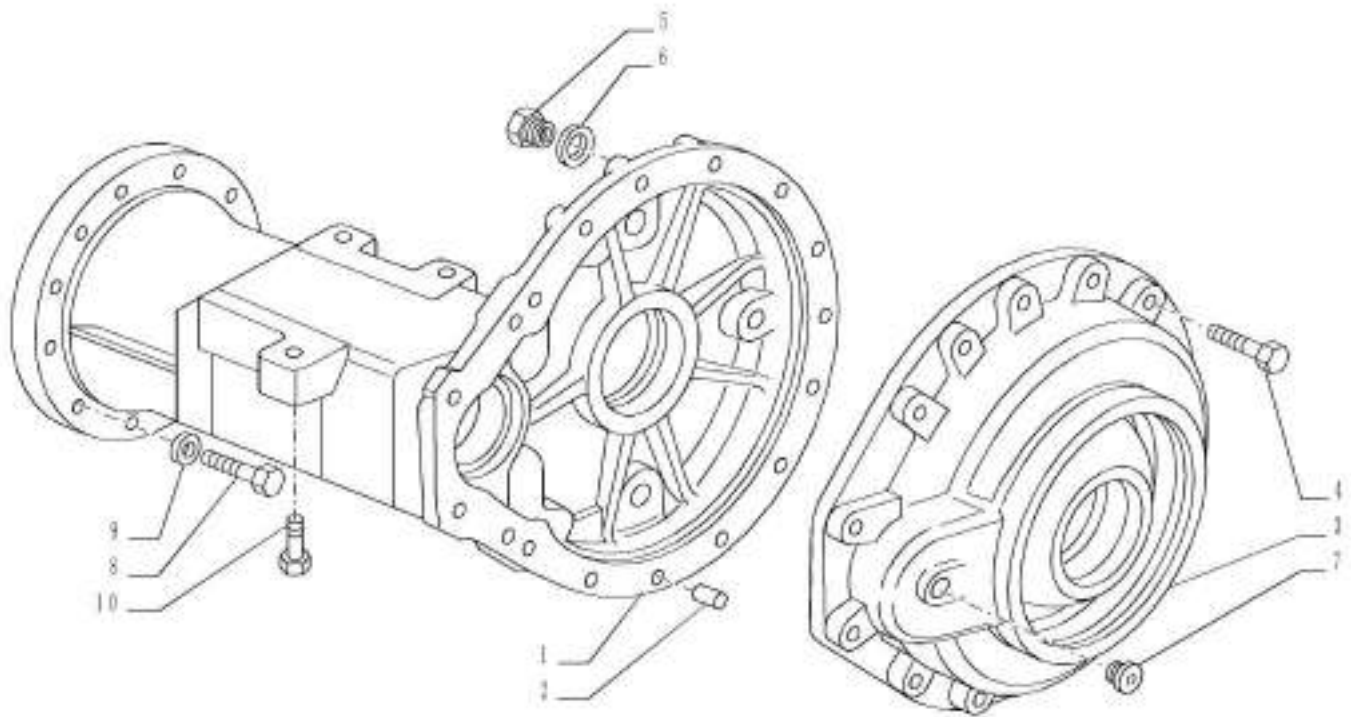

VAR - 334396, 334397 - SIDE REDUCER BOX AND COVERS

REF	FN	PART NUMBER	YR/SN	QTY	DESCRIPTION
1	1	84480380		1	FINAL DRIVE HOUSING RH
1	1	84480378		1	FINAL DRIVE HOUSING LH
1	2	5098564		1	FINAL DRIVE HOUSING RH
1	2	5098575		1	FINAL DRIVE HOUSING LH
1	3	5098560		1	FINAL DRIVE HOUSING RH
1	3	5098572		1	FINAL DRIVE HOUSING LH
2		10839910		2	DOWEL
3	^{3,4}	5144743		2	COVER
3	2	47411654		2	COVER
3	^{5,6}	84522545		2	COVER
3	^{7,6}	5092811		2	COVER
4		11307021			AR BOLT Hex, M10 x 1.25 x 40, 10.9, Full Thd
4	3	11306921		4	SCREW Hex, M10 x 1.25 x 30, 8.8, Full Thd
5		10305111		2	PLUG M22 x 1.5 x 21, CI5.8
6		10263460		2	SEAL 22.30mm ID x 28.00mm OD, 1.50mm, Copper
7		84209347		2	PLUG
8		15540831			AR BOLT Hex, M12 x 1.25 x 50, 10.9
8		15541031			AR BOLT Hex, M12 x 1.25 x 60mm, CI 10.9
9		11198679			AR BELLEVILLE WASHER Belleville, M13
10		15540931			AR BOLT Hex, M12 x 1.25 x 55, 10.9
10		15540831			AR BOLT Hex, M12 x 1.25 x 50, 10.9

- (1) Valid for FARMALL JX100, 110 Models Only
(2) Valid for FARMALL JX75, 80, 90 Models Only
(3) Valid for FARMALL JX70 Model Only
(4) VAR - 334396
(5) Valid for FARMALL JX110 Model Only
(6) VAR - 334397
(7) Valid for FARMALL JX100 Model Only

Valid for Var. 334396 or Var. 334397

FARMALL JX100 FARMALL
JX110 FARMALL JX70
FARMALL JX75 FARMALL
JX80 FARMALL JX90

VAR - 334396, 334397, 720450, 744745 - SHAFT & GEAR

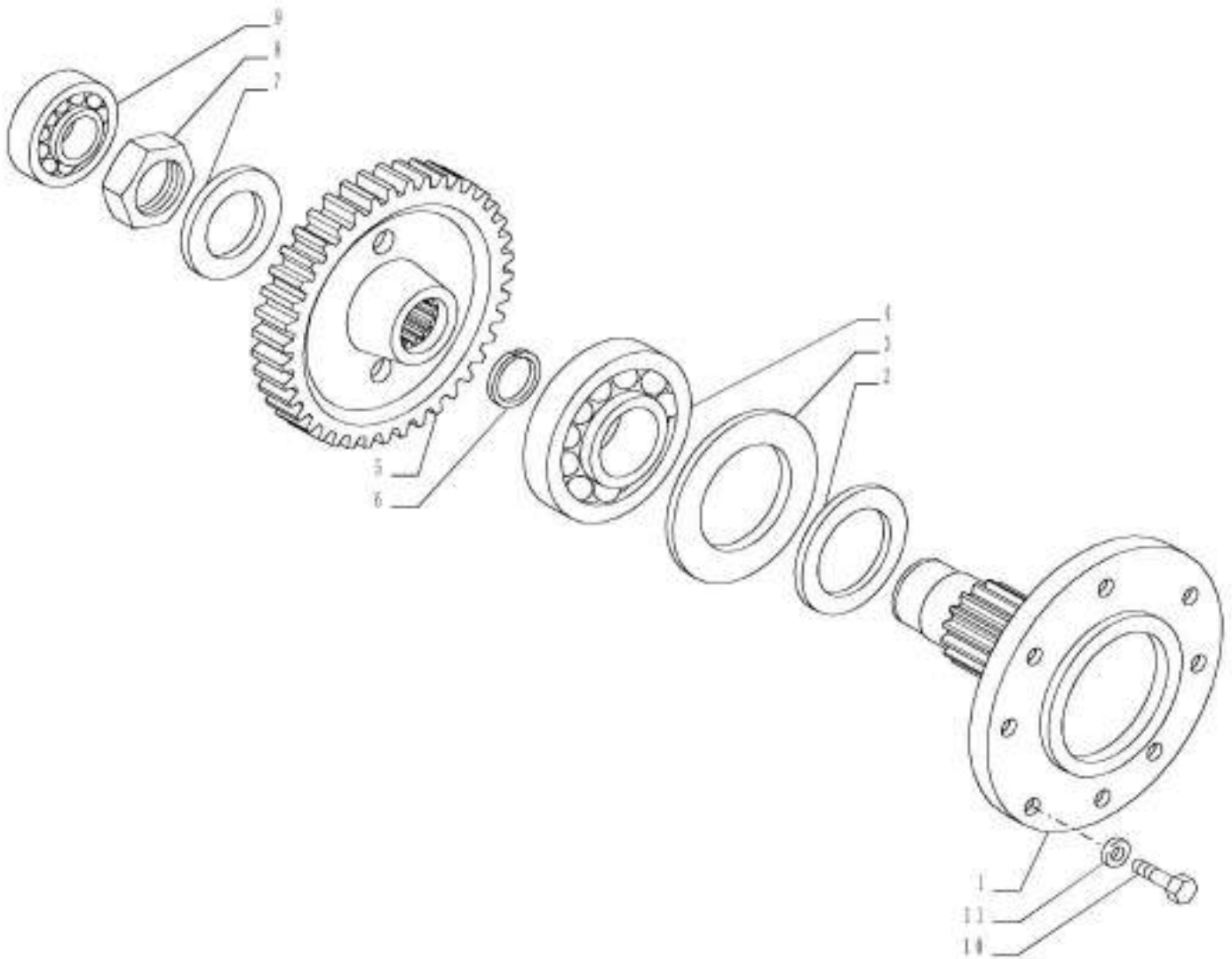

VAR - 334396, 334397, 720450, 744745 - SHAFT & GEAR

REF	FN	PART NUMBER	YR/SN	QTY	DESCRIPTION
1	1	5150148		2	CONTROL SHAFT
1	2	5142885		2	CONTROL SHAFT
1	3	5089368		2	SHAFT
1	4	5146834		2	CONTROL SHAFT
1	5	5144744		2	CONTROL SHAFT
1	6	5092812		2	SHAFT
2	7	5142887		2	SEAL
2	8	5123370		2	OIL SEAL
2	^{3,4}	5131916		2	SEAL
3	9	4995342		2	THRUST WASHER
3	¹⁰	5109810		2	WASHER, THRUST
4	9	26794760		2	BALL BEARING
4	¹¹	26794770		2	BALL BEARING
5	¹²	5140198		2	DRIVEN GEAR
5	9	5118431		2	DRIVEN GEAR
5	¹³	5128907		2	DRIVEN GEAR
5	¹⁴	5089367		2	GEAR
6	9	11076976		2	SNAP RING M140, Int
6	¹¹	11077476		2	SNAP RING M150, Int
7	9	563681		2	LOCK WASHER
(1)	VAR - 334414, 390258 (744745); Valid for FARMALL JX70 Model Only				
(2)	VAR - 334396, 334397; Valid for FARMALL JX75, 80, 90 Models Only				
(3)	VAR - 334416, 390895 (720450); Valid for FARMALL JX100 Model Only				
(4)	VAR - 334396 or 334397 or 334414, 390258 (744745) or 334315, 344416 (720450); Valid for FARMALL JX75, 80, 90				
(5)	VAR - 334396; Valid for FARMALL JX70 Model Only				
(6)	VAR - 334397; Valid for FARMALL JX100 Model Only				
(7)	VAR - 334396, 334397				
(8)	VAR - 34414, 390258 (744745); Valid for FARMALL JX70 Model Only				
(9)	Valid for FARMALL JX70 Model Only				
(10)	Valid for FARMALL JX75, 80, 90, 100 Models Only				
(11)	Valid for FARMALL JX75, 80, 90, 100 Models Only				
(12)	VAR - 334397 or 334315, 334416 (720450); Valid for FARMALL JX75, 90 Models Only				
(13)	VAR - 334396 or 334315, 334414, 390258 (744745); Valid for FARMALL JX75, 90 Models Only				
(14)	Valid for FARMALL JX100 Model Only				
Valid for Var. 334396 or Var. 334397 or Industrial Var. 334315, 334416 (720450) or Industrial Var. 344414, 390258 (744745)					FARMALL JX100 FARMALL JX70 FARMALL JX75 FARMALL JX80

VAR - 334396, 334397, 720450, 744745 - SHAFT & GEAR

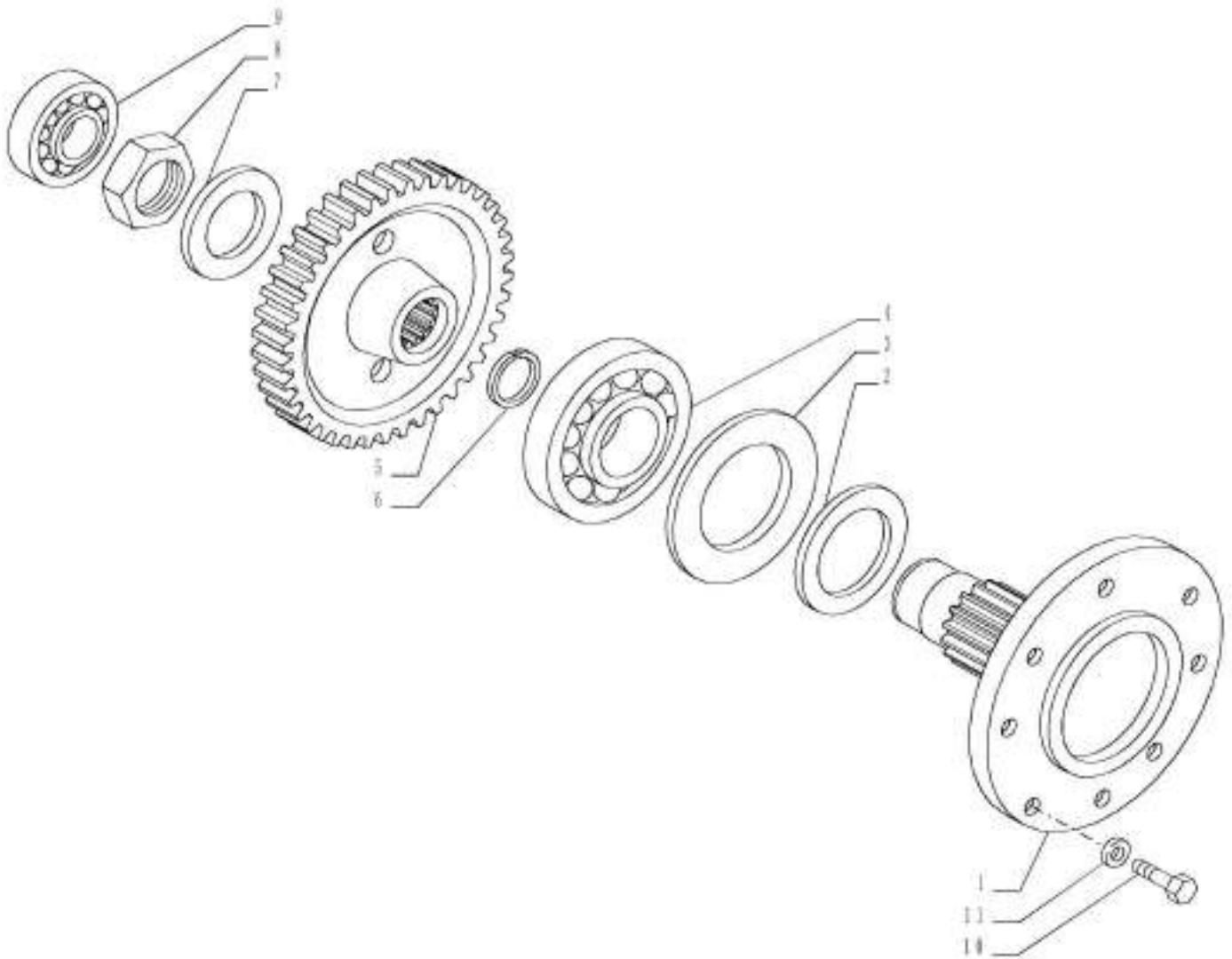

VAR - 334396, 334397, 720450, 744745 - SHAFT & GEAR

REF	FN	PART NUMBER	YR/SN	QTY	DESCRIPTION
7	1	5109858		2	WASHER
8	2	5140609		2	NUT
8	3	5140202		2	NUT
8	4	5089369		2	NUT
9	2	20033750		2	BALL BEARING 45 mm ID x 100 mm OD x 25 mm
9	^{5,4}	20065730		2	BALL BEARING 55 mm ID x 120 mm OD x 29 mm
9	6	5161994		2	CYLINDRICAL ROLLER BEARING 55 mm ID x 120 mm OD x 29 mm
10		11408524		16	SCREW Hex, M18 x 1.5 x 40, 8.8, Full Thd
11		44011091		16	WASHER 19.00mm ID x 40.00mm OD x 6.0mm

(1) Valid for FARMALL JX75, 80, 90, 100 Models Only

(2) Valid for FARMALL JX70 Model Only

(3) Valid for FARMALL JX75, 80, 90 Models Only

(4) Valid for FARMALL JX100 Model Only

(5) VAR - 334396 or 334315, 334414, 390258 (744745); Valid for FARMALL JX75, 90 Models Only

(6) VAR - 334397 or 334315, 334416 (720450); Valid for FARMALL JX75, 90 Models Only

Valid for Var. 334396 or Var. 334397 or Industrial Var. 334315, 334416 (720450) or Industrial Var. 344414, 390258 (744745)

FARMALL JX100
 FARMALL JX70
 FARMALL JX75
 FARMALL JX80

VAR - 334397, 334416, 390895, 720450 - SHAFT & GEAR

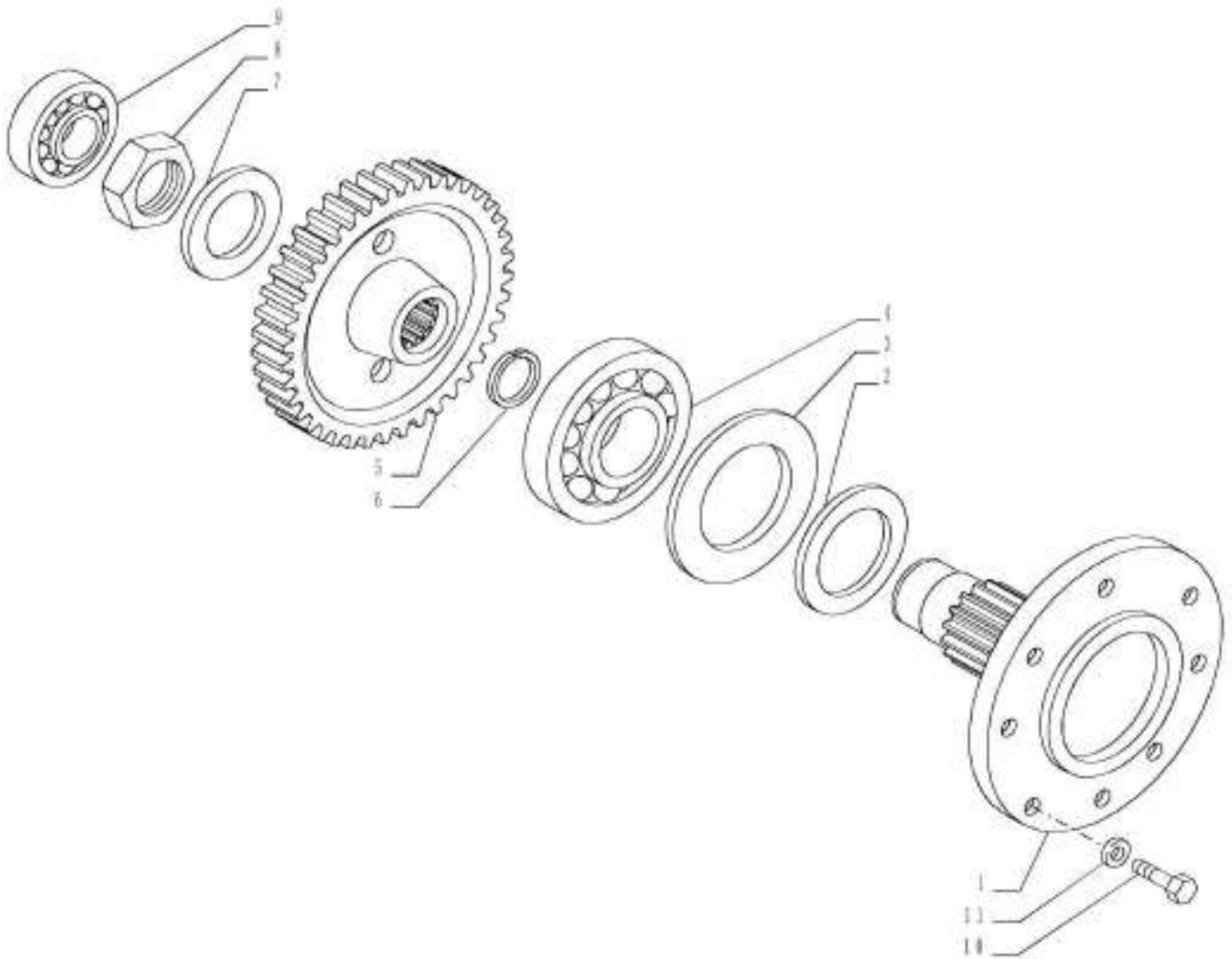

27.120.AR

02

p1

1/2014

VAR - 334397, 334416, 390895, 720450 - SHAFT & GEAR

REF FN	PART NUMBER	YR/SN	QTY DESCRIPTION
1	84401113		2 HALF SHAFT
1	1 84522547		2 SPINDLE
2	5131916		2 SEAL
3	5109858		2 WASHER
4	84481249		2 BALL BEARING
5	84401114		2 GEAR
6	11077976		2 SNAP RING M160, Int
7	84481252		2 WASHER
8	5089369		2 NUT
9	5161994		2 CYLINDRICAL ROLLER BEARING 55 mm ID x 120 mm OD x 29 mm
10	11408524		16 SCREW Hex, M18 x 1.5 x 40, 8.8, Full Thd
11	44011091		16 WASHER 19.00mm ID x 40.00mm OD x 6.0mm
(1)	VAR - 334397		

Valid for Var. 334397 or Industrial Var. 334416, 390895 (720450)

FARMALL JX110

SECTION INDEX

IMPLEMENT POWER TAKE OFF

31.000.00	01	SECTION INDEX - IMPLEMENT POWER TAKE-OFF
31.101.AB	01	VAR - 334394, 335805, 335818, 390813 - PTO CONTROLS
31.101.AB	02	VAR - 334394, 335805, 335818 - PTO, CONTROLS
31.101.AC	01	VAR - 390249 - PTO CONTROLS
31.101.AC	02	VAR - 390249 - PTO CONTROLS, BREAKDOWN
31.101.AC	03	VAR - 330120, 331120, 743846 - PTO CONTROLS
31.101.AC	04	VAR - 330120, 331120, 743846 - PTO CONTROLS
31.110.AB	01	VAR - 390813 - PTO SHAFT, GEAR
31.110.AB	02	VAR - 335818 - SHAFT & GEAR
31.110.AB	03	VAR - 334394, 335805, 335818 - FORK, ROD
31.110.AB	04	VAR - 334394, 335805 - PTO 540/1000 RPM - SHAFT AND GEARS
31.110.AI	01	VAR - 390813 - PTO, COVER
31.110.AI	02	VAR - 334394, 335805, 335818 - PTO, COVER
31.110.AI	03	VAR - 334394, 335805, 335818, 390813, 744751 - PTO, SHIELD
31.110.AO	01	VAR - 330120, 331120, 743846 - POWER SHUTTLE AND SERVO PTO FOR DIFF. LOCK, PTO CLUTCH CONTROL SAND LEVER LINK
31.201.AG	01	VAR - 390249 - PTO SHAFT
31.201.AG	02	VAR - 330120, 331120, 743846 - PTO SHAFT

SECTION INDEX - IMPLEMENT POWER TAKE-OFF

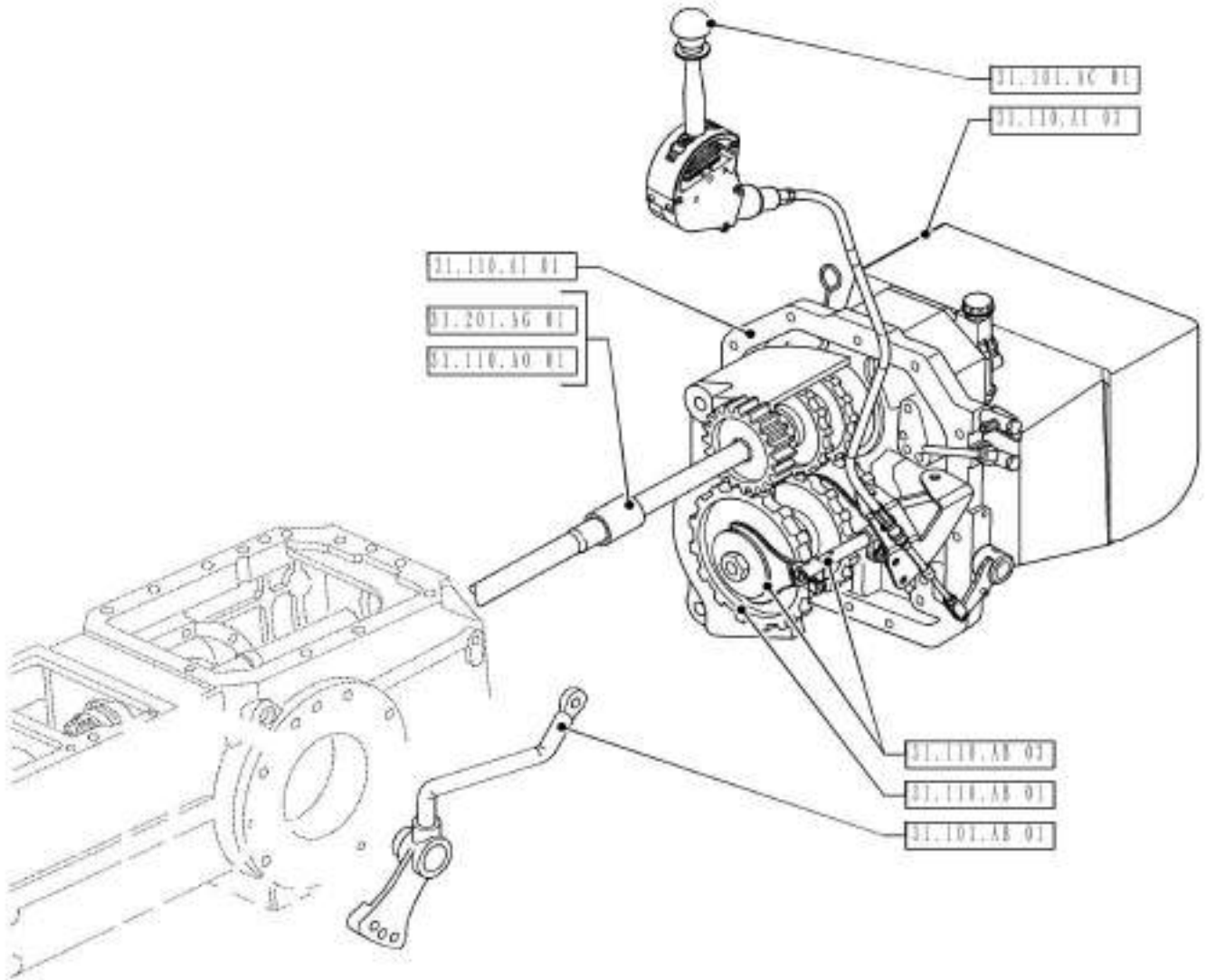

31.000.00

01

p1

1/2014

SECTION INDEX - IMPLEMENT POWER TAKE-OFF

REF FN	PART NUMBER	YR/SN	QTY	DESCRIPTION
---------------	--------------------	--------------	------------	--------------------

				FARMALL JX100 FARMALL JX110 FARMALL JX70 FARMALL JX75 FARMALL JX80 FARMALL JX90
--	--	--	--	--

VAR - 334394, 335805, 335818, 390813 - PTO CONTROLS

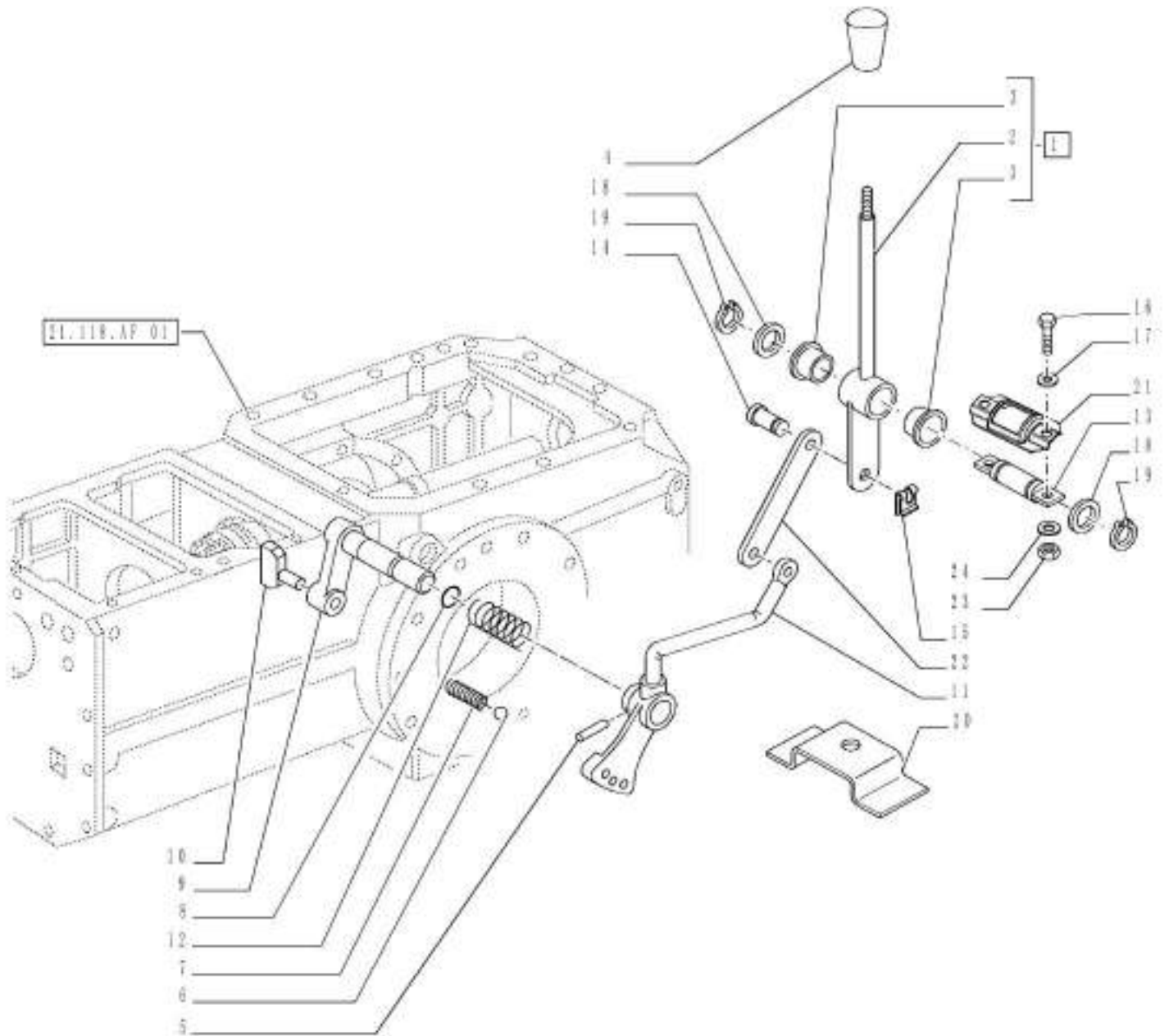

VAR - 334394, 335805, 335818, 390813 - PTO CONTROLS

REF FN	PART NUMBER	YR/SN	QTY DESCRIPTION
1	47374239		1 SHAFT Incl 2 - 3
2	NSS		1 NOT SERVICED SEPARATELY Lever Incl in 1
3	5089036		2 BUSHING
4	5087838		1 KNOB
5	13910370		1 ROLL PIN M6 x 30, Coiled
6	20063390		1 BALL
7	4994342		1 SPRING
8	14453180		1 O-RING 12.42mm ID x 1.78mm
9	5129848		1 LEVER
10	4984096		1 LEVER
11	5094439		1 ARM
12	580548		1 SPRING
13	5089034		1 LEVER
14	5092892		2 PIN
15	11064174		2 CLIP
16	10902721		2 SCREW Hex, M6 x 28, 8.8, Full Thd
17	12601274		2 WAVE WASHER Wave, M6.4
18	5089106		2 WASHER
19	11066676		2 SNAP RING M18, Ext
20	5095547		2 SUPPORT
21	5094622		1 GASKET
22	5094550		1 ARM
23	15896211		2 NUT M6, CI 8
24	11194671		2 BELLEVILLE WASHER Belleville, M6.4

Valid for Var. 334394 or Var. 335805 or Var. 335818 or Var. 390813

FARMALL JX100 FARMALL
JX110 FARMALL JX70
FARMALL JX75 FARMALL
JX80 FARMALL JX90

31.101.AB

02

p1

1/2014

VAR - 334394, 335805, 335818 - PTO, CONTROLS

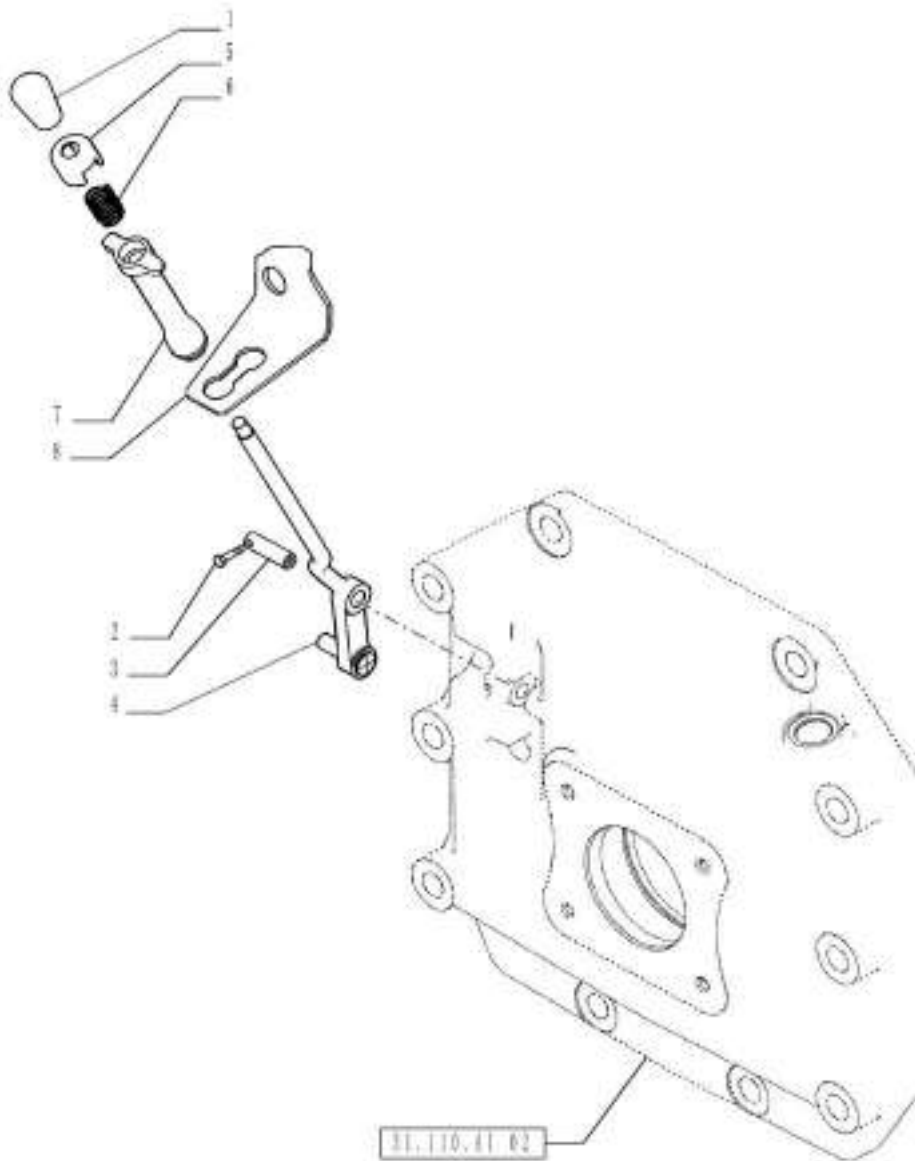

VAR - 334394, 335805, 335818 - PTO, CONTROLS

REF FN	PART NUMBER	YR/SN	QTY DESCRIPTION
1	5087838		1 KNOB
2	84217535		1 LEVER
3	5117036		1 PIN
4	13910470		1 ROLL PIN M6 x 32, Coiled
5	5153685		1 CUP
6	4952341		1 SPRING
7	5096582		1 SELECTOR
8	87732042		1 SUPPORT

Valid for Var. 334394 or Var. 335805 or Var. 335818	FARMALL JX100 FARMALL JX110 FARMALL JX70 FARMALL JX75 FARMALL JX80 FARMALL JX90
---	--

VAR - 390249 - PTO CONTROLS

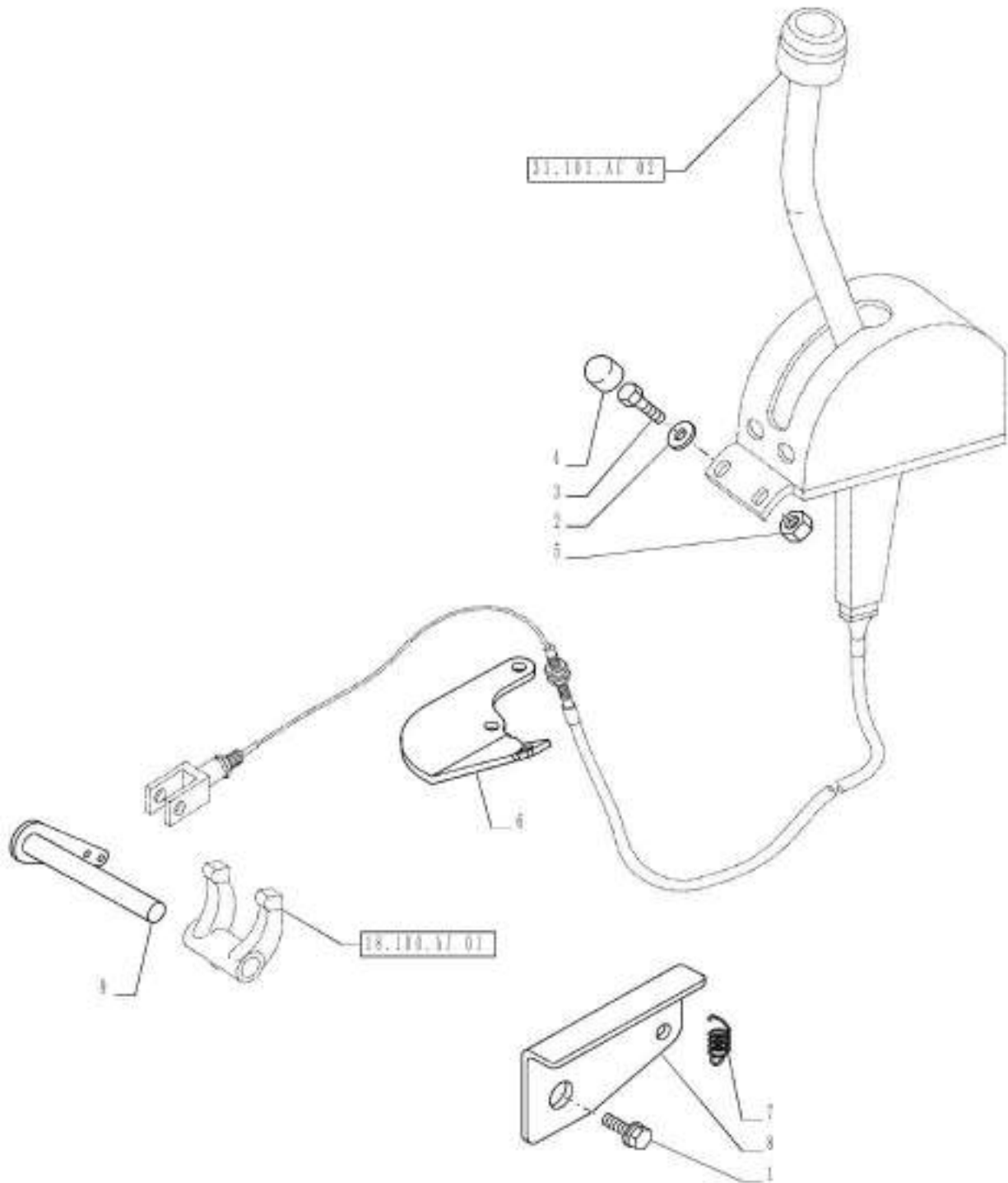

VAR - 390249 - PTO CONTROLS

REF	FN	PART NUMBER	YR/SN	QTY	DESCRIPTION
1	1	15854424		1	BOLT Hex, M16 x 1.5 x 18mm, CI 8.8, Full Thd
2		12601374		4	WAVE WASHER Wave, 8.40mm ID x 15.00mm OD x 0.80mm, 3.00mm, CST, DAC
3		86625000		2	BOLT Hex, M8 x 18mm, CI 8.8, Full Thd
4		5089481		2	CAP
5		16100821		2	NUT M8, CI 10
6	2	84327690		1	SUPPORT
6	1	5097823		1	SUPPORT
7	1	84342335		1	SPRING
7	2	84325650		1	SPRING
8		84325649		1	SUPPORT
9	2	5097667		1	LEVER
9	1	84355759		1	LEVER

(1) Valid for FARMALL JX70, 75, 80, 90, 100 Models Only

(2) Valid for FARMALL JX110 Model Only

Valid for Var. 390249

FARMALL JX100 FARMALL
JX110 FARMALL JX70
FARMALL JX75 FARMALL
JX80 FARMALL JX90

VAR - 390249 - PTO CONTROLS, BREAKDOWN

REF FN	PART NUMBER	YR/SN	QTY DESCRIPTION
1	47410758		1 CONTROL LEVER
2	NSS		1 NOT SERVICED SEPARATELY Support Incl in 1
3	5098019		1 COVER
4	5087838		1 KNOB
5	84327700		1 PIN
6	11065476		1 SNAP RING M6, Ext
7	5098024		4 RIVET
8	47385791		1 CABLE
9	84148267		1 ELECTRIC CABLE
10	5093385		1 PARK BRAKE SWITCH

Valid for Var. 390249

FARMALL JX100 FARMALL
 JX110 FARMALL JX70
 FARMALL JX75 FARMALL
 JX80 FARMALL JX90

VAR - 330120, 331120, 743846 - PTO CONTROLS

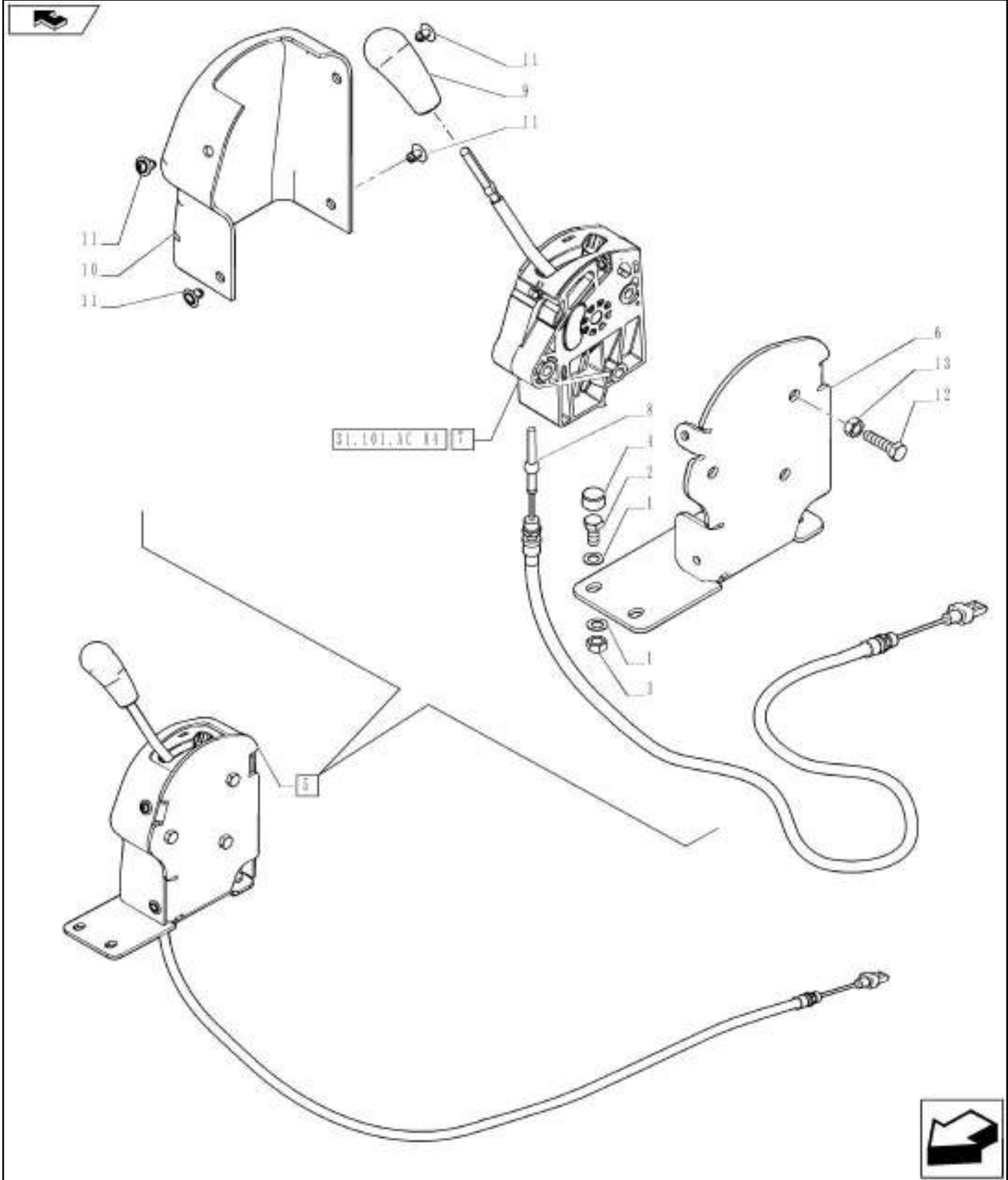

VAR - 330120, 331120, 743846 - PTO CONTROLS

REF FN	PART NUMBER	YR/SN	QTY DESCRIPTION
1	12601374		4 WAVE WASHER Wave, 8.40mm ID x 15.00mm OD x 0.80mm, 3.00mm, CST, DAC
2	86625000		2 BOLT Hex, M8 x 18mm, CI 8.8, Full Thd
3	16100821		2 NUT M8, CI 10
4	5089481		2 CAP
5	84519410		1 LEVER
6	84519412		1 SUPPORT
7	84550094		1 LEVER
8	84550918		1 CABLE
9	5194972		1 KNOB
10	84388724		1 COVER
11	5098024		4 RIVET
12	16043821		3 SCREW Hex, M8 x 1.25 x 30mm, CI 8.8, Full Thd
13	16100821		3 NUT M8, CI 10
14	15896221		2 NUT M6, CI 10

Valid for Industrial Var. 330120, 331120 (743846)

FARMALL JX100
 FARMALL JX110
 FARMALL JX75
 FARMALL JX90

VAR - 330120, 331120, 743846 - PTO CONTROLS

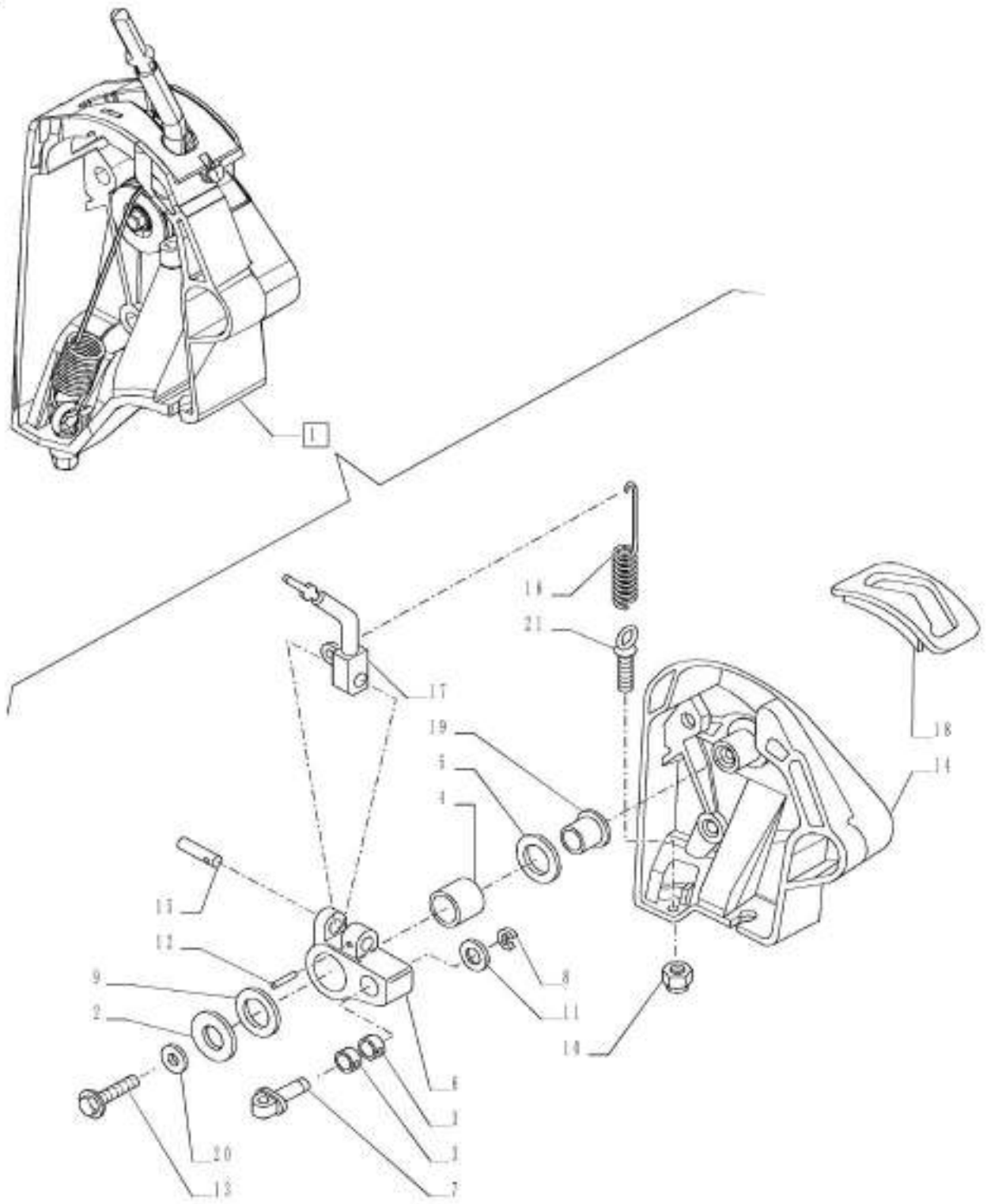

VAR - 330120, 331120, 743846 - PTO CONTROLS

REF FN	PART NUMBER	YR/SN	QTY DESCRIPTION
1	84550094		1 LEVER Incl 2 - 21
2	87528262		1 ANTI-WRAP PLATE
3	5188230		2 NEEDLE BEARING D=8
4	5191013		1 ROLLER BEARING 22 mm ID x 28 mm OD x 20 mm D=22
5	5191656		1 CUP WASHER
6	5191700		1 BUSHING
7	47131077		1 PIN
8	11087874		1 CIRCLIP M6
9	87528222		1 WASHER
10	12574221		1 NUT M6 x 1, CI 10
11	12638504		1 WASHER M8 x 15 x 1.5
12	14159674		1 ROLL PIN
13	15924904		1 SCREW
14	87325898		1 SUPPORT Incl 19
15	47123110		1 PIN
16	84206711		1 SPRING
17	NSS		1 NOT SERVICED SEPARATELY Lever Incl in 1
18	87325900		1 SECTOR
19	87325901		1 BUSHING
20	12644404		1 WASHER M6 x 15 x 1
21	5115351		1 HOOK

Valid for Industrial Var. 330120, 331120 (743846)

FARMALL JX100
 FARMALL JX110
 FARMALL JX75
 FARMALL JX90

31.110.AB

01

p1

1/2014

VAR - 390813 - PTO SHAFT, GEAR

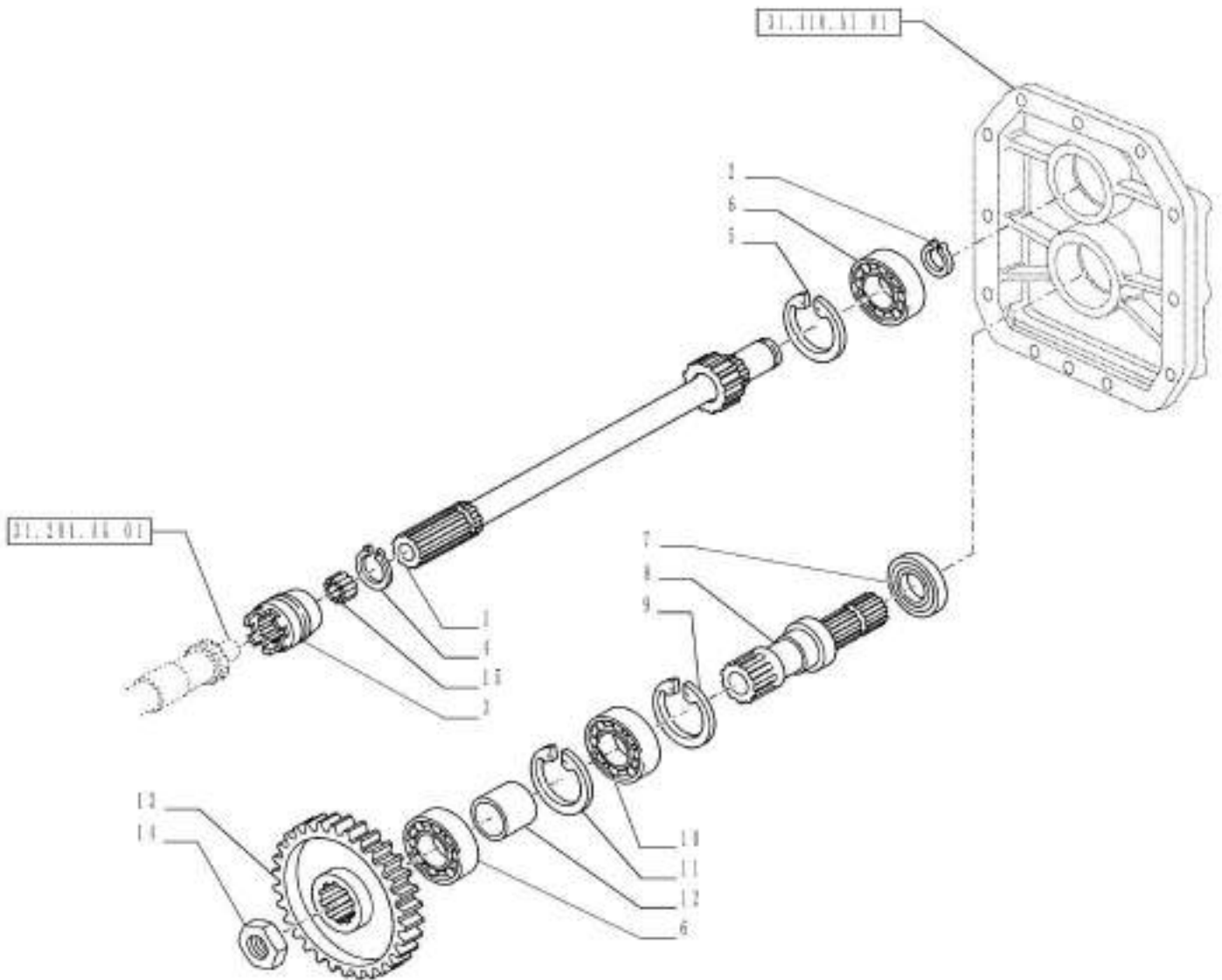

31.110.AB

01

p1

1/2014

VAR - 390813 - PTO SHAFT, GEAR

REF FN	PART NUMBER	YR/SN	QTY DESCRIPTION
1	47132989		1 SHAFT
2	11068876		1 SNAP RING M40, Ext
3	5167983		1 DRIVE BUSHING
4	11068376		1 SNAP RING M35, Ext x 1.5 Thk
5	11062476		1 SNAP RING M90, Int
6	20943310		2 BALL BEARING 40.00mm x 90.00mm x 23.00mm
7	5111518		1 SEAL
8	5109726		1 SHAFT
9	11061976		1 SNAP RING M80, Int
10	20915780		1 BALL BEARING 40.00mm ID x 80.00mm OD x 18.00mm
11	5164109		1 CIRCLIP
12	5109727		1 SPACER
13	5109725		1 DRIVEN GEAR
14	5122985		1 NUT Ring, M32, 1.5 Pitch
15	5103238		1 NEEDLE BEARING 15mm ID x 21mm OD x 16mm

Valid for Var. 390813

FARMALL JX100 FARMALL
JX110 FARMALL JX70
FARMALL JX75 FARMALL
JX80 FARMALL JX90

VAR - 335818 - SHAFT & GEAR

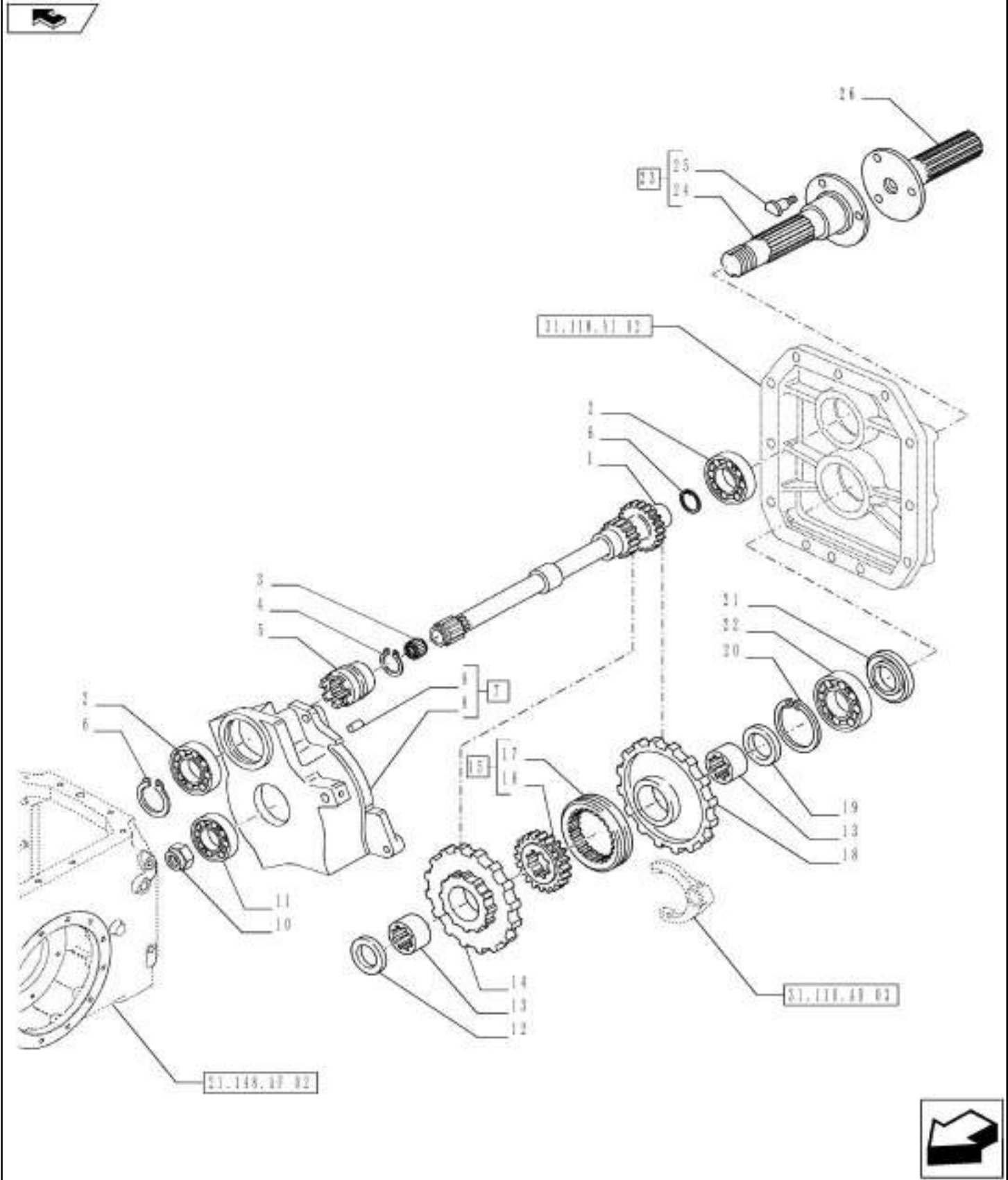

31.110.AB

02

p1

1/2014

VAR - 335818 - SHAFT & GEAR

REF FN	PART NUMBER	YR/SN	QTY DESCRIPTION
1	87578800		1 SHAFT
2	20943310		2 BALL BEARING 40.00mm x 90.00mm x 23.00mm 40 x 90 x 23
3	5103238		1 NEEDLE BEARING 15mm ID x 21mm OD x 16mm 15 x 21 x 16
4	11068376		2 SNAP RING M35, Ext x 1.5 Thk
5	5167983		1 DRIVE BUSHING
6	11062476		1 SNAP RING M90, Int
7	84209983		1 COVER Assy Incl 8 - 9
8	NSS		1 NOT SERVICED SEPARATELY Cover Incl in 7
9	10839710		2 DOWEL M10 x 15.00mm 10 x 15
10	5122985		1 NUT Ring, M32, 1.5 Pitch
11	20045200		1 BALL BEARING 35 mm ID x 80 mm OD x 21 mm
12	5122797		1 THRUST WASHER
13	5101537		2 BUSHING
14	47124070		1 GEAR
15	87311694		1 SLEEVE Incl 16 - 17
16	5129512		1 SLEEVE
17	5129513		1 SLEEVE
18	47124071		1 GEAR
19	5109656		1 THRUST WASHER
20	11062476		1 SNAP RING M90, Int
21	5119203		1 SEAL
22	20943310		1 BALL BEARING 40.00mm x 90.00mm x 23.00mm
23	5117501		1 SHAFT Assy Incl 24 - 25
24	NSS		1 NOT SERVICED SEPARATELY Shaft Incl in 1
25	44012300		3 SCREW
26	5185602		1 SHAFT 540 RPM

Valid for Var. 335818

FARMALL JX100 FARMALL
 JX110 FARMALL JX70
 FARMALL JX75 FARMALL
 JX80 FARMALL JX90

31.110.AB

03

p1

1/2014

VAR - 334394, 335805, 335818 - FORK, ROD

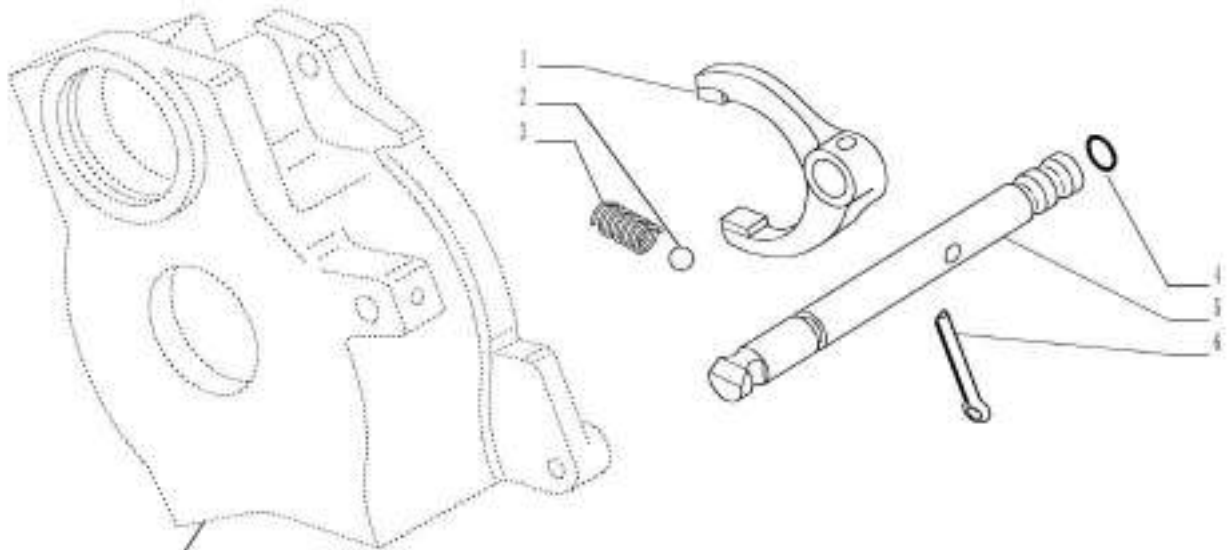

31.110.AB 03



31.110.AB

03

p1

1/2014

VAR - 334394, 335805, 335818 - FORK, ROD

REF FN	PART NUMBER	YR/SN	QTY DESCRIPTION
1	5097820		1 FORK
2	20063390		1 BALL
3	4994342		1 SPRING
4	14457080		1 O-RING 0.487" ID x 0.103"
5	84237856		1 PIN
6	14163170		1 LOCK PIN M4 x 24, Slotted

Valid for Var. 334394 or Var. 335805 or Var. 335818

FARMALL JX100 FARMALL
JX110 FARMALL JX70
FARMALL JX75 FARMALL
JX80 FARMALL JX90

VAR - 334394, 335805 - PTO 540/1000 RPM - SHAFT AND GEARS

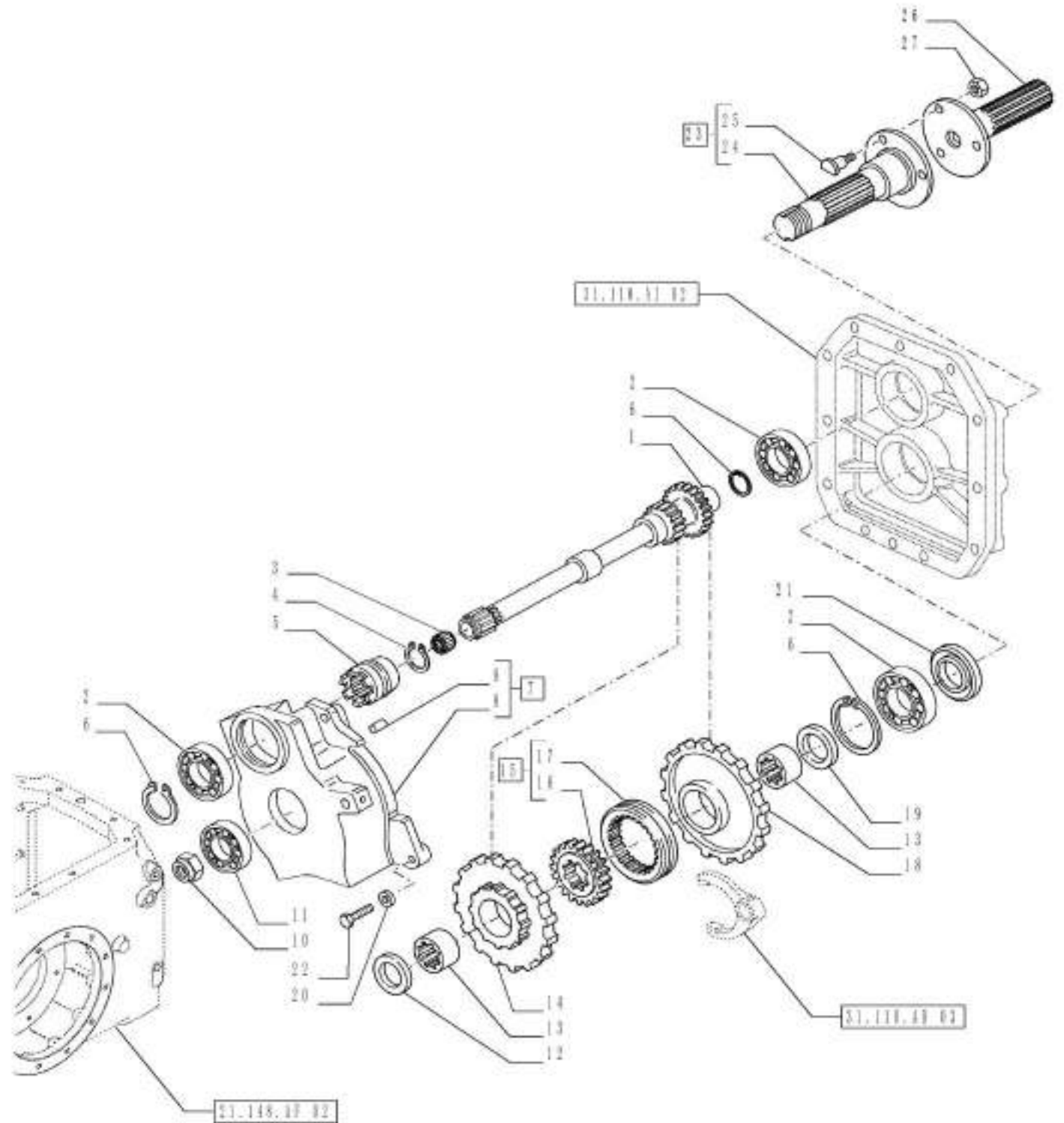

31.110.AB

04

p1

1/2014

VAR - 334394, 335805 - PTO 540/1000 RPM - SHAFT AND GEARS

REF FN	PART NUMBER	YR/SN	QTY DESCRIPTION
1	87578799		1 SHAFT
2	20943310		3 BALL BEARING 40.00mm x 90.00mm x 23.00mm
3	5103238		1 NEEDLE BEARING 15mm ID x 21mm OD x 16mm 15x21x16
4	11068376		1 SNAP RING M35, Ext x 1.5 Thk
5	5167983		1 DRIVE BUSHING
6	11062476		2 SNAP RING M90, Int
7	84209983		1 COVER Incl. 8, 9
8	NSS		1 NOT SERVICED SEPARATELY Inc in 7
9	10839710		2 DOWEL M10 x 15.00mm
10	5122985		1 NUT Ring, M32, 1.5 Pitch
11	20045200		1 BALL BEARING 35 mm ID x 80 mm OD x 21 mm
12	5122797		1 THRUST WASHER
13	5101537		2 BUSHING
14	47124070		1 GEAR
15	87311694		1 SLEEVE Incl. 16, 17
16	5129512		1 SLEEVE
17	5129513		1 SLEEVE
18	47124069		1 GEAR
19	5109656		1 THRUST WASHER
20	11198674		4 BELLEVILLE WASHER Belleville, M13
21	5119203		1 SEAL 55x80x10
22	15540634		4 BOLT Hex, M12 x 1.25 x 40, 10.9, Full Thd
23	5117501		1 SHAFT Incl 24, 25
24	NSS		1 NOT SERVICED SEPARATELY Shaft Incl in 23
25	44012300		3 SCREW
26	5185602		1 SHAFT 540 RPM, Z=6
27	16105021		3 LOCK NUT M12 x 1.25, CI 10

Valid for Var. 334394 or Var. 335805

FARMALL JX100 FARMALL
 JX110 FARMALL JX70
 FARMALL JX75 FARMALL
 JX80 FARMALL JX90

VAR - 390813 - PTO, COVER

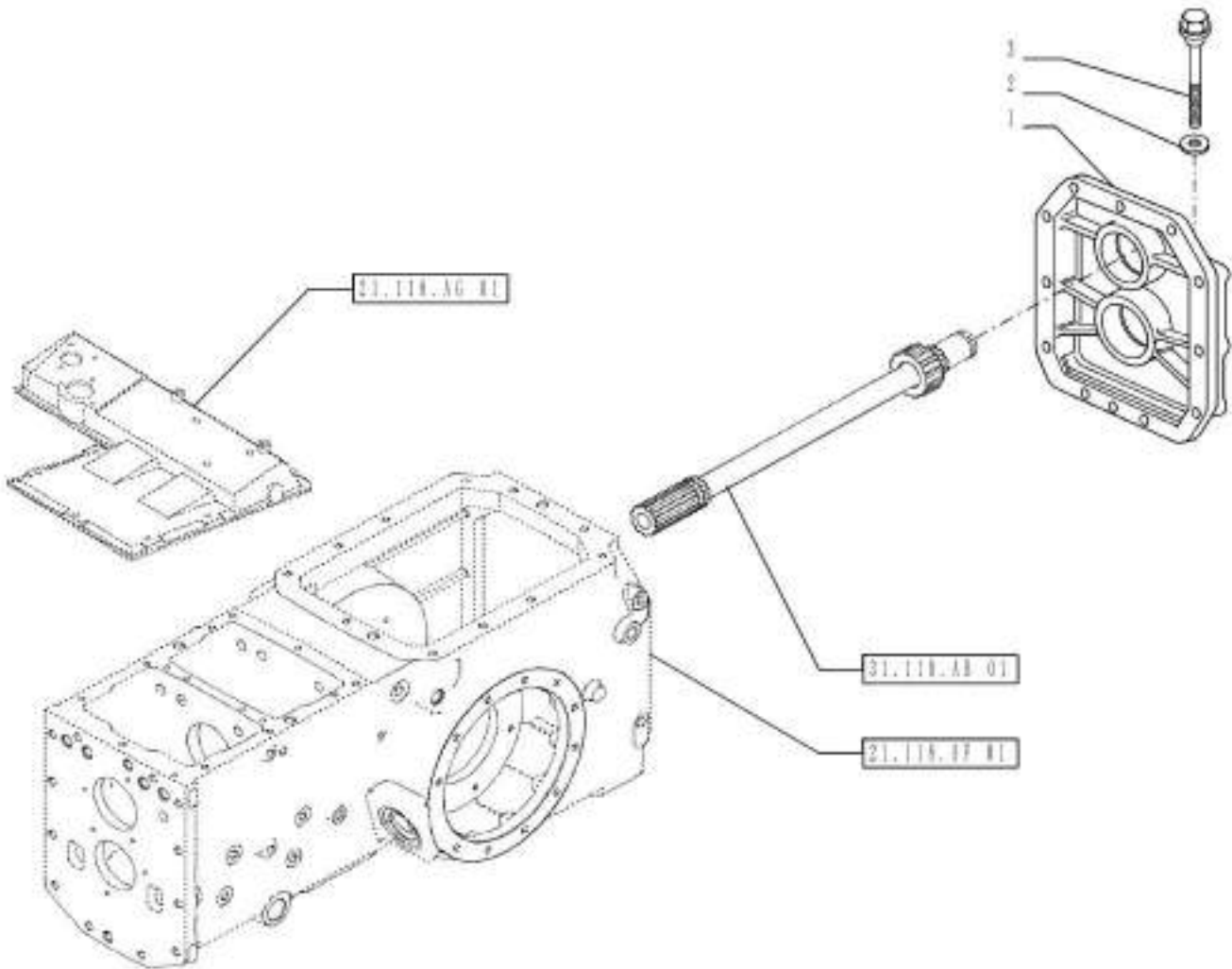

31.110.AI

01

p1

1/2014

VAR - 390813 - PTO, COVER

REF FN	PART NUMBER	YR/SN	QTY DESCRIPTION
1	5164003		1 COVER
2	10263460		1 SEAL 22.30mm ID x 28.00mm OD, 1.50mm, Copper
3	47134050		1 DIPSTICK

Valid for Var. 390813

FARMALL JX100 FARMALL
JX110 FARMALL JX70
FARMALL JX75 FARMALL
JX80 FARMALL JX90

VAR - 334394, 335805, 335818 - PTO, COVER

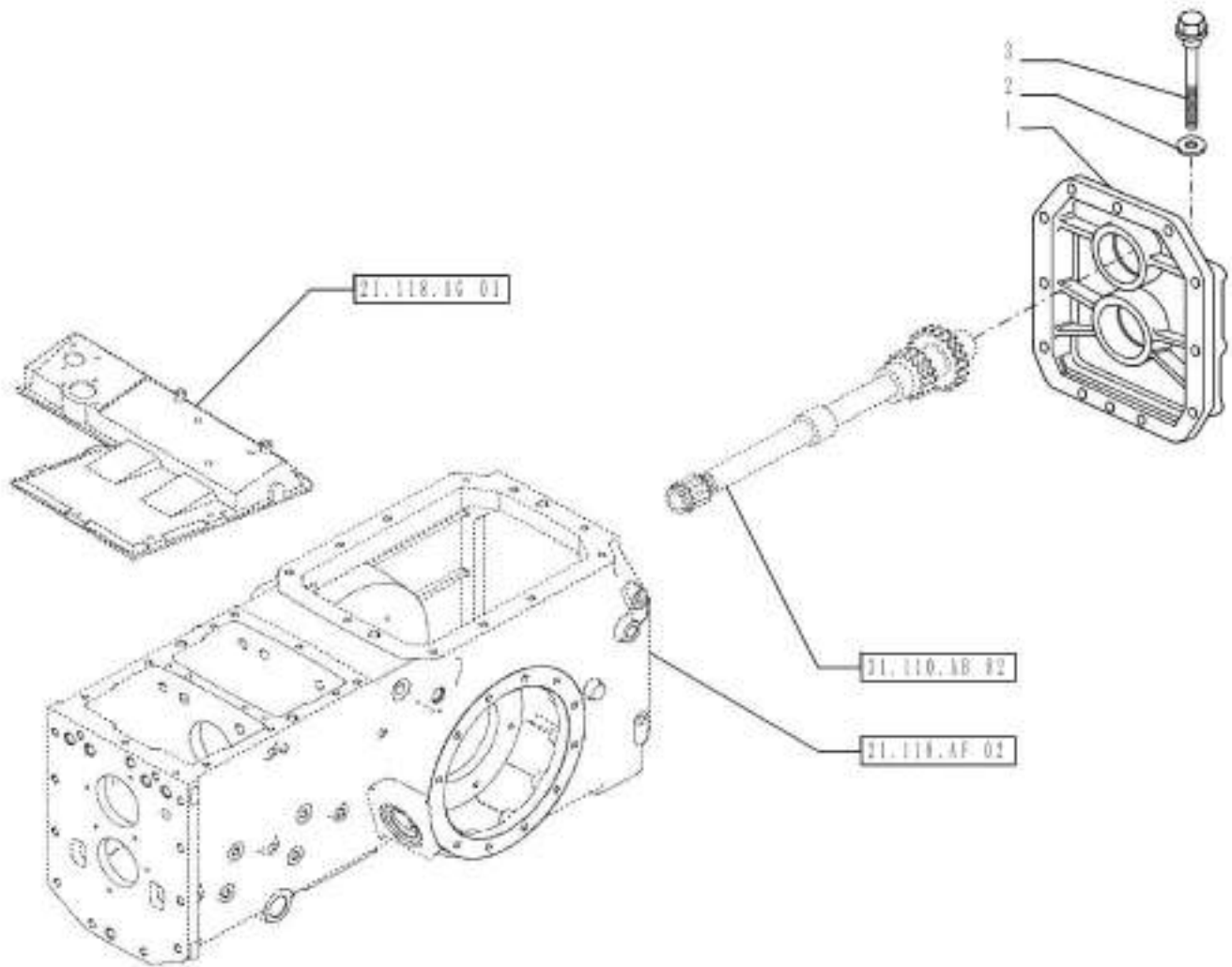

31.110.AI

02

p1

1/2014

VAR - 334394, 335805, 335818 - PTO, COVER

REF FN	PART NUMBER	YR/SN	QTY DESCRIPTION
1	84204869		1 COVER
2	10263460		1 SEAL 22.30mm ID x 28.00mm OD, 1.50mm, Copper
3	47134050		1 DIPSTICK

Valid for Var. 334394 or Var. 335805 or Var. 335818

FARMALL JX100 FARMALL
JX110 FARMALL JX70
FARMALL JX75 FARMALL
JX80 FARMALL JX90

31.110.AI

03

p1

1/2014

VAR - 334394, 335805, 335818, 390813, 744751 - PTO, SHIELD

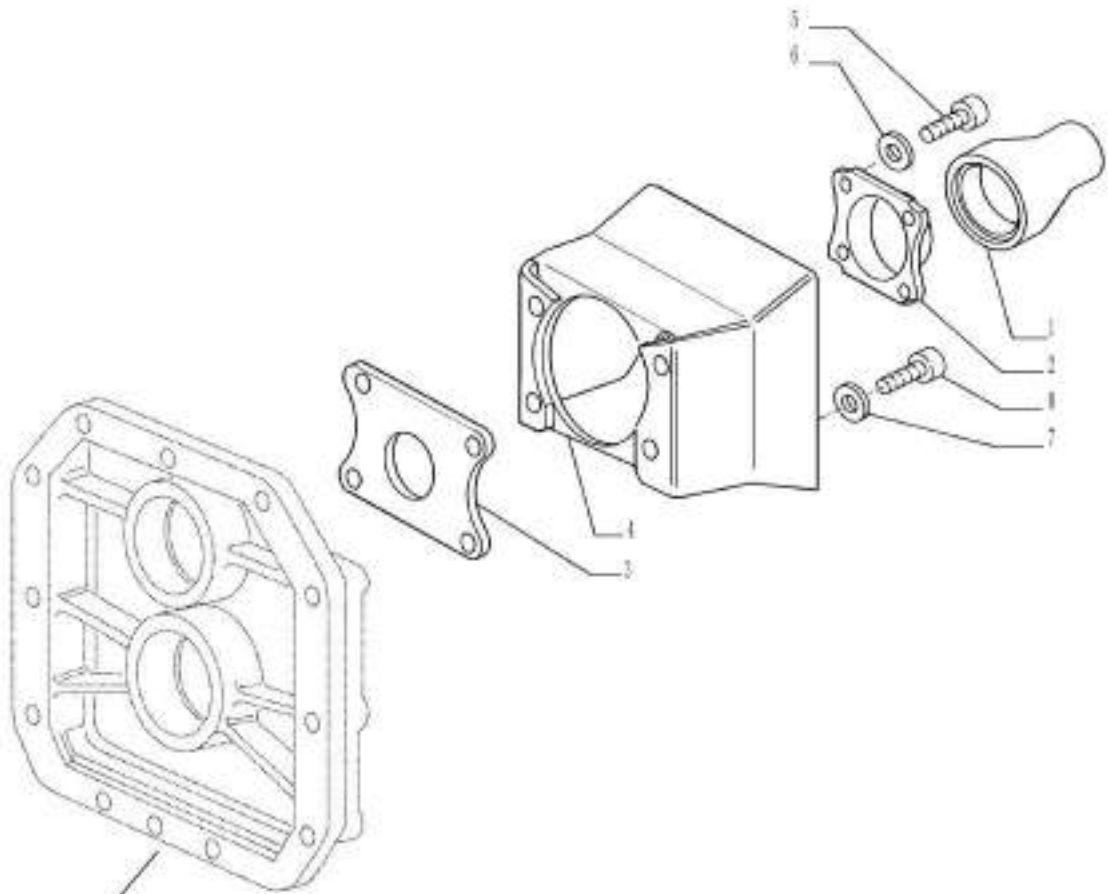

31.110.AI 01



VAR - 334394, 335805, 335818, 390813, 744751 - PTO, SHIELD

REF FN	PART NUMBER	YR/SN	QTY DESCRIPTION
1	5171520		1 SHIELD
2	1 84402411		1 GUARD
3	2 5104039		1 GUARD
3	3 4997320		1 GUARD
4	5093969		1 GUARD
4	4 5104469		1 SHIELD
5	120104		4 BOLT Hex, M8 x 1.25 x 20mm, Cl 8.8, Full Thd
6	12601374		4 WAVE WASHER Wave, 8.40mm ID x 15.00mm OD x 0.80mm, 3.00mm, CST, DAC
7	14499404		4 WASHER M8 x 14 x 1.6
8	14306324		4 HEX SOC SCREW M8 x 1.25 x 20mm, Cl 8.8, Full Thd

- (1) VAR - 335818, 390813
(2) VAR - 390813
(3) VAR - 334394, 335805, 335818
(4) VAR - 335893 (744751)

Valid for Var. 334394 or Var. 335805 or Var. 335818 or Var. 390813 or
Industrial Var. 335893 (744751)

FARMALL JX100 FARMALL
JX110 FARMALL JX70
FARMALL JX75 FARMALL
JX80 FARMALL JX90

31.110.AO

01

p1

1/2014

VAR - 330120, 331120, 743846 - POWER SHUTTLE AND SERVO PTO FOR DIFF. LOCK, PTO CLUTCH CONTROL SAND LEVER LINK

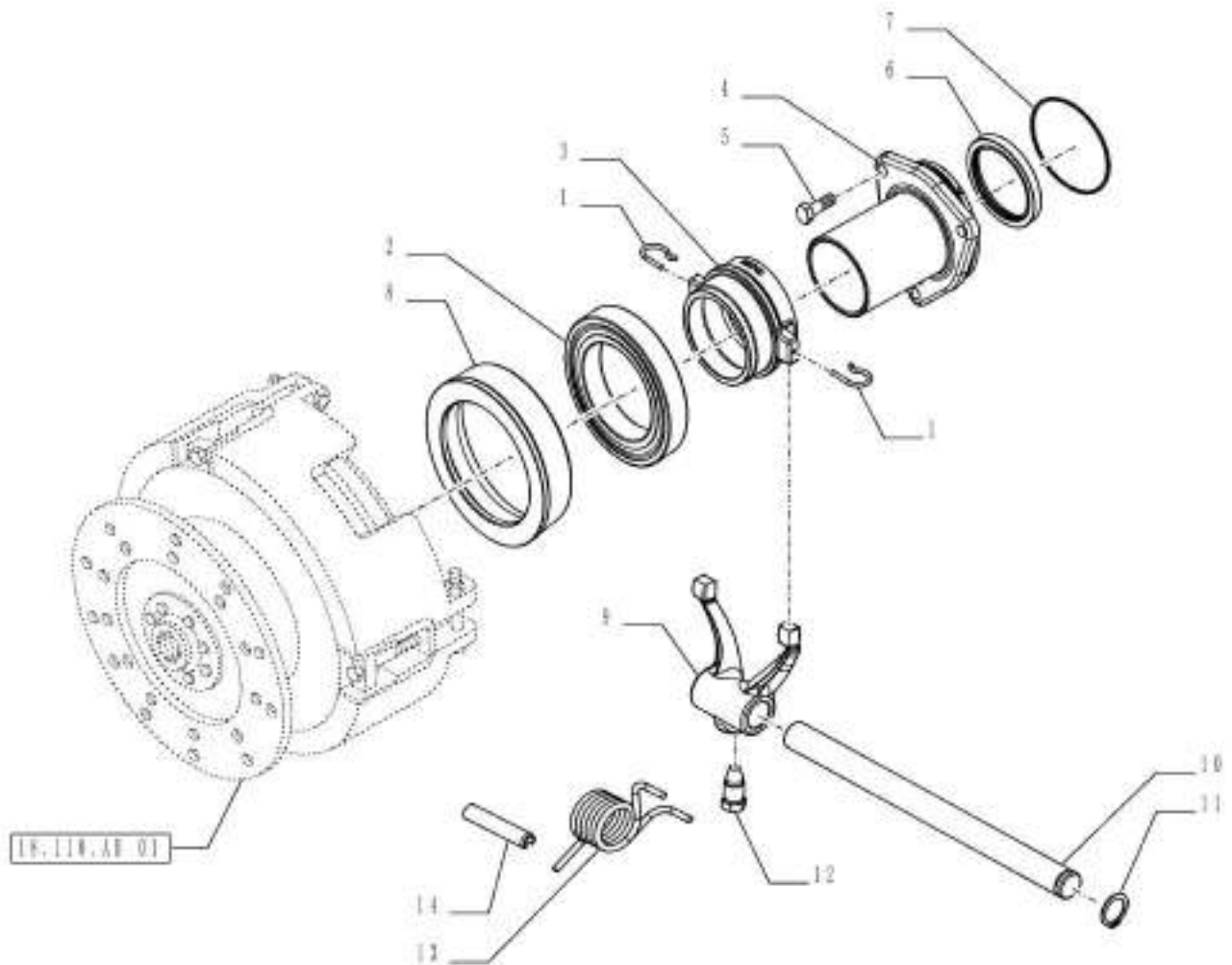

VAR - 330120, 331120, 743846 - POWER SHUTTLE AND SERVO PTO FOR DIFF. LOCK, PTO CLUTCH CONTROL SAND LEVER LINK

REF FN	PART NUMBER	YR/SN	QTY DESCRIPTION
1	44011615		2 SPRING
2	47127081		1 BALL BEARING 75 mm ID x 115 mm OD x 20 mm
3	5191807		1 SLEEVE
4	5177143		1 COVER
5	43127		3 BOLT Hex, M8 x 1.25 x 25mm, Cl 8.8, Full Thd
6	5159078		1 SEAL
7	14461080		1 O-RING 3.237" ID x 3.442" OD x 0.103"
8 1	84335406		1 SLEEVE
8 2	84335412		1 SLEEVE
9	5172487		1 YOKE
10	84286497		1 SHAFT
11	11067276		1 SNAP RING M24, Ext
12	4968813		2 SCREW Hex, M16 x 1.5 x 32mm
13	5189889		1 SPRING
14	14610370		1 LOCK PIN M10 x 50, Slotted

(1) Valid for FARMALL JX75, 80, 90 Models Only

(2) Valid for FARMALL JX100, 110 Models Only

Valid for Industrial Var. 330120, 331120 (743846)

FARMALL JX100
 FARMALL JX110
 FARMALL JX75
 FARMALL JX90

31.201.AG

01

p1

1/2014

VAR - 390249 - PTO SHAFT

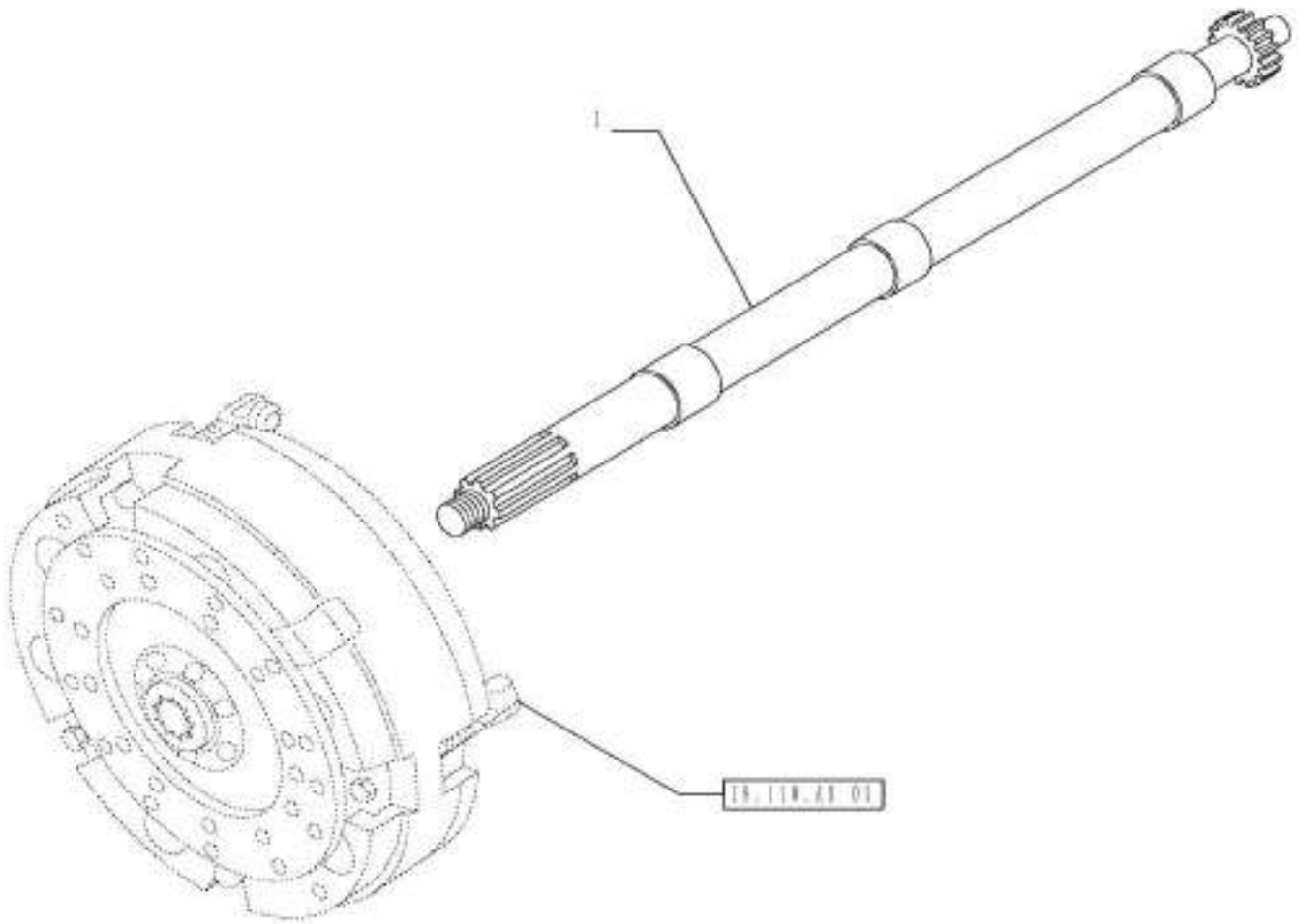

31.201.AG

01

p1

1/2014

VAR - 390249 - PTO SHAFT

REF	FN	PART NUMBER	YR/SN	QTY	DESCRIPTION
1	1	5089354		1	PTO SHAFT
1	2	5189501		1	SHAFT

(1) Valid for FARMALL JX75, 80, 90, 100, 110 Models Only
(2) Valid for FARMALL JX70 Model Only

Valid for Var. 390249

FARMALL JX100 FARMALL
JX110 FARMALL JX70
FARMALL JX75 FARMALL
JX80 FARMALL JX90

31.201.AG

02

p1

1/2014

VAR - 330120, 331120, 743846 - PTO SHAFT

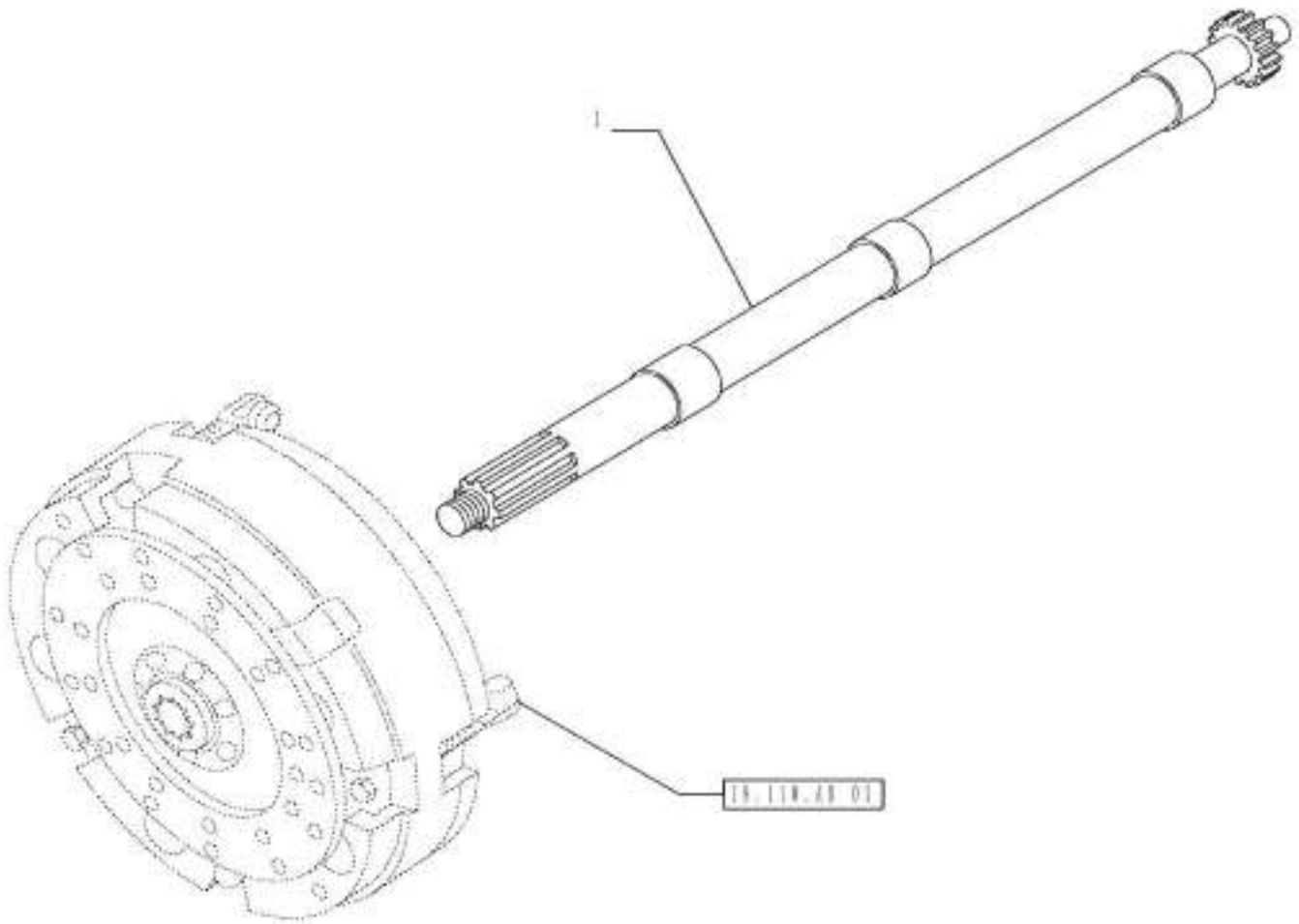

31.201.AG

02

p1

1/2014

VAR - 330120, 331120, 743846 - PTO SHAFT

REF FN	PART NUMBER	YR/SN	QTY DESCRIPTION
---------------	--------------------	--------------	------------------------

1	84286496		1 SHAFT
---	----------	--	---------

Valid for Industrial Var. 330120, 331120 (743846)

FARMALL JX100
FARMALL JX110
FARMALL JX75
FARMALL JX90

SECTION INDEX

BRAKES & CONTROLS

33.000.00	01	SECTION INDEX - BRAKES & CONTROLS
33.110.AJ	01	VAR - 744738, 744739, 744744 - HAND BRAKE CONTROL
33.110.AJ	02	VAR - 744738, 744739, 744744 - HAND BRAKE, BREAKDOWN
33.120.AD	01	VAR - 744738, 744739, 744744 - BRAKE CONTROLS
33.120.AD	02	VAR - 335113, 390110, 390249, 744735 - BRAKE CONTROLS
33.202.AJ	01	VAR - 335113, 390110, 390249, 744735 - HYDRAULIC BRAKE, BRAKE CYLINDER
33.202.AK	01	VAR - 744738, 744739, 744744 - BRAKE DISCS
33.202.AN	01	VAR - 744738, 744739, 744744 - BRAKE RESERVOIR
33.202.AP	01	VAR - 335113, 390110, 390249, 744735 - BRAKE PIPING
33.202.AR	01	VAR - 333606, 334318, 334319, 391606, 392315 - BRAKE CYLINDER
33.202.BE	01	VAR - 744738, 744739, 744744 - BRAKE CYLINDER PIPING
33.202.BE	02	VAR - 330120, 331120, 335116, 743846 - BRAKE CYLINDER PIPING
33.202.BN	01	VAR - 333606, 334318, 334319, 391606, 392315 - BRAKE, PEDAL
33.220.AK	01	VAR - 334336, 334337, 744751, 744752, 744753, 744754, 744755 - TRAILER BRAKE LEVER SUPPORT
33.220.AM	01	VAR - 335370, 336370, 337370, 720396 - TRAILER BRAKE VALVE (FRANCE)

SECTION INDEX - BRAKES & CONTROLS

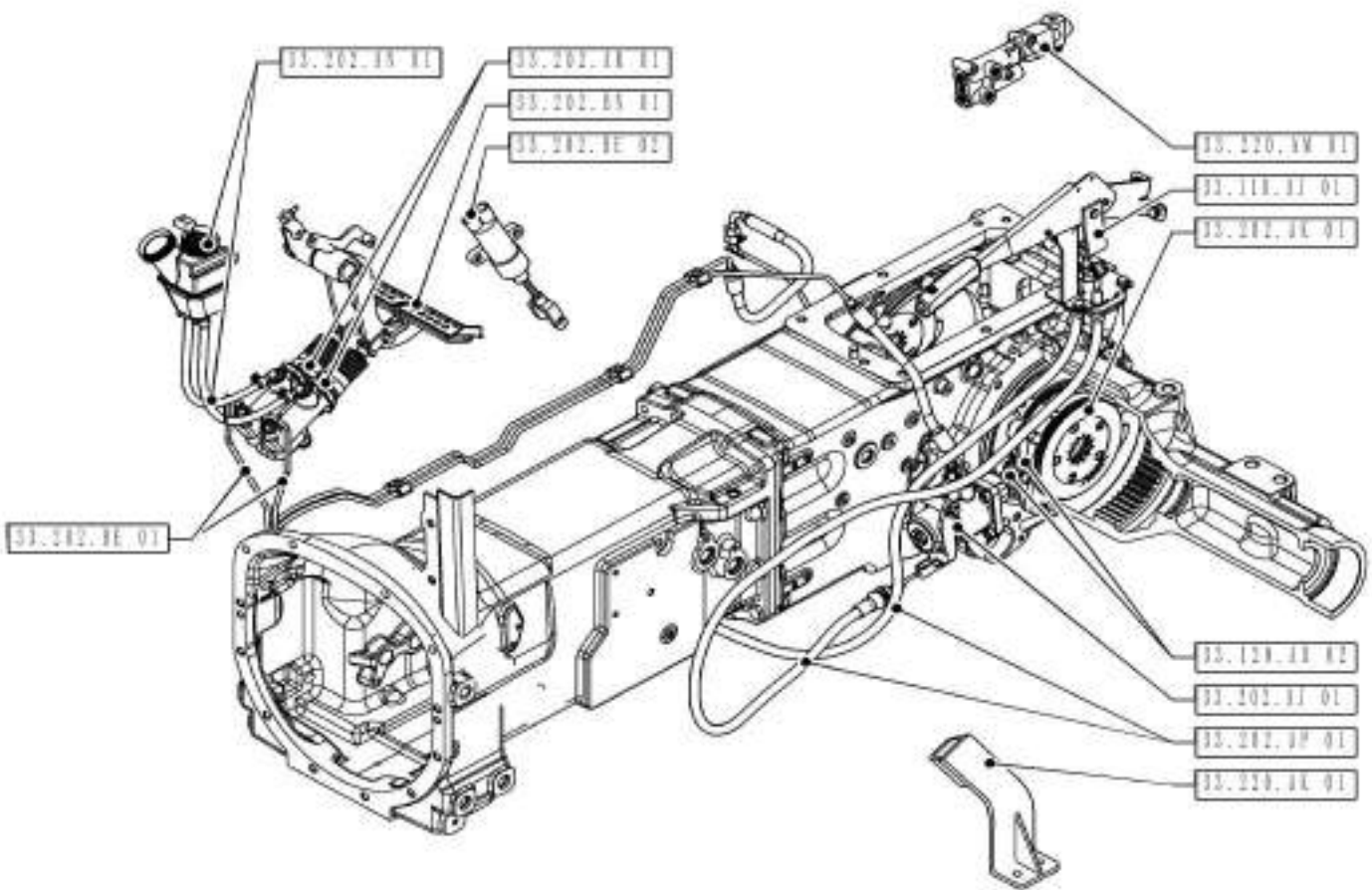

33.000.00

01

p1

1/2014

SECTION INDEX - BRAKES & CONTROLS

REF FN	PART NUMBER	YR/SN	QTY	DESCRIPTION
---------------	--------------------	--------------	------------	--------------------

				FARMALL JX100 FARMALL JX110 FARMALL JX70 FARMALL JX75 FARMALL JX80 FARMALL JX90
--	--	--	--	--

VAR - 744738, 744739, 744744 - HAND BRAKE CONTROL

REF FN	PART NUMBER	YR/SN	QTY DESCRIPTION
1	5089160		1 HAND BRAKE
2	84554139		1 CABLE
3	5122167		1 PIN
4	11065976		1 CIRCLIP M10, Ext
5	5089467		1 BOOT
6	84216490		1 SUPPORT
7	120104		4 BOLT Hex, M8 x 1.25 x 20mm, Cl 8.8, Full Thd
8	12601374		4 WAVE WASHER Wave, 8.40mm ID x 15.00mm OD x 0.80mm, 3.00mm, CST, DAC
9	15970921		1 SCREW Hex, M10 x 1.25 x 35mm, Cl 8.8, Full Thd
10	12164721		1 NUT M10 x 1.25, Cl 10
11	12601474		1 WAVE WASHER Wave, 10.50mm ID x 21.00mm OD x 0.80mm, 3.00mm, CST, DAC

Valid for Industrial Var. 334321, 390268 (744738) or Industrial Var.
330384, 334322 (744739) or Industrial Var. 334320, 390267 (744744)

FARMALL JX100 FARMALL
JX110 FARMALL JX70
FARMALL JX75 FARMALL
JX80 FARMALL JX90

VAR - 744738, 744739, 744744 - HAND BRAKE, BREAKDOWN

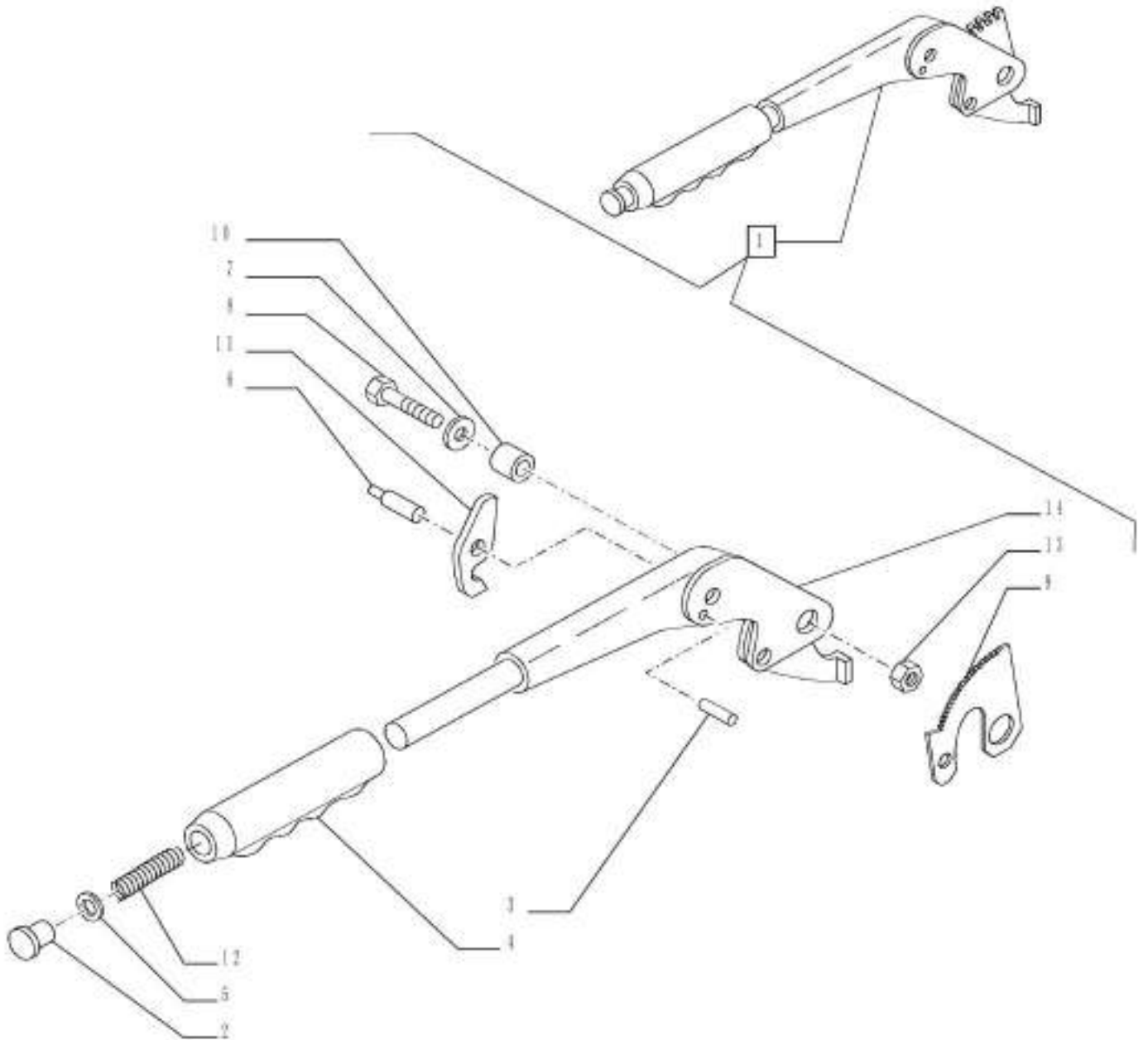

VAR - 744738, 744739, 744744 - HAND BRAKE, BREAKDOWN

REF FN	PART NUMBER	YR/SN	QTY DESCRIPTION
1	5089160		1 HAND BRAKE ASSY Incl 2 - 14
2	4985122		1 BUTTON
3	4985127		1 RIVET
4	5105572		1 HANDLE GRIP
5	5110154		1 SPRING WASHER
6	5110157		1 PIN
7	5111658		1 WASHER 17 x 35 x 3
8	11391521		1 SCREW Hex, M16 x 1.5 x 45, 8.8, Full Thd
9	5122060		1 TOOTHED SECTOR
10	5122161		1 BUSHING
11	5122165		1 PAWL
12	5122223		1 SPRING
13	10791411		1 THIN NUT Thin, M16, 1.50mm Pitch, 8.00mm High, CI 04, ZND
14	NSS		1 NOT SERVICED SEPARATELY Lever Incl in 1

Valid for Industrial Var. 334321, 390268 (744738) or Industrial Var. 330384, 334322 (744739) or Industrial Var. 334320, 390267 (744744)

FARMALL JX100 FARMALL
JX110 FARMALL JX70
FARMALL JX75 FARMALL
JX80 FARMALL JX90

VAR - 744738, 744739, 744744 - BRAKE CONTROLS

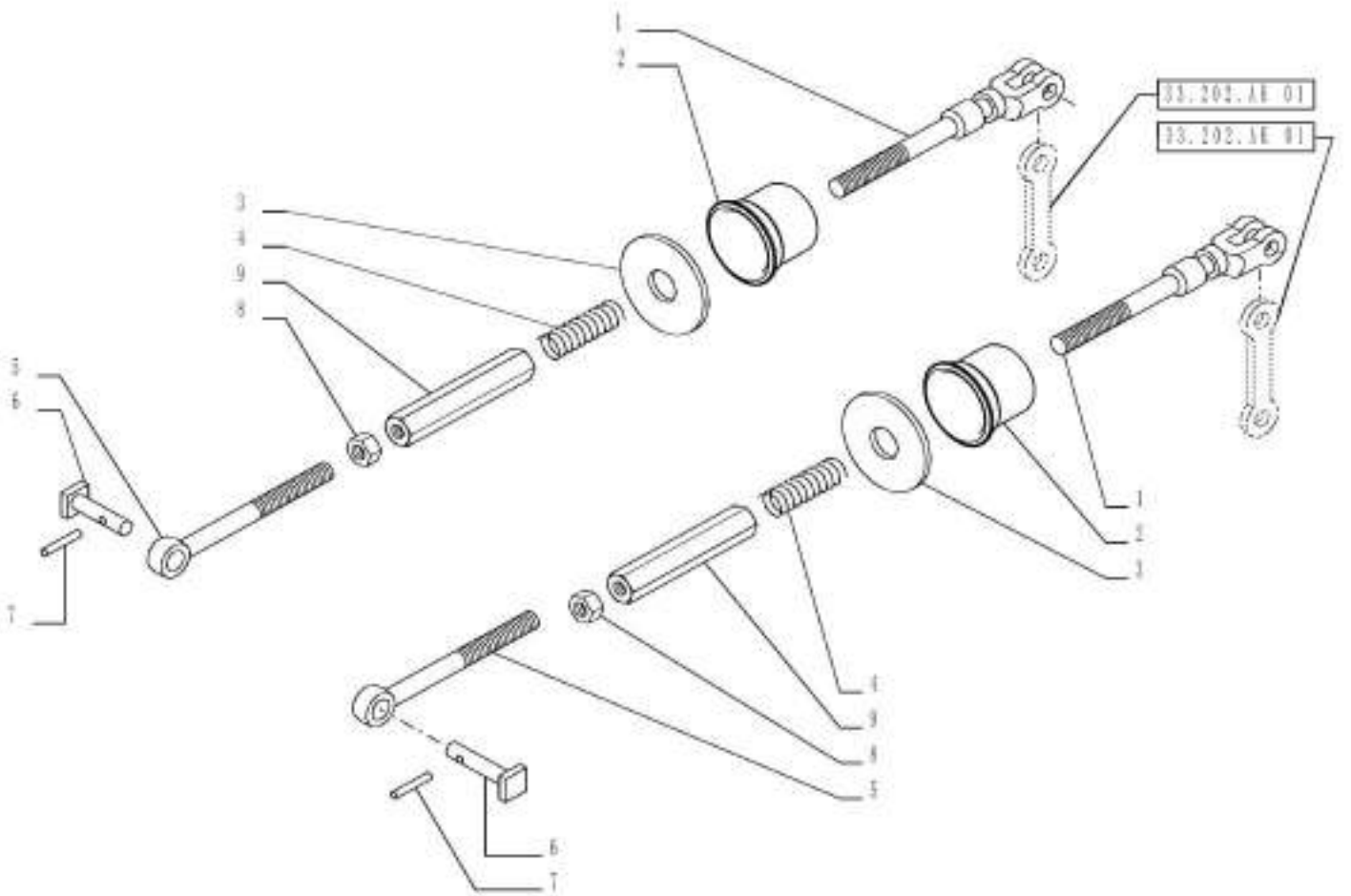

VAR - 744738, 744739, 744744 - BRAKE CONTROLS

REF FN	PART NUMBER	YR/SN	QTY DESCRIPTION
1	5117517		2 TIE-ROD
2	82037652		2 SEAL
3	5117519		2 GUARD
4	5117515		2 SPRING
5	5117516		2 TIE-ROD
6	5117523		2 PIN
7	10796401		2 COTTER PIN M3.2 x 18
8	10791911		2 NUT
9	10092611		2 NUT Adjusting, M12 x 1.5 x 100mm

Valid for Industrial Var. 334321, 390268 (744738) or Industrial Var. 330384, 334322 (744739) or Industrial Var. 334320, 390267 (744744)

FARMALL JX100 FARMALL
JX110 FARMALL JX70
FARMALL JX75 FARMALL
JX80 FARMALL JX90

VAR - 335113, 390110, 390249, 744735 - BRAKE CONTROLS

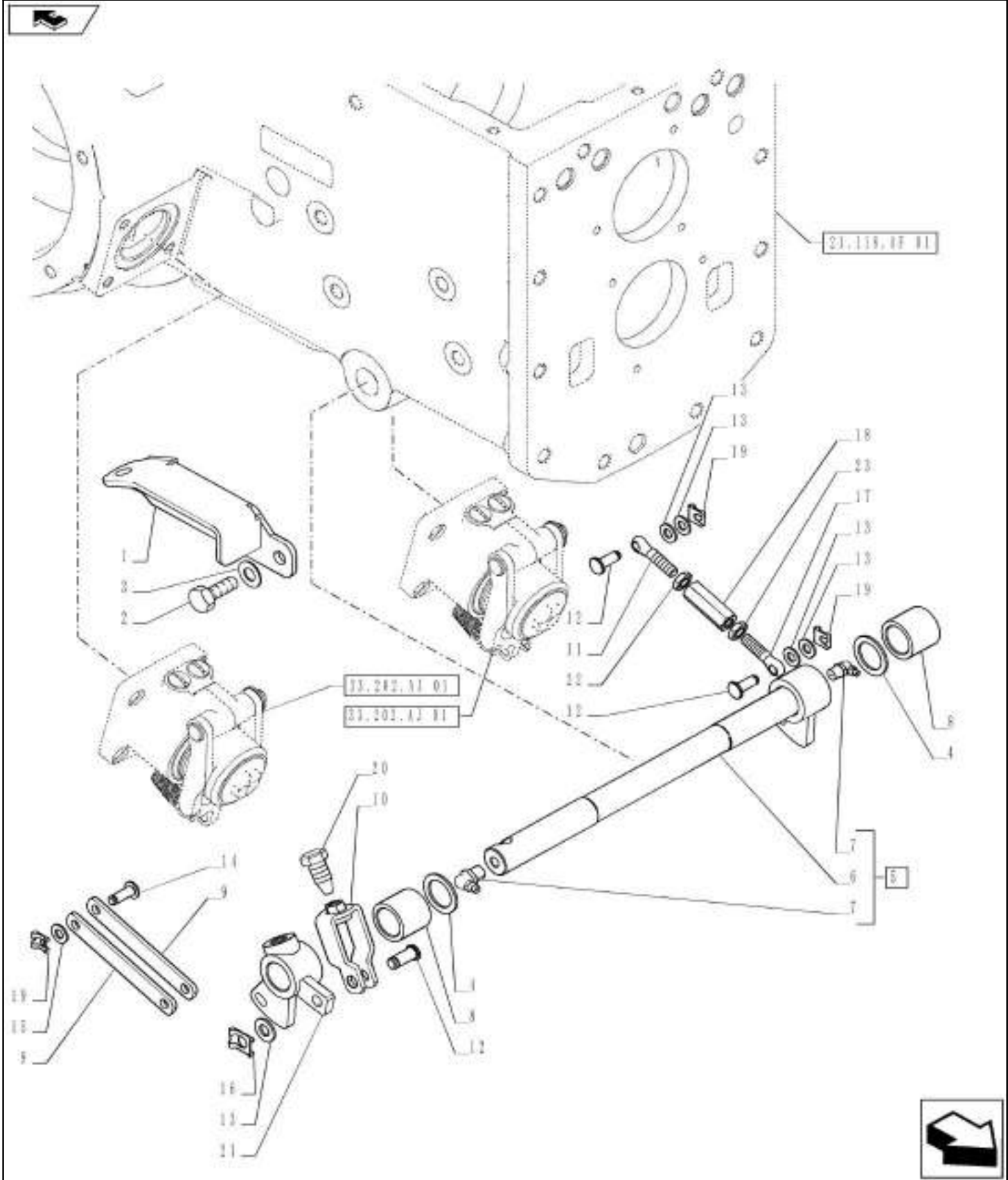

VAR - 335113, 390110, 390249, 744735 - BRAKE CONTROLS

REF FN	PART NUMBER	YR/SN	QTY DESCRIPTION
1	84413498		1 SUPPORT
2	15540321		2 SCREW Hex, M12 x 1.25 x 25mm, CI 8.8, Full Thd
3	12581779		2 WASHER
4	5117525		2 WASHER
5	84480467		1 LEVER ASSY, Incl 6, 7
6	NSS		1 NOT SERVICED SEPARATELY Shaft, Incl in 5
7	13408411		2 LUBE NIPPLE 90°, M10 x1
8	84368385		2 SPACER
9	84368153		2 LINK
10	84385412		1 FORK
11	84480067		1 END FITTING
12	84479478		4 PIN
13	10519601		6 WASHER M8 x 17 x 2
14	84385715		1 PIN
15	14496604		1 WASHER M10 x 21 x 2
16	11064174		1 CLIP
17	84479197		1 END FITTING
18	84415359		1 NUT
19	11064074		4 RETAINER
20	84385424		1 SPECIAL BOLT
21	84366005		1 SUPPORT
22	10791521		1 THIN NUT Thin, M10 x 1.25, CI 05, LH
23	10791021		1 THIN NUT Thin, M10 x 1.25, CI 05

Valid for Var. 335113 or Var. 390249 or Industrial Var. 390110 (744735)

FARMALL JX100 FARMALL
 JX110 FARMALL JX70
 FARMALL JX75 FARMALL
 JX80 FARMALL JX90

VAR - 335113, 390110, 390249, 744735 - HYDRAULIC BRAKE, BRAKE CYLINDER

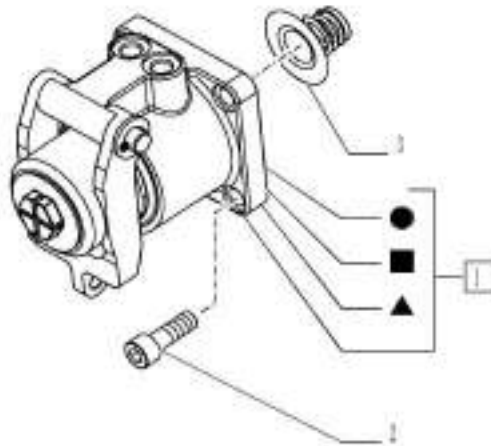
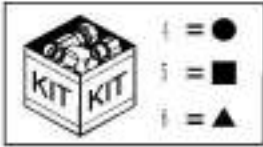

33.202.AJ

01

p1

1/2014

VAR - 335113, 390110, 390249, 744735 - HYDRAULIC BRAKE, BRAKE CYLINDER

REF FN	PART NUMBER	YR/SN	QTY DESCRIPTION
1	84392195		2 MASTER CYLINDER
2	14307534		8 BOLT Hex, M10 x 1.25 x 30, 10.9, Full Thd
3	84478831		2 SPRING KIT
4	84392603		1 SEAL KIT Seals
5	84392604		1 SERVICE KIT Washer and Plug
6	84392605		1 SERVICE KIT Lever

Valid for Var. 335113 or Var. 390249 or Industrial Var. 390110 (744735)

FARMALL JX100 FARMALL
JX110 FARMALL JX70
FARMALL JX75 FARMALL
JX80 FARMALL JX90

VAR - 744738, 744739, 744744 - BRAKE DISCS

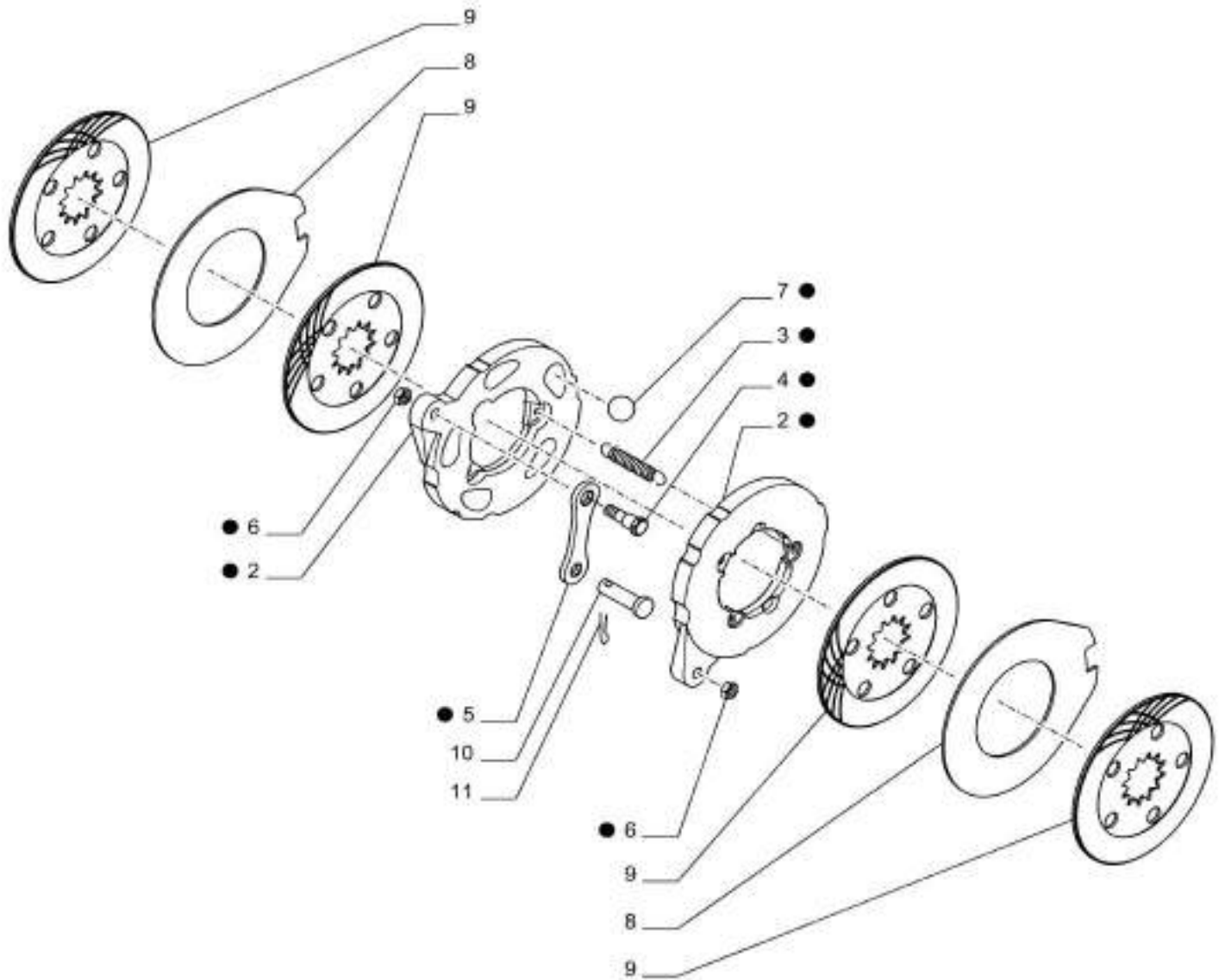
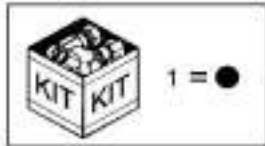

VAR - 744738, 744739, 744744 - BRAKE DISCS

REF FN	PART NUMBER	YR/SN	QTY DESCRIPTION
1	5099136		2 BRAKE ASSY Incl 2 - 7
2	5099137		2 BRAKE DISC
3	5086612		3 SPRING
4	5086610		2 PIN
5	5086609		2 LEVER
6	5086611		2 NUT
7	20063060		5 BALL M22
8	5119327		4 BRAKE DISC
9	5096755		8 BRAKE DISC
10	5119336		2 PIN
11	10733601		2 COTTER PIN M3.2 x 22

Valid for Industrial Var. 334321, 390268 (744738) or Industrial Var. 330384, 334322 (744739) or Industrial Var. 334320, 390267 (744744)

FARMALL JX100 FARMALL
JX110 FARMALL JX70
FARMALL JX75 FARMALL
JX80 FARMALL JX90

VAR - 744738, 744739, 744744 - BRAKE RESERVOIR

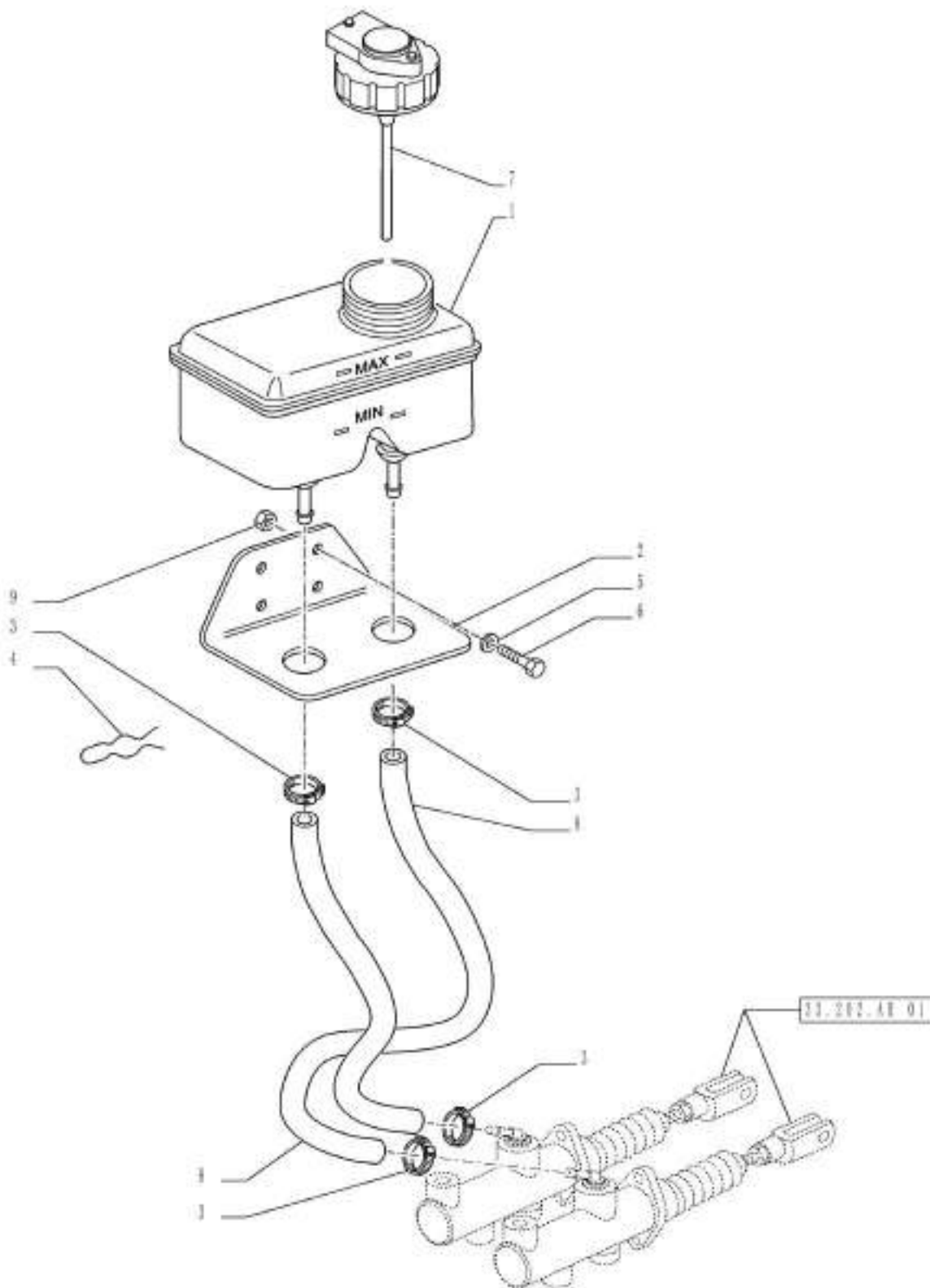

VAR - 744738, 744739, 744744 - BRAKE RESERVOIR

REF FN	PART NUMBER	YR/SN	QTY DESCRIPTION
1	5141671		1 RESERVOIR
2	84518406		1 SUPPORT
3	10186590		4 COLLAR M11-13, Worm
4	84187457		2 SPRING
5	12601274		2 WAVE WASHER Wave, M6.4
6	86977790		2 BOLT Hex, M6 x 45mm, CI 8.8
7	5181824		1 DIPSTICK
8	5094402		2 HOSE
9	15896211		2 NUT M6, CI 8

Valid for Industrial Var. 334321, 390268 (744738) or Industrial Var. 330384, 334322 (744739) or Industrial Var. 334320, 390267 (744744)

FARMALL JX100 FARMALL
JX110 FARMALL JX70
FARMALL JX75 FARMALL
JX80 FARMALL JX90

VAR - 335113, 390110, 390249, 744735 - BRAKE PIPING

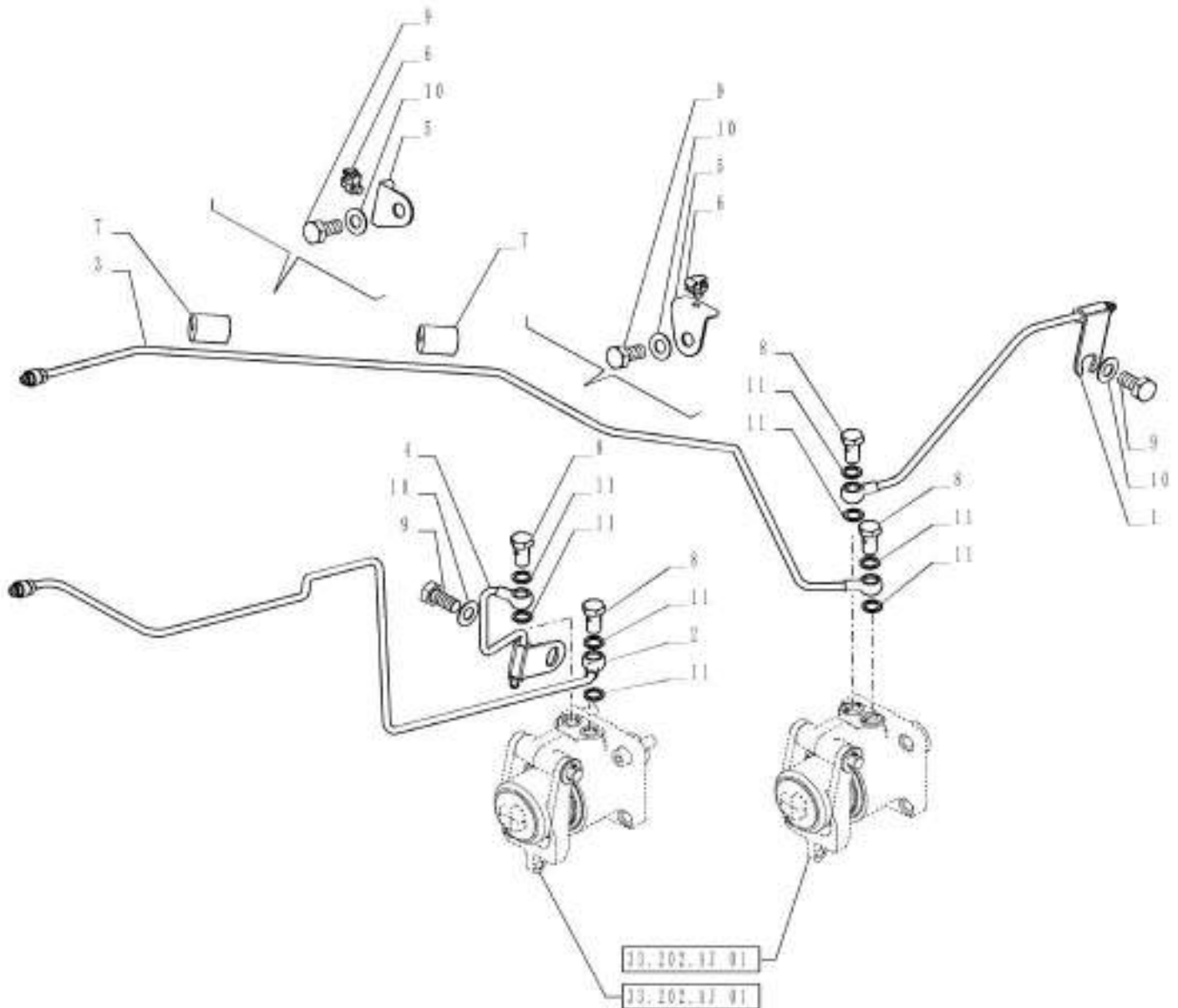

VAR - 335113, 390110, 390249, 744735 - BRAKE PIPING

REF FN	PART NUMBER	YR/SN	QTY DESCRIPTION
1	84330979		1 PIPE
2	84330977		1 PIPE
3	84329664		1 PIPE
4	84329667		1 PIPE
5	5152163		4 BRACKET
6	14571880		2 SPRING CLIP
7	84337327		2 RUBBER SLEEVE
8	5155703		4 BANJO BOLT M12 x 1.25 x 22.00mm
9	15540321		3 SCREW Hex, M12 x 1.25 x 25mm, Cl 8.8, Full Thd
10	12581779		4 WASHER
11	4858607		8 COPPER WASHER 12mm ID x 17mm OD x 1.50mm

Valid for Var. 335113 or Var. 390249 or Industrial Var. 390110 (744735)

FARMALL JX100 FARMALL
 JX110 FARMALL JX70
 FARMALL JX75 FARMALL
 JX80 FARMALL JX90

33.202.AR

01

p1

1/2014

VAR - 333606, 334318, 334319, 391606, 392315 - BRAKE CYLINDER

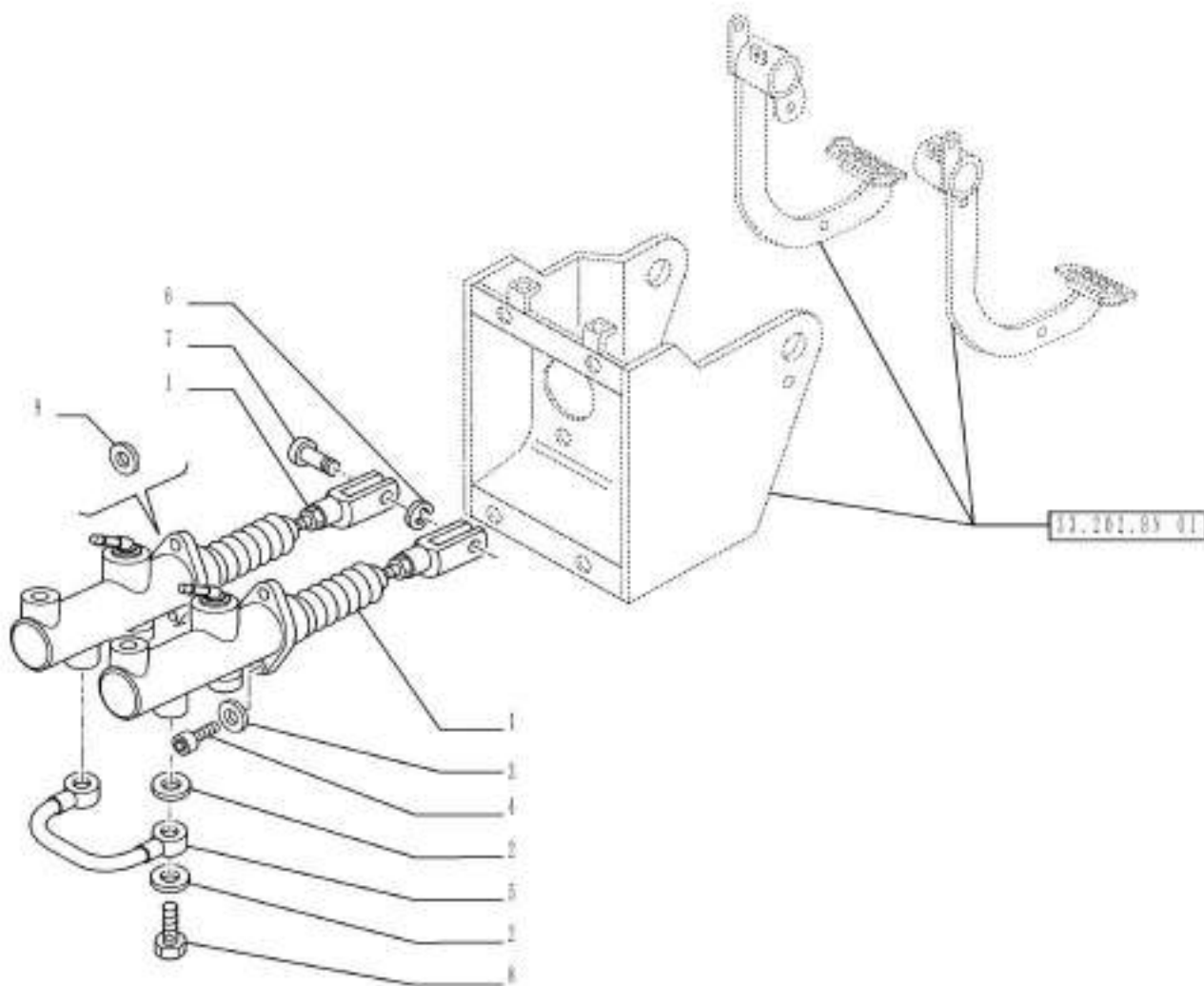

VAR - 333606, 334318, 334319, 391606, 392315 - BRAKE CYLINDER

REF	FN	PART NUMBER	YR/SN	QTY	DESCRIPTION
1	1	87354681		2	MASTER CYLINDER
1	2	87748269		2	MASTER CYLINDER ASSY, Contains Ref. 9
2		4858607		4	COPPER WASHER 12mm ID x 17mm OD x 1.50mm
3		12601374		4	WAVE WASHER Wave, 8.40mm ID x 15.00mm OD x 0.80mm, 3.00mm, CST, DAC
4		120104		4	BOLT Hex, M8 x 1.25 x 20mm, Cl 8.8, Full Thd
5		5155701		1	TUBE
6		11064174		2	CLIP
7		5111590		2	PIN
8		5155703		2	BANJO BOLT M12 x 1.25 x 22.00mm
9	3	84336253		2	GASKET
(1)		Alternative to Master Cylinder 87748269			
(2)		Alternative to Master Cylinder 87354681			
(3)		Only with Master Cylinder 87748269			

Valid for Var. 333606 or Var. 334318 or Var. 334319 or Var. 391606 or
Var. 392315

FARMALL JX100 FARMALL
JX110 FARMALL JX70
FARMALL JX75 FARMALL
JX80 FARMALL JX90

VAR - 744738, 744739, 744744 - BRAKE CYLINDER PIPING

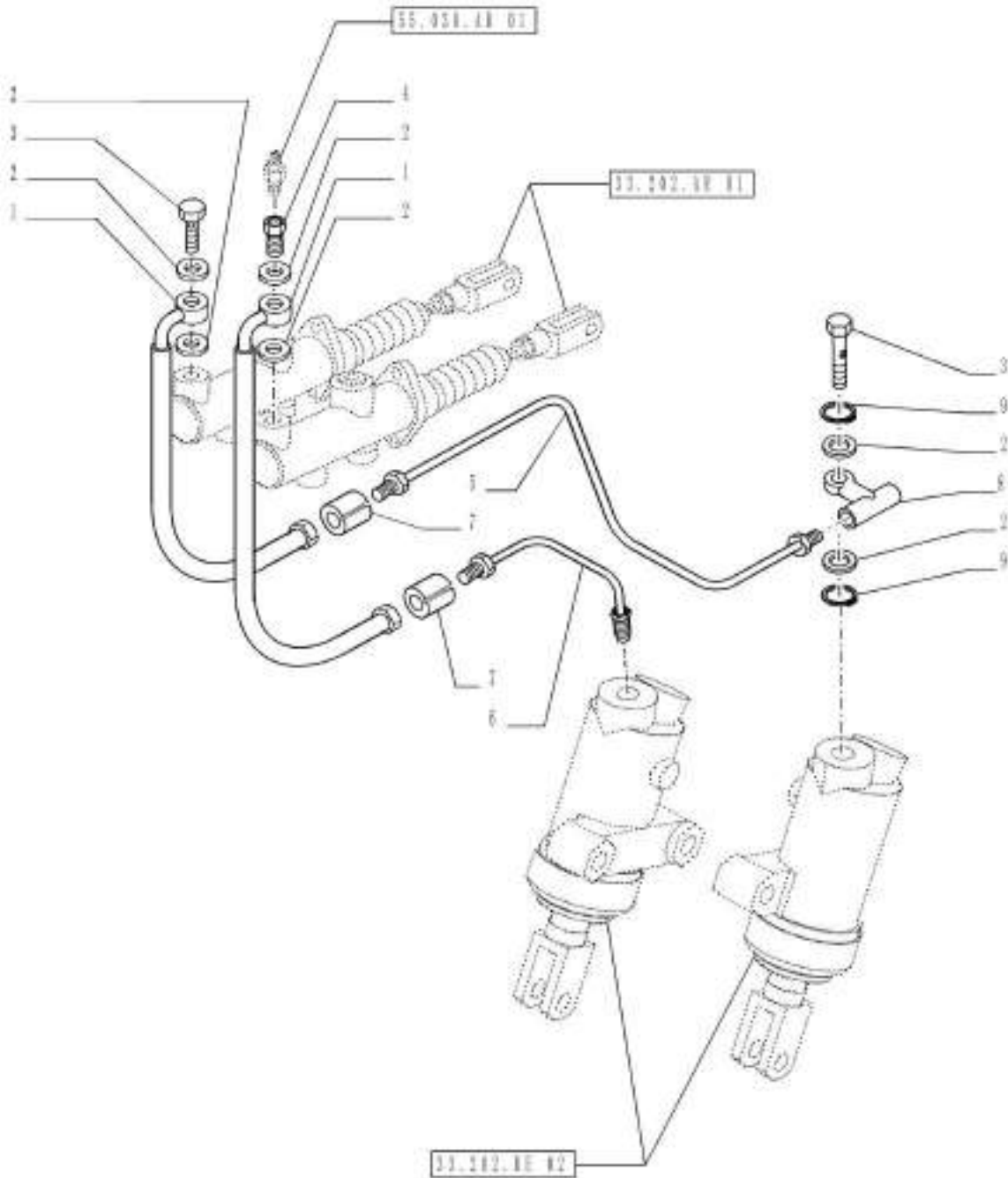

VAR - 744738, 744739, 744744 - BRAKE CYLINDER PIPING

REF FN	PART NUMBER	YR/SN	QTY DESCRIPTION
1	87752246		2 FLEXIBLE HOSE
2	4858607		6 COPPER WASHER 12mm ID x 17mm OD x 1.50mm
3	5155703		2 BANJO BOLT M12 x 1.25 x 22.00mm
4	5155704		1 BANJO BOLT
5	84554371		1 PIPE
6	84554376		1 PIPE
7	84337327		2 RUBBER SLEEVE
8	87751801		1 TEE
9	13397876		2 SNAP RING

Valid for Industrial Var. 334321, 390268 (744738) or Industrial Var. 330384, 334322 (744739) or Industrial Var. 334320, 390267 (744744)

FARMALL JX100 FARMALL
JX110 FARMALL JX70
FARMALL JX75 FARMALL
JX80 FARMALL JX90

VAR - 330120, 331120, 335116, 743846 - BRAKE CYLINDER PIPING

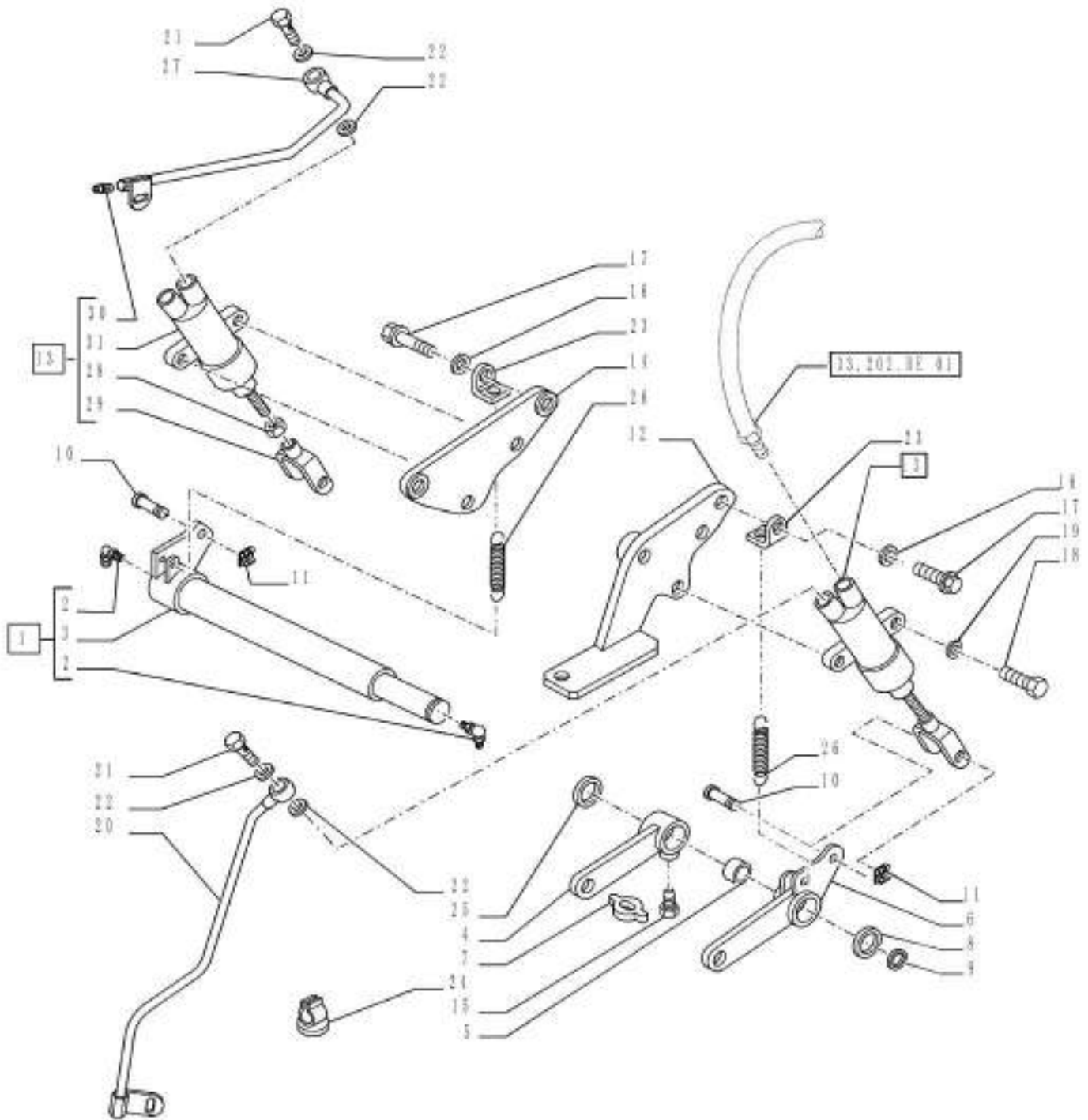

VAR - 330120, 331120, 335116, 743846 - BRAKE CYLINDER PIPING

REF FN	PART NUMBER	YR/SN	QTY DESCRIPTION
1	84343782		1 SHAFT ASSY Incl 2 - 3
2	13408411		2 LUBE NIPPLE 90°, M10 x1
3	NSS		1 NOT SERVICED SEPARATELY Shaft Incl in 1
4	5097630		1 SUPPORT
5	5122339		2 BUSHING
6	5097622		1 SUPPORT
7	5125342		1 ROCKER ARM
8	5118949		1 WASHER
9	11067376		1 SNAP RING M25, Ext
10	87725815		2 PIN
11	11064174		2 CLIP M10 x 8 x 1.05
12	5097618		1 SUPPORT
13	87748455		2 BRAKE CYLINDER M12 x 1.25/ ASSY Incl 28 - 31
14	5097634		1 SUPPORT
15	4968813		1 SCREW Hex, M16 x 1.5 x 32mm
16	12601574		4 WAVE WASHER Wave, M13
17	15540534		4 SCREW Hex, M12 x 1.25 x 35mm, Cl 10.9, Full Thd
18	15970921		4 SCREW Hex, M10 x 1.25 x 35mm, Cl 8.8, Full Thd
19	12601474		4 WAVE WASHER Wave, 10.50mm ID x 21.00mm OD x 0.80mm, 3.00mm, CST, DAC
20	87487201		1 PIPE Air Breath
21	5143514		2 BANJO BOLT M10 x 1 x 20
22	10298360		4 SEALING WASHER M10.2 x 16 x 1, Copper
23	5152163		4 BRACKET
24	14571880		2 SPRING CLIP
25	5117525		1 WASHER
26	87725931		2 SPRING
27	84137989		1 PIPE Air Breath
28	11701714		1 NUT

Valid for Var. 335116 or Industrial Var. 330120, 331120 (743846)

FARMALL JX100 FARMALL
 JX110 FARMALL JX70
 FARMALL JX75 FARMALL
 JX80 FARMALL JX90

VAR - 330120, 331120, 335116, 743846 - BRAKE CYLINDER PIPING

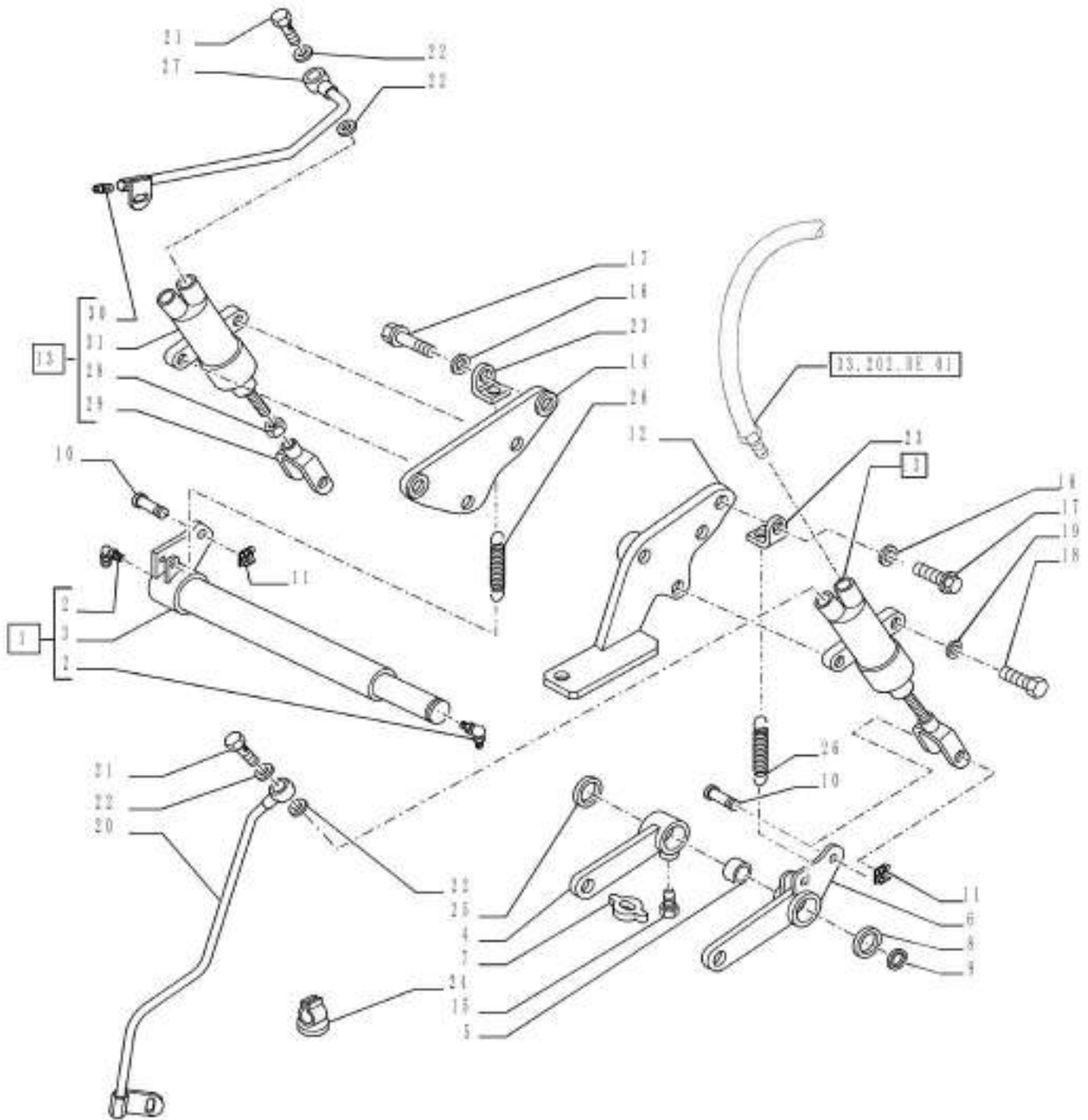

33.202.BN

01

p1

1/2014

VAR - 333606, 334318, 334319, 391606, 392315 - BRAKE, PEDAL

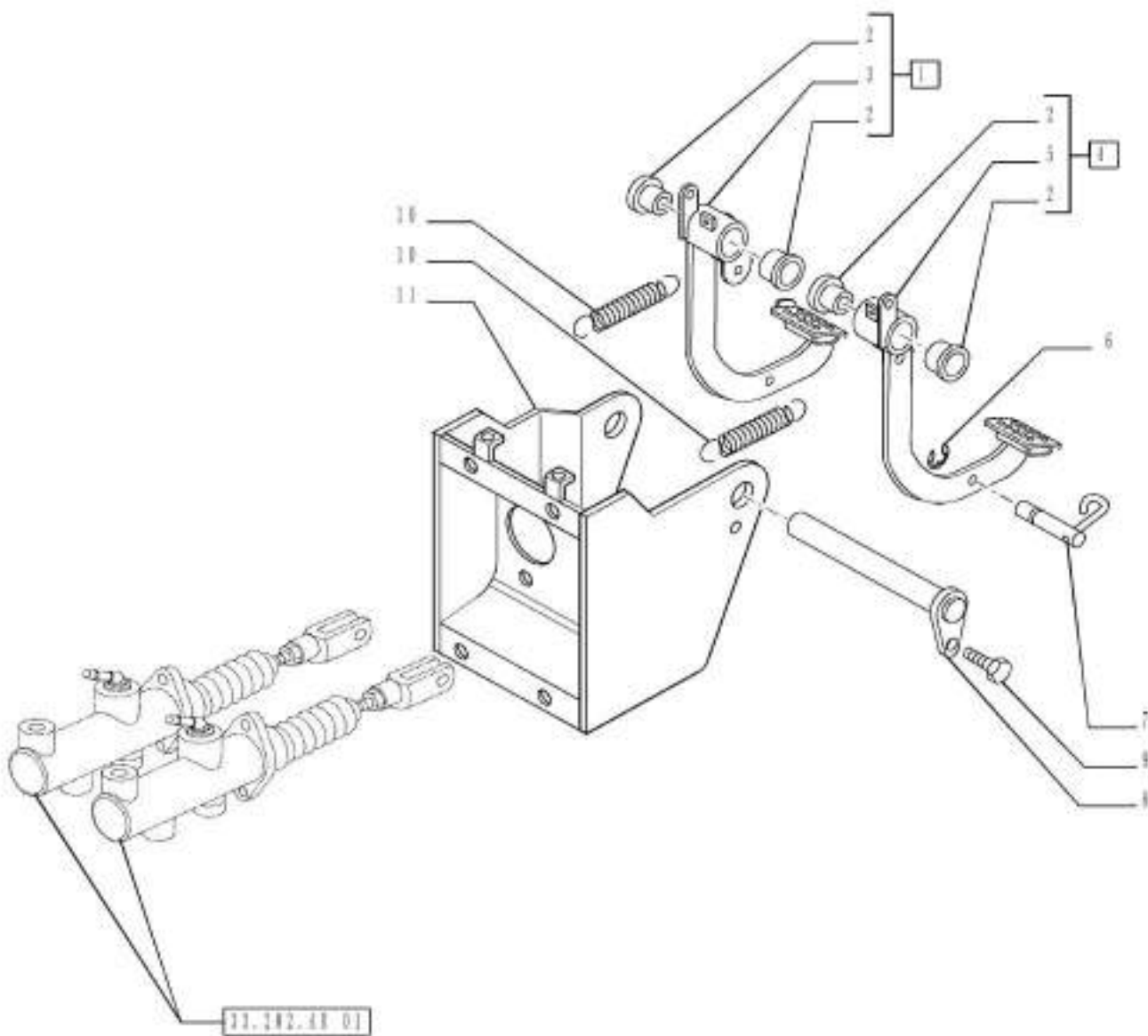

VAR - 333606, 334318, 334319, 391606, 392315 - BRAKE, PEDAL

REF FN	PART NUMBER	YR/SN	QTY DESCRIPTION
1	47411322		1 PEDAL RH, ASSY Incl 2, 3
2	5097550		4 BUSHING
3	NSS		1 NOT SERVICED SEPARATELY Pedal Incl in 1
4	47411317		1 PEDAL LH, ASSY Incl 2, 5
5	NSS		1 NOT SERVICED SEPARATELY Pedal Incl in 4
6	11088180		1 CIRCLIP M11, Stainless
7	47411319		1 PIN
8	5097582		1 SHAFT
9	86508568		1 BOLT Hex, M6 x 16mm, Cl 8.8, Full Thd
10	5153180		2 SPRING
11	84388756		1 SUPPORT

Valid for Var. 333606 or Var. 334318 or Var. 334319 or Var. 391606 or Var. 392315	FARMALL JX100 FARMALL JX110 FARMALL JX70 FARMALL JX75 FARMALL JX80 FARMALL JX90
---	---

33.220.AK

01

p1

1/2014

VAR - 334336, 334337, 744751, 744752, 744753, 744754, 744755 - TRAILER BRAKE LEVER SUPPORT

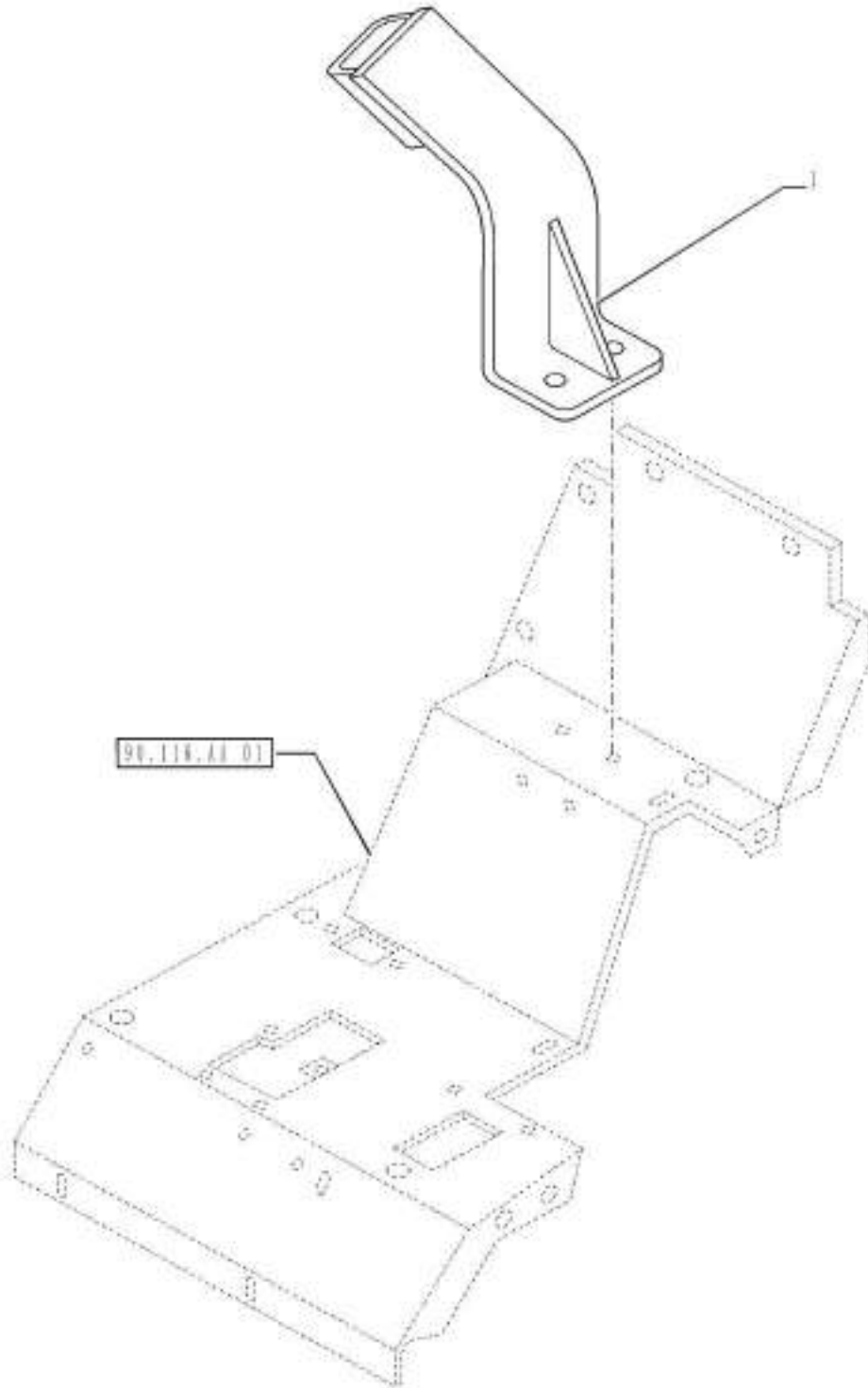

33.220.AK

01

p1

1/2014

VAR - 334336, 334337, 744751, 744752, 744753, 744754, 744755 - TRAILER BRAKE LEVER SUPPORT

REF FN	PART NUMBER	YR/SN	QTY DESCRIPTION
--------	-------------	-------	-----------------

1	84524362		1 SUPPORT
---	----------	--	-----------

Valid for Var. 334336 or Var. 334337 or Industrial Var. 334334, 334421 (744751) or Industrial Var. 334335, 334422 (744752) or Industrial Var. 335893 (744753) or Industrial Var. 334338, 334423 (744754) or Industrial Var. 334340, 334424 (744755)

FARMALL JX100 FARMALL JX110 FARMALL JX70 FARMALL JX75 FARMALL JX80 FARMALL JX90

VAR - 335370, 336370, 337370, 720396 - TRAILER BRAKE VALVE (FRANCE)

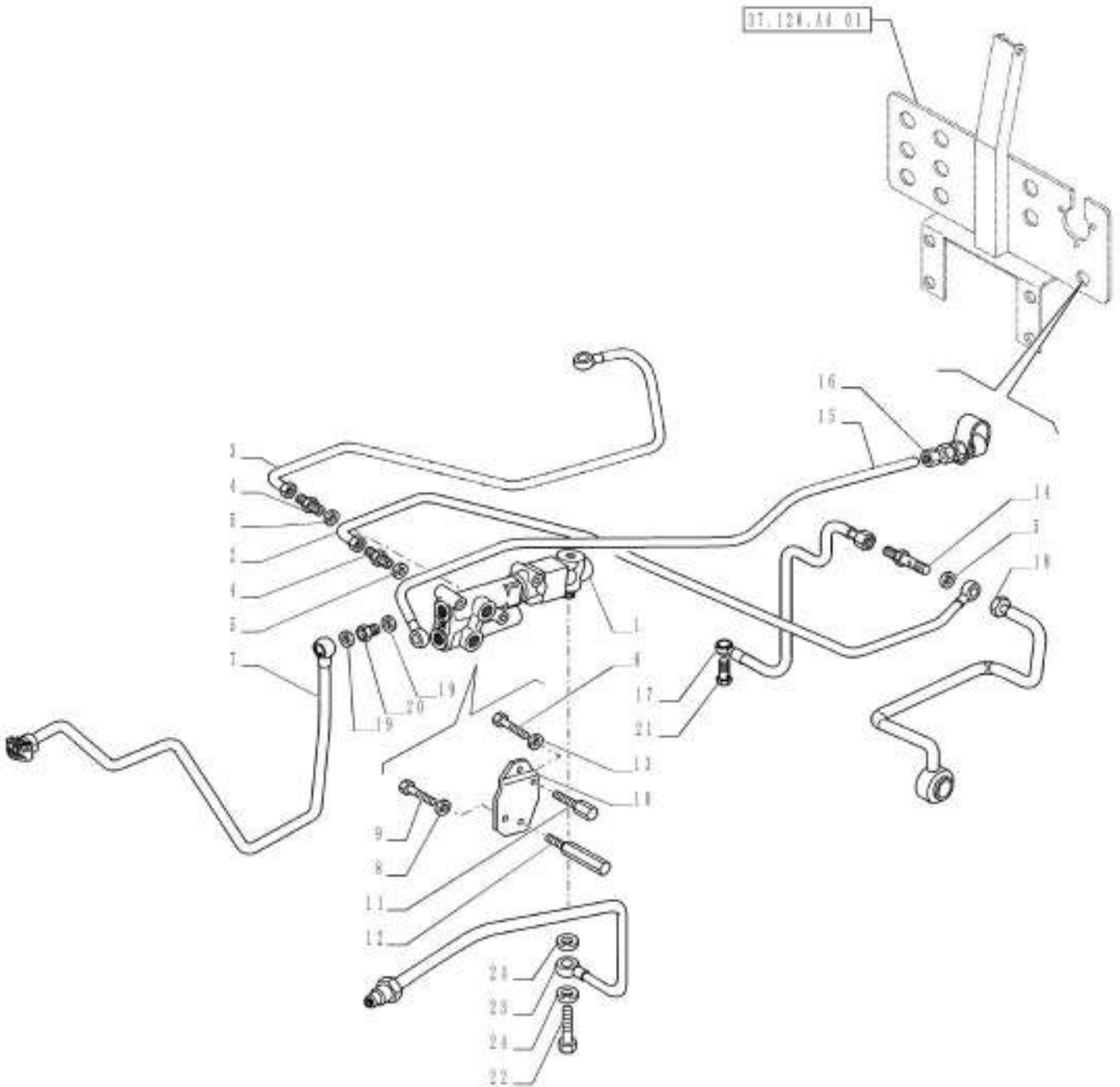

VAR - 335370, 336370, 337370, 720396 - TRAILER BRAKE VALVE (FRANCE)

REF FN	PART NUMBER	YR/SN	QTY DESCRIPTION
1	5165720		1 TRAILER BRAKE VALVE
2	1 5095102		1 BRAKE LINE
2	2 5099367		1 PIPE
3	3 84221115		1 PIPE
4	5108830		2 HYD CONNECTOR
5	10263460		2 SEAL 22.30mm ID x 28.00mm OD, 1.50mm, Copper
6	120104		2 BOLT Hex, M8 x 1.25 x 20mm, Cl 8.8, Full Thd
7	4 47364091		1 PIPE
7	5 47364095		1 PIPE
7	6 84526749		1 PIPE
8	11193874		2 BELLEVILLE WASHER 8.4mm ID x 16.00mm OD x 1.4mm, 1.85mm, Cl 8.8
9	120061		2 BOLT Hex, M8 x 60, 8.8
10	5121943		1 SUPPORT
11	87393489		1 SPACER 72MM
12	5092562		1 SPACER 100MM
13	11193871		2 BELLEVILLE WASHER Belleville, M8.4
14	87640345		1 HYD CONNECTOR
15	5093776		1 BRAKE LINE
16	44015354		1 QUICK MALE COUPLING
17	1 5092061		1 BRAKE LINE
17	2 84221051		1 PIPE
18	5093239		1 BRAKE LINE
19	10259960		5 SEAL Rectangular, 18.30mm ID x 24.00mm OD x 1.50mm, Copper
20	5092080		1 SPACER

(1) VAR - 337370 (720396)

(2) VAR - 335370, 336370 (720396)

(3) VAR - 335370 (720396)

(4) Valid for FARMALL JX75, 90, 100, 110 Models Only

(5) Valid for FARMALL JX70 Model Only

(6) Valid for FARMALL JX80 Model Only

Valid for Industrial Var. 335370, 336370, 337370 (720396)

FARMALL JX100 FARMALL
 JX110 FARMALL JX70
 FARMALL JX75 FARMALL
 JX80 FARMALL JX90

VAR - 335370, 336370, 337370, 720396 - TRAILER BRAKE VALVE (FRANCE)

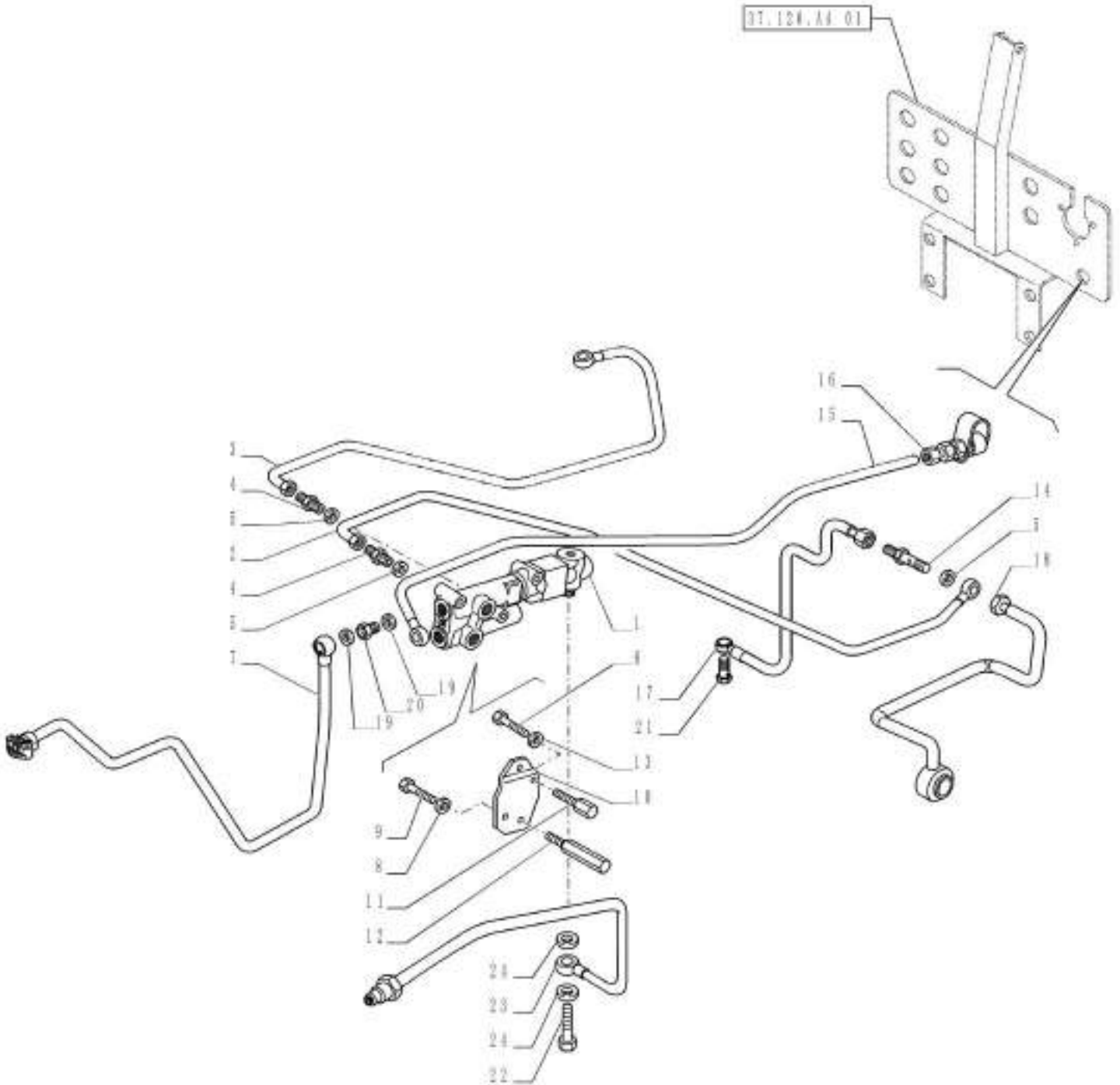

33.220.AM

01

p2

1/2014

VAR - 335370, 336370, 337370, 720396 - TRAILER BRAKE VALVE (FRANCE)

REF FN	PART NUMBER	YR/SN	QTY DESCRIPTION
21	5112588		1 BANJO BOLT M22 x 1.5 x 40.00mm
22	4864082		1 BANJO BOLT
23	87397065		1 BRAKE LINE
24	4858607		2 COPPER WASHER 12mm ID x 17mm OD x 1.50mm

Valid for Industrial Var. 335370, 336370, 337370 (720396)

FARMALL JX100 FARMALL
JX110 FARMALL JX70
FARMALL JX75 FARMALL
JX80 FARMALL JX90

SECTION INDEX

HYDRAULIC SYSTEMS

35.000.00	01	SECTION INDEX, HYDRAULIC SYSTEMS
35.000.00	02	SECTION INDEX, HYDRAULIC SYSTEMS
35.100.AR	01	HYDRAULIC LIFT, LINE, PRESSURE RELIEF VALVE
35.104.AA	01	VAR - 334314, 390257 - LIFTER PUMP
35.104.AA	02	VAR - 334314, 390257 - LIFTER PUMP, BREAKDOWN
35.104.AF	01	VAR - 334395, 390814 - HYDRAULIC LIFT PIPES, OIL FILTER
35.104.AF	05	STD, VAR - 334395, 390814 - HYDRAULIC LIFT PIPES
35.104.AF	07	VAR - 728054, 728366, 728368, 729103, 729412, 729413, 729417 - HYDRAULIC LIFT PIPES
35.114.AA	01	VAR - 334395, 390814 - LIFTER DISTRIBUTOR AND VALVES
35.114.AA	02	VAR - 334395, 390814 - LIFTER DISTRIBUTOR AND VALVES, BREAKDOWN
35.114.AA	03	VAR - 334395, 390814 - LIFTER DISTRIBUTOR AND VALVES, BREAKDOWN
35.204.BB	01	VAR - 728054, 728366, 728368, 729103, 729412, 729413, 729417 - QUICK COUPLER, COMPONENTS
35.204.BE	01	VAR - 334332, 335103, 729103 - 3 CONTROL VALVES (2 S/D W/FLOAT W/KICK OUT + 1 S/D W/KICK OUT)
35.204.BE	02	VAR - 334332, 335103, 729103 - 3 CONTROL VALVES (2 S/D W/FLOAT W/KICK OUT + 1 S/D W/KICK OUT) - BREAKDOWN
35.204.BE	03	VAR - 334331, 335054, 728054 - 3 CONTROL VALVES (2S/D + 1S/D W/KICK OUT)
35.204.BE	04	VAR - 334331, 335054, 728054 - 3 CONTROL VALVES (2 S/D W/FLOAT W/KICK OUT + 1 S/D W/KICK OUT), BREAKDOWN
35.204.BE	05	VAR - 334328, 335368, 728368 - 2 CONTROL VALVE (1 S/D + 1 DOUBLE ACTING)
35.204.BE	06	VAR - 334328, 335368, 728368 - 2 CONTROL VALVE (1 S/D W/KICK OUT + 1 DOUBLE ACTING) - BREAKDOWN
35.204.BE	07	VAR - 334329, 335413, 729413 - 2 CONTROL VALVE (1 S/D + 1 DOUBLE ACTING WITH FLOAT AND KICK OUT)
35.204.BE	08	VAR - 334329, 335413, 729413 - 2 CONTROL VALVES (1 S/D W/KICK OUT + 1 DOUBLE ACTING W/FLOAT W/KICK OUT), BREAKDOWN
35.204.BE	09	VAR - 334330, 335417, 729417 - 2 CONTROL VALVE (1 S/D W/KICK OUT + 1 DOUBLE ACTING WITH FLOAT AND KICK OUT)
35.204.BE	10	VAR - 334330, 335417, 729417 - 2 CONTROL VALVES (1 S/D W/KICK OUT + 1 DOUBLE ACTING W/FLOAT W/KICK OUT) - BREAKDOWN
35.204.BE	11	VAR - 728366, 729412 - 1 CONTROL VALVE (1 S/D)
35.204.BE	12	VAR - 334325, 335366, 728366 - 1 CONTROL VALVE (1 S/D), BREAKDOWN
35.204.BE	13	VAR - 334326, 334327, 729412 - 1 CONTROL VALVE, BREAKDOWN
35.204.BJ	01	VAR - 728054, 729103 - PIPES
35.204.BJ	02	VAR - 728368, 729413, 729417 - PIPES
35.204.BJ	03	VAR - 728366, 729412 - PIPES
35.204.BJ	04	VAR - 334326, 335366, 728366, 729412 - 1 CONTROL VALVE, PIPES
35.204.BJ	05	VAR - 728368, 729413, 729417 - 2 CONTROL VALVE, PIPES

SECTION INDEX

HYDRAULIC SYSTEMS

35.204.BL	05	VAR - 728054, 729103 - 3 CONTROL VALVES, LEVER AND KNOB, CAB
35.204.BL	06	VAR - 728368, 729413, 729417 - 2 CONTROL VALVES, LEVER AND KNOB, CAB
35.204.BL	07	VAR - 728366, 729412 - 1 CONTROL VALVE, LEVER AND KNOB, CAB
35.204.BL	08	VAR - 728366, 728368, 729412, 729413, 729417 - CONTROL LEVER
35.359.AB	01	VAR - 336125 - 2 MID MOUNT VALVES WITH JOYSTICK, VALVES AND PIPES
35.359.AB	02	VAR - 336125 - TWO FRONT CONTROL VALVES, BREAKDOWN
35.701.AX	01	VAR - 344351 - FRONT LOADER HYDRAULIC SYSTEM
35.701.AX	02	VAR - 330489, 334351, 334352 - 4 MULTIFASTER COUPLERS
35.701.AX	03	VAR - 334351, 334352 - FRONT LOADER WITH 4 COUPLERS, FRONT QUICK COUPLINGS
35.701.AX	04	VAR - 334352 - FRONT LOADER HYDRAULIC SYSTEM (SELF LEVELLING)
35.701.CB	01	VAR - 334351, 334352 - LIFT ARM, CYLINDER, COMPONENTS
35.723.AA	01	VAR - 334351 - BUCKET CYLINDER, COMPONENTS
35.723.AA	02	VAR - 334352 - BUCKET CYLINDER, COMPONENTS
35.724.AE	01	VAR - 336125 - 2 MID MOUNTS VALVES WITH JOYSTICK, JOYSTICK AND SUPPORT
35.724.AE	02	VAR - 336125 - JOYSTICK FOR MID MOUNT, BREAKDOWN

SECTION INDEX, HYDRAULIC SYSTEMS

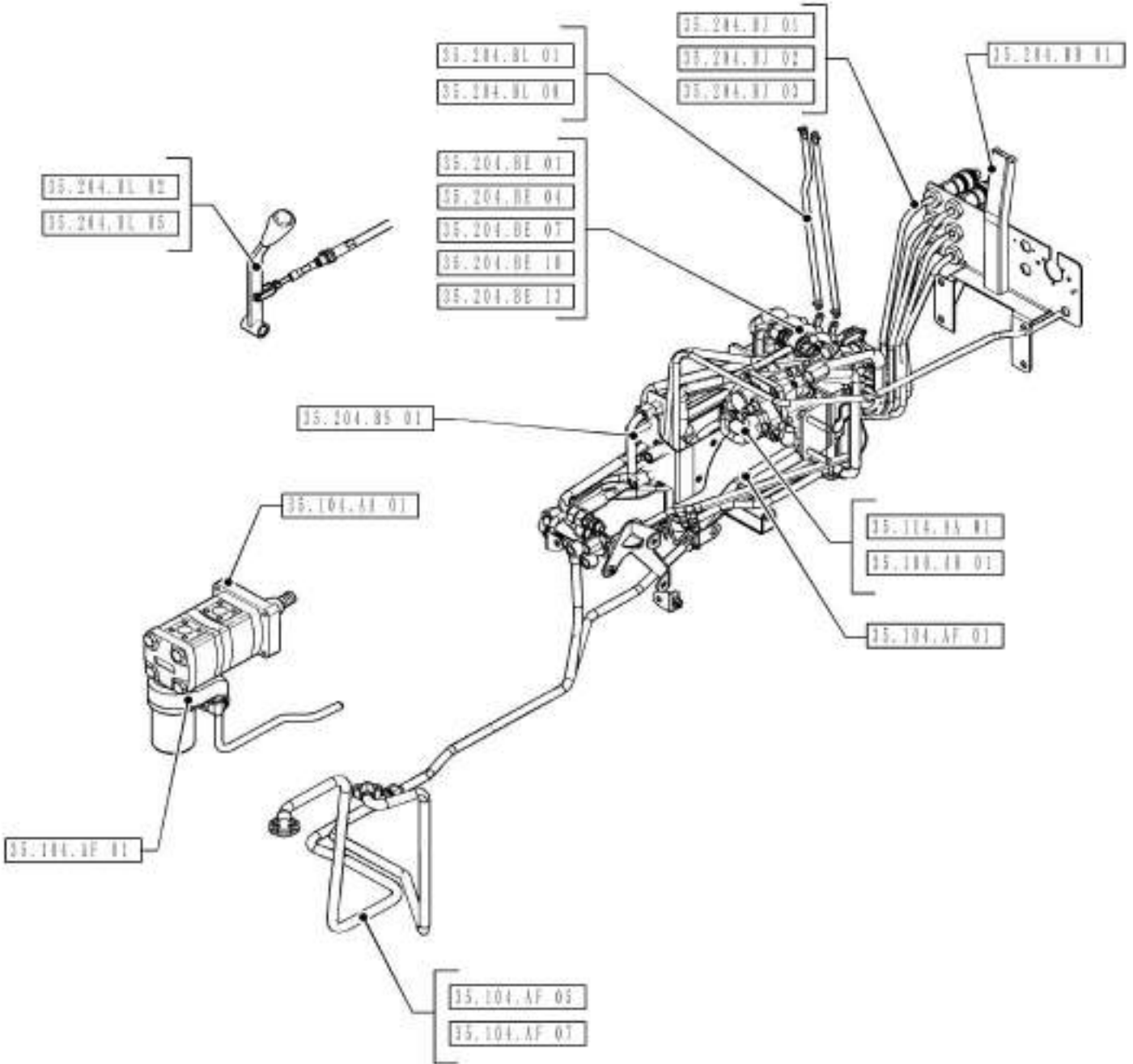

35.000.00

01

p1

1/2014

SECTION INDEX, HYDRAULIC SYSTEMS

REF FN	PART NUMBER	YR/SN	QTY	DESCRIPTION
---------------	--------------------	--------------	------------	--------------------

FARMALL JX100 FARMALL JX110 FARMALL JX70 FARMALL JX75 FARMALL JX80 FARMALL JX90
--

SECTION INDEX, HYDRAULIC SYSTEMS

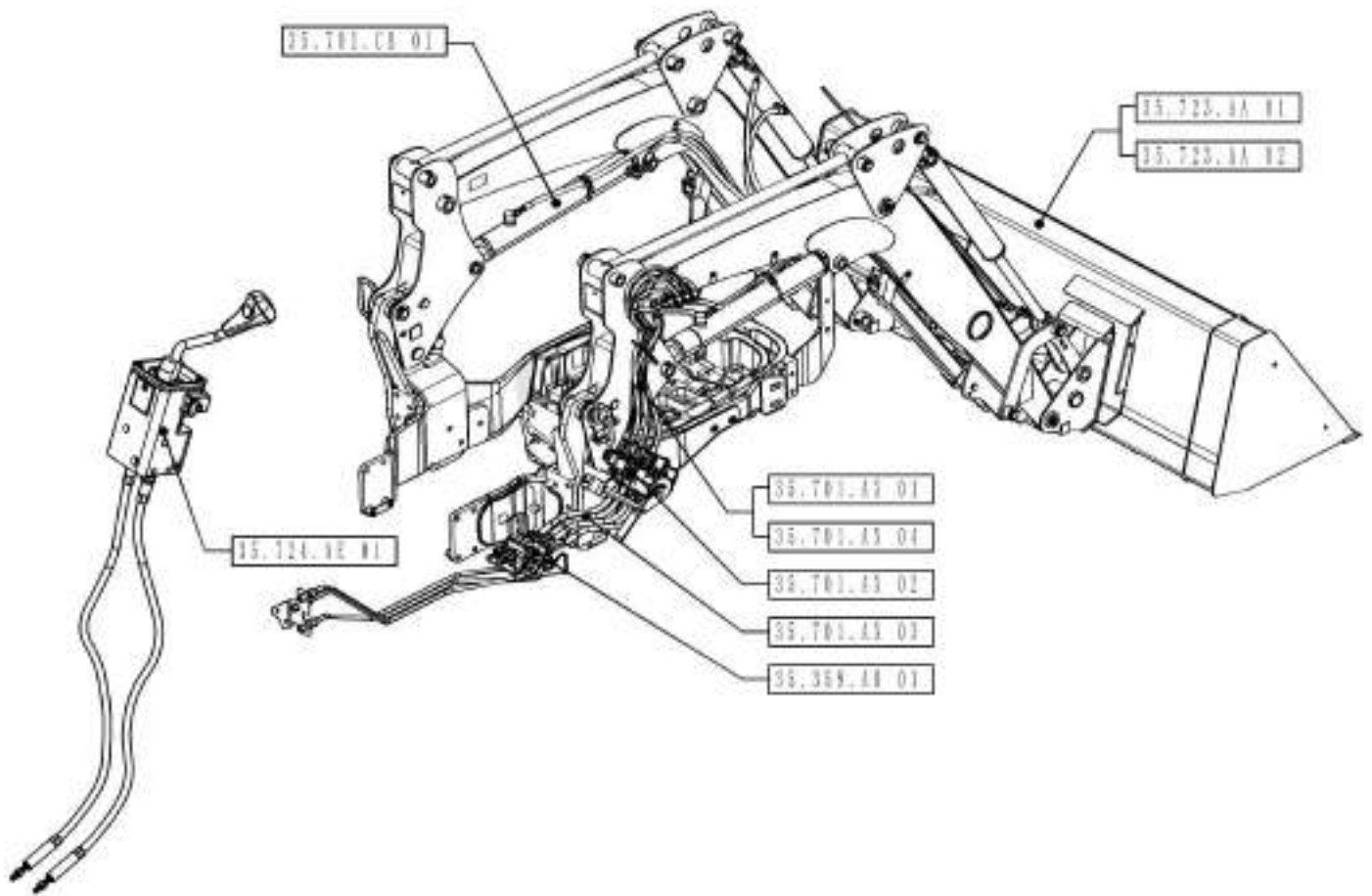

35.000.00

02

p1

1/2014

SECTION INDEX, HYDRAULIC SYSTEMS

REF FN	PART NUMBER	YR/SN	QTY	DESCRIPTION
---------------	--------------------	--------------	------------	--------------------

				FARMALL JX100 FARMALL JX110 FARMALL JX70 FARMALL JX75 FARMALL JX80 FARMALL JX90
--	--	--	--	--

35.100.AR

01

p1

1/2014

HYDRAULIC LIFT, LINE, PRESSURE RELIEF VALVE

REF FN	PART NUMBER	YR/SN	QTY DESCRIPTION
1	5011763		1 PRESSURE RELIEF VALVE Incl 11 - 13
2	10264560		1 SEAL M24.4 x 32 x 1.5
3	5120450		1 BANJO BOLT
4	5120449		1 BODY
5	10263460		1 SEAL 22.30mm ID x 28.00mm OD, 1.50mm, Copper
6	84241042		1 PIPE
7	84237320		1 PIPE
8	10184411		1 BANJO BOLT M16 x 1.5 x 31.00mm, R50, ZND
9	10257060		2 SEALING WASHER 16.3mm ID x 22.00mm OD x 1.50mm, Copper
10	84237059		1 PIPE
11	NSS		1 NOT SERVICED SEPARATELY Valve Incl in 1
12	14457381		1 O-RING 17.12mm ID x 2.62" Width
13	14453980		1 O-RING 25.12mm ID x 1.78mm Width

Valid for Industrial Var. 395366

FARMALL JX100 FARMALL
 JX110 FARMALL JX70
 FARMALL JX75 FARMALL
 JX80 FARMALL JX90

35.104.AA

01

p1

1/2014

VAR - 334314, 390257 - LIFTER PUMP

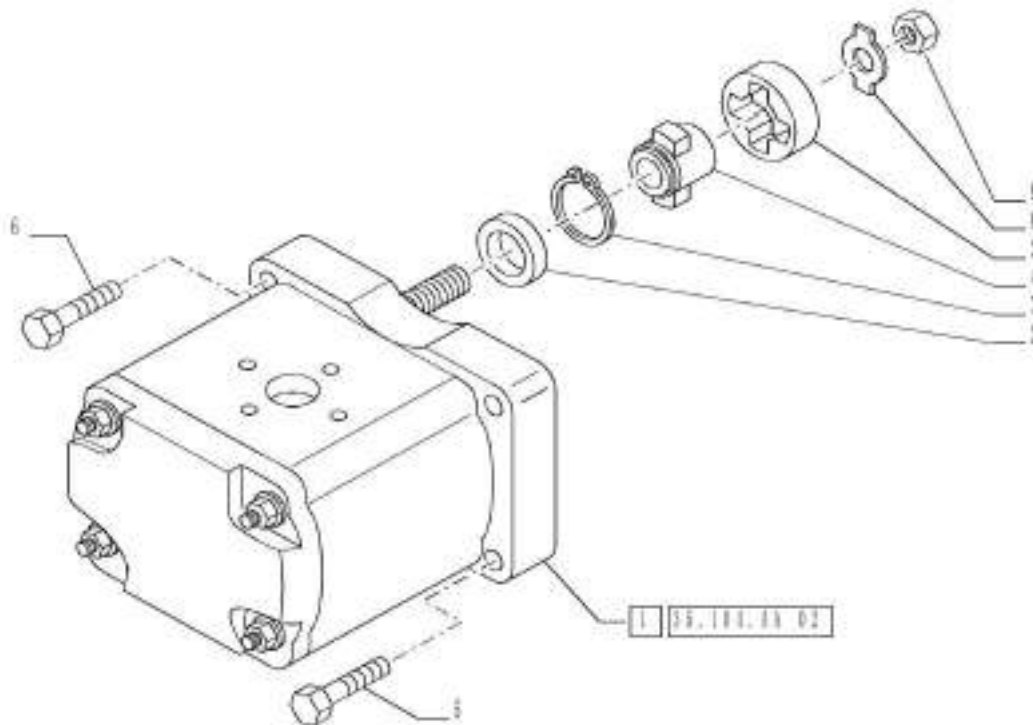

VAR - 334314, 390257 - LIFTER PUMP

REF	FN	PART NUMBER	YR/SN	QTY	DESCRIPTION
1	1	87721169		1	HYDRAULIC PUMP 14.6 CC/REV
1	2	87716629		1	HYDRAULIC PUMP 19 CC/REV
2		5118568		1	CENTERING RING
3		5118569		1	COUPLING
4		5118570		1	HUB
5		43117		2	SCREW Hex, M6 x 1 x 30mm, CI 8.8
6		86977789		2	BOLT Hex, M6 x 1 x 35mm, CI 8.8
7		13398376		1	SNAP RING M40, Int
8		8273920		1	LOCK WASHER
9		5093733		1	NUT

(1) VAR - 390257

(2) VAR - 334314

Valid for Var. 334314 or Var. 390257

FARMALL JX100 FARMALL
 JX110 FARMALL JX70
 FARMALL JX75 FARMALL
 JX80 FARMALL JX90

VAR - 334314, 390257 - LIFTER PUMP, BREAKDOWN

REF FN	PART NUMBER	YR/SN	QTY DESCRIPTION
1	87341173		1 SEAL KIT
2	1 87721169		1 HYDRAULIC PUMP ASSY Incl 1, 3, 4, 7-10
2	2 87716629		1 HYDRAULIC PUMP Incl 1, 3 - 4, 6 - 10
3	NSS		4 NOT SERVICED SEPARATELY Screw Incl in 2
4	8273918		1 KEY
5	8273919		1 NUT
6	8273920		1 LOCK WASHER
7	NSS		1 NOT SERVICED SEPARATELY Cover Incl in 2
8	NSS		1 NOT SERVICED SEPARATELY Housing Incl in 2
9	NSS		1 NOT SERVICED SEPARATELY Cover Incl in 2
10	NSS		1 NOT SERVICED SEPARATELY Gear Incl in 2

(1) VAR - 390257

(2) VAR - 334314

Valid for Var. 334314 or Var. 390257

FARMALL JX100 FARMALL
 JX110 FARMALL JX70
 FARMALL JX75 FARMALL
 JX80 FARMALL JX90

VAR - 334395, 390814 - HYDRAULIC LIFT PIPES, OIL FILTER

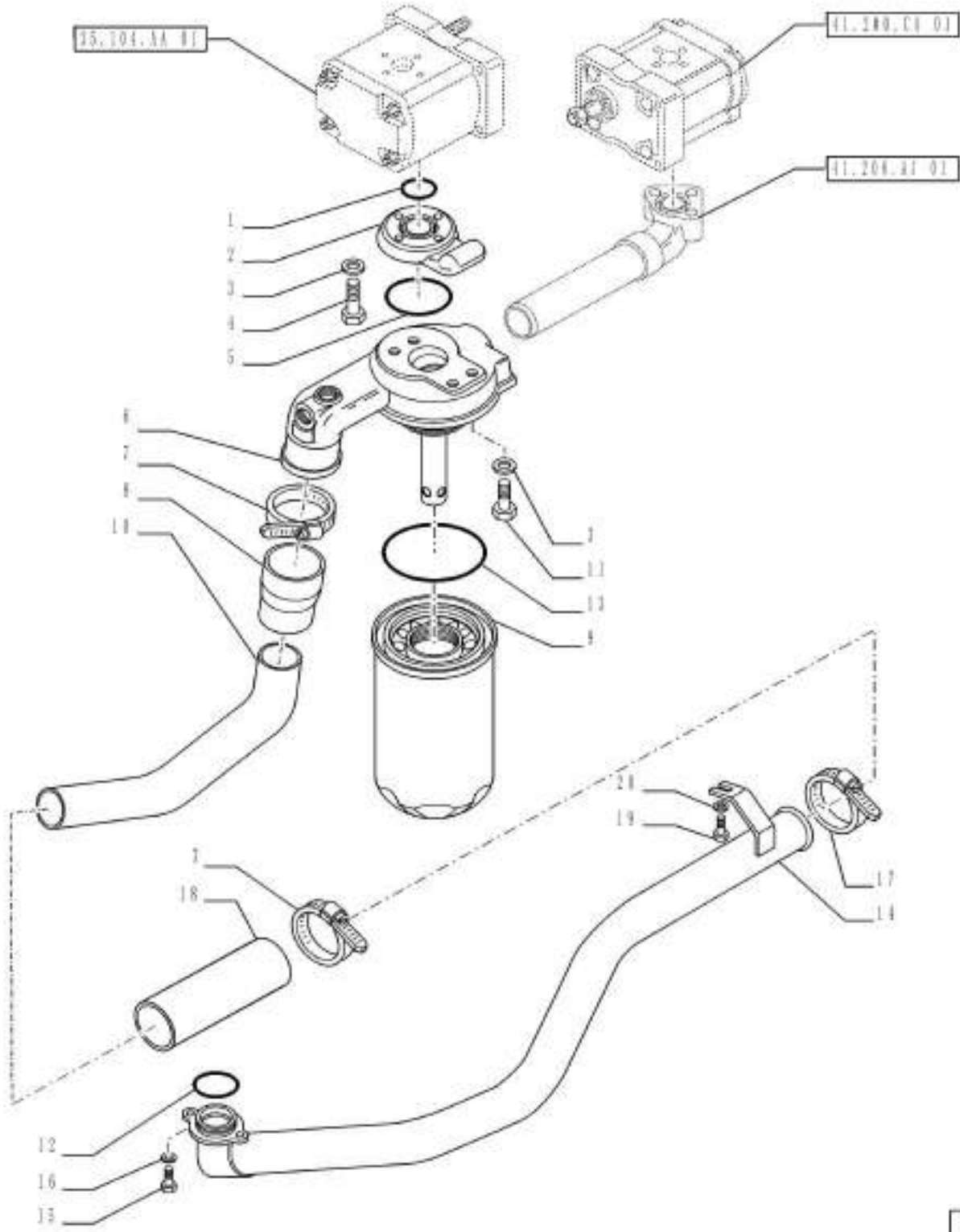

VAR - 334395, 390814 - HYDRAULIC LIFT PIPES, OIL FILTER

REF FN	PART NUMBER	YR/SN	QTY DESCRIPTION
1	14457681		3 O-RING 21.89mm ID x 2.62" Width
2	47129555		1 PLATE
3	14330260		8 SEALING WASHER M8.2 x 12 x 1 8 x 12
4	14306321		4 HEX SOC SCREW M8 x 20mm, Cl 8.8
5	14460180		1 O-RING 61.6mm ID x 2.62" Width
6	84175176		1 SUPPORT
7	13000790		3 HOSE CLAMP D=50-70
8	84198652		1 LARGE HOSE
9	84123428		1 HYDRAULIC OIL FILTER
10	1 84232796		1 PIPE
10	2 84248000		1 PIPE
10	3 84518529		1 PIPE
11	14306221		4 HEX SOC SCREW M8 x 16mm, Cl 8.8, Full Thd
12	5174527		1 O-RING 49.21mm ID x 3.53mm
13	14457180		1 O-RING 13.94mm ID x 2.62" Width
14	84344746		1 PIPE Oil Suction Rear
15	15540421		2 SCREW Hex, M12 x 1.25 x 30mm, Cl 8.8, Full Thd
16	12601574		2 WAVE WASHER Wave, M13
17	5098812		1 COLLAR
18	87626258		1 FUEL HOSE 45.00 mm ID x 90.00 mm, SAE J200
19	43117		1 SCREW Hex, M6 x 1 x 30mm, Cl 8.8
20	12601274		1 WAVE WASHER Wave, M6.4

(1) Valid for FARMALL JX70 Model Only

(2) Valid for FARMALL JX75, 90, 100, 110 Models Only

(3) Valid for FARMALL JX80 Model Only

Valid for Var. 334395 or Var. 390814

FARMALL JX100 FARMALL
 JX110 FARMALL JX70
 FARMALL JX75 FARMALL
 JX80 FARMALL JX90

35.104.AF

05

p1

1/2014

STD, VAR - 334395, 390814 - HYDRAULIC LIFT PIPES

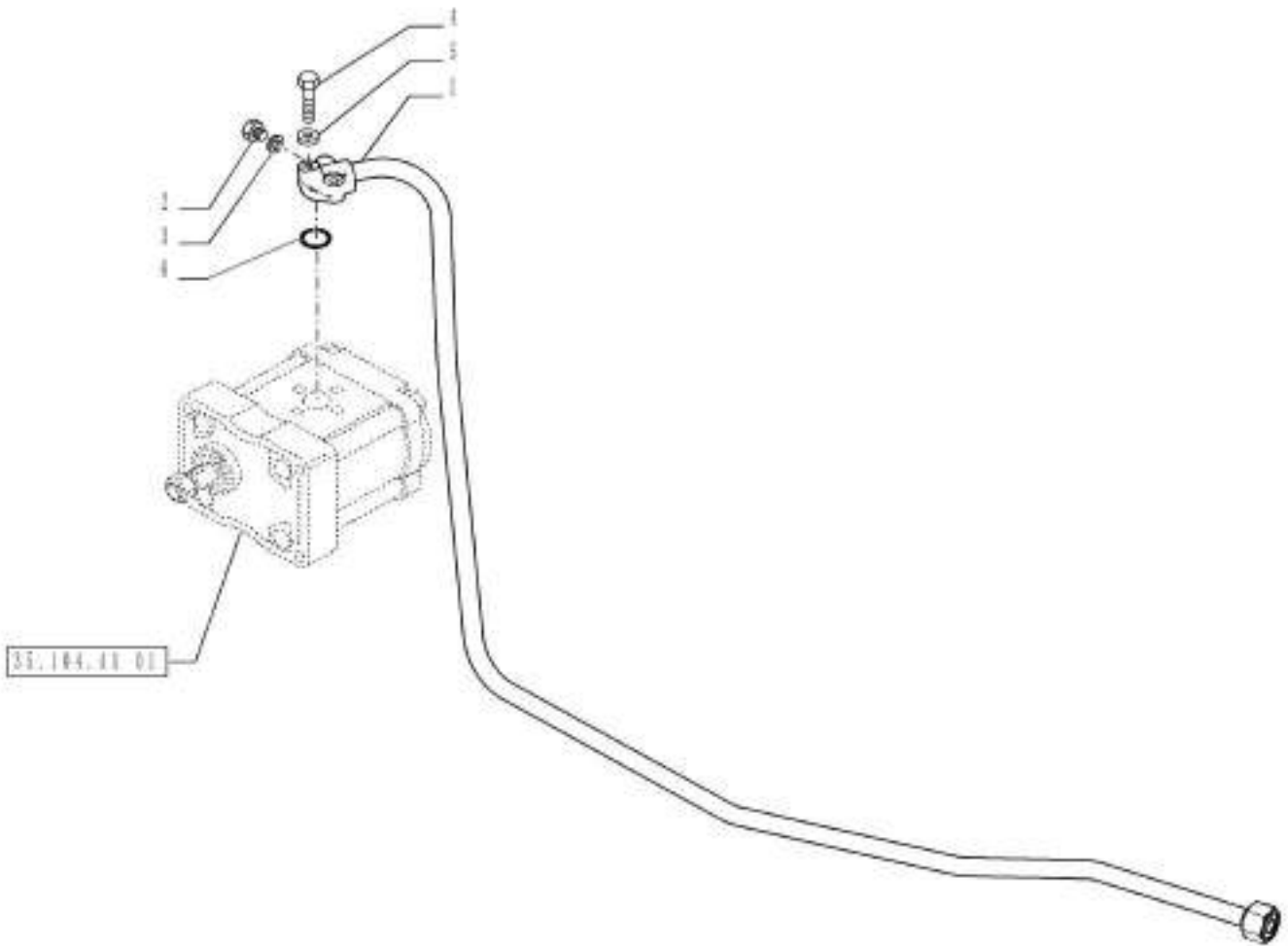

35.104.AF

05

p1

1/2014

STD, VAR - 334395, 390814 - HYDRAULIC LIFT PIPES

REF	FN	PART NUMBER	YR/SN	QTY	DESCRIPTION
1	1	84328203		1	PIPE
1	2	84518534		1	PIPE
2		11903111		1	PLUG M10 x 1.25 x 11, CI5.8
3		10260160		3	SEAL M10.2 x 14 x 1
4		43117		2	SCREW Hex, M6 x 1 x 30mm, CI 8.8
5		12601274		2	WAVE WASHER Wave, M6.4
6		14457180		1	O-RING 13.94mm ID x 2.62" Width
(1)		Valid for FARMALL JX70 Model Only			
(2)		Valid for FARMALL JX80 Model Only			

Valid for Var. 334395 or Var. 390814 or Industrial Var. 390370

**FARMALL JX70
FARMALL JX80**

VAR - 728054, 728366, 728368, 729103, 729412, 729413, 729417 - HYDRAULIC LIFT PIPES

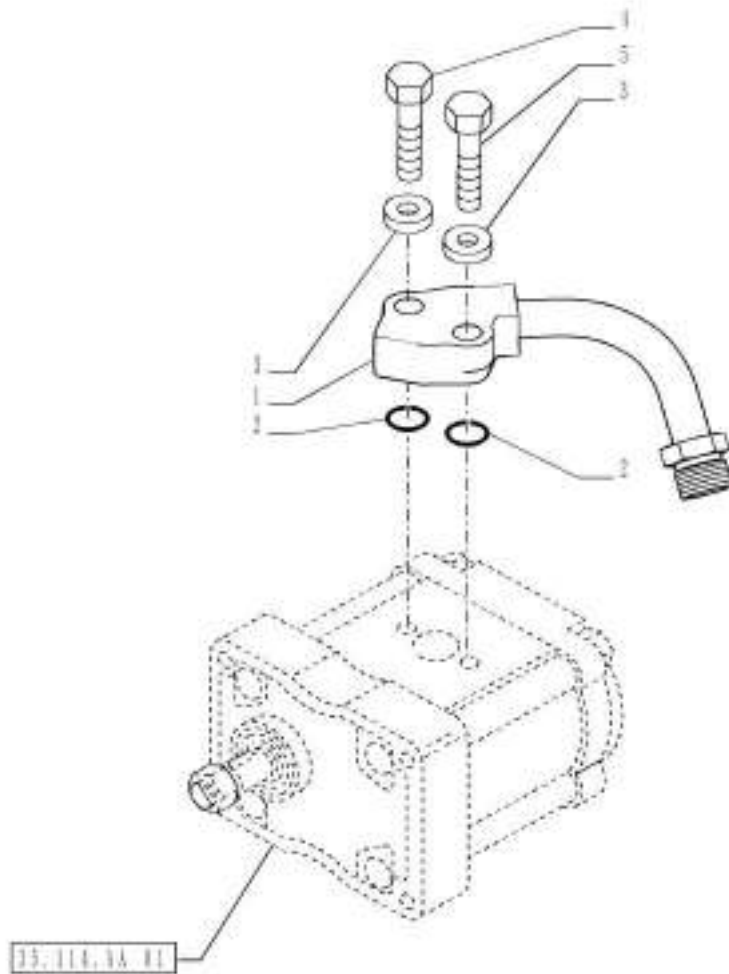

35.104.AF

07

p1

1/2014

VAR - 728054, 728366, 728368, 729103, 729412, 729413, 729417 - HYDRAULIC LIFT PIPES

REF FN	PART NUMBER	YR/SN	QTY DESCRIPTION
1	5128343		1 RIGID TUBE
2	14457180		2 O-RING 13.94mm ID x 2.62" Width
3	10569479		2 LOCK WASHER
4	14307421		1 HEX SOC SCREW M10 x 1.25 x 25mm, CI 8.8
5	14308221		1 HEX SOC SCREW M10 x 1.25 x 65mm, CI 8.8

Valid for Industrial Var. 334331, 335054 (728054) or Industrial Var. 334325, 335366 (728366) or Industrial Var. 334328, 335368 (728368) or Industrial Var. 334332, 335103 (729103) or Industrial Var. 334326, 334327 (729412) or Industrial Var. 334329, 335413 (729413) or Industrial Var. 334330, 335417 (729417)

FARMALL JX100 FARMALL
JX110 FARMALL JX70
FARMALL JX75 FARMALL
JX80 FARMALL JX90

35.114.AA

01

p1

1/2014

VAR - 334395, 390814 - LIFTER DISTRIBUTOR AND VALVES

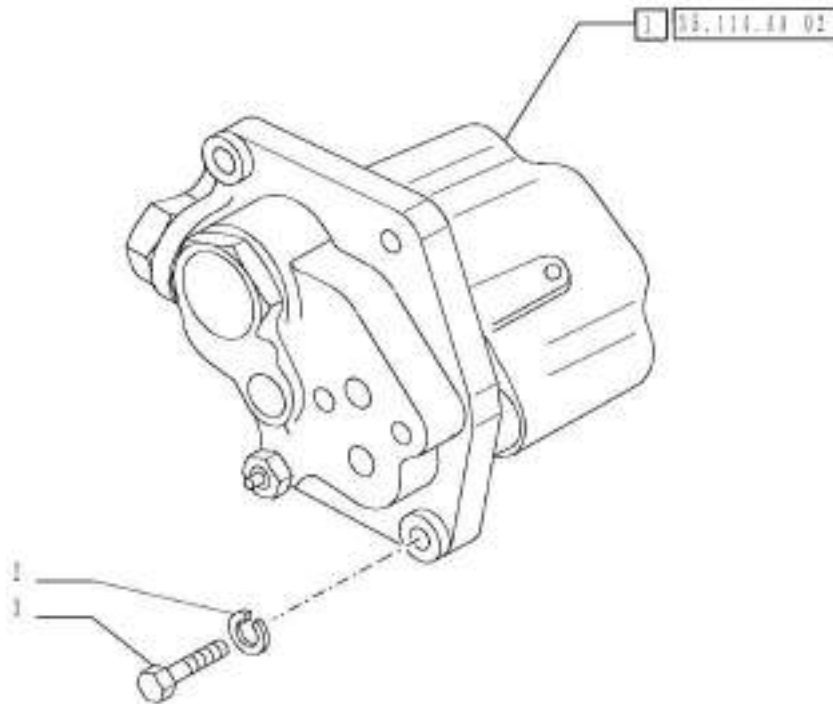

35.114.AA

01

p1

1/2014

VAR - 334395, 390814 - LIFTER DISTRIBUTOR AND VALVES

REF FN	PART NUMBER	YR/SN	QTY DESCRIPTION
1	5089469		1 CONTROL VALVE ASSY
2	12601374		4 WAVE WASHER Wave, 8.40mm ID x 15.00mm OD x 0.80mm, 3.00mm, CST, DAC
3	16043821		4 SCREW Hex, M8 x 1.25 x 30mm, Cl 8.8, Full Thd

Valid for Var. 334395 or Var. 390814

FARMALL JX100 FARMALL
JX110 FARMALL JX70
FARMALL JX75 FARMALL
JX80 FARMALL JX90

VAR - 334395, 390814 - LIFTER DISTRIBUTOR AND VALVES, BREAKDOWN

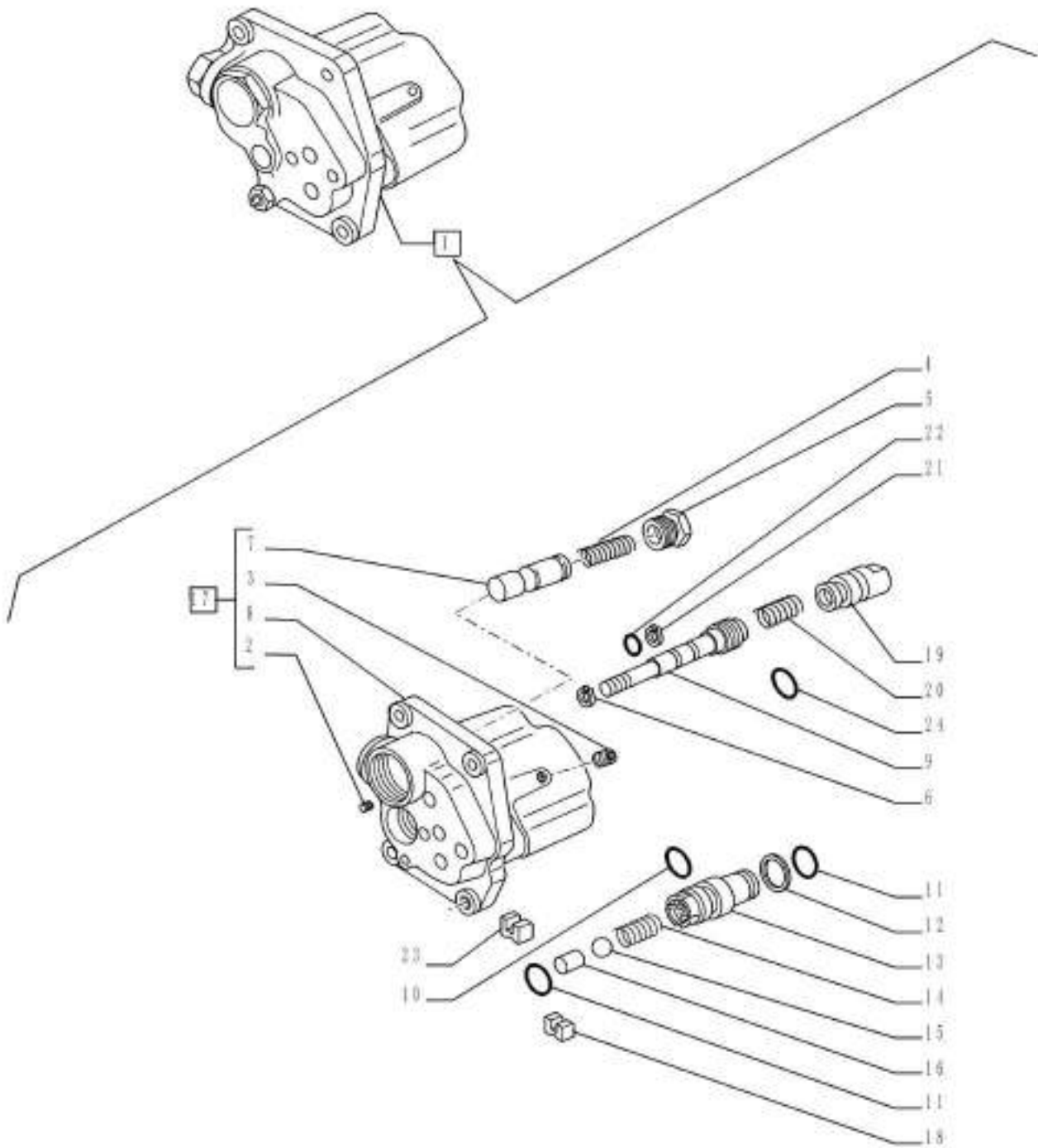

VAR - 334395, 390814 - LIFTER DISTRIBUTOR AND VALVES, BREAKDOWN

REF FN	PART NUMBER	YR/SN	QTY DESCRIPTION
1	5089469		1 CONTROL VALVE ASSY Incl 2 - 24, See also Figure 35.114.AA 03
2	10269150		3 PLUG
3	5162458		2 PLUG
4	5117729		1 SPRING
5	5117734		1 PLUG
6	13397476		1 SNAP RING M10.8, Int
7	5117727		1 SPOOL
8	NSS		1 NOT SERVICED SEPARATELY Body Incl in 1
9	5170591		1 PIN
10	14457581		1 O-RING 0.799" ID x 0.103" Width
11	14457281		2 O-RING 0.612" ID x 0.103" Width
12	4958830		1 BACK-UP RING
13	5156291		1 HYD CONNECTOR
14	5156289		1 SPRING DO=8.5 DW=1.2 25.5MM
15	20063580		1 BALL
16	5156290		1 VALVE SEAT
17	5170596		1 BODY ASSY Incl 2, 3, 7, 8
18	5148905		1 SPACER Lower
19	5178017		1 SPOOL
20	5155844		1 SPRING DO=11 DW=1.6 34MM
21	5120772		1 O-RING 1.78 x 6.75
22	5120771		1 WASHER
23	5148907		1 SPACER Upper
24	14457381		2 O-RING 17.12mm ID x 2.62" Width

Valid for Var. 334395 or Var. 390814

FARMALL JX100 FARMALL
 JX110 FARMALL JX70
 FARMALL JX75 FARMALL
 JX80 FARMALL JX90

VAR - 334395, 390814 - LIFTER DISTRIBUTOR AND VALVES, BREAKDOWN

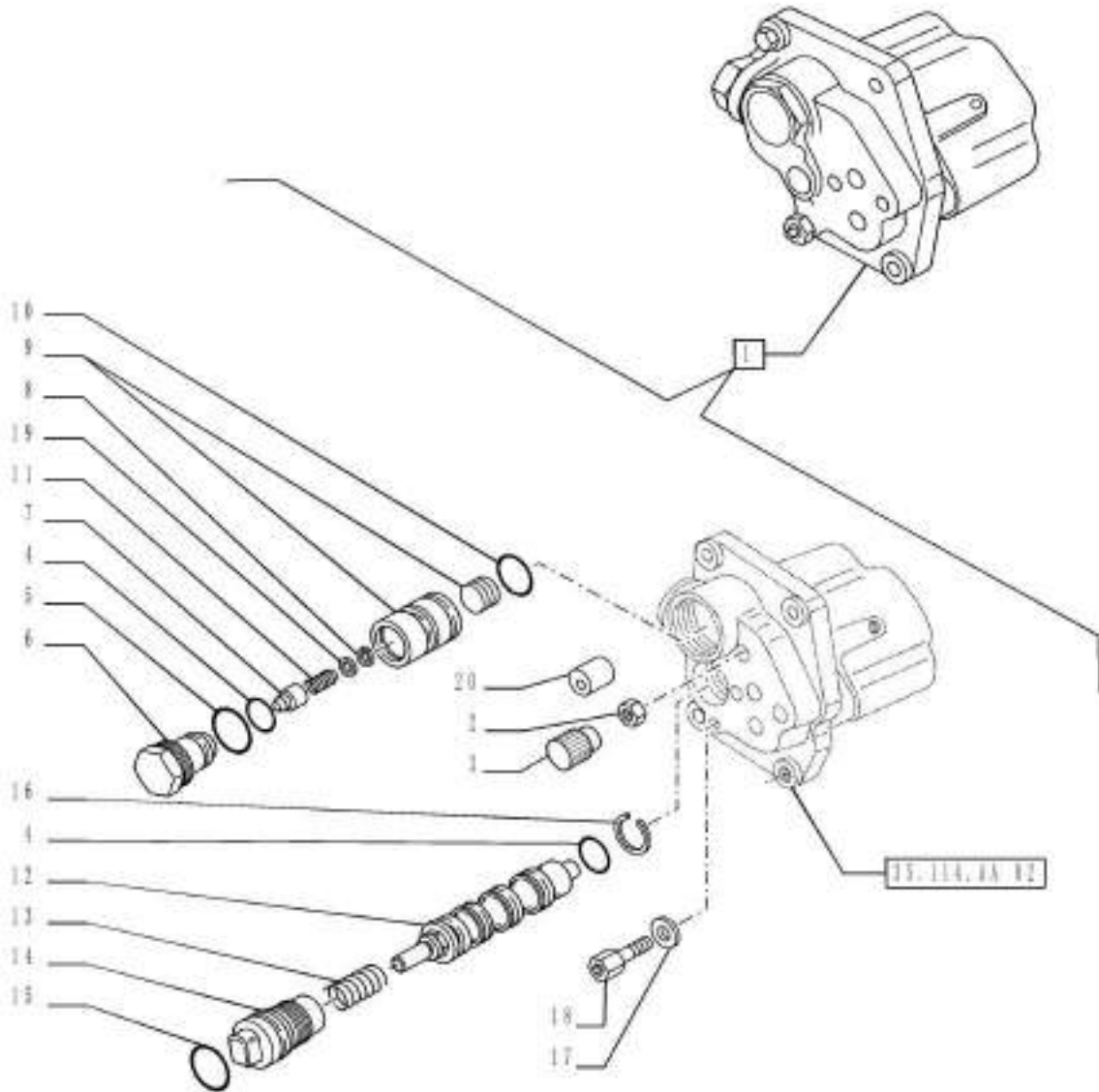

VAR - 334395, 390814 - LIFTER DISTRIBUTOR AND VALVES, BREAKDOWN

REF FN	PART NUMBER	YR/SN	QTY DESCRIPTION
1	5089469		1 CONTROL VALVE ASSY Incl 2 - 20, See also Figure 35.114.AA 02
2	16100814		1 NUT M8, CI 8, DAC
3	5120798		1 KNOB
4	14457381		3 O-RING 17.12mm ID x 2.62" Width
5	14458081		1 O-RING 1.112" ID x 0.103" Width
6	5122029		1 PLUG
7	5117732		1 SPOOL
8	13420376		1 SNAP RING M12, Int
9	5117731		1 SPOOL
10	14454081		1 O-RING 1.051" ID x 0.07" Width
11	5115469		1 SPRING DO=7.7 DW=0.9 14.5MM
12	5163230		1 HYDRAULIC VALVE
13	4973361		1 SPRING DO=15.5 DW=1.5 50.5MM
14	5117725		1 PLUG
15	14453980		1 O-RING 25.12mm ID x 1.78mm Width
16	5117726		2 BACK-UP RING
17	10296160		1 SEALING WASHER M12.2 x 18 x 1, Copper
18	14360524		1 HEX SOC SCREW M12 x 1.25 x 20mm, CI 8.8, Full Thd
19	5122030		1 SPRING WASHER
20	5170590		1 SPACER

Valid for Var. 334395 or Var. 390814

FARMALL JX100 FARMALL
 JX110 FARMALL JX70
 FARMALL JX75 FARMALL
 JX80 FARMALL JX90

VAR - 728054, 728366, 728368, 729103, 729412, 729413, 729417 - QUICK COUPLER, COMPONENTS

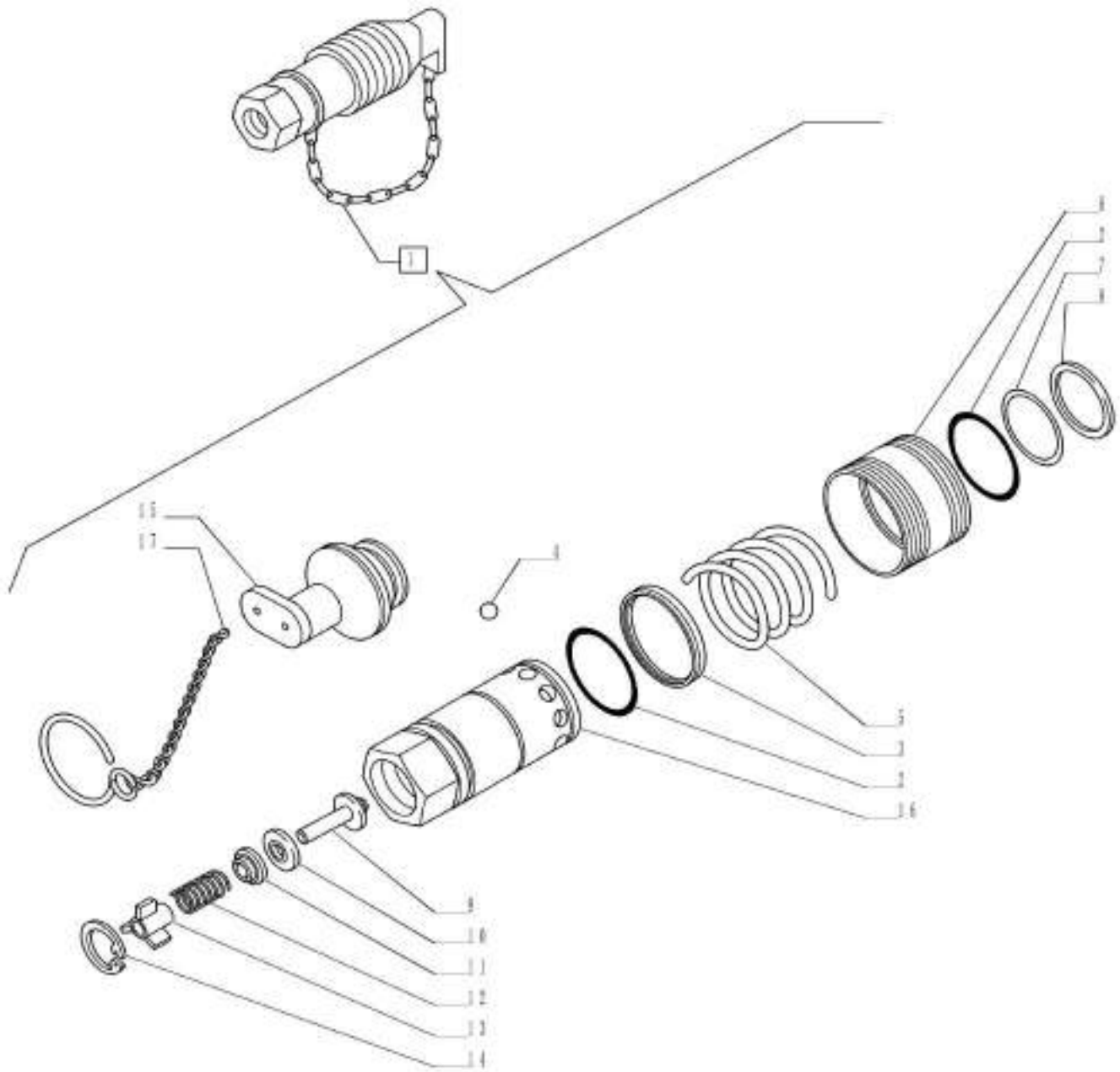

VAR - 728054, 728366, 728368, 729103, 729412, 729413, 729417 - QUICK COUPLER, COMPONENTS

REF FN	PART NUMBER	YR/SN	QTY DESCRIPTION
1	5093853		1 QUICK FEMALE COUPLING Black, Incl 2 - 17
2	5080712		2 RING
3	5080713		1 RING
4	14480670		12 BALL
5	5080715		1 SPRING
6	5080716		1 SHIELD
7	14457585		1 O-RING
8	84314394		1 SEAL
9	5080719		1 VALVE SECTION
10	5080720		1 SEAL
11	5080721		1 WASHER
12	5080722		1 SPRING
13	5080723		1 PIN
14	5080724		1 O-RING
15	5080725		1 DUST CAP Black
16	NSS		1 NOT SERVICED SEPARATELY Coupling Incl in 1
17	84314395		1 CHAIN

Valid for Industrial Var. 334331, 335054 (728054) or Industrial Var. 334325, 335366 (728366) or Industrial Var. 334328, 335368 (728368) or Industrial Var. 334332, 335103 (729103) or Industrial Var. 334326, 334327 (729412) or Industrial Var. 334329, 335413 (729413) or Industrial Var. 334330, 335417 (729417)

FARMALL JX100 FARMALL
JX110 FARMALL JX70
FARMALL JX75 FARMALL
JX80 FARMALL JX90

35.204.BE

01

p1

1/2014

VAR - 334332, 335103, 729103 - 3 CONTROL VALVES (2 S/D W/FLOAT W/KICK OUT + 1 S/D W/KICK OUT)

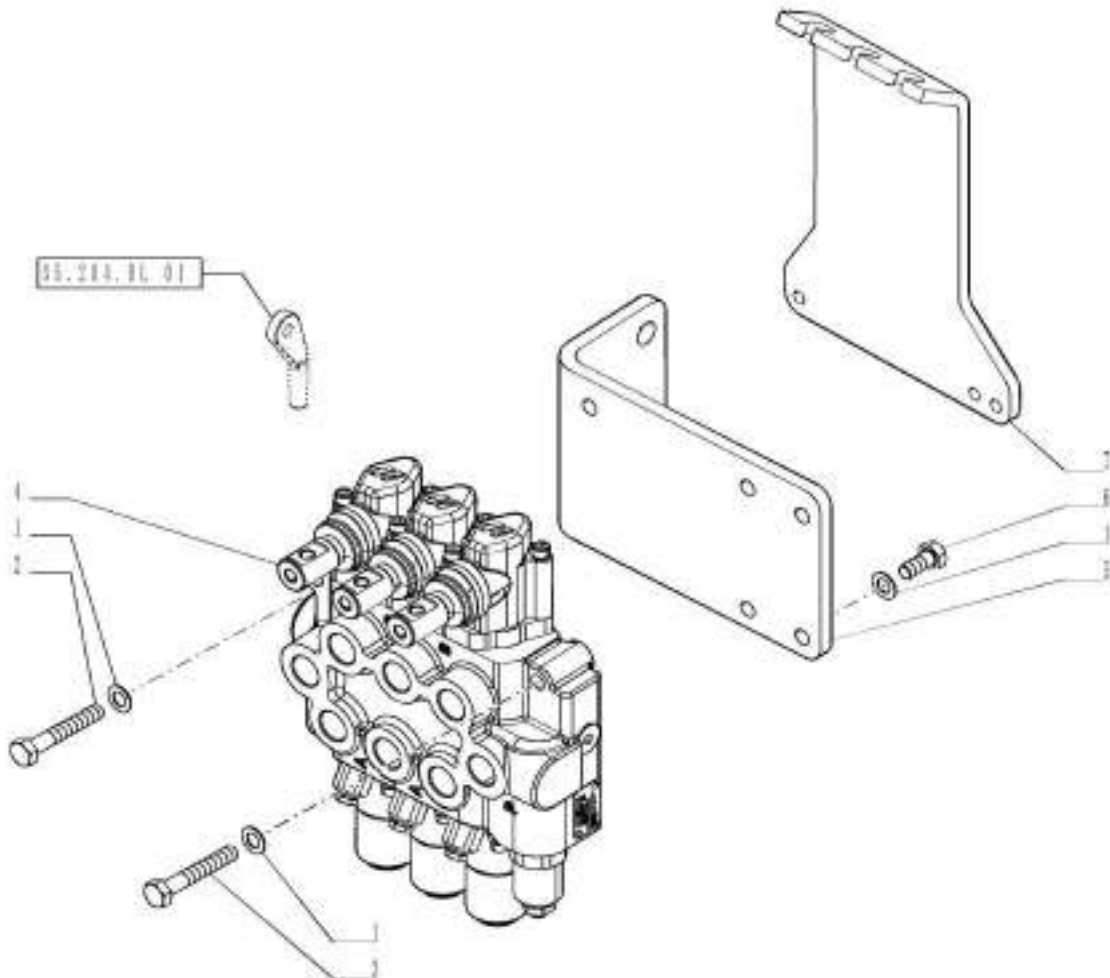

VAR - 334332, 335103, 729103 - 3 CONTROL VALVES (2 S/D W/FLOAT W/KICK OUT + 1 S/D W/KICK OUT)

REF FN	PART NUMBER	YR/SN	QTY DESCRIPTION
1	12601374		3 WAVE WASHER Wave, 8.40mm ID x 15.00mm OD x 0.80mm, 3.00mm, CST, DAC
2	1 16044321		1 SCREW Hex, M8 x 1.25 x 55mm, Cl 8.8
2	2 300510		1 SCREW Hex, M8 x 1.25 x 65mm, Cl 8.8
3	2 120061		1 BOLT Hex, M8 x 60, 8.8
3	1 43130		1 BOLT Hex, M8 x 1.25 x 50mm, Cl 8.8
4	84235970		1 CONTROL VALVE
5	5092077		1 SUPPORT
6	86625000		1 BOLT Hex, M8 x 18mm, Cl 8.8, Full Thd
7	2 84487126		1 SUPPORT

(1) ROPS

(2) CAB

Valid for Industrial Var. 334332, 335103 (729103)

FARMALL JX100 FARMALL
 JX110 FARMALL JX70
 FARMALL JX75 FARMALL
 JX80 FARMALL JX90

35.204.BE

02

p1

1/2014

VAR - 334332, 335103, 729103 - 3 CONTROL VALVES (2 S/D W/FLOAT W/KICK OUT + 1 S/D W/KICK OUT) - BREAKDOWN

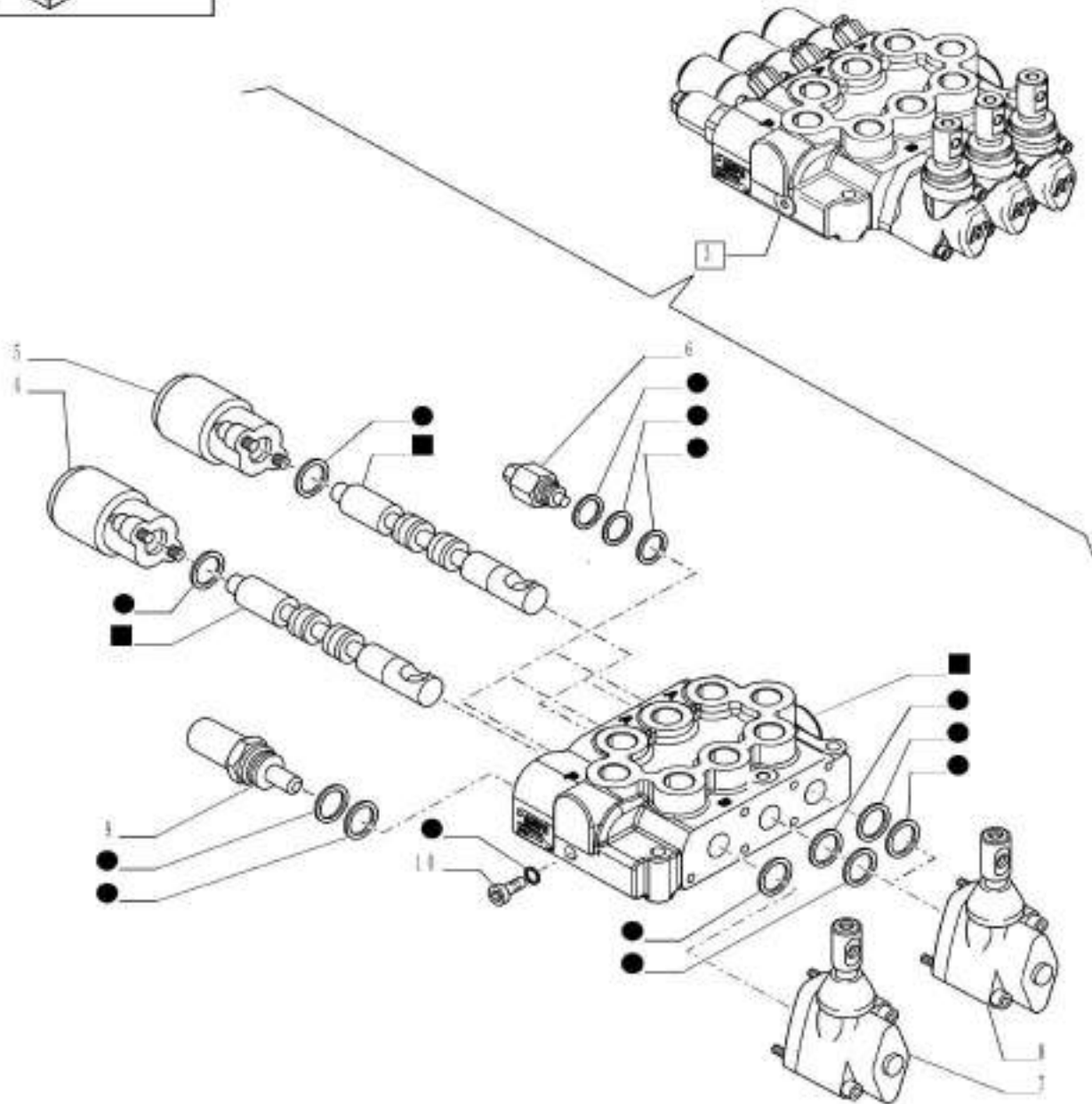
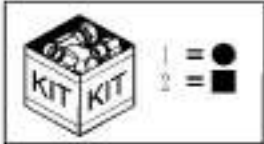

VAR - 334332, 335103, 729103 - 3 CONTROL VALVES (2 S/D W/FLOAT W/KICK OUT + 1 S/D W/KICK OUT) - BREAKDOWN

REF FN	PART NUMBER	YR/SN	QTY DESCRIPTION
1	84287238		1 SEAL KIT
2	84287237		1 OPERATOR MANUAL BULGARIAN
3	84235970		1 CONTROL VALVE Incl 1, 2, 4 - 10
4	5083053		1 ACTUATOR
5	84286924		2 ACTUATOR
6	5083049		3 VALVE
7	84286957		1 CONTROL
8	84286923		2 CONTROL
9	5083046		1 PRESSURE RELIEF VALVE
10	5083047		1 CHECK VALVE

Valid for Industrial Var. 334332, 335103 (729103)	FARMALL JX100 FARMALL JX110 FARMALL JX70 FARMALL JX75 FARMALL JX80 FARMALL JX90
---	--

VAR - 334331, 335054, 728054 - 3 CONTROL VALVES (2S/D + 1S/D W/KICK OUT)

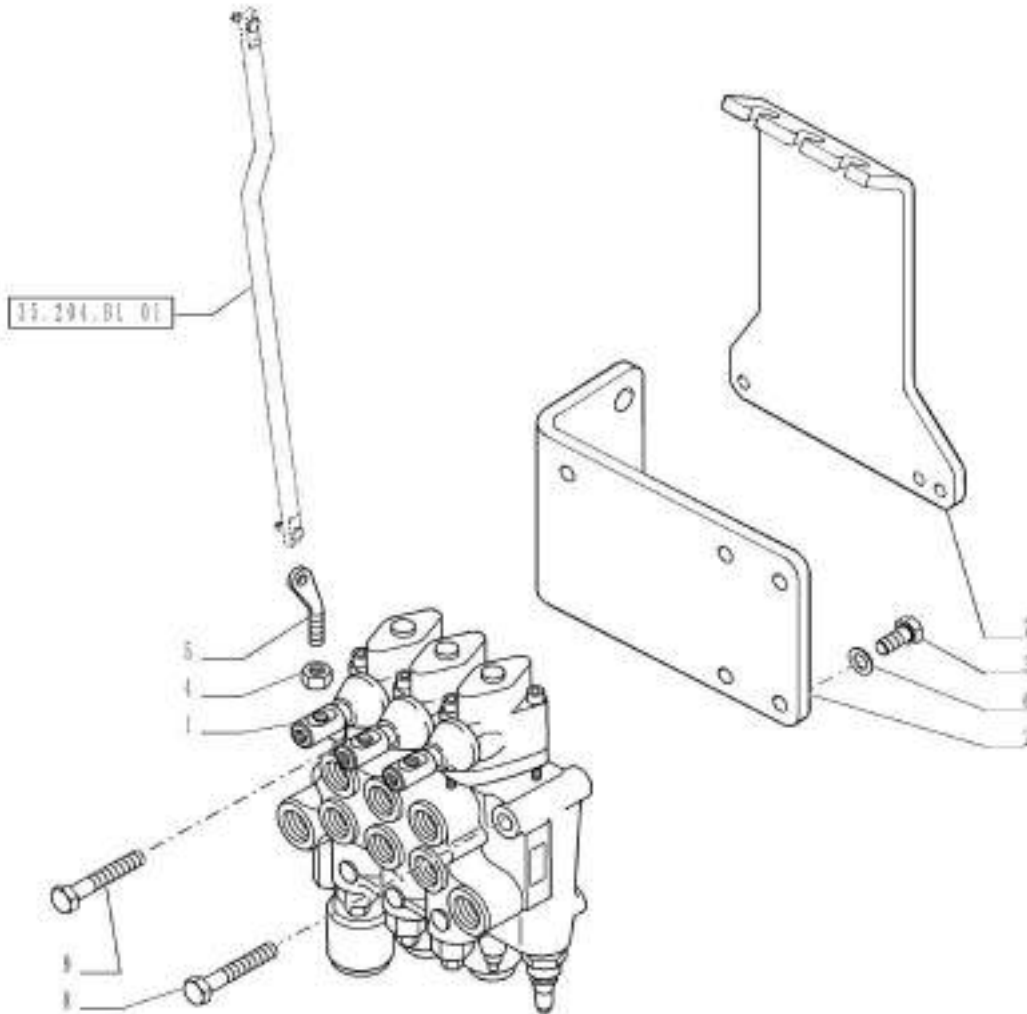

35.204.BE

03

p1

1/2014

VAR - 334331, 335054, 728054 - 3 CONTROL VALVES (2S/D + 1S/D W/KICK OUT)

REF FN	PART NUMBER	YR/SN	QTY DESCRIPTION
1	84235969		1 CONTROL VALVE
2	5092077		1 SUPPORT
3	86625000		1 BOLT Hex, M8 x 18mm, CI 8.8, Full Thd
4	16100811		6 NUT Hex, M8, 6.80mm, CI 8, ZND
5	5089075		3 SUPPORT
6	12601374		4 WAVE WASHER Wave, 8.40mm ID x 15.00mm OD x 0.80mm, 3.00mm, CST, DAC
7 1	84487126		1 SUPPORT
8 1	120061		2 BOLT Hex, M8 x 60, 8.8
8 2	43130		1 BOLT Hex, M8 x 1.25 x 50mm, CI 8.8
9 1	300510		1 SCREW Hex, M8 x 1.25 x 65mm, CI 8.8
9 2	16044321		1 SCREW Hex, M8 x 1.25 x 55mm, CI 8.8
(1)	CAB		
(2)	ROPS		

Valid for Industrial Var. 334331, 335054 (728054)

FARMALL JX100 FARMALL
JX110 FARMALL JX70
FARMALL JX75 FARMALL
JX80 FARMALL JX90

35.204.BE

04

p1

1/2014

VAR - 334331, 335054, 728054 - 3 CONTROL VALVES (2 S/D W/FLOAT W/KICK OUT + 1 S/D W/KICK OUT),
BREAKDOWN

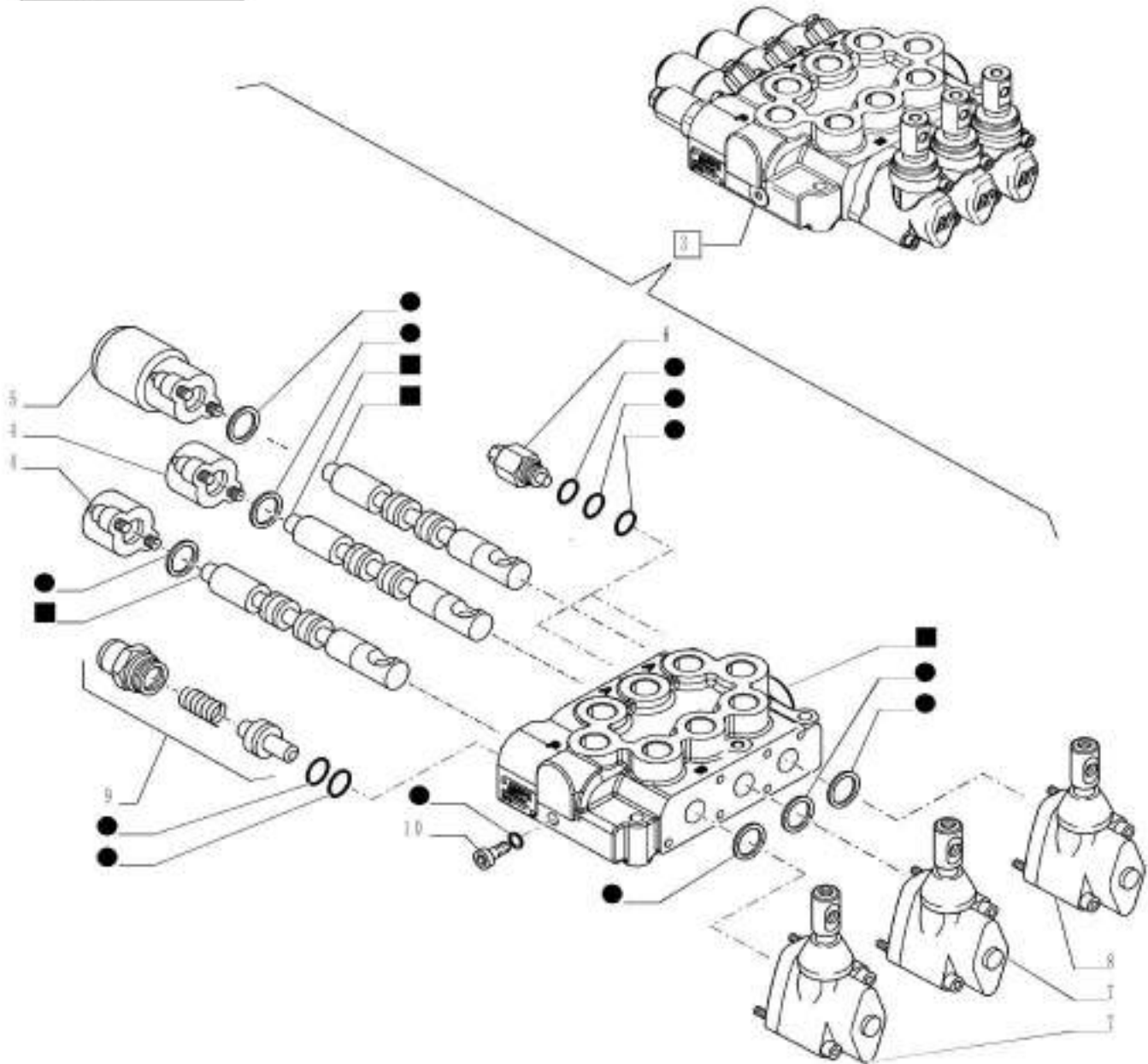
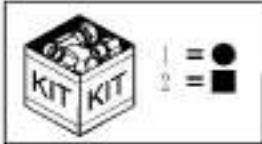

35.204.BE

04

p1

1/2014

**VAR - 334331, 335054, 728054 - 3 CONTROL VALVES (2 S/D W/FLOAT W/KICK OUT + 1 S/D W/KICK OUT),
BREAKDOWN**

REF FN	PART NUMBER	YR/SN	QTY DESCRIPTION
1	84287239		1 SEAL KIT
2	84287240		1 VALVE
3	84235969		1 CONTROL VALVE Incl 1, 2, 4 - 10
4	5083048		2 ACTUATOR
5	5083053		1 ACTUATOR
6	5083049		2 VALVE
7	5083050		2 CONTROL
8	84286957		1 CONTROL
9	5083046		1 PRESSURE RELIEF VALVE
10	5083047		1 CHECK VALVE

Valid for Industrial Var. 334331, 335054 (728054)	FARMALL JX100 FARMALL JX110 FARMALL JX70 FARMALL JX75 FARMALL JX80 FARMALL JX90
---	--

35.204.BE

05

p1

1/2014

VAR - 334328, 335368, 728368 - 2 CONTROL VALVE (1 S/D + 1 DOUBLE ACTING)

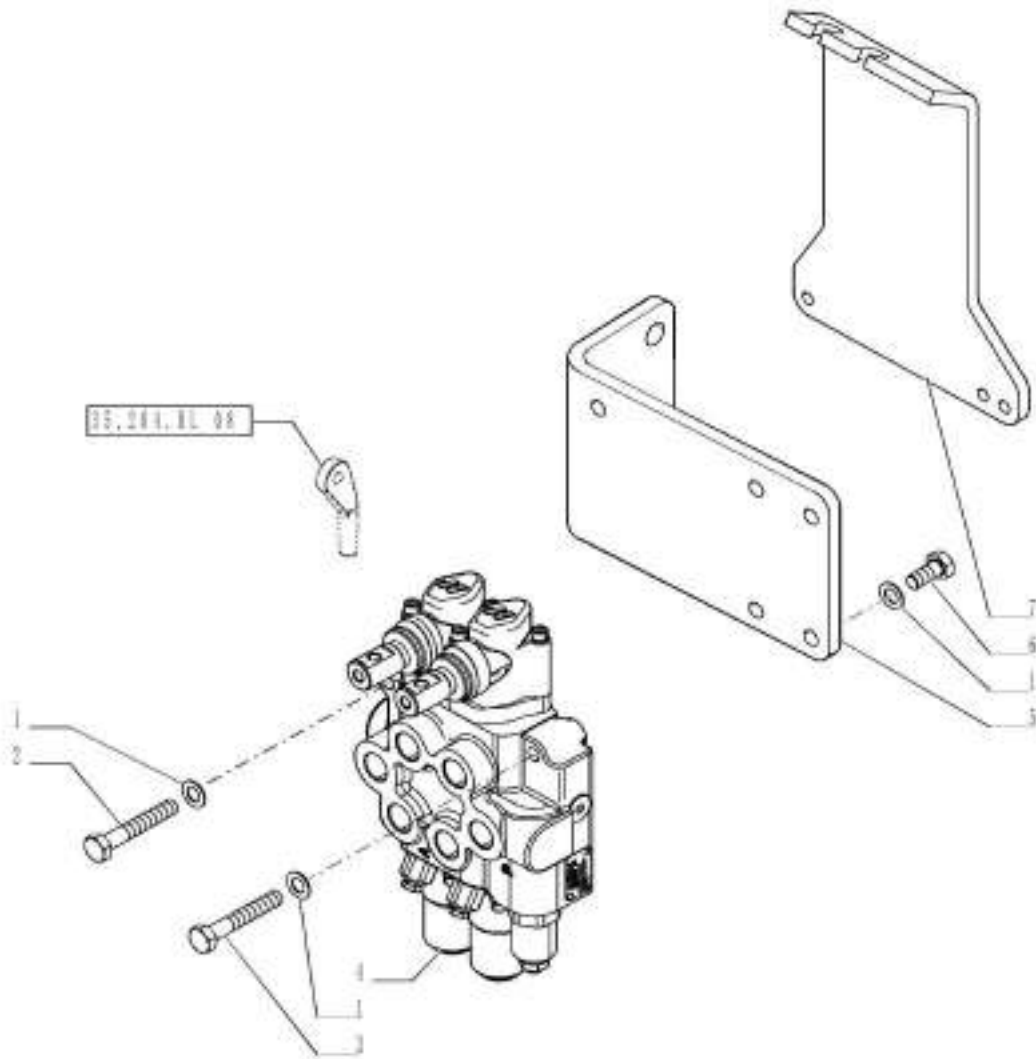

VAR - 334328, 335368, 728368 - 2 CONTROL VALVE (1 S/D + 1 DOUBLE ACTING)

REF FN	PART NUMBER	YR/SN	QTY DESCRIPTION
1	12601374		3 WAVE WASHER Wave, 8.40mm ID x 15.00mm OD x 0.80mm, 3.00mm, CST, DAC
2	1 16044321		1 SCREW Hex, M8 x 1.25 x 55mm, Cl 8.8
2	2 300510		1 SCREW Hex, M8 x 1.25 x 65mm, Cl 8.8
3	2 120061		1 BOLT Hex, M8 x 60, 8.8
3	1 43130		1 BOLT Hex, M8 x 1.25 x 50mm, Cl 8.8
4	5099440		1 DISTRIBUTOR
5	5092077		1 SUPPORT
6	86625000		1 BOLT Hex, M8 x 18mm, Cl 8.8, Full Thd
7	2 84487125		1 SUPPORT

(1) ROPS

(2) CAB

Valid for Industrial Var. 334328, 335368 (728368)

FARMALL JX100 FARMALL
 JX110 FARMALL JX70
 FARMALL JX75 FARMALL
 JX80 FARMALL JX90

VAR - 334328, 335368, 728368 - 2 CONTROL VALVE (1 S/D W/KICK OUT + 1 DOUBLE ACTING) - BREAKDOWN

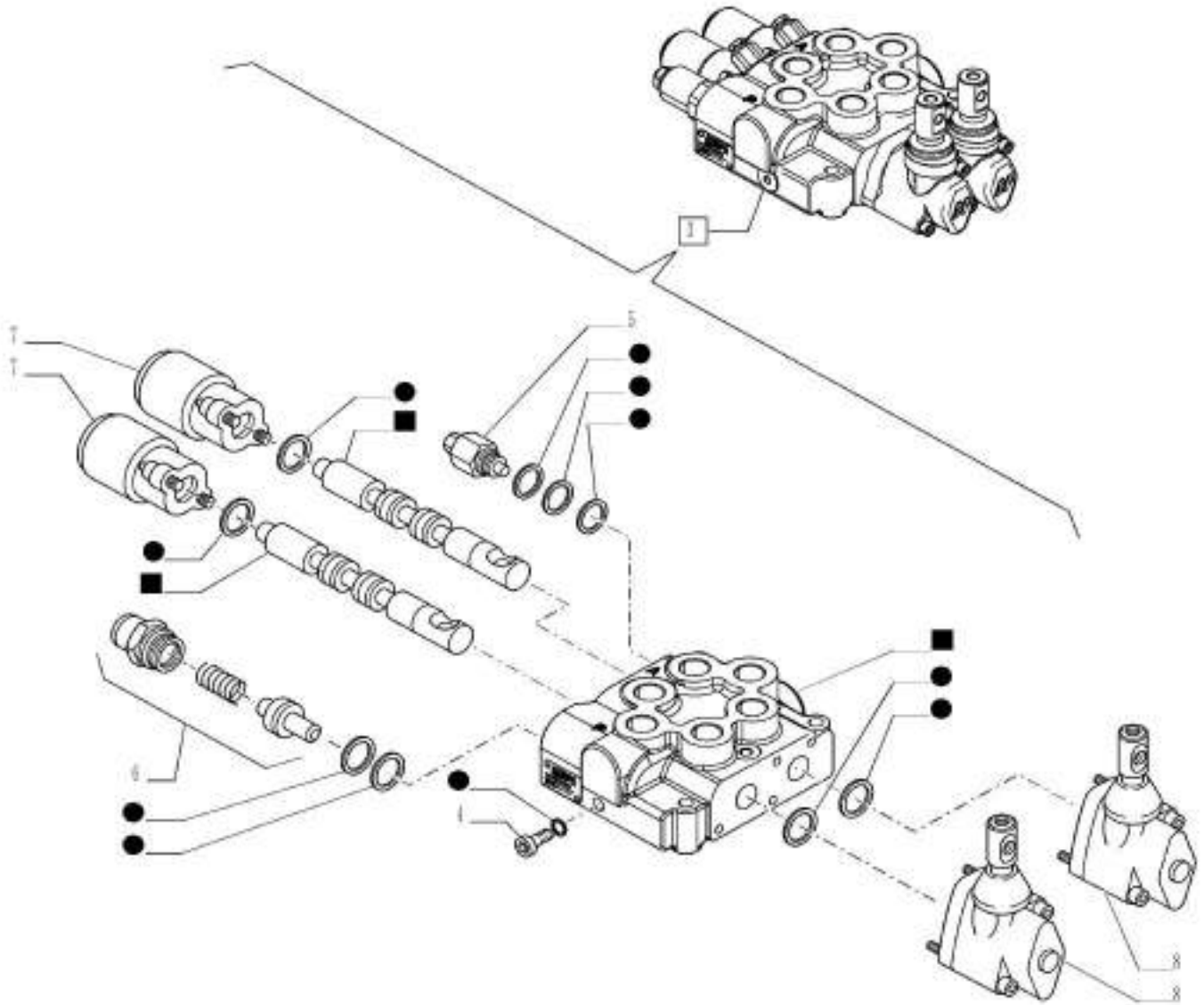
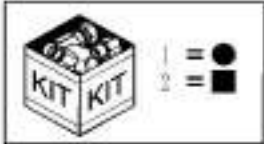

VAR - 334328, 335368, 728368 - 2 CONTROL VALVE (1 S/D W/KICK OUT + 1 DOUBLE ACTING) - BREAKDOWN

REF FN	PART NUMBER	YR/SN	QTY DESCRIPTION
1	5083055		1 SEAL KIT
2	5083054		1 CHECK VALVE
3	5099440		1 DISTRIBUTOR Incl 1, 2, 4 - 8
4	5083047		1 CHECK VALVE
5	5083049		1 VALVE
6	5083046		1 PRESSURE RELIEF VALVE
7	5083048		1 ACTUATOR
8	5083050		1 CONTROL

Valid for Industrial Var. 334328, 335368 (728368)	FARMALL JX100 FARMALL JX110 FARMALL JX70 FARMALL JX75 FARMALL JX80 FARMALL JX90
---	--

35.204.BE

07

p1

1/2014

VAR - 334329, 335413, 729413 - 2 CONTROL VALVE (1 S/D + 1 DOUBLE ACTING WITH FLOAT AND KICK OUT)

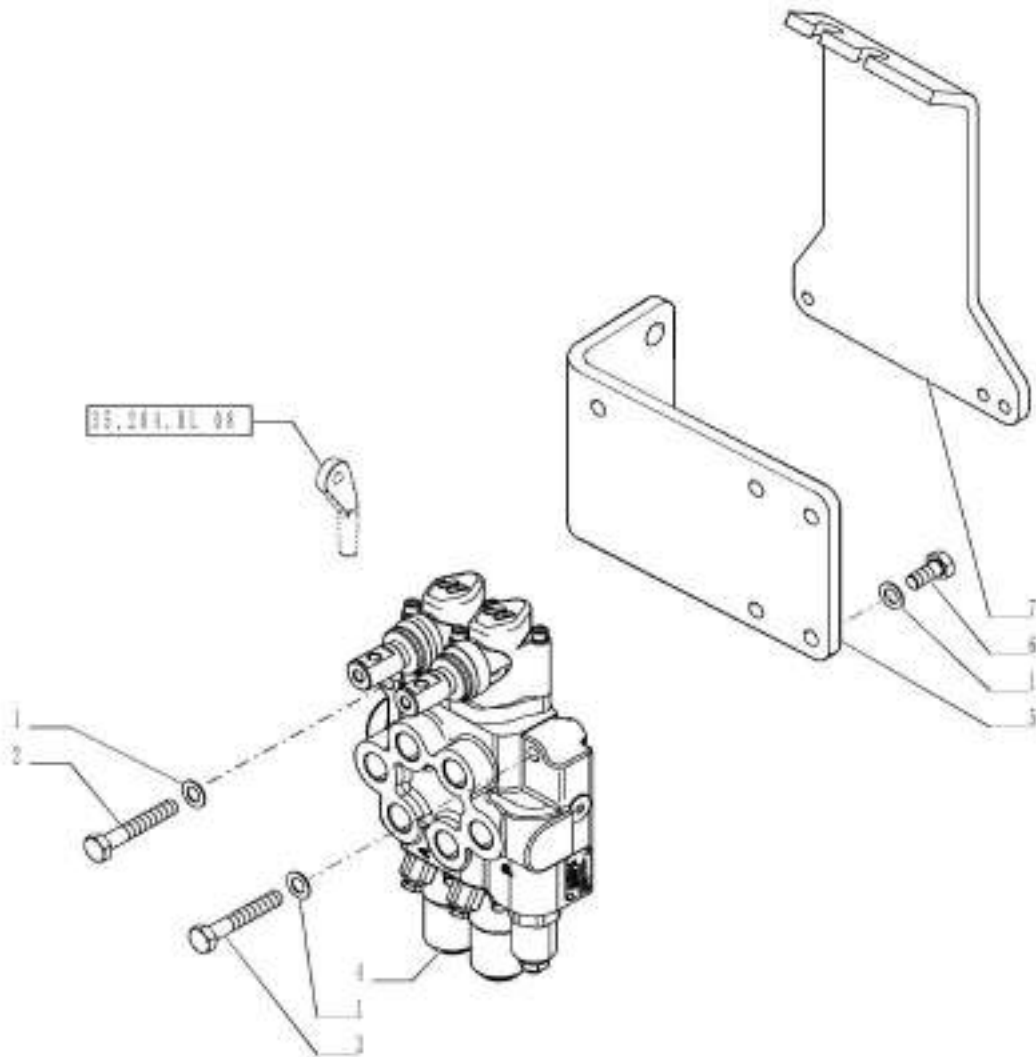

VAR - 334329, 335413, 729413 - 2 CONTROL VALVE (1 S/D + 1 DOUBLE ACTING WITH FLOAT AND KICK OUT)

REF FN	PART NUMBER	YR/SN	QTY DESCRIPTION
1	12601374		3 WAVE WASHER Wave, 8.40mm ID x 15.00mm OD x 0.80mm, 3.00mm, CST, DAC
2	1 16044321		1 SCREW Hex, M8 x 1.25 x 55mm, Cl 8.8
2	2 300510		1 SCREW Hex, M8 x 1.25 x 65mm, Cl 8.8
3	1 43130		1 BOLT Hex, M8 x 1.25 x 50mm, Cl 8.8
3	2 120061		1 BOLT Hex, M8 x 60, 8.8
4	84185655		1 CONTROL VALVE
5	5092077		1 SUPPORT
6	86625000		1 BOLT Hex, M8 x 18mm, Cl 8.8, Full Thd
7	2 84487125		1 SUPPORT

(1) ROPS

(2) CAB

Valid for Industrial Var. 334329, 335413 (729413)

FARMALL JX100 FARMALL
 JX110 FARMALL JX70
 FARMALL JX75 FARMALL
 JX80 FARMALL JX90

35.204.BE

08

p1

1/2014

VAR - 334329, 335413, 729413 - 2 CONTROL VALVES (1 S/D W/KICK OUT + 1 DOUBLE ACTING W/FLOAT W/KICK OUT), BREAKDOWN

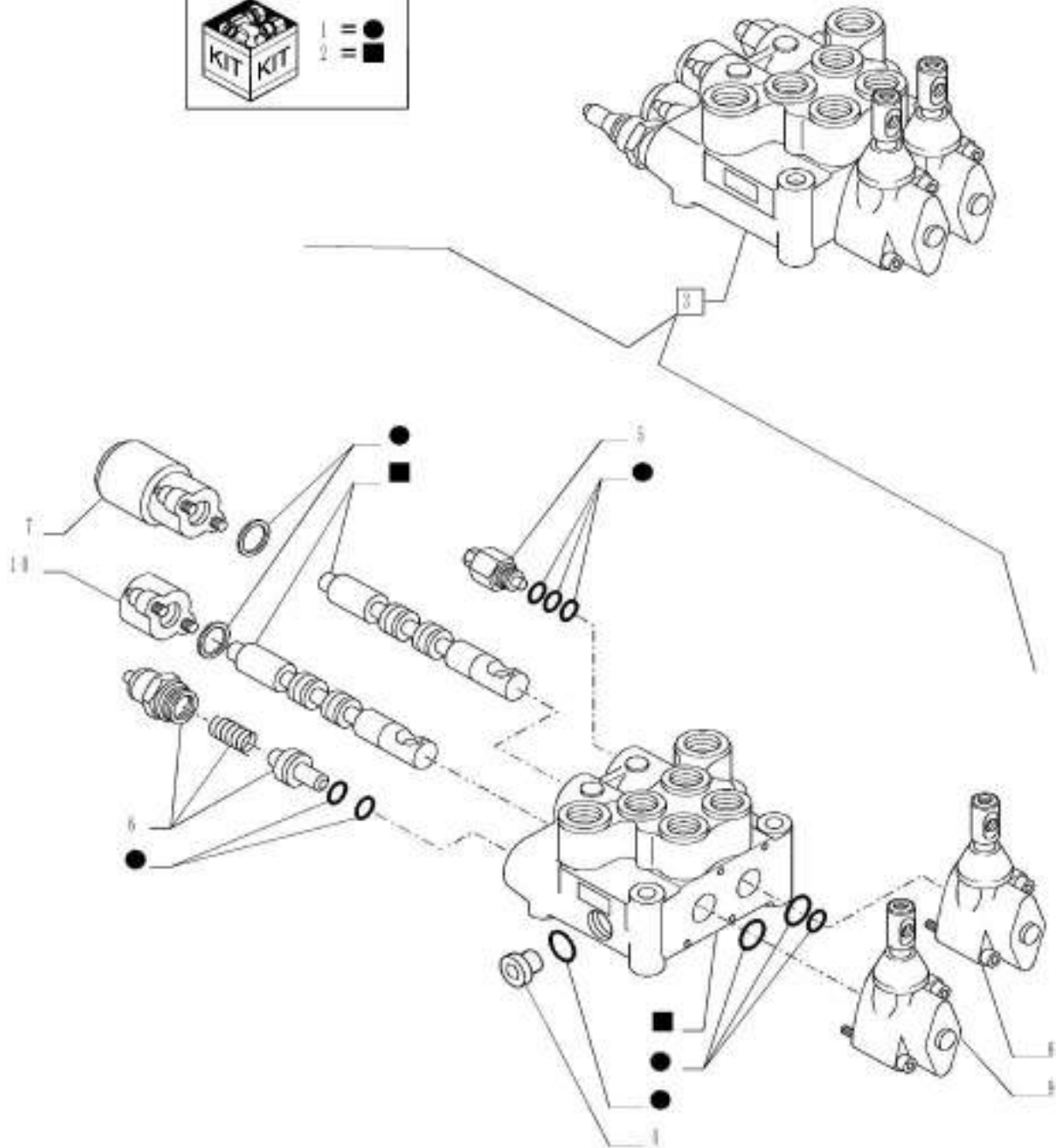
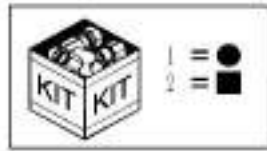

35.204.BE

08

p1

1/2014

VAR - 334329, 335413, 729413 - 2 CONTROL VALVES (1 S/D W/KICK OUT + 1 DOUBLE ACTING W/FLOAT W/KICK OUT), BREAKDOWN

REF FN	PART NUMBER	YR/SN	QTY DESCRIPTION
1	84285436		1 SEAL KIT
2	84286926		1 VALVE SECTION
3	84185655		1 CONTROL VALVE Incl 1, 2, 4 - 10
4	5083047		1 CHECK VALVE
5	5083049		1 VALVE
6	5083046		1 PRESSURE RELIEF VALVE
7	84286924		1 ACTUATOR
8	84286923		1 CONTROL
9	5083050		1 CONTROL
10	5083048		1 ACTUATOR

Valid for Industrial Var. 334329, 335413 (729413)

FARMALL JX100 FARMALL
JX110 FARMALL JX70
FARMALL JX75 FARMALL
JX80 FARMALL JX90

35.204.BE

09

p1

1/2014

VAR - 334330, 335417, 729417 - 2 CONTROL VALVE (1 S/D W/KICK OUT + 1 DOUBLE ACTING WITH FLOAT AND KICK OUT)

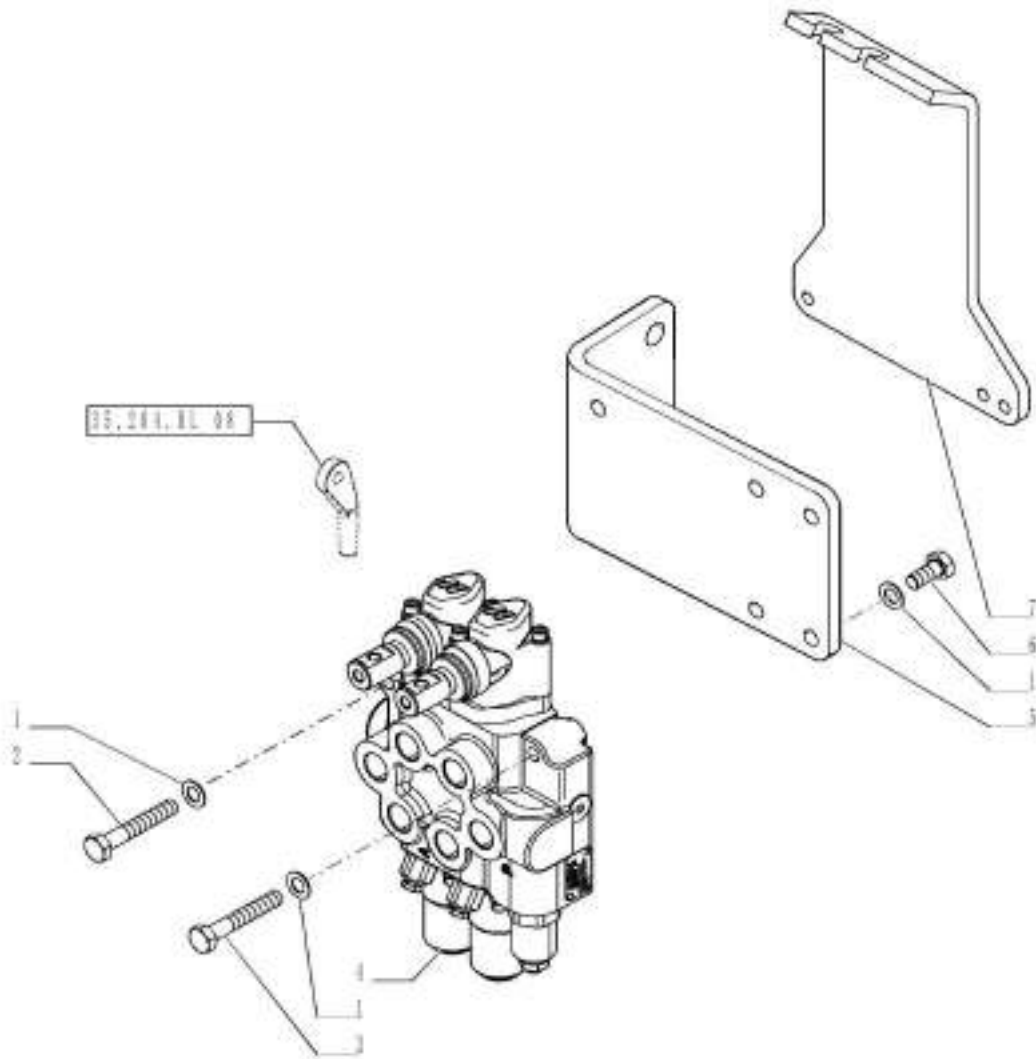

VAR - 334330, 335417, 729417 - 2 CONTROL VALVE (1 S/D W/KICK OUT + 1 DOUBLE ACTING WITH FLOAT AND KICK OUT)

REF FN	PART NUMBER	YR/SN	QTY DESCRIPTION
1	12601374		3 WAVE WASHER Wave, 8.40mm ID x 15.00mm OD x 0.80mm, 3.00mm, CST, DAC
2	1 16044321		1 SCREW Hex, M8 x 1.25 x 55mm, Cl 8.8
2	2 300510		1 SCREW Hex, M8 x 1.25 x 65mm, Cl 8.8
3	1 43130		1 BOLT Hex, M8 x 1.25 x 50mm, Cl 8.8
3	2 120061		1 BOLT Hex, M8 x 60, 8.8
4	84185650		1 CONTROL VALVE
5	5092077		1 SUPPORT
6	86625000		1 BOLT Hex, M8 x 18mm, Cl 8.8, Full Thd
7	2 84487125		1 SUPPORT

(1) ROPS

(2) CAB

Valid for Industrial Var. 334330, 335417 (729417)

FARMALL JX100 FARMALL
JX110 FARMALL JX70
FARMALL JX75 FARMALL
JX80 FARMALL JX90

35.204.BE

10

p1

1/2014

VAR - 334330, 335417, 729417 - 2 CONTROL VALVES (1 S/D W/KICK OUT + 1 DOUBLE ACTING W/FLOAT W/KICK OUT) - BREAKDOWN

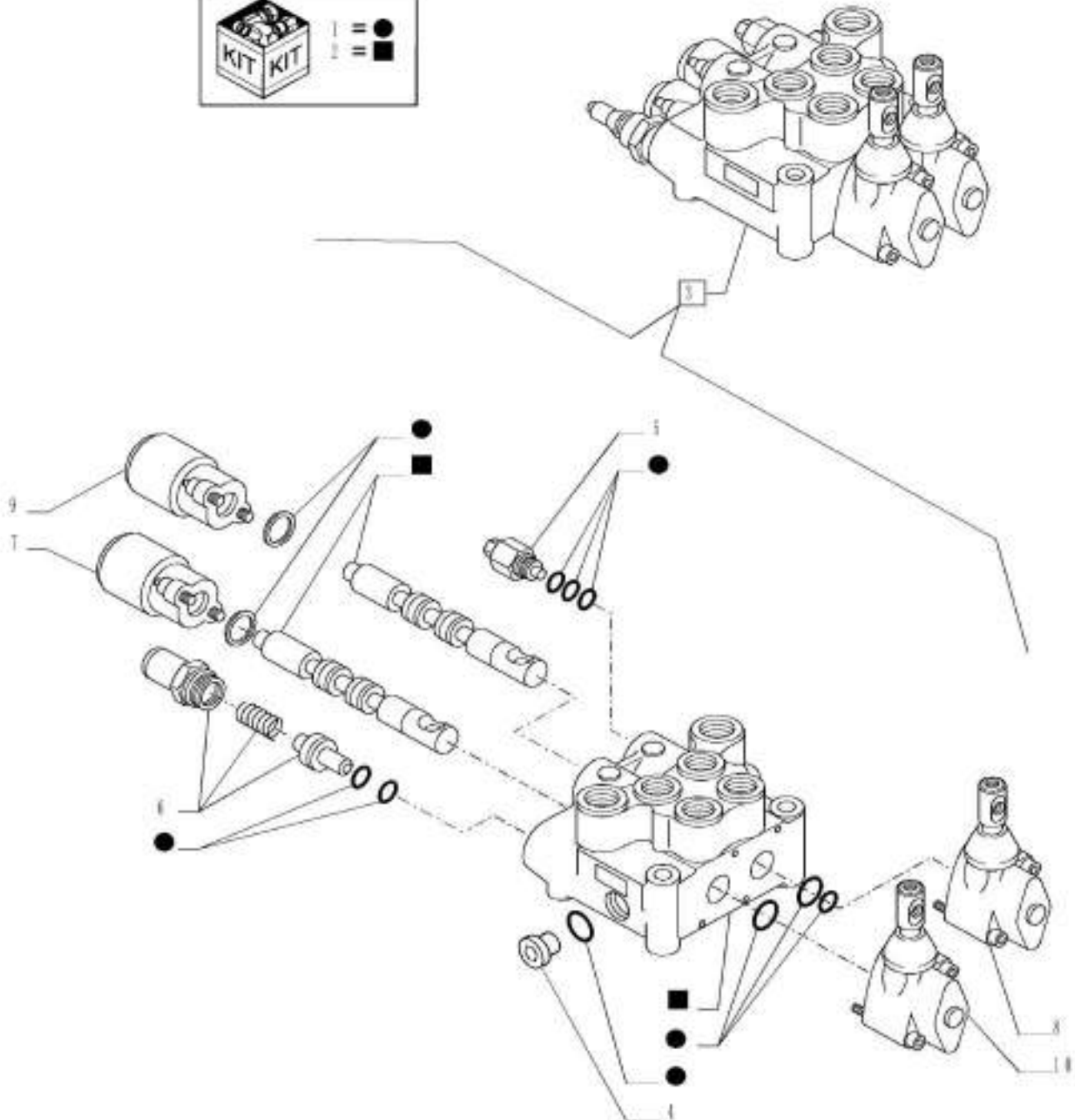
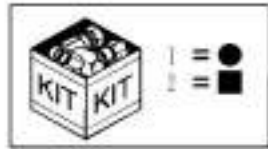

VAR - 334330, 335417, 729417 - 2 CONTROL VALVES (1 S/D W/KICK OUT + 1 DOUBLE ACTING W/FLOAT W/KICK OUT) - BREAKDOWN

REF FN	PART NUMBER	YR/SN	QTY DESCRIPTION
1	84285436		1 SEAL KIT
2	84286925		1 CONTROL VALVE
3	84185650		1 CONTROL VALVE Incl 1, 2, 4 - 10
4	5083047		1 CHECK VALVE
5	5083049		1 VALVE
6	5083046		1 PRESSURE RELIEF VALVE
7	5083053		1 ACTUATOR
8	84286923		1 CONTROL
9	84286924		1 ACTUATOR
10	84286957		1 CONTROL

Valid for Industrial Var. 334330, 335417 (729417)

FARMALL JX100 FARMALL
JX110 FARMALL JX70
FARMALL JX75 FARMALL
JX80 FARMALL JX90

35.204.BE

11

p1

1/2014

VAR - 728366, 729412 - 1 CONTROL VALVE (1 S/D)

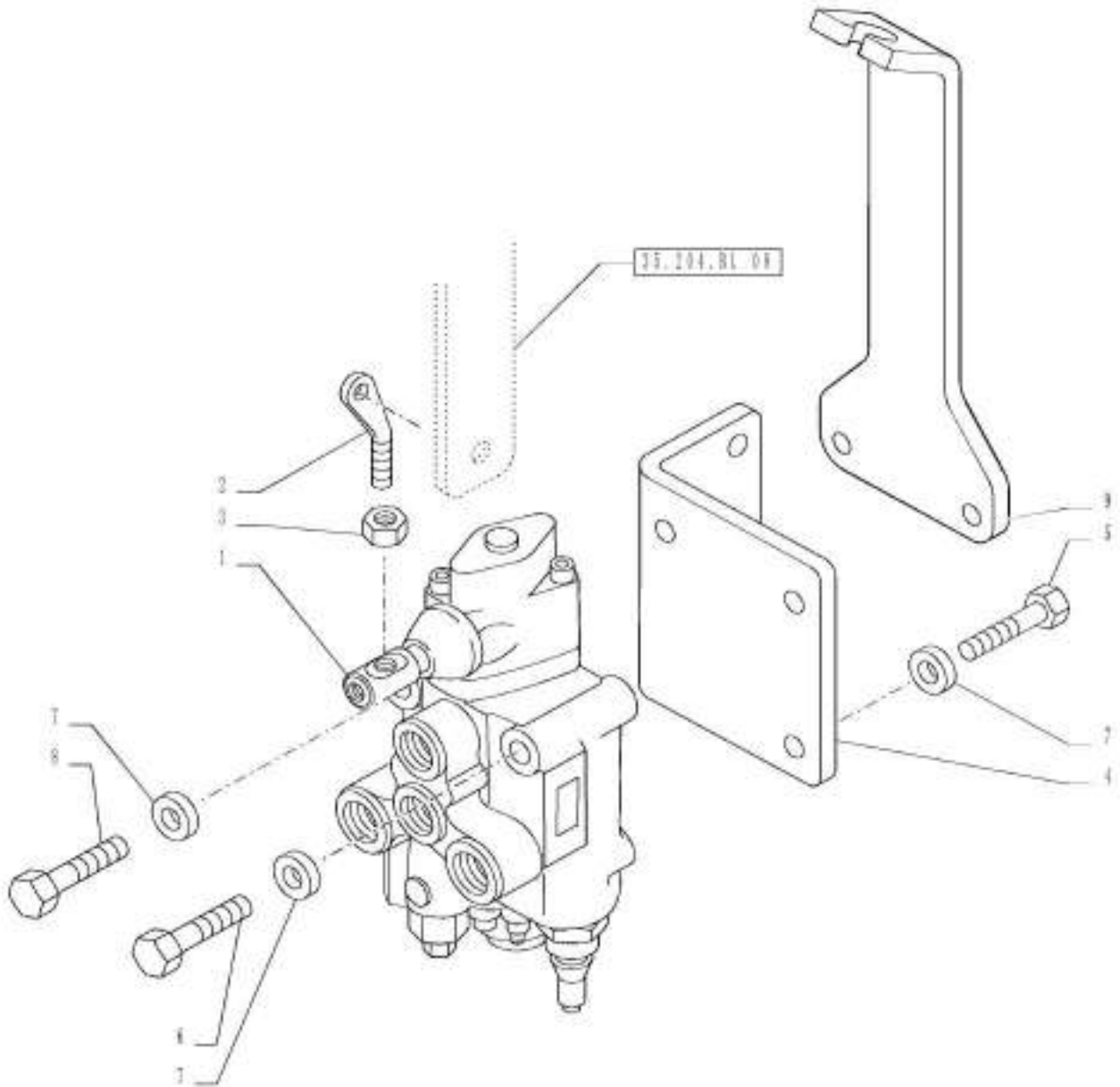

VAR - 728366, 729412 - 1 CONTROL VALVE (1 S/D)

REF	FN	PART NUMBER	YR/SN	QTY	DESCRIPTION
1	1	5099332		1	DISTRIBUTOR
1	2	5099333		1	DISTRIBUTOR
2		5089075		1	SUPPORT
3		16100811		2	NUT Hex, M8, 6.80mm, Cl 8, ZND
4		5092076		1	SUPPORT
5		86625000		1	BOLT Hex, M8 x 18mm, Cl 8.8, Full Thd
6	3	43130		1	BOLT Hex, M8 x 1.25 x 50mm, Cl 8.8
6	4	120061		1	BOLT Hex, M8 x 60, 8.8
7		12601374		3	WAVE WASHER Wave, 8.40mm ID x 15.00mm OD x 0.80mm, 3.00mm, CST, DAC
8	3	16044321		1	SCREW Hex, M8 x 1.25 x 55mm, Cl 8.8
8	4	300510		1	SCREW Hex, M8 x 1.25 x 65mm, Cl 8.8
9	4	84527889		1	SUPPORT
(1)		VAR - 335366, 334325 (728366)			
(2)		VAR - 334326, 334327 (729412)			
(3)		ROPS			
(4)		CAB			
Valid for Industrial Var. 334325, 335366 (728366) or Industrial Var. 334326, 334327 (729412)					FARMALL JX100 FARMALL JX110 FARMALL JX70 FARMALL JX75 FARMALL JX80 FARMALL JX90

VAR - 334325, 335366, 728366 - 1 CONTROL VALVE (1 S/D), BREAKDOWN

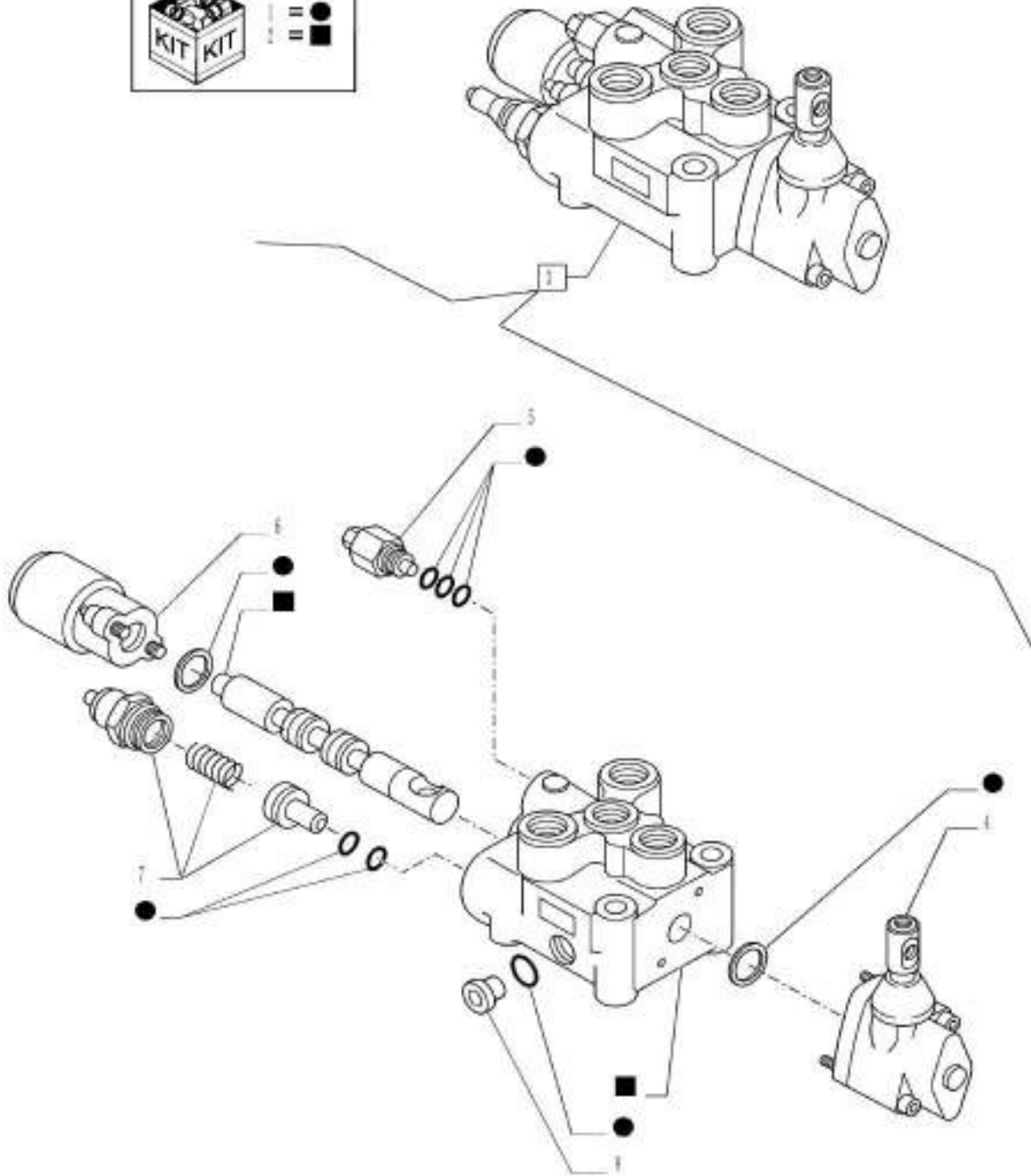
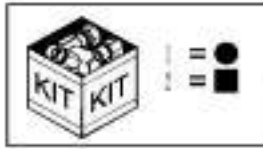

VAR - 334325, 335366, 728366 - 1 CONTROL VALVE (1 S/D), BREAKDOWN

REF FN	PART NUMBER	YR/SN	QTY DESCRIPTION
1	5083051		1 SEAL KIT
2	5083045		1 CHECK VALVE
3	5099332		1 DISTRIBUTOR Incl 1, 2, 4 - 8
4	5083050		1 CONTROL
5	5083049		1 VALVE
6	5083048		1 ACTUATOR
7	5083046		1 PRESSURE RELIEF VALVE
8	5083047		1 CHECK VALVE

Valid for Industrial Var. 334325, 335366 (728366)	FARMALL JX100 FARMALL JX110 FARMALL JX70 FARMALL JX75 FARMALL JX80 FARMALL JX90
---	--

VAR - 334326, 334327, 729412 - 1 CONTROL VALVE, BREAKDOWN

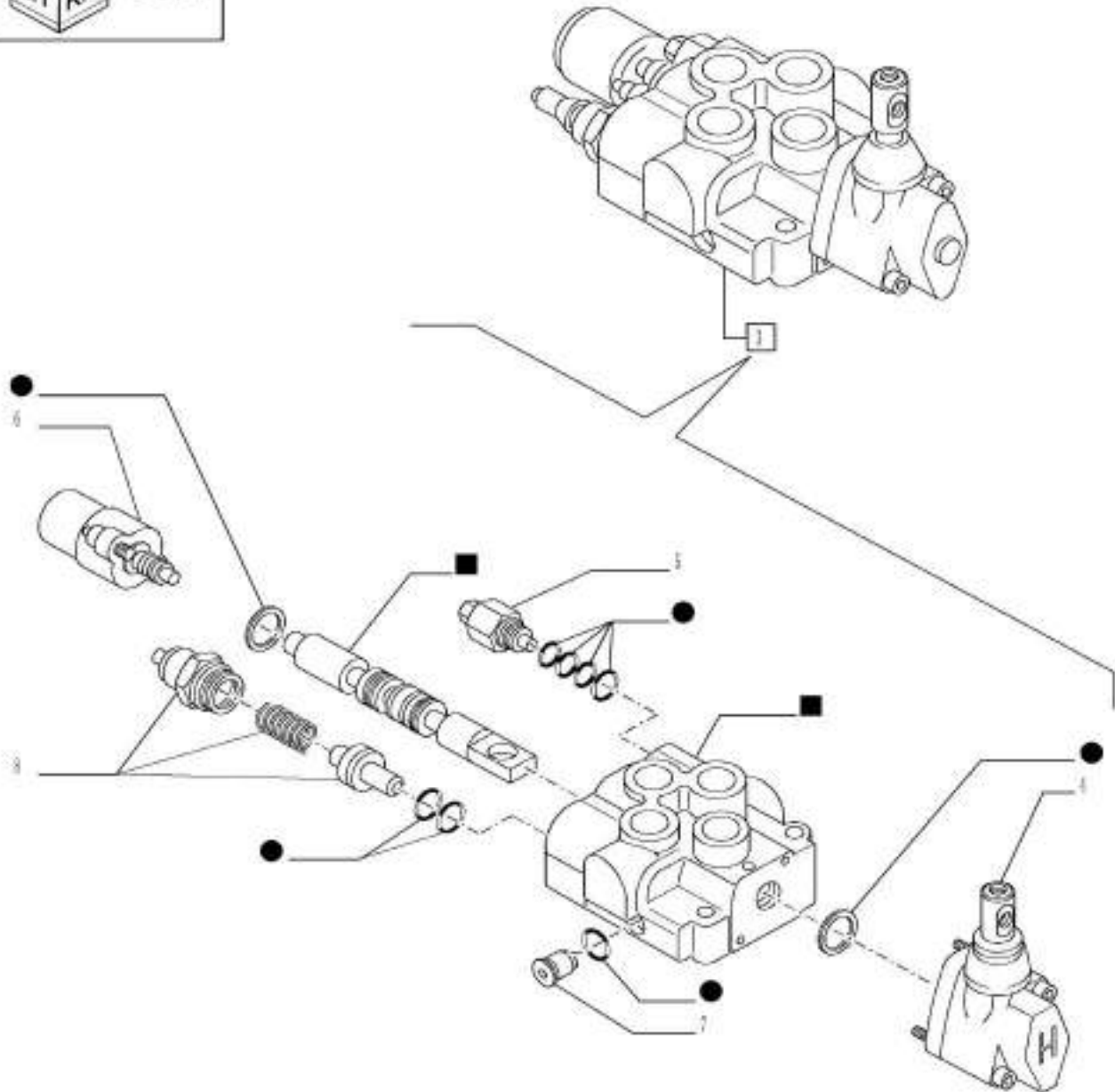

VAR - 334326, 334327, 729412 - 1 CONTROL VALVE, BREAKDOWN

REF FN	PART NUMBER	YR/SN	QTY DESCRIPTION
1	5083051		1 SEAL KIT
2	5083052		1 SPOOL
3	5099333		1 DISTRIBUTOR Incl 1, 2, 4 - 8
4	5083050		1 CONTROL
5	5083049		1 VALVE
6	5083053		1 ACTUATOR
7	5083047		1 CHECK VALVE
8	5083046		1 PRESSURE RELIEF VALVE

Valid for Industrial Var. 334326, 334327 (729412)	FARMALL JX100 FARMALL JX110 FARMALL JX70 FARMALL JX75 FARMALL JX80 FARMALL JX90
---	--

35.204.BJ

01

p1

1/2014

VAR - 728054, 729103 - PIPES

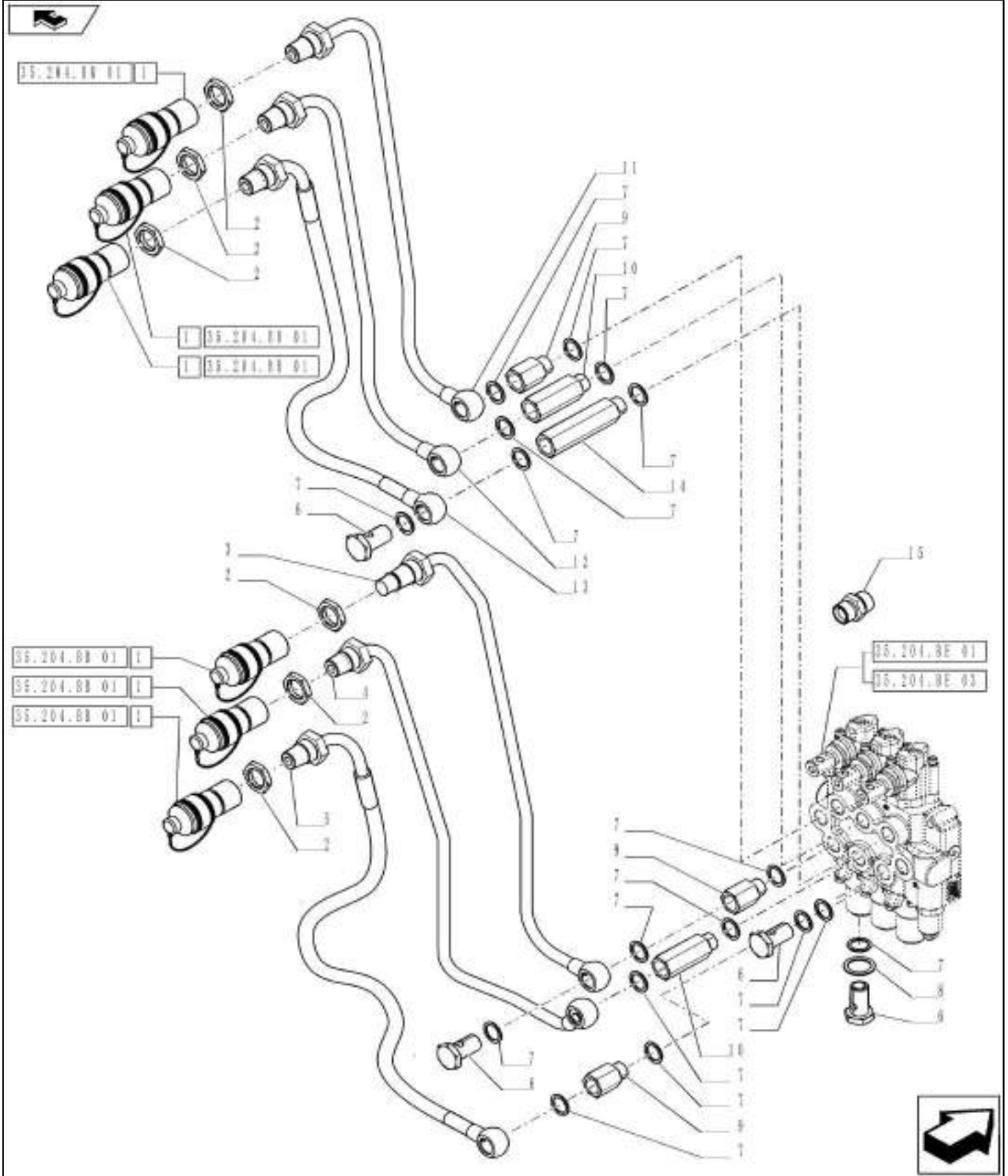

VAR - 728054, 729103 - PIPES

REF FN	PART NUMBER	YR/SN	QTY DESCRIPTION
1	5091860		6 QUICK FEMALE COUPLING Green
2	5129168		6 BHD LOCK NUT
3	5083274		1 PIPE
4	5083280		1 PIPE
5	87391315		1 FLEXIBLE HOSE Eighth
6	5100984		9 BANJO BOLT
7	10259960		25 SEAL Rectangular, 18.30mm ID x 24.00mm OD x 1.50mm, Copper
8	10264560		1 SEAL M24.4 x 32 x 1.5
9	5092080		3 SPACER
10	5092079		2 SPACER
11	5083276		1 PIPE
12	5083282		1 PIPE
13	87391314		1 FLEXIBLE HOSE Seventh
14	5092078		1 SPACER
15	5087002		1 HYD CONNECTOR

Valid for Industrial Var. 334331, 335054 (728054) or Industrial Var. 334332, 335103 (729103)

FARMALL JX100 FARMALL
JX110 FARMALL JX70
FARMALL JX75 FARMALL
JX80 FARMALL JX90

VAR - 728368, 729413, 729417 - PIPES

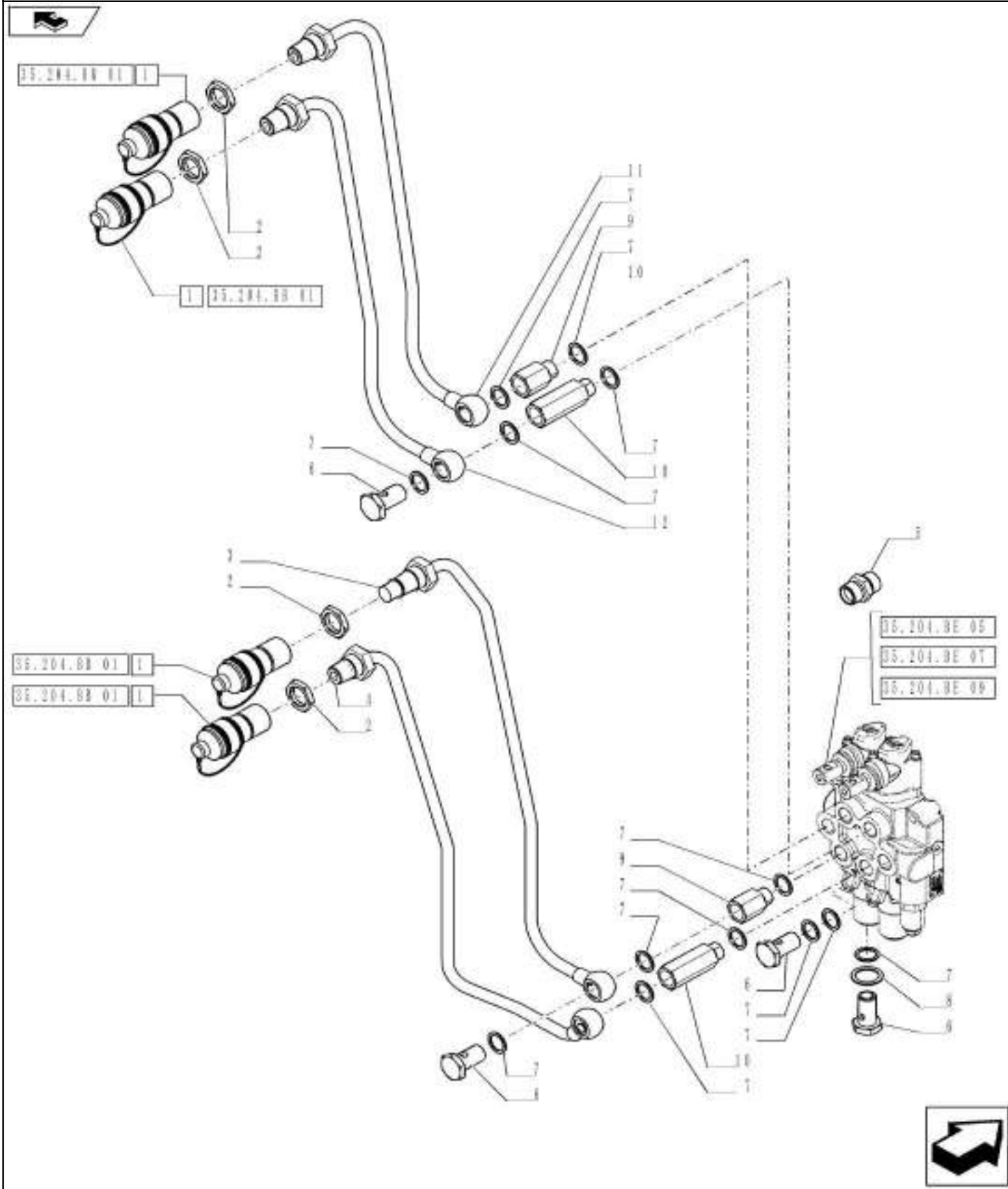

VAR - 728368, 729413, 729417 - PIPES

REF FN	PART NUMBER	YR/SN	QTY DESCRIPTION
1	5091860		4 QUICK FEMALE COUPLING Green
2	5129168		4 BHD LOCK NUT
3	5083274		1 PIPE
4	5083280		1 PIPE
5	5087002		1 HYD CONNECTOR
6	5100984		7 BANJO BOLT
7	10259960		19 SEAL Rectangular, 18.30mm ID x 24.00mm OD x 1.50mm, Copper
8	10264560		1 SEAL M24.4 x 32 x 1.5
9	5092080		2 SPACER
10	5092079		2 SPACER
11	5083276		1 PIPE
12	5083282		1 PIPE

Valid for Industrial Var. 334328, 335368 (728368) or Industrial Var. 334329, 335413 (729413) or Industrial Var. 334330, 335417 (729417)

FARMALL JX100 FARMALL
JX110 FARMALL JX70
FARMALL JX75 FARMALL
JX80 FARMALL JX90

VAR - 728366, 729412 - PIPES

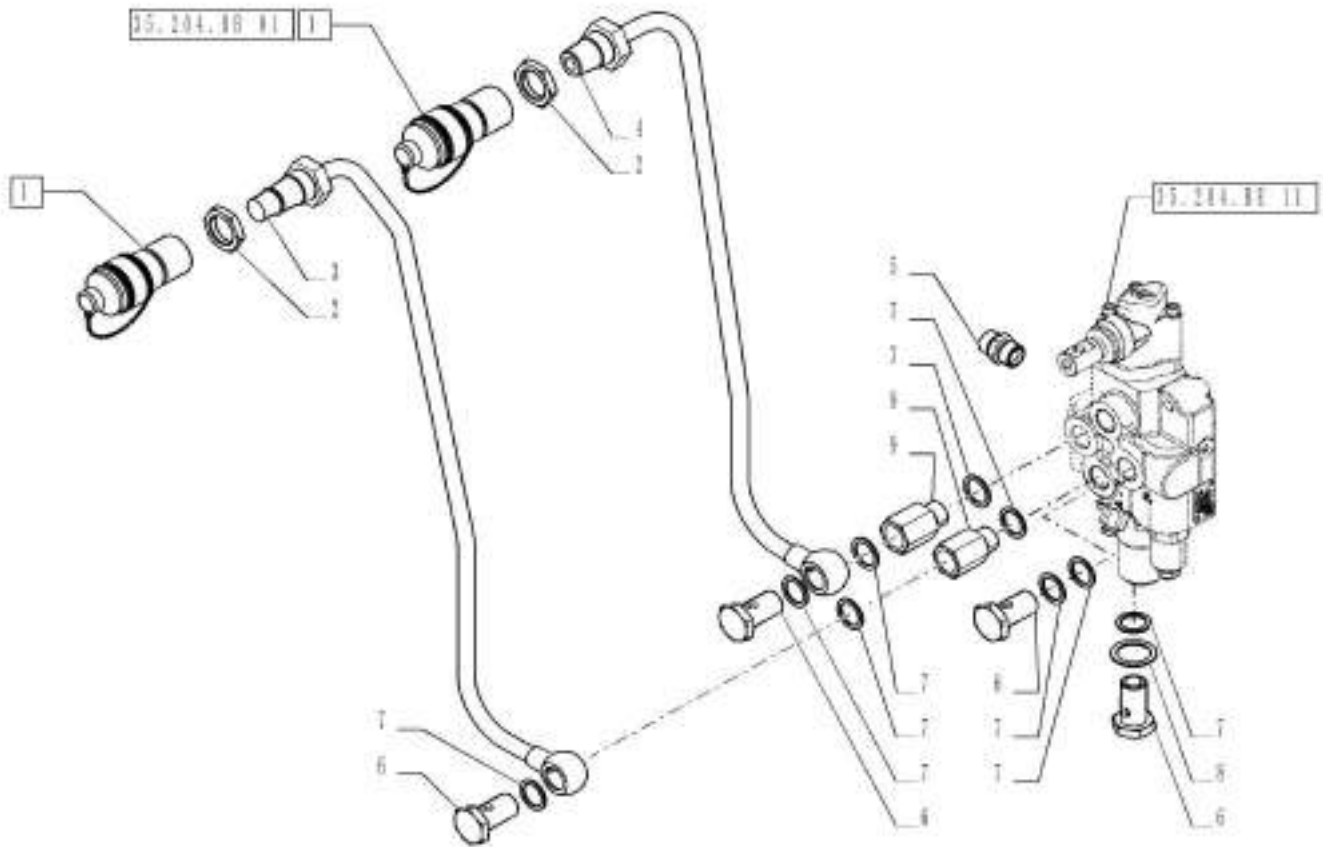

35.204.BJ

03

p1

1/2014

VAR - 728366, 729412 - PIPES

REF FN	PART NUMBER	YR/SN	QTY DESCRIPTION
1	5091860		2 QUICK FEMALE COUPLING Green
2	5129168		2 BHD LOCK NUT
3	5083274		1 PIPE
4	5083276		1 PIPE
5	5087002		1 HYD CONNECTOR
6	5100984		5 BANJO BOLT
7	10259960		13 SEAL Rectangular, 18.30mm ID x 24.00mm OD x 1.50mm, Copper
8	10264560		1 SEAL M24.4 x 32 x 1.5
9	5092080		2 SPACER

Valid for Industrial Var. 334325, 335366 (728366) or Industrial Var. 334326, 334327 (729412)

FARMALL JX100 FARMALL
JX110 FARMALL JX70
FARMALL JX75 FARMALL
JX80 FARMALL JX90

35.204.BJ

04

p1

1/2014

VAR - 334326, 335366, 728366, 729412 - 1 CONTROL VALVE, PIPES

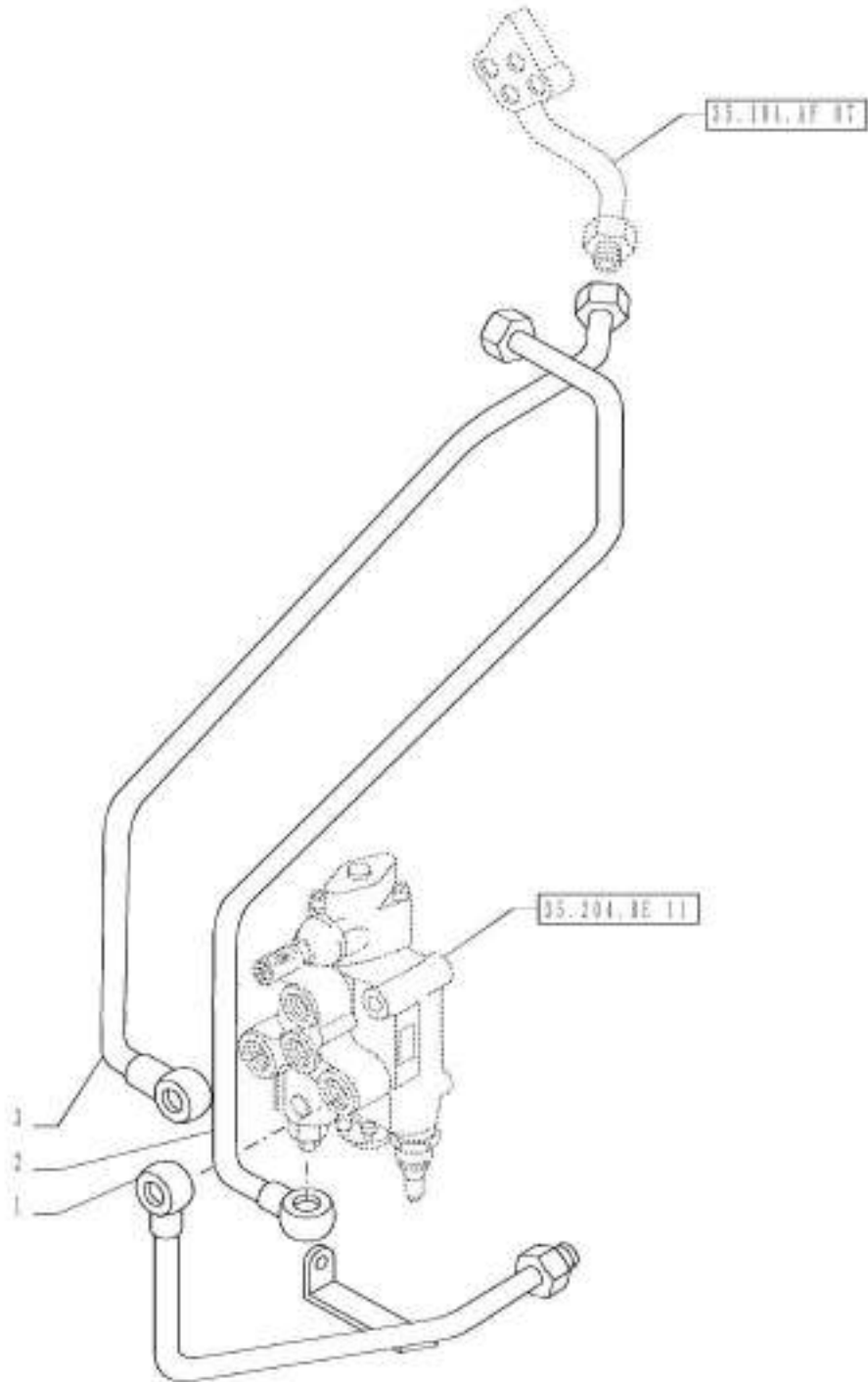

35.204.BJ

04

p1

1/2014

VAR - 334326, 335366, 728366, 729412 - 1 CONTROL VALVE, PIPES

REF FN	PART NUMBER	YR/SN	QTY DESCRIPTION
1	5083272		1 PIPE
2	5083270		1 PIPE
3	5099367		1 PIPE

Valid for Industrial Var. 335366 (728366) or Industrial Var. 334326 (729412)

FARMALL JX100 FARMALL
JX110 FARMALL JX70
FARMALL JX75 FARMALL
JX80 FARMALL JX90

35.204.BJ

05

p1

1/2014

VAR - 728368, 729413, 729417 - 2 CONTROL VALVE, PIPES

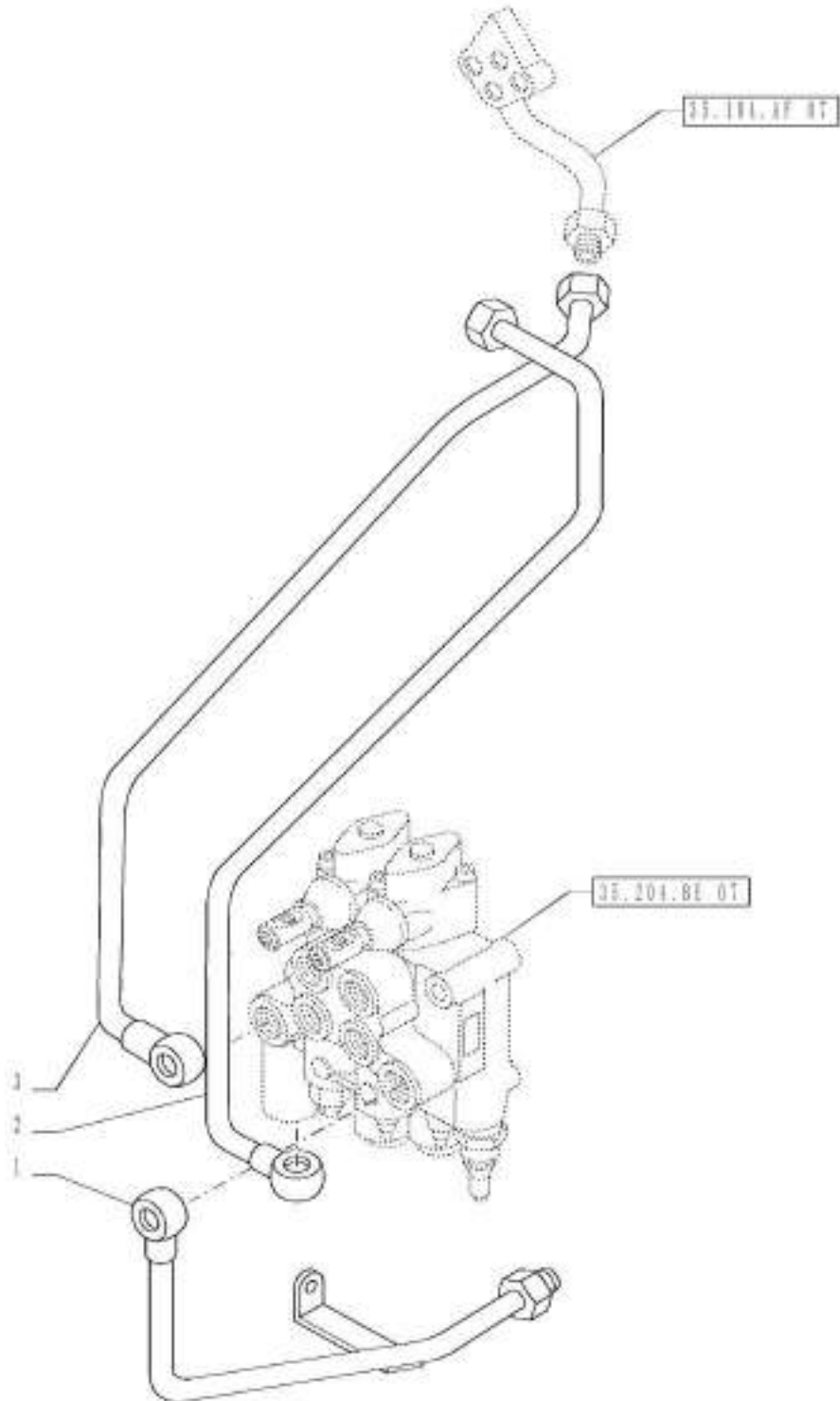

35.204.BJ

05

p1

1/2014

VAR - 728368, 729413, 729417 - 2 CONTROL VALVE, PIPES

REF FN	PART NUMBER	YR/SN	QTY DESCRIPTION
1	5083278		1 PIPE
2	5083270		1 PIPE
3	5099367		1 PIPE

Valid for Industrial Var. 335368 (728368) or Industrial Var. 335413 (729413) or Industrial Var. 335417 (729417)

FARMALL JX100 FARMALL
JX110 FARMALL JX70
FARMALL JX75 FARMALL
JX80 FARMALL JX90

35.204.BJ

06

p1

1/2014

VAR - 728054, 729103 - 3 CONTROL VALVE, PIPES

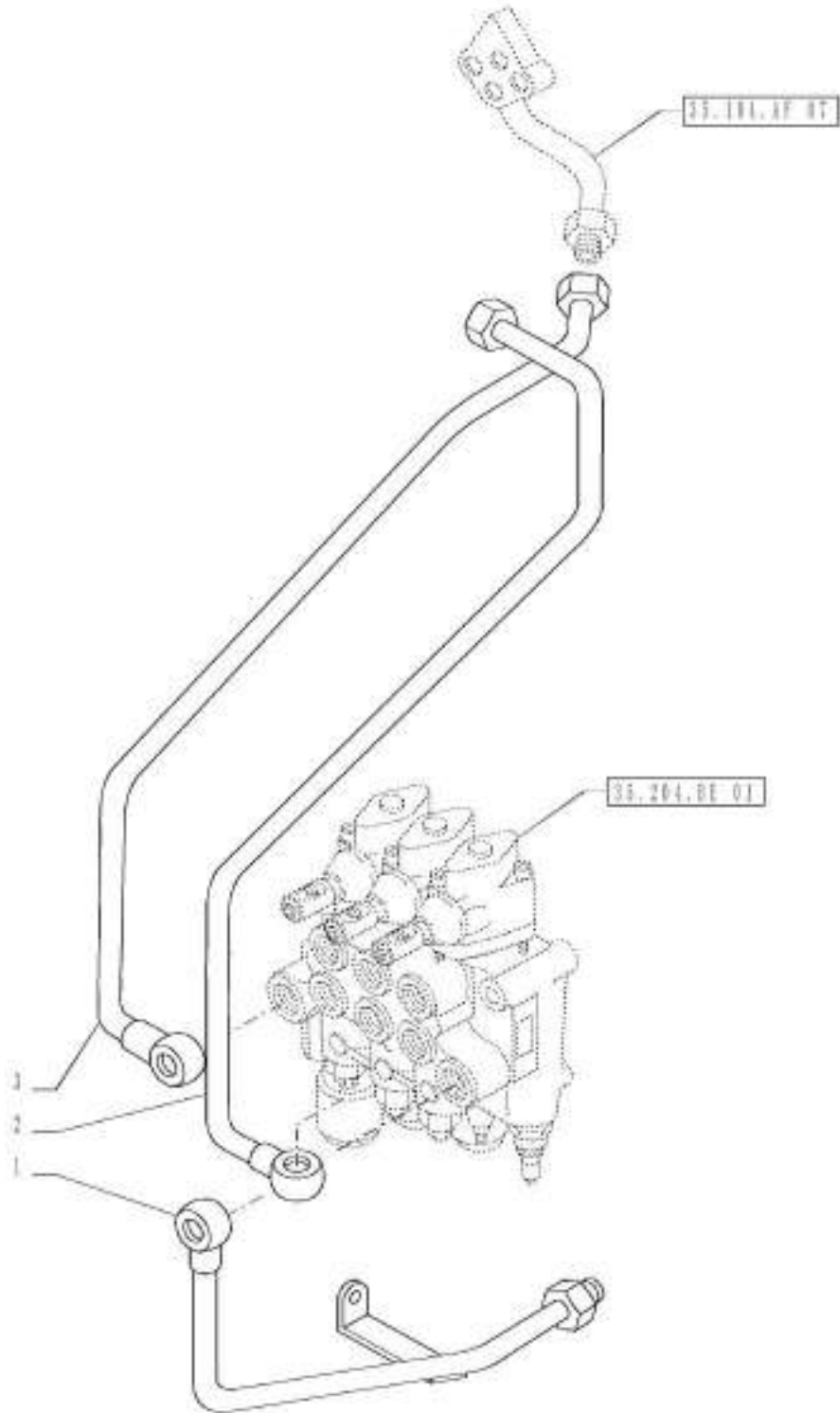

VAR - 728054, 729103 - 3 CONTROL VALVE, PIPES

REF	FN	PART NUMBER	YR/SN	QTY	DESCRIPTION
1	1	5092043		1	PIPE
1	2	5083284		1	PIPE
2	3	5092061		1	BRAKE LINE
2	2	5083270		1	PIPE
3	3	5097419		1	HYD. TUBE
3	2	5099367		1	PIPE
(1)		VAR - 335054 (728054), 335103 (729103); ROPS			
(2)		CAB			
(3)		ROPS			

Valid for Industrial Var. 334331, 335054 (728054) or Industrial Var. 334332, 335103 (729103)

FARMALL JX100 FARMALL
JX110 FARMALL JX70
FARMALL JX75 FARMALL
JX80 FARMALL JX90

35.204.BL

01

p1

1/2014

VAR - 728054, 729103 - CONTROL LEVER

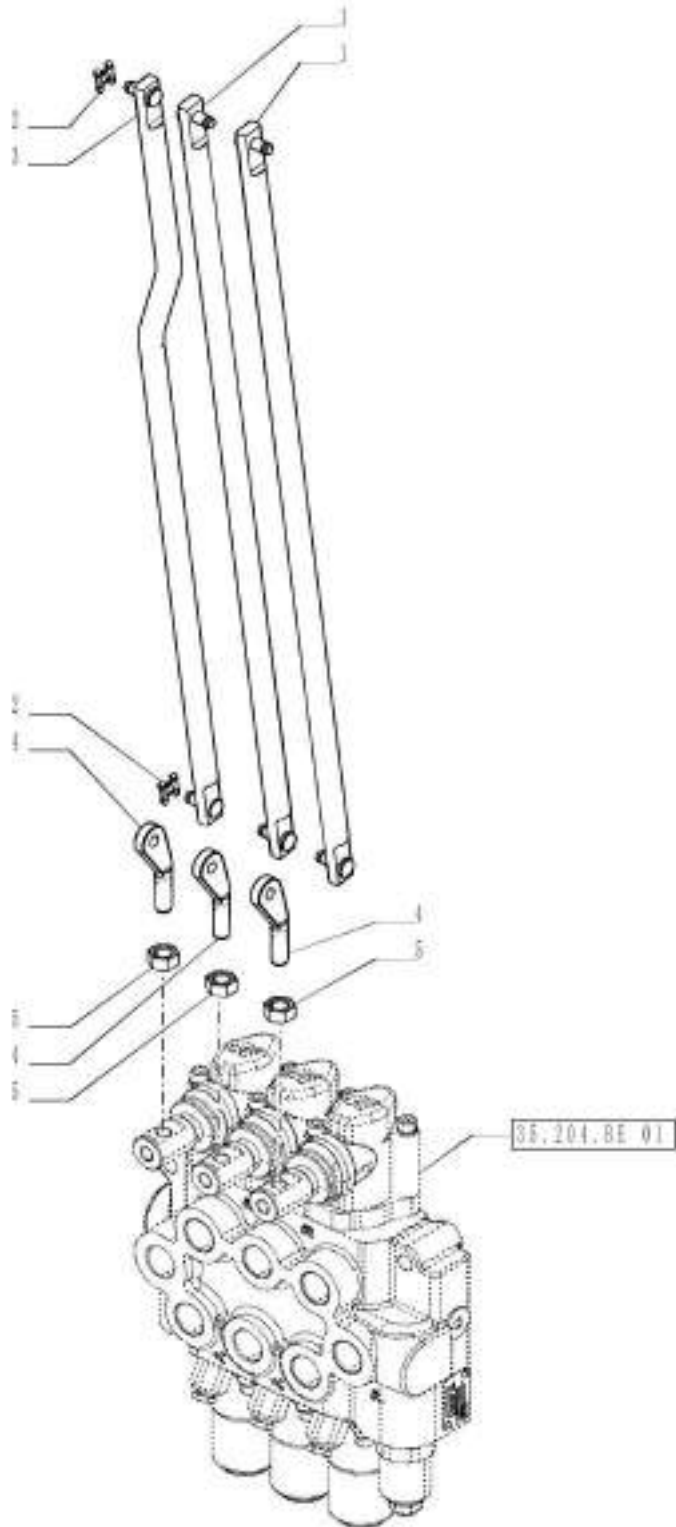

35.204.BL

01

p1

1/2014

VAR - 728054, 729103 - CONTROL LEVER

REF	FN	PART NUMBER	YR/SN	QTY	DESCRIPTION
1	1	84554380		2	LEVER
2	1	11063971		6	CLIP M6
3	1	84554377		1	LEVER
4		5089075		3	SUPPORT
5		16100811		3	NUT Hex, M8, 6.80mm, Cl 8, ZND
(1)		ROPS			

Valid for Industrial Var. 334331, 335054 (728054) or Industrial Var. 334332, 335103 (729103)

FARMALL JX100 FARMALL
JX110 FARMALL JX70
FARMALL JX75 FARMALL
JX80 FARMALL JX90

35.204.BL

02

p1

1/2014

VAR - 728054, 729103 - 3 CONTROL VALVES, LEVER AND KNOB, ROPS

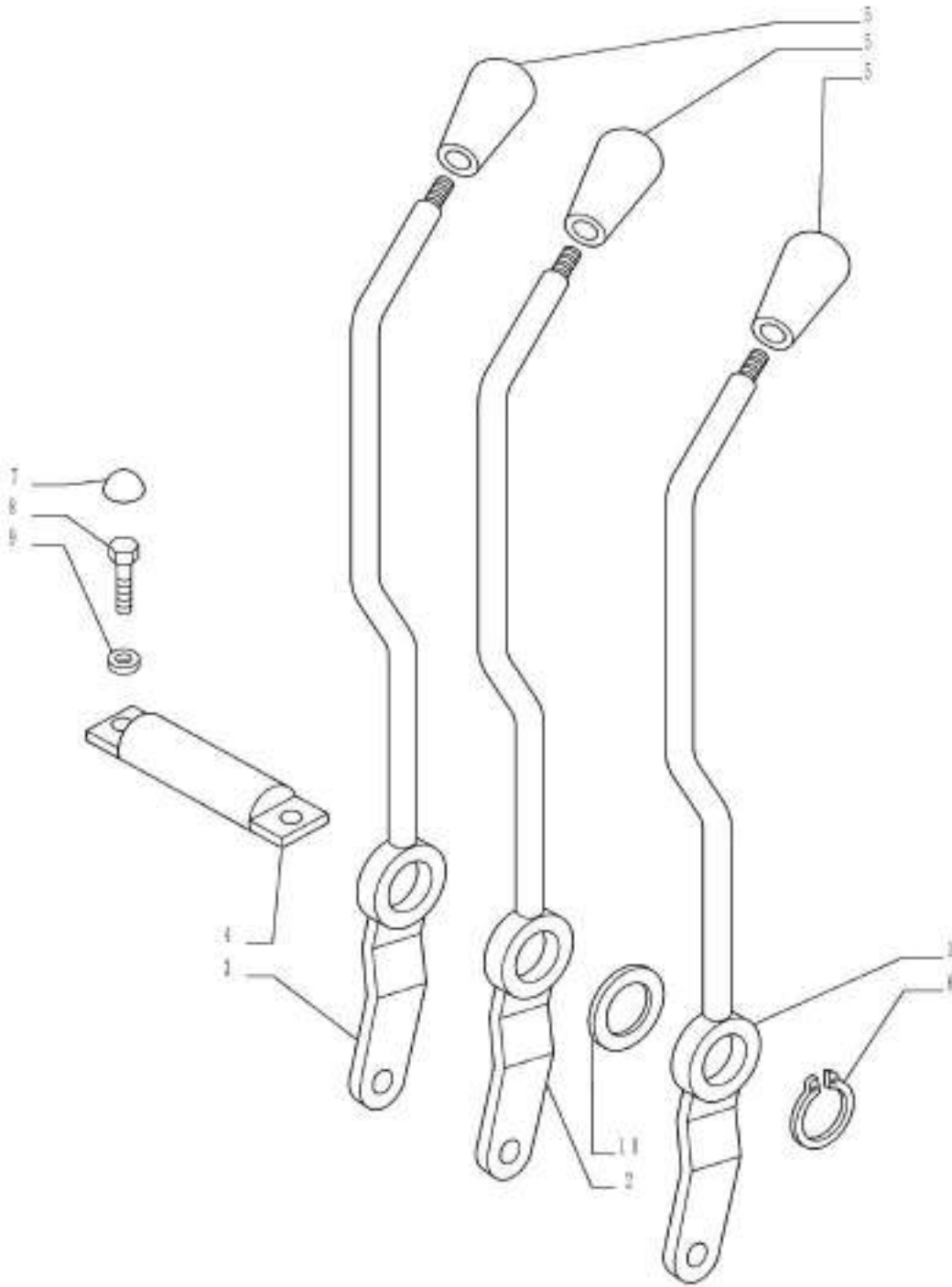

VAR - 728054, 729103 - 3 CONTROL VALVES, LEVER AND KNOB, ROPS

REF FN	PART NUMBER	YR/SN	QTY DESCRIPTION
1	84562676		1 LEVER 5-6 Command Lever
2	84562679		1 LEVER 3-4 Command Lever
3	84562680		1 LEVER 1-2 Command Lever
4	5133375		1 PIN
5	5177017		3 HANDLE GRIP Black
6	11066976		2 SNAP RING M21, Ext
7	5089481		2 CAP
8	86625001		2 BOLT Hex, M8 x 22mm, Cl 8.8, Full Thd
9	10571779		2 LOCK WASHER Helical Spring, 8.10mm ID x 14.80mm OD x 2.00mm, ZNM
10	5126031		4 WASHER

Valid for Industrial Var. 334331, 335054 (728054) or Industrial Var.
334332, 335103 (729103)

FARMALL JX100 FARMALL
JX110 FARMALL JX70
FARMALL JX75 FARMALL
JX80 FARMALL JX90

35.204.BL

03

p1

1/2014

VAR - 728366, 729413, 729417 - 2 CONTROL VALVES, LEVER AND KNOB, ROPS

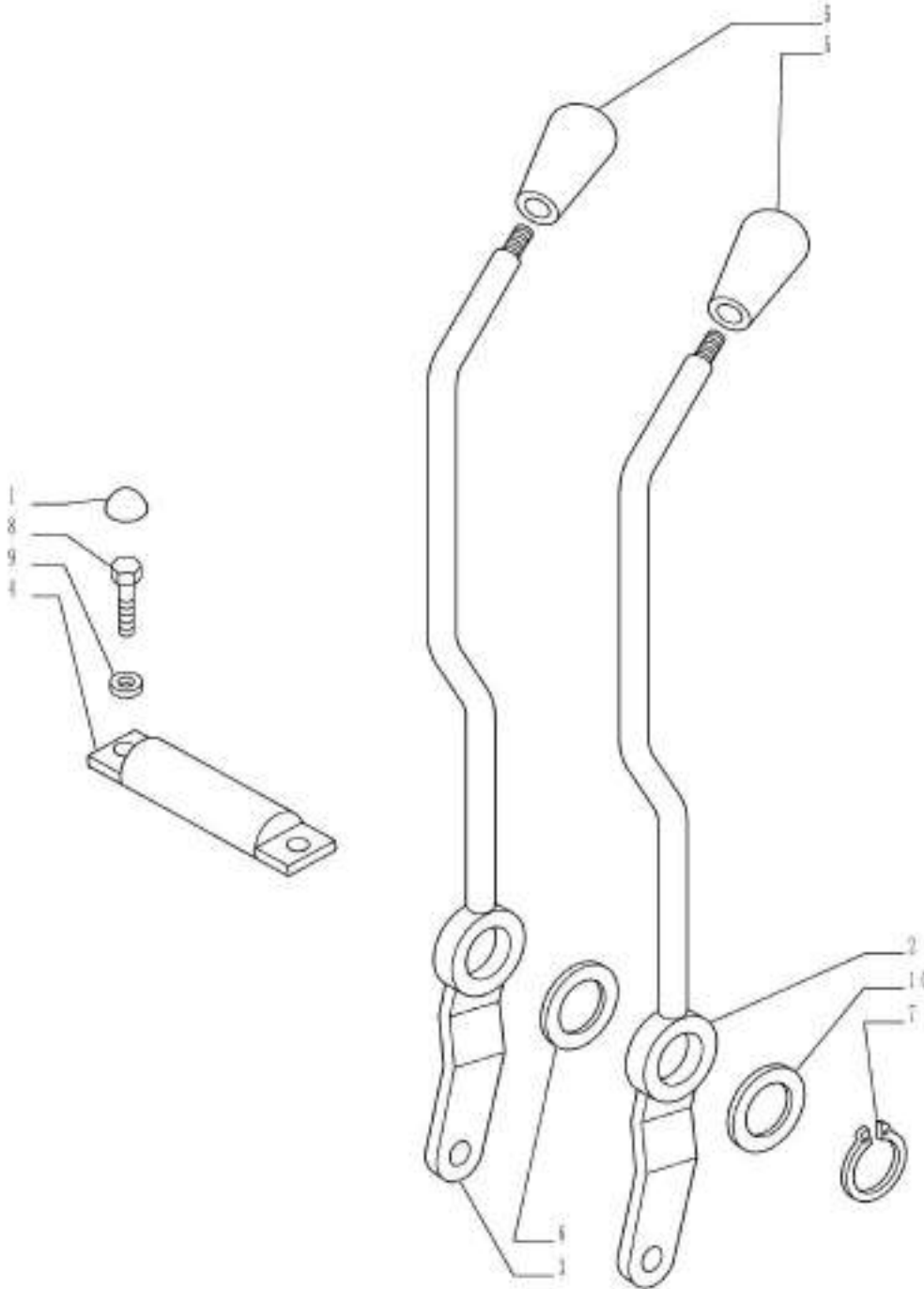

VAR - 728366, 729413, 729417 - 2 CONTROL VALVES, LEVER AND KNOB, ROPS

REF FN	PART NUMBER	YR/SN	QTY DESCRIPTION
1	5089481		2 CAP
2	84562679		1 LEVER 3-4 Command Lever
3	84562680		1 LEVER 1-2 Command Lever
4	5133375		1 PIN
5	5177017		2 HANDLE GRIP Black
6	5090174		1 GUIDE BUSHING
7	11066976		2 SNAP RING M21, Ext
8	86625001		2 BOLT Hex, M8 x 22mm, Cl 8.8, Full Thd
9	12601374		2 WAVE WASHER Wave, 8.40mm ID x 15.00mm OD x 0.80mm, 3.00mm, CST, DAC
10	5126031		4 WASHER

Valid for Industrial Var. 334328, 335368 (728368) or Industrial Var.
334329, 335413 (729413) or Industrial Var. 334330, 335417 (729417)

FARMALL JX100 FARMALL
JX110 FARMALL JX70
FARMALL JX75 FARMALL
JX80 FARMALL JX90

35.204.BL

04

p1

1/2014

VAR - 728366, 729412 - 1 CONTROL VALVE, LEVER AND KNOB, ROPS

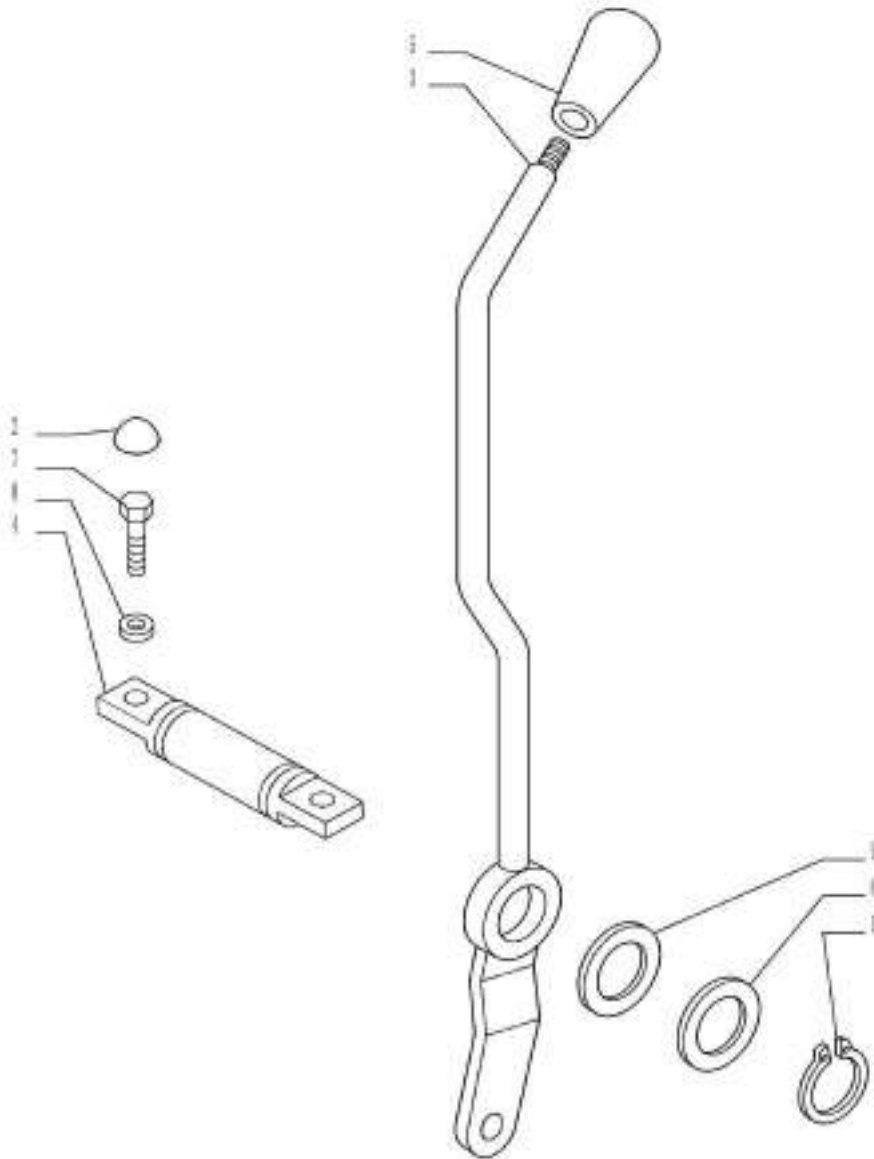

35.204.BL

04

p1

1/2014

VAR - 728366, 729412 - 1 CONTROL VALVE, LEVER AND KNOB, ROPS

REF FN	PART NUMBER	YR/SN	QTY DESCRIPTION
1	11066976		2 SNAP RING M21, Ext
2	5089481		2 CAP
3	84562680		1 LEVER 1-2 Command Lever
4	5133375		1 PIN
5	5177017		1 HANDLE GRIP Black
6	5126031		4 WASHER
7	86625001		2 BOLT Hex, M8 x 22mm, Cl 8.8, Full Thd
8	12601374		2 WAVE WASHER Wave, 8.40mm ID x 15.00mm OD x 0.80mm, 3.00mm, CST, DAC
9	5090174		2 GUIDE BUSHING

Valid for Industrial Var. 334325, 335366 (728366) or Industrial Var.
334326, 334327 (729412)FARMALL JX100 FARMALL
JX110 FARMALL JX70
FARMALL JX75 FARMALL
JX80 FARMALL JX90

35.204.BL

05

p1

1/2014

VAR - 728054, 729103 - 3 CONTROL VALVES, LEVER AND KNOB, CAB

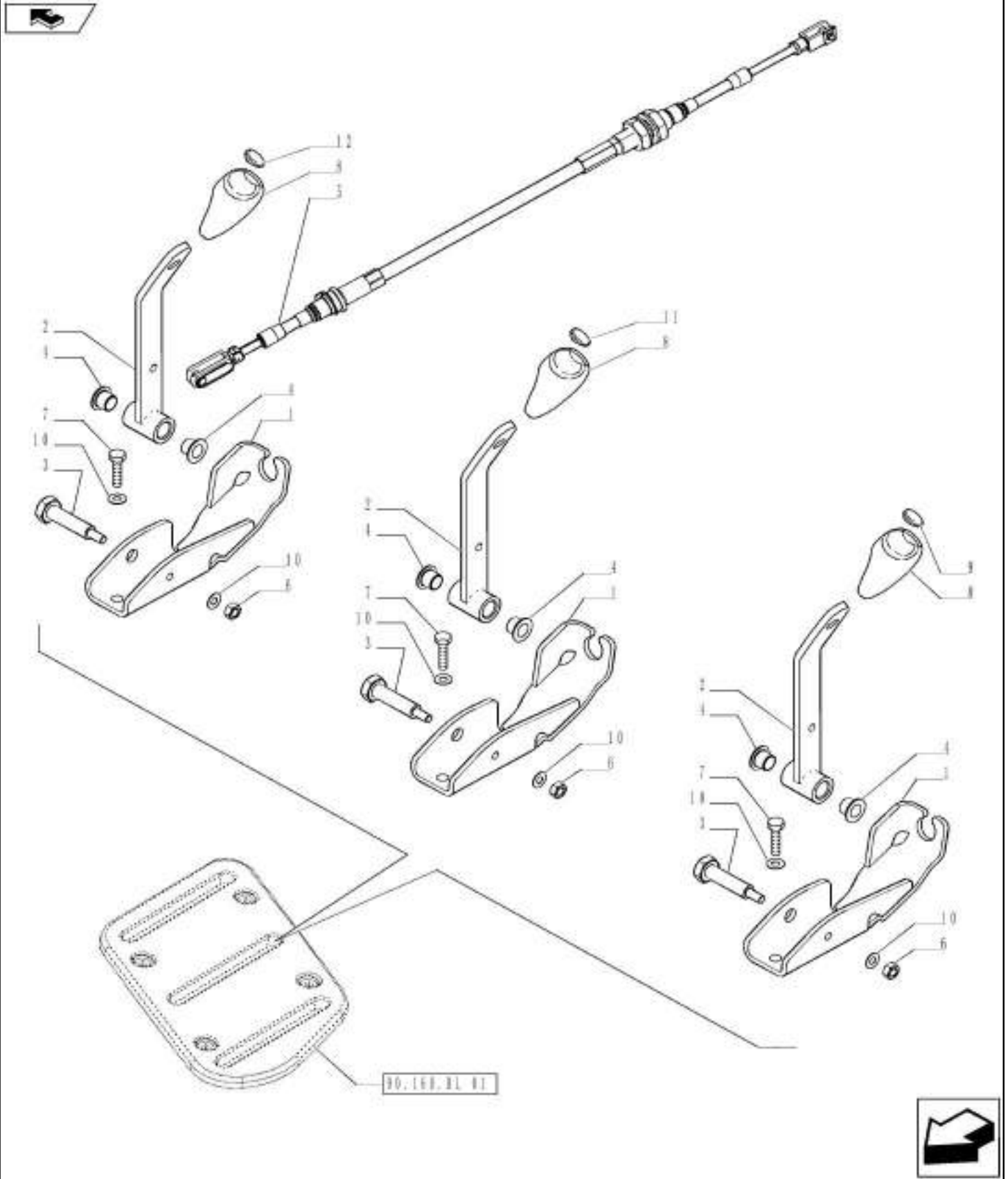

35.204.BL

05

p1

1/2014

VAR - 728054, 729103 - 3 CONTROL VALVES, LEVER AND KNOB, CAB

REF FN	PART NUMBER	YR/SN	QTY DESCRIPTION
1	84487124		3 SUPPORT
2	84487127		3 LEVER
3	84487136		3 PIN
4	84487137		6 BUSHING
5	84487129		3 CABLE
6	10720111		3 NUT M6, CI 8
7	10902321		6 SCREW Hex, M6 x 18, 8.8, Full Thd
8	47056482		3 KNOB
9	47057201		1 IDEOGRAM Shiftsymbol 3
10	12601279		9 WAVE WASHER Wave, M6.4
11	47057200		1 IDEOGRAM Shiftsymbol 2
12	47057199		1 IDEOGRAM Shiftsymbol 1

Valid for Industrial Var. 334331, 335054 (728054) or Industrial Var. 334332, 335103 (729103)	FARMALL JX100 FARMALL JX110 FARMALL JX70 FARMALL JX75 FARMALL JX80 FARMALL JX90
---	--

35.204.BL

06

p1

1/2014

VAR - 728368, 729413, 729417 - 2 CONTROL VALVES, LEVER AND KNOB, CAB

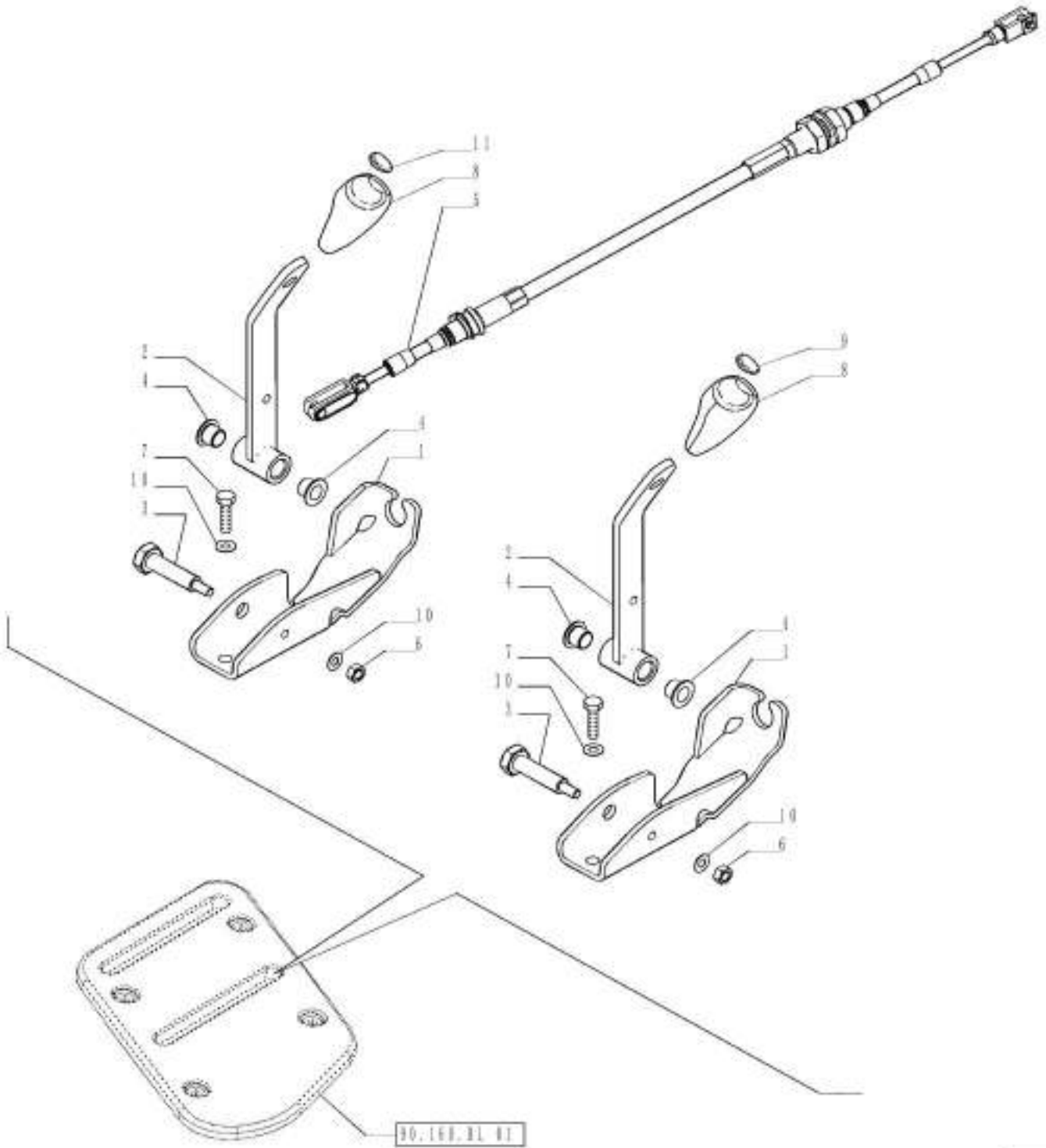

VAR - 728368, 729413, 729417 - 2 CONTROL VALVES, LEVER AND KNOB, CAB

REF FN	PART NUMBER	YR/SN	QTY DESCRIPTION
1	84487124		2 SUPPORT
2	84487127		2 LEVER
3	84487136		2 PIN
4	84487137		4 BUSHING
5	84487129		2 CABLE
6	10720111		2 NUT M6, CI 8
7	10902321		4 SCREW Hex, M6 x 18, 8.8, Full Thd
8	47056482		2 KNOB
9	47057200		1 IDEOGRAM Shiftsymbol 2
10	12601279		6 WAVE WASHER Wave, M6.4
11	47057199		1 IDEOGRAM Shiftsymbol 1

Valid for Industrial Var. 334328, 335368 (728368) or Industrial Var. 334329, 335413 (729413) or Industrial Var. 334330, 335417 (729417)	FARMALL JX100 FARMALL JX110 FARMALL JX70 FARMALL JX75 FARMALL JX80 FARMALL JX90
---	---

35.204.BL

07

p1

1/2014

VAR - 728366, 729412 - 1 CONTROL VALVE, LEVER AND KNOB, CAB

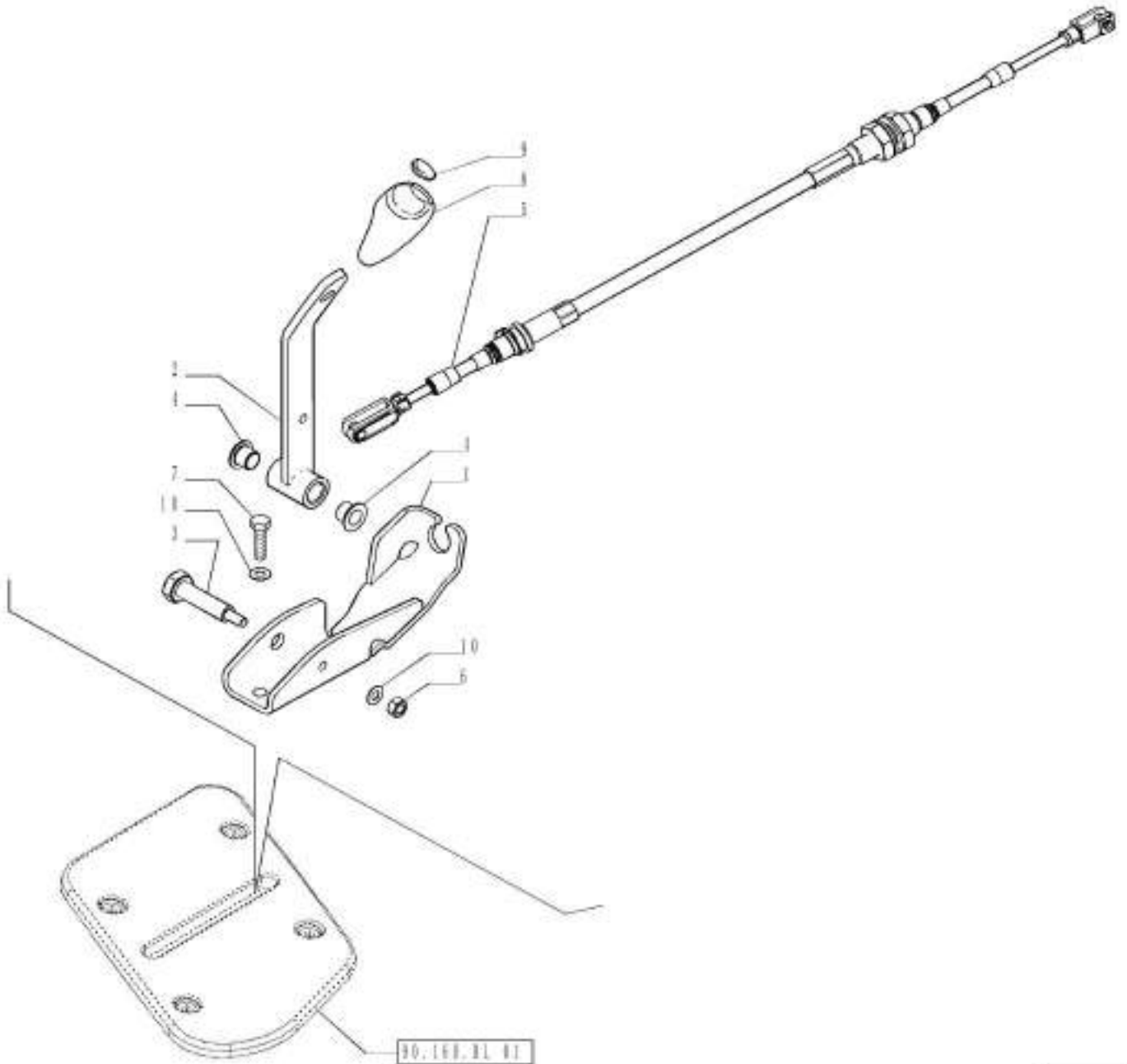

35.204.BL

07

p1

1/2014

VAR - 728366, 729412 - 1 CONTROL VALVE, LEVER AND KNOB, CAB

REF FN	PART NUMBER	YR/SN	QTY DESCRIPTION
1	84487124		1 SUPPORT
2	84487127		1 LEVER
3	84487136		1 PIN
4	84487137		2 BUSHING
5	84487129		1 CABLE
6	10720111		1 NUT M6, CI 8
7	10902321		2 SCREW Hex, M6 x 18, 8.8, Full Thd
8	47056482		1 KNOB
9	47057199		1 IDEOGRAM Shiftsymbol 1
10	12601279		3 WAVE WASHER Wave, M6.4

Valid for Industrial Var. 334325, 335366 (728366) or Industrial Var. 334326, 334327 (729412)	FARMALL JX100 FARMALL JX110 FARMALL JX70 FARMALL JX75 FARMALL JX80 FARMALL JX90
---	--

35.204.BL

08

p1

1/2014

VAR - 728366, 728368, 729412, 729413, 729417 - CONTROL LEVER

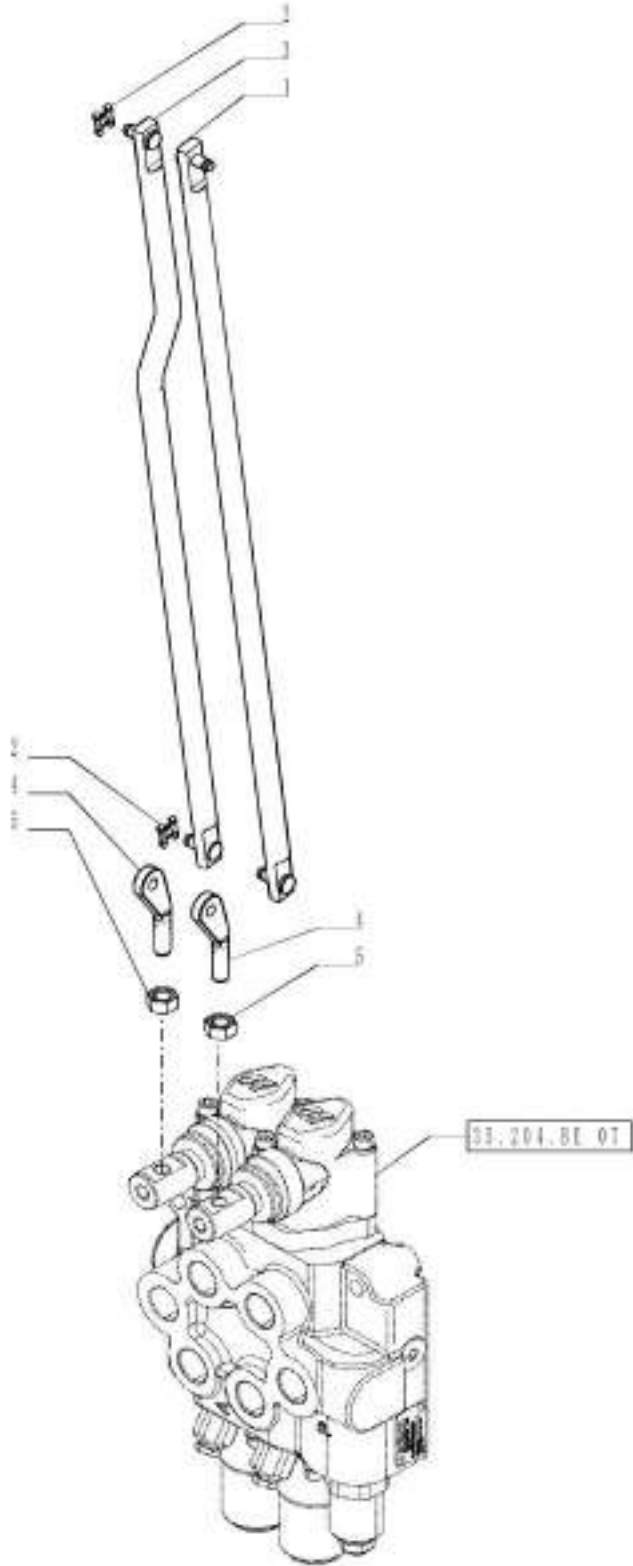

35.204.BL

08

p1

1/2014

VAR - 728366, 728368, 729412, 729413, 729417 - CONTROL LEVER

REF	FN	PART NUMBER	YR/SN	QTY	DESCRIPTION
1	1	84554380		1	LEVER
2	1	11063971		4	CLIP M6
3	1	84554377		1	LEVER
4		5089075		2	SUPPORT
5		16100811		2	NUT Hex, M8, 6.80mm, Cl 8, ZND
(1)		ROPS			

Valid for Industrial Var. 334325, 335366 (728366) or Industrial Var. 334328, 335368 (728368) or Industrial Var. 334326, 334327 (729412) or Industrial Var. 334329, 335413 (729413) or Industrial Var. 334330, 335417 (729417)

FARMALL JX100 FARMALL
JX110 FARMALL JX70
FARMALL JX75 FARMALL
JX80 FARMALL JX90

35.359.AB

01

p1

1/2014

VAR - 336125 - 2 MID MOUNT VALVES WITH JOYSTICK, VALVES AND PIPES

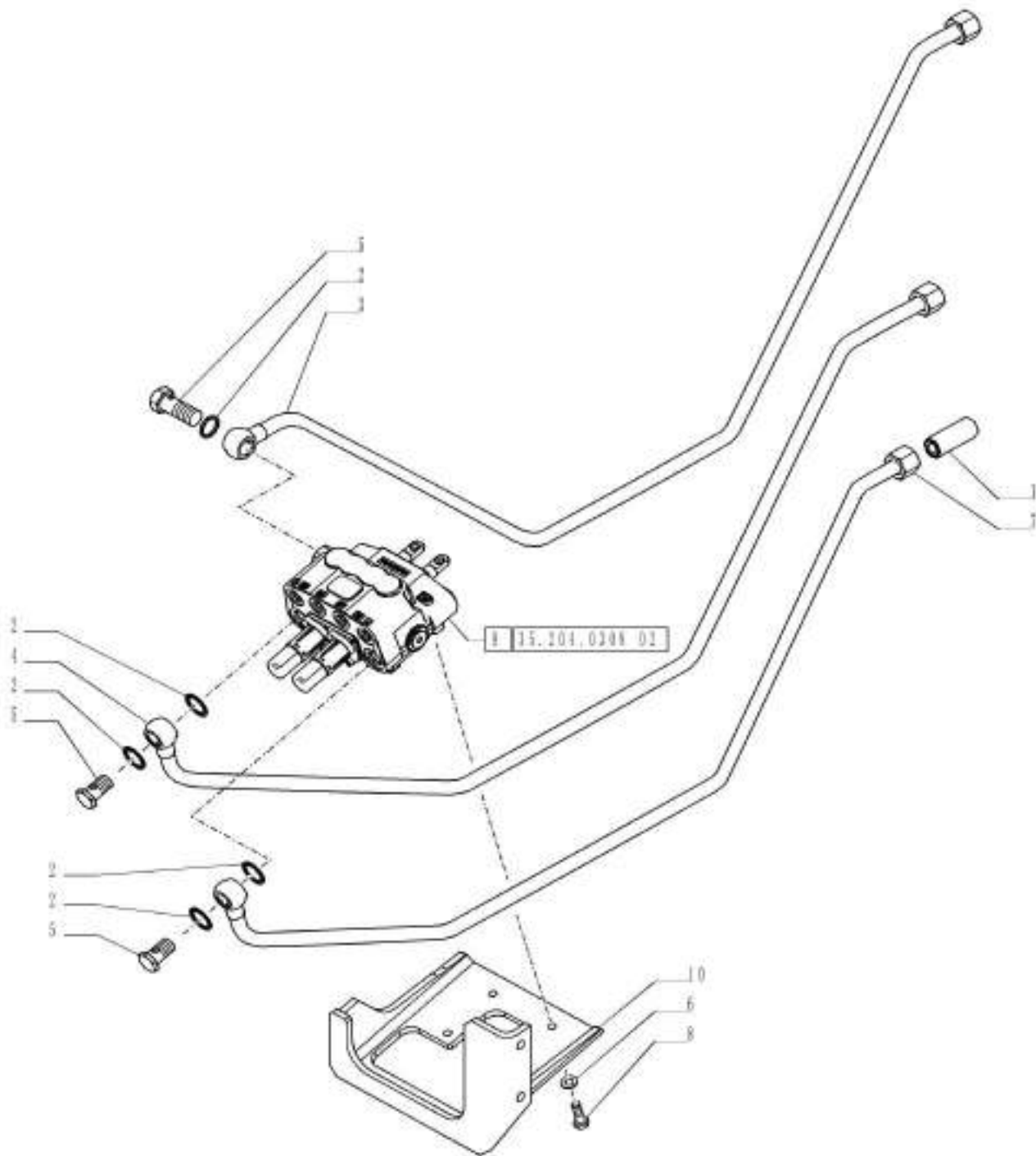

35.359.AB

01

p1

1/2014

VAR - 336125 - 2 MID MOUNT VALVES WITH JOYSTICK, VALVES AND PIPES

REF FN	PART NUMBER	YR/SN	QTY DESCRIPTION
1	87644433		3 HYD CONNECTOR
2	10263460		6 SEAL 22.30mm ID x 28.00mm OD, 1.50mm, Copper
3	84533816		1 PIPE
4	84533807		1 PIPE
5	5112588		3 BANJO BOLT M22 x 1.5 x 40.00mm
6	11193879		3 BELLEVILLE WASHER Belleville, M8.4
7	84533801		1 PIPE
8	43127		3 BOLT Hex, M8 x 1.25 x 25mm, Cl 8.8, Full Thd
9	47132112		1 HYDRAULIC VALVE
10	84533794		1 SUPPORT

Valid for Var. 336125

FARMALL JX100 FARMALL
JX110 FARMALL JX70
FARMALL JX75 FARMALL
JX80 FARMALL JX90

35.359.AB

02

p1

1/2014

VAR - 336125 - TWO FRONT CONTROL VALVES, BREAKDOWN

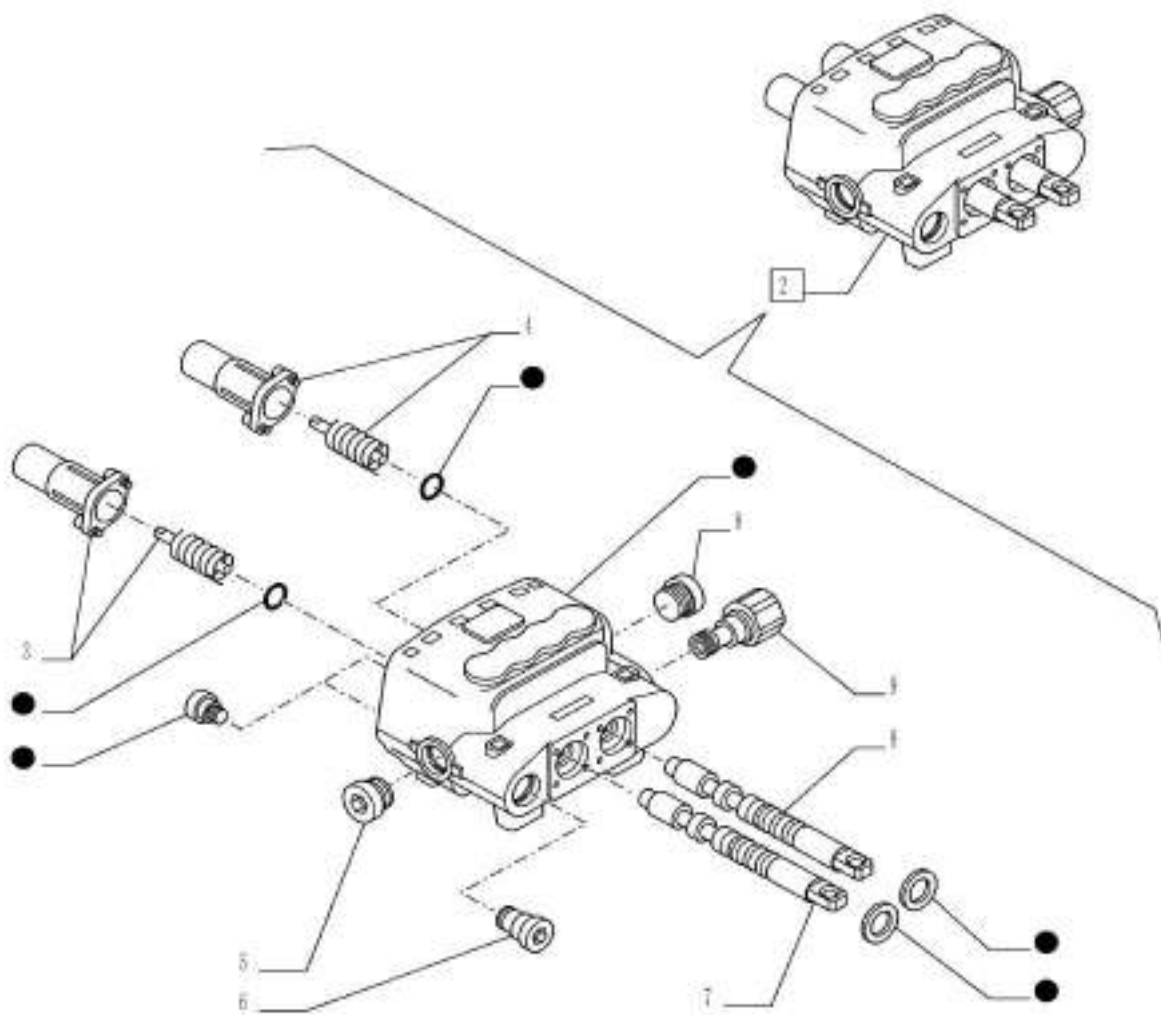
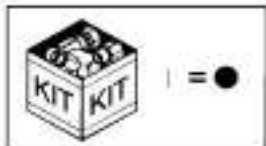

35.359.AB

02

p1

1/2014

VAR - 336125 - TWO FRONT CONTROL VALVES, BREAKDOWN

REF FN	PART NUMBER	YR/SN	QTY DESCRIPTION
1	87306629		1 KIT
2	47132112		1 HYDRAULIC VALVE ASSY, Incl 3 - 9
3	87306631		1 CONTROL
4	87306630		1 CONTROL
5	87306632		2 PLUG
6	87306633		1 PLUG
7	87306636		1 SPOOL
8	87306635		1 SPOOL
9	87306634		1 HYD CONNECTOR

Valid for Var. 336125	FARMALL JX100 FARMALL JX110 FARMALL JX70 FARMALL JX75 FARMALL JX80 FARMALL JX90
------------------------------	--

VAR - 344351 - FRONT LOADER HYDRAULIC SYSTEM

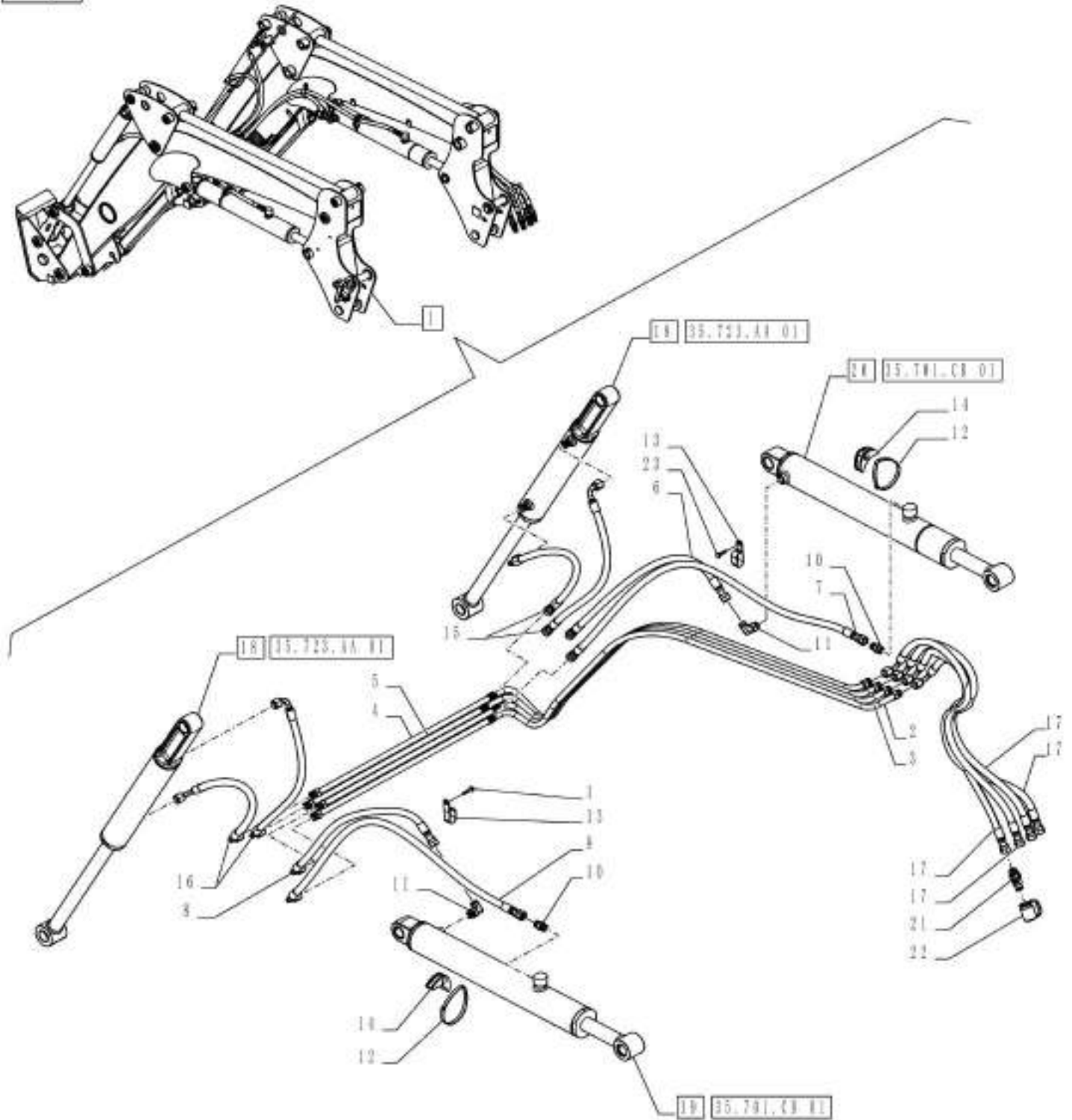

VAR - 344351 - FRONT LOADER HYDRAULIC SYSTEM

REF	FN	PART NUMBER	YR/SN	QTY	DESCRIPTION
1	1	84467877		1	LOADER ARM Incl 2 - 23
2		84575173		1	PIPE
3		84575176		1	PIPE
4		84575178		1	PIPE
5		84575177		1	PIPE
6		84575180		1	HOSE
7		84575183		1	HOSE
8		84575184		1	HOSE
9		84575185		1	HOSE
10		83963374		2	FITTING 13/16"-16 ORFS x 3/4"-16 ORB
11		83971549		2	90 ELBOW 13/16"-16 ORFS x 3/4"-16 ORB
12		84406396		2	FIXING STRIP
13		5145401		2	CLAMP
14		85805567		2	BLOCK
15		84575186		2	HOSE
16		84575188		2	HOSE
17		84406192		4	FLEXIBLE HOSE L=1250 MM
18		84601535		2	BUCKET CYLINDER
19		84575192		1	LIFT CYLINDER LH
20		84575190		1	LIFT CYLINDER RH
21		84406394		4	FITTING
22		84406395		1	PLASTIC PLUG Yellow
22		84406401		1	PLASTIC PLUG Red
22		84406402		1	PLASTIC PLUG Blue
22		84406403		1	PLASTIC PLUG Green
23		16043921		2	BOLT Hex, M8 x 1.25 x 35mm, Cl 8.8

(1) See Breakdown in Sections 35, 82 and 90

Valid for Var. 334351

FARMALL JX100
 FARMALL JX110
 FARMALL JX75
 FARMALL JX90

VAR - 330489, 334351, 334352 - 4 MULTIFASTER COUPLERS

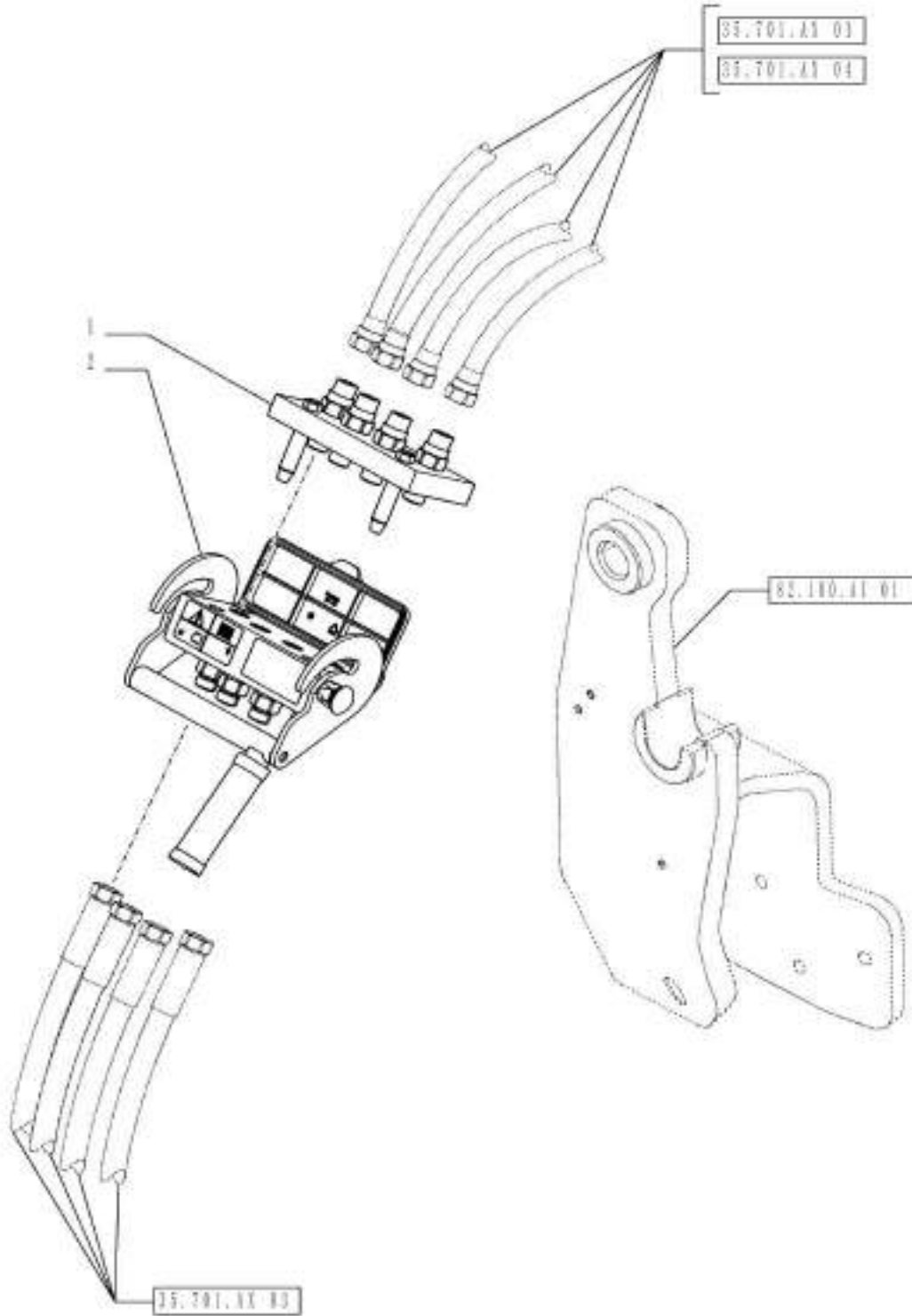

35.701.AX

02

p1

1/2014

VAR - 330489, 334351, 334352 - 4 MULTIFASTER COUPLERS

REF FN	PART NUMBER	YR/SN	QTY DESCRIPTION
1	84411205		1 PLATE
2	87733579		1 COUPLING

Valid for Var. 330489 or Var. 334351 or Var. 334352

FARMALL JX100
FARMALL JX110
FARMALL JX75
FARMALL JX90

VAR - 334351, 334352 - FRONT LOADER WITH 4 COUPLERS, FRONT QUICK COUPLINGS

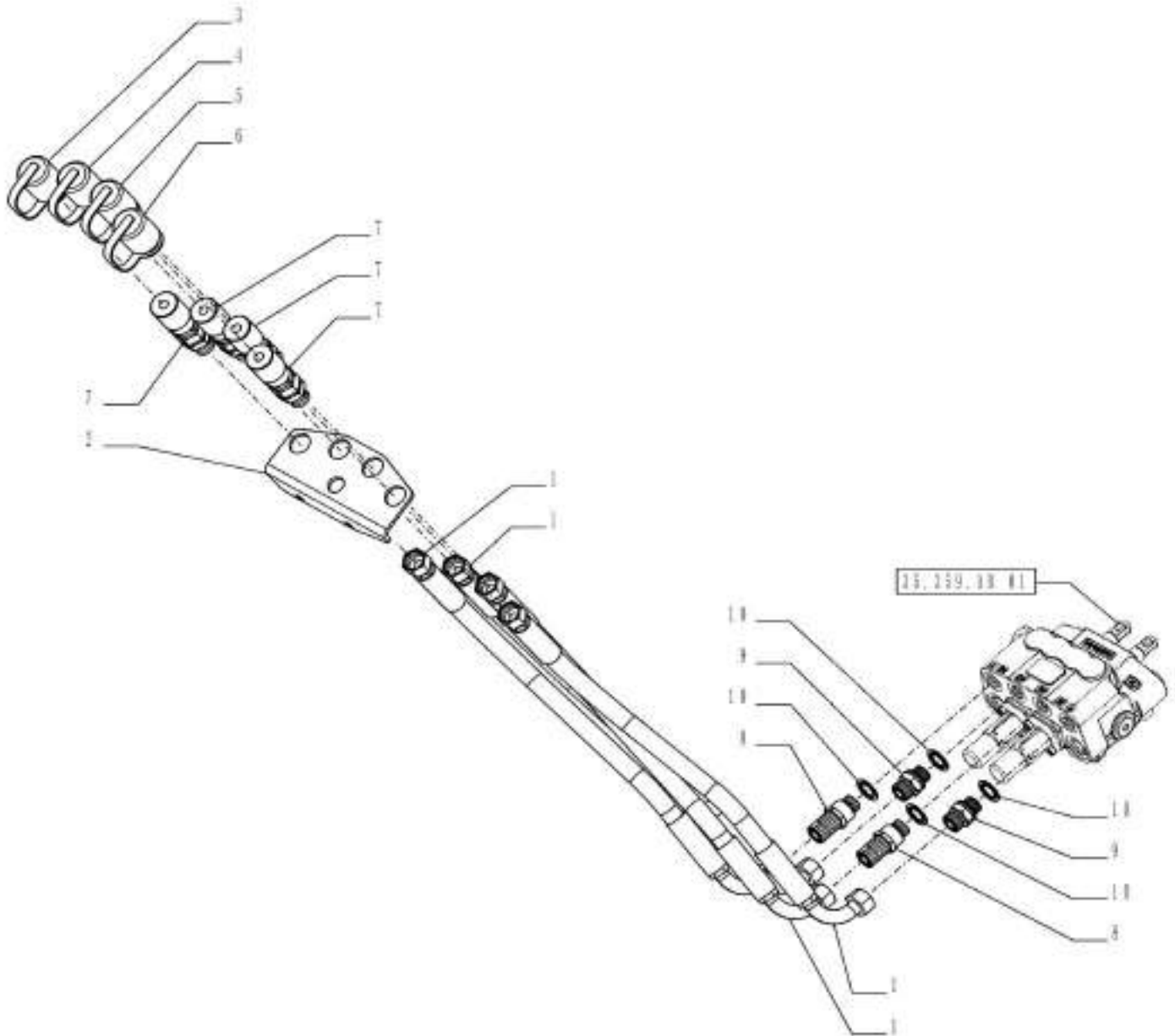

35.701.AX

03

p1

1/2014

VAR - 334351, 334352 - FRONT LOADER WITH 4 COUPLERS, FRONT QUICK COUPLINGS

REF FN	PART NUMBER	YR/SN	QTY DESCRIPTION
1	84372826		4 FLEXIBLE HOSE
2	87336093		1 BRACKET
3	87305167		1 PLUG Blue
4	87305168		1 PLUG Red
5	87305166		1 PLUG Green
6	87305169		1 PLUG Yellow
7	87305110		4 QUICK FEMALE COUPLING
8	87304603		2 HYD CONNECTOR
9	5185561		2 HYD CONNECTOR
10	5186176		4 SEALING WASHER 15.80mm ID x 26.92mm OD x 1.50mm, Steel, Zinc

Valid for Var. 334351 or Var. 334352

**FARMALL JX100
FARMALL JX110
FARMALL JX75
FARMALL JX90**

VAR - 334352 - FRONT LOADER HYDRAULIC SYSTEM (SELF LEVELLING)

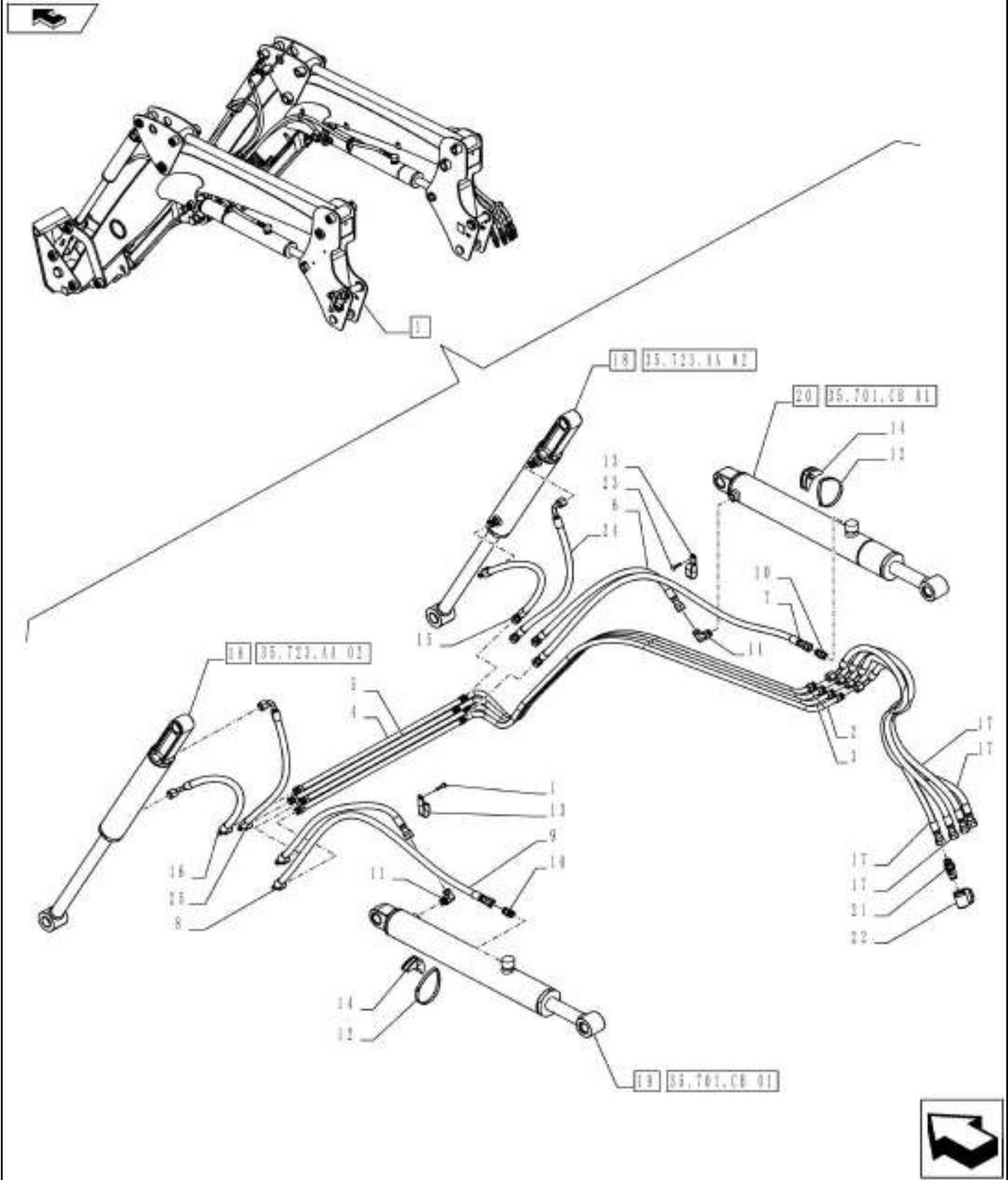

VAR - 334352 - FRONT LOADER HYDRAULIC SYSTEM (SELF LEVELLING)

REF	FN	PART NUMBER	YR/SN	QTY	DESCRIPTION
1	1	84467881		1	LOADER ARM ASSY, Incl 2 - 25
2		84575173		1	PIPE
3		84575176		1	PIPE
4		84575178		1	PIPE
5		84575177		1	PIPE
6		84575180		1	HOSE
7		84575183		1	HOSE
8		84575184		1	HOSE
9		84575185		1	HOSE
10		83963374		2	FITTING 13/16"-16 ORFS x 3/4"-16 ORB
11		83971549		2	90 ELBOW 13/16"-16 ORFS x 3/4"-16 ORB
12		84406396		2	FIXING STRIP
13		5145401		2	CLAMP
14		85805567		2	BLOCK
15		47413984		1	HOSE
16		47413986		1	HOSE
17		84406192		4	FLEXIBLE HOSE L=1250 MM
18		47413978		2	LIFT CYLINDER ASSY
19		84575192		1	LIFT CYLINDER ASSY, LH
20		84575190		1	LIFT CYLINDER ASSY, RH
21		84406394		4	FITTING PUSH PULL MALE
22		84406395		1	PLASTIC PLUG Yellow
22		84406401		1	PLASTIC PLUG Red
22		84406402		1	PLASTIC PLUG Blue
22		84406403		1	PLASTIC PLUG Green
23		16043921		2	BOLT Hex, M8 x 1.25 x 35mm, Cl 8.8
24		84575186		1	HOSE
25		84575188		1	HOSE

(1) See Breakdown in Sections 35, 82 and 90

Valid for Var. 334352

FARMALL JX100
 FARMALL JX110
 FARMALL JX75
 FARMALL JX90

35.701.CB

01

p1

1/2014

VAR - 334351, 334352 - LIFT ARM, CYLINDER, COMPONENTS

REF FN	PART NUMBER	YR/SN	QTY DESCRIPTION
1	84597377		1 SEAL KIT
2	84575192		1 LIFT CYLINDER LH Incl 3 - 10
2	84575190		1 LIFT CYLINDER RH Incl 3 - 10
3	84597383		1 RING
4	84406295		1 HEAD
5	84597376		2 BUSHING
6	84597378		1 SPACER
7	87588865		2 FITTING
8	84597361		1 PISTON ROD
9	84597366		1 PISTON
10	NSS		1 NOT SERVICED SEPARATELY Body Incl in 2

Valid for Var. 334351 or Var. 334352

**FARMALL JX100
FARMALL JX110
FARMALL JX75
FARMALL JX90**

VAR - 334351 - BUCKET CYLINDER, COMPONENTS

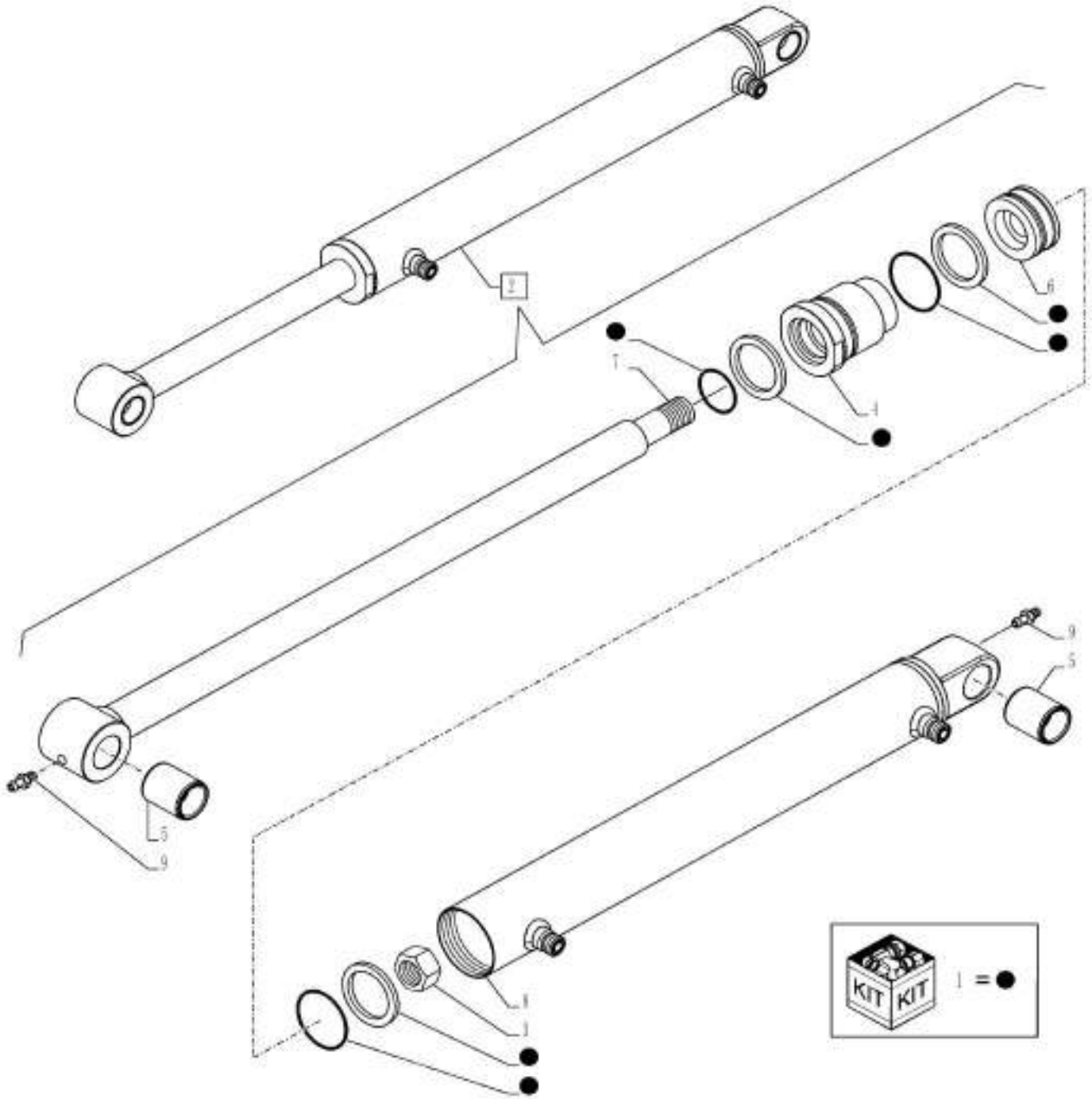

35.723.AA

02

p1

1/2014

VAR - 334352 - BUCKET CYLINDER, COMPONENTS

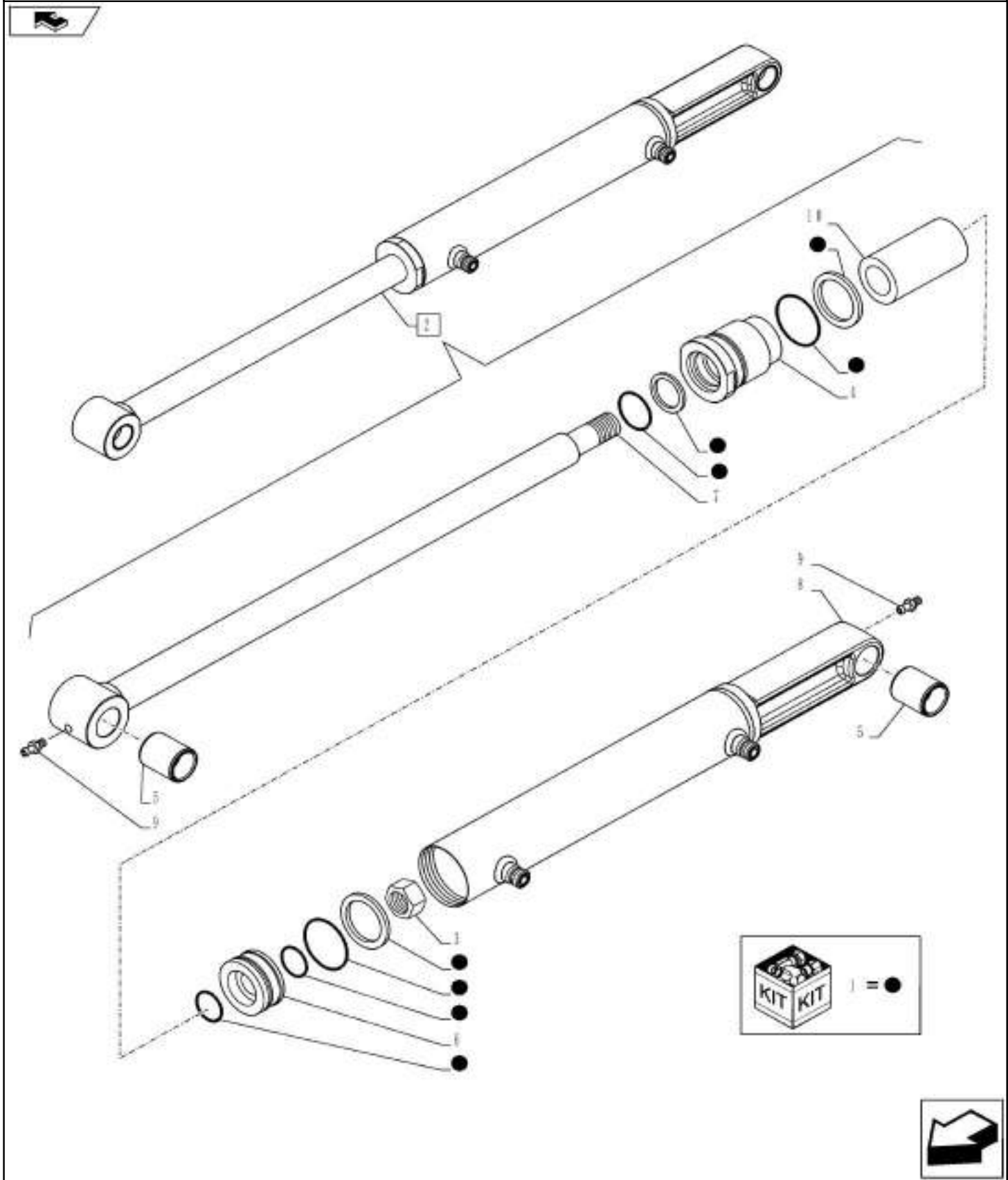

VAR - 334352 - BUCKET CYLINDER, COMPONENTS

REF FN	PART NUMBER	YR/SN	QTY DESCRIPTION
1	84597476		1 SEAL KIT ASSY
2	47413978		1 LIFT CYLINDER
3	84406293		1 NUT
4	84597473		1 CYLINDER HEAD
5	84597376		2 BUSHING
6	84597456		1 PISTON
7	84597448		1 PISTON ROD
8	NSS		1 NOT SERVICED SEPARATELY Body Incl in 2
9	87588865		2 FITTING
10	47413980		1 SPACER

Valid for Var. 334352

FARMALL JX100
FARMALL JX110
FARMALL JX75
FARMALL JX90

VAR - 336125 - 2 MID MOUNTS VALVES WITH JOYSTICK, JOYSTICK AND SUPPORT

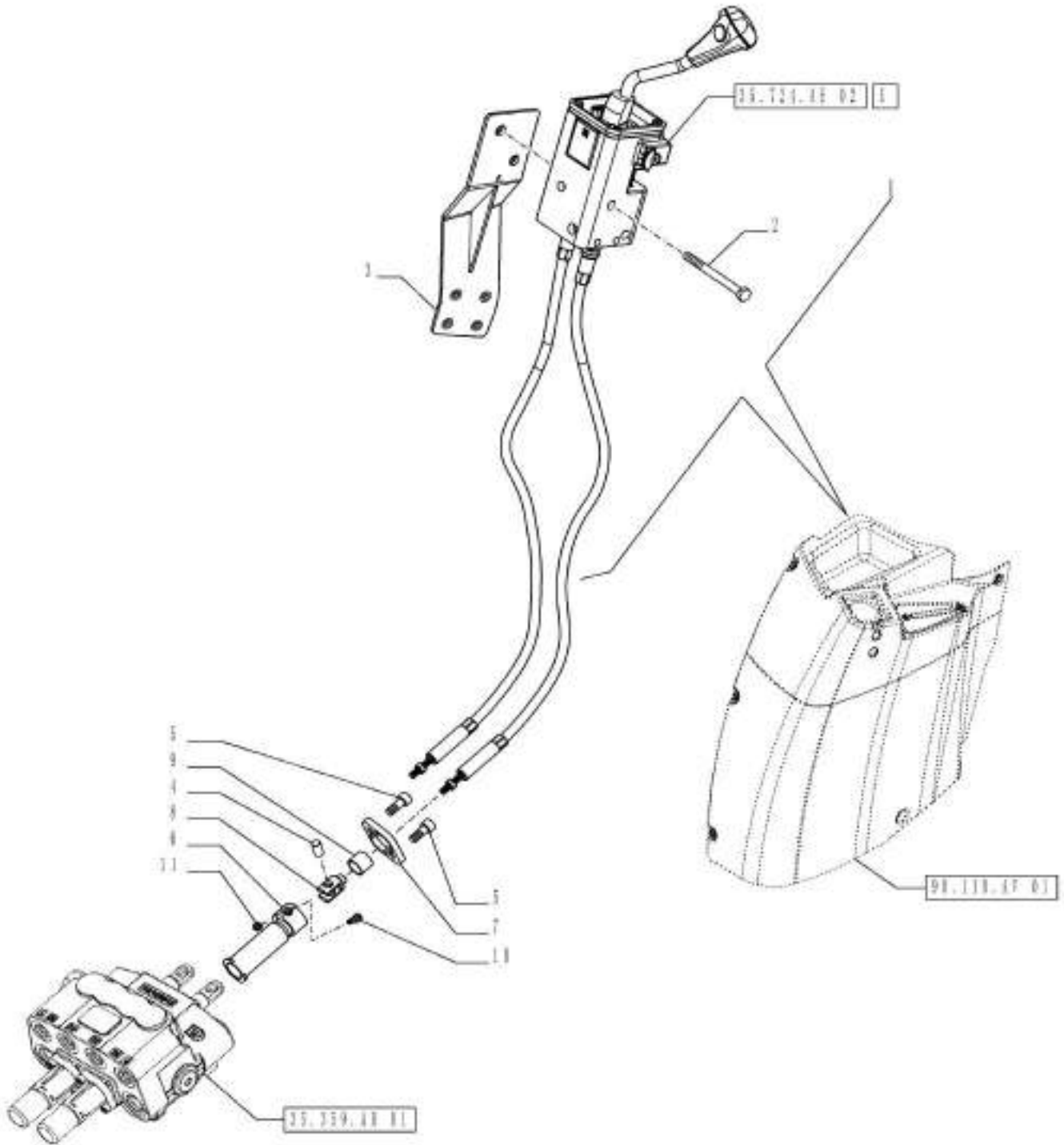

35.724.AE

01

p1

1/2014

VAR - 336125 - 2 MID MOUNTS VALVES WITH JOYSTICK, JOYSTICK AND SUPPORT

REF FN	PART NUMBER	YR/SN	QTY DESCRIPTION
1	84294395		1 JOYSTICK ASSY
2	86508571		2 BOLT Hex, M8 x 90mm, CI 8.8
3	84294398		1 BRACKET
4	87332065		4 PIN
5	14304627		4 HEX SOC SCREW M5 x 14mm, CI 8.8, Full Thd
6	87302881		2 TUBE 14 - 20 mm ID x 95 mm L
7	87303905		2 FLANGE
8	87303906		2 YOKE
9	87303907		1 BUSHING
10	14304321		2 HEX SOC SCREW M5 x 20mm, CI 8.8, Full Thd
11	15896411		2 NUT M5, CI 8
12	87332065		2 PIN
13	14304621		4 SCREW M5 x 14mm, CI 8.8, Full Thd

Valid for Var. 336125	FARMALL JX100 FARMALL JX110 FARMALL JX70 FARMALL JX75 FARMALL JX80 FARMALL JX90
------------------------------	--

VAR - 336125 - JOYSTICK FOR MID MOUNT, BREAKDOWN

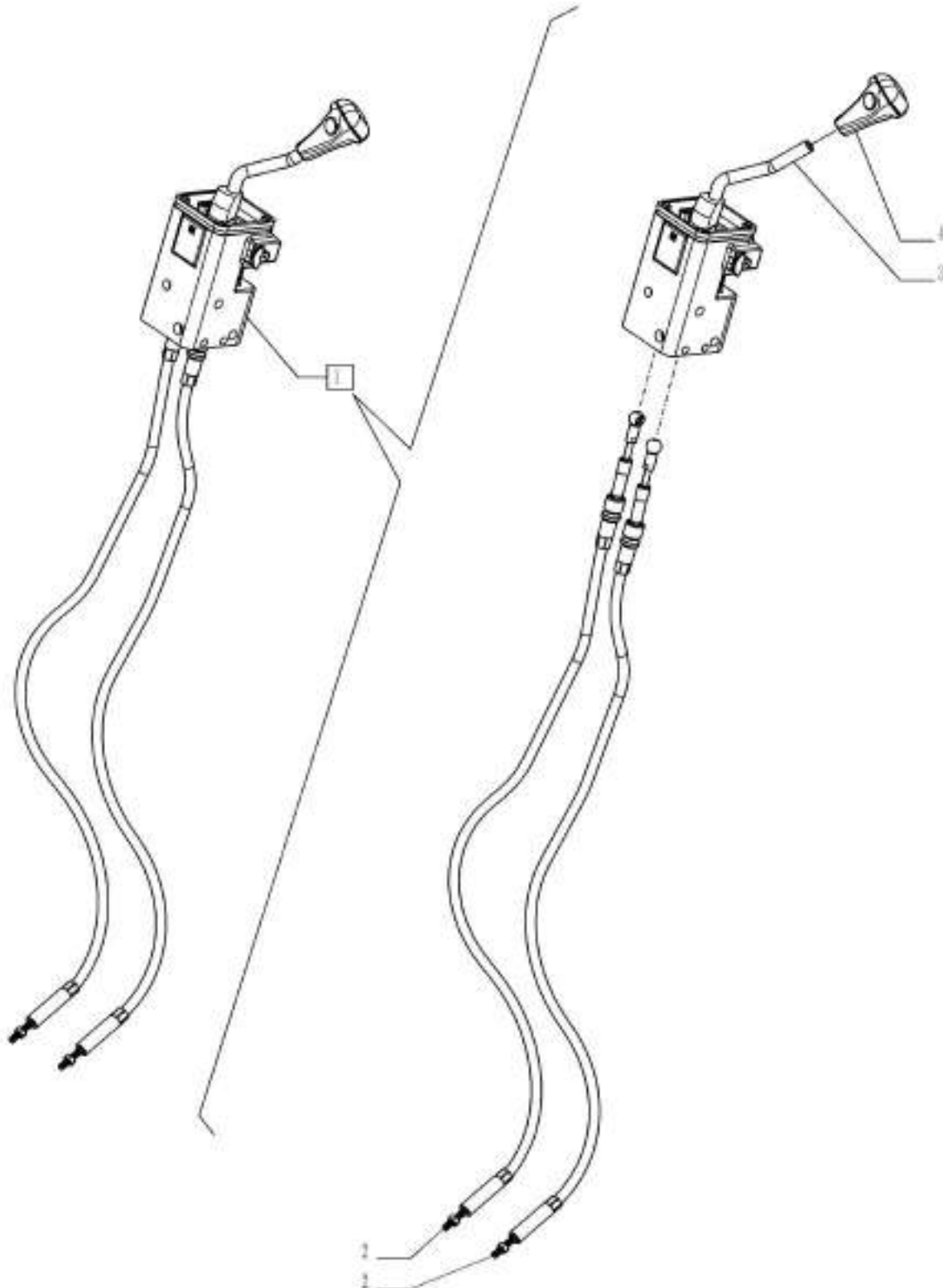

35.724.AE

02

p1

1/2014

VAR - 336125 - JOYSTICK FOR MID MOUNT, BREAKDOWN

REF FN	PART NUMBER	YR/SN	QTY DESCRIPTION
1	84294395		1 JOYSTICK Incl 2 - 4
2	84294411		2 BOWDEN CONTROL
3	84294397		1 LEVER
4	82038998		1 KNOB

Valid for Var. 336125

FARMALL JX100 FARMALL
JX110 FARMALL JX70
FARMALL JX75 FARMALL
JX80 FARMALL JX90

SECTION INDEX

HITCHES, DRAWBARS & IMPLEMENT COUPLINGS

37.000.00	01	SECTION INDEX - HITCHES, DRAWBARS AND IMPLEMENT COUPLINGS
37.100.AA	01	VAR - 334340, 334424, 744755 - DRAWBAR AND SUPPORT WITH PIN (HOLE DIAMETER 33MM)
37.100.AA	02	VAR - 744752, 744754 - TRAILER HITCH FRAME WITH HIGH POINT HITCH AND SWINGING DRAWBAR
37.100.AA	03	VAR - 330899 - LINKAGE DRAWBAR
37.100.AA	04	VAR - 335893, 744753 - DRAWBAR AND SUPPORT WITH PIN (FRANCE)
37.100.AB	02	VAR - 334334, 334421, 744751 - TRAILER HITCH FRAME WITH HIGH POINT HITCH AND SWINGING DRAWBAR - BREAKDOWN
37.100.AB	03	VAR - 334335, 334422, 744752 - TRAILER HITCH FRAME WITH HIGH POINT HITCH AND SWINGING DRAWBAR - BREAKDOWN
37.100.AB	04	VAR - 334338, 334423, 744754 - TRAILER HITCH FRAME LESS HIGH POINT HITCH, BREAKDOWN
37.100.AB	05	VAR - 334336, 334337 - SWIVEL TRAILER HITCH WITH SLIDER SUPPORT
37.100.AC	01	VAR - 335892 - FRONT TOW HOOK
37.100.AF	01	VAR - 334336, 334337 - TOW HOOK
37.100.AF	02	VAR - 335893, 744753 - TOW HOOK (FRANCE)
37.108.AD	01	VAR - 334395, 390814 - HYDRAULIC LIFT, CONTROL, KNOB
37.108.AD	02	VAR - 334395, 390814 - LIFT CONTROLS - HANDLE AND LEVERS - CAB
37.108.AD	03	VAR - 334395, 390814 - HYDRAULIC LIFT, CONTROL, KNOB, ROPS
37.108.AE	01	VAR - 334395 - LIFT CONTROLS - CABLE
37.108.AE	02	VAR - 334395 - CONTROL LEVER, BREAKDOWN
37.108.AL	01	VAR - 334395, 390814 - LIFTOMATIC RANGE LIMITER DEVICE
37.110.AK	01	VAR - 744738, 744739, 744744 - HYDRAULIC LIFT, CONTROL SHAFT
37.110.AM	01	VAR - 744738, 744739, 744744 - HYDRAULIC LIFT, HYDRAULIC LIFT, TIE-ROD, LEVER
37.110.AM	02	VAR - 744738, 744739, 744744 - HYDRAULIC LIFT, CONTROL, TIE-ROD, LEVER, BEARING
37.110.AM	03	VAR - 744738, 744739, 744744 - HYDRAULIC LIFT, CONTROL, TIE-ROD, LEVER, BEARING
37.110.AP	01	VAR - 334395, 390814 - HYDRAULIC LIFT, COVER
37.110.AP	02	VAR - 334395, 390814 - LIFTER OIL PAN AND RELATED PARTS
37.110.AQ	01	VAR - 334395, 390814 - LIFT - LIFT ARMS AND ROCKSHAFT
37.110.AQ	02	VAR - 334395, 390814 - LIFT CYLINDER, PISTON
37.120.AA	01	VAR - 334316, 334317, 390259 - IMPLEMENT CARRIER, LINK AND ARM
37.120.AA	02	VAR - 334316, 334317, 390259 - IMPLEMENT CARRIER, SWING CARRIAGE
37.120.AA	03	VAR - 334316, 334317, 390259 - IMPLEMENT CARRIER, UPPER LINK, BREAKDOWN
37.120.AA	04	VAR - 334317 - THREE POINT HITCH WITH QUICK ATTACH ENDS, THIRD LINK SPRAG, BREAKDOWN

SECTION INDEX

HITCHES, DRAWBARS & IMPLEMENT COUPLINGS

37.120.AV	02	VAR - 334316, 390259 - RH SIDE ADJUSTABLE TIE-ROD, BREAKDOWN
-----------	----	---

SECTION INDEX - HITCHES, DRAWBARS AND IMPLEMENT COUPLINGS

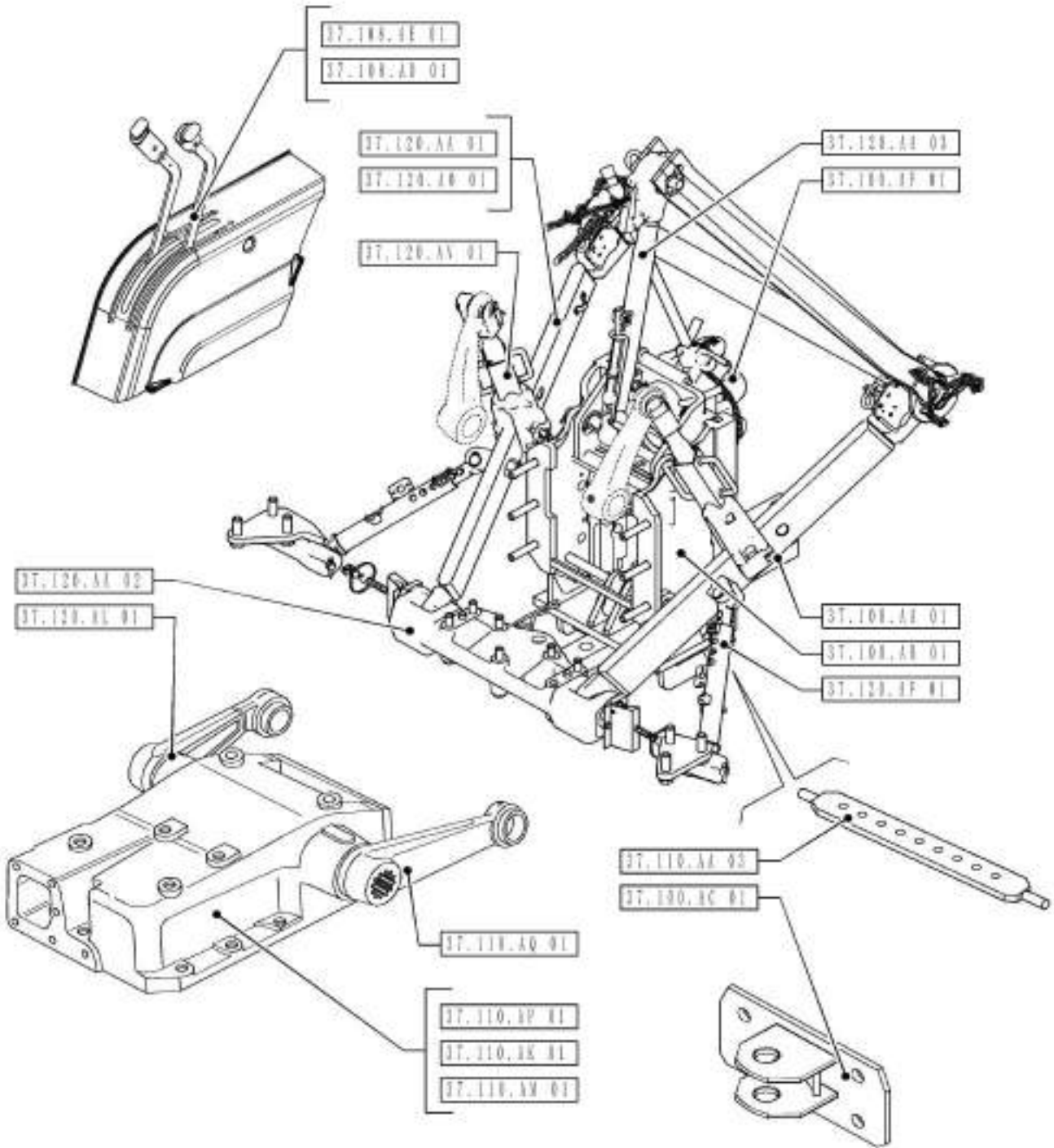

37.000.00

01

p1

1/2014

SECTION INDEX - HITCHES, DRAWBARS AND IMPLEMENT COUPLINGS

REF FN	PART NUMBER	YR/SN	QTY	DESCRIPTION
---------------	--------------------	--------------	------------	--------------------

				FARMALL JX100 FARMALL JX110 FARMALL JX70 FARMALL JX75 FARMALL JX80 FARMALL JX90
--	--	--	--	--

37.100.AA

01

p1

1/2014

VAR - 334340, 334424, 744755 - DRAWBAR AND SUPPORT WITH PIN (HOLE DIAMETER 33MM)

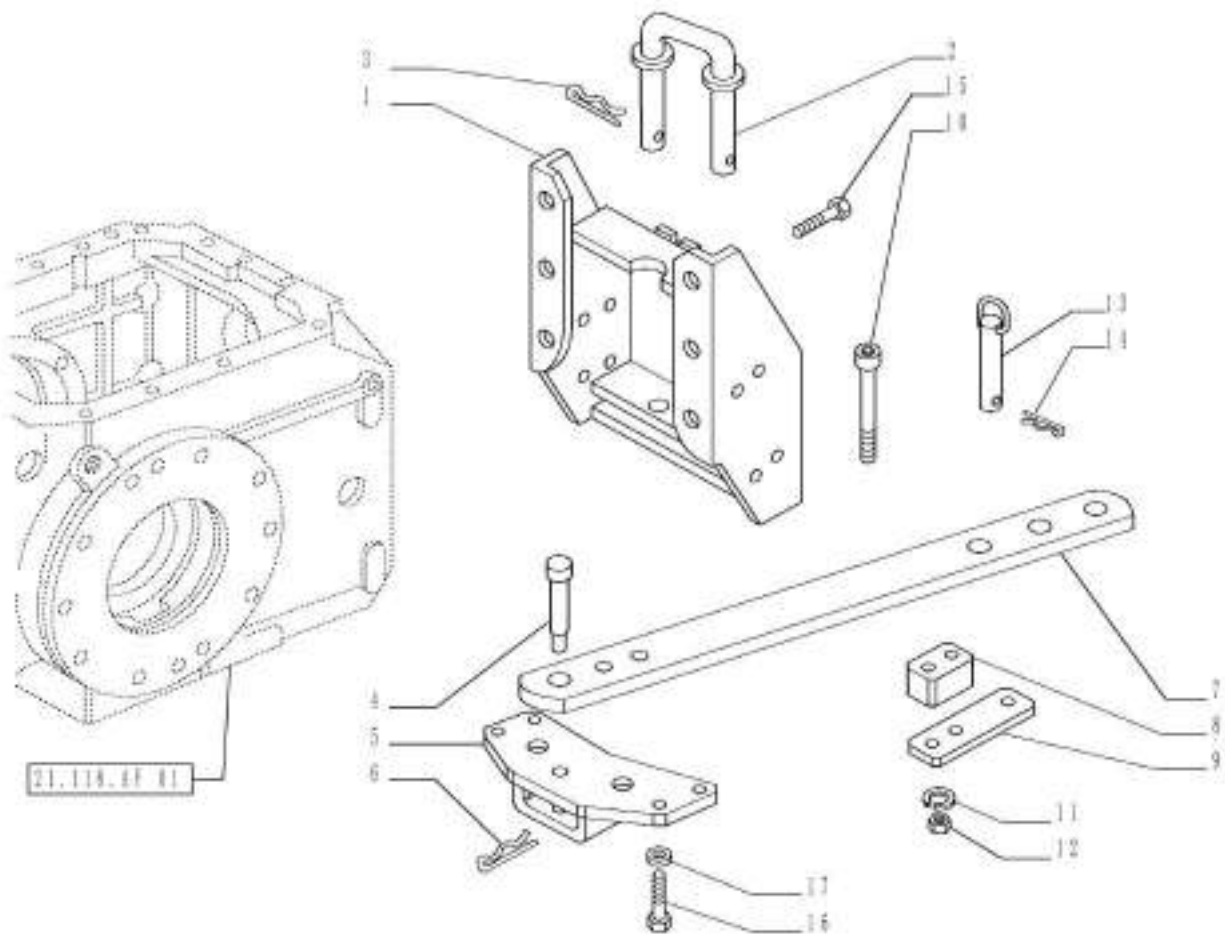

VAR - 334340, 334424, 744755 - DRAWBAR AND SUPPORT WITH PIN (HOLE DIAMETER 33MM)

REF FN	PART NUMBER	YR/SN	QTY DESCRIPTION
1	5093158		1 SUPPORT
2	5123643		1 PIN
3	5112606		1 COTTER PIN
4	84195997		1 PIN
5	5120238		1 BRACKET
6	84416689		1 COTTER PIN 4MM
7	5094000		1 DRAWBAR
8	5121551		1 SPACER
9	5093297		1 DRAWBAR
10	15986634		2 BOLT Hex, M18 x 1.5 x 170mm, Cl 10.9
11	10572279		2 WASHER M18
12	10721021		2 NUT M18 x 1.5, Cl 10
13	5093226		1 HITCH PIN
14	5085461		1 COTTER PIN
15	15981521		6 BOLT Hex, M16 x 1.5 x 90mm, Cl 8.8
16	15981821		4 SCREW Hex, M16 x 1.5 x 120mm, Cl 8.8
17	11194279		4 BELLEVILLE WASHER Belleville, M17
Valid for Industrial Var. 334340, 334424 (744755)			FARMALL JX100 FARMALL JX110 FARMALL JX70 FARMALL JX75 FARMALL JX80 FARMALL JX90

37.100.AA

02

p1

1/2014

VAR - 744752, 744754 - TRAILER HITCH FRAME WITH HIGH POINT HITCH AND SWINGING DRAWBAR

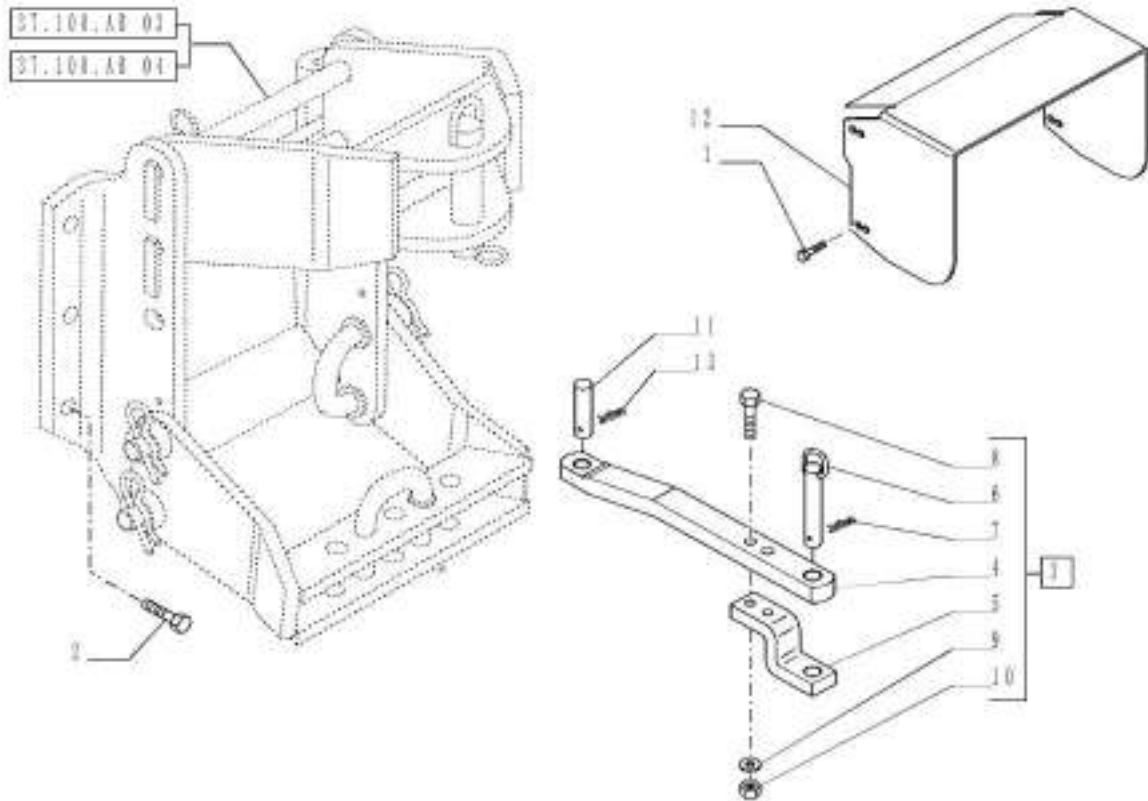

VAR - 744752, 744754 - TRAILER HITCH FRAME WITH HIGH POINT HITCH AND SWINGING DRAWBAR

REF FN	PART NUMBER	YR/SN	QTY DESCRIPTION
1	86625000		4 BOLT Hex, M8 x 18mm, CI 8.8, Full Thd
2	15981521		6 BOLT Hex, M16 x 1.5 x 90mm, CI 8.8
3	5087597		1 DRAWBAR Incl 4 - 10
4	5117439		1 DRAWBAR
5	598607		1 SUPPORT
6	596060		1 HITCH PIN
7	5085461		1 COTTER PIN
8	15985031		2 BOLT Hex, M18 x 1.5 x 90, 10.9
9	12601874		2 SPRING WASHER D=18
10	10721021		2 NUT M18 x 1.5, CI 10
11	5116252		1 PIN
12	5158411		1 SHIELD
13	44007661		1 COTTER PIN 4MM

Valid for Industrial Var. 334335, 334422 (744752) or Industrial Var. 334338, 334423 (744754)	FARMALL JX100 FARMALL JX110 FARMALL JX70 FARMALL JX75 FARMALL JX80 FARMALL JX90
--	---

37.100.AA

03

p1

1/2014

VAR - 330899 - LINKAGE DRAWBAR

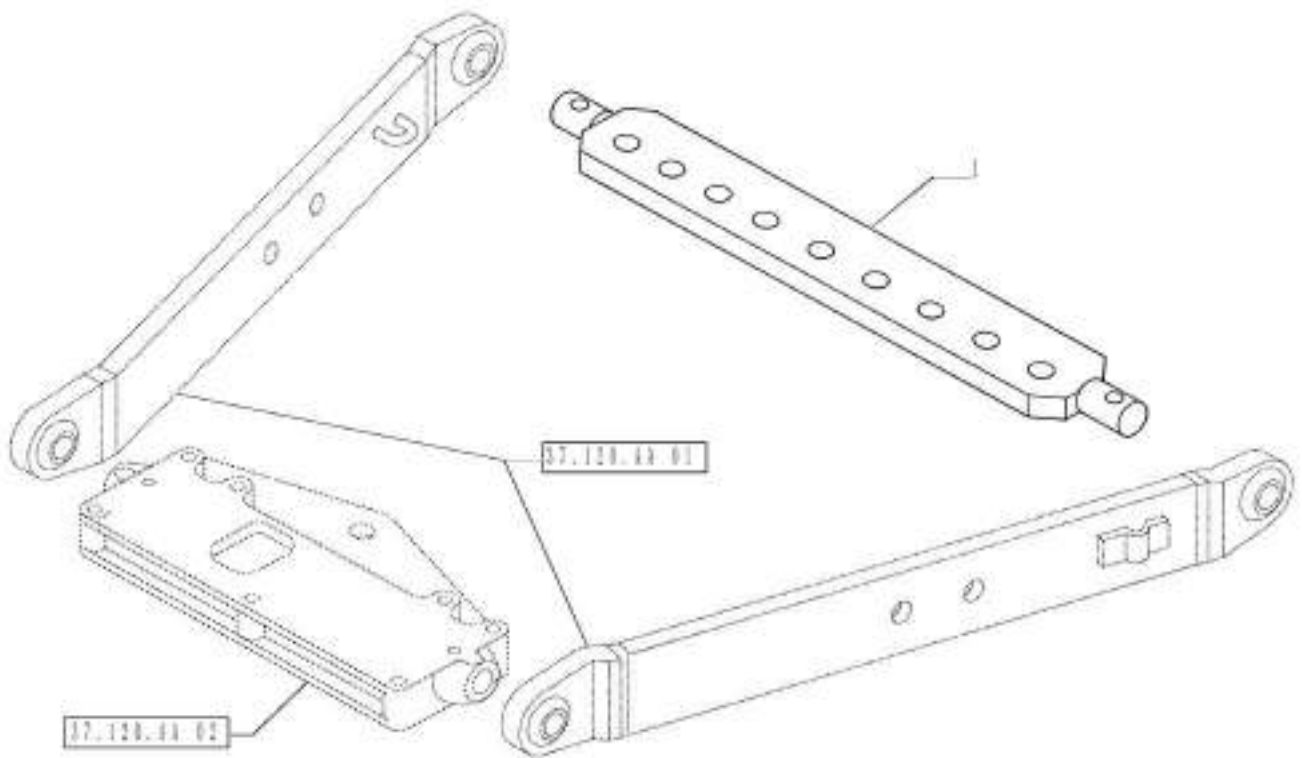

37.100.AA

03

p1

1/2014

VAR - 330899 - LINKAGE DRAWBAR

REF FN	PART NUMBER	YR/SN	QTY DESCRIPTION
1	595441		1 CROSSRAIL

Valid for Var. 330899

FARMALL JX100 FARMALL
JX110 FARMALL JX70
FARMALL JX75 FARMALL
JX80 FARMALL JX90

VAR - 335893, 744753 - DRAWBAR AND SUPPORT WITH PIN (FRANCE)

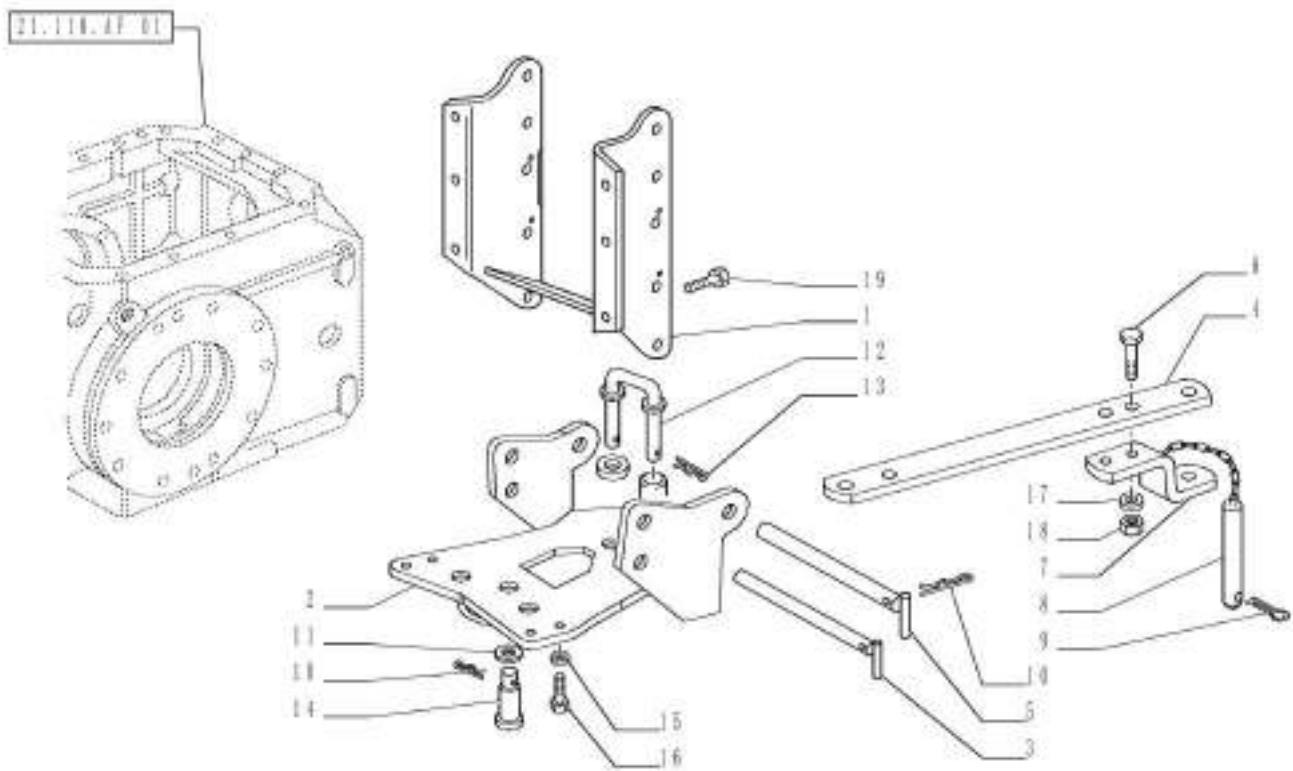

VAR - 335893, 744753 - DRAWBAR AND SUPPORT WITH PIN (FRANCE)

REF FN	PART NUMBER	YR/SN	QTY DESCRIPTION
1	5166314		1 SUPPORT
2	47133711		1 HITCH BRACKET
3	5117437		2 PIN
4	5118977		1 DRAWBAR
5	87302932		1 PIN
6	15984834		2 SCREW Hex, M18 x 1.5 x 80mm, CI 10.9
7	598607		1 SUPPORT
8	596060		1 HITCH PIN
9	5085461		1 COTTER PIN
10	84416689		4 COTTER PIN 4MM
11	562106		1 WASHER 25.50mm ID x 45.00mm OD
12	5123643		1 PIN
13	5112606		1 COTTER PIN
14	84195997		1 PIN
15	11194274		4 BELLEVILLE WASHER 17.00mm ID x 32.00mm OD x 3.40mm, 4.00mm, DAC
16	15981821		4 SCREW Hex, M16 x 1.5 x 120mm, CI 8.8
17	12601874		2 SPRING WASHER
18	10721021		2 NUT M18 x 1.5, CI 10
19	15981524		6 BOLT Hex, M16 x 1.5 x 90mm, CI 8.8

Valid for Industrial Var. 335893 (744753)

FARMALL JX100 FARMALL
 JX110 FARMALL JX70
 FARMALL JX75 FARMALL
 JX80 FARMALL JX90

37.100.AB

02

p1

1/2014

VAR - 334334, 334421, 744751 - TRAILER HITCH FRAME WITH HIGH POINT HITCH AND SWINGING DRAWBAR - BREAKDOWN

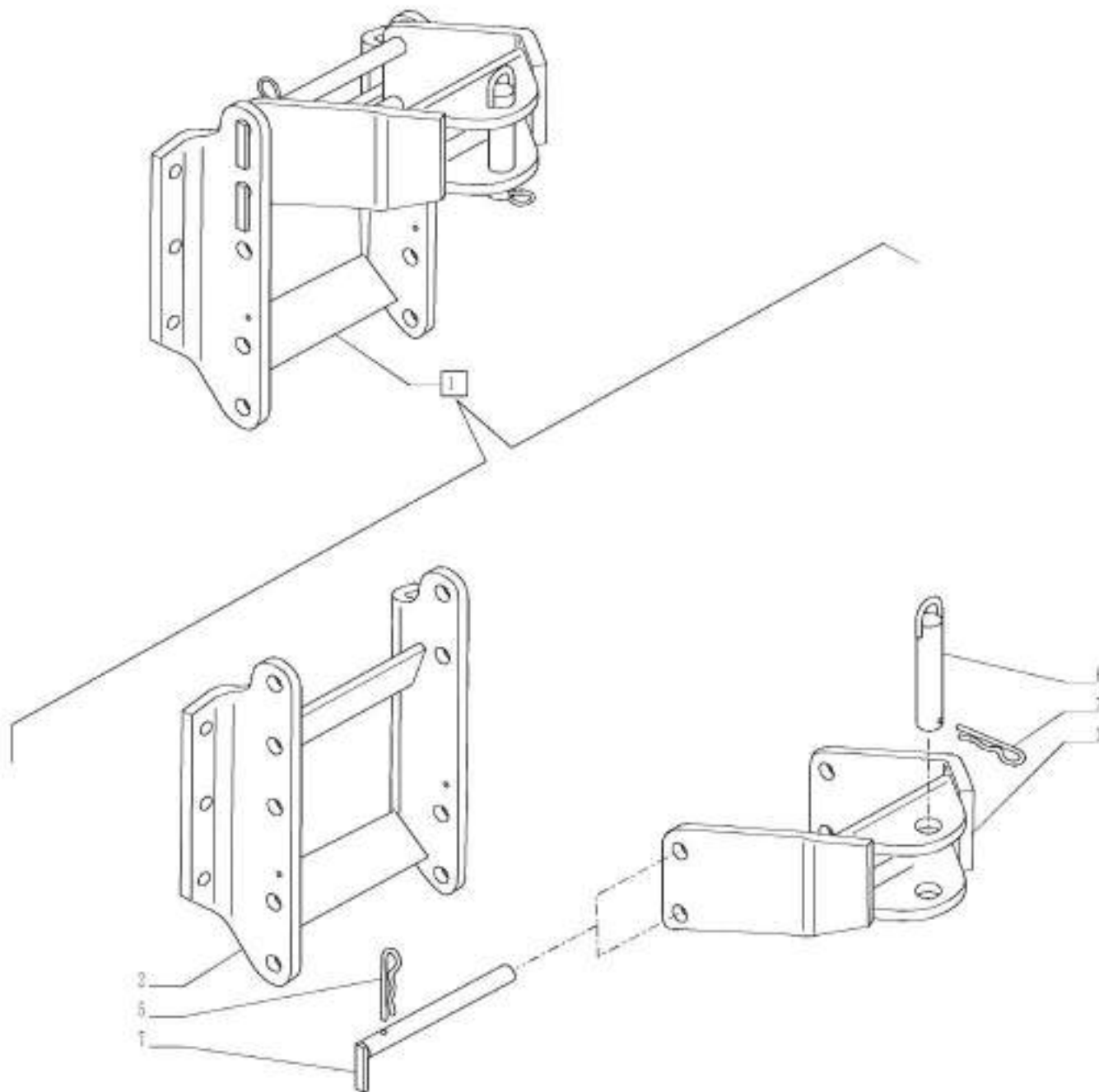

37.100.AB

03

p1

1/2014

VAR - 334335, 334422, 744752 - TRAILER HITCH FRAME WITH HIGH POINT HITCH AND SWINGING DRAWBAR - BREAKDOWN

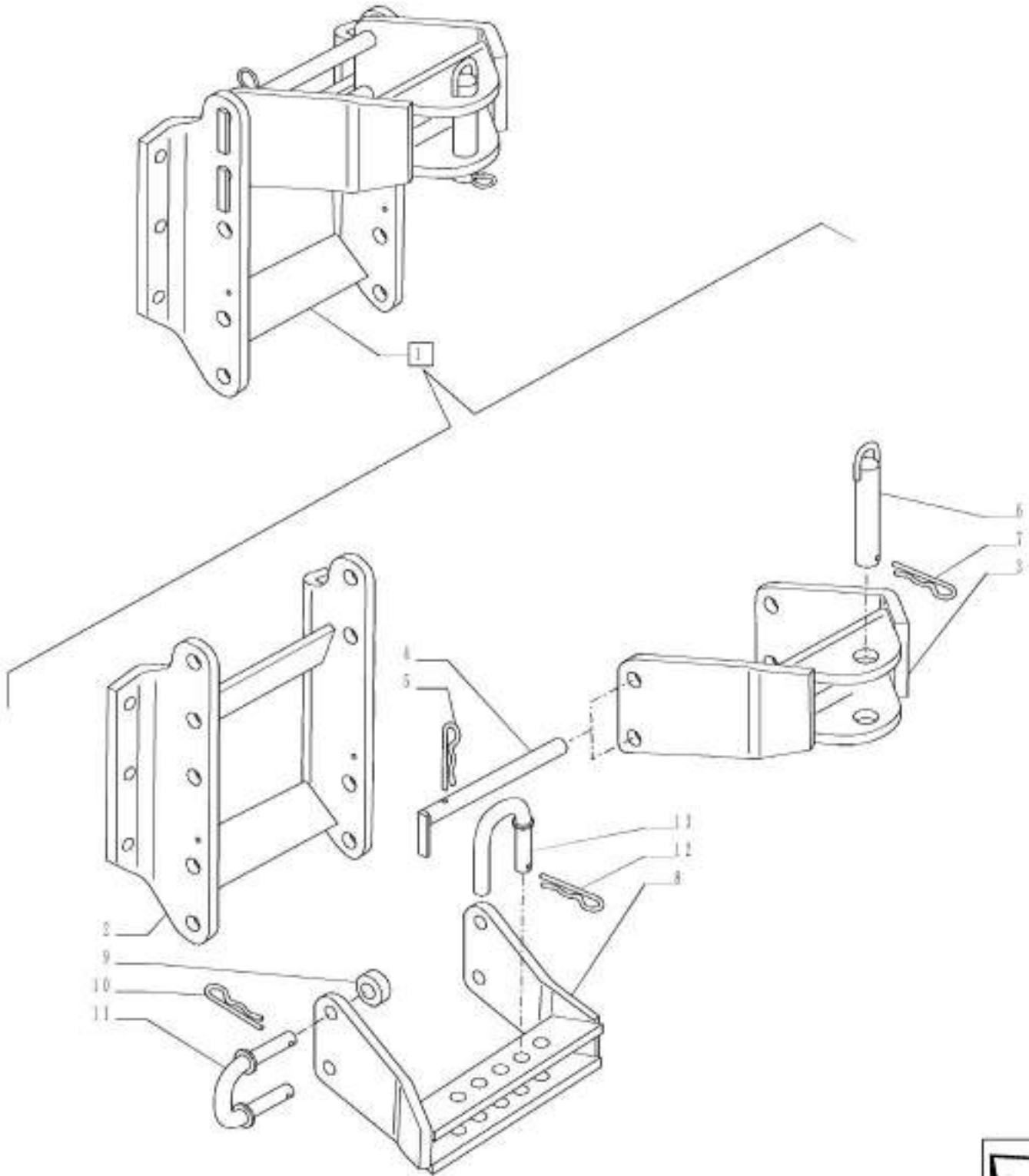

37.100.AB

03

p1

1/2014

VAR - 334335, 334422, 744752 - TRAILER HITCH FRAME WITH HIGH POINT HITCH AND SWINGING DRAWBAR - BREAKDOWN

REF FN	PART NUMBER	YR/SN	QTY DESCRIPTION
1	84198659		1 HITCH ASSY, Incl 2 - 13
2	84192381		1 HITCH BRACKET
3	47130044		1 HITCH
4	5164847		2 PIN
5	84416689		2 COTTER PIN 4MM
6	573185		1 HITCH PIN
7	5085461		1 COTTER PIN
8	5164859		1 DRAWBAR FRAME
9	84235943		4 SPACER
10	5085148		4 COTTER PIN
11	84223072		2 PIN
12	5112606		1 COTTER PIN
13	5094073		1 PIN

Valid for Industrial Var. 334335, 334422 (744752)	FARMALL JX100 FARMALL JX110 FARMALL JX70 FARMALL JX75 FARMALL JX80 FARMALL JX90
---	--

VAR - 334338, 334423, 744754 - TRAILER HITCH FRAME LESS HIGH POINT HITCH, BREAKDOWN

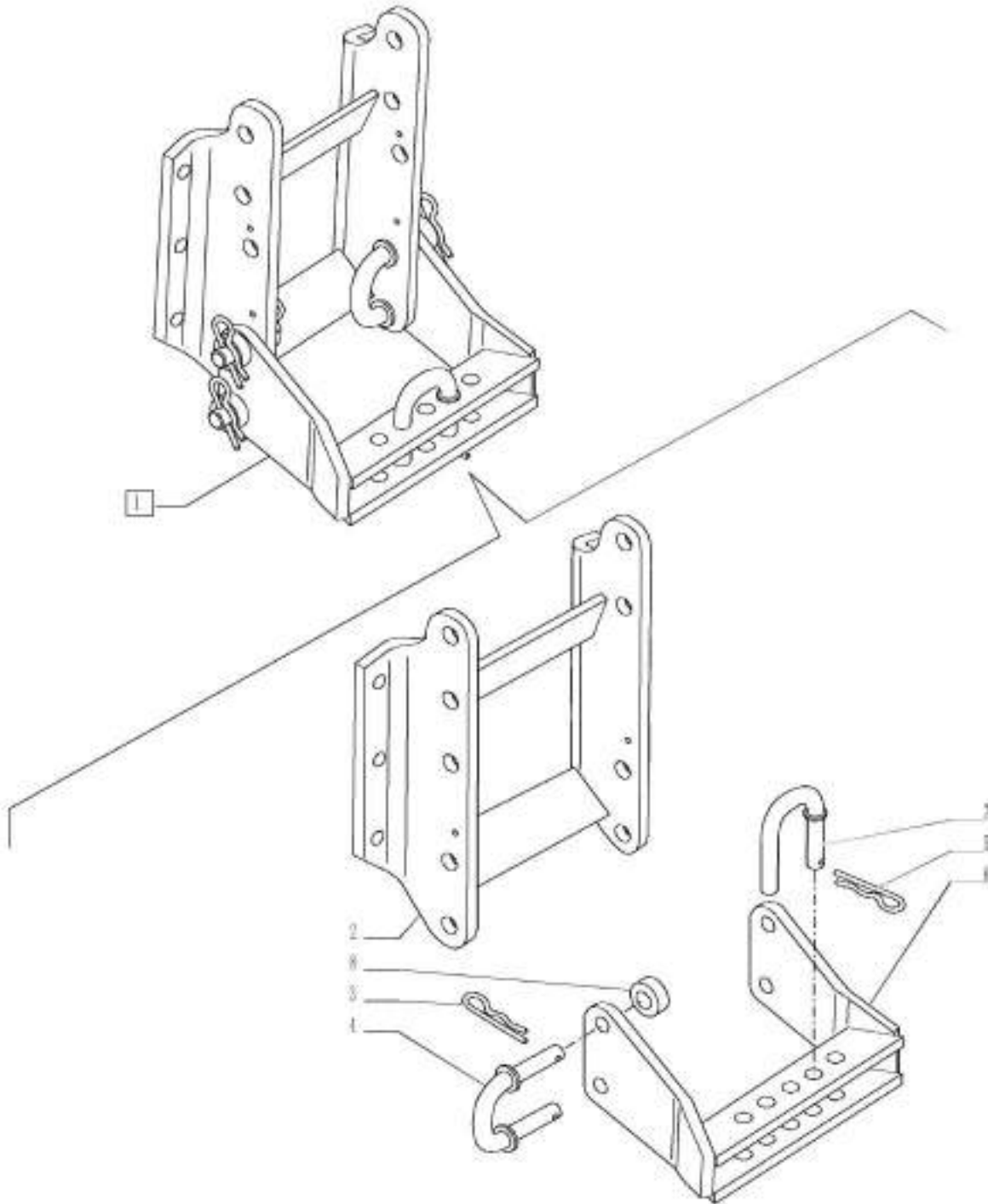

37.100.AB

05

p1

1/2014

VAR - 334336, 334337 - SWIVEL TRAILER HITCH WITH SLIDER SUPPORT

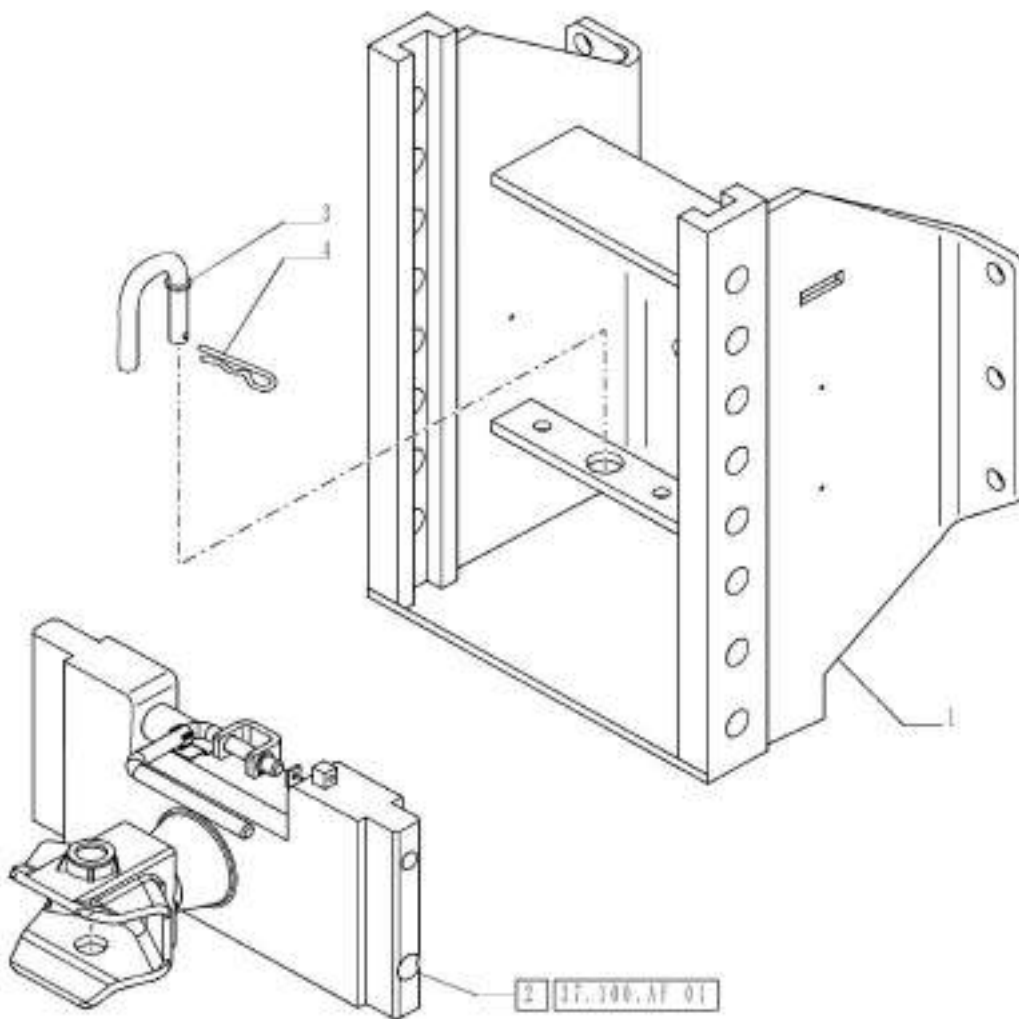

37.100.AC

01

p1

1/2014

VAR - 335892 - FRONT TOW HOOK

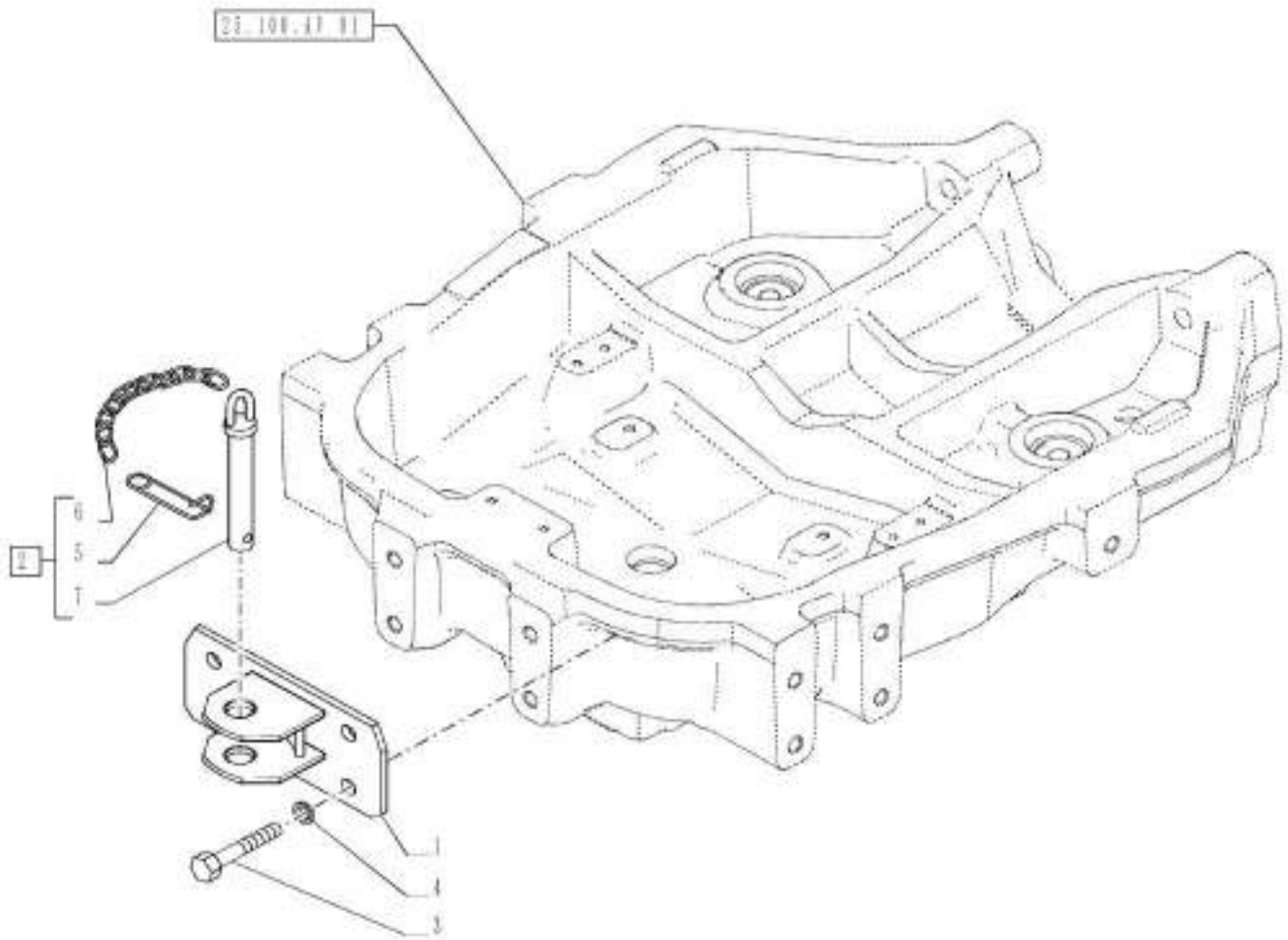

37.100.AC

01

p1

1/2014

VAR - 335892 - FRONT TOW HOOK

REF FN	PART NUMBER	YR/SN	QTY DESCRIPTION
1	5190265		1 TOW HOOK
2	5171214		1 HITCH PIN ASSY Incl 5 - 7
3	11391531		4 BOLT Hex, M16 x 1.5 x 45mm, Cl 10.9, Full Thd
4	12601774		4 WAVE WASHER 17mm ID x 30mm OD x 1.60mm, 6.30mm Max, CST, DAC
5	5152004		1 HAIR PIN COTTER
6	44901192		2 CLIP
7	NSS		1 NOT SERVICED SEPARATELY Pin Incl in 2

Valid for Var. 335892

FARMALL JX100 FARMALL
JX110 FARMALL JX70
FARMALL JX75 FARMALL
JX80 FARMALL JX90

VAR - 334336, 334337 - TOW HOOK

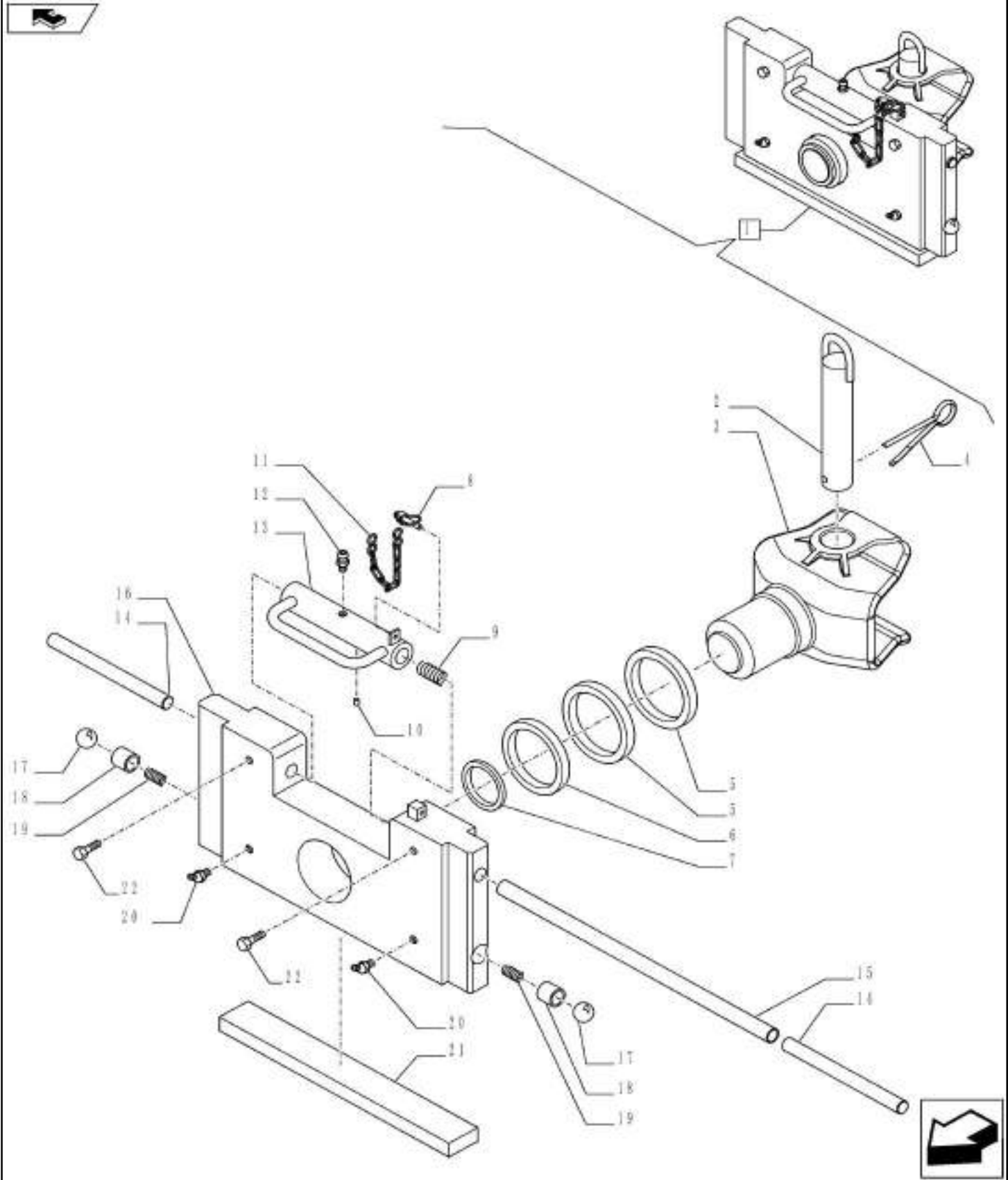

VAR - 334336, 334337 - TOW HOOK

REF FN	PART NUMBER	YR/SN	QTY DESCRIPTION
1	5098188		1 TOW HOOK ASSY, Incl 2 - 22
2	5097307		1 PIN
3	5097133		1 TRAILER HITCH
4	5112606		1 COTTER PIN
5	5097135		1 WASHER
6	5097134		1 WASHER
7	5097136		1 WASHER
8	5093976		1 PIN
9	NSS		1 NOT SERVICED SEPARATELY Spring, Incl in 1
10	14606470		2 LOCK PIN Slotted Spring, M8 x 20.00mm
11	5097311		1 PIN
12	13406911		1 LUBE NIPPLE Straight, 1/4"-28 x 0.54"
13	5097130		1 TOW HOOK
14	NSS		2 NOT SERVICED SEPARATELY Adjusting Pin, Incl in 1
15	NSS		1 NOT SERVICED SEPARATELY Inner Bearing, Incl in 1
16	NSS		1 NOT SERVICED SEPARATELY Body, Incl in 1
17	NSS		2 NOT SERVICED SEPARATELY Ball, Incl in 1
18	NSS		2 NOT SERVICED SEPARATELY Bush, Incl in 1
19	NSS		2 NOT SERVICED SEPARATELY Spring, Incl in 1
20	13406811		2 LUBE NIPPLE 45°, 1/4" NPT x .81" lg
21	NSS		1 NOT SERVICED SEPARATELY Reinforcement, Incl in 1
22	13797721		2 SET SCREW Hex Soc, M6 x 8, Cone Pt

Valid for Var. 334336 or Var. 334337

FARMALL JX100 FARMALL
 JX110 FARMALL JX70
 FARMALL JX75 FARMALL
 JX80 FARMALL JX90

37.100.AF

02

p1

1/2014

VAR - 335893, 744753 - TOW HOOK (FRANCE)

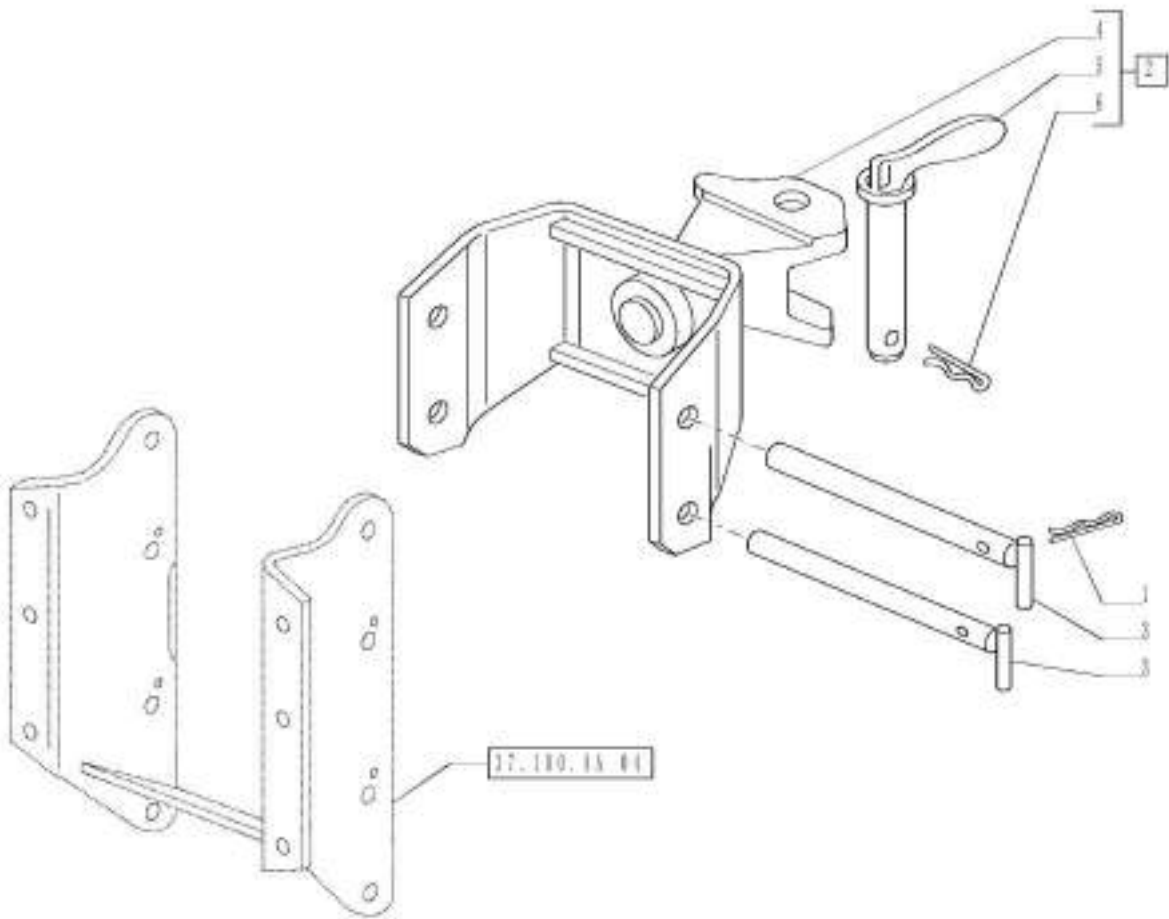

37.100.AF

02

p1

1/2014

VAR - 335893, 744753 - TOW HOOK (FRANCE)

REF FN	PART NUMBER	YR/SN	QTY DESCRIPTION
1	84416689		2 COTTER PIN 4 MM
2	47133714		1 HITCH Incl 4 - 6
3	5117437		2 PIN
4	NSS		1 NOT SERVICED SEPARATELY Hitch Incl in 2
5	5191362		1 HITCH PIN
6	5191364		1 COTTER PIN

Valid for Industrial Var. 335893 (744753)

FARMALL JX100 FARMALL
JX110 FARMALL JX70
FARMALL JX75 FARMALL
JX80 FARMALL JX90

VAR - 334395, 390814 - HYDRAULIC LIFT, CONTROL, KNOB

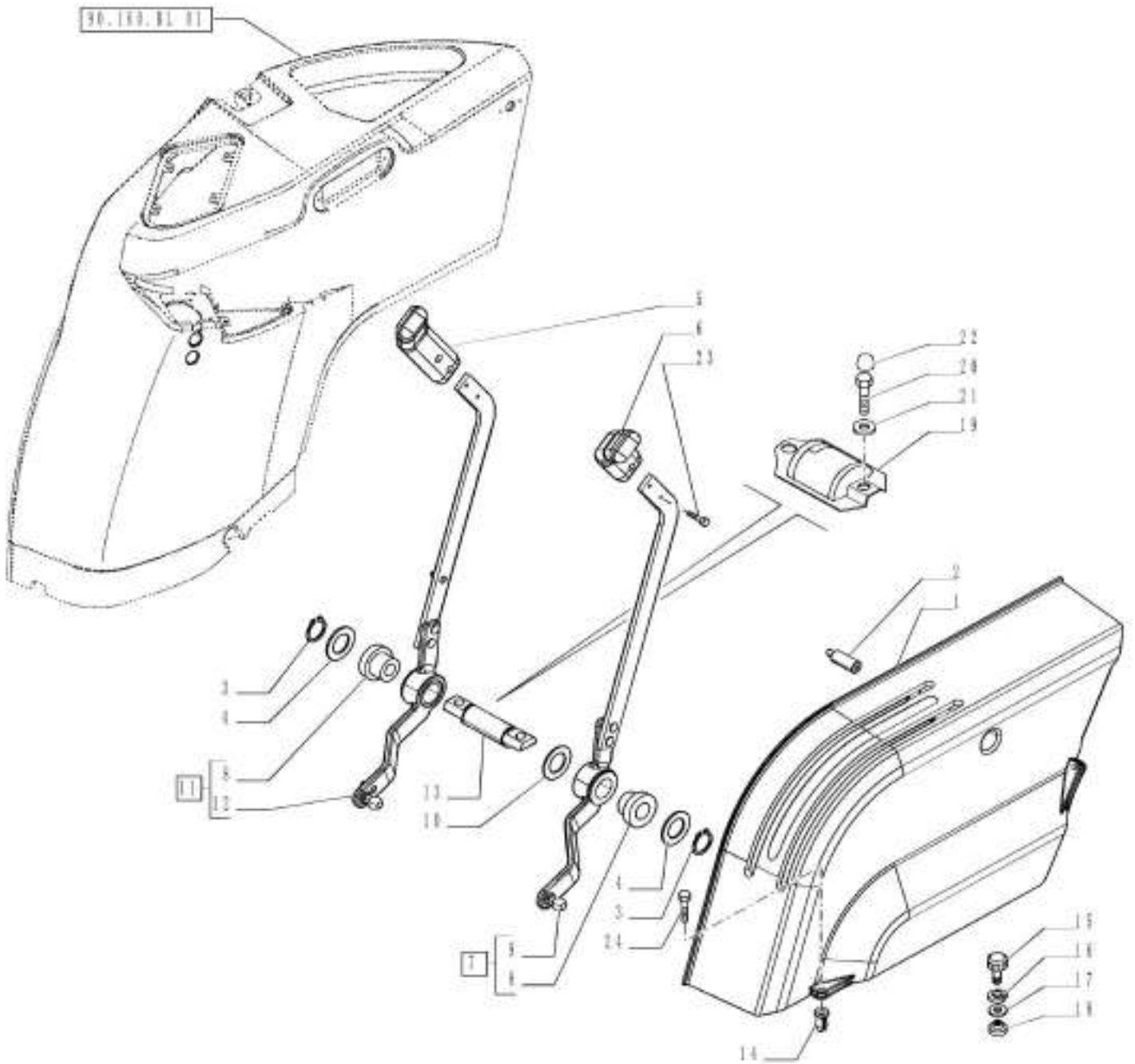

VAR - 334395, 390814 - HYDRAULIC LIFT, CONTROL, KNOB

REF FN	PART NUMBER	YR/SN	QTY DESCRIPTION
1	84487119		1 COVER
2	84585357		1 HYD CONNECTOR
3	11066976		2 SNAP RING M21, Ext
4	5126031		2 WASHER
5	5126315		1 KNOB
6	5126318		1 KNOB
7	84399845		1 LEVER Incl 8, 9
8	5154842		1 BUSHING
9	NSS		1 NOT SERVICED SEPARATELY Lever, Incl in 7
10	5089035		1 WASHER
11	84399849		1 CONTROL LEVER Incl 8, 12
12	NSS		1 NOT SERVICED SEPARATELY Lever, Incl in 11
13	5133375		1 PIN
14	14115780		4 BLOCK
15	47133460		2 KNOB
16	11087776		2 CIRCLIP Ext., M6, BLO
17	5108290		2 WASHER
18	47133761		2 STOP
19	5094624		1 COVER
20	86625001		2 BOLT Hex, M8 x 22mm, Cl 8.8, Full Thd
21	12601374		2 WAVE WASHER Wave, 8.40mm ID x 15.00mm OD x 0.80mm, 3.00mm, CST, DAC
22	5089481		4 CAP
23	14302928		4 BOLT
24	15959504		4 SELF-TAP SCREW Pan Hd, M5 x 30

Valid for Var. 334395 or Var. 390814

FARMALL JX100 FARMALL
 JX110 FARMALL JX70
 FARMALL JX75 FARMALL
 JX80 FARMALL JX90

VAR - 334395, 390814 - LIFT CONTROLS - HANDLE AND LEVERS - CAB

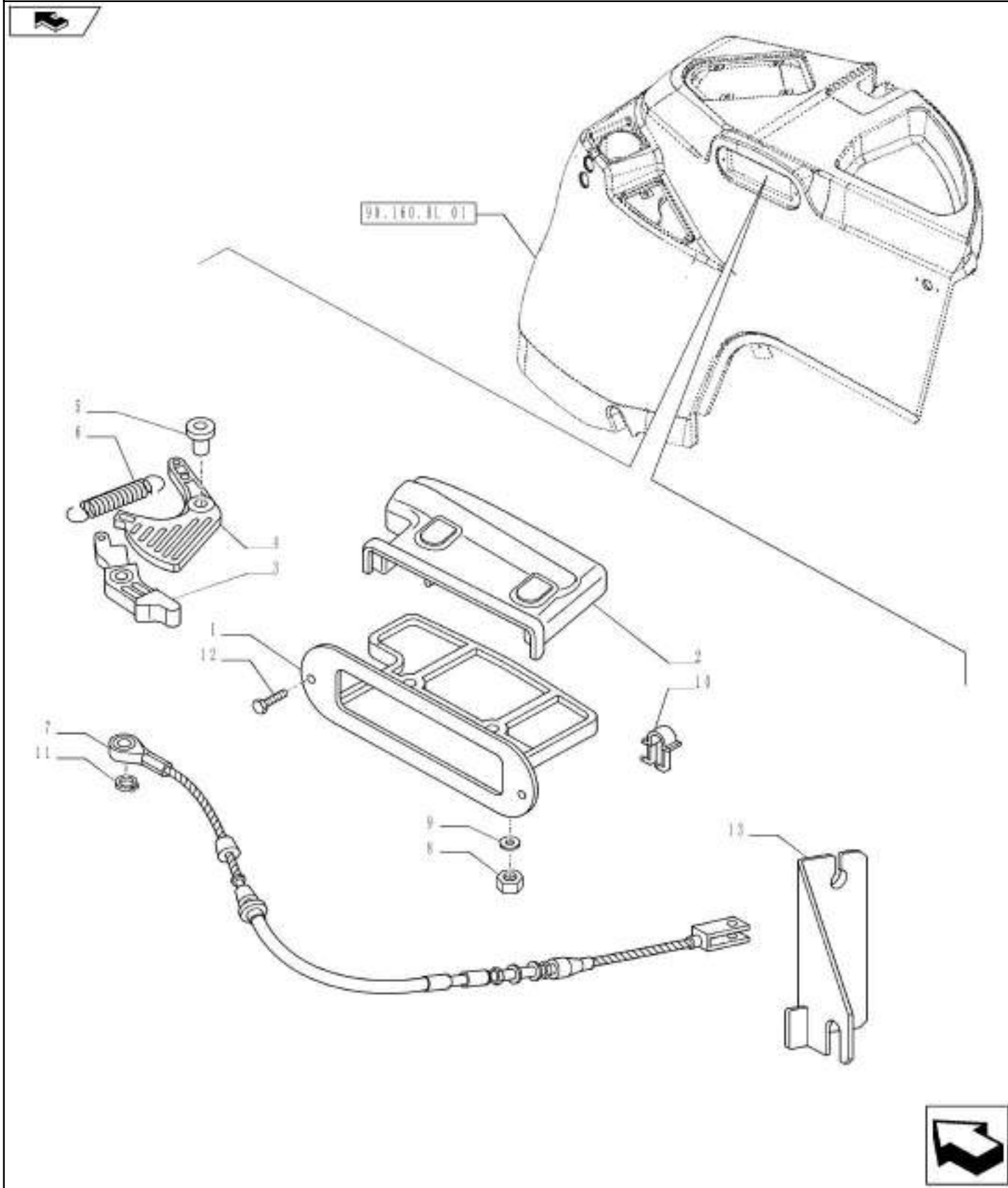

VAR - 334395, 390814 - LIFT CONTROLS - HANDLE AND LEVERS - CAB

REF FN	PART NUMBER	YR/SN	QTY DESCRIPTION
1	87390528		1 SUPPORT W/CAB
2	87390496		1 SUPPORT
3	87564632		1 LATCH
4	87564634		1 LEVER
5	87564636		2 SPACER
6	5128638		1 SPRING
7	84238070		1 CABLE
8	12574211		2 NUT M6 x 1, CI 8
9	10519401		2 WASHER M6 x 11.95 x 1.6
10	14569680		4 SPRING CLIP
11	11087676		1 CIRCLIP M5
12	15931411		4 SELF-TAP SCREW
13 1	87601161		1 SUPPORT
13 2	84488914		1 SUPPORT
(1)	VAR - 334321, 390268 (744738) or 334320, 390267 (744744)		
(2)	VAR - 330384, 334322 (744739)		

Valid for Var. 334395 or Var. 390814

FARMALL JX100 FARMALL
 JX110 FARMALL JX70
 FARMALL JX75 FARMALL
 JX80 FARMALL JX90

VAR - 334395, 390814 - HYDRAULIC LIFT, CONTROL, KNOB, ROPS

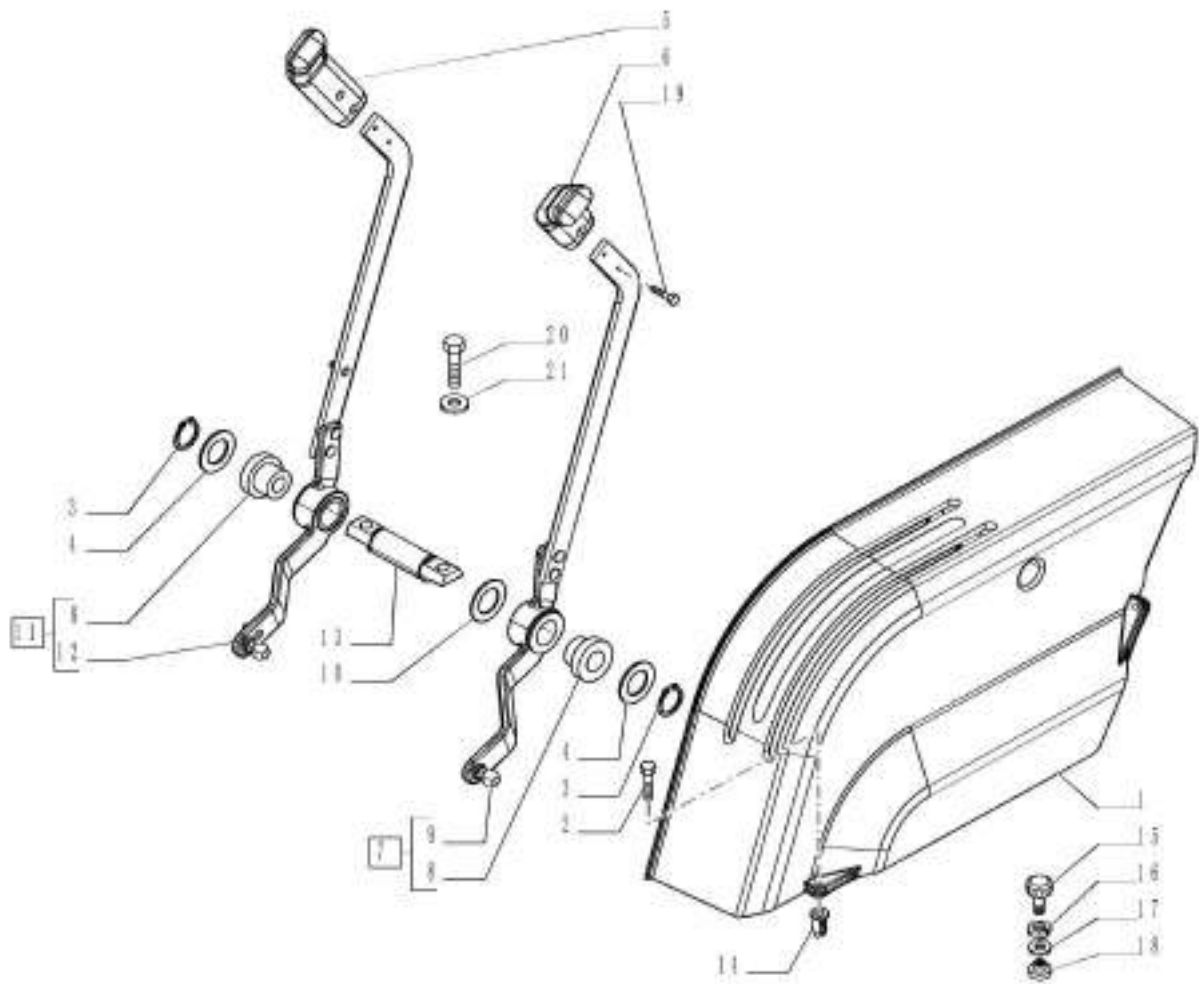

37.108.AD

03

p1

1/2014

VAR - 334395, 390814 - HYDRAULIC LIFT, CONTROL, KNOB, ROPS

REF FN	PART NUMBER	YR/SN	QTY DESCRIPTION
1	84548146		1 COVER
2	15959504		3 SELF-TAP SCREW Pan Hd, M5 x 30
3	11066976		2 SNAP RING M21, Ext
4	5126031		2 WASHER
5	5126315		1 KNOB
6	5126318		1 KNOB
7	84548139		1 LEVER Incl 8, 9
8	5154842		1 BUSHING
9	NSS		1 NOT SERVICED SEPARATELY Support, Incl in 7
10	5089035		1 WASHER
11	84590035		1 CONTROL LEVER Incl 8, 12
12	NSS		1 NOT SERVICED SEPARATELY Lever, Incl in 11
13	5133375		1 PIN
14	14115780		4 BLOCK
15	47133460		2 KNOB
16	11087776		2 CIRCLIP Ext., M6, BLO
17	5108290		2 WASHER
18	47133761		2 STOP
19	14302928		4 BOLT
20	86625001		2 BOLT Hex, M8 x 22mm, Cl 8.8, Full Thd
21	12601374		2 WAVE WASHER Wave, 8.40mm ID x 15.00mm OD x 0.80mm, 3.00mm, CST, DAC

Valid for Var. 334395 or Var. 390814

FARMALL JX100 FARMALL
 JX110 FARMALL JX70
 FARMALL JX75 FARMALL
 JX80 FARMALL JX90

37.108.AE

01

p1

1/2014

VAR - 334395 - LIFT CONTROLS - CABLE

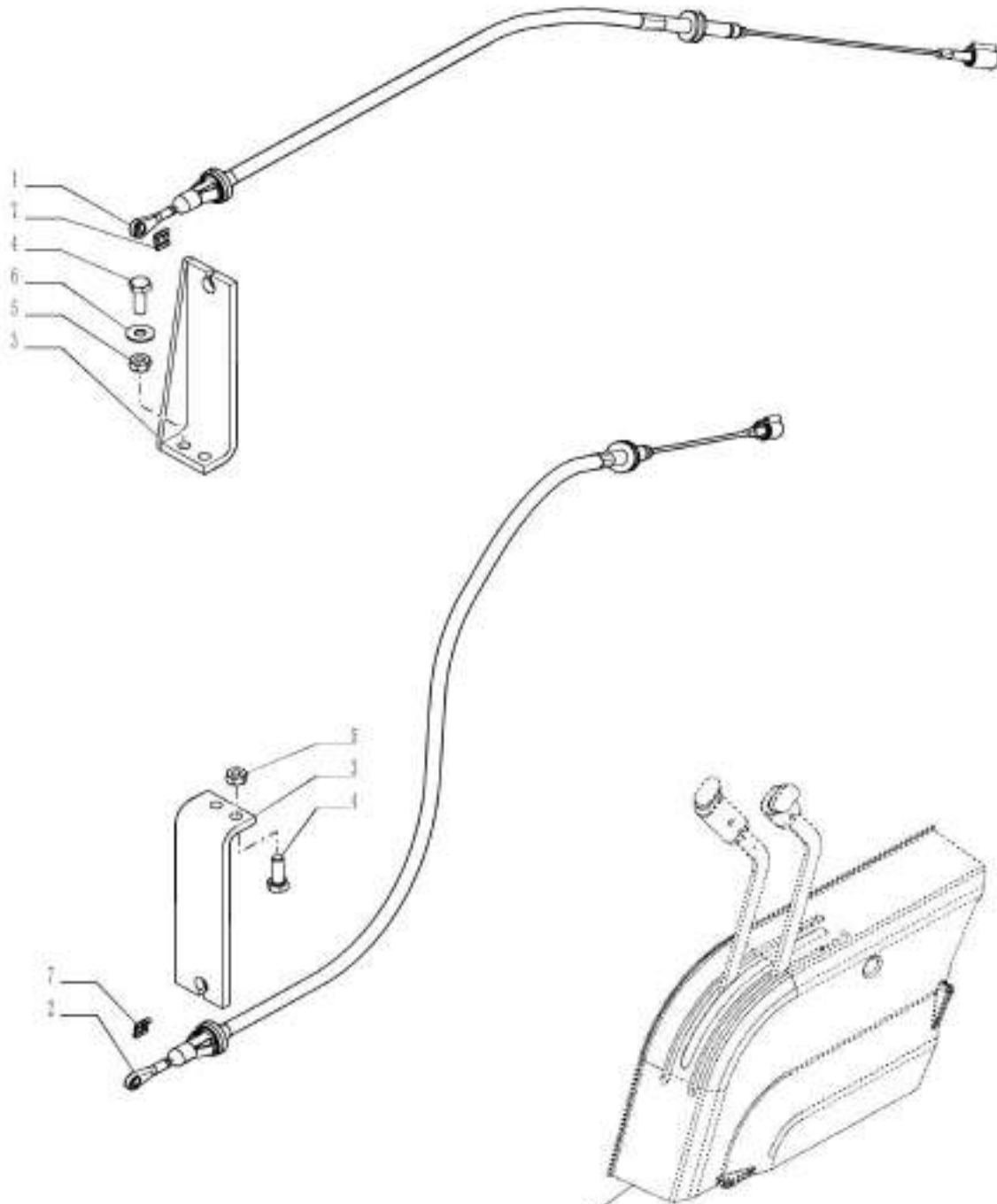

37.108.AE 01



VAR - 334395 - LIFT CONTROLS - CABLE

REF	FN	PART NUMBER	YR/SN	QTY	DESCRIPTION
1	1	84585081		1	CABLE
1	2	84590031		1	CABLE Upper
2	1	84585082		1	CABLE
2	2	84590034		1	CABLE Lower
3		84585086		2	SUPPORT
4		86508568		4	BOLT Hex, M6 x 16mm, CI 8.8, Full Thd
5		15896221		4	NUT M6, CI 10
6		12644401		4	WASHER M6 x 15 x 1
7		11063876		2	CLIP
8		47134319		2	CLIP
(1)		CAB			
(2)		ROPS			
Valid for Var. 334395					FARMALL JX100 FARMALL JX110 FARMALL JX70 FARMALL JX75 FARMALL JX80 FARMALL JX90

VAR - 334395 - CONTROL LEVER, BREAKDOWN

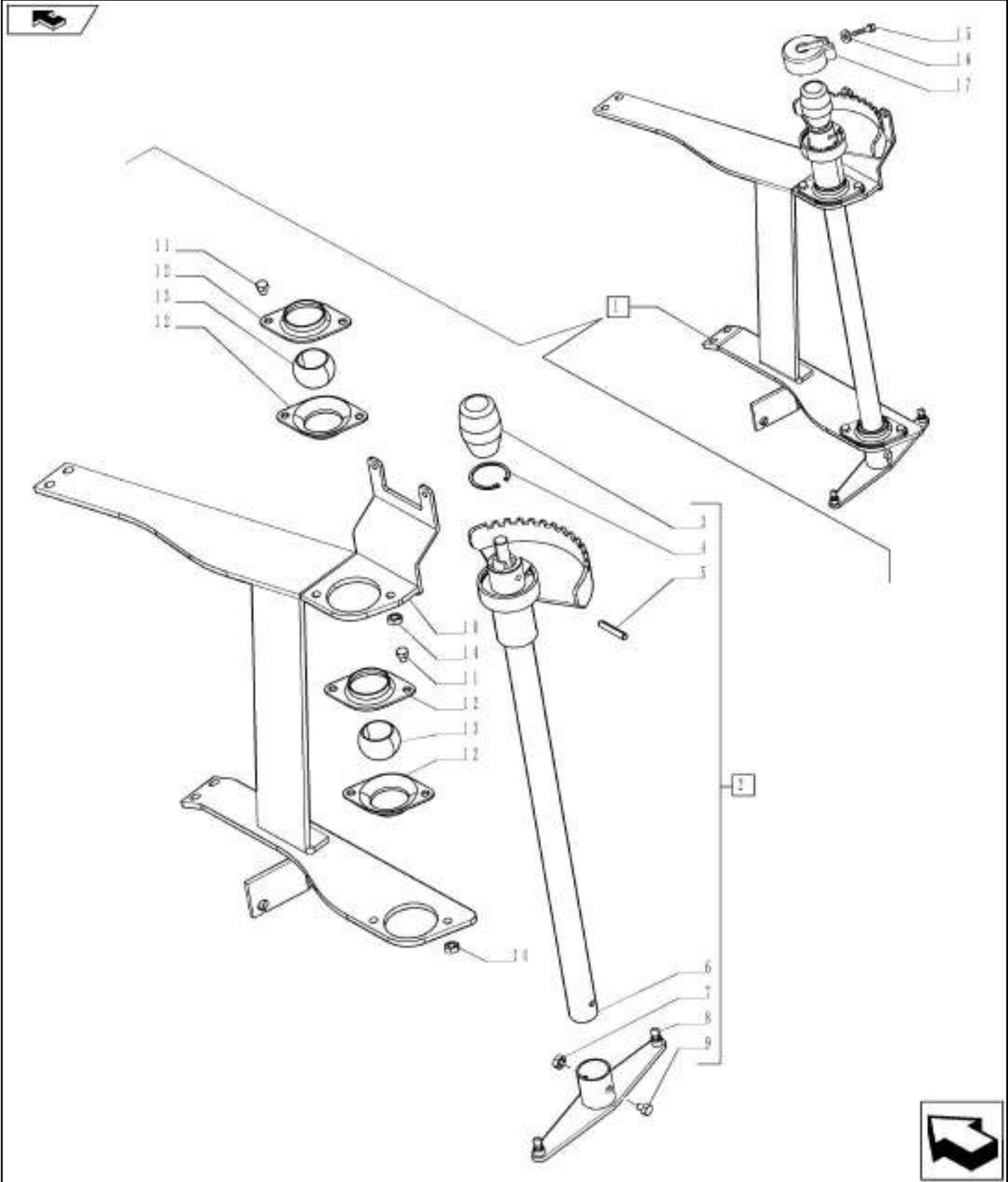

VAR - 334395 - CONTROL LEVER, BREAKDOWN

REF	FN	PART NUMBER	YR/SN	QTY	DESCRIPTION
1	1	84590045		1	CONTROL Incl 2 - 14
1	2	84585085		1	CONTROL LEVER Incl 2 - 14
2	1	84590040		1	CONTROL Incl 3 - 9
2	2	84585075		1	CONTROL LEVER Incl 3 - 9
3		87691190		1	KNOB
4		11059974		1	SNAP RING M40, Int
5		14601371		1	ROLL PIN
6		NSS		1	NOT SERVICED SEPARATELY Pipe, Incl in 2
7		15896221		1	NUT M6, CI 10
8		NSS		1	NOT SERVICED SEPARATELY Plate, Incl in 2
9		43117		1	SCREW Hex, M6 x 1 x 30mm, CI 8.8
10	1	84590030		1	SUPPORT
10	2	84585080		1	SUPPORT
11	1	86508568		4	BOLT Hex, M6 x 16mm, CI 8.8, Full Thd
12		5094636		4	COLLAR
13		5094631		2	BUSHING
14		15896221		4	NUT M6, CI 10
15		13275917		2	SCREW
16		12644401		6	WASHER M6 x 15 x 1
17		5095271		1	GUARD

(1) ROPS

(2) CAB

Valid for Var. 334395

FARMALL JX100 FARMALL
 JX110 FARMALL JX70
 FARMALL JX75 FARMALL
 JX80 FARMALL JX90

37.108.AL

01

p1

1/2014

VAR - 334395, 390814 - LIFTOMATIC RANGE LIMITER DEVICE

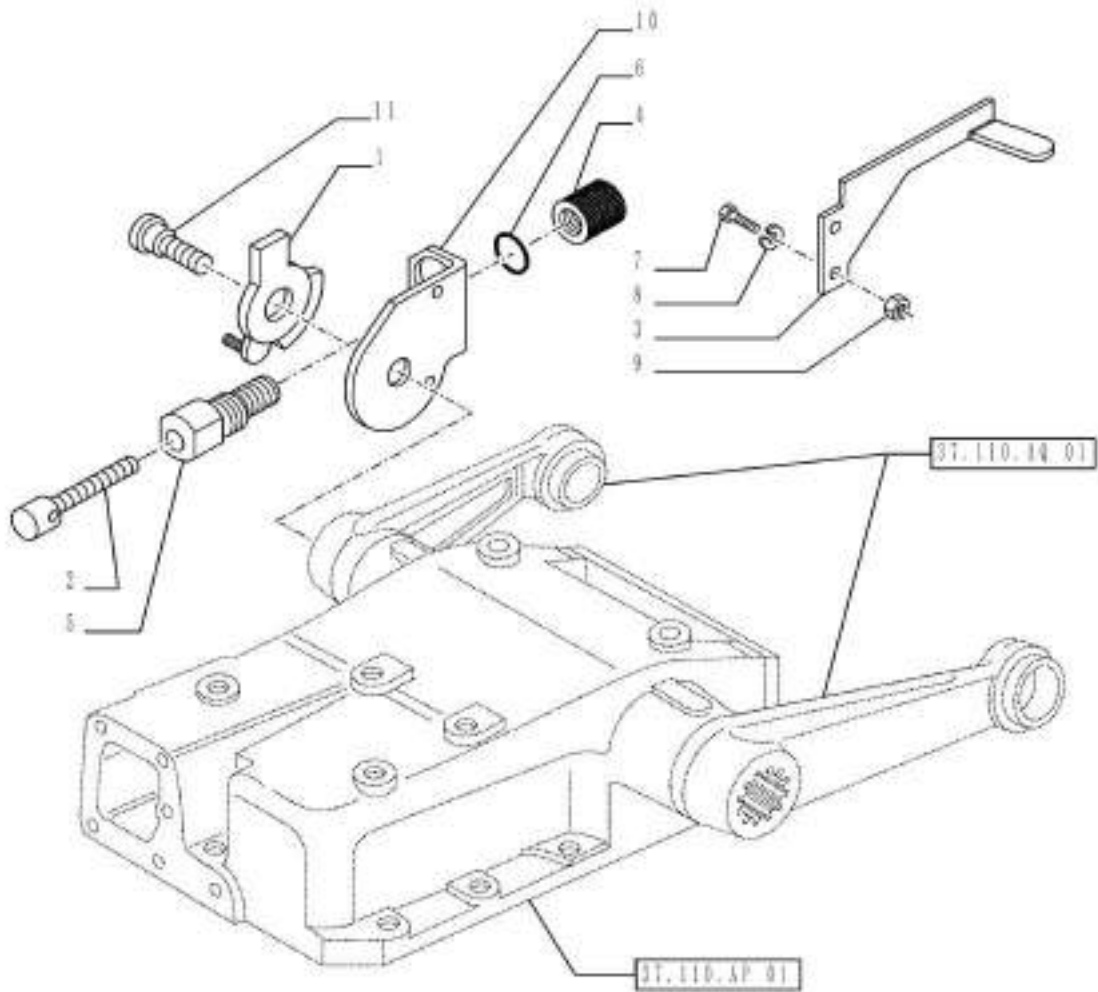

37.108.AL

01

p1

1/2014

VAR - 334395, 390814 - LIFTOMATIC RANGE LIMITER DEVICE

REF FN	PART NUMBER	YR/SN	QTY DESCRIPTION
1	47134217		1 SECTOR
2	47134219		1 ADJUSTMENT SCREW
3	84547795		1 SUPPORT
4	47134218		1 KNOB
5	5194677		1 SCREW
6	14457280		1 O-RING 0.612" ID x 0.103"
7	86977786		2 BOLT Hex, M6 x 1 x 25mm, CI 8.8, Full Thd
8	12601274		4 WAVE WASHER Wave, M6.4
9	15896211		2 NUT M6, CI 8
10	87696283		1 SUPPORT
11	5194674		1 HEX SOC SCREW

Valid for. 334395 or Var. 390814	FARMALL JX100 FARMALL JX110 FARMALL JX70 FARMALL JX75 FARMALL JX80 FARMALL JX90
---	--

37.110.AK

01

p1

1/2014

VAR - 744738, 744739, 744744 - HYDRAULIC LIFT, CONTROL SHAFT

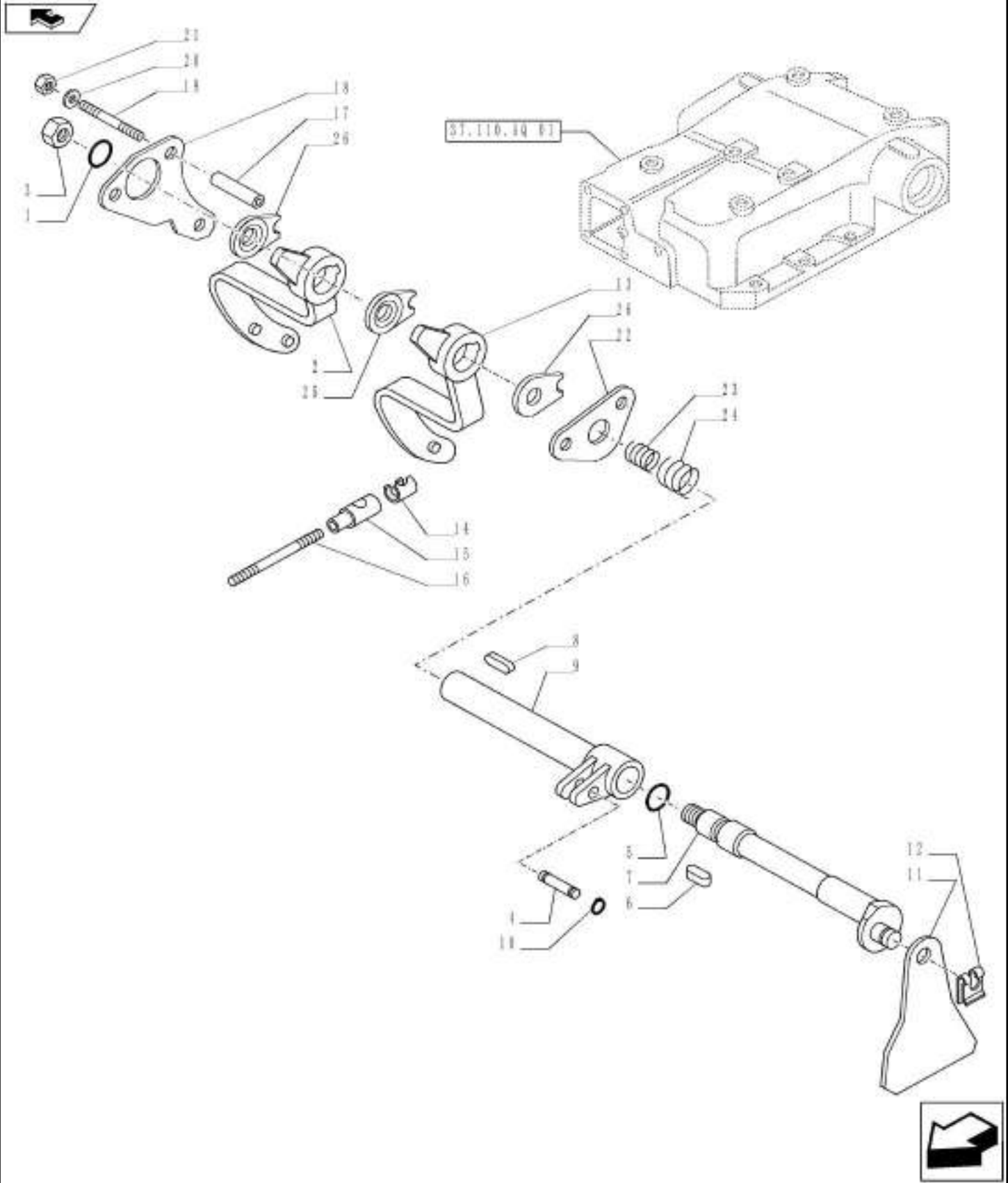

VAR - 744738, 744739, 744744 - HYDRAULIC LIFT, CONTROL SHAFT

REF FN	PART NUMBER	YR/SN	QTY DESCRIPTION
1	14457681		1 O-RING 21.89mm ID x 2.62" Width
2	84527675		1 LEVER
3	12575611		1 LOCK NUT
4	5117161		1 PIN
5	5135732		1 O-RING 0.426" ID x 0.566" OD x 0.07"
6	10617610		1 KEY Sq, M5 x 10
7	5097697		1 SHAFT
8	14721010		1 KEY Sq, M4 x 14
9	5097696		1 CONTROL SHAFT
10	11065676		1 SNAP RING M8, Ext
11	5117143		1 LEVER
12	11064174		1 CLIP
13	84526760		1 LEVER
14	10125574		4 CLIP
15	10124511		4 BALL JOINT HEAD
16	47375596		2 ROD
17	5117204		2 SPACER
18	5089614		1 SHIELD
19	13518021		3 STUD
20	12601374		5 WAVE WASHER Wave, 8.40mm ID x 15.00mm OD x 0.80mm, 3.00mm, CST, DAC
21	16100811		3 NUT Hex, M8, 6.80mm, Cl 8, ZND
22	5089939		1 SPACER
23	4952761		1 SPRING
24	4973370		1 SPRING
25	5165246		1 PLATE
26	5165184		2 PLATE

Valid for Industrial Var. 334321, 390268 (744738) or Industrial Var.
330384, 334322 (744739) or Industrial Var. 334320, 390267 (744744)

FARMALL JX100 FARMALL
JX110 FARMALL JX70
FARMALL JX75 FARMALL
JX80 FARMALL JX90

37.110.AM

01

p1

1/2014

VAR - 744738, 744739, 744744 - HYDRAULIC LIFT, HYDRAULIC LIFT, TIE-ROD, LEVER

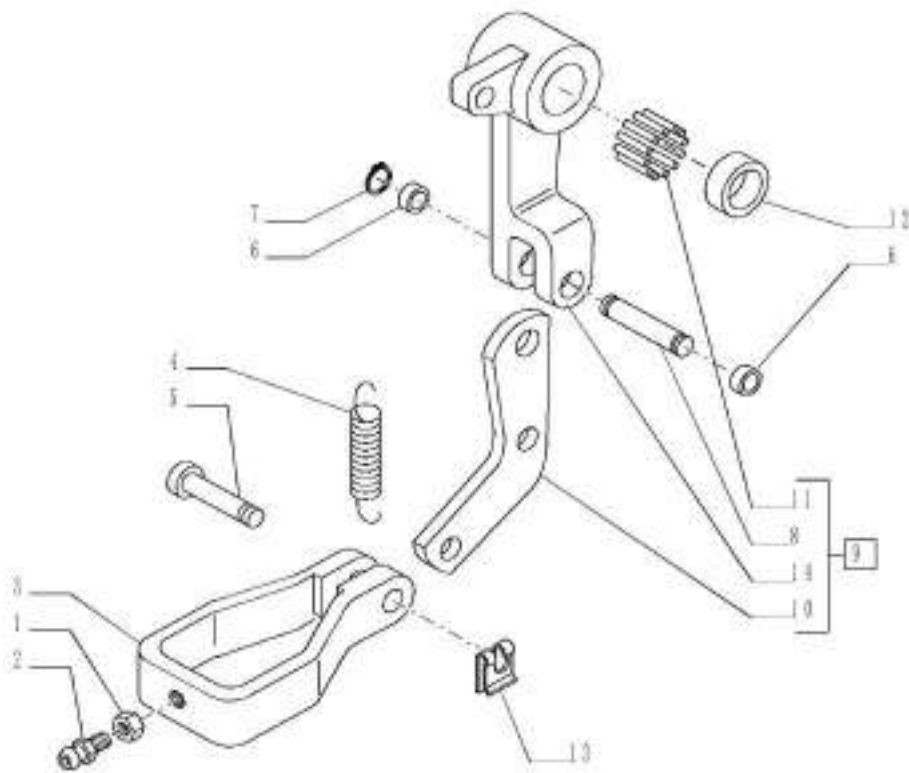
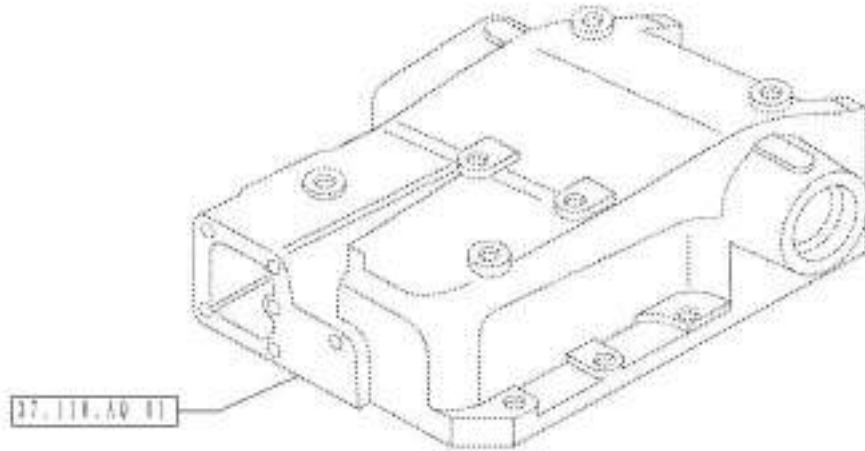

VAR - 744738, 744739, 744744 - HYDRAULIC LIFT, HYDRAULIC LIFT, TIE-ROD, LEVER

REF FN	PART NUMBER	YR/SN	QTY DESCRIPTION
1	10791011		1 THIN NUT Thin, M10 x 1.25, Cl 04
2	5120282		1 BOLT
3	5120281		1 TIE-ROD
4	5148884		1 SPRING
5	5011775		1 PIN
6	5111028		5 ROLLER
7	11065676		3 SNAP RING M8, Ext
8	5117136		1 PIN
9	5117135		1 ARM Incl 8, 10, 11, 14
10	5120291		1 LEVER
11	5109160		2 ROLLER BEARING 14 mm ID x 20 mm OD x 12 mm
12	5116251		2 SPACER
13	11064074		2 RETAINER
14	5117134		1 LEVER

Valid for Industrial Var. 334321, 390268 (744738) or Industrial Var. 330384, 334322 (744739) or Industrial Var. 334320, 390267 (744744)

FARMALL JX100 FARMALL
JX110 FARMALL JX70
FARMALL JX75 FARMALL
JX80 FARMALL JX90

37.110.AM

02

p1

1/2014

VAR - 744738, 744739, 744744 - HYDRAULIC LIFT, CONTROL, TIE-ROD, LEVER, BEARING

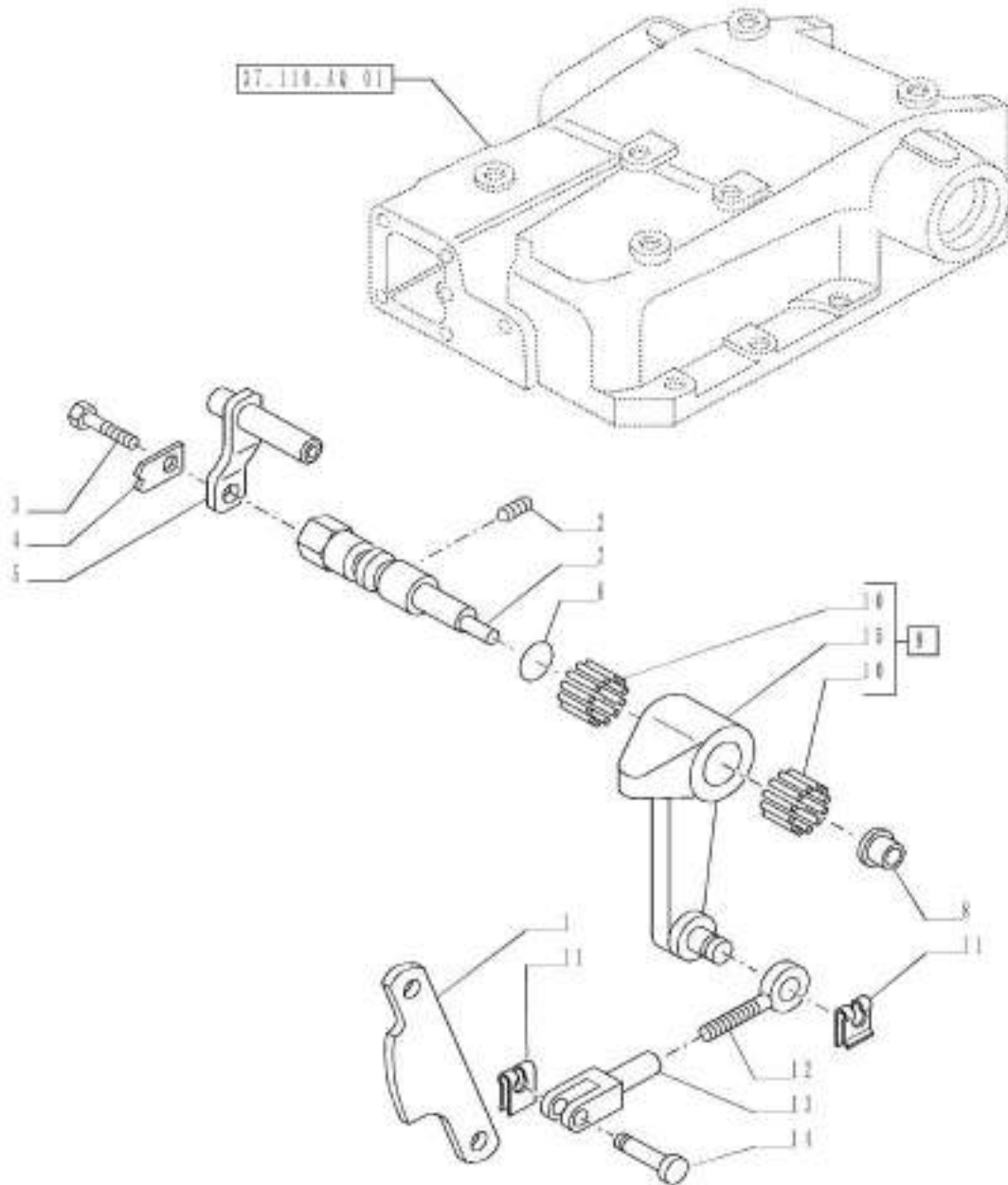

VAR - 744738, 744739, 744744 - HYDRAULIC LIFT, CONTROL, TIE-ROD, LEVER, BEARING

REF FN	PART NUMBER	YR/SN	QTY DESCRIPTION
1	5122497		1 LEVER
2	13739610		1 SET SCREW Hex Soc, M8 x 12, Cone Pt
3	15970421		1 SCREW Hex, M10 x 1.25 x 18mm, Cl 8.8, Full Thd
4	14198810		1 LOCKING PLATE
5	5135222		1 SPACER
6	14457280		1 O-RING 0.612" ID x 0.103"
7	5097666		1 PIN
8	5135219		1 SPACER
9	5117151		1 LEVER Incl 10, 15
10	5109160		2 ROLLER BEARING 14 mm ID x 20 mm OD x 12 mm
11	11064074		2 RETAINER
12	5136355		1 TIE-ROD
13	5136356		1 CLEVIS
14	5117161		1 PIN
15	NSS		1 NOT SERVICED SEPARATELY Lever, Incl in 9

Valid for Industrial Var. 334321, 390268 (744738) or Industrial Var. 330384, 334322 (744739) or Industrial Var. 334320, 390267 (744744)

FARMALL JX100 FARMALL
JX110 FARMALL JX70
FARMALL JX75 FARMALL
JX80 FARMALL JX90

VAR - 744738, 744739, 744744 - HYDRAULIC LIFT, CONTROL, TIE-ROD, LEVER, BEARING

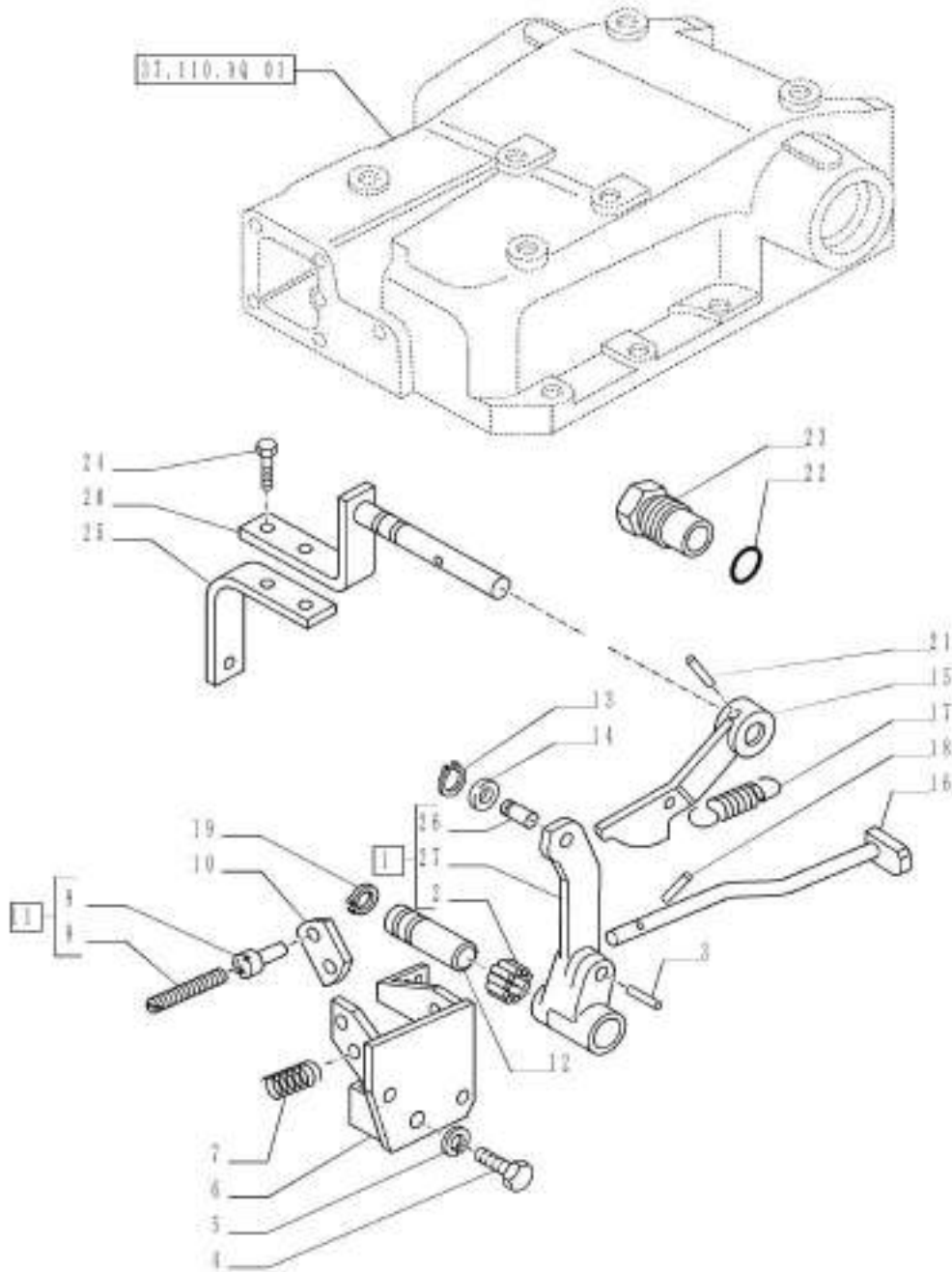

VAR - 744738, 744739, 744744 - HYDRAULIC LIFT, CONTROL, TIE-ROD, LEVER, BEARING

REF FN	PART NUMBER	YR/SN	QTY DESCRIPTION
1	5126221		1 ROD Incl 2, 26, 27
2	5117138		2 ROLLER BEARING 12 mm ID x 16 mm OD x 10 mm
3	14162070		1 LOCK PIN M3 x 22, Slotted
4	120104		2 BOLT Hex, M8 x 1.25 x 20mm, Cl 8.8, Full Thd
5	12644301		2 WASHER M10 x 35 x 3
6	5129400		1 SUPPORT
7	4959139		1 SPRING
8	5121522		1 ADJUSTMENT SCREW M8 x 1.25 x 55 mm
9	5121523		1 ADJUSTMENT SCREW
10	5120284		1 PAD
11	5087209		1 BOLT AND NUT Incl 8, 9
12	5117156		1 PIN
13	11065676		1 SNAP RING M8, Ext
14	5111028		1 ROLLER
15	5129396		1 LEVER
16	5120285		1 ROD
17	4973650		1 SPRING
18	14163970		1 COTTER PIN M4 x 20, Slotted
19	13397576		1 CIRCLIP
20	5089954		1 LEVER
21	13938070		1 ROLL PIN M4 x 24, Coiled
22	10263460		1 SEAL 22.30mm ID x 28.00mm OD, 1.50mm, Copper
23	5129399		1 PLUG
24	10902221		2 BOLT Hex, M6 x 16.00mm, CL 8.8, ZND
25	84547790		1 ARM
26	5129392		1 PIN
27	5126220		1 CONNECTING LINK

Valid for Industrial Var. 334321, 390268 (744738) or Industrial Var. 330384, 334322 (744739) or Industrial Var. 334320, 390267 (744744)

FARMALL JX100 FARMALL
JX110 FARMALL JX70
FARMALL JX75 FARMALL
JX80 FARMALL JX90

37.110.AP

01

p1

1/2014

VAR - 334395, 390814 - HYDRAULIC LIFT, COVER

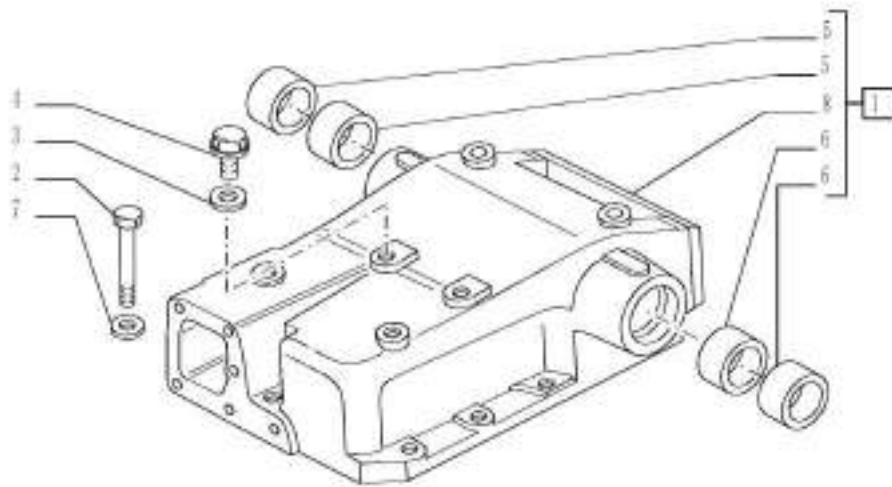

37.110.AP

01

p1

1/2014

VAR - 334395, 390814 - HYDRAULIC LIFT, COVER

REF FN	PART NUMBER	YR/SN	QTY DESCRIPTION
1	5098972		1 HOUSING ASSY Incl 5, 6, 8
2	15540521		1 SCREW Hex, M12 x 1.25 x 35mm, Cl 8.8, Full Thd
2	15541521		3 SCREW Hex, M12 x 1.25 x 90mm, Cl 8.8
2	15540734		7 BOLT Hex, M12 x 1.25 x 45, 10.9
3	10263460		1 SEAL 22.30mm ID x 28.00mm OD, 1.50mm, Copper
4	10305111		1 PLUG M22 x 1.5 x 21, Cl5.8
5	5186406		2 BUSHING RH
6	5186405		2 BUSHING LH
7	12601574		2 WAVE WASHER Wave, M13
8	NSS		1 NOT SERVICED SEPARATELY Housing Incl in 1

Valid for Var. 334395 or Var. 390814

FARMALL JX100 FARMALL
JX110 FARMALL JX70
FARMALL JX75 FARMALL
JX80 FARMALL JX90

VAR - 334395, 390814 - LIFTER OIL PAN AND RELATED PARTS

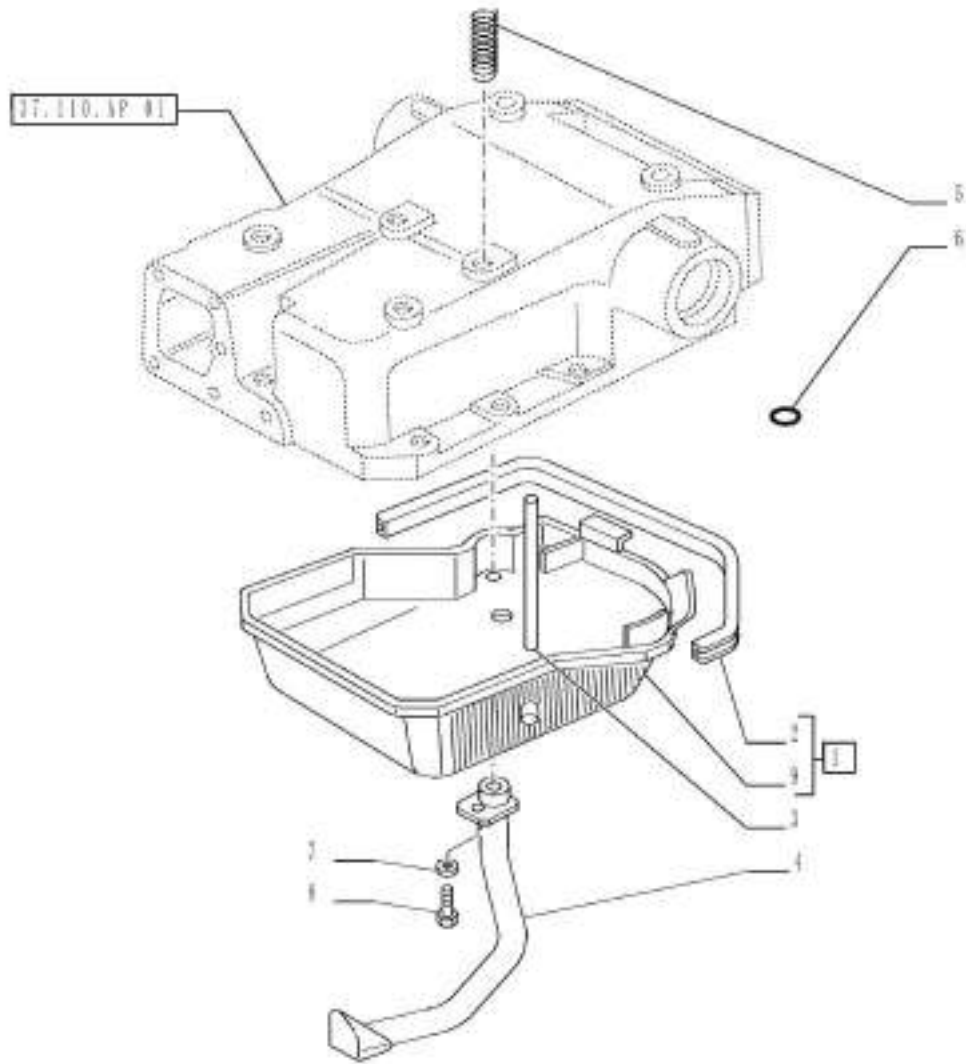

37.110.AP

02

p1

1/2014

VAR - 334395, 390814 - LIFTER OIL PAN AND RELATED PARTS

REF FN	PART NUMBER	YR/SN	QTY DESCRIPTION
1	5165978		1 PAN ASSY Incl 2, 9
2	5122962		1 OIL SEAL
3	5122987		1 TUBE
4	84183976		1 PIPE
5	559958		1 SPRING
6	44015841		2 BACK-UP RING 19mm ID x 20mm OD x 2.05mm
7	10519601		1 WASHER M8 x 17 x 2
8	86624003		1 BOLT Hex, M8 x 14mm, Cl 8.8, Full Thd
9	NSS		1 NOT SERVICED SEPARATELY Pan Incl in 1

Valid for Var. 334395 or Var. 390814

FARMALL JX100 FARMALL
JX110 FARMALL JX70
FARMALL JX75 FARMALL
JX80 FARMALL JX90

37.110.AQ

01

p1

1/2014

VAR - 334395, 390814 - LIFT - LIFT ARMS AND ROCKSHAFT

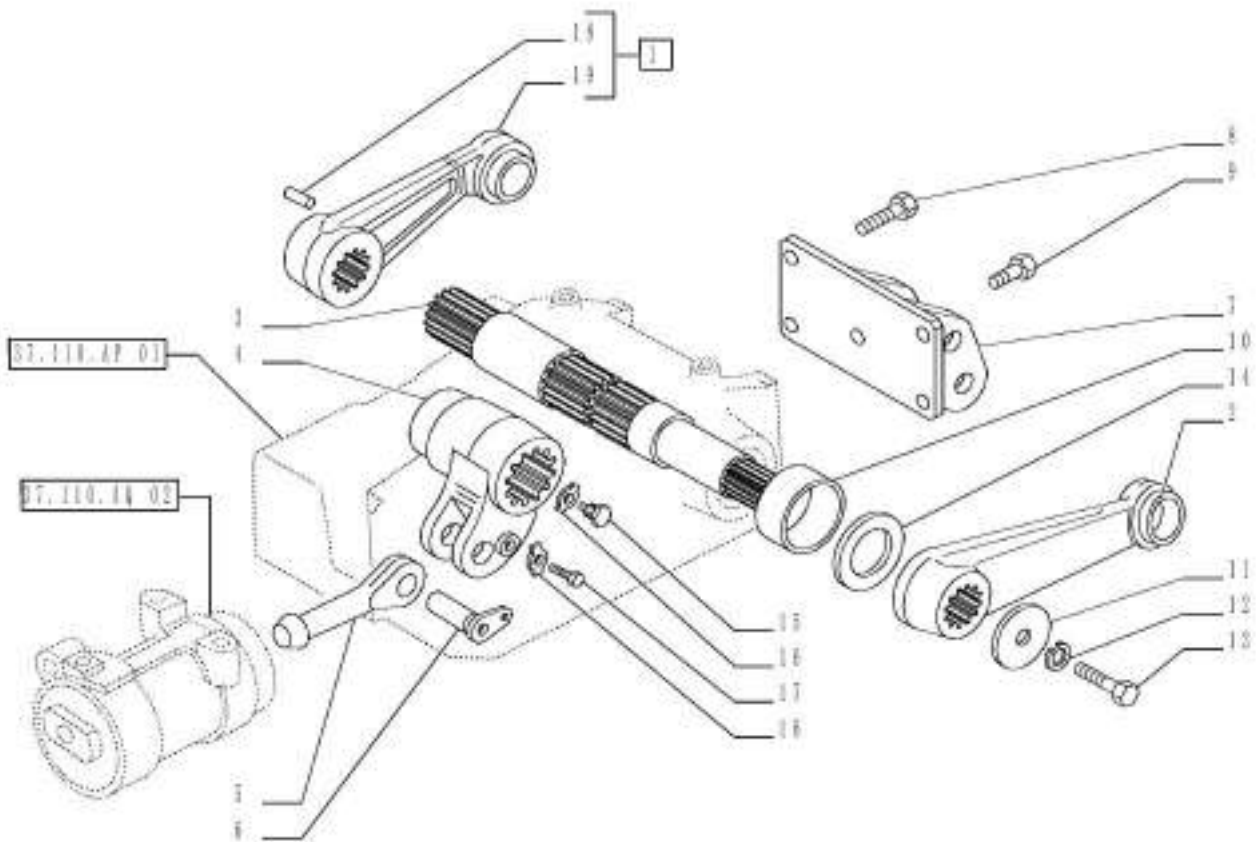

VAR - 334395, 390814 - LIFT - LIFT ARMS AND ROCKSHAFT

REF FN	PART NUMBER	YR/SN	QTY DESCRIPTION
1	5171471		1 LIFT ARM RH, ASSY Incl 18, 19
2	5123957		1 LIFT ARM LH
3	87486939		1 ROCKSHAFT
4	5165510		1 ARM
5	5121221		1 TOP LINK
6	5122356		1 PIN
7	5150842		1 SUPPORT
8	11394331		4 BOLT Hex, M14 x 1.5 x 45, 8.8, Full Thd
9	11408334		1 BOLT Hex, M14 x 1.5 x 35, 10.9, Full Thd
10	5159078		2 SEAL
11	5122898		2 WASHER Flat, 15.00mm ID x 70.00mm OD x 0.30mm
12	12601674		2 WAVE WASHER Wave, M15
13	11422321		2 BOLT Hex, M14 x 1.5 x 30.00mm, CI 8.8, ZND
14	5111082		2 SPACER
15	5117190		1 SET SCREW
16	14198810		2 LOCKING PLATE
17	15970321		1 SCREW Hex, M10 x 1.25 x 16mm, CI 8.8, Full Thd
18	10335010		1 DOWEL M5 x 22
19	NSS		1 NOT SERVICED SEPARATELY Lift Arm Incl in 1

Valid for Var. 334395 or Var. 390814

FARMALL JX100 FARMALL
 JX110 FARMALL JX70
 FARMALL JX75 FARMALL
 JX80 FARMALL JX90

37.110.AQ

02

p1

1/2014

VAR - 334395, 390814 - LIFT CYLINDER, PISTON

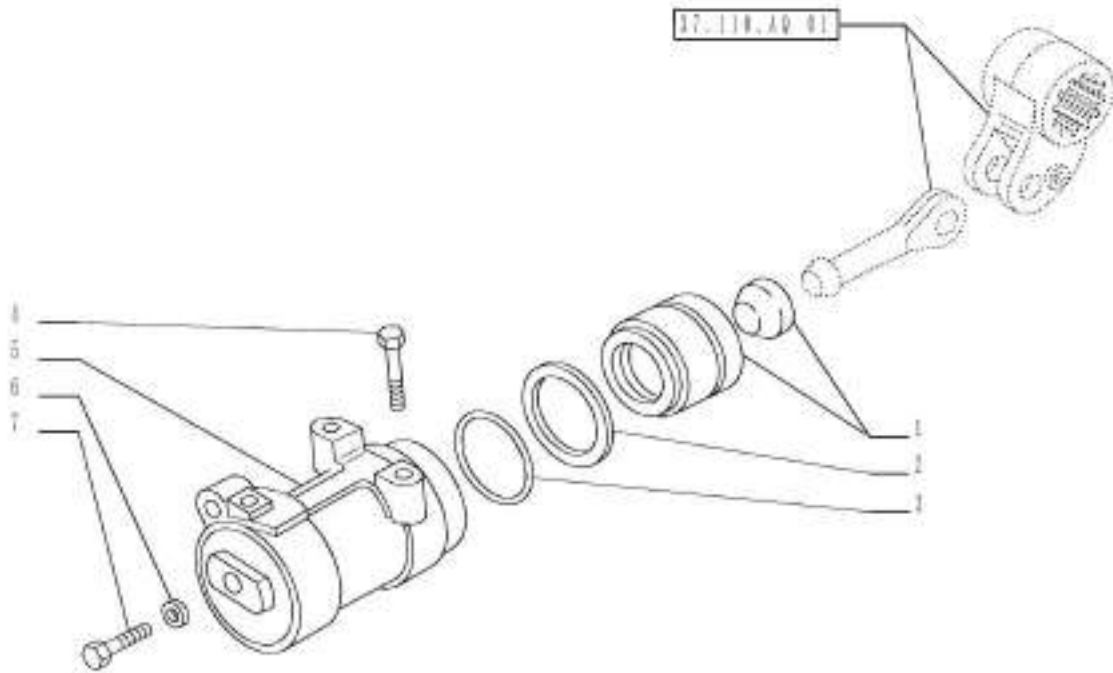

37.110.AQ

02

p1

1/2014

VAR - 334395, 390814 - LIFT CYLINDER, PISTON

REF FN	PART NUMBER	YR/SN	QTY DESCRIPTION
1	5132000		1 PISTON
2	5125941		1 GUIDE RING
3	14457380		1 O-RING 17.12mm ID x 2.62mm
4	15981334		2 BOLT Hex, M16 x 1.5 x 75mm, CI 10.9
5	5131998		1 LIFT CYLINDER
6	14465980		1 O-RING 98.02mm ID x 3.53mm Width
7	15977534		1 BOLT Hex, M14 x 1.5 x 60mm, CI 10.9

Valid for Var. 334395 or Var. 390814

FARMALL JX100 FARMALL
JX110 FARMALL JX70
FARMALL JX75 FARMALL
JX80 FARMALL JX90

37.120.AA

01

p1

1/2014

VAR - 334316, 334317, 390259 - IMPLEMENT CARRIER, LINK AND ARM

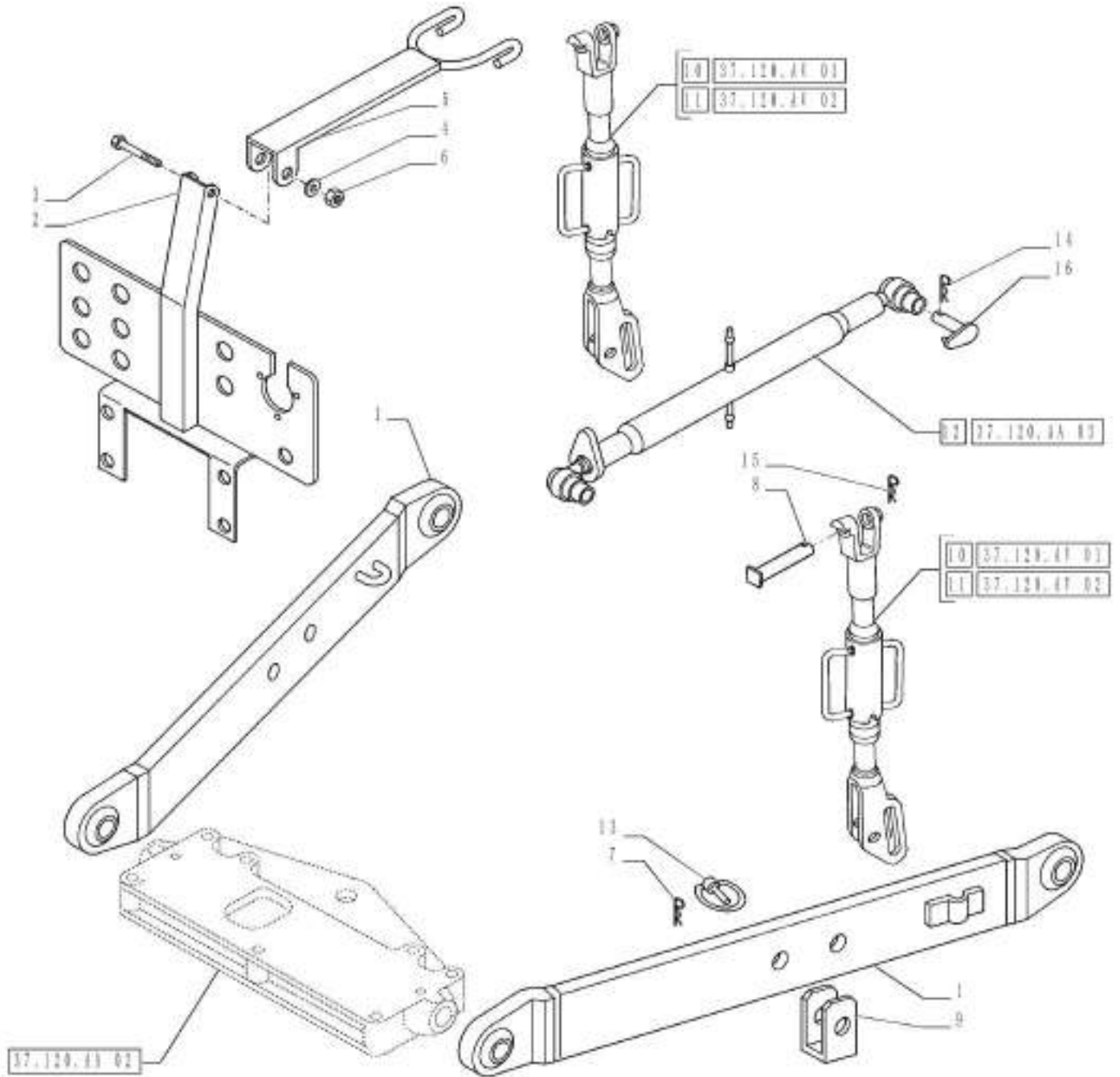

VAR - 334316, 334317, 390259 - IMPLEMENT CARRIER, LINK AND ARM

REF	FN	PART NUMBER	YR/SN	QTY DESCRIPTION
1	1	5098762		2 LOWER LINK
1	2	5099990		2 LOWER LINK
1	3	5092156		2 LIFT ARM
2		84573314		1 SUPPORT
3		300510		1 SCREW Hex, M8 x 1.25 x 65mm, CI 8.8
4		87597953		1 NUT M8, 1.25 Pitch, 10.6mm High, CI 8, ZND
5		5092607		1 SUPPORT
6		12601374		1 WAVE WASHER Wave, 8.40mm ID x 15.00mm OD x 0.80mm, 3.00mm, CST, DAC
7		5085461		3 COTTER PIN
8		47126271		2 PIN
9		5093188		1 CLAMP
10	4	5093193		1 UPPER LINK ASSY, RH
11	1	5093189		1 UPPER LINK ASSY, RH
12		84388389		1 UPPER LINK ASSY
13		5085063		2 PIN
14		87383335		1 COTTER PIN
15		10734401		2 COTTER PIN M2 x 22
16		5120672		1 PIN

- (1) Valid for FARMALL JX70 Model Only
(2) Valid for FARMALL JX75, 80, 90 Models Only
(3) Valid for FARMALL JX100, 110 Models Only
(4) Valid for FARMALL JX75, 80, 90, 100, 110 Models Only

Valid for Var. 334316 or Var. 334317 or Var. 390259

FARMALL JX100 FARMALL
JX110 FARMALL JX70
FARMALL JX75 FARMALL
JX80 FARMALL JX90

VAR - 334316, 334317, 390259 - IMPLEMENT CARRIER, SWING CARRIAGE

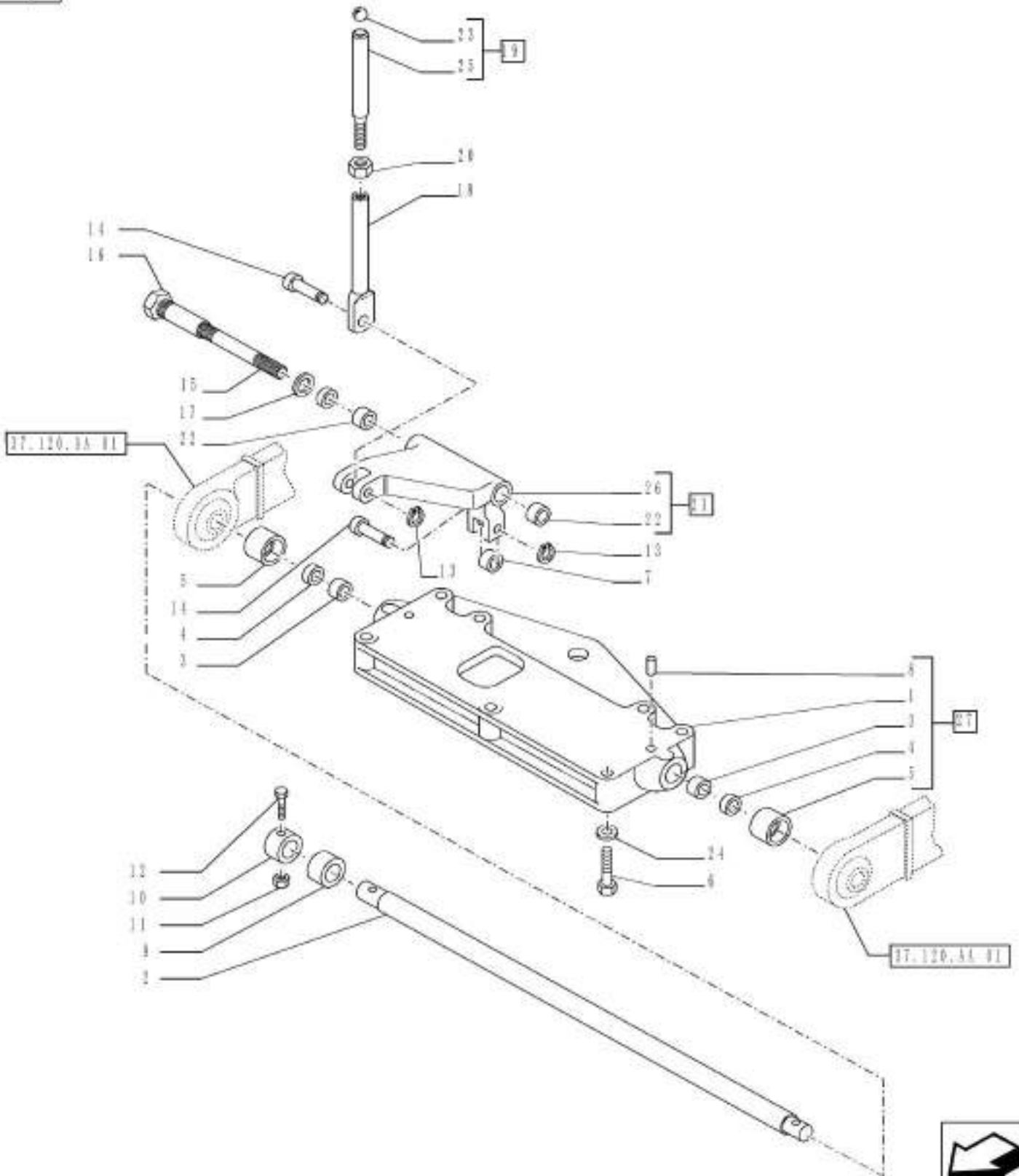

VAR - 334316, 334317, 390259 - IMPLEMENT CARRIER, SWING CARRIAGE

REF FN	PART NUMBER	YR/SN	QTY DESCRIPTION
1	5094343		1 HOUSING
1	5116242		1 SWING CARRIAGE
2	1 5116243		1 STABILIZER BAR
2	2 5094340		1 STABILIZER BAR
3	5116244		2 BUSHING
3	5109977		2 BUSHING
4	47129342		2 SEAL
4	47129340		2 OIL SEAL
5	5116245		2 SPACER
5	5171675		2 SPACER
6	15981624		7 BOLT Hex, M16 x 1.5 x 100mm, Cl 8.8
7	5109156		1 ROLLER
8	5119529		2 DOWEL
9	1 5116246		2 SPACER
9	2 5177788		2 SPACER
10	5116247		2 RING
11	12574511		2 LOCK NUT M10 x 1.25, Cl 8
12	15888721		2 BOLT Hex, M10 x 1.25 x 55, 8.8
13	11065976		2 CIRCLIP M10, Ext
14	5109172		2 PIN
15	10263460		1 SEAL 22.30mm ID x 28.00mm OD, 1.50mm, Copper
16	5094341		1 PIN
17	5117691		1 SPACER
18	5119957		1 ROD
19	5134791		1 PIN ASSY Incl 23, 25
20	10791011		1 THIN NUT Thin, M10 x 1.25, Cl 04
21	5118548		1 LEVER ASSY Incl 22, 26
22	5109160		2 ROLLER BEARING 14 mm ID x 20 mm OD x 12 mm
23	20063570		1 BALL

(1) Valid for FARMALL JX70, 75, 80, 90 Models Only

(2) Valid for FARMALL JX100, 110 Models Only

Valid for Var. 334316 or Var. 334317 or Var. 390259

FARMALL JX100 FARMALL
 JX110 FARMALL JX70
 FARMALL JX75 FARMALL
 JX80 FARMALL JX90

VAR - 334316, 334317, 390259 - IMPLEMENT CARRIER, SWING CARRIAGE

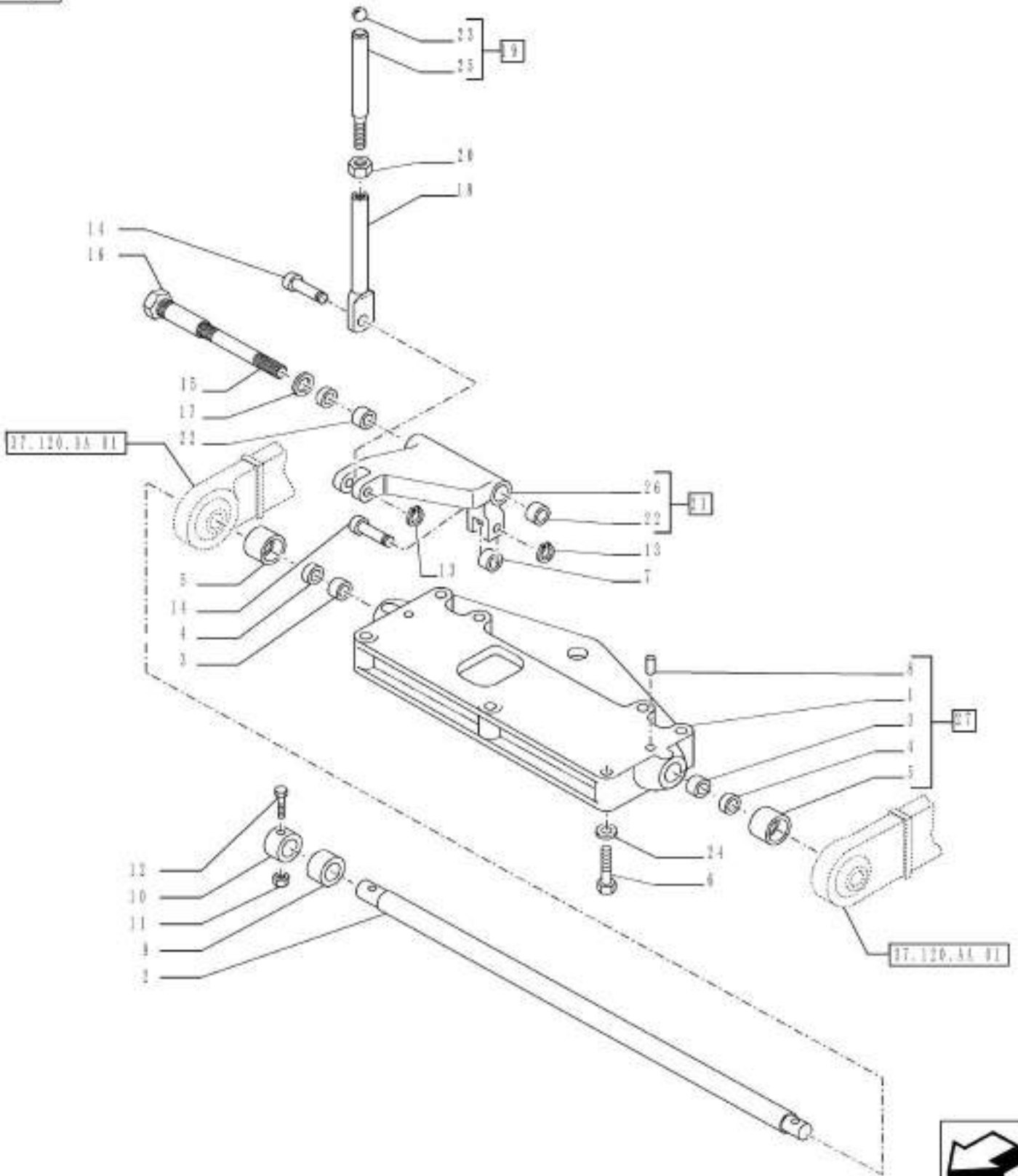

VAR - 334316, 334317, 390259 - IMPLEMENT CARRIER, SWING CARRIAGE

REF FN	PART NUMBER	YR/SN	QTY DESCRIPTION
24	12601774		7 WAVE WASHER 17mm ID x 30mm OD x 1.60mm, 6.30mm Max, CST, DAC
25	NSS		1 NOT SERVICED SEPARATELY Pin Incl in 19
26	NSS		1 NOT SERVICED SEPARATELY Lever Incl in 21
27 1	5162181		1 HITCH ASSY Incl 1, 3 - 5, 8
27 2	5094342		1 HOUSING ASSY Incl 1, 3 - 5, 8
(1)	Valid for FARMALL JX70, 75, 80, 90 Models Only		
(2)	Valid for FARMALL JX100, 110 Models Only		
Valid for Var. 334316 or Var. 334317 or Var. 390259			FARMALL JX100 FARMALL JX110 FARMALL JX70 FARMALL JX75 FARMALL JX80 FARMALL JX90

37.120.AA

03

p1

1/2014

VAR - 334316, 334317, 390259 - IMPLEMENT CARRIER, UPPER LINK, BREAKDOWN

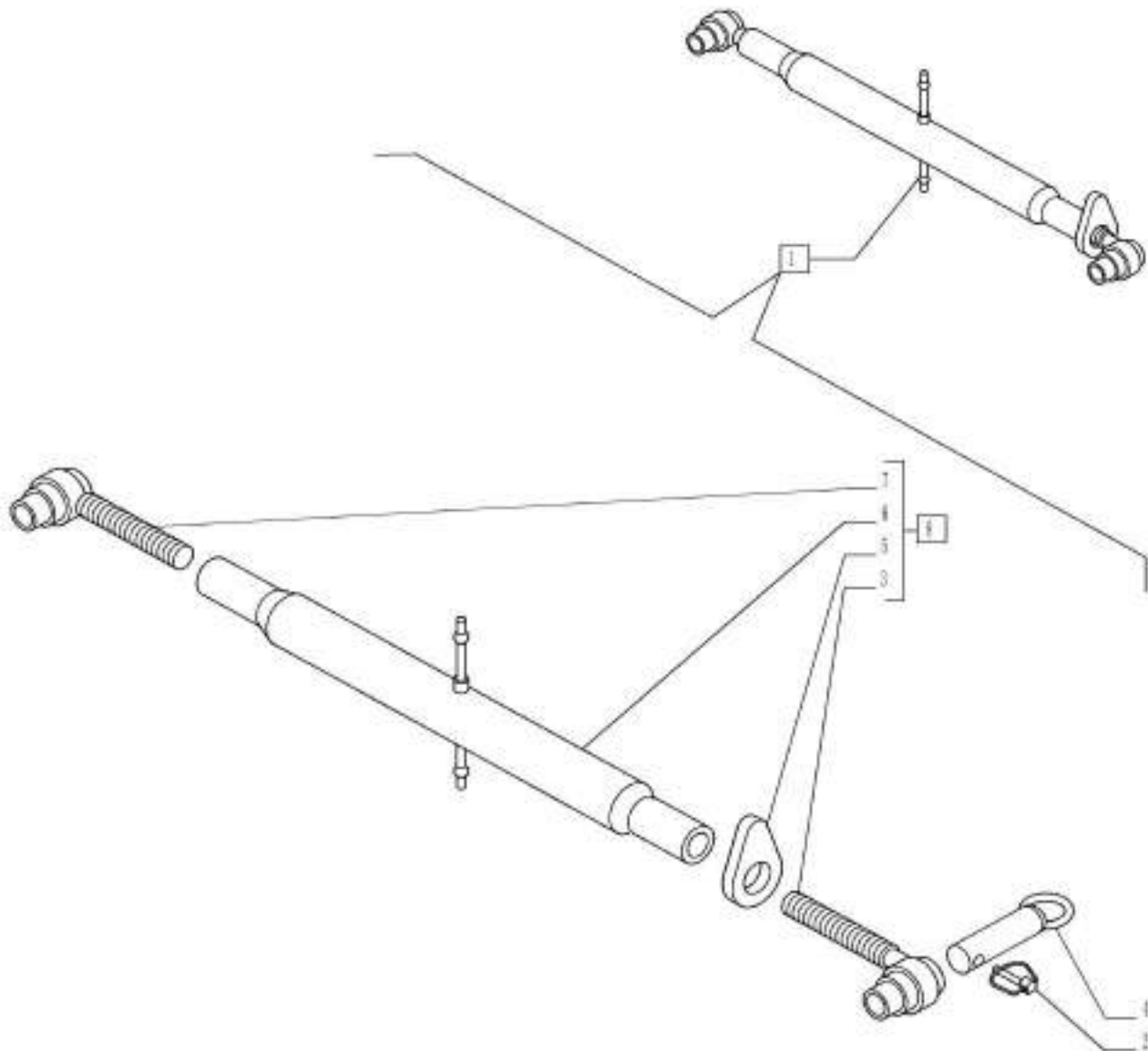

VAR - 334316, 334317, 390259 - IMPLEMENT CARRIER, UPPER LINK, BREAKDOWN

REF FN	PART NUMBER	YR/SN	QTY DESCRIPTION
1	84388389		1 UPPER LINK ASSY Incl 3, 5 - 8
2	5085063		1 PIN
3	5143012		1 LINK
4	5085029		1 PIN
5	5095398		1 LOCKING PLATE
6	5095818		1 ADJUSTING SLEEVE
7	5143011		1 TOP LINK
8	5095817		1 UPPER LINK ASSY Incl 3, 5 - 7

Valid for Var. 334316 or Var. 334317 or Var. 390259	FARMALL JX100 FARMALL JX110 FARMALL JX70 FARMALL JX75 FARMALL JX80 FARMALL JX90
---	--

VAR - 334317 - THREE POINT HITCH WITH QUICK ATTACH ENDS, THIRD-LINK SPRAG, BREAKDOWN

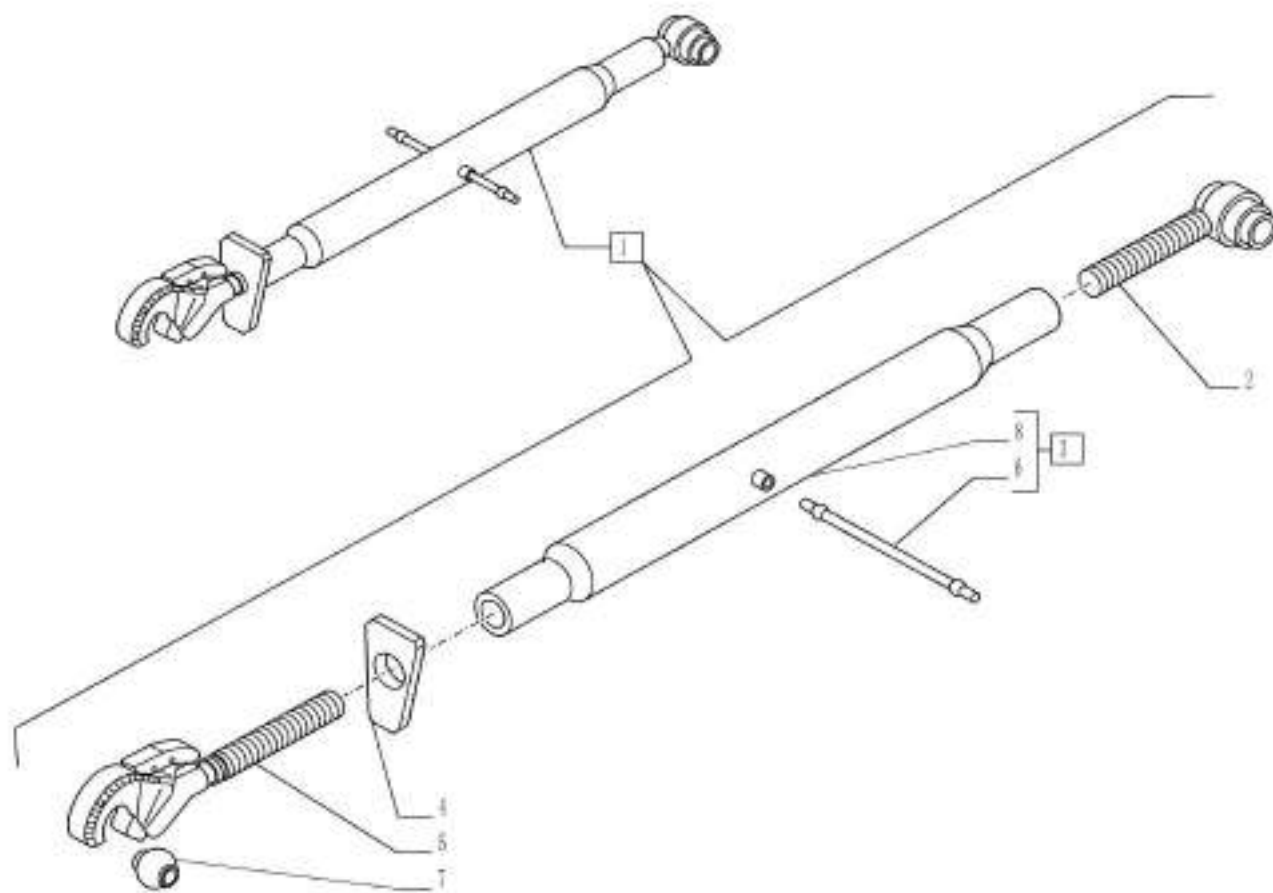

37.120.AF

01

p1

1/2014

VAR - 330899, 390269 - 2 PIN TYPE TELESCOPIC STABILIZERS

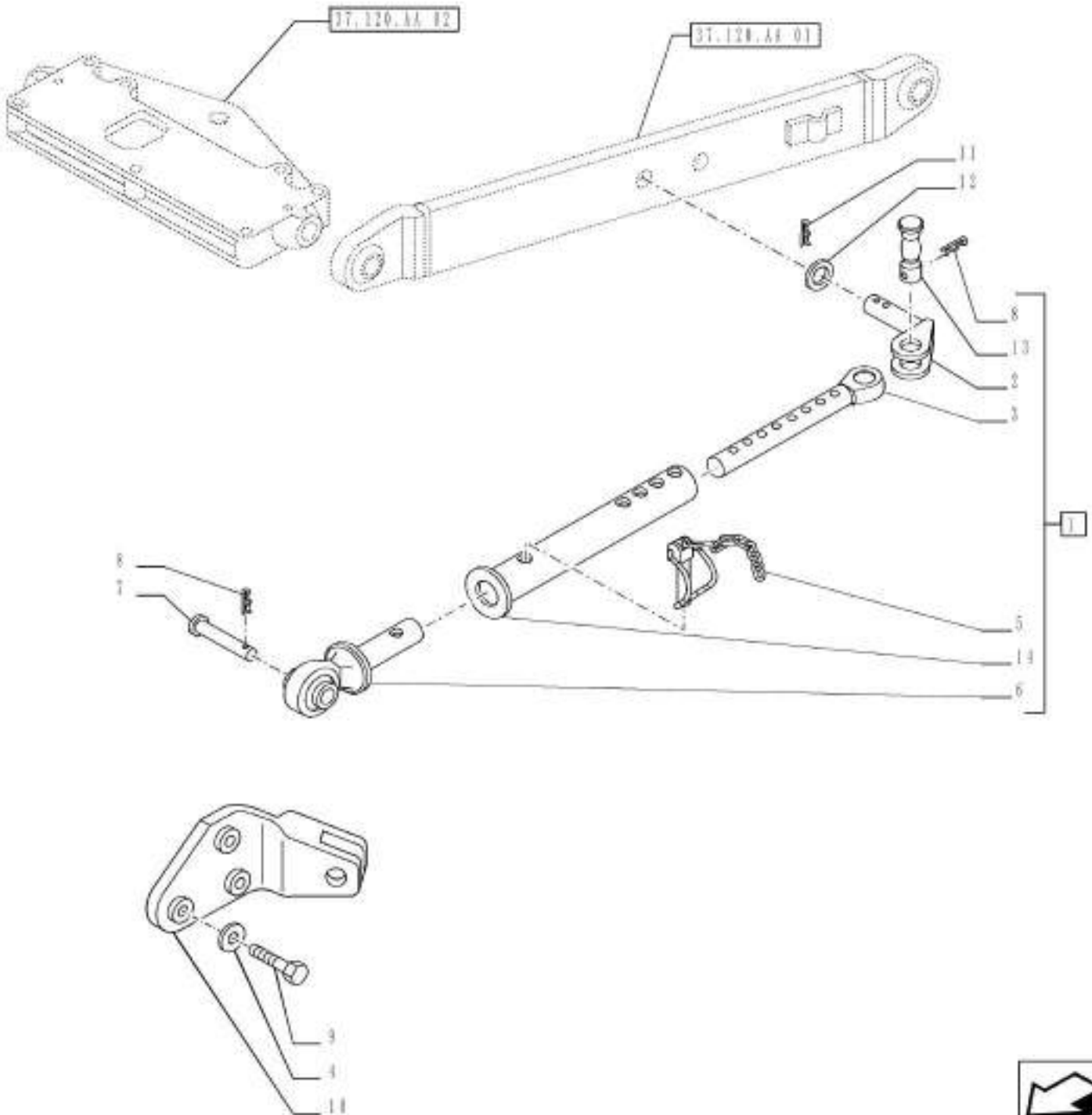

37.120.AF

01

p1

1/2014

VAR - 330899, 390269 - 2 PIN TYPE TELESCOPIC STABILIZERS

REF FN	PART NUMBER	YR/SN	QTY DESCRIPTION
1	84165450		2 STABILIZER ASSY Incl 2, 3, 5, 6, 8, 13, 14
2	5123274		1 PIN
3	5093711		1 TRACK ROD END ASSY
4	12601774		6 WAVE WASHER 17mm ID x 30mm OD x 1.60mm, 6.30mm Max, CST, DAC
5	82019234		2 PIN
6	5093705		1 BALL JOINT
7	5103860		2 PIN
8	10798301		5 COTTER PIN M6.3 x 36
9	15981021		4 SCREW Hex, M16 x 1.5 x 55mm, Cl 8.8
10	5146649		1 SUPPORT RH
10	5146650		1 SUPPORT LH
11	5112606		2 COTTER PIN
12	84275315		2 WASHER
13	5174920		1 PIN
14	NSS		1 NOT SERVICED SEPARATELY Link Incl in 1

Valid for Var. 330899 or Var. 390269

FARMALL JX100 FARMALL
JX110 FARMALL JX70
FARMALL JX75 FARMALL
JX80 FARMALL JX90

37.120.AO

01

p1

1/2014

VAR - 334316 - THREE POINT LINKAGE WITH CAT.2 FLEXIBLE ENDS

REF	FN	PART NUMBER	YR/SN	QTY	DESCRIPTION
1	1	87620533		1	LOWER LINK RH
1	2	5096994		1	TOP LINK RH
2	1	87620150		1	LOWER LINK LH
2	2	5096995		1	TOP LINK LH

(1) Valid for FARMALL JX75, 80, 90, 100, 110 Models Only

(2) Valid for FARMALL JX70 Model Only

Valid for Var. 334316

FARMALL JX100 FARMALL
JX110 FARMALL JX70
FARMALL JX75 FARMALL
JX80 FARMALL JX90

VAR - 334317 - THREE POINT HITCH WITH CAT2 QUICK ATTACH

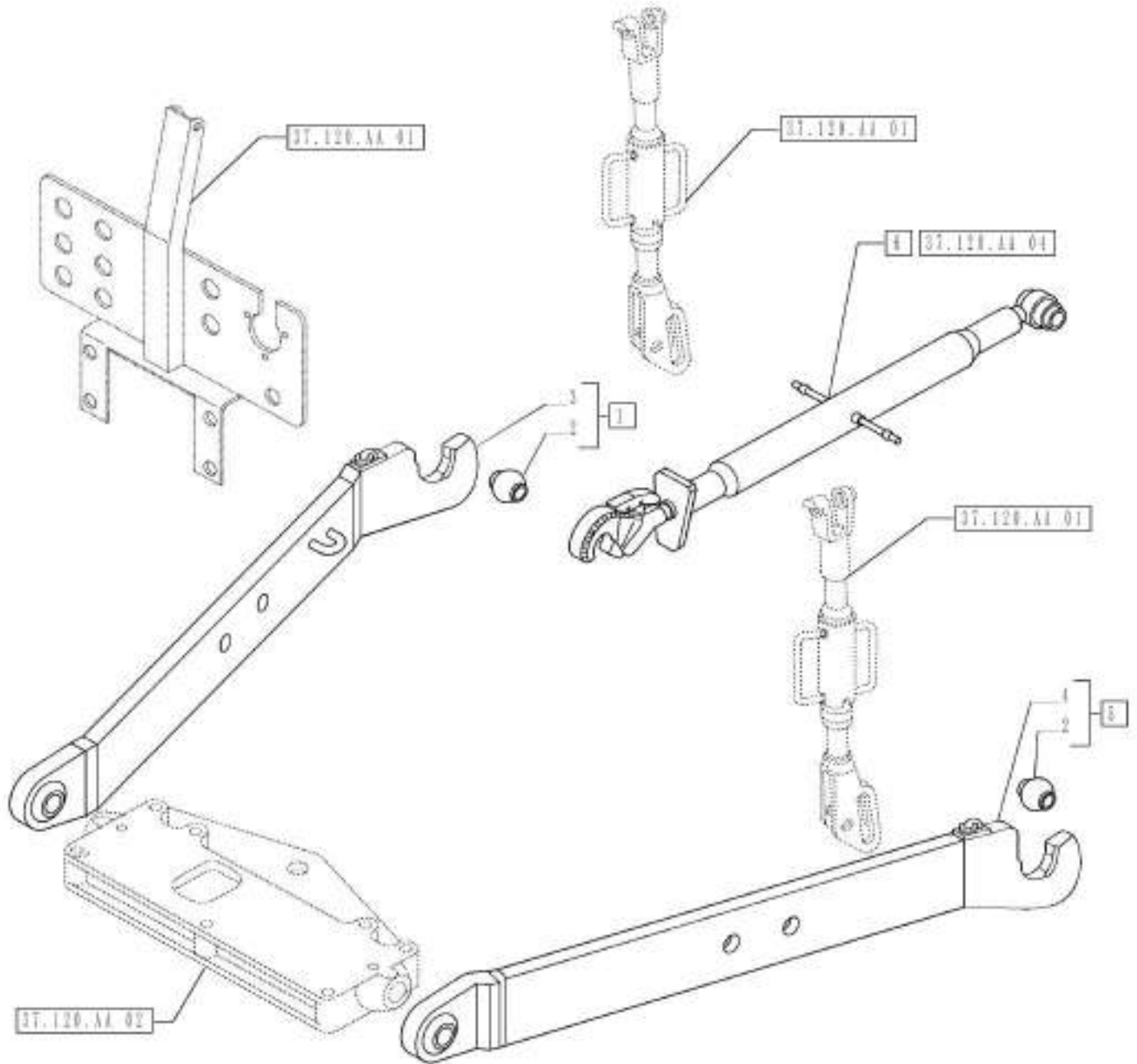

37.120.AO

02

p1

1/2014

VAR - 334317 - THREE POINT HITCH WITH CAT2 QUICK ATTACH

REF FN	PART NUMBER	YR/SN	QTY DESCRIPTION
1	84301069		1 LOWER LINK LH Incl 2, 3
2	822441		1 BUSHING
3	NSS		1 NOT SERVICED SEPARATELY Arm Incl in 1
4	NSS		1 NOT SERVICED SEPARATELY Arm Incl in 5
5	84301068		1 LOWER LINK RH Incl 2, 4
6	84301987		1 UPPER LINK

Valid for Var. 334317

**FARMALL JX100
FARMALL JX110
FARMALL JX90**

VAR - 334316 - TELESCOPIC LINK ENDS - BREAKDOWN

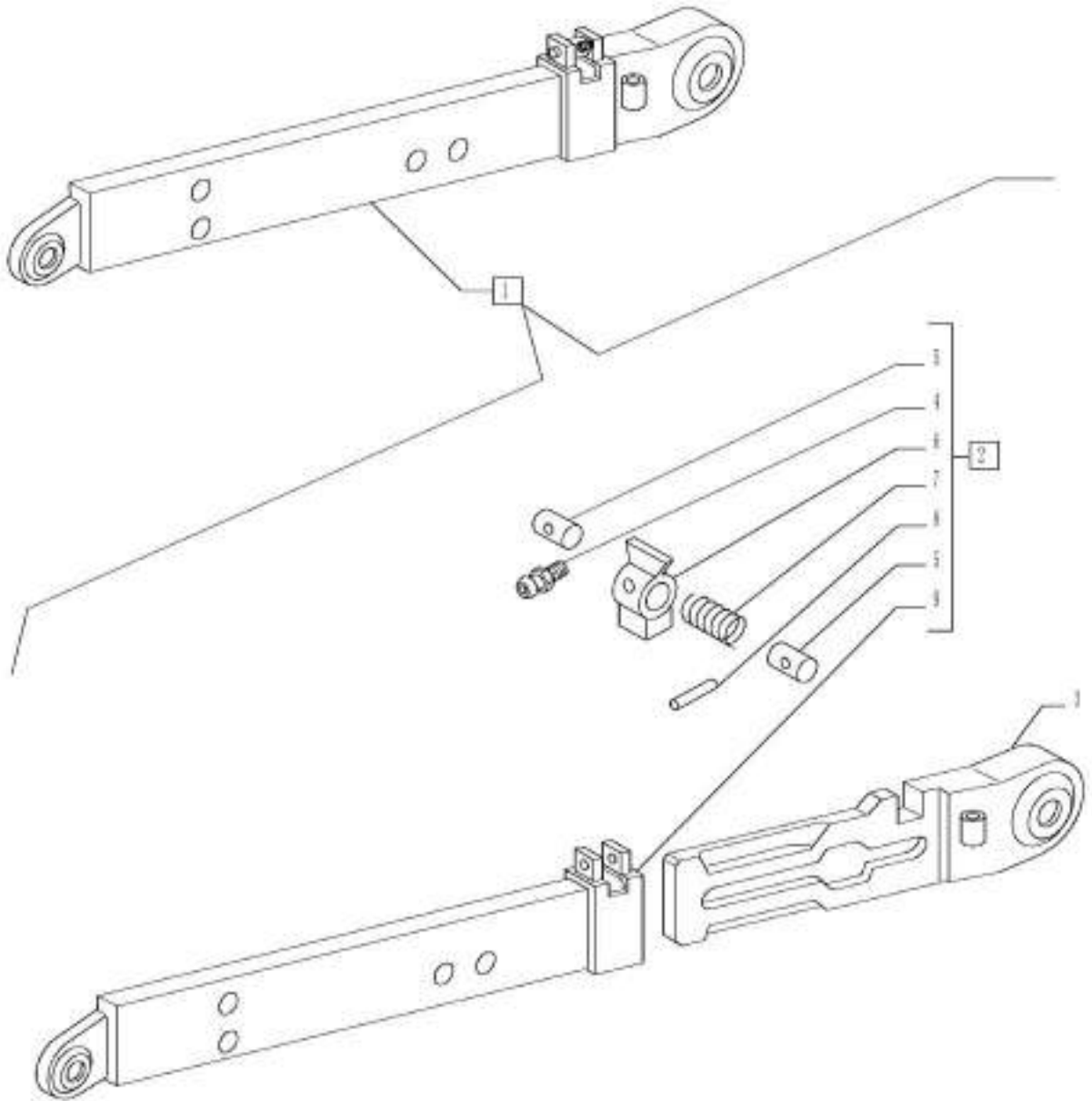

VAR - 334316 - TELESCOPIC LINK ENDS - BREAKDOWN

REF	FN	PART NUMBER	YR/SN	QTY	DESCRIPTION
1	1	87620533		1	LOWER LINK ASSY, RH, Incl 2 - 9
1	1	87620150		1	LOWER LINK ASSY, LH, Incl 2 - 9
1	2	5096994		1	TOP LINK Incl 2 - 9
1	2	5096995		1	TOP LINK Incl 2 - 9
2	1	87620532		1	LOWER LINK RH, Incl 4 - 9
2	1	87620151		1	LOWER LINK LH, Incl 4 - 9
2	2	5096674		1	TOP LINK RH, Incl 4 - 9
2	2	5096704		1	TOP LINK LH, Incl 4 - 9
3	1	44018642		1	TRACK ROD END ASSY RH
3	1	44018644		1	TRACK ROD END ASSY LH
3	2	5096696		1	END RH
3	2	5096698		1	END LH
4		13407211		1	LUBE NIPPLE M10 x 1
5		44012765		4	PIN
6		44012763		2	STOP
7		44012764		2	SPRING
8		14164770		3	LOCK PIN M4 x 40, Slotted
9		NSS		1	NOT SERVICED SEPARATELY Link Incl in 2
(1)	Valid for FARMALL JX75, 80, 90, 100, 110 Models Only				
(2)	Valid for FARMALL JX70 Model Only				
Valid for Var. 334316					FARMALL JX100 FARMALL JX110 FARMALL JX70 FARMALL JX75 FARMALL JX80 FARMALL JX90

37.120.AV

01

p1

1/2014

VAR - 334316, 334317, 390259 - RH SIDE ADJUSTABLE TIE-ROD, BREAKDOWN

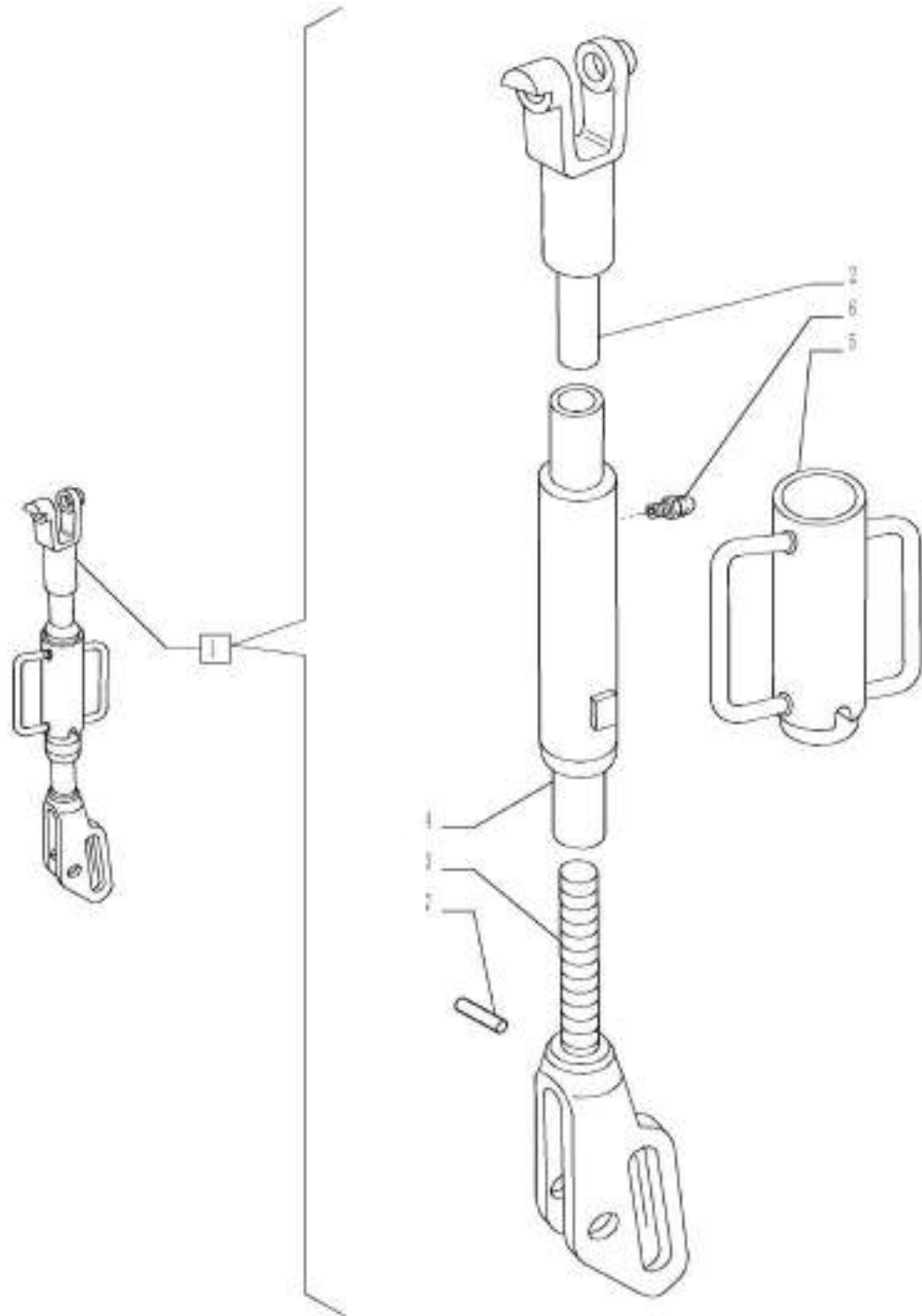

37.120.AV

01

p1

1/2014

VAR - 334316, 334317, 390259 - RH SIDE ADJUSTABLE TIE-ROD, BREAKDOWN

REF FN	PART NUMBER	YR/SN	QTY DESCRIPTION
1	5093193		1 UPPER LINK Incl 2 - 7
2	5095371		1 YOKE
3	5093688		1 FORK
4	5093682		1 TUBE
5	5093683		1 TUBE
6	13407211		1 LUBE NIPPLE M10 x 1
7	14606474		1 PIN

Valid for Var. 334316 or Var. 334317 or Var. 390259

FARMALL JX100
FARMALL JX110
FARMALL JX75
FARMALL JX80

VAR - 334316, 390259 - RH SIDE ADJUSTABLE TIE-ROD, BREAKDOWN

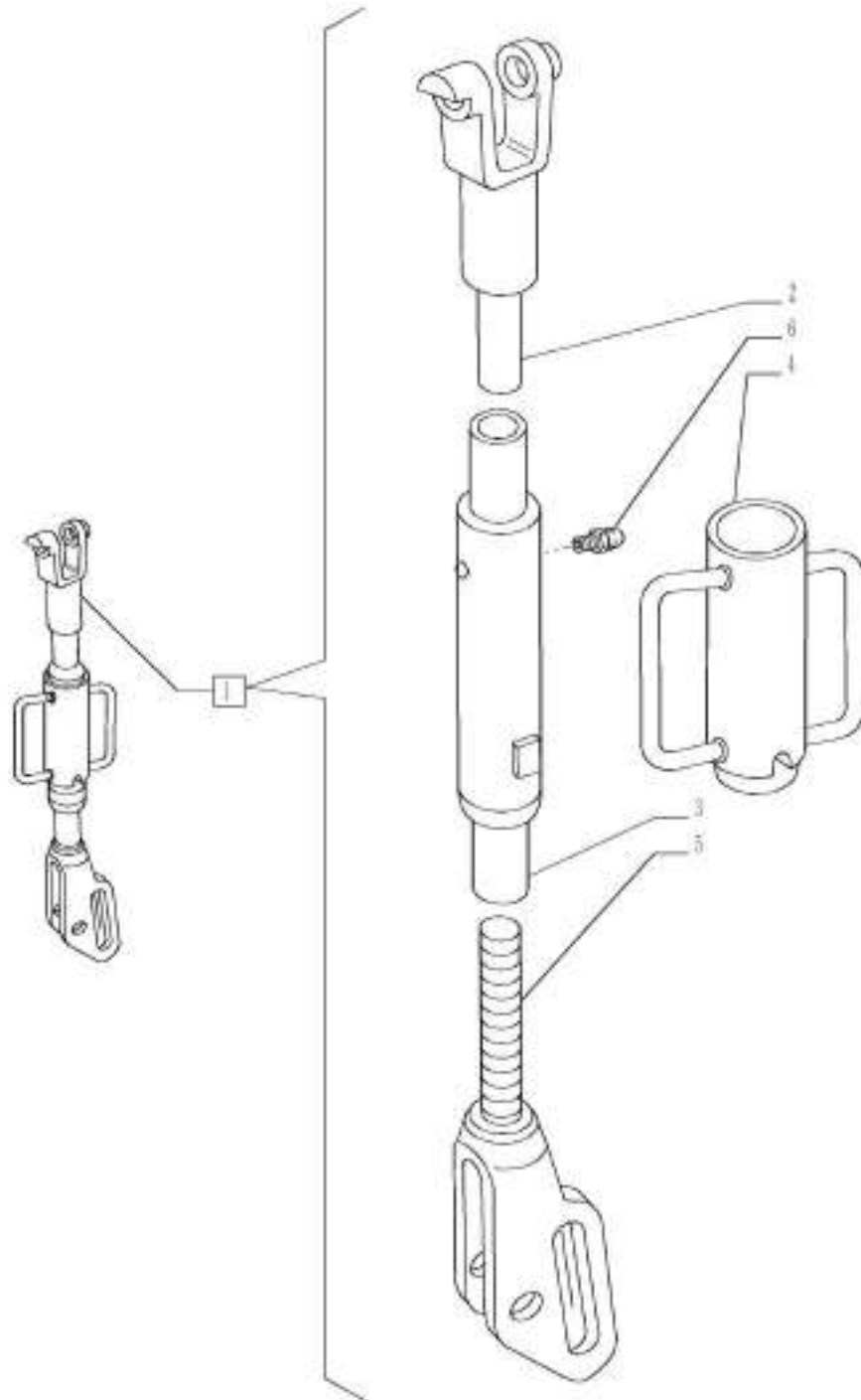

37.120.AV

02

p1

1/2014

VAR - 334316, 390259 - RH SIDE ADJUSTABLE TIE-ROD, BREAKDOWN

REF FN	PART NUMBER	YR/SN	QTY DESCRIPTION
1	5093189		1 UPPER LINK ASSY Incl 2 - 6
2	5093668		1 FORK
3	5093669		1 TURNBUCKLE
4	5093670		1 HANDLE
5	5093667		1 FORK
6	13407211		1 LUBE NIPPLE M10 x 1

Valid for Var. 334316 or Var. 390259

FARMALL JX70

SECTION INDEX

FRAMES & BALLASTING

39.000.00	01	SECTION INDEX - FRAMES AND BALLASTINGS
39.140.AF	01	VAR - 335240, 335241 - FRONT SUPPORT AND WEIGHTS WITH HOOK
39.140.AF	02	VAR - 335397 - FRONT SUPPORT AND WEIGHT WITH HOOK
39.140.AL	01	VAR - 330470, 330471 - REAR BALLAST

39.000.00

01

p1

1/2014

SECTION INDEX - FRAMES AND BALLASTINGS

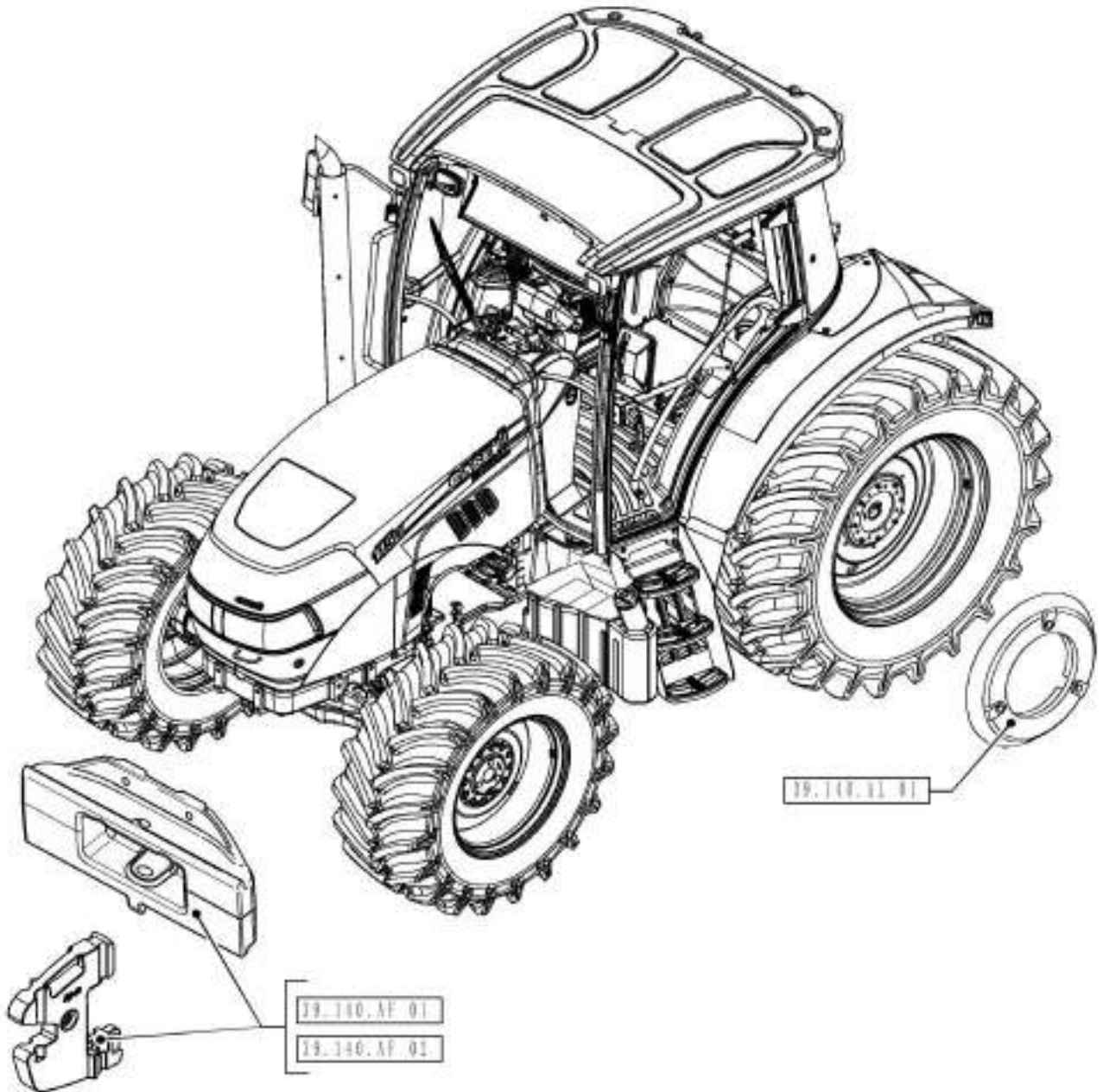

39.000.00

01

p1

1/2014

SECTION INDEX - FRAMES AND BALLASTINGS

REF FN	PART NUMBER	YR/SN	QTY	DESCRIPTION
---------------	--------------------	--------------	------------	--------------------

				FARMALL JX100 FARMALL JX110 FARMALL JX70 FARMALL JX75 FARMALL JX80 FARMALL JX90
--	--	--	--	--

VAR - 335240, 335241 - FRONT SUPPORT AND WEIGHTS WITH HOOK

REF FN	PART NUMBER	YR/SN	QTY DESCRIPTION
1	84558684		1 WEIGHT CARRIER
2	87694283		2 PIN ASSY Incl 5 - 8
3	11191579		4 BELLEVILLE WASHER Belleville, M17
4	15981221		4 SCREW Hex, M16 x 1.5 x 65mm, CI 8.8
5	44901192		2 CLIP
6	5093257		1 SPLIT PIN/SAFETY PIN
7	NSS		1 NOT SERVICED SEPARATELY Chain Incl in 2
8	NSS		1 NOT SERVICED SEPARATELY Pin Incl in 2
9	^{1,2,3} 5091956		AR WEIGHT
10	5092098		2 PLATE
11	2 5092099		2 ROD
11	1 5092101		2 THREADED ROD
12	5092100		4 SPACER
13	12164111		4 NUT M16, CI 8
14	5092096		1 WEIGHT

(1) Front Carrier and Weights (6x45KG) with Hook 100KG - 452KG, VAR - 335241

(2) Front Carrier and Weights (2x45KG) with Hook 100KG - 272KG, VAR - 335240

(3) Q.ty 2 for VAR - 335240; Qty. 6 for VAR - 335241; Q.ty 7 for VAR - 335242; Q.ty 9 for VAR - 335933

Valid for Var. 335240 or Var. 335241

FARMALL JX100 FARMALL
JX110 FARMALL JX70
FARMALL JX75 FARMALL
JX80 FARMALL JX90

39.140.AF

02

p1

1/2014

VAR - 335397 - FRONT SUPPORT AND WEIGHT WITH HOOK

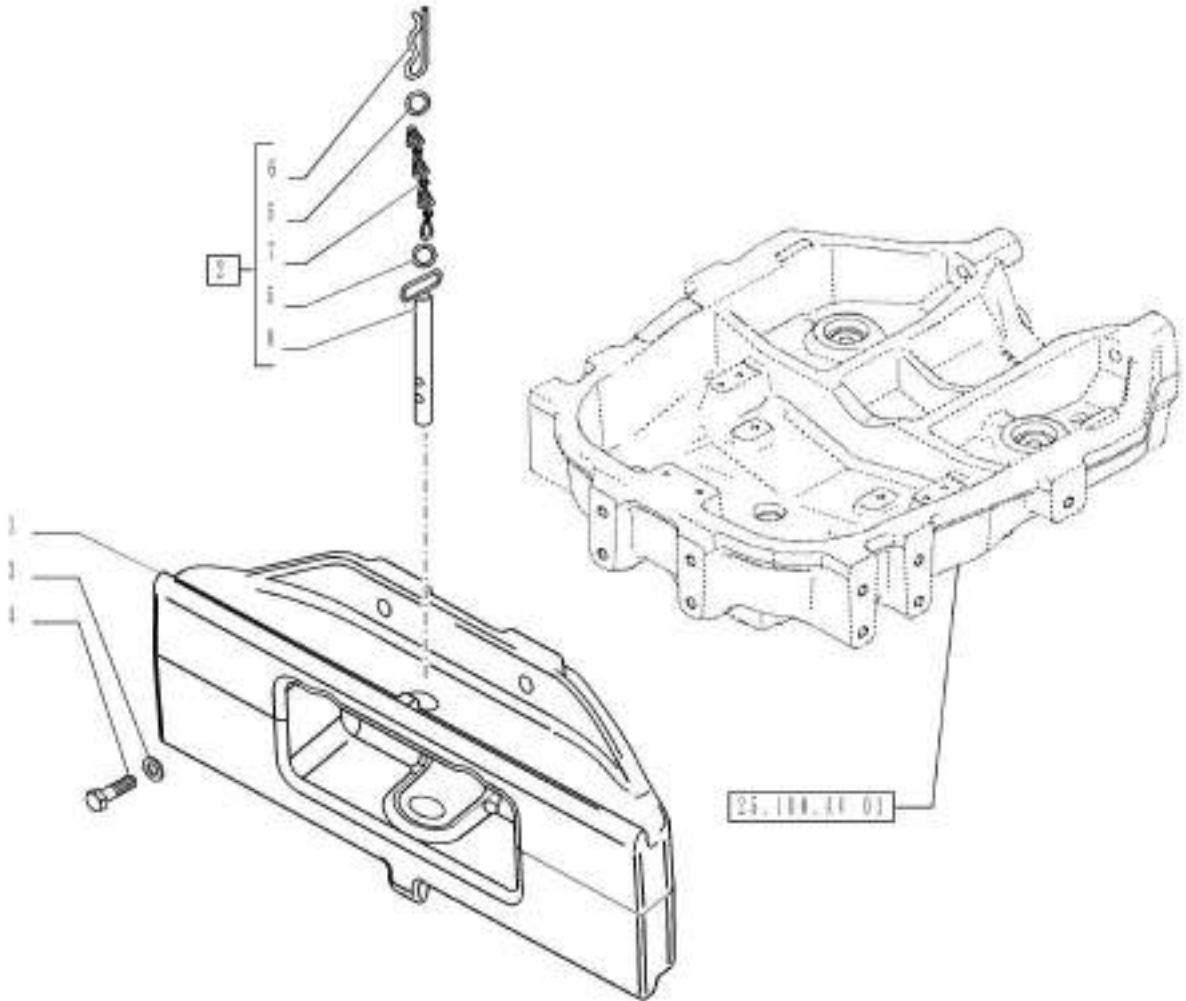

39.140.AF

02

p1

1/2014

VAR - 335397 - FRONT SUPPORT AND WEIGHT WITH HOOK

REF FN	PART NUMBER	YR/SN	QTY DESCRIPTION
1	84558684		1 WEIGHT CARRIER
2	87694283		1 PIN ASSY Incl 5 - 8
3	11191579		4 BELLEVILLE WASHER Belleville, M17
4	15981221		4 SCREW Hex, M16 x 1.5 x 65mm, Cl 8.8
5	44901192		2 CLIP
6	5093257		1 SPLIT PIN/SAFETY PIN
7	NSS		1 NOT SERVICED SEPARATELY Chain Incl in 2
8	NSS		1 NOT SERVICED SEPARATELY Pin Incl in 2

Valid for Var. 335397

FARMALL JX100 FARMALL
JX110 FARMALL JX70
FARMALL JX75 FARMALL
JX80 FARMALL JX90

39.140.AL

01

p1

1/2014

VAR - 330470, 330471 - REAR BALLAST

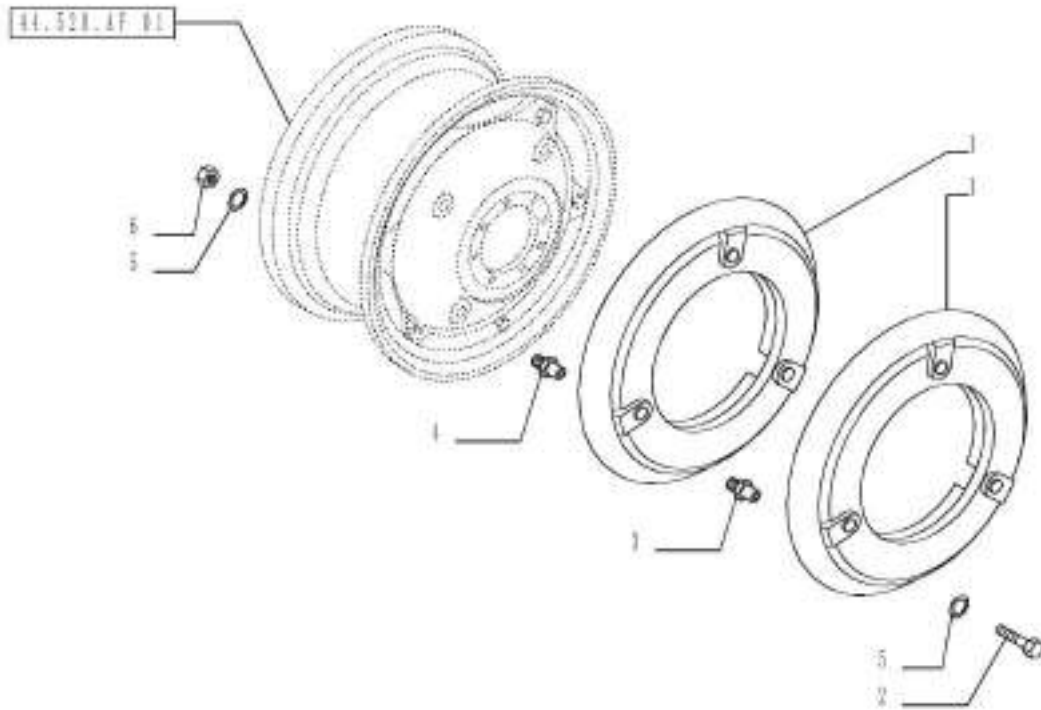

39.140.AL

01

p1

1/2014

VAR - 330470, 330471 - REAR BALLAST

REF	FN	PART NUMBER	YR/SN	QTY	DESCRIPTION
1	1	5093512			AR WEIGHT 50 Kg (110 Lbs)
2		15980521			6 BOLT Hex, M16 x 1.5 x 30mm, CI 8.8, Full Thd
3	2	44018047			AR SCREW M16 x 1.5 x 78mm
4		44018046			6 SCREW M16 x 1.5 x 60mm
5		11194279			6 BELLEVILLE WASHER Belleville, M17
6		12164111			6 NUT M16, CI 8
(1)		Qty 4 for VAR - 330470, Qty 6 for VAR - 330471			
(2)		Qty 6 for VAR - 330470, Qty 12 for VAR - 330471			

Valid for Var. 330470 or Var. 330471

FARMALL JX100 FARMALL
JX110 FARMALL JX70
FARMALL JX75 FARMALL
JX80 FARMALL JX90

SECTION INDEX

STEERING

41.000.00	01	SECTION INDEX - STEERING
41.101.AA	01	VAR - 333606, 334318, 334319, 391606, 392315 - STEERING WHEEL
41.101.AB	01	VAR - 333606, 334318, 334319, 391606, 392315 - STEERING COLUMN
41.106.AB	01	VAR - 338860, 390860 - 2WD, FRONT AXLE, LEVER
41.106.AC	01	VAR - 334413, 390338, 743515 - 2WD, FRONT AXLE
41.106.AD	01	VAR - 390250 - 4WD FRONT AXLE, TIE-ROD
41.106.AD	02	VAR - 335325 - 4WD FRONT AXLE, TIE-ROD
41.106.AD	03	VAR - 335539 - CLASS 2 FRONT AXLE WITH 2ND STEERING CYLINDER & LIMITED SLIP (30KM/H) - TIE ROD
41.200.AL	01	VAR - 330120, 331120, 743846 - STEERING ASSY, FILTER, COMPONENTS
41.200.AO	01	VAR - 390249, 743846, 744738, 744739, 744744 - HYDRAULIC STEERING HOSE
41.200.AO	02	VAR - 744738, 744739, 744744 - HYDRAULIC STEERING HOSE RETURN
41.200.AO	03	VAR - 330384, 744739 - HYDRAULIC STEERING HOSE RETURN
41.200.AO	04	VAR - 330120, 331120, 743846 - HYDRAULIC STEERING HOSE
41.200.CA	01	VAR - 333606, 334318, 334319, 391606, 392315 - STEERING CONTROL VALVE
41.206.AA	01	VAR - 330120, 331120, 390249, 743846 - HYDRAULIC STEERING PUMP
41.206.AA	02	VAR - 330120, 331120, 390249, 743846 - POWER STEERING PUMP, BREAKDOWN
41.206.AJ	01	VAR - 330120, 331120, 390249, 743846 - HYDRAULIC STEERING, PUMP, LINE
41.216.AN	01	VAR - 334413, 390338, 743515 - 2WD FRONT AXLE, HYDRAULIC STEERING CYLINDER HOSES
41.216.AN	02	VAR - 334413, 390338, 743515 - 2WD FRONT AXLE, HYDRAULIC STEERING CYLINDER, BREAKDOWN
41.216.AN	05	VAR - 390250 - 4WD FRONT AXLE - HYDRAULIC STEERING CYLINDER
41.216.AN	06	VAR - 390250 - HYDRAULIC STEERING, CYLINDER, COMPONENTS
41.216.AN	07	VAR - 335325 - 4WD FRONT AXLE - HYDRAULIC STEERING CYL
41.216.AN	08	VAR - 335325 - 4WD, FRONT AXLE, HYDRAULIC STEERING, CYLINDER, COMPONENTS
41.216.AN	10	VAR - 335539 - FRONT AXLE - HYDRAULIC STEERING CYLINDER - BREAKDOWN
41.216.AV	01	VAR - 335539 - HYDRAULIC STEERING CYLINDER LINES

SECTION INDEX - STEERING

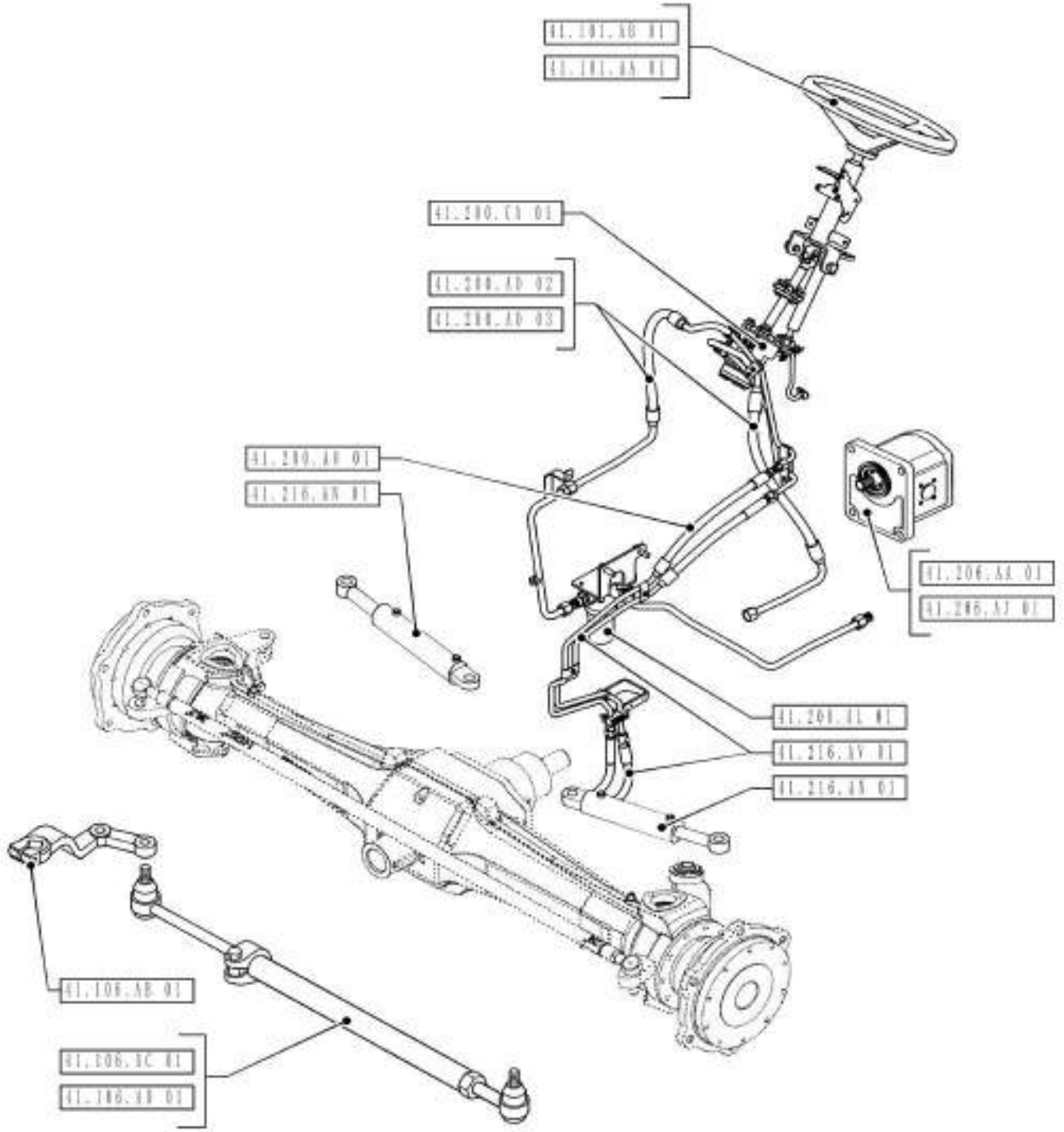

41.000.00

01

p1

1/2014

SECTION INDEX - STEERING

REF FN	PART NUMBER	YR/SN	QTY	DESCRIPTION
---------------	--------------------	--------------	------------	--------------------

				FARMALL JX100 FARMALL JX110 FARMALL JX70 FARMALL JX75 FARMALL JX80 FARMALL JX90
--	--	--	--	--

VAR - 333606, 334318, 334319, 391606, 392315 - STEERING WHEEL

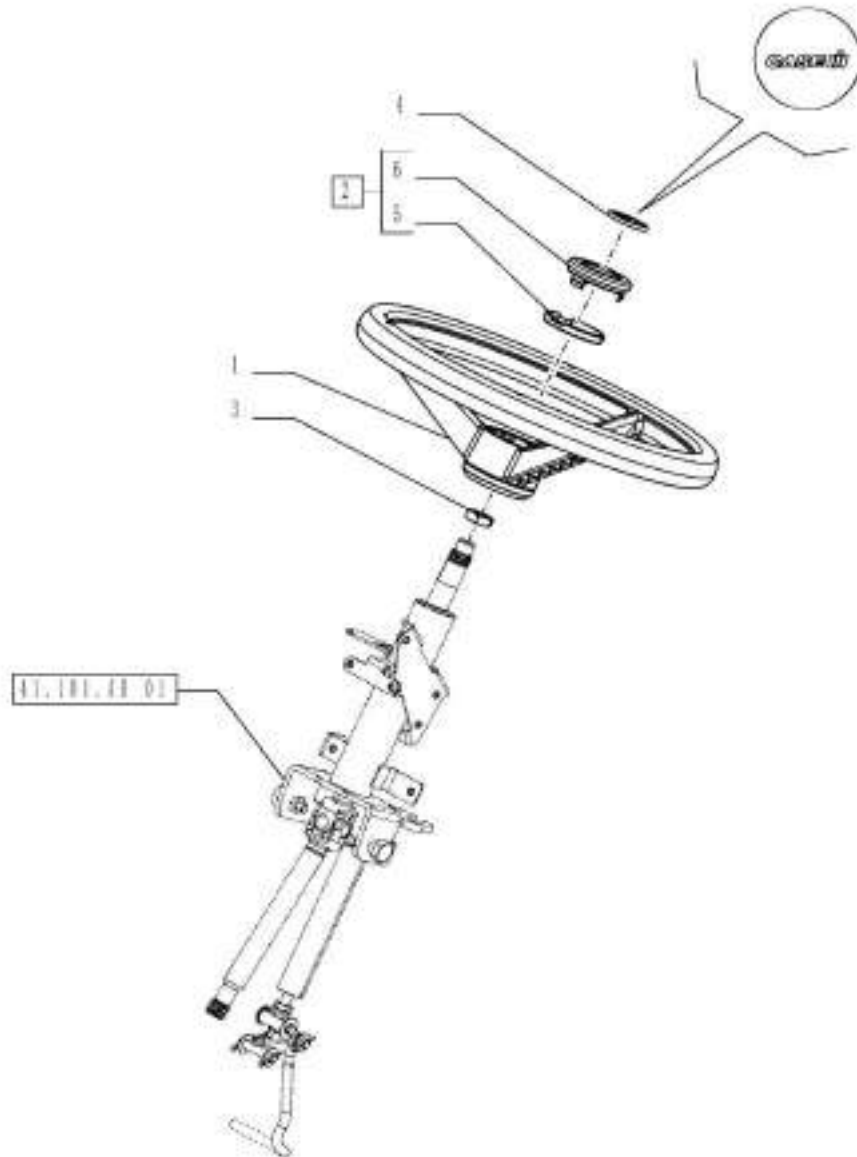

41.101.AA

01

p1

1/2014

VAR - 333606, 334318, 334319, 391606, 392315 - STEERING WHEEL

REF FN	PART NUMBER	YR/SN	QTY DESCRIPTION
1	5091213		1 STEERING WHEEL
2	87668104		1 PLUG ASSY Incl 5 - 6
3	10726611		1 THIN NUT Thin, M18, 1.5mm Pitch, CI 04, ZND
4	87698705		1 EMBLEM
5	5131883		1 GASKET
6	5167652		1 COVER

Valid for Var. 333606 or Var. 334318 or Var. 334319 or Var. 391606 or Var. 392315

FARMALL JX100 FARMALL
JX110 FARMALL JX70
FARMALL JX75 FARMALL
JX80 FARMALL JX90

VAR - 333606, 334318, 334319, 391606, 392315 - STEERING COLUMN

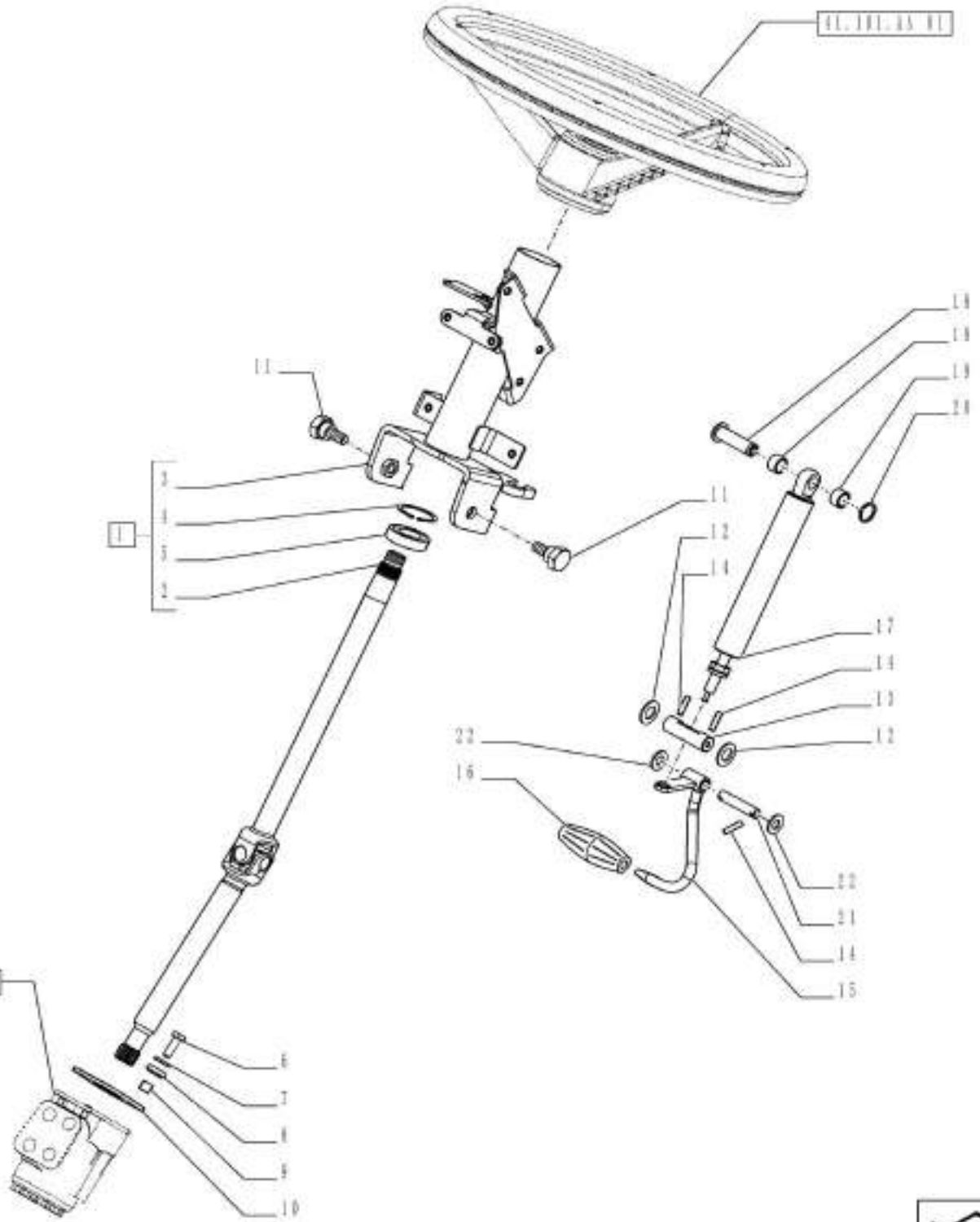

VAR - 333606, 334318, 334319, 391606, 392315 - STEERING COLUMN

REF FN	PART NUMBER	YR/SN	QTY DESCRIPTION
1	84487130		1 STEERING COLUMN ASSY Incl 2 - 5
2	84424693		1 STEERING COLUMN
3	84424698		1 STEERING COLUMN
4	11067376		2 SNAP RING M25, Ext
5	5090125		1 BALL BEARING 25 mm ID x 42 mm OD x 9 mm
6	11106624		4 SCREW Hex, M10 x 1.5 x 35 mm, Cl 8.8, Full Thd
7	12626224		4 WASHER M10 x 25 x 3
8	5091784		4 SPACER
9	5091785		4 BUSHING
10	5197927		1 SPACER
11	84519318		2 SCREW
12	14496901		2 WASHER M16 x 30 x 3
13	84487373		1 SUPPORT
14	10733601		4 COTTER PIN M3.2 x 22
15	84487377		1 PEDAL
16	84487386		1 HANDLE
17	87732038		1 GAS STRUT
18	84487132		1 PIN
19	84487134		2 BUSHING
20	11088076		1 CIRCLIP M10
21	84487384		1 PIN
22	14496601		1 WASHER Flat, 10.50mm ID x 21.00mm OD x 2.00mm, CST, ZND

Valid for Var. 333606 or Var. 334318 or Var. 334319 or Var. 391606 or Var. 392315

FARMALL JX100 FARMALL
JX110 FARMALL JX70
FARMALL JX75 FARMALL
JX80 FARMALL JX90

41.106.AB

01

p1

1/2014

VAR - 338860, 390860 - 2WD, FRONT AXLE, LEVER

REF FN	PART NUMBER	YR/SN	QTY DESCRIPTION
1	5110378		1 STEERING ARM RH
2	5110377		1 STEERING ARM LH
3 1	15977921		2 SCREW Hex, M14 x 1.5 x 90mm, CI 8.8
3	15977621		2 BOLT Hex, M14 x 1.5 x 70mm, CI 8.8
4	12601674		2 WAVE WASHER Wave, M15
5	12164021		2 NUT Thick Hex, M14, 1.50mm Pitch, 11.00mm High, CI 10, ZND
6 1	585876		2 WASHER
(1)	VAR - 338860		

Valid for Var. 338860 or Var. 390860

FARMALL JX100
FARMALL JX70
FARMALL JX75
FARMALL JX80

VAR - 334413, 390338, 743515 - 2WD, FRONT AXLE

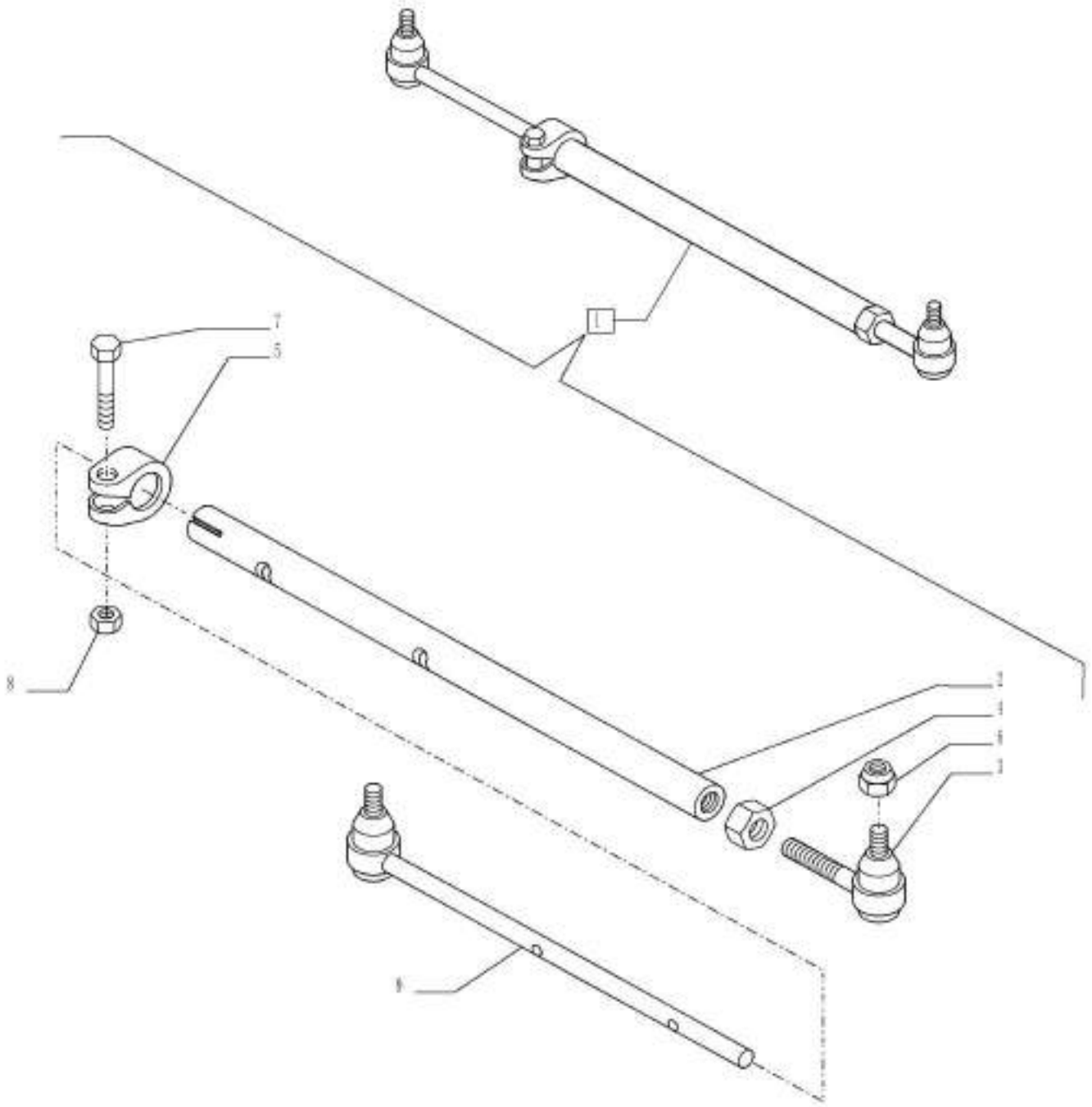

VAR - 334413, 390338, 743515 - 2WD, FRONT AXLE

REF FN	PART NUMBER	YR/SN	QTY DESCRIPTION
1	5086974		1 STEERING TIE-ROD ASSY Incl 2 - 9
2	5085084		1 STEERING TIE-ROD
3	5085076		1 BALL JOINT
4	5085078		1 NUT
5	5085086		1 CLAMP
6	12575821		2 LOCK NUT M14 x 1.5, CI 05
7	16160121		1 BOLT Hex, M10 x 50mm, CI 8.8, Full Thd
8	12577211		1 LOCK NUT Prevailing Torque, M10, 1.50mm Pitch, 12.30mm High, CI 8, ZND
9	5085085		1 BALL JOINT
Valid for Industrial Var. 334413, 390338 (743515)			FARMALL JX100 FARMALL JX70 FARMALL JX75 FARMALL JX80

VAR - 390250 - 4WD FRONT AXLE, TIE-ROD

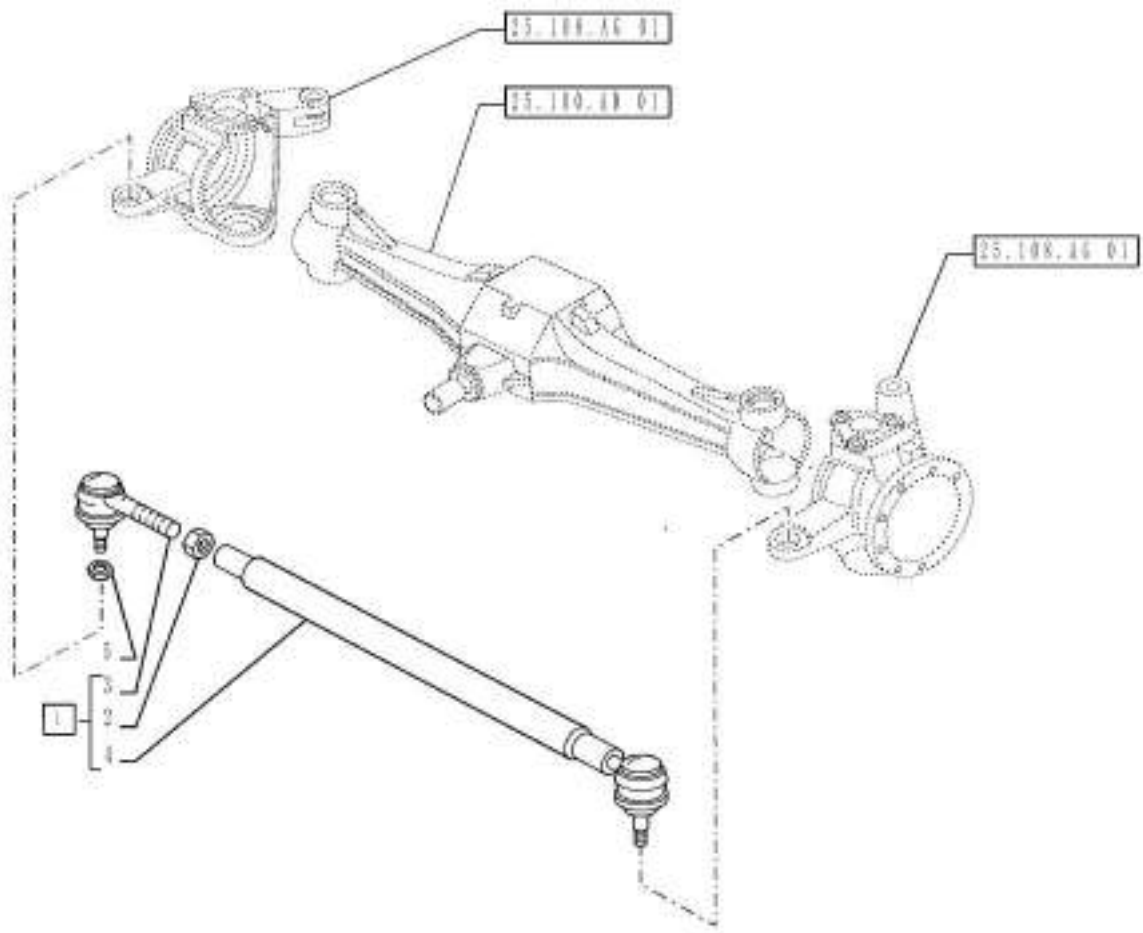

VAR - 390250 - 4WD FRONT AXLE, TIE-ROD

REF FN	PART NUMBER	YR/SN	QTY DESCRIPTION
1	5135076		1 TRACK ROD ASSY Incl 2 - 4
2	5109553		1 BALL JOINT M16xM20 Threads
3	587302		1 LOCK NUT
4	5135075		1 TIE-ROD
5	12575914		2 LOCK NUT

Valid for Var. 390250

FARMALL JX70

VAR - 335325 - 4WD FRONT AXLE, TIE-ROD

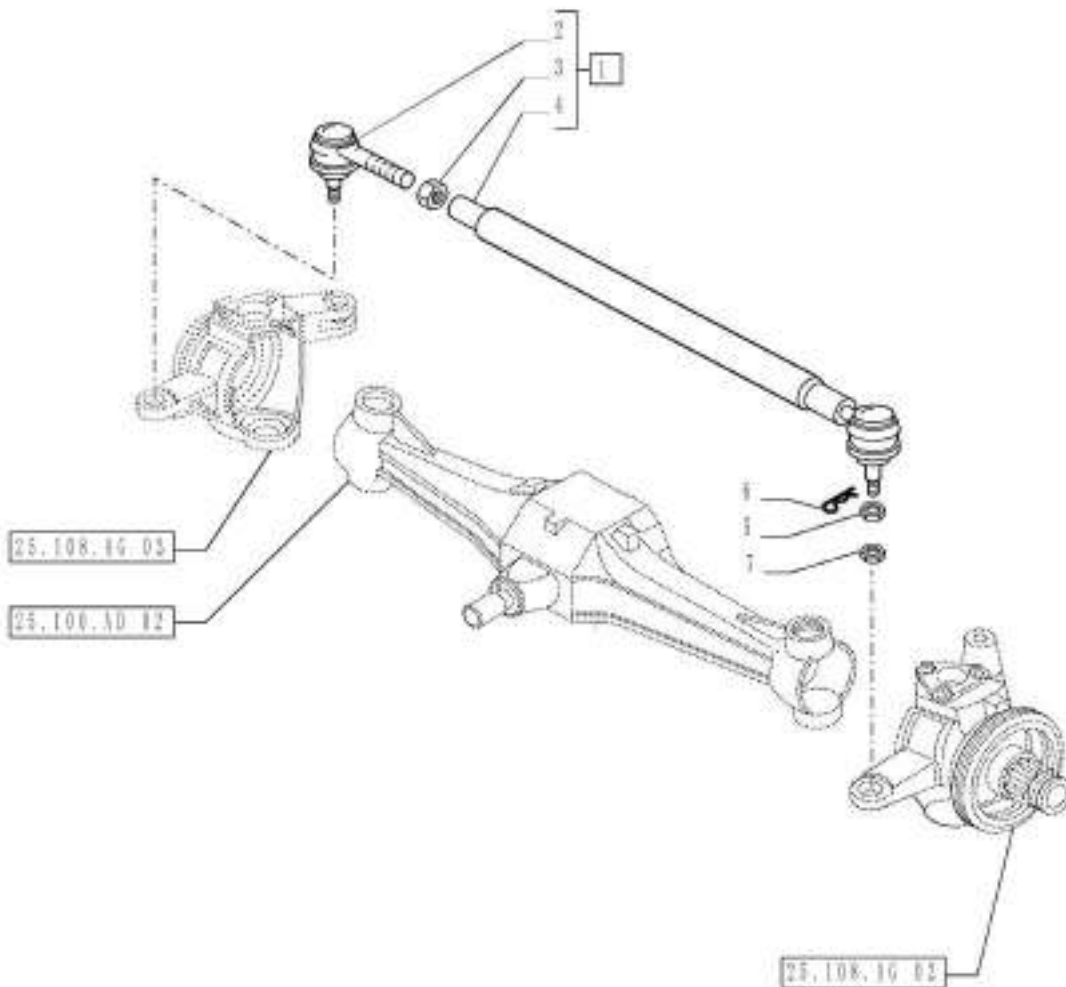

41.106.AD

02

p1

1/2014

VAR - 335325 - 4WD FRONT AXLE, TIE-ROD

REF FN	PART NUMBER	YR/SN	QTY DESCRIPTION
1	5142233		1 TRACK ROD ASSY Incl 2 - 4
2	87542553		1 BALL JOINT
3	10726914		1 THIN NUT Thin, M24 x 2.5, CI 04
4	5142234		1 TRACK ROD ASSY
5	10724614		2 SLOTTED NUT Thin Slotted, M18, 1.5mm Pitch, 15.00mm High, R80, DAC
6	10733804		2 COTTER PIN 4.00mm Dia x 16.00mm
7	12576014		2 NUT Prevailing Torque, M18, 1.5mm Pitch, 16.00mm High, CI 04, DAC

Valid for Var. 335325

FARMALL JX100
FARMALL JX110
FARMALL JX75
FARMALL JX80

VAR - 335539 - CLASS 2 FRONT AXLE WITH 2ND STEERING CYLYNDER & LIMITED SLIP (30KM/H) - TIE ROD

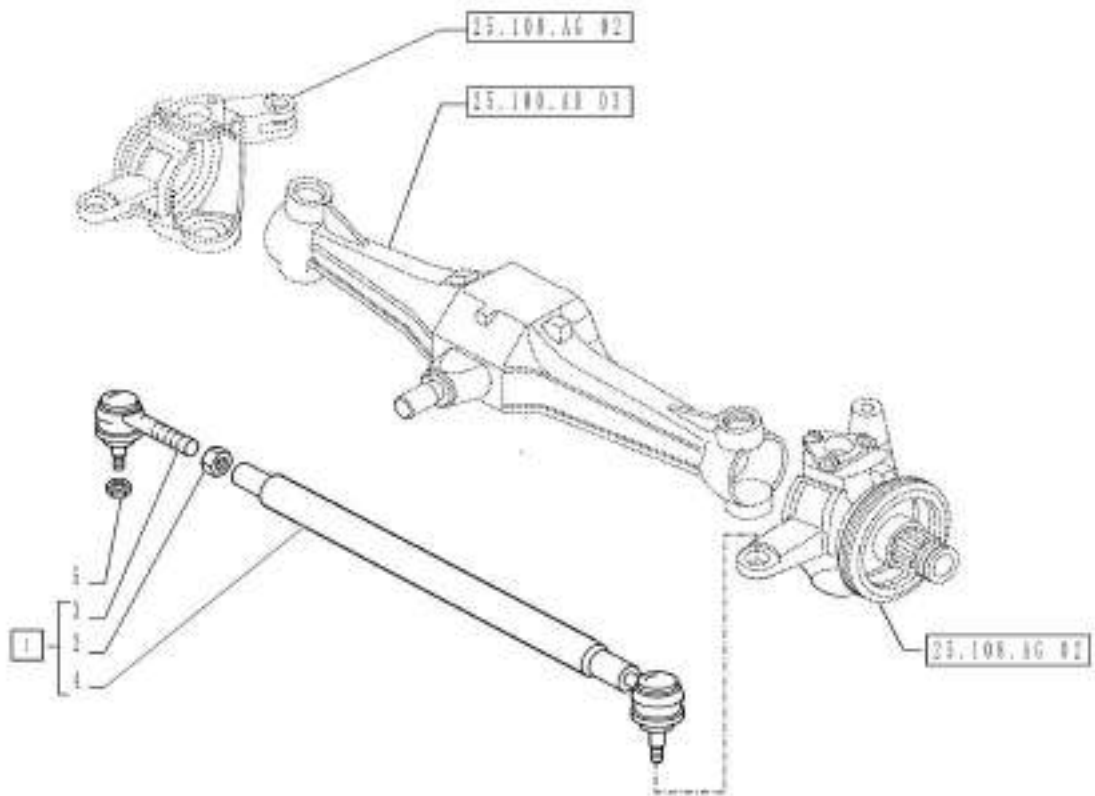

41.106.AD

03

p1

1/2014

VAR - 335539 - CLASS 2 FRONT AXLE WITH 2ND STEERING CYLYNDER & LIMITED SLIP (30KM/H) - TIE ROD

REF FN	PART NUMBER	YR/SN	QTY DESCRIPTION
1	5168933		1 TRACK ROD ASSY Incl 2 - 4
2	587302		1 LOCK NUT M20
3	5109553		1 BALL JOINT M16 x M20 Threads
4	NSS		1 NOT SERVICED SEPARATELY Rod Incl in 1
5	12575914		2 LOCK NUT

Valid for Var. 335539

FARMALL JX100
FARMALL JX110
FARMALL JX75
FARMALL JX80

VAR - 330120, 331120, 743846 - STEERING ASSY, FILTER, COMPONENTS

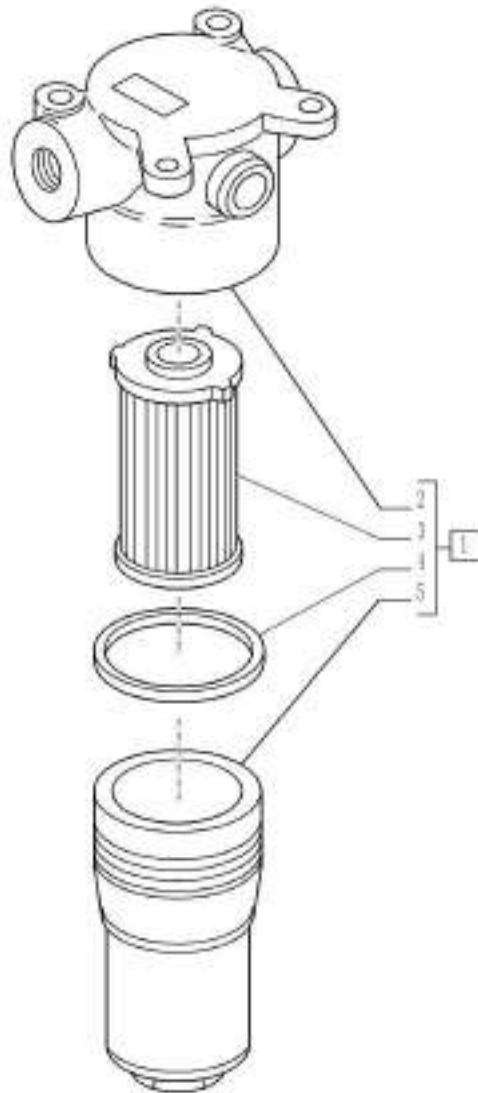

41.200.AL

01

p1

1/2014

VAR - 330120, 331120, 743846 - STEERING ASSY, FILTER, COMPONENTS

REF FN	PART NUMBER	YR/SN	QTY DESCRIPTION
1	5197006		1 FILTER ASSY Incl 2 - 5
2	NSS		1 NOT SERVICED SEPARATELY Cover Incl in 1
3	5178100		1 ELEMENT
4	5194880		1 KIT
5	NSS		1 NOT SERVICED SEPARATELY Housing Incl in 1

Valid for Industrial Var. 330120, 331120 (743846)

**FARMALL JX100
FARMALL JX110
FARMALL JX75
FARMALL JX90**

41.200.AO

01

p1

1/2014

VAR - 390249, 743846, 744738, 744739, 744744 - HYDRAULIC STEERING HOSE

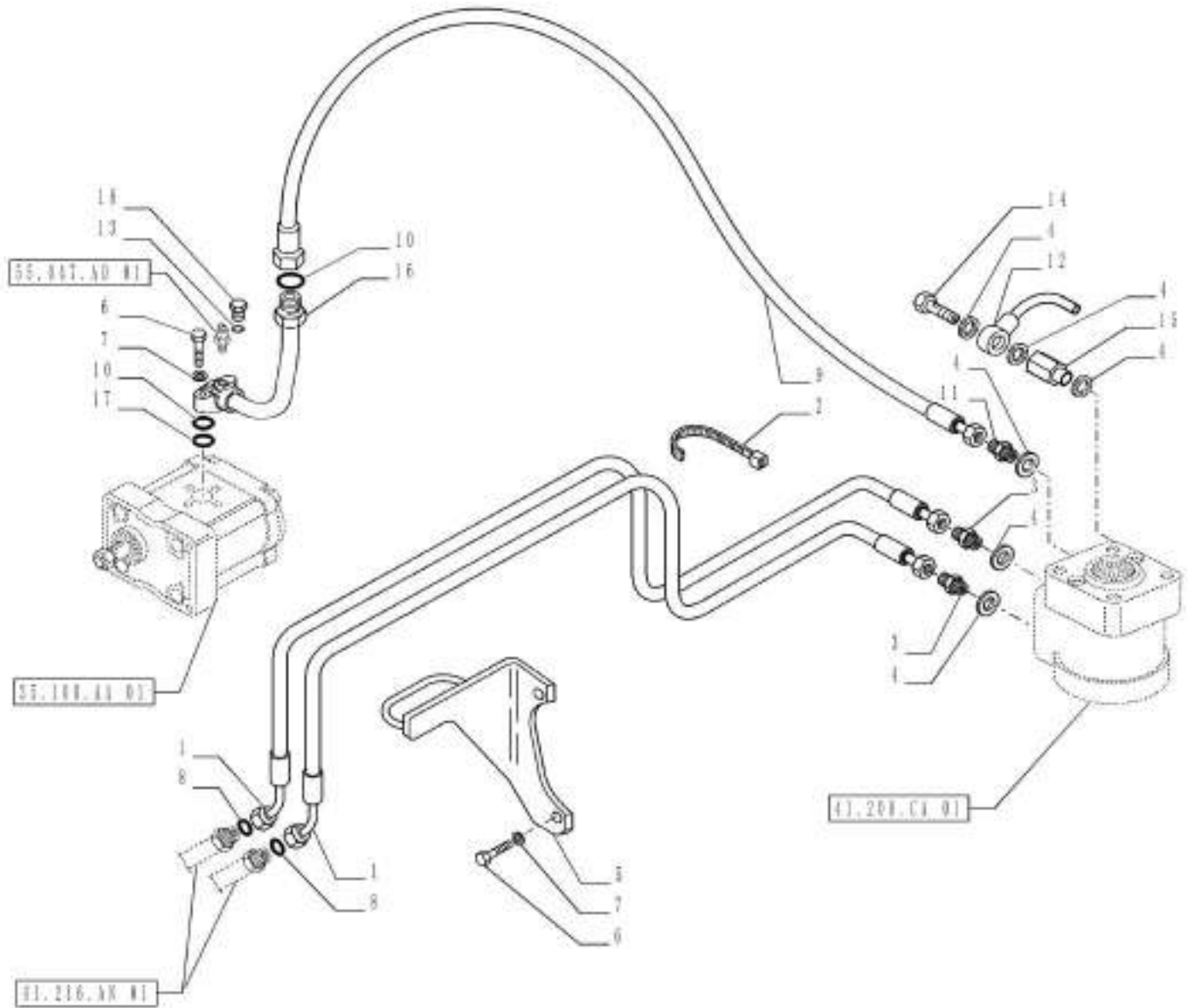

VAR - 390249, 743846, 744738, 744739, 744744 - HYDRAULIC STEERING HOSE

REF	FN	PART NUMBER	YR/SN	QTY	DESCRIPTION
1	1	84521706		2	FLEXIBLE HOSE
1	2	84512624		2	FLEXIBLE HOSE
1	3	84521705		2	FLEXIBLE HOSE
2		5112712		3	COLLAR M4.8 x 283
3		5091176		2	FITTING
4		44019496		6	GASKET
5		5091931		1	SUPPORT
6		43117		4	SCREW Hex, M6 x 1 x 30mm, CI 8.8
7		12601274		4	WAVE WASHER Wave, M6.4
8		14463280		2	O-RING 24.99mm ID x 3.53" Width
9	1	84425472		1	HOSE ASSY.
9	2	84521707		1	FLEXIBLE HOSE
9	3	5097735		1	FLEXIBLE HOSE
10		14457180		2	O-RING 13.94mm ID x 2.62" Width
11		87583556		1	HYD CONNECTOR
12		5120620		1	RIGID TUBE
13		10260160		1	SEAL M10.2 x 14 x 1
14		5112983		1	BANJO BOLT
15		84422802		1	HYD CONNECTOR
16	4	84521708		1	PIPE
16	5	5097594		1	HYD. TUBE
17		44015841		1	BACK-UP RING 19mm ID x 20mm OD x 2.05mm
18		11903111		1	PLUG M10 x 1.25 x 11, CI5.8
(1)	Valid for FARMALL JX70 Model Only				
(2)	Valid for FARMALL JX80 Model Only				
(3)	Valid for FARMALL JX75, 90, 100, 110 Models Only				
(4)	CAB Models Only				
(5)	ROPS Models Only				
Valid for Var. 390249 or Industrial Var. 330120, 331120 (743846) or Industrial Var. 334321, 390268 (744738) or Industrial Var. 330384, 334322 (744739) or Industrial Var. 334320, 390267 (744744)					FARMALL JX100 FARMALL JX110 FARMALL JX70 FARMALL JX75 FARMALL JX80 FARMALL JX90

41.200.AO

02

p1

1/2014

VAR - 744738, 744739, 744744 - HYDRAULIC STEERING HOSE RETURN

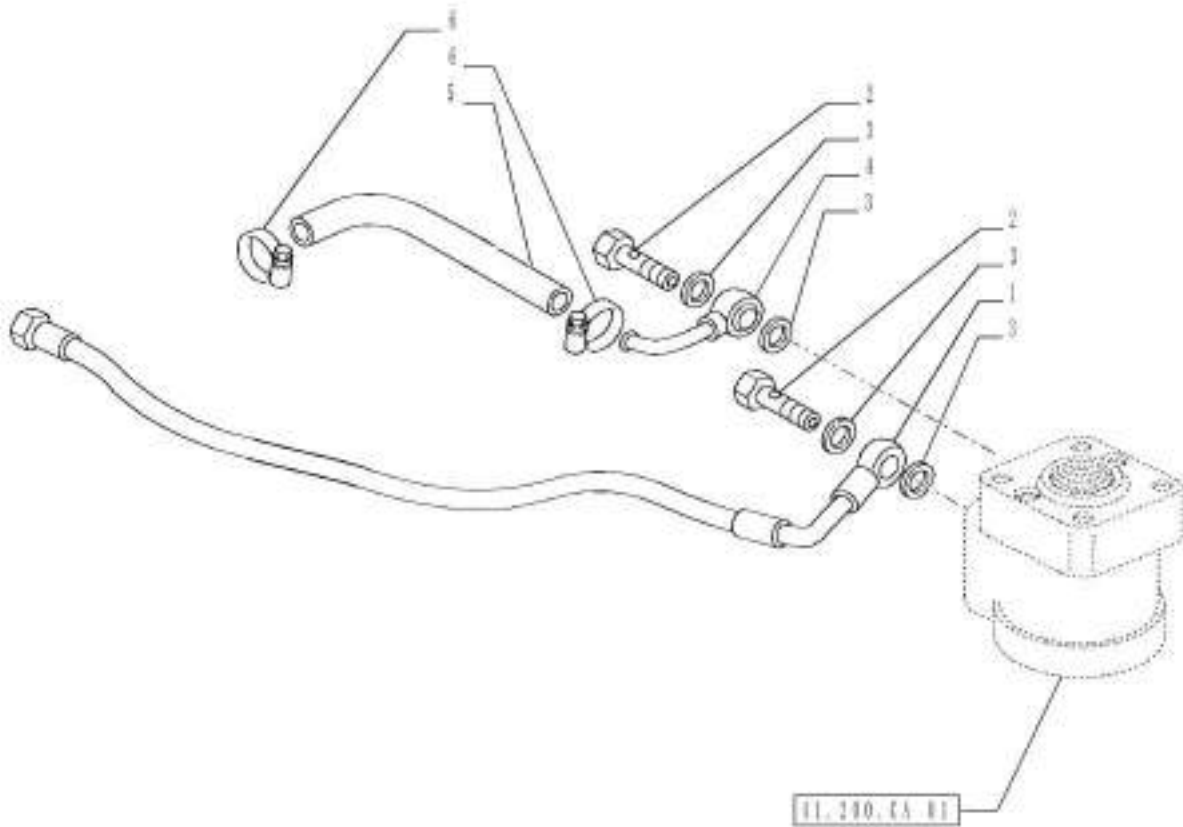

41.200.AO

02

p1

1/2014

VAR - 744738, 744739, 744744 - HYDRAULIC STEERING HOSE RETURN

REF FN	PART NUMBER	YR/SN	QTY DESCRIPTION
1	84222348		1 PIPE
2	5112983		2 BANJO BOLT
3	44019496		4 GASKET
4	5094789		1 TUBE
5	87626440		1 HYDRAULIC HOSE 1800.00 mm
6	87557209		2 CLAMP Adj Hose, M16-27

Valid for Industrial Var. 334321, 390268 (744738) or Industrial Var. 330384, 334322 (744739) or Industrial Var. 334320, 390267 (744744)

FARMALL JX100 FARMALL
JX110 FARMALL JX70
FARMALL JX75 FARMALL
JX80 FARMALL JX90

41.200.AO

03

p1

1/2014

VAR - 330384, 744739 - HYDRAULIC STEERING HOSE RETURN

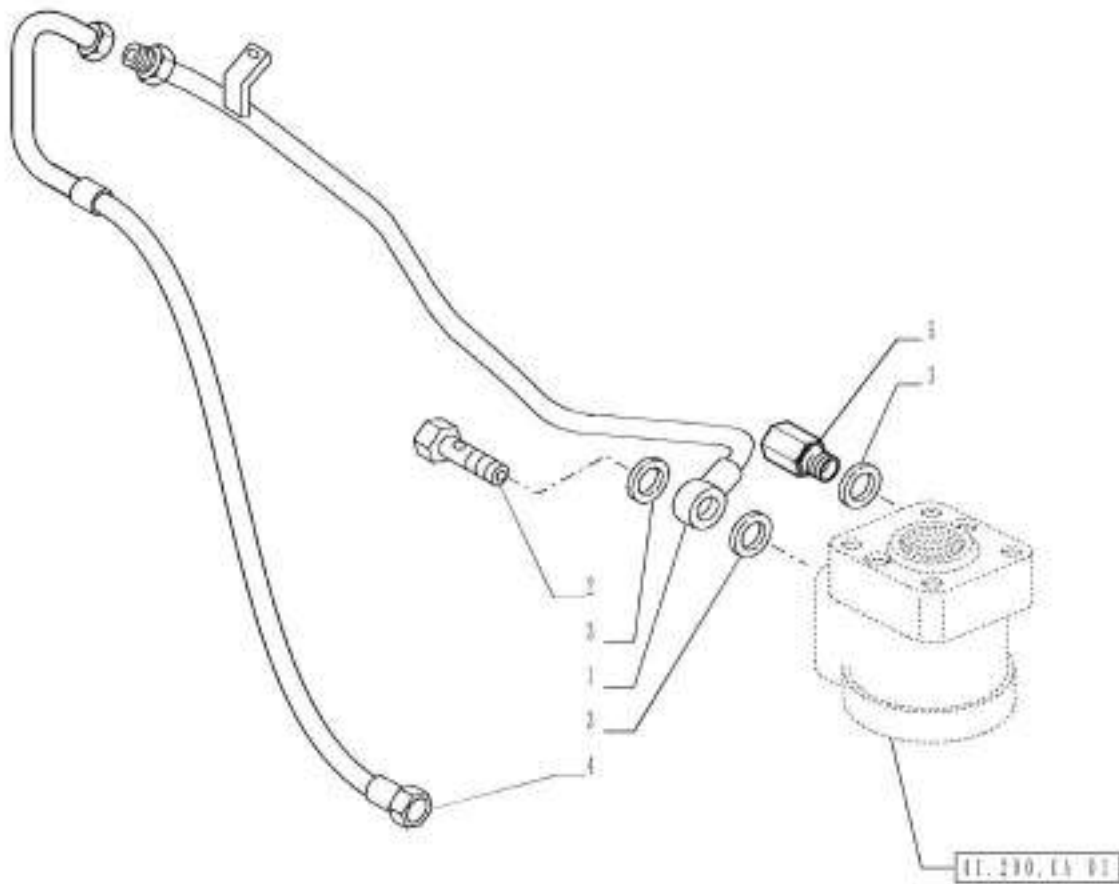

41.200.AO

03

p1

1/2014

VAR - 330384, 744739 - HYDRAULIC STEERING HOSE RETURN

REF FN	PART NUMBER	YR/SN	QTY DESCRIPTION
1	84211673		1 PIPE
2	5100984		1 BANJO BOLT
3	44019496		4 GASKET
4	84567183		1 FLEXIBLE HOSE
5	84422802		2 HYD CONNECTOR

Valid for Industrial Var. 330384 (744739)

FARMALL JX100 FARMALL
JX110 FARMALL JX70
FARMALL JX75 FARMALL
JX80 FARMALL JX90

41.200.AO

04

p1

1/2014

VAR - 330120, 331120, 743846 - HYDRAULIC STEERING HOSE

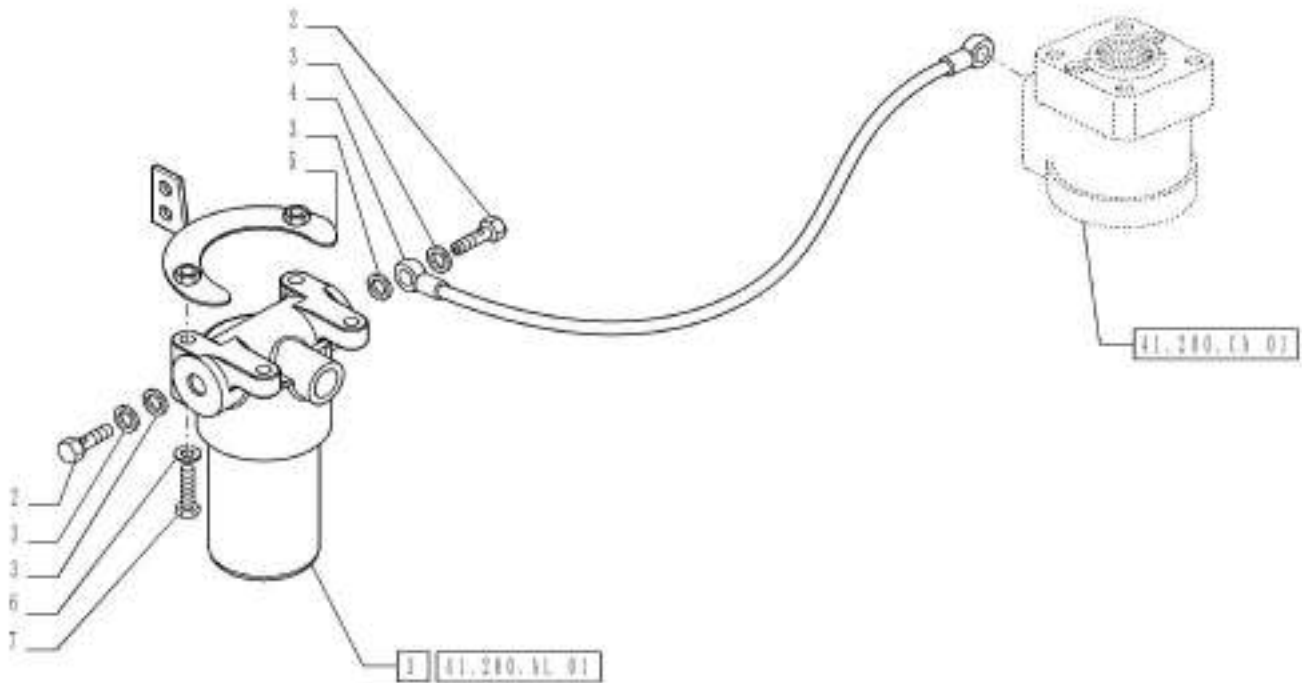

41.200.AO

04

p1

1/2014

VAR - 330120, 331120, 743846 - HYDRAULIC STEERING HOSE

REF FN	PART NUMBER	YR/SN	QTY DESCRIPTION
1	5197006		1 FILTER
2	5112588		2 BANJO BOLT M22 x 1.5 x 40.00mm
3	10263460		4 SEAL 22.30mm ID x 28.00mm OD, 1.50mm, Copper
4	84411123		1 FLEXIBLE HOSE
5	84494704		1 SUPPORT
6	12601374		2 WAVE WASHER Wave, 8.40mm ID x 15.00mm OD x 0.80mm, 3.00mm, CST, DAC
7	15213724		2 BOLT Hex, M8 x 60mm, Cl 8.8, Full Thd

Valid for Industrial Var. 330120, 331120 (743846)

**FARMALL JX100
FARMALL JX110
FARMALL JX75
FARMALL JX90**

41.200.CA

01

p1

1/2014

VAR - 333606, 334318, 334319, 391606, 392315 - STEERING CONTROL VALVE

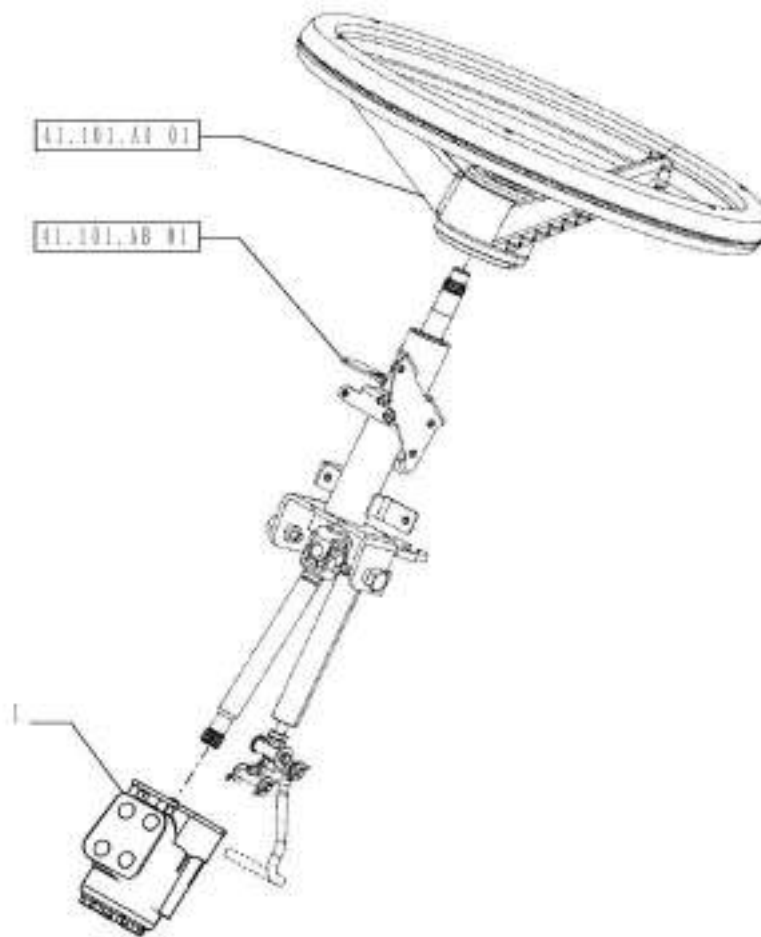

41.200.CA

01

p1

1/2014

VAR - 333606, 334318, 334319, 391606, 392315 - STEERING CONTROL VALVE

REF FN	PART NUMBER	YR/SN	QTY DESCRIPTION
1	84174896		1 HYDRAULIC STEERING 2WD
1	5094306		1 HYDRAULIC STEERING 4WD

Valid for Var. 333606 or Var. 334318 or Var. 334319 or Var. 391606 or Var. 392315

FARMALL JX100 FARMALL JX110 FARMALL JX70 FARMALL JX75 FARMALL JX80 FARMALL JX90

41.206.AA

01

p1

1/2014

VAR - 330120, 331120, 390249, 743846 - HYDRAULIC STEERING PUMP

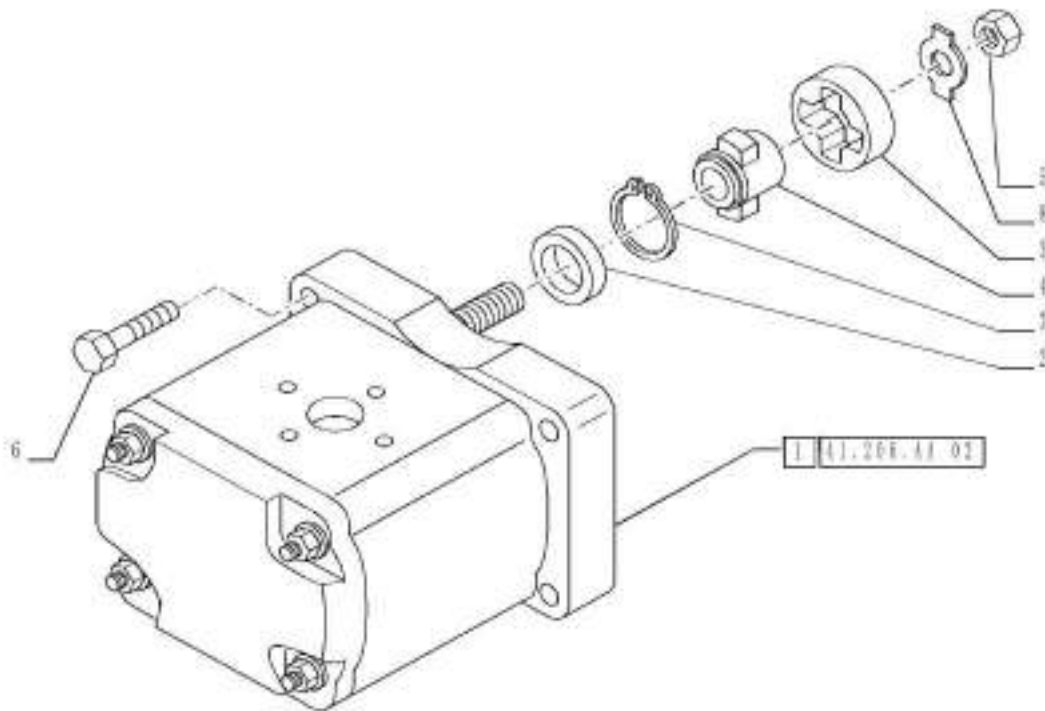

41.206.AA

01

p1

1/2014

VAR - 330120, 331120, 390249, 743846 - HYDRAULIC STEERING PUMP

REF FN	PART NUMBER	YR/SN	QTY DESCRIPTION
1	87725756		1 HYDRAULIC PUMP ASSY, 11 CC/Rev
2	5118568		1 CENTERING RING
3	5118569		1 COUPLING
4	5118570		1 HUB
5	5093733		4 NUT
6	86977789		4 BOLT Hex, M6 x 1 x 35mm, Cl 8.8
7	13398376		1 SNAP RING M40, Int
8	8273920		1 LOCK WASHER

Valid for Var. 390249 or Industrial Var. 330120, 331120 (743846)	FARMALL JX100 FARMALL JX110 FARMALL JX70 FARMALL JX75 FARMALL JX80 FARMALL JX90
--	--

VAR - 330120, 331120, 390249, 743846 - POWER STEERING PUMP, BREAKDOWN

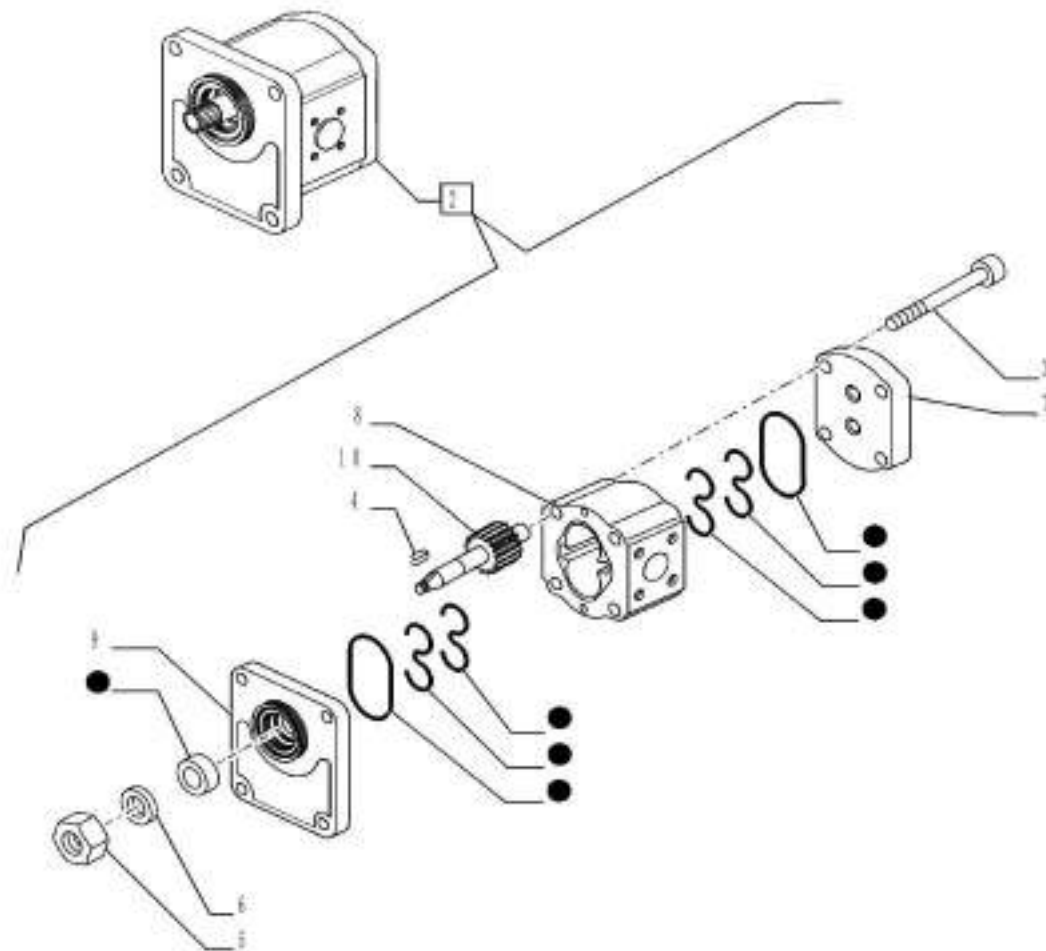

VAR - 330120, 331120, 390249, 743846 - POWER STEERING PUMP, BREAKDOWN

REF FN	PART NUMBER	YR/SN	QTY DESCRIPTION
1	87341173		1 SEAL KIT
2	87725756		1 HYDRAULIC PUMP ASSY, Incl 1, 2 - 10
3	NSS		4 NOT SERVICED SEPARATELY Screw Incl in 1
4	8273918		1 KEY
5	8273919		1 NUT
6	8273920		1 LOCK WASHER
7	NSS		1 NOT SERVICED SEPARATELY Cover Incl in 1
8	NSS		1 NOT SERVICED SEPARATELY Housing Incl in 1
9	NSS		1 NOT SERVICED SEPARATELY Cover Incl in 1
10	NSS		1 NOT SERVICED SEPARATELY Gear Incl in 1

Valid for Var. 390249 or Industrial Var. 330120, 331120 (743846)

FARMALL JX100 FARMALL
 JX110 FARMALL JX70
 FARMALL JX75 FARMALL
 JX80 FARMALL JX90

VAR - 330120, 331120, 390249, 743846 - HYDRAULIC STEERING, PUMP, LINE

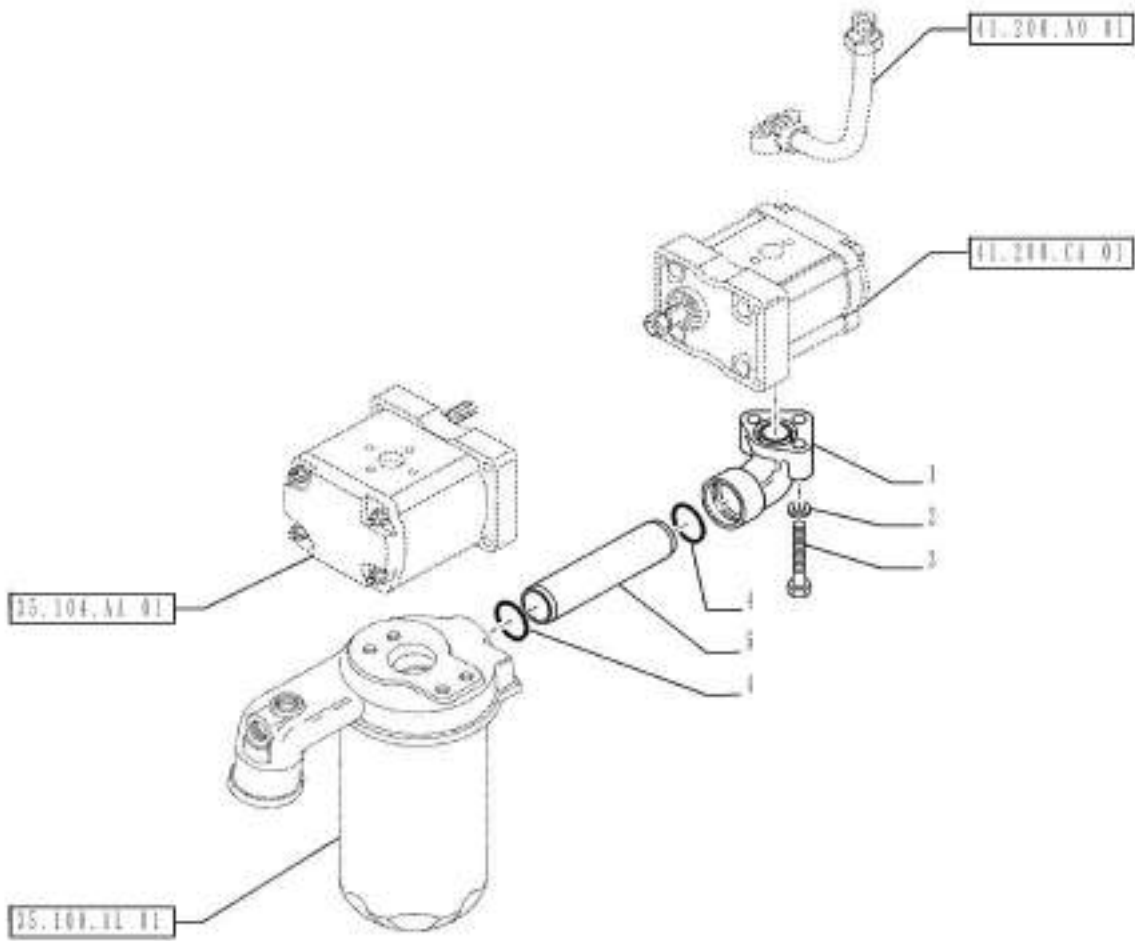

41.206.AJ

01

p1

1/2014

VAR - 330120, 331120, 390249, 743846 - HYDRAULIC STEERING, PUMP, LINE

REF FN	PART NUMBER	YR/SN	QTY DESCRIPTION
1	84210967		1 SUPPORT
2	10569374		3 LOCK WASHER M8
3	14302821		3 HEX SOC SCREW M8 x 1.25 x 18mm, Cl 8.8, Full Thd
4	14457681		2 O-RING 21.89mm ID x 2.62" Width
5	84210367		1 TUBE

Valid for Var. 390249 or Industrial Var. 330120, 331120 (743846)

FARMALL JX100 FARMALL
JX110 FARMALL JX70
FARMALL JX75 FARMALL
JX80 FARMALL JX90

41.216.AN

01

p1

1/2014

VAR - 334413, 390338, 743515 - 2WD FRONT AXLE, HYDRAULIC STEERING CYLINDER HOSES

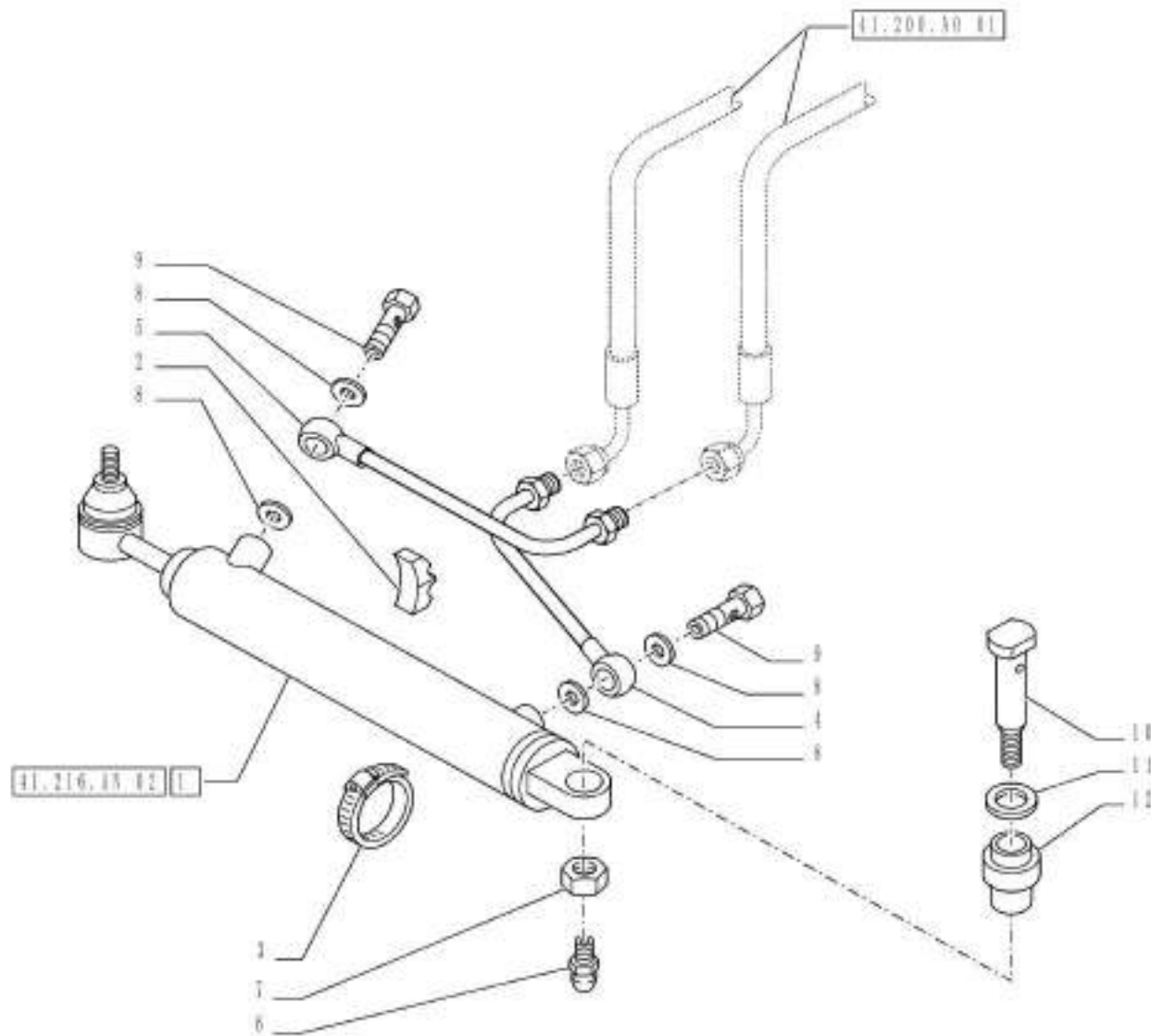

41.216.AN

01

p1

1/2014

VAR - 334413, 390338, 743515 - 2WD FRONT AXLE, HYDRAULIC STEERING CYLINDER HOSES

REF FN	PART NUMBER	YR/SN	QTY DESCRIPTION
1	5098112		1 STEERING CYLINDER ASSY
2	5121043		1 SPACER
3	5085782		1 CLAMP
4	5120997		1 HYD. TUBE LH Delivery
5	5098808		1 PIPE RH Delivery
6	80714		1 LUBE NIPPLE 1/4"-28 NPT x .54" lg
7	12576011		1 NUT
8	10280060		5 SEAL M14.2 x 20 x 1.5
9	10184311		1 BANJO BOLT M14-1.5 x 27
10	5088920		1 PIN
11	11191679		1 BELLEVILLE WASHER Belleville, M19
12	5102972		1 BUSHING

Valid for Industrial Var. 334413, 390338 (743515)

FARMALL JX100
FARMALL JX70
FARMALL JX75
FARMALL JX80

41.216.AN

02

p1

1/2014

VAR - 334413, 390338, 743515 - 2WD FRONT AXLE, HYDRAULIC STEERING CYLINDER, BREAKDOWN

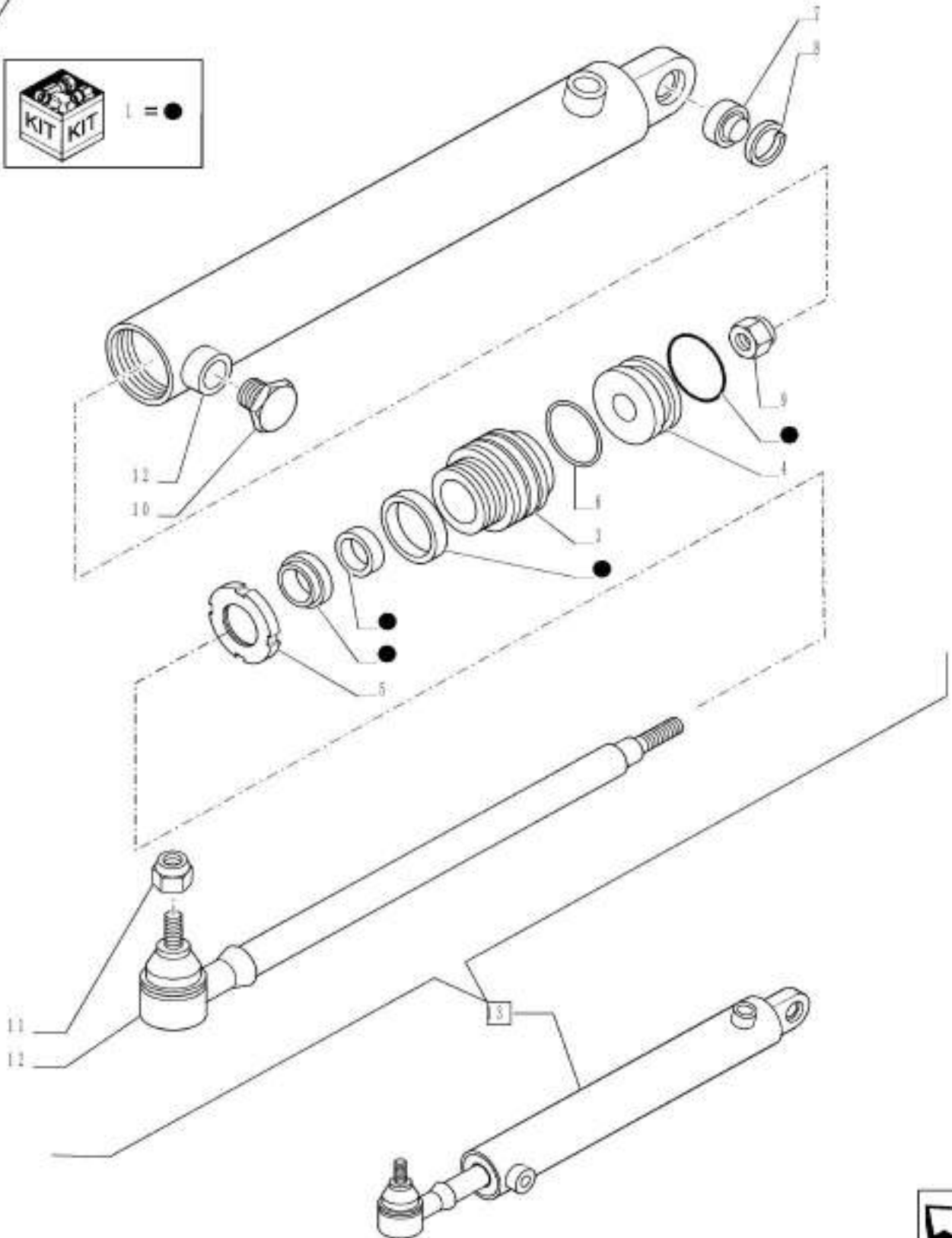
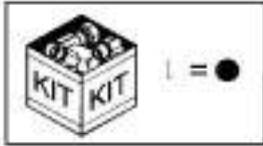

VAR - 334413, 390338, 743515 - 2WD FRONT AXLE, HYDRAULIC STEERING CYLINDER, BREAKDOWN

REF FN	PART NUMBER	YR/SN	QTY DESCRIPTION
1	5080358		1 SEAL KIT ASSY
2	5080344		1 PISTON ROD
3	5080345		1 TOP COVER
4	5080346		1 PISTON
5	5080347		1 NUT
6	5080348		1 RING
7	5080349		1 BUSHING
8	5080350		1 RING
9	5080351		1 NUT
10	5080356		1 PLUG
11	5080357		1 NUT
12	NSS		1 NOT SERVICED SEPARATELY Body Incl in 12
13	5098112		1 STEERING CYLINDER ASSY, Incl 2 - 12
Valid for Industrial Var. 334413, 390338 (743515)			FARMALL JX100 FARMALL JX70 FARMALL JX75 FARMALL JX90

VAR - 390250 - 4WD FRONT AXLE - HYDRAULIC STEERING CYLINDER

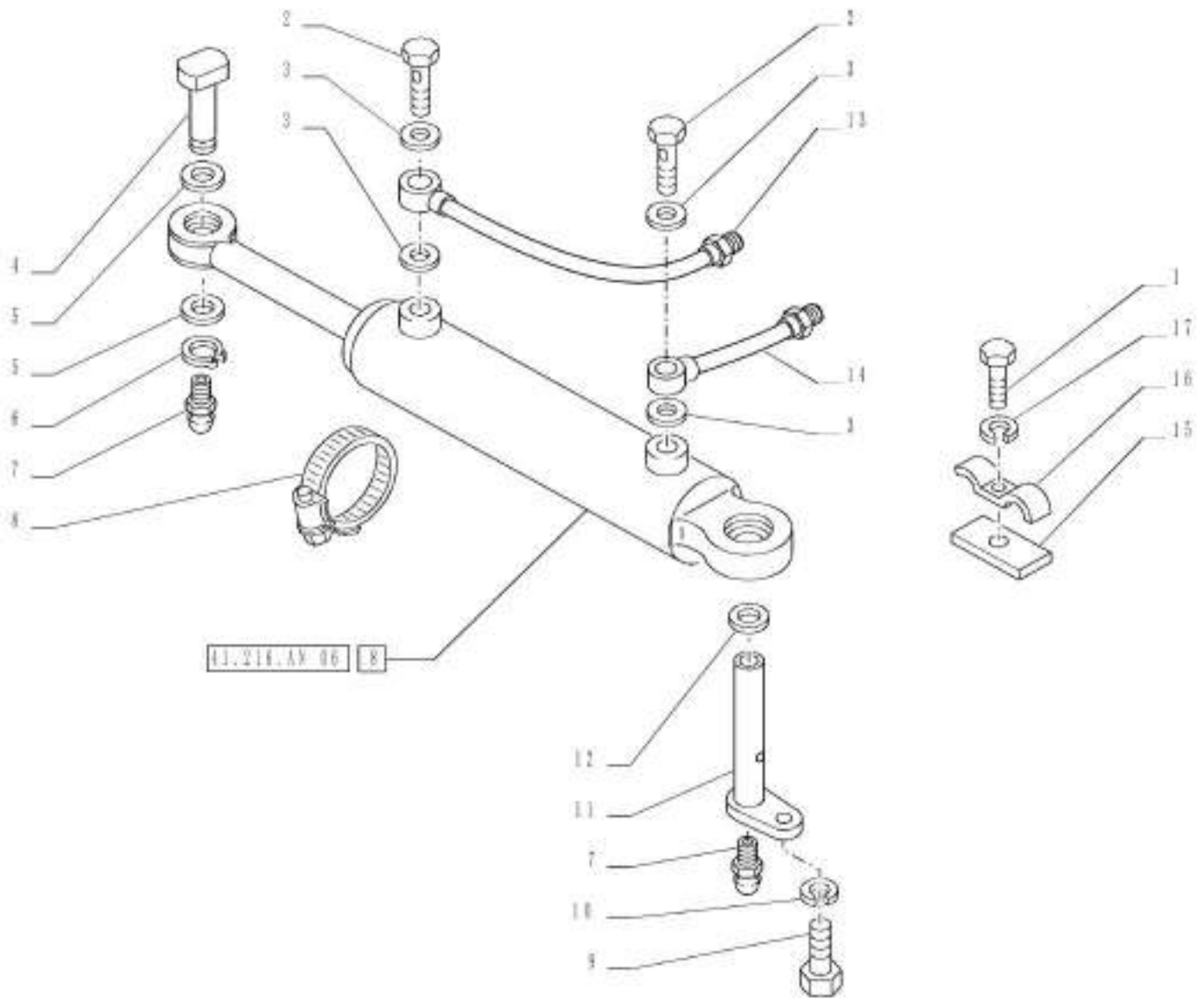

41.216.AN

05

p1

1/2014

VAR - 390250 - 4WD FRONT AXLE - HYDRAULIC STEERING CYLINDER

REF FN	PART NUMBER	YR/SN	QTY DESCRIPTION
1	86508568		1 BOLT Hex, M6 x 16mm, CI 8.8, Full Thd
2	10184311		2 BANJO BOLT M14-1.5 x 27
3	10280060		4 SEAL M14.2 x 20 x 1.5 14.86 x 22.23 x 2
4	4987671		1 PIN
5	5100730		2 WASHER 20.50mm ID x 28.00mm OD x 5.25mm, Zinc
6	11066876		2 SNAP RING M20, Ext
7	13406911		2 LUBE NIPPLE Straight, 1/4"-28 x 0.54"
8	5098812		1 COLLAR D= 50-70
9	120104		1 BOLT Hex, M8 x 1.25 x 20mm, CI 8.8, Full Thd
10	11193874		1 BELLEVILLE WASHER 8.4mm ID x 16.00mm OD x 1.4mm, 1.85mm, CI 8.8
11	4997489		1 PIN
12	5100731		1 WASHER
13	5144505		1 HYD. TUBE
14	5144503		1 FITTING
15	5138294		1 SUPPORT
16	4999554		1 CLAMP
17	11197779		1 BELLEVILLE WASHER 6.40mm ID x 12.00mm OD x 1.20mm, 1.63mm, CI 8.8, ZNM
18	5189895		1 STEERING CYLINDER 356MM

Valid for Var. 390250

FARMALL JX70

VAR - 390250 - HYDRAULIC STEERING, CYLINDER, COMPONENTS

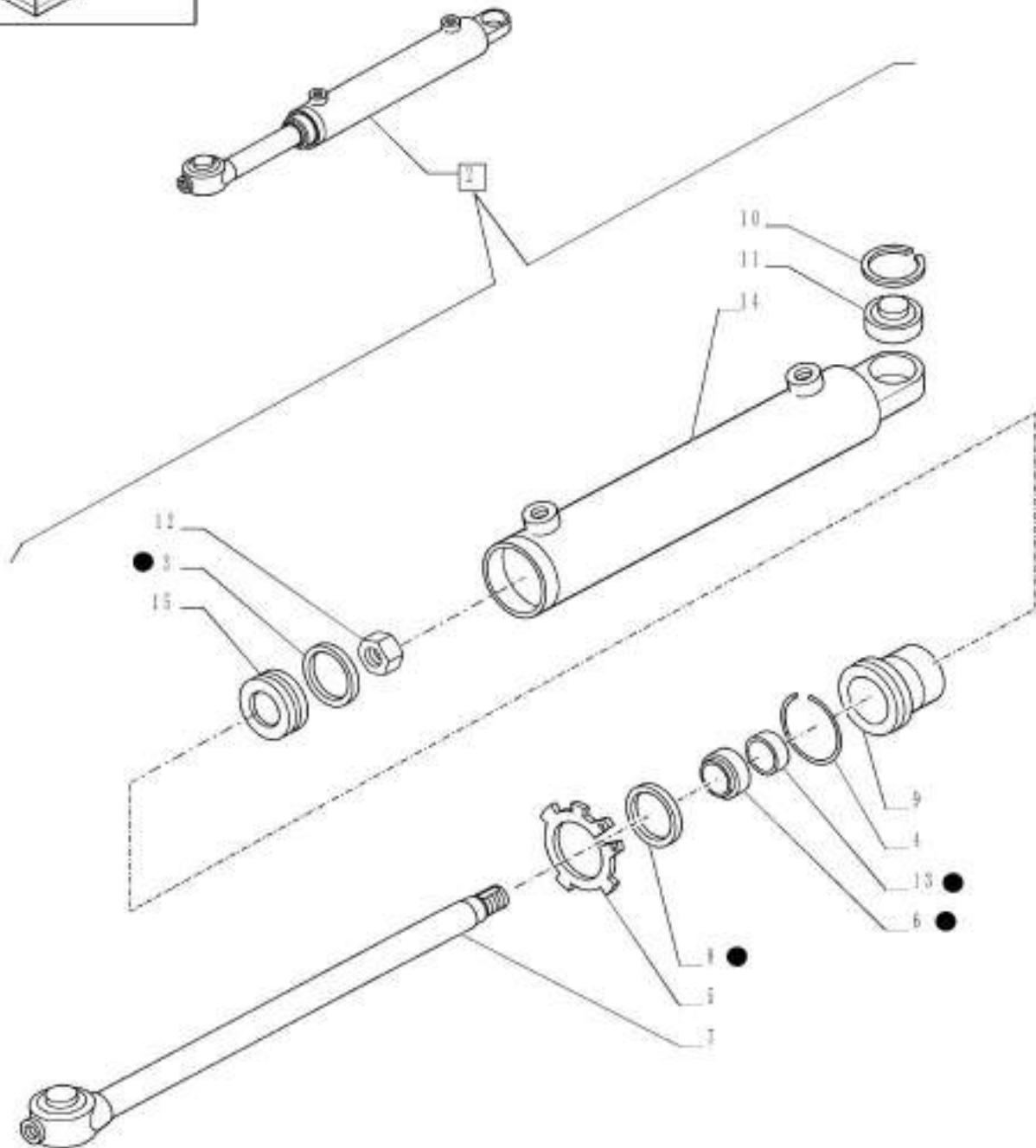

VAR - 390250 - HYDRAULIC STEERING, CYLINDER, COMPONENTS

REF FN	PART NUMBER	YR/SN	QTY DESCRIPTION
1	5190591		1 SEAL KIT
2	5189895		1 STEERING CYLINDER 356MM, Incl 3 - 15
3	5190909		1 SEAL
4	5190912		1 LOCKING RING
5	5190907		1 CIRCLIP
6	5190911		1 SEAL
7	5190921		1 THREADED ROD
8	5190589		1 RING
9	5190590		1 SPOOL
10	5190903		2 LOCKING RING
11	5190901		2 BUSHING
12	5190904		1 LOCK NUT
13	5190549		1 SCRAPER RING
14	NSS		1 NOT SERVICED SEPARATELY Body Incl in 2
15	5190908		1 ROD

Valid for Var. 390250

FARMALL JX70

VAR - 335325 - 4WD FRONT AXLE - HYDRAULIC STEERING CYL

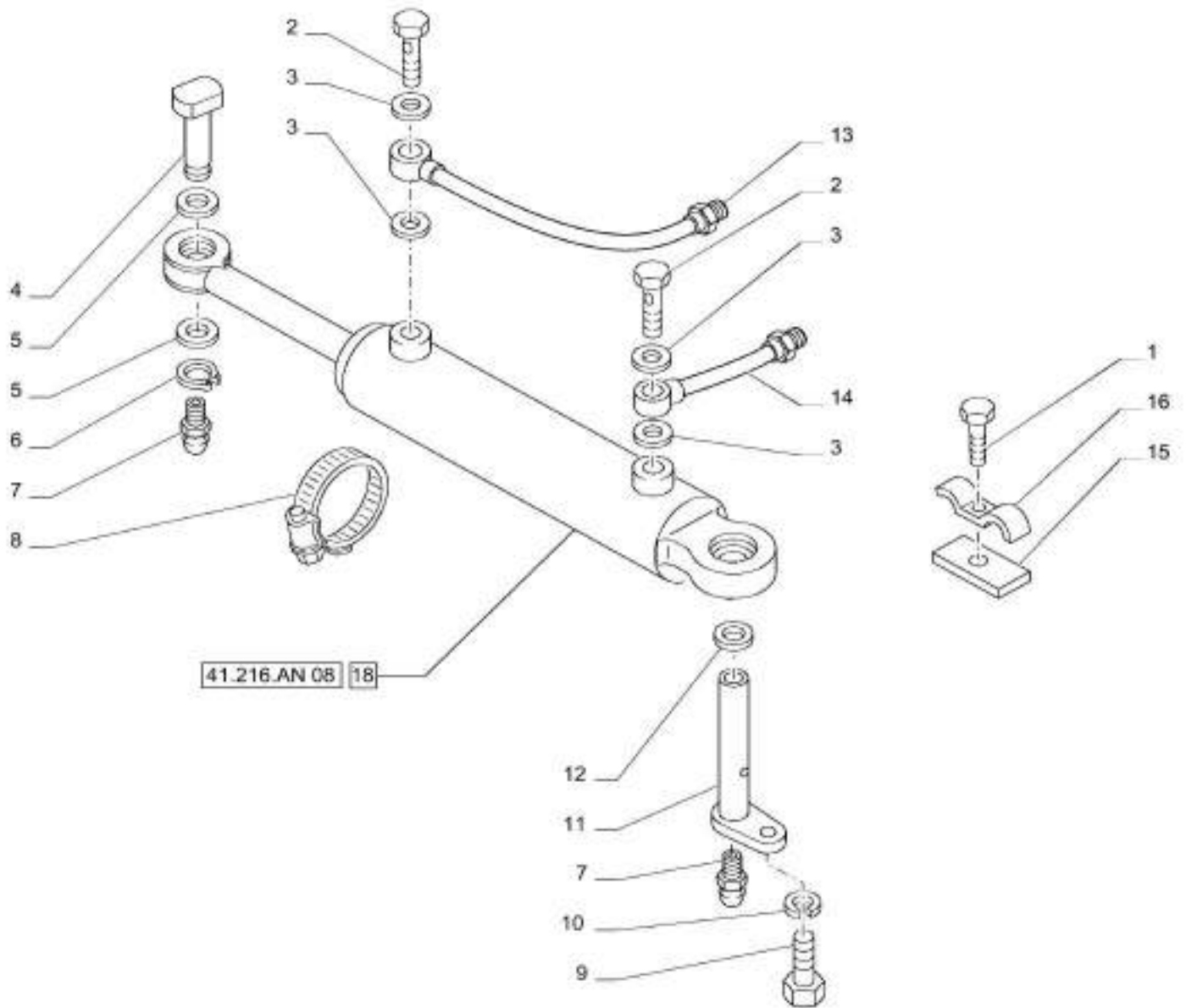

VAR - 335325 - 4WD FRONT AXLE - HYDRAULIC STEERING CYL

REF FN	PART NUMBER	YR/SN	QTY DESCRIPTION
1	10902224		1 SCREW Hex, M6 x 16, 8.8, Full Thd
2	10184311		2 BANJO BOLT M14-1.5 x 27
3	44906168		4 SEAL 14.86mm ID x 22.23mm OD x 3.00mm 14.86x22.23x2
4	5111572		1 PIN
5	5111573		2 SPACER
6	11067376		1 SNAP RING M25, Ext
7	5120532		1 LUBE NIPPLE Straight, M14 x 1.5 x 6.50mm
8	13000990		1 COLLAR D=60-80
9	16043224		1 BOLT Hex, M8 x 16.00mm, CI 8.8, DAC
10	11193874		1 BELLEVILLE WASHER 8.4mm ID x 16.00mm OD x 1.4mm, 1.85mm, CI 8.8
11	5142236		1 PIN
12	5111576		1 SPACER M25.5 x 34 x 11
13	1 5142238		1 HYD. TUBE
14	5145031		1 FITTING
15	5138294		1 SUPPORT
16	4999554		1 CLAMP
17	13406911		1 LUBE NIPPLE Straight, 1/4"-28 x 0.54" Replaced by 80714
18	5134221		1 STEERING CYLINDER 384MM
(1)	VAR - 335325		

Valid for Var. 335325

FARMALL JX100
 FARMALL JX110
 FARMALL JX75
 FARMALL JX80

VAR - 335325 - 4WD, FRONT AXLE, HYDRAULIC STEERING, CYLINDER, COMPONENTS

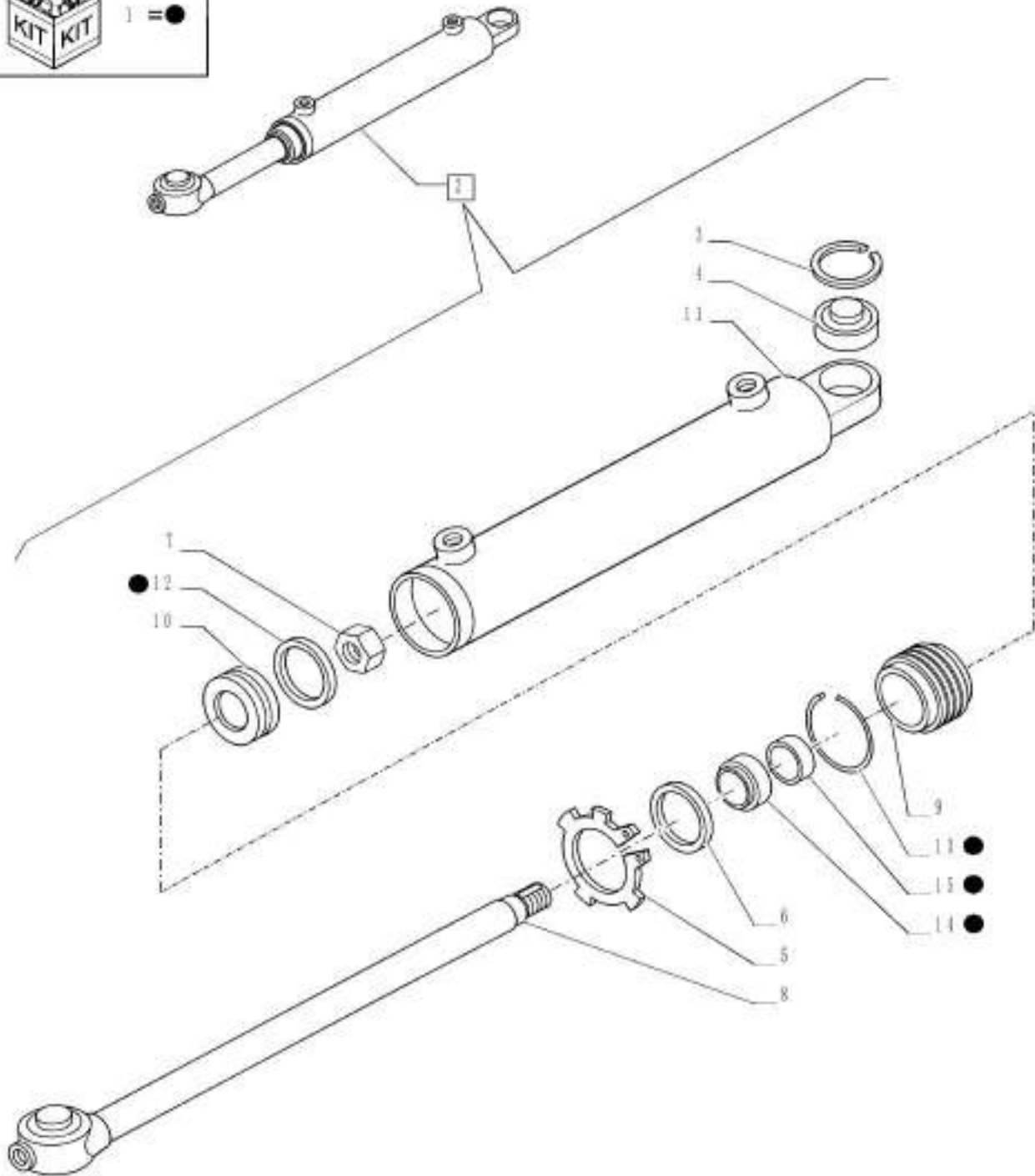

VAR - 335325 - 4WD, FRONT AXLE, HYDRAULIC STEERING, CYLINDER, COMPONENTS

REF FN	PART NUMBER	YR/SN	QTY DESCRIPTION
1	5192826		1 SEAL KIT
2	5134221		1 STEERING CYLINDER Incl 3 - 15
3	5192824		1 LOCKING RING
4	5192823		1 GUIDE BUSHING
5	5192813		1 LOCKING RING
6	5192815		1 RING
7	47127222		1 LOCK NUT
8	NSS		1 NOT SERVICED SEPARATELY Stem, Incl in 2
9	NSS		1 NOT SERVICED SEPARATELY Head, Incl in 2
10	5192819		1 PISTON
11	NSS		1 NOT SERVICED SEPARATELY Body, Incl in 2
12	5192820		1 GASKET
13	5192816		1 GASKET
14	5192811		1 GASKET
15	5192814		1 SEAL

Valid for Var. 335325

FARMALL JX100
 FARMALL JX110
 FARMALL JX75
 FARMALL JX80

VAR - 335539 - FRONT AXLE - HYDRAULIC STEERING CYLINDER - BREAKDOWN

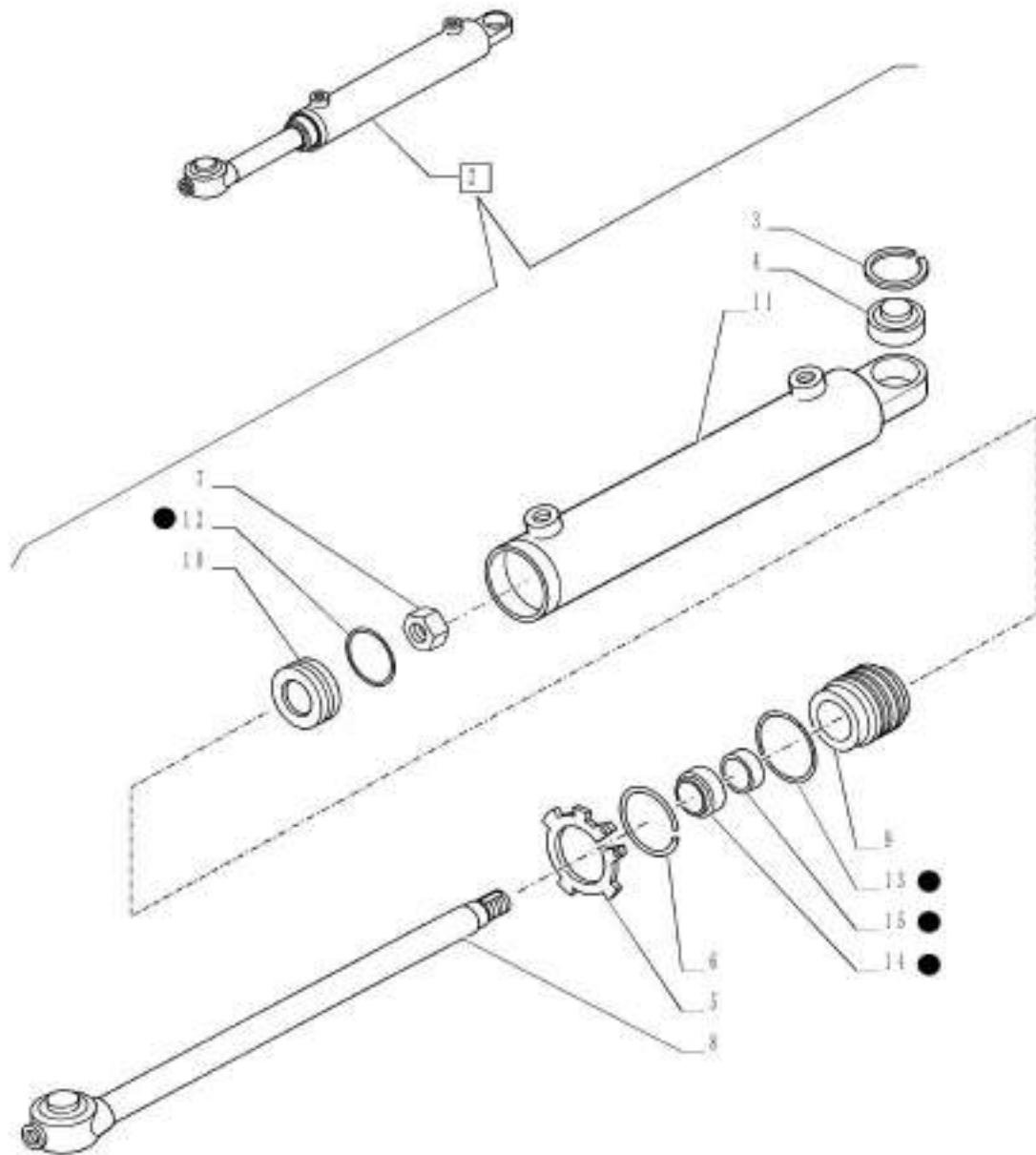

VAR - 335539 - FRONT AXLE - HYDRAULIC STEERING CYLINDER - BREAKDOWN

REF FN	PART NUMBER	YR/SN	QTY DESCRIPTION
1	5190916		1 SEAL KIT
2	5164023		2 STEERING CYLINDER ASSY Incl 3 - 15
3	5190903		1 LOCKING RING
4	5190901		1 BUSHING
5	5190568		1 LOCKING RING
6	5190575		1 RING
7	5190904		1 LOCK NUT
8	5190579		1 ROD
9	5190578		1 END PLATE
10	5190571		1 SPOOL
11	NSS		1 NOT SERVICED SEPARATELY Body Incl in 2
12	5190572		1 SEAL
13	5190574		1 FERRULE
14	5190549		1 SCRAPER RING
15	5190573		1 GASKET

Valid for Var. 335539

FARMALL JX100
 FARMALL JX110
 FARMALL JX75
 FARMALL JX80

41.216.AV

01

p1

1/2014

VAR - 335539 - HYDRAULIC STEERING CYLINDER LINES

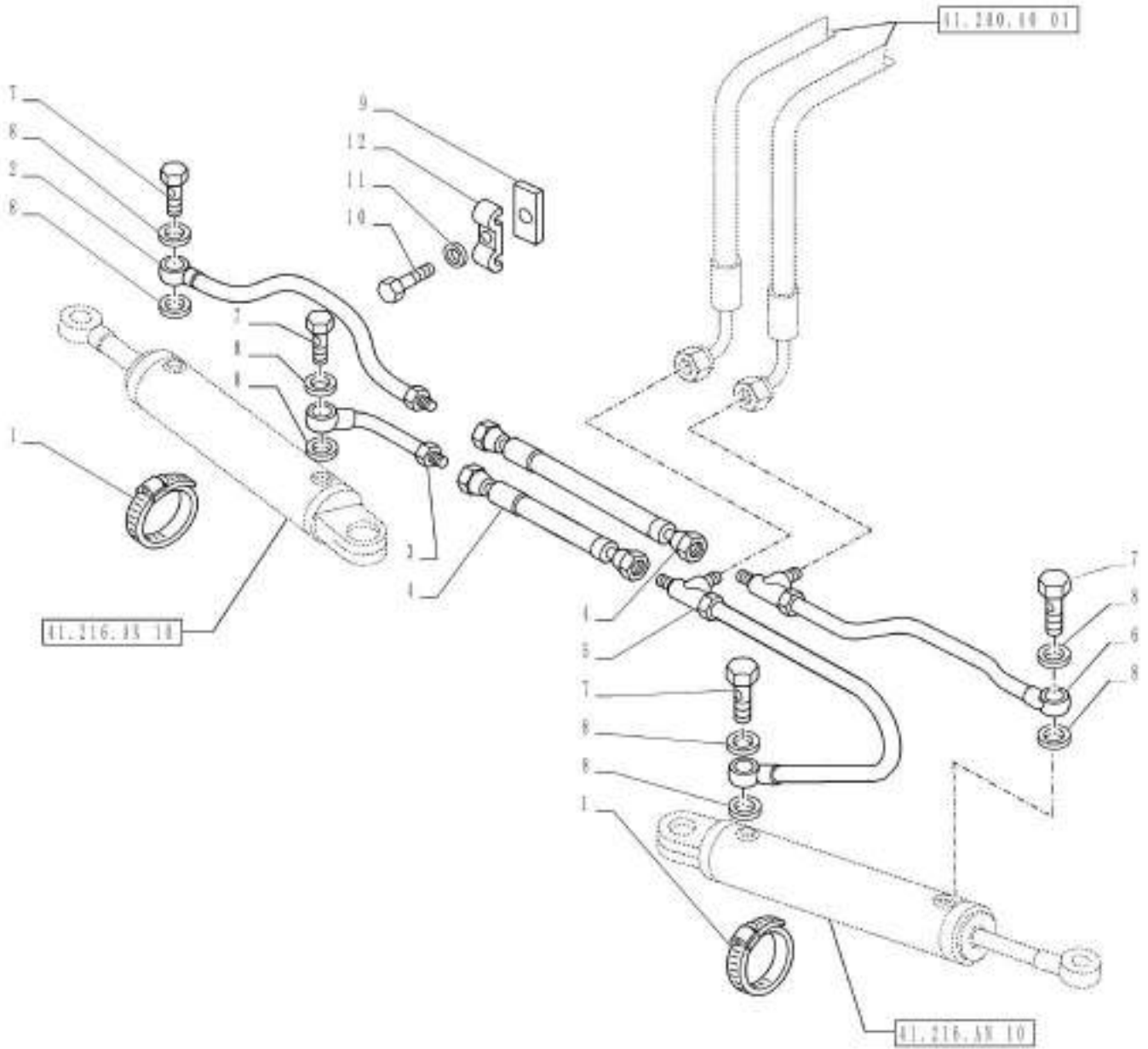

41.216.AV

01

p1

1/2014

VAR - 335539 - HYDRAULIC STEERING CYLINDER LINES

REF FN	PART NUMBER	YR/SN	QTY DESCRIPTION
1	5098812		2 COLLAR D=50-70
2	5139046		1 HYD. TUBE
3	5163738		1 TUBE
4	5126537		2 FLEXIBLE HOSE
5	87335652		1 HYD. TUBE
6	87335657		1 HYD. TUBE
7	10184311		4 BANJO BOLT M14-1.5 x 27 M14x1.5
8	10280060		8 SEAL M14.2 x 20 x 1.5
9	5138294		2 SUPPORT
10	10902221		2 BOLT Hex, M6 x 16.00mm, CL 8.8, ZND
11	11197779		2 BELLEVILLE WASHER 6.40mm ID x 12.00mm OD x 1.20mm, 1.63mm, CI 8.8, ZNM
12	4999554		2 CLAMP

Valid for Var. 335539

FARMALL JX100
FARMALL JX110
FARMALL JX75
FARMALL JX80

SECTION INDEX

WHEELS

44.000.00	01	SECTION INDEX - WHEELS
44.000.00	02	SECTION INDEX - WHEELS
44.511.AE	01	WHEEL, FRONT, 4WD
44.511.AE	02	WHEEL, FRONT, 4WD
44.511.AE	03	WHEEL, FRONT, 4WD
44.511.AE	04	WHEEL, FRONT, 4WD
44.511.AE	05	WHEEL, FRONT, 4WD
44.511.AE	06	WHEEL, FRONT, 4WD
44.511.AE	07	WHEEL, FRONT, 4WD
44.511.AE	08	WHEEL, FRONT, 4WD
44.511.AE	09	WHEEL, FRONT, 2WD
44.511.AE	10	WHEEL, FRONT, 2WD
44.511.AE	11	WHEEL, FRONT, 2WD
44.511.AE	12	WHEEL, FRONT, 2WD
44.520.AB	01	WHEEL, REAR
44.520.AB	02	WHEEL, REAR
44.520.AB	03	WHEEL, REAR
44.520.AB	04	WHEEL, REAR
44.520.AB	05	WHEEL, REAR
44.520.AB	06	WHEEL, REAR
44.520.AB	07	WHEEL, REAR
44.520.AB	07	WHEEL, REAR
44.520.AB	08	WHEEL, REAR

SECTION INDEX - WHEELS

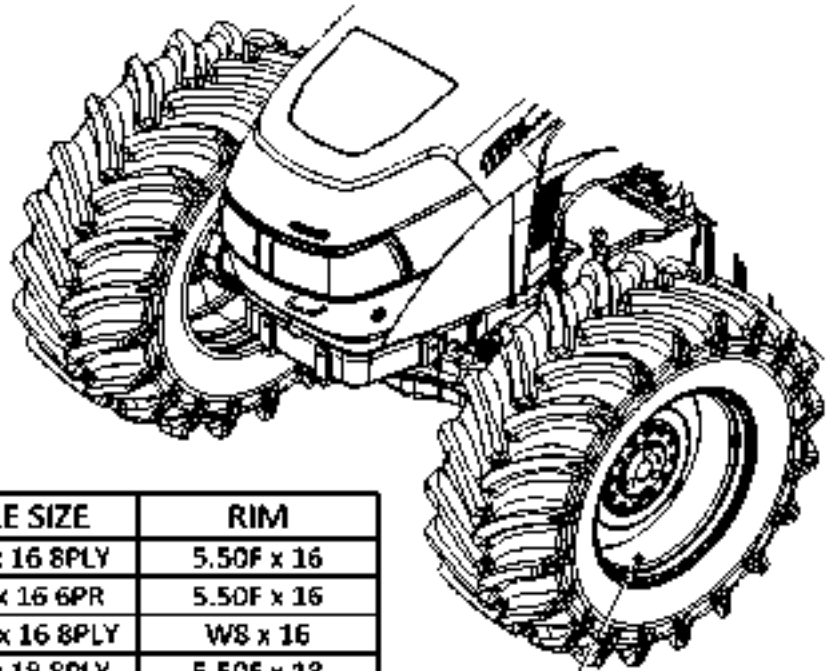

GROUP	EQUIP.	TYRE SIZE	RIM
44.511.AE	81.11	7.50 x 16 8PLY	5.50F x 16
	81.11	7.50 x 16 6PR	5.50F x 16
	81.14	10.00 x 16 8PLY	W8 x 16
	81.18	7.50 x 18 8PLY	5.50F x 18
	81.18	7.50 x 18 6PR	5.50F x 18
	81.18	7.50 x 18 8PR	5.50F x 18
	81.25	9.00 x 16 8PLY	W8 x 16
	81.26	7.50 x 20 8PLY	5.50F x 20
	82.03	12.4 R20	W11 x 20
	82.03	320/85 R20	W11 x 20
	82.32	11.2 R24	W10 x 24
	82.32	280/85 R24	W10 x 24
	82.32	11.2 R24	W10 x 24
	82.32	280/85 R24	W10 x 24
	82.33	9.5 R24 A8	W8 x 24
	82.35	12.4 R24	W10 x 24
	82.35	320/85 R24	W10 x 24
	82.35	12.4 R24	W10 x 24
	82.35	320/85 R24	W10 x 24
	82.36	13.6 R24	W12 x 24
	82.36	340/85 R24	W12 x 24
	82.47	11.2 R28	W10 x 28
	82.47	280/85 R28	W10 x 28
	88.29	360/70 R20	W11 x 20
	88.33	230/95 R32	W8 x 32
	88.38	13.6 R28	W12 x 28
	88.42	320/70 R24	W10 x 24
	88.83	14.9 R24	W12 x 24

44.000.00

01

p1

1/2014

SECTION INDEX - WHEELS

REF FN	PART NUMBER	YR/SN	QTY	DESCRIPTION
---------------	--------------------	--------------	------------	--------------------

FARMALL JX100 FARMALL JX110 FARMALL JX70 FARMALL JX75 FARMALL JX80 FARMALL JX90
--

44.000.00

02

p1

1/2014

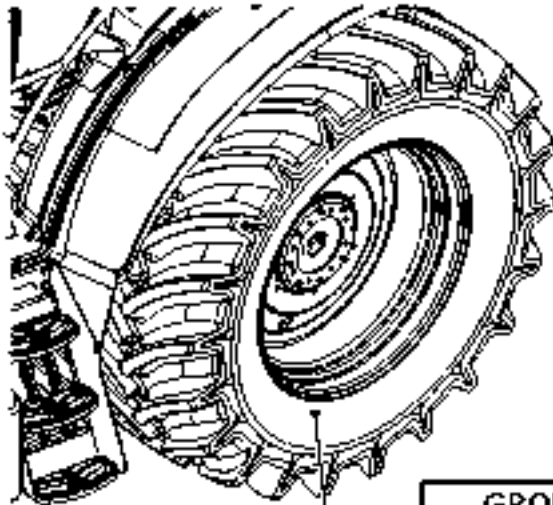
SECTION INDEX - WHEELS

GROUP	EQUIP.	TYRE SIZE	RIM
44.520.AB	83.16	14.9 R38	DWW12 x 38
	83.22	9.5 R48 A8	W8 x 48
	83.22	230/95 R48 A8	W8 x 48
	83.54	14.9 R30 6PR	W13 x 30
	83.55	16.9 R30 6PR	W14L x 30
	83.55	16.9 R30	DWW15L x 30
	83.55	420/85 R30	DWW15L x 30
	83.57	18.4 R30	DWW15L x 30
	83.57	460/85 R30	DWW15L x 30
	83.57	18.4 R30 A8	W15L x 30
	83.57	460/85 R30 A8	W15L x 30
	83.64	16.9 R34	DWW15L x 34
	83.64	420/85 R34	DWW15L x 34
	83.65	18.4 R34	DWW15L x 34
	83.65	460/85 R34	DWW15L x 34
	83.69	12.4 R36	W11 x 36
	83.69	320/85 R36	W11 x 36
	83.71	13.6 R36	W11 x 36
	83.71	340/85 R36	W11 x 36
	83.72	13.6 R38	DWW12 x 38
	83.72	340/85 R38	DWW12 x 38
	89.38	420/70 R30	W13 x 30
	89.54	480/70 R30	DWW15L x 30
89.55	420/70 R30	W13 x 30	
89.64	480/70 R34	DWW15L x 34	



44.000.00

02

p1

1/2014

SECTION INDEX - WHEELS

REF FN	PART NUMBER	YR/SN	QTY	DESCRIPTION
---------------	--------------------	--------------	------------	--------------------

				FARMALL JX100 FARMALL JX110 FARMALL JX70 FARMALL JX75 FARMALL JX80 FARMALL JX90
--	--	--	--	--

44.511.AE

01

p1

1/2014

WHEEL, FRONT, 4WD



EQUIP.	TYRE SIZE	RIM
88.29	360/70 R20	W11 x 20
82.03	12.4 R20	W11 x 20
82.03	320/85 R20	W11 x 20

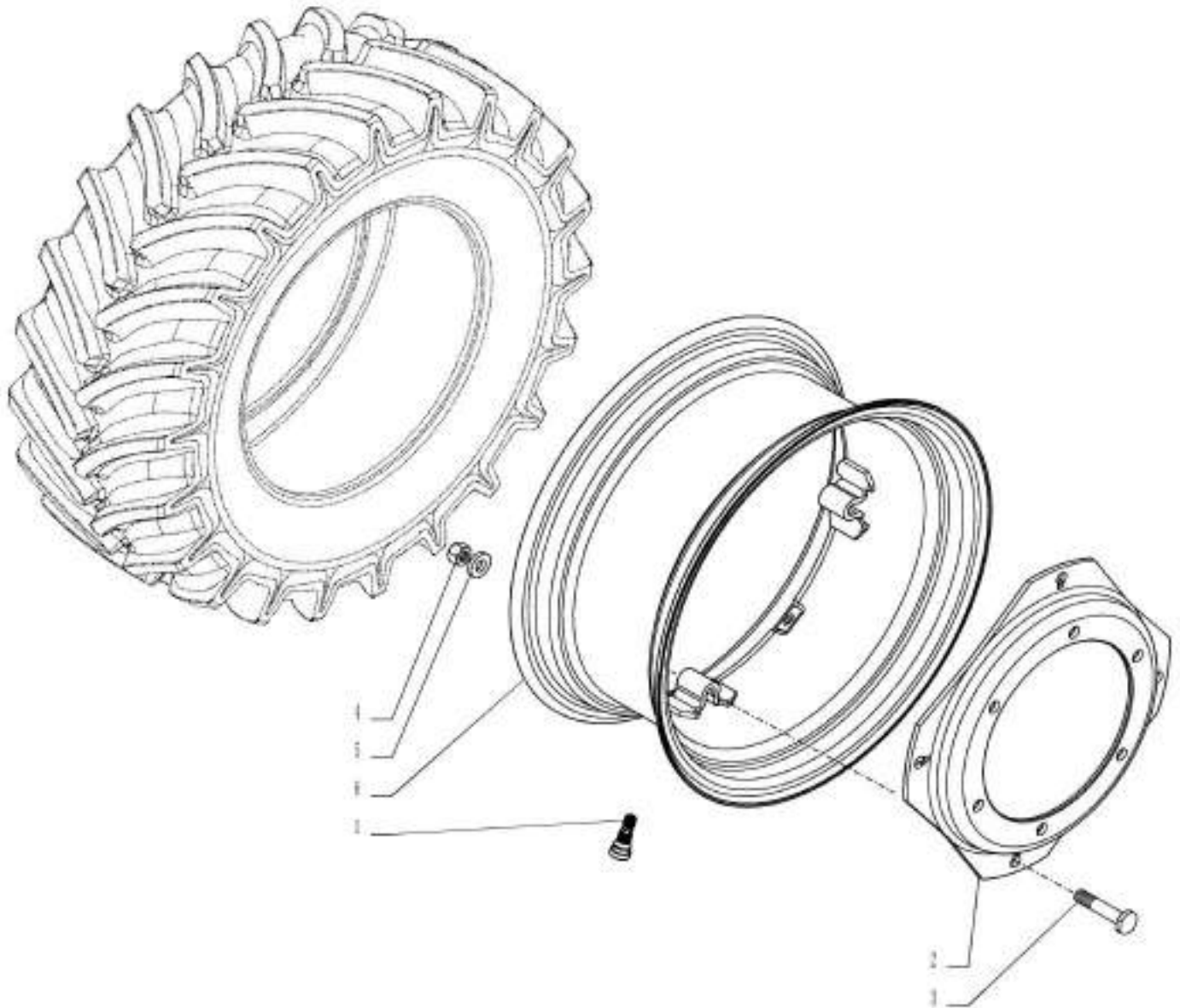

44.511.AE

02

p1

1/2014

WHEEL, FRONT, 4WD



EQUIP.	TYRE SIZE	RIM
82.33	9.5 R24 A8	W8 x 24

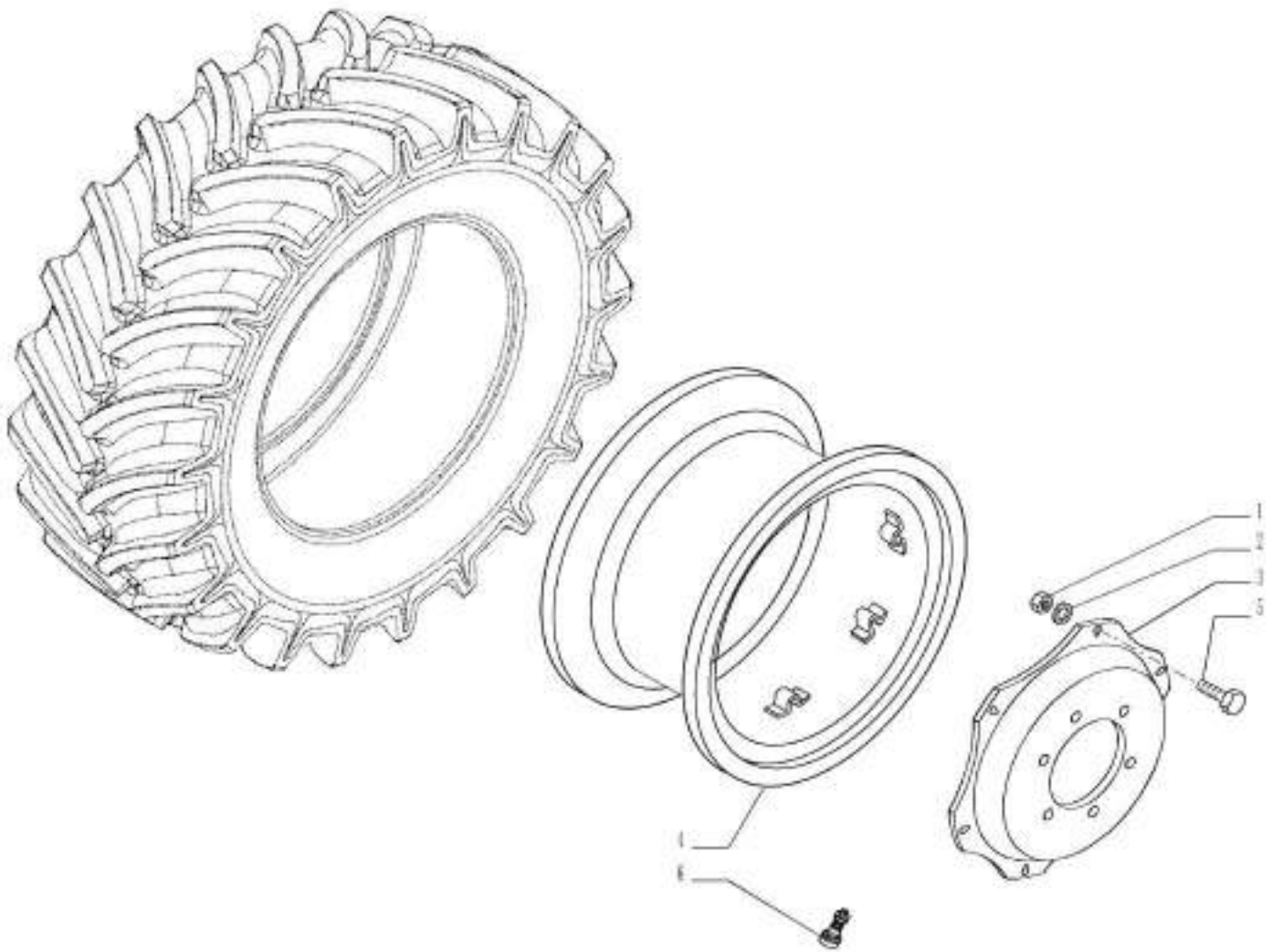

44.511.AE

02

p1

1/2014

WHEEL, FRONT, 4WD

REF FN	PART NUMBER	YR/SN	QTY DESCRIPTION
1	10790524		12 NUT M16 x 1.5
2	5164709		12 WASHER
3	5092240		2 WHEEL DISC
4	5093879		2 RIM
5	5112385		12 SCREW Wheel, M16 x 1.5 x 78.5
6	87323751		2 PNEUMATIC VALVE

FARMALL JX70

WHEEL, FRONT, 4WD



EQUIP.	TYRE SIZE	RIM
82.32	11.2 R24	W10 x 24
82.32	280/85 R24	W10 x 24
82.35	12.4 R24	W10 x 24
82.35	320/85 R24	W10 x 24
88.42	320/70 R24	W10 x 24

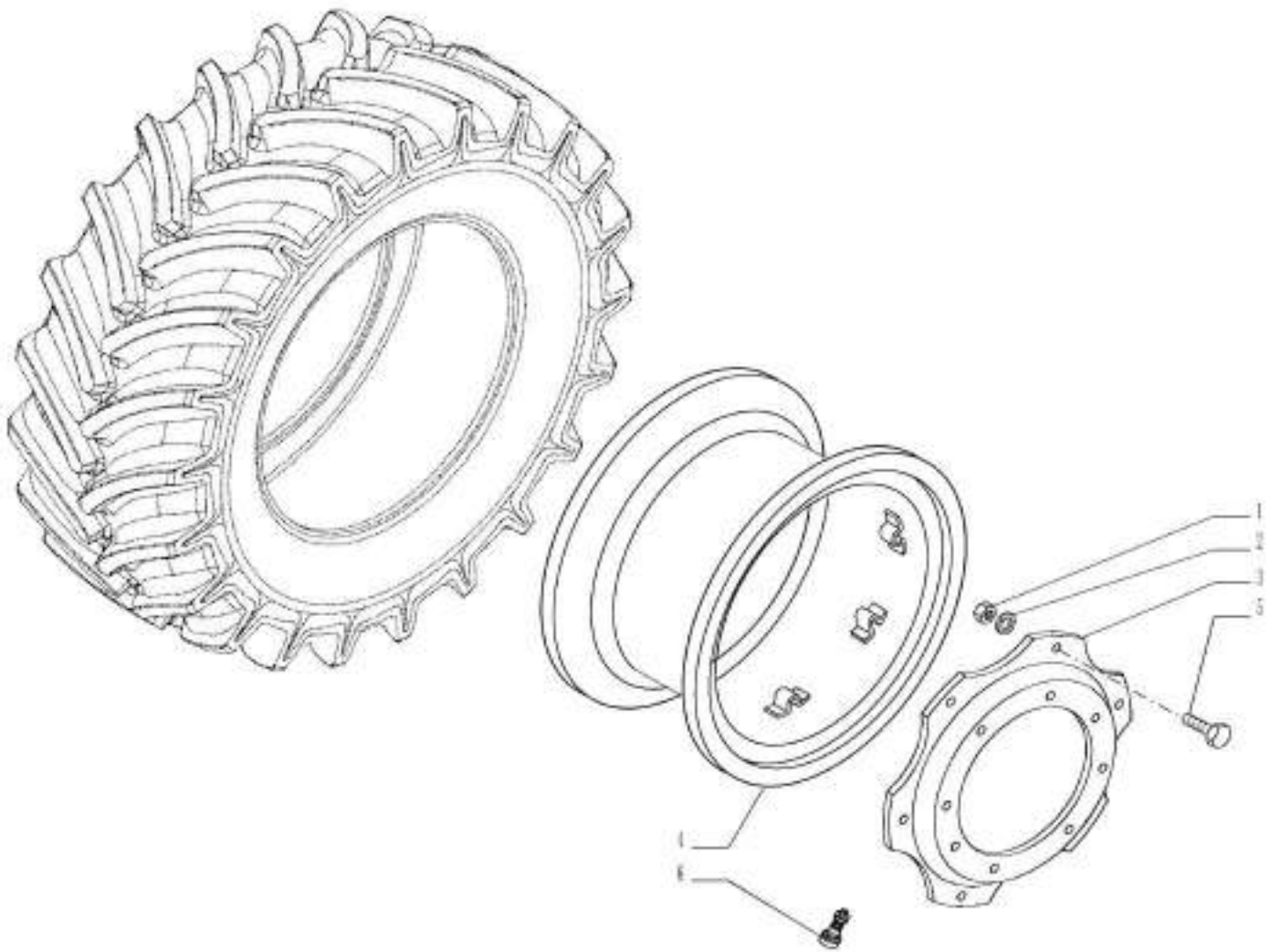

44.511.AE

04

p1

1/2014

WHEEL, FRONT, 4WD



EQUIP.	TYRE SIZE	RIM
82.32	11.2 R24	W10 x 24
82.32	280/85 R24	W10 x 24
82.35	12.4 R24	W10 x 24
82.35	320/85 R24	W10 x 24

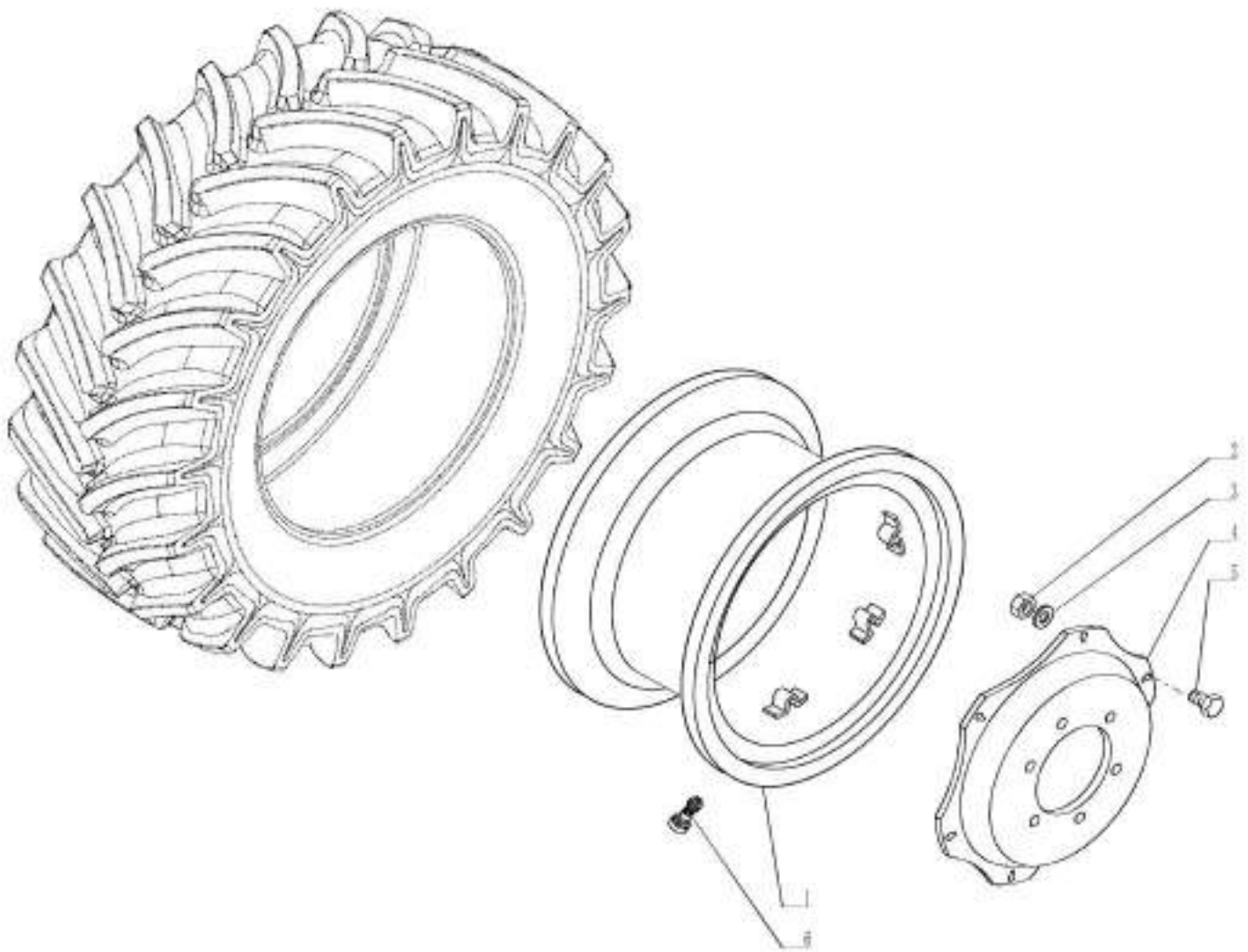

44.511.AE

05

p1

1/2014

WHEEL, FRONT, 4WD



EQUIP.	TYRE SIZE	RIM
82.36	13.6 R24	W12 x 24
82.36	340/85 R24	W12 x 24
88.83	14.9 R24	W12 x 24

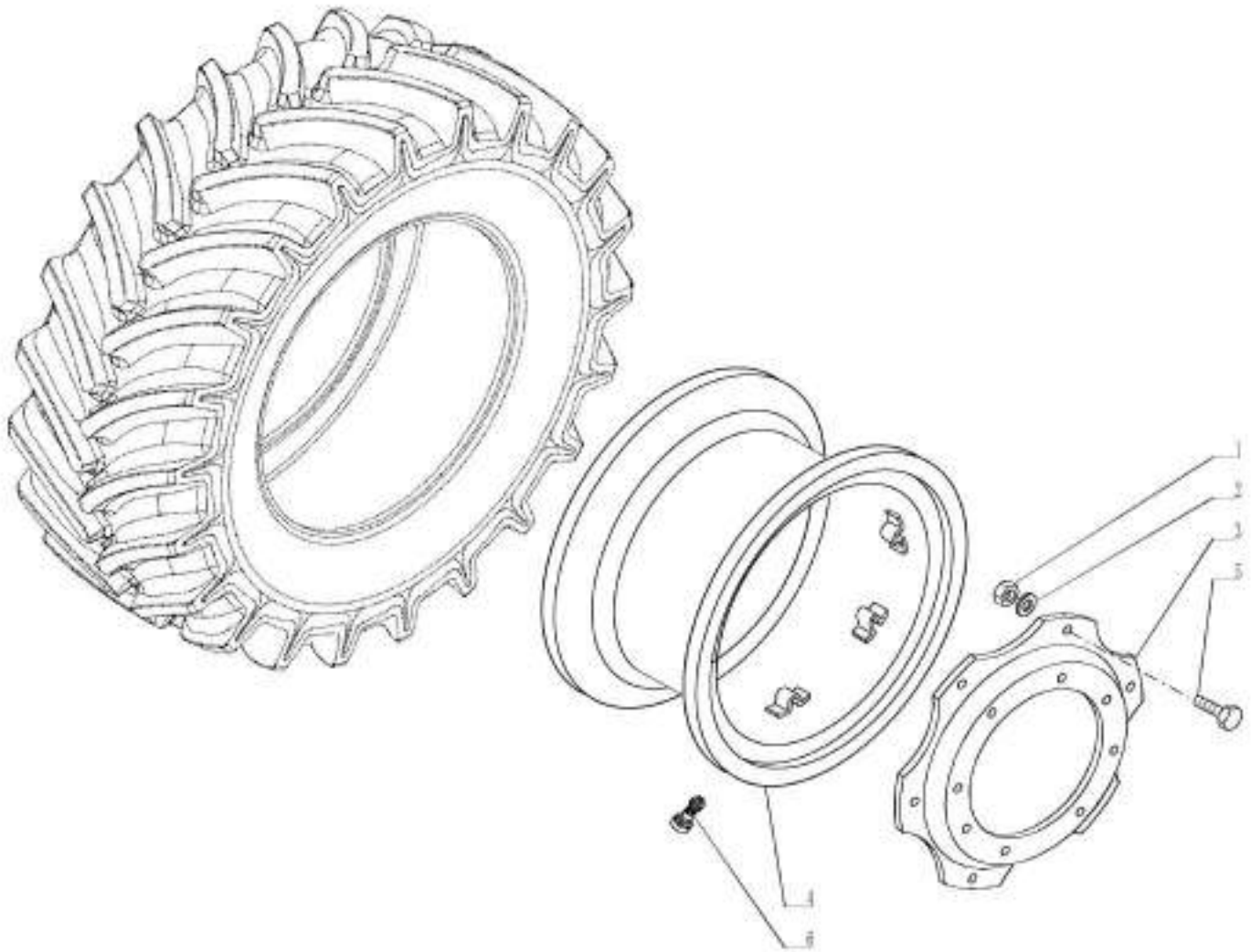

44.511.AE

06

p1

1/2014

WHEEL, FRONT, 4WD



EQUIP.	TYRE SIZE	RIM
82.47	11.2 R28	W10 x 28
82.47	280/85 R28	W10 x 28

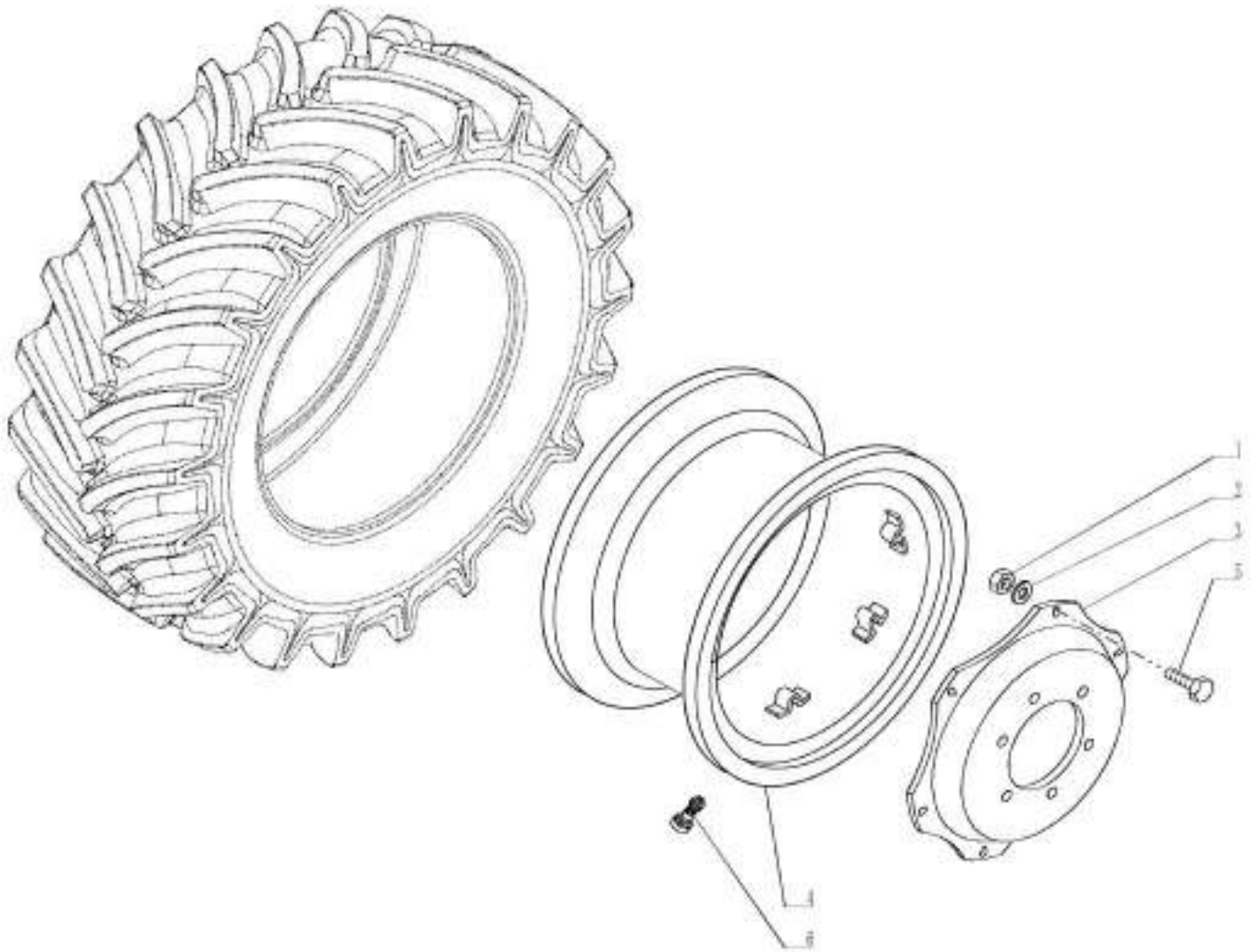

44.511.AE

07

p1

1/2014

WHEEL, FRONT, 4WD



EQUIP.	TYRE SIZE	RIM
88.38	13.6 R28	W12 x 28

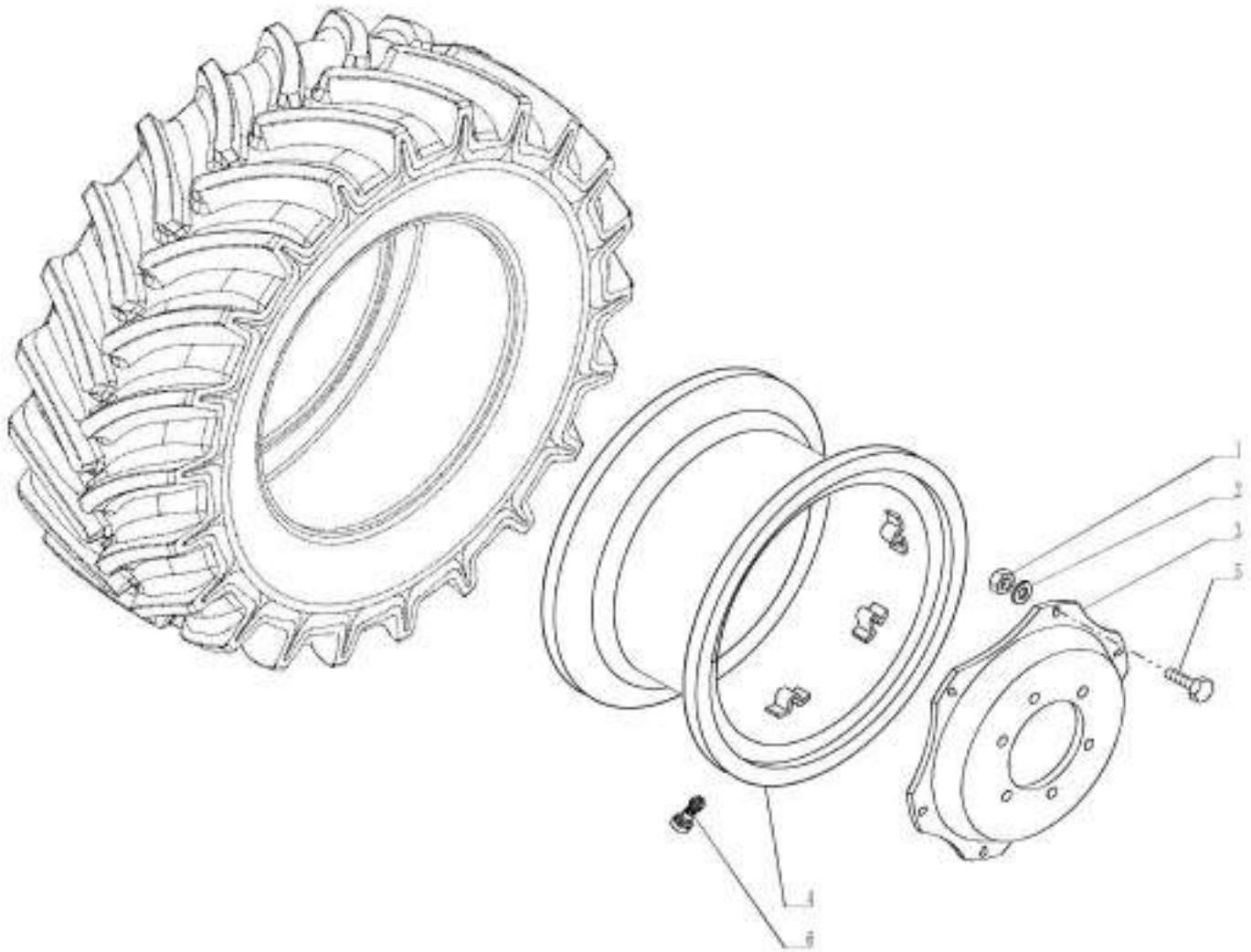

44.511.AE

08

p1

1/2014

WHEEL, FRONT, 4WD



EQUIP.	TYRE SIZE	RIM
88.33	230/95 R32	W8 x 32

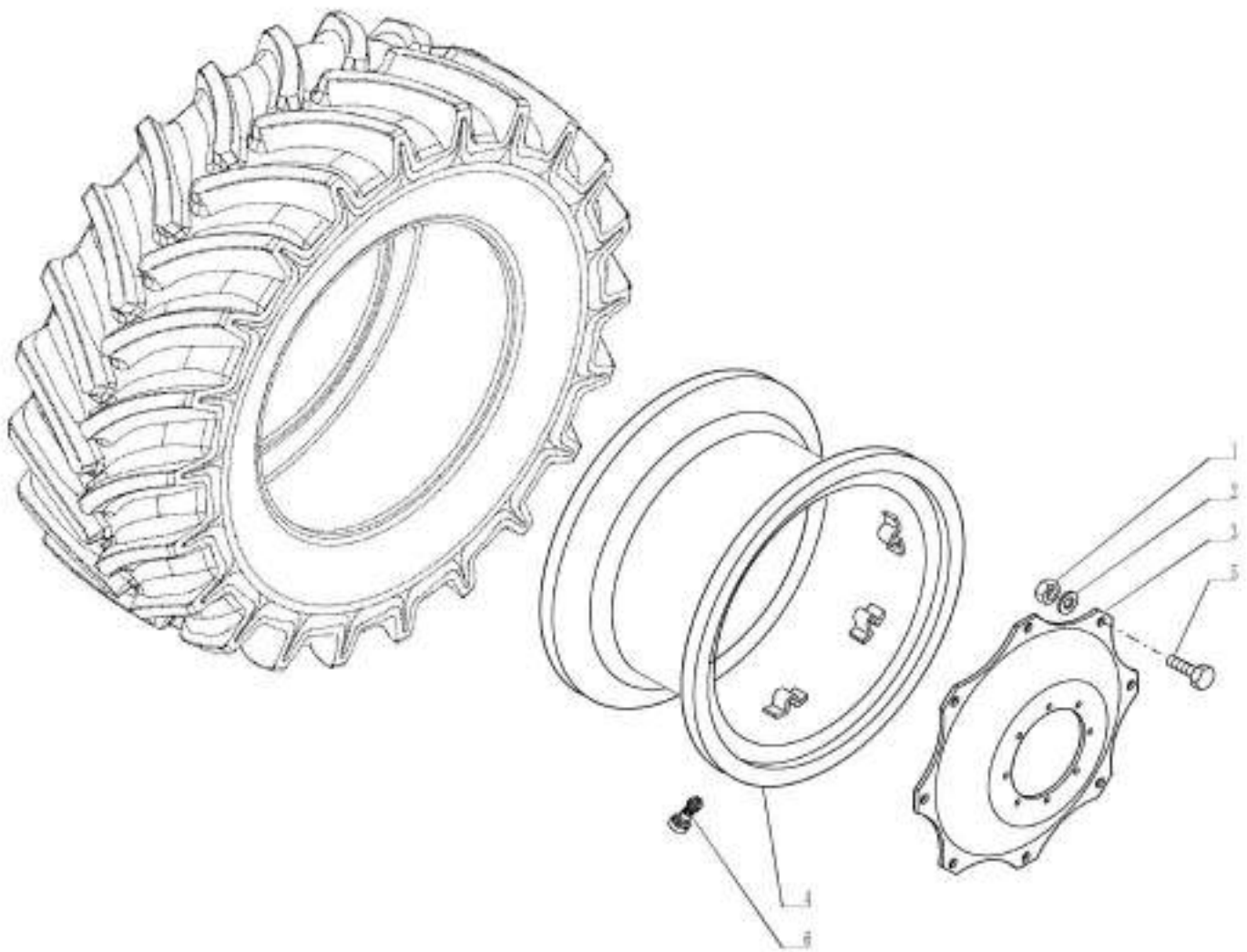

44.511.AE

09

p1

1/2014

WHEEL, FRONT, 2WD



EQUIP.	TYRE SIZE	RIM
81.11	7.50 x 16 8PLY	5.50F x 16
81.11	7.50 x 16 6PR	5.50F x 16

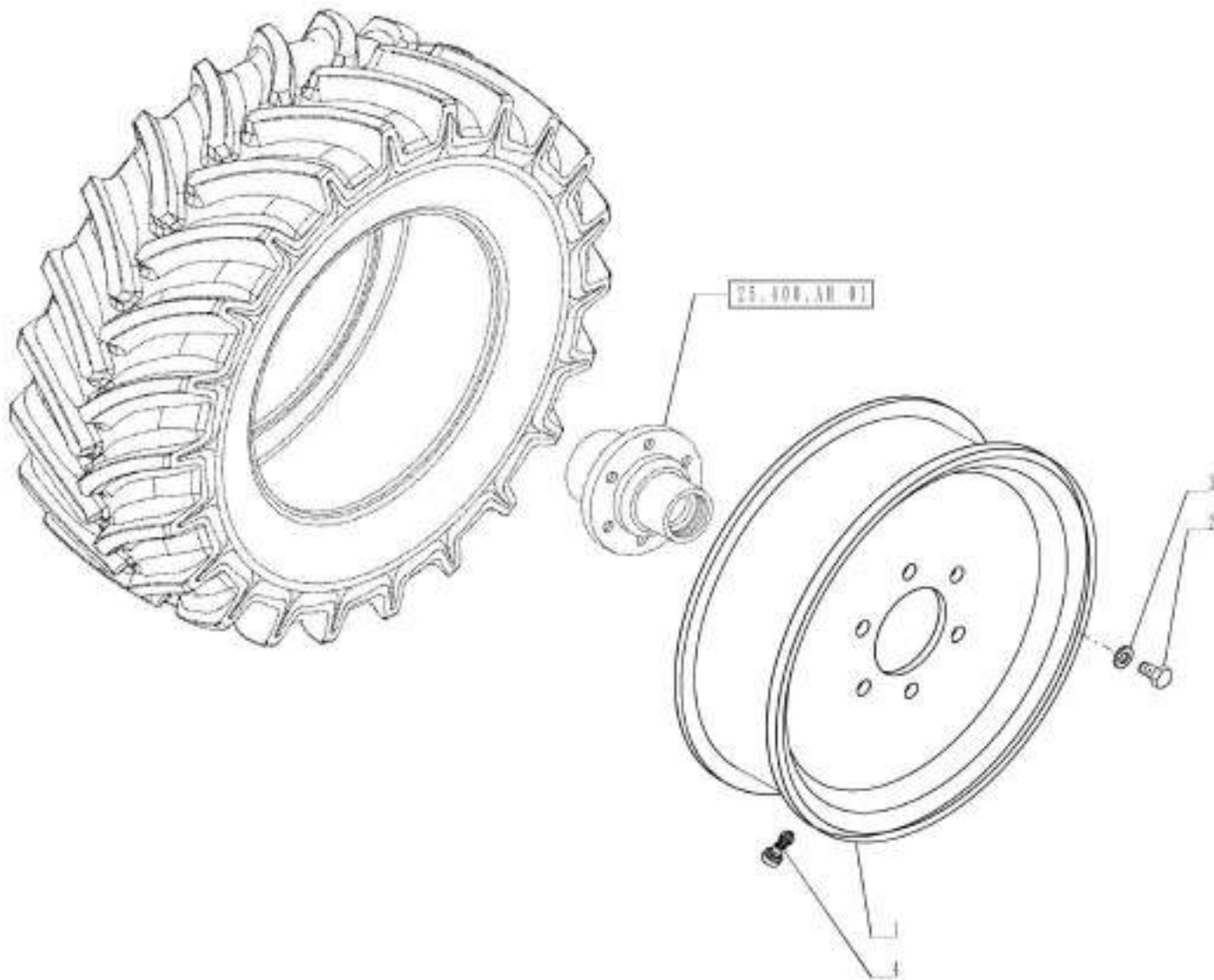

44.511.AE

10

p1

1/2014

WHEEL, FRONT, 2WD



EQUIP.	TYRE SIZE	RIM
81.14	10.00 x 16 8PLY	W8 x 16
81.25	9.00 x 16 8PLY	W8 x 16

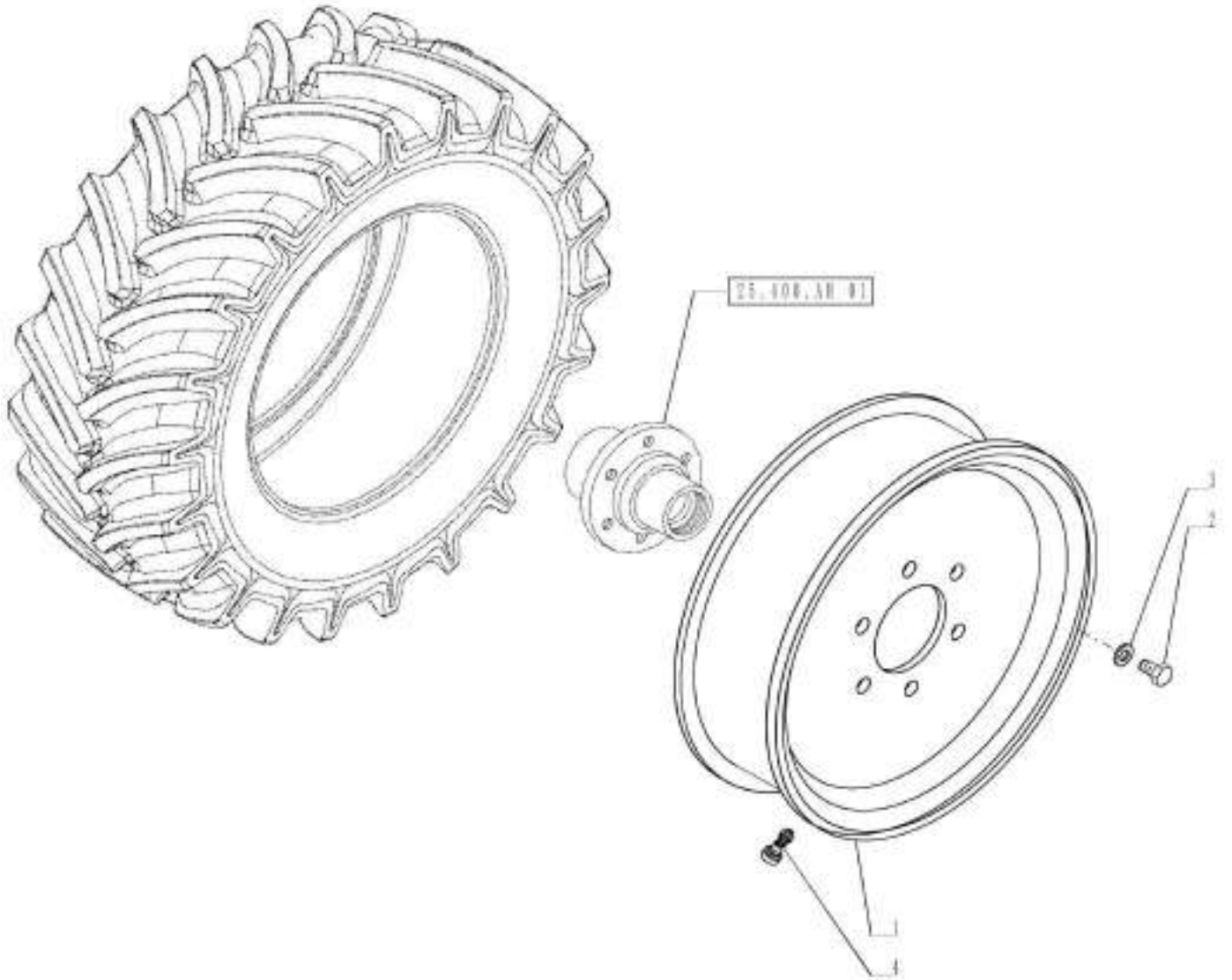

44.511.AE

10

p1

1/2014

WHEEL, FRONT, 2WD

REF FN	PART NUMBER	YR/SN	QTY DESCRIPTION
1	47137674		2 RIM W8X16
2	15983821		12 SCREW Hex, M18 x 1.5 x 35mm, Cl 8.8, Full Thd
3	12601874		12 SPRING WASHER
4	87323751		2 PNEUMATIC VALVE
			FARMALL JX100 FARMALL JX75 FARMALL JX80 FARMALL JX90

WHEEL, FRONT, 2WD



EQUIP.	TYRE SIZE	RIM
81.18	7.50 x 18 8PLY	5.50F x 18
81.18	7.50 x 18 6PR	5.50F x 18
81.18	7.50 x 18 8PR	5.50F x 18

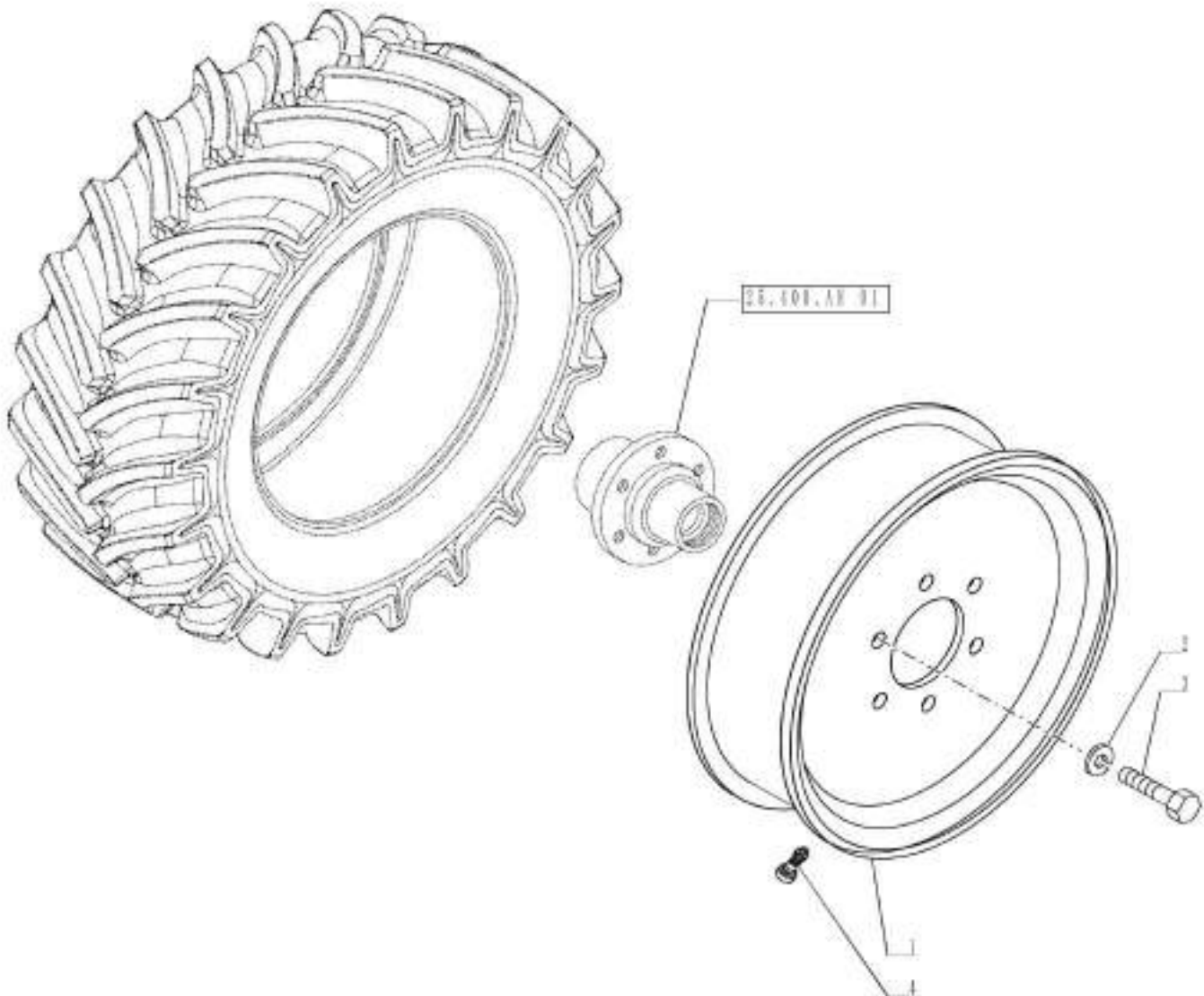

WHEEL, FRONT, 2WD

REF FN	PART NUMBER	YR/SN	QTY DESCRIPTION
1	5091734		2 RIM
2	12601874		12 SPRING WASHER
3	15983821		12 SCREW Hex, M18 x 1.5 x 35mm, Cl 8.8, Full Thd
4	87323751		2 PNEUMATIC VALVE

FARMALL JX100
FARMALL JX75
FARMALL JX80
FARMALL JX90

44.511.AE

12

p1

1/2014

WHEEL, FRONT, 2WD



EQUIP.	TYRE SIZE	RIM
81.26	7.50 x 20 8PLY	5.50F x 20

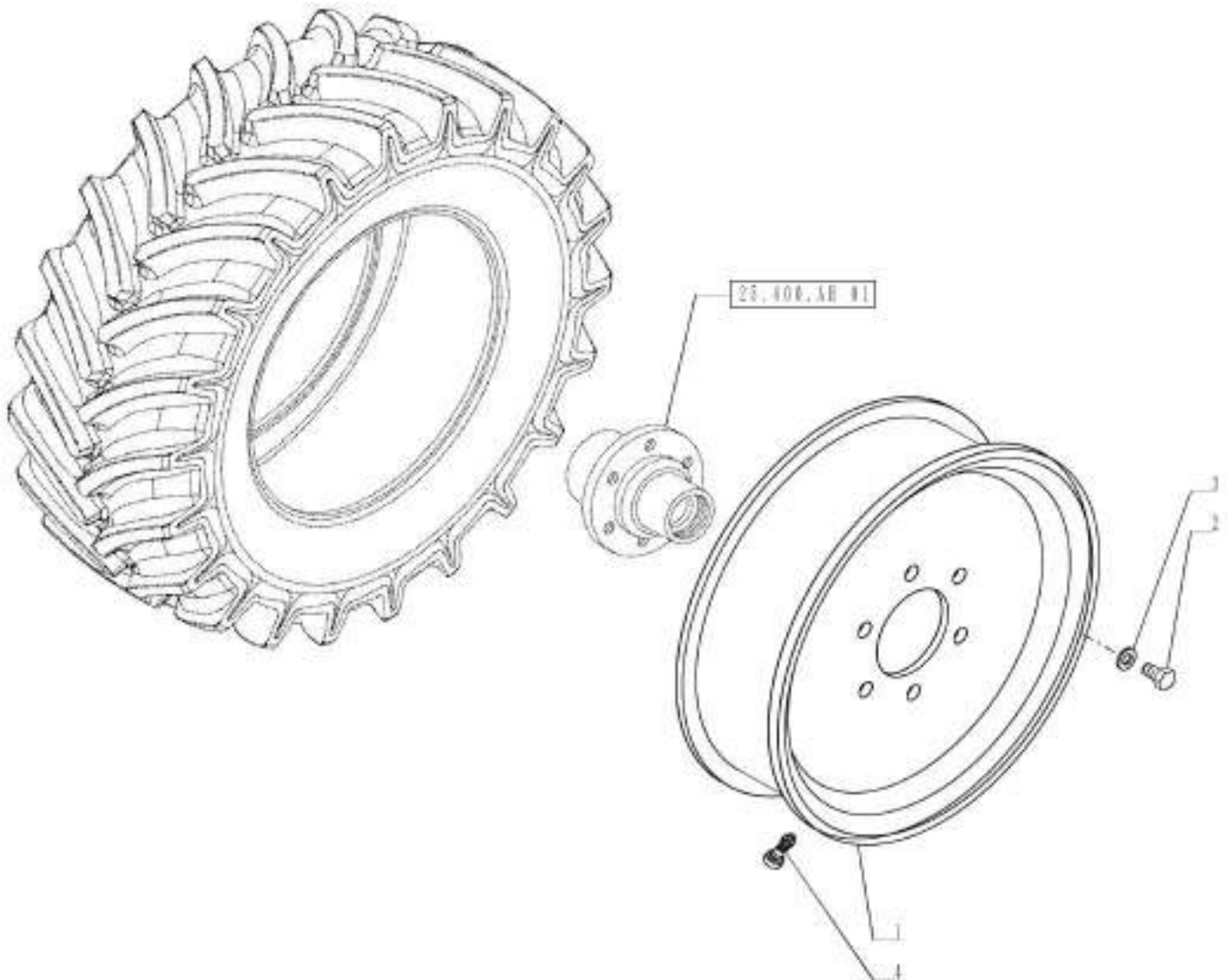

44.520.AB

01

p1

1/2014

WHEEL, REAR



EQUIP.	TYRE SIZE	RIM
89.55	420/70 R30	W13 x 30
89.38	420/70 R30	W13 x 30
83.54	14.9 R30 6PR	W13 x 30

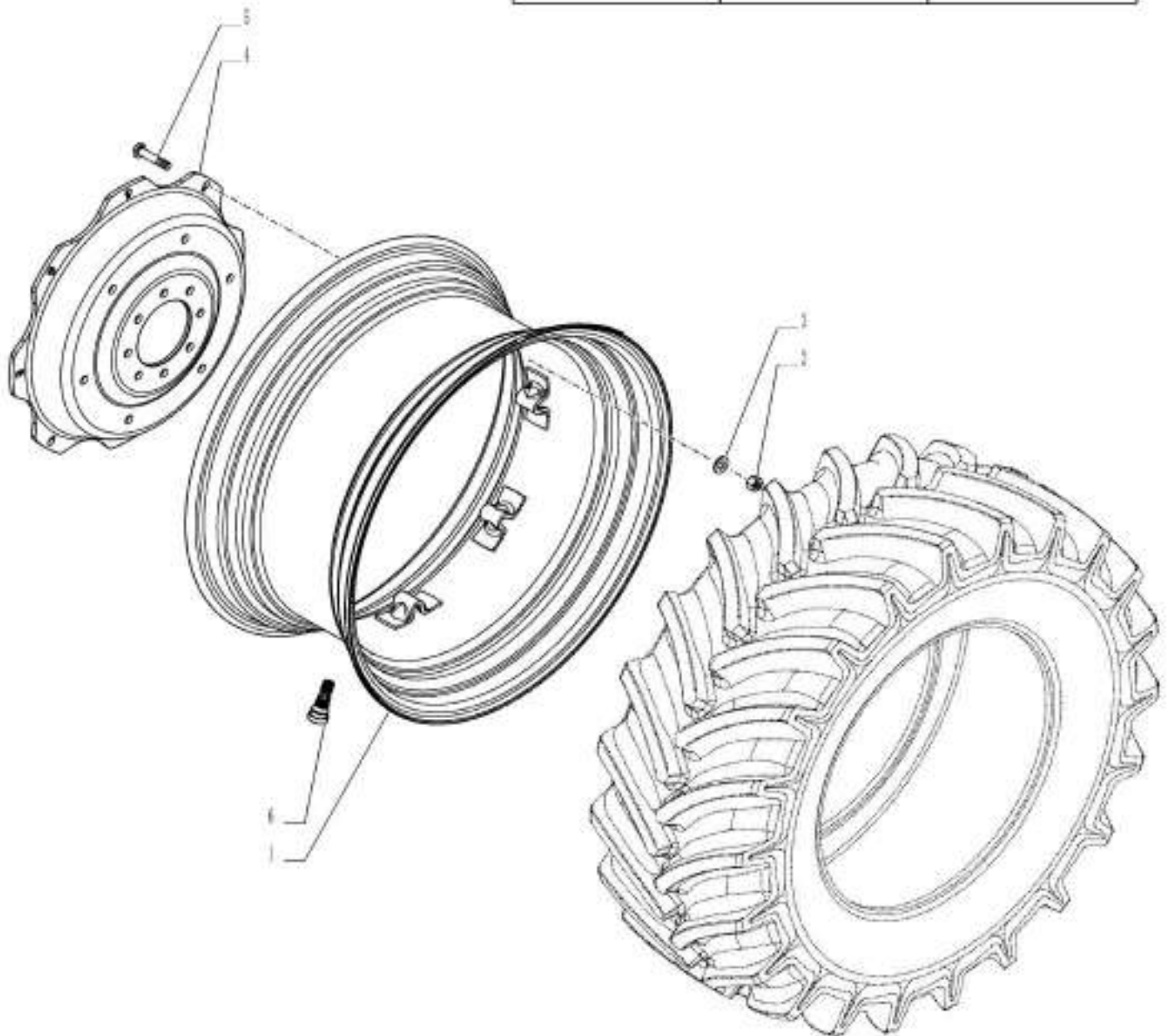

44.520.AB

02

p1

1/2014

WHEEL, REAR



EQUIP.	TYRE SIZE	RIM
83.22	9.5 R48 A8	W8 x 48
83.22	230/95 R48 A8	W8 x 48

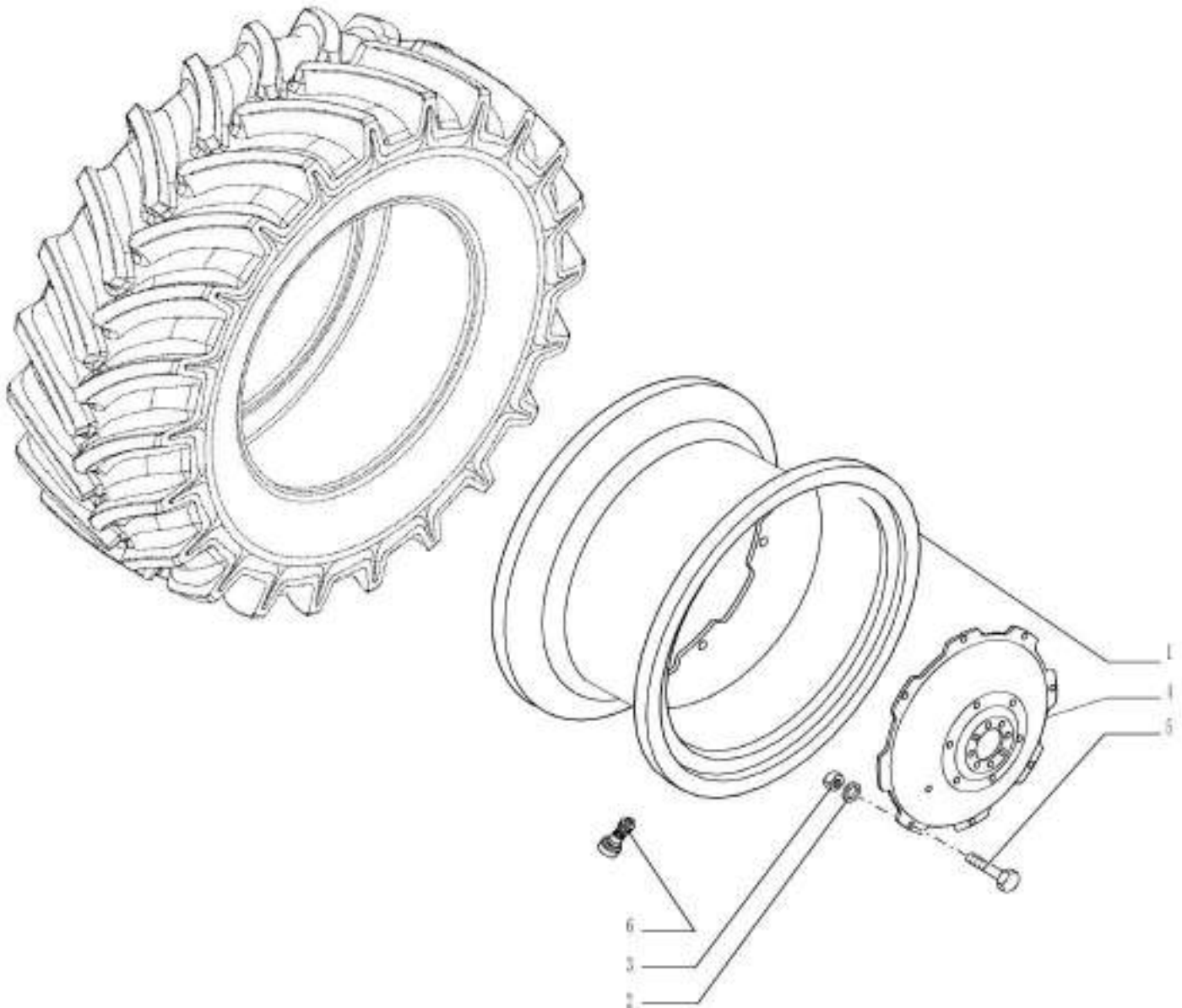

44.520.AB

02

p1

1/2014

WHEEL, REAR

REF FN	PART NUMBER	YR/SN	QTY DESCRIPTION
1	5083890		2 RIM
2	5083904		16 WASHER
3	10790524		16 NUT M16 x 1.5
4	5083842		2 WHEEL DISC
5	5083905		16 BOLT
6	87323751		2 PNEUMATIC VALVE

**FARMALL JX75
FARMALL JX80
FARMALL JX90**

WHEEL, REAR



EQUIP.	TYRE SIZE	RIM
83.55	16.9 R30	DWW15L x 30
83.55	420/85 R30	DWW15L x 30
83.57	18.4 R30	DWW15L x 30
83.57	460/85 R30	DWW15L x 30
89.54	480/70 R30	DWW15L x 30

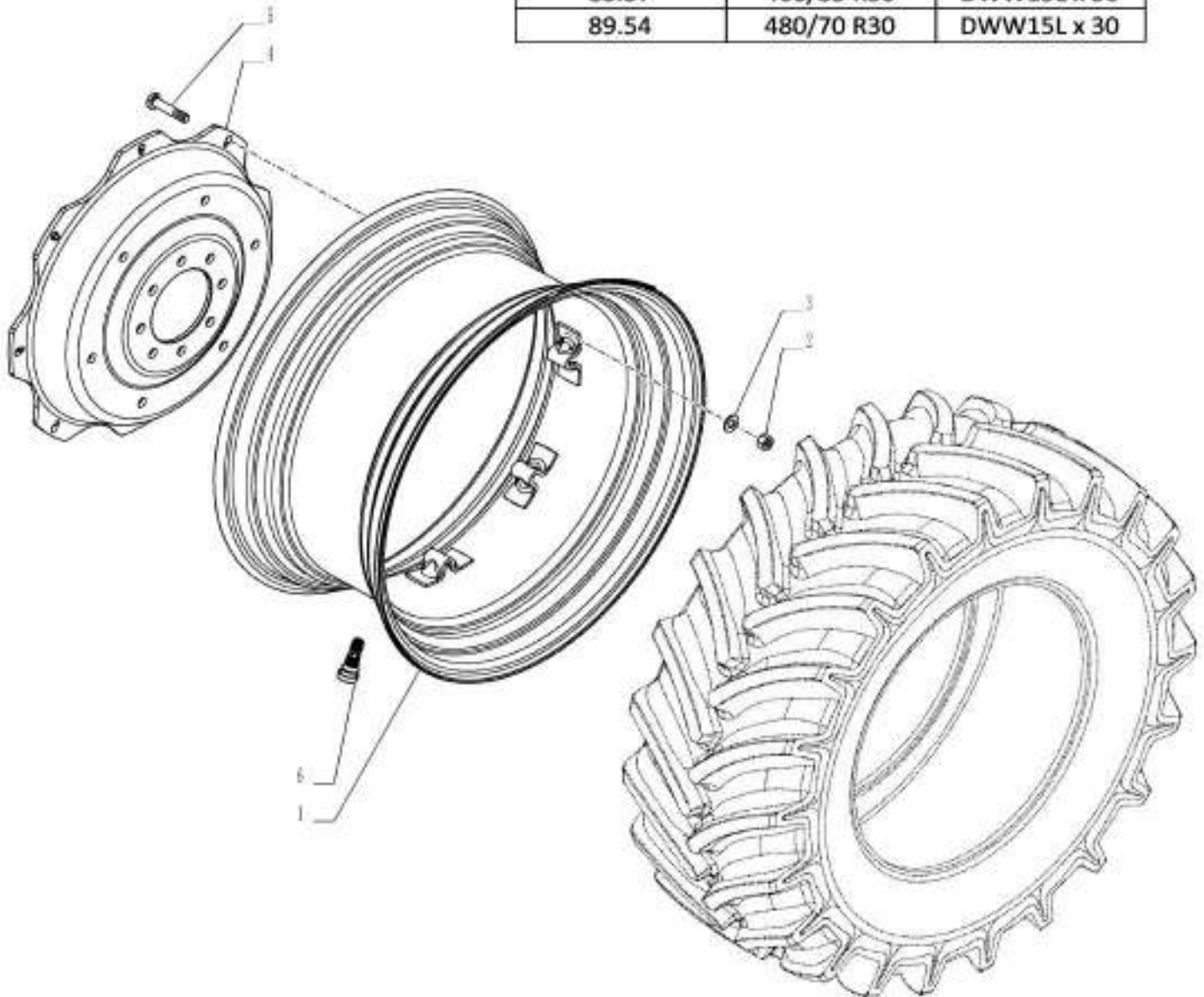

44.520.AB

04

p1

1/2014

WHEEL, REAR



EQUIP.	TYRE SIZE	RIM
83.57	18.4 R30 A8	W15L x 30
83.57	460/85 R30 A8	W15L x 30

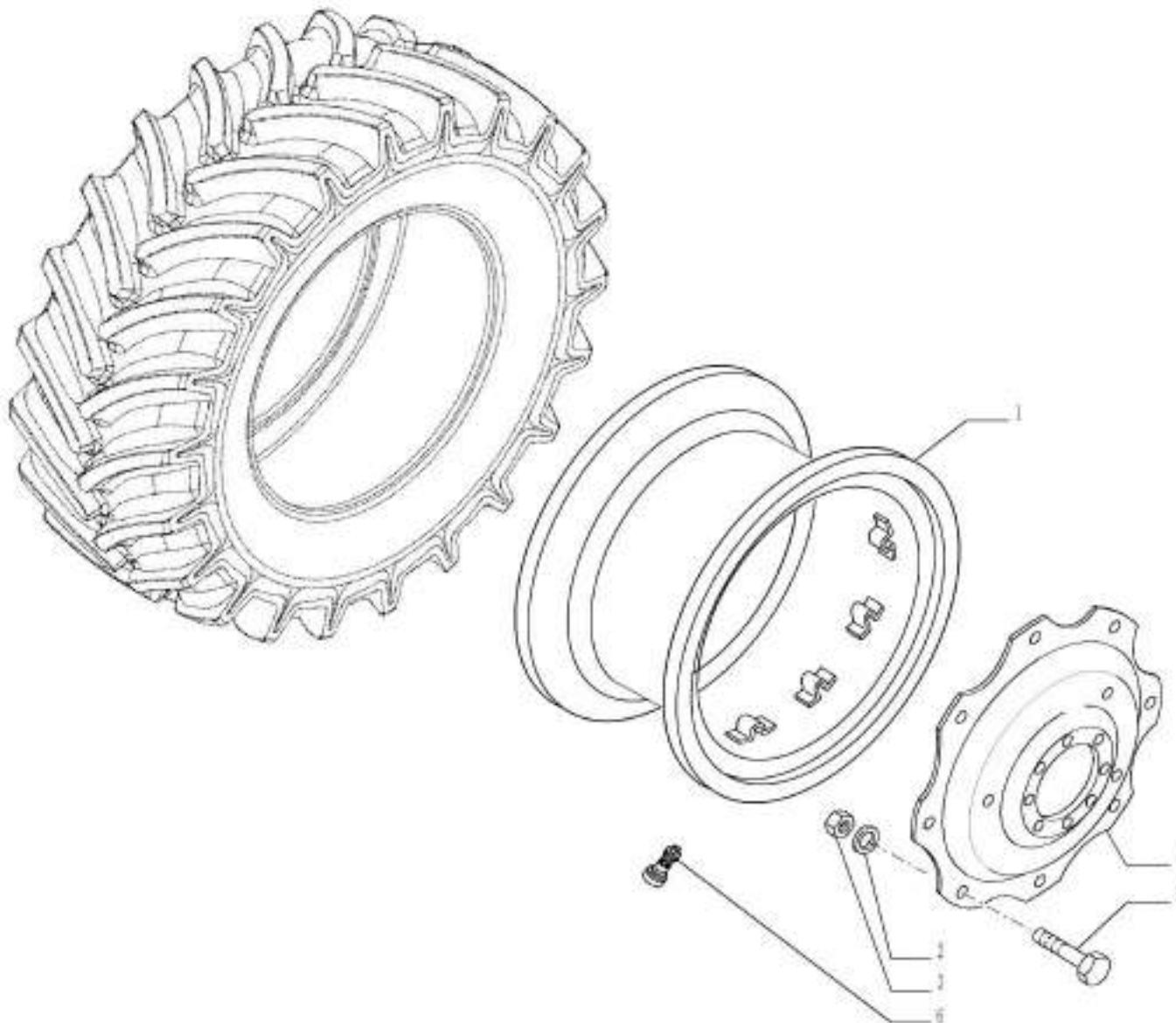

WHEEL, REAR



EQUIP.	TYRE SIZE	RIM
89.64	480/70 R34	DWW15Lx34
83.64	16.9 R34	DWW15Lx34
83.64	420/85 R34	DWW15Lx34
83.65	460/85 R34	DWW15Lx34
83.65	18.4 R34	DWW15Lx34

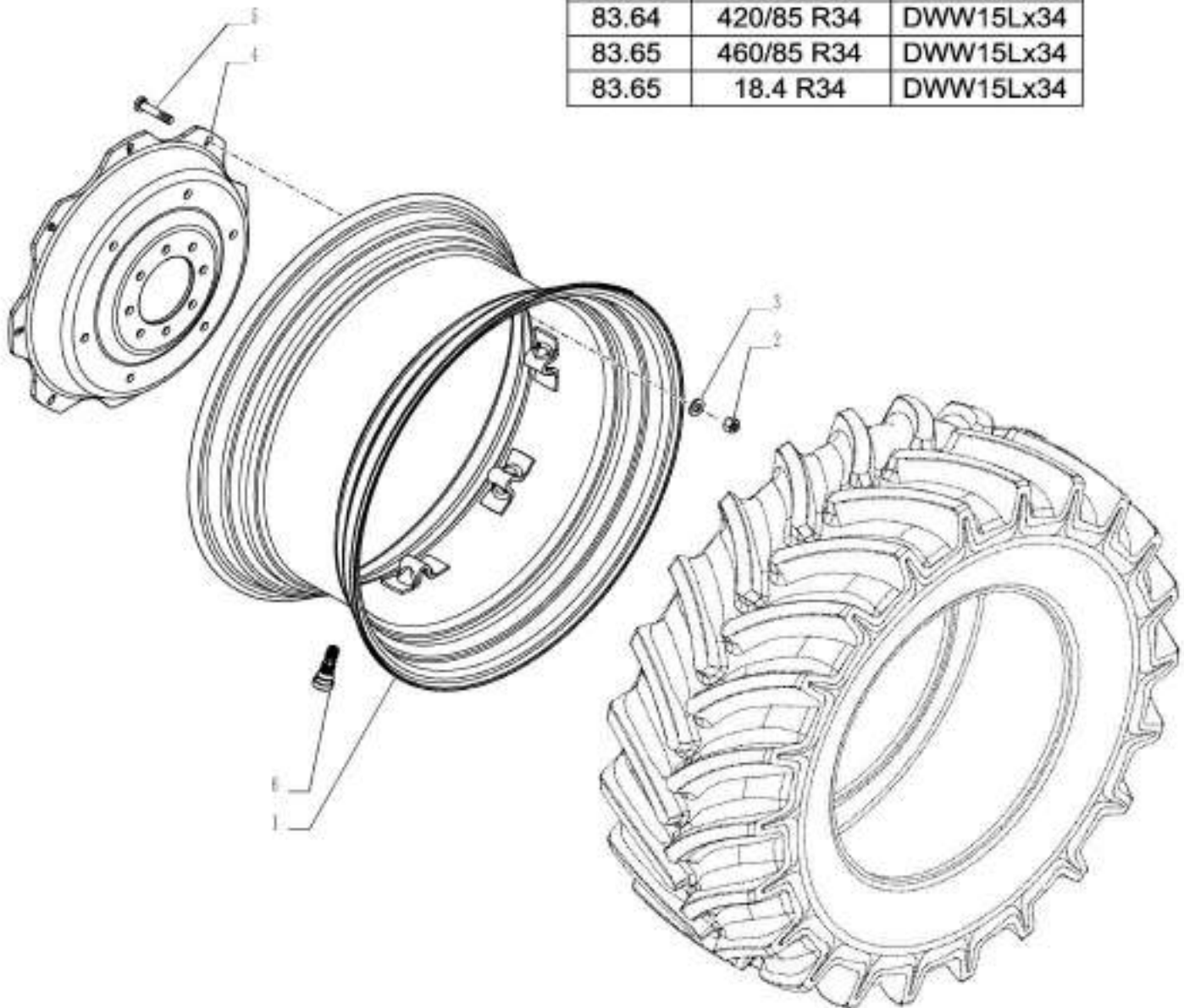

WHEEL, REAR



EQUIP.	TYRE SIZE	RIM
83.69	12.4 R36	W11x36
83.69	320/85 R36	W11x36
83.71	340/85 R36	W11x36
83.71	13.6 R36	W11x36

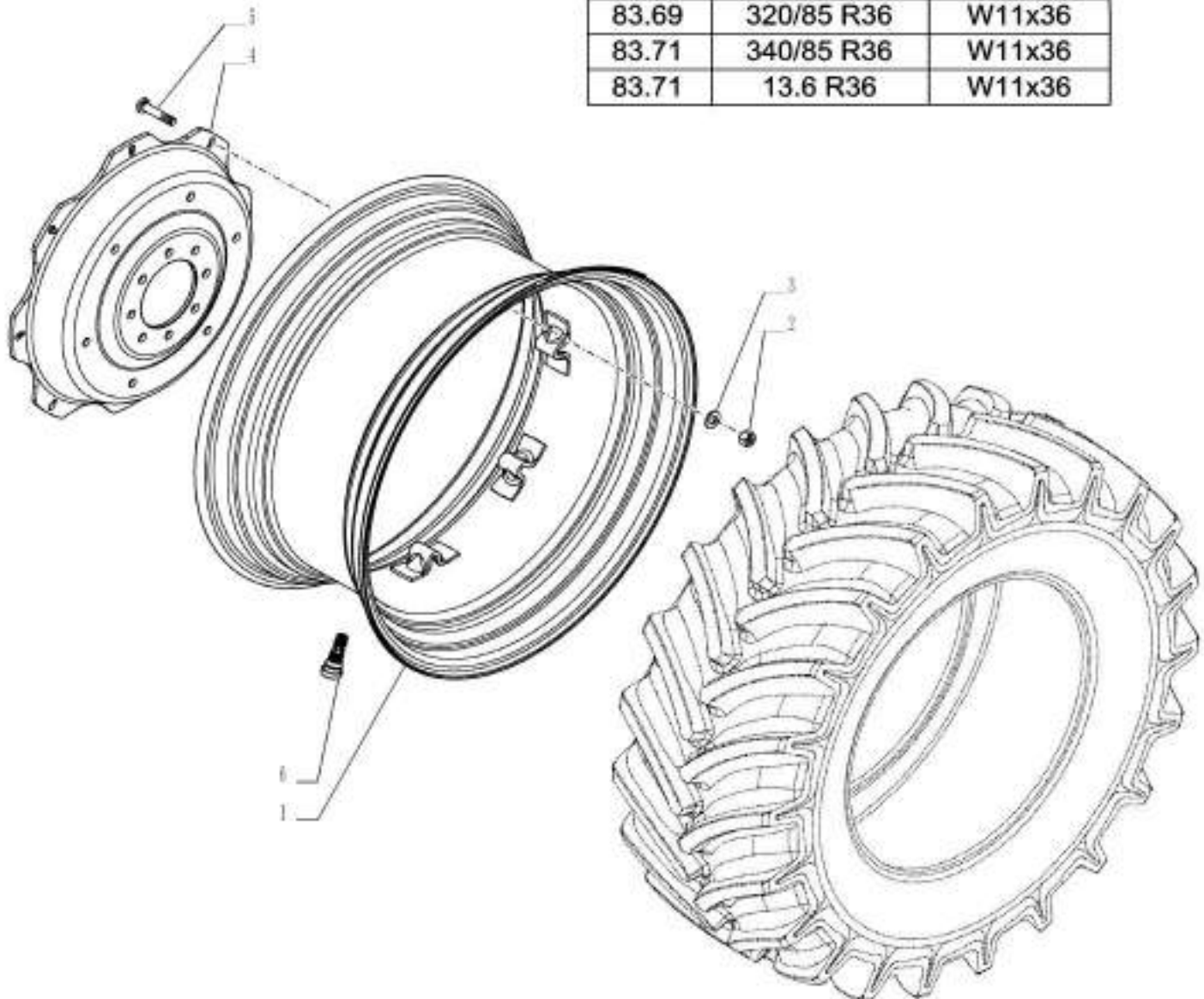

44.520.AB

07

p1

1/2014

WHEEL, REAR



EQUIP.	TYRE SIZE	RIM
83.72	13.6 R38	DWW12 x 38
83.72	340/85 R38	DWW12 x 38
83.16	14.9 R38	DWW12 x 38

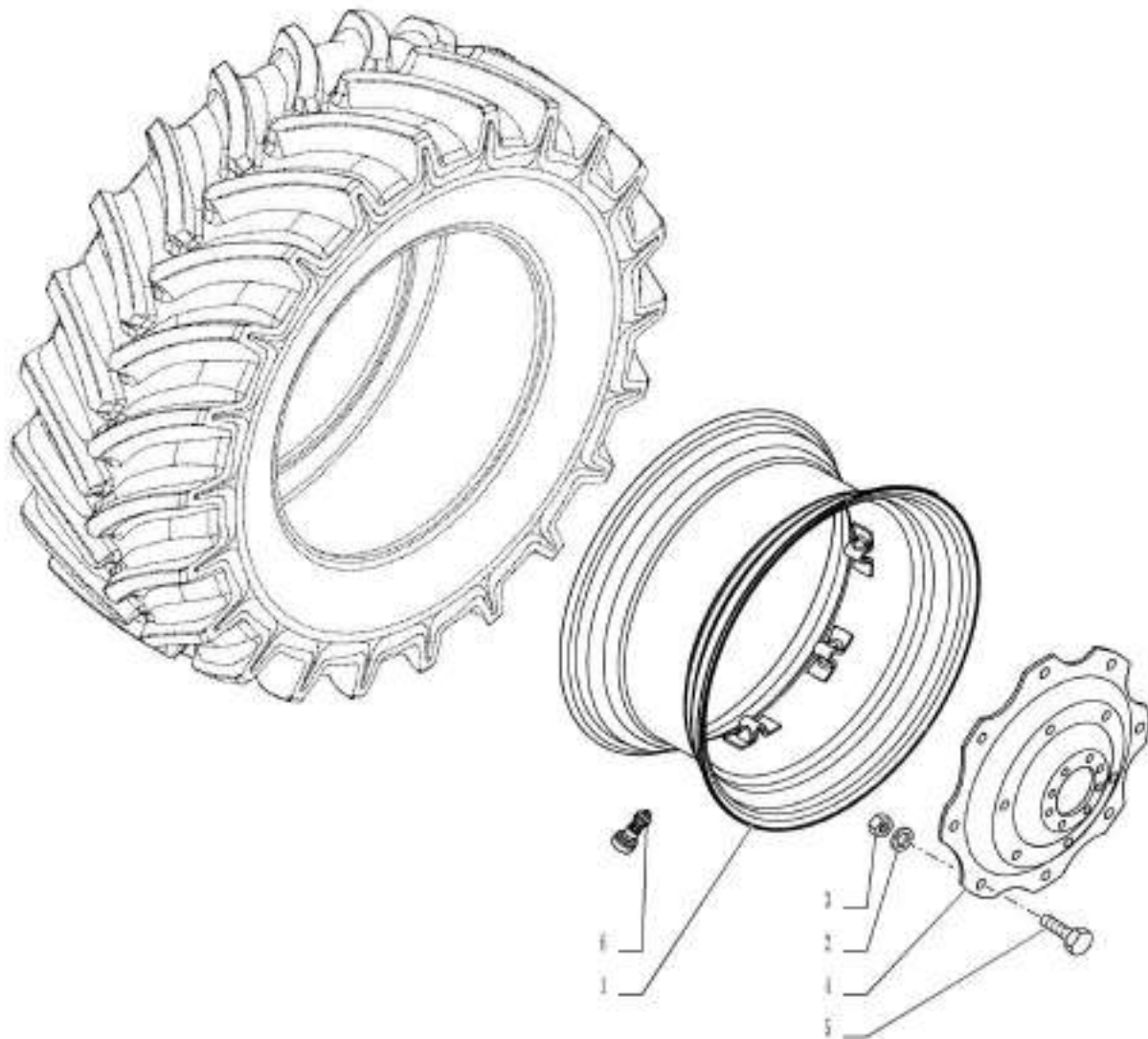

44.520.AB

07

p1

1/2014

WHEEL, REAR



EQUIP.	TYRE SIZE	RIM
83.72	13.6 R38	DWW12 x 38
83.72	340/85 R38	DWW12 x 38
83.16	14.9 R38	DWW12 x 38

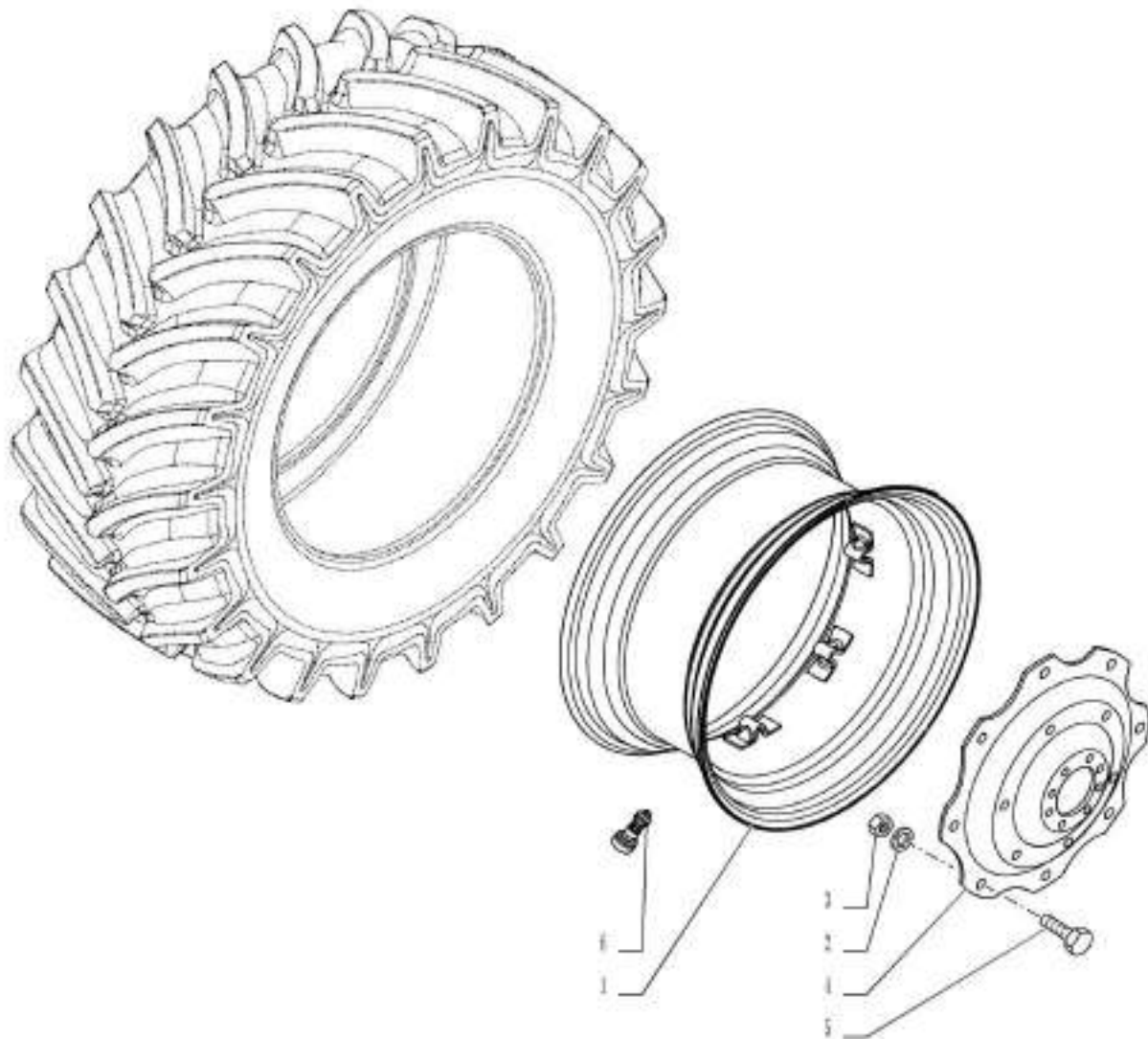

44.520.AB

08

p1

1/2014

WHEEL, REAR



EQUIP.	TYRE SIZE	RIM
83.55	16.9 R30 6PR	W14L x 30

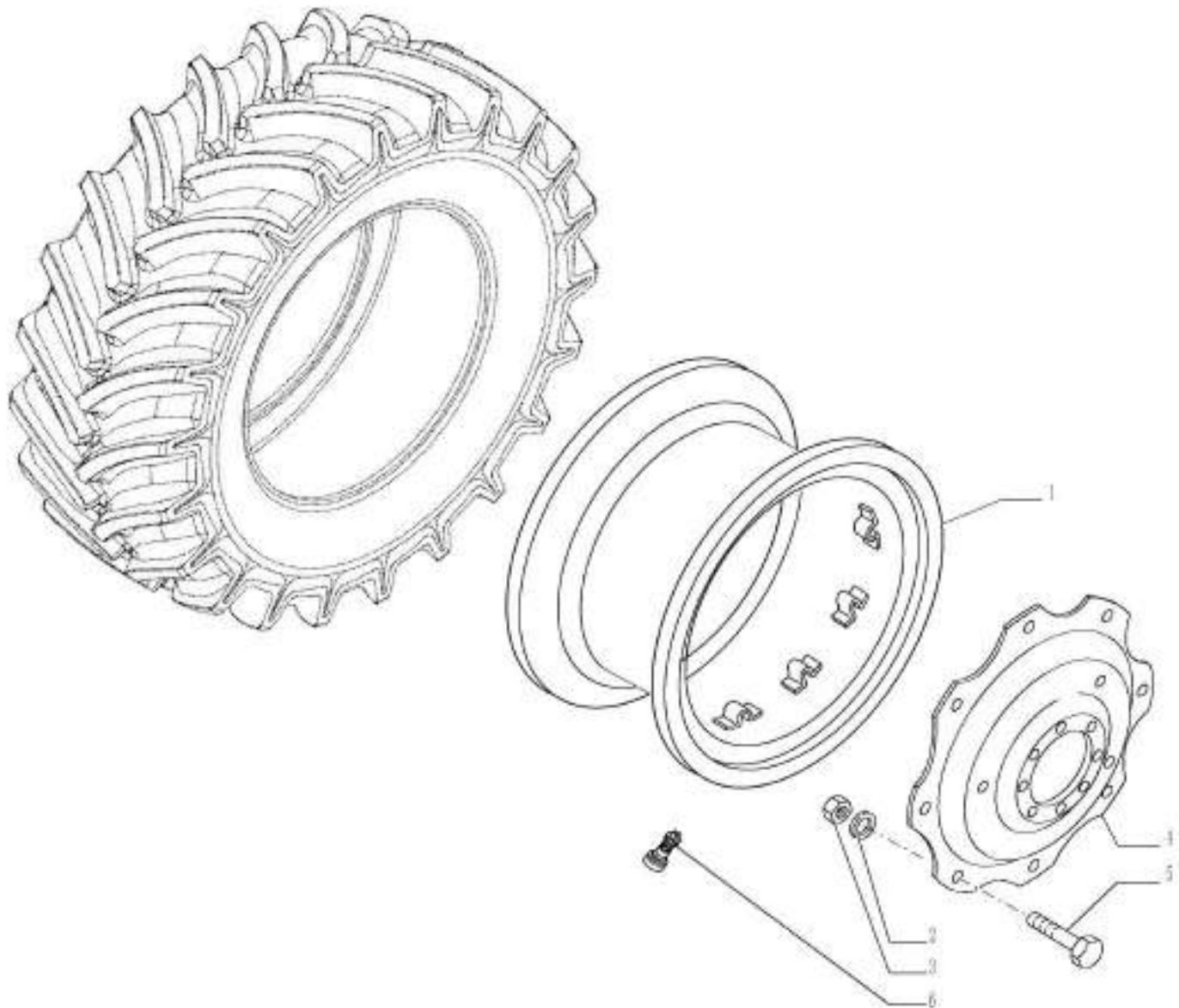

SECTION INDEX

CAB CLIMATE CONTROL

50.000.00	01	SECTION INDEX - CAB CLIMATE CONTROL
50.100.AC	01	VAR - 330641, 390641 - HEATER, HOSE
50.100.AP	01	VAR - 390641 - HEATER
50.100.AP	02	VAR - 390641 - HEATER, COMPONENT
50.104.AO	01	VAR - 330641, 390641 - AIR DUCT, GRILLE
50.104.AQ	01	VAR - 330641, 390641 - AIR FILTER, CAB
50.200.AK	01	VAR - 330641 - AIR CONDITIONER, CONDENSER
50.200.BB	01	VAR - 330641 - CONDENSER RECEIVER-DRYER HOSES
50.200.BY	01	VAR - 330641 - AIR CONDITIONER, LINE
50.200.CA	01	VAR - 330641 - AIR CONDITIONER
50.200.CA	02	VAR - 330641 - AIR CONDITIONER, COMPONENT

SECTION INDEX - CAB CLIMATE CONTROL

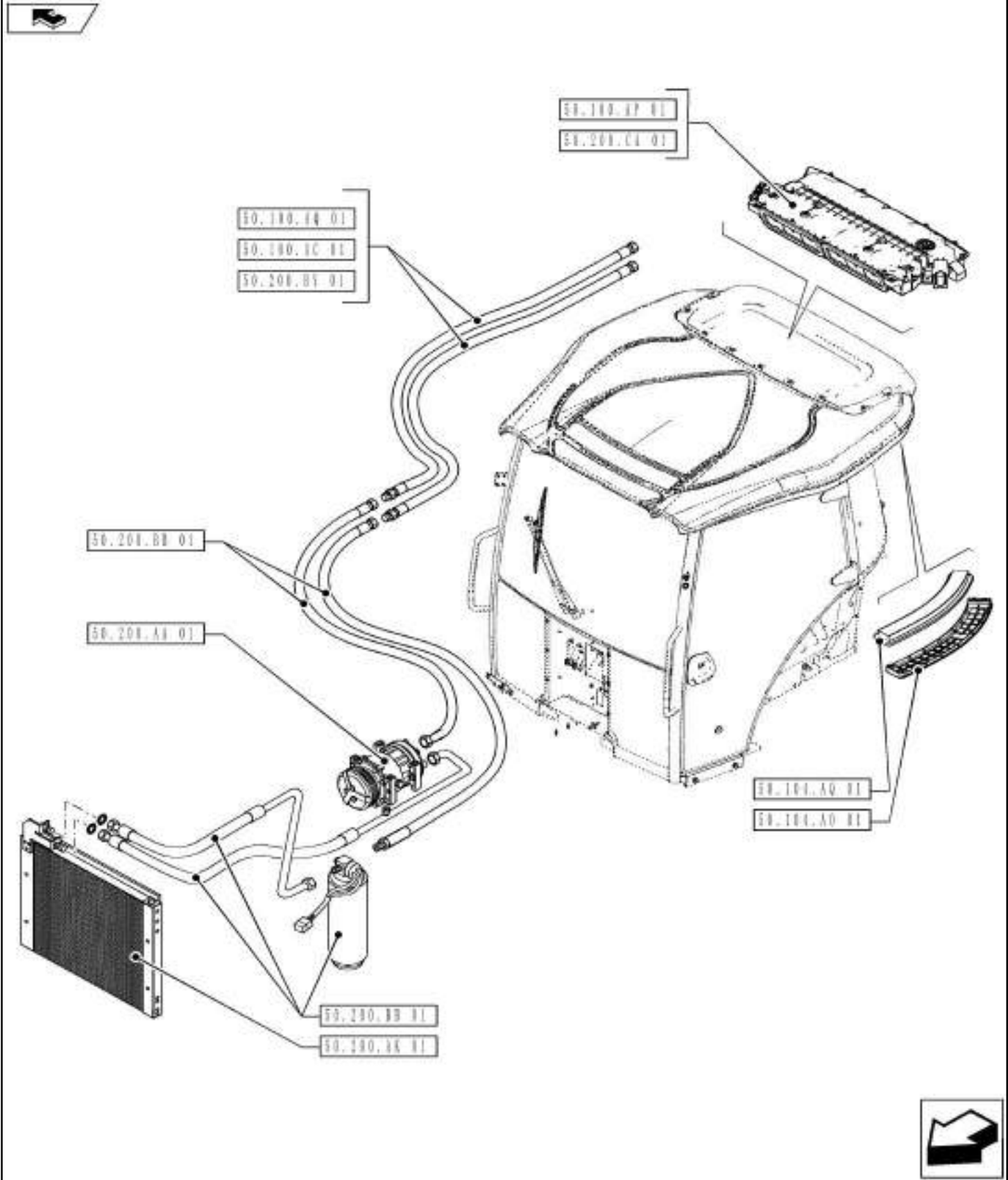

50.000.00

01

p1

1/2014

SECTION INDEX - CAB CLIMATE CONTROL

REF FN	PART NUMBER	YR/SN	QTY	DESCRIPTION
---------------	--------------------	--------------	------------	--------------------

				FARMALL JX100 FARMALL JX110 FARMALL JX70 FARMALL JX75 FARMALL JX80 FARMALL JX90
--	--	--	--	--

VAR - 330641, 390641 - HEATER, HOSE

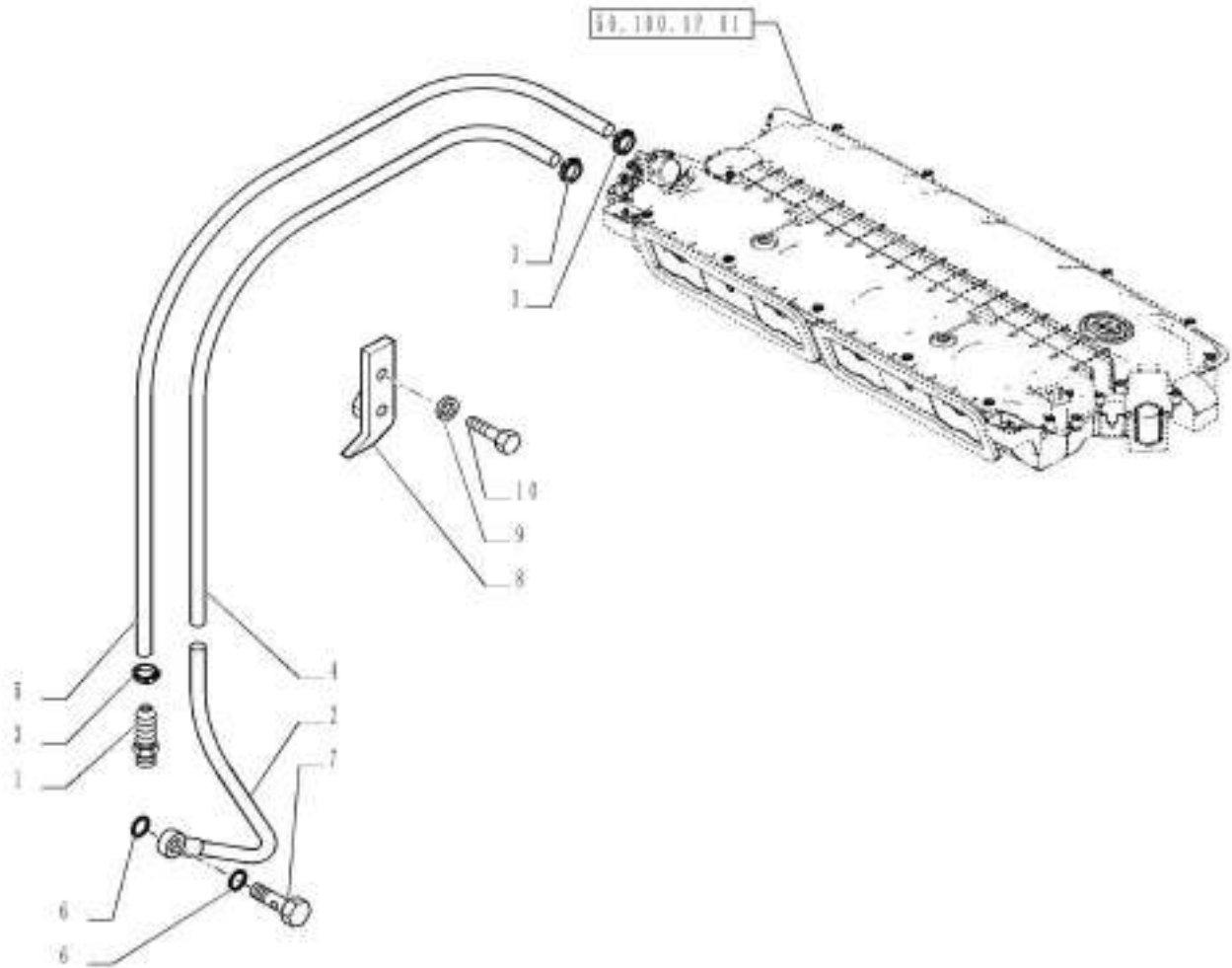

50.100.AC

01

p1

1/2014

VAR - 330641, 390641 - HEATER, HOSE

REF FN	PART NUMBER	YR/SN	QTY DESCRIPTION
1	5094423		1 HYD CONNECTOR
2	47405705		1 PIPE
3	87557209		3 CLAMP Adj Hose, M16-27
4 1	84527518		1 HOSE L=4690 mm, D=26 x 19 mm
4 2	84527520		1 HOSE L=4810 mm, D=26 x 19 mm
5 1	84524367		1 FLEXIBLE HOSE L=4660 mm, D=23.5 x 16 mm
5 2	84524368		1 FLEXIBLE HOSE L=4780 mm, D=23.5 x 16 mm
6	10257460		2 SEAL M20.3 x 26 x 1.5
7	10182611		1 BANJO BOLT M20 x 1.5 x 36
8	84553603		2 SUPPORT
9	12601279		4 WAVE WASHER Wave, M6.4
10	13276011		4 SCREW Cross Pan Hd, M6 x 12

(1) Valid for FARMALL JX70, 75, 80, 90 Models Only

(2) Valid for FARMALL JX100, 110 Models Only

Valid for Var. 330641 or Var. 390641

FARMALL JX100 FARMALL
 JX110 FARMALL JX70
 FARMALL JX75 FARMALL
 JX80 FARMALL JX90

50.100.AP

01

p1

1/2014

VAR - 390641 - HEATER

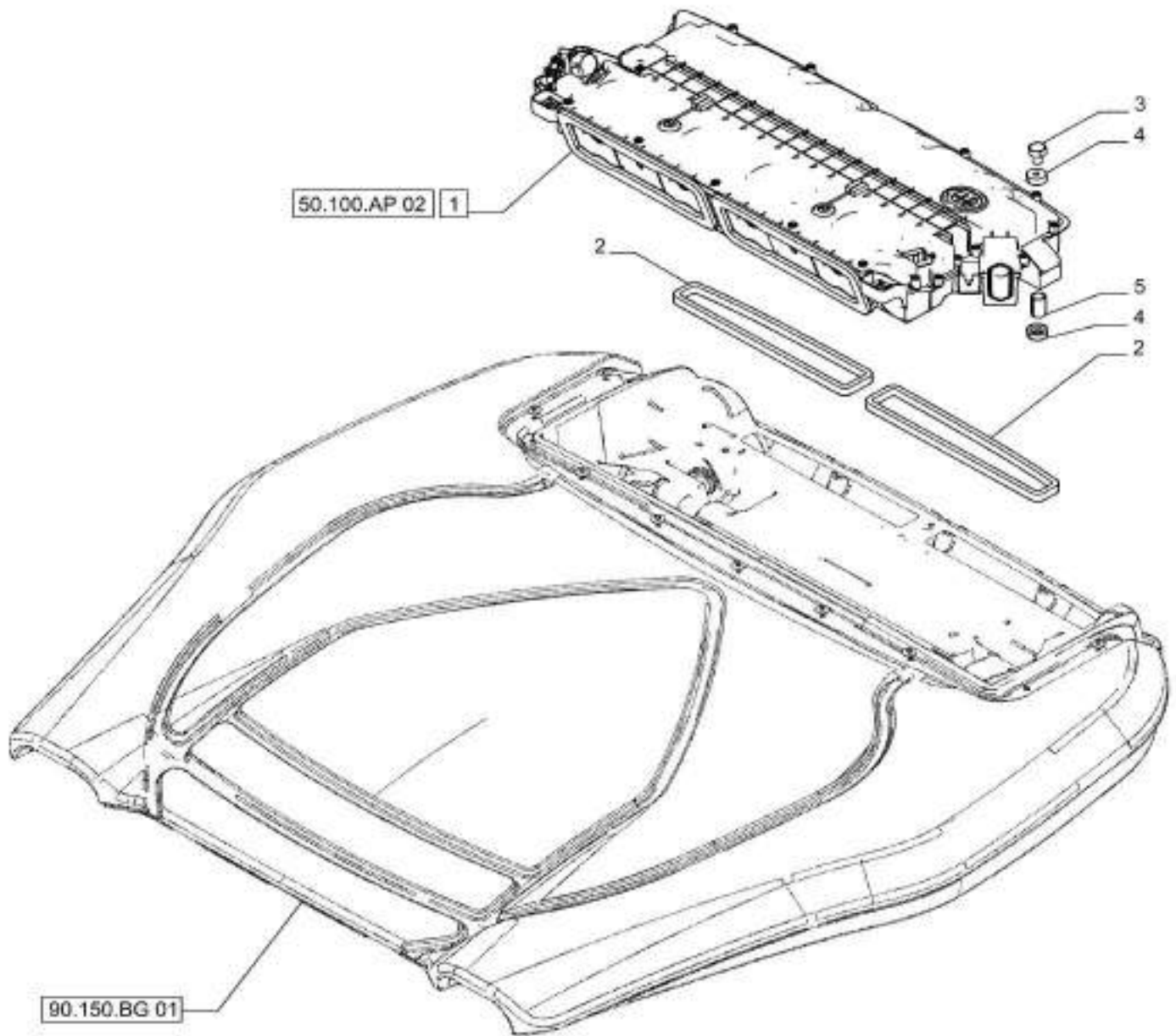

50.100.AP

01

p1

1/2014

VAR - 390641 - HEATER

REF FN	PART NUMBER	YR/SN	QTY DESCRIPTION
1	84524340		1 HEATER
2	84554027		2 GASKET
3	16043721		5 SCREW Hex, M8 x 1.25 x 28mm, Cl 8.8, Full Thd
4	84554033		10 ISOLATOR
5	84554036		5 SPACER

Valid for Var. 390641

FARMALL JX100 FARMALL
JX110 FARMALL JX70
FARMALL JX75 FARMALL
JX80 FARMALL JX90

VAR - 390641 - HEATER, COMPONENT

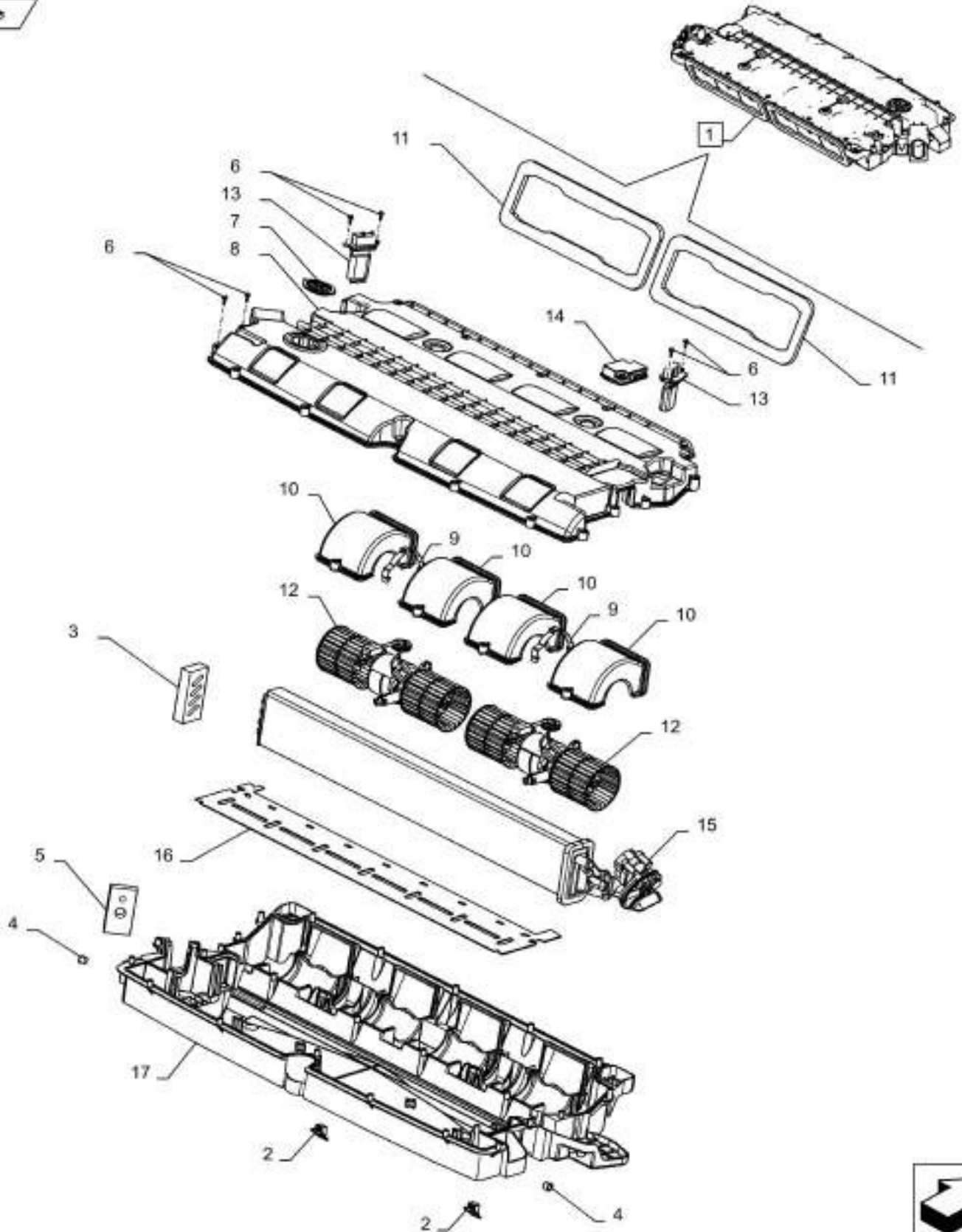

VAR - 390641 - HEATER, COMPONENT

REF FN	PART NUMBER	YR/SN	QTY DESCRIPTION
1	84524340		1 HEATER ASSY, Incl 2 - 17
2	47442568		2 RUBBER MOUNTING
3	47442569		1 PADDING
4	47462842		2 PADDING
5	47462840		1 GASKET
6	47442574		42 SCREW
7	47442575		1 GASKET
8	47442576		1 HOUSING
9	47442582		2 SPRING CLIP
10	47442577		4 PROTECTION STRIP
11	47442578		2 GASKET
12	47442579		2 ELECTRIC BLOWER
13	47442580		2 RESISTOR
14	47442581		1 ACTUATOR
15	47442583		1 HEAT EXCHANGER
16	47442584		1 PROTECTION PLATE
17	47442589		1 HOUSING
Valid for Var. 390641			FARMALL JX100 FARMALL JX110 FARMALL JX75 FARMALL JX80

50.104.AO

01

p1

1/2014

VAR - 330641, 390641 - AIR DUCT, GRILLE

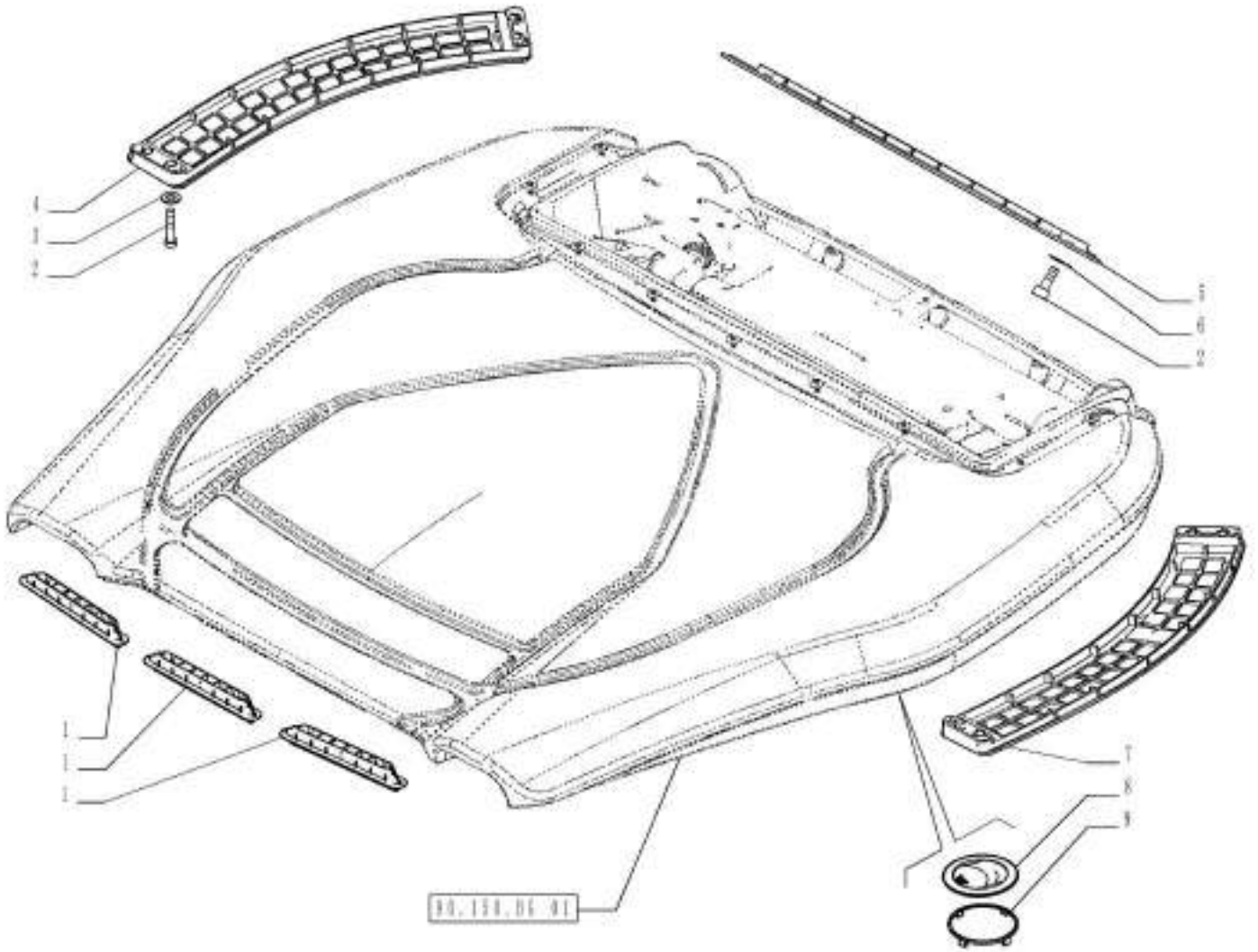

VAR - 330641, 390641 - AIR DUCT, GRILLE

REF FN	PART NUMBER	YR/SN	QTY DESCRIPTION
1	84524363		3 DEFROSTER
2	14305221		10 HEX SOC SCREW M6 x 16mm, Cl 8.8, Full Thd
3	12620474		8 WAVE WASHER Wave, M6.4
4	84524360		1 SCREEN
5	84524349		1 SCREEN
6	14498801		2 WASHER M6 x 16.3 x 1
7	84524361		1 SCREEN
8	5108700		6 SEALING RING
9	5108688		6 DIFFUSER

Valid for Var. 330641 or Var. 390641

FARMALL JX100 FARMALL
JX110 FARMALL JX70
FARMALL JX75 FARMALL
JX80 FARMALL JX90

50.104.AQ

01

p1

1/2014

VAR - 330641, 390641 - AIR FILTER, CAB

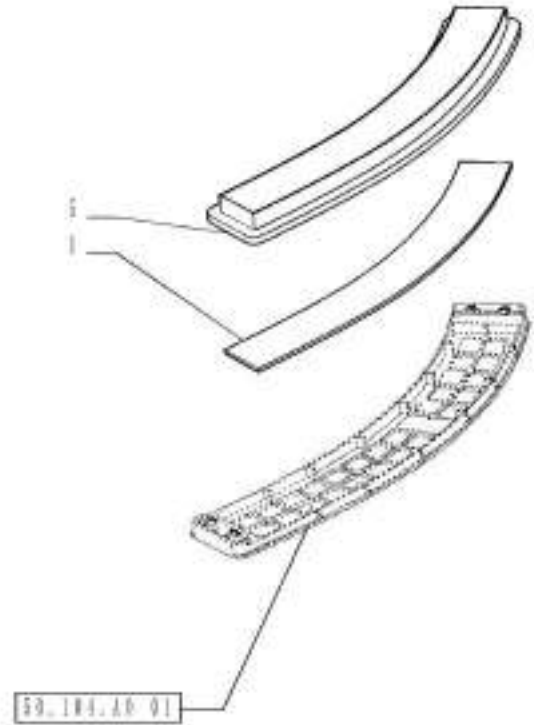
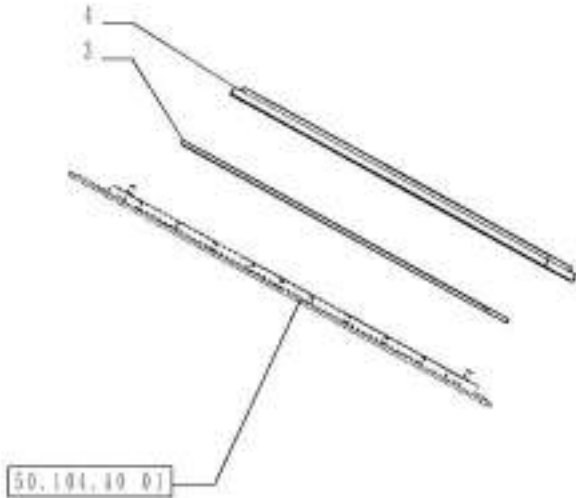
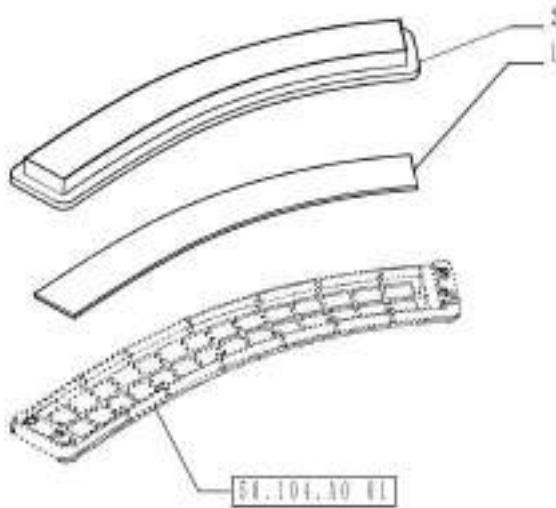

VAR - 330641, 390641 - AIR FILTER, CAB

REF FN	PART NUMBER	YR/SN	QTY DESCRIPTION
1	84554028		2 FILTER
2	84524359		1 CAB FILTER
3	84554034		1 FILTER
4	84524327		1 CAB FILTER
5	84524358		1 CAB FILTER

Valid for Var. 330641 or Var. 390641

FARMALL JX100 FARMALL
JX110 FARMALL JX70
FARMALL JX75 FARMALL
JX80 FARMALL JX90

VAR - 330641 - AIR CONDITIONER, CONDENSER

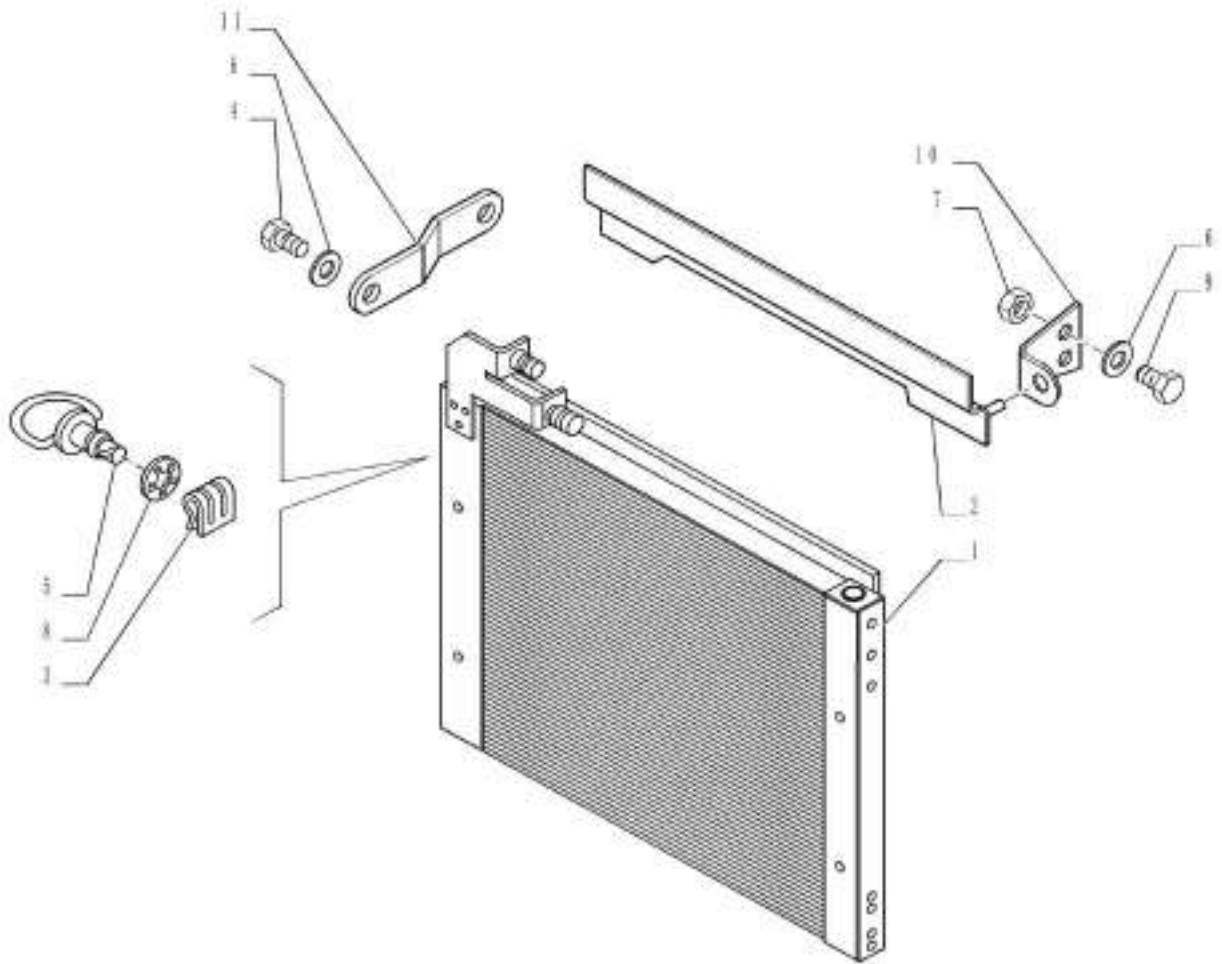

50.200.AK

01

p1

1/2014

VAR - 330641 - AIR CONDITIONER, CONDENSER

REF FN	PART NUMBER	YR/SN	QTY DESCRIPTION
1	84342887		1 CONDENSER
2	84562784		2 SUPPORT
3	82004582		1 CLIP
4	86977726		1 BOLT Hex, M6 x 12mm, Cl 8.8, Full Thd
5	87614935		1 STUD
6	12601274		12 WAVE WASHER Wave, M6.4
7	15896221		4 NUT M6, Cl 10
8	82004583		1 RETAINER
9	10902121		8 SCREW Hex, M6 x 1 x 14.00mm, Cl 8.8, ZND
10	84520308		4 SUPPORT
11	84561627		1 BRACKET

Valid for Var. 330641	FARMALL JX100 FARMALL JX110 FARMALL JX70 FARMALL JX75 FARMALL JX80 FARMALL JX90
------------------------------	--

50.200.BB

01

p1

1/2014

VAR - 330641 - CONDENSER RECEIVER-DRYER HOSES

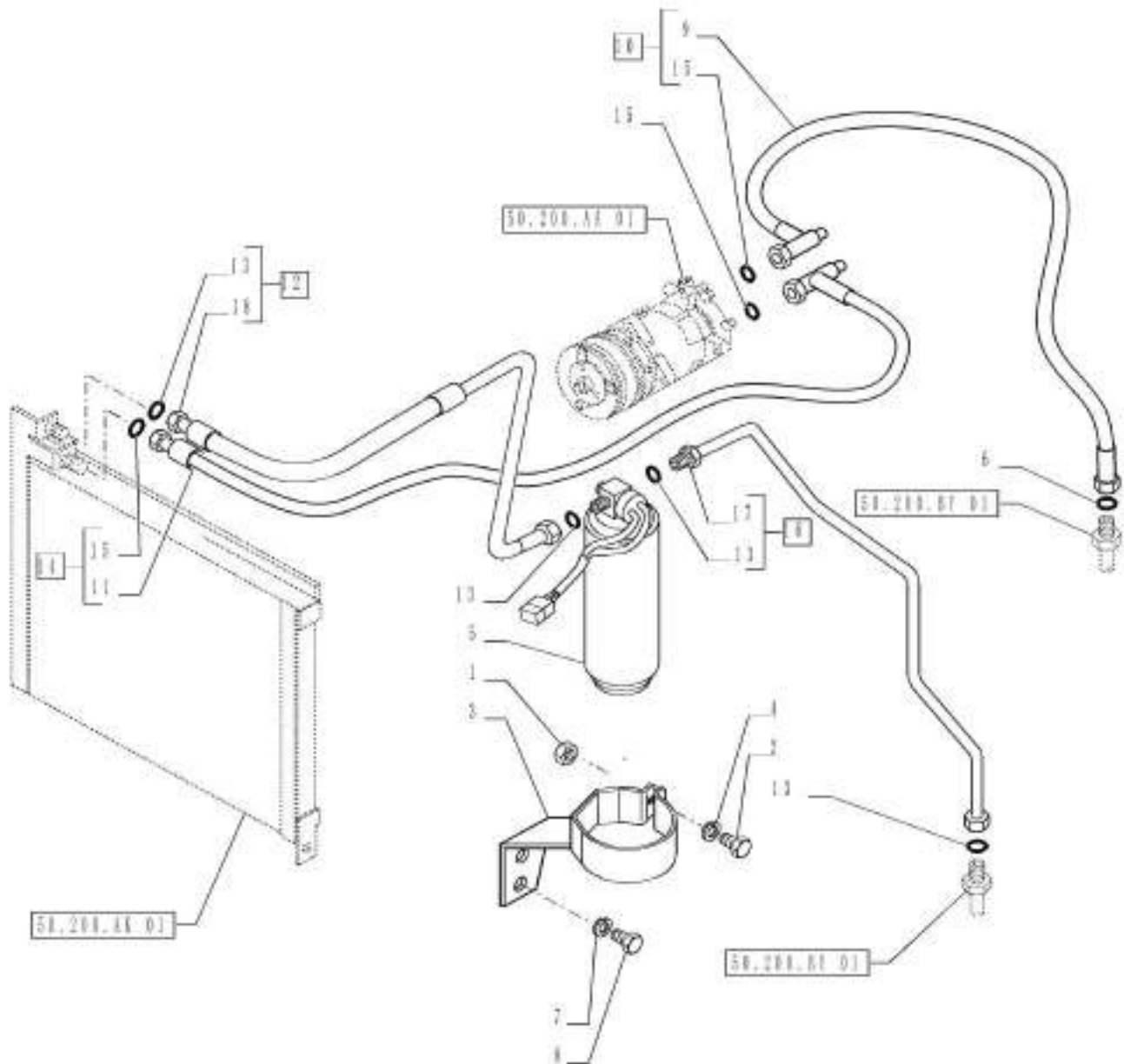

VAR - 330641 - CONDENSER RECEIVER-DRYER HOSES

REF FN	PART NUMBER	YR/SN	QTY DESCRIPTION
1	15896221		1 NUT M6, CI 10
2	86508568		1 BOLT Hex, M6 x 16mm, CI 8.8, Full Thd
3	5091898		1 BRACKET
4	12601274		2 WAVE WASHER Wave, M6.4
5	5165615		1 RECEIVER-DRYER
6	14453283		1 O-RING 14mm ID x 1.78mm Width
7	12601474		2 WAVE WASHER Wave, 10.50mm ID x 21.00mm OD x 0.80mm, 3.00mm, CST, DAC
8	15970521		2 BOLT Hex, M10 x 1.25 x 20, 8.8, Full Thd
9	NSS		1 NOT SERVICED SEPARATELY Pipe Incl in 10
10	84519355		1 FLEXIBLE HOSE Incl 6, 9, 15
11	NSS		1 NOT SERVICED SEPARATELY Pipe Incl in 14
12	84358642		1 FLEXIBLE HOSE Incl 13, 18
13	14452883		4 O-RING 7.65mm ID x 1.78mm Width
14	84358636		1 FLEXIBLE HOSE Incl 11, 15
15	14453083		3 O-RING
16	84519359		1 FLEXIBLE HOSE Incl 13, 17
17	NSS		1 NOT SERVICED SEPARATELY Pipe Incl in 16
18	NSS		1 NOT SERVICED SEPARATELY Pipe Incl in 12

Valid for Var. 330641

FARMALL JX100 FARMALL
 JX110 FARMALL JX70
 FARMALL JX75 FARMALL
 JX80 FARMALL JX90

VAR - 330641 - AIR CONDITIONER, LINE

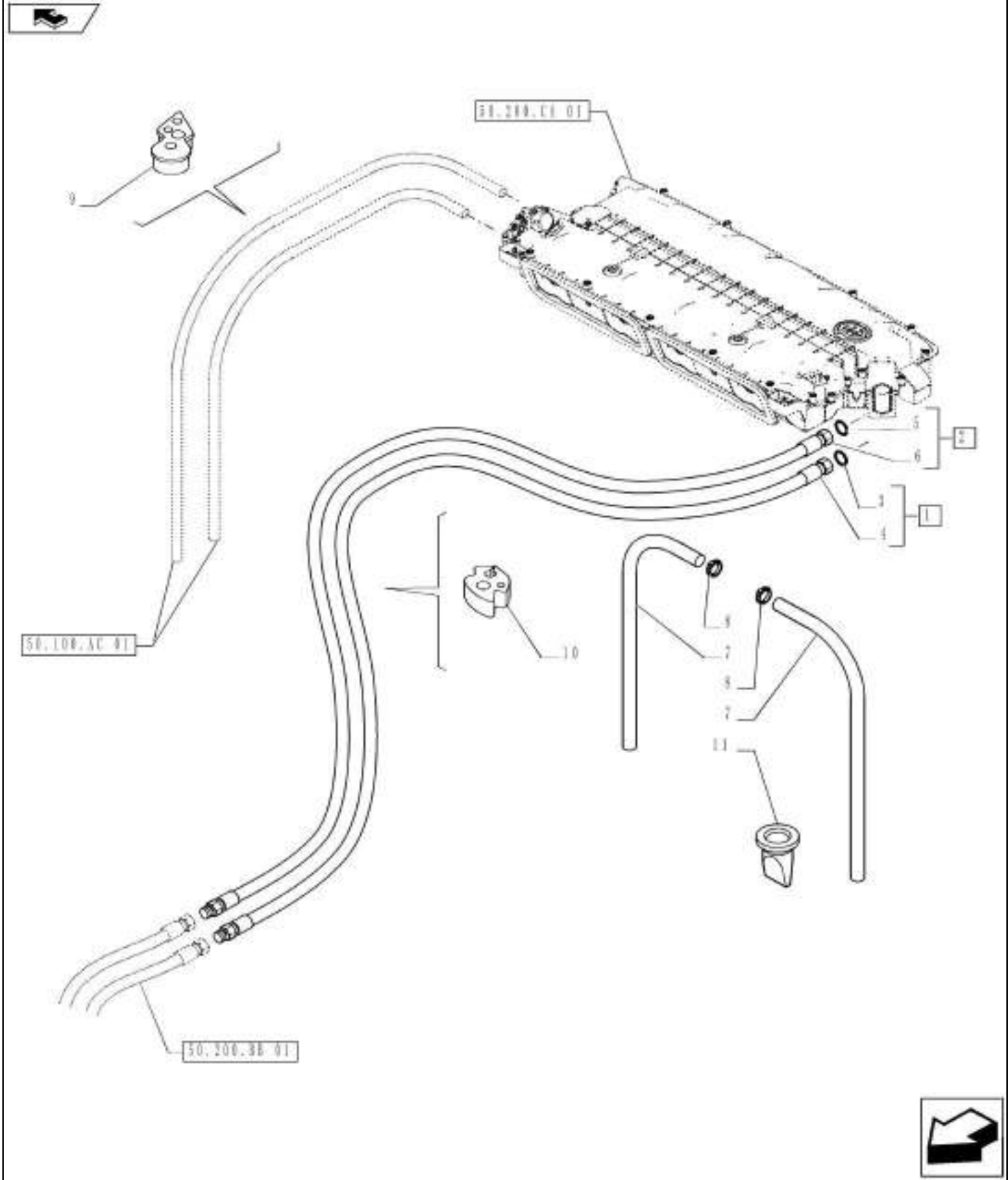

50.200.BY

01

p1

1/2014

VAR - 330641 - AIR CONDITIONER, LINE

REF FN	PART NUMBER	YR/SN	QTY DESCRIPTION
1	84519360		1 FLEXIBLE HOSE Incl 3, 4
2	84519357		1 FLEXIBLE HOSE Incl 5, 6
3	14452883		1 O-RING 7.65mm ID x 1.78mm Width
4	NSS		1 NOT SERVICED SEPARATELY Tube Incl in 1
5	14453283		1 O-RING 14mm ID x 1.78mm Width
6	NSS		1 NOT SERVICED SEPARATELY Tube Incl in 2
7	84524370		2 LARGE HOSE
8	13000290		2 HOSE CLAMP
9	47393326		1 PLUG RH
10	47393321		1 PLUG LH
11	84553569		1 DRAIN PLUG

Valid for Var. 330641	FARMALL JX100 FARMALL JX110 FARMALL JX70 FARMALL JX75 FARMALL JX80 FARMALL JX90
------------------------------	--

VAR - 330641 - AIR CONDITIONER

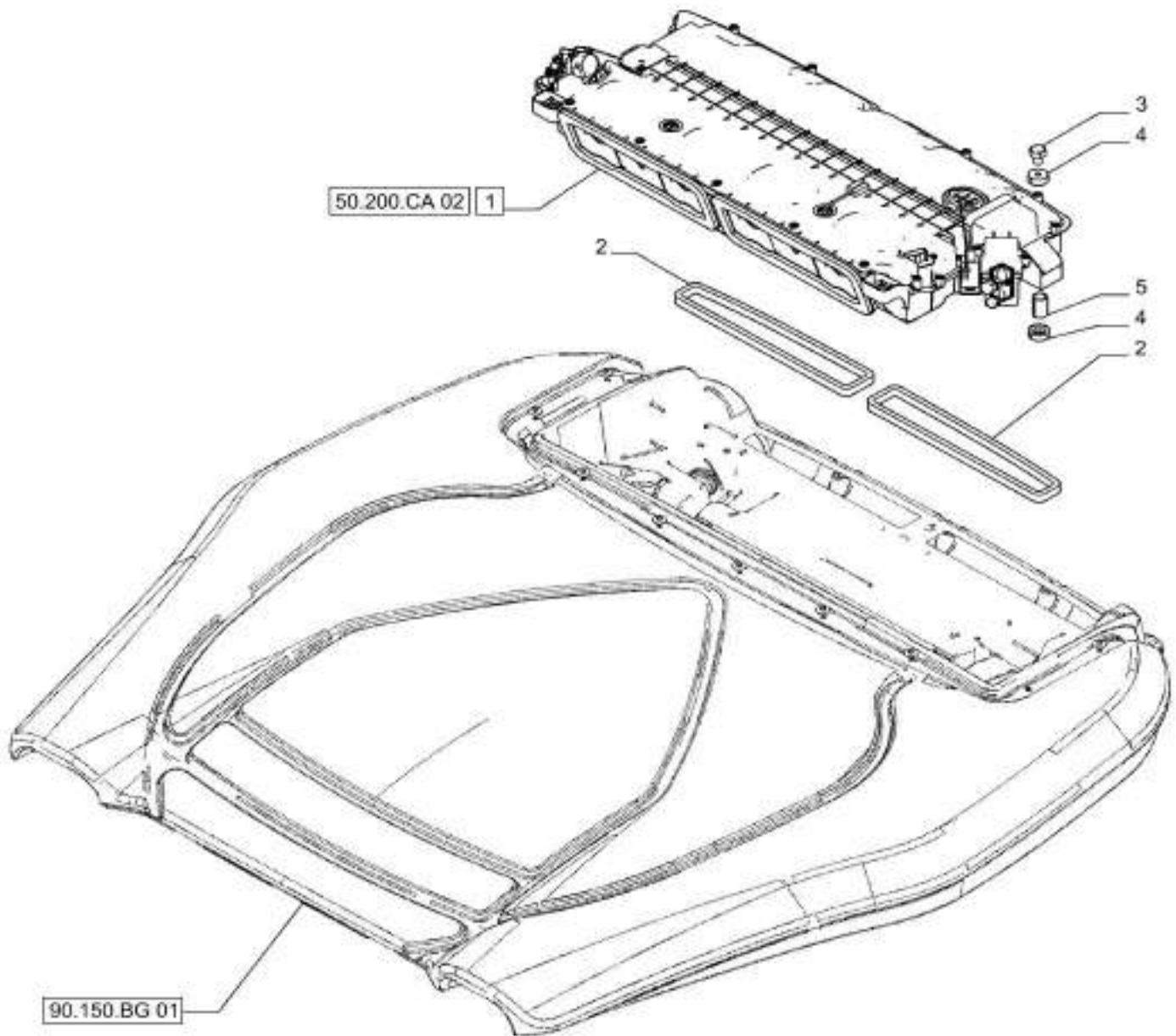

50.200.CA

01

p1

1/2014

VAR - 330641 - AIR CONDITIONER

REF FN	PART NUMBER	YR/SN	QTY DESCRIPTION
1	84524339		1 HEATER
2	84554027		2 GASKET
3	16043721		5 SCREW Hex, M8 x 1.25 x 28mm, Cl 8.8, Full Thd
4	84554033		10 ISOLATOR
5	84554036		5 SPACER

Valid for Var. 330641

FARMALL JX100 FARMALL
JX110 FARMALL JX70
FARMALL JX75 FARMALL
JX80 FARMALL JX90

VAR - 330641 - AIR CONDITIONER, COMPONENT

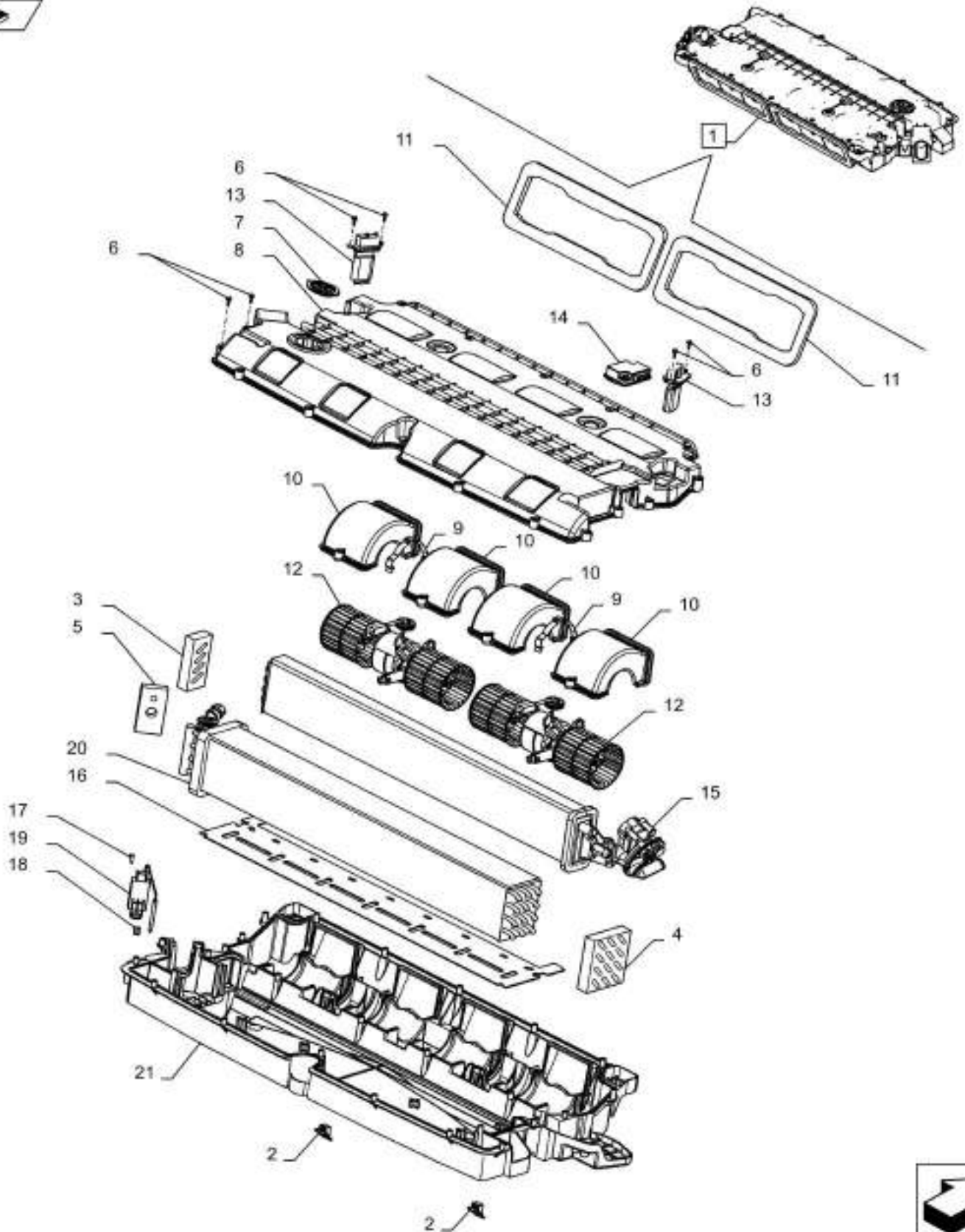

VAR - 330641 - AIR CONDITIONER, COMPONENT

REF FN	PART NUMBER	YR/SN	QTY DESCRIPTION
1	84524339		1 HEATER ASSY, Incl 2 - 21
2	47442568		2 RUBBER MOUNTING
3	47442569		1 PADDING
4	47442570		1 PADDING
5	47442572		1 GASKET
6	47442574		42 SCREW
7	47442575		1 GASKET
8	47442576		1 HOUSING
9	47442582		2 SPRING CLIP
10	47442577		4 PROTECTION STRIP
11	47442578		2 GASKET
12	47442579		2 ELECTRIC BLOWER
13	47442580		2 RESISTOR
14	47442581		1 ACTUATOR
15	47442583		1 HEAT EXCHANGER
16	47442584		1 PROTECTION PLATE
17	47442585		1 SCREW
18	47442586		1 SELF-TAP SCREW
19	47442587		1 THERMOSTAT
20	47442588		1 EVAPORATOR
21	47442589		1 HOUSING

Valid for Var. 330641

FARMALL JX100 FARMALL
 JX110 FARMALL JX70
 FARMALL JX75 FARMALL
 JX80 FARMALL JX90

SECTION INDEX

ELECTRICAL SYSTEMS

55.000.00	02	SECTION INDEX - ELECTRICAL SYSTEMS
55.000.00	03	SECTION INDEX - ELECTRICAL SYSTEMS
55.000.00	04	SECTION INDEX - ELECTRICAL SYSTEMS
55.010.AP	01	VAR - 333606, 334318, 334319, 391606, 392315 - ENGINE FUEL SENSOR
55.010.AQ	02	VAR - 334296 - WATER SEPARATOR, SENSOR
55.014.AC	01	VAR - 330200, 390227 - AIR CLEANER, RESTRICTION SWITCH, INDICATOR
55.015.AB	01	VAR - 333606, 334318, 334319, 391606, 392315 - ENGINE HARNESS
55.023.AA	01	VAR - 330120, 331120, 743846 - HYDRAULIC GEARBOX CONTROLS (POWER SHUTTLE) - SENSOR
55.030.AB	01	VAR - 744738, 744739, 744744 - BRAKE, SENSOR
55.031.AE	01	VAR - 333606, 334318, 334319, 391606, 392315 - PARKING BRAKE, SWITCH
55.046.AH	01	VAR - 743846, 744739 - DIFFERENTIAL LOCK, CONTROL, SWITCH
55.047.AD	01	VAR - 330120, 331120, 390249, 743846 - POWER STEERING KIT, PRESSURE SWITCH
55.048.AB	01	VAR - 333606, 334318, 334319, 391606, 392315 - PTO, CONTROL LEVER, SWITCH
55.051.AA	01	VAR - 330641 - AIR CONDITIONER, CONTROL PANEL, BREAKDOWN
55.051.AB	01	VAR - 390641 - HEATING SYSTEM, CONTROL PANEL, BREAKDOWN
55.100.DO	01	VAR - 333606, 391606 - FUSE BOX, CAB
55.100.DO	02	VAR - 334318, 334319, 392315 - FUSE BOX, ROPS
55.201.AH	01	VAR - 333606, 334318, 334319, 391606, 392315 - ENGINE STARTER SAFETY SWITCH
55.202.AY	01	VAR - 330203 - THERMOSTART
55.302.AG	01	VAR - 330740, 335210 - BATTERY MOUNTING
55.404.AC	01	VAR - 334343, 335914 - ROTARY BEACON, CAB
55.404.AC	02	VAR - 334343, 335914 - ROTARY BEACON, ROPS
55.404.BA	01	VAR - 334342, 334343 - NUMBER PLATE LIGHT
55.404.BH	01	VAR - 334344, 334345, 334346, 334347, 334348, 334349, 334350, 335914 - REFLECTOR, REAR
55.404.BS	01	VAR - 335767 - WORK LIGHT, ROPS
55.404.CA	01	VAR - 334344, 334345, 334346, 334347, 334348, 334339, 334350, 335914 - FRONT TURN INDICATORS
55.404.CL	01	VAR - 334344, 334345, 334346, 334347, 334348, 334349, 334950, 335914 - REAR TURN INDICATORS
55.404.CY	01	VAR - 334342, 334343, 334344, 334345, 334346, 334347, 334348, 334349, 334950, 335914 - ROAD LIGHTS - FRONT HEADLAMPS
55.404.CY	02	VAR - 334342, 334343, 334344, 334345, 334346, 334347, 334348, 334349, 334950, 335914 - FRONT HEADLAMPS - BREAKDOWN
55.405.CH	01	VAR - 334343, 335914 - ROTARY BEACON, SWITCH, CAB
55.405.CH	02	VAR - 334343, 335914 - ROTARY BEACON, SWITCH, ROPS

SECTION INDEX
ELECTRICAL SYSTEMS

55.510.AF	02	VAR - 333606, 334318, 334319, 391606, 392315 - MAIN HARNESS
55.510.BM	01	VAR - 334342, 334344, 334345, 334346, 334347, 334348, 334349, 334350 - AUXILIARY POWER SOCKET
55.510.BM	02	VAR - 335394 - INSIDE CAB POWER SOCKET
55.512.AA	01	VAR - 390777 - LESS RADIO READY, CAB
55.512.AA	02	VAR - 333777 - CAB, RADIO
55.512.AA	03	VAR - 330777 - CAB, 2 SPEAKERS AND ANTENNA
55.512.BG	01	VAR - 333606, 334318, 334319, 391606, 392315 - ELECTRIC CONTROLS, SWITCHES
55.512.BG	02	VAR - 333606, 334318, 334319, 391606, 392315 - ELECTRIC SYSTEM CONTROL, SWITCH
55.514.AA	01	VAR - 334344, 334345, 334346, 334347, 334348, 334349, 334950, 335914 - CAB LIGHTING
55.514.AB	01	VAR - 335709, 335769 - CAB WORK LIGHT
55.518.AH	01	VAR - 334339, 334402, 334403, 334404 - REAR WINDSHIELD WIPER
55.518.AT	01	VAR - 334399, 334402, 334403, 334404 - WINDSHIELD WIPER TANK
55.518.AW	01	VAR - 334399, 334402 - FRONT WINDSHIELD WIPER
55.518.AW	02	VAR - 334403, 334404 - PARALLEL FRONT WINDSHIELD WIPER

SECTION INDEX - ELECTRICAL SYSTEMS

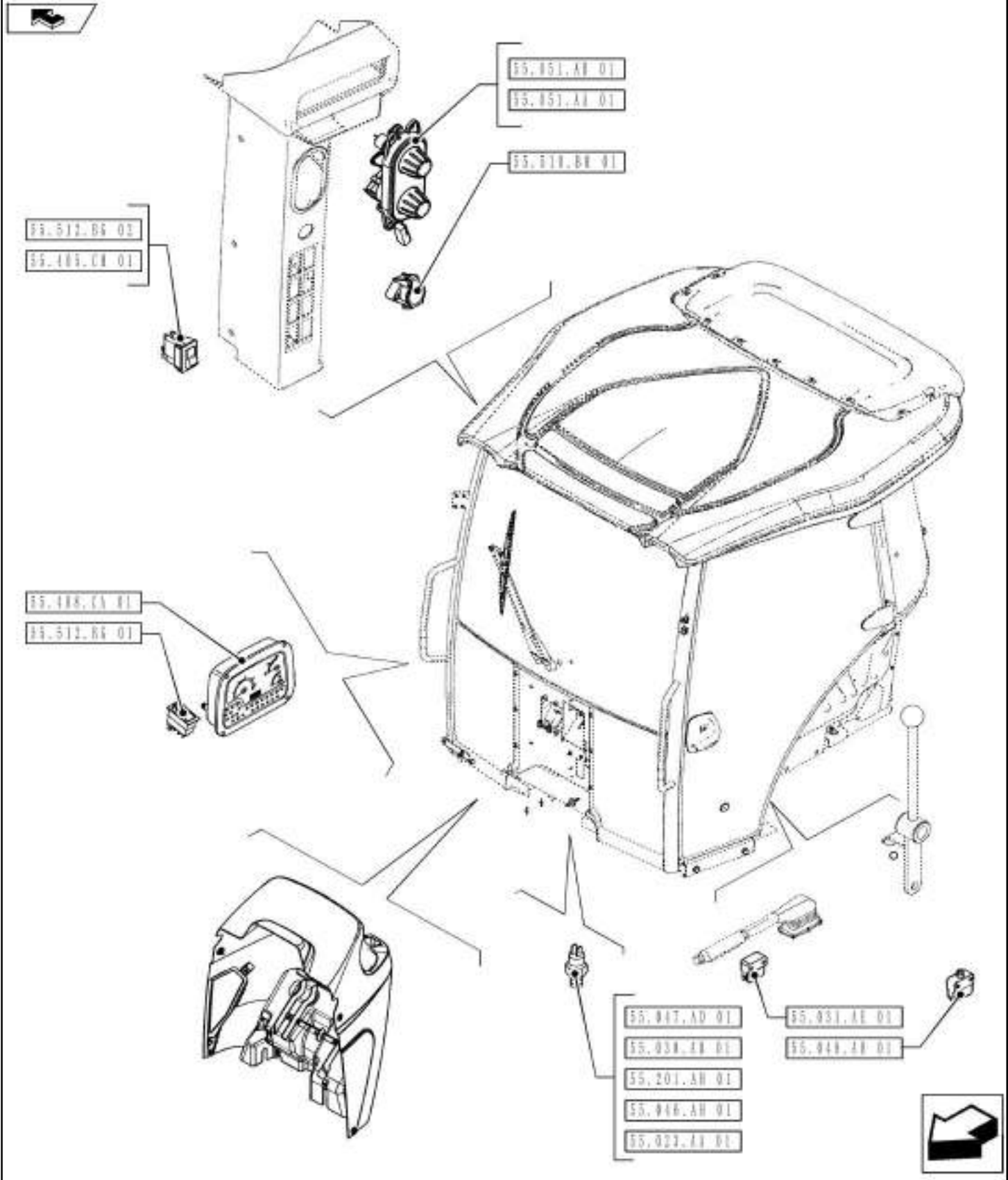

55.000.00

02

p1

1/2014

SECTION INDEX - ELECTRICAL SYSTEMS

REF FN	PART NUMBER	YR/SN	QTY	DESCRIPTION
---------------	--------------------	--------------	------------	--------------------

				FARMALL JX100 FARMALL JX110 FARMALL JX70 FARMALL JX75 FARMALL JX80 FARMALL JX90
--	--	--	--	--

SECTION INDEX - ELECTRICAL SYSTEMS

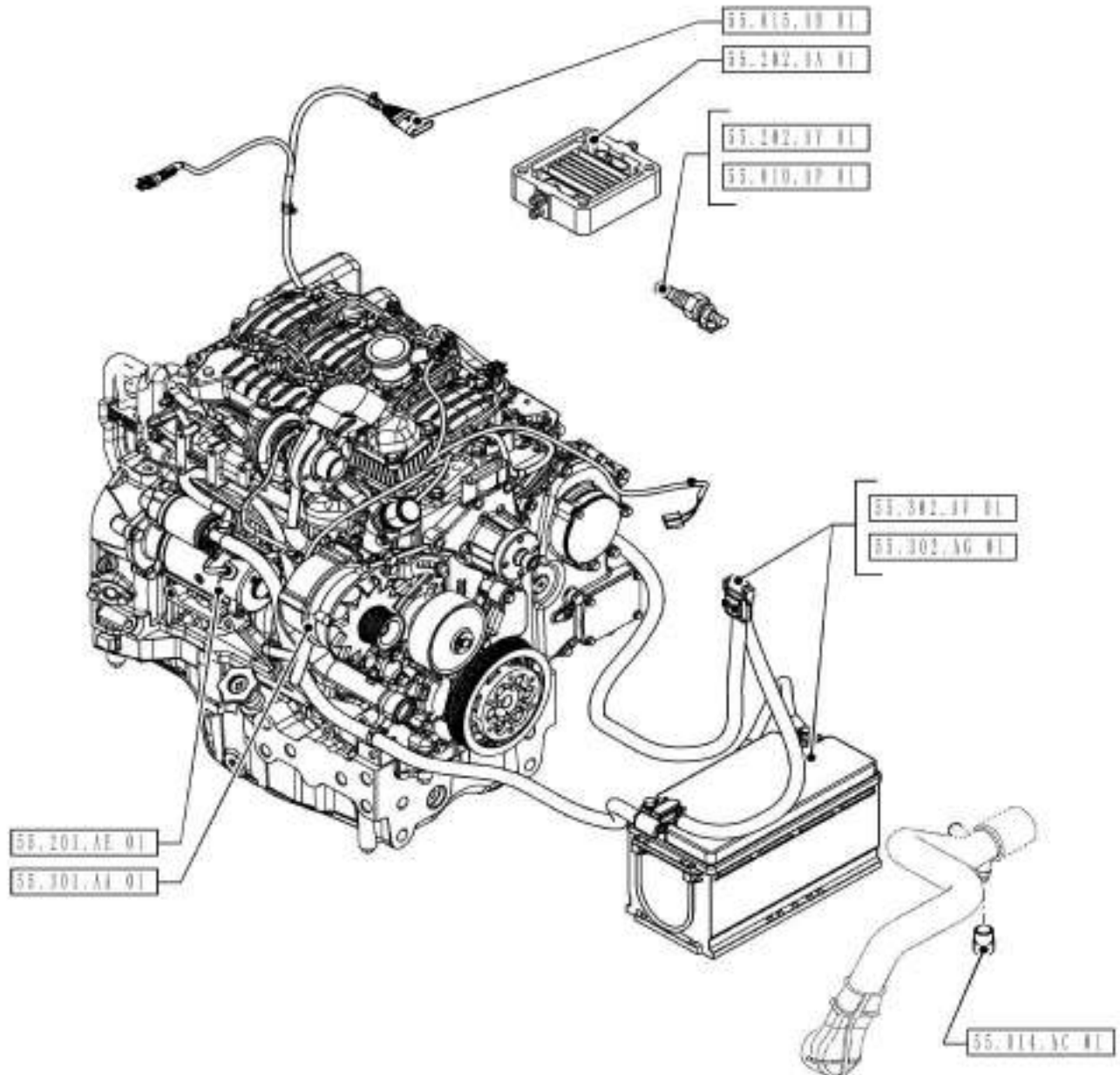

55.000.00

03

p1

1/2014

SECTION INDEX - ELECTRICAL SYSTEMS

REF FN	PART NUMBER	YR/SN	QTY	DESCRIPTION
---------------	--------------------	--------------	------------	--------------------

				FARMALL JX100 FARMALL JX110 FARMALL JX70 FARMALL JX75 FARMALL JX80 FARMALL JX90
--	--	--	--	--

SECTION INDEX - ELECTRICAL SYSTEMS

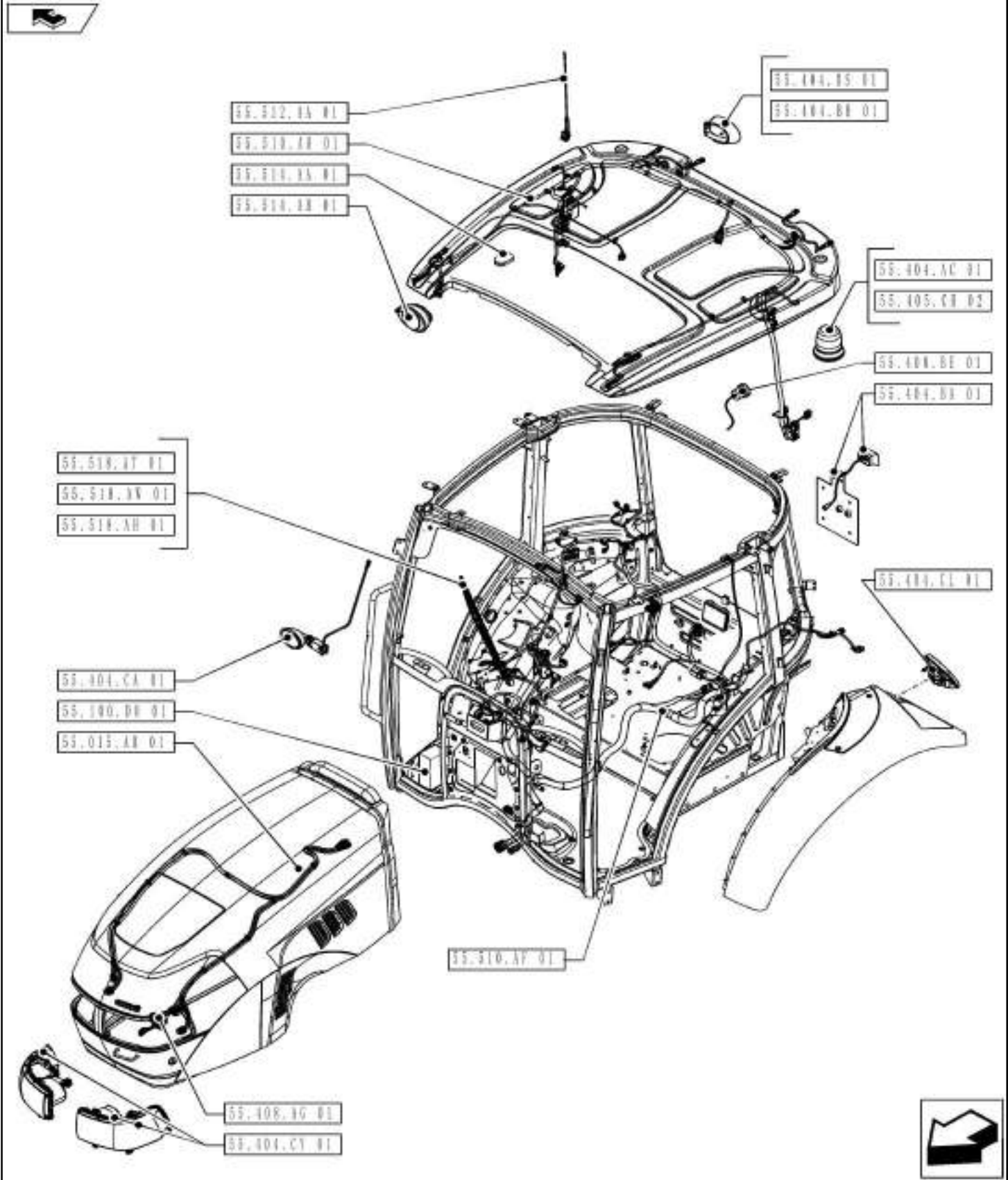

55.000.00

04

p1

1/2014

SECTION INDEX - ELECTRICAL SYSTEMS

REF FN	PART NUMBER	YR/SN	QTY	DESCRIPTION
---------------	--------------------	--------------	------------	--------------------

				FARMALL JX100 FARMALL JX110 FARMALL JX70 FARMALL JX75 FARMALL JX80 FARMALL JX90
--	--	--	--	--

55.010.AP

01

p1

1/2014

VAR - 333606, 334318, 334319, 391606, 392315 - ENGINE FUEL SENSOR

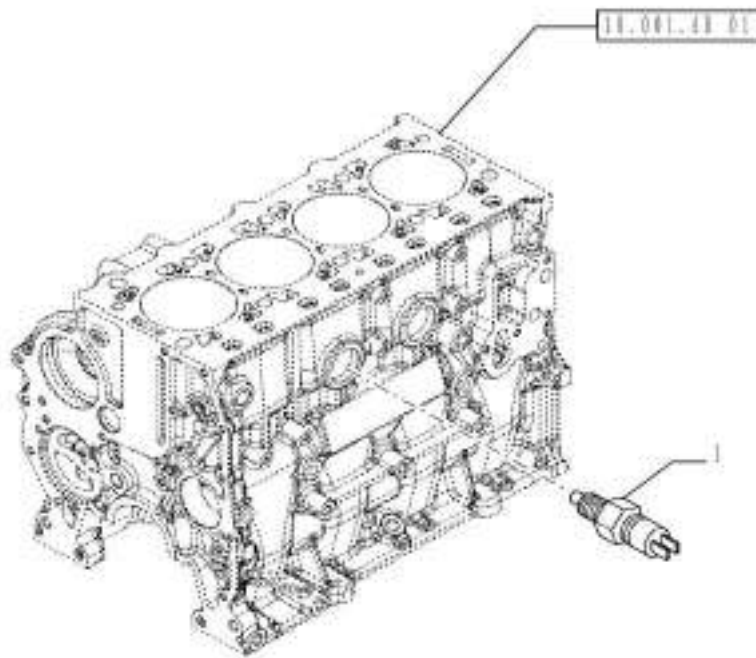

55.010.AP

01

p1

1/2014

VAR - 333606, 334318, 334319, 391606, 392315 - ENGINE FUEL SENSOR

REF FN	PART NUMBER	YR/SN	QTY	DESCRIPTION
--------	-------------	-------	-----	-------------

1	87548759		1	PRESSURE SWITCH
---	----------	--	---	-----------------

Valid for Var. 333606 or Var. 334318 or Var. 334319 or Var. 391606 or Var. 392315

FARMALL JX100 FARMALL
JX110 FARMALL JX70
FARMALL JX75 FARMALL
JX80 FARMALL JX90

55.010.AQ

02

p1

1/2014

VAR - 334296 - WATER SEPARATOR, SENSOR

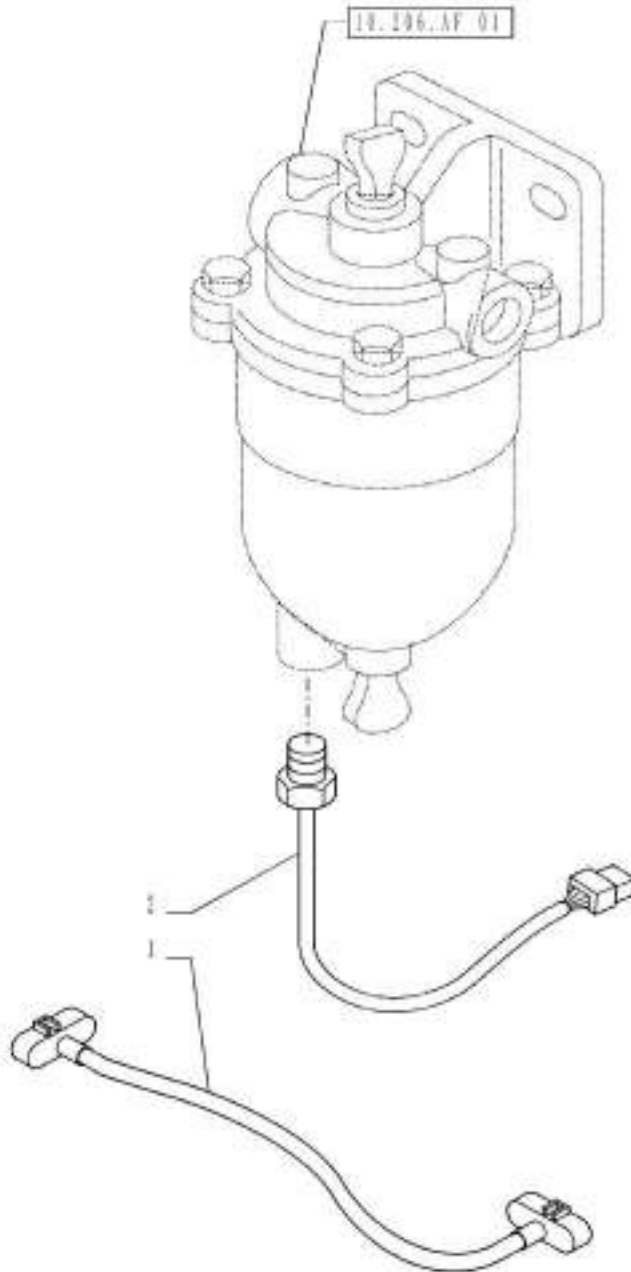

55.010.AQ

02

p1

1/2014

VAR - 334296 - WATER SEPARATOR, SENSOR

REF FN	PART NUMBER	YR/SN	QTY DESCRIPTION
1	84326969		1 WIRE HARNESS
2	84330658		1 SENSOR

Valid for Var. 334296

FARMALL JX100 FARMALL
JX110 FARMALL JX70
FARMALL JX75 FARMALL
JX80 FARMALL JX90

55.014.AC

01

p1

1/2014

VAR - 330200, 390227 - AIR CLEANER, RESTRICTION SWITCH, INDICATOR

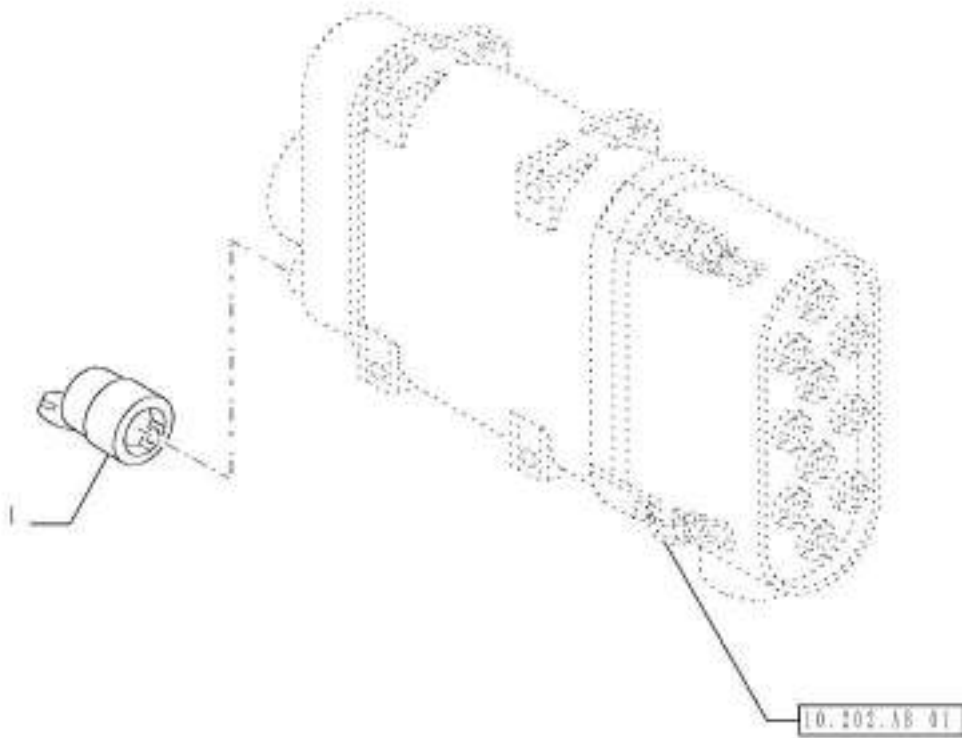

55.014.AC

01

p1

1/2014

VAR - 330200, 390227 - AIR CLEANER, RESTRICTION SWITCH, INDICATOR

REF FN	PART NUMBER	YR/SN	QTY	DESCRIPTION
---------------	--------------------	--------------	------------	--------------------

1	5138821		1	INDICATOR
---	---------	--	---	-----------

Valid for Var. 330200 or Var. 390227

FARMALL JX100 FARMALL
JX110 FARMALL JX70
FARMALL JX75 FARMALL
JX80 FARMALL JX90

55.015.AB

01

p1

1/2014

VAR - 333606, 334318, 334319, 391606, 392315 - ENGINE HARNESS

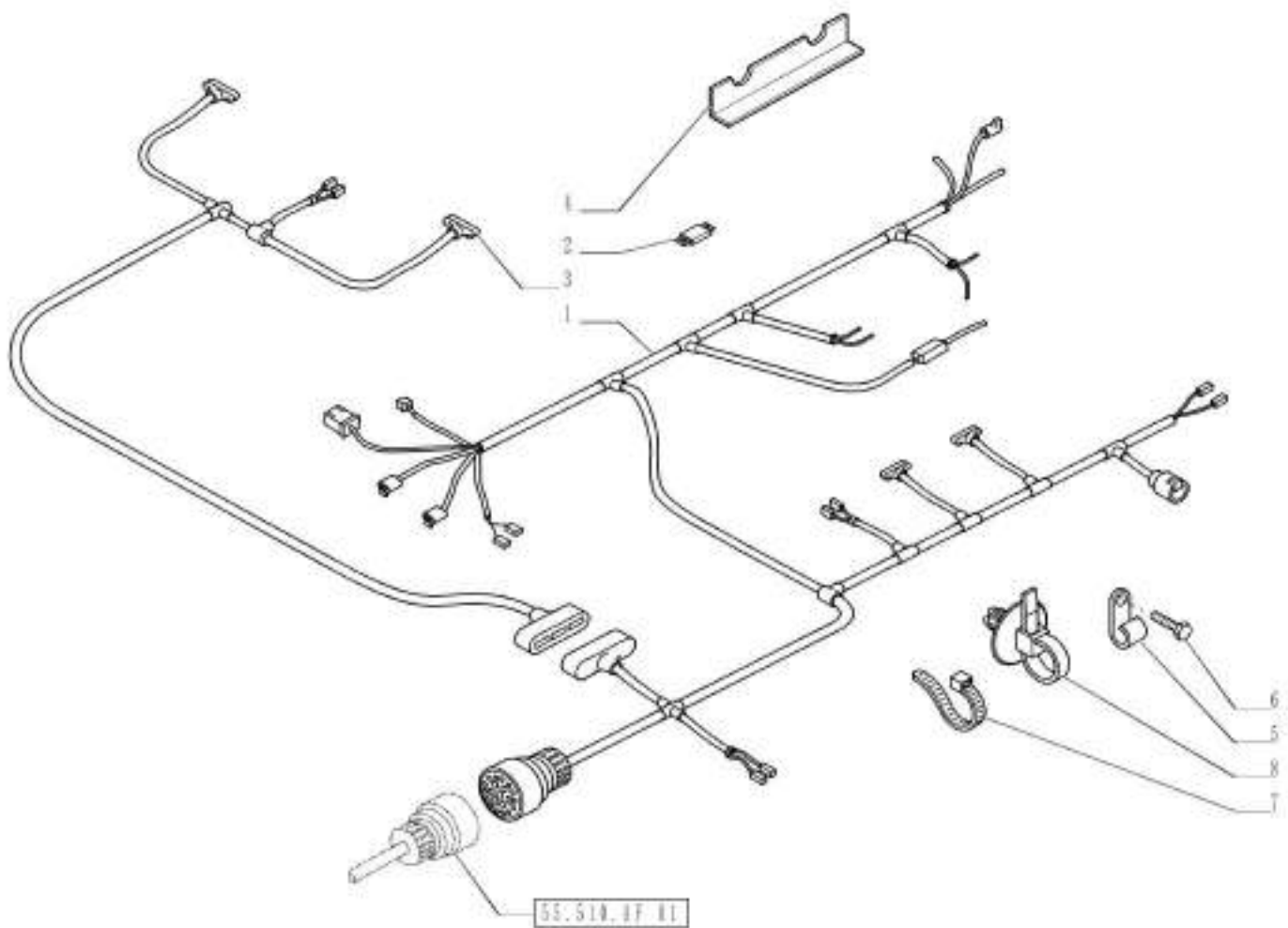

55.015.AB

01

p1

1/2014

VAR - 333606, 334318, 334319, 391606, 392315 - ENGINE HARNESS

REF FN	PART NUMBER	YR/SN	QTY DESCRIPTION
1	47401245		1 WIRE HARNESS
2	10404290		1 FUSE 80 A
3	84487197		1 WIRE HARNESS Headlamp
4	5089763		1 GUARD
5	5087916		2 CLAMP
6	11112121		2 SCREW Hex, M12 x 20, 8.8, Full Thd
7	5112712		AR COLLAR M4.8 x 283
8	82033028		4 COLLAR CLAMP

Valid for Var. 333606 or Var. 334318 or Var. 334319 or Var. 391606 or Var. 392315

FARMALL JX100 FARMALL
JX110 FARMALL JX70
FARMALL JX75 FARMALL
JX80 FARMALL JX90

55.023.AA

01

p1

1/2014

VAR - 330120, 331120, 743846 - HYDRAULIC GEARBOX CONTROLS (POWER SHUTTLE) - SENSOR

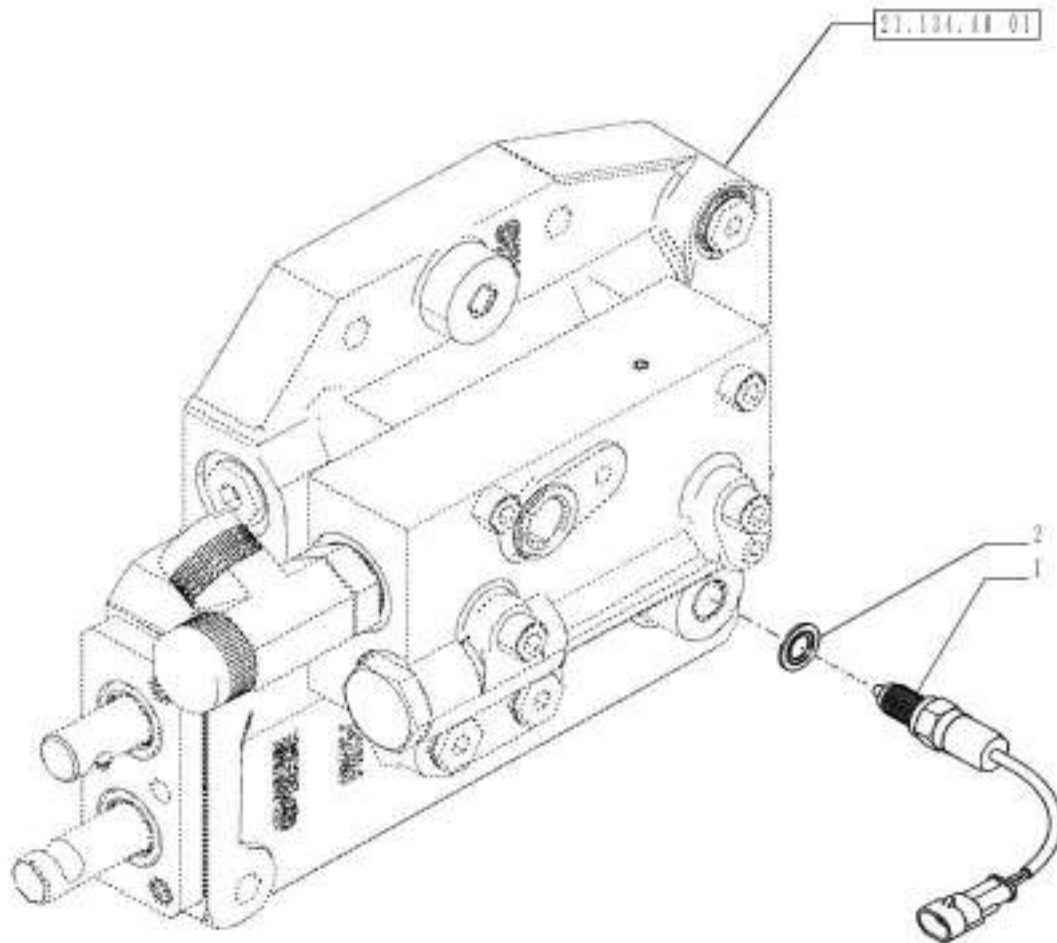

55.023.AA

01

p1

1/2014

VAR - 330120, 331120, 743846 - HYDRAULIC GEARBOX CONTROLS (POWER SHUTTLE) - SENSOR

REF FN	PART NUMBER	YR/SN	QTY DESCRIPTION
1	84292066		1 SWITCH Neutral Gearshift Position/ Green/ M14 x 1.5
2	5183780		1 SEALING WASHER 14.40mm ID x 18.00mm OD x 1.50mm, Steel, Zinc

Valid for Industrial Var. 330120, 331120 (743846)

**FARMALL JX100
FARMALL JX75
FARMALL JX90**

55.030.AB

01

p1

1/2014

VAR - 744738, 744739, 744744 - BRAKE, SENSOR

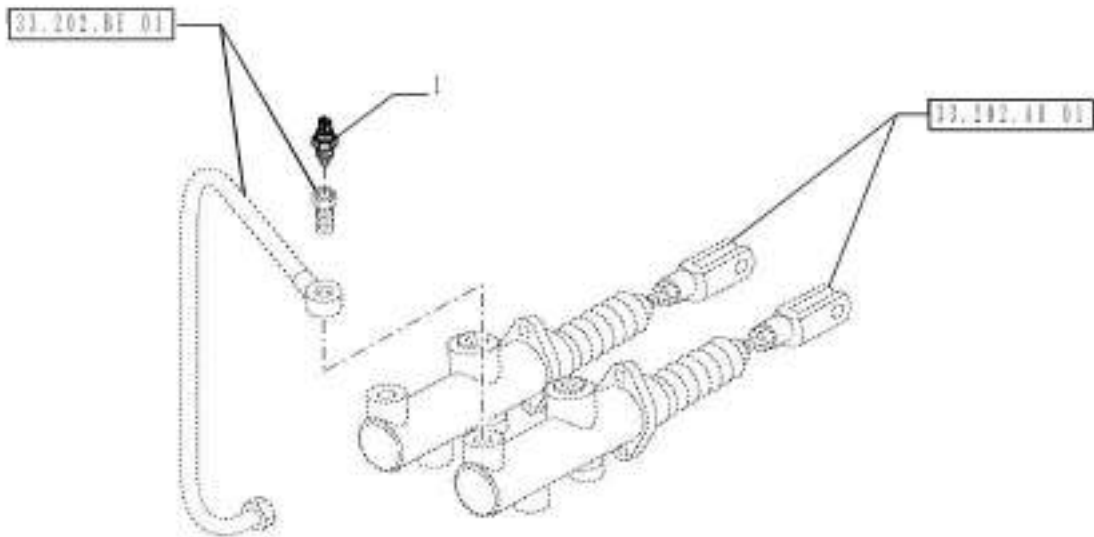

55.030.AB

01

p1

1/2014

VAR - 744738, 744739, 744744 - BRAKE, SENSOR

REF FN	PART NUMBER	YR/SN	QTY DESCRIPTION
1	1 87584696		1 PRESSURE SWITCH
(1)	Break Oil Pressure		

Valid for Industrial Var. 334321, 390268 (744738) or Industrial Var. 330384, 334322 (744739) or Industrial Var. 334320, 390267 (744744)

FARMALL JX100 FARMALL
JX110 FARMALL JX70
FARMALL JX75 FARMALL
JX80 FARMALL JX90

55.031.AE

01

p1

1/2014

VAR - 333606, 334318, 334319, 391606, 392315 - PARKING BRAKE, SWITCH

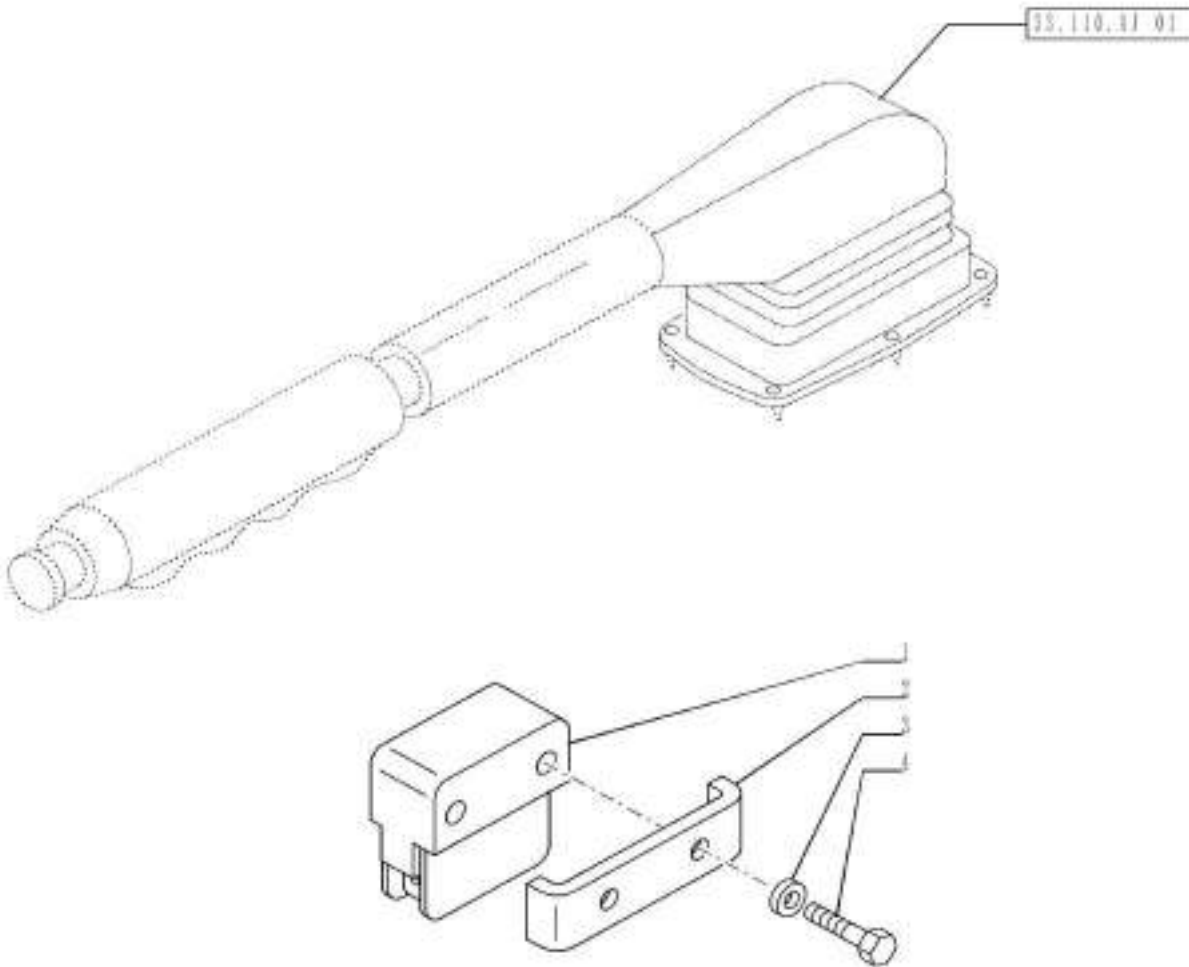

55.031.AE

01

p1

1/2014

VAR - 333606, 334318, 334319, 391606, 392315 - PARKING BRAKE, SWITCH

REF FN	PART NUMBER	YR/SN	QTY DESCRIPTION
1	87702928		1 PARK BRAKE SWITCH
2	5093339		1 BRACKET
3	12601074		2 WAVE WASHER 4.30mm ID x 9mm OD x 0.50mm, 2mm Max, CST, DAC
4	13272617		2 SCREW Cross Pan Hd, M4 x 25

Valid for Var. 333606 or Var. 334318 or Var. 334319 or Var. 391606 or Var. 392315

FARMALL JX100 FARMALL
JX110 FARMALL JX70
FARMALL JX75 FARMALL
JX80 FARMALL JX90

55.046.AH

01

p1

1/2014

VAR - 743846, 744739 - DIFFERENTIAL LOCK, CONTROL, SWITCH

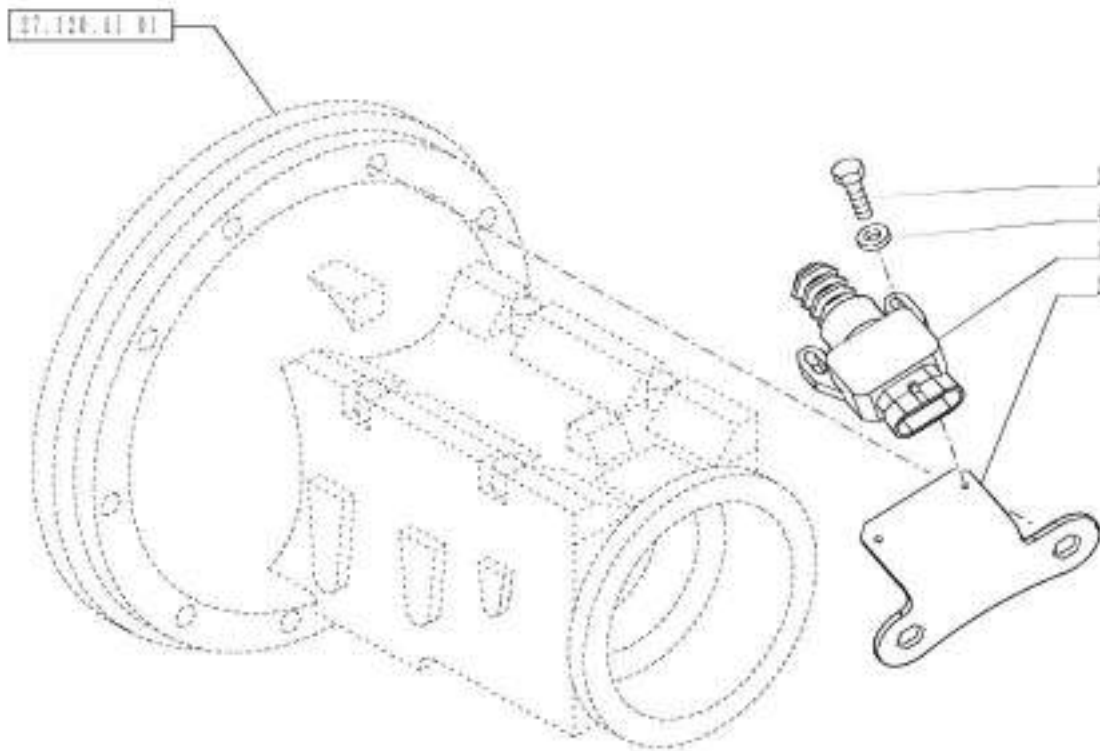

55.046.AH

01

p1

1/2014

VAR - 743846, 744739 - DIFFERENTIAL LOCK, CONTROL, SWITCH

REF FN	PART NUMBER	YR/SN	QTY DESCRIPTION
1	47137022		1 SWITCH
2	84128726		1 SUPPORT
3	13272111		2 SCREW Pan Hd, M4 x 14, 5.8
4	12601074		2 WAVE WASHER 4.30mm ID x 9mm OD x 0.50mm, 2mm Max, CST, DAC

Valid for Industrial Var. 330120, 331120 (743846) or Industrial Var. 330384, 334322 (744739)**FARMALL JX100 FARMALL
JX110 FARMALL JX70
FARMALL JX75 FARMALL
JX80 FARMALL JX90**

55.047.AD

01

p1

1/2014

VAR - 330120, 331120, 390249, 743846 - POWER STEERING KIT, PRESSURE SWITCH

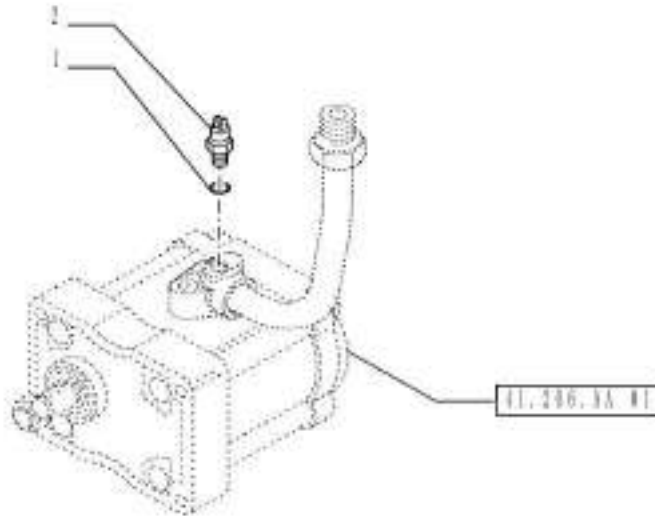

55.048.AB

01

p1

1/2014

VAR - 333606, 334318, 334319, 391606, 392315 - PTO, CONTROL LEVER, SWITCH

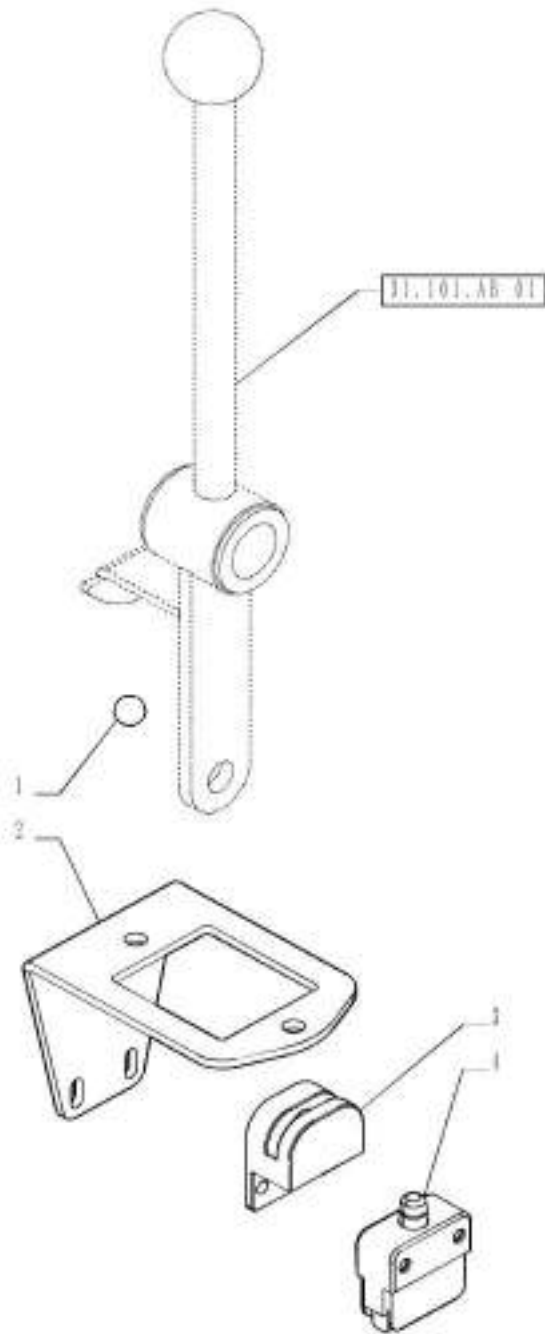

55.048.AB

01

p1

1/2014

VAR - 333606, 334318, 334319, 391606, 392315 - PTO, CONTROL LEVER, SWITCH

REF FN	PART NUMBER	YR/SN	QTY DESCRIPTION
1	20063390		1 BALL
2	47374134		1 PLATE
3	47374238		1 SOCKET/RECEPTACLE
4	87702928		1 PARK BRAKE SWITCH

Valid for Var. 333606 or Var. 334318 or Var. 334319 or Var. 391606 or Var. 392315

FARMALL JX100 FARMALL JX110 FARMALL JX70 FARMALL JX75 FARMALL JX80 FARMALL JX90

55.051.AA

01

p1

1/2014

VAR - 330641 - AIR CONDITIONER, CONTROL PANEL, BREAKDOWN

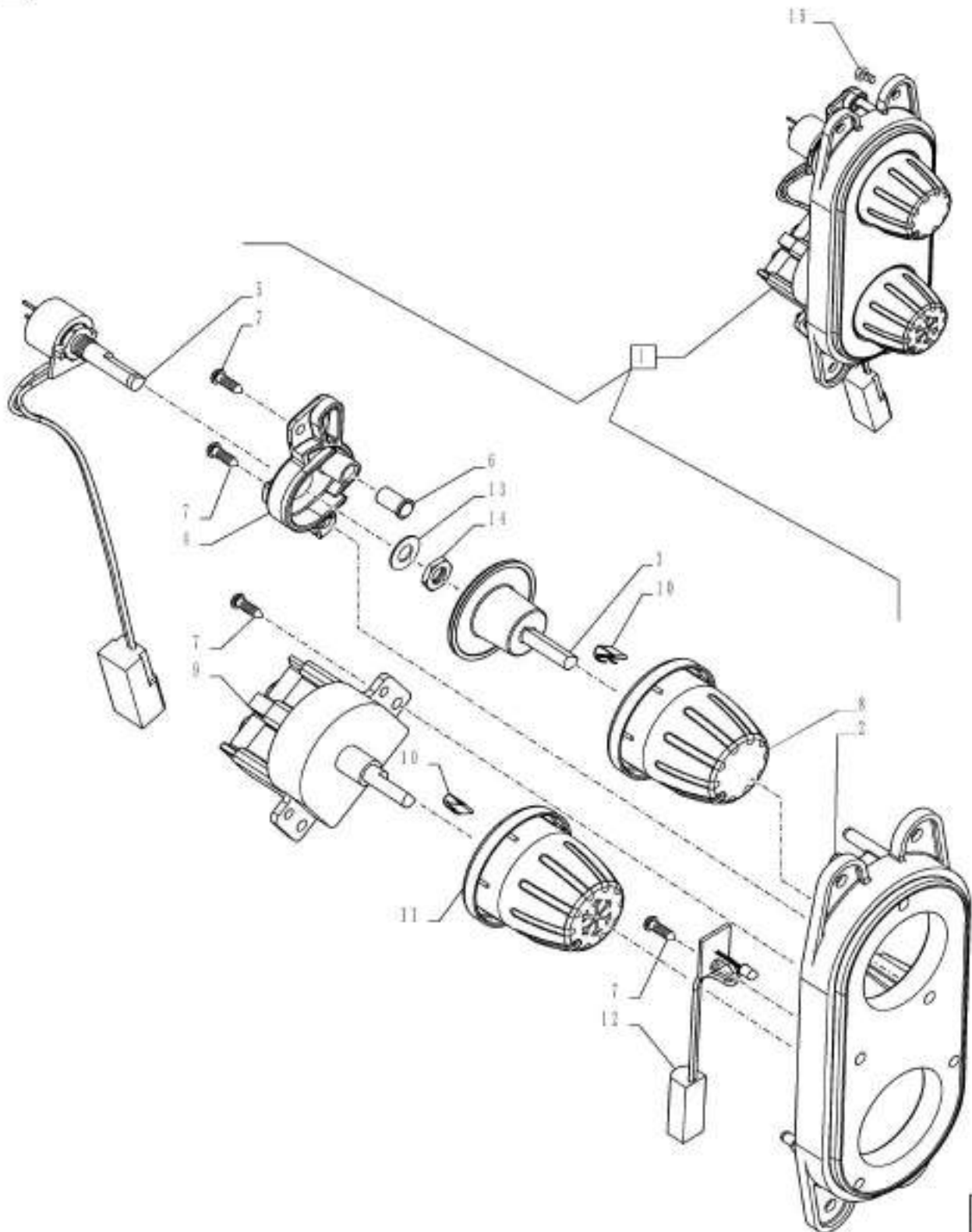

VAR - 330641 - AIR CONDITIONER, CONTROL PANEL, BREAKDOWN

REF FN	PART NUMBER	YR/SN	QTY DESCRIPTION
1	84296746		1 CONTROL ASSY, Incl 2 - 14
2	84582138		1 CONTROL PANEL
3	84582140		1 ADAPTER
4	84582141		1 SUPPORT
5	84582144		1 POTENTIOMETER
6	84582145		1 STOP LOCK
7	84582146		5 SCREW
8	84582147		1 KNOB
9	84582181		1 COMMUTATOR
10	84582158		2 CLIP
11	84582180		1 KNOB
12	84582179		1 PRINTED CIRCUIT BOARD
13	NSS		1 NOT SERVICED SEPARATELY Washer, Incl in 1
14	NSS		1 NOT SERVICED SEPARATELY Nut, Incl in 1
15	15516201		4 SCREW

Valid for Var. 330641

FARMALL JX100 FARMALL
 JX110 FARMALL JX70
 FARMALL JX75 FARMALL
 JX80 FARMALL JX90

55.051.AB

01

p1

1/2014

VAR - 390641 - HEATING SYSTEM, CONTROL PANEL, BREAKDOWN

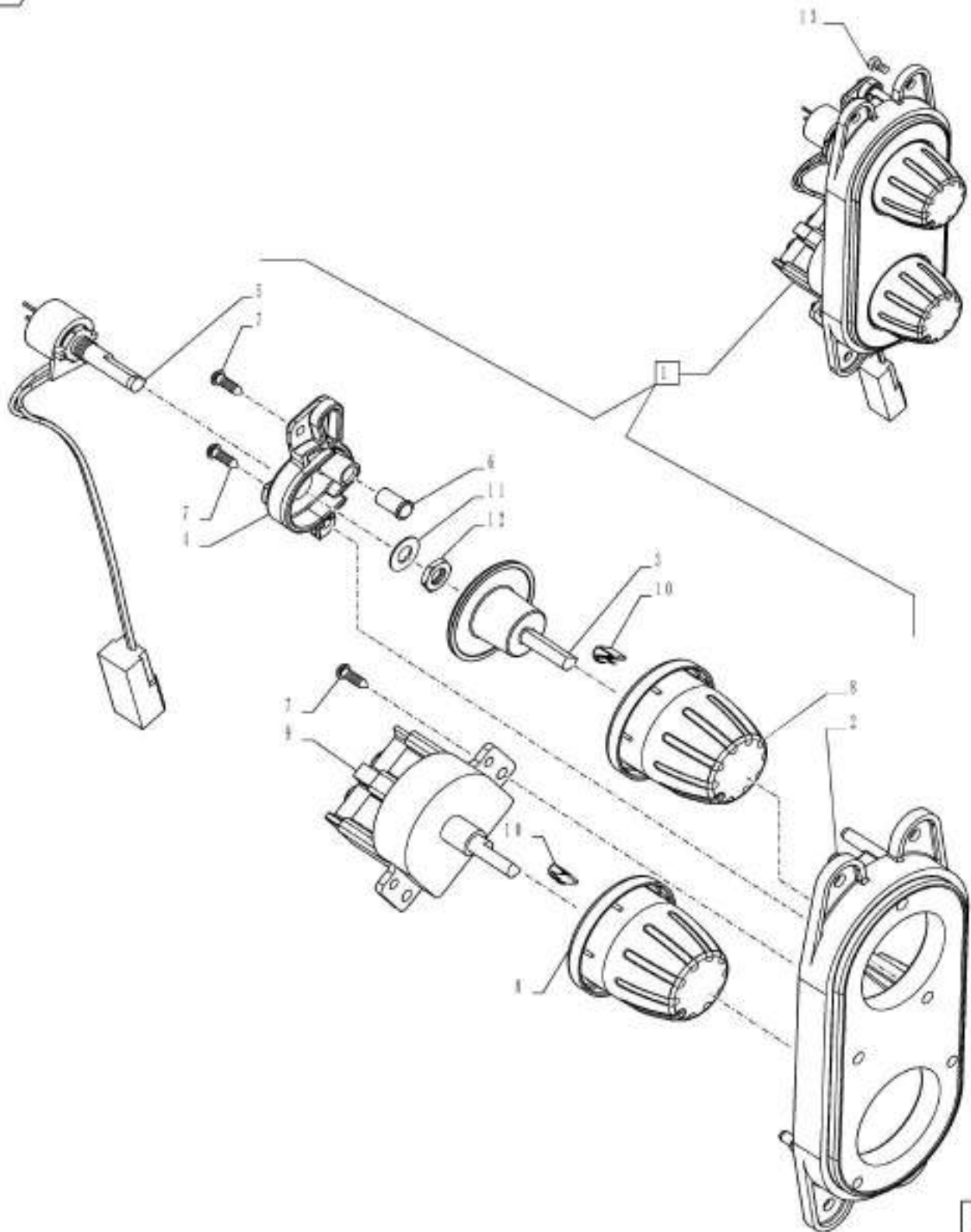

VAR - 390641 - HEATING SYSTEM, CONTROL PANEL, BREAKDOWN

REF FN	PART NUMBER	YR/SN	QTY DESCRIPTION
1	84297125		1 CONTROL ASSY, Incl 2 - 12
2	84582138		1 CONTROL PANEL
3	84582140		1 ADAPTER
4	84582141		1 SUPPORT
5	84582144		1 POTENTIOMETER
6	84582145		1 STOP LOCK
7	84582146		5 SCREW
8	84582147		2 KNOB
9	84582148		1 COMMUTATOR
10	84582158		2 CLIP
11	NSS		1 NOT SERVICED SEPARATELY Washer, Incl in 1
12	NSS		1 NOT SERVICED SEPARATELY Nut, Incl in 1
13	15516201		4 SCREW
Valid for Var. 390641			FARMALL JX100 FARMALL JX110 FARMALL JX70 FARMALL JX75 FARMALL JX80 FARMALL JX90

VAR - 333606, 391606 - FUSE BOX, CAB

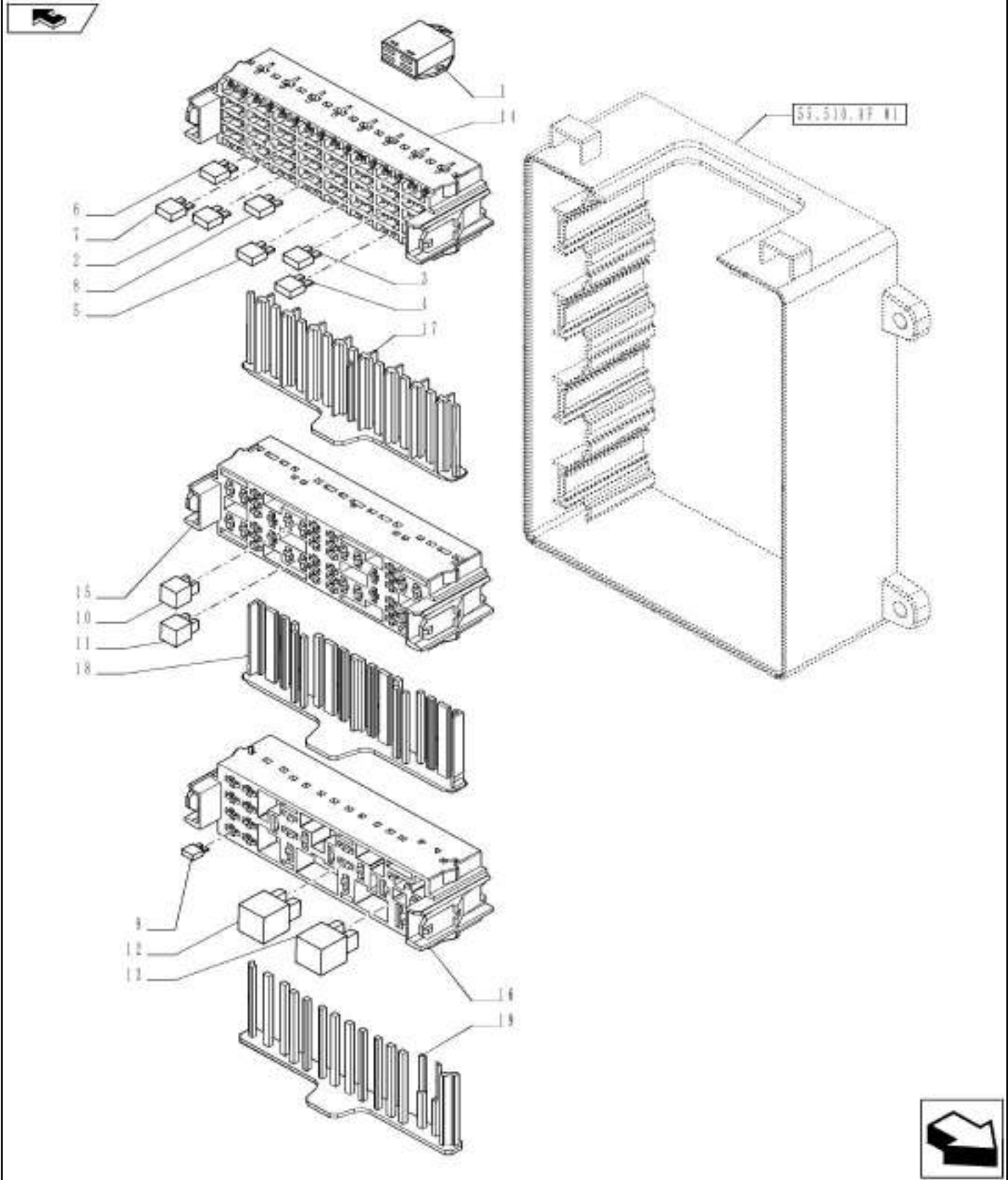

VAR - 333606, 391606 - FUSE BOX, CAB

REF FN	PART NUMBER	YR/SN	QTY DESCRIPTION
1	5083120		1 FLASHER LAMP
2	84127705		1 FUSE 25A
3	84152583		5 FUSE 7.5A
4	84127702		6 FUSE 10A
5	84127703		10 FUSE 15A
6	84127708		1 FUSE 30A
7	84153830		6 FUSE 5A
8	84127704		2 FUSE 20A
9	11055490		1 FUSE 40A
10	84157157		4 RELAY 20A
11	84157161		4 RELAY 10-20A
12	5080366		1 RELAY 30-40A
13	87341931		1 RELAY 70A
14	84487350		1 FUSE HOLDER
15	84487351		1 HOLDER
16	84487352		1 HOLDER
17	84554209		1 FUSE HOLDER
18	84554210		1 HOLDER
19	84554211		1 HOLDER

Valid for Var. 333606 or Var. 391606

FARMALL JX100 FARMALL
 JX110 FARMALL JX70
 FARMALL JX75 FARMALL
 JX80 FARMALL JX90

VAR - 334318, 334319, 392315 - FUSE BOX, ROPS

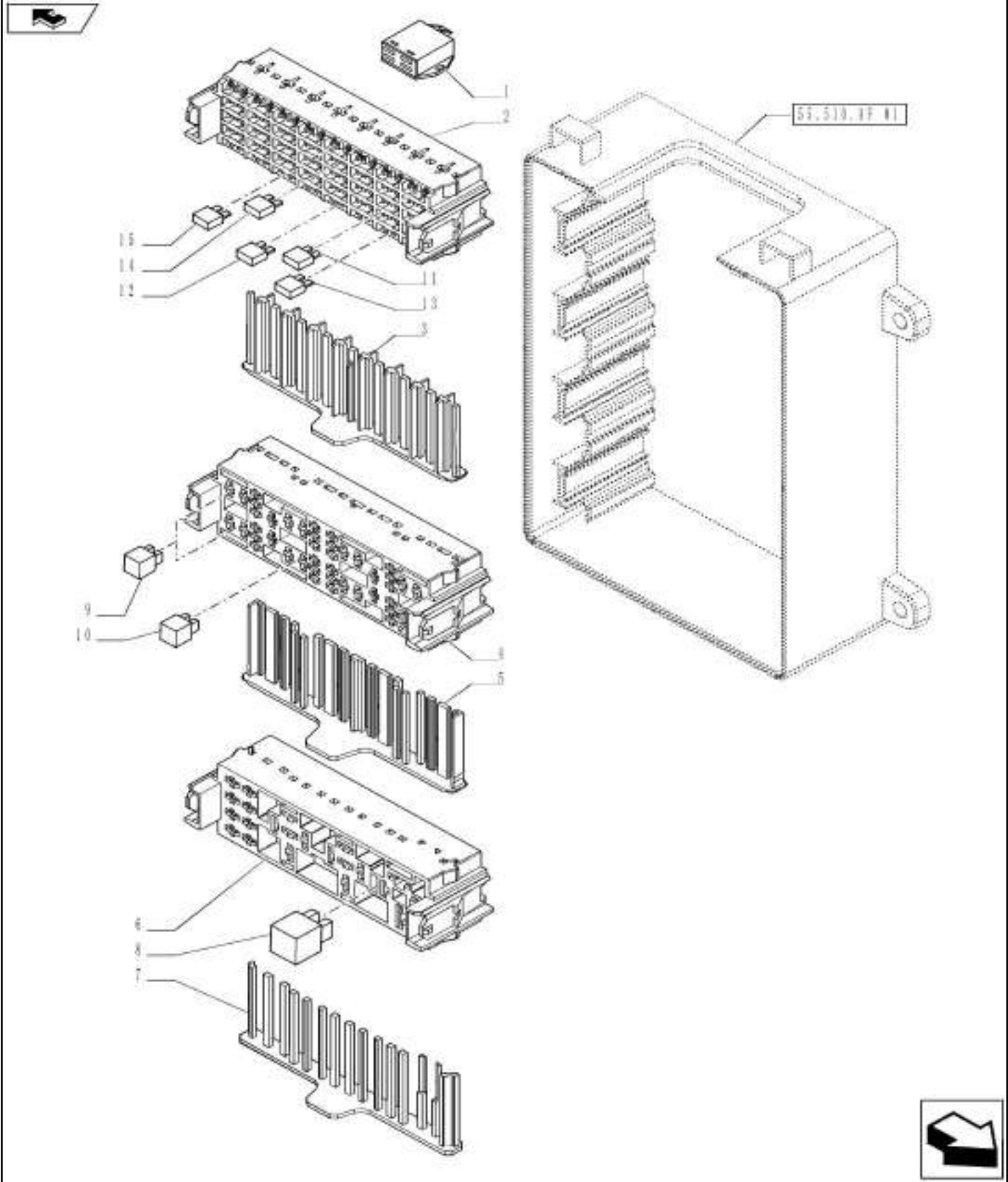

VAR - 334318, 334319, 392315 - FUSE BOX, ROPS

REF FN	PART NUMBER	YR/SN	QTY DESCRIPTION
1	5083120		1 FLASHER LAMP
2	84487350		1 FUSE HOLDER
3	84554209		1 FUSE HOLDER
4	84487351		1 HOLDER
5	84554210		1 HOLDER
6	84487352		1 HOLDER
7	84554211		1 HOLDER
8	5080366		1 RELAY 30-40A
9	84157157		3 RELAY 20A
10	84157161		1 RELAY 10-20A
11	84152583		3 FUSE 7.5A
12	84153830		3 FUSE 5A
13	84127702		4 FUSE 10A
14	84127704		2 FUSE 20A
15	84127703		8 FUSE 15A

Valid for Var. 334318 or Var. 334319 or Var. 392315	FARMALL JX100 FARMALL JX110 FARMALL JX70 FARMALL JX75 FARMALL JX80 FARMALL JX90
---	--

VAR - 333606, 334318, 334319, 391606, 392315 - ENGINE STARTER SAFETY SWITCH

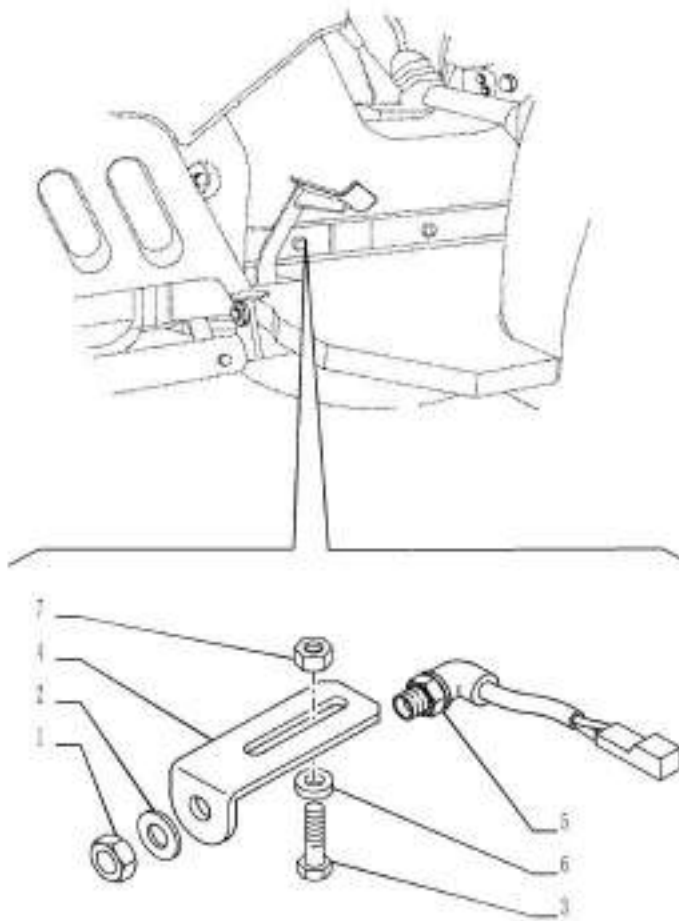

VAR - 330203 - THERMOSTART

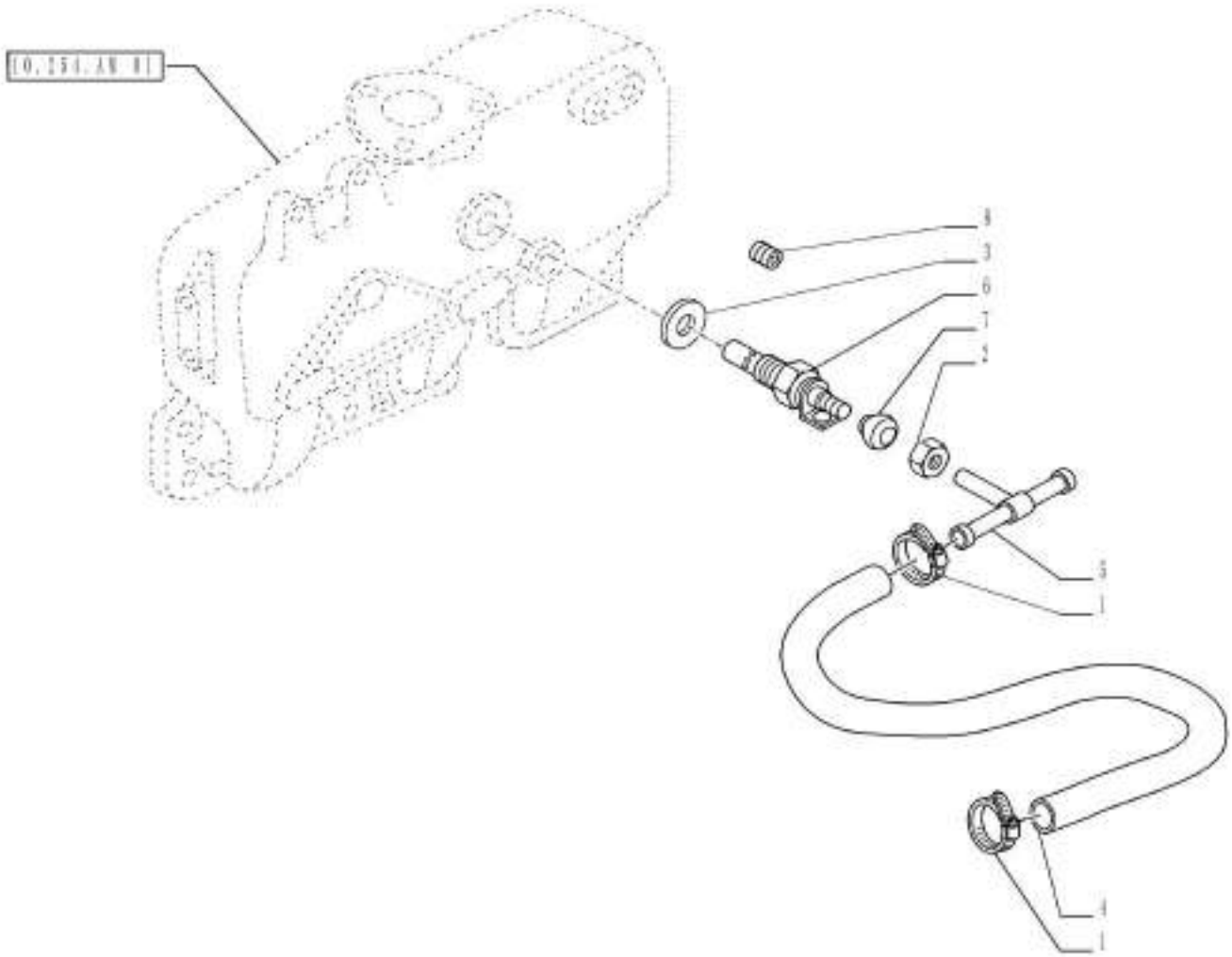

VAR - 330203 - THERMOSTART

REF FN	PART NUMBER	YR/SN	QTY DESCRIPTION
1	10186590		2 COLLAR M11-13, Worm
2	5122009		1 NUT 3/8"
3	10263360		1 SEAL M20.3 x 26 x 1
4	5095104		1 HOSE 7.00 mm ID x 320.0 mm
5	5159818		1 HYD CONNECTOR
6	5161845		1 THERMOSTART
7	5122008		1 GROMMET
8	1 14325211		1 PLUG M20 x 1.5

(1) VAR - 334300, 390002 (744731)

Valid for Var. 330203

FARMALL JX100 FARMALL
JX110 FARMALL JX70
FARMALL JX75 FARMALL
JX80 FARMALL JX90

VAR - 330740, 335210 - BATTERY MOUNTING

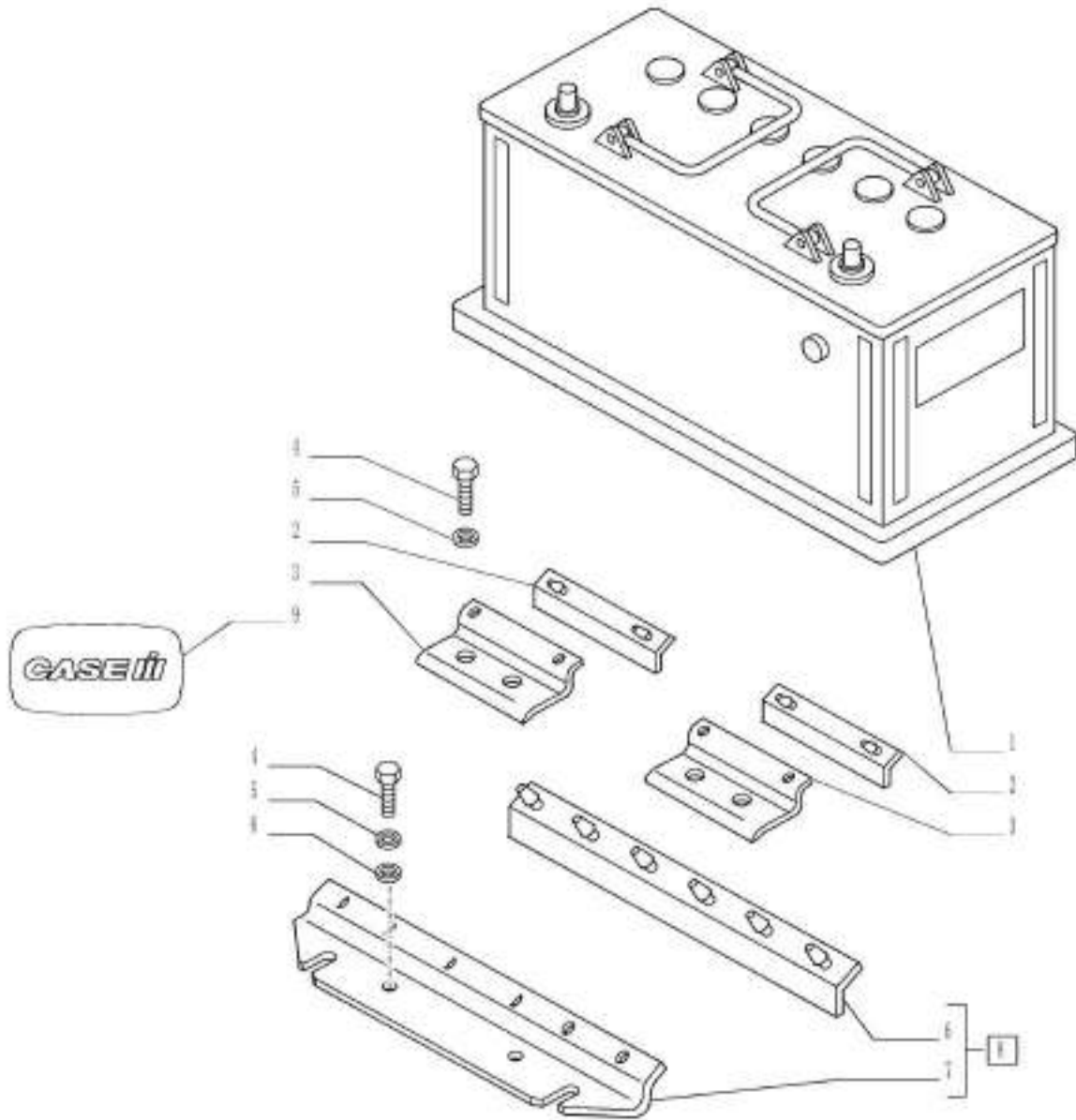

VAR - 330740, 335210 - BATTERY MOUNTING

REF	FN	PART NUMBER	YR/SN	QTY	DESCRIPTION
1	1	84247250		1	WET BATTERY 120 AH
1	2	84188027		1	WET BATTERY 100 AH
2		84211541		2	SUPPORT
3		84354364		2	SUPPORT
4		15970721		6	SCREW Hex, M10 x 1.25 x 25mm, Cl 8.8, Full Thd
5		12601474		6	WAVE WASHER Wave, 10.50mm ID x 21.00mm OD x 0.80mm, 3.00mm, CST, DAC
6		4975018		1	PAD
7		87680841		1	SUPPORT
8		87680862		1	SUPPORT ASSY Incl 6 - 7
9		87679098		1	DECAL

(1) VAR - 335210 CAB Models Only

(2) VAR - 330740 ROPS Models Only

Valid for Var. 330740 or Var. 335210

FARMALL JX100 FARMALL
 JX110 FARMALL JX70
 FARMALL JX75 FARMALL
 JX80 FARMALL JX90

55.404.AC

01

p1

1/2014

VAR - 334343, 335914 - ROTARY BEACON, CAB

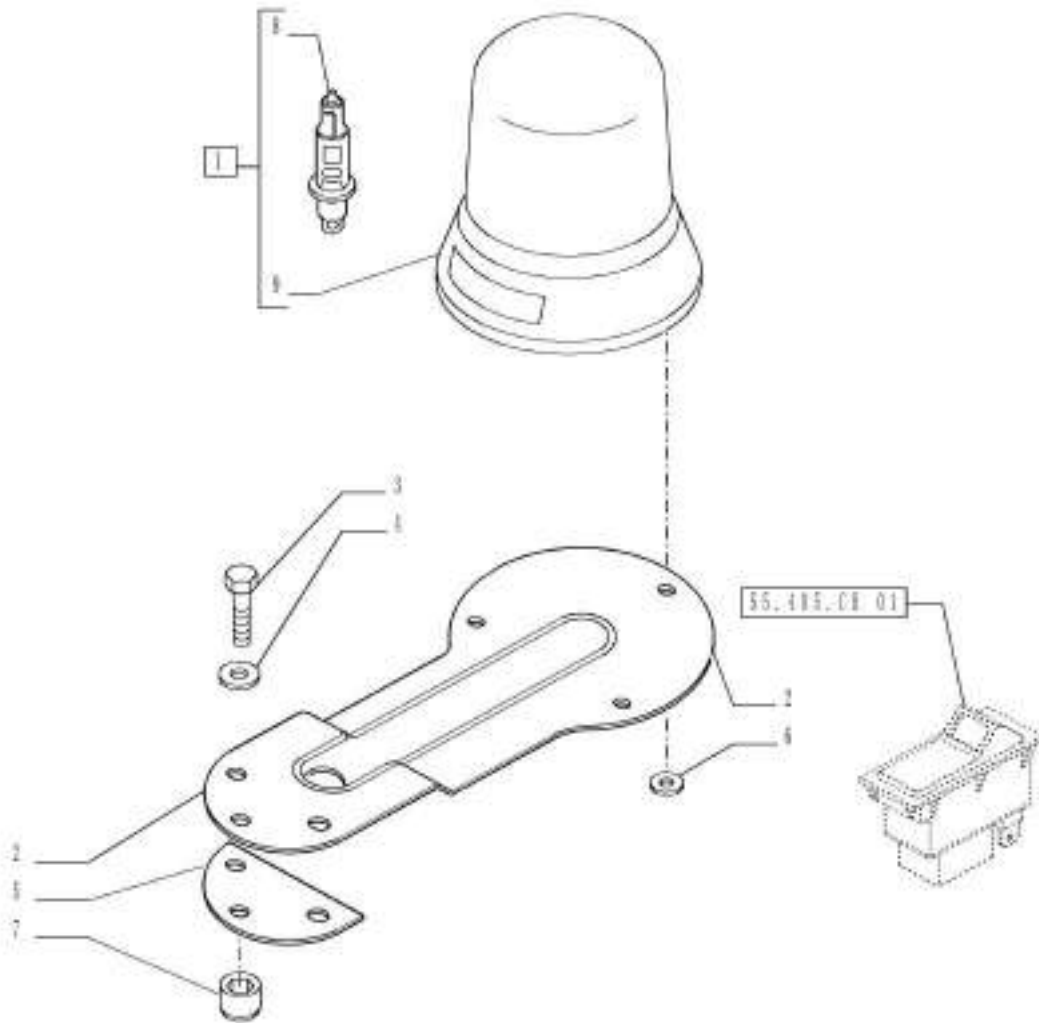

55.404.AC

01

p1

1/2014

VAR - 334343, 335914 - ROTARY BEACON, CAB

REF FN	PART NUMBER	YR/SN	QTY DESCRIPTION
1	84408659		1 BEACON ASSY Incl 8, 9
2	47393270		1 BRACKET
3	86624003		3 BOLT Hex, M8 x 14mm, Cl 8.8, Full Thd
4	12601374		3 WAVE WASHER Wave, 8.40mm ID x 15.00mm OD x 0.80mm, 3.00mm, CST, DAC
5	47393272		3 BUMPER
6	11197779		3 BELLEVILLE WASHER 6.40mm ID x 12.00mm OD x 1.20mm, 1.63mm, Cl 8.8, ZNM
7	5089481		3 CAP
8	86616248		1 BULB #HI, 55w
9	NSS		1 NOT SERVICED SEPARATELY Beacon Incl in 1

Valid for Var. 334343 or Var. 335914

FARMALL JX100 FARMALL
JX110 FARMALL JX70
FARMALL JX75 FARMALL
JX80 FARMALL JX90

VAR - 334343, 335914 - ROTARY BEACON, ROPS

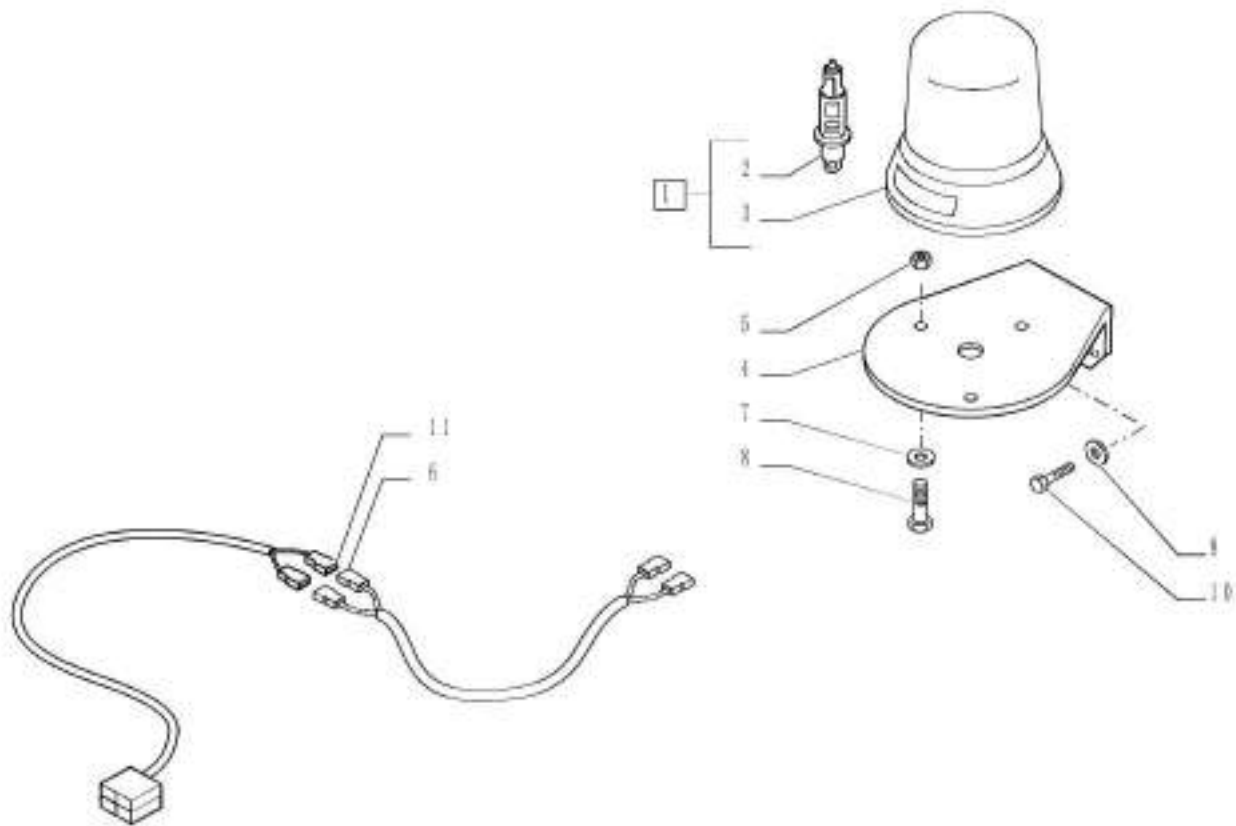

55.404.AC

02

p1

1/2014

VAR - 334343, 335914 - ROTARY BEACON, ROPS

REF FN	PART NUMBER	YR/SN	QTY DESCRIPTION
1	5092364		1 BEACON ASSY Incl 2 - 3
2	86616248		1 BULB #HI, 55w
3	NSS		1 NOT SERVICED SEPARATELY Beacon Incl in 1
4	5090581		1 SUPPORT
5	15896211		3 NUT M6, CI 8
6	5093819		1 WIRE HARNESS
7	11197779		3 BELLEVILLE WASHER 6.40mm ID x 12.00mm OD x 1.20mm, 1.63mm, CI 8.8, ZNM
8	120100		3 BOLT Hex, M6 x 1 x 20mm, CI 8.8
9	12601374		2 WAVE WASHER Wave, 8.40mm ID x 15.00mm OD x 0.80mm, 3.00mm, CST, DAC
10	43127		2 BOLT Hex, M8 x 1.25 x 25mm, CI 8.8, Full Thd
11	47416816		1 CABLE

Valid for Var. 334343 or Var. 335914

FARMALL JX100 FARMALL
JX110 FARMALL JX70
FARMALL JX75 FARMALL
JX80 FARMALL JX90

55.404.BA

01

p1

1/2014

VAR - 334342, 334343 - NUMBER PLATE LIGHT

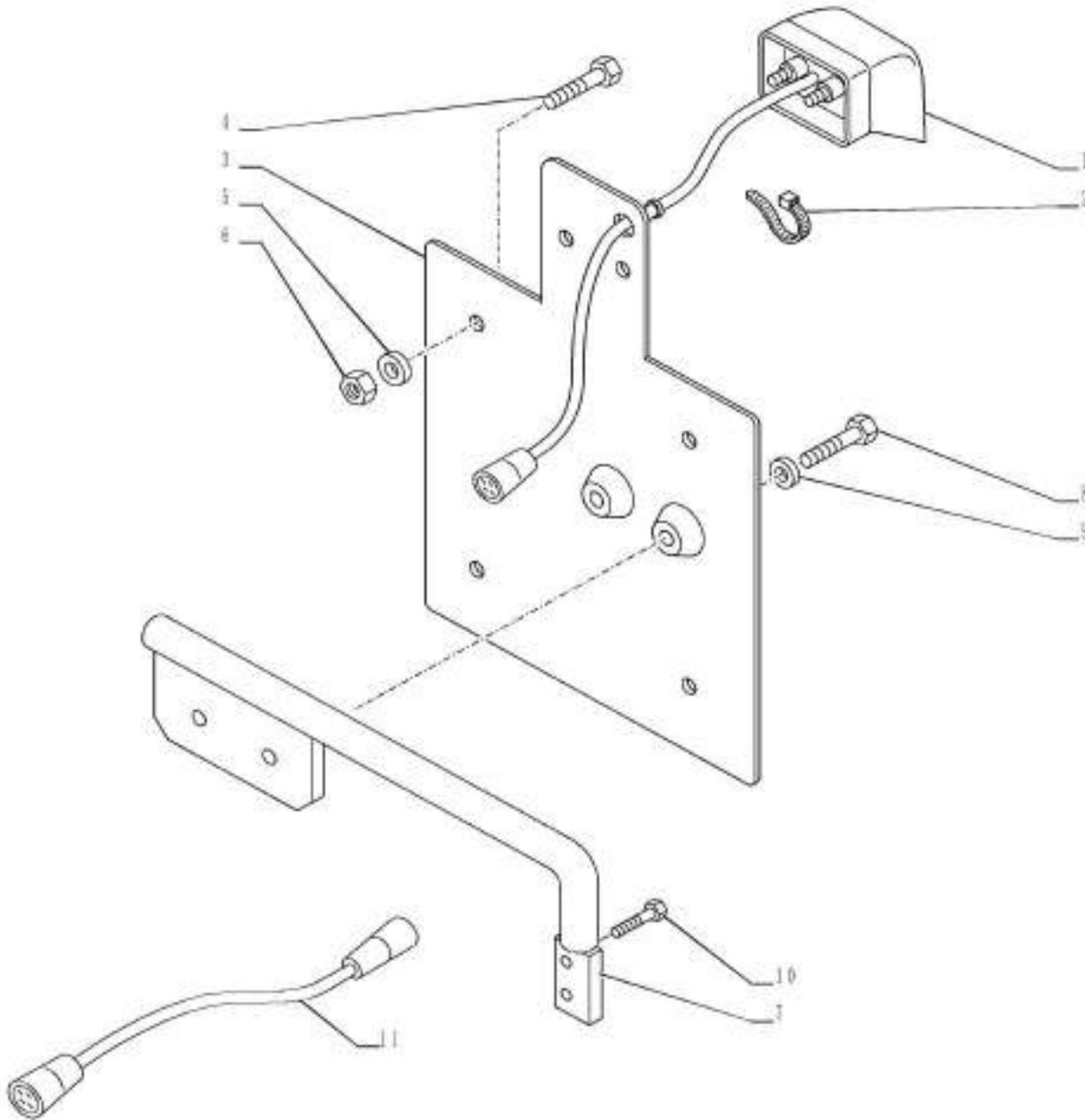

VAR - 334342, 334343 - NUMBER PLATE LIGHT

REF	FN	PART NUMBER	YR/SN	QTY	DESCRIPTION
1	1	5094438		1	NUMBER PLATE LAMP
2	1	5112712		1	COLLAR M4.8 x 283
3	2	5080925		1	SUPPORT
4	2	10375011		4	SCREW Slotted, Pan Hd, M4 x 14
5	2	10519201		4	WASHER M4
6	2	10794011		4	NUT M4, CI 8
7	2	84561813		1	SUPPORT
8	2	13279411		2	SCREW Cross Pan Hd, M8 x 20
9	2	12601374		2	WAVE WASHER Wave, 8.40mm ID x 15.00mm OD x 0.80mm, 3.00mm, CST, DAC
10	2	120100		2	BOLT Hex, M6 x 1 x 20mm, CI 8.8
11	3	84559866		1	ELECTRIC CABLE License Plate Lamp
11	2	84198660		1	ELECTRIC CABLE License Plate Lamp
(1)	VAR - 334344, 334345, 334346, 334347, 334348, 334349, 334350, 335914				
(2)	ROPS, VAR - 334342, 334343				
(3)	CAB, VAR - 334342, 334343				

Valid for Var. 334342 or Var. 334343 or Var. 334344 or Var. 334345 or Var. 334346 or Var. 334347 or Var. 335914

FARMALL JX100 FARMALL
JX110 FARMALL JX70
FARMALL JX75 FARMALL
JX80 FARMALL JX90

55.404.BH

01

p1

1/2014

VAR - 334344, 334345, 334346, 334347, 334348, 334349, 334350, 335914 - REFLECTOR, REAR

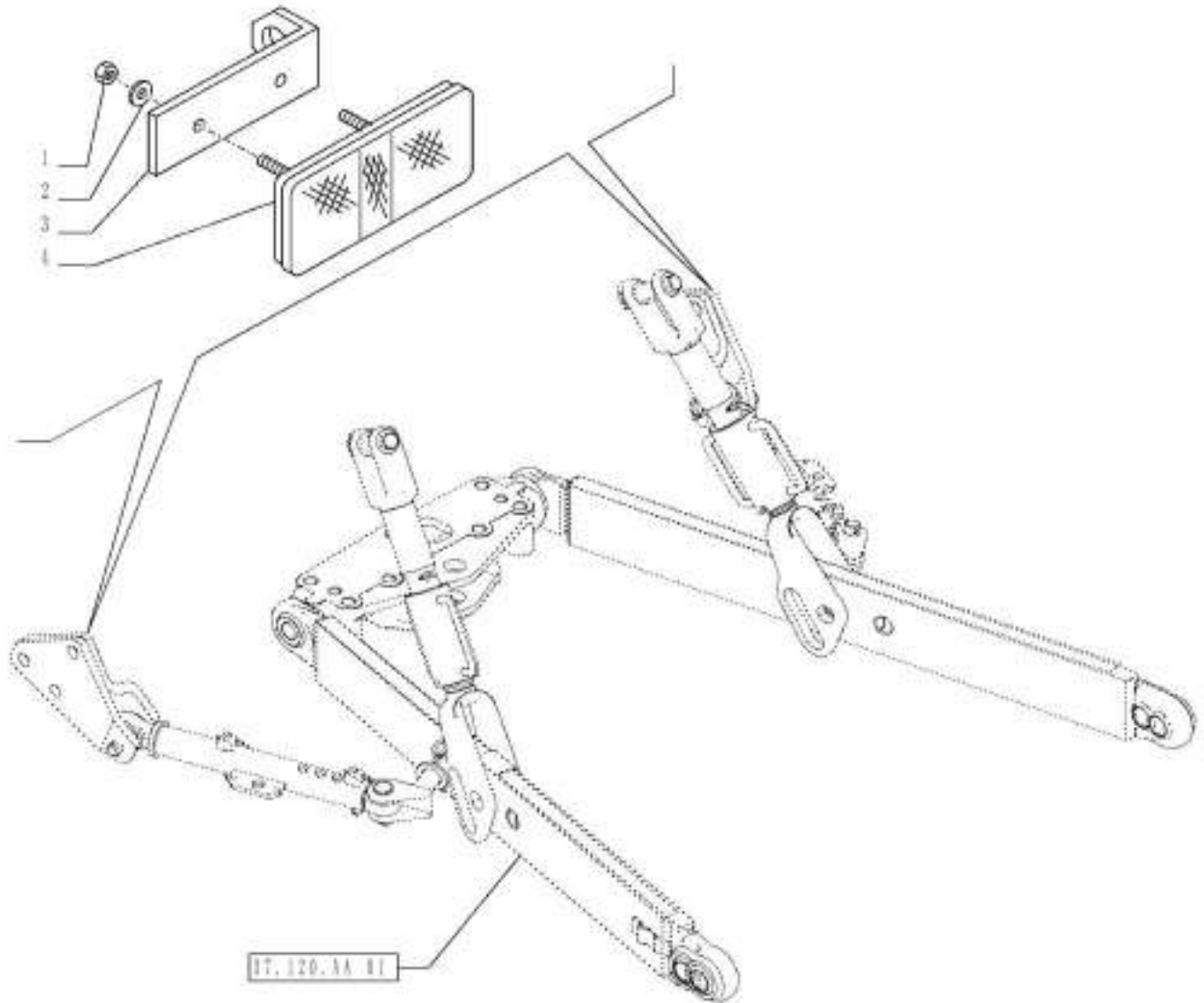

55.404.BH

01

p1

1/2014

VAR - 334344, 334345, 334346, 334347, 334348, 334349, 334350, 335914 - REFLECTOR, REAR

REF FN	PART NUMBER	YR/SN	QTY DESCRIPTION
1	15896411		4 NUT M5, CI 8
2	12601174		4 WAVE WASHER Wave, M4.3
3	5114096		2 SUPPORT
4	5097392		2 LAMP REFLECTOR

Valid for Var. 334344 or Var. 334345 or Var. 334346 or Var. 334347 or Var. 334348 or Var. 334349 or Var. 334350 or Var. 335914

FARMALL JX100
FARMALL JX110
FARMALL JX75
FARMALL JX80

VAR - 335767 - WORK LIGHT, ROPS

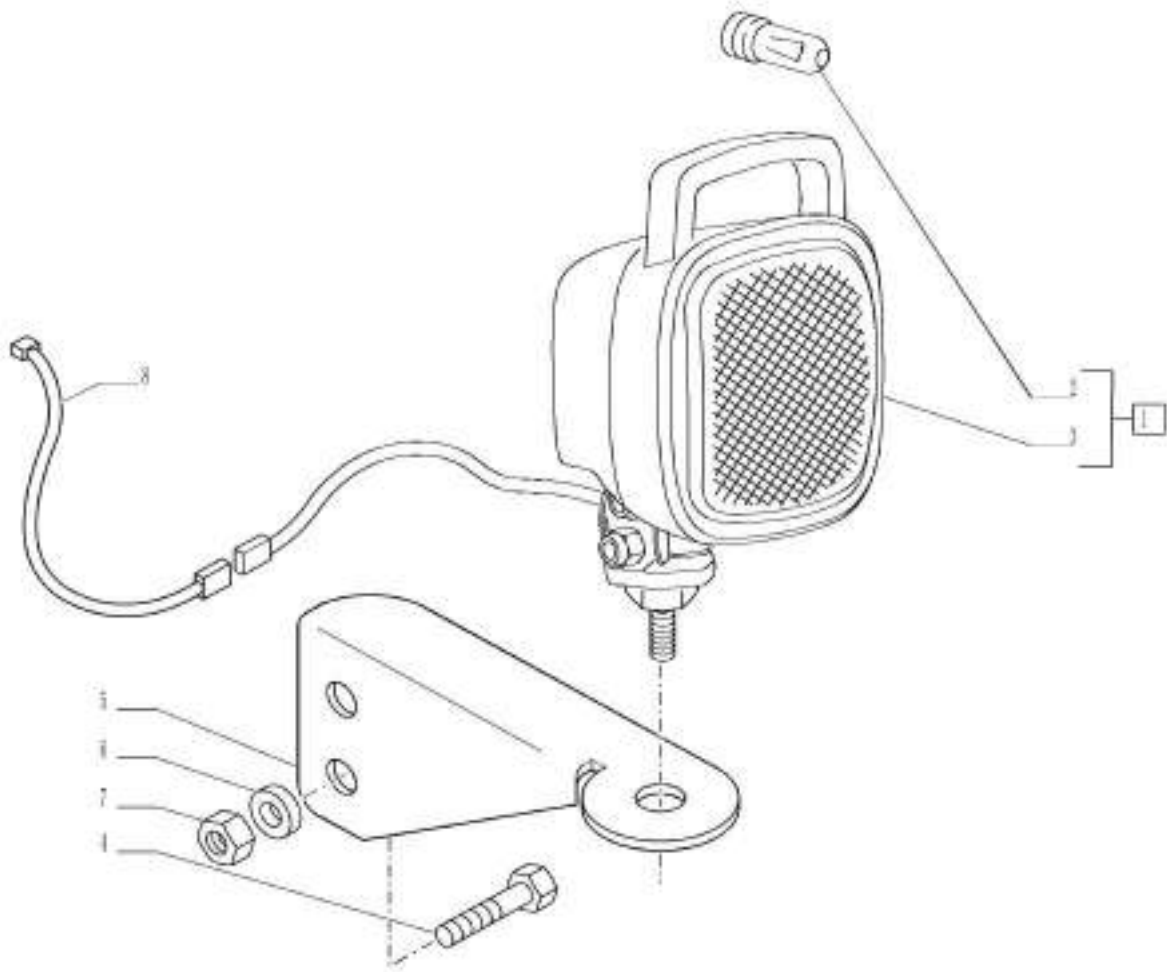

VAR - 335767 - WORK LIGHT, ROPS

REF FN	PART NUMBER	YR/SN	QTY	DESCRIPTION
1	87534765		1	PORTABLE LAMP ASSY Incl 2 - 3
2	87617349		1	BULB
3	NSS		1	NOT SERVICED SEPARATELY Lamp Incl in 1
4	10902121		2	SCREW Hex, M6 x 1 x 14.00mm, CI 8.8, ZND
5	84560132		1	SUPPORT
6	12601274		2	WAVE WASHER Wave, M6.4
7	15896221		2	NUT M6, CI 10
8	1 84198662		1	ELECTRIC CABLE Rear Work Light, LH
(1)	VAR - 334342, 334343			
Valid for Var. 335767				FARMALL JX100 FARMALL JX110 FARMALL JX70 FARMALL JX75 FARMALL JX80 FARMALL JX90

VAR - 334344, 334345, 334346, 334347, 334348, 334339, 334350, 335914 - FRONT TURN INDICATORS

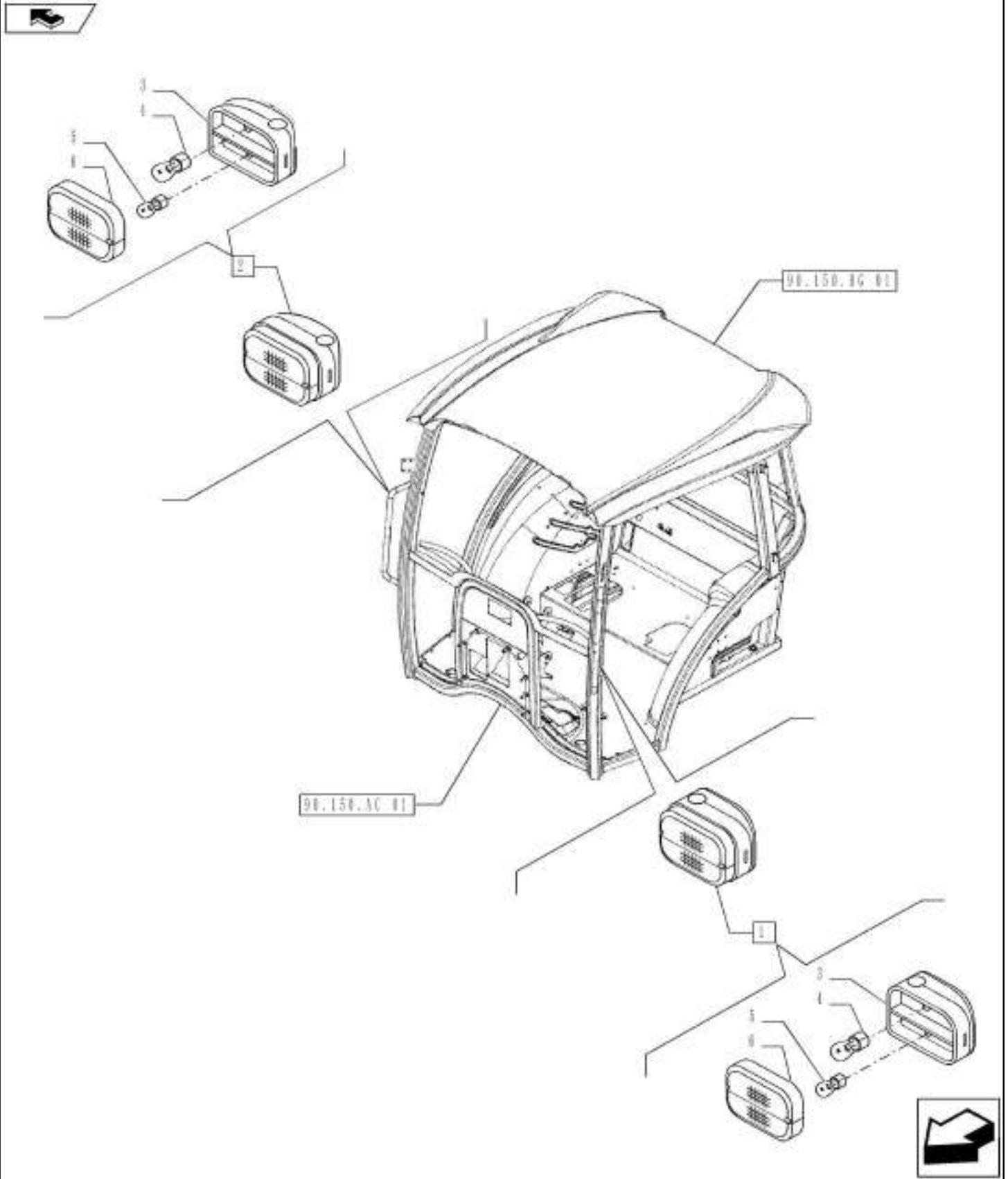

55.404.CA

01

p1

1/2014

VAR - 334344, 334345, 334346, 334347, 334348, 334339, 334350, 335914 - FRONT TURN INDICATORS

REF FN	PART NUMBER	YR/SN	QTY DESCRIPTION
1	5091438		1 INDICATOR LIGHT LH Incl 3 - 6
2	5091440		1 INDICATOR LIGHT RH Incl 3 - 6
3	5080707		2 LENS
4	5080613		2 BULB
5	5080705		2 BULB
6	5080704		2 COVER

Valid for Var. 334344 or Var. 334345 or Var. 334346 or Var. 334347 or Var. 334348 or Var. 334349 or Var. 334350 or Var. 335914

FARMALL JX100 FARMALL
JX110 FARMALL JX70
FARMALL JX75 FARMALL
JX80 FARMALL JX90

55.404.CL

01

p1

1/2014

VAR - 334344, 334345, 334346, 334347, 334348, 334349, 334950, 335914 - REAR TURN INDICATORS

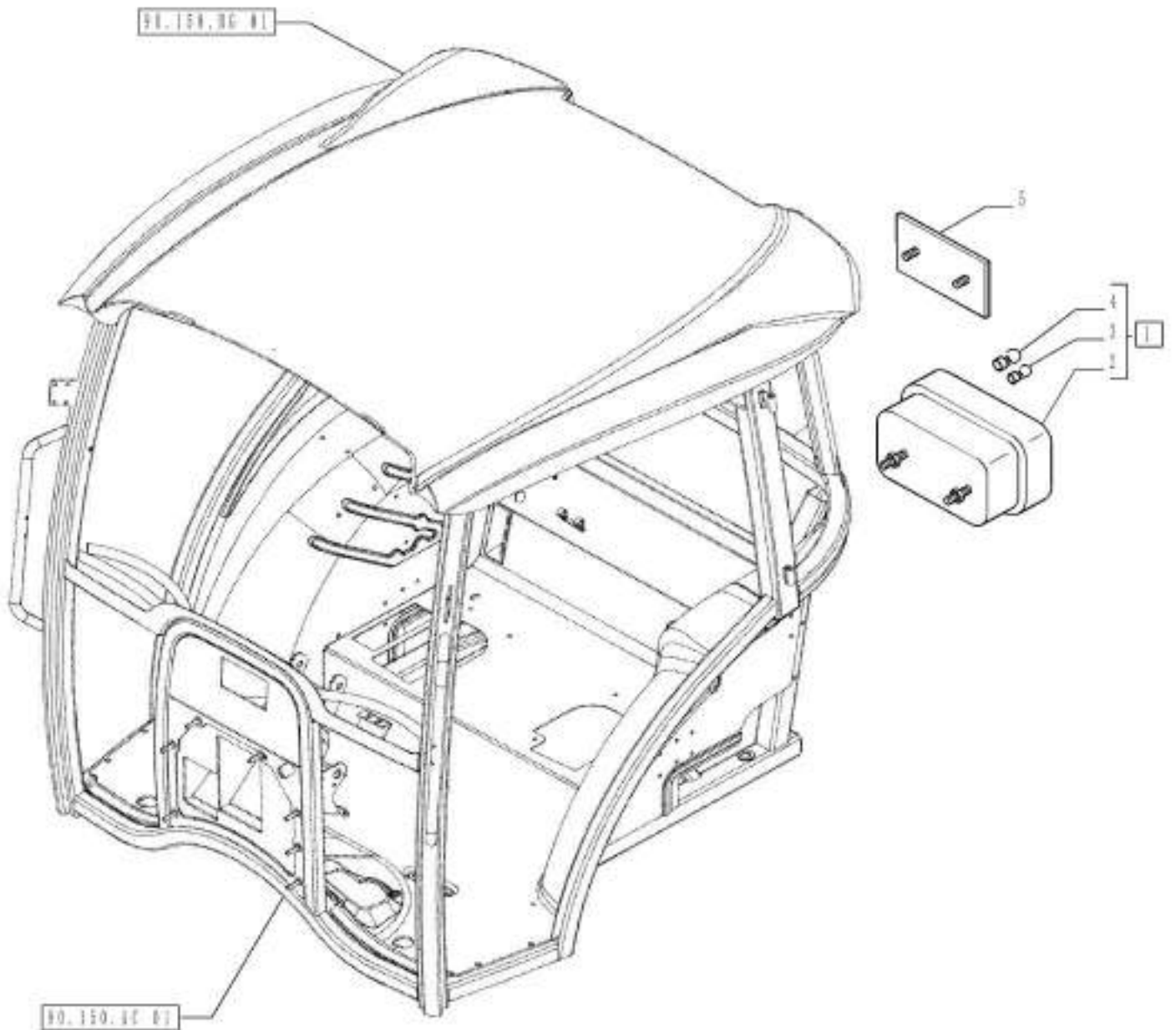

55.404.CL

01

p1

1/2014

VAR - 334344, 334345, 334346, 334347, 334348, 334349, 334950, 335914 - REAR TURN INDICATORS

REF FN	PART NUMBER	YR/SN	QTY DESCRIPTION
1	84487196		2 STOP LIGHT ASSY Incl 2 - 4
2	NSS		1 NOT SERVICED SEPARATELY Lamp Incl in 1
3	5080612		1 BULB 5,21W
4	5080613		1 BULB 21W
5	5097392		2 LAMP REFLECTOR

Valid for Var. 334344 or Var. 334345 or Var. 334346 or Var. 334347 or Var. 334348 or Var. 334349 or Var. 334350 or Var. 335914

FARMALL JX100 FARMALL
JX110 FARMALL JX70
FARMALL JX75 FARMALL
JX80 FARMALL JX90

55.404.CY

01

p1

1/2014

VAR - 334342, 334343, 334344, 334345, 334346, 334347, 334348, 334349, 334950, 335914 - ROAD LIGHTS - FRONT HEADLAMPS

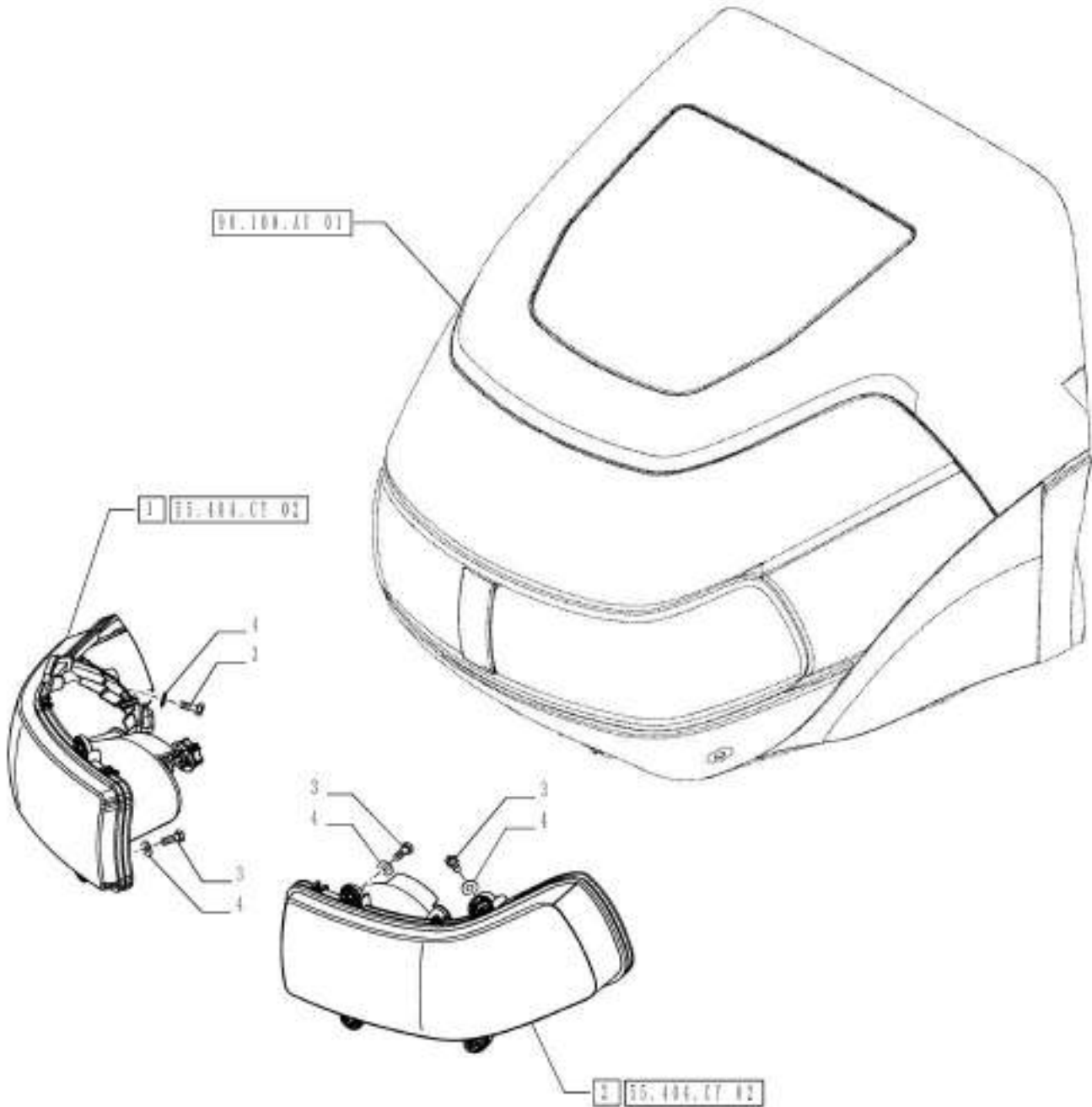

55.404.CY

01

p1

1/2014

VAR - 334342, 334343, 334344, 334345, 334346, 334347, 334348, 334349, 334950, 335914 - ROAD LIGHTS - FRONT HEADLAMPS

REF	FN	PART NUMBER	YR/SN	QTY	DESCRIPTION
1	1	87602451		1	RH HEADLAMP RH
1	2	87602449		1	RH HEADLAMP RH, ISO Market Only
2	1	87602450		1	LH HEADLAMP LH
2	2	87602448		1	LH HEADLAMP LH, ISO Market Only
3		86508568		8	BOLT Hex, M6 x 16mm, Cl 8.8, Full Thd
4		12644401		8	WASHER M6 x 15 x 1
(1)	VAR - 334344, 334345, 334346, 334347, 334348, 334349, 334350				
(2)	VAR - 334342, 334343				

Valid for Var. 334342 or Var. 334343 or Var. 334344 or Var. 334345 or Var. 334346 or Var. 334347 or Var. 334348 or Var. 334349 or Var. 334350 or Var. 335914

FARMALL JX100 FARMALL
JX110 FARMALL JX70
FARMALL JX75 FARMALL
JX80 FARMALL JX90

55.404.CY

02

p1

1/2014

VAR - 334342, 334343, 334344, 334345, 334346, 334347, 334348, 334349, 334950, 335914 - FRONT HEADLAMPS - BREAKDOWN

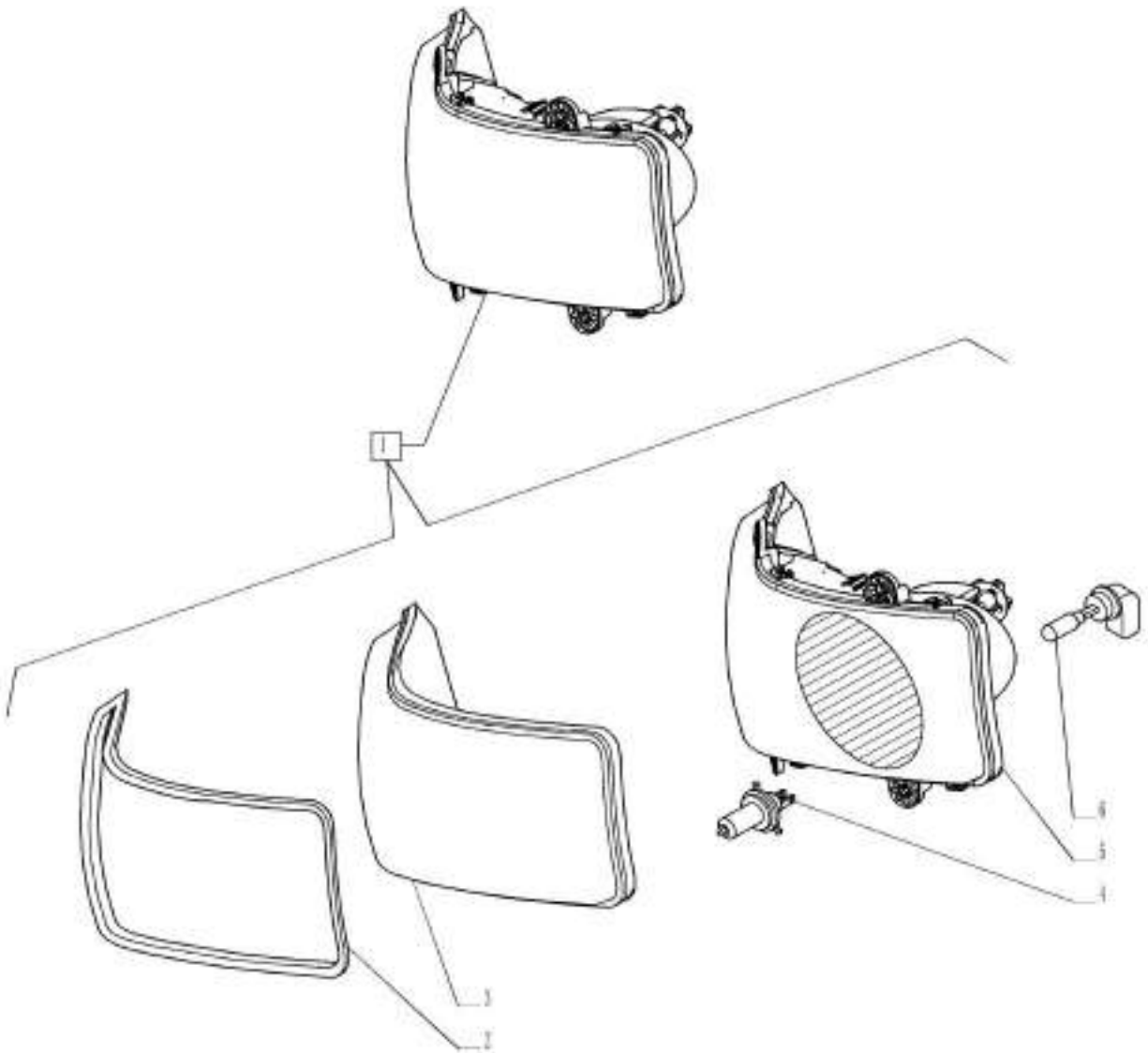

55.404.CY

02

p1

1/2014

VAR - 334342, 334343, 334344, 334345, 334346, 334347, 334348, 334349, 334950, 335914 - FRONT HEADLAMPS - BREAKDOWN

REF	FN	PART NUMBER	YR/SN	QTY	DESCRIPTION
1	1	87602451		1	RH HEADLAMP RH Incl 2 - 6
1	2	87602449		1	RH HEADLAMP RH Incl 2 - 6
1	1	87602450		1	LH HEADLAMP LH Incl 2 - 6
1	2	87602448		1	LH HEADLAMP LH Incl 2 - 6
2		{4321660}		1	
3		4436550		1	PADDING RH
3		{4436530}		1	LH
4		{4830990}		1	H4-12V 55,60W
5		NSS		1	NOT SERVICED SEPARATELY Headlamp Incl in 1
6		{4813060}		1	886-12.8V 55W Halogen

(1) VAR - 334344, 334345, 334346, 334347, 334348, 334349, 334950

(2) VAR - 334342, 334343

Valid for Var. 334342 or Var. 334343 or Var. 334344 or Var. 334345 or Var. 334346 or Var. 334347 or Var. 334348 or Var. 334349 or Var. 334350 or Var. 335914

FARMALL JX100 FARMALL
JX110 FARMALL JX70
FARMALL JX75 FARMALL
JX80 FARMALL JX90

VAR - 334343, 335914 - ROTARY BEACON, SWITCH, CAB

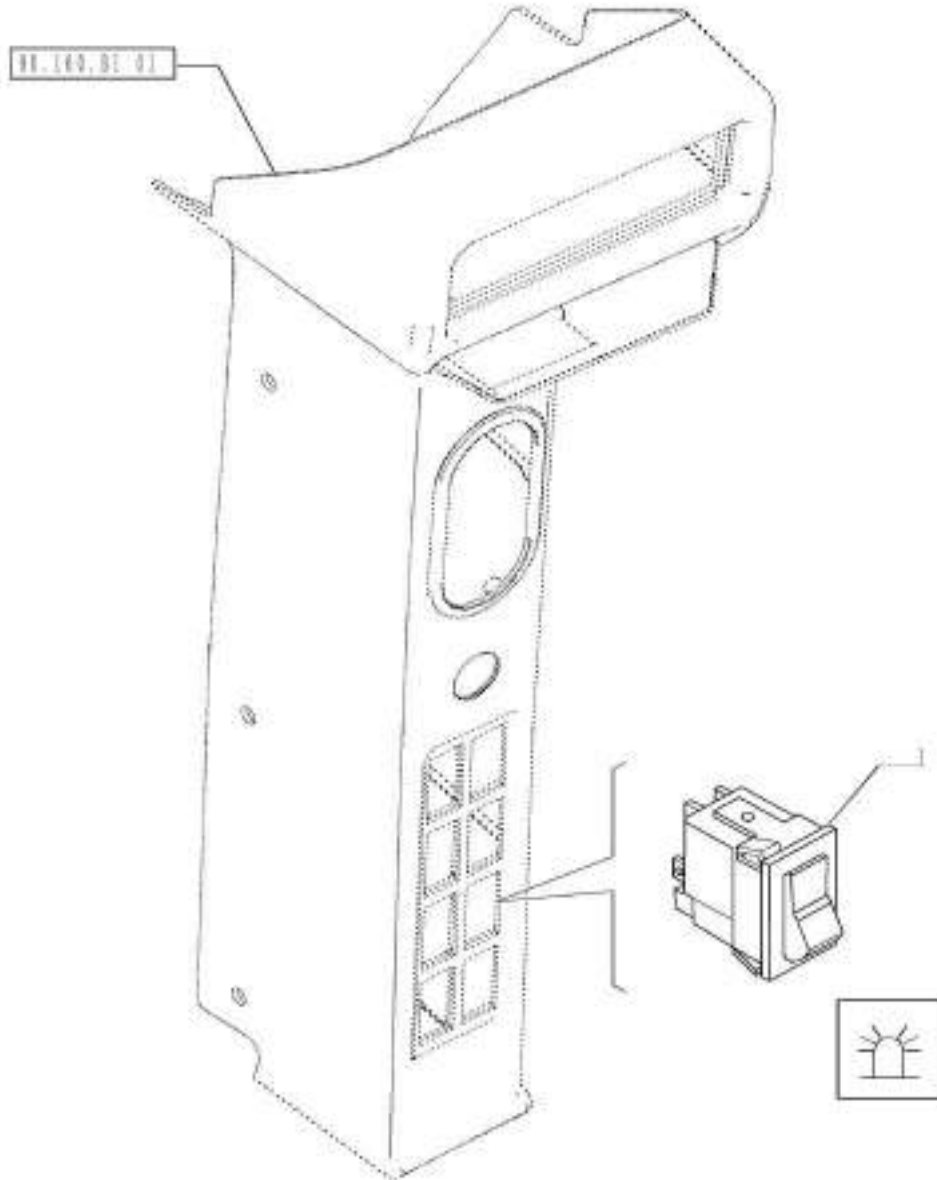

55.405.CH

01

p1

1/2014

VAR - 334343, 335914 - ROTARY BEACON, SWITCH, CAB

REF FN	PART NUMBER	YR/SN	QTY	DESCRIPTION
---------------	--------------------	--------------	------------	--------------------

1	87376568		1	BEACON SWITCH
---	----------	--	---	---------------

Valid for Var. 334343 or Var. 335914

FARMALL JX100 FARMALL
JX110 FARMALL JX70
FARMALL JX75 FARMALL
JX80 FARMALL JX90

VAR - 334343, 335914 - ROTARY BEACON, SWITCH, ROPS

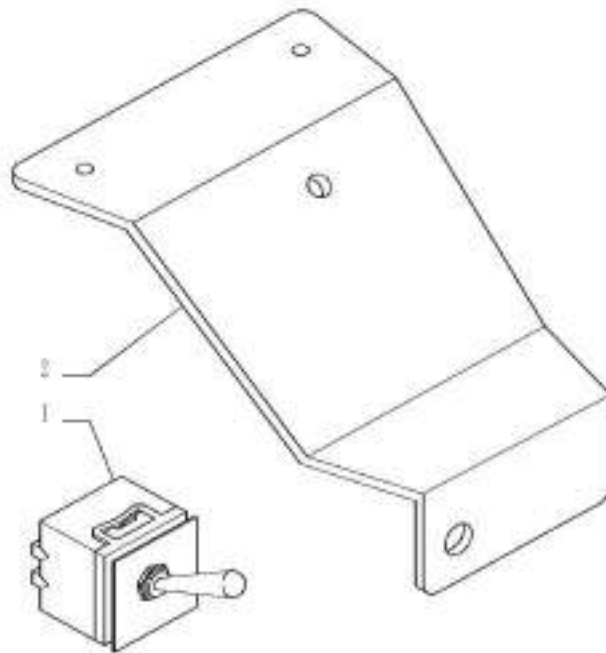

55.405.CH

02

p1

1/2014

VAR - 334343, 335914 - ROTARY BEACON, SWITCH, ROPS

REF FN	PART NUMBER	YR/SN	QTY DESCRIPTION
1	5093820		1 BEACON SWITCH
2	5090240		1 COVER

Valid for Var. 334343 or Var. 335914

FARMALL JX100 FARMALL
JX110 FARMALL JX70
FARMALL JX75 FARMALL
JX80 FARMALL JX90

55.408.AG

01

p1

1/2014

VAR - 333606, 334318, 334319, 391606, 392315 - SIGNAL HORN AND RELATED PARTS

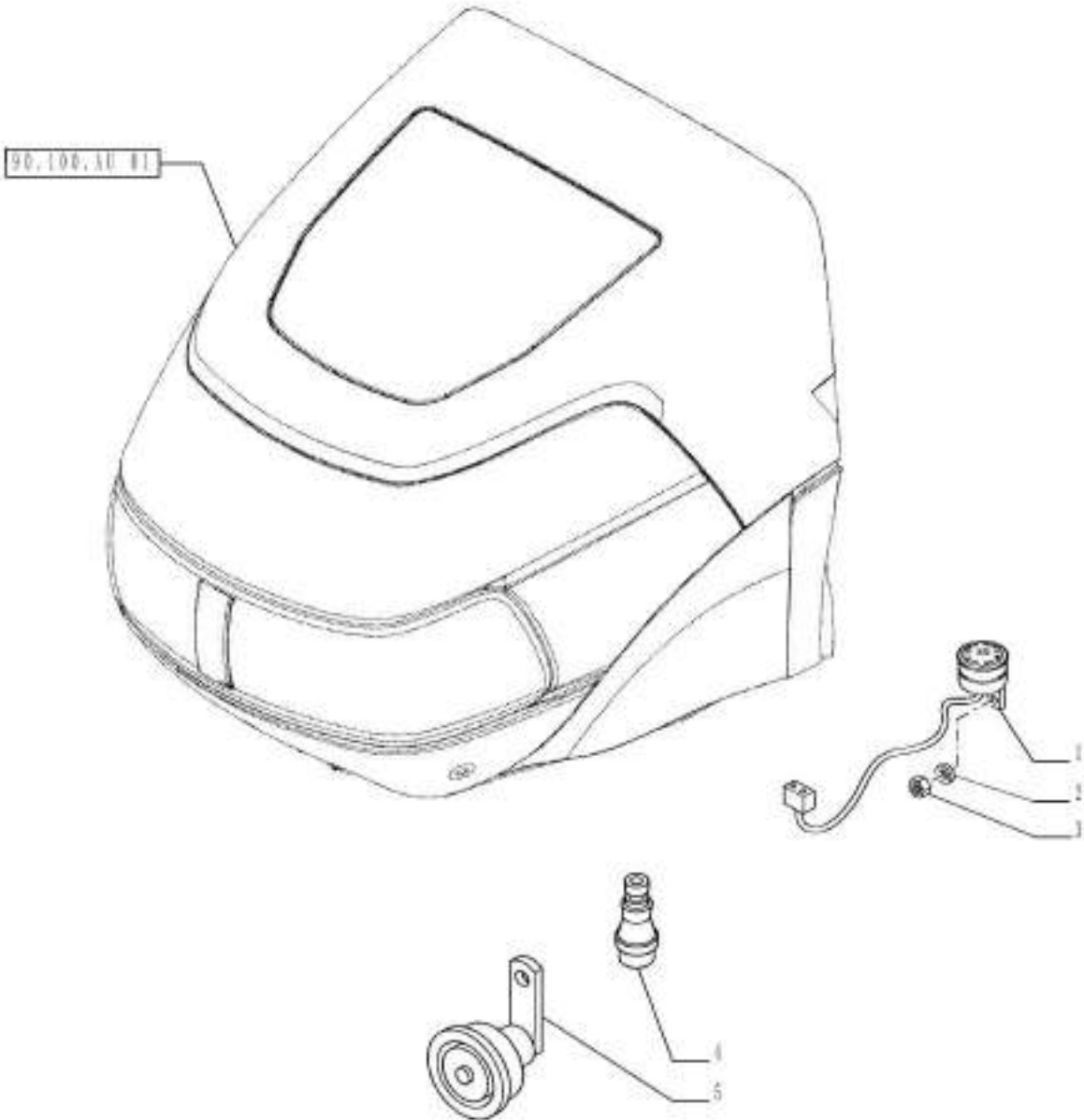

55.408.AG

01

p1

1/2014

VAR - 333606, 334318, 334319, 391606, 392315 - SIGNAL HORN AND RELATED PARTS

REF FN	PART NUMBER	YR/SN	QTY DESCRIPTION
1	5094111		1 HORN
2	12601374		1 WAVE WASHER Wave, 8.40mm ID x 15.00mm OD x 0.80mm, 3.00mm, CST, DAC
3	16100811		1 NUT Hex, M8, 6.80mm, Cl 8, ZND
4	5086173		1 ELEC CONNECTOR
5	5087129		1 HORN

Valid for Var. 333606 or Var. 334318 or Var. 334319 or Var. 391606 or Var. 392315

FARMALL JX100 FARMALL
JX110 FARMALL JX70
FARMALL JX75 FARMALL
JX80 FARMALL JX90

VAR - 334353, 335001, 336001, 744258 - REVERSE SPEED ALARM

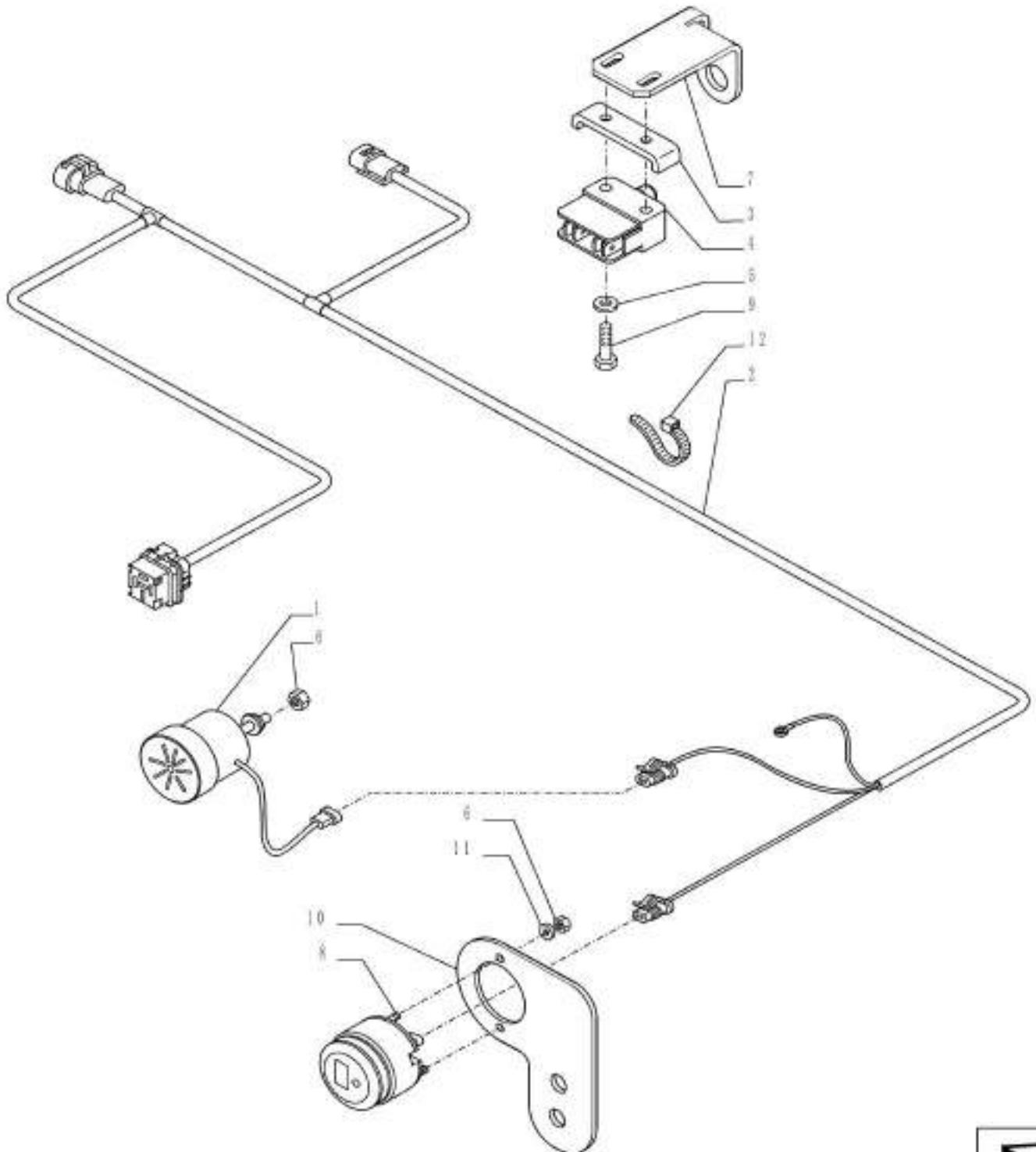

VAR - 334353, 335001, 336001, 744258 - REVERSE SPEED ALARM

REF FN	PART NUMBER	YR/SN	QTY DESCRIPTION
1	5094111		1 HORN
2	84576635		1 WIRE HARNESS Rear Gear Buzzer
3	1 5093339		1 BRACKET
4	1 87702928		1 PARK BRAKE SWITCH Hand Brake
5	1 12601074		2 WAVE WASHER 4.30mm ID x 9mm OD x 0.50mm, 2mm Max, CST, DAC
6	16100821		3 NUT M8, CI 10
7	2 84589687		1 SUPPORT
7	3 84589686		1 SUPPORT
8	84185527		1 LIGHT
9	1 13272617		2 SCREW Cross Pan Hd, M4 x 25
10	84576450		1 SUPPORT
11	12601374		3 WAVE WASHER Wave, 8.40mm ID x 15.00mm OD x 0.80mm, 3.00mm, CST, DAC
12	5112712		10 COLLAR M4.8 x 283
(1)	VAR - 335001, 336001 (744258)		
(2)	VAR - 335001 (744258)		
(3)	VAR - 336001 (744258)		

Valid for Industrial Var. 334353, 335001, 336001 (744258)

FARMALL JX100 FARMALL
 JX110 FARMALL JX70
 FARMALL JX75 FARMALL
 JX80 FARMALL JX90

VAR - 333606, 334318, 334319, 391606, 392315 - INSTRUMENT CLUSTER

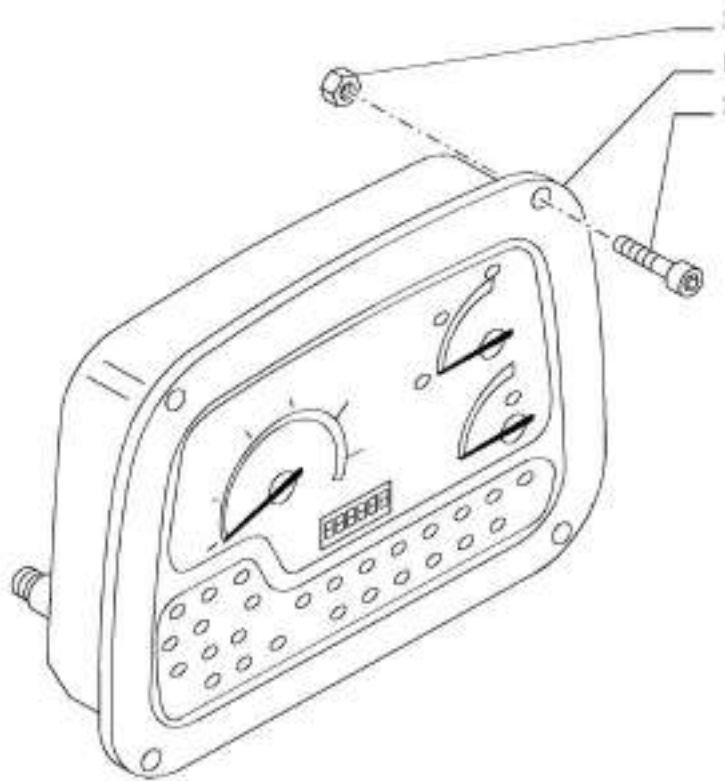

55.408.CA

01

p1

1/2014

VAR - 333606, 334318, 334319, 391606, 392315 - INSTRUMENT CLUSTER

REF FN	PART NUMBER	YR/SN	QTY DESCRIPTION
1	47406865		1 INSTRUMENT CLUSTER
2	84512383		4 SCREW
3	84492109		4 CLIP

Valid for Var. 333606 or Var. 334318 or Var. 334319 or Var. 391606 or Var. 392315

FARMALL JX100 FARMALL
JX110 FARMALL JX70
FARMALL JX75 FARMALL
JX80 FARMALL JX90

VAR - 333606, 334318, 334319, 391606, 392315 - MAIN HARNESS

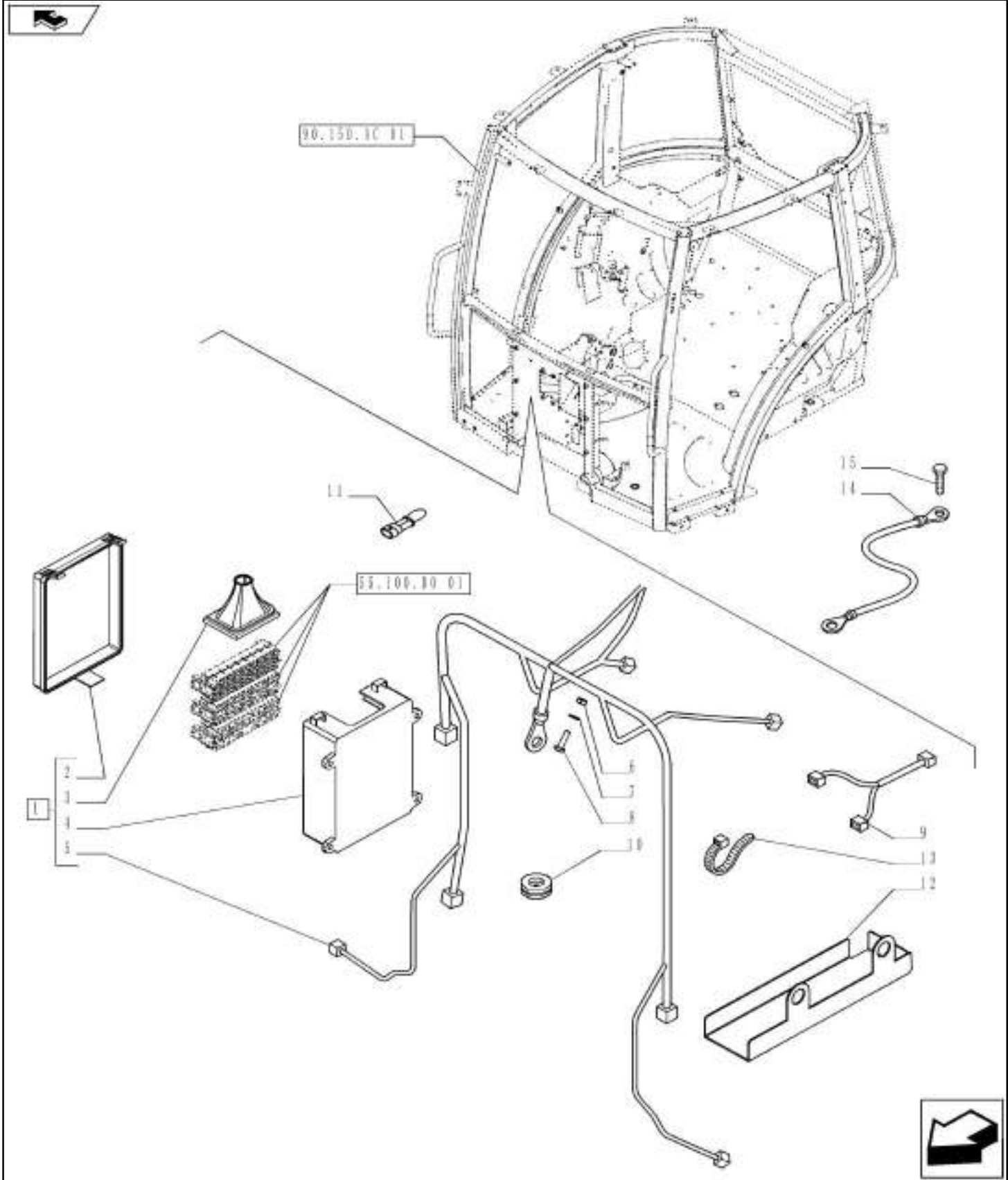

VAR - 333606, 334318, 334319, 391606, 392315 - MAIN HARNESS

REF	FN	PART NUMBER	YR/SN	QTY	DESCRIPTION
1	1	47401253		1	WIRE HARNESS Incl 2 - 5
1	2	47401255		1	WIRE HARNESS Incl 2 - 5
2		84487349		1	COVER Incl Decal
3		84554207		1	GROMMET
4		84487348		1	FUSE BOX
5		NSS		1	NOT SERVICED SEPARATELY Harness Incl in 1
6		13272111		4	SCREW Pan Hd, M4 x 14, 5.8
7		11181479		4	BELLEVILLE WASHER Belleville, M4.3
8		10794011		4	NUT M4, CI 8
9		47365084		1	CABLE Ground Speed PTO
10		10397480		2	GROMMET
11		84261590		1	ELEC CONNECTOR
12		84285635		1	PLATE
13		5112712		AR	COLLAR M4.8 x 283
14		84249654		1	ELECTRIC CABLE
15		15970321		2	SCREW Hex, M10 x 1.25 x 16mm, CI 8.8, Full Thd
(1)		VAR - 333606, 391606; CAB			
(2)		VAR - 334318, 334319, 392315; ROPS			

Valid for Var. 333606 or Var. 334318 or Var. 334319 or Var. 391606 or Var. 392315

FARMALL JX100 FARMALL
JX110 FARMALL JX70
FARMALL JX75 FARMALL
JX80 FARMALL JX90

55.510.AF

02

p1

1/2014

VAR - 333606, 334318, 334319, 391606, 392315 - MAIN HARNESS

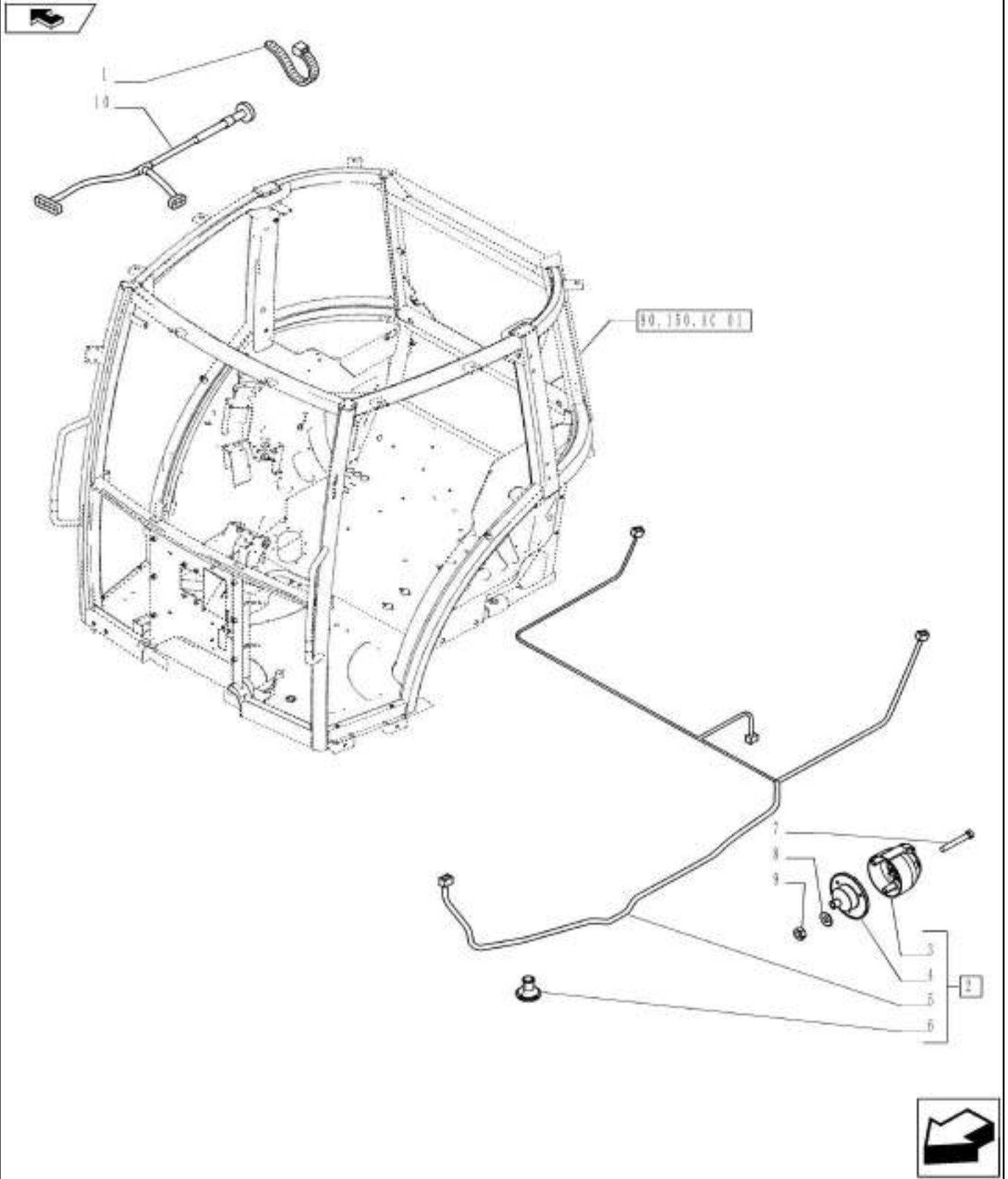

VAR - 333606, 334318, 334319, 391606, 392315 - MAIN HARNESS

REF FN	PART NUMBER	YR/SN	QTY DESCRIPTION
1	5112712		AR COLLAR M4.8 x 283
2	1 84424701		1 WIRE HARNESS Incl 3 - 6
2	2 84561224		1 WIRE HARNESS Incl 3 - 6
3	5086147		1 POWER SOCKET
4	5102234		1 CAP
5	NSS		1 NOT SERVICED SEPARATELY Cable Incl in 2
6	5080431		1 GROMMET
7	10390211		3 SCREW Slotted, Pan Hd, M5 x 35, 5.8
8	12601174		3 WAVE WASHER Wave, M4.3
9	15896411		3 NUT M5, CI 8
10	3 84369156		1 WIRE HARNESS Forward-Reverse and Servo PTO
(1)	VAR - 333606, 391606; CAB		
(2)	VAR - 334318, 334319, 392315; ROPS		
(3)	VAR - 330120, 331120		

Valid for Var. 333606 or Var. 334318 or Var. 334319 or Var. 391606 or Var. 392315

FARMALL JX100 FARMALL
JX110 FARMALL JX70
FARMALL JX75 FARMALL
JX80 FARMALL JX90

55.510.BM

01

p1

1/2014

VAR - 334342, 334344, 334345, 334346, 334347, 334348, 334349, 334350 - AUXILIARY POWER SOCKET

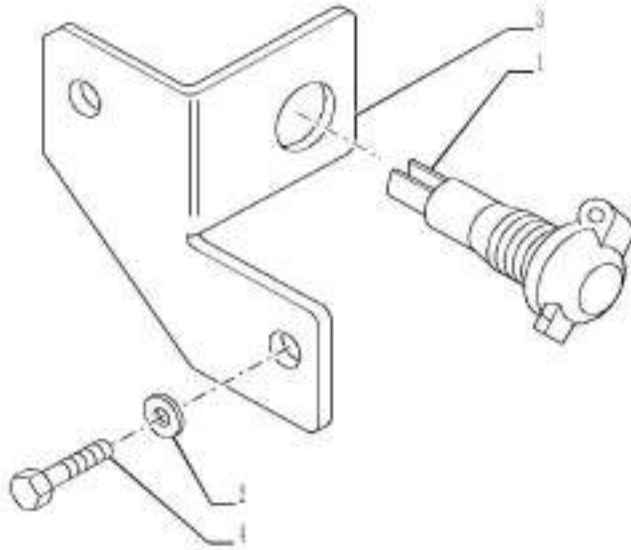

55.510.BM

01

p1

1/2014

VAR - 334342, 334344, 334345, 334346, 334347, 334348, 334349, 334350 - AUXILIARY POWER SOCKET

REF FN	PART NUMBER	YR/SN	QTY DESCRIPTION
1	82002966		1 POWER SOCKET EC-Socket ASSY Auxiliary Electric Power
2	1	12601374	2 WAVE WASHER Wave, 8.40mm ID x 15.00mm OD x 0.80mm, 3.00mm, CST, DAC
3	1	5089484	1 SUPPORT
3	2	84524373	1 BRACKET
4	1	43127	2 BOLT Hex, M8 x 1.25 x 25mm, Cl 8.8, Full Thd
(1)	ROPS		
(2)	CAB		

Valid for Var. 334342 or Var. 334344 or Var. 334345 or Var. 334346 or Var. 334347 or Var. 334348 or Var. 334349 or Var. 334350

FARMALL JX100 FARMALL
JX110 FARMALL JX70
FARMALL JX75 FARMALL
JX80 FARMALL JX90

55.510.BM

02

p1

1/2014

VAR - 335394 - INSIDE CAB POWER SOCKET

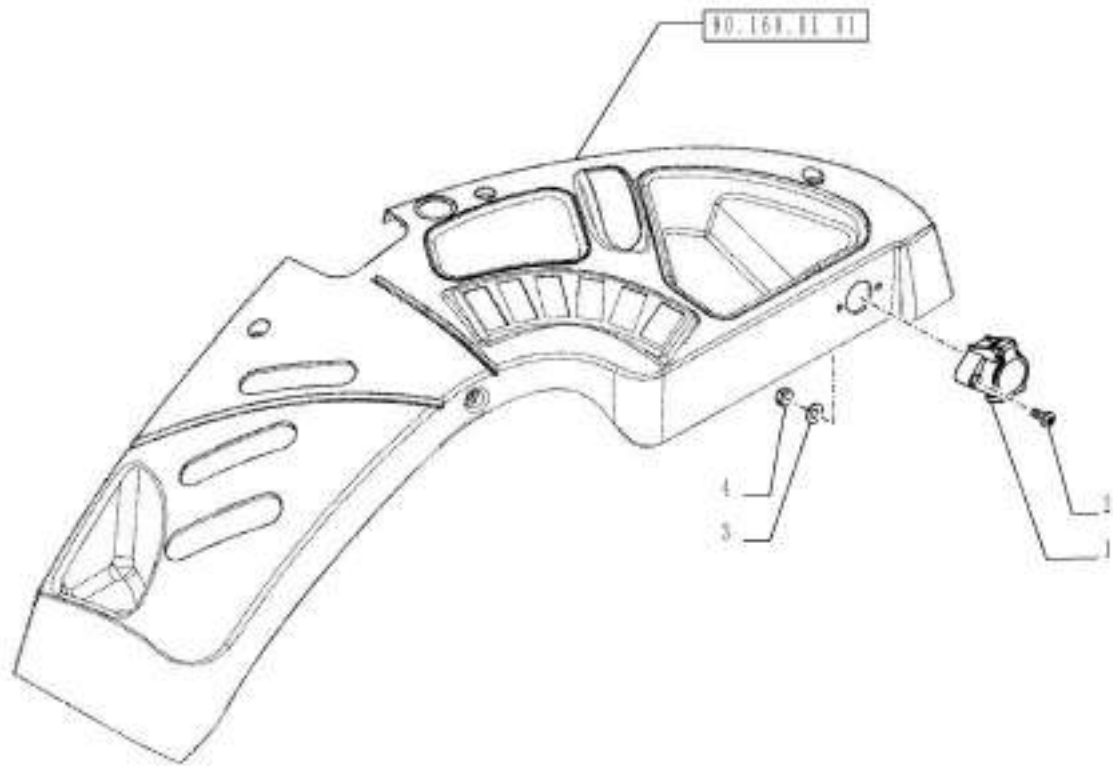

55.512.AA

01

p1

1/2014

VAR - 390777 - LESS RADIO READY, CAB

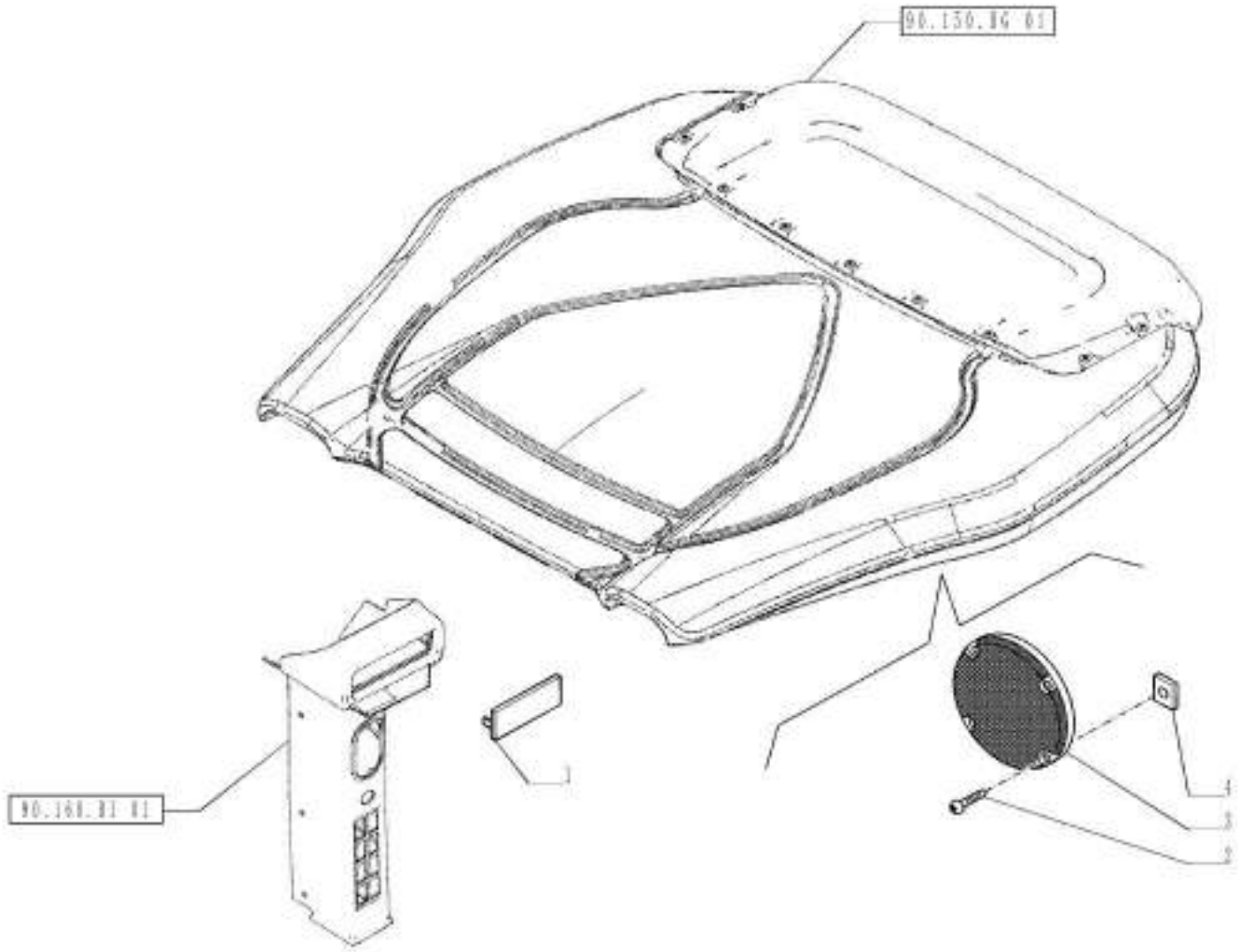

55.512.AA

01

p1

1/2014

VAR - 390777 - LESS RADIO READY, CAB

REF FN	PART NUMBER	YR/SN	QTY DESCRIPTION
1	84553615		1 COVER
2	15909407		8 SELF-TAP SCREW Cross Oval Hd, M3.5 x 19
3	5094415		2 COVER
4	14226690		8 SQUARE NUT

Valid for Var. 390777; CAB**FARMALL JX100 FARMALL
JX110 FARMALL JX70
FARMALL JX75 FARMALL
JX80 FARMALL JX90**

VAR - 333777 - CAB, RADIO

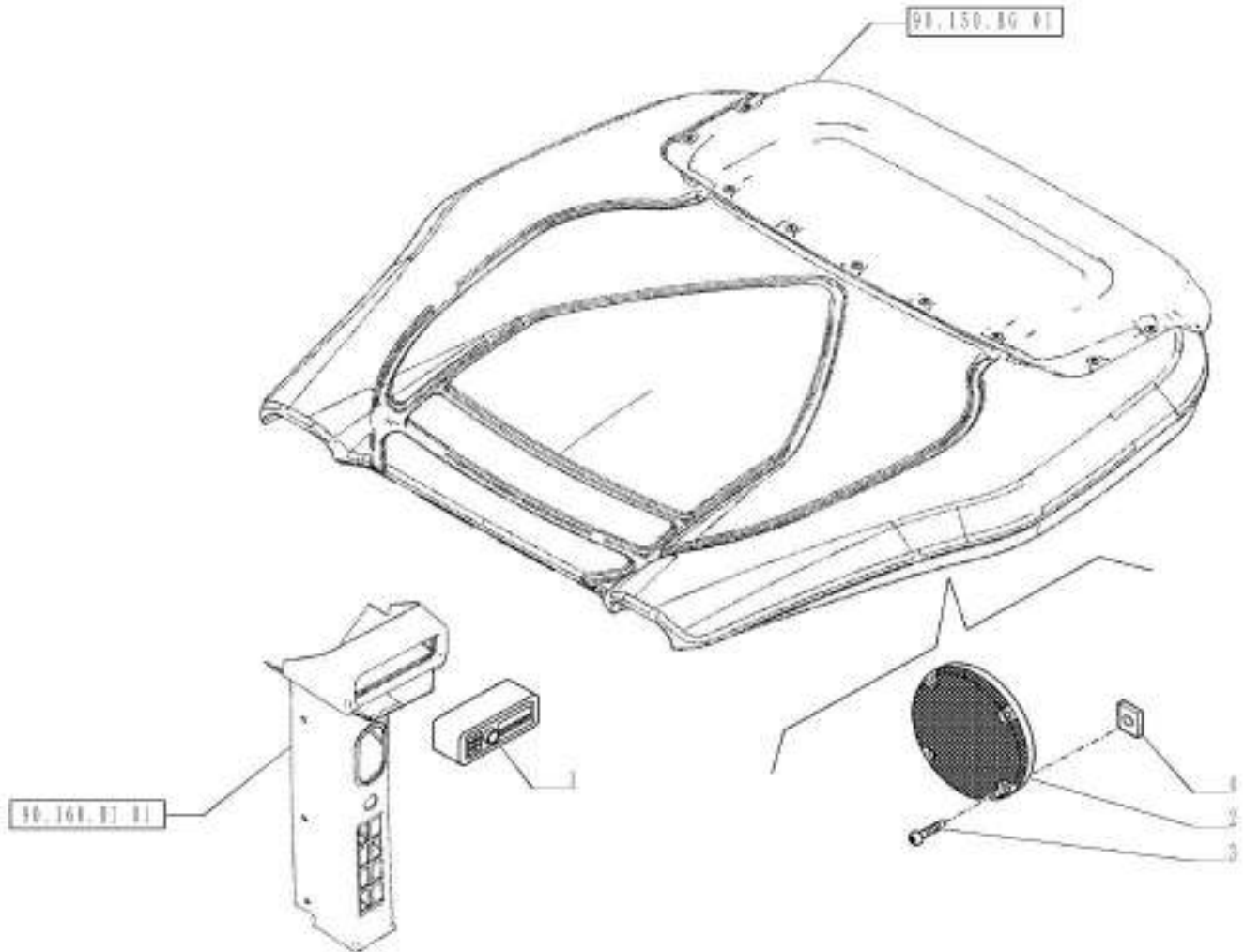

55.512.AA

02

p1

1/2014

VAR - 333777 - CAB, RADIO

REF FN	PART NUMBER	YR/SN	QTY DESCRIPTION
1	84520290		1 RADIO
2	5094415		2 COVER
3	15909407		8 SELF-TAP SCREW Cross Oval Hd, M3.5 x 19
4	14226690		8 SQUARE NUT

Valid for Var. 333777

FARMALL JX100 FARMALL
JX110 FARMALL JX70
FARMALL JX75 FARMALL
JX80 FARMALL JX90

VAR - 330777 - CAB, 2 SPEAKERS AND ANTENNA

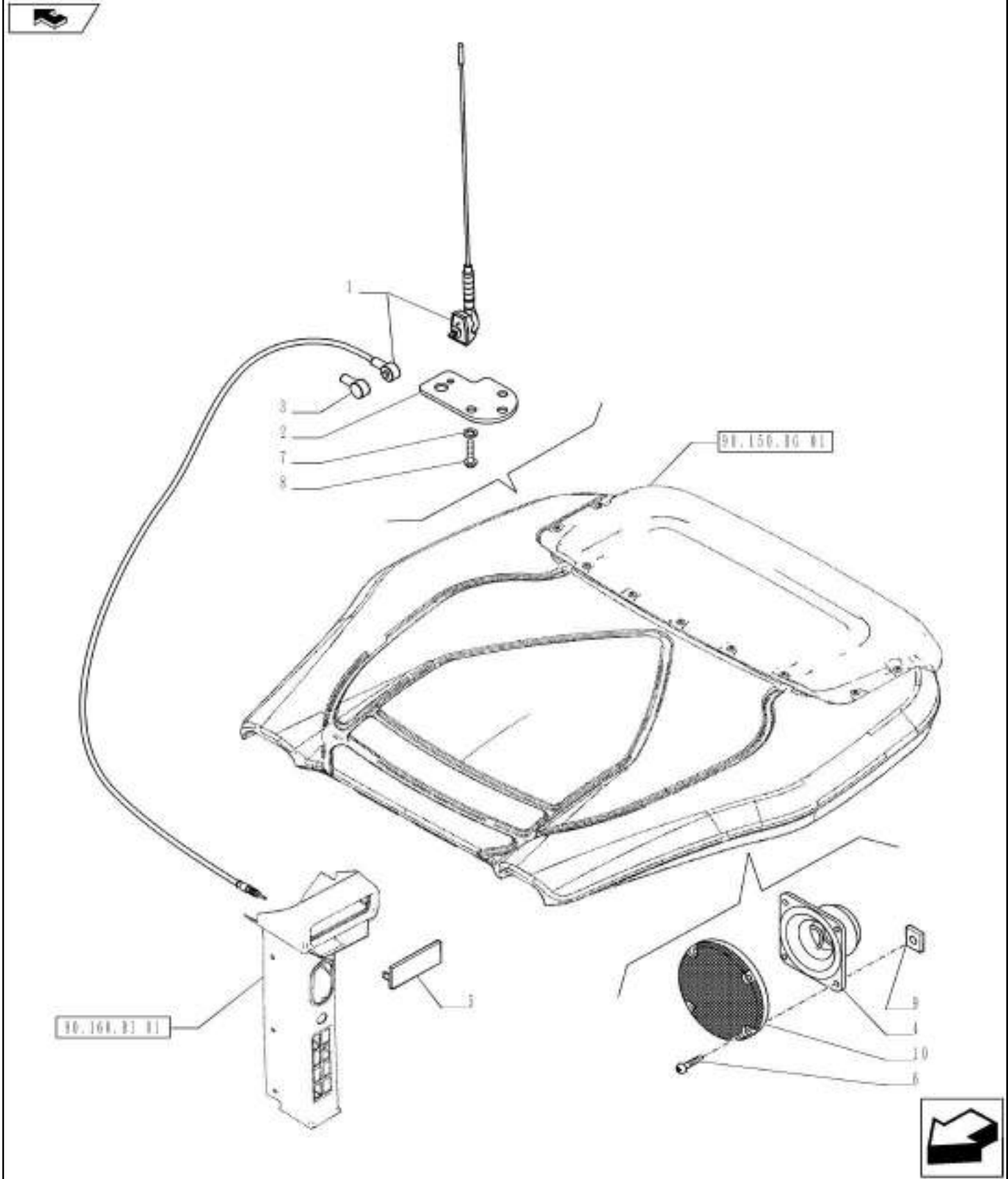

VAR - 330777 - CAB, 2 SPEAKERS AND ANTENNA

REF FN	PART NUMBER	YR/SN	QTY DESCRIPTION
1	84585065		1 ANTENNA
2	84554031		1 SUPPORT
3	47386074		1 INSULATOR BLOCK
4	84584598		2 SPEAKER
5	84553615		1 COVER
6	15909407		8 SELF-TAP SCREW Cross Oval Hd, M3.5 x 19
7	12601374		3 WAVE WASHER Wave, 8.40mm ID x 15.00mm OD x 0.80mm, 3.00mm, CST, DAC
8	86624003		3 BOLT Hex, M8 x 14mm, Cl 8.8, Full Thd
9	14226690		8 SQUARE NUT
10	5089509		2 COVER

Valid for Var. 330777

FARMALL JX100 FARMALL
 JX110 FARMALL JX70
 FARMALL JX75 FARMALL
 JX80 FARMALL JX90

VAR - 333606, 334318, 334319, 391606, 392315 - ELECTRIC CONTROLS, SWITCHES

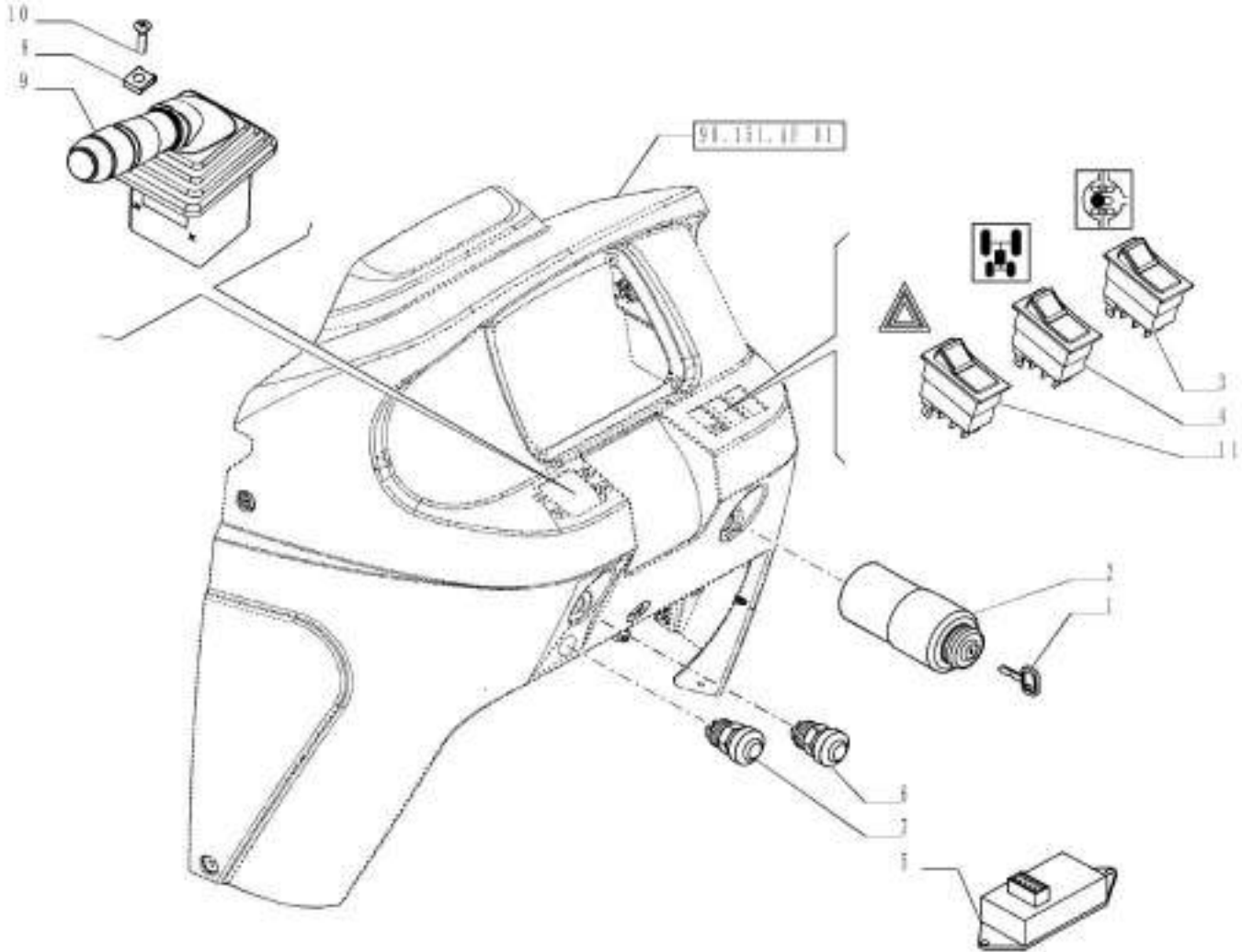

VAR - 333606, 334318, 334319, 391606, 392315 - ELECTRIC CONTROLS, SWITCHES

REF FN	PART NUMBER	YR/SN	QTY DESCRIPTION
1	5170782		1 IGNITION KEY Black
1	47126500		2 IGNITION KEY Red
2	5129862		1 IGNITION SWITCH
3	1 47128548		1 TOGGLE SWITCH 4WD
4	1 5184399		1 DIFF LOCK SWITCH
5	1 84130842		1 MODULE
6	2 5086006		1 SWITCH
7	5093168		1 LIGHT SWITCH
8	87720104		4 CLIP
9	84209856		1 SWITCH ASSY
10	15693501		4 SCREW Cross Oval Hd, M4.8 x 22
11	84155394		1 FLASHER SWITCH Hazard
(1)	VAR - 330384, 334322 (744739)		
(2)	VAR - 330203		

Valid for Var. 333606 or Var. 334318 or Var. 334319 or Var. 391606 or Var. 392315

FARMALL JX100 FARMALL
JX110 FARMALL JX70
FARMALL JX75 FARMALL
JX80 FARMALL JX90

VAR - 333606, 334318, 334319, 391606, 392315 - ELECTRIC SYSTEM CONTROL, SWITCH

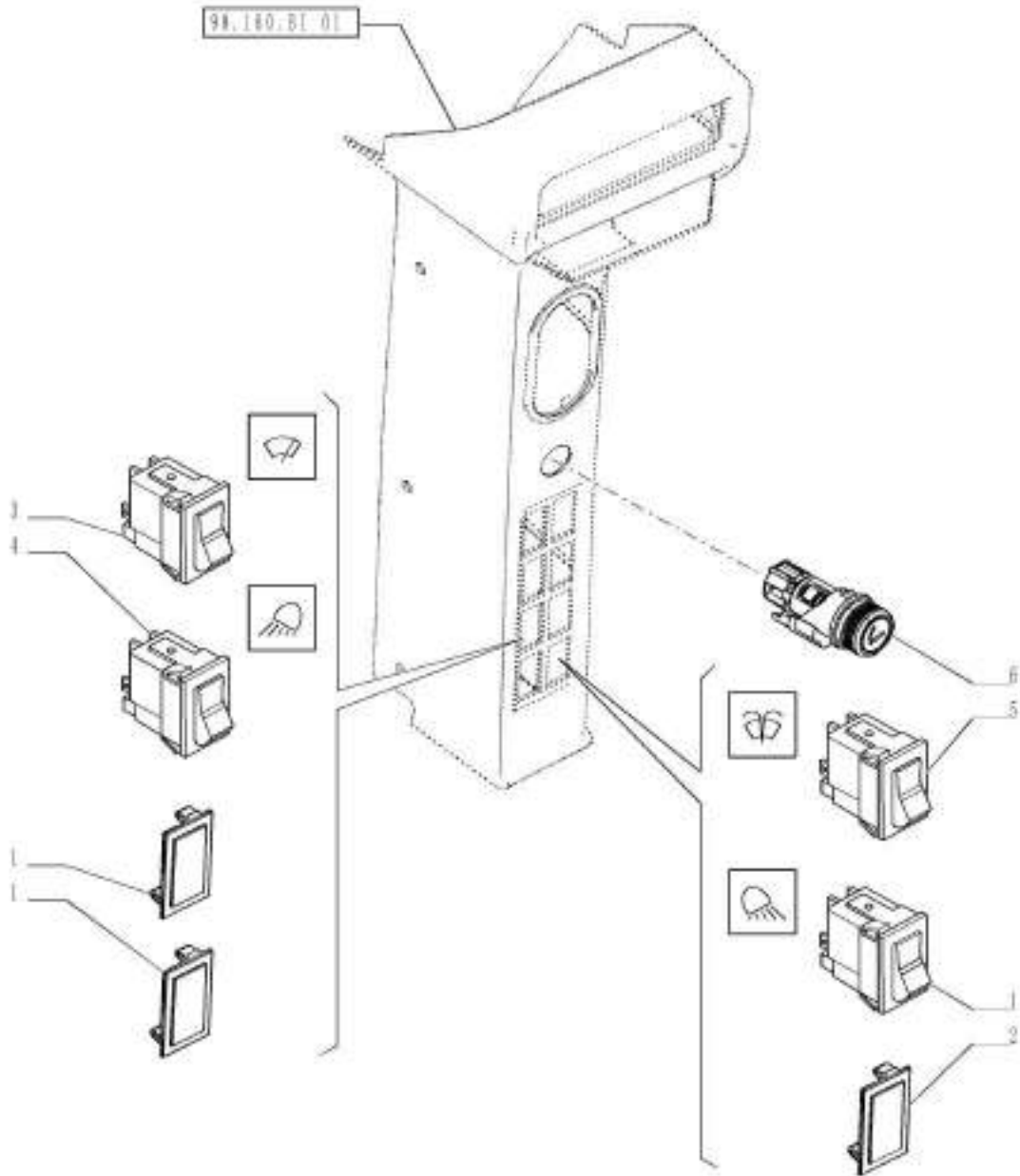

55.512.BG

02

p1

1/2014

VAR - 333606, 334318, 334319, 391606, 392315 - ELECTRIC SYSTEM CONTROL, SWITCH

REF FN	PART NUMBER	YR/SN	QTY DESCRIPTION
1	5166218		3 PLUG
2	87353539		1 CIGARETTE LIGHTER
3	84560042		1 SWITCH
4	1 87472544		1 SWITCH ASSY Front Work Lamp
5	1 87551489		1 LIGHT SWITCH Rear Work Lamp
6	2 5089430		1 WINDSHIELD WASHER SWITCH Washer
(1)	VAR - 335769, 335709		
(2)	VAR - 334402, 334404		

Valid for Var. 333606 or Var. 334318 or Var. 334319 or Var. 391606 or Var. 392315

FARMALL JX100 FARMALL
JX110 FARMALL JX70
FARMALL JX75 FARMALL
JX80 FARMALL JX90

55.514.AA

01

p1

1/2014

VAR - 334344, 334345, 334346, 334347, 334348, 334349, 334950, 335914 - CAB LIGHTING

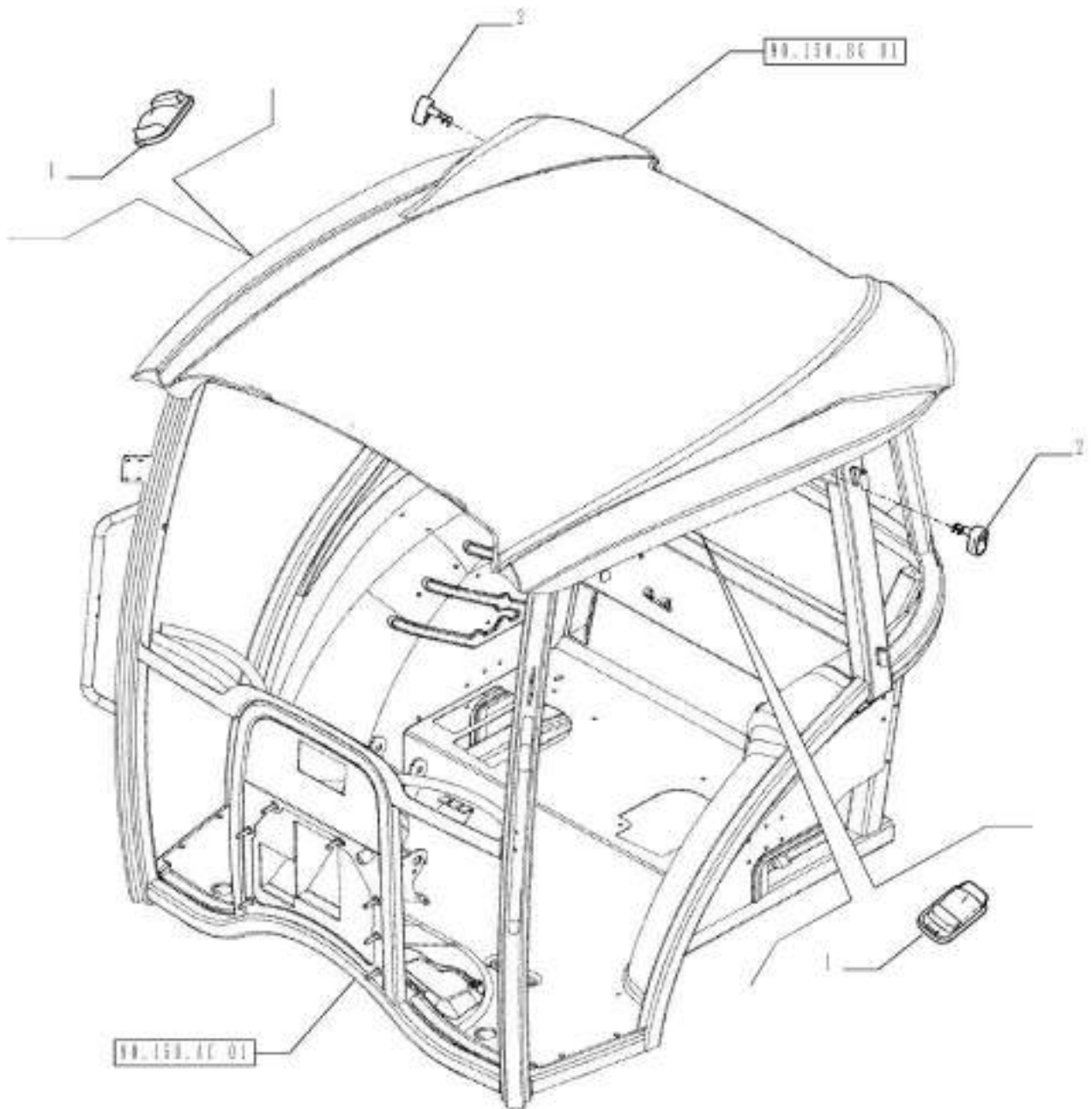

55.514.AA

01

p1

1/2014

VAR - 334344, 334345, 334346, 334347, 334348, 334349, 334950, 335914 - CAB LIGHTING

REF FN	PART NUMBER	YR/SN	QTY DESCRIPTION
1	87571338		2 CEILING LAMP
2	83961521		2 SWITCH ASSY

Valid for Var. 334344 or Var. 334345 or Var. 334346 or Var. 334347 or Var. 334348 or Var. 334349 or Var. 334350 or Var. 335914

FARMALL JX100 FARMALL
JX110 FARMALL JX70
FARMALL JX75 FARMALL
JX80 FARMALL JX90

55.514.AB

01

p1

1/2014

VAR - 335709, 335769 - CAB WORK LIGHT

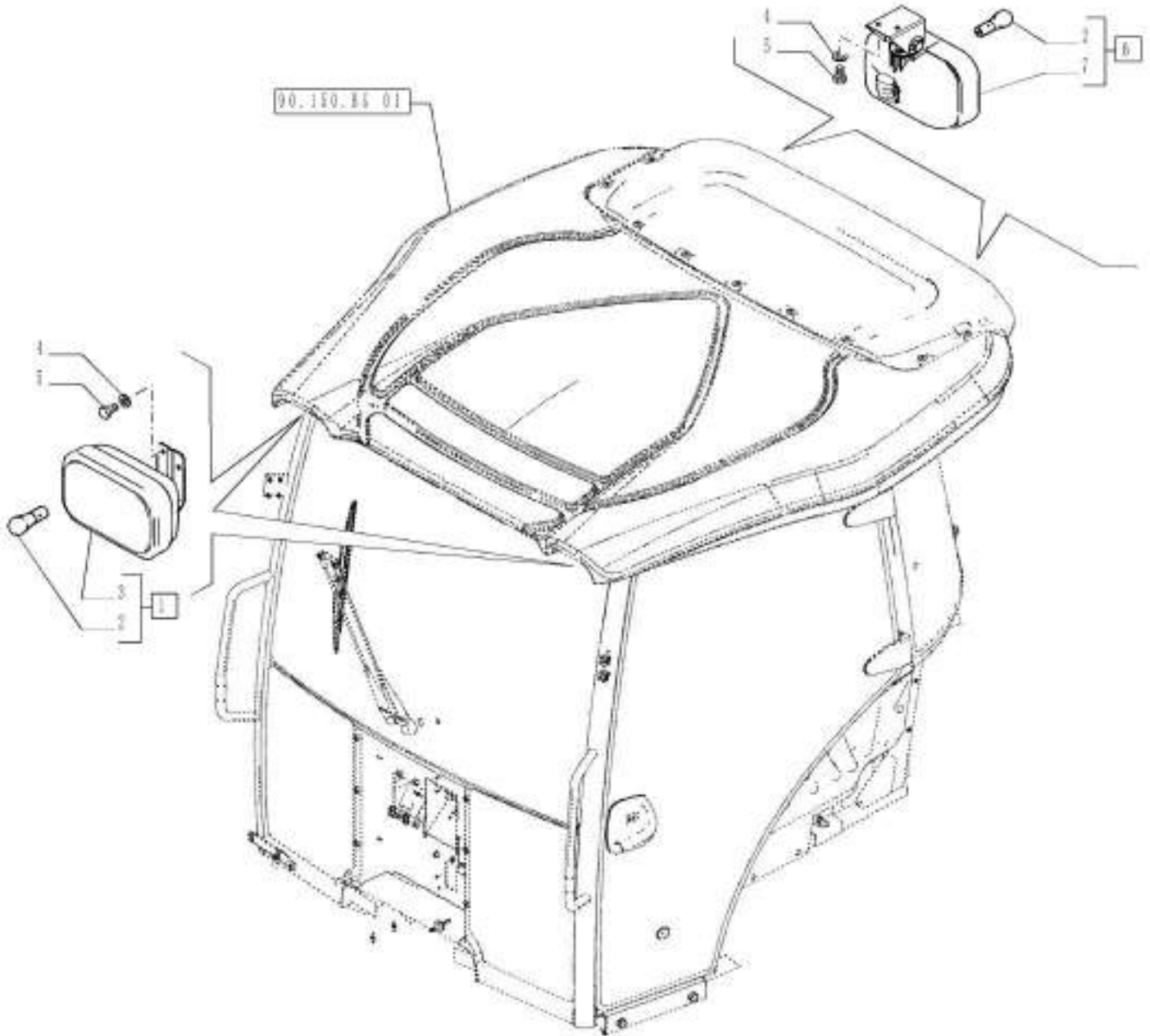

55.514.AB

01

p1

1/2014

VAR - 335709, 335769 - CAB WORK LIGHT

REF FN	PART NUMBER	YR/SN	QTY DESCRIPTION
1	84487193		2 WORK LAMP ASSY Incl 2, 3
2	84135750		1 BULB
3	NSS		1 NOT SERVICED SEPARATELY Lamp Incl in 1
4	12601274		AR WAVE WASHER Wave, M6.4
5	86977726		AR BOLT Hex, M6 x 12mm, Cl 8.8, Full Thd
6 1	84487194		AR WORK LAMP Incl 2, 7
7	NSS		1 NOT SERVICED SEPARATELY Lamp Incl in 6

(1) VAR - 335709, Q.ty = 4; VAR - 335769, Q.ty = 2

Valid for Var. 335709 or Var. 335769

FARMALL JX100 FARMALL
JX110 FARMALL JX70
FARMALL JX75 FARMALL
JX80 FARMALL JX90

55.518.AH

01

p1

1/2014

VAR - 334339, 334402, 334403, 334404 - REAR WINDSHIELD WIPER

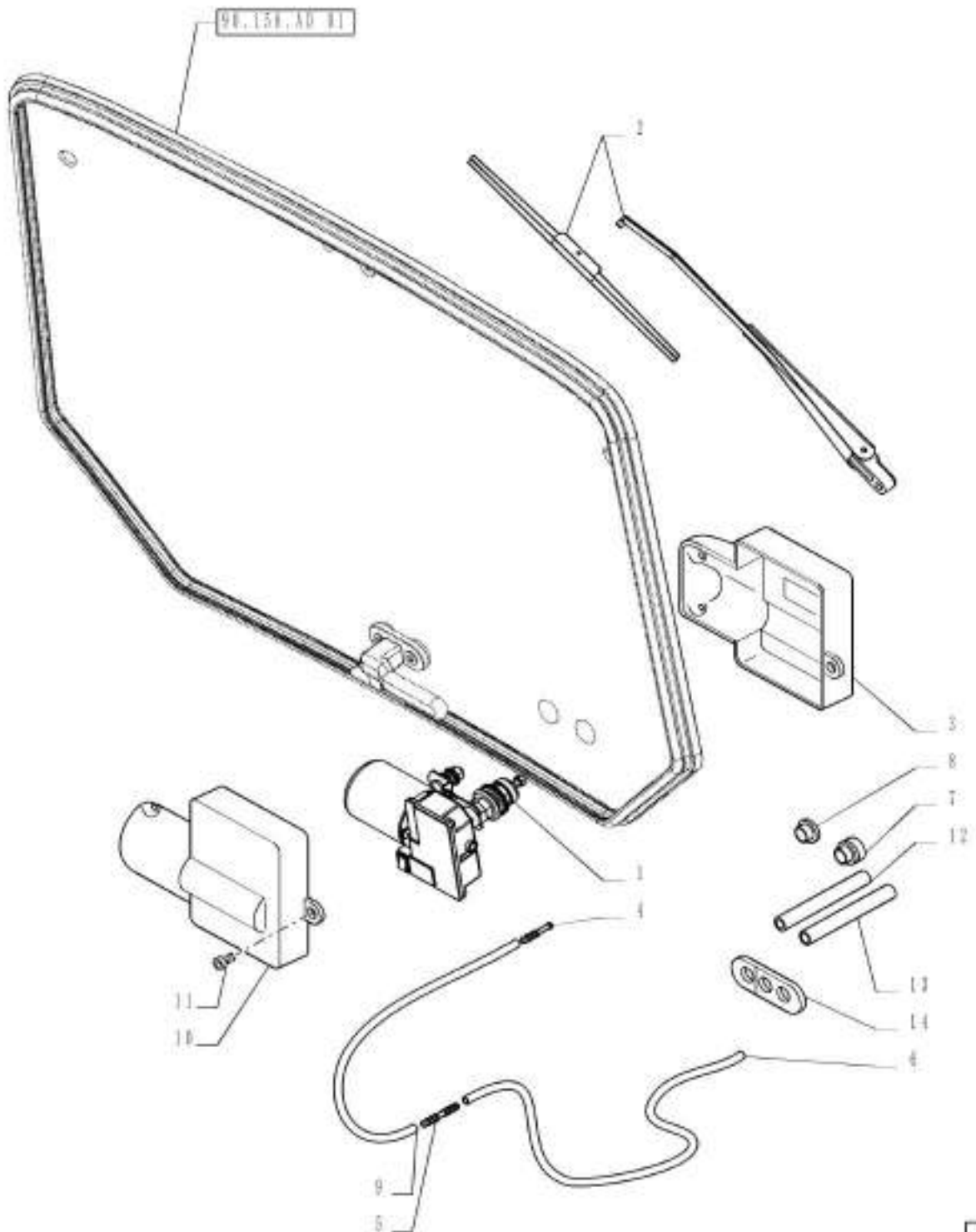

VAR - 334339, 334402, 334403, 334404 - REAR WINDSHIELD WIPER

REF	FN	PART NUMBER	YR/SN	QTY	DESCRIPTION
1	1	84585033		1	WIPER MOTOR
2	1	84585034		1	WIPER BLADE
3	1	84571243		1	COVER
4	1	5092907		1	NOZZLE
5	1	5092910		1	VALVE
6	1	84424606		1	LARGE HOSE
7	2	5094071		1	PLUG Less Wiper
8	2	5094373		1	PLUG Less Wiper
9	1	5093390		1	TUBE
10	1	84571242		1	COVER
11	1	15957877		1	SCREW
12	1	5094133		1	FLEXIBLE SHEATH
13	1	5094134		1	FLEXIBLE SHEATH
14	1	84524323		1	SUPPORT
(1)		VAR - 334402, 334404			
(2)		VAR - 334399, 334403			

Valid for Var. 334399 or Var. 334402 or Var. 334403 or Var. 334404

FARMALL JX100 FARMALL
 JX110 FARMALL JX70
 FARMALL JX75 FARMALL
 JX80 FARMALL JX90

55.518.AT

01

p1

1/2014

VAR - 334399, 334402, 334403, 334404 - WINDSHIELD WIPER TANK

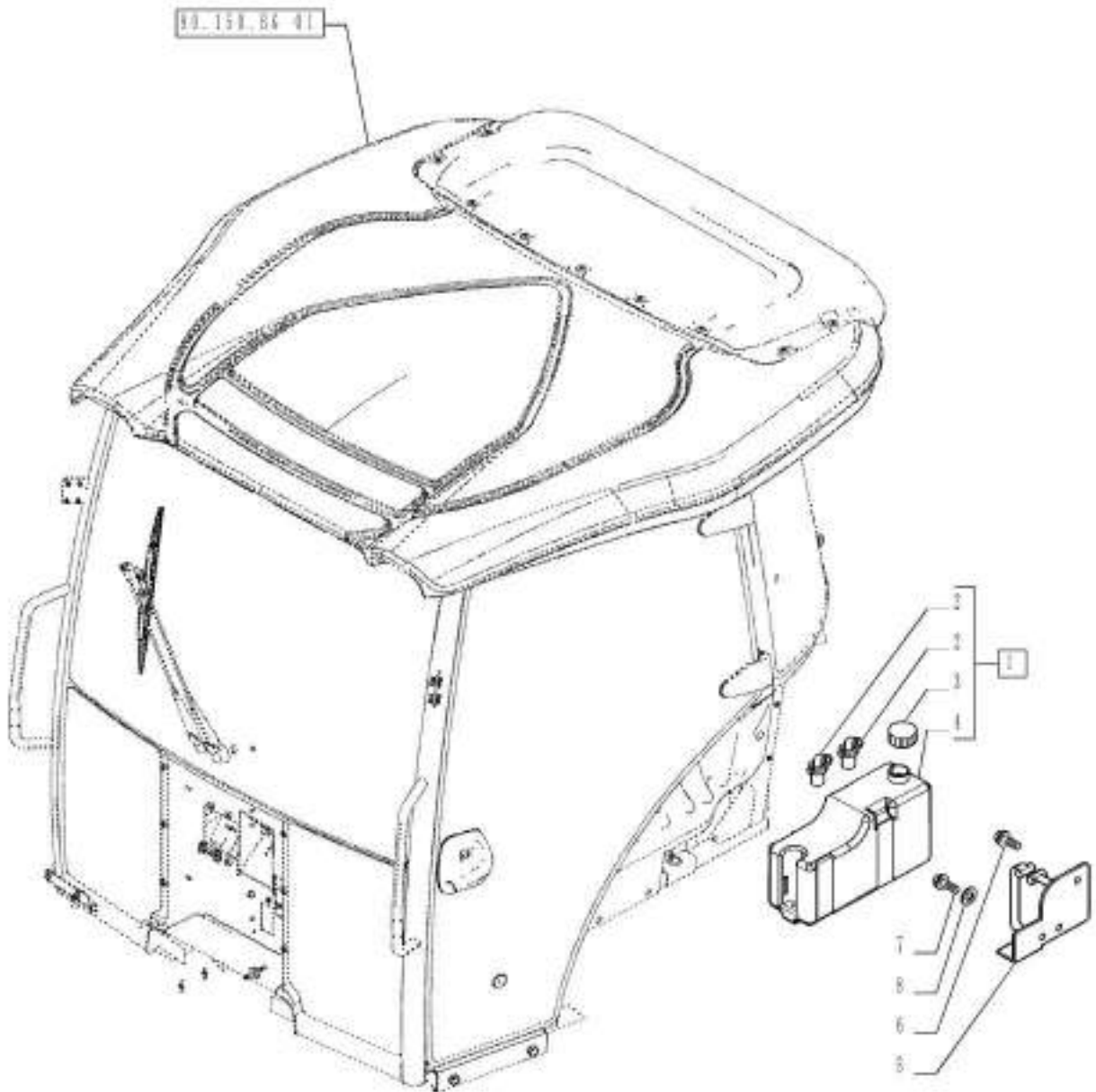

55.518.AT

01

p1

1/2014

VAR - 334399, 334402, 334403, 334404 - WINDSHIELD WIPER TANK

REF	FN	PART NUMBER	YR/SN	QTY	DESCRIPTION
1	1	84588888		1	TANK Incl 2 - 4
1	2	84588887		1	TANK Incl 2 - 4
2	1	87309569		2	PUMP
2	2	87309569		1	PUMP
3		87302624		1	CAP
4		NSS		1	NOT SERVICED SEPARATELY Incl in 1
5		47401147		1	SUPPORT
6		86977790		1	BOLT Hex, M6 x 45mm, Cl 8.8
7		43127		4	BOLT Hex, M8 x 1.25 x 25mm, Cl 8.8, Full Thd
8		12602479		4	WASHER

(1) VAR - 334402, 334404

(2) VAR - 334399, 334403

Valid for Var. 334399 or Var. 334402 or Var. 334403 or Var. 334404

FARMALL JX100 FARMALL
 JX110 FARMALL JX70
 FARMALL JX75 FARMALL
 JX80 FARMALL JX90

55.518.AW

01

p1

1/2014

VAR - 334399, 334402 - FRONT WINDSHIELD WIPER

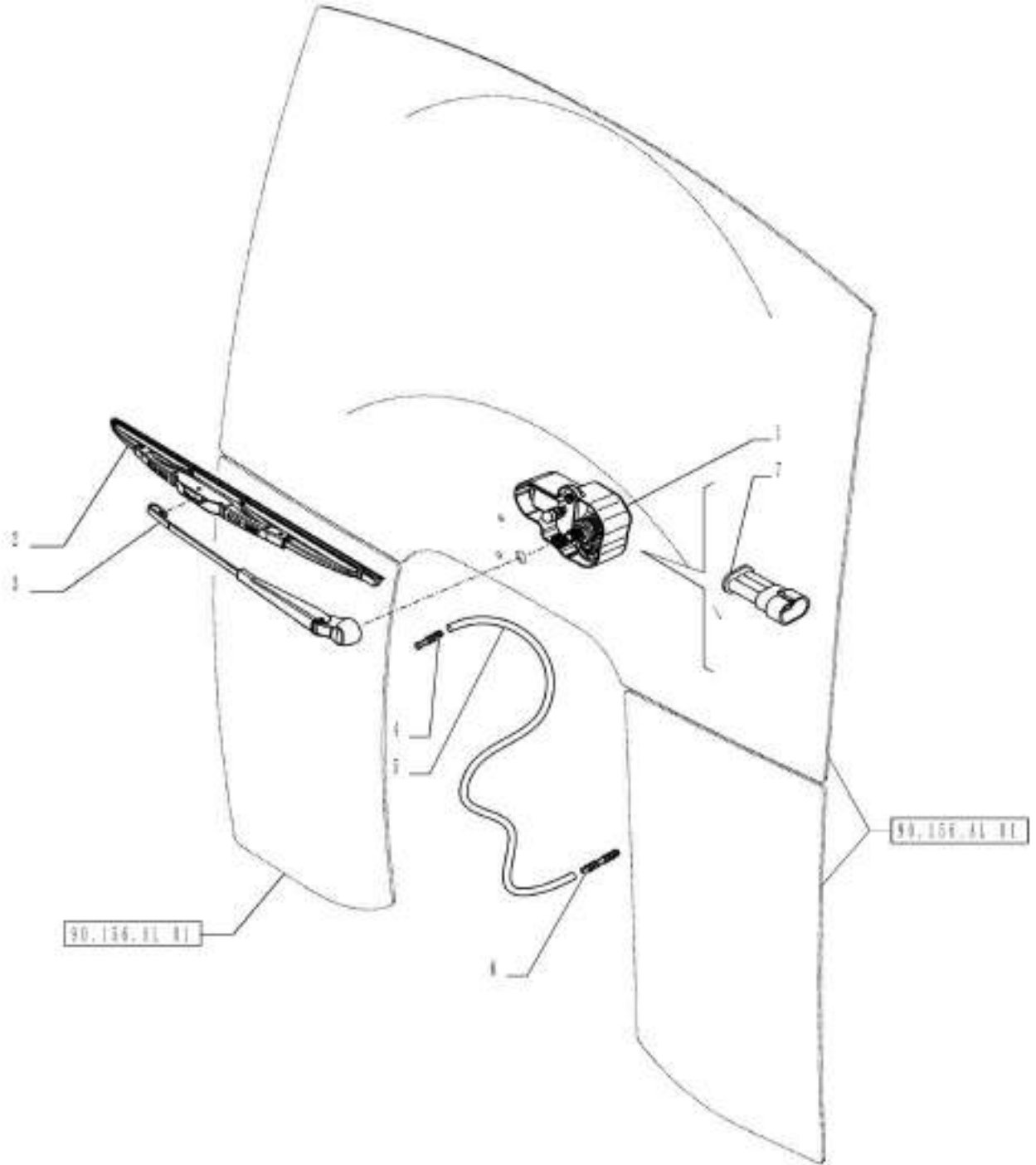

55.518.AW

01

p1

1/2014

VAR - 334399, 334402 - FRONT WINDSHIELD WIPER

REF FN	PART NUMBER	YR/SN	QTY DESCRIPTION
1	84346678		1 WIPER MOTOR
2	84407173		1 WIPER BLADE
3	84407170		1 WIPER ARM
4	82030999		1 JET
5	5092909		1 HOSE
6	5092910		1 VALVE
7	87680689		1 ELEC CONNECTOR

Valid for Var. 334399 or Var. 334402

FARMALL JX100 FARMALL
JX110 FARMALL JX70
FARMALL JX75 FARMALL
JX80 FARMALL JX90

55.518.AW

02

p1

1/2014

VAR - 334403, 334404 - PARALLEL FRONT WINDSHIELD WIPER

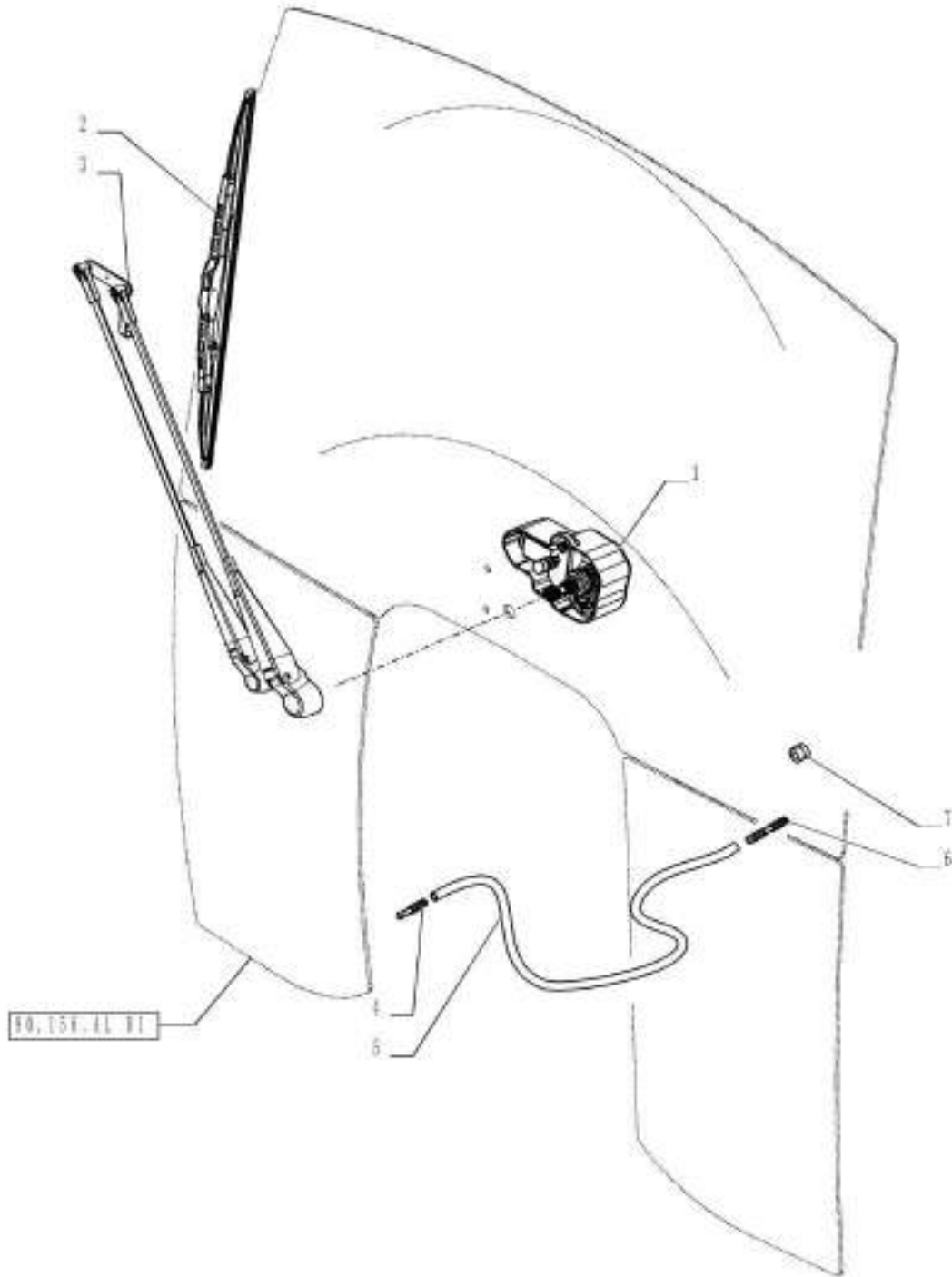

SECTION INDEX

FRONT LOADER & BUCKET

82.000.00	01	PICTORIAL INDEX - FRONT LOADER
82.100.AF	01	VAR - 334351 - FRONT LOADER WITH 4 COUPLERS AND GRILL GUARDS
82.100.AF	02	VAR - 334351 - LOADER ARM, BREAKDOWN
82.100.AF	03	VAR - 334351 - FRONT LOADER, BREAKDOWN, LOADER ARM AND LEVER
82.100.AF	04	VAR - 334351, 334352 - FRONT LOADER, BREAKDOWN, PARKING LEG AND PIPE PROTECTION
82.100.AF	05	VAR - 334351, 334352 - LOADER, FRONT, LINK
82.100.AF	06	VAR - 334352 - FRONT LOADER WITH 4 COUPLERS AND GRILL GUARDS (SELF LEVELLING)
82.100.AF	07	VAR - 334352 - LOADER ARM (SELF LEVELLING), BREAKDOWN
82.100.AF	08	VAR - 334352 - FRONT LOADER (SELF LEVELLING), BREAKDOWN, LOADER ARM LEVER
82.100.AI	01	VAR - 330489, 334351, 334352 - FRONT LOADER WITH 4 COUPLERS, REAR BRACKETS
82.100.BG	01	VAR - 334351 - FRONT LOADER, BREAKDOWN, PINS ARM AND LEVER
82.100.BG	02	VAR - 334352 - FRONT LOADER, BREAKDOWN, PINS ARM AND LEVER
82.300.AN	01	VAR - 334351, 334352 - FRONT LOADER WITH 4 COUPLERS AND GRILL GUARDS, LOADER BUCKET
82.300.AX	01	VAR - 334351, 334352 - FRONT LOADER, BREAKDOWN, QUICK COUPLER BUCKET

PICTORIAL INDEX - FRONT LOADER

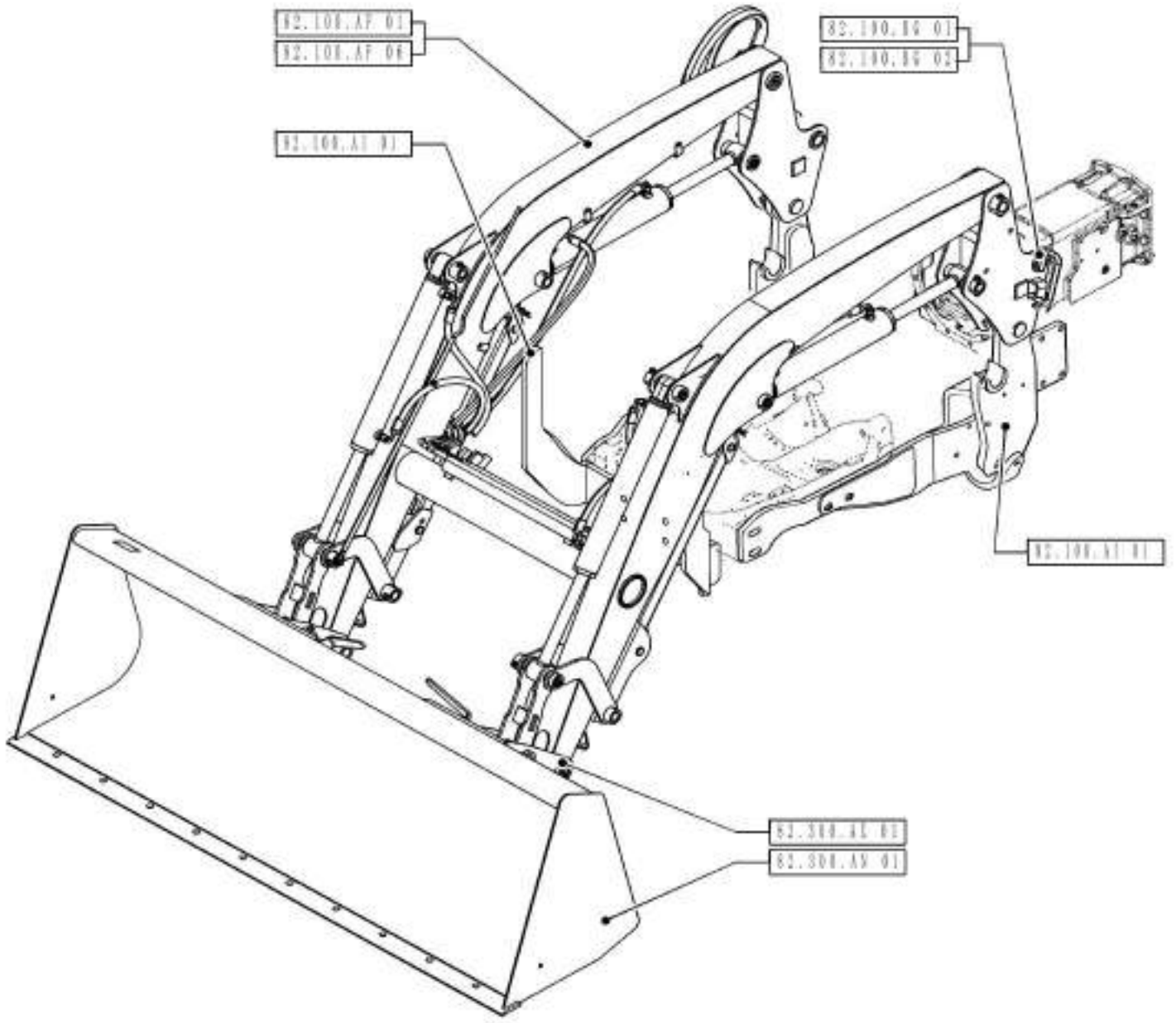

82.000.00

01

p1

1/2014

PICTORIAL INDEX - FRONT LOADER

REF FN	PART NUMBER	YR/SN	QTY	DESCRIPTION
---------------	--------------------	--------------	------------	--------------------

				FARMALL JX100 FARMALL JX110 FARMALL JX70 FARMALL JX75 FARMALL JX80 FARMALL JX90
--	--	--	--	--

82.100.AF

01

p1

1/2014

VAR - 334351 - FRONT LOADER WITH 4 COUPLERS AND GRILL GUARDS

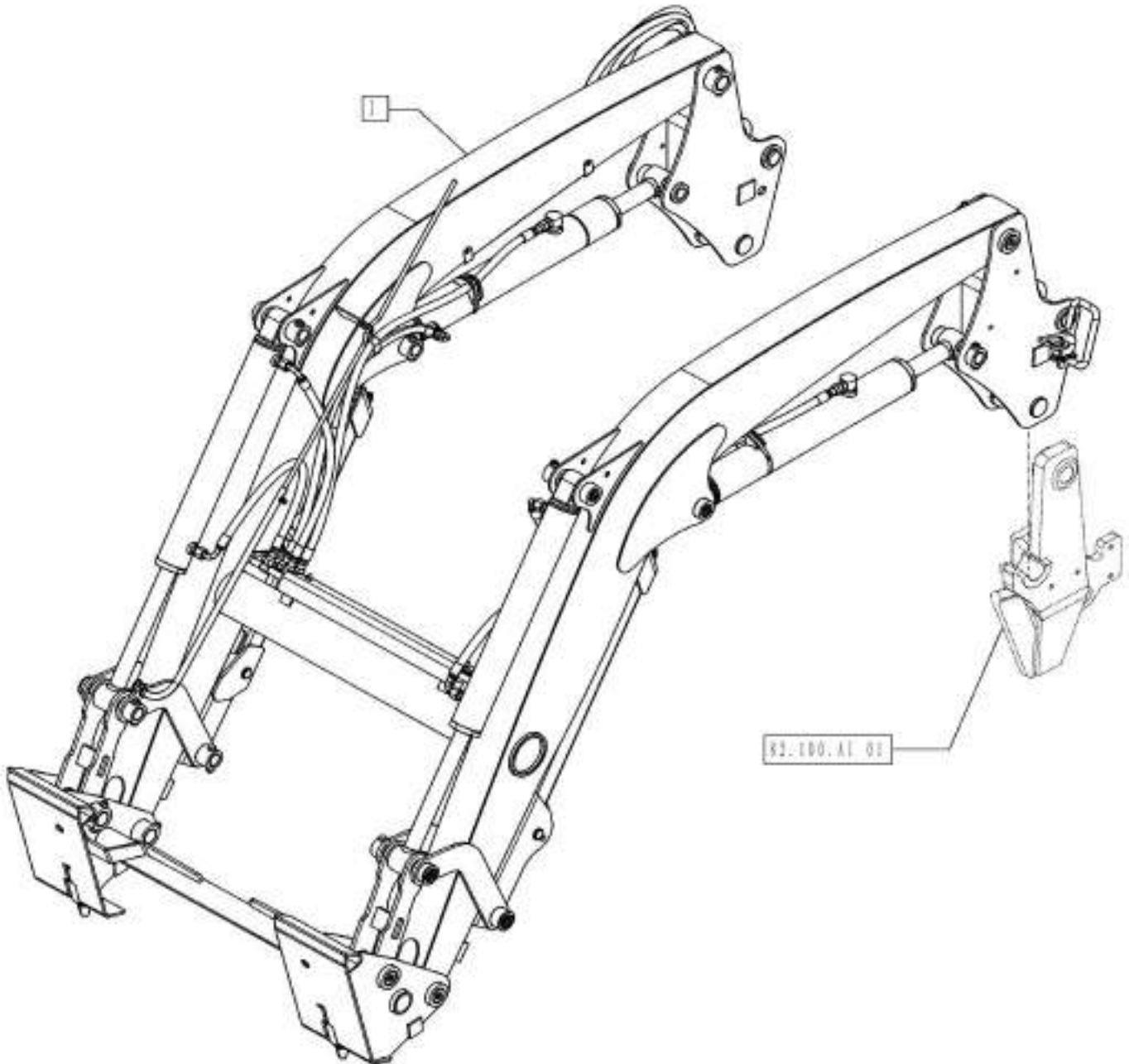

VAR - 334351 - FRONT LOADER WITH 4 COUPLERS AND GRILL GUARDS

REF	FN	PART NUMBER	YR/SN	QTY	DESCRIPTION
1	1	84467877		1	LOADER ARM

(1) See Breakdown in Sections 35, 82 and 90

Valid for Var. 334351

FARMALL JX100
FARMALL JX110
FARMALL JX75
FARMALL JX90

VAR - 334351 - LOADER ARM, BREAKDOWN

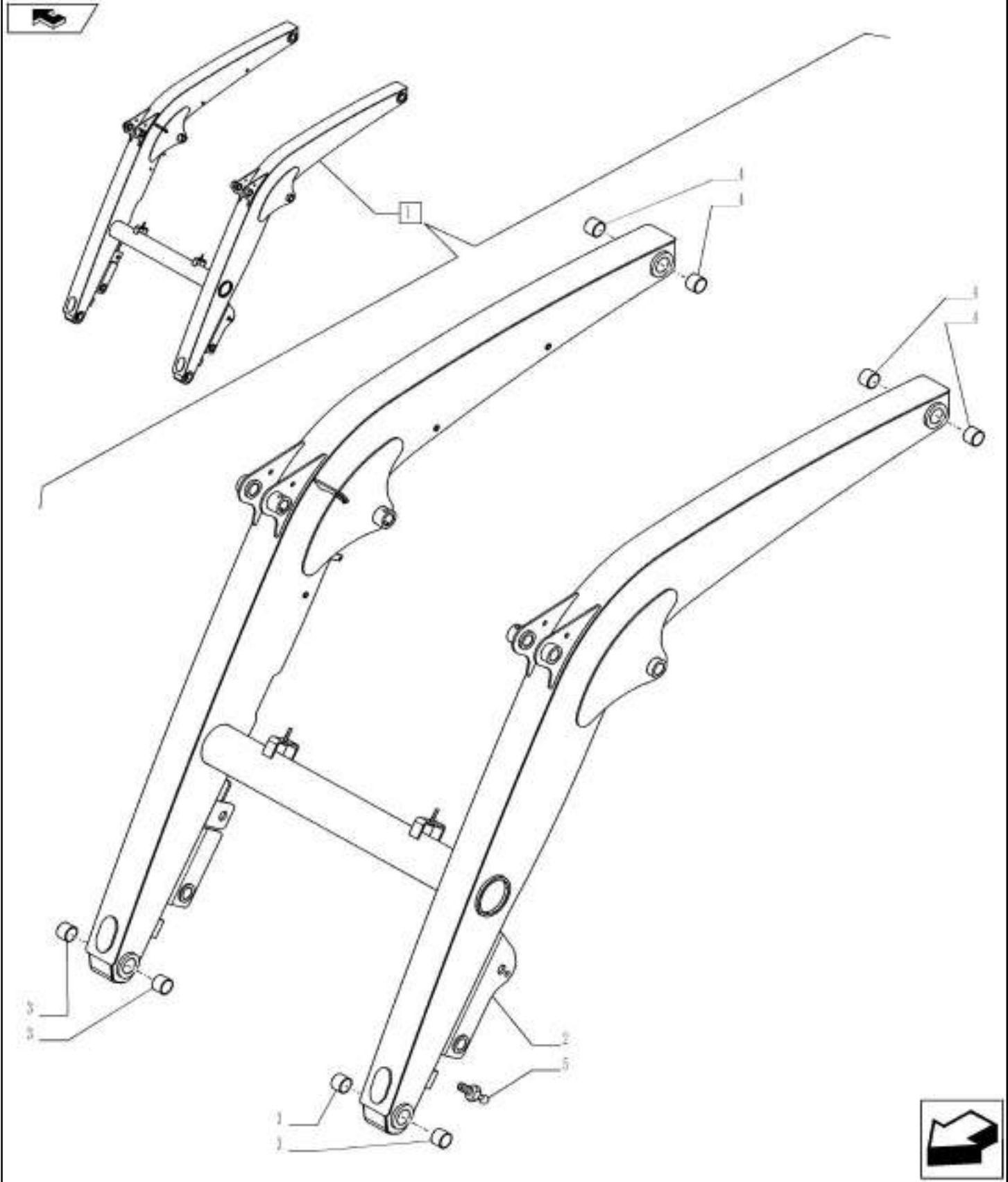

VAR - 334351 - LOADER ARM, BREAKDOWN

REF FN	PART NUMBER	YR/SN	QTY DESCRIPTION
1	84602330		1 LOADER BOOM Incl 2 - 5
2	NSS		1 NOT SERVICED SEPARATELY Incl in 1
3	81901809		4 BUSHING
4	84596883		4 BUSHING
5	87588865		2 FITTING M6 x 1

Valid for Var. 334351

**FARMALL JX100
FARMALL JX110
FARMALL JX75
FARMALL JX90**

VAR - 334351 - FRONT LOADER, BREAKDOWN, LOADER ARM AND LEVER

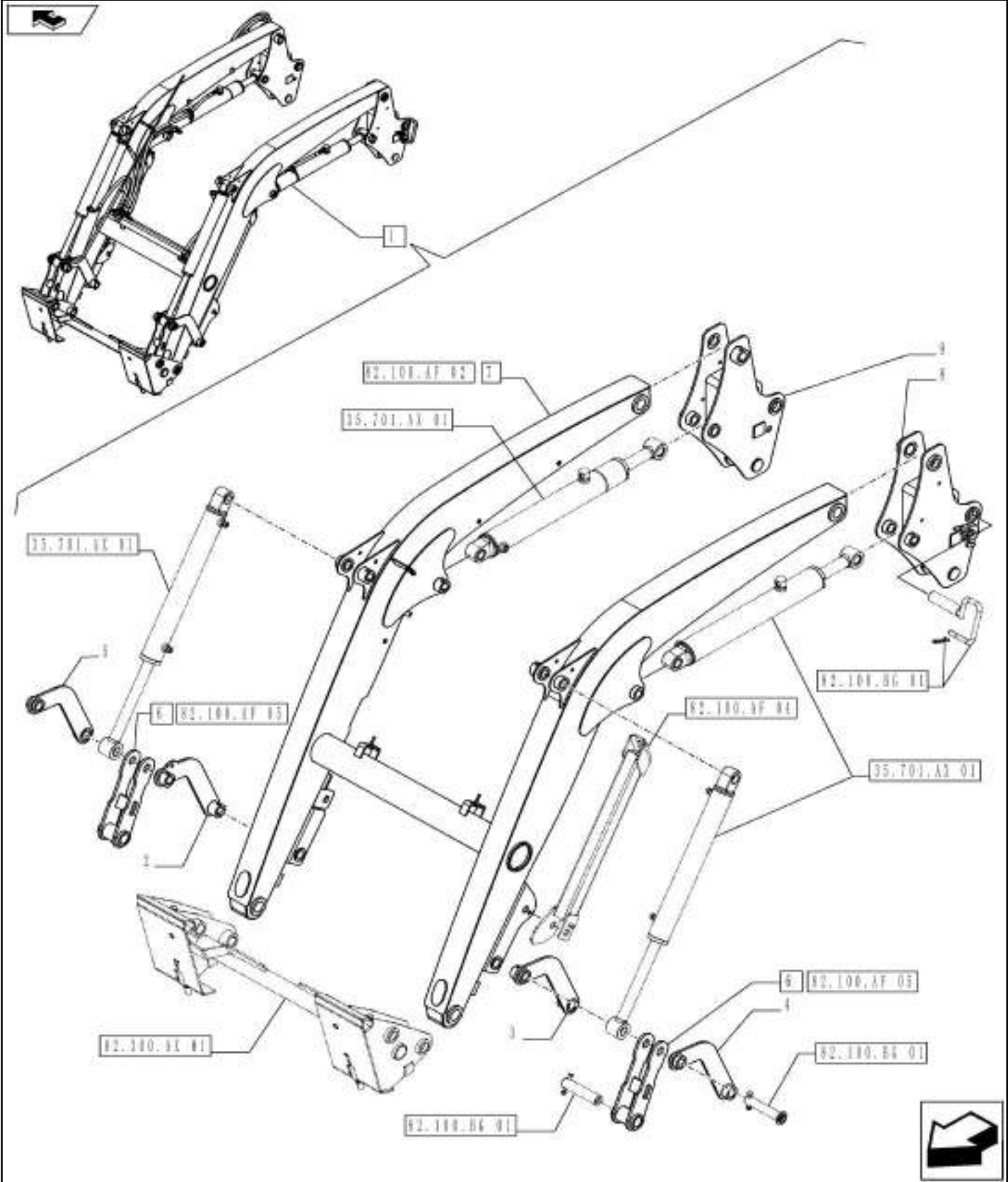

VAR - 334351 - FRONT LOADER, BREAKDOWN, LOADER ARM AND LEVER

REF	FN	PART NUMBER	YR/SN	QTY	DESCRIPTION
1	1	84467877		1	LOADER ARM Incl 2 - 9
2		84602307		1	LEVER RH, Internal
3		84602322		1	LEVER LH, Internal
4		84602315		1	LEVER RH, External
5		84602301		1	LEVER LH, External
6		84602335		2	CONNECTING LINK
7		84602330		1	LOADER BOOM
8		84602325		1	LEVER LH
9		84602327		1	LEVER RH

(1) See Breakdown in Sections 35, 82 and 90

Valid for Var. 334351

FARMALL JX100
 FARMALL JX110
 FARMALL JX75
 FARMALL JX90

VAR - 334351, 334352 - FRONT LOADER, BREAKDOWN, PARKING LEG AND PIPE PROTECTION

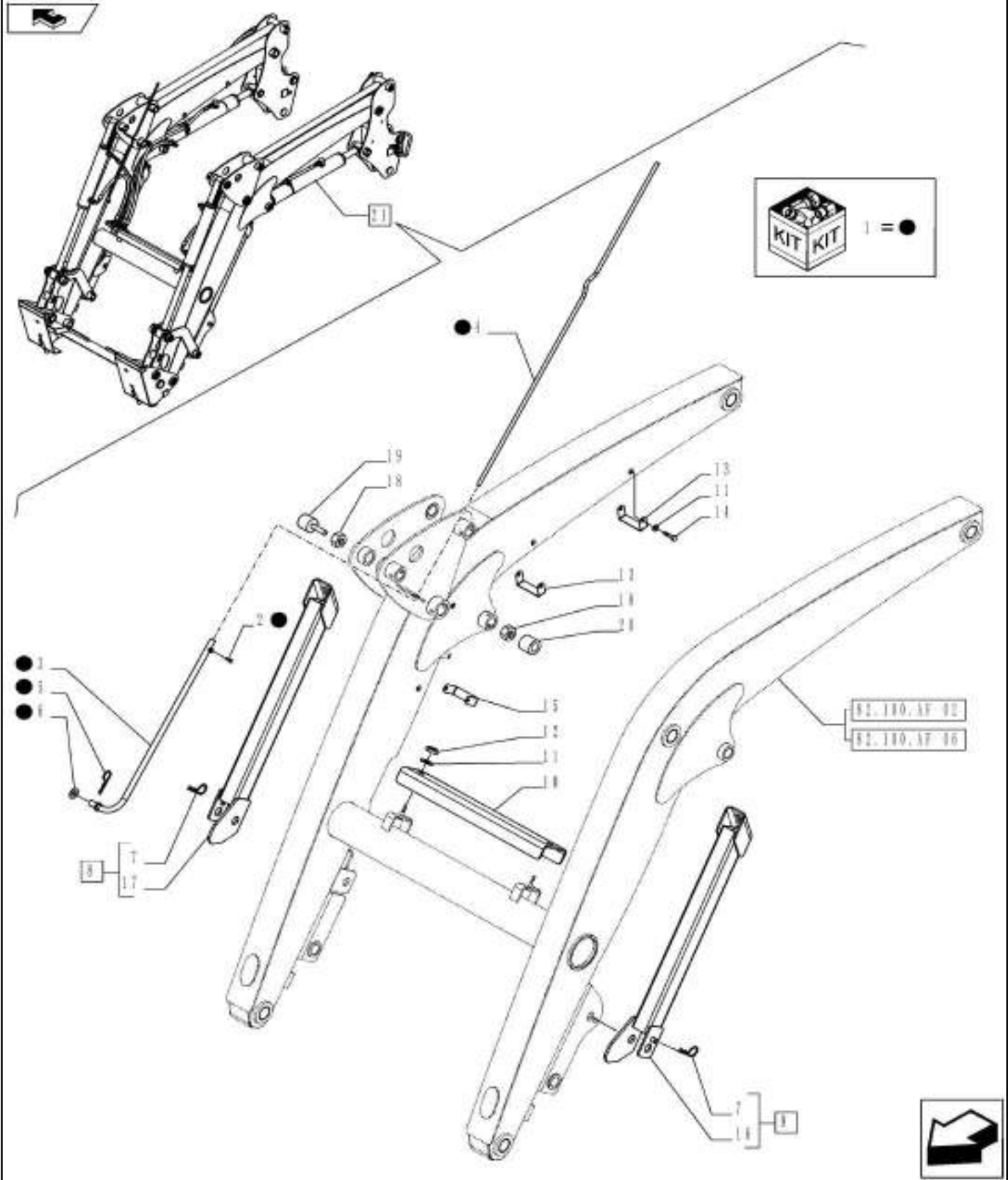

VAR - 334351, 334352 - FRONT LOADER, BREAKDOWN, PARKING LEG AND PIPE PROTECTION

REF FN	PART NUMBER	YR/SN	QTY DESCRIPTION
1	{47406829}		1
2	10902824		1 BOLT Hex, M6 x 30, 8.8
3	84405800		1 LEVEL INDICATOR
4	47406830		1 ROD
5	84408821		1 ROLL PIN
6	84410936		1 WASHER
7	84408821		2 ROLL PIN
8	84525214		1 LEVER ASSY, RH, Incl 7, 17
9	84525220		1 LEVER ASSY, LH, Incl 7, 16
10	84393589		1 COVER
11	14496501		8 WASHER Flat, 8.40mm ID x 16.00mm OD x 1.60mm, Carbon Steel, ZND
12	16104117		2 NUT
13	84405802		2 FIXING PLATE
14	16043921		6 BOLT Hex, M8 x 1.25 x 35mm, Cl 8.8
15	84526944		1 COVER
16	NSS		1 NOT SERVICED SEPARATELY Parking Leg Incl in 9
17	NSS		1 NOT SERVICED SEPARATELY Parking Leg Incl in 8
18	15896224		2 NUT
19	84599040		1 RUBBER PAD
20	84599118		1 CUSHION
21	^{1,2} 84467877		1 LOADER ARM Incl 1 - 20
21	^{1,3} 84467881		1 LOADER ARM Incl 1 - 20

(1) See Breakdown in Sections 35, 82 and 90

(2) VAR - 334351

(3) VAR - 334352

Valid for Var. 334351 or Var. 344352

FARMALL JX100
 FARMALL JX110
 FARMALL JX75
 FARMALL JX90

82.100.AF

05

p1

1/2014

VAR - 334351, 334352 - LOADER, FRONT, LINK

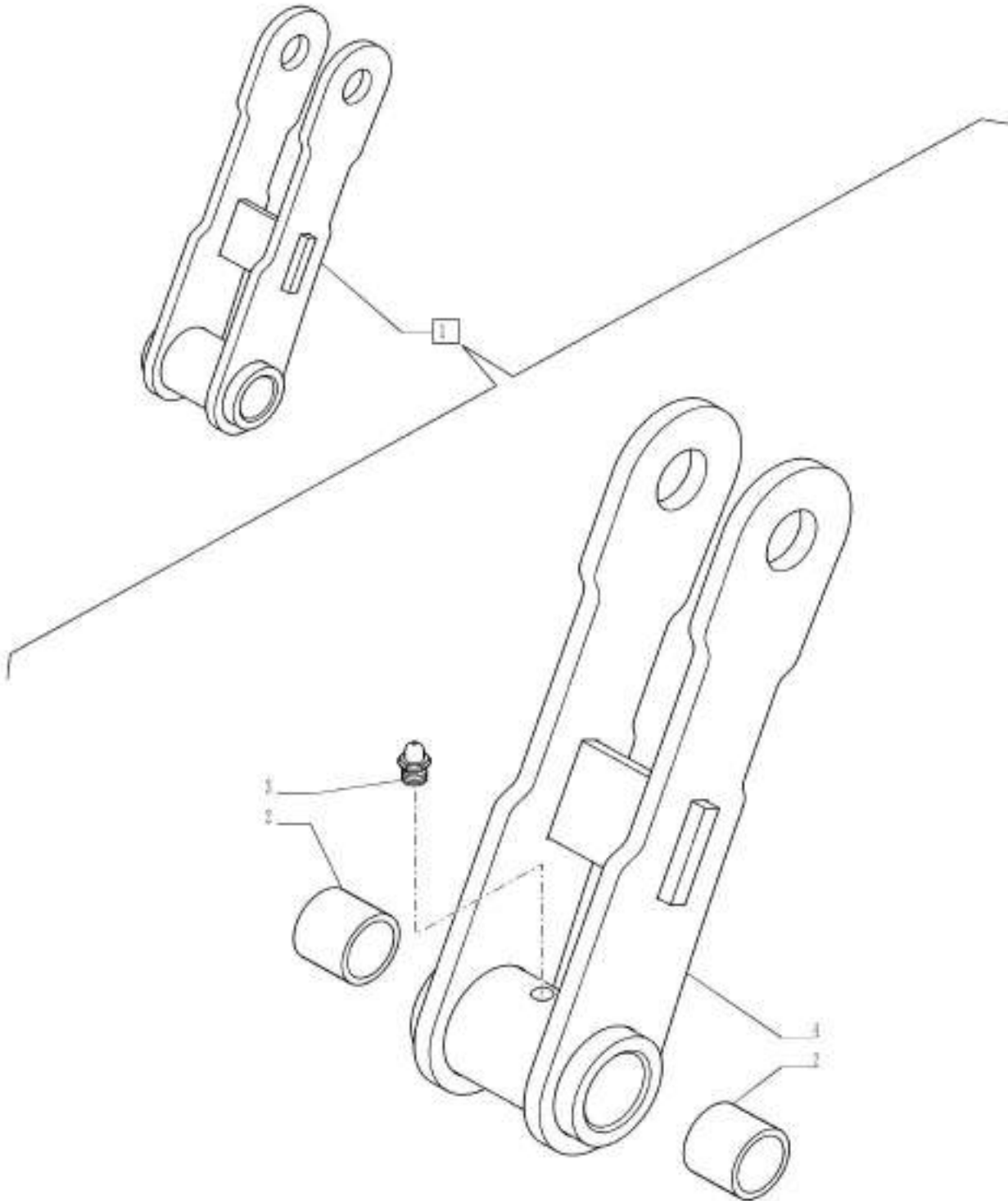

82.100.AF

05

p1

1/2014

VAR - 334351, 334352 - LOADER, FRONT, LINK

REF FN	PART NUMBER	YR/SN	QTY DESCRIPTION
1	84602335		1 CONNECTING LINK Incl 2 - 4
2	81901809		2 BUSHING
3	87588865		1 FITTING
4	NSS		1 NOT SERVICED SEPARATELY Double Rod Incl in 1

Valid for Var. 334351 or Var. 344352

FARMALL JX100
FARMALL JX110
FARMALL JX75
FARMALL JX90

82.100.AF

06

p1

1/2014

VAR - 334352 - FRONT LOADER WITH 4 COUPLERS AND GRILL GUARDS (SELF LEVELLING)

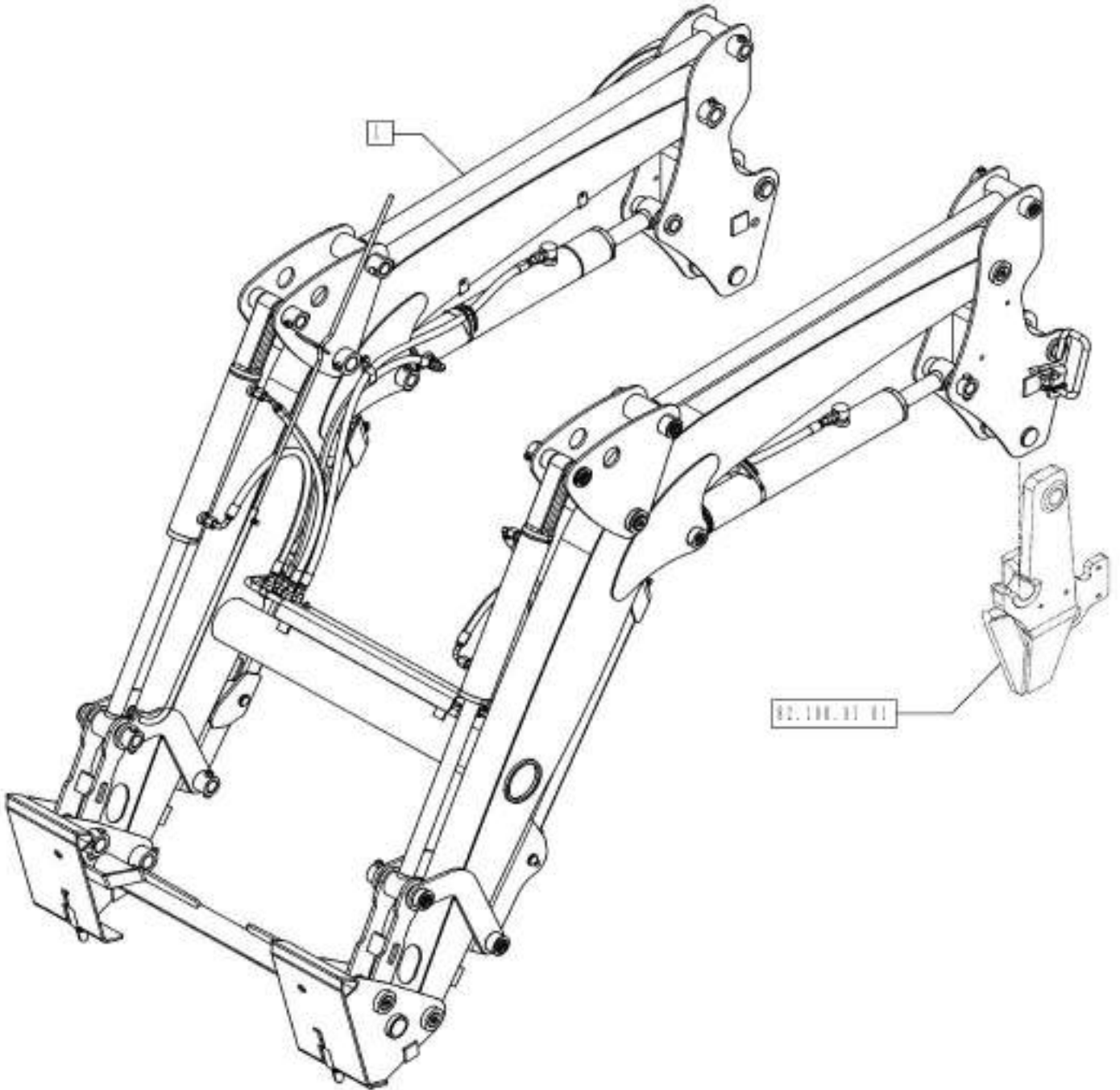

82.100.AF

06

p1

1/2014

VAR - 334352 - FRONT LOADER WITH 4 COUPLERS AND GRILL GUARDS (SELF LEVELLING)

REF	FN	PART NUMBER	YR/SN	QTY	DESCRIPTION
1	1	84467881		1	LOADER ARM ASSY
(1)		See Breakdown in Sections 35, 82 and 90			

Valid for Var. 344352

FARMALL JX100
FARMALL JX110
FARMALL JX75
FARMALL JX90

VAR - 334352 - LOADER ARM (SELF LEVELLING), BREAKDOWN

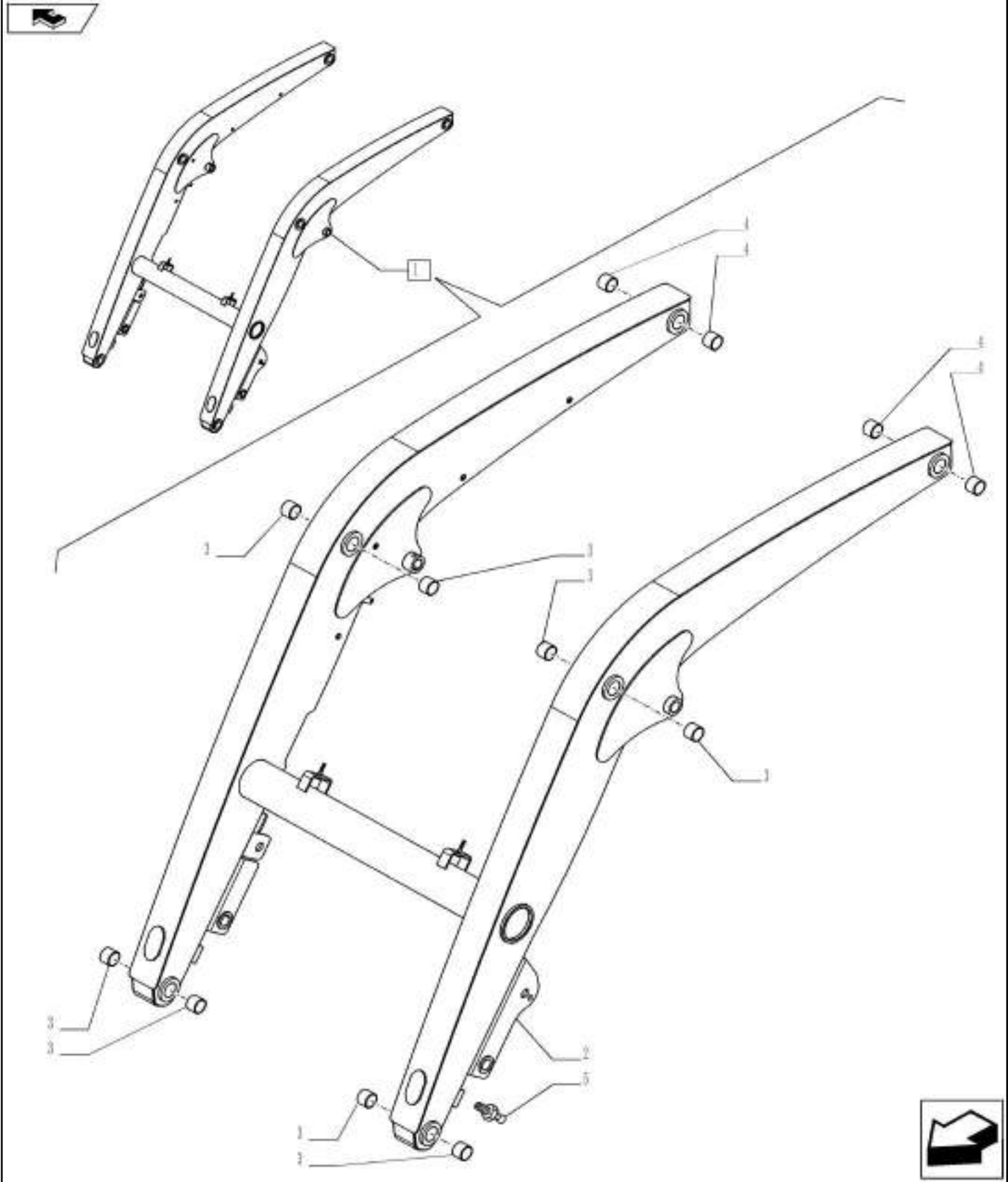

VAR - 334352 - FRONT LOADER (SELF LEVELLING), BREAKDOWN, LOADER ARM LEVER

REF FN	PART NUMBER	YR/SN	QTY DESCRIPTION
1	1 84467881		1 LOADER ARM Incl 2 - 17
2	84602307		1 LEVER RH, Internal
3	84602322		1 LEVER LH, Internal
4	84602315		1 LEVER LH, External
5	84602301		1 LEVER RH, External
6	84602335		2 CONNECTING LINK
7	47359357		1 LOADER BOOM
8	84603543		1 LEVER LH
9	47358719		1 LEVER RH
10	84422281		2 ROD
11	81901809		4 BUSHING
12	47359348		1 MOUNTING PLATE LH, External
13	47359351		1 MOUNTING PLATE LH, Internal
14	47359354		1 MOUNTING PLATE RH, Internal
15	47359345		1 MOUNTING PLATE RH, External
16	87588865		2 FITTING
17	NSS		1 NOT SERVICED SEPARATELY Rod Incl in 10

(1) See Breakdown in Sections 35, 82 and 90

Valid for Var. 344352

FARMALL JX100
 FARMALL JX110
 FARMALL JX75
 FARMALL JX90

82.100.AI

01

p1

1/2014

VAR - 330489, 334351, 334352 - FRONT LOADER WITH 4 COUPLERS, REAR BRACKETS

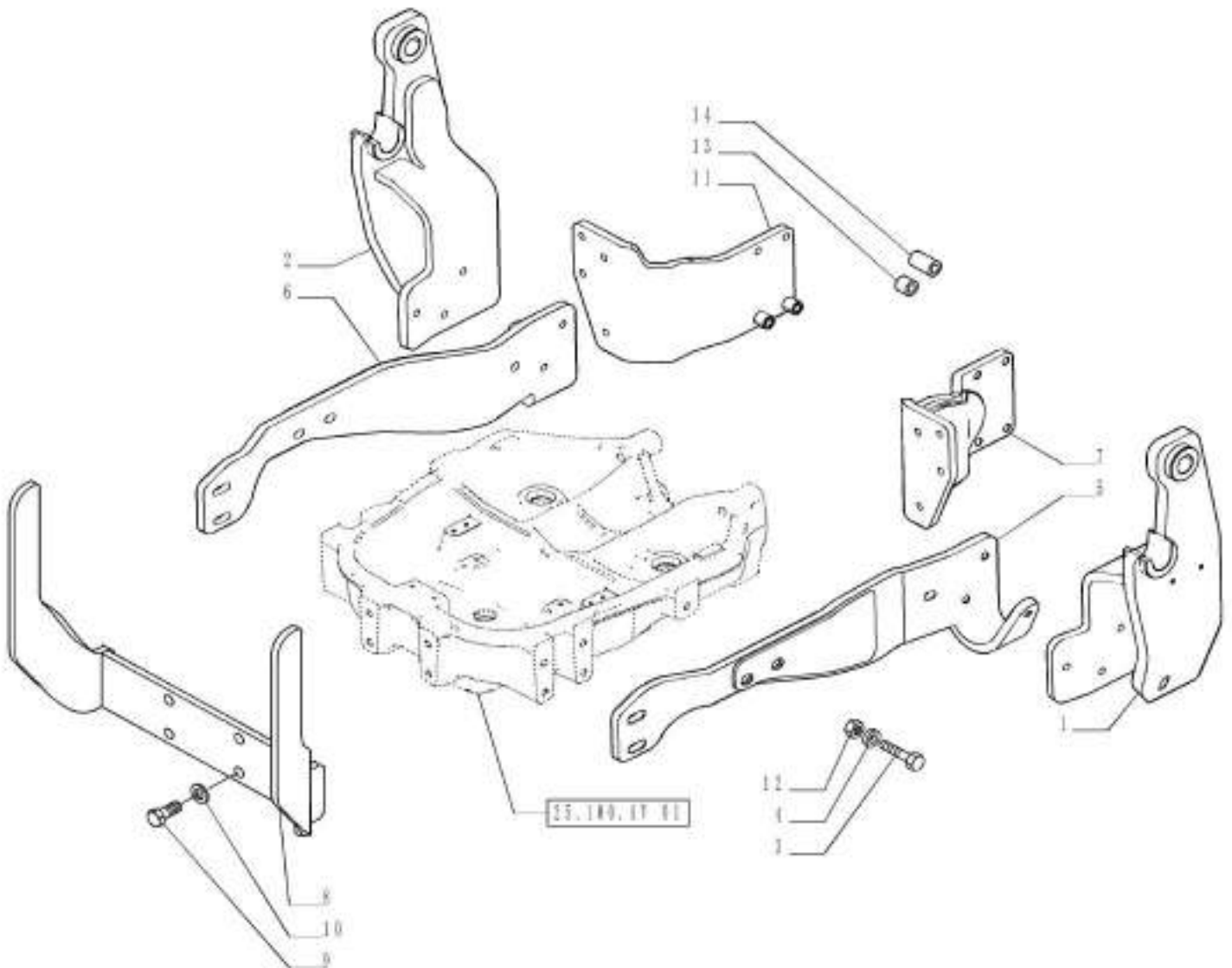

VAR - 330489, 334351, 334352 - FRONT LOADER WITH 4 COUPLERS, REAR BRACKETS

REF FN	PART NUMBER	YR/SN	QTY DESCRIPTION
1	84494699		1 SUPPORT LH
2	84494694		1 SUPPORT RH
3	15981334		10 BOLT Hex, M16 x 1.5 x 75mm, CI 10.9
3	15981231		6 BOLT Hex, M16 x 1.5 x 65mm, CI 10.9
3	15981021		6 SCREW Hex, M16 x 1.5 x 55mm, CI 8.8
4	11191579		22 BELLEVILLE WASHER Belleville, M17
5	84527678		1 SUPPORT LH
6	84527676		1 SUPPORT RH
7	84494679		1 SUPPORT LH
8	1 84319164		1 BRACKET
9	1 11124734		4 BOLT Hex, M20 x 50, 10.9, Full Thd
10	1 11191774		4 BELLEVILLE WASHER Conical Spring, 20.00mm ID x 38.00mm OD x 4.60mm, DAC
11	84494590		1 SUPPORT RH
12	10790521		16 NUT M16 x 1.5, CI 10
13	2 84525688		1 BUSHING Top, D30x17, L20
14	2 84525631		1 SPACER Bottom, D30x17, L45
(1)	VAR - 334351, 334352		
(2)	VAR - 390972; Less Loader		

Valid for Var. 330489 or Var. 343351 or Var. 334352

FARMALL JX100
 FARMALL JX110
 FARMALL JX75
 FARMALL JX90

82.100.BG

01

p1

1/2014

VAR - 334351 - FRONT LOADER, BREAKDOWN, PINS ARM AND LEVER

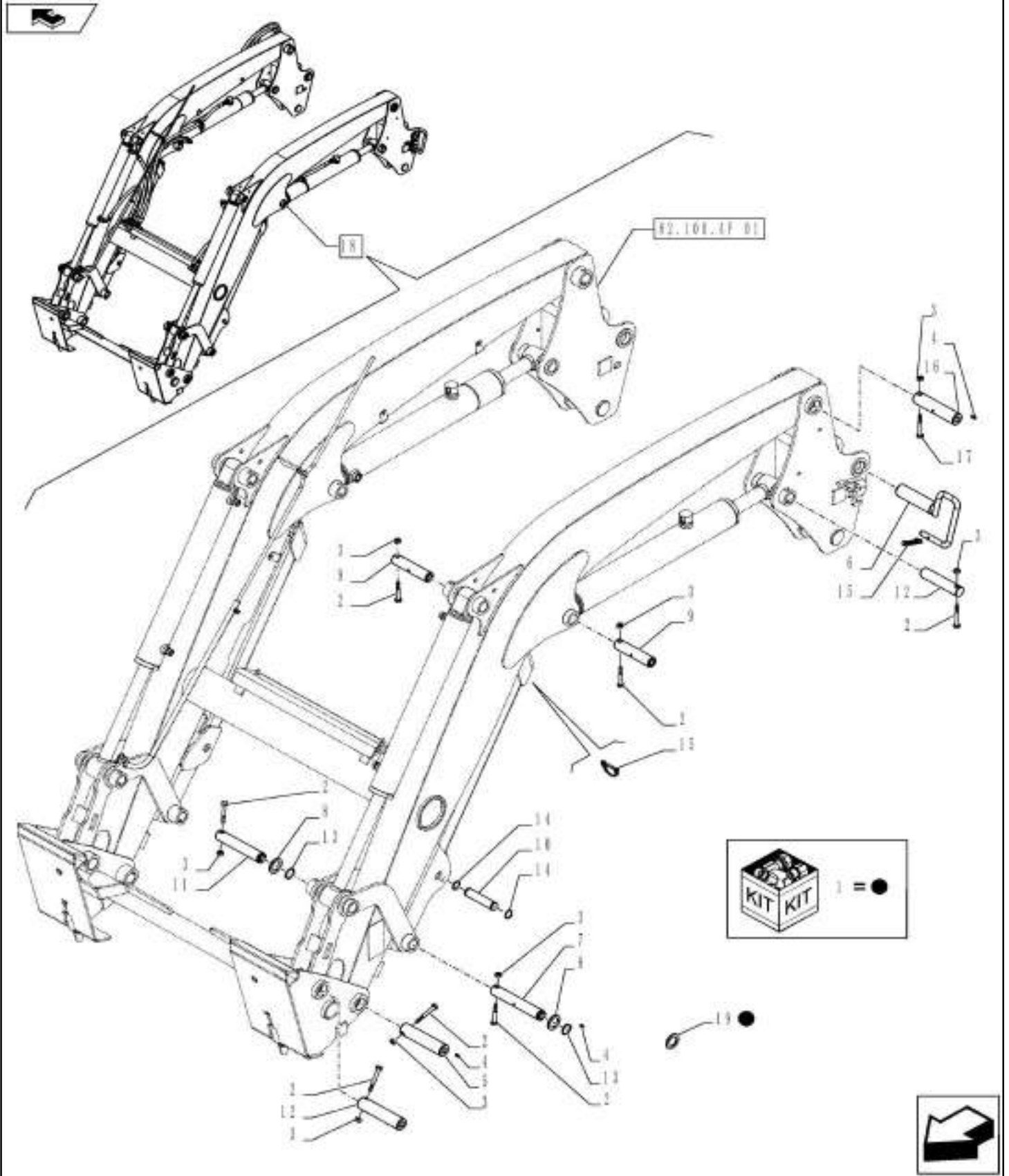

VAR - 334351 - FRONT LOADER, BREAKDOWN, PINS ARM AND LEVER

REF FN	PART NUMBER	YR/SN	QTY DESCRIPTION
1	{84601738}		1
2	86624979		14 BOLT Hex, M10 x 75mm, CI 10.9
3	12574511		16 LOCK NUT M10 x 1.25, CI 8
4	87588865		4 FITTING
5	84393572		2 PIN
6	84393576		2 PIN
7	84575162		2 PIN
8	84406164		2 SPACER
9	84575165		4 PIN
10	84405805		2 PIN
11	84575160		2 PIN
12	84575159		4 PIN
13	84406163		4 LOCKING RING
14	84406126		4 LOCKING RING
15	84406127		4 PIN
16	84575167		2 PIN
17	1537277		2 BOLT Hex, M10 x 1.5 x 85mm, CI 10.9
18	1 84467877		1 LOADER ARM Incl 2 - 17
19	84575168		10 SPACER THK 1 MM, D.39.5 MM
19	84575169		10 SPACER THK 1.5 MM, D.39.5 MM
19	84575170		10 SPACER THK 2 MM, D.39.5 MM

(1) See Breakdown in Sections 35, 82 and 90

Valid for Var. 344351

FARMALL JX100
 FARMALL JX110
 FARMALL JX75
 FARMALL JX90

VAR - 334352 - FRONT LOADER, BREAKDOWN, PINS ARM AND LEVER

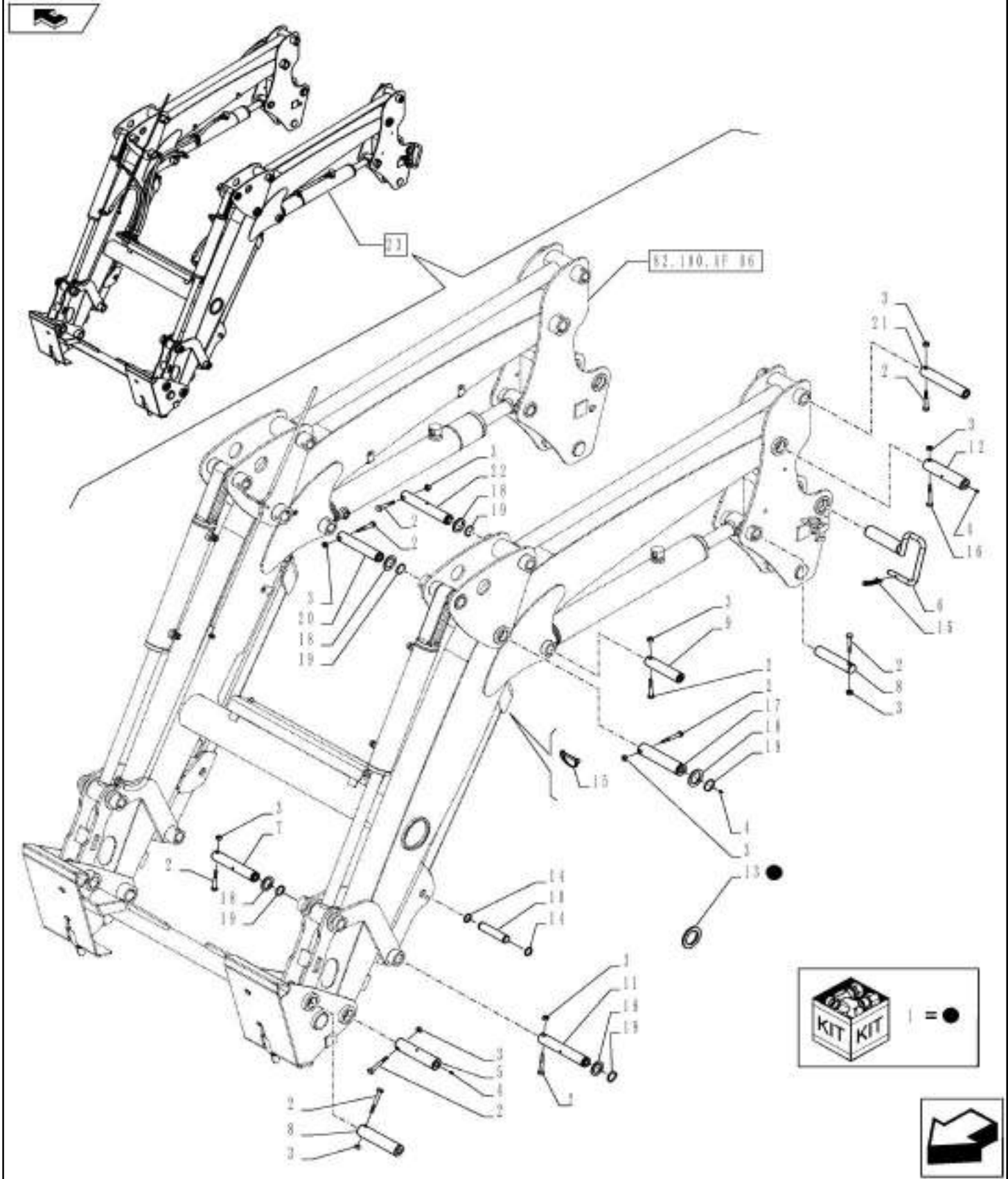

VAR - 334352 - FRONT LOADER, BREAKDOWN, PINS ARM AND LEVER

REF FN	PART NUMBER	YR/SN	QTY DESCRIPTION
1	{84601738}		1
2	86624979		20 BOLT Hex, M10 x 75mm, CI 10.9
3	12574511		22 LOCK NUT M10 x 1.25, CI 8
4	87588865		6 FITTING
5	84393572		2 PIN
6	84393576		2 PIN
7	84575160		2 PIN
8	84575159		4 PIN
9	84575165		2 PIN
10	84405805		2 PIN
11	84575162		2 PIN
12	84575167		2 PIN
13	84575168		10 SPACER THK, 1 MM, D.39.5 MM
13	84575169		10 SPACER THK, 1.5 MM, D.39.5 MM
13	84575170		10 SPACER THK, 2 MM, D.39.5 MM
14	84406126		4 LOCKING RING
15	84406127		4 PIN
16	1537277		2 BOLT Hex, M10 x 1.5 x 85mm, CI 10.9
17	84406161		2 PIN
18	84406164		10 SPACER
19	84406163		10 LOCKING RING
20	84575161		2 PIN
21	84406162		2 PIN
22	84511099		2 PIN
23	1 84467881		1 LOADER ARM ASSY, Incl 2 - 22

(1) See Breakdown in Sections 35, 82 and 90

Valid for Var. 344352

FARMALL JX100
 FARMALL JX110
 FARMALL JX75
 FARMALL JX90

VAR - 334351, 334352 - FRONT LOADER WITH 4 COUPLERS AND GRILL GUARDS, LOADER BUCKET

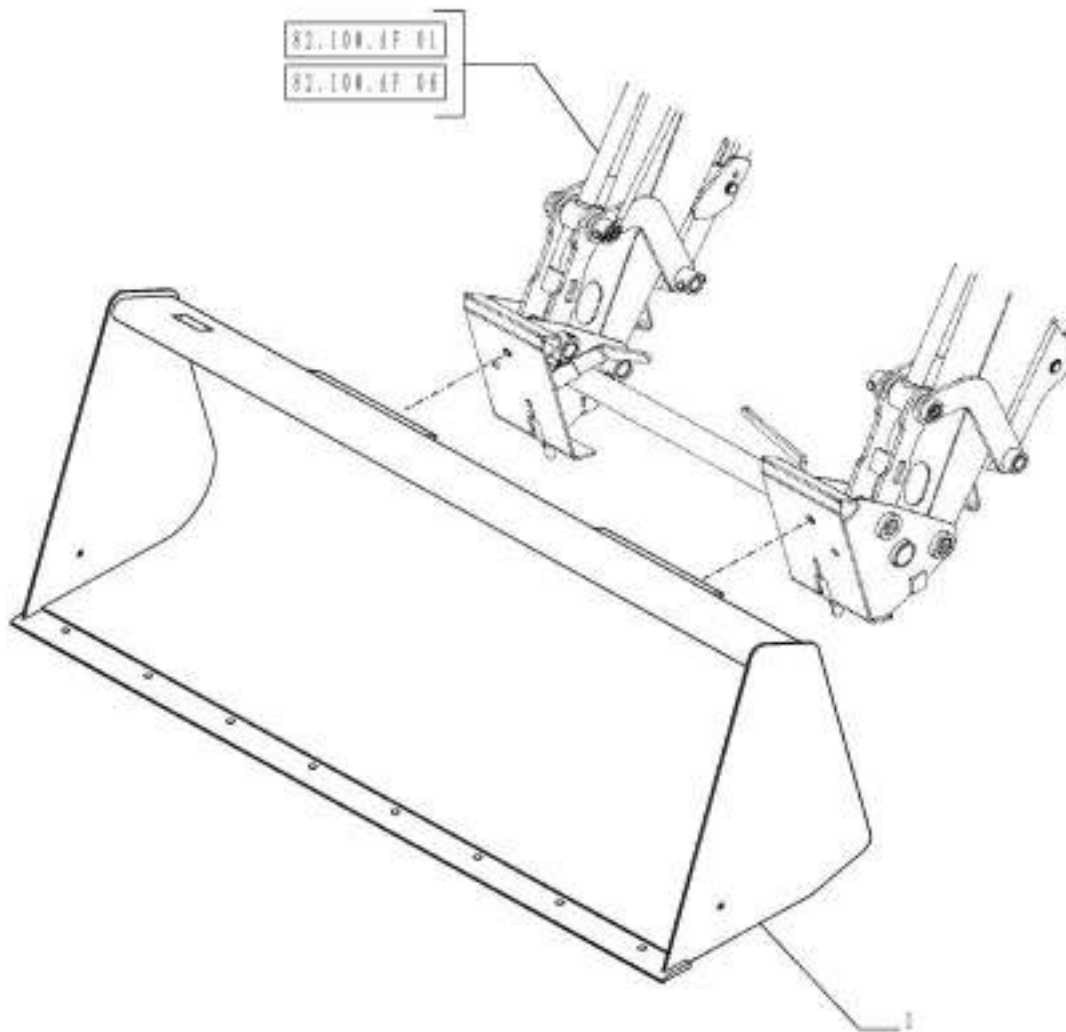

82.300.AN

01

p1

1/2014

VAR - 334351, 334352 - FRONT LOADER WITH 4 COUPLERS AND GRILL GUARDS, LOADER BUCKET

REF FN	PART NUMBER	YR/SN	QTY DESCRIPTION
1	47449819		1 BUCKET 72"

Valid for Var. 334351 or Var. 334352

FARMALL JX100
FARMALL JX110
FARMALL JX75
FARMALL JX90

VAR - 334351, 334352 - FRONT LOADER, BREAKDOWN, QUICK COUPLER BUCKET

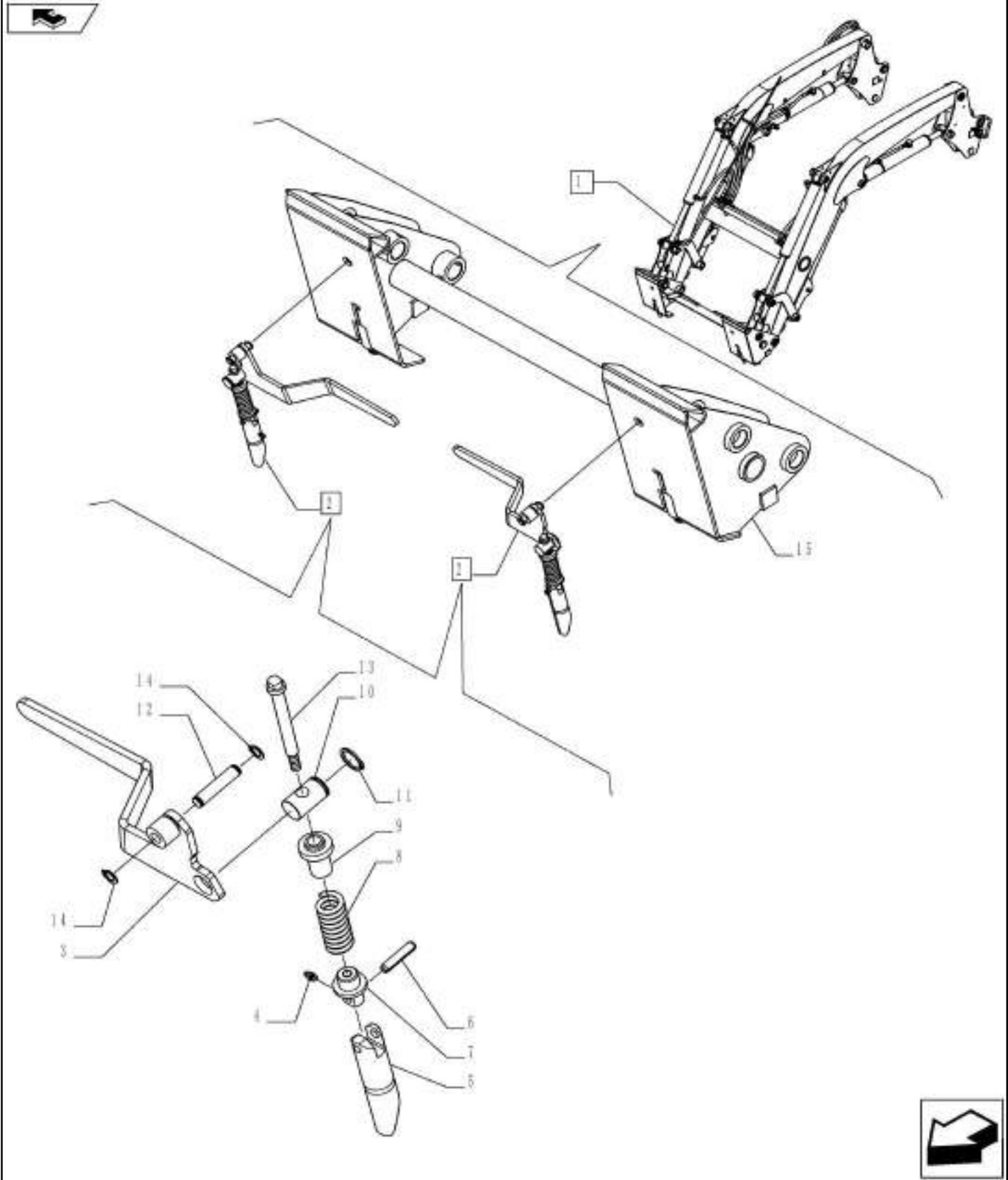

VAR - 334351, 334352 - FRONT LOADER, BREAKDOWN, QUICK COUPLER BUCKET

REF FN	PART NUMBER	YR/SN	QTY DESCRIPTION
1	^{1,2} 84467877		1 LOADER ARM ASSY, Incl 2 - 15
1	^{1,3} 84467881		1 LOADER ARM Incl 2 - 15
2	84406181		1 LEVER RH Incl 3 - 14
2	84408819		1 LEVER LH Incl 3 - 14
3	NSS		1 NOT SERVICED SEPARATELY ASSY, Lever Incl in 2
4	13407211		2 LUBE NIPPLE M10 x 1
5	86575348		2 PIN 31.75mm x 142mm L
6	84406182		2 SPLIT PIN/SAFETY PIN
7	84406183		2 GUIDE BUSHING
8	86610167		2 SPRING
9	86610166		2 GUIDE
10	84406184		2 PIN
11	84408820		2 SNAP RING
12	84406185		2 PIN
13	86506112		2 12 PT SCREW Flg, 1/2" - 3/8" - 16 x 5"
14	11066176		4 SNAP RING M13, Ext
15	84406180		1 QUICK-HITCH

(1) See Breakdown in Sections 35, 82 and 90

(2) VAR - 334351

(3) VAR - 334352

Valid for Var. 334351 or Var. 344352

FARMALL JX100
 FARMALL JX110
 FARMALL JX75
 FARMALL JX90

SECTION INDEX

ACCESSORIES

88.000.00	01	SECTION INDEX, ACCESSORIES
88.100.AC	01	VAR - 334342, 334343, 334344, 334345, 334346, 334347, 334348, 334349, 334350, 335914 - LICENSE PLATE LAMP & SUPPORT, CAB
88.100.AC	02	VAR - 334342, 334343, 334344, 334345, 334346, 334347, 334348, 334349, 334350, 335914 - LICENSE PLATE LAMP & SUPPORT, ROPS
88.100.AG	01	VAR - 334408 - SET OF TOOLS
88.100.AH	01	VAR - 332998, 334408 - TOOL BOX

88.000.00

01

p1

1/2014

SECTION INDEX, ACCESSORIES

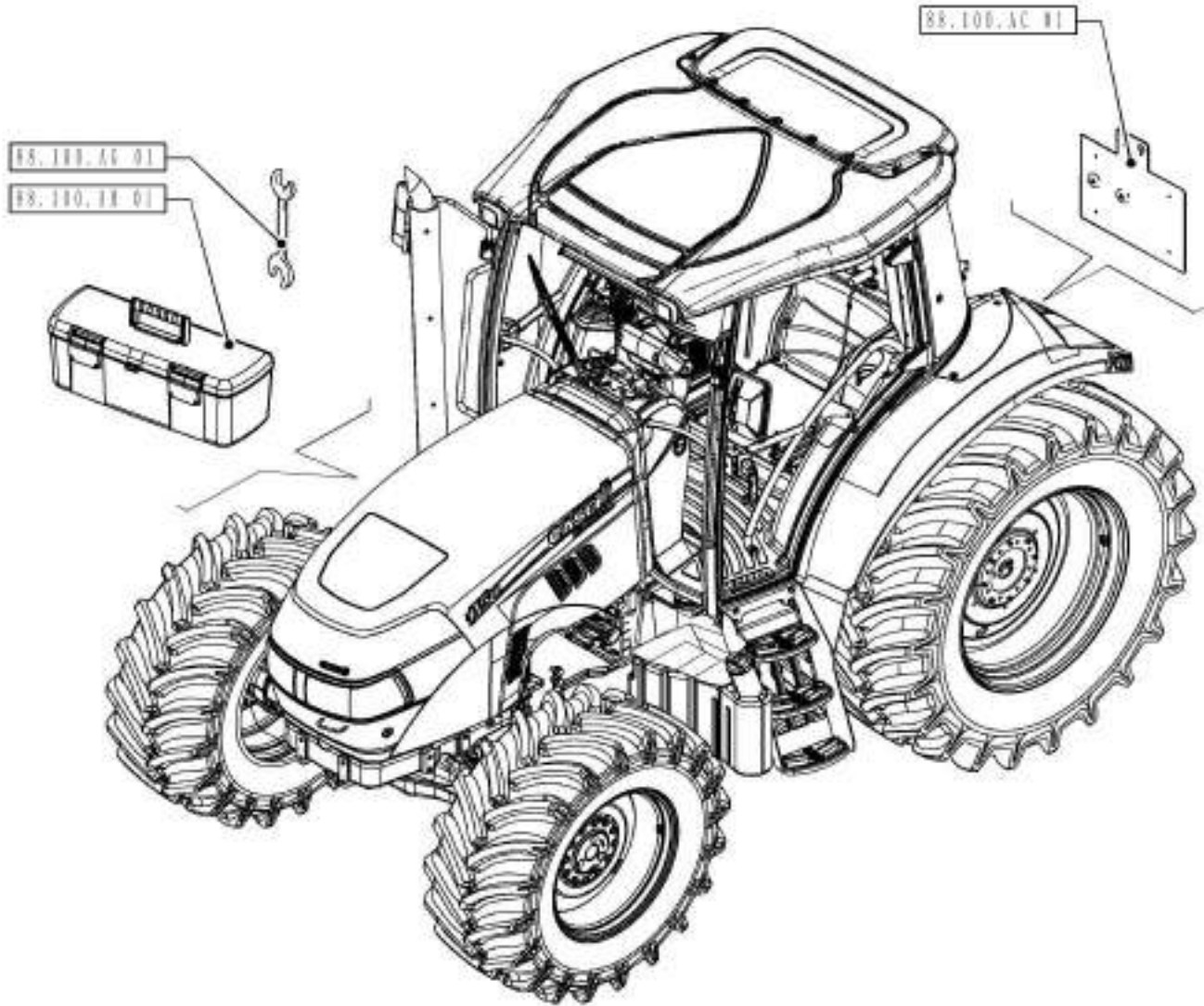

88.000.00

01

p1

1/2014

SECTION INDEX, ACCESSORIES

REF FN	PART NUMBER	YR/SN	QTY	DESCRIPTION
---------------	--------------------	--------------	------------	--------------------

FARMALL JX100 FARMALL JX110 FARMALL JX70 FARMALL JX75 FARMALL JX80 FARMALL JX90
--

88.100.AC

01

p1

1/2014

VAR - 334342, 334343, 334344, 334345, 334346, 334347, 334348, 334349, 334350, 335914 - LICENSE PLATE LAMP & SUPPORT, CAB

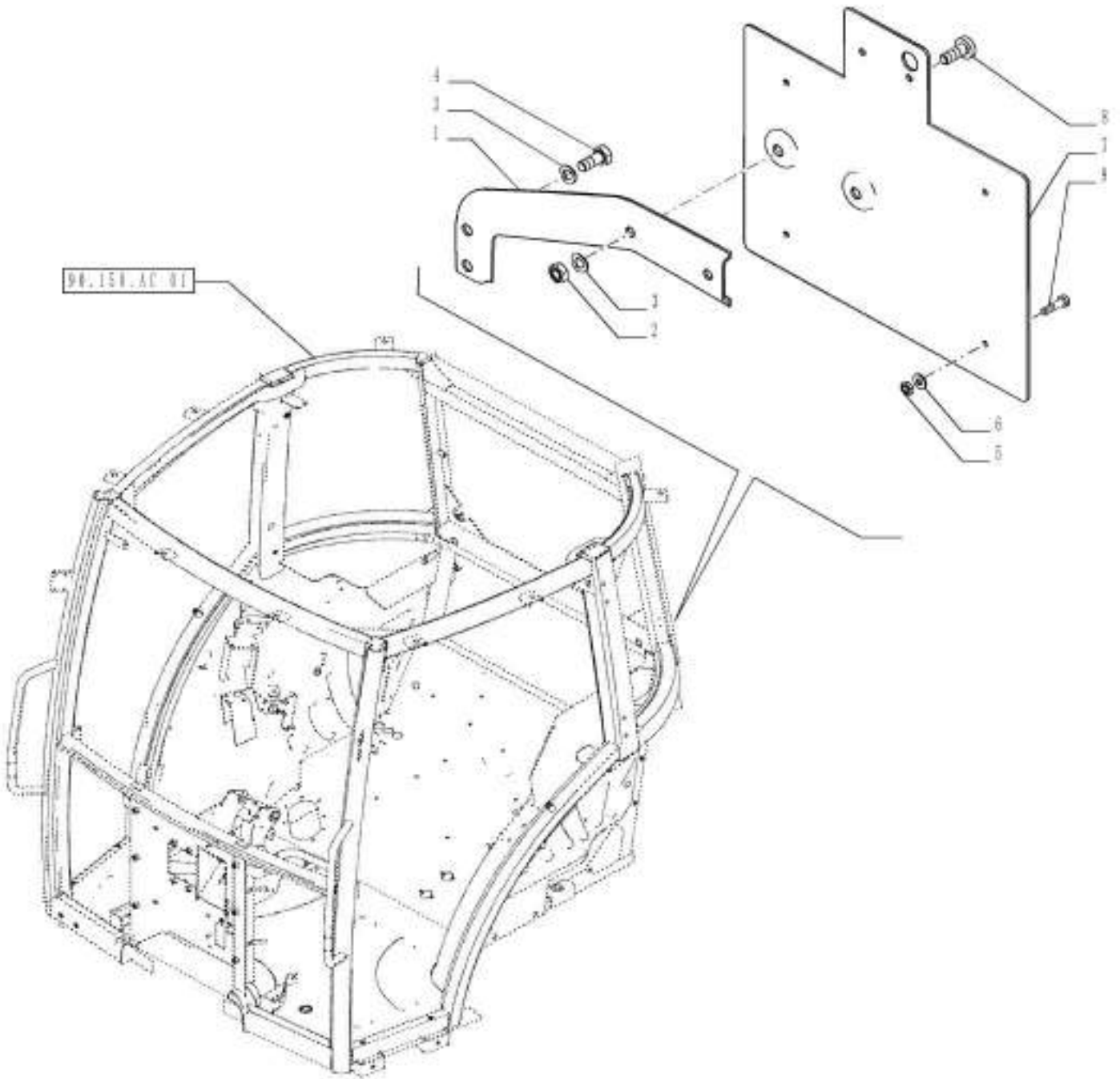

88.100.AC

01

p1

1/2014

VAR - 334342, 334343, 334344, 334345, 334346, 334347, 334348, 334349, 334350, 335914 - LICENSE PLATE LAMP & SUPPORT, CAB

REF	FN	PART NUMBER	YR/SN	QTY	DESCRIPTION
1	1	84524328		1	BRACKET
1	2	84528309		1	SUPPORT RH, Side
2		16100811		2	NUT Hex, M8, 6.80mm, CI 8, ZND
3		12601374		4	WAVE WASHER Wave, 8.40mm ID x 15.00mm OD x 0.80mm, 3.00mm, CST, DAC
4		86625000		2	BOLT Hex, M8 x 18mm, CI 8.8, Full Thd
5		100012		4	NUT M4, CI 8
6		10519201		4	WASHER M4
7		5080925		1	SUPPORT
8		13279411		2	SCREW Cross Pan Hd, M8 x 20
9		10375011		4	SCREW Slotted, Pan Hd, M4 x 14
(1)		VAR - 334344, 334345, 334346, 334347, 334348, 334349, 334350, 335914			
(2)		VAR - 334342, 334343			

Valid for Var. 334342 or Var. 334343 or Var. 334344 or Var. 334345 or Var. 334346 or Var. 334347 or Var. 334348 or Var. 334349 or Var. 334350 or Var. 335914

FARMALL JX100 FARMALL
JX110 FARMALL JX70
FARMALL JX75 FARMALL
JX80 FARMALL JX90

88.100.AC

02

p1

1/2014

VAR - 334342, 334343, 334344, 334345, 334346, 334347, 334348, 334349, 334350, 335914 - LICENSE PLATE LAMP & SUPPORT, ROPS

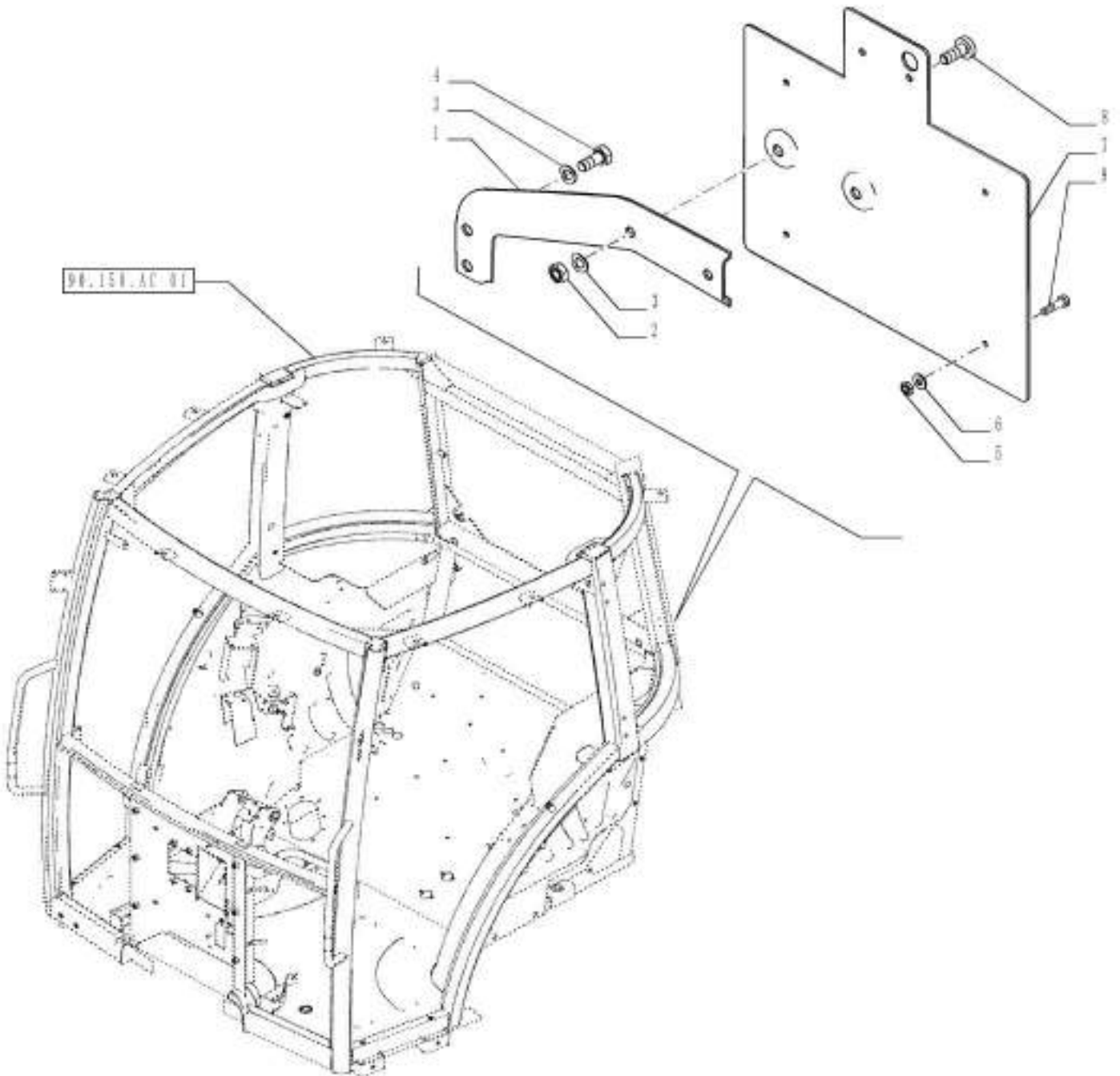

88.100.AC

02

p1

1/2014

VAR - 334342, 334343, 334344, 334345, 334346, 334347, 334348, 334349, 334350, 335914 - LICENSE PLATE LAMP & SUPPORT, ROPS

REF	FN	PART NUMBER	YR/SN	QTY	DESCRIPTION
1	1	84548153		1	SUPPORT
1	2	84561813		1	SUPPORT
2		10375011		4	SCREW Slotted, Pan Hd, M4 x 14
3		12601374		2	WAVE WASHER Wave, 8.40mm ID x 15.00mm OD x 0.80mm, 3.00mm, CST, DAC
4		120100		2	BOLT Hex, M6 x 1 x 20mm, CI 8.8
5		100012		4	NUT M4, CI 8
6		10519201		4	WASHER M4
7		5080925		1	SUPPORT
8		13279411		2	SCREW Cross Pan Hd, M8 x 20
(1)		VAR - 334344, 334345, 334346, 334347, 334348, 334349, 334350, 335914			
(2)		VAR - 334342, 334343			

Valid for Var. 334342 or Var. 334343 or Var. 334344 or Var. 334345 or Var. 334346 or Var. 334347 or Var. 334348 or Var. 334349 or Var. 334350 or Var. 335914

FARMALL JX100 FARMALL
JX110 FARMALL JX70
FARMALL JX75 FARMALL
JX80 FARMALL JX90

VAR - 334408 - SET OF TOOLS

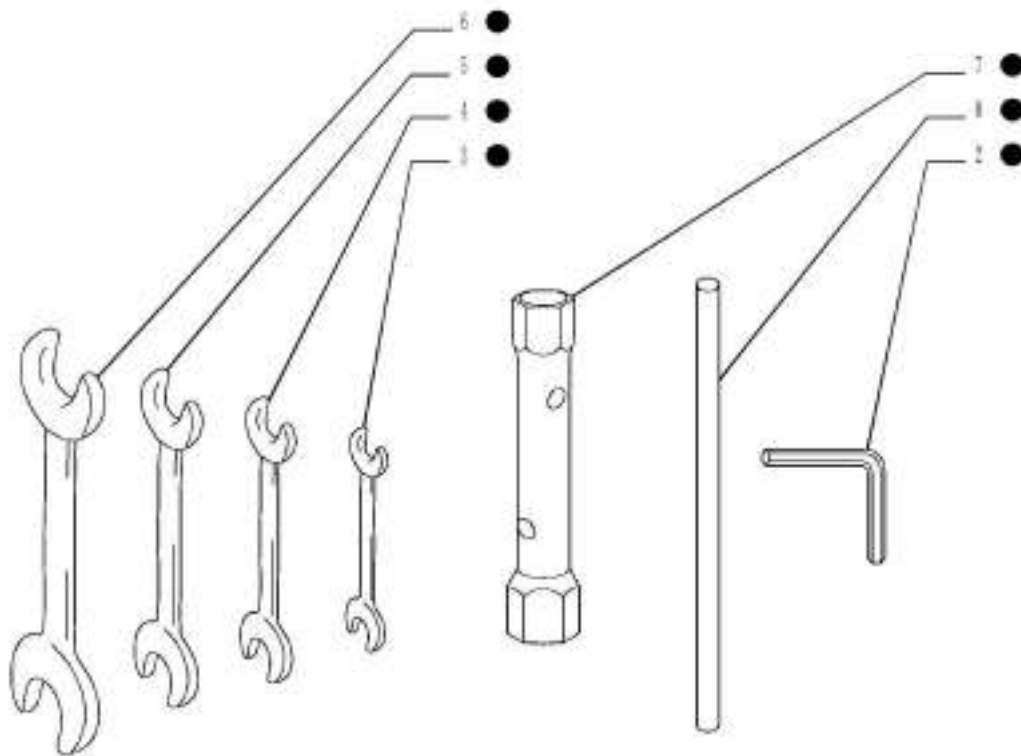
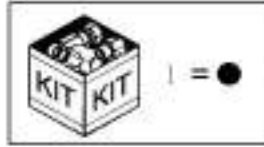

VAR - 332998, 334408 - TOOL BOX

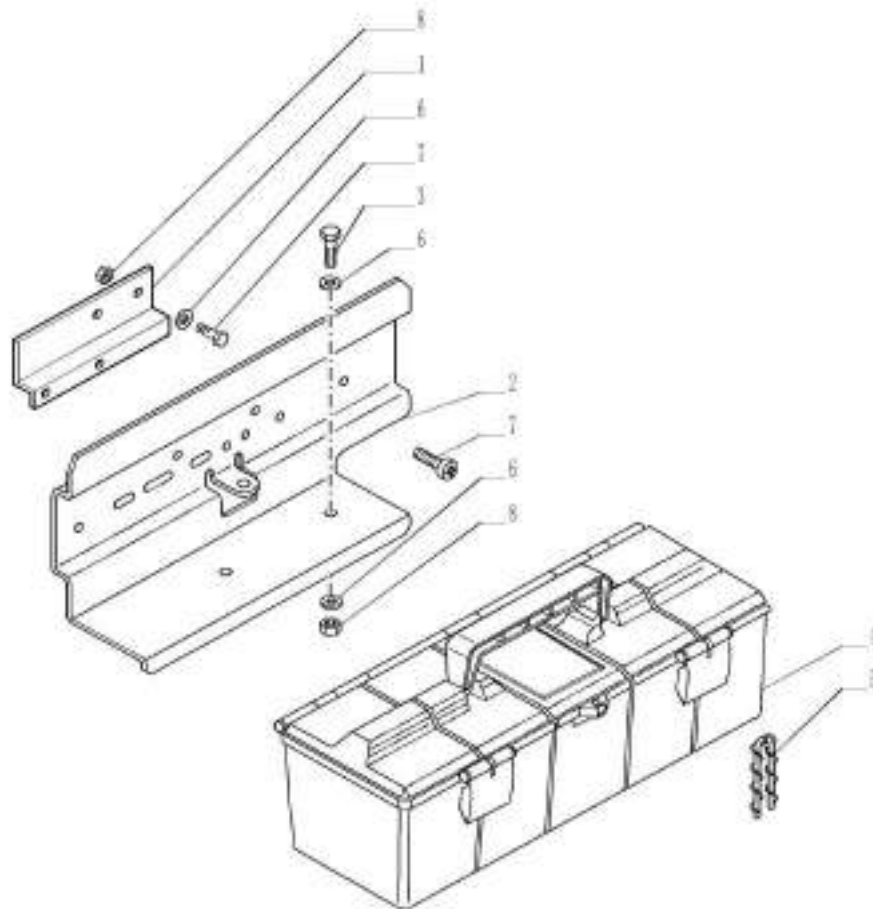

VAR - 332998, 334408 - TOOL BOX

REF FN	PART NUMBER	YR/SN	QTY DESCRIPTION
1	84527235		1 SUPPORT
2	5095986		1 SUPPORT
3	43127		2 BOLT Hex, M8 x 1.25 x 25mm, Cl 8.8, Full Thd
4	5095002		1 TOOL BOX
5	5088746		1 ELECTRICAL WIRE
6	12601374		6 WAVE WASHER Wave, 8.40mm ID x 15.00mm OD x 0.80mm, 3.00mm, CST, DAC
7	14781811		4 SELF-TAP SCREW
8	16100811		4 NUT Hex, M8, 6.80mm, Cl 8, ZND

Valid for Var. 332998 or Var. 334408

FARMALL JX100 FARMALL
 JX110 FARMALL JX70
 FARMALL JX75 FARMALL
 JX80 FARMALL JX90

SECTION INDEX

PLATFORM, CAB, BODYWORK & DECALS

90.000.00	01	SECTION INDEX - PLATFORM, CAB, BODYWORK AND DECALS
90.000.00	02	SECTION INDEX - PLATFORM, CAB, BODYWORK AND DECALS
90.000.00	03	SECTION INDEX - PLATFORM, CAB, BODYWORK AND DECALS
90.000.00	04	SECTION INDEX - PLATFORM, CAB, BODYWORK AND DECALS
90.100.AC	01	VAR - 333606, 334318, 334319, 391606, 392315 - SIDE PANELS
90.100.AC	02	VAR - 333606, 334318, 334319, 391606, 392315 - SIDE PANELS
90.100.AU	01	VAR - 333606, 334318, 334319, 391606, 392315 - ENGINE HOOD
90.100.AU	02	VAR - 333606, 334318, 334319, 391606, 392315 - ENGINE HOOD, SEALS
90.102.AU	01	VAR - 333606, 334318, 334319, 391606, 392315 - ENGINE HOOD
90.102.AW	01	VAR - 333606, 334318, 334319, 391606, 392315 - HOOD CLOSING SUPPORT
90.102.AW	02	VAR - 333606, 334318, 334319, 391606, 392315 - HOOD CLOSING SUPPORT
90.105.CQ	01	VAR - 333606, 334318, 334319, 391606, 392315 - BULKHEAD
90.108.AA	01	VAR - 330641, 390641 - DECALS, CONTROLS
90.108.AB	01	VAR - 334342, 334343, 334344, 334345, 334346, 334347 - DECALS, MODEL IDENTIFICATION
90.108.AB	02	VAR - 334351, 334352 - MODEL IDENTIFICATION DECALS, LOADER ARM
90.108.AC	01	VAR - 333606, 334318, 334319, 391606, 392315 - DECALS, WARNING, ISO
90.108.AC	02	VAR - 334395 - DECALS, WARNING, ISO
90.108.AC	03	VAR - 333606, 334318, 334319, 391606, 392315 - DECALS, WARNING, ISO
90.108.AC	04	VAR - 334351, 334352 - SAFETY DECALS, LOADER ARM
90.108.AD	01	VAR - 333606, 334318, 334319, 391606, 392315 - DECALS - TRADEMARK EMBLEM
90.110.AH	01	VAR - 333606, 334318, 334319, 391606, 392315 - INSTRUMENT PANEL, ROPS
90.110.AV	01	VAR - 334318, 334319, 392315 - PASSENGER SEAT, SIDE PANEL, ROPS
90.114.AQ	01	VAR - 334318, 334319, 392315 - ROPS, FRAME
90.114.AR	01	VAR - 334318, 334319 - ROPS, ROPS FRAME CANOPY
90.116.AC	01	VAR - 335928, 391460, 744756 - REAR FENDER
90.116.AC	02	VAR - 335897 - REAR FENDER EXTENSION
90.116.AC	04	VAR - 339860 - 4WD FRONT FENDERS, 340 MM
90.116.AC	05	VAR - 339860 - 4WD FRONT FENDERS, 340 MM
90.116.AC	06	VAR - 335495 - 4WD WIDE FRONT FENDERS, 400 MM
90.116.AC	07	VAR - 338860 - 2WD FRONT FENDERS, 240 MM.
90.118.BM	01	VAR - 330879 - REAR VIEW MIRROR, CAB
90.118.BM	02	VAR - 330879 - EXTENDABLE MIRROR, CAB

SECTION INDEX

PLATFORM, CAB, BODYWORK & DECALS

90.120.AD	02	VAR - 744747, 744749 - SEAT AND SUPPORT
90.120.AD	03	VAR - 744746, 744748 - SEAT, COMPONENTS
90.120.AD	04	VAR - 744746, 744748 - SEAT, COMPONENTS
90.120.AD	05	VAR - 744747, 744749 - SEAT, COMPONENTS
90.120.AD	06	VAR - 744747, 744749 - SEAT, COMPONENTS
90.120.AD	07	VAR - 744747, 744749 - SEAT, COMPONENTS
90.150.AC	01	VAR - 333606, 391606 - CAB, FRAME
90.150.AE	01	VAR - 333606, 334318, 334319, 391606, 392315 - CAB & ROPS FRONT SUPPORT
90.150.AG	01	VAR - 333606, 334318, 334319, 391606, 392315 - CAB & ROPS REAR SUPPORT
90.150.BC	01	VAR - 333606 - HIGH VISIBILITY ROOF FOR CAB
90.150.BG	01	VAR - 391606 - CAB ROOF
90.150.BG	02	VAR - 333606, 391606 - CAB ROOF
90.151.AC	01	VAR - 334418, 334420, 744748, 744749 - PASSENGER SEAT
90.151.AE	01	VAR - 333606, 391606 - CAB, SUNVISOR
90.151.AF	01	VAR - 333606, 391606 - INSTRUMENT PANEL, CAB
90.151.AK	01	VAR - 330879, 390879 - REAR VIEW MIRROR, CAB
90.154.AC	01	VAR - 334342, 334343, 334344, 334345, 334346, 334347, 334348, 334349, 334350, 335914 - CAB DOOR, LEFT, HANDLE
90.154.AC	02	VAR - 334342, 334343, 334344, 334345, 334346, 334347, 334348, 334349, 334350, 335914 - CAB DOOR, RIGHT, HANDLE
90.154.AV	01	VAR - 334342, 334343, 334344, 334345, 334346, 334347, 334348, 334349, 334350, 335914 - CAB DOOR, LEFT, GLASS
90.154.AV	02	VAR - 334342, 334343, 334344, 334345, 334346, 334347, 334348, 334349, 334350, 335914 - CAB DOOR, RIGHT, GLASS
90.156.AB	01	VAR - 333606, 334318, 334319, 391606, 392315 - REAR WINDOW GLASS
90.156.AD	01	VAR - 333606, 391606 - CAB REAR WINDOW
90.156.AG	01	VAR - 334318, 334319, 392315 - GLASS, FRONT, ROPS
90.156.AL	01	VAR - 333606, 392606 - CAB WINDSHIELD GLASS
90.156.AZ	01	VAR - 333606, 391606 - WINDOW, LEFT
90.156.AZ	02	VAR - 333606, 391606 - CAB WINDOW GLASS, RIGHT SIDE
90.160.AM	01	VAR - 744746, 744747, 744748, 744749 - CAB SIDE PANEL (LH)
90.160.AR	01	VAR - 744738, 744744 - CAB FLOOR, MAT
90.160.AR	02	VAR - 330384, 334322, 744739 - CAB FLOOR, MAT
90.160.AR	03	VAR - 330120, 331120, 390249, 743846 - FLOOR MAT, ROPS
90.160.AX	01	VAR - 391606 - CAB HEADLINER
90.160.AX	02	VAR - 333606 - HIGH VISIBILITY ROOF FOR CAB - HEADLINER
90.160.BI	01	VAR - 744746, 744747, 744748, 744749 - PILLAR, RIGHT, TRIM,

90.000.00

01

p1

1/2014

SECTION INDEX - PLATFORM, CAB, BODYWORK AND DECALS

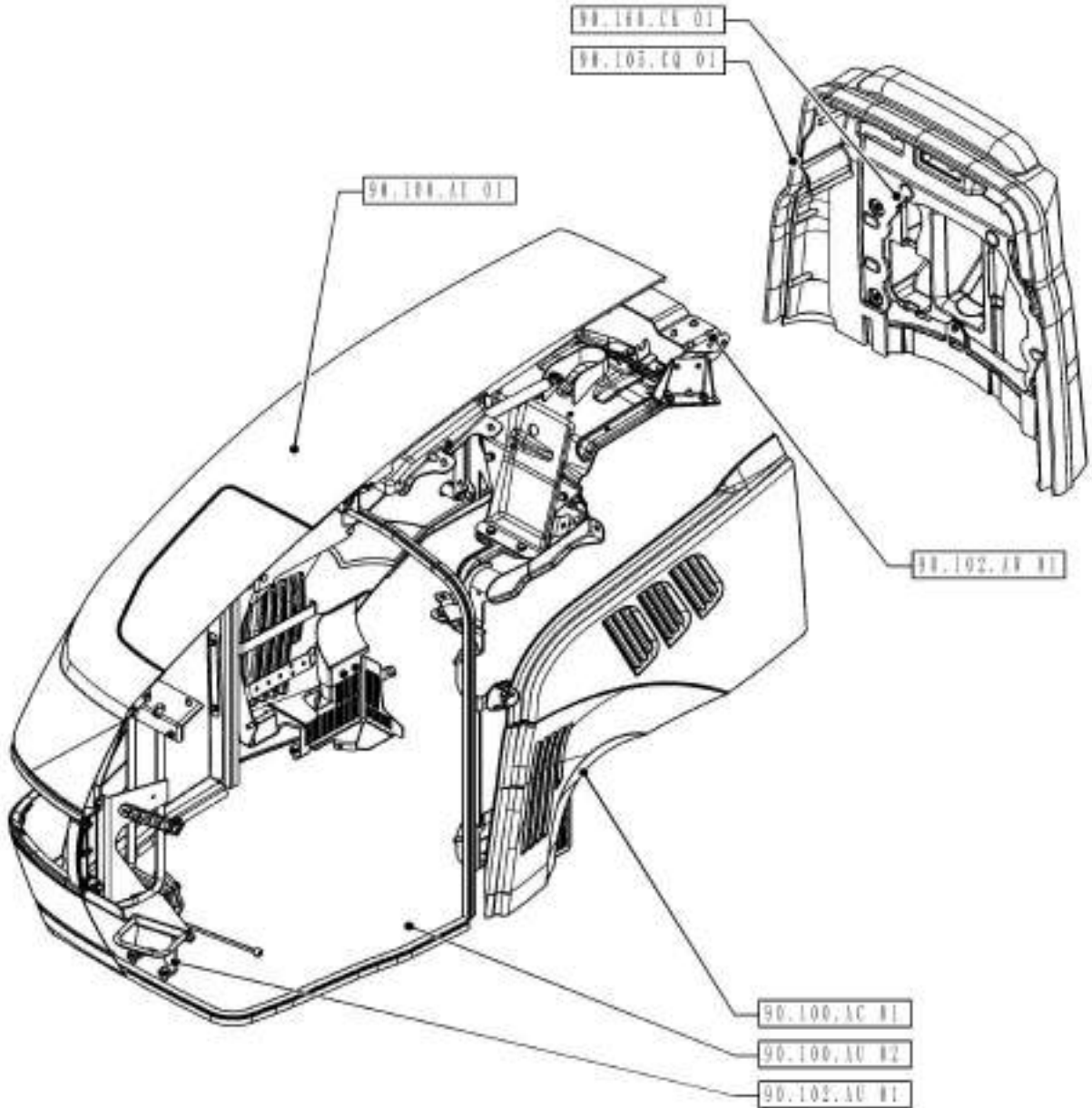

90.000.00

01

p1

1/2014

SECTION INDEX - PLATFORM, CAB, BODYWORK AND DECALS

REF FN PART NUMBER YR/SN QTY DESCRIPTION

FARMALL JX100 FARMALL
JX110 FARMALL JX70
FARMALL JX75 FARMALL
JX80 FARMALL JX90

SECTION INDEX - PLATFORM, CAB, BODYWORK AND DECALS

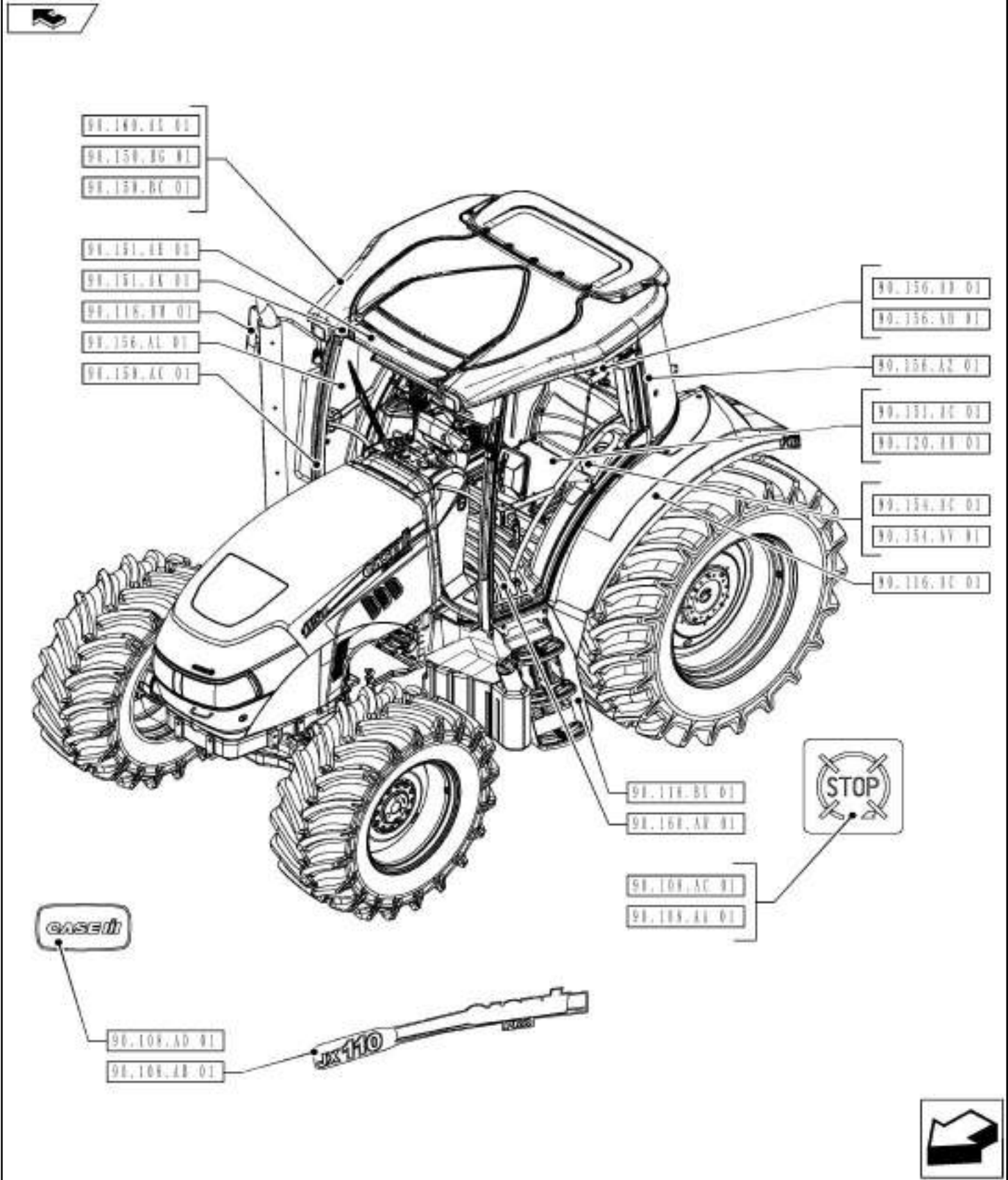

90.000.00

02

p1

1/2014

SECTION INDEX - PLATFORM, CAB, BODYWORK AND DECALS

REF FN PART NUMBER YR/SN QTY DESCRIPTION

FARMALL JX100 FARMALL
JX110 FARMALL JX70
FARMALL JX75 FARMALL
JX80 FARMALL JX90

90.000.00

03

p1

1/2014

SECTION INDEX - PLATFORM, CAB, BODYWORK AND DECALS

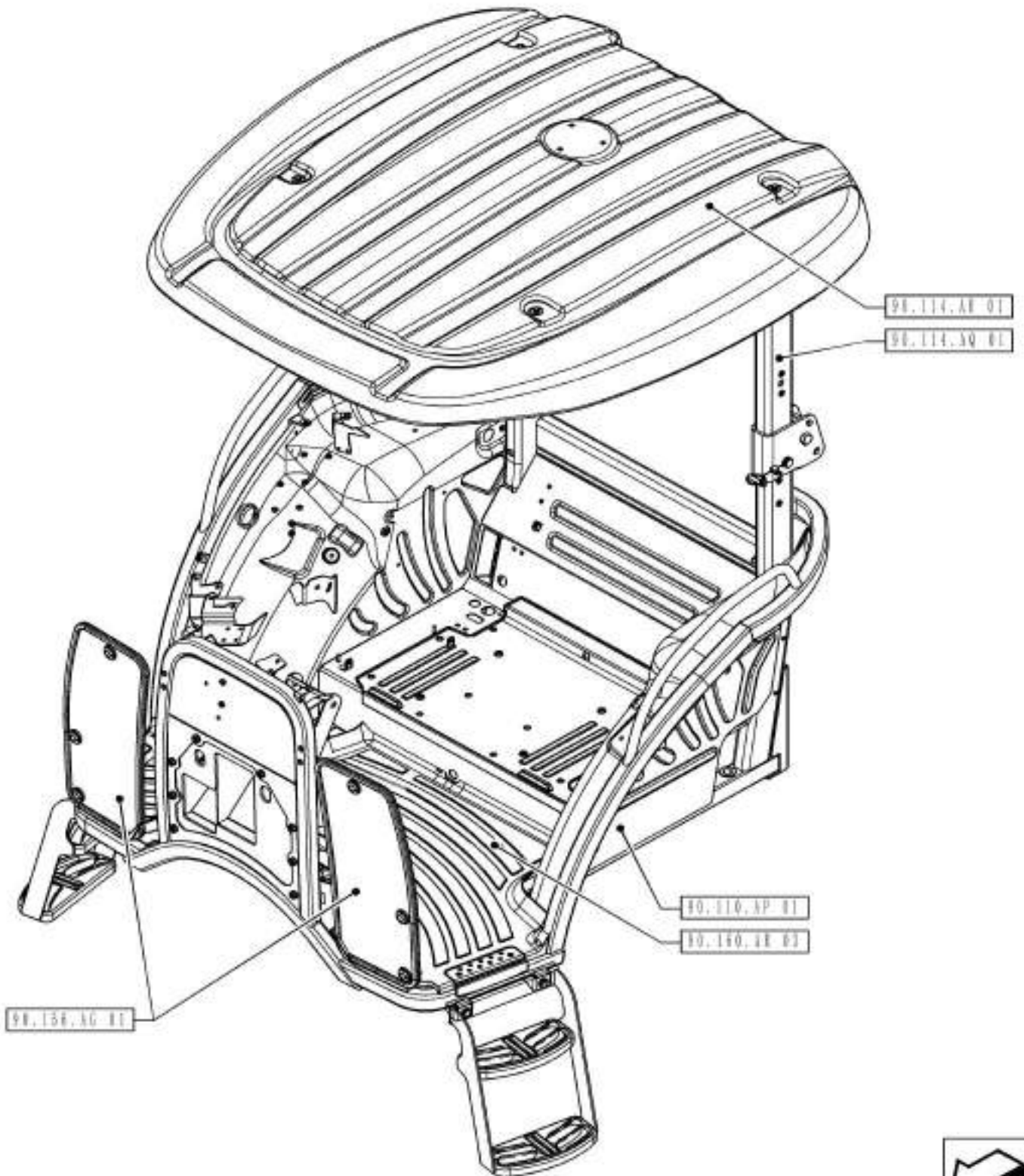

90.000.00

03

p1

1/2014

SECTION INDEX - PLATFORM, CAB, BODYWORK AND DECALS

REF FN	PART NUMBER	YR/SN	QTY	DESCRIPTION
---------------	--------------------	--------------	------------	--------------------

				FARMALL JX100 FARMALL JX110 FARMALL JX70 FARMALL JX75 FARMALL JX80 FARMALL JX90
--	--	--	--	--

SECTION INDEX - PLATFORM, CAB, BODYWORK AND DECALS

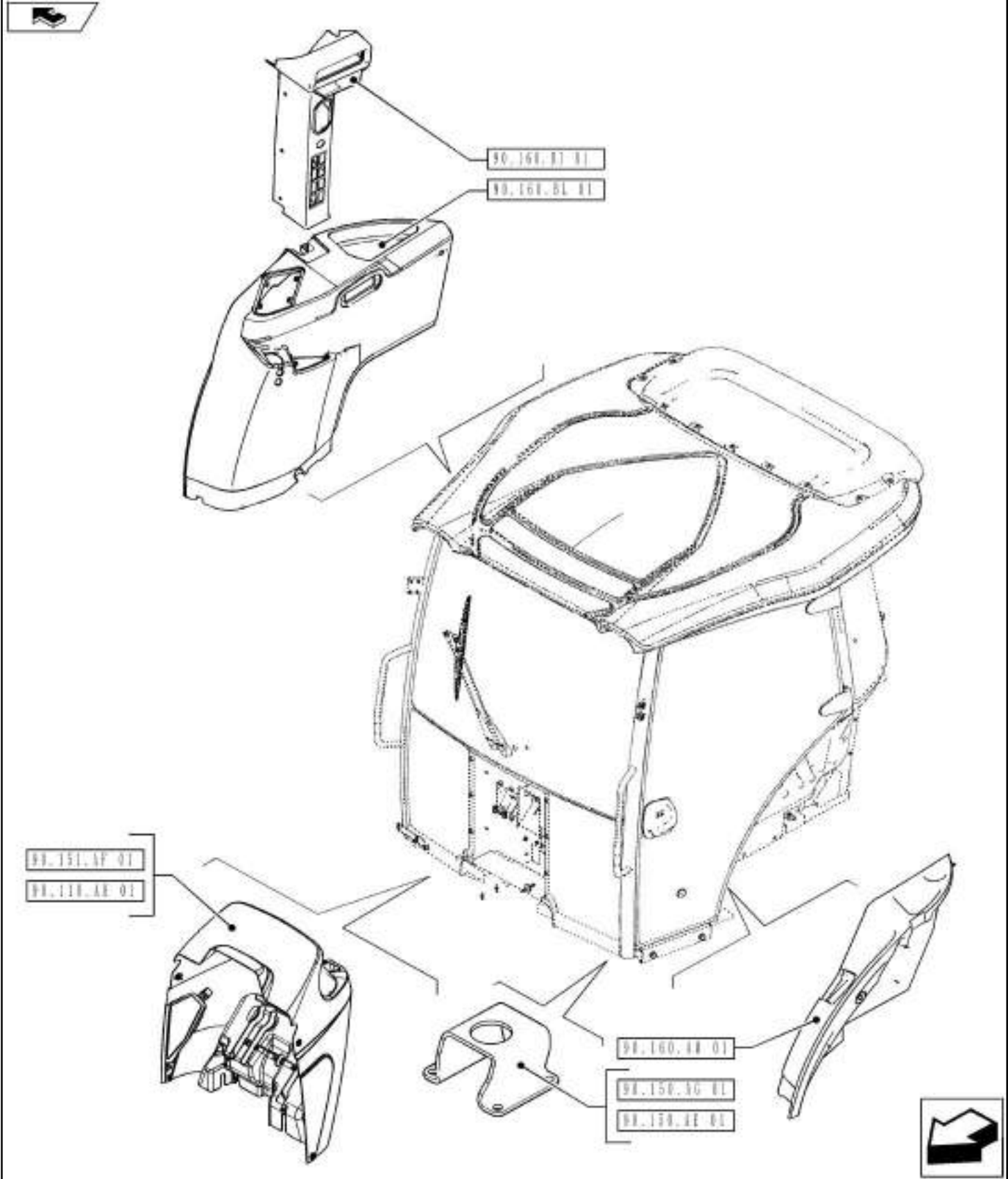

90.000.00

04

p1

1/2014

SECTION INDEX - PLATFORM, CAB, BODYWORK AND DECALS

REF FN PART NUMBER YR/SN QTY DESCRIPTION

FARMALL JX100 FARMALL
JX110 FARMALL JX70
FARMALL JX75 FARMALL
JX80 FARMALL JX90

90.100.AC

01

p1

1/2014

VAR - 333606, 334318, 334319, 391606, 392315 - SIDE PANELS

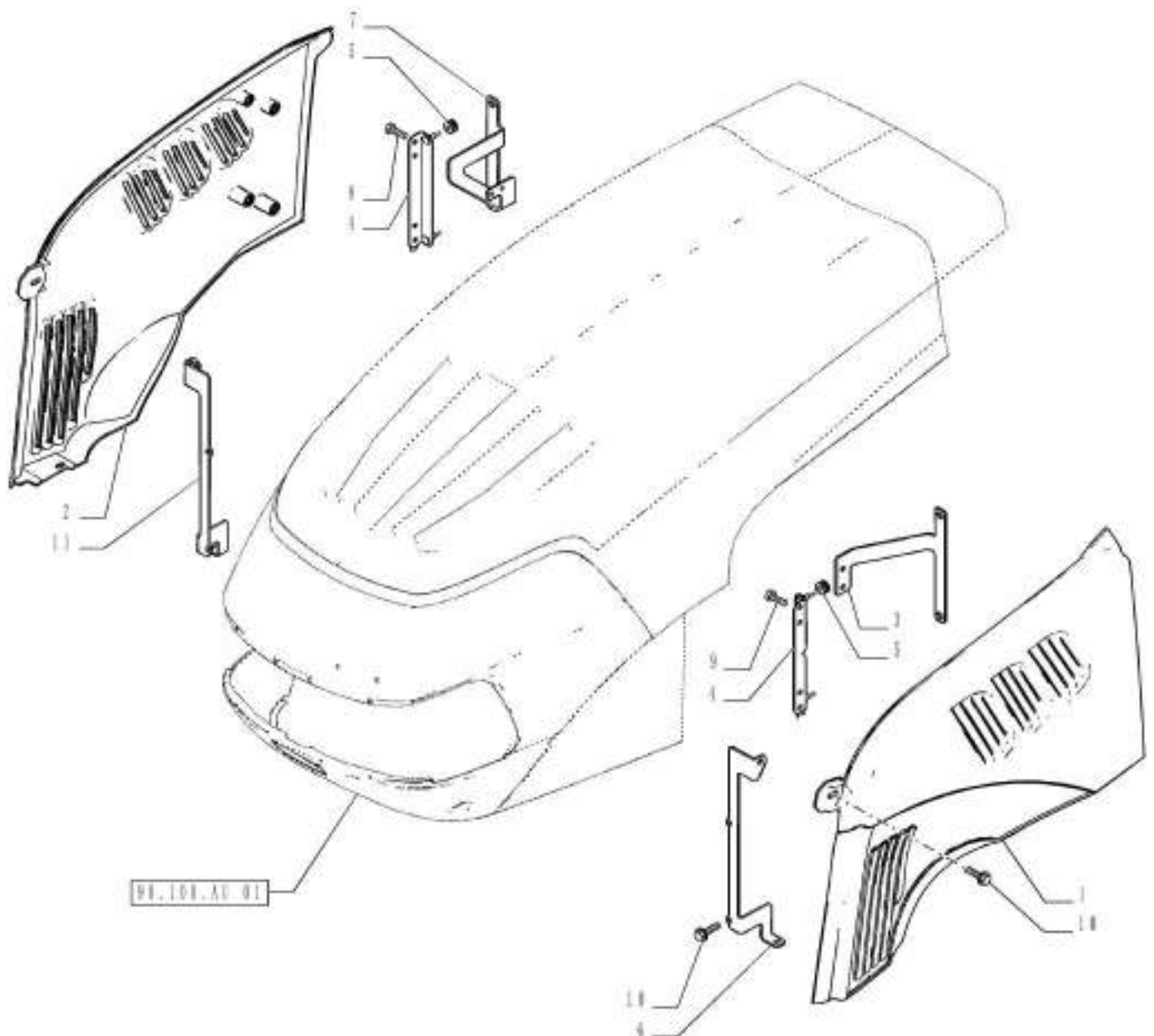

90.100.AC

01

p1

1/2014

VAR - 333606, 334318, 334319, 391606, 392315 - SIDE PANELS

REF FN	PART NUMBER	YR/SN	QTY DESCRIPTION
1	84519363		1 PANEL LH
2	84424722		1 PANEL RH
3	84424564		1 SUPPORT
4	84330851		2 BRACKET
5	10399280		4 GROMMET
6	84424588		1 SUPPORT
7	84424644		1 SUPPORT
8	16285924		4 BOLT Hvy Hex, M6 x 12mm, Cl 8.8, Full Thd
9	16043024		4 SCREW Hex, M8 x 12mm, Cl 8.8, Full Thd
10	16287021		AR BOLT Hex, M8 x 16mm, Cl 8.8
11	84424586		1 SUPPORT

Valid for Var. 333606 or Var. 334318 or Var. 334319 or Var. 391606 or Var. 392315

FARMALL JX70

90.100.AC

02

p1

1/2014

VAR - 333606, 334318, 334319, 391606, 392315 - SIDE PANELS

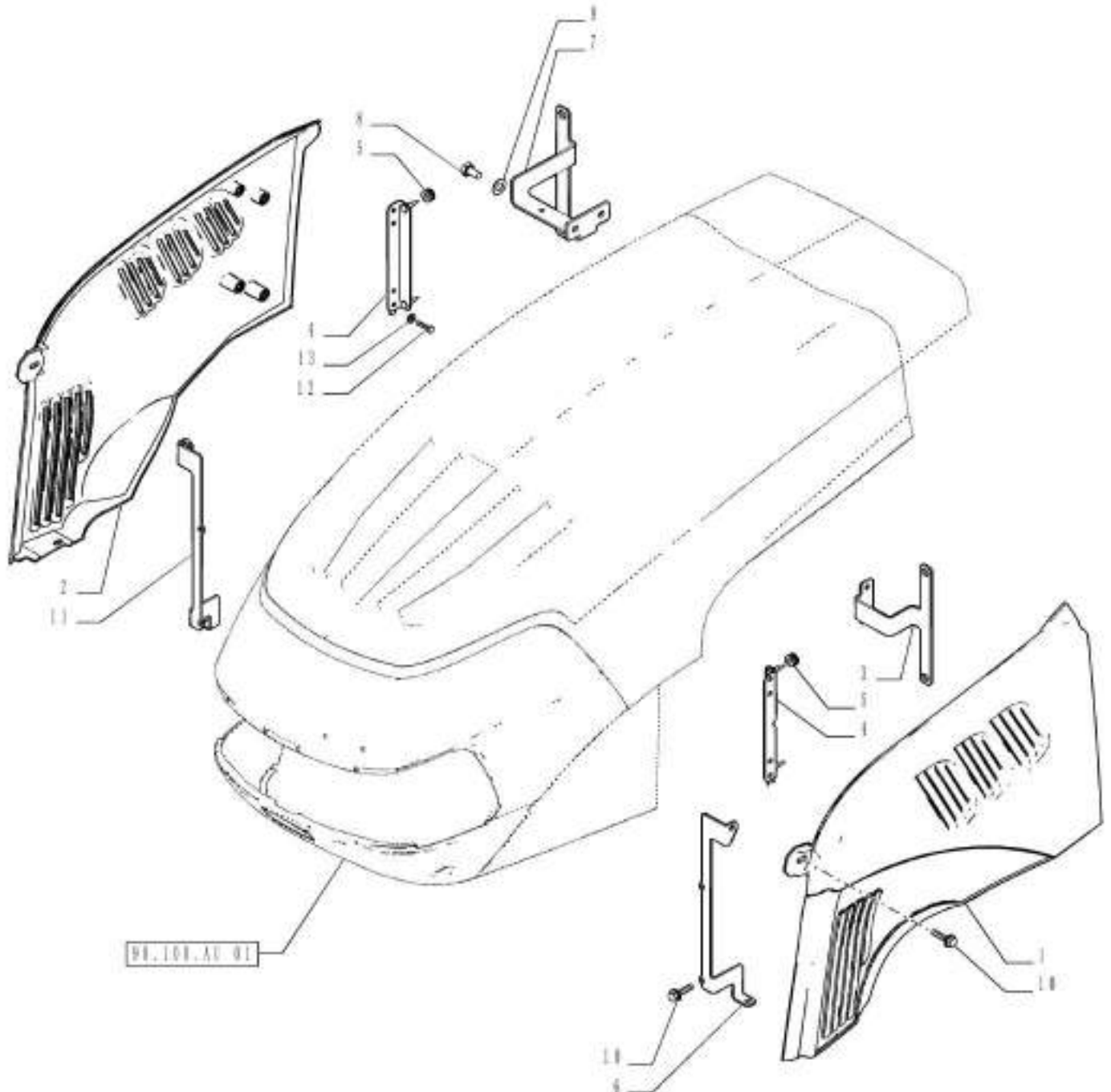

VAR - 333606, 334318, 334319, 391606, 392315 - SIDE PANELS

REF FN	PART NUMBER	YR/SN	QTY DESCRIPTION
1	84519365		1 PANEL LH
2	84485315		1 PANEL RH
3	1 84424582		1 SUPPORT
3	2 84424564		1 SUPPORT
4	84330851		2 BRACKET
5	10399280		4 GROMMET
6	84424588		1 SUPPORT
7	1 84424584		1 SUPPORT
7	2 84424644		1 SUPPORT
8	15970421		2 SCREW Hex, M10 x 1.25 x 18mm, CI 8.8, Full Thd
9	12601474		2 WAVE WASHER Wave, 10.50mm ID x 21.00mm OD x 0.80mm, 3.00mm, CST, DAC
10	16287021		AR BOLT Hex, M8 x 16mm, CI 8.8
11	84424586		1 SUPPORT
12	16043024		4 SCREW Hex, M8 x 12mm, CI 8.8, Full Thd
13	12601374		4 WAVE WASHER Wave, 8.40mm ID x 15.00mm OD x 0.80mm, 3.00mm, CST, DAC

(1) Valid for FARMALL JX75, 90, 100, 110 Models Only

(2) Valid for FARMALL JX80 Model Only

Valid for Var. 333606 or Var. 334318 or Var. 334319 or Var. 391606 or Var. 392315

FARMALL JX100
 FARMALL JX110
 FARMALL JX75
 FARMALL JX80

VAR - 333606, 334318, 334319, 391606, 392315 - ENGINE HOOD

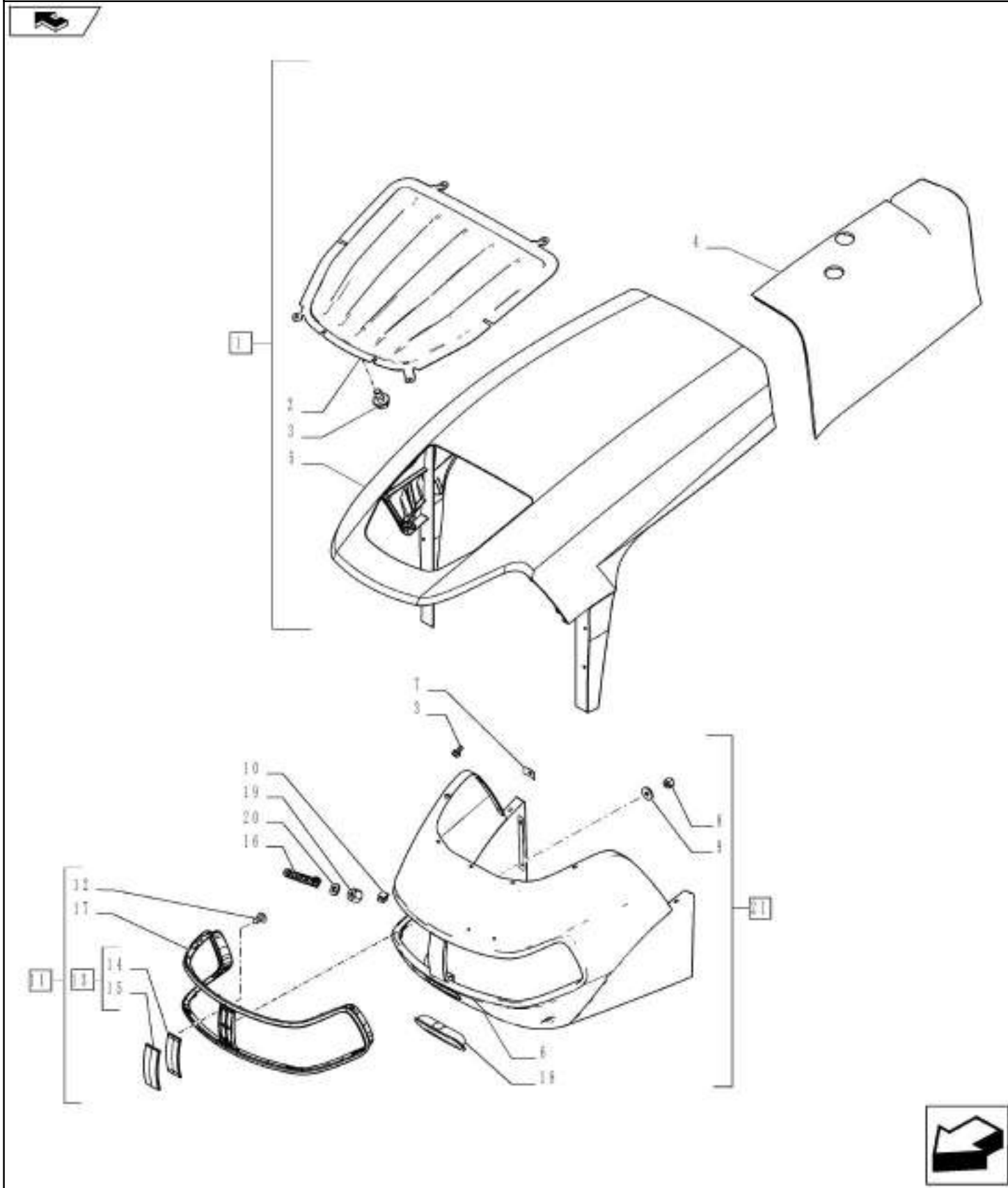

VAR - 333606, 334318, 334319, 391606, 392315 - ENGINE HOOD

REF	FN	PART NUMBER	YR/SN	QTY	DESCRIPTION
1	1	84487354		1	ENGINE HOOD Incl 2 - 5, Ref 3 Qty=4
1	2	84519364		1	ENGINE HOOD Incl 2 - 5, Ref 3 Qty=4
2		{84520303}		1	
3	1	16285924		AR	BOLT Hvy Hex, M6 x 12mm, CI 8.8, Full Thd
4		{84519383}		1	
5		NSS		1	NOT SERVICED SEPARATELY Hood Incl in 1
6		{84424613}		1	
7		14227674		8	NUT
8		12574211		3	NUT M6 x 1, CI 8
9		10523401		3	WASHER Flat, 6.15mm ID x 18.00mm OD x 2.00mm, Carbon Steel, ZND
10		87536288		4	CLIP
11		87734283		1	GRILLE Incl 12 - 15
12		16082104		4	SELF-TAP SCREW
13		87734282		1	PLATE Incl 14, 15
14		87632980		1	MOLDING
15		87677119		1	SOFT TRIM
16		87564049		1	EMBLEM
17		NSS		1	NOT SERVICED SEPARATELY Grille Incl in 11
18		84424609		1	HANDLE
19		14227874		2	SPRING NUT M4
20		5138360		2	RUBBER RING 4mm ID x 12mm OD x 4mm
21		84424614		1	GRILLE Incl 6 - 9, 11, 18

(1) Valid for FARMALL JX70 Model Only

(2)

Valid for Var. 333606 or Var. 334318 or Var. 334319 or Var. 391606 or Var. 392315

FARMALL JX100 FARMALL
JX110 FARMALL JX70
FARMALL JX75 FARMALL
JX80 FARMALL JX90

90.100.AU

02

p1

1/2014

VAR - 333606, 334318, 334319, 391606, 392315 - ENGINE HOOD, SEALS

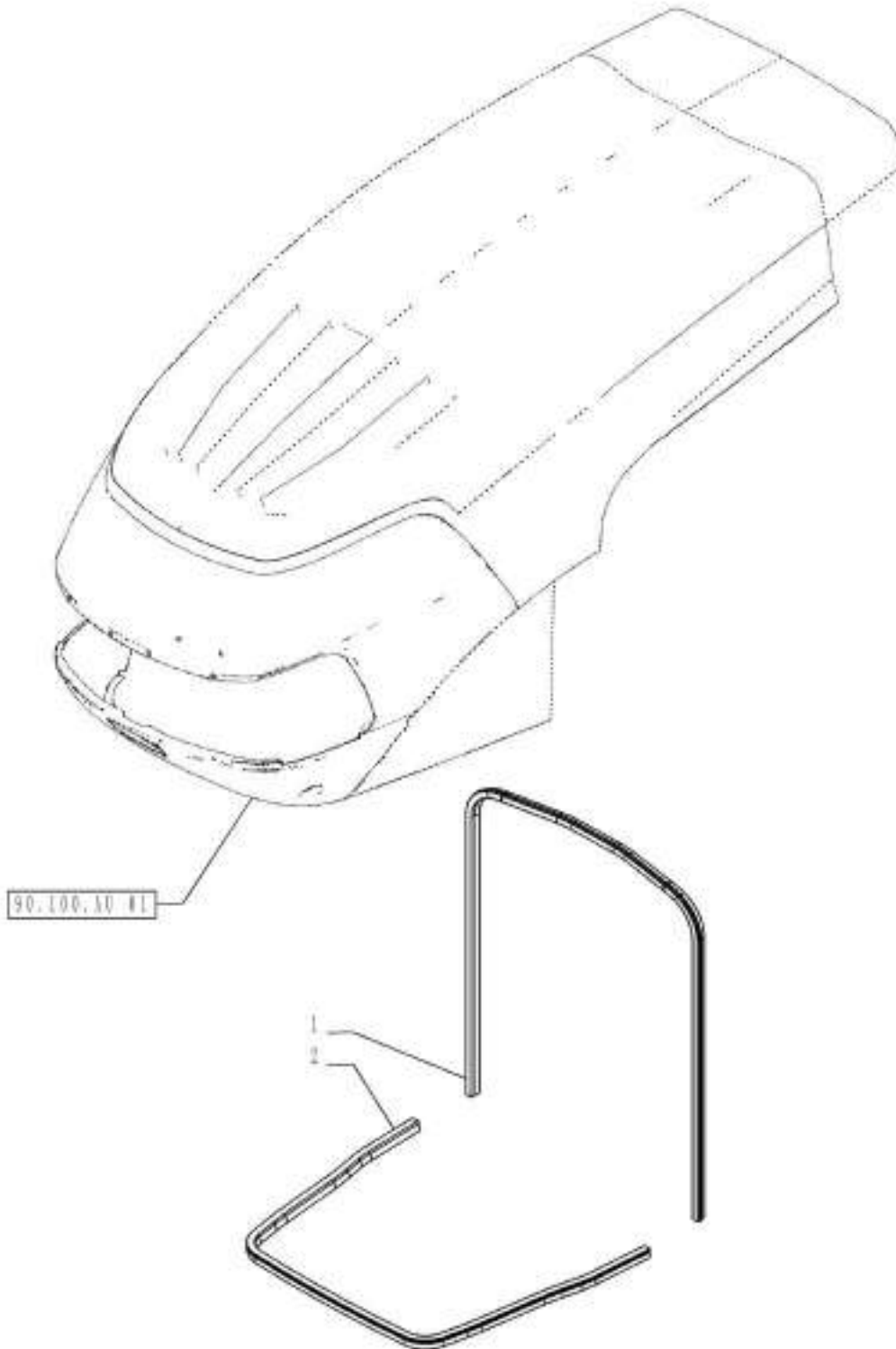

90.100.AU

02

p1

1/2014

VAR - 333606, 334318, 334319, 391606, 392315 - ENGINE HOOD, SEALS

REF FN	PART NUMBER	YR/SN	QTY DESCRIPTION
1	84308761		1 RUBBER SEAL
2	84424645		1 GASKET

Valid for Var. 333606 or Var. 334318 or Var. 334319 or Var. 391606 or Var. 392315

FARMALL JX100 FARMALL
JX110 FARMALL JX70
FARMALL JX75 FARMALL
JX80 FARMALL JX90

VAR - 333606, 334318, 334319, 391606, 392315 - ENGINE HOOD

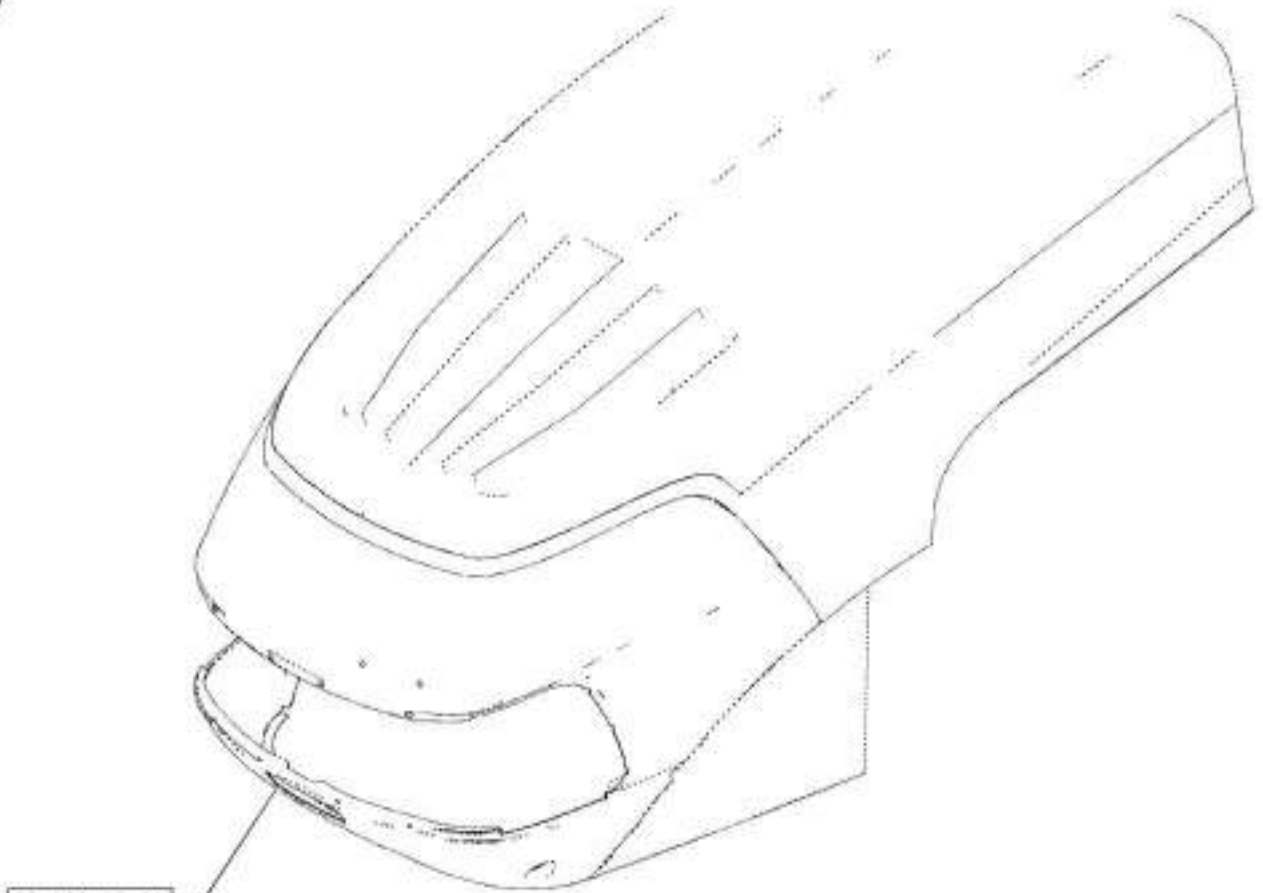

90.100.10 11

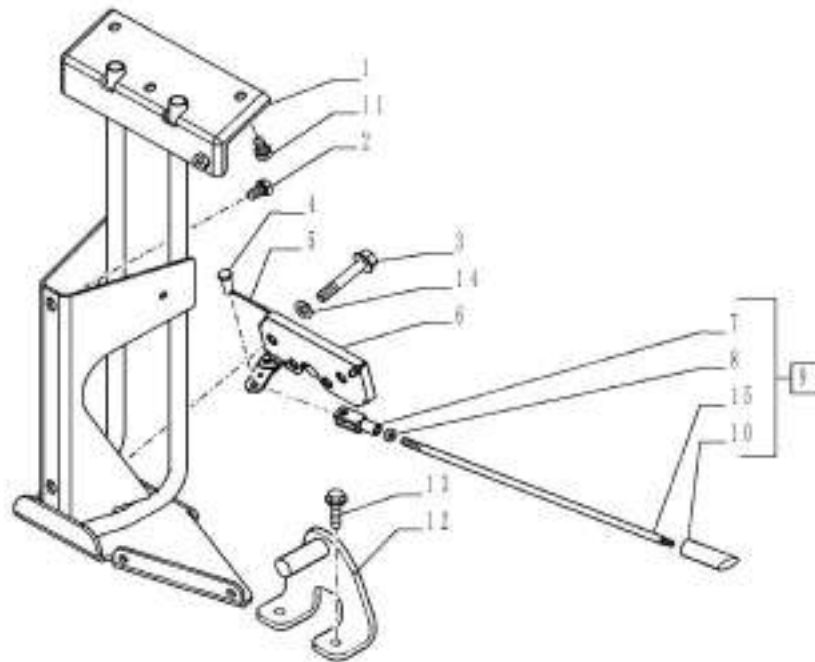

VAR - 333606, 334318, 334319, 391606, 392315 - ENGINE HOOD

REF FN	PART NUMBER	YR/SN	QTY DESCRIPTION
1	84278506		1 SUPPORT
2	16287021		2 BOLT Hex, M8 x 16mm, CI 8.8
3	87015931		4 BOLT Hvy Hex, M6 x 35mm, CI 8.8
4	10004911		1 PIN
5	10734101		1 COTTER PIN M1.6 x 12
6	84349450		1 LOCK
7	10007771		1 YOKE
8	15896211		1 NUT M6, CI 8
9	47389023		1 ROD Incl 7, 8, 10, 15
10	{84399914}		1
11	16281924		3 FLANGE BOLT
12	84399915		1 SUPPORT
13	9804258		2 BOLT Hvy Hex, M8 x 1.25 x 20mm, CI 8.8, Full Thd
14	86588450		4 WASHER M6 x 12 x 1.6 Thk
15	{47389024}		1

Valid for Var. 333606 or Var. 334318 or Var. 334319 or Var. 391606 or Var. 392315

FARMALL JX100 FARMALL
JX110 FARMALL JX70
FARMALL JX75 FARMALL
JX80 FARMALL JX90

VAR - 333606, 334318, 334319, 391606, 392315 - HOOD CLOSING SUPPORT

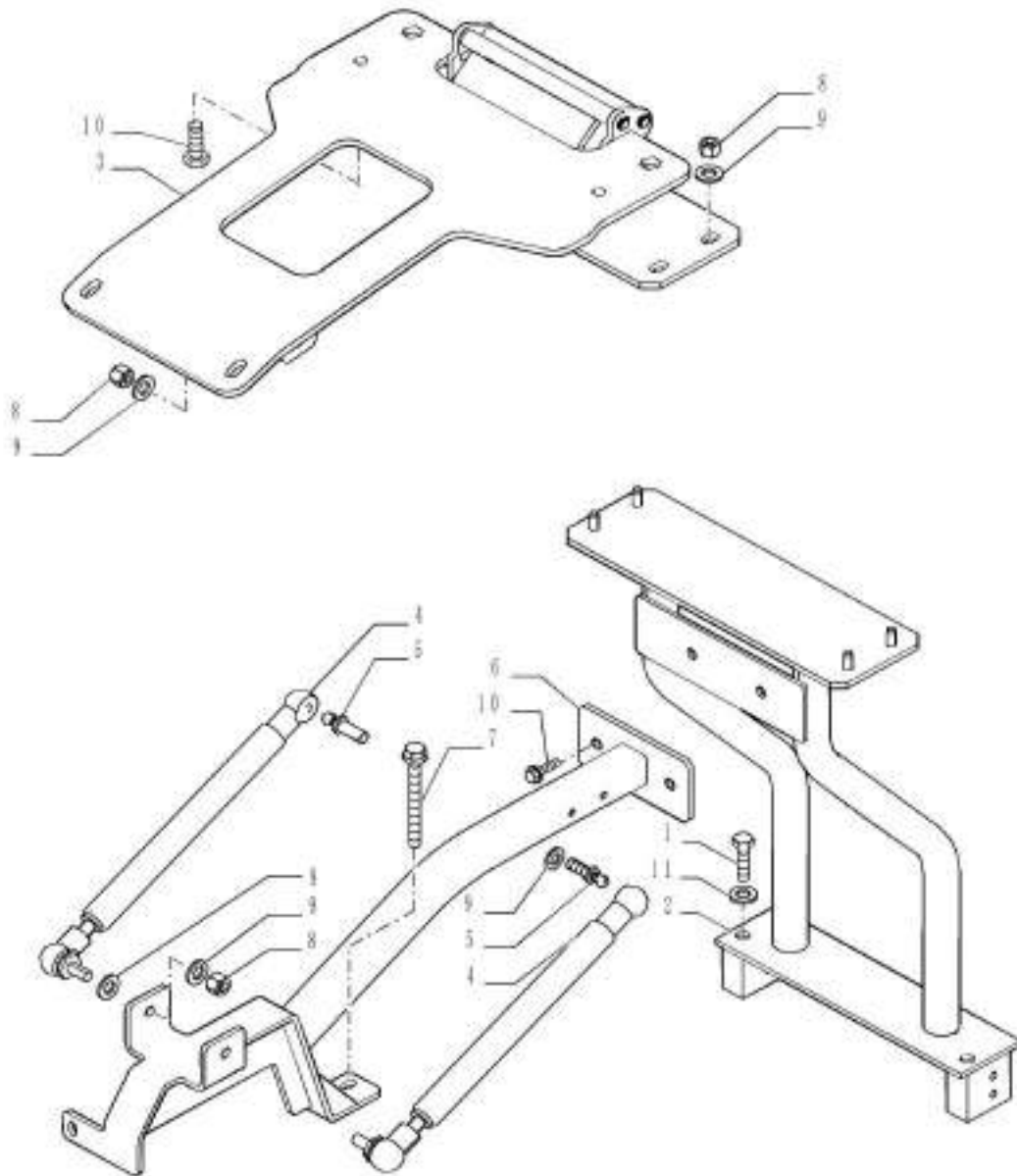

VAR - 333606, 334318, 334319, 391606, 392315 - HOOD CLOSING SUPPORT

REF FN	PART NUMBER	YR/SN	QTY DESCRIPTION
1	15541221		2 SCREW Hex, M12 x 1.25 x 70mm, CI 8.8
2	84424549		1 SUPPORT
3	84424638		1 SUPPORT
4	84599457		2 GAS STRUT
5	5097629		2 BALL JOINT
6	84424635		1 SUPPORT
7	NSS		2 NOT SERVICED SEPARATELY Screw
8	16100821		8 NUT M8, CI 10
9	12601374		16 WAVE WASHER Wave, 8.40mm ID x 15.00mm OD x 0.80mm, 3.00mm, CST, DAC
10	16287021		8 BOLT Hex, M8 x 16mm, CI 8.8
11	12601574		2 WAVE WASHER Wave, M13

Valid for Var. 333606 or Var. 334318 or Var. 334319 or Var. 391606 or Var. 392315

FARMALL JX70

90.102.AW

02

p1

1/2014

VAR - 333606, 334318, 334319, 391606, 392315 - HOOD CLOSING SUPPORT

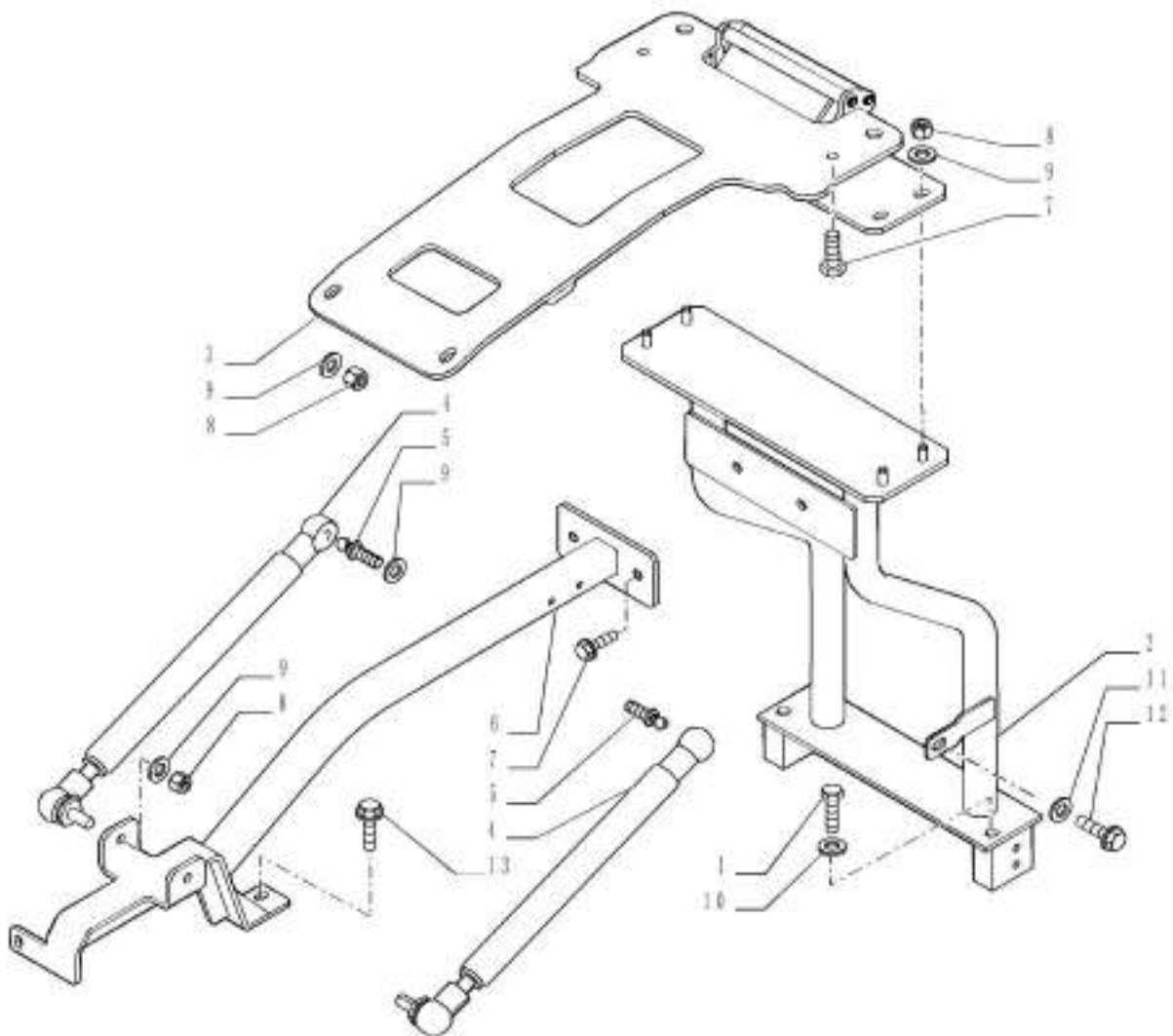

VAR - 333606, 334318, 334319, 391606, 392315 - HOOD CLOSING SUPPORT

REF FN	PART NUMBER	YR/SN	QTY DESCRIPTION
1	15541221		2 SCREW Hex, M12 x 1.25 x 70mm, CI 8.8
2	1 84424546		1 SUPPORT
2	2 84424633		1 SUPPORT
3	84424627		1 HINGE
4	84565969		2 GAS STRUT
5	5097629		2 BALL JOINT
6	84399923		1 SUPPORT
7	16287021		14 BOLT Hex, M8 x 16mm, CI 8.8
8	16100821		8 NUT M8, CI 10
9	12601374		16 WAVE WASHER Wave, 8.40mm ID x 15.00mm OD x 0.80mm, 3.00mm, CST, DAC
10	12601574		1 WAVE WASHER Wave, M13
11	12601474		1 WAVE WASHER Wave, 10.50mm ID x 21.00mm OD x 0.80mm, 3.00mm, CST, DAC
12	15970421		1 SCREW Hex, M10 x 1.25 x 18mm, CI 8.8, Full Thd
13	16297721		2 BOLT

(1) Valid for FARMALL JX75, 90, 100, 110 Models Only

(2) Valid for FARMALL JX80 Model Only

Valid for Var. 333606 or Var. 334318 or Var. 334319 or Var. 391606 or Var. 392315

FARMALL JX100
 FARMALL JX110
 FARMALL JX75
 FARMALL JX80

VAR - 333606, 334318, 334319, 391606, 392315 - BULKHEAD

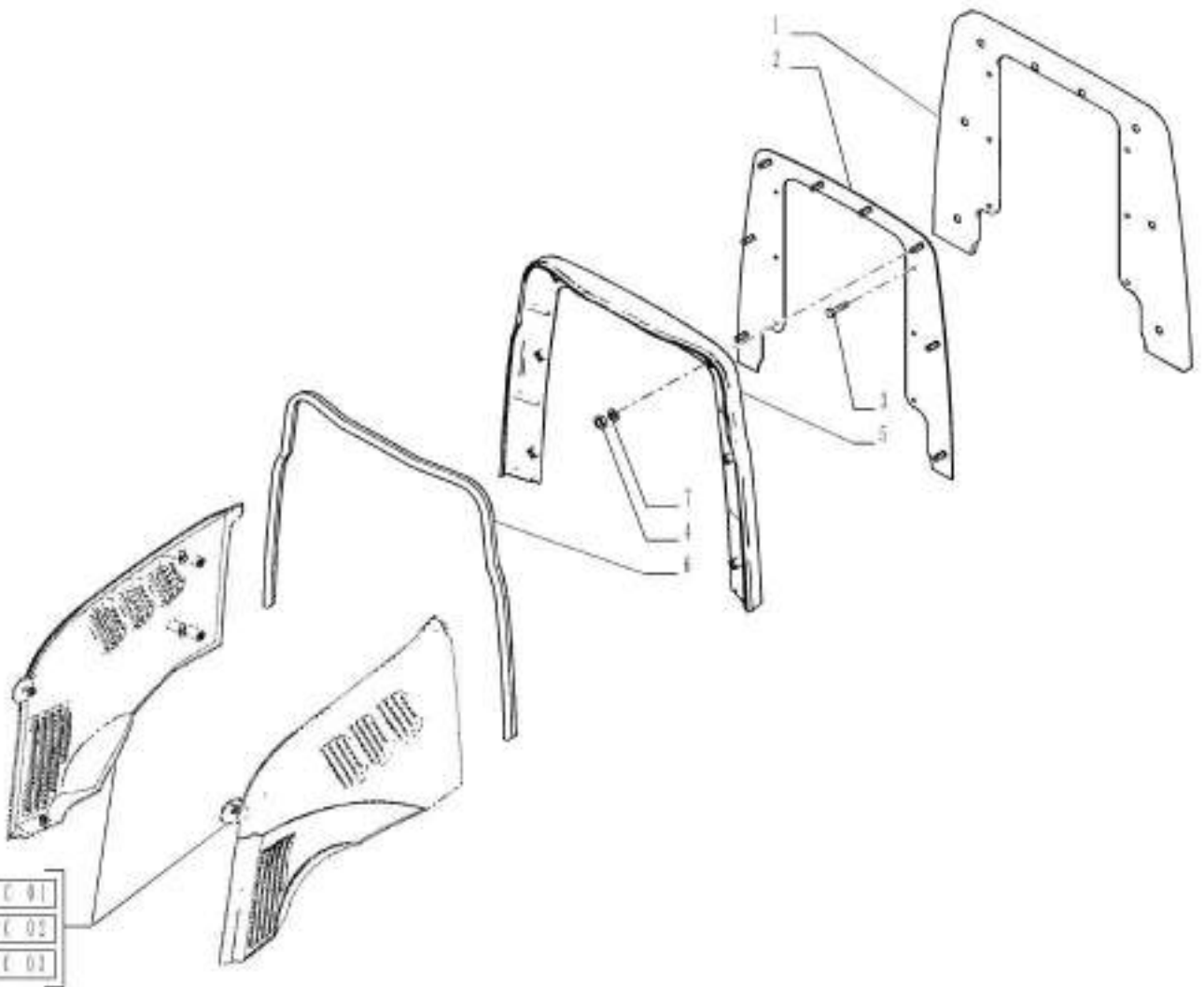

VAR - 333606, 334318, 334319, 391606, 392315 - BULKHEAD

REF FN	PART NUMBER	YR/SN	QTY DESCRIPTION
1	84424596		1 SPACER
2	^{1,2} 84487185		1 SUPPORT
3	9804258		8 BOLT Hvy Hex, M8 x 1.25 x 20mm, Cl 8.8, Full Thd
4	16100821		8 NUT M8, Cl 10
5	1 84487198		1 SPACER
5	2 84487199		1 SPACER
5	3 84527849		1 SPACER
6	1 84424597		1 GASKET
6	2 84424686		1 GASKET
7	12601374		8 WAVE WASHER Wave, 8.40mm ID x 15.00mm OD x 0.80mm, 3.00mm, CST, DAC

- (1) Valid for FARMALL JX70 Model Only
(2) Valid for FARMALL JX75, 90,100, 110 Models Only
(3) Valid for FARMALL JX80 Model Only

Valid for Var. 333606 or Var. 334318 or Var. 334319 or Var. 391606 or Var. 392315

FARMALL JX100 FARMALL
JX110 FARMALL JX70
FARMALL JX75 FARMALL
JX80 FARMALL JX90

90.108.AA

01

p1

1/2014

VAR - 330641, 390641 - DECALS, CONTROLS



55.091.41 01

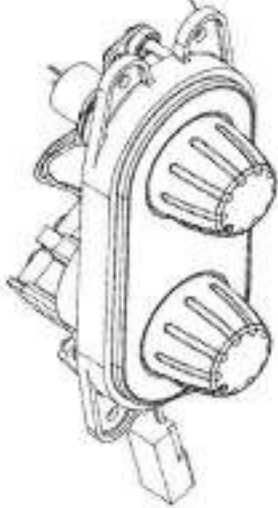

90.108.01 01

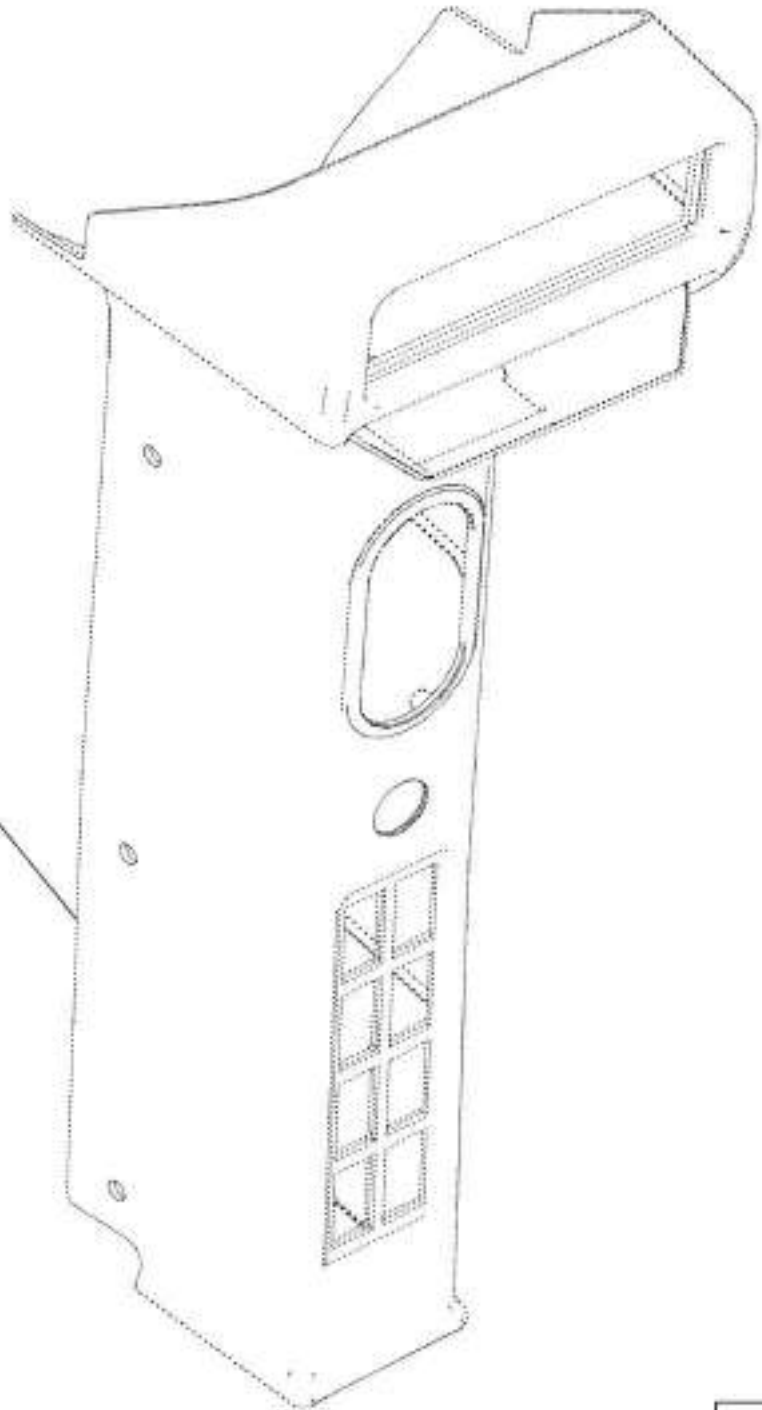

90.108.AA

01

p1

1/2014

VAR - 330641, 390641 - DECALS, CONTROLS

REF	FN	PART NUMBER	YR/SN	QTY	DESCRIPTION
1	1	84527891		1	DECAL A/C
1	2	84527892		1	DECAL Heater
(1)		VAR - 330641 - Air Conditioning			
(2)		VAR - 390641			

Valid for Var. 330641 or Var. 390641

FARMALL JX100 FARMALL
JX110 FARMALL JX70
FARMALL JX75 FARMALL
JX80 FARMALL JX90

VAR - 334342, 334343, 334344, 334345, 334346, 334347 - DECALS, MODEL IDENTIFICATION

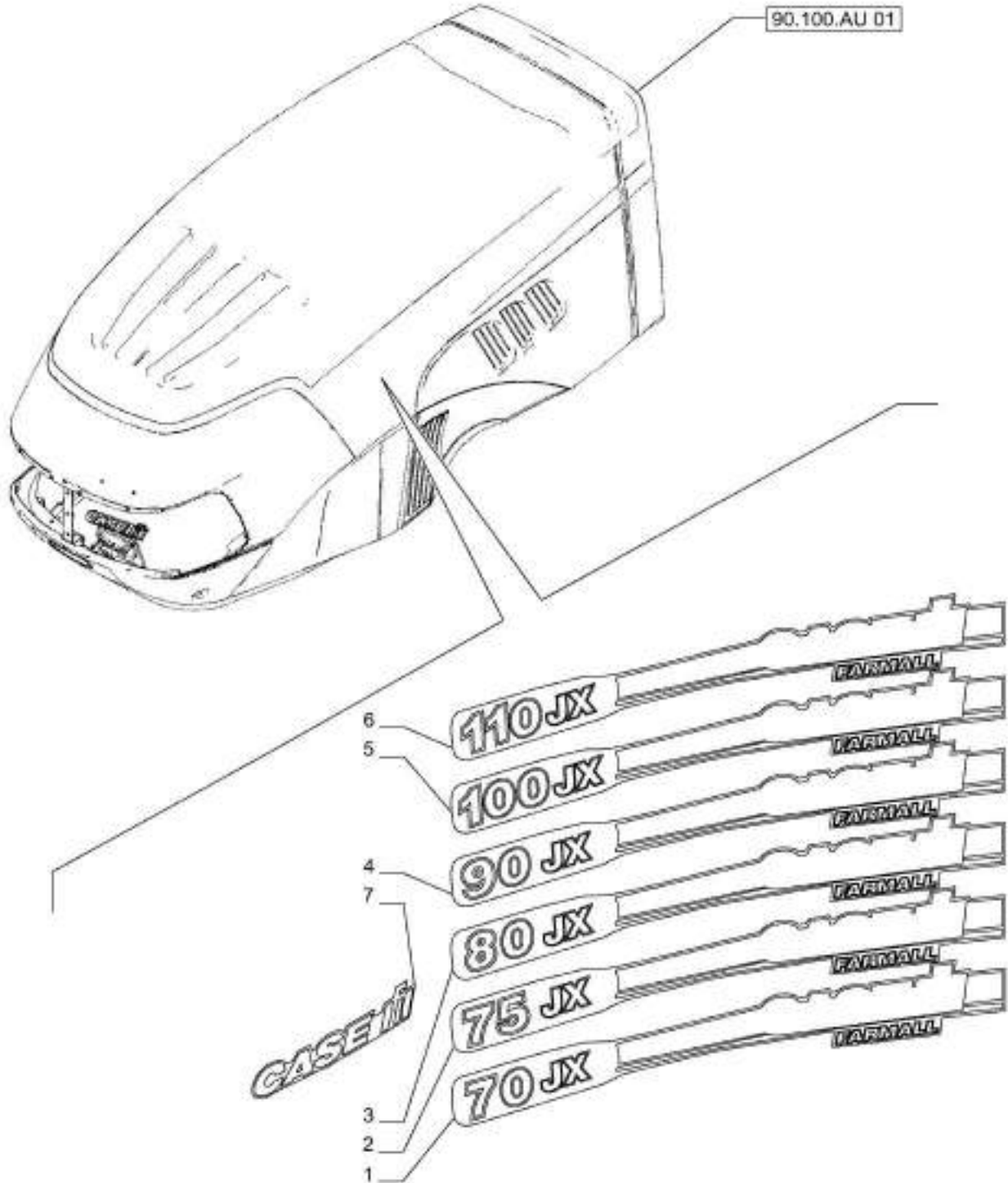

VAR - 334342, 334343, 334344, 334345, 334346, 334347 - DECALS, MODEL IDENTIFICATION

REF FN	PART NUMBER	YR/SN	QTY DESCRIPTION
1	84570861		1 DECAL RH, Farmall 70JX
1	84570893		1 DECAL LH, Farmall 70JX
2	84570636		1 DECAL RH, Farmall 75JX
2	84570610		1 DECAL LH, Farmall 75JX
3	84570846		1 DECAL RH, Farmall 80JX
3	84570887		1 DECAL LH, Farmall 80JX
4	84570626		1 DECAL RH, Farmall 90JX
4	84570608		1 DECAL LH, Farmall 90JX
5	84570624		1 DECAL RH, Farmall 100JX
5	84570606		1 DECAL LH, Farmall 100JX
6	84570620		1 DECAL RH, Farmall 110JX
6	84570602		1 DECAL LH, Farmall 110JX
7	87647875		2 DECAL

Valid for Var. 334342 or Var. 334343 or Var. 334344 or Var. 334345 or Var. 334346 or Var. 334347	FARMALL JX100 FARMALL JX110 FARMALL JX70 FARMALL JX75 FARMALL JX80 FARMALL JX90
--	---

90.108.AB

02

p1

1/2014

VAR - 334351, 334352 - MODEL IDENTIFICATION DECALS, LOADER ARM

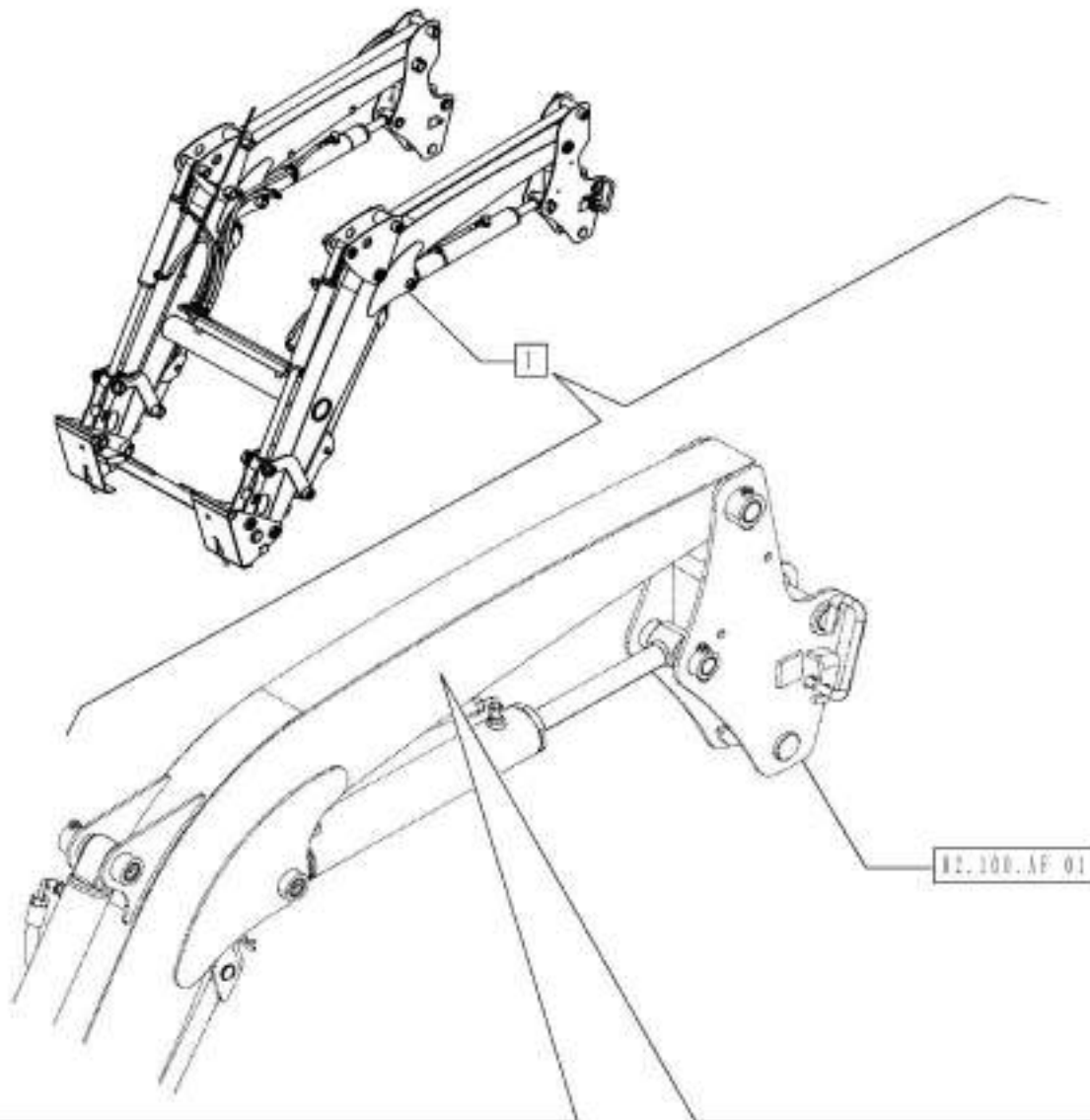

VAR - 334351, 334352 - MODEL IDENTIFICATION DECALS, LOADER ARM

REF FN	PART NUMBER	YR/SN	QTY DESCRIPTION
1	^{1,2} 84467877		1 LOADER ARM Incl 2 - 4
1	^{1,3} 84467881		1 LOADER ARM Incl 2 - 4
2	84524627		1 DECAL
3	84524628		1 DECAL
4	87647875		1 DECAL
(1)	See Breakdown in Section 35, 82 and 90		
(2)	VAR - 334351		
(3)	VAR - 334352		

Valid for Var. 334351 or Var. 334352

FARMALL JX100
FARMALL JX110
FARMALL JX75
FARMALL JX90

VAR - 333606, 334318, 334319, 391606, 392315 - DECALS, WARNING, ISO

REF FN	PART NUMBER	YR/SN	QTY DESCRIPTION
1	84590041		1 DECAL
2	5097514		1 DECAL
3	5095014		1 DECAL
4	47133620		1 DECAL
5	82010947		1 WARNING DECAL
6	47137032		1 DECAL
7	81871830		2 DECAL
8	5194556		1 DECAL
9	82015448		1 DECAL
10	87577208		1 DECAL
11	86521672		1 DECAL
12	87326817		1 DECAL
13	5094433		1 DECAL
14	5093063		1 DECAL
15	82010204		1 DECAL
16	1 5093065		1 DECAL

(1) Valid for FARMALL JX110 Model Only

Valid for Var. 333606 or Var. 334318 or Var. 334319 or Var. 391606 or Var. 392315

FARMALL JX100 FARMALL
JX110 FARMALL JX70
FARMALL JX75 FARMALL
JX80 FARMALL JX90

VAR - 334395 - DECALS, WARNING, ISO

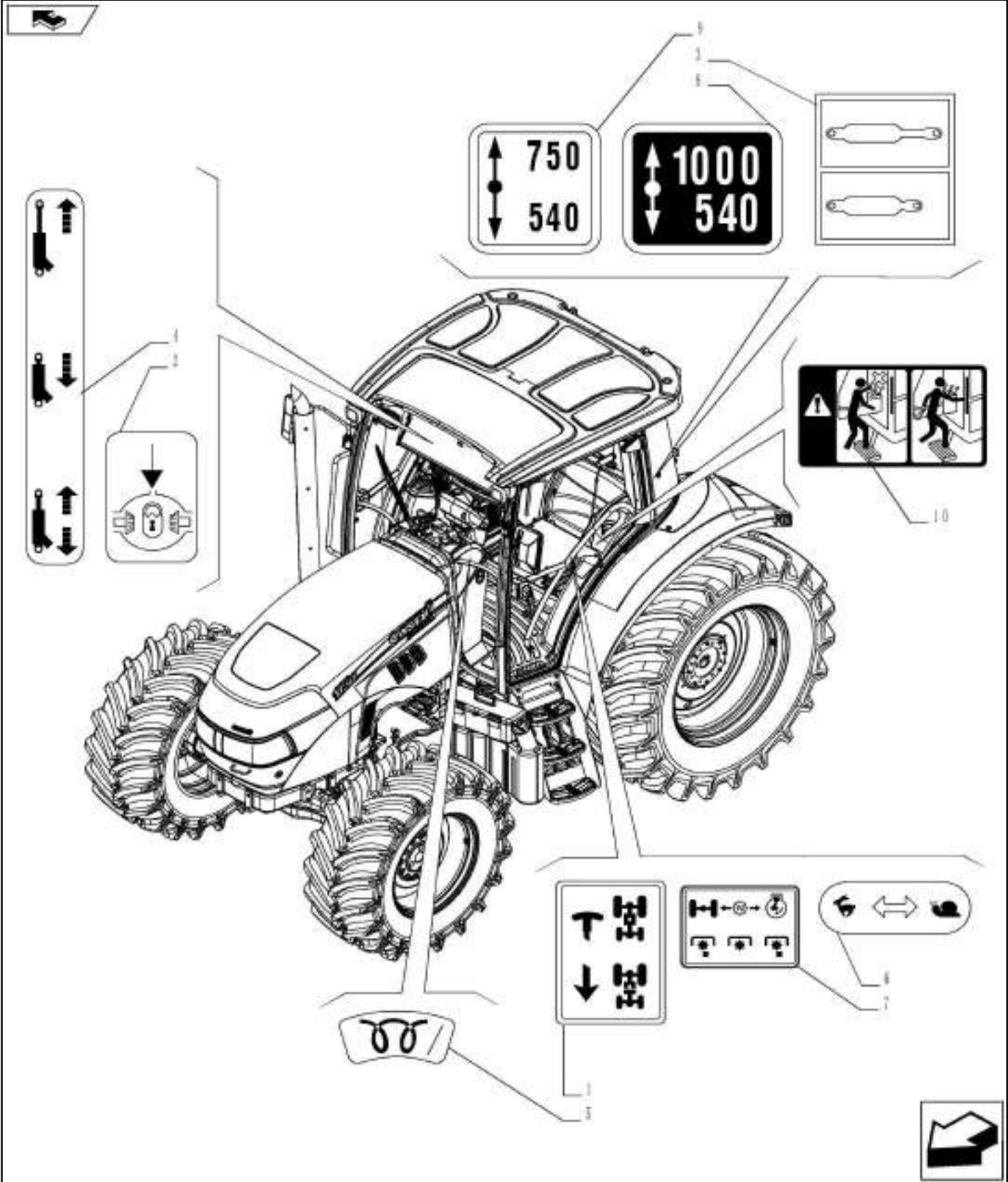

VAR - 334395 - DECALS, WARNING, ISO

REF	FN	PART NUMBER	YR/SN	QTY	DESCRIPTION
1	1	5093787		1	DECAL
2		83987788		1	DECAL
3		5095345		AR	DECAL
4		81871925		1	DECAL
5		5093064		1	DECAL
6		5097515		1	DECAL
7		5088947		1	DECAL
8		5163402		1	DECAL
9		44909184		1	DECAL
10		5122191		1	DECAL
10		81871702		2	DECAL
(1)		4WD Only			
Valid for Var. 334395					FARMALL JX100 FARMALL JX110 FARMALL JX70 FARMALL JX75 FARMALL JX80 FARMALL JX90

VAR - 333606, 334318, 334319, 391606, 392315 - DECALS, WARNING, ISO

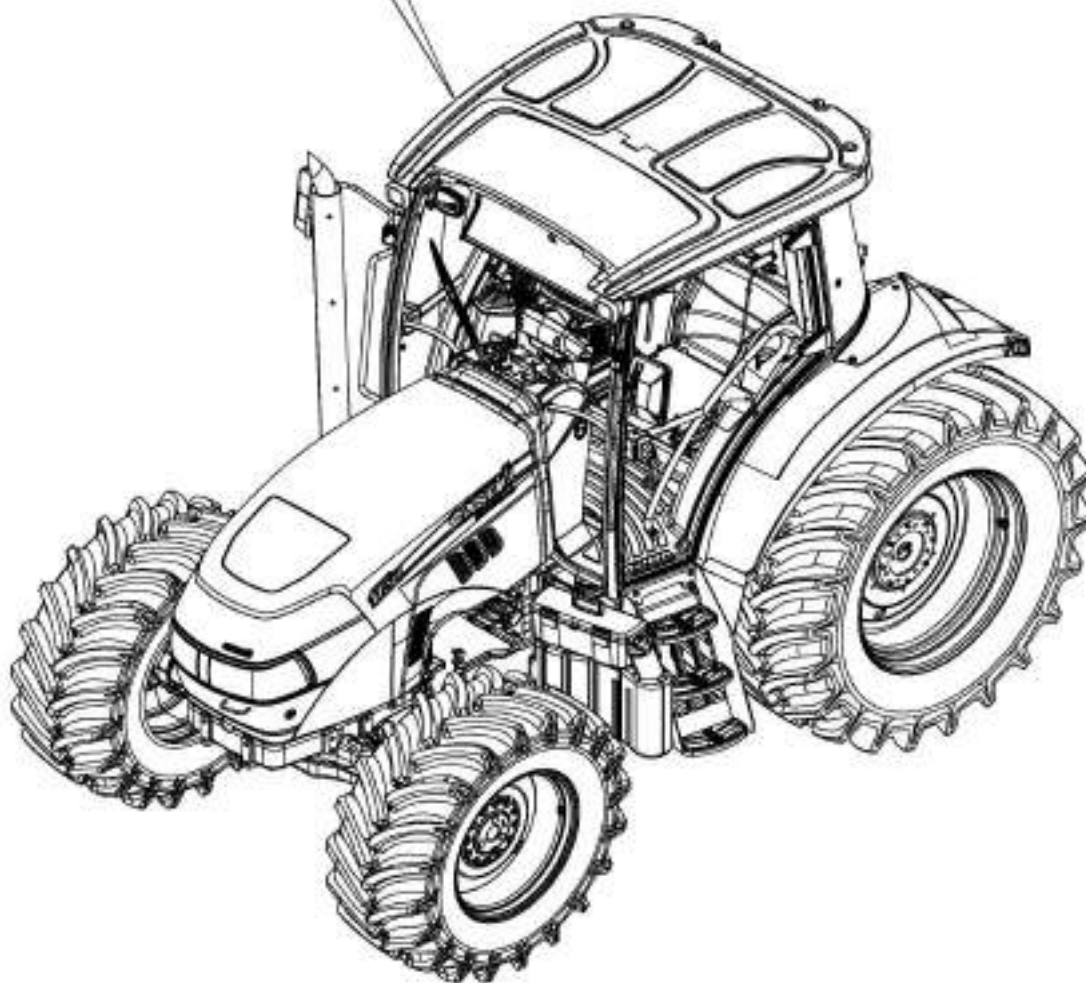

VAR - 333606, 334318, 334319, 391606, 392315 - DECALS, WARNING, ISO

REF	FN	PART NUMBER	YR/SN	QTY	DESCRIPTION
1	1	84390553		1	DECAL
2	2	84390554		1	DECAL
3	3	84390555		1	DECAL
4	4	84598971		1	DECAL
(1)		Valid for FARMALL JX70 Model Only			
(2)		Valid for FARMALL JX75, 80, 90 Models Only			
(3)		Valid for FARMALL JX100 Model Only			
(4)		Valid for FARMALL JX110 Model Only			

Valid for Var. 333606 or Var. 334318 or Var. 334319 or Var. 391606 or Var. 392315

FARMALL JX100 FARMALL
JX110 FARMALL JX70
FARMALL JX75 FARMALL
JX80 FARMALL JX90

VAR - 334351, 334352 - SAFETY DECALS, LOADER ARM



92.108.AF.01

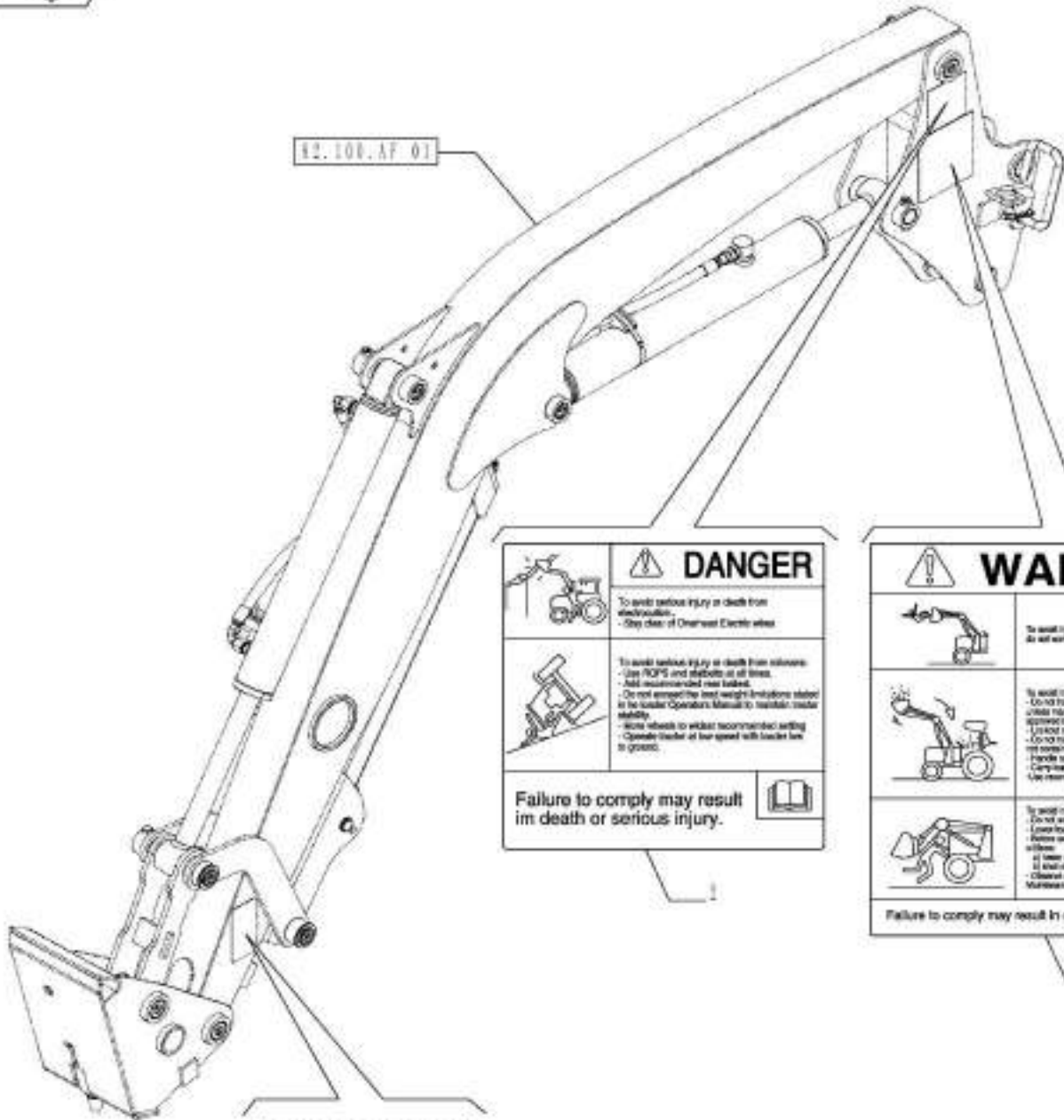

	⚠ DANGER To avoid serious injury or death from electrocution: - Stay clear of Overhead Electric wires
	To avoid serious injury or death from rollovers: - Use ROPS and seatbelts at all times. - Add recommended rear ballast. - Do not exceed the load weight limitations stated in the loader Operator's Manual to maintain tractor stability. - Avoid speeds to exceed recommended setting. - Operate loader at low speed with loader low to ground.
Failure to comply may result in death or serious injury.	

	⚠ WARNING To avoid injury or death from falls: - Do not work from or above the loader or its attachments.
	To avoid injury or death caused by falling loads: - Do not handle round logs or other large objects with loader. - Use manufacturer's approved buckets, grapples or other approved load handling equipment as permitted. - Do not handle loads or attach loads with loader that are not contained in bucket. - Handle speed limits with caution. - Compensate for use recommended POPS with loader application.
	To avoid injury or death caused from falling loads: - Do not work to perform service jobs a loaded bucket. - Lower bucket to ground when parked. - Before working, attaching equipment or disassembling, adjust: - all boom attachment to ground to support loader base. - all kind of angles and other hydraulic pressure. - Observe safety procedures in Loader Operation and Maintenance Manual.
Failure to comply may result in death or serious injury.	

⚠ WARNING
To avoid injury or death from falling attachments, make sure all tool pins are engaged/locking through holes.
Failure to comply may result in death or serious injury.



90.108.AD

01

p1

1/2014

VAR - 333606, 334318, 334319, 391606, 392315 - DECALS - TRADEMARK EMBLEM

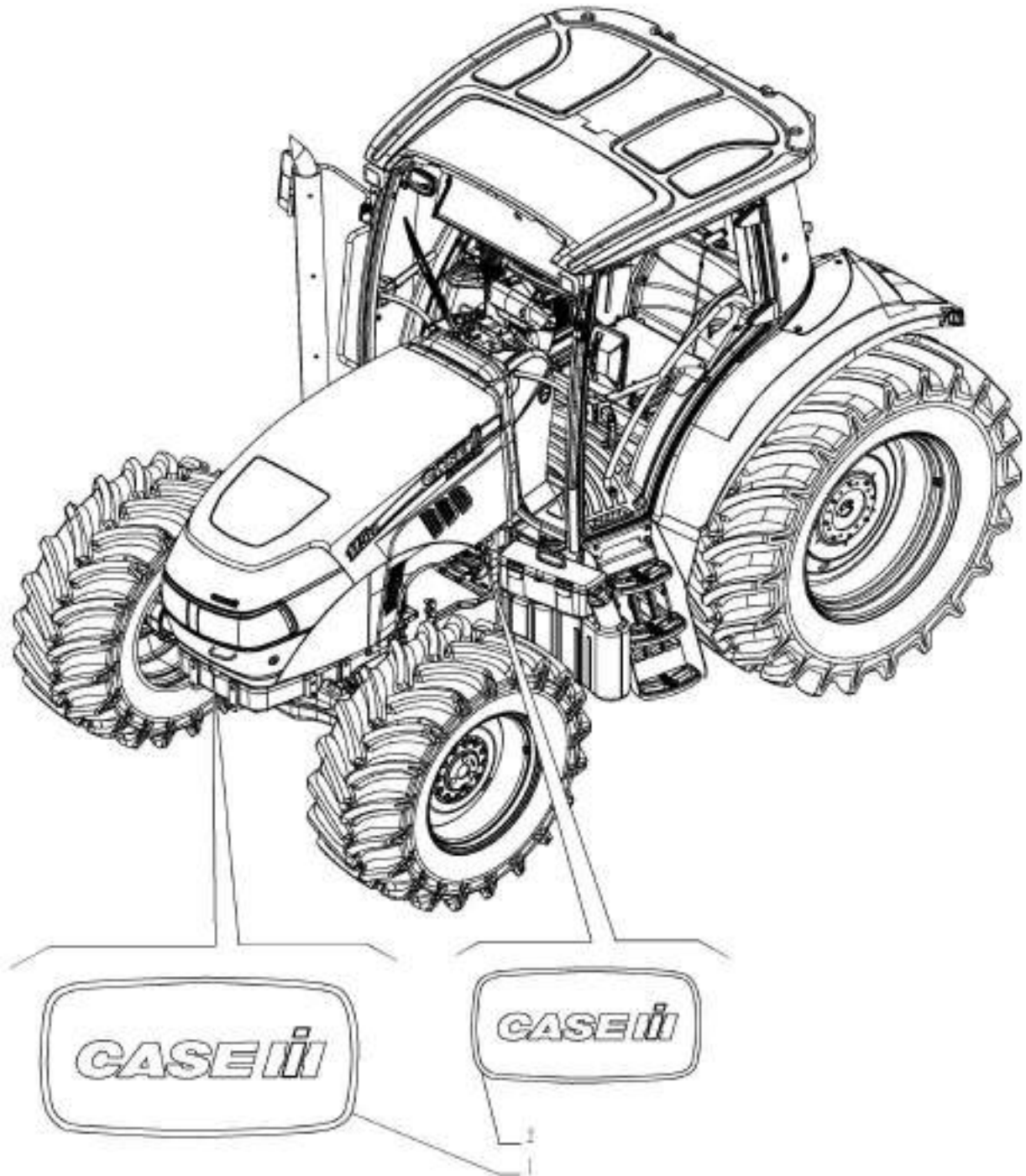

90.108.AD

01

p1

1/2014

VAR - 333606, 334318, 334319, 391606, 392315 - DECALS - TRADEMARK EMBLEM

REF FN	PART NUMBER	YR/SN	QTY DESCRIPTION
1	87679098		1 DECAL
2	87679108		1 DECAL

Valid for Var. 333606 or Var. 334318 or Var. 334319 or Var. 391606 or Var. 392315

FARMALL JX100 FARMALL
JX110 FARMALL JX70
FARMALL JX75 FARMALL
JX80 FARMALL JX90

90.110.AH

01

p1

1/2014

VAR - 333606, 334318, 334319, 391606, 392315 - INSTRUMENT PANEL, ROPS

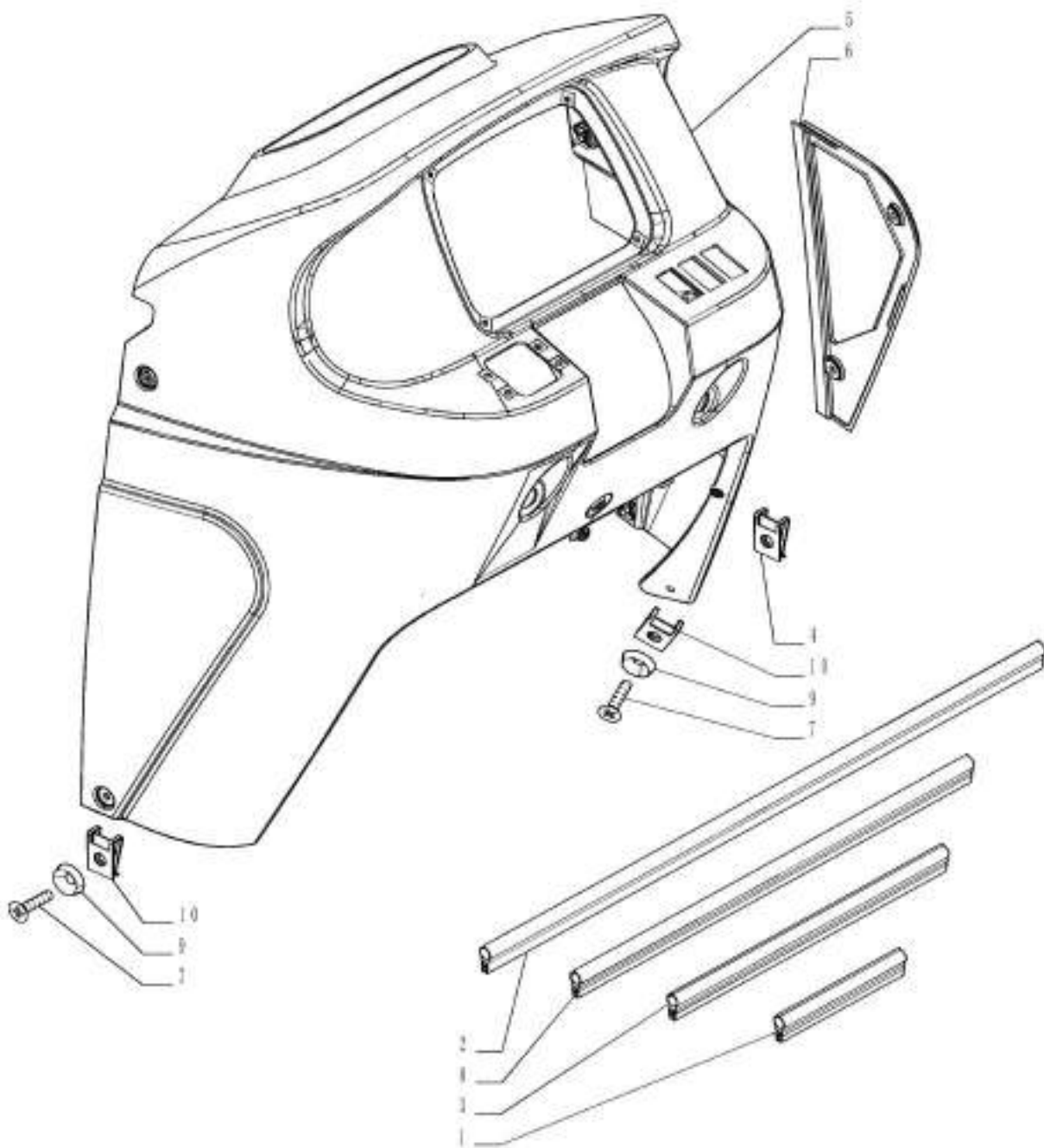

VAR - 333606, 334318, 334319, 391606, 392315 - INSTRUMENT PANEL, ROPS

REF FN	PART NUMBER	YR/SN	QTY DESCRIPTION
1	84526330		1 GASKET
2	84526331		1 GASKET
3	84526328		1 GASKET
4	5174673		2 KIT
5	84561819		1 HOOD
6	84520298		1 COVER
7	13301511		7 SCREW Phil Flat Hd, M6 x 20, 5.8
8	84526333		1 GASKET
9	84524958		7 WASHER
10	84524985		7 SPRING NUT

Valid for Var. 333606 or Var. 334318 or Var. 334319 or Var. 391606 or Var. 392315

FARMALL JX100 FARMALL
JX110 FARMALL JX70
FARMALL JX75 FARMALL
JX80 FARMALL JX90

90.110.AV

01

p1

1/2014

VAR - 334318, 334319, 392315 - PASSENGER SEAT, SIDE PANEL, ROPS

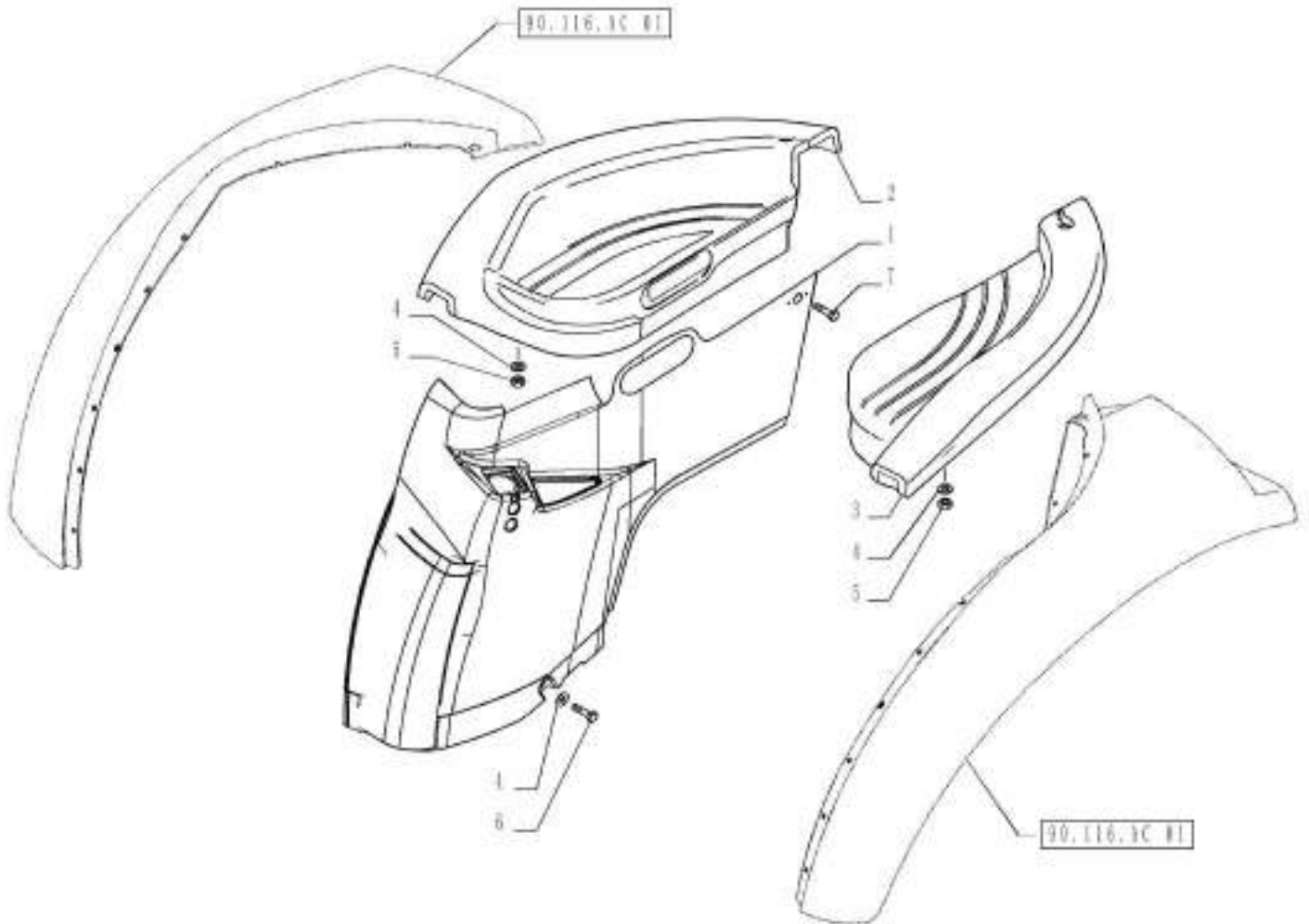

VAR - 334318, 334319, 392315 - ROPS, FRAME

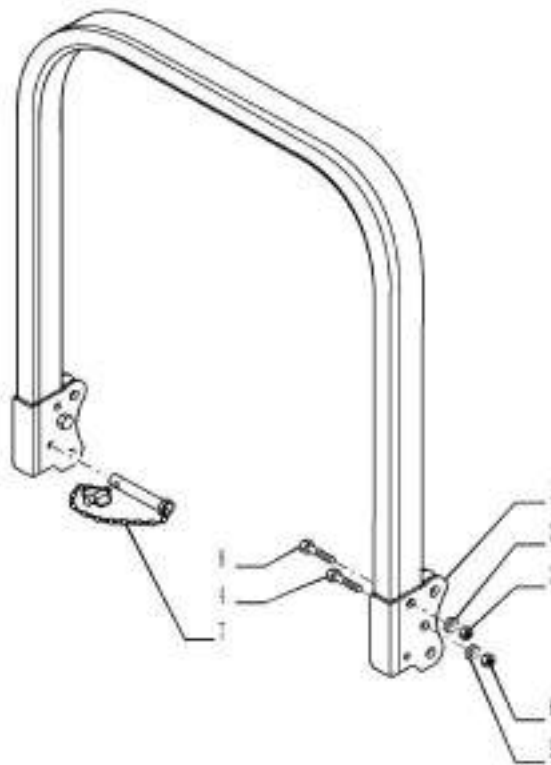

90.114.AQ

01

p1

1/2014

VAR - 334318, 334319, 392315 - ROPS, FRAME

REF FN	PART NUMBER	YR/SN	QTY DESCRIPTION
1	47365735		1 ROPS
2	12646701		2 WASHER Flat, 8.15mm ID x 20.00mm OD x 2.00mm, Carbon Steel, ZND
3	87597953		2 NUT M8, 1.25 Pitch, 10.6mm High, CI 8, ZND
4	15985234		2 SCREW
5	10520321		2 WASHER M18 x 32 x 4
6	12575021		2 NUT M18 x 1.5, CI 10
7	5095360		2 PIN
8	16233921		2 SCREW

Valid for Var. 334318 or Var. 334319 or Var. 392315	FARMALL JX100 FARMALL JX110 FARMALL JX70 FARMALL JX75 FARMALL JX80 FARMALL JX90
--	--

VAR - 334318, 334319 - ROPS, ROPS FRAME CANOPY

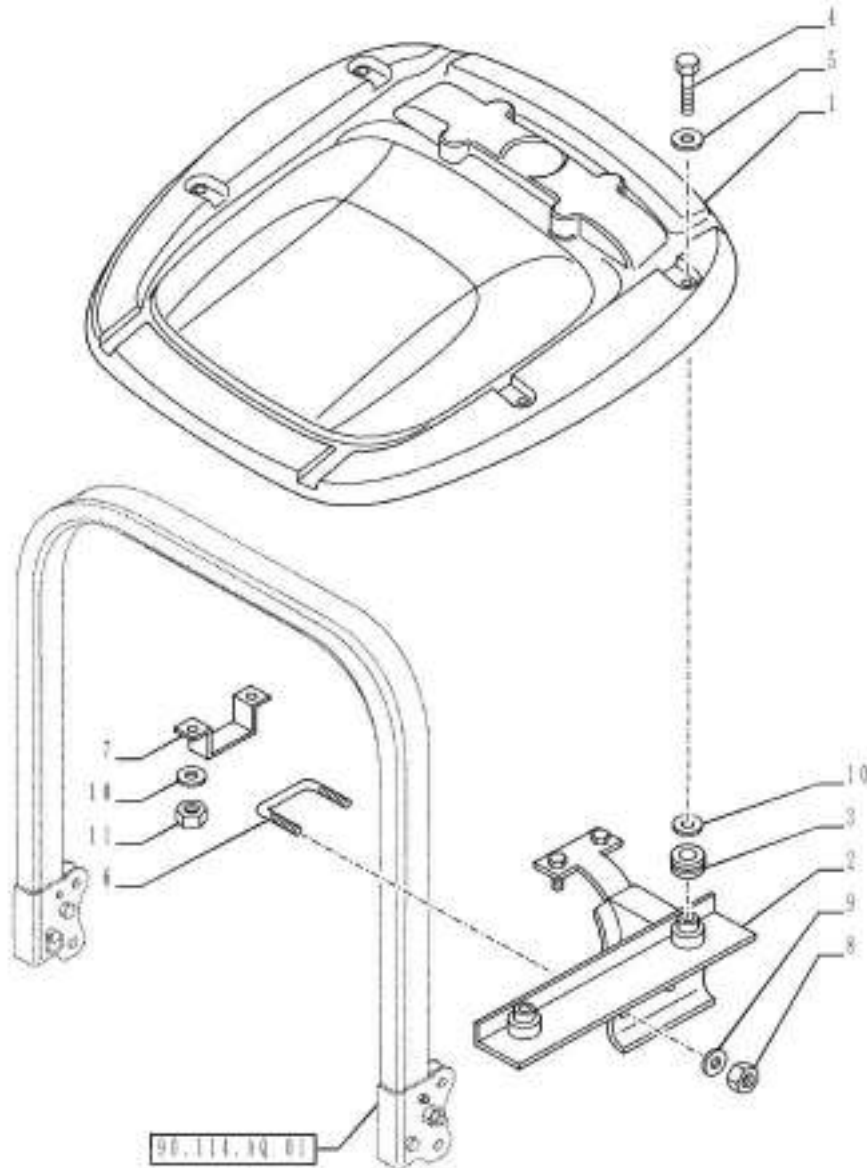

90.114.AR

01

p1

1/2014

VAR - 334318, 334319 - ROPS, ROPS FRAME CANOPY

REF FN	PART NUMBER	YR/SN	QTY DESCRIPTION
1	87550446		1 CANOPY
2	84527234		1 SUPPORT RH
2	84527233		1 SUPPORT LH
3	5089936		4 GROMMET
4	15970721		4 SCREW Hex, M10 x 1.25 x 25mm, Cl 8.8, Full Thd
5	12644301		4 WASHER M10 x 35 x 3
6	5097407		2 BOLT
7	5097408		2 SUPPORT
8	12574511		4 LOCK NUT M10 x 1.25, Cl 8
9	12638601		4 WASHER M10 x 18 x 2
10	12601474		8 WAVE WASHER Wave, 10.50mm ID x 21.00mm OD x 0.80mm, 3.00mm, CST, DAC
11	12164711		4 NUT M10 x 1.25, Cl 8

Valid for Var. 334318 or Var. 334319

FARMALL JX100 FARMALL
JX110 FARMALL JX70
FARMALL JX75 FARMALL
JX80 FARMALL JX90

90.116.AC

01

p1

1/2014

VAR - 335928, 391460, 744756 - REAR FENDER

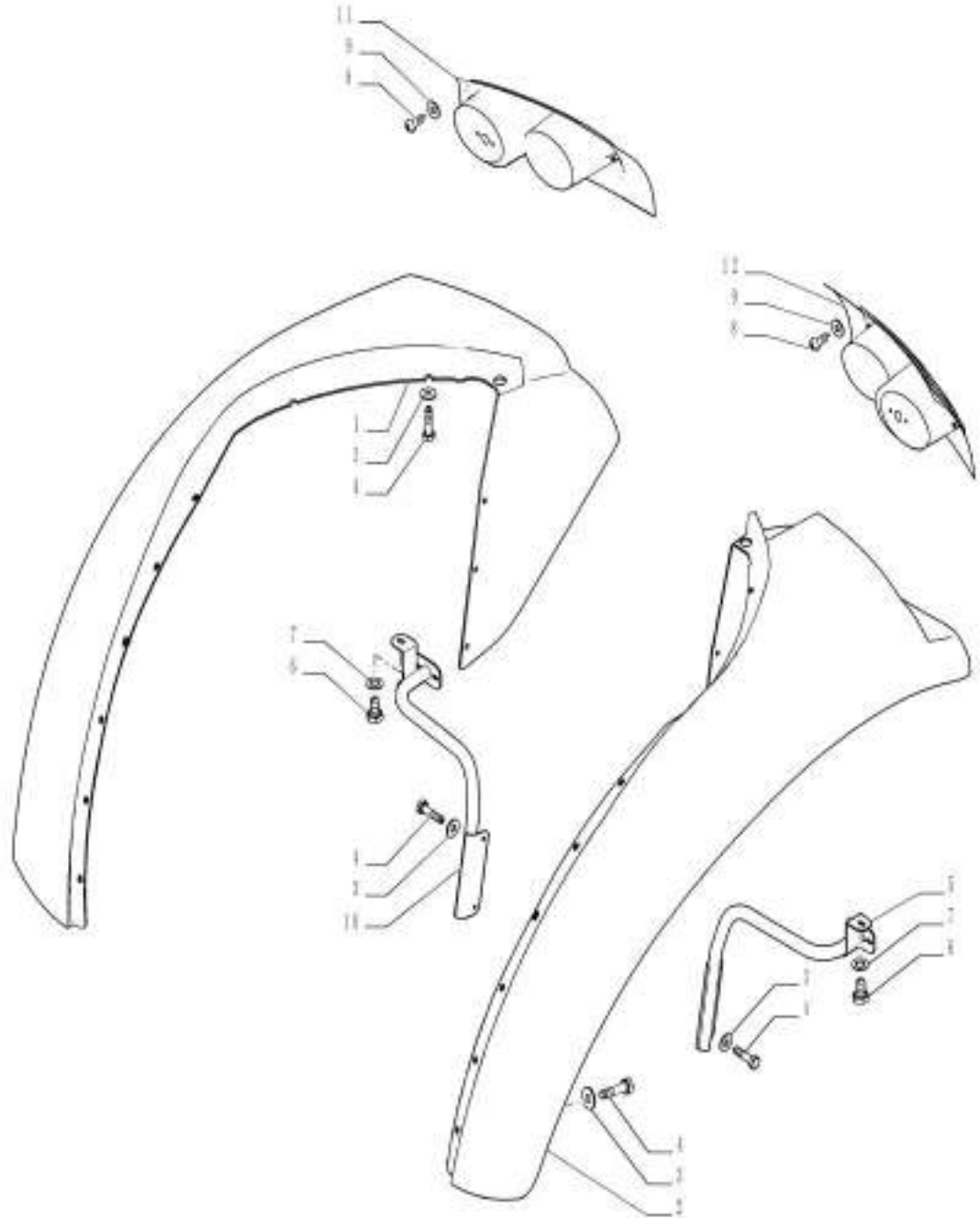

VAR - 335928, 391460, 744756 - REAR FENDER

REF FN	PART NUMBER	YR/SN	QTY DESCRIPTION
1	84520320		1 FENDER
2	84520319		1 FENDER
3	11193274		22 BELLEVILLE WASHER Belleville, M6.4
4	86977786		22 BOLT Hex, M6 x 1 x 25mm, Cl 8.8, Full Thd
5	84487115		1 SUPPORT
6	86624003		2 BOLT Hex, M8 x 14mm, Cl 8.8, Full Thd
7	12601374		2 WAVE WASHER Wave, 8.40mm ID x 15.00mm OD x 0.80mm, 3.00mm, CST, DAC
8	760-14313		4 SELF-TAP SCREW Pan Hd, M4.2 x 13
9	12637804		4 WASHER M5 x 11 x 1
10	84487118		1 SUPPORT
11	84487108		1 BEZEL RH
12	84487107		1 BEZEL LH

Valid for Industrial Var. 335928, 391460 (744756)

FARMALL JX100 FARMALL
 JX110 FARMALL JX70
 FARMALL JX75 FARMALL
 JX80 FARMALL JX90

90.116.AC

02

p1

1/2014

VAR - 335897 - REAR FENDER EXTENSION

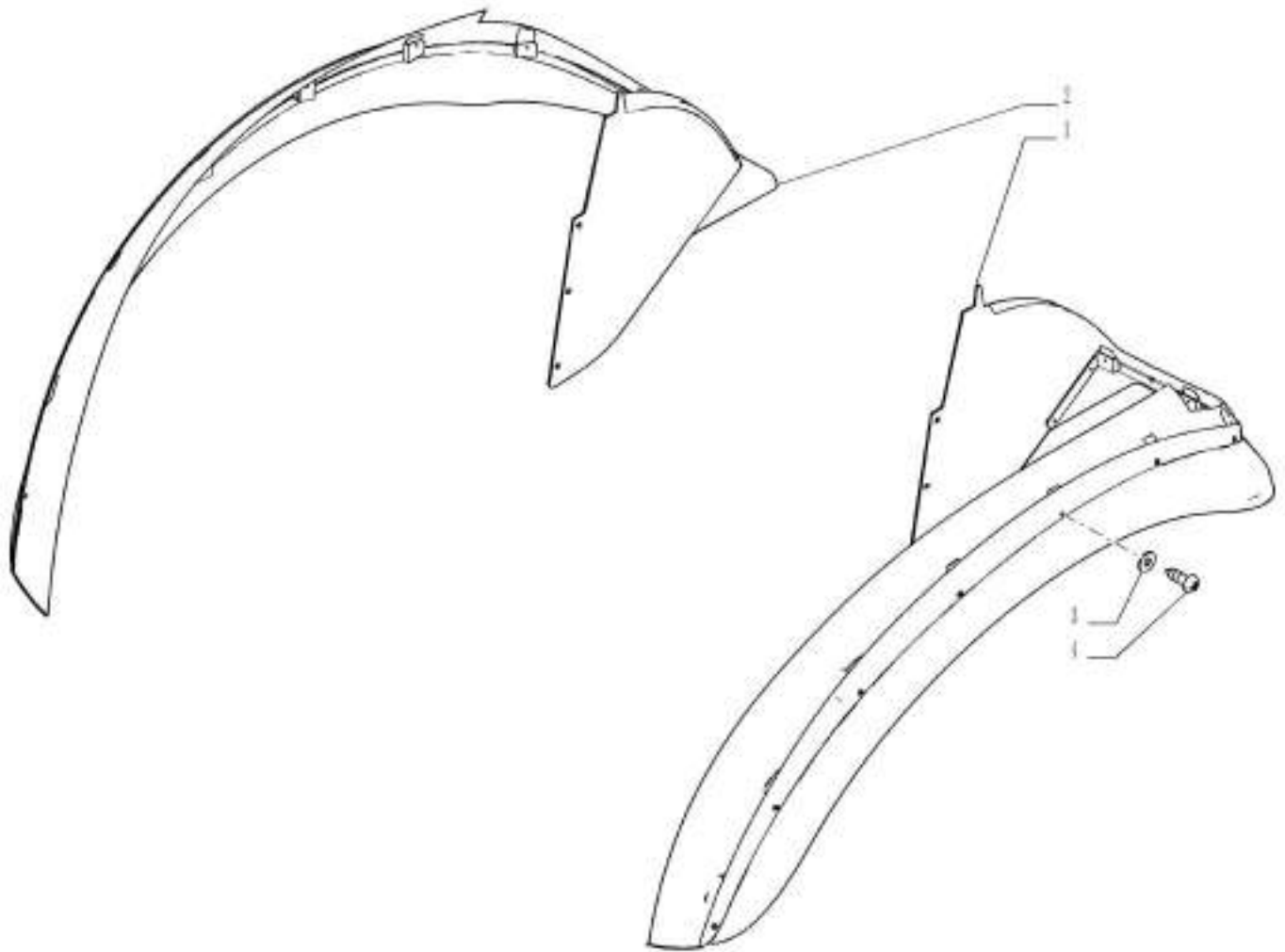

90.116.AC

02

p1

1/2014

VAR - 335897 - REAR FENDER EXTENSION

REF FN	PART NUMBER	YR/SN	QTY DESCRIPTION
1	84575473		1 FENDER EXTENSION
2	84575474		1 FENDER EXTENSION
3	12637804		AR WASHER M5 x 11 x 1
4	760-14313		AR SELF-TAP SCREW Pan Hd, M4.2 x 13

Valid for Var. 335897

FARMALL JX100 FARMALL
JX110 FARMALL JX70
FARMALL JX75 FARMALL
JX80 FARMALL JX90

VAR - 339860 - 4WD FRONT FENDERS, 340 MM

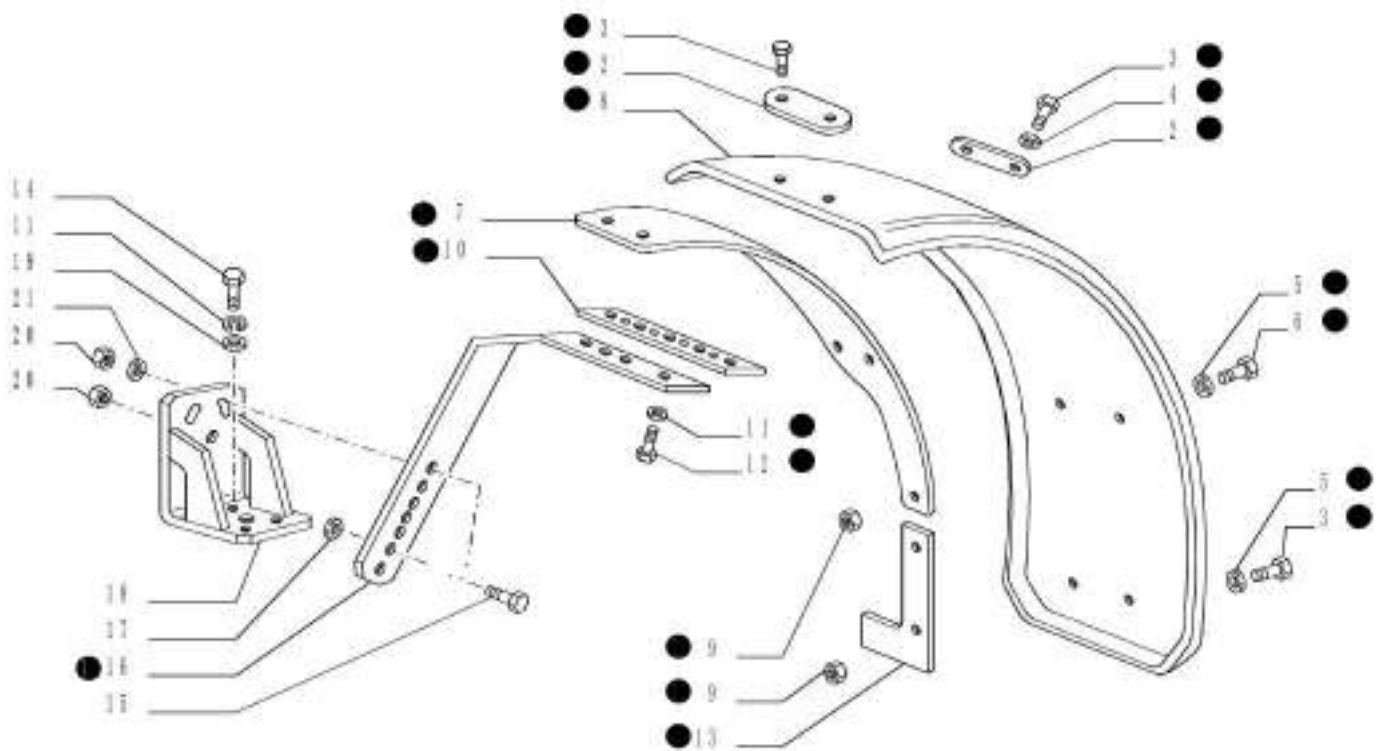
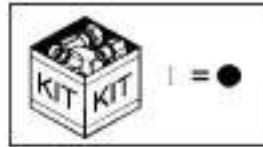

90.116.AC

04

p1

1/2014

VAR - 339860 - 4WD FRONT FENDERS, 340 MM

REF FN	PART NUMBER	YR/SN	QTY DESCRIPTION
1	5089277		1 FRONT FENDER RH, ASSY Incl 2 - 13, 16
1	5090122		1 FRONT FENDER LH, ASSY Incl 2 - 13, 16
2	5148599		2 REINFORCEMENT
3	14782614		5 SCREW Cheese Hd, M10 x 30
4	12601474		2 WAVE WASHER Wave, 10.50mm ID x 21.00mm OD x 0.80mm, 3.00mm, CST, DAC
5	12644301		2 WASHER M10 x 35 x 3
6	14782511		2 SCREW
7	5148596		1 PANEL LH
7	5148597		1 PANEL RH
8	5122261		1 FRONT FENDER
9	12574511		4 LOCK NUT M10 x 1.25, CI 8
10	5148598		1 PLATE
11	11190774		2 BELLEVILLE WASHER 13.00mm ID x 24.00mm OD x 2.80mm, 3.30mm, CI 8.8, DAC
12	15540621		2 SCREW Hex, M12 x 1.25 x 40mm, CI 8.8, Full Thd
13	5148600		3 REINFORCEMENT RH
13	5149441		3 REINFORCEMENT LH
14	15540831		6 BOLT Hex, M12 x 1.25 x 50, 10.9
15	11227021		4 BOLT Hex, M14 x 1.5 x 65, 8.8
16	5148594		1 SUPPORT LH
16	5148595		1 SUPPORT RH
17	5116400		2 LOCK WASHER 12,5 x 35 x 5
18	84291524		2 SUPPORT
19	11198674		4 BELLEVILLE WASHER Belleville, M13
20	12575821		4 LOCK NUT M14 x 1.5, CI 05
21	10520101		4 WASHER M14 x 26 x 3

Valid for Var. 339860

FARMALL JX100
 FARMALL JX110
 FARMALL JX75
 FARMALL JX80

VAR - 339860 - 4WD FRONT FENDERS, 340 MM

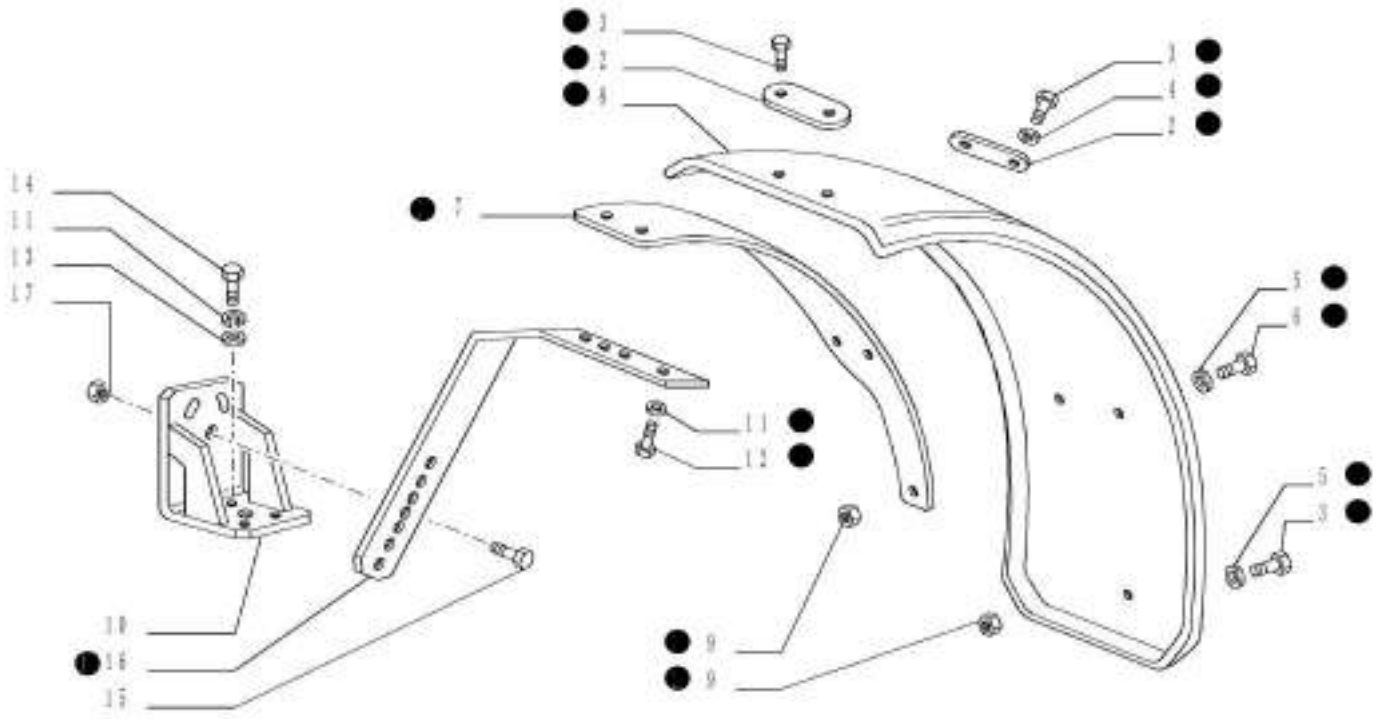
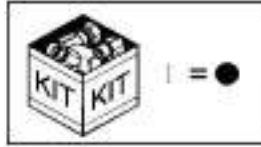

90.116.AC

05

p1

1/2014

VAR - 339860 - 4WD FRONT FENDERS, 340 MM

REF FN	PART NUMBER	YR/SN	QTY DESCRIPTION
1	5090210		1 FENDER RH, ASSY Incl 2 - 9, 11, 12, 16
1	5090211		1 FENDER LH, ASSY Incl 2 - 9, 11, 12, 16
2	5152355		2 PLATE
3	14782614		5 SCREW Cheese Hd, M10 x 30
4	14780511		3 SCREW Cheese Hd, M8 x 25
5	12644301		2 WASHER M10 x 35 x 3
6	12646201		3 WASHER M8 x 35 x 3
7	5152356		1 FRAME LH
7	5152357		1 FRAME RH
8	5137714		1 FRONT FENDER LH
9	16104111		4 NUT Prevailing Torque, M8, 1.25 Pitch, 10.6mm High, CI 08, ZND
10	5152354		2 SUPPORT
11	11190774		2 BELLEVILLE WASHER 13.00mm ID x 24.00mm OD x 2.80mm, 3.30mm, CI 8.8, DAC
12	15540621		2 SCREW Hex, M12 x 1.25 x 40mm, CI 8.8, Full Thd
13	11198674		4 BELLEVILLE WASHER Belleville, M13
14	14233831		6 SCREW M10 x 1.25 x 40mm
15	15541021		4 SCREW Hex, M12 x 1.25 x 60mm, CI 8.8
16	5152353		1 ARM
16	5152352		1 ARM
17	16105021		4 LOCK NUT M12 x 1.25, CI 10

Valid for Var. 339860

FARMALL JX70

VAR - 335495 - 4WD WIDE FRONT FENDERS, 400 MM

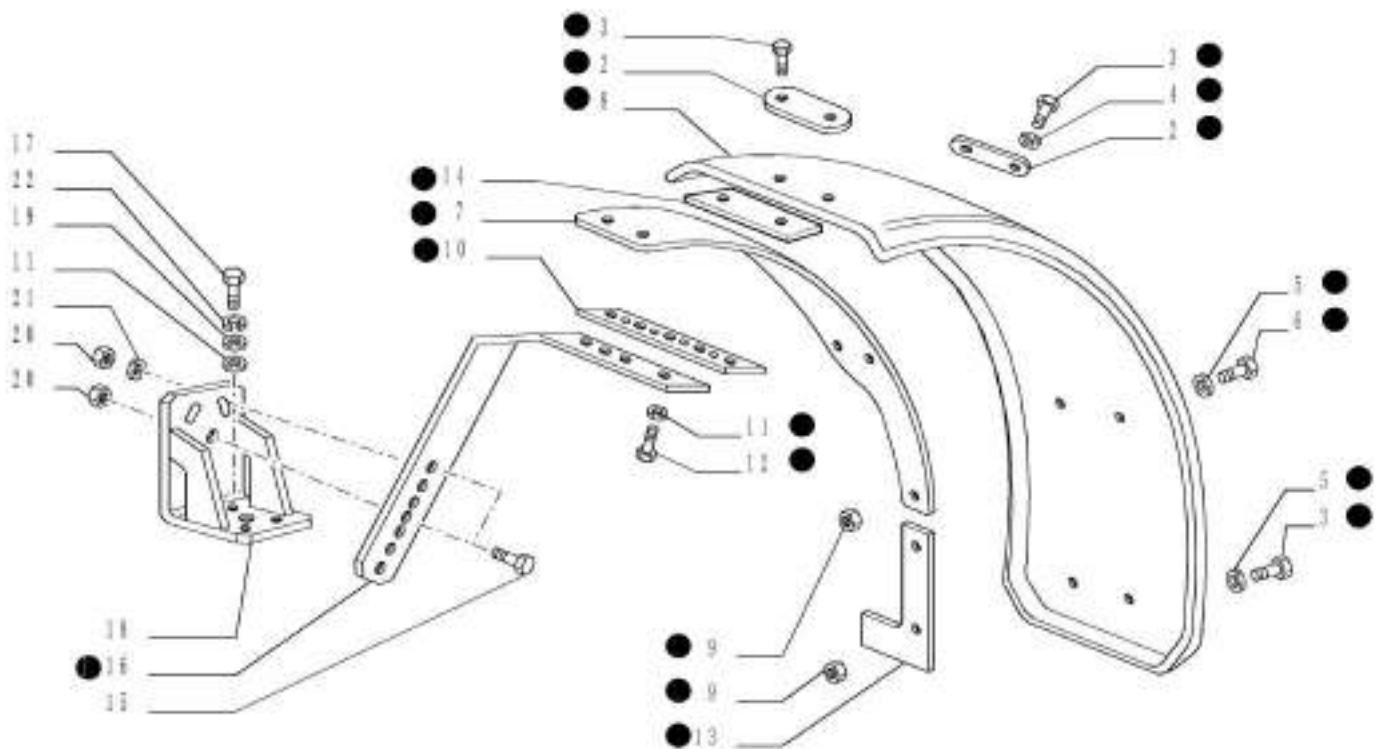
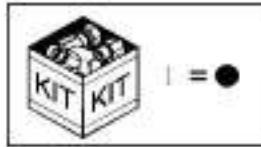

90.116.AC

06

p1

1/2014

VAR - 335495 - 4WD WIDE FRONT FENDERS, 400 MM

REF FN	PART NUMBER	YR/SN	QTY DESCRIPTION
1	5093268		1 FRONT FENDER LH, ASSY, Incl 2 - 14, 16
1	5093271		1 FRONT FENDER RH, ASSY, Incl 2 - 14, 16
2	5148599		2 REINFORCEMENT
3	14782614		5 SCREW Cheese Hd, M10 x 30
4	12601474		2 WAVE WASHER Wave, 10.50mm ID x 21.00mm OD x 0.80mm, 3.00mm, CST, DAC
5	12644301		2 WASHER M10 x 35 x 3
6	14782511		1 SCREW
7	5148596		1 PANEL LH
7	5148597		1 PANEL RH
8	5122325		1 FRONT FENDER 400MM
9	12574511		4 LOCK NUT M10 x 1.25, CI 8
10	5148598		2 PLATE
11	11190774		2 BELLEVILLE WASHER 13.00mm ID x 24.00mm OD x 2.80mm, 3.30mm, CI 8.8, DAC
12	15540621		2 SCREW Hex, M12 x 1.25 x 40mm, CI 8.8, Full Thd
13	5148600		3 REINFORCEMENT LH
13	5149441		3 REINFORCEMENT RH
14	5148601		2 GUARD
15	11227021		4 BOLT Hex, M14 x 1.5 x 65, 8.8
16	5148594		1 SUPPORT LH
16	5148595		1 SUPPORT RH
17	15540831		2 BOLT Hex, M12 x 1.25 x 50, 10.9
18	84291524		2 SUPPORT
19	11198674		4 BELLEVILLE WASHER Belleville, M13
20	12575821		4 LOCK NUT M14 x 1.5, CI 05
21	10520101		4 WASHER M14 x 26 x 3
22	5116400		2 LOCK WASHER 12.5 x 35 x 5

Valid for Var. 335495

FARMALL JX100
 FARMALL JX110
 FARMALL JX75
 FARMALL JX80

90.116.AC

07

p1

1/2014

VAR - 338860 - 2WD FRONT FENDERS, 240 MM.

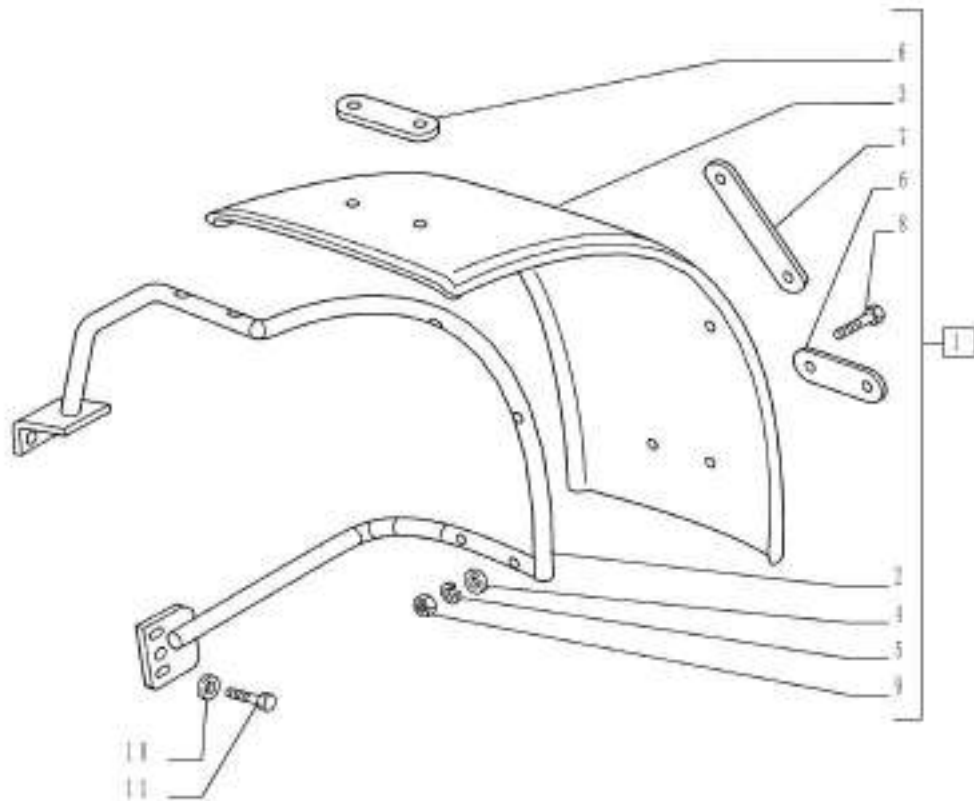

VAR - 338860 - 2WD FRONT FENDERS, 240 MM.

REF FN	PART NUMBER	YR/SN	QTY DESCRIPTION
1	5125199		1 REAR FENDER RH, ASSY Incl 2 - 9
1	5125190		1 REAR FENDER LH, ASSY Incl 2 - 9
2	5125197		1 REAR FENDER RH
2	5125188		1 REAR FENDER LH
3	5125270		1 FRONT FENDER
4	10519601		6 WASHER M8 x 17 x 2
5	12605579		6 WASHER
6	5122259		2 REINFORCEMENT
7	5122260		1 COVER PLATE
8	13181301		6 CARRIAGE BOLT Sq Nk, M8 x 1.25 x 45mm, CI 4.6
9	16102311		6 THIN NUT Thin, M8 x 1.25, CI 04
10	12601474		4 WAVE WASHER Wave, 10.50mm ID x 21.00mm OD x 0.80mm, 3.00mm, CST, DAC
11	15970721		4 SCREW Hex, M10 x 1.25 x 25mm, CI 8.8, Full Thd

Valid for Var. 338860

FARMALL JX100 FARMALL
 JX110 FARMALL JX70
 FARMALL JX75 FARMALL
 JX80 FARMALL JX90

90.118.BM

01

p1

1/2014

VAR - 390879 - REAR VIEW MIRROR, CAB

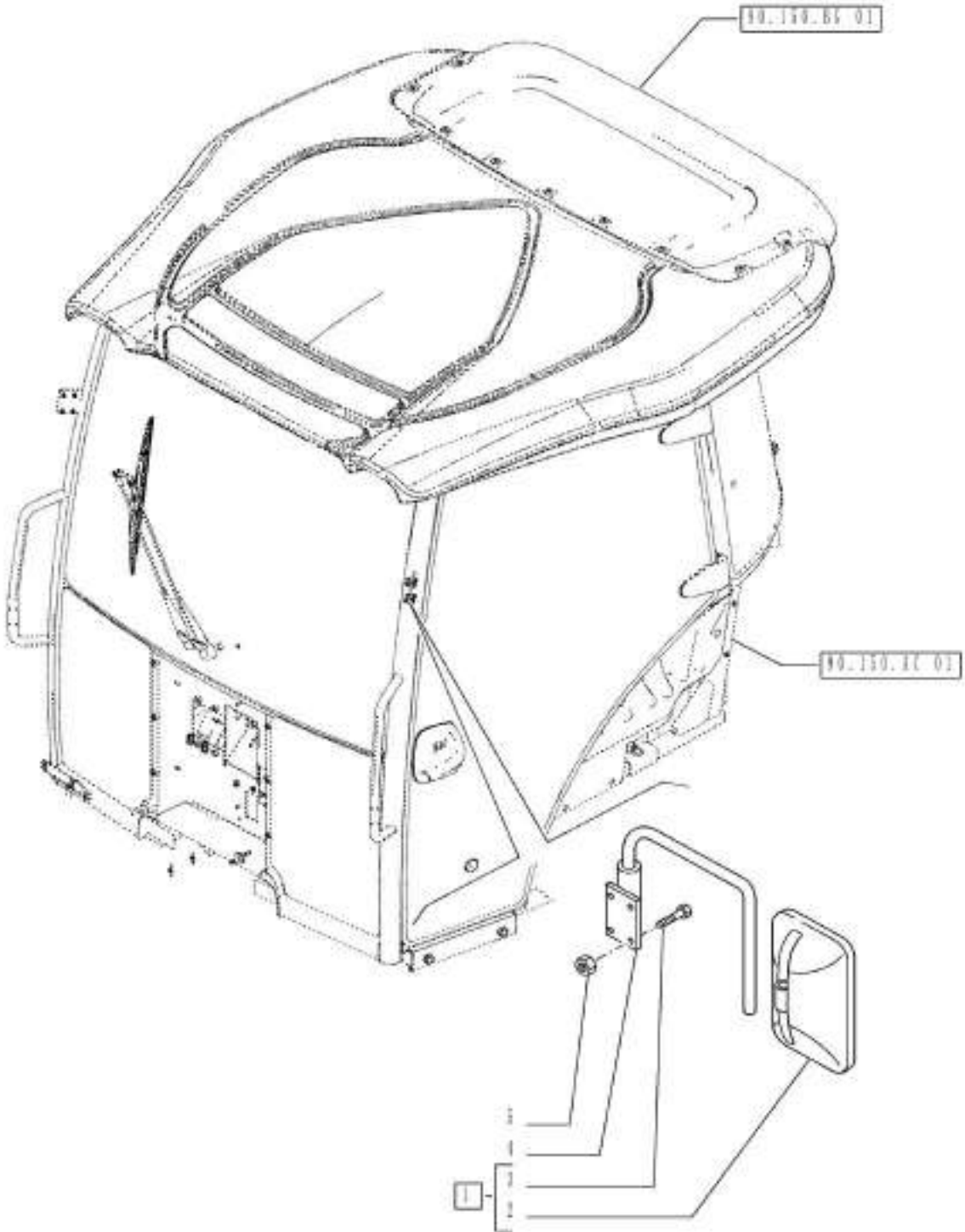

90.118.BM

02

p1

1/2014

VAR - 330879 - EXTENDABLE MIRROR, CAB

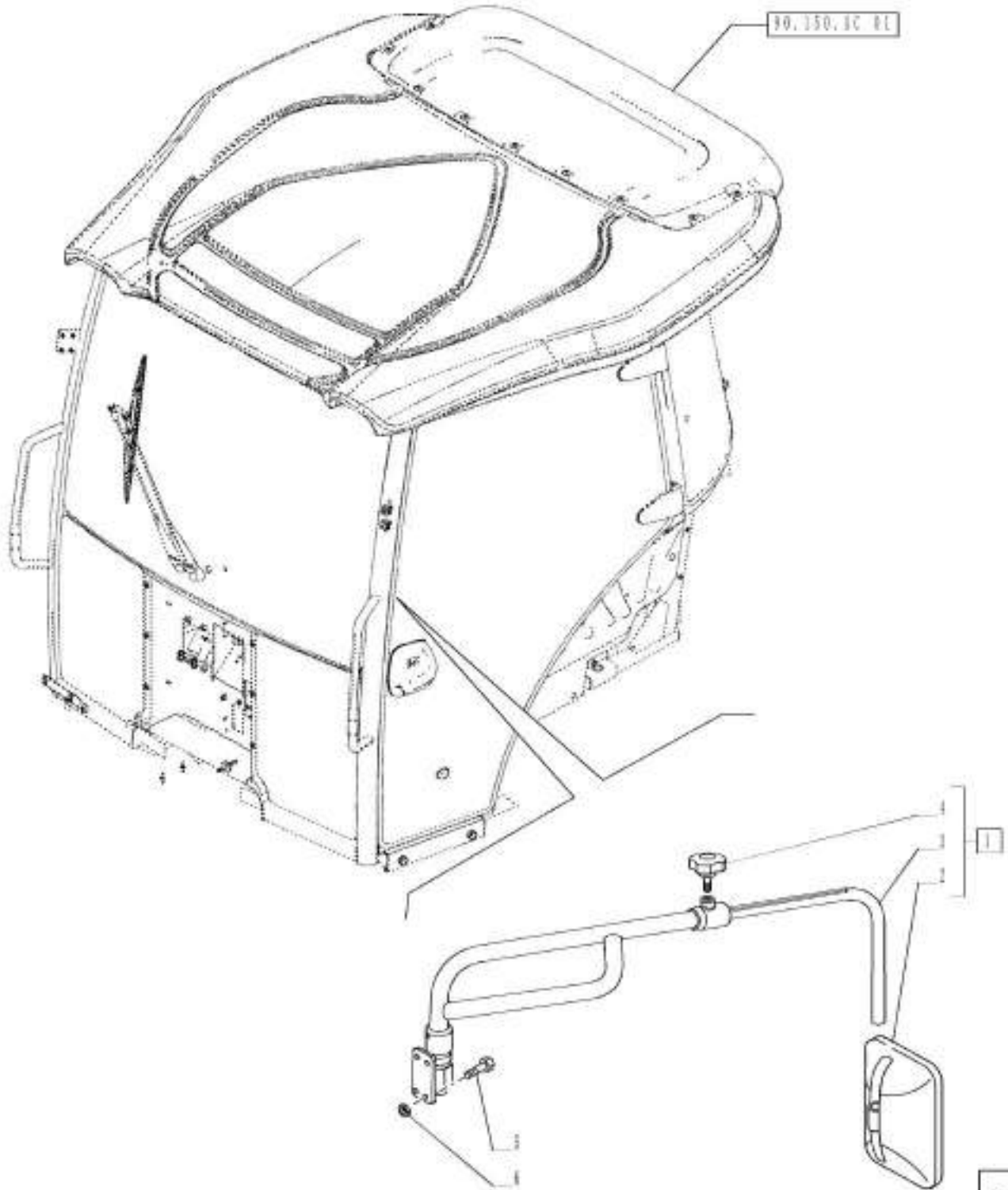

VAR - 337652, 337653, 337654 - REAR MIRROR, ROPS

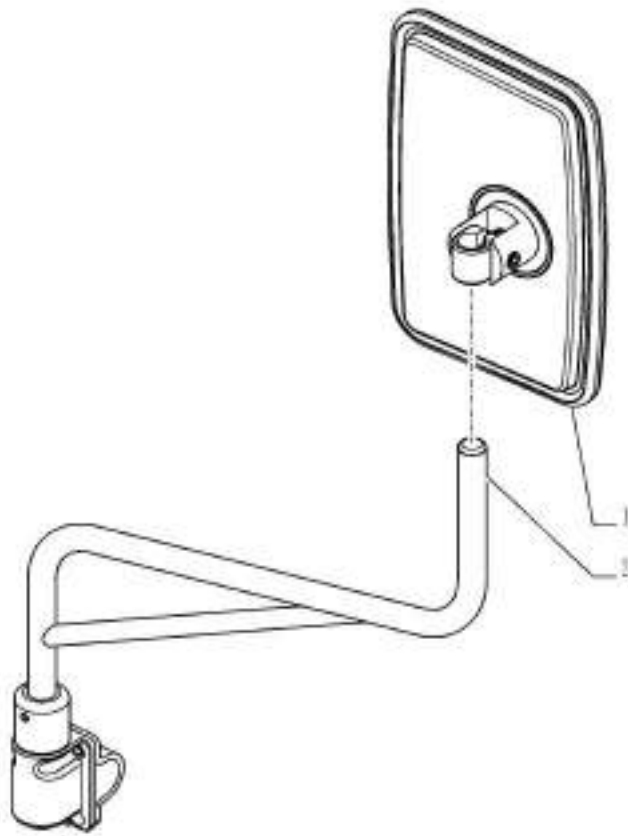

90.118.BM

03

p1

1/2014

VAR - 337652, 337653, 337654 - REAR MIRROR, ROPS

REF FN	PART NUMBER	YR/SN	QTY DESCRIPTION
1	5089603		1 MIRROR
2	5089749		1 SUPPORT

Valid for Var. 337652 or Var. 337653 or Var. 337654

FARMALL JX100 FARMALL
JX110 FARMALL JX70
FARMALL JX75 FARMALL
JX80 FARMALL JX90

90.118.BX

01

p1

1/2014

VAR - 335928, 391460, 744756 - LADDER

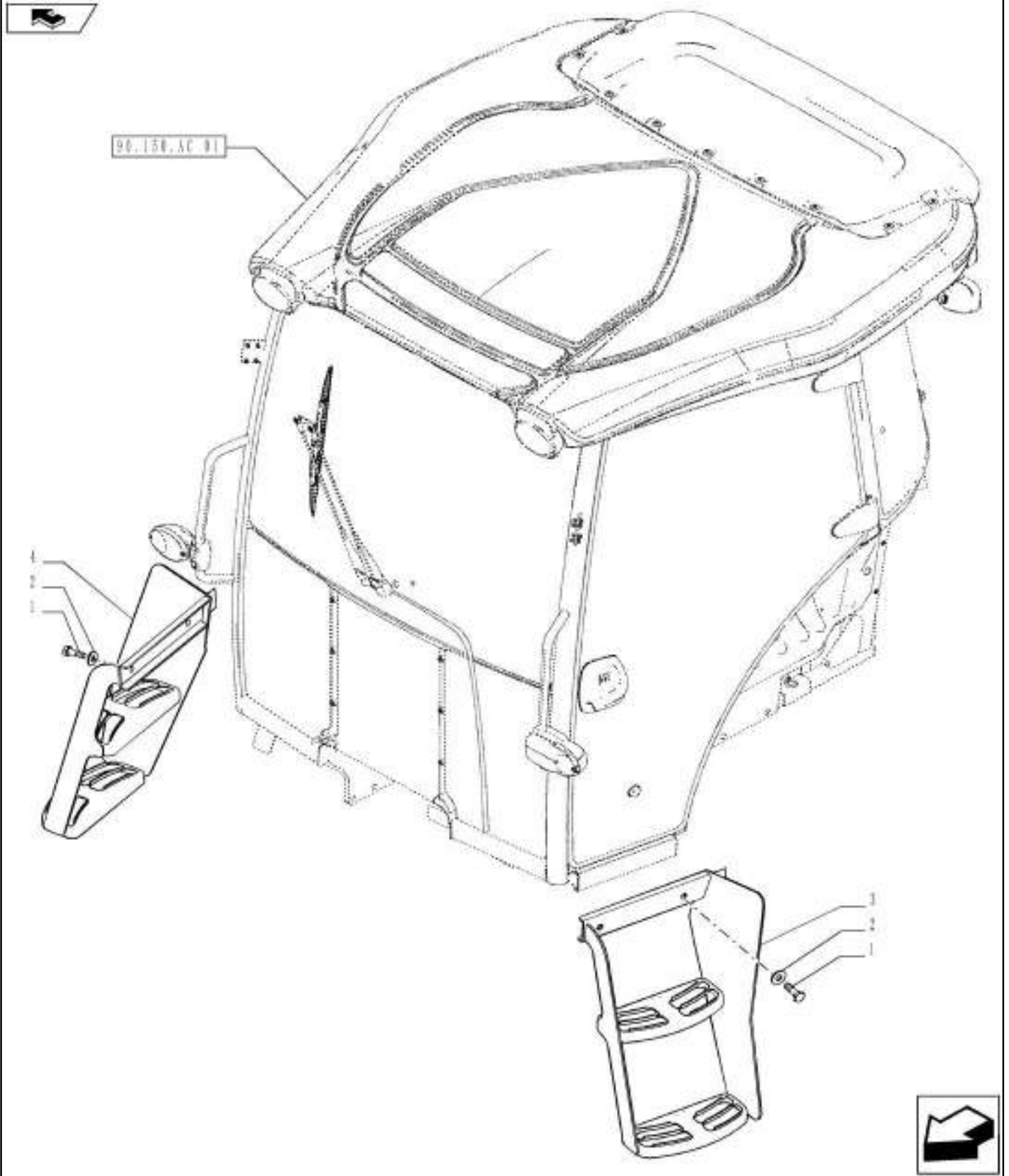

VAR - 335928, 391460, 744756 - LADDER

REF FN	PART NUMBER	YR/SN	QTY DESCRIPTION
1	87026053		4 BOLT Hex, M10 x 1.25 x 30mm, Cl 10.9, Full Thd
2	12646821		4 WASHER M10 x 25 x 2
3 1	47386275		1 FOOT BOARD
3 2	47386281		1 FOOT BOARD
4 1	47386278		1 FOOT BOARD
4 2	47386283		1 FOOT BOARD

(1) VAR - 335928 (744756)

(2) VAR - 391460 (744756)

Valid for Industrial Var. 335928, 391460 (744756)

FARMALL JX100 FARMALL
 JX110 FARMALL JX70
 FARMALL JX75 FARMALL
 JX80 FARMALL JX90

VAR - 744746, 744748 - SEAT AND SUPPORT

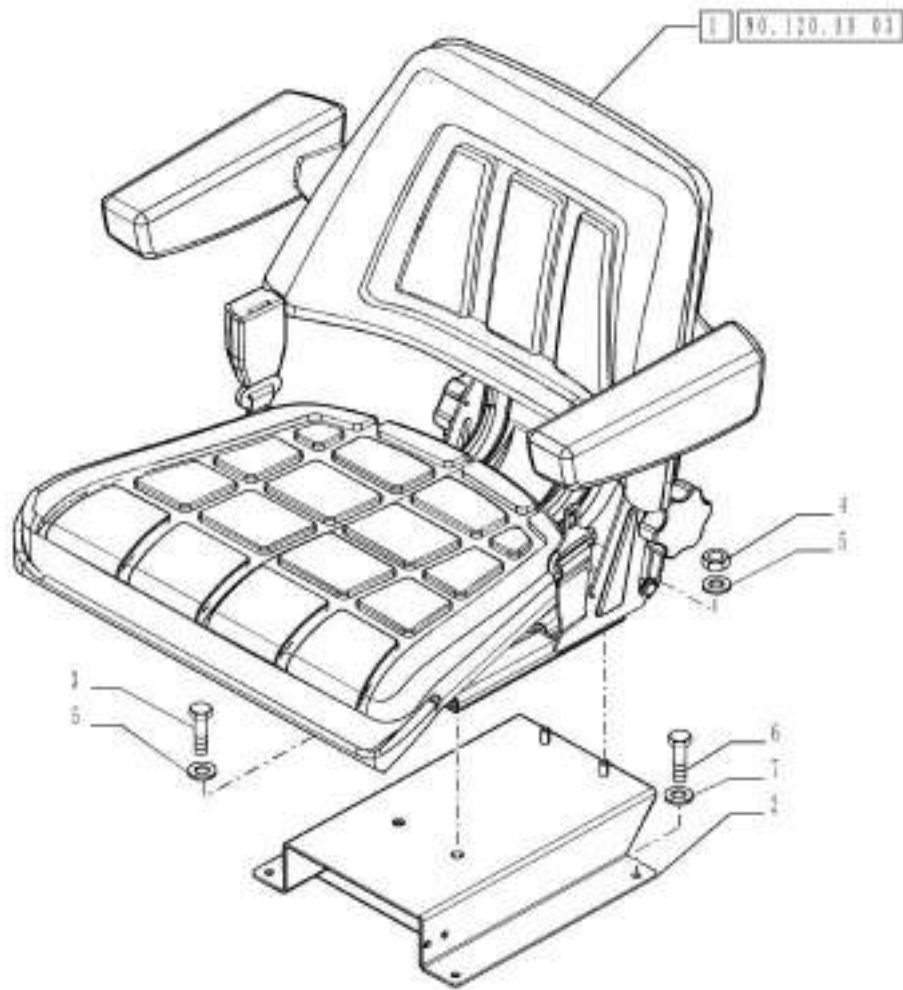

VAR - 744746, 744748 - SEAT AND SUPPORT

REF	FN	PART NUMBER	YR/SN	QTY	DESCRIPTION
1	1	84204474		1	DRIVER SEAT
1	2	84204475		1	DRIVER SEAT
2		84520321		1	SUPPORT
3		15970521		2	BOLT Hex, M10 x 1.25 x 20, 8.8, Full Thd
4		12164711		2	NUT M10 x 1.25, CI 8
5		12601474		4	WAVE WASHER Wave, 10.50mm ID x 21.00mm OD x 0.80mm, 3.00mm, CST, DAC
6	1	43127		5	BOLT Hex, M8 x 1.25 x 25mm, CI 8.8, Full Thd
6	2	86625000		5	BOLT Hex, M8 x 18mm, CI 8.8, Full Thd
7		12601374		5	WAVE WASHER Wave, 8.40mm ID x 15.00mm OD x 0.80mm, 3.00mm, CST, DAC

(1) CAB Models

(2) ROPS Models

Valid for Industrial Var. 395190, 396190 (744746) or Industrial Var. 334417, 334418 (744748)

FARMALL JX100 FARMALL
JX110 FARMALL JX70
FARMALL JX75 FARMALL
JX80 FARMALL JX90

VAR - 744747, 744749 - SEAT AND SUPPORT

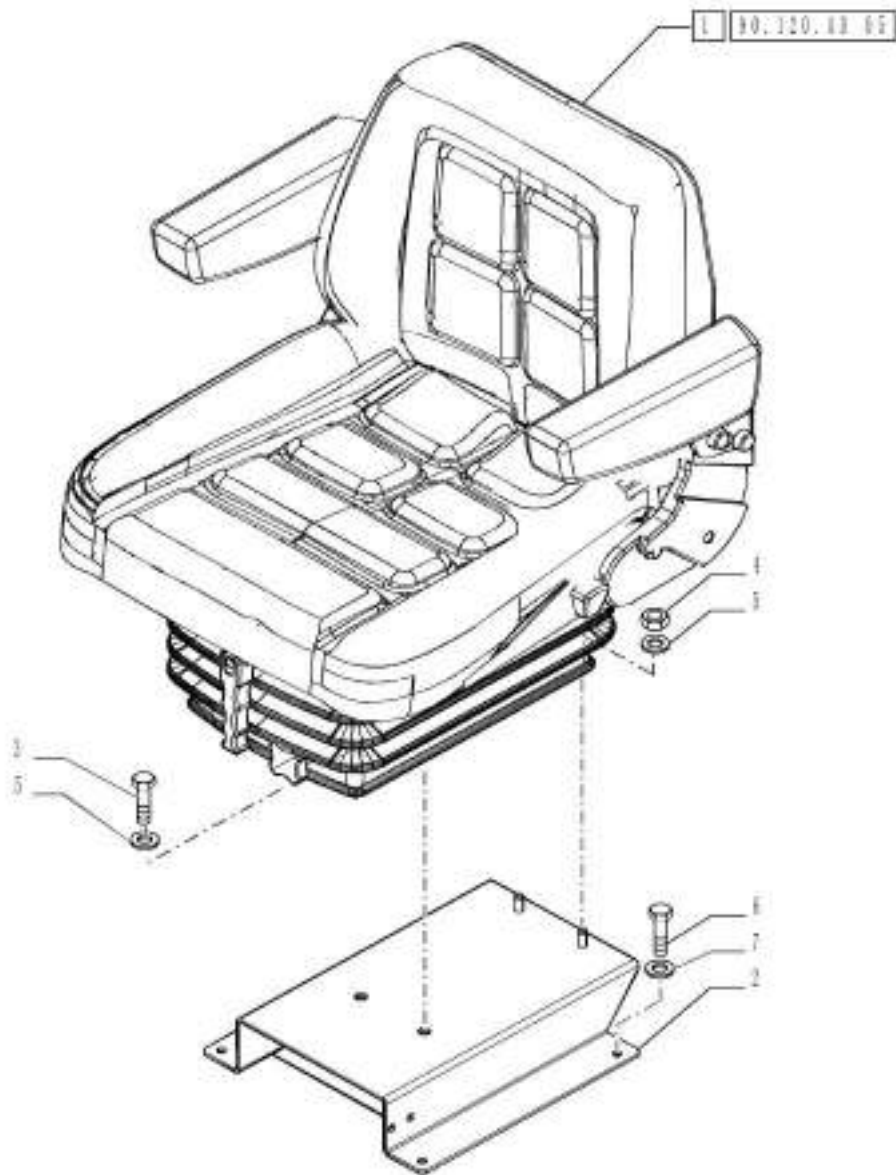

VAR - 744747, 744749 - SEAT AND SUPPORT

REF	FN	PART NUMBER	YR/SN	QTY	DESCRIPTION
1	1	84519377		1	DRIVER SEAT Fabric Seat
1	2	84561719		1	DRIVER SEAT Vinyl Seat
2		84520321		1	SUPPORT
3		15970521		2	BOLT Hex, M10 x 1.25 x 20, 8.8, Full Thd
4		12164711		2	NUT M10 x 1.25, CI 8
5		12601474		4	WAVE WASHER Wave, 10.50mm ID x 21.00mm OD x 0.80mm, 3.00mm, CST, DAC
6	1	43127		6	BOLT Hex, M8 x 1.25 x 25mm, CI 8.8, Full Thd
6	2	86625000		6	BOLT Hex, M8 x 18mm, CI 8.8, Full Thd
7		12601374		6	WAVE WASHER Wave, 8.40mm ID x 15.00mm OD x 0.80mm, 3.00mm, CST, DAC

(1) VAR - 336191 (744747), 334420 (744749); CAB Models

(2) VAR - 335191 (744747), 334419 (744749); ROPS Models

Valid for Industrial Var. 335191, 336191 (744747) or Industrial Var.
334419, 334420 (744749)FARMALL JX100 FARMALL
JX110 FARMALL JX70
FARMALL JX75 FARMALL
JX80 FARMALL JX90

VAR - 744746, 744748 - SEAT, COMPONENTS

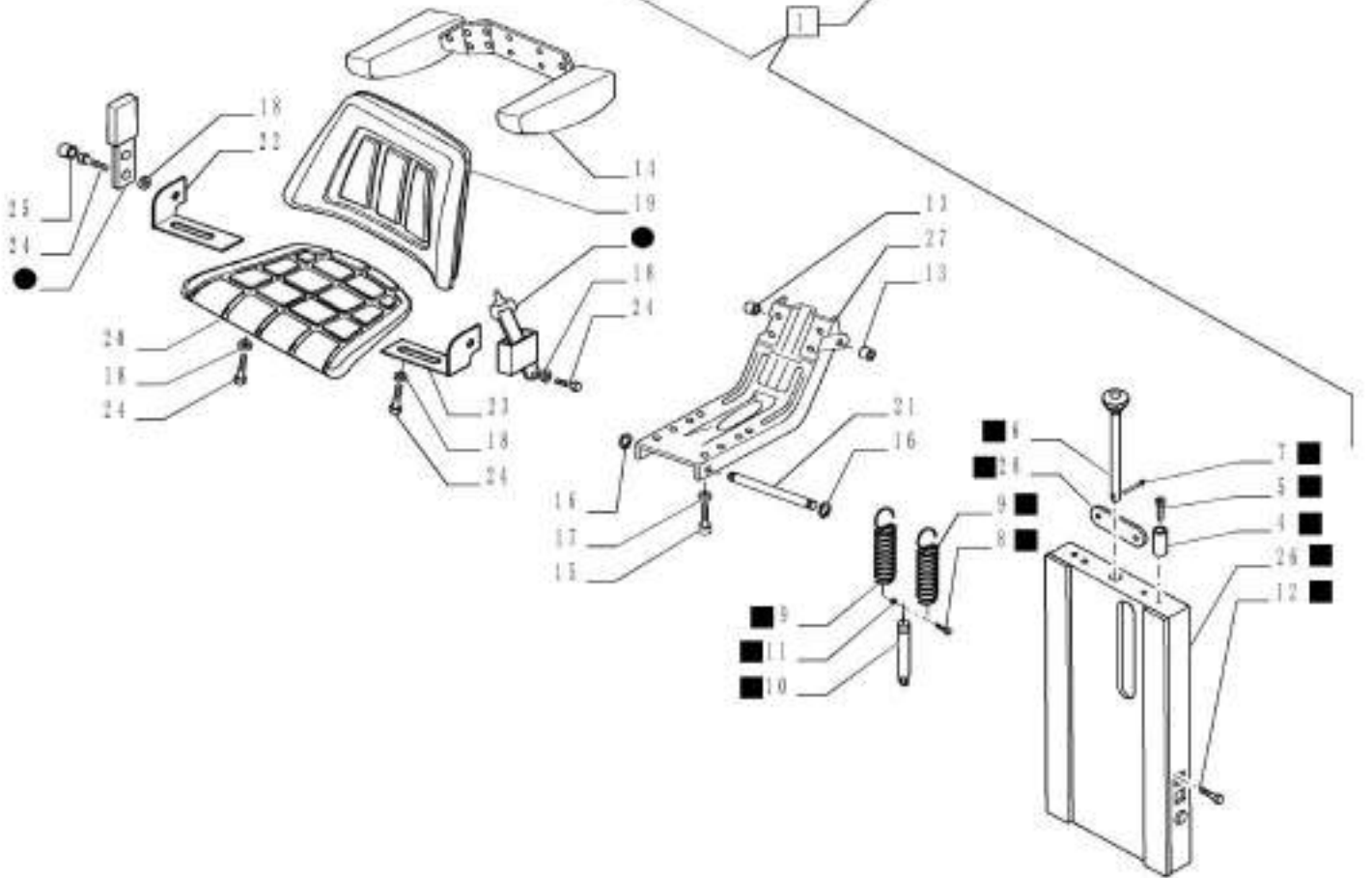
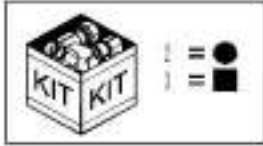

VAR - 744746, 744748 - SEAT, COMPONENTS

REF FN	PART NUMBER	YR/SN	QTY DESCRIPTION
1	^{1,2} 84204474		1 DRIVER SEAT Incl 2 - 28
1	^{3,2} 84204475		1 DRIVER SEAT Incl 2 - 28
2	5080280		1 SAFETY BELT
3	5083207		1 KIT
4	5080302		2 SPACER
5	5080303		2 BOLT
6	5080304		1 ADJUSTMENT SCREW Hex, 1/4" - 20 x 3/4", Gr 5
7	5080204		1 COTTER PIN
8	15210521		1 SCREW
9	5080306		2 SPRING
10	5080307		1 GAS STRUT
11	12574021		1 NUT M4 x .7, CI 10
12	5080299		2 BOLT
13	5080309		2 ROLLER
14	¹ 5081311		1 SEAT CUSHION
14	³ 5080311		1 ARMREST
15	5080274		4 BOLT
16	5080289		2 RING
17	5080248		4 SPRING WASHER
18	5080290		8 WASHER
19	¹ 84264794		1 SEAT BACK
19	³ 5080904		1 BACKREST
20	¹ 84264810		1 SEAT CUSHION
20	³ {84252035}		1
21	5080308		1 ROD
22	{5083747}		1
23	{5083746}		1
24	5080270		8 SCREW
25	5080271		2 PLUG
26	5080300		1 FRAME

(1) CAB Models

(2) See also Figure 90.120.AD 04

(3) ROPS Models

Valid for Industrial Var. 395190, 396190 (744746) or Industrial Var. 334417, 334418 (744748)

FARMALL JX100 FARMALL
JX110 FARMALL JX70
FARMALL JX75 FARMALL
JX80 FARMALL JX90

VAR - 744746, 744748 - SEAT, COMPONENTS

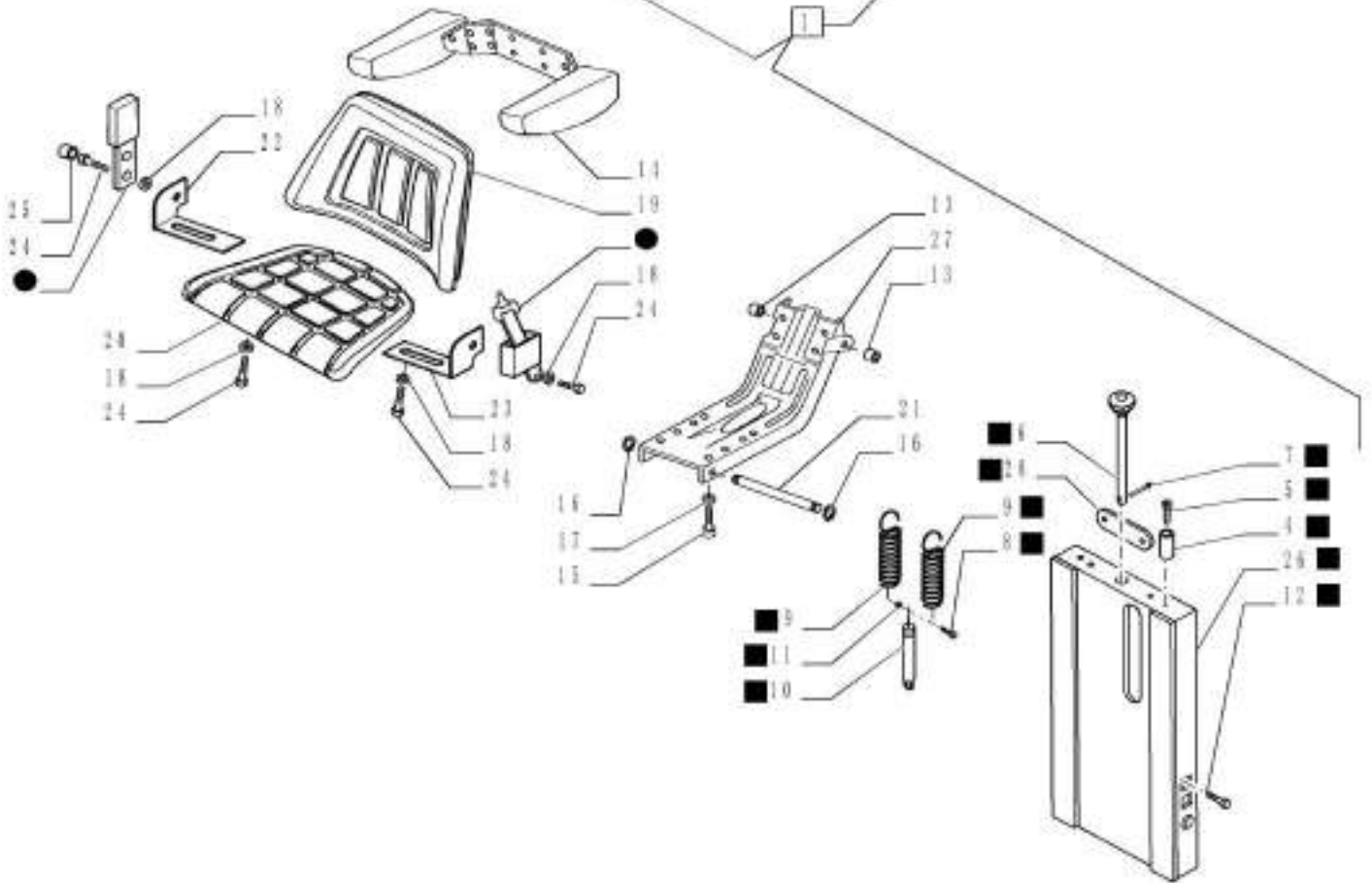
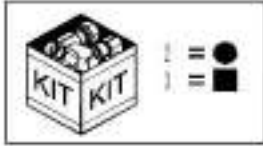

VAR - 744746, 744748 - SEAT, COMPONENTS

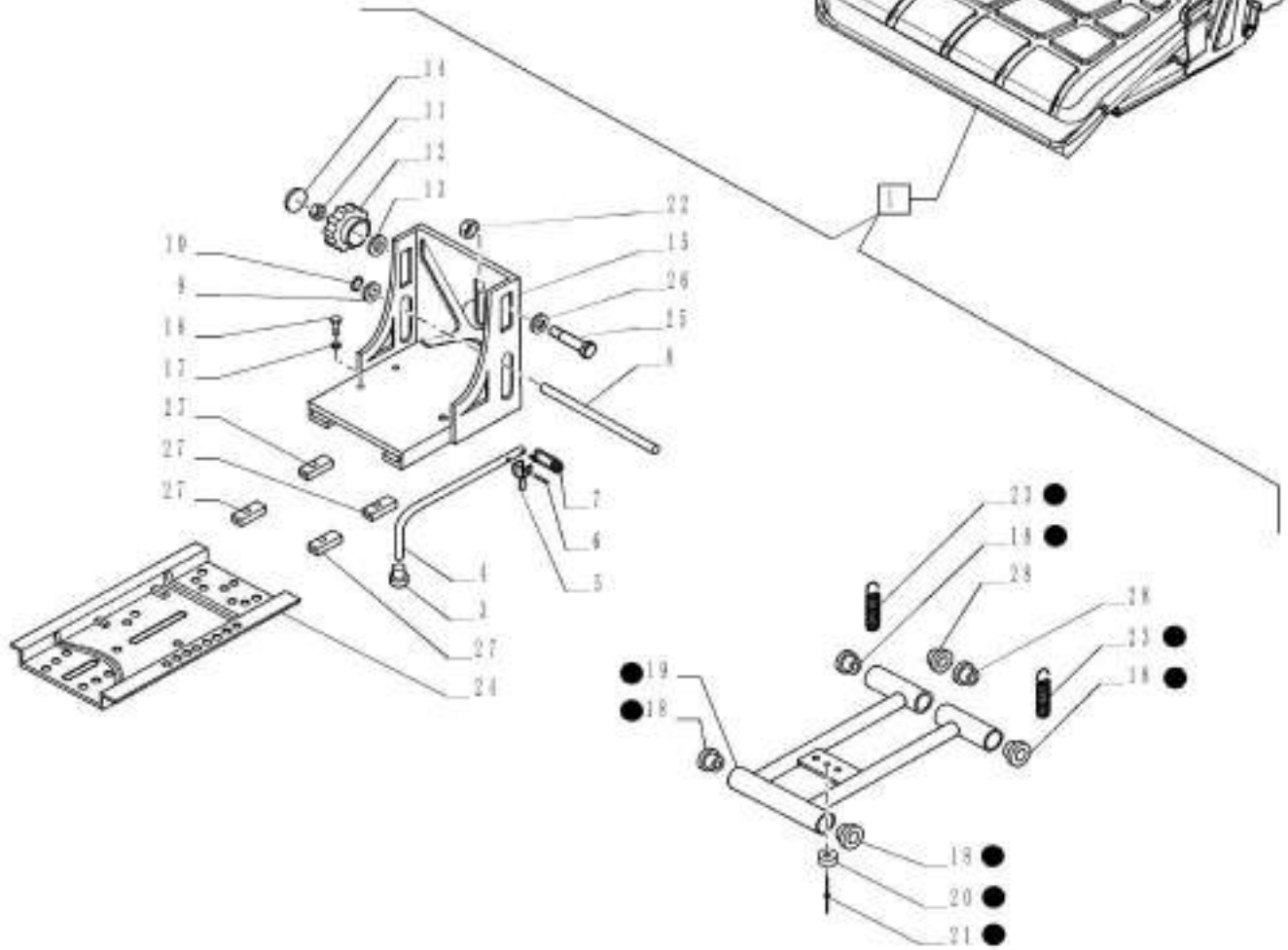

VAR - 744746, 744748 - SEAT, COMPONENTS

REF FN	PART NUMBER	YR/SN	QTY DESCRIPTION
1	^{1,2} 84204474		1 DRIVER SEAT Incl 2 - 28
1	^{3,2} 84204475		1 DRIVER SEAT Incl 2 - 28
2	5083209		1 KIT
3	5080283		1 KNOB
4	5080284		1 HANDLE
5	5080285		1 HANDLE
6	5080286		1 PIN
7	5080287		1 SPRING
8	5080288		1 STEM
9	5080289		2 RING
10	5080290		2 WASHER
11	5080236		2 NUT
12	5080291		2 KNOB
13	5080292		2 WASHER
14	5080419		2 PLUG
15	5080493		1 FRAME
16	5080294		1 BOLT
17	5080292		1 WASHER
18	5080765		4 BUSHING
19	5080760		1 SUPPORT
20	5080297		1 SPACER
21	5080298		1 RIVET
22	5080762		2 NUT
23	5080763		2 SPRING
24	5080281		1 PLATE
25	5080759		2 PIN
26	5080761		2 WASHER
27	5080282		4 U-BRACKET
28	5080295		2 BUSHING

- (1) CAB Models
(2) See also Figure 90.120.AD 03
(3) ROPS Models

Valid for Industrial Var. 395190, 396190 (744746) or Industrial Var. 334417, 334418 (744748)

FARMALL JX100 FARMALL
JX110 FARMALL JX70
FARMALL JX75 FARMALL
JX80 FARMALL JX90

VAR - 744747, 744749 - SEAT, COMPONENTS

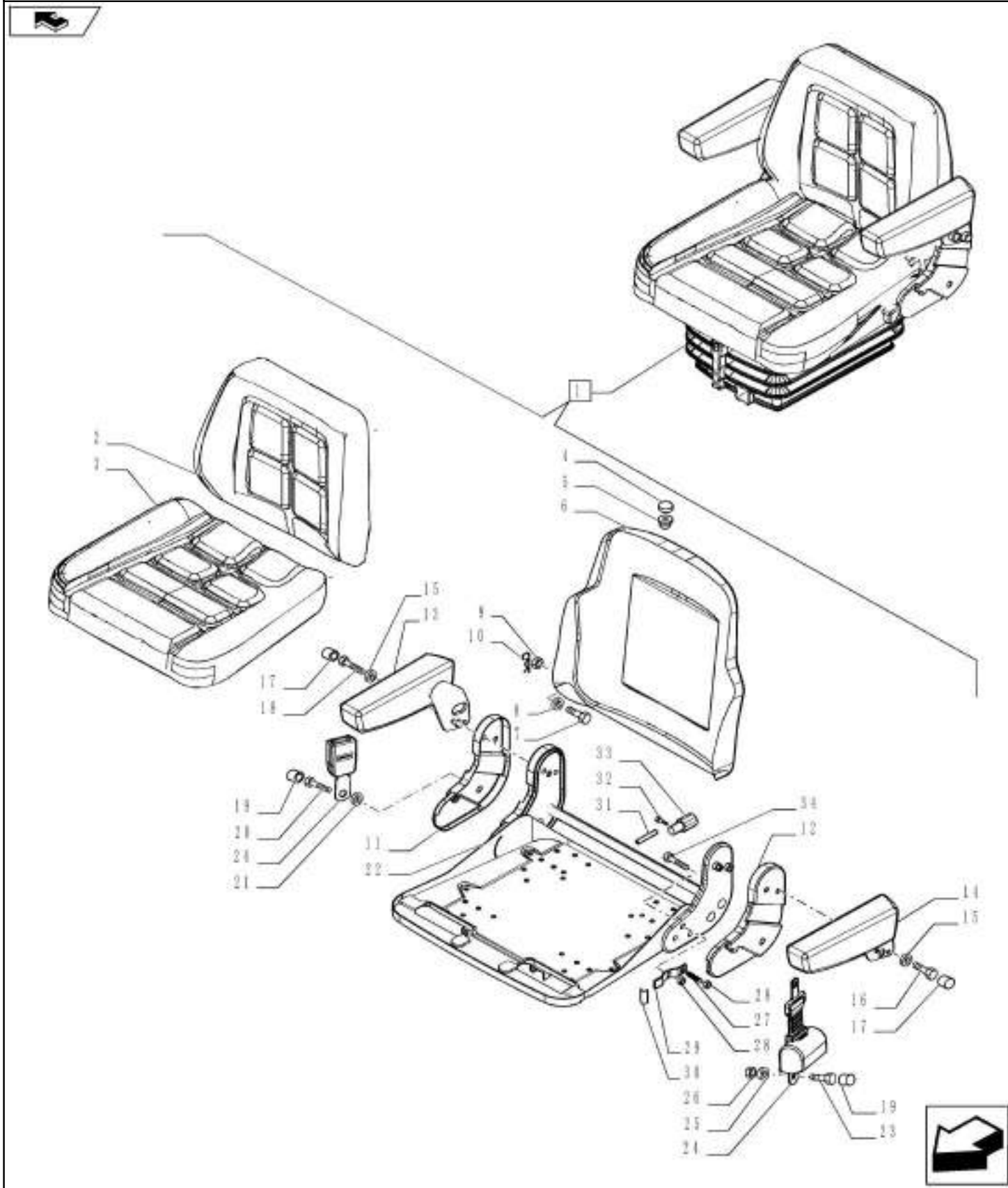

VAR - 744747, 744749 - SEAT, COMPONENTS

REF FN	PART NUMBER	YR/SN	QTY DESCRIPTION
1	^{1,2} 84519377		1 DRIVER SEAT Fabric Seat, Incl 2 - 34
1	^{3,2} 84561719		1 DRIVER SEAT Vinyl Seat, Incl 2 - 34
2	1 84264813		1 SEAT BACK
2	3 5080906		1 BACKREST
3	1 84264814		1 SEAT CUSHION
3	3 5080907		1 SEAT CUSHION
4	5081317		2 PLUG
5	5081316		2 PLUG
6	5080263		1 BACKREST
7	5080262		2 BOLT
8	5080902		2 WASHER
9	5081315		2 NUT
10	5080259		1 SPRING
11	5080267		1 COVER
12	5080268		1 COVER
13	5080272		1 ARMREST
14	5080273		1 ARMREST
15	5080248		4 SPRING WASHER
16	84412920		3 SCREW
17	5080497		4 PLUG
18	84424280		1 BOLT
19	5080271		2 PLUG
20	5080270		1 SCREW
21	5080292		1 WASHER
22	5080277		1 PAN
23	84361158		1 SCREW
24	84359360		1 SEAT BELT
25	84361166		1 BUSHING
26	5080290		1 WASHER
27	5080257		1 SPRING

(1) VAR - 336191 (744747) or 334420 (744749); CAB Models

(2) See also Figure 90.120.AD 07 and 90.120.AD 06

(3) VAR - 335191 (744747) or 334419 (744749); ROPS Models

Valid for Industrial Var. 335191, 336191 (744747) or Industrial Var. 334419, 334420 (744749)

FARMALL JX100 FARMALL
JX110 FARMALL JX70
FARMALL JX75 FARMALL
JX80 FARMALL JX90

VAR - 744747, 744749 - SEAT, COMPONENTS

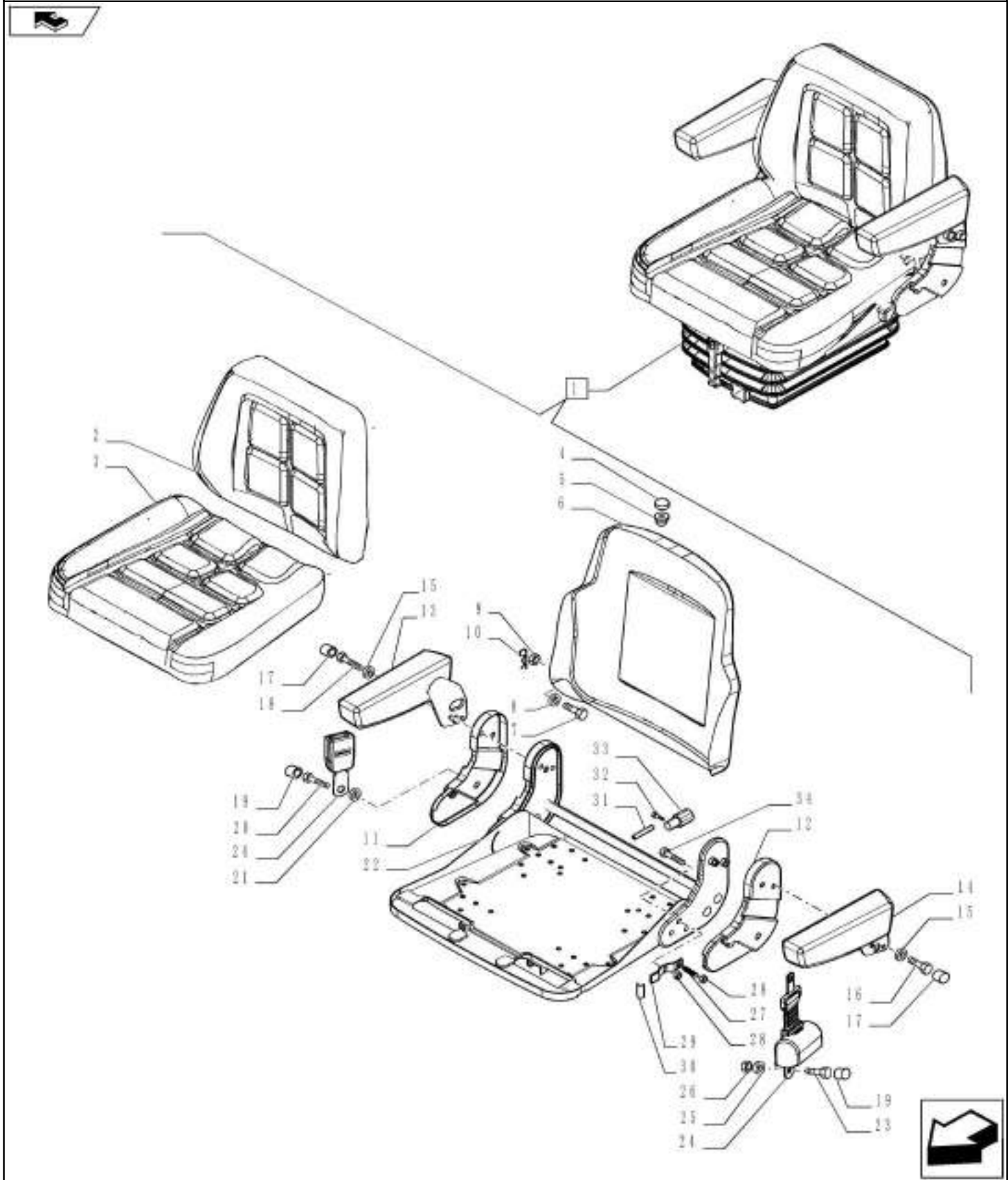

VAR - 744747, 744749 - SEAT, COMPONENTS

REF FN	PART NUMBER	YR/SN	QTY DESCRIPTION
28	5080256		1 NUT
29	5080254		1 LEVER
30	5080258		1 KNOB
31	5080252		1 PIN
32	5080253		2 PIN
33	84424319		1 GEAR
34	5080255		1 BOLT

Valid for Industrial Var. 335191, 336191 (744747) or Industrial Var. 334419, 334420 (744749)

FARMALL JX100 FARMALL JX110 FARMALL JX70 FARMALL JX75 FARMALL JX80 FARMALL JX90

VAR - 744747, 744749 - SEAT, COMPONENTS

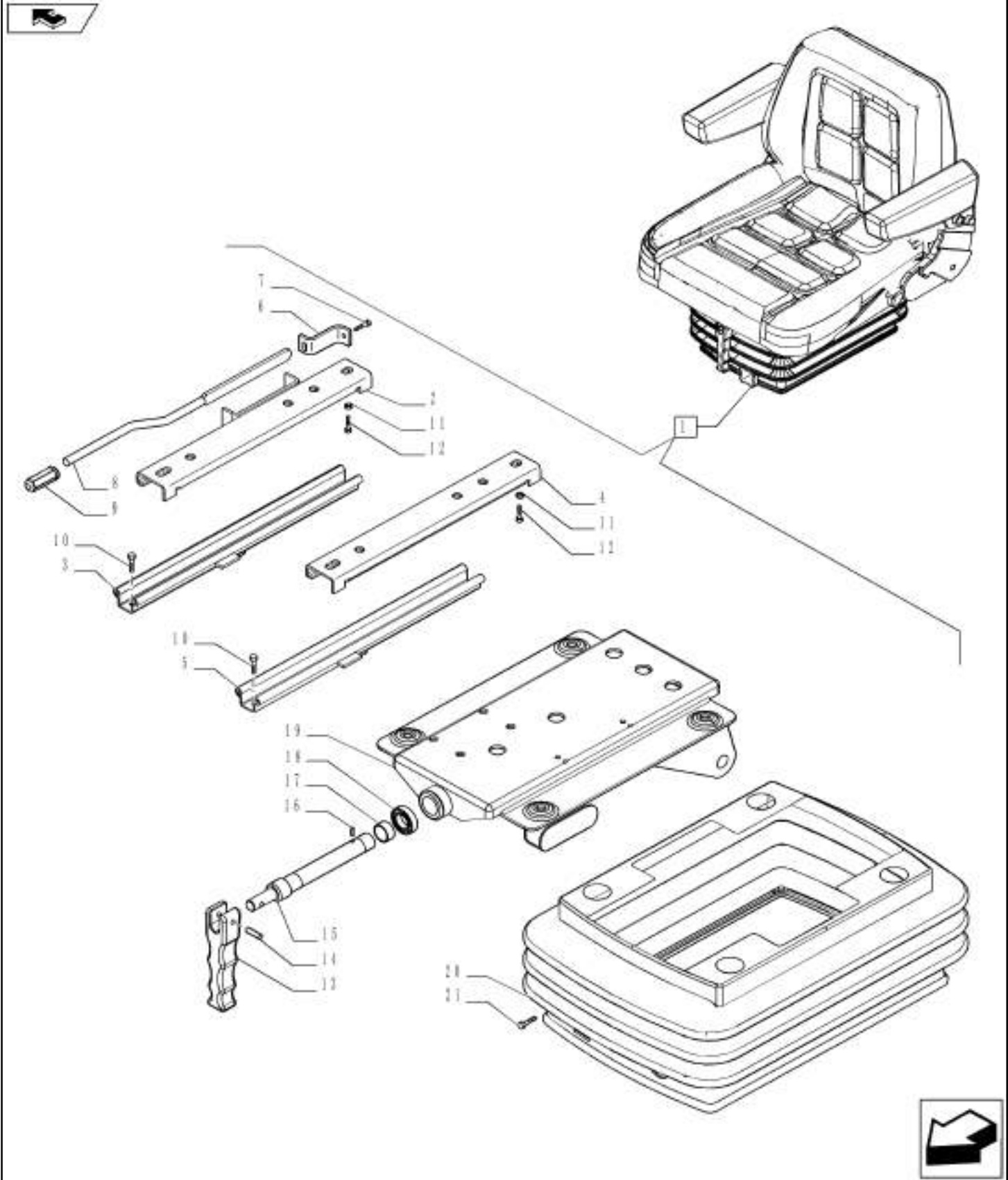

VAR - 744747, 744749 - SEAT, COMPONENTS

REF FN	PART NUMBER	YR/SN	QTY DESCRIPTION
1	^{1,2} 84519377		1 DRIVER SEAT Fabric Seat, Incl 2 - 21
1	^{3,2} 84561719		1 DRIVER SEAT Vinyl Seat, Incl 2 - 21
2	5080239		1 SLIDE
3	5080238		1 SLIDE
4	5080245		1 SLIDE
5	5080244		1 SLIDE
6	5080243		1 SPRING
7	5080242		2 BOLT
8	5080240		1 HANDLE
9	5080241		1 KNOB
10	5080481		4 BOLT
11	5080237		4 NUT
12	5080314		4 BACKREST
13	5080231		1 CONTROL
14	5080233		1 PIN
15	5080230		1 SCREW
16	5080204		1 COTTER PIN
17	5081318		1 SPACER
18	5080232		1 BEARING
19	5080220		1 BASE
20	5080234		1 BELLOWS
21	5080246		6 BOLT

(1) VAR - 336191 (744747) or 334420 (744749); CAB Models

(2) See also Figure 90.120.AD 05 and 90.120.AD 07

(3) VAR - 335191 (744747) or 334419 (744749); ROPS Models

Valid for Industrial Var. 335191, 336191 (744747) or Industrial Var. 334419, 334420 (744749)

FARMALL JX100 FARMALL
JX110 FARMALL JX70
FARMALL JX75 FARMALL
JX80 FARMALL JX90

VAR - 744747, 744749 - SEAT, COMPONENTS

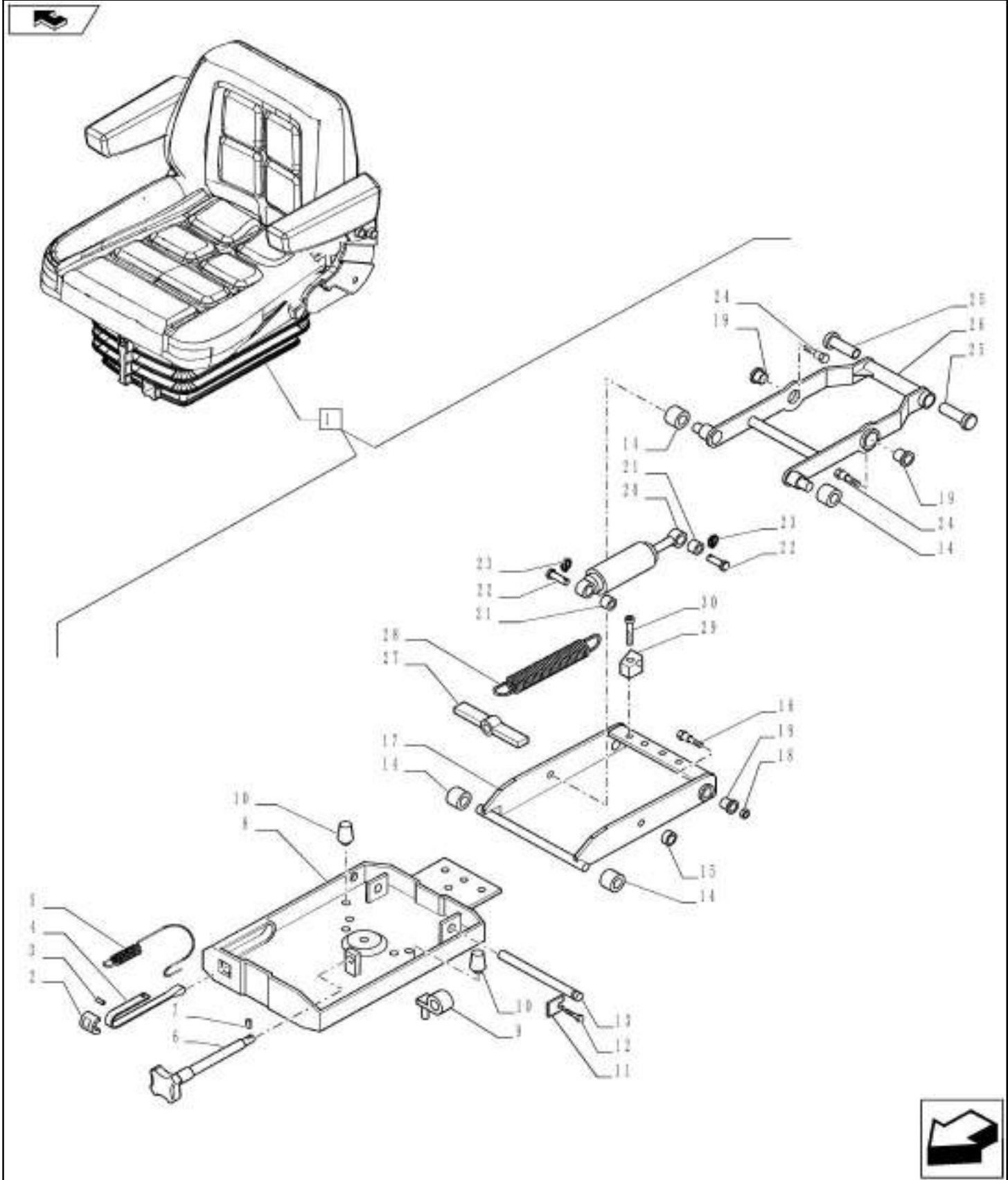

VAR - 744747, 744749 - SEAT, COMPONENTS

REF FN	PART NUMBER	YR/SN	QTY DESCRIPTION
1	^{1,2} 84519377		1 DRIVER SEAT Fabric Seat, Incl 2 - 30
1	^{3,2} 84561719		1 DRIVER SEAT Vinyl Seat, Incl 2 - 30
2	5080208		1 COVER
3	5080207		1 ROLLER
4	5080209		1 DECAL
5	5080210		1 SPRING
6	5080897		1 KNOB
7	5080204		1 COTTER PIN
8	{84558736}		1
9	5080202		1 ADJUSTER
10	5080213		2 SPACER
11	5080218		1 PLATE
12	5080219		1 BOLT
13	5080205		1 ROD
14	5080214		4 ROLLER
15	5080236		2 NUT
16	5083580		2 BOLT
17	5080223		1 SUSPENSION
18	5080237		2 NUT
19	5080898		4 PLUG
20	5080215		1 GAS STRUT
21	84424312		2 SUPPORT
22	5080216		2 PIN
23	5080217		2 RING
24	5083579		2 SCREW
25	5080212		2 PLASTIC RING
26	5080222		1 SUSPENSION
27	5080228		1 TENSIONER
28	5080229		4 SPRING
29	5080224		4 CLIP

(1) VAR - 336191 (744747) or 334420 (744749); CAB Models

(2) See also Figure 90.120.AD 06 and 90.120.AD 05

(3) VAR - 335191 (744747) or 334419 (744749); ROPS Models

Valid for Industrial Var. 335191, 336191 (744747) or Industrial Var. 334419, 334420 (744749)

FARMALL JX100 FARMALL
JX110 FARMALL JX70
FARMALL JX75 FARMALL
JX80 FARMALL JX90

VAR - 744747, 744749 - SEAT, COMPONENTS

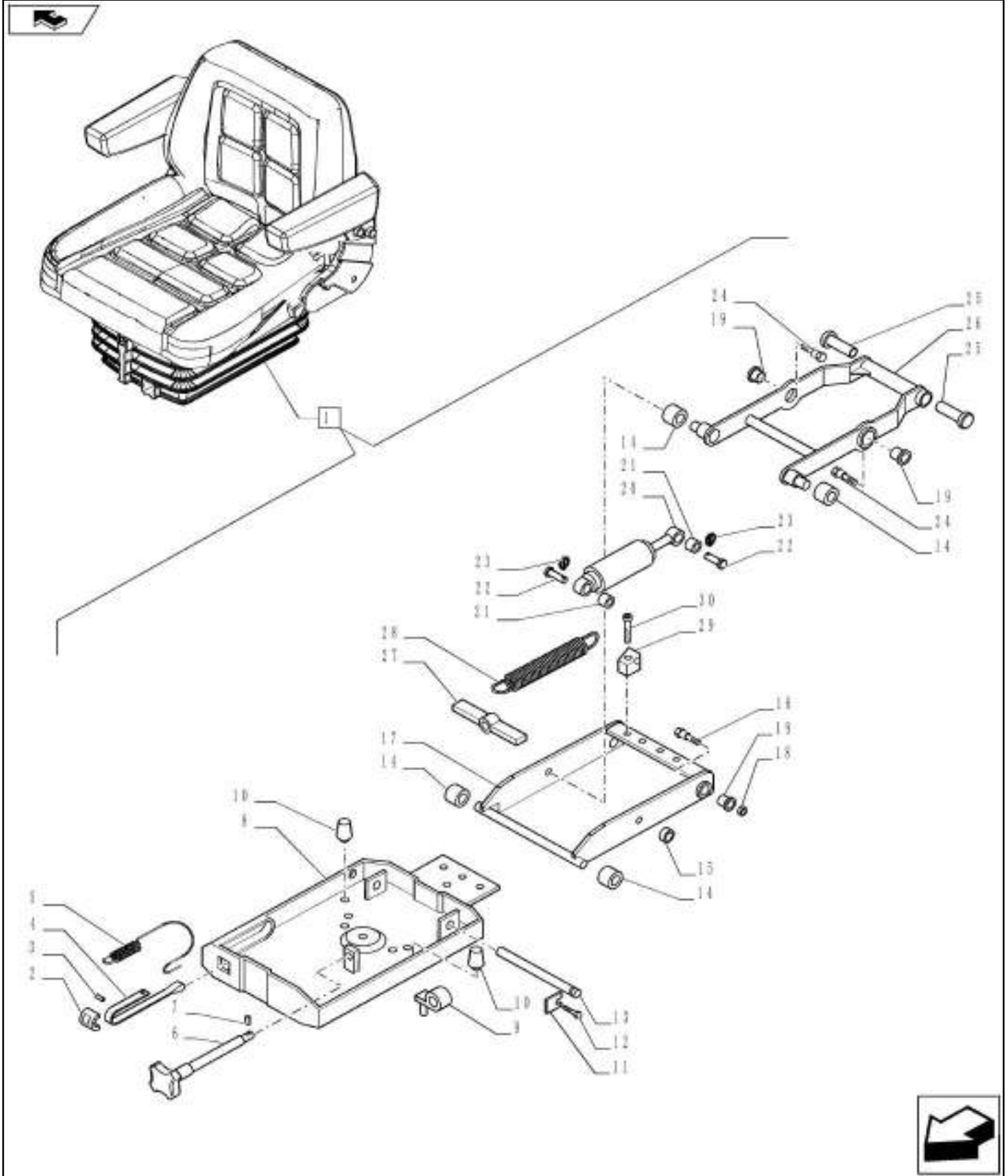

VAR - 744747, 744749 - SEAT, COMPONENTS

REF FN	PART NUMBER	YR/SN	QTY	DESCRIPTION
30	5080899		4	SCREW

Valid for Industrial Var. 335191, 336191 (744747) or Industrial Var. 334419, 334420 (744749)

FARMALL JX100 FARMALL
JX110 FARMALL JX70
FARMALL JX75 FARMALL
JX80 FARMALL JX90

90.150.AC

01

p1

1/2014

VAR - 333606, 391606 - CAB, FRAME

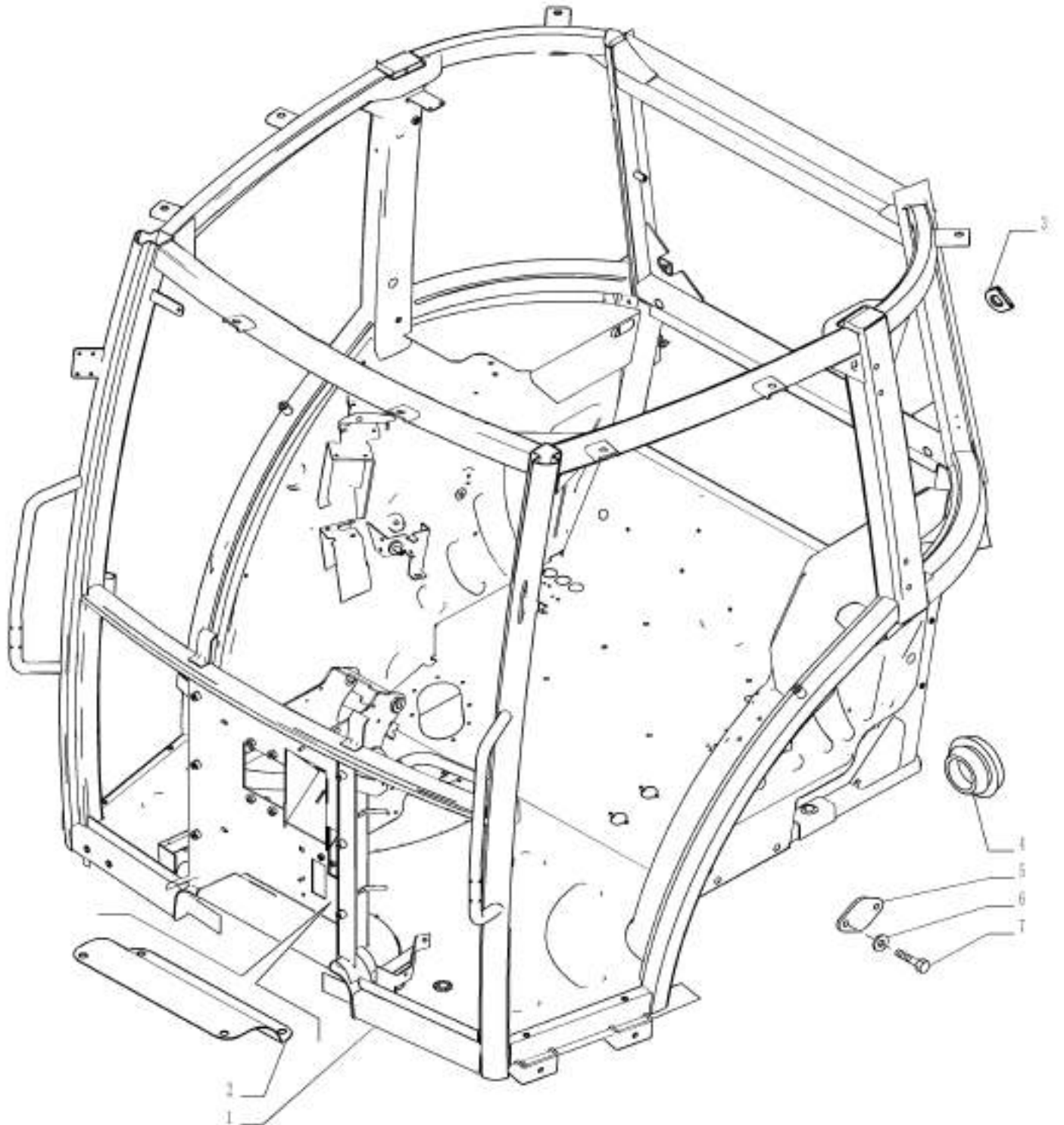

VAR - 333606, 391606 - CAB, FRAME

REF FN	PART NUMBER	YR/SN	QTY DESCRIPTION
1	84396384		1 FRAME
2	84388815		1 COVER
3	84290317		1 PLUG
4	47413828		4 PLUG
5	1 5094448		1 PLATE
6	2 12601274		2 WAVE WASHER Wave, M6.4
7	2 13276114		2 SCREW Cross Pan Hd, M6 x 14
(1)	VAR - 330384, 334322 (744739) or 334303, 390110 (744735) or 335116 - Qty 2		
(2)	VAR - 330384, 334322 (744739) or 334303, 390110 (744735) or 335116 - Qty 4		

Valid for Var. 333606 or Var. 391606

FARMALL JX100 FARMALL
 JX110 FARMALL JX70
 FARMALL JX75 FARMALL
 JX80 FARMALL JX90

VAR - 333606, 334318, 334319, 391606, 392315 - CAB & ROPS FRONT SUPPORT

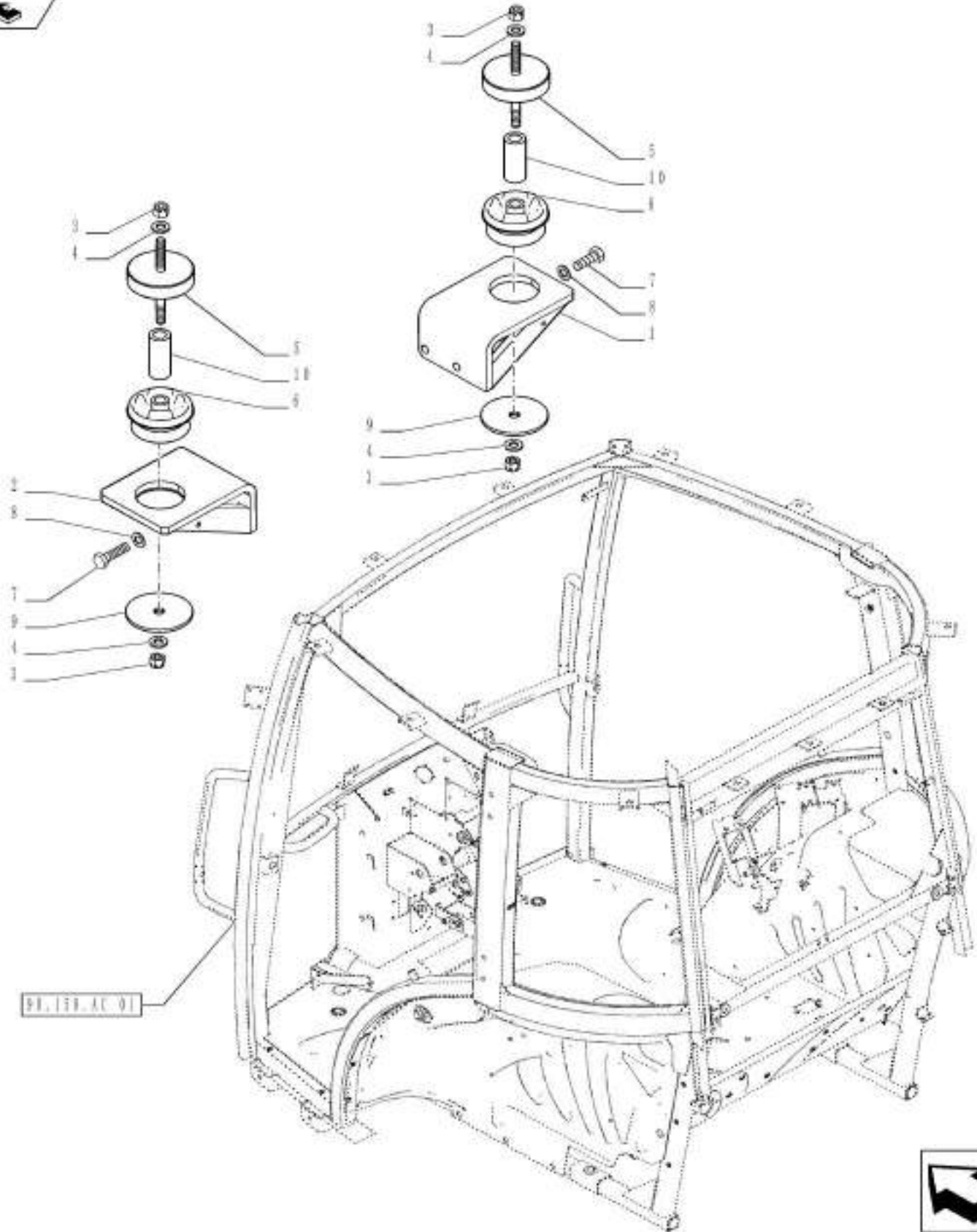

VAR - 333606, 334318, 334319, 391606, 392315 - CAB & ROPS FRONT SUPPORT

REF FN	PART NUMBER	YR/SN	QTY DESCRIPTION
1	84388795		1 FOOT BOARD RH
2	84388789		1 FOOT BOARD LH
3	12574911		2 NUT M16 x 1.5, CI 8
4	13580101		4 WASHER M16 x 32 x 4
5	1 84524309		2 SUPPORT
5	2 84388801		2 PLATE
6	83983548		2 SILENTBLOC
7	11391521		4 SCREW Hex, M16 x 1.5 x 45, 8.8, Full Thd
8	12601774		4 WAVE WASHER 17mm ID x 30mm OD x 1.60mm, 6.30mm Max, CST, DAC
9	84388805		2 WASHER
10	84388808		2 SPACER
(1)	ROPS Models Only		
(2)	CAB Models Only		
Valid for Var. 333606 or Var. 334318 or Var. 334319 or Var. 391606 or Var. 392315			FARMALL JX100 FARMALL JX110 FARMALL JX70 FARMALL JX75 FARMALL JX80 FARMALL JX90

VAR - 333606, 334318, 334319, 391606, 392315 - CAB & ROPS REAR SUPPORT

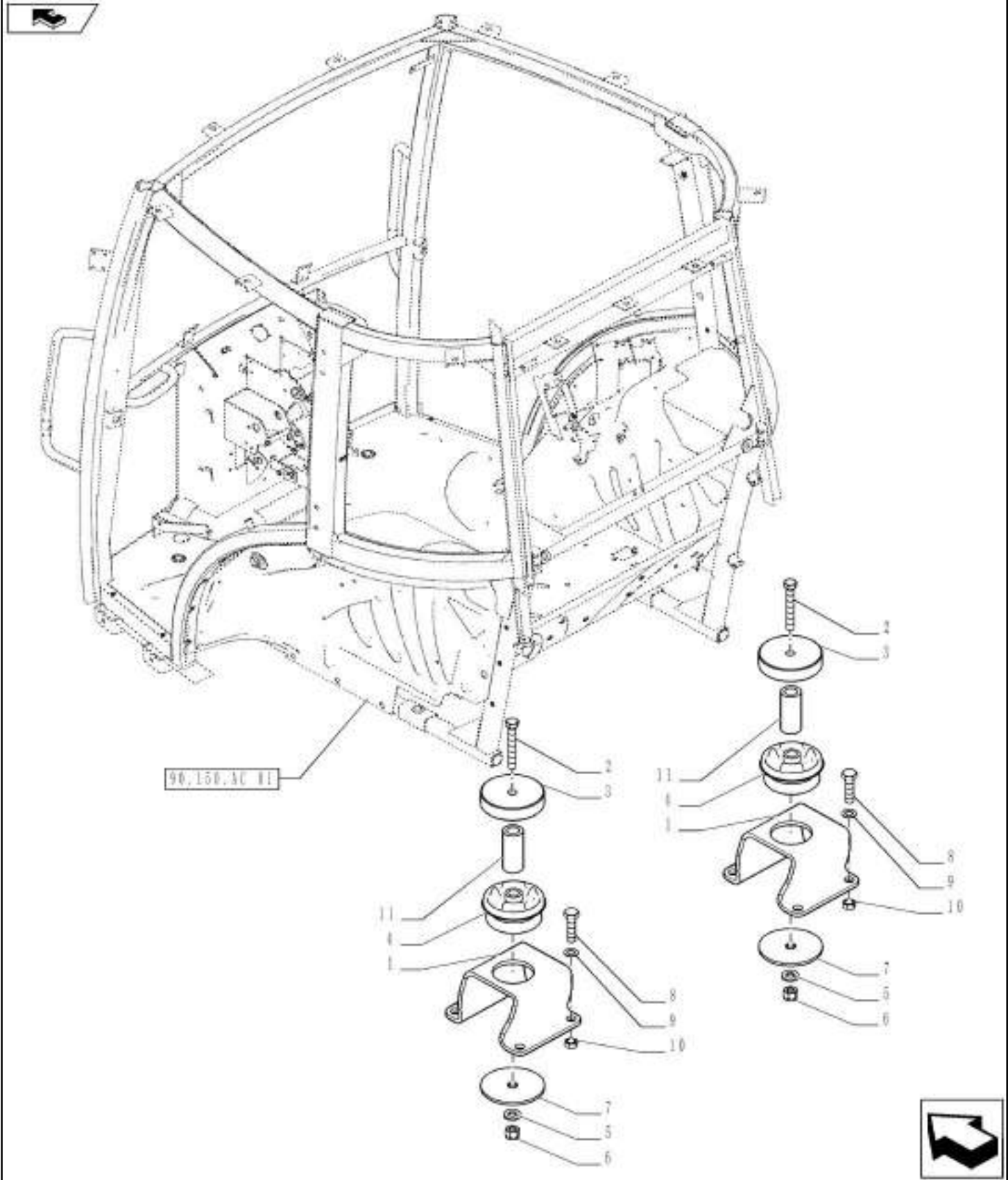

VAR - 333606, 334318, 334319, 391606, 392315 - CAB & ROPS REAR SUPPORT

REF FN	PART NUMBER	YR/SN	QTY DESCRIPTION
1	84388799		2 SUPPORT
2	15982521		2 BOLT Hex, M16 x 1.5 x 160mm, CI 8.8
3	1 84524308		2 RUBBER WASHER
4	83983548		2 SILENTBLOC
5	2 12601774		2 WAVE WASHER 17mm ID x 30mm OD x 1.60mm, 6.30mm Max, CST, DAC
5	1 13580101		2 WASHER M16 x 32 x 4
6	12574911		2 NUT M16 x 1.5, CI 8
7	84388805		2 WASHER
8	15985031		6 BOLT Hex, M18 x 1.5 x 90, 10.9
9	12601874		6 SPRING WASHER
10	10721021		6 NUT M18 x 1.5, CI 10
11	84388808		2 SPACER
(1)	CAB Models Only		
(2)	ROPS Models Only		

Valid for Var. 333606 or Var. 334318 or Var. 334319 or Var. 391606 or Var. 392315

FARMALL JX100 FARMALL
JX110 FARMALL JX70
FARMALL JX75 FARMALL
JX80 FARMALL JX90

VAR - 333606 - HIGH VISIBILITY ROOF FOR CAB

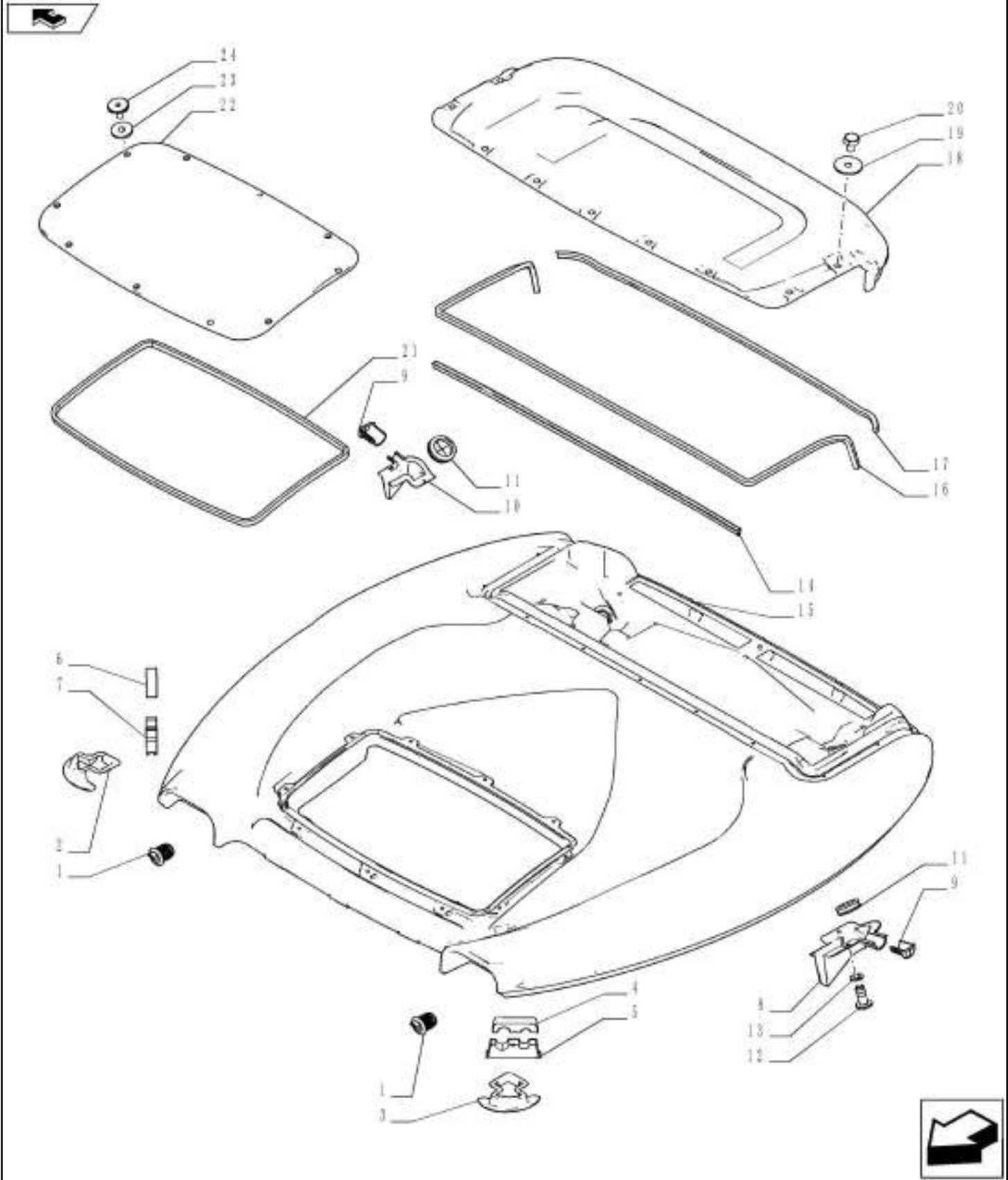

VAR - 333606 - HIGH VISIBILITY ROOF FOR CAB

REF FN	PART NUMBER	YR/SN	QTY DESCRIPTION
1	84578369		2 GROMMET
2	84553574		1 COVER RH
3	84527223		1 COVER LH
4	84553586		1 BLOCK
5	84553585		1 BLOCK
6	84553584		1 BLOCK
7	84553583		1 BLOCK
8	84524341		1 COVER LH
9	84553577		2 COVER
10	84551805		1 COVER RH
11	84553578		2 COVER
12	13274011		4 SCREW Cross Pan Hd, M5 x 12
13	12601174		4 WAVE WASHER Wave, M4.3
14	84553616		1 GASKET
15	84524330		1 ROOF
16	84553621		1 GASKET
17	84553620		1 GASKET
18	84524344		1 CANOPY KIT
19	11195574		14 BELLEVILLE WASHER Belleville, M6.4
20	86977786		14 BOLT Hex, M6 x 1 x 25mm, Cl 8.8, Full Thd
21	84524347		1 GASKET
22	84524338		1 GLASS
23	84524348		10 GASKET
24	84554035		10 SCREW
Valid for Var. 333606			FARMALL JX100 FARMALL JX110 FARMALL JX70 FARMALL JX75 FARMALL JX80 FARMALL JX90

VAR - 391606 - CAB ROOF

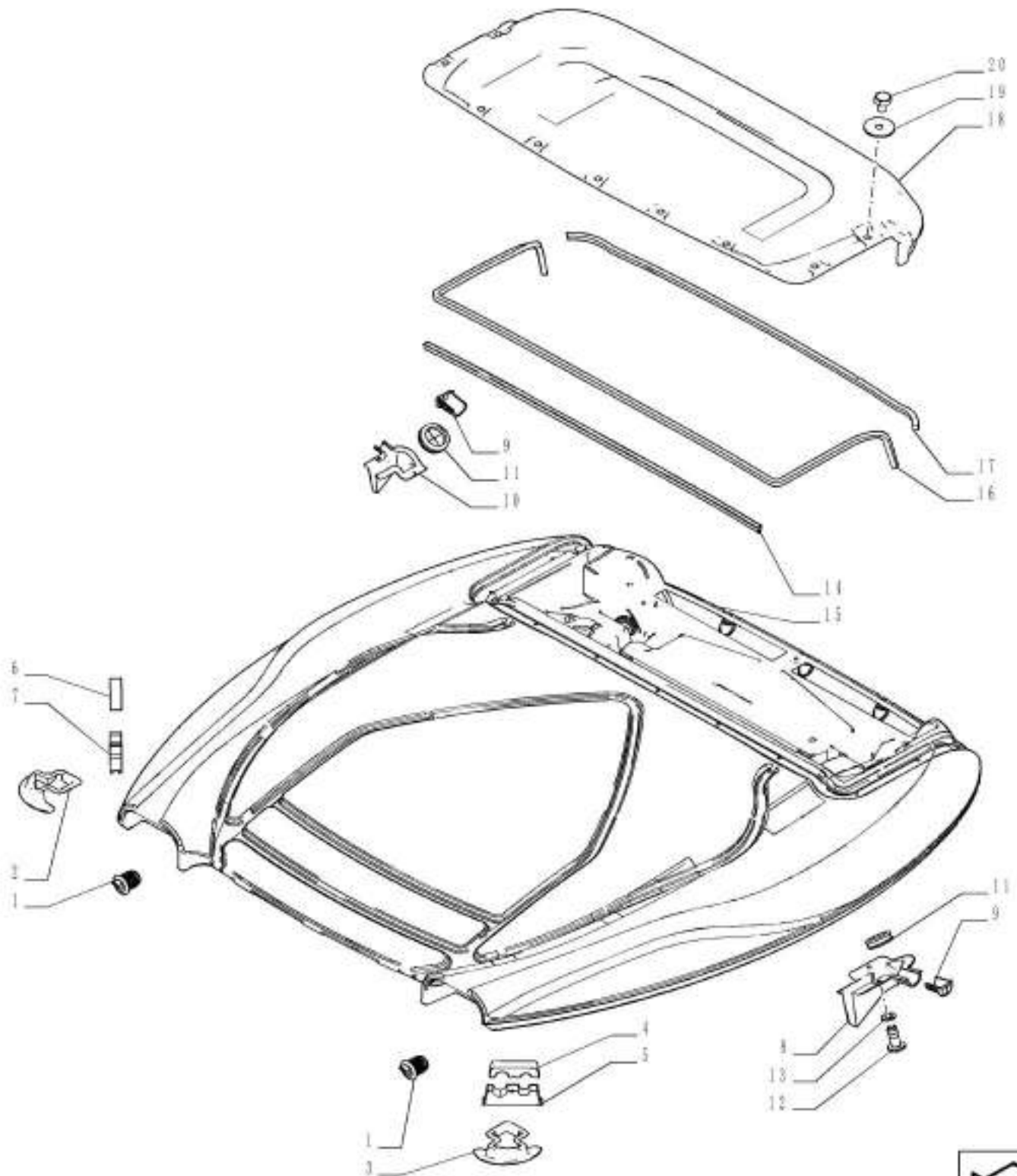

VAR - 391606 - CAB ROOF

REF FN	PART NUMBER	YR/SN	QTY DESCRIPTION
1	84578369		2 GROMMET
2	84553574		1 COVER RH
3	84527223		1 COVER LH
4	84553586		1 BLOCK
5	84553585		1 BLOCK
6	84553584		1 BLOCK
7	84553583		1 BLOCK
8	84524341		1 COVER LH
9	84553577		2 COVER
10	84551805		1 COVER RH
11	84553578		2 COVER
12	13274011		4 SCREW Cross Pan Hd, M5 x 12
13	12601174		4 WAVE WASHER Wave, M4.3
14	84553616		1 GASKET
15	84524329		1 ROOF
16	84553621		1 GASKET
17	84553620		1 GASKET
18	84524344		1 CANOPY KIT
19	11195574		14 BELLEVILLE WASHER Belleville, M6.4
20	86977786		14 BOLT Hex, M6 x 1 x 25mm, Cl 8.8, Full Thd

Valid for Var. 391606

FARMALL JX100 FARMALL
 JX110 FARMALL JX70
 FARMALL JX75 FARMALL
 JX80 FARMALL JX90

VAR - 333606, 391606 - CAB ROOF

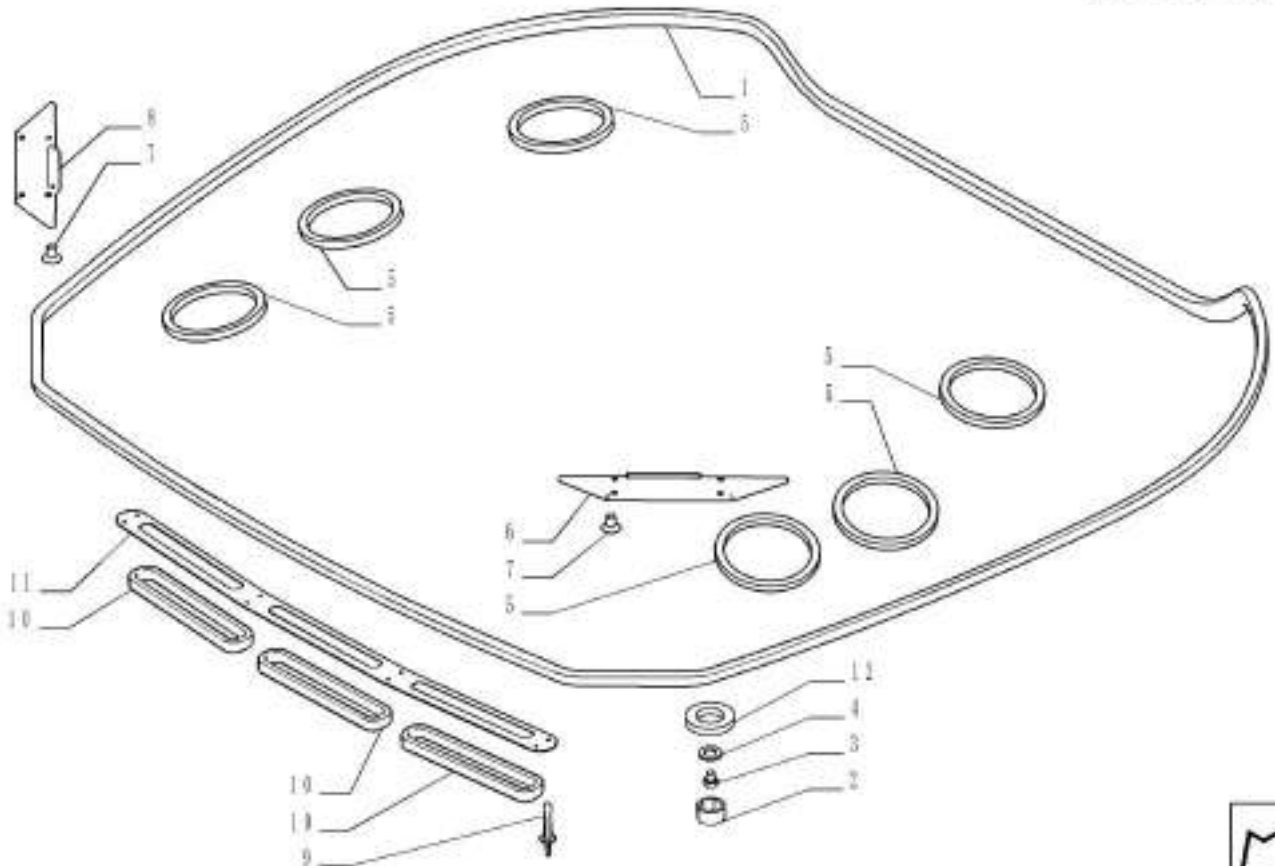
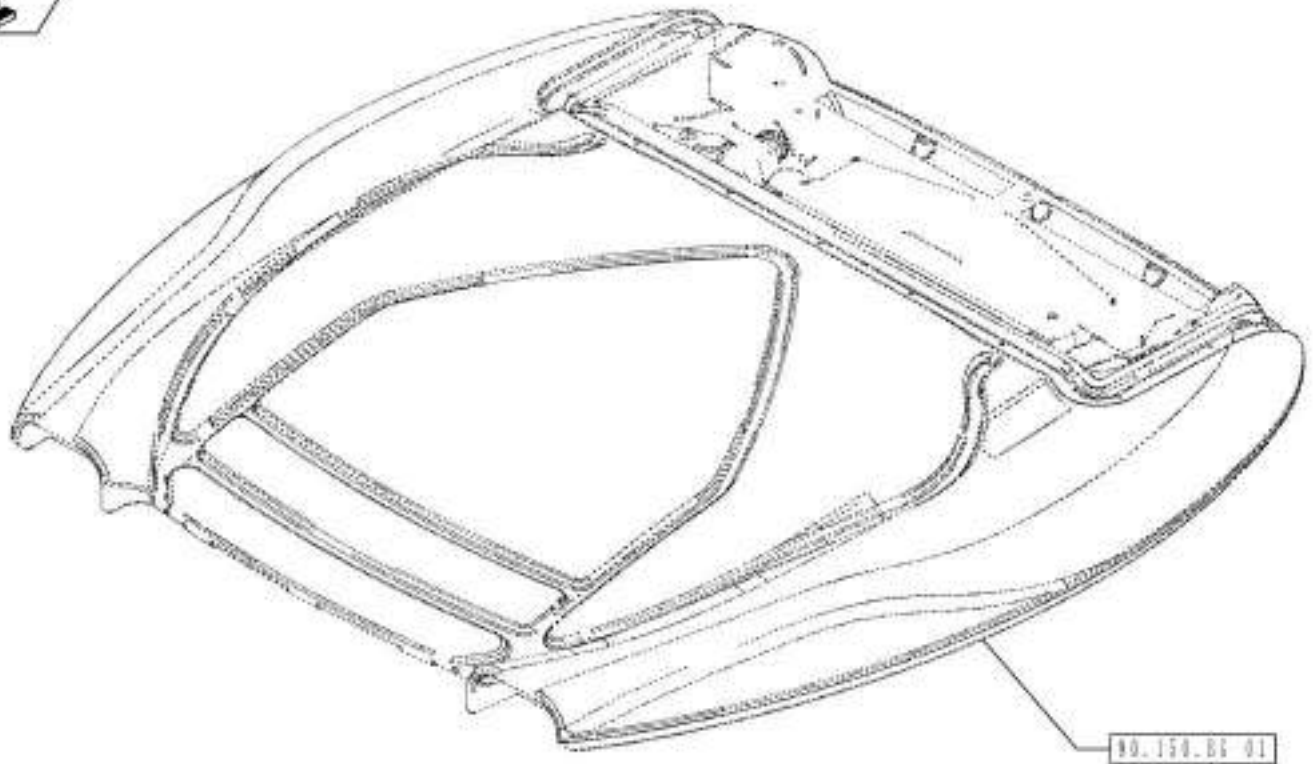

VAR - 333606, 391606 - CAB ROOF

REF FN	PART NUMBER	YR/SN	QTY DESCRIPTION
1	84524342		1 GASKET
2	5089481		11 CAP
3	120104		10 BOLT Hex, M8 x 1.25 x 20mm, Cl 8.8, Full Thd
4	14499401		10 WASHER Flat, 8.40mm ID x 14.00mm OD x 1.60mm, R40, ZND
5	84553610		6 GASKET
6	84524350		1 SUPPORT
7	14441121		4 SCREW
8	84553591		1 BRACKET
9	14642091		8 RIVET
10	84553607		3 GASKET
11	84553608		1 BRACKET
12	5094375		10 WASHER

Valid for Var. 333606 or Var. 391606

FARMALL JX100 FARMALL
 JX110 FARMALL JX70
 FARMALL JX75 FARMALL
 JX80 FARMALL JX90

90.151.AC

01

p1

1/2014

VAR - 334418, 334420, 744748, 744749 - PASSENGER SEAT

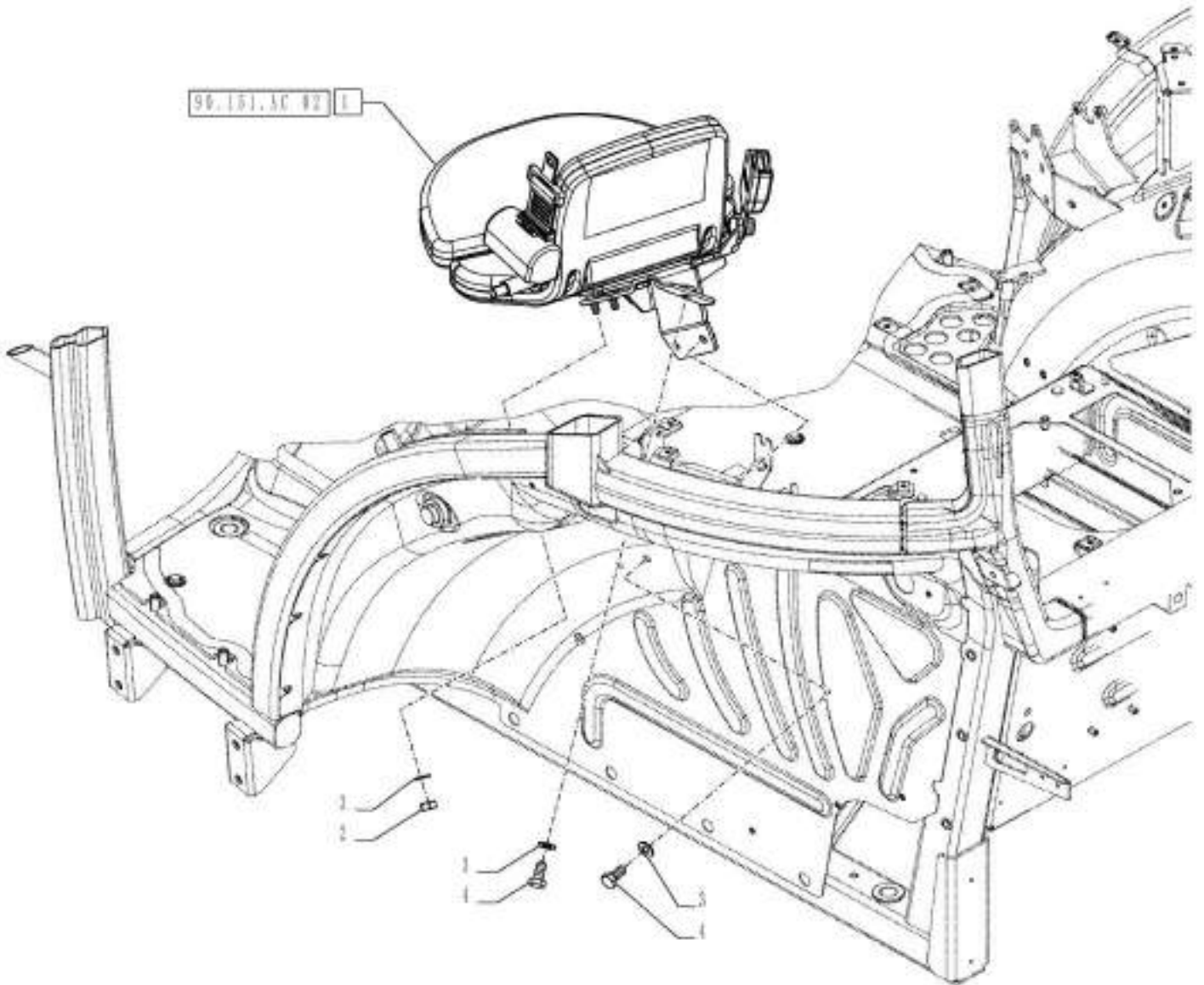

90.151.AC

01

p1

1/2014

VAR - 334418, 334420, 744748, 744749 - PASSENGER SEAT

REF FN	PART NUMBER	YR/SN	QTY DESCRIPTION
1	84281902		1 INSTRUCTIONAL SEAT
2	16100811		2 NUT Hex, M8, 6.80mm, CI 8, ZND
3	11193874		5 BELLEVILLE WASHER 8.4mm ID x 16.00mm OD x 1.4mm, 1.85mm, CI 8.8
4	86625000		3 BOLT Hex, M8 x 18mm, CI 8.8, Full Thd

Valid for Industrial Var. 334418 (744748) or Industrial Var. 334420 (744749)

FARMALL JX100 FARMALL
JX110 FARMALL JX70
FARMALL JX75 FARMALL
JX80 FARMALL JX90

VAR - 333606, 391606 - CAB, SUNVISOR

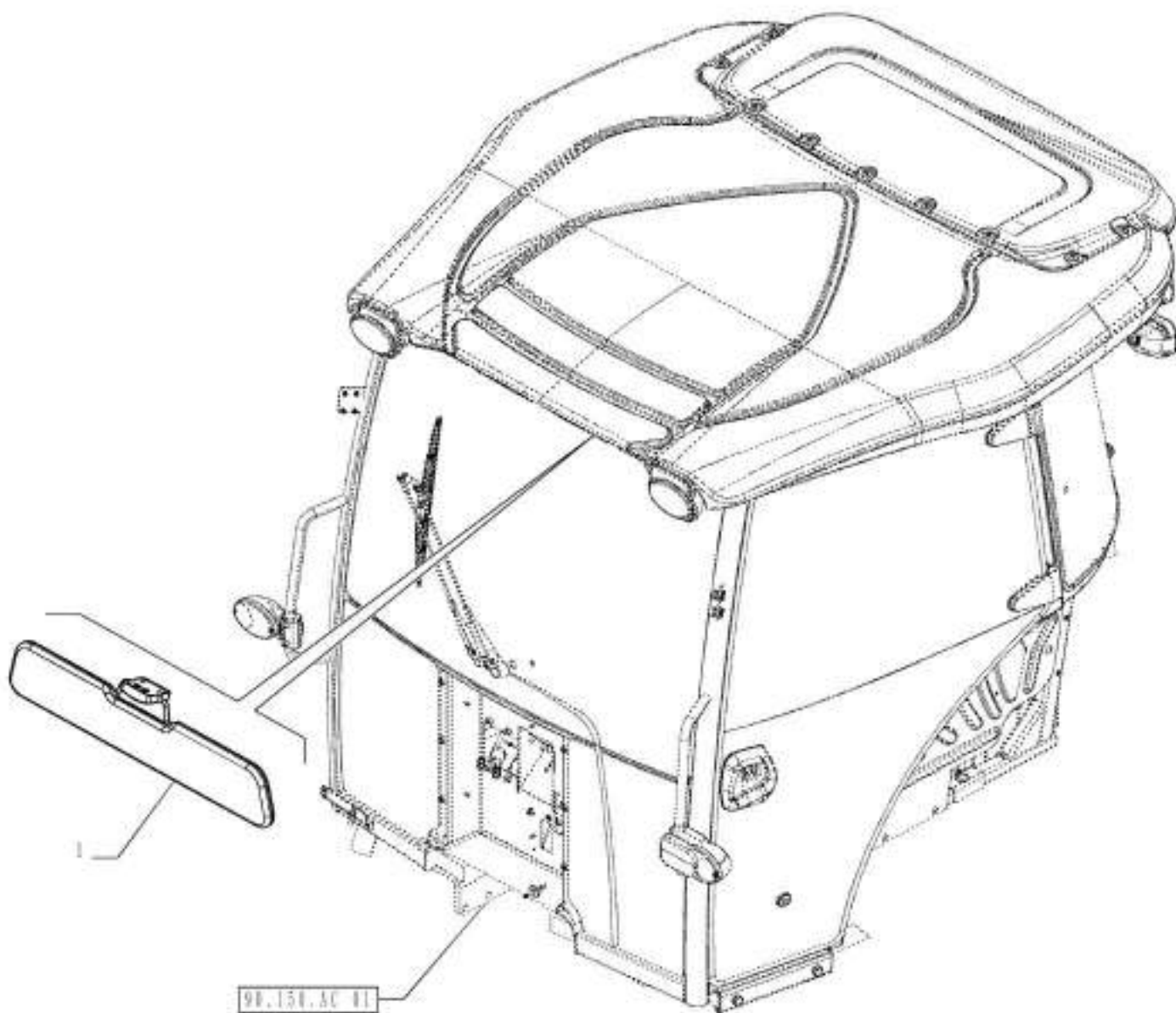

90.151.AE

01

p1

1/2014

VAR - 333606, 391606 - CAB, SUNVISOR

REF FN	PART NUMBER	YR/SN	QTY DESCRIPTION
---------------	--------------------	--------------	------------------------

1	84424617		1 SUN VISOR 080R
---	----------	--	------------------

Valid for Var. 333606 or Var. 391606

FARMALL JX100 FARMALL
JX110 FARMALL JX70
FARMALL JX75 FARMALL
JX80 FARMALL JX90

90.151.AF

01

p1

1/2014

VAR - 333606, 391606 - INSTRUMENT PANEL, CAB

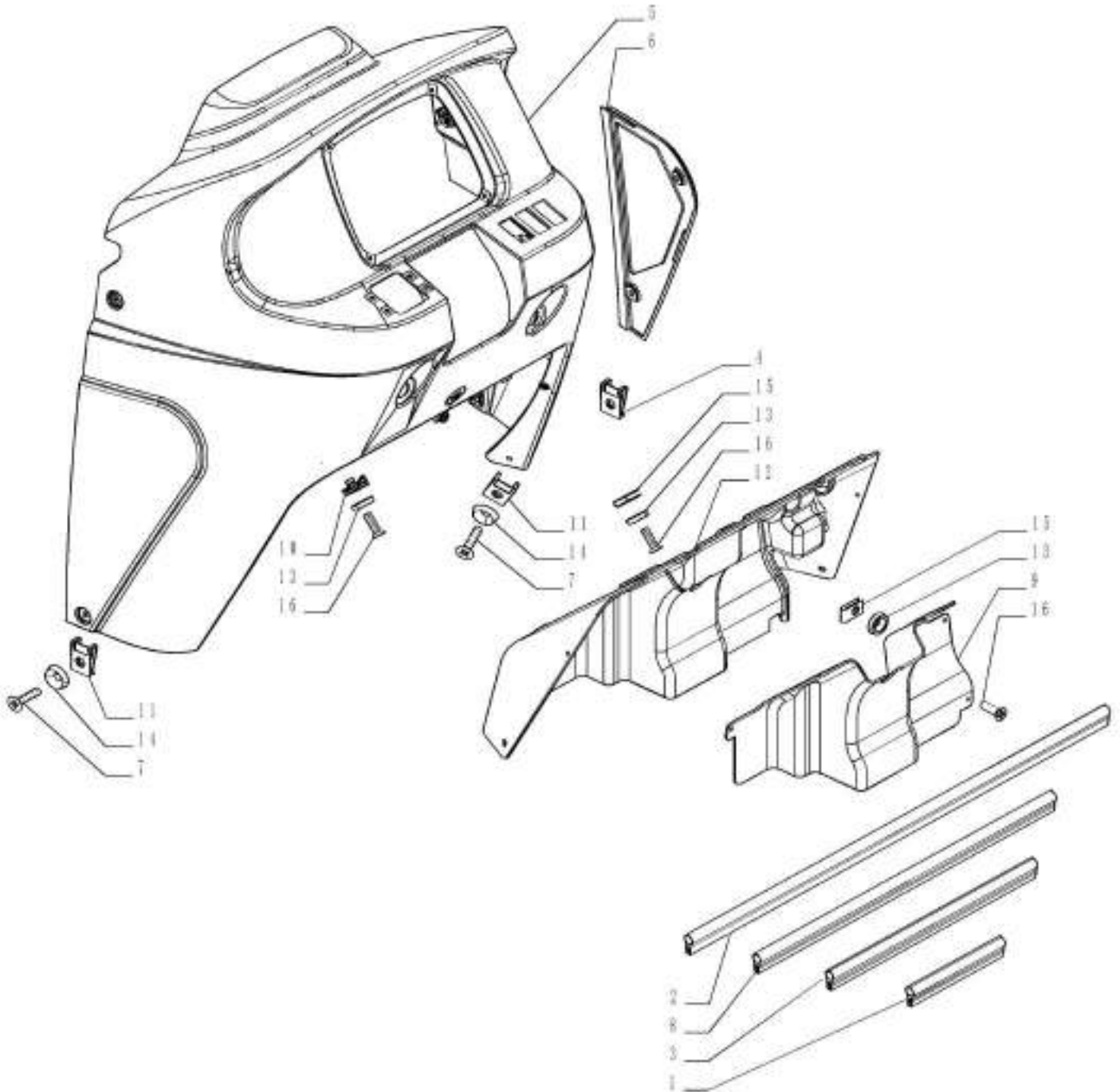

90.151.AF

01

p1

1/2014

VAR - 333606, 391606 - INSTRUMENT PANEL, CAB

REF FN	PART NUMBER	YR/SN	QTY DESCRIPTION
1	84526330		1 GASKET
2	84526331		1 GASKET
3	84526328		1 GASKET
4	5174673		2 KIT
5	84520296		1 ENGINE HOOD
6	84520298		1 COVER
7	13301511		7 SCREW Phil Flat Hd, M6 x 20, 5.8
8	84526333		1 GASKET
9	84575472		1 COVER
10	84553472		4 SUPPORT
11	{84524985}		7
12	84575471		1 COVER
13	84604726		12 HEADLINER
14	{84524958}		7
15	14369474		7 NUT M4.2, U, 16.3mm long
16	13299414		12 SCREW Pan Hd, M5 x 16, 5.8

Valid for Var. 333606 or Var. 391606	FARMALL JX100 FARMALL JX110 FARMALL JX70 FARMALL JX75 FARMALL JX80 FARMALL JX90
---	--

90.151.AK

01

p1

1/2014

VAR - 330879, 390879 - REAR VIEW MIRROR, CAB

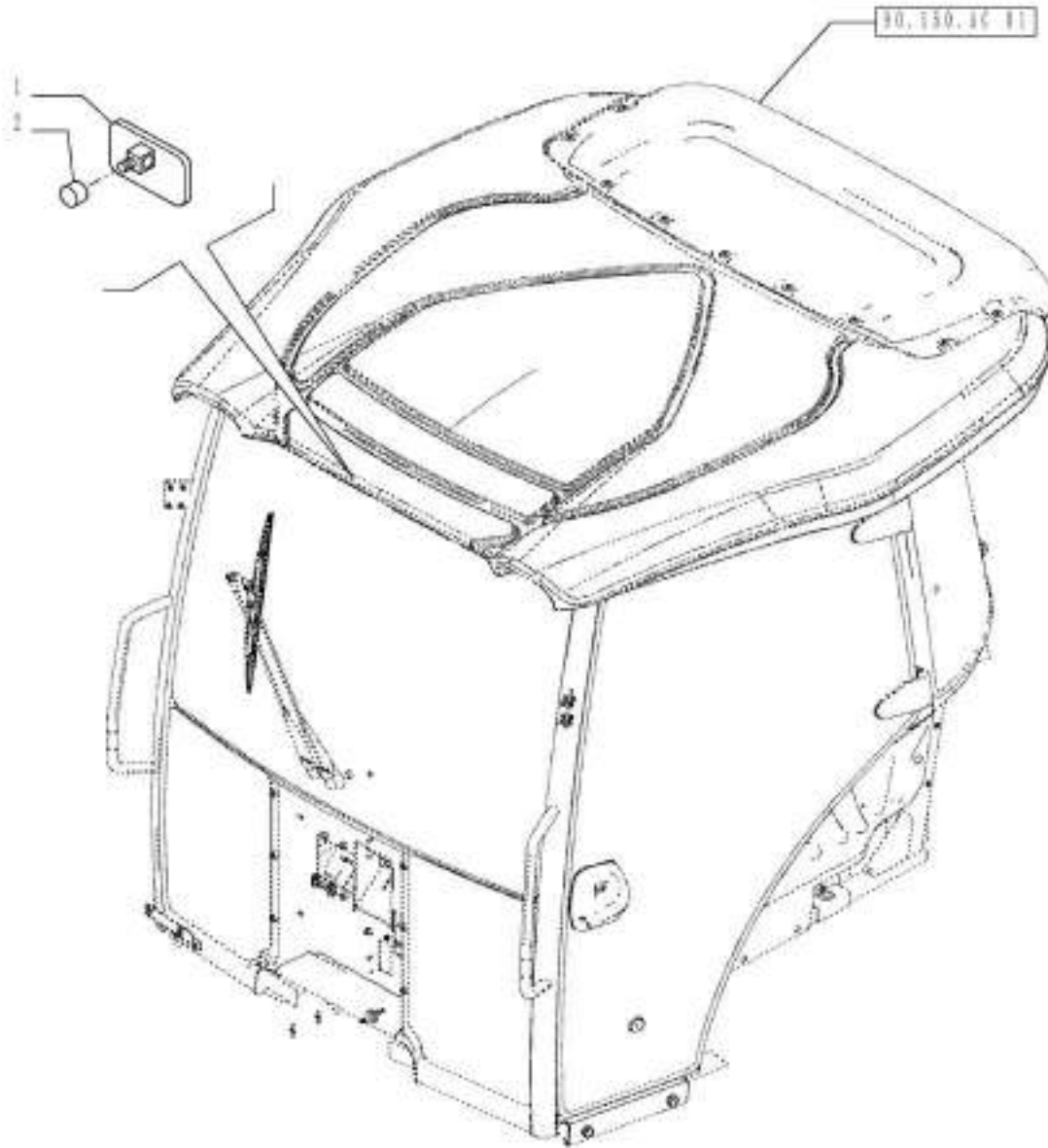

90.151.AK

01

p1

1/2014

VAR - 330879, 390879 - REAR VIEW MIRROR, CAB

REF FN	PART NUMBER	YR/SN	QTY DESCRIPTION
1	47381727		1 REAR VIEW MIRROR
2	5089481		1 CAP

Valid for Var. 330879 or Var. 390879

FARMALL JX100 FARMALL
JX110 FARMALL JX70
FARMALL JX75 FARMALL
JX80 FARMALL JX90

90.154.AC

01

p1

1/2014

VAR - 334342, 334343, 334344, 334345, 334346, 334347, 334348, 334349, 334350, 335914 - CAB DOOR, LEFT, HANDLE

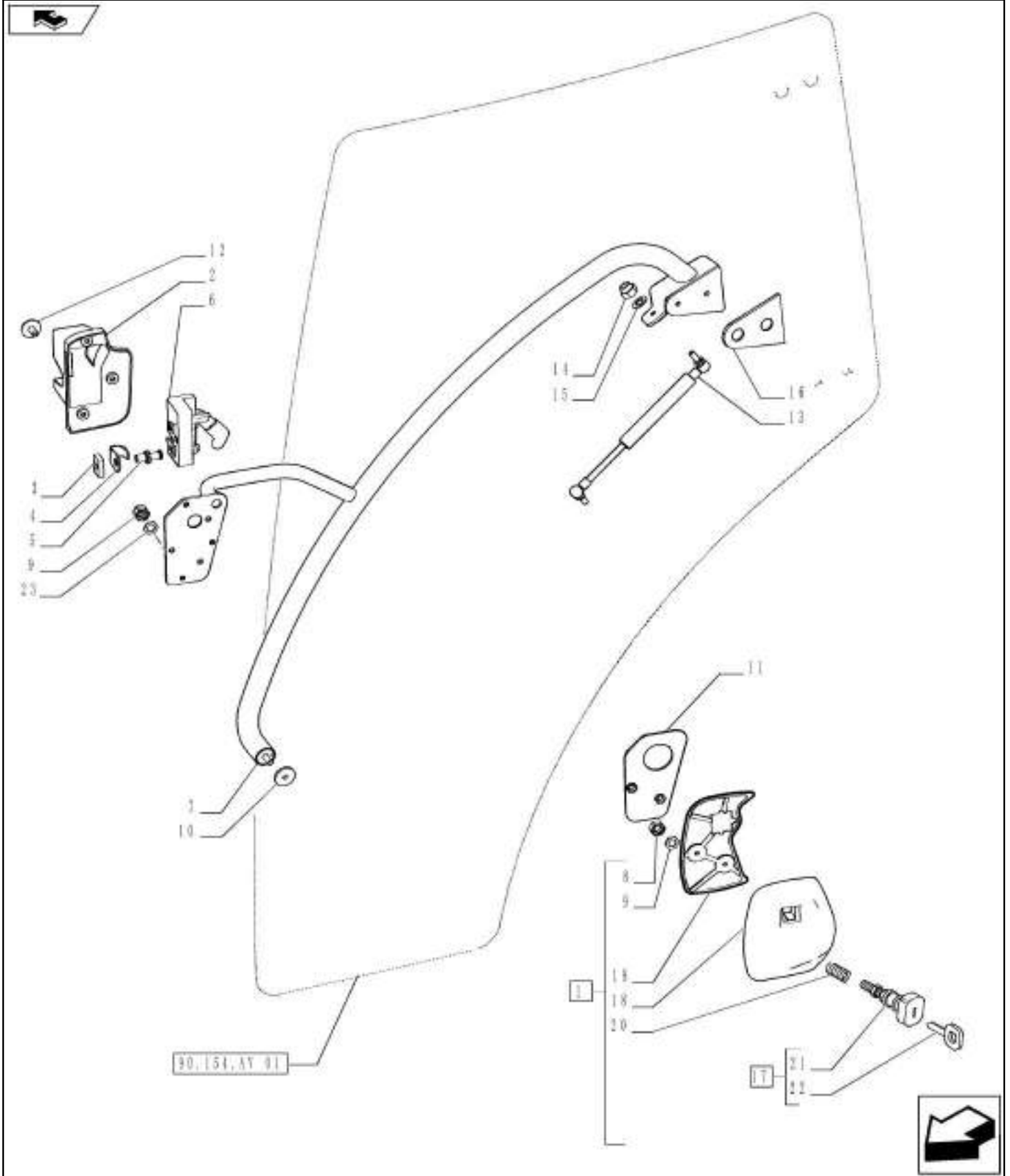

90.154.AC

01

p1

1/2014

VAR - 334342, 334343, 334344, 334345, 334346, 334347, 334348, 334349, 334350, 335914 - CAB DOOR, LEFT, HANDLE

REF FN	PART NUMBER	YR/SN	QTY DESCRIPTION
1	5097438		1 LOCK
2	5091200		1 COVER
3	5094358		1 NUT
4	5094359		1 COVER
5	5094360		1 PIN
6	5094363		1 LOCK
7	84396446		1 HANDLE Incl 8, 9, 17-22
8	14488701		3 WASHER
9	12574211		6 NUT M6 x 1, CI 8
10	5080558		1 SEALING WASHER
11	5098750		1 RUBBER PAD
12	14778711		3 SCREW
13	84198394		1 GAS STRUT
14	16104121		1 NUT M8 x 1.25, CI 10
15	12601374		1 WAVE WASHER Wave, 8.40mm ID x 15.00mm OD x 0.80mm, 3.00mm, CST, DAC
16	87620476		1 RUBBER PAD
17	5097444		1 LOCK ASSY Incl 21 - 22
18	5097449		1 COVER
19	5097450		1 DOOR SEAL
20	5094368		1 SPRING
21	NSS		1 NOT SERVICED SEPARATELY Hub Incl in 17
22	5097445		1 DOOR LOCK KEY
23	14499301		3 WASHER M6 x 12.00mm OD x 1.60mm Overwrite

Valid for Var. 334342 or Var. 334343 or Var. 334344 or Var. 334345 or Var. 334346 or Var. 334347 or Var. 334348 or Var. 334349 or Var. 334350 or Var. 335914

FARMALL JX100 FARMALL
JX110 FARMALL JX70
FARMALL JX75 FARMALL
JX80 FARMALL JX90

90.154.AC

02

p1

1/2014

VAR - 334342, 334343, 334344, 334345, 334346, 334347, 334348, 334349, 334350, 335914 - CAB DOOR, RIGHT, HANDLE

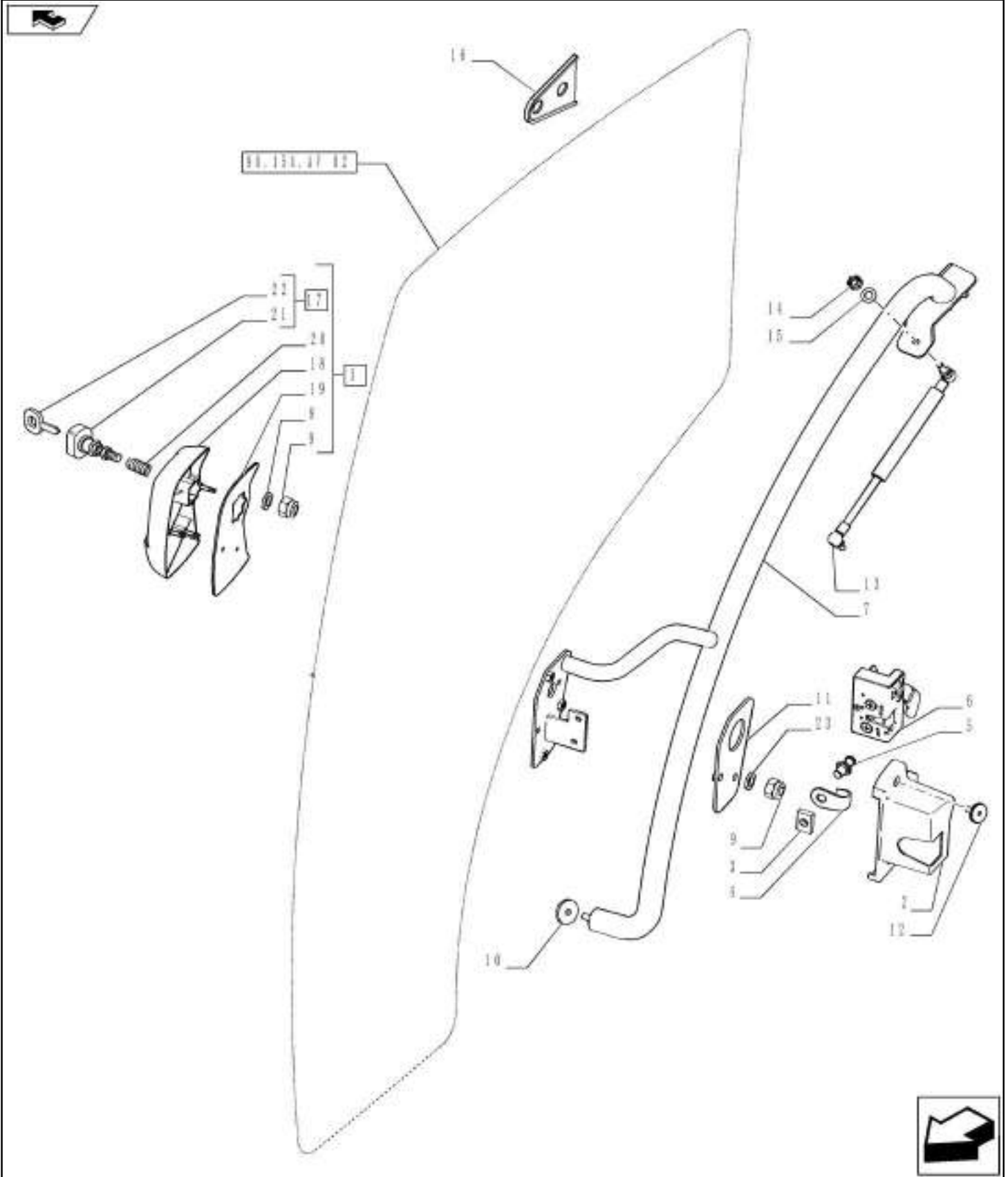

90.154.AC

02

p1

1/2014

VAR - 334342, 334343, 334344, 334345, 334346, 334347, 334348, 334349, 334350, 335914 - CAB DOOR, RIGHT, HANDLE

REF FN	PART NUMBER	YR/SN	QTY DESCRIPTION
1	5097439		1 LOCK Incl 8, 9, 17 - 22
2	5091199		1 COVER
3	5094358		1 NUT
4	5094359		1 COVER
5	5094360		1 PIN
6	5089546		1 LOCK
7	84396449		1 HANDLE
8	14488701		3 WASHER
9	12574211		6 NUT M6 x 1, CI 8
10	5080558		1 SEALING WASHER
11	87620482		1 RUBBER PAD
12	14778711		3 SCREW
13	84198394		1 GAS STRUT
14	16104121		1 NUT M8 x 1.25, CI 10
15	12601374		1 WAVE WASHER Wave, 8.40mm ID x 15.00mm OD x 0.80mm, 3.00mm, CST, DAC
16	87620476		1 RUBBER PAD
17	5097444		1 LOCK ASSY Incl 21 - 22
18	5097453		1 COVER
19	5097454		1 DOOR SEAL
20	5094368		1 SPRING
21	NSS		1 NOT SERVICED SEPARATELY Hub Incl in 17
22	5097445		1 DOOR LOCK KEY
23	14499301		3 WASHER M6 x 12.00mm OD x 1.60mm Overwrite

Valid for Var. 334342 or Var. 334343 or Var. 334344 or Var. 334345 or Var. 334346 or Var. 334347 or Var. 334348 or Var. 334349 or Var. 334350 or Var. 335914

FARMALL JX100 FARMALL
JX110 FARMALL JX70
FARMALL JX75 FARMALL
JX80 FARMALL JX90

90.154.AV

01

p1

1/2014

VAR - 334342, 334343, 334344, 334345, 334346, 334347, 334348, 334349, 334350, 335914 - CAB DOOR, LEFT, GLASS

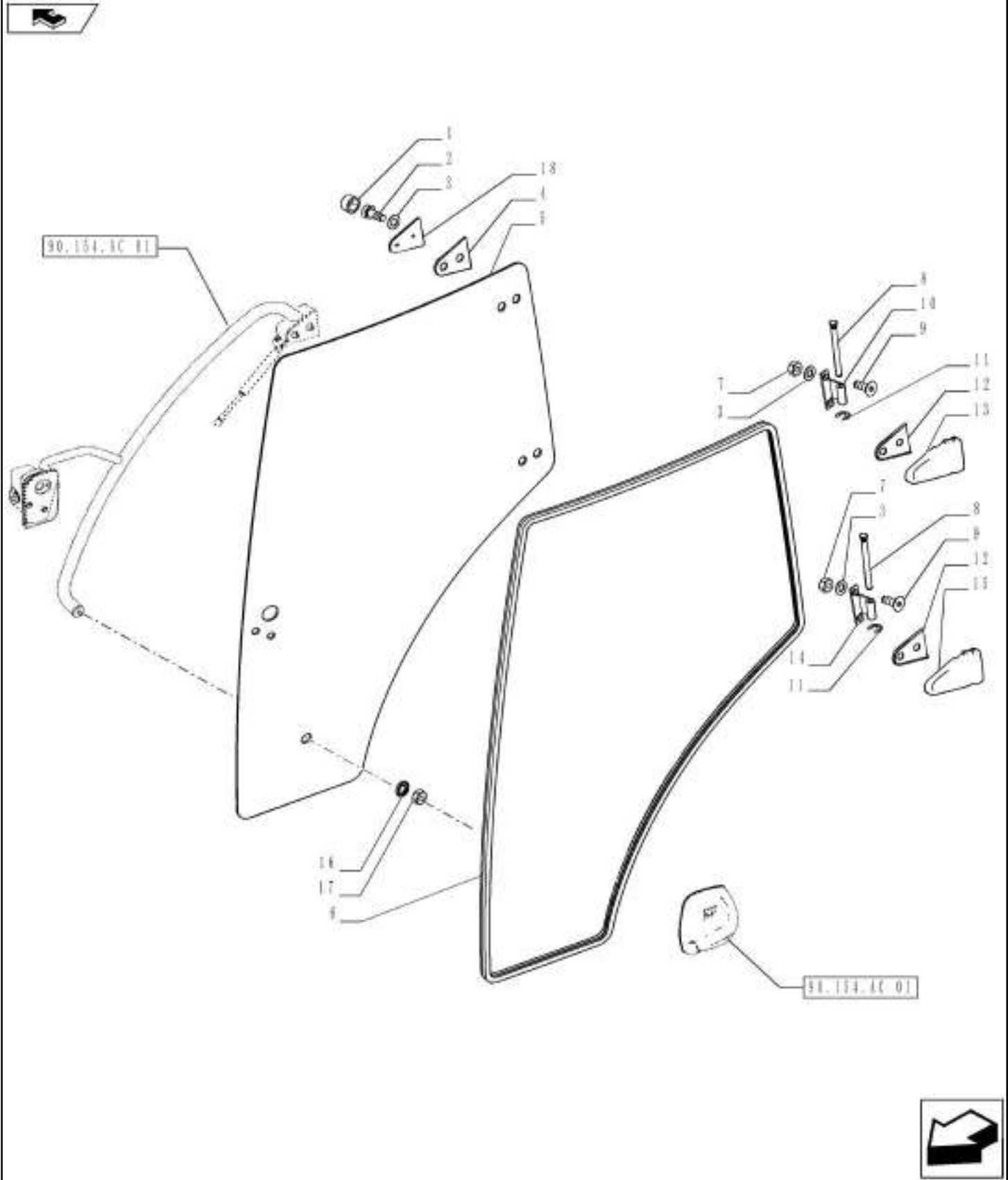

90.154.AV

01

p1

1/2014

VAR - 334342, 334343, 334344, 334345, 334346, 334347, 334348, 334349, 334350, 335914 - CAB DOOR, LEFT, GLASS

REF FN	PART NUMBER	YR/SN	QTY DESCRIPTION
1	5089481		8 CAP
2	120104		8 BOLT Hex, M8 x 1.25 x 20mm, CI 8.8, Full Thd
3	12601374		18 WAVE WASHER Wave, 8.40mm ID x 15.00mm OD x 0.80mm, 3.00mm, CST, DAC
4	87620476		4 RUBBER PAD
5	84396396		1 CAB GLASS ASSY
6	84396397		1 GASKET
7	16100821		8 NUT M8, CI 10
8	5091925		4 PIN
9	14442021		8 SCREW Flat Csk Hd, M8 x 1.25 x 20mm, CI 8.8
10	84396443		1 HINGE
11	11087976		4 CIRCLIP Ext., M8, BLO
12	87620762		4 RUBBER PAD
13	84329980		1 HINGE
14	84396444		2 HINGE
15	87700818		2 HINGE
16	5094140		2 WASHER
17	5094141		2 NUT
18	87620253		2 PLATE

Valid for Var. 334342 or Var. 334343 or Var. 334344 or Var. 334345 or Var. 334346 or Var. 334347 or Var. 334348 or Var. 334349 or Var. 334350 or Var. 335914

FARMALL JX100 FARMALL
JX110 FARMALL JX70
FARMALL JX75 FARMALL
JX80 FARMALL JX90

90.154.AV

02

p1

1/2014

VAR - 334342, 334343, 334344, 334345, 334346, 334347, 334348, 334349, 334350, 335914 - CAB DOOR, RIGHT, GLASS

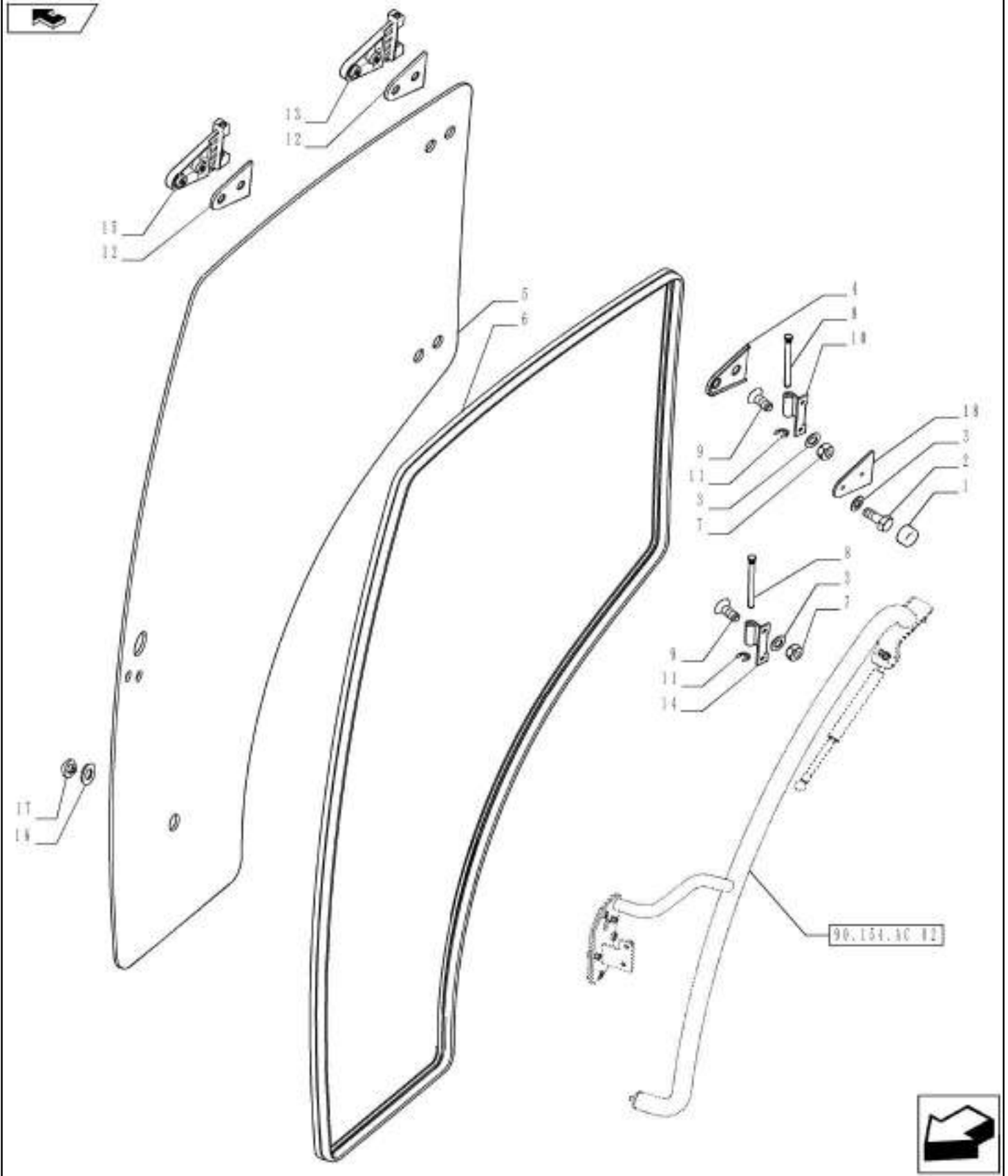

90.154.AV

02

p1

1/2014

VAR - 334342, 334343, 334344, 334345, 334346, 334347, 334348, 334349, 334350, 335914 - CAB DOOR, RIGHT, GLASS

REF FN	PART NUMBER	YR/SN	QTY DESCRIPTION
1	5089481		4 CAP
2	120104		4 BOLT Hex, M8 x 1.25 x 20mm, CI 8.8, Full Thd
3	12601374		8 WAVE WASHER Wave, 8.40mm ID x 15.00mm OD x 0.80mm, 3.00mm, CST, DAC
4	87620476		1 RUBBER PAD
5	84396432		1 CAB GLASS ASSY
6	84396433		1 GASKET
7	16100821		4 NUT M8, CI 10
8	5091925		2 PIN
9	14442021		4 SCREW Flat Csk Hd, M8 x 1.25 x 20mm, CI 8.8
10	84396442		1 HINGE
11	11087976		2 CIRCLIP Ext., M8, BLO
12	87620762		2 RUBBER PAD
13	84330148		1 HINGE
14	84396444		1 HINGE
15	87700818		1 HINGE
16	5094140		1 WASHER
17	5094141		1 NUT
18	87620253		1 PLATE

Valid for Var. 334342 or Var. 334343 or Var. 334344 or Var. 334345 or Var. 334346 or Var. 334347 or Var. 334348 or Var. 334349 or Var. 334350 or Var. 335914

FARMALL JX100 FARMALL
JX110 FARMALL JX70
FARMALL JX75 FARMALL
JX80 FARMALL JX90

90.156.AB

01

p1

1/2014

VAR - 333606, 334318, 334319, 391606, 392315 - REAR WINDOW GLASS

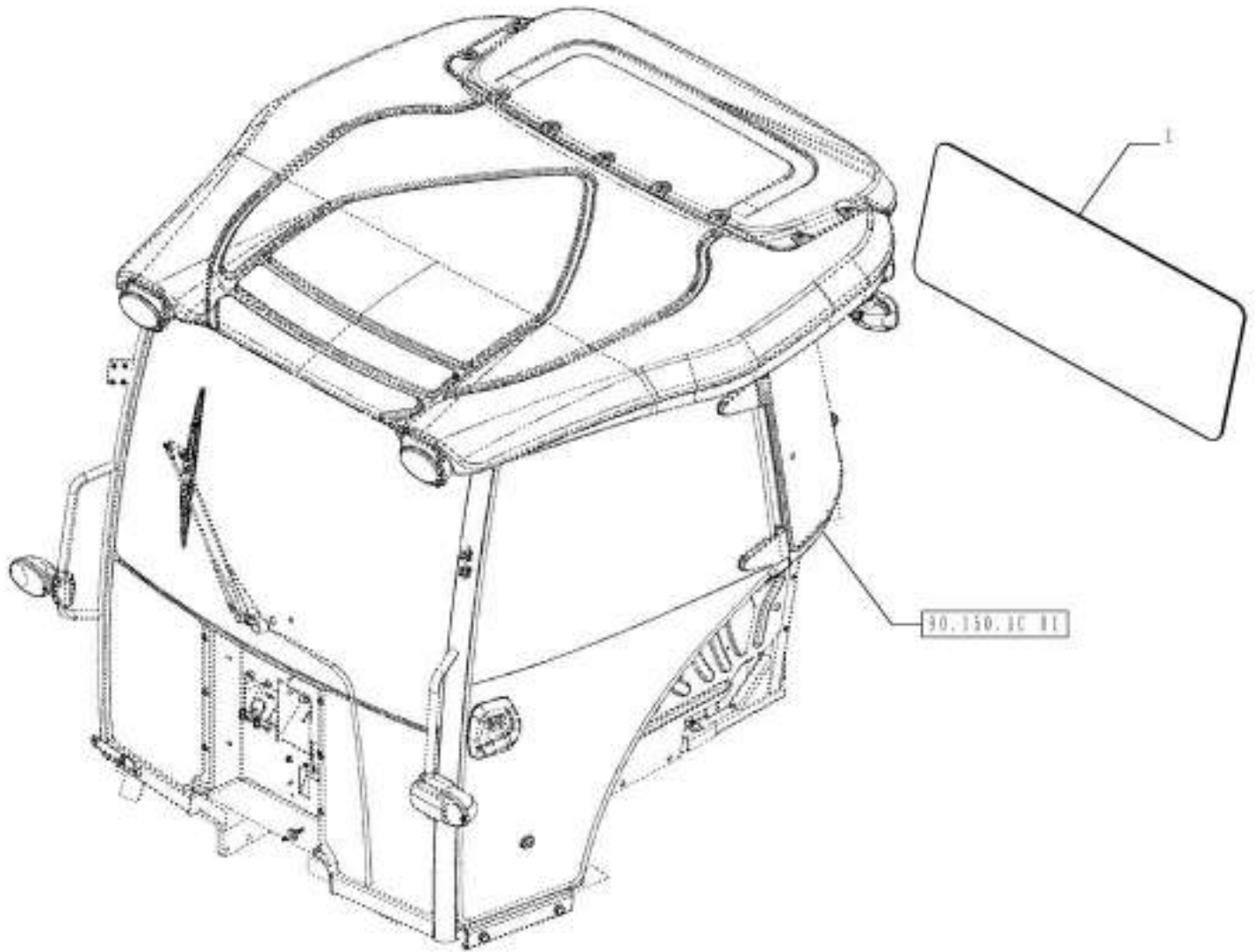

VAR - 333606, 334318, 334319, 391606, 392315 - REAR WINDOW GLASS

REF	FN	PART NUMBER	YR/SN	QTY	DESCRIPTION
1	1	84396389		1	GLASS
1	2	84524317		1	GLASS
(1)		VAR - 333606, 391606; CAB			
(2)		VAR - 334318, 334319, 392315; ROPS			

Valid for Var. 333606 or Var. 334318 or Var. 334319 or Var. 391606 or Var. 392315

FARMALL JX100 FARMALL
JX110 FARMALL JX70
FARMALL JX75 FARMALL
JX80 FARMALL JX90

VAR - 333606, 391606 - CAB REAR WINDOW

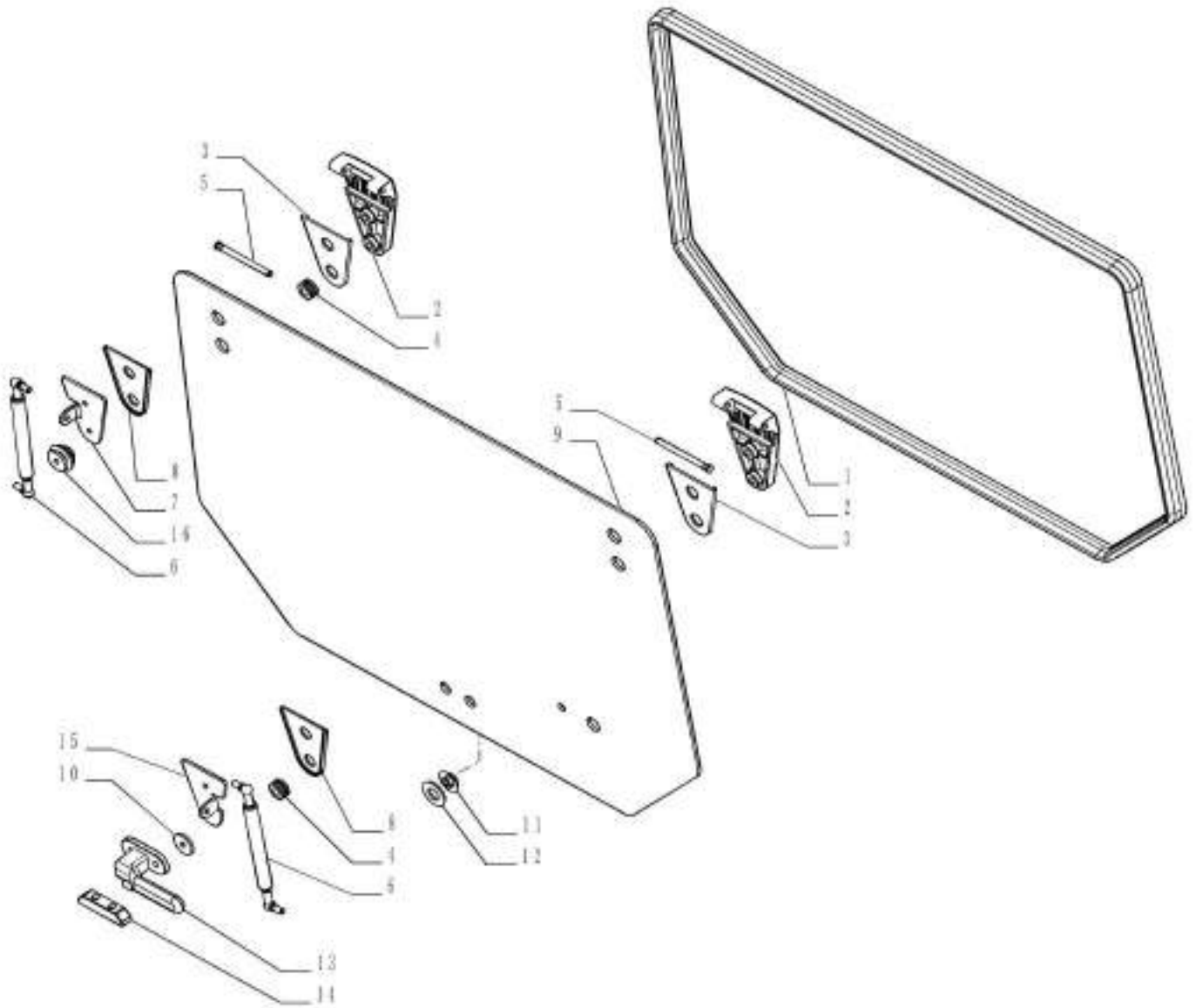

90.156.AD

01

p1

1/2014

VAR - 333606, 391606 - CAB REAR WINDOW

REF FN	PART NUMBER	YR/SN	QTY DESCRIPTION
1	47406274		1 SEAL, GLASS
2	87700818		2 HINGE
3	87620476		2 RUBBER PAD
4	87602808		2 GROMMET
5	5091925		2 PIN
6	5089567		2 GAS STRUT
7	84399835		1 SUPPORT
8	87620762		2 RUBBER PAD
9	84396387		1 GLASS
10	5094375		2 WASHER
11	5094141		2 NUT
12	5094140		2 WASHER
13	5089564		1 HANDLE
14	5094377		1 BRACKET
15	84396460		1 SUPPORT
16	5089481		4 CAP

Valid for Var. 333606 or Var. 391606	FARMALL JX100 FARMALL JX110 FARMALL JX70 FARMALL JX75 FARMALL JX80 FARMALL JX90
---	--

90.156.AG

01

p1

1/2014

VAR - 334318, 334319, 392315 - GLASS, FRONT, ROPS

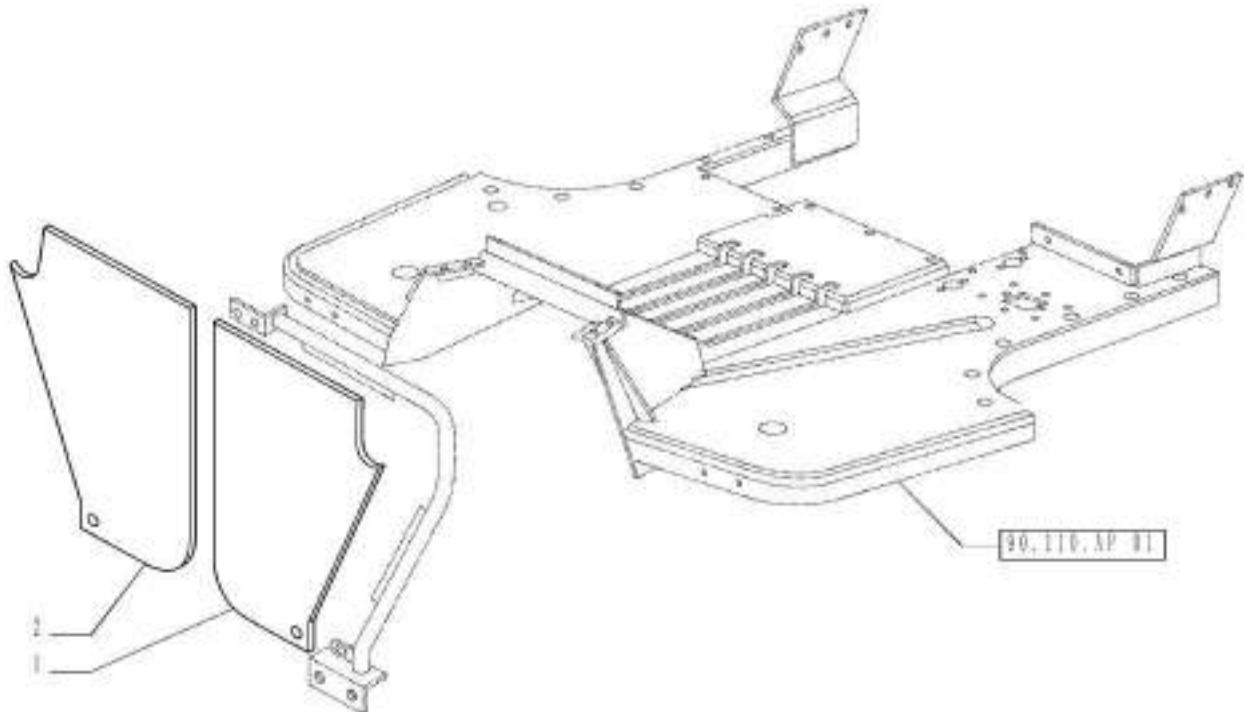

90.156.AG

01

p1

1/2014

VAR - 334318, 334319, 392315 - GLASS, FRONT, ROPS

REF FN	PART NUMBER	YR/SN	QTY DESCRIPTION
1	84524316		1 GLASS LH
2	84524318		1 GLASS RH

Valid for Var. 334318 or Var. 334319 or Var. 392315

FARMALL JX100 FARMALL
JX110 FARMALL JX70
FARMALL JX75 FARMALL
JX80 FARMALL JX90

90.156.AL

01

p1

1/2014

VAR - 333606, 392606 - CAB WINDSHIELD GLASS

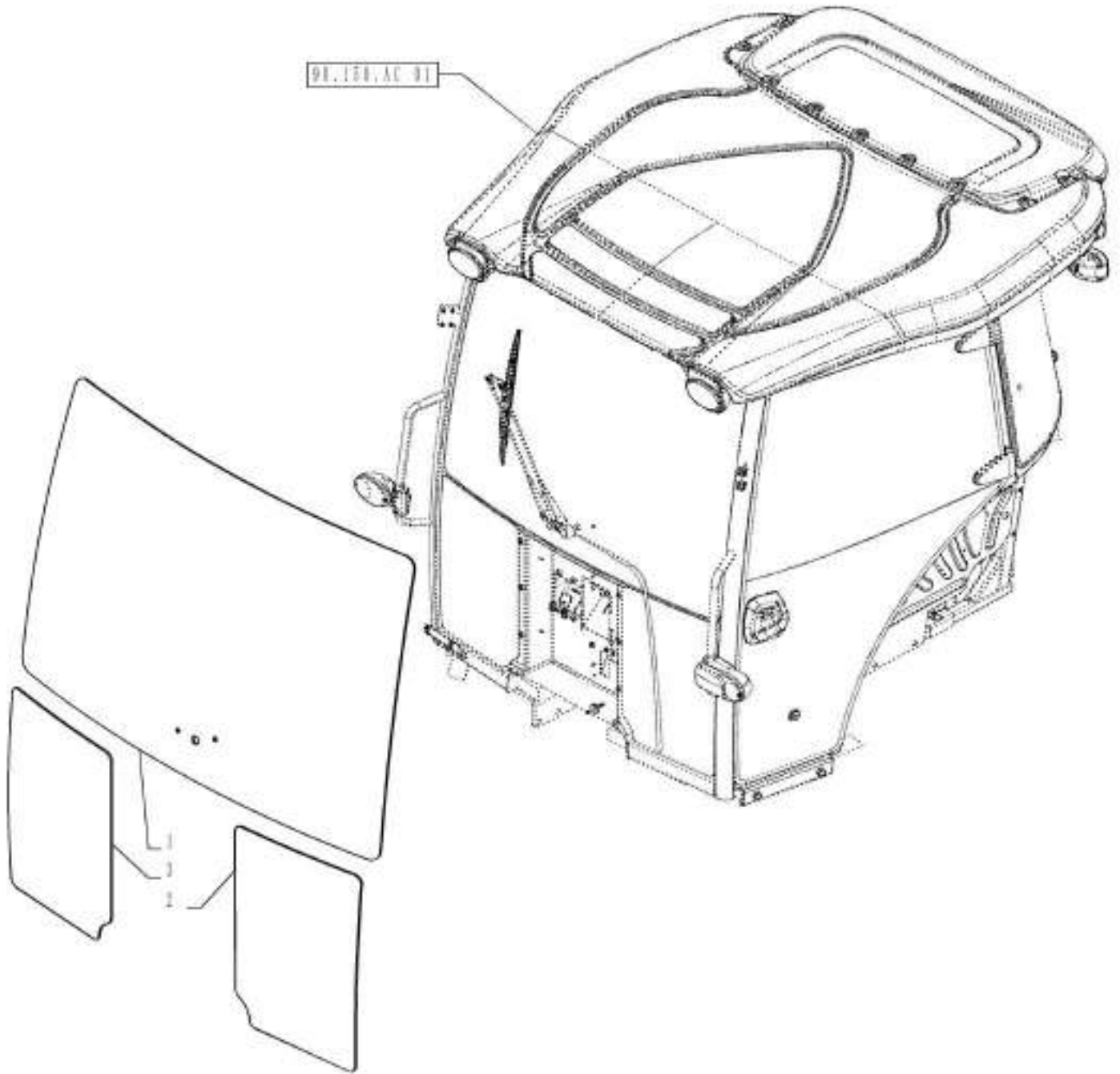

90.156.AL

01

p1

1/2014

VAR - 333606, 392606 - CAB WINDSHIELD GLASS

REF FN	PART NUMBER	YR/SN	QTY DESCRIPTION
1	84396386		1 GLASS
2	84396388		1 GLASS
3	84396392		1 GLASS

Valid for Var. 333606 or Var. 391606

FARMALL JX100 FARMALL
JX110 FARMALL JX70
FARMALL JX75 FARMALL
JX80 FARMALL JX90

VAR - 333606, 391606 - WINDOW, LEFT

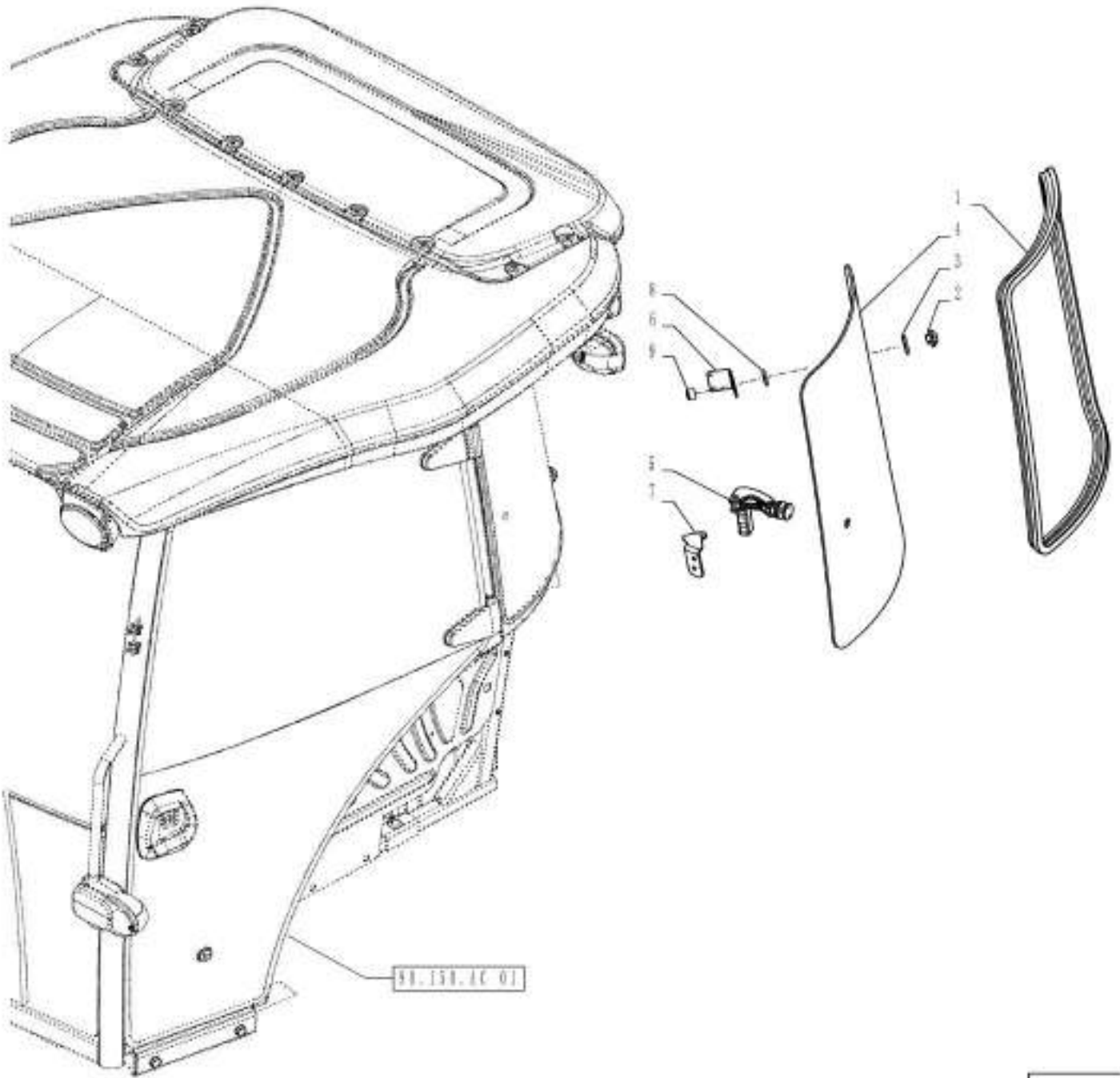

VAR - 333606, 391606 - WINDOW, LEFT

REF FN	PART NUMBER	YR/SN	QTY DESCRIPTION
1	84396393		1 SEAL, GLASS
2	5094141		2 NUT
3	5094140		2 WASHER
4	84396385		1 GLASS
5	84540524		1 HANDLE
6	5089560		2 BRACKET
7	47393020		1 SUPPORT
8	5094375		2 WASHER
9	5089481		2 CAP

Valid for Var. 333606 or Var. 391606

FARMALL JX100 FARMALL
JX110 FARMALL JX70
FARMALL JX75 FARMALL
JX80 FARMALL JX90

90.156.AZ

02

p1

1/2014

VAR - 333606, 391606 - CAB WINDOW GLASS, RIGHT SIDE

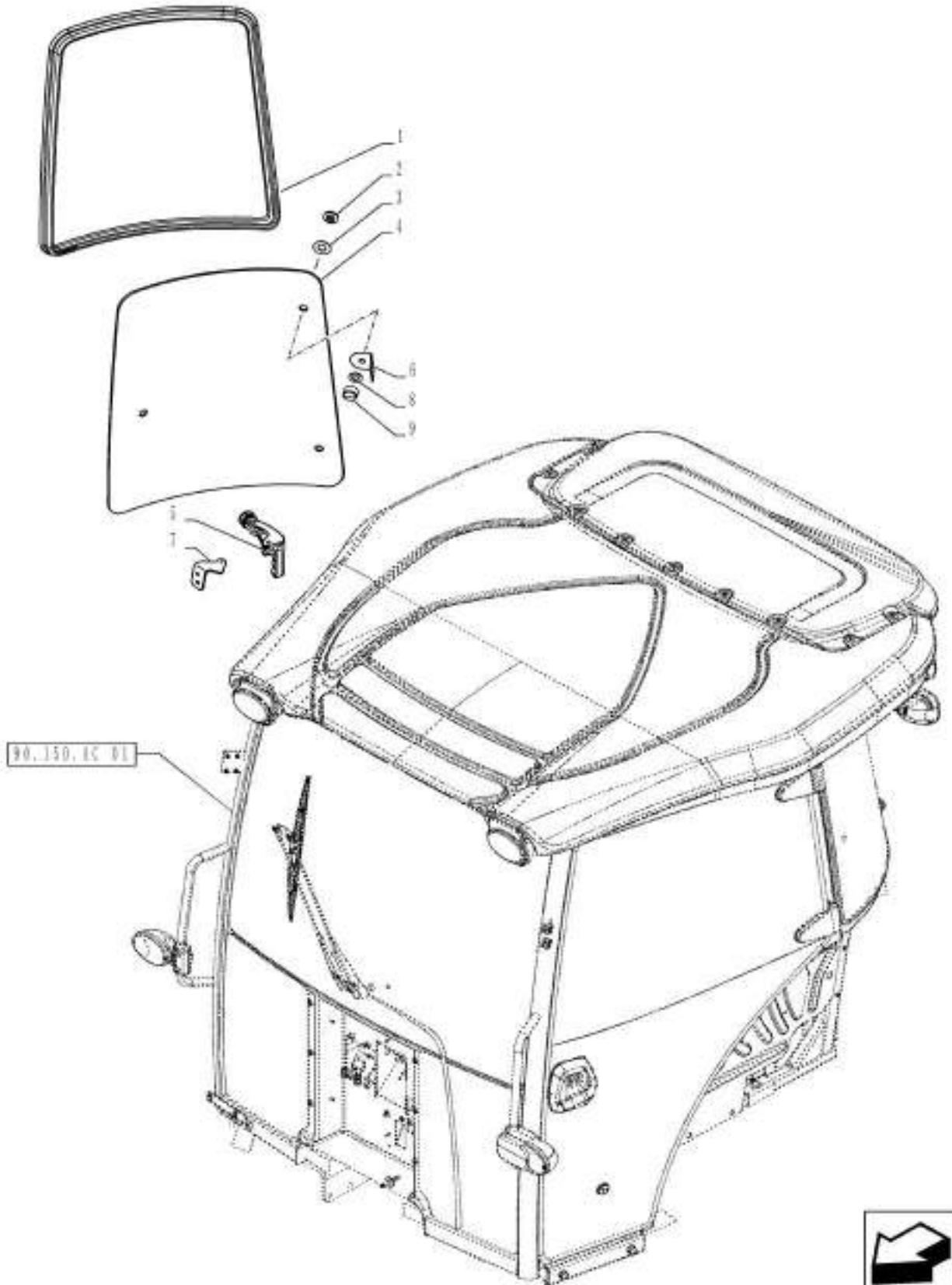

VAR - 333606, 391606 - CAB WINDOW GLASS, RIGHT SIDE

REF FN	PART NUMBER	YR/SN	QTY DESCRIPTION
1	84396395		1 SEAL, GLASS
2	5094141		2 NUT
3	5094140		2 WASHER
4	84396391		1 GLASS
5	84540520		1 HANDLE
6	5089560		2 BRACKET
7	47393018		1 SUPPORT
8	5094375		2 WASHER
9	5089481		2 CAP

Valid for Var. 333606 or Var. 391606

FARMALL JX100 FARMALL
JX110 FARMALL JX70
FARMALL JX75 FARMALL
JX80 FARMALL JX90

90.160.AM

01

p1

1/2014

VAR - 744746, 744747, 744748, 744749 - CAB SIDE PANEL (LH)

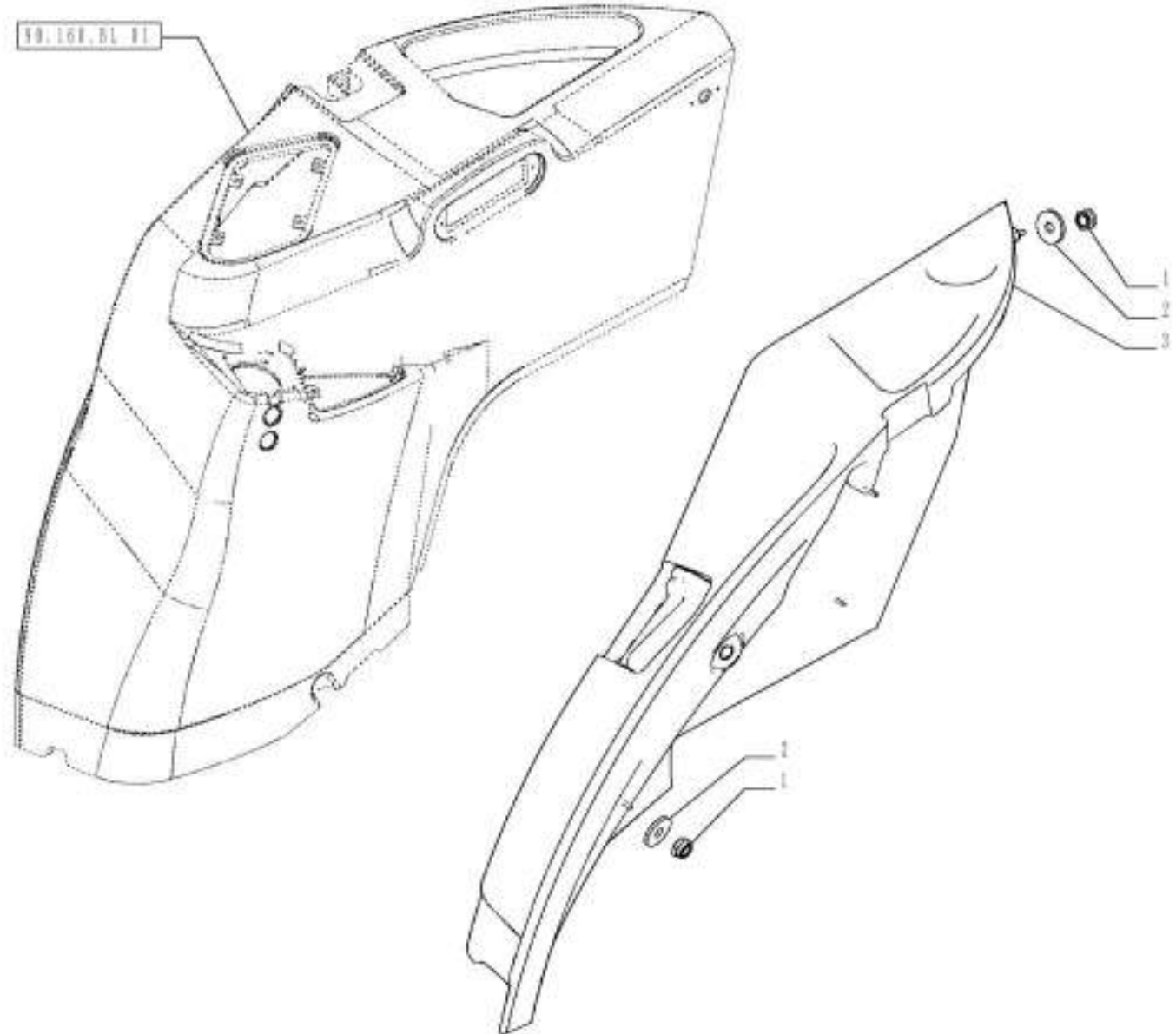

VAR - 744746, 744747, 744748, 744749 - CAB SIDE PANEL (LH)

REF FN	PART NUMBER	YR/SN	QTY DESCRIPTION
1	12575411		4 LOCK NUT M6 x 1, CI 8
2	10523401		4 WASHER Flat, 6.15mm ID x 18.00mm OD x 2.00mm, Carbon Steel, ZND
3 1	84524383		1 LINING
3 2	84524386		1 TRIM
(1)	VAR - 334418 (744748) or 334420 (744749)		
(2)	VAR - 396190 (744746) or 336191 (744747)		
Valid for Industrial Var. 396190 (744746) or Industrial Var. 336191 (744747) or Industrial Var. 334418 (744748) or Industrial Var. 334420 (744749)			FARMALL JX100 FARMALL JX110 FARMALL JX70 FARMALL JX75 FARMALL JX80 FARMALL JX90

VAR - 744738, 744744 - CAB FLOOR, MAT

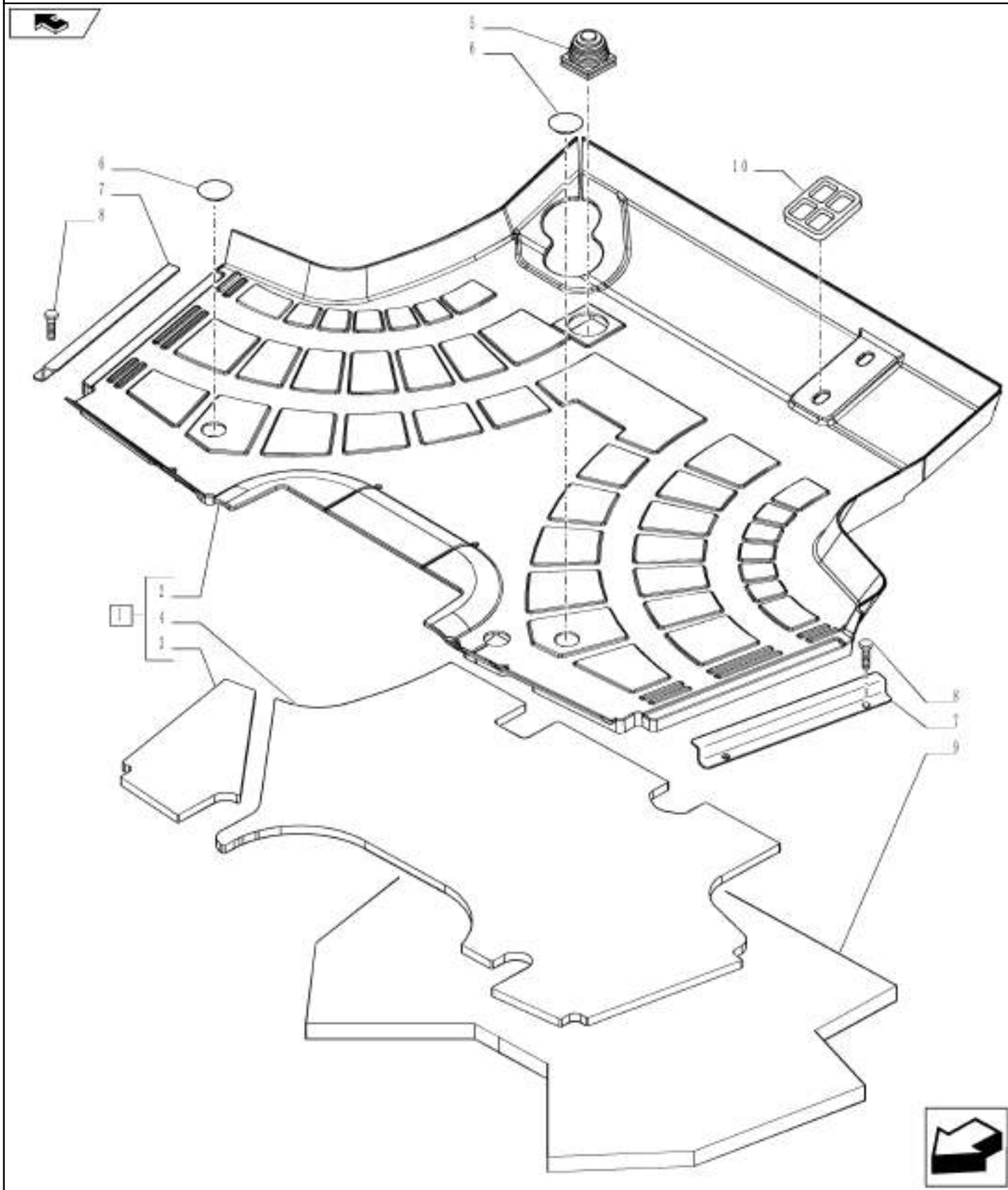

VAR - 744738, 744744 - CAB FLOOR, MAT

REF FN	PART NUMBER	YR/SN	QTY DESCRIPTION
1	84519414		1 FLOOR MAT ASSY Incl 2 - 4
2	NSS		1 NOT SERVICED SEPARATELY Floor Mat Incl in 1
3	84520289		1 INSULATION
4	84519416		1 INSULATION
5	84527939		1 BELLOWS
6	47368045		2 CAP
7	84520291		2 PLATE
8	87015849		4 SCREW M6 x 20mm, Cl 5.8
9	47406161		1 FLOOR MAT
10	84527938		1 PLUG

Valid for Industrial Var. 334321, 390268 (744738) or Industrial Var. 334320, 390267 (744744)

FARMALL JX100 FARMALL
JX110 FARMALL JX70
FARMALL JX75 FARMALL
JX80 FARMALL JX90

VAR - 330384, 334322, 744739 - CAB FLOOR, MAT

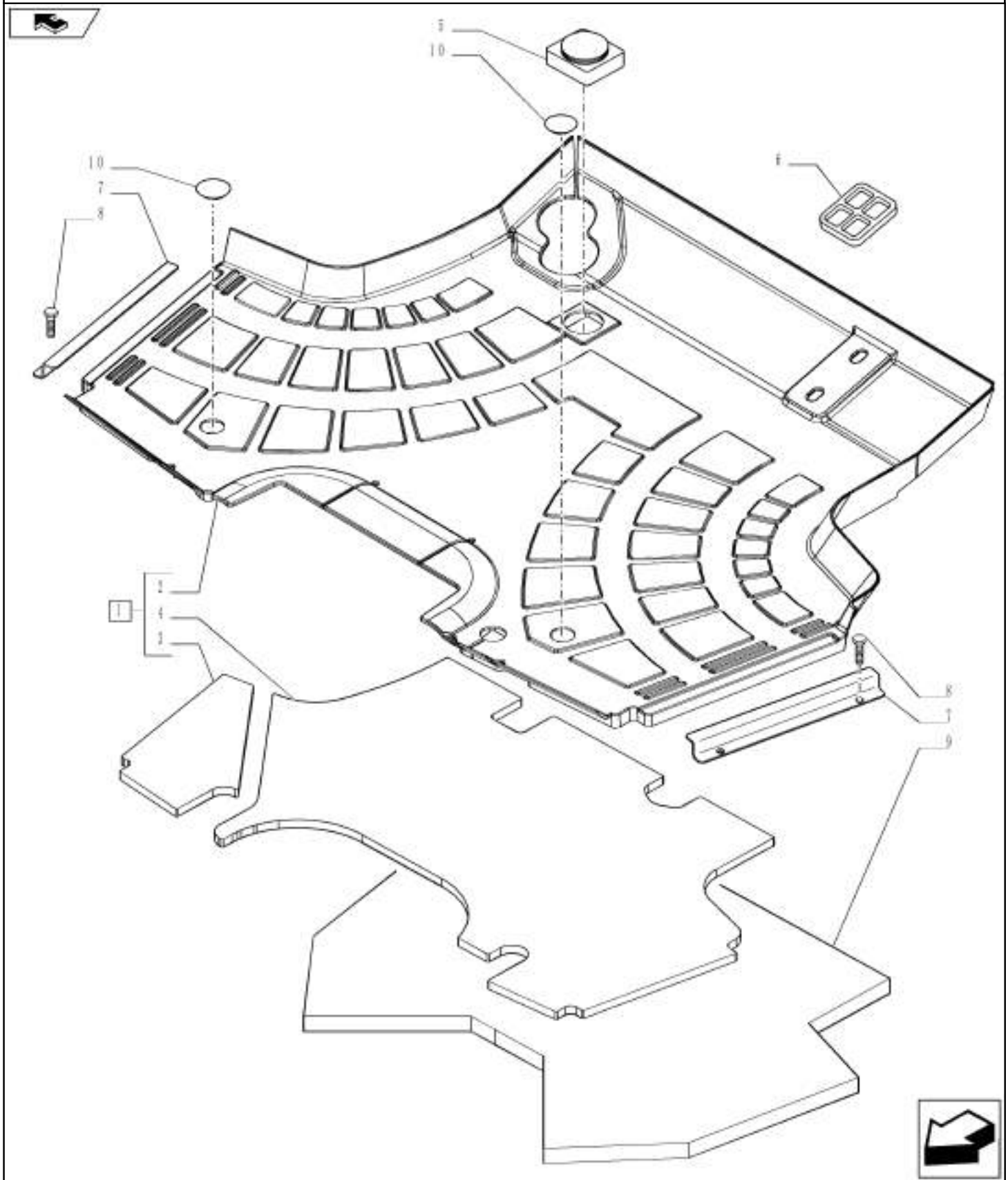

VAR - 330384, 334322, 744739 - CAB FLOOR, MAT

REF FN	PART NUMBER	YR/SN	QTY DESCRIPTION
1	84519414		1 FLOOR MAT ASSY Incl 2 - 4
2	NSS		1 NOT SERVICED SEPARATELY Floor Mat Incl in 1
3	84520289		1 INSULATION
4	84519416		1 INSULATION
5	84527932		1 PLUG
6	84527938		1 PLUG
7	84520291		2 PLATE
8	87015849		4 SCREW M6 x 20mm, Cl 5.8
9	47406161		1 FLOOR MAT
10	47368045		2 CAP

Valid for Industrial Var. 330384, 334322 (744739)

FARMALL JX100 FARMALL
 JX110 FARMALL JX70
 FARMALL JX75 FARMALL
 JX80 FARMALL JX90

90.160.AR

03

p1

1/2014

VAR - 330120, 331120, 390249, 743846 - FLOOR MAT, ROPS

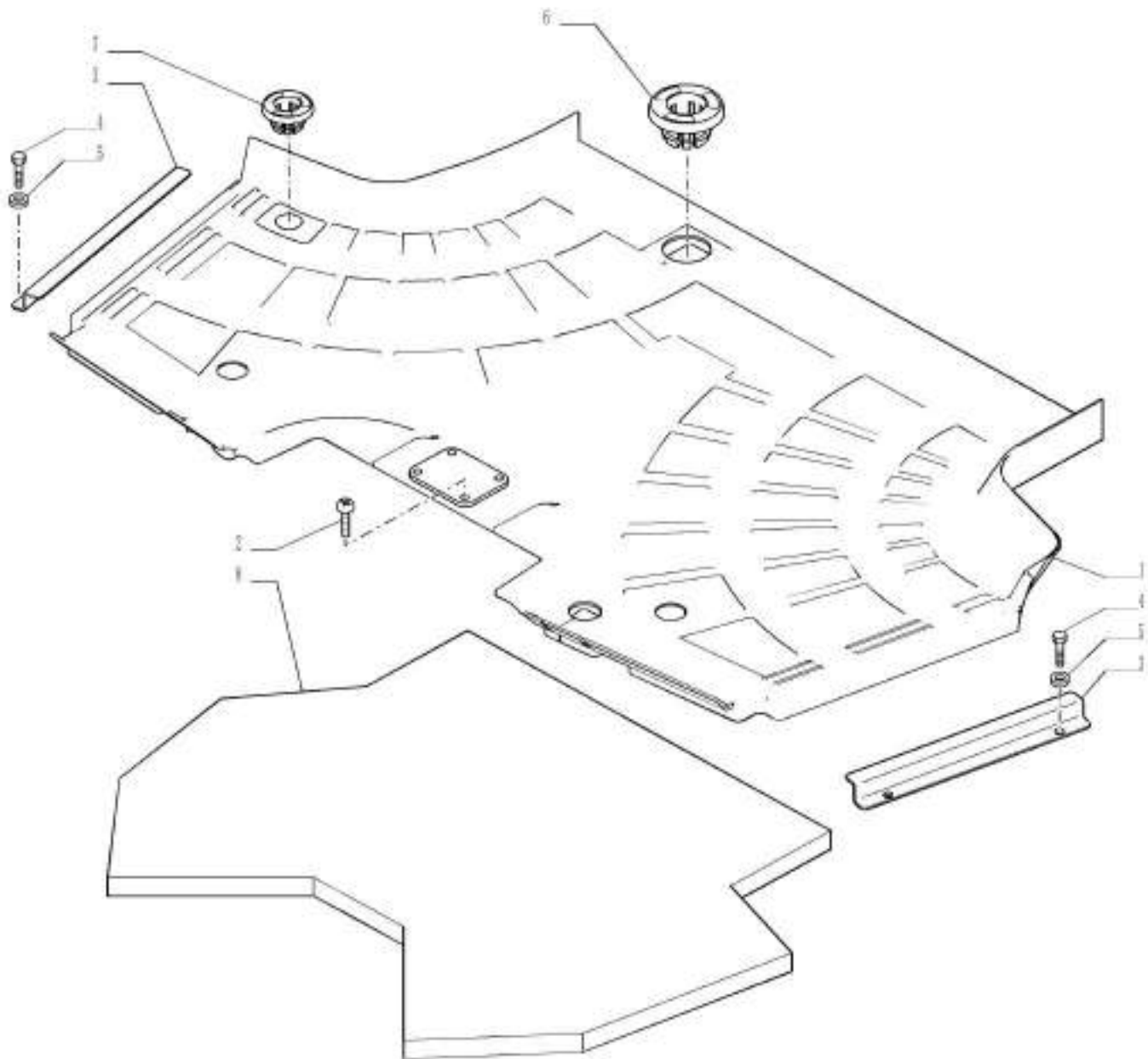

VAR - 330120, 331120, 390249, 743846 - FLOOR MAT, ROPS

REF FN	PART NUMBER	YR/SN	QTY DESCRIPTION
1	84559741		1 FLOOR MAT
2	15903801		4 SELF-TAP SCREW
3	84562006		2 PLATE
4	13276217		4 SCREW Cross Pan Hd, M6 x 16
5	12601274		4 WAVE WASHER Wave, M6.4
6 1	84559742		1 PLUG
7	84559743		1 PLUG
8	47406161		1 FLOOR MAT
(1)	VAR - 331120		

Valid for Industrial Var. 330120, 331120 (743846) or Var. 390249

FARMALL JX100 FARMALL
 JX110 FARMALL JX70
 FARMALL JX75 FARMALL
 JX80 FARMALL JX90

90.160.AX

01

p1

1/2014

VAR - 391606 - CAB HEADLINER

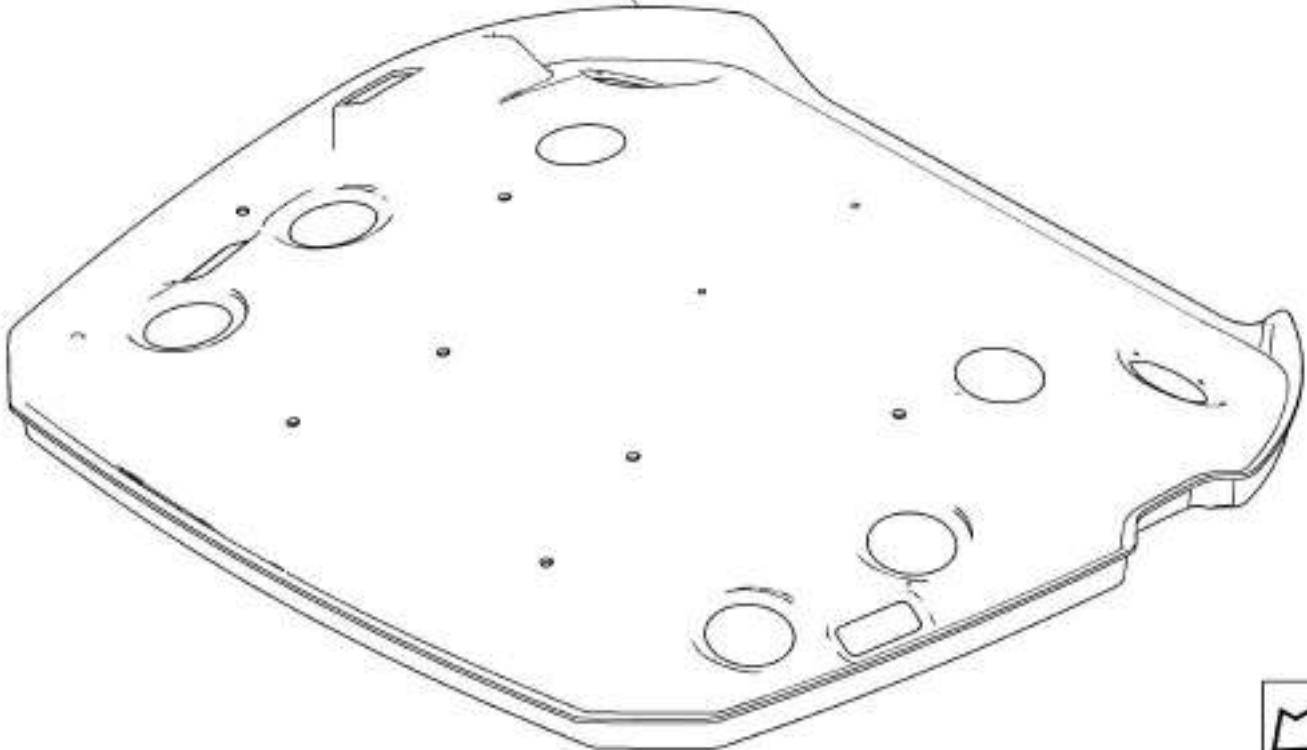
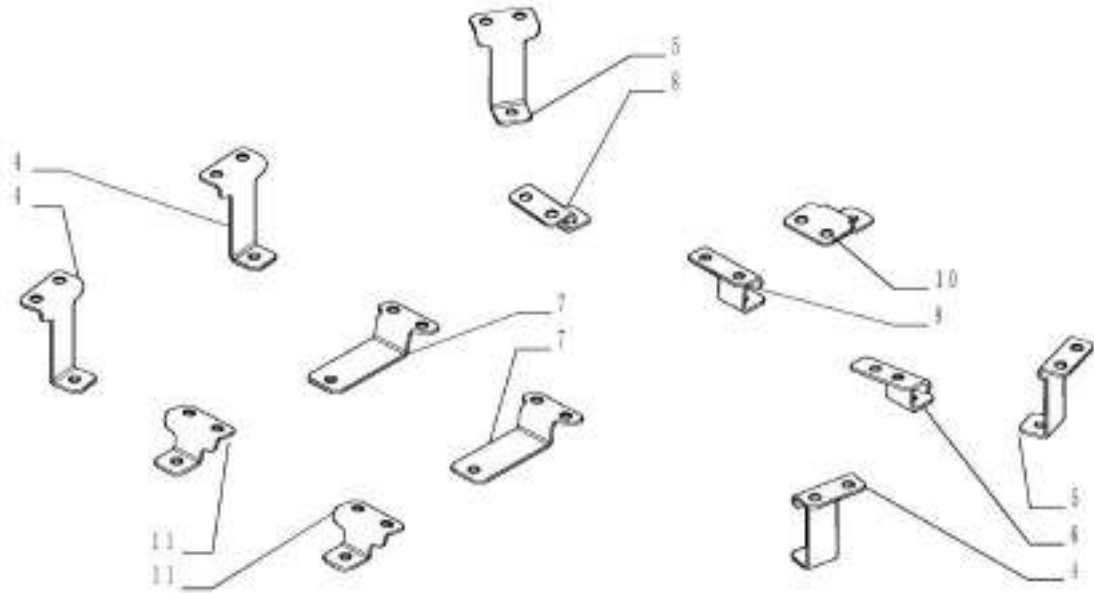

VAR - 391606 - CAB HEADLINER

REF FN	PART NUMBER	YR/SN	QTY DESCRIPTION
1	84524333		1 ROOF LINING
2	47132418		14 BUTTON
3	14441121		28 SCREW
4	84553598		4 BRACKET
5	84553599		2 BRACKET
6	84553596		1 BRACKET
7	84553601		2 BRACKET
8	84553595		1 BRACKET
9	84553594		1 BRACKET
10	84553600		1 BRACKET
11	84553602		2 BRACKET

Valid for Var. 391606	FARMALL JX100 FARMALL JX110 FARMALL JX70 FARMALL JX75 FARMALL JX80 FARMALL JX90
-----------------------	--

90.160.AX

02

p1

1/2014

VAR - 333606 - HIGH VISIBILITY ROOF FOR CAB - HEADLINER

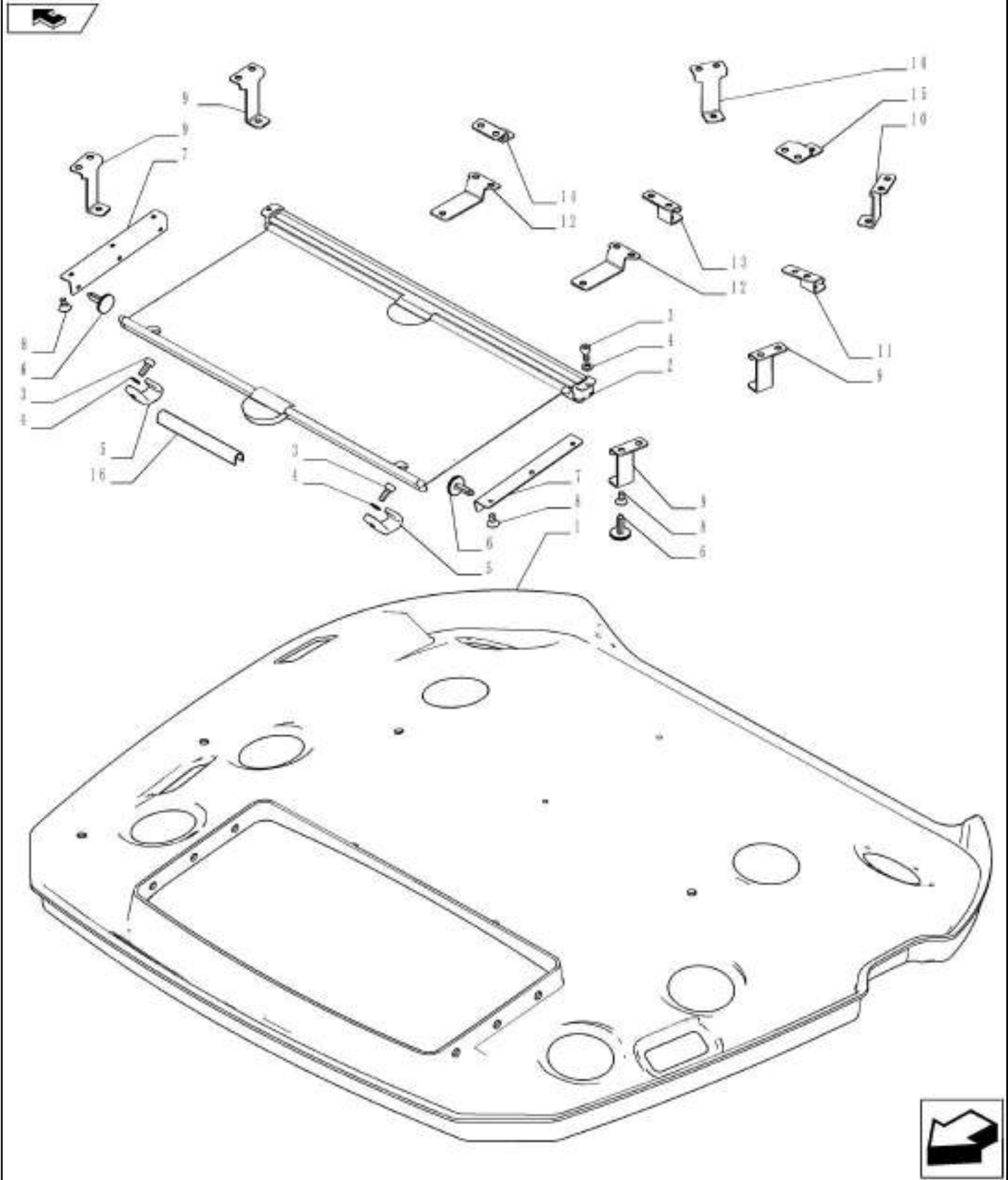

VAR - 333606 - HIGH VISIBILITY ROOF FOR CAB - HEADLINER

REF FN	PART NUMBER	YR/SN	QTY DESCRIPTION
1	84524334		1 ROOF LINING
2	84524355		1 CURTAIN
3	14304121		4 HEX SOC SCREW M5 x 12mm, CI 8.8
4	10730010		4 WASHER
5	84524356		2 HOOK
6	47132418		18 BUTTON
7	84553597		2 SUPPORT
8	14441121		30 SCREW
9	84553598		4 BRACKET
10	84553599		2 BRACKET
11	84553596		1 BRACKET
12	84553601		2 BRACKET
13	84553594		1 BRACKET
14	84553595		1 BRACKET
15	84553600		1 BRACKET
16	47385683		1 GASKET

Valid for Var. 333606

FARMALL JX100 FARMALL
 JX110 FARMALL JX70
 FARMALL JX75 FARMALL
 JX80 FARMALL JX90

90.160.BI

01

p1

1/2014

VAR - 744746, 744747, 744748, 744749 - PILLAR, RIGHT, TRIM, CAB

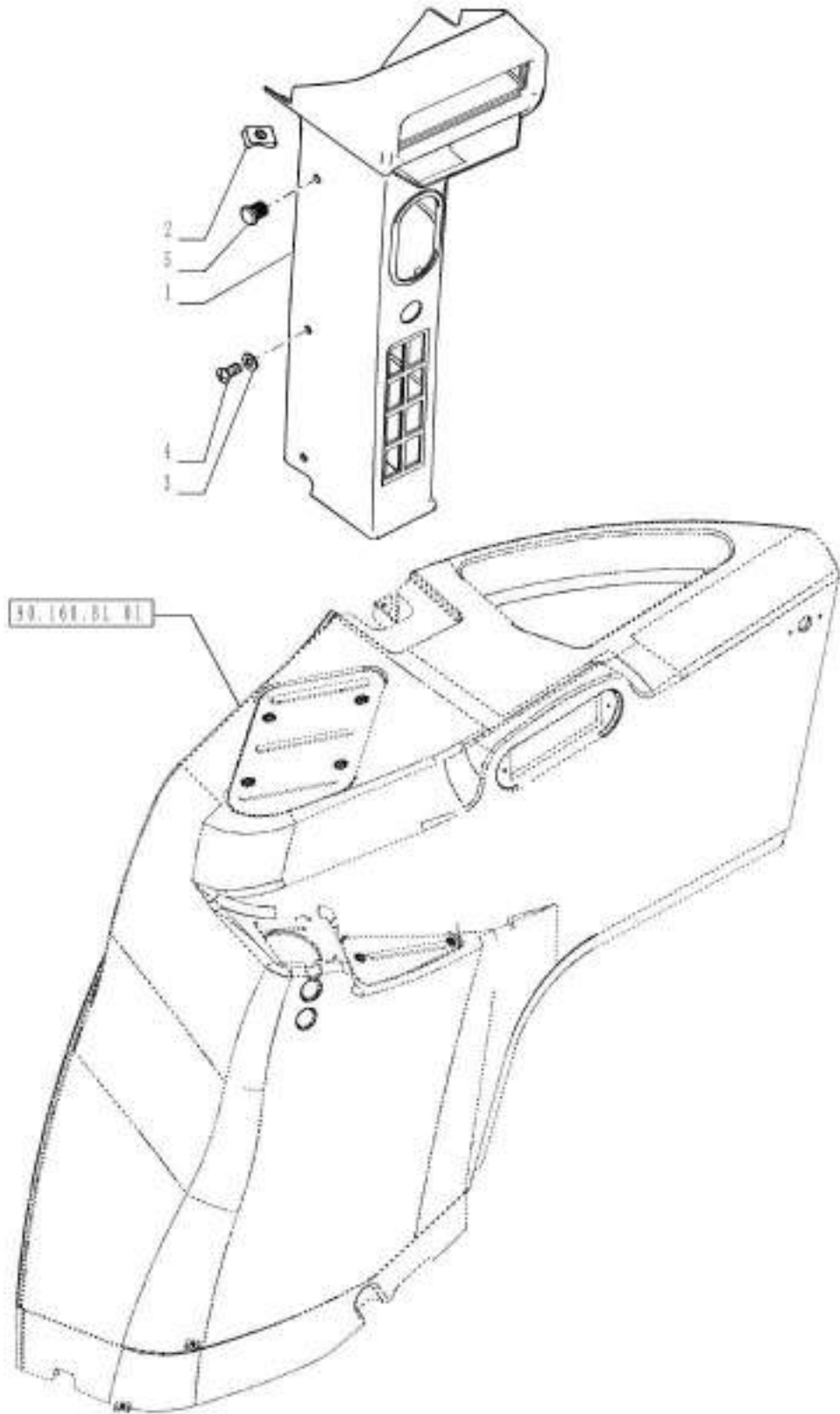

90.160.BI

01

p1

1/2014

VAR - 744746, 744747, 744748, 744749 - PILLAR, RIGHT, TRIM, CAB

REF FN	PART NUMBER	YR/SN	QTY DESCRIPTION
1	84527896		1 LINING
2	84527893		6 CLIP
3	13550001		4 WASHER
4	13271911		4 SCREW Cross Pan Hd, M4 x 10
5	82023460		6 STUD M7.85 x 19.50mm, Plastic

Valid for Industrial Var. 396190 (744746) or Industrial Var. 336191 (744747) or Industrial Var. 334418 (744748) or Industrial Var. 334420 (744749)

FARMALL JX100 FARMALL
JX110 FARMALL JX70
FARMALL JX75 FARMALL
JX80 FARMALL JX90

90.160.BL

01

p1

1/2014

VAR - 336125, 390124 - CONTROL PANEL, RIGHT, CAB

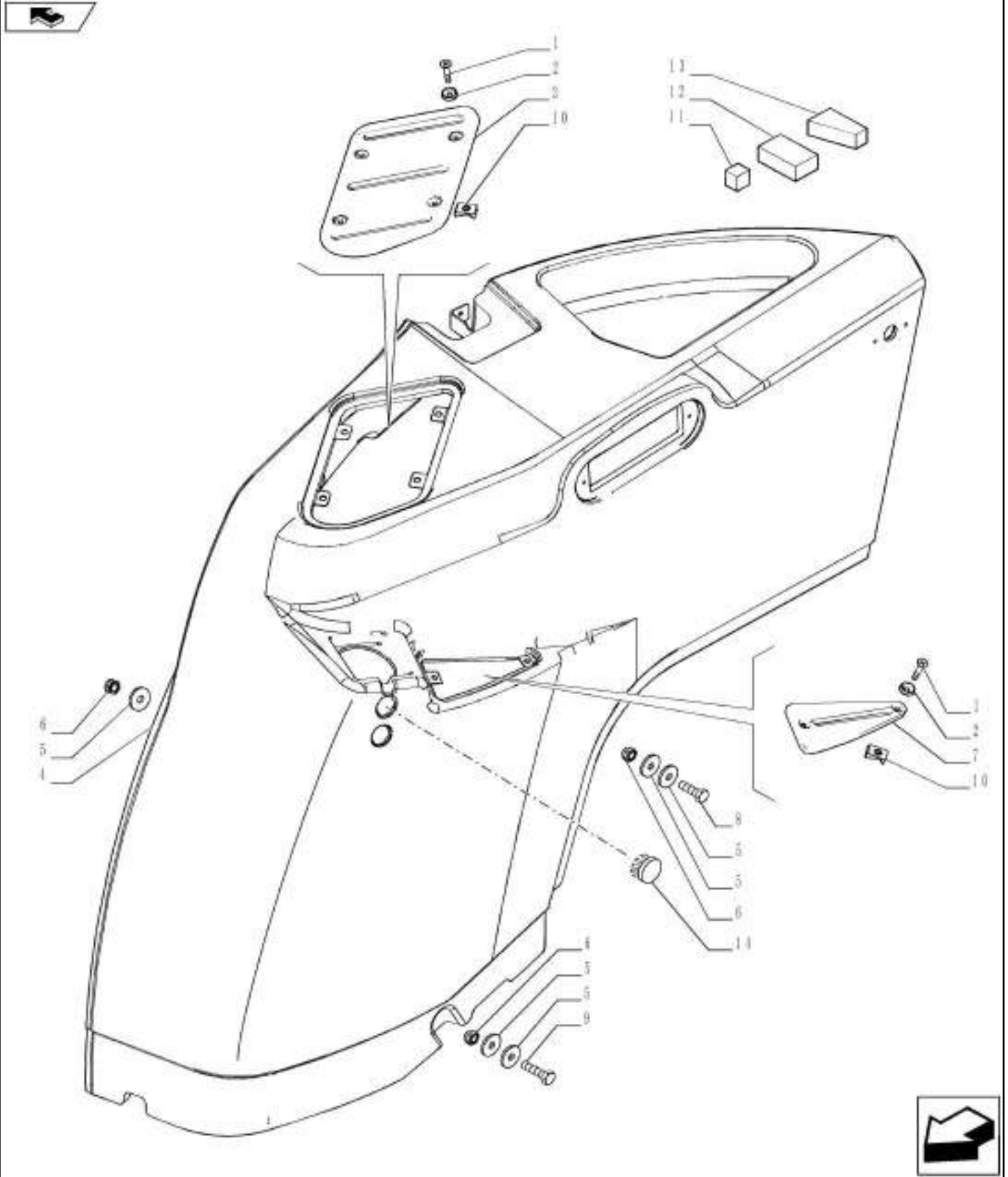

VAR - 336125, 390124 - CONTROL PANEL, RIGHT, CAB

REF FN	PART NUMBER	YR/SN	QTY	DESCRIPTION
1	13297817		6	SCREW
2	84552825		6	WASHER 4.30mm ID x 11.80mm OD x 3mm, Plastic, Wheat
2	1	84552823	6	WASHER 4.30mm ID x 11.80mm OD x 3mm, Plastic, Black
3	2	84524391	1	COVER Triple Control
3	3	84554119	1	COVER Single Control
3	4	84554120	1	COVER Double Control
3	5	84554121	1	COVER Less Remote Control
4		84524395	1	TRIM RH
4	1	{84524392}	1	
5		10523401	5	WASHER Flat, 6.15mm ID x 18.00mm OD x 2.00mm, Carbon Steel, ZND
6		12575411	3	LOCK NUT M6 x 1, CI 8
7		84524390	1	COVER
8		86508568	1	BOLT Hex, M6 x 16mm, CI 8.8, Full Thd
9		10902721	1	SCREW Hex, M6 x 28, 8.8, Full Thd
9	1	120100	1	BOLT Hex, M6 x 1 x 20mm, CI 8.8
10		84553471	6	CLIP
11		84556567	1	SUPPORT
12		84556565	1	SUPPORT
13		84556566	1	SUPPORT
14	1	{84539686}	2	
(1)	VAR - 336125			
(2)	VAR - 334331, 335054 (728054) or 334332, 335103 (729103)			
(3)	VAR - 334325, 335366 (728366) or 334326, 334327 (729412)			
(4)	VAR - 334328, 335368 (728368) or 334329, 335413 (729413) or 334330, 335417 (729417)			
(5)	VAR - 395366			
Valid for Var. 336125 or Var. 390124				FARMALL JX100 FARMALL JX110 FARMALL JX70 FARMALL JX75 FARMALL JX80 FARMALL JX90

VAR - 333606, 391606 - CAB, INSULATION

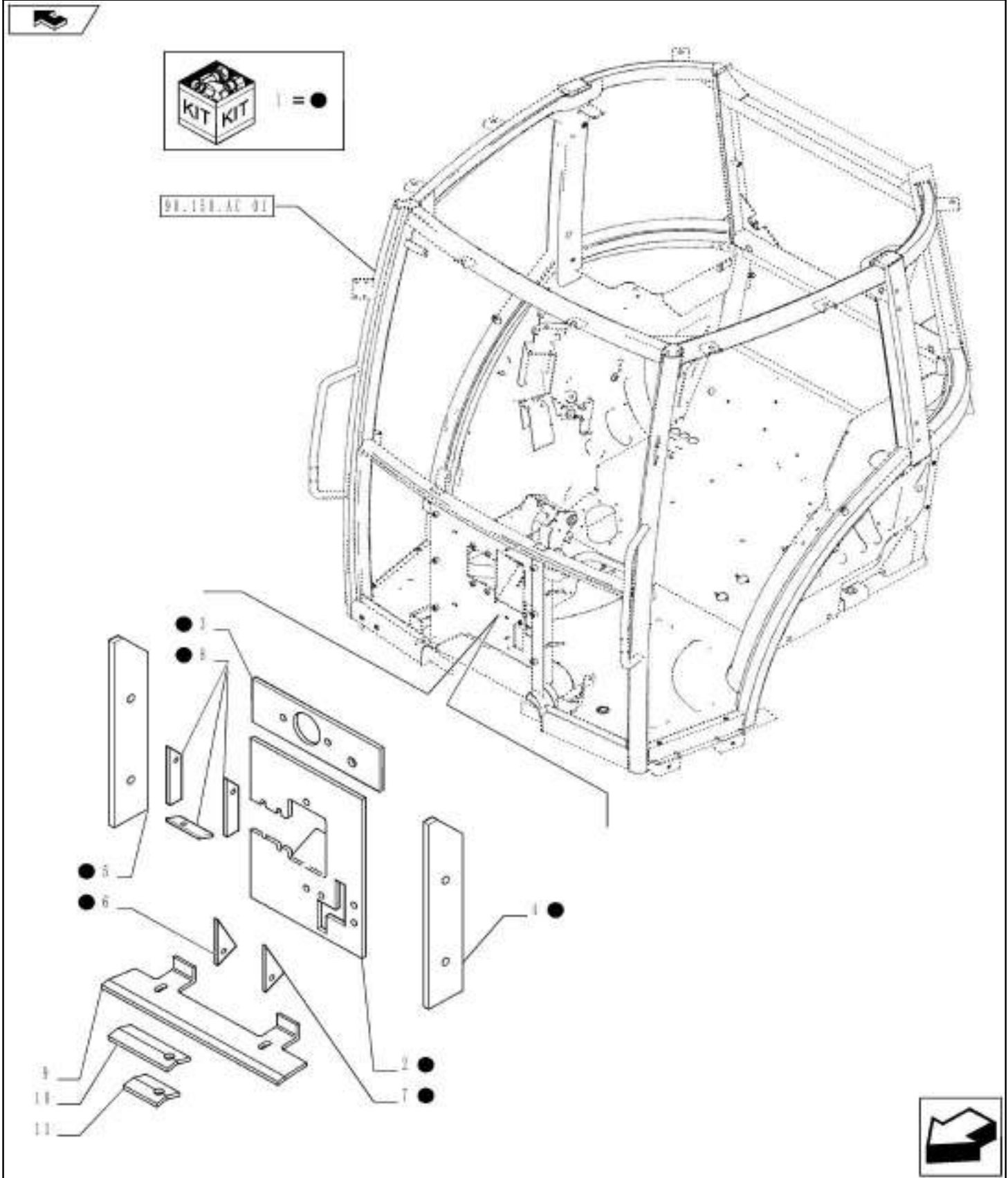

VAR - 333606, 391606 - CAB, INSULATION

REF FN	PART NUMBER	YR/SN	QTY DESCRIPTION
1	84547722		1 KIT Incl 2 - 8
2	84547725		1 ISOLATOR
3	87534285		1 FOAM INSULATION
4	84547723		1 INSULATOR
5	84547724		1 INSULATOR
6	87534288		1 FOAM INSULATION
7	87534289		1 FOAM INSULATION
8	87534290		3 FOAM INSULATION
9	84313765		2 ISOLATOR
10	84313778		2 ISOLATOR
11	84313787		1 ISOLATOR

Valid for Var. 333606 or Var. 391606	FARMALL JX100 FARMALL JX110 FARMALL JX70 FARMALL JX75 FARMALL JX80 FARMALL JX90
--------------------------------------	--