

**Farmall 95U Pro EP  
Farmall 105U Pro EP  
Farmall 115U Pro EP**  
Tractor

**SERVICE MANUAL**

Part number 47735452

English

July 2014

Copyright © 2014 CNH Industrial Österreich GmbH. All Rights Reserved.

<https://www.tractormanualpdf.info/>





## **SERVICE MANUAL**

**Farmall 105U Pro EP  
Farmall 115U Pro EP  
Farmall 95U Pro EP**

# Link Product / Engine

---

<b>Product</b>	<b>Market Product</b>	<b>Engine</b>
Farmall 105U Pro EP	Europe	F5DFL413J*A003
Farmall 115U Pro EP	Europe	F5DFL413H*A006
Farmall 95U Pro EP	Europe	F5DFL413K*A003

# Contents

---

## INTRODUCTION

<b>Engine</b> .....	<b>10</b>
[10.216] Fuel tanks .....	10.1
[10.254] Intake and exhaust manifolds and muffler .....	10.2
[10.501] Exhaust Gas Recirculation (EGR) - Diesel Particulate Filter (DPF) exhaust treatment .....	10.3
[10.414] Fan and drive .....	10.4
<b>Clutch</b> .....	<b>18</b>
[18.112] Slip clutch or flywheel damper .....	18.1
<b>Transmission</b> .....	<b>21</b>
[21.111] Semi-Powershift transmission .....	21.1
[21.133] Semi-Powershift transmission external controls .....	21.2
[21.103] Semi-Powershift transmission lubrication system.....	21.3
[21.152] Semi-Powershift transmission internal components .....	21.4
[21.902] Field-road group.....	21.5
[21.900] Hydraulic pump drive.....	21.6
[21.109] Transmission cooler and lines.....	21.7
<b>Four-Wheel Drive (4WD) system</b> .....	<b>23</b>
[23.202] Electro-hydraulic control .....	23.1
<b>Front axle system</b> .....	<b>25</b>
[25.100] Powered front axle .....	25.1
[25.102] Front bevel gear set and differential .....	25.2
[25.108] Final drive hub, steering knuckles, and shafts .....	25.3
<b>Rear axle system</b> .....	<b>27</b>
[27.100] Powered rear axle.....	27.1
[27.106] Rear bevel gear set and differential .....	27.2
[27.120] Planetary and final drives .....	27.3

<b>Power Take-Off (PTO)</b> .....	<b>31</b>
[31.104] Rear electro-hydraulic control.....	31.1
[31.119] Four-speed rear Power Take-Off (PTO).....	31.2
[31.142] Front Power Take-Off (PTO) control .....	31.3
<b>Brakes and controls</b> .....	<b>33</b>
[33.202] Hydraulic service brakes .....	33.1
[33.110] Parking brake or parking lock .....	33.2
[33.220] Trailer brake hydraulic control.....	33.3
[33.204] Front axle brake .....	33.4
<b>Hydraulic systems</b> .....	<b>35</b>
[35.000] Hydraulic systems.....	35.1
[35.300] Reservoir, cooler, and filters.....	35.2
[35.104] Fixed displacement pump.....	35.3
[35.106] Variable displacement pump .....	35.4
[35.204] Remote control valves .....	35.5
[35.114] Three-point hitch control valve .....	35.6
[35.160] Front hitch controls and lines .....	35.7
<b>Steering</b> .....	<b>41</b>
[41.200] Hydraulic control components.....	41.1
<b>Wheels</b> .....	<b>44</b>
[44.520] Rear wheels.....	44.1
<b>Cab climate control</b> .....	<b>50</b>
[50.200] Air conditioning .....	50.1
<b>Electrical systems</b> .....	<b>55</b>
[55.000] Electrical system .....	55.1
[55.100] Harnesses and connectors.....	55.2
[55.015] Engine control system.....	55.3

[55.301] Alternator.....	55.4
[55.302] Battery.....	55.5
[55.202] Cold start aid .....	55.6
[55.011] Fuel tank system .....	55.7
[55.014] Engine intake and exhaust system.....	55.8
[55.012] Engine cooling system .....	55.9
[55.013] Engine oil system .....	55.10
[55.640] Electronic modules .....	55.11
[55.024] Transmission control system.....	55.12
[55.020] Transmission speed sensors.....	55.13
[55.021] Transmission pressure sensors.....	55.14
[55.022] Transmission temperature sensors .....	55.15
[55.522] Cab Power Take-Off (PTO) controls .....	55.16
[55.048] Rear Power Take-Off (PTO) control system .....	55.17
[55.032] Trailer brake electrical system .....	55.18
[55.035] Remote control valve electric control .....	55.19
[55.036] Hydraulic system control .....	55.20
[55.050] Heating, Ventilation, and Air-Conditioning (HVAC) control system.....	55.21
[55.130] Rear three-point hitch electronic control system .....	55.22
[55.160] Front hitch electronic control system.....	55.23
[55.408] Warning indicators, alarms, and instruments .....	55.24
[55.680] Autopilot/Autoguidance .....	55.25
[55.DTC] FAULT CODES.....	55.26
<b>Platform, cab, bodywork, and decals.....</b>	<b>90</b>
[90.150] Cab.....	90.1





# INTRODUCTION



# Contents

---

## INTRODUCTION

Foreword .....	3
Foreword - How to use and navigate through this manual .....	4
Foreword Ecology and the Environment .....	9
Safety rules .....	10
Torque .....	14
Basic instructions .....	16
Conversion factors .....	18
Consumables Lubrications and Coolants .....	19
Capacities .....	21

## **Foreword**

### **IMPORTANT INFORMATION**

All repair and maintenance works listed in this manual must be carried out only by staff belonging to the CASE IH Service network, strictly complying with the instructions given and using, whenever required, the special tools.

Anyone who carries out the above operations without complying with the prescriptions shall be responsible for the subsequent damages.

The manufacturer and all the organizations of its distribution chain, including - without limitation - national, regional or local dealers, reject any responsibility for damages due to the anomalous behavior of parts and/or components not approved by the manufacturer himself, including those used for the servicing or repair of the product manufactured or marketed by the Manufacturer. In any case, no warranty is given or attributed on the product manufactured or marketed by the Manufacturer in case of damages due to an anomalous behavior of parts and/or components not approved by the Manufacturer.

No reproduction, though partial of text and illustrations allowed.

---

## Foreword - How to use and navigate through this manual

This manual has been produced by a new technical information system. This new system is designed to deliver technical information electronically through web delivery (eTIM), DVD, and paper manuals. A coding system called SAP has been developed to link the technical information to other Product Support functions, e.g., Warranty.

Technical information is written to support the maintenance and service of the functions or systems on a customer's machine. When a customer has a concern on their machine it is usually because a function or system on their machine is not working at all, is not working efficiently, or is not responding correctly to their commands. When you refer to the technical information in this manual to resolve that customer's concern, you will find all the information classified using the SAP coding, according to the functions or systems on that machine. Once you have located the technical information for that function or system, you will then find all the mechanical, electrical or hydraulic devices, components, assemblies, and sub assemblies for that function or system. You will also find all the types of information that have been written for that function or system: the technical data (specifications), the functional data (how it works), the diagnostic data (fault codes and troubleshooting), and the service data (remove, install adjust, etc.).

By integrating SAP coding into technical information, you will be able to search and retrieve just the right piece of technical information you need to resolve that customer's concern on his machine. This is made possible by attaching 3 categories to each piece of technical information during the authoring process.

The first category is the Location, the second category is the Information Type and the third category is the Product:

- LOCATION - the component or function on the machine, that the piece of technical information is going to describe (e.g., Fuel tank).
- INFORMATION TYPE - the piece of technical information that has been written for a particular component or function on the machine (e.g., Capacity would be a type of Technical Data describing the amount of fuel held by the fuel tank).
- PRODUCT - the model for which the piece of technical information is written.

Every piece of technical information will have those three categories attached to it. You will be able to use any combination of those categories to find the right piece of technical information you need to resolve that customer's concern on their machine.

That information could be:

- the procedure for how to remove the cylinder head
- a table of specifications for a hydraulic pump
- a fault code
- a troubleshooting table
- a special tool

## Manual content

This manual is divided into Sections. Each Section is then divided into Chapters. Contents pages are included at the beginning of the manual, then inside every Section and inside every Chapter. An alphabetical Index is included at the end of each Chapter. Page number references are included for every piece of technical information listed in the Chapter Contents or Chapter Index.

Each Chapter is divided into four Information types:

- Technical Data (specifications) for all the mechanical, electrical or hydraulic devices, components, assemblies or sub-assemblies.
- Functional Data (how it works) for all the mechanical, electrical or hydraulic devices, components, assemblies or sub-assemblies.
- Diagnostic Data (fault codes, electrical and hydraulic troubleshooting) for all the mechanical, electrical or hydraulic devices, components, assemblies or sub-assemblies.
- Service Data (remove disassemble, assemble, install) for all the mechanical, electrical or hydraulic devices, components, assemblies or sub-assemblies.

## Sections

Sections are grouped according to the main functions or a systems on the machine. Each Section is identified by a number (00, 35, 55, etc.). The Sections included in the manual will depend on the type and function of the machine that the manual is written for. Each Section has a Contents page listed in alphabetic/numeric order. This table illustrates which Sections could be included in a manual for a particular product.

SECTION	PRODUCT					
	Tractors					
	Vehicles with working arms: backhoes, excavators, skid steers, ....					
	Combines, forage harvesters, balers, ....					
	Seeding, planting, floating, spraying equipment, ....					
Mounted equipment and tools, ....						
00 - Maintenance	X	X	X	X	X	
05 - Machine completion and equipment	X	X	X	X	X	
10 - Engine	X	X	X	X		
14 - Main gearbox and drive	X	X	X	X		
18 - Clutch	X	X	X			
21 - Transmission	X	X	X	X		
23 - Four wheel drive (4WD) system	X	X	X	X		
25 - Front axle system	X	X	X	X		
27 - Rear axle system	X	X	X	X		
29 - Hydrostatic drive	X	X	X	X		
31 - Power Take-Off (PTO)	X		X			
33 - Brakes and controls	X	X	X	X		
35 - Hydraulic systems	X	X	X	X		
36 - Pneumatic system	X	X	X	X		
37 - Hitches, drawbars and implement couplings	X		X	X		
39 - Frames and ballasting	X	X	X	X	X	
41 - Steering	X	X	X	X		
44 - Wheels	X	X	X	X		
46 - Steering clutches						
48 - Tracks and track suspension	X	X	X			
50 - Cab climate control	X	X	X	X		
55 - Electrical systems	X	X	X	X	X	
56 - Grape harvester shaking						
58 - Attachments/headers			X			
60 - Product feeding			X			

INTRODUCTION

61 - Metering system				X	
62 - Pressing - Bale formation			X		
63 - Chemical applicators				X	
64 - Chopping			X		
66 - Threshing			X		
68 - Tying/Wrapping/Twisting			X		
69 - Bale wagons					
70 - Ejection			X		
71 - Lubrication system	X	X	X	X	X
72 - Separation			X		
73 - Residue handling			X		
74 - Cleaning			X		
75 - Soil preparation/Finishing					
76 - Secondary cleaning / Destemmer					
77 - Seeding				X	
78 - Spraying				X	
79 - Planting				X	
80 - Crop storage / Unloading			X		
82 - Front loader and bucket	X	X			
83 - Telescopic single arm	X	X			
84 - Booms, dippers and buckets	X	X			
86 - Dozer blade and arm	X	X			
88 - Accessories	X	X	X	X	X
89 - Tools	X	X	X	X	X
90 - Platform, cab, bodywork and decals	X	X	X	X	

## Chapters

Each Chapter is identified by a number e.g. Engine - Engine and crankcase - 10.001. The first number is identical to the Section number i.e. Chapter 10.001 is inside Section 10, Engine. The second number is representative of the Chapter contained within the Section.

### CONTENTS

The Chapter Contents lists all the technical data (specifications), functional data (how it works), diagnostic data (fault codes and troubleshooting), and service data (remove, install, adjust, etc.), that have been written in that Chapter for that function or system on the machine.

### Contents

	ENGINE	
	ENGINE - Engine and crankcase – 10.001	
TECHNICAL DATA		
ENGINE - Engine and crankcase - General specification (10.001 - D.40.A.10)		4
FUNCTIONAL DATA		
ENGINE - Engine and crankcase - Dynamic description (10.001 - C.30.A.10)		6
SERVICE		
ENGINE - Engine and crankcase - Remove (10.001 -F.10.A.10)		8
DIAGNOSTIC		
ENGINE - Engine and crankcase - Troubleshooting (10.001 - G.40.A.10)		10

### INDEX

The Chapter Index lists in alphabetical order all the types of information (called information units) that have been written in that Chapter for that function or system on the machine.

### Index

	ENGINE - 10	
	ENGINE	
ENGINE - Engine and crankcase - Dynamic description (10.001 - C.30.A.10)		6
ENGINE - Engine and crankcase - General specification (10.001 - D.40.A.10)		4
ENGINE - Engine and crankcase - Remove (10.001 -F.10.A.10)		8
ENGINE - Engine and crankcase - Troubleshooting (10.001 - G.40.A.10)		10

## Information units and information search

Each chapter is composed of information units. Each information unit has the SAP code shown in parentheses. This indicates the function and type of information in that information unit. Each information unit has a page reference within that Chapter. The information units provide a quick and easy way to find just the right piece of technical information you are looking for.

Example information unit	Engine block cover - Front – Remove (10.102.AP.01 - F.10.A.10)					
Information Unit SAP code	10	102	AK	01	F	10.A.10
SAP code classification	Engine	Pan and covers	Engine block cover	Front cover	Service data	Remove

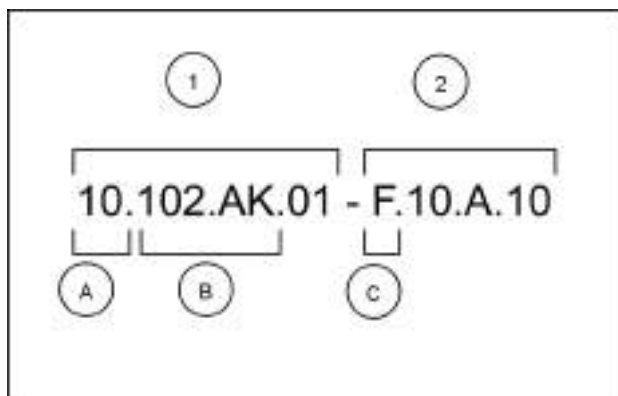

NHIL12GEN0070A 1

Navigate to the correct information unit you are searching for by identifying the function and information type from the SAP code.

- **(1)** Location and **(2)** Information type.
- **(A)** corresponds to the sections of the service manual.  
**(B)** corresponds to the chapters of the service manual. After **(B)** there may be some additional information. In this case it shows “.01”, which represents the “Front” block cover. These options may be front/rear, left/right, hydraulic/mechanical etc.
- **(C)** corresponds to the type of information listed in the chapter contents: Technical Data, Functional Data, Diagnostic, or Service.
- **(A)** and **(B)** are also shown in the page numbering on the page footer.  
THE REST OF THE CODING IS NOT LISTED IN ALPHANUMERIC ORDER IN THIS MANUAL.
- You will find a table of contents at the beginning and end of each section and chapter.  
You will find an alphabetical index at the end of each chapter.
- By referring to **(A)**, **(B)** and **(C)** of the coding, you can follow the contents or index (page numbers) and quickly find the information you are looking for.

## Page header and footer

The page header will contain the following references:

- Section and Chapter description

The page footer will contain the following references:

- Publication number for that Manual.
- Version reference for that publication.
- Publication date
- Section, chapter, and page reference e.g. 10.102 / 9

---

## Foreword Ecology and the Environment

Soil, air, and water are vital factors of agriculture and life in general. When legislation does not yet rule the treatment of some of the substances which are required by advanced technology, common sense should govern the use and disposal of products of a chemical and petrochemical nature.

**NOTICE:** *The following are recommendations which may be of assistance:*

- Become acquainted with and ensure that you understand the relative legislation applicable to your country.
- Where no legislation exists, obtain information from suppliers of oils, filters, batteries, fuels, antifreeze, cleaning agents, etc., with regard to their effect on man and nature and how to safely store, use and dispose of these substances.
- Agricultural consultants will, in many cases, be able to help you as well.

### HELPFUL HINTS

- Avoid filling tanks using cans or inappropriate pressurized fuel delivery systems which may cause considerable spillage.
- In general, avoid skin contact with all fuels, oils, acids, solvents, etc. Most of them contain substances which may be harmful to your health.
- Modern oils contain additives. Do not burn contaminated fuels and or waste oils in ordinary heating systems.
- Avoid spillage when draining off used engine coolant mixtures, engine, gearbox and hydraulic oils, brake fluids, etc. Do not mix drained brake fluids or fuels with lubricants. Store them safely until they can be disposed of in a proper way to comply with local legislation and available resources.
- Modern coolant mixtures, i.e. antifreeze and other additives, should be replaced every two years. They should not be allowed to get into the soil but should be collected and disposed of properly.
- Do not open the air-conditioning system yourself. It contains gases which should not be released into the atmosphere. Your CASE IH dealer or air conditioning specialist has a special extractor for this purpose and will have to recharge the system properly.
- Repair any leaks or defects in the engine cooling or hydraulic system immediately.
- Do not increase the pressure in a pressurized circuit as this may lead to a component failure.
- Protect hoses during welding as penetrating weld splatter may burn a hole or weaken them, allowing the loss of oils, coolant, etc.



## Safety rules

### PRECAUTIONARY STATEMENTS

#### Personal Safety





This is the safety alert symbol. It is used to alert you to potential personal injury hazards. Obey all safety messages that follow this symbol to avoid possible injury or death.

Throughout this manual, you will find the signal words DANGER, WARNING, and CAUTION followed by special instructions. These precautions are intended for the personal safety of you and those working with you.

Read and understand all the safety messages in this manual before you operate or service the machine.

 DANGER indicates a hazardous situation which, if not avoided, will result in death or serious injury.

 WARNING indicates a hazardous situation which, if not avoided, could result in death or serious injury.

 CAUTION, used with the safety alert symbol, indicates a hazardous situation which, if not avoided, could result in minor or moderate injury.

### FAILURE TO FOLLOW DANGER, WARNING, AND CAUTION MESSAGES COULD RESULT IN DEATH OR SERIOUS INJURY.

*NOTICE: Install new decals if the old decals are destroyed, lost painted over or cannot be read. When parts are replaced that have decals make sure you install a new decal with each new part.*

### MACHINE SAFETY

*NOTICE: Notice indicates a situation which, if not avoided, could result in machine or property damage.*

Throughout this manual you will find the signal word Notice followed by special instructions to prevent machine or property damage. The word Notice is used to address practices not related to personal safety.

### INFORMATION

*NOTE: Note indicates additional information which clarifies steps, procedures, or other information in this manual.*

Throughout this manual you will find the word Note followed by additional information about a step, procedure, or other information in the manual. The word Note is not intended to address personal safety or property damage.

## ACCIDENT PREVENTION

### **▲ WARNING**

**Avoid injury! Always do the following before lubricating, maintaining, or servicing the machine.**

- 1. Disengage all drives.**
- 2. Engage parking brake.**
- 3. Lower all attachments to the ground, or raise and engage all safety locks.**
- 4. Shut off engine.**
- 5. Remove key from key switch.**
- 6. Switch off battery key, if installed.**
- 7. Wait for all machine movement to stop.**

**Failure to comply could result in death or serious injury.**

W0047A

Most accidents or injuries that occur in workshops are the result of non compliance to simple and fundamental safety principles. For this reason, IN MOST CASES THESE ACCIDENTS CAN BE AVOIDED by applying the fundamental safety principles, acting with the necessary caution and care.

Accidents may occur with all types of machine, regardless of how well the machine in question was designed and built.

## **SAFETY REQUIREMENTS FOR FLUID POWER SYSTEMS AND COMPONENTS - HYDRAULICS (EUROPEAN STANDARD EN982)**

- Flexible hose assemblies must not be constructed from hoses which have been previously used as part of a hose assembly.
- Do not weld hydraulic pipes: when flexible hoses or piping are damaged, replace them immediately.
- It is forbidden to modify a hydraulic accumulator by machining, welding or any other way.
- Before removing hydraulic accumulators for servicing, the liquid pressure in the accumulators must be reduced to zero.
- Pressure check on hydraulic accumulators must be carried out by a method recommended by the accumulator manufacturer.
- Take care not to exceed the maximum allowed pressure of the accumulator. After any check or adjustment, check for leakages or gas in the hoses or pipes.

## **SAFETY RULES**

### General guidelines

- Carefully follow specified repair and maintenance procedures.
- When appropriate, use P.P.E (Personal Protective Equipment)
- Do not wear rings, wristwatches, jewellery, unbuttoned or loose articles of clothing such as: ties, torn clothing, scarves, open jackets or shirts with open zips that may remain entangled in moving parts. It is advised to wear approved safety clothing, e.g.: non-slip footwear, gloves, safety goggles, helmets, etc.
- Do not carry out repair operations with someone sitting in the driver's seat, unless the person is a trained technician who is assisting with the operation in question.
- Do not operate the machine or use any of the implements from different positions, other than the driver's seat.
- Do not carry out operations on the machine with the engine running, unless specifically indicated.
- Bring all hydraulic cylinders to the home positions (down, retracted, etc.) before engine shut down.
- Stop the engine and check that the hydraulic circuits are pressure-free before removing caps, covers, valves, etc.
- All repair and maintenance operations must be carried out using extreme care and attention.
- Service steps and platforms used in the workshop or elsewhere should be built according to the applicable standards and legislation.
- Disconnect the power take off (p.t.o). and label the controls to indicate that the machine is being serviced. Any parts that are to be raised must be locked in position.

## INTRODUCTION

---

- Brakes are inoperative when manually released for repair or maintenance purposes. Use blocks or similar devices to secure the machine in these conditions.
- Only use specified towing points for towing the machine. Connect parts carefully. Make sure that all pins and/or locks are secured in position before applying traction. Never remain near the towing bars, cables or chains that are operating under load.
- When loading or unloading the machine from the trailer (or other means of transport), select a flat area capable of sustaining the trailer or truck wheels. Firmly secure the machine to the truck or trailer and lock the wheels in the position used by the carrier.
- Electric heaters, battery-chargers and similar equipment must only be powered by auxiliary power supplies with efficient ground insulation to avoid electrical shock hazards.
- Always use suitable hoisting or lifting devices when raising or moving heavy parts.
- Keep bystanders away.
- Never use gasoline, diesel oil or other inflammable liquids as cleaning agents. Use non-inflammable, non toxic commercially available solvents.
- Wear safety goggles with side guards when cleaning parts with compressed air.
- Do not run the engine in enclosed spaces without suitable ventilation or exhaust extraction.
- Never use open flames for lighting when working on the machine or checking for leaks.
- All movements must be carried out carefully when working under, on or near the machine. Wear personal protective equipment (P.P.E.): helmets, goggles and special footwear.
- When carrying out checks with the engine running, request the assistance of an operator in the driver's seat. The operator must maintain visual contact with the service technician at all times.
- If operating outside the workshop, position the machine on a flat surface and lock in position. If working on a slope, lock the machine in position. Move to a flat area as soon as is safely possible.
- Damaged or bent chains or cables are unreliable. Do not use them for lifting or towing. Always use suitable protective gloves when handling chains or cables.
- Chains should always be safely secured. Make sure that the hitch-up point is capable of sustaining the load in question. Keep the area near the hitch-up point, chains or cables free of all bystanders.
- Maintenance and repair operations must be carried out in a CLEAN and DRY area. Clean up any water or oil spillage immediately.
- Do not create piles of oil or grease-soaked rags as they represent a serious fire hazard. Always store rags in a closed metal container.
- Before engaging the machine, make sure that there are no persons within the machine or implement range of action.
- Empty your pockets of all objects that may fall accidentally unobserved into the machine inner compartments.
- When metal parts are sticking out, use protective goggles or goggles with side guards, helmets, special footwear and gloves.
- When welding, use protective safety devices: tinted safety goggles, helmets, special overalls, gloves and footwear. All persons present in the area where welding is taking place must wear tinted goggles. NEVER LOOK DIRECTLY AT THE WELDING ARC WITHOUT SUITABLE EYE PROTECTION.
- Always disconnect battery ground terminal when welding.
- Metal cables tend to fray with repeated use. Always use suitable protective devices (gloves, goggles, etc.) when handling cables.

### Machine start-up.

- Never run the engine in confined spaces that are not equipped with adequate ventilation for exhaust gas extraction.
- Never place the head, body, limbs, feet, hands or fingers near rotating and moving parts.

### Hydraulic systems and fuel injection systems

- A liquid leaking from a tiny hole may be almost invisible but, at the same time, be powerful enough to penetrate the skin. Therefore, **NEVER USE HANDS TO CHECK FOR LEAKS** but use a piece of cardboard or paper for this purpose. If any liquid penetrates skin tissue, call for medical aid immediately. Failure to treat this condition with correct medical procedure may result in serious infection or death.
- In order to check the pressure in the system use suitable instruments.

### Wheels and Tires

- Make sure that the tires are correctly inflated at the pressure specified by the manufacturer. Periodically check the rims and tires for damage.
- Stand away from (at the side of) the tire when checking inflation pressure.
- Do not use parts of recovered wheels as incorrect welding brazing or heating may weaken and eventually cause damage to the wheel.
- Never cut or weld a rim mounted with an inflated tire.
- Deflate the tire before removing any objects that may be jammed in the tire tread.
- Never inflate tires using inflammable gases, as this may result in explosions and injury to bystanders.

### Removal and Re-fitting

- Lift and handle all heavy parts using suitable hoisting equipment. Make sure that parts are sustained by appropriate hooks and slings. Use the hoisting eyebolts for lifting operations. Extra care should be taken if persons are present near the load to be lifted.
- Handle all parts carefully. Do not put your hands or fingers between parts. Wear suitable safety clothing - safety goggles, gloves and shoes.
- Avoid twisting chains or metal cables. Always wear safety gloves when handling cables or chains.

# Torque

## Minimum hardware tightening torques (in N m or lb in /lb ft) for normal assembly applications unless otherwise stated

**NOTICE:** Shown below is the suggested initial torque tightening sequences for general applications, tighten in sequence from item 1 through to the last item of the hardware.

The minimum hardware tightening torque on drawings, in specifications etc. have priority. The applicable CNH Standard is ENS7001.

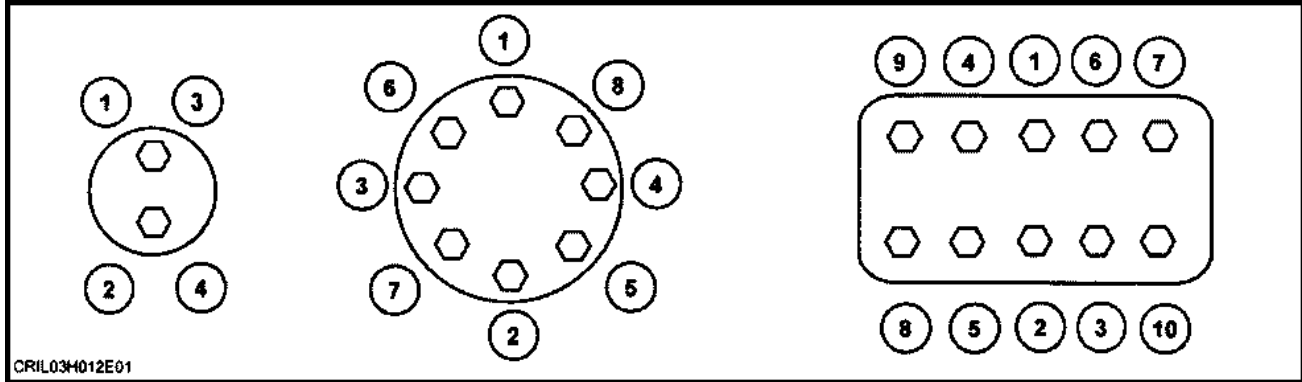

CRIL03H012E01

DF5019-1 1

### Metric hardware

Nominal Size	Class 8.8 in N m (lb in or lb ft)			Class 10.9 in N m (lb in or lb ft)		
	Plated nut	Lock nut	Hardened nut	Plated nut	Lock nut	Hardened nut
M3	1.3 N·m (11.5 lb in)	0.7 N·m (6.2 lb in)	1.2 N·m (10.6 lb in)	1.8 N·m (15.9 lb in)	0.9 N·m (8.0 lb in)	1.6 N·m (14.2 lb in)
M4	2.9 N·m (25.7 lb in)	1.6 N·m (14.2 lb in)	2.6 N·m (23.0 lb in)	4.2 N·m (37.2 lb in)	2.3 N·m (20.4 lb in)	3.7 N·m (32.7 lb in)
M5	5.9 N·m (52.2 lb in)	3.2 N·m (28.3 lb in)	5.3 N·m (46.9 lb in)	8.5 N·m (75.2 lb in)	4.6 N·m (40.7 lb in)	7.6 N·m (67.3 lb in)
M6	10.1 N·m (89.4 lb in)	5.5 N·m (48.7 lb in)	9.1 N·m (80.5 lb in)	14.5 N·m (10.7 lb ft)	7.9 N·m (69.9 lb in)	13 N·m (9.6 lb ft)
M8	24.5 N·m (18.1 lb ft)	13.5 N·m (10.0 lb ft)	22 N·m (16.2 lb ft)	35.1 N·m (25.9 lb ft)	19.3 N·m (14.2 lb ft)	31.5 N·m (23.2 lb ft)
M10	48.7 N·m (35.9 lb ft)	26.8 N·m (19.8 lb ft)	43.8 N·m (32.3 lb ft)	69.5 N·m (51.3 lb ft)	38.2 N·m (28.2 lb ft)	62.5 N·m (46.1 lb ft)
M12	85 N·m (62.7 lb ft)	46.7 N·m (34.4 lb ft)	76.5 N·m (56.4 lb ft)	121 N·m (89.2 lb ft)	66.5 N·m (49.0 lb ft)	108.9 N·m (80.3 lb ft)
M14	135 N·m (99.6 lb ft)	74.2 N·m (54.7 lb ft)	121.5 N·m (89.6 lb ft)	193 N·m (142.3 lb ft)	106.1 N·m (78.3 lb ft)	173.7 N·m (128.1 lb ft)
M16	210 N·m (154.9 lb ft)	115.5 N·m (85.2 lb ft)	189 N·m (139.4 lb ft)	301 N·m (222 lb ft)	165.5 N·m (122.1 lb ft)	270.9 N·m (199.8 lb ft)
M18	299 N·m (220.5 lb ft)	164.4 N·m (121.3 lb ft)	269.1 N·m (198.5 lb ft)	414 N·m (305.4 lb ft)	227.7 N·m (167.9 lb ft)	372.6 N·m (274.8 lb ft)
M20	425 N·m (313.5 lb ft)	233.72 N·m (172.4 lb ft)	382.5 N·m (282.1 lb ft)	587 N·m (432.9 lb ft)	322.8 N·m (238.1 lb ft)	528.3 N·m (389.7 lb ft)
M22	579 N·m (427 lb ft)	318.4 N·m (234.8 lb ft)	521.1 N·m (384.3 lb ft)	801 N·m (590.8 lb ft)	440.5 N·m (324.9 lb ft)	720.9 N·m (531.7 lb ft)
M24	735 N·m (542.1 lb ft)	404.2 N·m (298.1 lb ft)	661.5 N·m (487.9 lb ft)	1016 N·m (749.4 lb ft)	558.8 N·m (412.1 lb ft)	914.4 N·m (674.4 lb ft)
M27	1073 N·m (791.4 lb ft)	590.1 N·m (435.2 lb ft)	967.5 N·m (713.6 lb ft)	1486 N·m (1096 lb ft)	817.3 N·m (602.8 lb ft)	1337 N·m (986.1 lb ft)
M30	1461 N·m (1077.6 lb ft)	803.5 N·m (592.6 lb ft)	1315 N·m (969.9 lb ft)	2020 N·m (1489.9 lb ft)	1111 N·m (819.4 lb ft)	1818 N·m (1340.9 lb ft)

**IDENTIFICATION  
HEX CAP SCREW AND CARRIAGE BOLTS**



SAE GRADE 2



SAE GRADE 5



SAE GRADE 8



REGULAR NUTS



SAE GRADE 4H  
HEX NUTS



SAE GRADE 8H  
HEX NUTS

**LOCKNUTS**



GRADE IDENTIFICATION  
GRADE A: NO NOTCHES  
GRADE B: ONE CIRCUMFERENTIAL NOTCH  
GRADE C: TWO CIRCUMFERENTIAL NOTCHES



GRADE IDENTIFICATION  
GRADE A: NO MARK  
GRADE B: LETTER B  
GRADE C: LETTER C



GRADE IDENTIFICATION  
GRADE A: NO MARKS  
GRADE B: THREE MARKS  
GRADE C: SIX MARKS

Z1 INCS0135F0A

**IDENTIFICATION  
HEX CAP SCREW AND CARRIAGE BOLTS  
CLASSES 5, 8 AND UP**

**MANUFACTURER'S IDENTIFICATION**

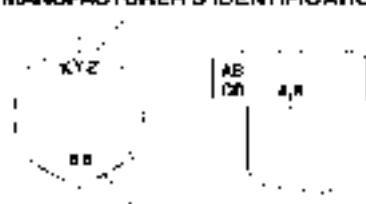

**PROPERTY CLASS**

**HEX NUTS AND LOCKNUTS  
CLASSES 05 AND UP**

**MANUFACTURER'S IDENTIFICATION**



PROPERTY CLASS

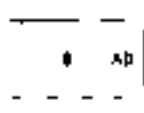

PROPERTY CLASS



CLOCK MARKING

Z1 INCS0135F0A

## Basic instructions

### SHIMMING

For each adjustment operation, select adjusting shims and measure individually using a micrometer, then add up the recorded values. Do not rely on measuring the entire shimming set, which may be incorrect, or the rated value indicated on each shim.

### ROTATING SHAFT SEALS

For correct rotating shaft seal installation, proceed as follows:

- before assembly, allow the seal to soak in the oil it will be sealing for at least thirty minutes
- thoroughly clean the shaft and check that the working surface on the shaft is not damaged
- position the sealing lip facing the fluid; with hydrodynamic lips, take into consideration the shaft rotation direction and position the grooves so that they will deviate the fluid towards the inner side of the seal
- coat the sealing lip with a thin layer of lubricant (use oil rather than grease) and fill the gap between the sealing lip and the dust lip on double lip seals with grease
- insert the seal in its seat and press down using a flat punch, do not tap the seal with a hammer or mallet
- whilst inserting the seal, check that it is perpendicular to the seat; once settled, make sure that it makes contact with the thrust element, if required
- to prevent damaging the seal lip on the shaft, position a protective guard during installation operations

### O-RING SEALS

Lubricate the O-RING seals before inserting them in the seats, this will prevent them from overturning and twisting, which would jeopardize sealing efficiency.

### SEALING COMPOUNDS

Only use the sealants which are recommended in this manual! Before applying the sealing compound, prepare the surfaces as follows:

- remove any incrustations using a metal brush;
- thoroughly de-grease the surfaces using one of the following cleaning agents: trichlorethylene, petrol or a water and soda solution.

### COTTER PINS

When fitting split cotter pins, ensure that the pin notch is positioned in the direction of the force required to stress the pin. Spiral cotter pins do not require special positioning.

## PROTECTING THE ELECTRONIC/ ELECTRICAL SYSTEMS DURING CHARGING OR WELDING

### **⚠ WARNING**

**Battery acid causes burns. Batteries contain sulfuric acid. Avoid contact with skin, eyes or clothing. Antidote (external): Flush with water. Antidote (eyes): flush with water for 15 minutes and seek medical attention immediately. Antidote (internal): Drink large quantities of water or milk. Do not induce vomiting. Seek medical attention immediately. Failure to comply could result in death or serious injury.**

W0111A

To avoid damage to the electronic/electrical systems, always observe the following:

1. Never make or break any of the charging circuit connections, including the battery connections, when the engine is running.
2. Never short any of the charging components to ground.
3. Always disconnect the ground cable from the battery before arc welding on the unit.
  - Position the welder ground clamp as close to the welding area as possible.
  - If welding in close proximity to a computer module, then the module should be removed from the unit.
  - Never allow welding cables to lay on, near or across any electrical wiring or electronic component while welding is in progress.
4. Always disconnect the negative cable from the battery when charging the battery in the unit with a battery charger.

**NOTICE:** *If welding must be performed on the unit, the battery ground cable must be disconnected from the battery. The electronic monitoring system and charging system will be damaged if this is not done.*

### SPARE PARTS

Only use "CNH Original Parts" or "CASE IH Parts".

Only genuine spare parts guarantee the same quality, duration and safety as original parts, as they are the same parts that are assembled during standard production. Only "CNH Original Parts" or "CASE IH Parts" can offer this guarantee. When ordering spare parts, always provide the following information:

- Machine model (commercial name) and serial number
- part number of the ordered part, which can be found in the "Spare Parts Catalogue", used for order processing

### TOOLS

The tools that CASE IH suggests and illustrate in this manual have been:

- specifically researched and designed for use with CASE IH machines
- essential for reliable repair operations
- accurately built and rigorously tested so as to offer efficient and long-lasting operation

By using these tools, Repair Personnel will benefit from:

- operating in optimal technical conditions
- obtaining the best results
- saving time and effort
- working in safe conditions

**NOTE:** *Wear limit values indicated for certain parts should be considered to be recommended, but not binding. The terms "front", "rear", "right-hand" and "left-hand" (when referred to different parts) are determined from the rear, facing in the direction of travel of the machine during operation.*



---

## Conversion factors

### Length

1 mm	=	0.0393 in	1 in	=	25.4 mm
1 km	=	0.621 miles	1 miles	=	1.609 km
1 m	=	3.281 ft	1 ft	=	0.3048 m

### Area

1 ha	=	2.471 ac	1 ac	=	0.404 US fl oz
1 m <sup>2</sup>	=	10.76 ft <sup>2</sup>	1 ft <sup>2</sup>	=	0.0923 m <sup>2</sup>

### Volume

1 litre	=	0.26 US gal	1 US gal	=	3.78 litre
1 litre	=	0.028 Bu	1 Bu	=	35.23 litre
1 litre	=	1.057 US quart	1 US quart	=	0.9464 litre
1 cm <sup>3</sup> (cc)	=	0.061 in <sup>3</sup>	1 in <sup>3</sup>	=	16.38 cm <sup>3</sup> (cc)
1 m <sup>3</sup>	=	35.31 ft <sup>3</sup>	1 ft <sup>3</sup>	=	0.028 m <sup>3</sup>
1 ml	=	0.033 US fl oz	1 US fl oz	=	29.57 ml

### Mass

1 kg	=	2.204 lb	1 lb	=	0.4536 kg
------	---	----------	------	---	-----------

### Torque

1 N·m	=	0.7376 lb ft	1 lb ft	=	1.3558 N·m
-------	---	--------------	---------	---	------------

### Power

1 kW	=	1.358 Hp	1 Hp	=	0.746 kW
------	---	----------	------	---	----------

### Pressure

1 bar	=	100 kPa			
1 bar	=	14.505 psi	1 psi	=	0.06894 bar

### Temperature

1 °C	=	((1.8 x ° C) + 32) °F	1 °F	=	(0.56 x (° F - 32)) °C
------	---	-----------------------	------	---	------------------------

### Flow

1 l/min	=	0.2642 US gpm	1 US gpm	=	3.7853 l/min
---------	---	---------------	----------	---	--------------

### Speed

1 km/h	=	0.62 mph	1 mph	=	1.6 km/h
--------	---	----------	-------	---	----------

## Consumables Lubrications and Coolants

### Lubrications

The correct engine oil viscosity grade is dependent upon ambient temperature. Refer to the chart when selecting oil for your tractor engine.

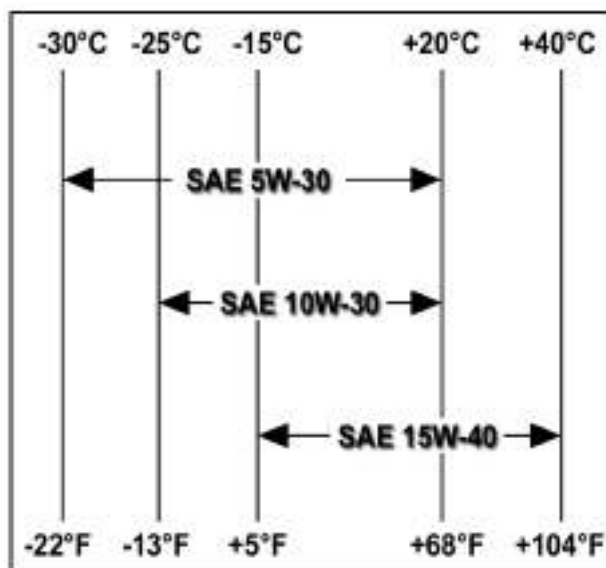

SS09J076 1

**NOTE:** In areas where prolonged periods of extreme temperatures are encountered, local lubricant practices are acceptable; such as the use of SAE 5W-30 in extreme low temperatures or SAE 50 in extreme high temperatures.

### Biodegradable Transmission and Hydraulic Oil

#### ⚠ WARNING

**Burn hazard!**

**Be very careful to avoid contact with hot fluids. If fluid is extremely hot, allow it to cool to a moderately warm temperature before proceeding.**

**Failure to comply could result in death or serious injury.**

W0362A

A biodegradable oil has been approved for use in the transmission, 4WD front axle and hubs, and the hydraulic system of your tractor. Although the oil is **90 %** biodegradable, it is important to follow safe handling and disposal practices.

The **CASE IH AKCELA TSM BIO** oil is available from your authorised dealer.

Biodegradable oil should not be used in conjunction with other oils. Use the following procedure to replace standard oil with biodegradable lubricant.

1. Operate the tractor until the oil that is being changed reaches a temperature greater than **60 °C (140 °F)**.
2. Stop the engine and immediately drain the oil.
3. Replace all transmission and hydraulic filters.
4. Add the biodegradable oil to the correct level and run the tractor to circulate the oil.
5. Check for oil leaks and recheck the oil level.

### Sulfur in fuel

The engine oil and filter change period are shown in the Lubrication and Maintenance in the operators manual. However, locally available fuel may have a high sulphur content, in which case the engine oil and filter change period should be adjusted as follows:

## INTRODUCTION

Sulfur content	Oil change period
Below <b>0.5 %</b>	Normal
From <b>0.5 - 1.0 %</b>	Half the normal
Above <b>1.0 %</b>	One quarter normal

**NOTE:** The use of fuel with a sulphur content above **1.3 %** is not recommended.

### Coolants

#### **▲ WARNING**

**Hazardous chemicals!**

**Chemical agent may be harmful.**

**-Avoid contact with eyes, and prolonged/repeated skin contact.**

**-Wear protective goggles when handling.**

**-Eye contact: Flush with water for 15 minutes. Seek immediate medical assistance.**

**-Wash skin with soap and water after handling.**

**-Keep out of reach of children.**

**Failure to comply could result in death or serious injury.**

W0370A

To reduce the amount of deposits and corrosion, the water used in the cooling system must comply with the following values.

Total Hardness	Chloride	Sulfate
300 parts per million	100 parts per million	100 parts per million

### Using Plain water

If you reside in a country where antifreeze is not available, use clean water premixed with **5 %** chemical inhibitor. The inhibitor is available from your authorised dealer.

### Lubrications and Coolant Specifications

Recommended fluids and applications	CIH specification	International specification
Engine oil <b>CASE IH AKCELA UNITEK NO. 1™ SBL CJ-4 SAE 10W-40</b>	MS 3521	API CJ-4
Transmission oil, rear axle oil and steering oil <b>CASE IH AKCELA NEXPLORE™ FLUID</b>	MAT 3525	API GL4 (SAE 10W-30) (ISO VG32/46)
Hydraulic system oil <b>CASE IH AKCELA NEXPLORE™ FLUID</b>		
Front axle casing and hubs <b>CASE IH AKCELA NEXPLORE™ FLUID</b>		
Front Power Take-Off (PTO) <b>CASE IH AKCELA NEXPLORE™ FLUID</b>		
Cooling system <b>CASE IH AKCELA PREMIUM ANTI-FREEZE</b> (mixed with <b>50 %</b> of water)	MS 1710	Ethylene Glycol
Brake fluid reservoir <b>CASE IH AKCELA LHM FLUID</b>	n/a	ISO 7308
Air-conditioning compressor oil Low viscosity oil SP10	n/a	PAG-E13 ISO100 Viscosity
Grease fittings and bearings <b>CASE IH AKCELA 251H EP MULTI-PURPOSE GREASE</b>	251H EP	NLGI2, Li-Ca

Regarding filling quantity - see **Capacities ( )** .

## Capacities

Unit	Farmall 95U Pro EP	Farmall 105U Pro EP	Farmall 115U Pro EP
Fuel tank	150 l (39.6 US gal)		
Cooling system	17 l (4.5 US gal)		
Engine (including filter)	6.4 - 8.1 l (1.7 - 2.1 US gal)		
Transmission oil, rear axle oil, steering oil	45 l (11.9 US gal)		
Hydraulic system oil	44 l (11.6 US gal)		
Front axle – differential	9.5 l (2.5 US gal)		
Front axle – hubs (Class 1.5 axle – less brakes)	1.2 l (0.3 US gal)		
Front axle – hubs (Class 1.5 axle – with brakes)	1.6 l (0.4 US gal)		
Front Power Take-Off (PTO)	0.4 l (0.1 US gal)		
Brake fluid	0.6 l (0.2 US gal)		
Antifreeze for air trailer brake	0.5 l (0.1 US gal)		





# **SERVICE MANUAL**

## **Engine**

**Farmall 105U Pro EP  
Farmall 115U Pro EP  
Farmall 95U Pro EP**

# Contents

---

## Engine - 10

[10.216] Fuel tanks .....	10.1
[10.254] Intake and exhaust manifolds and muffler .....	10.2
[10.501] Exhaust Gas Recirculation (EGR) - Diesel Particulate Filter (DPF) exhaust treatment	10.3
[10.414] Fan and drive .....	10.4



## **Engine - 10**

**Fuel tanks - 216**

**Farmall 105U Pro EP  
Farmall 115U Pro EP  
Farmall 95U Pro EP**



# Contents

---

## Engine - 10

## Fuel tanks - 216

### SERVICE

Fuel tank	
Remove .....	3
Install .....	5

## Fuel tank - Remove

### **⚠ WARNING**

Fuel vapors are explosive and flammable.  
Do not smoke while handling fuel. Keep fuel away from flames or sparks. Shut off engine and remove key before servicing. Always work in a well-ventilated area. Clean up spilled fuel immediately.  
Failure to comply could result in death or serious injury.

W0904A

### **Prior operation:**

Remove the battery. See **Battery - Remove (55.302)**.

Remove the left-hand side rear wheel. See **Rear wheels - Remove (44.520)**.

1. Remove the steps on the left-hand side of the cab. See also **Cab - Remove (90.150)**.
2. Open the bolt and drain the fuel from the fuel tank.

**NOTE:** Place a container of suitable capacity below the fuel tank.

3. Disconnect the electrical connector (1) from the fuel tank sensor.

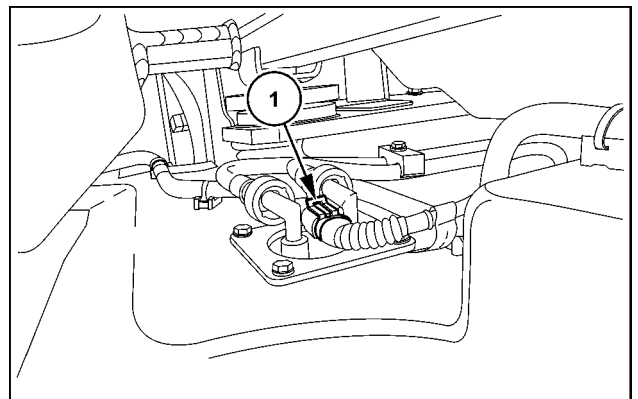

SVIL13TR00646AB 1

4. Remove the bolts (1).

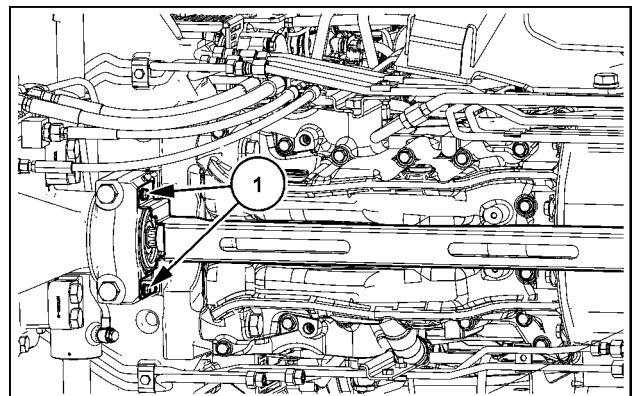

SS13H206 2

5. Put a jack below the 4WD cover.
6. Remove the nuts and the clamps of the air operated trailer brake pipe (where fitted).
7. Remove the bolts.
8. Remove the 4WD cover.

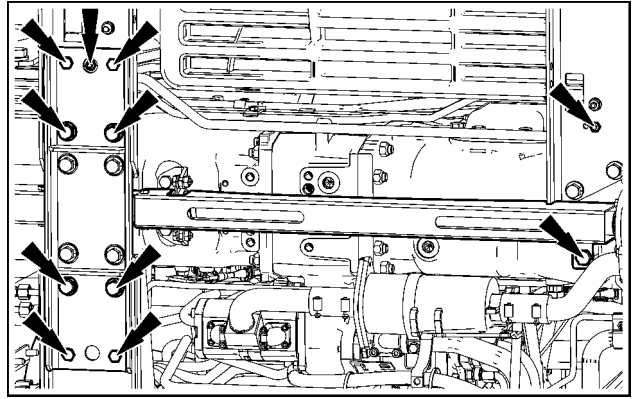

SS13H207 3

9. Remove the bolts (1).

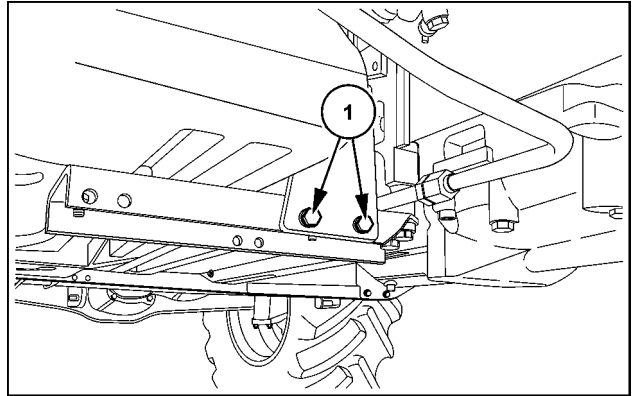

SVIL13TR00654AB 4

10. **⚠ WARNING**

**Heavy objects!**  
 Lift and handle all heavy components using lifting equipment with adequate capacity. Always support units or parts with suitable slings or hooks. Make sure the work area is clear of all bystanders. Failure to comply could result in death or serious injury.

W0398A

Put a jack below the fuel tank.

11. Remove the bolts (1) and the thick washers.
12. Remove the clamps (1) and the fuel pipes.

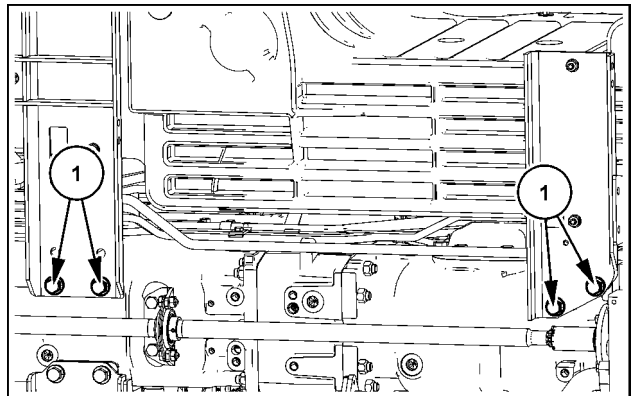

SS13H208 5

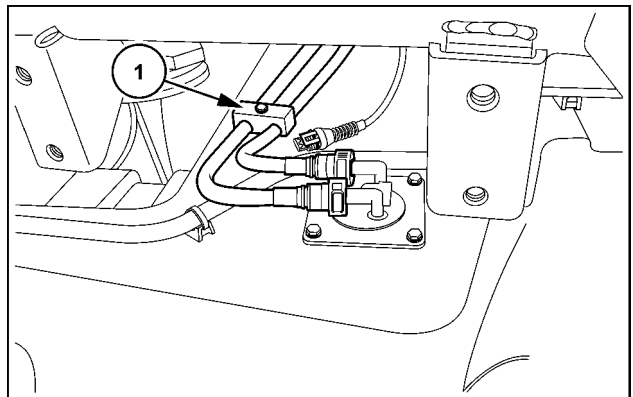

SVIL13TR00644AB 6

13. Remove the fuel tank with a jack.

**Next operation:**  
**Fuel tank - Install (10.216)**

## Fuel tank - Install

Prior operation:

Fuel tank - Remove (10.216)

1. **⚠ WARNING**

**Heavy objects!**

Lift and handle all heavy components using lifting equipment with adequate capacity. Always support units or parts with suitable slings or hooks. Make sure the work area is clear of all bystanders.

Failure to comply could result in death or serious injury.

W0398A

Position the fuel tank with a jack near the fixing points.

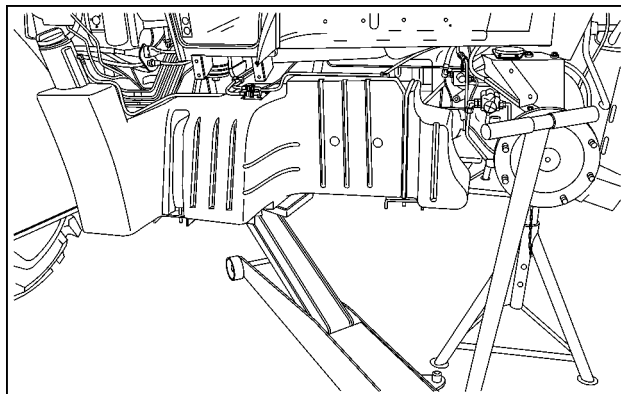

SVIL13TR00643AB 1

2. Connect the fuel pipes.

**NOTE:** Fix the fuel pipes with the clamps (1).

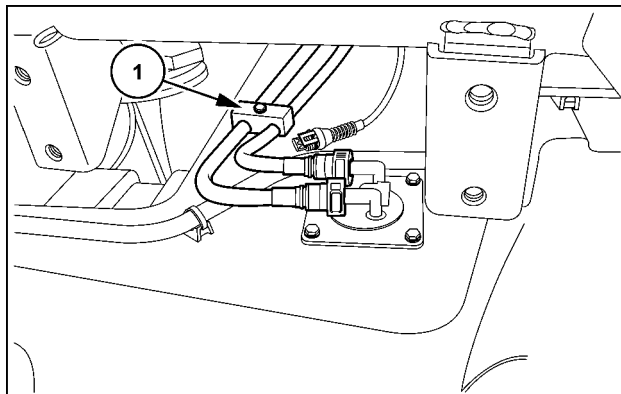

SVIL13TR00644AB 2

3. Position the fuel tank on the correct place.

4. Fix the fuel tank with the bolts (1) and the thick washers.

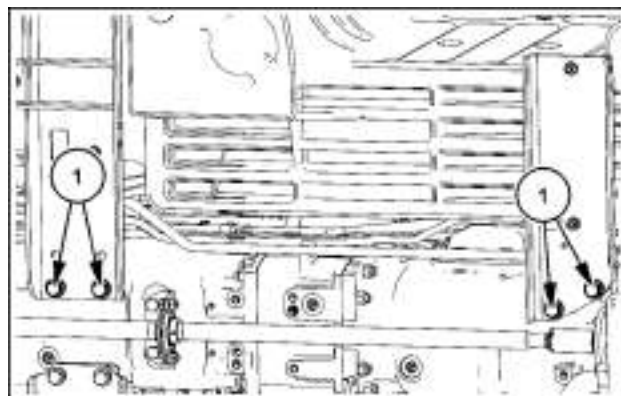

SS13H208 3

5. Fix the fuel tank with the bolts (1).

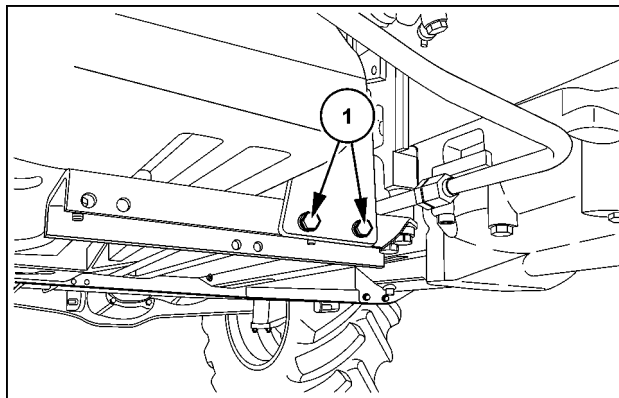

SVIL13TR00654AB 4

6. Install the 4WD cover with the bolts.

7. Fix the air operated trailer brake pipe with clamps and nuts.

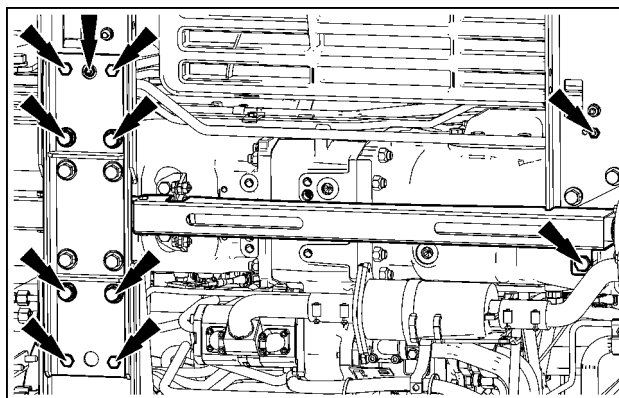

SS13H207 5

8. Install the bolts (1).

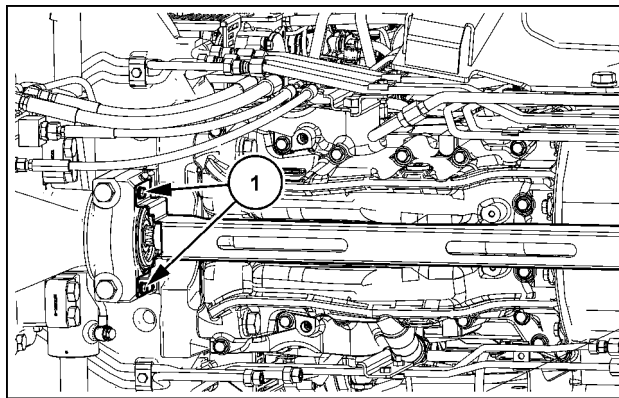

SS13H206 6

9. Connect the electrical connector (1) of the fuel tank sensor.

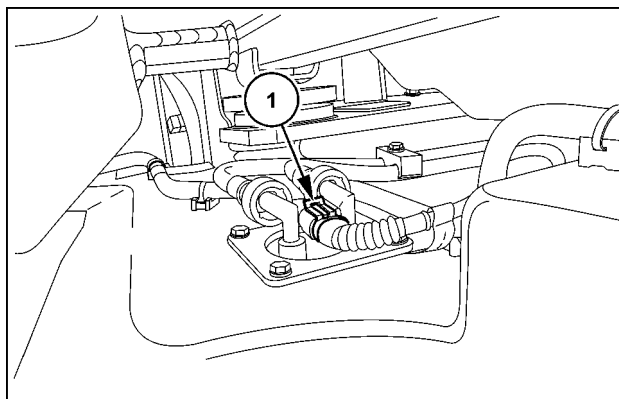

SVIL13TR00646AB 7

10. Fill in the fuel. See also **Capacities** ().

11. Install the steps on the left-hand side of the cab. See also **Cab - Install (90.150)**.

**Next operation:**

Install the left-hand side rear wheel. See **Rear wheels - Install (44.520)**.  
Install the battery. See **Battery - Install (55.302)**.

# Index

---

## Engine - 10

### Fuel tanks - 216

Fuel tank - Install .....	5
Fuel tank - Remove .....	3



## **Engine - 10**

**Intake and exhaust manifolds and muffler - 254**

**Farmall 105U Pro EP  
Farmall 115U Pro EP  
Farmall 95U Pro EP**



# Contents

---

## Engine - 10

### Intake and exhaust manifolds and muffler - 254

#### SERVICE

##### Exhaust pipes

Remove .....	3
Install .....	4

## Exhaust pipes - Remove

### ⚠ WARNING

#### Heavy objects!

Lift and handle all heavy components using lifting equipment with adequate capacity. Always support units or parts with suitable slings or hooks. Make sure the work area is clear of all bystanders. Failure to comply could result in death or serious injury.

W0398A

1. Remove the nuts (1).
2. Remove the cover (2).

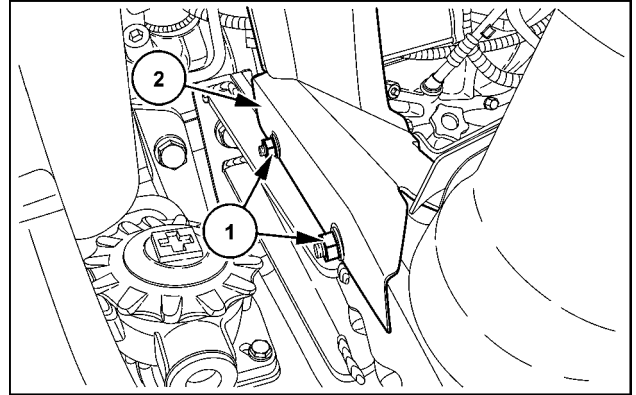

SVIL13TR00921AB 1

3. Open the clamp (1).

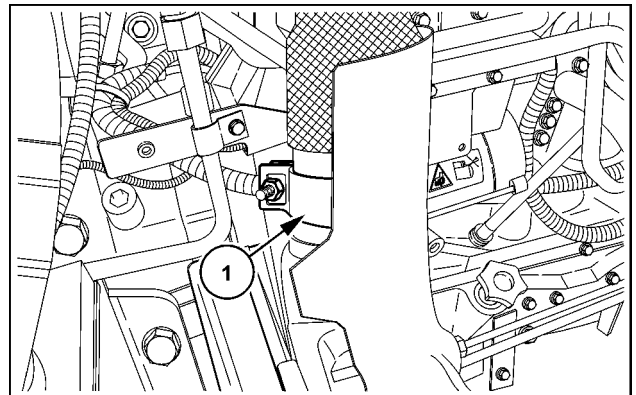

SVIL13TR00920AB 2

4. Fix the exhaust pipe with two lifting slings and a crane.

**NOTICE:** Clap the exterior mirror backwards before using the crane.

5. Remove the bolts (1) on the support.

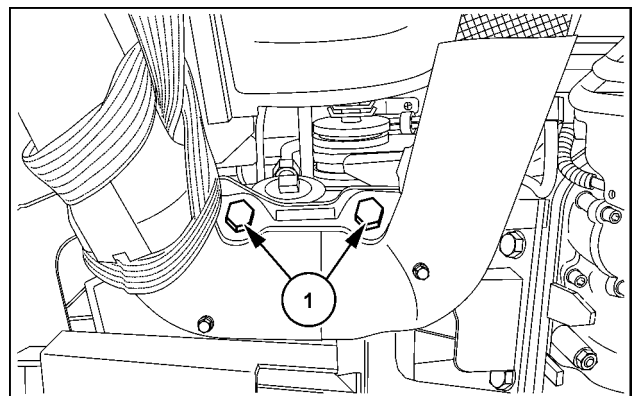

SVIL13TR00919AB 3

6. Remove the exhaust pipe.

#### Next operation:

Install the exhaust pipe. See **Exhaust pipes - Install (10.254)**.

## Exhaust pipes - Install

### ⚠ WARNING

#### Heavy objects!

Lift and handle all heavy components using lifting equipment with adequate capacity. Always support units or parts with suitable slings or hooks. Make sure the work area is clear of all bystanders. Failure to comply could result in death or serious injury.

W0398A

#### Prior operation:

Remove the exhaust pipe. See **Exhaust pipes - Remove (10.254)**.

1. Position the exhaust pipe with a crane.
2. Fix the exhaust pipe with the bolts (1) on the support.

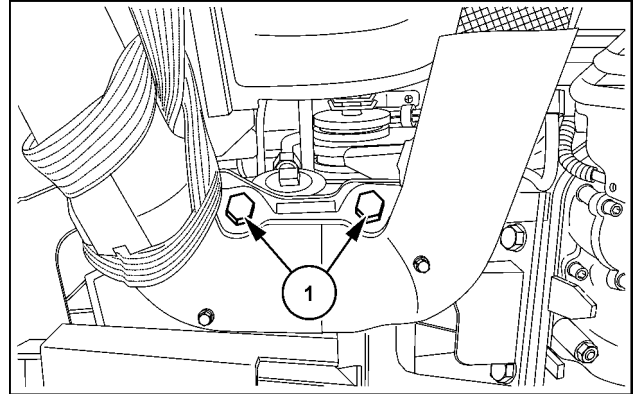

SVIL13TR00919AB 1

3. Tighten the clamp (1).

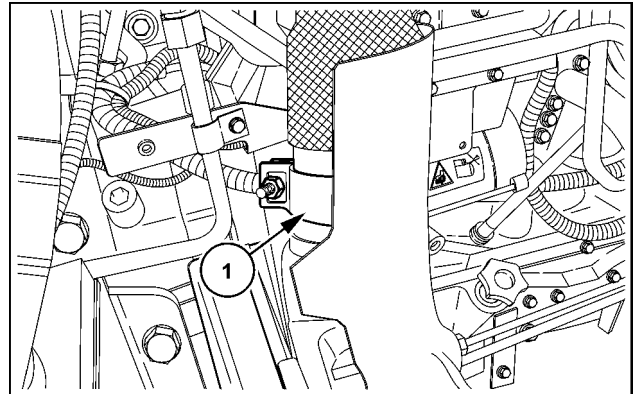

SVIL13TR00920AB 2

4. Install the cover (2).
5. Fix the cover (2) with the nuts (1).

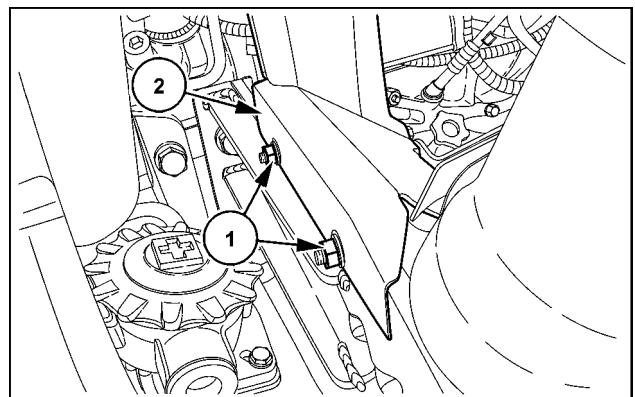

SVIL13TR00921AB 3

# Index

---

## Engine - 10

### Intake and exhaust manifolds and muffler - 254

Exhaust pipes - Install .....	4
Exhaust pipes - Remove .....	3





## **Engine - 10**

### **Exhaust Gas Recirculation (EGR) - Diesel Particulate Filter (DPF) exhaust treatment - 501**

**Farmall 105U Pro EP  
Farmall 115U Pro EP  
Farmall 95U Pro EP**

# Contents

---

## Engine - 10

### Exhaust Gas Recirculation (EGR) - Diesel Particulate Filter (DPF) exhaust treatment - 501

#### TECHNICAL DATA

##### Diesel Particulate Filters (DPF)

Torque .....	3
General specification Installation measurements .....	4

#### FUNCTIONAL DATA

##### Diesel Particulate Filters (DPF)

Dynamic description manual regeneration of the diesel particulate filter (DPF) .....	6
--	---

## Diesel Particulate Filters (DPF) - Torque

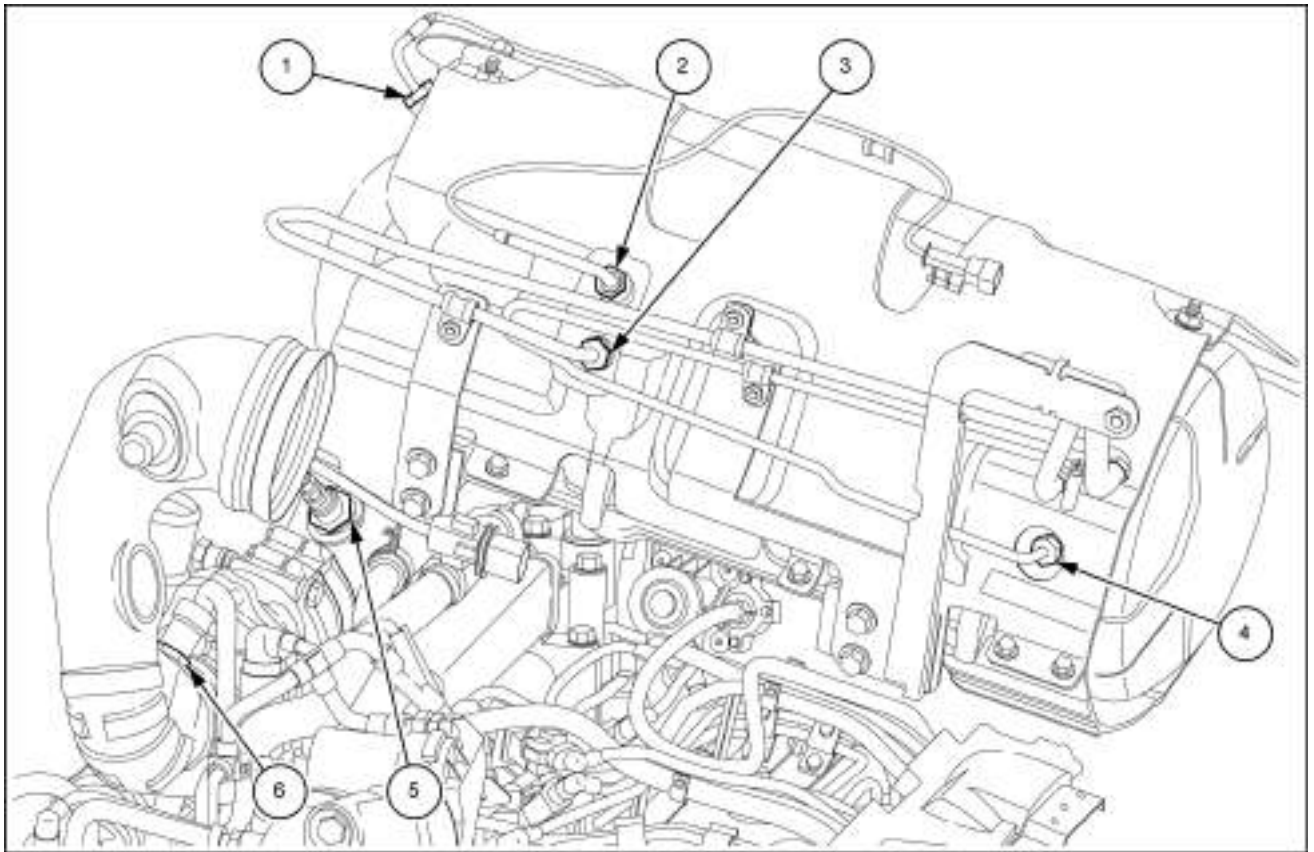

MOIL12APL92 1

### TORQUE SETTINGS

No.	Part to tighten	Thread size	Torque settings		
			Nm	kg	lbf. ft
1	Gas temperature sensor on DPF intake	M 14x1.5	40.5 to 49.5	4.14 to 5.12	30.2 to 36.9
2	DPF filter first section temperature sensor	M 14x1.5	40.5 to 49.5	4.14 to 5.12	30.2 to 36.9
3	Pressure pipe fitting on turbine side	M 14x1.5	40.5 to 49.5	4.14 to 5.12	30.2 to 36.9
4	Pressure pipe fitting on muffler side	M 12x1.5	27 to 33	2.80 to 3.42	20.1 to 24.6
5	Lambda sensor	M 18x1.5	45 to 55	4.66 to 5.70	33.6 to 41
6	Air temperature sensor	M 12x1.5	15 to 25	1.55 to 2.59	9 to 18.6



## Diesel Particulate Filters (DPF) - General specification Installation measurements

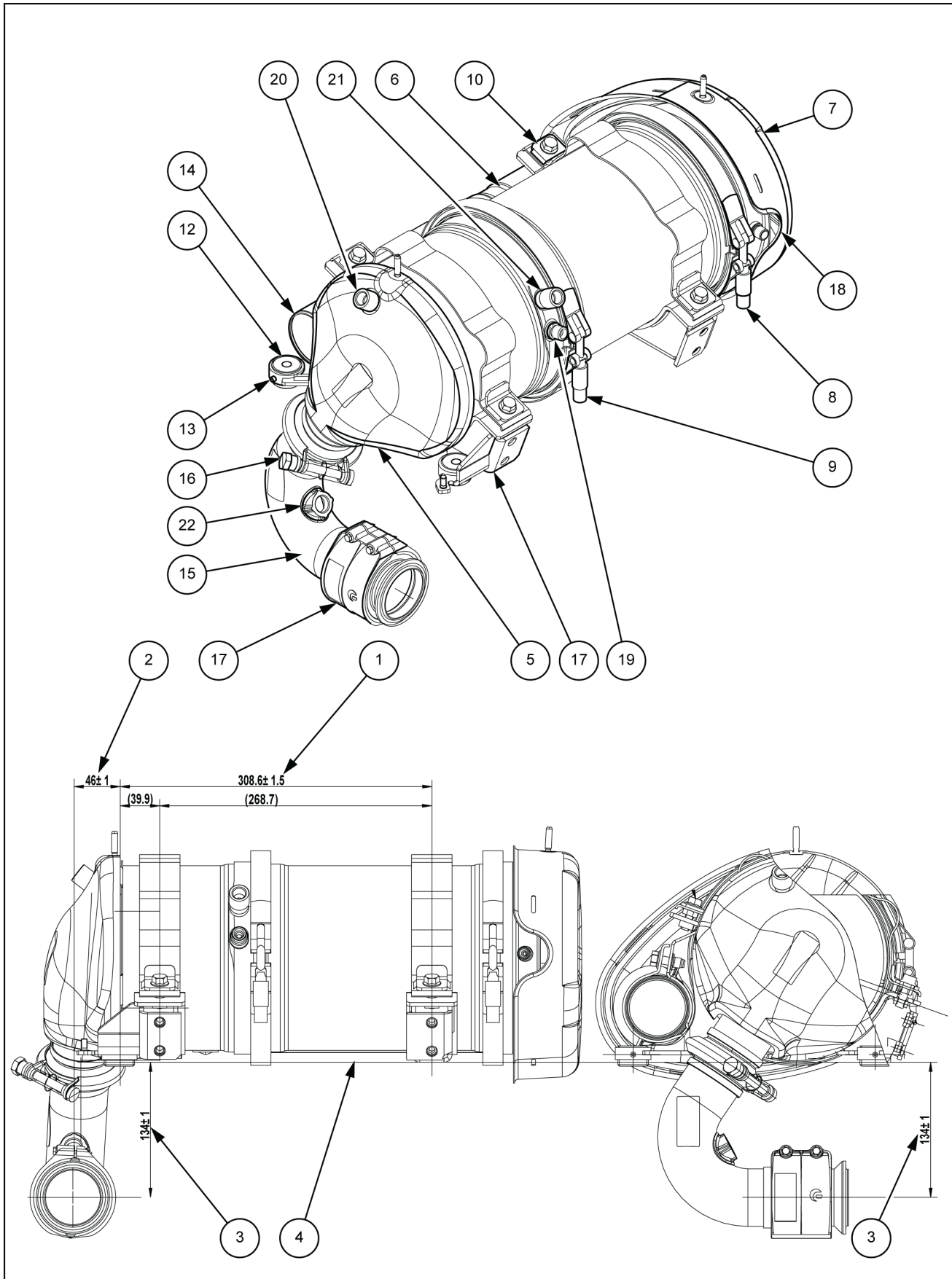

MOIL12APL104 1

47735452 03/07/2014

Measurements to respect for installing the filter — Legend of components — Legend of sensor fixing holes:

1. **308.6 mm (12.1496 in) ± 1.5 mm (0.0591 in)** Distance between the two bands of the cradle, the one with the set fixing holes **(10)** and the one with the adjustable fixing holes **(11)** .
2. **46 mm (1.8110 in) ± 1 mm (0.0394 in)** Distance between the centre of the turbine or the centre of the union of the decoupler/turbine and the adjustable filter fixing bushings **(12)** .
3. **134 mm (5.2756 in) ± 1 mm (0.0394 in)** Distance between the centre of the turbine or the centre of the union / turbine and the band supporting surface **(4)** with set fixing holes on the filter support.
4. Band supporting surface with set fixing holes.
5. Initial part of the DPF filter, connected with the sleeve. **(15)** to the turbine.
6. Middle part of the DPF filter, inside which there is the ceramic part to clean.
7. End part of the DPF filter, connected with the sleeve. **(14)** to the exhaust pipe.
8. Clamp retaining the middle part **(6)** \ end part **(7)** .
9. Clamp retaining the middle part **(6)** \ initial part **(5)** .
10. Band with the set fixing holes.
11. Band with the adjustable fixing holes.
12. Threaded bushings, screwing them in or out enables changing the adjustment distance **(3)** .
13. Grub screw fixing the bushing **(12)** .
14. Filter outlet union, it is inserted on the exhaust pipe.
15. Union joining the filter to the turbine.
16. Clamp fixing the union **(15)** to the filter.
17. Tutor, protects the decoupler during the handling from the supplier, it is dismantled after assembly (it is advised to keep one to hand and to reassemble it before starting to disassemble the filter so that the decoupler undergoes no deformation).
18. Gas pressure detection after the middle part of the filter, the pipe that goes on the differential pressure sensor is connected here.
19. Gas pressure detection before the middle part of the filter, the pipe that goes on the differential pressure sensor is connected here.
20. Exhaust gas temperature sensor from the turbine.
21. Exhaust gas temperature sensor to the intake of the middle part of the filter.
22. Lambda sensor.

## Diesel Particulate Filters (DPF) - Dynamic description manual regeneration of the diesel particulate filter (DPF)

A diesel particulate filter (DPF) is a device designed to remove polluting diesel engine particulate from exhaust gas; when clogged, it needs to be regenerated.

The diesel particulate filter can be regenerated automatically or by forcing.

The regeneration process is signaled to the operator on the central monitor of the dashboard and with an acoustic signal. The indication is necessary for the purposes of safety to warn the operator about the high exhaust temperature reached during the process.

The automatic regeneration shall not affect engine performance. During the procedure, the operator can continue working normally.

Under certain operating conditions automatic regeneration might not be completed (engine continuously stopping and starting, lengthy periods at idle speed) and it must then be repeated.



The start of automatic regeneration, if set, is highlighted with the following warning light blinking on the dashboard and the same symbol appears every 5 minutes on the central monitor with the word "ON" combined with a single beep. On concluding the operation the symbol appears with the word "OFF".

When the level of soot exceeds a certain level, the electronic control unit asks you to proceed with manual filter regeneration.

**NOTICE:** If the filter is not regenerated when required, whether manually or by forcing, the functionality of the filter is impaired. Continuing to ignore this request, besides greatly reducing engine horsepower, damages the filter to such an extent that it is necessary for the dealer to replace the filter with a new one.

When the following warnings appear on the dashboard it is necessary to proceed as follows:

### DPF to be regenerated

Start of automatic regeneration or, with the control, start of forced regeneration

#### Image legend:

- (A) - Warning light on the dashboard
- (B) - Flasher
- (C) - On
- (D) - Off
- (E) - Central display

Spia su cruscotto (A)			
	Lampeggiante (B)	Accesa (C)	Spenta (D)
Display centrale (E)			

WLAPL4S55C111A 1

### DPF to be regenerated

#### Low severity





Automatic regeneration inhibited, only start of forced regeneration with control

Spia su cruscotto			
	Lampeggiante	Spenta	Accesa
Display centrale			

DCAPLT5NE058S3A 2

**DPF to be regenerated**  
**High severity**

Automatic regeneration inhibited, only start of forced re-generation with control

Spia su cruscotto			
	Lampeggiante	Spenta	Accesa
Display centrale	 3433		

DCAPLT5NE059S3A 3

**DPF damaged**  
**Technical support required**

Automatic and forced regeneration inhibited

Spia su cruscotto			
	Lampeggiante	Spenta	Accesa
Display centrale	 3434		

DCAPLT5NE060S3A 4

## Manual regeneration of the diesel particulate filter DPF

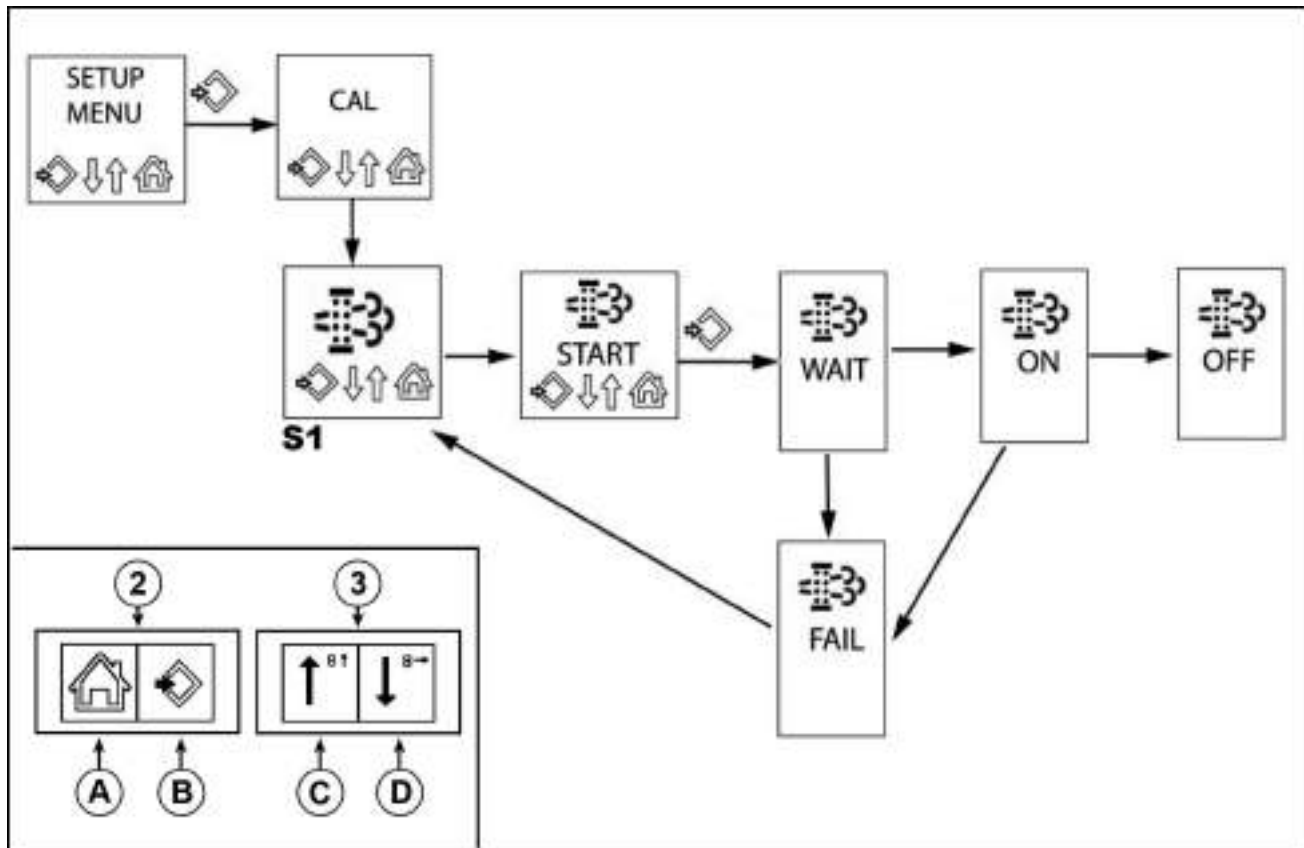

DCAPLT5NE072S3F 5

To be able to activate the procedure of manual regeneration when required, it is necessary to stop work for the entire duration of the procedure ( **15 — 20 min**) and get into the following conditions:

- engine running, machine stationary and hand brake on
- hand throttle at minimum position
- foot throttle released
- PTO not engaged
- hydraulic system not active

**NOTE:** *If the conditions described above are changed, throughout the entire process of regeneration, the operation is stopped.*

To activate forced regeneration, proceed as follows:

- Press the switch (2) on the symbol (B) for more than three seconds to enter the programming menu. The central monitor will show "SETUP MENU". Release the symbol (B).
- Press the switch (3) on the symbol (D) a number of consecutive times until the monitor shows the symbol of the filter (S1).
- Press the switch (2) on the symbol (B).
- If manual filter regeneration is required, the monitor will automatically display "START" with the symbol of the filter.
- Press the switch (2) on the symbol (B) to move on to the message "WAIT". Filter regeneration now commences. In this phase, if everything proceeds normally, the operator must give no commands and the electronic control unit will automatically display the various phases of the procedure.
- At the end of regeneration the monitor will show "OFF" with the filter symbol. After two seconds the control unit automatically returns to the initial situation. Press the switch (2) on the symbol (A) a number of times until you exit the programming menu.

**NOTE:** *If during manual regeneration the operator modifies the conditions described above, or other conditions connected with the engine are not satisfactory, regeneration is stopped. The stop is signaled to the operator by the*

*monitor displaying the filter symbol together with "FAIL" and a single acoustic signal. After 2 seconds, the control unit goes back into the situation at the start of regeneration "START". From this situation, after restoring the necessary conditions to carry out the operation it is necessary to press the switch (2) on the symbol (B) to restart the regeneration procedure.*

## Automatic diesel particulate filter regeneration inhibition DPF

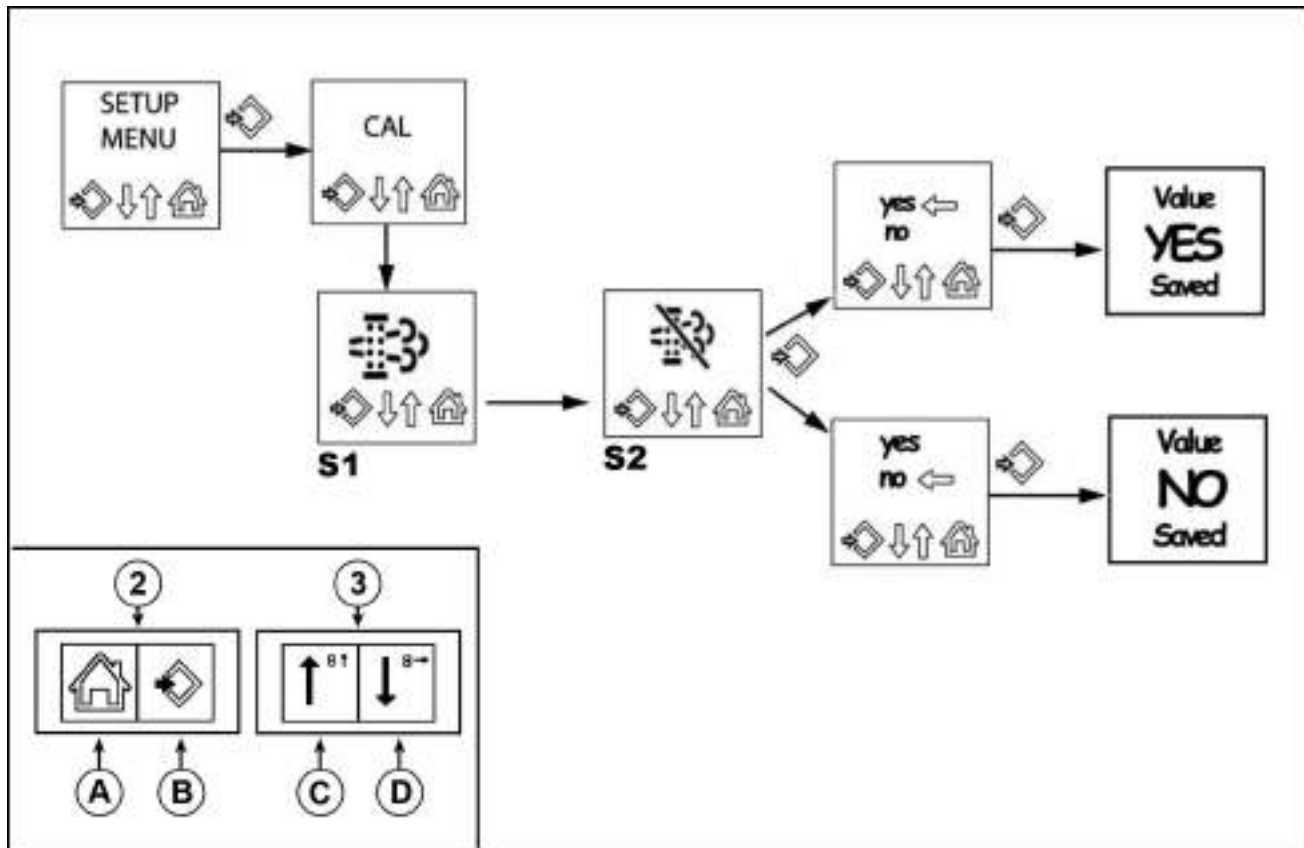

DCAPLT5NE071S3F 6

If you want to inhibit or enable automatic regeneration of the diesel particulate filter, proceed as described below:

- Press the switch **(2)** on the symbol **(B)** for more than three seconds to enter the programming menu. The central monitor will show "SETUP MENU". Release the symbol **(B)**.
- Press the switch **(3)** on the symbol **(D)** a number of consecutive times until the monitor shows the symbol of the filter S1 .
- Press the switch **(2)** on the symbol **(B)** and press the switch **(3)** on the symbol **(D)** to display the screen S2 then press button **(B)**
- YES = automatic regeneration of the filter INHIBITED
- NO = automatic regeneration of the filter ENABLED
- It is possible to change the setting status by moving with the direction keys of the switch **(3)** on the symbols **(C)** and **(D)** to pass from "yes" to "no" and vice versa, then confirm by pressing the switch **(2)** on the symbol **(B)**.



If automatic regeneration is disabled the following warning light on the dashboard remains on steady



and every 5 minutes the central monitor shows the following symbol combined with a single beep.

If the setting in the system matches the needs of the work to perform, press the switch **(2)** on the symbol **(A)** a number of times to exit the programming menu.

**NOTICE:** It is always advisable to have the automatic regeneration function ENABLED.

# Index

---

## Engine - 10

### **Exhaust Gas Recirculation (EGR) - Diesel Particulate Filter (DPF) exhaust treatment - 501**

Diesel Particulate Filters (DPF) - Dynamic description manual regeneration of the diesel particulate filter (DPF)	6
Diesel Particulate Filters (DPF) - General specification Installation measurements .....	4
Diesel Particulate Filters (DPF) - Torque .....	3







## **Engine - 10**

**Fan and drive - 414**

**Farmall 105U Pro EP  
Farmall 115U Pro EP  
Farmall 95U Pro EP**

# Contents

---

## Engine - 10

### Fan and drive - 414

#### SERVICE

##### Belt

Remove – 120 A alternator .....	3
Install – 120 A alternator .....	4
Remove – 200 A alternator .....	5
Install – 200 A alternator .....	6

##### Belt tensioner

Remove – 120 A alternator .....	7
Install – 120 A alternator .....	8
Remove – 200 A alternator .....	9
Install – 200 A alternator .....	10

## Belt - Remove – 120 A alternator

### Prior operation:

Removal of the engine fan.

1. Remove the mounting bolts (1).
2. Remove the cover.

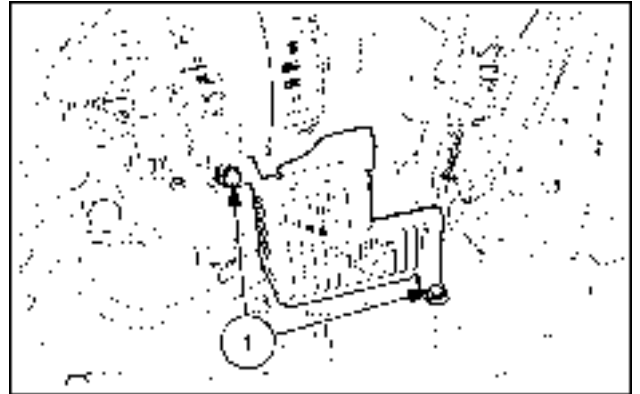

SVIL13TR00174AB 1

3. Loosen the pivot bolt (3) and the retaining nut.
4. Loosen the retaining nut (4).
5. Loosen the screw in the slot of the belt tensioner (2).
6. Loosen the counter nut of the adjusting screw (1).
7. Turn the adjusting screw (1) counter-clockwise. Relieve the tension from the poly V-belt.
8. Remove the poly V-belt.

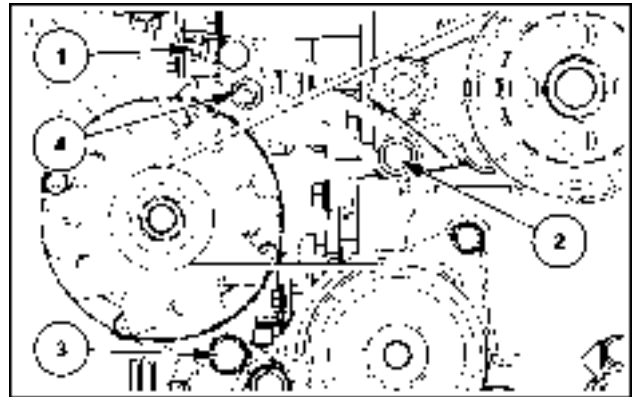

SS13A814 2

### Next operation:

**Belt - Install – 120 A alternator (10.414)**

## Belt - Install – 120 A alternator

### Prior operation:

#### Belt - Remove – 120 A alternator (10.414)

1. Ensure that the mounting bolts of the alternator (1) and the belt tensioner are loosely mounted.
2. Install the poly V-belt (2).

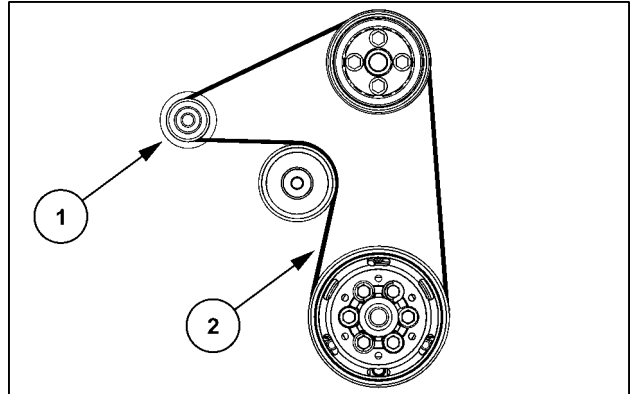

SS13A810 1

3. For tensioning the poly V-belt, turn the adjusting screw (1) clockwise until the screw in the slot of the belt tensioner (2) reaches the stop position (maximum belt tension).

**NOTE:** The screw in the slot of the belt tensioner (2) always has to be at the stop position (only a single setting option for the belt tensioning).

4. Tighten the pivot bolt (3) with the retaining nut to a torque of **50.0 Nm (36.9 lb ft)**.
5. Tighten the retaining nut (4).
6. Tighten the screw (2) to a torque of **50.0 Nm (36.9 lb ft)**.
7. Turn the adjusting screw (1) two full turns counter-clockwise.
8. Tighten the counter nut of the adjusting screw (1) to a torque of **30.0 Nm (22.1 lb ft)**.
9. Install the cover.
10. Tighten the mounting bolts (1).

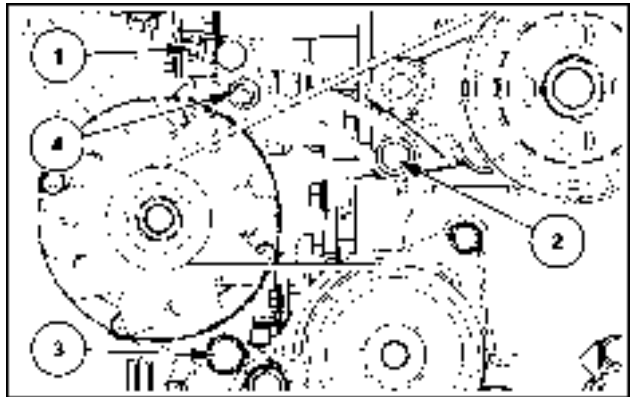

SS13A814 2

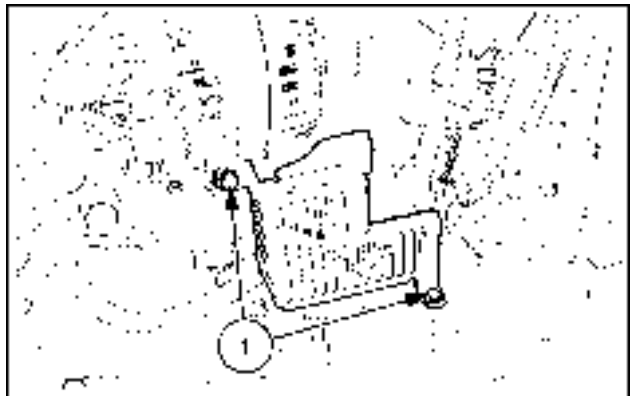

SVIL13TR00174AB 3

### Next operation:

Installation of the engine fan.

## Belt - Remove – 200 A alternator

### Prior operation:

Removal of the engine fan.

1. Remove the mounting bolts (1).
2. Remove the cover.



SVIL13TR00174AB 1

3. Loosen the counter nut of the adjusting screw (1).
4. Turn the adjusting screw (1) of the belt tensioner clockwise until the adjusting screw (1) contacts the sledge of the idler wheel.
5. Slightly loosen the screw (2) of the idler wheel to allow the lifting of the sledge (preparation for the unlatching of the sledge).

**NOTE:** Do not fully loosen the screw (2). For a secure lifting of the sledge, the screw (2) should hold with some thread turns in the bore.

6. Use a suitable tool for the lifting and the unlatching of the sledge. Fully loosen the screw (2).
7. Turn the adjusting screw (1) counter-clockwise in order that the unlatched sledge moves up. Relieve the tension from the poly V-belt.
8. Remove the poly V-belt.

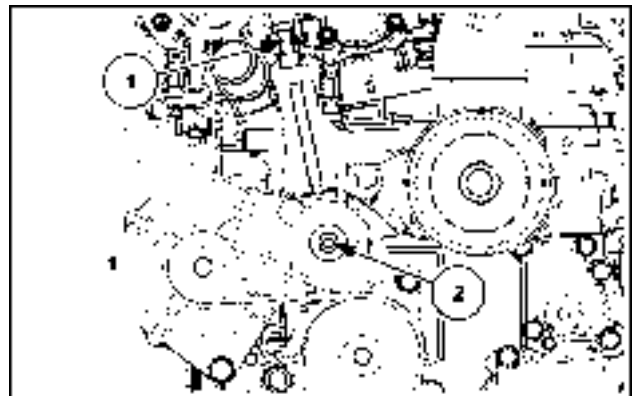

SS13A816 2

### Next operation:

**Belt - Install – 200 A alternator (10.414)**

## Belt - Install – 200 A alternator

### Prior operation:

### Belt - Remove – 200 A alternator (10.414)

1. Install the poly V-belt (2) to the alternator pulley (1).

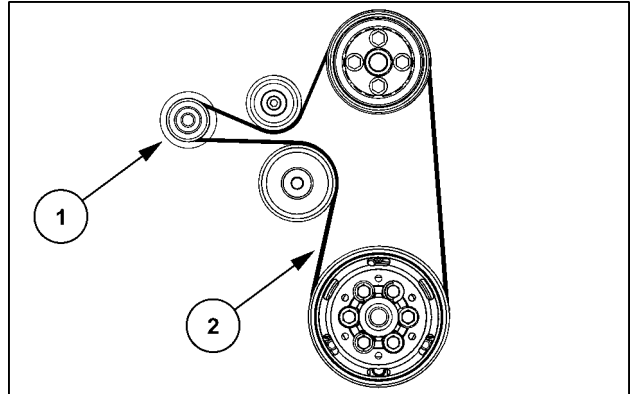

SS13A809 1

2. For tensioning the poly V-belt, turn the adjusting screw (1) clockwise until the sledge for the idler wheel (2) locks in place (maximum belt tension).

**NOTE:** The sledge for the idler wheel (2) always has to be locked in place (only a single setting option for the belt tensioning).

3. Tighten the screw of the idler wheel (2) to a torque of **46.0 Nm (33.9 lb ft)**.
4. Turn the adjusting screw (1) two full turns counter-clockwise.
5. Tighten the counter nut of the adjusting screw (1) to a torque of **30.0 Nm (22.1 lb ft)**.
6. Install the cover.
7. Tighten the mounting bolts (1).

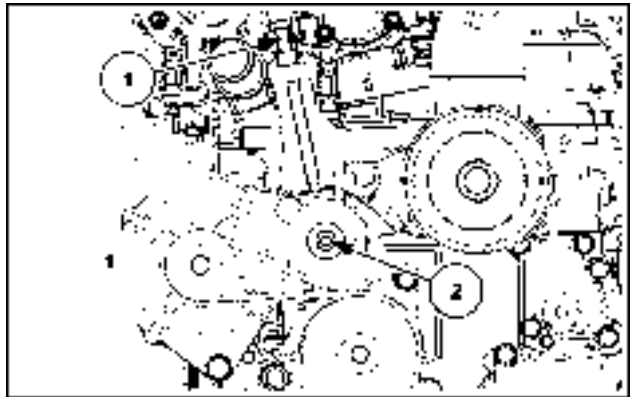

SS13A816 2

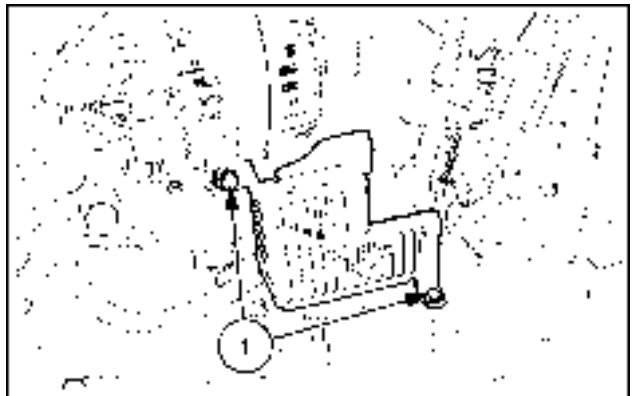

SVIL13TR00174AB 3

### Next operation:

Installation of the engine fan.

---

## Belt tensioner - Remove – 120 A alternator

### Prior operation:

#### Belt - Remove – 120 A alternator (10.414)

1. Remove the retaining nut (1).
2. Remove the screw in the slot of the belt tensioner (2).
3. Remove the belt tensioner.

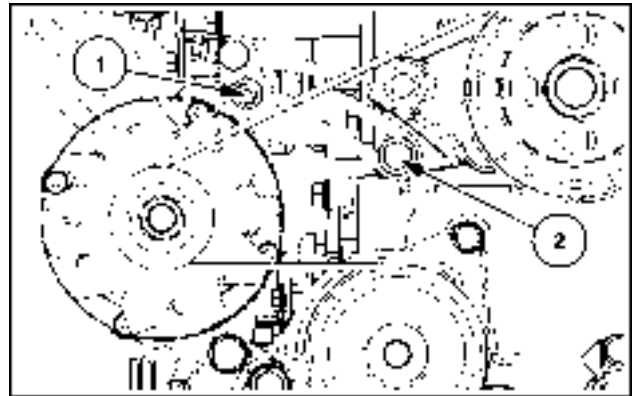

SS13A813 1

### Next operation:

#### Belt tensioner - Install – 120 A alternator (10.414)



---

## Belt tensioner - Install – 120 A alternator

### Prior operation:

#### Belt tensioner - Remove – 120 A alternator (10.414)

1. Install the belt tensioner with the retaining nut (1).
2. Install the screw in the slot of the belt tensioner (2).

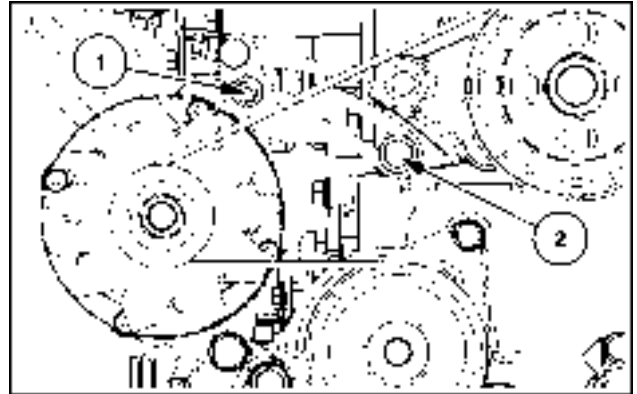

SS13A813 1

### Next operation:

#### Belt - Install – 120 A alternator (10.414)

---

## Belt tensioner - Remove – 200 A alternator

**Prior operation:**

**Belt - Remove – 200 A alternator (10.414)**

**Alternator - Remove – 200 A alternator (55.301)**

1. The mounting bolt (1) gets removed during the prior operation of removing the alternator.
2. Remove the mounting bolt (2) and remove the belt tensioner.

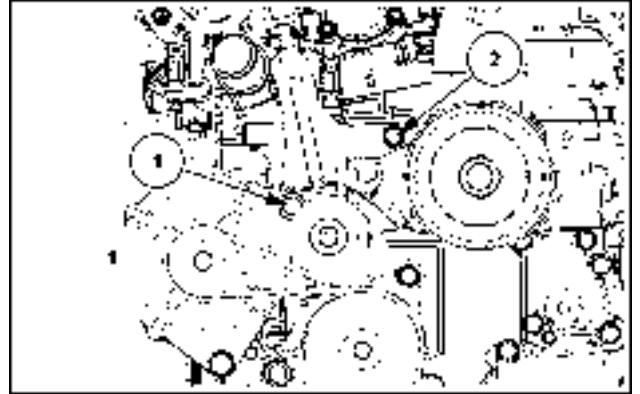

SS13A815 1

**Next operation:**

**Belt tensioner - Install – 200 A alternator (10.414)**

---

## Belt tensioner - Install – 200 A alternator

### Prior operation:

#### Belt tensioner - Remove – 200 A alternator (10.414)

1. Install the belt tensioner with the mounting bolt (1).

**NOTE:** The mounting bolt (1) gets tightened during the installation of the alternator.

2. Install the mounting bolt (2).
3. Tighten the mounting bolt (2) to a torque of **26.0 Nm (19.2 lb ft)**.

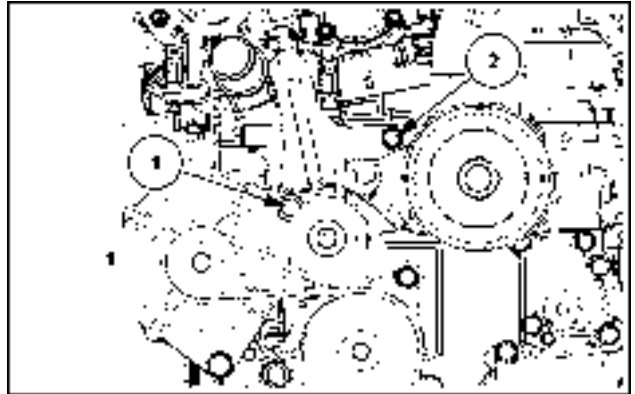

SS13A815 1

### Next operation:

#### Belt - Install – 200 A alternator (10.414)

# Index

---

## Engine - 10

### Fan and drive - 414

Belt - Install – 200 A alternator .....	6
Belt - Install – 120 A alternator .....	4
Belt - Remove – 120 A alternator .....	3
Belt - Remove – 200 A alternator .....	5
Belt tensioner - Install – 120 A alternator .....	8
Belt tensioner - Install – 200 A alternator .....	10
Belt tensioner - Remove – 120 A alternator .....	7
Belt tensioner - Remove – 200 A alternator .....	9



© 2014 CNH Industrial Österreich GmbH

All rights reserved. No part of the text or illustrations of this publication may be reproduced.

CASE IH policy is one of continuous improvement and the right to change prices, specification or equipment at any time without notices is reserved.

All data given in this publication is subject to production variations. Dimensions and weight are approximate only and the illustrations do not necessarily show products in standard condition. For exact information about any particular product, please consult your CASE IH Dealer.



# **SERVICE MANUAL**

## **Clutch**

**Farmall 105U Pro EP  
Farmall 115U Pro EP  
Farmall 95U Pro EP**

# Contents

---

## Clutch - 18

[18.112] Slip clutch or flywheel damper .....	18.1
---	------



## **Clutch - 18**

**Slip clutch or flywheel damper - 112**

**Farmall 105U Pro EP  
Farmall 115U Pro EP  
Farmall 95U Pro EP**



# Contents

---

## Clutch - 18

### Slip clutch or flywheel damper - 112

#### TECHNICAL DATA

Flywheel damper

Torque ..... 3

## Flywheel damper - Torque

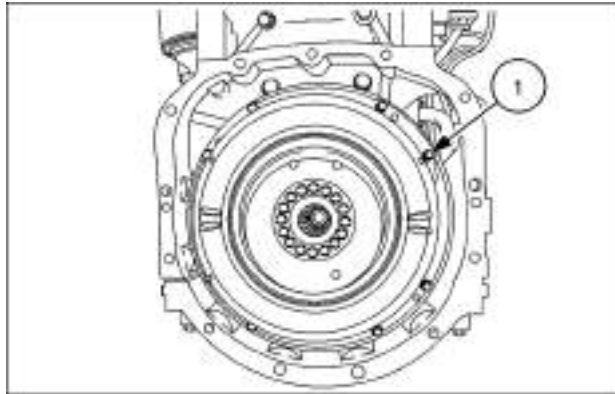

SVIL14TR00015AA 1

Reference	Description	Torque
1	Bolt	32 Nm (24 lb ft)

# Index

---

## Clutch - 18

### Slip clutch or flywheel damper - 112

Flywheel damper - Torque .....	3
--------------------------------	---





© 2014 CNH Industrial Österreich GmbH

All rights reserved. No part of the text or illustrations of this publication may be reproduced.

CASE IH policy is one of continuous improvement and the right to change prices, specification or equipment at any time without notices is reserved.

All data given in this publication is subject to production variations. Dimensions and weight are approximate only and the illustrations do not necessarily show products in standard condition. For exact information about any particular product, please consult your CASE IH Dealer.



# **SERVICE MANUAL**

## **Transmission**

**Farmall 105U Pro EP  
Farmall 115U Pro EP  
Farmall 95U Pro EP**

# Contents

---

## Transmission - 21

[21.111] Semi-Powershift transmission .....	21.1
[21.133] Semi-Powershift transmission external controls .....	21.2
[21.103] Semi-Powershift transmission lubrication system.....	21.3
[21.152] Semi-Powershift transmission internal components .....	21.4
[21.902] Field-road group.....	21.5
[21.900] Hydraulic pump drive.....	21.6
[21.109] Transmission cooler and lines.....	21.7



## **Transmission - 21**

### **Semi-Powershift transmission - 111**

**Farmall 105U Pro EP  
Farmall 115U Pro EP  
Farmall 95U Pro EP**



# Contents

---

## Transmission - 21

### Semi-Powershift transmission - 111

#### TECHNICAL DATA

Semi-Powershift transmission	
General specification .....	3
Special tools .....	3

#### FUNCTIONAL DATA

Semi-Powershift transmission	
Exploded view .....	6
Overview .....	9
Overview .....	12
Overview .....	13
Static description .....	14
Mechanical schema .....	16

#### SERVICE

Semi-Powershift transmission	
Pressure test – Transmission system pressure .....	30
Pressure test - Powershift clutches .....	33
Transmission housing cover	
Remove .....	45
Disassemble .....	46
Assemble .....	47
Install .....	49
Gear housing	
Disconnect (gearbox housing – range housing) .....	50
Connect (gearbox housing – range housing) .....	51
Intermediate housing	
Remove .....	52
Install .....	54

## Semi-Powershift transmission - General specification

### Maximum permissible driving mechanism loads

Input power (P)	Maximum <b>81 kW (110 Hp)</b>
input speed	Maximum <b>2200 RPM</b>
Input torque (T)	Maximum <b>453 Nm (334 lb ft)</b>

### Permissible oil temperature

For heavy pulling work in the field (< 12.0 km/h (7.5 mph))	Permanently = <b>80 °C (176 °F)</b> For a short time = <b>100 °C (212 °F)</b>
For transport at maximum speed	Permanently = <b>100 °C (212 °F)</b> For a short time = <b>110 °C (230 °F)</b>

### Powershift

Type of System	Wet multi-disc clutch
Operating system	Electrohydraulic solenoid valve
Clutch A (number of friction discs)	6
Clutch B (number of friction discs)	6
Clutch C (number of friction discs)	9
Clutch D (number of friction discs)	9
Clutch F (number of friction discs)	6
Clutch G (number of friction discs)	6

### Synchronized gearbox

Type of System	Four gears
Operating system	Mechanical, by means of cables
1. gear and 2nd gear	Double-cone synchronization
3. gear and 4th gear	Single-cone synchronization

## Semi-Powershift transmission - Special tools

**NOTE:** The operations described in this section can only be carried out with the **ESSENTIAL** tools indicated by an (X). To work in safety, to obtain the best technical results, and to save both time and energy, you should also use the other special tool we recommend below. You should also use the relevant locally manufactured devices. This manual contains the construction drawings for these devices.

List of the special tools required for the work steps in this section:

Tool Number	Designation / Use
(X) 380200021	Holding bracket
(X) 380000078	Box wrenches
(X) 380000815	Drive Shaft Nut Socket
(X) 380001733	Box wrenches
(X) 380200374	Wrapping bearing
(X) 380200445	Lifting device for clutch shafts

Locally manufactured tools:

Name	Usage
Center bush for the main shaft (Figure 1)	A guide for the installation of the front bearing of the main shaft
Center bush for the counter shaft (Figure 2)	A guide for the installation of the front bearing of the counter shaft
Mounting device (1 item) (Figure 3)	To install clutch shaft K1/K2
Mounting device (2 item) (Figure 4)	To install clutches A/C, B/D and F/G

Material: S235JR in accordance with DIN 10025

**NOTE:** All specifications are in millimeters.

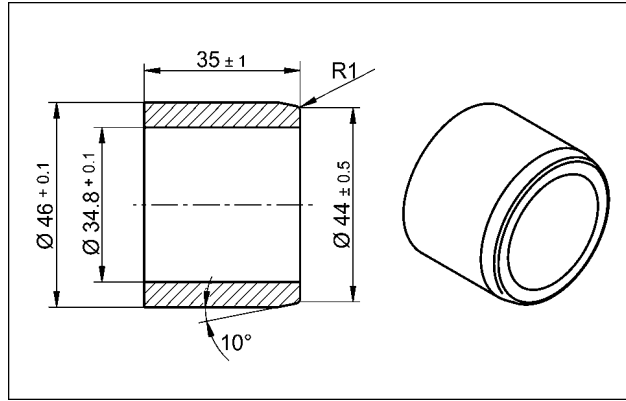

SS11J088 1

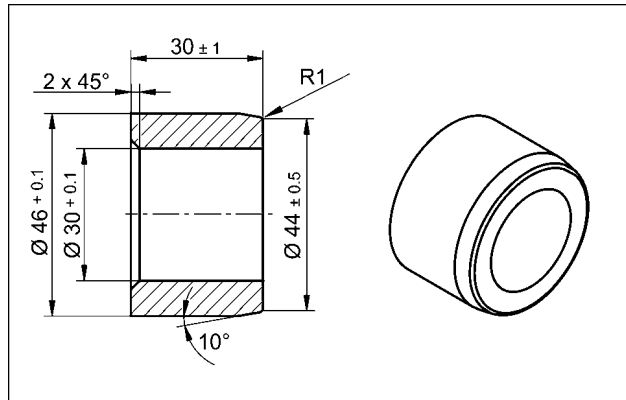

SS11J089 2

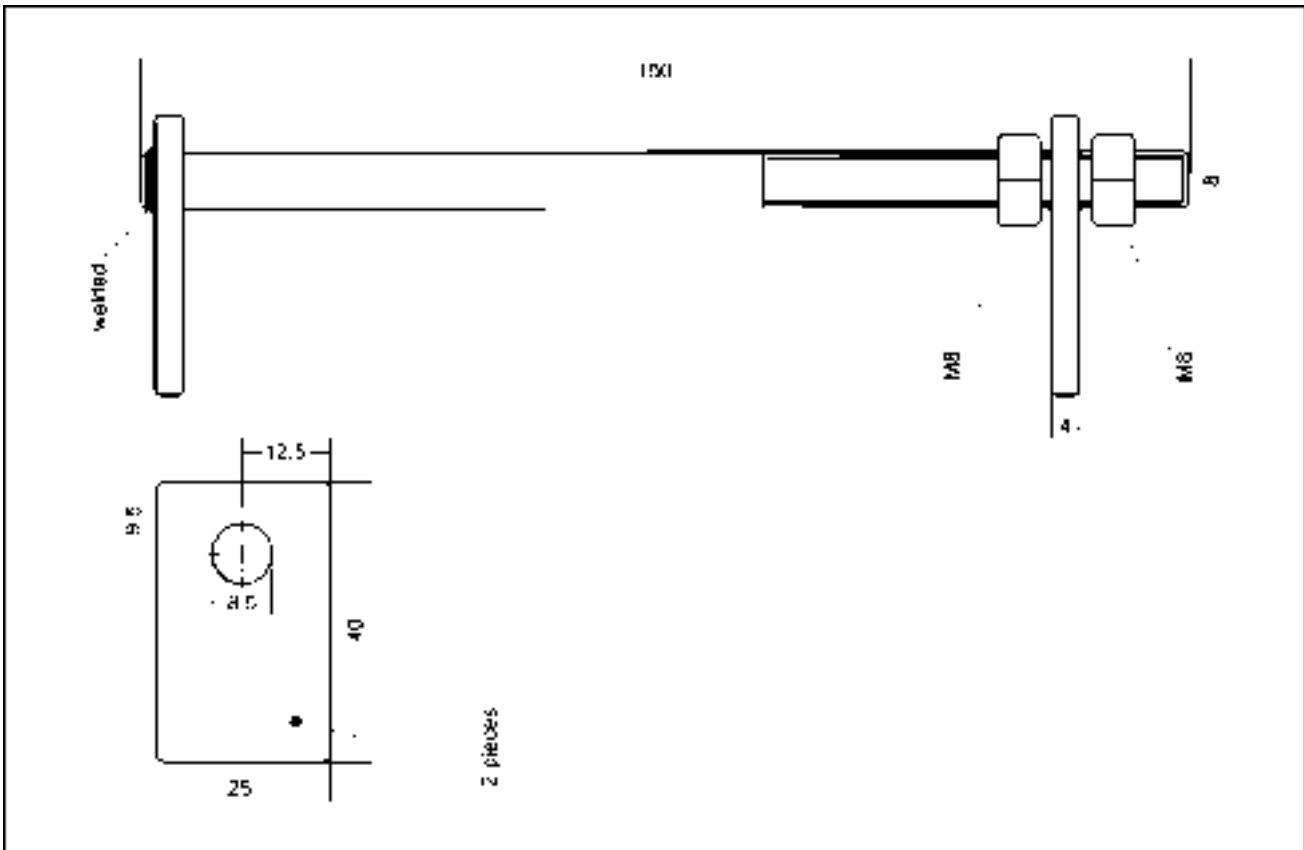

SS13G377 3

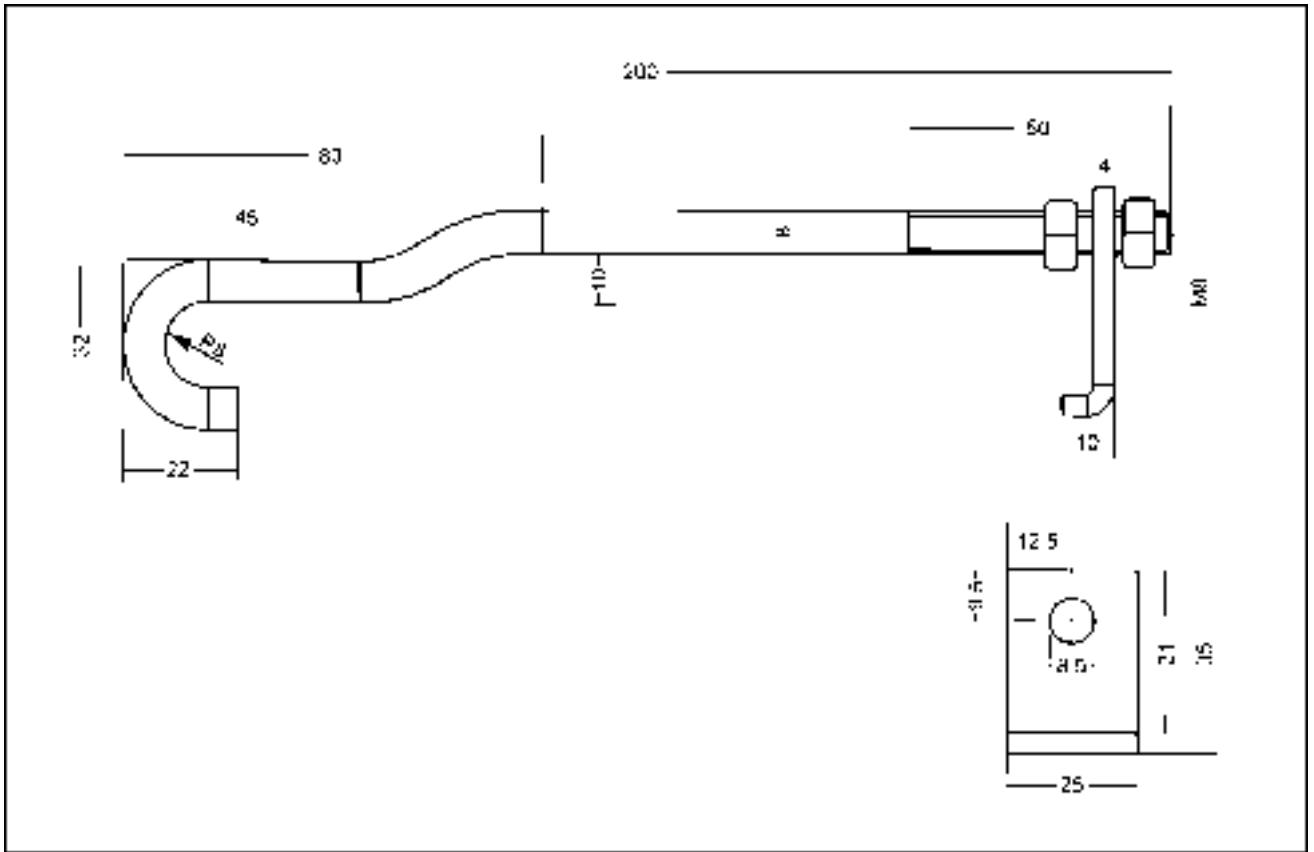

SS13G376 4

---

## Semi-Powershift transmission - Exploded view

1	Range housing	2	Ball
3	seal	4	Screw plug
5	Screw plug	6	seal
7	Ball	8	Nut.
9	Stud bolt	10	Ball
11	Nut.	12	Stud bolt
13	Oil drain plug	14	Oil drain plug
15	Intermediate housing	16	Dowel pin
17	Ball	18	Dowel pin
19	Ball	20	Ball
21	O-Ring	22	Bolt
23	Powershift input speed sensor	24	Ball
25	Dowel pin	26	Bolt
27	Ball	28	Ball
29	Dowel pin	30	seal
31	Bolt	32	O-Ring
33	Bolt	34	Powershift output speed sensor
35	Bolt	36	Clamp
37	Screw plug	38	Screw plug
39	seal	40	seal
41	Gear Case	42	Nut.
43	Stud bolt	44	Bolt
45	Stud bolt	46	Nut.
47	Nut.	48	Stud bolt
49	Oil drain plug	50	Clamp
51	Bolt	52	Breather
53	Selector shaft	54	O-Ring
55	Retainer Ring	56	Selector finger
57	Bolt	58	Nut.
59	Stud bolt	60	Bolt
61	Bolt	62	Gearbox covers

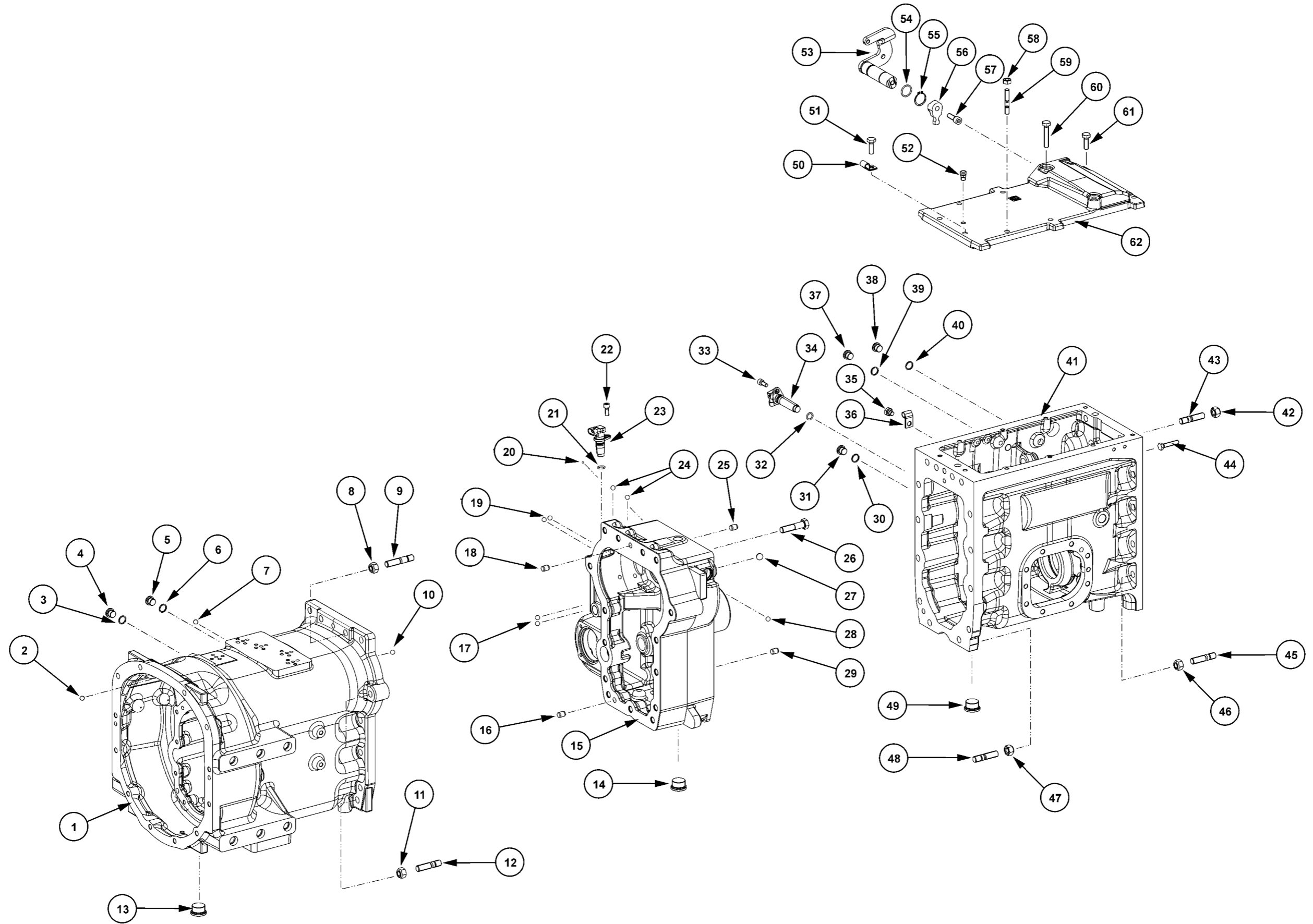

SS13F110 1



## Semi-Powershift transmission - Overview

### Mechanical components

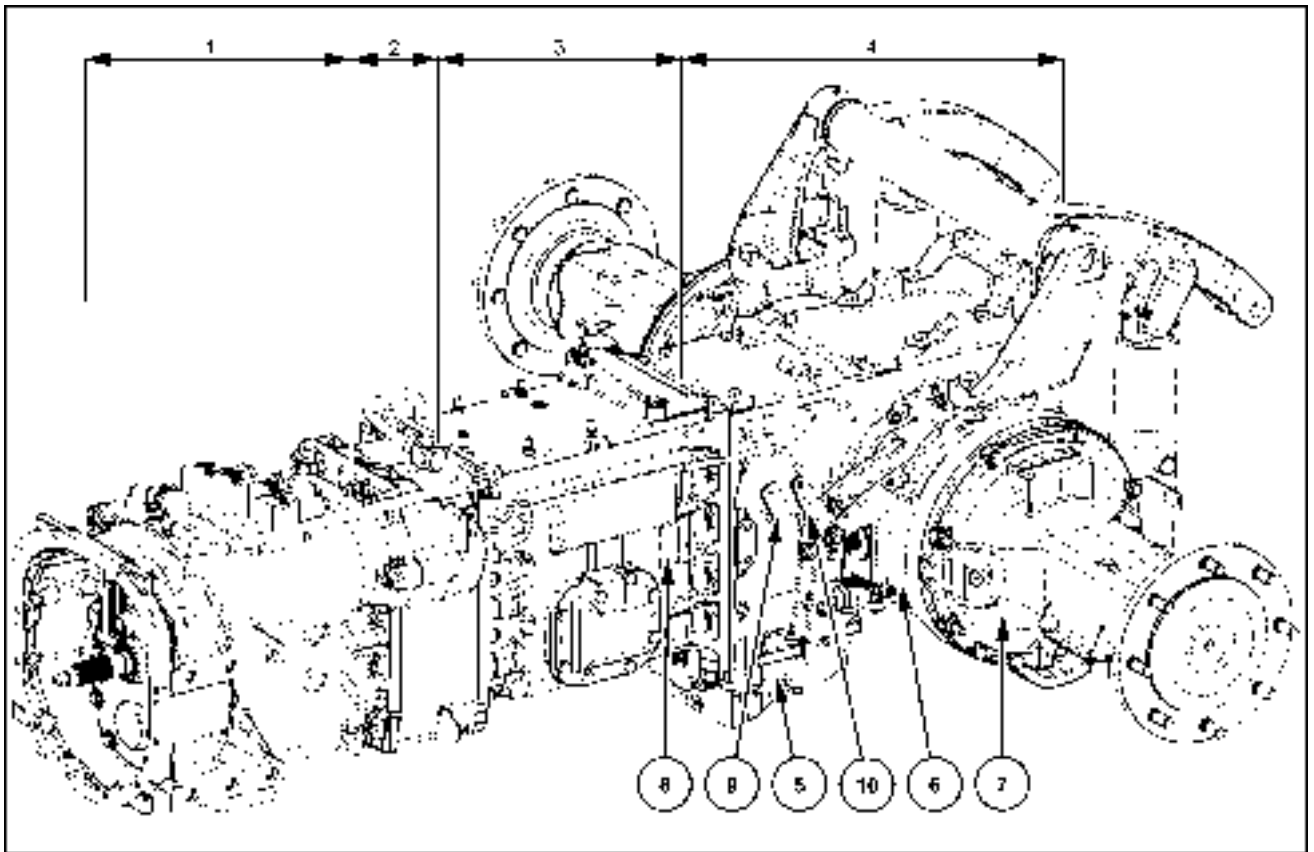

SS13E014 1

- |   |  |
|---|--|
| 1. Powershift   | 2. Intermediate housing with pump drive  |
| 3. Synchronized gearbox                               | 4. Rear axle with field range and road range   |
| 5. All wheel drive                                    | 6. Brake housing   |
| 7. Final drive with planetary gears                   | 8. Shift lever for the engine Power Take-Off (PTO),<br>the ground speed PTO and the stationary PTO |
| 9. Shift lever for the field range and the road range | 10. Control lever for the hand brake   |



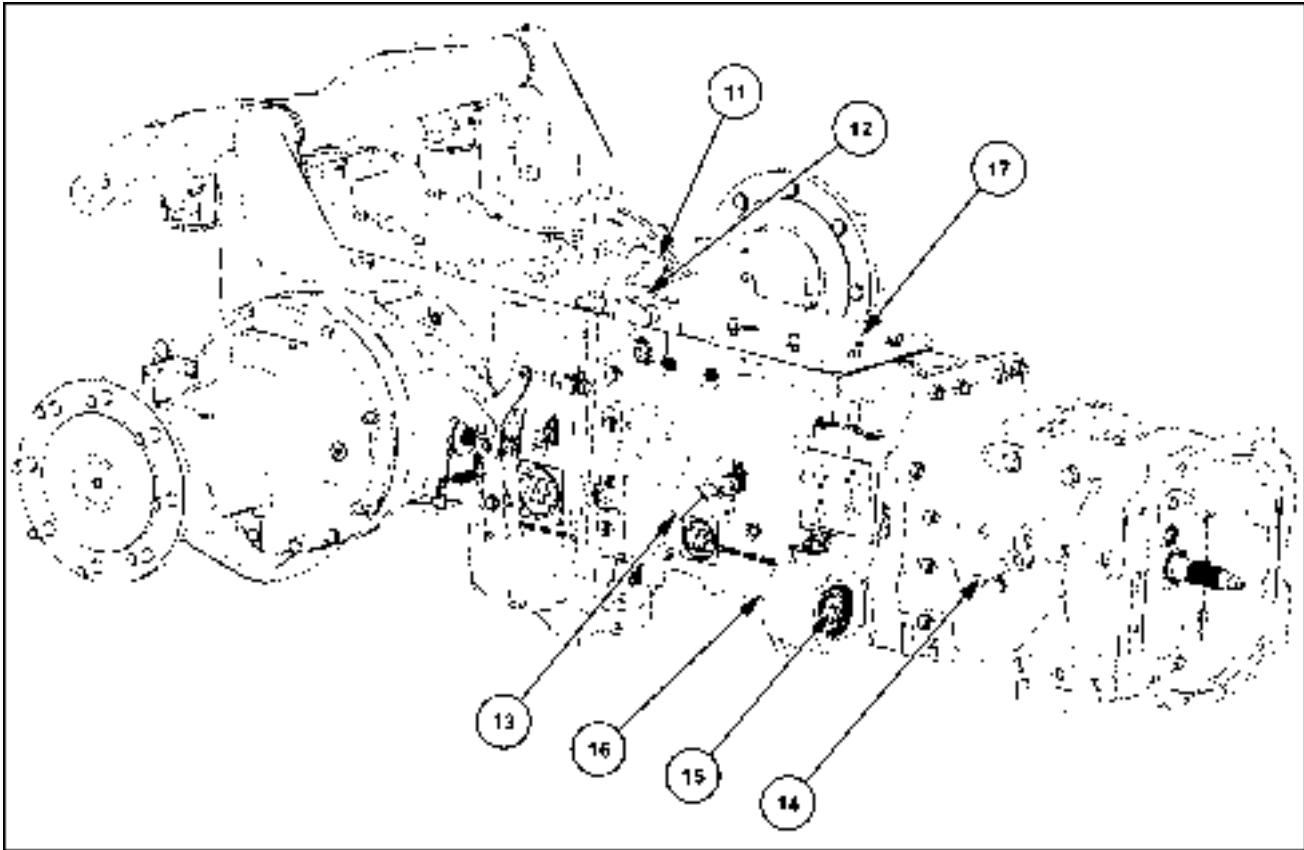

SS13E020 2

- |   |  |
|---|--|
| 11. Shift lever for the 3rd–4th gear synchronization                            | 12. Shift lever for the 1st–2nd gear synchronization |
| 13. Shift lever for the 540/1000 PTO  | 14. Shift lever for the ECONOMIC/NORMAL PTO          |
| 15. Drive for the system pressure pump of the gearbox and for the steering pump | 16. Drive for the hydraulic pump                     |
| 17. Air breather transmission   |  |

## Electrical components

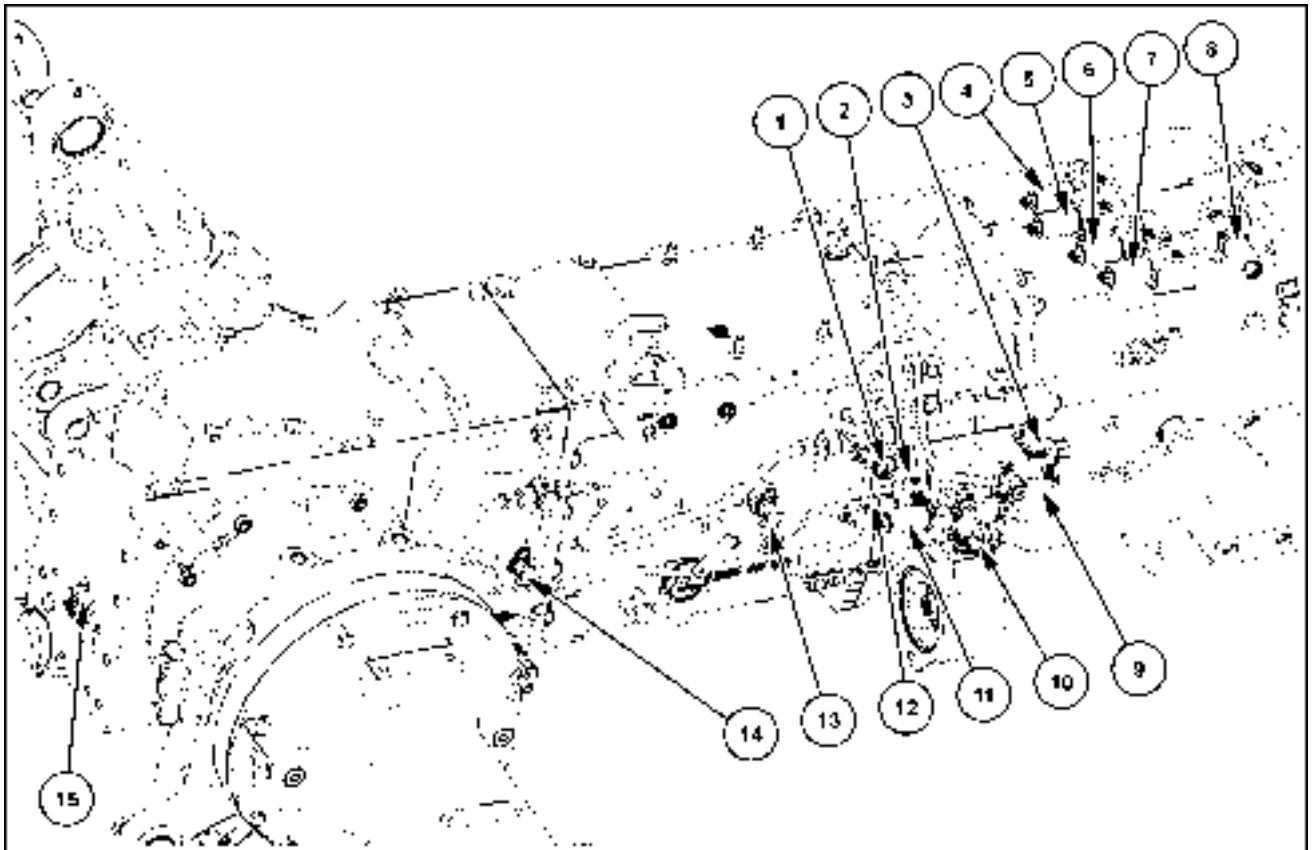

SS13E002 3

- |   |   |
|---|---|
| 1. Transmission oil temperature sensor                | 2. Four-wheel drive solenoid valve          |
| 3. Solenoid valve for the rear-axle differential lock | 4. Clutch G solenoid valve                  |
| 5. Clutch F solenoid valve                            | 6. Clutch B solenoid valve                  |
| 7. Clutch D solenoid valve                            | 8. Rear Power Take-Off (PTO) solenoid valve |
| 9. Clutch C solenoid valve                            | 10. Powershift – Input speed sensor         |
| 11. Clutch A solenoid valve                           | 12. Transmission oil pressure switch        |
| 13. Powershift – Output speed sensor                  | 14. Gearbox – Output speed sensor           |
| 15. Speed sensor for the rear PTO                     |   |

## Semi-Powershift transmission - Overview

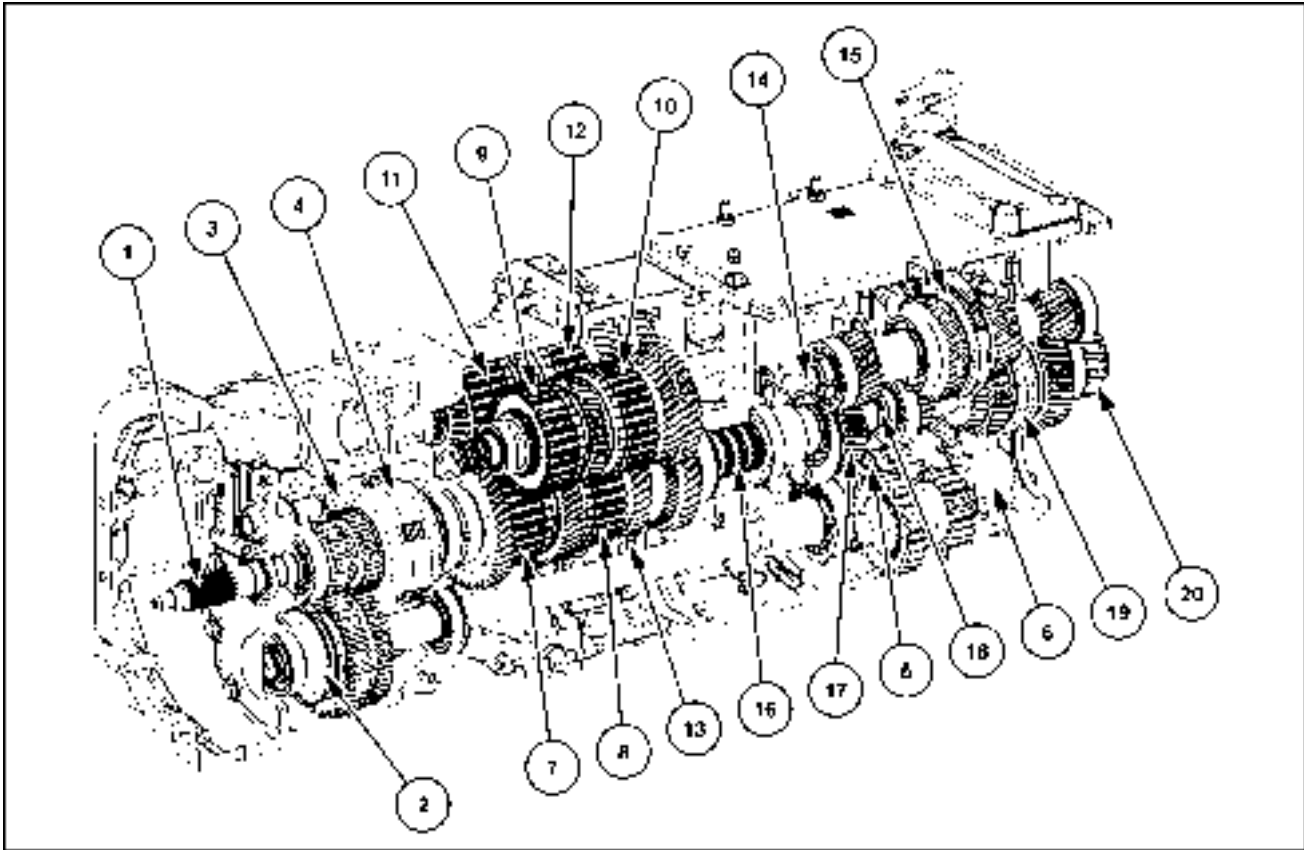

SS13E001 1

- |   |  |
|---|--|
| 1. Input shaft (the vibration damper on the flywheel drives this input shaft) | 2. Dog clutch shift for the ECONOMIC/NORMAL power take-off (PTO) |
| 3. Power take off (PTO) brake   | 4. Rear PTO clutch   |
| 5. Dog clutch shift for the 540/1000 power take-off (PTO)                     | 6. Connecting sleeve on the engine PTO version                   |
| 7. Powershift clutch C (main clutch)  | 8. Powershift clutch A   |
| 9. Powershift clutch G (main clutch)  | 10. Powershift clutch F  |
| 11. Powershift clutch D   | 12. Powershift clutch B  |
| 13. Idler gear for the pump drive   | 14. Countershaft   |
| 15. Synchronizer for 3rd gear and 4th gear                                    | 16. Hollow shaft   |
| 17. Jackshaft   | 18. Main shaft   |
| 19. Synchronizer for 2nd gear and 1st gear                                    | 20. Dog clutch shift for field range and road range              |

## Semi-Powershift transmission - Overview

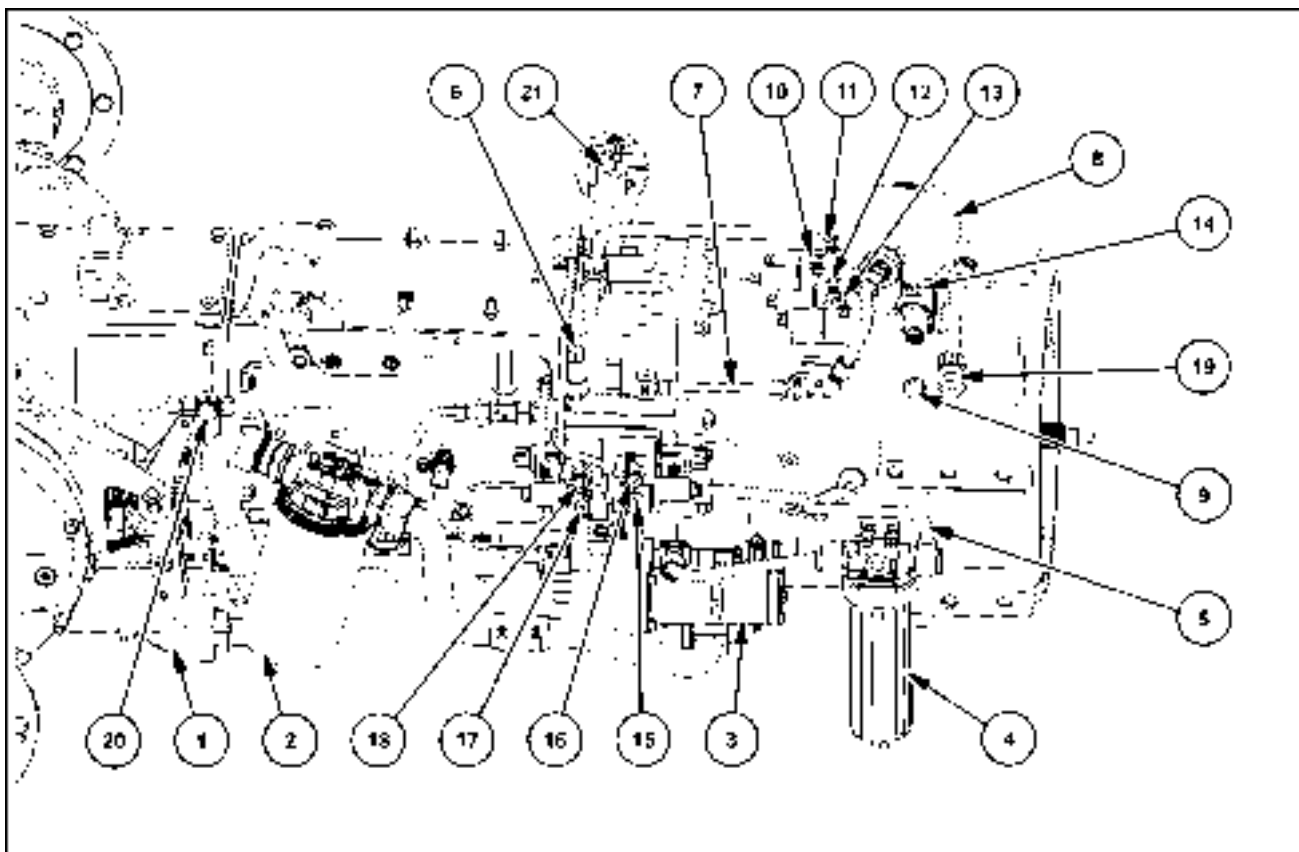

SS13E003 1

- |   |   |
|---|---|
| 1. Oil reservoir  | 2. Suction filter   |
| 3. Fixed displacement pump for gearbox  | 4. Pressure filter  |
| 5. Pressure line toward the pressure-regulating valve                             | 6. System pressure-regulating valve <b>19 - 20 bar (276 - 290 psi)</b>        |
| 7. Pressure line toward the powershift gearbox housing                            | 8. System pressure accumulator (pressure port for front power take-off [PTO]) |
| 9. System-pressure measuring point (pressure port for front power take-off [PTO]) | 10. Pressure measuring point for the F coupling                               |
| 11. Pressure measuring point for the G coupling                                   | 12. Pressure measuring point for the B coupling                               |
| 13. Pressure measuring point for the D coupling                                   | 14. Pressure measuring point for the rear PTO coupling                        |
| 15. Pressure measuring point for the C coupling                                   | 16. Pressure measuring point for differential locks                           |
| 17. Pressure measuring point for the A coupling                                   | 18. Pressure measuring point for the 4WD coupling                             |
| 19. Pressure measuring point for lubrication pressure 1                           | 20. Pressure measuring point for lubrication pressure 2                       |
| 21. Lubrication pressure limiter valve  |   |

---

## Semi-Powershift transmission - Static description

- Input shaft for the ground drive and for the power take-off (PTO) drive
- Four-speed powershift transmission with electrohydraulic switching
- Power shuttle with electrohydraulic switching
- Fully synchronized four-gear main gearbox with mechanical switching
- Field range and road range (dog clutch shift)
- High level of user comfort thanks to electrohydraulic load shifts and shuttle shifts as well as safely sized synchronizers

### NUMBER OF GEARS

- Powershift transmission group – power shuttle: four forward gears and four reverse gears
- Main gearbox: four gears
- Field range and road range: two ranges
- Total number of gears: 32 forward gears and 32 reverse gears

### SHIFTING AND CONTROL

- Powershift transmission group: The powershift transmission group has power-assisted clutches with electrohydraulic closure and thrust-spring opening. Control via the +/- button switch on the Multicontroller or with the programmable AUTO shift with adjustable shift point.
- Power shuttle: clutches with electrohydraulic closure and thrust-spring opening. Control via the steering column switch or via the button switch on the Multicontroller (forward/reverse).
- Main gearbox:
  - 1st–2nd gear (synchronized)
  - 3rd–4th gear (synchronized)
- Range transmission: field range and road range (dog clutch shift), mechanical shift lever

### FRONT-WHEEL DRIVE

- Shifting under load
- With wet multi-disk clutch
- Electrohydraulic opening
- Cup-washer closure

### FOUR-SPEED PTO

- With wet multi-disk clutch with electrohydraulic operation (thrust-spring opening)
- With PTO brake with electrohydraulic opening (thrust-spring closure)
- Four PTO speeds with dog clutch shift and connection for mechanical control
- NORMAL = PTO speed **1000/540 RPM**
- ECONOMIC = PTO speed **1000E/540E RPM**

### REAR AXLE DIFFERENTIAL

- With multi-disk lock, electrohydraulic operation

### BRAKING

- Service brakes: built-in, wet multi-disk brakes with hydraulic operation
- Parking brakes: built-in, wet multi-disk brakes with mechanical operation

### FINAL DRIVES

- With a single planetary gearset

### LUBRICATE

- Positive lubrication of the power shuttle and the rear-axle center section via the transmission pump
- Positive lubrication of the bevel drive and the brakes via the transmission pump
- The rear axle drives have splash lubrication

POSSIBLE ADDITIONAL EQUIPMENT

- Gear-dependent PTO (ground speed PTO) with dog clutch shift and connection for mechanical control

TRANSMISSION HYDRAULICS

- The power shuttle has a combined circuit for control, lubrication and cooling. Refer **Semi-Powershift transmission lubrication system - Hydraulic schema (21.103)** and **Hydraulic systems - Static description (35.000)**

---

## Semi-Powershift transmission - Mechanical schema

- I. Power take-off ECONOMIC/NORMAL
- III. Synchronized gearbox
- V. Rear axle (differential)
- VII. Power take-off 540/1000
- IX. Four wheel drive
- 1. Powershift – input speed sensor
- 3. Gearbox speed sensor
- A. Transmission input shaft ( n = **2200 RPM**)
- II. Couplings for the powershift and the power shuttle
- IV. Field shift or road shift
- VI. Hydraulic pump drive
- VIII. Engine power take-off (PTO)/ground speed PTO
- X. Planetary gears and multi-disc brake
- 2. Powershift – output speed sensor
- 4. Speed sensor for the rear PTO

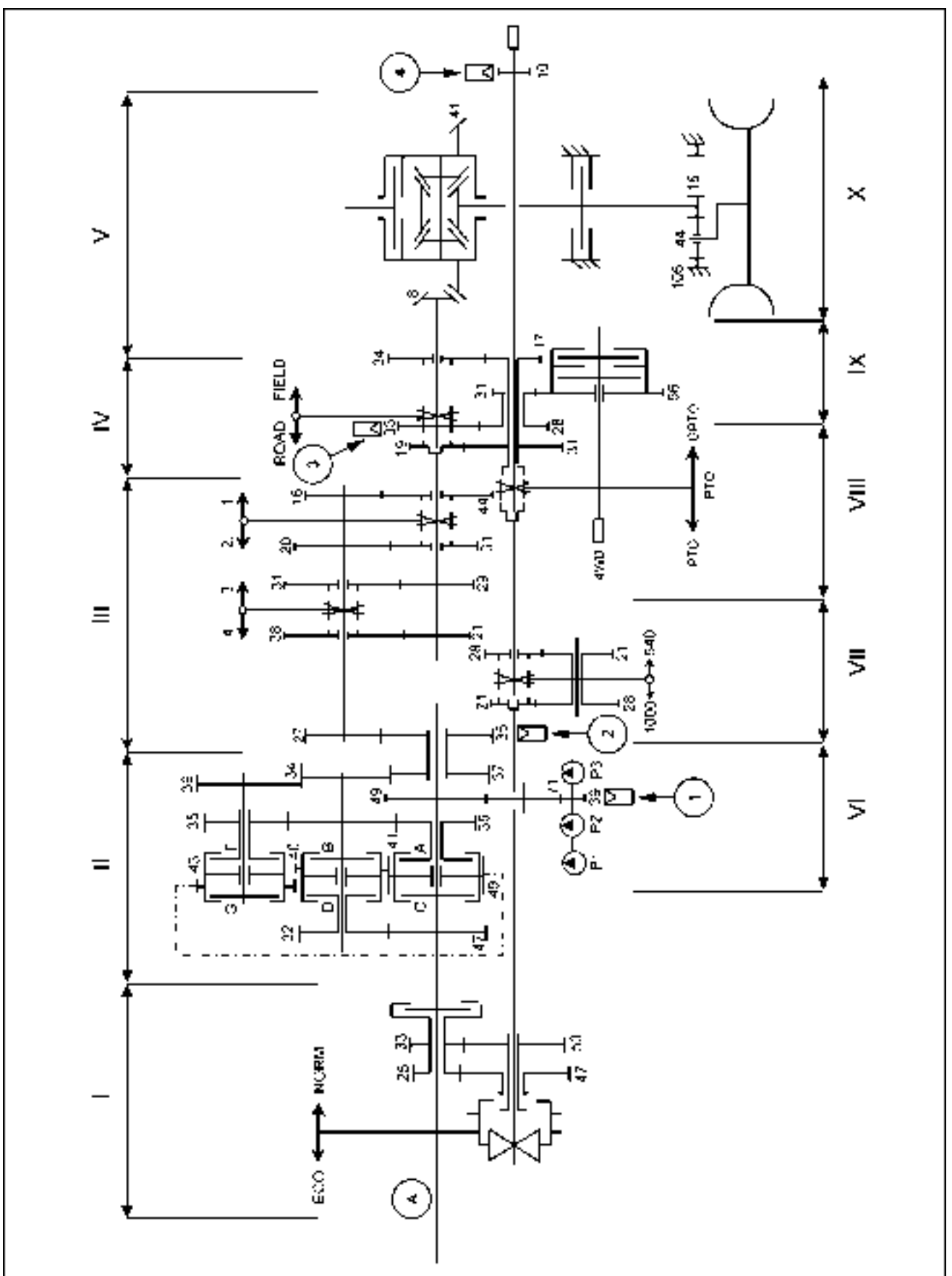

SS13E004 1



**Representation of the power flow: first powershift ratio, forwards, first synchronized gear, road range**

- |   |                                     |
|---|-------------------------------------|
| 1. Powershift – input speed sensor                  | 2. Powershift – output speed sensor |
| 3. Gearbox speed sensor                             | 4. Speed sensor for the rear PTO    |
| A. Transmission input shaft ( n = <b>2200 RPM</b> ) |                                     |

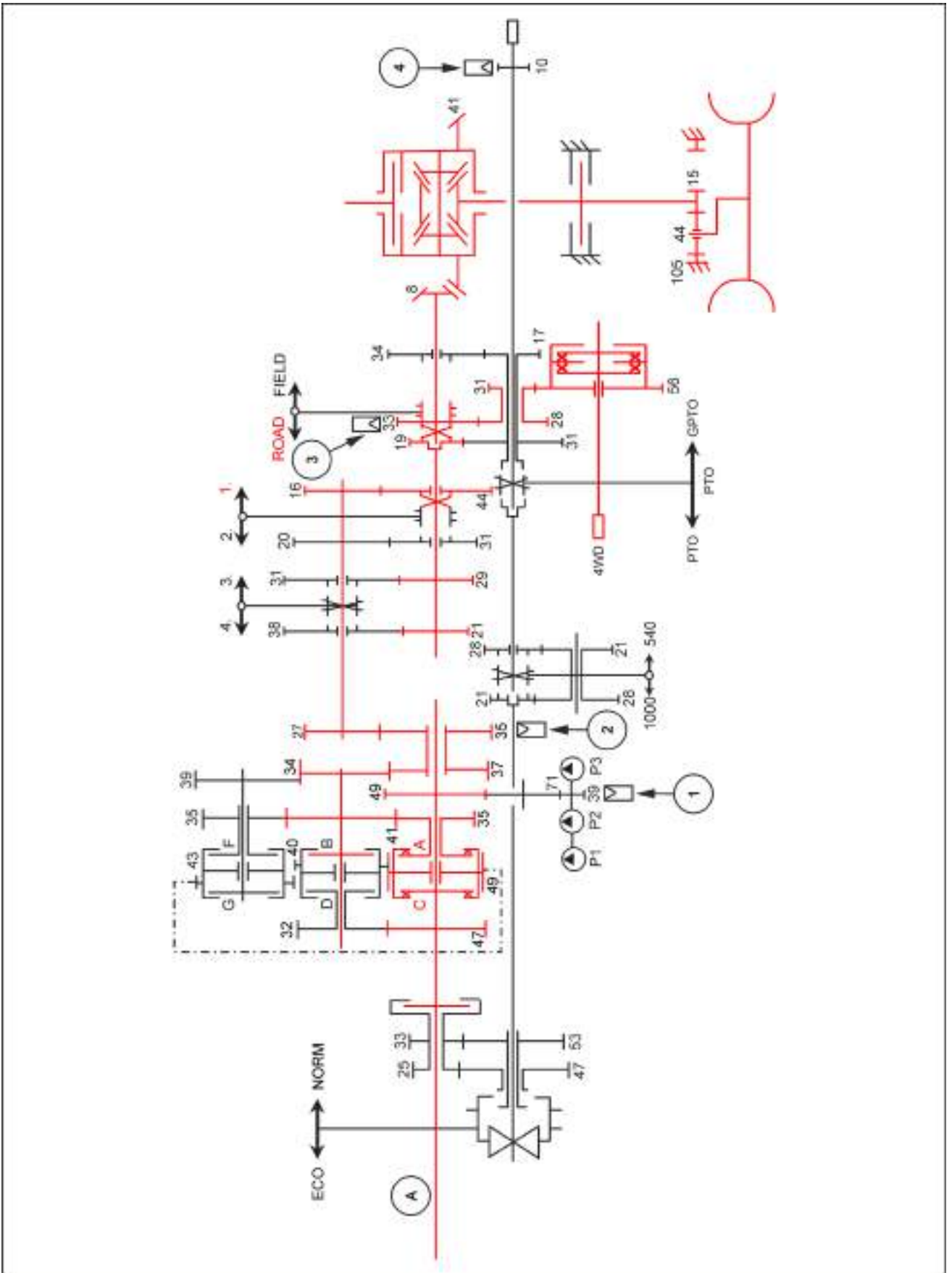

**Representation of the power flow: first powershift ratio, forwards, first synchronized gear, field range**

- |   |                                     |
|---|-------------------------------------|
| 1. Powershift – input speed sensor                  | 2. Powershift – output speed sensor |
| 3. Gearbox speed sensor                             | 4. Speed sensor for the rear PTO    |
| A. Transmission input shaft ( n = <b>2200 RPM</b> ) |                                     |

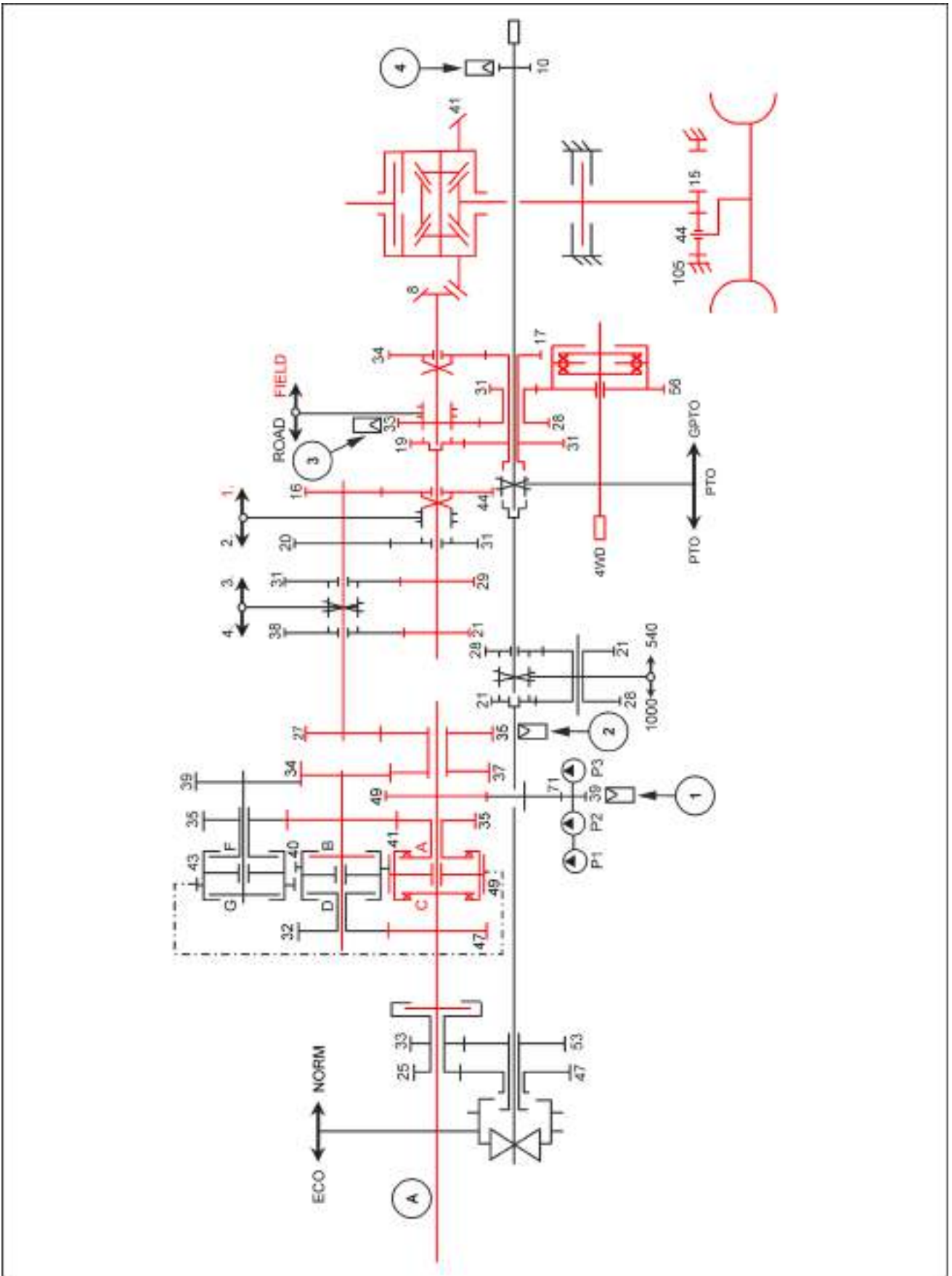

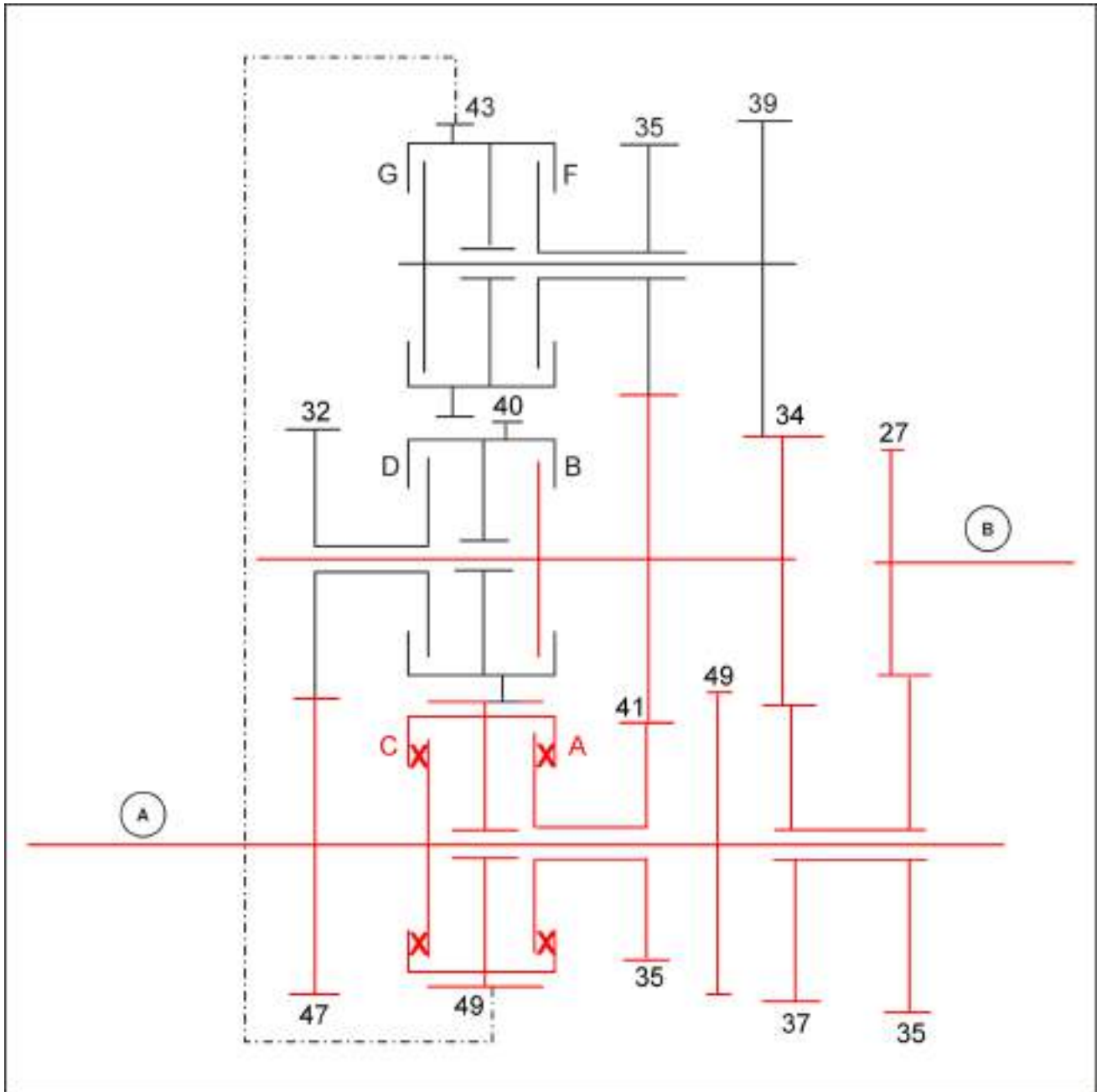

SS13A999 4

**Representation of the power flow: first powershift ratio, forwards**

A. Transmission input shaft ( n = 2200 RPM)

B. Countershaft

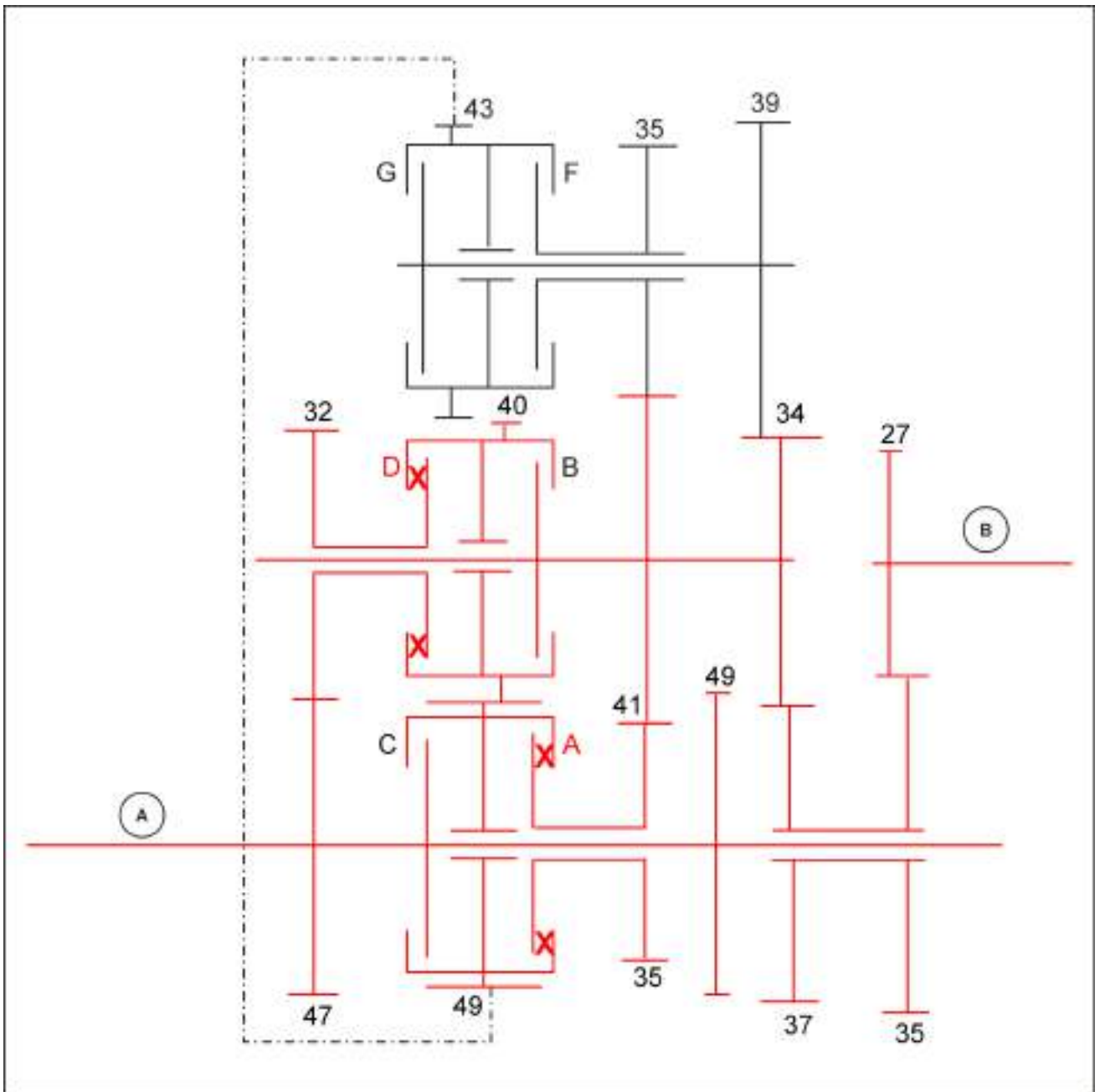

SS13E007 5

**Representation of the power flow: second powershift ratio, forwards**

A. Transmission input shaft (  $n = 2200 \text{ RPM}$  )

B. Countershaft

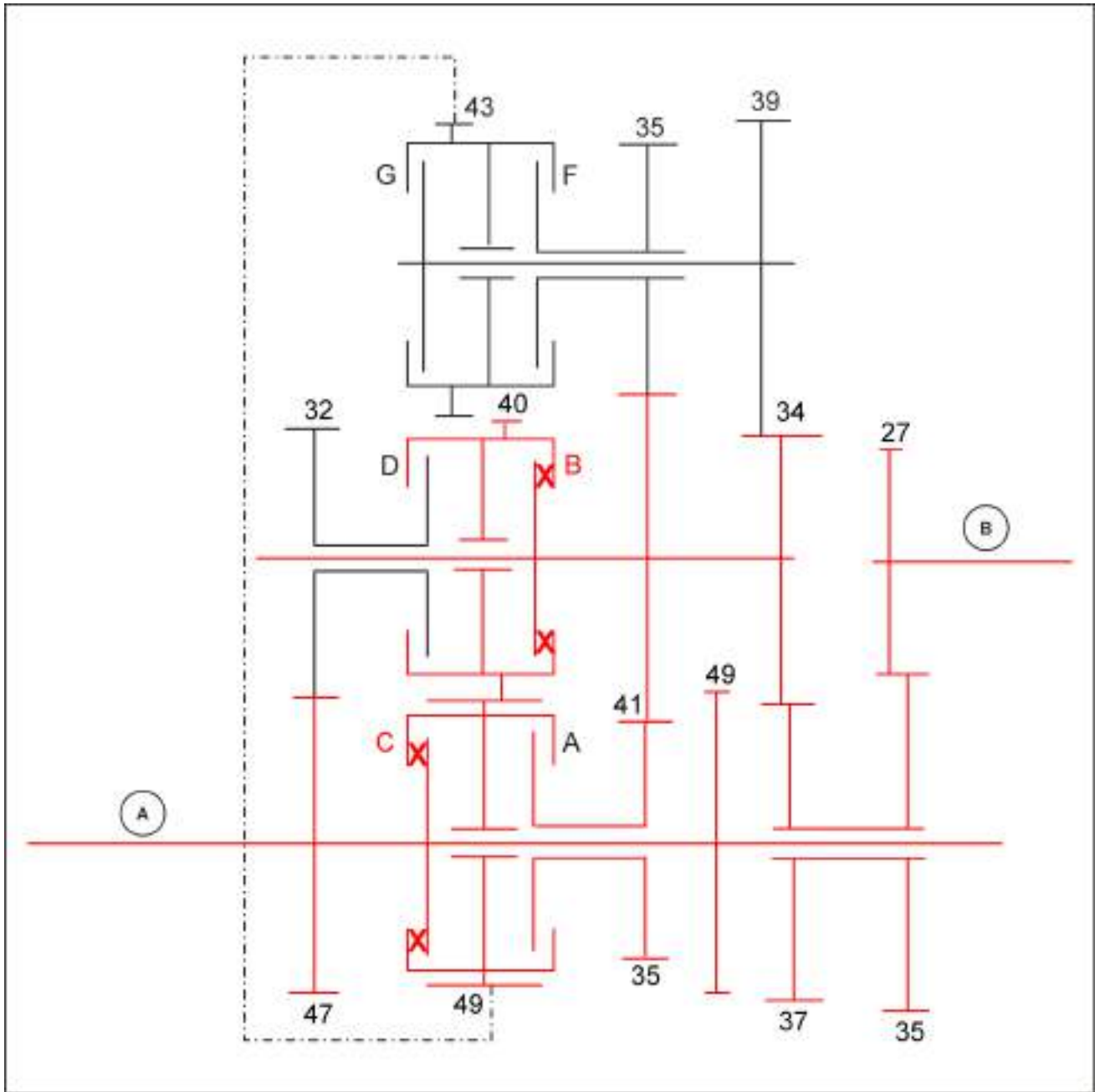

SS13E008 6

**Representation of the power flow: third powershift ratio, forwards**

A. Transmission input shaft ( n = 2200 RPM)

B. Countershaft

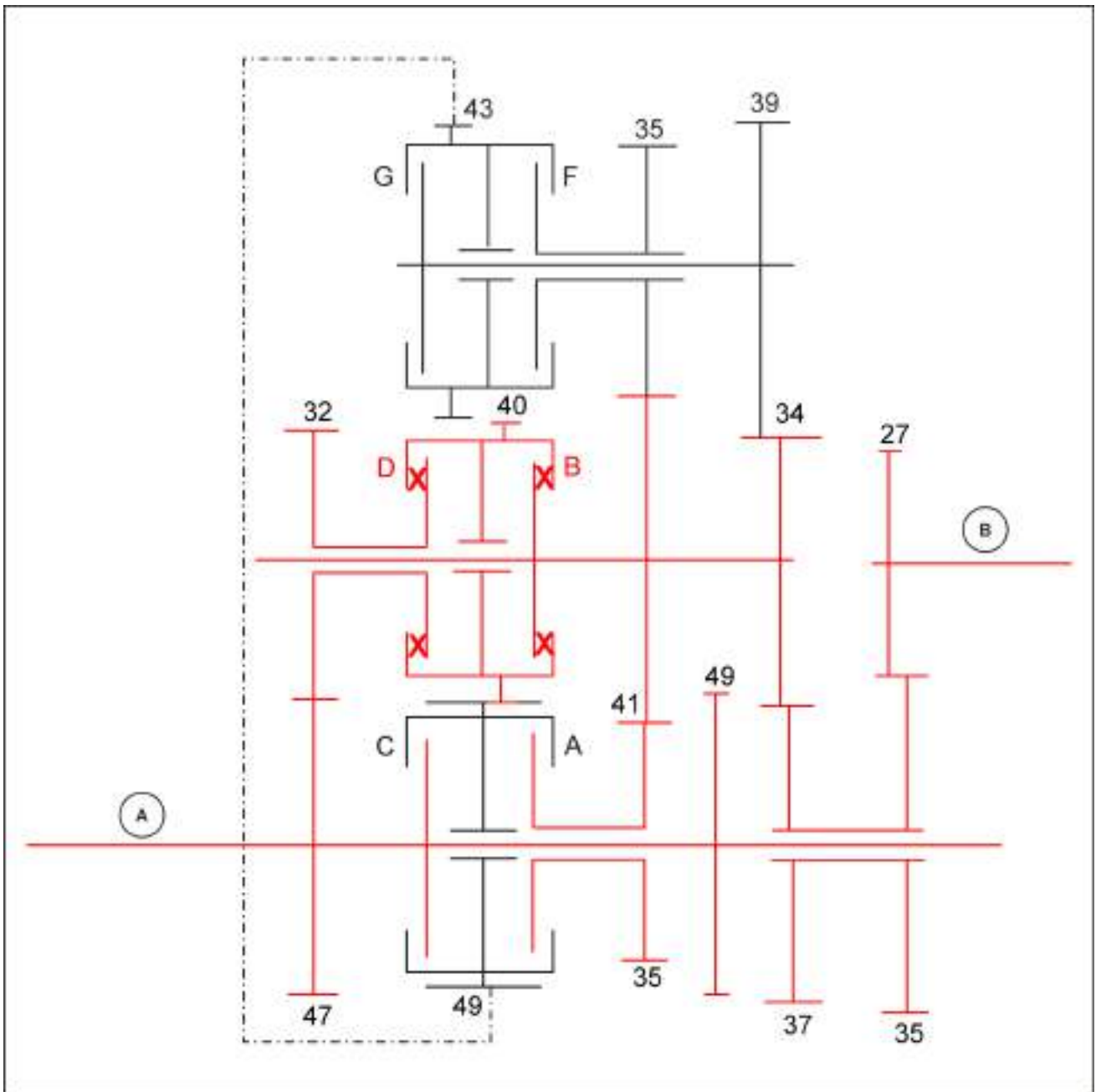

SS13E009 7

**Representation of the power flow: fourth powershift ratio, forwards**

A. Transmission input shaft ( n = 2200 RPM)

B. Countershaft



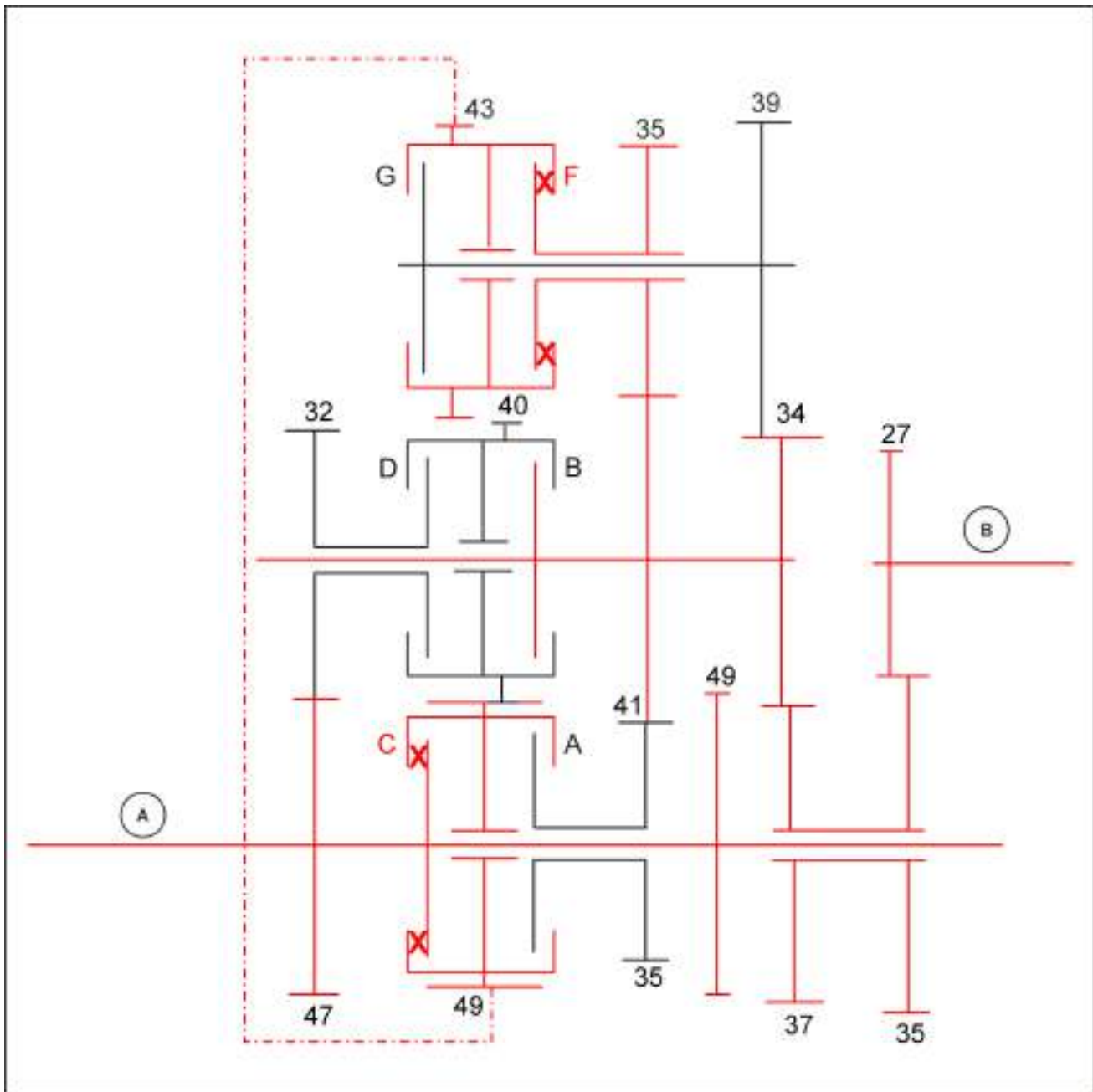

SS13E010 8

**Representation of the power flow: first powershift ratio, reverse**

A. Transmission input shaft ( n = 2200 RPM)

B. Countershaft

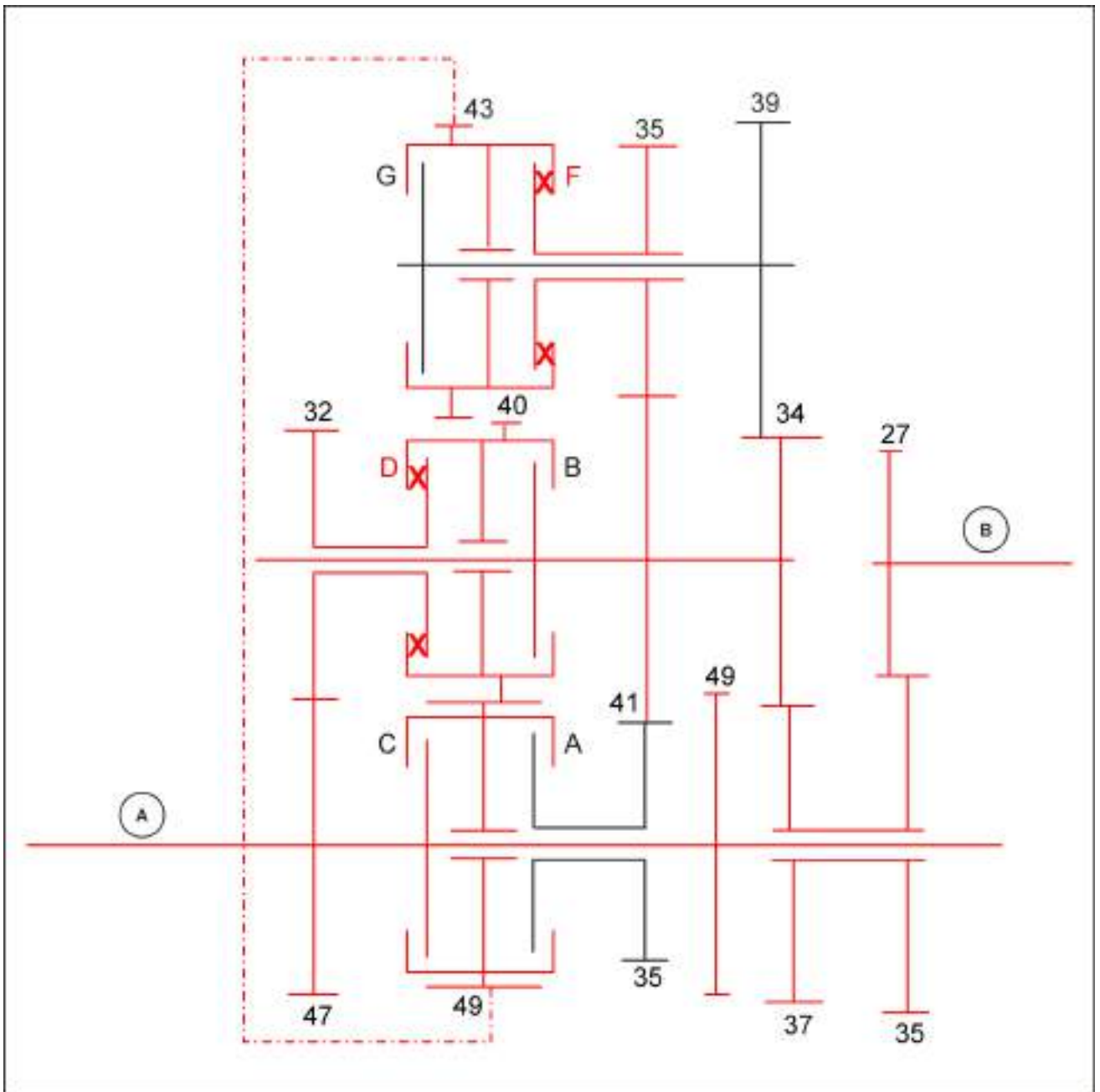

SS13E011 9

**Representation of the power flow: second powershift ratio, reverse**

A. Transmission input shaft (  $n = 2200 \text{ RPM}$  )

B. Countershaft

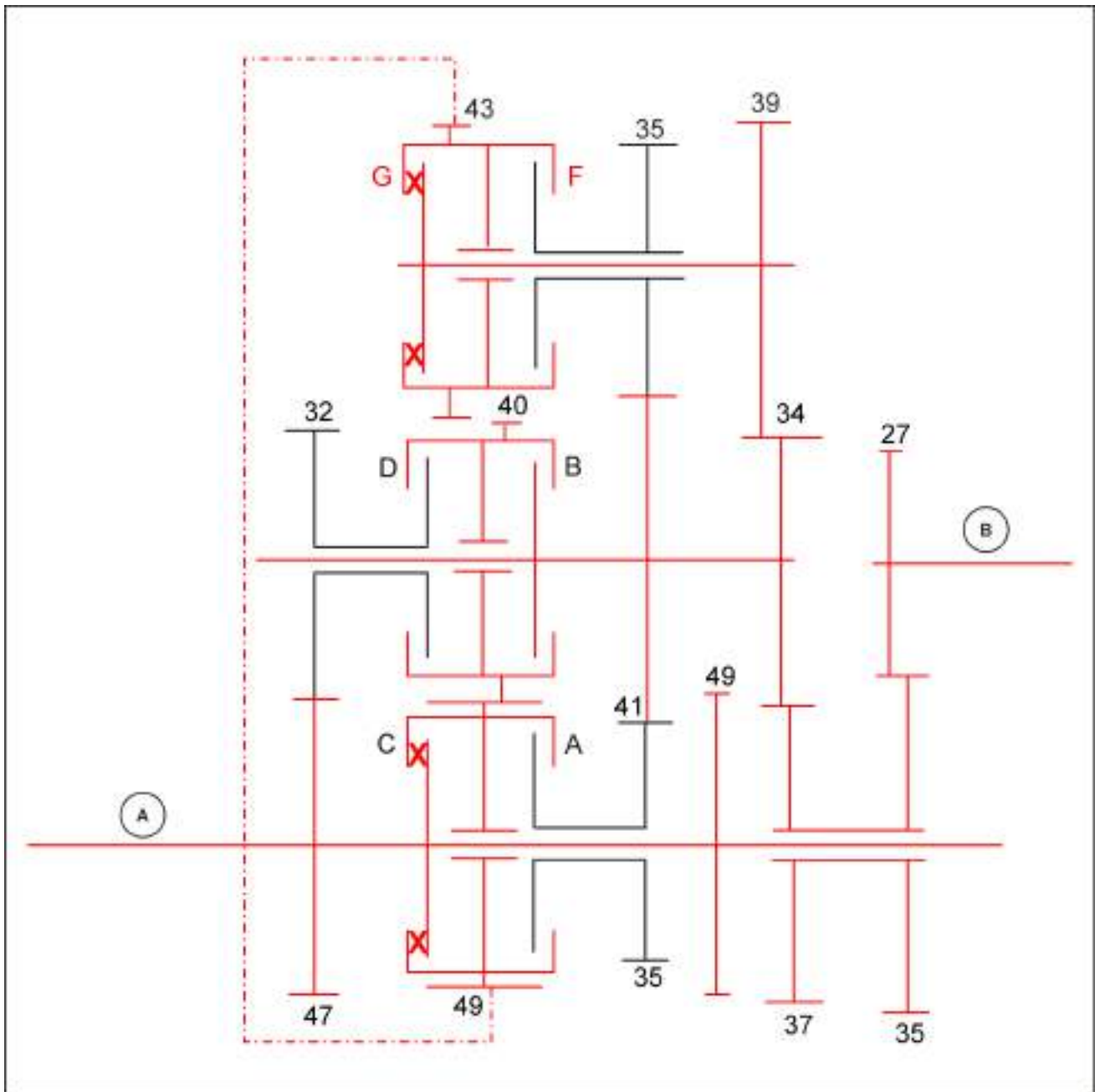

SS13E012 10

**Representation of the power flow: third powershift ratio, reverse**

A. Transmission input shaft ( n = 2200 RPM)

B. Countershaft

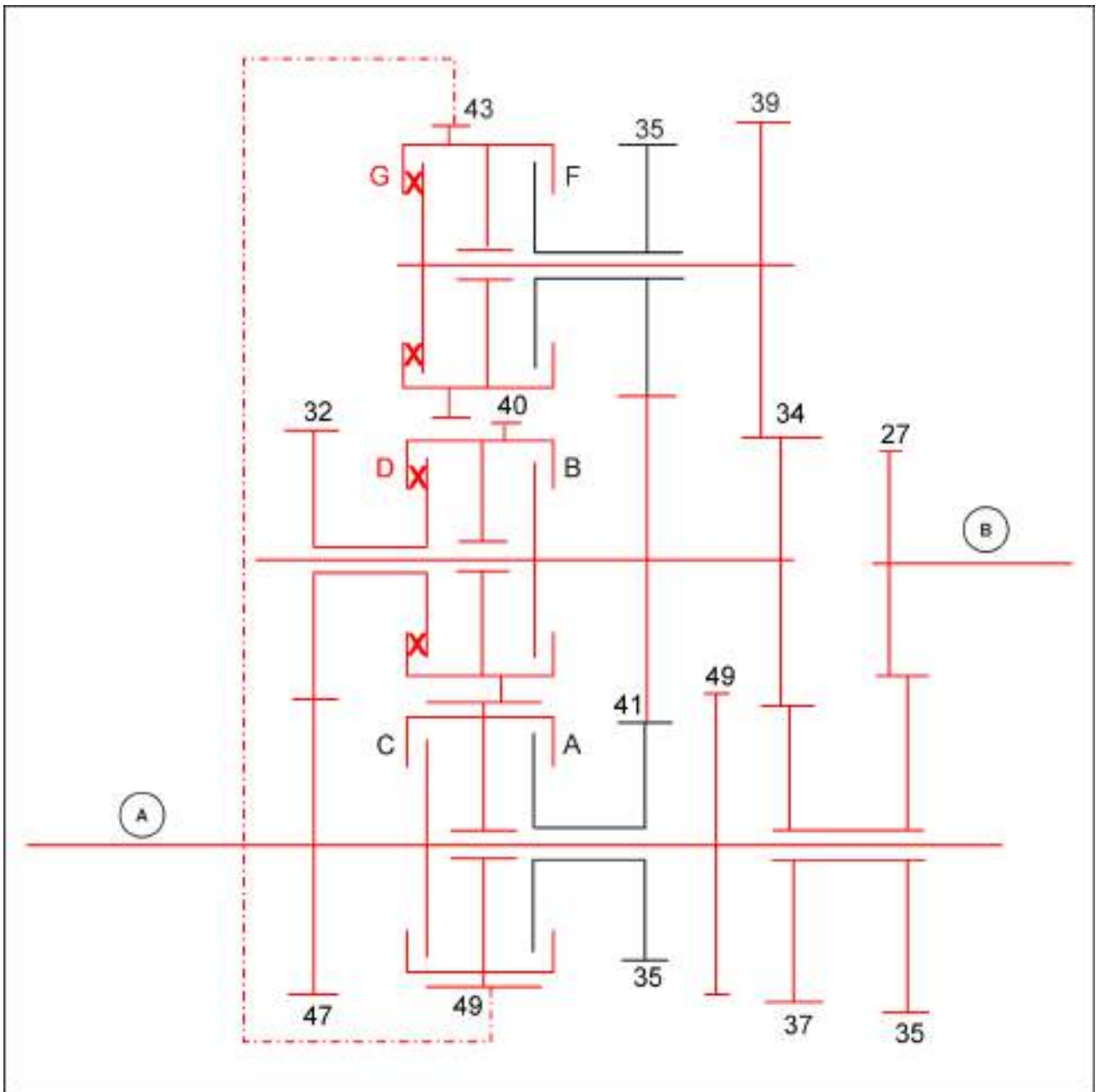

SS13E013 11

**Representation of the power flow: fourth powershift ratio, reverse**

A. Transmission input shaft ( n = 2200 RPM)

B. Countershaft

## Semi-Powershift transmission - Pressure test – Transmission system pressure

These diagrams from the DATAR software provide information on the condition of the electrical, hydraulic and mechanical components during start-up, during switching between the forward and reverse powershift ratios, and during the activation and deactivation of the differential lock, 4WD and the rear power take-off (PTO).

To achieve optimum comparability between the diagrams, it is important to observe all test conditions.

1. Use the test adapter (M16x1,5) to fit the pressure sensor in place of the screw plug **(1)**.

If the tractor has a PTO at the front, there will be a connection to the supply line at this location. Before you complete any other actions, first remove the supply line.

**NOTE:** Make sure that the pressure sensor battery is in a charged state. Then perform a calibration. Switch the pressure sensor to the **60 bar (870 psi)** measurement range.

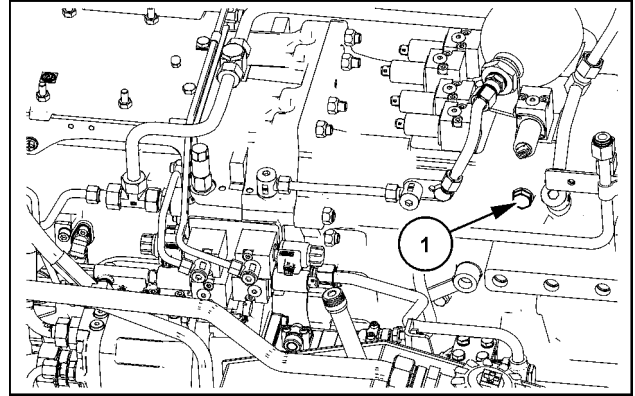

SS13K193 1

2. You can read off all settings on the DATAR software for channels A to D from the subsequent Scope images. You can also apply these settings to your DATAR.

Test conditions for the transmission system pressure test:

- Transmission oil temperature **50 °C (122 °F)**
- motor speed **1500 RPM**
- Flat road with no equipment present
- Second gear, field/road groups lever in neutral position
- Start the tractor. Set off with the shuttle lever in the forward position. Shift the powershift ratios up to the fourth ratio with small pauses in between. Then change the direction of travel. Switch the power shift back to the first ratio again. Switch the differential lock, the 4WD and the PTO on and off again. Then switch off the engine.

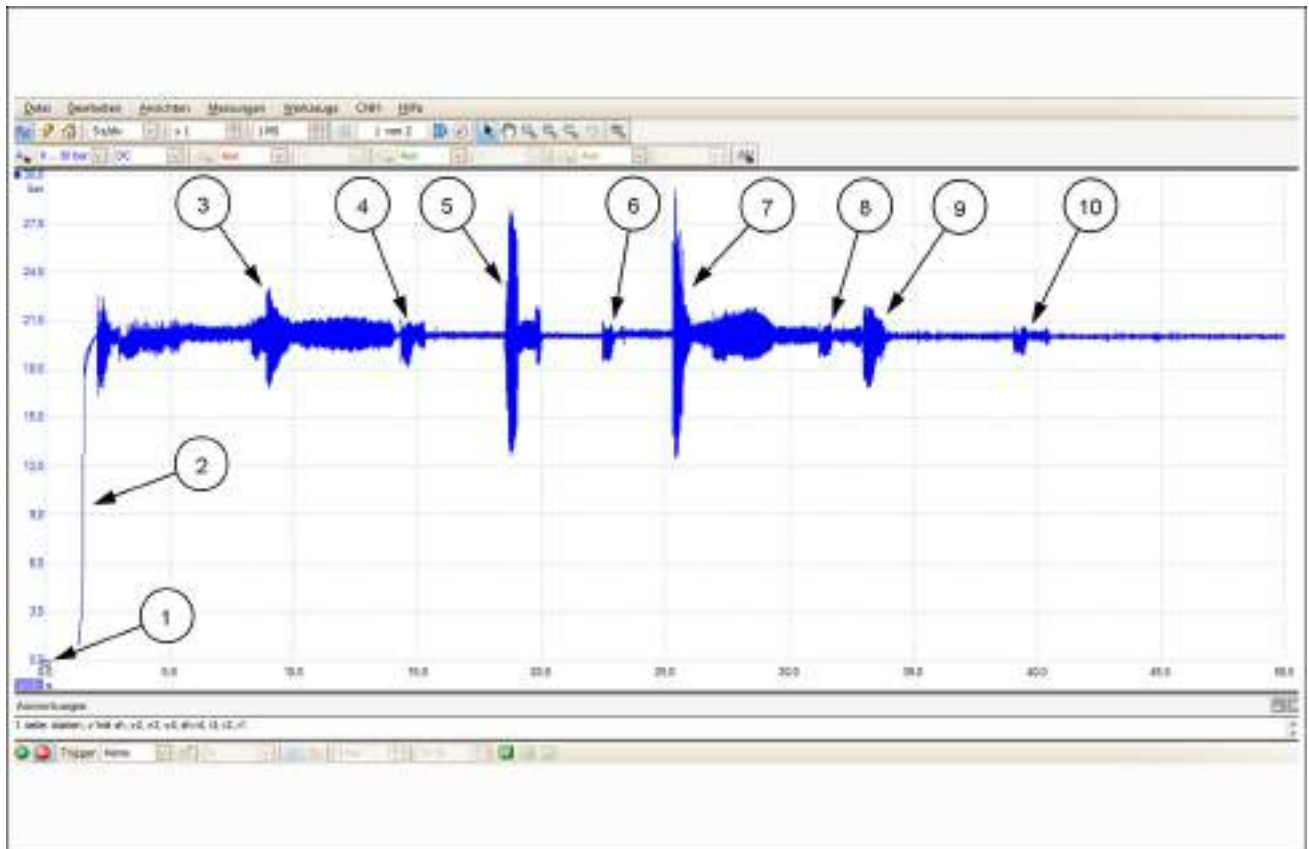

SS13K180 2

- (1) Engine off (system pressure **0 bar (0 psi)**)
- (2) Engine start-up (system pressure builds)
- (3) Set-off with shuttle lever
- (4) Switch of powershift ratio from Forward 1 to Forward 2
- (5) Switch of powershift ratio from Forward 2 to Forward 3
- (6) Switch of powershift ratio from Forward 3 to Forward 4
- (7) Switch from Forward travel to Reverse travel
- (8) Switch of powershift ratio from Reverse 4 to Reverse 3
- (9) Switch of powershift ratio from Reverse 3 to Reverse 2
- (10) Switch of powershift ratio from Reverse 2 to Reverse 1

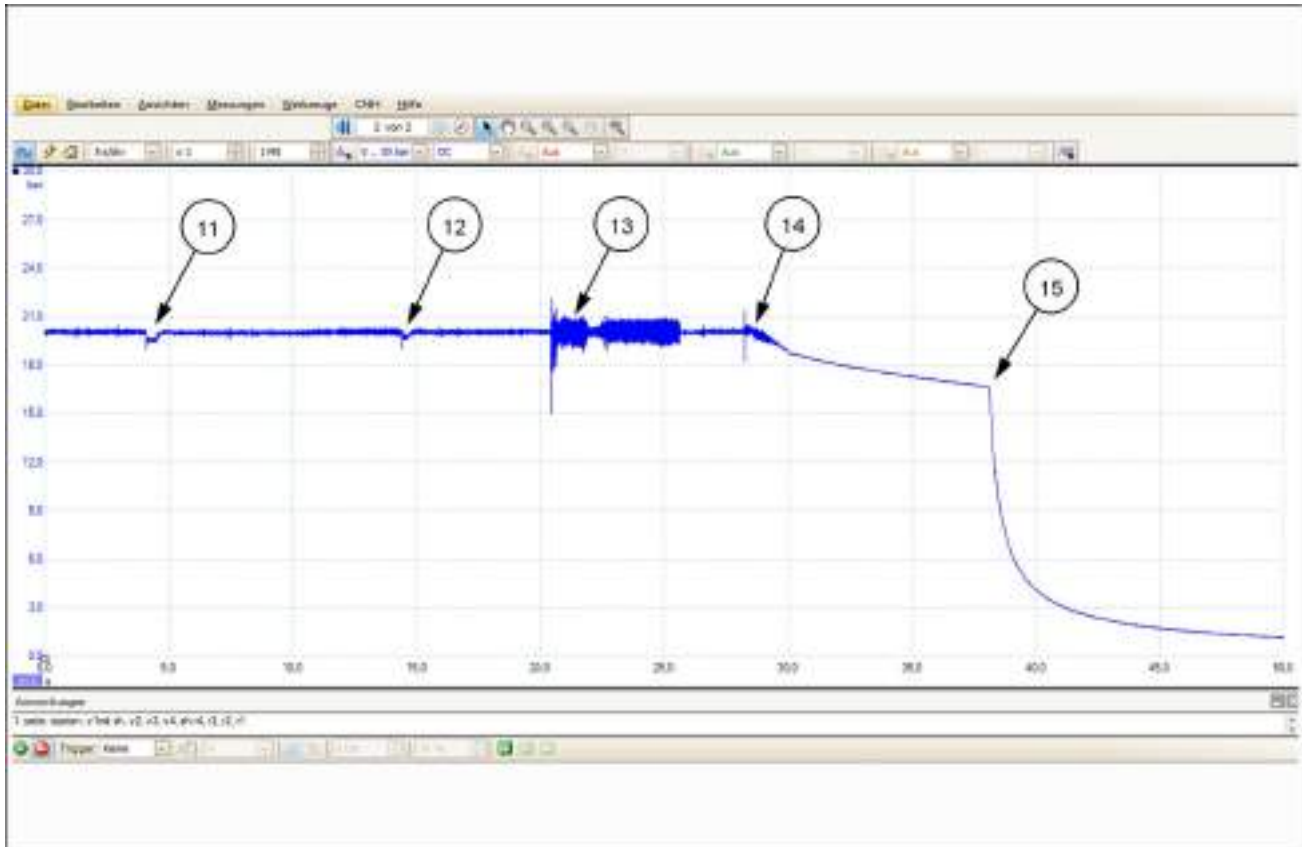

SS13K181 3

- (11) Activation of differential lock
- (12) Deactivation of 4WD
- (13) Activation of rear PTO
- (14) Engine off
- (15) Discharge of system accumulator (gas pressure in the accumulator)

**NOTE:** After each activation or deactivation of the individual system consumers, the system pressure can drop more or less steeply. However, after a certain period of time, the system pressure must revert to the initial value. If the pressure does not return to its initial value, this shows that there is an abnormal leak on the consumer.

## Semi-Powershift transmission - Pressure test - Powershift clutches

These diagrams from the DATAR software provide information on the condition of the electrical components, the hydraulic components, and the mechanical components during start-up in the various powershift ratios for forward travel and reverse travel and when you switch between powershift ratios.

To achieve optimum comparability between the diagrams, it is important to observe all test conditions.

1. Use the test adapter (M14x1,5) to connect the pressure sensors to the corresponding test ports of the powershift clutches that you wish to test:

(1) Clutch G (K5)  
 Clutch (2) F (K6)  
 Clutch (3) B (K4)  
 Clutch (4) D (K3)  
 Clutch (5) A (K2)  
 Clutch (6) C (K1)

**NOTE:** Make sure that the pressure sensor battery is in a charged state. Then perform a calibration. Switch the pressure sensor to the **60 bar (870 psi)** measurement range.

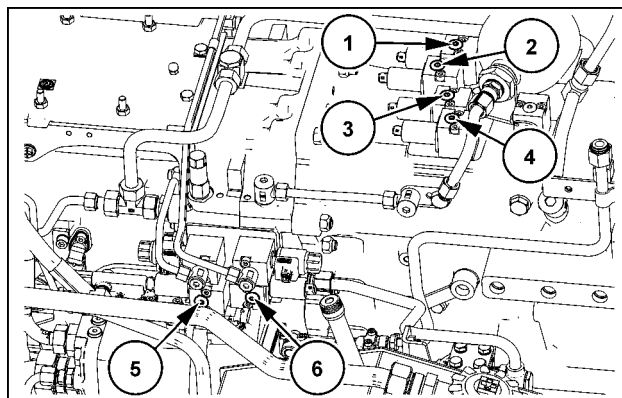

SS13K194 1

2. The solenoid valves of powershift clutches G, F, B and D are on the top of the powershift transmission. Remove the service plates in the cab floor to gain easy access to these ports. Powershift clutches A and C are on the right-hand side of the powershift transmission.
3. Connect the current clamps to one of the cables that lead to the solenoid valves of the powershift clutches. Connect the pressure sensors to channels A and C on the DATAR Scope. Connect the current clamps to channels B and D.

**NOTE:** Switch the current clamps to the **20 A** range. Press the Zero Reset button. When you clamp the current clamp onto the cable, always observe the current direction specification on the current clamp (arrow).

4. You can read off all settings on the DATAR software for channels A to D from the subsequent Scope images. You can also apply these settings to your DATAR.



Test conditions for powershift ratio 1 Forward:

- Transmission oil temperature **50 °C (122 °F)**
- motor speed **1500 RPM**
- Flat road with no equipment present
- Second gear, road range and first powershift ratio
- Push the shuttle lever into the Forward position to move off. Then press the neutral button to stop again

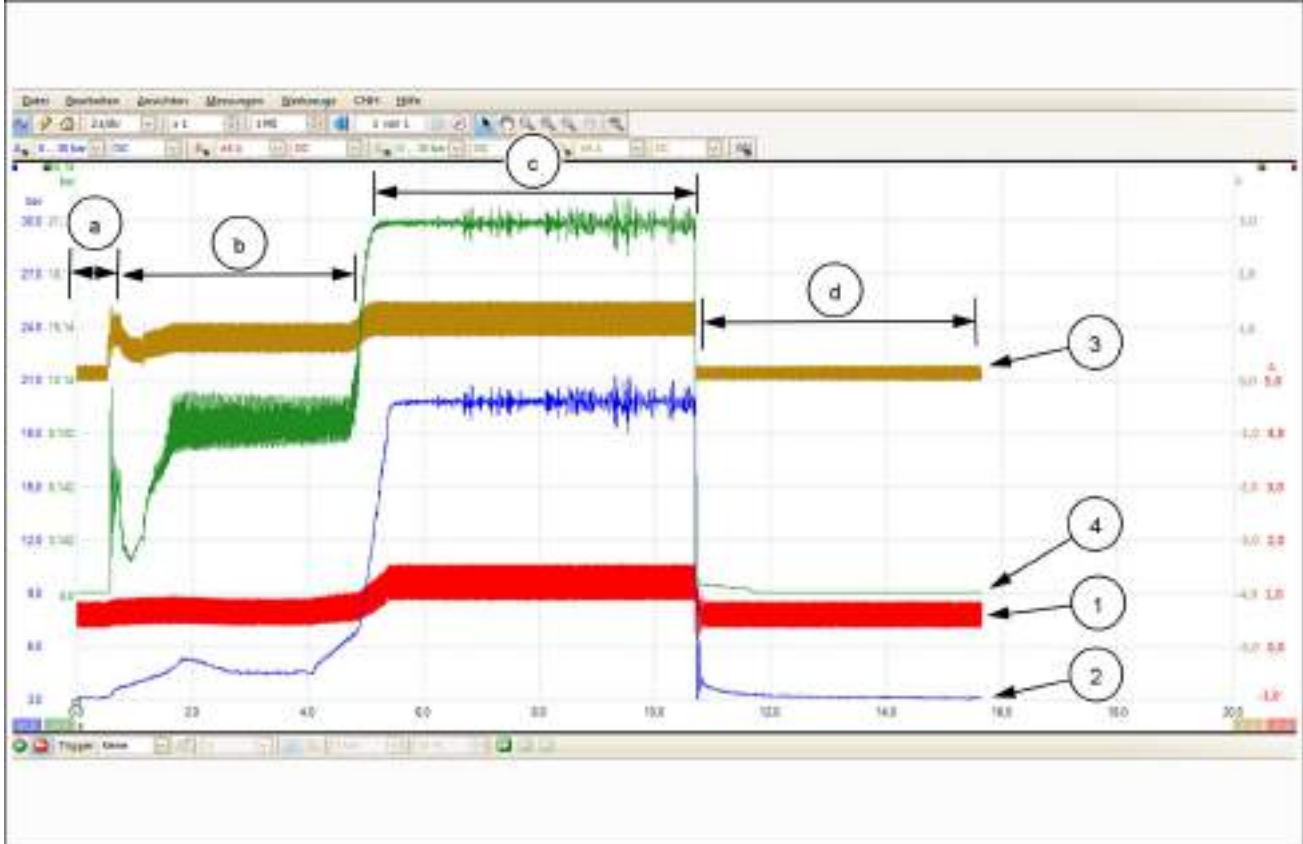

SS13K182 2

- (a) Both clutches are open (the transmission is in neutral, the tractor is stationary)
- (b) The system closes both clutches in a controlled manner (the clutches are in the sliding phase, the tractor starts to move)
- (c) Both clutches are in a fully closed state (the tractor is in motion)
- (d) Both clutches are open again (transmission in neutral, tractor remains stationary)
- (1) Current through the solenoid valve for clutch C
- (2) Hydraulic pressure in clutch C
- (3) Current through the solenoid valve for clutch A
- (4) Hydraulic pressure in clutch A

Test conditions for powershift ratio 2 Forward:

- Transmission oil temperature **50 °C (122 °F)**
- motor speed **1500 RPM**
- Flat road with no equipment present
- Second gear, road range and second powershift ratio
- Push the shuttle lever into the Forward position to move off. Then press the neutral button to stop again

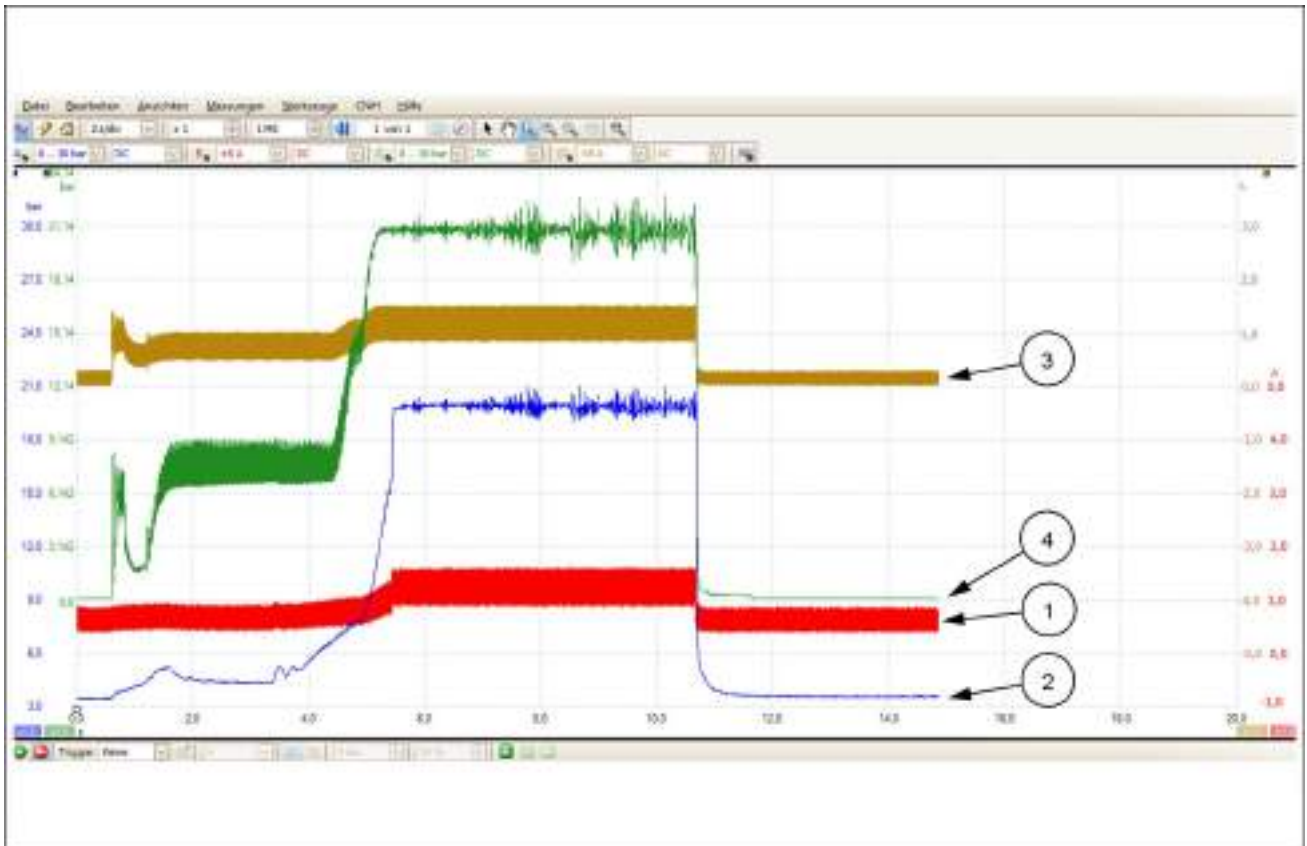

SS13K183 3

- (1) Current through the solenoid valve for clutch D
- (2) Hydraulic pressure in clutch D
- (3) Current through the solenoid valve for clutch A
- (4) Hydraulic pressure in clutch A

Test conditions for powershift ratio 3 Forward:

- Transmission oil temperature **50 °C (122 °F)**
- motor speed **1500 RPM**
- Flat road with no equipment present
- Second gear, road range and third powershift ratio
- Push the shuttle lever into the Forward position to move off. Then press the neutral button to stop again

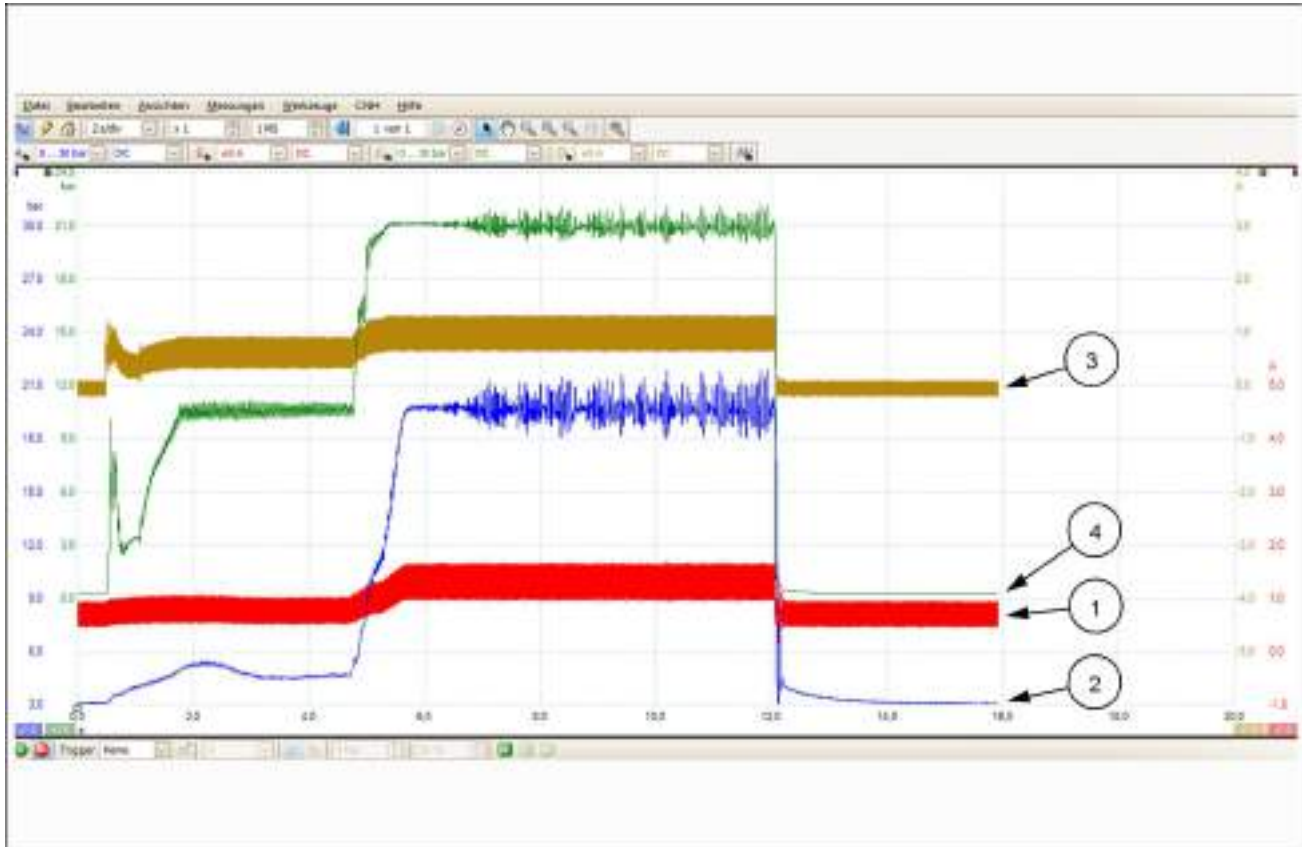

SS13K184 4

- (1) Current through the solenoid valve for clutch C
- (2) Hydraulic pressure in clutch C
- (3) Current through the solenoid valve for clutch B
- (4) Hydraulic pressure in clutch B

Test conditions for powershift ratio 4 Forward:

- Transmission oil temperature **50 °C (122 °F)**
- motor speed **1500 RPM**
- Flat road with no equipment present
- Second gear, road range and fourth powershift ratio
- Push the shuttle lever into the Forward position to move off. Then press the neutral button to stop again

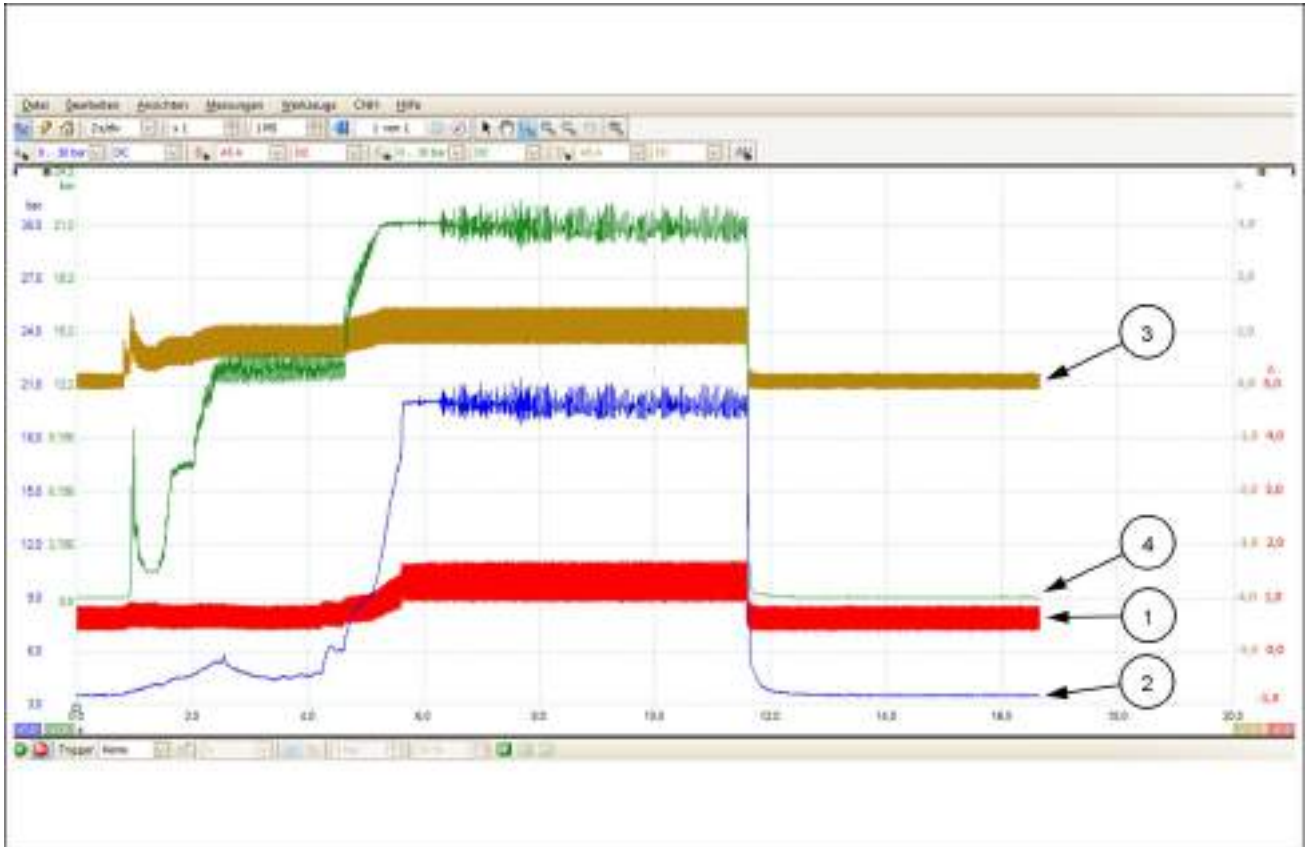

SS13K185 5

- (1) Current through the solenoid valve for clutch D
- (2) Hydraulic pressure in clutch D
- (3) Current through the solenoid valve for clutch B
- (4) Hydraulic pressure in clutch B

Test conditions for powershift ratio 1 Reverse:

- Transmission oil temperature **50 °C (122 °F)**
- motor speed **1500 RPM**
- Flat road with no equipment present
- Second gear, road range and first powershift ratio
- Push the shuttle lever into the Reverse position to move off. Then press the neutral button to stop again

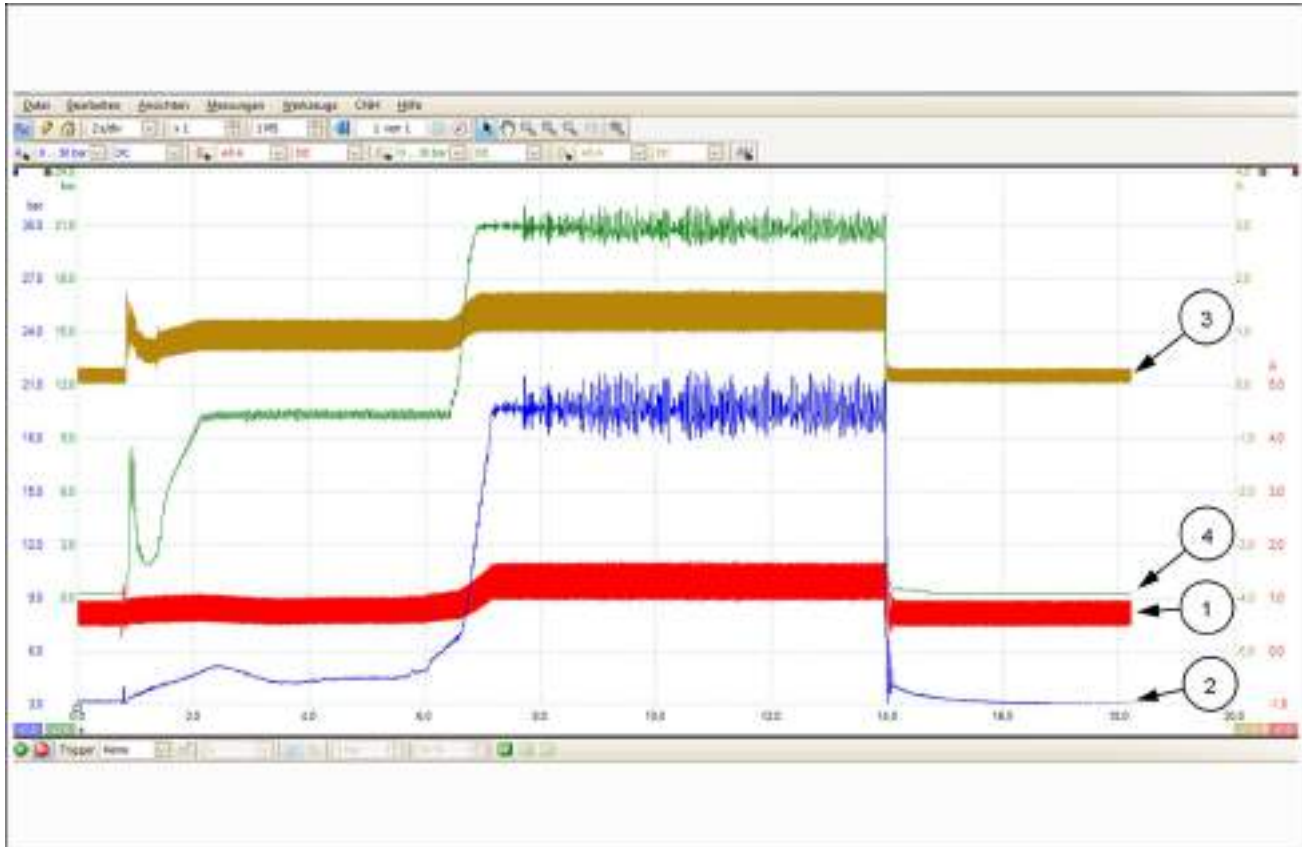

SS13K186 6

- (1) Current through the solenoid valve for clutch C
- (2) Hydraulic pressure in clutch C
- (3) Current through the solenoid valve for clutch F
- (4) Hydraulic pressure in clutch F

Test conditions for powershift ratio 2 Reverse:

- Transmission oil temperature **50 °C (122 °F)**
- motor speed **1500 RPM**
- Flat road with no equipment present
- Second gear, road range and second powershift ratio
- Push the shuttle lever into the Reverse position to move off. Then press the neutral button to stop again

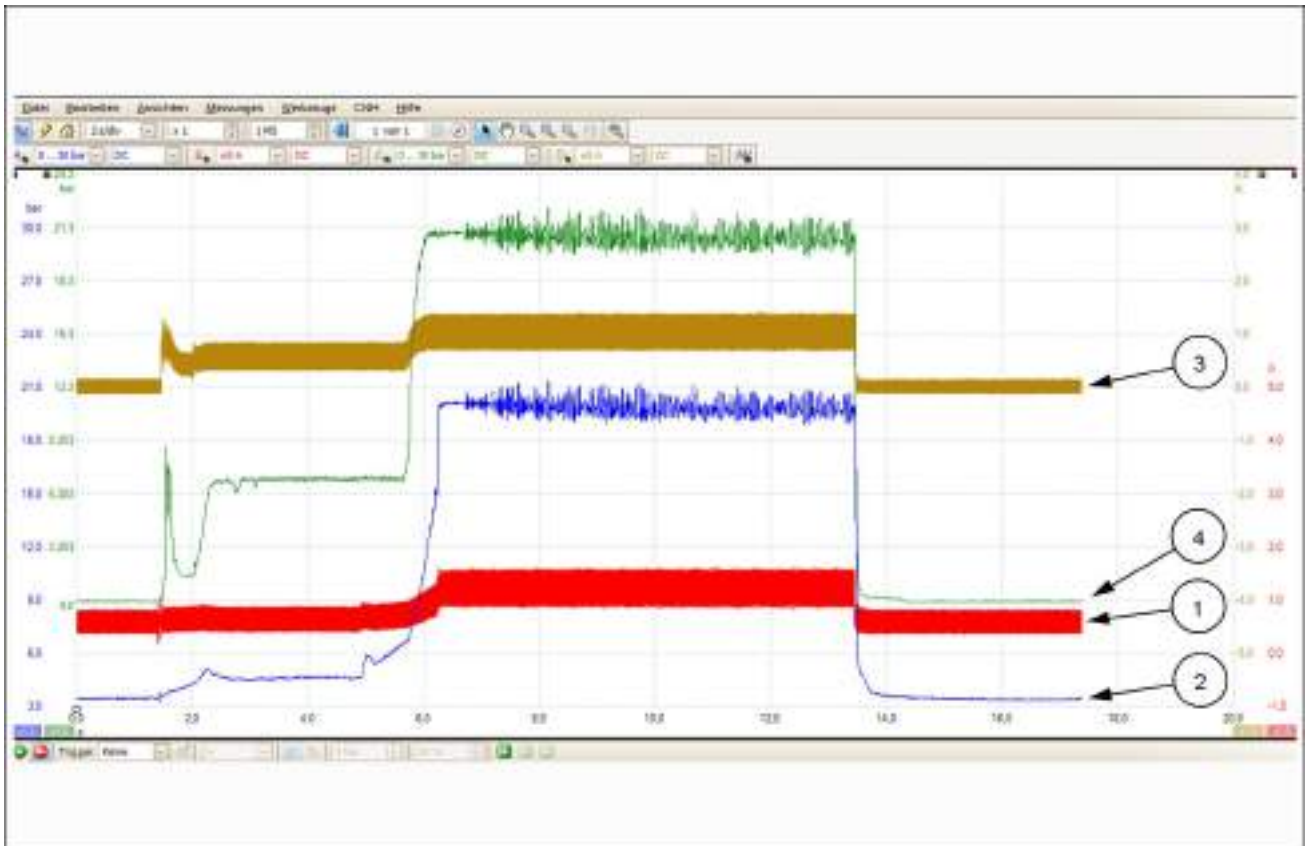

SS13K187 7

- (1) Current through the solenoid valve for clutch D
- (2) Hydraulic pressure in clutch D
- (3) Current through the solenoid valve for clutch F
- (4) Hydraulic pressure in clutch F

Test conditions for powershift ratio 3 Reverse:

- Transmission oil temperature **50 °C (122 °F)**
- motor speed **1500 RPM**
- Flat road with no equipment present
- Second gear, road range and third powershift ratio
- Push the shuttle lever into the Reverse position to move off. Then press the neutral button to stop again

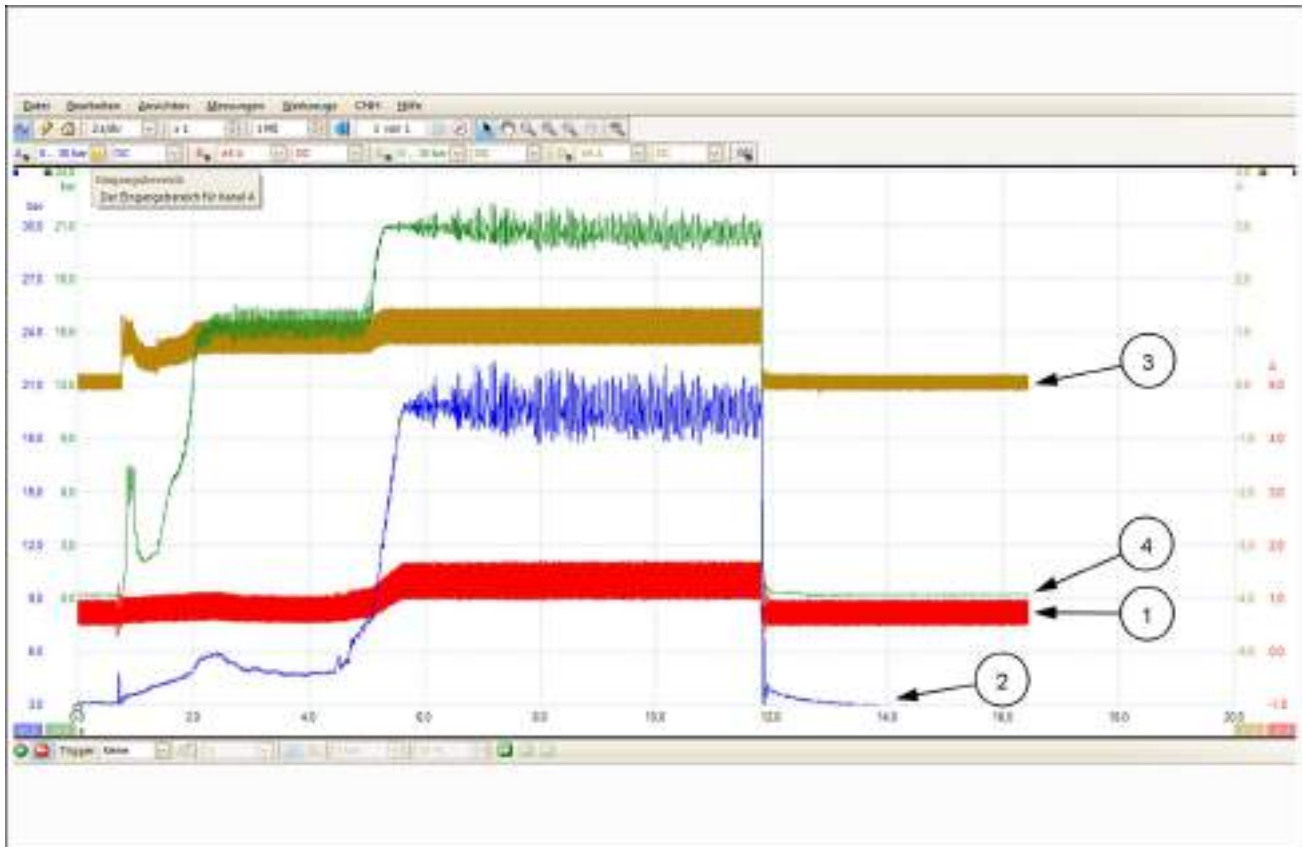

SS13K188 8

- (1) Current through the solenoid valve for clutch C
- (2) Hydraulic pressure in clutch C
- (3) Current through the solenoid valve for clutch G
- (4) Hydraulic pressure in clutch G

Test conditions for powershift ratio 4 Reverse:

- Transmission oil temperature **50 °C (122 °F)**
- motor speed **1500 RPM**
- Flat road with no equipment present
- Second gear, road range and fourth powershift ratio
- Push the shuttle lever into the Reverse position to move off. Then press the neutral button to stop again

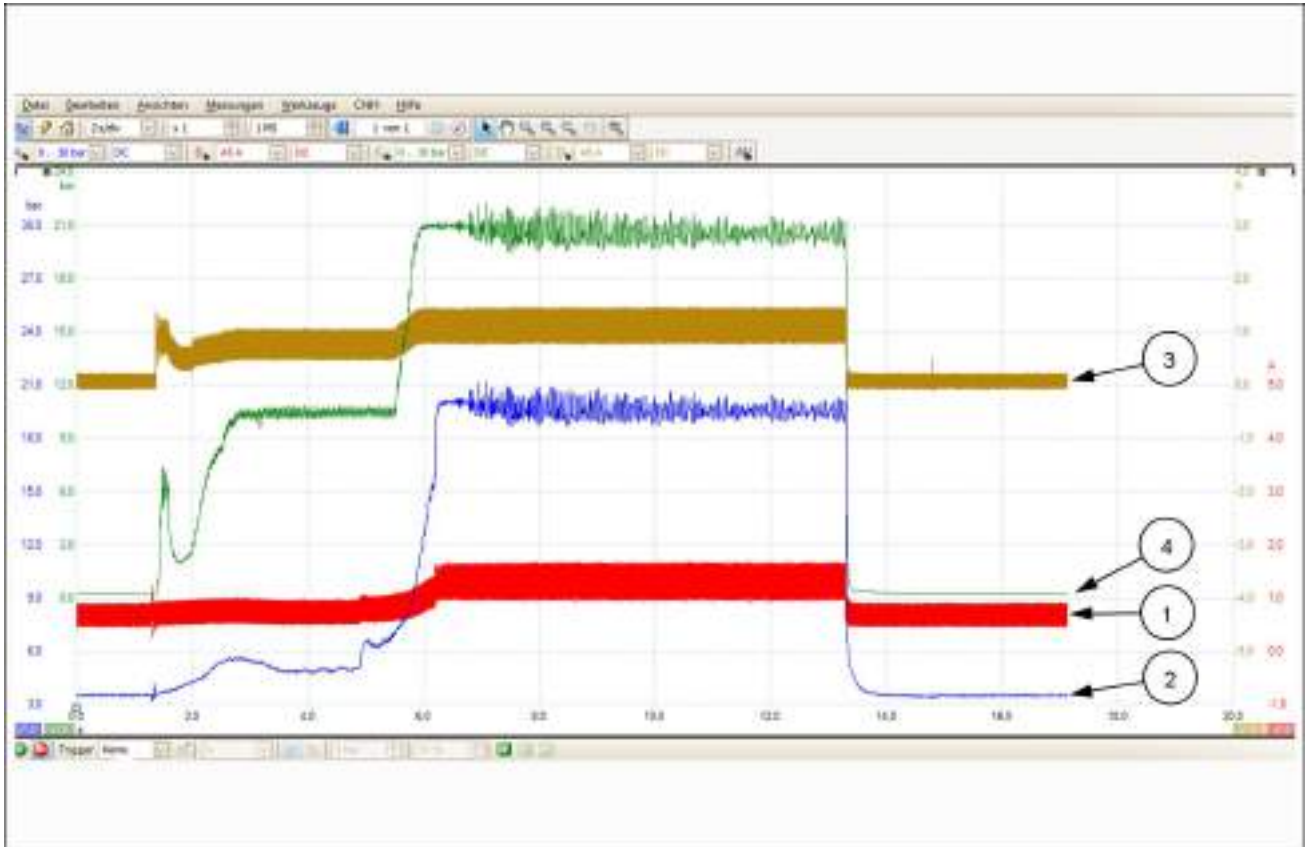

SS13K189 9

- (1) Current through the solenoid valve for clutch D
- (2) Hydraulic pressure in clutch D
- (3) Current through the solenoid valve for clutch G
- (4) Hydraulic pressure in clutch G



Test conditions for the torque distribution of the two main clutches when the tractor moves off:

- Transmission oil temperature **50 °C (122 °F)**
- motor speed **1500 RPM**
- Flat road with no equipment present
- Second gear, road range and second powershift ratio
- Push the clutch pedal to move off. Then press the neutral button to stop again

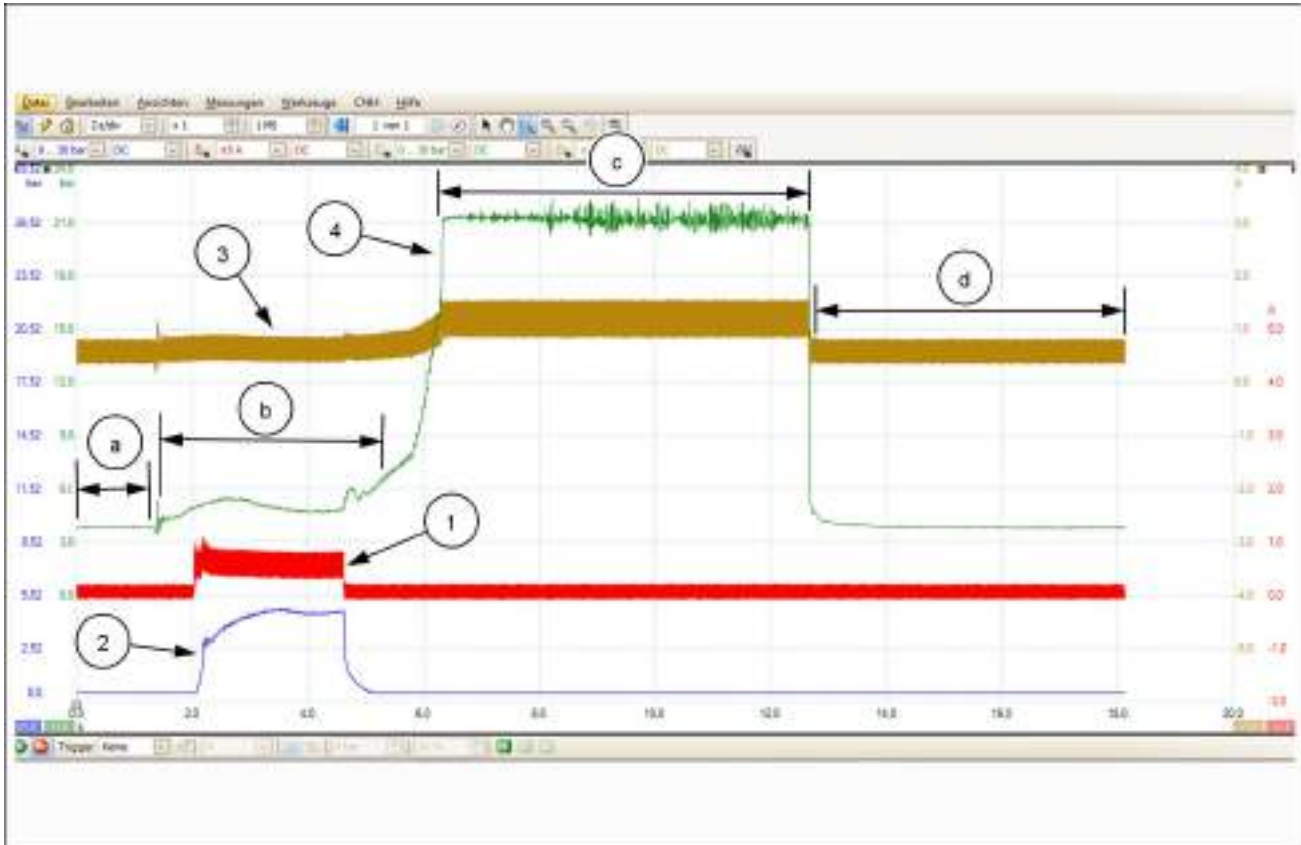

SS13K190 10

**(a)** The operator fully depressed the clutch pedal. There is already low pressure in main clutch (D). Main clutch (C) is without pressure (the tractor is stationary).

**(b)** The operator slowly releases the clutch pedal. In this range, the system closes both main clutches (D) and (C) in a controlled manner. The system pressurizes main clutch (C) up to a certain pressure in order to support clutch (D) (torque distribution). The system then deactivates main clutch (C) again (the clutches are in the sliding phase, the tractor starts to move)

**(c)** The clutch pedal moves in the fully engaged direction. Main clutch (D) is initially still in the modulation phase. At the same time, main clutch (C) has fully completed its support phase (the tractor is in motion).

**(d)** Main clutch (C) is open again (the transmission is in neutral, the tractor remains stationary)

- (1)** Current through the solenoid valve for clutch C
- (2)** Hydraulic pressure in clutch C
- (3)** Current through the solenoid valve for clutch D
- (4)** Hydraulic pressure in clutch D

Test conditions for upshift of powershift ratios Forward 1 to Forward 4:

- Transmission oil temperature **50 °C (122 °F)**
- motor speed **1500 RPM**
- Flat road with no equipment present
- Second gear, road range and first powershift ratio
- Push the shuttle lever into the Forward position to move off. Shift into the second powershift ratio, third powershift ratio and fourth powershift ratio. Then press the neutral button to stop again

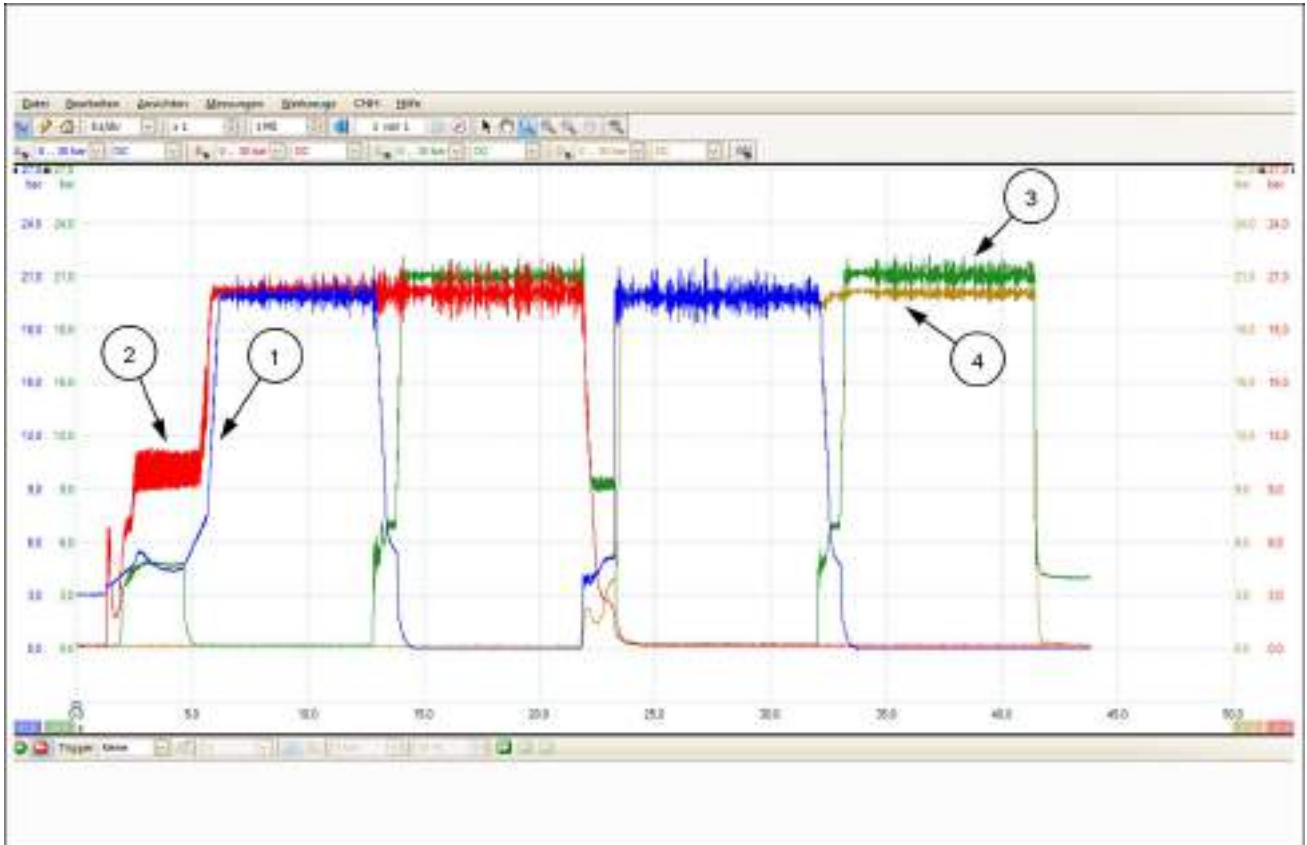

SS13K191 11

- (1) Hydraulic pressure in clutch C (blue)
- (2) Hydraulic pressure in clutch A (red)
- (3) Hydraulic pressure in clutch D (green)
- (4) Hydraulic pressure in clutch B (brown)

Test conditions for upshift of powershift ratios Reverse 1 to Reverse 4:

- Transmission oil temperature **50 °C (122 °F)**
- motor speed **1500 RPM**
- Flat road with no equipment present
- Second gear, road range and first powershift ratio
- Push the shuttle lever into the Reverse position to move off. Shift into the second powershift ratio, third powershift ratio and fourth powershift ratio. Then press the neutral button to stop again

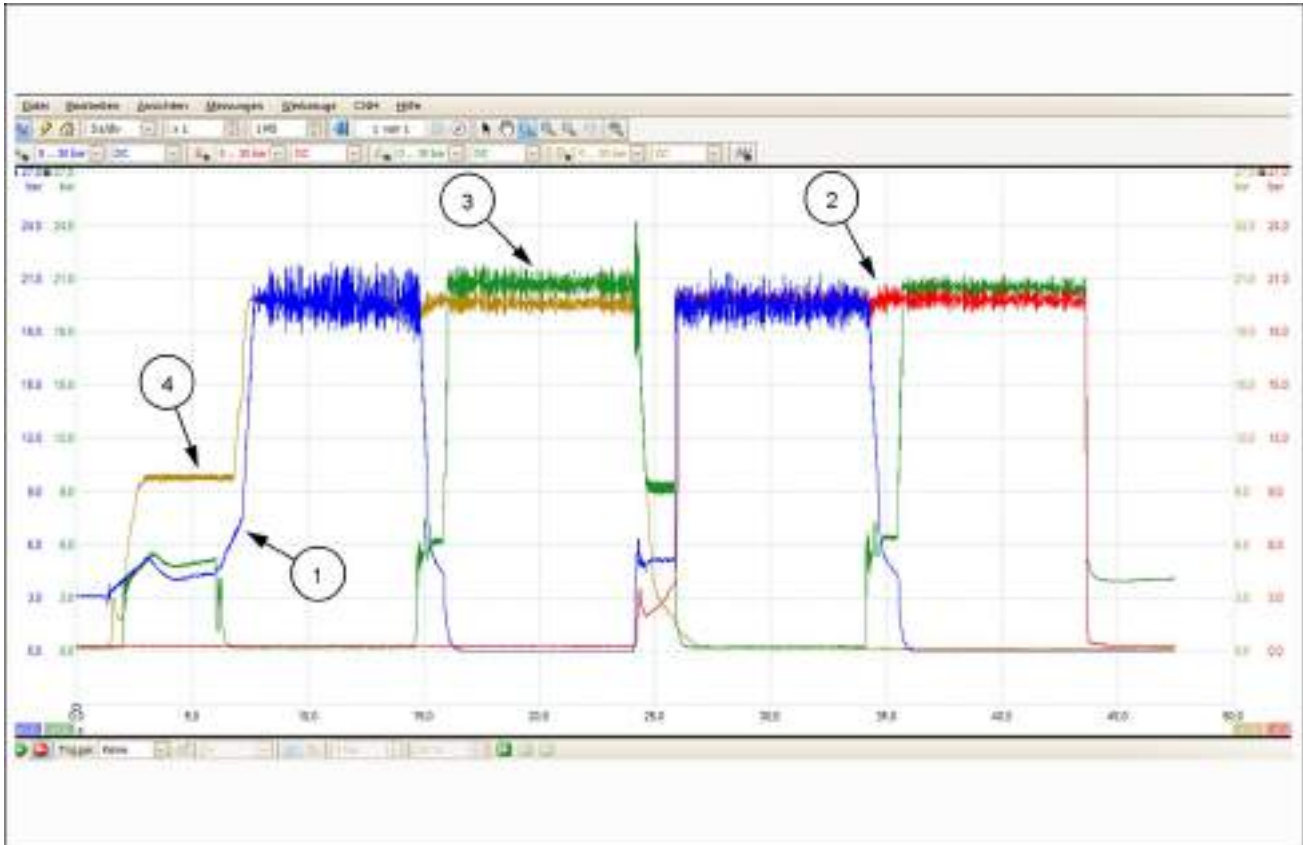

SS13K192 12

- (1) Hydraulic pressure in clutch C (blue)
- (2) Hydraulic pressure in clutch G (red)
- (3) Hydraulic pressure in clutch D (green)
- (4) Hydraulic pressure in clutch F (brown)

---

## Transmission housing cover - Remove

### Prior operation:

#### Cab - Remove (90.150)

1. From the gearbox cover, remove the bolts and the nuts.
2. Remove the gearbox cover (62).

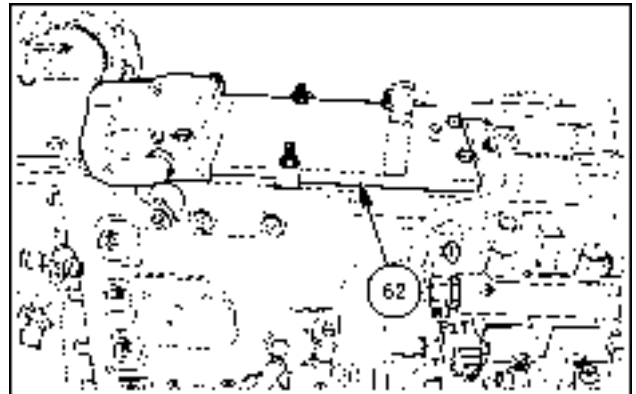

SVL13TR00140AB 1

### Next operation:

#### Transmission housing cover - Disassemble (21.111)

## Transmission housing cover - Disassemble

### Prior operation:

#### Transmission housing cover - Remove (21.111)

1. Loosen the screw (57).
2. Remove the shift finger (56).

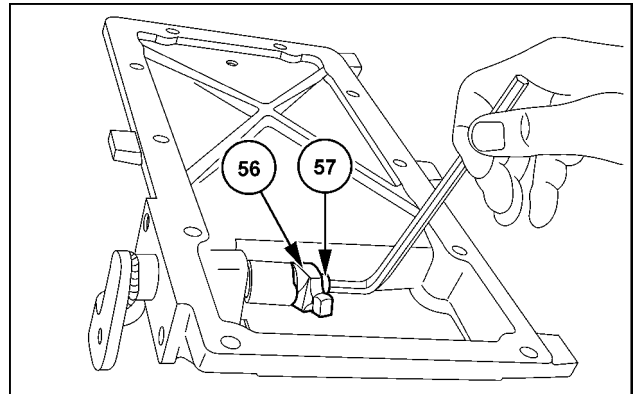

SVIL13TR00268AB 1

3. Release circlip (55) from its position.
4. Remove the selector shaft (53).

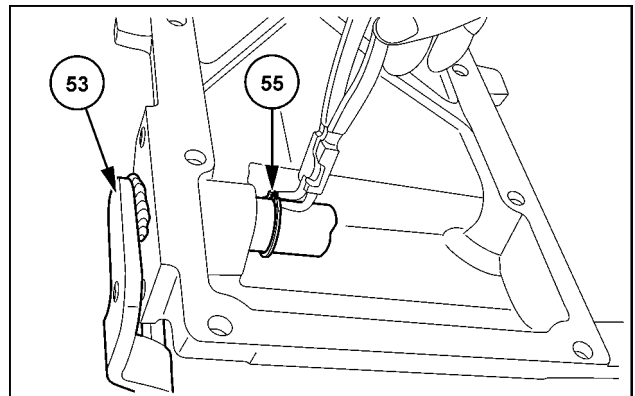

SVIL13TR00269AB 2

5. Remove the O-ring (54).

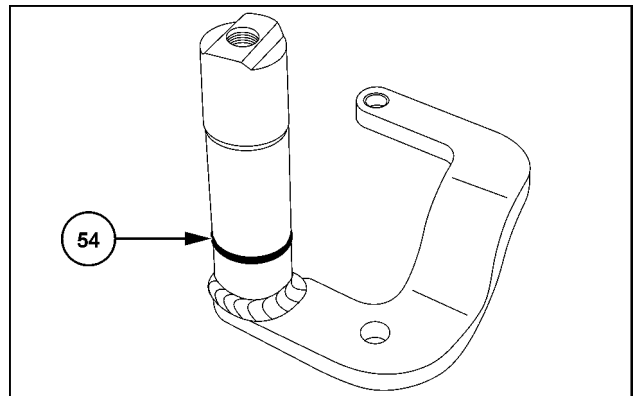

SVIL13TR00270AB 3

### Next operation:

#### Transmission housing cover - Assemble (21.111)

## Transmission housing cover - Assemble

### Prior operation:

#### Transmission housing cover - Disassemble (21.111)

1. Fit the O-ring (54) into the ring groove of the selector shaft.

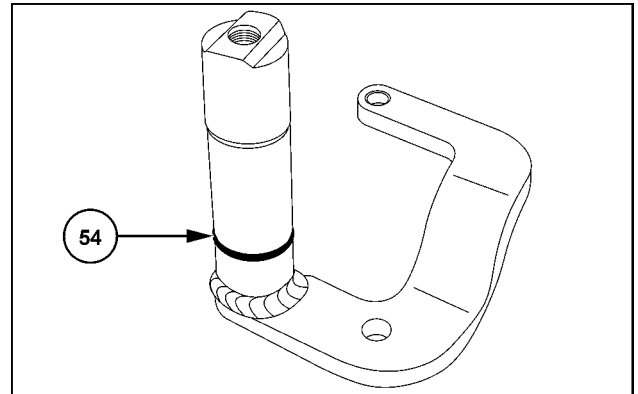

SVIL13TR00270AB 1

2. Fit the selector shaft (53) into the cover hole.
3. Insert the circlip (55).

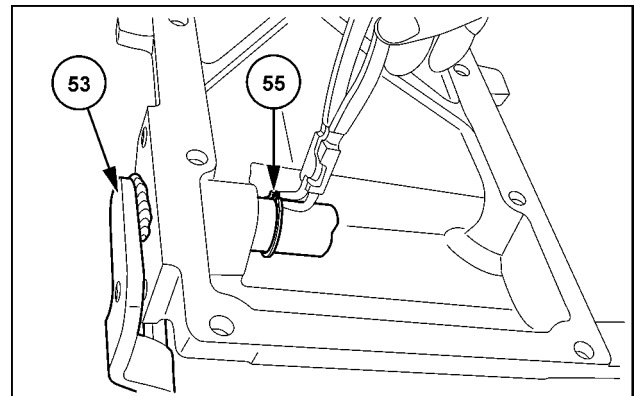

SVIL13TR00269AB 2

4. Spray the screw with **LOCTITE® 243**.
5. Secure the shift finger (56) with the bolt (57). Tighten plug to **68 Nm (50 lb ft)**.

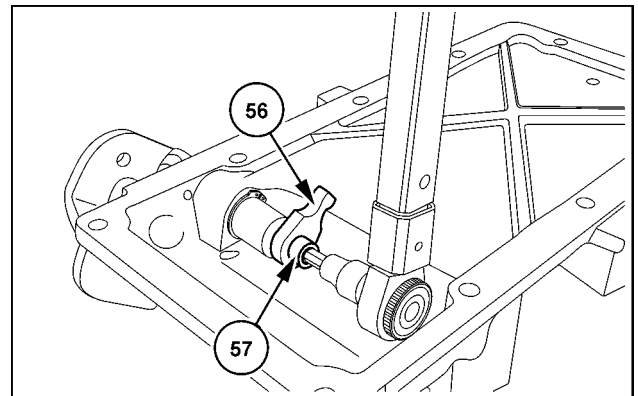

SVIL13TR00415AB 3

6. Fit the breather (52).

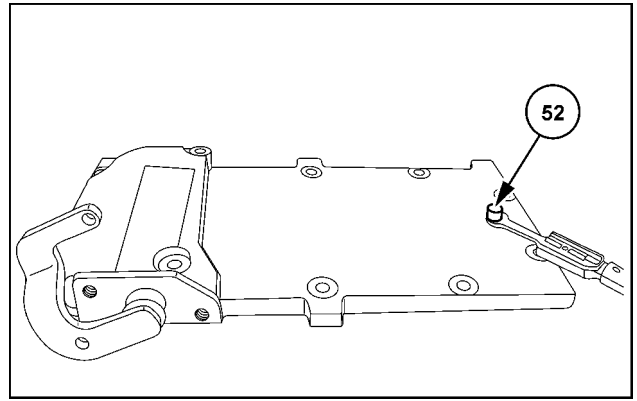

SVIL13TR00416AB 4

**Next operation:**  
**Transmission housing cover - Install (21.111)**

## Transmission housing cover - Install

### Prior operation:

#### Transmission housing cover - Assemble (21.111)

1. If you removed the four stud bolts (59), refit these stud bolts.

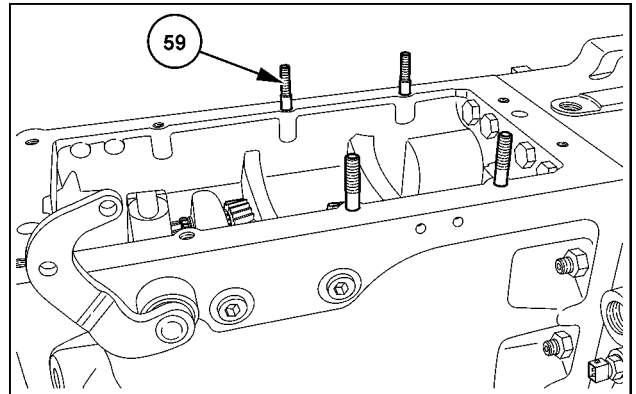

SVIL13TR00439AB 1

2. Coat the sealing surfaces with **LOCTITE® 518**.
3. Fit the cover (62).

**NOTE:** The shift finger (57) must engage in the synchronizer.

4. Install the bolts and the nuts. Tighten the bolts and the nuts to **46 Nm (34 lb ft)**.

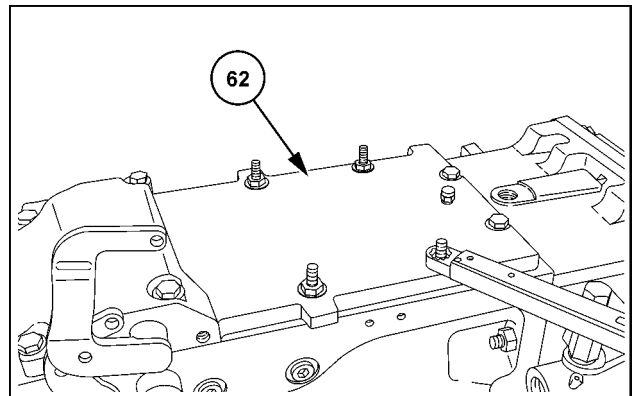

SVIL13TR00441AB 2

### Next operation:

#### Cab - Install (90.150)



## Gear housing - Disconnect (gearbox housing – range housing)

### **⚠ DANGER**

#### **Heavy objects!**

Lift and handle all heavy components using lifting equipment with adequate capacity. Always support units or parts with suitable slings or hooks. Make sure the work area is clear of all bystanders. Failure to comply will result in death or serious injury.

D0076A

1. Remove the bolts and the nuts.
2. Disconnect the gearbox housing (41) from the intermediate housing (15).

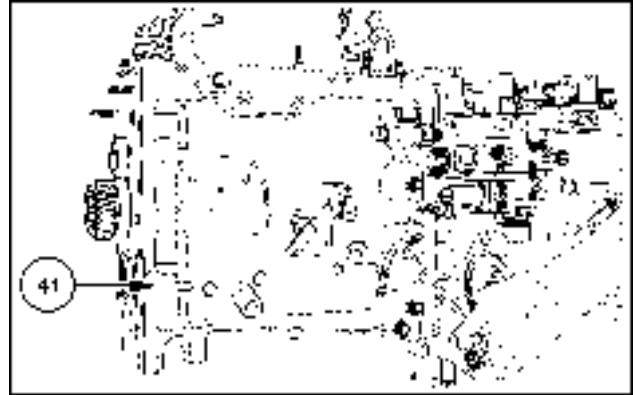

SVIL13TR00141AB 1

#### **Next operation:**

**Gear housing - Connect (gearbox housing – range housing) (21.111)**

## Gear housing - Connect (gearbox housing – range housing)

### Prior operation:

#### Gear housing - Disconnect (gearbox housing – range housing) (21.111)

1. Insert the bushing (380).
2. Install the dowels (25) and (29).

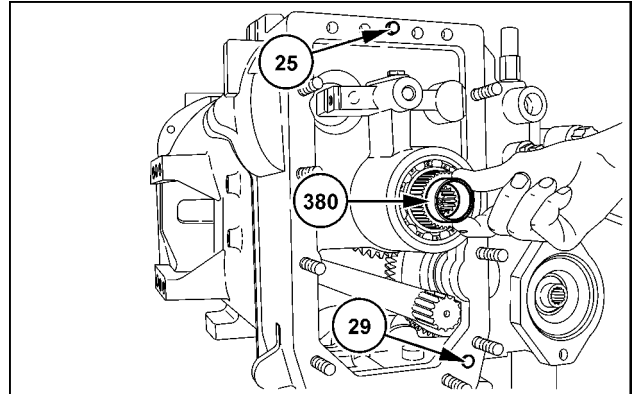

SVIL13TR00432AB 1

3. Coat the sealing surfaces with **LOCTITE® 518**.
4. Connect the gearbox housing to the intermediate housing. Secure the gearbox housing with the bolts and the nuts. Tighten the bolts and the nuts to **185 Nm (136 lb ft)**.

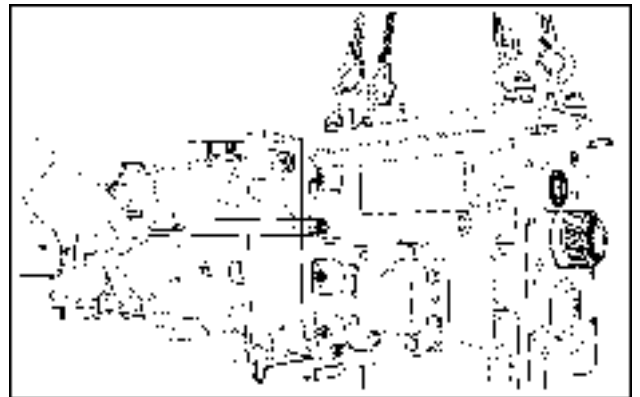

SVIL13TR00433AB 2

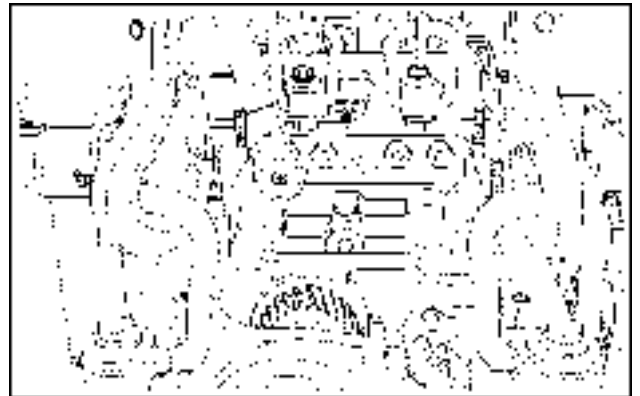

SVIL13TR00434AB 3

## Intermediate housing - Remove

### Prior operation:

### Gear housing - Disconnect (gearbox housing – range housing) (21.111)

1. Loosen the pressure line (141).

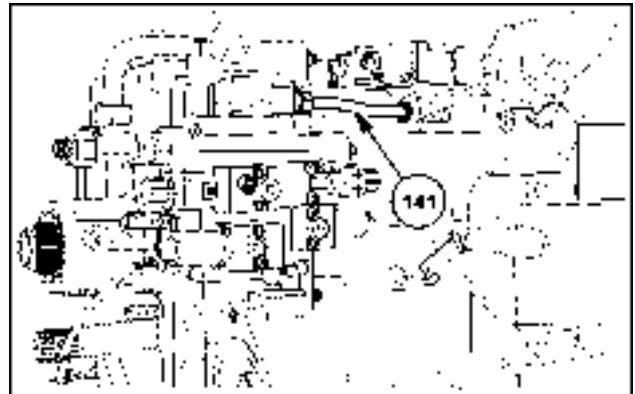

SVIL13TR00143AB 1

2. Remove the connectors (140) and (142).
3. Remove the pressure line.

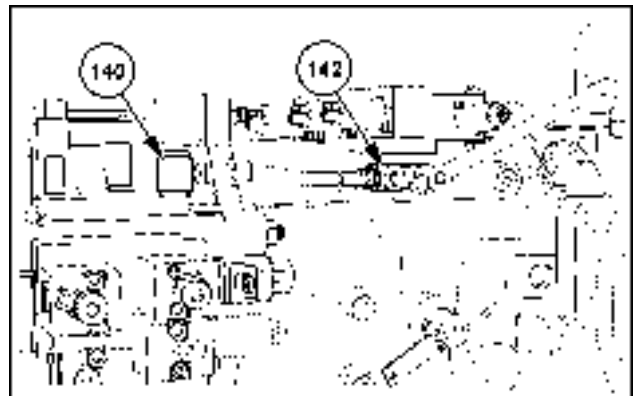

SVIL13TR00145AB 2

4. Remove the grease line (121).

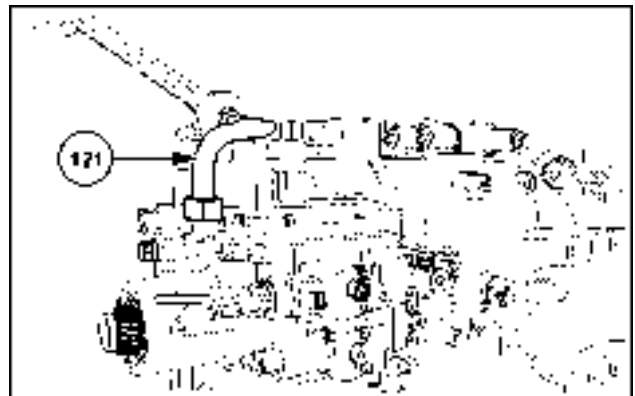

SVIL13TR00144AB 3

5. Remove the fitting (122). Remove the connector (123).

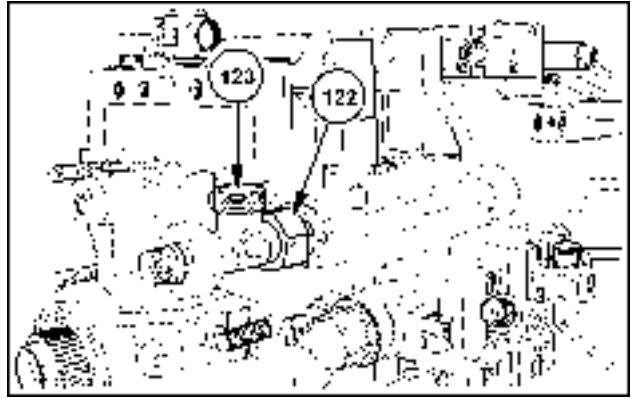

SVIL13TR00146AB 4

6. Remove the grease line (127). Remove the connector (128).

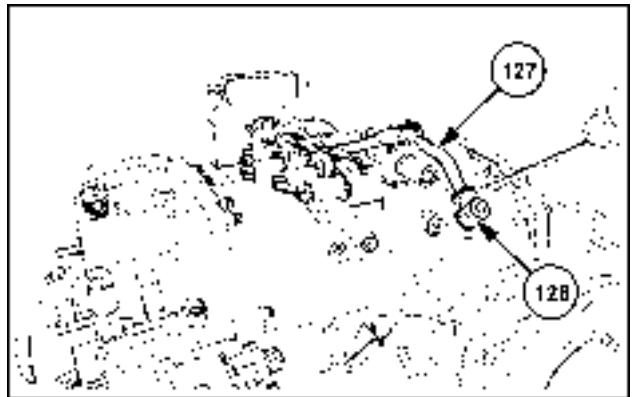

SVIL13TR00147AB 5

7. Loosen the bolt connection.  
8. Lift up the intermediate housing (15).

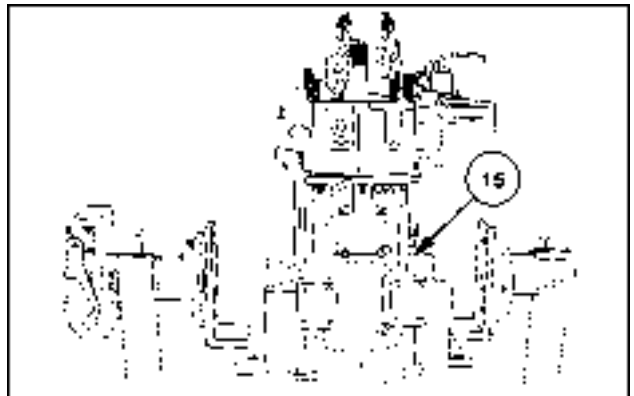

SVIL13TR00148AB 6

**Next operation:**  
**Hydraulic pump drive gears - Disassemble (21.900)**

## Intermediate housing - Install

### Prior operation:

#### Hydraulic pump drive gears - Assemble (21.900)

1. Coat the contact surfaces of both housings with **LOCTITE® 518**.
2. Attach the intermediate housing (15) to the range housing.
3. Tighten the screws to **185 Nm (136 lb ft)**.

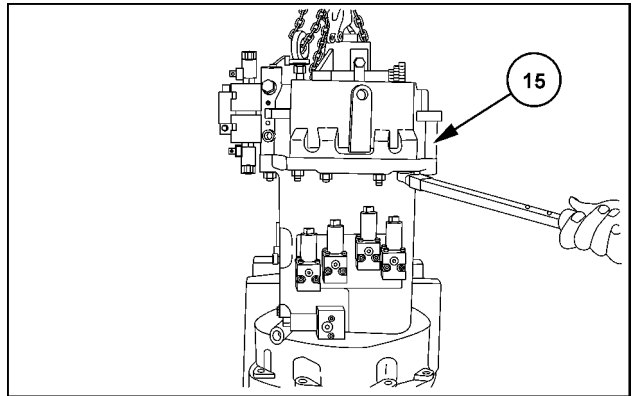

SVIL13TR00431AB 1

4. Fit the grease line (127). Fit the connector (128).

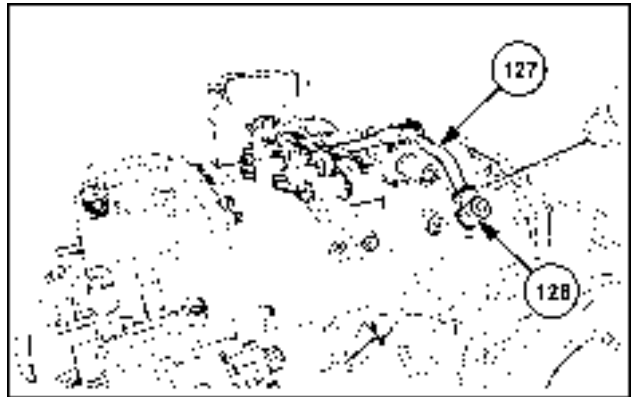

SVIL13TR00147AB 2

5. Fit the fitting (122). Fit the connector (123).

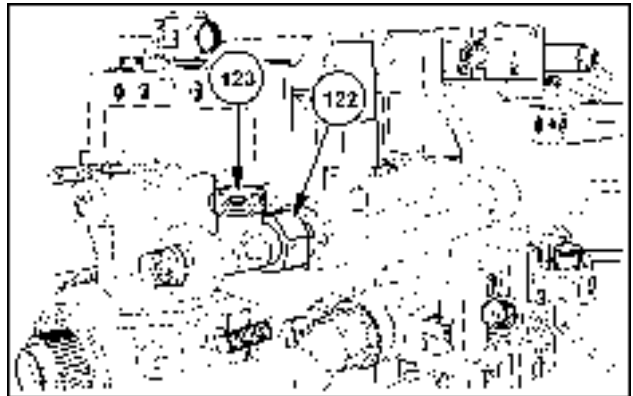

SVIL13TR00146AB 3

6. Fit the grease line (121).

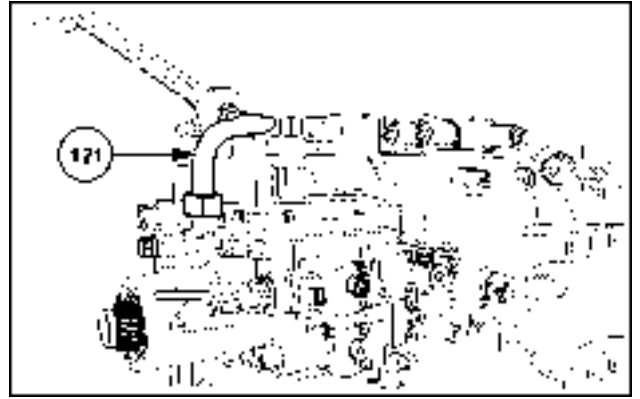

SVIL13TR00144AB 4

7. Fit the pressure line (141).
8. Fit the connectors (140) and (142).

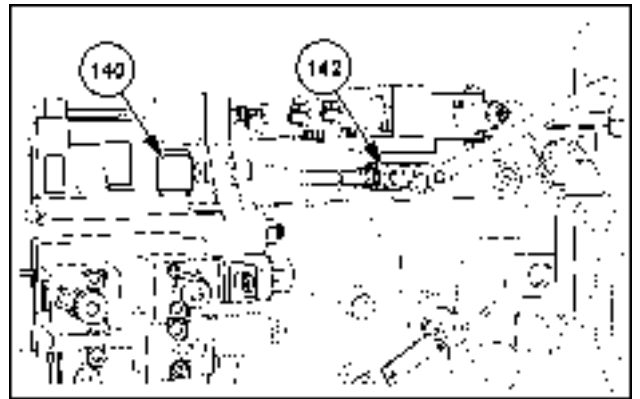

SVIL13TR00145AB 5

**Next operation:**

**Gear housing - Connect (gearbox housing – range housing) (21.111)**

# Index

---

## Transmission - 21

### Semi-Powershift transmission - 111

Gear housing - Connect (gearbox housing – range housing) .....	51
Gear housing - Disconnect (gearbox housing – range housing) .....	50
Intermediate housing - Install .....	54
Intermediate housing - Remove .....	52
Semi-Powershift transmission - Exploded view .....	6
Semi-Powershift transmission - General specification .....	3
Semi-Powershift transmission - Mechanical schema .....	16
Semi-Powershift transmission - Overview .....	9
Semi-Powershift transmission - Overview .....	12
Semi-Powershift transmission - Overview .....	13
Semi-Powershift transmission - Pressure test - Powershift clutches .....	33
Semi-Powershift transmission - Pressure test – Transmission system pressure .....	30
Semi-Powershift transmission - Special tools .....	3
Semi-Powershift transmission - Static description .....	14
Transmission housing cover - Assemble .....	47
Transmission housing cover - Disassemble .....	46
Transmission housing cover - Install .....	49
Transmission housing cover - Remove .....	45



## **Transmission - 21**

**Semi-Powershift transmission external controls - 133**

**Farmall 105U Pro EP  
Farmall 115U Pro EP  
Farmall 95U Pro EP**



# Contents

---

## Transmission - 21

### Semi-Powershift transmission external controls - 133

#### FUNCTIONAL DATA

Semi-Powershift transmission external controls	
Exploded view .....	4
Transmission control valve	
Overview .....	7

#### SERVICE

Transmission control	
Remove – Control cable gear shift .....	9
Install – Control cable gear shift .....	13



---

## Semi-Powershift transmission external controls - Exploded view

81	O-ring	82	O-ring
83	Clutch C solenoid valve	84	Clutch A solenoid valve
85	Bolt	86	Solenoid valve for the rear differential lock
87	Four-Wheel Drive (4WD) solenoid valve	88	Union
89	Hydraulic tube	90	Fitting
91	Union	92	Hydraulic tube
93	Union	94	Clutch D solenoid valve
95	Clutch B solenoid valve	96	Clutch F solenoid valve
97	Clutch G solenoid valve	98	Solenoid valve for rear power take-off

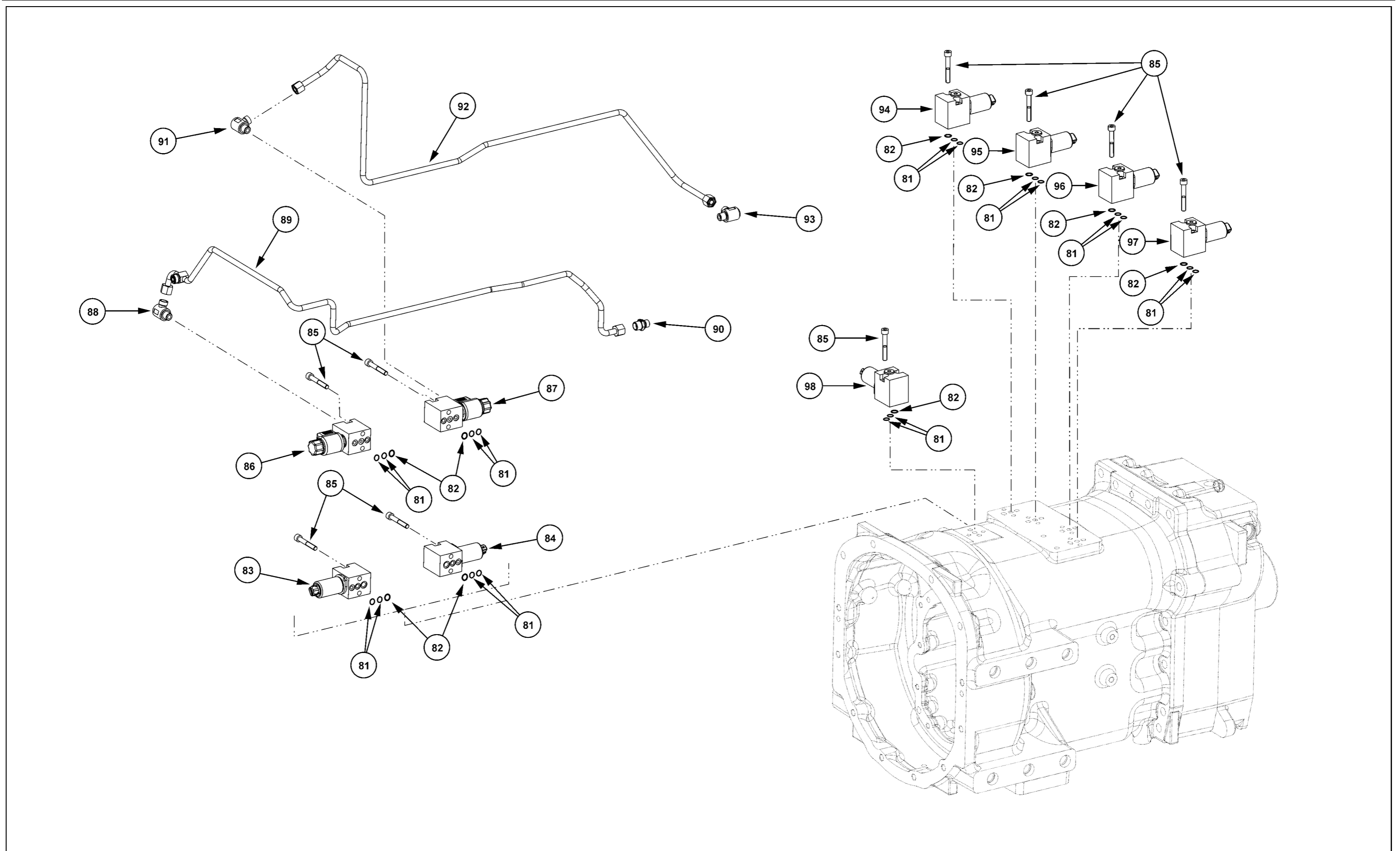

SS13E022 1



## Transmission control valve - Overview

### Clutch solenoid valves

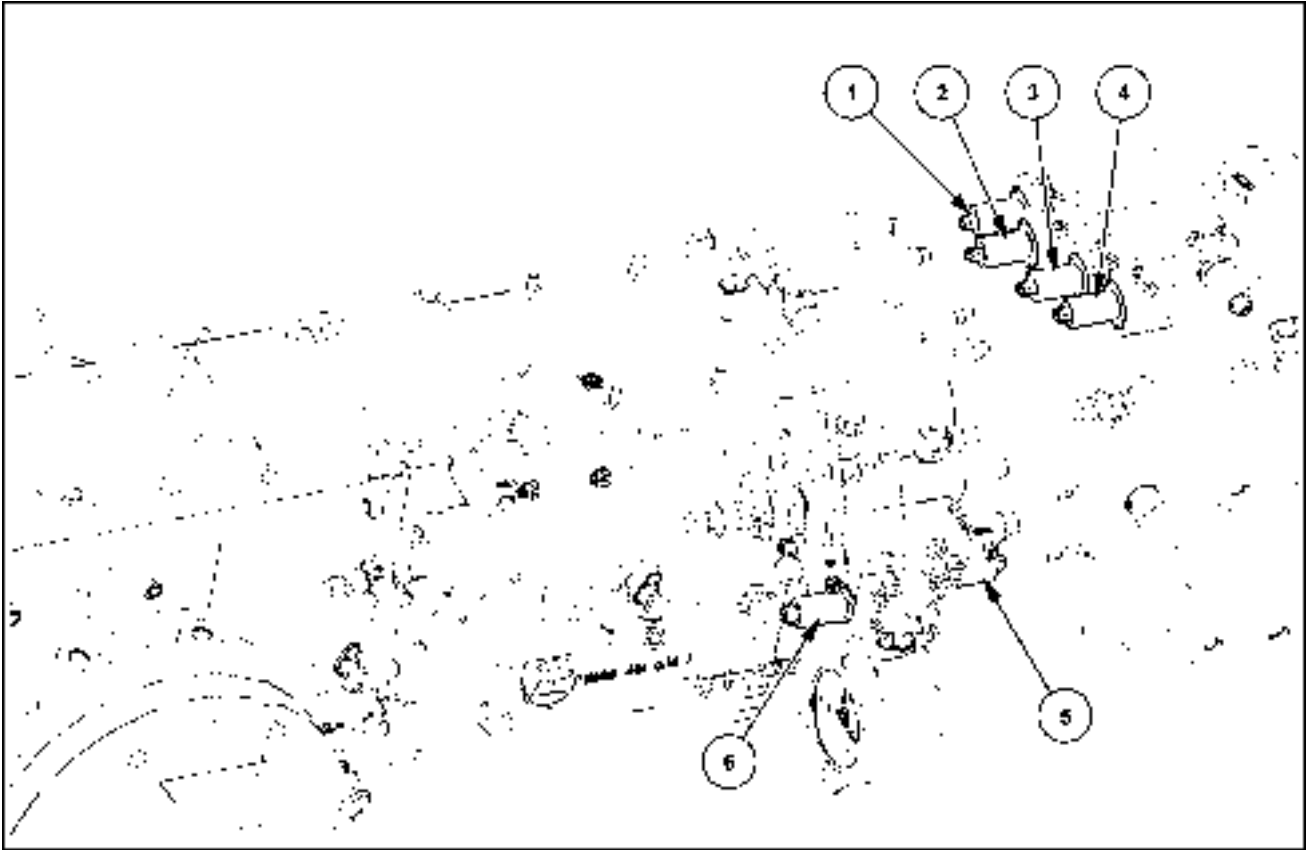

SS13E048 1

The following solenoid valves are located on the top side and on the right-hand side of the transmission housing:

1. Clutch G solenoid valve (Y-060)
2. Clutch F solenoid valve (Y-059)
3. Clutch B solenoid valve (Y-025)
4. Clutch D solenoid valve (Y-054)
5. Clutch C solenoid valve (Y-053)
6. Clutch A solenoid valve (Y-024)

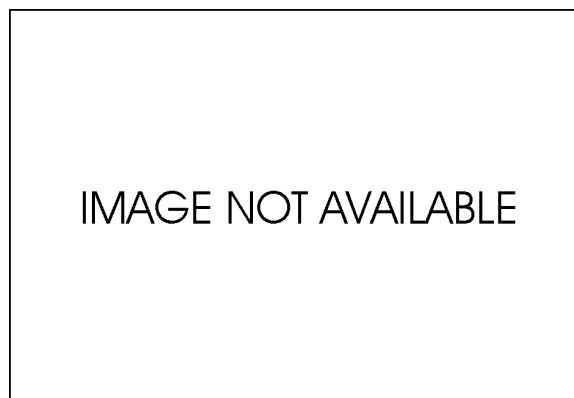

INA 2

<b>Specifications</b>	
Solenoid valve type	Proportional pressure regulating valve
Nominal voltage	<b>12 V +/- 15%</b>

Transmission - Semi-Powershift transmission external controls

<b>Specifications</b>	
PWM frequency	<b>100 Hz</b>
Coil resistance	<b>5.2 <math>\Omega</math> +/- 5% at 20 °C (68 °F)</b>
Ambient temperature	<b>-30 - 80 °C (-22 - 176 °F)</b>
Oil temperature	<b>-25 - 100 °C (-13 - 212 °F)</b>
Nominal flow	<b>0.0 - 25.0 l/min (0.0 - 0.9 cfm)</b>
Regulated pressure	<b>0 - 20 bar (0 - 290 psi)</b>
Inlet pressure (maximum)	<b>60 bar (870 psi)</b>
Tightening torque (for each mounting bolt)	<b>5.5 Nm +/- 0.5 (4.1 lb ft)</b>

## Transmission control - Remove – Control cable gear shift

### Prior operation:

Remove the right-hand rear wheel. See **Rear wheels - Remove (44.520)**.

1. Remove the bolts (1) and the nuts (2).
2. Remove the rubber cover.

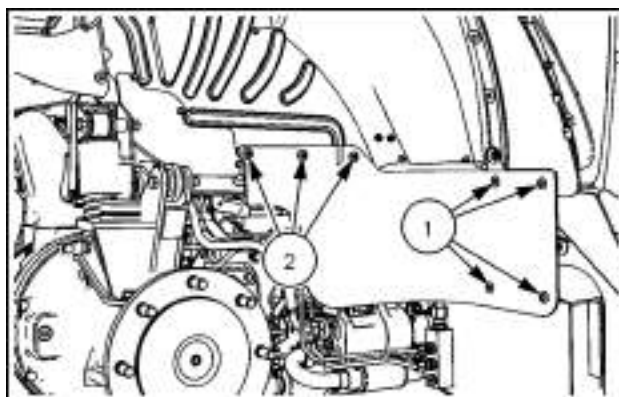

SS14D098 1

3. Remove the bolts (1).
4. Remove the fixing plates.
5. Remove the floor mat.

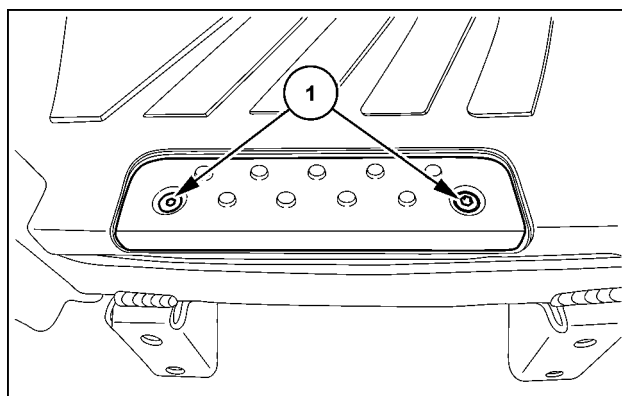

SVIL13TR00636AB 2

6. Remove the bolts (1).
7. Remove the cover (2).

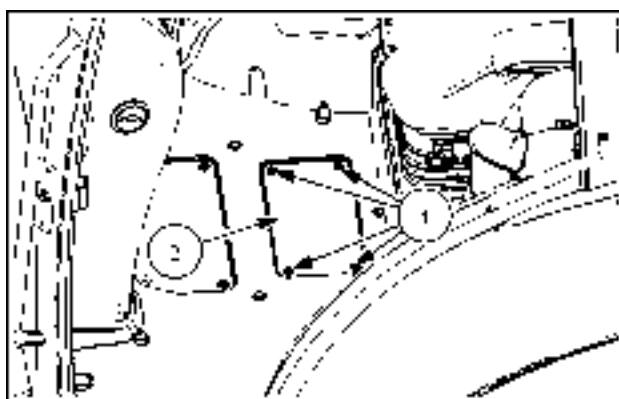

SS14D088 3



8. Remove the rubber cover (1).

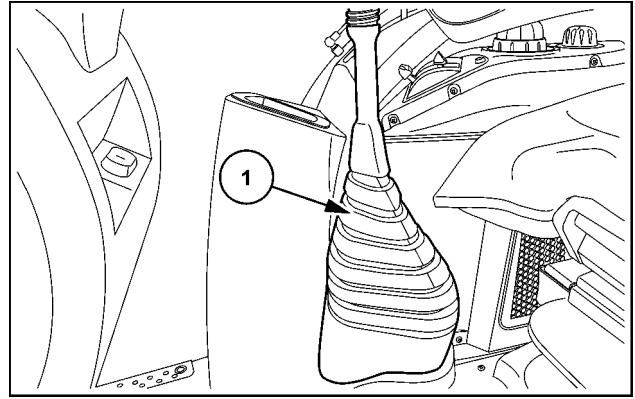

SVIL13TR00648AB 4

9. Install a fixing bolt into the hole on the gear lever.

**NOTE:** The diameter of the fixing bolt should be 9.5 mm (0.37 in).

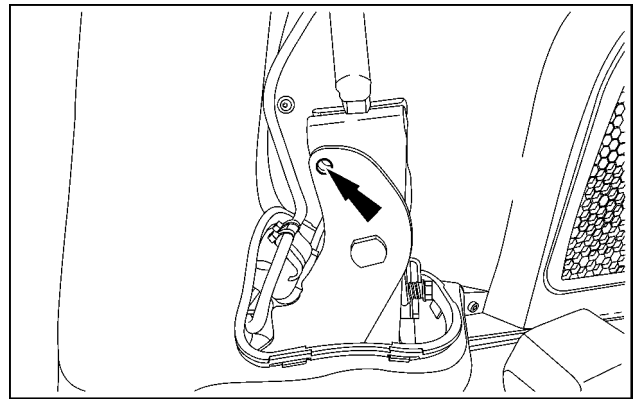

SVIL13TR00647AB 5

10. Remove the fixing bolt from the Power Take-Off (PTO) range lever (1). Remove the Power Take-Off (PTO) range lever.

11. Remove the six bolts from the trim panel (2).

12. Lift up the trim panel.

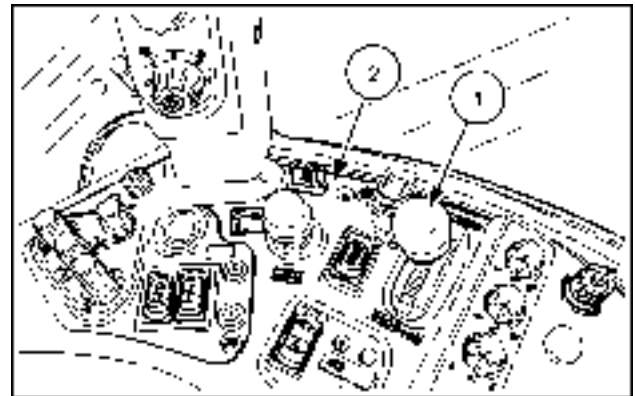

SS14A153 6

13. Remove the bolts (1).

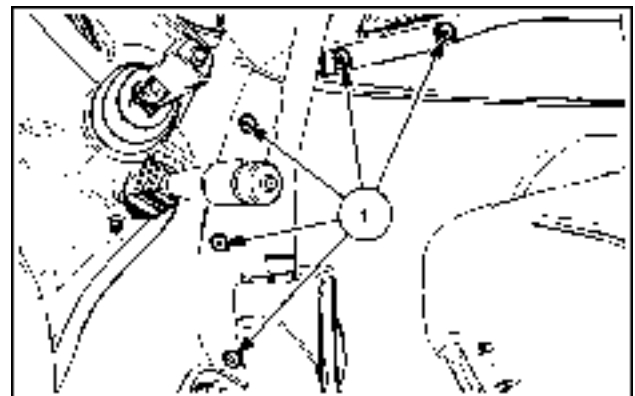

SS14D089 7

14. Remove the bolts from the trim panel (1).
15. Remove the trim panel (1).

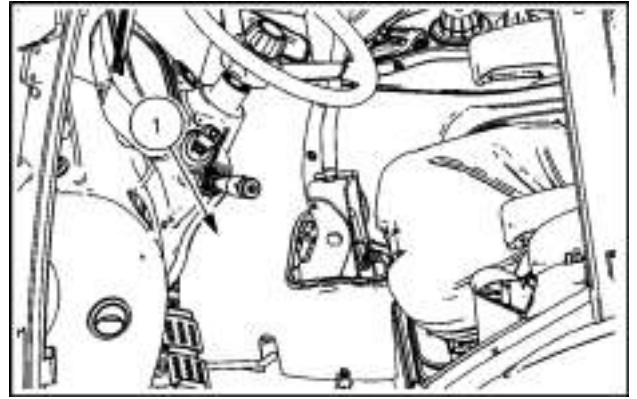

SS14D090 8

16. Install a fixing bolt into the holes of the gear selector levers.

**NOTE:** The diameter of the fixing bolt should be 9.5 mm (0.37 in).

17. Remove the clevis pins (1).

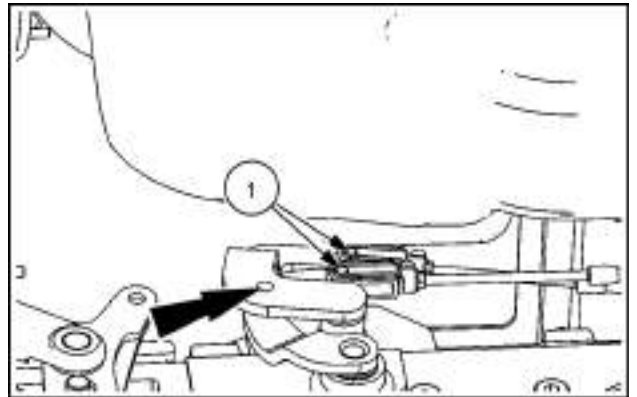

SS14D094 9

18. Remove the bolts (1).

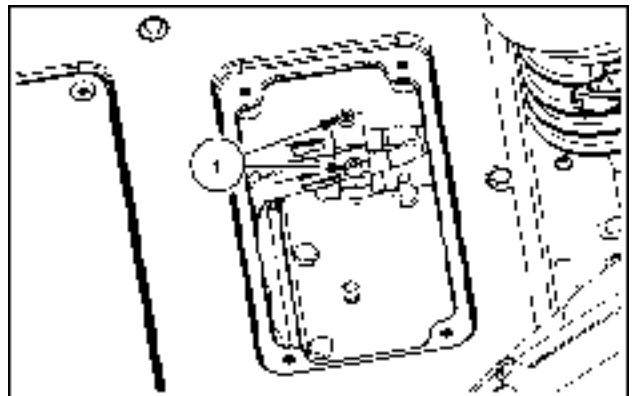

SS14D087 10

19. Remove the clevis pins (1).
20. Remove the clevis (2) from both control cables.
21. Remove the nuts (3) from both control cables.

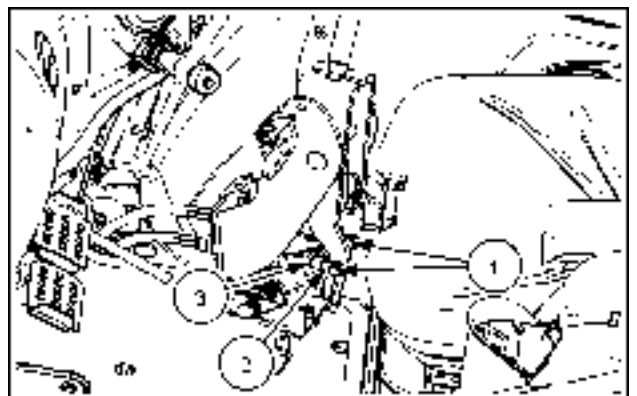

SS14D091 11

22. Remove the nuts (4).

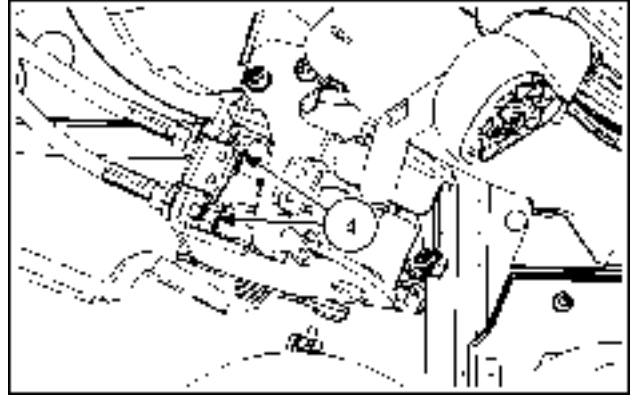

SS14D092 12

23. Remove the bolts (1).

24. Remove the control cable.

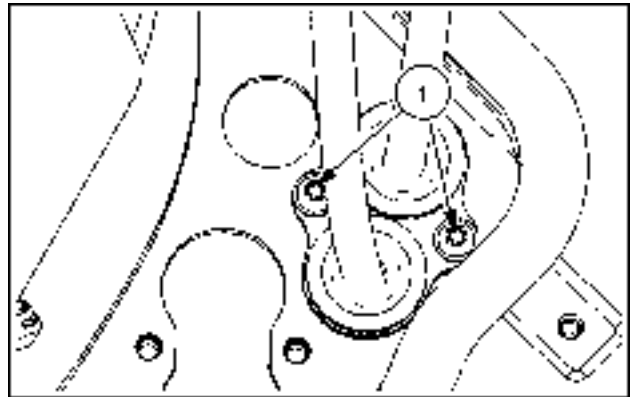

SS14D095 13

**Next operation:**  
**Transmission control - Install (21.133)**

## Transmission control - Install – Control cable gear shift

### Prior operation:

#### Transmission control - Remove (21.133)

1. Remove the clevis (2), the nuts (3), the nuts (4) and the plate (5) from the control cable.

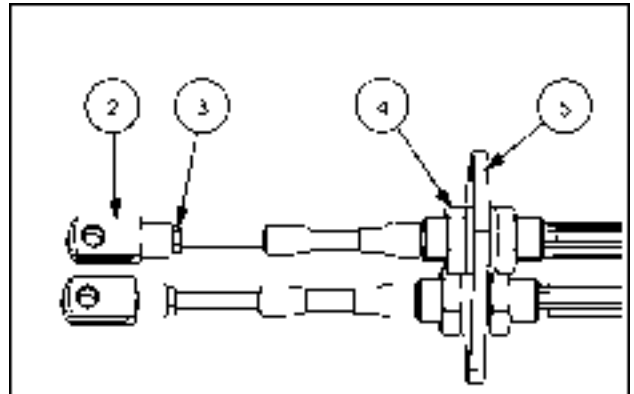

SS14D096 1

2. Install the control cable.
3. Fit the bolts (1).

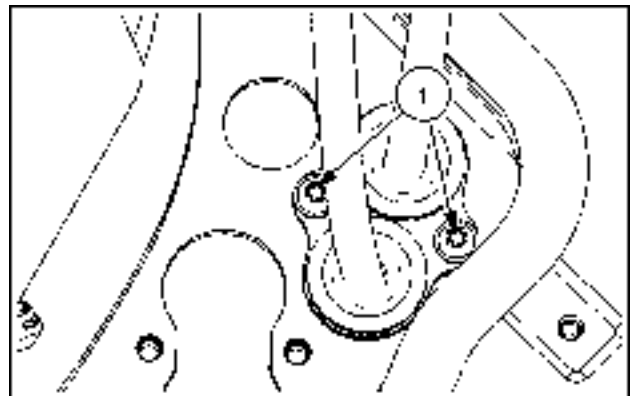

SS14D095 2

4. Install the clevis pins (1).

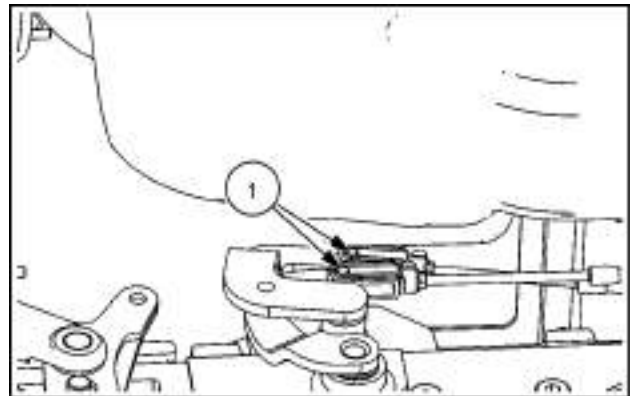

SS14D094 3

5. Fix the control cable with the nuts (4).

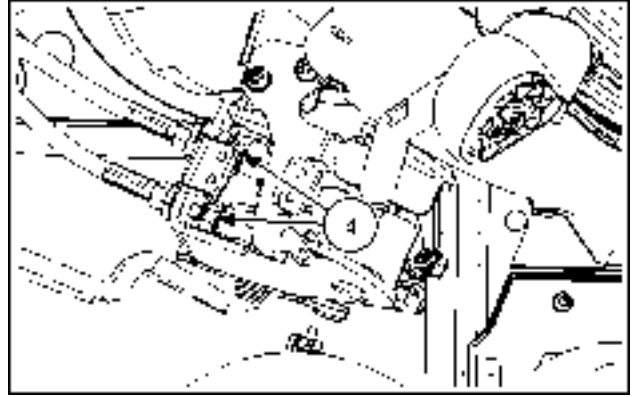

SS14D092 4

6. Install the nuts (3) and the clevis (2).
7. Fix the clevis with the nuts.

**NOTE:** Make sure that the distance (A) between the middle of the hole in the clevis and the plate is 154 mm (6.06 in).

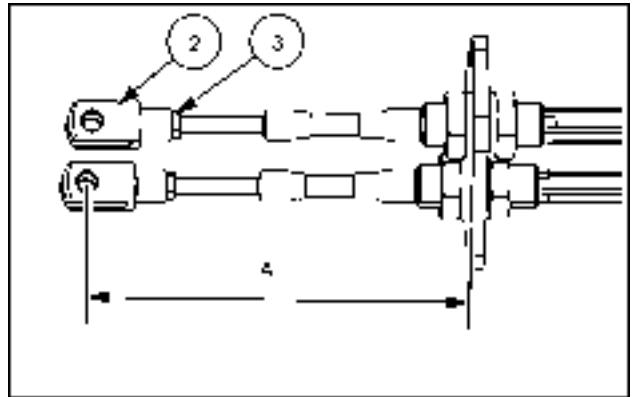

SS14D097 5

8. Install the clevis pins (1).

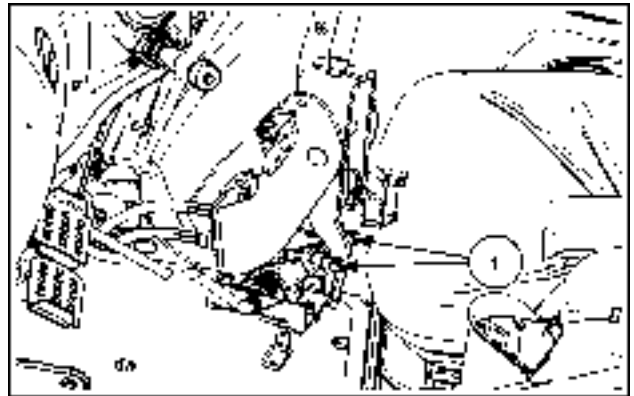

SS14D091 6

9. Install the bolts (1).
10. Tighten the bolts to 23 N·m (17 lb ft).

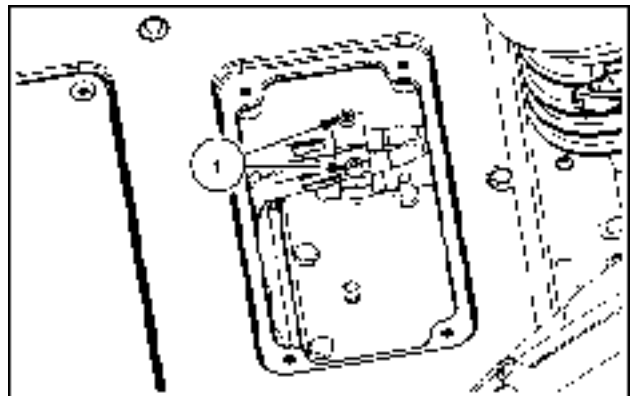

SS14D087 7

11. Remove the fixing bolts from the gear selector levers and the gear lever.

12. Install the trim panel (1).
13. Fix the trim panel (1) with the bolts.

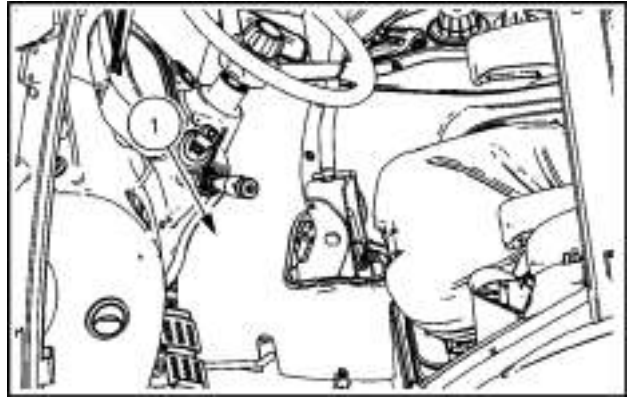

SS14D090 8

14. Install the bolts (1).

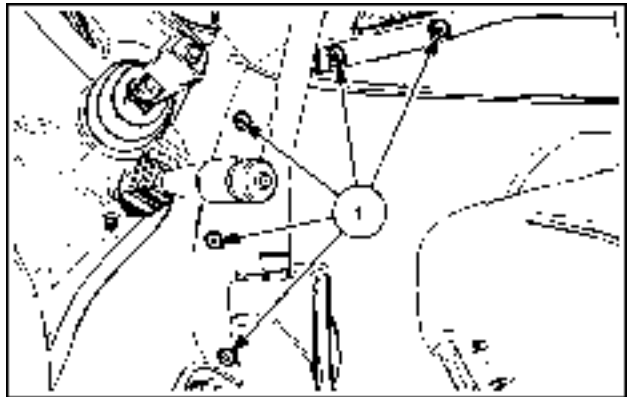

SS14D089 9

15. Fix the trim panel (2) with the bolts.
16. Install the Power Take-Off (PTO) range lever (1). Fix the Power Take-Off (PTO) range lever with the fixing bolt.

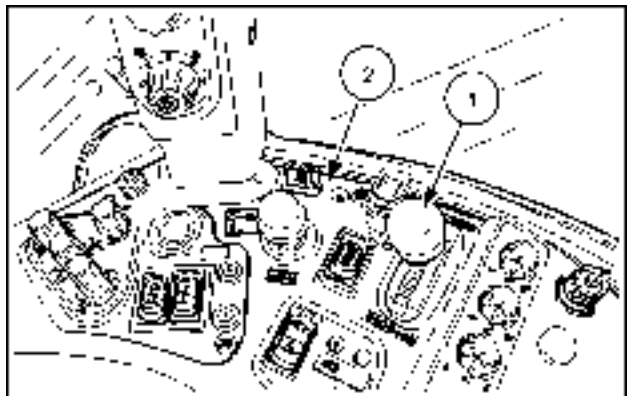

SS14A153 10

17. Install the rubber cover (1).

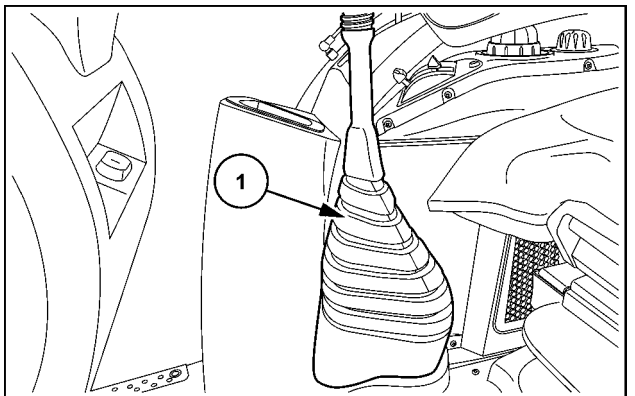

SVIL13TR00648AB 11

18. Install the cover (2).
19. Install the bolts (1).

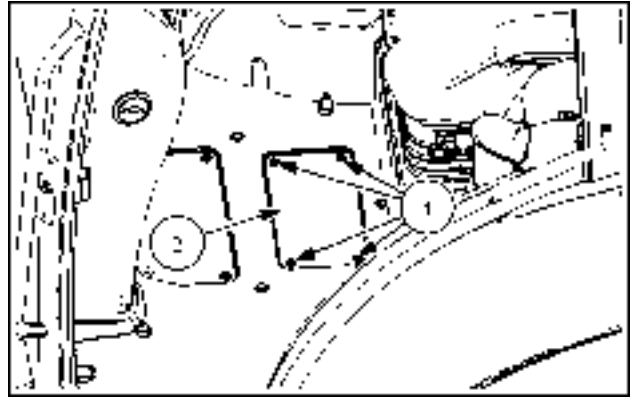

SS14D088 12

20. Install the floor mat.
21. Install the fixing plates.
22. Install the bolts (1).

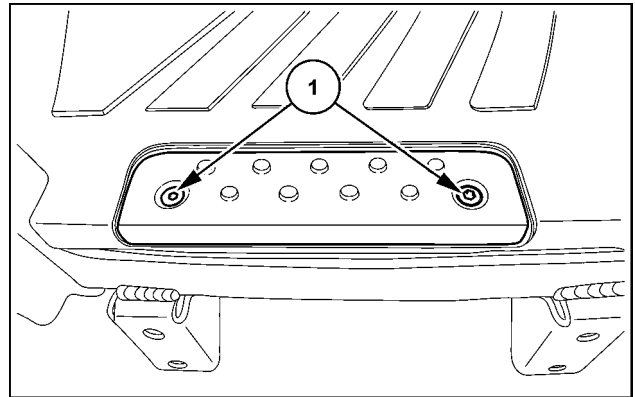

SVIL13TR00636AB 13

23. Install the rubber cover.
24. Install the bolts (1) and the nuts (2).

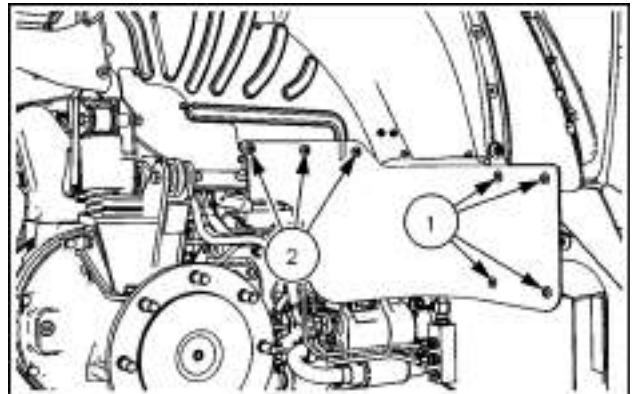

SS14D098 14

**Next operation:**

Install the right-hand rear wheel. See **Rear wheels - Install (44.520)**.

# Index

---

## Transmission - 21

### Semi-Powershift transmission external controls - 133

Semi-Powershift transmission external controls - Exploded view .....	4
Transmission control - Install – Control cable gear shift .....	13
Transmission control - Remove – Control cable gear shift .....	9
Transmission control valve - Overview .....	7







## **Transmission - 21**

### **Semi-Powershift transmission lubrication system - 103**

**Farmall 105U Pro EP  
Farmall 115U Pro EP  
Farmall 95U Pro EP**

# Contents

---

## Transmission - 21

### Semi-Powershift transmission lubrication system - 103

#### TECHNICAL DATA

Semi-Powershift transmission lubrication system	
General specification .....	3
Accumulator	
General specification .....	4

#### FUNCTIONAL DATA

Semi-Powershift transmission lubrication system	
Hydraulic schema .....	6
Static description .....	8
Exploded view .....	10

## **Semi-Powershift transmission lubrication system - General specification**

Permitted angle to the front and to the rear at a normal oil level	<b>30 °</b>
Permitted angle to the left and to the right at a normal oil level	<b>30 °</b>
Permitted angle to the front and to the rear in combination at a normal oil level	<b>30 °</b>
Pressure lubrication point 1 at an engine rpm of <b>2200 RPM</b>	<b>1.5 bar (21.8 psi)</b>
Pressure lubrication point 2 at an engine rpm of <b>2200 RPM</b>	<b>0.7 bar (10.1 psi)</b>

## Accumulator - General specification

Design	Membrane accumulator
Capacity	<b>1 l (0.26 US gal)</b>
Filling gas	Nitrogen
Filling gas pressure at <b>20 °C (68 °F)</b>	<b>* 15 bar +/- 1 (218 psi +/- 14)</b> <b>* 11 bar +/- 1 (160 psi +/- 14)</b>
Operating temperature	<b>-30 - 80 °C (-22 - 176 °F)</b>
Maximum service pressure	<b>120 bar (1740 psi)</b>

\*) Depending on the production date, the accumulator is filled at **15 bar (218 psi)** or **11 bar (160 psi)**. See the decal on the accumulator.



## Semi-Powershift transmission lubrication system - Hydraulic schema

- |  |   |
|--|---|
| 1. Oil sump  | 2. 40 $\mu$ suction filter with bypass valve  |
| 3. Hydraulic pump <b>14 cm<sup>3</sup> (0.85 in<sup>3</sup>)</b>                                 | 4. Hydraulic trailer brake valve (if fitted) <b>Hydraulic systems - Hydraulic schema (35.000)</b>               |
| 5. Filter with bypass valve  | 6. Transmission   |
| 7. Clutch solenoid valve C   | 8. Clutch measuring point C (M14x1.5)   |
| 9. Clutch C  | 10. Clutch solenoid valve B   |
| 11. Clutch measuring point A (M14x1.5)   | 12. Clutch A  |
| 13. Differential lock solenoid valve   | 14. Differential lock measuring point (M14x1.5)   |
| 15. Rear differential lock   | 16. Clutch solenoid valve 4WD   |
| 17. Clutch measuring point 4WD (M14x1.5)   | 18. Clutch 4WD  |
| 19. Clutch solenoid valve D  | 20. Clutch measuring point D (M14x1.5)  |
| 21. Clutch D   | 22. Clutch solenoid valve B   |
| 23. Clutch measuring point B (M14x1.5)   | 24. Clutch B  |
| 25. Trans Oil Press SW   | 26. Temperature sensor  |
| 27. Clutch solenoid valve G  | 28. Clutch measuring point G (M14x1.5)  |
| 29. Clutch G   | 30. Clutch solenoid valve F   |
| 31. Clutch measuring point F (M14x1.5)   | 32. Clutch F  |
| 33. Rear power take-off clutch solenoid valve  | 34. Power take-off clutch measuring point (M14x1.5)   |
| 35. Power take-off clutch (PTO)  | 36. Power Take-Off (PTO) clutch brake   |
| 37. System pressure control valve  | 38. Front power take-off clutch solenoid valve  |
| 39. Front PTO clutch   | 40. Electric parking brake solenoid valves (EPB)  |
| 41. Spring energy cylinder (EPB)   | 42. Front differential lock solenoid valve (if fitted)  |
| 43. Front axle differential lock cylinder  | 44. Hydraulic pump <b>14 cm<sup>3</sup> (0.85 in<sup>3</sup>) Hydraulic systems - Hydraulic schema (35.000)</b> |
| 45. Steering valve   | 46. Thermostat <b>45 °C (113 °F)</b>  |
| 47. Transmission oil cooler  | 48. Heat exchanger for hydraulic oil (if fitted)  |
| 49. Connections to high-pressure hydraulics <b>Hydraulic systems - Hydraulic schema (35.000)</b> | 50. Lubricant pressure limiter valve <b>5 bar (72 psi)</b>  |
| 51. System pressure accumulator  | 52. rear axle   |

### Lubrication points

- |   |   |
|---|---|
| K1. Power take-off and power take-off clutch    | K2. Clutch shaft with clutch D and clutch B |
| K3. Central clutch shaft, clutch C and clutch A | K4. Clutch shaft with clutch G and clutch F |
| K5. Differential                                | K6. Countershaft                            |
| K7. Crown Wheel & Pinion                        | K8. Left-hand brake and right-hand brake    |

### Color legend

- |   |                                      |
|---|--------------------------------------|
| A. High-pressure circuit                          | G. Trapped oil                       |
| B. Pressure drop in the high-pressure circuit     | H. Oil to the tank                   |
| C. Steering Circuit                               | I. Feed oil circuit or trailer brake |
| D. Low-pressure circuit (P1)                      | J. Load Sensing (LS) line            |
| E. Pressure drop in the low-pressure circuit (P1) | K. Lubrication Circuit               |
| F. Oil in suction                                 |                                      |

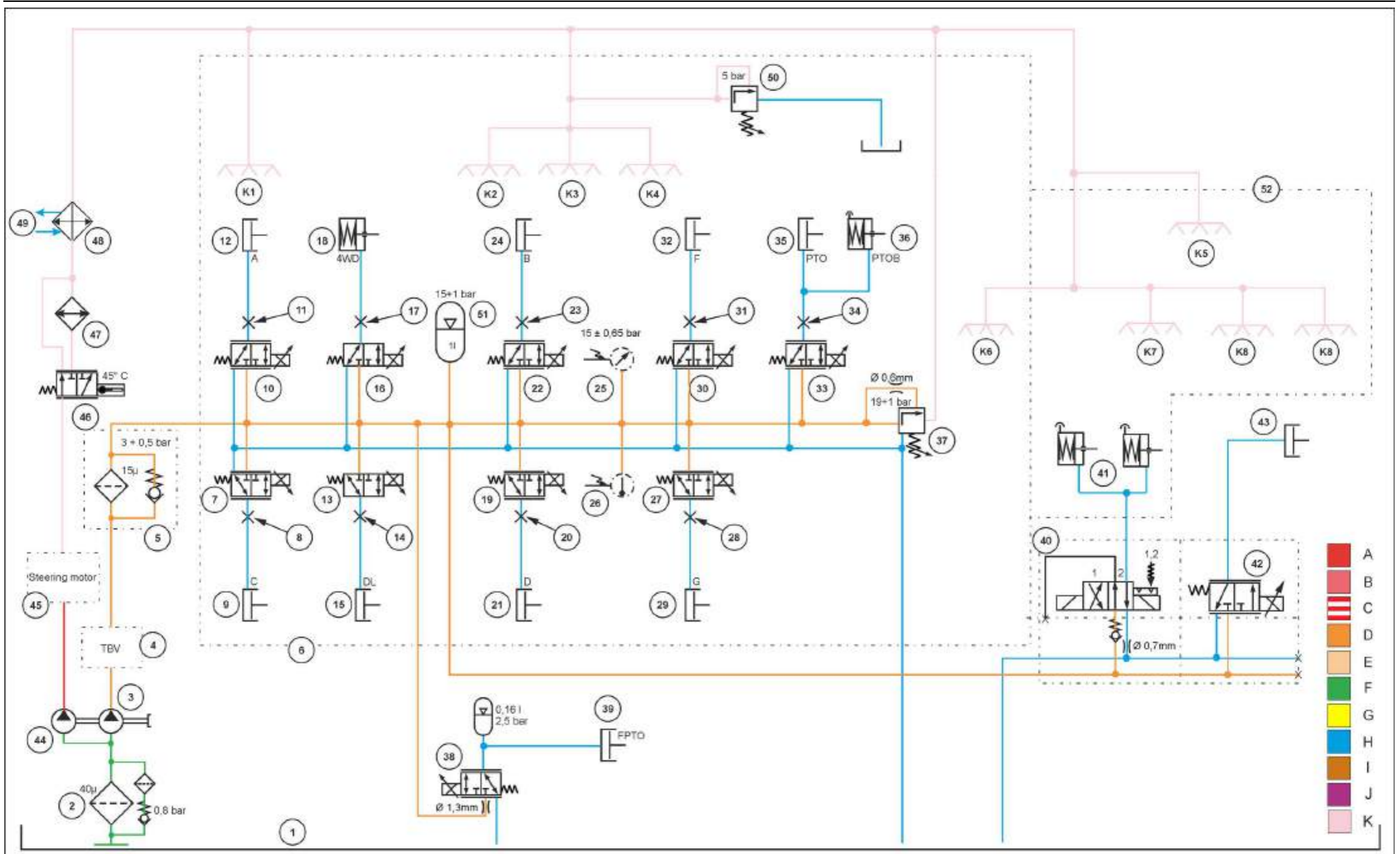

SS13A221 1



## Semi-Powershift transmission lubrication system - Static description

### Lubrication circuit

1. Oil from steering circuit (transmission oil cooler)
2. Transmission system-pressure regulating valve **19 - 20 bar (276 - 290 psi)**
3. Oil from transmission circuit
4. Lubrication to Power Take-Off (PTO) shaft and clutch
5. Power Take-Off (PTO) clutch
6. Lubrication oil to transmission shafts and clutches A, B, C, D, F and G
7. Clutch C and A
8. Clutch D and B
9. Clutch G and F
10. Lubrication oil pressure limiter valve
11. Lubrication oil to distributor rear axle
12. Lubrication oil to differential and differential lock
13. Lubrication oil to layshaft
14. Lubrication oil to bevel gear pinion bearings
15. Lubrication oil to differential crown wheel
16. Lubrication oil to brake left-hand and right-hand

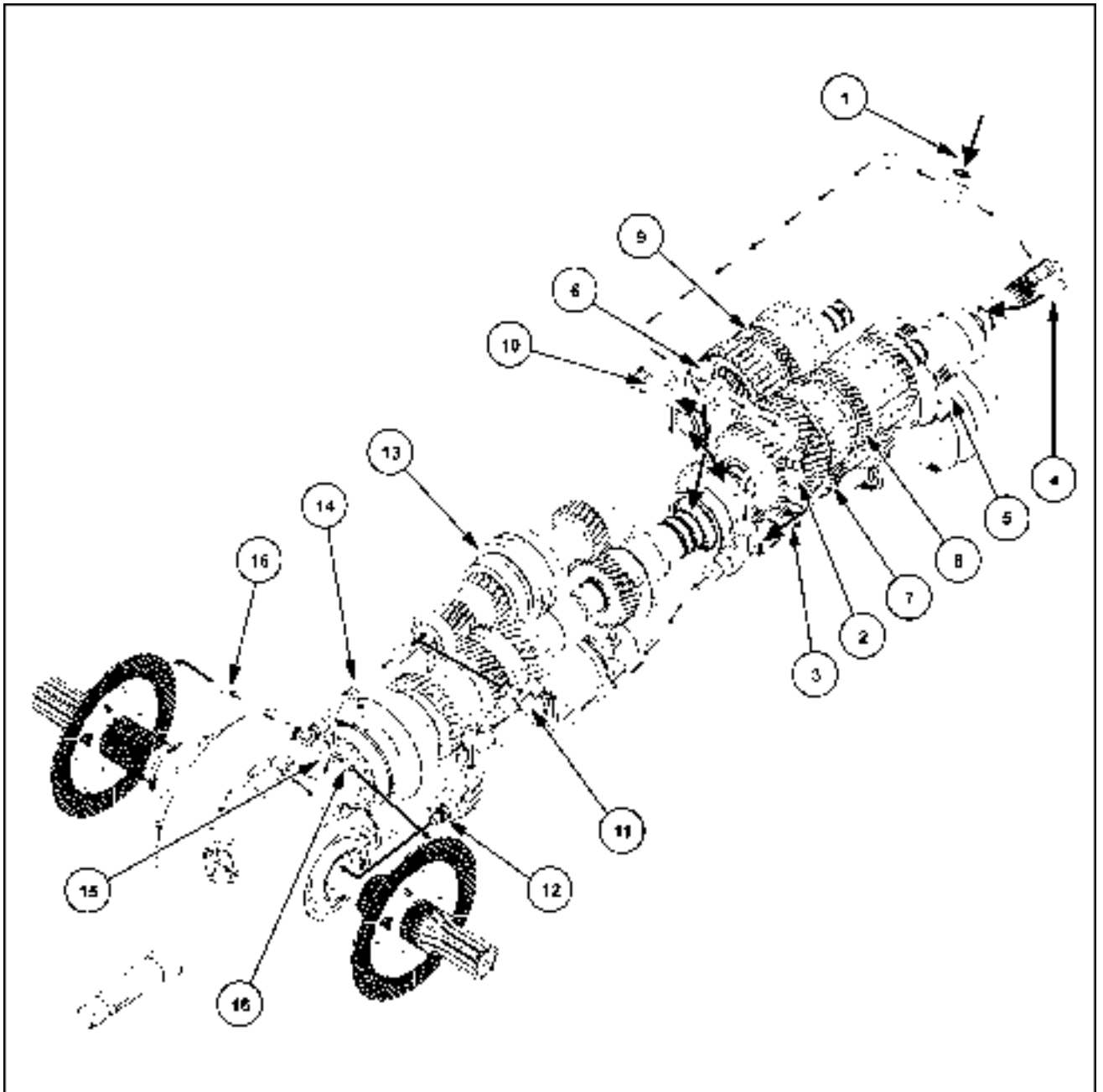

SS13A640 1

---

## Semi-Powershift transmission lubrication system - Exploded view

121	Lubrication line	122	Fitting
123	Union	124	Union
125	Lubrication line	126	Union
127	Lubrication line	128	Union
129	Screw plug	130	O-ring
131	Spring	132	Pistons
133	Transmission oil pressure switch	134	O-ring
135	O-ring	136	Transmission Oil Temp Sensor
137	seal	138	Screw plug
139	Pressure regulator valve ( <b>19 bar</b> )	140	Union
141	Pressure line ( <b>19 bar</b> )	142	Union

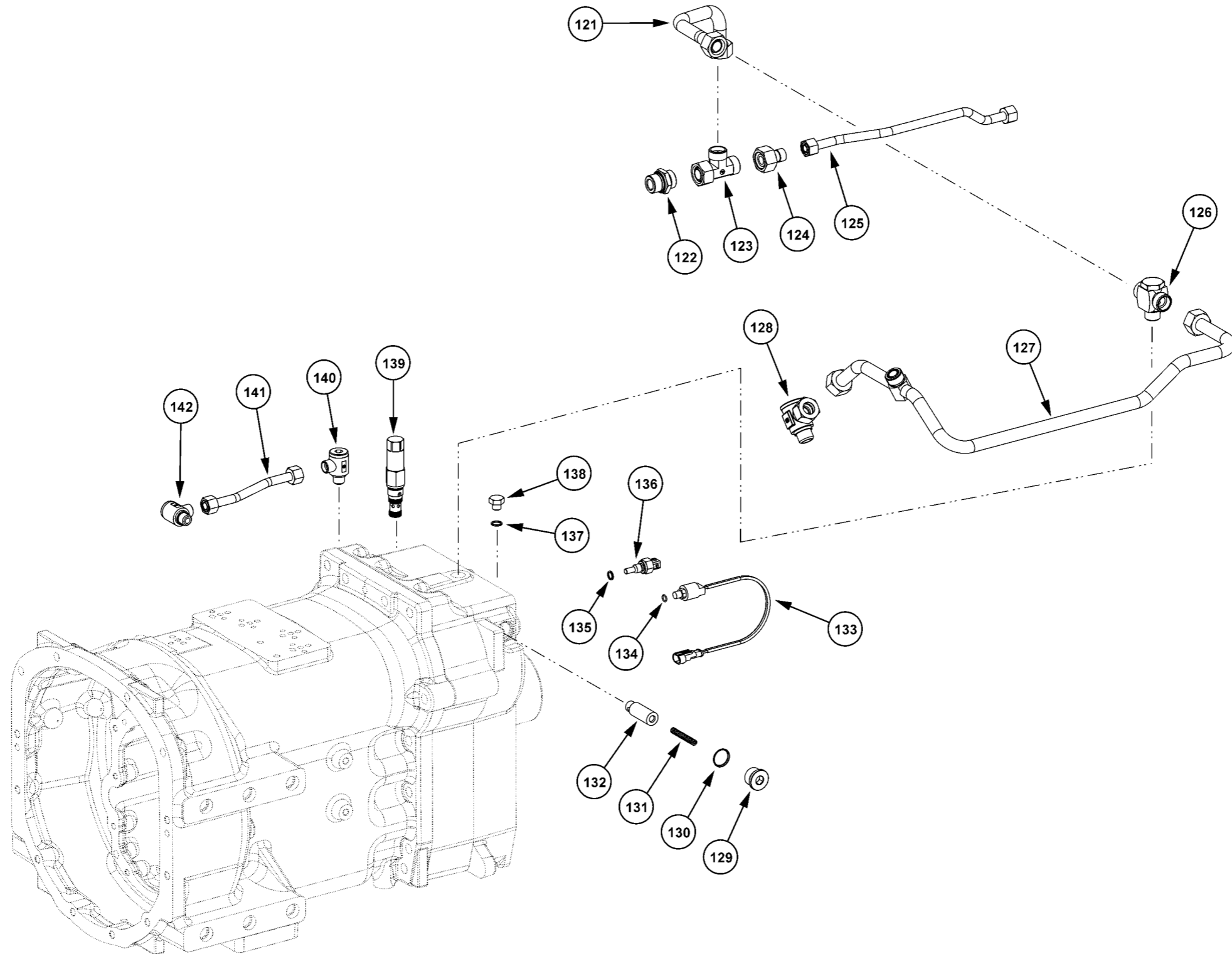



# Index

---

## Transmission - 21

### Semi-Powershift transmission lubrication system - 103

Semi-Powershift transmission lubrication system - Static description .....	8
Accumulator - General specification .....	4
Semi-Powershift transmission lubrication system - Exploded view .....	10
Semi-Powershift transmission lubrication system - General specification .....	3
Semi-Powershift transmission lubrication system - Hydraulic schema .....	6





## **Transmission - 21**

### **Semi-Powershift transmission internal components - 152**

**Farmall 105U Pro EP  
Farmall 115U Pro EP  
Farmall 95U Pro EP**



# Contents

---

## Transmission - 21

### Semi-Powershift transmission internal components - 152

#### FUNCTIONAL DATA

##### Semi-Powershift transmission internal components

Exploded view – A/C clutch and B/D clutch .....	4
Exploded view – clutch F/G .....	6
Exploded view – 1st - 4th gear .....	8

#### SERVICE

##### Clutch

Remove .....	11
Install .....	12
Adjust – Clutch shafts .....	14
Reverser clutch - Disassemble – clutch F/G .....	17
Reverser clutch - Assemble – clutch F/G .....	23
Range clutch - Disassemble – Clutch A/C .....	31
Range clutch - Assemble – Clutch A/C .....	37
Range clutch - Disassemble – Clutch B/D .....	46
Range clutch - Assemble – Clutch B/D .....	52

##### Transmission internal controls

Remove – Third/fourth gear shift .....	61
Remove – First/second gear shift .....	63
Install – First/second gear shift .....	64
Install – Third/fourth gear shift .....	65
Adjust – First/second gear shift and third/fourth gear shift .....	67

##### Transmission drive and driven shaft

Remove – Countershaft .....	68
Remove – Intermediate shaft .....	70
Remove – Main shaft .....	72
Install – Main shaft .....	73
Install – Intermediate shaft .....	78
Install – Countershaft .....	80



## Semi-Powershift transmission internal components - Exploded view – A/C clutch and B/D clutch

161	Rectangular ring (35x2)	162	Journal
163	Retainer Ring	164	Washer
165	Journal	166	Gear
167	Journal	168	Washer
169	Retainer Ring	170	Retainer Ring
171	Closing disk	172	Friction plate
173	Wave spring	174	Separator plate
175	Piston (clutch D)	176	O-Ring
177	O-Ring	178	Retainer Ring
179	Thrust bearing	180	Belleville spring
181	Guide ring	182	Needle bearing
183	Rectangular ring (38x2)	184	Piston carrier
185	O-Ring	186	O-Ring
187	Piston (clutch B)	188	Friction plate
189	Wave spring	190	Separator plate
191	Closing disk	192	Retainer Ring
193	Guide ring	194	Pressure spring.
195	Guide ring	196	Needle bearing
197	Thrust bearing	198	Blank Plug
199	Clutch shaft ( B/D clutch)	200	Journal
201	Adjuster return plate	202	Rectangular ring
203	Journal	204	Gear
205	Retainer Ring	206	Closing disk
207	Friction plate	208	Wave spring
209	Separator plate	210	Piston (clutch C)
211	O-Ring	212	O-Ring
213	Retainer Ring	214	Thrust bearing
215	Belleville spring	216	Guide ring
217	Needle bearing	218	Rectangular ring (38x2)
219	Piston carrier	220	O-Ring
221	O-Ring	222	Piston (clutch A)
223	Friction plate	224	Wave spring
225	Separator plate	226	Closing disk
227	Retainer Ring	228	Guide ring
229	Pressure spring.	230	Guide ring
231	Needle bearing	232	Thrust bearing
233	Retainer Ring	234	Retainer Ring
235	Adjuster return plate	236	Journal
237	Gear	238	Journal
239	Clutch shaft ( A/C clutch)	240	Blank Plug
241	Shutter	242	Rectangular ring (38x2)
243	Gear shaft	244	Needle bearing
245	Retainer Ring	246	Journal
247	Adjuster return plate	248	Rectangular ring (52x56x2,5)
249	Journal	250	Retainer Ring

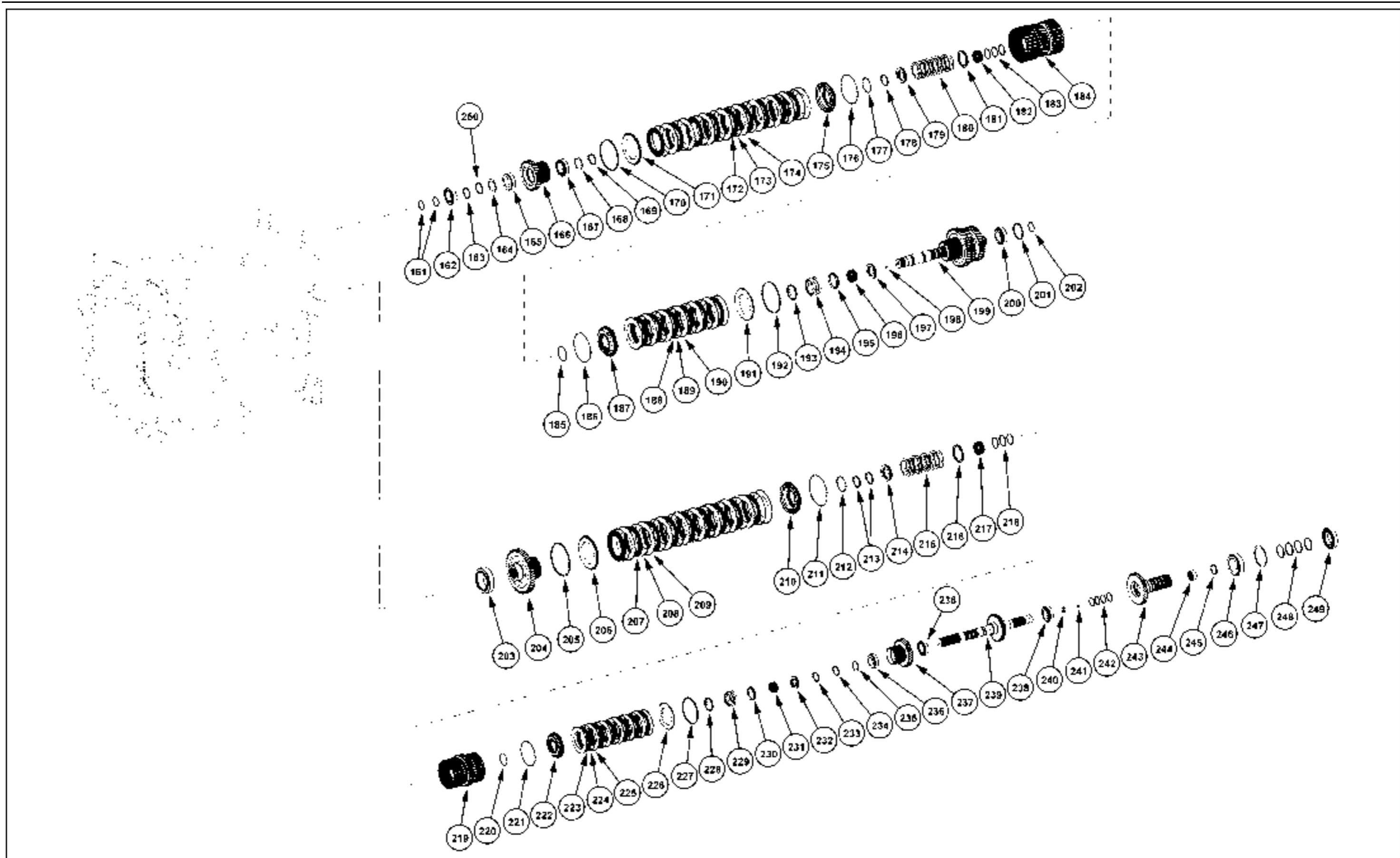

SS13G086 1

---

## Semi-Powershift transmission internal components - Exploded view – clutch F/G

271	Rectangular ring (35x2)	272	Journal
273	Disc holder	274	Retainer Ring
275	Thrust bearing	276	Needle bearing
277	Guide ring	278	Pressure spring.
279	Guide ring	280	Retainer Ring
281	Closing disk	282	Friction plate
283	Wave spring	284	Separator plate
285	Piston (clutch G)	286	O-Ring
287	O-Ring	288	Piston carrier
289	Rectangular ring (38x2)	290	O-Ring
291	O-Ring	292	Piston (clutch F)
293	Separator plate	294	Wave spring
295	Friction plate	296	Closing disk
297	Retainer Ring	298	Guide ring
299	Pressure spring.	300	Guide ring
301	Needle bearing	302	Thrust bearing
303	Retainer Ring	304	Washer
305	Journal	306	Gear
307	Journal	308	Clutch shaft ( F/G clutch)
309	Journal	310	Adjuster return plate
311	Rectangular ring (35x2)		

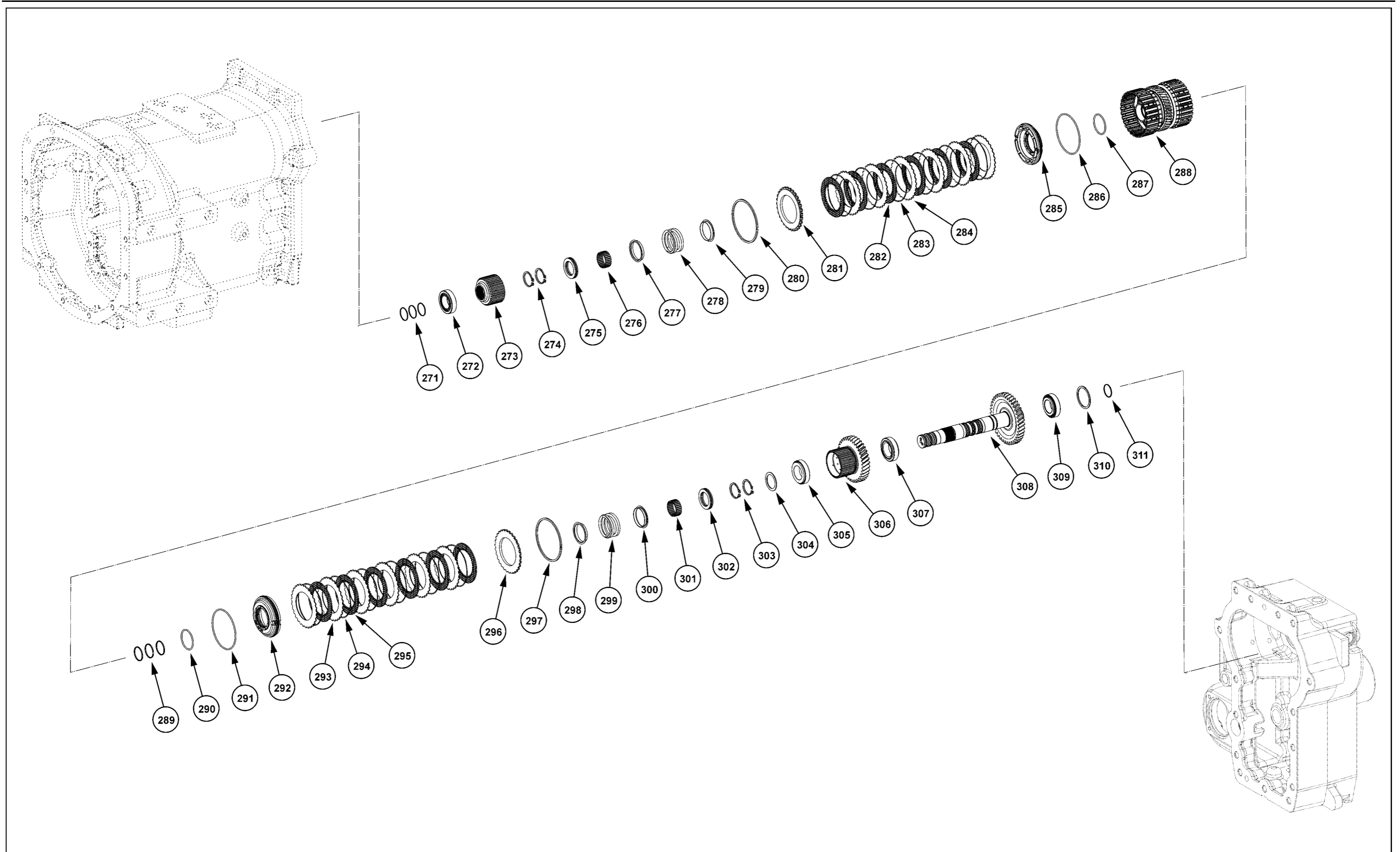

## Semi-Powershift transmission internal components - Exploded view – 1st - 4th gear

331 Selector shaft	332 Retainer Ring
333 Bushing	334 O-Ring
335 Selector finger	336 Bolt
337 Bolt	338 Sweeper
339 Bolt	340 Shifter rod
341 Sweeper	342 Bolt
343 Bolt	344 Ball
345 Stop pin	346 Ball
347 Ball	348 Spring
349 Stop pin	350 Ball
351 Shifter rod	352 Shift fork (2nd gear)
353 Shift fork (3rd gear)	354 Grooved nut
355 Journal	356 Gear
357 Spacer Sleeve	358 Journal
359 Thrust washer.	360 Gear
361 Needle bearing	362 Liner
363 Ring, spacer	364 Synchronizer
365 Gear	366 Ring, spacer
367 Liner	368 Needle bearing
369 Thrust washer.	370 Gear
371 Spacer Sleeve	372 Countershaft
373 Ring	374 Washer
375 Ring	376 Journal
377 Adjuster return plate	378 Retainer Ring
379 Bolt	380 Bushing
381 Jackshaft	382 Shutter
383 Retaining ring	384 Retainer Ring
385 Journal	386 Gear
387 Retainer Ring	388 Needle bearing
389 Grooved nut	390 Journal
391 Gear	392 Spacer Sleeve
393 Gear	394 Gear
395 Bushing	396 Synchronizer
397 Gear	398 Bushing
399 Thrust washer.	400 Retainer Ring
401 Journal	402 Main shaft
403 Needle bearing	

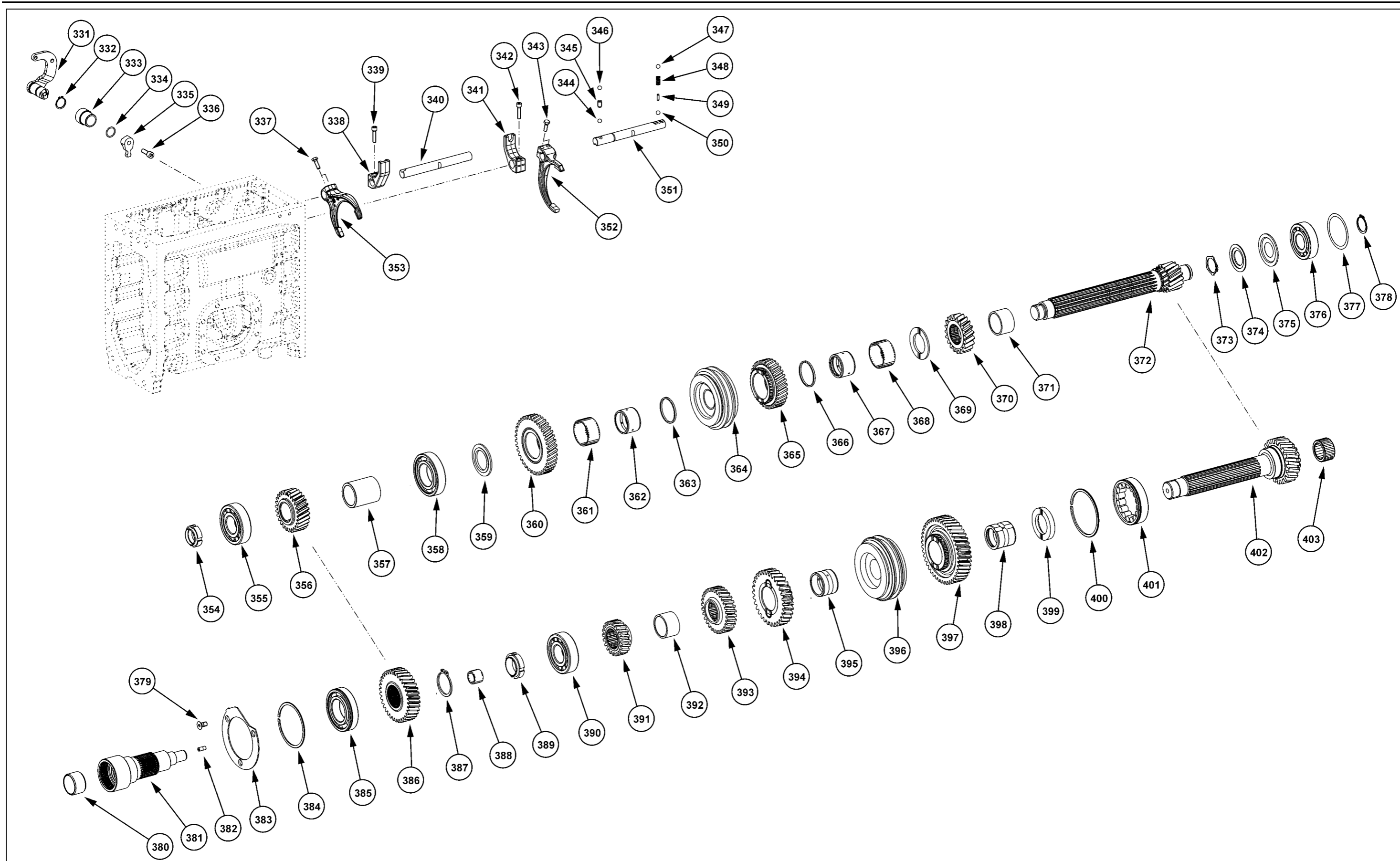

SS13E026 1





## Clutch - Remove

### Prior operation:

#### Intermediate housing - Remove (21.111)

1. Fit the lifting device **380200445 (X)**.
2. Lift the clutch shafts together from the intermediate housing.

**NOTE:** Be careful with the gear (**204**). The gear can remain in the housing when you lift the clutch shaft A/C.

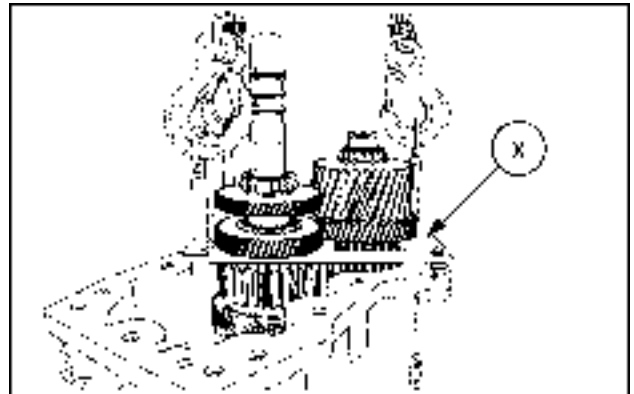

SVIL14TR00076AA 1

3. Remove the bearing (**272**) from the range housing.

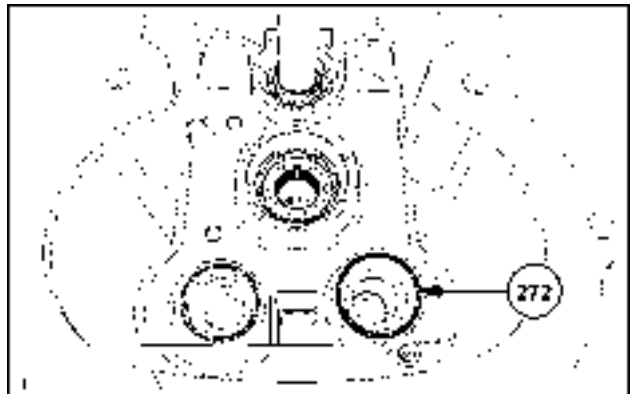

SVIL13TR00170AB 2

4. Remove the bearing (**309**) from the intermediate housing.

**NOTE:** Be careful with the adjustment disks.

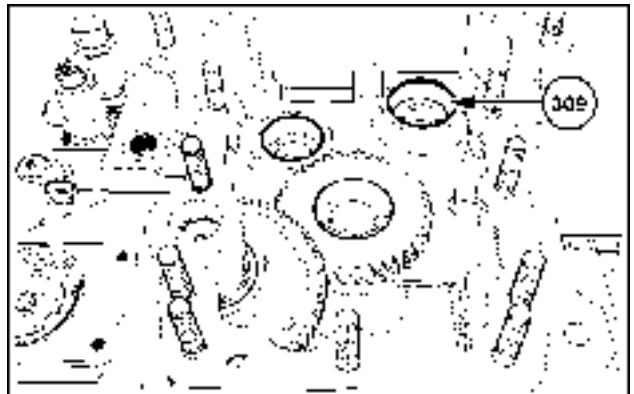

SVIL13TR00171AB 3

### Next operation:

Clutch Reverser clutch - Disassemble – clutch F/G (21.152)

Clutch Range clutch - Disassemble – Clutch A/C (21.152)

Clutch Range clutch - Disassemble – Clutch B/D (21.152)

## Clutch - Install

### Prior operation:

Clutch Reverser clutch - Assemble – clutch F/G (21.152)

Clutch Range clutch - Assemble – Clutch A/C (21.152)

Clutch Range clutch - Assemble – Clutch B/D (21.152)

1. Install the bearings (162), (203) and (272) in the intermediate housing.

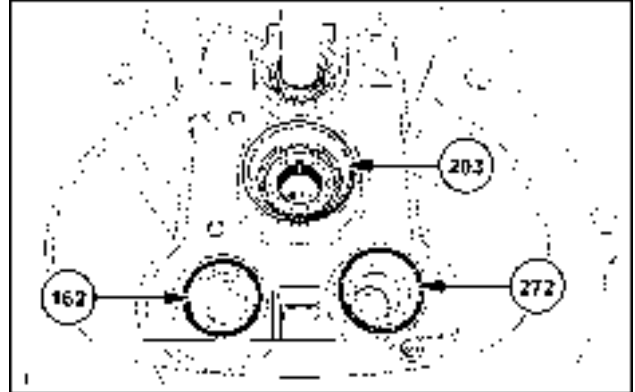

SVIL13TR00170AC 1

2. Use the mounting device to prevent slippage of the gear (204) of the clutch K1/K2.

**NOTE:** Produce the mounting device in accordance with the technical drawing. Refer to **Semi-Powershift transmission - Special tools (21.111)**.

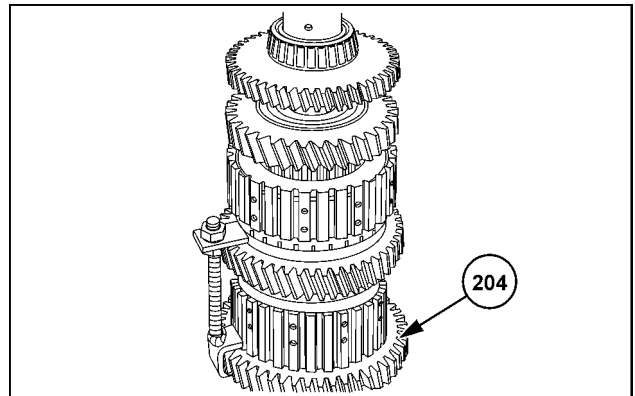

SVIL13TR00442AB 2

3. Position all three clutch shafts on the lifting device **380200445 (X)**. Secure the clutch shafts with the bracket.
4. Lift the clutches together into the intermediate housing.
5. If you removed the two dowels from the transmission housing, install the two dowels again.

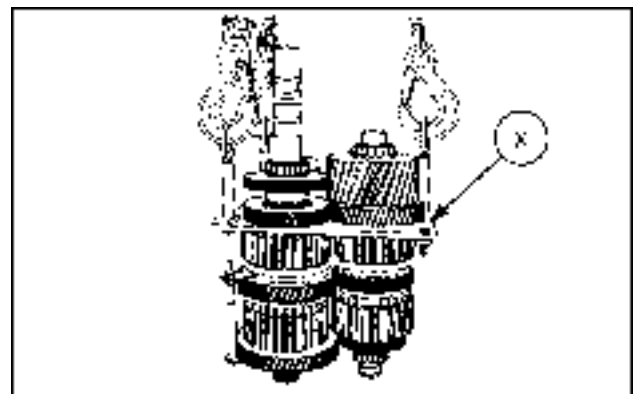

SVIL14TR00075AA 3

6. Press the bearing (246) onto the drive shaft (243) until the bearing sits in place.

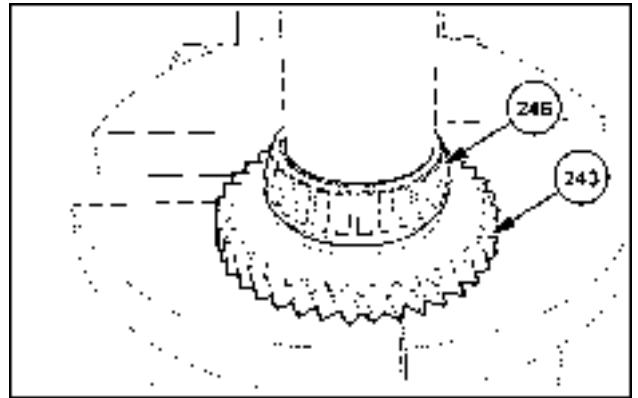

SVIL13TR00444AB 4

7. Insert the bearing (238) into the drive shaft (243) until the bearing sits in place.

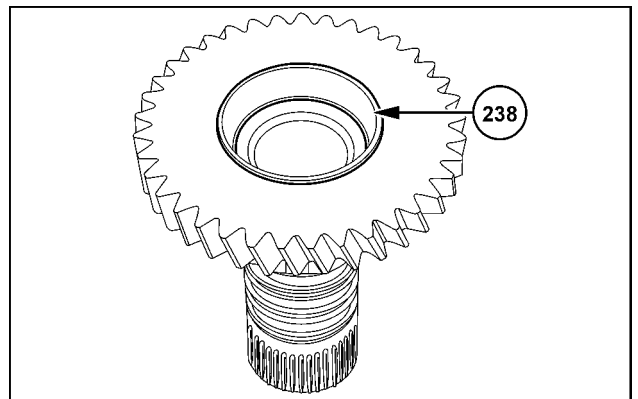

SVIL13TR00445AB 5

8. Slide on the pre-assembled drive shaft.

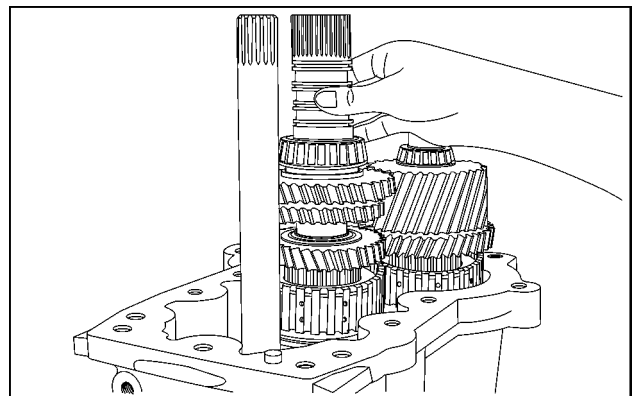

SVIL13TR00446AB 6

9. Install the bearing (246).

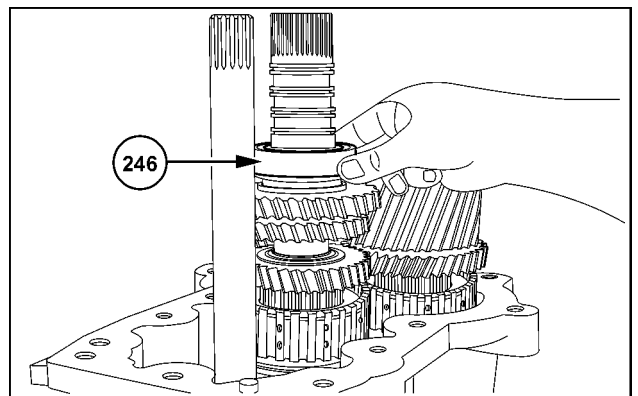

SVIL13TR00447AB 7

**Next operation:**  
**Clutch - Adjust – Clutch shafts (21.152)**

## Clutch - Adjust – Clutch shafts

### Prior operation:

#### Clutch - Install (21.152)

Adjust the axial play from **0.02 - 0.10 mm (0.0008 - 0.0039 in)** in the clutch shaft (K1/K2).

**NOTE:** Use commercially available measurement tools to determine the dimensions below.

1. Measure dimension "A" from the flange surface to the bearing outer ring.

Measurement "A" e.g: **149.350 mm (5.880 in)**

**NOTE:** Take measurements at various points to determine the mean value.

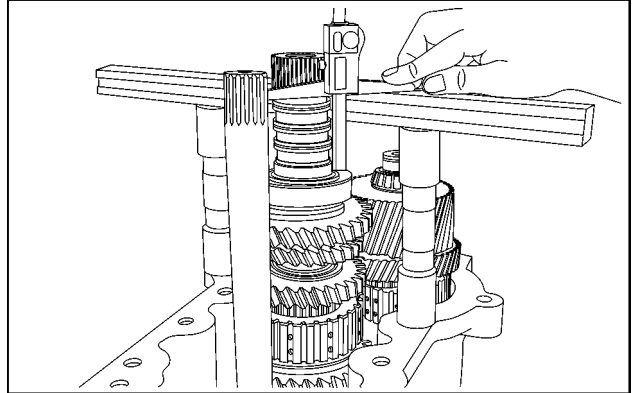

SVIL13TR00448AB 1

2. Measure dimension "B" from the flange surface to the drill base of the intermediate housing (pump drive).

Measurement "B" e.g: **151.580 mm (5.968 in)**

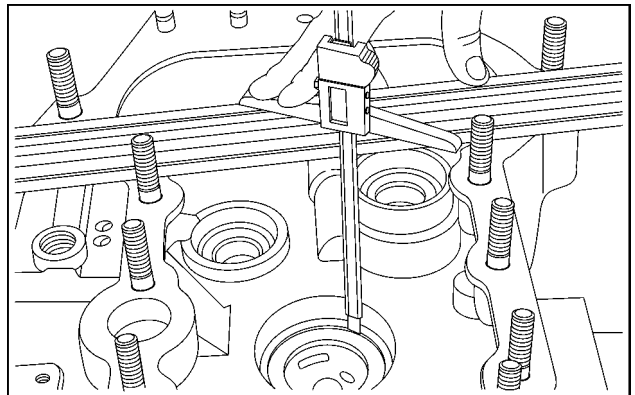

SVIL13TR00449AB 2

### Example calculation:

Dimension "B":	<b>151.580 mm (5.968 in)</b>
Dimension "A":	<b>- 149.350 mm (5.880 in)</b>
Axial play <b>0.020 - 0.100 mm (0.001 - 0.004 in)</b>	<b>- 0.060 mm (0.002 in)</b>
Result = adjustment disc	<b>2.170 mm (0.085 in)</b>

3. Insert the calculated adjustment disk (**247**).

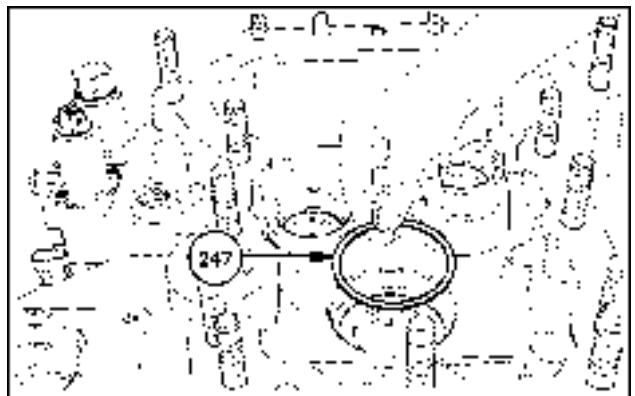

SVIL13TR00450AB 3

4. Insert the bearing outer ring (**246**) into the intermediate housing.

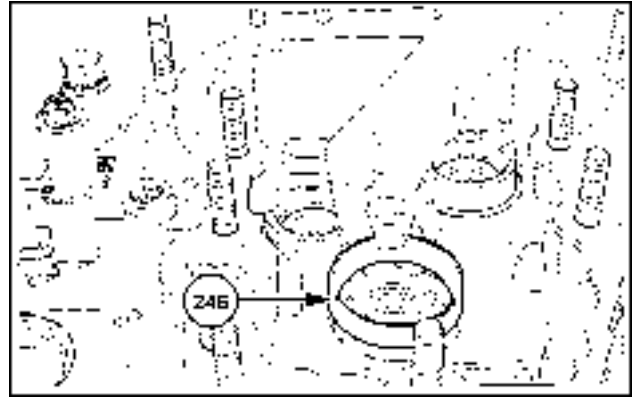

SVIL13TR00451AB 4

5. Adjust the axial play **0.02 - 0.10 mm (0.001 - 0.004 in)** of the clutch shaft (K3/K4).  
 6. Install the bearing outer ring.  
 7. Measure dimension "A" from the flange surface to the bearing outer ring.  
 Measurement "A" e.g: **133.250 mm (5.246 in)**

**NOTE:** Take measurements at various points to determine the mean value.

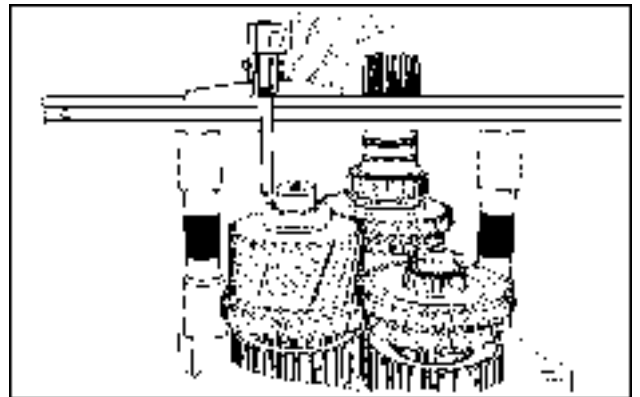

SVIL13TR00452AB 5

8. Measure dimension "B" from the flange surface to the drill base of the intermediate housing (pump drive).  
 Measurement "B" e.g: **135.050 mm (5.317 in)**

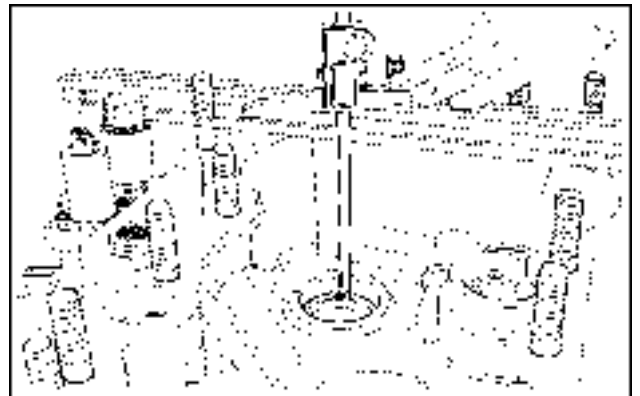

SVIL13TR00453AB 6

**Example calculation:**

Dimension "B":	<b>135.050 mm (5.317 in)</b>
Dimension "A":	<b>- 133.250 mm (5.246 in)</b>
Axial play <b>0.020 - 0.100 mm (0.001 - 0.004 in)</b>	<b>- 0.060 mm (0.002 in)</b>
<hr/>	
Result = adjustment disc	<b>1.740 mm (0.069 in)</b>

9. Insert the calculated adjustment disk (201).

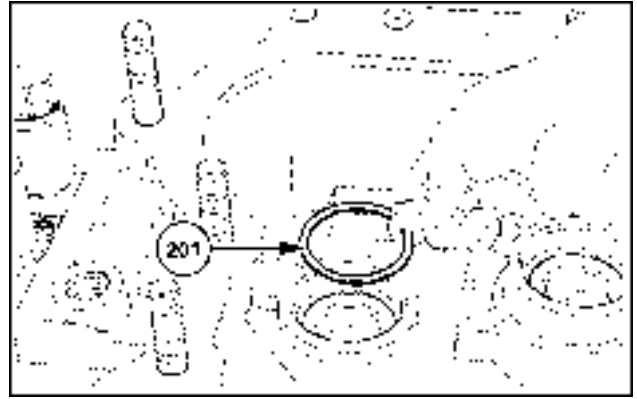

SVIL13TR00454AB 7

10. Insert the bearing outer ring (200) into the intermediate housing.

**NOTE:** Adjust the axial play of the clutch shaft (K5/K6) according to the clutch shaft (K3/4). See illustrations 5 to 8.

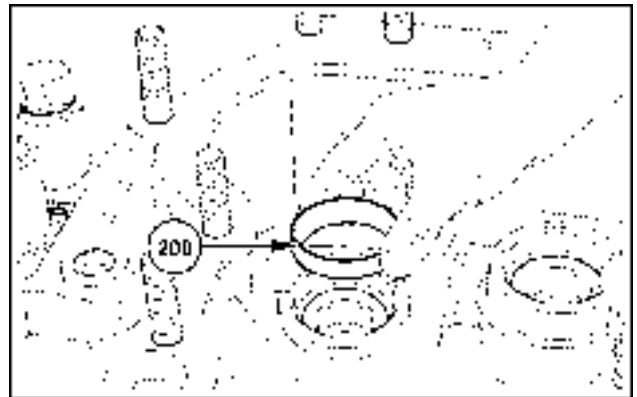

SVIL13TR00456AB 8

**Next operation:**  
Intermediate housing - Install (21.111)

## Clutch Reverser clutch - Disassemble – clutch F/G

Prior operation:

Clutch - Remove (21.152)

1. Remove the rectangular rings (271) and (311).

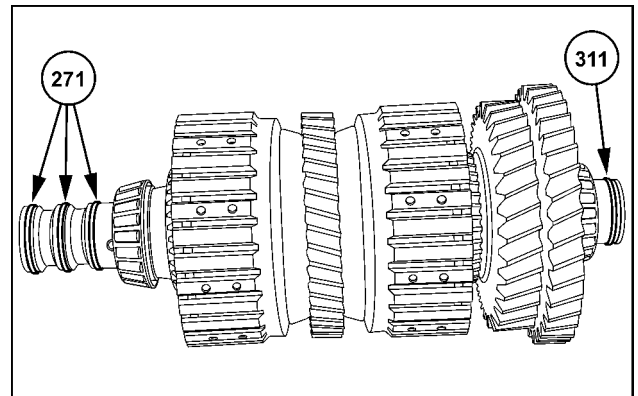

SVIL13TR00150AB 1

2. Remove the bearing (272).

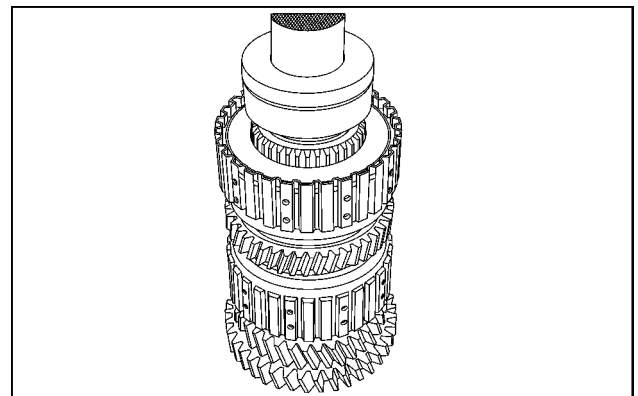

SVIL13TR00151AB 2

3. Remove the disc holder (273).

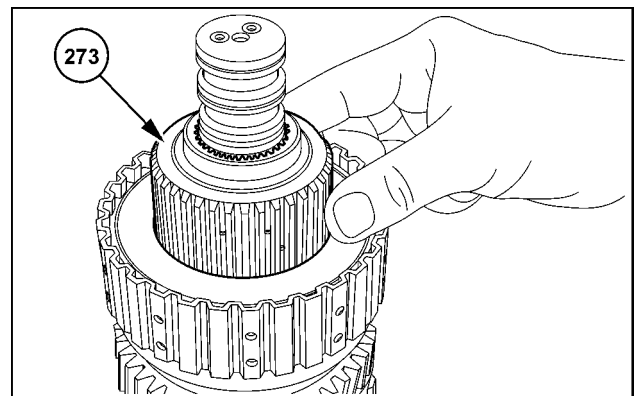

SVIL13TR00152AB 3



4. Remove the top circlip (**274**).

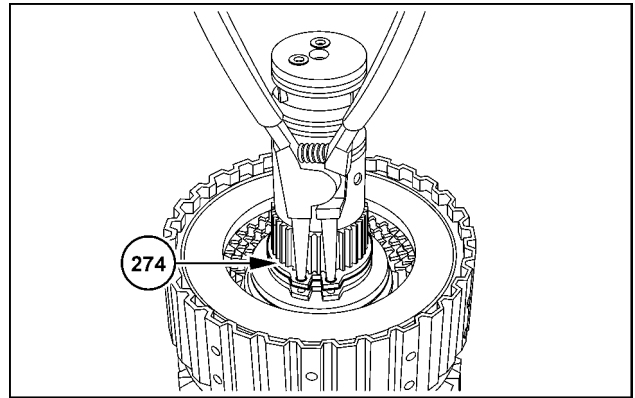

SVIL13TR00153AB 4

5. Preload the disc set (clutch G).

6. Release circlip (**280**) from its position.

7. Remove the closing disc (**281**). Remove the disc set.

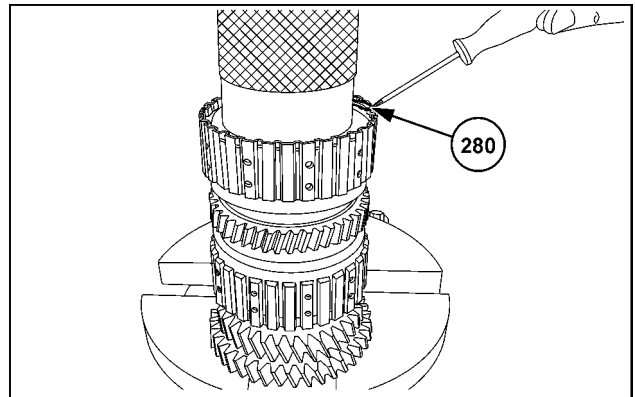

SVIL13TR00154AB 5

8. Preload the thrust spring (**278**) with the bushing 380xxxxxx.

9. Release circlip (**274**) from its position.

10. Remove any loose components.

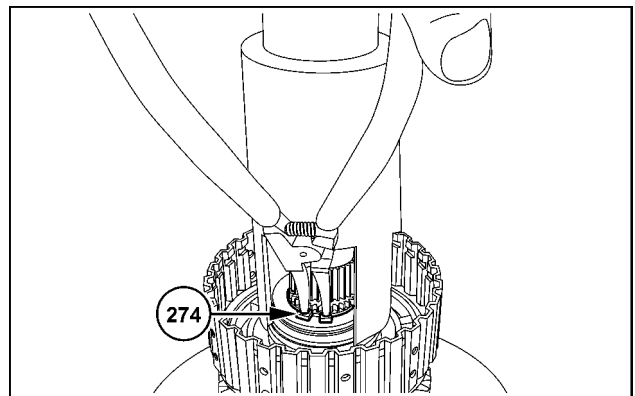

SVIL13TR00155AB 6

11. Remove the piston carrier (**288**).

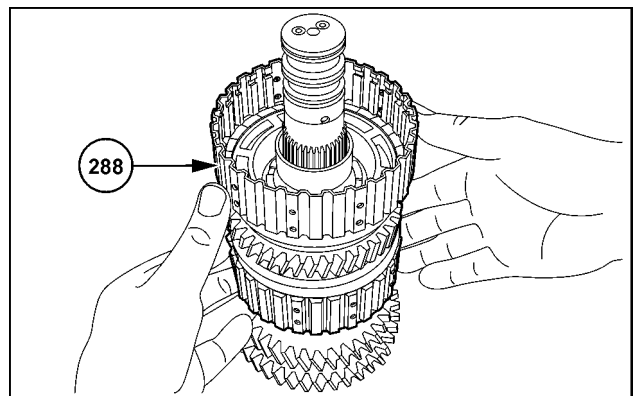

SVIL13TR00156AB 7

12. Remove the piston (285).
13. Remove the needle bearing (276).

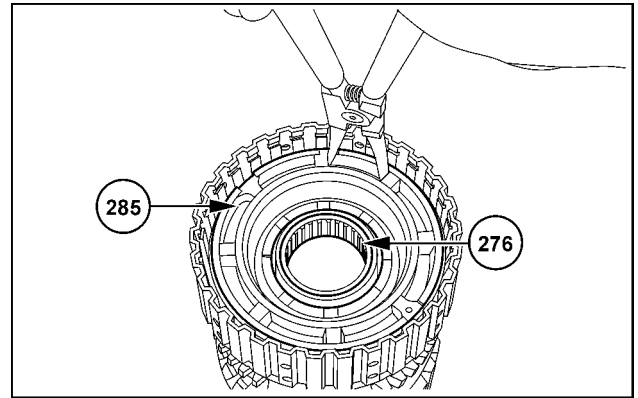

SVIL13TR00157AB 8

14. Remove the O-rings (286) and (287).

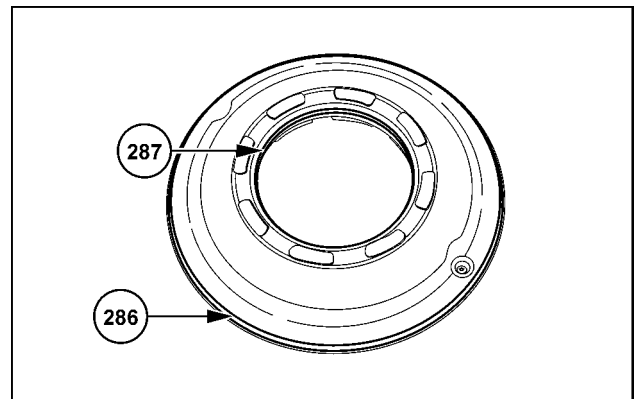

SVIL13TR00158AB 9

15. Preload the disc set (clutch F).
16. Release circlip (297) from its position.
17. Remove the closing disc (296). Remove the disc set.

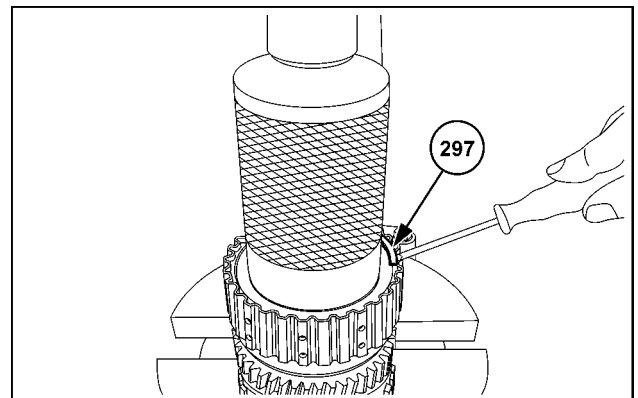

SVIL13TR00159AB 10

18. Remove the piston (292).
19. Remove the needle bearing (301).

**NOTE:** The needle bearing can also remain on the shaft when you lift the piston carrier.

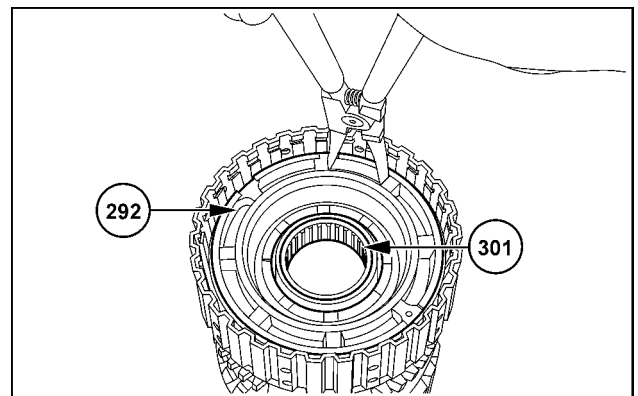

SVIL13TR00160AB 11

20. Remove the O-rings (290) and (291).

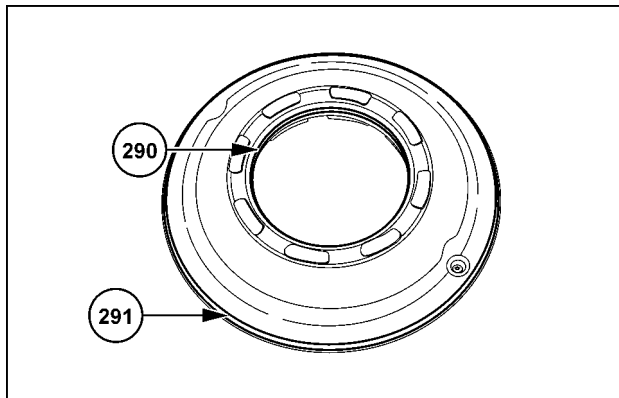

SVIL13TR00161AB 12

21. Remove the guide rings and the thrust spring (299).

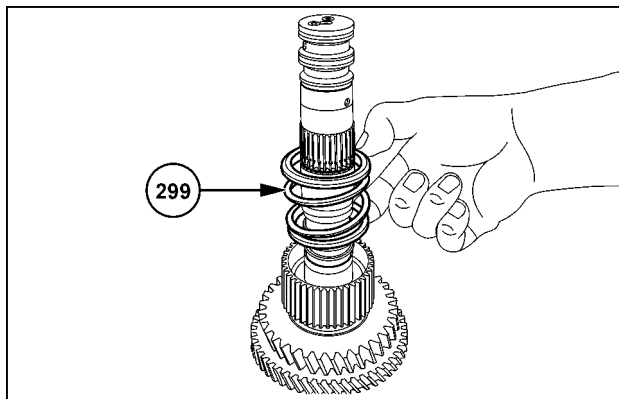

SVIL13TR00162AB 13

22. Remove the rectangular rings (289).

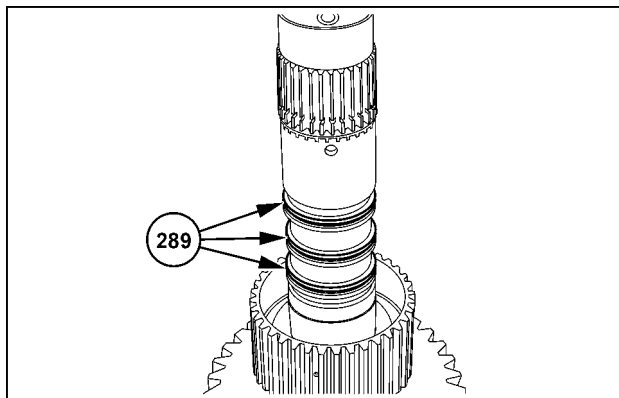

SVIL13TR00163AB 14

23. Remove the thrust bearing (302).

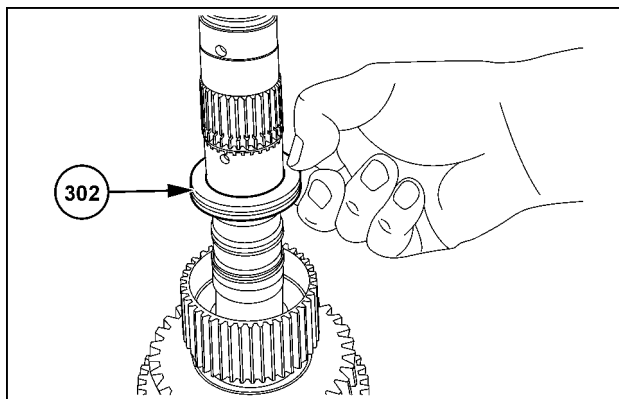

SVIL13TR00164AB 15

24. Release both circlips (303).
25. Remove the disc (304).

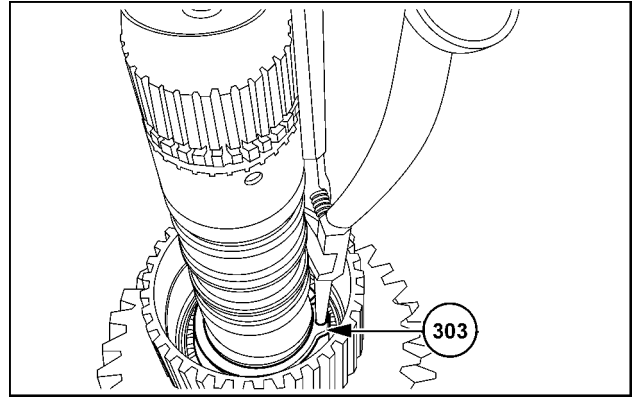

SVIL13TR00165AB 16

26. Press off the gear (306) via the intermediate shaft.

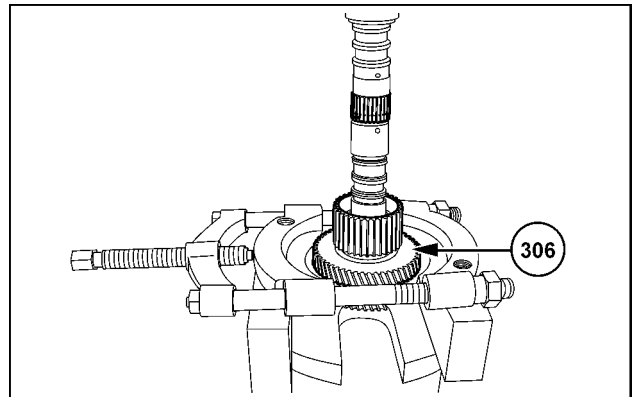

SVIL13TR00166AB 17

27. Remove both bearing outer rings (305) and (307).

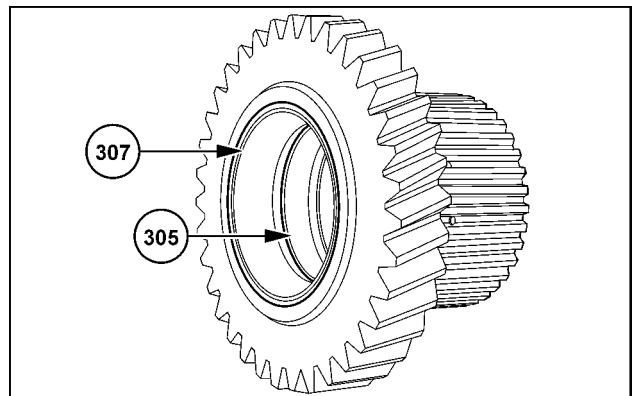

SVIL13TR00167AB 18

28. Remove the inner bearing ring (307).

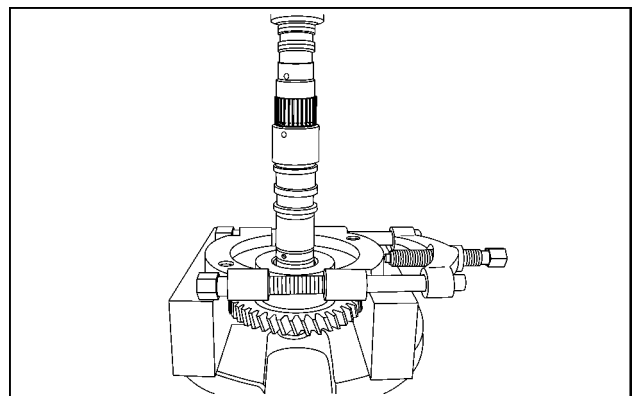

SVIL13TR00168AB 19

29. Remove the inner bearing ring (309).

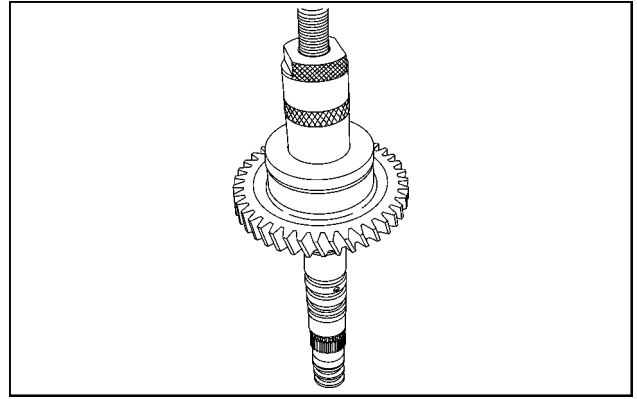

SVIL13TR00169AB 20

**Next operation:**  
**Clutch Reverser clutch - Assemble – clutch F/G (21.152)**

## Clutch Reverser clutch - Assemble – clutch F/G

### Prior operation:

### Clutch Reverser clutch - Disassemble – clutch F/G (21.152)

1. Use a suitable tube to press the bearing inner ring (309) onto the clutch shaft.

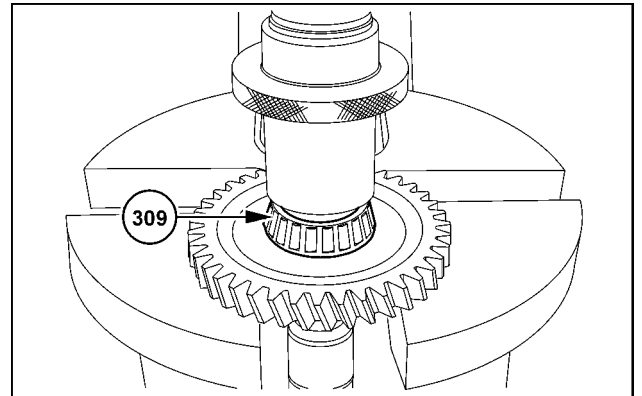

SVIL13TR00465AB 1

2. Use a suitable tube to press the bearing inner ring (307) onto the clutch shaft.

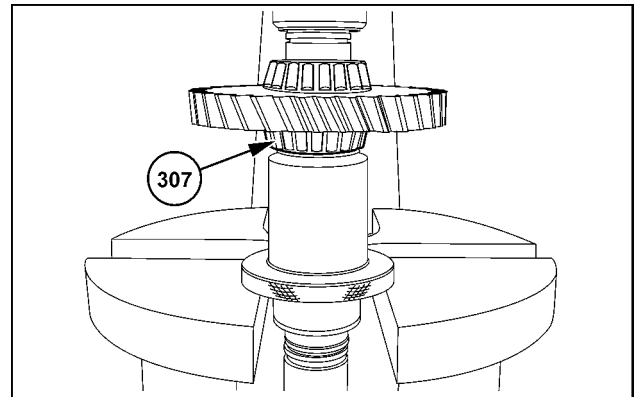

SVIL13TR00466AB 2

3. Use a suitable bushing to insert the two bearing outer rings (307) and (305) into the gear (306) until the two bearing outer rings sit in place.

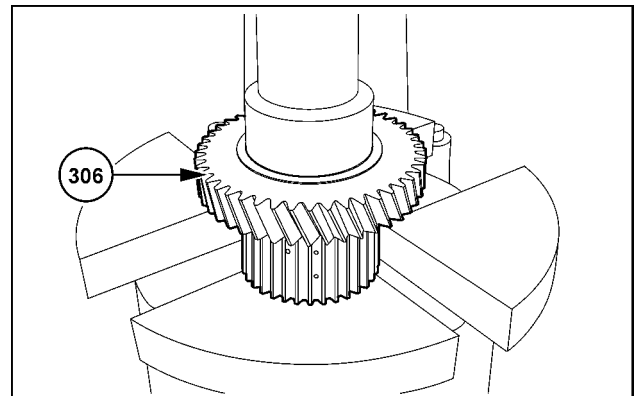

SVIL13TR00467AB 3

- Place the bearing inner ring (305) and the gear (306) on a press.

**NOTE:** Place the bearing inner ring and the gear on a suitable sleeve.

- Insert the clutch shaft (308) until the clutch shaft sits in place.

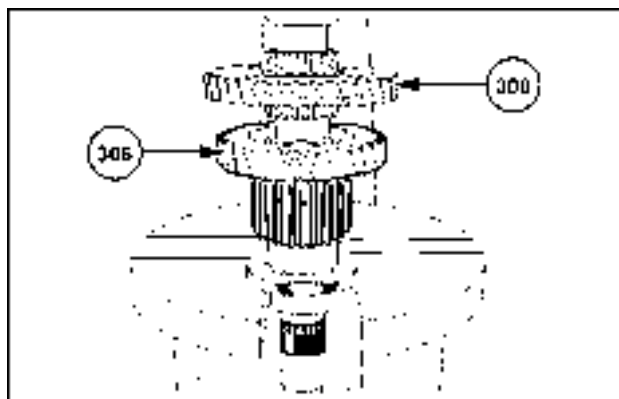

SVIL13TR00468AB 4

- Install the disk (304).

- Insert the circlip (303) into the lower ring groove.

**NOTE:** The circlip is ground on both sides.

**NOTE:** If you do not use new bearings, you can use the existing adjustment disks. However, you must check the bearing clearance.

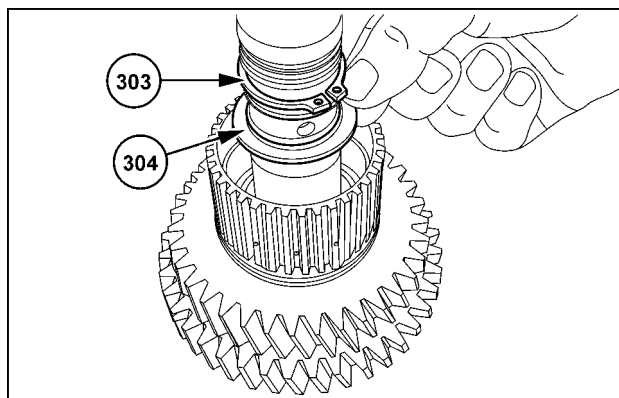

SVIL13TR00469AB 5

- Check the bearing adjustment of 0.02 - 0.05 mm (0.001 - 0.002 in).

**NOTE:** Before you check the bearing adjustment, position the bearing inner ring (305) against the circlip. To perform this step, tap a rubber hammer (306) on the gear.

**NOTE:** Use the relevant disk to correct any deviations from the necessary adjustment value. Refer to the figure 5.

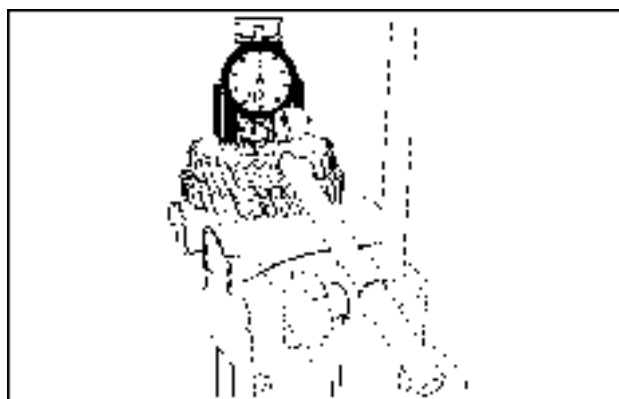

SVIL13TR00470AB 6

- Grease the O-rings (290) and (292) with industrial Vaseline.

- Insert the O-rings (290) and (292) into the ring grooves of the piston.

**NOTE:** Check the function of the purging valve (see arrow). The ball must not jam.

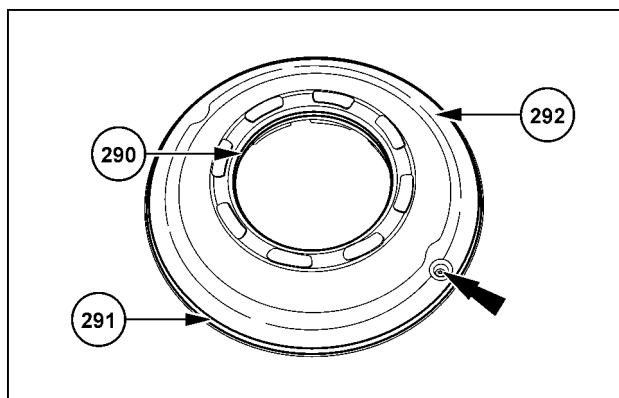

SVIL13TR00161AC 7

11. Install the piston (clutch F) **(292)** in the piston carrier so that the piston sits in place.

**NOTE:** Install the opposite piston (clutch G) **(285)** in the same way.

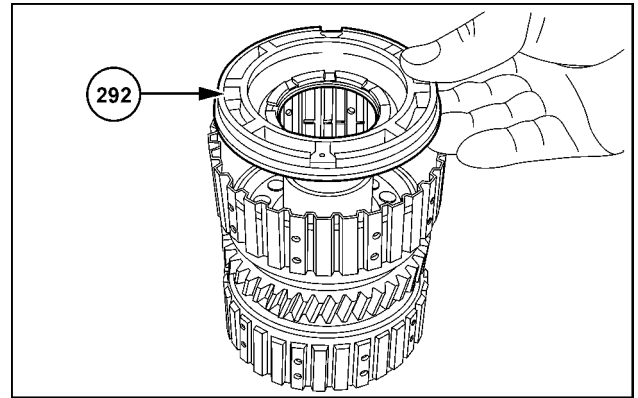

SVIL13TR00471AB 8

12. Install the disk set of the clutch F.

**NOTE:** Layer the friction disks and the steel disks alternately. Start with a steel disk.

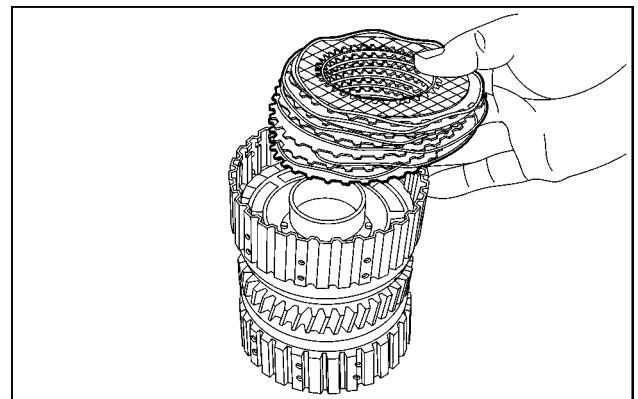

SVIL13TR00472AB 9

13. Install the closing disk **(296)**.
14. Position the circlip **(297)** in the ring groove of the piston carrier.

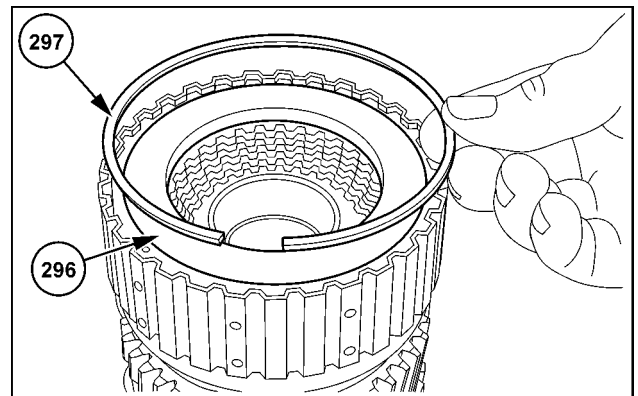

SVIL13TR00473AB 10

Adjust the disk clearance to **3.80 - 4.30 mm (0.15 - 0.17 in)**.

15. Press together the disk set.
16. Measure the dimension "l" from the front face of the piston carrier to the closing disk. Measurement "l", e.g. **9.00 mm (0.35 in)**.

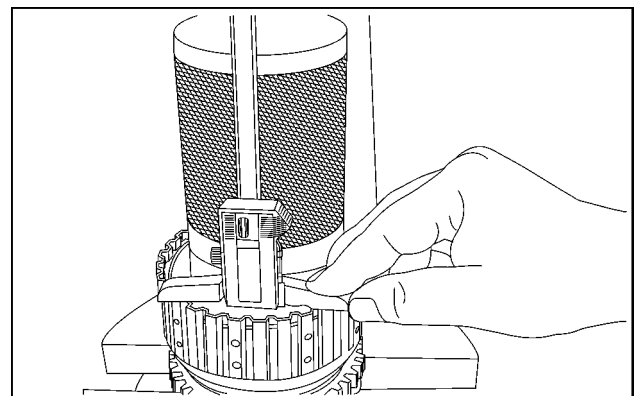

SVIL13TR00474AB 11



17. Move the closing disk upward until the closing disk sits in place on the circlip.
18. Determine dimension "II". Measurement "II", e.g. **4.90 mm (0.19 in)**

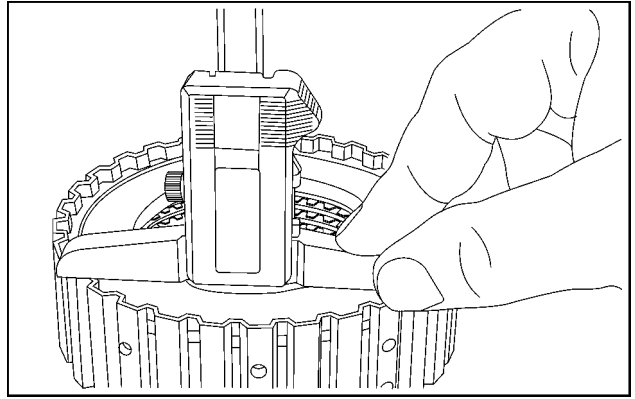

SVIL13TR00475AB 12

**Example calculation:**

Dimension "I":	<b>9.00 mm (0.35 in)</b>
Dimension "II":	<b>- 4.90 mm (0.19 in)</b>
Difference = disk clearance	<b>4.10 mm (0.16 in)</b>

**NOTE:** If there is a deviation from the required disk clearance, use an appropriate circlip (297) to correct this deviation.

19. Fit the circlip (303).

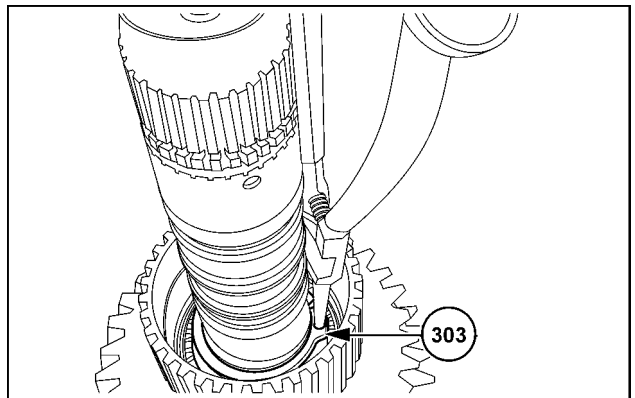

SVIL13TR00165AB 13

20. Install the thrust bearing (302).

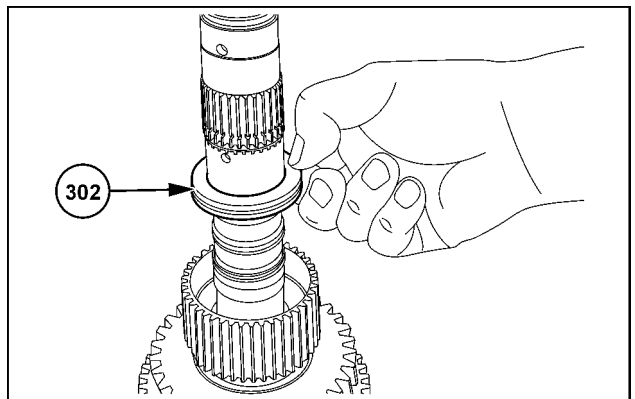

SVIL13TR00164AB 14

21. Fit the needle bearing (301).

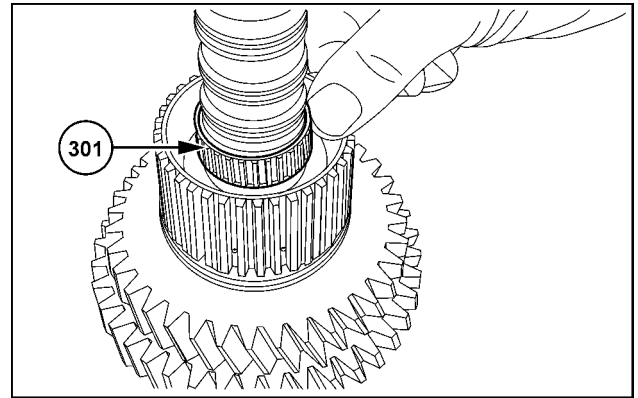

SVIL13TR00476AB 15

22. Grease the ring grooves of the rectangular rings (289) with industrial Vaseline.

23. Fit the rectangular rings so that the rectangular rings interlock in place. Align the rectangular rings centrally.

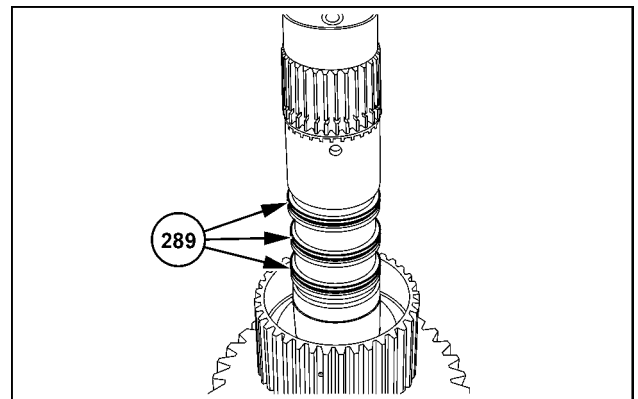

SVIL13TR00163AB 16

24. Align the pre-assembled disk set on the gear.

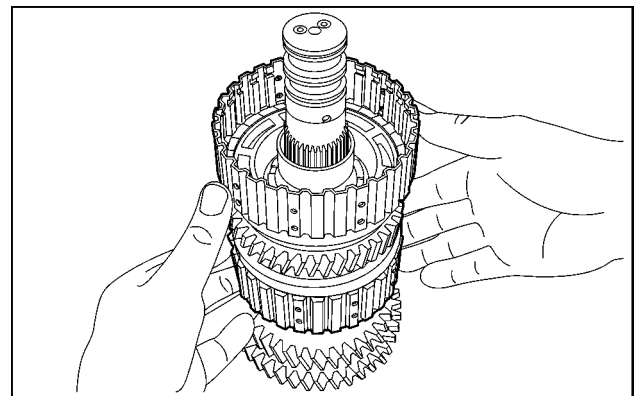

SVIL13TR00156AC 17

25. Pre-load the disk set equally with the mounting device.

**NOTE:** Produce the mounting device in accordance with the technical drawing. See **Semi-Powershift transmission - Special tools (21.111)**.

26. Remove the pre-tensioned disk set.

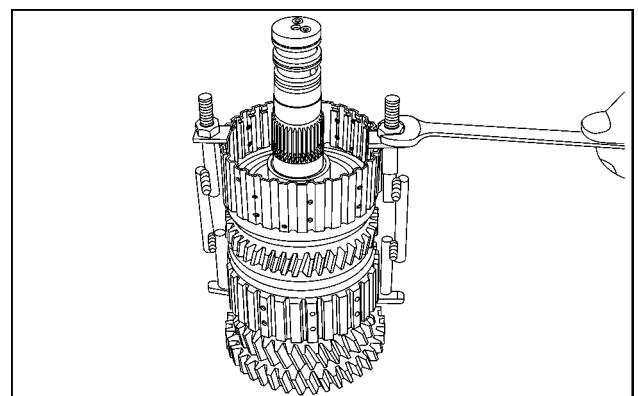

SVIL13TR00477AB 18

27. Install the guide ring (300). Install the thrust spring (299). Install the guide ring (298).

**NOTE:** Ensure that the guide rings are in the correct position. Install the guide ring with a curved internal diameter so that the guide ring faces the thrust bearing.

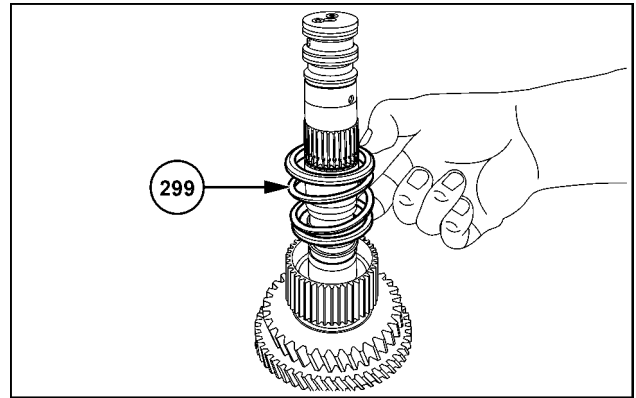

SVIL13TR00162AB 19

28. Fit the pre-assembled pressure cylinder until the pre-assembled pressure cylinder sits in place.

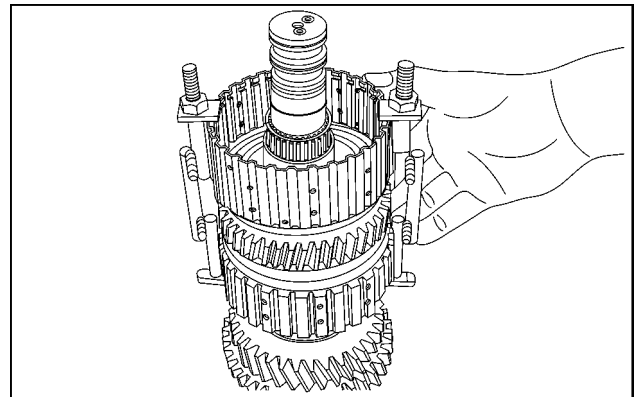

SVIL13TR00478AB 20

29. Fit the needle bearing (276).

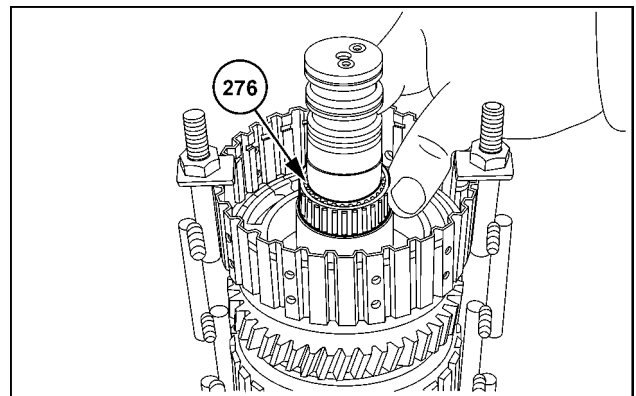

SVIL13TR00479AB 21

30. Install the guide ring (279). Install the thrust spring (278). Install the guide ring (277).

**NOTE:** Ensure that the guide rings are in the correct position. Install the guide ring with a curved internal diameter so that the guide ring faces the thrust bearing.

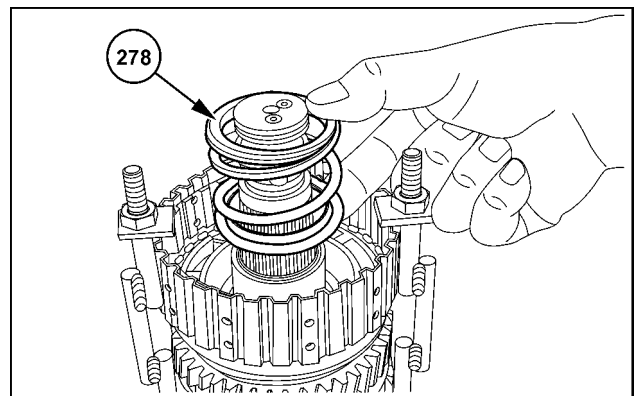

SVIL13TR00480AB 22

31. Install the (275) thrust bearing.

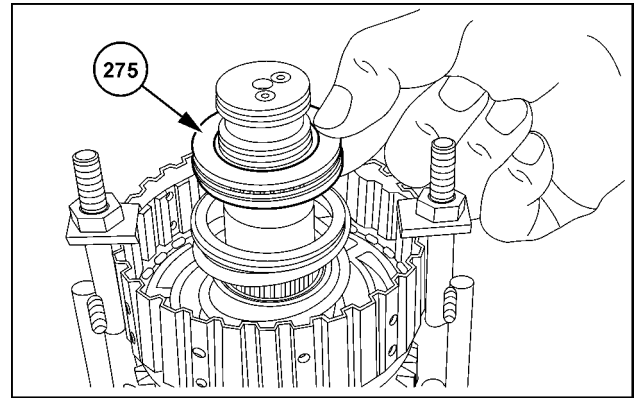

SVIL13TR00481AB 23

32. Fit the circlip (274).

33. **⚠ CAUTION**

**Spring under tension!**  
**This assembly is spring-loaded. Remove the parts carefully!**  
**Failure to comply could result in minor or moderate injury.**

C0147A

Preload the thrust spring 380200374 with the bushing.

34. Insert the circlip.

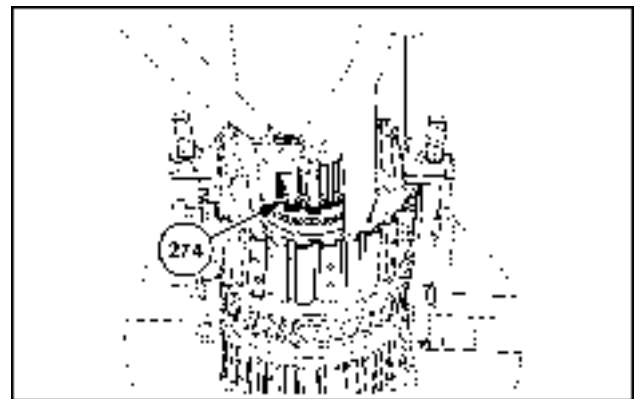

SVIL13TR00482AB 24

35. Remove the mounting device.

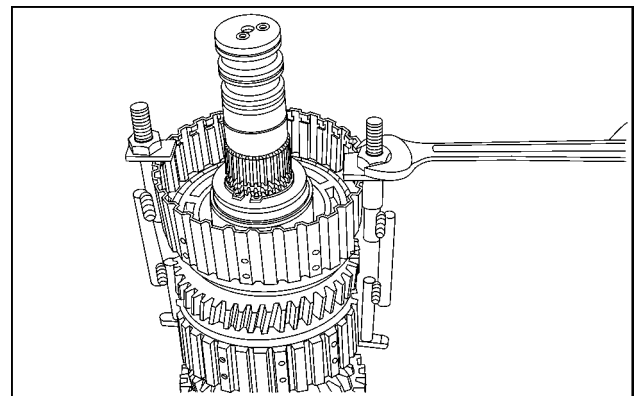

SVIL13TR00483AB 25

36. Fit the circlip (274).

**NOTE:** Install and adjust the disk set (clutch G) in the same way as steps 12 to 18.

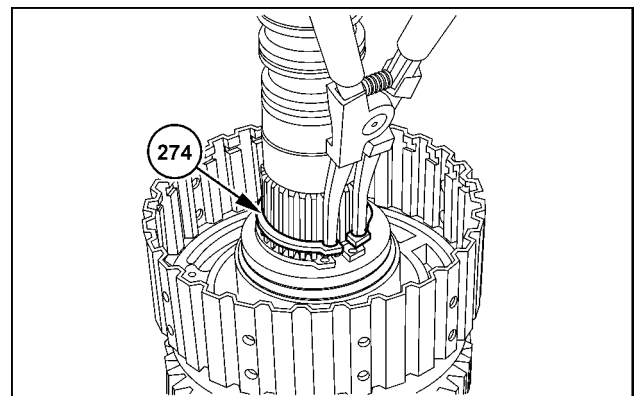

SVIL13TR00484AB 26

37. Install the disk holder (273).

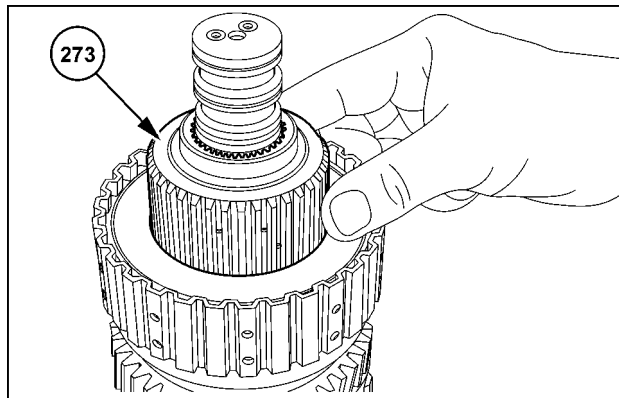

SVIL13TR00152AB 27

38. Press on the bearing (272).

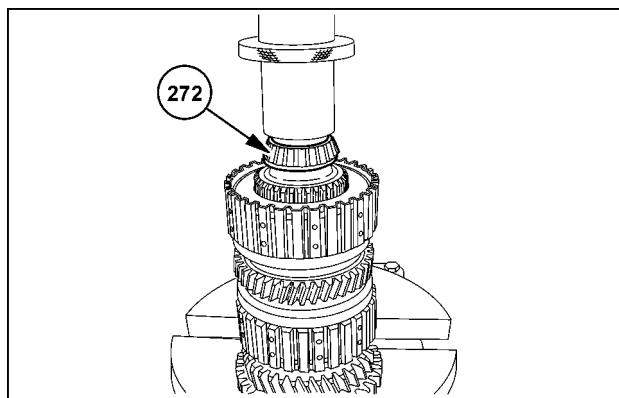

SVIL13TR00485AB 28

39. Grease the ring grooves of the rectangular rings (271) and (311) in the intermediate shaft with industrial Vaseline.

40. Fit the rectangular rings so that the rectangular rings interlock in place. Align the rectangular rings centrally.

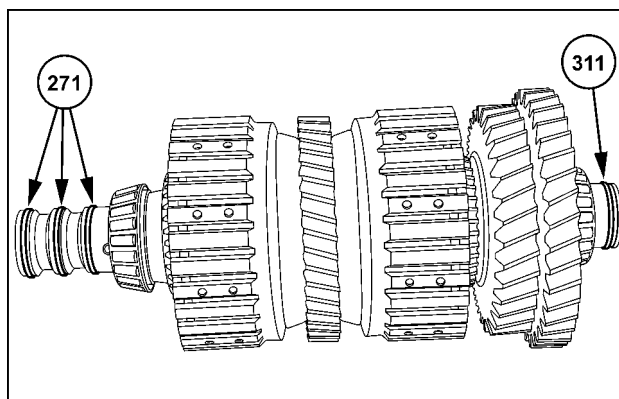

SVIL13TR00150AB 29

**Next operation:**

**Clutch - Install (21.152)**

**Clutch - Adjust – Clutch shafts (21.152)**

## Clutch Range clutch - Disassemble – Clutch A/C

Prior operation:

Clutch - Remove (21.152)

1. Remove the rectangular rings (248).

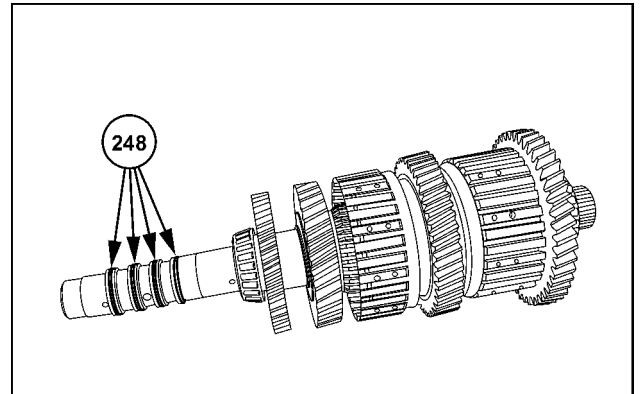

SVIL13TR00002AB 1

2. Remove the gear (204).

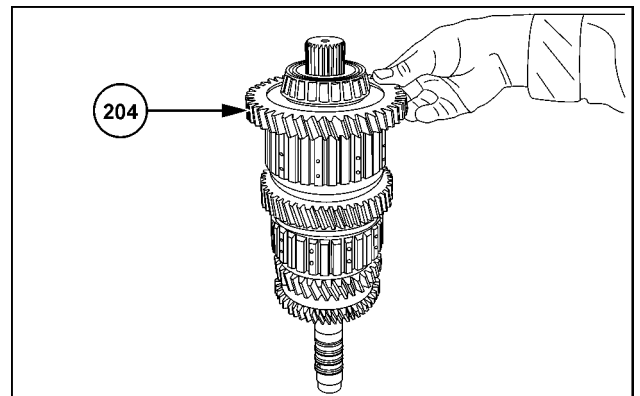

SVIL13TR00003AB 2

3. Remove the bearing (203) from the gear.

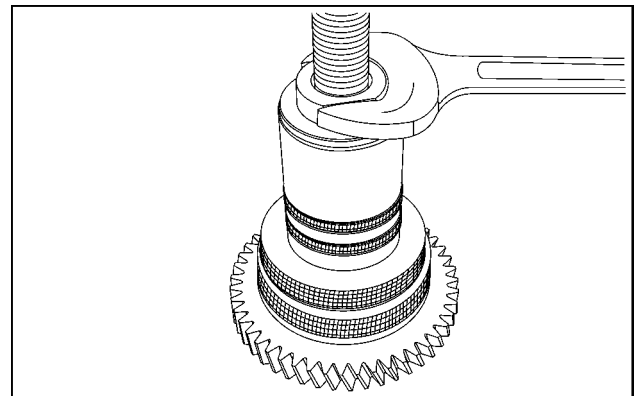

SVIL13TR00004AB 3

4. Release circlip (205) from its position.
5. Remove the closing disc (206). Remove the disc set (clutch C).

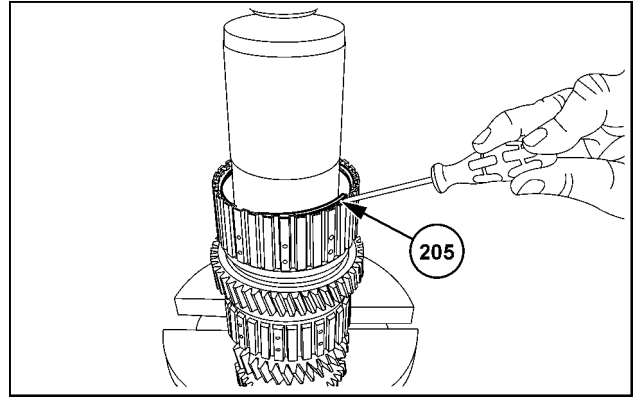

SVIL13TR00005AB 4

6. Remove the top circlip (213).

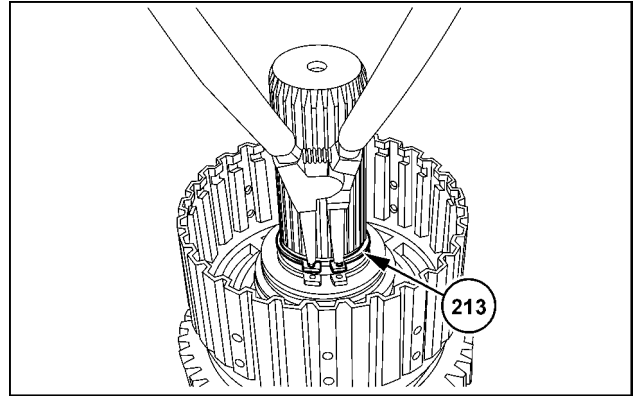

SVIL13TR00006AB 5

7. **⚠ WARNING**

**Spring under tension!**  
**Compressed springs have potentially dangerous stored energy. Always assemble and disassemble properly.**  
**Failure to comply could result in death or serious injury.**

W0356A

Preload the cup washers with bushing 380xxxxxx.

8. Release circlip (213) from its position.
9. Remove the piston carrier (219) with the following parts: the thrust bearing (214), the cup washers (215), and the guide ring (216).

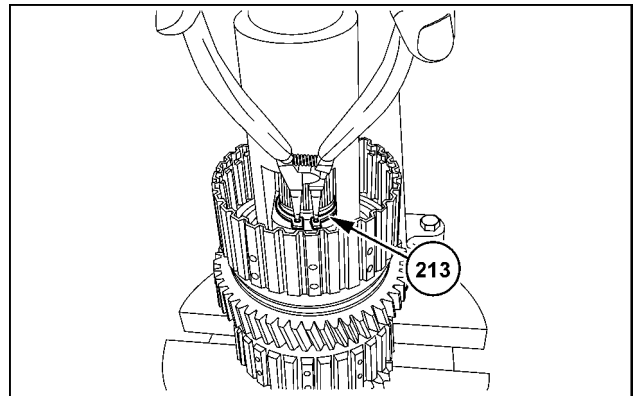

SVIL13TR00007AB 6

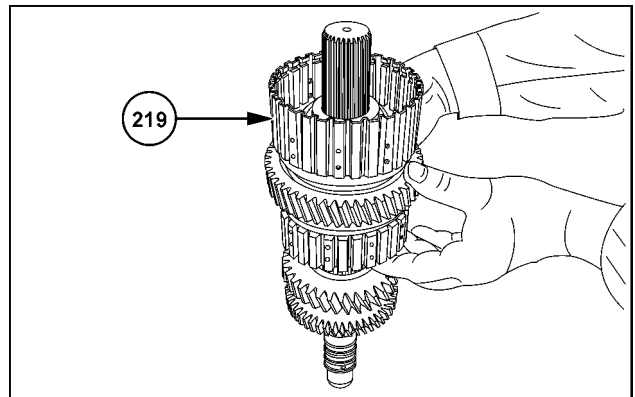

SVIL13TR00008AB 7

10. Remove the piston (210).

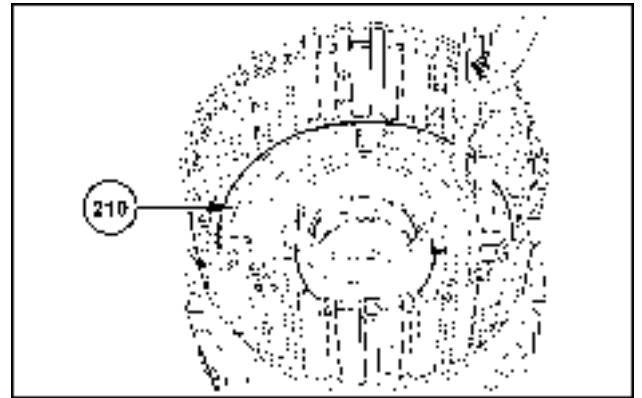

SVIL13TR00009AB 8

11. Remove the O-rings (211) and (212).

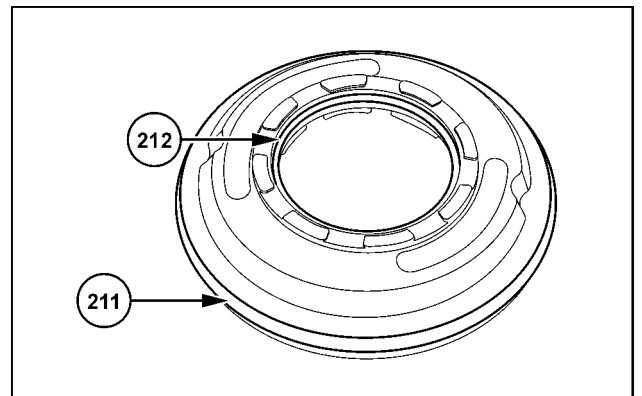

SVIL13TR00010AB 9

12. Release circlip (227) from its position.

13. Remove the closing disc (226). Remove the disc set (clutch A).

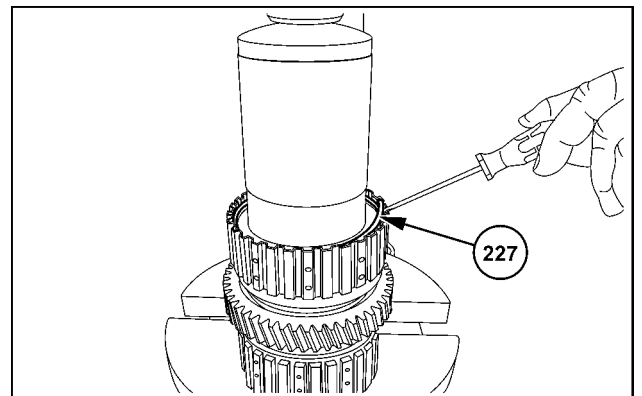

SVIL13TR00011AB 10

14. Remove the piston (222).

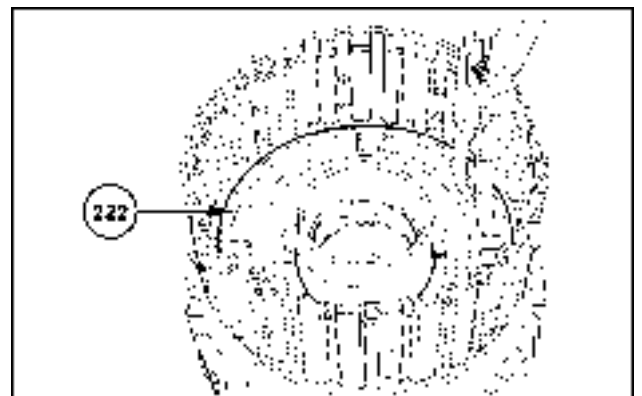

SVIL13TR00012AB 11



15. Remove the O-rings (220) and (221).

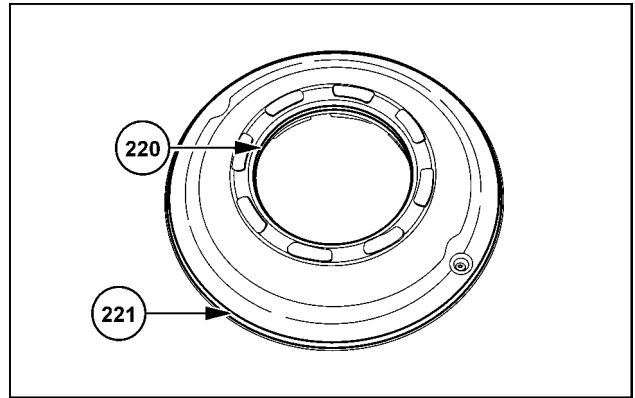

SVIL13TR00013AB 12

16. Remove the guide rings and the thrust spring (229).

17. Remove the needle bearing (231).

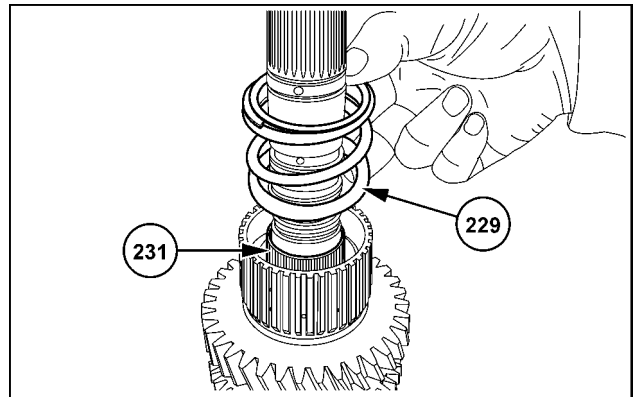

SVIL13TR00014AB 13

18. Remove the rectangular rings (218).

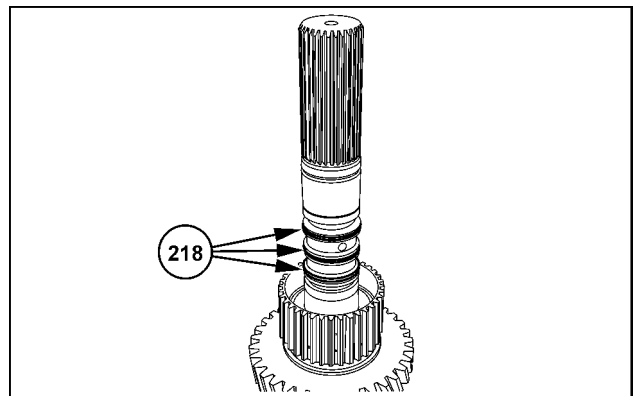

SVIL13TR00015AB 14

19. Remove the thrust bearing (232).

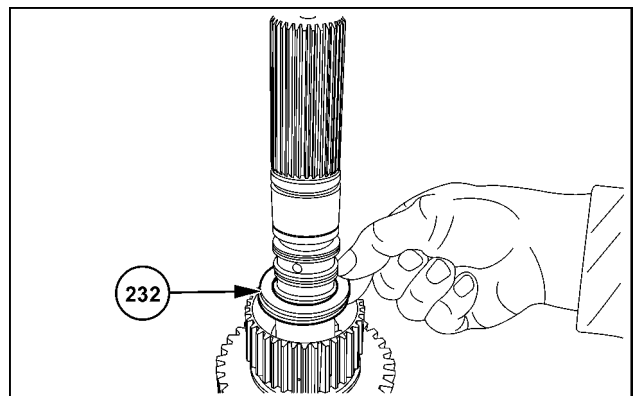

SVIL13TR00016AB 15

20. Release both circlips **(233)** and **(234)**.
21. Remove the adjustment disc **(235)**.

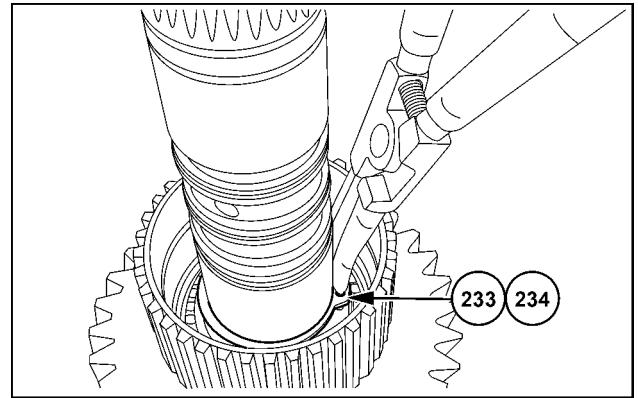

SVIL13TR00017AB 16

22. Remove the gear **(237)**.

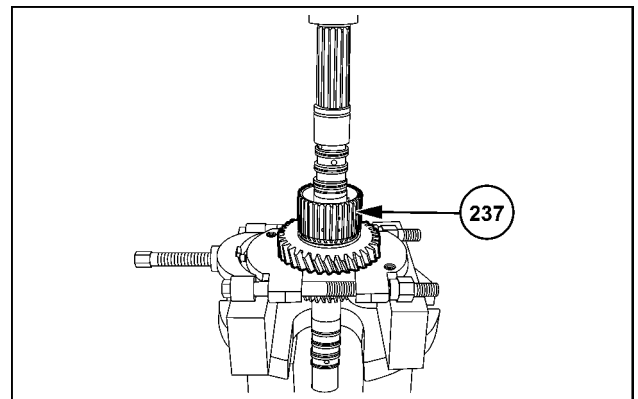

SVIL13TR00018AB 17

23. Remove both bearing outer rings **(236)**.

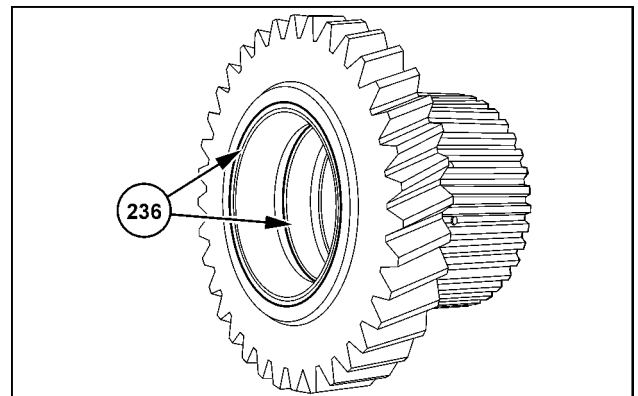

SVIL13TR00019AB 18

24. Remove the bearing **(236)**.

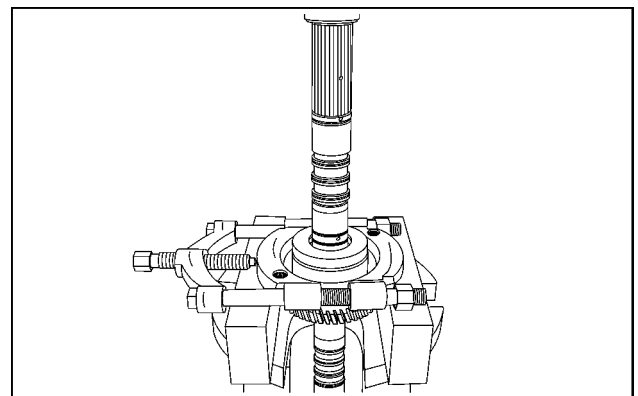

SVIL13TR00020AB 19

25. Remove the bearing (238).

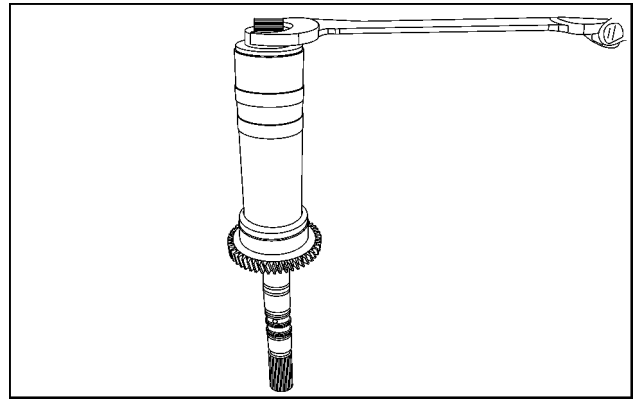

SVIL13TR00021AB 20

**Next operation:**  
**Clutch Range clutch - Assemble – Clutch A/C (21.152)**

## Clutch Range clutch - Assemble – Clutch A/C

### Prior operation:

### Clutch Range clutch - Disassemble – Clutch A/C (21.152)

1. Use a suitable tube to press the bearing (238) onto the clutch shaft (239).

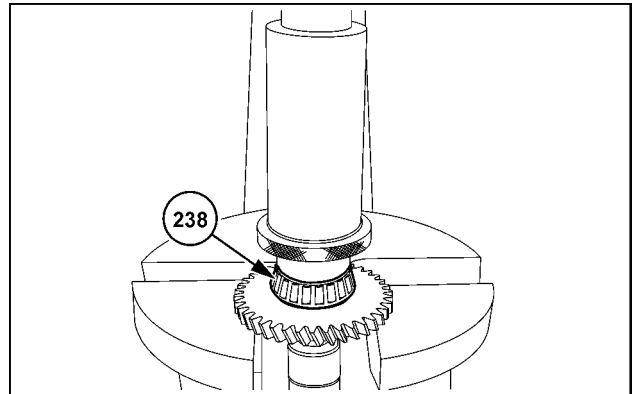

SVIL13TR00486AB 1

2. Use a suitable tube to press the bearing inner ring (236) onto the clutch shaft.

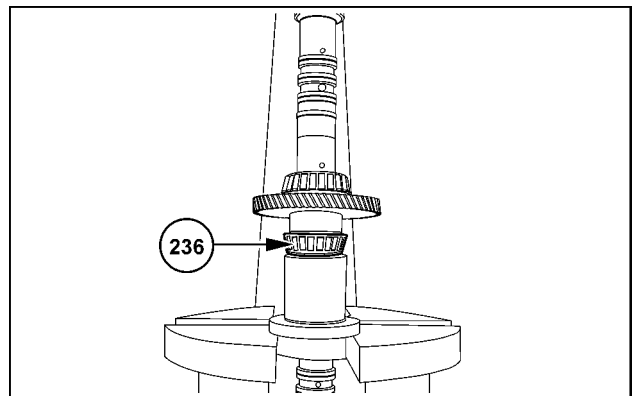

SVIL13TR00487AB 2

3. Use a suitable bushing to press the two bearing outer rings (236) into the gear until the two bearing outer rings sit in place.

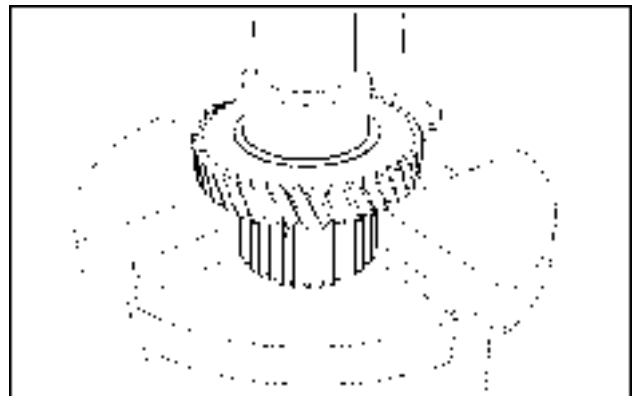

SVIL13TR00488AB 3

- Place the bearing inner ring (236) and the gear (237) on a press.

**NOTE:** Place the bearing inner ring and the gear on a suitable sleeve.

- Insert the clutch shaft. Press on the clutch shaft until the clutch shaft sits in place.

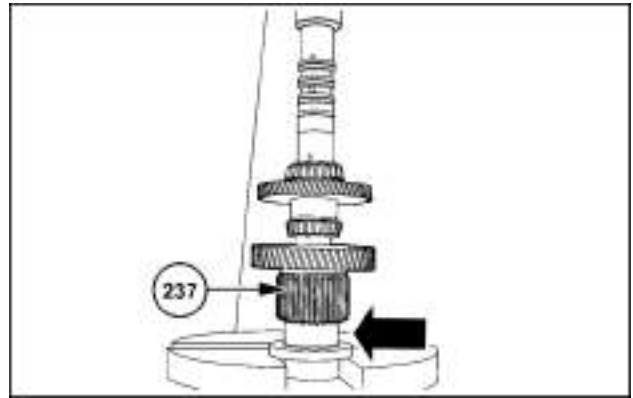

SVIL13TR00489AB 4

- Install the adjustment disk (235). Install the circlip (234).

- Insert the circlip (without any axial force) into the lower ring groove.

**NOTE:** The circlip is ground on both sides.

**NOTE:** If you do not use new bearings, you can use the existing adjustment disks. However, you must check the bearing clearance.

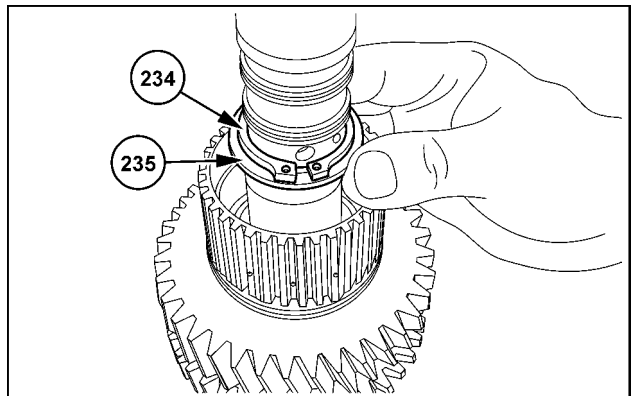

SVIL13TR00490AB 5

- Check the bearing adjustment of 0.02 - 0.05 mm (0.001 - 0.002 in).

**NOTE:** Before you check the bearing adjustment, position the bearing inner ring (236) against the circlip. To perform this step, tap a rubber hammer (237) on the gear.

**NOTE:** Use the relevant disk to correct any deviations from the necessary adjustment value. Refer to the figure 5.

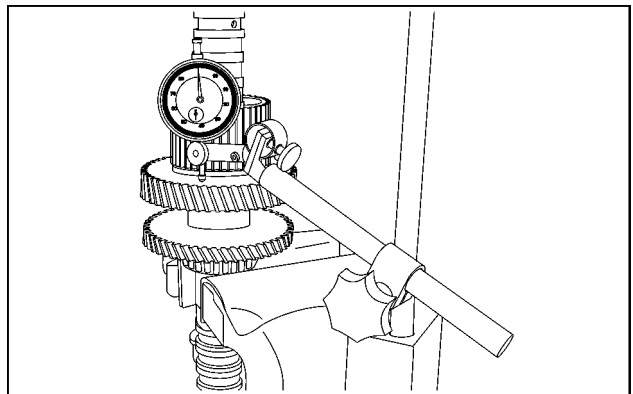

SVIL13TR00491AB 6

- Grease the O-rings (220) and (221) with industrial Vaseline.

- Install the O-rings (220) and (221) into the ring grooves of the piston (clutch A) (222).

**NOTE:** Check the function of the purging valve. The ball must not jam.

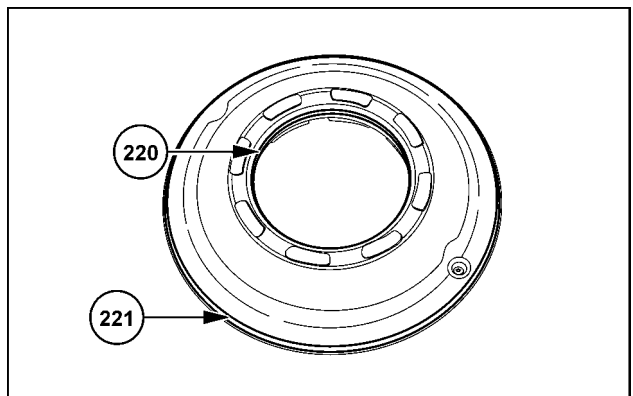

SVIL13TR00013AB 7

11. Install the piston (clutch A) **(222)** into the piston carrier on the short disk carrier side until the piston sits in place.

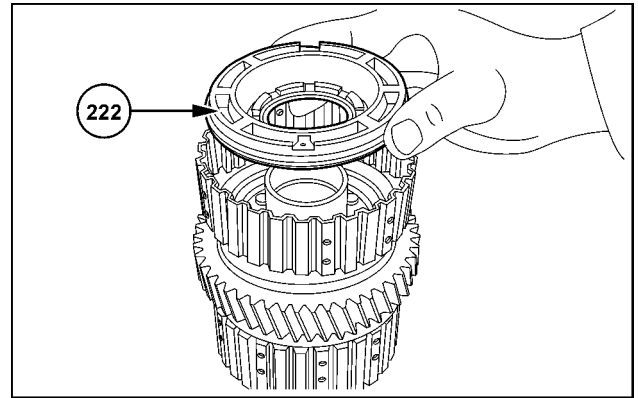

SVIL13TR00492AB 8

12. Grease the O-rings **(211)** and **(212)** with industrial Vaseline.
13. Install the O-rings **(211)** and **(212)** into the ring grooves of the piston (clutch C) **(210)**.

**NOTE:** The piston design does not include a purging valve.

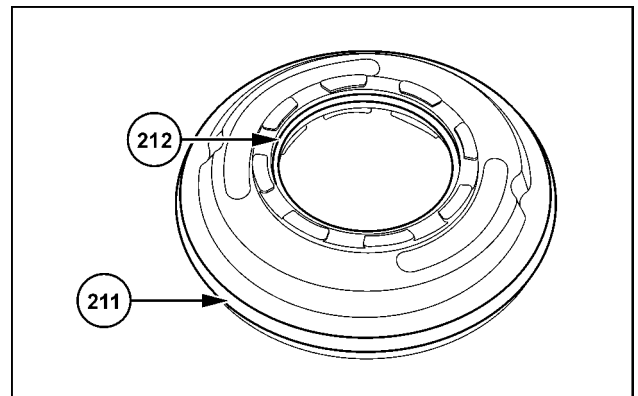

SVIL13TR00010AB 9

14. Install the piston (clutch C) **(210)** in the piston carrier so that the piston sits in place.

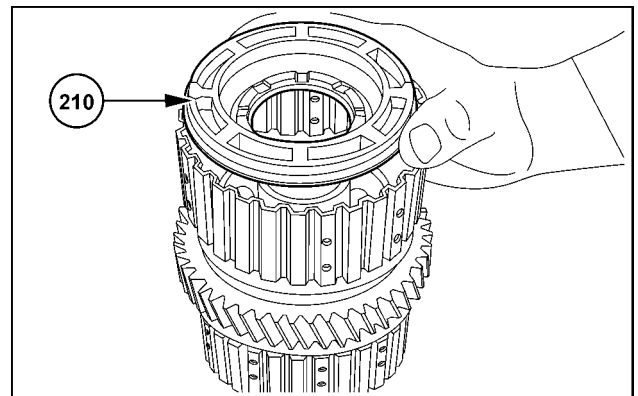

SVIL13TR00493AB 10

15. Install the disk set of the clutch A (short disk carrier side).

**NOTE:** Layer the friction disks and the steel disks alternately. Start with a steel disk.

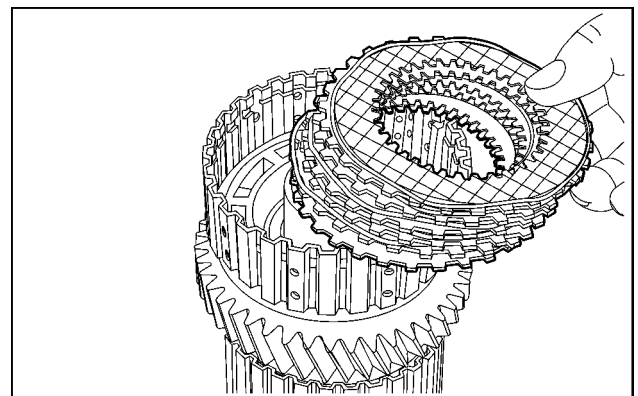

SVIL13TR00494AB 11

16. Install the closing disk (226).
17. Position the circlip (227) in the ring groove of the piston carrier.

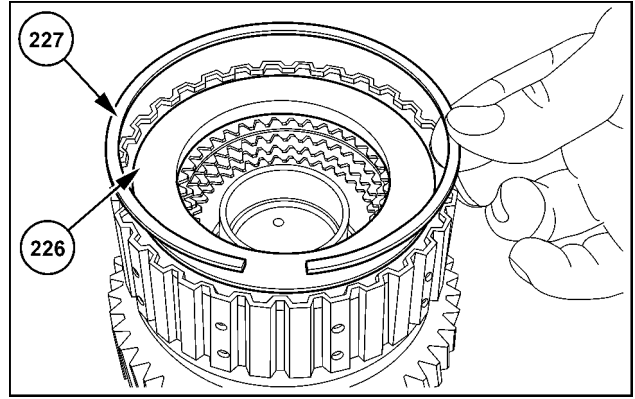

SVIL13TR00495AB 12

Adjust the disk set **3.80 - 4.30 mm (0.15 - 0.17 in)**.

18. Press together the disk set.
19. Measure the dimension "I" from the front face of the piston carrier to the closing disk. Measurement "I", e.g. **9.50 mm (0.37 in)**

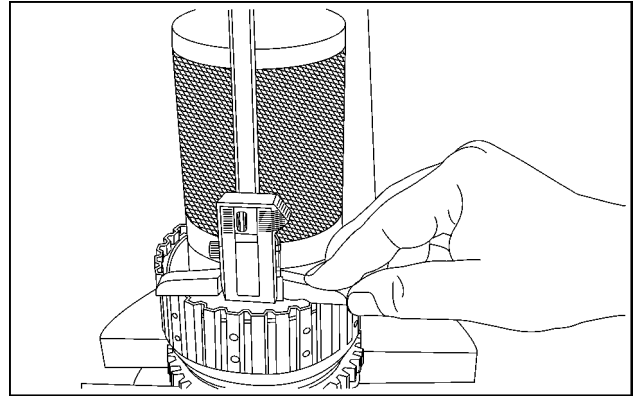

SVIL13TR00474AB 13

20. Move the closing disk upward until the closing disk sits in place on the circlip.
21. Determine dimension "II". Measurement "II", e.g. **5.40 mm (0.21 in)**

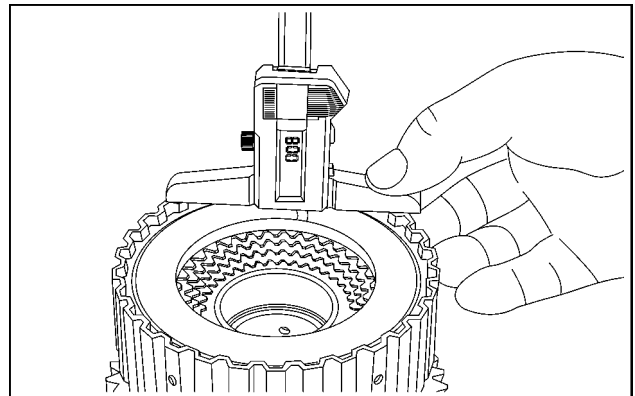

SVIL13TR00496AB 14

**Example calculation:**

Dimension "I":	<b>9.50 mm (0.37 in)</b>
Dimension "II":	<b>- 5.40 mm (0.21 in)</b>
<hr/>	
Difference = disk clearance	<b>4.10 mm (0.16 in)</b>

**NOTE:** If there is a deviation from the required disk clearance, use an appropriate circlip (227) to correct this deviation.

22. Fit the circlip (233).

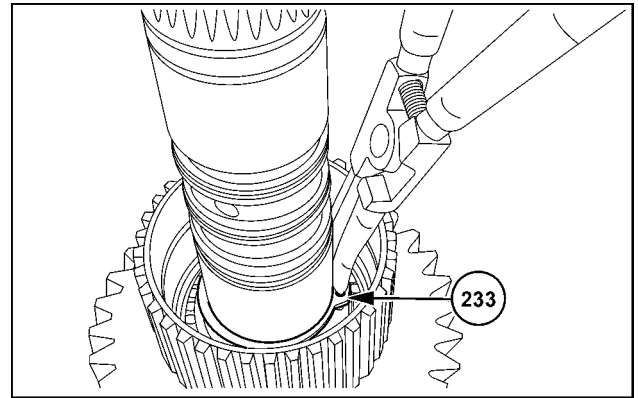

SVIL13TR00017AC 15

23. Install the thrust bearing (232).

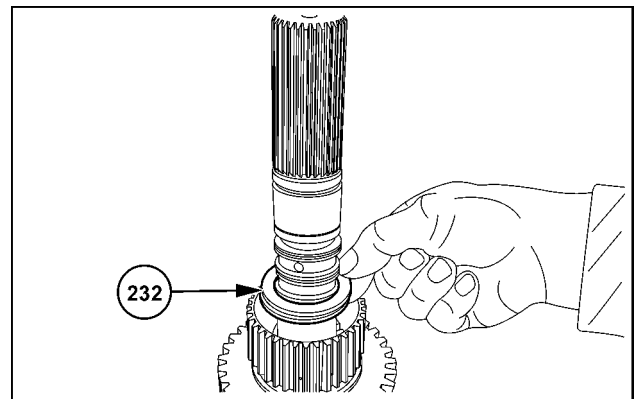

SVIL13TR00016AB 16

24. Fit the needle bearing (231).

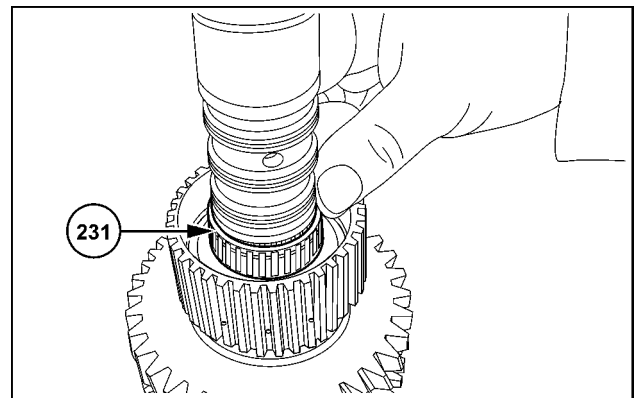

SVIL13TR000497AB 17

25. Grease the ring grooves of the rectangular rings (218) with industrial Vaseline.

26. Fit the rectangular rings so that the rectangular rings interlock in place. Align the rectangular rings.

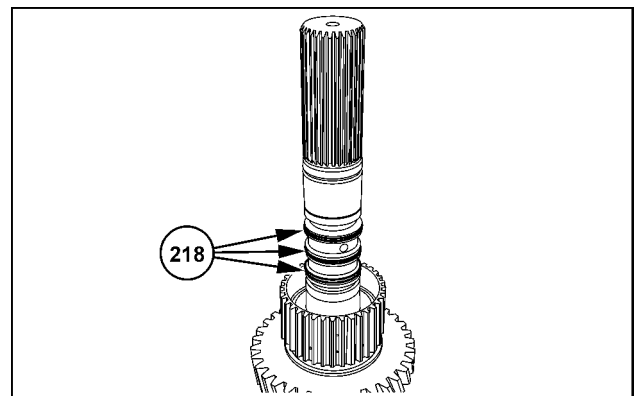

SVIL13TR00015AB 18



27. Align the pre-assembled disk set on the gear (237).

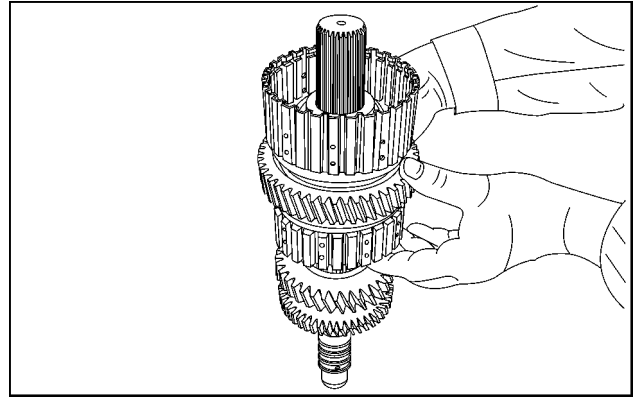

SVIL13TR00008AC 19

28. Pre-load the disk set equally with the mounting device.

**NOTE:** Produce the mounting device in accordance with the technical drawing. See **Semi-Powershift transmission - Special tools (21.111)**.

29. Remove the pre-tensioned disk set.

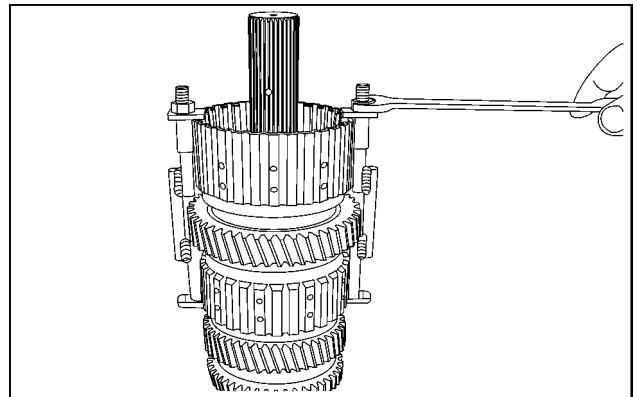

SVIL13TR00498AB 20

30. Install the guide ring (230). Install the thrust spring (229). Install the guide ring (228).

**NOTE:** Ensure that the guide rings are in the correct position. Install the guide ring with a curved internal diameter so that the guide ring faces the thrust bearing.

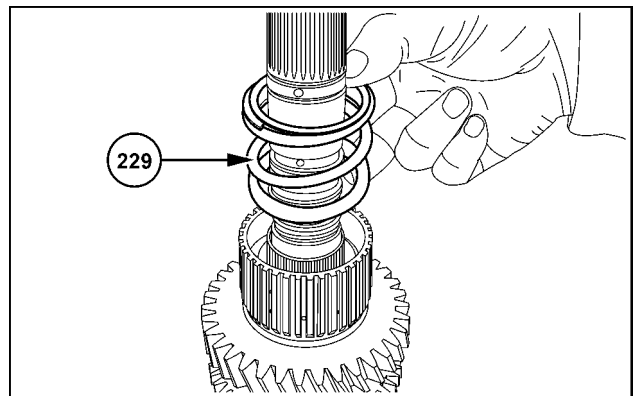

SVIL13TR00014AC 21

31. Fit the pre-assembled pressure cylinder until the pre-assembled pressure cylinder sits in place.

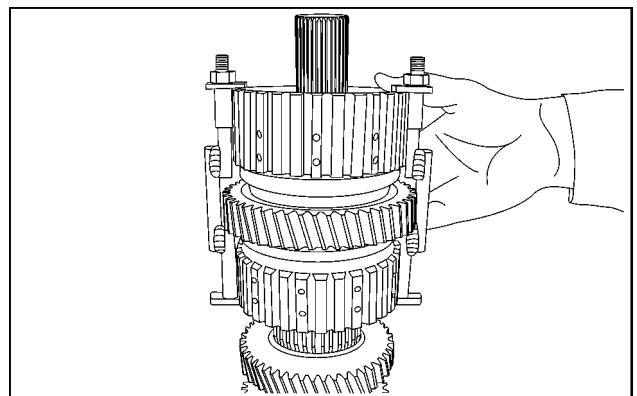

SVIL13TR00499AB 22

32. Fit the needle bearing (217).

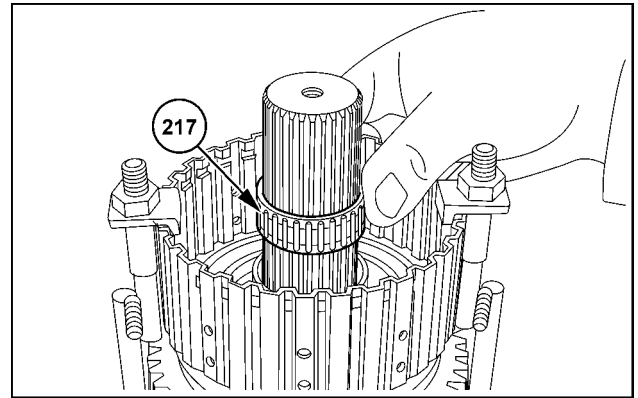

SVIL13TR00500AB 23

33. Install the guide ring (216). The radius of the guide ring must face upward.

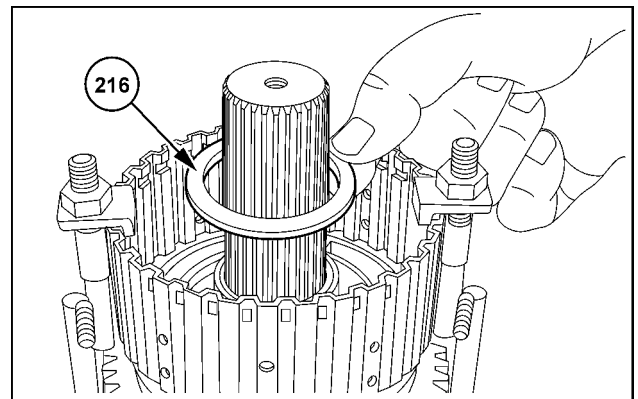

SVIL13TR00501AB 24

34. Install the cup washer set (215).

**NOTE:** See also figure 26.

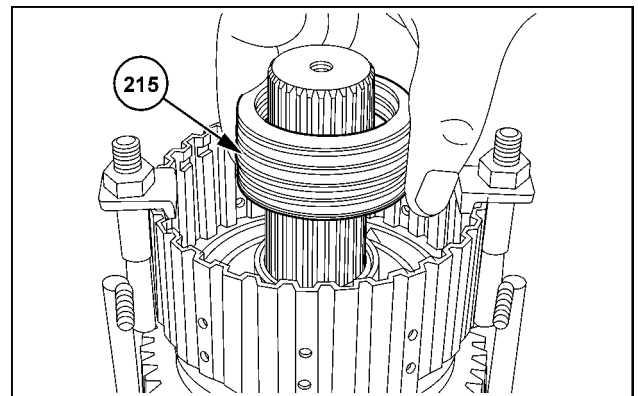

SVIL13TR00502AB 25

35. Image:  
 Belleville washers (215)  
 Needle Bearing (217)  
 Drive shaft (239)  
 Guide ring (216)  
 Piston (210)  
 Piston carrier (219)

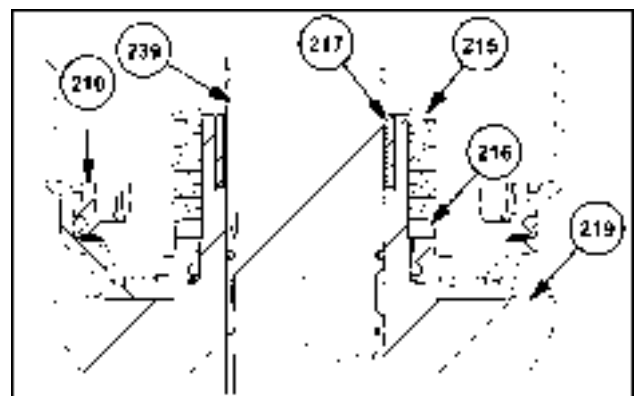

SS13F115 26

36. Install the (214) thrust bearing.

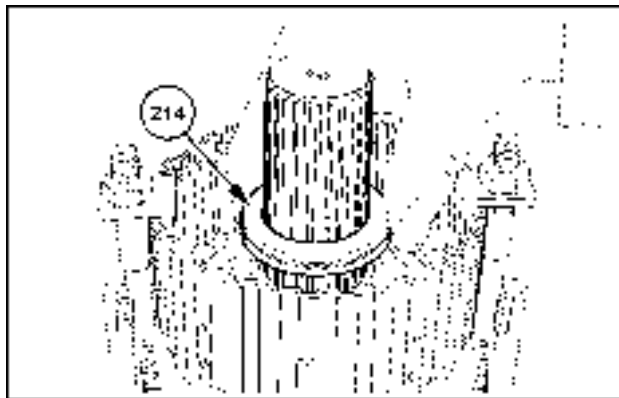

SVIL13TR00503AB 27

37. Fit the circlip (213).

38. **▲ CAUTION**

**Spring under tension!**  
**This assembly is spring-loaded. Remove the parts carefully!**  
**Failure to comply could result in minor or moderate injury.**

C0147A

Use the bushing 380200374 to pre-tension the thrust springs and the cup washers.

39. Insert the circlip.

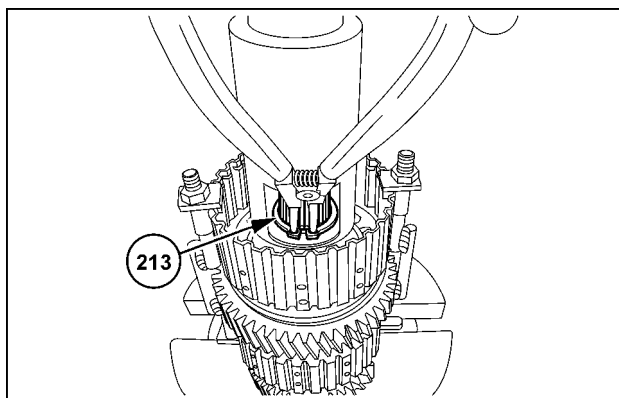

SVIL13TR00504AB 28

40. Remove the mounting device.

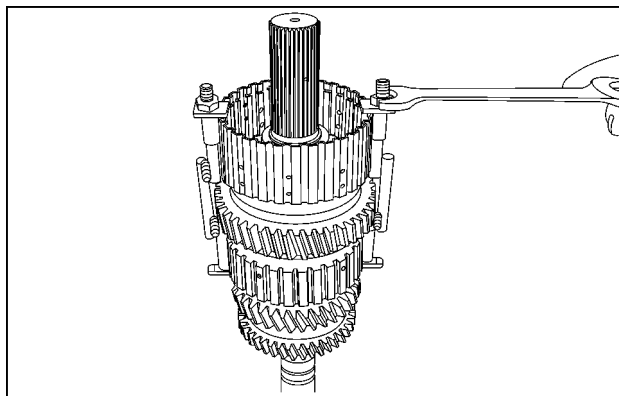

SVIL13TR00505AB 29

41. Fit the circlip (213).

**NOTE:** Install and adjust the disk set (clutch C) in the same way as steps 15 to 21.

42. Adjust the disk set 4.5 - 4.9 mm (0.18 - 0.19 in).

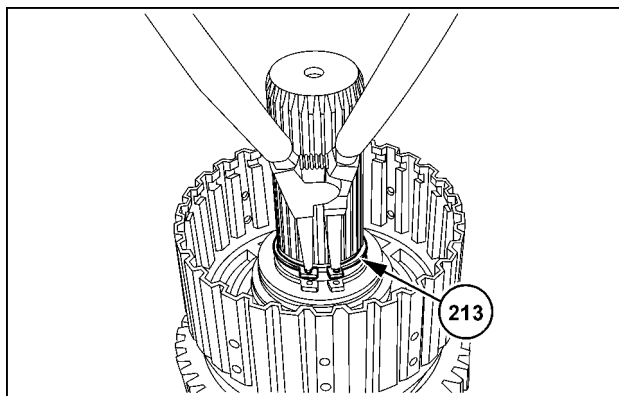

SVIL13TR00006AB 30

43. Press the bearing (203) onto the gear (204).

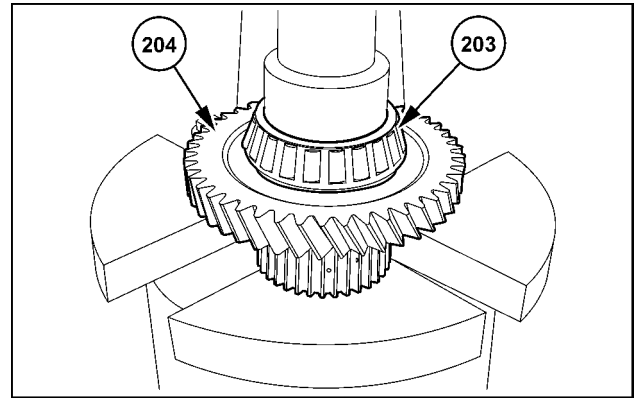

SVIL13TR00506AB 31

44. Install the gear (204).

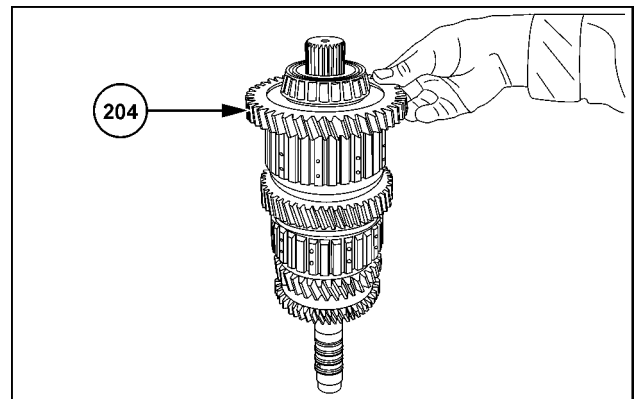

SVIL13TR00003AB 32

45. Grease the ring grooves of the rectangular rings (248) in the drive shaft with industrial Vaseline.

46. Fit the rectangular rings so that the rectangular rings interlock in place. Align the rectangular rings centrally.

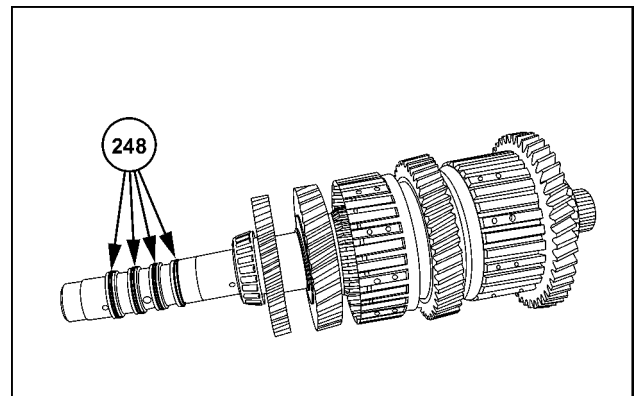

SVIL13TR00002AB 33

**Next operation:**

**Clutch - Install (21.152)**

**Clutch - Adjust – Clutch shafts (21.152)**

## Clutch Range clutch - Disassemble – Clutch B/D

Prior operation:

Clutch - Remove (21.152)

1. Remove the rectangular rings (161) and (202).

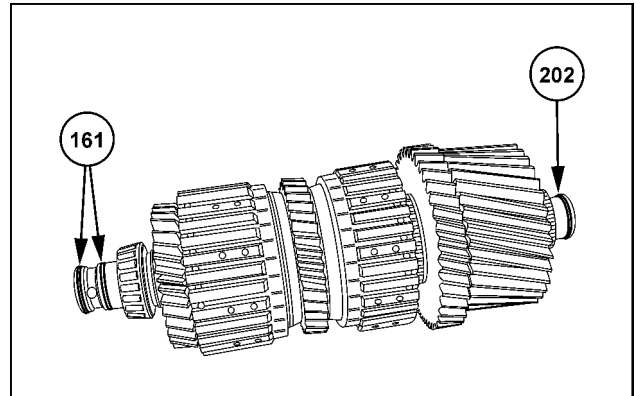

SVIL13TR00022AB 1

2. Remove the bearing (162).

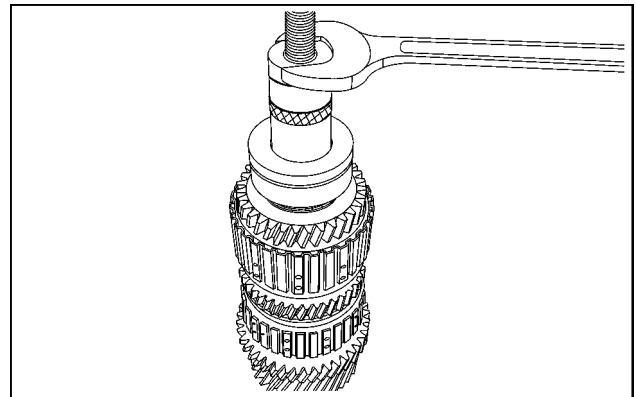

SVIL13TR00023AB 2

3. Release both circlips (163) and (250).

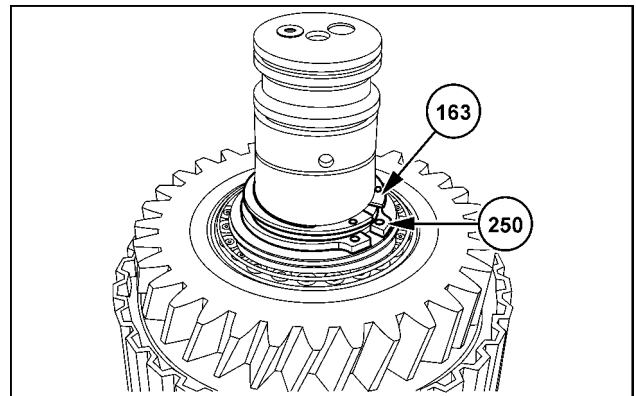

SVIL13TR00024AB 3

4. Remove the disk (164).

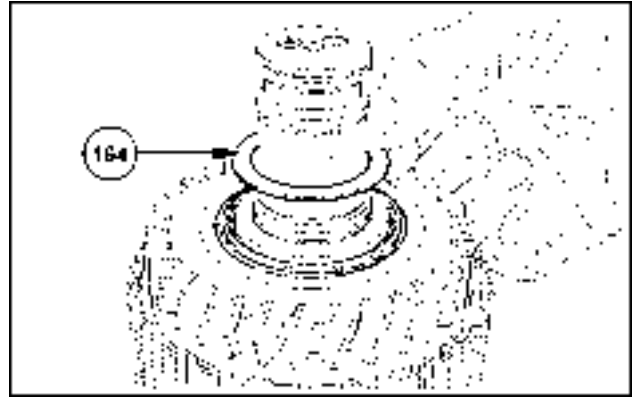

SVIL13TR00025AB 4

5. Remove the gear (166).

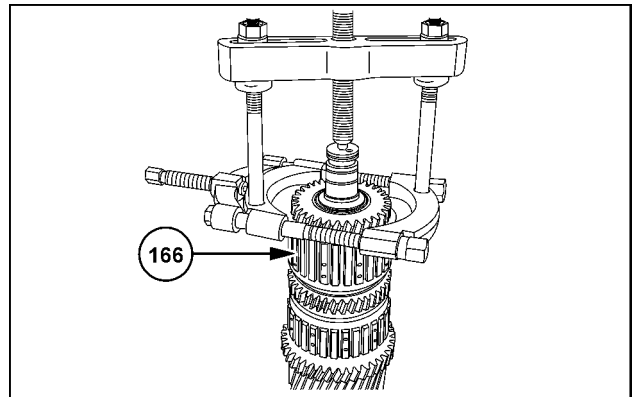

SVIL13TR00026AB 5

6. Remove the bearing outer rings (165) and (167).

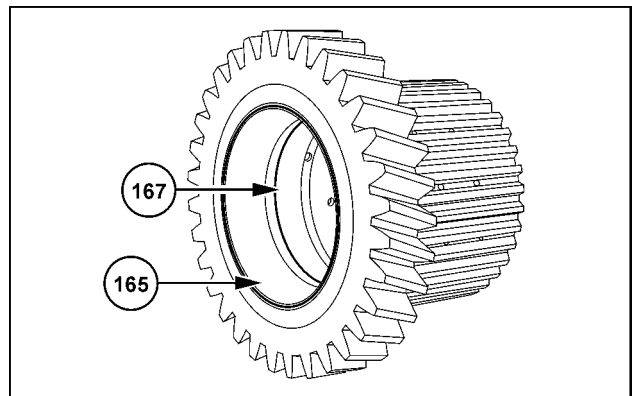

SVIL13TR00027AB 6

7. Preload the disc set.

8. Release circlip (170) from its position.

9. Remove the closing disc (171). Remove the disc set (clutch D).

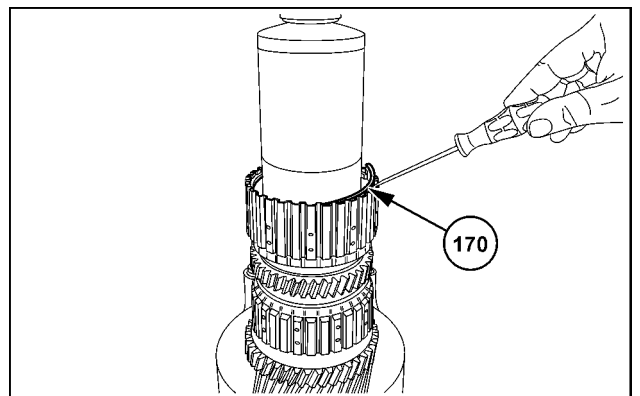

SVIL13TR00028AB 7

10. Remove the bearing (167).

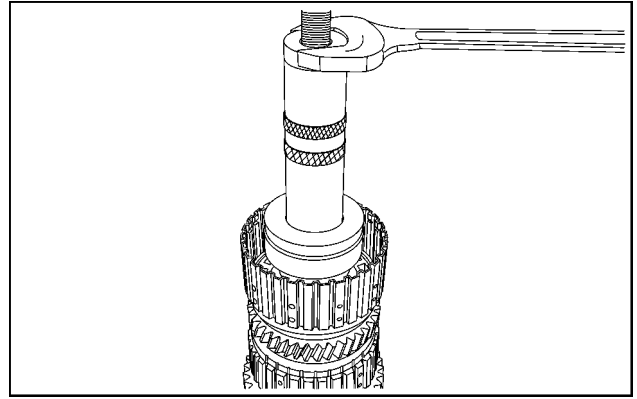

SVIL13TR00029AB 8

11. Remove the disk (168).

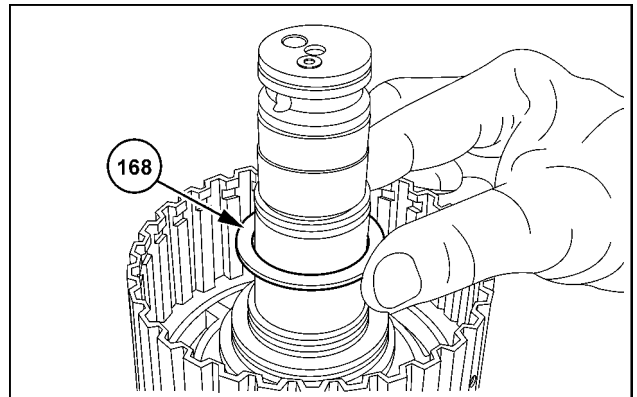

SVIL13TR00030AB 9

12. Release circlip (169) from its position.

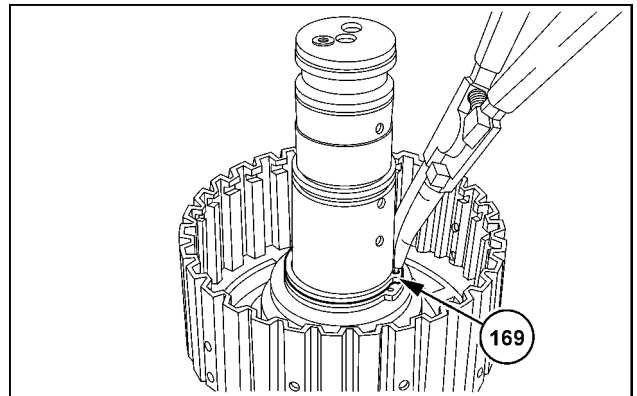

SVIL13TR00031AB 10

13. **⚠ WARNING**

**Spring under tension!**  
 Compressed springs have potentially dangerous stored energy. Always assemble and disassemble properly.  
 Failure to comply could result in death or serious injury.

W0356A

Preload the cup washers with bushing 380200374.

14. Release circlip (178) from its position.

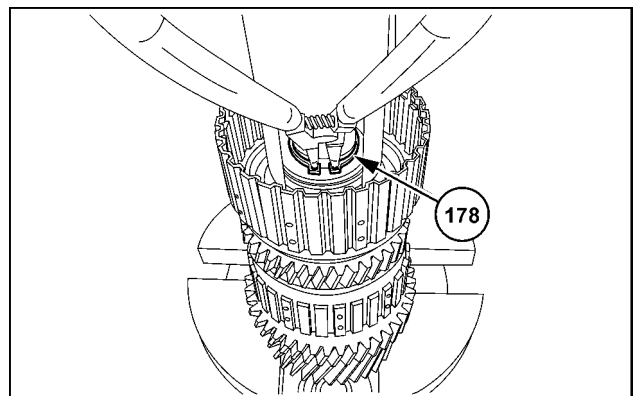

SVIL13TR00032AB 11

15. Remove the piston carrier (184) with the following parts: the thrust bearing (179), the cup washers (180), and the guide ring (181).

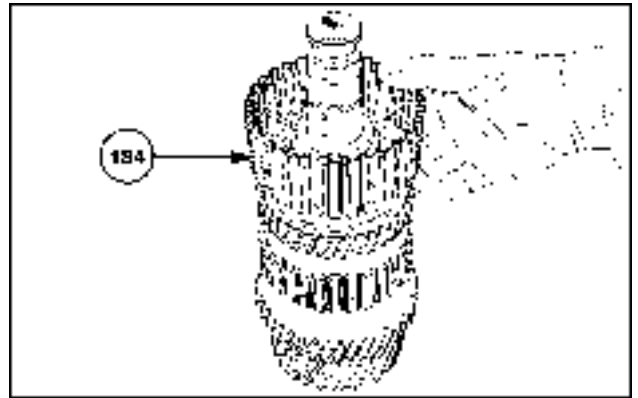

SVIL13TR00033AB 12

16. Remove the piston (175).

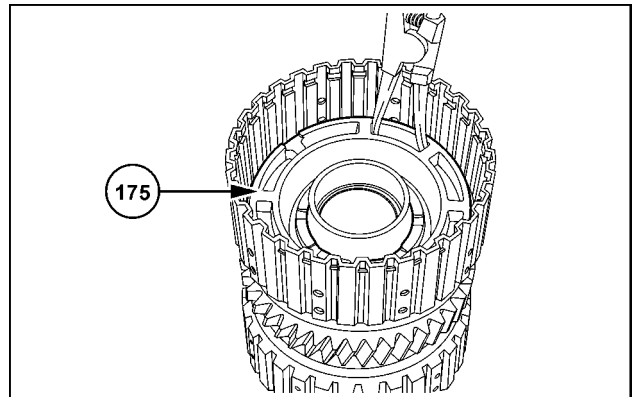

SVIL13TR00034AB 13

17. Remove the O-rings (176) and (177).

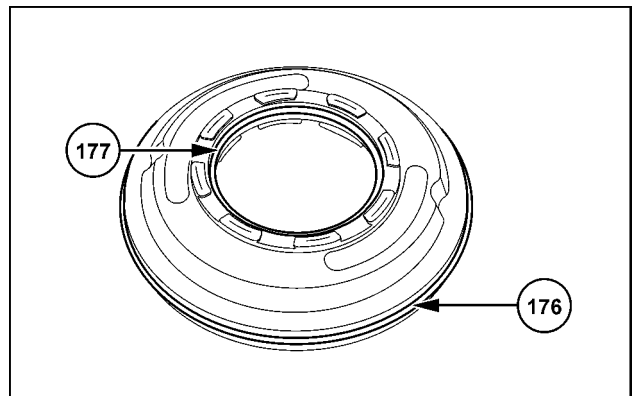

SVIL13TR00035AB 14

18. Preload the disc set.  
 19. Release circlip (192) from its position.  
 20. Remove the closing disc (191). Remove the disc set (clutch B).

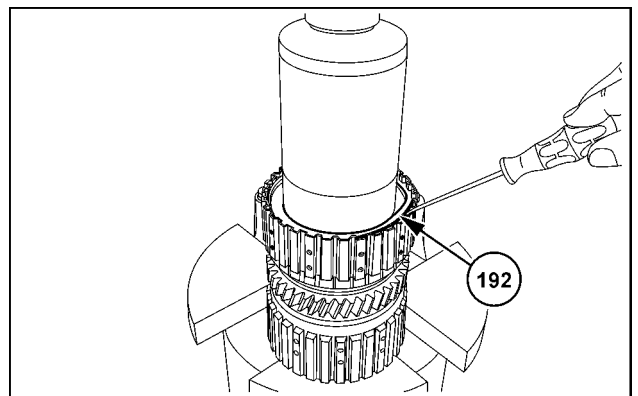

SVIL13TR00036AB 15



21. Remove the piston (187).

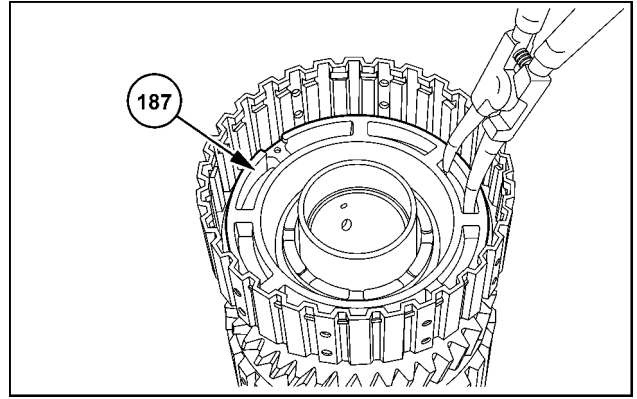

SVIL13TR00037AB 16

22. Remove the O-rings (185) and (186).

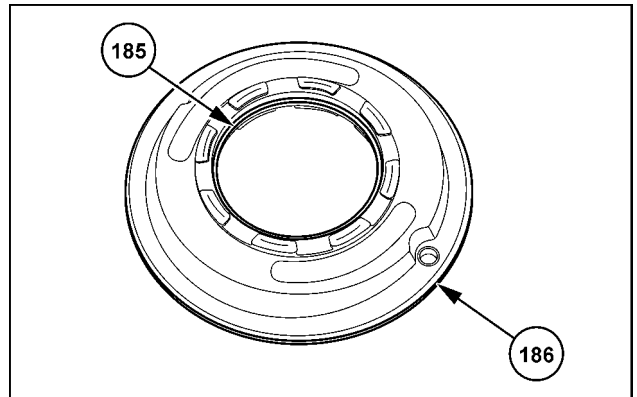

SVIL13TR00038AB 17

23. Remove the guide rings (193) and (195). Remove the thrust spring (194).

24. Remove the needle bearing (196).

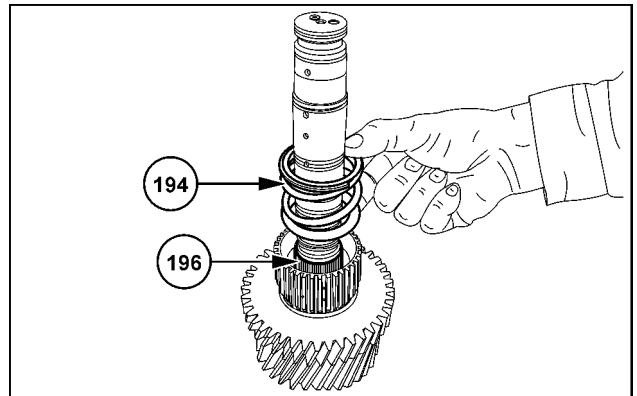

SVIL13TR00039AB 18

25. Remove the rectangular rings (183).

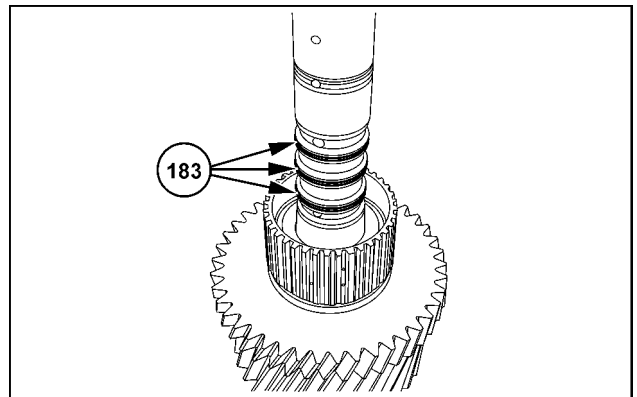

SVIL13TR00040AB 19

26. Remove the thrust bearing (197).

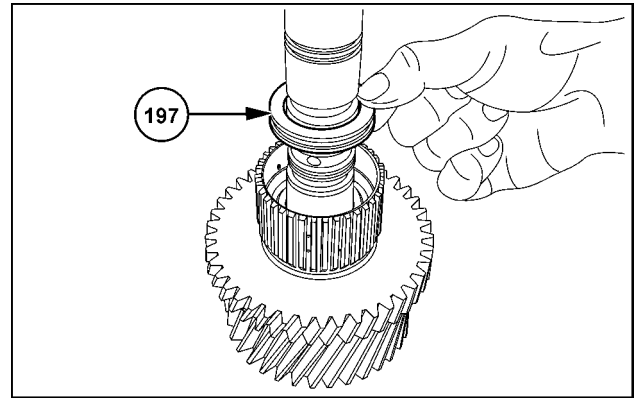

SVIL13TR00041AB 20

27. Remove the bearing (200).

**NOTICE:** Any further disassembly of the drive shaft is not permissible.

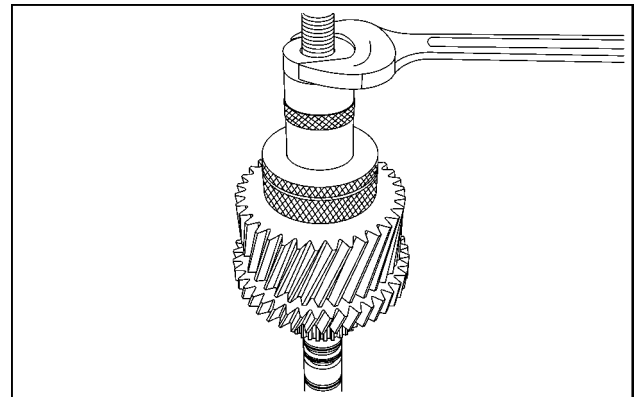

SVIL13TR00042AB 21

**Next operation:**  
**Clutch Range clutch - Assemble – Clutch B/D (21.152)**

## Clutch Range clutch - Assemble – Clutch B/D

### Prior operation:

### Clutch Range clutch - Disassemble – Clutch B/D (21.152)

1. Use a suitable tube to press the bearing (200) onto the clutch shaft (199).

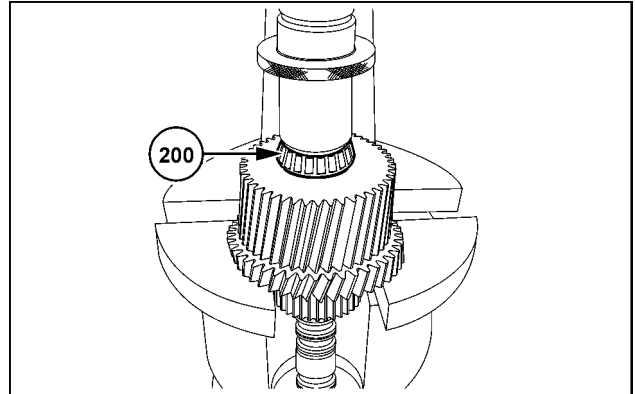

SVIL13TR00507AB 1

2. Install the thrust bearing (197).

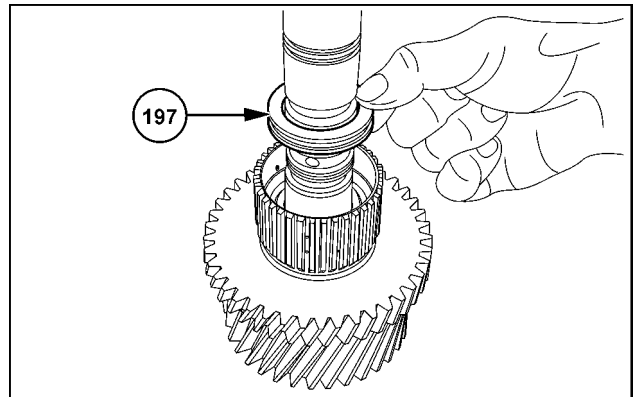

SVIL13TR00041AB 2

3. Fit the needle bearing (196).

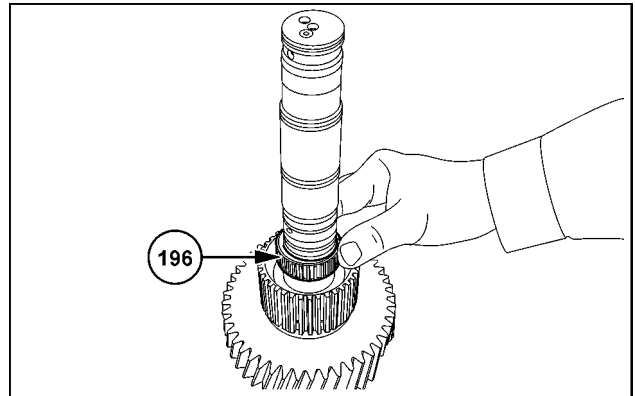

SVIL13TR00508AB 3

4. Grease the ring grooves of the rectangular rings (183) with industrial Vaseline.
5. Fit the rectangular rings so that the rectangular rings interlock in place. Align the rectangular rings centrally.

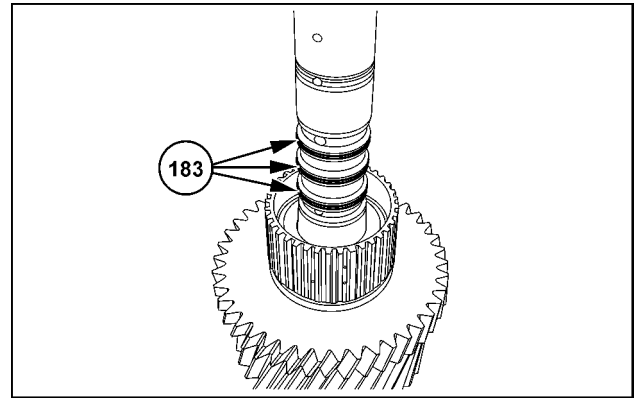

SVIL13TR00040AB 4

6. Grease the O-rings (185) and (186) with industrial Vaseline.
7. Install the O-rings (185) and (186) into the ring grooves of the piston (clutch B) (187).

**NOTE:** Check the function of the purging valve. The ball must not jam.

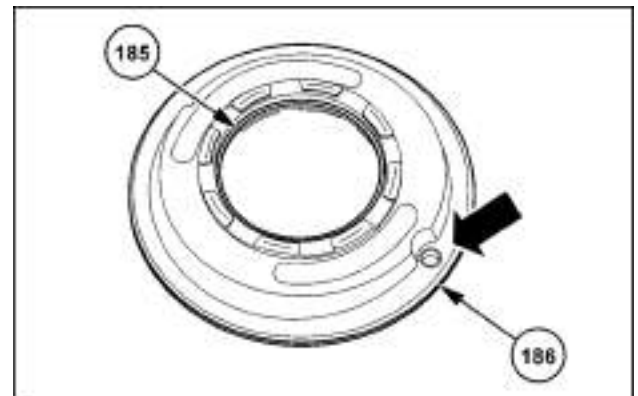

SVIL13TR00038AB 5

8. Install the piston (clutch B) (187) into the piston carrier on the short disk carrier side until the piston sits in place.

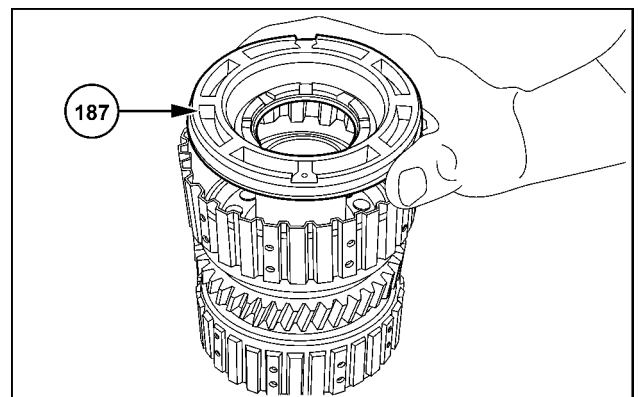

SVIL13TR000509AB 6

9. Grease the O-rings (176) and (177) with industrial Vaseline.
10. Install the O-rings (176) and (177) into the ring grooves of the piston (clutch D) (175).

**NOTE:** The piston design does not include a purging valve.

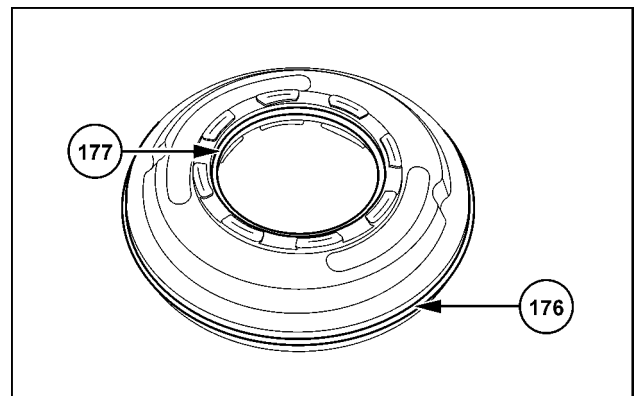

SVIL13TR00035AB 7

11. Install the piston (clutch D) (175) in the piston carrier so that the piston sits in place.

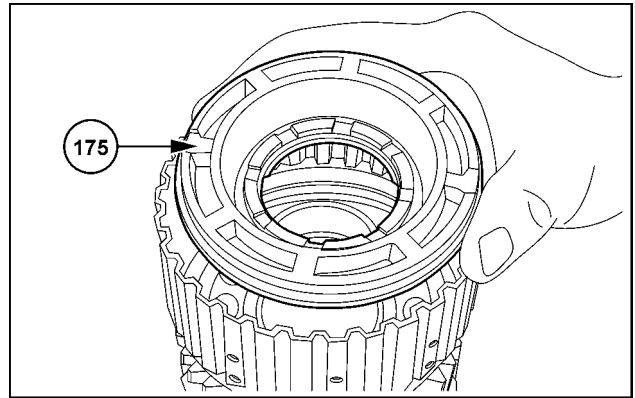

SVIL13TR00510AB 8

12. Install the disk set of the clutch B (short disk carrier side).

**NOTE:** Layer the friction disks and the steel disks alternately. Start with a steel disk.

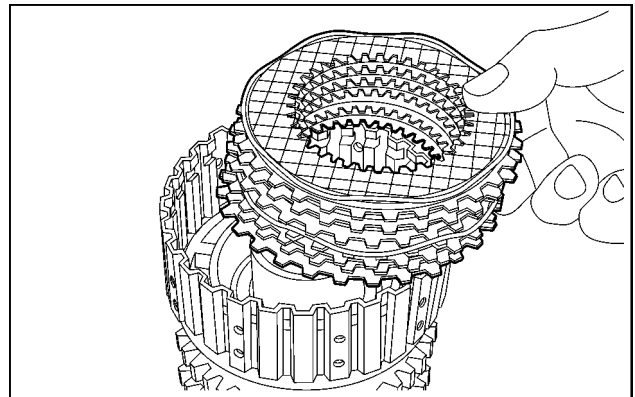

SVIL13TR00511AB 9

13. Install the closing disk (191).
14. Position the circlip (192) in the ring groove of the piston carrier.

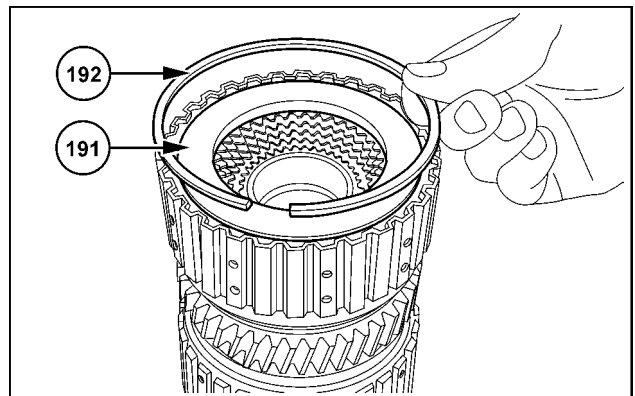

SVIL13TR00512AB 10

Adjust the disk set **3.80 - 4.30 mm (0.15 - 0.17 in)**.

15. Press together the disk set.
16. Measure the dimension "I" from the front face of the piston carrier to the closing disk. Measurement "I", e.g. **9.50 mm (0.37 in)**

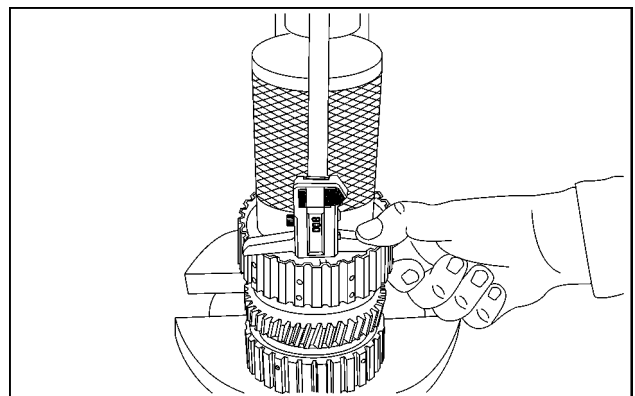

SVIL13TR00513AB 11

17. Move the closing disk upward until the closing disk sits in place on the circlip.
18. Determine dimension "II". Measurement "II", e.g. **5.40 mm (0.21 in)**

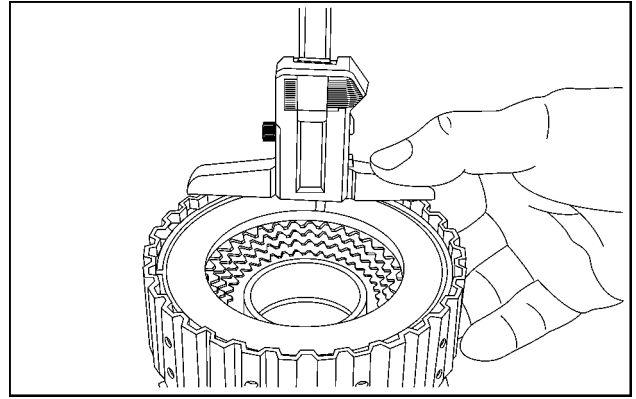

SVIL13TR00514AB 12

**Example calculation:**

Dimension "I":	<b>9.50 mm (0.37 in)</b>
Dimension "II":	<b>- 5.40 mm (0.21 in)</b>
Difference = disk clearance	<b>4.10 mm (0.16 in)</b>

**NOTE:** If there is a deviation from the required disk clearance, use an appropriate circlip (192) to correct this deviation.

19. Align the pre-assembled disk set on the gear.

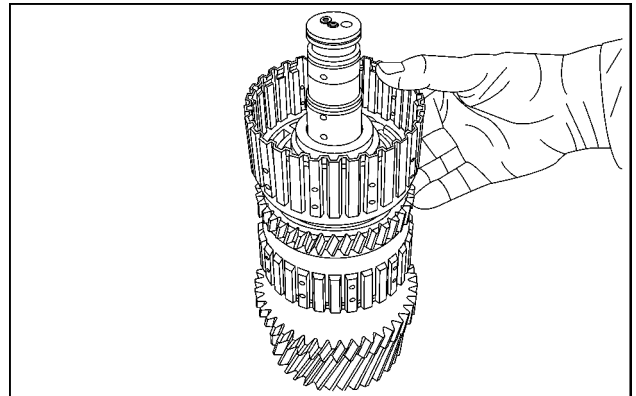

SVIL13TR00033AC 13

20. Pre-load the disk set equally with the mounting device.

**NOTE:** Produce the mounting device in accordance with the technical drawing. See **Semi-Powershift transmission - Special tools (21.111)** .

21. Remove the pre-tensioned disk set.

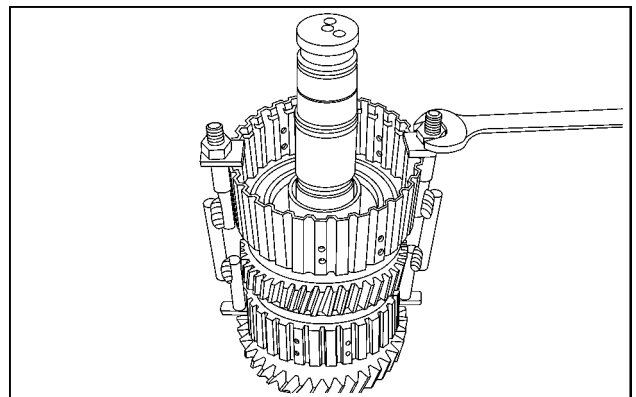

SVIL13TR00515AB 14

22. Install the guide ring (195). Install the thrust spring (194). Install the guide ring (193).

**NOTE:** Ensure that the guide rings are in the correct position. Install the guide ring with a curved internal diameter so that the guide ring faces the thrust bearing.

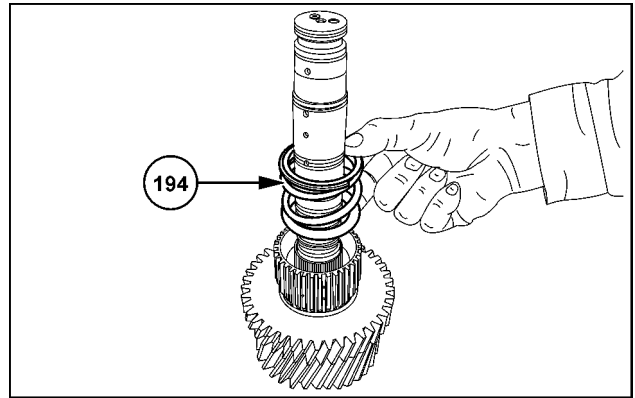

SVIL13TR00039AC 15

23. Install the pre-assembled piston carrier (184) until the pre-assembled piston carrier sits in place.

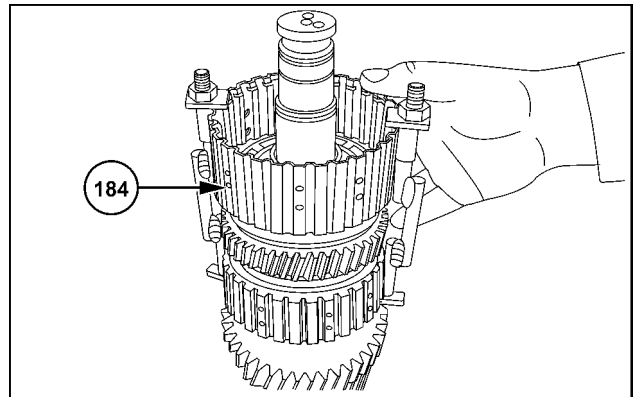

SVIL13TR00516AB 16

24. Fit the needle bearing (182).

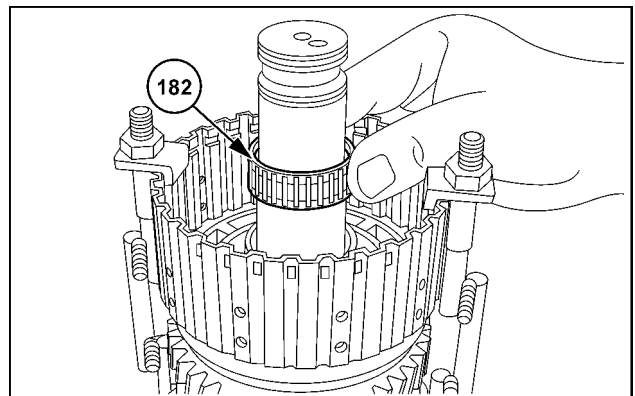

SVIL13TR00517AB 17

25. Install the guide ring (181). The radius of the guide ring must face upward.

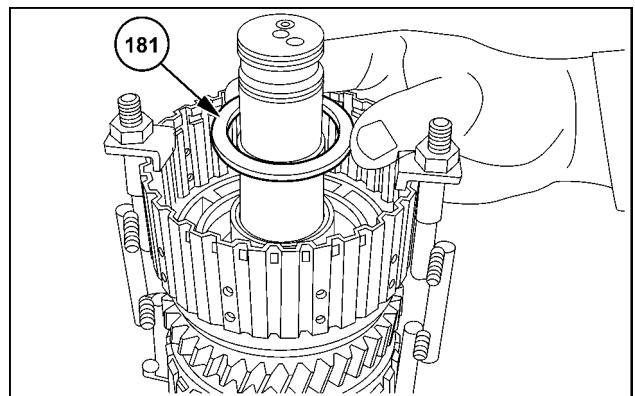

SVIL13TR00518AB 18

26. Install the cup washer set (180).

**NOTE:** See also figure 20.

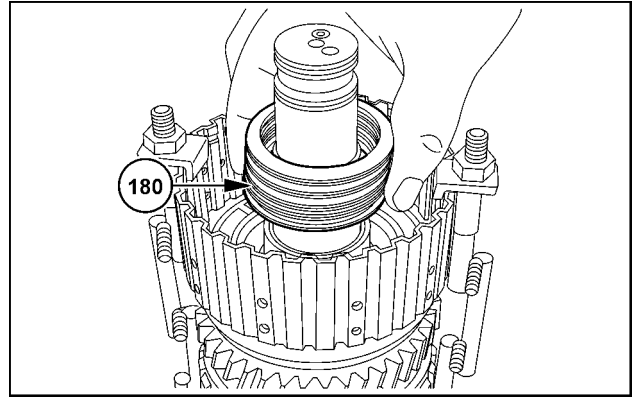

SVIL13TR00519AB 19

27. Image:  
 Belleville washers (180)  
 (182)  
 Needle BearingClutch shaft (199)  
 Guide ring (181)  
 Piston (175)  
 Piston carrier (184)

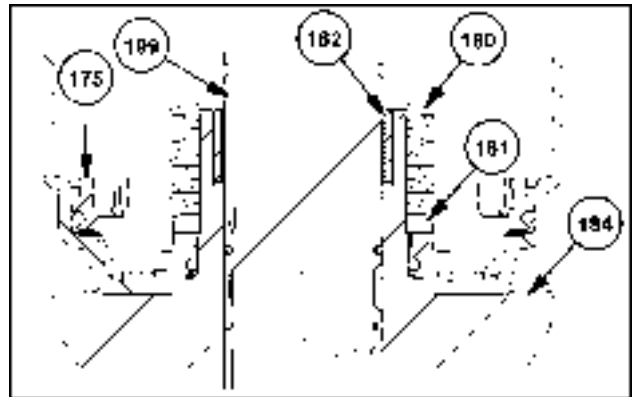

SS13F116 20

28. Install the (179) thrust bearing.

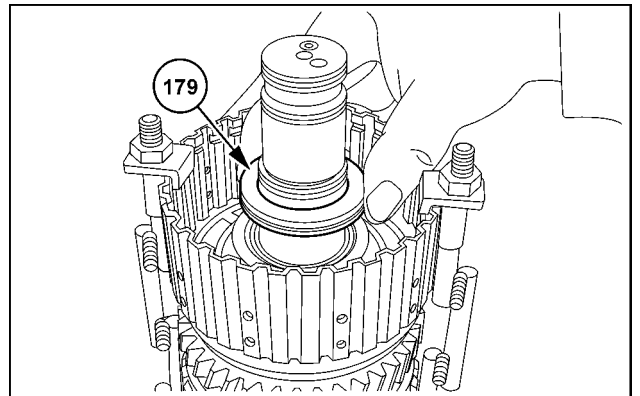

SVIL13TR00520AC 21

29. Fit the circlip (178).

30. **⚠ CAUTION**

**Spring under tension!**  
**This assembly is spring-loaded. Remove the parts carefully!**  
**Failure to comply could result in minor or moderate injury.**

C0147A

Use the bushing 380200374 to pre-tension the thrust springs and cup washers.

31. Insert the circlip.

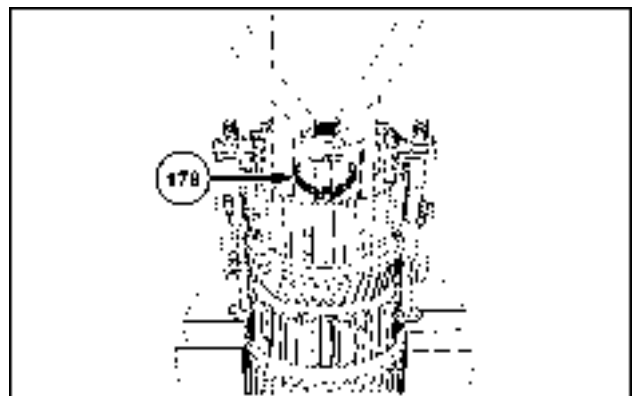

SVIL13TR00521AB 22



32. Remove the mounting device.

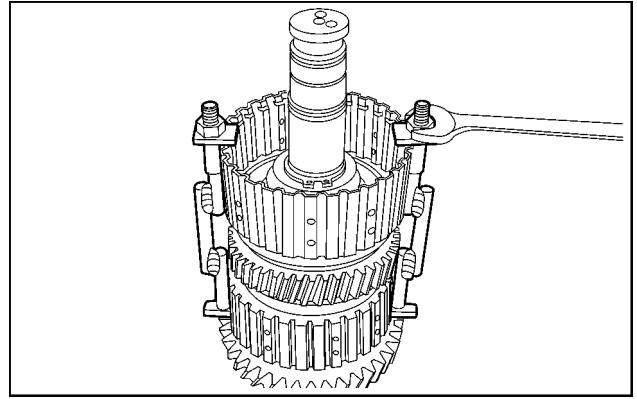

SVIL13TR00522AB 23

33. Fit the circlip (169).

**NOTE:** Install the disk set (clutch D) in the same way as steps 12 to 17.  
Adjust the disk set 4.50 - 4.90 mm (0.18 - 0.19 in).

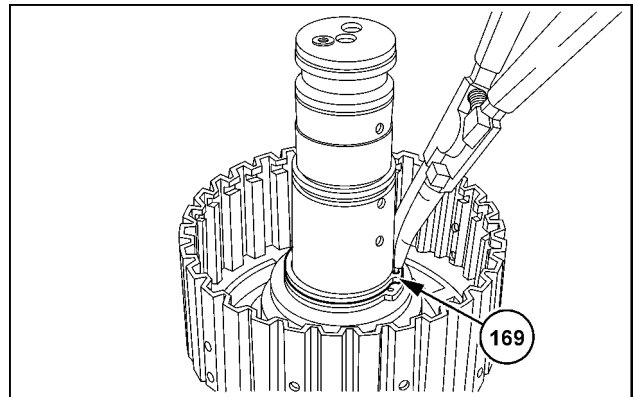

SVIL13TR00031AB 24

34. Install the disk (168).

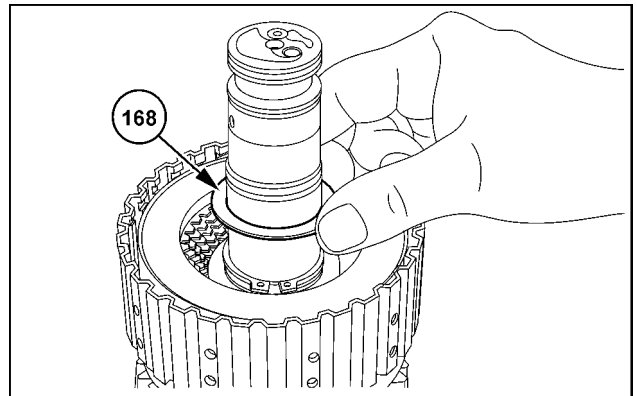

SVIL13TR00523AB 25

35. Use a suitable tube to press on the bearing inner ring (167) until the bearing inner ring sits in place.

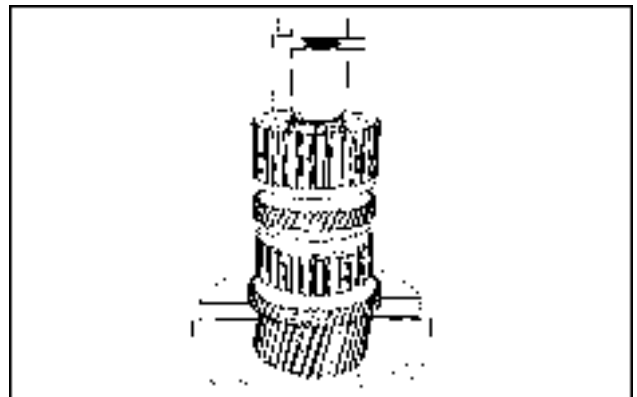

SVIL13TR00524AB 26

36. Use a suitable bushing to insert the two bearing outer rings (165) and (167) into the gear (166) until the two bearing outer rings sit in place.

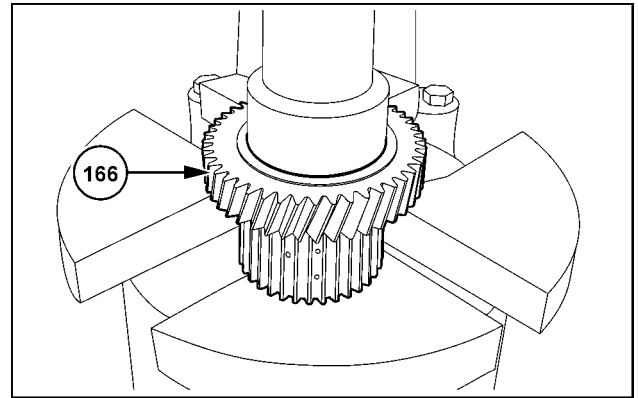

SVIL13TR00525AB 27

37. Install the gear (166).

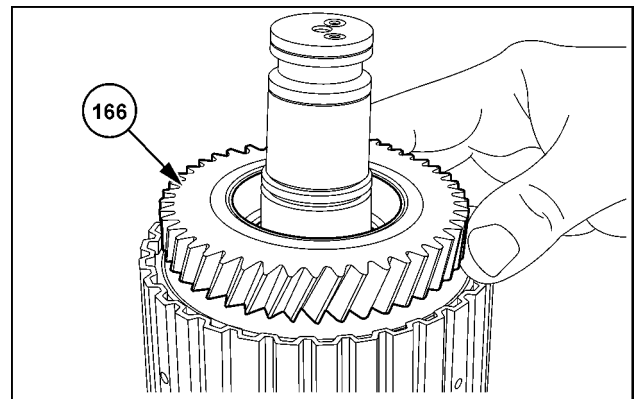

SVIL13TR00526AB 28

38. Use a suitable tube to press on the bearing inner ring (165) until the bearing inner ring sits in place.

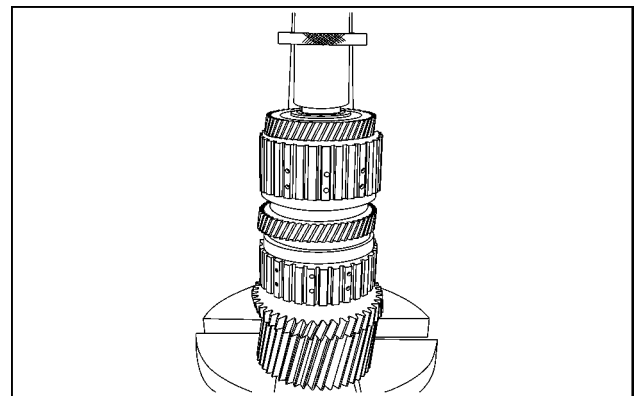

SVIL13TR00527AB 29

39. Install the disk (164).  
 40. Insert the circlip (250) (without any axial force) into the lower ring groove.

**NOTE:** The circlip is ground on both sides.

**NOTE:** If you do not use new bearings, you can use the existing adjustment disks. However, you must check the bearing clearance.

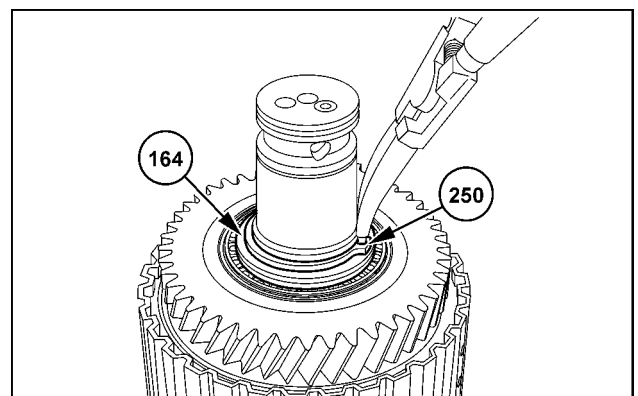

SVIL13TR00528AB 30

41. Check the bearing adjustment of **0.020 - 0.050 mm** (**0.001 - 0.002 in**).

**NOTE:** Before you check the bearing adjustment, position the bearing inner ring (**165**) against the circlip. To perform this step, tap a rubber hammer (**166**) on the gear.

**NOTE:** Use the relevant disk to correct any deviations from the necessary adjustment value. Refer to the figure 30.

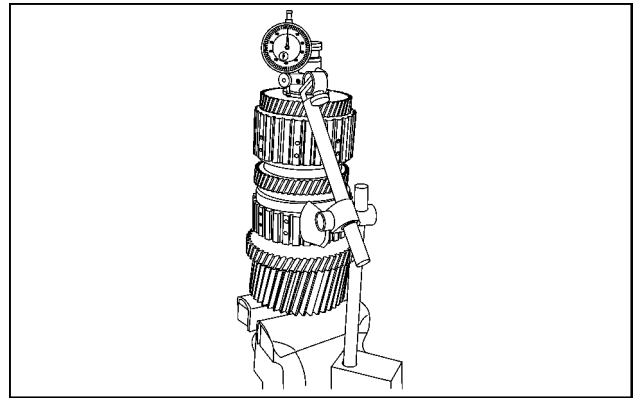

SVIL13TR00529AB 31

42. Fit the circlip (**163**).

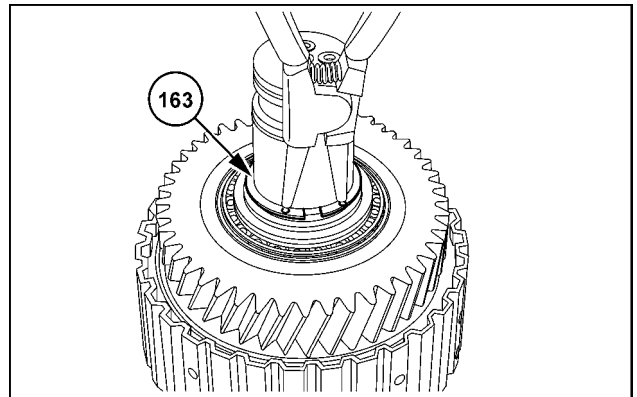

SVIL13TR00530AB 32

43. Use a suitable tube to press the inner bearing ring (**162**) onto the clutch shaft until the inner bearing ring sits in place.

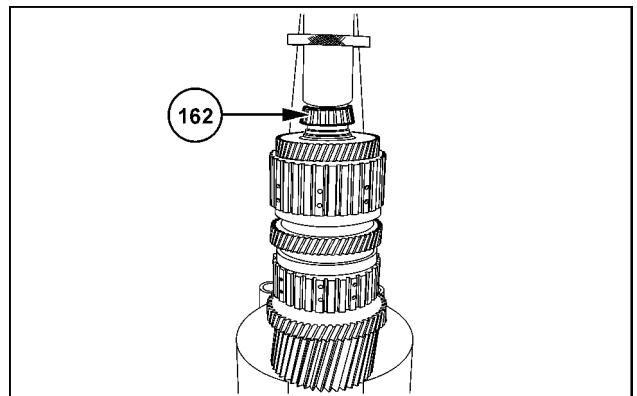

SVIL13TR00531AB 33

44. Grease the ring grooves of the rectangular rings (**161**) and (**202**) in the clutch shaft with industrial Vaseline.
45. Fit the rectangular rings so that the rectangular rings interlock in place. Align the rectangular rings centrally.

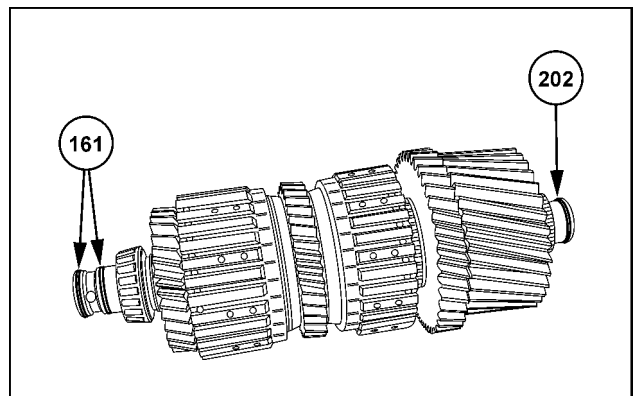

SVIL13TR00022AB 34

**Next operation:**

**Clutch - Install (21.152)**

**Clutch - Adjust – Clutch shafts (21.152)**

## Transmission internal controls - Remove – Third/fourth gear shift

### Prior operation:

#### Rear axle housing - Disconnect (27.100)

1. Loosen the screw (336).
2. Remove the shift finger (335). Remove the selector shaft (331).

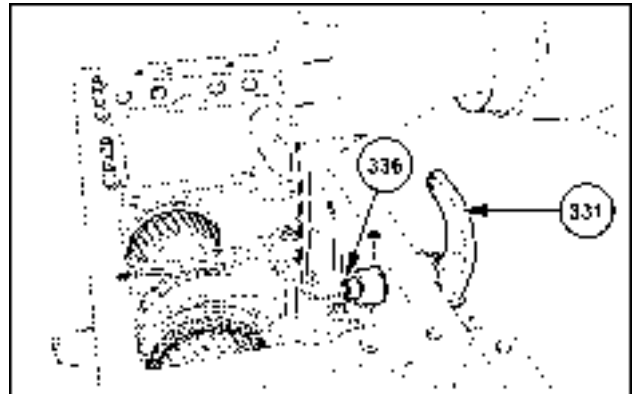

SVIL13TR00236AB 1

3. Remove the O-ring (334). Remove the circlip (332).

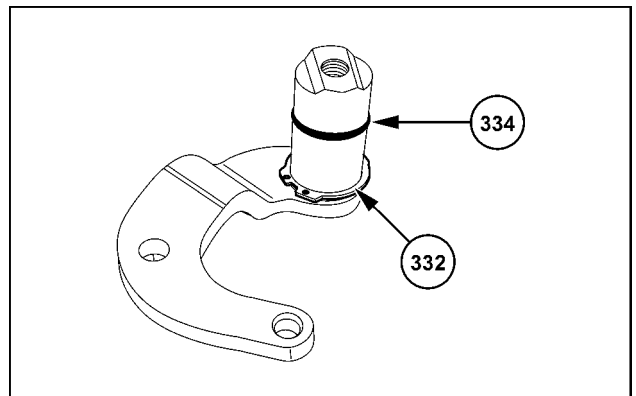

SVIL13TR00237AB 2

4. Set transmission in third gear.
5. Loosen the bolts (337) and (339).

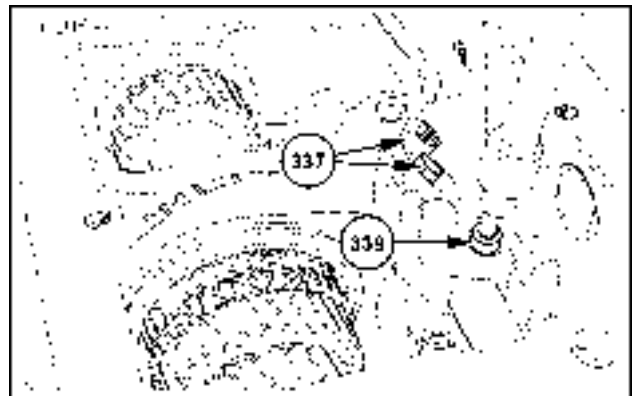

SVIL13TR00238AB 3

6. Remove the **(340)** gearshift bar.
7. Remove the shift fork **(353)**. Remove the driver **(338)**.

**NOTE:** Be careful with the ball.

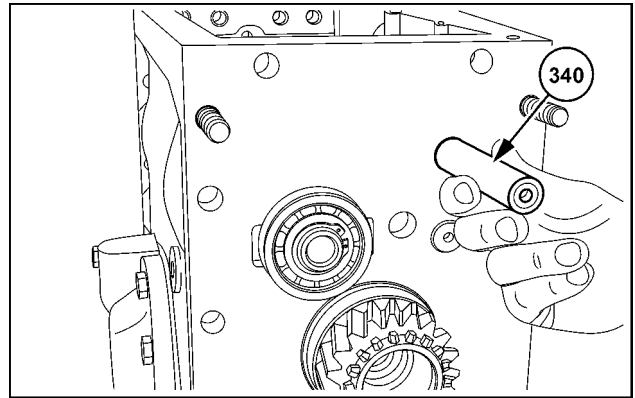

SVIL13TR00245AB 4

8. Use a magnetic rod to remove the ball **(347)**, the spring **(348)**, the locking pin **(349)** and the ball **(350)** (see arrow **(A)**) of the shift stop.
9. Remove the ball **(346)**, the locking pin **(345)** and the ball **(344)** (see arrow **(B)**) of the detent assembly.

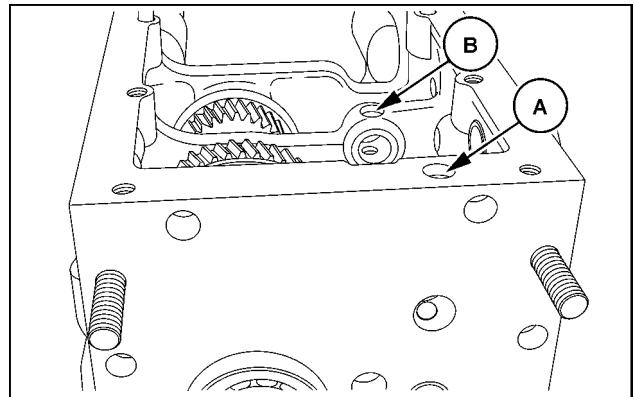

SVIL13TR00239AB 5

**Next operation:**

**Transmission drive and driven shaft - Remove – Countershaft (21.152)**

---

## Transmission internal controls - Remove – First/second gear shift

### Prior operation:

#### Transmission drive and driven shaft - Remove – Countershaft (21.152)

1. Loosen the bolts (342) and (343).
2. Remove the selector shaft (351). Remove the driver (341). Remove the shift fork (352).



SVIL13TR00253AB 1

### Next operation:

#### Transmission drive and driven shaft - Remove – Main shaft (21.152)

## Transmission internal controls - Install – First/second gear shift

### Prior operation:

#### Transmission drive and driven shaft - Install – Main shaft (21.152)

1. Install the gearshift bar for the first/second gear (351) in the transmission housing. During installation, thread on the shift fork and the driver (341).

**NOTE:** Install the gearshift bar so that the notches face up.

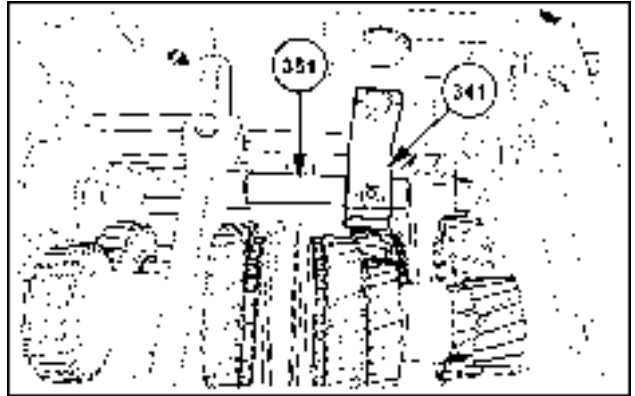

SVIL13TR00397AB 1

2. Tighten the shift fork in advance by hand with a bolt.

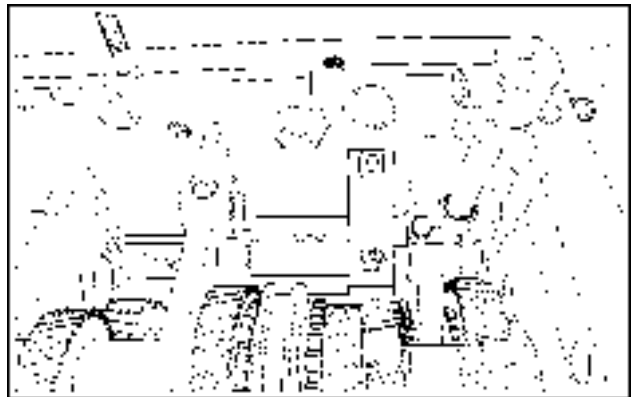

SVIL13TR00405AB 2

3. Moisten the bolt (342) with **LOCTITE® 243**.
4. Secure the driver (341) on the selector shaft. Tighten plug to **34 Nm (25 lb ft)**.

**NOTE:** Unclamp the shift fork again.

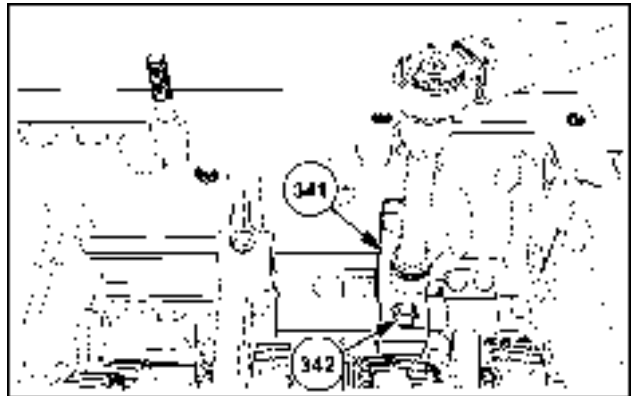

SVIL13TR00399AB 3

### Next operation:

#### Transmission drive and driven shaft - Install – Intermediate shaft (21.152)

## Transmission internal controls - Install – Third/fourth gear shift

### Prior operation:

#### Transmission drive and driven shaft - Install – Countershaft (21.152)

1. Insert the ball (350), the spring (348), the lock pin (349) and the ball (347) into the housing bore.

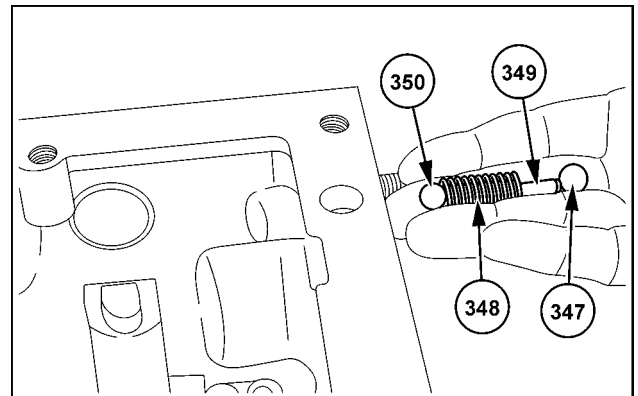

SVIL13TR00406AB 1

2. Insert the ball (344), the lock pin (345) and the ball (346) into the housing bore.

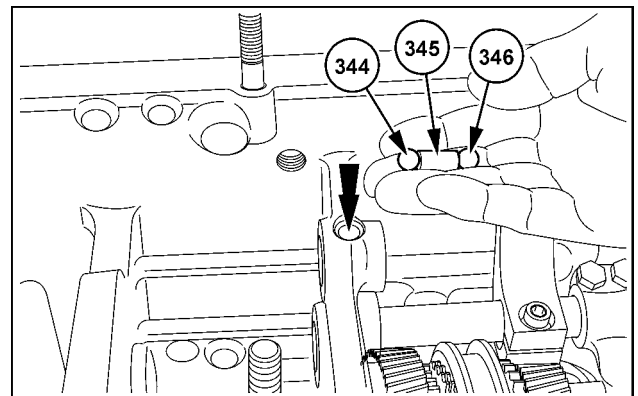

SVIL13TR00409AB 2

3. Install the gearshift bar for the third/fourth gear (340) in the gearbox housing. During installation, slide the shift fork for third/fourth gear (353) and the driver (338) onto the gearshift bar.

**NOTE:** Install the gearshift bar so that the notches face down.

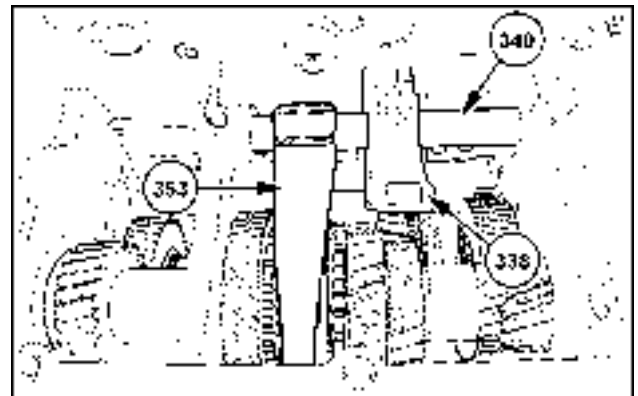

SVIL13TR00407AB 3



4. Coat the bolts with **LOCTITE® 243**.
5. Secure the driver on the selector shaft.  
Tighten the screws to **34 Nm (25 lb ft)**.



SVIL13TR00408AB 4

6. Adjust the gear shift. See **Transmission internal controls - Adjust – First/second gear shift and third/fourth gear shift (21.152)**.
7. Fit the circlip (**332**).
8. Fit the O-ring (**334**) into the ring groove of the selector shaft.

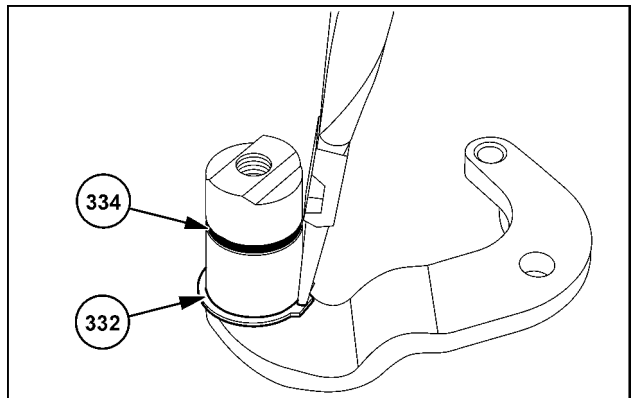

SVIL13TR00579AB 5

9. Insert the selector shaft (**331**) into the transmission housing bore.
10. Moisten the bolt (**336**) with **LOCTITE® 243**.
11. Use the bolt to secure the shift finger (**336**).  
Tighten plug to **68 Nm (50 lb ft)**.

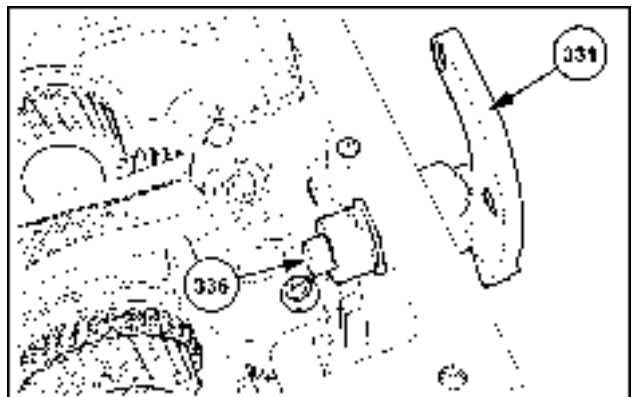

SVIL13TR00413AB 6

**Next operation:**  
**Rear axle housing - Connect (27.100)**

## Transmission internal controls - Adjust – First/second gear shift and third/fourth gear shift

### Prior operation:

### Transmission internal controls - Install – Third/fourth gear shift (21.152)

1. Support the main shaft against the gearbox housing.
2. Spray the screw with **LOCTITE® 243**.
3. Use a bolt to secure the lower shift fork for the first/second gear on the gearshift bar in advance. Tighten plug to **23 Nm (17 lb ft)**.
4. Check the cycling **0.7 - 1.0 mm (0.028 - 0.039 in)** on both sides.



SVIL13TR00410AB 1

5. To correct any deviation in the cycling, release the shift fork. Then calibrate the shift fork to the gearshift bar.
6. Coat the bolts with **LOCTITE® 243**. Tighten both bolts to **23 Nm (17 lb ft)**.



SVIL13TR00411AB 2

7. Perform cycling of the third/fourth gear in the same way as the first/second gear. During this procedure, support the countershaft instead of the main shaft against the gearbox housing.

## Transmission drive and driven shaft - Remove – Countershaft

### Prior operation:

#### Rear axle housing - Disconnect (27.100)

1. Release the groove nut (**354**). Use the wrench **38000078** to loosen the groove nut. To loosen the groove nut, engage third gear and hold the main shaft with the socket wrench **380000815**.
2. Use the main shaft to loosen the groove nut.

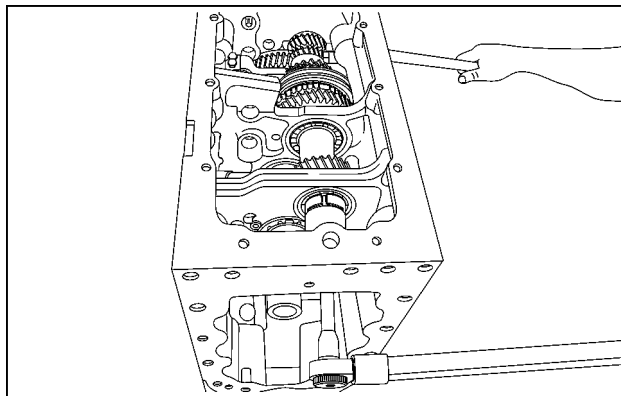

SVIL13TR00403AB 1

3. Press out the countershaft (**372**) toward the rear.
4. Remove any loose components.

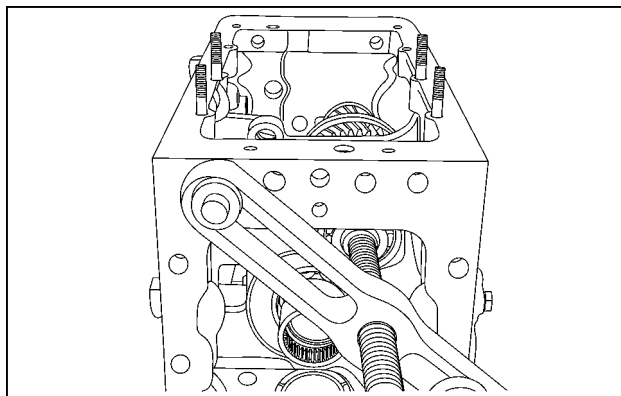

SVIL13TR00244AB 2

5. Release circlip (**378**) from its position.
6. Remove the bearing (**376**) from the countershaft.
7. Remove any loose parts.

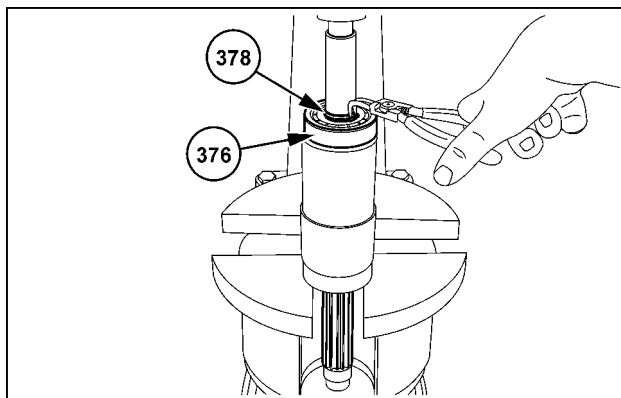

SVIL13TR00248AB 3

8. Remove both bearings (355) and (358).

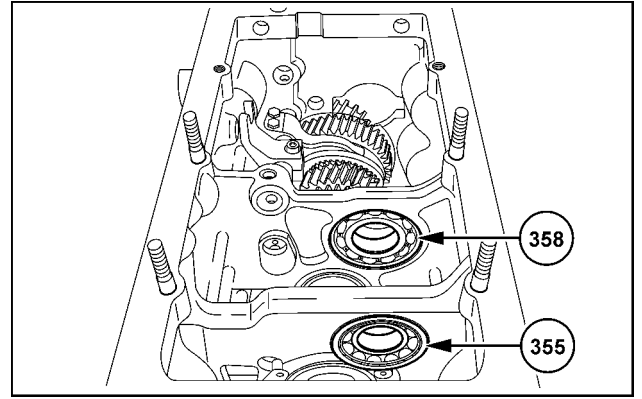

SVIL13TR00240AB 4

**Next operation:**

**Transmission drive and driven shaft - Remove – Intermediate shaft (21.152)**

## Transmission drive and driven shaft - Remove – Intermediate shaft

### Prior operation:

### Transmission drive and driven shaft - Remove – Countershaft (21.152)

1. Remove the retaining ring (383).

**NOTE:** The bolts are secured with **LOCTITE®**.

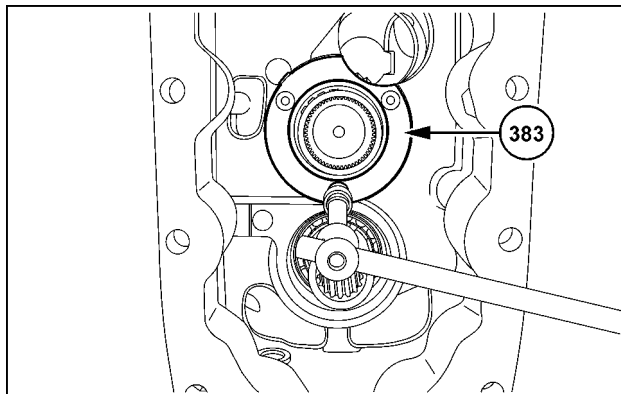

SVIL13TR00242AB 1

2. Release circlip (387) from its position.



SVIL13TR00243AB 2

3. Pry the intermediate shaft (381) with the bearing (385) out of the housing bore.
4. Remove any loose components.

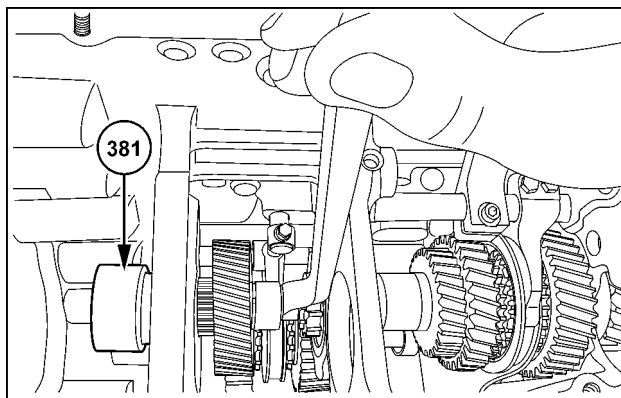

SVIL13TR00249AB 3

5. Release circlip (384) from its position.

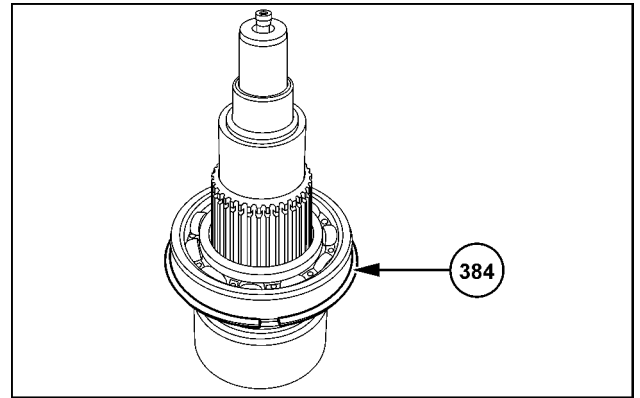

SVIL13TR00247AB 4

6. Remove the bearing (385) from the intermediate shaft.

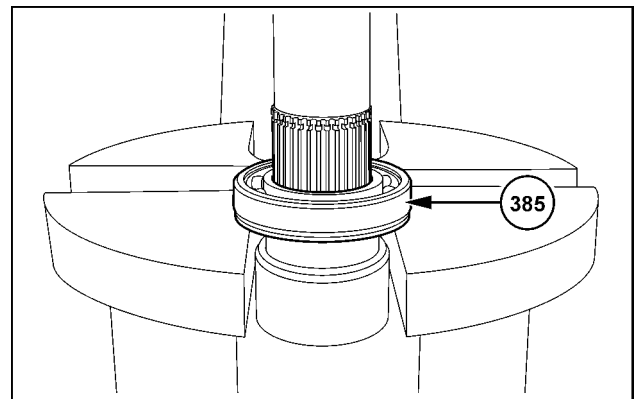

SVIL13TR00250AB 5

**Next operation:**  
**Transmission internal controls - Remove – First/second gear shift (21.152)**

## Transmission drive and driven shaft - Remove – Main shaft

### Prior operation:

#### Transmission internal controls - Remove – First/second gear shift (21.152)

1. Release the groove nut (**389**).
2. Use the groove nut wrench **380001733** to loosen the groove nut. To loosen the groove nut, use the socket wrench **380000815** to hold the main shaft via the rear shift-collar spline of the main shaft.

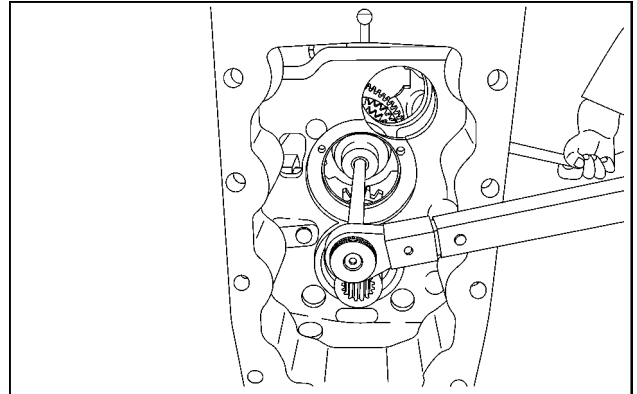

SVIL13TR00367AB 1

3. Press out the main shaft (**402**) toward the rear.
4. Remove any loose components.

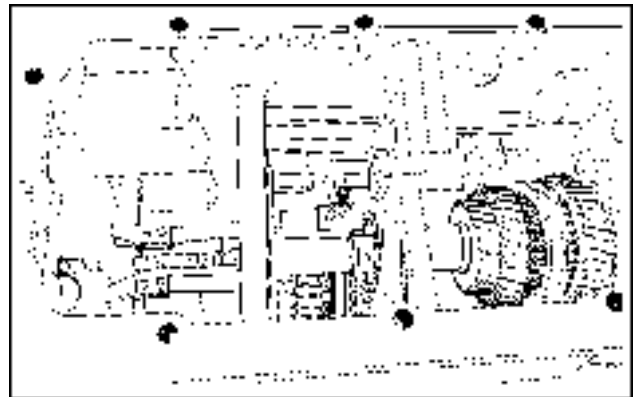

SVIL13TR00252AB 2

5. Remove the bearing (**390**).

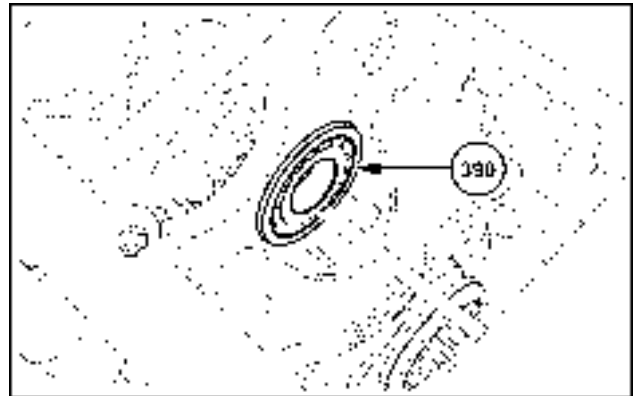

SVIL13TR00254AB 3

### Next operation:

#### Transmission drive and driven shaft - Install – Main shaft (21.152)

## Transmission drive and driven shaft - Install – Main shaft

### Prior operation:

#### Transmission drive and driven shaft - Remove – Main shaft (21.152)

1. Install the bearing (401) with the circlip (400) and the thrust washer (399) on the main shaft.

**NOTE:** Ensure that the thrust washer is fitted in the correct position. Slide on the thrust washer. The oil pockets must face upward.

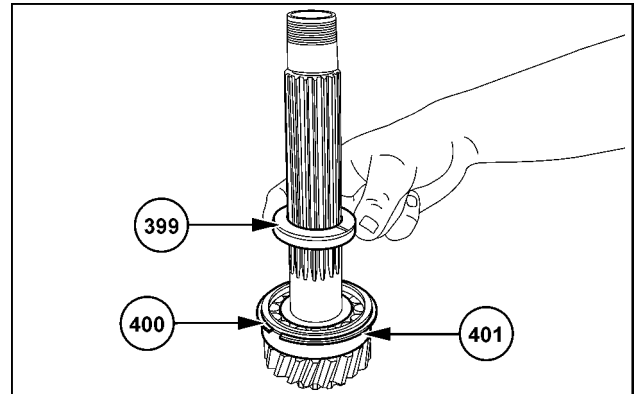

SVIL13TR00354AB 1

2. Insert the bushing (398) (length = 41.5 mm (1.63 in)) onto the main shaft until the bushing sits in place.

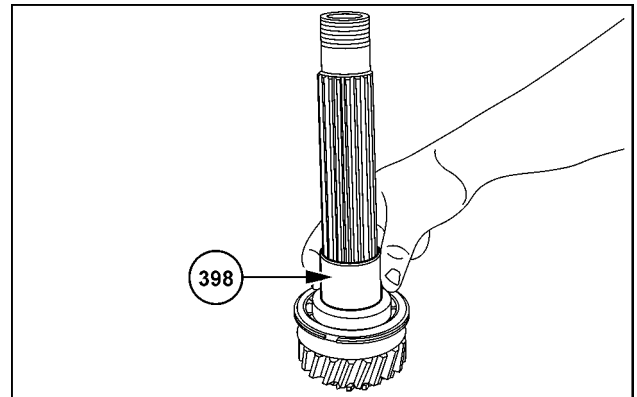

SVIL13TR00355AB 2

3. Prepare the first gear and the second gear for later installation with the synchronizer.
4. Pre-assemble the synchronizer in accordance with the diagram:
  - (A) Collar holder
  - (B) Synchronizer ring
  - (C) Sliding sleeve
  - (D) Spool
  - (E) Thrust spring
  - (F) Ball
  - (G) Clutch body ring

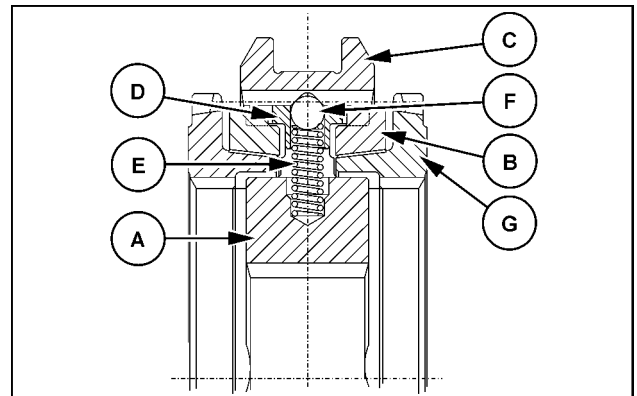

SS13F107 3



5. Install the pre-assembled synchronizer on the first gear (397).

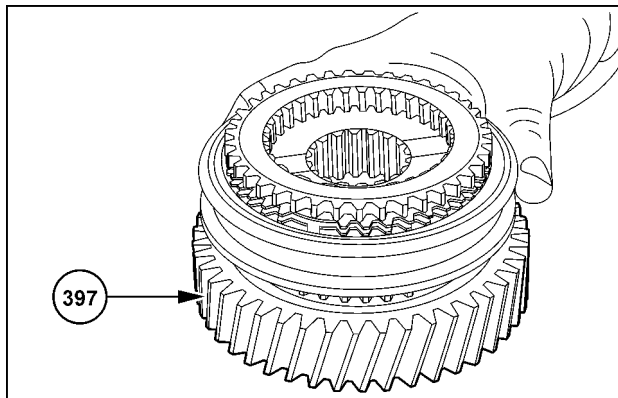

SVIL13TR00356AB 4

6. Install the second gear (394).

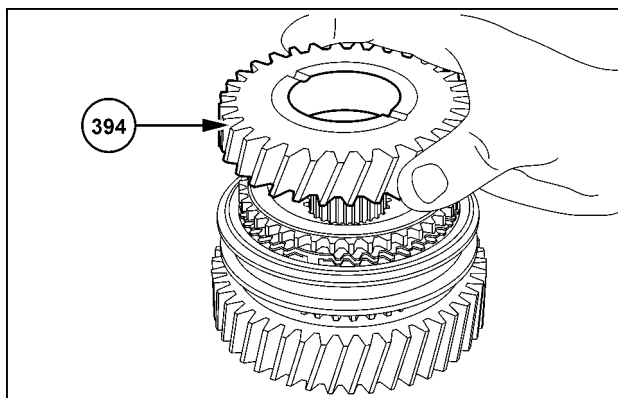

SVIL13TR00357AB 5

7. Install the bushing (395). The inner synchronization teeth must point toward the synchronizer.

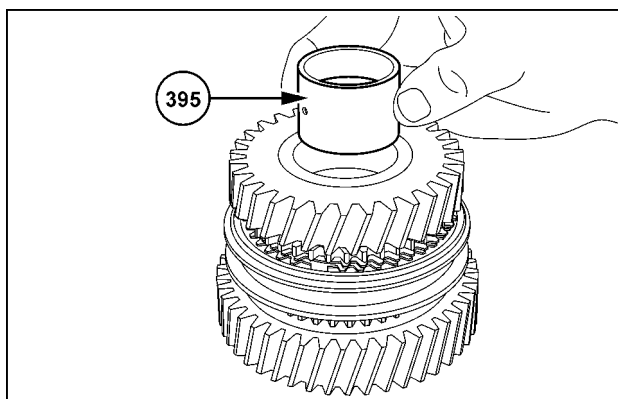

SVIL13TR00358AB 6

8. Prepare the third gear (393), the spacer sleeve (392) and the fourth gear (391) for subsequent installation.

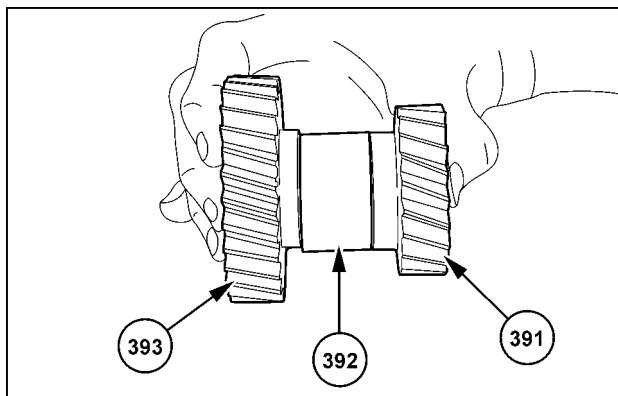

SVIL13TR00359AB 7

9. Fit the main shaft into the transmission housing.
10. Fit the assembled first gear, the synchronizer and the second gear into the transmission housing.

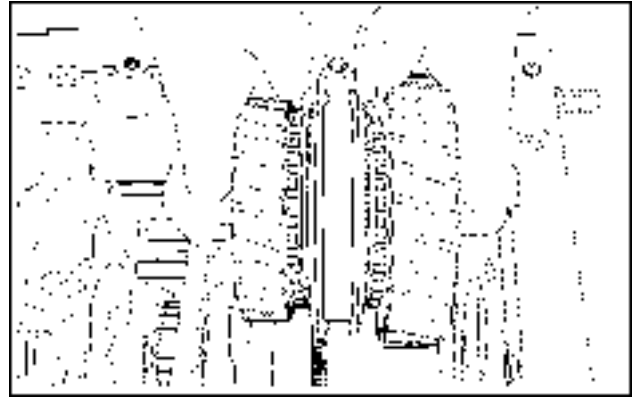

SVIL13TR00360AB 8

11. Install the pre-assembled main shaft into the transmission housing. Install the components in illustration 8.

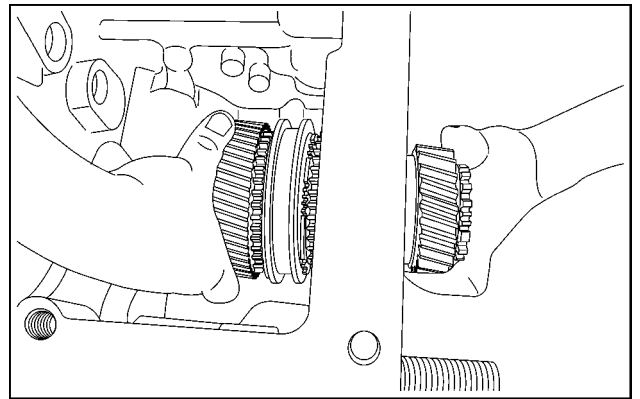

SVIL13TR00361AB 9

12. Install the third gear (393), the spacer sleeve (392) and the fourth gear (391) on the main shaft.

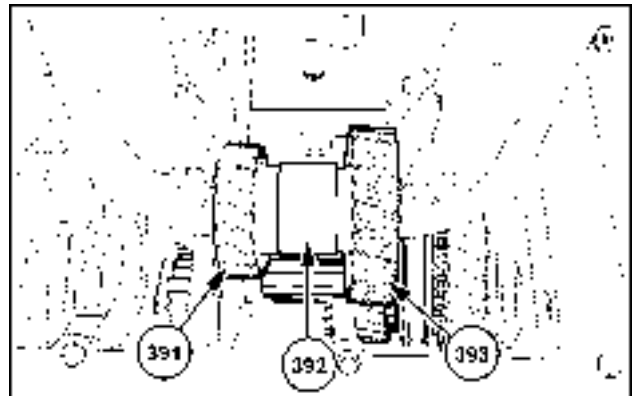

SVIL13TR00362AB 10

13. Use the circlip of the bearing to support the main shaft against the transmission housing.

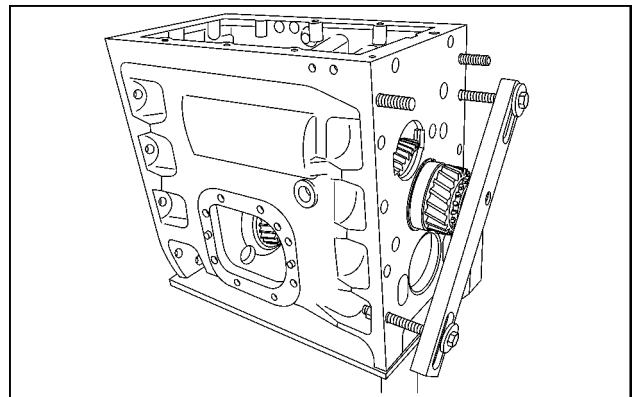

SVIL13TR00363AB 11

14. **CAUTION**

**Burn hazard!**  
**Always wear heat-resistant protective gloves**  
**when handling heated parts.**  
**Failure to comply could result in minor or moderate injury.**

C0047A

Install the heated bearing inner ring (**385**) on the main shaft until the heated bearing inner ring sits in place on the fourth gear (**391**).

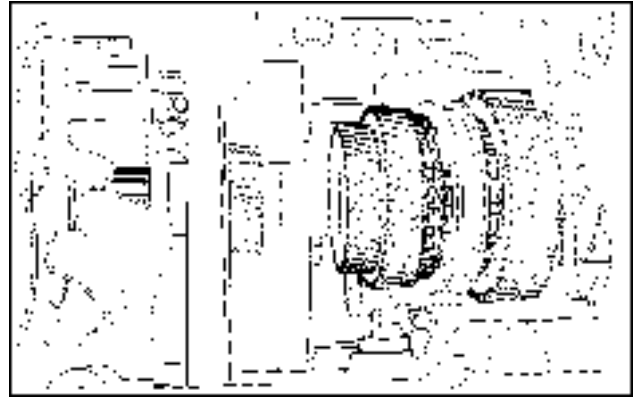

SVIL13TR00364AB 12

- 15. Install the center bush over the main shaft thread.
- 16. Install the bearing (**390**) until the bearing sits in place on the transmission housing.

**NOTE:** Produce the center bush in accordance with the technical drawing. See **Semi-Powershift transmission - Special tools (21.111)** .

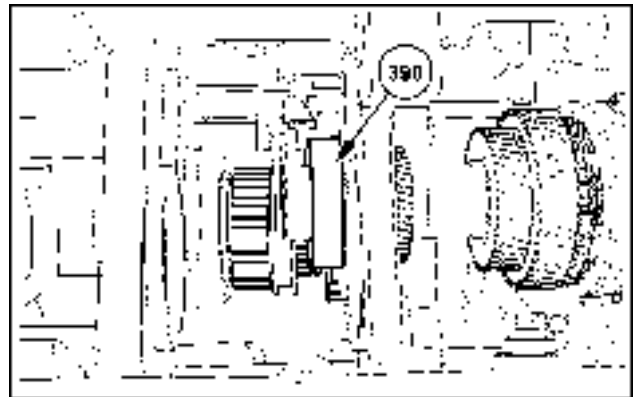

SVIL13TR00365AB 13

- 17. Press the bearing via the outer ring into the transmission housing until the bearing sits in place.

**NOTE:** Remove the center bush.

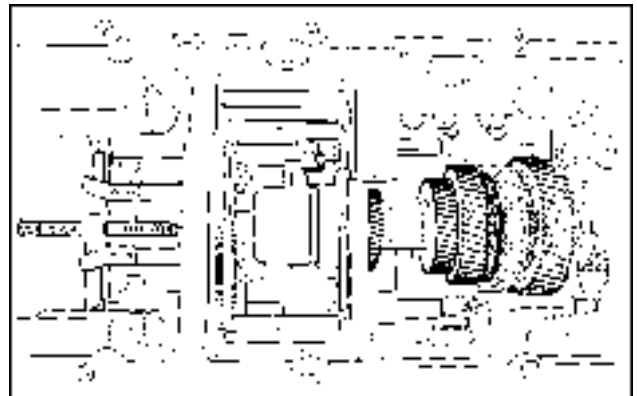

SVIL13TR00366AB 14

- 18. Fit the bearing shim. The internal chamfered side must face the bearing.
- 19. Screw the groove nut (**389**) by hand onto the main shaft until the groove nut sits in place.

**NOTE:** Remove the clamping bar of the main shaft. Refer to the figure 11.

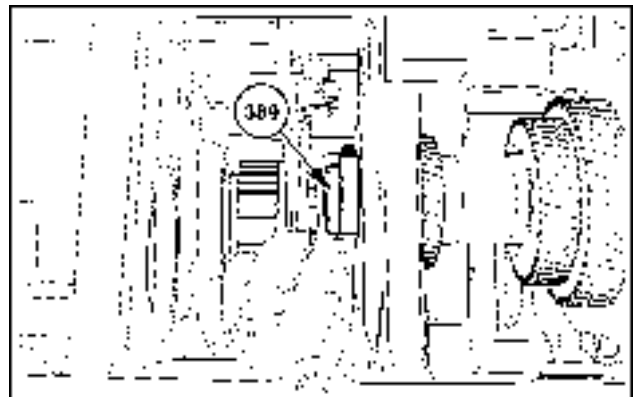

SVIL13TR00369AB 15

20. Use the groove nut wrench **380001733** to tighten the groove nut. To tighten the groove nut, hold the main shaft via the rear shift-collar spline **380000815** of the main shaft.
21. Tighten the groove nut to **150 - 170 Nm (111 - 125 lb ft)**.

**NOTE:** Check the axial play of the first gear for clearance. Check the axial play of the second gear for clearance.

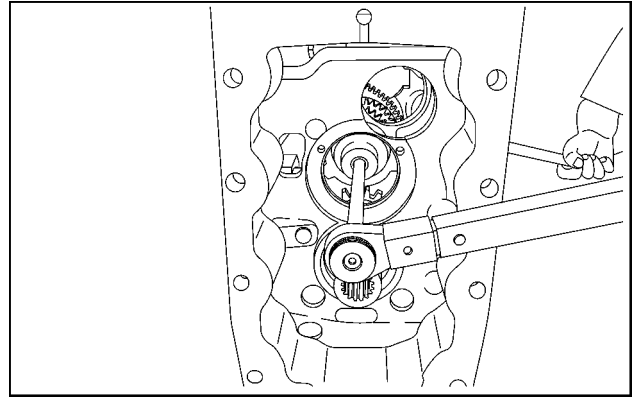

SVIL13TR00367AB 16

22. To secure the groove nut (**389**), use a suitable mandrel. Notch the groove of the main shaft.

**NOTE:** The collar of the groove nut must not tear.



SVIL13TR00368AB 17

23. Fit the needle bearing (**403**) in the main shaft.

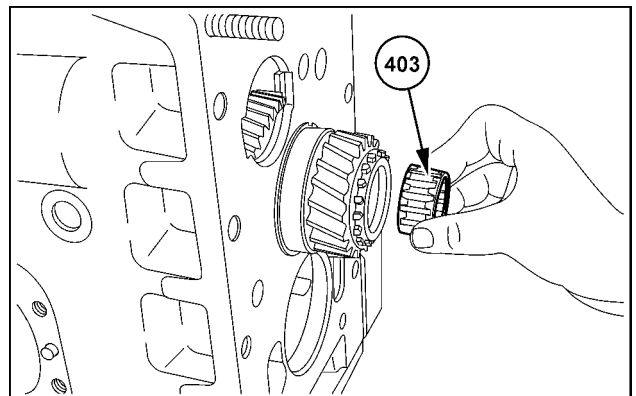

SVIL13TR00370AB 18

**Next operation:**

**Transmission internal controls - Install – First/second gear shift (21.152)**

## Transmission drive and driven shaft - Install – Intermediate shaft

### Prior operation:

### Transmission internal controls - Install – First/second gear shift (21.152)

1. Press the bearing (385) onto the shaft until the bearing sits in place.
2. If necessary, install the orifice (382).

**NOTE:** Spray the orifice with **LOCTITE® 648**.

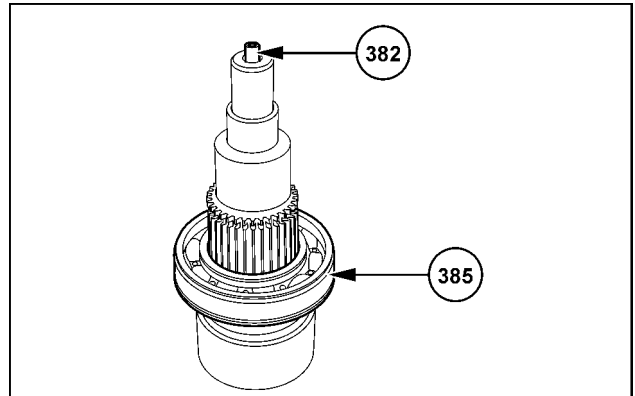

SVIL13TR00371AB 1

3. Position the circlip (384) in the ring groove of the bearing.

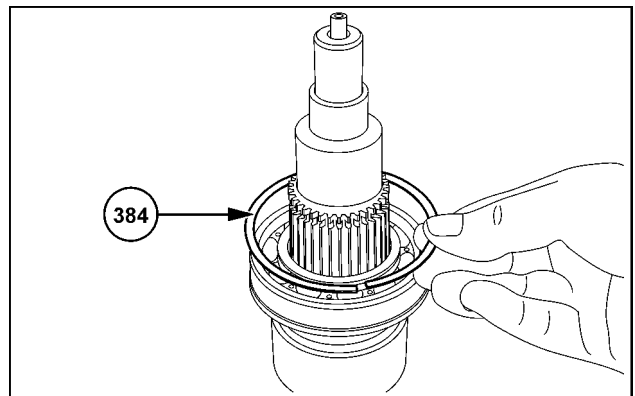

SVIL13TR00372AB 2

4. Fit the needle bearing (388).

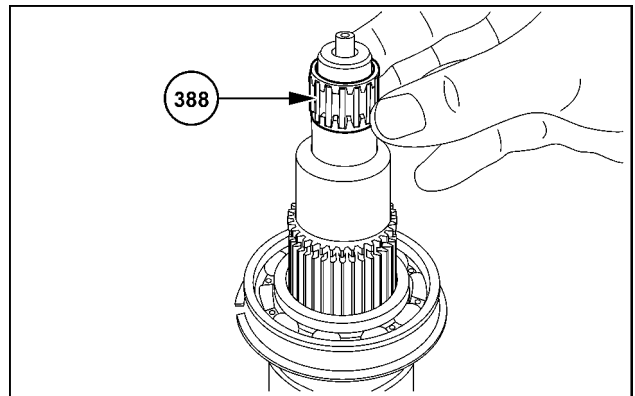

SVIL13TR00373AB 3

5. Insert the pre-assembled shaft into the transmission housing until the pre-assembled shaft sits in place. During this procedure, install the gear (386) and the circlip (387).

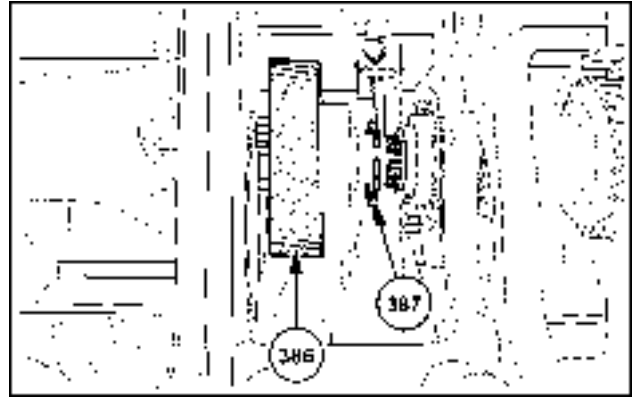

SVIL13TR00374AB 4

6. Position the circlip (387) in the ring groove on the shaft to fix the gear in place.

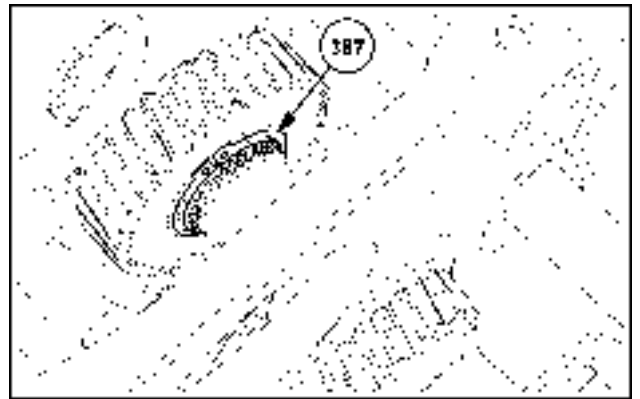

SVIL13TR00376AB 5

7. Secure the retaining ring (383) to the gearbox housing.
8. Coat the bolts with **LOCTITE® 243**.  
Tighten the screws to **23 Nm (17 lb ft)**.

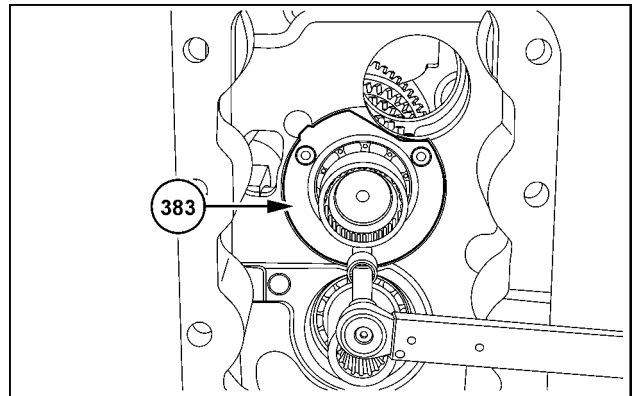

SVIL13TR00375AB 6

**Next operation:**  
**Transmission drive and driven shaft - Install – Countershaft (21.152)**

## Transmission drive and driven shaft - Install – Countershaft

### Prior operation:

#### Transmission drive and driven shaft - Install – Intermediate shaft (21.152)

1. Install the ring (373), the washer (374) and the ring (375) on the countershaft.

Image:

(373) Ring

Disc (374)

(375) Ring

**NOTE:** Note the installation position. Install the ring (373). The convex side must face the spline. Use a new ring (375) for assembly.

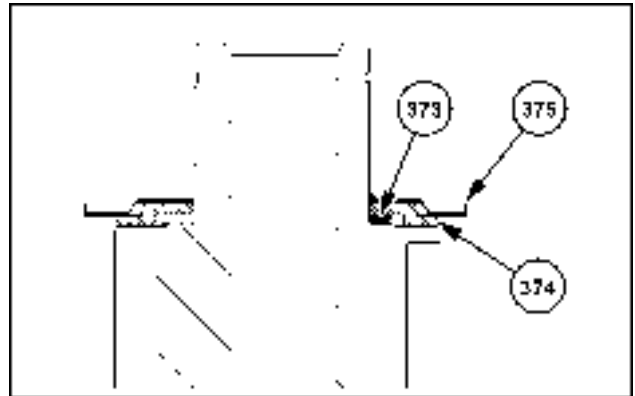

SS13F106 1

### 2. **CAUTION**

#### **Burn hazard!**

Always wear heat-resistant protective gloves when handling heated parts.

Failure to comply could result in minor or moderate injury.

C0047A

Install the heated bearing inner ring (376) on the drive shaft until the heated bearing inner ring sits in place.

**NOTE:** Adjust the bearing inner ring once it is cold.

3. Fit the bearing (376) and the bearing shim on the intermediate shaft. The internally chamfered side of the bearing shim must face the bearing.
4. Fit the circlip (378).
5. Prepare the gear set for subsequent installation.
6. Grease the thrust washer (369) with industrial Vaseline.
7. Install the thrust washer (369) on the second gear (370). The oil pockets must face upward.

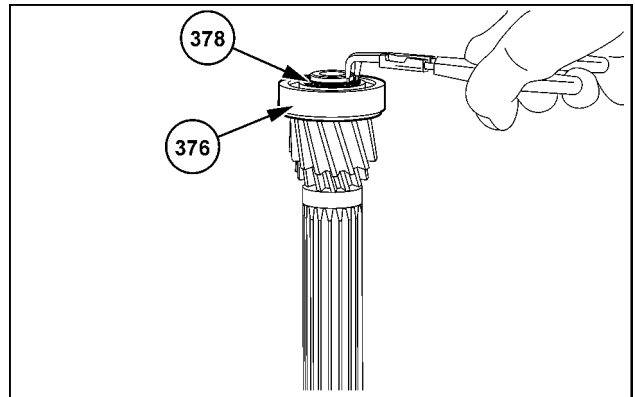

SVIL13TR00380AB 2

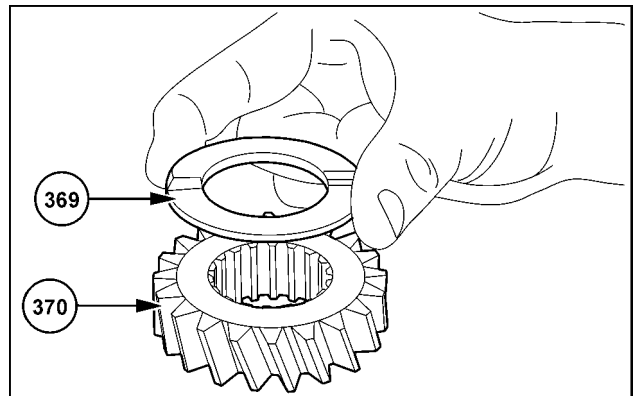

SVIL13TR00381AB 3

8. Install the third gear (365).

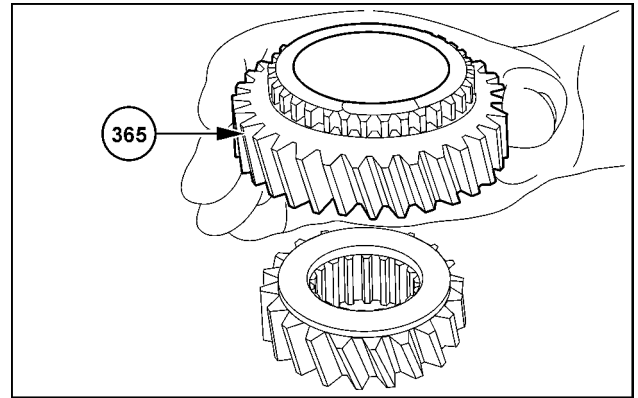

SVIL13TR00382AB 4

9. Install the liner (367) in the gear. Install the needle bearing (368) in the gear.

**NOTE:** Note the installation position. Install the liner. The inner synchronization teeth must face the collar holder (upward).

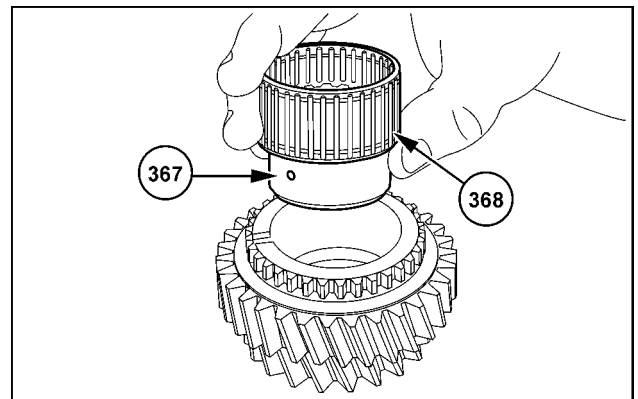

SVIL13TR00383AB 5

10. Install the spacer ring (366) on the needle bearing.

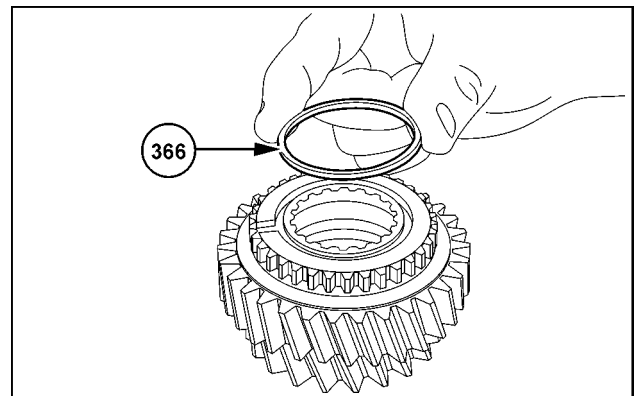

SVIL13TR00384AB 6

11. Pre-assemble the synchronizer (364) in accordance with the diagram:

- (A) Collar holder
- (B) Synchronizer ring
- (C) Shift collar
- (D) Spool
- (E) Spring
- (F) Ball
- (G) Clutch body ring

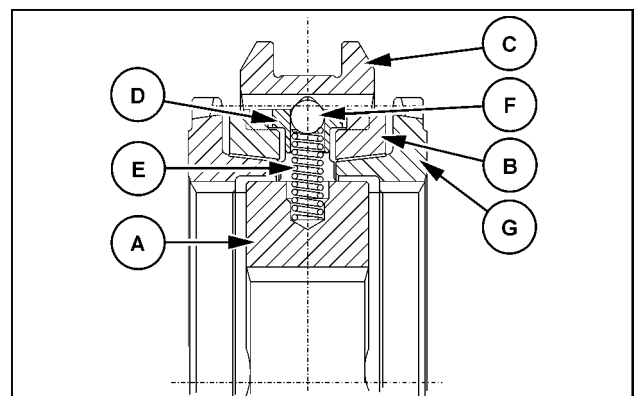

SS13F107 7



12. Install the pre-assembled synchronizer (364) on the third gear.

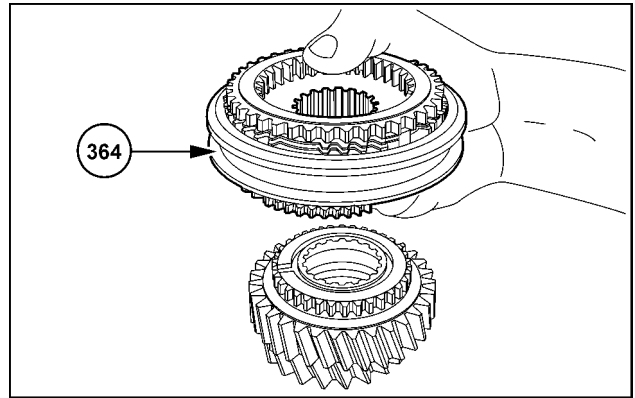

SVIL13TR00385AB 8

13. Install the fourth gear (360).

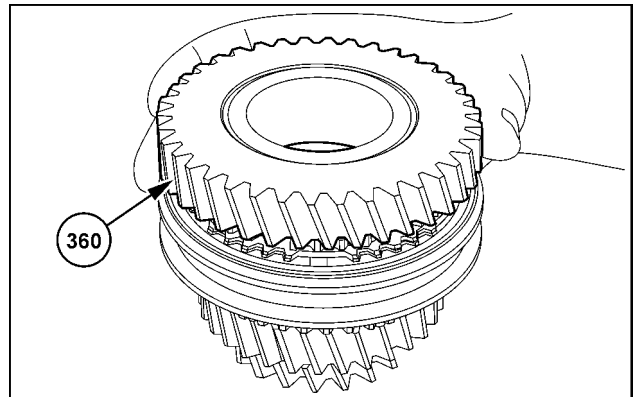

SVIL13TR00386AB 9

14. Install the spacer ring (363).

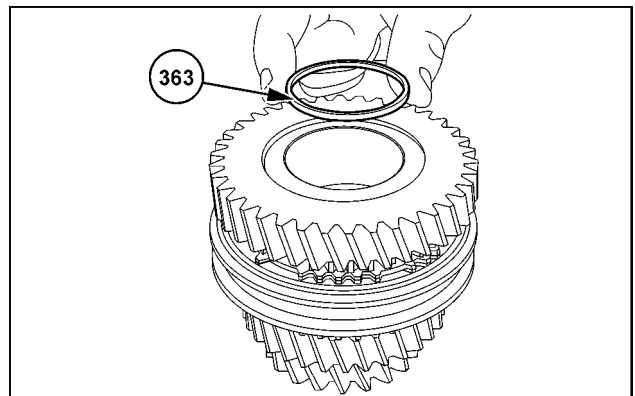

SVIL13TR00387AB 10

15. Install the liner (362) in the gear. Install the needle bearing (361) in the gear.

**NOTE:** Note the installation position. Install the liner. The inner synchronization teeth must face the collar holder (downward).

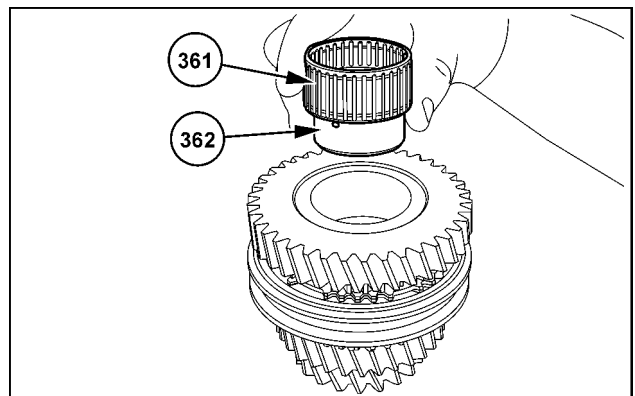

SVIL13TR00388AB 11

16. Grease the thrust washer (359) with industrial Vaseline.
17. Install the thrust washer (359) on the fourth gear. The oil pockets must face downward.

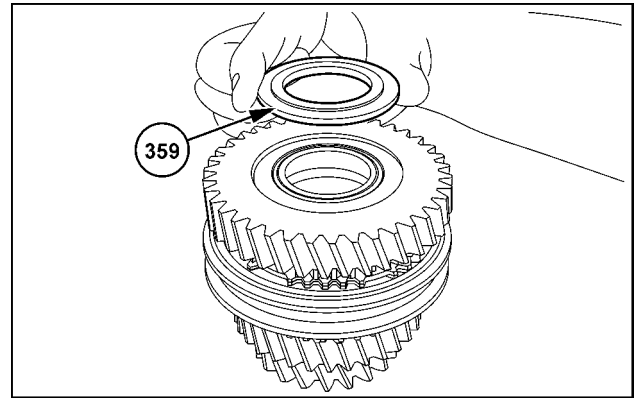

SVIL13TR00389AB 12

18. Use a suitable positioning tool to press the bearing (358) into the transmission housing via the bearing outer ring.

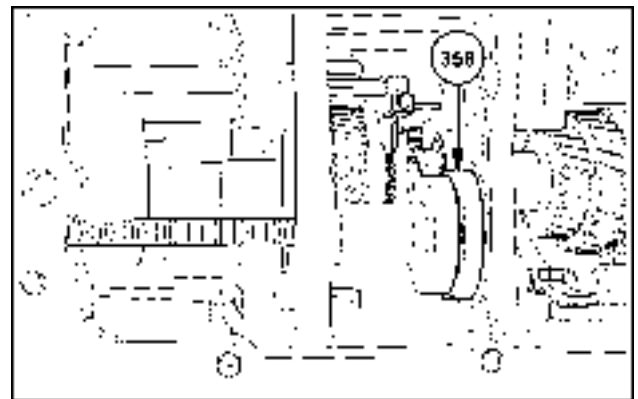

SVIL13TR00390AB 13

19. Install the prepared gear set with the synchronizer in the transmission housing on the main shaft.

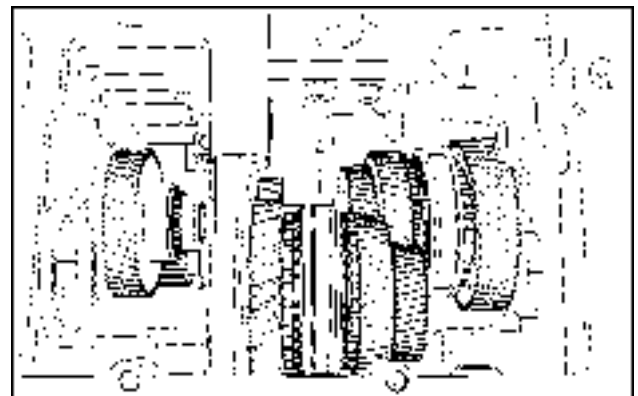

SVIL13TR00391AB 14

20. Install the shift fork for first and second gear (352) over the shift collar.

**NOTICE:** Subsequent installation of the shift fork is no longer possible.

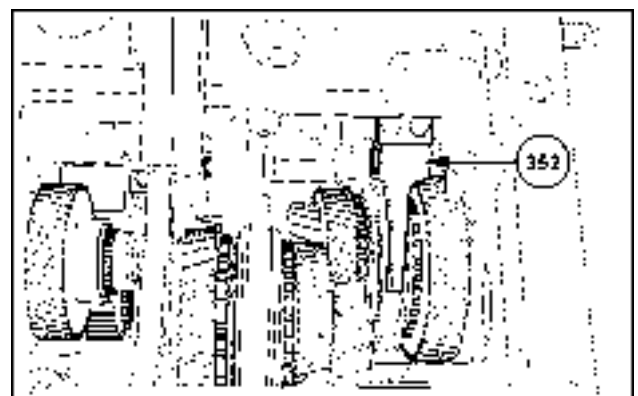

SVIL13TR00392AB 15

21. Install the spacer sleeve (371) onto the countershaft.

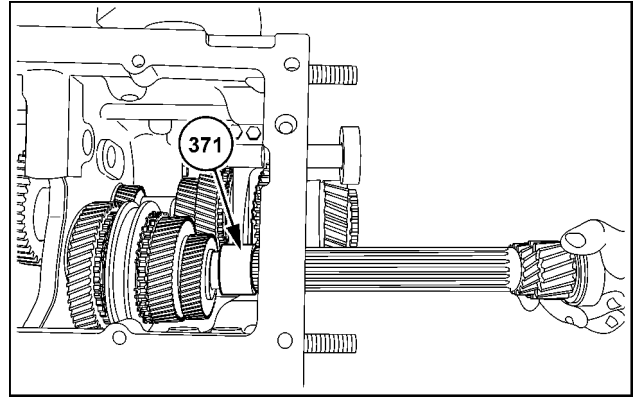

SVIL13TR00393AB 16

22. Install the gear set on the countershaft.

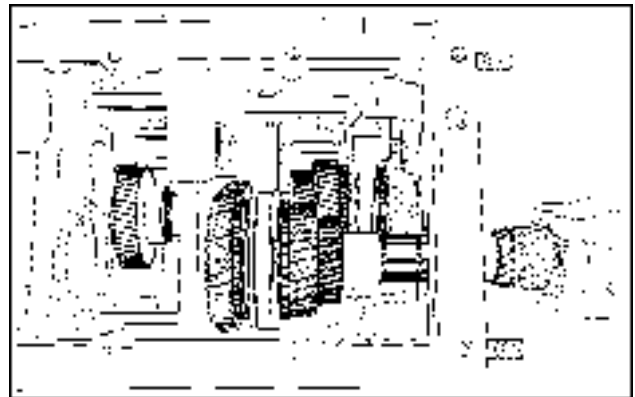

SVIL13TR00394AB 17

23. Install the spacer sleeve (357). Install the gear (356).

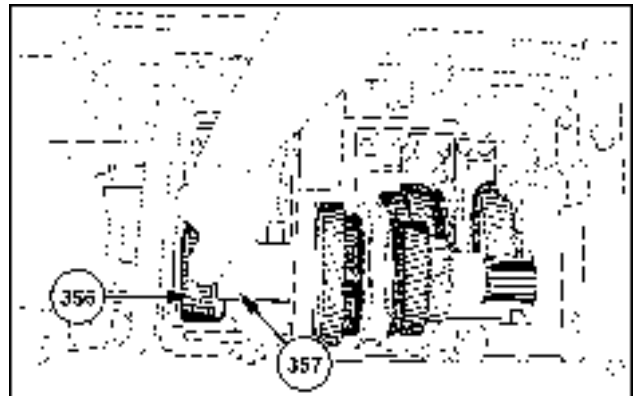

SVIL13TR00401AB 18

24. **CAUTION**

**Burn hazard!**  
Always wear heat-resistant protective gloves when handling heated parts.  
Failure to comply could result in minor or moderate injury.

C0047A

Heat the bearing inner ring (355). Install the bearing inner ring on the countershaft until the bearing inner ring sits in place on the gear.

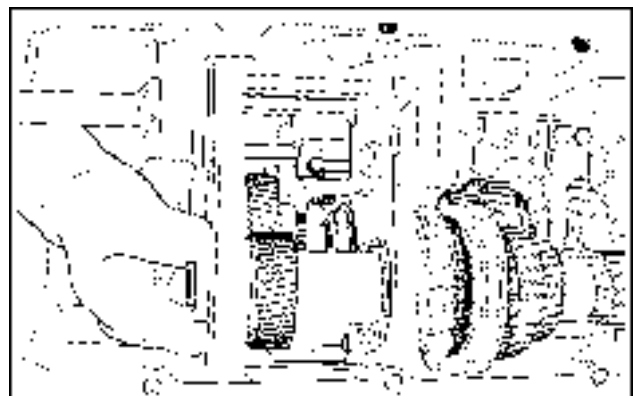

SVIL13TR00398AB 19

25. Install the center bush over the countershaft.

**NOTE:** Produce the center bush in accordance with the technical drawing. See **Semi-Powershift transmission - Special tools (21.111)**.

26. Install the bearing (355) until the bearing sits in place on the transmission housing.

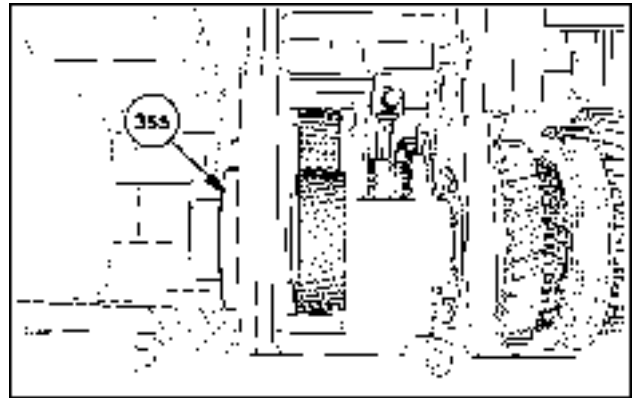

SVIL13TR00395AB 20

27. Press the bearing via the outer ring into the transmission housing until the bearing sits in place.

**NOTE:** Remove the center bush.



SVIL13TR00396AB 21

28. Install the bearing shim on the intermediate shaft. The internally chamfered side of the bearing shim must face the bearing.

29. Install the groove nut (354) by hand on the countershaft until the groove nut sits in place.

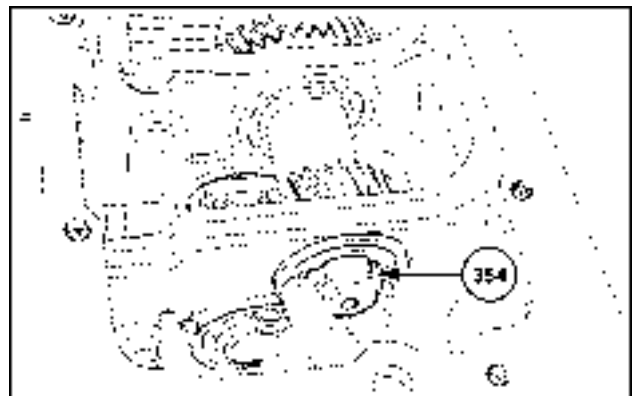

SVIL13TR00402AB 22

30. Set transmission in third gear.

31. Use the wrench **380000078** to tighten the groove nut. To tighten the groove nut, use the socket wrench **380000815** to hold the main shaft. Tighten the groove nut to **200 - 220 Nm (148 - 162 lb ft)**.

**NOTE:** Check the third gear for clearance. Check the fourth gear for clearance.

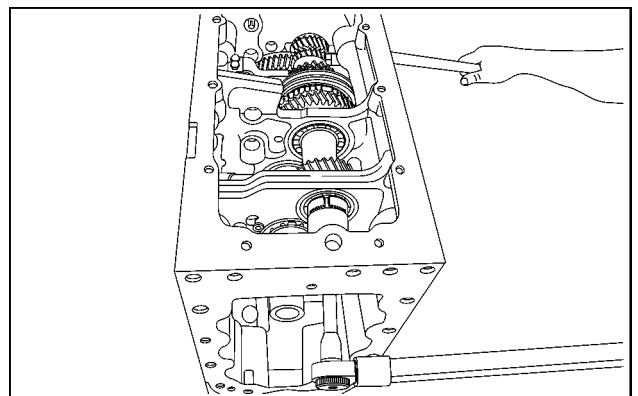

SVIL13TR00403AB 23

32. Secure the groove nut (**354**) with a suitable mandrel.

**NOTE:** The collar of the groove nut must not tear.

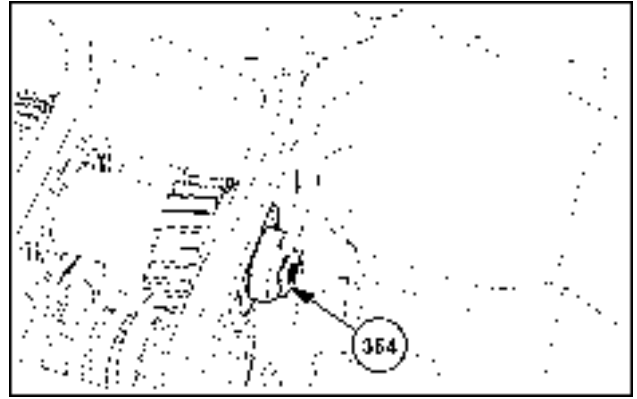

SVIL13TR00404AB 24

**Next operation:**

**Transmission internal controls - Install – Third/fourth gear shift (21.152)**

**Transmission internal controls - Adjust – First/second gear shift and third/fourth gear shift (21.152)**

# Index

---

## Transmission - 21

### Semi-Powershift transmission internal components - 152

Semi-Powershift transmission internal components - Exploded view – clutch F/G .....	6
Semi-Powershift transmission internal components - Exploded view – 1st - 4th gear .....	8
Clutch - Adjust – Clutch shafts .....	14
Clutch - Install .....	12
Clutch - Remove .....	11
Clutch Range clutch - Assemble – Clutch A/C .....	37
Clutch Range clutch - Assemble – Clutch B/D .....	52
Clutch Range clutch - Disassemble – Clutch A/C .....	31
Clutch Range clutch - Disassemble – Clutch B/D .....	46
Clutch Reverser clutch - Assemble – clutch F/G .....	23
Clutch Reverser clutch - Disassemble – clutch F/G .....	17
Semi-Powershift transmission internal components - Exploded view – A/C clutch and B/D clutch .....	4
Transmission drive and driven shaft - Install – Countershaft .....	80
Transmission drive and driven shaft - Install – Intermediate shaft .....	78
Transmission drive and driven shaft - Install – Main shaft .....	73
Transmission drive and driven shaft - Remove – Countershaft .....	68
Transmission drive and driven shaft - Remove – Intermediate shaft .....	70
Transmission drive and driven shaft - Remove – Main shaft .....	72
Transmission internal controls - Adjust – First/second gear shift and third/fourth gear shift .....	67
Transmission internal controls - Install – First/second gear shift .....	64
Transmission internal controls - Install – Third/fourth gear shift .....	65
Transmission internal controls - Remove – First/second gear shift .....	63
Transmission internal controls - Remove – Third/fourth gear shift .....	61





## **Transmission - 21**

**Field-road group - 902**

**Farmall 105U Pro EP  
Farmall 115U Pro EP  
Farmall 95U Pro EP**



# Contents

---

## Transmission - 21

### Field-road group - 902

#### TECHNICAL DATA

Field-road group	
General specification .....	3

#### FUNCTIONAL DATA

Field-road group	
Exploded view .....	4

#### SERVICE

Hollow shaft and gears	
Remove .....	7
Install .....	9

---

## Field-road group - General specification

Type of System  
Operating system

Two-gear dog-clutch shift  
Mechanical, by means of cables

## Field-road group - Exploded view

431	Retainer ring	432	Clearance washer
433	Gear	434	Selector sleeve
435	Gear	436	Ring, spacer
437	Needle bearing	438	Thrust washer.
439	Retainer ring	440	Distance Piece
441	Journal	442	Gear
443	Cluster gear	444	Needle bearing
445	Ring, spacer	446	Needle bearing
447	Thrust washer.	448	Hollow shaft
449	Journal	450	Retainer ring
451	Bolt	452	Selector finger
453	Shifter fork	454	Roll pin
455	Shifter rod	456	O-ring
457	Shuttle lever	458	Ball
459	Spring	460	seal
461	Screw plug		

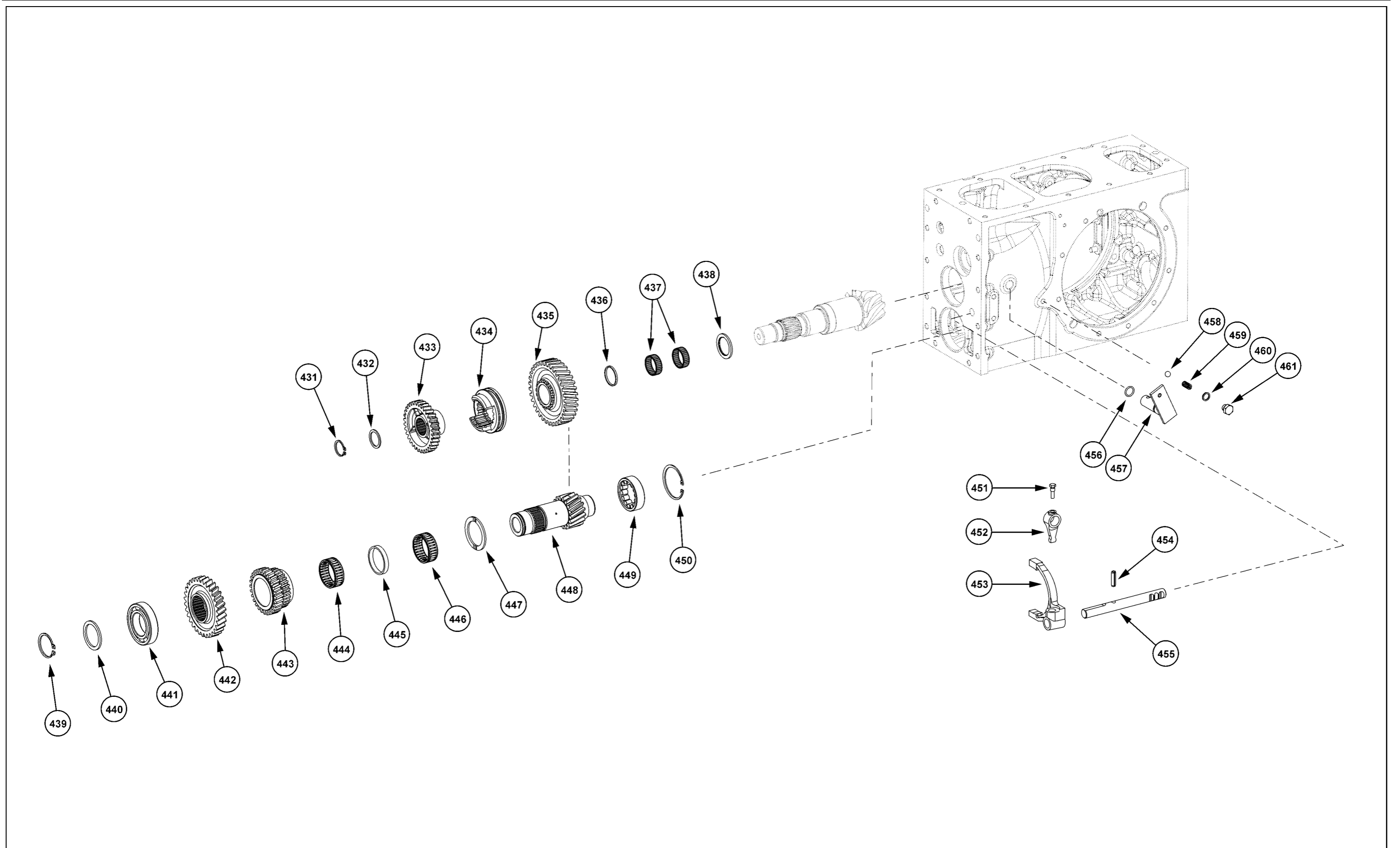



## Hollow shaft and gears - Remove

### Powered rear axle - Exploded view – Front bevel gear set and differential (27.100)

#### Prior operation:

#### Output shaft - Remove (31.119)

**NOTE:** In the standard version of the intermediate shaft (without ground speed PTO), steps 1 to 4 are not necessary.

1. Release the circlip from its position.
2. Move the driver back toward the rear axle housing.

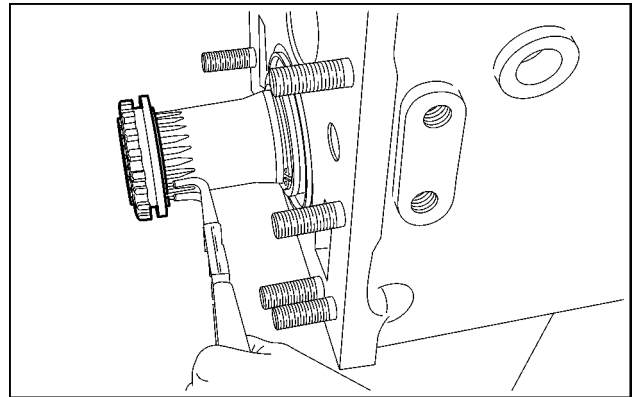

SS13H176 1

3. Release the front circlip from its position.
4. Remove any loose components.

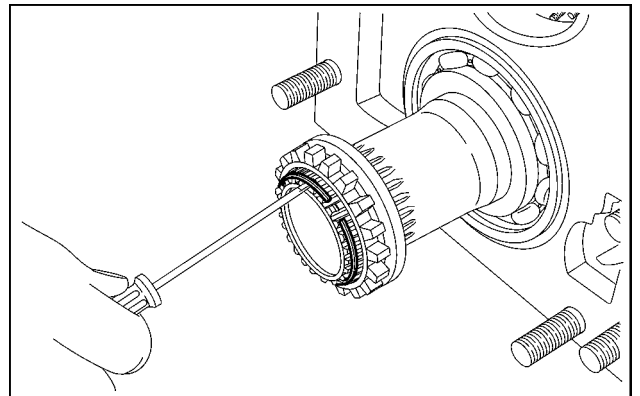

SS13H177 2

5. Remove the circlip (**439**) from the ring groove of the hollow shaft (**448**).
6. Remove the spacer (**440**).

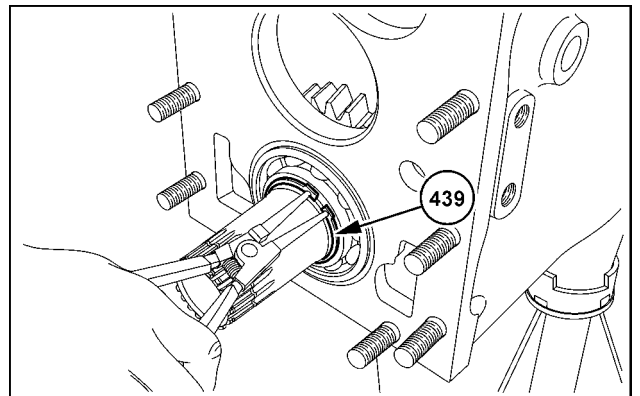

SS13H178 3

7. Release the circlip (450) from the ring groove of the rear axle housing.

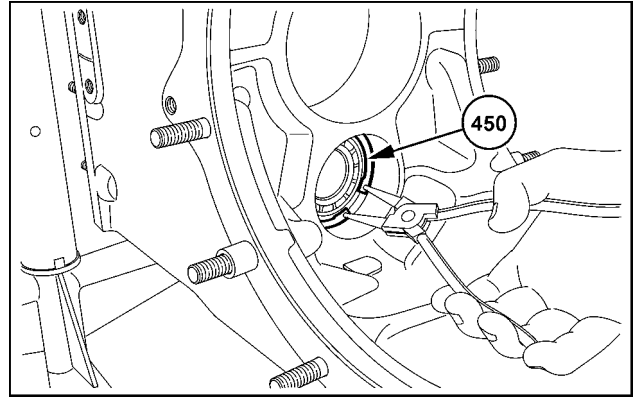

SS13H179 4

8. Push out the hollow shaft (448) and the bearing (449) toward the rear.

**NOTE:** When you remove the hollow shaft, be careful of loosened components.

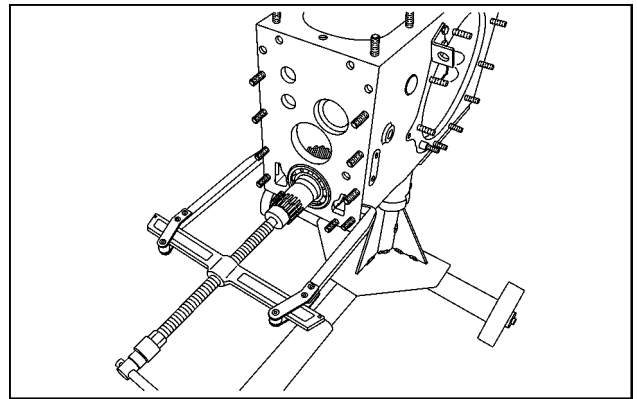

SS13H182 5

**NOTE:** Clean the components, check carefully for wear and damage, and replace if necessary.

**Next operation:**  
Hollow shaft and gears - Install (21.902)

## Hollow shaft and gears - Install

### Powered rear axle - Exploded view – Front bevel gear set and differential (27.100)

#### Prior operation:

#### Hollow shaft and gears - Remove (21.902)

**NOTE:** All components must be lubricated prior to installation.

- When installing the hollow shaft, slide the components into the rear axle housing. Slide the components one after the other, as shown in the cross-section:

Hollow shaft (**448**)

(**442**) Gear

(**443**) Double gear

(**444**) and (**446**) Needle bearing

Spacer ring (**445**)

(**447**) Thrust washer

**NOTICE:** Fit the thrust washer (**447**) with the oil groove facing toward the double gear (**443**).

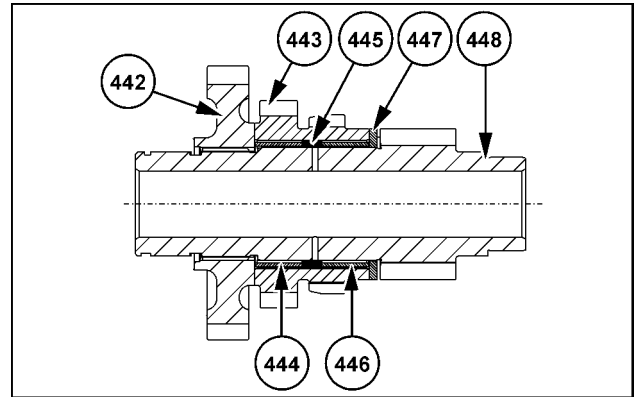

SS13H183 1

- The illustration shows the hollow shaft with the fitted components in the rear axle housing.

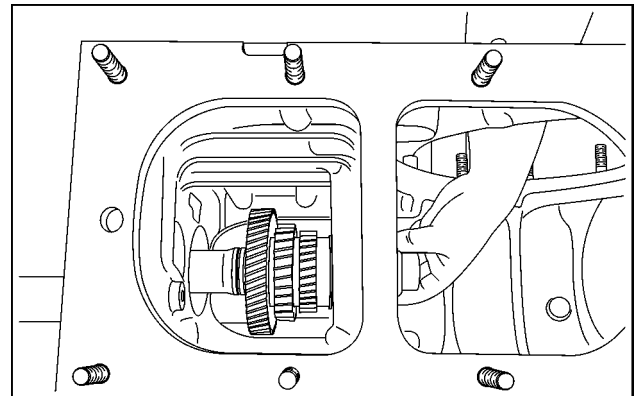

SS13H184 2

- Grease the bearing (**449**). Slide the bearing onto the pre-assembled hollow shaft (**448**).
- Fit the hollow shaft with the bearing in the rear axle housing.

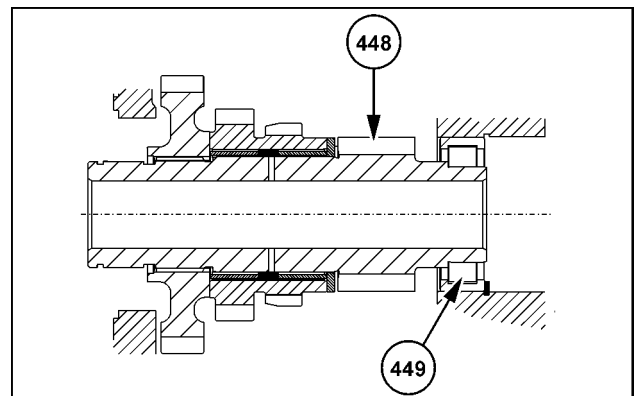

SS13H185 3



5. Position the circlip (**450**) in the ring groove of the rear axle housing in order to axially secure the bearing.

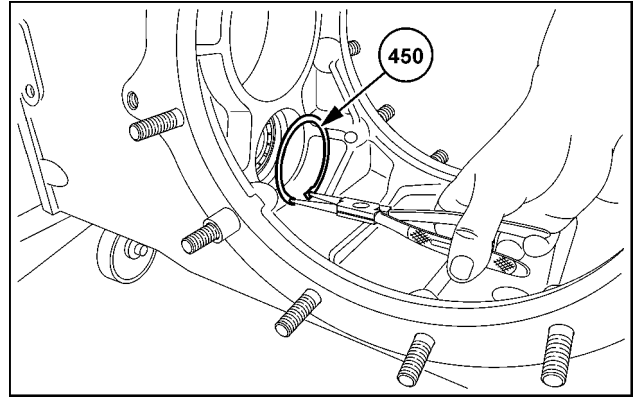

6. Insert the bearing (**441**) with the fitted circlip. To do so, use a standard two-armed puller.

**NOTE:** In the standard version of the intermediate shaft (without ground speed PTO), steps 7 to 12 are not necessary.

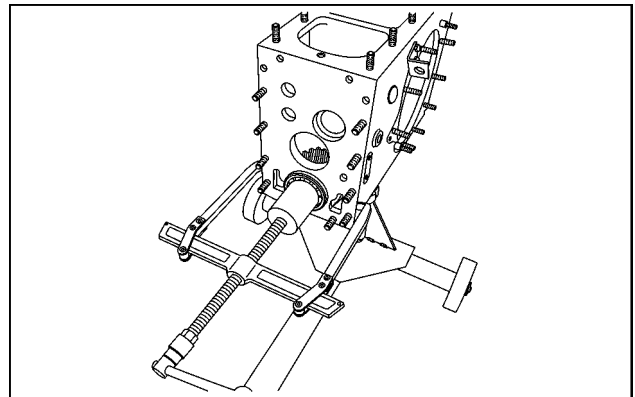

7. Slide the spacer onto the bearing until the spacer sits in place.

8. Position the circlip in the ring groove of the hollow shaft.

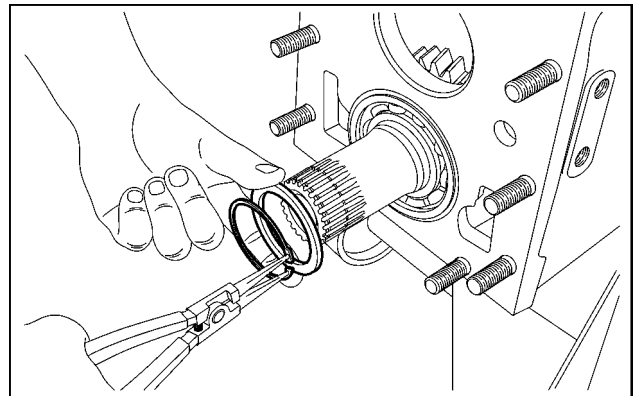

9. Fit the circlip in a position past the ring groove of the hollow shaft.

10. Slide on the driver until the driver sits in place.

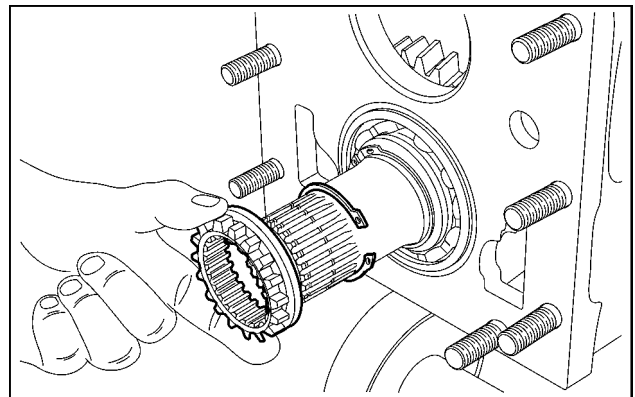

11. Fit the circlip in the ring groove of the hollow shaft.
12. Move the driver back against the circlip. Position the circlip in the ring groove of the hollow shaft.

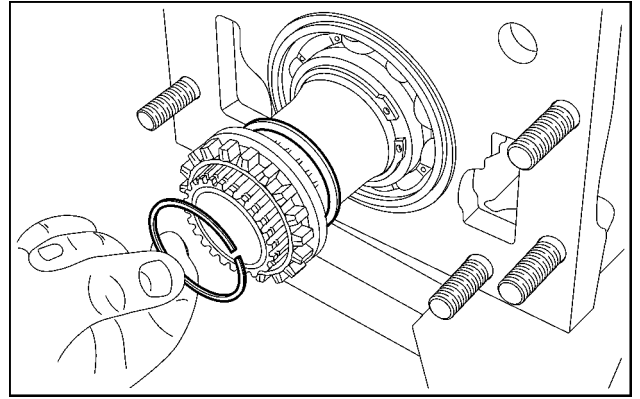

SS13H190 8

**Next operation:**  
**Output shaft - Install (31.119)**

# Index

---

## Transmission - 21

### Field-road group - 902

Field-road group - Exploded view .....	4
Field-road group - General specification .....	3
Hollow shaft and gears - Install .....	9
Hollow shaft and gears - Remove .....	7



## **Transmission - 21**

**Hydraulic pump drive - 900**

**Farmall 105U Pro EP  
Farmall 115U Pro EP  
Farmall 95U Pro EP**

# Contents

---

## Transmission - 21

### Hydraulic pump drive - 900

#### TECHNICAL DATA

Hydraulic pump drive	
General specification .....	3

#### FUNCTIONAL DATA

Hydraulic pump drive	
Exploded view .....	4

#### SERVICE

Hydraulic pump drive gears	
Disassemble .....	5
Assemble .....	9

---

## Hydraulic pump drive - General specification

Engine:pump ratio

1:1.256

## Hydraulic pump drive - Exploded view

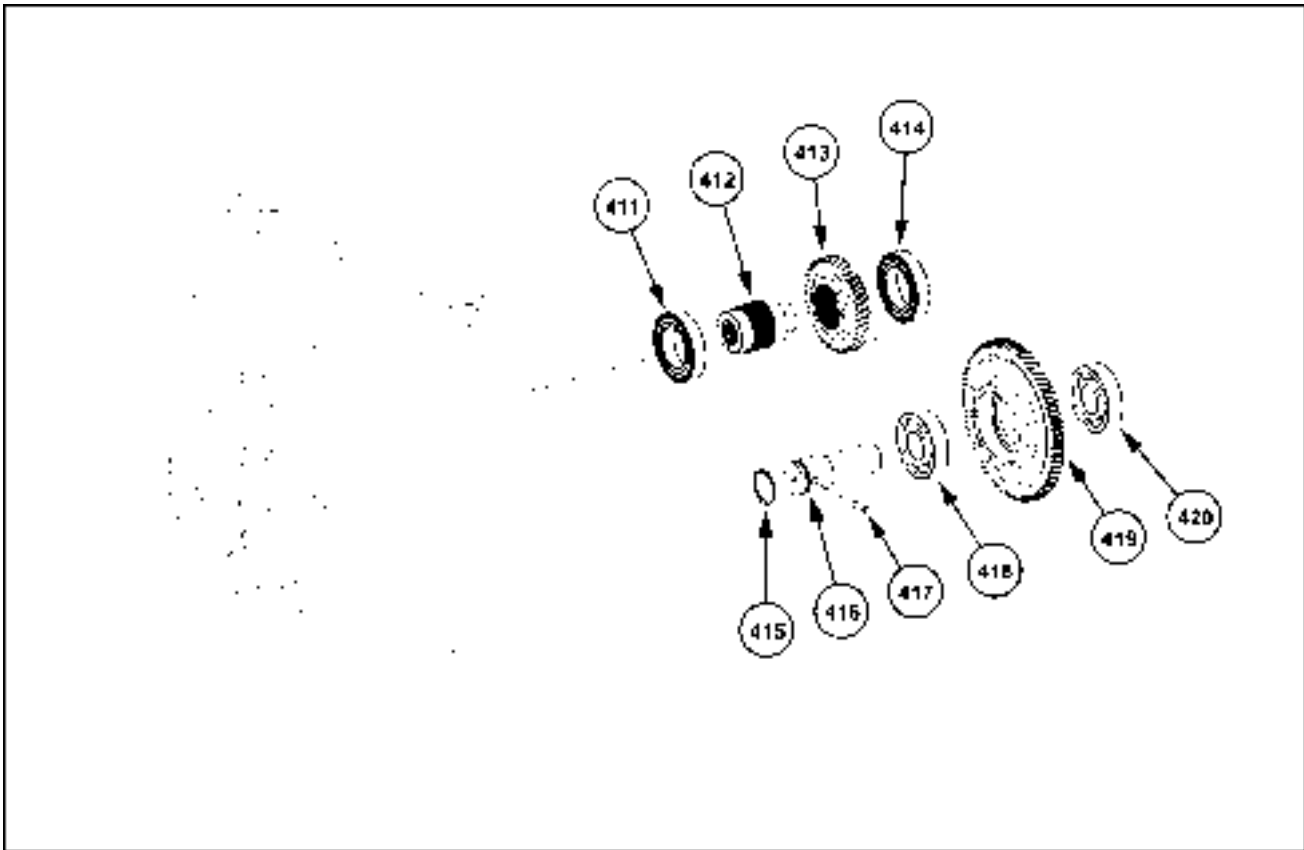

SS13E027 1

- |                   |             |
|-------------------|-------------|
| 411 Journal       | 412 Bushing |
| 413 Gear          | 414 Journal |
| 415 Retainer ring | 416 shaft   |
| 417 Roll pin      | 418 Journal |
| 419 Gear          | 420 Journal |

## Hydraulic pump drive gears - Disassemble

Prior operation:

Intermediate housing - Remove (21.111)

1. **⚠ DANGER**

**Heavy objects!**

Lift and handle all heavy components using lifting equipment with adequate capacity. Always support units or parts with suitable slings or hooks. Make sure the work area is clear of all bystanders.

Failure to comply will result in death or serious injury.

D0076A

Secure the intermediate housing to a suitable stand.

2. Drive the roll pin (417) into the shaft.

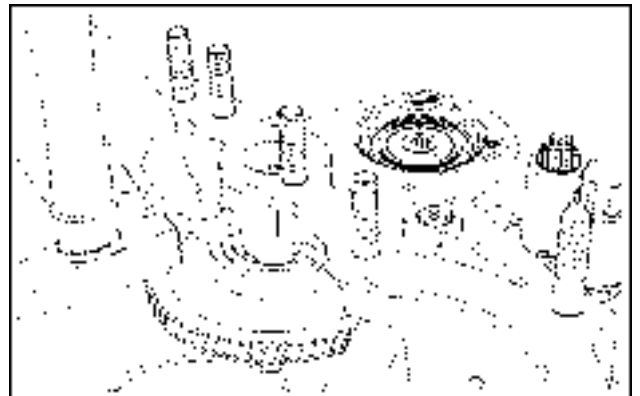

SVIL13TR00222AB 1

3. Release circlip (415) from its position.

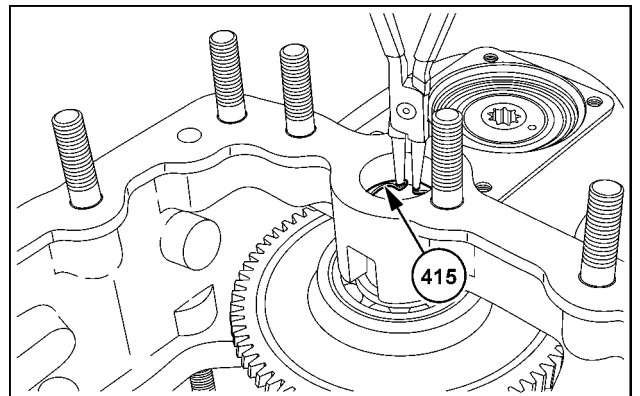

SVIL13TR00223AB 2

4. Pull the shaft (416) out of the intermediate housing bore.

**NOTE:** Remove any loose components.

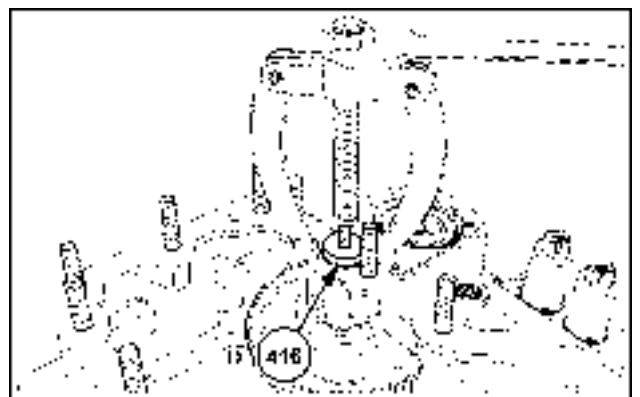

SVIL13TR00224AB 3



5. Remove the roll pin (417) from the shaft.

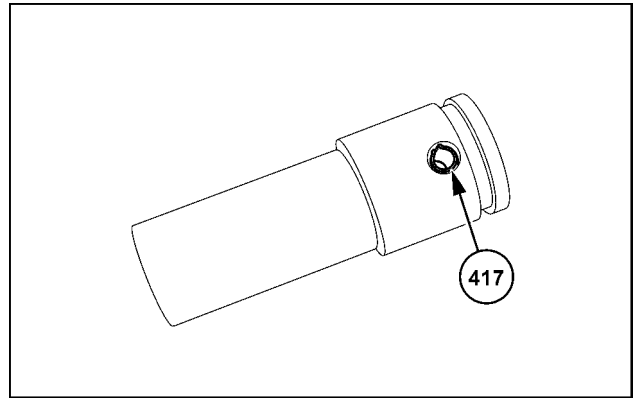

SVIL13TR00225AB 4

6. Remove both bearings (418) and (420) from the gear (419).

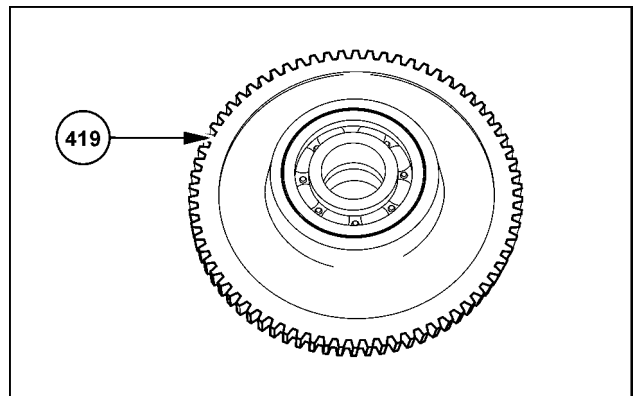

SVIL13TR00226AB 5

7. Remove the bushing (412) complete with the bearing.
8. Remove the gear.

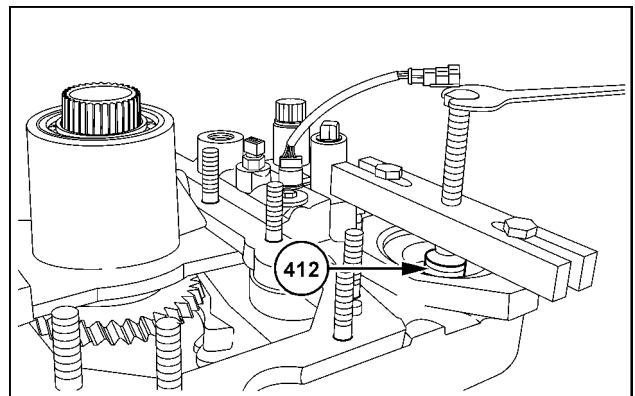

SVIL13TR00227AB 6

9. Remove the bearing (411) from the bushing.

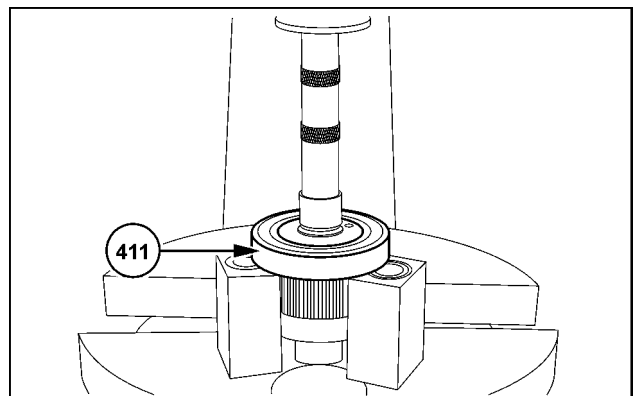

SVIL13TR00228AB 7

10. Remove the bearing (414) from the intermediate housing.

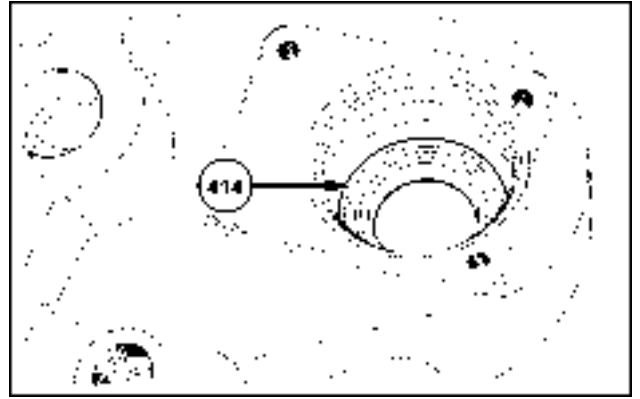

SVIL13TR00229AB 8

11. Press the drive shaft (243) from the bearing housing with a suitable prying tool.

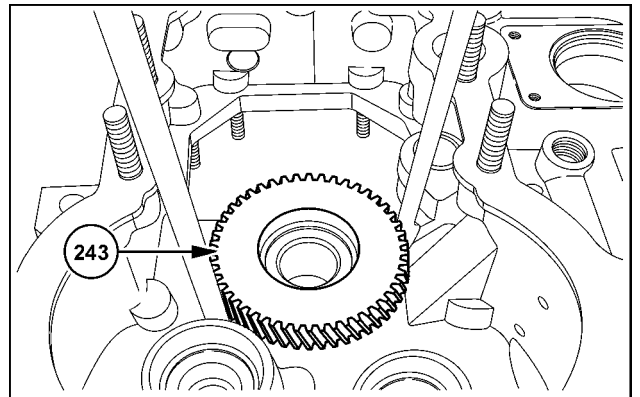

SVIL13TR00230AB 9

12. Remove the rectangular rings (248).

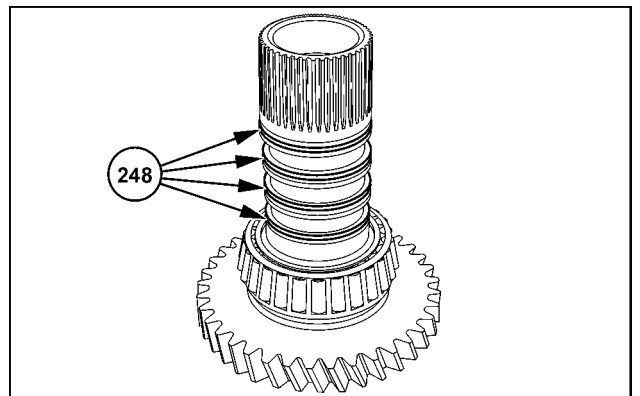

SVIL13TR00231AB 10

13. Remove the bearing (246).

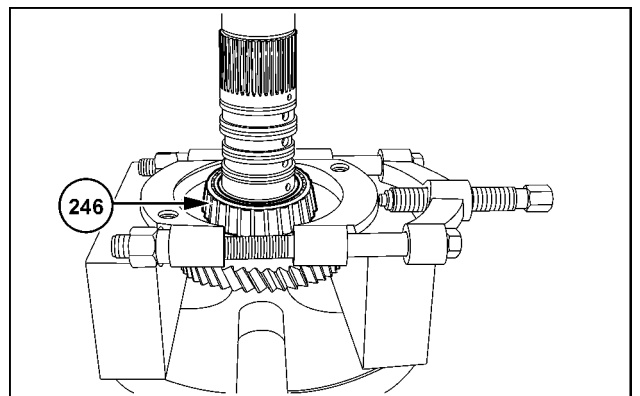

SVIL13TR00232AB 11

14. Release circlip (245) from its position.

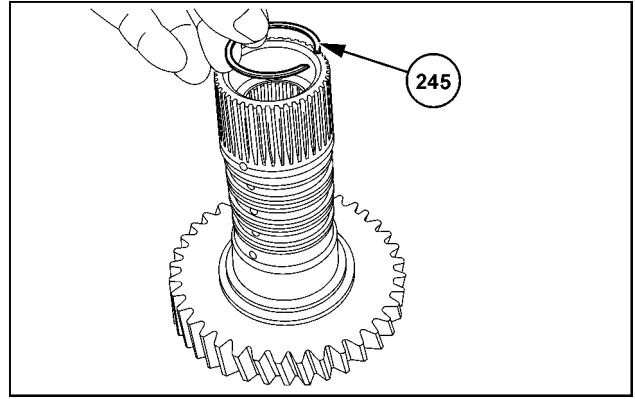

SVIL13TR00233AB 12

15. Pull the needle bearing (244) from the drive shaft.

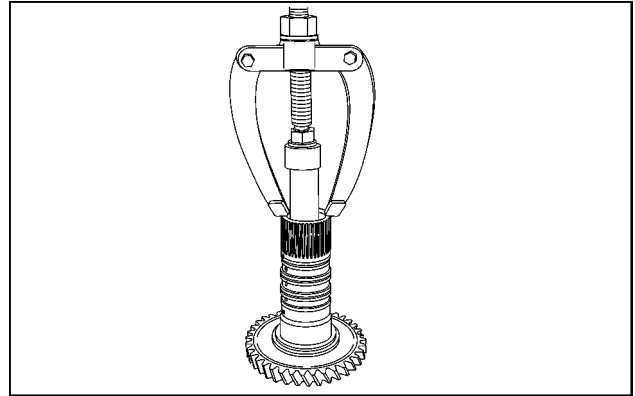

SVIL13TR00234AB 13

16. Remove the bearing (246).

**NOTE:** Check the adjustment shim.

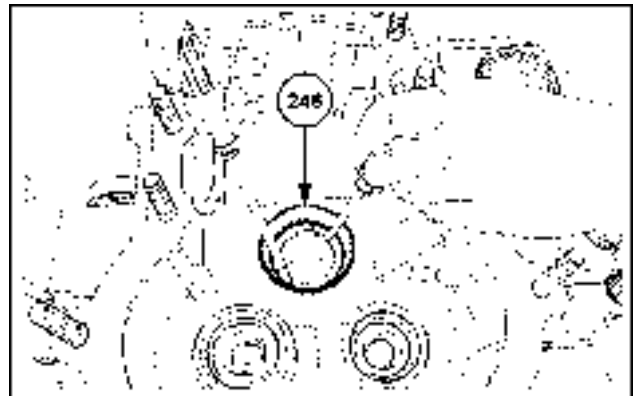

SVIL13TR00235AB 14

**Next operation:**  
Hydraulic pump drive gears - Assemble (21.900)

## Hydraulic pump drive gears - Assemble

### Prior operation:

### Hydraulic pump drive gears - Disassemble (21.900)

1. Insert the needle bearing (244) as far as possible into the drive shaft with a suitable punch.

**NOTE:** Insert the needle bearing so that the end face faces upward.

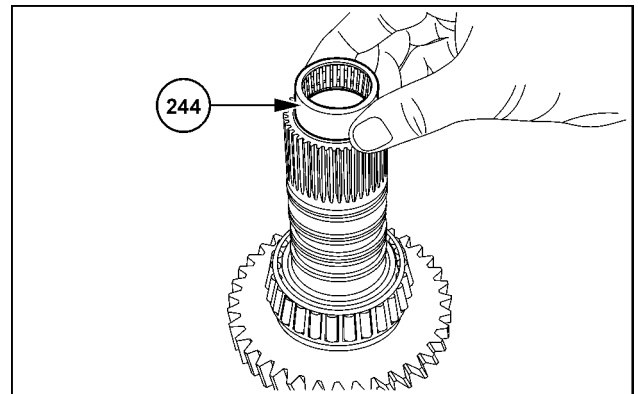

SVIL13TR00423AB 1

2. Insert the circlip (245) into the ring groove above the needle bearing.

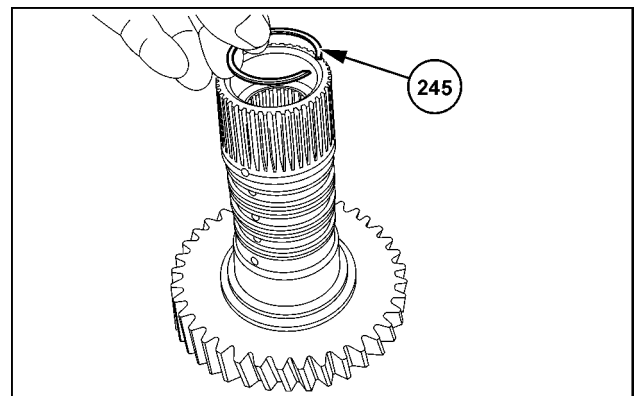

SVIL13TR00233AB 2

3. Insert the rectangular rings (248) so that the rectangular rings interlock.

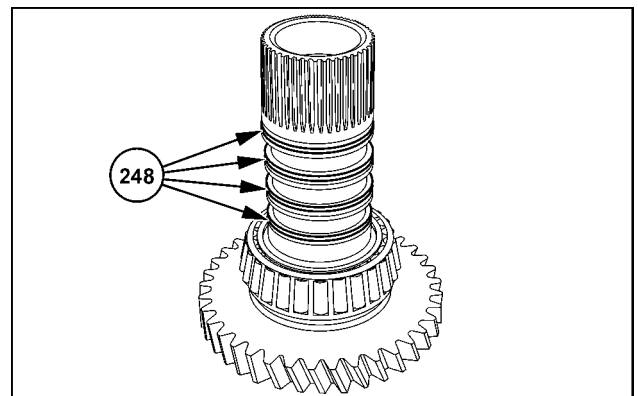

SVIL13TR00231AB 3

4. Insert the pre-assembled drive shaft (**243**) into the intermediate housing.

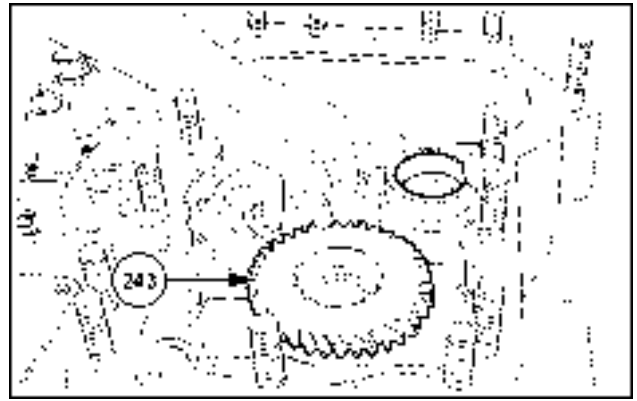

SVIL13TR00424AB 4

5. Support the inserted drive shaft.

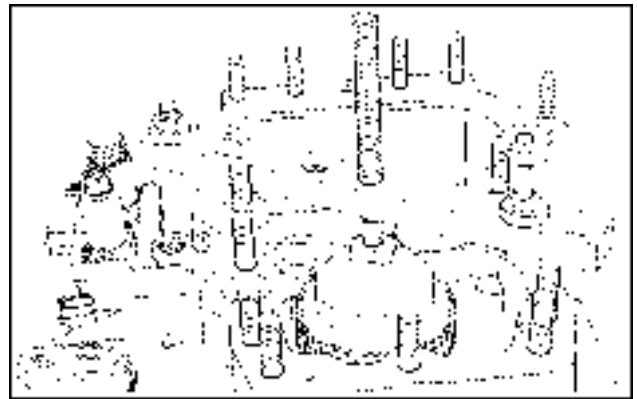

SVIL13TR00425AB 5

6. Swivel the intermediate housing.
7. Install the bearing (**249**) until the bearing sits in place.
8. Remove the clamping strip.

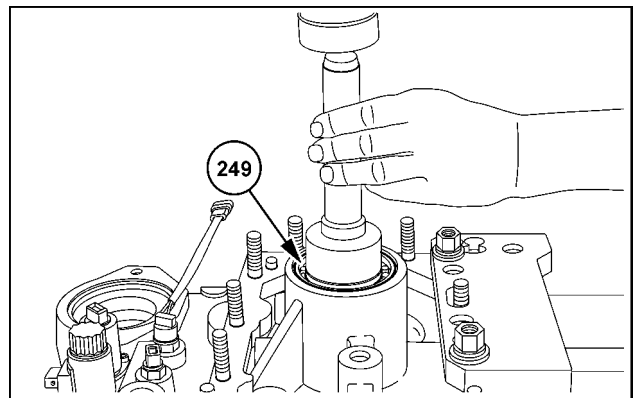

SVIL13TR00426AB 6

9. Insert the bearing (**414**).

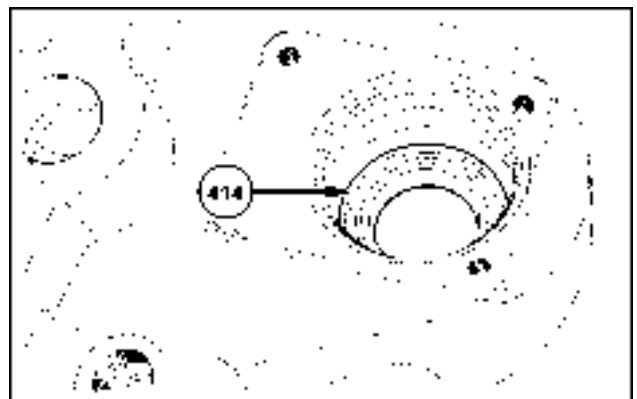

SVIL13TR00229AB 7

10. Bring the gear (413) into position.

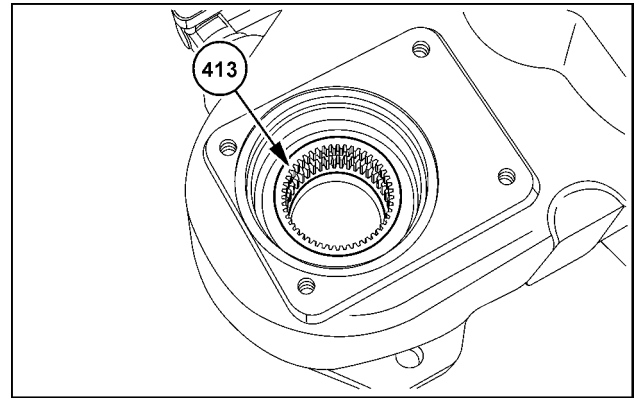

SVIL13TR00427AB 8

11. Press the bearing (411) over the bearing inner ring on the bushing.

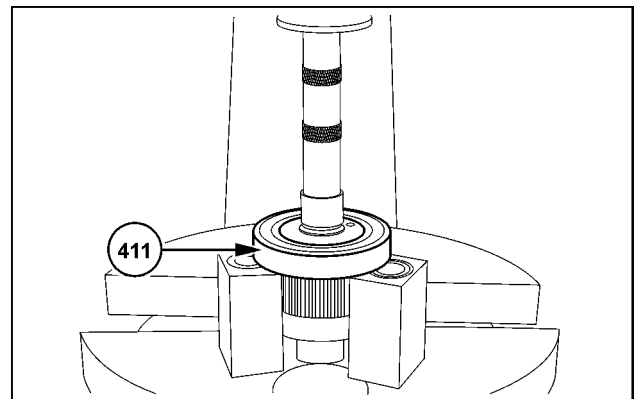

SVIL13TR00228AB 9

12. Install the pre-assembled bushing (412) until the bushing sits in place.

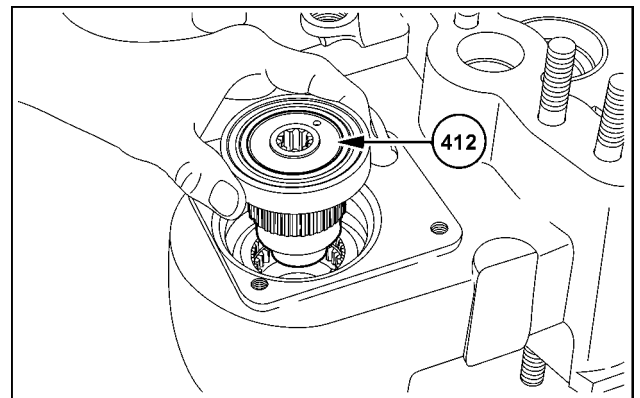

SVIL13TR00428AB 10

13. Install the bearings (418) and (420) in the gear (419).

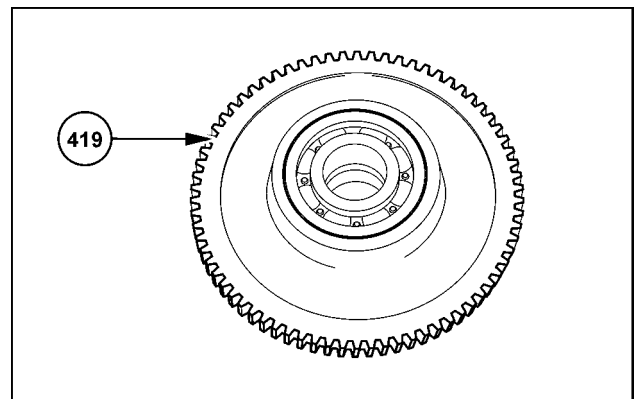

SVIL13TR00226AB 11

14. Bring the pre-assembled gear (419) into position.

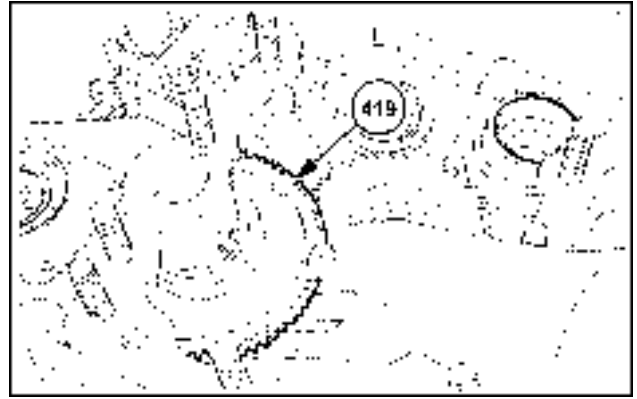

SVIL13TR00429AB 12

15. Insert the shaft (416) fully.

**NOTE:** Note the installation position. The roll pin hole in the shaft must be parallel to the recess in the intermediate housing.

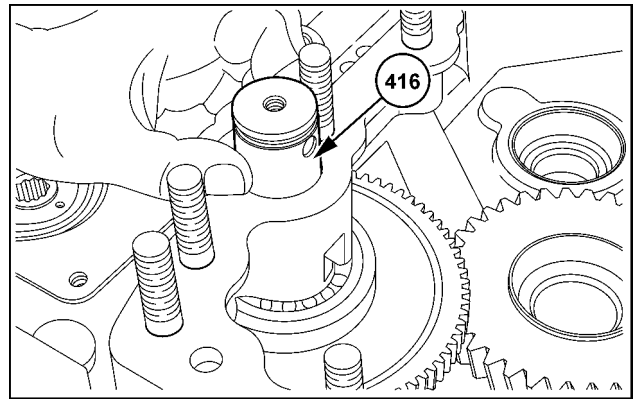

SVIL13TR00430AB 13

16. Drive in the roll pin (417) until the roll pin protrudes approximately 6.00 mm (0.24 in) (anti-rotation).

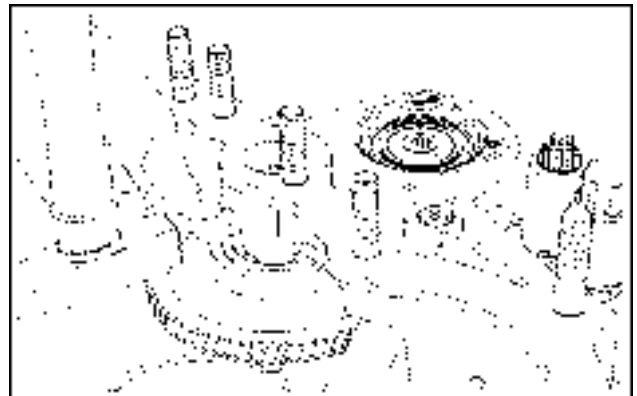

SVIL13TR00222AB 14

17. Fit the circlip (415).

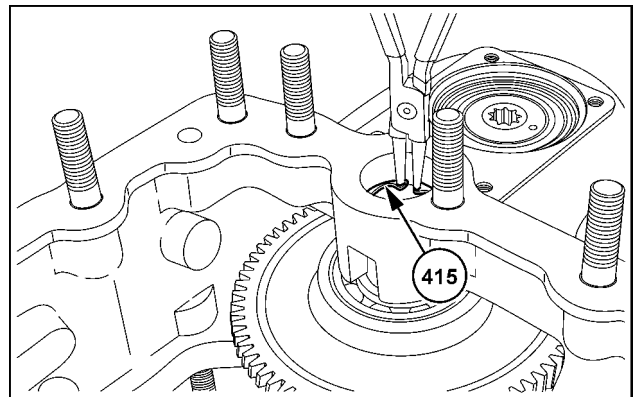

SVIL13TR00223AB 15

**Next operation:**  
Intermediate housing - Install (21.111)

# Index

---

## Transmission - 21

### Hydraulic pump drive - 900

Hydraulic pump drive - Exploded view .....	4
Hydraulic pump drive - General specification .....	3
Hydraulic pump drive gears - Assemble .....	9
Hydraulic pump drive gears - Disassemble .....	5







## **Transmission - 21**

**Transmission cooler and lines - 109**

**Farmall 105U Pro EP  
Farmall 115U Pro EP  
Farmall 95U Pro EP**

# Contents

---

## Transmission - 21

### Transmission cooler and lines - 109

#### TECHNICAL DATA

Regulating oil thermostat	
General specification .....	3

## **Regulating oil thermostat - General specification**

Opening temperature	<b>45 °C (113 °F)</b>
Maximum opening at	<b>60 °C (140 °F)</b>
Maximum flow rate	<b>66 l/min (17.4 US gpm)</b>
Maximum operating pressure	<b>16 bar (232 psi)</b>

# Index

---

## Transmission - 21

### Transmission cooler and lines - 109

Regulating oil thermostat - General specification ..... 3





© 2014 CNH Industrial Österreich GmbH

All rights reserved. No part of the text or illustrations of this publication may be reproduced.

CASE IH policy is one of continuous improvement and the right to change prices, specification or equipment at any time without notices is reserved.

All data given in this publication is subject to production variations. Dimensions and weight are approximate only and the illustrations do not necessarily show products in standard condition. For exact information about any particular product, please consult your CASE IH Dealer.



# **SERVICE MANUAL**

## **Four-Wheel Drive (4WD) system**

**Farmall 105U Pro EP  
Farmall 115U Pro EP  
Farmall 95U Pro EP**



# Contents

---

## Four-Wheel Drive (4WD) system - 23

[23.202] Electro-hydraulic control .....	23.1
--	------



## **Four-Wheel Drive (4WD) system - 23**

### **Electro-hydraulic control - 202**

**Farmall 105U Pro EP  
Farmall 115U Pro EP  
Farmall 95U Pro EP**

# Contents

---

## Four-Wheel Drive (4WD) system - 23

### Electro-hydraulic control - 202

#### TECHNICAL DATA

##### Front-Wheel Drive (FWD)

Special tools .....	3
General specification .....	3

#### FUNCTIONAL DATA

##### Front-Wheel Drive (FWD) control valve

Overview .....	4
----------------	---

##### Front-Wheel Drive (FWD)

Exploded view .....	6
---------------------	---

#### SERVICE

##### Front-Wheel Drive (FWD)

Remove .....	9
Disassemble .....	10
Assemble .....	14
Install .....	24

---

## Front-Wheel Drive (FWD) - Special tools

**NOTE:** The special tool with a (X) marking is essential for the operations in this section. To work in safety and to obtain the best technical results while saving both time and energy, you should also use the other special tool we recommend below.

List of the special tools required for the work steps in this section:

Tool Number	Designation / Use
(X) 380000813	Bearing Outer And Inner Ring Extractor Front Axle Drive
(X) 380000816	Tensioner for the cup washers

## Front-Wheel Drive (FWD) - General specification

Type of System	Wet multi-disc clutch
Operating system	Electrohydraulic solenoid valve
Force-locking by	Belleville washers
Number of Friction Plates	8
Front-wheel drive – drive torque (T)	Maximum <b>1450 Nm (1069 lb ft)</b>
Front-wheel drive – number of teeth	56

## Front-Wheel Drive (FWD) control valve - Overview

### Four-Wheel Drive (4WD) – Solenoid valve (Y-040)

The solenoid valve (1) is located on the right-hand side of the transmission housing.



SS13E042 1

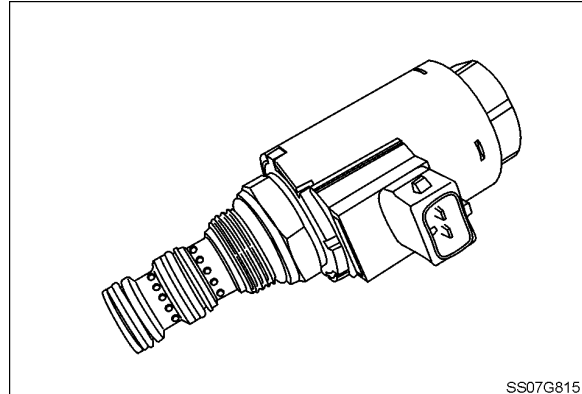

SS07G815 2

#### Specifications

Solenoid valve type	3/2-way solenoid valve
Nominal voltage	<b>12 V</b>
Nominal current	<b>1.5 A at 20 °C (68 °F)</b>
Coil resistance	<b>8 Ω at 20 °C (68 °F)</b>
Activation period	<b>100 %</b>
Ambient temperature	<b>-20 - 60 °C (-4 - 140 °F)</b>
Oil temperature	<b>-20 - 120 °C (-4 - 248 °F)</b>
Operating pressure (maximum)	<b>350 bar (5075 psi)</b>
Nominal flow (maximum)	<b>19.0 l/min (0.7 cfm)</b>
Tightening torque	<b>25 - 30 Nm (18 - 22 lb ft)</b>



## Front-Wheel Drive (FWD) - Exploded view

1	Cluster gear	2	Needle bearing
3	Ring, spacer	4	Needle bearing
5	Washer	6	Clutch housing
7	Disc holder	8	Pressure ring
9	Separator plate	10	Friction plate
11	Thrust washer	12	Output shaft
13	Rectangular ring	14	seal
15	Pistons	16	seal
17	Adjuster return plate	18	Pressure spring.
19	Push cylinder	20	seal
21	Adjuster return plate	22	Belleville spring
23	Clearance washer	24	Clearance washer
25	Adjuster return plate	26	Retainer ring
27	Oil deflector plate	28	Dowel pin
29	perforated sheet	30	Adjuster return plate
31	Bolt	32	Cover cup
33	Shaft sealing ring	34	Adjuster return plate
35	Journal	36	Housing
37	Screw plug	38	Bolt
39	Bolt	40	Bolt
41	Journal	42	Cover cup
43	Bolt		

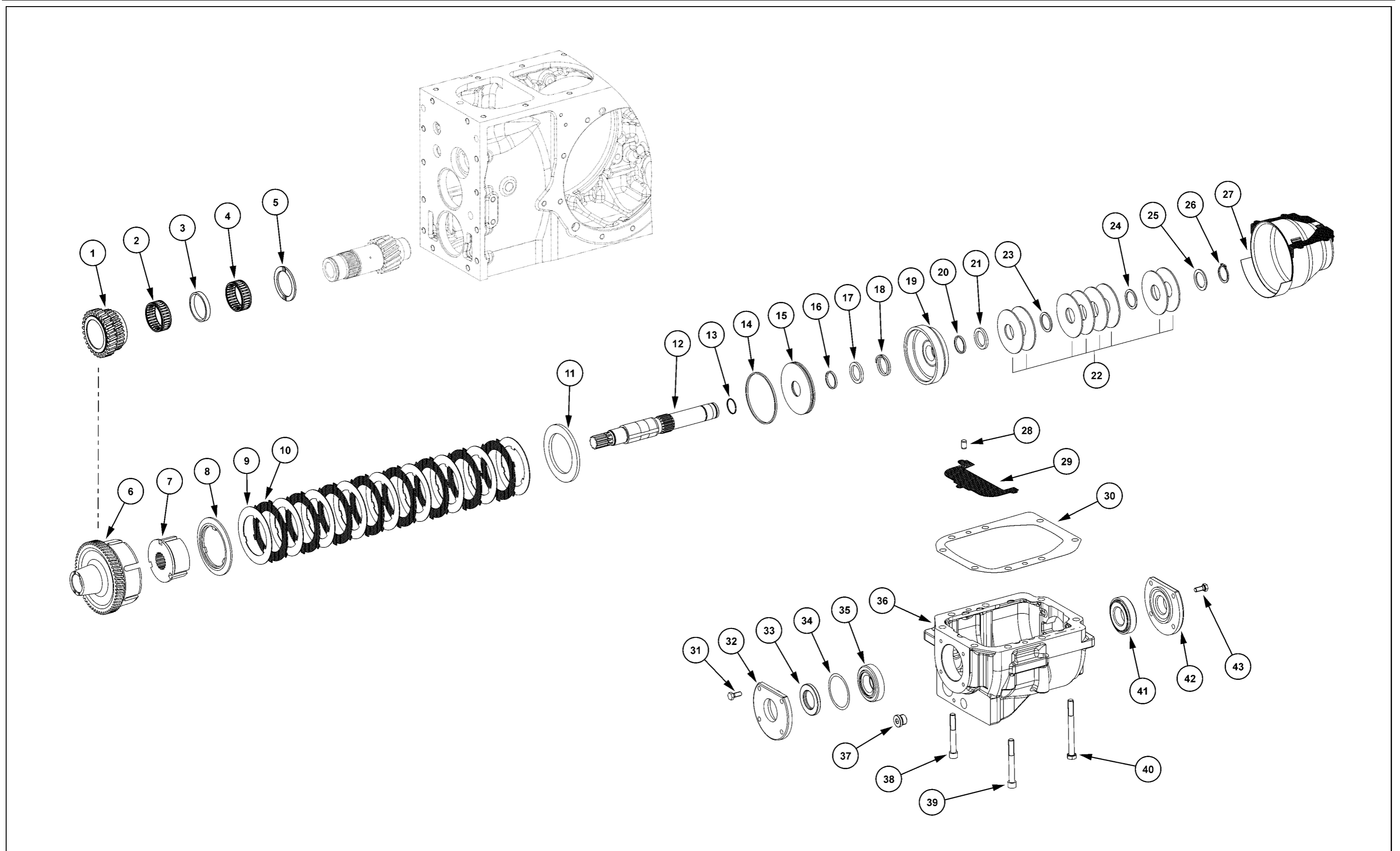

SS13E029 1





## Front-Wheel Drive (FWD) - Remove

Prior operation:

Differential - Disassemble (27.106)

1. **⚠ WARNING**

**Heavy objects!**

**Lift and handle all heavy components using lifting equipment with adequate capacity. Always support units or parts with suitable slings or hooks. Make sure the work area is clear of all bystanders.**

**Failure to comply could result in death or serious injury.**

W0398A

Undo the screws. Disconnect the front-wheel drive from the rear axle housing.

**NOTE:** Be careful with the adjustment disks.

Next operation:

Front-Wheel Drive (FWD) - Disassemble (23.202)

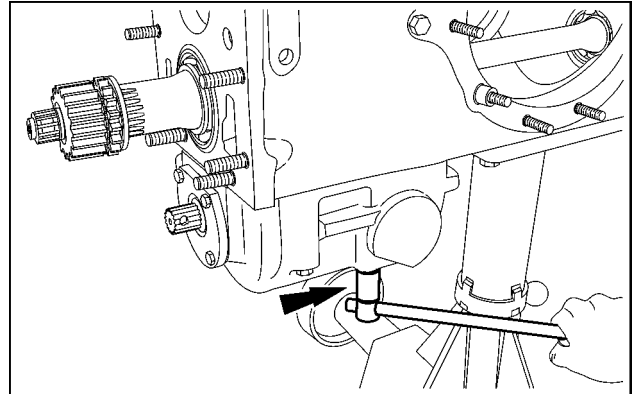

SS13H195 1

## Front-Wheel Drive (FWD) - Disassemble

### Front-Wheel Drive (FWD) - Exploded view (23.202)

#### Prior operation:

#### Front-Wheel Drive (FWD) - Remove (23.202)

1. Undo the screws. Remove the rear cover (42) from the housing (36).

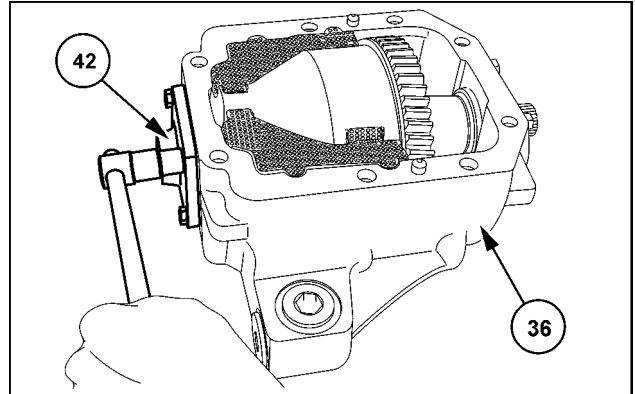

SS13H001 1

2. Remove the rectangular ring (13) from the drive shaft (12).

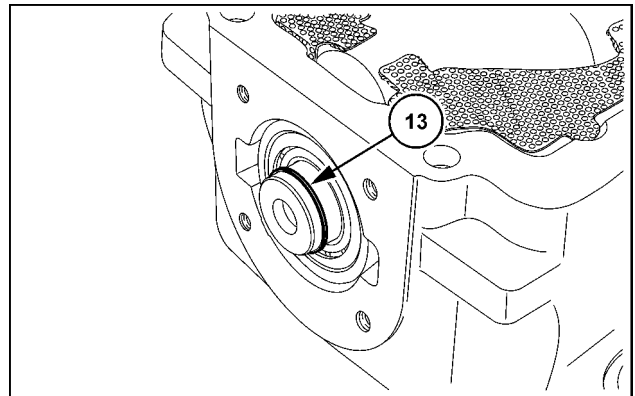

SS13H002 2

3. Undo the bolts (31). Remove the front cover (32) from the housing.

**NOTE:** Be careful with the adjustment disks (34).

4. Push the shaft sealing ring (33) out of the cover hole.

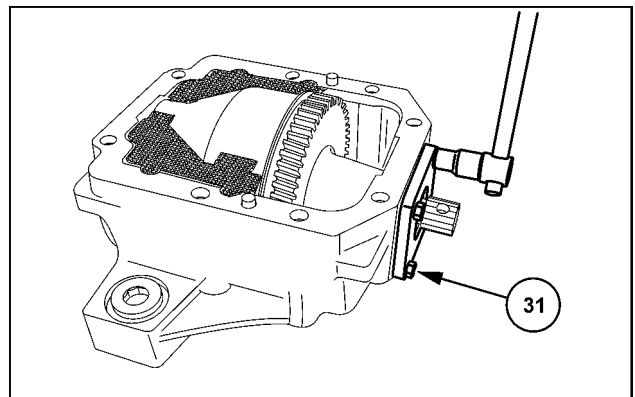

SS13H003 3

5. Disassemble the rear bearing outer ring (**41**) with the special tool **380000813**.

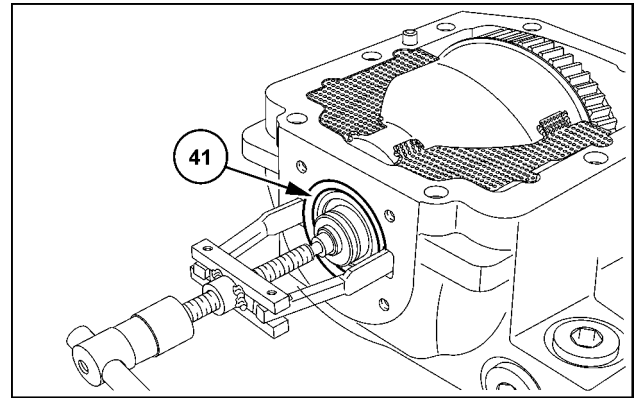

SS13H004 4

6. Push out the front bearing outer ring (**35**).

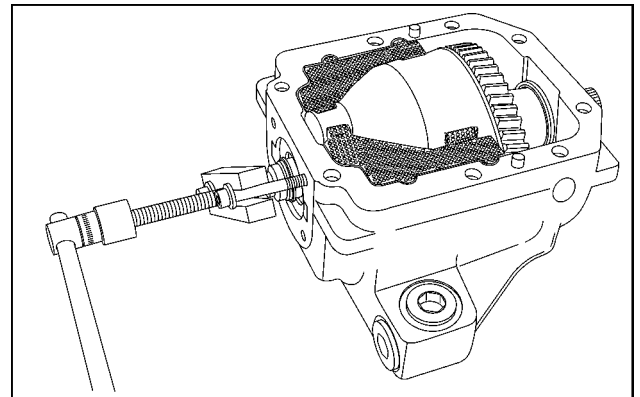

SS13H037 5

7. Remove the entire drive unit from the housing.

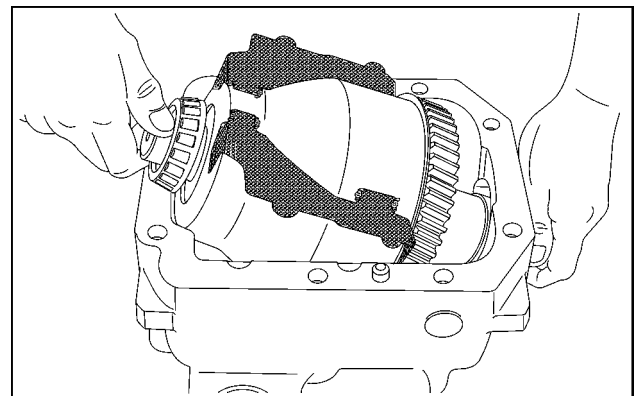

SS13H038 6

8. Remove the oil deflector plate (**27**).

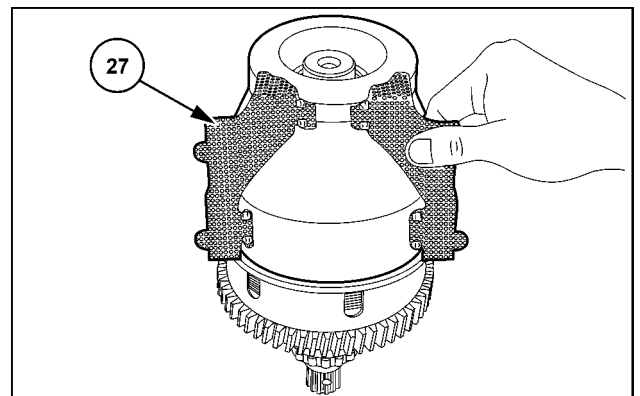

SS13H005 7

9. Disassemble the bearing inner ring (41) with the special tool 380000813.

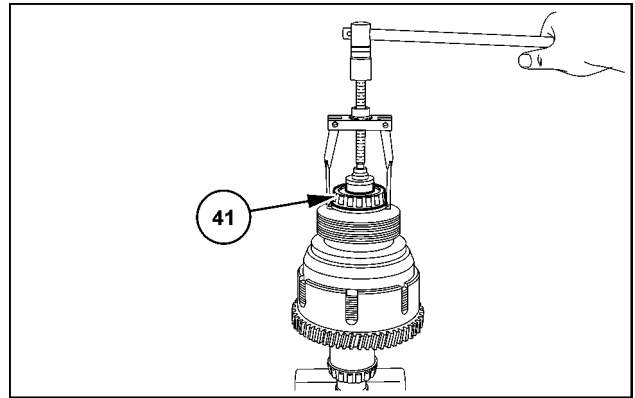

SS13H006 8

10. **⚠ WARNING**

**Spring under tension!**  
 Compressed springs have potentially dangerous stored energy. Always assemble and disassemble properly.  
 Failure to comply could result in death or serious injury.

W0356A

Pre-load the cup washer set with the mounting device 380000816. Release circlip (26) from its position. Loosen the pre-load of the cup washers. Remove the cup washer set.

**NOTE:** Hold the inner nut of the assembly device (see arrow) to relieve the cup washers.

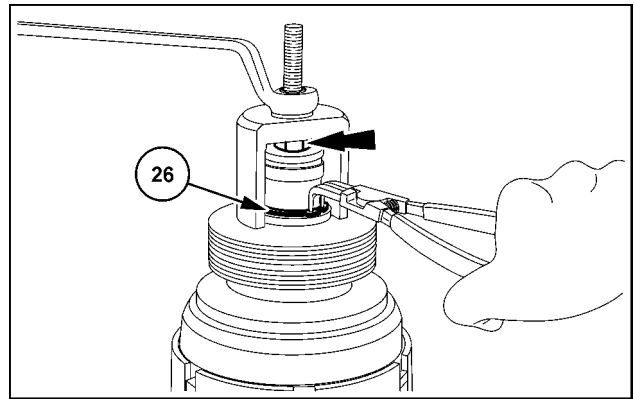

SS13H007 9

11. Remove the push cylinder (19).

**NOTE:** Be careful with the ring seal.

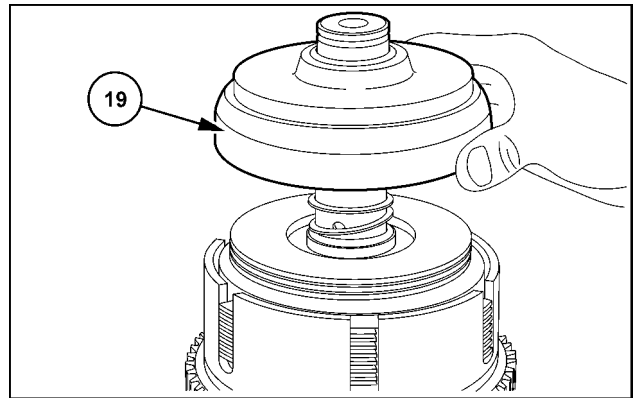

SS13H008 10

12. Remove the thrust spring (18). Remove the adjustment disk (17). Remove the ring seal (16).

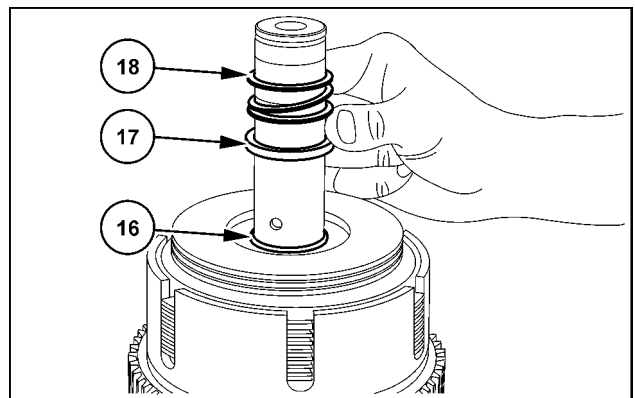

SS13H009 11

13. Remove the entire clutch.

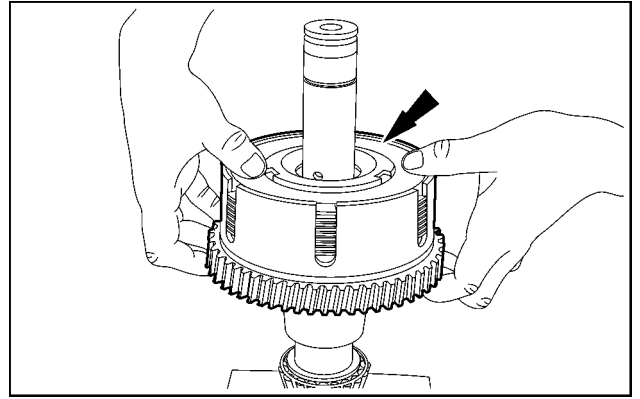

SS13H039 12

14. Disassemble the front bearing inner ring (35) with the special tool 380000813.

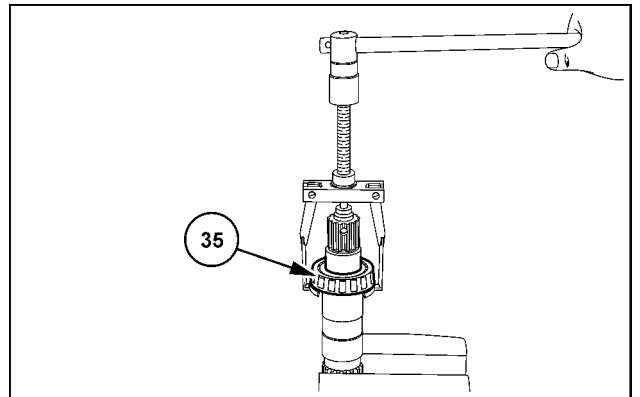

SS13H040 13

**NOTE:** Clean the components, check carefully for wear and damage, and replace if necessary.

**Next operation:**  
**Front-Wheel Drive (FWD) - Assemble (23.202)**

## Front-Wheel Drive (FWD) - Assemble

### Front-Wheel Drive (FWD) - Exploded view (23.202)

Prior operation:

Front-Wheel Drive (FWD) - Disassemble (23.202)

**NOTE:** All components must be lubricated prior to installation.

1. **⚠ CAUTION**

**Burn hazard!**

**Always wear heat-resistant protective gloves when handling heated parts.**

**Failure to comply could result in minor or moderate injury.**

C0047A

Heat up the bearing inner ring of the bearing (35).  
Fit the bearing inner ring (35) so that the bearing inner ring sits in place on the drive shaft (12).

**NOTE:** Adjust the bearing inner ring once it is cold.

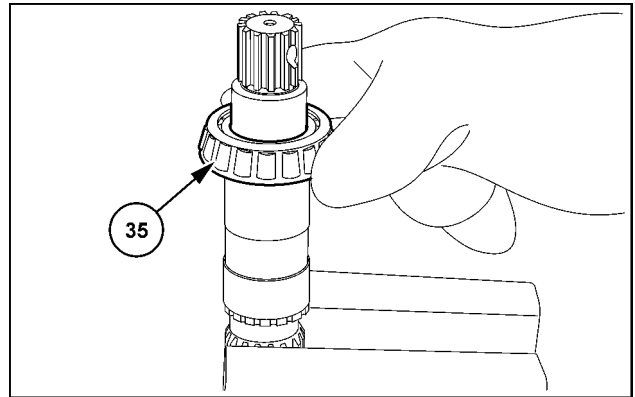

SS13H010 1

2. Fit the clutch housing (6) on the drive shaft (12).

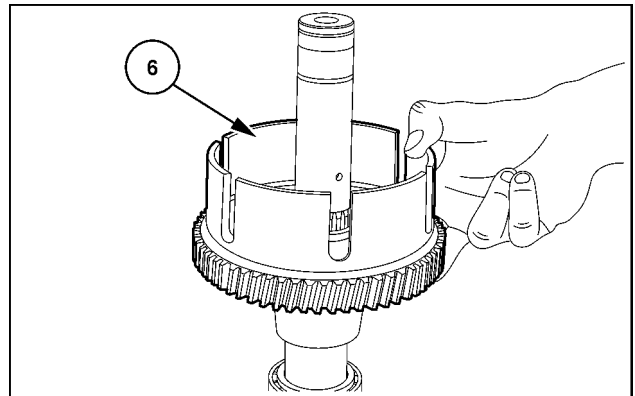

SS13H011 2

3. Fit the disk holder (7) and the thrust ring (8).

**NOTE:** Fit the thrust ring. Make sure that the chamfering on the thrust ring faces the clutch housing.

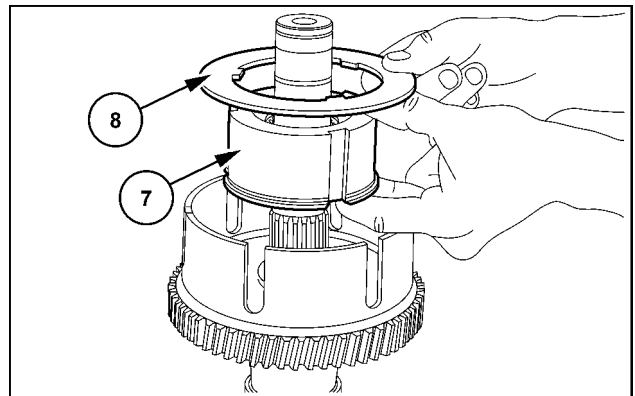

SS13H012 3

4. Fit the discs. Start with a steel disc (9).

**NOTE:** Layer the steel discs (9) and the friction discs (10) alternately.

**NOTE:** If you are using new friction disks, the new friction disks must be soaked in engine oil for at least 30 min.

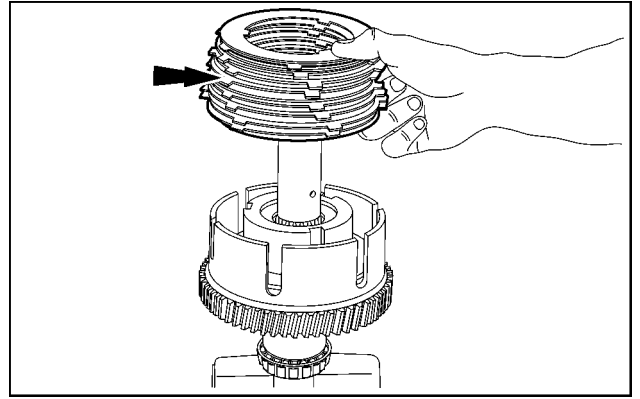

SS13H013 4

5. Fit the thrust washer (11).

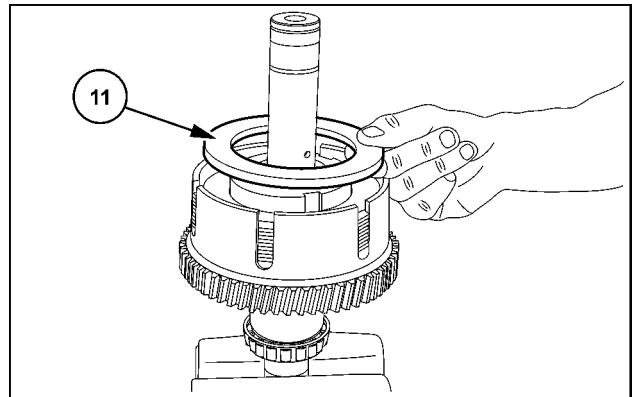

SS13H014 5

6. Insert the ring seal (14) into the ring groove of the piston.  
Fit the piston. Make sure that the flat side of the piston faces the disk set.

**NOTE:** Grease the ring seal with industrial Vaseline.

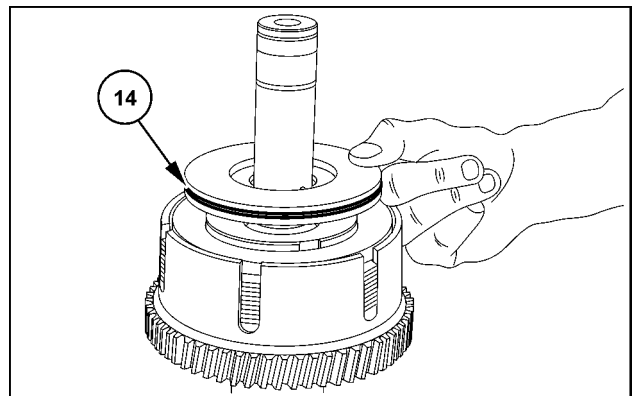

SS13H015 6

7. Insert the ring seal (16) into the ring groove of the piston.

**NOTE:** Grease the ring seal with industrial Vaseline.

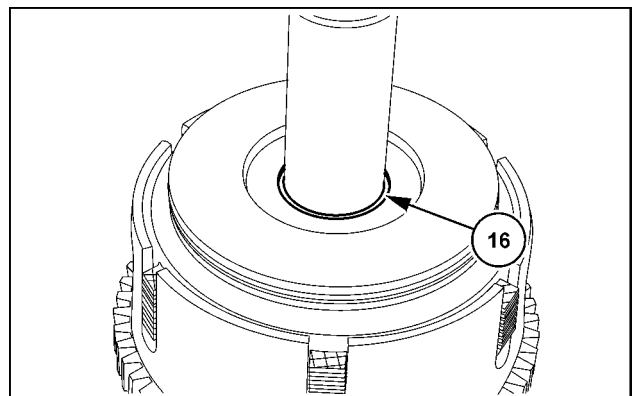

SS13H016 7



8. Fit the **5 mm (0.2 in)** shim (**17**) so that the shim fits in place. Fit the thrust spring (**18**) so that the thrust spring sits in place.

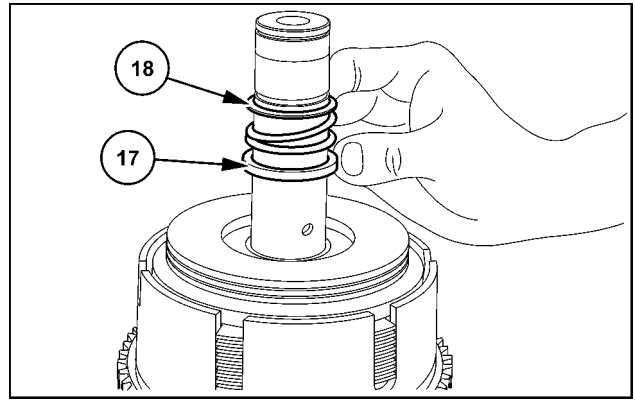

SS13H017 8

9. Fit the push cylinder (**19**).

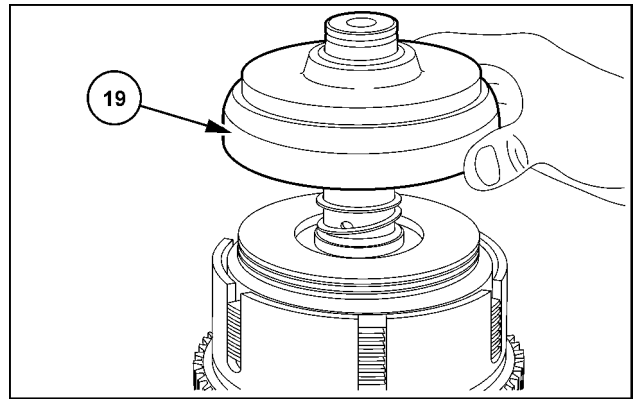

SS13H018 9

10. Thread on the shim (**21**).

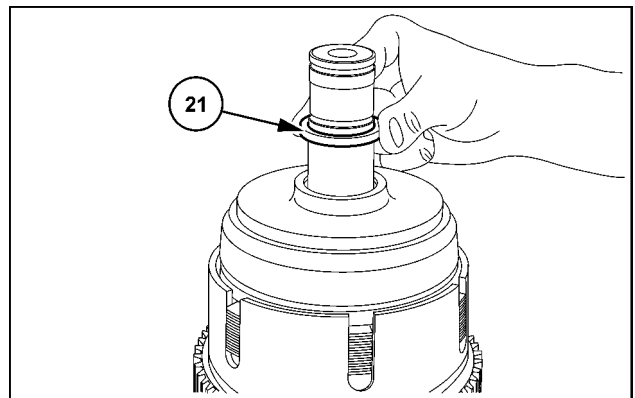

SS13H019 10

### Front-wheel drive adjustment

11. Fit the circlip (26) into the ring groove of the drive shaft.
12. Press together the pre-mounted drive shaft and the disk clutch over the push cylinder. Determine dimension (A).
13. Position the cup washers (22) one on top of the other. Press the cup washers together. Measure the thickness (s) of the cup washer set, plus 8.36 mm (0.329 in) = dimension (B)
14. Calculate the thickness of the adjustment disk: (A) minus (B) = thickness of the adjustment disk
15. After the calculation of the shim thickness, remove the shim (21) that you fitted in step 10.

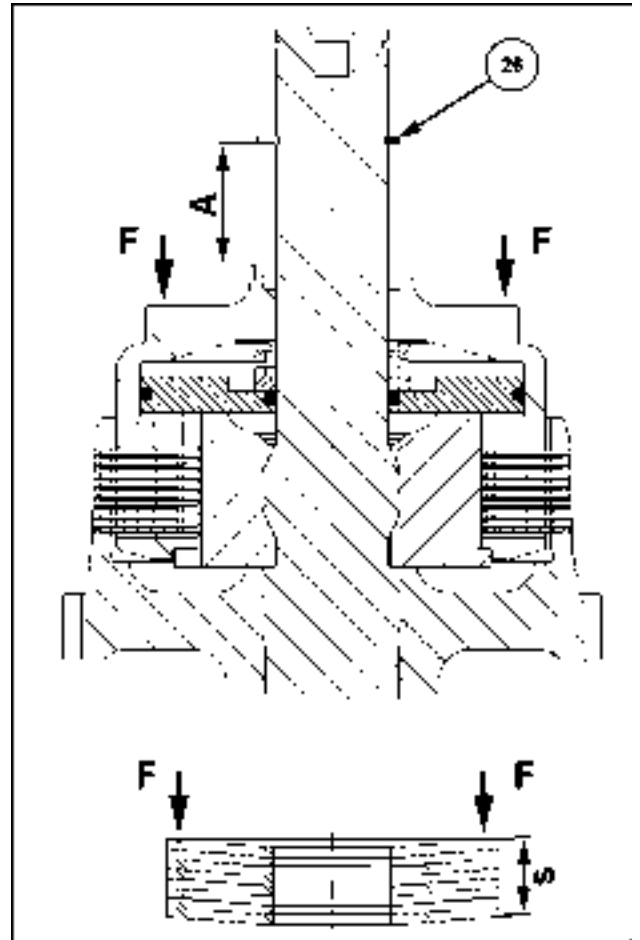

SS13H020 11

16. Insert the ring seal (16) into the ring groove. Make sure that the ring seal is between the push cylinder and the drive shaft. Thread on the shim (21) again.

**NOTE:** Grease the ring seal with industrial Vaseline.

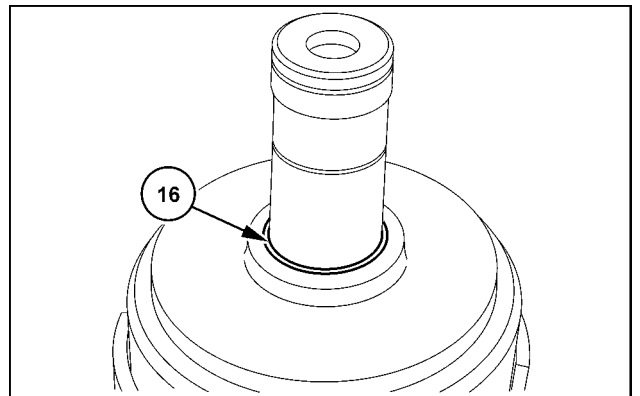

SS13H021 12

17. Fit the cup washers (22) and the shims (23) and (24) as per the sectional view.

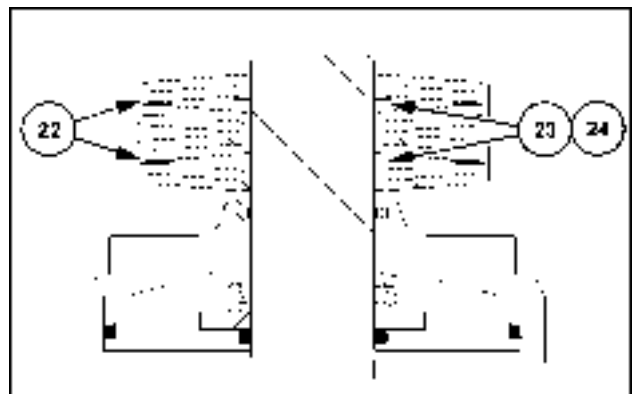

SS13H022 13

18. Fit the calculated adjustment disk (25) and the circlip (26).

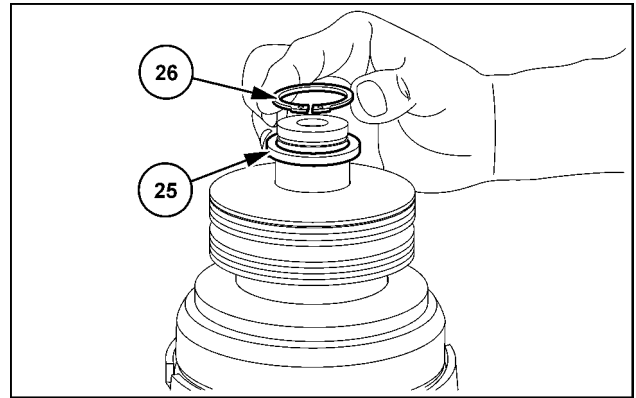

SS13H023 14

19. **⚠ WARNING**

**Spring under tension!**  
 Compressed springs have potentially dangerous stored energy. Always assemble and disassemble properly.  
 Failure to comply could result in death or serious injury.

W0356A

Pre-load the cup washer set with the special tool 380000816. Insert the circlip (26) into the ring groove of the drive shaft.

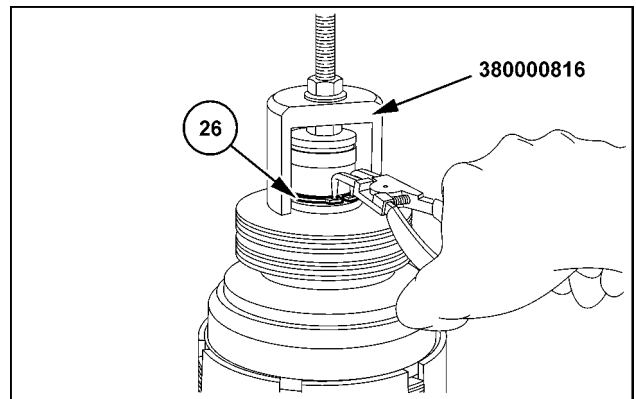

SS13H024 15

20. **⚠ CAUTION**

**Burn hazard!**  
 Always wear heat-resistant protective gloves when handling heated parts.  
 Failure to comply could result in minor or moderate injury.

C0047A

Warm the bearing inner ring of the bearing (41). Fit the bearing inner ring so that the bearing inner ring sits in place on the circlip.

**NOTE:** Adjust the bearing inner ring once it is cold.

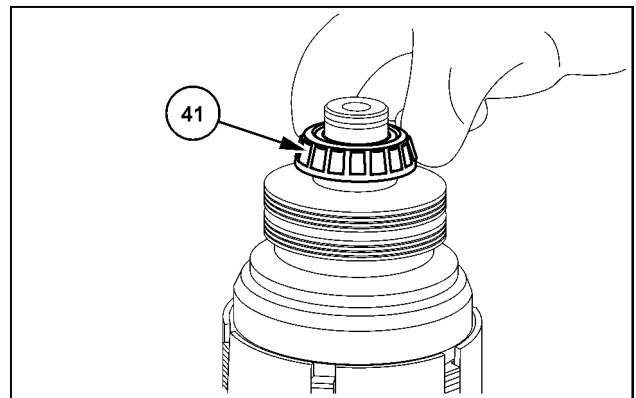

SS13H025 16

21. Thread on the oil deflector plate (27).

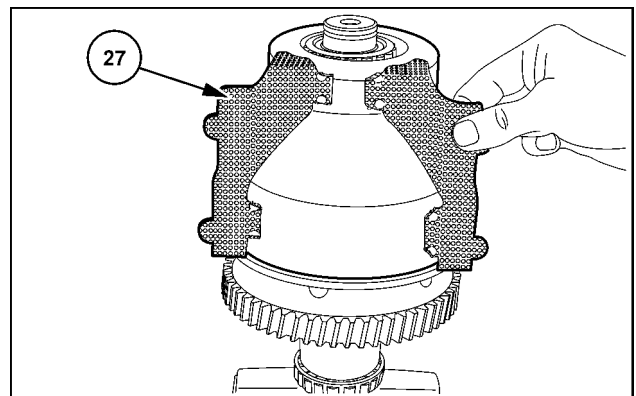

SS13H026 17

22. Fit the entire drive unit in the housing (36).

**NOTE:** After the installation in the bell housing, check for the correct centering of the oil deflector plate (27).

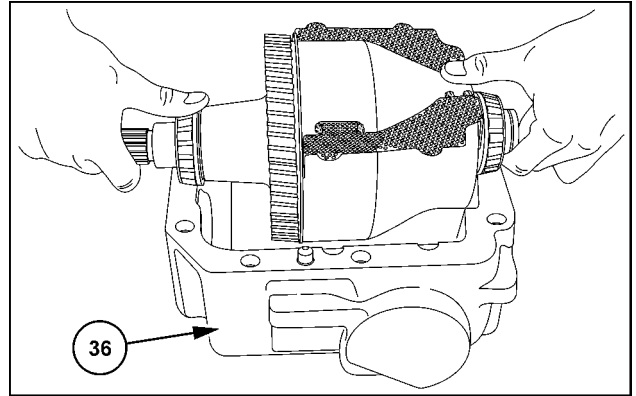

SS13H027 18

23. Fit the bearing outer ring (35) and the bearing outer ring (41).

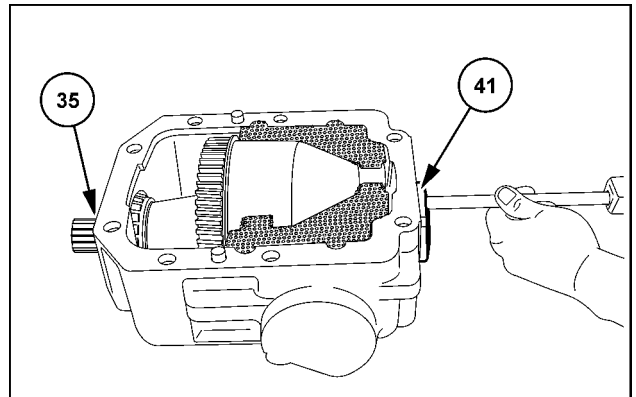

SS13H028 19

24. Insert the rectangular ring (13) into the ring groove of the drive shaft (12). Center the rectangular ring.

**NOTE:** Grease the rectangular ring with industrial Vaseline.

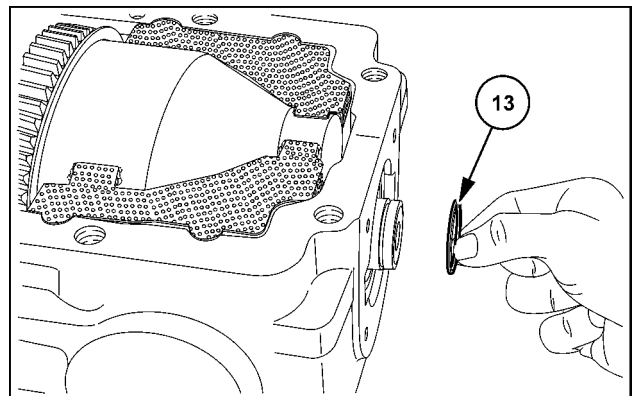

SS13H029 20

25. Clean the sealing surfaces on the rear cover (42). Spray the sealing surfaces with **LOCTITE® 518**. Fit the cover (42). Secure the cover with the screws (541). Tighten the screws to **23 Nm (17 lb ft)**.

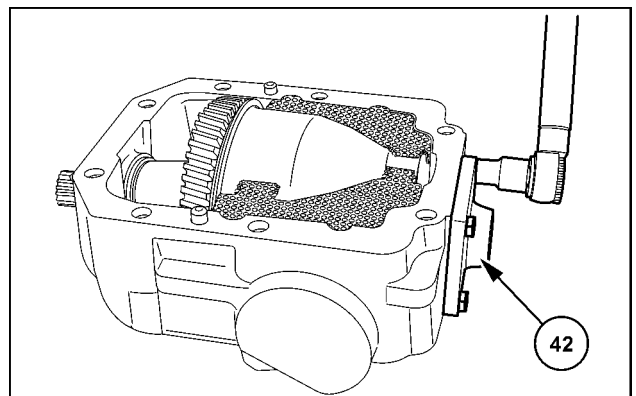

SS13H030 21

26. Insert the shaft sealing ring (33) into the front cover (32) with a suitable pin so that the shaft sealing ring sits in place.

**NOTE:** Spray the outer skirt surface of the shaft sealing ring with spirit immediately before installing it.

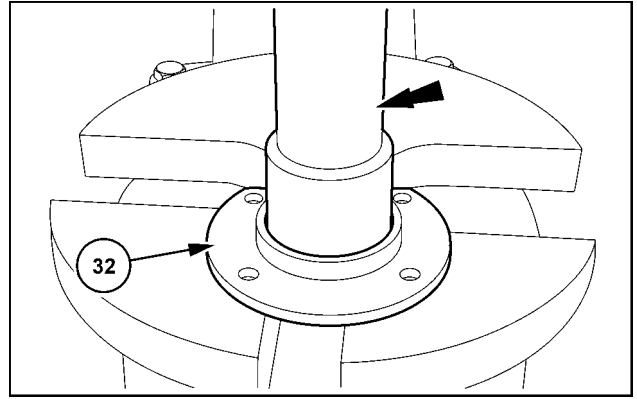

SS13H031 22

27. Adjust the bearing outer ring.

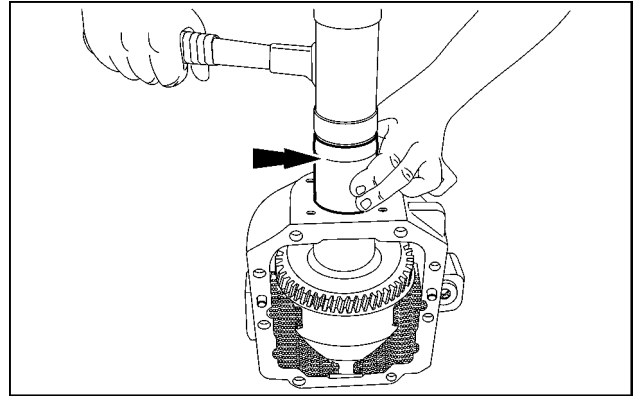

SS13H041 23

### Adjusting axial play

28. The endfloat should be **0.02 - 0.15 mm (0.001 - 0.006 in)**.

Measure the dimension ("A") from the housing flange surface to the bearing outer ring.

Example: dimension ("A") = **10.42 mm (0.410 in)**.

**NOTE:** Use more than one measuring point to measure the dimension.

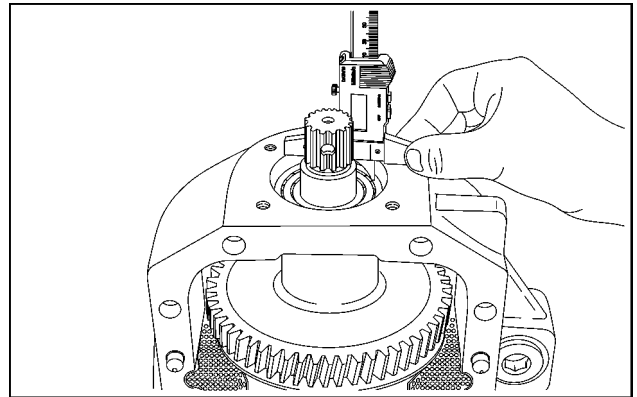

SS13H042 24

29. Measure the dimension ("**B**") from the cover collar to the flange surface.  
 Example: dimension ("**B**") = **9.88 mm (0.389 in)**  
 Calculate the adjustment disk thickness:  
 ("**S**") = dimension ("**A**") - dimension ("**B**") - axial play

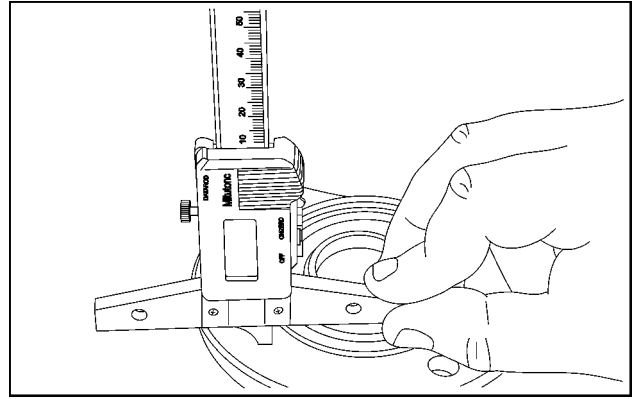

SS13H043 25

**Example calculation:**

Dimension (" <b>A</b> "):	<b>10.42 mm (0.410 in)</b>
Dimension (" <b>B</b> "):	<b>- 9.88 mm (0.390 in)</b>
Example axial play:	<b>- 0.04 mm (0.002 in)</b>
Thickness of the adjustment disk (" <b>S</b> "):	<b>= 0.50 mm (0.020 in)</b>

**NOTE:** With used bearings, aim for an upper end play value. With new bearings, aim for the lower value.

30. Insert the calculated adjustment disk (**34**).

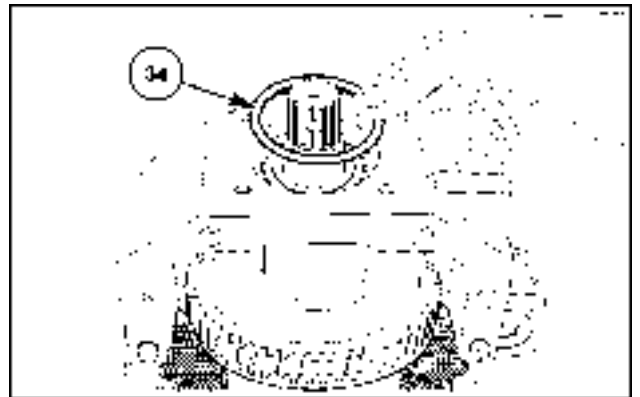

SS13H032 26

31. Clean the sealing surfaces and spray with **LOCTITE® 518**.  
 Fit the front cover (**32**).

**NOTE:** Before you fit the front cover: Cover the profile of the drive shaft with a sleeve or with masking tape. Grease the shaft sealing ring with industrial Vaseline.

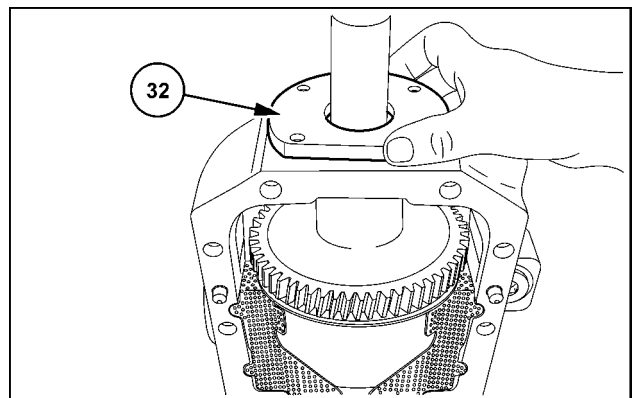

SS13H033 27

32. Insert the screws (31) and tighten to **23 Nm (17 lb ft)**.

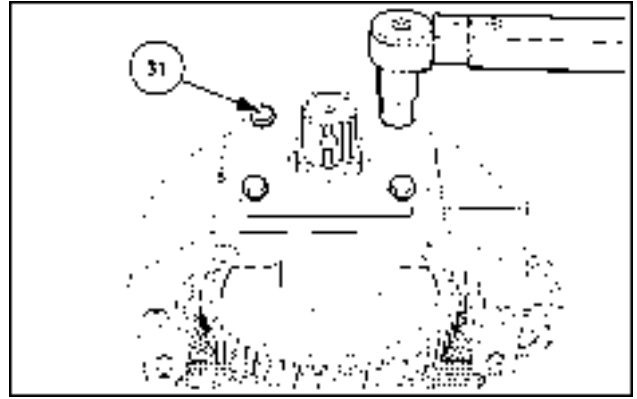

SS13H034 28

33. Check the end play ( **0.02 - 0.15 mm (0.001 - 0.006 in)**) of the bearing.

**NOTE:** Move the drive shaft by hand in the push direction and the pull direction.

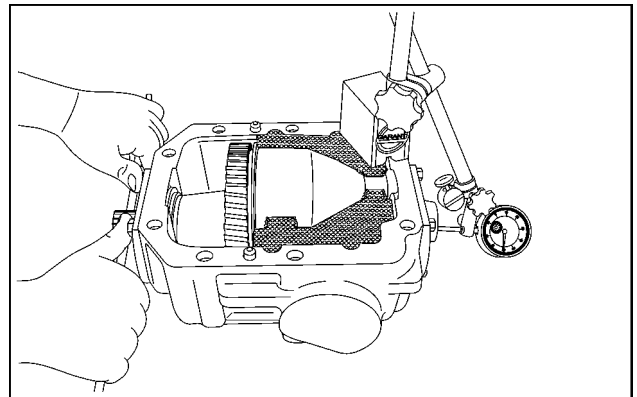

SS13H044 29

34. Measure the adjustment disk for the gear backlash:  
 The housing deviation is punched on the lower housing surface (see arrow). (Given in **1/100 mm**)  
 Available adjustment disks (s) = **0.2 mm (0.008 in)** or **0.3 mm (0.012 in)**  
 Dimension punched:  
 Up to **0.22 mm (0.009 in)** = adjustment disk **0.2 mm (0.008 in)**  
 From **0.23 mm (0.009 in)** = adjustment disk **0.3 mm (0.012 in)**

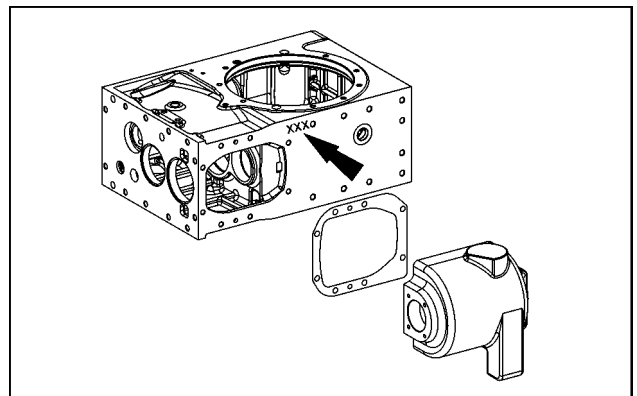

SS13H035 30

35. Fit the guide dowels (28) if necessary.  
 A punch mark in the housing (36) indicates the number of teeth of the clutch housing (6) (see the arrow).

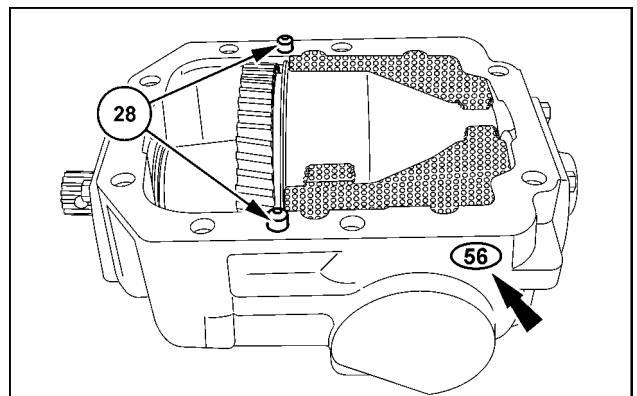

SS13H036 31

36. Fit the studs with a new ring seal. Fit the studs in the rear cover. Tighten the studs to a torque of **35 Nm (26 lb ft)**.

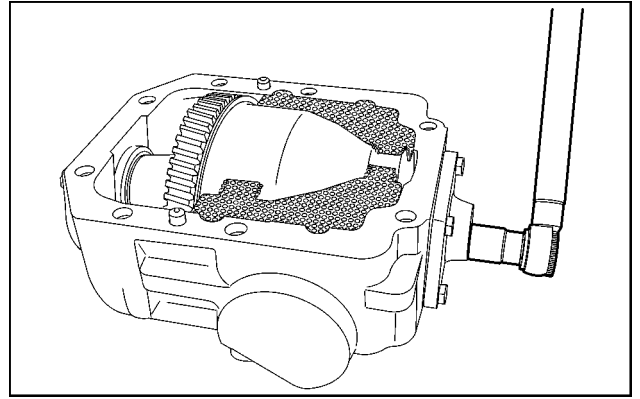

SS13H045 32

37. Fit the caps (**37**).

**Next operation:**  
**Front-Wheel Drive (FWD) - Install (23.202)**



## Front-Wheel Drive (FWD) - Install

### Front-Wheel Drive (FWD) - Exploded view (23.202)

#### Prior operation:

#### Front-Wheel Drive (FWD) - Assemble (23.202)

1. Clean the sealing surfaces.  
Moisten the sealing surface of the drive housing with **LOCTITE® 518**.
2. Install the adjustment disk (30).  
Also coat the sealing surface of the adjustment disk with **LOCTITE® 518**.

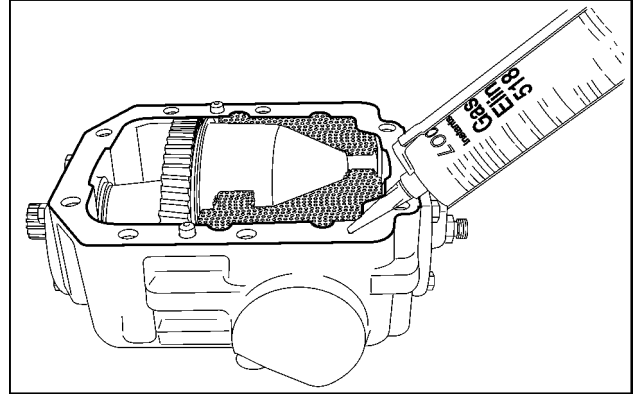

SS13H196 1

### 3. **⚠ WARNING**

#### Heavy objects!

Lift and handle all heavy components using lifting equipment with adequate capacity. Always support units or parts with suitable slings or hooks. Make sure the work area is clear of all bystanders.

Failure to comply could result in death or serious injury.

W0398A

Fit the front-wheel drive onto the rear axle housing.  
Insert screws and tighten to **115 Nm (84.8 lb ft)**.

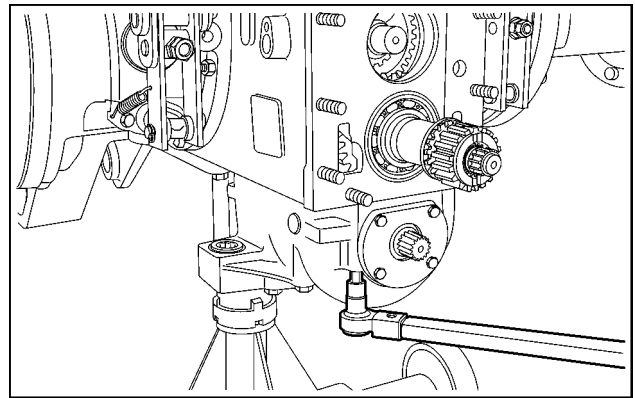

SS13H197 2

#### Next operation:

#### Rear axle housing - Connect (27.100)

# Index

---

## Four-Wheel Drive (4WD) system - 23

### Electro-hydraulic control - 202

Front-Wheel Drive (FWD) - Assemble .....	14
Front-Wheel Drive (FWD) - Disassemble .....	10
Front-Wheel Drive (FWD) - Exploded view .....	6
Front-Wheel Drive (FWD) - General specification .....	3
Front-Wheel Drive (FWD) - Install .....	24
Front-Wheel Drive (FWD) - Remove .....	9
Front-Wheel Drive (FWD) - Special tools .....	3
Front-Wheel Drive (FWD) control valve - Overview .....	4



© 2014 CNH Industrial Österreich GmbH

All rights reserved. No part of the text or illustrations of this publication may be reproduced.

CASE IH policy is one of continuous improvement and the right to change prices, specification or equipment at any time without notices is reserved.

All data given in this publication is subject to production variations. Dimensions and weight are approximate only and the illustrations do not necessarily show products in standard condition. For exact information about any particular product, please consult your CASE IH Dealer.



## **SERVICE MANUAL**

### **Front axle system**

**Farmall 105U Pro EP  
Farmall 115U Pro EP  
Farmall 95U Pro EP**

# Contents

---

## Front axle system - 25

[25.100] Powered front axle .....	25.1
[25.102] Front bevel gear set and differential .....	25.2
[25.108] Final drive hub, steering knuckles, and shafts .....	25.3



## **Front axle system - 25**

### **Powered front axle - 100**

**Farmall 105U Pro EP  
Farmall 115U Pro EP  
Farmall 95U Pro EP**

# Contents

---

## Front axle system - 25

### Powered front axle - 100

#### TECHNICAL DATA

Powered front axle	
Torque .....	3
Special tools .....	5

#### FUNCTIONAL DATA

Powered front axle	
Static description .....	11
Four-Wheel Drive (4WD) axle	
Sectional view .....	12
Axle support	
Sectional view .....	17

#### SERVICE

Four-Wheel Drive (4WD) axle	
Disassemble 4 WD .....	18
Assemble 4 WD .....	25
Axle support	
Adjust .....	26

## Powered front axle - Torque

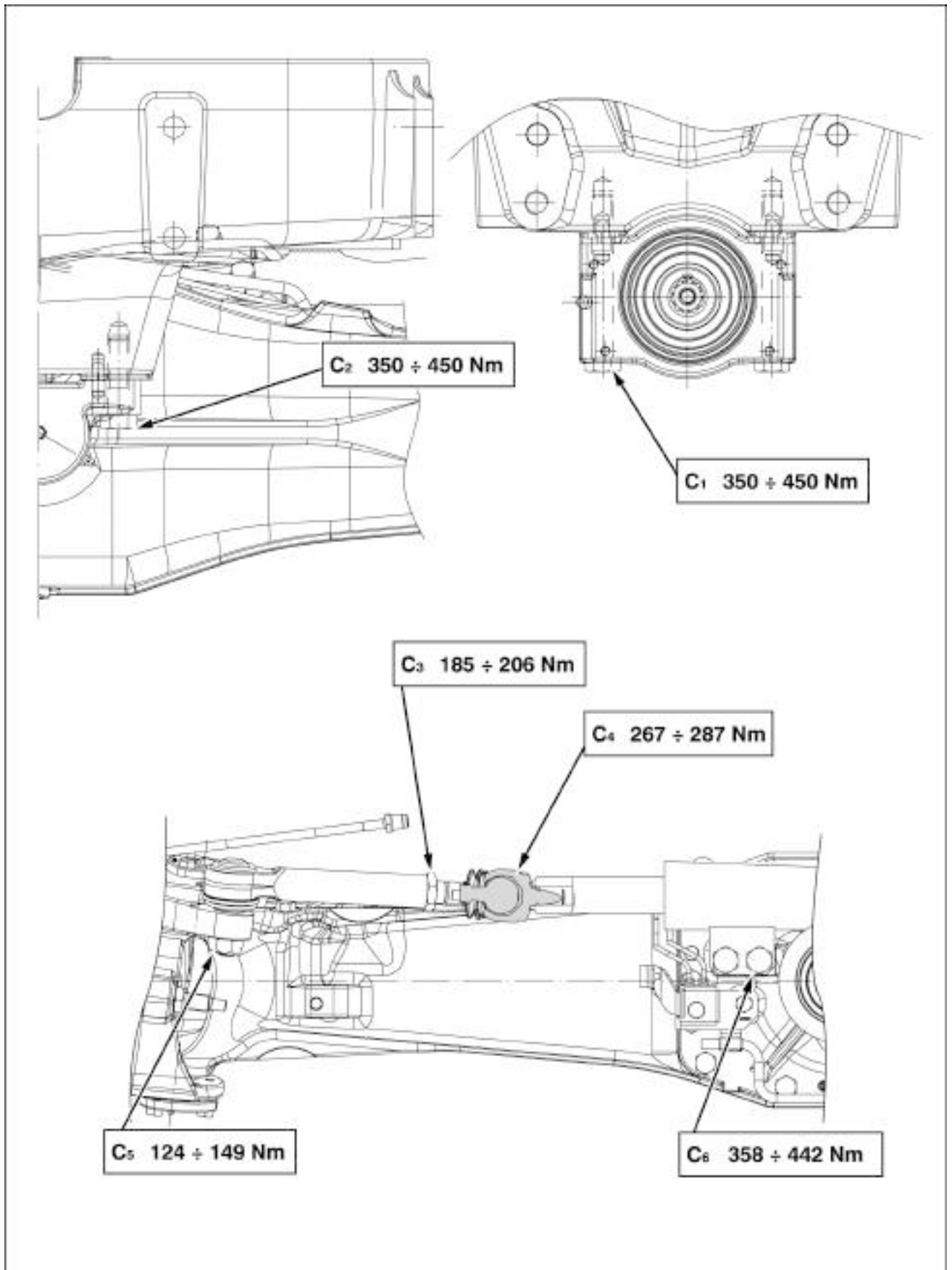

WLAPL4S25C101H 1



Front axle system - Powered front axle

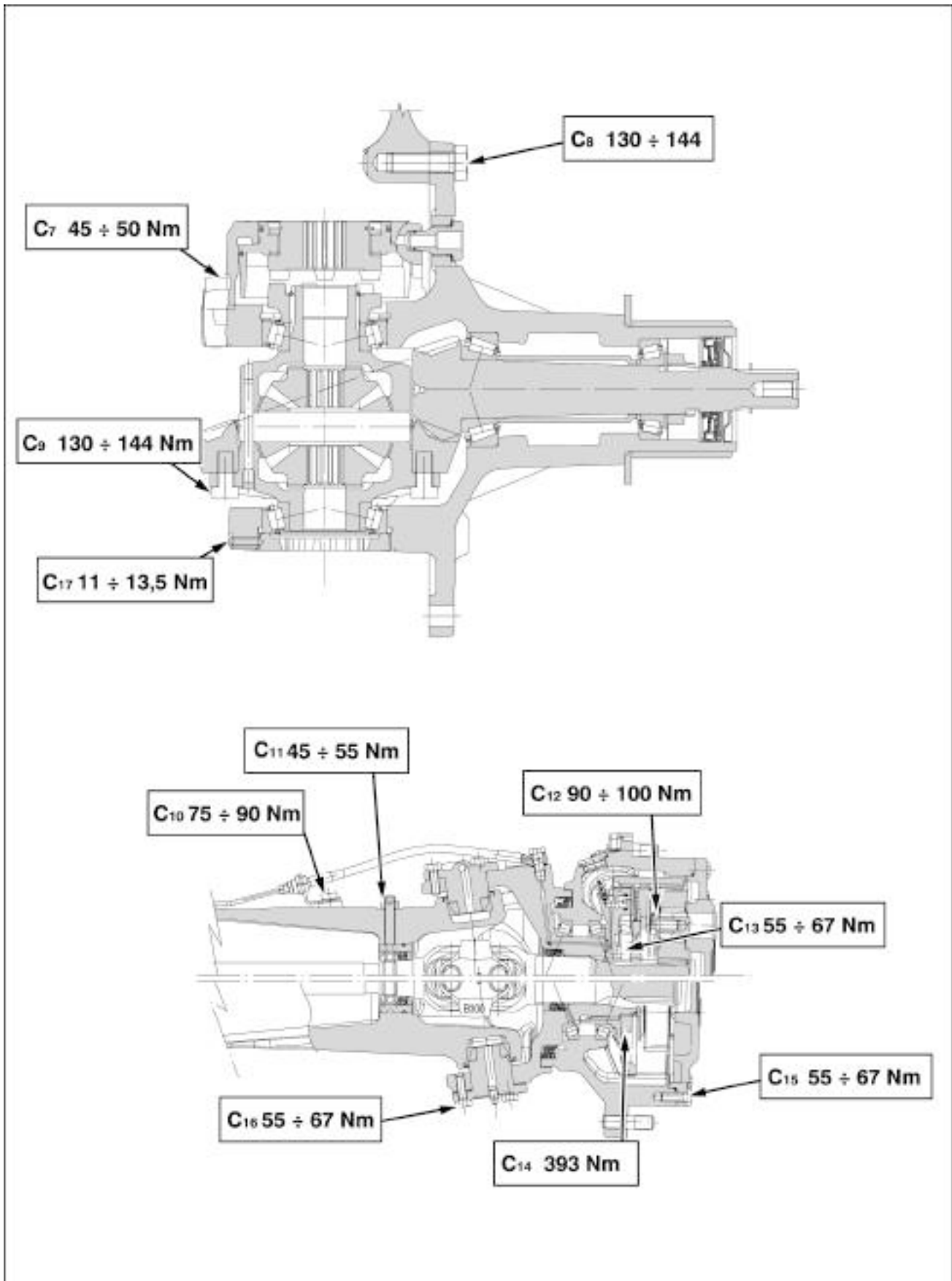

WLAPL4S25C102H 2

## Front axle torque settings

PARTS TO BE TIGHTENED	Thread	Tightening torque	
		Nm (lbft)	Kgm
Front axle support retaining bolt ( <b>(C1)</b> , 1 )	M18 x 1.5	350 - 410 N·m (258.15 - 302.40 lb ft)	35.5 to 41.6
Rear axle support retaining bolt ( <b>(C2)</b> , 1 )	M18 x 1.5	350 - 410 N·m (258.15 - 302.40 lb ft)	35.5 to 41.6
Steering cylinder head locking ring nut ( <b>(C3)</b> , 1 )	M22 x 1.5	185 - 206 N·m (136.45 - 151.94 lb ft)	18.8 to 20.9
Steering knuckle fixing on the piston ( <b>(C4)</b> , 1 )	M22 x 1.5	267 - 287 N·m (196.93 - 211.68 lb ft)	27.1 to 29.1
Nut retaining steering ball joint on the stub axle ( <b>(C5)</b> , 1 )	M20 x 1.5	124 - 149 N·m (91.46 - 109.90 lb ft)	12.6 to 15.2
Steering cylinder retaining screws ( <b>(C6)</b> , 1 )	M18 x 1.5	385 - 442 N·m (283.96 - 326.00 lb ft)	36.5 to 45
Locking piston seat retaining bolt ( <b>(C7)</b> , 2 )	M10 x 1.25	45 - 50 N·m (33.19 - 36.88 lb ft)	4.6 to 5.1
Differential housing support casing retaining bolt ( <b>(C8)</b> , 2 )	M14x1	130 - 144 N·m (95.88 - 106.21 lb ft)	13.2 to 14.6
Bevel crown wheel to differential support retaining bolt ( <b>(C9)</b> , 2 )	M12 x 1	130 - 144 N·m (95.88 - 106.21 lb ft)	13.2 to 14.6
Brake pipe bracket retaining bolt ( <b>(C10)</b> , 2 )	M12 x 1.25	75 - 90 N·m (55.32 - 66.38 lb ft)	7.6 to 9.1
Axle shaft bearing bushes retaining bolt ( <b>(C11)</b> , 2)*	M12 x 1.25	45 - 55 N·m (33.19 - 40.57 lb ft)	4.5 to 5.6
Final drive bearing retaining thrust washer retaining bolts ( <b>(C12)</b> , 2 )	M12 x 1.25	90 - 100 N·m (66.38 - 73.76 lb ft)	9.1 to 10.1
Final drive ring gear support retaining bolts, axle version with brakes ( <b>(C13)</b> , 2 )	M10 x 1.25	75 - 82 N·m (55.32 - 60.48 lb ft)	7.6 to 8.4
Ring nut locking hub on stub axle, axle version without brakes ( <b>(C14)</b> , 2 )	M72x2	394 N·m (290.60 lb ft)	40
Final drive to hub retaining bolt ( <b>(C15)</b> , 2 )	M10 x 1.25	55 - 67 N·m (40.57 - 49.42 lb ft)	5.6 to 6.8
Stub axle pin retaining bolt ( <b>(C16)</b> , 2 )	M10 x 1.25	55 - 67 N·m (40.57 - 49.42 lb ft)	5.6 to 6.8
Ring gear positioning ring nuts retaining grub screw ( <b>(C17)</b> , 2 * )	M12 x 1.25	11 - 13.5 N·m (8.11 - 9.96 lb ft)	1.1 to 1.3

**NOTE:** \* Apply **LOCTITE® 243** on the thread.

## Powered front axle - Special tools

### Indispensable tools

**380000268:** Front axle drive pinion nut spanner.

**380000257:** Front axle drive pinion retaining tool.

**380000252:** Front axle differential casing bearing ring nut spanner.

- 380000269:** Wrench for front axle wheel hub bearing retaining nut.
- 380000270:** Pair of grips for front axle hub bearing extraction.
- 380000265:** Front axle pivot pin removal tool.
- 380000234:** Front axle swivel pin bearing outer race puller.
- 380000235:** Tool for measurement of rolling drag torque of front axle bearings.
- 380200017:** Sunken seal key on hub (version without brakes).
- 380200018:** Sunken seal key on spindle (version with brakes).
- 380200019:** Sunken seal key on spindle for axle shafts.
- 380200041:** Sunken seal key on pinion.
- 380200042:** Dust seal key on pinion.

Tools that can be made in the workshop

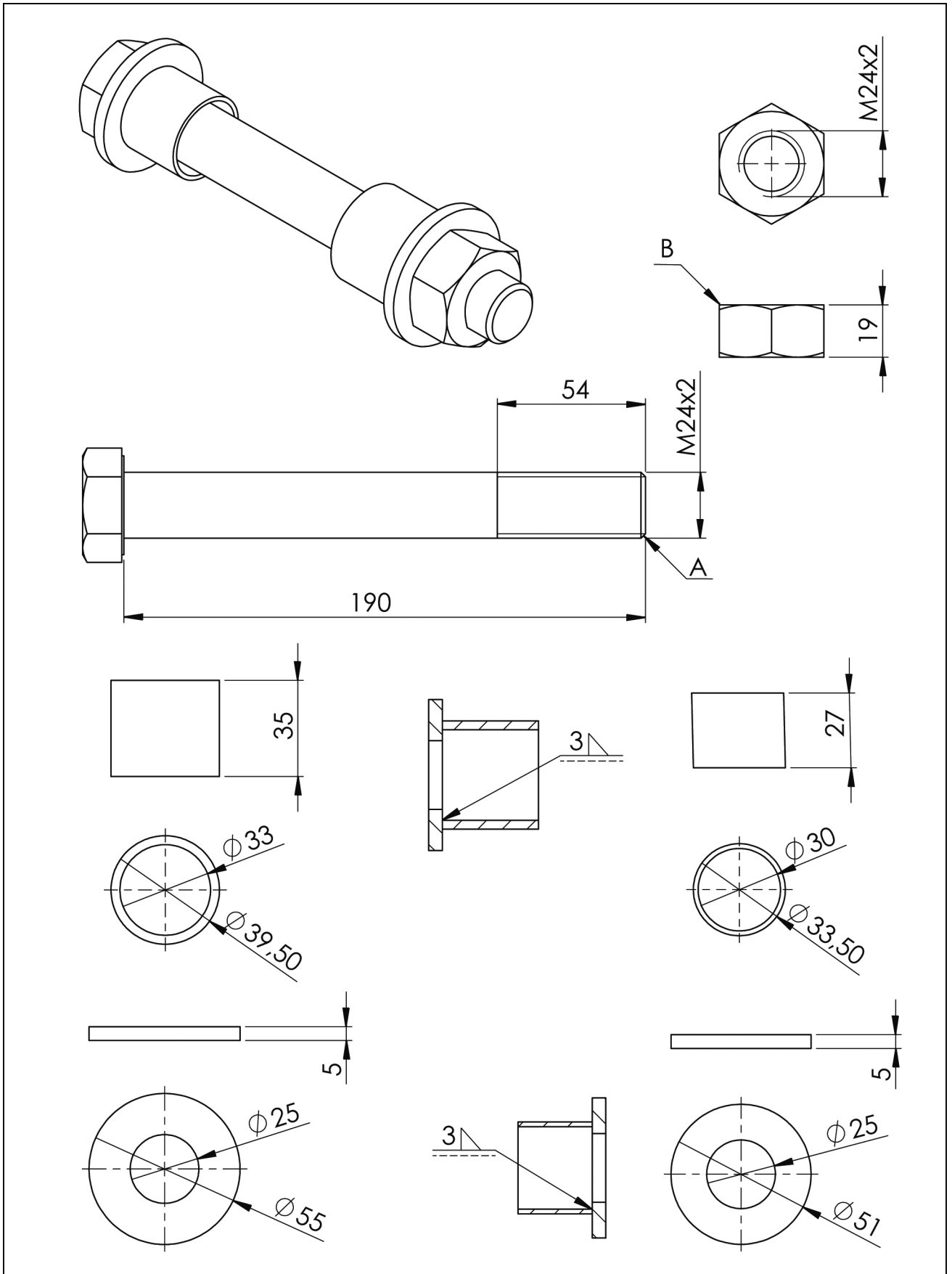

WLAPL4S25C103H 1

Tool to be made for adjustment of pinion bearing pre-load

For the screw order P/N 15998934, for the nut order P/N 12164524 The remainder make of **UNI C40** .

**(A)** . - Machine the end of the hole to remove approximately **1 mm (0.0394 in)** obtaining a level surface to facilitate measuring.

**(B)** . - Machine a face of the nut to remove approximately **1 mm (0.0394 in)** obtaining a level surface to facilitate measuring.

**Tool to make for front axle wheel disassembly-assembly**

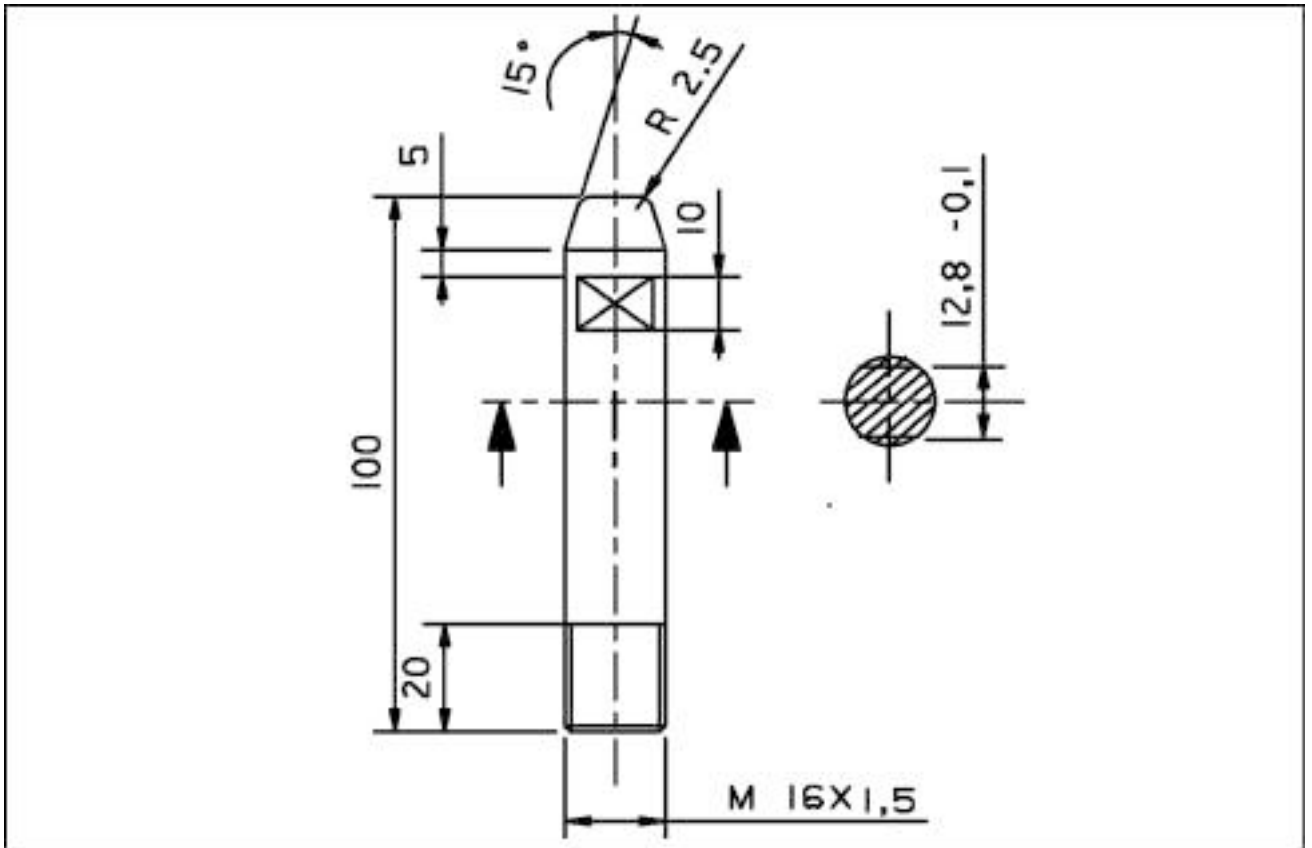

SEZ25CAP1F-1 2

**Stamp number 50165 on the tool - Measurements in mm.  
Make using UNI C40 material.**

**Tool to make for removal–installation of the final drive cover**

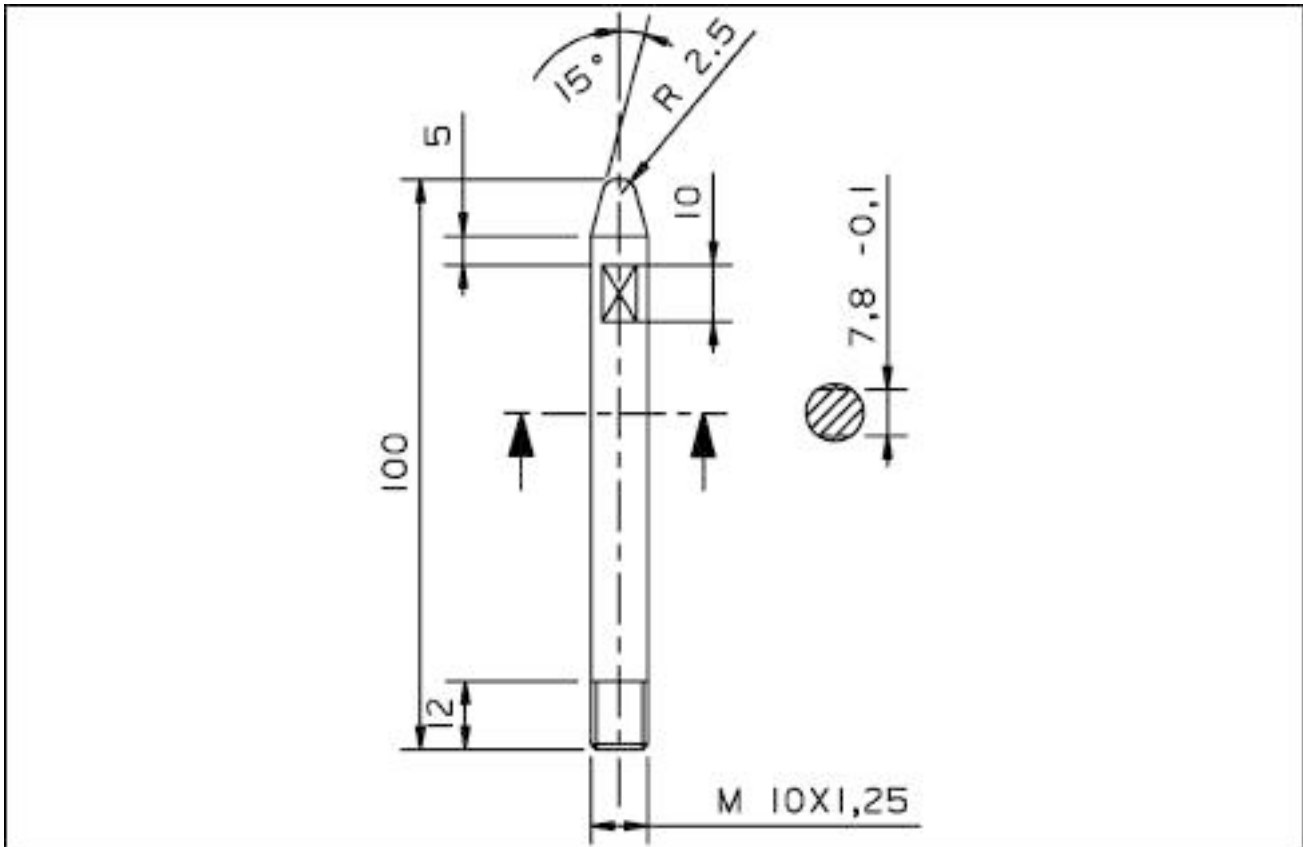

SEZ25CAP1F-2 3

**Stamp number 50164 on the tool - Measurements in mm.  
Make using UNI C40 material.**

## Powered front axle - Static description

All the models in the range have their front axle pivoted at the centre with the pivot and drive gear shaft coaxial to the tractor's longitudinal axis; the drive gear shaft has no universal joints.

The differential has two planet pinions; drive is transmitted to lateral epicyclic final drive units (installed on the wheel hubs) through universal joints which do not require any maintenance.

For the hydraulically controlled front gear--type differential lock, see **Differential lock - Static description (25.102)** .



## Four-Wheel Drive (4WD) axle - Sectional view

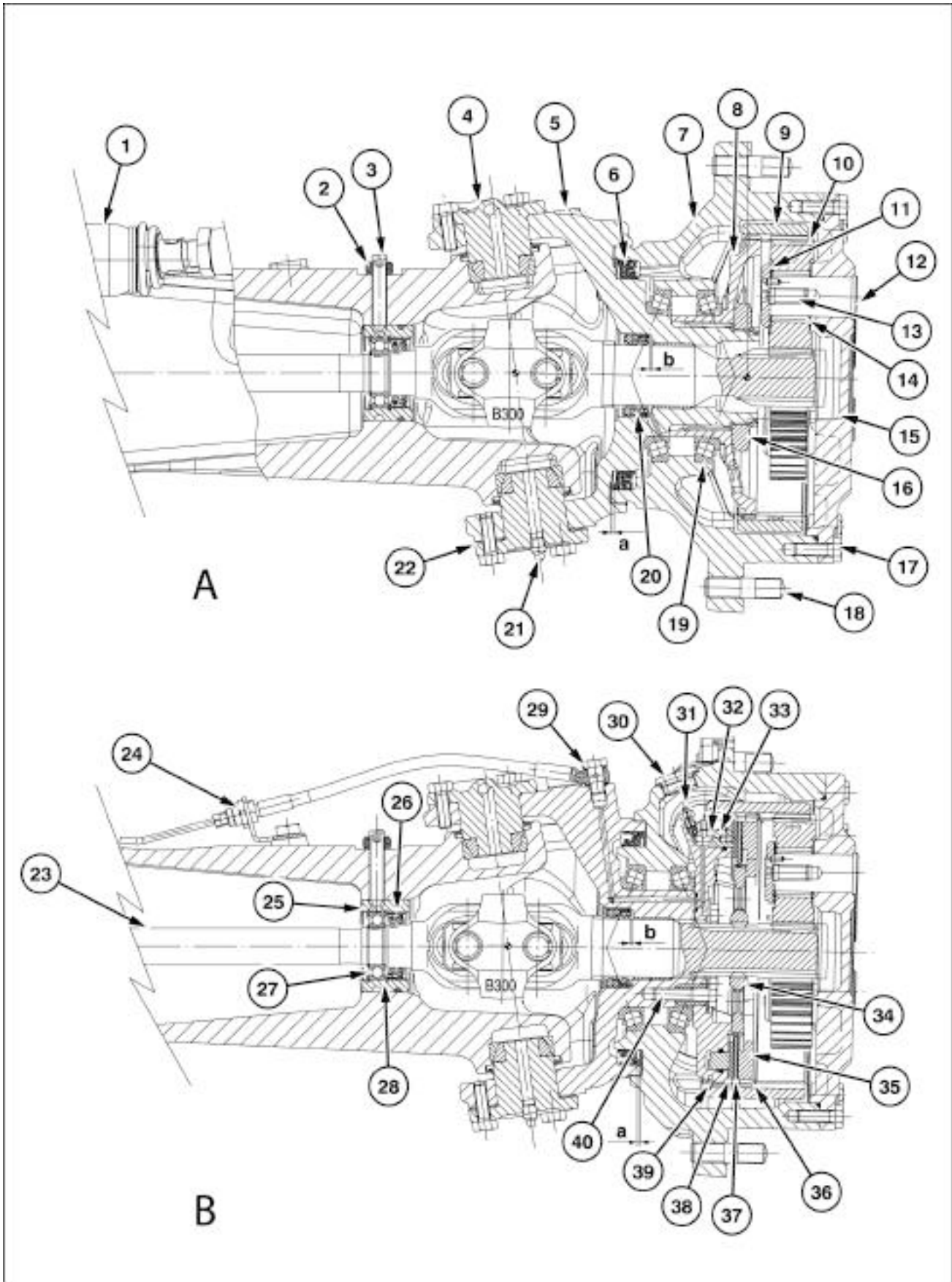

WLAPL4S25C104H 1

axle with brake and normal — steering cylinder and bevel drive with hydraulic differential — bevel drive with self-locking differential (Lim Slip)

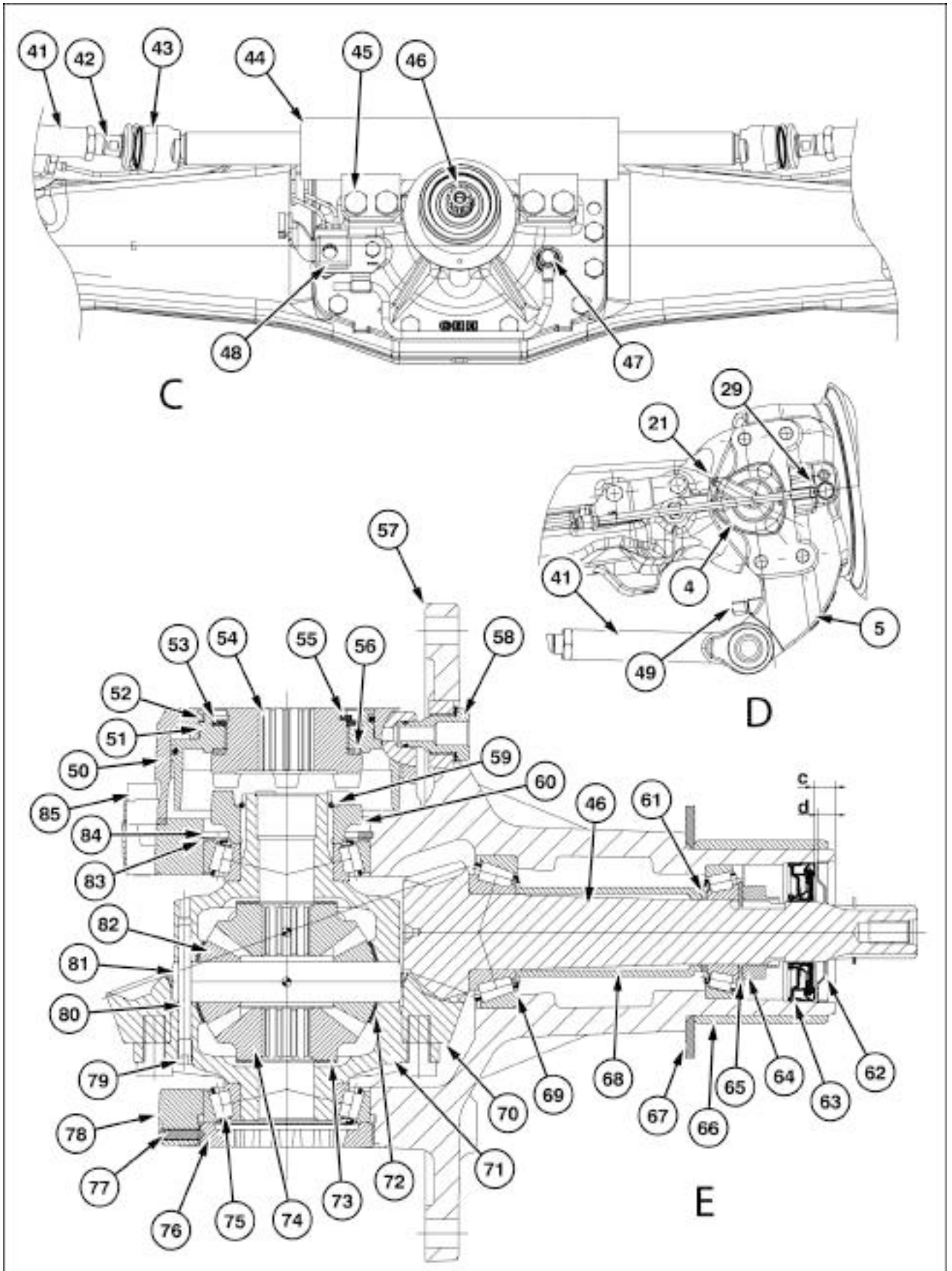

WLAPL4S25C105H 2

steering cylinder and bevel drive with hydraulic differential

Front axle system - Powered front axle

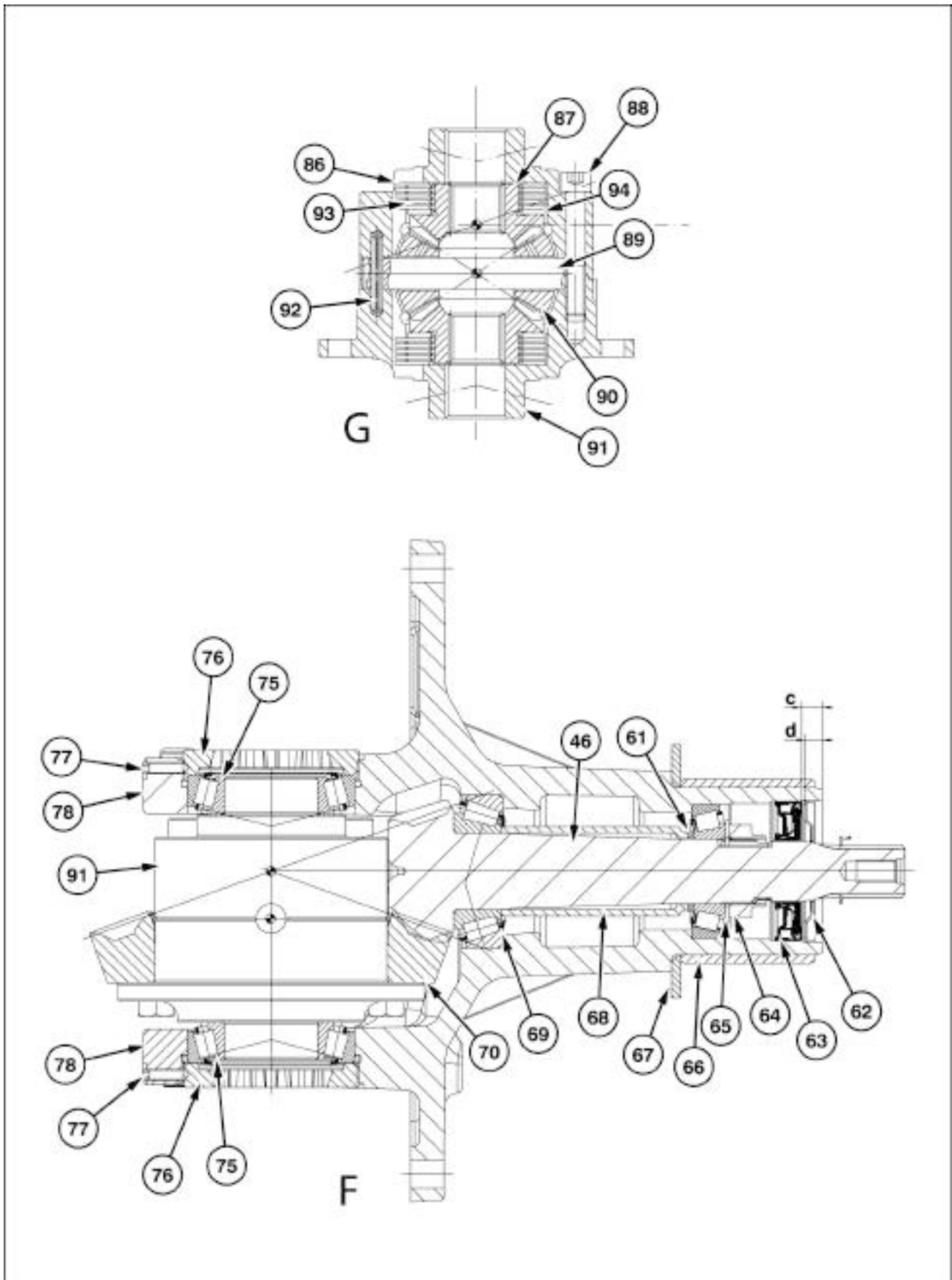

WLAPL4S25C106H 3

**bevel drive with self--locking differential ( Lim Slip )**

- 
- (A)** - Standard axle (without brakes).
  - (B)** - Axle with braking.
  - (C)** - Bolt fastening steering cylinder to axle.
  - (D)** - Fixing steering cylinder arm to stub axle.
  - (E)** - Differential unit with electro-hydraulic locking
  - (F)** - Self-locking differential unit ( Lim Slip ).
  - (G)** - Self-locking differential ( Lim Slip ).
  - (a)** - **2.5 - 3 mm (0.0984 - 0.1181 in)** – Slide seal assembly stand-in
  - (b)** - **1 mm (0.0394 in)** – Seal gap on axle shaft.
  - (c)** - Seal assembly distance **11 mm (0.4331 in)** .
  - (d)** - Dust seal assembly distance **10 mm (0.3937 in)** .
  - (1)** - Steering cylinder unit.
  - (2)** - Grub screw locknut.
  - (3)** . Axle shaft bush grub screw.
  - (4)** . Stub axle pin.
  - (5)** . Stub axle.
  - (6)** . Sunken seal.
  - (7)** . Wheel hub.
  - (8)** . Final drive ring gear support.
  - (9)** . Final drive ring gear.
  - (10)** . Final drive driven gears.
  - (11)** . Driven gear retaining thrust washer.
  - (12)** . Driven gear pin.
  - (13)** . Thrust washer retaining screw.
  - (14)** . Needle bearing.
  - (15)** . Wheel hub cover.
  - (16)** . Ring nut retaining ring gear support to stub axle.
  - (17)** . Wheel hub cover retaining bolts.
  - (18)** . Wheel studs.
  - (19)** . Final drive ring gear unit support bearings.
  - (20)** . Seal.
  - (21)** . Stub axle pin grease fitting.
  - (22)** . Stub axle rolling torque adjustment shims
  - (23)** . Axle shaft
  - (24)** . Brakes circuit.
  - (25)** . Axle shaft bearing carrier bushing.
  - (26)** . Seal.
  - (27)** . Axle shaft support bearing.
  - (28)** . Bearing retaining circlips.
  - (29)** . Front braking fitting.
  - (30)** . Cover of compartment for front brakes bleeder on wheel hub.
  - (31)** . Front brakes bleed screw.
  - (32)** . Front brake ring cylinder.
  - (33)** . Front brake ring piston.
  - (34)** . Disc brake support gear.
  - (35)** . Brake reaction disc.
  - (36)** . Brake reaction disc retaining circlip.
  - (37)** . Brake disc.
  - (38)** . Brake reaction disc.
  - (39)** . Circlip retaining ring gear to the carrier.
  - (40)** . Screws retaining ring gear support to stub axle.
  - (41)** . Steering cylinder end.
  - (43)** . Ball joint gasket.
  - (44)** . Steering cylinder.
  - (45)** . Bolt fastening steering cylinder.
  - (46)** . Pinion.
  - (47)** . Differential lock fitting.
  - (48)** . Front axle braking spool valve.
  - (49)** . Steering stop
  - (50)** . Differential lock cylinder / casing.
  - (51)** . Differential lock piston.
  - (52)** . Differential lock piston O--ring.
  - (53)** . Front gear outer thrust washer.
  - (54)** . Differential lock front gear on right axle shaft.
  - (55)** . Front gear retaining circlip on the locking piston.
  - (56)** . Front gear inner thrust washer.
  - (57)** . Differential lock unit support.
  - (58)** . Differential lock hydraulic circuit fitting.
  - (59)** . Front gear retaining circlip on the differential cage.
  - (60)** . Front gear, differential cage side.
  - (61)** . Pinion bearing pre-load adjustment shim.
  - (62)** . Dust Seal.
  - (63)** . Seal.
  - (64)** . Differential unit retaining ring nut.
  - (65)** . Thrust washer preventing pinion ring nut from unscrewing.
  - (66)** . Rear axle support bushing.
  - (67)** . Rear axle support thrust washer.
  - (68)** . Pinion bearing pre-load adjustment spacer.
  - (69)** . Pinion support bearings.
  - (70)** . Crown wheel.
  - (71)** . Differential unit cage.
  - (72)** . Planet thrust washers.
  - (73)** . Planet and sun gear teeth clearance adjustment shims.
  - (74)** . Sun gear.
  - (75)** . Differential unit support bearings.
  - (76)** . Differential unit positioning ring nut.
  - (77)** . Ring nut retaining grub screw.
  - (78)** . Bearing support cap.
  - (79)** . Grub screw retaining pin 80.
  - (80)** . Planet gear journal retaining pin.
  - (81)** . Planet gear pin.
  - (82)** . Planet gears.
  - (83)** . Differential unit position adjustment shim.
  - (84)** . Differential carrier right bearing retaining circlip.
  - (85)** . Differential lock cylinder / casing retaining screw.
  - (86)** . Metal disc keyed onto differential casing.
  - (87)** . Sun gear.
  - (88)** . Differential cage half shell retaining bolt.
  - (89)** . Planet gear pin.
  - (90)** . Planet gears.
  - (91)** . Differential cage.
  - (92)** . Pin retainer **(89)** .
  - (93)** . Friction disc keyed onto sun gear.
  - (94)** . Friction disc keyed onto sun gear.
-

(42) . Steering cylinder coupling.

## Axle support - Sectional view

Approximate cross-sectional view for correctly fitting the axle support to the engine

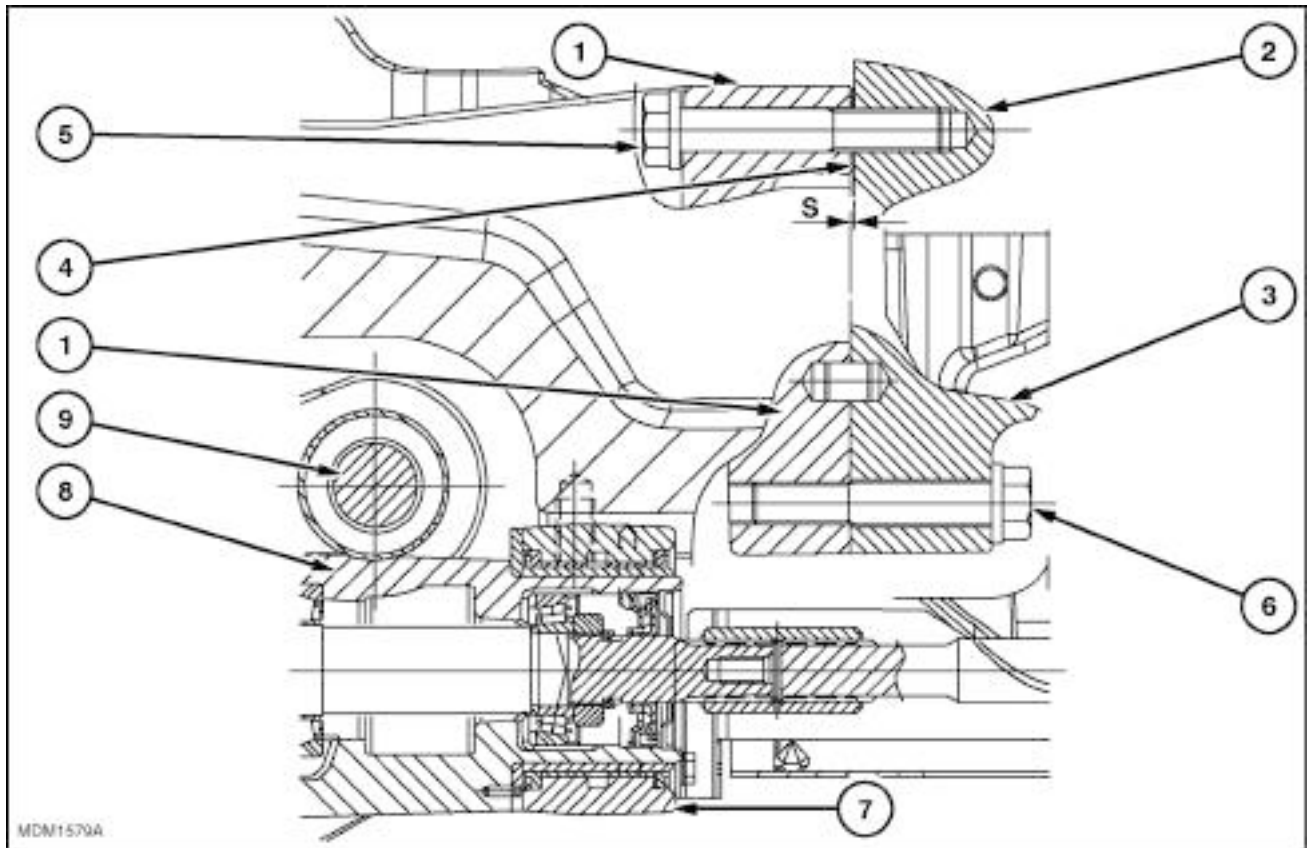

SEZ25CAP1F-4 1

- (1). Front axle support.
- (2). Crankcase front surface.
- (3). Engine sump front surface.
- (4). Shim.
- (5). Axle support to crankcase retaining bolt.
- (6). Sump to axle support retaining bolt.
- (7). Rear axle retaining bracket.
- (8). Differential support.
- (9). Steering cylinder.

## Four-Wheel Drive (4WD) axle - Disassemble 4 WD

**NOTE:** Front axle overhaul operations must be carried out on the stand.

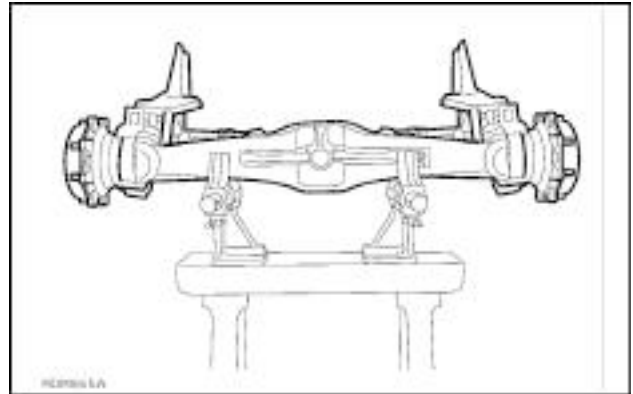

SEZ25CAP1A-13 1

1. Take out the three bolts (1) retaining the mudguard support (2).

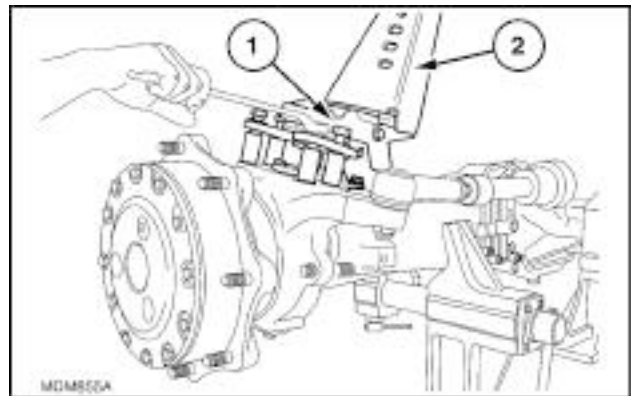

SEZ25CAP1A-14 2

2. Remove the plug and drain the oil from the axle casing.

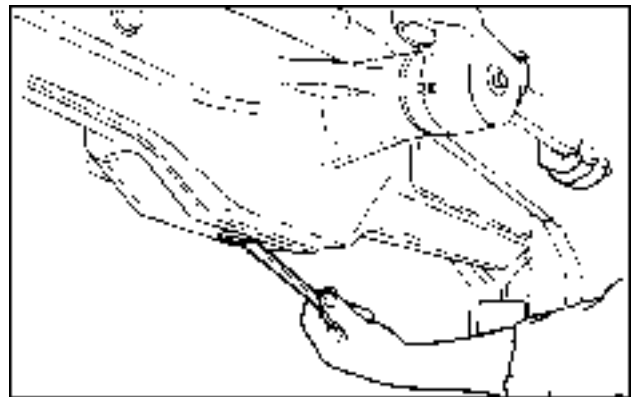

WLAPL4S25C115A 3

3. Remove the plug (1) from the left-hand epicyclic final drive casing; repeat the same operation on the right-hand casing.

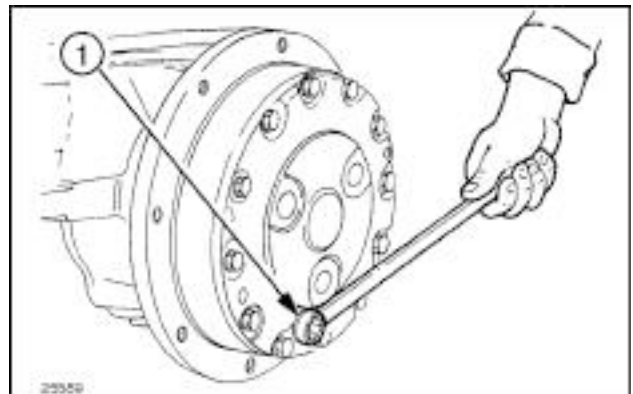

SEZ25CAP1A-16 4

4. Remove the nuts **(1)** locking steering heads on stub axles.

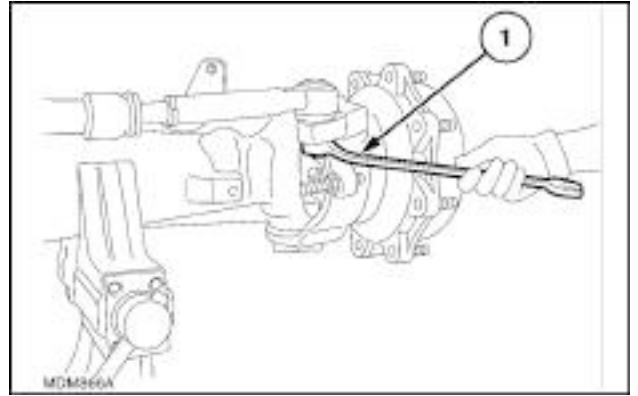

SEZ25CAP1A-17 5

5. Using an extractor, extract the steering heads from the seats on the stub axle housings.
6. Extract the steering heads governing the stub axles, on both sides.

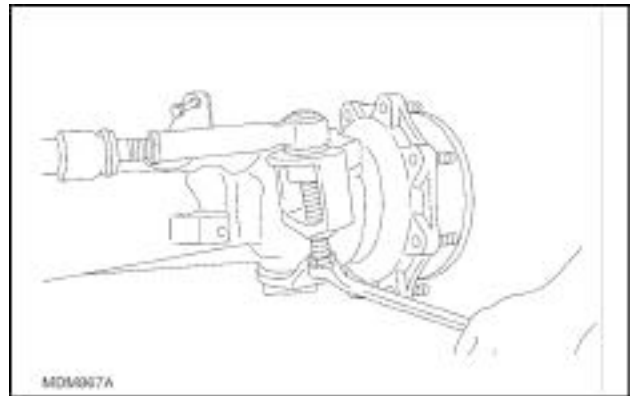

SEZ25CAP1A-18 6

7. Take out the power steering pipe bracket retaining bolt **(1)**, remove the related unions and extract them. Remove the front axle rear support **(2)**; remove the front support and washer.

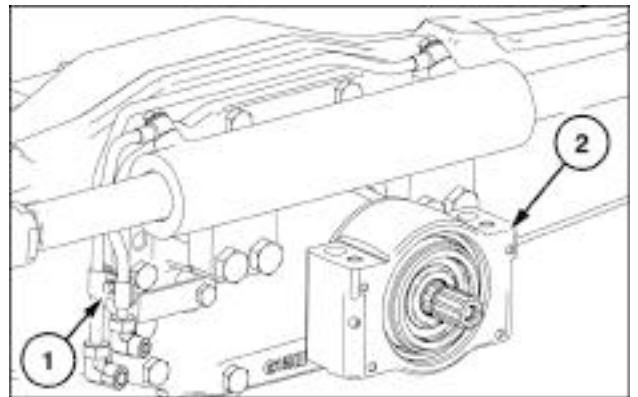

WLAPL4S25C119A 7

8. Take out the four bolts retaining the steering cylinder **(1)** then remove it.

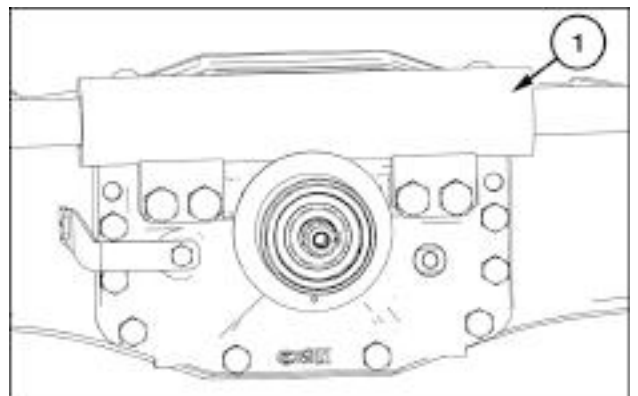

WLAPL4S25C120A 8



9. Take out the bolts (1) securing the left-hand final drive cover. Tighten two pins (2) and, using an extracting tool screwed into the oil drainage plug hole, remove the cover (1) .

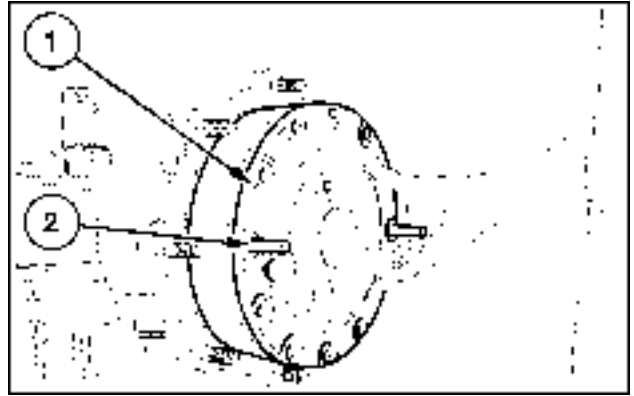

WLAPL4S25C121A 9

10. Remove the notching (1) on the ring nut (2) retaining the wheel hub bearings.

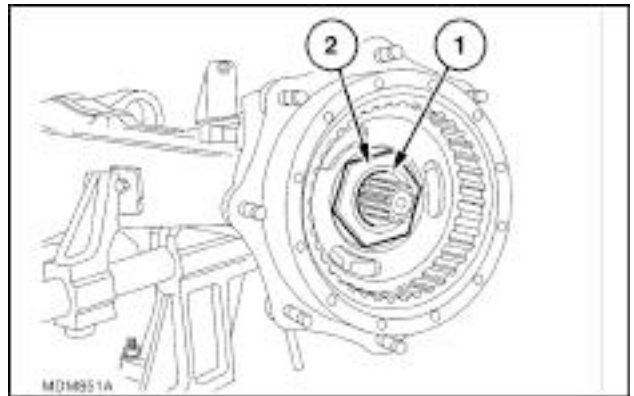

SEZ25CAP1A-25 10

11. Remove the lock nut on the wheel hub bearings using wrench 380000269 (1).

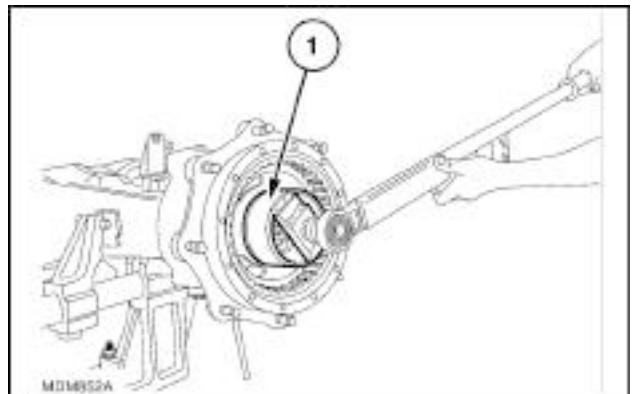

SEZ25CAP1A-26 11

12. Remove the wheel hub (1) together with the epicyclic crown (2) and recover the disassembled parts.

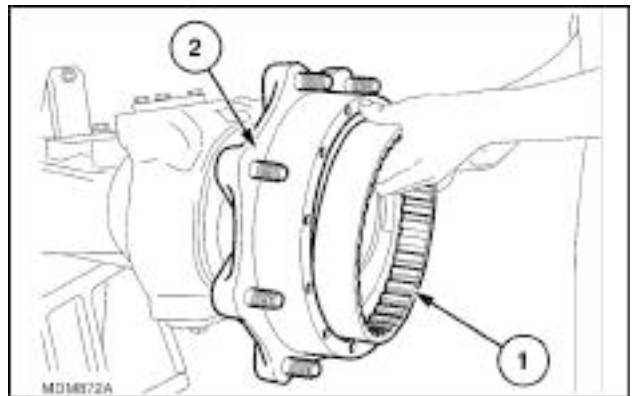

SEZ25CAP1A-27 12

13. Take out the three upper pin retaining bolts (1) take out those of the lower pin and retrieve the shims.

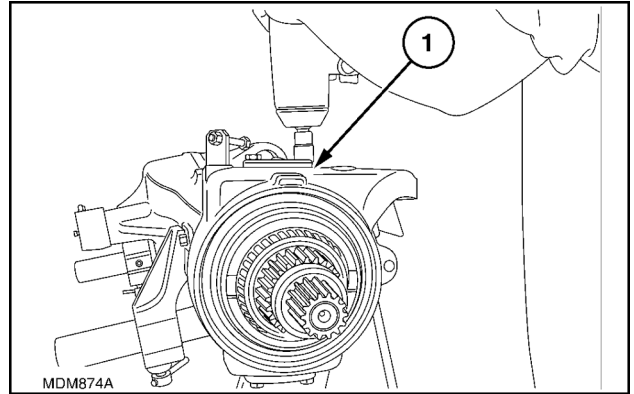

MDM874A

SEZ25CAP1A-28 13

14. Extract the upper pivot pin (1) as well as the lower one and remove the stub axle. Recover all disassembled parts.

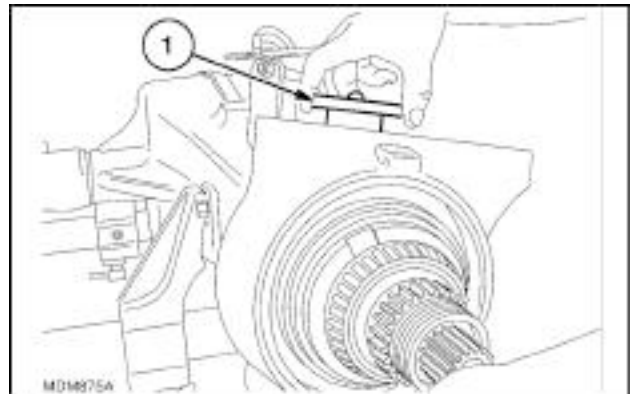

MDM875A

SEZ25CAP1A-29 14

15. Unscrew the locknut then take out the axle shaft support bushing retaining bolt.

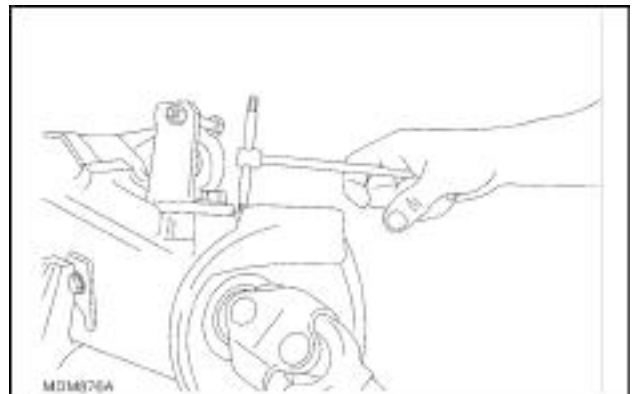

MDM876A

SEZ25CAP1A-30 15

16. Using a crowbar, remove the axle shaft (1).
17. To disassemble the right-hand final drive follow the operations carried out for left-hand final drive disassembly, from 9 to 17 .

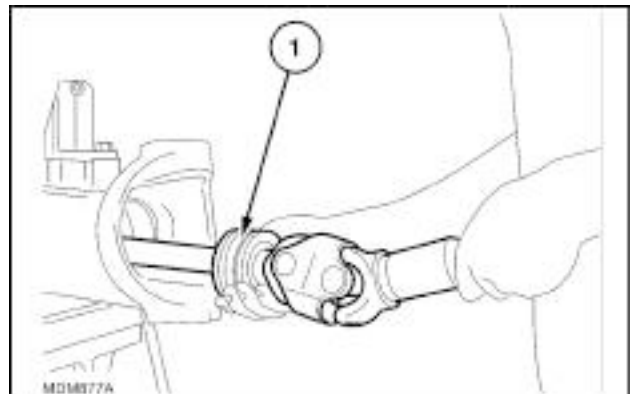

MDM877A

SEZ25CAP1A-31 16

18. Unscrew the two bevel drive-differential support retaining bolts from the axle casing, screw in two guide pins.

Remove the remaining bolts and the bevel drive-differential support (1), attach a chain and put the hoist under strain.

Remove the bevel drive-differential support from the axle casing.

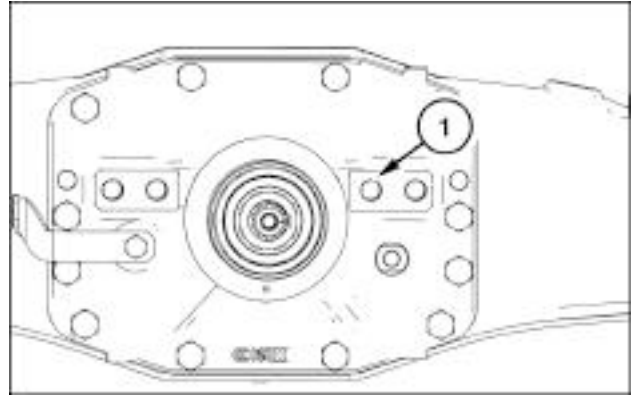

WLAPL4S25C129A 17

19. Mount the unit in the vice. From the back of the differential unit, remove the propeller shaft thrust circlip, dust plate (1) and oil seal from the pinion stem.

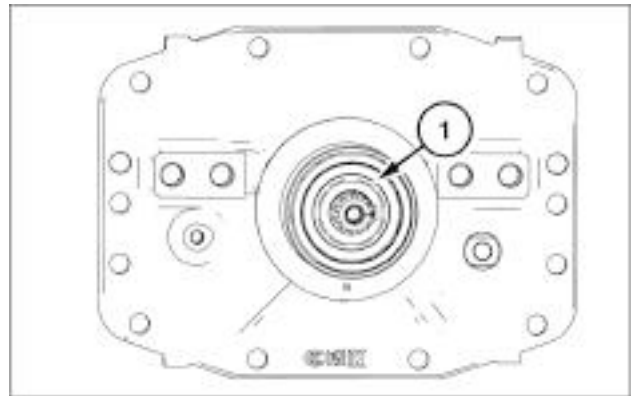

WLAPL4S25C130A 18

20. Remove the rigid coupling for introducing oil into the differential lock (1).

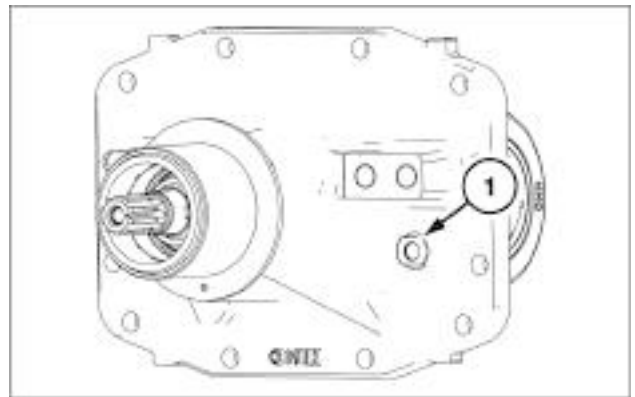

WLAPL4S25C131A 19

21. Replace two screws of the differential lock actuator unit (select the ones diametrically opposite) with two screws at least **70 mm (2.76 in)** long; set them at least 5 turns. Unscrew the others by a few turns alternately so as to allow stretching out the differential release spring, then remove both these and the two long ones. Remove the differential lock actuator unit.

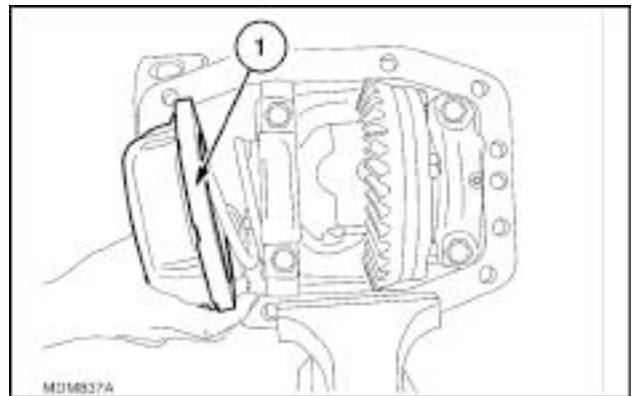

SEZ25CAP1A-36 20

**NOTE:** It is necessary to install two bolts with a minimum length of **70 mm (2.76 in)** because the normal bell housing bolts are not long enough to allow the spring to extend to its full free length.

22. Using a screwdriver, remove the circlip (1) and the differential lock sleeve keyed onto the differential casing.

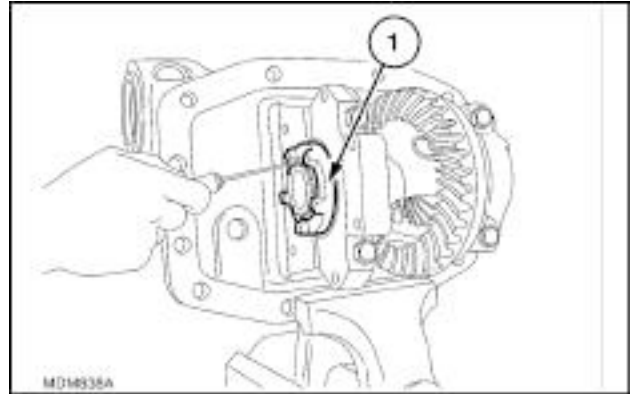

SEZ25CAP1A-37 21

23. Using an Allen wrench remove the right ring nut lock screw (1); using pliers, remove the circlip on the left bearing support.

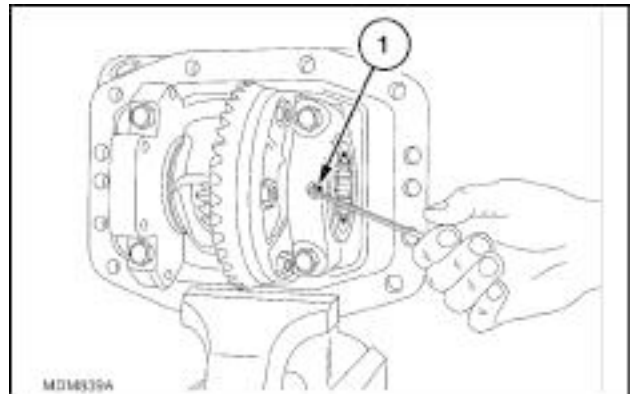

SEZ25CAP1A-38 22

24. Take out the bolts (1) retaining the bevel crown wheel-differential support caps and remove them.

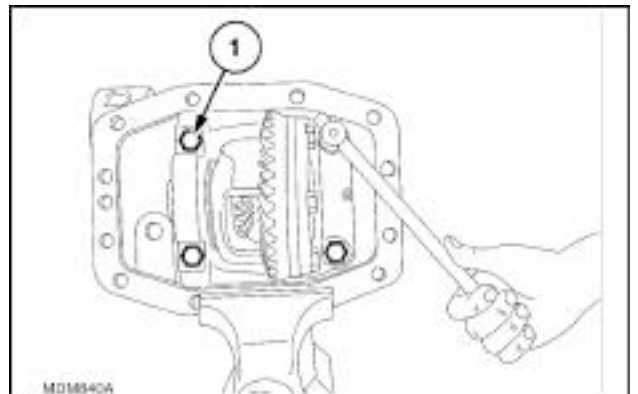

SEZ25CAP1A-39 23

25. Remove the crown wheel-differential unit (1) from the casing, retrieve the races of the bearings and the right shim.

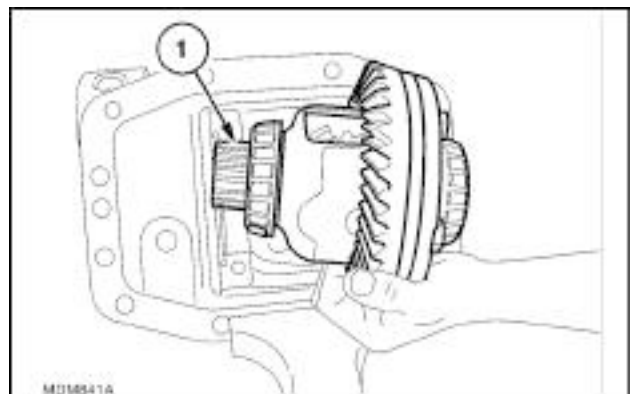

SEZ25CAP1A-40 24

26. Remove the securing ring on the pinion ring nut. Take off the ring nut with wrench **380000268 (1)** keeping the bevel pinion shaft locked with wrench **380000257 (2)**. Remove the pinion together with the front bearing, rear bearing, bearing preload adjuster shim, spacer and the thrust washer preventing the ring nut from unscrewing.

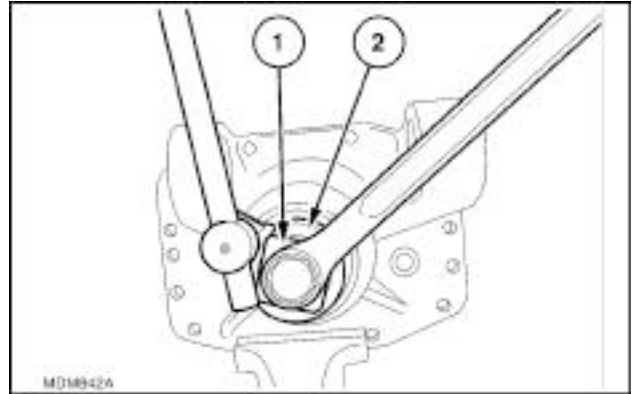

---

## Four-Wheel Drive (4WD) axle - Assemble 4 WD

1. Refer to the illustrations on **Front bevel gear set and differential - Sectional view (25.102)**, figures 1 and 2, for the positioning of the various parts.
2. Respect the tightening torques prescribed (see **Powered front axle - Torque (25.100)** ).
3. Carry out the adjustments described in **Bevel gear set and differential carrier - Adjust (25.102)** , **Bevel gear set and differential carrier - Adjust Ring/Pinion Gears (25.102)** , **Steering knuckle and king pin - Adjust (25.108)** .
4. Secure the ring nut, fit the seal, dust ring and propeller shaft sleeve thrust ring on the back of the bevel pinion.

**NOTE:** To mount the sunken oil seal use the tool **380200041**, for the dust cup use tool **380200042**.

5. Mount the differential lock sleeve ( **60**), **Front bevel gear set and differential - Sectional view (25.102)** figure 1) and the stop ring.
6. Mount the differential lock actuator unit together with the spring ( **50**), **Front bevel gear set and differential - Sectional view (25.102)** figure 1) and secure it with the 2 screws size **70 mm (2.76 in)**, tighten the other bolts then replace the two long ones with those of normal use.
7. Mount the rigid pipe for delivering oil to the differential lock (**58**) **Front bevel gear set and differential - Sectional view (25.102)** figure 1.
8. Install the bevel drive--differential support to the front axle housing applying sealing compound of diameter approximately **2 mm (0.08 in)** mount the differential lock outside pipe.
9. Fit the axle shaft and screw.
10. Fit the stub axle, the adjustment shims, the upper and lower pivot pins.
11. Fit the wheel hub, final drive crown wheel and ring nut and tighten to the prescribed torque whilst rotating the hub to settle the bearings.
12. Fit the final drive cover.
13. Fit the front and rear supports and the oil drainage plugs.
14. Mount the steering cylinder, secure it with the relevant screws and tighten them.
15. Then reposition the power steering pipes.
16. Inset the steering head on the stub axles then insert the lower nut and secure it.
17. Mount the hoses to the rigid pipes of the power steering, fill up with oil then secure the filler caps.
18. Mount the differential lock system pipes.
19. Fit the front mudguard supports.
20. Check the toe-in.

## Axle support - Adjust

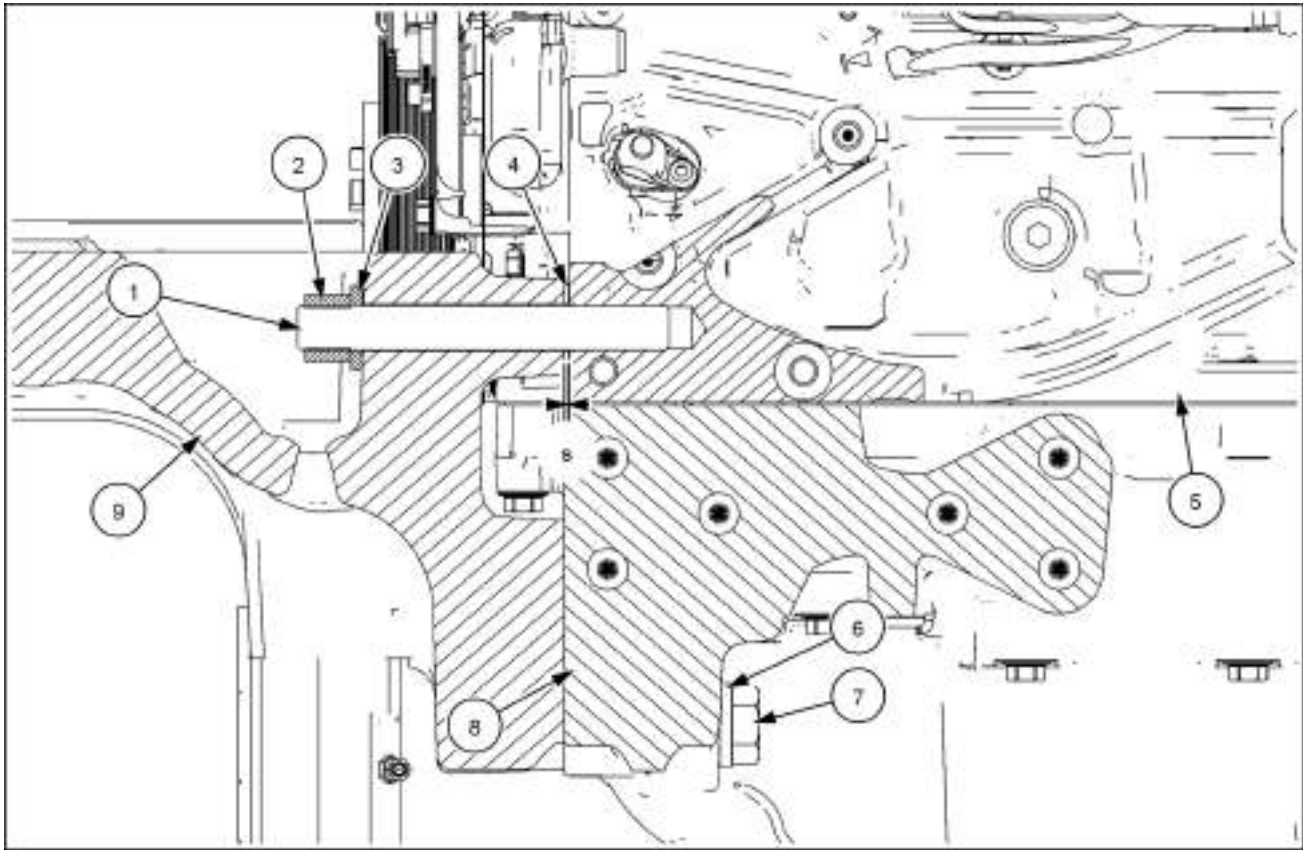

SS14B018 1

1. Use a depth gauge to measure the distance (**s**) between the engine oil pan (**8**) and the engine block (**5**).
2. Use the measured distance to select the correct shims (**4**) in the table.

Distance (s)	Shim (4)	Spare part number
1.300 - 1.500 mm (0.051 - 0.059 in)	1.600 mm (0.063 in) (black)	47136468
1.510 - 1.700 mm (0.059 - 0.067 in)	1.800 mm (0.071 in)(Yellow)	47128135
1.710 - 1.900 mm (0.067 - 0.075 in)	2.000 mm (0.079 in)(Red)	47128136
1.910 - 2.100 mm (0.075 - 0.083 in)	2.200 mm (0.087 in)(Green)	47128137
2.110 - 2.300 mm (0.083 - 0.091 in)	2.400 mm (0.094 in)(blue)	47128138

3. Position the shims (**4**) on the stud bolts (**1**).
4. Fit the front axle support (**9**).
5. Fit the shims (**3**) and the nuts (**2**).
6. Fit the bolts (**7**) with the shims (**6**).
7. Torque the nuts (**2**) to **450 N·m (332 lb ft)**.
8. Tighten the bolts (**6**) to a torque of **600 N·m (443 lb ft)**.

# Index

---

## Front axle system - 25

### Powered front axle - 100

Axle support - Adjust .....	26
Axle support - Sectional view .....	17
Four-Wheel Drive (4WD) axle - Assemble 4 WD .....	25
Four-Wheel Drive (4WD) axle - Disassemble 4 WD .....	18
Four-Wheel Drive (4WD) axle - Sectional view .....	12
Powered front axle - Special tools .....	5
Powered front axle - Static description .....	11
Powered front axle - Torque .....	3







## **Front axle system - 25**

### **Front bevel gear set and differential - 102**

**Farmall 105U Pro EP  
Farmall 115U Pro EP  
Farmall 95U Pro EP**

# Contents

---

## Front axle system - 25

### Front bevel gear set and differential - 102

#### TECHNICAL DATA

Differential	
General specification .....	3
Limited slip differential	
General specification .....	4
Differential lock	
General specification .....	5

#### FUNCTIONAL DATA

Limited slip differential	
Sectional view .....	6
Static description .....	7
Differential lock	
Static description .....	8

#### SERVICE

Bevel gear set and differential carrier	
Adjust Ring/Pinion Gears .....	10
Adjust .....	13
Differential	
Overhaul .....	16
Limited slip differential	
Overhaul .....	17
Differential lock	
Dog clutch - Overhaul .....	20

#### DIAGNOSTIC

Differential lock	
Troubleshooting .....	22

## Differential - General specification

### Bevel drive -- differential

Type	steering, load bearing structure, pivoting at centre
Pinion-crown gear ratio: - all models	13/36 = 1:2.77
Backlash between bevel drive teeth: - all models	<b>0.15 - 0.20 mm (0.006 - 0.008 in)</b>
Thickness of bevel pinion bearing adjustment rings ( <b>(61)</b> , <b>Front bevel gear set and differential - Sectional view (25.102)</b> figure 1)	<b>2.50 mm (0.098 in) - 2.55 mm (0.100 in) - 2.60 mm (0.102 in) - 2.65 mm (0.104 in) - 2.70 mm (0.106 in) - 2.75 mm (0.108 in) - 2.80 mm (0.110 in) - 2.85 mm (0.112 in) - 2.90 mm (0.114 in) - 2.95 mm (0.116 in) - 3 mm (0.118 in) - 3.05 mm (0.120 in) - 3.10 mm (0.122 in) - 3.15 mm (0.124 in) - 3.20 mm (0.126 in) - 3.25 mm (0.128 in) - 3.30 mm (0.130 in) - 3.35 mm (0.132 in) - 3.40 mm (0.134 in) - 3.45 mm (0.136 in) - 3.50 mm (0.138 in) - 3.55 mm (0.140 in) - 3.60 mm (0.142 in) - 3.65 mm (0.144 in) - 3.70 mm (0.146 in) - 3.75 mm (0.148 in) - 3.80 mm (0.150 in) - 3.85 mm (0.152 in) - 3.90 mm (0.154 in) - 3.95 mm (0.156 in) - 4 mm (0.157 in) - 4.05 mm (0.159 in) - 4.10 mm (0.161 in) - 4.15 mm (0.163 in) - 4.20 mm (0.165 in) - 4.25 mm (0.167 in) - 4.30 mm (0.169 in) - 4.35 mm (0.171 in) - 4.40 mm (0.173 in) - 4.45 mm (0.175 in) - 4.50 mm (0.177 in) - 4.55 mm (0.179 in) - 4.60 mm (0.181 in) - 4.65 mm (0.183 in) - 4.70 mm (0.185 in) - 4.75 mm (0.187 in) - 4.80 mm (0.189 in)</b>
Thickness of bevel crown wheel position adjustment rings ( <b>(83)</b> , <b>Front bevel gear set and differential - Sectional view (25.102)</b> figure 1) (version with differential lock)	<b>0.9 mm (0.035 in) - 1 mm (0.039 in) - 1.1 mm (0.043 in) - 1.2 mm (0.047 in) - 1.3 mm (0.051 in) - 1.4 mm (0.055 in) - 1.5 mm (0.059 in) - 1.6 mm (0.063 in) - 1.7 mm (0.067 in) - 1.8 mm (0.071 in) - 1.9 mm (0.075 in) - 2 mm (0.079 in)</b>
Clearance ( gn ) between sides of sun and planet pinion teeth	<b>0.12 - 0.18 mm (0.0047 - 0.0071 in)</b>
Endfloat ( ga ) of the sun gears such as to determine ( gn)	<b>0.2 - 0.3 mm (0.0079 - 0.0118 in)</b>
Thickness of sun pinion thrust washers ( <b>(73)</b> , <b>Front bevel gear set and differential - Sectional view (25.102)</b> figure 1)	<b>1.4 mm (0.055 in) - 1.5 mm (0.059 in) - 1.6 mm (0.063 in) - 1.7 mm (0.067 in) - 1.8 mm (0.071 in) - 1.9 mm (0.075 in) - 2 mm (0.079 in)</b>

## Limited slip differential - General specification

### LIM--SLIP self--locking differential

Friction disc, keyed on side gear ( <b>94</b> ), <b>Front bevel gear set and differential - Sectional view (25.102)</b> : - quantity - thickness - maximum wear	2 <b>2.8 mm (0.11 in)</b> <b>0.10 mm (0.004 in)</b>
Friction disc, keyed on side gear ( <b>93</b> ), <b>Front bevel gear set and differential - Sectional view (25.102)</b> : - quantity - thickness - maximum wear	8 <b>1.6 mm (0.06 in)</b> <b>0.15 mm (0.006 in)</b>
Metal disc, keyed on differential casing ( <b>86</b> ), <b>Front bevel gear set and differential - Sectional view (25.102)</b> : - quantity - thickness	10 <b>1.5 mm (0.06 in)</b>

## Differential lock - General specification

Type	With front gears
Operation	By means of two front teeth gears, one integral with the right axle shaft the other integral with the differential cage
Control	Controlled by the control unit of the gearbox / lift
Operation	Electro-hydraulic, it is switched on simultaneously with the rear one by means of a button located on the operator's right-hand side

## Limited slip differential - Sectional view

LIM--SLIP self--locking differential.

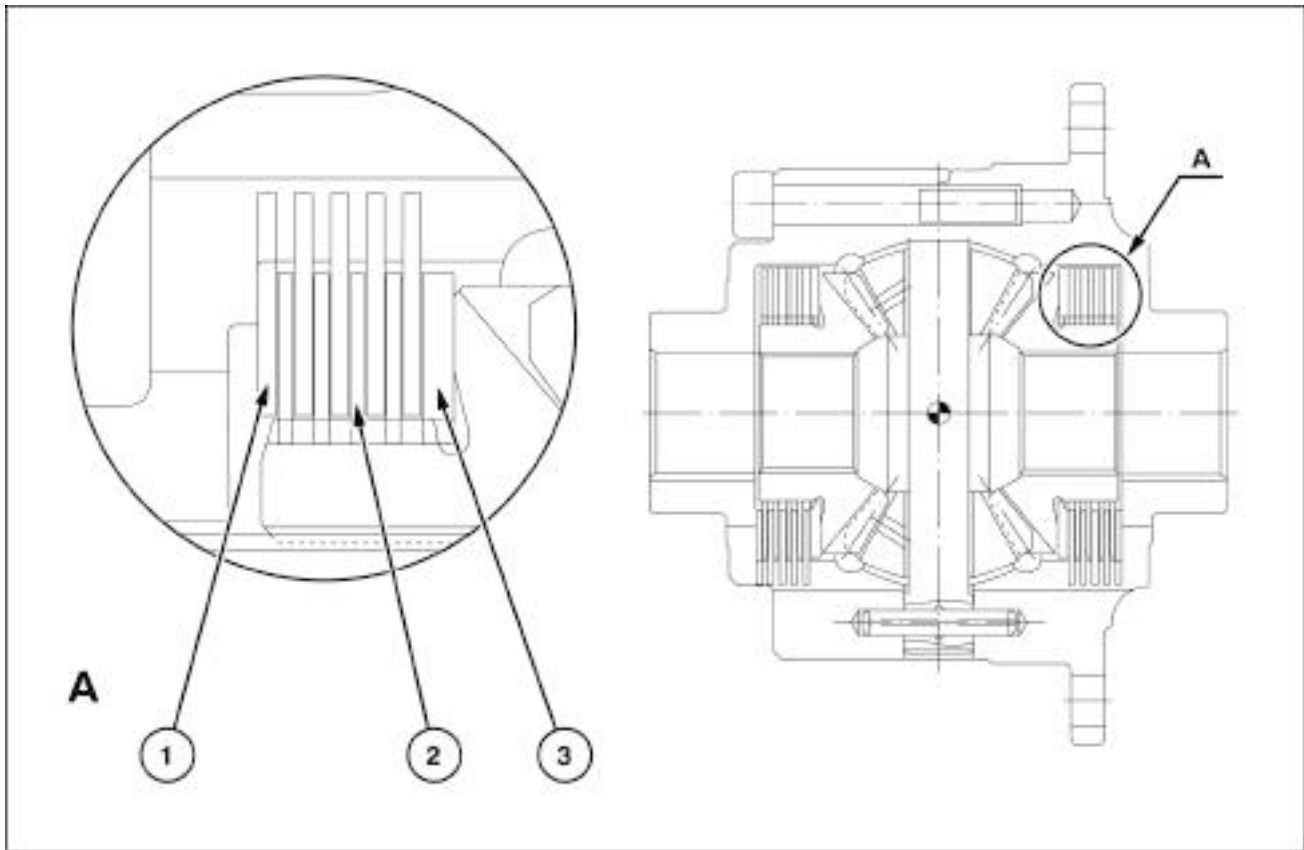

WLAPL4S25C101F 1

- (1). Metal disc keyed onto differential casing.
- (2). Friction disc keyed onto side gear.
- (3). Friction disc keyed onto side gear.

## Limited slip differential - Static description

### LIM--SLIP self locking differential operation

The differential with limited--slip locking ( LIM-SLIP ), (see **Front bevel gear set and differential - Sectional view (25.102)**, detail **(F)** and **(G)**, **Limited slip differential - Sectional view (25.102)** ) is of the two planet gear--type, provided with two multi--disk clutch assemblies fitted between the side gears and the differential casing. This differential lock device is totally automatic, requires no manual operation and notably reduces (without completely eliminating) wheel slipping that may result from tractor grip loss.

The difference in revolutions, between the sun gears and the differential casing when a wheel begins to slip as a result of grip loss, is impeded by clutch assemblies that are compressed by axial thrusts from the bevel drive torque transmitted to the sun gears by means of the teeth on the two planet gears.

These torque values may be different, according to the nature of the ground and the route followed by the tractor, and may vary in intensity thereby proportionally determining the axial stress on the clutches, allowing the sun gears to mesh with the differential casing which, in turn, permits the axle to overcome the unevenness of the ground.



## Differential lock - Static description

### Front differential lock

In rest conditions the oil inside the annular chamber of the piston **(1)** is static and not pressurized as the relative solenoid valve is in the discharge position (not energized). In these conditions, the helical spring **(2)** keeps the teeth of the two coupling sleeves of the differential lock apart.

**A** : Front differential lock disengaged

**B** : Front differential lock engaged

Front axle system - Front bevel gear set and differential

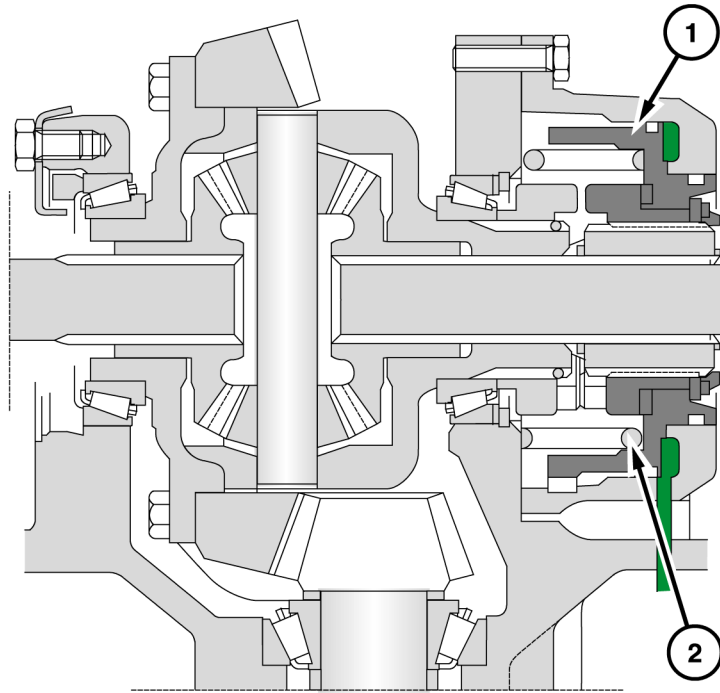

A

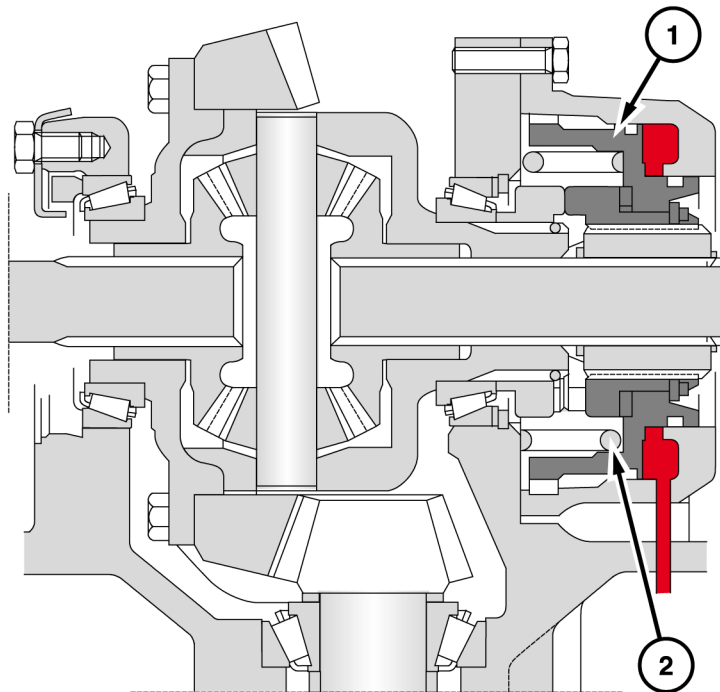

B

WLAPL4S25C107H 1

 : Discharge oil

 : Pressurized oil

## Bevel gear set and differential carrier - Adjust Ring/Pinion Gears

### Adjusting the bevel pinion shaft bearing preload with shims ( (61) Front bevel gear set and differential - Sectional view (25.102) )

**NOTE:** Refer to (84), *Front bevel gear set and differential - Sectional view (25.102)* .

- Use the tool to be made in the workshop, of drawing **Powered front axle - Special tools (25.100)** . Mount the bush on the screw of this tool in the inner race of the pinion rear support bearing supporting, the spacer ( (68) , **Front bevel gear set and differential - Sectional view (25.102)** ) and the race of the front support bearing with the relevant bush, as shown in the figure. Position the end of the two bushes inside the spacer so as to center the latter too.  
Screw the relevant nut on the end of the screw, keeping its machined part facing towards the end.  
Once all the surfaces inside the tool are in contact; using a depth caliper or a micrometer make the measurement ( **L** ) , between the end of the screw and the face beneath the nut, for a more exact measurement, make three measurements at **120°** then calculate the average.
- Remove it all and reassemble the tool with the two bushes and related bearings, on the differential support, without the spacer as shown in the figure.  
Also in this case, screw on the nut keeping the machined part on the outside.

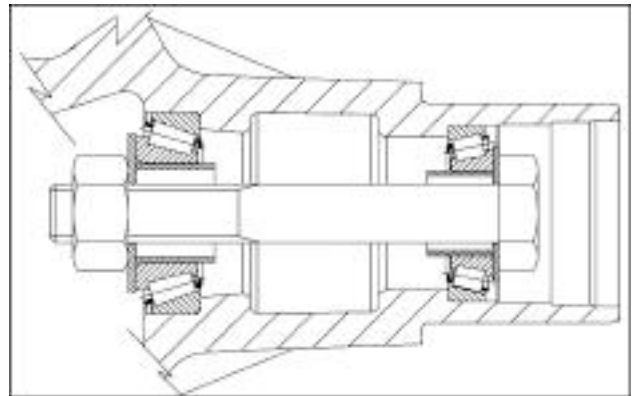
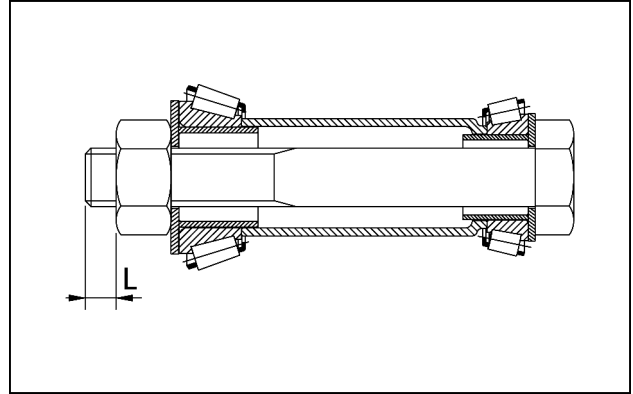

Using a wrench ( **1** ) and an appropriate bush ( **2** ) for the screw and another wrench to keep the nut stationary, tighten the nut ensuring the bearings settle.

**NOTE:** During these operations certain that the bearings settle. Tighten the ring nut in successive stages, turning the pinion between each stage.

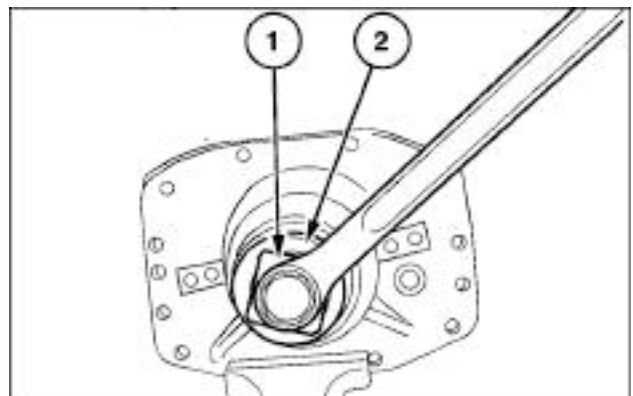

3. Tighten the ring nut to reach a rolling torque **0.49 - 0.98 N·m (0.36 - 0.72 lb ft)** (0.05 to 0.1 kgm), measured with the torque wrench (1), without considering the break-out torque.

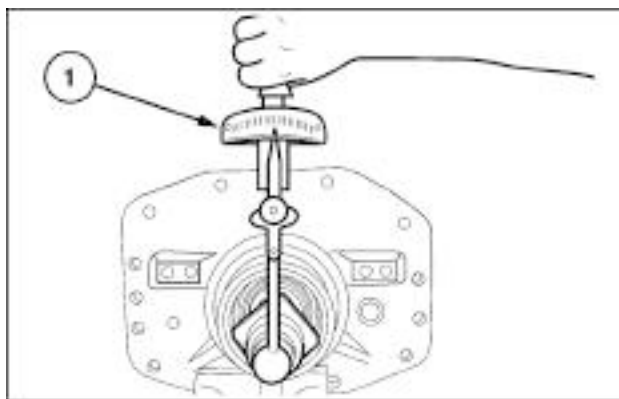

WLAPL4S25C173A 4

4. Measure the distance (L1) from the end of the screw to the face of the bolt beneath, also in this case, for a more precise measurement, make three readings at **120°** then calculate the average. The bearing pre-load adjustment shim S (61), **Front bevel gear set and differential - Sectional view (25.102)** will be:  $S = (L) - (L1) + 0.05 \text{ mm (0.0020 in)}$

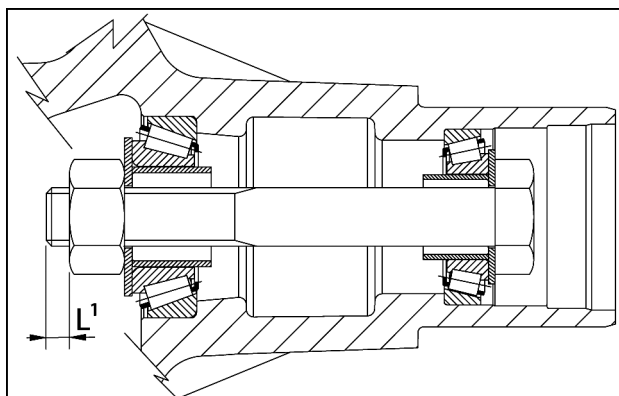

WLAPL4S25C174A 5

5. With the wrench (1) and the relevant bush (2), remove the tool.

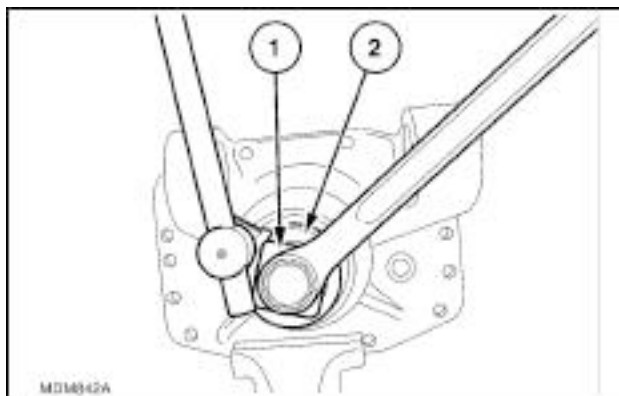

SEZ25CAP1A-74 6

6. Refit the pinion on the support complete with the bearings, spacer, thrust washer (65), **Front bevel gear set and differential - Sectional view (25.102)** of the adjustment shim (61), **Front bevel gear set and differential - Sectional view (25.102)**, keeping it still with the tool 380000257 (1), then tighten the ring nut with the tool 380000268 (2).

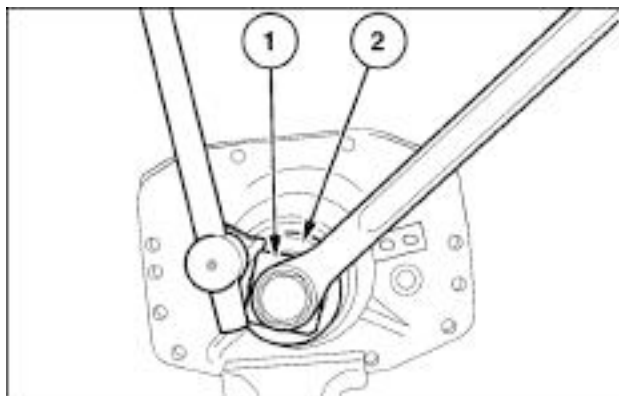

WLAPL4S25C137A 7

7. Tighten the ring nut to a torque of **382.5 N·m (282.12 lb ft)** (39 Kgm) ensuring the bearings bed in. Then check again that the rolling torque is:  
A1 <= **0.49 N·m (0.36 lb ft)** (0.05 kgm) without considering the break-out torque. Select a thinner shim if the torque is greater otherwise select one with a greater thickness if it is less

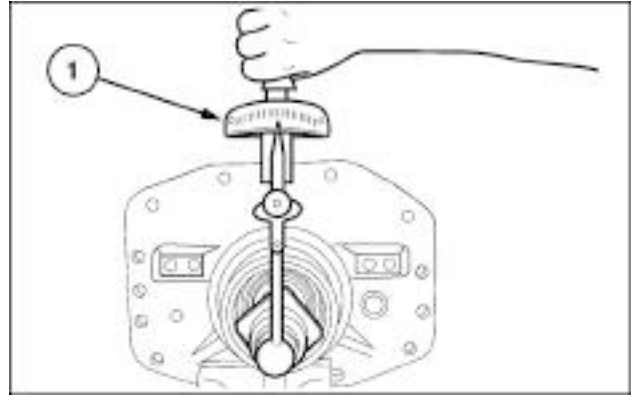

WLAPL4S25C173A 8

## Bevel gear set and differential carrier - Adjust

### Pinion and crown wheel

#### Adjusting the bevel crown wheel bearings and checking the clearance between the sides of the bevel drive teeth.

1. Fit the differential unit on the differential bevel drive support together with the bevel drive complete with bearings ( **75**), **Front bevel gear set and differential - Sectional view (25.102)** figure 1) and, on the right-hand side, bearing adjustment ring ( **83**), **Front bevel gear set and differential - Sectional view (25.102)** figure 1) Sp , after measuring it.

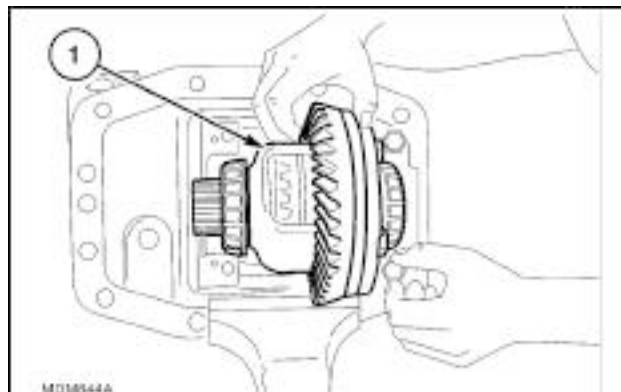

SEZ25CAP1A-75 1

2. Install the differential casing support caps, tighten the relative bolts to a torque value of **59 - 108 N·m (43.52 - 79.66 lb ft)** (6 to 11 kgm), then loosen and re-tighten to a torque of **20 N·m (14.75 lb ft)** (2 kgm). Mount the adjuster shim ( **83** ), **Front bevel gear set and differential - Sectional view (25.102)** figure 1) size **3 mm (0.1181 in)** and the relevant retaining circlip on the right-hand side.

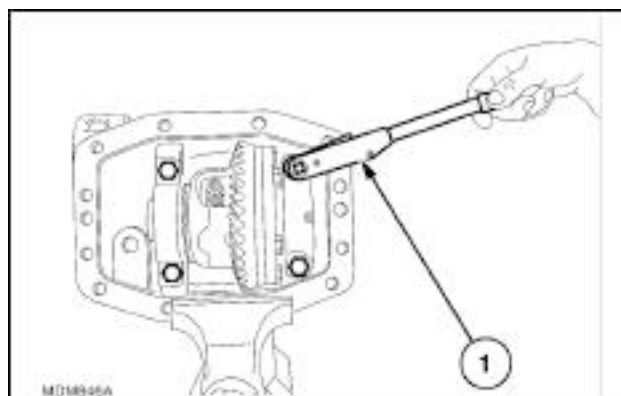

SEZ25CAP1A-76 2

3. With the bearings perfectly lubricated, rotate the crown wheel and, at the same time, tighten the ring nut, on the left-hand side, using wrench **380000252 (1)** to a torque value of **49 N·m (36.14 lb ft)** (5 kgm) to take up the axial play between the components.

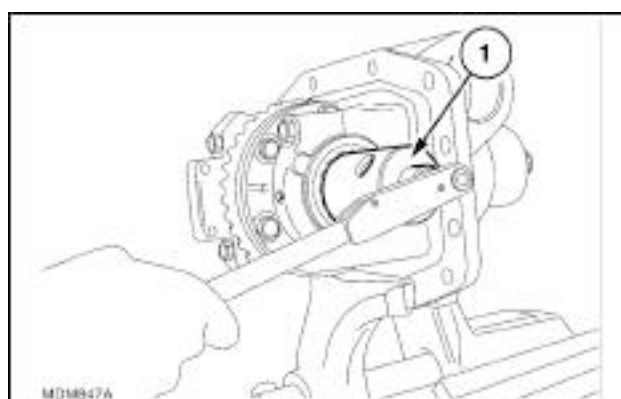

SEZ25CAP1A-77 3

4. Measure the backlash between pinion and crown wheel, using a 1/100 dial gauge (1) perpendicular to the outer edge of a tooth on the ring gear. Repeat the measurement in a further two positions **120°** apart and calculate the average of the three values ( Gm ). Define the shim Sc to fit in place of the one of **3 mm (0.1181 in)** , that is such as to produce a greater clearance between the teeth than the intended maximum.  
 $S = 3 - ( Gm \times 1.34)$

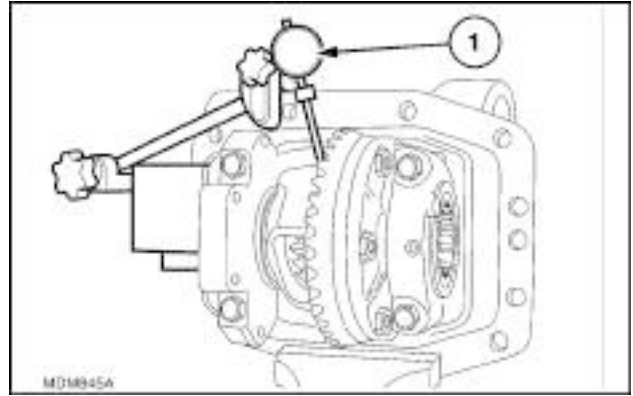

SEZ25CAP1A-78 4

5. Fit a shim ( 83), **Front bevel gear set and differential - Sectional view (25.102)** figure 1) of the calculated thickness and with a 1/100 scale dial gauge (1) positioned perpendicular to the outside edge of one of the crown wheel teeth, check that the backlash between the pinion and the crown wheel is within the prescribed tolerance limits **0.15 - 0.20 mm (0.006 - 0.008 in)**.

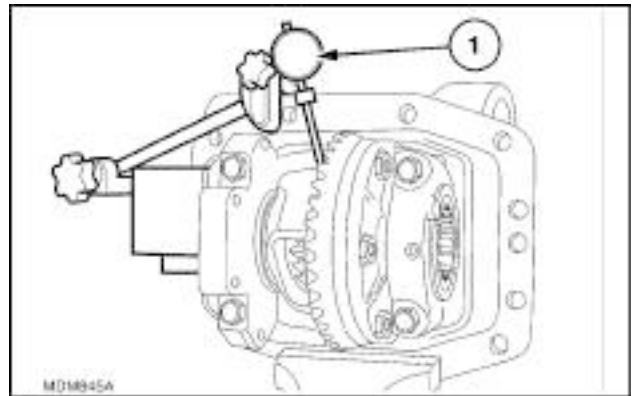

SEZ25CAP1A-78 5

6. Using wrench **38000257** adjust the ring nut and check, using torque wrench (1), that the rolling resistance torque of the crown wheel and pinion bearings, as measured in the same conditions used to check only the pinion, is:  
 $A2 = A1 + 1 - 1.5 \text{ N}\cdot\text{m} (8.85 - 13.28 \text{ lb in})$   
 , where:  
 A2 = pinion--crown wheel rolling resistance torque.  
 A1 = rolling resistance torque of pinion only, as previously measured.

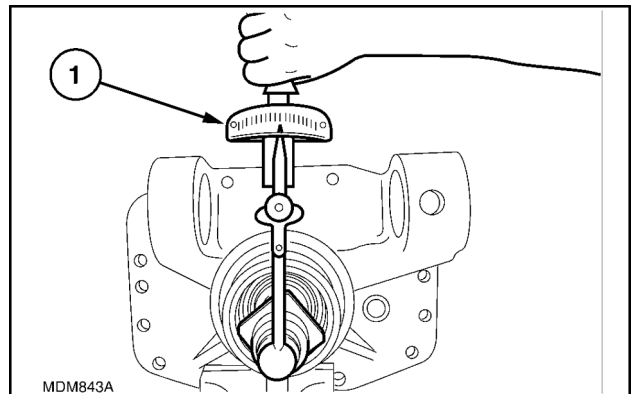

SEZ25CAP1A-80 6

7. Tighten the cap retaining bolts to a torque of **113 N·m (1000.13 lb in)**.  
 8. Fit the safety plate, screwing the adjustment ring nut in or out, to reach the nearest notch.  
 9. Attach the bevel drive--differential to the axle casing after having carefully cleaned and degreased the mating surfaces and apply sealing compound (approx. **2 mm (0.08 in)**) along the marked line shown in the drawing below.

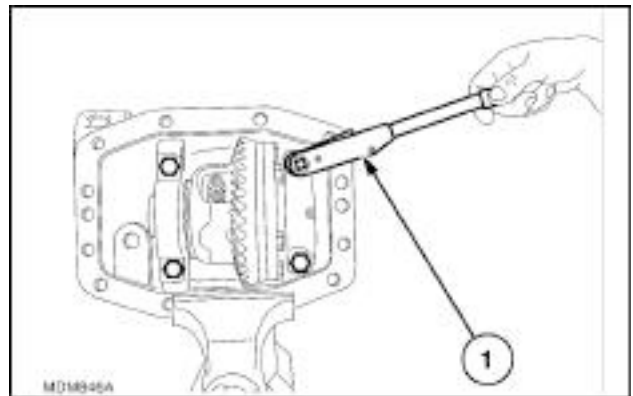

SEZ25CAP1A-76 7

**NOTE:** On Lim Slip version models measure the clearance between the teeth with the aid of the ring nuts, unscrewing one and screwing in the other, always recovering the clearance, to reach the prescribed value for the clearance: **0.15 - 0.20 mm (0.0059 - 0.0079 in)**

On reaching the prescribed clearance, use both ring nuts in an equal manner to reach the rolling resistance torque of the pinion - crown wheel:

$$A2 = A1 + 1 - 1.5 \text{ N}\cdot\text{m} \text{ (0.74 - 1.11 lb ft)} \text{ (0.10 to 0.15 kgm)}$$

**Sealing compound application diagram for assembly of bevel drive unit and epicyclic final drive unit.**

10. The types of sealing compounds to be applied are specified in **Basic instructions** ().

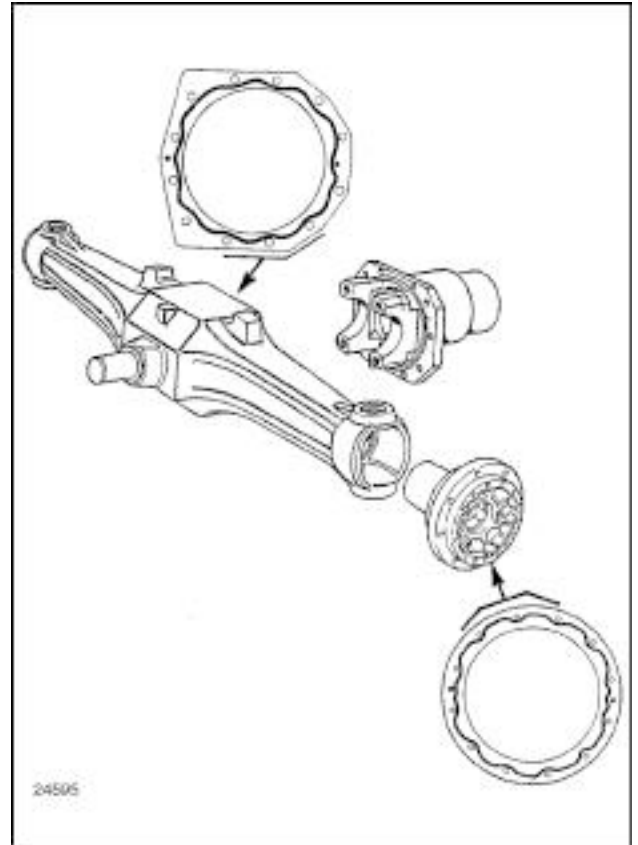



## Differential - Overhaul

### FRONT AXLE DIFFERENTIAL

**NOTE:** This procedure is to be considered valid for planet gears with  $Z1 = 12$  teeth and sun gears with  $Z2 = 20$  teeth and modulus  $m = 4.1$

**NOTE:** When overhauling the differential assembly it is necessary to adjust the backlash between the teeth of the planet pinions and the side gears.

1. Thoroughly clean the components of the differential to remove any traces of oil that would otherwise prevent accurate backlash measurement.
2. Fit the two sun gears without thrust washers on the differential casing.
3. Fit the planet pinions complete with thrust washers and pins and screw down the pin retaining bolts by a few turns to hold the pins in place.
4. Position a dial gauge on the differential housing.
5. Move the left-hand side gear to bring it into full contact with the planet pinion and then push it up against the differential housing, reading the end float (  $G_s$  ) on the micrometer.

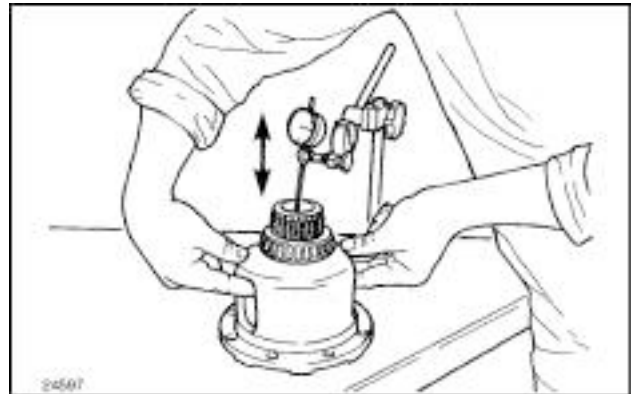

SEZ25CAP1A-42 1

6. Repeat the above operations to measure the end float on the right-hand side gear (  $G_d$  ).
  - The side gear end float will be **0.25 mm (0.010 in)**.
  - Therefore the rings to be inserted in the differential housing are given by:
    - $S_s = G_s - 0.25 \text{ mm (0.010 in)}$  for the left-hand sun gear;
    - $S_d = G_d - 0.25 \text{ mm (0.010 in)}$  for the right-hand sun gear.
7. Install shims as near as possible to the calculated value and, using a dial gauge and following the previously described procedure, check that the end float of the left- and right-hand sun gears is approximately **0.25 mm (0.010 in)**.



SEZ25CAP1A-43 2

**NOTE:** With an endfloat of  $g_a = 0.20 - 0.30 \text{ mm (0.0079 - 0.0118 in)}$  a clearance will be obtained between the teeth of  $g_n = 0.12 - 0.18 \text{ mm (0.0047 - 0.0071 in)}$  .

## Limited slip differential - Overhaul

### Front axle differential with LIM-SLIP unit

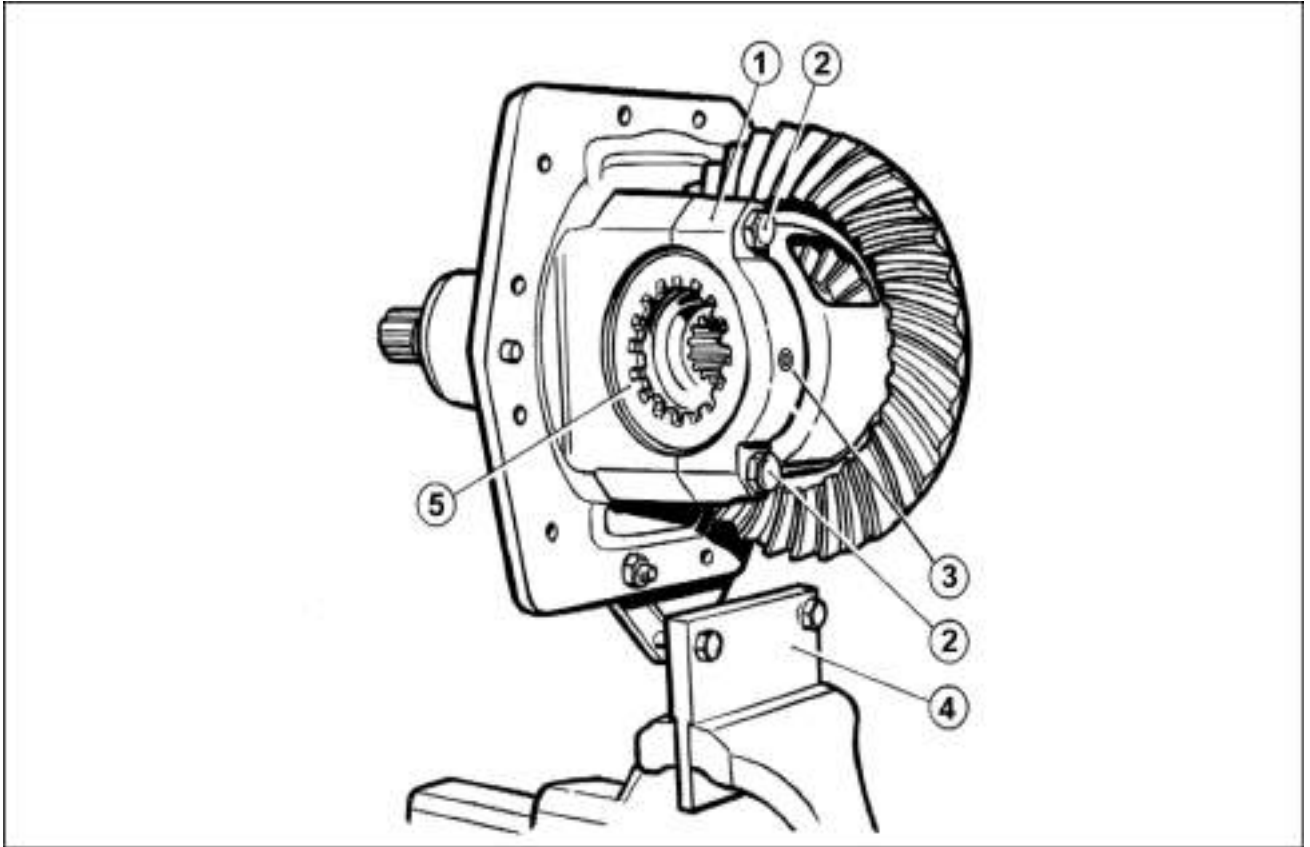

WLAPL4S25C102F 1

#### Front axle differential with LIM - SLIP

1. Remove the bevel drive--differential casing assembly from the front axle, attach to support (4), lock in a vice and proceed with disassembly operations as follows.
2. Take out the Allen screws (3) retaining the right (5) and left ring nuts.
3. Check that the right-- and left--hand caps (1) are marked so as not to interchange them during assembly.
4. Remove the right (5) and left--hand bearing adjustment ring nuts from the bevel crown wheel.
5. Take out the bolts (2) and caps (1) and separate the bevel crown wheel from the bevel pinion support.
6. If necessary, take out the retaining bolts (C9), **Powered front axle - Torque (25.100)** figure 2) and the bevel crown wheel.

Disassemble the LIM--SLIP self--locking differential lock as follows.

7. Remove the retaining bolts (6) from the differential half-casings.
8. Remove the differential pin (9), complete with the planet gears (7) the shims (8) and the retaining pin (2) from the half-casing (4).

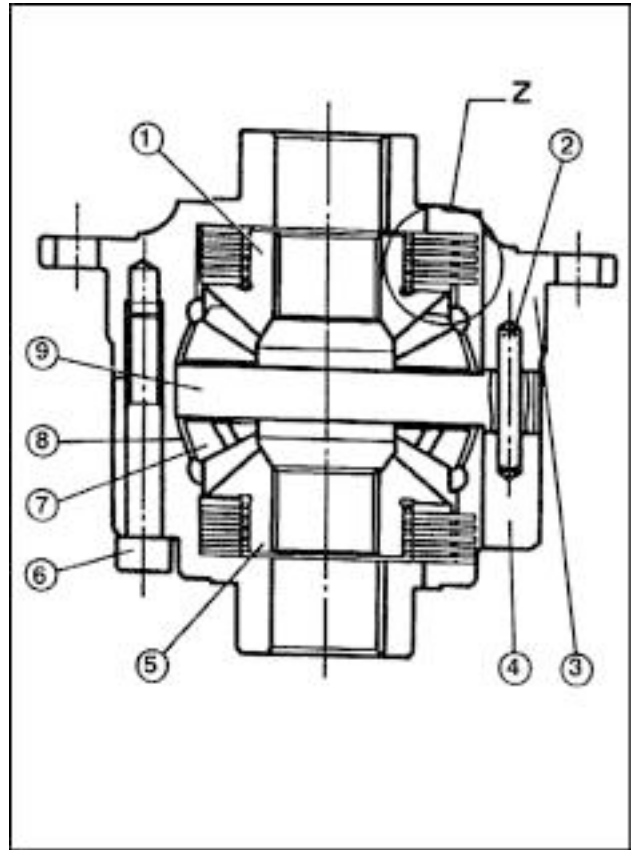

SEZ25CAP1B-1 2

9. Remove the side gear (5), friction disk ( (11), 3), metal disks (10) and friction disks (12).
10. Remove the side gear (1), friction disk (11), metal disks (10) and the friction disks (12) from the half-casing (3).
11. Check the wear on the metal disks (10) and the friction disks ( (11) and (12), see table below), replacing parts that are near their wear limit.

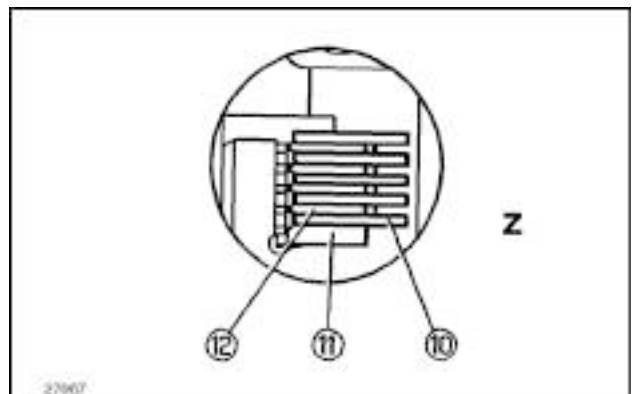

SEZ25CAP1A-44 3

12. Proceed with self-locking differential assembly operations, carrying out the previously described operations in reverse order, apply **LOCTITE® 270** to the threads on the screws (6) and tighten to a torque value of **50 N·m (442.54 lb in)**.
13. Refit the crown wheel (if previously disassembled) on the half-casing (3), tightening the bolts ( (C9), **Powered front axle - Torque (25.100)** figure 2) to a torque of **113 N·m (1000.13 lb in)**.
14. Check the rolling torque of the bevel pinion, as indicated in **Bevel gear set and differential carrier - Adjust Ring/Pinion Gears (25.102)** .

15. Assemble the crown wheel, complete with LIM-SLIP self-locking differential lock, on the bevel drive support, remembering to fit the previously marked crown wheel bearing support caps in the correct order and assemble and adjust the crown wheel bearings as indicated in **Bevel gear set and differential carrier - Adjust (25.102)** .

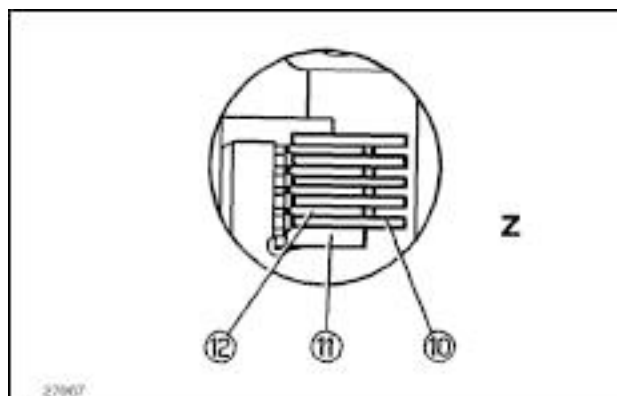

**Friction parts detail**

Self--locking differential friction disks ( LIM-SLIP)				
Item no.	Description	Quantity	Thickness mm-in .	Maximum wear per disc mm-in .
(10)	Metal disk	10	1.5 mm (0.06 in)	-
(11)	Friction disk	2	2.8 mm (0.11 in)	0.10 mm (0.004 in)
(12)	Friction disk	8	1.6 mm (0.06 in)	0.15 mm (0.006 in)

## Differential lock Dog clutch - Overhaul

### Front axle differential lock clutch assembly

**NOTE:** Position the bevel crown wheel--differential assembly on the support **380000255** and proceed as follows:

1. Remove the differential lock control internal pipe.
2. Remove the upper **(2)** and lower **(1)** bolts of the external differential lock bell housing and install two bolts (minimum length **70 mm (2.76 in)**) in their place. Gradually unscrew the four remaining bell housing bolts so as to allow the gradual extension of the differential lock release spring.

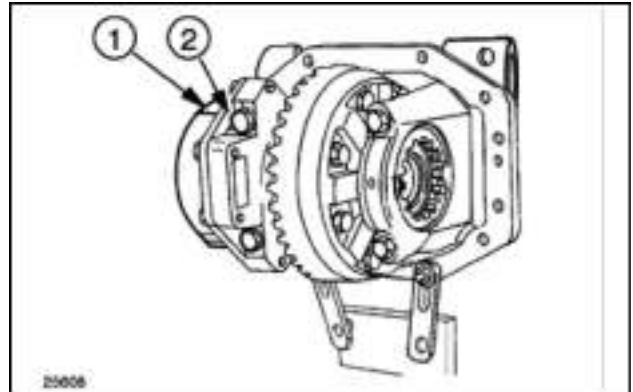

SEZ25CAP1A-45 1

**NOTE:** It is necessary to install two bolts with a minimum length of **70 mm (2.76 in)** because the normal bell housing bolts are not long enough to allow the spring to extend to its full free length.

3. Unscrew the two **70 mm (2.76 in)** bolts last of all, remove the bell **(1)**, the spring **(2)** and differential lock control piston.

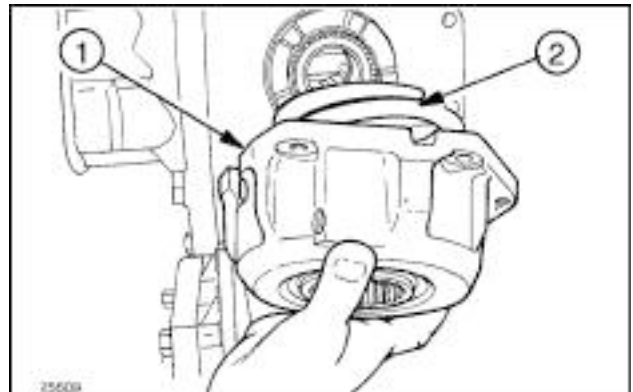

SEZ25CAP1A-46 2

4. Using a screwdriver, remove the circlip **(2)** and the differential lock sleeve.

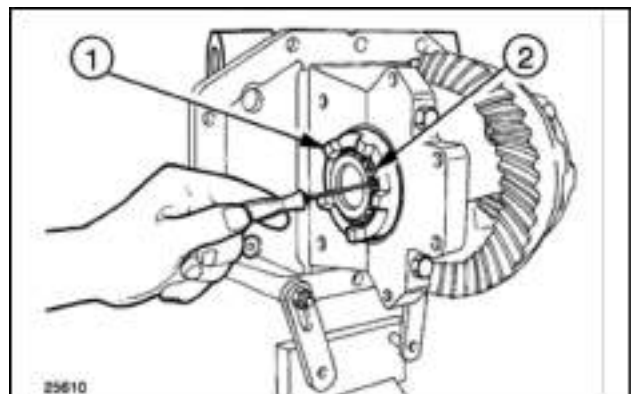

SEZ25CAP1A-47 3

5. Remove the circlip securing the differential lock piston, recover the sliding sleeve with the two thrust washers.

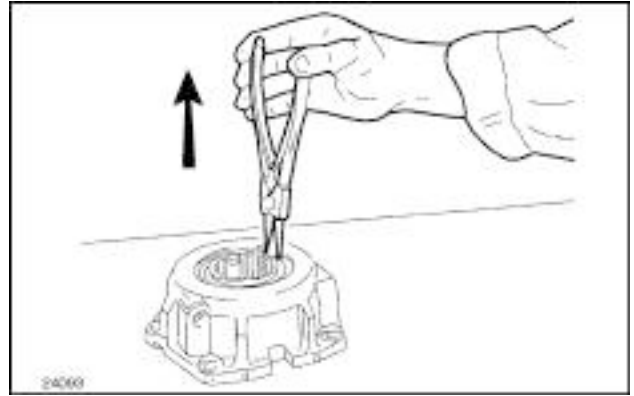

SEZ25CAP1A-48 4

6. Gently tap the piston out of the clutch bell housing.

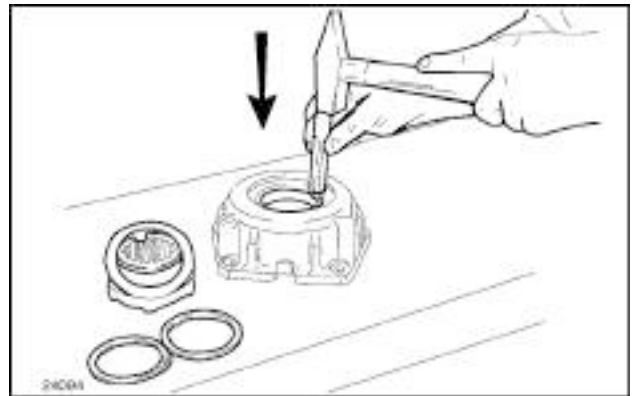

SEZ25CAP1A-49 5

7. Remove the differential lock piston.
8. To refit the differential lock clutch parts follow the disassembly procedure in reverse order, proceeding as follows.
9. Carefully check the condition of the two O-ring seals installed on the piston.
10. Fit the clutch bell unit complete with spring and piston using the two **70 mm (2.76 in)** bolts used during disassembly operations.

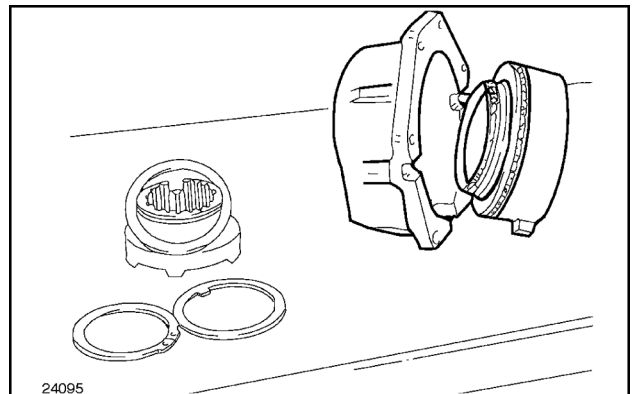

SEZ25CAP1A-50 6

## Differential lock - Troubleshooting

Problem	Possible Cause	Correction
<b>The differential lock fails to engage.</b>	Transmission oil level low.	Top up oil.
	Clogged oil filter.	Replace filter.
	Hydraulic pump faulty.	Overhaul or replace the pump.
	Faulty differential lock--unlock switch.	Replace switch.
	Lack of power supply to the solenoid valve: connections loose or damaged, contactor faulty.	Check electrical connections and replace defective parts.
	Differential lock control solenoid valve jammed in discharge position.	Overhaul or replace solenoid valve.
	Oil leakage through the seals with consequent pressure drop: piston seals or delivery pipe seals.	Replace damaged seals.
<b>Differential lock fails to disengage.</b>	Differential lock solenoid valve jammed in delivery position.	Overhaul or replace solenoid valve.
	Differential lock release spring broken.	Replace spring.
	Lack of power supply to the solenoid valve: connections loose or damaged, contactor faulty.	Check electrical connections and replace defective parts.
<b>With differential lock engaged, the differential lock does not disengage when brake pedals are pressed.</b>	Switch governed by the brake pedal, connected to the control unit, defective.	Change the switch or repair the electrical system.

# Index

---

## Front axle system - 25

### Front bevel gear set and differential - 102

Bevel gear set and differential carrier - Adjust .....	13
Bevel gear set and differential carrier - Adjust Ring/Pinion Gears .....	10
Differential - General specification .....	3
Differential - Overhaul .....	16
Differential lock - General specification .....	5
Differential lock - Static description .....	8
Differential lock - Troubleshooting .....	22
Differential lock Dog clutch - Overhaul .....	20
Limited slip differential - General specification .....	4
Limited slip differential - Overhaul .....	17
Limited slip differential - Sectional view .....	6
Limited slip differential - Static description .....	7







## **Front axle system - 25**

**Final drive hub, steering knuckles, and shafts - 108**

**Farmall 105U Pro EP  
Farmall 115U Pro EP  
Farmall 95U Pro EP**

# Contents

---

## Front axle system - 25

### Final drive hub, steering knuckles, and shafts - 108

#### TECHNICAL DATA

Planetary drive and hub	
General specification .....	3
Steering knuckle and king pin	
General specification .....	4

#### SERVICE

Planetary drive and hub	
Disassemble .....	5
Assemble .....	7
Disassemble .....	9
Assemble .....	11
Steering knuckle and king pin	
Adjust .....	12
Wheel hub	
Replace .....	14

---

## Planetary drive and hub - General specification

### Epicyclic final drive

Reduction Ratio: - all models	$12 : (12 + 72) = 1 : 7$
Front axle brake disk thickness - all models	<b>4.45 - 4.55 mm (0.175 - 0.179 in)</b>

---

## Steering knuckle and king pin - General specification

Thickness of steering knuckle bearing adjuster plates	<b>0.10 mm (0.0039 in)</b>	<b>0.15 mm (0.0059 in)</b>	<b>0.20 mm (0.0079 in)</b>	<b>0.25 mm (0.0098 in)</b>	<b>0.30 mm (0.0118 in)</b>
---	----------------------------	----------------------------	----------------------------	----------------------------	----------------------------

## Planetary drive and hub - Disassemble

### Front epicyclic final drive without brake

**NOTE:** Front epicyclic final drive removal and installation can be carried out with the axle detached and positioned on the stand **380000251**, or with the axle fitted on the tractor. If the operation is performed with the axle fitted on the tractor, a support stand must be positioned under the engine sump.

1. Position the axle on stand **380000251**.

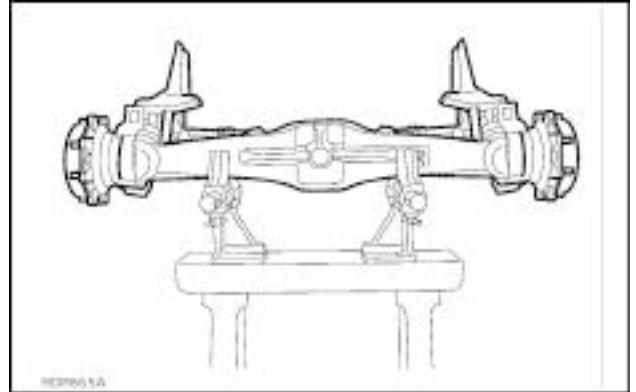

SEZ25CAP1A-51 1

2. Remove the plug **(1)** and drain the oil from the epicyclic final drive.

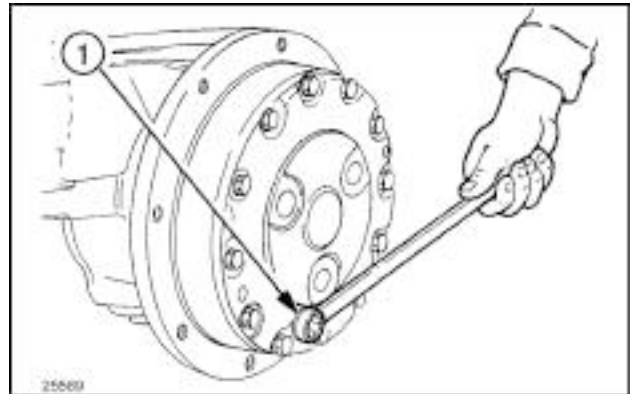

SEZ25CAP1A-52 2

3. Unscrew the cover retaining bolts **(1)** on the final drive, screw in two pins **(2)** and, using an extracting tool inserted in the oil drainage plug hole, detach the cover **(1)**.

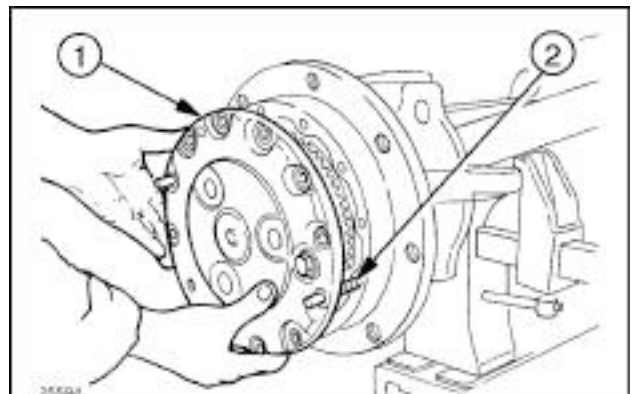

SEZ25CAP1A-53 3

4. Remove the notching (1) on the ring nut (2) retaining the wheel hub bearings.

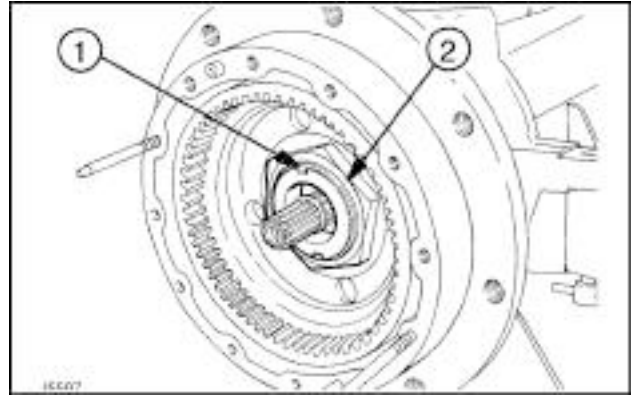

SEZ25CAP1A-54 4

5. Remove the lock nut on the wheel hub bearings using wrench 38000269 (1).

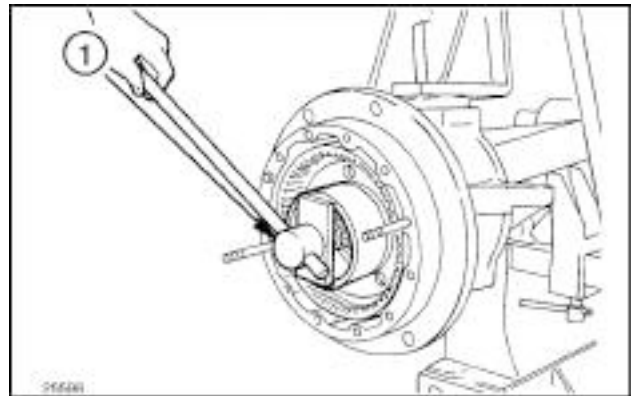

SEZ25CAP1A-55 5

6. Remove the wheel hub (1) together with the epicyclic final drive fixed gear (2). Recover all disassembled parts.

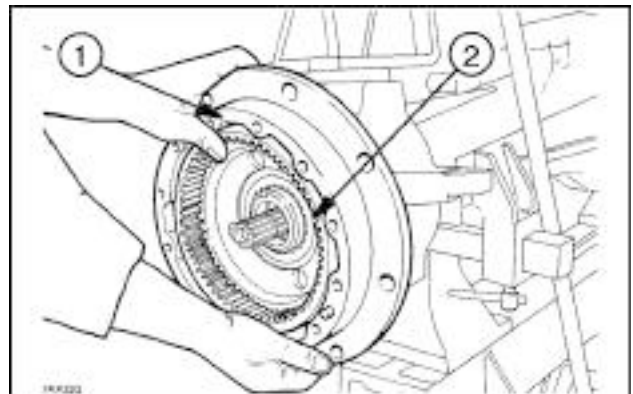

SEZ25CAP1A-56 6

## Planetary drive and hub - Assemble

1. Refer to the illustrations on **Front bevel gear set and differential - Sectional view (25.102)**, figure 1 **Front bevel gear set and differential - Sectional view (25.102)** figure 2, for the positioning of the various parts.
2. Respect the tightening torques prescribed (see **Powered front axle - Torque (25.100)** figure 2).
3. Check the state of the seal, if it should be changed then remove it and turn the hub over on a bench, clean the seat of the seal thoroughly. Set it inside the circumference of the hub and, with tool **380200017 (1)**, drive it in until the edge of the tool meets the top surface of the hub so as to ensure the assembly stand--in of the oil seal.

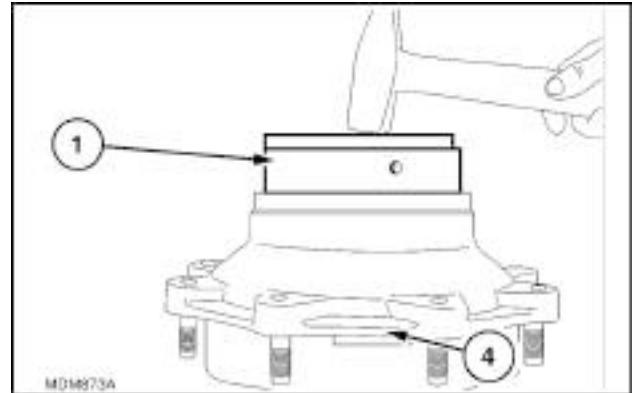

SEZ25CAP1A-57 1

4. Also check the state of the seal on the wheel hub between it and the axle shaft, if it should be changed then take it out and using tool **380200019** insert it until the tool makes contact with the spindle so as to leave the gap.
5. Assemble the wheel hub and the epicyclic final drive fixed gear.
6. Progressively tighten the ring nut, using the torque wrench and wrench **380000269 (1)** to obtain a torque value of **392 N·m (3469.49 lb in)**; at the same time, rotate the wheel hub to ensure that the bearings are correctly seated.

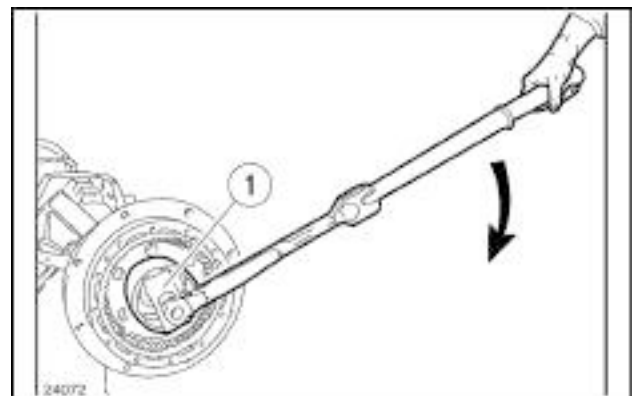

SEZ25CAP1A-58 2

7. Measure the rolling resistance ( $R_t$ ) of the wheel hub using the relative torque wrench, or a torque meter and cord positioned on the base of the wheel disk flange.
8. Loosen the ring nut by half a turn and measure the rolling resistance ( $R$ ) as described previously. The difference between the two measurements is the rolling torque value of the wheel hub bearings ( $R_c$ ):



9.
  - $R_c = R_t - R = 5.9 - 14.7 \text{ N}\cdot\text{m} (52.22 - 130.11 \text{ lb in})$  or,  
if measured with a dial torque,
  - $R_c = R_t - R = 4.28 - 10.71 \text{ kg} (9.44 - 23.61 \text{ lb})$
  - If the measurement is less than  
 **$5.9 \text{ N}\cdot\text{m} (52.22 \text{ lb in})$**   
or, if measured with a dial torque, at  
 **$4.28 \text{ kg} (9.44 \text{ lb})$**   
, replace the relevant parts and repeat the check.
10. Progressively tighten the ring nut, using the torque wrench and wrench **380000269 (1)** to obtain a torque value of  **$392 \text{ N}\cdot\text{m} (3469.49 \text{ lb in})$** ; at the same time, rotate the wheel hub to ensure that the bearings are correctly seated.
11. Carefully secure the ring nut.
12. Before reassembling the epicyclic final drive casing, carefully clean and degrease the mating surfaces, then apply sealing compound (approx.  **$2 \text{ mm} (0.08 \text{ in})$** ) along the marked line shown in **Bevel gear set and differential carrier - Adjust (25.102)**.
13. Assemble the epicyclic final drive casing, complete with gears.
14. Fill up the front epicyclic final drive (for recommended products and quantities see **Consumables ( )**).
15. Mount the steering heads.

## Planetary drive and hub - Disassemble

### Front epicyclic final drive with brake

**NOTE:** Front epicyclic final drive removal and installation can be carried out with the axle detached and positioned on the stand **380000251**, or with the axle fitted on the tractor. If the operation is performed with the axle fitted on the tractor, a support stand must be positioned under the engine sump.

1. Position the axle on stand **380000251**.
2. Remove the plug (1) and drain the oil from the epicyclic final drive.

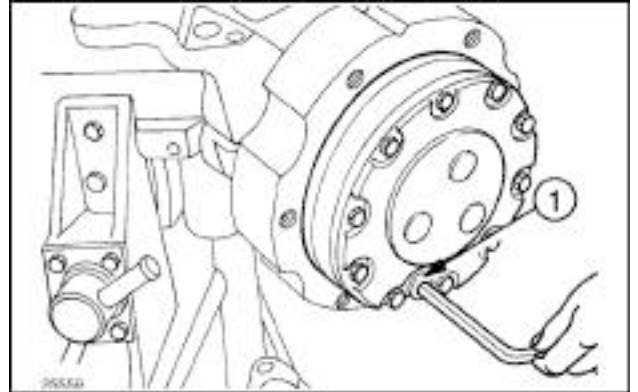

SEZ25CAP1A-59 1

3. Unscrew all of the epicyclic final drive casing retaining bolts (1).

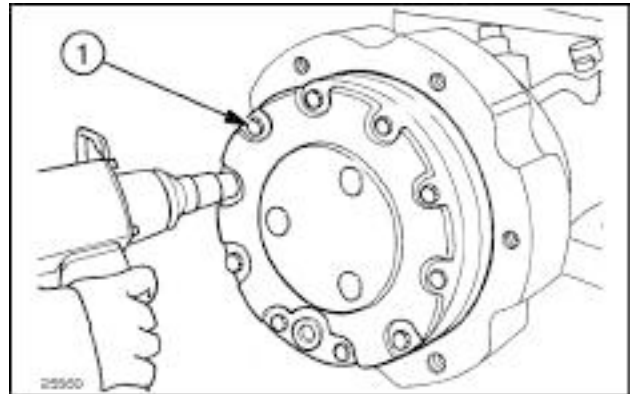

SEZ25CAP1A-60 2

4. Using an extractor (1), fitted on the oil drainage plug, detach the epicyclic final drive casing (2).

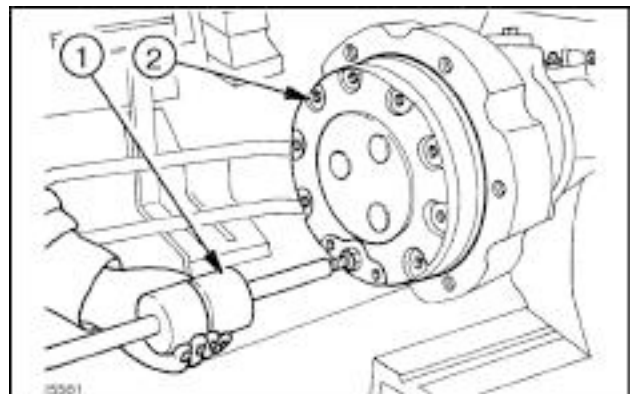

SEZ25CAP1A-61 3

5. Remove the circlip (1) and extract the external brake disk (2).

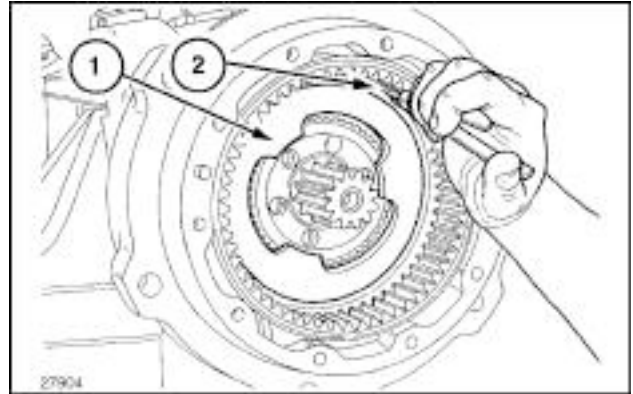

SEZ25CAP1A-62 4

6. Remove the hub (1) and associated brake friction disk.

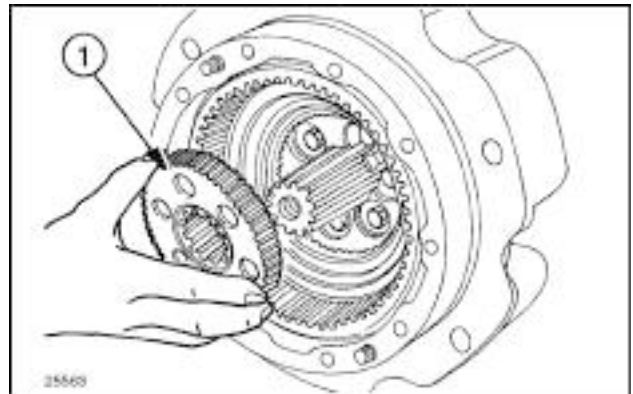

SEZ25CAP1A-63 5

7. Take out the retaining bolts and remove the final drive fixed gear (1) using two screws as an extractor.

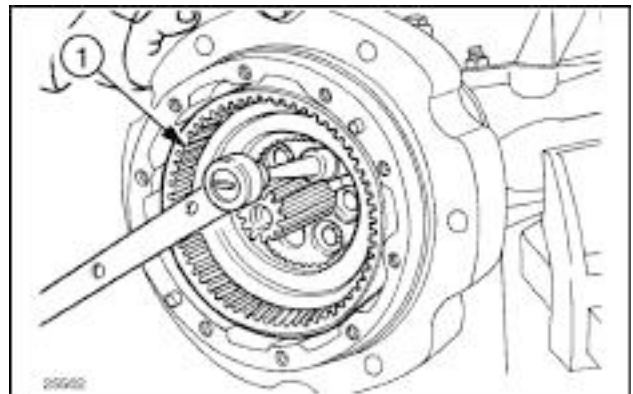

SEZ25CAP1A-64 6

## Planetary drive and hub - Assemble

### Front epicyclic final drive with brake

1. Refer to the illustrations on **Front bevel gear set and differential - Sectional view (25.102)**, figure 1 **Front bevel gear set and differential - Sectional view (25.102)** figure 2, for the positioning of the various parts.
2. Respect the tightening torques prescribed (see **Powered front axle - Torque (25.100)** ).
3. Refit the drive fixed gear.
4. Refit the brake disk hub.
5. Fit the outer brake disk and secure in position.
6. Before reassembling the epicyclic final drive casing, carefully clean and degrease the mating surfaces, then apply sealing compound (approx. **2 mm (0.08 in)**) along the marked line shown in **Bevel gear set and differential carrier - Adjust (25.102)** .
7. Assemble the epicyclic final drive casing, complete with gears.
8. Fill up the front epicyclic final drive (for recommended products and quantities see **Consumables ( )** ).

## Steering knuckle and king pin - Adjust

### Stub axle

**NOTE:** Position the front axle on stand 380000251 and proceed as follows:

1. Smear **CASE IH AKCELA 251H EP MULTI-PURPOSE GREASE** on the outer races of the bearings and fit the upper cover, without the plates, but with tool **380000235 (1)**. Tighten the retaining bolts to **64 N·m (566.45 lb in)**.

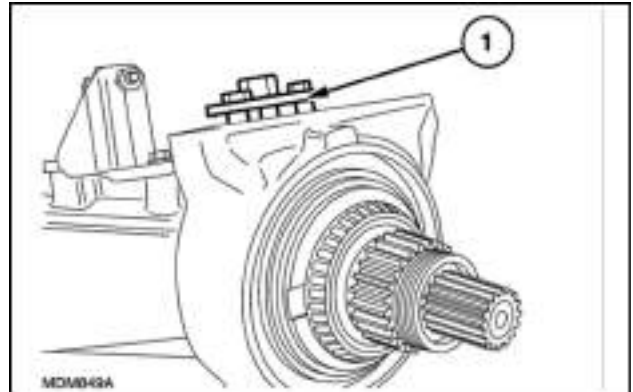

SEZ25CAP1A-69 1

**NOTE:** At some points on the upper pin the lubricator is no longer positioned vertically, but is horizontal, for access with the front mudguard support. Put a few washers under the tool as shims, temporarily inserting longer screws.

2. Fit the lower cover without the adjustment plate and lubricate the three retaining bolts with engine oil.
3. Gradually tighten the lower cover bolts in sequence, while simultaneously rotating the casing to allow excess grease to escape.

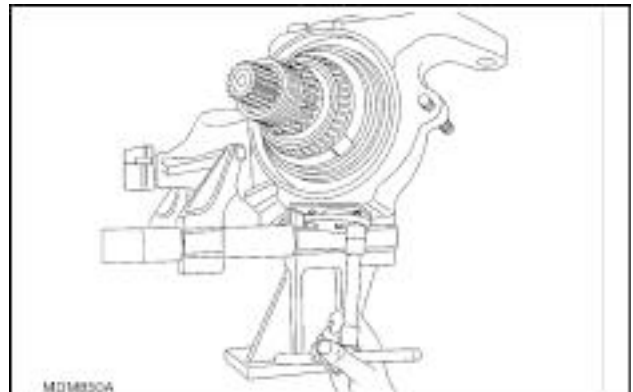

SEZ25CAP1A-70 2

4. Using a torque wrench and tool **380000235 (1)**, check that the torque required to rotate the casing is: **3.9 - 5.8 N·m (34.52 - 51.33 lb in)**, without considering the peak starting torque. If not, adjust by way of the lower cover bolts.
5. Measure the gap (**H**) created between the lower cover and the casing adjacent to each of the three bolts.

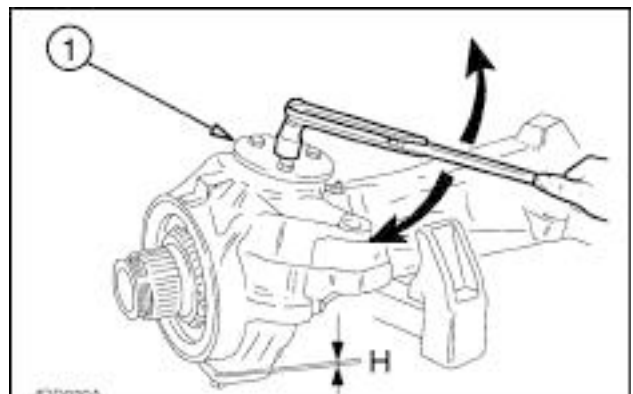

SEZ25CAP1A-71 3

6. Calculate the average of the three values measured. The total thickness of the adjustment plates to be fitted under the lower cover will be given by:  
**(S) = (H)**  
If necessary, round the value down to the next **0.05 mm (0.002 in)**.

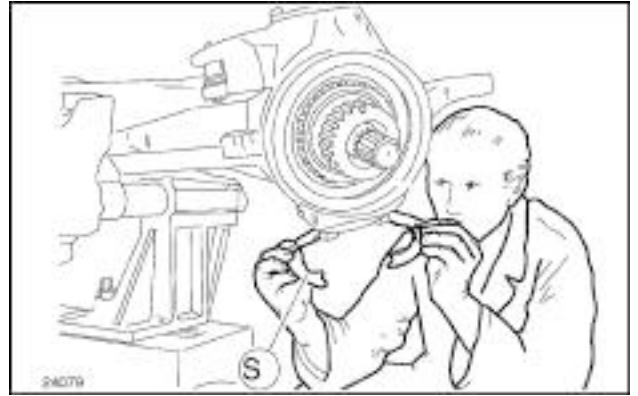

SEZ25CAP1A-72 4

7. Partially unscrew the lower cover bolts, insert the selected shims and tighten the bolts to a torque of: **64 N·m (566.45 lb in)**.
8. Check that the torque necessary to rotate the casing is **3.9 - 9.8 N·m (34.52 - 86.74 lb in)**, without considering the initial peak torque.
9. If the torque value measured is greater than the specified value, increase the thickness of the shims, if it is less than the specified value, reduce the thickness of the shims.
10. Fit the grease nipples in the upper and lower covers and grease the assembly.

## Wheel hub - Replace

1. Disassemble the front epicyclic final drive with brake (see **Planetary drive and hub - Disassemble (25.108)**) and remove the hub casing (1).

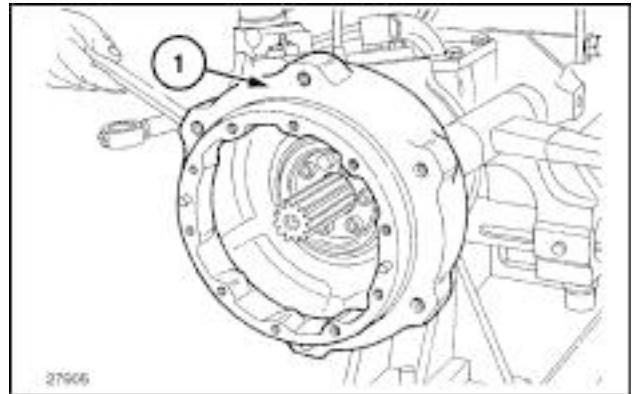

SEZ25CAP1A-65 1

2. Remove the seal and fit the pins (1) of tool **380200018**.

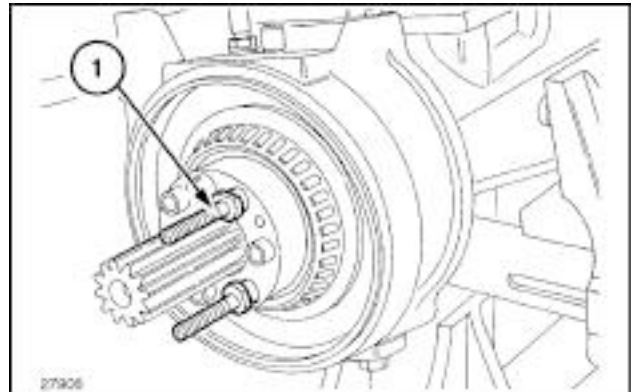

SEZ25CAP1A-66 2

3. Carefully clean the seat and position the seal (1), ready for fitting.

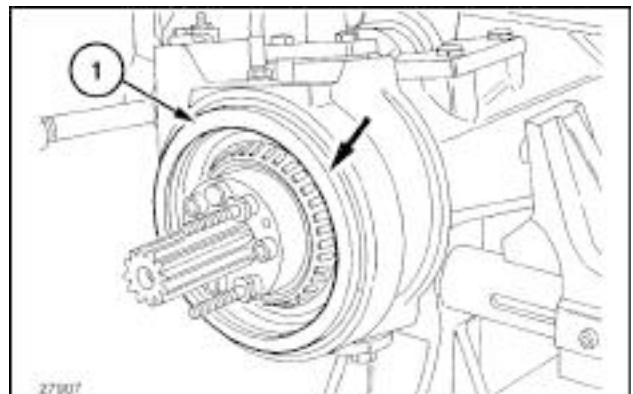

SEZ25CAP1A-67 3

**NOTE:** The external surface on the seal (1), indicated by the arrow, does not require lubrication.

4. Fit the seal (2, 4) fully tightening the screws on tool **380200018** (1).

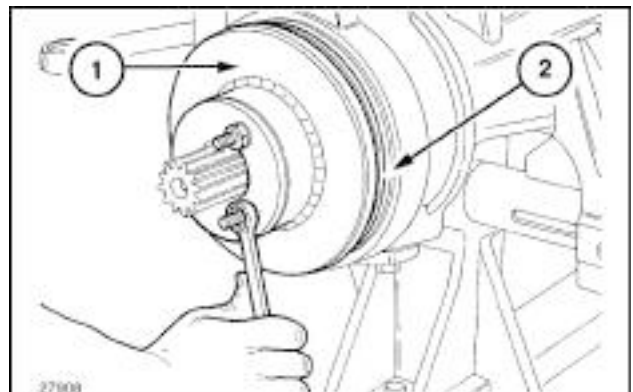

SEZ25CAP1A-68 4

5. Remove tool **380200018** from the hub.

6. Mount the front epicyclic final drive with brake (see **Planetary drive and hub - Assemble (25.108)** ).



# Index

---

## Front axle system - 25

### Final drive hub, steering knuckles, and shafts - 108

Planetary drive and hub - Assemble .....	7
Planetary drive and hub - Assemble .....	11
Planetary drive and hub - Disassemble .....	5
Planetary drive and hub - Disassemble .....	9
Planetary drive and hub - General specification .....	3
Steering knuckle and king pin - Adjust .....	12
Steering knuckle and king pin - General specification .....	4
Wheel hub - Replace .....	14





© 2014 CNH Industrial Österreich GmbH

All rights reserved. No part of the text or illustrations of this publication may be reproduced.

CASE IH policy is one of continuous improvement and the right to change prices, specification or equipment at any time without notices is reserved.

All data given in this publication is subject to production variations. Dimensions and weight are approximate only and the illustrations do not necessarily show products in standard condition. For exact information about any particular product, please consult your CASE IH Dealer.



# **SERVICE MANUAL**

## **Rear axle system**

**Farmall 105U Pro EP  
Farmall 115U Pro EP  
Farmall 95U Pro EP**

# Contents

---

## Rear axle system - 27

[27.100] Powered rear axle.....	27.1
[27.106] Rear bevel gear set and differential.....	27.2
[27.120] Planetary and final drives.....	27.3



## **Rear axle system - 27**

### **Powered rear axle - 100**

**Farmall 105U Pro EP  
Farmall 115U Pro EP  
Farmall 95U Pro EP**

# Contents

---

## Rear axle system - 27

### Powered rear axle - 100

#### TECHNICAL DATA

Powered rear axle	
Special tools .....	3
General specification .....	3

#### FUNCTIONAL DATA

Powered rear axle	
Exploded view – Rear axle housing and final drive .....	4
Exploded view – Front bevel gear set and differential .....	6

#### SERVICE

Rear axle housing	
Disconnect .....	9
Connect .....	11
Brake housing - Remove .....	13
Brake housing - Install .....	14

## Powered rear axle - Special tools

**NOTE:** The special tool with an (X) mark is ESSENTIAL for the operations in this section. To work safely, to obtain the best technical results and to save both time and energy, you should also use the other special tool we recommend below. You should also use the relevant locally manufactured devices. This manual contains the construction drawings for these devices.

List of the special tools required for the work steps in this section:

Tool Number	Designation / Use
(X) 38000050	Guide for the installation of the cassette seal for the rear axle shaft
(X) 38000051	Installer for the installation of the cassette seal for the rear axle shaft
(X) 380001730	Box wrenches
(X) 380001731	Socket for the pinion shaft
(X) 380001746	Installation tool for the installation of the cassette seal for the rear axle shaft

Locally manufactured tools:

Name	Usage
Center bush (Figure 1)	A guide to adjust the bearing preload of the bevel pinion bearings. For installation.

Material: S235JR in accordance with DIN 10025

**NOTE:** All specifications are in millimeters.

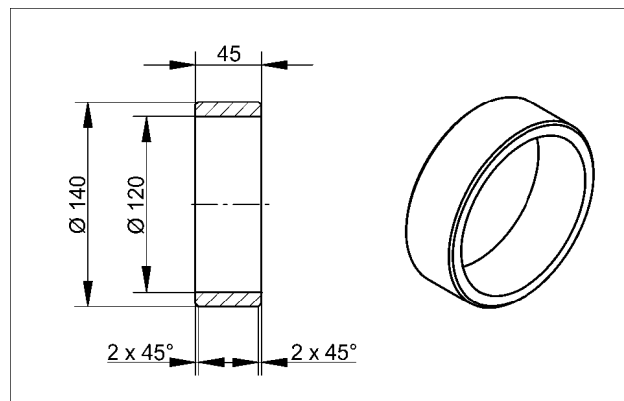

SS11J091 1

## Powered rear axle - General specification

### rear axle

Type of System

Rear-axle flange dimension

Ratio of pinion gear:crown wheel

Ratio of rear axle:front axle

Ratio of rear axle overall

Planetary axle

**1770 mm (70 in)**

1:5.125

1:1.38

1:41

### Diff lock

Type of System

Operating system

Number of Friction Plates

Wet multi-disc clutch

Electrohydraulic solenoid valve

8

### Final drive

Type of System

Ratio

Single planetary gearset

1:8



---

## Powered rear axle - Exploded view – Rear axle housing and final drive

- |    |                       |    |                                  |
|----|-----------------------|----|----------------------------------|
| 1  | Wheel shaft           | 2  | Wheel stud                       |
| 3  | Ball                  | 4  | Grub screw                       |
| 5  | Shaft sealing ring    | 6  | Roller bearing                   |
| 7  | Screw plug            | 8  | Screw plug                       |
| 9  | Bolt                  | 10 | Angle                            |
| 11 | Housing               | 12 | Nut.                             |
| 13 | Stud bolt             | 14 | Drain plug                       |
| 15 | Roller bearing        | 16 | Grooved nut                      |
| 17 | Roll pin              | 18 | Planetary gear carrier           |
| 19 | Retainer Ring         | 20 | Thrust washer.                   |
| 21 | Planetary gear        | 22 | Roller bearing                   |
| 23 | Thrust washer.        | 24 | Retainer Ring                    |
| 25 | Retainer Ring         | 26 | Ring Gear                        |
| 27 | Dowel pin             | 28 | shaft                            |
| 29 | Union                 | 30 | Reduction                        |
| 31 | Tube                  | 32 | Shutter                          |
| 33 | Fitting               | 34 | Brake housing                    |
| 35 | Nut.                  | 36 | Stud bolt                        |
| 37 | Oil level sight glass | 38 | Fitting                          |
| 39 | Lubrication line      | 40 | Lubrication line                 |
| 41 | Union                 | 42 | Lubrication line                 |
| 43 | O-Ring                | 44 | Bushing                          |
| 45 | Bolt                  | 46 | Transmission output speed sensor |
| 47 | O-Ring                | 48 | Rear axle housing                |
| 49 | Bushing               | 50 | Stud bolt                        |
| 51 | Nut.                  |    |                                  |

Rear axle system - Powered rear axle

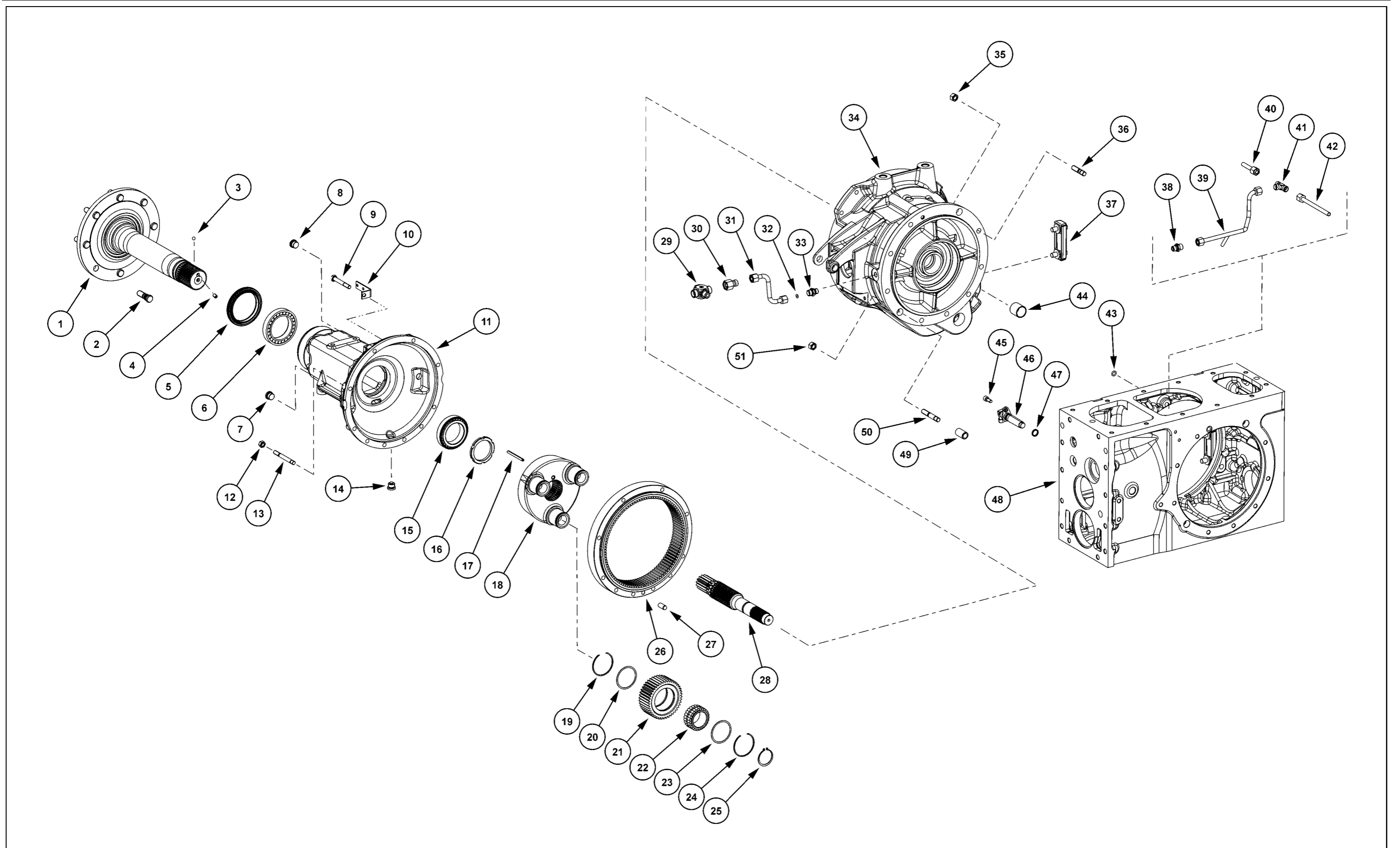

SS13E030 1

---

## Powered rear axle - Exploded view – Front bevel gear set and differential

71	Adjuster return plate	72	Ball bearings
73	Differential housing	74	Roll pin
75	Thrust washer.	76	Pinion
77	Thrust washer.	78	Pinion
79	axle	80	Pinion
81	Disc holder	82	Thrust washer.
83	Friction plate	84	Separator plate
85	Grooved nut	86	Roller bearing
87	Adjuster return plate	88	Retainer Ring
89	Washer	90	Roller bearing
91	Pinion shaft	92	Ball
93	Crownwheel	94	Pistons
95	O-Ring	96	seal
97	Differential housing	98	Bolt
99	Rectangular ring	100	Ball bearings

Rear axle system - Powered rear axle

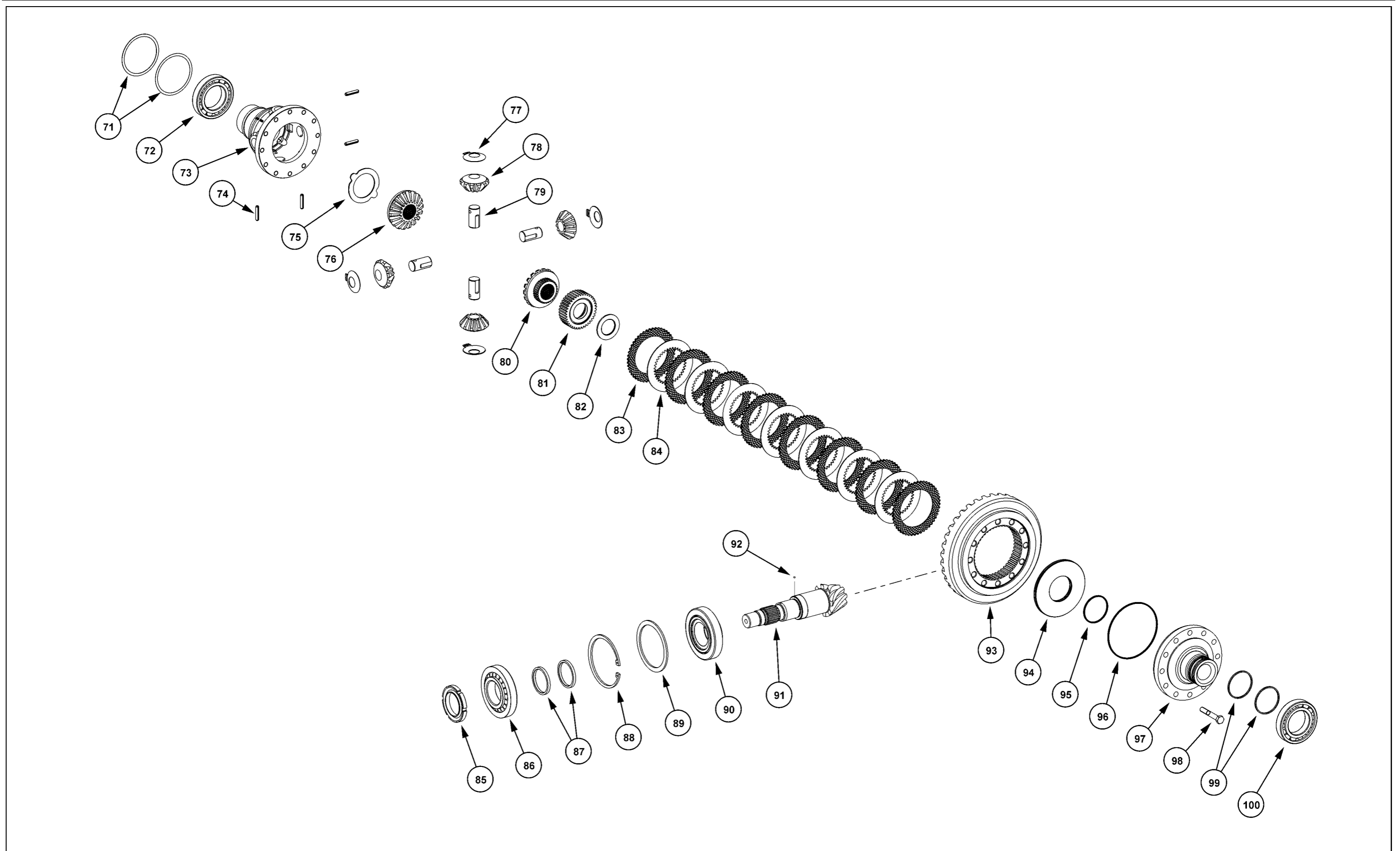

SS13E035 1



## Rear axle housing - Disconnect

### **⚠ DANGER**

**Heavy objects!**

**Lift and handle all heavy components using lifting equipment with adequate capacity. Always support units or parts with suitable slings or hooks. Make sure the work area is clear of all bystanders.**

**Failure to comply will result in death or serious injury.**

D0076A

### **Prior operation:**

#### **Transmission housing cover - Remove (21.111)**

1. Loosen all oil lines. Remove all oil lines.



SVIL13TR00137AB 1

2. Remove the suction pipe.

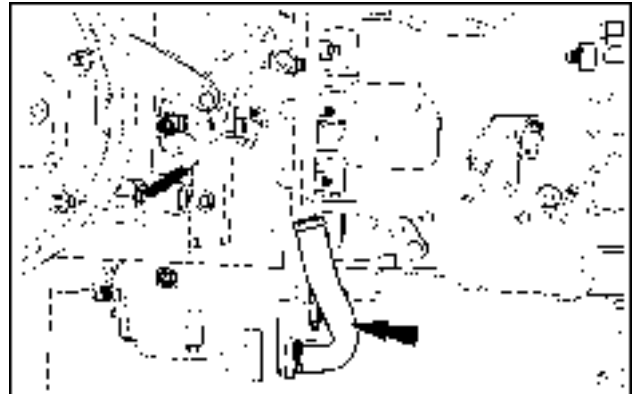

SVIL13TR00138AB 2

3. Remove the two bolts **(44)**.

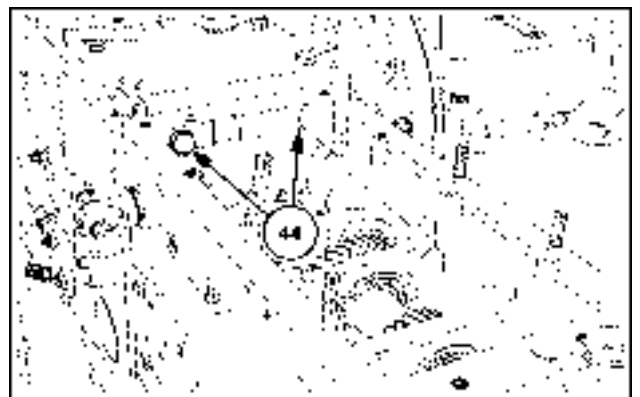

SVIL13TR00139AB 3

4. Loosen the nuts **(42)** and **(46)**.
5. Disengage the gearbox housing from the rear axle.

**NOTE:** Be careful with the adjustment disc (counter shaft). See position **(377)** — **Semi-Powershift transmission internal components - Exploded view - 1st - 4th gear (21.152)**.



SVIL13TR00142AB 4

**Next operation:**  
**Rear axle housing - Connect (27.100)**

## Rear axle housing - Connect

### Prior operation:

Rear axle housing - Disconnect (27.100)

### Axial play of the counter shaft — Determine the adjustment disc

Axial play **0.0 - 0.1 mm (0.000 - 0.004 in)**

1. Measure the dimension "A" from the flush side of the gearbox housing to the drill base.  
Dimension "A" = **14.20 mm (0.559 in)**

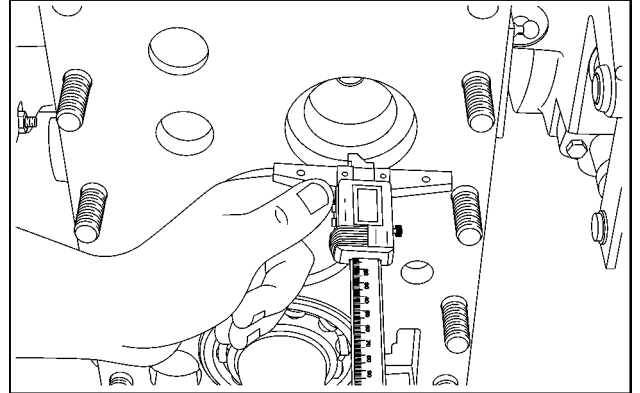

SVIL13TR00435AB 1

2. Measure the dimension "B" from the top of the bearing to the gearbox housing.  
Dimension "B" = **13.90 mm (0.547 in)**

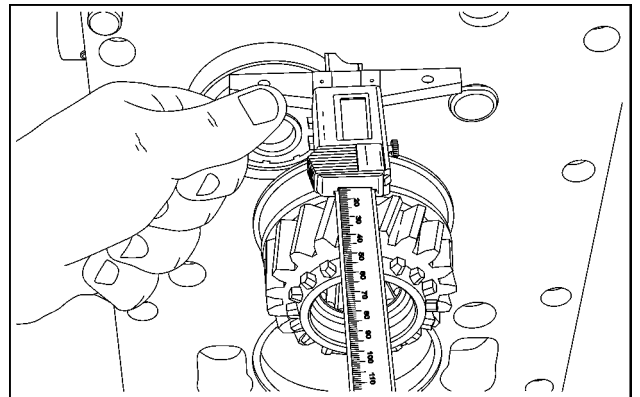

SVIL13TR00436AB 2

### Example calculation:

Measurement "A"	<b>14.20 mm (0.559 in)</b>
Measurement "B"	<b>- 13.90 mm (0.547 in)</b>
Axial play <b>0.0 - 0.1 mm (0.000 - 0.004 in)</b>	<b>- 0.05 mm (0.002 in)</b>
Result = adjustment disc	<b>0.250 mm (0.010 in)</b>

### Connect the rear axle housing

3. Fix the calculated adjustment disc (**377**) in the housing bore with industrial Vaseline.

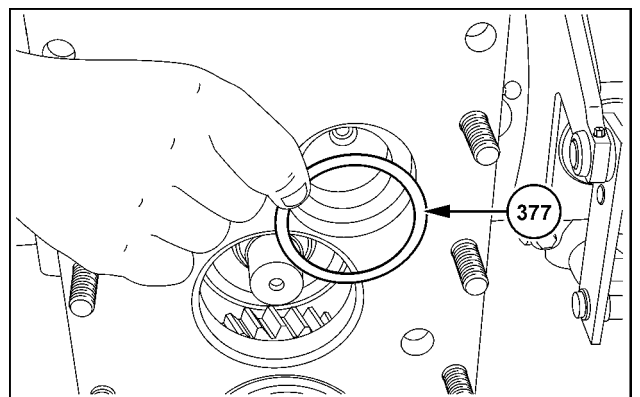

SVIL13TR00438AB 3



---

**Version with ground-speed Power Take-Off (PTO):**

4. Insert the shift collar into the shift fork. Fit the shift collar onto the synchronization teeth.

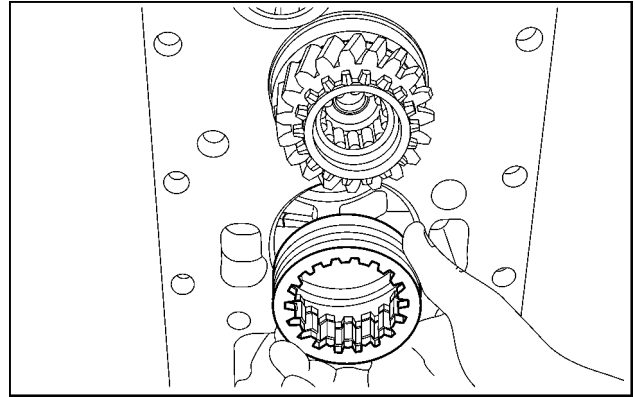

SVIL13TR00437AB 4

5. Coat the sealing surfaces with **LOCTITE® 518**.

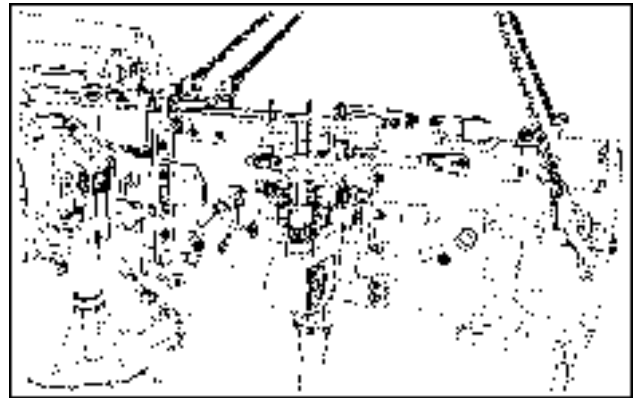

SVIL13TR00440AB 5

6. Use the bolts and the nuts to secure the gearbox to the rear axle housing.
7. Tighten the bolts and nuts to **185 Nm (136 lb ft)**.

**Next operation:**

**Transmission housing cover - Install (21.111)**

## Rear axle housing Brake housing - Remove

### Prior operation: Brakes - Remove (33.202)

1. Loosen the line union nuts.
2. Remove the line.

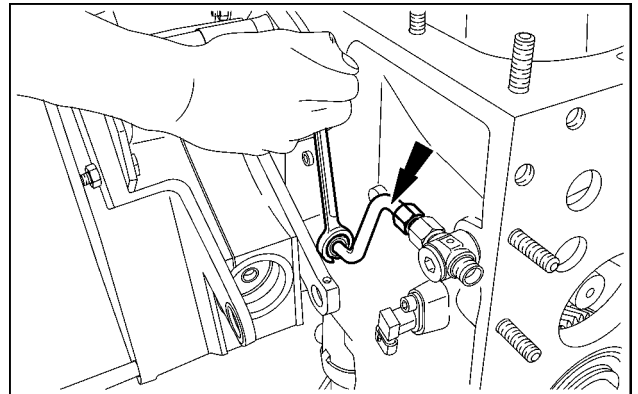

SS13H192 1

3. Loosen the bolts on the brake housing and the rear axle housing.

**NOTE:** To remove the differential, remove the brake housing on the left-hand side (when viewed in the direction of travel).

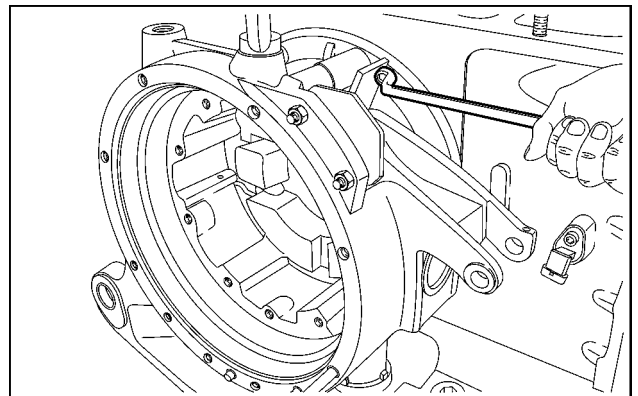

SS13H193 2

### 4. **⚠ WARNING**

#### Heavy objects!

Lift and handle all heavy components using lifting equipment with adequate capacity. Always support units or parts with suitable slings or hooks. Make sure the work area is clear of all bystanders.

Failure to comply could result in death or serious injury.

W0398A

Remove the left-hand axle trumpet housing and the brake housing from the rear axle housing.



SS13H194 3

**NOTE:** Clean the components, check carefully for wear and damage, and replace if necessary.

### Next operation: Differential - Remove (27.106)

## Rear axle housing Brake housing - Install

Powered rear axle - Exploded view – Rear axle housing and final drive (27.100)  
Hydraulic service brakes - Exploded view (33.202)

Prior operation:

Bevel pinion - Install (27.106)

1. Fit the stud bolts (36) and (50). Fit the dowel (27).

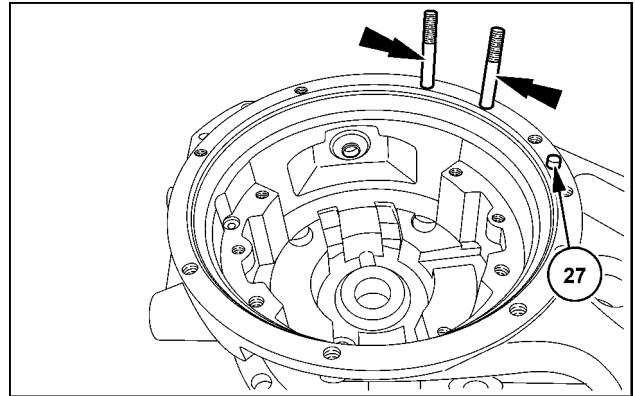

SS13H046 1

2. Coat the bolts with **LOCTITE® 243**.
3. Use the bolts to fit the oil level sight glass (37).  
Tighten the screws to **2 Nm (1.48 lb ft)**.

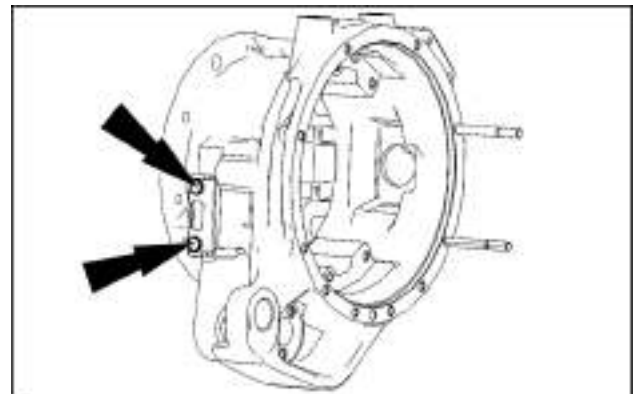

SS13K018 2

4. Use a suitable mandrel to insert the bushing (44). Make sure that the bushing is flush.
5. Fit the bushings (49) onto the studs.

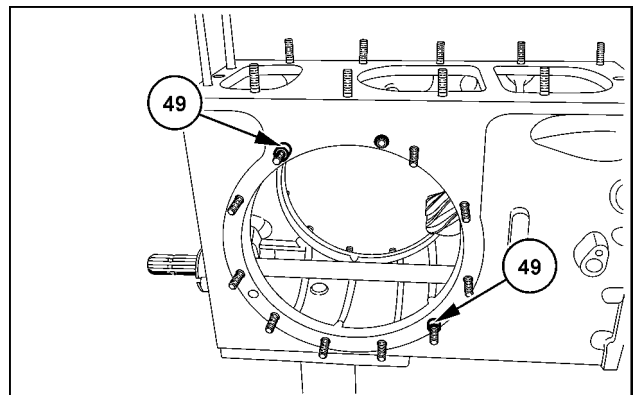

SS13H049 3

6. **⚠ WARNING**

**Heavy objects!**  
Lift and handle all heavy components using lifting equipment with adequate capacity. Always support units or parts with suitable slings or hooks. Make sure the work area is clear of all bystanders.  
Failure to comply could result in death or serious injury.

W0398A

Clean the sealing surfaces on the brake housing and rear axle housing. Coat the sealing surfaces with **LOCTITE® 518**.

7. Fit the brake housing. Use the nuts to secure the brake housing. Tighten the nuts to **115 Nm (84.8 lb ft)**.

**NOTE:** Use the shouldered nuts for the bushings (49).

**Next operation:**  
**Brakes - Install (33.202)**

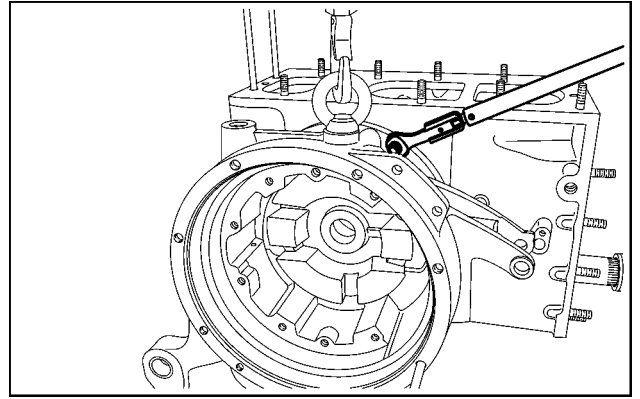

SS13H050 4

# Index

---

## Rear axle system - 27

### Powered rear axle - 100

Powered rear axle - Exploded view – Front bevel gear set and differential .....	6
Powered rear axle - Exploded view – Rear axle housing and final drive .....	4
Powered rear axle - General specification .....	3
Powered rear axle - Special tools .....	3
Rear axle housing - Connect .....	11
Rear axle housing - Disconnect .....	9
Rear axle housing Brake housing - Install .....	14
Rear axle housing Brake housing - Remove .....	13



## **Rear axle system - 27**

**Rear bevel gear set and differential - 106**

**Farmall 105U Pro EP  
Farmall 115U Pro EP  
Farmall 95U Pro EP**

# Contents

---

## Rear axle system - 27

### Rear bevel gear set and differential - 106

#### FUNCTIONAL DATA

Differential lock control valve	
Overview .....	3

#### SERVICE

Differential	
Remove .....	4
Disassemble .....	5
Assemble .....	7
Install .....	11
Bevel pinion	
Remove .....	13
Gear tooth contact .....	17
Preload .....	19
Install .....	20

## Differential lock control valve - Overview

### Rear axle differential lock – Solenoid valve (Y-038)

The solenoid valve (1) is located on the right-hand side of the transmission housing.



SS13E039 1

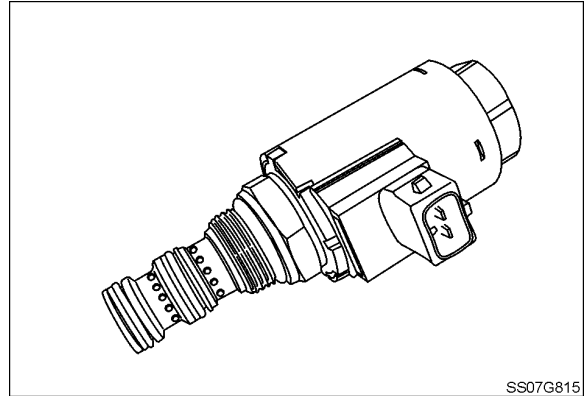

SS07G815 2

SS07G815

<b>Specifications</b>	
Solenoid valve type	3/2-way solenoid valve
Nominal voltage	<b>12 V</b>
Nominal current	<b>1.5 A at 20 °C (68 °F)</b>
Coil resistance	<b>8 Ω at 20 °C (68 °F)</b>
Activation period	<b>100 %</b>
Ambient temperature	<b>-20 - 60 °C (-4 - 140 °F)</b>
Oil temperature	<b>-20 - 120 °C (-4 - 248 °F)</b>
Operating pressure (maximum)	<b>350 bar (5075 psi)</b>
Nominal flow (maximum)	<b>19.0 l/min (0.7 cfm)</b>
Tightening torque	<b>25 - 30 Nm (18 - 22 lb ft)</b>



## Differential - Remove

Prior operation:

Rear axle housing Brake housing - Remove (27.100)

1. **▲ WARNING**

**Heavy objects!**

**Lift and handle all heavy components using lifting equipment with adequate capacity. Always support units or parts with suitable slings or hooks. Make sure the work area is clear of all bystanders.**

**Failure to comply could result in death or serious injury.**

W0398A

Remove the differential using the lifting device.

**NOTE:** Check the adjustment shims.

**NOTE:** Clean the components, check carefully for wear and damage, and replace if necessary.

Next operation:

Differential - Disassemble (27.106)

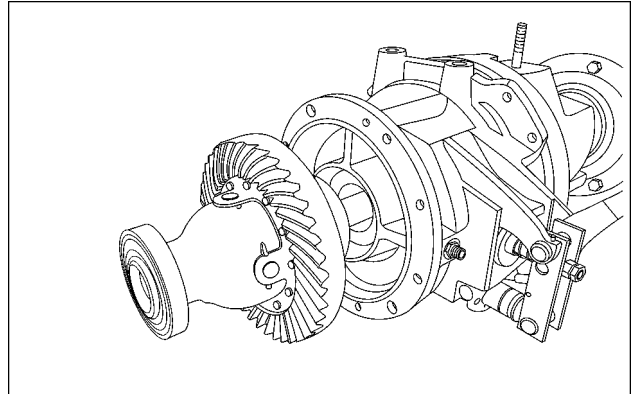

SS11G531 1

## Differential - Disassemble

Hydraulic service brakes - Exploded view (33.202)

Powered rear axle - Exploded view – Front bevel gear set and differential (27.100)

Prior operation:

Differential - Remove (27.106)

1. Remove the rectangular rings (99) from the ring grooves of the differential housing (97).

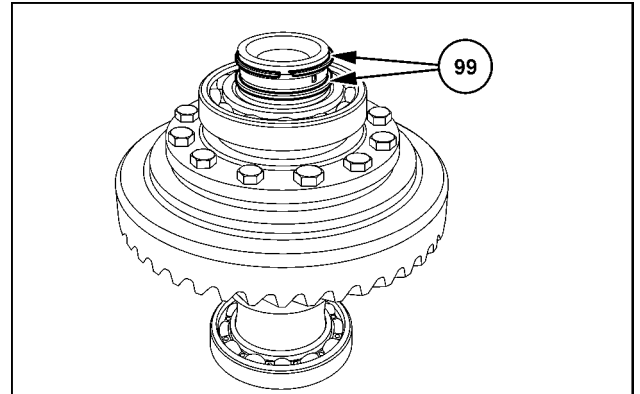

SS13H051 1

2. Remove the two ball bearings (72) and (100).

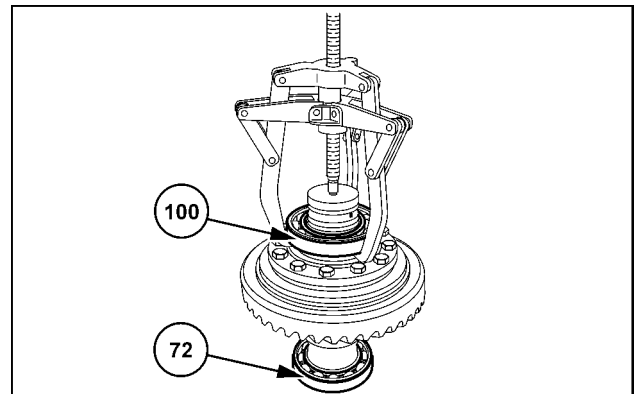

SS13H052 2

3. Undo the bolts (98).

**NOTE:** Use a press to secure the differential so that the differential does not turn.

4. Disconnect the differential housing from the differential case.

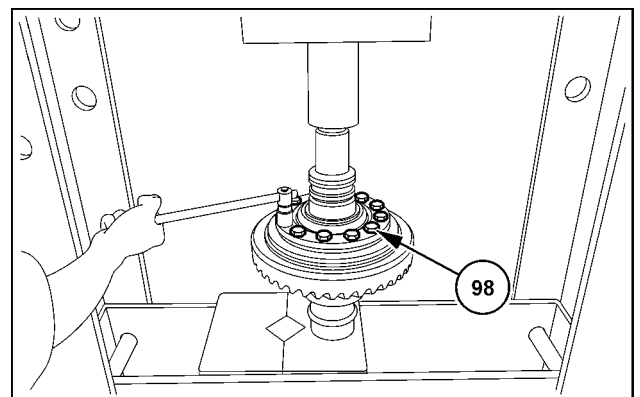

SS13H053 3

5. **⚠ CAUTION**

**Eye injury hazard!**  
**Wear protective goggles when using compressed air.**  
**Failure to comply could result in minor or moderate injury.**

C0035A

Use compressed air to carefully remove the piston (94) from the differential housing.

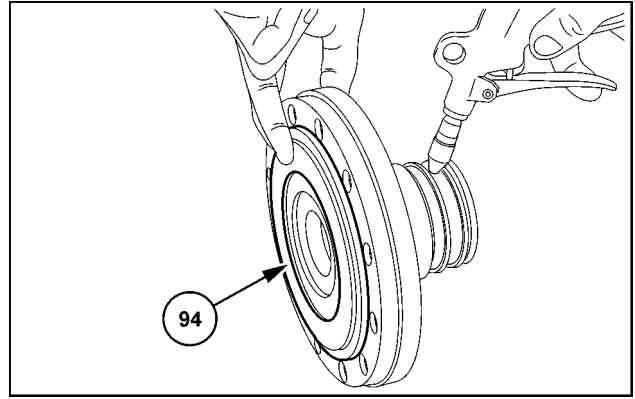

SS13H054 4

6. Remove the O-rings (95) and (96) from the ring grooves of the piston.

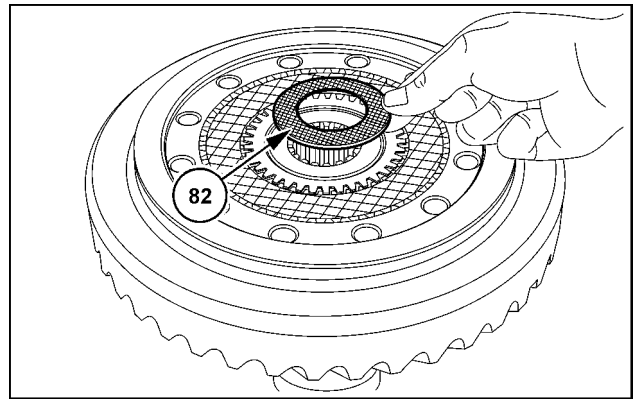

SS13H055 5

7. Remove the thrust washer (82) from the bevel gear (80).

8. Remove the bevel gear (80) together with the disk carrier (81).

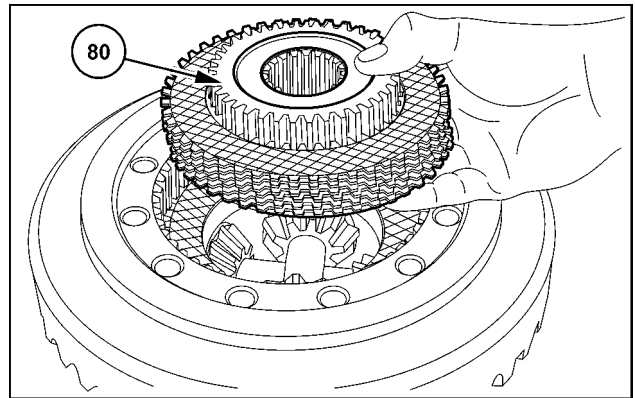

SS13H056 6

9. Remove the loose crown wheel (93) from the differential case.

10. Push out the roll pin (74).

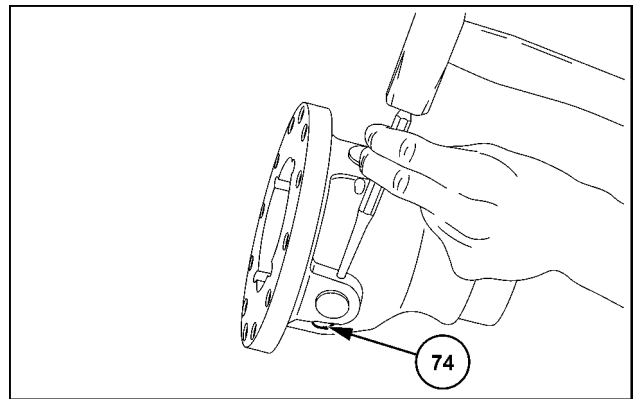

SS13H057 7

11. Remove the differential axles.

12. Remove the bevel gears (78) with the thrust washers (77) from the housing. Remove the bevel gear (76) and the thrust washer (75) from the housing.

**NOTE:** Clean the components, check carefully for wear and damage, and replace if necessary.

**Next operation:**  
**Front-Wheel Drive (FWD) - Remove (23.202)**

## Differential - Assemble

### Powered rear axle - Exploded view – Front bevel gear set and differential (27.100)

Prior operation:

Final drive housing - Install (27.120)

**NOTE:** All components must be lubricated prior to installation.

1. Insert the thrust washer (75) and the bevel gear (76) into the differential housing (73).

**NOTE:** Fit the thrust washer so that the bevel on the inside diameter faces the bevel gear (upward).

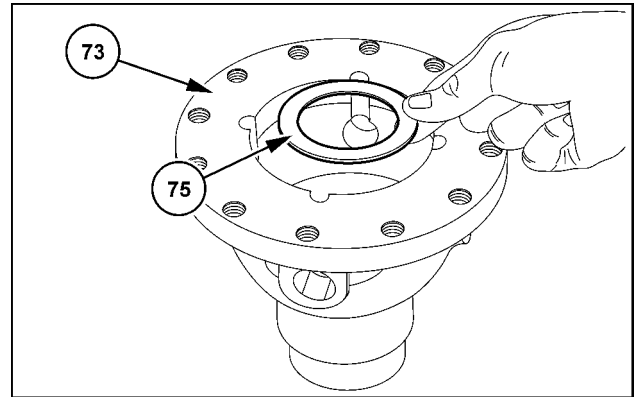

SS13H058 1

2. Fit the bevel gear (76) in the differential housing (73).

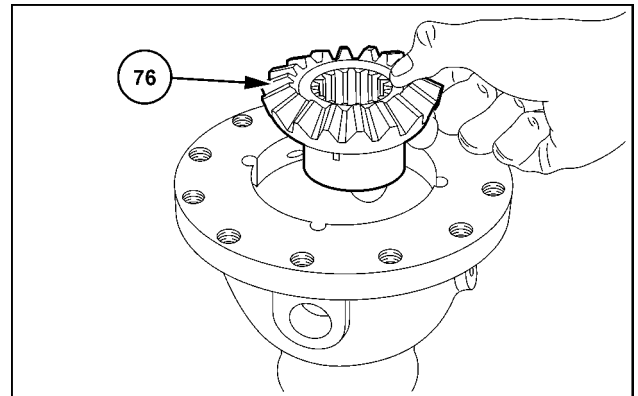

SS13H059 2

3. Fit the bevel gears (78) with the thrust washer (77) and the axle (79) in the differential housing (73).

**NOTE:** Position the tab of the thrust washer in the groove (see arrow) of the differential housing.

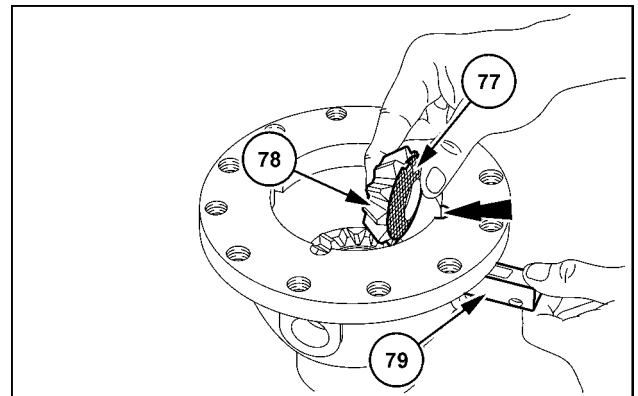

SS13H060 3

- Secure the axles (79) with the roll pin (74).

**NOTE:** Fit the roll pin with the opening facing upward.

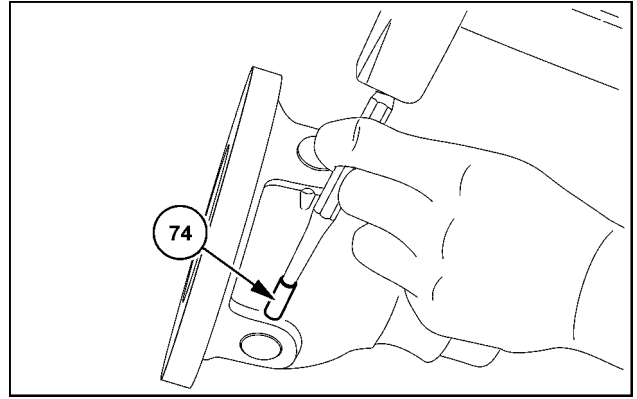

SS13H061 4

- Fit the two grub screws (M12).
- Fit the crown wheel (93) on the differential housing (73).

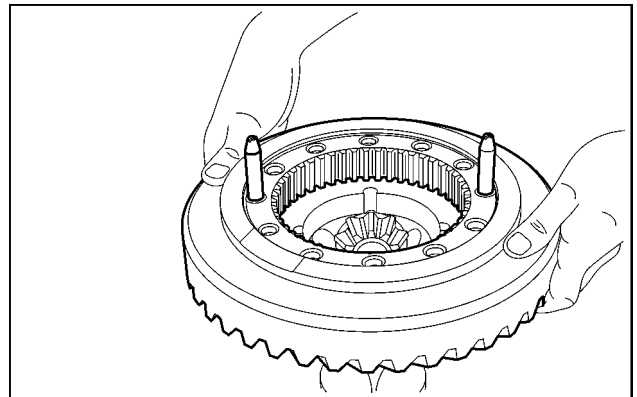

SS13H062 5

- Fit the bevel gear (80) together with the disk carrier (81).

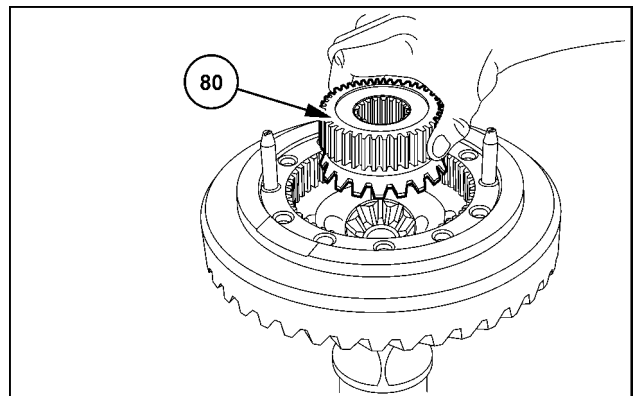

SS13H063 6

- Fit the disks. Start with a friction disk (83).

**NOTE:** If you are using new friction disks, the new friction disks must be soaked in engine oil for at least 30 min.

**NOTE:** Layer the friction disks and the steel disks alternately.

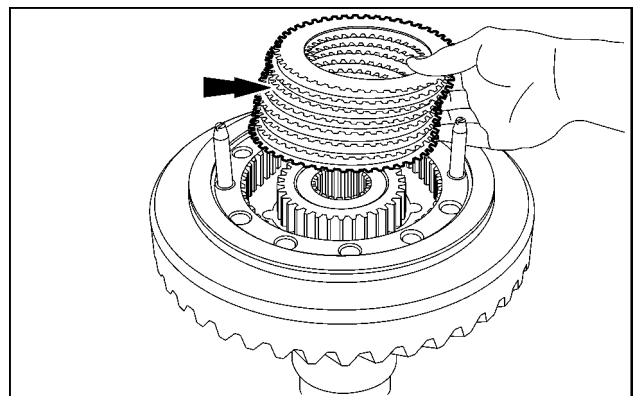

SS13H064 7

9. Insert the thrust washer (82) into the bevel gear (80).

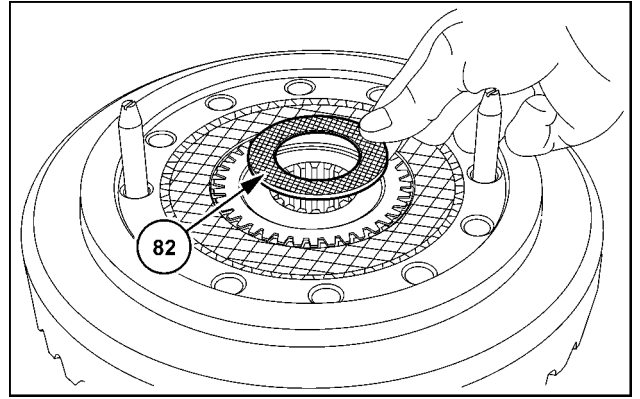

SS13H065 8

10. Insert the O-rings (95) and (96) into the ring grooves of the piston (94).

**NOTE:** Grease the O-rings with industrial Vaseline.

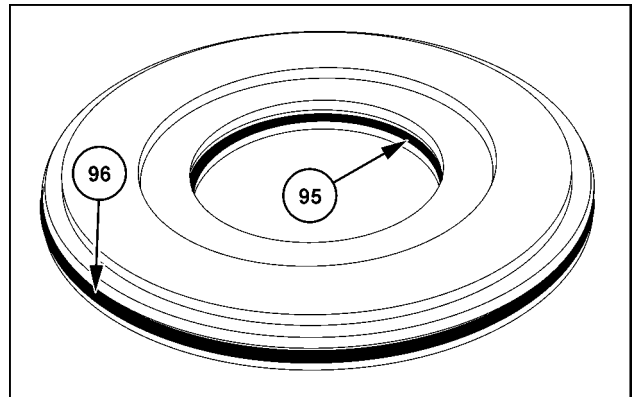

SS13H066 9

11. Fit the piston (94). Make sure that the flat side of the piston faces the differential housing (97).

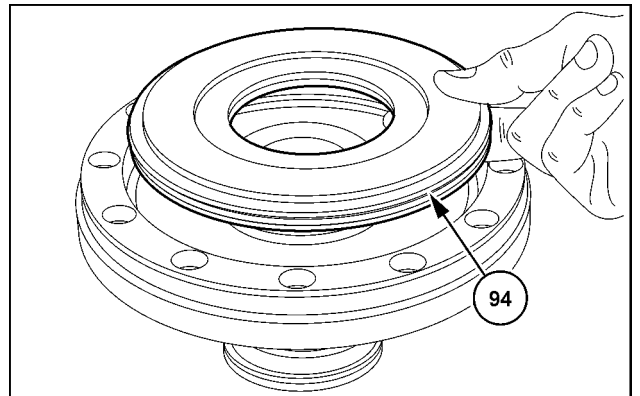

SS13H067 10

12. Coat the bolts (98) with **LOCTITE® 243**.
13. Fit the differential housing (97) on the differential housing (73).
14. Insert screws and tighten to **115 Nm (84.8 lb ft)**.

**NOTE:** Use the press to secure the differential so that the differential does not turn.

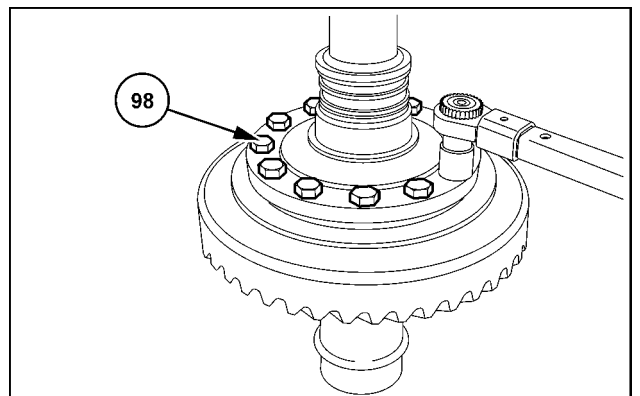

SS13H068 11

15. **⚠ CAUTION**

**Burn hazard!**  
**Always wear heat-resistant protective gloves when handling heated parts.**  
**Failure to comply could result in minor or moderate injury.**

C0047A

Heat the two ball bearings (72) and (100). Slide on the two ball bearings until they sit in place.

**NOTE:** Adjust the ball bearings once they have cooled down.

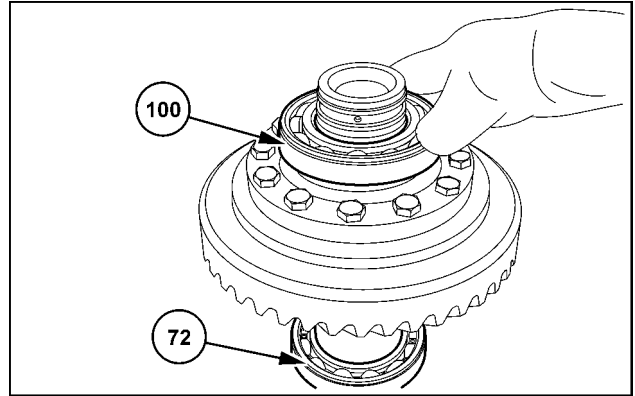

SS13H069 12

16. Fit the rectangular rings (99) in the ring grooves of the differential housing (97) and interlock them.

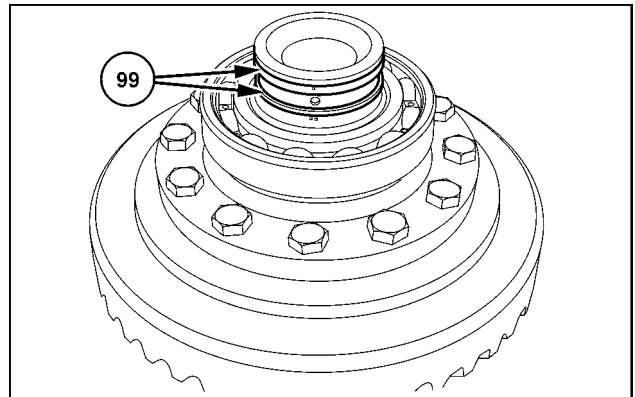

SS13H070 13

**Next operation:**  
**Differential - Install (27.106)**

## Differential - Install

### Powered rear axle - Exploded view – Front bevel gear set and differential (27.100)

#### Prior operation:

#### Differential - Assemble (27.106)

**NOTE:** All components must be lubricated prior to installation.

1. Insert the adjustment disks (71) in the brake housing.
2. Align the rectangular rings (99).
3. Fit the pre-assembled differential in the brake housing.

**NOTE:** Grease the rectangular rings with industrial Vaseline.

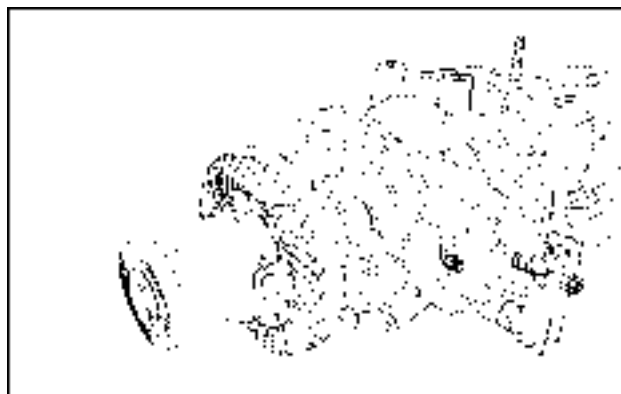

SS10E032 1

#### 4. **⚠ WARNING**

##### Heavy objects!

Lift and handle all heavy components using lifting equipment with adequate capacity. Always support units or parts with suitable slings or hooks. Make sure the work area is clear of all bystanders.

Failure to comply could result in death or serious injury.

W0398A

Clean the sealing surfaces on the brake housing and on the rear axle and coat with **LOCTITE® 518**.

5. Fit the complete output transmission, together with the differential, on the rear axle housing. Tighten the screws to **115 Nm (84.8 lb ft)**.
6. Use a suitable mandrel (plastic, aluminum) to move the differential back.

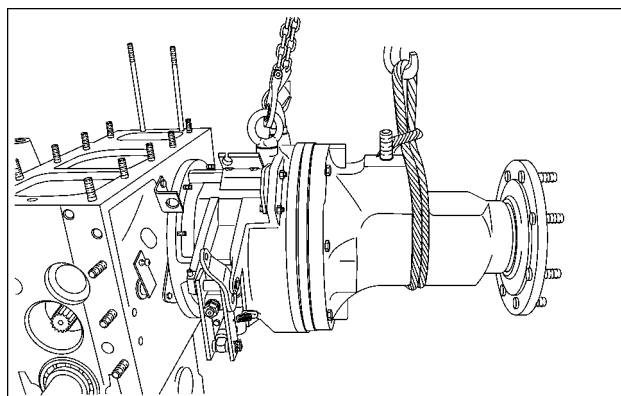

SS10E033 2

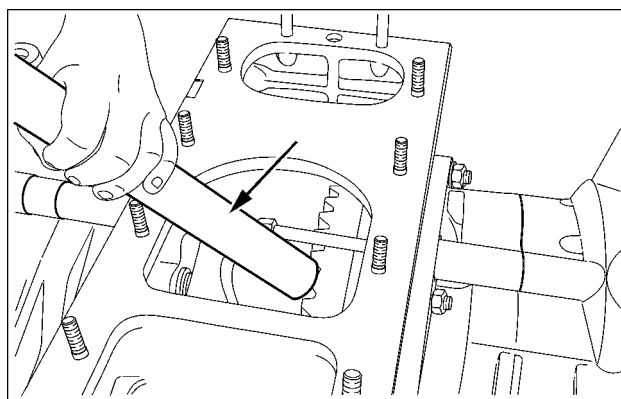

SS10E034 3



7. Check the gear backlash **0.15 - 0.3 mm (0.006 - 0.012 in)** at a minimum of 3 to 4 points around the periphery of the crown wheel.

**NOTE:** In the event of any deviations from the target value, correct the issue with adjustment disks (71) of a different thickness.

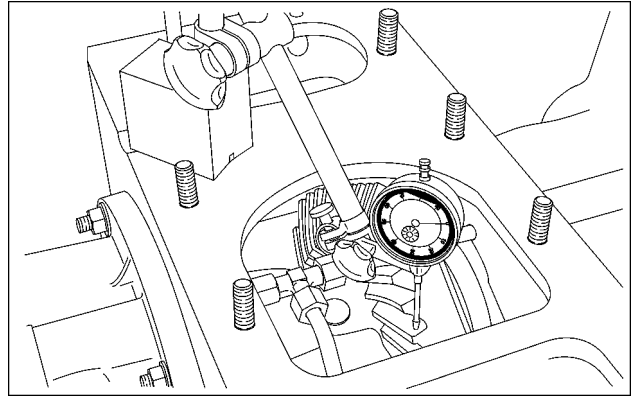

### Gear contact pattern check

8. Coat several teeth on both sides with whiting.
9. Roll over the teeth with the pinion. Check the gear contact pattern.

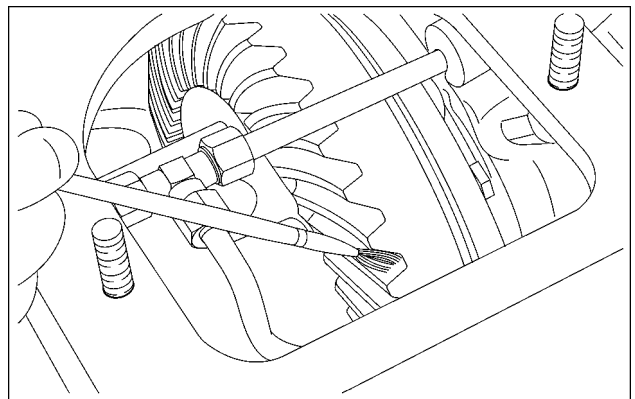

Ideal gear contact pattern for thrust flank (concave)

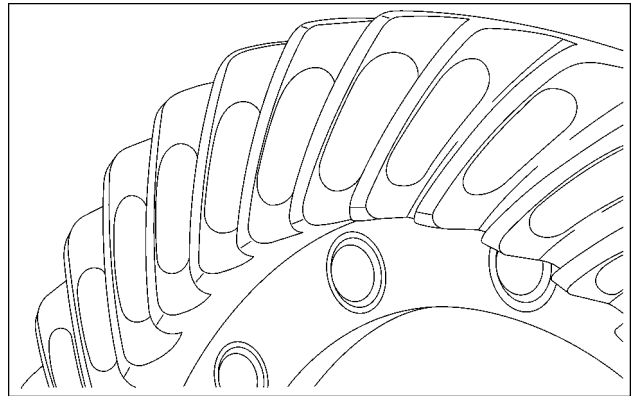

Ideal gear contact pattern for traction flank (convex)

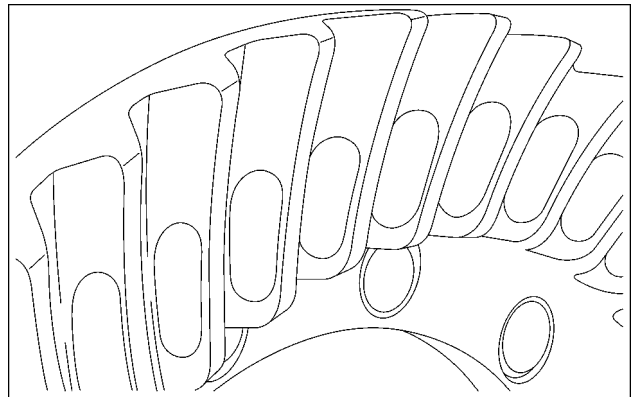

## Bevel pinion - Remove

Powered rear axle - Exploded view – Rear axle housing and final drive (27.100)

Powered rear axle - Exploded view – Front bevel gear set and differential (27.100)

Prior operation:

Front-Wheel Drive (FWD) - Disassemble (23.202)

1. Remove the bolts from the lubrication lines (39), (40), and (41).
2. Remove the lubrication lines with the fittings and the O-rings.

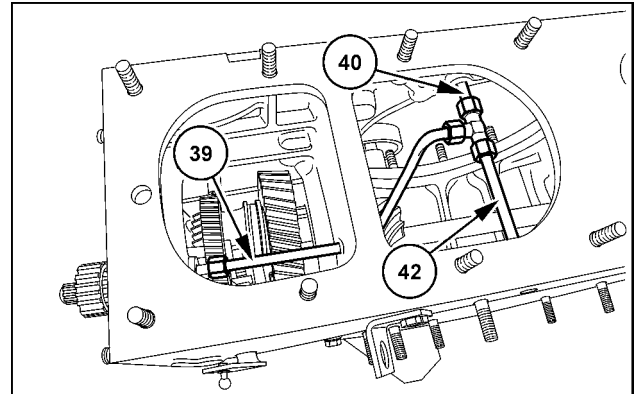

SS13H071 1

3. Unscrew the bolt. Remove the bolt together with the transmission output speed sensor (46).

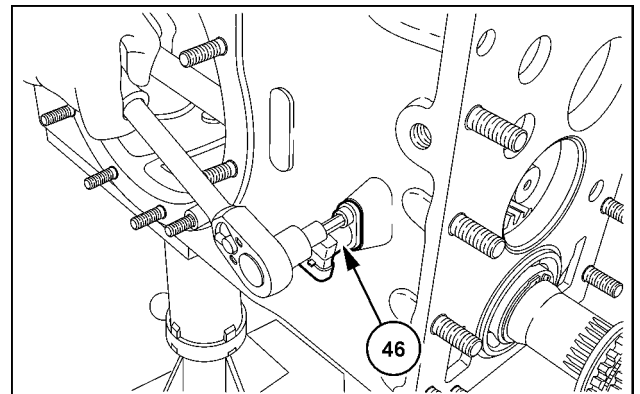

SS13H072 2

4. Release the circlip (431) from the pinion shaft (91). Remove the clearance washer (432).

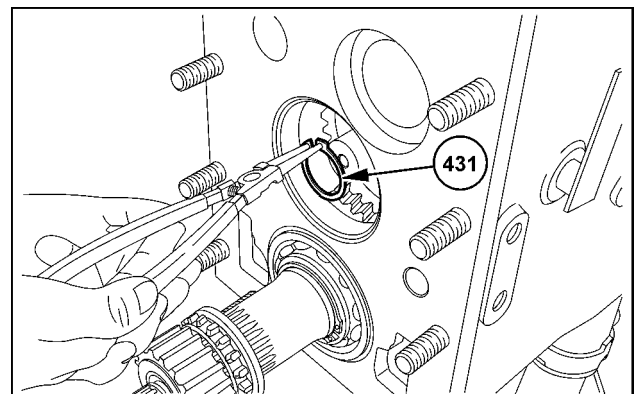

SS13H073 3

5. Use the special tool **380001731** and the ring nut wrench to open the groove nut (**85**).

**NOTE:** This work step can only be carried out when the lever is in the rear position.

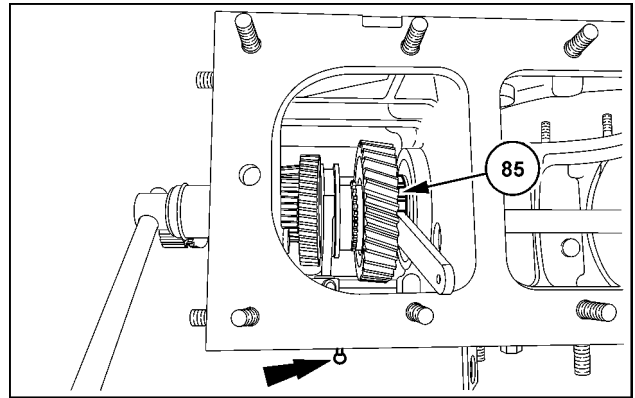

SS13H074 4

6. Push the pinion shaft (**91**) out toward the rear. When doing so, open the groove nut (**85**) further.

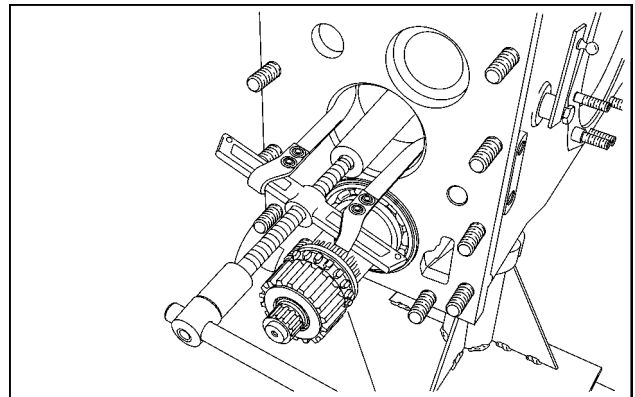

SS13H075 5

7. Remove the pinion shaft (**91**) and any loose components.

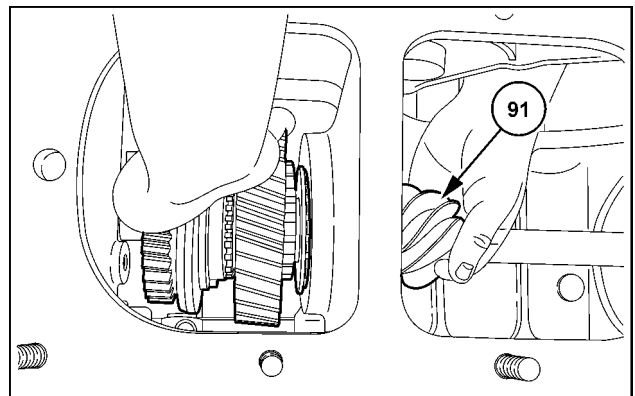

SS13H076 6

8. Remove the ball (**92**).

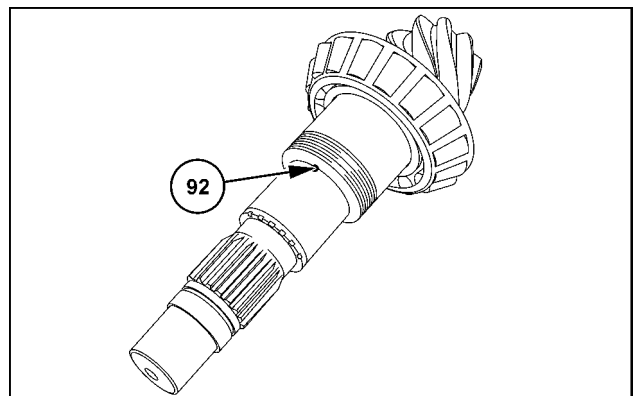

SS13H077 7

9. Press the roller bearing (90) off the pinion shaft (91).

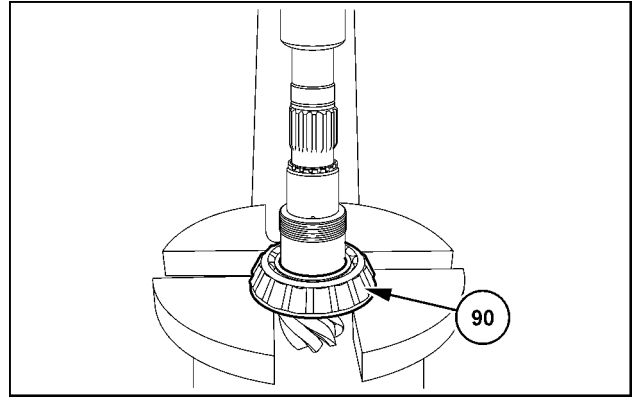

SS13H078 8

### Removing the field/road shift

10. Undo the screw plug (461).  
11. Remove the spring (459). Remove the ball (458).

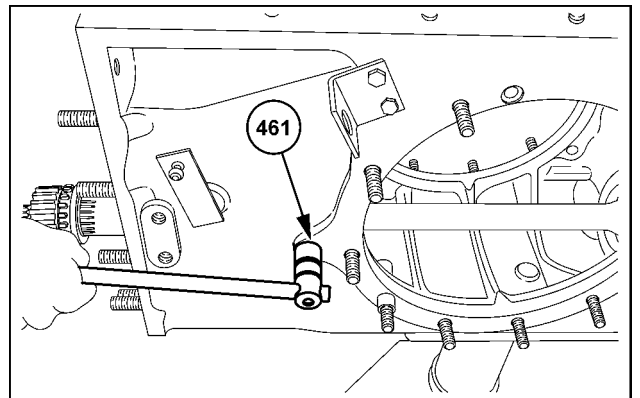

SS13H079 9

12. Unscrew the bolt (451) from the shift finger (452).  
13. Remove the shift finger. Remove the shift lever (457).

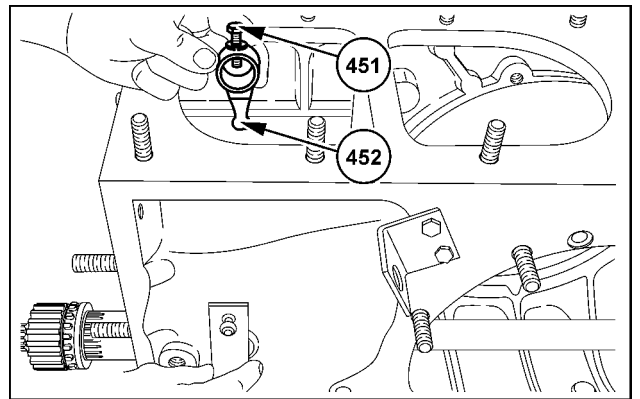

SS13H080 10

14. Push out the roll pin (454) from the shift fork (453).  
15. Remove any loose components.

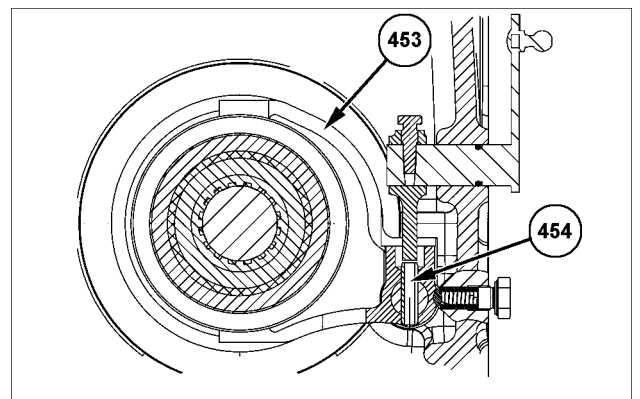

SS13H081 11

16. Push the two bearing outer rings **(86)** and **(90)** off of the roller bearings.
17. Remove the disk **(89)**.

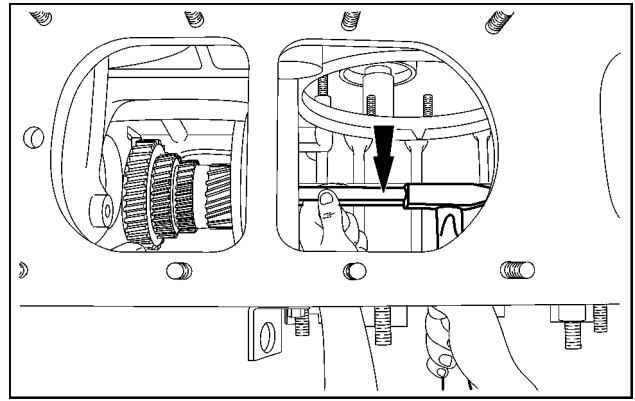

SS13H082 12

18. Release the circlip **(88)** from the ring groove of the rear axle housing.

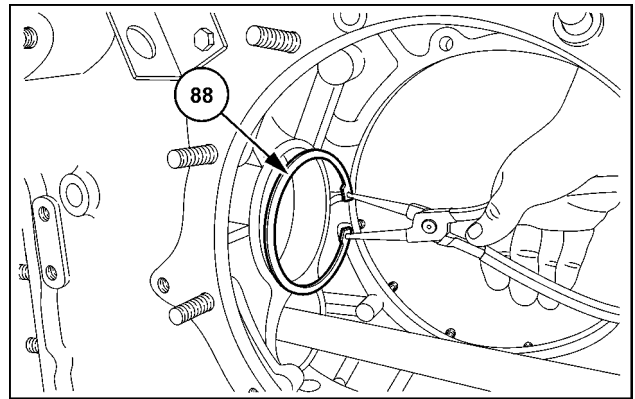

SS13H083 13

**NOTE:** Clean the components, check carefully for wear and damage, and replace if necessary.

**Next operation:**  
**Output shaft - Remove (31.119)**

## Bevel pinion - Gear tooth contact

### Prior operation:

#### Output shaft - Install (31.119)

This procedure involves the setting of dimensions. A standard shim ( $s = 4 \text{ mm (0.16 in)}$ ) forms the basis for the standard dimensions of the housing (0), the bevel pinion (0), and the rear (in the direction of travel) bevel pinion bearing ( $31.5 \text{ mm (1.24 in)}$ ). If there is any deviation from a standard dimension, you must change the thickness of the shims to correct this deviation.

To facilitate the adjustment procedure, it is not the measured dimension that is written on the housing or bevel pinion, but rather its deviation (correction) from the nominal dimension in hundredths of a millimeter. In each case, you must measure the actual dimension of the reverse bevel pinion bearing. You must then compare this actual dimension with the standard dimension ( $T = 31.5 \text{ mm (1.24 in)}$ ) in order to determine the correction.

A	Housing correction: Read this correction on the upper surface of the rear axle housing (on the right-hand side in the direction of travel).
B	Bevel pinion correction: Read this correction on the front surface of the bevel pinion.
C	Standard shim $s = 4 \text{ mm (0.16 in)}$
D	Correction of the rear bevel pinion bearing: Calculate this correction from the difference between the measured dimension and the standard dimension $T = 31.5 \text{ mm (1.24 in)}$ .
X	Shim thickness: Calculate the shim thickness from the standard shim $s = 4 \text{ mm (0.16 in)}$ with the aid of the corrections.

**NOTE:** Round down for figures up to  $0.04 \text{ mm (0.0016 in)}$ .

Round up for figures from  $0.05 \text{ mm (0.0020 in)}$ .

A Housing correction (e.g. 06)      Either add or subtract the correction "A" to or from the shim thickness (s) in accordance with the sign.  
(- on the housing = - disk | + on the housing = + disk)

B Bevel pinion correction (e.g. 05)      For corrections "B" and "D", reverse the signs from (+) to (-) and from (-) to (+).

Actual dimension of taper roller bearing      **31.62 mm (1.245 in)**

Standard dimension of taper roller bearing      **31.50 mm (1.240 in)**

D (Bearing correction)      **+ 0.12 mm (0.005 in)**

C (Standard disk)      **4 mm (0.157 in)**

A (+06)      **+ 0.06 mm (0.003 in)**  
**= 4.06 mm (0.160 in)**

B (+05)      **- 0.05 mm (0.002 in)**  
**= 4.01 mm (0.158 in)**

D (+12)      **- 0.12 mm (0.005 in)**

X (Shim thickness)      **= 3.89 mm (0.153 in) = 3.90 mm (0.154 in)**

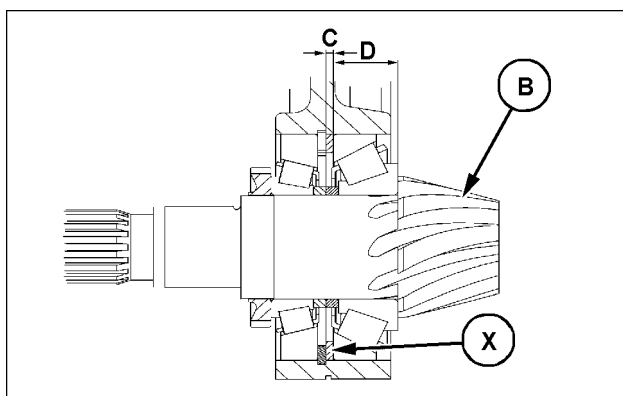

SS13H084 1

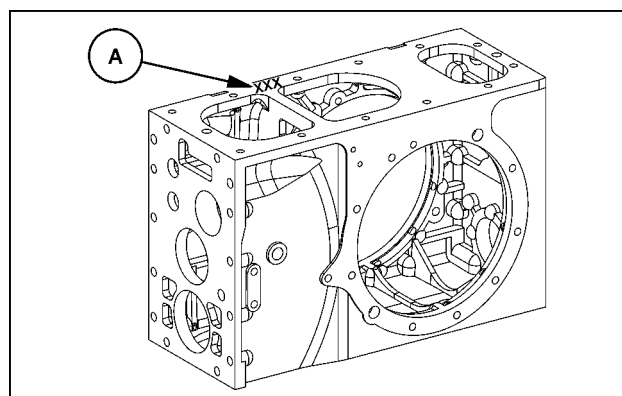

SS13H085 2

**Next operation:**

**Bevel pinion - Preload (27.106)**

## Bevel pinion - Preload

### Powered rear axle - Exploded view – Front bevel gear set and differential (27.100)

**Prior operation:**

**Bevel pinion - Gear tooth contact (27.106)**

**NOTE:** Before you fit the pinion shaft, readjust the bearing pre-load.

Rolling torque: **0.1 - 1.5 Nm (0.07 - 1.11 lb ft)**

1. Measure the rolling torque with the spring scale on the diameter: **140 mm (5.5 in)** (the center bush) **1.4 - 21.4 N (0.31 - 4.81 lb)** or **0.14 - 2.14 kg (0.31 - 4.72 lb)**
2. For the adjustment of the bearing pre-load, pre-assemble the bearing unit according to figure 1:
  - (A) Center bush
  - (B) Press
  - (C) Support plate
  - (86) Roller bearing
  - (87) Adjustment disks that you need to calculate
  - (88) Circlip
  - (89) Calculated adjustment disk
  - (90) Roller Bearing

**NOTE:** Make the center bush (A) yourself in accordance with the dimensional sketch – see **Powered rear axle - Special tools (27.100)**.

**NOTE:** An adjustment is only possible with the already calculated adjustment disk for the contact adjustment. To make adjustment easier in advance, use the adjustment disks you find at disassembly.

3. Preload the pre-assembled bearing unit on the press with **10000 N (2248.1 lb)** or **1000 kg (2204.6 lb)**. During the pre-load, crank the roller bearing at all times. Check the rolling torque. Replace the adjustment disks (**422**) if you need to correct the rolling torque.

**NOTICE:** It must always be possible to rotate the roller bearings by hand.

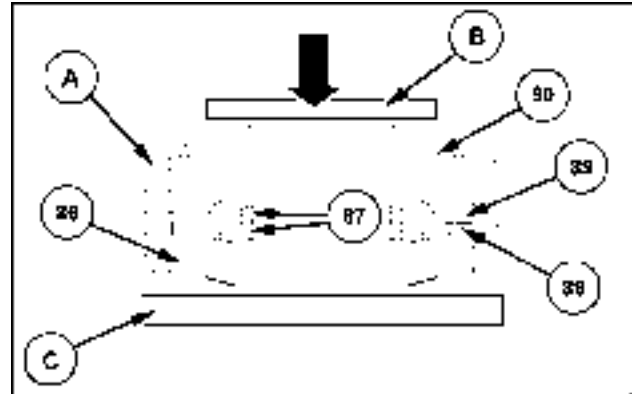

SS13H086 1

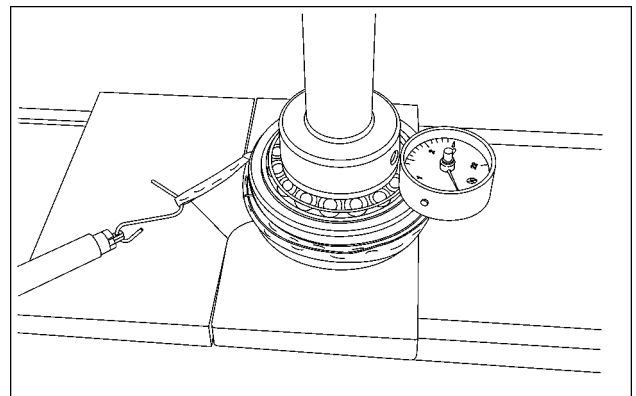

SS11G553 2

**Next operation:**

**Bevel pinion - Install (27.106)**



## Bevel pinion - Install

Powered rear axle - Exploded view – Rear axle housing and final drive (27.100)

Powered rear axle - Exploded view – Front bevel gear set and differential (27.100)

Field-road group - Exploded view (21.902)

Prior operation:

Bevel pinion - Preload (27.106)

**NOTE:** All components must be lubricated prior to installation.

### Install the field/road shift:

- (434) Shift collar
- (453) Shift fork
- (454) Roll pin
- (455) Gearshift bar

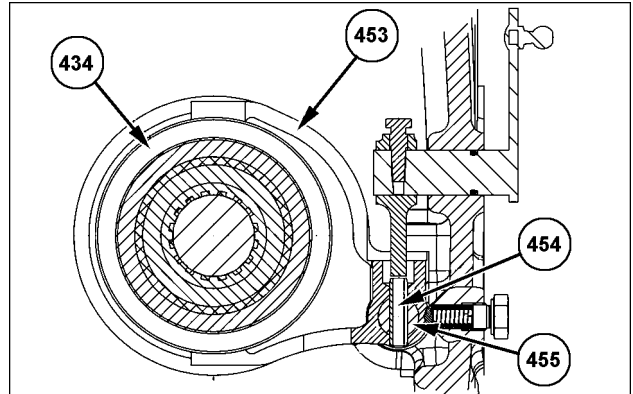

SS13H088 1

1. Install the gearshift bar (455). Install the shift fork (453).
2. Attach the shift fork (453) with the roll pin (454) to the gearshift bar.

**NOTE:** Install the shift stops of the gearshift bar on the housing exterior.

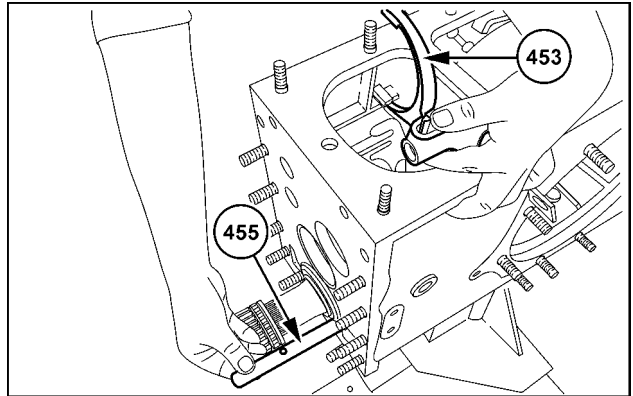

SS13H089 2

3. Thread the shift collar (434) onto the gear (435).

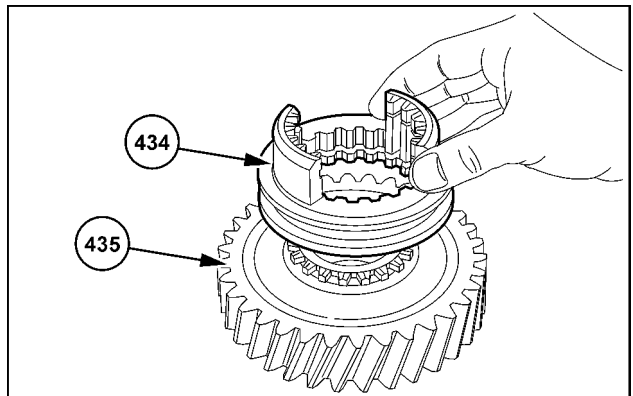

SS13H090 3

4. Install the gear (433) in the shift collar (434).

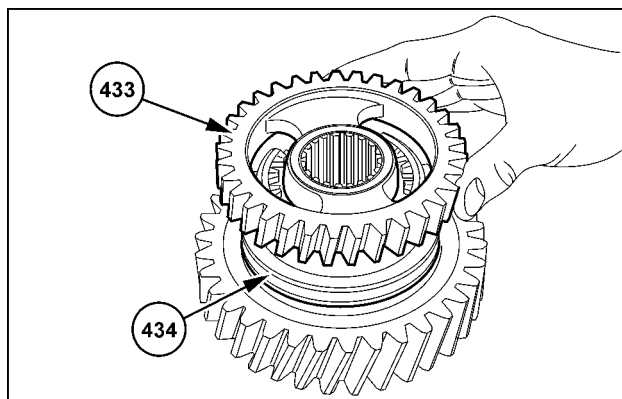

SS13H091 4

5. Insert the pre-assembled gear (435) with the shift collar (434) and the gear (433) into the rear axle housing.

**NOTE:** To insert the components, lift the shift fork. Then thread the shift fork over the shift collar.

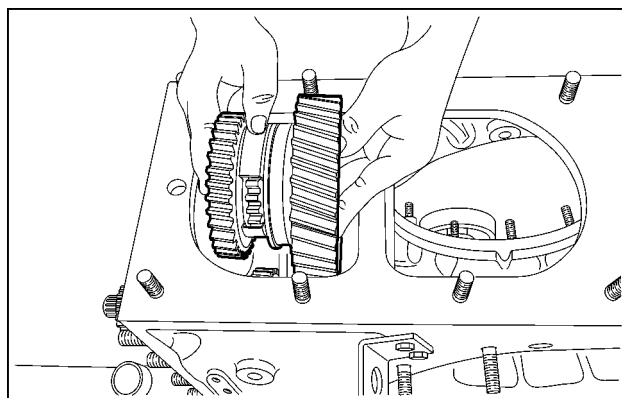

SS13H092 5

### Pinion shaft assembly

6. **CAUTION**

**Burn hazard!**  
 Always wear heat-resistant protective gloves when handling heated parts.  
 Failure to comply could result in minor or moderate injury.

C0047A

Heat the bearing inner ring (90). Install the bearing inner ring on the pinion shaft (91) until the bearing inner ring sits in place.

**NOTE:** Adjust the bearing inner ring once it is cold.

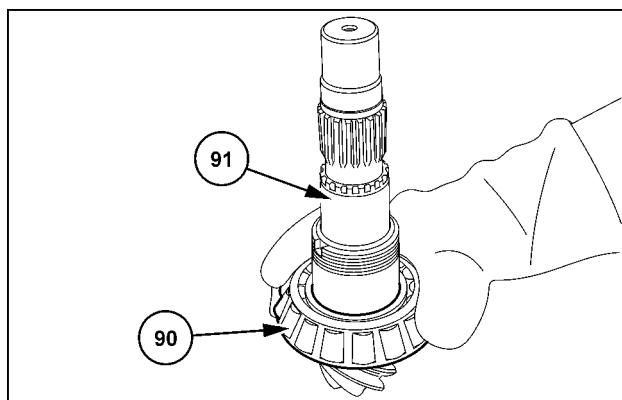

SS13H093 6

7. Thread on the calculated adjustment disks (87).

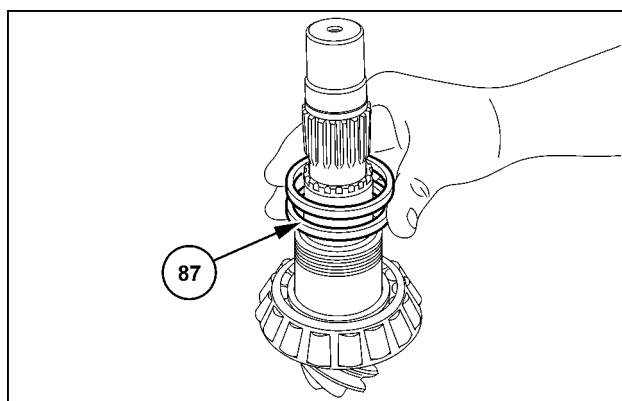

SS13H094 7

8. Install the bearing outer ring of the roller bearing (90).

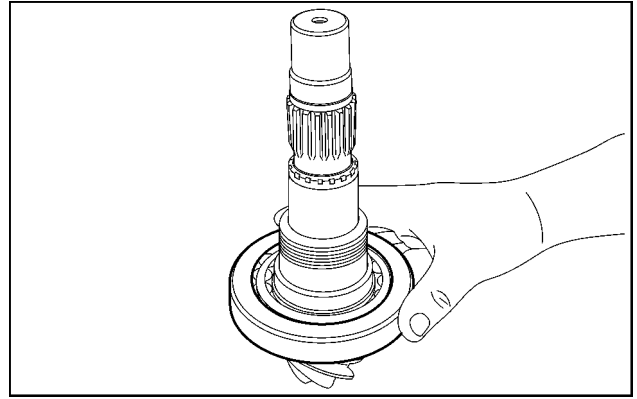

SS13H095 8

9. Install the calculated disk (89).

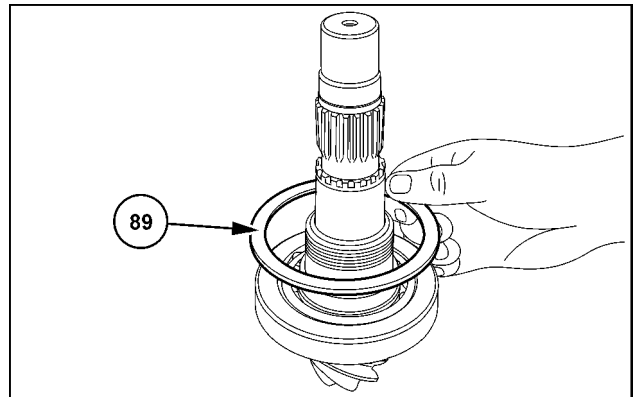

SS13H096 9

10. Thread on the center bush (A) with the assembled circlip.

**NOTE:** Make the center bush (A) yourself in accordance with the dimensional sketch. See **Powered rear axle - Special tools (27.100)** .

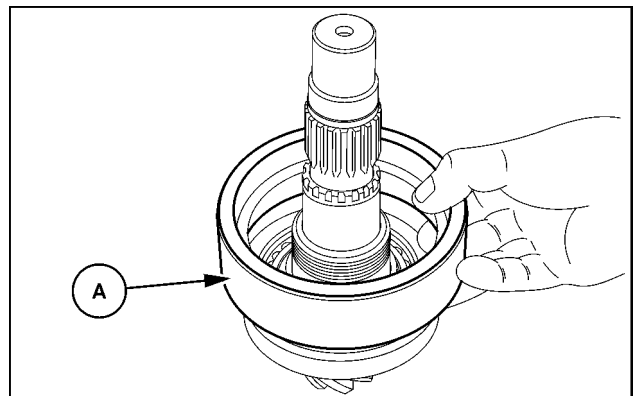

SS13H097 10

11. Install the bearing outer ring of the roller bearing (86) in the center bush.

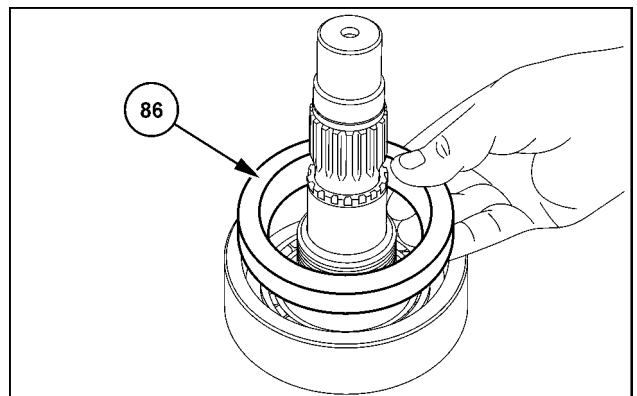

SS13H098 11

12. **⚠ CAUTION**

**Burn hazard!**  
**Always wear heat-resistant protective gloves when handling heated parts.**  
**Failure to comply could result in minor or moderate injury.**

C0047A

Heat the bearing inner ring of the roller bearing (86).  
Install the bearing inner ring until it sits in place.

**NOTE:** Adjust the bearing inner ring once it is cold.

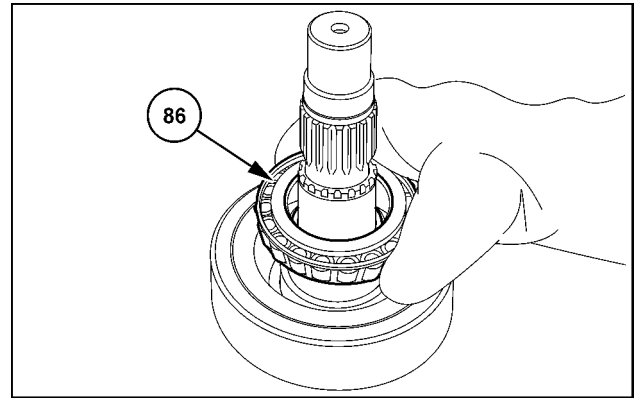

SS13H099 12

13. Screw on the groove nut (85) so that the flat side faces the bearing inner ring.

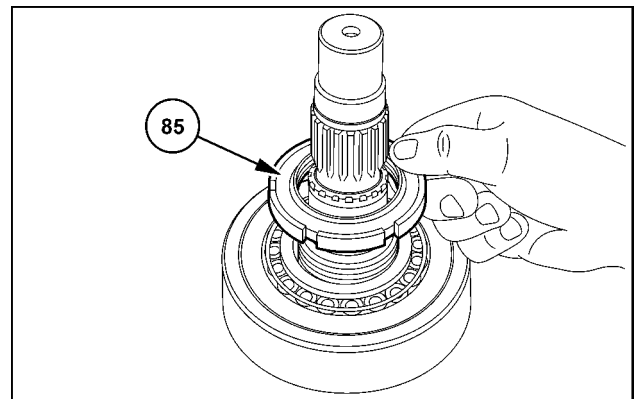

SS13H100 13

14. Install the anti-rotation ball (see arrow) in the pinion shaft (91) with industrial Vaseline.

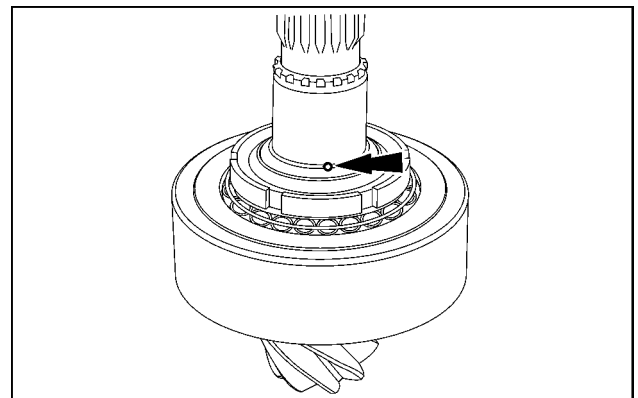

SS13H101 14

15. Thread on the thrust washer (438) until it sits in place.

**NOTE:** Grease the thrust washer with industrial Vaseline.

**NOTE:** Position the groove correctly (disk toward ball).

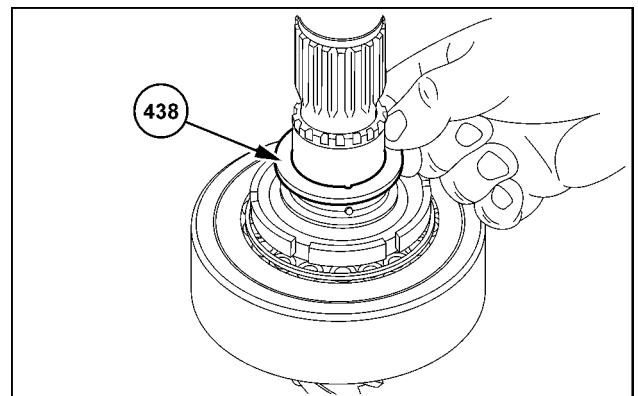

SS13H102 15

16. Thread on the needle bearings (437) until they sit in place.
17. Thread on the spacer ring (436).

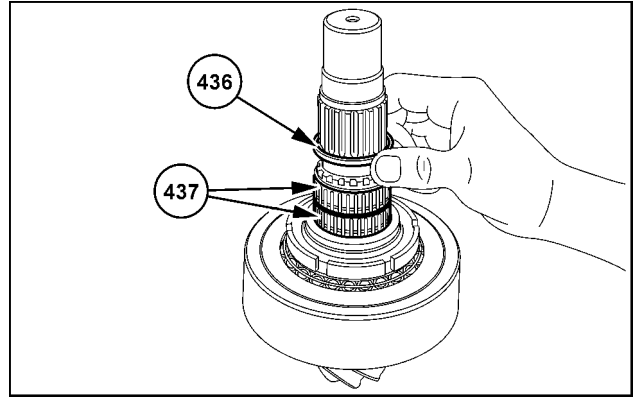

SS13H103 16

18. Thread the pre-assembled pinion shaft into the installed components.
19. Press the pinion shaft bearing until the circlip compresses into the ring groove of the bore of the rear axle housing.

**NOTE:** Make the threaded rod for the pressing yourself.

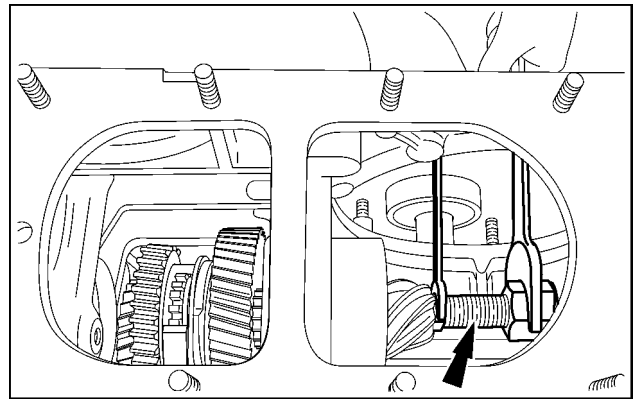

SS13H104 17

20. Secure the pinion shaft (91) with the ring nut wrench. Use the socket wrench 380001731 to tighten the ring nut (85) to a torque of 450 Nm (331.9 lb ft).
21. Check the bearing pre-load ( 0.1 - 1.5 Nm (0.1 - 1.1 lb ft)).

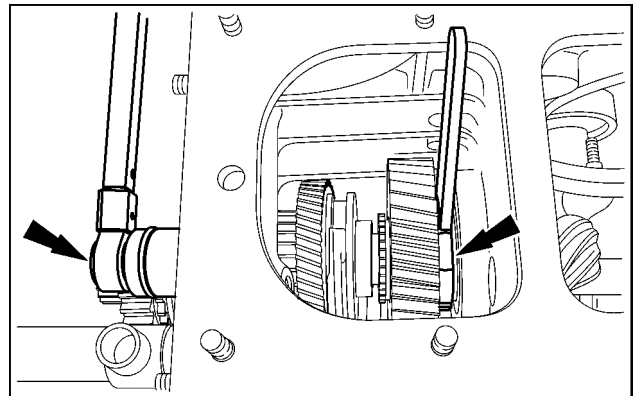

SS13H105 18

22. To prevent any loosening of the slotted nut (85), use a suitable mandrel. Notch the groove of the bevel pinion.
23. After you have prevented any loosening, check the anti-rotation (disk toward ball).

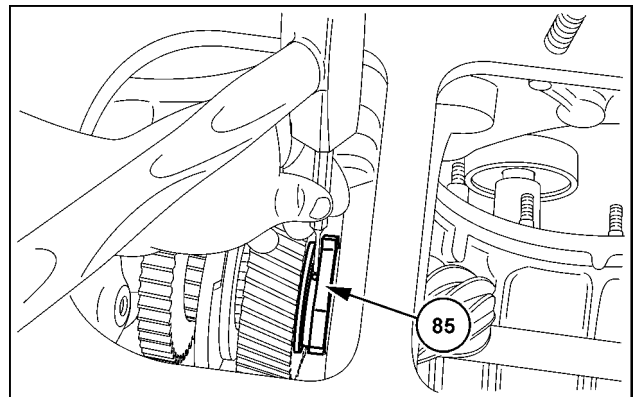

SS13H106 19

24. Thread on the clearance washer (432) until it sits in place.
25. Insert the circlip (431) into the ring groove of the bevel pinion.

**NOTE:** If it is not possible to compress the circlip, the spacer ring is not in the correct location or the anti-rotation is incorrect.

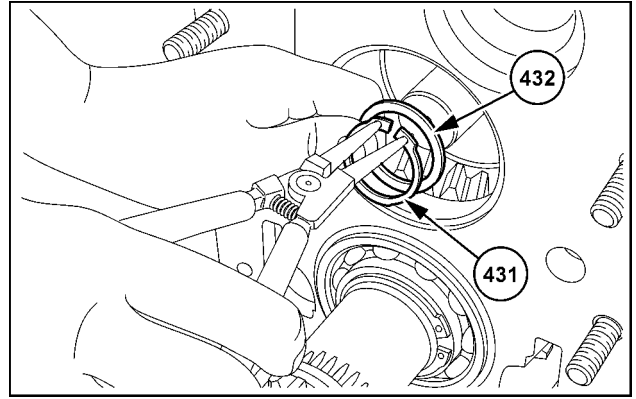

SS13H107 20

26. Install the O-ring (456) in the ring groove of the shift lever (457).
27. Install the lever. Install the shift finger (452).
28. Fix the shift finger on the lever with the bolt (451). Tighten to a torque of 24 Nm (17.7 lb ft).

**NOTE:** Grease the O-ring with industrial Vaseline.

**NOTE:** Note the installation position. Refer to the figure 22.

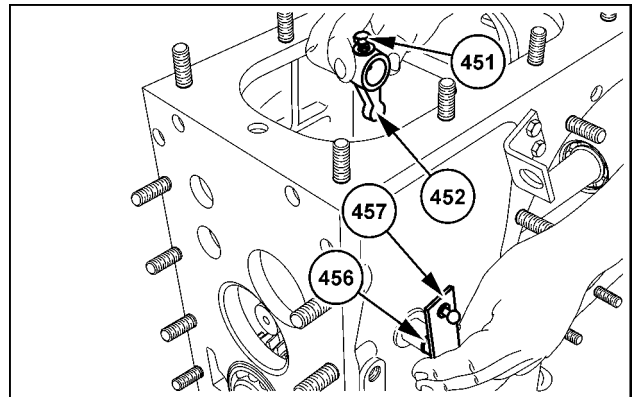

SS13H108 21

29. Insert both the ball (458) and the spring (459) into the housing bore.
- (451) Screw
  - (453) Shift fork
  - (454) Roll pin
  - (455) Gearshift bar
  - (457) Shift lever
  - (458) Ball
  - (459) Spring
  - (461) Screw plug

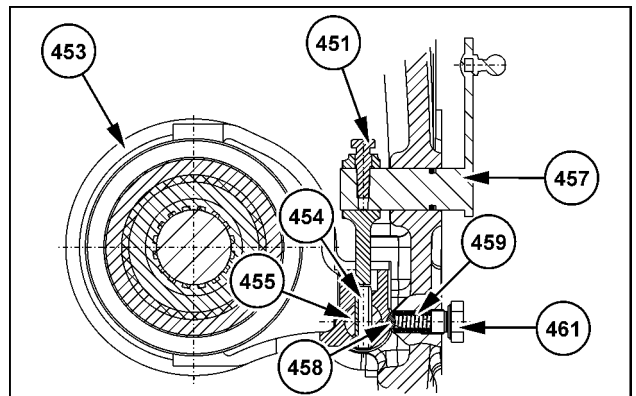

SS13H109 22

30. Spray the screw plug (461) with LOCTITE® 243. Install a new ring seal (394) on the screw plug. Install the screw plug (461) and tighten to 15 Nm (11.1 lb ft).

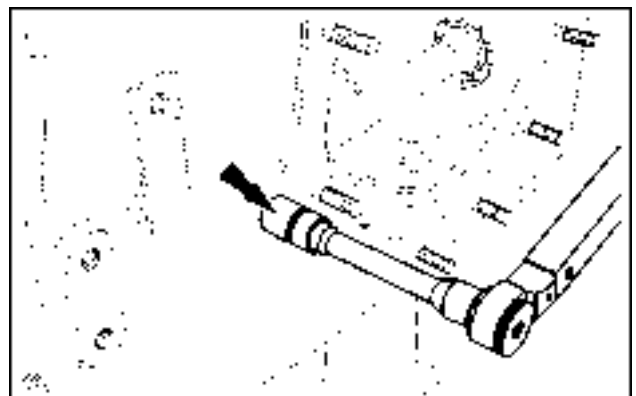

SS13H110 23

31. Apply an O-ring to the fitting (38). Install the fitting. Tighten the fitting to a torque of **35 Nm (25.8 lb ft)**.
32. Install the lines (39), (40) and (42). Tighten the union nuts to a torque of **35 Nm (25.8 lb ft)**.

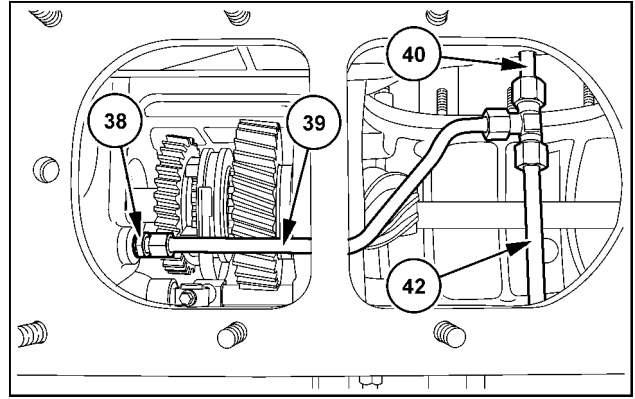

SS13H111 24

33. Install the O-rings on both sides over the oil line until the O-rings sit in place in the rear axle housing.

**NOTE:** Grease the O-rings with industrial Vaseline.

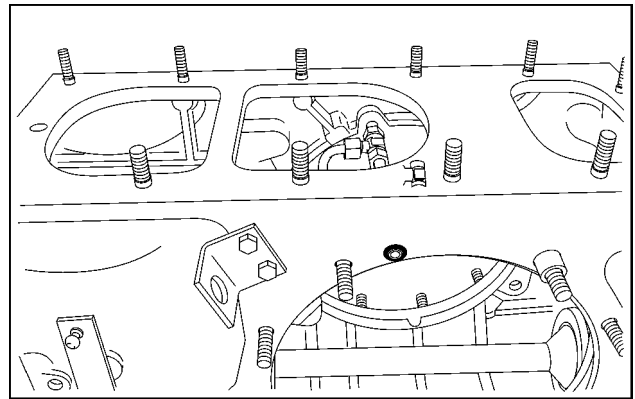

SS13H112 25

**Next operation:**  
**Rear axle housing Brake housing - Install (27.100)**

# Index

---

## Rear axle system - 27

### Rear bevel gear set and differential - 106

Bevel pinion - Gear tooth contact .....	17
Bevel pinion - Install .....	20
Bevel pinion - Preload .....	19
Bevel pinion - Remove .....	13
Differential - Assemble .....	7
Differential - Disassemble .....	5
Differential - Install .....	11
Differential - Remove .....	4
Differential lock control valve - Overview .....	3







## **Rear axle system - 27**

### **Planetary and final drives - 120**

**Farmall 105U Pro EP  
Farmall 115U Pro EP  
Farmall 95U Pro EP**

# Contents

---

## Rear axle system - 27

### Planetary and final drives - 120

#### SERVICE

##### Planetary final drive

Disassemble – Axle trumpet housing and planetary drive ..... 3

Assemble – Axle trumpet housing and planetary drive ..... 6

##### Final drive housing

Remove ..... 11

Install ..... 12

## Planetary final drive - Disassemble – Axle trumpet housing and planetary drive

Powered rear axle - Exploded view – Rear axle housing and final drive (27.100)

Prior operation:

Final drive housing - Remove (27.120)

1. Loosen the grub screw (4).
2. Remove the planetary gear carrier (18).

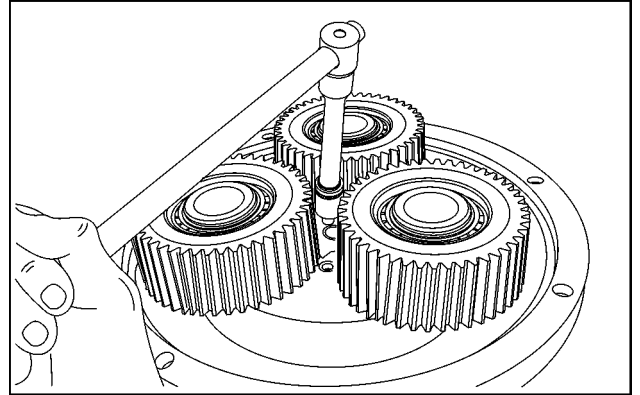

SS13H113 1

3. Remove the ball (3) from the axle shaft (1).

**NOTE:** Use a magnetic rod to remove the ball.

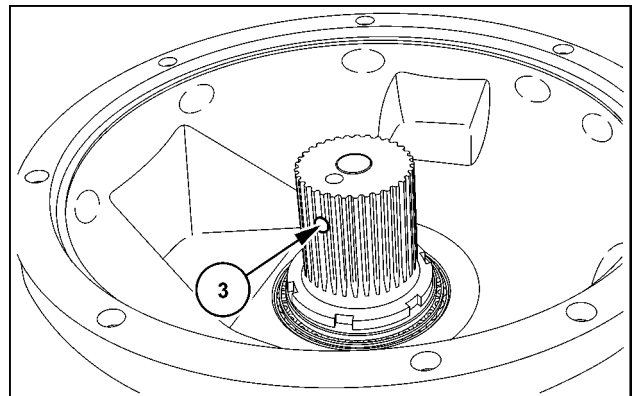

SS13H114 2

4. Remove the circlip (25) from the ring groove of the planetary carrier bolt.

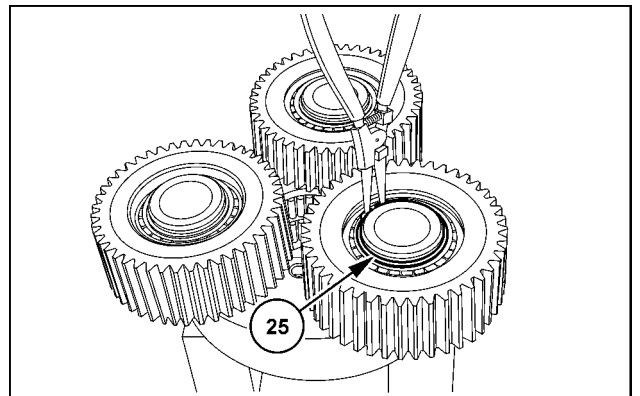

SS13H115 3

5. Remove the planetary gear (21).

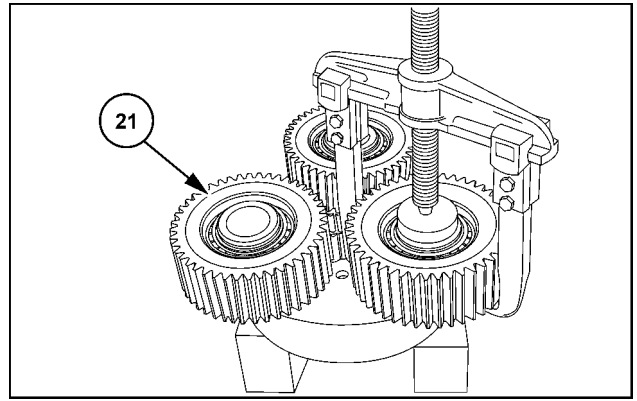

SS13H116 4

6. Remove the circlips (24) from both sides.
7. Remove the loosened individual parts.

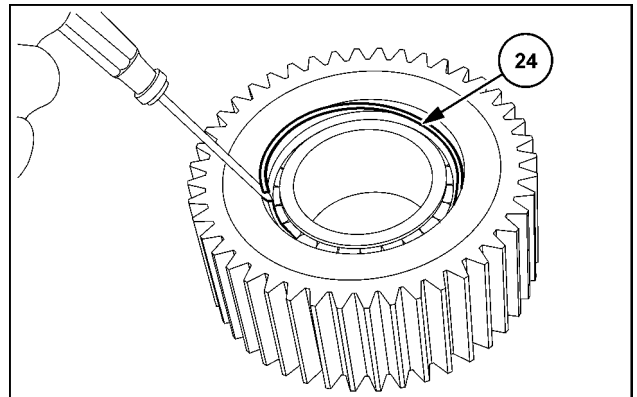

SS13H117 5

8. Remove the ring nut (16) with the special tool 380001730.

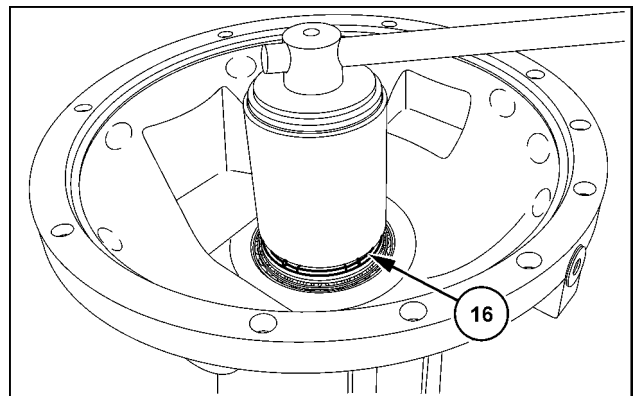

SS13H118 6

9. Remove the axle shaft (1).
10. Remove the bearing inner ring (15).
11. Remove both bearing outer rings from the axle trumpet housing.

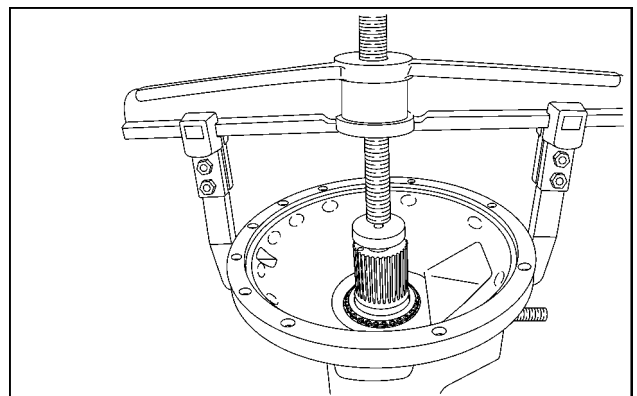

SS13H119 7

12. Remove the bearing inner ring (6) from the axle shaft.

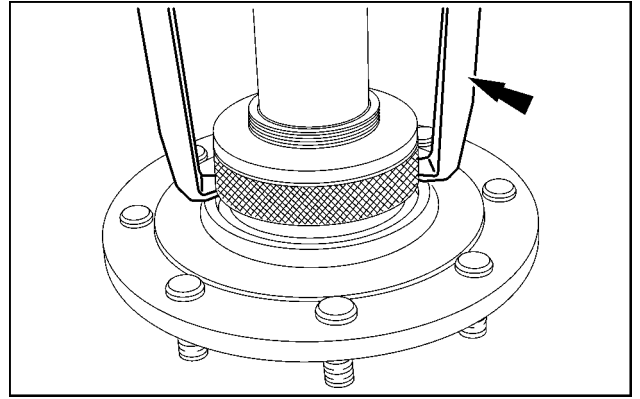

SS13H120 8

13. Remove the shaft sealing ring (5) from the axle shaft.

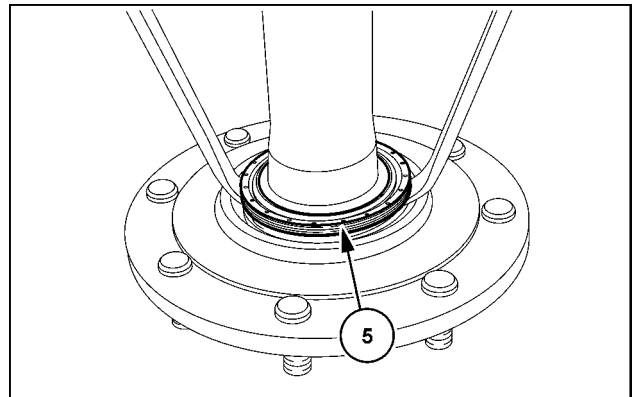

SS13H121 9

**NOTE:** Clean the components, check carefully for wear and damage, and replace if necessary.

**Next operation:**  
**Brakes - Remove (33.202)**

## Planetary final drive - Assemble – Axle trumpet housing and planetary drive

Powered rear axle - Exploded view – Rear axle housing and final drive (27.100)

Prior operation:

Brakes - Install (33.202)

**NOTE:** All components must be lubricated prior to installation.

1. Fit the shaft sealing ring (5) with the special tools  
Installer **380000051**,  
Guide **380000050**  
And positioning tool **380001746**

**NOTE:** Spray the internal diameter of the shaft sealing ring with spirit immediately before installation.

**NOTE:** You can only ensure that the component is installed in exactly the right position with the positioning tool designed for this purpose.

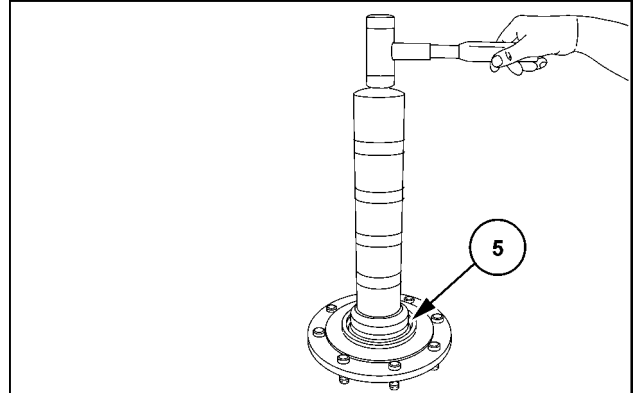

SS13H122 1

### 2. **CAUTION**

**Burn hazard!**

**Always wear heat-resistant protective gloves when handling heated parts.**

**Failure to comply could result in minor or moderate injury.**

C0047A

Heat the bearing inner ring of the roller bearing (6). Insert the bearing inner ring into the axle shaft as far as the bearing inner ring will go.

**NOTE:** Adjust the bearing inner ring once it is cold.

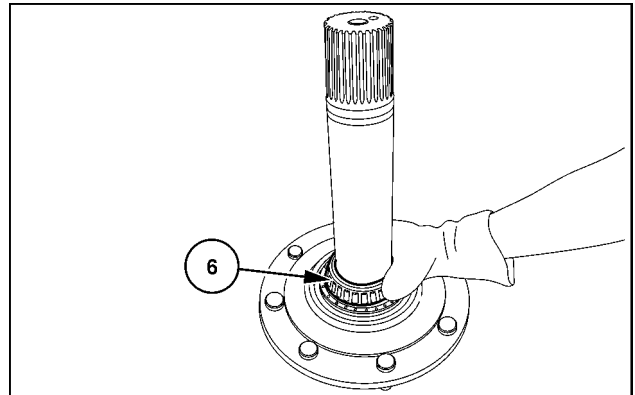

SS13H123 2

3. Fit the outer and the inner bearing rings so that the bearing rings sit in place in the axle trumpet housing.

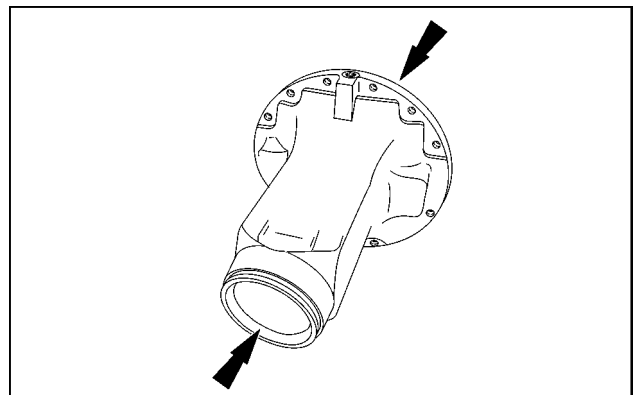

SS13H124 3

4. Fit the axle shaft in the axle trumpet housing.

**NOTE:** Spray the outer skirt surface of the shaft sealing ring with spirit immediately before installing it.

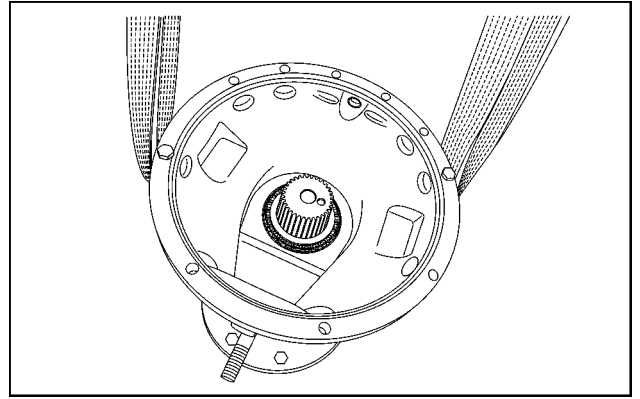

SS13H125 4

5. **CAUTION**

**Burn hazard!**  
**Always wear heat-resistant protective gloves when handling heated parts.**  
**Failure to comply could result in minor or moderate injury.**

C0047A

Heat the bearing inner ring (15). Fit the bearing inner ring.

**NOTE:** Adjust the bearing inner ring once it is cold.

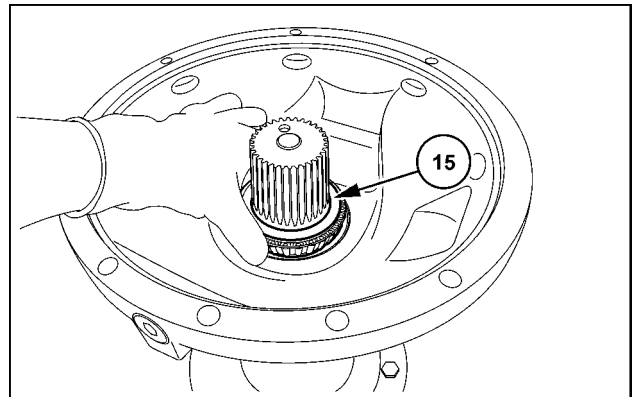

SS13H126 5

6. Fix the ring nut (16) on the axle shaft. The chamfer must face toward the bearing.
7. Use the special tool 380001730 to tighten the ring nut to a torque of 250 Nm (184.4 lb ft). Then loosen by 20°.
8. Before you check the bearing adjustment, tap the axle shaft with a rubber hammer.

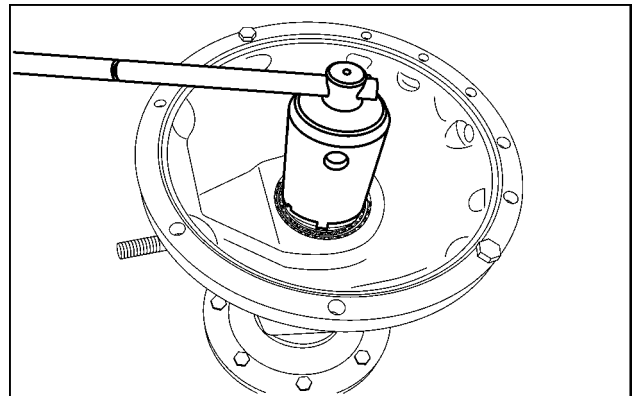

SS13H127 6

Shaft bearing adjustment (bearing preload): 0 - 0.01 mm (0 - 0.0004 in).

Turn the ring nut to set the bearing preload (end play).

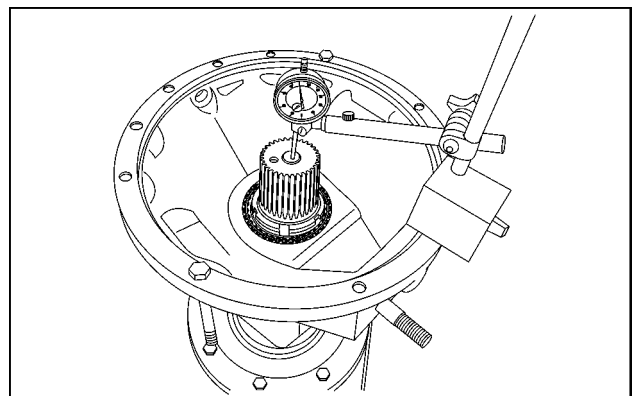

SS13H128 7



9. Position the circlip (19) in the ring nut of the planetary gear (21) (driven side – see arrow).
10. From the opposite side, insert a thrust washer (20).

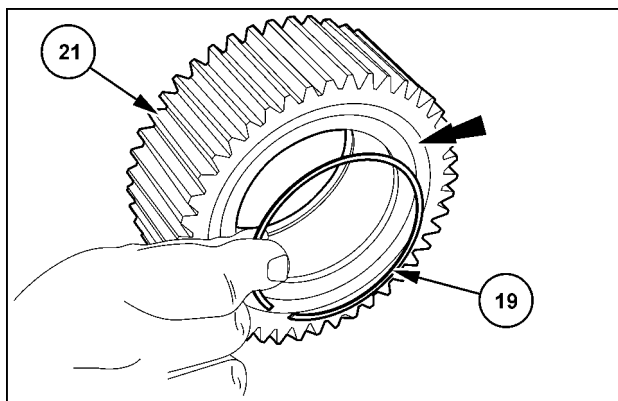

SS13H129 8

11. Fit the roller bearing (22). The rounded side on the inside diameter must face toward the circlip (19).
12. Fit the thrust washer (23) and the second circlip (24).

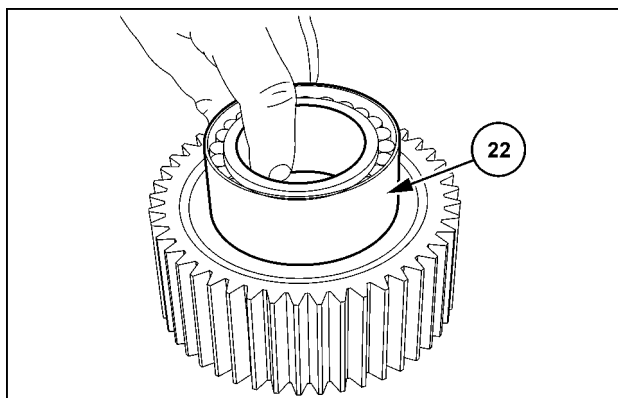

SS13H130 9

13. Fit the pre-assembled planetary gears, with the inside diameter rounded sides (roller bearings) facing the planetary gear carrier.

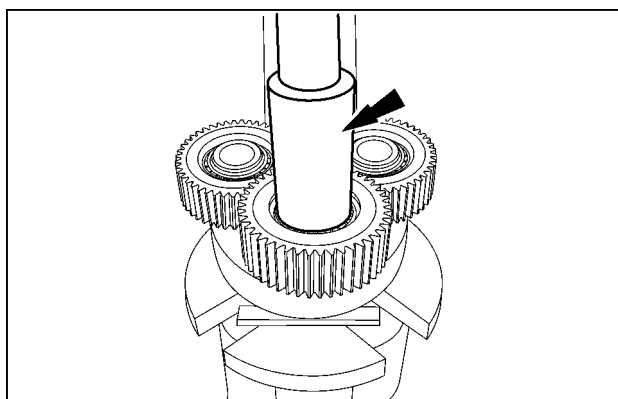

SS13H131 10

14. Position the circlip (25) in the ring groove of the planetary gear carrier.

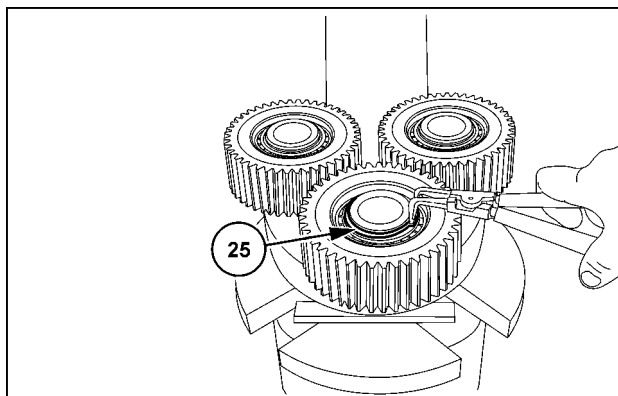

SS13H132 11

15. Fit the roll pin (17) in the planetary gear carrier. Leave **30 mm (1.18 in)** of the roll pin protruding from the planetary gear carrier (18).

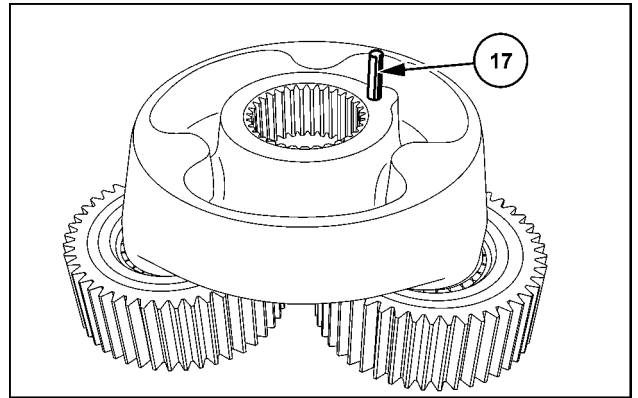

SS13H133 12

16. Grease the ball (3) with industrial Vaseline.

17. Fit the ball in the shaft.

**NOTE:** Note the installation position. Refer to the figure 15.

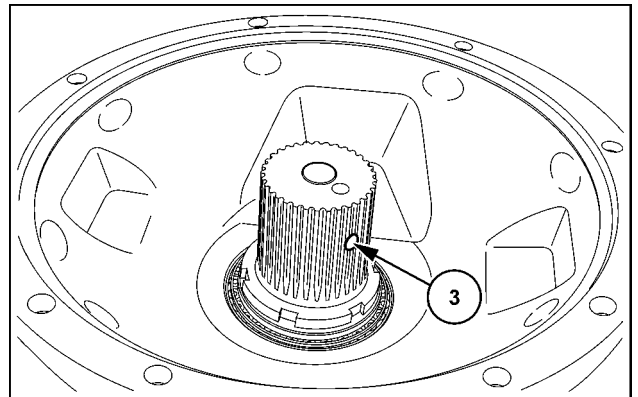

SS13H134 13

18. Fit the planetary gear carrier on the axle shaft.

**NOTE:** The roll pin (17) must be positioned in the groove of the ring nut. Refer to the figure 15.

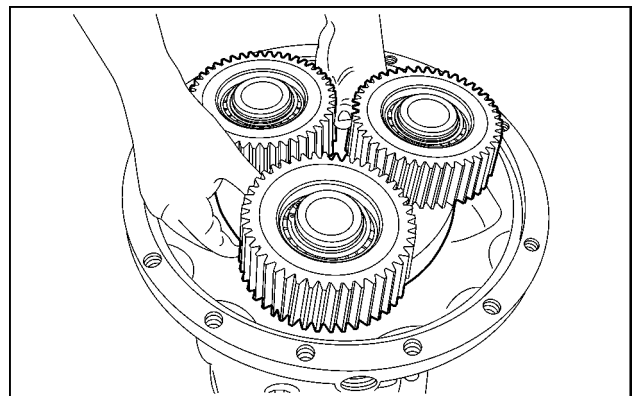

SS13H135 14

19. The roll pin in the planetary gear carrier prevents the shaft ring nut from turning out of position.

- (1) Shaft
- (3) Ball
- (4) Grub screw
- (11) Housing
- (16) Ring nut
- (17) Roll pin
- (18) Planetary gear carrier

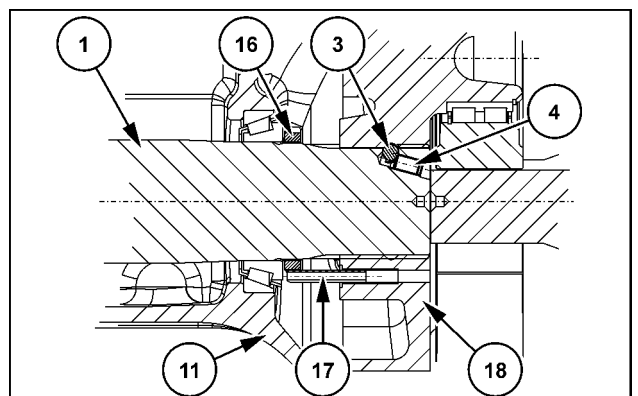

SS13H136 15

20. Coat a new grub screw (4) with **LOCTITE® 243**. Fit the grub screw.

**NOTE:** Note the installation position. Refer to the figure 15.

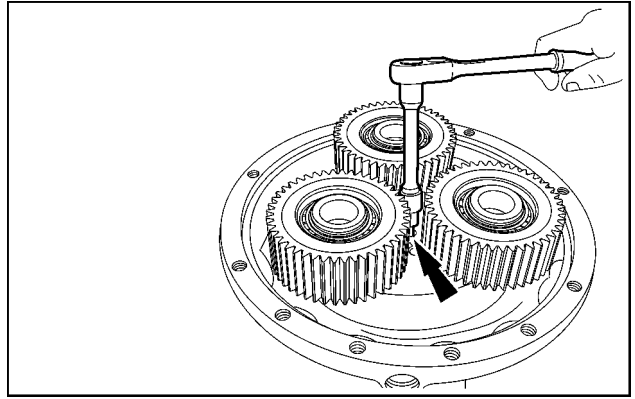

SS13H137 16

21. Adjustment of the end play at the planetary gear carrier:

Adjust the end play to **1 mm (0.039 in)**.

Readjust the roll pin until it reaches the bearing inner ring. Turn the grub screw to set the end play to **0.1 - 0.4 mm (0.004 - 0.016 in)**.

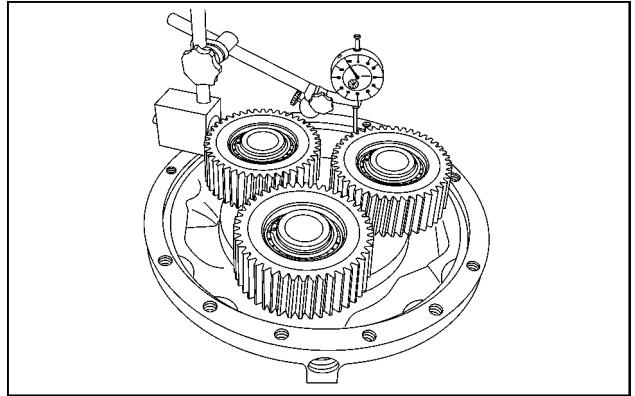

SS13H138 17

22. Clean the sealing surfaces.  
23. Coat the sealing surface of the axle trumpet housing with **LOCTITE® 518**.  
24. Fit the shaft (28) on the housing (11). Align the bores.

**NOTE:** The dowel pin bore must point toward the side of the brake housing.

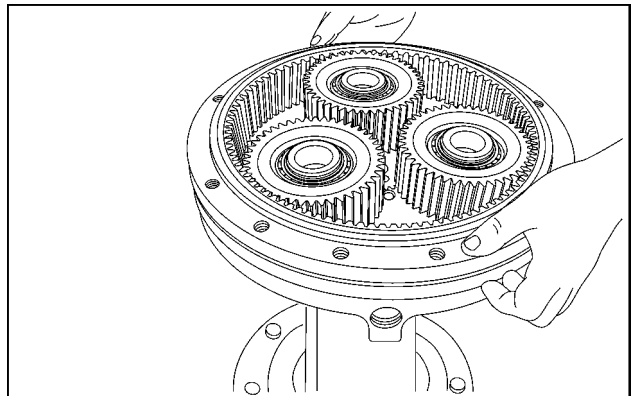

SS13H139 18

**Next operation:**  
**Final drive housing - Install (27.120)**

## Final drive housing - Remove

### **⚠ WARNING**

#### **Heavy objects!**

**Lift and handle all heavy components using lifting equipment with adequate capacity. Always support units or parts with suitable slings or hooks. Make sure the work area is clear of all bystanders. Failure to comply could result in death or serious injury.**

W0398A

1. Undo the bolts (9) and nuts (12).
2. Disconnect the axle trumpet housing from the brake housing.
3. Remove the axle trumpet housing with the internal ring gear.

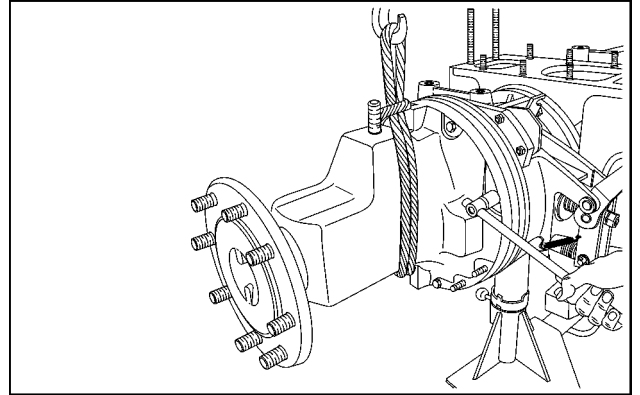

SS13H140 1

#### **Next operation:**

**Planetary final drive - Disassemble – Axle trumpet housing and planetary drive (27.120)**

## Final drive housing - Install

### ⚠ WARNING

#### Heavy objects!

Lift and handle all heavy components using lifting equipment with adequate capacity. Always support units or parts with suitable slings or hooks. Make sure the work area is clear of all bystanders. Failure to comply could result in death or serious injury.

W0398A

### Powered rear axle - Exploded view – Rear axle housing and final drive (27.100)

#### Prior operation:

#### Planetary final drive - Assemble – Axle trumpet housing and planetary drive (27.120)

1. Clean the sealing surface of the brake housing, the sealing surface of the housing and the sealing surface of shaft. Coat the surfaces with **LOCTITE® 518**.
2. Fit the shaft (**28**) and the pre-assembled housing (**11**).
3. Coat the bolts with **LOCTITE® 243**.  
Insert screws and tighten to **115 Nm (84.8 lb ft)**.

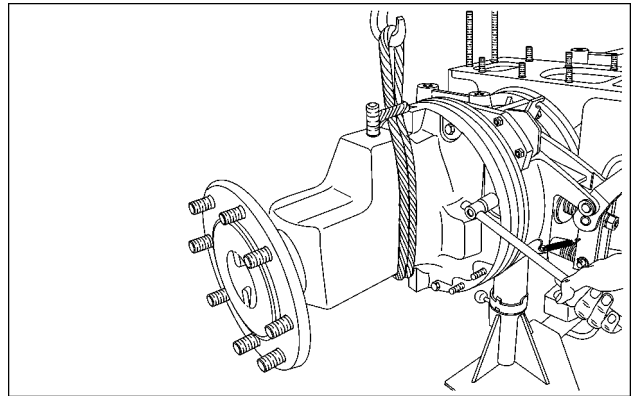

SS11G601 1

4. Moisten the bolt (**9**) with **LOCTITE® 243**.  
Fit the bolt together with the angle bracket (**10**). Tighten plug to **115 Nm (84.8 lb ft)**.

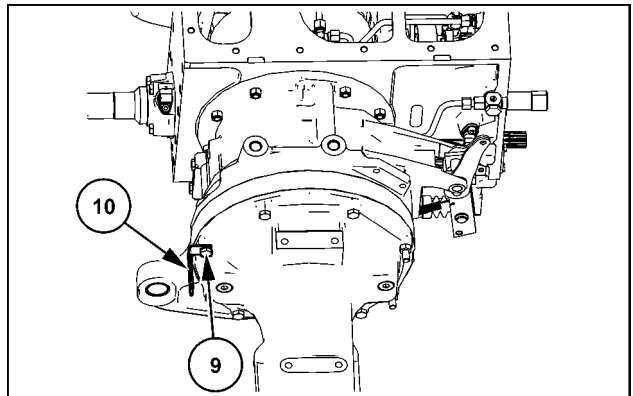

SS13H141 2

#### Next operation:

#### Differential - Assemble (27.106)

# Index

---

## Rear axle system - 27

### Planetary and final drives - 120

Final drive housing - Install .....	12
Final drive housing - Remove .....	11
Planetary final drive - Assemble – Axle trumpet housing and planetary drive .....	6
Planetary final drive - Disassemble – Axle trumpet housing and planetary drive .....	3



© 2014 CNH Industrial Österreich GmbH

All rights reserved. No part of the text or illustrations of this publication may be reproduced.

CASE IH policy is one of continuous improvement and the right to change prices, specification or equipment at any time without notices is reserved.

All data given in this publication is subject to production variations. Dimensions and weight are approximate only and the illustrations do not necessarily show products in standard condition. For exact information about any particular product, please consult your CASE IH Dealer.



# **SERVICE MANUAL**

## **Power Take-Off (PTO)**

**Farmall 105U Pro EP  
Farmall 115U Pro EP  
Farmall 95U Pro EP**



# Contents

---

## Power Take-Off (PTO) - 31

[31.104] Rear electro-hydraulic control .....	31.1
[31.119] Four-speed rear Power Take-Off (PTO).....	31.2
[31.142] Front Power Take-Off (PTO) control .....	31.3



## **Power Take-Off (PTO) - 31**

**Rear electro-hydraulic control - 104**

**Farmall 105U Pro EP  
Farmall 115U Pro EP  
Farmall 95U Pro EP**

# Contents

---

## Power Take-Off (PTO) - 31

## Rear electro-hydraulic control - 104

### FUNCTIONAL DATA

Power Take-Off (PTO) control valve	
Overview .....	3

### SERVICE

Rear electro-hydraulic control	
Pressure test .....	4

## Power Take-Off (PTO) control valve - Overview

### Rear Power Take-Off (PTO) – Solenoid valve (Y-019)

The solenoid valve (1) is located on the top side of the transmission housing.

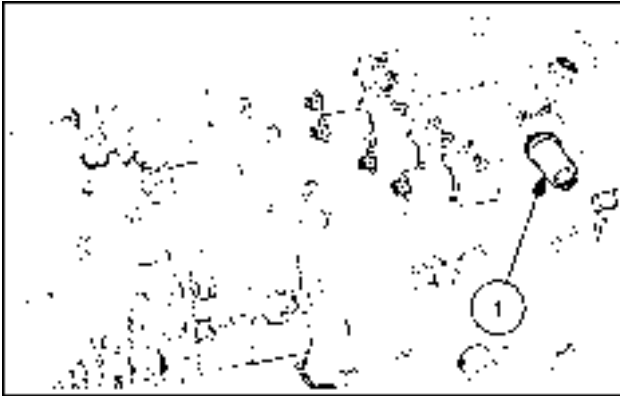

SS13E036 1

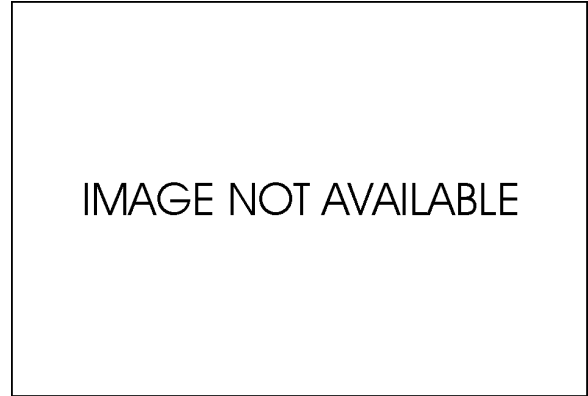

INA 2

<b>Specifications</b>	
Solenoid valve type	Proportional pressure regulating valve
Nominal voltage	<b>12 V +/- 15%</b>
PWM frequency	<b>100 Hz</b>
Coil resistance	<b>5.2 Ω +/- 5% at 20 °C (68 °F)</b>
Ambient temperature	<b>-30 - 80 °C (-22 - 176 °F)</b>
Oil temperature	<b>-25 - 100 °C (-13 - 212 °F)</b>
Nominal flow	<b>0.0 - 25.0 l/min (0.0 - 0.9 cfm)</b>
Regulated pressure	<b>0 - 20 bar (0 - 290 psi)</b>
Inlet pressure (maximum)	<b>60 bar (870 psi)</b>
Tightening torque (for each mounting bolt)	<b>5.5 Nm +/- 0.5 (4.1 lb ft)</b>

## Rear electro-hydraulic control - Pressure test

These recordings with the DATAR should supply information on the status of the electrical components, hydraulic components, and mechanical components. Make the recordings during the start-up procedure of the rear Power Take-Off (PTO) both with and without various implements. To achieve optimum comparability between the diagrams, it is important to observe all test conditions.

PTO operation:

- (1) Rear PTO – control knob
- (2) Switch for both the rear PTO soft-start function and the automatic PTO function
- (3) 540/1000 PTO speed lever
- (4) ECO/NORM PTO speed lever

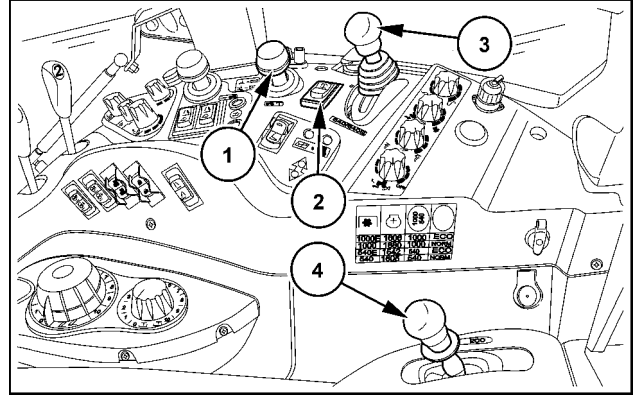

SVIL13TR00898AB 1

1. Connect the pressure sensor at the test connection (1) for the PTO clutch to the test adapter (M14x1,5).

**NOTE:** Make sure that the pressure sensor battery is in a charged state. Then perform a calibration. Switch the pressure sensor to the **60 bar (870 psi)** measurement range.

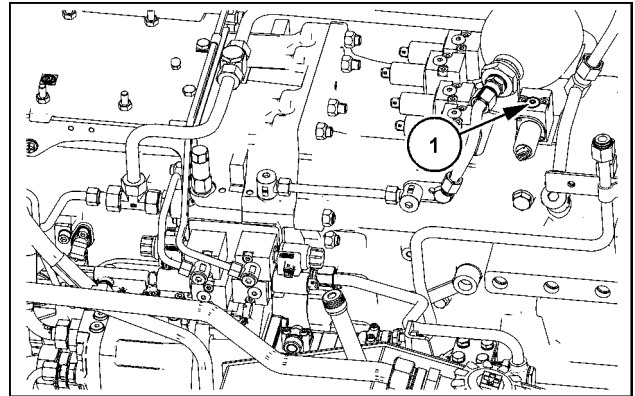

SS13K203 2

2. The solenoid valve for the PTO clutch is at the top of the Powershift. The connections must be easily accessible without the need to remove the cab floor from the right-hand side of the tractor.
3. Connect the current clamp to one of the cables for the PTO clutch solenoid valve. Connect the pressure sensor to channel A of the DATAR Scope. Connect the current clamp to channel B of the DATAR Scope.

**NOTE:** Switch the current clamp to the **20 A** range. Press the Zero Reset button. Always observe the current direction specification on the current clamp (arrow) when you clamp the current clamp to the cable.

4. You can read off all settings on the DATAR software for channels A to D from the subsequent Scope images. You can also apply these settings to your DATAR.

Test conditions:

- Transmission oil temperature **50 °C (122 °F)**
- Motor speed **1500 RPM**
- PTO lever in the 1000/NORM position
- Switch for both the rear PTO soft-start function and the automatic PTO function in the normal start-up position (Figure 1)
- No connection of any implement to the PTO

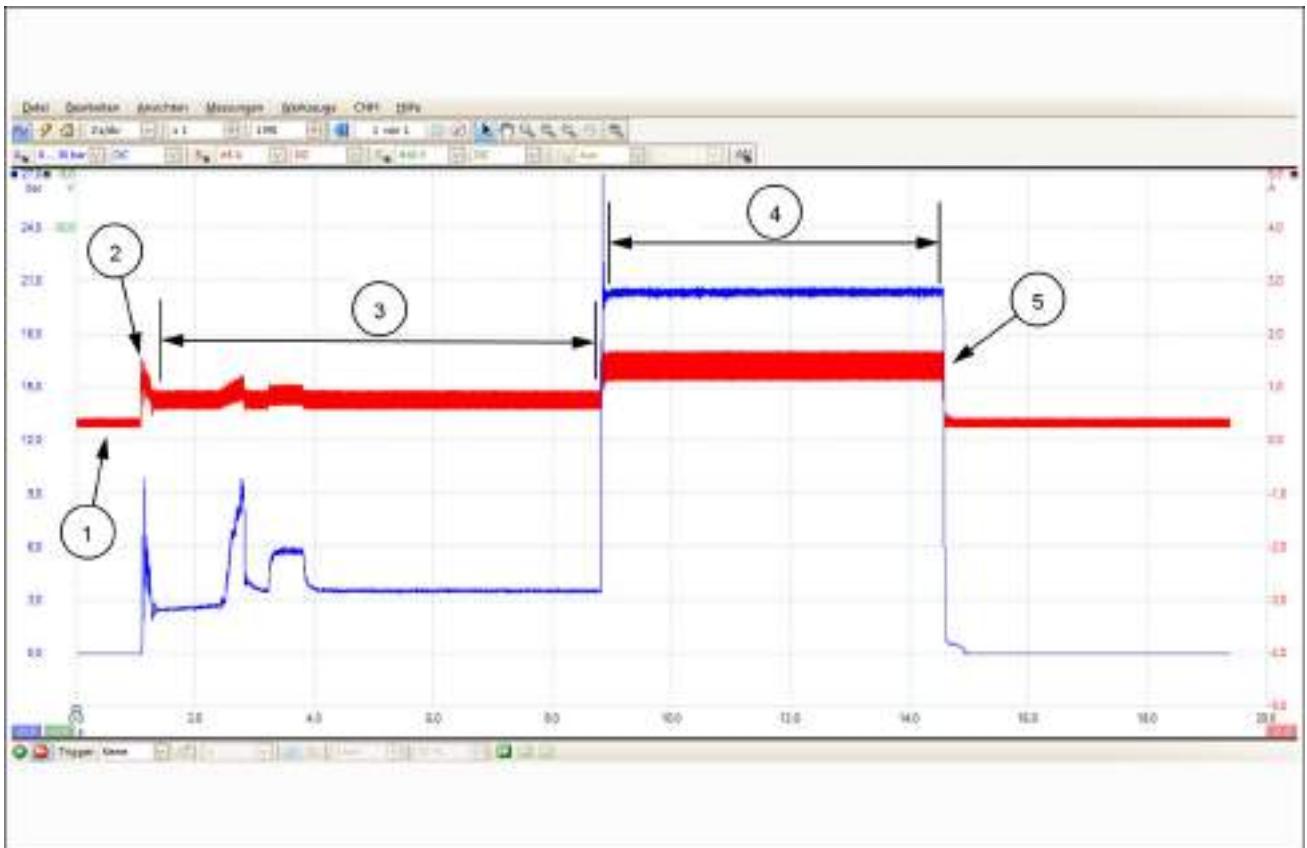

SS13K196 3

- (1) PTO switch in the OFF position (a low current flows, but this current does not open the valve)
- (2) PTO switch in the ON position (a large current temporarily flows in order to fill the clutch)
- (3) Start-up phase
- (4) The clutch is in the fully closed position
- (5) PTO switch in the OFF position

Test conditions:

- Transmission oil temperature **50 °C (122 °F)**
- Motor speed **1500 RPM**
- PTO lever in the 1000/NORM position
- Switch for both the rear PTO soft-start function and the automatic PTO function in the normal start-up position (Figure 1)
- Connection of a light implement to the PTO ( **30 Nm (22 lb ft)** rotary windrower)

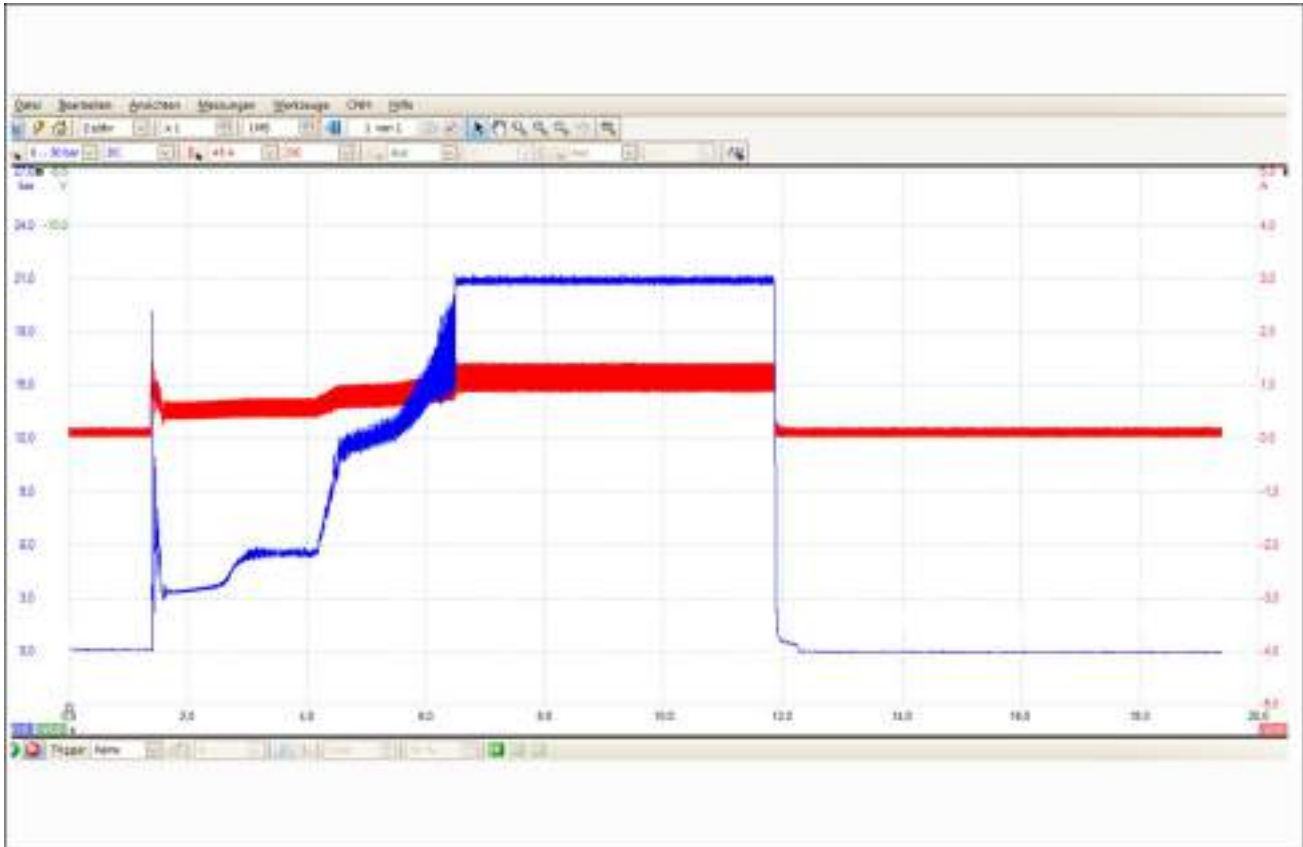

SS13K197 4

Test conditions:

- Transmission oil temperature **50 °C (122 °F)**
- Motor speed **1500 RPM**
- PTO lever in the 1000/NORM position
- Switch for both the rear PTO soft-start function and the automatic PTO function in the soft start-up position (Figure 1)
- Connection of a light implement to the PTO ( **30 Nm (22 lb ft)** rotary windrower)

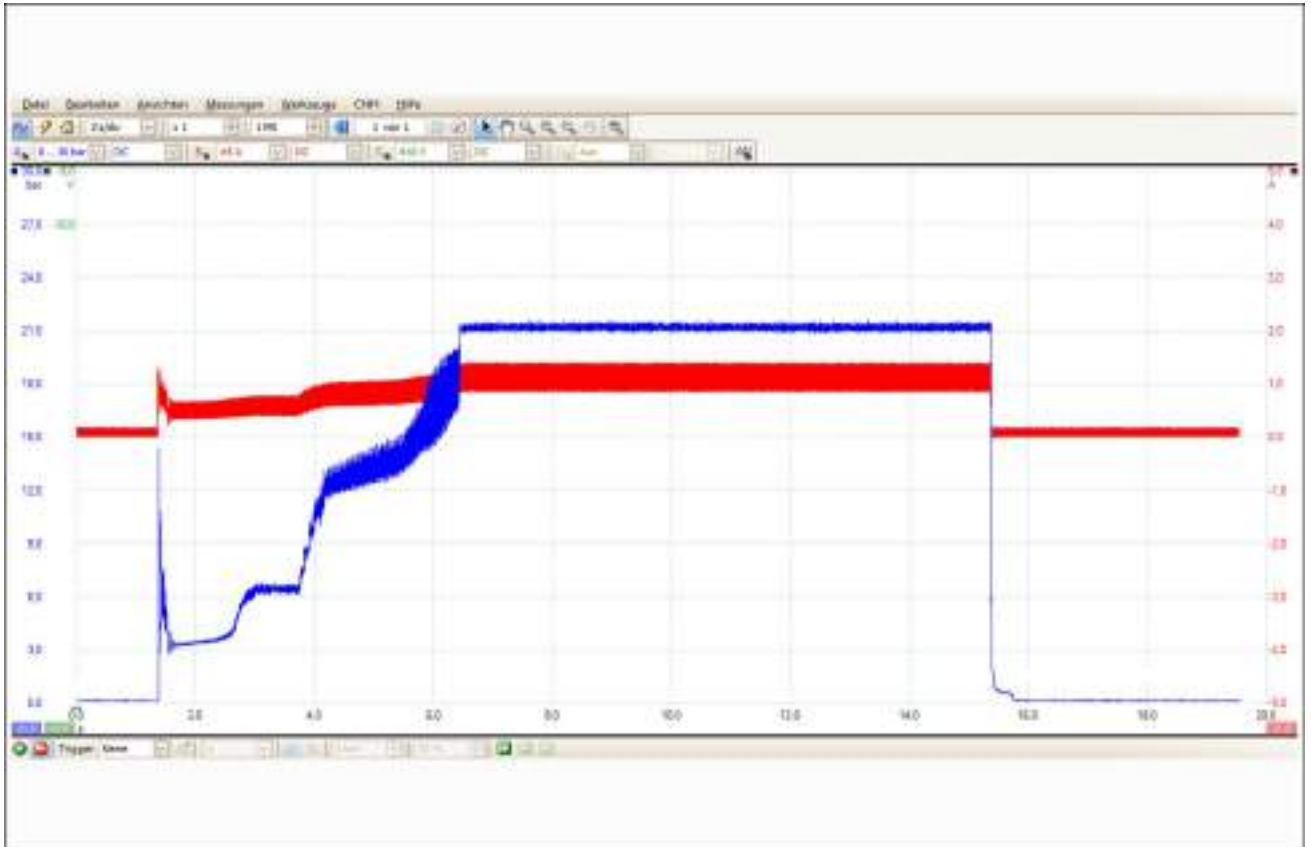



Test conditions:

- Transmission oil temperature **50 °C (122 °F)**
- Motor speed **1500 RPM**
- PTO lever in the 1000/NORM position
- Switch for both the rear PTO soft-start function and the automatic PTO function in the normal start-up position (Figure 1)
- Connection of a medium implement to the PTO (**180 Nm (133 lb ft)** mower)

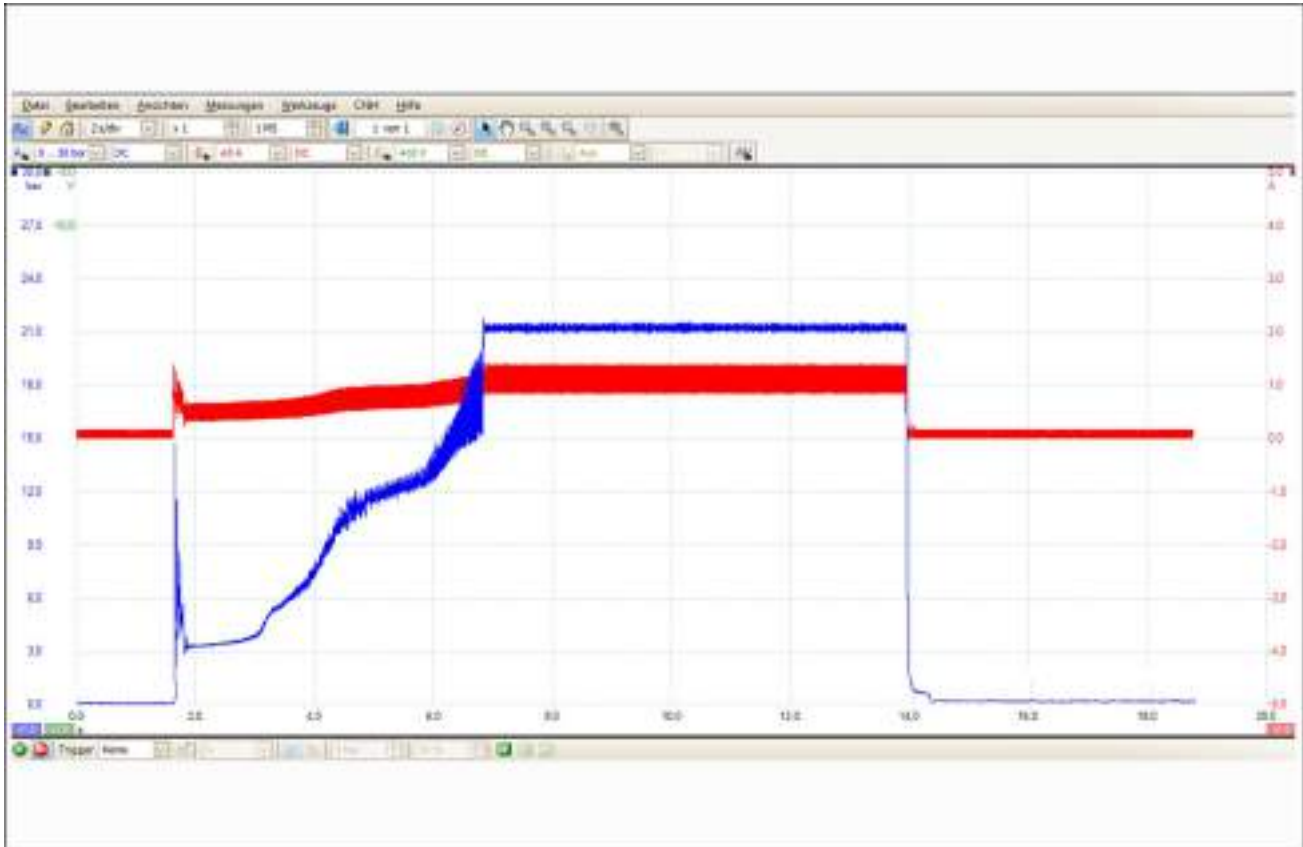

SS13K199 6

Test conditions:

- Transmission oil temperature **50 °C (122 °F)**
- Motor speed **1500 RPM**
- PTO lever in the 1000/NORM position
- Switch for both the rear PTO soft-start function and the automatic PTO function in the soft start-up position (Figure 1)
- Connection of a medium implement to the PTO (**180 Nm (133 lb ft)** mower)

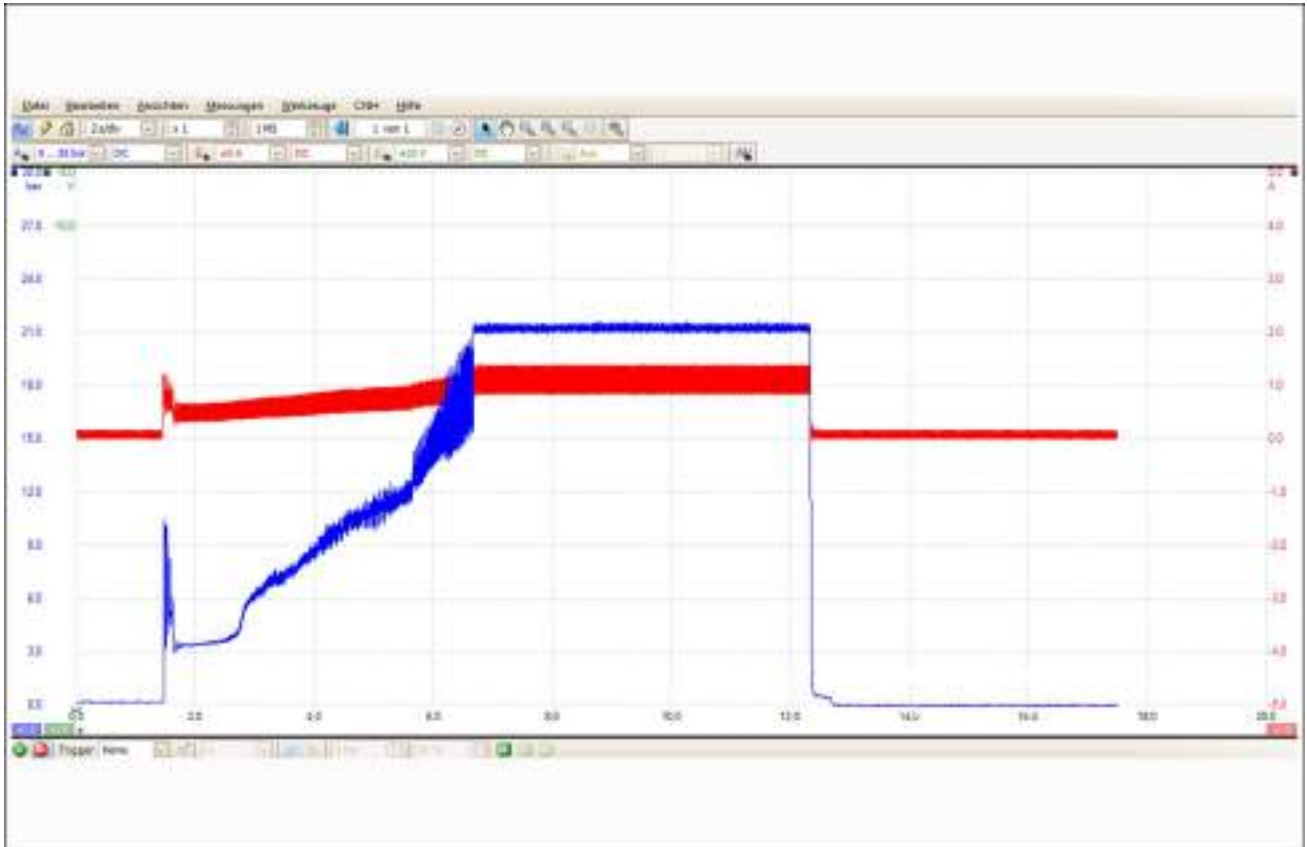

SS13K200 7

Test conditions:

- Transmission oil temperature **50 °C (122 °F)**
- Motor speed **1500 RPM**
- PTO lever in the 1000/NORM position
- Switch for both the rear PTO soft-start function and the automatic PTO function in the normal start-up position (Figure 1)
- Connection of a heavy attachment to the PTO (**450 Nm (332 lb ft)** medium press)

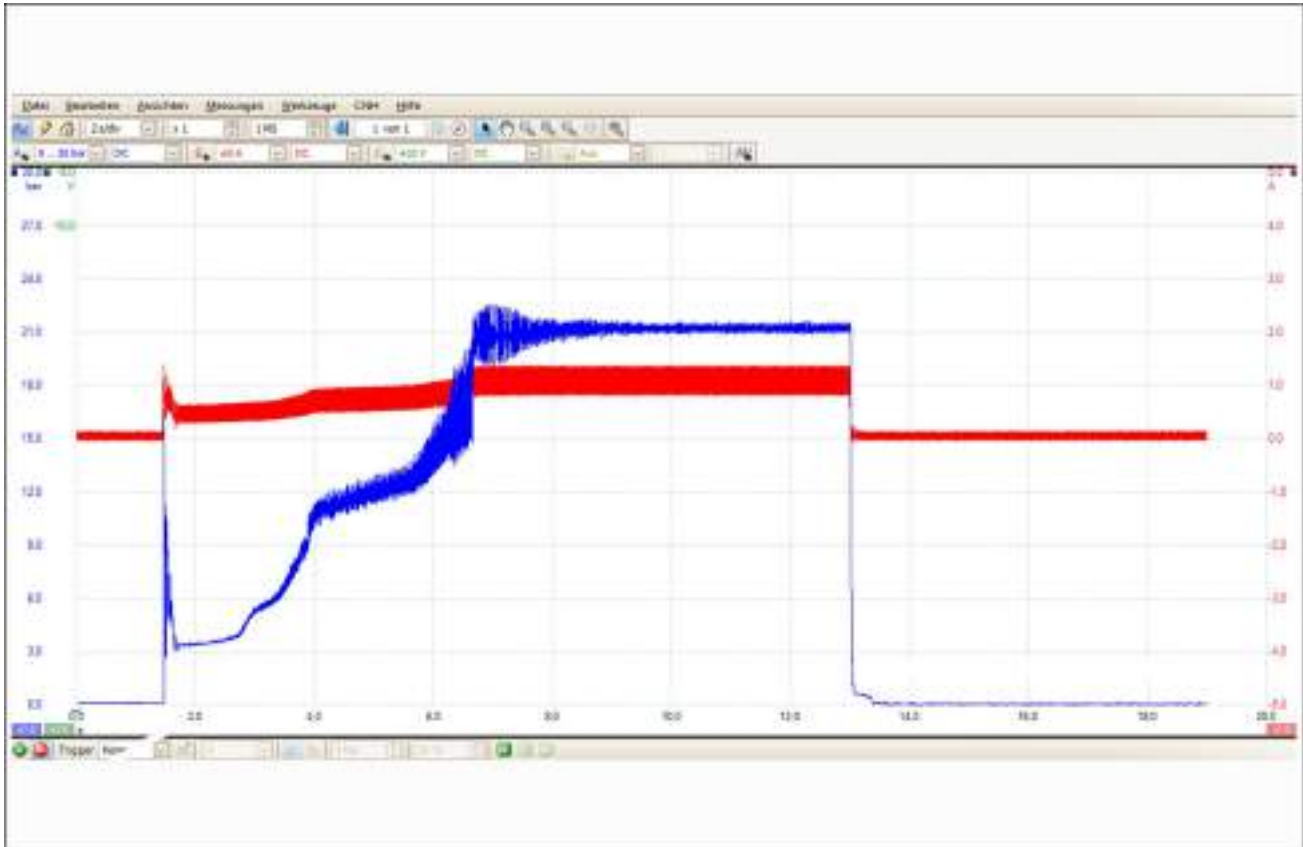

Test conditions:

- Transmission oil temperature **50 °C (122 °F)**
- Motor speed **1500 RPM**
- PTO lever in the 1000/NORM position
- Switch for both the rear PTO soft-start function and the automatic PTO function in the soft start-up position (Figure 1)
- Connection of a heavy attachment to the PTO (**450 Nm (332 lb ft)** medium press)

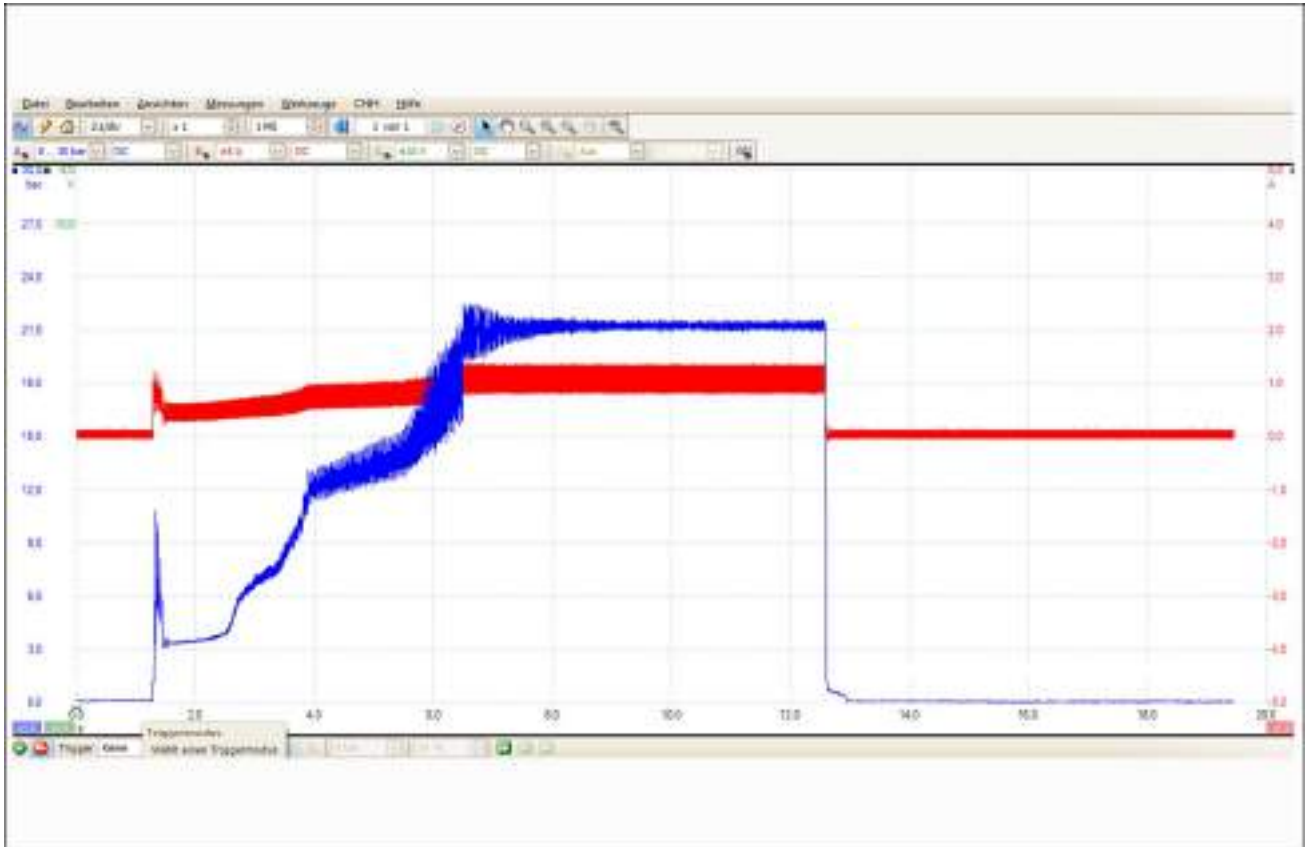

# Index

---

## **Power Take-Off (PTO) - 31**

### **Rear electro-hydraulic control - 104**

Power Take-Off (PTO) control valve - Overview .....	3
Rear electro-hydraulic control - Pressure test .....	4



## **Power Take-Off (PTO) - 31**

### **Four-speed rear Power Take-Off (PTO) - 119**

**Farmall 105U Pro EP  
Farmall 115U Pro EP  
Farmall 95U Pro EP**

# Contents

---

## Power Take-Off (PTO) - 31

### Four-speed rear Power Take-Off (PTO) - 119

#### TECHNICAL DATA

Four-speed rear Power Take-Off (PTO)	
Special tools .....	4
General specification .....	4

#### FUNCTIONAL DATA

Four-speed rear Power Take-Off (PTO)	
Exploded view – NORMAL/ECONOMIC clutch and shift .....	6
Exploded view – shift 540/1000 and output .....	8
Mechanical schema .....	10

#### SERVICE

Front drive shaft	
Remove – NORMAL/ECONOMIC .....	22
Install – NORMAL/ECONOMIC .....	25
Output shaft	
Remove .....	31
Install .....	33
Power Take-Off (PTO) case	
Cover - Remove .....	36
Cover - Install .....	38
Power Take-Off (PTO) clutch	
Disassemble .....	39
Assemble .....	42
Power Take-Off (PTO) clutch brake	
Disassemble .....	47
Assemble .....	49
Power Take-Off (PTO) speed rate selector control	
Normal-Economic speed rate selector control - Remove .....	51
Normal-Economic speed rate selector control - Install .....	52
540-1000 rpm speed rate selector control - Remove .....	53
540-1000 rpm speed rate selector control - Install – Power Take-Off (PTO) gearshift .....	54
Remove – Ground speed Power Take-Off (PTO) .....	56

Install – Ground speed Power Take-Off (PTO) .....	57
<b>Rear drive shaft</b>	
Remove .....	58
Install .....	60
<b>Counter shaft</b>	
Remove – Power Take-Off (PTO) 540/1000 .....	65
Disassemble – Power Take-Off (PTO) 540/1000 .....	66
Assemble – Power Take-Off (PTO) 540/1000 .....	67
Install – Power Take-Off (PTO) 540/1000 .....	68



## Four-speed rear Power Take-Off (PTO) - Special tools

**NOTE:** The operations described in this section can only be carried out with the **ESSENTIAL** tools indicated by an **(X)**. To work in safety, to obtain the best technical results, and to save both time and energy, you should also use the other special tool we recommend below. You should also use the relevant locally manufactured devices. This manual contains the construction drawings for these devices.

List of the special tools required for the work steps in this section:

Tool Number	Designation / Use
<b>(X) 380200021</b>	Retaining bracket

## Four-speed rear Power Take-Off (PTO) - General specification

### Output power (P) of the power take-off (PTO), four speeds

At a speed of <b>540 RPM</b>	Maximum <b>59 kW (80 Hp)</b>
At a speed of ECO <b>540 RPM</b>	Maximum <b>59 kW (80 Hp)</b>
At a speed of <b>1000 RPM</b>	<b>77 kW (105 Hp)</b>
At a speed of ECO <b>1000 RPM</b>	<b>77 kW (105 Hp)</b>

### PTO speed at Engine Speed

Power take-off 540	<b>1805 RPM</b>
Power take-off 1000	<b>1880 RPM</b>
Power take-off 540E	<b>1542 RPM</b>
Power take-off 1000E	<b>1606 RPM</b>

### PTO clutch

Type of System	Wet multi-disc clutch
Operating system	Electrohydraulic solenoid valve
Number of Friction Plates	4
PTO brake (operation by)	Spring force

### Ground speed PTO – gear ratio

PTO revolutions to rear wheel revolutions	82:1
---	------



---

## Four-speed rear Power Take-Off (PTO) - Exploded view – NORMAL/ECONOMIC clutch and shift

1	Retainer Ring	2	Plug.
3	O-Ring	4	Pins
5	O-Ring	6	O-Ring
7	Spring	8	Roll pin
9	cap	10	Ball
11	Dowel pin	12	Shaft sealing ring
13	Bolt	14	Rectangular ring
15	Journal	16	Retainer Ring
17	Thrust washer.	18	Needle bearing
19	Spacer tube	20	Needle bearing
21	Double tooth gear/clutch housing	22	Thrust washer.
23	Retainer Ring	24	Disc holder
25	Separator plate	26	Wave spring
27	Friction plate	28	Spring
29	Cylinders	30	O-Ring
31	O-Ring	32	Pistons
33	Gear shaft	34	Shutter
35	Blank Plug	36	Journal
37	Shifter fork	38	Roll pin
39	Shifter rod	40	Screw plug
41	seal	42	Spring
43	Ball	44	Shuttle lever
45	O-Ring	46	Bushing
47	Roll pin	48	Selector shaft
49	Retainer Ring	50	Washer
51	Journal	52	Collar holder
53	Selector sleeve	54	Sweeper
55	Needle bearing	56	Gear
57	Needle bearing	58	Cluster gear
59	Spacer tube	60	Needle bearing
61	Ball	62	Thrust washer.
63	Clearance washer	64	Journal
65	Retainer Ring	66	shaft
67	Clearance washer	68	Retainer Ring

Power Take-Off (PTO) - Four-speed rear Power Take-Off (PTO)

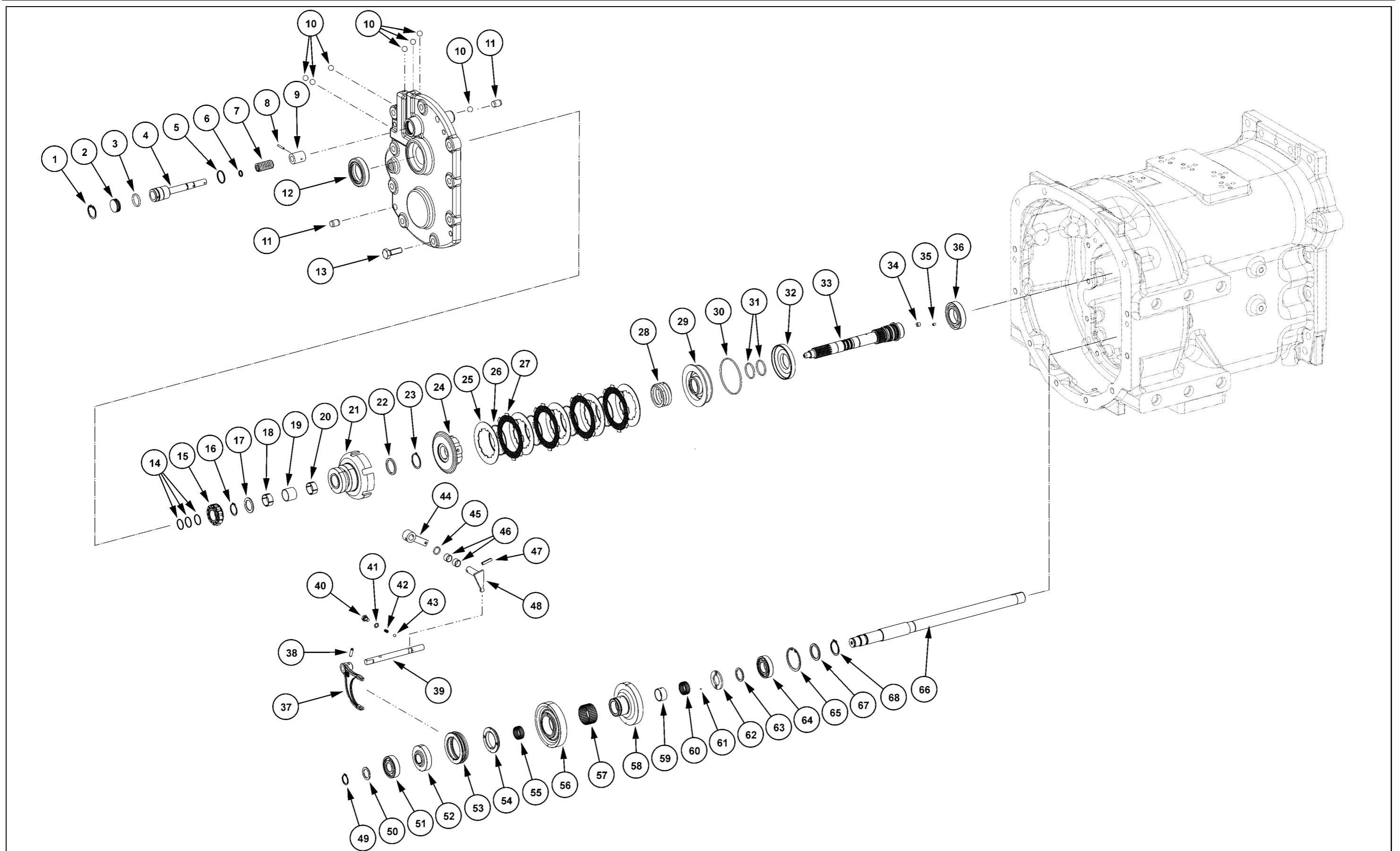

SS13E052 1

## Four-speed rear Power Take-Off (PTO) - Exploded view – shift 540/1000 and output

91	Shifter fork	92	Locking screw
93	Selector shaft	94	O-Ring
95	Bolt	96	Selector finger
97	Ball	98	Spring
99	Shifter rod	102	Retainer Ring
103	Thrust washer.	104	Retainer Ring
105	Journal	106	Distance Piece
107	Needle bearing	108	Ring, spacer
109	Jackshaft	110	Distance Piece
111	Retainer Ring	112	Thrust washer.
113	Selector sleeve	114	Collar holder
115	Needle bearing	116	Ring, spacer
117	Gear	118	Thrust washer.
119	Retainer Ring	120	Journal
121	Retainer Ring	122	Jackshaft
123	Sleeve	124	Roll pin
125	Thrust washer.	126	Needle bearing
127	Cluster gear	128	Bushing
129	Needle bearing	130	Thrust washer.
131	Adjuster return plate	132	Cover cup
133	Bolt	134	Bolt
135	Dowel pin	136	Bearing bolt
137	Output shaft	138	Journal
139	Retainer Ring	140	Thrust washer.
141	Retainer Ring	142	Sensor wheel
143	Grub screw	144	Shaft sealing ring
145	Bearing cover	146	Bolt
147	Protective cap	148	O-Ring
149	Rear Power Take-Off (PTO) – Speed sensor	150	Bolt

Power Take-Off (PTO) - Four-speed rear Power Take-Off (PTO)

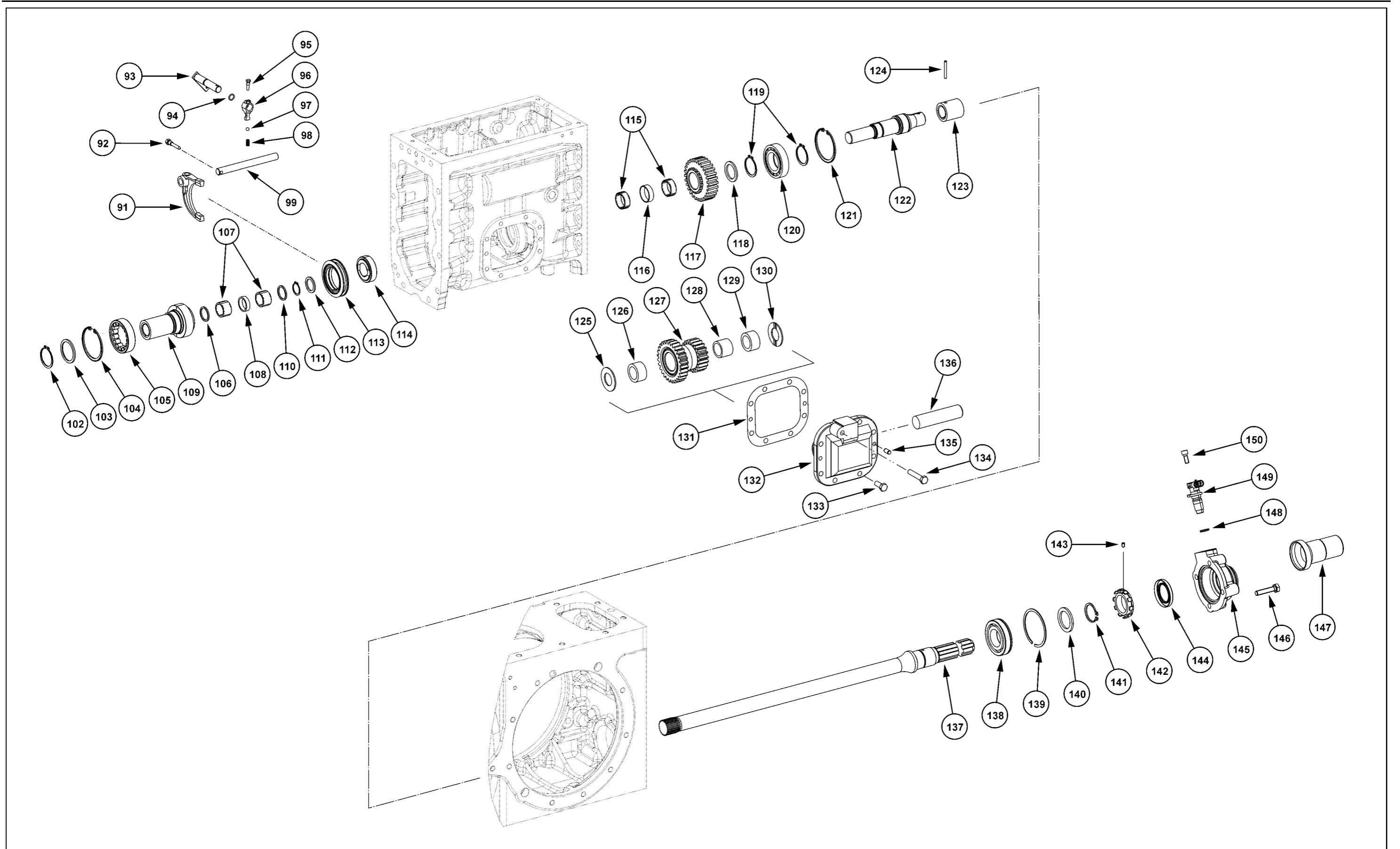

SS13E054 1

47735452 03/07/2014

<https://www.tractormanualpdf.info/>

## Four-speed rear Power Take-Off (PTO) - Mechanical schema

- I. Power take-off ECONOMIC/NORMAL
  - III. Synchronized gearbox
  - V. Rear axle (differential)
  - VII. Power take-off 540/1000
  - IX. Four wheel drive
  - II. Couplings for the powershift and the power shuttle
  - IV. Field shift or road shift
  - VI. Hydraulic pump drive
  - VIII. Engine power take-off (PTO)/ground speed PTO
  - X. Planetary gears and multi-disc brake
- 
- 1. Powershift – input speed sensor
  - 3. Gearbox speed sensor
  - A. Transmission input shaft ( n = **2200 RPM**)
  - 2. Powershift – output speed sensor
  - 4. Speed sensor for the rear PTO

Power Take-Off (PTO) - Four-speed rear Power Take-Off (PTO)

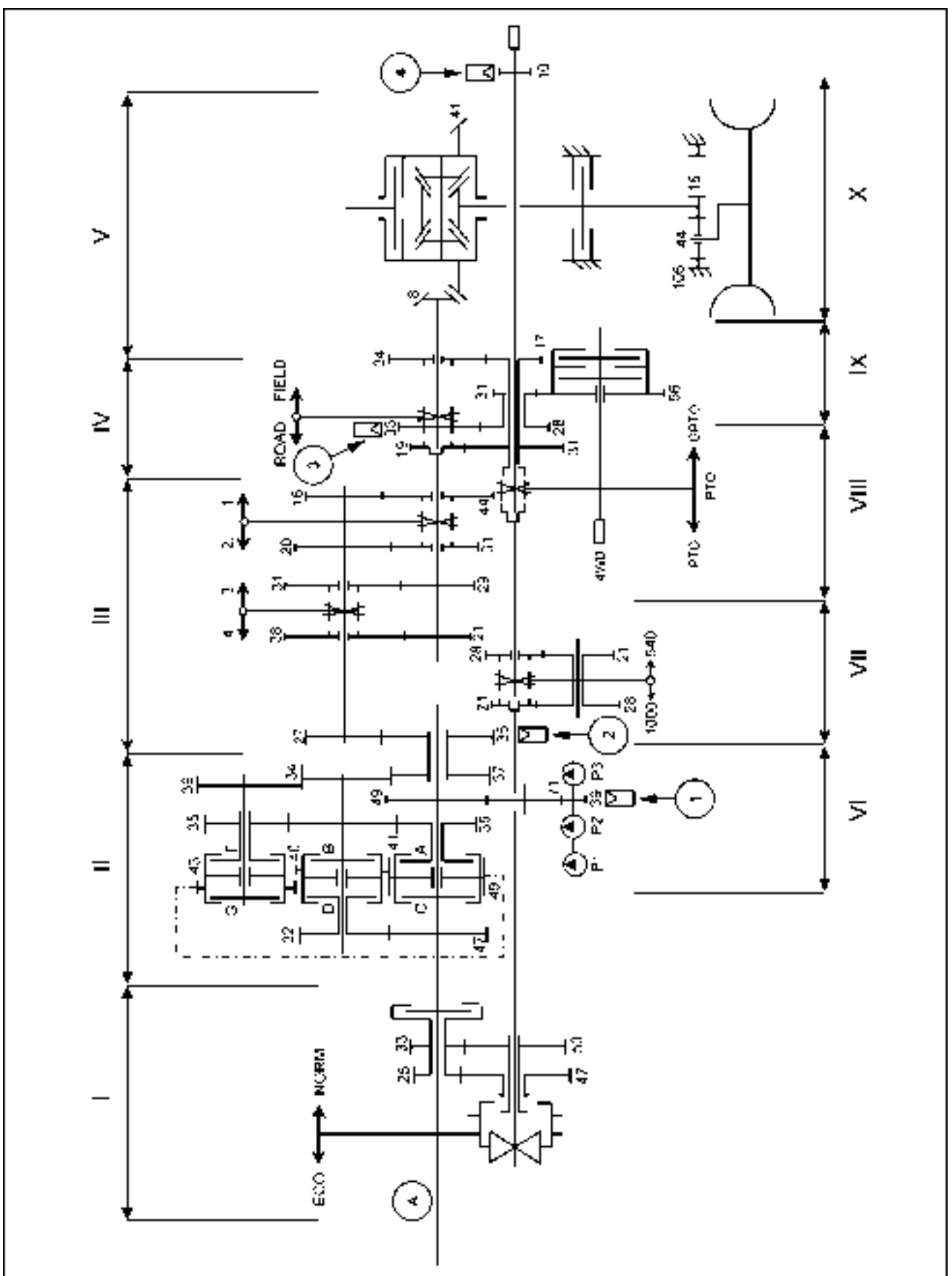

SS13E004 1



### ENGINE PTO

#### Representation of the power flow: engine PTO in shift position "NORMAL" and "540"

1. Powershift – input speed sensor
  2. Powershift – output speed sensor
  3. Gearbox speed sensor
  4. Speed sensor for the rear PTO
- A. Transmission input shaft ( n = **2200 RPM**)

Power Take-Off (PTO) - Four-speed rear Power Take-Off (PTO)

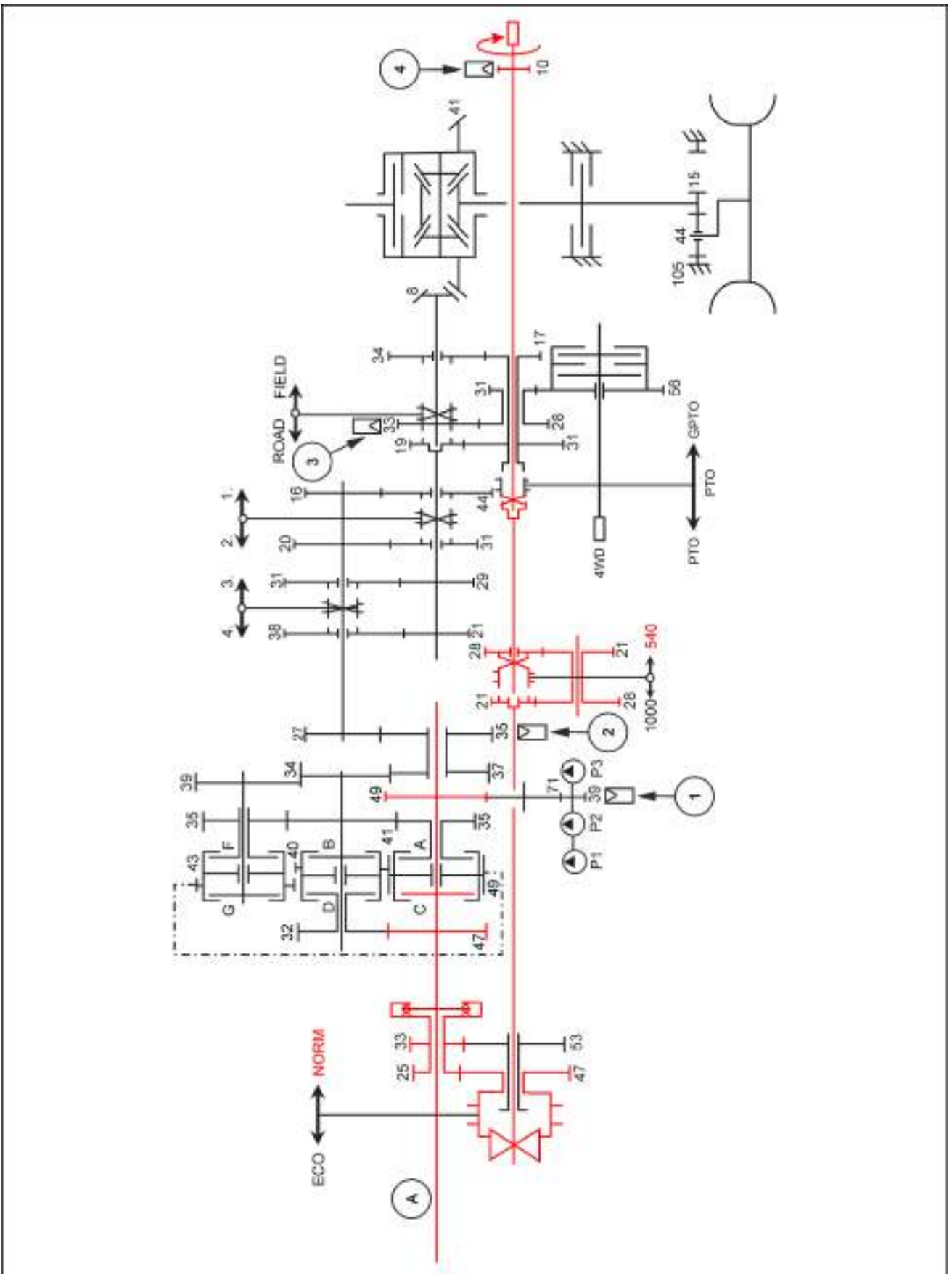

**Representation of the power flow: engine PTO in shift position “ECONOMIC” and “1000”**

- |   |                                     |
|---|-------------------------------------|
| 1. Powershift – input speed sensor                  | 2. Powershift – output speed sensor |
| 3. Gearbox speed sensor                             | 4. Speed sensor for the rear PTO    |
| A. Transmission input shaft ( n = <b>2200 RPM</b> ) |                                     |

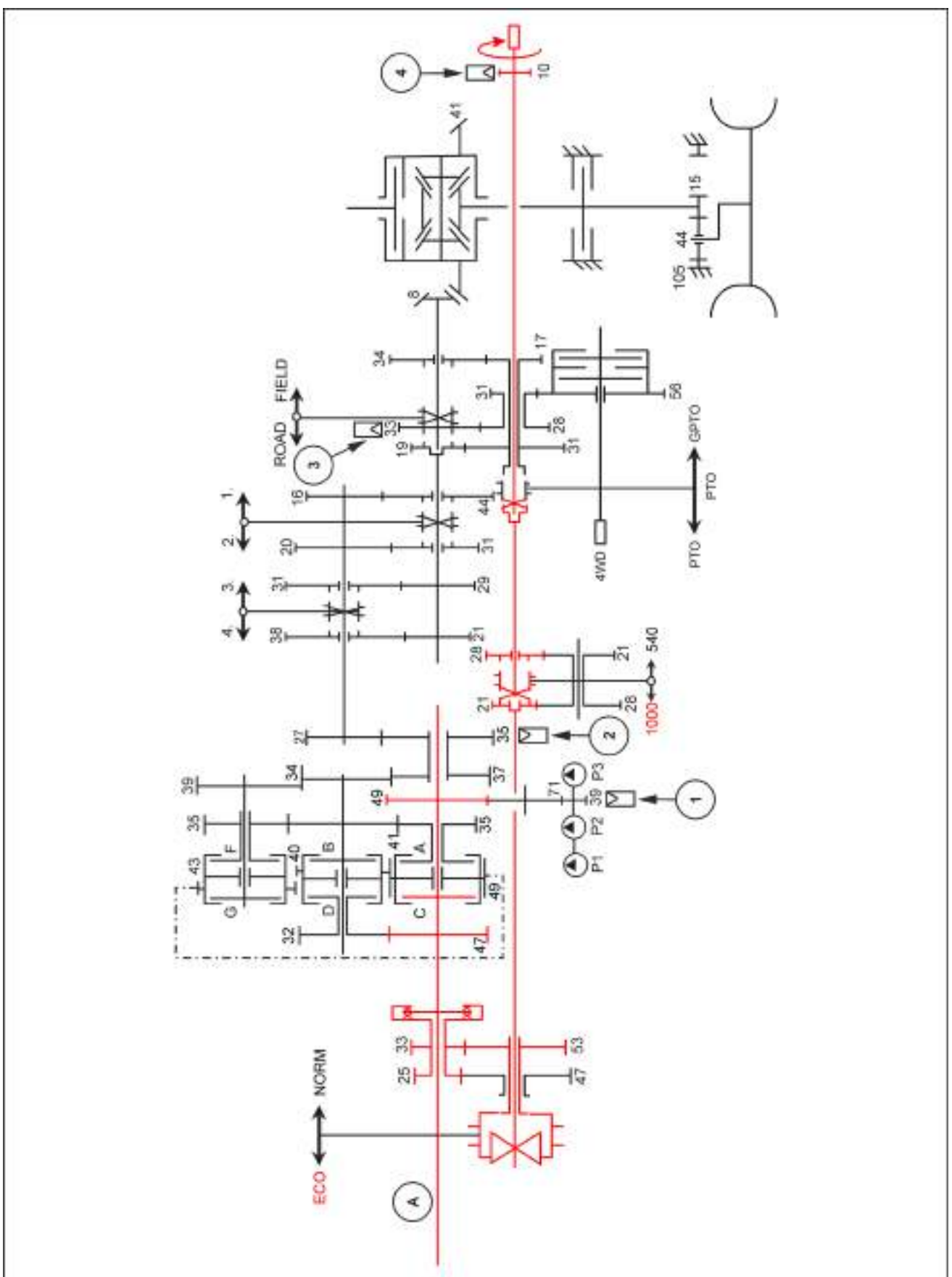

### GROUND SPEED PTO

**Representation of the power flow in: first powershift ratio, forwards (right-hand), first synchronized gear, field range**

In the operation of the ground speed PTO, the field range has 16 gears for forward travel and 16 gears for reverse travel (4 synchronized gears x 4 powershift ratios) with a right-hand PTO or a left-hand PTO.

**NOTE:** *Engagement of the road range places the ground speed PTO in the neutral position.*

Power Take-Off (PTO) - Four-speed rear Power Take-Off (PTO)

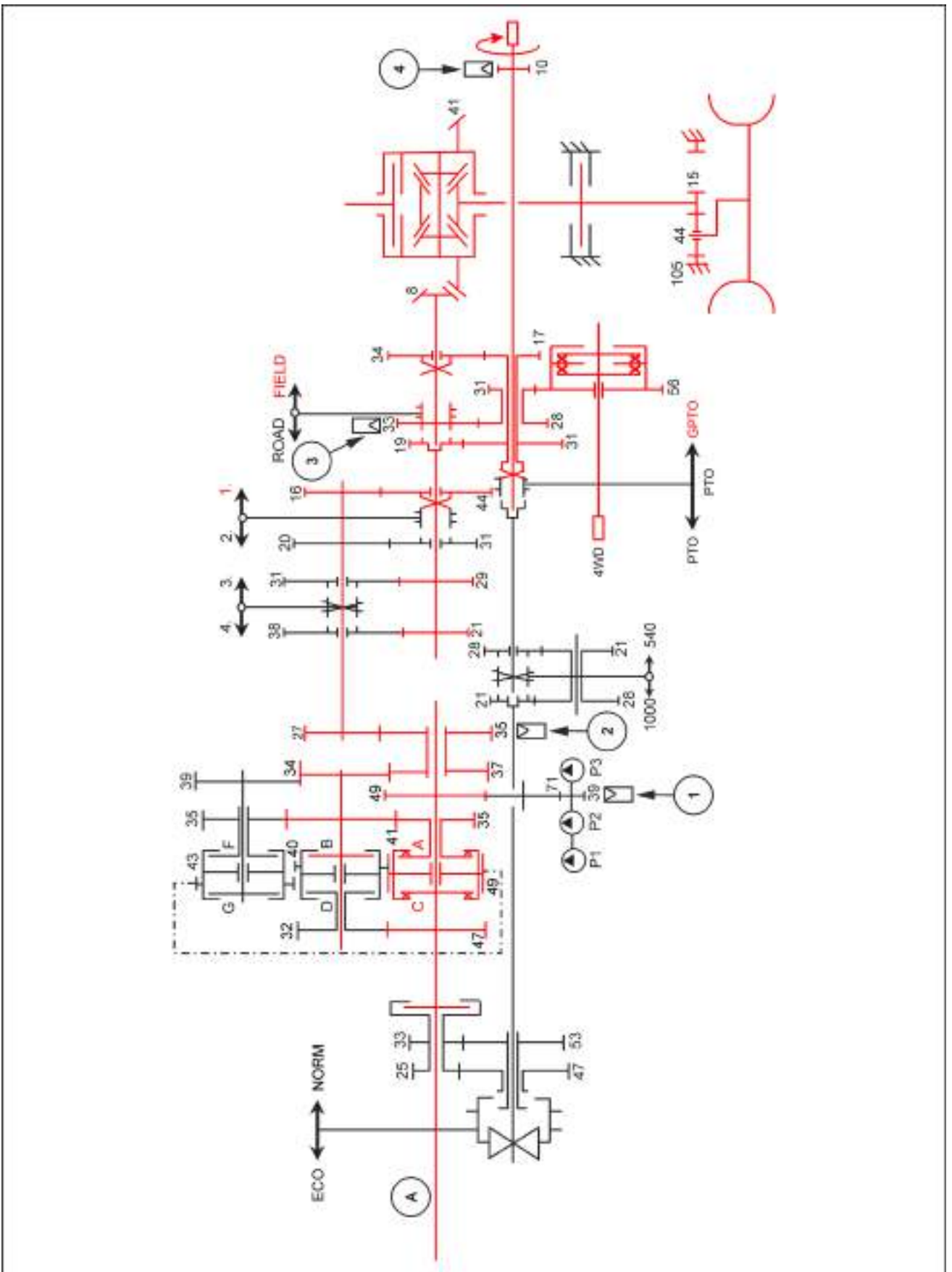

SS13E017 4

### STATIONARY PTO

**Representation of the power flow in: first powershift ratio, forwards (right-hand), first synchronized gear, field range or road range in the "NEUTRAL" position**

In the operation of the stationary PTO, there are 16 steps (4 synchronized gears x 4 powershift ratios) with a right-hand PTO.

Power Take-Off (PTO) - Four-speed rear Power Take-Off (PTO)

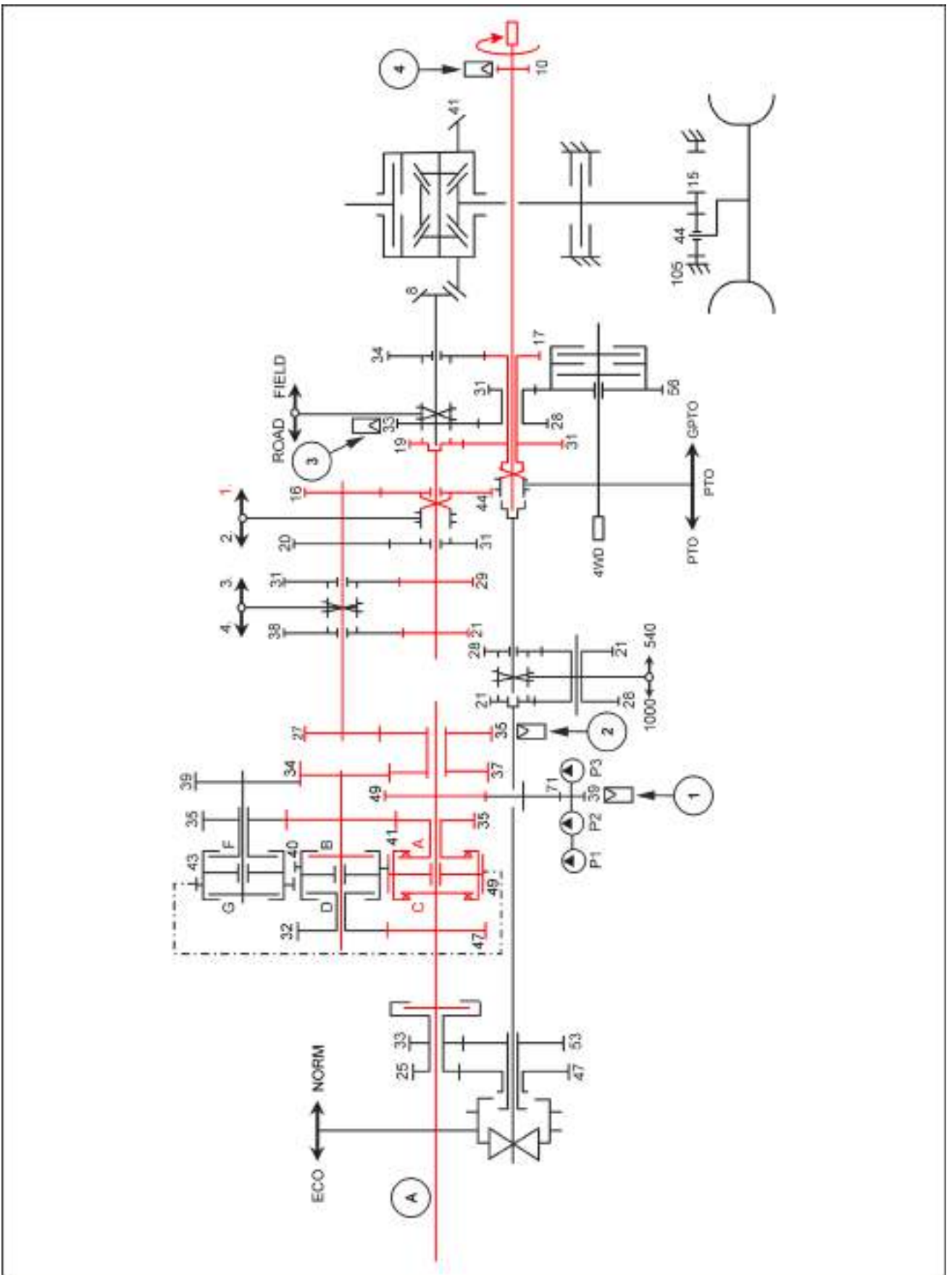



**Representation of the power flow in: first powershift ratio, reverse (left-hand), first synchronized gear, field range or road range in the "NEUTRAL" position**

Power Take-Off (PTO) - Four-speed rear Power Take-Off (PTO)

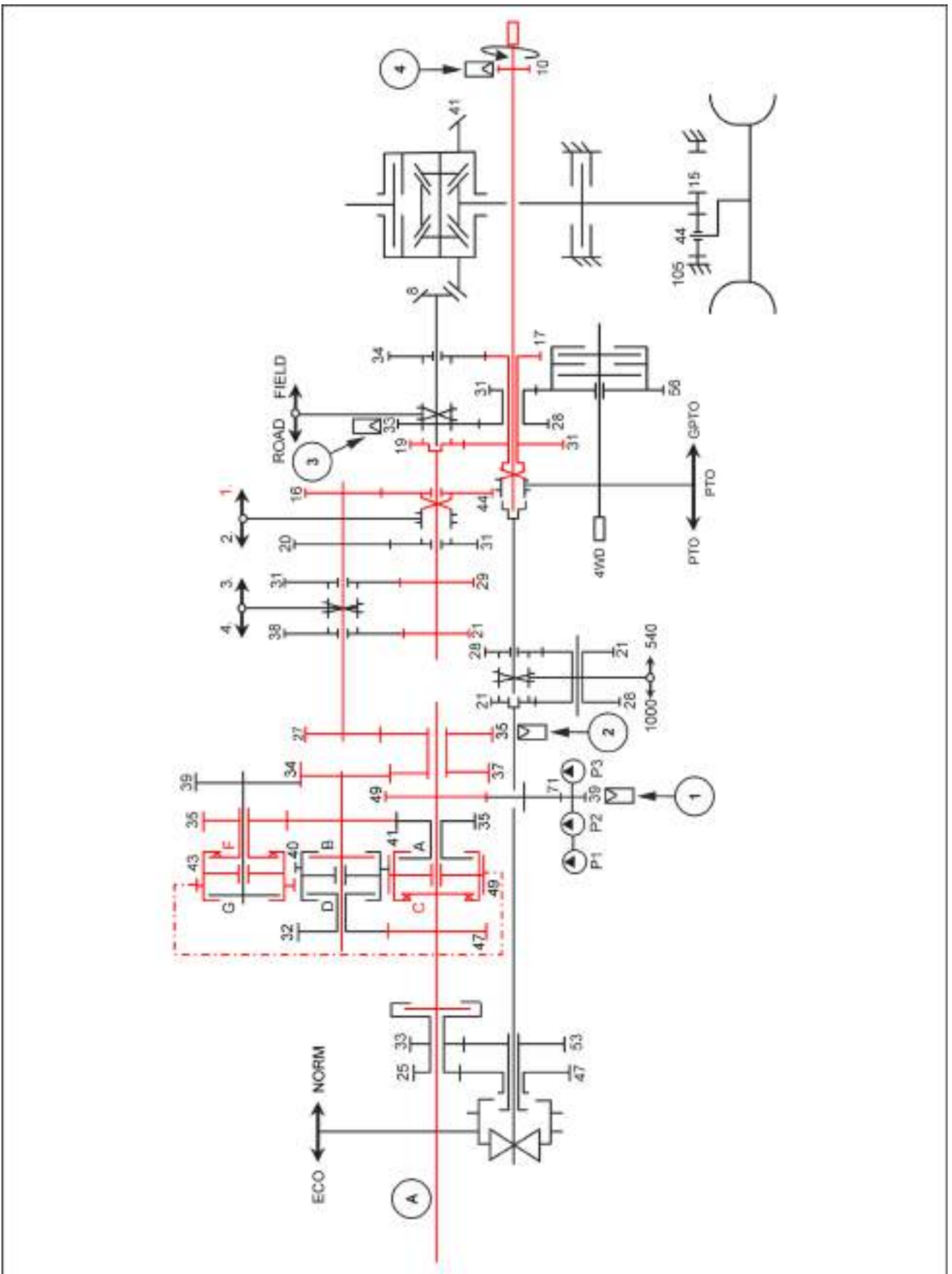

SS13E019 6

## Front drive shaft - Remove – NORMAL/ECONOMIC

**Prior operation:**

**Power Take-Off (PTO) case Cover - Remove (31.119)**

1. Remove the circlip (**65**) from the ring groove of the housing.

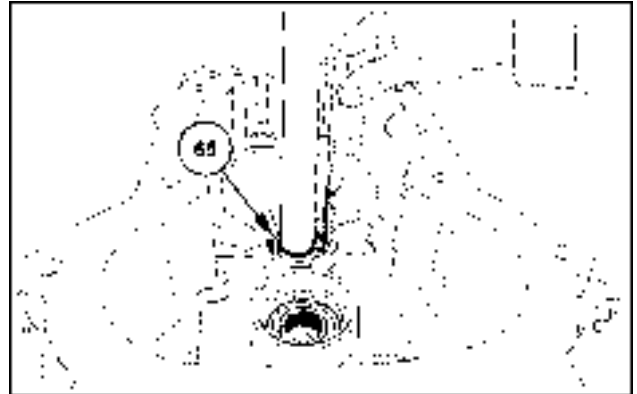

SVIL13TR00184AB 1

2. Release circlip (**49**) from its position.
3. Remove the disk (**50**).

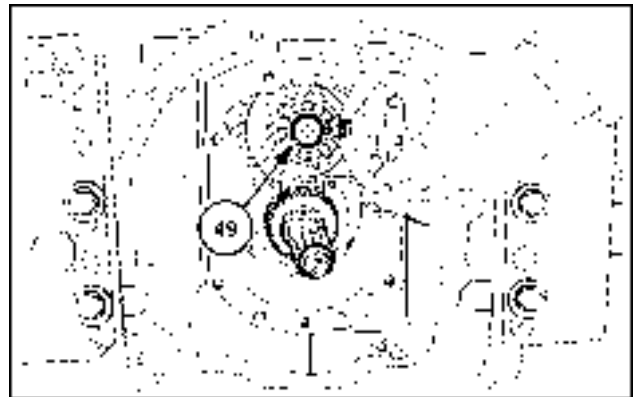

SVIL13TR00185AB 2

4. Remove the bearing (**51**).

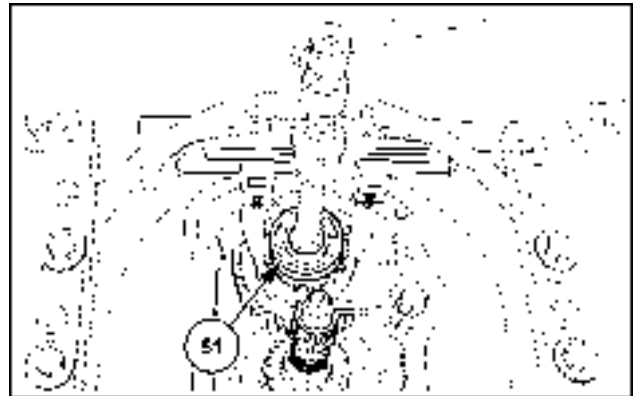

SVIL13TR00186AB 3

5. Push out the shaft **(66)**.

**NOTE:** Be careful of loosened components.

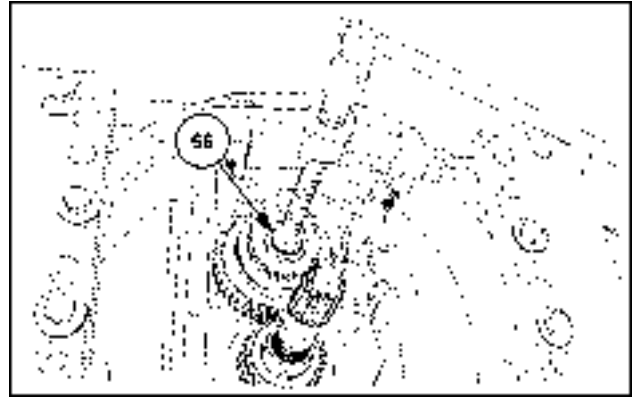

SVIL13TR00187AB 4

6. Remove the ball **(61)** from the shaft.

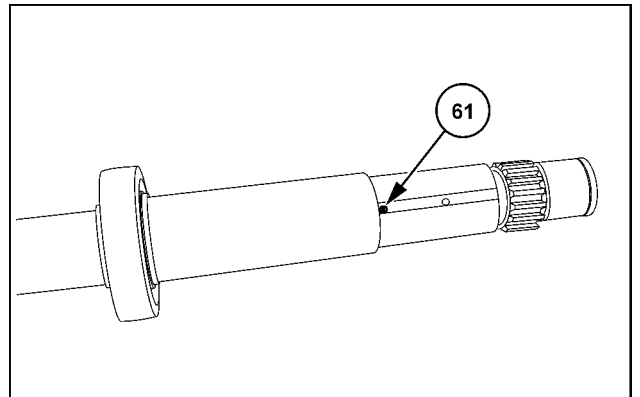

SVIL13TR00188AB 5

7. Release circlip **(68)** from its position.

8. Remove the disk **(67)**.

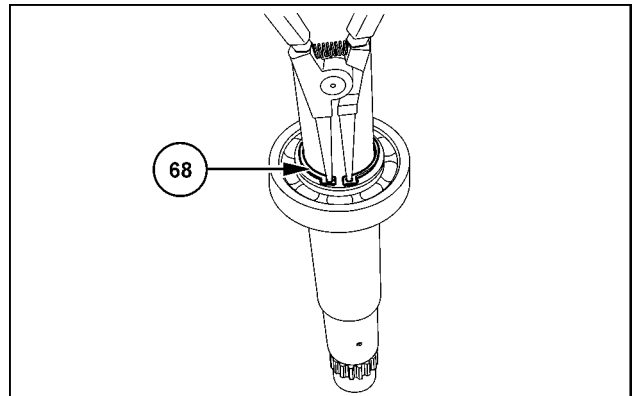

SVIL13TR00189AB 6

9. Remove the bearing **(64)** from the shaft.

10. Remove the clearance washer **(63)**.

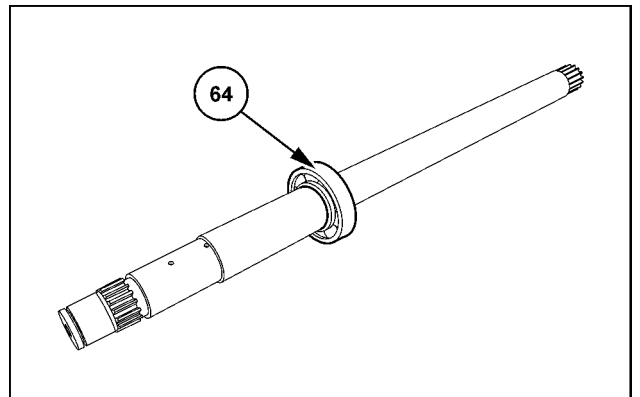

SVIL13TR00190AB 7

11. Undo the screw plug (40).
12. Remove the spring (42). Remove the ball (43).

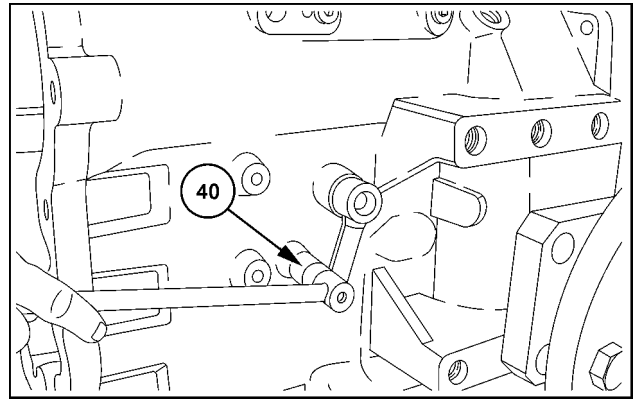

SVIL13TR00191AB 8

13. Remove the collar holder (52). Remove the shift collar (53). Remove the selector fork (37) with the gearshift bar (39).
14. Remove the gear (56). Remove the double gear (58).

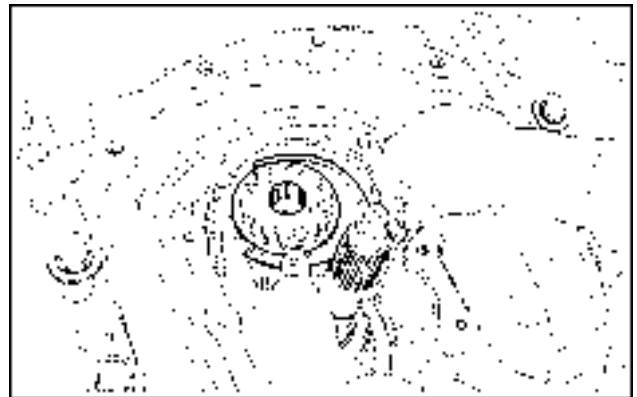

SVIL13TR00192AB 9

15. If necessary, drive out the roll pin (38).

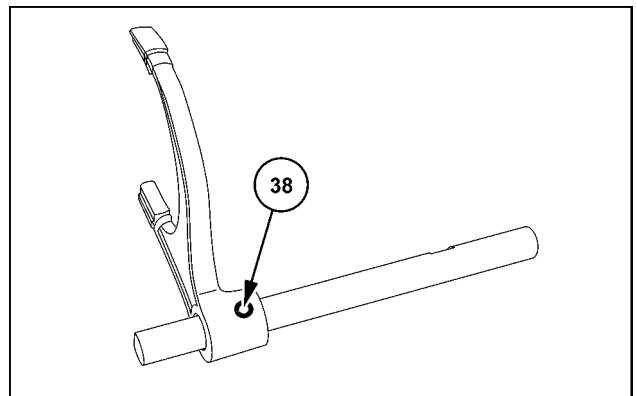

SVIL13TR00193AB 10

16. Remove the complete drive shaft (33).

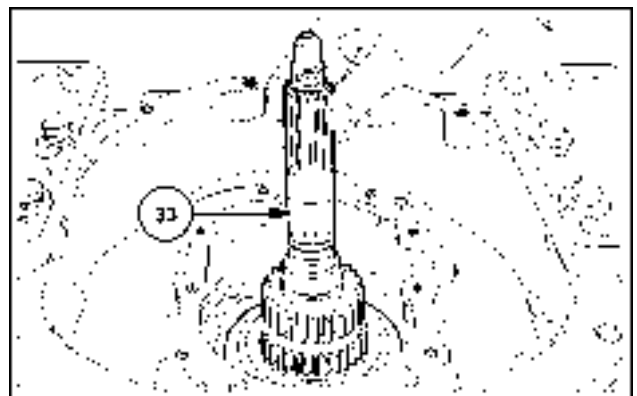

SVIL13TR00194AB 11

**Next operation:**  
**Front drive shaft - Install – NORMAL/ECONOMIC (31.119)**

## Front drive shaft - Install – NORMAL/ECONOMIC

### Prior operation:

### Front drive shaft - Remove – NORMAL/ECONOMIC (31.119)

1. Insert the pre-assembled drive shaft (33) until the drive shaft sits in place in the housing.

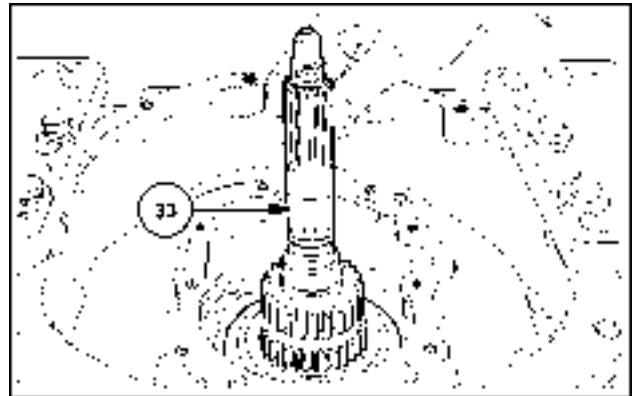

SVIL13TR00194AB 1

2. Slide the needle bearing (57) onto the double gear (58).

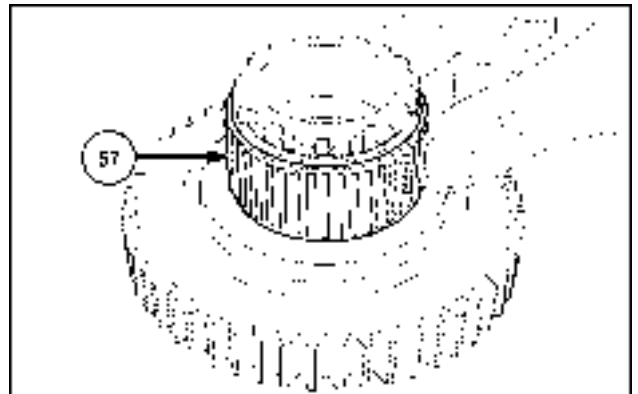

SVIL13TR00314AB 2

3. Slide on the gear (56).

**NOTE:** Note the installation position.

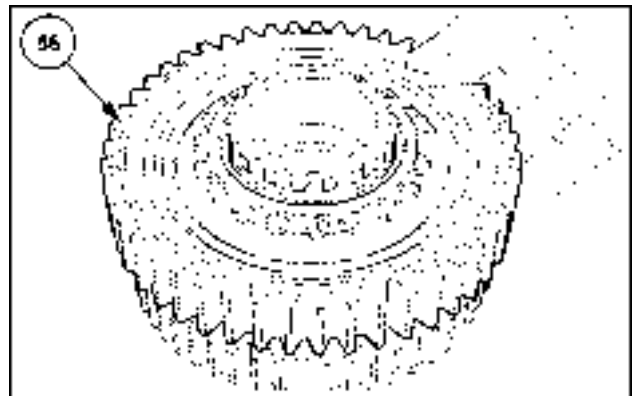

SVIL13TR00315AB 3

- Slide on the drive disk (54).

**NOTE:** Note the installation position.

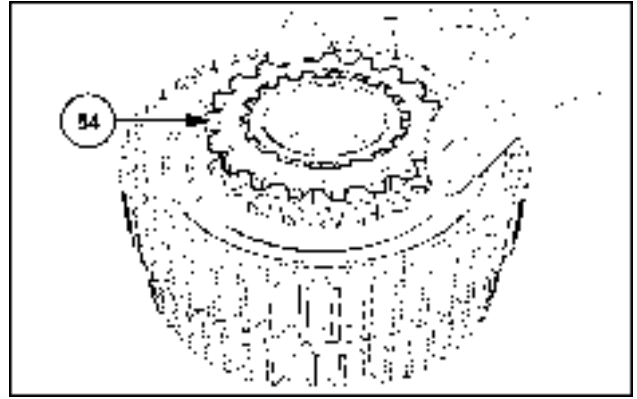

SVIL13TR00316AB 4

- Swing the housing (horizontally).
- Fit the pre-assembled components.

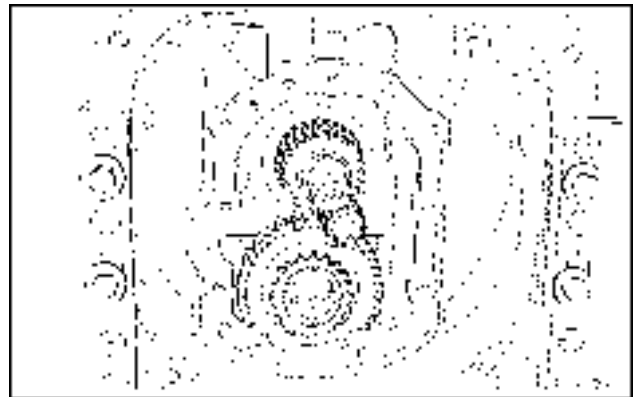

SVIL13TR00317AB 5

- Attach the selector fork (37) with the roll pin (38) to the gearshift bar (39).

**NOTE:** Note the gearshift bar position.

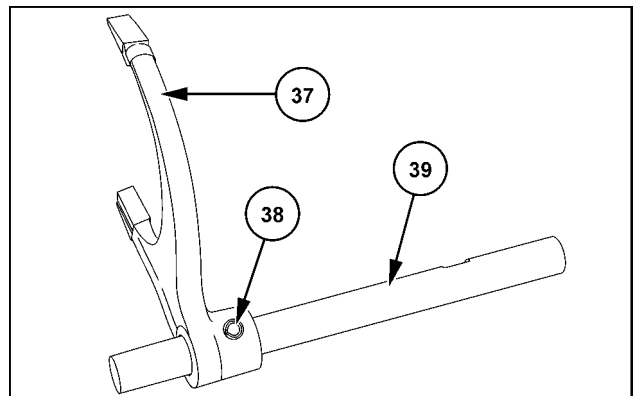

SVIL13TR00318AB 6

- Insert the shift collar (53) into the selector fork.

**NOTE:** Note the installation position.

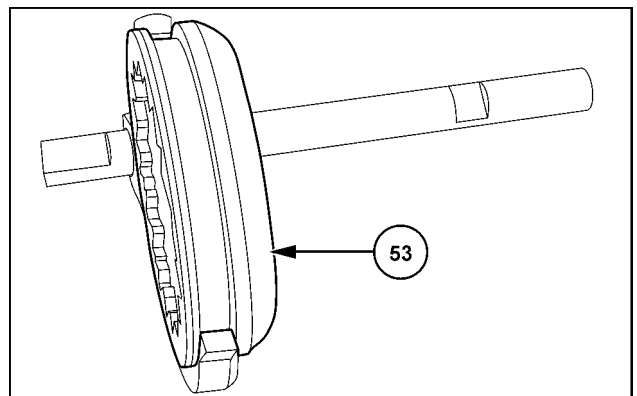

SVIL13TR00319AB 7

9. Insert the pre-assembled gearshift bar (39) with the shift collar (53) into the housing.

**NOTE:** During installation, ensure that the selector finger (48) engages in the gearshift bar.

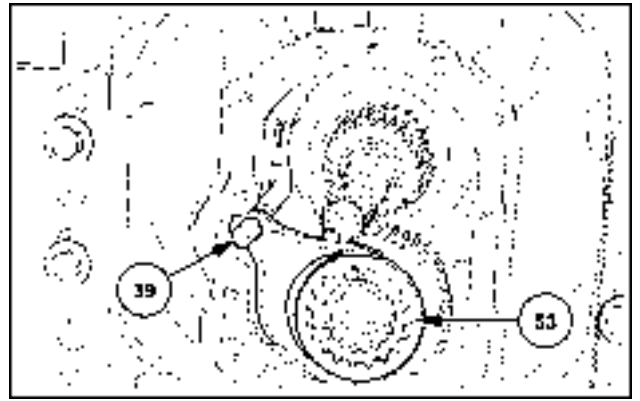

SVIL13TR00320AB 8

10. Fit the clearance washer (63) onto the shaft.
11. Press on the bearing (64) until the bearing sits in place.

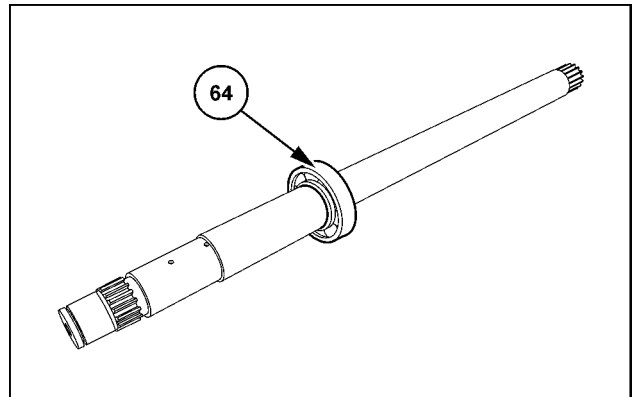

SVIL13TR00190AB 9

12. Slide on the disk (67).
13. Fit the circlip (68).

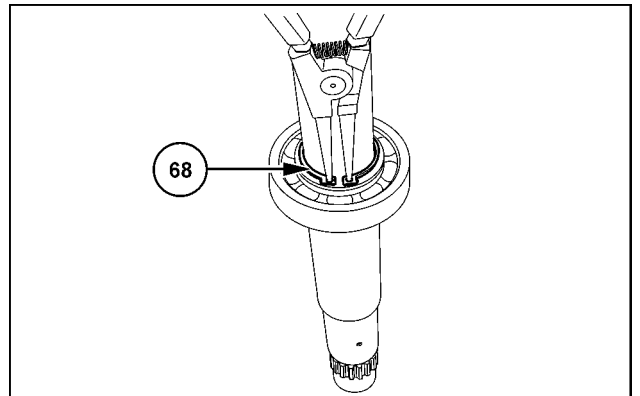

SVIL13TR00189AB 10

14. Secure the ball (61) in the shaft with industrial Vaseline.

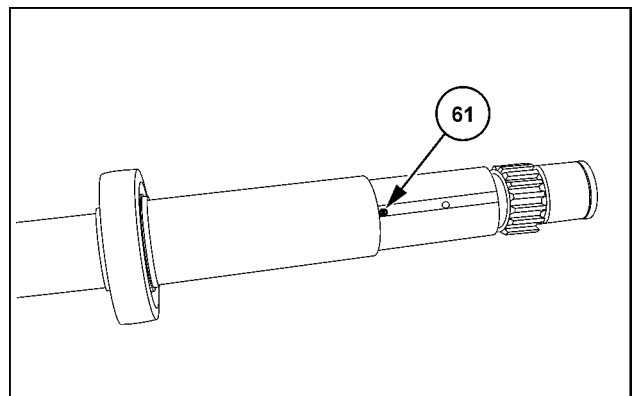

SVIL13TR00188AB 11



15. Slide on the thrust washer (62). The lubricating grooves must face upward.

**NOTE:** Align the groove in the thrust washer with the ball (61).

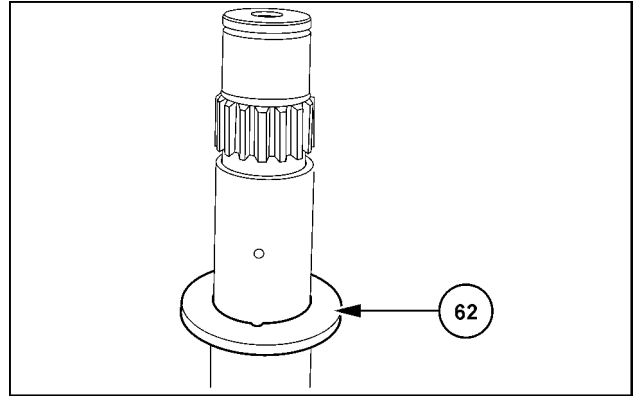

SVIL13TR00321AB 12

16. Slide on the needle bearing (60), the spacer tube (59) and the needle bearing (55).

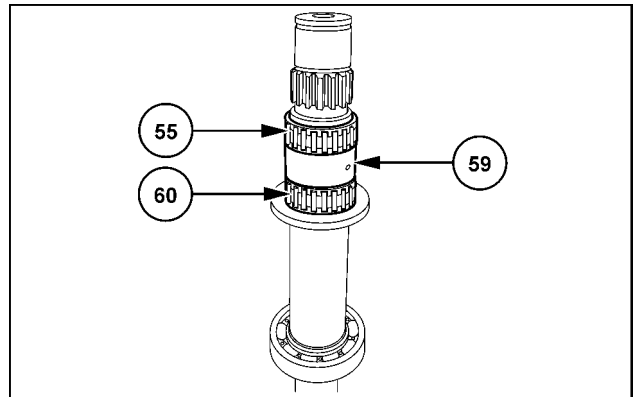

SVIL13TR00322AB 13

17. Insert the pre-assembled shaft into the housing. When you insert the pre-assembled shaft, the components you already inserted (see figures 5 and 8) must slide onto the shaft. Insert the shaft until the shaft sits in place in the housing.

**NOTE:** When you install the shaft, ensure that the ball (61) and the disk (62) remain in the correct position.

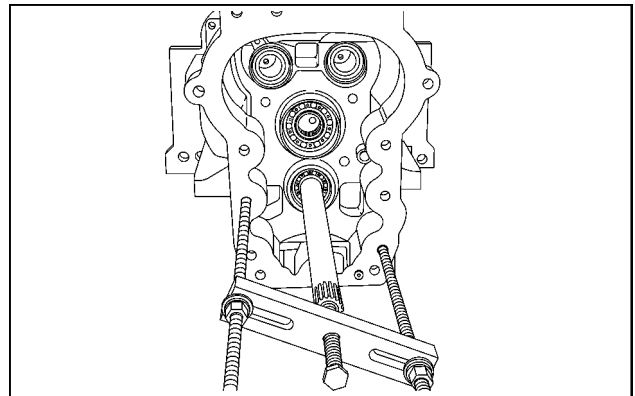

SVIL13TR00323AB 14

18. Fit the circlip (65).

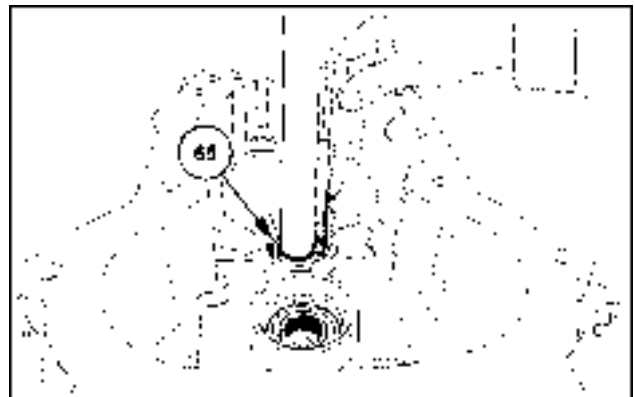

SVIL13TR00184AB 15

19. Install the ball (43) and the spring (42).

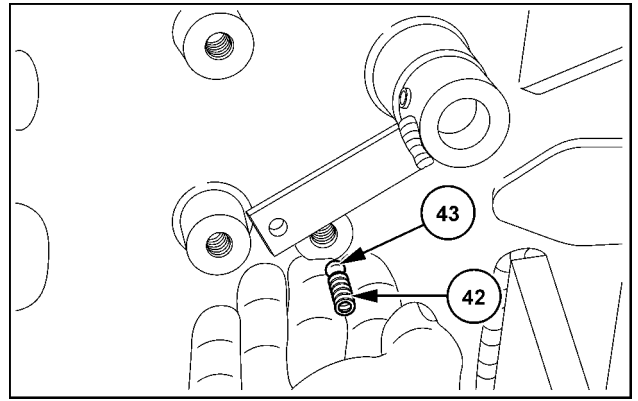

SVIL13TR00324AB 16

20. Fit the screw plug (40) with a new ring seal (41). Install the screw plug. Tighten the screw plug to **11 Nm (8 lb ft)**.

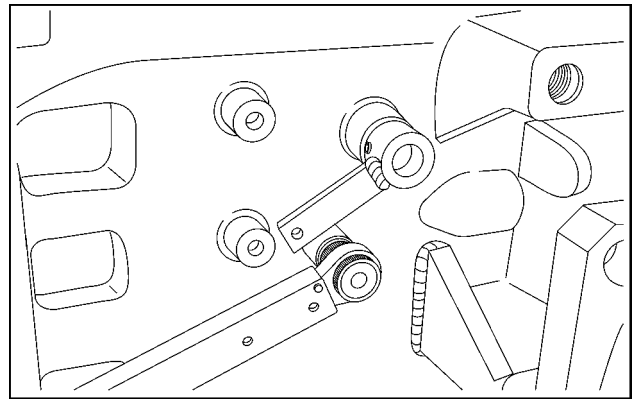

SVIL13TR00325AB 17

21. Move the shaft against the circlip.

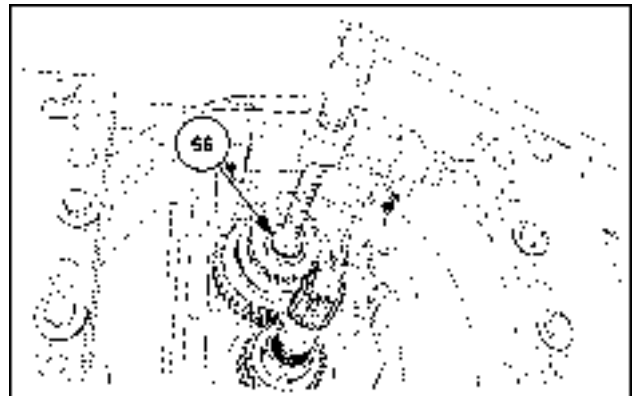

SVIL13TR00187AB 18

22. Insert the collar holder (52).

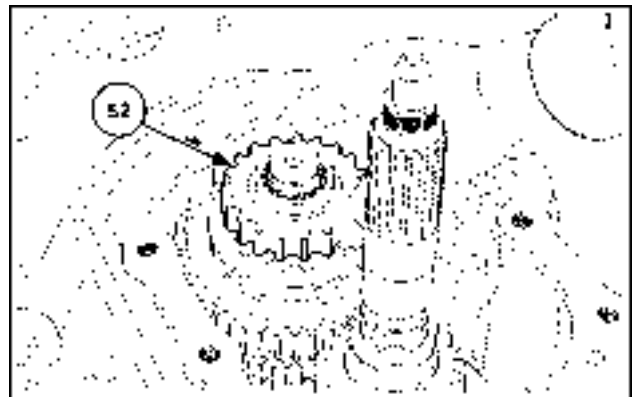

SVIL13TR00326AB 19

23. **⚠ CAUTION**

**Burn hazard!**  
**Always wear heat-resistant protective gloves when handling heated parts.**  
**Failure to comply could result in minor or moderate injury.**

C0047A

Install the heated bearing (51) until the bearing sits in place.

**NOTE:** Adjust the bearing once it has cooled down.

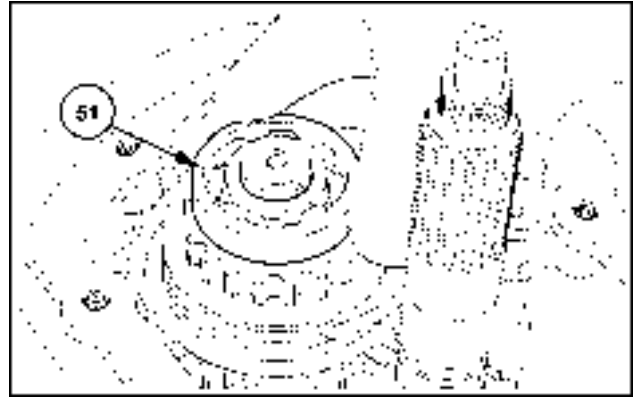

SVIL13TR00327AB 20

24. Slide on the disk (50).

25. Feed the circlip (49) into the ring groove of the PTO.

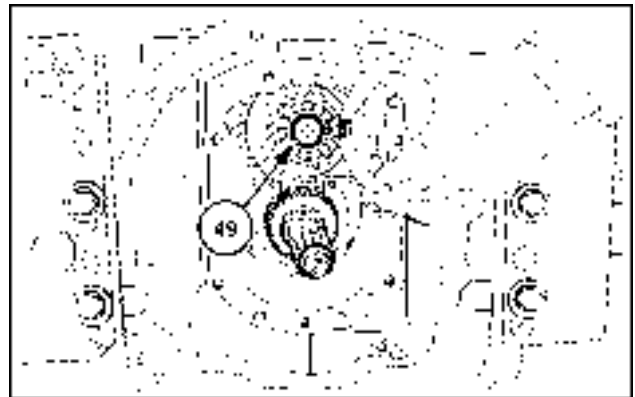

SVIL13TR00185AB 21

**Next operation:**  
**Power Take-Off (PTO) case Cover - Install (31.119)**

## Output shaft - Remove

### Prior operation:

#### Bevel pinion - Remove (27.106)

**NOTE:** This manual does not describe the standard version of the output shaft (without ground-speed Power Take-Off (PTO)). Some of the required steps may differ from the steps in this manual.

1. Version with ground-speed PTO:  
Remove the needle bearing and the collar holder.

**NOTE:** This step is not necessary if you do not remove the rear axle.

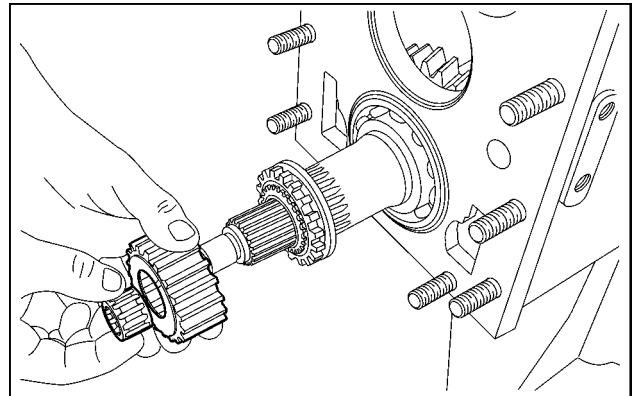

SS13H142 1

2. Unscrew the bolt (150). Remove the "speed sensor for the rear PTO" (149).

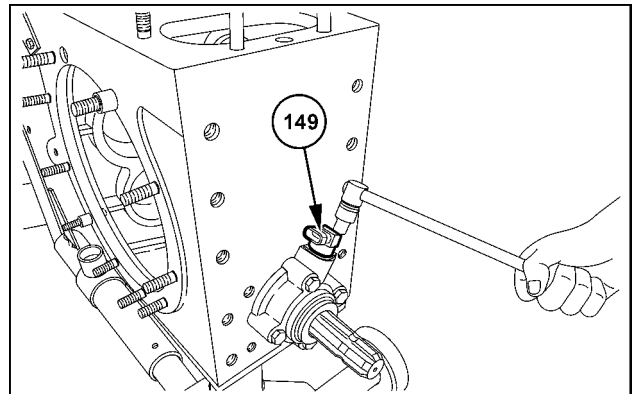

SS13H143 2

3. Remove the bearing cap (145). Remove the shaft sealing ring (144) from the bearing cap.

**NOTE:** If you remove the output shaft when the rear axle is still in place, you must switch the ground-speed PTO to the ON position. If you do not switch on the ground-speed PTO, the collar holder (figure 1) and the shift collar will fall into the gearbox housing when you remove the output shaft.

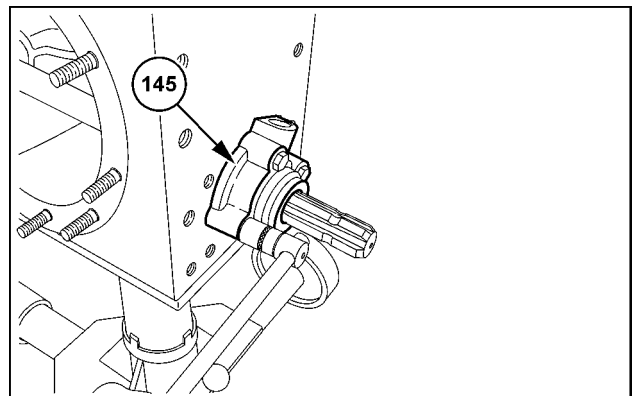

SS13H144 3

4. Loosen the grub screw (143).
5. Remove the sensor wheel (142).

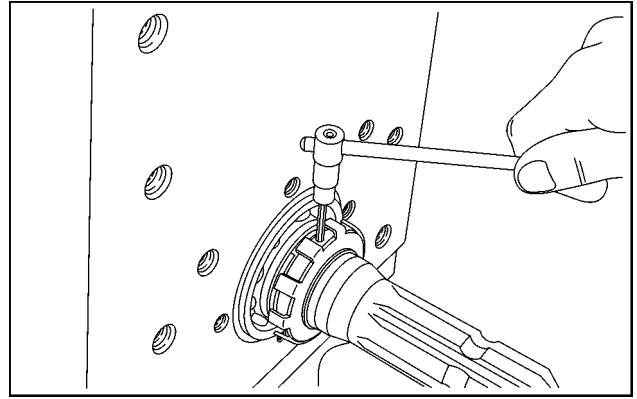

SS13H145 4

6. Release the circlip (141) from the ring groove on the PTO.
7. Remove the thrust washer.

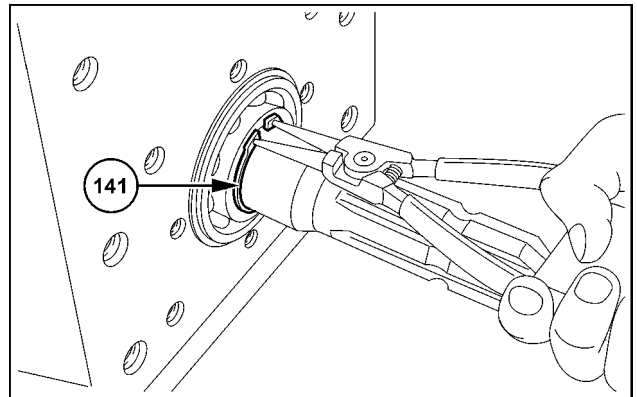

SS13H146 5

8. Remove the PTO.

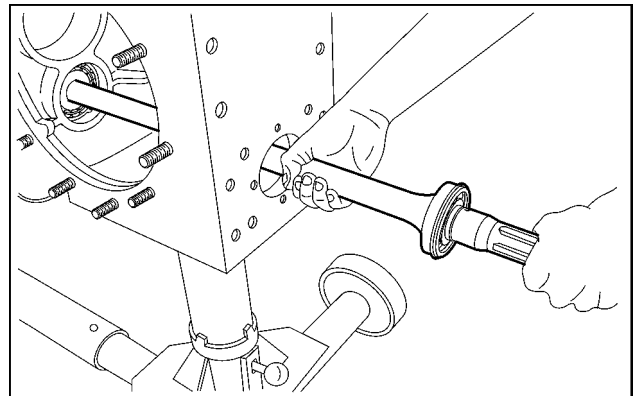

SS13H147 6

9. Remove the bearing (138) from the PTO.

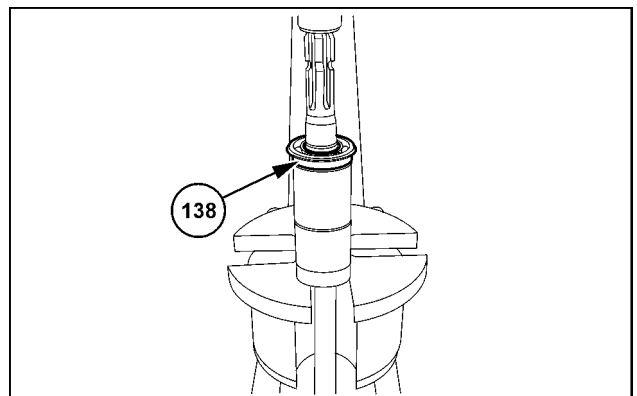

SS13H148 7

**NOTE:** Clean the components, check carefully for wear and damage, and replace if necessary.

**Next operation:**  
**Hollow shaft and gears - Remove (21.902)**

## Output shaft - Install

### Prior operation:

### Hollow shaft and gears - Install (21.902)

**NOTE:** All components must be lubricated prior to installation.

#### 1. **CAUTION**

##### **Burn hazard!**

**Always wear heat-resistant protective gloves when handling heated parts.**

**Failure to comply could result in minor or moderate injury.**

C0047A

Warm up the bearing (138) and the circlip (139). Slide the bearing and the circlip onto the Power Take-Off (PTO) until the bearing and circlip sit in place.

**NOTE:** Adjust the bearing once it has cooled down.

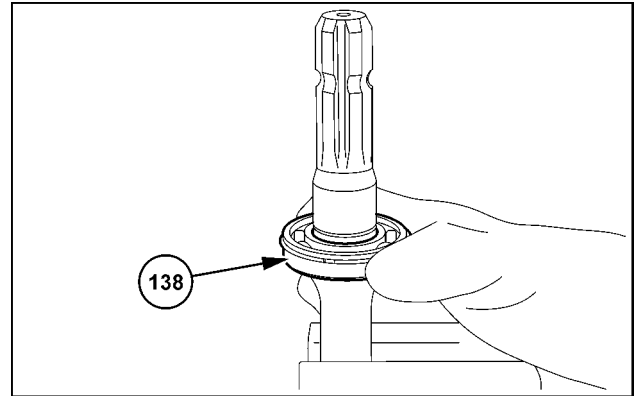

SS13H149 1

2. Slide on the thrust washer (140).
3. Feed the circlip (141) into the ring groove of the PTO.

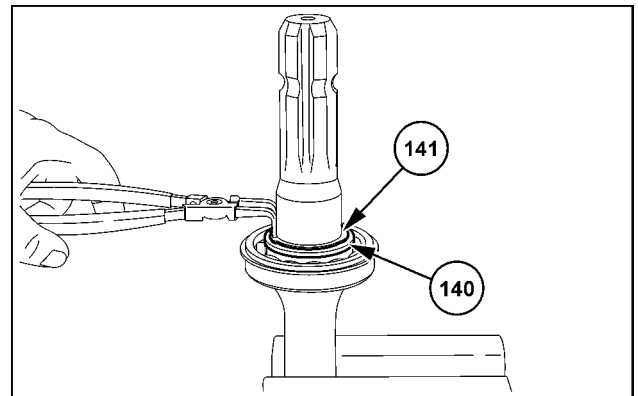

SS13H150 2

4. Coat the grub screw with **LOCTITE® 243**.
5. Fit the sensor wheel (142) on the PTO with the grub screw (143). Tighten the grub screw to a torque of **6 Nm (4.4 lb ft)**.

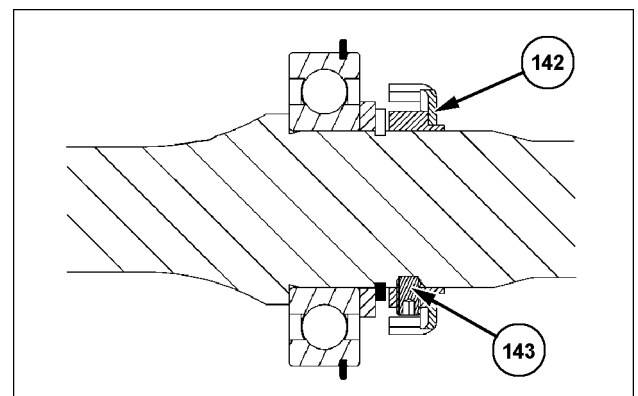

SS13G326 3

6. Insert the pre-assembled PTO into the rear axle housing until the pre-assembled PTO sits in place.



SS13G327 4

7. Insert the shaft sealing ring (144) into the bearing cap (145) using a suitable positioning tool. Push the shaft sealing ring into the bearing cap until the shaft sealing ring sits in place.

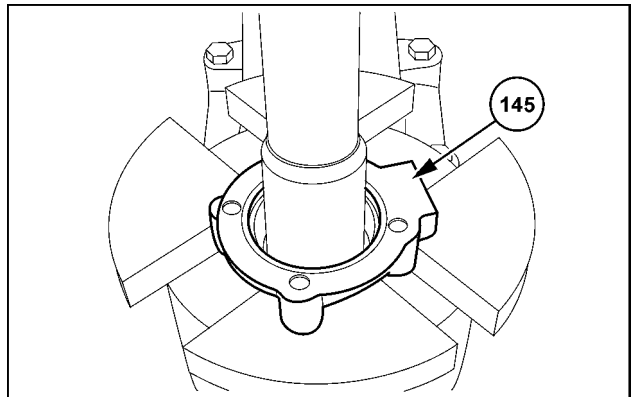

SS13G328 5

8. Grease the shaft sealing ring (144) with industrial Vaseline. Clean the sealing surfaces and spray with **LOCTITE® 518**.

9. Fit the bearing cap (145) on the rear axle housing.

**NOTE:** Pay attention to the installation position of the bearing cap (145).

10. Insert the screws (146) and tighten to **46 Nm (33.9 lb ft)**.

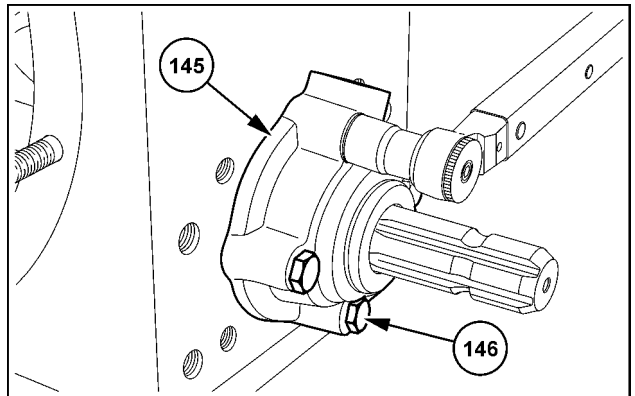

SS13G329 6

11. Insert the O-ring (148) into the ring groove of the "speed sensor for the rear PTO" (149).

**NOTE:** Grease the O-ring with industrial Vaseline.

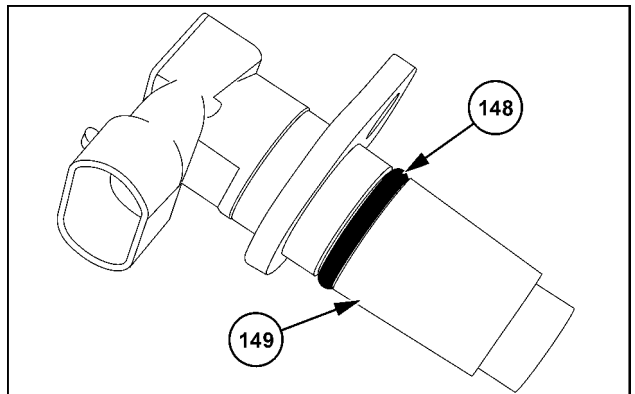

SS13G330 7

12. Fit the "speed sensor for the rear PTO" (149).
13. Moisten the bolt (150) with **LOCTITE® 243**.  
Fit the bolt. Tighten the bolt to a torque of **23 Nm**  
(**17 lb ft**).

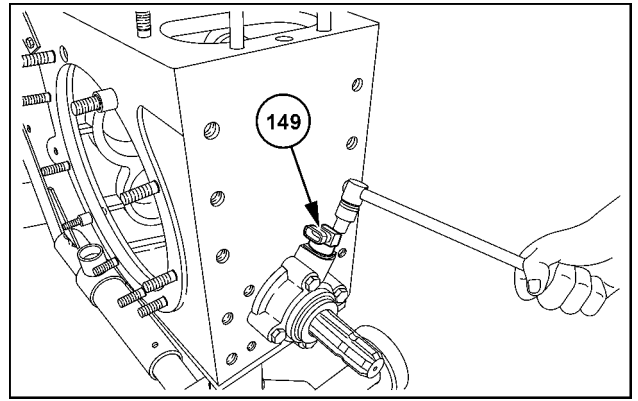

SS13G331 8

14. On the opposite side, fit the shift collar and the needle bearing.

**NOTE:** This step is not necessary if you do not remove the rear axle.



SS13G332 9

**Next operation:**  
**Bevel pinion - Gear tooth contact (27.106)**



## Power Take-Off (PTO) case Cover - Remove

**Prior operation:**

**Gear housing - Disconnect (gearbox housing – range housing) (21.111)**

1. Undo the bolts (13).

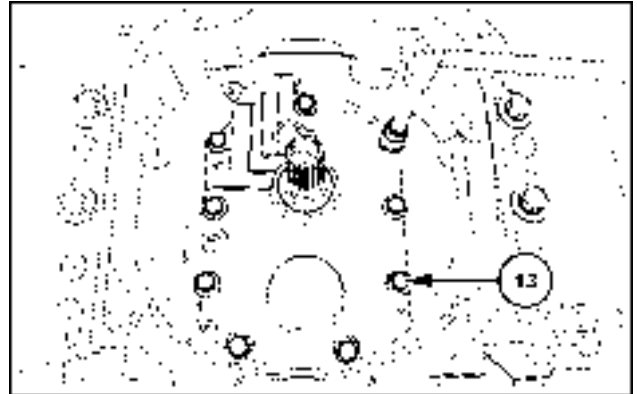

SVIL13TR00175AB 1

2. Apply even pressure to press off the cover with the screws.

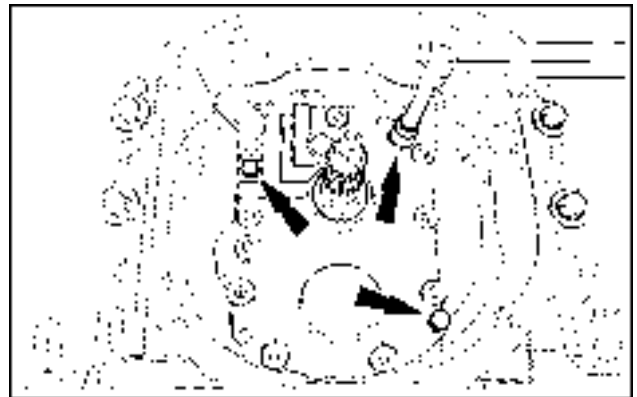

SVIL13TR00176AB 2

3. Remove the bearing (15) from the cover bore.

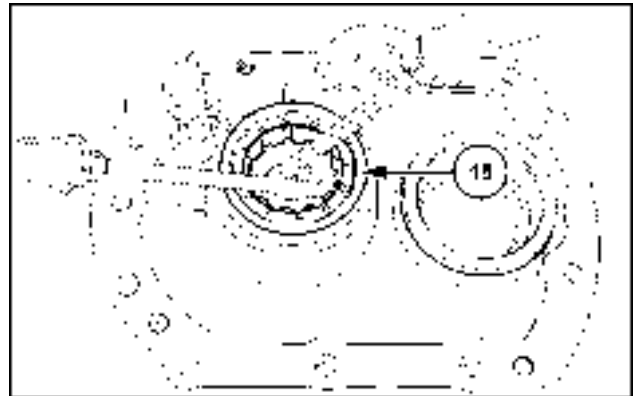

SVIL13TR00177AB 3

4. If necessary, remove the shaft seal (12).

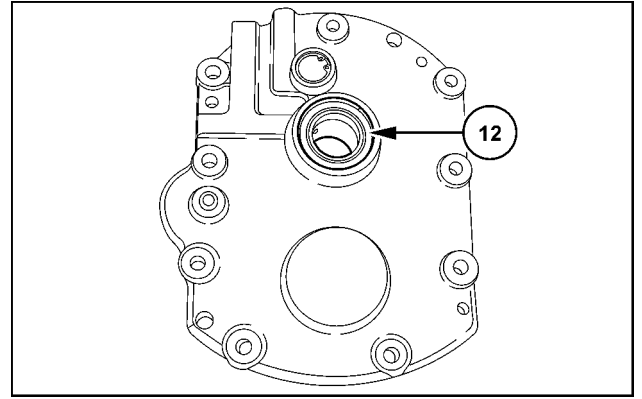

SVIL13TR00178AB 4

**Next operation:**

**Power Take-Off (PTO) clutch brake - Disassemble (31.119)**

**Front drive shaft - Remove – NORMAL/ECONOMIC (31.119)**

## Power Take-Off (PTO) case Cover - Install

**Prior operation:**

Front drive shaft - Install – NORMAL/ECONOMIC (31.119)

Power Take-Off (PTO) clutch brake - Assemble (31.119)

1. Fit the bearing (15).

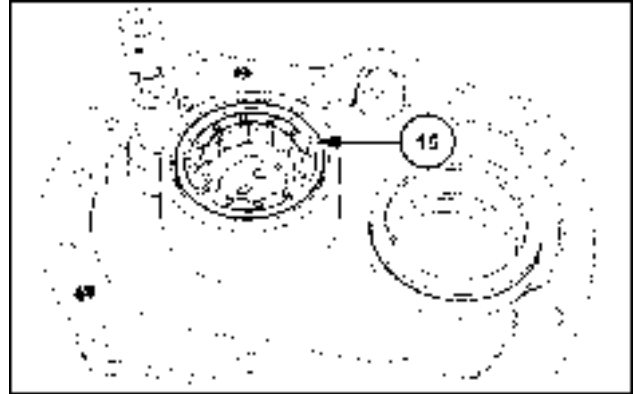

SVIL13TR00330AB 1

2. Insert the dowel (11) until the dowel sits in place.

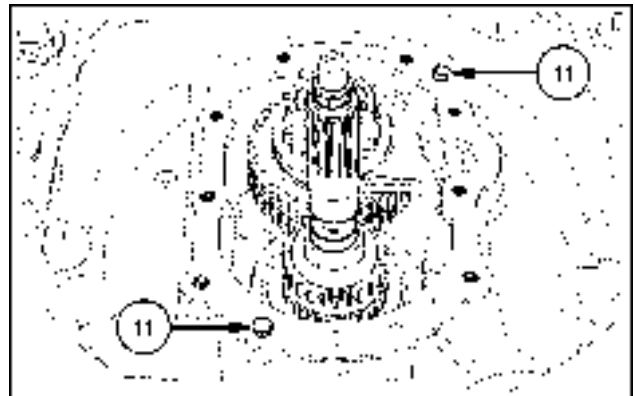

SVIL13TR00331AB 2

3. Coat the sealing surfaces with **LOCTITE® 518**.
4. Secure the cover with the screws (13). Tighten the screws to **46 Nm (34 lb ft)**.

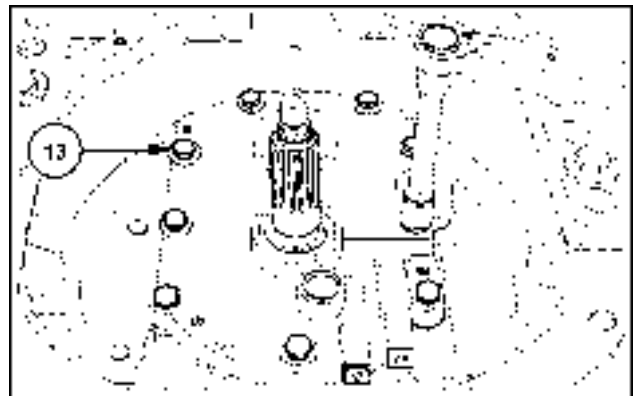

SVIL13TR00332AB 3

**Next operation:**

Gear housing - Connect (gearbox housing – range housing) (21.111)

## Power Take-Off (PTO) clutch - Disassemble

Prior operation:

Front drive shaft - Remove – NORMAL/ECONOMIC (31.119)

1. Remove the three rectangular rings (14).

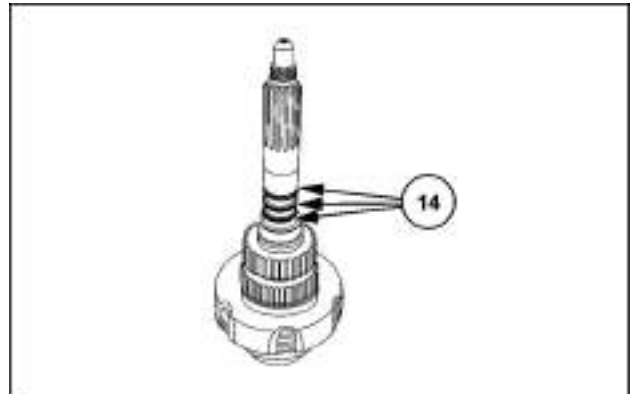

SVIL13TR00195AB 1

2. Remove the bearing (36).

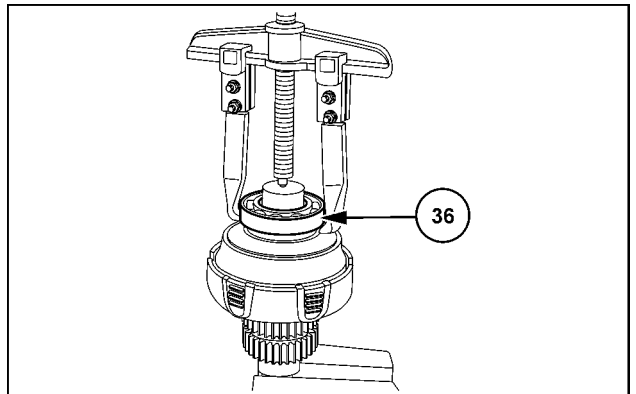

SVIL13TR00196AB 2

3. Remove the bearing inner ring.

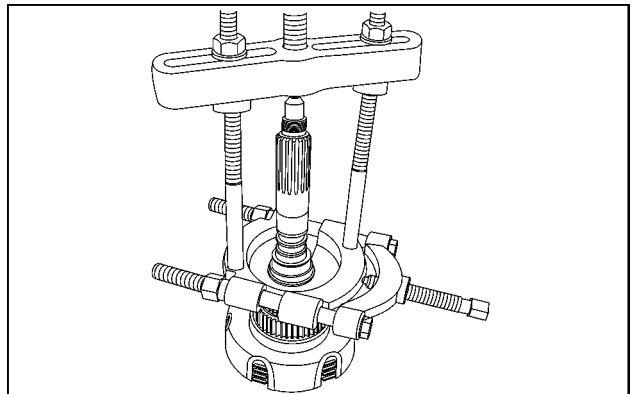

SVIL13TR00197AB 3

4. Release circlip (16) from its position.
5. Remove any loose components.

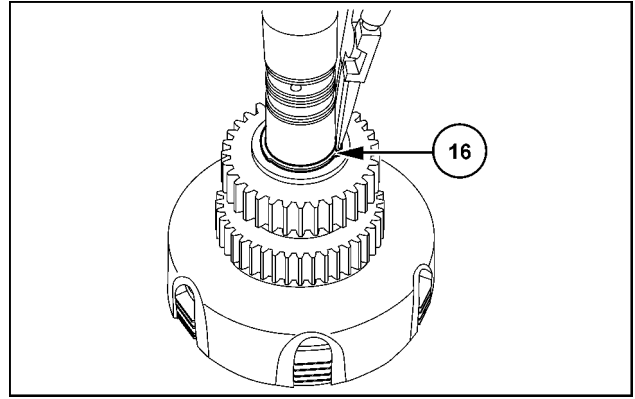

SVIL13TR00198AB 4

6. **CAUTION**  
**Spring under tension!**  
**This assembly is spring-loaded. Remove the parts carefully!**  
**Failure to comply could result in minor or moderate injury.**

C0147A

Preload the spring (28).

7. Release circlip (23) from its position.
8. Remove any loose components.

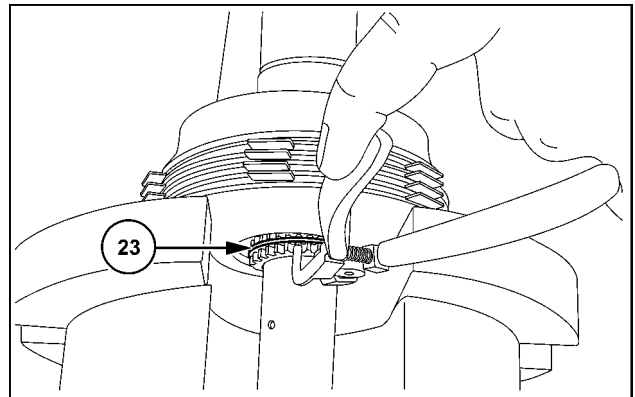

SVIL13TR00199AB 5

9. **CAUTION**  
**Eye injury hazard!**  
**Wear protective goggles when using compressed air.**  
**Failure to comply could result in minor or moderate injury.**

C0035A

Use compressed air to separate the cylinder (29) carefully from the piston (32).

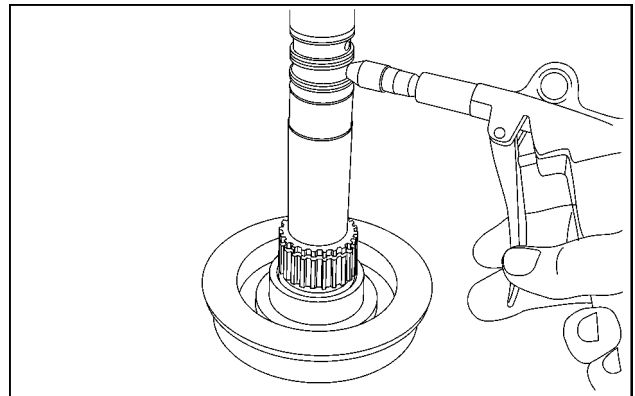

SVIL13TR00200AB 6

10. Remove the O-ring (30).

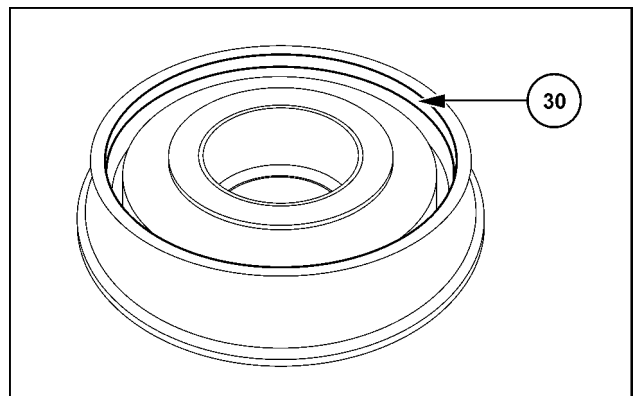

SVIL13TR00201AB 7

11. Remove the piston (32).

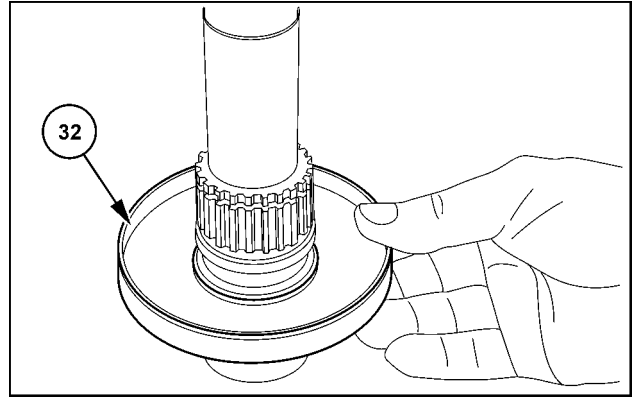

SVIL13TR00202AB 8

12. Remove the two O-rings (31).

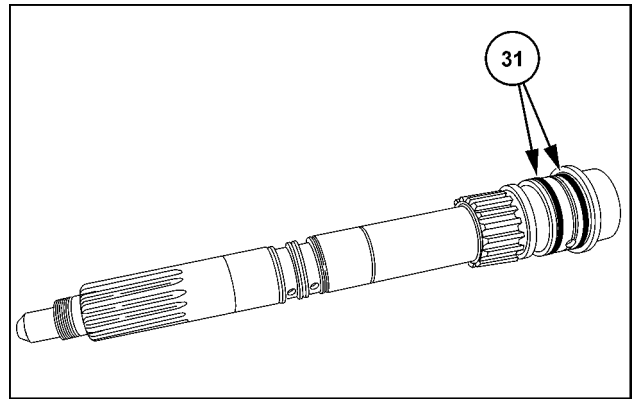

SVIL13TR00203AB 9

**Next operation:**  
**Power Take-Off (PTO) clutch - Assemble (31.119)**

## Power Take-Off (PTO) clutch - Assemble

**Prior operation:**

**Power Take-Off (PTO) clutch - Disassemble (31.119)**

1. Insert the two O-rings (31) into the ring grooves of the drive shaft.

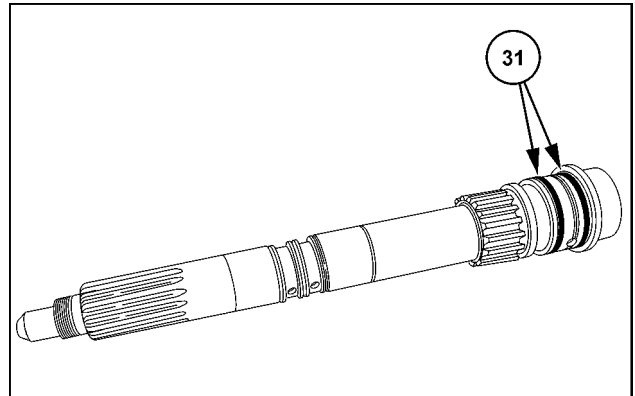

SVIL13TR00203AB 1

2. Insert the O-ring (30) into the ring groove of the cylinder.

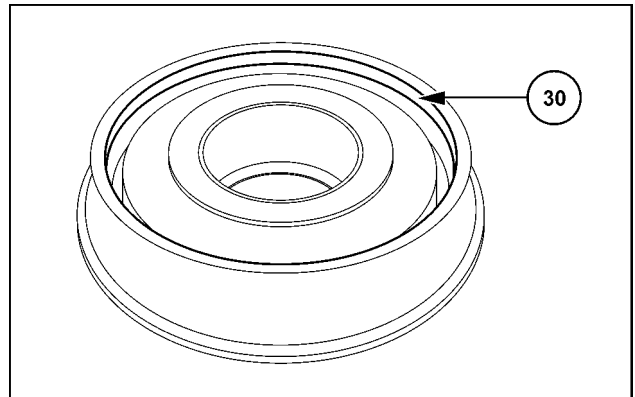

SVIL13TR00201AB 2

3. Fit the piston (32) into the cylinder (29).

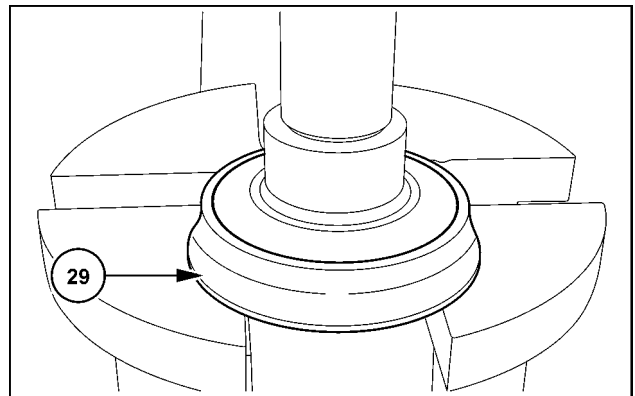

SVIL13TR00300AB 3

4. Fit the drive shaft into the pre-assembled cylinder (29).

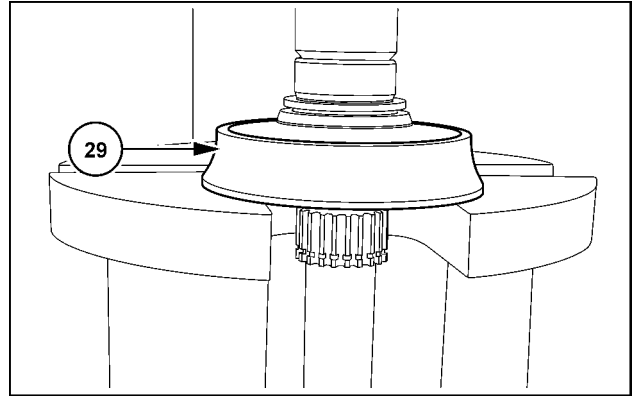

SVIL13TR00301AB 4

5. Slide the steel disk (25) onto the disk holder (24).

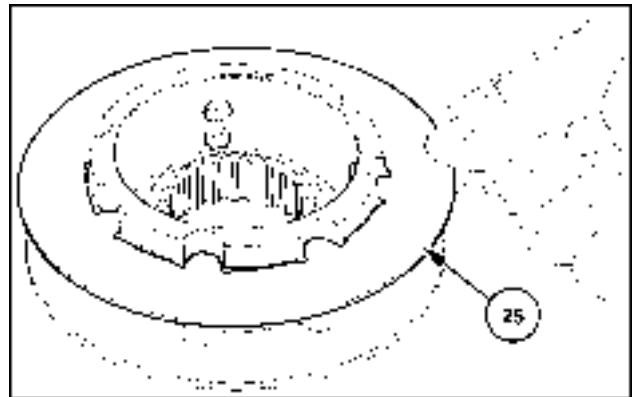

SVIL13TR00302AB 5

6. Slide on the wave spring (26).

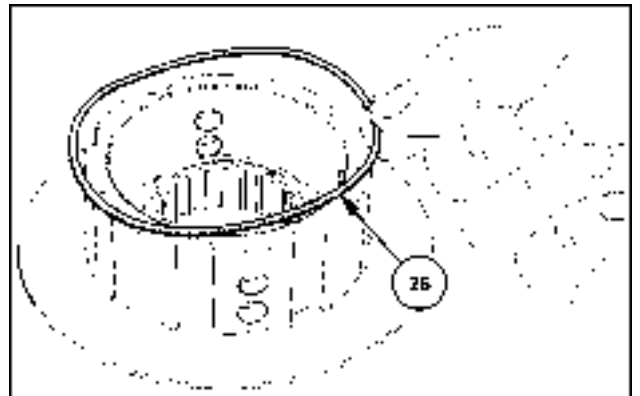

SVIL13TR00303AB 6

7. Slide on the friction disk (27).  
8. Complete the disk set in the sequence shown.

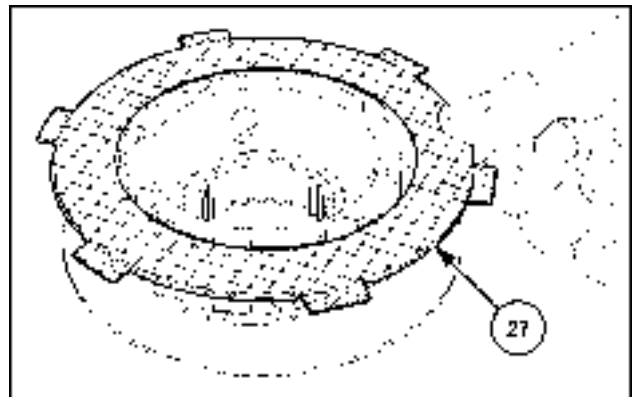

SVIL13TR00421AB 7



9. Use the retaining brackets **380200021** to fix the completed disk set in place.

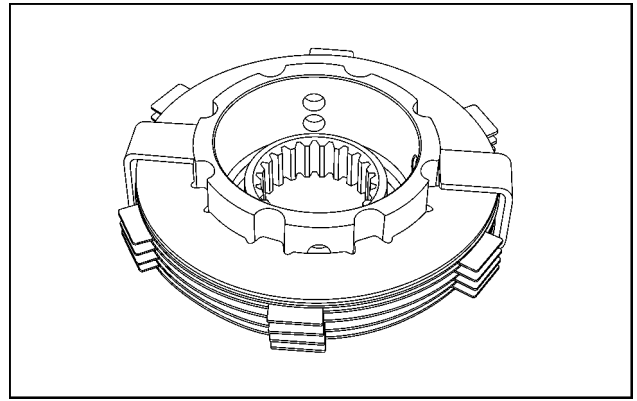

SVIL13TR00304AB 8

10. Slide on the spring (**28**).

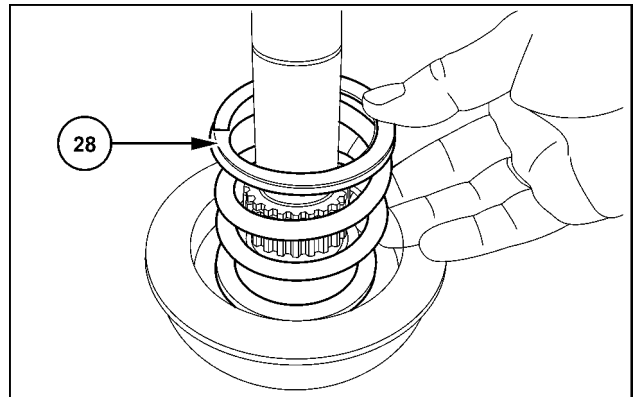

SVIL13TR00305AB 9

11. Slide on the pre-assembled components.

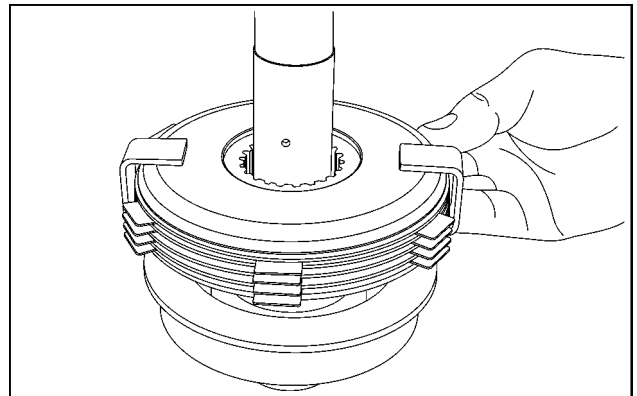

SVIL13TR00306AB 10

12. Fit the circlip (**23**).

13. **CAUTION**

**Spring under tension!**  
**This assembly is spring-loaded. Remove the parts carefully!**  
**Failure to comply could result in minor or moderate injury.**

C0147A

Preload the spring (**28**).

14. Fit the circlip (**23**).

15. Remove the retaining bracket.

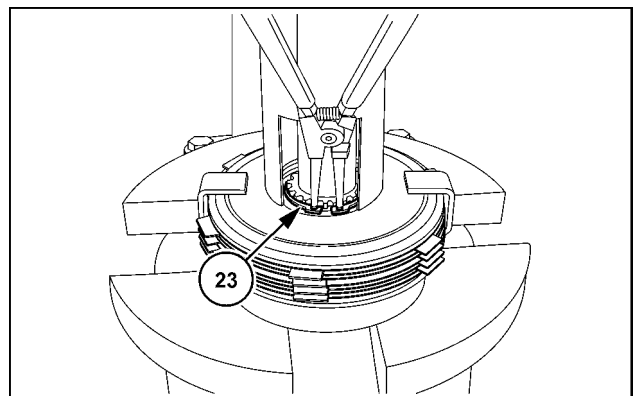

SVIL13TR00307AB 11

16. Slide on the thrust washer (22).

**NOTE:** Note the installation position. Fit the thrust washer. The lubricating grooves must face upward (toward the double gear).

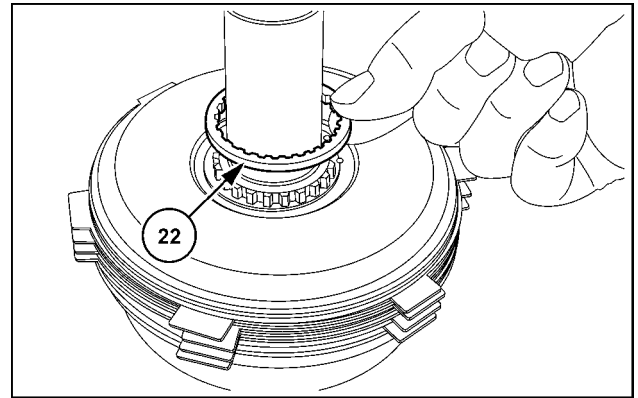

SVIL13TR00308AB 12

17. Slide on the needle bearing (20). Slide on the spacer ring (19). Slide on the needle bearing (18).

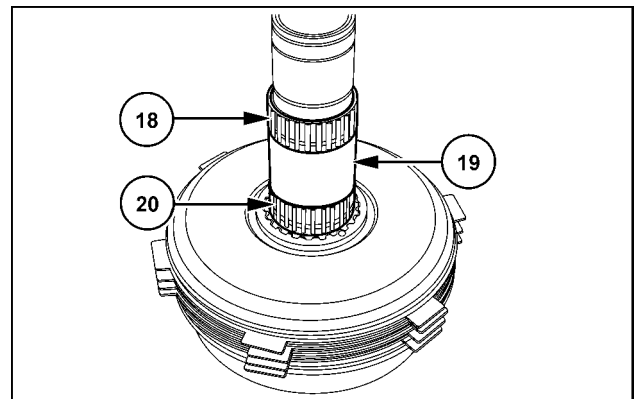

SVIL13TR00309AB 13

18. Slide on the double gear (21).

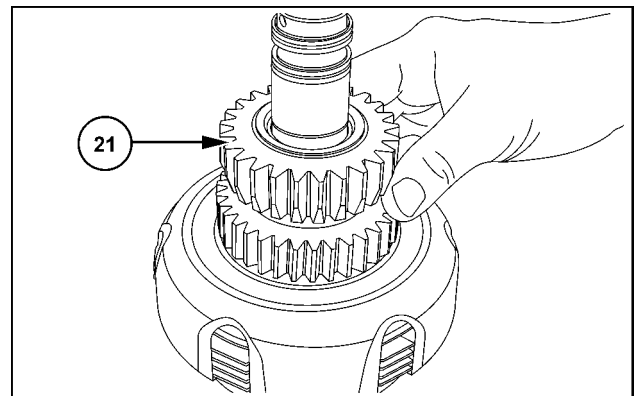

SVIL13TR00310AB 14

19. Slide on the thrust washer (17).

**NOTE:** Note the installation position. Fit the thrust washer. The lubricating grooves must face downward (toward the double gear).

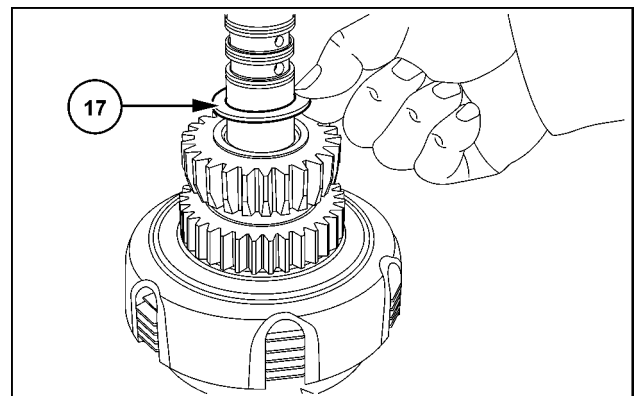

SVIL13TR00311AB 15

20. Fit the circlip (16).

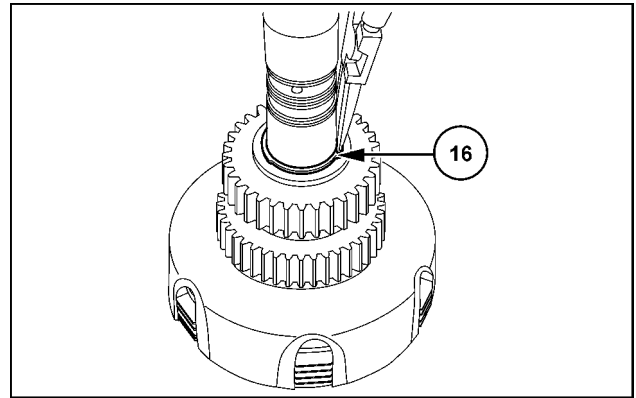

SVIL13TR00198AB 16

21. Press on the bearing inner ring of the bearing (15) until the bearing inner ring sits in place on the circlip.

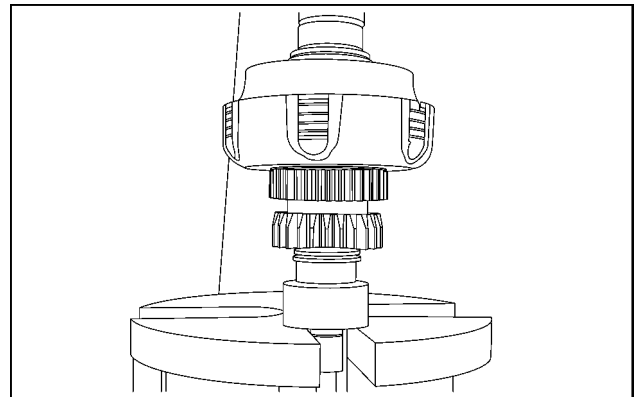

SVIL13TR00312AB 17

22. Grease the ring grooves of the rectangular rings.

23. Fit the three rectangular rings (14) so that the three rectangular rings interlock in place. Align the three rectangular rings.

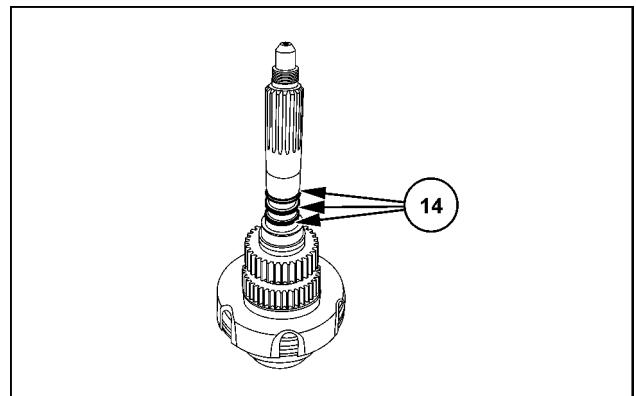

SVIL13TR00195AB 18

24. Press on the bearing (15) until the bearing sits in place.

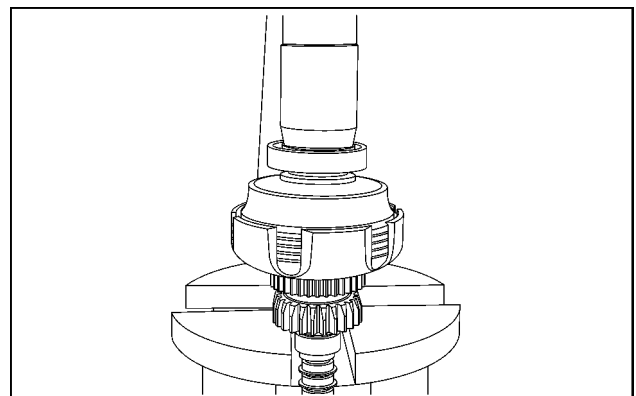

SVIL13TR00313AB 19

**Next operation:**  
**Front drive shaft - Install – NORMAL/ECONOMIC (31.119)**

## Power Take-Off (PTO) clutch brake - Disassemble

### Prior operation:

#### Power Take-Off (PTO) case Cover - Remove (31.119)

1. Push out the roll pin (8).
2. Remove the cap (9).

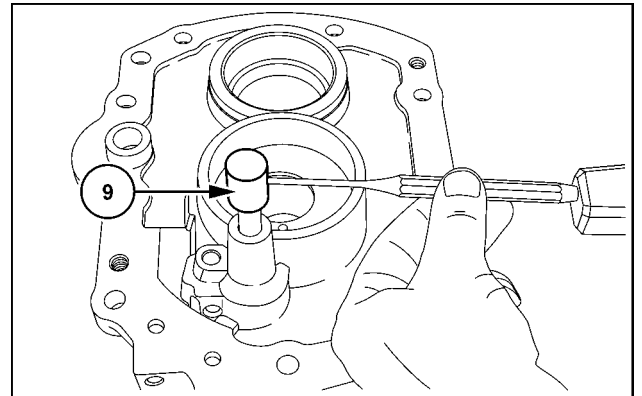

SVIL13TR00179AB 1

### 3. **CAUTION**

**Spring under tension!**  
**This assembly is spring-loaded. Remove the parts carefully!**  
**Failure to comply could result in minor or moderate injury.**

C0147A

Preload the spring (7).

4. Release circlip (1) from its position.
5. Remove the plug (2) and the spring (7).
6. Remove the O-ring (3).

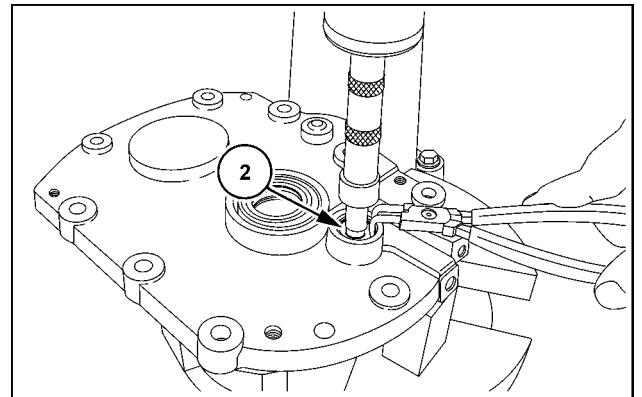

SVIL13TR00180AB 2

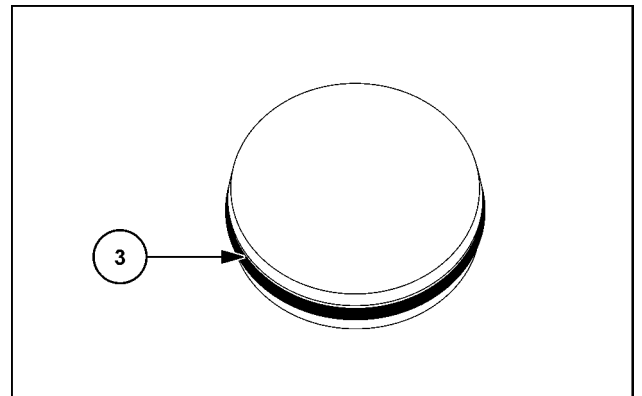

SVIL13TR00181AB 3

7. Remove the pin (4) from the cover.

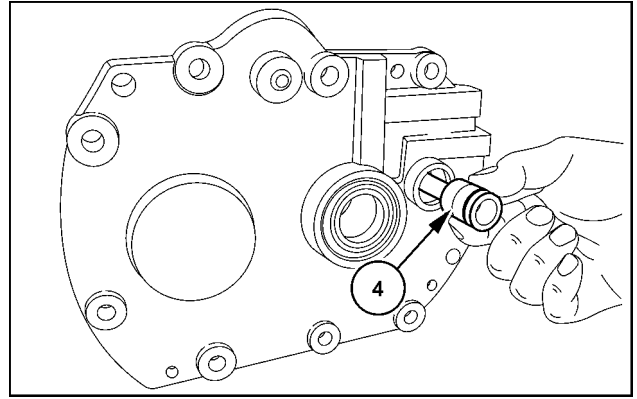

SVIL13TR00182AB 4

8. Remove the O-rings (5) and (6).

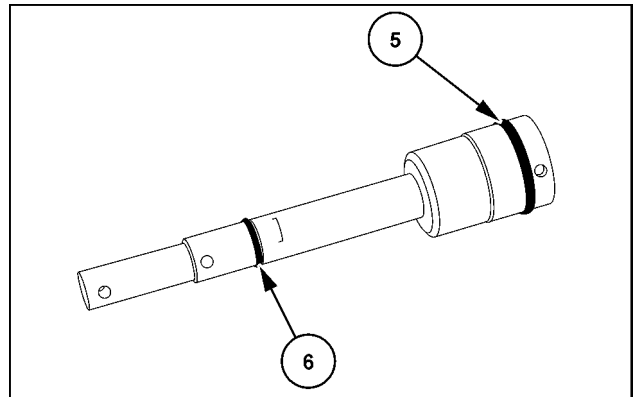

SVIL13TR00183AB 5

**Next operation:**  
**Power Take-Off (PTO) clutch brake - Assemble (31.119)**

## Power Take-Off (PTO) clutch brake - Assemble

Prior operation:

Power Take-Off (PTO) clutch brake - Disassemble (31.119)

1. Insert the O-rings (5) and (6) into the ring grooves of the pin.

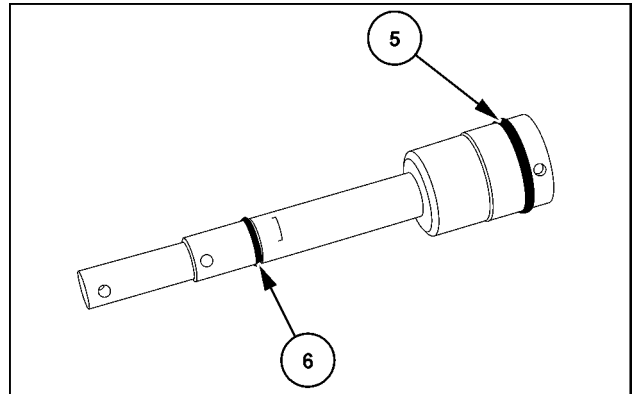

SVIL13TR00183AB 1

2. Insert the pin (4) into the cover bore.

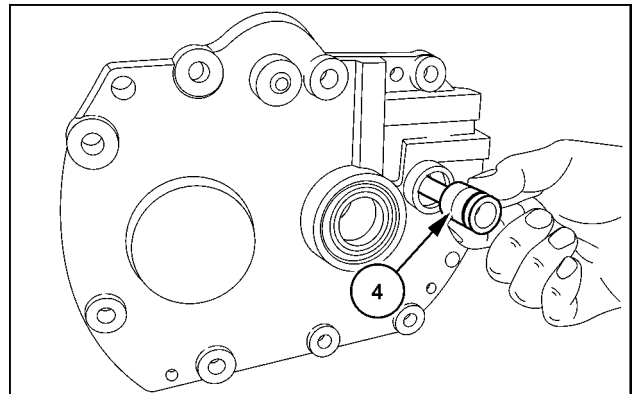

SVIL13TR00182AB 2

3. Fit the cap (9).
4. Use the roll pin (8) to fix the cap to the pin.

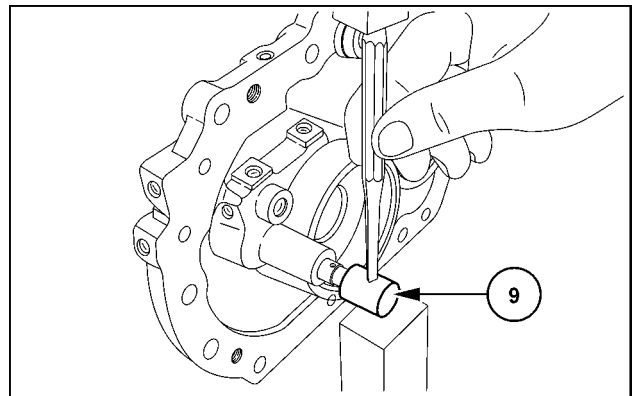

SVIL13TR00328AB 3

5. Insert the spring (7).

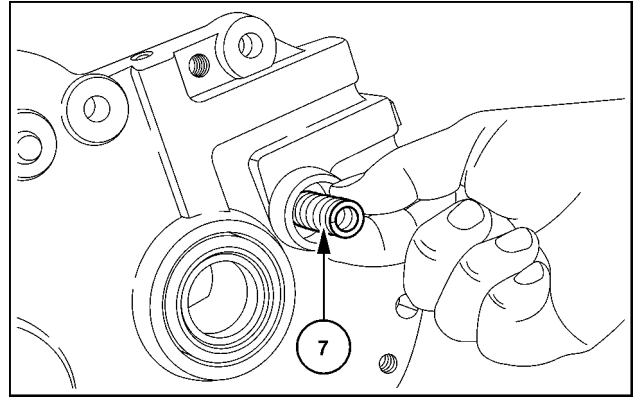

SVIL13TR00329AB 4

6. Fit the O-ring (3) in the ring groove of the plug (2).

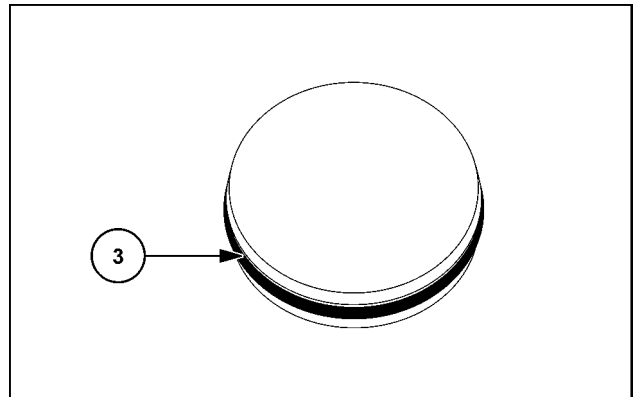

SVIL13TR00181AB 5

7. Place the pre-assembled plug (2) and the circlip (1) on the spring.

8. **⚠ CAUTION**

**Spring under tension!**  
**This assembly is spring-loaded. Remove the parts carefully!**  
**Failure to comply could result in minor or moderate injury.**

C0147A

Preload the spring (7) with the plug.

9. Position the circlip (1) in the ring groove of the cover.

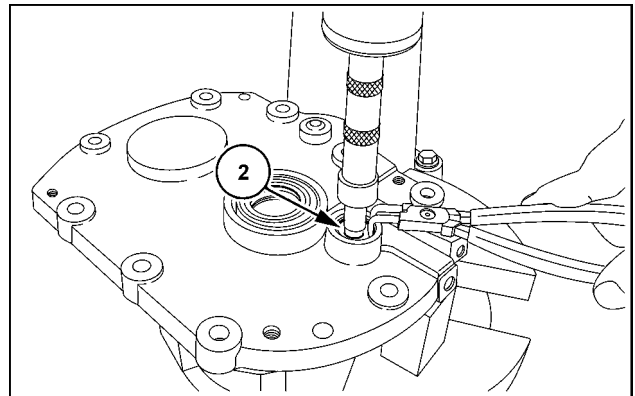

SVIL13TR00180AB 6

**Next operation:**  
**Power Take-Off (PTO) case Cover - Install (31.119)**

## Power Take-Off (PTO) speed rate selector control Normal-Economic speed rate selector control - Remove

### Prior operation:

#### Front drive shaft - Remove – NORMAL/ECONOMIC (31.119)

1. Push out the roll pin (47).
2. Remove the shift lever (44). Remove the selector shaft (48).

**NOTE:** Be careful of the O-rings.

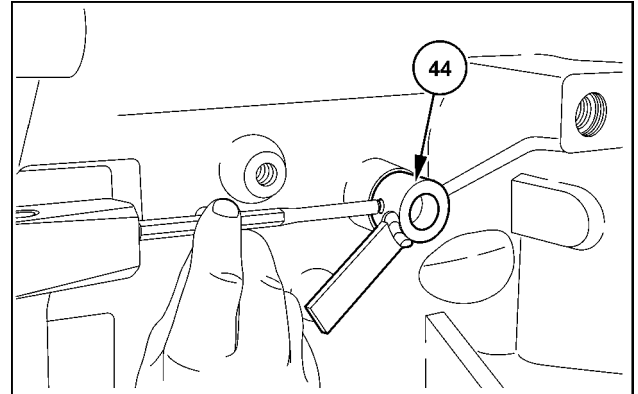

SVIL13TR00204AB 1

3. Drive out the bushing (46).

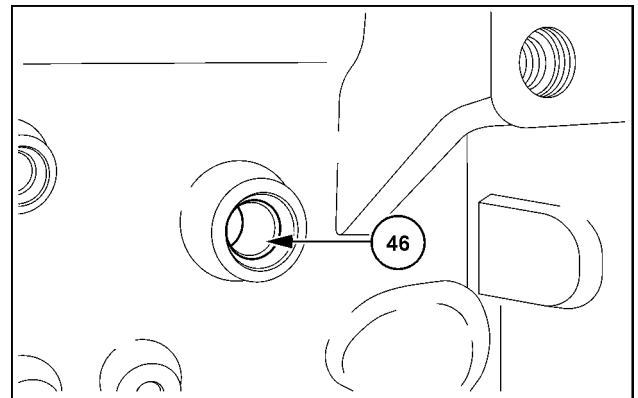

SVIL13TR00205AB 2

### Next operation:

#### Power Take-Off (PTO) speed rate selector control Normal-Economic speed rate selector control - Install (31.119)



## Power Take-Off (PTO) speed rate selector control Normal-Economic speed rate selector control - Install

**Prior operation:**

**Power Take-Off (PTO) speed rate selector control Normal-Economic speed rate selector control - Remove (31.119)**

1. Insert the bushing (46) into the housing bore.

**NOTE:** Note the installation position. Insert the bushing until the bushing is flush with the chamfer on the inside of the housing.

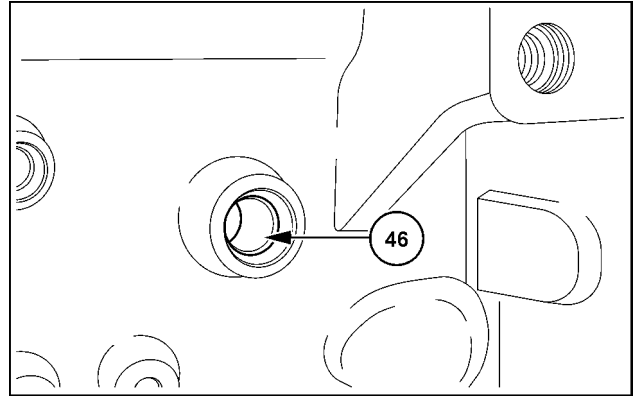

SVIL13TR00205AB 1

2. Insert the selector shaft (48) into the housing from the inside.
3. Install the O-ring (45).

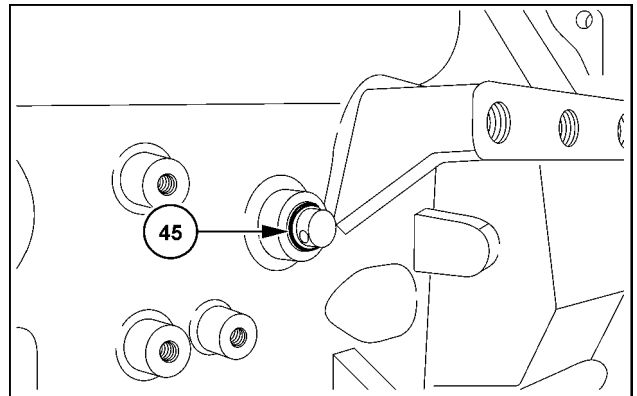

SVIL13TR00299AB 2

4. Attach the shift lever (44) to the selector shaft with the roll pin (47).

**NOTE:** Note the installation position. The selector shaft finger must face downward.

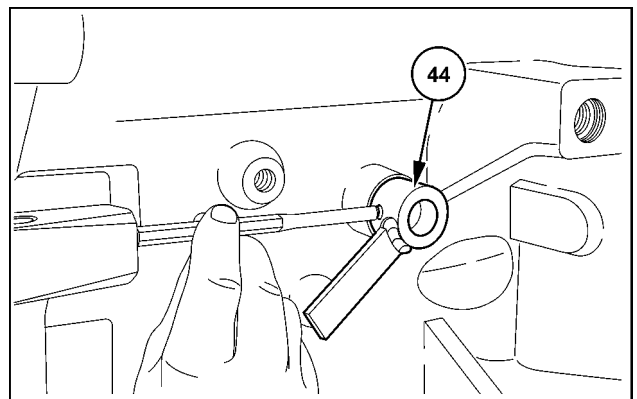

SVIL13TR00204AB 3

**Next operation:**

**Front drive shaft - Install – NORMAL/ECONOMIC (31.119)**

## Power Take-Off (PTO) speed rate selector control 540-1000 rpm speed rate selector control - Remove

### Prior operation:

Rear drive shaft - Remove (31.119)

1. Remove the locking screw (92) from the gearshift bar.

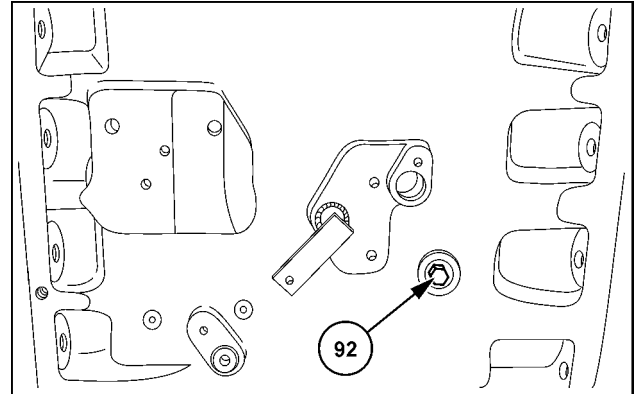

SVIL13TR00400AB 1

2. Remove the bolt (95) from the selector finger.
3. Remove the selector shaft (93). Remove the gearshift bar (99). Remove the selector fork (91).

**NOTE:** During the removal of the selector fork from the gearshift bar, pay attention to the ball (97) and the spring (98).

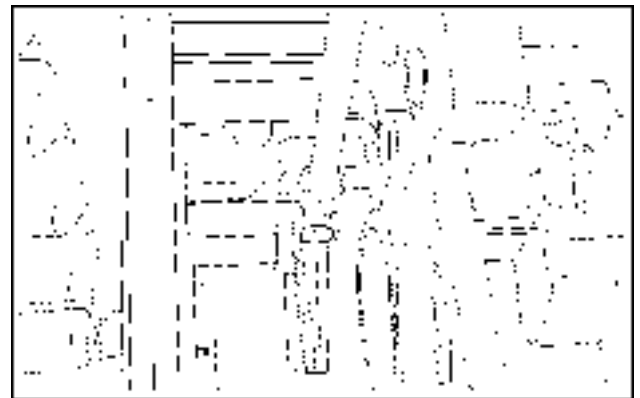

SVIL13TR00267AB 2

### Next operation:

Power Take-Off (PTO) speed rate selector control 540-1000 rpm speed rate selector control - Install – Power Take-Off (PTO) gearshift (31.119)

## Power Take-Off (PTO) speed rate selector control 540-1000 rpm speed rate selector control - Install – Power Take-Off (PTO) gearshift

Prior operation:

Power Take-Off (PTO) speed rate selector control 540-1000 rpm speed rate selector control - Remove (31.119)

Image:

- (93) Selector shaft
- Bolt (95)
- (96) Shifting finger
- (97) Ball
- Spring (98)
- (99) Gearshift bar

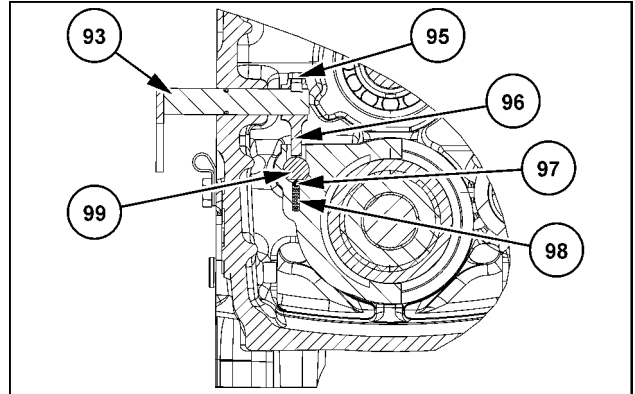

SS13K019 1

1. Fit the spring (98) and the ball (97) (shift stop) in the selector fork (91).

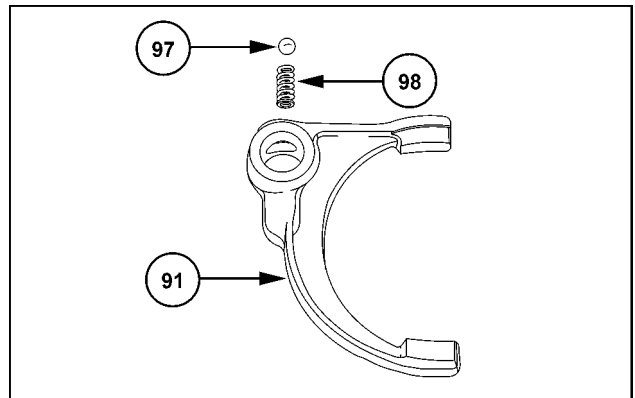

SVIL13TR00344AB 2

2. Use a tapered bolt to fix the ball (97) in the selector fork bore for subsequent installation of the gearshift bar.

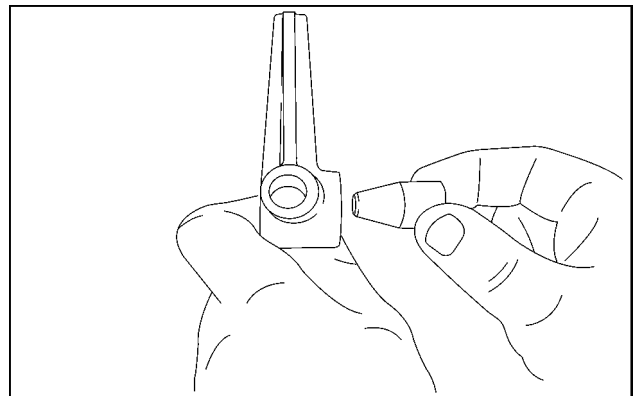

SVIL13TR00351AB 3

3. Center the pre-assembled selector fork over the shift collar.
4. Fit the gearshift bar (**99**).

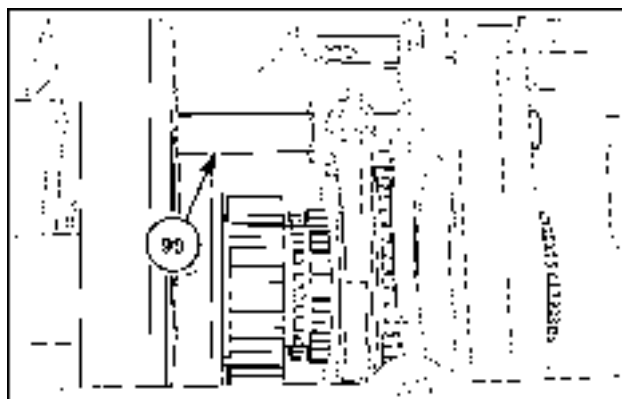

SVIL13TR00346AB 4

5. Use the locking screw (**92**) and a new ring seal to fix the gearshift bar in place.
6. Tighten the locking screw to **46 Nm (34 lb ft)**.

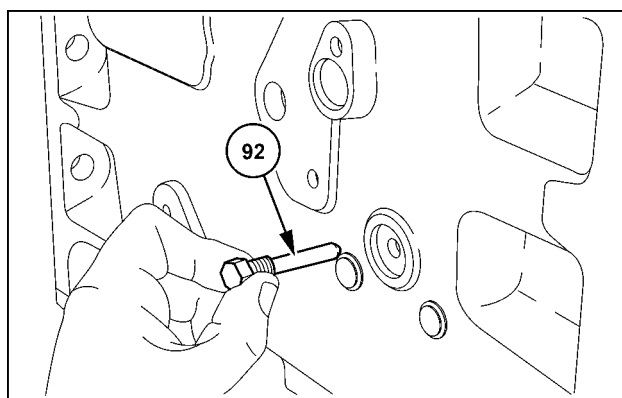

SVIL13TR00353AB 5

7. Grease the new O-ring (**94**) with industrial Vaseline. Fit the new O-ring on the selector shaft (**93**).
8. Fit the selector shaft with the O-ring in the housing bore.

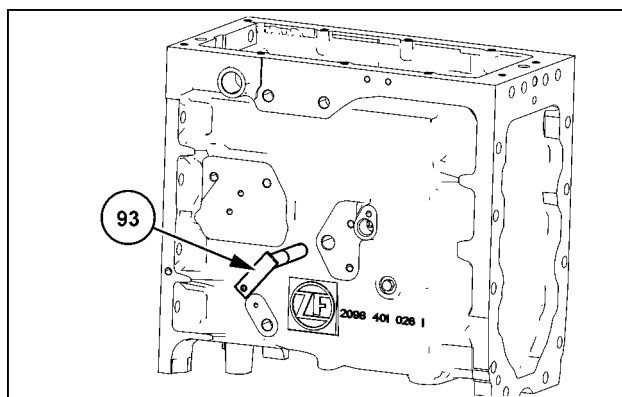

SS13K020 6

9. Insert the selector finger (**96**) into the selector fork.
10. Install the selector shaft in the selector finger bore.
11. Use the bolt (**95**) to attach the selector finger to the selector shaft.  
Tighten plug to **24 Nm (18 lb ft)**.

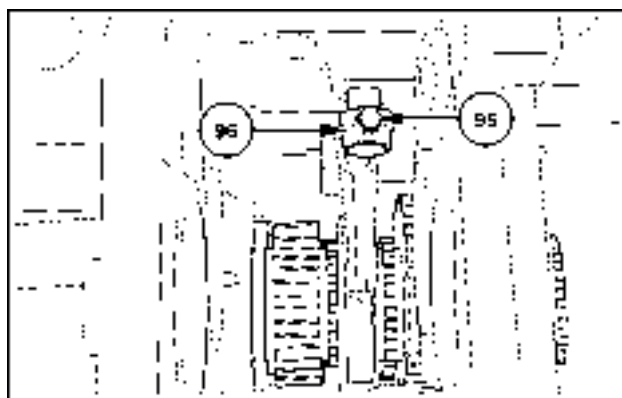

SVIL13TR00348AB 7

**Next operation:**  
**Rear drive shaft - Install (31.119)**

## Power Take-Off (PTO) speed rate selector control - Remove – Ground speed Power Take-Off (PTO)

### Prior operation:

#### Counter shaft - Remove – Power Take-Off (PTO) 540/1000 (31.119)

1. Drive out the roll pin from the selector finger of the ground speed PTO gearshift.
2. Remove the components.

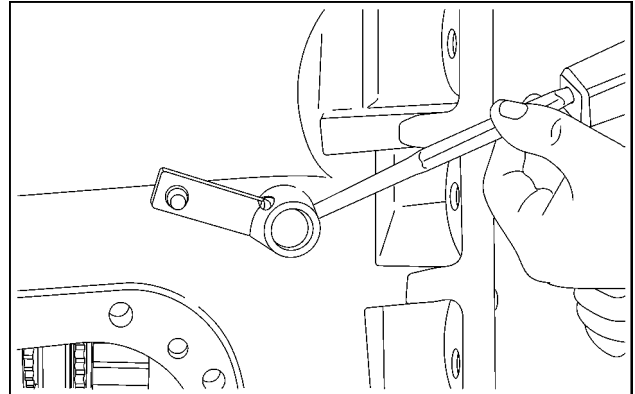

SVIL13TR00258AB 1

3. Remove the bolt from the selector fork.
4. Remove the selector fork. Remove the gearshift bar. Remove the shift collar.

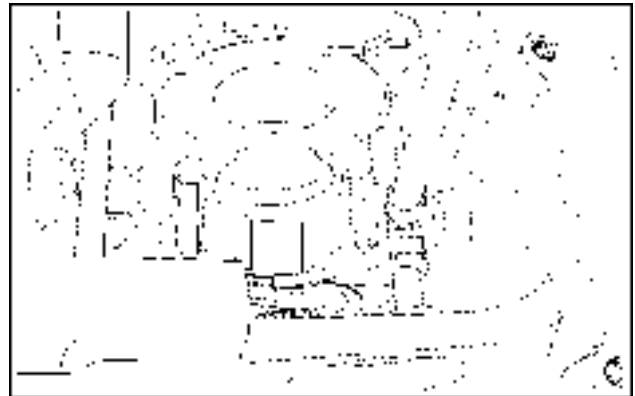

SVIL13TR00259AB 2

### Next operation:

#### Power Take-Off (PTO) speed rate selector control - Install – Ground speed Power Take-Off (PTO) (31.119)

## Power Take-Off (PTO) speed rate selector control - Install – Ground speed Power Take-Off (PTO)

### Prior operation:

### Power Take-Off (PTO) speed rate selector control - Remove – Ground speed Power Take-Off (PTO) (31.119)

1. Fit the gearshift bar in the transmission housing. When you fit the gearshift bar, slide the selector fork onto the gearshift bar.

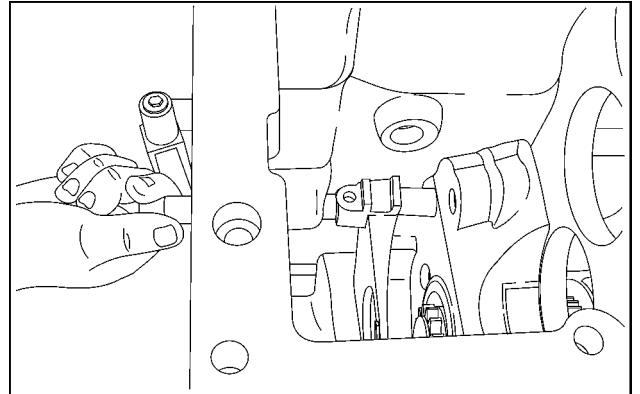

SVIL13TR00350AB 1

2. Use the bolt (A) to attach the selector fork to the gearshift bar.  
Tighten plug to **24 Nm (18 lb ft)**.
3. Install the O-ring (B) in the ring groove of the selector finger.
4. Install the selector finger in the housing bore.

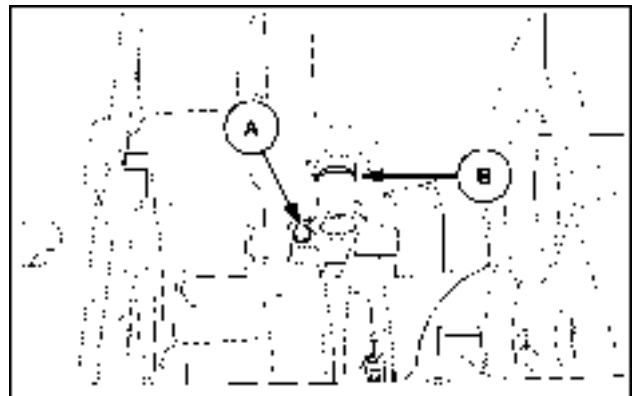

SVIL13TR00352AB 2

**NOTICE:** Subsequent installation of the shift finger is no longer possible.

5. Use the roll pin to attach the lever to the selector finger.

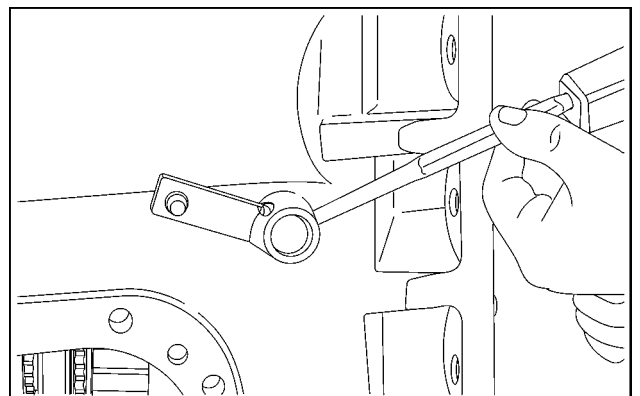

SVIL13TR00258AB 3

### Next operation:

### Counter shaft - Install – Power Take-Off (PTO) 540/1000 (31.119)

## Rear drive shaft - Remove

**Prior operation:**

**Counter shaft - Remove – Power Take-Off (PTO) 540/1000 (31.119)**

**Power Take-Off (PTO) speed rate selector control - Remove – Ground speed Power Take-Off (PTO) (31.119) – if equipped**

1. Remove the outer circlip (**104**).

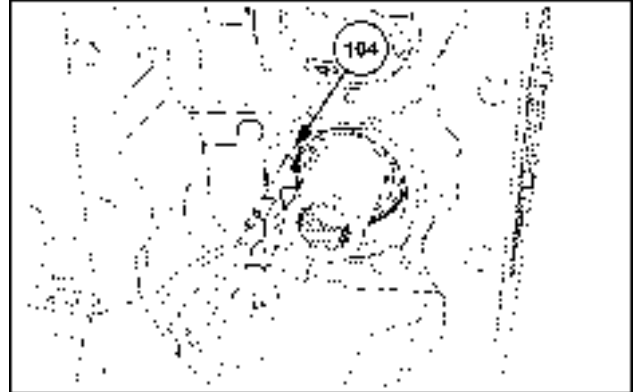

SVIL13TR00260AB 1

2. Remove the bearing (**105**) from the housing over the splined end of the intermediate shaft.
3. Remove the two spacer disks. Remove the two needle bearings. Remove the spacer ring.

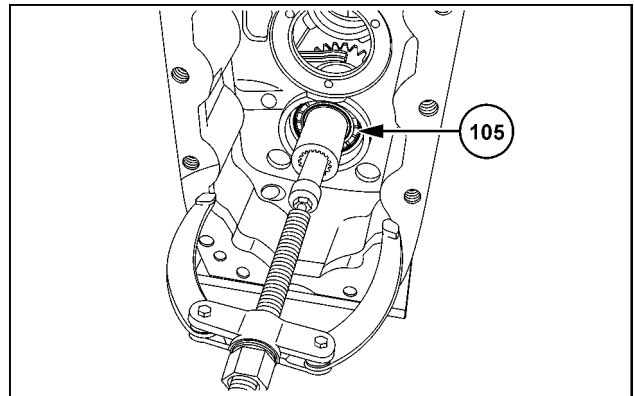

SVIL13TR00261AB 2

4. Release circlip (**102**) from its position.
5. Remove the bearing (**105**).

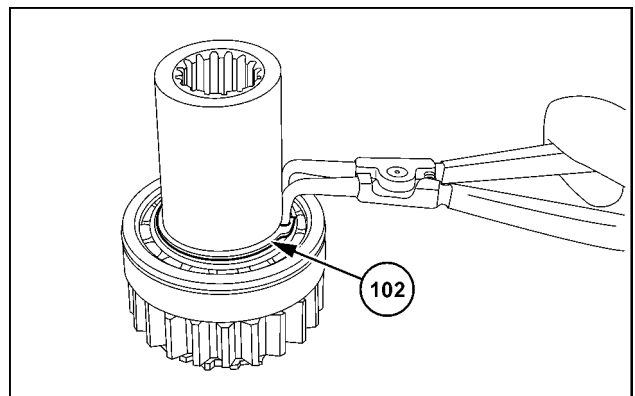

SVIL13TR00262AB 3

6. Release the rear circlip (**121**) from its position.

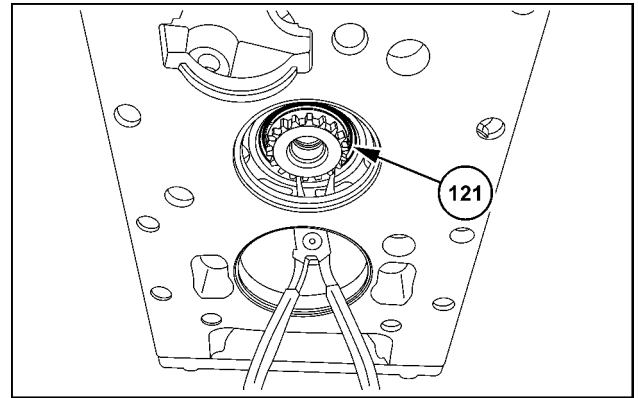

SVIL13TR00263AB 4

7. Release the front circlip (**111**) from its position.

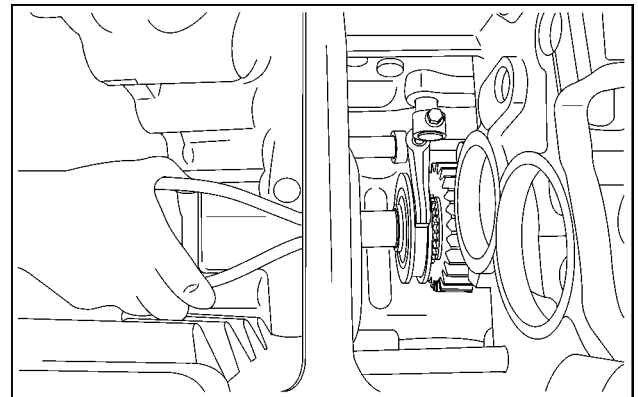

SVIL13TR00264AB 5

8. Slide the intermediate shaft (**122**) out toward the rear.

9. Remove the loosened components.

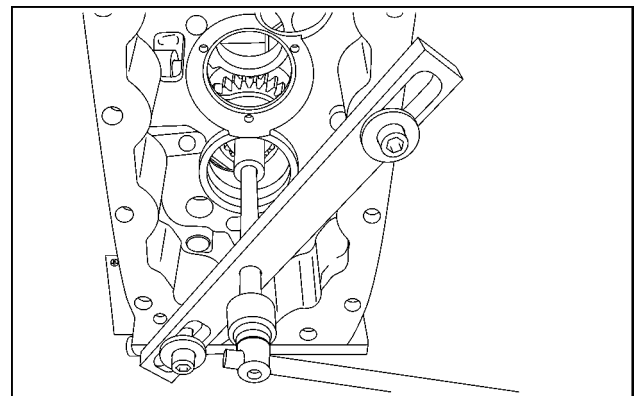

SVIL13TR00265AB 6

10. Release circlip (**119**) from its position.

11. Remove the bearing from the intermediate shaft.

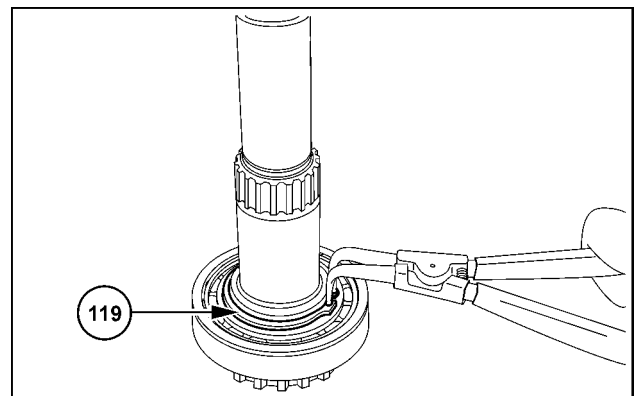

SVIL13TR00266AB 7

**Next operation:**  
**Rear drive shaft - Install (31.119)**



## Rear drive shaft - Install

### Prior operation:

#### Rear drive shaft - Remove (31.119)

The figure shows the standard version (without ground speed Power Take-Off [PTO]) of the intermediate shaft.

**NOTE:** The repair manual does not describe this variant. A qualified technician must identify and implement any deviations from the procedure independently.

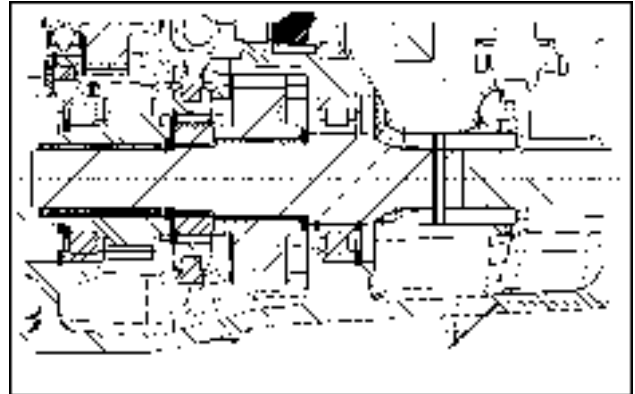

SS13F102 1

The figure shows the version with ground speed PTO.

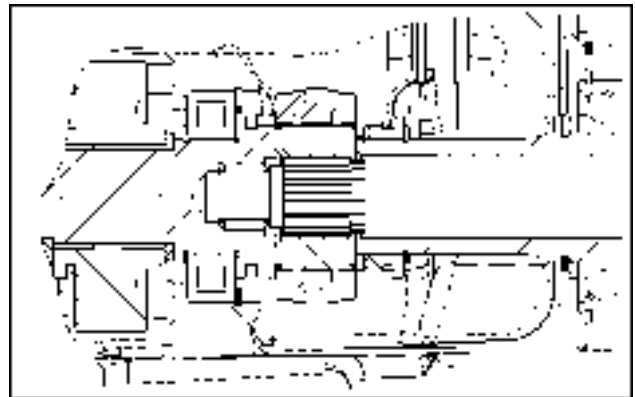

SS13F103 2

### 1. CAUTION

**Burn hazard!**

**Always wear heat-resistant protective gloves when handling heated parts.**

**Failure to comply could result in minor or moderate injury.**

C0047A

Heat the bearing inner ring. Install the bearing inner ring on the intermediate shaft until the bearing inner ring sits in place.

**NOTE:** Adjust the bearing inner ring once it is cold.

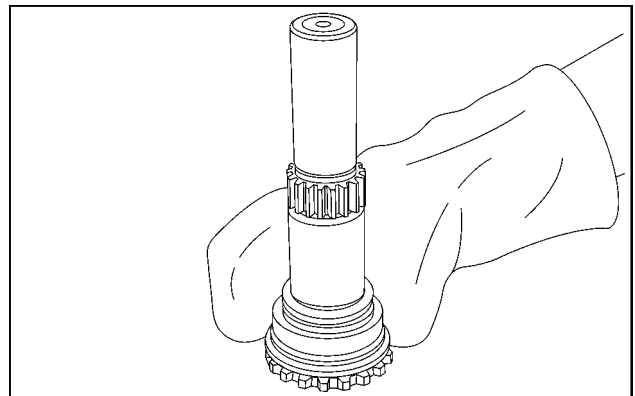

SVIL13TR00333AB 3

2. Install the bearing (120) and the disk.

**NOTE:** Install the disk on the intermediate shaft. The internally chamfered side of the disk must face the bearing.

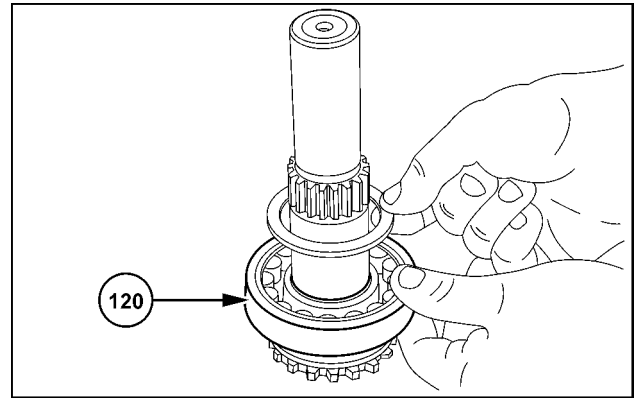

SVIL13TR00334AB 4

3. Fit the circlip (119).

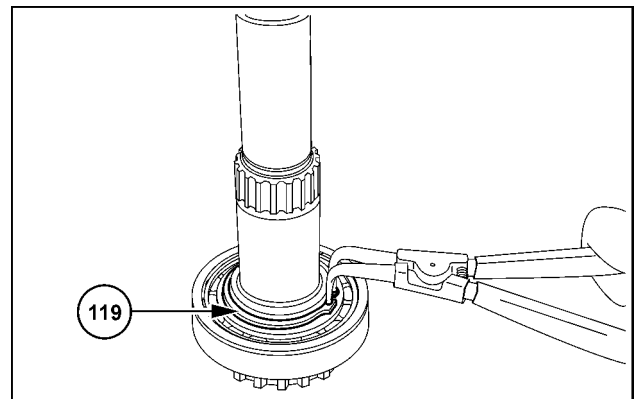

SVIL13TR00266AB 5

4. Fit the thrust washer (118). Fit the two needle bearings (115). Fit the spacer ring (116).

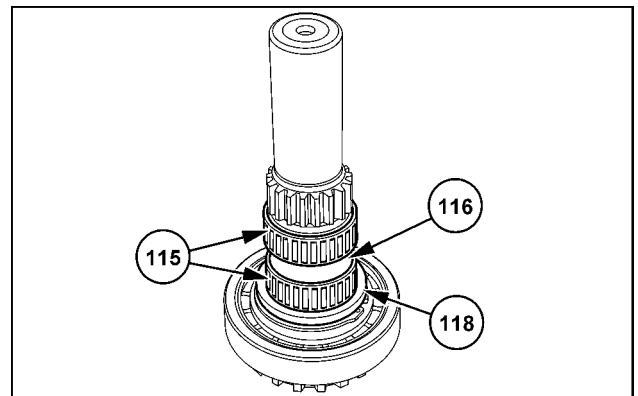

SVIL13TR00335AB 6

5. Pre-assemble the gear (117). Pre-assemble the collar holder (114). Pre-assemble the shift collar (113).

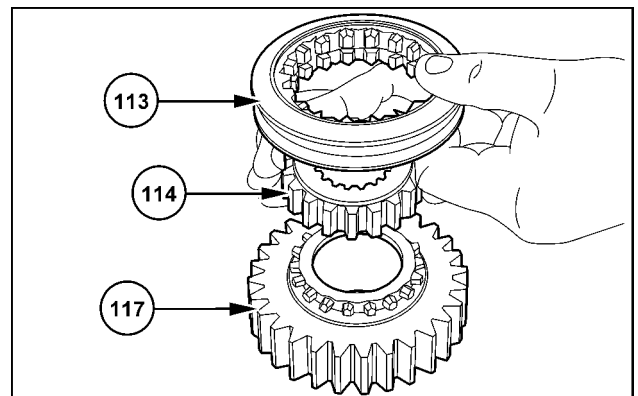

SVIL13TR00336AB 7

6. Fit the pre-assembled intermediate shaft, the gear, the collar holder and the shift collar into the transmission housing.



SVIL13TR00337AB 8

7. Press the bearing via the outer ring into the transmission housing until the bearing sits in place.

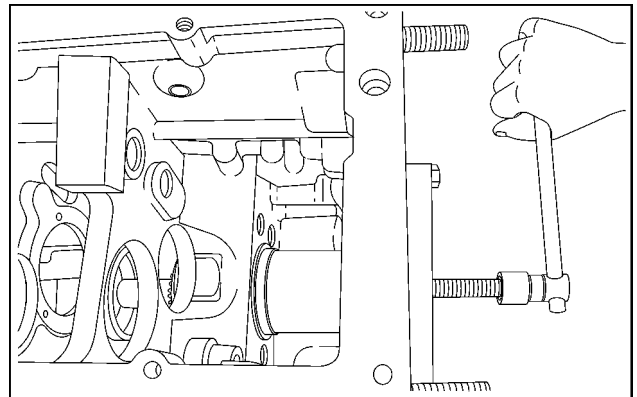

SVIL13TR00338AB 9

8. Position the circlip (121) in the ring groove on the housing bore to fix the bearing in place.

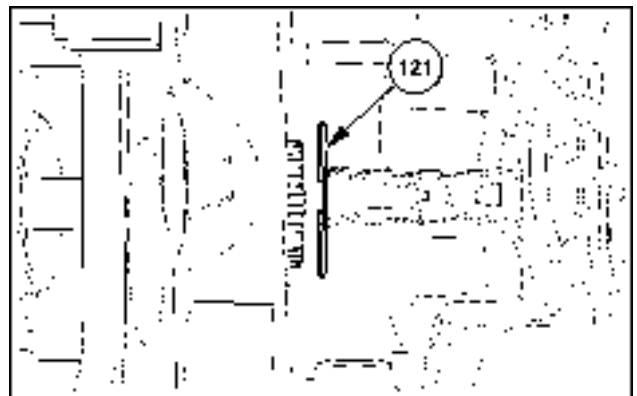

SVIL13TR00339AB 10

9. Fit the thrust washer (112) on the collar holder until the thrust washer sits in place.
10. Position the circlip (111) in the ring groove of the intermediate shaft.

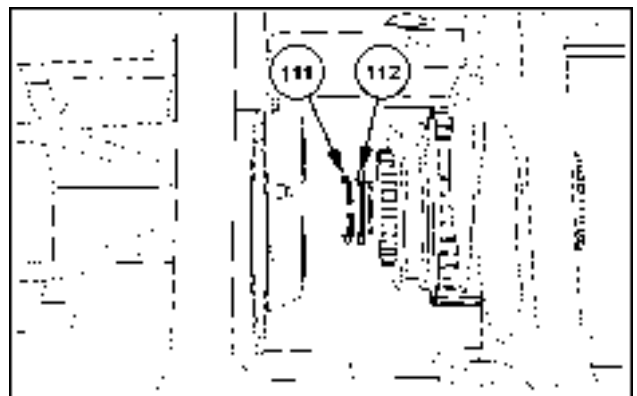

SVIL13TR00345AB 11

11. Fit the bearing (105) and the thrust washer (103) on the intermediate shaft. The internally chamfered side of the thrust washer must face the bearing.

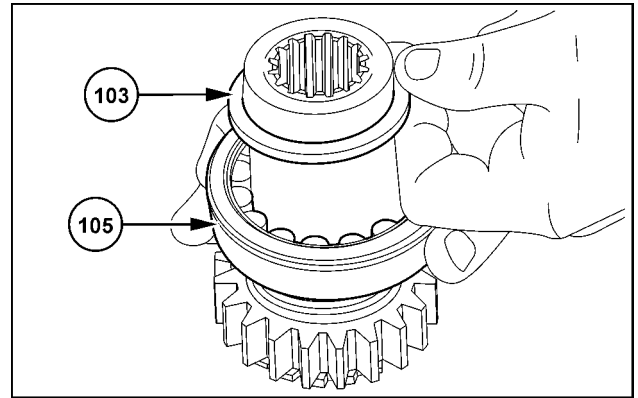

SVIL13TR00340AB 12

12. Fit the circlip (102).

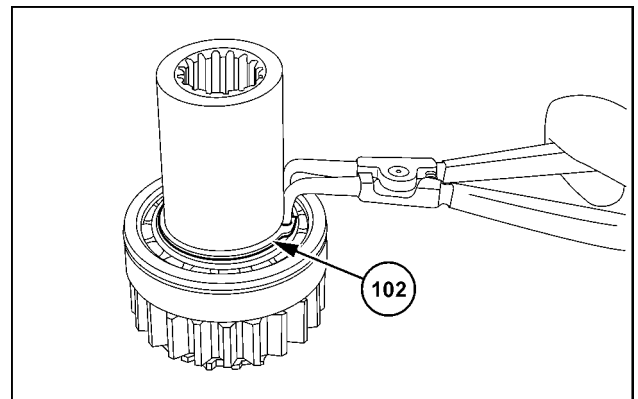

SVIL13TR00262AB 13

13. Fit the spacer disk (106), the needle bearing (107), the spacer ring (108), the needle bearing (107) and the spacer disk (110).

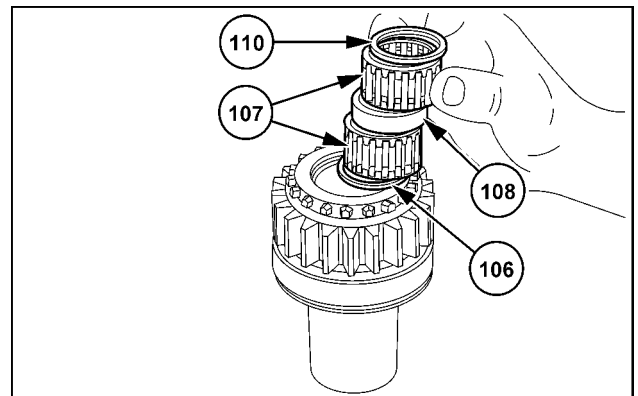

SVIL13TR00341AB 14

14. Fit the pre-assembled intermediate shaft in the transmission housing bore. See also figure 16.

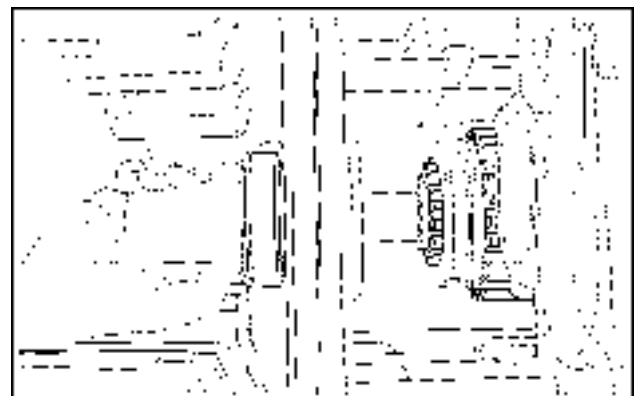

SVIL13TR00343AB 15

15. Press the bearing via the outer ring into the transmission housing.

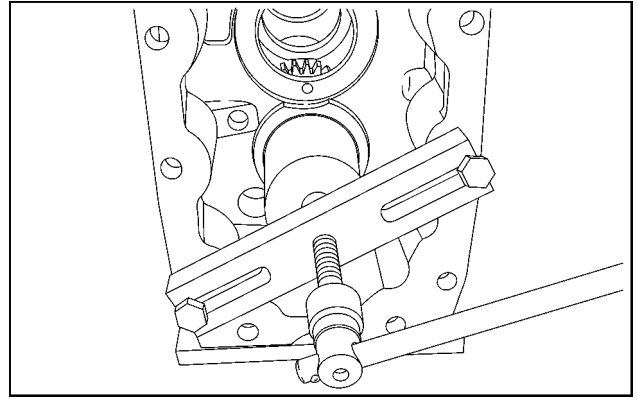

SVIL13TR00342AB 16

16. Fit the circlip (104).
17. Move the bearing back until the bearing sits in place on the circlip.

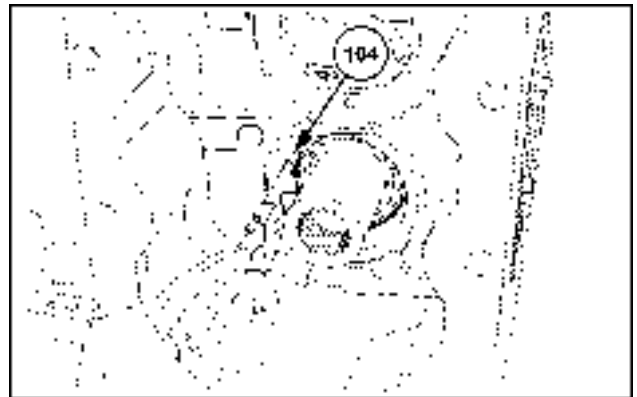

SVIL13TR00260AB 17

**Next operation:**

**Power Take-Off (PTO) speed rate selector control - Install – Ground speed Power Take-Off (PTO) (31.119) – if equipped**

**Counter shaft - Install – Power Take-Off (PTO) 540/1000 (31.119)**

## Counter shaft - Remove – Power Take-Off (PTO) 540/1000

### Prior operation:

#### Transmission drive and driven shaft - Remove – Main shaft (21.152)

1. Loosen the bolts (133) and (134).
2. Remove cap.

**NOTE:** Be careful of the adjustment disk.

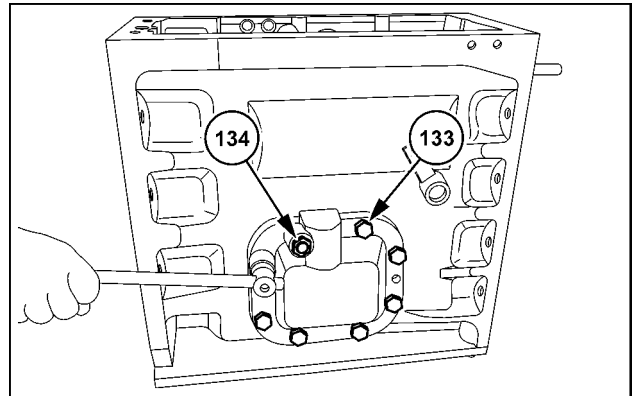

SVIL13TR00255AB 1

3. Version with ground-speed Power Take-Off (PTO):  
Remove the shift stop (spring and ball) from the housing.

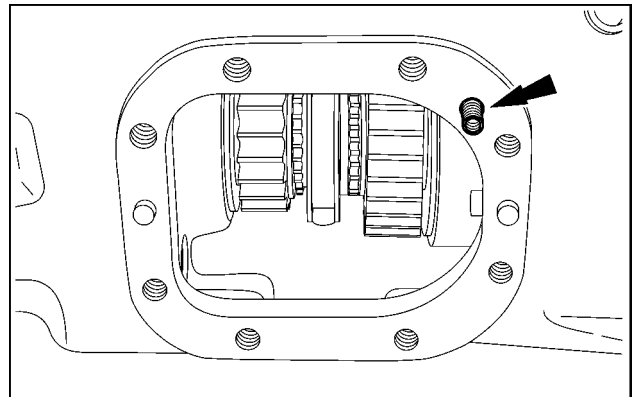

SVIL13TR00256AB 2

### Next operation:

#### Counter shaft - Disassemble – Power Take-Off (PTO) 540/1000 (31.119)

---

## Counter shaft - Disassemble – Power Take-Off (PTO) 540/1000

### Prior operation:

#### Counter shaft - Remove – Power Take-Off (PTO) 540/1000 (31.119)

1. Remove the bearing pin (136).
2. Remove the two thrust washers. Remove the two needle cages. Remove the bushing. Remove the double spur gear.

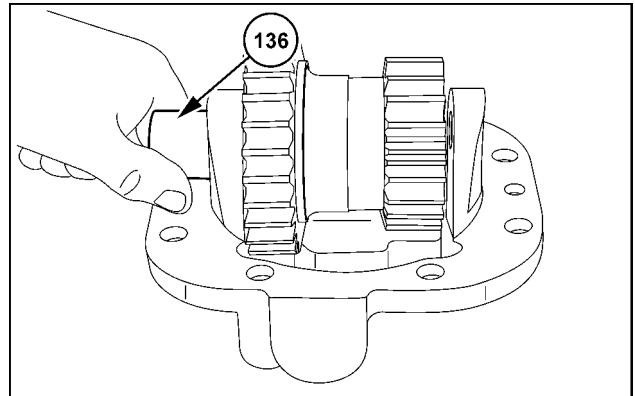

SVIL13TR00257AB 1

### Next operation:

#### Counter shaft - Assemble – Power Take-Off (PTO) 540/1000 (31.119)

## Counter shaft - Assemble – Power Take-Off (PTO) 540/1000

### Prior operation:

#### Counter shaft - Disassemble – Power Take-Off (PTO) 540/1000 (31.119)

1. Fit the needle bearing (129) into the double gear (127).  
Fit the bushing (128) into the double gear. Fit the needle bearing (126) into the double gear.

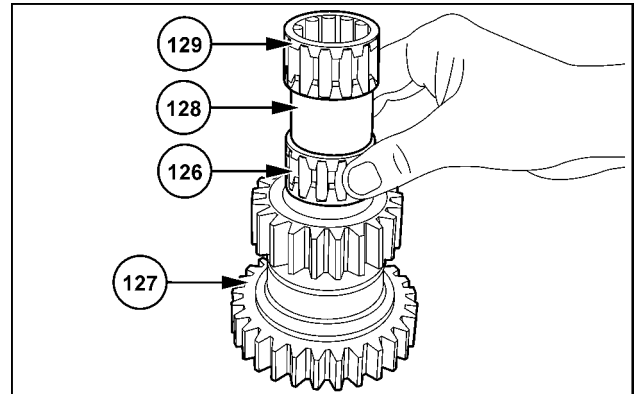

SVIL13TR00418AB 1

2. Grease the thrust washers (125) and (130) with industrial Vaseline.
3. Install the thrust washers (125) and (130). The lubricating grooves must face the double gear.



SVIL13TR00417AB 2

4. Use the bearing bolt (136) to position the pre-assembled components in the cover.

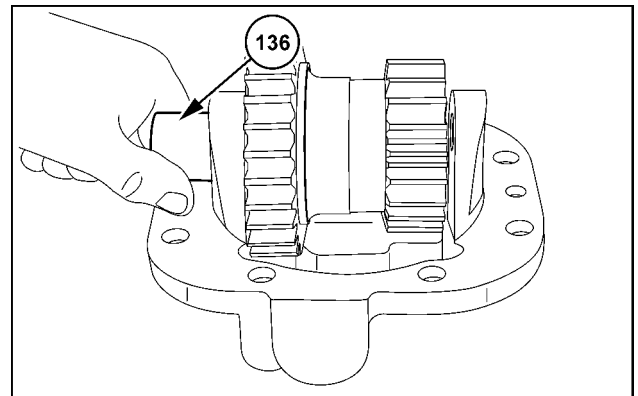

SVIL13TR00257AB 3

### Next operation:

#### Counter shaft - Install – Power Take-Off (PTO) 540/1000 (31.119)



## Counter shaft - Install – Power Take-Off (PTO) 540/1000

### Prior operation:

#### Counter shaft - Assemble – Power Take-Off (PTO) 540/1000 (31.119)

1. Insert the two dowels (**135**) into the transmission housing until the dowels sit in place.
2. Version with ground-speed Power Take-Off (PTO):  
Fit the shift stop (ball and spring) for the ground speed PTO.

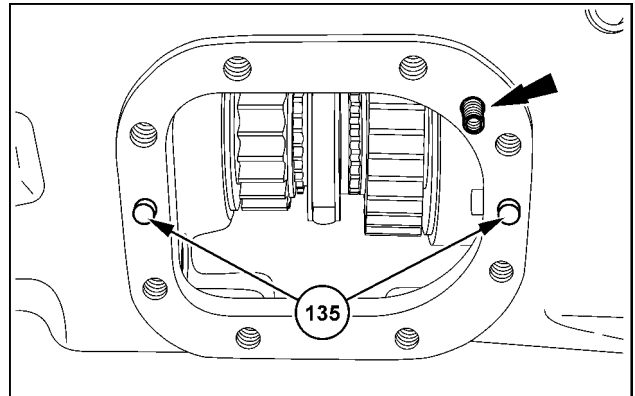

SVIL13TR00256AC 1

3. Determine the required adjustment disk (**131**) for the gear backlash:  
The dimension (see arrow) is stamped into the transmission housing. Dimension in 1/100 mm.  
Possible adjustment disks: **0.1 mm (0.004 in)** or **0.2 mm (0.008 in)**

To determine the adjustment disk:

- Up to **0.02 mm (0.0008 in)**, round down
- From **0.03 mm (0.0012 in)**, round up

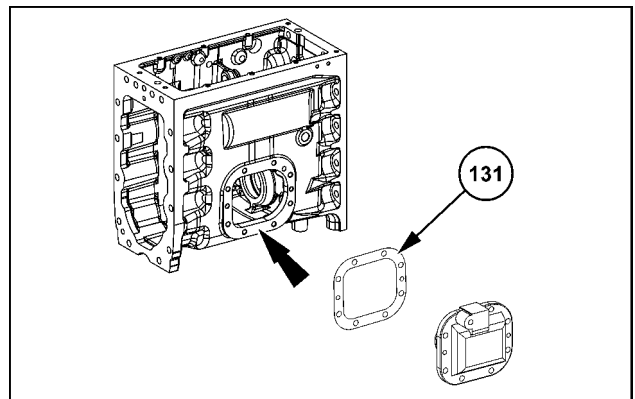

SS13F101 2

4. Apply **LOCTITE® 518** to the contact surfaces for installation.
5. Attach the pre-assembled cover (**132**) with the adjustment disk to the transmission housing.
6. Tighten the screws to **115 Nm (85 lb ft)**.

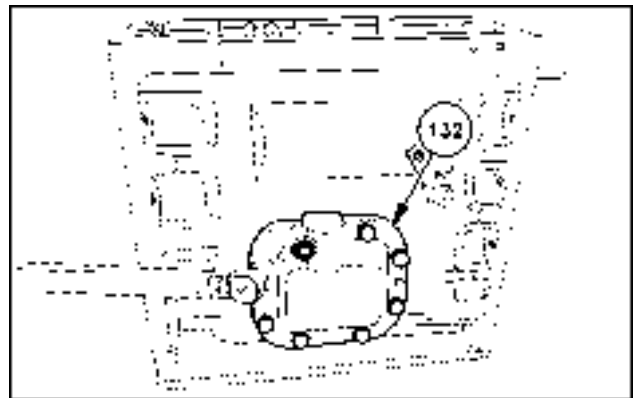

SVIL13TR00256AC 3

### Next operation:

#### Transmission drive and driven shaft - Install – Main shaft (21.152)

# Index

---

## Power Take-Off (PTO) - 31

### Four-speed rear Power Take-Off (PTO) - 119

Four-speed rear Power Take-Off (PTO) - Exploded view – shift 540/1000 and output .....	8
Four-speed rear Power Take-Off (PTO) - Mechanical schema .....	10
Counter shaft - Assemble – Power Take-Off (PTO) 540/1000 .....	67
Counter shaft - Disassemble – Power Take-Off (PTO) 540/1000 .....	66
Counter shaft - Install – Power Take-Off (PTO) 540/1000 .....	68
Counter shaft - Remove – Power Take-Off (PTO) 540/1000 .....	65
Four-speed rear Power Take-Off (PTO) - Exploded view – NORMAL/ECONOMIC clutch and shift .....	6
Four-speed rear Power Take-Off (PTO) - General specification .....	4
Four-speed rear Power Take-Off (PTO) - Special tools .....	4
Front drive shaft - Install – NORMAL/ECONOMIC .....	25
Front drive shaft - Remove – NORMAL/ECONOMIC .....	22
Output shaft - Install .....	33
Output shaft - Remove .....	31
Power Take-Off (PTO) case Cover - Install .....	38
Power Take-Off (PTO) case Cover - Remove .....	36
Power Take-Off (PTO) clutch - Assemble .....	42
Power Take-Off (PTO) clutch - Disassemble .....	39
Power Take-Off (PTO) clutch brake - Assemble .....	49
Power Take-Off (PTO) clutch brake - Disassemble .....	47
Power Take-Off (PTO) speed rate selector control - Install – Ground speed Power Take-Off (PTO) .....	57
Power Take-Off (PTO) speed rate selector control - Remove – Ground speed Power Take-Off (PTO) .....	56
Power Take-Off (PTO) speed rate selector control 540-1000 rpm speed rate selector control - Install – Power Take-Off (PTO) gearshift .....	54
Power Take-Off (PTO) speed rate selector control 540-1000 rpm speed rate selector control - Remove .....	53
Power Take-Off (PTO) speed rate selector control Normal-Economic speed rate selector control - Install .....	52
Power Take-Off (PTO) speed rate selector control Normal-Economic speed rate selector control - Remove .....	51
Rear drive shaft - Install .....	60
Rear drive shaft - Remove .....	58





## **Power Take-Off (PTO) - 31**

### **Front Power Take-Off (PTO) control - 142**

**Farmall 105U Pro EP  
Farmall 115U Pro EP  
Farmall 95U Pro EP**

# Contents

---

## Power Take-Off (PTO) - 31

### Front Power Take-Off (PTO) control - 142

#### TECHNICAL DATA

Power Take-Off (PTO) control valve	
General specification .....	3
Accumulator	
General specification .....	4

#### FUNCTIONAL DATA

Power Take-Off (PTO) control valve	
Overview .....	5

---

## Power Take-Off (PTO) control valve - General specification

Design	3/2 directional control valve
Supplier	Tecnord
Maximum operating pressure	<b>50 bar (725 psi)</b>
Nominal flow rate	<b>30 l/min (7.9 US gpm)</b>
Filter in P-duct	280 $\mu$
Position of the solenoid valve	Vertically downward to a maximum of $\pm 20\text{ }^{\circ}\text{C}$ (68 $^{\circ}\text{F}$ )
Oil temperature range	<b>-30 - 125 <math>^{\circ}\text{C}</math> (-22 - 257 <math>^{\circ}\text{F}</math>)</b>

## Accumulator - General specification

Accumulator design	Membrane accumulator
Capacity	<b>0.16 l (0.34 US pt)</b>
Charge gas	Nitrogen
Filling gas pressure at <b>20 °C (68 °F)</b>	<b>2.5 - 3.0 bar (36.2 - 43.5 psi)</b>
Operating temperature	<b>-30 - 80 °C (-22 - 176 °F)</b>
Nominal operating pressure	<b>19 - 20 bar (276 - 290 psi)</b>
Maximum operating pressure	<b>30 bar (435 psi)</b>

## Power Take-Off (PTO) control valve - Overview

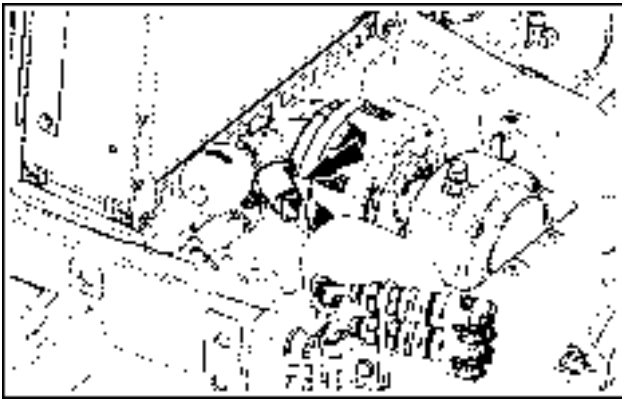

SS13A643 1

Location: underneath the intercooler

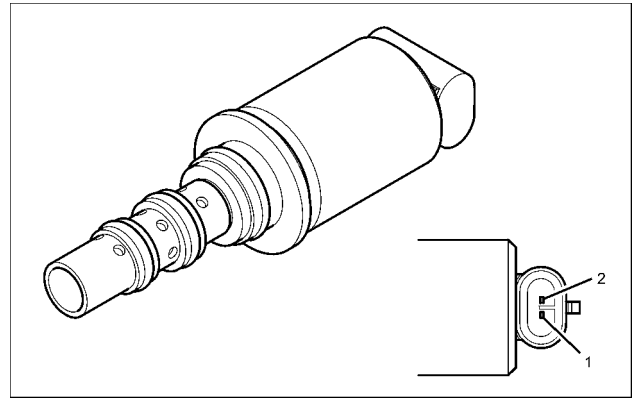

SS12E197 2

Characteristic power supply	PWM
Clock frequency	120 Hz +15 %
Resistance of the coil at 20 °C (68 °F)	9.9 Ω
Powe	14 W
Duty cycle	100 %
Working temperature	-30 - 120 °C (-22 - 248 °F)
Tightening torque of solenoid coil retainer	5 Nm +/- 1 (3.7 lb ft +/- 0.7)



# Index

---

## Power Take-Off (PTO) - 31

### Front Power Take-Off (PTO) control - 142

Accumulator - General specification .....	4
Power Take-Off (PTO) control valve - General specification .....	3
Power Take-Off (PTO) control valve - Overview .....	5





© 2014 CNH Industrial Österreich GmbH

All rights reserved. No part of the text or illustrations of this publication may be reproduced.

CASE IH policy is one of continuous improvement and the right to change prices, specification or equipment at any time without notices is reserved.

All data given in this publication is subject to production variations. Dimensions and weight are approximate only and the illustrations do not necessarily show products in standard condition. For exact information about any particular product, please consult your CASE IH Dealer.



# **SERVICE MANUAL**

## **Brakes and controls**

**Farmall 105U Pro EP  
Farmall 115U Pro EP  
Farmall 95U Pro EP**

# Contents

---

## Brakes and controls - 33

[33.202] Hydraulic service brakes .....	33.1
[33.110] Parking brake or parking lock .....	33.2
[33.220] Trailer brake hydraulic control.....	33.3
[33.204] Front axle brake .....	33.4



## **Brakes and controls - 33**

### **Hydraulic service brakes - 202**

**Farmall 105U Pro EP  
Farmall 115U Pro EP  
Farmall 95U Pro EP**

# Contents

---

## Brakes and controls - 33

### Hydraulic service brakes - 202

#### TECHNICAL DATA

Hydraulic service brakes	
General specification .....	3

#### FUNCTIONAL DATA

Hydraulic service brakes	
Exploded view .....	4

#### SERVICE

Hydraulic service brakes	
Bleed .....	7
Brakes	
Remove .....	9
Install .....	12

## Hydraulic service brakes - General specification

Type of System	Wet multi-disk brakes
Operation of the service brake	Hydraulically
Actuation of the hand brake (acts on the service brake)	Mechanical, by means of cables
Number of liner disks per side	4
Diameter of the liner disks	9.5"x7"
Park brake (acts on the service brake)	Option
Type of System	Spring energy cylinder 2
Actuation	Electrohydraulic solenoid valves



---

## Hydraulic service brakes - Exploded view

1	Bolt	2	Cover cup
3	Brake Disc	4	Disk plate
5	Actuation unit	6	Brake Disc
7	Disk plate	8	Retaining screw
9	Brake housing	10	Pins
11	Drawbar	12	Cotter pin
13	Pins	14	Rubber grommet
15	Shield	16	Pressure spring.
17	Sweeper	18	Washer
19	Nut.	20	Brake cylinder
21	Washer	22	Lever
23	Cotter pin	24	Washer
25	Brake levers	26	Distance Piece
27	Bolt	28	Tab
29	Spring	30	Pins
31	Washer	32	Lever

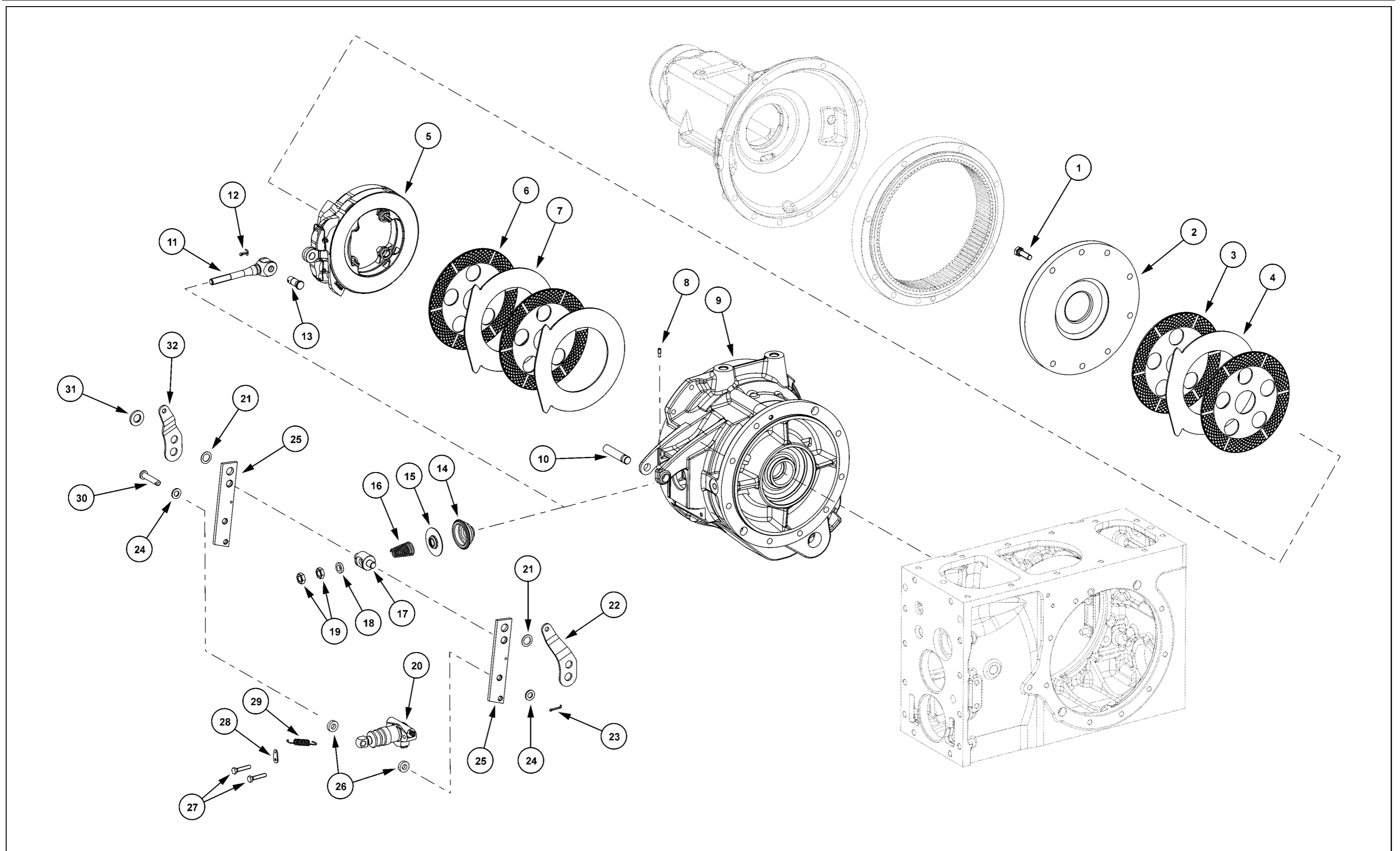

SS13E034 1



## Hydraulic service brakes - Bleed

1. Bleed the hydraulic service brake with the air vent nipples (1) on the brake cylinder.

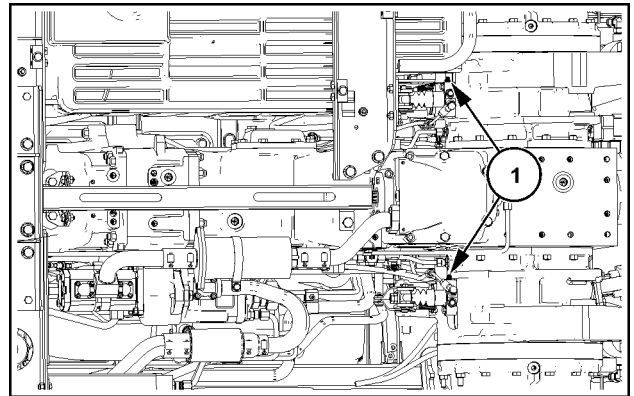

SS13K089 1

**NOTE:** If the tractor is equipped with front axle brake, four additional air vent nipples have to be bled. See step 2 up to step 5.

**NOTE:** If the tractor is equipped with air operated trailer brake, two additional air vent nipples have to be bled. See step 6.

**NOTE:** If the tractor is equipped with hydraulic trailer brake, one additional air vent nipple has to be bled. See step 7.

2. Bleed the air vent nipples (1) on the left-hand side in front of the cab.

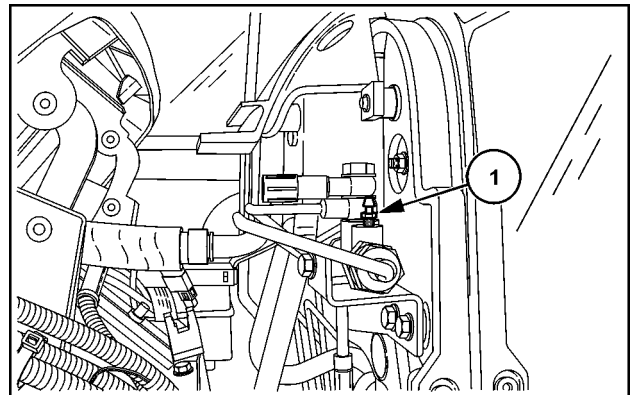

SVIL13TR00649AB 2

3. Remove the bolts on the wheel hubs.
4. Bleed the hydraulic service brake on the front axle, by opening the air vent nipples (1).
5. Install the bolts on the wheel hubs.

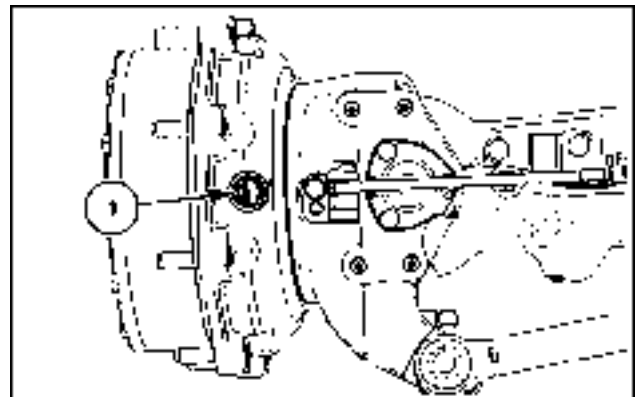

SS13K077 3

6. Bleed the air vent nipples **(1)** from the air operated trailer brake.

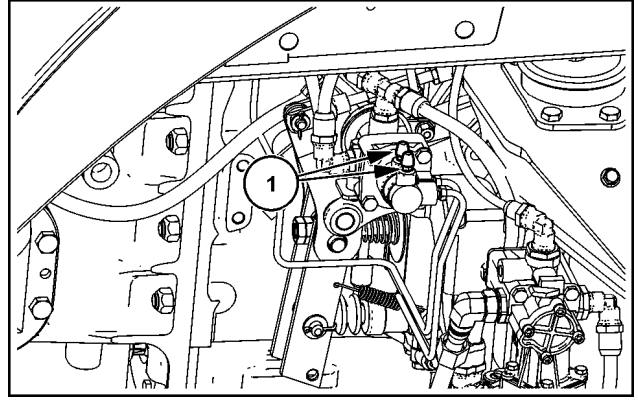

SS13K088 4

7. Bleed the air vent nipple **(1)** from the hydraulic trailer brake.

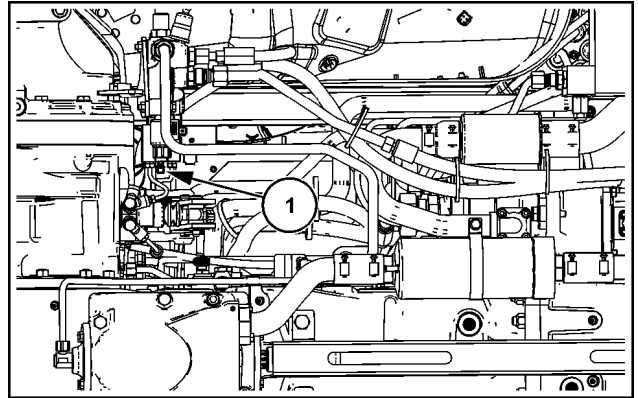

SS13K087 5

8. Check the brake fluid level. If necessary top up. For the correct specification see **Consumables Lubrications and Coolants ()**.

## Brakes - Remove

### Hydraulic service brakes - Exploded view (33.202)

#### Prior operation:

#### Planetary final drive - Disassemble – Axle trumpet housing and planetary drive (27.120)

1. Loosen the nuts (**19**) from the drawbar and remove with the disk (**18**).

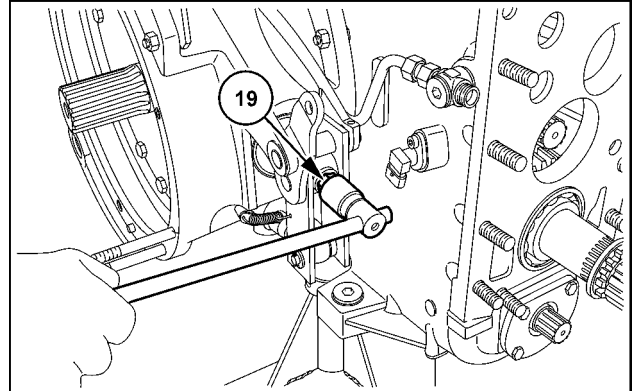

SS13H151 1

2. Undo the bolts (**27**). Remove the bolts with the tab (**28**) and the spring (**29**).

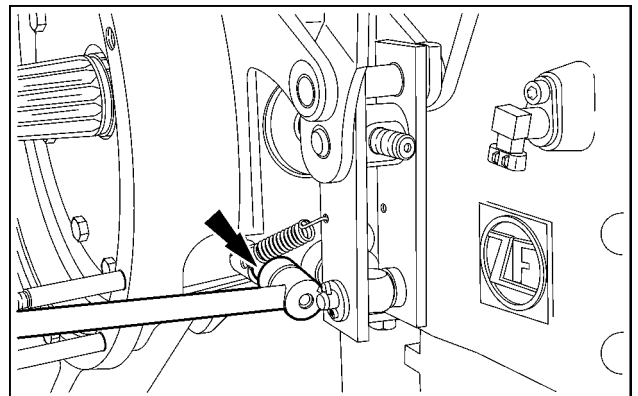

SS13H152 2

3. Undo the retaining bolt (**8**). Remove the retaining bolt.

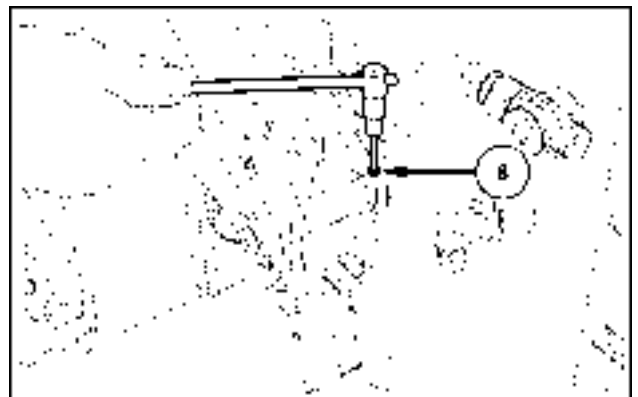

SS13H153 3

4. Move the pin toward the transmission housing to drive out the pin (10).
5. Remove the complete brake actuator with the loosened components.
6. Remove the pin in the opposite direction.

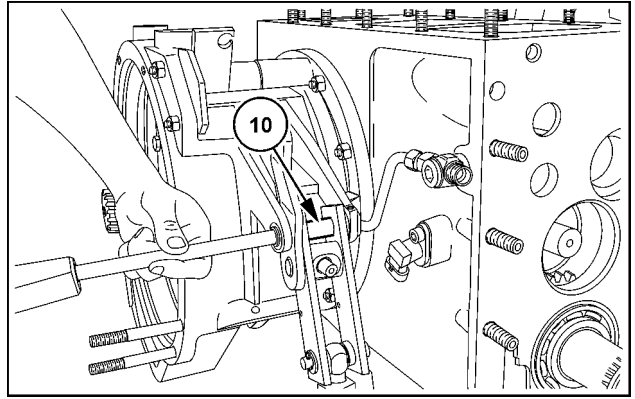

SS13H154 4

7. Remove the cotter pin (12).
8. Remove the pin and the loosened components.

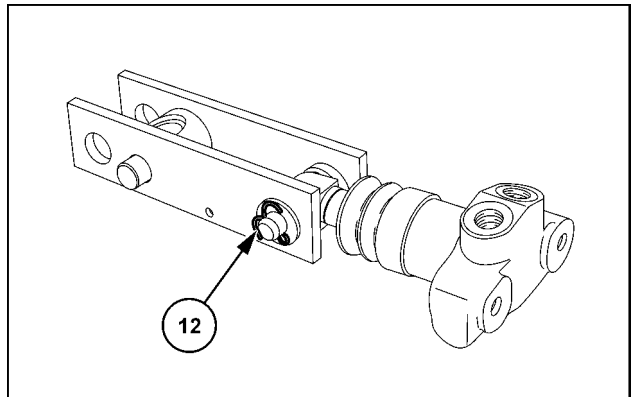

SS13H155 5

9. If necessary, remove the grommet (14).

**NOTICE:** If you do not replace the grommet, cover the drawbar with adhesive tape or a similar product when you remove the actuation unit. This will prevent damage to the grommet.

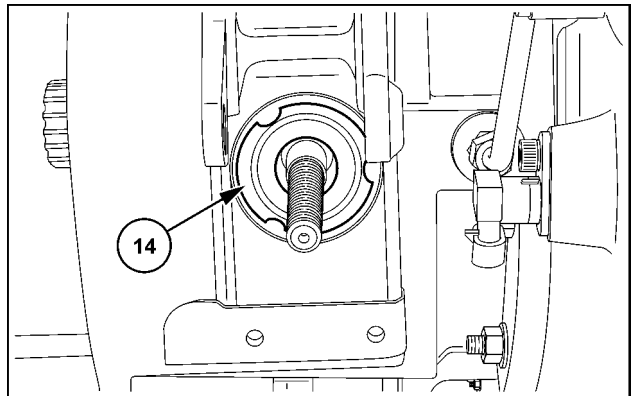

SS13H156 6

10. Undo the bolts (1).
11. Remove cover (2).

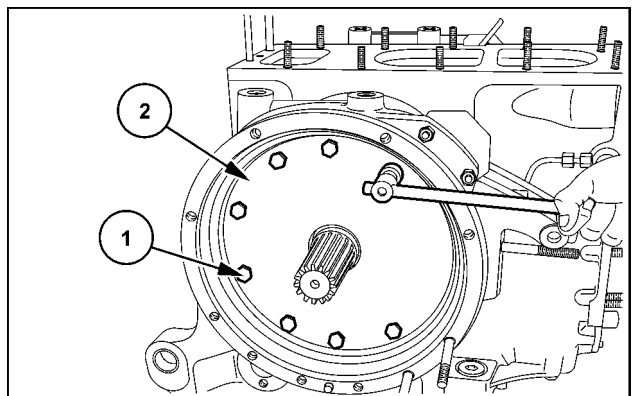

SS13H157 7

12. Remove the pinion shaft.

**NOTE:** Be careful of the liner disks and plates.

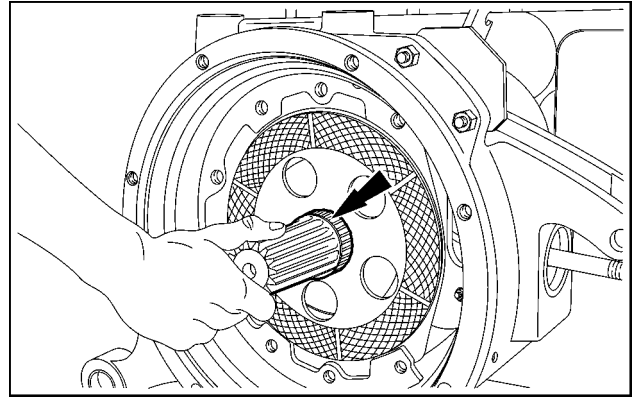

SS13H158 8

13. Remove the actuation unit (5).

**NOTE:** When retracting the drawbar through the grommet, make sure the grommet does not become damaged by the drawbar thread.

**NOTE:** Be careful of the liner disks and plates.

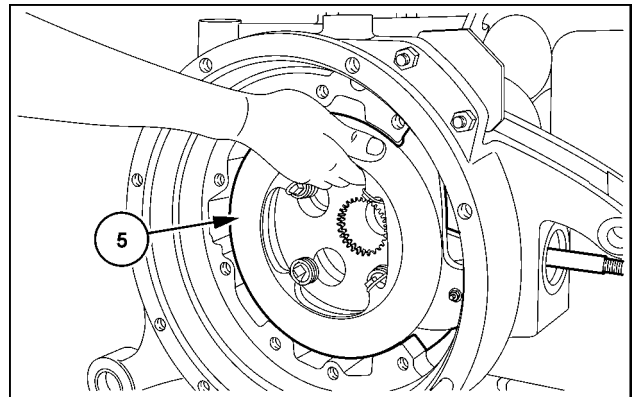

SS13H159 9

14. If necessary, unlock the cotter pin (12) and drive out the pin.

**NOTICE:** Safety component! No further dismantling of the brake unit is permitted. The brake is only supplied as a complete component.

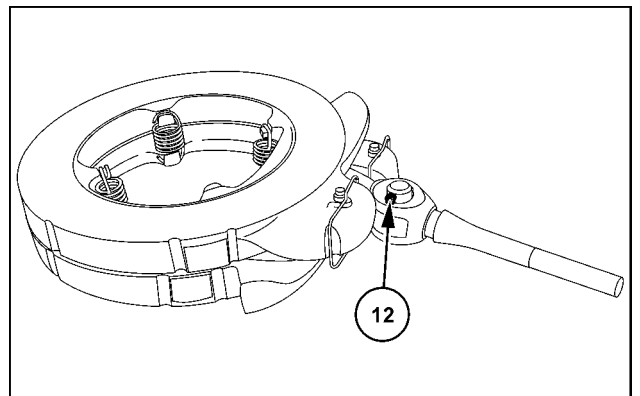

SS13H160 10

**NOTE:** Clean the components, check carefully for wear and damage, and replace if necessary.

**Next operation:**

**Rear axle housing Brake housing - Remove (27.100)**



## Brakes - Install

### Hydraulic service brakes - Exploded view (33.202)

#### Prior operation:

#### Rear axle housing Brake housing - Install (27.100)

**NOTE:** All components must be lubricated prior to installation.

1. Carefully install the grommet (14).

**NOTE:** Seal the grommet with **LOCTITE® 574**.



SS13H161 1

2. Fit the two intermediate disks (7) and the two liner disks (6). Alternate between the intermediate disks and liner disks.

Start with an intermediate disk (no lining).

**NOTE:** Safety component! No further dismantling of the brake unit is permitted. The brake is only supplied as a complete component.

**NOTE:** If you are using new liner disks, they must be soaked in engine oil for at least **30 min**.

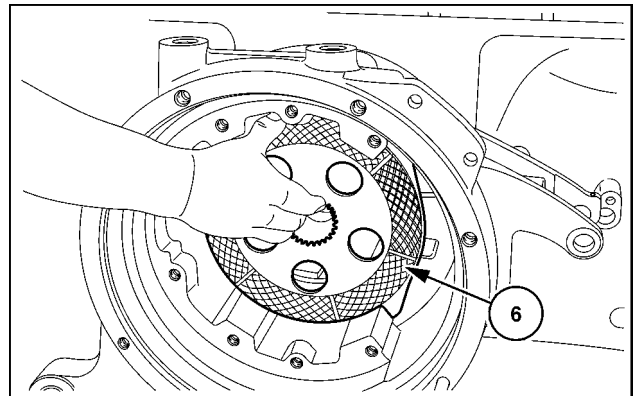

SS13H162 2

3. Fit the drawbar (11) on the actuation unit using the pins (13). Secure the drawbar with the cotter pin (12).

**NOTICE:** Apply adhesive tape or a similar product to the thread of the drawbar to prevent damage to the grommet during installation.

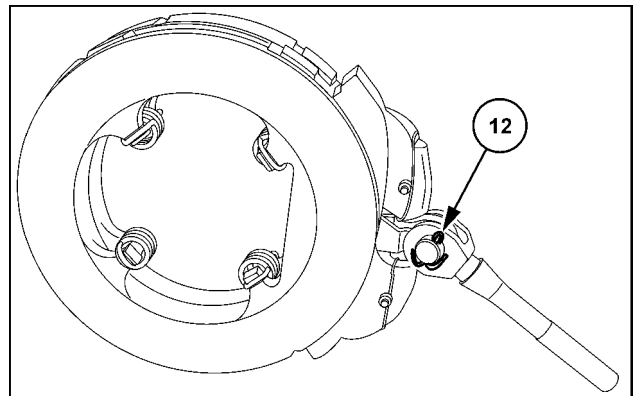

SS13H163 3

- Fit the actuation unit complete with the fitted drawbar in the brake housing.

**NOTE:** The shoulder of the grommet must engage in the ring groove of the drawbar.

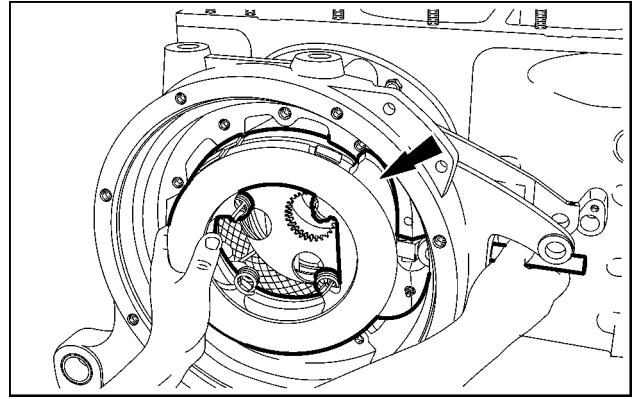

SS13H164 4

- Fit the two liner disks (3) and one intermediate disk (4). Alternate between the liner disks and the intermediate disk. Start with a liner disk.

**NOTE:** If you are using new liner disks, they must be soaked in engine oil for at least 30 min.

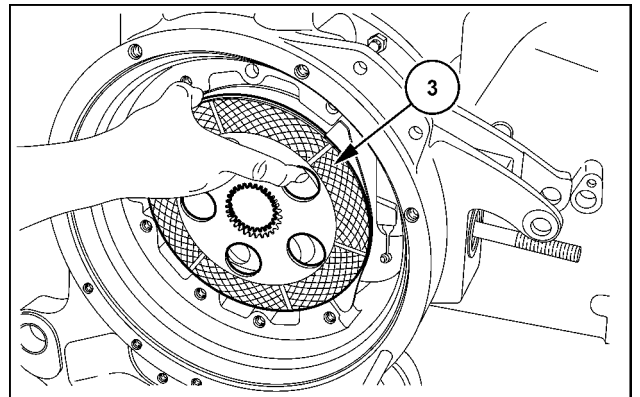

SS13H165 5

- Fit the cover (2).
- Insert the screws (1) and tighten to 79 Nm (58.3 lb ft).

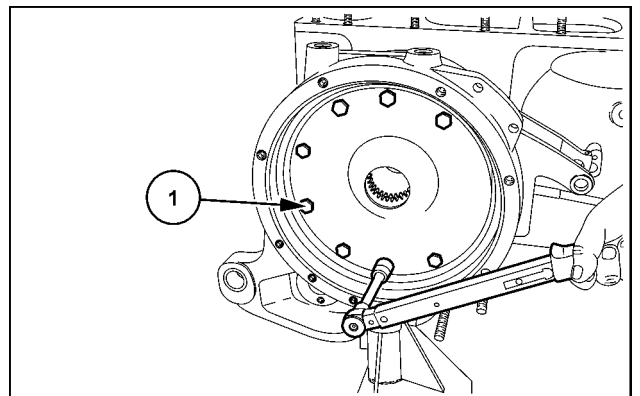

SS13H166 6

- Pre-assemble the brake actuation unit as shown. Fix the pins (30) using the cotter pin (23).

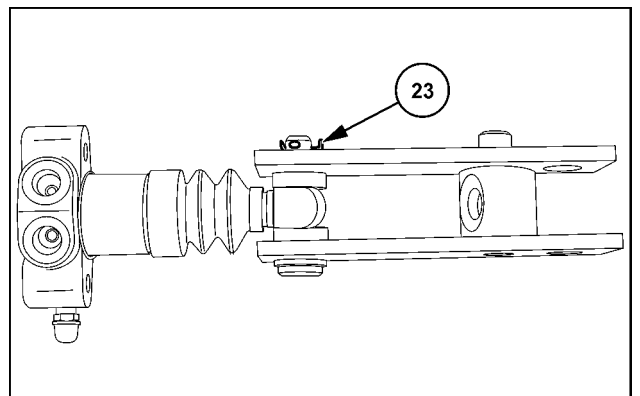

SS13H167 7

9. Slide the cover (15) and the thrust spring (16) onto the drawbar.

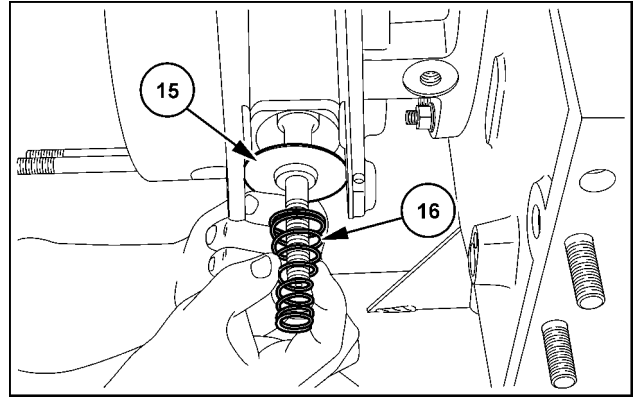

SS13H168 8

10. Fit the pre-assembled brake actuation unit on the brake housing.
11. Fit the tab (28) of the spring retainer.
12. Coat the bolts (27) with **LOCTITE® 243**. Tighten the bolts to a torque of **23 Nm (17 lb ft)**.

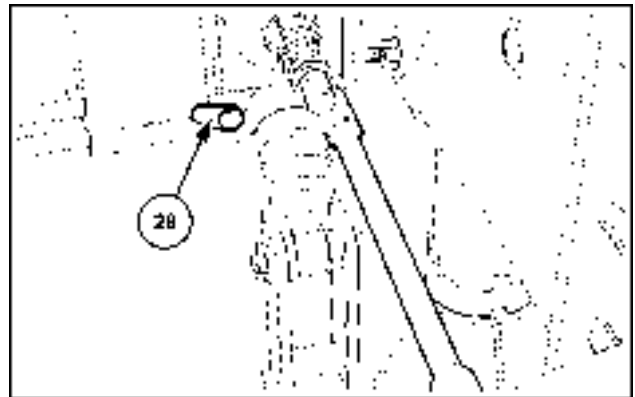

SS13H169 9

13. Fit the lever (32).
  14. Thread the drive disk (17) over the drawbar.
- NOTE:** Fit the drive disk (17) with the round inner counter-bore facing toward the front.
15. Secure the actuation unit to the rear axle housing with the pin (10), the disk (21) and the disks (21).

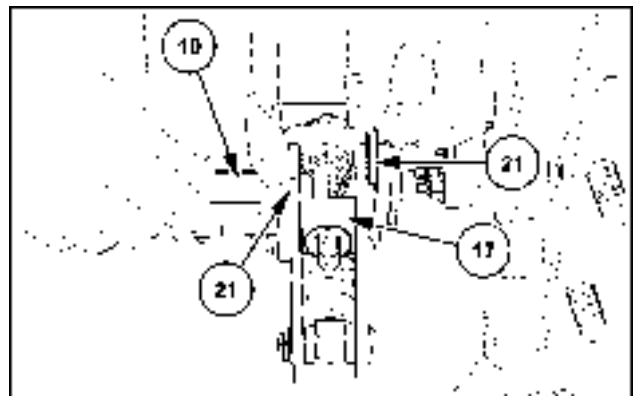

SS13H170 10

- NOTE:** For installation, coat the bolt surface in **MOLYKOTE® P-74**.
16. Adjust the end play of the actuation unit (**0.1 - 0.4 mm (0.004 - 0.016 in)**) with the disks (21).
  17. Fix the pin (10) with the retaining bolt (8). Coat the bolt with **LOCTITE® 243**. Fit the bolt. Tighten the bolt to a torque of **9.5 Nm (7.01 lb ft)**.

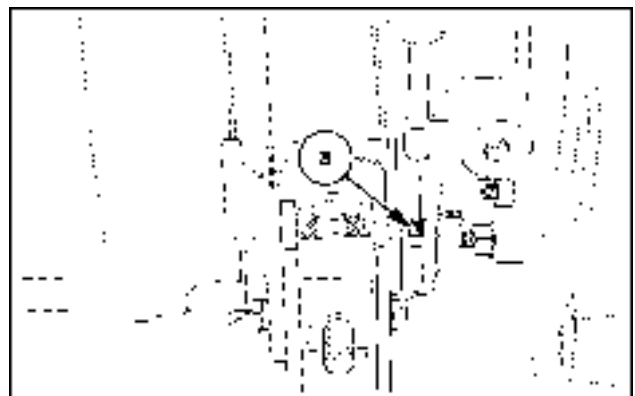

SS13H171 11

18. Slide the disk (18) with the rounded side onto the drawbar.
19. Tighten the nut (19) to a torque of **10 - 12 Nm (7.4 - 8.9 lb ft)**. Then loosen the nut by 1.25 turns.
20. Secure the nut (19) using the jam nut. Tighten the jam nut to a torque of **80 Nm (59 lb ft)**.

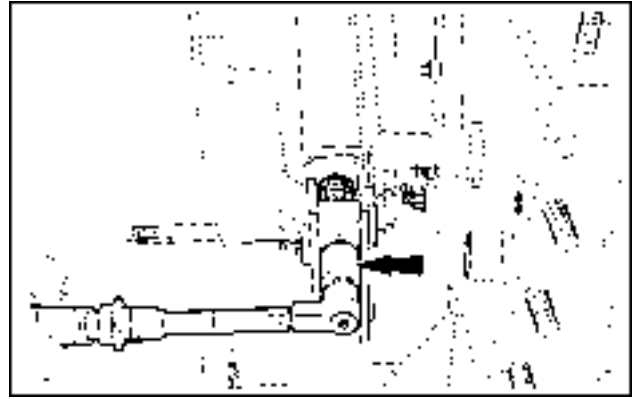

SS13H172 12

21. Hook the spring (29) into the tab and into the brake lever.

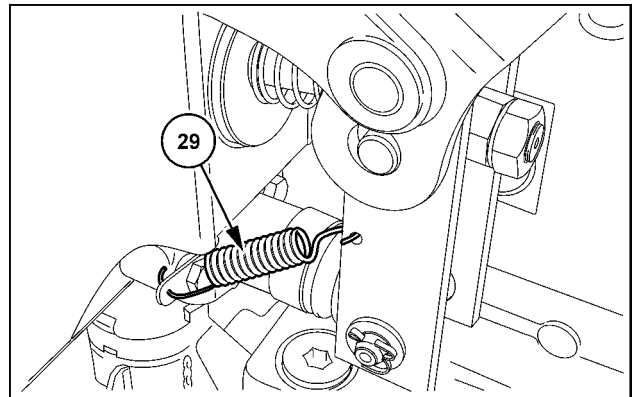

SS13H173 13

22. Fit the pinion shaft.

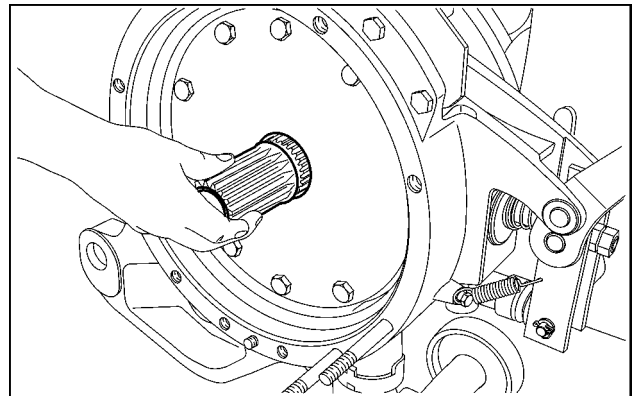

SS13H174 14

23. Fit the lubrication line.
24. Tighten the union nuts of the line to a torque of **35 Nm (25.8 lb ft)**.



SS13H175 15

**Next operation:**  
**Planetary final drive - Assemble – Axle trumpet housing and planetary drive (27.120)**

# Index

---

## Brakes and controls - 33

### Hydraulic service brakes - 202

Brakes - Install .....	12
Brakes - Remove .....	9
Hydraulic service brakes - Bleed .....	7
Hydraulic service brakes - Exploded view .....	4
Hydraulic service brakes - General specification .....	3



## **Brakes and controls - 33**

### **Parking brake or parking lock - 110**

**Farmall 105U Pro EP  
Farmall 115U Pro EP  
Farmall 95U Pro EP**

# Contents

---

## Brakes and controls - 33

### Parking brake or parking lock - 110

#### FUNCTIONAL DATA

Parking brake or parking lock	
Dynamic description – Electric parking brake .....	3
Static description – Electric parking brake .....	5
Parking brake control valve	
Overview .....	7

#### SERVICE

Parking brake or parking lock	
Adjust .....	8
Spring-loaded cylinder	
Service instruction – Manual release of the electric park brake .....	10
Adjust .....	11

## Parking brake or parking lock - Dynamic description – Electric parking brake

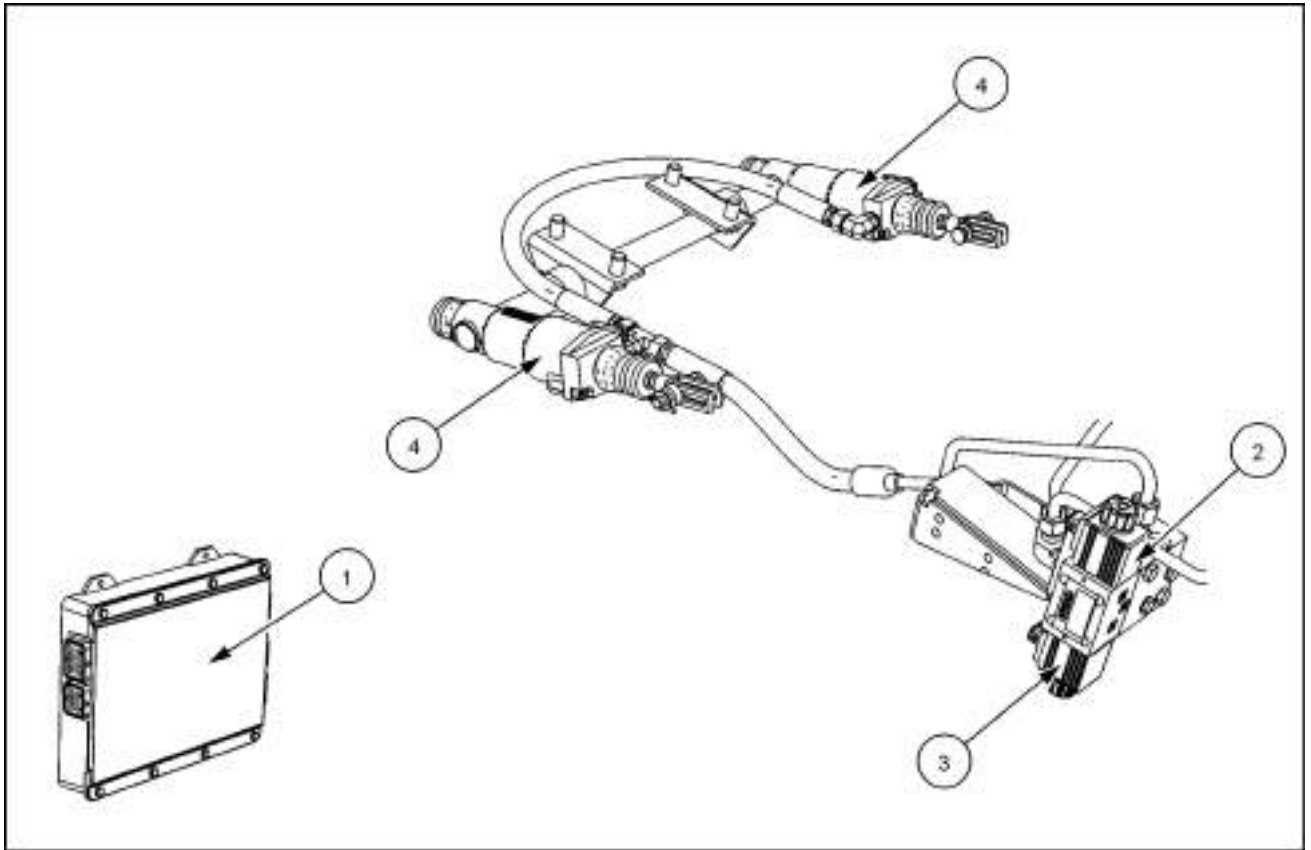

SS14F096 1

The Parking brake engagement – Solenoid valve (2) is activated momentarily by the Central Control Unit (1). This allows the oil to escape from the parking brake cylinder (4) into the tank. The retaining mechanism holds the solenoid valve in place. The spring force in the two parking brake cylinders operates the driving brake actuators, which are fitted on the left-hand and right-hand of the rear axle.

To release the electric parking brake, parking brake disengagement – Solenoid valve (3) is activated momentarily by the Central Control Unit (1) and held in this position by the retaining mechanism. This effects that the hydraulic pressure P1 operates the parking brake cylinder pistons, applying **19 bar (276 psi)** pressure to release the parking brake.

The electric parking brake is activated automatically when the following conditions are achieved:

- Gearbox in "NEUTRAL".  
Forwards and reverse clutches are in an open position. The gearbox controller transmits this information to the Central Control Unit via the CAN bus.
- Vehicle speed is less than **1.5 km/h (0.9 mph)**.  
The gearbox controller transmits this information to the Central Control Unit via the CAN bus.
- Parking brake engaged.  
This information is transmitted directly to the Central Control Unit from the handbrake switch (hard wire).

**NOTE:** *If one of these conditions is not achieved, the electric parking brake is released immediately.*

In stationary or ground speed Power Take-Off (PTO) operation mode, only the following conditions must be achieved:

- Vehicle speed is less than **1.5 km/h (0.9 mph)**.
- Parking brake engaged.

Once the ignition key has been turned to the "OFF" position, the electric parking brake will only be activated if the parking brake is applied within **25 s**.



For further information on gearbox hydraulics, see **Semi-Powershift transmission lubrication system - Hydraulic schema (21.103)**.

## Parking brake or parking lock - Static description – Electric parking brake

The electric parking brake is a country-specific or optional piece of equipment. The parking brake is an electro-hydraulic, spring-loaded brake that acts on the rear axle driving brake in addition to the mechanically actuated parking brake. The main advantage of an electric parking brake is that it significantly increases comfort and safety when operating the tractor.

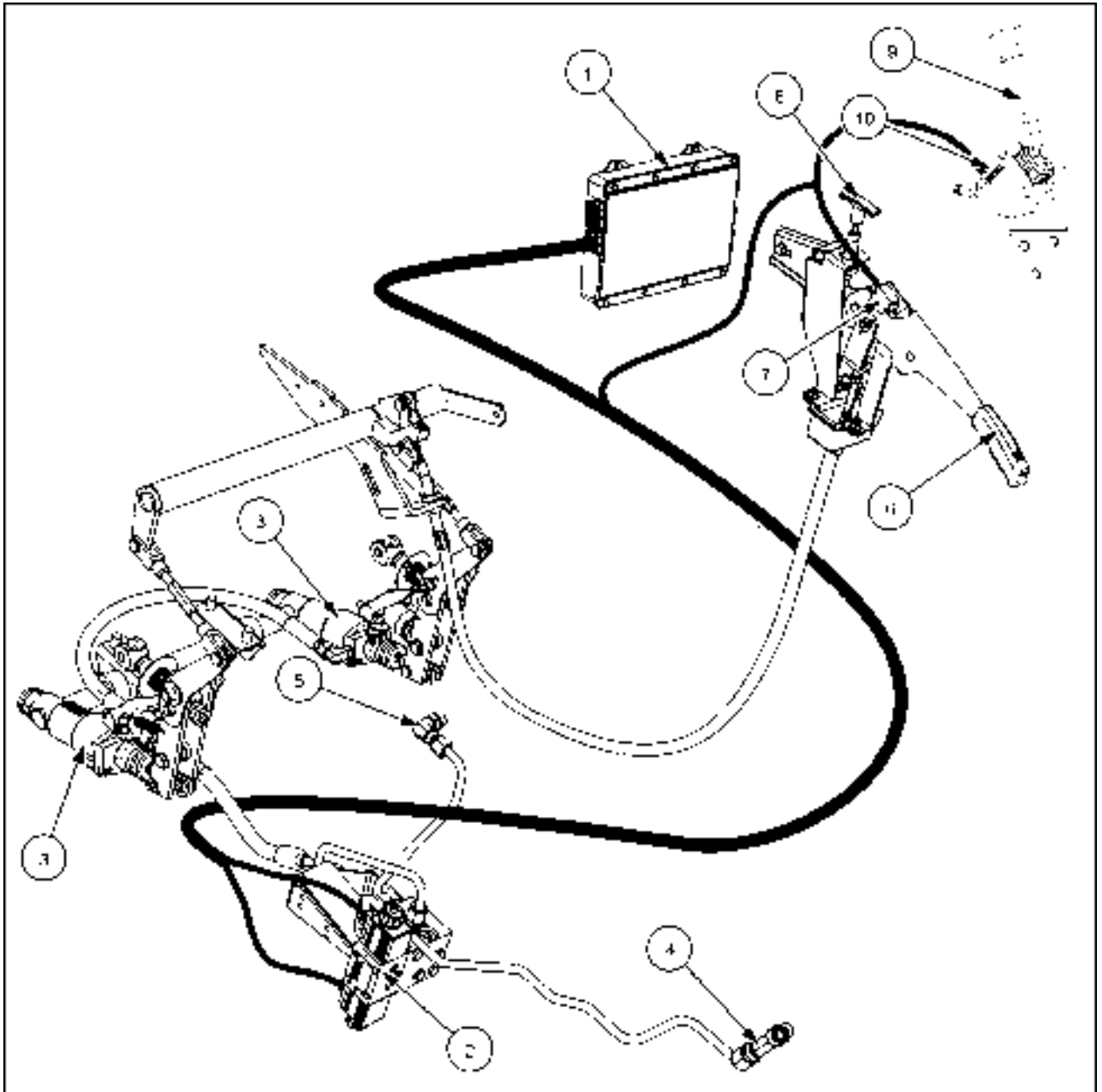

SS14F097 1

**Main components of the system:**

	<b>Component name</b>	<b>Location</b>	<b>Operation</b>
1	Central Control Unit	Inside cab, behind the driver seat	The Central Control Unit controls the solenoid valves.
2	Electric parking brake valve	On transmission, right-hand side	The electric parking brake valve (Parking brake engagement – Solenoid valve and Parking brake disengagement – Solenoid valve) allows oil to be transferred to the parking brake cylinders.
3	Parking brake cylinder	On rear axle, left and right	The parking brake cylinders actuate the driving brake.
4	Pipe	On transmission, right-hand side	The pipe supplies the parking brake solenoid valves with P1 pressure.
5	Pipe	On transmission, right-hand side	The pipe returns the oil to the transmission.
6	Hand brake lever	Inside cab, on the left-hand side at the driver seat	The hand brake lever operates the hand brake.
7	Hand brake position switch	At the hand brake lever	The hand brake position switch controls the park brake.
8	Ground speed Power Take-Off (PTO) lever	Inside cab, on the left-hand side at the driver seat	The Ground speed Power Take-Off (PTO) lever controls the Ground speed Power Take-Off (PTO).
9	Field/road lever	Inside cab, on the left-hand side at the driver seat	The field/road lever controls the field/road group.
10	Ground speed Power Take-Off (PTO) – Stationary operation switch	Inside cab, on the left-hand side at the field/road lever	The Ground speed Power Take-Off (PTO) – Stationary operation switch controls the parking brake.

## Parking brake control valve - Overview

### Parking brake engagement – Solenoid valve (Y-084)

### Parking brake disengagement – Solenoid valve (Y-085)

The solenoid valve Y-084 (1) and the solenoid valve Y-085 (2) are located on the right-hand side of the transmission housing.

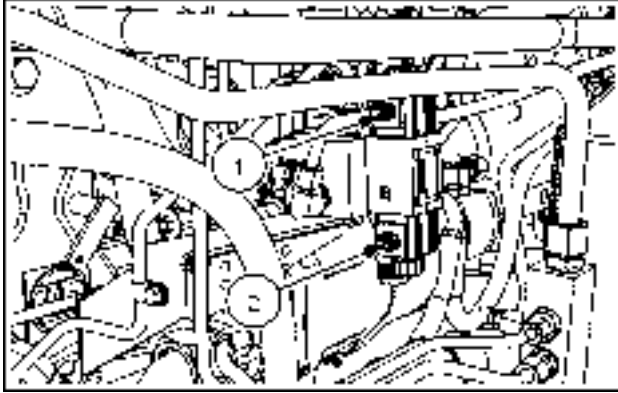

SS14F098 1

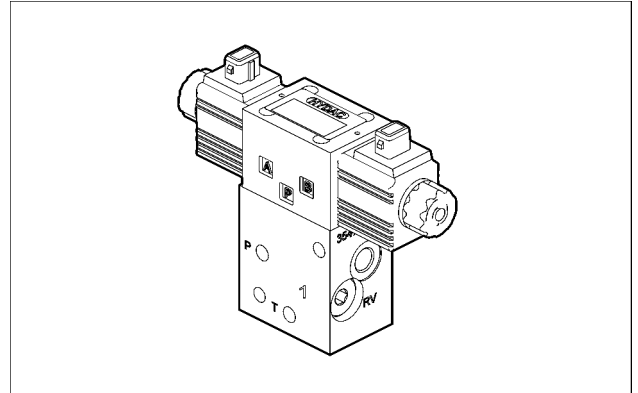

SS12F008 2

<b>Specifications</b>	
Design	4/2-way valve with mechanical catch
Nominal voltage	12 V +/- 10%
Rated resistance (at 20 °C (68 °F))	4,8 Ω
Duty cycle	100 %
Rated current	2,5 A
Nominal Power	30 W
Oil temperature	-20 - 80 °C (-4 - 176 °F)
Max. Input pressure	50 bar (725 psi)
Operating pressure	19 - 20 bar (276 - 290 psi)
Ambient Temperature	-20 - 50 °C (-4 - 122 °F)
Insulation resistance	> 100 kΩ
Tightening torque (M8)	23 N·m (17 lb ft)

## Parking brake or parking lock - Adjust

**NOTE:** Before you adjust the parking brake, you must check the adjustment of the service brake or adjust the service brake. Refer **Brakes - Install (33.202)**.

1. Rotate the nut (1) until the thread of the clevis (2) is flush with the nut (1).
2. Use nut (3) to secure nut (1).
3. Place the parking brake lever in the lowest position (parking brake released).

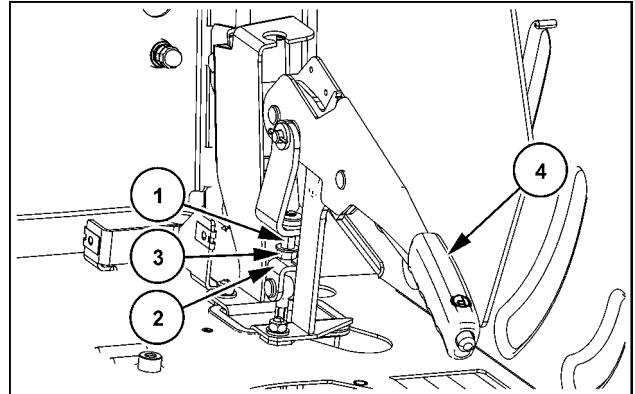

SS13H202 1

4. Fit the cable (1) in the console (2).
5. Use the nuts (3) to attach the cable so that the adjustment range on both sides is equal.

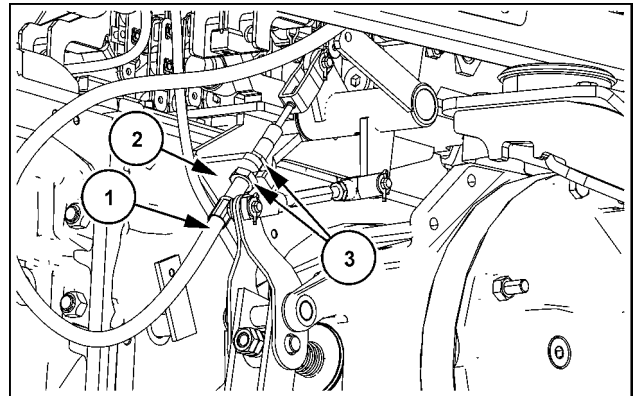

SS13H203 2

6. Undo the nut (1). Turn the nut several millimeters back from the clevis.
7. Rotate the adjusting screw (2) until the drawbar (3) lifts from the brake cylinder (4).
8. Turn the adjusting screw (2) back again until the drawbar (3) rests against the brake cylinder (4) again.
9. Tighten the nut (1).

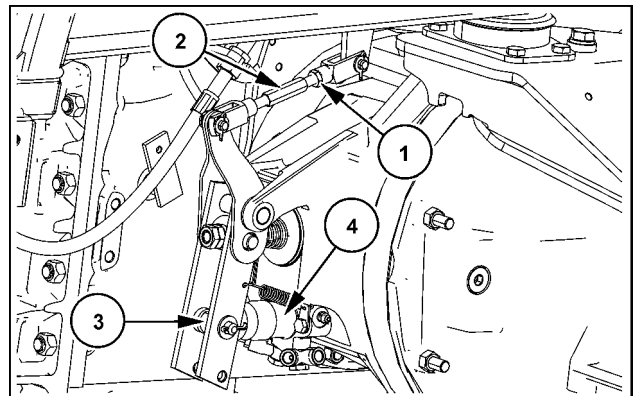

SS13H204 3

10. Undo the nut (1). Turn the nut several millimeters back from the clevis.
11. Rotate the adjusting screw (2) until the drawbar (3) lifts from the brake cylinder (4).
12. Turn the adjusting screw (2) back again until the drawbar (3) rests against the brake cylinder (4) again.
13. Tighten the nut (1).

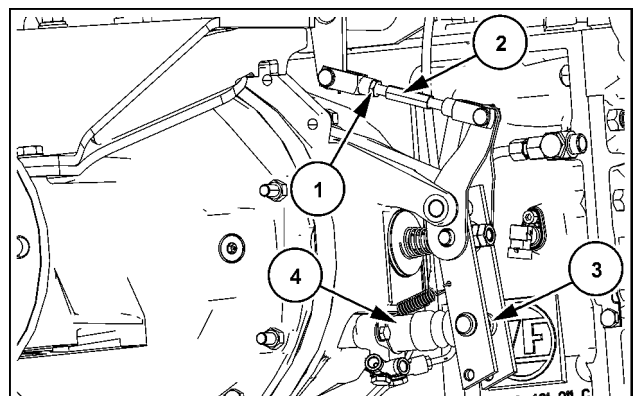

SS13H205 4

### Check the adjustment

14. You must adjust the parking brake cable so that the tie rods on the left-hand side and right-hand side lift between tooth one and tooth two of the brake cylinder when you operate the parking brake lever.
15. Operate the parking brake lever with **30 kg (66 lb)**. The lever should reach tooth seven or tooth eight. If the lever does not reach tooth seven or tooth eight, the cable must be adjusted.

**NOTE:** *If a compressed-air trailer brake is present, the compressed-air trailer brake must be adjusted so that the trailer brake valve switches between tooth three and tooth four.*

## Spring-loaded cylinder - Service instruction – Manual release of the electric park brake

### ⚠ WARNING

#### Equipment rolling hazard!

Always try to park the machine on firm level ground. Avoid parking on slopes. Block the wheels in both directions.

Failure to comply could result in death or serious injury.

W0265A

If the electric park brake is not released when the parking brake is released, the electric park brake can be also released manually.

The parking brake cylinders of the electric park brake are located in the rear near the lower link support.

The release fixture is located at the rear end of the parking brake cylinder.

1. Pull off the rubber cap (1).

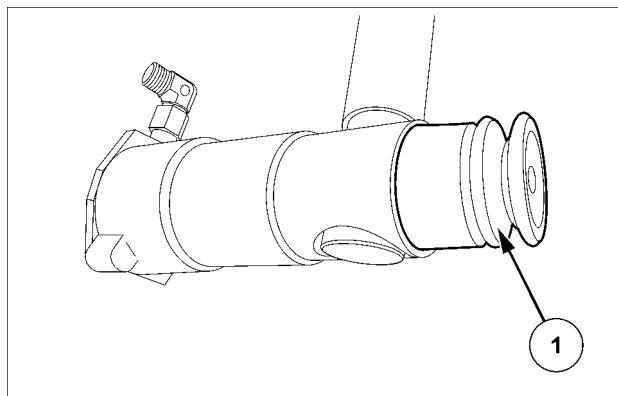

SS12F001 1

2. Screw the lock nut (2) against the cylinder wall. Fix the threaded rod (3) during the process.

**NOTE:** During this process the piston is pulled back and the electric parking brake is released.

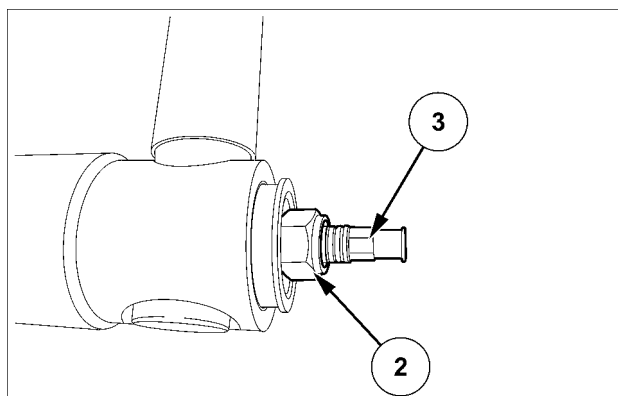

SS12F002 2

**NOTE:** Once the cause of the non-automatic release of the park brake has been found and the problem rectified, the release fixture must be reset.

3. Turn the lock nut (2) counter-clockwise up to the end of the threaded rod (3).
4. Refit the rubber cap.

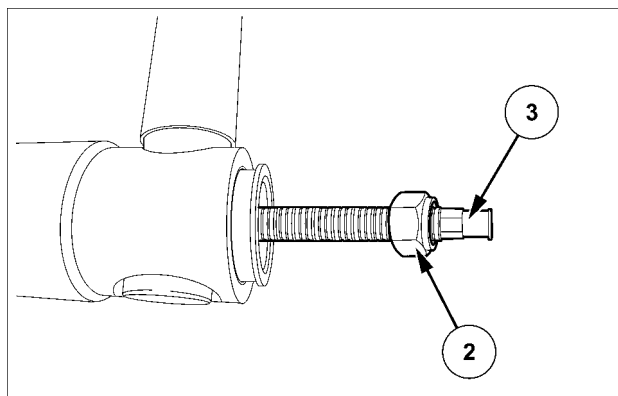

SS12F003 3

## Spring-loaded cylinder - Adjust

### ⚠ WARNING

Equipment rolling hazard!

Always try to park the machine on firm level ground. Avoid parking on slopes. Block the wheels in both directions.

Failure to comply could result in death or serious injury.

W0265A

**NOTE:** If a parking brake cylinder has been replaced or repaired, the linkage must be re-adjusted.

1. Release the parking brake and the electric park brake.
2. Unscrew the nut (1).
3. Rotate the threaded rod (2) until there is a gap (X) of **0.500 mm (0.020 in)** between bolt and clevis yoke.
4. Tighten the nut (1).

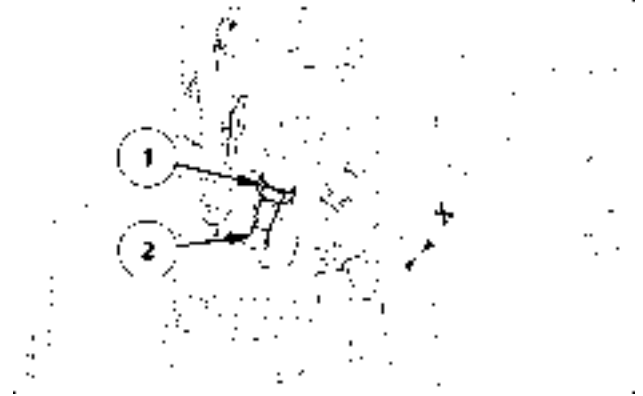

SS12F004 1



# Index

---

## Brakes and controls - 33

### Parking brake or parking lock - 110

Parking brake control valve - Overview .....	7
Parking brake or parking lock - Adjust .....	8
Parking brake or parking lock - Dynamic description – Electric parking brake .....	3
Parking brake or parking lock - Static description – Electric parking brake .....	5
Spring-loaded cylinder - Adjust .....	11
Spring-loaded cylinder - Service instruction – Manual release of the electric park brake .....	10



## **Brakes and controls - 33**

### **Trailer brake hydraulic control - 220**

**Farmall 105U Pro EP  
Farmall 115U Pro EP  
Farmall 95U Pro EP**

# Contents

---

## Brakes and controls - 33

### Trailer brake hydraulic control - 220

#### TECHNICAL DATA

##### Trailer brake valve

General specification – version for France ..... 3

General specification – Version for Italy ..... 3

---

## Trailer brake valve - General specification – version for France

Design	Open center line valve
Supplier	Safim
Operating system	Hydraulic
Oil flow pump	<b>20 - 130 l/min (5.3 - 34 US gpm)</b>
Maximum brake pressure at connection B	<b>130 - 150 bar (1885 - 2175 psi)</b>
Maximum pressure at connection N	<b>220 bar (3190 psi)</b>
Temperature range of hydraulic oil	<b>-20 - 115 °C (-4.0 - 239 °F)</b>
Drive piston gear ratio	1:11.1
Drive piston diameter	<b>20 mm (0.79 in)</b>

## Trailer brake valve - General specification – Version for Italy

Design	Open center line valve
Supplier	Safim
Operating system	Hydraulic
Oil flow pump	<b>20 - 130 l/min (5.3 - 34 US gpm)</b>
Maximum brake pressure at connection B	<b>130 bar +/- 10 (1885 psi +/- 145)</b>
Maximum pressure at connection N	<b>220 bar (3190 psi)</b>
Temperature range of hydraulic oil	<b>-20 - 115 °C (-4.0 - 239 °F)</b>
Drive piston gear ratio	1:11.1
Drive piston diameter	<b>20 mm (0.79 in)</b>

# Index

---

## Brakes and controls - 33

### Trailer brake hydraulic control - 220

Trailer brake valve - General specification – Version for Italy .....	3
Trailer brake valve - General specification – version for France .....	3



## **Brakes and controls - 33**

### **Front axle brake - 204**

**Farmall 105U Pro EP  
Farmall 115U Pro EP  
Farmall 95U Pro EP**

# Contents

---

## Brakes and controls - 33

### Front axle brake - 204

#### TECHNICAL DATA

##### Select valve

General specification - Adding valve ..... 3

---

## Select valve - General specification - Adding valve

Design  
Supplier  
Operating system  
Logic

Line valve  
ATE  
Hydraulic  
The front axle only brakes when both  
pedals are applied.

Valve opens at

**2 - 5 bar (29 - 72 psi)**



# Index

---

## Brakes and controls - 33

### Front axle brake - 204

Select valve - General specification - Adding valve ..... 3





© 2014 CNH Industrial Österreich GmbH

All rights reserved. No part of the text or illustrations of this publication may be reproduced.

CASE IH policy is one of continuous improvement and the right to change prices, specification or equipment at any time without notices is reserved.

All data given in this publication is subject to production variations. Dimensions and weight are approximate only and the illustrations do not necessarily show products in standard condition. For exact information about any particular product, please consult your CASE IH Dealer.



# **SERVICE MANUAL**

## **Hydraulic systems**

**Farmall 105U Pro EP**

**Farmall 115U Pro EP**

**Farmall 95U Pro EP**

# Contents

---

## Hydraulic systems - 35

[35.000] Hydraulic systems.....	35.1
[35.300] Reservoir, cooler, and filters.....	35.2
[35.104] Fixed displacement pump.....	35.3
[35.106] Variable displacement pump.....	35.4
[35.204] Remote control valves.....	35.5
[35.114] Three-point hitch control valve.....	35.6
[35.160] Front hitch controls and lines.....	35.7



## **Hydraulic systems - 35**

### **Hydraulic systems - 000**

**Farmall 105U Pro EP  
Farmall 115U Pro EP  
Farmall 95U Pro EP**

# Contents

---

## Hydraulic systems - 35

### Hydraulic systems - 000

#### TECHNICAL DATA

Hydraulic systems	
General specification .....	3

#### FUNCTIONAL DATA

Hydraulic systems	
Dynamic description – Closed center load sensing (CCLS) hydraulic system .....	4
Dynamic description – Open center load sensing (OCLS) hydraulic system .....	12
Hydraulic schema .....	20
Static description .....	24
Static description – Transmission, steering .....	32

## Hydraulic systems - General specification

### Open center load-sensing (OCLS) system

System components

Hydraulic oil reservoir

Oil grade

Gear Pump **22.5 cm<sup>3</sup> (1.37 in<sup>3</sup>)**

Maximum flow rate at **2200 RPM**

Max working pressure

Front and rear linkage, front and rear auxiliary distributors

**Oil reservoir - General specification (35.300)**

**Consumables Lubrications and Coolants ()**

**Pump Gear pump - General specification (35.104)**

**60 l/min (16 US gpm)**

**173 - 182 bar (2508 - 2639 psi)**

### Connecting plate with pressure compensator

Supplier

Neutral circuit from P-R  $\Delta p$

Consumer in operation  $\Delta p$

Pressure limiter valve opens at Q **20 l/min (5.28 US gpm)**

Pressure limiter valve opens at Q **60 l/min (16 US gpm)**

p max at R

Bosch Rexroth

**4 - 6 bar (58 - 87 psi)**

**11 bar (160 psi)**

**173 - 182 bar (2508 - 2639 psi)**

**173 - 202 bar (2508 - 2929 psi)**

**20 bar (290 psi)**

### Closed center load-sensing (CCLS) system

System components

Hydraulic oil reservoir

Oil grade

Variable displacement pump **40 cm<sup>3</sup> (2.44 in<sup>3</sup>)**

Maximum flow rate at **2200 RPM**

Max working pressure

Front and rear linkage, front and rear auxiliary distributors

**Oil reservoir - General specification (35.300)**

**Consumables Lubrications and Coolants ()**

**Pump - General specification (35.106)**

**100 l/min (26 US gpm)**

**195 - 205 bar (2828 - 2972 psi)**

### Connecting plate with pilot pressure controller

Supplier

Maximum pressure at connection P, P2, P3

Maximum pressure at connection LS

Maximum pressure at connection R, R1

Pilot pressure at connection X, X3

Filter at input P

Bosch Rexroth

**250 bar (3625 psi)**

**250 bar (3625 psi)**

**45 bar (652 psi)**

**18 bar (261 psi)**

100 $\mu$



---

## Hydraulic systems - Dynamic description – Closed center load sensing (CCLS) hydraulic system

No particular emphasis is placed on the actual equipment in the schematic diagrams. The schematic diagrams simply facilitate understanding of the operating principle of the Closed Center Load Sensing (CCLS) hydraulic system. The technical details of assemblies are described in the subsections.

### Low-pressure standby

The variable flow pump (2) draws the oil in through the suction filter (1). At low-pressure standby, all auxiliary distributors (AUX) are in the neutral position. This means that the variable flow pump (2) only reaches a small swivel angle and compensates for any leaks.

The low-pressure standby is generated by the force of the spring (3) (adjustable) and by the pump pressure. The pump pressure acts on the front face of the spool (4).

The spool (4) therefore regulates the pressure to the piston (5). The piston pushes against the swash plate (6). The spring (7) acts on the opposite side of the swash plate. This action creates a balanced position in the pump regulator.

The low-pressure standby is ready when the control spools of the individual consumer valves are closed. At the pump outlet, the pressure gauge (8) displays the **20 bar (290 psi)** value of the low-pressure standby.

### Color legend

- |   |                                      |
|---|--------------------------------------|
| A. High-pressure circuit                          | G. Trapped oil                       |
| B. Pressure drop in the high-pressure circuit     | H. Oil to the tank                   |
| C. Steering Circuit                               | I. Feed oil circuit or trailer brake |
| D. Low-pressure circuit (P1)                      | J. Load Sensing (LS) line            |
| E. Pressure drop in the low-pressure circuit (P1) | K. Lubrication Circuit               |
| F. Oil in suction                                 |                                      |

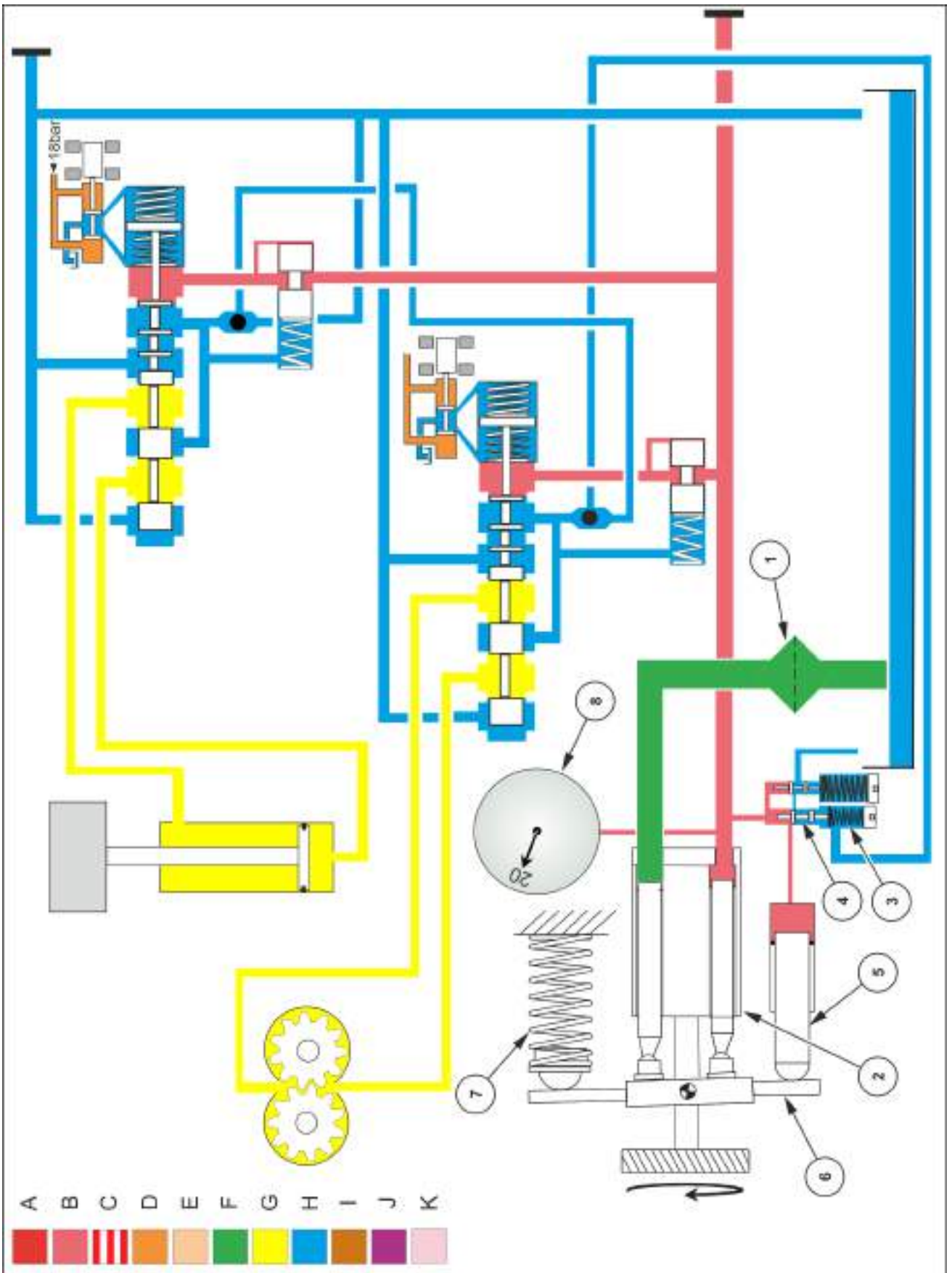

## One consumer in operation

When the control spool **(9)** opens, the control spool puts the consumer **(I)** into operation. This action establishes a connection to the pump regulator via the shuttle valve **(10)** and the signal line.

Together with the spring **(3)**, the low-pressure standby now acts on the spool **(4)**. This action opens the pressure space of the piston **(5)** to the tank. The spring **(7)** can therefore move the swash plate **(6)** against the piston **(5)**.

The pressure in the pump line increases and the consumer **(I)** begins to rotate. The working pressure on the consumer **(I)** is derived from the working resistance. The rotation speed is determined by the cross-section when the control spool **(9)** is opened. The LS line continuously reports the load pressure at the pump regulator.

The oil flows to the consumer. The oil flow increases at both ends of the spool **(4)** until a force equilibrium is created. The spring **(3)** acts on one end of the spool **(4)**. This means a pressure drop (usually  $\Delta p$ ) must occur at the control spool **(9)**. This pressure drop corresponds to the spring force. The pressure drop creates a balanced position in the variable flow pump. The variable flow pump can now generate the required oil flow and working pressure for the consumer.

In this example, a pump pressure of **120 bar (1740 psi)** is created. The pump pressure is displayed on the pressure gauge **(8)**. A working pressure of **100 bar (1450 psi)** is displayed on the pressure gauge **(11)**. An LS pressure of **100 bar (1450 psi)** is displayed on the pressure gauge **(12)**.

## Color legend

- |   |                                      |
|---|--------------------------------------|
| A. High-pressure circuit                          | G. Trapped oil                       |
| B. Pressure drop in the high-pressure circuit     | H. Oil to the tank                   |
| C. Steering Circuit                               | I. Feed oil circuit or trailer brake |
| D. Low-pressure circuit (P1)                      | J. Load Sensing (LS) line            |
| E. Pressure drop in the low-pressure circuit (P1) | K. Lubrication Circuit               |
| F. Oil in suction                                 |                                      |

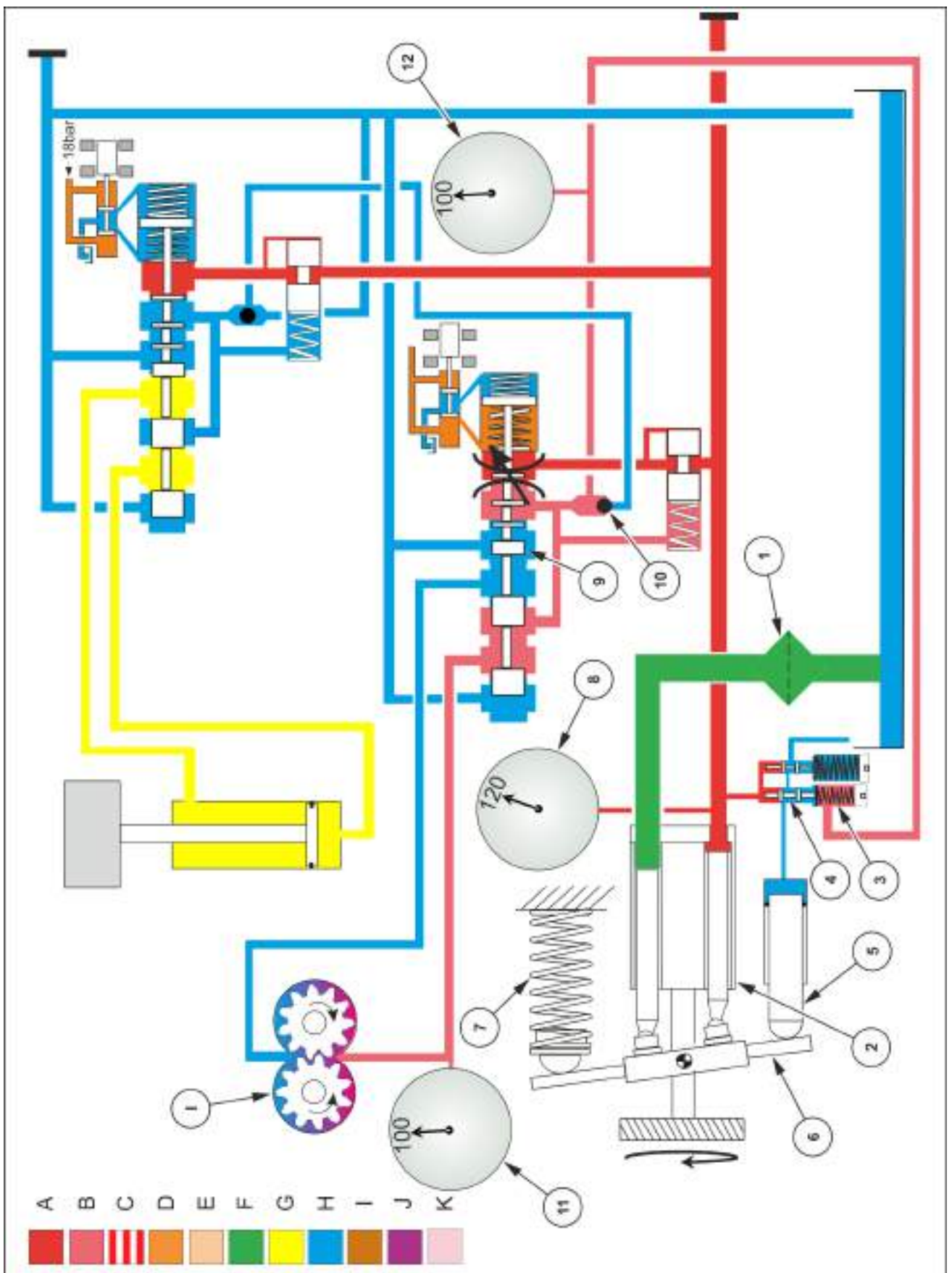

---

## Two consumers in operation

In this diagram, the consumer (II) is put into operation with another controller. The spool (13) has released the path to the consumer (II). The working pressure of the consumer (II) is derived from the load that is moved with the cylinder.

The speed with which the load is moved is determined by the cross-section when the control spool (13) is opened. As shown in this diagram, the working pressure of the consumer (II) is higher than the working pressure of the consumer (I).

Only the maximum working pressure of all consumers that are in operation can be relayed to the pump regulator via the shuttle valves (10) and (14). In this case, the shuttle valve (14) relays the higher pressure from the consumer (II) to the pump regulator. Via the pump regulator, the swash plate swivels out far enough for the variable flow pump to supply the additional required working pressure and oil flow.

The pump regulator and the variable flow pump have reached a balanced position. A force equilibrium is now created at the spool (4). The force equilibrium is created by the working pressure and by the signal pressure plus the spring force (3).

The two-way oil flow regulator (15) enables the rotation speed (oil flow) to be kept constant at the consumer (I), despite the increased pump pressure. Only two consumers are shown in the diagram. A maximum of six auxiliary distributors can be installed in the vehicle in addition to the electronically controlled hitch valve. During operation, all consumers with different working pressures and volumes can operate at the same time. This operation is possible as long as the required oil flow is not greater than the maximum oil flow of the variable flow pump.

In this example, a pump pressure of **170 bar (2465 psi)** is created. The pump pressure is displayed on the pressure gauge (18). A working pressure of **150 bar (2175 psi)** at the consumer (II) is displayed on the pressure gauge (8). A working pressure of **100 bar (1450 psi)** at the consumer (I) is displayed on the pressure gauge (11). An LS pressure of **150 bar (2175 psi)** is displayed on the pressure gauge (12).

## Color legend

- |   |                                      |
|---|--------------------------------------|
| A. High-pressure circuit                          | G. Trapped oil                       |
| B. Pressure drop in the high-pressure circuit     | H. Oil to the tank                   |
| C. Steering Circuit                               | I. Feed oil circuit or trailer brake |
| D. Low-pressure circuit (P1)                      | J. Load Sensing (LS) line            |
| E. Pressure drop in the low-pressure circuit (P1) | K. Lubrication Circuit               |
| F. Oil in suction                                 |                                      |

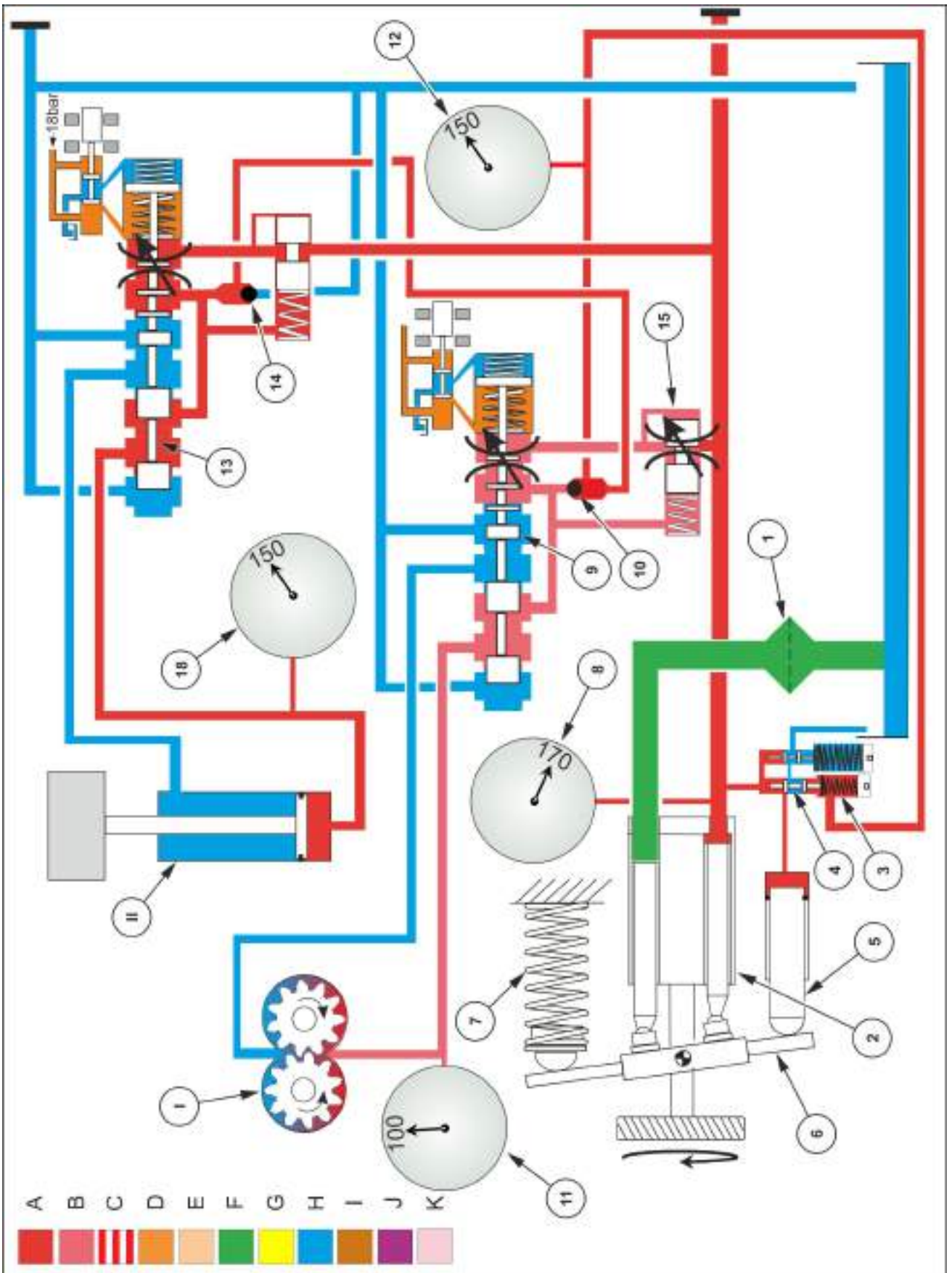

## Max working pressure

The consumer **(II)** is driven to its end stop. The second consumer **(I)** remains switched on.

The working pressure of the consumer **(II)** increases up to the maximum pressure of the variable flow pump. No oil flows to the consumer **(II)**. This means there are also no pressure drops ( $\Delta p$ ) in the controller of the consumer **(II)**. Therefore, if the pressure in the signal line is the same as the pressure at the pump outlet, an infinite pressure increase would occur.

The pump regulator comprises another spool **(16)**. This spool is connected with the pump pressure. The pump pressure can continue to increase until the spool **(16)** is pushed against the spring **(17)**. This movement establishes a connection to the piston **(5)**. The maximum working pressure is reached and cannot continue to increase. The variable flow pump works at the maximum working pressure until the consumer **(II)** switches off.

Thanks to the two-way oil flow regulator **(15)**, the consumer **(I)** is not influenced by pressure and volume changes. This means that the set oil flow to the consumer **(I)** remains constant and the rotation speed of the oil motor does not change.

In this example, a pump pressure of **200 bar (2900 psi)** is created. The pump pressure is displayed on the pressure gauge **(8)**. A working pressure of **200 bar (2900 psi)** at the consumer **(II)** is displayed on the pressure gauge **(18)**. A working pressure of **100 bar (1450 psi)** at the consumer **(I)** is displayed on the pressure gauge **(11)**. An LS pressure of **200 bar (2900 psi)** is displayed on the pressure gauge **(12)**.

## Color legend

- |   |                                      |
|---|--------------------------------------|
| A. High-pressure circuit                          | G. Trapped oil                       |
| B. Pressure drop in the high-pressure circuit     | H. Oil to the tank                   |
| C. Steering Circuit                               | I. Feed oil circuit or trailer brake |
| D. Low-pressure circuit (P1)                      | J. Load Sensing (LS) line            |
| E. Pressure drop in the low-pressure circuit (P1) | K. Lubrication Circuit               |
| F. Oil in suction                                 |                                      |

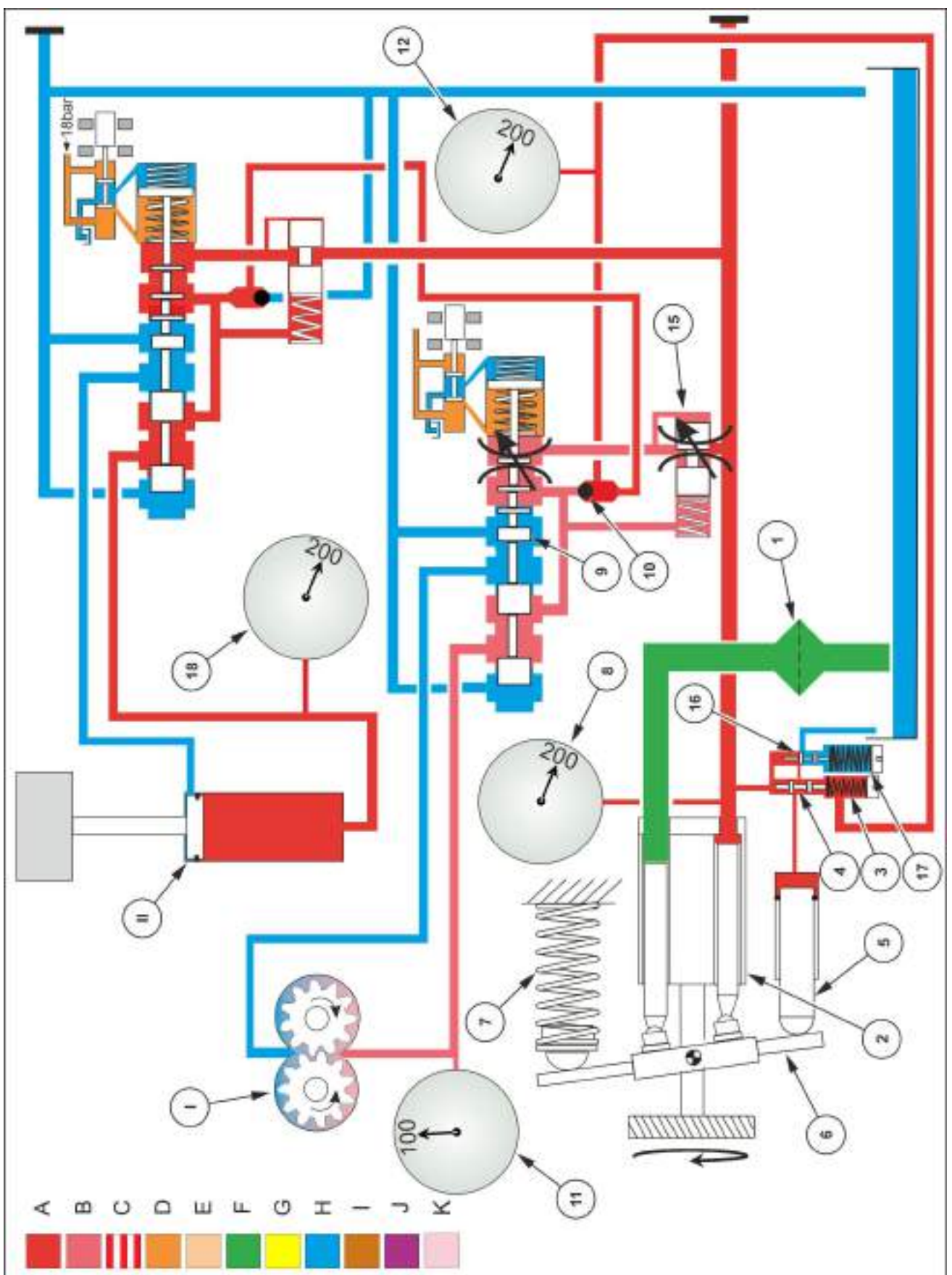

SS12N805 4



---

## Hydraulic systems - Dynamic description – Open center load sensing (OCLS) hydraulic system

The purpose of the load sensing system (LS) is to minimize loss of throttle and load-independent volume flow control. The hydraulic system is a load sensing system (LS) with a fixed displacement pump (1). We also refer to the hydraulic system as an OCLS (open center load sensing) hydraulic system.

This system feeds the flow of oil to the directional valves (5) via a connecting plate (2) with a pressure compensator. The arrangement of the pressure compensator (3) is parallel to the supply line (4) for the directional valves (consumers). In conjunction with the throttle sections on the directional valves (5), the pressure compensator works as a three-way flow regulator with pressure difference ( $\Delta p$ ) switchover (4 bar (58 psi) to 11 bar (160 psi)). The load pressure (signal) that the pressure compensator requires in order to function acts on the spring side (6) of the pressure compensator. The system feeds this load pressure from the directional valves, via the LS output of the directional valves with the integrated shuttle valve (7), and into the signal line (8) and the LS connection of the connecting plate (2).

### Neutral position

When all of the control valves for the directional valves are in the neutral position, the signal line connects to the return flow (9). The signal line is therefore without pressure.

If there is no load pressure on the spring side of the pressure compensator (neutral), the oil flow of the fixed displacement pump enters the neutral circuit (10) at a very low pressure ( $\Delta p$  is 4 bar (58 psi)). The spring force determines this very low pressure. This very low neutral circuit pressure in OCLS systems causes a significant improvement in the energy balance in comparison with OC (open center) systems.

The pressure limiter valve (11) with the function of a pilot valve is in the LS channel of the connecting plate. Together with the pressure compensator, the pilot valve forms the pressure limiter valve.

### Color legend

- |   |                                      |
|---|--------------------------------------|
| A. High-pressure circuit                          | G. Trapped oil                       |
| B. Pressure drop in the high-pressure circuit     | H. Oil to the tank                   |
| C. Steering Circuit                               | I. Feed oil circuit or trailer brake |
| D. Low-pressure circuit (P1)                      | J. Load Sensing (LS) line            |
| E. Pressure drop in the low-pressure circuit (P1) | K. Lubrication Circuit               |
| F. Oil in suction                                 |                                      |

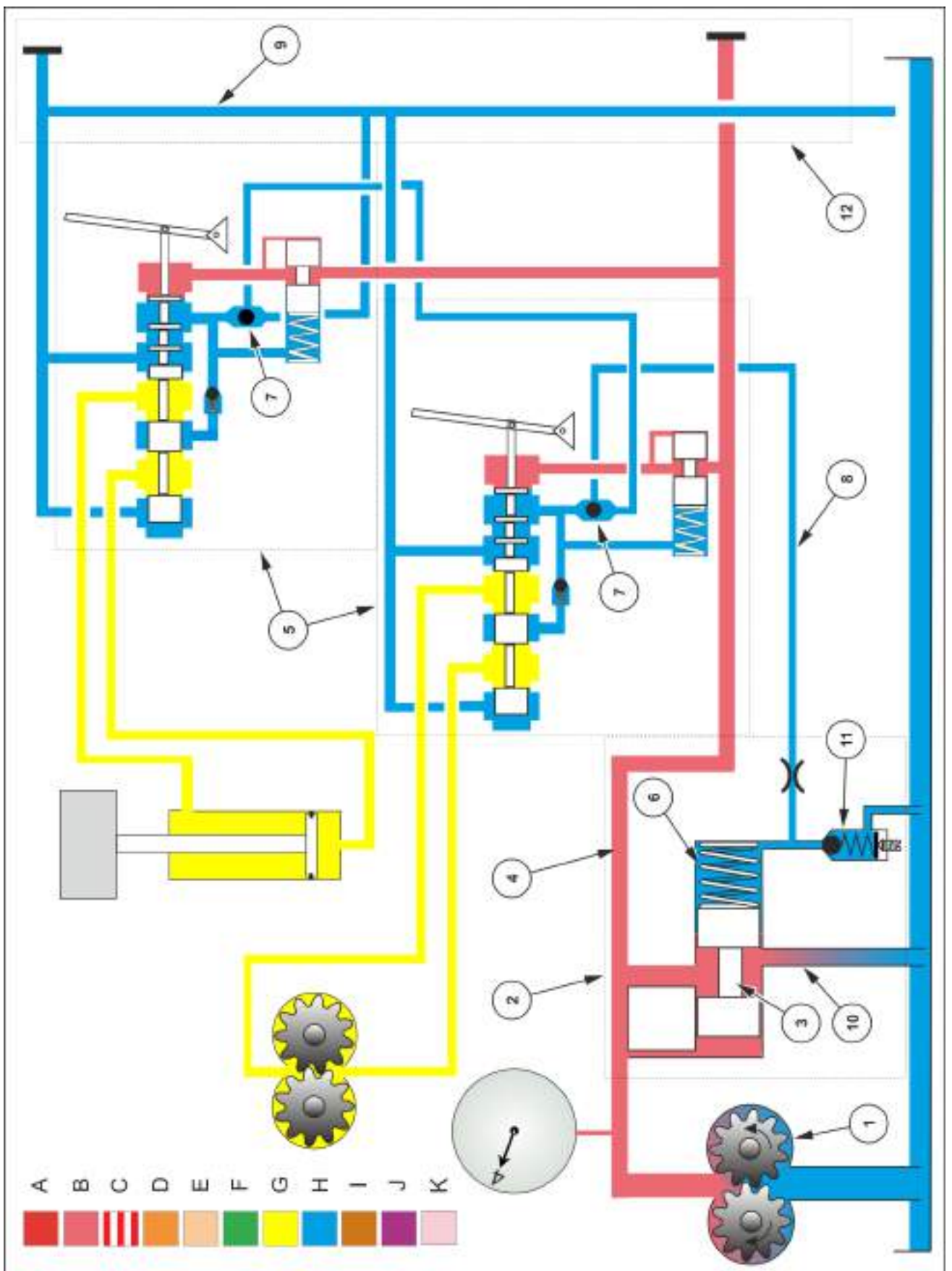

SS12N807 1

## One consumer in operation

To operate a consumer, the control valve **(14)** for the appropriate directional valve **(5)** moves until the required amount of oil can flow. Connections P and A connect together. At the same time, the connection of the load sensing line (LS) **(8)** to the return flow **(9)** closes.

The system feeds the pressure (load pressure) that results at the consumer **(1)** via a channel in the load sensing (LS) line **(8)**. The system then feeds the pressure on to the spring side of the pressure compensator **(3)**. However, to achieve this, the system must isolate the load sensing (LS) line in the direction of the remaining (non-actuated) directional valves. The integrated shuttle valve **(7)** in the directional valve isolates the load sensing (LS) line in the required direction.

As long as the full oil flow of the fixed displacement pump flows to the consumer and the full oil flow does not create a certain pressure difference ( $\Delta p$ ) at the control valve, the pump pressure and load pressure are almost identical. The spring force **(6)** moves the pressure compensator **(3)** up to the stop. This action closes the neutral circuit **(10)**. However, if the system restricts the oil flow to the consumer, the restrictor **(13)** causes a pressure difference ( $\Delta p$ ) between the load pressure and the pump pressure. This pressure difference causes the pressure compensator **(3)** to open the neutral circuit **(10)** and divide the oil flow from the fixed displacement pump into a consumer oil flow and a neutral oil flow. The unneeded proportion of the oil flow therefore enters the neutral circuit **(10)** directly due to the pump pressure. This results in an improvement to OC (open center) systems. In OC systems, the unneeded oil flow (with a maximum pressure of **175 bar (2538 psi)**) would flow into the tank.

The restrictor **(13)** sets the oil flow. This oil flow determines the working speed (rotational speed) of the consumer **(1)**, independent of the load. Each required pump pressure is a result of the load pressure and the flow resistance at the restrictor **(13)** of the directional valve.

**NOTE:** To make this functional description easier to understand, this functional description does not mention delta-pressure ( $\Delta p$ ) switchover. Tractors work with a pressure difference ( $\Delta p$ ) switchover ( **4 bar (58 psi)** to **11 bar (160 psi)**) in the connecting plate (pressure compensator). The spring **(6)** causes a low neutral circuit pressure ( **4 bar (58 psi)**) in the neutral circuit. This neutral circuit pressure leads to a reduction in oil heat-up and therefore a lower power demand. If consumers are in operation, the system switches the pressure difference ( $\Delta p$ ) hydraulically to **11 bar (160 psi)**. This means that the oil flows reach up to **80 l/min (21.1 US gpm)** at a directional valve.

## Color legend

- |   |                                      |
|---|--------------------------------------|
| A. High-pressure circuit                          | G. Trapped oil                       |
| B. Pressure drop in the high-pressure circuit     | H. Oil to the tank                   |
| C. Steering Circuit                               | I. Feed oil circuit or trailer brake |
| D. Low-pressure circuit (P1)                      | J. Load Sensing (LS) line            |
| E. Pressure drop in the low-pressure circuit (P1) | K. Lubrication Circuit               |
| F. Oil in suction                                 |                                      |

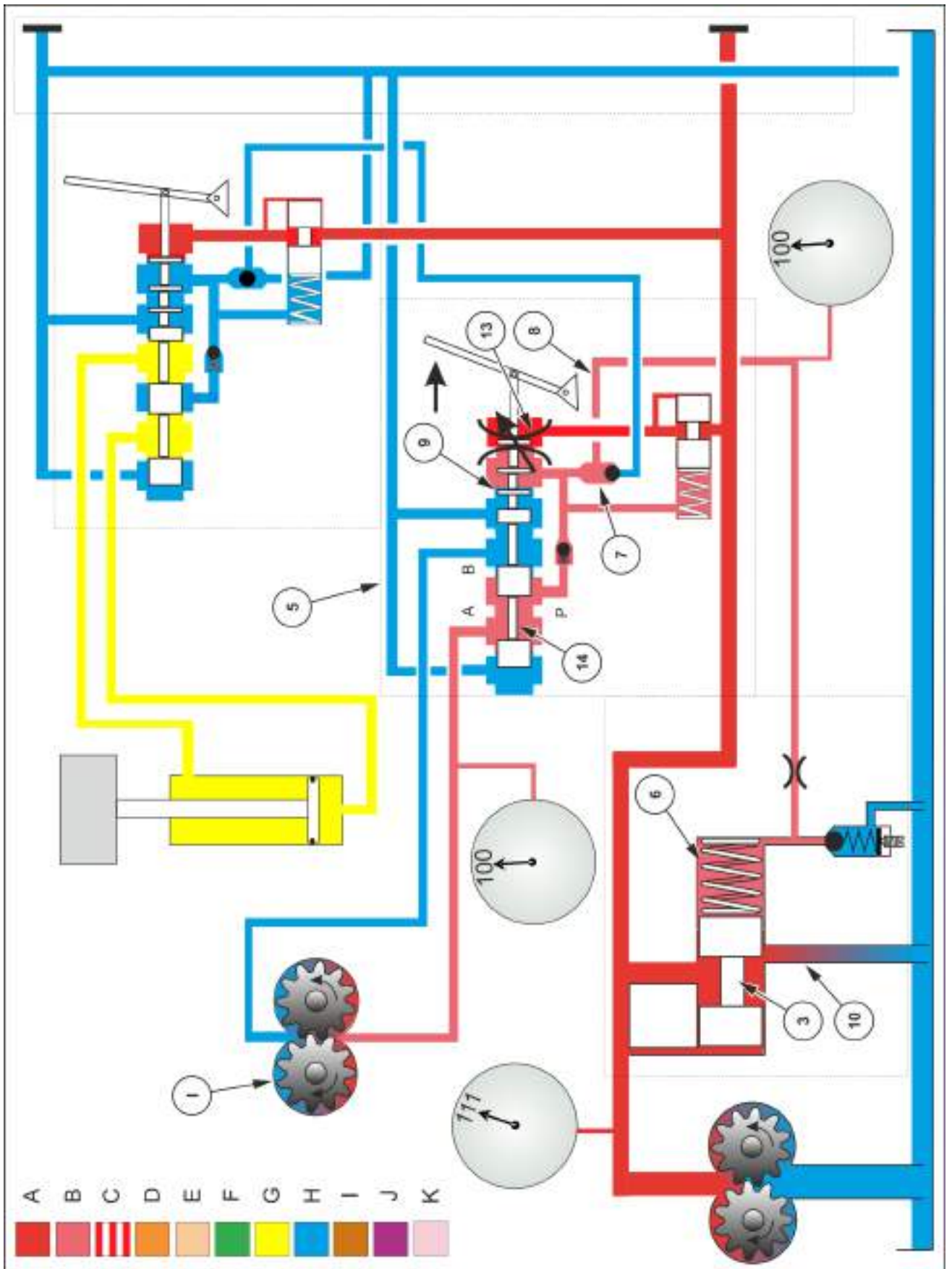

---

## Two or more consumers in operation

If another consumer **(15)** is active, almost the same procedure takes place as in the first directional valve **(5)** when the load pressure drops. The difference is that the system compares the load pressure of both consumers at the shuttle valve **(7)** of the consumer **(I)**.

In the diagram, a higher load pressure is present at the consumer **(II)**. This higher load pressure causes the shuttle valve **(7)** to switch. If several consumers are active at the same time, this procedure takes place at the remaining shuttle valves in the same way as at the shuttle valve of the consumer **(I)**. In all cases, only the highest load pressure reaches the pressure compensator **(3)** in the connecting plate.

If the load pressure of consumer **(II)** remains below the load pressure of consumer **(I)**, nothing changes at the shuttle valve **(7)**. As a result of the increased oil demand **(10)**, the pressure compensator **(3)** reduces the neutral oil flow.

In the diagram, the load pressure of consumer **(II)** is **150 bar (2175 psi)**. This pressure in turn causes a pressure of **161 bar (2334 psi)** in the fixed displacement pump. The higher pump pressure is now also available to the directional valve of consumer **(II)**. If there were no integrated pressure compensator **(16)** in the directional valve of consumer **(I)**, the higher pump pressure would lead to an increase in the working speed (rotational speed) in consumer **(I)**. The spring **(17)** of the integrated pressure compensator **(16)** creates a constant pressure difference ( $\Delta p$ ). This constant pressure difference causes the working speed of consumer **(I)** to remain the same, despite the higher pump pressure.

**NOTE:** *The simultaneous operation of several consumers with varying load pressures only works with directional valves with an integrated pressure compensator. For simultaneous operation, the oil flow of the fixed displacement pump must be greater than or at least equal to the oil flow of all consumers that are currently in operation.*

## Color legend

- |   |                                      |
|---|--------------------------------------|
| A. High-pressure circuit                          | G. Trapped oil                       |
| B. Pressure drop in the high-pressure circuit     | H. Oil to the tank                   |
| C. Steering Circuit                               | I. Feed oil circuit or trailer brake |
| D. Low-pressure circuit (P1)                      | J. Load Sensing (LS) line            |
| E. Pressure drop in the low-pressure circuit (P1) | K. Lubrication Circuit               |
| F. Oil in suction                                 |                                      |

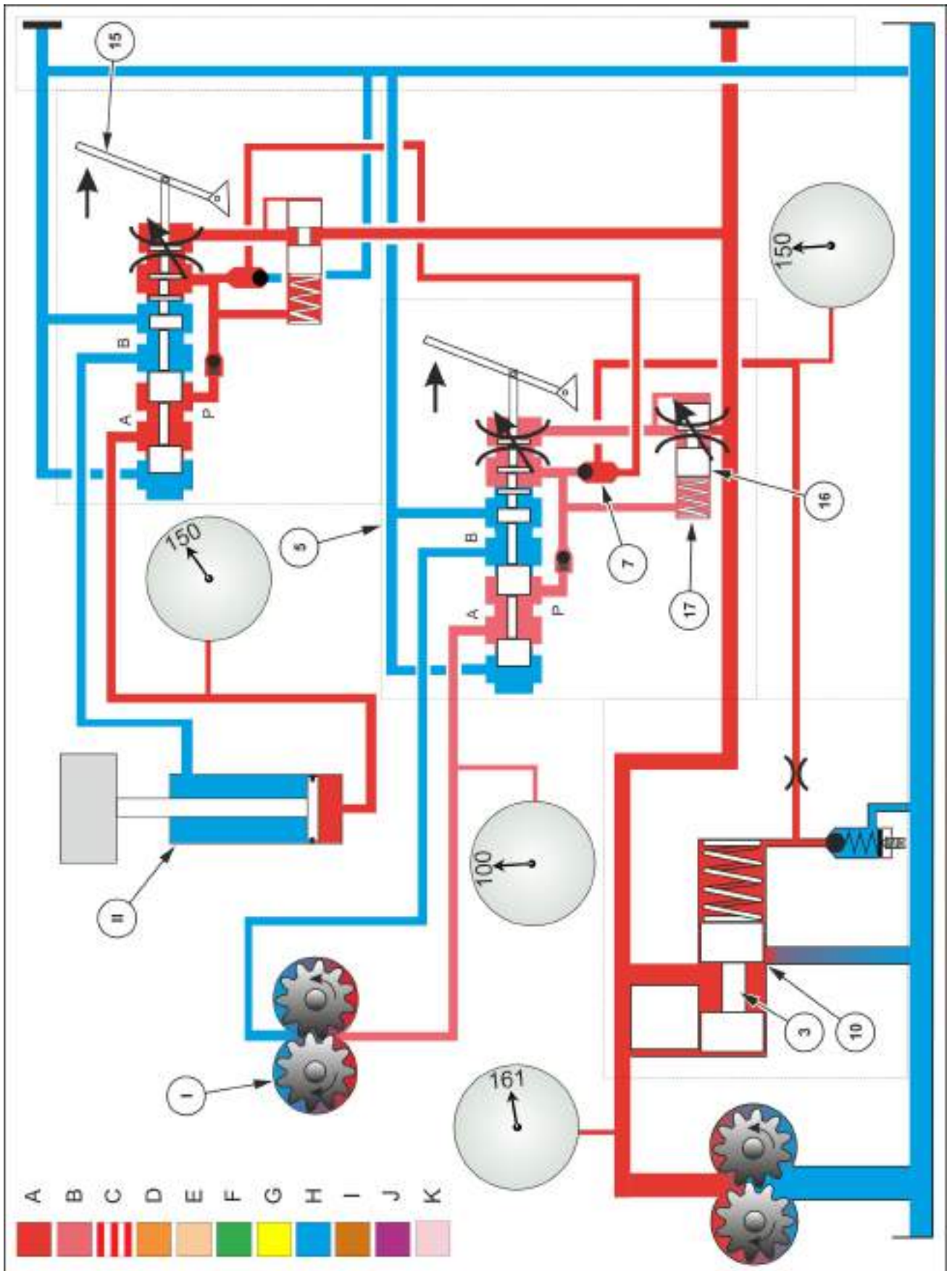

### Max working pressure

If a consumer stops the oil flow, the pressure balances out before and after the restrictor **(18)**. If the control unit **(15)** remains active during this process, the load pressure increases to the maximum working pressure.

The shuttle valve **(7)** remains in its position and now reports the pump pressure to the pressure compensator **(3)**. As no oil can now flow to the consumer **(II)**, there is also no drop in pressure at the restrictor **(18)**. In turn, this results in an increase in pressure in the load sensing (LS) line. This would lead to a continuous increase in the pump pressure. At a pressure of **175 bar (2538 psi)**, the pilot valve **(11)** opens and prevents the rise in LS pressure after the restrictor **(19)**. In turn, this leads to a balance of the forces at the pressure compensator **(3)**. The unneeded oil from the fixed displacement pump flows into the neutral circuit **(10)**.

In the diagram, the load pressure of **175 bar (2538 psi)** is the same as the pump pressure of the consumer **(II)**. The higher pump pressure is now also available to the directional valve of consumer **(I)**. If there were no integrated pressure compensator **(16)** in the directional valve of consumer **(I)**, the higher pump pressure would lead to an increase in the working speed (rotational speed). The spring **(17)** of the integrated pressure compensator **(16)** creates a constant pressure difference ( $\Delta p$ ). This constant pressure difference causes the working speed of consumer **(I)** to remain the same, despite the maximum pump pressure.

### Color legend

- |   |                                      |
|---|--------------------------------------|
| A. High-pressure circuit                          | G. Trapped oil                       |
| B. Pressure drop in the high-pressure circuit     | H. Oil to the tank                   |
| C. Steering Circuit                               | I. Feed oil circuit or trailer brake |
| D. Low-pressure circuit (P1)                      | J. Load Sensing (LS) line            |
| E. Pressure drop in the low-pressure circuit (P1) | K. Lubrication Circuit               |
| F. Oil in suction                                 |                                      |

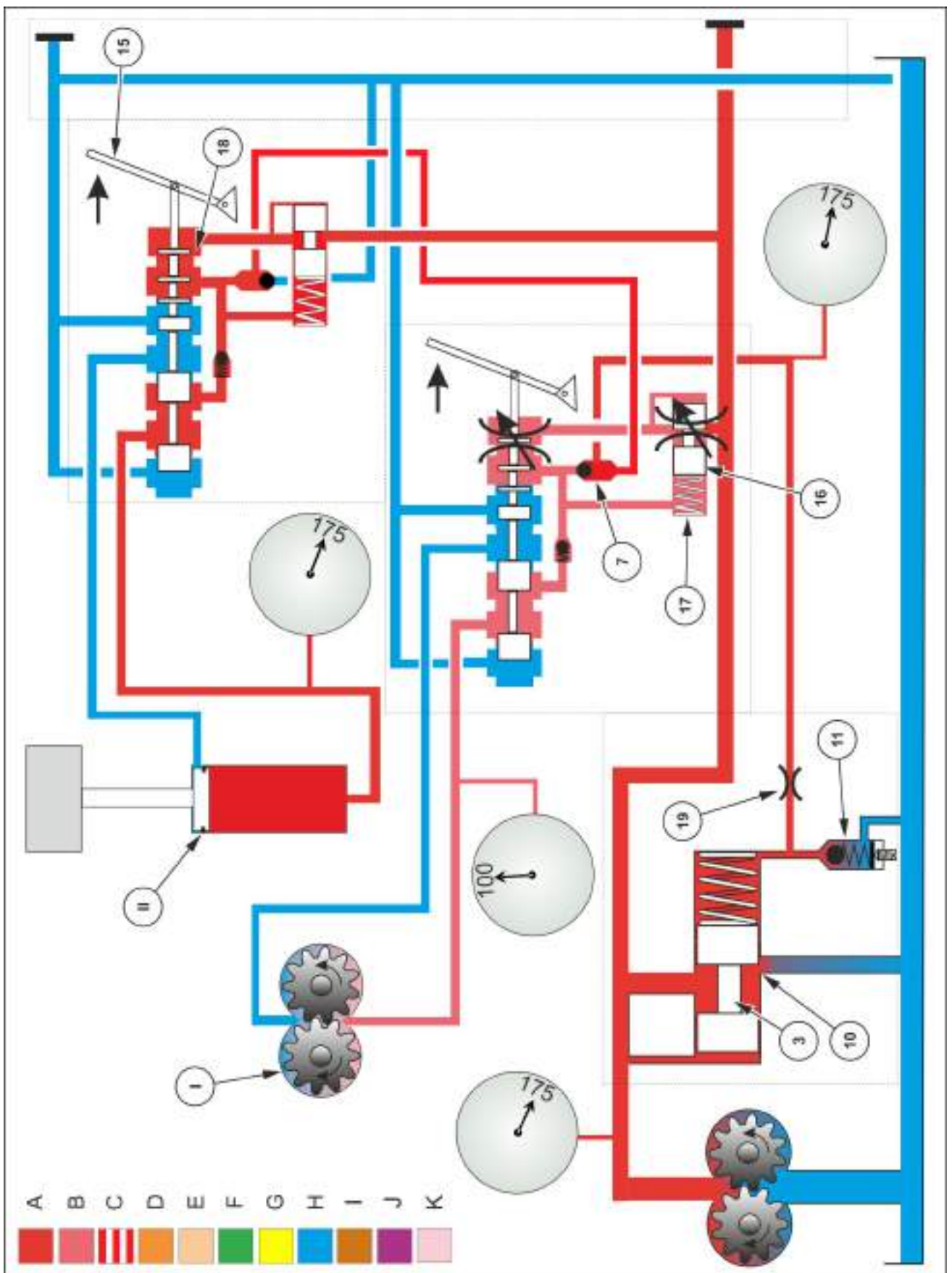



## Hydraulic systems - Hydraulic schema

### OCLS (open center load sensing) hydraulic system with hydraulic trailer brake (France)

- |  |   |
|--|---|
| 1. hydraulic fluid reservoir <b>44 l (12 US gal)</b>                                     | 2. 60µ suction filter with bypass valve   |
| 3. <b>22.5 cm<sup>3</sup> (1.37 in<sup>3</sup>)</b> fixed displacement pump (hydraulics) | 4. Connecting plate (with pressure compensator)   |
| 5. Connection (not used)   | 6. Test connection for load-sensing pressure  |
| 7. Pump pressure test connection   | 8. Plug-in coupling for non-pressurized return flow   |
| 9. Mechanical remote valve   | 10. Mechanical remote valve   |
| 11. Intermediate plate   | 12. EDC control valve   |
| 13. Right-hand lift cylinder and left-hand lift cylinder                                 | 14. Mechanical remote valve (valve snaps into "clearance" position)   |
| 15. Mechanical remote valve (no clearance, no detents)                                   | 16. Closing plate   |
| 17. Changeover valve (single-acting/double-acting)                                       | 18. Lift cylinder   |
| 19. Front right plug-in couplings  | 20. Transmission case   |
| 21. 40µ suction filter with <b>0.8 bar (12 psi)</b> bypass valve                         | 22. Fixed displacement pump for steering  |
| 23. Fixed displacement pump for gearbox  | 24. Pressure switch for steering  |
| 25. steering valve <b>125 cm<sup>3</sup> (7.63 in<sup>3</sup>)</b>                       | 26. Pressure limiter valve <b>170 bar (2465 psi)</b>  |
| 27. Steering cylinder  | 28. Thermostat <b>45 °C (113 °F)</b>  |
| 29. Transmission oil cooler  | 30. Transmission lubrication  |
| 31. 15µ return filter with <b>0.3 bar (4 psi)</b> filter bypass valve                    | 32. Hydraulic trailer brake valve   |
| 33. Control valve for service brake  | 34. Plug-in coupling for trailer brake valve (France)   |
| 35. 15µ transmission oil filter with <b>3.5 bar (51 psi)</b> filter bypass valve         | 36. Valve block for transmission control – <b>Semi-Powershift transmission lubrication system - Hydraulic schema (21.103)</b> |
| 37. Limiter valve for lubricant pressure   | 38. Transmission lubrication  |
| 39. Right Hand Brake Master Cylinder Assembly  | 40. Left Hand Brake Master Cylinder Assembly  |
| 41. Steering brake valve   | 42. Right-hand brake cylinder   |
| 43. Left-hand brake cylinder   | 44. Right-hand brake cylinder (front axle)  |
| 45. Left-hand brake cylinder (front axle)  | 46. Plug-in connector interface   |
| 47. Quick coupling for front loader  |   |

### Abbreviations in the table.

- |    |  |    |   |
|----|--|----|---|
| A  | Lift cylinder connection                 | B  | Lift cylinder connection                            |
| LS | Load Sensing (LS) line                   | M  | Measuring port                                      |
| N  | Connection for pump pressure output      | P  | Connection for pump pressure input                  |
| R1 | Connection of EDC control valve (return) | T  | Connection of return line into transmission housing |
| TB | Trailer brake connection                 | Y1 | Right-hand brake line for service brake             |
| Y2 | Left-hand brake line for service brake   |    |   |

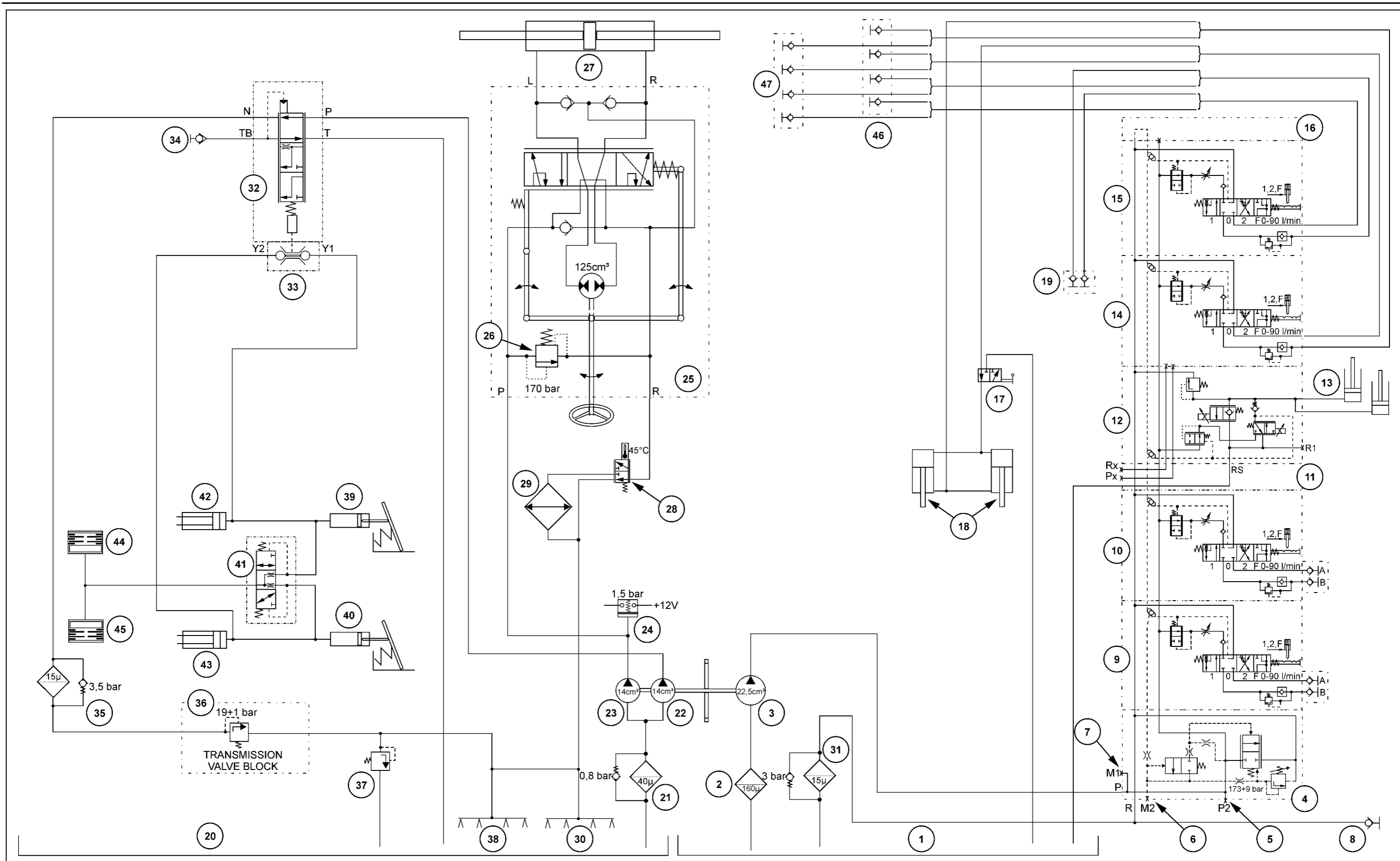

SS13A119 1

**CCLS (closed center load sensing) hydraulic system with hydraulic trailer brake (Italy)**

- |   |  |
|---|--|
| 1. hydraulic fluid reservoir <b>44 l (12 US gal)</b>  | 2. 60µ suction filter with bypass valve  |
| 3. <b>40 cm³ (2.44 in³)</b> variable displacement pump (hydraulics)   | 4. Pump regulator for variable displacement pump                                 |
| 5. Pressure regulator (maximum pressure)  | 6. controller (ΔP)   |
| 7. Port plate   | 8. Pump pressure test connection   |
| 9. Test connection for load-sensing pressure  | 10. Plug-in coupling for non-pressurized return flow                             |
| 11. Mechanical remote valve   | 12. Mechanical remote valve  |
| 13. Intermediate plate  | 14. EDC control valve  |
| 15. Right-hand lift cylinder and left-hand lift cylinder  | 16. Electric remote valve  |
| 17. Electric remote valve   | 18. Electric remote valve  |
| 19. Closing plate   | 20. Transmission case  |
| 21. 40µ suction filter with <b>0.8 bar (12 psi)</b> bypass valve  | 22. Fixed displacement pump for steering   |
| 23. Fixed displacement pump for gearbox   | 24. Pressure switch for steering   |
| 25. steering valve <b>125 cm³ (7.63 in³)</b>  | 26. Pressure limiter valve <b>170 bar (2465 psi)</b>                             |
| 27. Steering cylinder   | 28. Thermostat <b>45 °C (113 °F)</b>   |
| 29. Transmission oil cooler   | 30. Heat exchanger (transmission oil/hydraulic oil)                              |
| 31. Transmission lubrication  | 32. 15µ return filter with <b>0.3 bar (4 psi)</b> filter bypass valve            |
| 33. Hydraulic trailer brake valve (Italy)   | 34. Control valve for service brake  |
| 35. Solenoid valve for trailer brake valve (Italy)  | 36. Pressure switch for trailer brake valve (Italy)                              |
| 37. Plug-in coupling for trailer brake valve (Italy)  | 38. 15µ transmission oil filter with <b>3.5 bar (51 psi)</b> filter bypass valve |
|   | 40. Limiter valve for lubricant pressure   |
| <b>39. Valve block for transmission control – Semi-Powershift transmission lubrication system - Hydraulic schema (21.103)</b> |  |
| 41. Transmission lubrication  | 42. Right Hand Brake Master Cylinder Assembly                                    |
| 43. Left Hand Brake Master Cylinder Assembly  | 44. Steering brake valve   |
| 45. Right-hand brake cylinder   | 46. Left-hand brake cylinder   |
| 47. Right-hand brake cylinder (front axle)  | 48. Left-hand brake cylinder (front axle)  |
| 49. Control valve for electronic front hitch (EFH)  | 50. <b>14 bar (203 psi)</b> solenoid valve for accumulator                       |
| 51. <b>40 bar (580 psi)</b> solenoid valve for accumulator  | 52. Pressure sensor for electronic front hitch (EFH)                             |
| 53. Lift cylinder   | 54. Changeover valve (single-acting/double-acting)                               |
| 55. Lift cylinder   | 56. Front left plug-in coupling  |

**Abbreviations in the table.**

- |   |   |
|---|---|
| A Lift cylinder connection                            | B Lift cylinder connection                |
| L Leak-off line                                       | LS Load Sensing (LS) line                 |
| M Measuring port                                      | N Connection for pump pressure output     |
| P Connection for pump pressure input                  | Px Pilot pressure for EHS1                |
| R1 Connection of EDC control valve (return)           | Rx Load sensing (return)                  |
| T Connection of return line into transmission housing | TB Trailer brake connection               |
| Y1 Right-hand brake line for service brake            | Y2 Left-hand brake line for service brake |

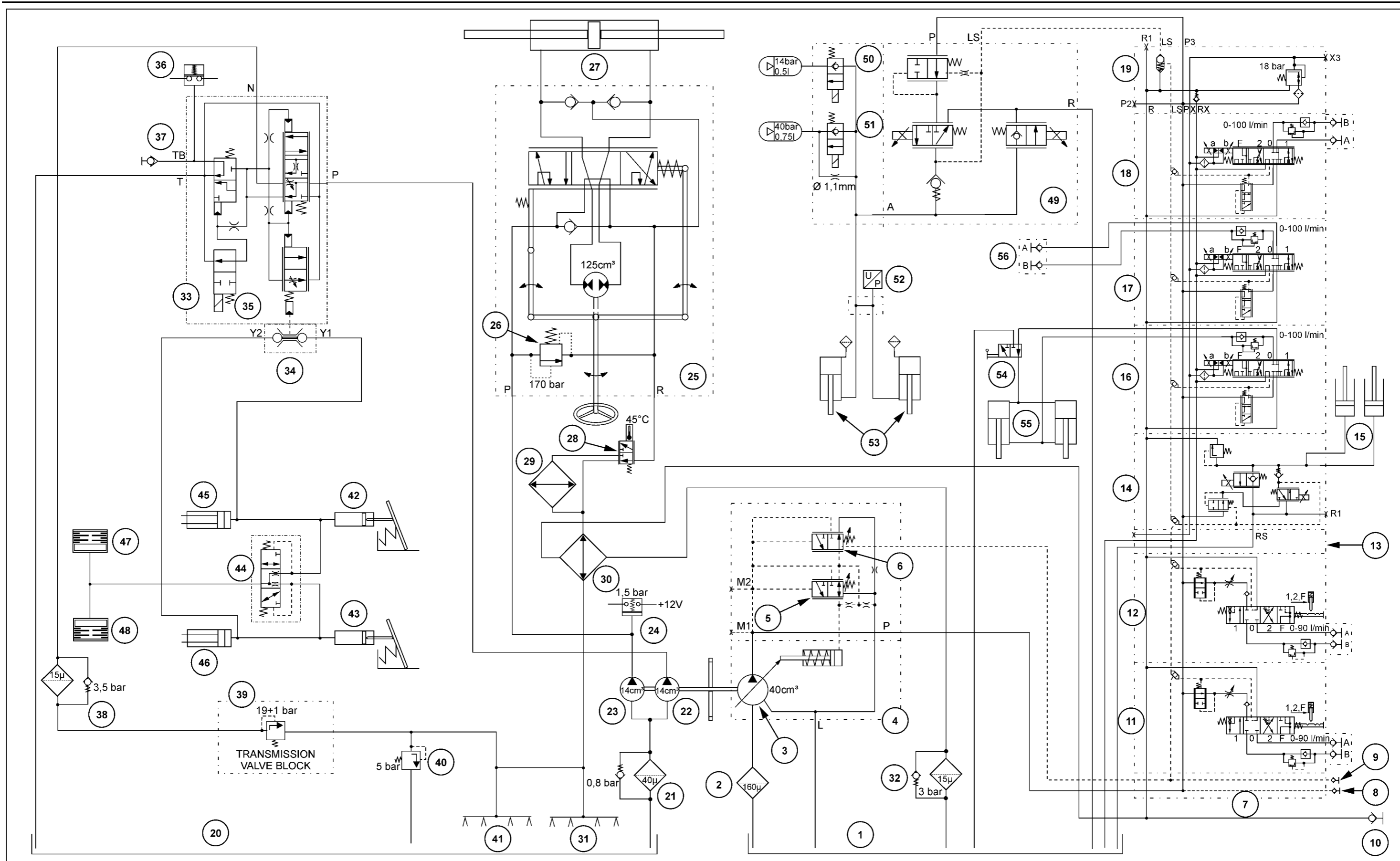

SS13A303 2

## Hydraulic systems - Static description

### High pressure circuit:

1. Hydraulic oil reservoir
2. Suction filter
3. Gear pump for the Open Center Load Sensing (OCLS) system or variable displacement pump for the Closed Center Load Sensing (CCLS) system
4. High pressure feed pipe
5. Remote valve block
6. Oil return pipe
7. Oil return filter
8. Hydraulic lift cylinder
9. Alternative oil return (where fitted)
10. Valve block Electronic Front Hitch (EFH) (where fitted)
11. Front hydraulic lift cylinder (where fitted)
12. Front coupler (where fitted)
13. Front hydraulic lift single or double active valve (without Electronic Front Hitch (EFH))

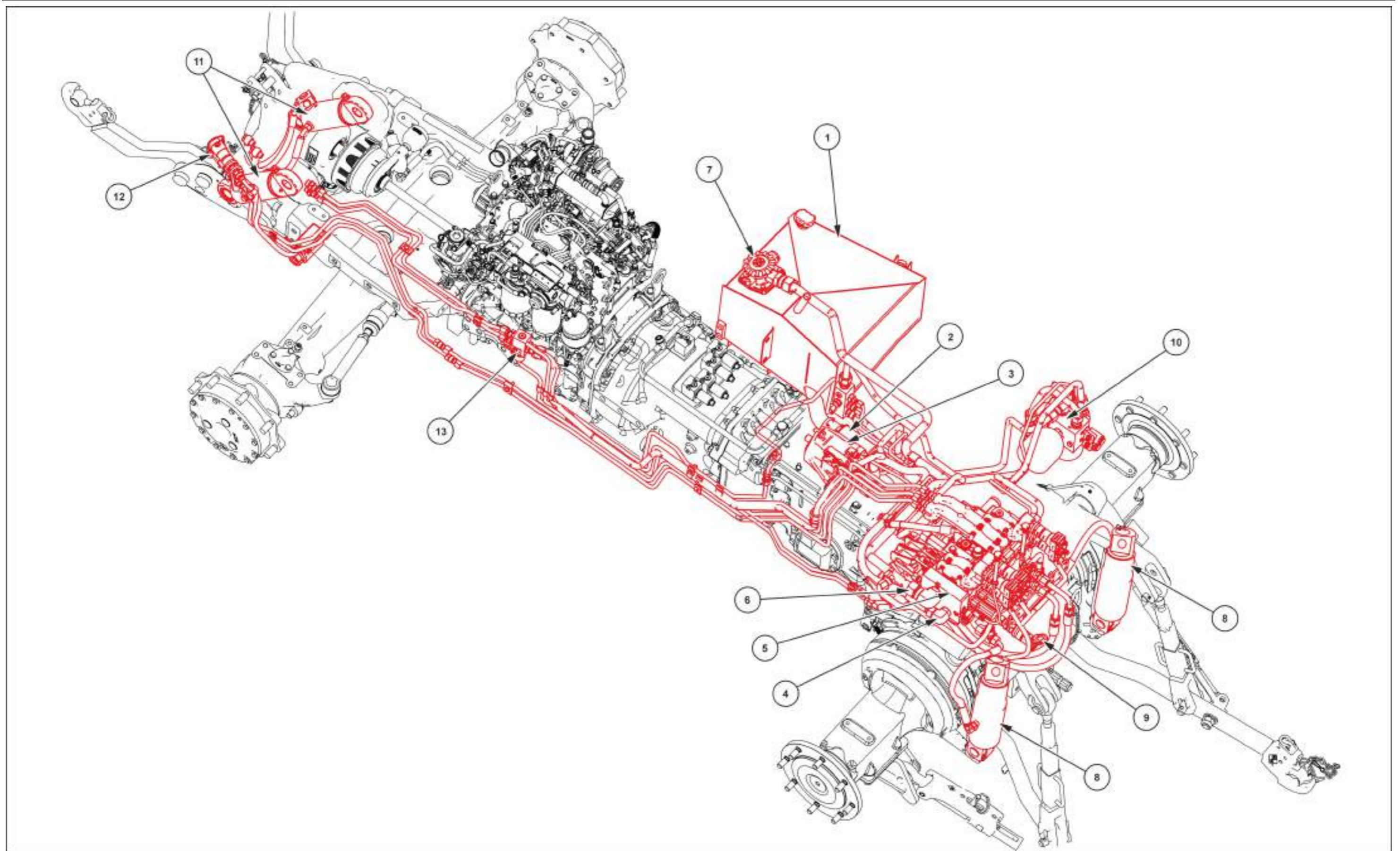

SS13A632 1

**Remote valve block at Open Center Load Sensing (OCLS) system:**

1. Connection plate with three-way oil flow divider
2. Mechanically hydraulic remote valve
3. Flow control adjuster
4. Cast manifold with quick couplers (rear)
5. Mechanically hydraulic remote valve
6. Flow control adjuster
7. Cast manifold with quick couplers (rear)
8. Electronic Draft Control (EDC) valve
9. Mechanically hydraulic remote valve (front-end loader where fitted)
10. Flow control adjuster (where fitted)
11. Cast manifold with quick coupler front (where fitted)
12. Mechanically hydraulic remote valve (front-end loader where fitted)
13. Flow control adjuster (where fitted)
14. Cast manifold with quick coupler front (where fitted)
15. End plate

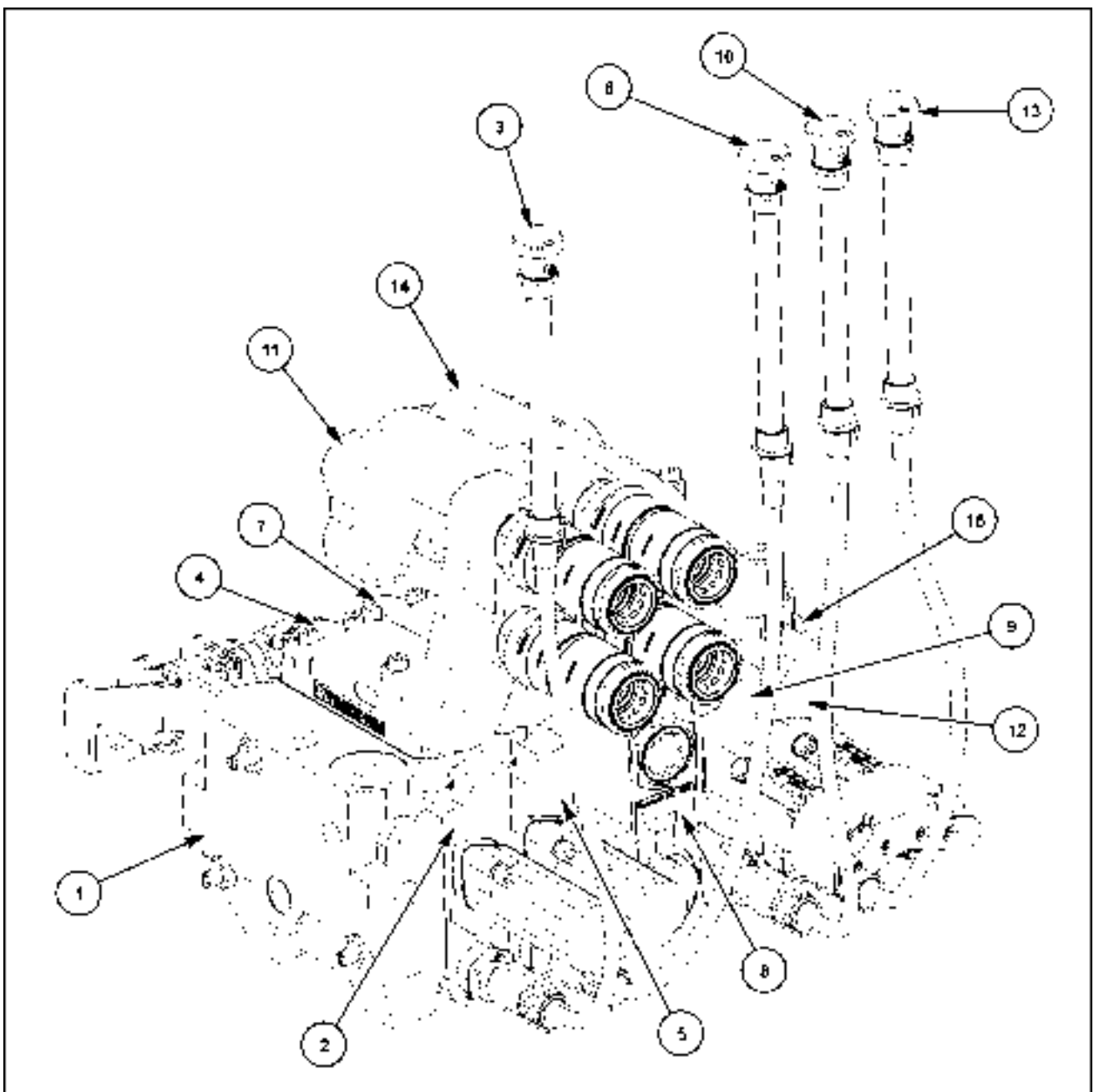

SS13A633 2



**Remote valve block at Closed Center Load Sensing (CCLS) system:**

1. Connection plate
2. Test coupler signal-pressure (LS)
3. Test coupler pump-pressure
4. Mechanically hydraulic remote valve
5. Flow control adjuster
6. Cast manifold with quick couplers (rear)
7. Mechanically hydraulic remote valve
8. Flow control adjuster
9. Cast manifold with quick couplers (rear)
10. Spacer plate
11. Electronic Draft Control (EDC) valve
12. Electro Hydraulic Remote (EHR) valve front 1 (where fitted)
13. Cast manifold (where fitted)
14. Electro Hydraulic Remote (EHR) valve front 2 (where fitted)
15. Cast manifold (where fitted)
16. Electro Hydraulic Remote (EHR) valve rear 3 (where fitted)
17. Cast manifold with quick coupler rear (where fitted)
18. Electro Hydraulic Remote (EHR) valve rear 4 (where fitted)
19. Cast manifold with quick coupler rear (where fitted)
20. End plate with integrated pressure regulating valve for pilot pressure Electro Hydraulic Remote (EHR) valves

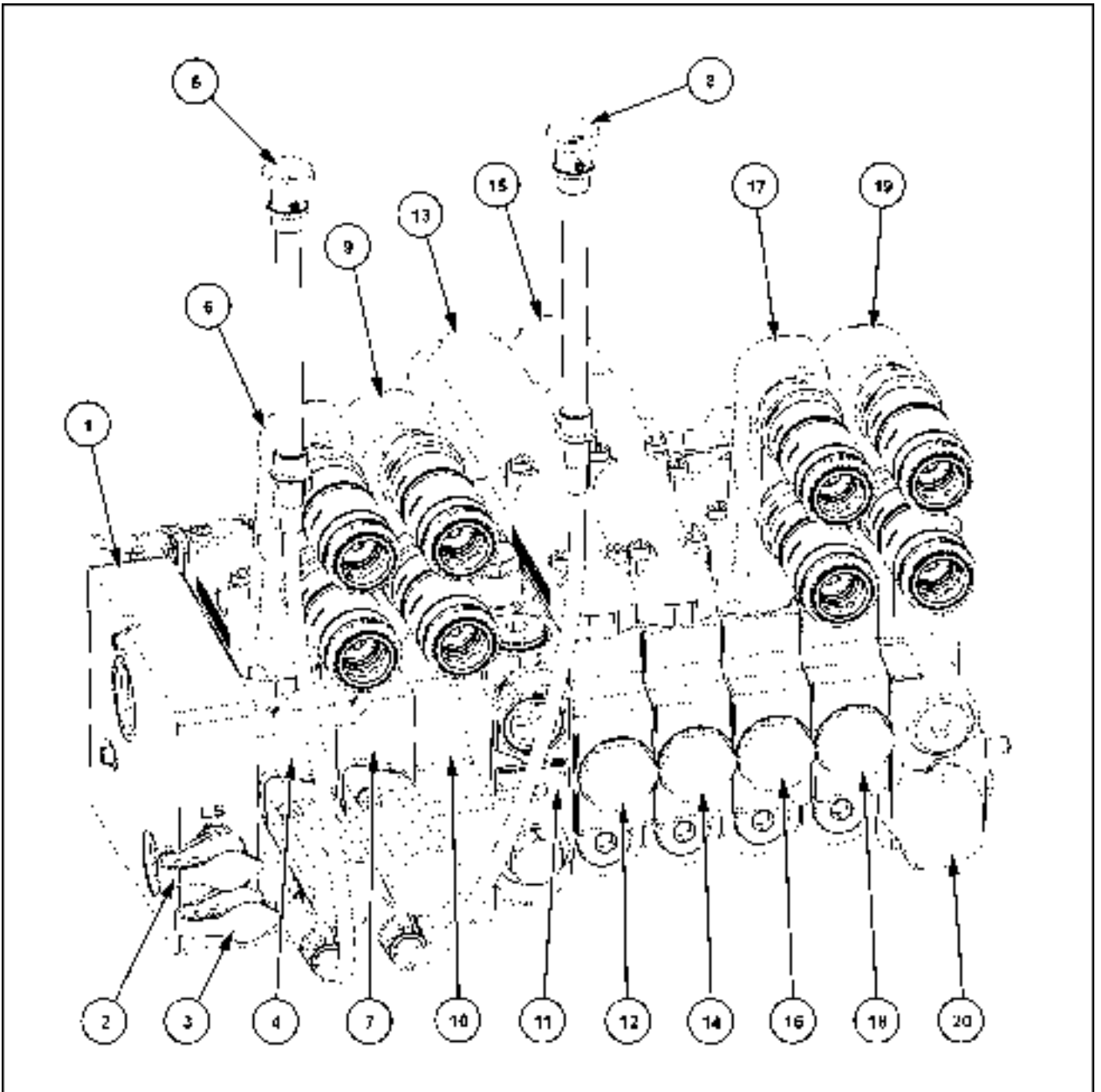

SS13A634 3

**Electronic Front Hitch (EFH) valve block:**

1. Electronic Front Hitch (EFH) valve block
2. Pressure feed
3. Return pipe to hydraulic oil reservoir
4. Load sensing pipe
5. Front hitch raise solenoid valve
6. Front hitch lower solenoid valve
7. Electronic Front Hitch (EFH) control valve
8. Accumulator **14 bar** – Front hitch
9. Accumulator **40 bar** – Front hitch
10. Front hitch solenoid valve – Accumulator **14 bar**
11. Front hitch solenoid valve – Accumulator **40 bar**
12. Pipe to front hitch distributor
13. Distributor block
14. Front hitch pressure sensor
15. Pipes to front hitch cylinder

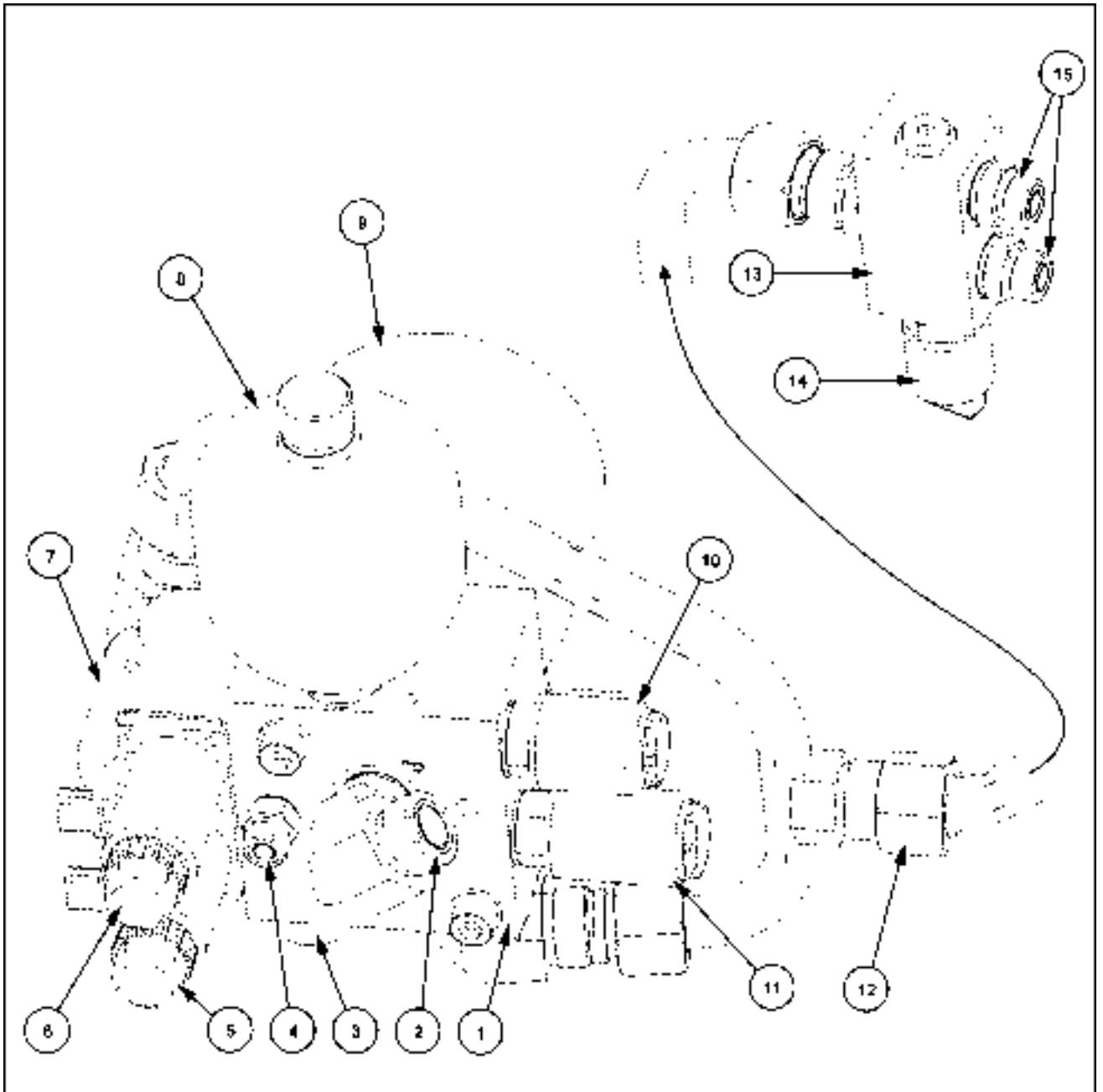

SS13A635 4

## Hydraulic systems - Static description – Transmission, steering

### Steering circuit:

1. Oil reservoir transmission housing
2. Suction filter for tandem gear pump (transmission, steering)
3. Steering pump
4. Steering motor
5. Steering cylinder
6. Thermostat transmission oil cooler
7. Transmission oil cooler
8. Transmission lubrication pipe (blue)



SS13A631 1

**Low pressure circuit:**

1. Oil reservoir transmission housing
2. Suction filter for tandem gear pump (transmission, steering)
3. Transmission hydraulic pump
4. Trailer brake valve France or Italy version (where fitted)
5. Coupler for hydraulic trailer brake
6. Transmission oil filter
7. Transmission clutch solenoid valves
8. Transmission system pressure accumulator
9. Front Power Take-Off (PTO) (where fitted) – see also image 5
10. Front differential lock – see also image 4
11. Rear differential lock – see also image 4
12. Parking brake valve (where fitted) – see also image 4
13. Parking brake cylinder (where fitted)

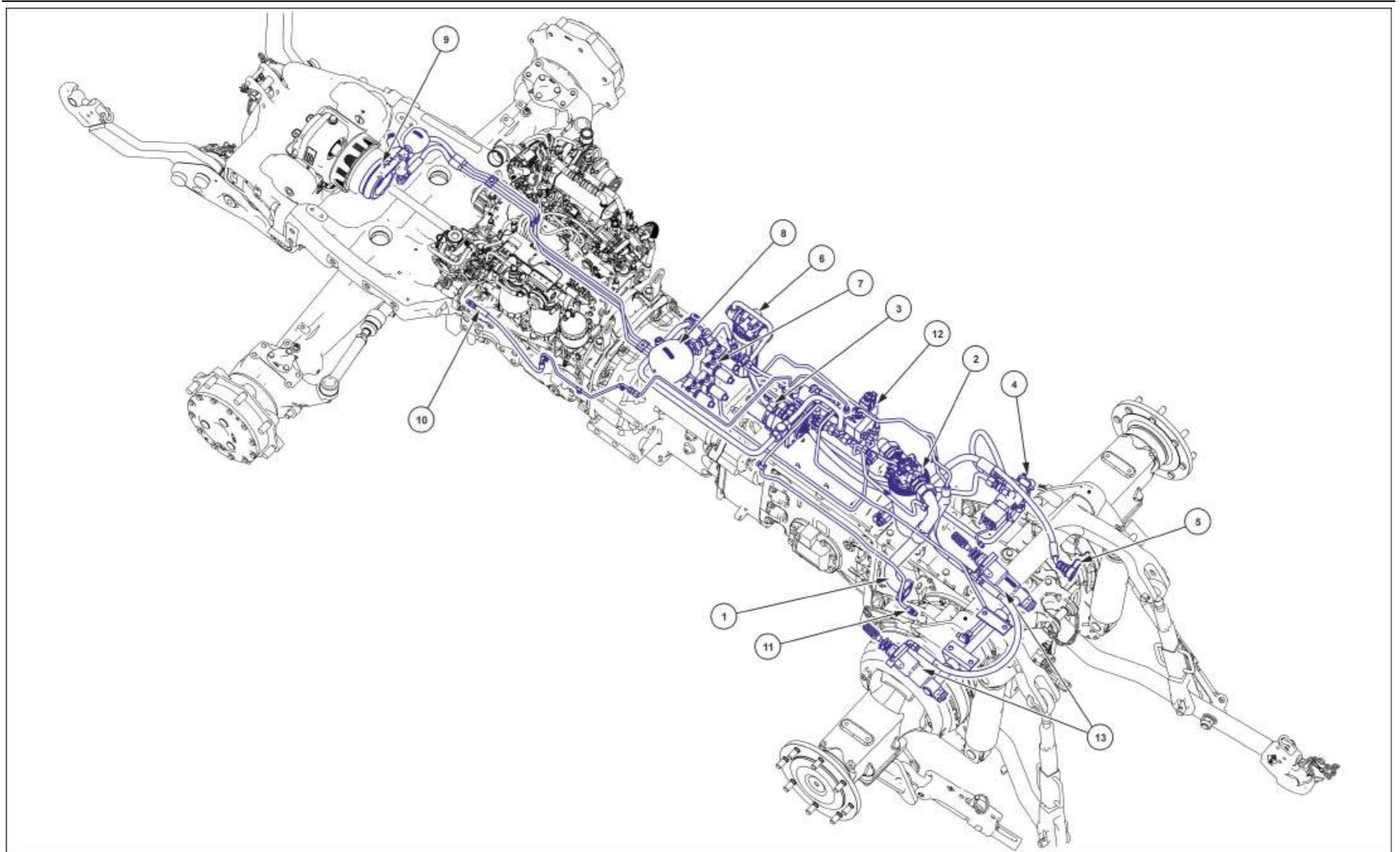

SS13A636 2



**Low pressure circuit:**

1. Suction filter for tandem gear pump (transmission, steering)
2. Transmission hydraulic pump
3. Transmission oil filter
4. Transmission system pressure regulating valve **19 - 20 bar (276 - 290 psi)**
5. Transmission system pressure accumulator
6. Clutch (A) solenoid valve
7. Clutch (C) solenoid valve
8. Clutch (B) solenoid valve
9. Clutch (D) solenoid valve
10. Clutch (F) solenoid valve
11. Clutch (G) solenoid valve
12. Rear Power Take-Off (PTO) solenoid valve
13. Four-Wheel Drive (4WD) solenoid valve
14. Front and rear differential lock solenoid valve
15. Lubrication oil from steering circuit
16. Lubrication oil from transmission oil circuit

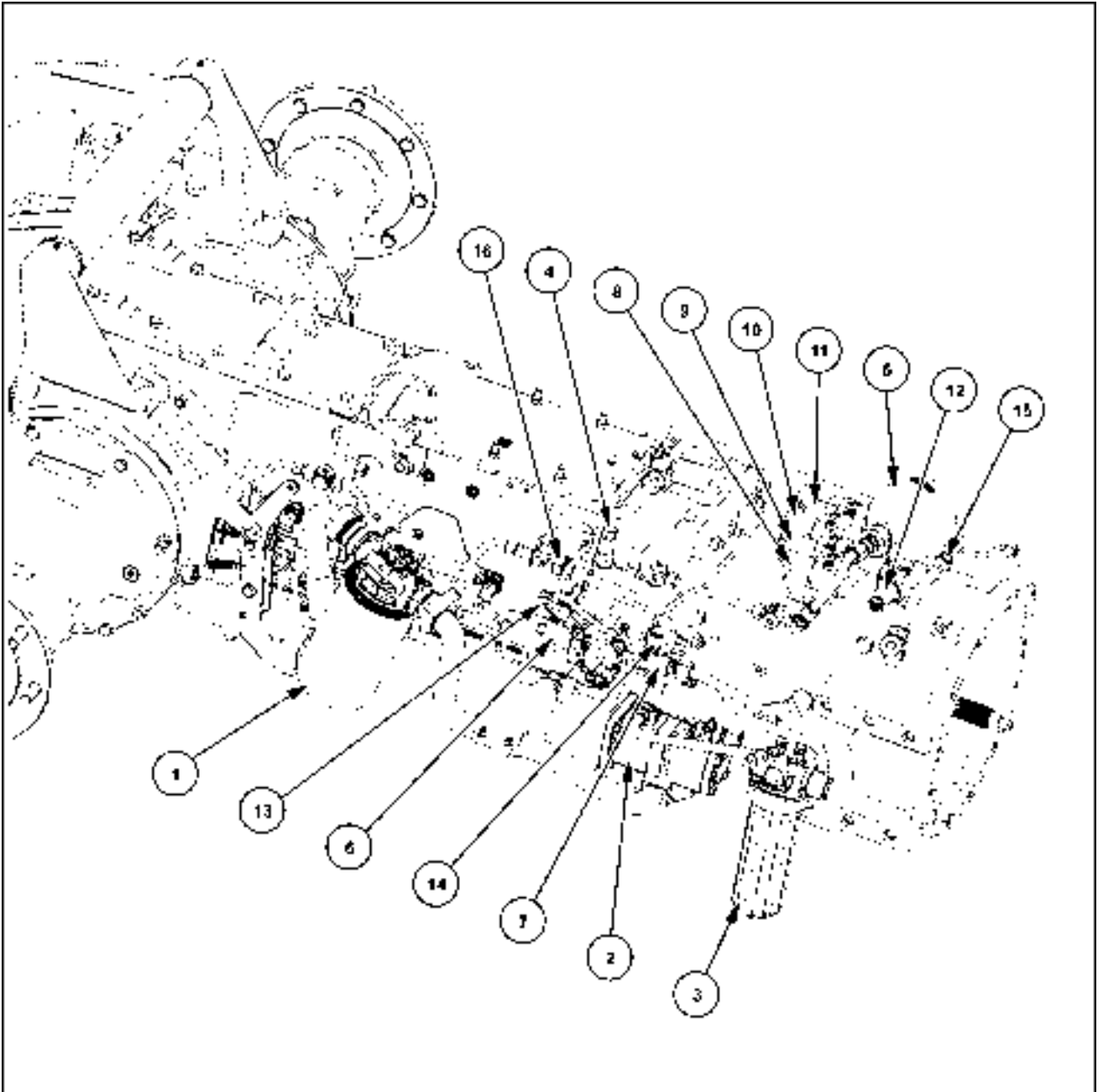

SS13A637 3

**Low pressure circuit parking brake and differential lock front axle (where fitted):**

1. Transmission system-pressure supply **19 - 20 bar (276 - 290 psi)**
2. Transmission system-pressure accumulator
3. Connecting plate
4. Oil return to the transmission housing
5. Parking brake solenoid valve
6. Front differential lock solenoid valve
7. Pipe to the front differential lock
8. Parking brake cylinder right-hand side
9. Parking brake cylinder left-hand side

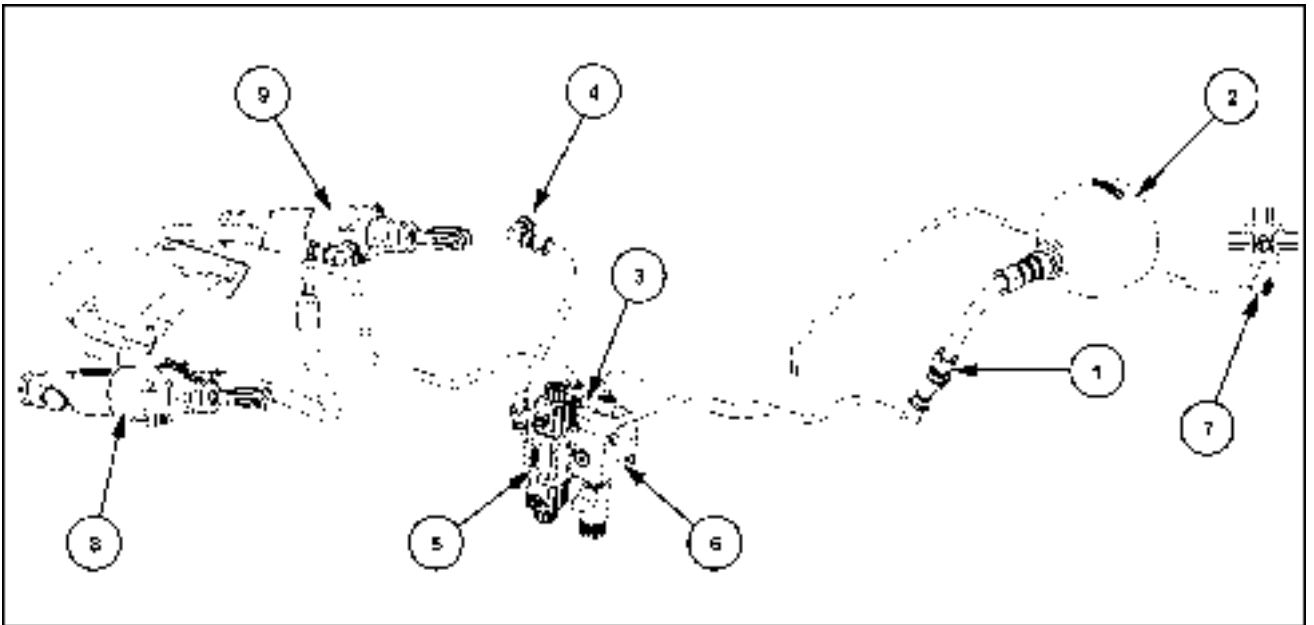

SS13A638 4

**Low pressure circuit front PTO (where fitted):**

1. Transmission system-pressure supply **19 - 20 bar (276 - 290 psi)**
2. Oil return to the transmission housing
3. Front Power Take-Off (PTO) solenoid valve
4. Front Power Take-Off (PTO) clutch accumulator
5. Front Power Take-Off (PTO) clutch

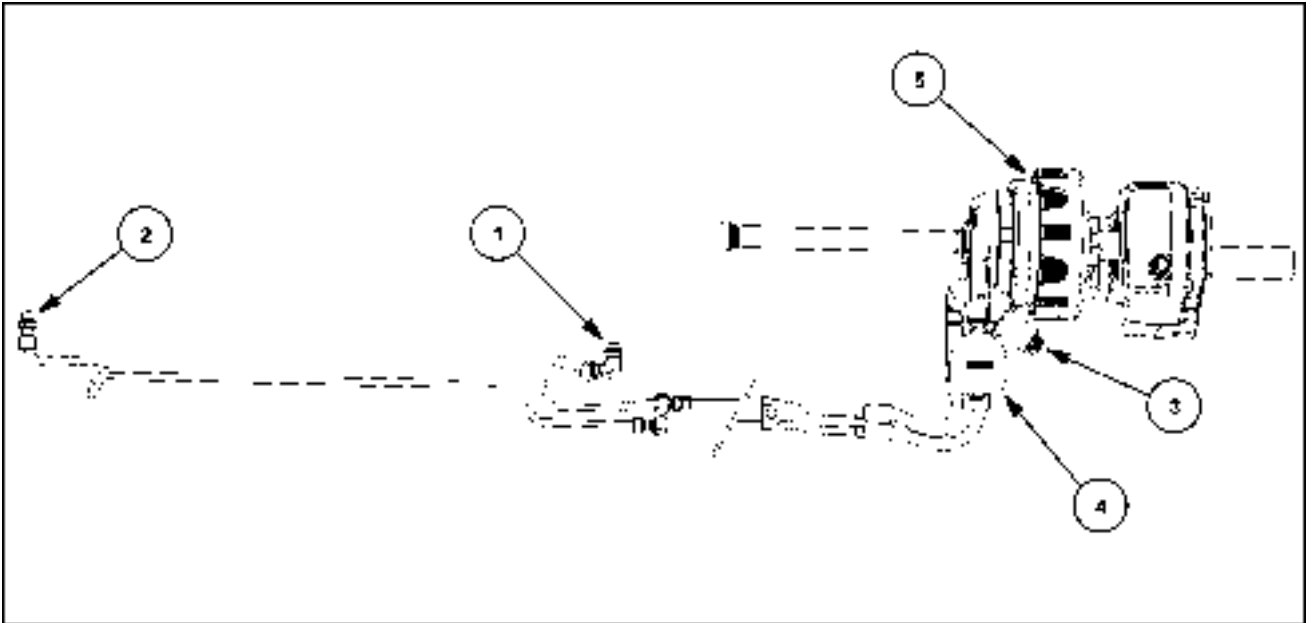

SS13A639 5

# Index

---

## Hydraulic systems - 35

### Hydraulic systems - 000

Hydraulic systems - Static description .....	24
Hydraulic systems - Dynamic description – Closed center load sensing (CCLS) hydraulic system .....	4
Hydraulic systems - Dynamic description – Open center load sensing (OCLS) hydraulic system .....	12
Hydraulic systems - General specification .....	3
Hydraulic systems - Hydraulic schema .....	20
Hydraulic systems - Static description – Transmission, steering .....	32



## **Hydraulic systems - 35**

### **Reservoir, cooler, and filters - 300**

**Farmall 105U Pro EP  
Farmall 115U Pro EP  
Farmall 95U Pro EP**



# Contents

---

## Hydraulic systems - 35

### Reservoir, cooler, and filters - 300

#### TECHNICAL DATA

Oil reservoir	
General specification .....	3
Oil filters	
General specification – suction filter .....	4
General specification - Suction filter (transmission, steering) .....	4
General specification - Pressure filter (transmission, steering) .....	4
Oil return filter	
General specification .....	5

#### SERVICE

Oil reservoir	
Remove .....	6
Install .....	9

## Oil reservoir - General specification

Design	Weldment with wash plates
Level bar	Sight glass
Tank capacity (sight glass max.)	<b>44 l (12 US gal)</b>
Tank capacity (sight glass min.)	<b>28 l (7.4 US gal)</b>
Oil quantity that can be removed (on a flat road and min. oil level)	<b>20 l (5.3 US gal)</b>
Oil quantity that can be removed (on a flat road and max. oil level)	<b>36 l (9.5 US gal)</b>
Fill medium	<b>Consumables Lubrications and Coolants ()</b>

## Oil filters - General specification – suction filter

Position	After the hydraulic oil tank
Filtration efficiency	160 $\mu\text{m}$
Direction of flow	Identification with arrow
Maximum flow rate	<b>100 l/min (26 US gpm)</b>
Operating temperature	<b>-20 - 107 °C (-4.0 - 225 °F)</b>

## Oil filters - General specification - Suction filter (transmission, steering)

Call out reference	In the suction pipe to the tandem pump
Filtration efficiency in accordance with ISO 16889	$\beta_{42\mu\text{m}} \geq 200$
Filter bypass valve opens at	<b>0.8 bar (12 psi)</b>
Direction of flow	From outside to inside
Operating temperature	<b>-30 - 120 °C (-22 - 248 °F)</b>

## Oil filters - General specification - Pressure filter (transmission, steering)

Call out reference	Before the transmission input
Direction of flow (identification with triangles)	At the input and output
Filtration efficiency in accordance with ISO 16889	$\beta_{15\mu\text{m}} \geq 200$
Filter bypass valve opens at	<b>3.5 bar (51 psi)</b>
Maximum operating pressure	<b>50 bar (725 psi)</b>
Operating temperature	<b>-30 - 100 °C (-22 - 212 °F)</b>

## Oil return filter - General specification

Position	In hydraulic oil tank
Filtration efficiency in accordance with ISO 16889	$\beta_{15\mu\text{m}} \geq 200$
Filter bypass valve opens at	<b>3 bar (44 psi)</b>
Maximum operating pressure	<b>10 bar (145 psi)</b>
Operating temperature	<b>-30 - 100 °C (-22 - 212 °F)</b>
Cover torque	<b>15 Nm (11 lb ft)</b>

## Oil reservoir - Remove

### Prior operation:

Remove the rear wheels. See **Rear wheels - Remove (44.520)**

**NOTICE:** Avoid open pipes or hoses to be sure that they are free of debris.

1. Remove the four bolts (1).
2. Remove the steps on the right-hand side.

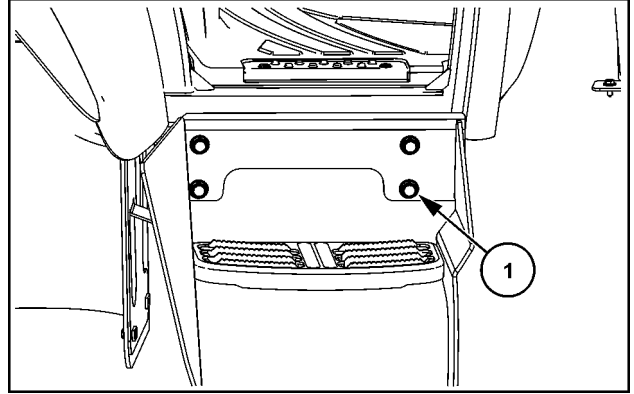

SS13K074 1

3. Remove the drain plug (1) and completely drain all oil into a suitable container. Dispose of the oil properly.

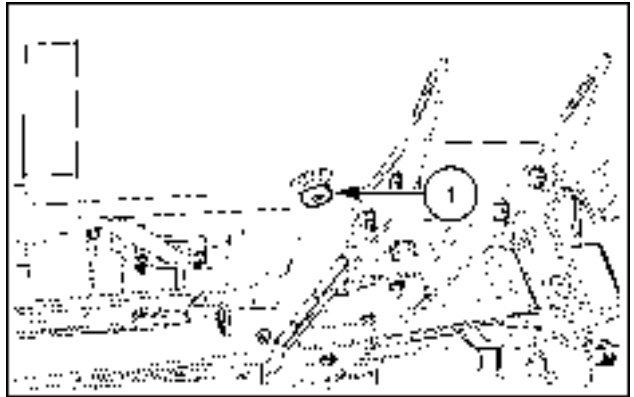

SVIL13TR00078AB 2

4. Remove the hydraulic pipes (1), (2) and (3).

**NOTE:** The hydraulic pipe (2) is only obstructed if the option variable displacement pump is fitted.  
The hydraulic pipe (3) is only obstructed if the option Electronic Front Hitch (EFH) is fitted.

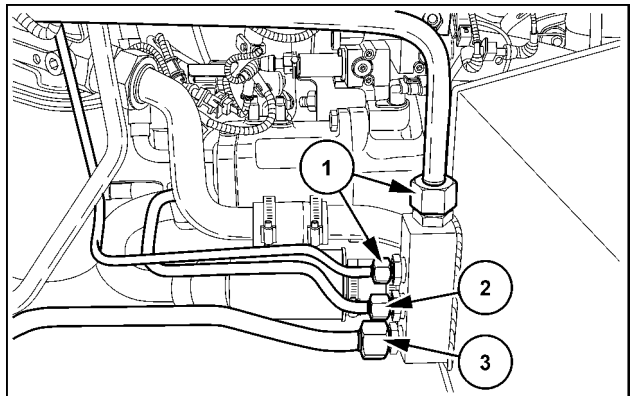

SVIL13TR00899AB 3

5. Remove the return pipe (1).

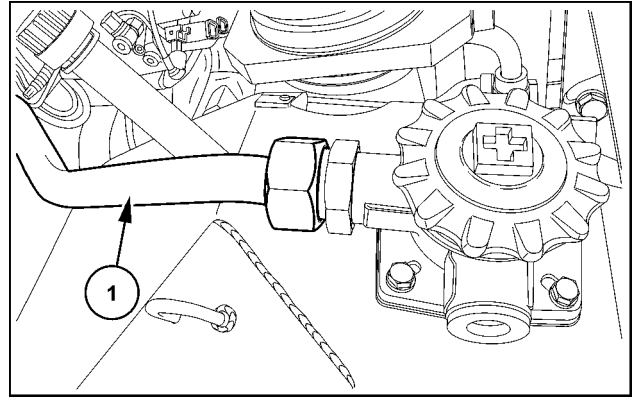

SVIL13TR00900AB 4

6. Remove the bolts (1).  
7. Remove the wheel chock (2).

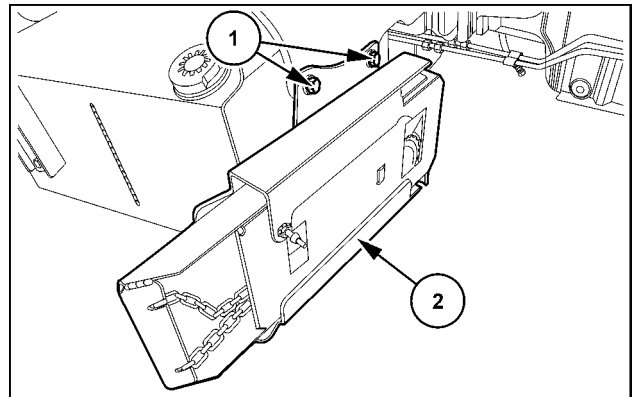

SVIL13TR00902AB 5

8. Remove the four bolts (1).

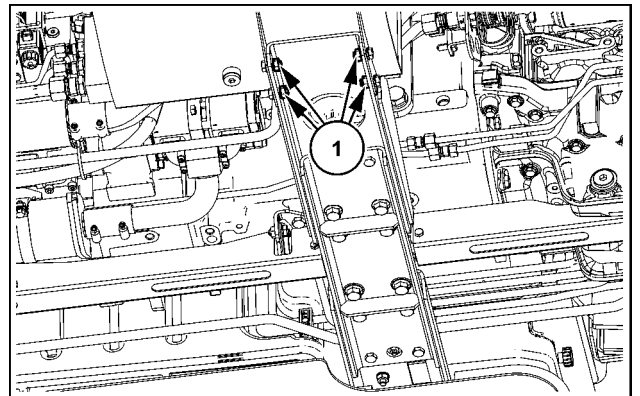

SS13K030 6

9. Open the hose clamps (1). Put a suitable container under the suction filter (2).  
10. Remove the suction filter (2).

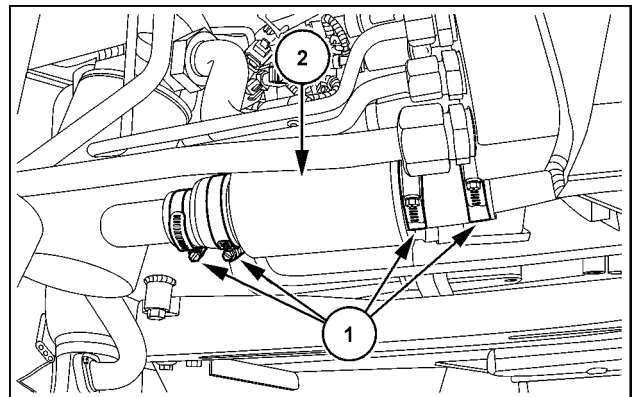

SVIL13TR00086AB 7

11. Remove the two bolts (1) on the back side of the hydraulic oil reservoir.

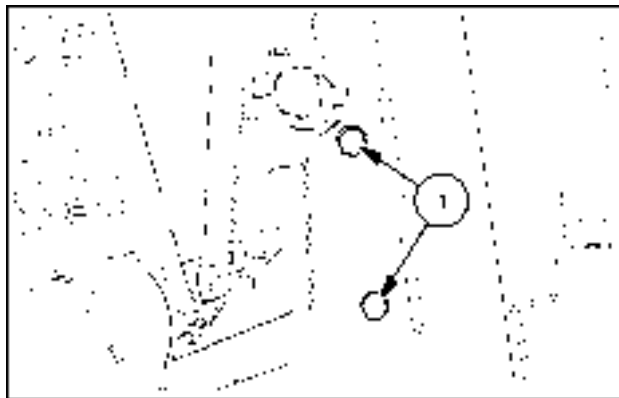

SVIL13TR00901AB 8

12. **⚠ WARNING**

**Heavy objects!**

Lift and handle all heavy components using lifting equipment with adequate capacity. Always support units or parts with suitable slings or hooks. Make sure the work area is clear of all bystanders.

Failure to comply could result in death or serious injury.

W0398A

Remove the hydraulic oil reservoir (1) with a jack. If the cab is removed you can also use a crane.

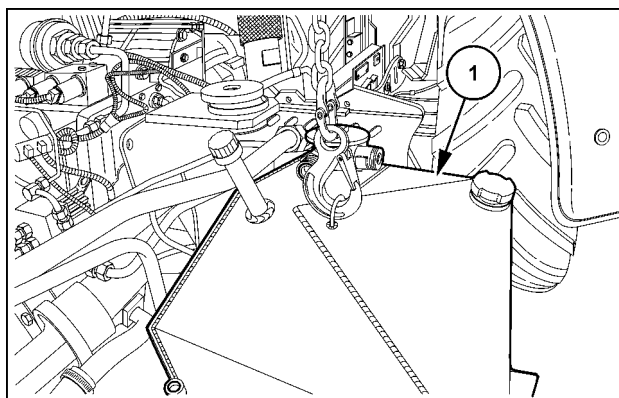

SVIL13TR00903AB 9

**Next operation:**

Install the hydraulic oil reservoir. See **Oil reservoir - Install (35.300)**.

## Oil reservoir - Install

### Prior operation:

Remove the hydraulic oil reservoir. See **Oil reservoir - Remove (35.300)**.

### 1. **⚠ WARNING**

#### Heavy objects!

Lift and handle all heavy components using lifting equipment with adequate capacity. Always support units or parts with suitable slings or hooks. Make sure the work area is clear of all bystanders.

Failure to comply could result in death or serious injury.

W0398A

Install the hydraulic oil reservoir (1) with a crane or a jack.

### 2. Install the two bolts (1) on the back side of the hydraulic oil reservoir.

### 3. Install the return pipe (1).

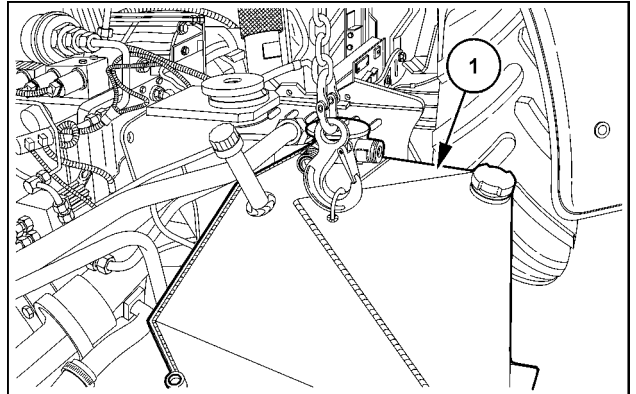

SVIL13TR00903AB 1

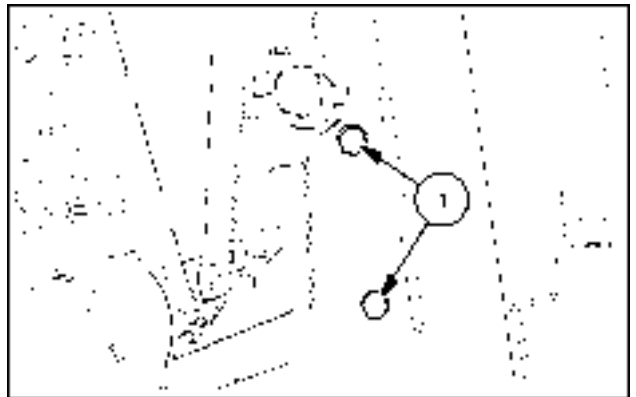

SVIL13TR00901AB 2

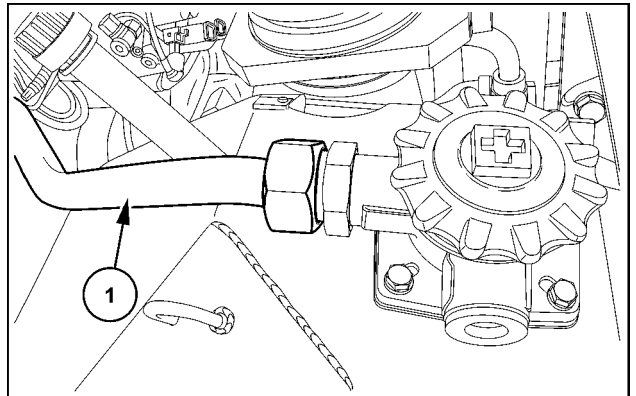

SVIL13TR00900AB 3



4. Install the hydraulic pipes (1), (2) and (3).

**NOTE:** The hydraulic pipe (2) is only obstructed if the option variable displacement pump is fitted.  
The hydraulic pipe (3) is only obstructed if the option Electronic Front Hitch (EFH) is fitted.

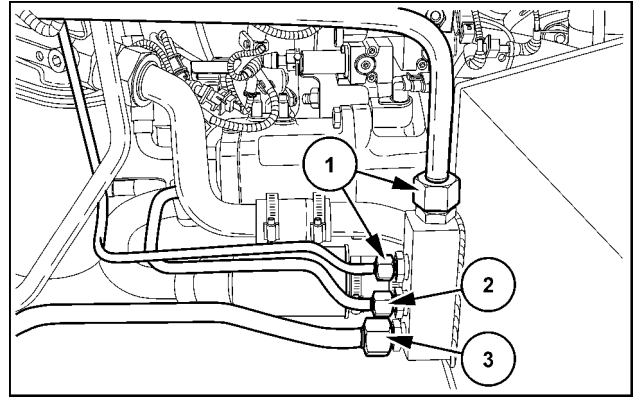

SVIL13TR00899AB 4

5. Install the four bolts (1).

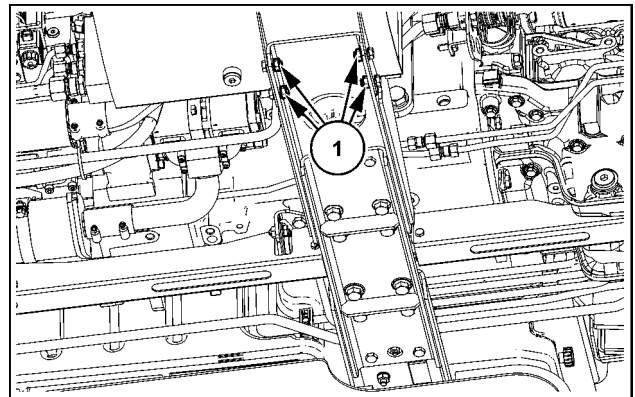

SS13K030 5

6. Install the suction filter (2). Tighten the hose clamps (1).

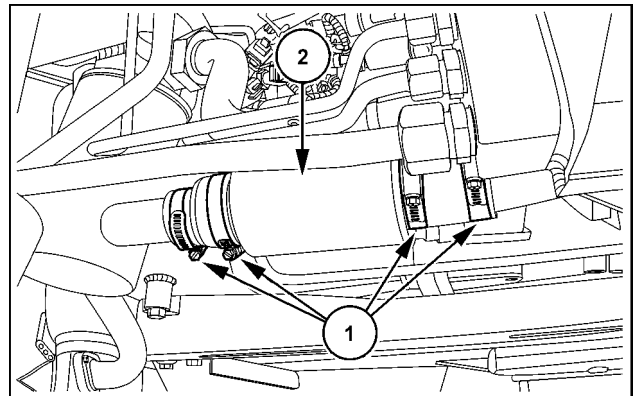

SVIL13TR00086AB 6

7. Install the wheel chock (2).

8. Install the bolts (1).

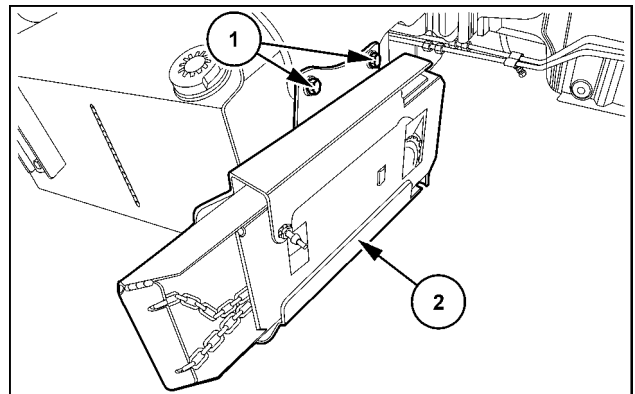

SVIL13TR00902AB 7

9. Install the steps on the right-hand side.
10. Install the four bolts (1).

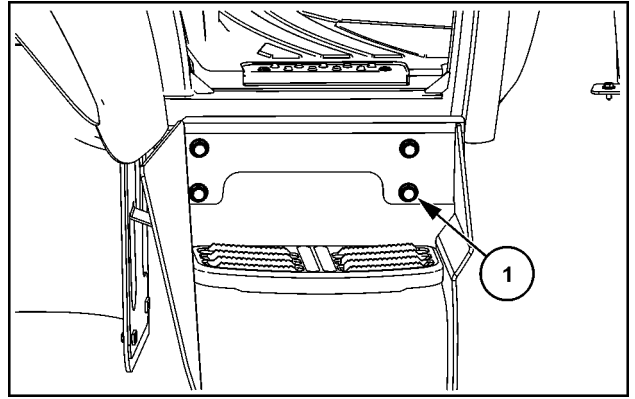

SS13K074 8

11. Fill in the hydraulic oil. For the correct specification see **Consumables Lubrications and Coolants ( )**.

**Next operation:**

Install the rear wheels. See **Rear wheels - Install (44.520)**.

# Index

---

## Hydraulic systems - 35

### Reservoir, cooler, and filters - 300

Oil filters - General specification - Pressure filter (transmission, steering) .....	4
Oil filters - General specification - Suction filter (transmission, steering) .....	4
Oil filters - General specification – suction filter .....	4
Oil reservoir - General specification .....	3
Oil reservoir - Install .....	9
Oil reservoir - Remove .....	6
Oil return filter - General specification .....	5



## **Hydraulic systems - 35**

### **Fixed displacement pump - 104**

**Farmall 105U Pro EP  
Farmall 115U Pro EP  
Farmall 95U Pro EP**

# Contents

---

## Hydraulic systems - 35

### Fixed displacement pump - 104

#### TECHNICAL DATA

##### Pump

Gear pump - General specification .....	3
Tandem gear pump - General specification - Transmission, steering .....	3

#### SERVICE

##### Pump

Gear pump - Remove .....	4
Gear pump - Install .....	6
Tandem gear pump - Remove .....	8
Tandem gear pump - Install .....	10

## Pump Gear pump - General specification

Design	Gear pump
Supplier	Bosch Rexroth
Displacement per revolution (V)	<b>22.5 cm<sup>3</sup> (1.37 in<sup>3</sup>)</b>
Maximum flow rate	<b>60 l/min (16 US gpm)</b>
Direction of rotation (viewed toward drive shaft)	right hand
Pump rated speed (at engine speed of <b>2200 RPM</b> ) (n)	<b>2763 RPM</b>
Maximum speed	<b>3000 RPM</b>
rated engine speed (n)	<b>2200 RPM</b>
Engine ratio: pump (i)	1:256

## Pump Tandem gear pump - General specification - Transmission, steering

Design	Tandem gear pump
Supplier	Bosch Rexroth
Displacement of steering pump per revolution (V)	<b>14 cm<sup>3</sup> (0.85 in<sup>3</sup>)</b>
Displacement of transmission pump per revolution (V)	<b>14 cm<sup>3</sup> (0.85 in<sup>3</sup>)</b>
Maximum flow rate (steering pump)	<b>35 l/min (9.2 US gpm)</b>
Maximum flow rate (transmission pump)	<b>35 l/min (9.2 US gpm)</b>
Direction of rotation (viewed toward drive shaft)	left hand
Pump rated speed (at engine speed of <b>2200 RPM</b> ) (n)	<b>2763 RPM</b>
Maximum speed	<b>3000 RPM</b>
rated engine speed (n)	<b>2200 RPM</b>
Engine ratio: pump (i)	1:256

## Pump Gear pump - Remove

### Prior operation:

Remove the right-hand rear wheel. See **Rear wheels - Remove (44.520)**.

**NOTICE:** Avoid open pipes or hoses to be sure that they are free of debris.

1. Remove the drain plug (1) and completely drain all hydraulic oil into a suitable container. Dispose of the oil properly.

**NOTE:** Be sure that the three-point hitch is lowered.

2. Re-install the drain plug (1) with a new ring seal.

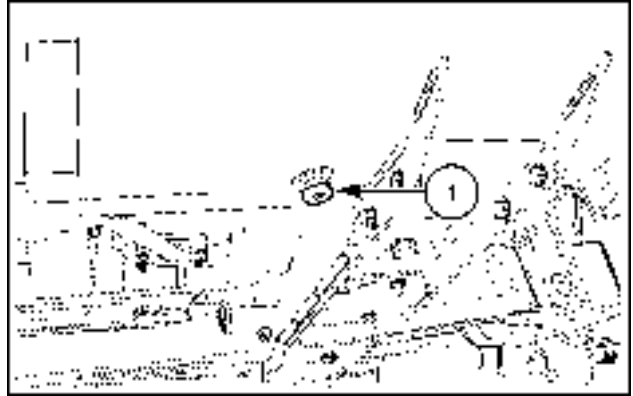

SVIL13TR00078AB 1

3. Open the hose clamp (1).

**NOTE:** Put a suitable container under the suction filter.

4. Remove the four bolts (2).
5. Remove the suction pipe (with filter) (3).

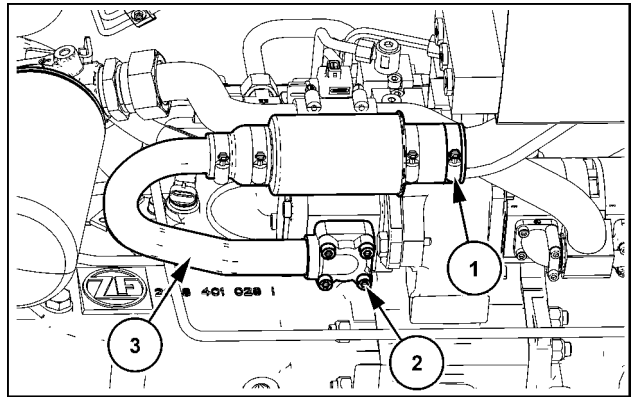

SS13N033 2

6. Remove the pressure hose (1).

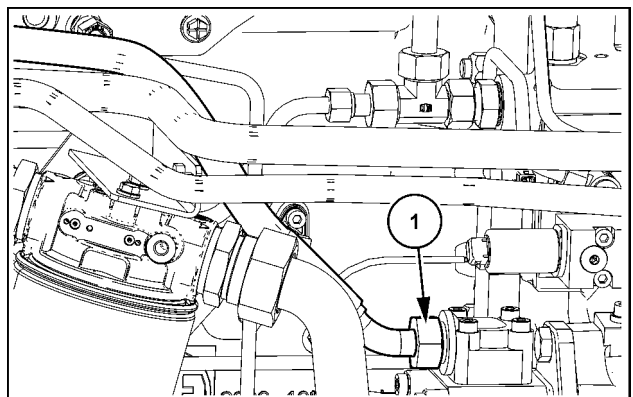

SS13N034 3

7. Remove the two bolts (1).
8. Remove the fixed displacement pump (2).

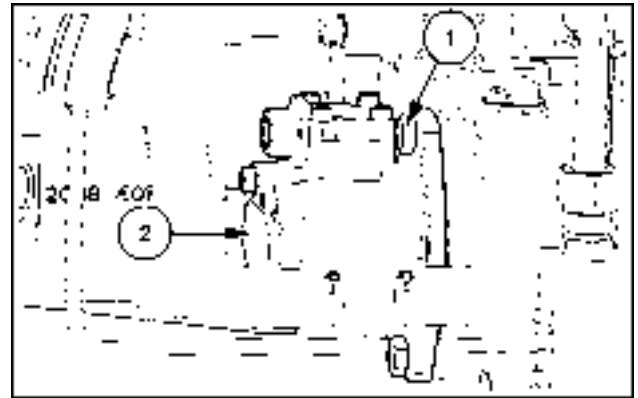

SS13N037 4

9. Remove the four bolts (1).
10. Remove the pressure connection (2).

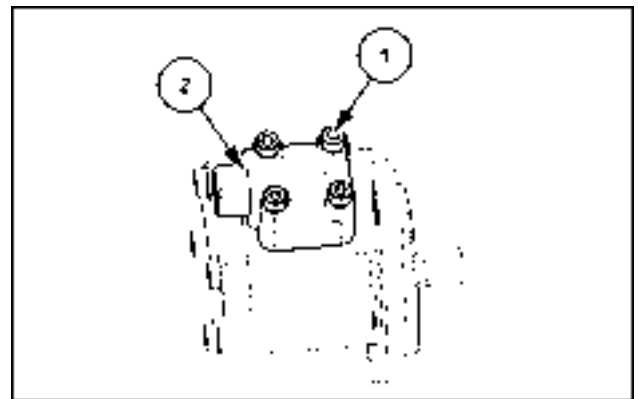

SS13N036 5

**Next operation:**

Install the fixed displacement pump. See **Pump Gear pump - Install (35.104)**.



## Pump Gear pump - Install

### Prior operation:

Remove the fixed displacement pump. See **Pump Gear pump - Remove (35.104)**.

1. Install the pressure connection (2) with a new ring seal.
2. Install the four bolts (1).  
Tighten the bolts with **10 - 13 Nm (7 - 10 lb ft)**.

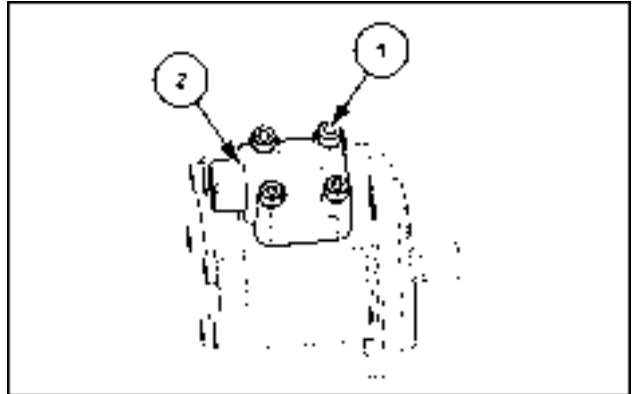

SS13N036 1

3. Install the fixed displacement pump (2) with a new ring seal.
4. Install the two bolts (1).

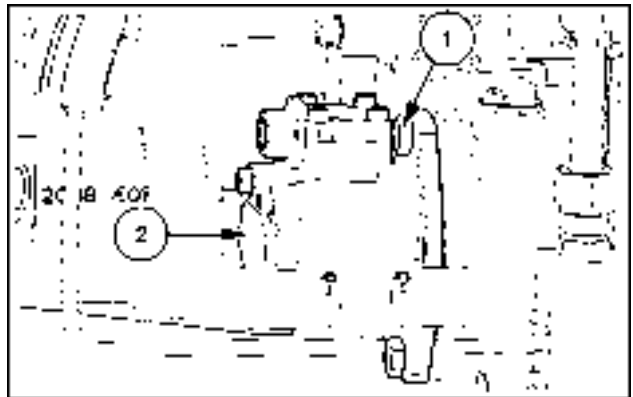

SS13N037 2

5. Install the pressure hose (1).

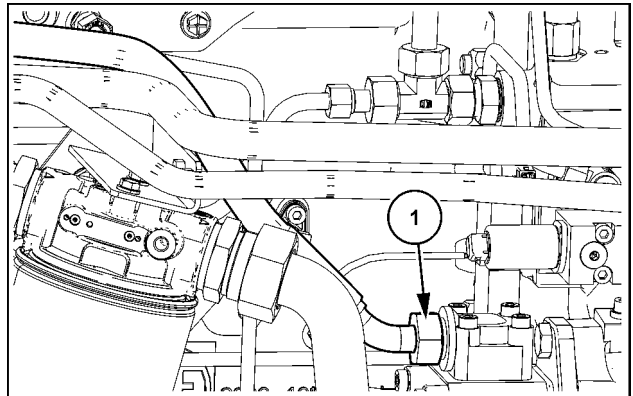

SS13N034 3

6. Install the suction pipe (with filter) **(3)** and a new ring seal.
7. Install the four bolts **(2)**.  
Tighten the bolts with **10 - 13 Nm (7 - 10 lb ft)**.
8. Tighten the hose clamp **(1)**.

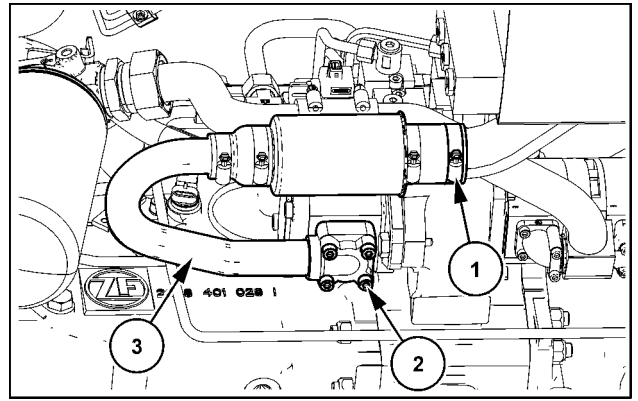

SS13N033 4

9. Fill in the hydraulic oil. For the correct specification see **Consumables Lubrications and Coolants ()**.

**Next operation:**

Install the right-hand rear wheel. See **Rear wheels - Install (44.520)**.

## Pump Tandem gear pump - Remove

### Prior operation:

Remove the hydraulic oil reservoir. See **Oil reservoir - Remove (35.300)**.

**NOTE:** It is not necessary to drain the transmission oil, when removing the tandem gear pump.

**NOTICE:** Avoid open pipes or hoses to be sure that they are free of debris.

1. Put a suitable container under the tandem gear pump.
2. Open the clamps (2) on the suction pipe.

**NOTE:** Depending on the day of manufacturing the suction pipe has a variety installation. See image 1 or image 2.

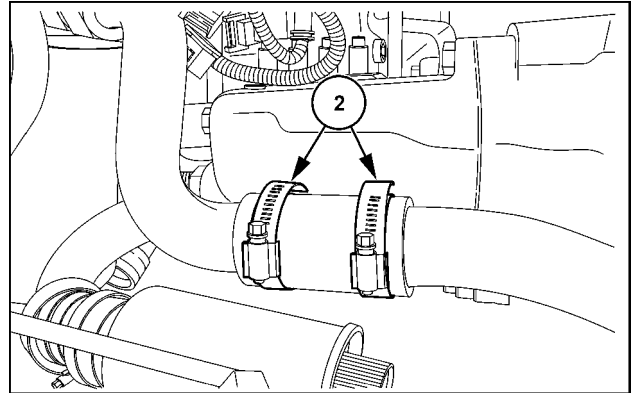

SVIL13TR00910AB 1

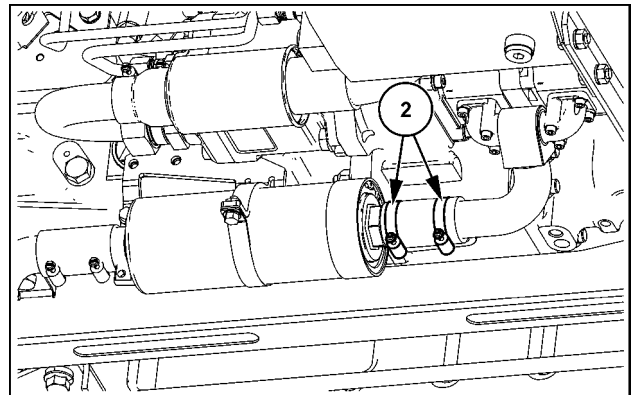

SS13M024 2

3. Open the pressure pipes (3).
4. Remove the four bolts (4).
5. Remove the tandem gear pump with the suction pipe.

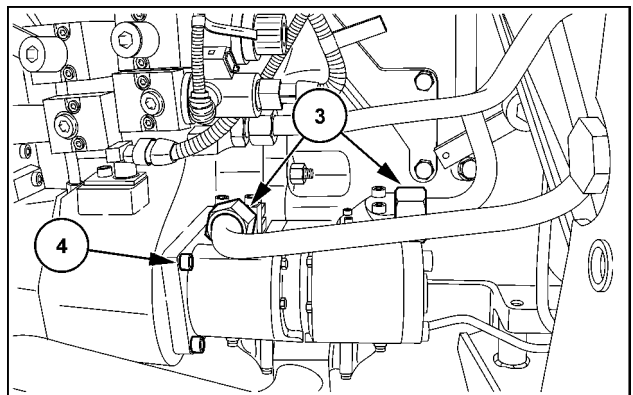

SVIL13TR00909AB 3

6. Remove the eight bolts (5).
7. Remove the suction pipe (6).

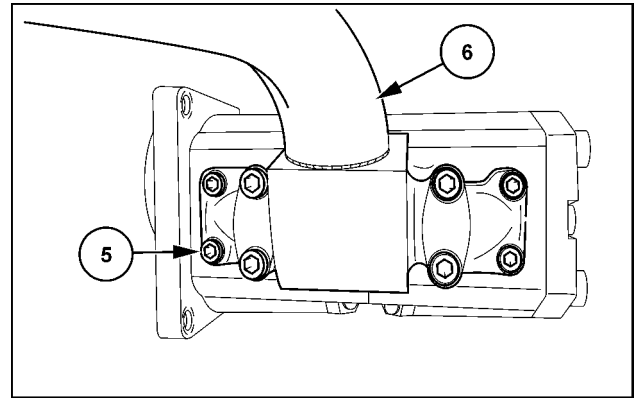

SVIL13TR00911AB 4

8. Remove the eight bolts (7).
9. Remove the two pressure connections (8).

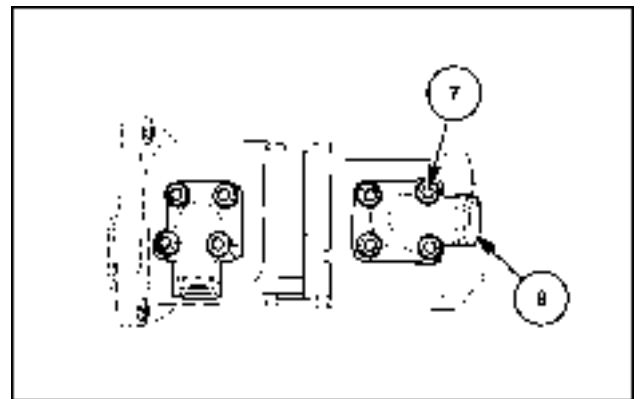

SVIL13TR00943AB 5

**Next operation:**

Install the tandem gear pump. See **Pump Tandem gear pump - Install (35.104)**.

## Pump Tandem gear pump - Install

### Prior operation:

Remove the tandem gear pump. See **Pump Tandem gear pump - Remove (35.104)**.

1. Install the two pressure connections (8) with new ring seals.
2. Install the eight bolts (7).  
Tighten the bolts with **10 - 13 Nm (7 - 10 lb ft)**.

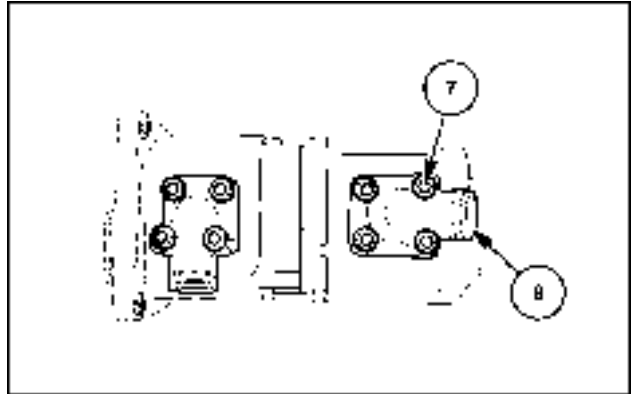

SVIL13TR00943AB 1

3. Install the suction pipe (6) with two new ring seals.
4. Install the eight bolts (5).  
Tighten the bolts with **10 - 13 Nm (7 - 10 lb ft)**.

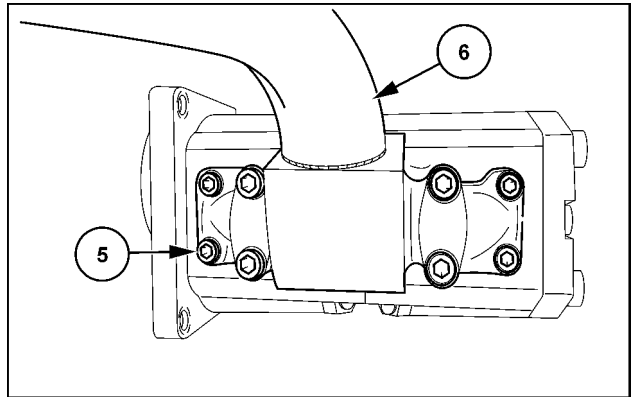

SVIL13TR00911AB 2

5. Install the tandem gear pump with the suction pipe and a new ring seal.
6. Install the four bolts (4).
7. Install the pressure pipes (3).

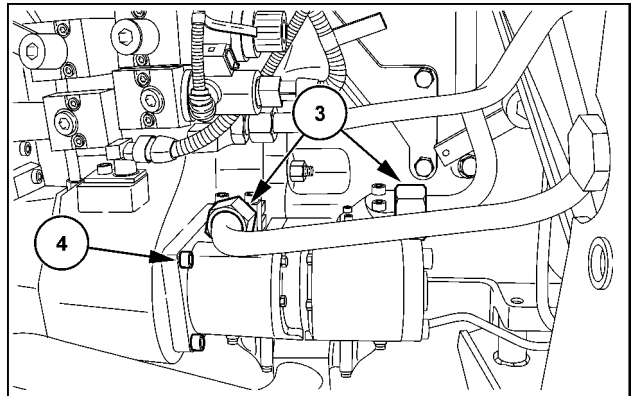

SVIL13TR00909AB 3

8. Tighten the clamp on the suction pipe.

**NOTE:** Top up the transmission oil after the first start of the engine. For the correct specification see **Consumables Lubrications and Coolants ()**.

### Next operation:

Install the hydraulic oil reservoir. See **Oil reservoir - Install (35.300)**.

# Index

---

## Hydraulic systems - 35

### Fixed displacement pump - 104

Pump Gear pump - General specification .....	3
Pump Gear pump - Install .....	6
Pump Gear pump - Remove .....	4
Pump Tandem gear pump - General specification - Transmission, steering .....	3
Pump Tandem gear pump - Install .....	10
Pump Tandem gear pump - Remove .....	8





## **Hydraulic systems - 35**

### **Variable displacement pump - 106**

**Farmall 105U Pro EP  
Farmall 115U Pro EP  
Farmall 95U Pro EP**



# Contents

---

## Hydraulic systems - 35

### Variable displacement pump - 106

#### TECHNICAL DATA

##### Pump

General specification ..... 3

##### Pump compensator

General specification ..... 4

#### SERVICE

##### Variable displacement pump

Remove ..... 5

Install ..... 7

## Pump - General specification

Pump Type	A10VNO
Supplier	Bosch Rexroth
Displacement per revolution (V)	<b>40 cm<sup>3</sup> (2.44 in<sup>3</sup>)</b>
Maximum flow	<b>100 l/min (26 US gpm)</b>
Direction of rotation (viewed toward drive shaft)	right hand
Engine rated speed (n)	<b>2200 RPM</b>
Pump rated speed when engine is at <b>2200 RPM</b> (n)	<b>2763 RPM</b>
Maximum speed (n)	<b>2900 RPM</b>
Engine ratio: pump (i)	1:256

## Pump compensator - General specification

Supplier

Bosch Rexroth

Max. adjustment Charge Pressure

**200 bar +/- 5 (2900 psi +/- 72)**

$\Delta p$  pressure adjustment

**18 bar +/- 1 (261 psi +/- 14)**

## Variable displacement pump - Remove

### Prior operation:

Remove the rear wheels. See **Rear wheels - Remove (44.520)**.

**NOTICE:** Avoid open pipes or hoses to be sure that they are free of debris.

1. Remove the drain plug **(1)** and completely drain all hydraulic oil into a suitable container. Dispose of the oil properly.

**NOTE:** Be sure that the three-point hitch is lowered.

2. Re-install the drain plug **(1)** with a new ring seal.

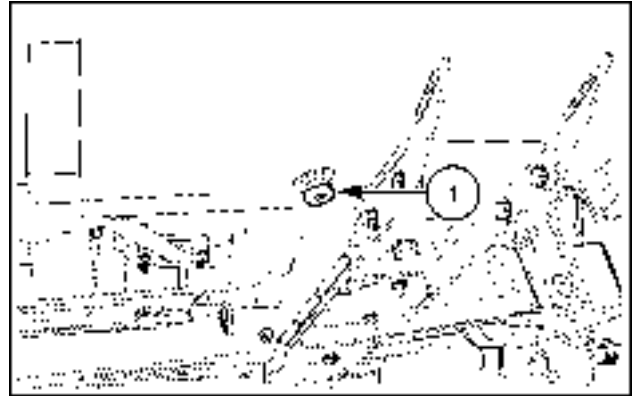

SVIL13TR00078AB 1

3. Remove the relief pipe **(1)**.

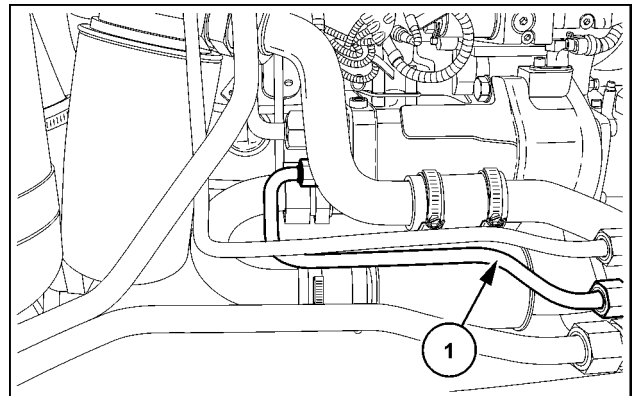

SVIL13TR00908AB 2

4. Remove the hose clamps **(1)**.
5. Remove the suction pipe (transmission) **(2)**.

**NOTE:** The steps **4** and **5** are only necessary if the suction filter **(X)** is obstructed.

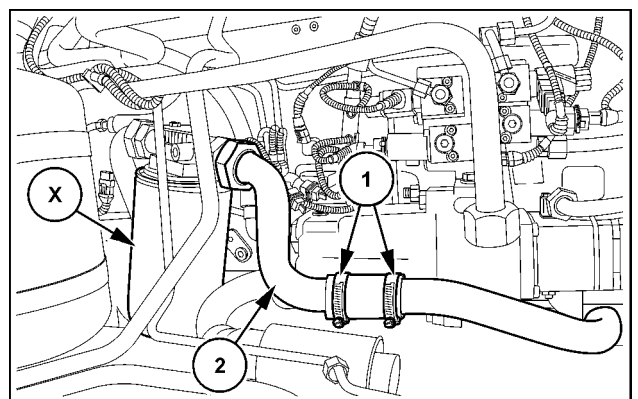

SVIL13TR00904AB 3

6. Open the hose clamps (1). Put a suitable container under the suction filter (2).
7. Remove the hydraulic oil suction filter (2).

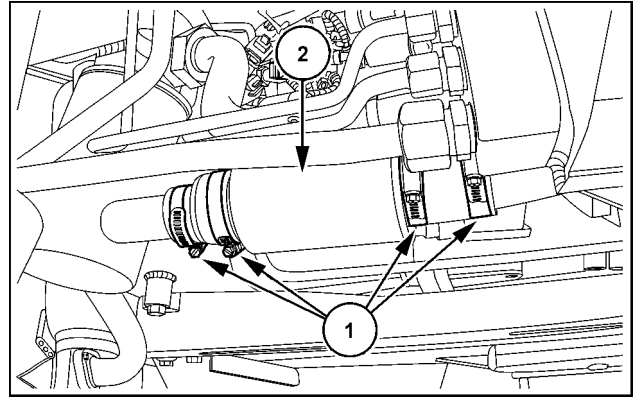

SVIL13TR00086AB 4

8. Remove the suction pipe (1).
9. Remove the pressure hose (2).

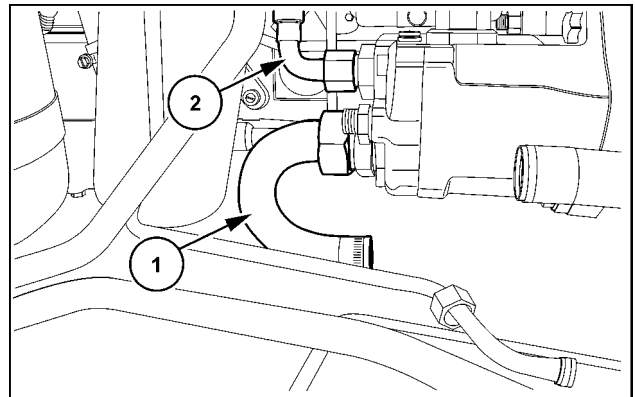

SVIL13TR000907AB 5

10. Remove the Load-Sensing (LS) pipe (1).

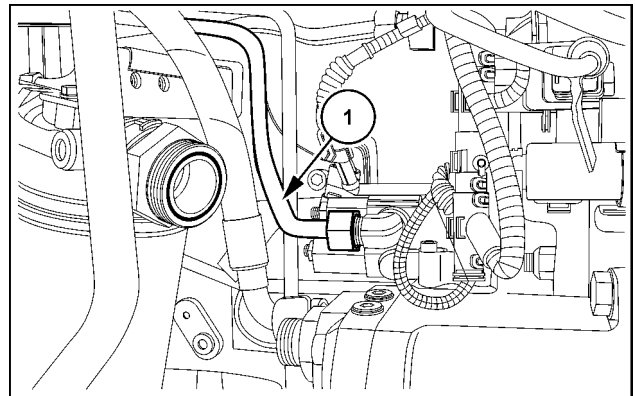

SVIL13TR000905AB 6

11. Remove the two bolts (1).
12. Remove the variable displacement pump (2).

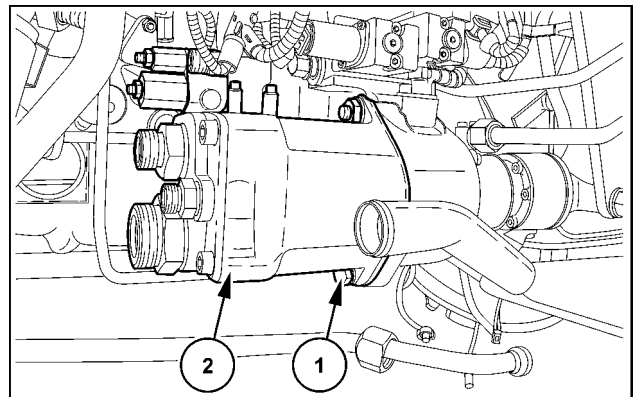

SVIL13TR000906AB 7

**Next operation:**

Install the variable displacement pump. See **Variable displacement pump - Install (35.106)**.

## Variable displacement pump - Install

### Prior operation:

Remove the variable displacement pump. See **Variable displacement pump - Remove (35.106)**.

1. Clean the flange surface.
2. Install a new O-ring on the variable displacement pump.
3. Install the variable displacement pump (2). Fix the variable displacement pump with the bolts (1).

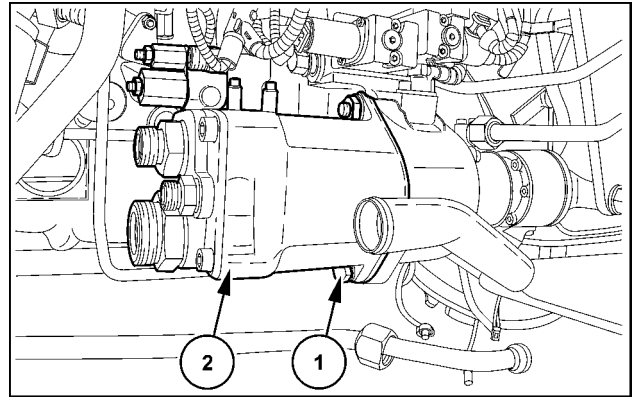

SVIL13TR00906AB 1

4. Install the Load-Sensing (LS) pipe (1).

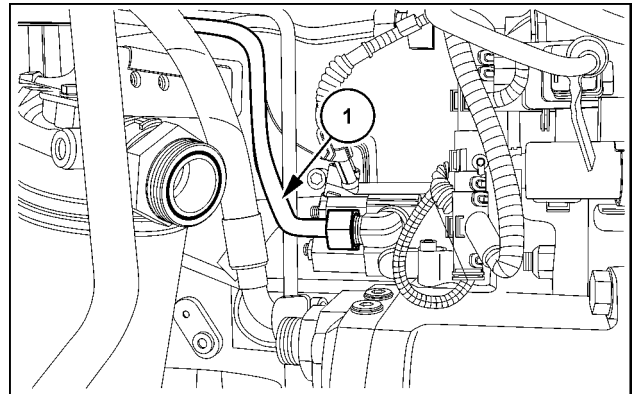

SVIL13TR00905AB 2

5. Install the pressure hose (2).
6. Install the suction pipe (1).

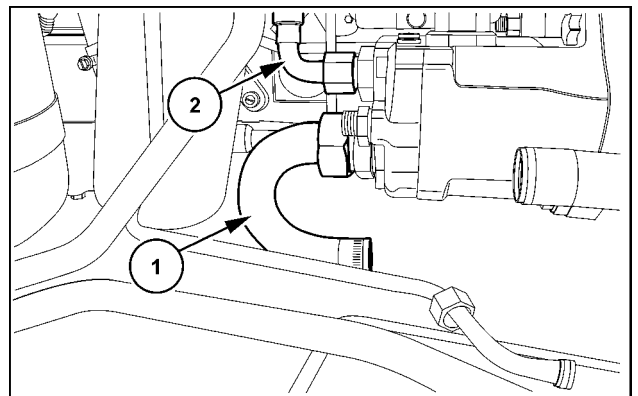

SVIL13TR00907AB 3

7. Install the suction filter (2).
8. Tighten the hose clamps (1).

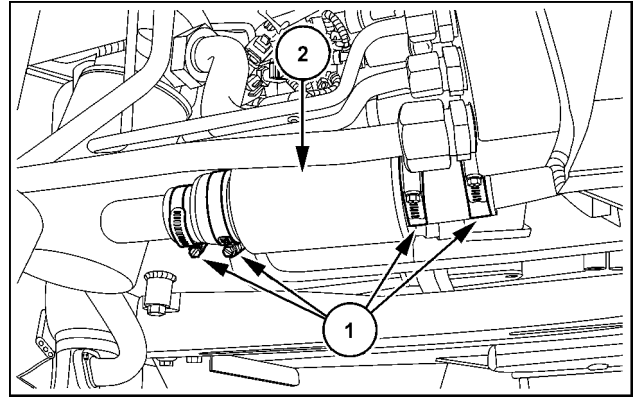

SVIL13TR00086AB 4

9. Install the suction pipe (transmission) (2).
10. Tighten the hose clamps (1).

**NOTE:** The steps 9 and 10 are only necessary if the suction filter (X) is obstructed.

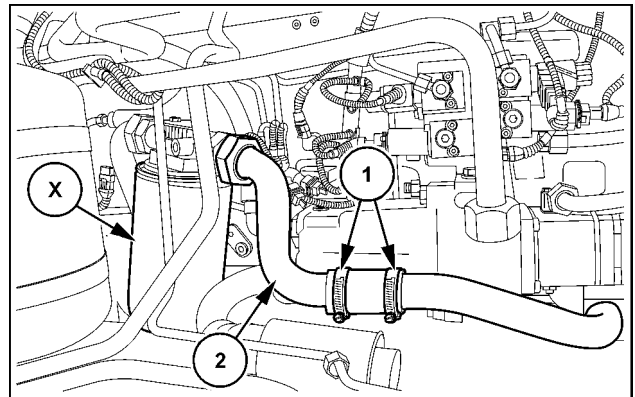

SVIL13TR00904AB 5

11. Install the relief pipe (1).

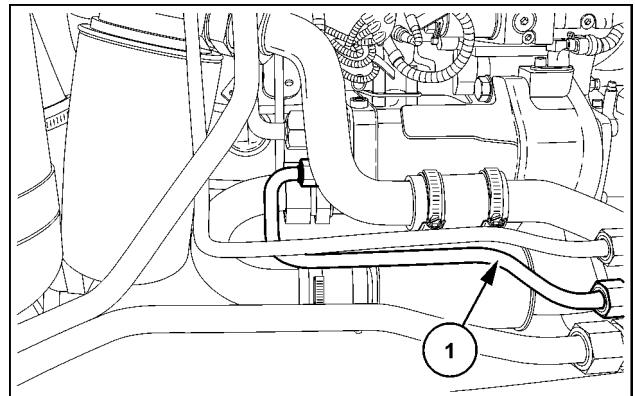

SVIL13TR00908AB 6

12. Fill in the hydraulic oil. For the correct specification see **Consumables Lubrications and Coolants ()**.
13. Check the transmission oil level. For the correct specification see **Consumables Lubrications and Coolants ()**.

**Next operation:**

Install the rear wheels. See **Rear wheels - Install (44.520)**.

# Index

---

## Hydraulic systems - 35

### Variable displacement pump - 106

Pump - General specification .....	3
Pump compensator - General specification .....	4
Variable displacement pump - Install .....	7
Variable displacement pump - Remove .....	5







**Hydraulic systems - 35**

**Remote control valves - 204**

**Farmall 105U Pro EP  
Farmall 115U Pro EP  
Farmall 95U Pro EP**

# Contents

---

## Hydraulic systems - 35

### Remote control valves - 204

#### TECHNICAL DATA

Remote control valve	
General specification .....	3
Electro-hydraulic control valve	
General specification .....	4

---

## Remote control valve - General specification

### Double-acting remote valve SB 23 Q3 – LS with flow control

Design	Modular design
Supplier	Bosch Rexroth
Operating system	Mechanical
Positions	Clearance – Lower – Neutral – Raise
Locks in position	Raise, lower and clearance
Hydraulic unlocking	In the raise and lower position
Hydraulic unlocking at (p)	<b>175 - 190 bar (2538 - 2755 psi)</b>
Individual pressure compensator	Two-way flow control valve
Setting range for individual compensator (Q)	<b>16 - 90 l/min (4.23 - 24 US gpm)</b>
Lockout valve in the output	B
Leaks A after R at <b>125 bar (1812 psi)</b> , T <b>50 °C (122 °F)</b> , v <b>33 mm<sup>2</sup> (33 in<sup>2</sup>)</b> /s	<b>33 cm<sup>3</sup> (2.0 in<sup>3</sup>) /min</b>
Leaks B after R at <b>125 bar (1812 psi)</b> , T <b>50 °C (122 °F)</b> , v <b>33 mm<sup>2</sup> (33 in<sup>2</sup>)</b> /s	<b>1 cm<sup>3</sup> (0.06 in<sup>3</sup>) /min</b>
Thermal pressure limiter valve in the output B (p)	Opens > <b>242 bar (3509 psi)</b> Closes < <b>215 bar (3118 psi)</b>

---

## Electro-hydraulic control valve - General specification

### Electronic remote valve SB23-EHS1

Design	Modular design
Manufacturer	Bosch Rexroth
Control	CAN bus
Actuation	Electric
Pilot pressure	<b>18 bar +/- 1 (261 psi +/- 14.5)</b>
Control oil flow max., at max. control speed	<b>4.40 L/min (1.16 US gpm)</b>
Control oil flow in position N	<b>0.250 L/min (0.066 US gpm)</b>
Control oil flow in position A and B	<b>0.600 L/min (0.159 US gpm)</b>
Positions	Clearance – Lower – Neutral – Raise
Individual pressure compensator	Two-way flow control valve
Setting range for individual compensator (Q)	<b>16.0 - 90 L/min (4.2 - 24 US gpm)</b>
Nominal oil flow at connection P > A or B	<b>100.0 L/min (26.4 US gpm)</b>
Nominal oil flow at connection A or B > R	<b>120.0 L/min (31.7 US gpm)</b>
Mechanically actuated lockout valve at output	B
Leaks A towards R at <b>125 bar (1812 psi)</b> , T <b>50 °C (122 °F)</b> , v <b>33 mm<sup>2</sup> (33 in<sup>2</sup>) /s</b>	<b>33 cm<sup>3</sup> (2.0 in<sup>3</sup>) /min</b>
Leaks B towards R at <b>125 bar (1812 psi)</b> , T <b>50 °C (122 °F)</b> , v <b>33 mm<sup>2</sup> (33 in<sup>2</sup>) /s</b>	<b>2 cm<sup>3</sup> (0.12 in<sup>3</sup>) /min</b>
Thermal pressure limiter valve in the output B (p)	Opens > <b>242 bar (3509 psi)</b> Closes < <b>215 bar (3118 psi)</b>

# Index

---

## Hydraulic systems - 35

### Remote control valves - 204

Electro-hydraulic control valve - General specification .....	4
Remote control valve - General specification .....	3





## **Hydraulic systems - 35**

### **Three-point hitch control valve - 114**

**Farmall 105U Pro EP  
Farmall 115U Pro EP  
Farmall 95U Pro EP**



# Contents

---

## Hydraulic systems - 35

### Three-point hitch control valve - 114

#### TECHNICAL DATA

Electronically-controlled hitch valve	
General specification .....	3

#### FUNCTIONAL DATA

Electronically-controlled hitch valve	
Dynamic description - EDC controller .....	4

---

## Electronically-controlled hitch valve - General specification

Supplier	Rexroth
Maximum pressure in channel P, Y	<b>250 bar (3625 psi)</b>
Maximum pressure in channel R	<b>30 bar (435 psi)</b>
Load safety valve opens at	<b>218 - 240 bar (3161 - 3480 psi)</b>
Internal leak at connection A at:	<b>4 cm<sup>3</sup> (0.24 in<sup>3</sup>) /min</b>
Viscosity: <b>35 mm<sup>2</sup> (35 in<sup>2</sup>) /s</b>	
Pressure: <b>125 bar (1812 psi)</b>	
Maximum oil temperature	<b>100 °C (212 °F)</b>
Actuation type	Two proportional solenoids

## Electronically-controlled hitch valve - Dynamic description - EDC controller

The EDC controller is in the third position, after the two mechanical valves, when you look at it from the connection plate. The EDC controller is an electromagnetic, proportional controller with a modular design. The EDC controller has an integrated two-way flow control valve that is parallel to duct (P). The (CCU) central controller operates the "lift" solenoid valve and "lower" solenoid valve by means of pulse width modulation (PWM).

### Function – neutral

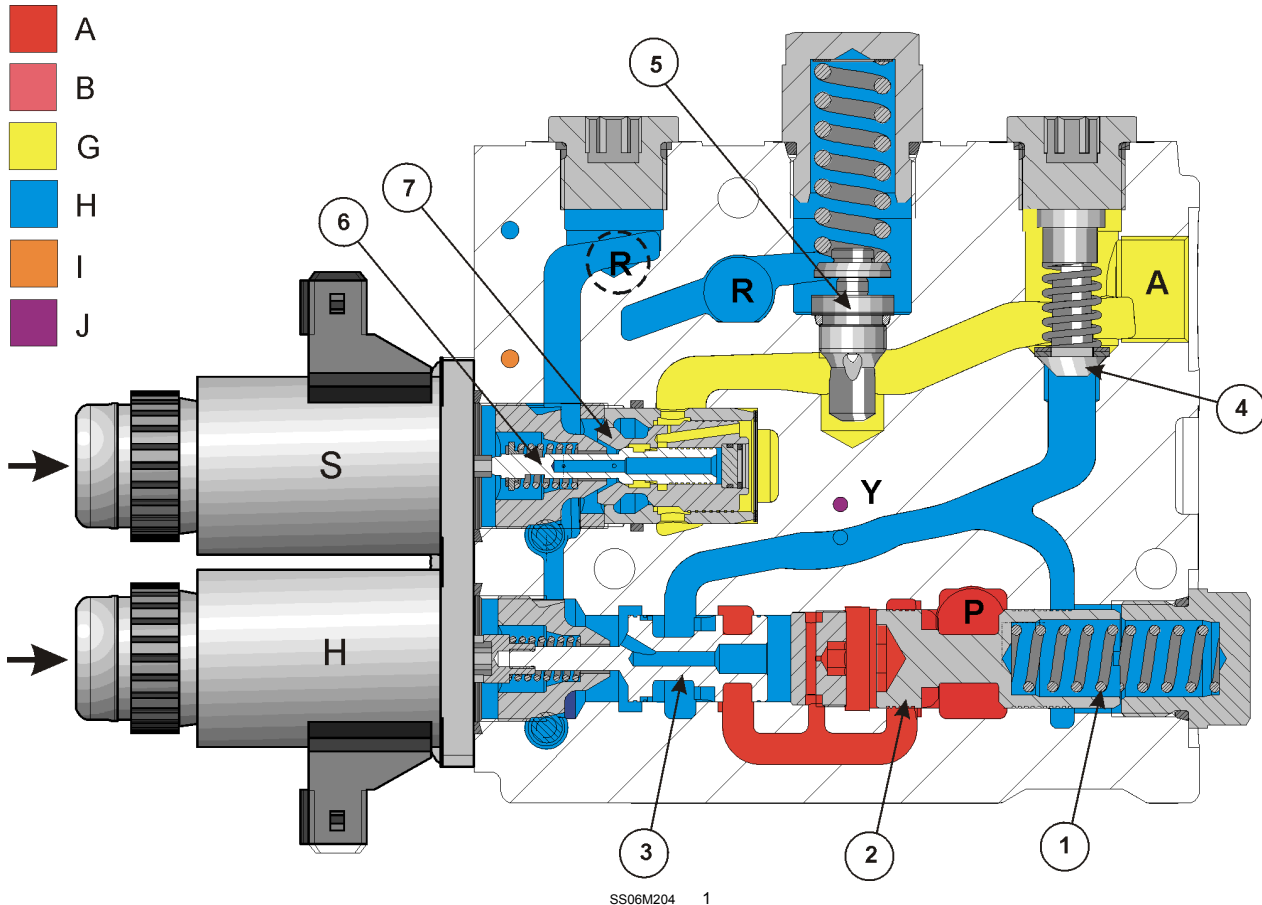

### Color legend

- |                                   |                            |
|-----------------------------------|----------------------------|
| A. High-pressure circuit          | H. Oil to the tank         |
| B. Pressure drop in high pressure | I. Low pressure circuit P1 |
| G. Trapped oil                    | J. Load-sensing line (LS)  |

The "lift" and "lower" solenoid valves are de-energized. The spring (1) has brought the spool (2) of the two-way flow control valve into a balanced position against the low-pressure standby. The pressure can reach the spool (3) for the lift function from duct (P). The load-sensing duct is connected to duct (R). The load pressure is available from output (A) on the non-return valve (4), the load safety valve (5), pilot poppet (6) and main poppet valve (7) for lowering.

### Emergency activation

If there is an interruption in the electronics, it is possible to lift or lower the linkage through manual control of the spool. At the front end of the corresponding solenoid valve, push the rubber cap using a pin.

**NOTE:** The engine does not need to run during the lowering operation.

**Function – lift**

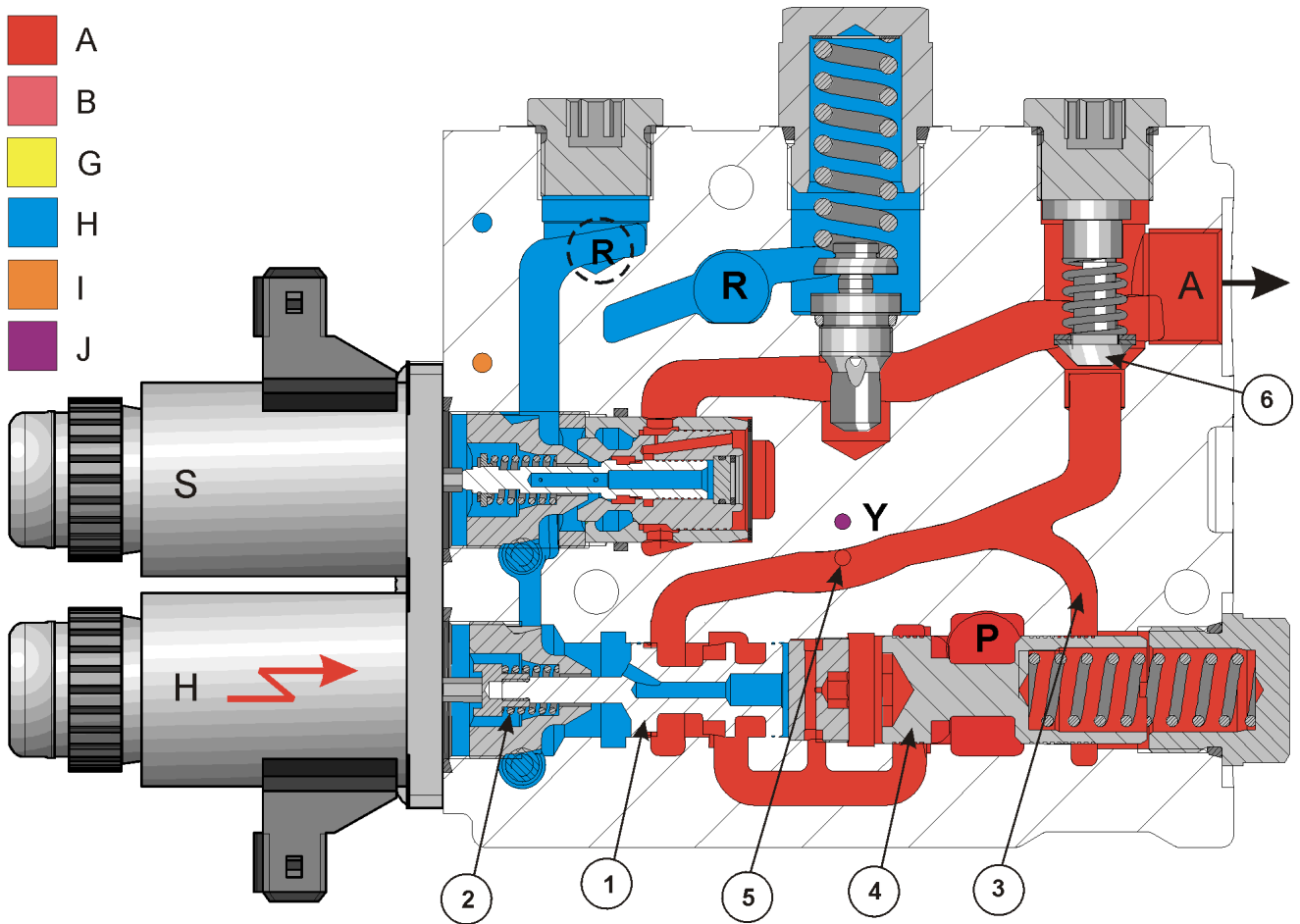

SS06M205 2

**Color legend**

- |                                   |                            |
|-----------------------------------|----------------------------|
| A. High-pressure circuit          | H. Oil to the tank         |
| B. Pressure drop in high pressure | I. Low pressure circuit P1 |
| G. Trapped oil                    | J. Load-sensing line (LS)  |

The CCU powers the "lift" solenoid valve. The current supply changes in accordance with the control deviation. The spool (1) is pushed against the spring (2) of the "lift" solenoid valve. On the one hand, the pressurized oil from duct (P) can now flow via the open spool (1) through the bore (3) to the spring side of the two-way flow control valve (4). On the other hand, the pressurized oil from duct (P) can flow via the shuttle valve (5) into the LS duct and to the pump regulator. At the same time, the oil flow to output (A) opens poppet valve (6). The working pressure that is set results from the device load and the lift speed. The lift speed depends on the electrical current that flows through the "lift" solenoid valve and that opens the spool (1). The spool (1) acts as the adjustable restrictor for the two-way flow control valve (4).

This produces the following options:

- A lift speed that is independent of the load flow and pump flow
- Parallel operation of several auxiliary distributors and the linkage. The auxiliary distributors and the linkage work with various flows and pressures until they reach the pump flow that is currently present

Function – lower

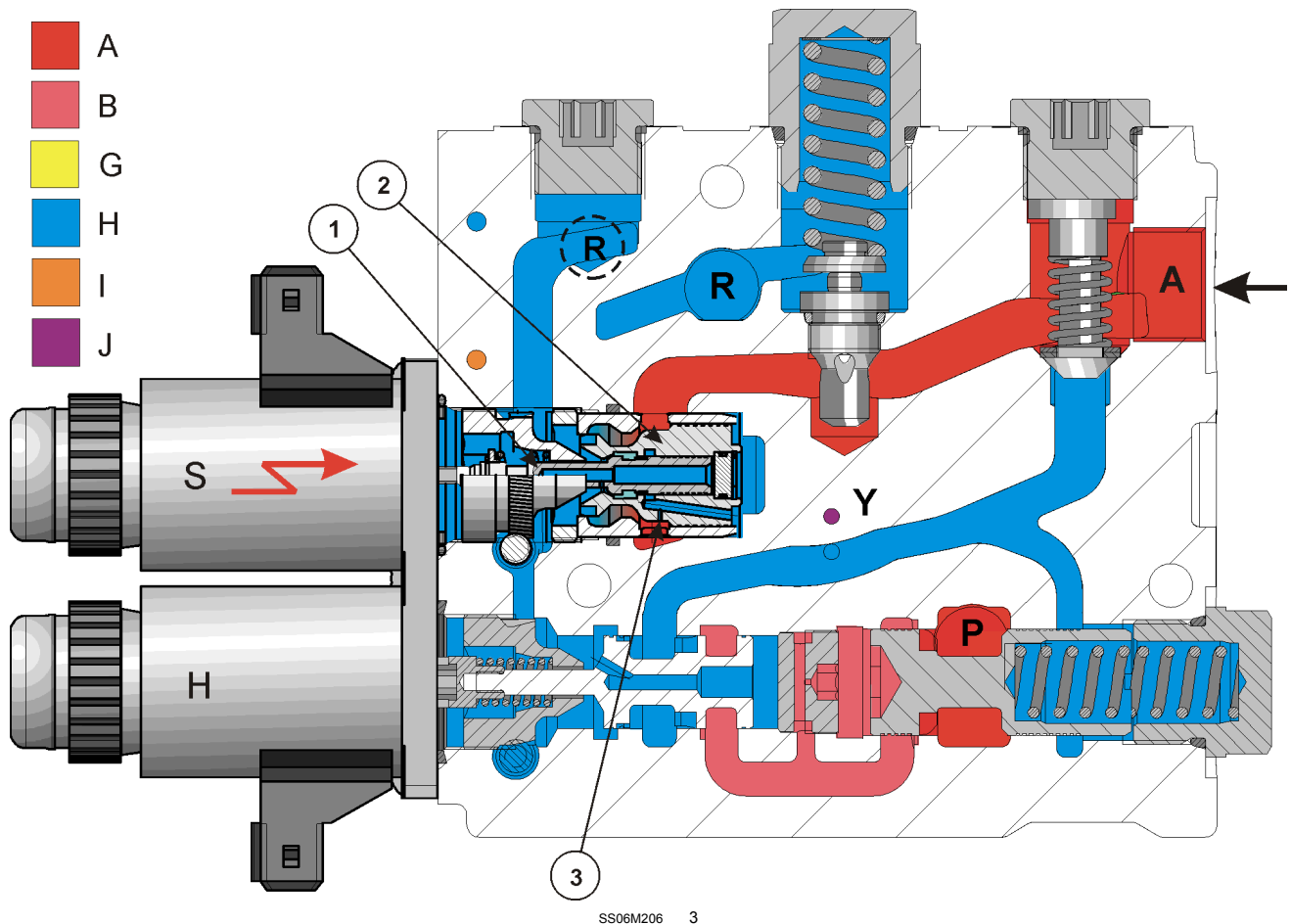

Color legend

- |                                   |                            |
|-----------------------------------|----------------------------|
| A. High-pressure circuit          | H. Oil to the tank         |
| B. Pressure drop in high pressure | I. Low pressure circuit P1 |
| G. Trapped oil                    | J. Load-sensing line (LS)  |

You can set the "drop rate" potentiometer (setpoint) so that the CCU supplies the "lower" solenoid valve with a specific current. The actual value of the drop rate is signaled to the CCU controller via the position sensor. The controller carries out a constant comparison of the SETPOINT and ACTUAL values and varies the current at the solenoid valve accordingly. This produces a load-independent drop rate.

When the "lower" solenoid valve is supplied with current, the pilot poppet (1) opens. The load pressure on the rear side of the main poppet (2) is diverted into the return flow. An insufficient amount of oil is able to flow through the restrictor (3). The closing pressure at the main poppet therefore drops. The load pressure that acts on the front side of the main poppet now opens the main poppet (2).

The travel of the "lower" solenoid valve and of the pilot poppet (1) determines the travel of the main poppet (2). When the main poppet (2) opens, the pilot poppet (1) closes. When the pilot poppet (1) closes, the load pressure acts on the rear side of the main poppet.

# Index

---

## Hydraulic systems - 35

### Three-point hitch control valve - 114

Electronically-controlled hitch valve - Dynamic description - EDC controller .....	4
Electronically-controlled hitch valve - General specification .....	3





## **Hydraulic systems - 35**

### **Front hitch controls and lines - 160**

**Farmall 105U Pro EP  
Farmall 115U Pro EP  
Farmall 95U Pro EP**



# Contents

---

## Hydraulic systems - 35

### Front hitch controls and lines - 160

#### TECHNICAL DATA

##### Accumulator

General specification – 14 bar (electronic front hitch) ..... 3

General specification – 40 bar (electronic front hitch) ..... 3

---

## Accumulator - General specification – 14 bar (electronic front hitch)

Accumulator design	Membrane accumulator
Capacity	<b>0.5 l (0.13 US gal)</b>
Filling gas	Nitrogen
Filling gas pressure	<b>14 bar +/- 1 (203 psi +/- 14)</b>
Operating temperature	<b>-20 - 80 °C (-4.0 - 176 °F)</b>
Maximum operating pressure	<b>210 bar (3045 psi)</b>

## Accumulator - General specification – 40 bar (electronic front hitch)

Accumulator design	Membrane accumulator
Capacity	<b>0.75 l (0.20 US gal)</b>
Filling gas	Nitrogen
Filling gas pressure	<b>40 bar +/- 1 (580 psi +/- 14)</b>
Operating temperature	<b>-20 - 80 °C (-4.0 - 176 °F)</b>
Maximum operating pressure	<b>210 bar (3045 psi)</b>

# Index

---

## Hydraulic systems - 35

### Front hitch controls and lines - 160

Accumulator - General specification – 14 bar (electronic front hitch) .....	3
Accumulator - General specification – 40 bar (electronic front hitch) .....	3





© 2014 CNH Industrial Österreich GmbH

All rights reserved. No part of the text or illustrations of this publication may be reproduced.

CASE IH policy is one of continuous improvement and the right to change prices, specification or equipment at any time without notices is reserved.

All data given in this publication is subject to production variations. Dimensions and weight are approximate only and the illustrations do not necessarily show products in standard condition. For exact information about any particular product, please consult your CASE IH Dealer.



# **SERVICE MANUAL**

## **Steering**

**Farmall 105U Pro EP  
Farmall 115U Pro EP  
Farmall 95U Pro EP**

# Contents

---

## Steering - 41

[41.200] Hydraulic control components.....	41.1
--	------



## **Steering - 41**

### **Hydraulic control components - 200**

**Farmall 105U Pro EP  
Farmall 115U Pro EP  
Farmall 95U Pro EP**



# Contents

---

## Steering - 41

### Hydraulic control components - 200

#### TECHNICAL DATA

Steering valve	
General specification .....	3

## Steering valve - General specification

Supplier	Ognibene
Supplier Description	ST OR 125 M170
Displacement per revolution	<b>125 cm<sup>3</sup> (7.63 in<sup>3</sup>)</b>
Pressure limiter valve opens with oil flow <b>25 l/min (6.6 US gpm)</b> at	<b>170 - 180 bar (2465 - 2610 psi)</b>
Maximum pressure in channel T	<b>35 bar (508 psi)</b>
Maximum oil temperature	<b>-30 - 90 °C (-22 - 194 °F)</b>

# Index

---

## Steering - 41

### Hydraulic control components - 200

Steering valve - General specification .....	3
--	---





© 2014 CNH Industrial Österreich GmbH

All rights reserved. No part of the text or illustrations of this publication may be reproduced.

CASE IH policy is one of continuous improvement and the right to change prices, specification or equipment at any time without notices is reserved.

All data given in this publication is subject to production variations. Dimensions and weight are approximate only and the illustrations do not necessarily show products in standard condition. For exact information about any particular product, please consult your CASE IH Dealer.



# **SERVICE MANUAL**

## **Wheels**

**Farmall 105U Pro EP  
Farmall 115U Pro EP  
Farmall 95U Pro EP**

# Contents

---

## Wheels - 44

[44.520] Rear wheels .....	44.1
----------------------------	------



## **Wheels - 44**

**Rear wheels - 520**

**Farmall 105U Pro EP  
Farmall 115U Pro EP  
Farmall 95U Pro EP**



# Contents

---

## Wheels - 44

### Rear wheels - 520

#### SERVICE

Rear wheels	
Remove .....	3
Install .....	4

---

## Rear wheels - Remove

### **⚠ WARNING**

#### **Crushing hazard!**

**The wheels on this vehicle are very heavy. Always use a wheel remover or chain hoists to remove and install the wheels. Use an assistant as required.**

**Failure to comply could result in death or serious injury.**

W0149A

1. Position wooden wedges between the front axle and the front support. These prevent articulation of the front axle.
2. Raise the rear of the tractor and place two suitable axle stands under the final drive cases.

**NOTE:** *If required, detach the lift rods from the lower links.*

3. Remove the rear wheels.

---

## Rear wheels - Install

### **⚠ WARNING**

#### **Crushing hazard!**

**The wheels on this vehicle are very heavy. Always use a wheel remover or chain hoists to remove and install the wheels. Use an assistant as required.**

**Failure to comply could result in death or serious injury.**

W0149A

1. Install the rear wheels.
2. Tighten the nuts to **250 N·m (184 lb ft)**.
3. Remove the axle stands from under the final drive cases.

**NOTE:** *If required, attach the lift rods to the lower links.*

4. Remove the wooden wedges from between the front axle and the front support.

# Index

---

## Wheels - 44

### Rear wheels - 520

Rear wheels - Install .....	4
Rear wheels - Remove .....	3



© 2014 CNH Industrial Österreich GmbH

All rights reserved. No part of the text or illustrations of this publication may be reproduced.

CASE IH policy is one of continuous improvement and the right to change prices, specification or equipment at any time without notices is reserved.

All data given in this publication is subject to production variations. Dimensions and weight are approximate only and the illustrations do not necessarily show products in standard condition. For exact information about any particular product, please consult your CASE IH Dealer.



## **SERVICE MANUAL**

### **Cab climate control**

**Farmall 105U Pro EP**

**Farmall 115U Pro EP**

**Farmall 95U Pro EP**

# Contents

---

## Cab climate control - 50

[50.200] Air conditioning.....	50.1
--------------------------------	------



## **Cab climate control - 50**

**Air conditioning - 200**

**Farmall 105U Pro EP  
Farmall 115U Pro EP  
Farmall 95U Pro EP**



# Contents

---

## Cab climate control - 50

### Air conditioning - 200

#### TECHNICAL DATA

Air conditioning	
General specification .....	3

#### SERVICE

Air conditioning	
Decontaminating .....	4
Discharging .....	5
Evacuate .....	6
Charging .....	8
Leakage test .....	9
Receiver/Dryer	
Replace – Dryer element .....	10

## Air conditioning - General specification

Refrigerant specifications	<b>R134A</b>
Refrigerant filling	<b>650 g (23 oz)</b>
Refrigerator oil specifications	PAG SP10 (ISO 46 viscosity)
Refrigerant oil filling quantity (air conditioner and system)	<b>190 cm<sup>3</sup> (12 in<sup>3</sup>)</b>

### Air-conditioning compressor

Manufacturer and type	Sanden SD7H15
Number of cylinders	7
Displacement per revolution	<b>154.9 cm<sup>3</sup>/rev (9.5 in<sup>3</sup>/rev)</b>

At an ambient temperature of **22 - 49 °C (72 - 120 °F)** the cooling power is approximately **4.5 kW**.

**NOTE:** *The actual cooling power depends on the setting made by the driver.*

## Air conditioning - Decontaminating

Air-conditioning systems may occasionally become contaminated with solid particles. This contamination may be the result of allowing dirt to enter the system while it was open, from aluminum corrosion or sludge, or from disintegrated compressor reed plates. Contamination of this nature can result in plugged evaporators, condensers and expansion valves.

1. Contaminated systems must be flushed with a special flushing solvent to remove the unwanted material. Prior to flushing, the system must be discharged. See **Air conditioning - Discharging (50.200)**. Each individual component must be flushed after disconnecting every hose fitting. The compressor and expansion valve can not be flushed, therefore, the compressor should be disassembled and cleaned or replaced and the expansion valve should be replaced. When flushing the system always replace the receiver-drier.
2. Re- assemble and evacuate the system to remove air and moisture as described in **Air conditioning - Evacuate (50.200)**.

**NOTICE:** Never use any solvent for flushing an air-conditioning system other than a special flush solvent made specifically for air-conditioning systems. Always follow the manufacturer's recommendations and directions for using the flushing equipment and solvent.

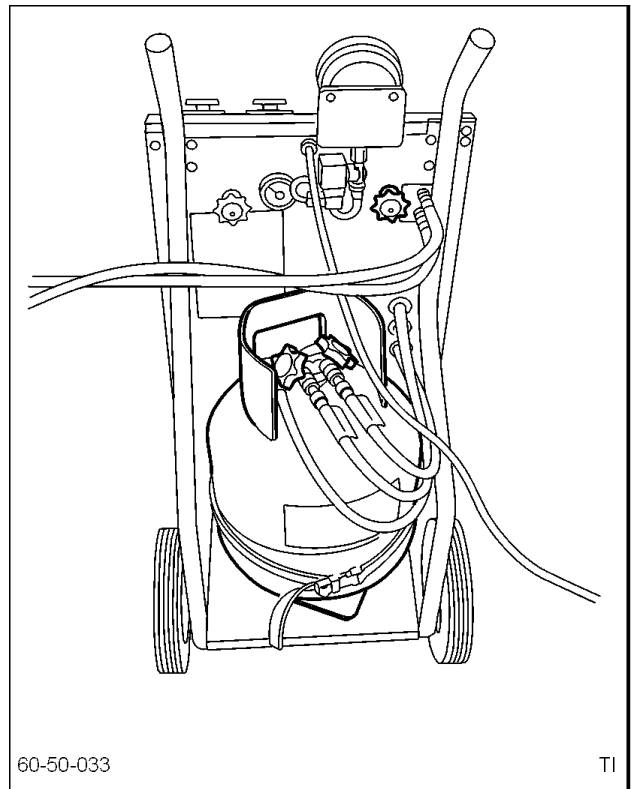

60-50-033 1

## Air conditioning - Discharging

### **⚠ WARNING**

**Avoid chemical burns!**

**Wear protective goggles and non-permeable gloves when working with the fluorescent dye and leak testing an air-conditioning system.**

**Failure to comply could result in death or serious injury.**

W0918A

**NOTE:** Legislation bans the release of refrigerant into the atmosphere.

Whenever overhauling the air-conditioning system or performing other tasks which require the air-conditioning system to be dismantled, it is necessary to discharge the refrigerant gas before commencing repair.

Before dismantling an air-conditioning system for repairs, you must discharge and recover the refrigerant using a certified recovery unit in accordance with the manufacturers instructions.

Image 1 shows a combined refrigerant recovery, evacuation and recycling/charging station. This equipment removes **R134A** refrigerant from the air-conditioning system, recycles and recharges all in one hook up. The unit is designed to be used with the manifold gauge set built into the control panel.

Other recovery systems are available where the manifold gauges are not an integral part of the machine. When this type of equipment is used a separate manifold gauge set must be used.

**NOTE:** Always follow the manufactures instructions when operating recovery equipment.

The following is a summary of the steps for discharging the system using a recovery/recycling equipment:

1. Run the air-conditioning system for a few minutes.
2. Set up the recovery unit following the manufacturer's instructions. Make sure that the units red (high side) hose is connected to the high side fitting (1) and the blue (low side) hose to the low side fitting (2).

**NOTE:** If a unit requiring the manifold gauge set is being used, the low and high sides of the manifold set are connected to the low and high sides of the air-conditioning system. The hose from the recovery unit is then connected to the manifold centre port. See **Air conditioning - Decontaminating (50.200)**.

3. To recover refrigerant, open both high and low side valves on the control panel or the valves on the manifold gauge set if being used, refer to **Air conditioning - Decontaminating (50.200)**.
4. Open the valves labeled "gas" and "liquid" on the recovery unit refrigerant reservoir. See **Air conditioning - Decontaminating (50.200)**.
5. Operate the recovery system in accordance with the manufacturers instructions.

**NOTE:** The compressor will shut off automatically when the recovery is complete.



BAIL07APH231GV4 1

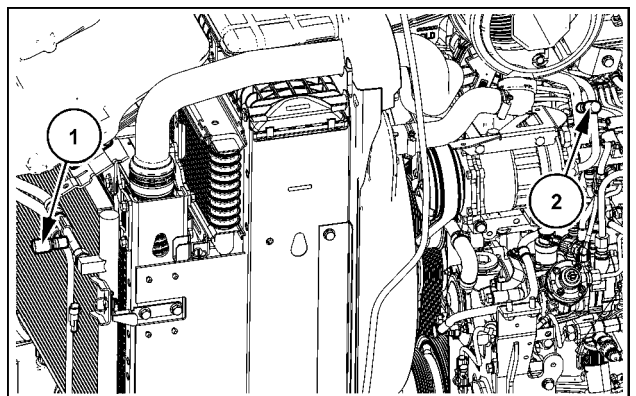

SS13N032 2

## Air conditioning - Evacuate

**NOTICE:** A system in which the refrigerant has been recovered to facilitate repairs, must be evacuated before new refrigerant is installed.

**NOTE:** Air and moisture are removed by evacuating the system using a vacuum pump.

The automatic recycling, recharge and evacuation stations or evacuating and charging stations available throughout the air conditioning industry incorporate a vacuum pump within the assembly. If this type of equipment is not available a separate vacuum pump and manifold gauge set must be used.

As the system is evacuated the boiling point of any moisture within the system is similarly lowered. As the vacuum increases the boiling reduces to below that of the ambient temperature and the moisture is subsequently boiled away. The relationship of system vacuum to the boiling temperature at which the water vapor is removed from the system is as follows:

**NOTE:** For every **305 m (1001 ft)** above sea level, the vacuum gauge reading must be corrected by adding **2.54 cm (1.00 in)** of mercury to compensate for the change in atmospheric pressure.

**NOTICE:** Be sure the system is completely discharged as refrigerant will damage the vacuum pump.

### System vacuum

Height of mercury	Temperature
71.0 cm (28.0 in)	37 °C (99 °F)
73.4 cm (28.9 in)	27 °C (81 °F)
74.6 cm (29.4 in)	16 °C (61 °F)
75.4 cm (29.7 in)	5 °C (41 °F)
75.7 cm (29.8 in)	-7 °C (19 °F)
75.9 cm (29.9 in)	-18 °C (0 °F)

1. If the manifold gauge set is being used connect the low and high sides of the manifold to the low and high sides of the tractor air-conditioning system as described for discharging the system. See **Air conditioning - Discharging (50.200)**.  
Connect the manifold center hose to the vacuum pump suction port as per the manufacturers instructions. Fully open both the low and high side gauge shutoff valves.
2. If a combined recovery/evacuation equipment is to be used attach the unit to the air-conditioning system in accordance with the manufacturers instructions. Be sure to read all installation and operating instructions carefully before starting the unit.
3. After starting the evacuation cycle, note the low side gauge to be sure the system pulls down into a vacuum.
4. Time the evacuation for a minimum of **20 min** from the point when lowest vacuum is attained.
5. When the low side gauge attains the lowest steady vacuum, stop the evacuation process.

**NOTE:** The vacuum pump achieves ultimate vacuum with the vented exhaust valve closed.

6. Check the system by closing the gauge shutoff valves, turning the vacuum pump off and noting the low side gauge reading. A loss of more than **5 cm (2 in)** of vacuum in **5 min** indicates either a leak or moisture in the system.

7. If the gauge needle remains stationary and the vacuum is maintained for **3 - 5 min**, close both the high and low side manifold hand valves, turn off and disconnect the center hose from the pump. The system is now ready for charging.
8. If a leak is detected, charge the system with approximately **400 g (14.1 oz)** of refrigerant and identify leak using a leak detector. See **Air conditioning - Leakage test (50.200)**.
9. Once the leak is located discharge and recover the refrigerant in the system, repair the leak, then repeat the evacuation procedure.

## Air conditioning - Charging

**NOTE:** Make sure that there are no leaks in the air-conditioning system and that the air-conditioning system has been fully evacuated. Observe all safety recommendations when handling refrigerant **R134A**.

1. Make sure that the charging unit is correctly connected to the vehicle air-conditioning system in accordance with the manufacturers instructions.  
High side service valve (1)  
Low side service valve (2)

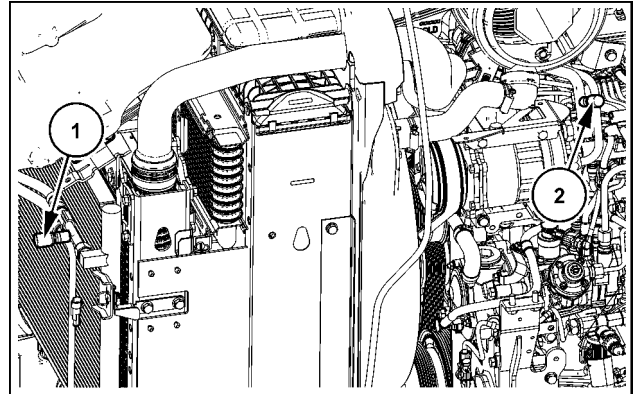

SS13N032 1

2. If a charging unit, in conjunction with the manifold gauge set is used, open the high and low side hand valves on the manifold.
3. Charge the air-conditioning system with the corresponding filling quantity of refrigerant. See **Air conditioning - General specification (50.200)**.
4. If the charging rate becomes very slow close the high side valve, start the engine and set the engine speed to idle. Turn the air-conditioning system ON so that the compressor can pull the remainder of the refrigerant into the air-conditioning system.
5. If the refrigerant charge will not completely transfer to the air-conditioning system, recover and recharge the air-conditioning system.
6. Close the high and low side valves on the units control panel, or manifold gauge set if being used and test the air-conditioning system.

**NOTE:** After charging an air-conditioning system use the following start up procedure to make sure that the lubricating oil is properly dispersed around the air-conditioning system.

7. Make sure that the air-conditioning system is switched OFF.
8. Start the engine and bring the engine speed down to idle.
9. Turn the air-conditioning system ON and allow the system to operate for at least **1 min** before increasing engine speed.

## Air conditioning - Leakage test

### ⚠ WARNING

**Avoid injury!**

**Avoid breathing air-conditioning refrigerant, lubricant vapor or mist. If accidental system discharge occurs, ventilate the work area before resuming service.**

**Failure to comply could result in death or serious injury.**

W1000B

To perform a leak test if refrigerant leakage is suspected, use an electronic leak detector (image 1) and follow the manufacturer's instructions.

Electronic leak detectors use flashing lights or sound to alert the operator to a leak. If the leak detector's sensitivity is adjustable, be sure you calibrate the detector according to the manufacturer's instructions before use.

When using a leak detector, keep in mind that a very slight amount of leakage in the compressor pulley area is normal and does not necessarily indicate a repair is required.

When a leak is located, follow these steps:

- Discharge the system using a certified refrigerant recovery system
- Repair the leak
- Evacuate the system
- Partially charge system with **400 g (14.1 oz)** of refrigerant
- Check system for leaks
- Fully charge the system

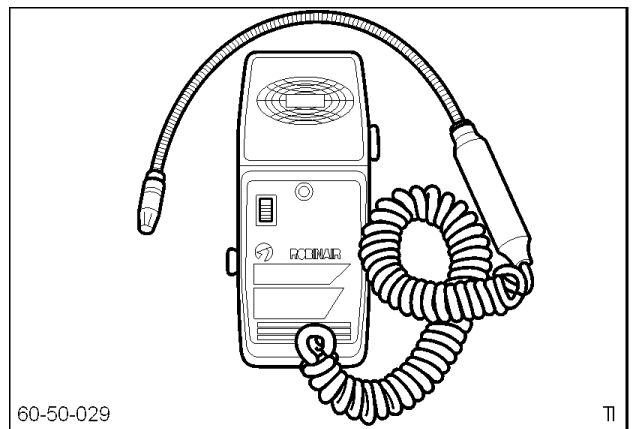

60-50-029

TI

60-50-029 1

Always check the system for leaks as a final test after evacuating and before recharging. See **Air conditioning - Evacuate (50.200)**.



## Receiver/Dryer - Replace – Dryer element

### Prior operation:

#### Air conditioning - Discharging (50.200)

1. Remove the bolt (1).

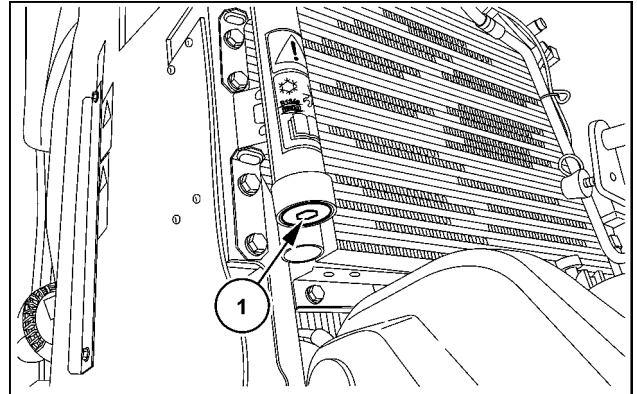

SVIL13TR00922AB 1

2. Put the dryer element out of the condenser and replace it with a new dryer element.

3. Clean the strainer on the bolt.

4. Replace the ring seal (1).

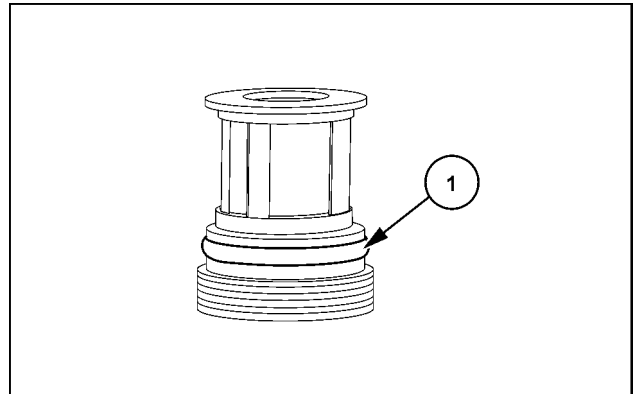

SVIL13TR00938AB 2

5. Install the bolt (1).  
Tighten the bolt with **25 - 30 Nm (18 - 22 lb ft)**.

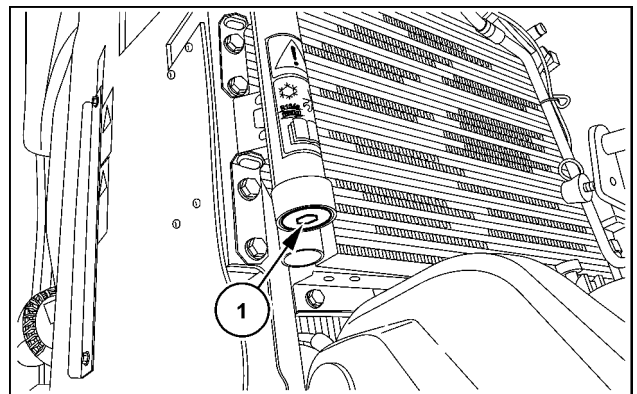

SVIL13TR00922AB 3

### Next operation:

#### Air conditioning - Evacuate (50.200)

# Index

---

## Cab climate control - 50

### Air conditioning - 200

Air conditioning - Charging .....	8
Air conditioning - Decontaminating .....	4
Air conditioning - Discharging .....	5
Air conditioning - Evacuate .....	6
Air conditioning - General specification .....	3
Air conditioning - Leakage test .....	9
Receiver/Dryer - Replace – Dryer element .....	10



© 2014 CNH Industrial Österreich GmbH

All rights reserved. No part of the text or illustrations of this publication may be reproduced.

CASE IH policy is one of continuous improvement and the right to change prices, specification or equipment at any time without notices is reserved.

All data given in this publication is subject to production variations. Dimensions and weight are approximate only and the illustrations do not necessarily show products in standard condition. For exact information about any particular product, please consult your CASE IH Dealer.



# **SERVICE MANUAL**

## **Electrical systems**

**Farmall 105U Pro EP**

**Farmall 115U Pro EP**

**Farmall 95U Pro EP**

# Contents

---

## Electrical systems - 55

[55.000] Electrical system .....	55.1
[55.100] Harnesses and connectors.....	55.2
[55.015] Engine control system.....	55.3
[55.301] Alternator.....	55.4
[55.302] Battery.....	55.5
[55.202] Cold start aid .....	55.6
[55.011] Fuel tank system .....	55.7
[55.014] Engine intake and exhaust system.....	55.8
[55.012] Engine cooling system .....	55.9
[55.013] Engine oil system .....	55.10
[55.640] Electronic modules .....	55.11
[55.024] Transmission control system.....	55.12
[55.020] Transmission speed sensors.....	55.13
[55.021] Transmission pressure sensors.....	55.14
[55.022] Transmission temperature sensors .....	55.15
[55.522] Cab Power Take-Off (PTO) controls .....	55.16
[55.048] Rear Power Take-Off (PTO) control system .....	55.17
[55.032] Trailer brake electrical system .....	55.18

[55.035] Remote control valve electric control .....	55.19
[55.036] Hydraulic system control .....	55.20
[55.050] Heating, Ventilation, and Air-Conditioning (HVAC) control system.....	55.21
[55.130] Rear three-point hitch electronic control system .....	55.22
[55.160] Front hitch electronic control system.....	55.23
[55.408] Warning indicators, alarms, and instruments .....	55.24
[55.680] Autopilot/Autoguidance .....	55.25
[55.DTC] FAULT CODES.....	55.26





## **Electrical systems - 55**

### **Electrical system - 000**

**Farmall 105U Pro EP  
Farmall 115U Pro EP  
Farmall 95U Pro EP**



# Contents

---

## Electrical systems - 55

### Electrical system - 000

#### FUNCTIONAL DATA

##### Electrical system

Static description – Circuit components .....	3
---	---

#### SERVICE

##### Electrical system

Electrical test .....	11
Electrical test – Usage of a digital multimeter .....	14

## Electrical system - Static description – Circuit components

**NOTE:** The chapters dealing with electrical components refer to the state of these components (e.g. normally open state or normally closed state of a switch). These references to the state of an electrical component are always to be considered with the machine in stationary state (the component is disconnected from the circuit).

### CIRCUIT PROTECTION DEVICES

Circuit protection devices are used to protect wiring and components from excessive current. Fuses protect electrical circuits with thin pieces of metal or wire which heat up and melt to open up the circuit when too much current flows through them. In the automotive industry the fuses are mostly located in fuse boxes (see figure 1).



SS11M174 1

### Fuses

Fuses are used to protect the electrical circuit from overload. This can occur in the event of a short circuit or by connecting equipment which demands a current greater than the electrical circuit is designed to carry. There are several types of fuses, but they all consist of a metal conductor which is capable of carrying a limited current. If the specified current is exceeded then the metal conductor will overheat, causing it to melt and break. This will cause an open circuit.

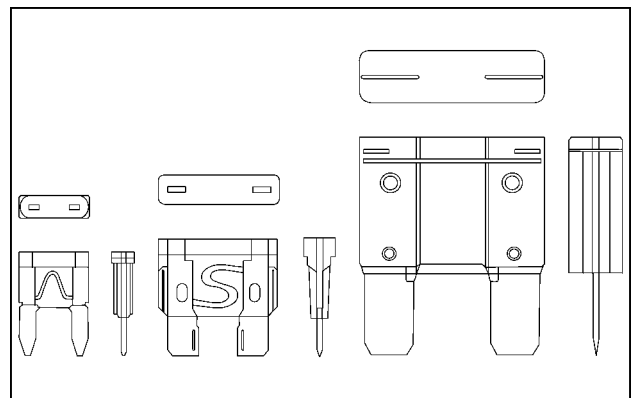

SVIL13TR00281AB 2

In the automotive industry used fuse types are blade fuses (see figure 2) and screwable fuses (see figure 3). The rating of the fuse relates to the current that the fuse can carry continuously. If a fuse blows, it must be replaced with a fuse of the correct rating. If a fuse blows again, the cause must be investigated.

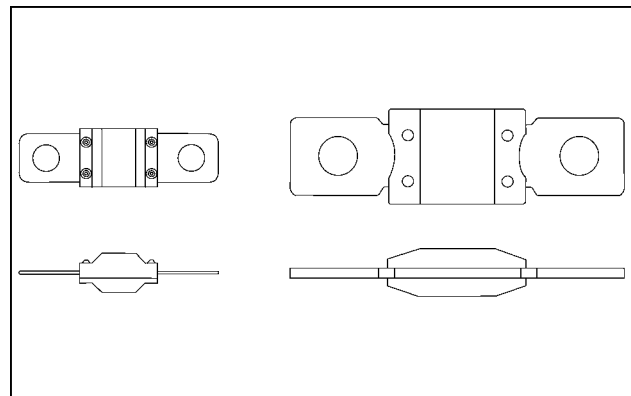

SVIL13TR00280AB 3

### Fusible links

A fusible link is a wire that acts like a fuse. A fusible link is breaking down and causing an open circuit when the current that passes through it exceeds a certain amperage. For primary fuse protection the main supplies from the starter solenoid can be fitted with fusible links.

## CIRCUIT CONTROL DEVICES

Some of the components in an electrical circuit are used to interrupt and direct the current flow either through an action of the operator or automatically (see figure 4). Other circuit control devices are described in the following “electromagnetic devices” section (e.g. relays).

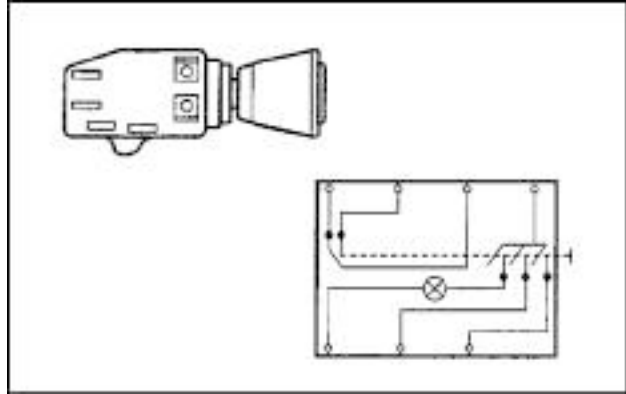

SEZ55CAP9A-56 4

## Switches

Switches are a vital part of an electrical circuit, providing a method of controlling the circuit itself. One switch can control a number of different circuits at the same time. This is achieved by having several separate connections and/or multi-connector switches (several switch positions). There are several types of switches, and they may incorporate a warning light. A common type of a sensor switch is for example the pressure switch (see figure 5). A pressure switch is turned ON or OFF by the pressure of a fluid. An example of this type of switch is the engine oil pressure switch. The engine oil pressure switch opens (or closes) when the oil pressure rises above a specific threshold.

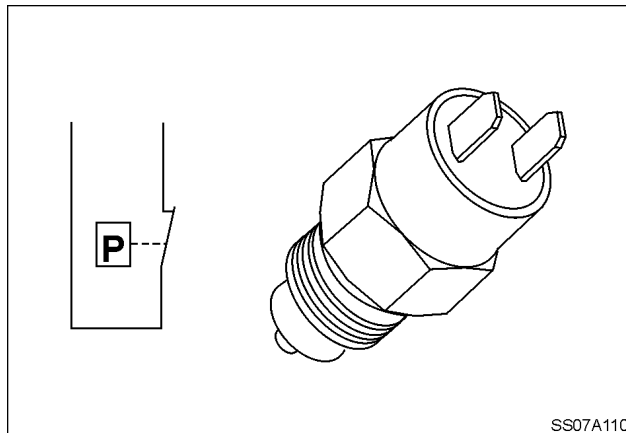

SS07A110 5

## Diodes

Some components use a semiconductor material instead of moving parts to direct the current. Diodes for example allow the current flow in one direction only (see figure 6). They are essential components for converting the alternating current that an alternator produces to the direct current that the electrical system of the tractor uses.

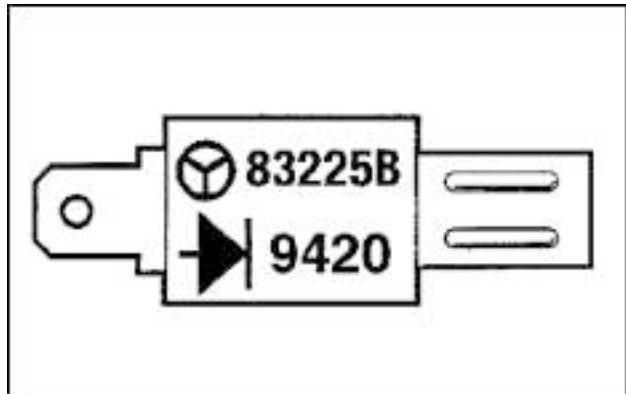

SEZ55CAP9A-7 6

## RESISTANCE DEVICES

A number of electrical components alter or make use of electricity through their resistance to current flow. Resistors are components which are generally used to regulate the supply of voltage and current to other electrical components. In some cases, the purpose of resistance in an electrical circuit is to provide light or heat. Light bulbs and cigar lighters are examples for this (see figure 7).

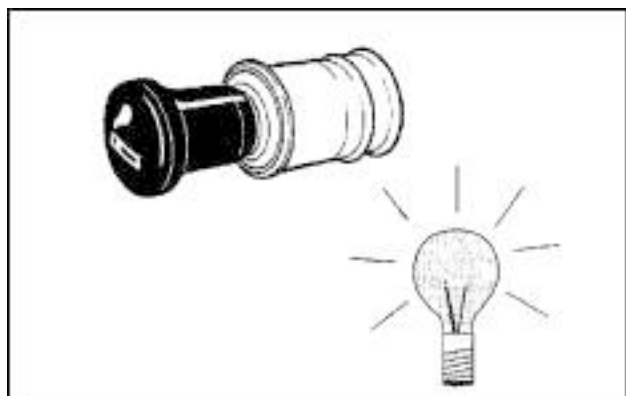

SEZ55CAP9A-59 7

## Potentiometers

Potentiometers are variable resistors which are dependant on (linear or rotary) mechanical movement of a sliding contact (see figure 8). The movement of the sliding contact varies the resistance and therefore alters the output voltage. A potentiometer can be used as an electrical control device as well as a sensor. In order to verify the correct operation of a potentiometer, the resistance should be measured between the minimum and the maximum position (therefore smoothly move the sliding contact between the minimum and the maximum position). As the resistance varies with temperature, the test specifications are usually given at **20 °C (68.00 °F)**.

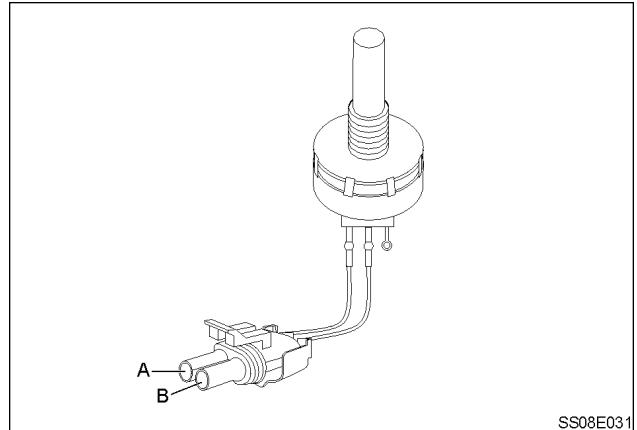

SS08E031 8

SS08E031

## ELECTROMAGNETIC DEVICES

In general, electromagnetic devices use the magnetic field created by flowing current to move metal parts within the component. An electromagnetic device is for example a relay (see figure 9) or a solenoid valve (see figure 12).

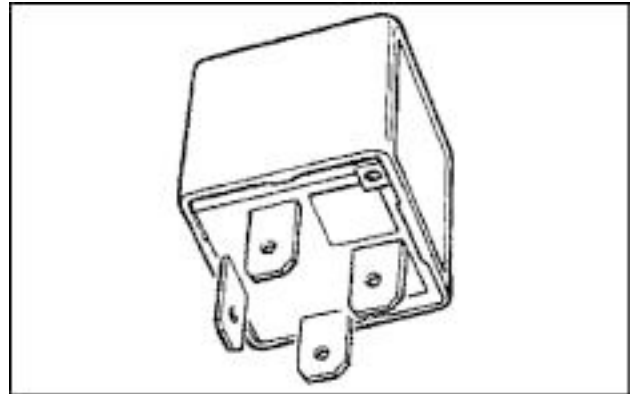

SEZ55CAP9A-9 9

## Relays

Relays are basically electrically operated switches (see figure 10). They are used to switch an electrical circuit ON or OFF in similar way to a manual switch.

Two electrical circuits are connected to the relay:

- A work circuit, which is opened and closed by the relay (high current). The work circuit provides the supply for the equipment to be operated (e.g. lights, solenoids, etc.).
- A control circuit, which is opened and closed by manual switches and used to actuate the relay (low current).

The part of the relay which is connected to the control circuit consists of the winding of an electromagnet ( **(85)** and **(86)** ). When the control circuit is switched OFF, the contacts **(87)** are kept apart by a return spring. When the control circuit is switched ON, a current flows through the coil and a magnetic force is produced. This force is stronger than the spring force and pulls the contacts **(87)** of the relay together (closing of the work circuit). This causes a current flow in the work circuit ( **(30)** and **(87)** ).

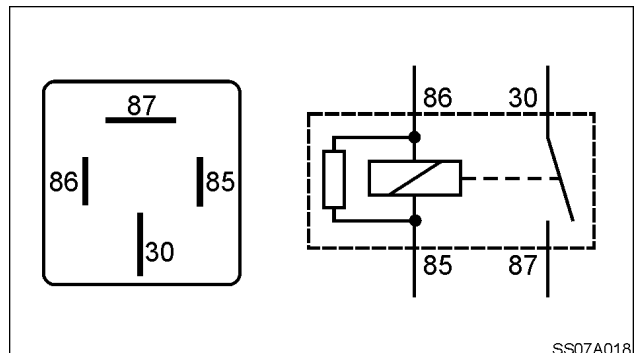

SS07A018 10

SS07A018

A switch-relay system has two main advantages over a simple switch:

- The current that flows through the switch (control circuit) is smaller than the current required by the equipment to be operated (work circuit). This allows the usage of smaller and less expensive electrical components in the control circuit.
- The distance from the supply to the equipment, can be made as short as possible to minimize voltage drop.

There are several types of relays. They can be normally open or normally closed. They may have an internal electronic circuit to give special operating features. There are relays which can switch the work circuit ON and OFF at timed intervals (flasher units). Other relay types are sensitive to current or temperature. The relay cover usually gives information about the features of the relay. Brown relays are normally open relays, blue ones are normally closed.

On the relay cover there are usually 4 or 5 terminal markings (see figure 10):

- 30: The input terminal is usually connected to the battery (positive)
- 85: The winding output terminal is usually connected to ground (control circuit)
- 86: The winding input terminal (control circuit)
- 87: The output terminal for normally closed contact (work circuit)
- 87a: The output terminal for normally open contact (work circuit)

### Flasher units

Flasher units work automatically to interrupt and connect the flow of current (see figure 11). In the flasher unit a heating element heats a bimetallic strip that bends, breaking the contact with the power supply. When it cools down, the bimetallic strip once again makes contact and the cyclical process begins again.

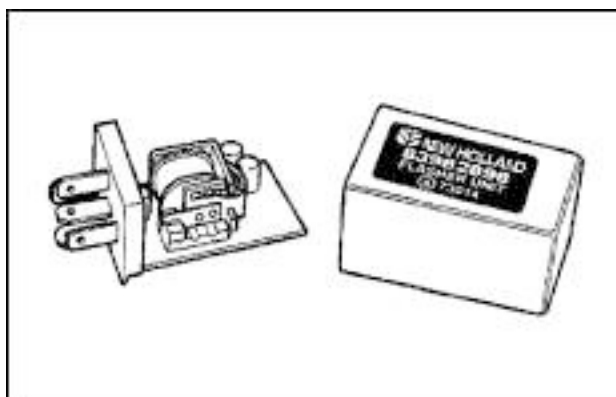

SEZ55CAP9A-58 11

## Solenoid valves

The solenoid valves (see figure 12) work in much the same way as relays, except that the iron core of the electromagnet is not fixed in place. As a result, the windings in the control circuit cause the iron core to move. A solenoid is basically a winding around an iron core. In the center of the core there is a plunger which is free to move through the core. When an electrical current passes through the winding, an electromagnetic force is produced which causes the plunger to move through the core. If the current is switched OFF, the force is stopped and the plunger is returned by a spring. The plunger is used for example for the moving of a hydraulic spool or a mechanical lever.

Common faults of solenoid valves are a shorted (short circuit to ground) or broken (open circuit) winding, as well as sticking internal component parts.

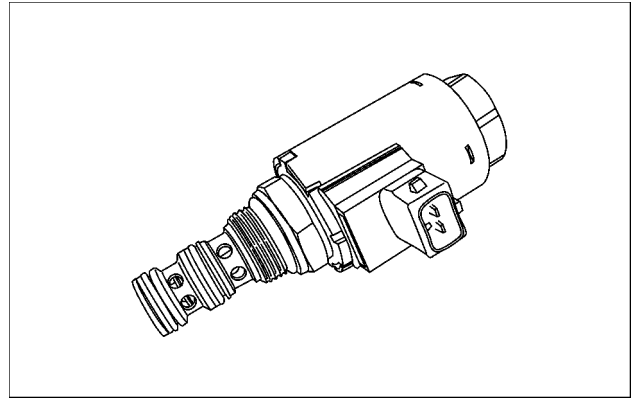

SS12D188 12

## Proportional solenoid valves

Whenever it is necessary to provide proportional control of a solenoid valve, the principle of operation called pulse width modulation (PWM) is used. The pulse width modulation uses a variable DC voltage signal to control a solenoid valve. The voltage signal is pulsed ON and OFF many times a second at a constant voltage level. The processors for a pulse width modulation contain transistors that are supplied with a constant input voltage which is switched ON and OFF to achieve the variable voltage signal. With a proportional solenoid valve (see figure 13) and an appropriate pulse width modulation for example the hydraulic output flow is proportional to the average DC voltage. The lower average voltage allows the proportional solenoid valve to operate with less residual magnetism and so the entire circuit will operate smoother.

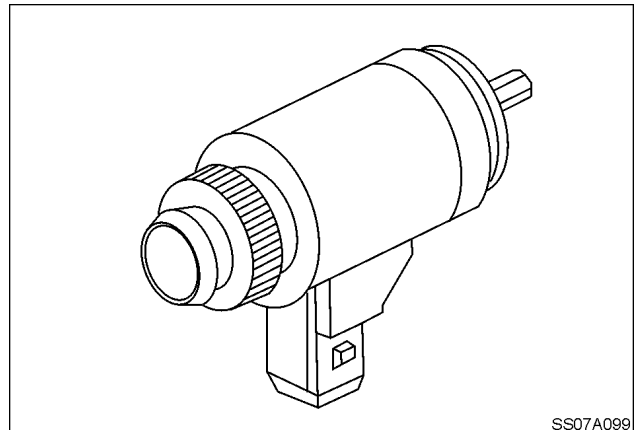

SS07A099 13

The variable DC voltage signal is determined by varying the duration of the ON pulse relative to the OFF pulse (see figure 14). The ratio between the ON time and the cycle time is called duty cycle and is stated as a percentage of one complete cycle. The diagrams in column (A) show the voltage signal that is sent to the solenoid valve (pulse width modulation). The diagrams in column (B) show the spring displacement of the solenoid valve (appropriate to the solenoid valve opening). The diagrams in column (C) show the reading on a voltmeter connected to the solenoid valve terminals (average DC voltage). The diagrams (1) to (3) show the normal operating range of a proportional solenoid valve controlled by pulse width modulation. Diagram (4) shows the behavior of the solenoid valve with a constant input voltage signal (full opening). Diagram (1) shows the OFF position (no signal is directed to the solenoid valve). Increasing the duty cycle causes the increase of the pressure in the hydraulic circuit, which results in a voltmeter reading increase. Diagram (3) shows the maximum signal that is used during the normal activity of the solenoid valve (its duty cycle is around 0.5).

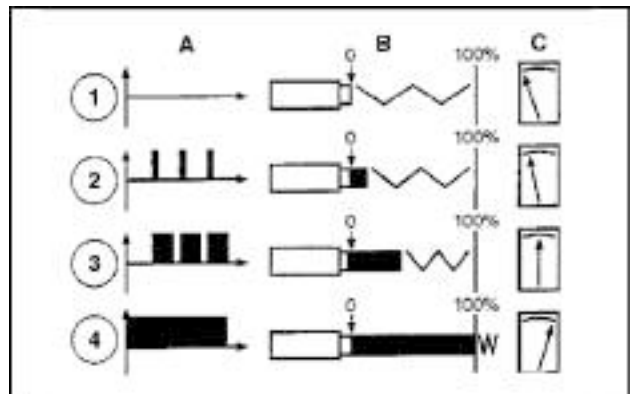

SEZ55CAP9A-11 14

## SENSORS

A sensor measures a physical quantity and converts it into a signal which can be read for example of an electronic control unit. The relationship between the physical quantity and the output signal is a characteristic of the sensor (see figure 15 for the example of a combined temperature and pressure sensor).

Some sensor measurement principles and sensor examples:

- Resistive sensors: Potentiometer, thermistor, strain gauge (force sensor)
- Inductive sensors: Position encoder, speed sensor
- Magnetic field sensors: Hall-effect sensor (speed sensor, position sensor, or pressure sensor)
- Electrochemical sensors: Lambda sensor
- Capacitive sensors: Displacement sensor, pressure sensor
- Piezoelectric sensors: Piezoelectric accelerometer, strain gauge (force sensor)
- Electromagnetic waves: Radar sensor

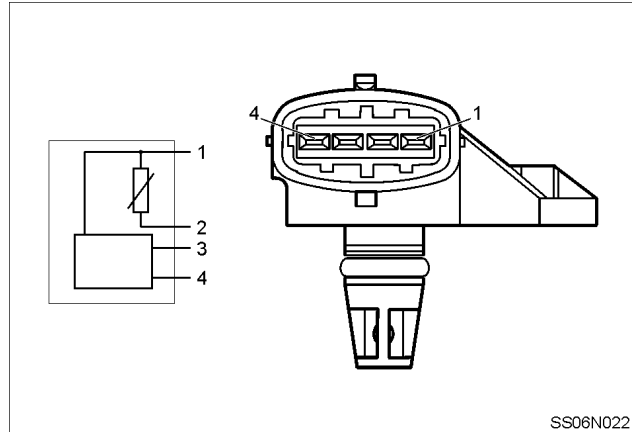

SS06N022 15

SS06N022

### Temperature sensors

Temperature sensors are mostly resistive sensors (so called thermistors). A thermistor is a resistor that significantly changes its resistance according to the temperature (see figure 16).

There are two groups of thermistors:

- The resistance of a thermistor with a negative temperature coefficient (NTC) decreases with increasing temperature. These thermistors are often used as sensors to indicate the temperature of fluids (e.g. engine coolant fluid).
- The resistance of a thermistor with a positive temperature coefficient (PTC) increases with increasing temperature.

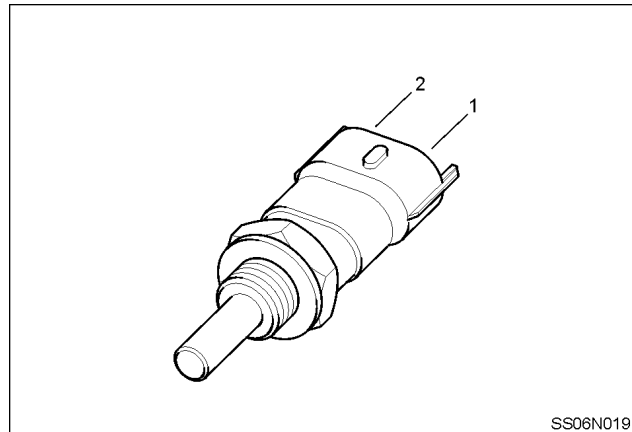

SS06N019 16

SS06N019

### Pressure sensors

A pressure sensor measures mostly the pressure of gases or liquids. The pressure sensor (see figure 17) generates an electrical signal as a function of the pressure imposed (e.g. oil pressure). A pressure sensor can base on a piezoelectric, capacitive, or electromagnetic measurement principle.

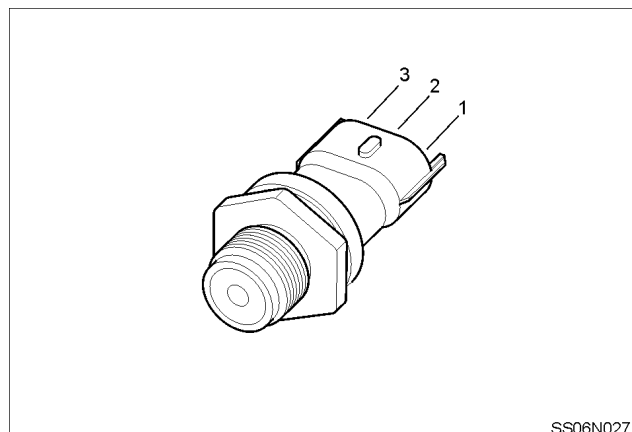

SS06N027 17

SS06N027

## Speed sensors

A speed sensor measures the speed of a rotating object (e.g. wheel or shaft). A speed sensor can be realized as a Hall-effect sensor (see figure 19) or as an inductive sensor (variable reluctance sensor, see figure 18). Both sensor types operate contactless (no wear or friction). The variable reluctance sensor consists of a permanent magnet, a ferromagnetic pole piece and a magnetic pickup. A Hall-effect speed sensor consists of semiconductor elements and measures a change in magnetic flux caused by a ferromagnetic gear.

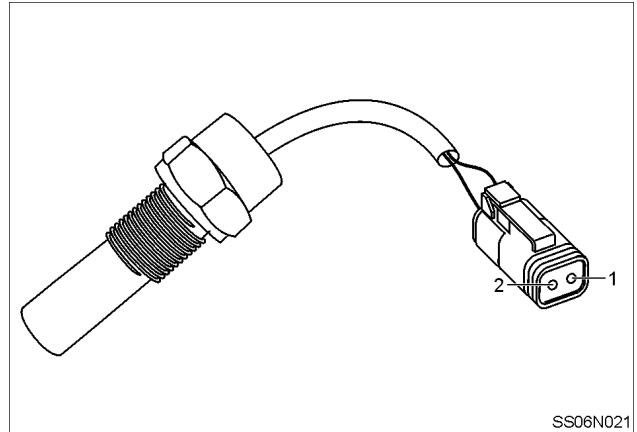

SS06N021 18

For the measurement of the rotation speed of a shaft, both sensor types are located in the immediate proximity of some kind of transmitter wheel which is attached to the shaft. The movement of the transmitter wheel leads for both sensor types to a time-varying proportional sensor output voltage. The sensor output voltage is transmitted to a control unit. The control unit converts the sensor output voltage into an appropriate speed signal.

The advantages of the Hall-effect speed sensor:

- Measurement of very low speed (standstill detection)
- Wide temperature range
- Highly repeatable operation

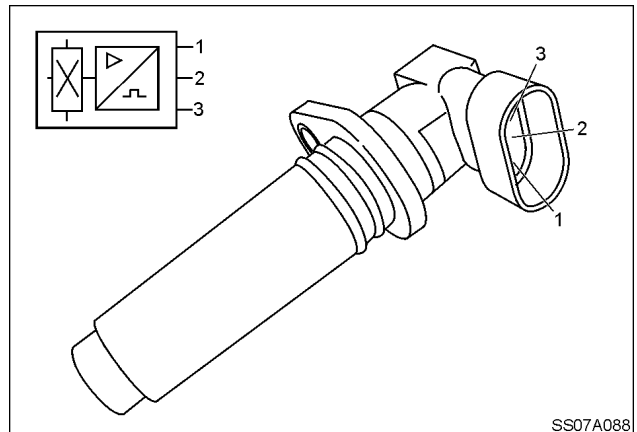

SS07A088 19

## Water in fuel sensors

A water in fuel sensor indicates the presence of water in the fuel (see figure 20). The measurement principle is based on the different electric conductivity of water and fuel. The water in fuel sensor is usually located in the fuel filter.

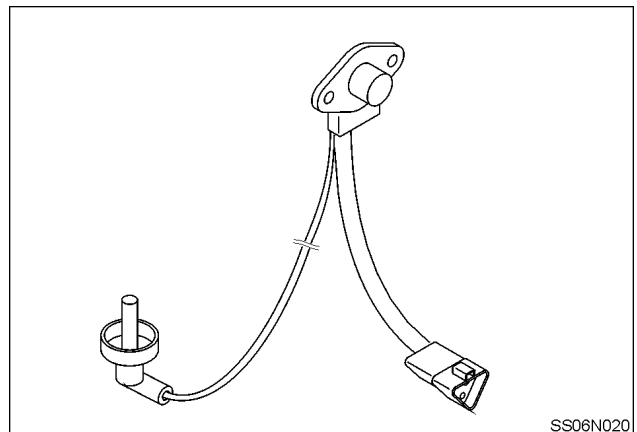

SS06N020 20



## Position sensors

A position sensor is a device that performs position measurement. A position sensor can be either a relative position sensor (displacement sensor) or an absolute position sensor. There are linear, angular, or multi-axis position sensors. A position sensor can base for example on a capacitive, an inductive, or a resistive (rotary potentiometer, see figure 21) measurement principle.

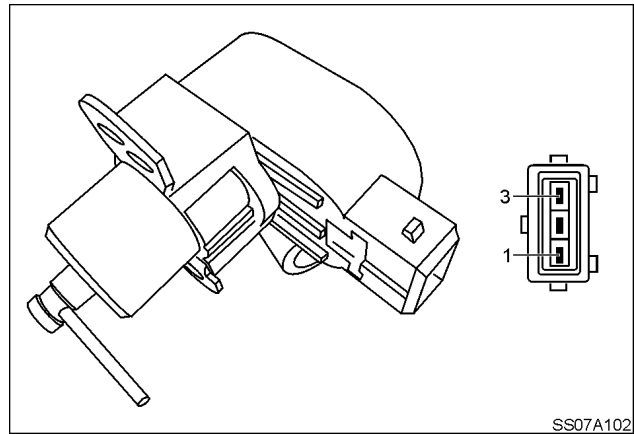

SS07A102 21

## Fluid level sensors

A fluid level sensor can be realized as a resistive sensor. A resistive sensor variant operates by varying the resistance through the movement of a float (like a potentiometer). An example is the fuel level sensor (see figure 22).

- (1) and (4): Fuel pipes
- (2): Gauge body with the potentiometer
- (3): Float

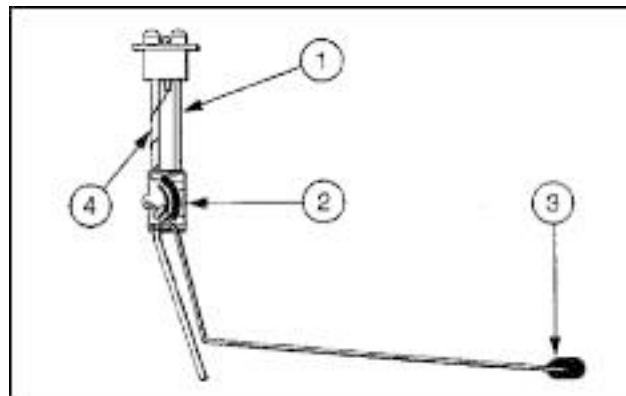

SEZ55CAP9A-13 22

## Electrical system - Electrical test

**NOTE:** This section is intended as a general guide for electrical testing on the vehicle.

Four electrical tests will be required to properly troubleshoot electrical concerns on the vehicle. The following electrical tests are based on the usage of a digital multimeter. The necessary nominal values are given in the appropriate test procedures (e.g. fault code resolution).

1. Detection of a short circuit to ground (continuity test)
2. Detection of a short circuit to a supply voltage (voltage measurement)
3. Detection of an open circuit (continuity test)
4. Resistance test (testing an electrical component)

**NOTE:** It is recommended to switch OFF the power supply (ignition key in the OFF position) before you disconnect an electrical connector.

### Detection of a short circuit to ground (continuity test)

1. Switch OFF the power supply (ignition key in the OFF position). Depending on the specific test procedure, sometimes the battery has to be disconnected or a fuse has to be removed.
2. Disconnect the connectors at the ends of the investigated circuit to prevent false measurement results. All other connectors must be connected.
3. Set the digital multimeter to resistance measurement (Ohm). Measure the resistance in the circuit.
4. Use the black lead of the multimeter to make contact with a ground connection (e.g. with a bare metal part on the chassis such as a jump start post if fitted). Make sure that the ground connection is not corroded.
5. Use the red lead of the multimeter to touch the connector pins (one pin at a time).
6. Determine if the measured resistance falls within guidelines specified in the procedure. A resistance below **4  $\Omega$**  indicates a direct short to circuit ground. Higher resistances usually indicate circuit paths through modules. In such case additional connectors need to be disconnected to perform additional tests. A resistance above **100 k $\Omega$**  indicates that the circuit is free of a short circuit to ground.

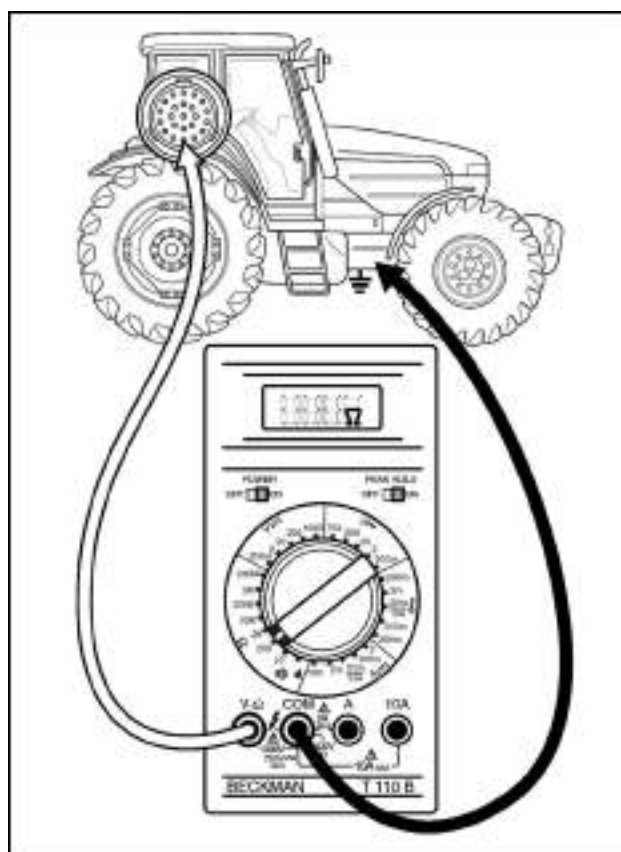

SEZ55CAP9B-6 1

### Detection of a short circuit to a supply voltage (voltage measurement)

1. Switch ON the power supply (ignition key in the ON position). Depending on the specific test procedure, sometimes the power supply needs to be switched OFF.
2. Disconnect the connector at the investigated electrical component (e.g. sensor). Depending on the specific test procedure, sometimes you need special connector adapters to perform the measurement in a closed circuit. All other connectors must be connected.
3. Set the digital multimeter to voltage measurement (DC). Measure the voltage as illustrated.
4. Use the black lead of the multimeter to make contact with a ground connection (e.g. with a plated metal part on the chassis such as a jump start post if fitted). Make sure that the ground connection is not corroded.
5. Use the red lead of the multimeter to touch the connector pins (one pin at a time).
6. Determine if the measured voltage falls within guidelines specified in the procedure.

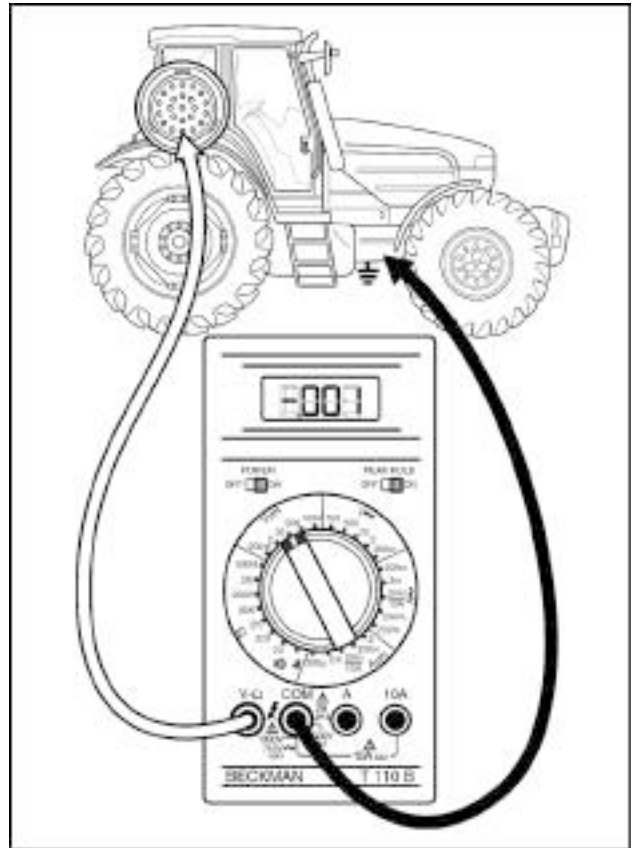

SEZ55CAP9B-1 2

### Detection of an open circuit (continuity test)

1. Switch OFF the power supply (ignition key in the OFF position). Depending on the specific test procedure, sometimes the battery has to be disconnected or a fuse has to be removed.
2. Disconnect the connectors at the ends of the investigated circuit to prevent false measurement results. All other connectors must be connected.
3. Set the digital multimeter to resistance measurement (Ohm). Measure the resistance in the circuit as illustrated.
4. Use the red lead of the multimeter to touch the connector pins (one pin at a time).
5. Use the black lead of the multimeter to make contact with the connector pin at the other end of the investigated circuit.
6. Determine if the measured resistance falls within guidelines specified in the procedure. A resistance below  $4 \Omega$  indicates a continuous circuit. Higher resistances usually indicate dirty or corroded terminals of the connectors. A resistance above  $100 \text{ k}\Omega$  indicates an open circuit.

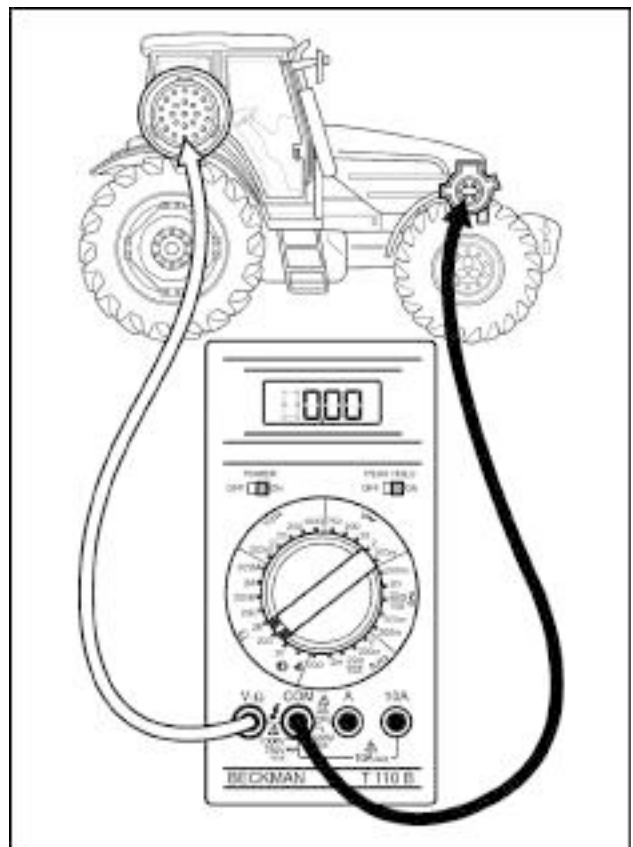

SEZ55CAP9B-2 3

## Resistance test (testing an electrical component)

**NOTE:** Nominal resistance values are usually valid for a temperature of **20 °C (68.00 °F)**. With higher or lower tractor temperatures, the relative resistance values shown in the manual should vary accordingly.

1. Disconnect the electrical component from the vehicle by unplugging the connectors to expose the component connector for testing.
2. Set the digital multimeter to resistance measurement (Ohm). Measure the resistance in the circuit.
3. Insert the red and the black lead of the multimeter into the connector terminals (connector pins) as specified in the test procedure.
4. In order to verify the correct operation of a potentiometer, the resistance should be measured between the minimum and the maximum position. Therefore smoothly move the sliding contact between the minimum and the maximum position. Execute this measurement twice with the test leads in both connection possibilities (as illustrated).
5. In order to verify the correct operation of a switch, operate the switch while checking for an open circuit or a short circuit.
6. Compare the measured resistance values to the values specified in the test procedure.

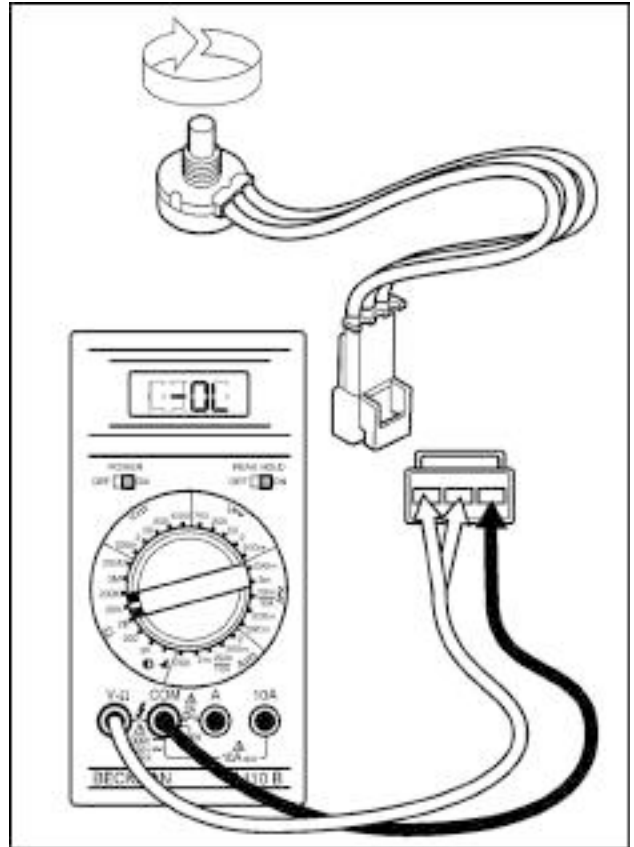

SEZ55CAP9B-7 4

## Electrical system - Electrical test – Usage of a digital multimeter

**NOTE:** This section is intended as a general guide for the usage of a digital multimeter. Always refer to the manufacturer's operator's manual for correct operation.

### Measurement type

A digital multimeter is an electronic measuring device. The different types of measurement that can be made depend upon the model of the multimeter.

Most types of multimeter have the capacity to measure:

- AC or DC current (A)
- AC or DC voltage (V)
- Resistance (Ohm)
- Continuity (buzzer test)
- Signal frequency (Hz)
- Temperature (with a connected thermistor)
- Testing of diodes or capacitors



SEZ55CAP9A-50 1

### General operation

Choose the measurement type:

- Before proceeding with a test, decide on what is going to be measured (voltage, current, etc.)
- Rotate the dial until the pointer is within the relevant zone (measurement type). Within each zone there are different scales.
- The scale that is selected will represent the maximum value that the multimeter will read. Always select a scale which is greater than the value that you intend to measure.
- If you are unsure of the value to be measured, always select the highest scale and then reduce the scale once you have an idea of the measured value.

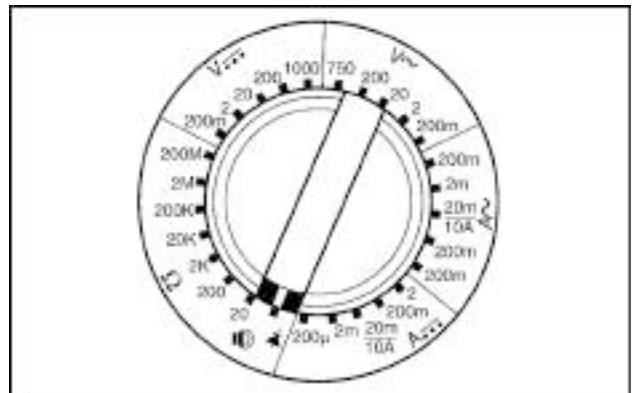

SEZ55CAP9A-51 2

Choose the right scale:

- The closer the selected scale is to the measured value, the more accurate the reading will be.
- For example, if you measure the voltage of a battery with the scale set at **200 V**, the display may read **12 V**.
- If the scale was set to **20 V** the display may read a more accurate reading of **12.27 V**.

Giga	G	1,000,000,000	$10^9$
Mega	M	1,000,000	$10^6$
Kilo	K	1,000	$10^3$
milli	m	0.001	$10^{-3}$
micro	$\mu$	0.000 001	$10^{-6}$
nano	n	0.000 000 001	$10^{-9}$
pico	p	0.000 000 000 001	$10^{-12}$

SEZ55CAP9A-2 3

### Measuring voltage (V)

**NOTE:** Connect the multimeter parallel to the component (circuit closed).

1. Depending on the voltage you intend to measure, set the range dial to either AC or DC voltage.
2. Connect the black lead of the multimeter to the COM terminal.
3. Connect the red lead of the multimeter to the V/ $\Omega$  terminal.
4. Place the leads across the component to be measured with the circuit complete (closed).
5. Read off the display value.

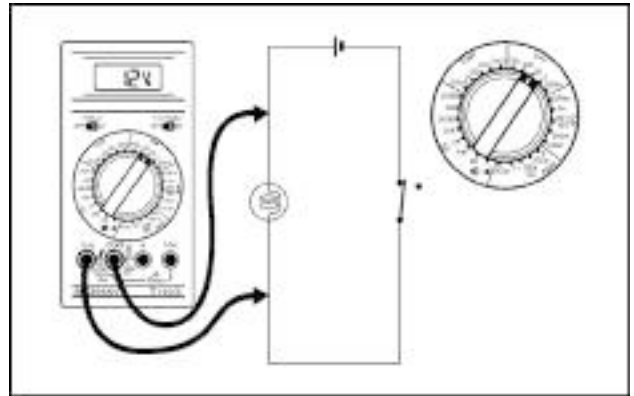

SEZ55CAP9A-52 4

### Measuring current (A)

**NOTE:** Connect the multimeter in series with the circuit (circuit closed).

**NOTE:** Digital multimeters are usually protected with a **10 A** fuse.

1. Depending on the current you intend to measure, set the range dial to either AC or DC current.
2. Connect the black lead of the multimeter to the COM terminal.
3. When you measure a current up to **2 A**, connect the red lead of the multimeter to the A terminal. When you measure a current up to **10 A**, connect the red lead of the multimeter to the **10 A** terminal.
4. For the measurement of current, always break the circuit and connect the multimeter in series with the circuit.
5. Read off the display value.

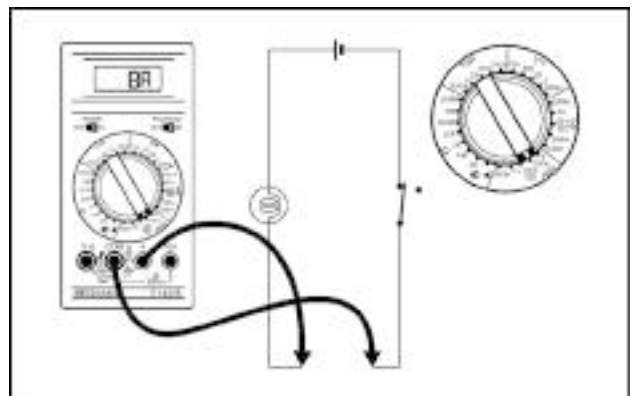

SEZ55CAP9A-53 5

### Measuring resistance (Ohm)

**NOTE:** Connect the multimeter parallel to the component (circuit open).

1. Set the range dial to the desired resistance range.
2. Connect the black lead of the multimeter to the COM terminal.
3. Connect the red lead of the multimeter to the V/ $\Omega$  terminal.
4. If the resistance being measured is connected in a circuit, then switch OFF the power supply for the circuit.
5. Connect the leads of the multimeter to the measuring points (e.g. connector pins).
6. Read off the display value.

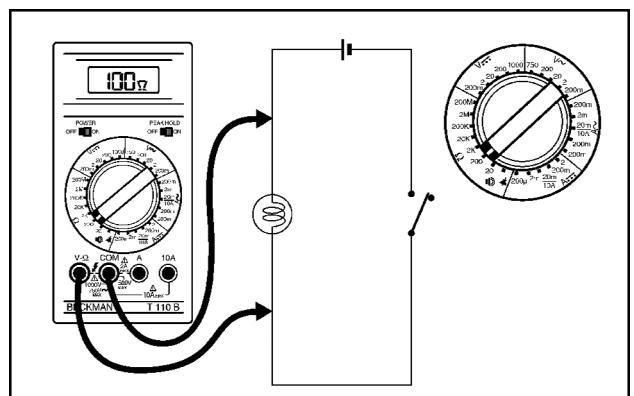

SEZ55CAP9A-3 6

### Continuity test (buzzer test)

**NOTE:** Connect the multimeter parallel to the component (circuit open).

1. Set the range dial to the buzzer position.
2. Connect the black lead of the multimeter to the COM terminal.
3. Connect the red lead of the multimeter to the V/ $\Omega$  terminal.
4. Connect the leads of the multimeter to the measuring points (e.g. connector pins).
5. In general, if the resistance is less than **50  $\Omega$**  then the buzzer will sound, indicating continuity.

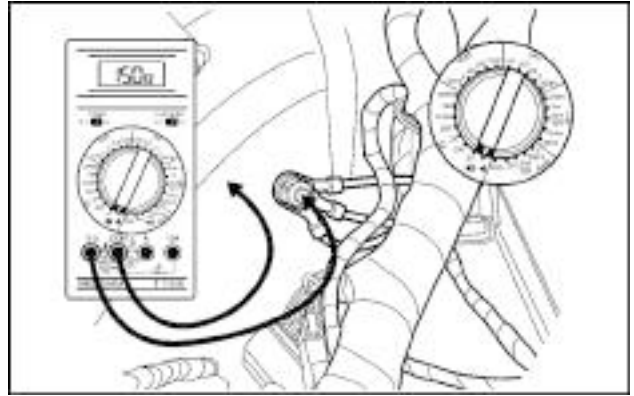

SEZ55CAP9A-54 7

**NOTE:** The buzzer tests on different multimeters can sound at different resistance values, depending on the quality of the multimeter. This can be misleading, for example when checking a corroded ground point. A poor quality multimeter may buzz at **150  $\Omega$** , indicating continuity and no problem. When using a higher quality multimeter for the same test, it would not buzz due to the high resistance. When you carry out a buzzer test, you should always additionally check the value of resistance. A good connection gives low resistance. A bad connection gives high resistance.

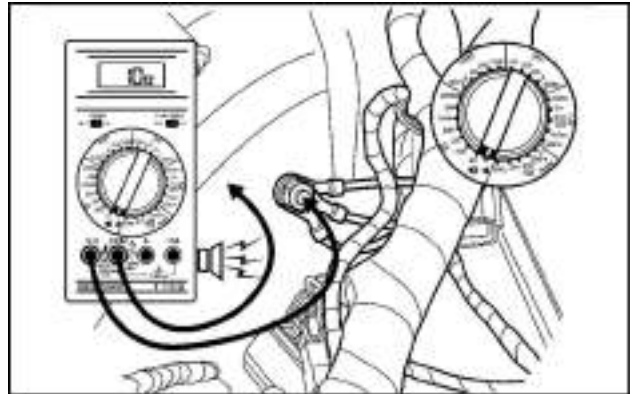

SEZ55CAP9A-69 8

# Index

---

## Electrical systems - 55

### Electrical system - 000

Electrical system - Electrical test – Usage of a digital multimeter .....	14
Electrical system - Electrical test .....	11
Electrical system - Static description – Circuit components .....	3







## **Electrical systems - 55**

### **Harnesses and connectors - 100**

**Farmall 105U Pro EP  
Farmall 115U Pro EP  
Farmall 95U Pro EP**

# Contents

---

## Electrical systems - 55

### Harnesses and connectors - 100

#### FUNCTIONAL DATA

##### Fuse and relay box

Static description .....	5
Identification .....	7

##### Wiring harnesses

Electrical schema – Symbols .....	12
Electrical schematic sheet 01 - STARTING, CHARGING, POWER DISTRIBUTION and FUSES .....	14
Electrical schematic sheet 02 - IGNITION SWITCH and FUSES .....	16
Electrical schematic sheet 03 - INSTRUMENT CLUSTER 1 .....	18
Electrical schematic sheet 04 - INSTRUMENT CLUSTER 2 .....	20
Electrical schematic sheet 05 - ENGINE CONTROL UNIT 1 .....	22
Electrical schematic sheet 06 - ENGINE CONTROL UNIT 2 .....	24
Electrical schematic sheet 07 - TRANSMISSION CONTROL UNIT 1 .....	26
Electrical schematic sheet 08 - TRANSMISSION CONTROL UNIT 2 .....	28
Electrical schematic sheet 09 - CENTRAL CONTROL UNIT (four-wheel drive, differential lock and backup alarm) .....	30
Electrical schematic sheet 10 - CENTRAL CONTROL UNIT (front and rear power take-off) .....	32
Electrical schematic sheet 11 - CENTRAL CONTROL UNIT (electronic draft control 1) .....	34
Electrical schematic sheet 12 - CENTRAL CONTROL UNIT (electronic draft control 2) .....	36
Electrical schematic sheet 13 - ELECTRO HYDRAULIC REMOTE VALVES (front and rear) .....	38
Electrical schematic sheet 14 - ELECTRONIC FRONT HITCH .....	40
Electrical schematic sheet 15 - FRONT LOADER (Hydrac) .....	42
Electrical schematic sheet 16 - FRONT LOADER (Stoll) .....	44
Electrical schematic sheet 17 - HEATING, VENTILATION and AIR-CONDITIONING .....	46
Electrical schematic sheet 18 - LIGHTING (headlights, side lights, cab interior light) .....	48
Electrical schematic sheet 19 - RADIO and MIRRORS (electrically adjustable and heated) .....	50
Electrical schematic sheet 20 - LIGHTING (flasher, hazard light switch and follow me home) .....	52
Electrical schematic sheet 21 - WORK LIGHT and ROTATING BEACON .....	54
Electrical schematic sheet 22 - WIPER and WASHER (front and rear) .....	56
Electrical schematic sheet 23 - POWER SOCKETS .....	58
Electrical schematic sheet 24 - CAN bus 1 and ELECTRO HYDRAULIC REMOTE VALVES – CAN bus .....	60
Electrical schematic sheet 25 - GROUND DISTRIBUTION .....	62
Static description .....	65
Identification .....	67

## Wire connectors

Component Diagram 00 .....	86
Component diagram 01 .....	102
Component diagram 02 .....	112
Component diagram 03 .....	123
Component diagram 04 .....	131
Component diagram 05 .....	142
Component diagram 06 .....	154
Component diagram 07 .....	162
Component diagram 08 .....	173
Component diagram 09 .....	180
Component diagram 10 .....	191
Component diagram 11 .....	192
Component diagram 12 .....	195
Component diagram 13 .....	203
Component diagram 15 .....	208
Component diagram 16 .....	212
Component diagram 17 .....	213
Component diagram 18 .....	214
Component diagram 19 .....	221
Component diagram 20 .....	223
Component diagram 21 .....	225
Component diagram 22 .....	227
Component diagram 23 .....	229
Component diagram 24 .....	231
Component diagram 25 .....	233
Component diagram 26 .....	234
Component diagram 28 .....	235
Component diagram 29 .....	236
Component diagram 30 .....	238
Component diagram 31 .....	250
Component diagram 32 .....	256
Component diagram 33 .....	266
Component diagram 34 .....	275
Component diagram 35 .....	287
Component diagram 36 .....	296
Component diagram 37 .....	303
Component diagram 38 .....	313
Component diagram 39 .....	324
Component diagram 40 .....	334
Component diagram 41 .....	350
Component diagram 42 .....	351
Component diagram 43 .....	352

Component diagram 44 .....	356
Component diagram 45 .....	358
Component diagram 46 .....	360
Component diagram 47 .....	373
Component diagram 50 .....	375
Component diagram 51 .....	384
Component diagram 52 .....	389
Component diagram 53 .....	400
Component diagram 55 .....	407
Component diagram 57 .....	409
Component diagram 60 .....	410
Component diagram 65 .....	411
Component diagram 69 .....	413
Component diagram 70 .....	416
Component diagram 80 .....	418
Component diagram 93 .....	420
Component diagram 94 .....	430
Component diagram 95 .....	445
Component diagram 96 .....	454
Component diagram 97 .....	464
Component diagram 98 .....	474
Component diagram 99 .....	478

## SERVICE

### Wiring harnesses

Repair .....	479
Rewire .....	481

## Fuse and relay box - Static description

For the description and function of a specific fuse or a specific relay, refer to **Fuse and relay box - Identification (55.100)**.

### Fuse and relay box – Cab

The fuse and relay box is located inside the cab underneath the left-hand side panel (1). Remove the left-hand side panel (1) to get access to the fuse and relay box.

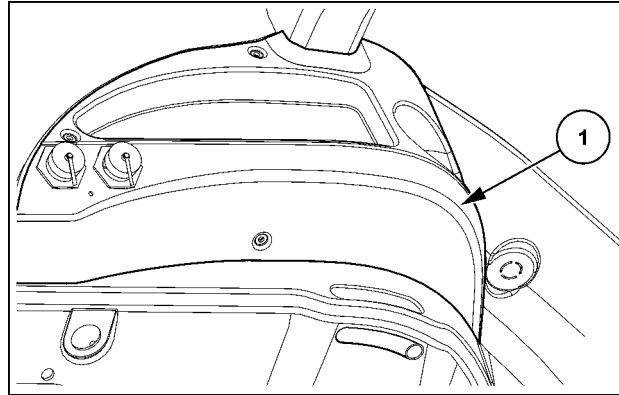

SS13A822 1

### Power distribution unit – Engine

The power distribution unit (1) is located on the right-hand side of the engine. Open the engine hood to get access to the power distribution unit (1).

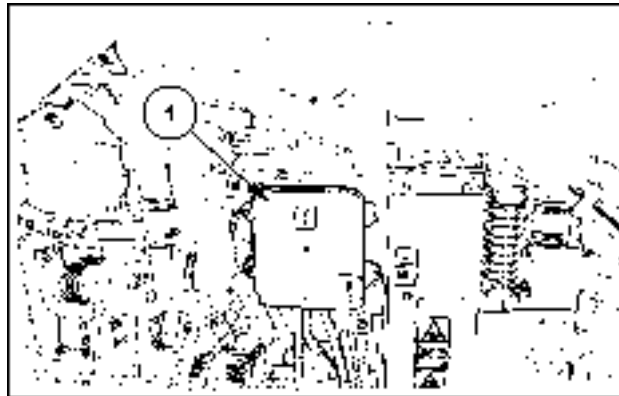

SVIL13TR00080AD 2

### Relay and fuse block – Roof

The relay and fuse block is located on the right-hand side B-pillar behind a cover (1). Remove the cover (1) to get access to the relay and fuse block.

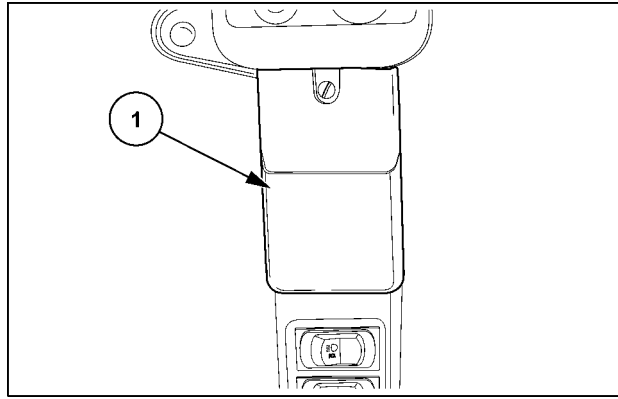

SS13A823 3

### Additional fuses and relays

The fuse F-059 (permanent battery power supply) (1) is located on the left-hand side of the tractor next to the battery.

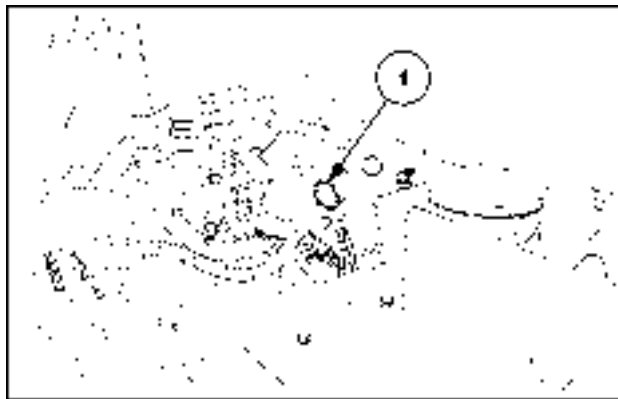

SVIL13TR00272AB 4

The intermittent windshield wiper module (K-034) (1) is located inside the cab underneath the left-hand side panel next to the fuse and relay box.

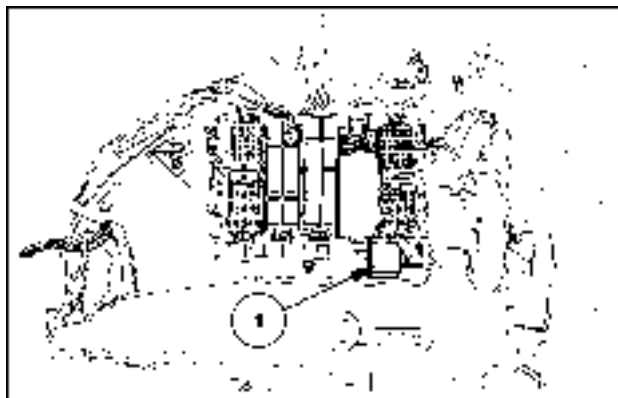

SVIL13TR00275AB 5

The following relays are located behind the operator's seat behind the cab side panel:

No.	Description
K-010	Hydraulic trailer brake relay
K-055	Front loader relay – Valve 1
K-056	Front loader relay – Valve 2
K-080	Front hitch raise relay
K-081	Front hitch lower relay
K-083	Front hitch lock relay

## Fuse and relay box - Identification

**NOTICE:** Do not replace a blown fuse with another fuse of a different rating.

### Fuse and relay box – Cab

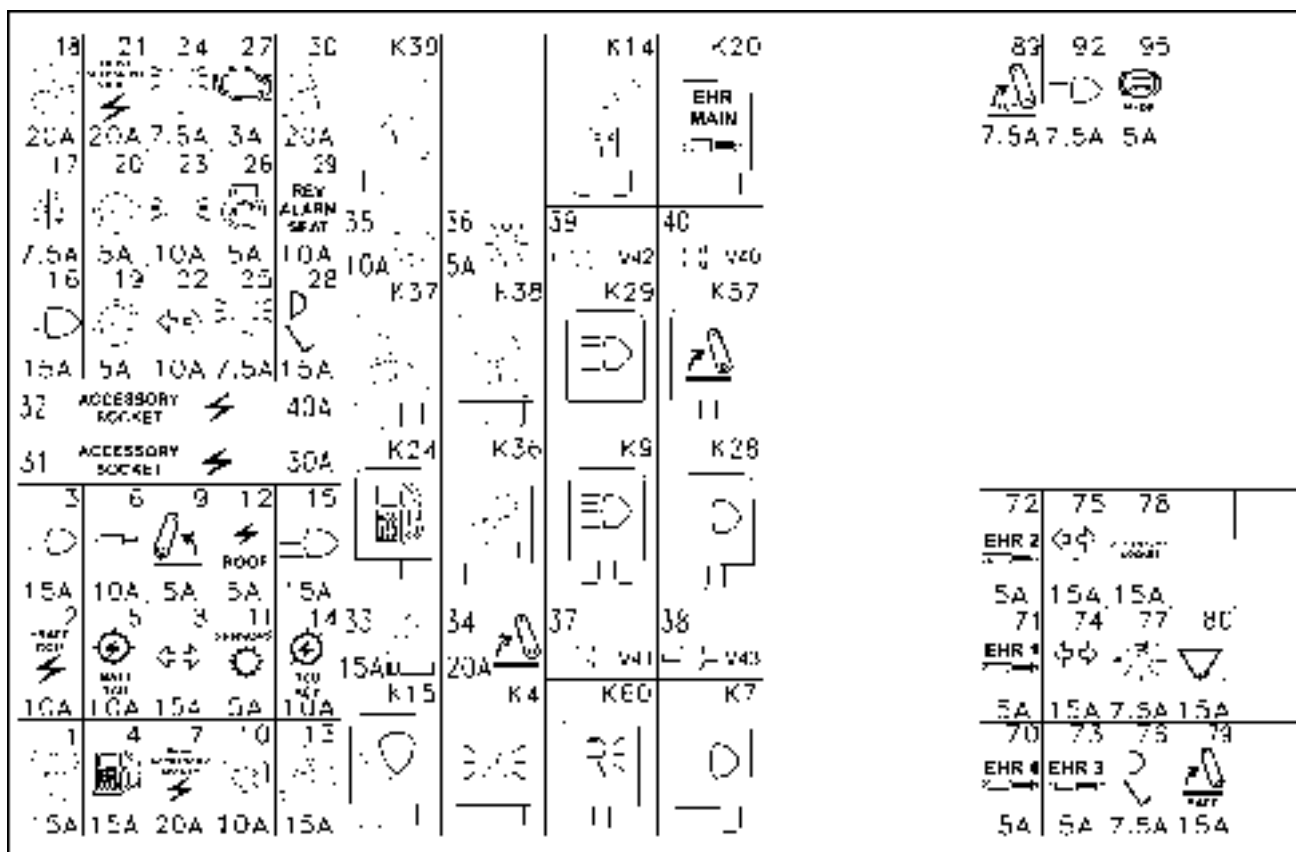

SS13A923 1

### Fuses

No.	Rating	Description
F-001	15 A	Blower motor left-hand (third speed step)
F-002	10 A	Central Control Unit (CCU) – Permanent battery power supply (keep alive memory)
F-003	15 A	Low beam headlights
F-004	15 A	Fuel heater
F-005	10 A	Transmission Control Unit (TCU) – Battery power supply
F-006	10 A	Electro Hydraulic Remote (EHR) valves, Hydraulic master switch
F-007	20 A	Power socket 40 A – Cab outside (switched battery power supply)
F-008	15 A	Flasher unit (battery power supply)
F-009	5 A	Electronic Draft Control (EDC), Radar sensor
F-010	10 A	Rear Power Take-Off (PTO), Front Power Take-Off (PTO), Four-Wheel Drive (4WD), Rear axle differential lock, Front axle differential lock, Parking brake
F-011	5 A	Transmission Control Unit (TCU) and rear Power Take-Off (PTO) – Switched battery power supply
F-012	5 A	Air-conditioning compressor, Cab roof power supply (switched battery power supply), Main light switch
F-013	15 A	Blower motor right-hand (third speed step)
F-014	10 A	Transmission Control Unit (TCU) – Switched battery power supply
F-015	15 A	Main beam headlights
F-016	15 A	Engine hood work lights
F-017	7.5 A	Heating control unit
F-018	20 A	Blower motor left-hand (fourth speed step)
F-019	5 A	Instrument cluster (permanent battery power supply), Diagnostic socket (CAN bus 1)



Electrical systems - Harnesses and connectors

No.	Rating	Description
F-020	5 A	Instrument cluster (switched battery power supply), Foot throttle position sensor
F-021	20 A	Trailer socket front (7-Pin) – Switched battery power supply
F-022	10 A	Flasher unit (switched battery power supply)
F-023	10 A	Position light left-hand – Trailer socket rear (7-Pin) and trailer socket front (7-Pin)
F-024	7.5 A	Position light left-hand
F-025	7.5 A	Position light right-hand
F-026	5 A	Start relay, Clutch pedal switch – Start interlock
F-027	3 A	Engine Control Unit (ECU) – Switched battery power supply
F-028	15 A	Brake light
F-029	10 A	Seat assembly (compressor, heater, and seat switch), Backup alarm buzzer
F-030	20 A	Blower motor right-hand (fourth speed step)
F-031	30 A	Power socket 25 A – Cab inside (switched battery power supply)
F-032	40 A	Power socket 40 A – Cab outside (switched battery power supply)
F-033	15 A	Cigarette lighter (optional)
F-034	20 A	Electronic Front Hitch (EFH) – Power supply relay (switched battery power supply)
F-035	10 A	Horn, Front window wiper motor, Front window washer pump
F-036	5 A	Position lights, Main light switch
F-070	5 A	Electro Hydraulic Remote (EHR) valve 4 – Rear implement
F-071	5 A	Electro Hydraulic Remote (EHR) valve 1 – Front implement
F-072	5 A	Electro Hydraulic Remote (EHR) valve 2 – Front implement
F-073	5 A	Electro Hydraulic Remote (EHR) valve 3 – Rear implement
F-074	15 A	Flasher left-hand – Trailer socket rear (7-Pin) and trailer socket front (7-Pin)
F-075	15 A	Flasher right-hand – Trailer socket rear (7-Pin) and trailer socket front (7-Pin)
F-076	7.5 A	Brake light – Trailer socket rear (7-Pin)
F-077	7.5 A	Position light right-hand – Trailer socket rear (7-Pin) and trailer socket front (7-Pin)
F-078	15 A	Power socket 8 A – Cab inside, Cigarette lighter
F-079	15 A	Electronic Front Hitch (EFH) – Power supply (battery power supply)
F-080	15 A	Front loader power supply (switched battery power supply)
F-089	7.5 A	Electronic Front Hitch (EFH) – Power supply (switched battery power supply)
F-092	7.5 A	Headlight flasher
F-095	5 A	Hydraulic trailer brake – Power supply (switched battery power supply)

Relays

No.	Description
K-004	Position light relay
K-007	Low beam relay – Headlights
K-008	spare
K-009	Main beam relay – Headlights
K-014	Follow me home relay
K-015	Engine hood work lights – Relay
K-020	Remote valve relay
K-024	Fuel heater relay
K-028	Low beam relay – Grab rail headlights
K-029	Main beam relay – Grab rail headlights
K-036	Blower motor left-hand – Relay (third speed step)
K-037	Blower motor right-hand – Relay (third speed step)
K-038	Blower motor left-hand – Relay (fourth speed step)
K-039	Blower motor right-hand – Relay (fourth speed step)
K-057	Electronic Front Hitch (EFH) – Power supply relay
K-060	Backup alarm buzzer relay

**Power distribution unit – Engine**

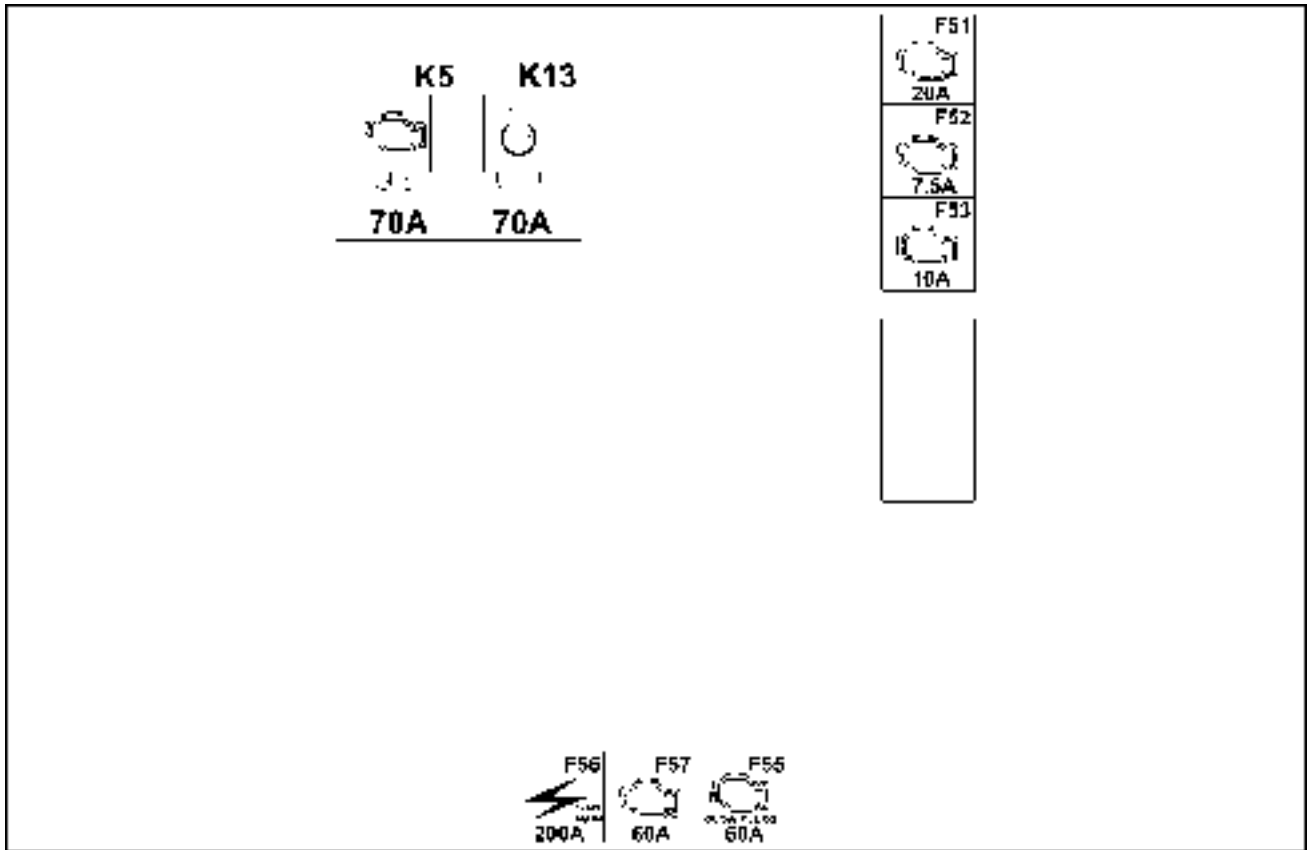

SS13A826 2

**Fuses**

No.	Rating	Description
F-051	<b>20 A</b>	Engine Control Unit (ECU) – Power supply (battery power supply)
F-052	<b>7.5 A</b>	Engine Control Unit (ECU) – Power supply (battery power supply)
F-053	<b>10 A</b>	Waste gate modulation solenoid, Lambda sensor
F-054		spare
F-055	<b>60 A</b>	Glow plug control module
F-056	<b>200 A</b>	Battery power supply (main fuse)
F-057	<b>60 A</b>	Start relay, Engine Control Unit (ECU) – Power supply relay
F-058		spare

**Relays**

No.	Description
K-005	Start relay
K-013	Engine Control Unit (ECU) – Power supply relay

**Relay and fuse block – Roof**

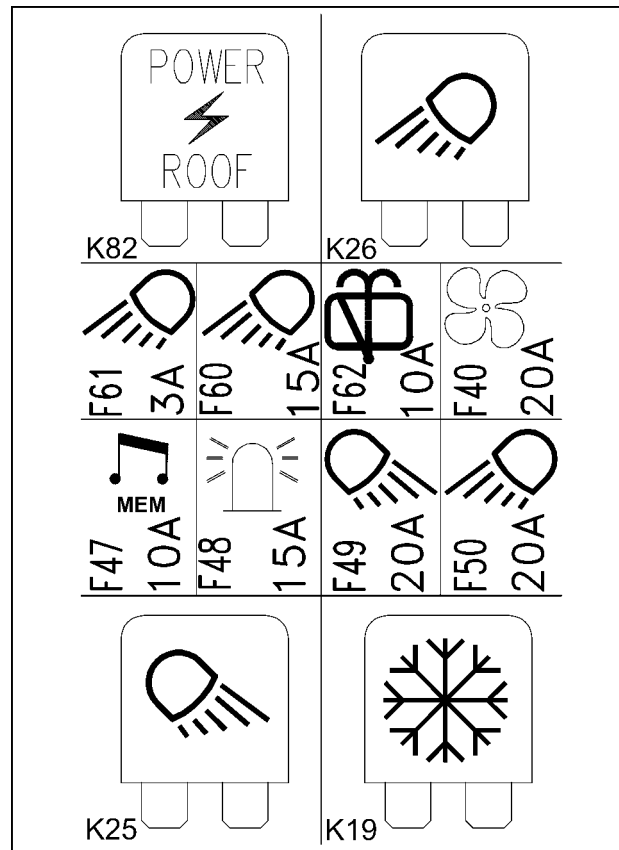

SS13A821 3

**Fuses**

No.	Rating	Description
F-040	20 A	Blower motors
F-047	10 A	Radio
F-048	15 A	Radio, Rotating beacons, Work light switch panel, Cab interior light
F-049	20 A	Rear work lights
F-050	20 A	Front work lights
F-060	15 A	Grab rail work lights
F-061	3 A	Work light switch panel
F-062	10 A	Rear window wiper motor, Rear window washer pump

**Relays**

No.	Description
K-019	Air-conditioning compressor relay
K-025	Second rear work lights – Relay
K-026	Second front work lights – Relay
K-082	Cab roof – Power supply relay

**Additional fuses and relays**

**Fuses**

No.	Rating	Description
F-059	15 A	Permanent battery power supply (main fuse)

---

**Relays**

<b>No.</b>	<b>Description</b>
K-010	Hydraulic trailer brake relay
K-034	Intermittent windshield wiper module
K-055	Front loader relay – Valve 1
K-056	Front loader relay – Valve 2
K-080	Front hitch raise relay
K-081	Front hitch lower relay
K-083	Front hitch lock relay

## Wiring harnesses - Electrical schema – Symbols

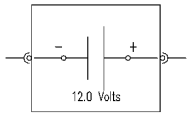

Battery

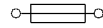

Fuse

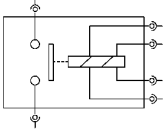

Battery isolator

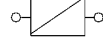

Solenoid

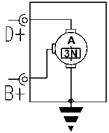

Alternator

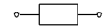

Resistor

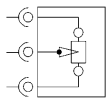

Potentiometer



Heating resistor

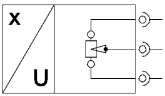

Sensor

- x: Physical quantity
- U: Voltage



Diode

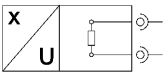

Sensor

- x: Physical quantity
- U: Voltage

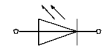

LED (Light Emitting Diode)

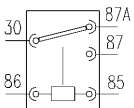

Relay

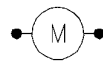

Motor

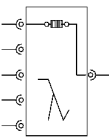

Lambda sensor

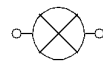

Light

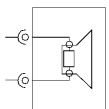

Speaker



Connector pin

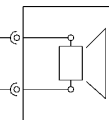

Horn



Wire break arrow

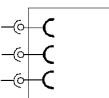

Socket



Ground connection



Switch



## Wiring harnesses - Electrical schematic sheet 01 - STARTING, CHARGING, POWER DISTRIBUTION and FUSES

Component	Connector	Description	
F-051	–	Engine Control Unit (ECU) – Power supply (battery power supply)	
F-052	–	Engine Control Unit (ECU) – Power supply (battery power supply)	
F-053	–	Waste gate modulation solenoid, Lambda sensor	
F-055	–	Glow plug control module	
F-056	–	Battery power supply (main fuse)	
F-057	–	Start relay, Engine Control Unit (ECU) – Power supply relay	
F-059	<b>X-552</b>	Permanent battery power supply (main fuse)	
G-001	<b>X-500, X-600</b>	Battery	
G-002	<b>X-012, X-013</b>	Alternator	
K-005	–	Start relay	
K-013	–	Engine Control Unit (ECU) – Power supply relay	
M-003	<b>X-010, X-011, X-304</b>	Starter motor	
Q-001	<b>X-008, X-009-A, X-009-B</b>	Battery isolator	
S-006	<b>X-197</b>	Battery isolator control switch	
Z-083	<b>X-003, X-004, X-005, X-006, X-007, X-014, X-049, X-533</b>	Power distribution unit	
–	<b>X-570</b>	Ground connection battery	
Additional connectors: <b>X-001, X-002, X-060, X-385, X-553</b>			
Wire color codes			
BK Black	GN Green	PK Pink	BL Blue
TN Light Brown	BR Brown	OR Orange	LG Light Green
RD Red	GY Grey	LB Light Blue	
WH White	YE Yellow	VT Violet	

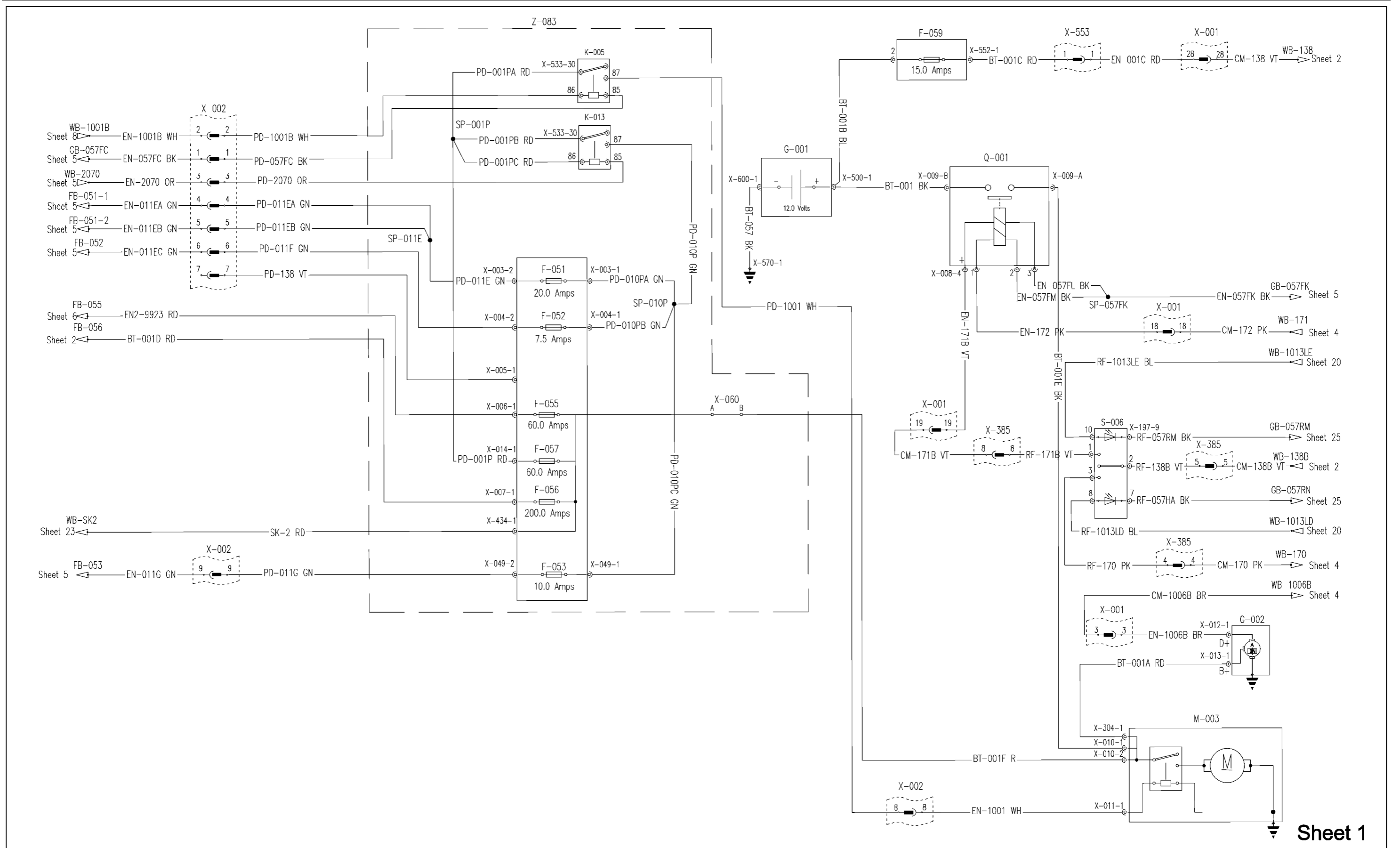

SS13A305 1



## Wiring harnesses - Electrical schematic sheet 02 - IGNITION SWITCH and FUSES

Component	Connector	Description	
F-003	–	Low beam headlights	
F-008	–	Flasher unit (battery power supply)	
F-012	–	Air-conditioning compressor, Cab roof power supply (switched battery power supply), Main light switch	
F-014	–	Transmission Control Unit (TCU) – Switched battery power supply	
F-015	–	Main beam headlights	
F-019	–	Instrument cluster (permanent battery power supply), Diagnostic socket (CAN bus 1)	
F-020	–	Instrument cluster (switched battery power supply), Foot throttle position sensor	
F-021	–	Trailer socket front (7-Pin) – Switched battery power supply	
F-022	–	Flasher unit (switched battery power supply)	
F-023	–	Position light left-hand – Trailer socket rear (7-Pin) and trailer socket front (7-Pin)	
F-024	–	Position light left-hand	
F-025	–	Position light right-hand	
F-026	–	Start relay, Clutch pedal switch – Start interlock	
F-027	–	Engine Control Unit (ECU) – Switched battery power supply	
F-028	–	Brake light	
F-029	–	Seat assembly (compressor, heater, and seat switch), Backup alarm buzzer	
F-078	–	Power socket <b>8 A</b> – Cab inside, Cigarette lighter	
S-007	<b>X-509, X-510, X-511, X-512</b>	Ignition switch	
Z-002	<b>X-130, X-180</b>	Fuse block	
Additional connectors: <b>X-050, X-370</b>			
Wire color codes			
BK Black	GN Green	PK Pink	BL Blue
TN Light Brown	BR Brown	OR Orange	LG Light Green
RD Red	GY Grey	LB Light Blue	
WH White	YE Yellow	VT Violet	

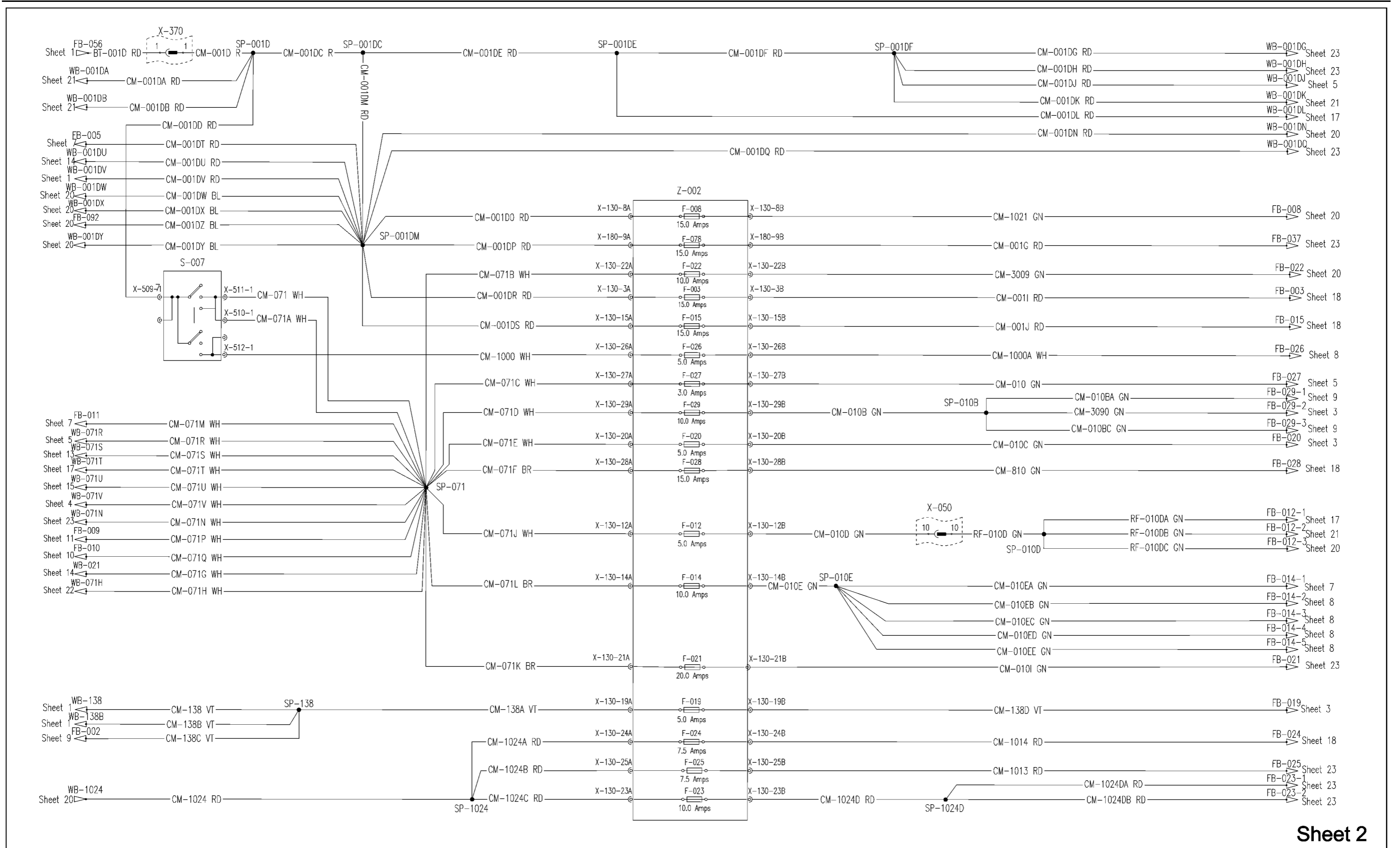

## Wiring harnesses - Electrical schematic sheet 03 - INSTRUMENT CLUSTER 1

Component	Connector	Description	
A-063	X-377, X-450, X-460	Instrument cluster	
B-024	X-354	Fuel level sensor	
B-040	X-184, X-185	Air brake pressure sensor	
B-061	X-324	Hand throttle sensor	
B-104	X-321	Foot throttle position sensor	
J-020	X-376	Diagnostic socket (CAN bus 1)	
M-009	-	Seat compressor	
R-017	-	Seat heater	
S-096	-	Seat switch	
Z-065	X-029, X-355	Seat assembly	
Additional connectors: X-001, X-300			
Wire color codes			
BK Black	GN Green	PK Pink	BL Blue
TN Light Brown	BR Brown	OR Orange	LG Light Green
RD Red	GY Grey	LB Light Blue	
WH White	YE Yellow	VT Violet	

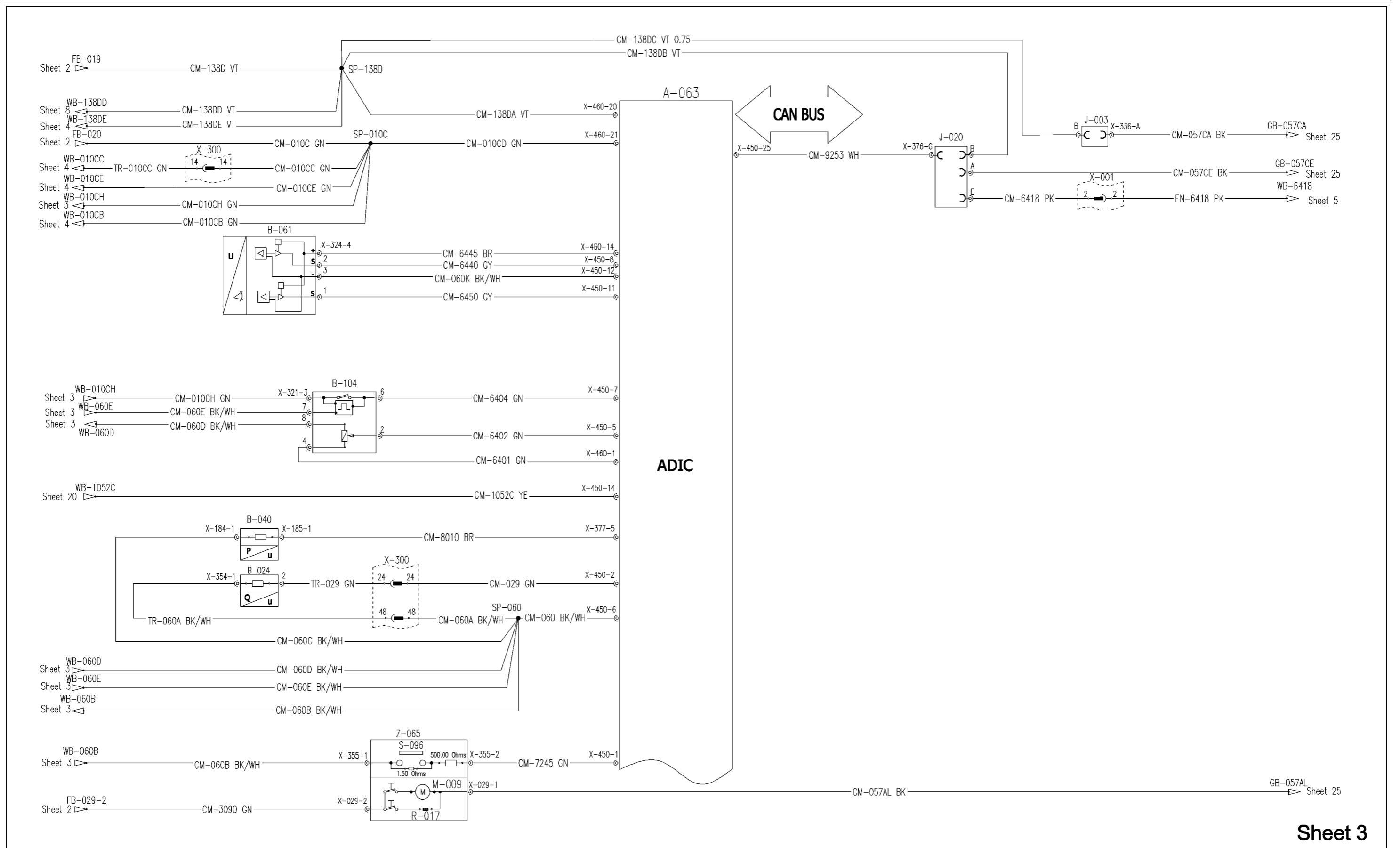

Sheet 3

SS13A307 1

## Wiring harnesses - Electrical schematic sheet 04 - INSTRUMENT CLUSTER 2

Component	Connector	Description	
A-063	X-377, X-450, X-460	Instrument cluster	
F-095	–	Hydraulic trailer brake – Power supply (switched battery power supply)	
J-005	X-378	Implement signal socket (ISO 11786)	
K-010	X-999	Hydraulic trailer brake relay	
S-022	X-357	Air cleaner restriction switch	
S-029	X-360	Brake fluid level switch	
S-030	X-358	Hand brake position switch	
S-073	X-303	Constant engine speed – Selector switch	
S-075	X-369	Constant engine speed – Adjust switch	
S-086	X-353, X-371	Steering pressure switch	
S-188	X-250	Home/enter menu switch	
S-189	X-260	Up/down menu switch	
S-195	X-359, X-399	Hydraulic trailer brake – Pressure switch	
Y-037	X-361	Hydraulic trailer brake – Solenoid valve	
Z-002	X-180	Fuse block	
Additional connectors: X-001, X-300, X-381, X-404, X-405			
Wire color codes			
BK Black	GN Green	PK Pink	BL Blue
TN Light Brown	BR Brown	OR Orange	LG Light Green
RD Red	GY Grey	LB Light Blue	
WH White	YE Yellow	VT Violet	

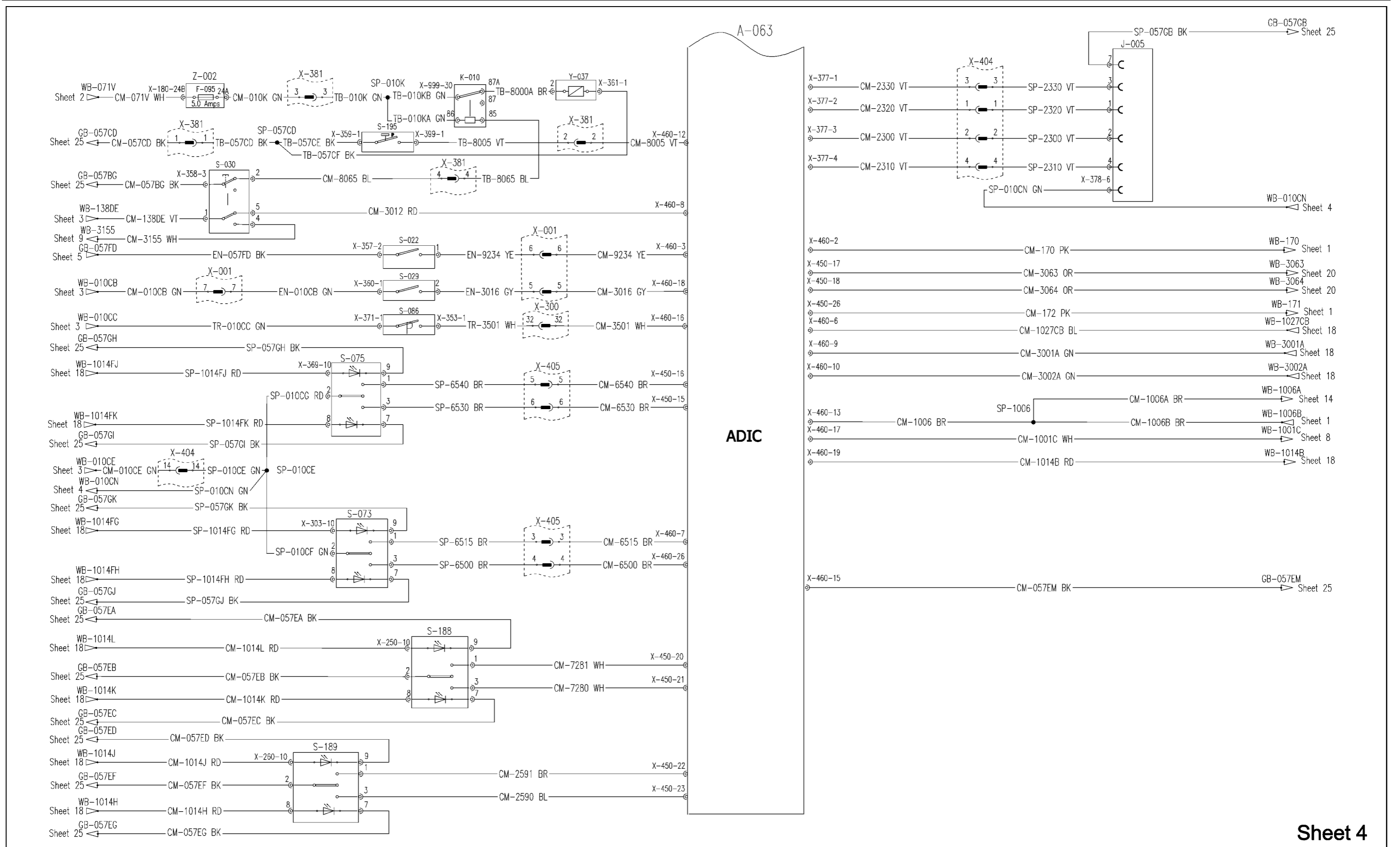

SS13A308 1

## Wiring harnesses - Electrical schematic sheet 05 - ENGINE CONTROL UNIT 1

Component	Connector	Description	
A-057	<b>X-937</b>	Engine Control Unit (ECU)	
B-012	<b>X-950</b>	Water in fuel sensor	
B-094	<b>X-945</b>	Diesel Particulate Filter (DPF) – Inlet temperature sensor	
B-095	<b>X-946</b>	Diesel Oxidation Catalyst (DOC) – Inlet temperature sensor	
B-096	<b>X-947</b>	Differential pressure sensor	
B-097	<b>X-971</b>	Exhaust manifold temperature sensor	
B-102	<b>X-942</b>	Inlet air temperature sensor	
B-103	<b>X-943</b>	Lambda sensor	
F-004	–	Fuel heater	
K-024	–	Fuel heater relay	
R-001	<b>X-362</b>	Fuel heater	
Z-002	<b>X-130</b>	Fuse block	
Z-080	<b>X-110</b>	Relay and fuse block (K-004 to K-039 and F-033 to F-036)	
–	<b>X-420</b>	Ground connection engine	
Additional connectors: <b>X-001, X-941, X-949</b>			
Wire color codes			
BK Black	GN Green	PK Pink	BL Blue
TN Light Brown	BR Brown	OR Orange	LG Light Green
RD Red	GY Grey	LB Light Blue	
WH White	YE Yellow	VT Violet	

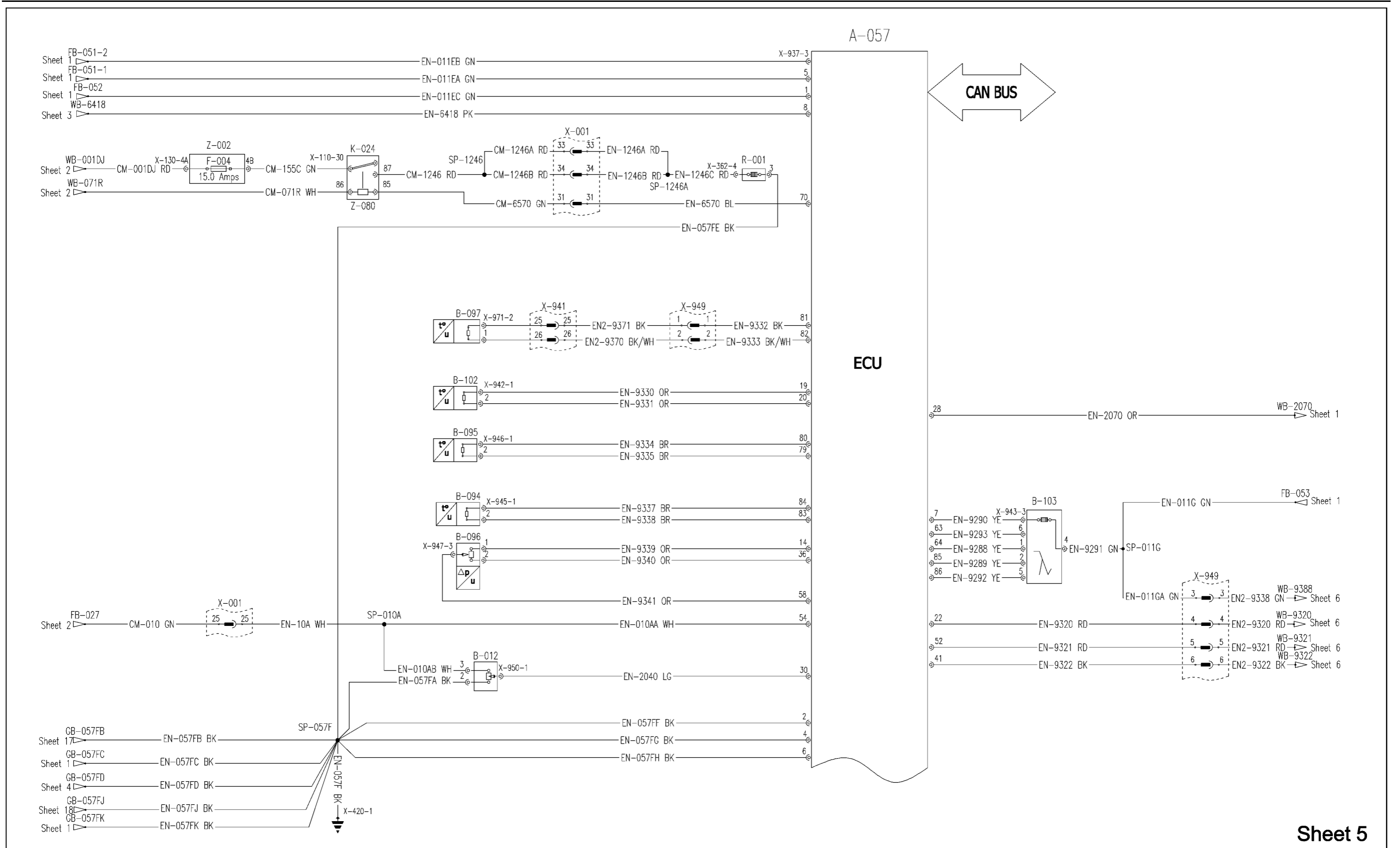

SS13A309 1



## Wiring harnesses - Electrical schematic sheet 06 - ENGINE CONTROL UNIT 2

Component	Connector	Description	
A-057	X-939	Engine Control Unit (ECU)	
A-101	X-938	Glow plug control module	
B-013	X-961	Intake air pressure and temperature sensor	
B-015	X-967	Common rail pressure sensor	
B-016	X-969	Engine coolant temperature sensor	
B-017	X-968	Fuel temperature sensor	
B-018	X-962	Camshaft sensor	
B-019	X-965	Crankshaft sensor	
B-098	X-963	Exhaust manifold pressure sensor	
M-018	X-964	Exhaust Gas Recirculation (EGR) – Valve actuator	
M-019	X-966	Throttle Valve Actuator (TVA)	
R-060	X-955	Glow plug (cylinder 1)	
R-061	X-956	Glow plug (cylinder 2)	
R-062	X-957	Glow plug (cylinder 3)	
R-063	X-958	Glow plug (cylinder 4)	
S-190	X-959	Engine oil pressure switch	
Y-011	X-970	High pressure pump – Solenoid valve	
Y-061	X-980	Injector cylinder 1	
Y-062	X-981	Injector cylinder 2	
Y-063	X-982	Injector cylinder 3	
Y-064	X-983	Injector cylinder 4	
Y-087	X-960	Waste gate modulation solenoid	
Additional connectors: X-940, X-941			
Wire color codes			
BK Black	GN Green	PK Pink	BL Blue
TN Light Brown	BR Brown	OR Orange	LG Light Green
RD Red	GY Grey	LB Light Blue	
WH White	YE Yellow	VT Violet	

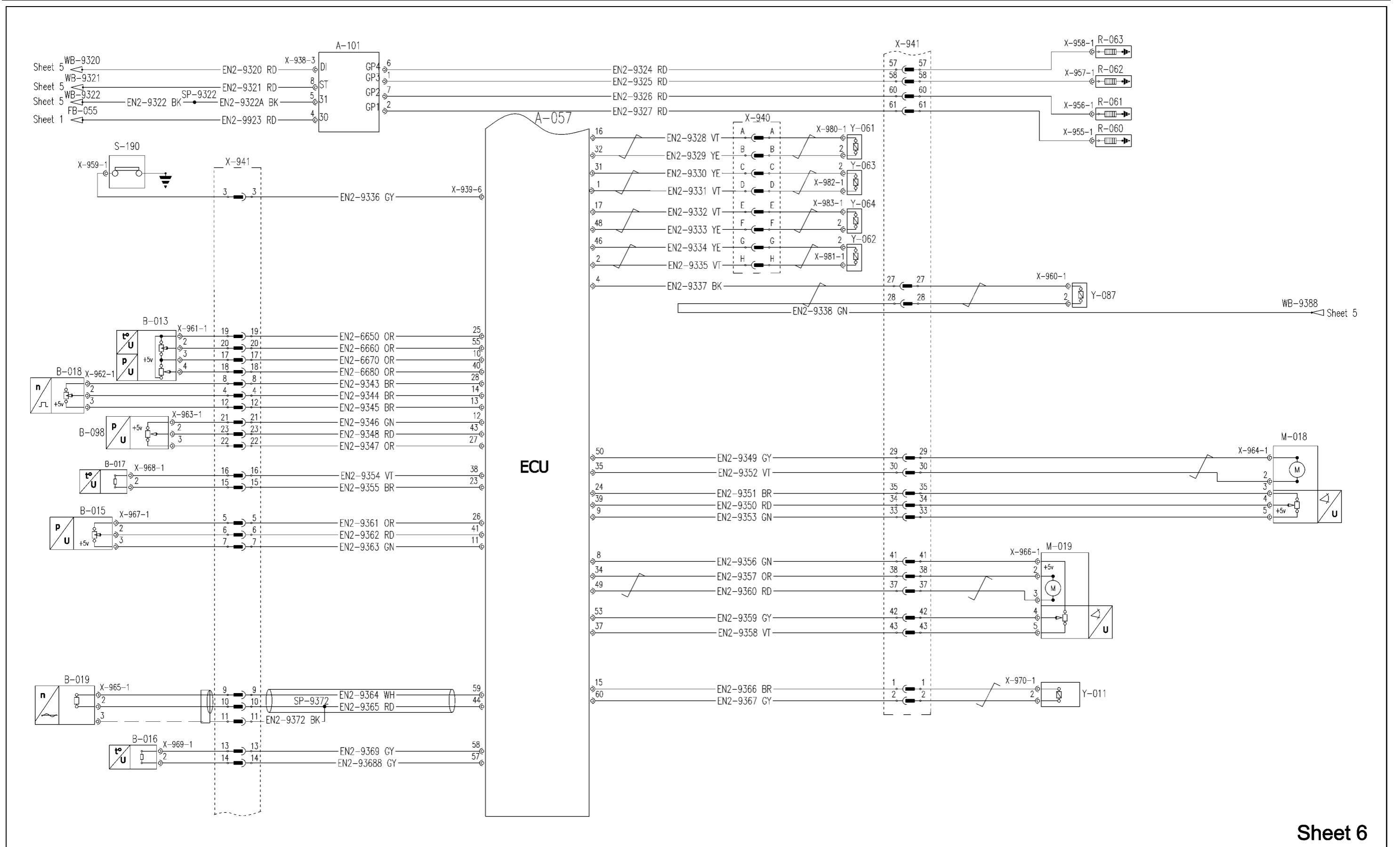

SS13A310 1

## Wiring harnesses - Electrical schematic sheet 07 - TRANSMISSION CONTROL UNIT 1

Component	Connector	Description	
A-092	<b>X-504</b>	Transmission Control Unit (TCU)	
B-026	<b>X-341</b>	Rear Power Take-Off (PTO) – Speed sensor	
B-034	<b>X-309</b>	Transmission output speed sensor	
B-090	<b>X-199</b>	Powershift input speed sensor	
B-101	<b>X-807</b>	Powershift output speed sensor	
F-005	–	Transmission Control Unit (TCU) – Battery power supply	
F-011	–	Transmission Control Unit (TCU) and rear Power Take-Off (PTO) – Switched battery power supply	
S-036	<b>X-308</b>	Transmission oil pressure switch	
S-187	<b>X-183</b>	Ground speed Power Take-Off (PTO) – Stationary operation switch	
Y-024	<b>X-100</b>	Clutch A solenoid valve	
Y-025	<b>X-364</b>	Clutch B solenoid valve	
Y-053	<b>X-383</b>	Clutch C solenoid valve	
Y-059	<b>X-806</b>	Clutch F solenoid valve	
Z-002	<b>X-130</b>	Fuse block	
Additional connectors: <b>X-300</b>			
Wire color codes			
BK Black	GN Green	PK Pink	BL Blue
TN Light Brown	BR Brown	OR Orange	LG Light Green
RD Red	GY Grey	LB Light Blue	
WH White	YE Yellow	VT Violet	

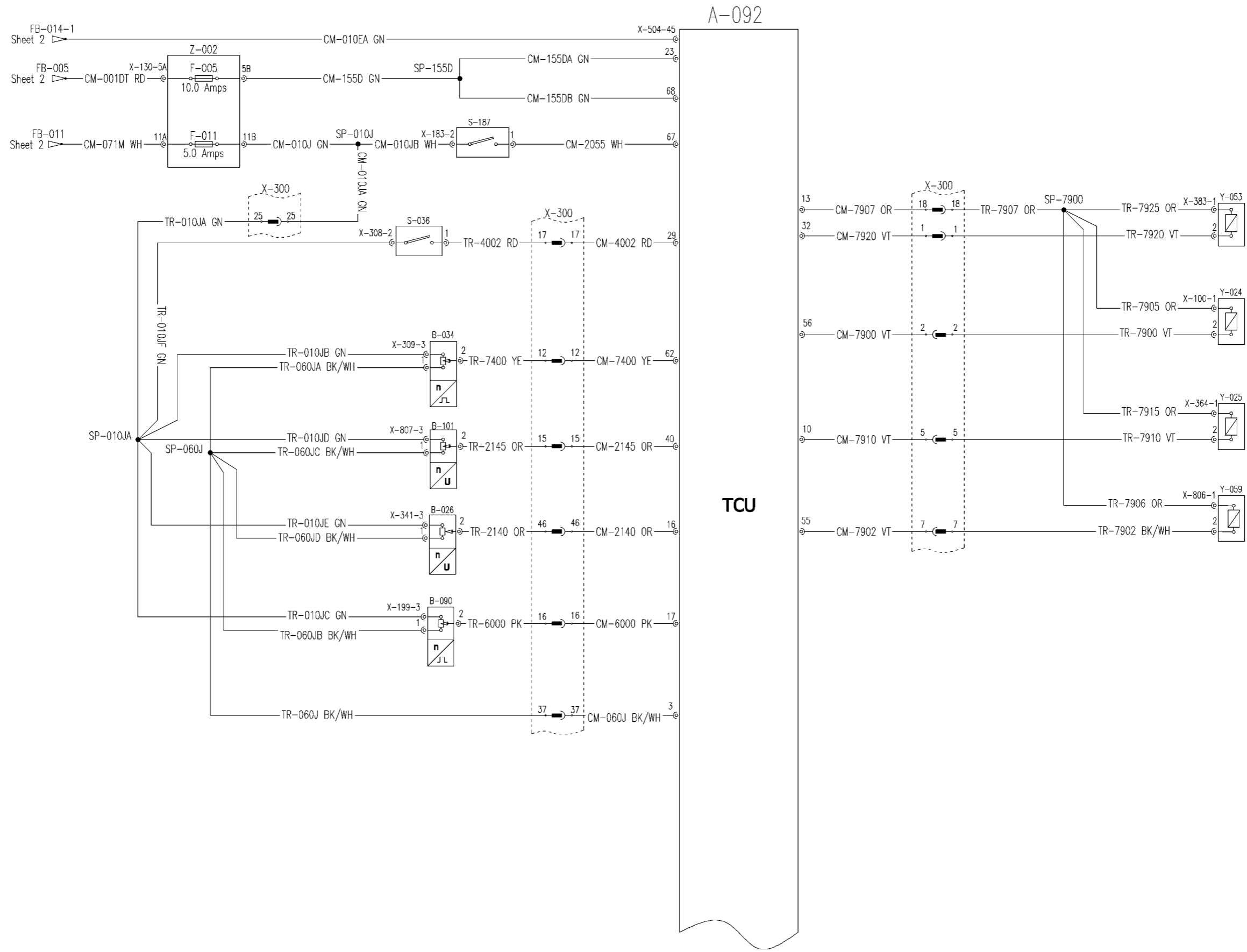

## Wiring harnesses - Electrical schematic sheet 08 - TRANSMISSION CONTROL UNIT 2

Component	Connector	Description	
A-092	<b>X-504</b>	Transmission Control Unit (TCU)	
B-029	<b>X-316</b>	Transmission oil temperature sensor	
B-089	<b>X-322</b>	Clutch pedal sensor	
J-022	<b>X-067</b>	Diagnostic socket (ZF)	
S-091	–	Shuttle lever neutral switch	
S-092	–	Shuttle lever deadman switch	
S-094	–	Shuttle lever forward switch	
S-095	–	Shuttle lever reverse switch	
S-110	–	Forward switch	
S-111	–	Reverse switch	
S-112	–	Powershift range increase switch	
S-113	–	Powershift range decrease switch	
S-193	<b>X-181</b>	Clutch pedal switch – Transmission	
S-194	<b>X-319</b>	Clutch pedal switch – Start interlock	
S-205	–	Auto-shift select switch	
S-207	–	Comfort shift switch	
S-208	<b>X-182</b>	Auto-shift programming switch	
Y-019	<b>X-344</b>	Rear Power Take-Off (PTO) – Solenoid valve	
Y-038	<b>X-343</b>	Rear axle differential lock – Solenoid valve	
Y-040	<b>X-342</b>	Four-Wheel Drive (4WD) – Solenoid valve	
Y-054	<b>X-301</b>	Clutch D solenoid valve	
Y-060	<b>X-365</b>	Clutch G solenoid valve	
Z-024	<b>X-170</b>	Multicontroller	
Z-062	<b>X-318</b>	Shuttle lever	
Additional connectors: <b>X-001, X-300</b>			
Wire color codes			
BK Black	GN Green	PK Pink	BL Blue
TN Light Brown	BR Brown	OR Orange	LG Light Green
RD Red	GY Grey	LB Light Blue	
WH White	YE Yellow	VT Violet	

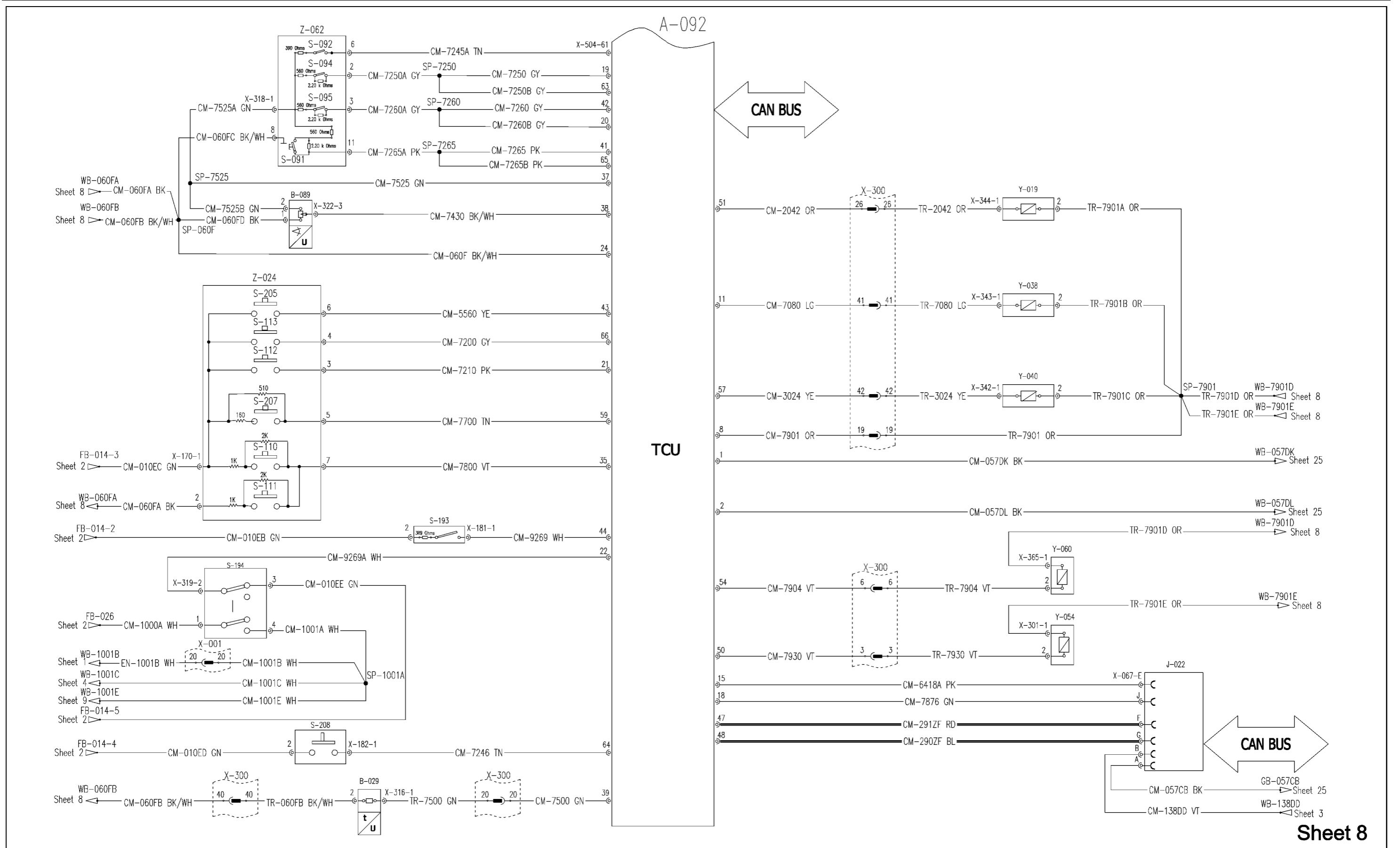

SS13A312 1

## Wiring harnesses - Electrical schematic sheet 09 - CENTRAL CONTROL UNIT (four-wheel drive, differential lock and backup alarm)

Component	Connector	Description	
A-090	X-200, X-210, X-220, X-230, X-240	Central Control Unit (CCU)	
E-043	X-389	Backup light	
F-002	–	Central Control Unit (CCU) – Permanent battery power supply (keep alive memory)	
H-083	X-389	Backup alarm buzzer	
K-060	–	Backup alarm buzzer relay	
S-063	X-374	Four-Wheel Drive (4WD) switch	
S-074	X-375	Rear axle differential lock – Switch	
S-182	X-290	Front axle differential lock – Switch	
Y-084	X-368	Parking brake engagement – Solenoid valve	
Y-085	X-315	Parking brake disengagement – Solenoid valve	
Y-086	X-340	Front axle differential lock – Solenoid valve	
Z-002	X-130	Fuse block	
Z-081	X-120	Relay and diode block (K-007 to K-060 and V-040 to V-044)	
Additional connectors: X-300, X-405			
Wire color codes			
BK Black	GN Green	PK Pink	BL Blue
TN Light Brown	BR Brown	OR Orange	LG Light Green
RD Red	GY Grey	LB Light Blue	
WH White	YE Yellow	VT Violet	

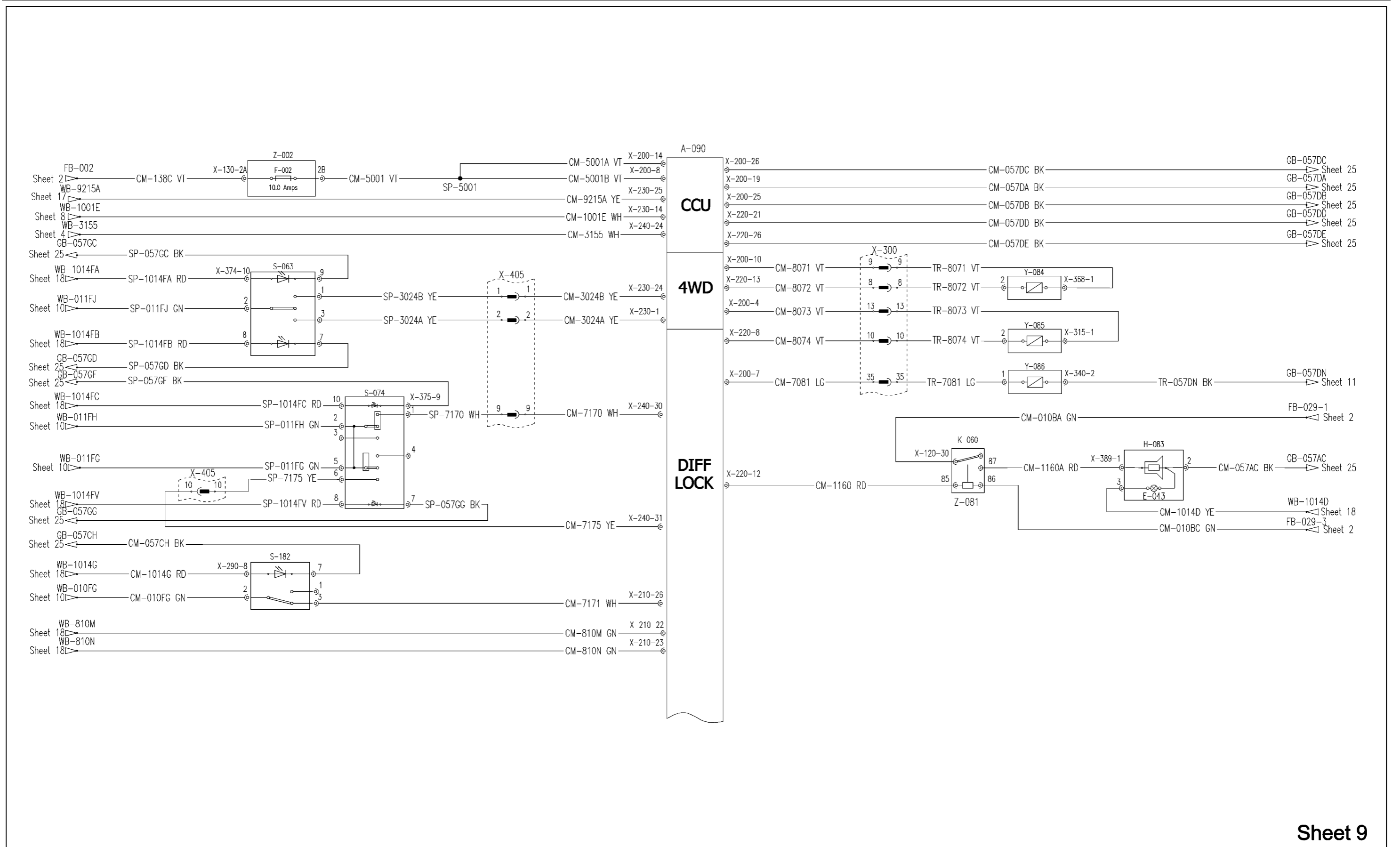



## Wiring harnesses - Electrical schematic sheet 10 - CENTRAL CONTROL UNIT (front and rear power take-off)

Component	Connector	Description	
A-090	X-200, X-220, X-230, X-240	Central Control Unit (CCU)	
A-092	X-504	Transmission Control Unit (TCU)	
F-010	–	Rear Power Take-Off (PTO), Front Power Take-Off (PTO), Four-Wheel Drive (4WD), Rear axle differential lock, Front axle differential lock, Parking brake	
S-002	X-348	Front Power Take-Off (PTO) – ON/OFF switch	
S-012	X-350	Rear Power Take-Off (PTO) – ON/OFF switch	
S-047	X-349	Power Take-Off (PTO) ON/OFF switch – Fender right-hand	
S-083	X-347	Power Take-Off (PTO) ON/OFF switch – Fender left-hand	
S-181	X-351	Rear Power Take-Off (PTO) – Soft-start/auto switch	
Y-016	X-352	Front Power Take-Off (PTO) – Solenoid valve	
Z-002	X-130	Fuse block	
Additional connectors: X-001, X-404, X-405			
Wire color codes			
BK Black	GN Green	PK Pink	BL Blue
TN Light Brown	BR Brown	OR Orange	LG Light Green
RD Red	GY Grey	LB Light Blue	
WH White	YE Yellow	VT Violet	

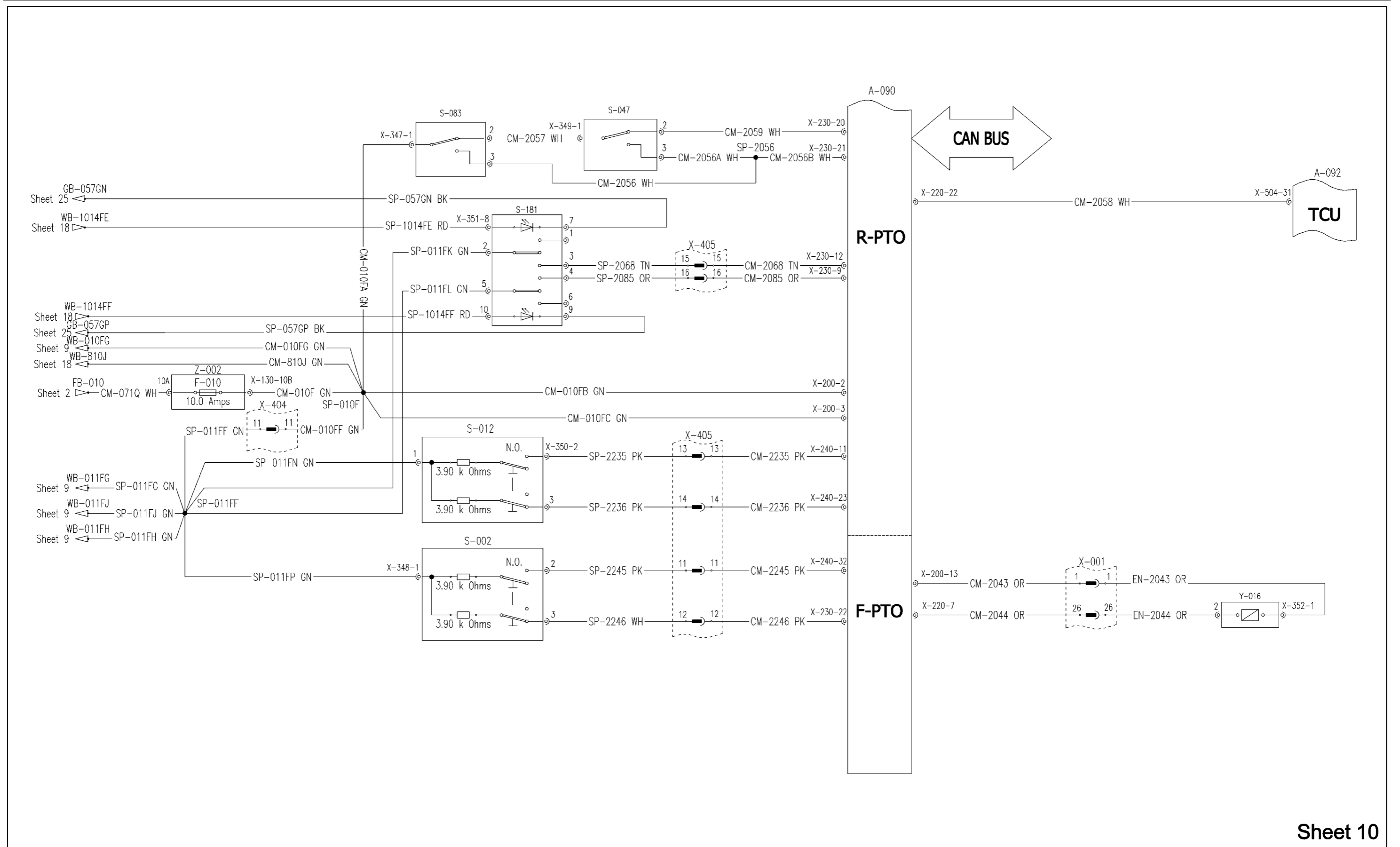

## Wiring harnesses - Electrical schematic sheet 11 - CENTRAL CONTROL UNIT (electronic draft control 1)

Component	Connector	Description	
A-090	X-200, X-210, X-220, X-230	Central Control Unit (CCU)	
B-042	X-333	Radar sensor	
E-133	X-534	Hitch status indicator light	
E-134	X-534	Hitch raise indicator light	
E-135	X-534	Hitch lower indicator light	
E-136	X-534	Slip control indicator light	
F-009	–	Electronic Draft Control (EDC), Radar sensor	
S-010	X-337	Hydraulic master switch	
S-024	X-329	Hitch up/down switch – Fender left-hand	
S-050	X-330	Hitch up/down switch – Fender right-hand	
S-149	X-314	Hitch up/down switch – Cab inside	
Z-002	X-130	Fuse block	
Additional connectors: X-300, X-404, X-405			
Wire color codes			
BK Black	GN Green	PK Pink	BL Blue
TN Light Brown	BR Brown	OR Orange	LG Light Green
RD Red	GY Grey	LB Light Blue	
WH White	YE Yellow	VT Violet	

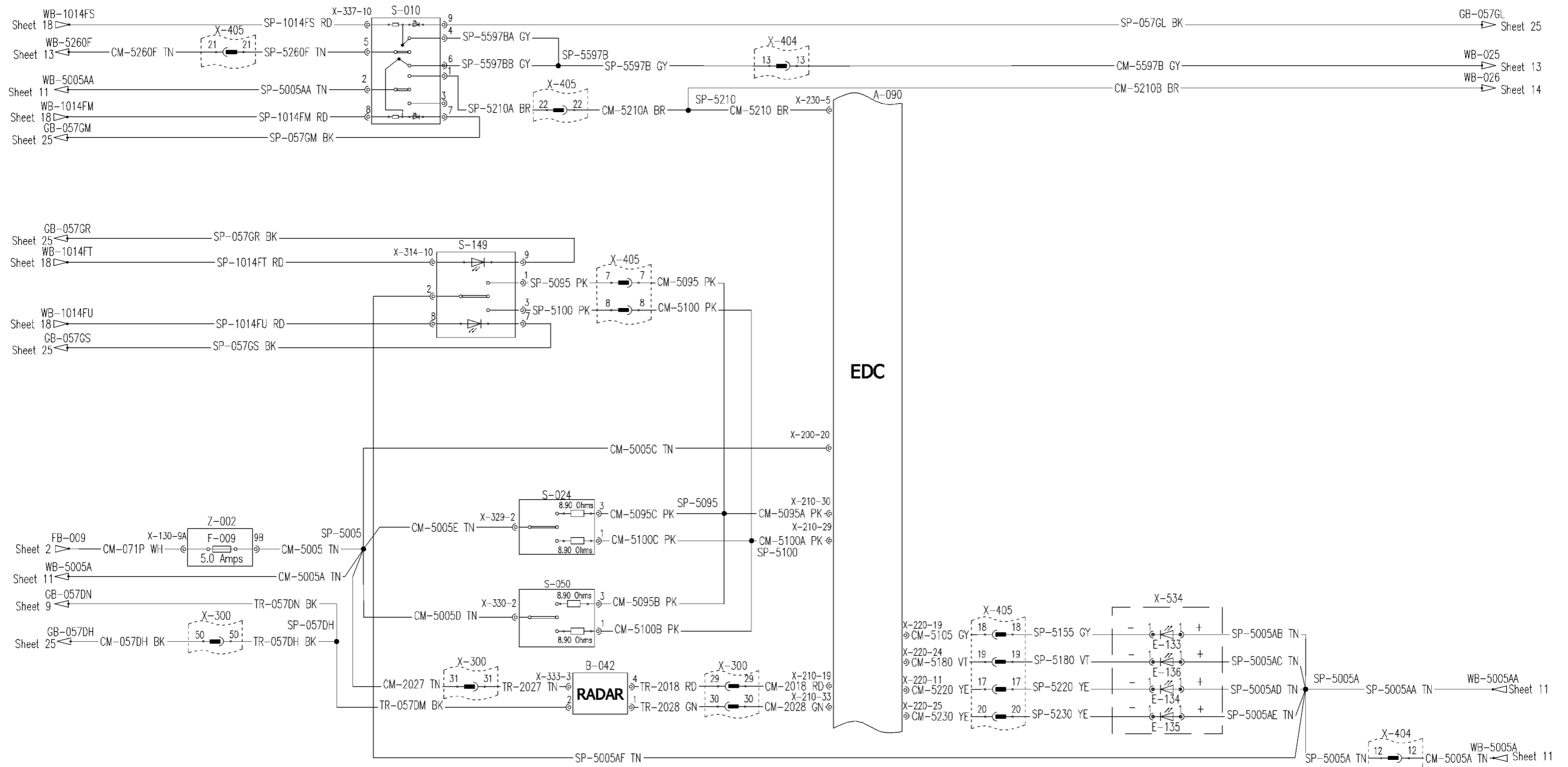

## Wiring harnesses - Electrical schematic sheet 12 - CENTRAL CONTROL UNIT (electronic draft control 2)

Component	Connector	Description	
A-090	X-200, X-210, X-220, X-230	Central Control Unit (CCU)	
B-005	X-331	Draft pin sensor left-hand	
B-006	X-332	Draft pin sensor right-hand	
B-007	X-328	Hitch position sensor	
R-021	–	Hitch position control potentiometer	
R-022	X-037	Hitch draft control potentiometer	
R-023	–	Hitch sensitivity control potentiometer	
R-024	–	Hitch drop rate potentiometer	
R-025	–	Hitch height limit potentiometer	
R-026	–	Hitch slip control potentiometer	
S-116	–	Hitch raise switch	
S-117	–	Hitch lower switch	
Y-012	X-334	Raise solenoid valve	
Y-013	X-335	Lower solenoid valve	
Z-021	X-327	Hitch electronic control panel	
Z-022	X-326	Hitch position control potentiometer	
Z-024	X-320	Multicontroller	
Additional connectors: X-300, X-404			
Wire color codes			
BK Black	GN Green	PK Pink	BL Blue
TN Light Brown	BR Brown	OR Orange	LG Light Green
RD Red	GY Grey	LB Light Blue	
WH White	YE Yellow	VT Violet	

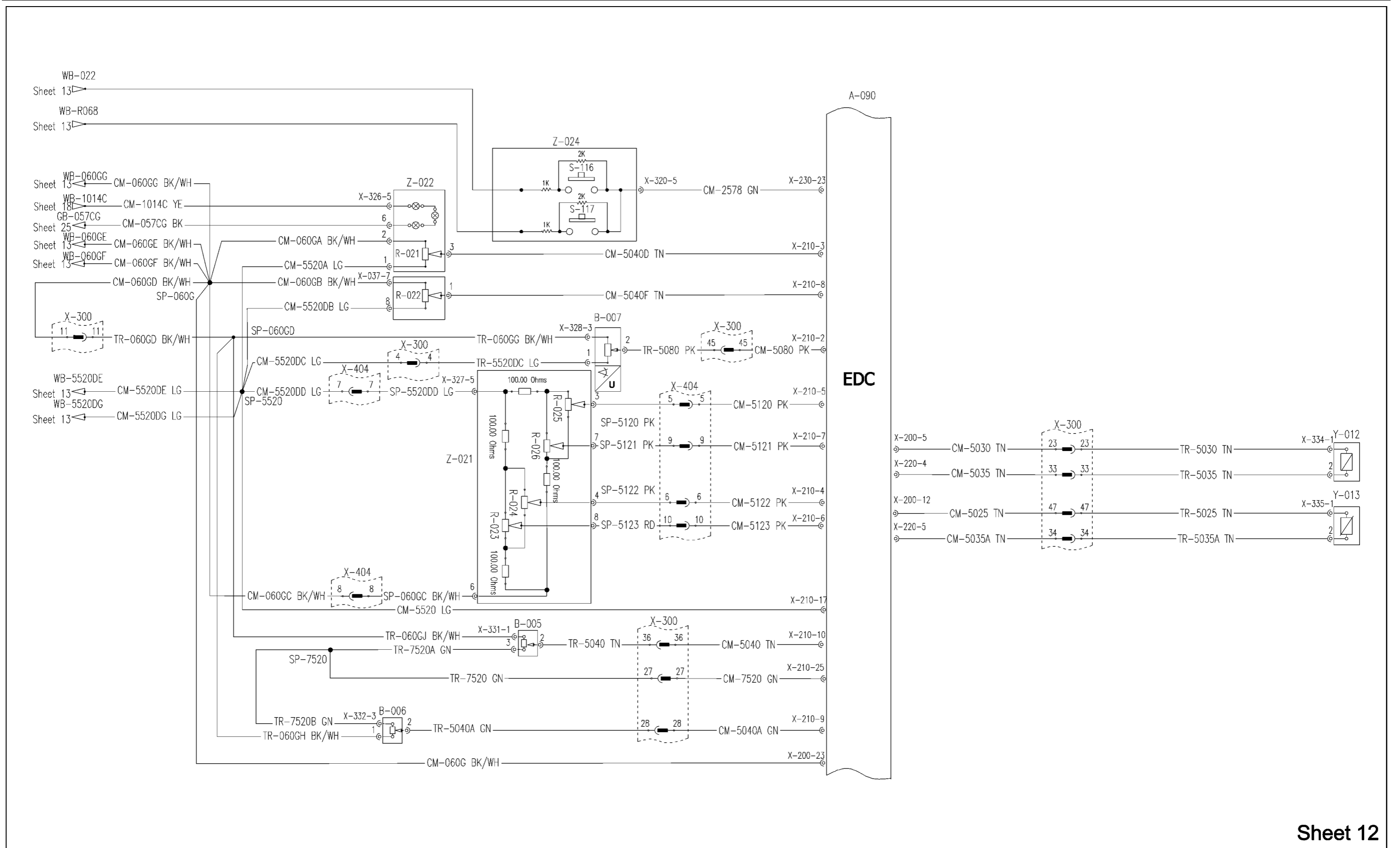

## Wiring harnesses - Electrical schematic sheet 13 - ELECTRO HYDRAULIC REMOTE VALVES (front and rear)

Component	Connector	Description
A-023	<b>X-699</b>	Electro Hydraulic Remote (EHR) valve 3 – Rear implement
A-024	<b>X-700</b>	Electro Hydraulic Remote (EHR) valve 4 – Rear implement
A-076	<b>X-698</b>	Electro Hydraulic Remote (EHR) valve 2 – Front implement
A-079	<b>X-697</b>	Electro Hydraulic Remote (EHR) valve 1 – Front implement
A-090	<b>X-210, X-220, X-230, X-240</b>	Central Control Unit (CCU)
B-063	–	Remote valve joystick – Sensor Y (remote valve 1/3)
B-064	–	Remote valve joystick – Sensor X (remote valve 2/4)
E-102	–	Remote valve 1 – Timer indicator light
E-104	–	Remote valve 2 – Timer indicator light
E-106	–	Remote valve 3 – Timer indicator light
E-108	–	Remote valve 4 – Timer indicator light
E-150	–	Multicontroller lighting
F-006	–	Electro Hydraulic Remote (EHR) valves, Hydraulic master switch
F-070	–	Electro Hydraulic Remote (EHR) valve 4 – Rear implement
F-071	–	Electro Hydraulic Remote (EHR) valve 1 – Front implement
F-072	–	Electro Hydraulic Remote (EHR) valve 2 – Front implement
F-073	–	Electro Hydraulic Remote (EHR) valve 3 – Rear implement
K-020	–	Remote valve relay
R-068	–	Finger wheel
R-070	–	Multicontroller lighting resistor
S-035	<b>X-032</b>	Remote valve switch – Fender left-hand
S-048	<b>X-388</b>	Front/rear selector switch – Remote valve joystick
S-101	<b>X-520</b>	Front hitch up/down switch – External
S-121	<b>X-338</b>	Remote valve encoder
S-122	–	Front loader switch – Valve 1
S-123	–	Front loader switch – Valve 2
S-124	–	Remote valve joystick – Reversal switch
S-126	<b>X-388</b>	Remote valve float switch
S-200	–	Remote valve 3 – Extend switch
S-201	–	Remote valve 3 – Retract switch
S-202	–	Remote valve 1/4 – Extend switch
S-203	–	Remote valve 1/4 – Retract switch
S-204	–	Second function switch
S-206	–	Constant engine speed – 1/2 selector switch
Z-002	<b>X-130, X-180</b>	Fuse block
Z-011	<b>X-338</b>	Remote valve joystick
Z-024	<b>X-320</b>	Multicontroller
Z-025	<b>X-338</b>	Remote valve timer – Indicator light panel
Z-081	<b>X-120</b>	Relay and diode block (K-007 to K-060 and V-040 to V-044)

Additional connectors: **X-001, X-310, X-346, X-382, X-388, X-446**

### Wire color codes

BK Black	GN Green	PK Pink	BL Blue
TN Light Brown	BR Brown	OR Orange	LG Light Green
RD Red	GY Grey	LB Light Blue	
WH White	YE Yellow	VT Violet	

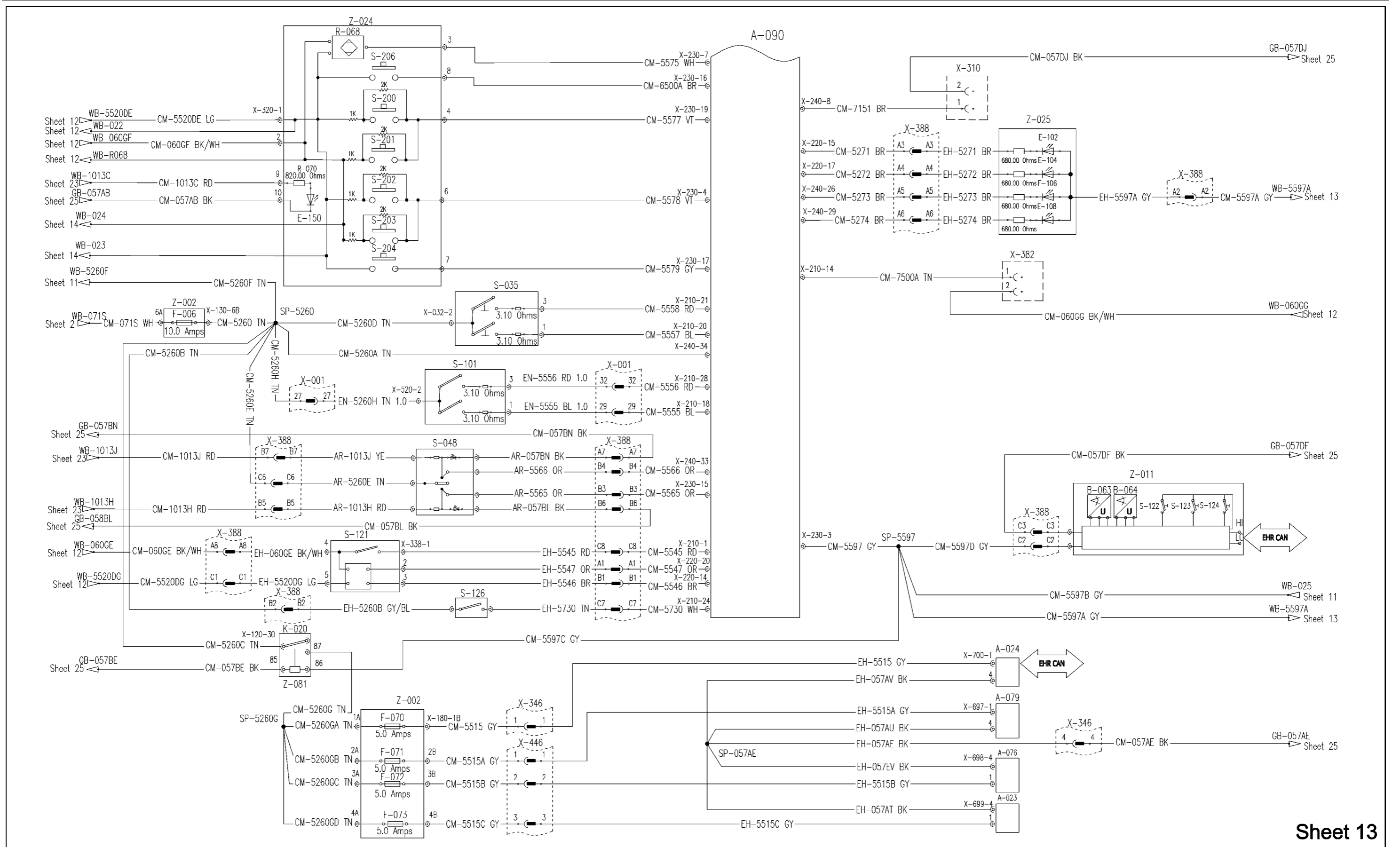

SS13A317 1



## Wiring harnesses - Electrical schematic sheet 14 - ELECTRONIC FRONT HITCH

Component	Connector	Description	
A-090	<b>X-230, X-240</b>	Central Control Unit (CCU)	
A-100	<b>X-524</b>	Electronic Front Hitch (EFH) control unit	
B-027	<b>X-526</b>	Front hitch position sensor	
B-099	<b>X-527</b>	Front hitch pressure sensor	
E-114	<b>X-650</b>	Front hitch diagnostic light	
E-115	<b>X-650</b>	Front hitch relief pressure – Indicator light	
F-034	–	Electronic Front Hitch (EFH) – Power supply relay (switched battery power supply)	
F-079	–	Electronic Front Hitch (EFH) – Power supply (battery power supply)	
F-089	–	Electronic Front Hitch (EFH) – Power supply (switched battery power supply)	
K-057	–	Electronic Front Hitch (EFH) – Power supply relay	
K-080	<b>X-951</b>	Front hitch raise relay	
K-081	<b>X-952</b>	Front hitch lower relay	
K-083	<b>X-953</b>	Front hitch lock relay	
R-064	–	Front hitch position or pressure value – Control potentiometer	
R-065	–	Front hitch position and/or pressure mix – Control potentiometer	
R-066	–	Front hitch height limit – Control potentiometer	
R-067	–	Front hitch drop rate – Control potentiometer	
S-183	<b>X-519</b>	Front hitch up/down switch – Cab inside	
S-184	<b>X-517</b>	Front hitch switch – Auto/manual raise mode	
S-186	<b>X-521</b>	Front hitch up/down switch – External	
S-209	–	Front hitch raise switch	
S-210	–	Front hitch lower switch	
Y-088	<b>X-529</b>	Front hitch – Lower solenoid valve	
Y-089	<b>X-528</b>	Front hitch – Raise solenoid valve	
Y-090	<b>X-530</b>	Front hitch solenoid valve – Accumulator ( <b>14 bar</b> )	
Y-091	<b>X-531</b>	Front hitch solenoid valve – Accumulator ( <b>40 bar</b> )	
Z-002	<b>X-180</b>	Fuse block	
Z-023	<b>X-525</b>	Front hitch electronic control panel	
Z-024	<b>X-320</b>	Multicontroller	
Z-080	<b>X-110</b>	Relay and fuse block (K-004 to K-039 and F-033 to F-036)	
Z-081	<b>X-120</b>	Relay and diode block (K-007 to K-060 and V-040 to V-044)	
Additional connectors: <b>X-373, X-944</b>			
Wire color codes			
BK Black	GN Green	PK Pink	BL Blue
TN Light Brown	BR Brown	OR Orange	LG Light Green
RD Red	GY Grey	LB Light Blue	
WH White	YE Yellow	VT Violet	

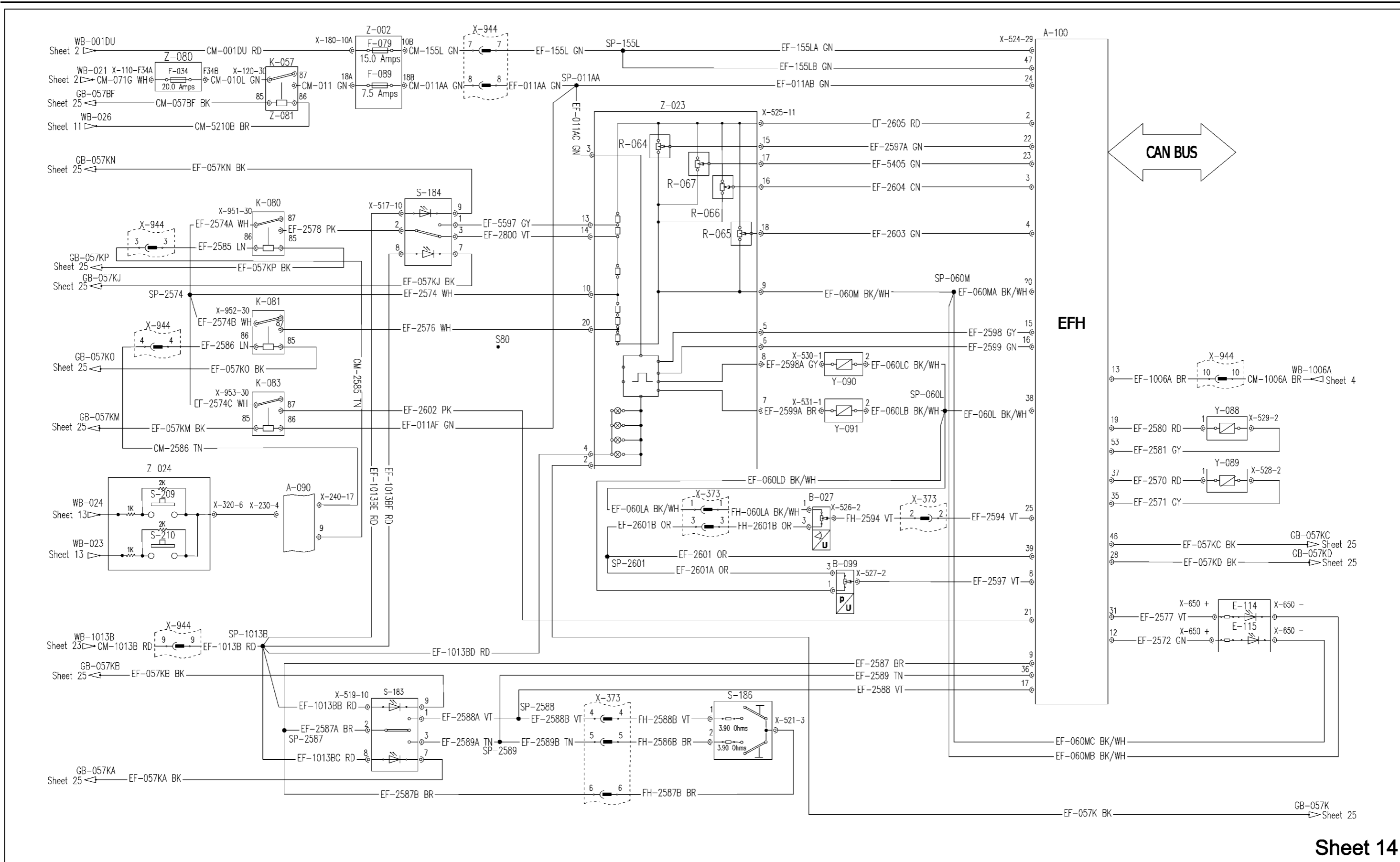

Sheet 14

## Wiring harnesses - Electrical schematic sheet 15 - FRONT LOADER (Hydrac)

Component	Connector	Description	
A-090	<b>X-240</b>	Central Control Unit (CCU)	
F-080	–	Front loader power supply (switched battery power supply)	
K-055	<b>X-469</b>	Front loader relay – Valve 1	
K-056	<b>X-470</b>	Front loader relay – Valve 2	
S-122	<b>X-323</b>	Front loader switch – Valve 1	
S-123	<b>X-323</b>	Front loader switch – Valve 2	
S-196	<b>X-462, X-463</b>	Front loader switch – Jack support lock (Hydrac)	
S-197	<b>X-464, X-465</b>	Front loader switch (Hydrac)	
S-198	<b>X-466, X-467</b>	Front loader latch switch (Hydrac)	
V-030	–	Front loader diode (Hydrac)	
V-031	–	Front loader diode (Hydrac)	
V-032	–	Front loader diode (Hydrac)	
V-033	–	Front loader diode (Hydrac)	
V-034	–	Front loader diode (Hydrac)	
Z-002	<b>X-180</b>	Fuse block	
Z-026	<b>X-461</b>	Front loader diode pack (Hydrac)	
–	<b>X-471</b>	Ground connection front loader (Hydrac)	
Additional connectors: <b>X-393, X-468, X-468A</b>			
Wire color codes			
BK Black	GN Green	PK Pink	BL Blue
TN Light Brown	BR Brown	OR Orange	LG Light Green
RD Red	GY Grey	LB Light Blue	
WH White	YE Yellow	VT Violet	

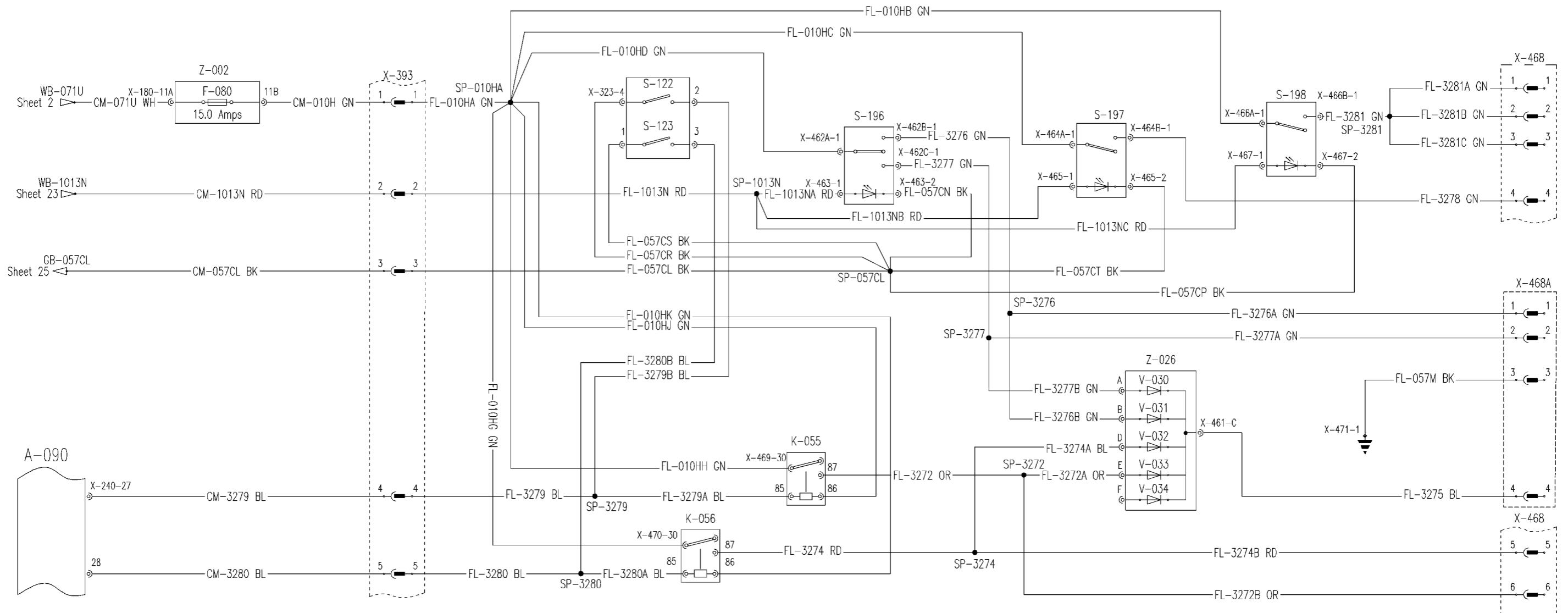

## Wiring harnesses - Electrical schematic sheet 16 - FRONT LOADER (Stoll)

Component	Connector	Description	
A-090	<b>X-240</b>	Central Control Unit (CCU)	
F-080	–	Front loader power supply (switched battery power supply)	
J-023	<b>X-395</b>	Front loader socket (Stoll)	
K-055	<b>X-155</b>	Front loader relay – Valve 1	
K-056	<b>X-156</b>	Front loader relay – Valve 2	
S-122	<b>X-323</b>	Front loader switch – Valve 1	
S-123	<b>X-323</b>	Front loader switch – Valve 2	
V-035	<b>X-295</b>	Front loader diode (Stoll)	
Z-002	<b>X-180</b>	Fuse block	
Additional connectors: <b>X-380, X-392, X-393, X-394, X-396</b>			
Wire color codes			
BK Black	GN Green	PK Pink	BL Blue
TN Light Brown	BR Brown	OR Orange	LG Light Green
RD Red	GY Grey	LB Light Blue	
WH White	YE Yellow	VT Violet	

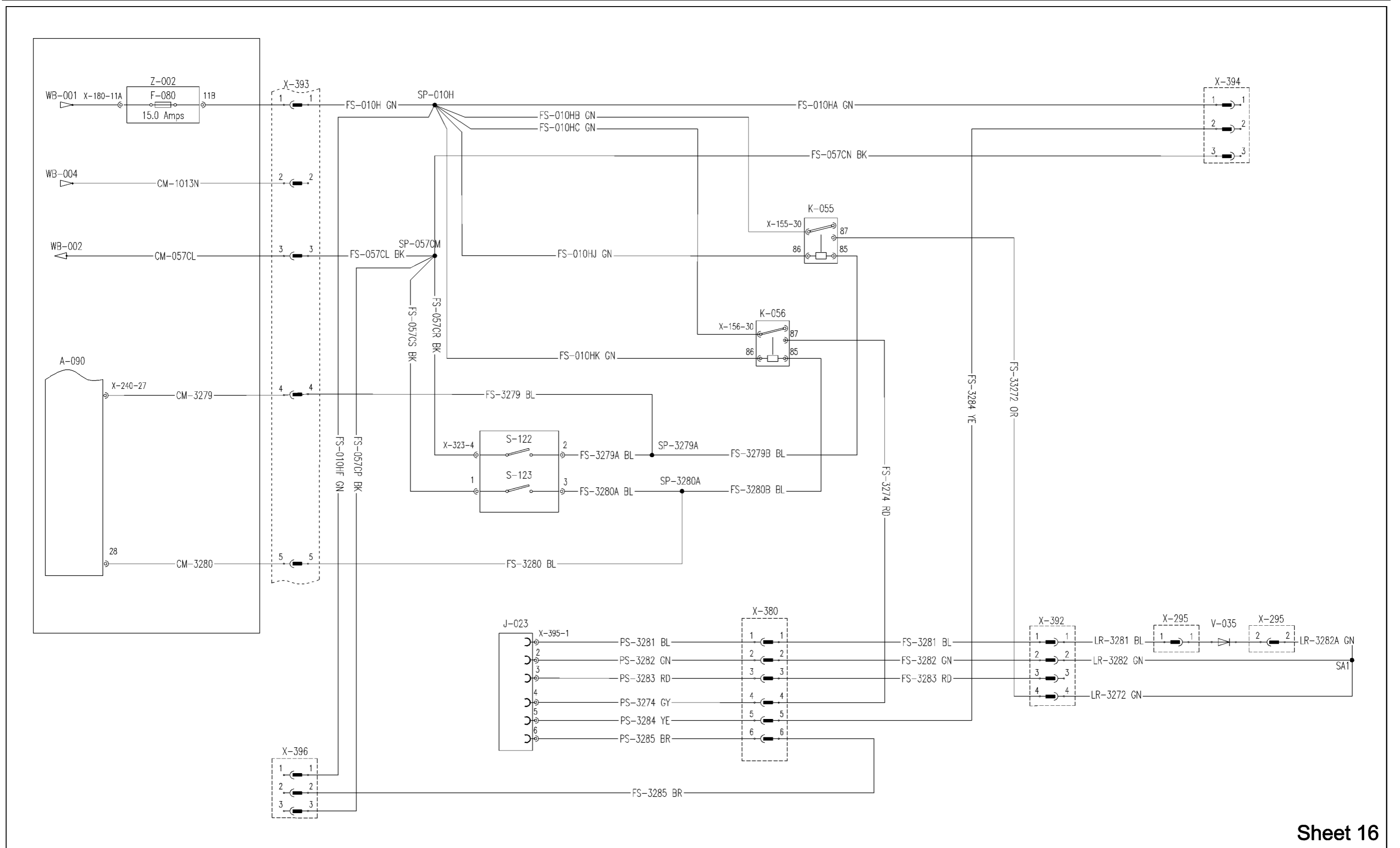

## Wiring harnesses - Electrical schematic sheet 17 - HEATING, VENTILATION and AIR-CONDITIONING

Component	Connector	Description	
A-026	X-045	Heating control unit	
A-091	X-044	Antifreeze module	
B-105	–	Evaporator temperature sensor	
E-001	X-040	Air-conditioning system – ON/OFF indicator light	
F-001	–	Blower motor left-hand (third speed step)	
F-013	–	Blower motor right-hand (third speed step)	
F-017	–	Heating control unit	
F-018	–	Blower motor left-hand (fourth speed step)	
F-030	–	Blower motor right-hand (fourth speed step)	
F-040	–	Blower motors	
K-019	–	Air-conditioning compressor relay	
K-036	–	Blower motor left-hand – Relay (third speed step)	
K-037	–	Blower motor right-hand – Relay (third speed step)	
K-038	–	Blower motor left-hand – Relay (fourth speed step)	
K-039	–	Blower motor right-hand – Relay (fourth speed step)	
M-015	X-973, X-974	Blower motor	
M-016	X-973, X-974	Blower motor	
M-017	X-043	Heating control valve	
R-030	X-041	Temperature control potentiometer	
S-013	X-030	Blower switch	
S-016	X-031	Air-conditioning system – Mode switch	
S-017	X-042	Air-conditioning system – Pressure switch	
Y-082	X-088	Air-conditioning compressor – Magnetic clutch	
Z-002	X-130	Fuse block	
Z-080	X-110	Relay and fuse block (K-004 to K-039 and F-033 to F-036)	
Z-082	X-150	Relay and fuse block – Roof	
Additional connectors: X-001, X-046, X-047, X-050			
Wire color codes			
BK Black	GN Green	PK Pink	BL Blue
TN Light Brown	BR Brown	OR Orange	LG Light Green
RD Red	GY Grey	LB Light Blue	
WH White	YE Yellow	VT Violet	

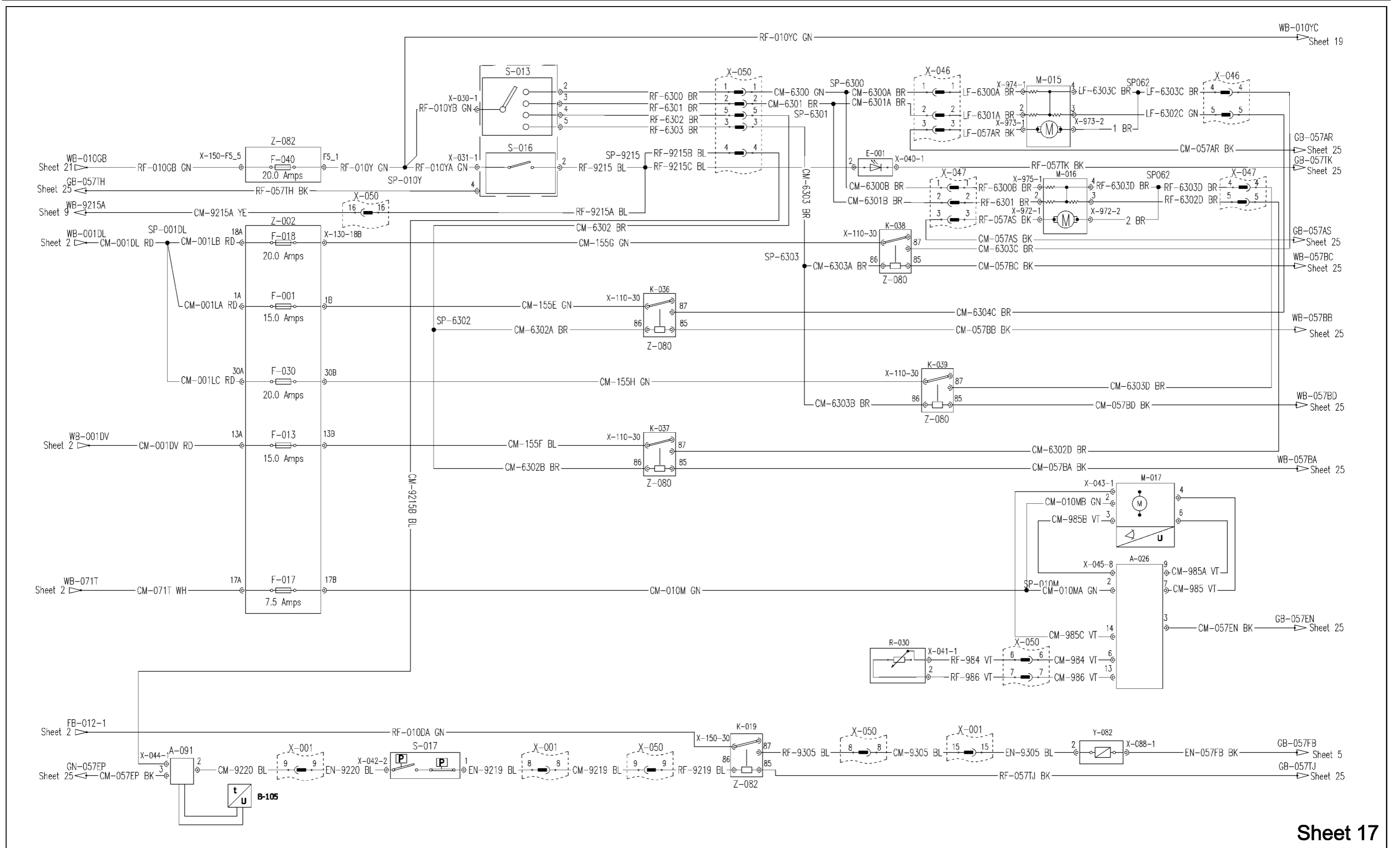

Sheet 17

SS13A321 1



## Wiring harnesses - Electrical schematic sheet 18 - LIGHTING (headlights, side lights, cab interior light)

Component	Connector	Description	
E-006	<b>X-051, X-052, X-053</b>	Cab interior light	
E-007	<b>X-019, X-978</b>	Headlight left-hand	
E-008	<b>X-020, X-979</b>	Headlight right-hand	
E-018	<b>X-024</b>	Tail light right-hand	
E-019	<b>X-023</b>	Tail light left-hand	
E-049	<b>X-021</b>	Grab rail light – Left-hand	
E-050	<b>X-022</b>	Grab rail light – Right-hand	
E-051	<b>X-121</b>	Grab rail headlight left-hand	
E-052	<b>X-122</b>	Grab rail headlight right-hand	
E-055	<b>X-977</b>	License plate light – Cab left-hand (Italy)	
H-002	<b>X-015, X-016</b>	Horn	
K-007	–	Low beam relay – Headlights	
K-009	–	Main beam relay – Headlights	
K-028	–	Low beam relay – Grab rail headlights	
K-029	–	Main beam relay – Grab rail headlights	
S-026	<b>X-061</b>	Roof headlight switch	
S-042	<b>X-064</b>	Door switch left-hand	
S-044	<b>X-094</b>	Brake light switch – Right-hand	
S-045	<b>X-093</b>	Brake light switch – Left-hand	
Z-081	<b>X-120</b>	Relay and diode block (K-007 to K-060 and V-040 to V-044)	
Additional connectors: <b>X-001, X-025, X-050, X-050A, X-050B, X-095, X-385, X-405</b>			
Wire color codes			
BK Black	GN Green	PK Pink	BL Blue
TN Light Brown	BR Brown	OR Orange	LG Light Green
RD Red	GY Grey	LB Light Blue	
WH White	YE Yellow	VT Violet	

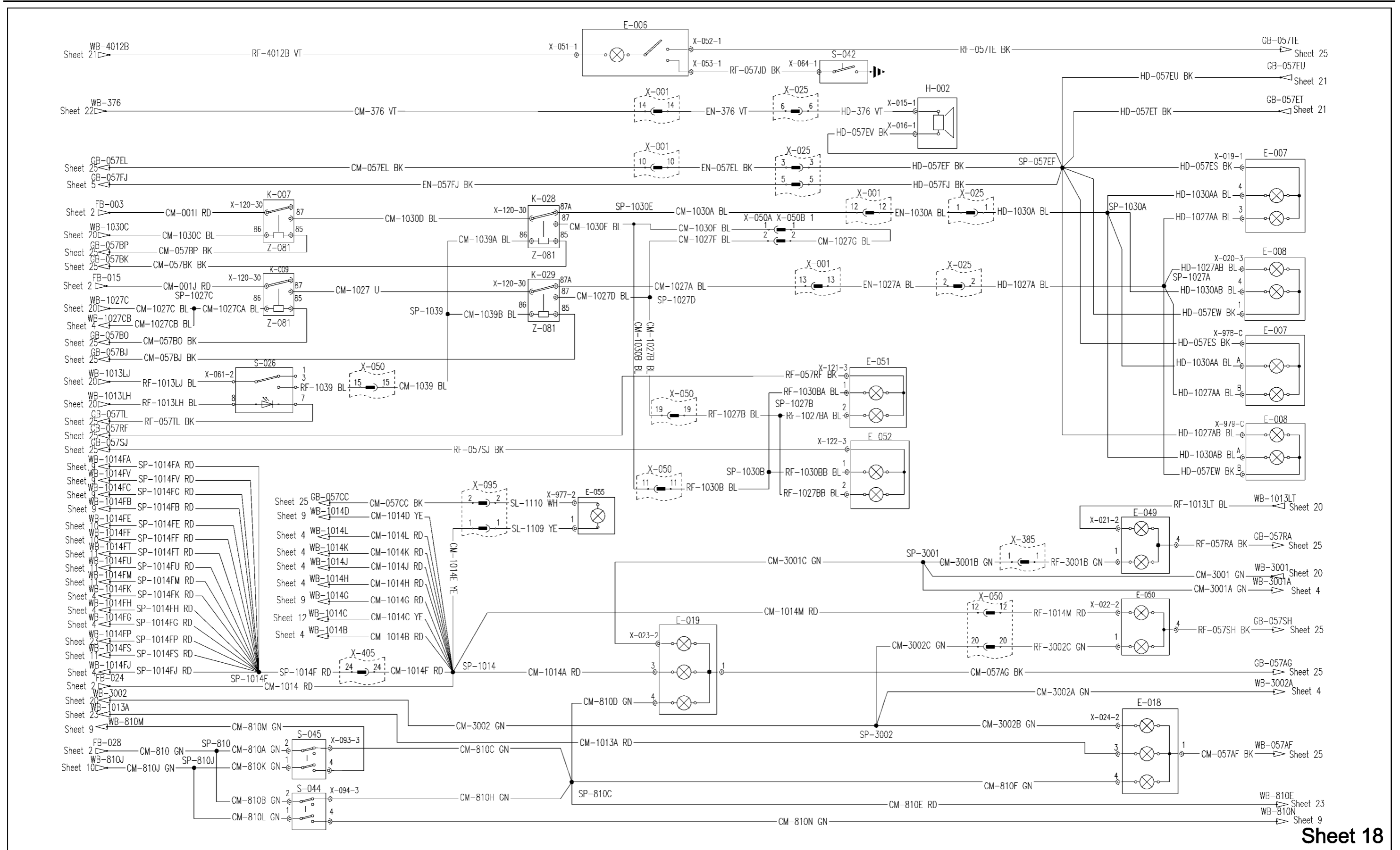

## Wiring harnesses - Electrical schematic sheet 19 - RADIO and MIRRORS (electrically adjustable and heated)

Component	Connector	Description	
A-064	<b>X-039</b>	Radio	
F-047	–	Radio	
H-003	<b>X-082, X-083</b>	Speaker rear right-hand	
H-006	<b>X-084, X-085</b>	Speaker rear left-hand	
Z-082	<b>X-150</b>	Relay and fuse block – Roof	
Additional connectors: <b>X-372</b>			
Wire color codes			
BK Black	GN Green	PK Pink	BL Blue
TN Light Brown	BR Brown	OR Orange	LG Light Green
RD Red	GY Grey	LB Light Blue	
WH White	YE Yellow	VT Violet	

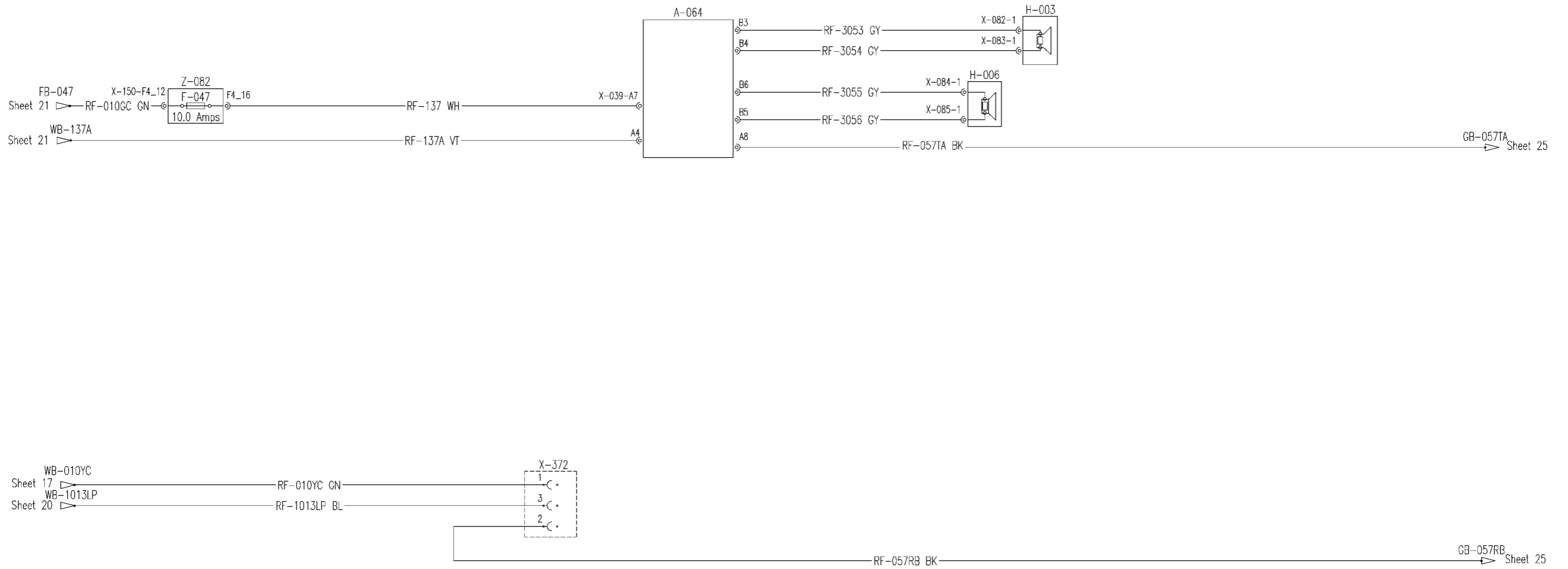

**Wiring harnesses - Electrical schematic sheet 20 - LIGHTING (flasher, hazard light switch and follow me home)**

Component	Connector	Description	
A-062	<b>X-090</b>	Flasher unit	
E-009	<b>X-054</b>	Console light right-hand	
E-016	<b>X-096</b>	License plate light – Roof left-hand	
E-017	<b>X-097</b>	License plate light – Roof right-hand	
F-036	–	Position lights, Main light switch	
F-074	–	Flasher left-hand – Trailer socket rear (7-Pin) and trailer socket front (7-Pin)	
F-075	–	Flasher right-hand – Trailer socket rear (7-Pin) and trailer socket front (7-Pin)	
F-092	–	Headlight flasher	
K-004	–	Position light relay	
K-014	–	Follow me home relay	
S-021	<b>X-034</b>	Main light switch	
S-046	<b>X-092</b>	Hazard switch	
S-191	<b>X-091</b>	Steering column light switch	
V-040	–	Follow me home diode	
V-041	–	Follow me home diode	
V-042	–	Follow me home diode	
V-043	–	Follow me home diode	
Z-002	<b>X-130, X-180</b>	Fuse block	
Z-080	<b>X-110</b>	Relay and fuse block (K-004 to K-039 and F-033 to F-036)	
Z-081	<b>X-120</b>	Relay and diode block (K-007 to K-060 and V-040 to V-044)	
Additional connectors: <b>X-091, X-385</b>			
Wire color codes			
BK Black	GN Green	PK Pink	BL Blue
TN Light Brown	BR Brown	OR Orange	LG Light Green
RD Red	GY Grey	LB Light Blue	
WH White	YE Yellow	VT Violet	

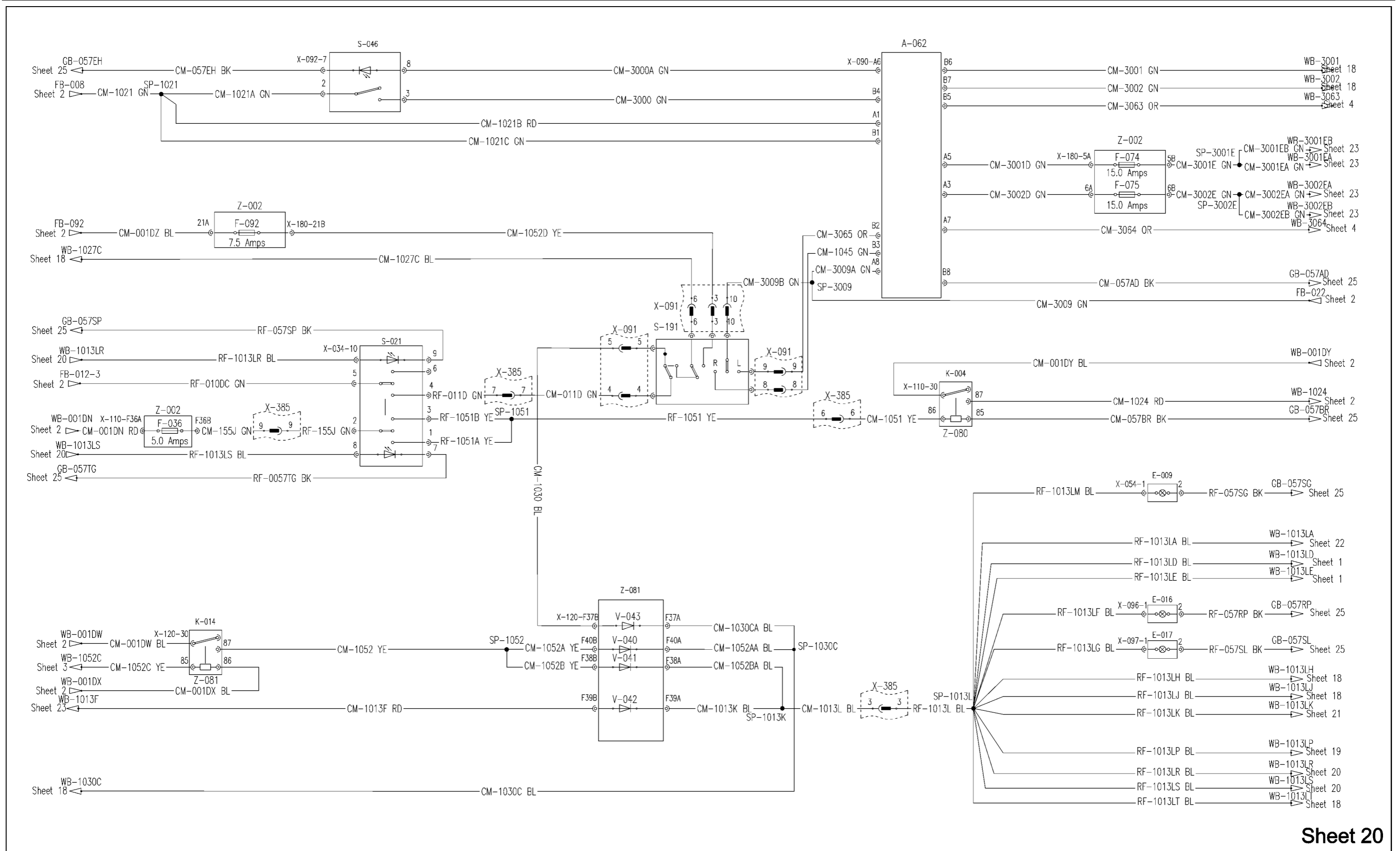

## Wiring harnesses - Electrical schematic sheet 21 - WORK LIGHT and ROTATING BEACON

Component	Connector	Description	
A-068	<b>X-065</b>	Work light switch panel	
E-015	<b>X-307</b>	Second rear work light – Left-hand	
E-020	<b>X-306</b>	Second rear work light – Right-hand	
E-026	<b>X-018</b>	Engine hood work light – Right-hand	
E-027	<b>X-017</b>	Engine hood work light – Left-hand	
E-028	<b>X-069</b>	Second front work light – Left-hand	
E-029	<b>X-058, X-058_C</b>	Front work light left-hand	
E-030	<b>X-123</b>	Grab rail work light – Left-hand	
E-031	<b>X-056</b>	Rear work light left-hand	
E-032	<b>X-055</b>	Rear work light right-hand	
E-033	<b>X-068_C</b>	Front work light right-hand	
E-034	<b>X-124</b>	Grab rail work light – Right-hand	
E-035	<b>X-070, X-390</b>	Rotating beacon	
E-036	<b>X-070, X-390</b>	Rotating beacon	
E-037	<b>X-068</b>	Second front work light – Right-hand	
E-040	<b>X-057</b>	Front work light right-hand	
F-016	–	Engine hood work lights	
F-048	–	Radio, Rotating beacons, Work light switch panel, Cab interior light	
F-049	–	Rear work lights	
F-050	–	Front work lights	
F-060	–	Grab rail work lights	
F-061	–	Work light switch panel	
K-015	–	Engine hood work lights – Relay	
K-025	–	Second rear work lights – Relay	
K-026	–	Second front work lights – Relay	
K-082	–	Cab roof – Power supply relay	
Z-002	<b>X-130</b>	Fuse block	
Z-080	<b>X-110</b>	Relay and fuse block (K-004 to K-039 and F-033 to F-036)	
Z-082	<b>X-150</b>	Relay and fuse block – Roof	
Additional connectors: <b>X-001, X-025, X-050, X-071, X-073, X-160</b>			
Wire color codes			
BK Black	GN Green	PK Pink	BL Blue
TN Light Brown	BR Brown	OR Orange	LG Light Green
RD Red	GY Grey	LB Light Blue	
WH White	YE Yellow	VT Violet	





## Wiring harnesses - Electrical schematic sheet 22 - WIPER and WASHER (front and rear)

Component	Connector	Description	
F-035	–	Horn, Front window wiper motor, Front window washer pump	
F-062	–	Rear window wiper motor, Rear window washer pump	
K-034	<b>X-048</b>	Intermittent windshield wiper module	
M-004	<b>X-074</b>	Front window wiper motor (fixed front window)	
M-004	<b>X-976</b>	Front window wiper motor (openable front window)	
M-005	<b>X-038</b>	Rear window wiper motor	
M-006	<b>X-076</b>	Front window washer pump	
M-007	<b>X-077</b>	Rear window washer pump	
S-079	<b>X-091</b>	Front wiper and washer switch	
S-080	<b>X-036</b>	Rear wiper and washer switch	
Z-080	<b>X-110</b>	Relay and fuse block (K-004 to K-039 and F-033 to F-036)	
Z-082	<b>X-150</b>	Relay and fuse block – Roof	
Additional connectors: <b>X-038, X-050, X-074, X-075, X-091, X-385, X-976</b>			
Wire color codes			
BK Black	GN Green	PK Pink	BL Blue
TN Light Brown	BR Brown	OR Orange	LG Light Green
RD Red	GY Grey	LB Light Blue	
WH White	YE Yellow	VT Violet	

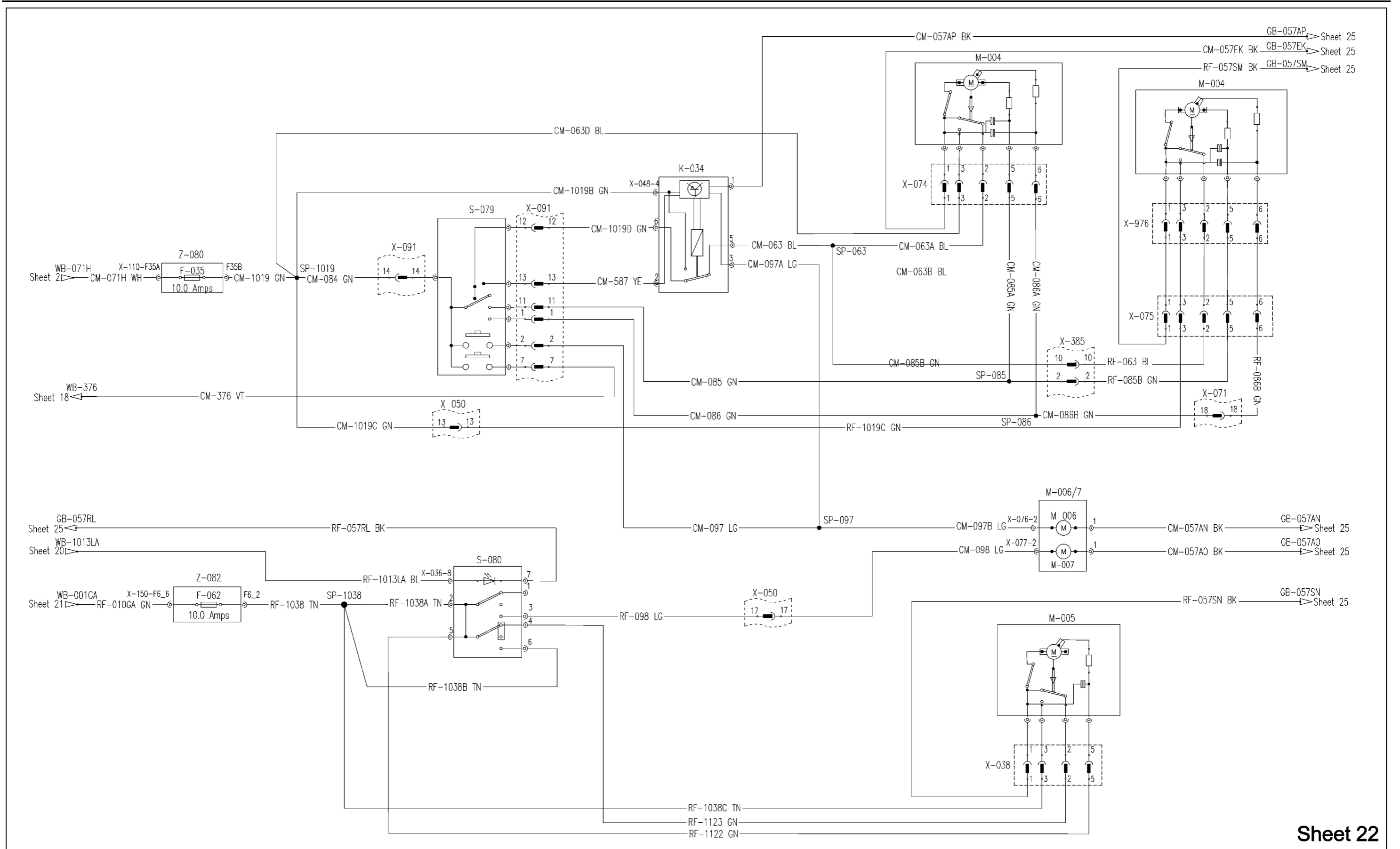

SS13A326 1

**Wiring harnesses - Electrical schematic sheet 23 - POWER SOCKETS**

Component	Connector	Description	
F-007	–	Power socket <b>40 A</b> – Cab outside (switched battery power supply)	
F-031	–	Power socket <b>25 A</b> – Cab inside (switched battery power supply)	
F-032	–	Power socket <b>40 A</b> – Cab outside (switched battery power supply)	
F-033	–	Cigarette lighter (optional)	
F-076	–	Brake light – Trailer socket rear (7-Pin)	
F-077	–	Position light right-hand – Trailer socket rear (7-Pin) and trailer socket front (7-Pin)	
J-001	<b>X-501</b>	Power socket <b>40 A</b> – Cab outside	
J-006	<b>X-026</b>	Power socket <b>8 A</b> – Cab inside	
J-007	<b>X-027, X-080</b>	Cigarette lighter	
J-008	<b>X-408, X-409</b>	Power supply pin socket	
J-010	<b>X-098</b>	Trailer socket rear (7-Pin)	
J-011	<b>X-099</b>	Trailer socket front (7-Pin)	
J-012	<b>X-028, X-081</b>	Cigarette lighter (optional)	
J-013	<b>X-078, X-079</b>	Power socket <b>25 A</b> – Cab inside	
J-014	<b>X-506</b>	Power socket <b>25 A</b> – Front	
Z-002	<b>X-130, X-180</b>	Fuse block	
Z-080	<b>X-110</b>	Relay and fuse block (K-004 to K-039 and F-033 to F-036)	
Additional connectors: <b>X-001, X-404, X-406, X-407, X-501</b>			
Wire color codes			
BK Black	GN Green	PK Pink	BL Blue
TN Light Brown	BR Brown	OR Orange	LG Light Green
RD Red	GY Grey	LB Light Blue	
WH White	YE Yellow	VT Violet	

Electrical systems - Harnesses and connectors

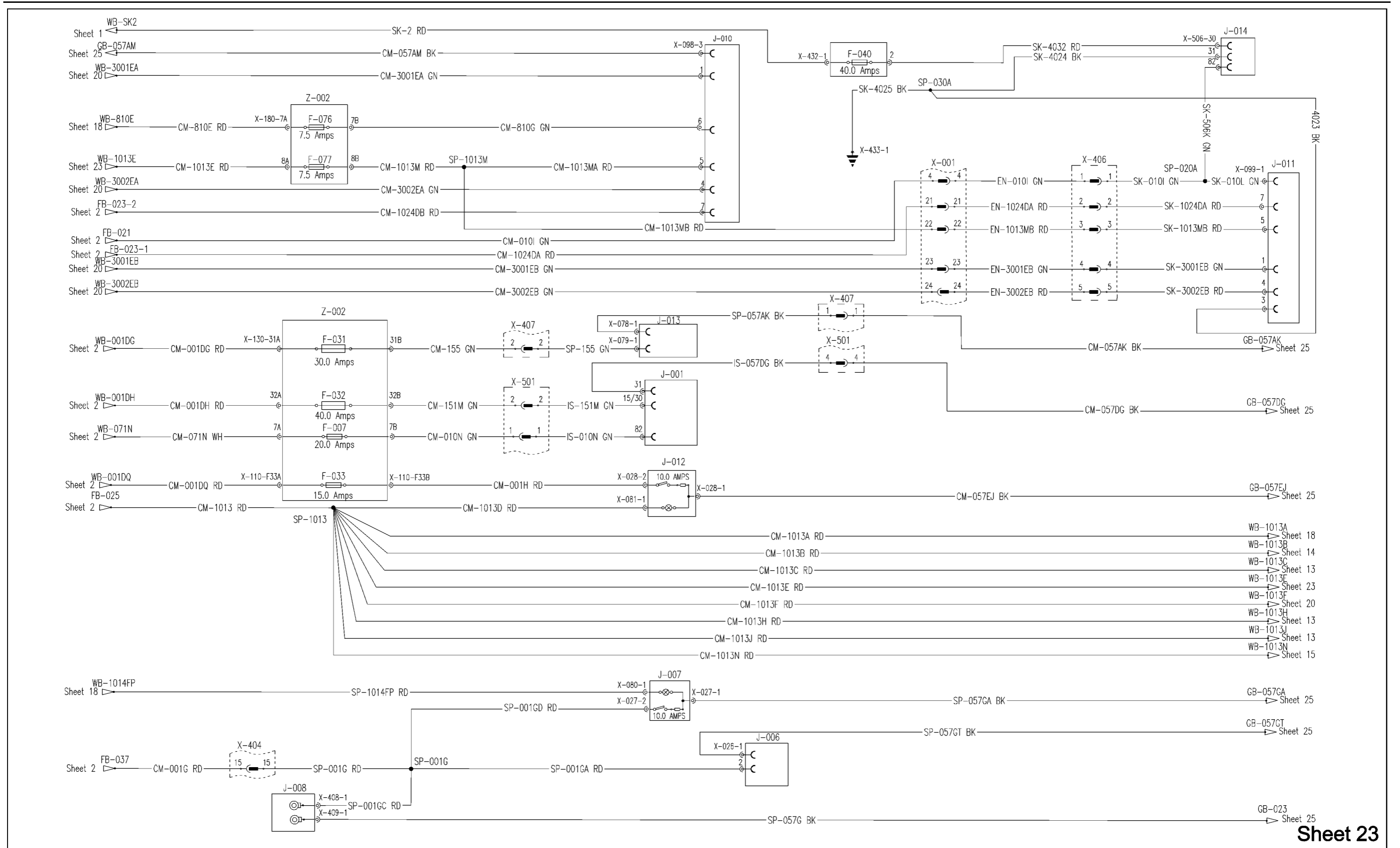

Sheet 23

SS13A327 1

## Wiring harnesses - Electrical schematic sheet 24 - CAN bus 1 and ELECTRO HYDRAULIC REMOTE VALVES – CAN bus

Component	Connector	Description	
A-023	X-699	Electro Hydraulic Remote (EHR) valve 3 – Rear implement	
A-024	X-700	Electro Hydraulic Remote (EHR) valve 4 – Rear implement	
A-057	X-937	Engine Control Unit (ECU)	
A-063	X-450	Instrument cluster	
A-076	X-698	Electro Hydraulic Remote (EHR) valve 2 – Front implement	
A-079	X-697	Electro Hydraulic Remote (EHR) valve 1 – Front implement	
A-090	X-200	Central Control Unit (CCU)	
A-092	X-504	Transmission Control Unit (TCU)	
A-100	X-524	Electronic Front Hitch (EFH) control unit	
J-020	X-376	Diagnostic socket (CAN bus 1)	
J-021	X-336	Diagnostic socket (CAN bus 2)	
J-022	X-067	Diagnostic socket (ZF)	
R-016	X-702	CAN bus termination resistor	
Z-011	X-388	Remote valve joystick	
Additional connectors: X-001, X-346, X-388, X-944			
Wire color codes			
BK Black	GN Green	PK Pink	BL Blue
TN Light Brown	BR Brown	OR Orange	LG Light Green
RD Red	GY Grey	LB Light Blue	
WH White	YE Yellow	VT Violet	

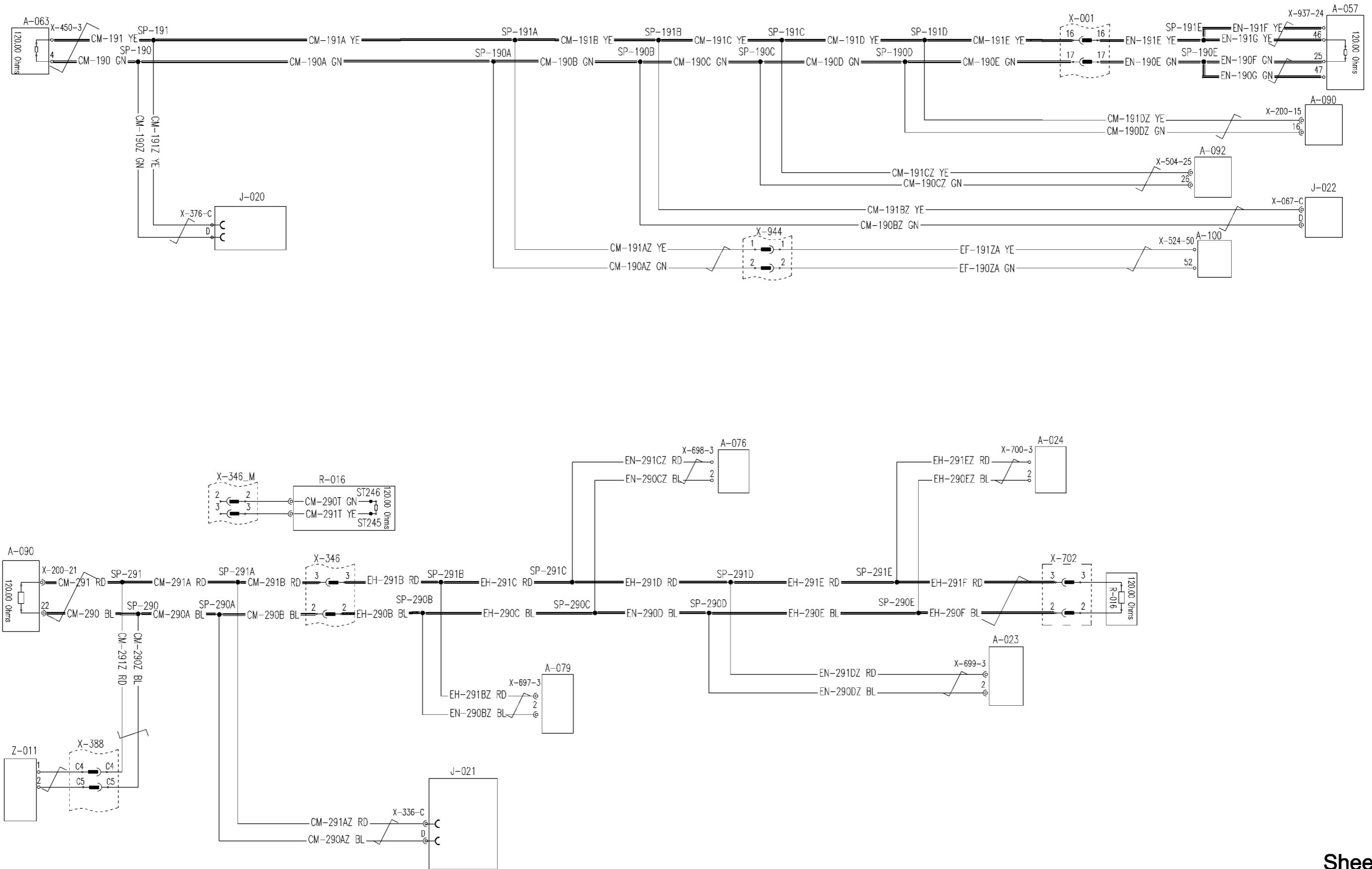

## Wiring harnesses - Electrical schematic sheet 25 - GROUND DISTRIBUTION

Component	Connector	Description	
-	<b>X-280</b>	Ground connection Central Control Unit (CCU) and Transmission Control Unit (TCU)	
-	<b>X-400</b>	Ground connection fuse block	
-	<b>X-403_A</b>	Ground connection roof right-hand	
-	<b>X-403_B</b>	Ground connection roof left-hand 1	
-	<b>X-403_C</b>	Ground connection roof left-hand 2	
-	<b>X-410</b>	Ground connection steering column	
Additional connectors: <b>X-405, X-944</b>			
Wire color codes			
BK Black	GN Green	PK Pink	BL Blue
TN Light Brown	BR Brown	OR Orange	LG Light Green
RD Red	GY Grey	LB Light Blue	
WH White	YE Yellow	VT Violet	

Electrical systems - Harnesses and connectors

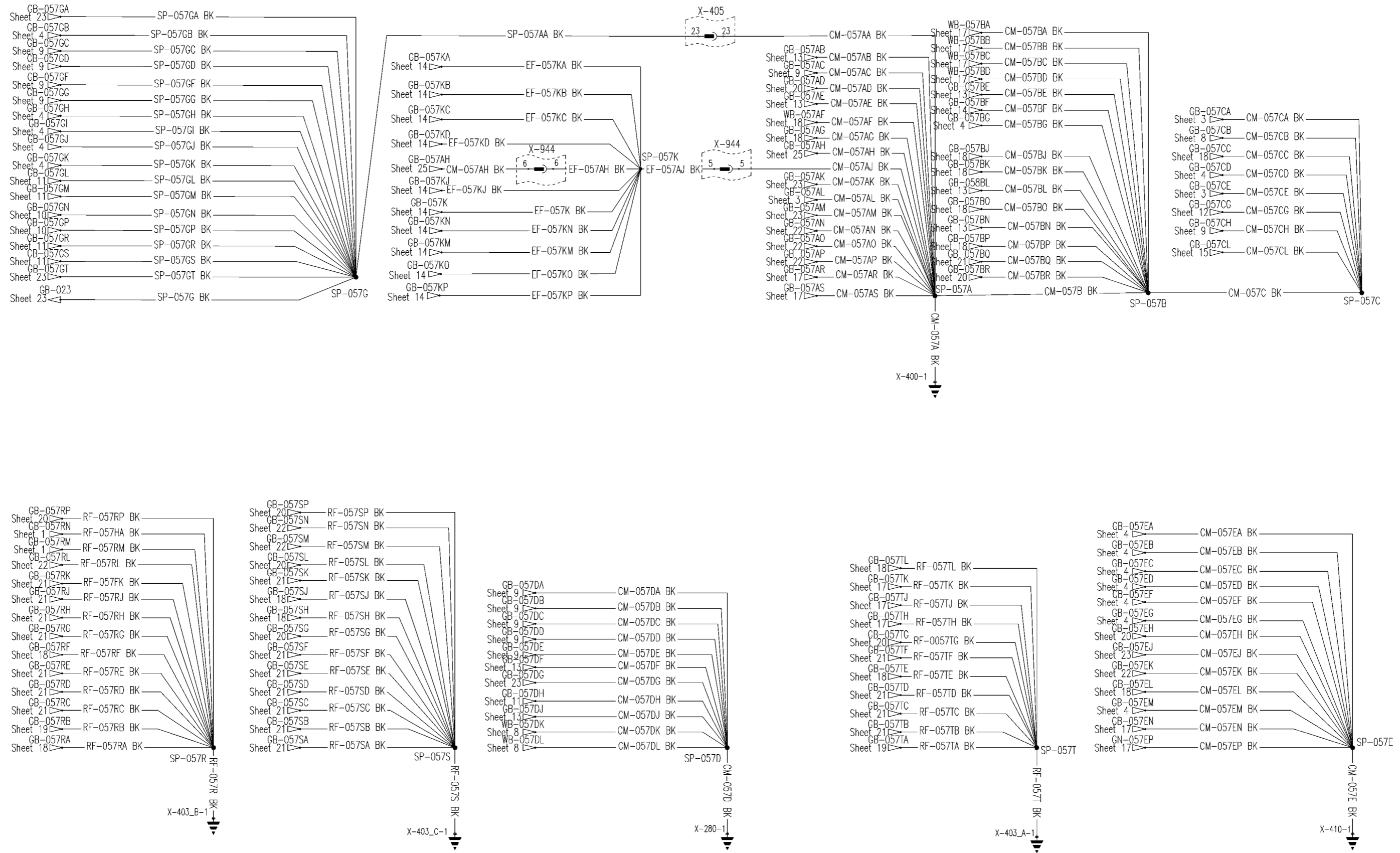

Sheet 25





## Wiring harnesses - Static description

The wiring diagrams for a tractor model are divided into several sections, whereby when possible one page includes one individual vehicle function (e.g. engine, transmission, and instrument cluster).

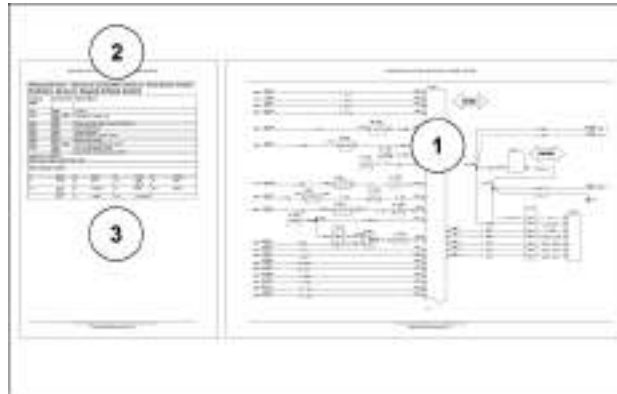

SS09B053 1

1. The wiring diagrams **(1)** are located on the right-hand side. The title and the diagram key **(2)** are located on the left-hand side along with the table for the wire color code **(3)**. The title includes the frame number and the frame description. The frame description defines the vehicle function to which the specific page refers. The diagram key identifies all the components used within that specific page.
2. Every component and every connector has its own unique reference number. A reference number is placed next to the appropriate electrical symbol within the wiring diagram. To identify the type of a component, a prefix is provided before a numerical reference (progressive number). For example the reference number 'S-001' indicates with the prefix 'S-' a switch. The table below provides a complete listing of the possible reference numbers.
3. Every wire has a code assigned to it. The wire code is physically marked on each specific wire. The wire code refers to the function of the wire. The wire code includes information about the correspondent wiring harness, the wire reference number, and the wire color. For example the wire code 'BT-057 BK' indicates that the wire belongs to the battery wiring harness ('BT'). The wire reference number is '057' and the wire color is black ('BK').
4. The wiring diagrams are drawn in sections according to a vehicle function. There are several components that influence multiple sections (such as a control unit or a multi-function switch). These components are existent in different sections.
5. A number of wires are existent on multiple pages of the wiring diagrams (e.g. power supplies and ground connections). Such a wire ends with an arrow on the side of the page, making it possible to follow the electrical circuit in its entirety. Next to an arrow is placed a reference to the page on which the wire continues or from which the wire comes. 'WB-138 Sheet 2' is an example for a wire break reference. 'WB-138' is a unique sequential reference. 'WB' is an abbreviation for wire break. 'Sheet 2' indicates the frame number for the continuation of the electrical circuit. The table below provides a complete listing of the wire break references.

Electrical systems - Harnesses and connectors

Reference number	Component type
A-001	Module
B-001	Sensor, transmitter
C-001	Capacitor
E-001	Light, Light Emitting Diode (LED)
F-001	Fuse
G-001	Battery
G-002	Alternator
H-001	Audible device
J-001	Socket
K-001	Relay
M-001	Motor
Q-001	Battery isolator
R-001	Resistor
S-001	Switch
SP-001	Splice
V-001	Diode
W-001	Antenna, splice block
X-001	Connector
Y-001	Solenoid valve, injector
Z-001	Assembly

Wire break reference	Wire break description
FB-001	Fuse break
GB-001	Ground break
WB-001	Wire break

## Wiring harnesses - Identification

WIRE COLOR CODES		
BK (B) Black	BR (N) Brown	LB (TQ) Light Blue
TN (LN) Light Brown	GY (S) Grey	VT (P) Violet
RD (R) Red	YE (Y) Yellow	BL (U) Blue
WH (W) White	PK (K) Pink	LG Light Green
GN (G) Green	OR (O) Orange	

**NOTE:** Color codes in brackets are the previous codes. (---> serial number)

### WIRE CODE REFERENCES

CIRC	COLOR	DESCRIPTION
1	RD (R)	BATTERY SUPPLY
10	GN (G)	IGNITION SUPPLY
11	GN (G)	IGNITION SUPPLY (2ND)
12	BL (U)	MAIN BEAM HEADLAMP FUSE SUPPLY
13	BL (U)	DIP BEAM HEADLAMP FUSE SUPPLY
15	BL (U)	LIGHTING SWITCH SUPPLY
28	YE (Y)	WIPER MOTOR (PARK RETURN)
29	GN (G)	MAIN FUEL SENDER SIGNAL
31	YE (Y)	ENGINE OIL PRESSURE SENDER SIGNAL
39	GN (G)	TEMPERATURE GAUGE SIGNAL
44	VT (P)	FLASHER UNIT (49A)
49	GN (G)	RIGHT HAND TURN SIGNAL
50	GN (G)	LEFT HAND TURN SIGNAL
56	WH (W)	WIPER MOTOR-HIGH
57	BK (B)	EARTH (ALL)
58	RD (R)	WIPER MOTOR-LOW
60	BK/WH (B/W)	SENSOR GROUND
61	BK (B)	CASE GROUND
63	BL (U)	WIPER MOTOR-PARK FEED
65	WH (W)	DUAL POWER/4 WHEEL DRIVE SWITCH FEED
71	WH (W)	IGNITION SWITCHED FEEDS (UNFUSED)
84	GN (G)	WINDSHIELD WASHER SWITCH FEED
90	GN (G)	DUAL POWER / FOUR WHEEL DRIVE SWITCH
97	LG	WINDSHIELD WASHER FEED
137	WH (W)	RADIO FEED
138	VT (P)	RADIO KAM
150	BR (N)	BATTERY FEED (UNFUSED)(ALL)
155	GN (G)	BATTERY FEED (FUSED)
160	BL (U)	BATTERY SUPPLY ELECTRONICS
170	WH (K/N/B)	BATTERY ISOLATOR CONTROL SWITCH
171	WH (W/TQ/B)	BATTERY ISOLATOR RELAY COIL
172	WH (W/TQ/Y)	BATTERY ISOLATOR RELAY COIL (OFF)
173	WH (W)	BATTERY ISOLATOR RELAY COIL +12V
181	GN (G)	BLOWER MOTOR FEED
182	VT (P)	THERMOSTATIC SWITCH FEED
249	LG	SMV LAMPS RH
250	LG	SMV LAMPS LH
252	BR (N)	ALTERNATOR FIELD
349	TN (LN)	TRAILER TURN LAMPS RH
350	TN (LN)	TRAILER TURN LAMPS LH
365	GN (G)	LOW FUEL WARNING LAMP (DELAY ON)
366	OR (O)	LOW FUEL WARNING LAMP (DELAY SWITCH)
376	VT (P)	HORN FEED

Electrical systems - Harnesses and connectors

CIRC	COLOR	DESCRIPTION
587	LG	WINDSHIELD WIPER INTERMITTENT DELAY
649	OR (O)	COOLANT TEMPERATURE SWITCH
650	LB (TQ)	COOLANT LEVEL SWITCH
666	VT (P)	DOMELAMP SWITCH FEED
787	GN (G)	AUXILIARY FUEL PUMP SUPPLY
810	GN (G)	STOPLAMPS
820	RD (R)	STOPLAMP SWITCH LH
825	YE (Y)	PNEUMATIC TRAILER SOLENOID +12V
830	BL (U)	STOPLAMP SWITCH RH
840	GN (G)	R & L STOPLAMP SIGNAL
976	WH (W/N/B)	LICENCE PLATE LAMP / WORKLAMP DIODE
978	WH (W)	LICENCE PLATE LAMP
979	GY (S)	BLOWER MOTOR HIGH SPEED (4th)
980	BR (N)	THERMOSTAT SWITCH SUPPLY
981	GN (G)	A/C CLUTCH RELAY FEED
982	GN (G)	BLOWER MOTOR FEED
984	VT (P)	TEMPERATURE CONTROL POT. INPUT
986	VT (P)	TEMPERATURE CONTROL POT. OUTPUT
989	VT (P)	BLOWER MOTOR MEDIUM SPEED (2nd)
996	VT (P)	BLOWER MOTOR HIGH SPEED (3RD)
997	GN (G)	WORK LAMP-REAR FEED (OUTER)
998	GN (G)	WORK LAMP-REAR FEED (INNER)
999	GN (G)	BLOWER MOTOR LOW SPEED (1st)
1000	WH (W)	SAFETY START SWITCH SUPPLY
1001	WH (W)	STARTER SOLENOID FEED
1002	VT (P)	IMPLEMENT LAMP SWITCH SUPPLY
1003	GN (G)	SUPPLY TO GAUGES
1004	GN (G)	SUPPLY TO HORN AND HEADLAMP FLASH
1005	GY (S)	AIR CLEANER WARNING LAMP
1006	BR (N)	ALTERNATOR WARNING LAMP
1007	WH (W)	ETHER START BUTTON SUPPLY
1008	BR (N)	ETHER START SOLENOID SUPPLY
1009	BR (N)	ALTERNATOR FIELD
1010	GN (G)	IGNITION RELAY (COIL)
1011	YE (Y)	SUPPLY TO FUSES
1012	RD (R)	ILLUMINATION
1013	RD (R)	RIGHT HAND LAMPS
1014	RD (R)	LEFT HAND LAMPS
1015	VT (P)	DOMELAMP SWITCH FEED
1016	VT (P)	HORN FEED
1017	LG	AIR CON. THERMOSTATIC SWITCH FEED
1018	LG	AIR CONDITIONER CLUTCH
1019	GN (G)	WINDSHIELD WIPER FEED
1020	GN (G)	HAZARD SWITCH SUPPLY
1021	VT (P)	HAZARD SWITCH SUPPLY (BATTERY)
1022	BR (N)	THERMOSTART
1023	BR (N)	LIGHT SWITCH FEED
1024	RD (R)	RIGHT & LEFT HAND SIDELAMP FEED
1025	GN (G)	HZD SWITCH IGN FEED
1026	BL (U)	HIGH BEAM INDICATOR LAMP
1027	BL (U)	HEADLAMP MAIN BEAM
1028	BL (U)	HEADLAMP MAIN BEAM FUSE
1029	BL (U)	HEADLAMP DIP BEAM FUSE
1030	BL (U)	HEADLAMP DIP BEAM

Electrical systems - Harnesses and connectors

CIRC	COLOR	DESCRIPTION
1031	RD (R)	INSTRUMENT ILLUMINATION
1032	LG	URN SIGNAL WARNING LAMP (TERM C)
1033	LG	TURN SIGNAL WARNING LAMP (TERM C2)
1034	LG	TURN SIGNAL WARNING LAMP (TERM C3)
1035	WH (W)	ENGINE OIL PRESSURE WARNING LAMP
1036	BR (N)	IGNITION SWITCH (BATTERY)
1037	LG	FLASHER UNIT (TERM 49A)
1038	TN (LN)	WINDSHIELD WIPER FEED-REAR
1039	LG	NASO LIGHTS INPUT
1040	LG	FLASHER SWITCH TO RELAY-RHS CUT OUT
1041	LG	FLASHER SWITCH TO RELAY-LHS CUT OUT
1042	BL (U)	RELAY FEED ELECTRONICS
1043	BL (U)	RELAY FEED TO FUSES
1044	WH (W/U/S)	GRID HEATER FEEDBACK
1050	GN (G)	ACCESSORY FEED
1051	YE (Y)	SIDE LIGHTS RELAY COIL FEED
1052	YE (Y)	GET U HOME LIGHTS RELAY
1070	RD (R)	FRONT WORKLAMP SWITCH FEED
1071	VT (P)	WORKLAMP FRONT FEED
1072	VT (P)	WORKLAMP FRONT RELAY SUPPLY
1073	VT (P)	WORKLAMP FRONT FEED
1090	RD (R)	REAR WORKLAMP RELAY SIGNAL
1080	RD (R)	FRONT SCREEN HEATER
1082	YE (Y)	REAR SCREEN HEATER
1085	BR (N)	FRONT SCREEN HEATER RELAY CONTROL
1086	BR (N)	REAR SCREEN HEATER RELAY CONTROL
1091	RD (R)	FRONT WORKLAMP LOWER RELAY SIGNAL
1092	RD (R)	FRONT WORKLAMP RELAY SIGNAL
1093	RD (R)	FENDER WORKLAMP RELAY SIGNAL
1096	RD (R)	WORKLAMP FENDER MOUNTED
1097	RD (R)	FEED FRONT WORKLAMP OUTER
1098	WH (W)	FRONT WORKLAMP RELAY GROUND
1099	RD (R)	FEED FRONT WORKLAMP INNER
1119	GN (G)	RR WINDSHIELD WIPER
1120	GN (G)	RR WINDSHIELD WIPER PARK RETURN
1121	GN (G)	RR WINDSHIELD WASH
1130	BR (N)	ENGINE HEATER CONTROL TO IGN SWITCH
1135	GN (G)	THERMOSTART WARNING LAMP
1140	PK (K)	THERMOSTART INITIATE SIGNAL TO RELAY
1141	BR (N)	GRID HEATER +
1142	BR (N)	GRID HEATER FUSE TO PWR. RELAY
1143	BR (N)	POWER RELAY TO GRID HEATER
1150	BR (N)	CAL/SEL SWITCH
1160	RD (R)	REVERSE ALARM
1900	LG (LG/B/S)	HEATED FRONT WINDSCREEN SW SIGNAL
1901	TN (LN/LG/S)	HEATED FRONT WINDSCREEN POWER
1902	OR (O/LN/S)	HEATED FRONT WINDSCREEN WARNING LAMP
1903	VT (P/B/S)	HEATED REAR SCREEN SW SIGNAL
1904	YE (Y/B/S)	HEATED REAR SCREEN POWER
1905	BL (U/W/S)	HEATED REAR SCREEN WARNING LAMP
1920	OR (O)	LH MIRROR CONTROL SIDE-SIDE
1921	YE (Y)	LH MIRROR CONTROL UP-DOWN
1922	GN (G)	MIRROR CONTROL COMMON
1923	OR (O)	RH MIRROR CONTROL SIDE-SIDE

Electrical systems - Harnesses and connectors

CIRC	COLOR	DESCRIPTION
1924	YE (Y)	RH MIRROR CONTROL UP-DOWN
1925	RD (R)	MIRROR CONTROL +12V
1927	RD (R)	MIRROR ILLUMINATION
1928	RD (R)	HEATED MIRROR RELAY COIL +12V FROM SW
2001	BR (N)	BATTERY TEMPERATURE SENSOR
2002	BR (N)	BATTERY TEMP SENSOR (ALT OUTPUT)
2003	WH (W)	STARTER SOLENOID FEED
2005	OR (O)	AIR CON CLUTCH RELAY
2006	BL (U)	DE-ICING SWITCH - AIR CONDITIONER
2007	YE (Y)	AIR CONDITIONER LOW PRESSURE
2008	BR (N)	LIFT PUMP SUPPLY
2009	GN (G)	FUEL PUMP SUPPLY
2010	LG	AIRCON PLUG TO DE-ICING SWITCH
2011	VT (P)	HORN RETURN
2012	YE (Y)	TRANS OIL PRESSURE WARNING LAMP
2013	YE (Y)	PTO OVERSPEED WARNING LAMP
2014	GN (G)	ENGINE OIL PRESSURE SENDER (+5 VOLT)
2015	WH (W)	TACHOMETER SENSOR-SIGNAL
2016	YE (Y)	REAR AXLE SPEED SENSOR-SIGNAL
2017	VT (P)	BULB TEST (EIC)
2018	RD (R)	RADAR PRESENT
2019	PK (K)	ENGINE RPM (TACHO MODULE TO TPM)
2020	YE (Y)	ENGINE SHUT DOWN (TACHO MODULE TO TPM)
2021	YE (Y)	AXLE GROUND SPEED (TACHO MODULE TO TPM)
2022	YE (Y)	PTO 540/1000 RPM (TACHO MODULE TO TPM)
2023	GY (S)	TPM TO EIC (AXLE SPEED DRIVE)
2024	GY (S)	RADAR SIGNAL DRIVE
2025	GY (S)	AUDIO ALARM CONTROL
2026	GY (S)	IMPLEMENT SWITCH SIGNAL
2027	RD (R)	RADAR ASSEMBLY (GUN) POWER
2028	GN (G)	RADAR ASSEMBLY (GUN) SIGNAL
2029	VT (P)	INSTRUMENT MEMORY SUPPLY
2030	BR (N)	ELECTRONIC DRAFT CONTROL
2031	YE (Y)	RADAR PRESENT
2040	LG	WATER IN FUEL SENSOR
2041	VT (P)	FUEL SHUT OFF
2042	OR (O)	PTO SOLENOID-REAR
2043	OR (O)	PTO SOLENOID-FRONT
2044	OR (O)	PTO SOLENOID-FRONT RETURN(-)
2045	OR (O)	PTO SWITCH TO MODULE
2046	OR (O)	PTO SWITCH (VCC)
2047	OR (O)	PTO SWITCH (VCCO)
2048	OR (O)	PTO SWITCH (VCCS)
2049	OR (O)	PTO SWITCH 1000RPM WARNING LAMP
2050	GN (G)	PTO SUPPLY / DOG SUPPLY
2051	OR (O)	PTO SOLENOID RETURN (-)
2052	WH (W)	PTO LUBE SOL
2053	VT (P)	PTO LUBE SOL RETURN
2055	WH (W)	PTO SYNCHRO GROUND SPEED ENGAGED
2056	WH (W)	PTO FENDER PTO SWITCH ON
2057	WH (W)	PTO FENDER SWITCH LH - RH LINK
2059	WH (W)	FENDER PTO SWITCH INPUT
2060	OR (O)	PTO 540/1000 SWITCH
2062	WH (W)	PTO TWIST SENSOR

## Electrical systems - Harnesses and connectors

CIRC	COLOR	DESCRIPTION
2065	BR (N)	PTO ENGAGED
2068	BR (N)	PTO SOFT START
2069	BL (U)	PTO MANAGEMENT ON
2070	OR (O)	ENGINE SHUT OFF RELAY +12V
2080	OR (O)	ENGINE SHUT OFF RELAY
2087	OR (O)	EXHAUST BRAKE SOLENOID
2085	OR (O)	
2090	WH (W)	STARTER RELAY TO START INHIBIT SWITCH
2095	GN (G)	INSTRUMENT SIGNAL GROUND
2100	GN (G)	A/C CONDENSER MOTOR FEED
2120	TN (LN)	PTO BRAKE SIGNAL
2130	BR (N)	PTO BRAKE SOLENOID
2140	OR (O)	PTO SPEED SENSOR
2150	VT (P)	PTO EXT. SWITCH OFF
2151	PK (K)	ESPTO DRIVE RELAY UPPER SPEED
2152	PK (K)	ESPTO DRIVE RELAY LOWER SPEED
2153	RD (R)	ESPTO ACTUATOR UPPER SPEED
2154	BR (N)	ESPTO ACTUATOR LOWER SPEED
2155	BR (N)	ESPTO ACTUATOR POWER +12V
2156	BR (N)	ESPTO ACTUATOR POS SIGNAL
2157	BL (U)	ESPTO NEUTRAL
2158	BR (N)	ESPTO LOWER SPEED
2159	BL (U)	ESPTO UPPER SPEED
2200	GN (G)	SERVICE MODE INITIATE
2245	PK (K)	PTO FRONT - SWITCH TO MODULE (MOM)
2248	PK (K)	PTO FRONT - SWITCH (VCCS)
2250	PK (K)	PTO FRONT - SUPPLY
2260	OR (O)	PTO FRONT - SPEED SIGNAL
2270	OR (O)	PTO FRONT - WARNING LAMP
2300	VT (P)	THEORETICAL GROUND SPEED ISO 11786 SKT.PIN#2
2310	VT (P)	IN/OUT OF WORK-HPL MODE ISO11786 SKT.PIN#4
2320	VT (P)	TRUE GROUND SPEED ISO 11786 SKT.PIN#1
2330	VT (P)	PTO SPEED ISO11876 SKT.PIN#3
2500	BR (N)	FRONT HITCH SOLENOID
2510	BR (N)	FRONT HITCH POSITION SIGNAL
2520	BR (N)	FRONT HITCH SET POSITION SIGNAL
2530	BR (N)	FRONT HITCH V REF
2540	BR (N)	FRONT HITCH +12v IGN
2550	BR (N)	FRONT HITCH OVERRIDE SWITCH
2556	BR (N)	FRONT HITCH SWITCH COMMON RAIL
2560	BR (N)	FRONT HITCH 0v REF
2570	RD (R)	FRONT HITCH RAISE SOLENOID
2571	GY (S)	FRONT HITCH RAISE SOLENOID RETURN(-)
2575	WH (W)	STEYR EFH TRANSPORT SIGNAL – BOSCH EFH MODULE
2576	WH (W)	STEYR EFH WORK SIGNAL – BOSCH EFH MODULE
2577	VT (P)	STEYR EFH DIAGNOSTIC LAMP – BOSCH EFH MODULE
2578	GN (G)	STEYR EFH TRANSPORT SWITCH – EOLBAU ARMREST
2579	BR (N)	STEYR EFH WORK SWITCH – EOLBAU ARMREST
2580	RD (R)	FRONT HITCH LOWER SOLENOID
2581	GY (S)	FRONT HITCH LOWER SOLENOID RETURN (-)
2582	LG	STEYR - EXT SWITCHES
2583	TN (LN)	STEYR - EXT SWITCHES.
2584	WH (W)	OILMOTOR MODE
2585	TN (LN)	EFH RAISE SWITCH



Electrical systems - Harnesses and connectors

CIRC	COLOR	DESCRIPTION
2586	TN (LN)	EFH WORK SWITCH
2587	BR (N)	EFH EXTERNAL SWITCH +
2588	VT (P)	EFH EXTERNAL SWITCH UP
2589	RD (R)	EFH EXTERNAL SWITCH DOWN
2590	TN (LN)	EXTERNAL SWITCH FHPL UP
2591	TN (LN)	EXTERNAL SWITCH FHPL DOWN
2592	BR (N)	EFH VALVE DOWN +
2593	BR (N)	EFH VALVE DOWN
2594	OR (O)	EFH POSITION SENSOR +
2595	VT (P)	EFH POSITION SENSOR SIGNAL
2596	RD (R)	EFH POSITION SENSOR
2597	TN (LN)	EFH PRESSURE SENSOR SIGNAL
2598	GY (S)	EFH ACCUMULATOR 14 BAR
2599	BR (N)	EFH ACCUMULATOR 40 BAR
2600	YE (Y)	REAR AXLE SPEED MONITOR
3000	GN (G)	FLASHER UNIT SUPPLY (TERMINAL 49)
3001	GN (G)	LEFT HAND FLASHER CIRCUIT
3002	GN (G)	RIGHT HAND FLASHER CIRCUIT
3003	WH (W)	RADIO FEED
3004	GN (G)	RIGHT HAND TURN SIGNAL WARNING LAMP
3005	GN (G)	LEFT HAND TURN SIGNAL WARNING LAMP
3006	GN (G)	AUXILIARY FUEL TANK SENDER
3007	GN (G)	FUEL GAUGE FEED
3008	BL (U)	WORKLAMP WARNING LIGHT
3009	GN (G)	FLASHER UNIT SUPPLY B+
3010	RD (R)	FOGLAMP FEED
3011	RD (R)	FOGLAMP FEED
3012	GN (G)	HANDBRAKE WARNING FEED
3013	LG	AUXILIARY FUEL TANK SIGNAL
3014	RD (R)	HANDBRAKE WARNING LAMP SIGNAL
3015	VT (P)	ACCESSORY SOCKET (POWER)
3016	GY (S)	BRAKE FLUID LEVEL SIGNAL
3017	GN (G)	EPB SYSTEM FAILURE WARNING LIGHT
3018	GN (G)	FLASHER UNIT BUZZER FEED
3019	GN (G)	EPB SYSTEM OPERATION STATUS LIGHT
3020	YE (Y)	DUAL POWER SOLENOID SUPPLY
3022	YE (Y)	DUAL POWER (HIGH) WARNING LAMP
3023	VT (P)	EPB SYSTEM BATTERY ISOLATOR INTERLOCK
3024	YE (Y)	2WD SOLENOID
3025	YE (Y)	FOUR WHEEL DRIVE SOLENOID (MANUAL)
3026	YE (Y)	BRAKE PEDAL SWITCH - RIGHT
3027	YE (Y)	FOUR WHEEL DRIVE SOLENOID (AUTO)
3028	YE (Y)	BRAKE PEDAL SWITCH LEFT
3029	TN (LN)	EPB +5V REFERENCE
3030	WH (W)	ACCESSORY RELAY SIGNAL
3031	BR (N)	EPB +12 HOT
3032	GN (G)	EPB +12 IGNITION
3033	OR (O)	EPB MOTOR SUPPLY "A"
3034	YE (Y)	EPB POSITION SIGNAL
3035	OR (O)	EPB MOTOR SUPPLY "B"
3036	OR (O)	EPB SHUTTLE PARK SWITCH INPUT
3037	YE (Y)	EPB PROPORTIONAL BRAKE SIGNAL
3038	YE (Y)	EPB HAND THROTTLE SWITCH
3039	OR (O)	EPB SHUTTLE PARK SWITCH OUTPUT

Electrical systems - Harnesses and connectors

CIRC	COLOR	DESCRIPTION
3045	YE (Y)	FOUR WHEEL DRIVE WARNING LAMP
3050	VT (P)	AUXILIARY FEED CONNECTOR SUPPLY
3051	VT (P)	CIGAR LIGHTER SUPPLY
3052	VT (P)	DOME LAMP TO DOOR SWITCH
3053	GY (S)	SPEAKER RIGHT HAND
3054	GY (S)	SPEAKER NEGATIVE RH
3055	GY (S)	SPEAKER LEFT HAND
3056	BR (N)	SPEAKER NEGATIVE LH
3057	VT (P)	PUDDLE LAMP RETURN
3060	VT (P)	IMPLEMENT SOCKET RELAY
3061	VT (P)	IMPLEMENT SOCKET
3062	VT (P)	IMPLEMENT SOCKET SWITCH
3070	VT (P)	'B' PILLAR SKT SUPPLY
3073	WH (W)	MICROPHONE
3074	BK (B)	SCREEN FOR 3073
3075	OR (O)	TRAILER SOCKET (ACCESSORY FEED)
3076	OR (O)	ACCESSORY SWITCH FEED
3077	YE (Y)	RADIO +12VB
3078	OR (O)	RADIO +12V ILLUMINATION
3079	RD (R)	RADIO +12V IGNITION
3080	VT (P)	CONSOLE LAMP
3081	YE (Y)	TELEPHONE OUT
3082	OR (O)	TELEPHONE OUT 1
3083	BR (N)	TELEPHONE MUTE
3084	VT (P)	AUXILIARY INPUT COMMON RAIL
3085	WH (W)	AUXILIARY INPUT (LEFT CHANNEL)
3086	RD (R)	AUXILIARY INPUT (RIGHT CHANNEL)
3087	GY (S)	BUTTONS COMMON
3088	GN (G)	BUTTONS 'TELEPHONE'
3089	BL (U)	BUTTONS 'VOICE'
3090	YE (Y)	SEAT PUMP SUPPLY
3091	VT (P)	SPEAKER RR-RHS +
3092	VT (P)	SPEAKER RR-RHS-
3093	GY (S)	SPEAKER FRT-RHS +
3094	GY (S)	SPEAKER FRT-RHS-
3095	WH (W)	SPEAKER FRT-LHS +
3096	GY (S)	SPEAKER FRT-LHS-
3097	GN (G)	SPEAKER RR-LHS +
3098	GN (G)	SPEAKER RR-LHS-
3099	LB (TQ)	BUTTONS 'REMOTE'
3100	GN (G)	STEERING SENSOR +5v
3120	PK (K)	STEERING SENSOR SIGNAL
3140	LG	STEERING SENSOR GROUND
3150	WH (W)	HANDBRAKE SWITCH (N.C CONTACT) OFF SIG
3155	WH (W)	HANDBRAKE TRANS INTERLOCK
3160	OR (O)	AUTO GUIDANCE STEERING PRESS SENSOR SIGNAL
3161	OR (O)	AUTO GUIDANCE STEERING PRESS SENSOR RETURN
3163	OR (O)	AUTO GUIDANCE STEERING SOLENOID VLV R FEED
3164	OR (O)	AUTO GUIDANCE STEERING SOLENOID VLV R RETURN
3165	OR (O)	AUTO GUIDANCE STEERING SOLENOID VLV L FEED
3166	OR (O)	AUTO GUIDANCE STEERING SOLENOID VLV L RETURN
3167	OR (O)	AUTO GUIDANCE STEERING PRESS SNSR +5V REF
3168	OR (O)	AUTO GUIDANCE DUMP SOLENOID FEED (HSD)
3169	OR (O)	AUTO GUIDANCE DUMP SOLENOID RETURN (CURSEN)

Electrical systems - Harnesses and connectors

CIRC	COLOR	DESCRIPTION
3170	OR (O)	FSS – ENABLE
3171	OR (O)	FSS – LAMP
3172	VT (P)	FSS – STEERING PROXIMITY SENSOR POSITION
3173	RD (R)	FSS – HYDRAULIC VALVE HIGH SIDE DRIVER
3174	GN (G)	FSS – HYDRAULIC VALVE LOW SIDE DRIVER
3175	WH (W)	FSS – POSITION SENSOR PRIMARY POSITIVE
3176	BK (B)	FSS – POSITION SENSOR PRIMARY NEGATIVE
3177	YE (Y)	FSS – POSITION SENSOR SECONDARY COMMON
3178	GN (G)	FSS – POSITION SENSOR SECONDARY POSITIVE
3179	BR (N)	FSS – POSITION SENSOR SECONDARY NEGATIVE
3180	BK (B)	FSS – SAFETY SWITCH
3181	GY (S)	AUTO GUIDANCE PPS SIGNAL INPUT TO GPS
3185	BR (N)	AUTO GUIDANCE REMOTE ENGAGE
3186	GY (S)	CERES PPS IN
3187	BR (N)	AUTO GUIDANCE ROADING SELECT
3200	OR (O)	SUSPENSION SWITCH FEED
3210	BL (U)	SUSPENSION SWITCH RETURN
3215	BL (U)	SUSPENSION LAMP
3220	OR (O)	AXLE HEIGHT SENSOR 5V REF
3230	BL (U)	AXLE HEIGHT SENSOR POSITION
3235	OR (O)	ACCELEROMETER SIGNAL
3240	OR (O)	RAISE SOLENOID PWR
3250	OR (O)	RAISE SOLENOID RET
3260	OR (O)	LOWER SOLENOID PWR
3270	OR (O)	LOWER SOLENOID RET
3271	BL (U)	LOADER RELAY FEED
3272	OR (O)	LOADER VALVE #1 OUT
3273	OR (O)	LOADER VALVE #1 RETURN
3274	RD (R)	LOADER VALVE #2 OUT
3275	RD (R)	LOADER VALVE #2 RETURN
3276	GN (G)	LOADER VALVE
3277	BL (U)	LOADER VALVE #3 COIL
3278	BL (U)	LOADER VALVE #3 RELAY
3280	OR (O)	SUSPENSION LOCKOUT SOLENOID UPPER
3281	TN (LN)	SUSPENSION LOCKOUT SOLENOID UPPER RETURN (-)
3285	TN (LN)	SUSPENSION LOCKOUT SOLENOID LOWER
3286	TN (LN)	SUSPENSION LOCKOUT SOLENOID LOWER RETURN (-)
3290	OR (O)	SUSPENSION LOCKOUT LAMP (OR SOLENOID RET)
3295	OR (O)	FRONT SUSPENSION PRESSURE SWITCH SIGNAL
3300	OR (O)	SENSE LINE CONTROL SOLENOID
3310	BL (U)	RAISE LOCKOUT SOLENOID
3500	WH (W)	POWER STEERING PRESSURE SIGNAL
4001	RD (R)	TRANSMISSION OIL WARNING LAMP (TEMP)
4002	RD (R)	TRANSMISSION OIL WARNING LAMP SWITCH
4010	BR (N)	RETURN TO DIG
4011	VT (P)	ROTATING BEACON SWITCH SUPPLY
4012	VT (P)	ROTATING BEACON FEED
4013	BL (U)	TRANS CONTROL FEED
4014	BL (U)	FORWARD CLUTCH SOLENOID FEED
4015	BL (U)	REVERSE CLUTCH SOLENOID FEED
4016	BL (U)	TORQUE CONVERTOR LOCK-UP RELAY FEED
4017	BL (U)	TORQUE CONVERTOR LOCK-UP LAMP
4018	GY (S)	TORQUE CONVERTOR LOCK-UP SOLENOID FEED
4019	GY (S)	HYDRAULIC FILTER BY-PASS SWITCH FEED

## Electrical systems - Harnesses and connectors

CIRC	COLOR	DESCRIPTION
4020	GY (S)	HYDRAULIC FILTER BY-PASS LAMP
4021	GY (S)	BACK-UP ALARM RELAY FEED
4022	GY (S)	BACK-UP ALARM FEED
4025	YE (Y)	4 IN 1 BUCKET FEED
4040	GN (G)	LINK LEVEL SWITCH SUPPLY
4050	WH (W)	LINK LEVEL SWITCH - RAISE
4051	WH (W)	LINK LEVEL SWITCH - LOWER
4052	WH (W)	LINK LEVEL SWITCH SIDE EXTEND
4053	WH (W)	LINK LEVEL SWITCH SIDE RETRACT
4054	WH (W)	LINK LEVEL DUMP SOLENOID
4055	WH (W)	LINK LEVEL TOP LINK EXTEND SOLENOID
4056	WH (W)	LINK LEVEL TOP LINK RETRACT SOLENOID
4057	WH (W)	LINK LEVEL RIGHT LINK RAISE SOLENOID
4058	WH (W)	LINK LEVEL RIGHT LINK LOWER SOLENOID
4060	WH (W)	HYDRAULIC SELECT FRONT
4061	WH (W)	HYDRAULIC SELECT REAR
4100	LB (TQ)	TRANS RANGE ENABLE SWITCH SUPPLY
4101	LB (TQ)	TRANS RANGE ENABLE
4120	VT (P)	BEACON RELAY COIL
5000	VT (P)	EDC MEMORY POWER
5005	BR (N)	EDC KEY SWITCH FEED
5010	BK/WH (B/W)	EDC EARTH
5011	BK (B)	EDC EARTH CASE RFI
5015	RD (R)	EDC CONTROLS BACKLIGHTING
5020	TN (LN)	EDC PROC +5V REF VOLTAGE DROP POSN/RATE
5021	PK (K)	EDC PROCESSOR REF VOLT (+5V) ROCKSHAFT
5022	PK (K)	EDC PROCESSOR REF VOLT +5V QUADRANT
5023	PK (K)	EDC PROCESSOR REF VOLT +5V HEIGHT LIMIT
5025	TN (LN)	EDC LOWER SIGNAL
5030	TN (LN)	EDC RAISE SIGNAL
5035	TN (LN)	EDC RETURN REF. VOLTAGE EARTH
5040	TN (LN)	EDC DRAFT POSITION
5045	TN (LN)	EDC DROP RATE
5050	TN (LN)	EDC QUADRANT
5055	TN (LN)	EDC CLOCK LINE TO DISPLAY
5060	TN (LN)	SERIAL DATA TO CLUSTER
5065	TN (LN)	EDC RIGHT PIN
5070	TN (LN)	EDC LEFT PIN
5075	PK (K)	EDC VOLTAGE TO PINS
5080	PK (K)	EDC ROCKSHAFT
5085	PK (K)	EDC VALVE UP
5087	PK (K)	EDC VALVE UP RETURN
5090	PK (K)	EDC VALVE DOWN
5095	PK (K)	EDC EXTERNAL SWITCH DOWN
5097	PK (K)	EDC VALVE DOWN RETURN
5100	PK (K)	EDC EXTERNAL SWITCH UP
5105	GY (S)	EDC IMPLEMENT STATUS SWITCH
5110	PK (K)	EDC LAMP SIGNAL
5115	PK (K)	EDC SLIP SIGNAL
5120	PK (K)	EDC HEIGHT LIMIT SIGNAL
5125	LB (TQ)	EDC RAISE SIGNAL-RAISE WORK SWITCH
5130	LB (TQ)	EDC WORK SIGNAL-RAISE WORK SWITCH
5132	LB (TQ)	EDC FLOAT
5133	LB (TQ)	EDC STOP

Electrical systems - Harnesses and connectors

CIRC	COLOR	DESCRIPTION
5135	LB (TQ)	EDC +WHEEL SPEED SIGNAL
5140	LB (TQ)	EDC -WHEEL SPEED SIGNAL
5145	LB (TQ)	EDC SLIP LIMIT POT
5150	GN (G)	EDC EXTERNAL SWITCH SUPPLY
5155	BL (U)	EDC LOWER LIMIT POT
5160	LB (TQ)	EDC HEIGHT LIMIT POT FEED
5170	TN (LN)	SERIAL DATA FROM CLUSTER
5175	RD (R)	ADIC KEY PAD DISABLE
5180	LB (TQ)	EDC SLIP INDICATOR LAMP
5190	RD (R)	HPL INTERLOCK / LIFT-O-MATIC
5200	BR (N)	EDC VALVE SUPPLY
5205	BR (N)	INTERNAL FENDER HITCH SWITCH - UP
5210	BR (N)	EDC VALVE ENABLE
5215	BR (N)	INTERNAL FENDER HITCH SWITCH - DOWN
5220	YE (Y)	EDC RAISE LAMP
5230	YE (Y)	EDC LOWER LAMP
5240	OR (O)	EDC RAISE SIGNAL-RAISE WORK SWITCH No.2
5250	OR (O)	EDC WORK SIGNAL-RAISE WORK SWITCH No.2
5260	TN (LN)	HYDRAULIC MASTER SW #1
5265	TN (LN)	HYDRAULIC MASTER SW #2
5270	BR (N)	JOYSTICK LED – FRONT
5300	PK (K)	ECU FLASH PROGRAM SIGNAL
5400	YE (Y)	CAN H
5420	GN (G)	CAN L
5500	RD (R)	EHR CAN HIGH
5510	BL (U)	EHR CAN LOW
5515	GY (S)	EHR +12V IGN.
5520	LG	EHR 5V REF.
5521	LG	EHR MOTOR #1
5522	LG	EHR MOTOR #2
5523	LG	EHR MOTOR #3
5524	LG	EHR MOTOR #4
5531	LG	EHR NEUTRAL SWITCH VALVE #1
5532	GN (G)	EHR NEUTRAL SWITCH VALVE #2
5533	PK (K)	EHR NEUTRAL SWITCH VALVE #3
5534	LG	EHR NEUTRAL SWITCH VALVE #4
5535	LG	EHR FLOAT SWITCH VALVE#1
5536	TN (LN)	EHR FLOAT SWITCH VALVE#2
5537	BR (N)	EHR FLOAT SWITCH VALVE#3
5538	OR (O)	EHR FLOAT SWITCH VALVE#4
5541	OR (O)	EHR MAX.FLOW SWITCH VALVE #1
5542	VT (P)	EHR MAX.FLOW SWITCH VALVE #2
5543	GY (S)	EHR MAX.FLOW SWITCH VALVE #3
5544	LB (TQ)	EHR MAX.FLOW SWITCH VALVE #4
5551	OR (O)	EHR POTENTIOMETER SIGNAL VALVE#1
5552	BL (U)	EHR POTENTIOMETER SIGNAL VALVE#2
5553	WH (W)	EHR POTENTIOMETER SIGNAL VALVE#3
5554	BL (U)	EHR POTENTIOMETER SIGNAL VALVE#4
5561	OR (O)	EHR TIMED FLOW SWITCH #1
5562	OR (O)	EHR TIMED FLOW SWITCH #2
5563	OR (O)	EHR TIMED FLOW SWITCH #3
5564	VT (P)	EHR TIMED FLOW SWITCH #4
5570	VT (P)	FENDER 3RD EHR SWITCH (RES)
5571	VT (P)	FENDER 3RD EHR SWITCH (RES)
5572	VT (P)	FENDER 3RD EHR SWITCH (RES)

Electrical systems - Harnesses and connectors

CIRC	COLOR	DESCRIPTION
5574	VT (P)	FENDER 3RD EHR SWITCH – UP
5576	VT (P)	FENDER 3RD EHR SWITCH – DOWN
5580	LB (TQ)	JOYSTICK REAR LAMP (MC)
5585	LB (TQ)	JOYSTICK FRONT LAMP (MC)
5591	VT (P)	EHR WARNING LAMP#1
5592	VT (P)	EHR WARNING LAMP#2
5593	VT (P)	EHR WARNING LAMP#3
5594	VT (P)	EHR WARNING LAMP#4
5595	GY (S)	EHR MASTER STOP SWITCH
5596	GY (S)	EHR MASTER STOP LAMP
5597	GY (S)	EHR MASTER ENABLE
5600	RD (R)	HTS LIVE SIGNAL
5610	RD (R)	HTS PROGRAM
5620	RD (R)	HTS ON/OFF SWITCH
5625	RD (R)	LIFT-O-MATIC SWITCH
5630	RD (R)	HTS MANUAL SWITCH
5640	RD (R)	HTS AUTO SWITCH
5700	WH (W)	EHR J-STICK X+
5710	WH (W)	EHR J-STICK X ACTIVE SWITCH
5720	WH (W)	EHR J-STICK X FULL FLOW SWITCH
5730	WH (W)	EHR J-STICK X FLOAT SWITCH
5740	WH (W)	EHR J-STICK Y+
5750	WH (W)	EHR J-STICK Y ACTIVE SWITCH
5760	WH (W)	EHR J-STICK Y FULL FLOW SWITCH
5770	WH (W)	EHR J-STICK Y FLOAT SWITCH
5820	GY (S)	EDC ROCKSHAFT POT
5830	BL (U)	HIGH FLOW PUMP LINK
5840	WH (W)	FRONT HITCH DETECT INPUT
5835	GY (S)	HYDRAULIC MASTER SWITCH HIGH FLOW PUMP LINK
5900	GN (G)	ISO BUS CAN SIGNAL LOW
5910	YE (Y)	ISO BUS CAN SIGNAL HIGH
5915	BK (B)	ISO BUS CAN SUPPLY GROUND
5920	RD (R)	ISO BUS CAN SUPPLY POSITIVE
5930	TN (LN)	ROTARY ENCODER SUPPLY
5935	OR (O)	ROTARY ENCODER SIGNAL - "Home"
5940	OR (O)	ROTARY ENCODER SIGNAL - "Esc"
5945	LB (TQ)	ROTARY ENCODER SIGNAL - "P1"
5950	LB (TQ)	ROTARY ENCODER SIGNAL - "P2"
5955	BK (B)	RS232 INPUT TECU
5960	WH (W)	RS232 OUTPUT TECU
5962	RD (R)	USB +5v REF
5964	WH (W)	USB DATA
5966	GN (G)	USB DATA +
5968	BK (B)	USB GROUND
5970	OR (O)	ISO BUS ECU SIGNAL
5975	OR (O)	ISO RELAY 2 POWER OUT
5980	OR (O)	ISO BUS IMPLEMENT SIGNAL
5985	BL (U)	ISO RELAY 1 POWER OUT
5990	OR (O)	ROTARY ENCODER SIGNAL - "Enter"
6000	PK (K)	ENGINE SPEED SIGNAL
6001	BK (B)	ENGINE ECU RESISTOR #1
6002	WH (W)	ENGINE ECU RESISTOR #2
6003	RD (R)	ENGINE ECU RESISTOR #3
6004	GN (G)	ENGINE ECU RESISTOR #4

Electrical systems - Harnesses and connectors

CIRC	COLOR	DESCRIPTION
6057	LB (TQ)	ENGINE STARTER RELAY GROUND
6010	YE (Y)	THROTTLE POSITION SWITCH
6100	BL (U)	ENGINE COLD ADVANCE CONTROL
6200	RD (R)	MANIFOLD (GRID) HEATER SUPPLY
6300	BR (N)	FAN SPEED
6305	BR (N)	REVERSIBLE FAN OPTION - MOTOR FEED
6310	BR (N)	FAN SOLENOID
6315	BR (N)	REVERSIBLE FAN OPTION - RELAY CONTROL
6320	BR (N)	FAN 5V REF.
6325	BR (N)	REVERSIBLE FAN OPTION - RELAY FEED
6327	RD (R)	REVERSIBLE FAN RELAY POWER OUT
6330	BR (N)	VISTRONIC FAN INPUT
6331	BR (N)	ECM SWITCHED GROUND VISCTRONIC
6355	BR (N)	+5V LOW POWER REFERENCE
6400	TN (LN)	ECU BATTERY SUPPLY
6401	GN (G)	ECU TO THROTTLE POT +5V
6402	GN (G)	ECU TO THROTTLE POT. VAR
6403	GN (G)	ECU TO THROTTLE POT.
6404	GN (G)	THROTTLE POT. TO LOW IDLE SWITCH
6405	GN (G)	ECU TO THROTTLE POT. SWITCH
6407	OR (O)	ENGINE SHUTDOWN SIGNAL (EDC16)
6408	GN (G)	FUSED B+ TO ECU 1
6409	GN (G)	FUSED B+ TO ECU 2
6410	GN (G)	FUSED B+ TO ECU 3
6411	GN (G)	FUSED B+ TO ECU 4
6413	OR (O)	ENGINE SHUTDOWN RELAY SUPPLY
6414	GN (G)	FUSED IGN.+ TO ECU
6415	GN (G)	ECU TO J1939 TERFACE CAN#1 CONN.(HI)
6416	GN (G)	ECU TO J1939 TERFACE CAN#1 CONN.(LO)
6417	(N/A)	SCREEN BRAID FOR 6415 & 6416
6418	PK (K)	ECU TO J1941(ISO) INTERFACE #2 CONNECTOR ISO K
6419	PK (K)	ECU TO J1941(ISO) INTERFACE #2 CONNECTOR ISO L
6420	PK (K)	ECU SINK DRIVER#6 TO DIAGNOSTIC LAMP
6421	PK (K)	ECU SINK DRIVER#6 TO DIAGNOSTIC LAMP
6422	PK (K)	ENGINE MOUNTED B- TO ECU 1
6423	PK (K)	ENGINE MOUNTED B- TO ECU 23
6424	PK (K)	ENGINE MOUNTED B- TO ECU
6425	PK (K)	ENGINE MOUNTED B- TO ECU 4
6427	PK (K)	ECU TO MULTIPLE STATE SWITCH (PASS.INPUT#06)
6428	PK (K)	ECU TO MULTIPLE STATE SWITCH (PASS.INPUT#06)
6431	PK (K)	ECU TO DIAGNOSTIC REQUEST SWITCH (DIG 15)
6432	PK (K)	ECU SWITCHED BATT OUTPUT TO DIAG REQUEST SW.
6440	GY (S)	HAND THROTTLE POSITION 1
6450	GY (S)	HAND THROTTLE POSITION 2
6460	GY (S)	HAND THROTTLE SWITCH (NOT IDLE)
6500	BR (N)	CONSTANT ERPM ON/OFF
6510	BR (N)	CONSTANT ERPM SET 1
6520	BR (N)	CONSTANT ERPM SET 2
6530	BR (N)	CONSTANT ERPM INCREASE
6540	BR (N)	CONSTANT ERPM DECREASE
6550	BR (N)	CONSTANT ERPM SET LAMP
6560	BL (U)	ECU TO FUEL FILTER HEATER
6570	GN (G)	ECU TO FUEL FILTER HEATER RETURN
6580	PK (K)	ECU TO GRID HEATER RELAY#1

## Electrical systems - Harnesses and connectors

CIRC	COLOR	DESCRIPTION
6585	OR (O)	ECU TO GRID HEATER RELAY#2
6586	VT (P)	ECU TO GRID HEATER RELAY RETURN
6590	LG	ECU DIGITAL GROUND
6600	TN (LN)	ECU BATTERY SUPPLY
6610	BR (N)	ECU IGNITION SUPPLY
6620	OR (O)	ECU COOLANT TEMP. SIGNAL
6630	OR (O)	ECU COOLANT TEMP. GROUND
6640	OR (O)	ECU AC PRESSURE NOT HIGH SWITCH
6650	OR (O)	ECU BOOST GROUND
6660	OR (O)	ECU BOOST TEMP
6670	OR (O)	ECU 5V BOOST
6680	OR (O)	ECU BOOST PRESSURE
6690	OR (O)	ECU SOLENOID VALVE SHUT OFF
6700	OR (O)	ECU CRANK SHAFT OUTPUT SHAFT
6710	OR (O)	ECU ENGINE SPEED
7000	BL (U)	TRANS CONTROL SUPPLY
7001	BL (U)	TRANS DISPLAY ILLUMINATION
7002	BL (U)	TRANS MAIN CLUTCH SOL (C3/C4)
7003	BL (U)	TRANS DUMP SOL
7004	BL (U)	TRANS FRONT CLUTCH SOL (C1/C2)
7005	BL (U)	TRANS CREEPER GR SOL
7007	RD (R)	TRANS DUAL POWER PRESSURE SWITCH HIGH
7008	RD (R)	TRANS DUAL POWER PRESSURE SWITCH LOW
7009	WH (W)	TRANS RANGE DISABLE SWITCH
7010	BL (U)	TRANS RANGE INDICATOR SWITCH (GR 1-4)
7020	BL (U)	TRANS RANGE INDICATOR SWITCH (GR 5-8)
7025	RD (R)	TRANS DISPLAY ENABLE
7030	BL (U)	TRANS RANGE INDICATOR SWITCH COMMON
7035	BR (N)	TRANS DUMP SOLENOID FEED
7040	BR (N)	TRANS CREEPER SWITCH
7050	RD (R)	TRANS RELAY SUPPLY - RUN
7060	RD (R)	TRANS RELAY SUPPLY - START
7068	BL (U)	TRANS CVT POWER SUPPLY (CVT)
7070	RD (R)	TRANS FEED (IGN +)
7071	BR (N)	FEED HYD FILTER RESTRICTION IND LAMP
7080	LG	DIFF-LOCK SOLENOID FEED
7090	LG	DIFF-LOCK SWITCH TO BRAKE SWITCH
7100	BR (N)	DIFF-LOCK RELAY TO BRAKE SWITCH
7110	RD (R)	PTO INHIBITOR SWITCH TO TRANS
7120	YE (Y)	DIFF-LOCK WNG LP (MAUAL)
7125	LG	DIFF-LOCK WNG LP (AUTO)
7126	LG	DIFF LOCK PRESSURE SWITCH
7130	BR (N)	HYD FILTER WNG LP
7135	BR (N)	HYD FILTER PRESSURE SWITCH
7140	OR (O)	DIFF-LOCK OFF SOLENOID
7150	GY (S)	LOW OIL PRESSURE WRN FEED
7155	BL (U)	VANE PUMP PRESSURE SENSOR SIGNAL
7160	RD (R)	HYD LOW CHARGE WARNING
7170	WH (W)	DIFF LOCK SWITCH (AUTO ON)
7175	YE (Y)	DIFF LOCK SWITCH (MANUAL ON)
7180	BL (U)	CREEPER SWITCH MOM SIGNAL
7190	PK (K)	TRANS SOLENOID VALVE SUPPLY
7195	PK (K)	TRANS SOLENOID VALVE RETURN
7196	YE (Y)	TRANS FR/REV LOW SIDE RETURN (CVT)



Electrical systems - Harnesses and connectors

CIRC	COLOR	DESCRIPTION
7197	YE (Y)	TRANS RANGE LOW SIDE RETURN (CVT)
7198	BL (U)	TRANS HYROSTATIC LOW SIDE RETURN (CVT)
7200	GY (S)	TRANSMISSION SHIFT DOWN
7210	GY (S)	TRANSMISSION SHIFT UP
7220	GY (S)	TRANSMISSION HIGH RANGE
7225	WH (W)	TRANS HI RANGE SOL - RET
7230	GY (S)	TRANSMISSION LOW RANGE
7235	YE (Y)	TRANS LOW RANGE SOL - RET
7240	GY (S)	TRANSMISSION DISPLAY SWITCH
7245	TN (LN)	DEADMAN
7250	GY (S)	TRANSMISSION FORWARD SIGNAL
7260	GY (S)	TRANSMISSION REVERSE SIGNAL
7265	PK (K)	TRANS NEUTRAL SWITCH TO PROCESSOR (GR.SW 1)
7267	LG	TRANS NEUTRAL SWITCH 2 TO PROCESSOR
7270	RD (R)	TCM SERIAL DATA IN-DISPLY DATA OUT
7275	WH (W)	TCM SERIAL DATA OUT-DISPLY DATA IN
7280	WH (W)	LIMP HOME SWITCH 18x18 TRANS.
7290	WH (W)	DIRECTIONAL INTERRUPT RELAY TO SOLENOID
7295	WH (W)	DRIVE DISABLE SIGNAL
7300	WH (W)	TRANSMISSION PWM SOLENOID 1-4 SYNCRO
7301	YE (Y)	SOLENOID 1 18x9 RETURN
7320	WH (W)	SOLENOID 2 18x9 TRANSMISSION
7321	VT (P)	SOLENOID 2 18x9 RETURN
7330	WH (W)	SOLENOID 3 18x9 TRANSMISSION
7331	YE (Y)	SOLENOID 3 18x9 RETURN
7340	WH (W)	SOLENOID F1 18x9 TRANSMISSION
7341	YE (Y)	SOLENOID F1 18x9 RETURN
7350	WH (W)	SOLENOID F2 18x9 TRANSMISSION
7351	GY (S)	SOLENOID F2 18x9 RETURN
7355	GY (S)	SOLENOID R 18x9 TRANSMISSION
7356	BL (U)	SOLENOID R 18x9 RETURN
7360	WH (W)	SOLENOID A 18x9 TRANSMISSION
7361	VT (P)	SOLENOID A 18x9 RETURN
7370	YE (Y)	SOLENOID B 18x9 TRANSMISSION
7371	VT (P)	SOLENOID B 18x9 RETURN
7380	YE (Y)	SOLENOID C 18x9 TRANSMISSION
7381	VT (P)	SOLENOID C 18x9 RETURN
7390	YE (Y)	SOLENOID PWM (F1) 18x9 TRANSMISSION
7391	VT (P)	SOLENIOD PWM (F1) 18x9 RETURN
7392	OR (O)	SOLENOID PWM (F2) 18x9 TRANSMISSION
7393	OR (O)	SOLENOID PWM (F2) 18x9 RETURN
7395	VT (P)	SOLENOID CREEP 18x9 TRANSMISSION
7396	VT (P)	SOLENOID CREEP 18x9 RETURN
7400	YE (Y)	TRANS RPM SPEED SENSOR TO TCM INPUT
7401	VT (P)	TRANS RPM SPEED SENSOR
7402	YE (Y)	TRANS WHLSP FORWARD (CVT)
7403	YE (Y)	TRANS WHLSP REVERSE (CVT)
7404	YE (Y)	TRANS HYDROSTAT FORWARD (CVT)
7405	YE (Y)	TRANS HYDROSTAT REVERSE (CVT)
7406	LG	TRANS BI-DI SPEED SENSOR RET (CVT)
7407	PK (K)	HYDROSTAT 1 SOLENOID +
7408	VT (P)	HYDROSTAT 1 SOLENOID GND
7410	YE (Y)	TRANS RPM SPEED SENSOR TO TCM OUTPUT
7411	YE (Y)	TRANS HYDROSTAT INPUT SPEED SENSOR (SPS)

## Electrical systems - Harnesses and connectors

CIRC	COLOR	DESCRIPTION
7420	YE (Y)	TCM TO CLUTCH POSITION SWITCH
7425	YE (Y)	DRIVE SIGNAL
7430	YE (Y)	CLUTCH POSITION SIGNAL
7431	LB (TQ)	SUPPLY
7440	YE (Y)	TCM TO TRACTOR EIC-AXLE OUTPUT
7450	WH (W)	TRANS CREEPER INTERLOCK SUPPLY
7460	WH (W)	TRANS CREEPER CLUTCH ENGAGED
7470	GY (S)	TRANS CREEPER CLUTCH DISENGAGED
7475	RD (R)	TRANS AUTO OFF
7476	RD (R)	TRANS AUTO ON
7480	GN (G)	TRANS AUTO FUNCTION 1
7482	GN (G)	TRANS AUTO ON/INCREASE
7485	PK (K)	TRANS AUTO FUNCTION LAMP 1
7490	GN (G)	TRANS AUTO FUNCTION 2
7492	GN (G)	TRANS AUTO OFF/DECREASE
7495	PK (K)	TRANS AUTO FUNCTION LAMP 2
7500	GN (G)	TRANS OIL TEMP. SENSOR
7520	GN (G)	TRANS SENSOR SUPPLY 8v
7525	GN (G)	TRANS SENSOR SUPPLY 5v
7560	GN (G)	TRANS WARNING LAMP
7570	BK/WH (B/W)	SIGNAL GROUND
7579	BL (U)	PARKLOCK SWITCH
7580	BL (U)	CREEPER SOLENOID MONITOR
7581	OR (O)	CREEPER POSITION SIGNAL
7582	BL (U)	CREEPER RAIL SWITCH NOT
7583	BL (U)	PARKLOCK SWITCH #2
7584	BL (U)	PARKLOCK SENSOR SWITCH SIGNAL
7585	BL (U)	PARKLOCK SOLENOID #2
7586	BL (U)	BRAKE LUBRICATON SOLENOID
7587	BL (U)	PARKLOCK OVERRIDE SWITCH
7588	BL (U)	PARKLOCK POSITION SIGNAL
7589	BL (U)	BRAKE PRESSURE SIGNAL
7590	OR (O)	TRANS CREEPER GEAR STATUS LAMP
7600	BR (N)	TRANS FEATHERING SOLENOID
7620	BR (N)	TRANS FEATHERING SOL. MONITOR
7630	BR (N)	TRANS MAIN CLUTCH PRESSURE SWITCH
7640	TN (LN)	DIAGNOSTIC PLUG RS232 IN
7650	WH (W)	DIAGNOSTIC PLUG RS232 OUT
7655	YE (Y)	RS232 GROUND
7660	RD (R)	TRANS CLUTCH DISCONNECT
7670	RD (R)	TRANS FRONT SYNCHRO POSITION
7671	BL (U)	SYNCHRO_F2_R1_POS_1
7672	RD (R)	SYNCHRO_F2_R1_POS_2
7700	TN (LN)	TRANS SHUTTLE DUMP SWITCH
7710	TN (LN)	TRANS OIL TEMPERATURE SWITCH
7730	TN (LN)	NOT IN PARKLOCK
7735	TN (LN)	TRANS MID SPEED SIGNAL +
7740	TN (LN)	TRANS MID SPEED SIGNAL -
7750	RD (R)	TCM TO DOG 30/40 KPH SELECT
7755	VT (P)	DOG ENABLE
7760	WH (W)	TORQUE SENSOR
7770	BL (U)	TRANS FORWARD PRESSURE SWITCH
7775	PK (K)	B CLUTCH PRESSURE SIGNAL
7780	BL (U)	TRANS FORWARD PRESSURE SWITCH

Electrical systems - Harnesses and connectors

CIRC	COLOR	DESCRIPTION
7785	OR (O)	A CLUTCH PRESSURE SIGNAL
7790	LB (TQ)	TRANS RANGE INPUT DIGITAL FEEDBACK (CVT)
7800	LB (TQ)	TRANS FR / REV INPUT DIGITAL FEEDBACK (CVT)
7810	PK (K)	TRANS PWM SOLENOID C1
7815	PK (K)	TRANS PWM SOLENOID C1 RETURN
7820	PK (K)	TRANS PWM SOLENOID C2
7825	PK (K)	TRANS PWM SOLENOID C2 RETURN
7830	PK (K)	TRANS PWM SOLENOID C3
7835	PK (K)	TRANS PWM SOLENOID C3 RETURN
7840	PK (K)	TRANS PWM SOLENOID C4
7845	PK (K)	TRANS PWM SOLENOID C4 RETURN
7846	LB (TQ)	TRANS BRAKE SOLENOID (CVT)
7847	LB (TQ)	TRANS HYDROSTATIC - POSITIVE SOLENOID (CVT)
7848	LB (TQ)	TRANS HYDROSTATIC - NEGATIVE SOLENOID (CVT)
7850	GN (G)	TRANS DIAGNOSTIC PROGRAM VOLTAGE
7855	GN (G)	TRANS DIAGNOSTIC EA
7860	GN (G)	TRANS DIAGNOSTIC RCV
7865	GN (G)	TRANS DIAGNOSTIC XMT
7870	GN (G)	TRANS DIAGNOSTIC RTS
7875	PK (K)	TRANS DIAGNOSTIC CTS
7880	BK/WH (B/W)	TCM SIGNAL GROUND
7890	LB (TQ)	TRANS L-LINE DIAGNOSTIC (CVT)
7900	LB (TQ)	CLUTCH 'A' SIGNAL
7910	LB (TQ)	CLUTCH 'B' SIGNAL
7915	VT (P)	TCM CLUTCH B RETURN
7920	LB (TQ)	CLUTCH 'C' SIGNAL
7925	VT (P)	TCM CLUTCH C RETURN
7930	LB (TQ)	CLUTCH 'D' SIGNAL
7935	VT (P)	TCM CLUTCH D RETURN
7940	LB (TQ)	CLUTCH 'E' SIGNAL
7945	VT (P)	TCM CLUTCH E RETURN
7950	LB (TQ)	CLUTCH SUPPLY
7960	VT (P)	TRANS SLOW/FAST
7965	VT (P)	HI/LO SYNCHRO SIGNAL
7970	VT (P)	TRANS MED/REV
7980	PK (K)	TRANS MED. RANGE
7981	RD (R)	SOLENOID VALVE HYDROSTAT PLUS
7982	WH (W)	TRANS MED. RANGE RET
7985	GN (G)	TRANS REVERSE RANGE
7990	PK (K)	TRANS BRAKE
7995	PK (K)	BRAKE FLUID LEVEL
7996	RD (R)	BRAKE PEDALS UNLATCHED SIGNAL
8000	BR (N)	TRAILER BRAKE SOLENOID
8010	TN (LN)	TRAILER BRAKE PRESSURE
8020	TN (LN)	TRAILER BRAKE PRESSURE
8030	LG	TRANS FWD SOLENIOD
8035	VT (P)	TRANS FWD SOL RET
8040	LG	TRANS REV SOLENIOD
8045	VT (P)	TRANS REV SOL RET
8050	RD (R)	TRANS REV PRESSURE
8060	BL (U)	TRAILER BRAKE SUPPLY
8070	VT (P)	TRAILER PARK BRAKE SOLENOID
9000	TN (LN)	DIVERTER VALVE
9010	TN (LN)	DIVERTER VALVE SUPPLY

Electrical systems - Harnesses and connectors

CIRC	COLOR	DESCRIPTION
9020	TN (LN)	HYDRAULIC REMOTE VALVE SOL
9025	TN (LN)	HYDRAULIC REMOTE VALVE SWITCH
9026	WH (W)	
9027	WH (W)	CAL/ SEL INPUT ADIC
9028	WH (W)	ADIC MEMORY B+
9029	WH (W)	
9030	WH (W)	
9031	VT (P)	ADIC MEMORY B+
9032	YE (Y)	IGN+ TO POWER SKT.
9033	TN (LN)	50KPH SOLENOID+
9034	TN (LN)	50KPH SOLENOID-
9035	TN (LN)	50KPH DUMP SOLENOID
9036	TN (LN)	50KPH DUMP SOLENOID RETURN
9050	VT (P)	CN1A 10
9051	VT (P)	CN2 13
9200	BL (U)	SPARE FUNCTION 97-12
9201	RD (R)	SPARE FUNCTION 97-13
9210	GN (G )	AC-SWITCH POWER
9211	GN (G)	AC-BLOWER SPEED LOW (1)
9212	PK (K)	AC-BLOWER SPEED MED.1 (2)
9213	PK (K)	AC-BLOWER SPEED MED .2 (3)
9214	GN (G)	AC-BLOWER SPEED HIGH .2 (2)
9215	BL (U)	AC-SWITCH ON
9216	LG	AC-TEMPERATURE POTI CAB
9217	BR (N)	AC-SWITCH MAX DEFROST
9218	GY (S)	AC-SWITCH ECONOMY
9219	BL (U)	AC-LOW PRESSURE SWITCH OUTPUT
9220	BL (U)	AC-LOW PRESSURE SWITCH INPUT
9221	VT (P)	AC-EVAPORATOR TEMPERATURE SENSOR
9222	YE (Y)	AC-SIGNAL OUTLET TEMPERATURE SENSOR
9223	RD (R)	AC-SIGNAL CAB TEMPERATURE SENSOR
9224	OR (O)	AC-SIGNAL AMBIENT TEMPERATURE SENSOR
9225	BL (U)	AC-BLOWER SPEED
9226	YE (Y)	AC-SIGNAL WATER VALVE
9227	VT (P)	AC-BLOWER SWITCH SUPPLY
9228	GN (G)	AC-AUTOMATIC BLOWER SPEED
9229	OR (O)	AC-DE-FOG
9230	BR (N)	ECU B+ OUTPUT (EDC7 )
9231	YE (Y)	SUPPLY FOR DIGITAL SWITCHES
9232	YE (Y)	ECU TO RESERVE LSD
9233	YE (Y)	ECU TO INTERCOOLER BY PASS VALVE
9235	OR (O)	ECU SWITCHED B+
9236	YE (Y)	ECU TO DIAGNOSTIC LAMP
9237	YE (Y)	ECU TO DIAGNOSTIC LAMP RETURN
9238	YE (Y)	ECU TO WATER IN FUEL SWITCH
9239	YE (Y)	ECU TO ENGINE COMPARTMENT START SWITCH
9240	YE (Y)	ECU TO ENGINE COMPARTMENT STOP SWITCH
9241	YE (Y)	ECU TO OBD LAMP
9242	YE (Y)	ECU TO COLD START LAMP
9243	YE (Y)	ECU TO SPEED LIMITER VALVE
9244	YE (Y)	ECU TO ADDTITIVE VALVE
9245	TN (LN)	+5V REDUCTION AGENT LEVEL SENSOR
9246	LG	SIGNAL REDUCTION LEVEL AGENT SENSOR
9247	BL (U)	GROUND REDUCTION LEVEL AGENT SENSOR

Electrical systems - Harnesses and connectors

CIRC	COLOR	DESCRIPTION
9248	YE (Y)	REDUCTION AGENT LEVEL TEMP SENSOR
9249	YE (Y)	ECU TO CATALYST TEMP SENSOR (UPSTREAM)
9250	YE (Y)	ECU TO CATALYST TEMP SENSOR (UPTREAM) RETURN
9251	YE (Y)	ECU TO CATALYST TEMP SENSOR (DOWNSTREAM)
9252	YE (Y)	ECU TO CATALYST TEMP SENSOR (DOWNSTEAM) RET
9253	YE (Y)	ECU TO SERVICE SOON LAMP
9254	YE (Y)	ECU TO BLOW BY 3 WAY VALVE
9255	YE (Y)	ECU TO FILTER OUTLET HEATING RETURN
9256	YE (Y)	ECU TO SUCTION LINE HTG RETURN
9257	YE (Y)	ECU TO BACK FLOW TO TANK LINE HEATING RETURN
9258	YE (Y)	ECU TO PRESSURE LINE HEATING RETURN
9259	YE (Y)	ECU TO BACK FLOW SUPPLY HEATING RETURN
9260	YE (Y)	ECU TO COMPENSATION LINE HEATING RETURN
9261	YE (Y)	ECU TO DOSING VALVE
9262	YE (Y)	ECU TO DOSING VALVE RETURN
9263	WH (W)	CRUISE CONTROL +VE
9264	BK (B)	CRUISE CONTROL -VE
9265	BL (U)	CRUISE OFF
9266	BL (U)	CRUISE RES
9267	BR (N)	BRAKE SWITCH BROWN
9268	BK (B)	BRAKE SWICH RED/BLACK
9269	WH (W)	CLUTCH SWITCH
9270	BR (N)	12 V SUPPLY TO DENNOX CONVERTOR
9271	LG	24V OUTPUT FROM 12/24V CONVERTOR
9272	LG	24V FUSED SUPPLY
9273	LG	24V SWITCHED SUPPLY TO DENNOX CONTROLLER
9274	GN (G)	24V SUPPLY
9276	GY (S)	ECU TO COMBUST AIR & HUMIDITY SENSOR
9277	GY (S)	ECU TO COMBUST AIR & HUMIDIY SENSOR RETURN
9278	RD (R)	COMBUST AIR TEMPERATURE
9280	BR (N)	ECU 12V SUPPLY OUTPUT (EDC7)
9281	YE (Y)	LOCAL INTERCONNECT NETWORK
9282	YE (Y)	ENGINE SPEED FOR SPEEDOMETER(TACHO)
9283	YE (Y)	CAMSHAFT REPITION O/P
9284	YE (Y)	RESERVE #1 SINK DRIVER
9285	YE (Y)	ACTIVE ANALOG 2 SUPPLY
9286	YE (Y)	VEHICLE SPEED FEED
9287	YE (Y)	VEHICLE SPEED RETURN
9288	YE (Y)	LAMBDA #1 SIGNAL (PAS08)
9289	YE (Y)	LAMBDA #2 SIGNAL (PAS09)
9290	YE (Y)	LAMBDA #3 SIGNAL (ACT10)
9291	YE (Y)	LAMBDA #4 SIGNAL (ACT11)
9292	YE (Y)	LAMBDA #5 HEATER SUPPLY
9293	YE (Y)	LAMBDA #6 HEATER
9294	YE (Y)	ECU TO EXHAUST GAS TEMPERATURE SENSOR
9295	YE (Y)	ECU TO EXHAUST GAS TEMPERATURE SENS RETURN
9296	YE (Y)	ECU TO TURBO COMPOUND SENSOR
9297	YE (Y)	ECU TO TURBO COMPOUND SENSOR RETURN
9298	YE (Y)	TURBO COMPONUD +5V REF
9299	YE (Y)	ECU TO BLOW BY DELTA P SENSOR
9300	YE (Y)	ECU TO BLOW BY DELTA P SENSOR RETURN
9301	YE (Y)	ECU TO TORQUE LIMIT MULTIPLE STAGE SWITCH
9302	YE (Y)	ECU TO TORQUE LIMIT MULTIPLE STAGE SW RETURN
9303	YE (Y)	ECU TO STARTER RELAY COIL EDC7

Electrical systems - Harnesses and connectors

CIRC	COLOR	DESCRIPTION
9304	YE (Y)	ECU TO STARTER RELAY COIL EDC7 RETURN
9305	YE (Y)	ECU TO A/C COMPRESSOR RELAY EDC7
9306	YE (Y)	ECU TO A/C COMPRESSOR RELAY EDC7 RETURN
9310	RD (R)	ESPTO MOTOR +VE
9311	BL (U)	ESPTO MOTOR -VE
9312	GN (G)	+VE POSITION
9313	YE (Y)	SIGNAL POSITION
9314	BK (B)	-VE POSITION
9501	WH (W)	UCM FUSE 12 V Ignition
9502	WH (W)	UCM FUSE 12 V Ignition
9503	WH (W)	UCM FUSE 12 V Ignition
9504	WH (W)	UCM FUSE 12 V Ignition
9505	WH (W)	UCM FUSE 12 V Ignition
9506	WH (W)	UCM FUSE 12 V Ignition
9507	WH (W)	UCM FUSE 12 V Ignition
9508	WH (W)	UCM FUSE 12 V Ignition
9509	WH (W)	UCM FUSE 12 V Ignition
9510	WH (W)	UCM FUSE 12 V Ignition
9600	RD (R)	ABS (BATTERY SUPPLY)
9601	OR (O)	ABS (IGNITION SUPPLY)
9602	YE (Y)	ABS (CAN-H)
9603	GN (G)	ABS (CAN-L)
9604	WH (W)	ABS (PRESSURE CONTR. VALVE B)
9605	GY (S)	ABS (PRESSURE CONTR. VALVE A)
9606	BK/WH (B/W)	ABS (PRESSURECONTR. VALVE GND)
9607	PK (K)	ABS (1st Diagnostic Switch-To EBM Module)
9608	BR (N)	ABS (1st Diagnostic Switch-To 2nd Diagn. Switch)
9609	BR (N)	ABS (2nd Diagnostic Switch-To 3rd Diagn. Switch)
9610	BK/WH (B/W)	ABS (3rd Diagnostic Switch-To EBM Module)
9611	YE (Y)	ABS (AIRBRAKE PRESSURE SENSOR 1 SIGNAL)
9612	YE (Y)	ABS (AIRBRAKE PRESSURE SENSOR 2 SIGNAL)
9613	YE (Y)	ABS (LH BRAKE PRESSURE SENSOR SIGNAL)
9614	BR (N)	ABS (FRONT RIGHT WHEEL SPEED SENSOR)
9615	BR (N)	ABS (FRONT RIGHT WHEEL SPEED SENSOR RETURN)
9616	BR (N)	ABS (FRONT LEFT WHEEL SPEED SENSOR)
9617	BR (N)	ABS (FRONT LEFT WHEEL SPEED SENSOR RETURN)
9618	BR (N)	ABS (REAR LEFT WHEEL SPEED SENSOR)
9619	BR (N)	ABS (REAR LEFT WHEEL SPEED SENSOR RETURN)
9620	BR (N)	ABS (REAR RIGHT WHEEL SPEED SENSOR)
9621	BR (N)	ABS (REAR RIGHT WHEEL SPEED SENSOR RETURN)
9622	OR (O)	ABS (AIR PROCESSING UNIT HEATER SUPPLY)
9623	WH (W)	ABS (WARNING LAMP SUPPLY)
9624	WH (W)	ABS Trailer Socket (Warning lamp)
9625	RD (R)	ABS Trailer Socket (Battery supply)
9626	RD (R)	ABS Trailer Socket (Battery supply)
9627	WH (W)	ABS Trailer Socket (Warning lamp)

## Wire connectors - Component Diagram 00

### CONNECTOR X-001 - Cab main harness to engine harness 1

CONNECTOR X-001 - Cab main harness to engine harness 1			
PIN NUMBER	WIRE NUMBER	CIRCUIT REFERENCE	ELECTRICAL SCHEMATIC FRAME
1	CM-2043 (OR) EN-2043 (OR)	X-200 Central Control Unit (CCU) – CN1A X-001 Cab main harness to engine harness 1 X-001 Cab main harness to engine harness 1 X-352 Front Power Take-Off (PTO) – Solenoid valve	Wiring harnesses - Electrical schematic sheet 01 (55.100) Wiring harnesses - Electrical schematic sheet 03 (55.100) Wiring harnesses - Electrical schematic sheet 04 (55.100)
2	CM-6418 (PK) EN-6418 (PK)	X-376 Diagnostic socket (CAN bus 1) X-001 Cab main harness to engine harness 1 X-937 Engine Control Unit (ECU) X-001 Cab main harness to engine harness 1	Wiring harnesses - Electrical schematic sheet 05 (55.100) Wiring harnesses - Electrical schematic sheet 08 (55.100) Wiring harnesses - Electrical schematic sheet 10 (55.100)
3	CM-1006B (BR) EN-1006B (BR)	X-001 Cab main harness to engine harness 1 SP-1006 X-012 Alternator D+ X-001 Cab main harness to engine harness 1	Wiring harnesses - Electrical schematic sheet 13 (55.100) Wiring harnesses - Electrical schematic sheet 17 (55.100)
4	CM-010I (GN) EN-010I (GN)	X-130 Fuse block (F-001 to F-032) X-001 Cab main harness to engine harness 1 X-406 Engine harness 1 to trailer socket front (7-Pin) X-001 Cab main harness to engine harness 1	Wiring harnesses - Electrical schematic sheet 18 (55.100) Wiring harnesses - Electrical schematic sheet 21 (55.100) Wiring harnesses - Electrical schematic sheet 23 (55.100)
5	CM-3016 (GY) EN-3016 (GY)	X-460 Instrument cluster CN2 X-001 Cab main harness to engine harness 1 X-360 Brake fluid level switch X-001 Cab main harness to engine harness 1	Wiring harnesses - Electrical schematic sheet 24 (55.100)

<b>CONNECTOR X-001 - Cab main harness to engine harness 1</b>			
<b>PIN NUMBER</b>	<b>WIRE NUMBER</b>	<b>CIRCUIT REFERENCE</b>	<b>ELECTRICAL SCHEMATIC FRAME</b>
6	CM-9234 (YE) EN-9234 (YE)	X-460 Instrument cluster CN2 X-001 Cab main harness to engine harness 1 X-357 Air cleaner restriction switch X-001 Cab main harness to engine harness 1	<b>Wiring harnesses - Electrical schematic sheet 01 (55.100)</b> <b>Wiring harnesses - Electrical schematic sheet 03 (55.100)</b> <b>Wiring harnesses - Electrical schematic sheet 04 (55.100)</b>
7	CM-010CB (GN) EN-010CB (GN)	SP-010C X-001 Cab main harness to engine harness 1 X-360 Brake fluid level switch X-001 Cab main harness to engine harness 1	<b>Wiring harnesses - Electrical schematic sheet 05 (55.100)</b> <b>Wiring harnesses - Electrical schematic sheet 08 (55.100)</b> <b>Wiring harnesses - Electrical schematic sheet 10 (55.100)</b>
8	CM-9219 (BL) EN-9219 (BL)	X-001 Cab main harness to engine harness 1 X-050 Cab main harness to roof harness 1 X-042 Air-conditioning system – Pressure switch X-001 Cab main harness to engine harness 1	<b>Wiring harnesses - Electrical schematic sheet 13 (55.100)</b> <b>Wiring harnesses - Electrical schematic sheet 17 (55.100)</b> <b>Wiring harnesses - Electrical schematic sheet 18 (55.100)</b>
9	CM-9220 (BL) EN-9220 (BL)	X-001 Cab main harness to engine harness 1 X-044 Antifreeze module X-042 Air-conditioning system – Pressure switch X-001 Cab main harness to engine harness 1	<b>Wiring harnesses - Electrical schematic sheet 21 (55.100)</b> <b>Wiring harnesses - Electrical schematic sheet 23 (55.100)</b> <b>Wiring harnesses - Electrical schematic sheet 24 (55.100)</b>
10	CM-057EL (BK) EN-057EL (BK)	X-001 Cab main harness to engine harness 1 SP-057E CAB GND 3 X-001 Cab main harness to engine harness 1 X-025 Engine harness to engine hood harness	



<b>CONNECTOR X-001 - Cab main harness to engine harness 1</b>			
<b>PIN NUMBER</b>	<b>WIRE NUMBER</b>	<b>CIRCUIT REFERENCE</b>	<b>ELECTRICAL SCHEMATIC FRAME</b>
11	CM-1053 (WH) EN-1053 (WH)	X-110 Relay and fuse block (K-004 to K-039 and F-033 to F-036) X-001 Cab main harness to engine harness 1 X-001 Cab main harness to engine harness 1 X-025 Engine harness to engine hood harness	<b>Wiring harnesses - Electrical schematic sheet 01 (55.100)</b> <b>Wiring harnesses - Electrical schematic sheet 03 (55.100)</b> <b>Wiring harnesses - Electrical schematic sheet 04 (55.100)</b> <b>Wiring harnesses - Electrical schematic sheet 05 (55.100)</b>
12	CM-1030A (BL) EN-1030A (BL)	X-001 Cab main harness to engine harness 1 X-120 Relay and diode block (K-007 to K-060 and V-040 to V-044) X-001 Cab main harness to engine harness 1 X-025 Engine harness to engine hood harness	<b>Wiring harnesses - Electrical schematic sheet 08 (55.100)</b> <b>Wiring harnesses - Electrical schematic sheet 10 (55.100)</b> <b>Wiring harnesses - Electrical schematic sheet 13 (55.100)</b>
13	CM-1027A (BL) EN-1027A (BL)	X-120 Relay and diode block (K-007 to K-060 and V-040 to V-044) X-001 Cab main harness to engine harness 1 X-001 Cab main harness to engine harness 1 X-025 Engine harness to engine hood harness	<b>Wiring harnesses - Electrical schematic sheet 17 (55.100)</b> <b>Wiring harnesses - Electrical schematic sheet 18 (55.100)</b> <b>Wiring harnesses - Electrical schematic sheet 21 (55.100)</b> <b>Wiring harnesses - Electrical schematic sheet 23 (55.100)</b>
14	CM-376 (VT) EN-376 (VT)	X-091 Steering column multi-function lever X-001 Cab main harness to engine harness 1 X-001 Cab main harness to engine harness 1 X-025 Engine harness to engine hood harness	<b>Wiring harnesses - Electrical schematic sheet 24 (55.100)</b>
15	CM-9305 (BL) EN-9305 (BL)	X-050 Cab main harness to roof harness 1 X-001 Cab main harness to engine harness 1 X-088 Air-conditioning compressor – Magnetic clutch X-001 Cab main harness to engine harness 1	
16	CM-191E (YE) EN-191E (YE)	SP-191D X-001 Cab main harness to engine harness 1 X-001 Cab main harness to engine harness 1 SP-191E	<b>Wiring harnesses - Electrical schematic sheet 01 (55.100)</b> <b>Wiring harnesses - Electrical schematic sheet 03 (55.100)</b>
17	CM-190E (GN) EN-190E (GN)	X-001 Cab main harness to engine harness 1 SP-190D X-001 Cab main harness to engine harness 1 SP-190E	<b>Wiring harnesses - Electrical schematic sheet 04 (55.100)</b> <b>Wiring harnesses - Electrical schematic sheet 05 (55.100)</b>
18	CM-172 (PK) EN-172 (PK)	X-001 Cab main harness to engine harness 1 X-450 Instrument cluster CN1 X-008 Battery isolator X-001 Cab main harness to engine harness 1	<b>Wiring harnesses - Electrical schematic sheet 08 (55.100)</b> <b>Wiring harnesses - Electrical schematic sheet 10 (55.100)</b> <b>Wiring harnesses - Electrical schematic sheet 13 (55.100)</b>
19	CM-171B (VT) EN-171B (VT)	X-385 Cab main harness to roof harness 2 X-001 Cab main harness to engine harness 1 X-001 Cab main harness to engine harness 1 X-008 Battery isolator	<b>Wiring harnesses - Electrical schematic sheet 17 (55.100)</b> <b>Wiring harnesses - Electrical schematic sheet 18 (55.100)</b>
20	CM-1001B (WH) EN-1001B (WH)	SP-1001A X-001 Cab main harness to engine harness 1 X-001 Cab main harness to engine harness 1 X-002 Engine harness 1 to power distribution unit	<b>Wiring harnesses - Electrical schematic sheet 21 (55.100)</b> <b>Wiring harnesses - Electrical schematic sheet 23 (55.100)</b> <b>Wiring harnesses - Electrical schematic sheet 24 (55.100)</b>

<b>CONNECTOR X-001 - Cab main harness to engine harness 1</b>			
<b>PIN NUMBER</b>	<b>WIRE NUMBER</b>	<b>CIRCUIT REFERENCE</b>	<b>ELECTRICAL SCHEMATIC FRAME</b>
21	CM-1024DA (RD) EN-1024DA (RD)	X-001 Cab main harness to engine harness 1 SP-1024D 58L socket X-406 Engine harness 1 to trailer socket front (7-Pin) X-001 Cab main harness to engine harness 1	<b>Wiring harnesses - Electrical schematic sheet 01 (55.100)</b> <b>Wiring harnesses - Electrical schematic sheet 03 (55.100)</b> <b>Wiring harnesses - Electrical schematic sheet 04 (55.100)</b> <b>Wiring harnesses - Electrical schematic sheet 05 (55.100)</b> <b>Wiring harnesses - Electrical schematic sheet 08 (55.100)</b>
22	CM-1013MB (RD) EN-1013MB (RD)	X-001 Cab main harness to engine harness 1 SP-1013M 58R socket X-406 Engine harness 1 to trailer socket front (7-Pin) X-001 Cab main harness to engine harness 1	<b>Wiring harnesses - Electrical schematic sheet 10 (55.100)</b> <b>Wiring harnesses - Electrical schematic sheet 13 (55.100)</b> <b>Wiring harnesses - Electrical schematic sheet 17 (55.100)</b> <b>Wiring harnesses - Electrical schematic sheet 18 (55.100)</b> <b>Wiring harnesses - Electrical schematic sheet 21 (55.100)</b> <b>Wiring harnesses - Electrical schematic sheet 23 (55.100)</b> <b>Wiring harnesses - Electrical schematic sheet 24 (55.100)</b>
23	CM-3001EB (GN) EN-3001EB (GN)	X-001 Cab main harness to engine harness 1 SP-3001E FLASHER LH socket X-406 Engine harness 1 to trailer socket front (7-Pin) X-001 Cab main harness to engine harness 1	
24	CM-3002EB (GN) EN-3002EB (RD)	X-001 Cab main harness to engine harness 1 SP-3002E FLASHER RH socket X-406 Engine harness 1 to trailer socket front (7-Pin) X-001 Cab main harness to engine harness 1	
25	CM-010 (GN) EN-10A (WH)	X-130 Fuse block (F-001 to F-032) X-001 Cab main harness to engine harness 1 SP-010A X-001 Cab main harness to engine harness 1	
26	CM-2044 (OR) EN-2044 (OR)	X-220 Central Control Unit (CCU) – CN2 X-001 Cab main harness to engine harness 1 X-001 Cab main harness to engine harness 1 X-352 Front Power Take-Off (PTO) – Solenoid valve	<b>Wiring harnesses - Electrical schematic sheet 01 (55.100)</b> <b>Wiring harnesses - Electrical schematic sheet 03 (55.100)</b> <b>Wiring harnesses - Electrical schematic sheet 04 (55.100)</b>
27	CM-5260H (TN)	SP-5260 X-001 Cab main harness to engine harness 1	<b>Wiring harnesses - Electrical schematic sheet 05 (55.100)</b>
28	CM-138 (VT) EN-001C (RD)	X-001 Cab main harness to engine harness 1 SP-138 X-553 Battery harness to engine harness 1 (permanent battery power supply) X-001 Cab main harness to engine harness 1	<b>Wiring harnesses - Electrical schematic sheet 08 (55.100)</b> <b>Wiring harnesses - Electrical schematic sheet 10 (55.100)</b> <b>Wiring harnesses - Electrical schematic sheet 13 (55.100)</b>
29	CM-5555 (BL)	X-210 Central Control Unit (CCU) – CN1B X-001 Cab main harness to engine harness 1	<b>Wiring harnesses - Electrical schematic sheet 17 (55.100)</b> <b>Wiring harnesses - Electrical schematic sheet 18 (55.100)</b>
30	-	-	<b>Wiring harnesses - Electrical schematic sheet 21 (55.100)</b> <b>Wiring harnesses - Electrical schematic sheet 23 (55.100)</b> <b>Wiring harnesses - Electrical schematic sheet 24 (55.100)</b>

<b>CONNECTOR X-001 - Cab main harness to engine harness 1</b>			
<b>PIN NUMBER</b>	<b>WIRE NUMBER</b>	<b>CIRCUIT REFERENCE</b>	<b>ELECTRICAL SCHEMATIC FRAME</b>
31	CM-6570 (GN) EN-6570 (BL)	X-110 Relay and fuse block (K-004 to K-039 and F-033 to F-036) X-001 Cab main harness to engine harness 1 X-001 Cab main harness to engine harness 1 X-937 Engine Control Unit (ECU)	<b>Wiring harnesses - Electrical schematic sheet 01 (55.100)</b> <b>Wiring harnesses - Electrical schematic sheet 03 (55.100)</b> <b>Wiring harnesses - Electrical schematic sheet 04 (55.100)</b> <b>Wiring harnesses - Electrical schematic sheet 05 (55.100)</b> <b>Wiring harnesses - Electrical schematic sheet 08 (55.100)</b>
32	CM-5556 (RD)	X-210 Central Control Unit (CCU) – CN1B X-001 Cab main harness to engine harness 1	<b>Wiring harnesses - Electrical schematic sheet 10 (55.100)</b> <b>Wiring harnesses - Electrical schematic sheet 13 (55.100)</b>
33	CM-1246A (RD) EN-1246A (RD)	SP-1246 X-001 Cab main harness to engine harness 1 SP-1246A X-001 Cab main harness to engine harness 1	<b>Wiring harnesses - Electrical schematic sheet 17 (55.100)</b> <b>Wiring harnesses - Electrical schematic sheet 18 (55.100)</b> <b>Wiring harnesses - Electrical schematic sheet 21 (55.100)</b> <b>Wiring harnesses - Electrical schematic sheet 23 (55.100)</b> <b>Wiring harnesses - Electrical schematic sheet 24 (55.100)</b>
34	CM-1246B (RD) EN-1246B (RD)	SP-1246 X-001 Cab main harness to engine harness 1 SP-1246A X-001 Cab main harness to engine harness 1	

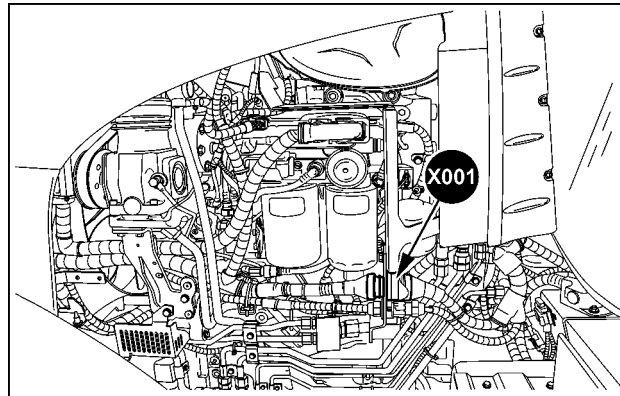

SVIL13TR00700AE 1

**Rear left-hand engine**

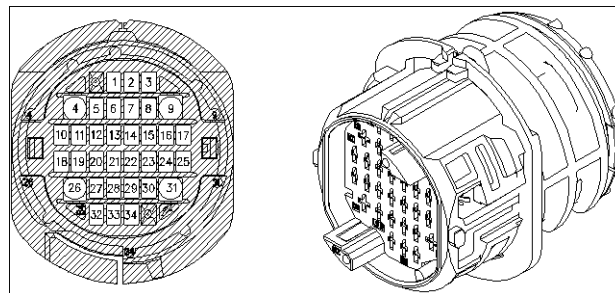

84142903 2

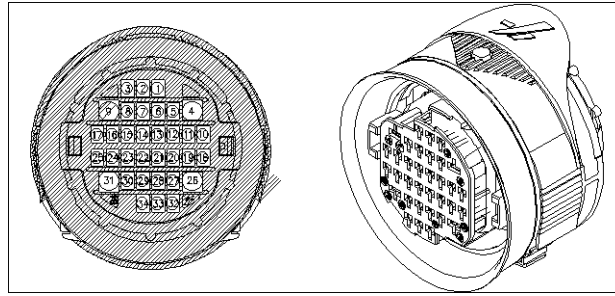

84142902 3

**CONNECTOR X-002 - Engine harness 1 to power distribution unit**

<b>CONNECTOR X-002 - Engine harness 1 to power distribution unit</b>			
<b>PIN NUMBER</b>	<b>WIRE NUMBER</b>	<b>CIRCUIT REFERENCE</b>	<b>ELECTRICAL SCHEMATIC FRAME</b>
1	PD-057FC (BK) EN-057FC (BK)	X-533 Power distribution unit X-002 Engine harness 1 to power distribution unit SP-057F GND - Engine X-002 Engine harness 1 to power distribution unit	<b>Wiring harnesses - Electrical schematic sheet 01 (55.100)</b>
2	PD-1001B (WH) EN-1001B (WH)	X-533 Power distribution unit X-002 Engine harness 1 to power distribution unit X-001 Cab main harness to engine harness 1 X-002 Engine harness 1 to power distribution unit	
3	PD-2070 (OR) EN-2070 (OR)	X-533 Power distribution unit X-002 Engine harness 1 to power distribution unit X-937 Engine Control Unit (ECU) X-002 Engine harness 1 to power distribution unit	
4	PD-011EA (GN) EN-011EA (GN)	SP-003 X-002 Engine harness 1 to power distribution unit X-937 Engine Control Unit (ECU) X-002 Engine harness 1 to power distribution unit	
5	PD-011EB (GN) EN-011EB (GN)	SP-003 X-002 Engine harness 1 to power distribution unit X-937 Engine Control Unit (ECU) X-002 Engine harness 1 to power distribution unit	
6	PD-011F (GN) EN-011EC (GN)	X-004 Power distribution unit X-002 Engine harness 1 to power distribution unit X-937 Engine Control Unit (ECU) X-002 Engine harness 1 to power distribution unit	<b>Wiring harnesses - Electrical schematic sheet 01 (55.100)</b>
7	PD-138 (VT)	X-005 Power distribution unit X-002 Engine harness 1 to power distribution unit	
8	PD-1001 (WH) EN-1001 (WH)	X-002 Engine harness 1 to power distribution unit X-533 Power distribution unit X-002 Engine harness 1 to power distribution unit X-011 Starter motor (cranking)	
9	PD-011G (GN) EN-011G (GN)	X-049 Power distribution unit X-002 Engine harness 1 to power distribution unit SP-011G X-002 Engine harness 1 to power distribution unit	
10	-	-	

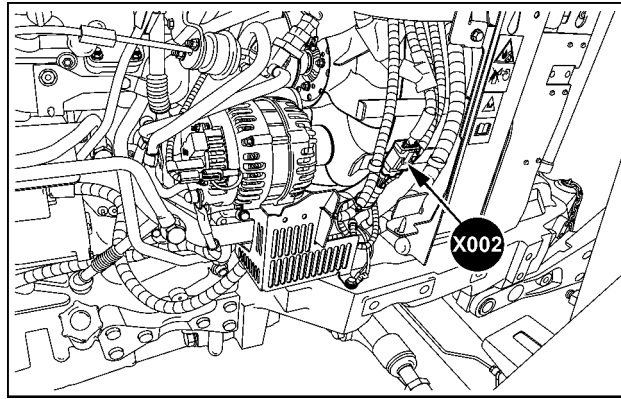

SVIL13TR00698AD 4

**Front right-hand engine**

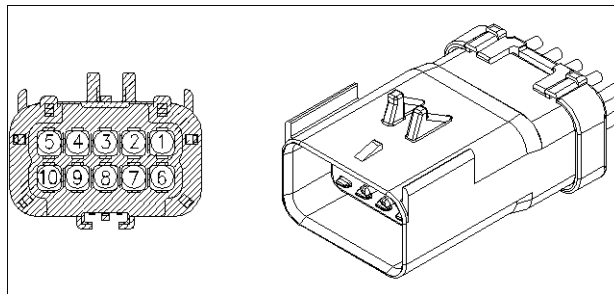

87382925 5

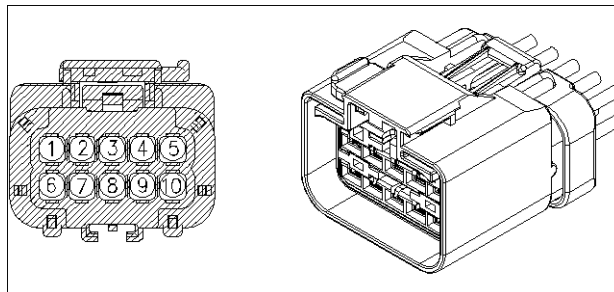

87382924 6

**CONNECTOR X-003 - Power distribution unit**

CONNECTOR X-003 - Power distribution unit			
PIN NUMBER	WIRE NUMBER	CIRCUIT REFERENCE	ELECTRICAL SCHEMATIC FRAME
1	PD-010PA (GN)	SP-002 X-003 Power distribution unit	<b>Wiring harnesses - Electrical schematic sheet 01 (55.100)</b>
2	PD-011E (GN)	X-003 Power distribution unit SP-003	

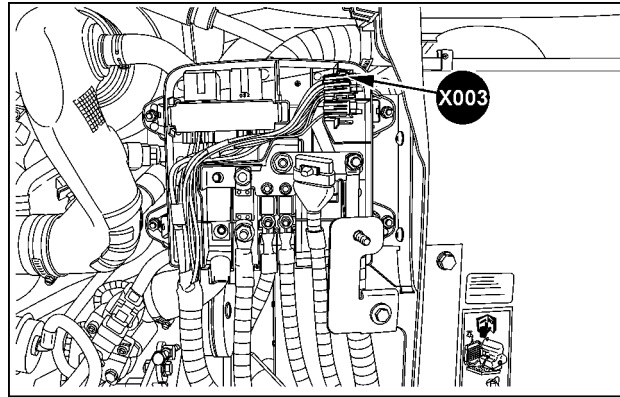

SVIL13TR00798AB 7

**Front top right-hand engine**

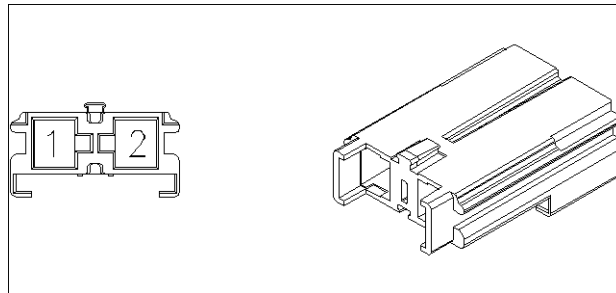

84157160 8

**CONNECTOR X-004 - Power distribution unit**

<b>CONNECTOR X-004 - Power distribution unit</b>			
<b>PIN NUMBER</b>	<b>WIRE NUMBER</b>	<b>CIRCUIT REFERENCE</b>	<b>ELECTRICAL SCHEMATIC FRAME</b>
1	PD-010PB (GN)	SP-002 X-004 Power distribution unit	<b>Wiring harnesses - Electrical schematic sheet 01 (55.100)</b>
2	PD-011F (GN)	X-004 Power distribution unit X-002 Engine harness 1 to power distribution unit	

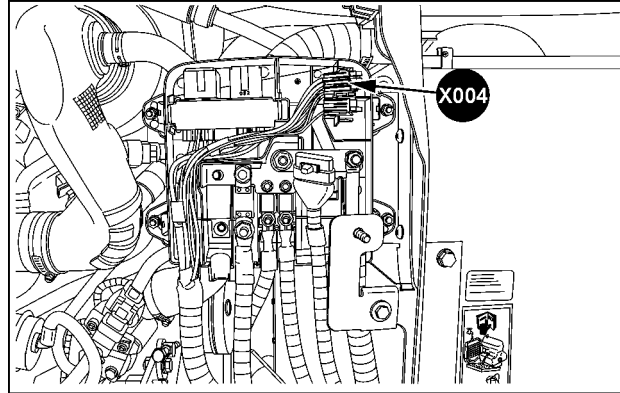

SVIL13TR00798AC 9

**Front top right-hand engine**

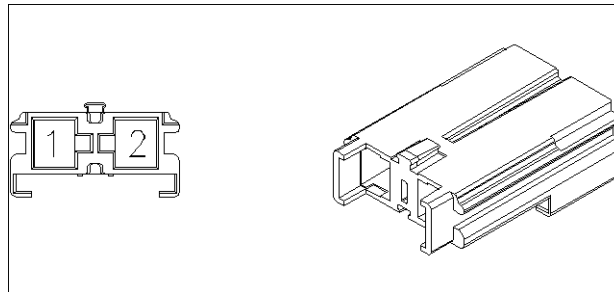

84157160 10



**CONNECTOR X-005 - Power distribution unit**

CONNECTOR X-005 - Power distribution unit			
PIN NUMBER	WIRE NUMBER	CIRCUIT REFERENCE	ELECTRICAL SCHEMATIC FRAME
1	PD-138 (VT)	X-005 Power distribution unit X-002 Engine harness 1 to power distribution unit	<b>Wiring harnesses - Electrical schematic sheet 01 (55.100)</b>

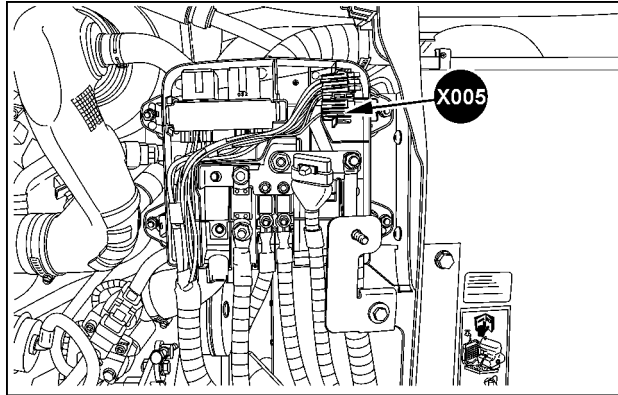

SVIL13TR00798AD 11

**Front top right-hand engine**

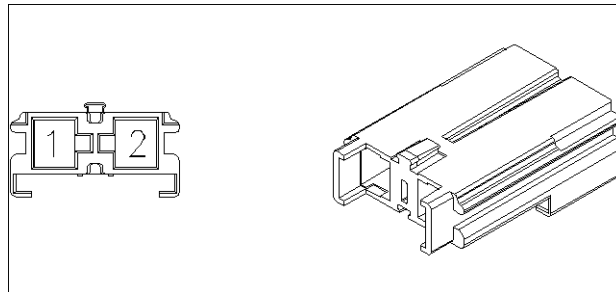

84157160 12

**CONNECTOR X-006 - Power distribution unit**

CONNECTOR X-006 - Power distribution unit			
PIN NUMBER	WIRE NUMBER	CIRCUIT REFERENCE	ELECTRICAL SCHEMATIC FRAME
1	EN2-9923 (RD)	X-938 Glow plug control module X-006 Power distribution unit	Wiring harnesses - Electrical schematic sheet 01 (55.100)

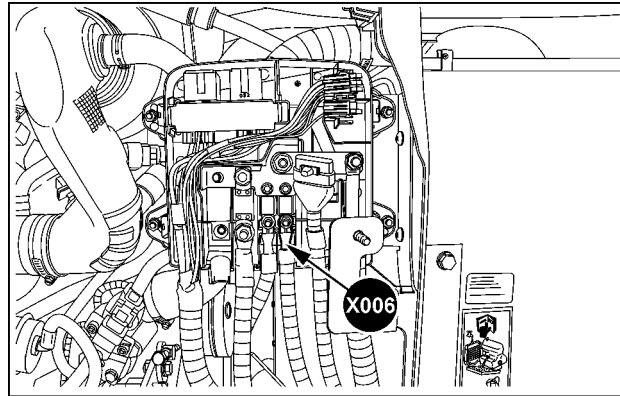

SVIL13TR00798AE 13

**Front top right-hand engine**

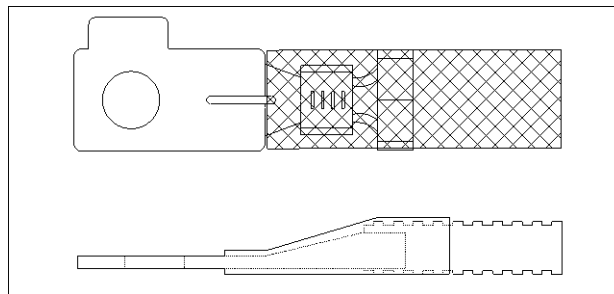

84407991 14

**CONNECTOR X-007 - Battery power supply (main fuse)**

CONNECTOR X-007 - Battery power supply (main fuse)			
PIN NUMBER	WIRE NUMBER	CIRCUIT REFERENCE	ELECTRICAL SCHEMATIC FRAME
1	BT-001D (RD)	X-533 Power distribution unit X-002 Engine harness 1 to power distribution unit	<b>Wiring harnesses - Electrical schematic sheet 01 (55.100)</b>

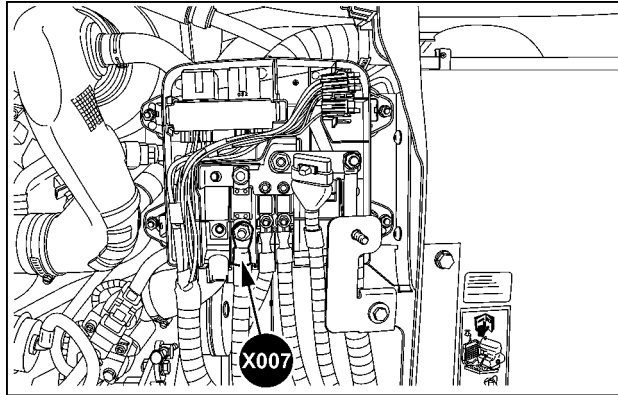

SVIL13TR00798AF 15

**Front top right-hand engine**

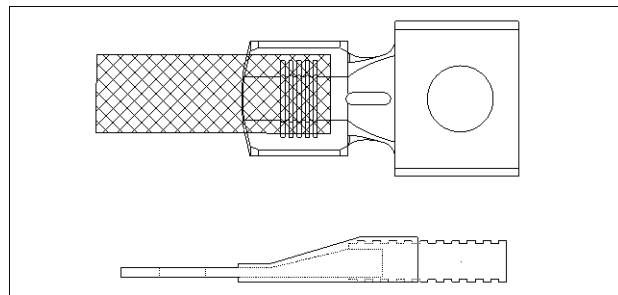

84128187 16

**CONNECTOR X-008 - Battery isolator**

CONNECTOR X-008 - Battery isolator			
PIN NUMBER	WIRE NUMBER	CIRCUIT REFERENCE	ELECTRICAL SCHEMATIC FRAME
1	EN-172 (PK)	X-008 Battery isolator X-001 Cab main harness to engine harness 1	<b>Wiring harnesses - Electrical schematic sheet 01 (55.100)</b>
2	EN-057FM (BK)	X-008 Battery isolator SP-057FK	
3	EN-057FL (BK)	X-008 Battery isolator SP-057FK	
4	EN-171B (VT)	X-001 Cab main harness to engine harness 1 X-008 Battery isolator	

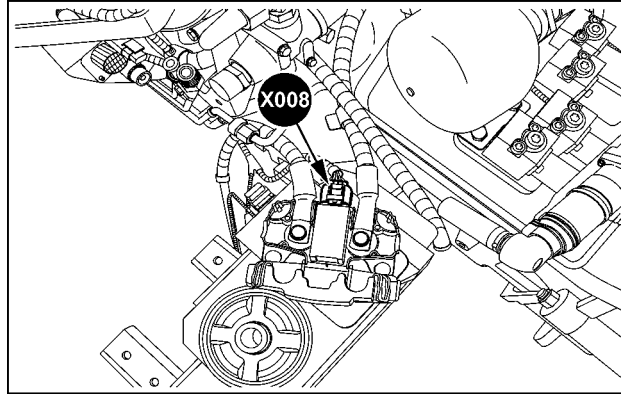

SVIL13TR00703AB 17

**Left-hand behind steps**

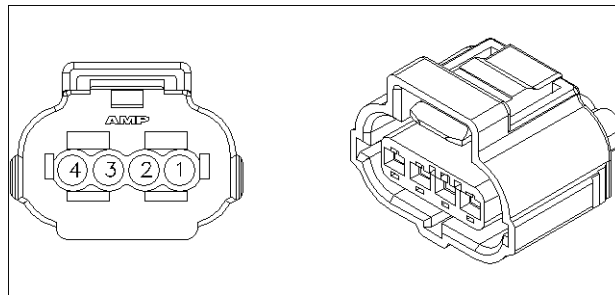

87745968 18

**CONNECTOR X-009-A - Battery isolator**

CONNECTOR X-009-A - Battery isolator			
PIN NUMBER	WIRE NUMBER	CIRCUIT REFERENCE	ELECTRICAL SCHEMATIC FRAME
A	BT-001E (BK)	X-009-A Battery isolator X-010 Starter motor	Wiring harnesses - Electrical schematic sheet 01 (55.100)

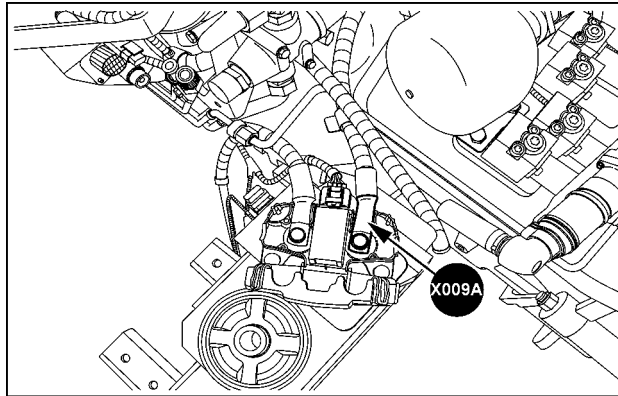

SVIL13TR00703AC 19

**Left-hand behind steps**

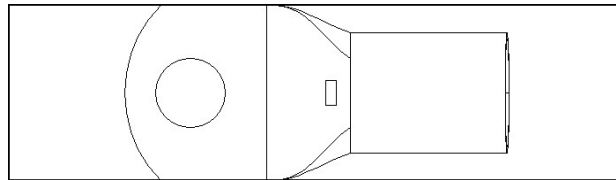

84549335 20

**CONNECTOR X-009-B - Battery isolator**

CONNECTOR X-009-B - Battery isolator			
PIN NUMBER	WIRE NUMBER	CIRCUIT REFERENCE	ELECTRICAL SCHEMATIC FRAME
B	BT-001 (BK)	X-009-B Battery isolator X-500 Battery terminal (positive)	Wiring harnesses - Electrical schematic sheet 01 (55.100)

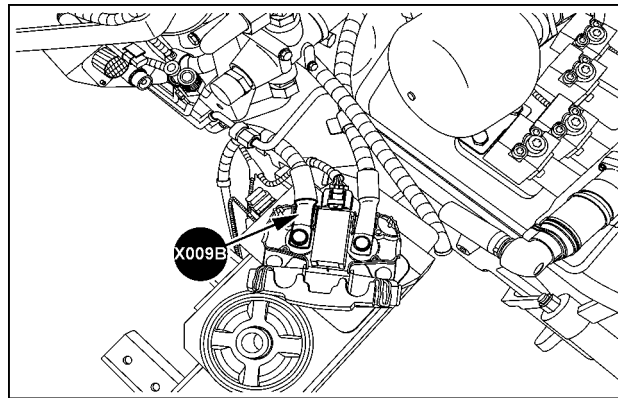

SVIL13TR00703AD 21

**Left-hand behind steps**

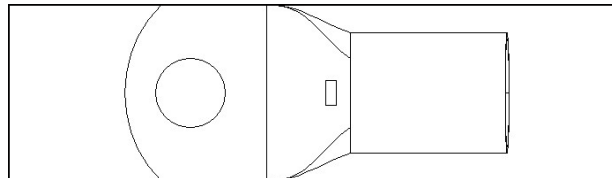

84549335 22

## Wire connectors - Component diagram 01

### CONNECTOR X-010 - Starter motor (battery power supply)

CONNECTOR X-010 - Starter motor (battery power supply)			
PIN NUMBER	WIRE NUMBER	CIRCUIT REFERENCE	ELECTRICAL SCHEMATIC FRAME
1	BT-001E (BK)	X-009-A Battery isolator X-010 Starter motor	<b>Wiring harnesses - Electrical schematic sheet 01 (55.100)</b>
2	BT-001F (R)	X-010 Starter motor (battery power supply) X-060 Starter motor to power distribution unit	

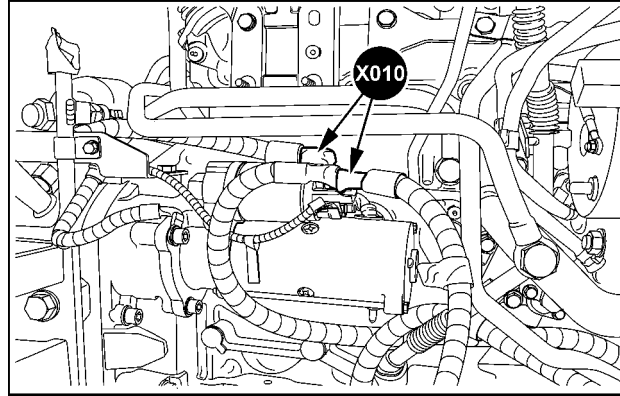

SVIL13TR00699AG 1

**Rear right-hand engine**

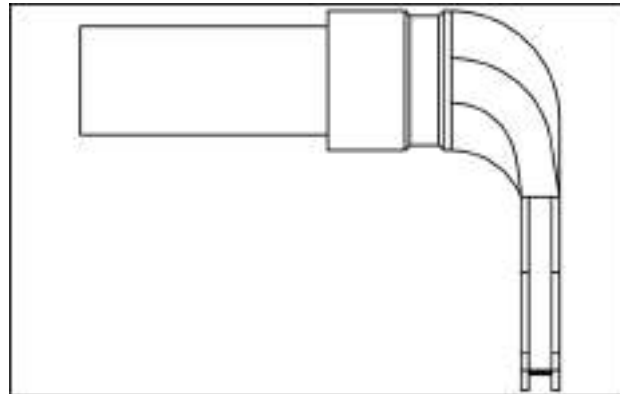

84138052 2

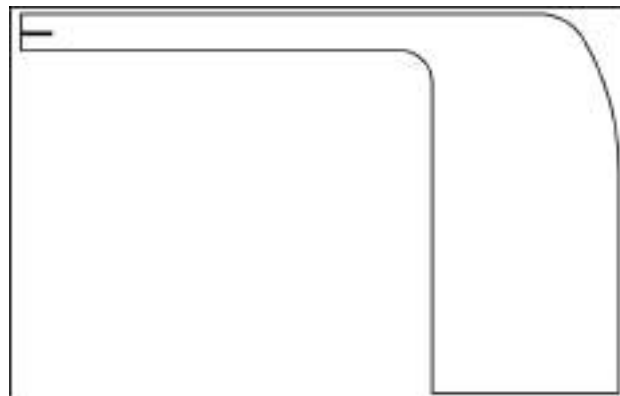

82013012 3

**CONNECTOR X-011 - Starter motor (cranking)**

CONNECTOR X-011 - Starter motor (cranking)			
PIN NUMBER	WIRE NUMBER	CIRCUIT REFERENCE	ELECTRICAL SCHEMATIC FRAME
1	EN-1001 (WH)	X-002 Engine harness 1 to power distribution unit X-011 Starter motor (cranking)	Wiring harnesses - Electrical schematic sheet 01 (55.100)

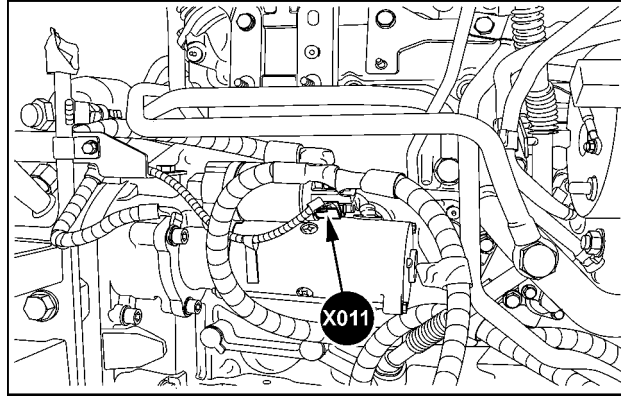

SVIL13TR00699AF 4

**Rear right-hand engine**

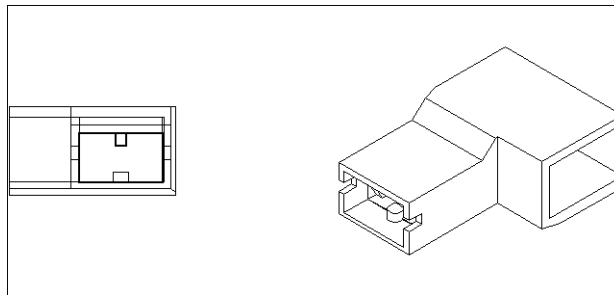

82944111 5



**CONNECTOR X-012 - Alternator D+**

<b>CONNECTOR X-012 - Alternator D+</b>			
<b>PIN NUMBER</b>	<b>WIRE NUMBER</b>	<b>CIRCUIT REFERENCE</b>	<b>ELECTRICAL SCHEMATIC FRAME</b>
1	EN-1006B (BR)	X-012 Alternator D+ X-001 Cab main harness to engine harness 1	<b>Wiring harnesses - Electrical schematic sheet 01 (55.100)</b>

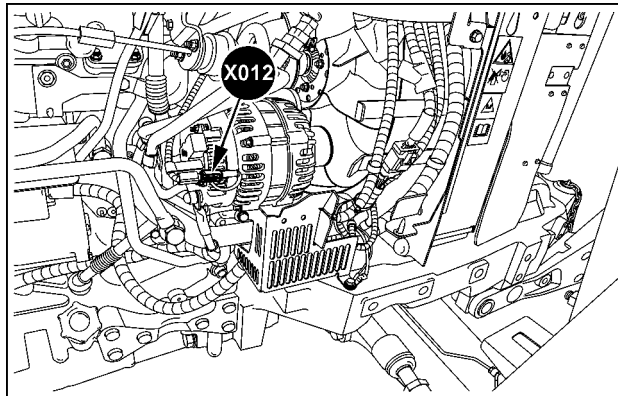

SVIL13TR00698AB 6

**Front right-hand engine**

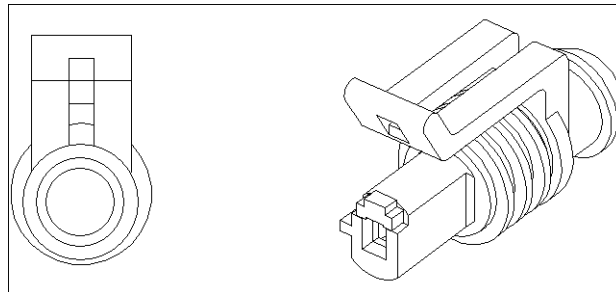

87687239 7

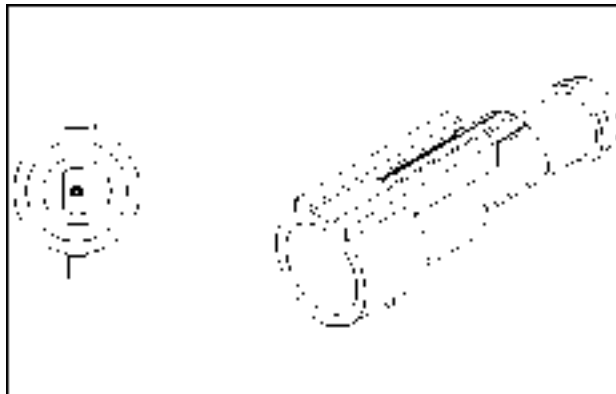

87679525 8

**CONNECTOR X-013 - Alternator B+**

CONNECTOR X-013 - Alternator B+			
PIN NUMBER	WIRE NUMBER	CIRCUIT REFERENCE	ELECTRICAL SCHEMATIC FRAME
1	BT-001A (RD)	X-304 Starter motor X-013 Alternator B+	Wiring harnesses - Electrical schematic sheet 01 (55.100)

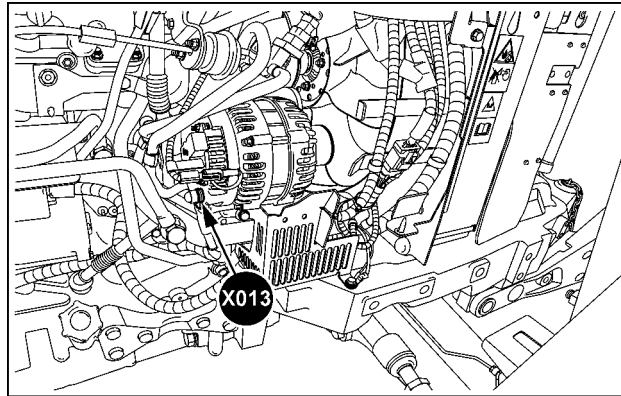

SVIL13TR00698AC 9

**Front right-hand engine**

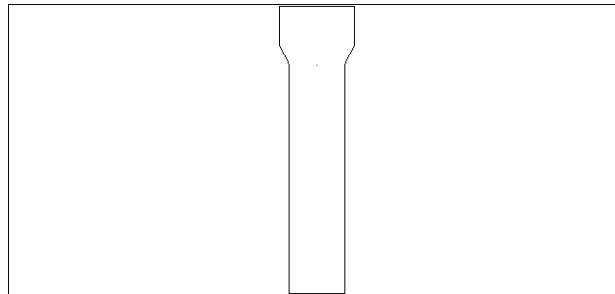

84153306 10

**CONNECTOR X-014 - Power distribution unit**

CONNECTOR X-014 - Power distribution unit			
PIN NUMBER	WIRE NUMBER	CIRCUIT REFERENCE	ELECTRICAL SCHEMATIC FRAME
1	PD-001P (RD)	SP-001 X-014 Power distribution unit	<b>Wiring harnesses - Electrical schematic sheet 01 (55.100)</b>

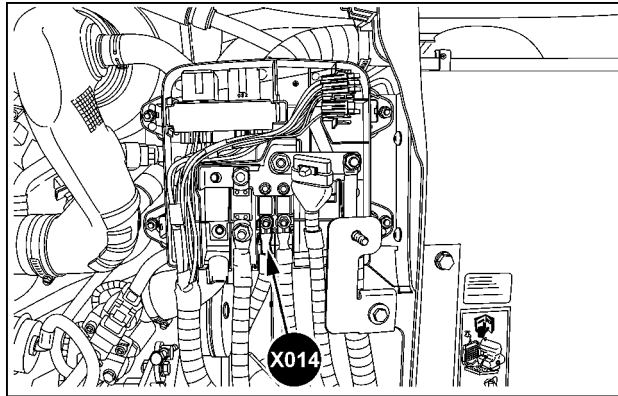

SVIL13TR00798AG 11

**Front top right-hand engine**

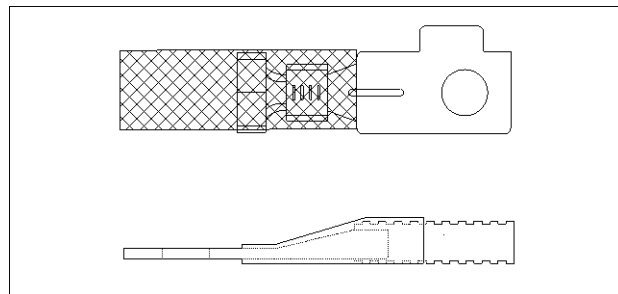

84407968 12

**CONNECTOR X-015 - Horn**

<b>CONNECTOR X-015 - Horn</b>			
<b>PIN NUMBER</b>	<b>WIRE NUMBER</b>	<b>CIRCUIT REFERENCE</b>	<b>ELECTRICAL SCHEMATIC FRAME</b>
1	HD-376 (VT)	X-015 Horn X-025 Engine harness to engine hood harness	<b>Wiring harnesses - Electrical schematic sheet 18 (55.100)</b>

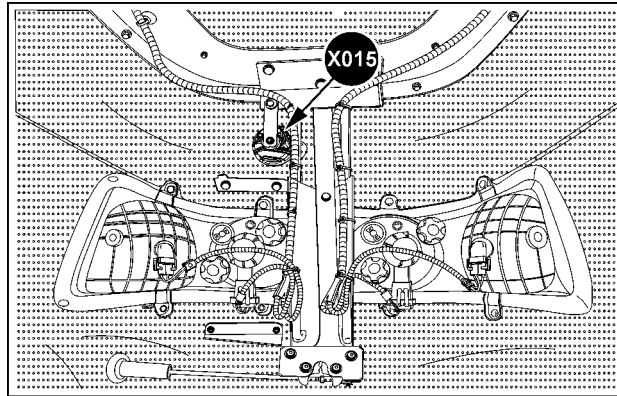

SVIL13TR00729AB 13

**Front hood**

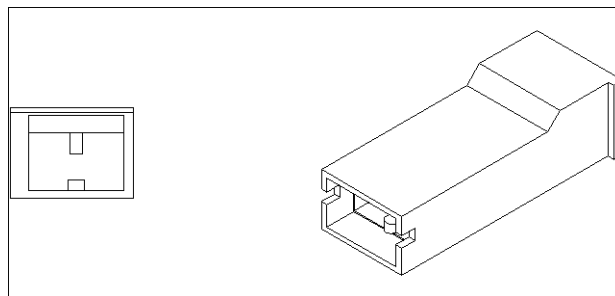

87702238 14

**CONNECTOR X-016 - Horn**

CONNECTOR X-016 - Horn			
PIN NUMBER	WIRE NUMBER	CIRCUIT REFERENCE	ELECTRICAL SCHEMATIC FRAME
1	HD-057EV (BK)	X-016 Horn SP-046	Wiring harnesses - Electrical schematic sheet 18 (55.100)

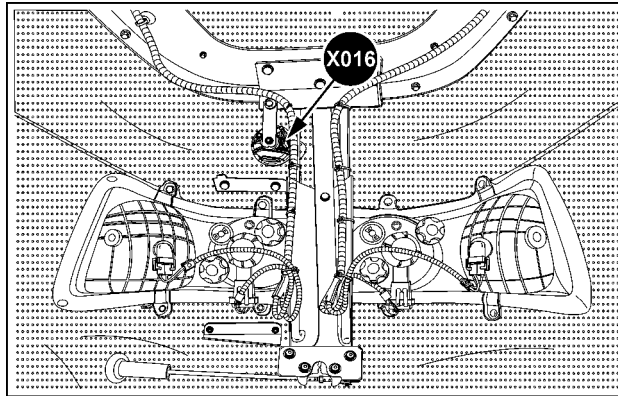

SVIL13TR00729AC 15

**Front hood**

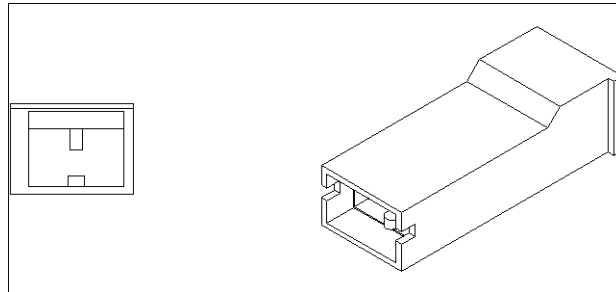

87702238 16

**CONNECTOR X-017 - Engine hood work light – Left-hand**

CONNECTOR X-017 - Engine hood work light – Left-hand			
PIN NUMBER	WIRE NUMBER	CIRCUIT REFERENCE	ELECTRICAL SCHEMATIC FRAME
A	HD-1053A (WH)	SP-047 X-017 Engine hood work light – Left-hand	Wiring harnesses - Electrical schematic sheet 21 (55.100)
B	HD-057EU (BK)	SP-046 X-017 Engine hood work light – Left-hand	

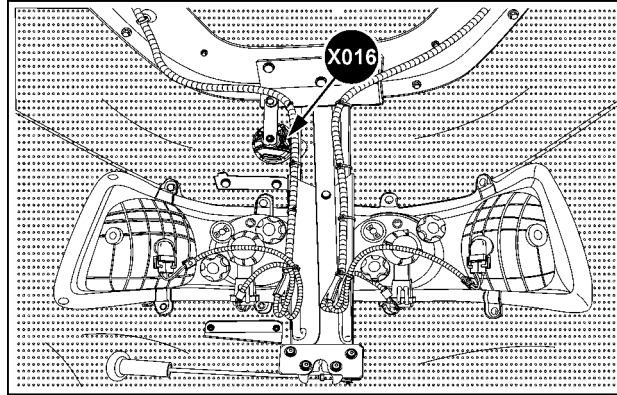

SVIL13TR00729AC 17

**Front hood**

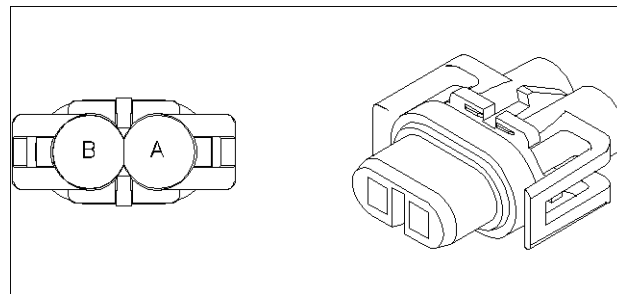

82003123 18

**CONNECTOR X-018 - Engine hood work light – Right-hand**

CONNECTOR X-018 - Engine hood work light – Right-hand			
PIN NUMBER	WIRE NUMBER	CIRCUIT REFERENCE	ELECTRICAL SCHEMATIC FRAME
A	HD-1053B (WH)	SP-047 X-018 Engine hood work light – Right-hand	Wiring harnesses - Electrical schematic sheet 21 (55.100)
B	HD-057ET (BK)	SP-046 X-018 Engine hood work light – Right-hand	

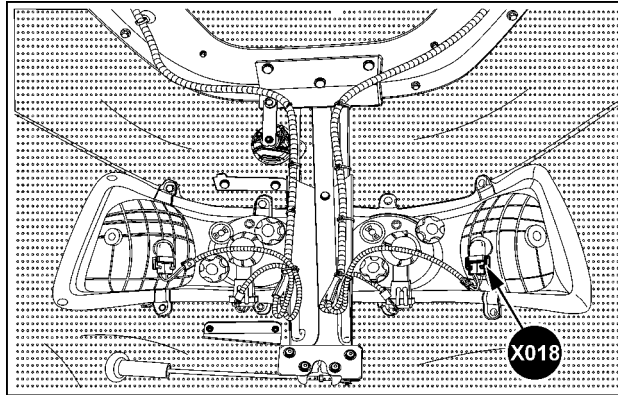

SVIL13TR00729AG 19

**Front hood**

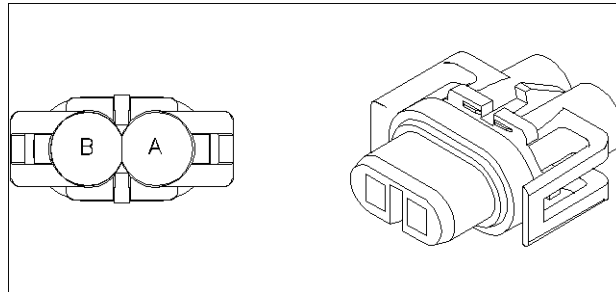

82003123 20





---

**Wire connectors - Component diagram 02**

<b>CONNECTOR X-020 - Headlight right-hand</b>			
<b>PIN NUMBER</b>	<b>WIRE NUMBER</b>	<b>CIRCUIT REFERENCE</b>	<b>ELECTRICAL SCHEMATIC FRAME</b>
1	HD-057EW (BK)	SP-046 X-979 Headlight right-hand	<b>Wiring harnesses - Electrical schematic sheet 18 (55.100)</b>
2	-	-	
3	HD-1027AB (BL)	SP-048 X-979 Headlight right-hand	
4	HD-1030AB (BL)	SP-049 X-979 Headlight right-hand	

**CONNECTOR X-021 - Grab rail light – Left-hand**

CONNECTOR X-021 - Grab rail light – Left-hand			
PIN NUMBER	WIRE NUMBER	CIRCUIT REFERENCE	ELECTRICAL SCHEMATIC FRAME
1	RF-3001B (GN)	X-021 Grab rail light – Left-hand X-385 Cab main harness to roof harness 2	Wiring harnesses - Electrical schematic sheet 18 (55.100)
2	RF-1013LT (BL)	SP-1013L X-021 Grab rail light – Left-hand	
4	RF-057RA (BK)	X-021 Grab rail light – Left-hand SP-057R	

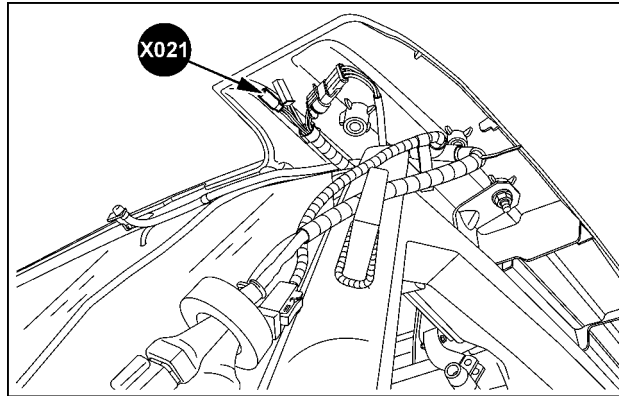

SVIL13TR00701AB 1

**Front left-hand cab roof**

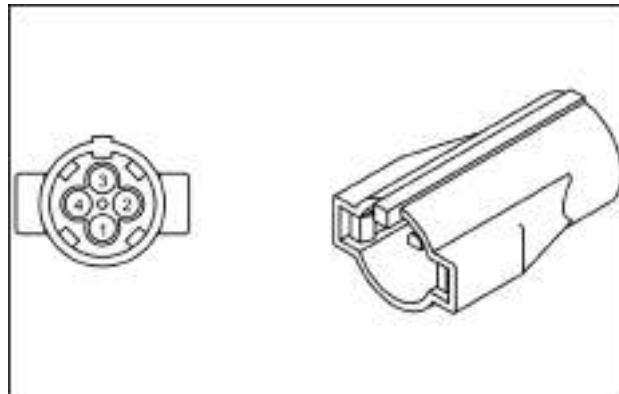

87311796 2

**CONNECTOR X-022 - Grab rail light – Right-hand**

CONNECTOR X-022 - Grab rail light – Right-hand			
PIN NUMBER	WIRE NUMBER	CIRCUIT REFERENCE	ELECTRICAL SCHEMATIC FRAME
1	RF-3002C (GN)	X-022 Grab rail light – Right-hand X-050 Cab main harness to roof harness 1	<b>Wiring harnesses - Electrical schematic sheet 18 (55.100)</b>
2	RF-1014M (RD)	X-022 Grab rail light – Right-hand X-050 Cab main harness to roof harness 1	
4	RF-057SH (BK)	SP-057S ROOF GROUND LH2 X-022 Grab rail light – Right-hand	

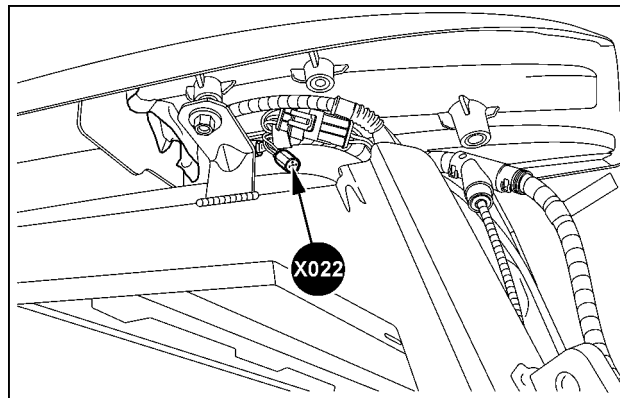

SVIL13TR00702AB 3

**Front right-hand cab roof**

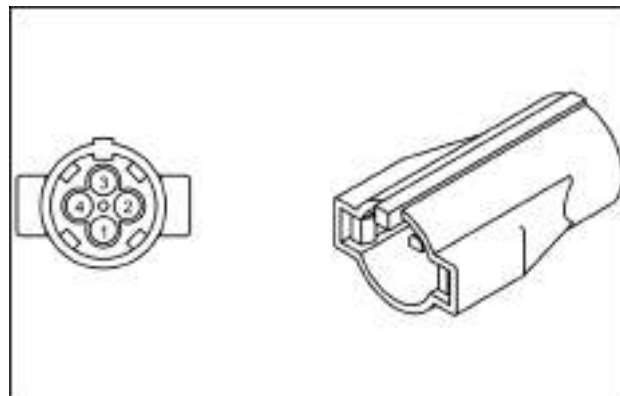

87311796 4

**CONNECTOR X-023 - Tail light left-hand**

CONNECTOR X-023 - Tail light left-hand			
PIN NUMBER	WIRE NUMBER	CIRCUIT REFERENCE	ELECTRICAL SCHEMATIC FRAME
1	CM-057AG (BK)	X-023 Tail light left-hand SP-057A CAB GND	<b>Wiring harnesses - Electrical schematic sheet 18 (55.100)</b>
2	CM-3001C (GN)	X-023 Tail light left-hand SP-3001	
3	CM-1014A (RD)	X-023 Tail light left-hand SP-1014	
4	CM-810D (GN)	X-023 Tail light left-hand SP-810C	

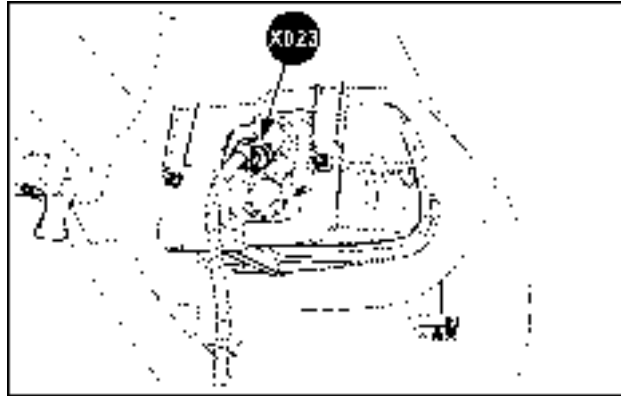

SVIL13TR00704AB 5

**Left-hand rear fender**

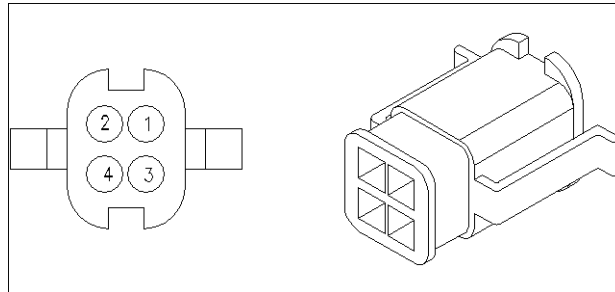

87745334 6

**CONNECTOR X-024 - Tail light right-hand**

CONNECTOR X-024 - Tail light right-hand			
PIN NUMBER	WIRE NUMBER	CIRCUIT REFERENCE	ELECTRICAL SCHEMATIC FRAME
1	CM-057AF (BK)	X-024 Tail light right-hand SP-057A CAB GND	<b>Wiring harnesses - Electrical schematic sheet 18 (55.100)</b>
2	CM-3002B (GN)	X-024 Tail light right-hand SP-3002	
3	CM-1013A (RD)	X-024 Tail light right-hand SP-1013	
4	CM-810F (GN)	SP-810C X-024 Tail light right-hand	

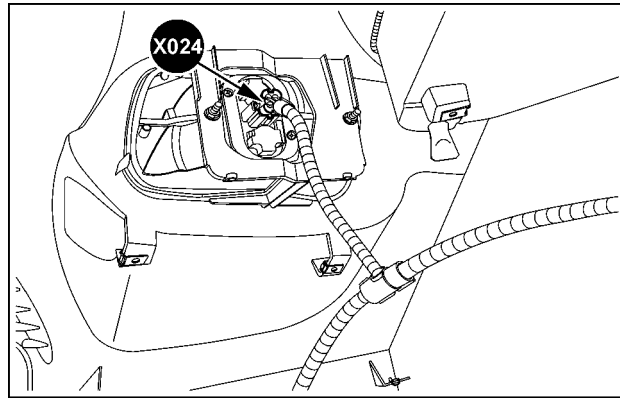

SVIL13TR00708AB 7

**Right-hand rear fender**

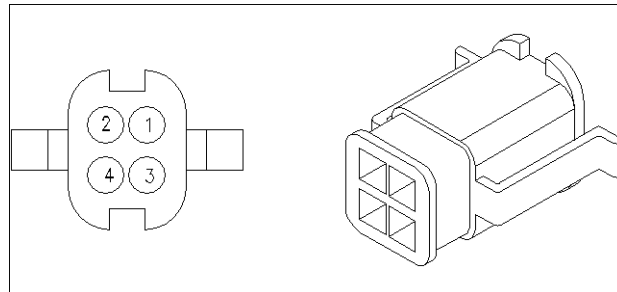

87745334 8

**CONNECTOR X-025 - Engine harness to engine hood harness**

CONNECTOR X-025 - Engine harness to engine hood harness			
PIN NUMBER	WIRE NUMBER	CIRCUIT REFERENCE	ELECTRICAL SCHEMATIC FRAME
1	HD-1030A (BL) EN-1030A (BL)	SP-049 X-025 Engine harness to engine hood harness X-001 Cab main harness to engine harness 1 X-025 Engine harness to engine hood harness	Wiring harnesses - Electrical schematic sheet 18 (55.100) Wiring harnesses - Electrical schematic sheet 21 (55.100)
2	HD-1027A (BL) EN-1027A (BL)	SP-048 X-025 Engine harness to engine hood harness X-001 Cab main harness to engine harness 1 X-025 Engine harness to engine hood harness	
3	HD-057EF (BK) EN-057EL (BK)	SP-046 X-025 Engine harness to engine hood harness X-001 Cab main harness to engine harness 1 X-025 Engine harness to engine hood harness	
4	HD-1053 (WH) EN-1053 (WH)	SP-047 X-025 Engine harness to engine hood harness X-001 Cab main harness to engine harness 1 X-025 Engine harness to engine hood harness	
5	HD-057FJ (BK) EN-057FJ (BK)	X-025 Engine harness to engine hood harness SP-046 SP-057F GND - Engine X-025 Engine harness to engine hood harness	
6	HD-376 (VT) EN-376 (VT)	X-015 Horn X-025 Engine harness to engine hood harness X-001 Cab main harness to engine harness 1 X-025 Engine harness to engine hood harness	

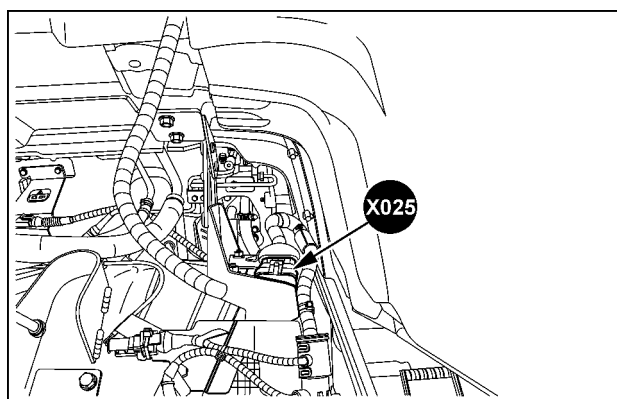

SVIL13TR00705AB 9

**Top left-hand engine**

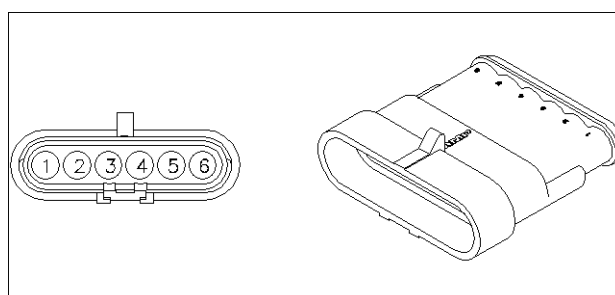

87691968 10

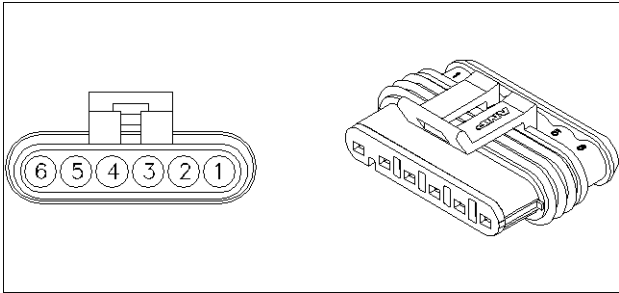

87710588 11

**CONNECTOR X-026 - Power socket 8 A – Cab inside**

<b>CONNECTOR X-026 - Power socket 8 A – Cab inside</b>			
<b>PIN NUMBER</b>	<b>WIRE NUMBER</b>	<b>CIRCUIT REFERENCE</b>	<b>ELECTRICAL SCHEMATIC FRAME</b>
1	SP-057GT (BK)	X-026 Power socket 8 A – Cab inside SP-057G POT GND SWITCH PANEL	<b>Wiring harnesses - Electrical schematic sheet 23 (55.100)</b>
2	SP-001GA (RD)	X-026 Power socket 8 A – Cab inside SP-001G POT 30 SWITCH PANEL 8A	

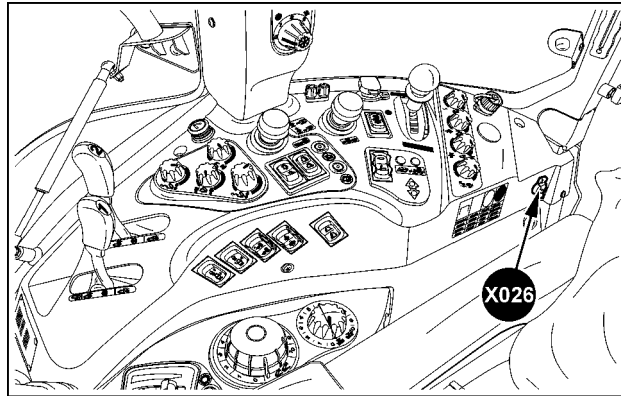

SVIL13TR00706AP 12

**Cab right-hand side**

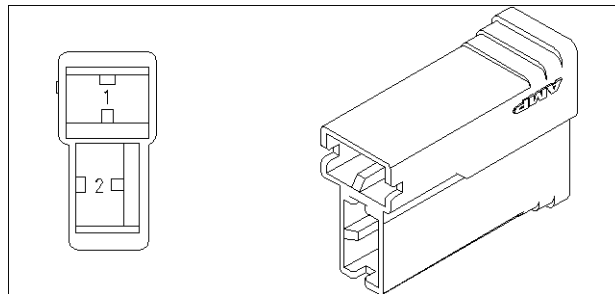

87691950 13



**CONNECTOR X-027 - Cigarette lighter power supply**

CONNECTOR X-027 - Cigarette lighter power supply			
PIN NUMBER	WIRE NUMBER	CIRCUIT REFERENCE	ELECTRICAL SCHEMATIC FRAME
1	SP-057GA (BK)	SP-057G POT GND SWITCH PANEL X-027 Cigarette lighter power supply	<b>Wiring harnesses - Electrical schematic sheet 23 (55.100)</b>
2	SP-001GD (RD)	X-027 Cigarette lighter power supply SP-001G POT 30 SWITCH PANEL 8A	

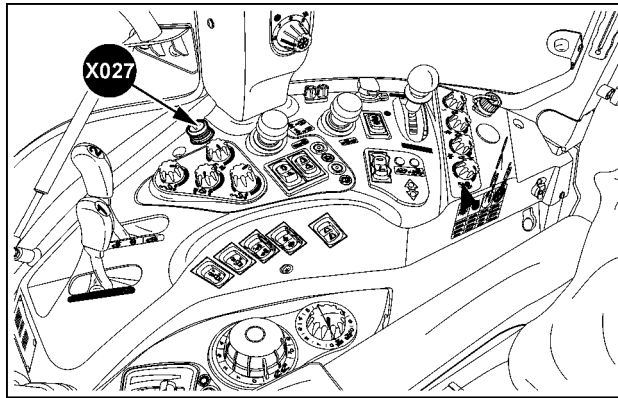

SVIL13TR00706AB 14

**Cab right-hand side**

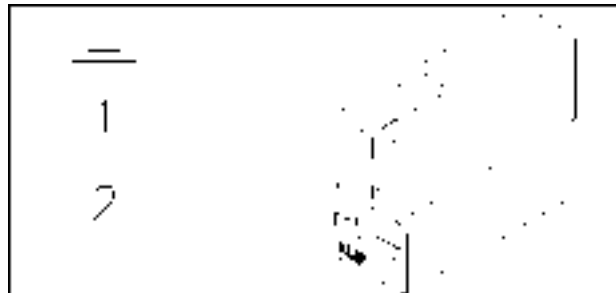

87699736 15

**CONNECTOR X-028 - Cigarette lighter power supply (optional)**

CONNECTOR X-028 - Cigarette lighter power supply (optional)			
PIN NUMBER	WIRE NUMBER	CIRCUIT REFERENCE	ELECTRICAL SCHEMATIC FRAME
1	CM-057EJ (BK)	SP-057E CAB GND 3 X-028 Cigarette lighter power supply (optional)	Wiring harnesses - Electrical schematic sheet 23 (55.100)
2	CM-001H (RD)	X-028 Cigarette lighter power supply (optional) X-110 Relay and fuse block (K-004 to K-039 and F-033 to F-036)	

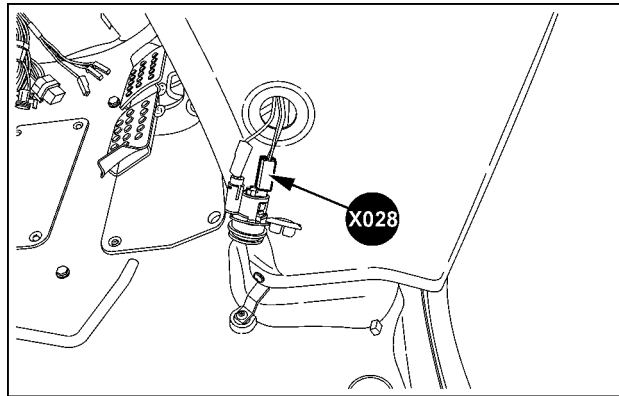

SVIL13TR00745AB 16

**Front right-hand cab floor**

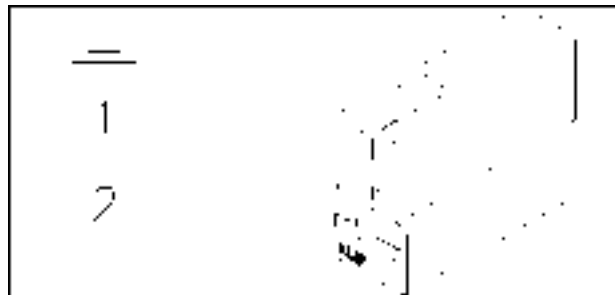

87699736 17

**CONNECTOR X-029 - Seat assembly (seat compressor and seat heater)**

CONNECTOR X-029 - Seat assembly (seat compressor and seat heater)			
PIN NUMBER	WIRE NUMBER	CIRCUIT REFERENCE	ELECTRICAL SCHEMATIC FRAME
1	CM-057AL (BK)	SP-057A CAB GND X-029 Seat assembly (seat compressor and seat heater)	Wiring harnesses - Electrical schematic sheet 03 (55.100)
2	CM-3090 (GN)	X-029 Seat assembly (seat compressor and seat heater) SP-010B	

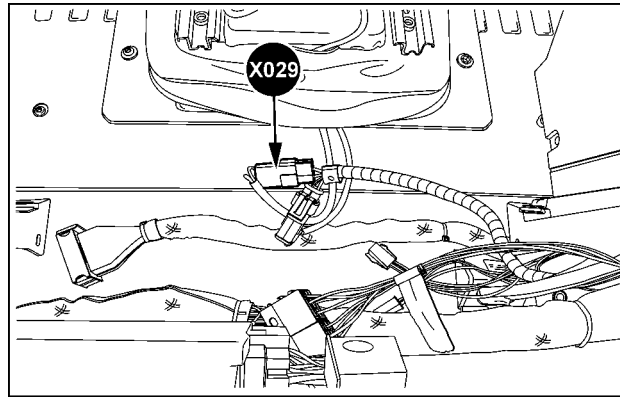

SVIL13TR00710AB 18

**In cab behind operator's seat**

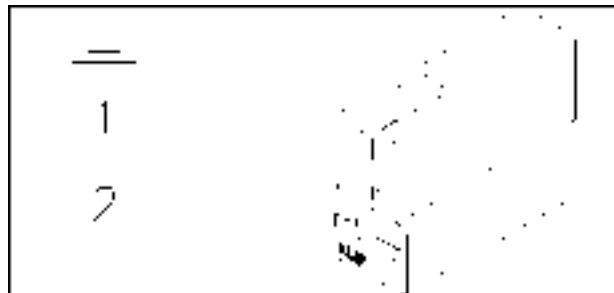

87699736 19

## Wire connectors - Component diagram 03

### CONNECTOR X-030 - Blower switch

CONNECTOR X-030 - Blower switch			
PIN NUMBER	WIRE NUMBER	CIRCUIT REFERENCE	ELECTRICAL SCHEMATIC FRAME
1	RF-010YB (GN)	SP-010Y X-030 Blower switch	Wiring harnesses - Electrical schematic sheet 17 (55.100)
2	RF-6300 (BR)	X-030 Blower switch X-050 Cab main harness to roof harness 1	
3	RF-6301 (BR)	X-030 Blower switch X-050 Cab main harness to roof harness 1	
4	RF-6302 (BR)	X-030 Blower switch X-050 Cab main harness to roof harness 1	
5	RF-6303 (BR)	X-030 Blower switch X-050 Cab main harness to roof harness 1	

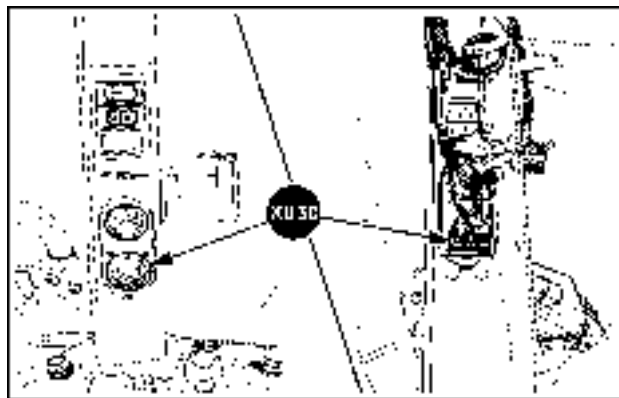

SS13J064 1

Right-hand B-pillar

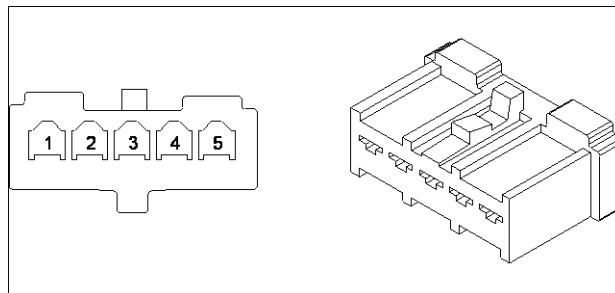

84279647 2

**CONNECTOR X-031 - Air-conditioning system – Mode switch**

CONNECTOR X-031 - Air-conditioning system – Mode switch			
PIN NUMBER	WIRE NUMBER	CIRCUIT REFERENCE	ELECTRICAL SCHEMATIC FRAME
1	RF-010YA (GN)	SP-010Y X-031 Air-conditioning system – Mode switch	<b>Wiring harnesses - Electrical schematic sheet 17 (55.100)</b>
2	RF-9215 (BL)	X-031 Air-conditioning system – Mode switch SP-9215	
4	RF-057TH (BK)	X-031 Air-conditioning system – Mode switch SP-057T ROOF GROUND LH1	

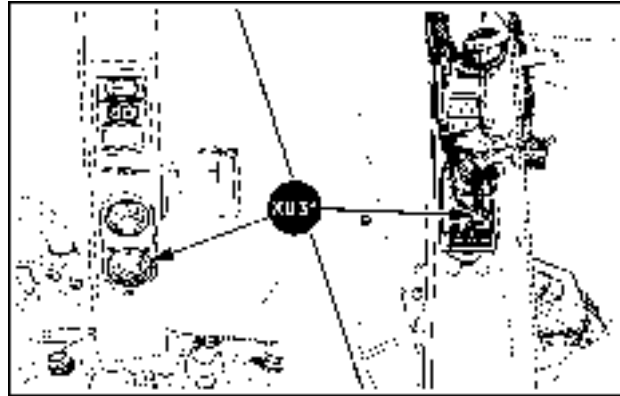

SS13J065 3

**Right-hand B-pillar**

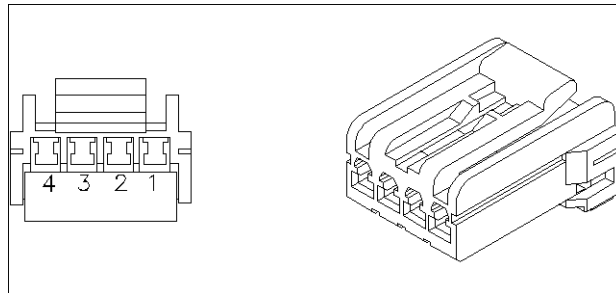

87736481 4

**CONNECTOR X-032 - Remote valve switch – Fender left-hand**

<b>CONNECTOR X-032 - Remote valve switch – Fender left-hand</b>			
<b>PIN NUMBER</b>	<b>WIRE NUMBER</b>	<b>CIRCUIT REFERENCE</b>	<b>ELECTRICAL SCHEMATIC FRAME</b>
1	CM-5557 (BL)	X-032 Remote valve switch – Fender left-hand X-210 Central Control Unit (CCU) – CN1B	<b>Wiring harnesses - Electrical schematic sheet 13 (55.100)</b>
2	CM-5260D (TN)	SP-5260 X-032 Remote valve switch – Fender left-hand	
3	CM-5558 (RD)	X-032 Remote valve switch – Fender left-hand X-210 Central Control Unit (CCU) – CN1B	

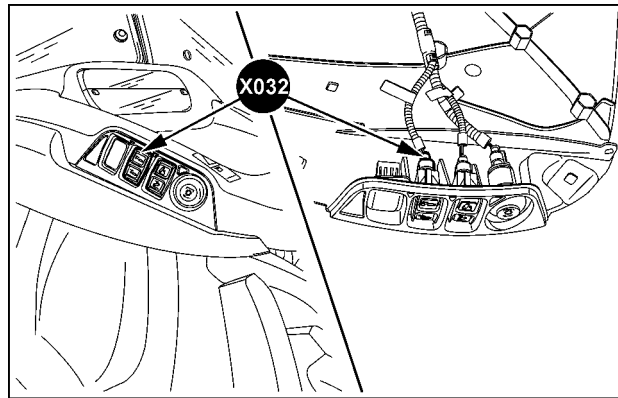

SS13J068 5

**Left-hand rear fender**

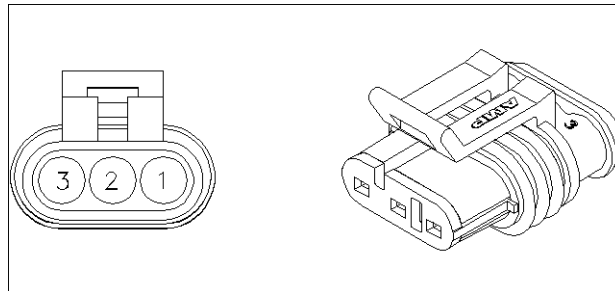

84062580 6

**CONNECTOR X-034 - Main light switch**

CONNECTOR X-034 - Main light switch			
PIN NUMBER	WIRE NUMBER	CIRCUIT REFERENCE	ELECTRICAL SCHEMATIC FRAME
1	RF-1051A (YE)	SP-1051 X-034 Main light switch	<b>Wiring harnesses - Electrical schematic sheet 20 (55.100)</b>
2	RF-155J (GN)	X-034 Main light switch X-385 Cab main harness to roof harness 2	
3	RF-1051B (YE)	X-034 Main light switch SP-1051	
4	RF-011D (GN)	X-385 Cab main harness to roof harness 2 X-034 Main light switch	
5	RF-010DC (GN)	SP-010D X-034 Main light switch	
7	RF-0057TG (BK)	X-034 Main light switch SP-057T ROOF GROUND LH1	
8	RF-1013LS (BL)	X-034 Main light switch SP-1013L	
9	RF-057SP (BK)	X-034 Main light switch SP-057S ROOF GROUND LH2	
10	RF-1013LR (BL)	X-034 Main light switch SP-1013L	

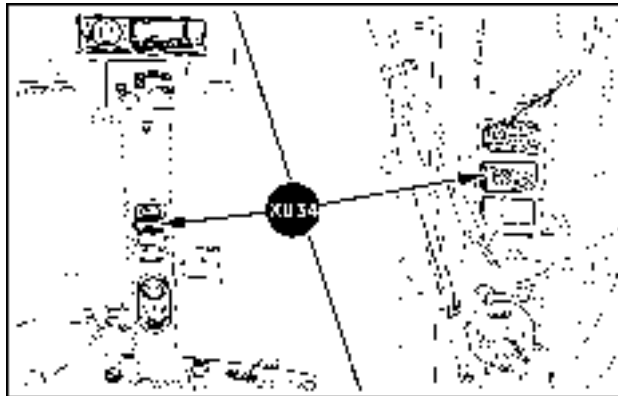

SS13K002 7

**Right-hand B-pillar**

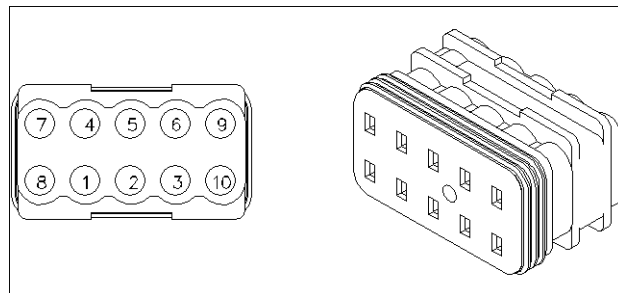

84819781 8

**CONNECTOR X-036 - Rear wiper and washer switch**

CONNECTOR X-036 - Rear wiper and washer switch			
PIN NUMBER	WIRE NUMBER	CIRCUIT REFERENCE	ELECTRICAL SCHEMATIC FRAME
2	RF-1038A (TN)	SP-1038 X-036 Rear wiper and washer switch	Wiring harnesses - Electrical schematic sheet 22 (55.100)
3	RF-098 (LG)	X-036 Rear wiper and washer switch X-050 Cab main harness to roof harness 1	
4	RF-1123 (GN)	X-036 Rear wiper and washer switch X-038 Rear window wiper motor	
5	RF-1122 (GN)	X-036 Rear wiper and washer switch X-038 Rear window wiper motor	
6	RF-1038B (TN)	X-036 Rear wiper and washer switch SP-1038	
7	RF-057RL (BK)	X-036 Rear wiper and washer switch SP-057R	
8	RF-1013LA (BL)	SP-1013L X-036 Rear wiper and washer switch	

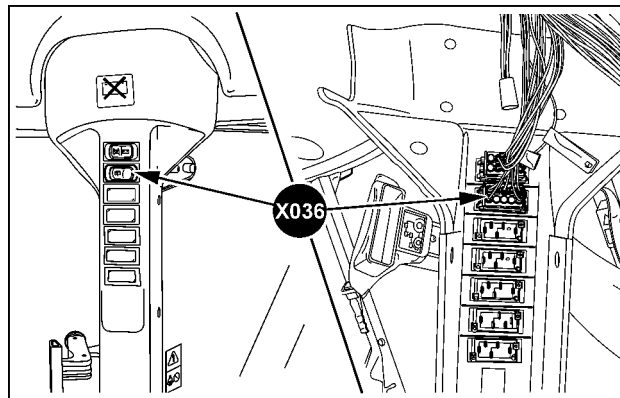

SS13J067 9

**Left-hand B-pillar**

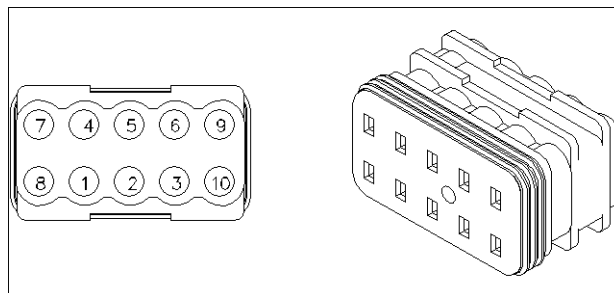

84819781 10



**CONNECTOR X-037 - Hitch draft control potentiometer**

CONNECTOR X-037 - Hitch draft control potentiometer			
PIN NUMBER	WIRE NUMBER	CIRCUIT REFERENCE	ELECTRICAL SCHEMATIC FRAME
1	CM-5040F (TN)	X-037 Hitch draft control potentiometer X-210 Central Control Unit (CCU) – CN1B	<b>Wiring harnesses - Electrical schematic sheet 12 (55.100)</b>
7	CM-060GB (BK/WH)	SP-060G X-037 Hitch draft control potentiometer	
8	CM-5520DB (LG)	X-037 Hitch draft control potentiometer SP-5520	

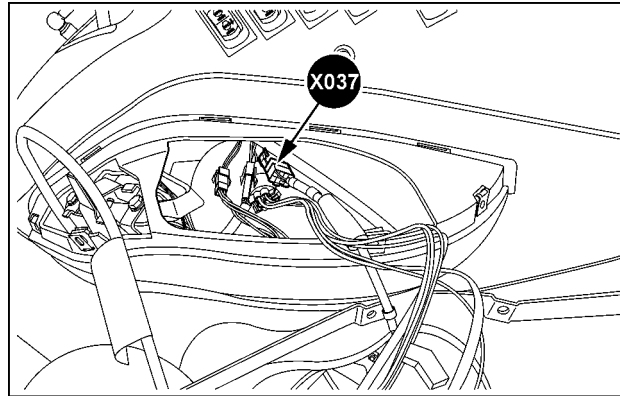

SVIL13TR00732AD 11

**On the right-hand trim behind switch panel**

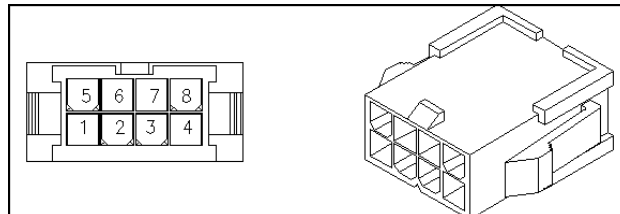

84355097 12

**CONNECTOR X-038 - Rear window wiper motor**

CONNECTOR X-038 - Rear window wiper motor			
PIN NUMBER	WIRE NUMBER	CIRCUIT REFERENCE	ELECTRICAL SCHEMATIC FRAME
1	RF-057SN (BK)	X-038 Rear window wiper motor SP-057S ROOF GROUND LH2	<b>Wiring harnesses - Electrical schematic sheet 22 (55.100)</b>
2	RF-1123 (GN)	X-036 Rear wiper and washer switch X-038 Rear window wiper motor	
3	RF-1038C (TN)	SP-1038 X-038 Rear window wiper motor	
4	-	-	
5	RF-1122 (GN)	X-036 Rear wiper and washer switch X-038 Rear window wiper motor	
6	-	-	

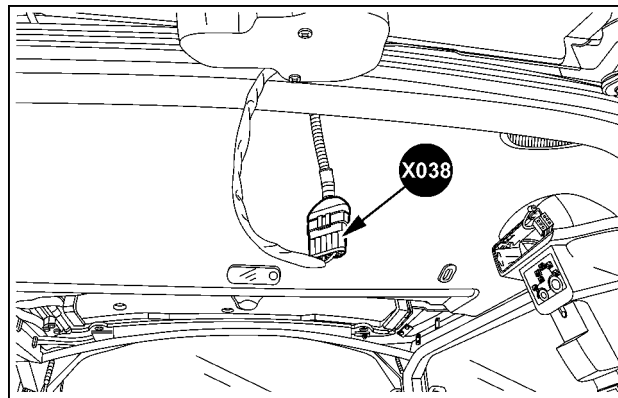

SVIL13TR00733AB 13

**Rear cab roof**

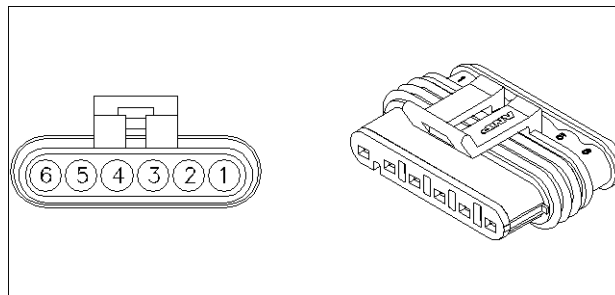

87710588 14

**CONNECTOR X-039 - Radio**

<b>CONNECTOR X-039 - Radio</b>			
<b>PIN NUMBER</b>	<b>WIRE NUMBER</b>	<b>CIRCUIT REFERENCE</b>	<b>ELECTRICAL SCHEMATIC FRAME</b>
A4	RF-137A (VT)	X-039 Radio SP-4012	<b>Wiring harnesses - Electrical schematic sheet 19 (55.100)</b>
A7	RF-137 (WH)	X-150 Relay and fuse block – Roof X-039 Radio	
A8	RF-057TA (BK)	X-039 Radio SP-057T ROOF GROUND LH1	
B3	RF-3053 (GY)	X-039 Radio X-082 Speaker rear right-hand	
B4	RF-3054 (GY)	X-039 Radio X-083 Speaker rear right-hand	
B5	RF-3056 (GY)	X-039 Radio X-085 Speaker rear left-hand	
B6	RF-3055 (GY)	X-039 Radio X-084 Speaker rear left-hand	

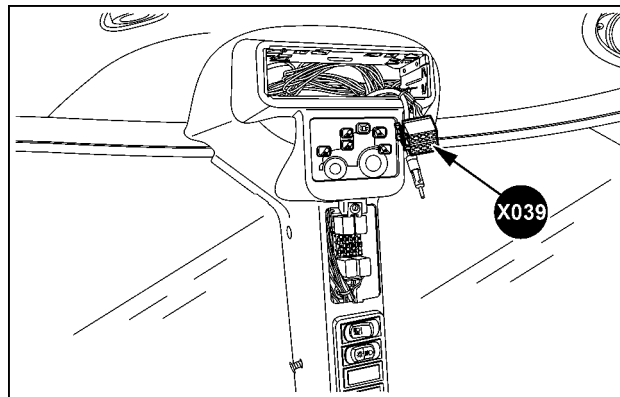

SVIL13TR00771AB 15

**Right-hand B-pillar**

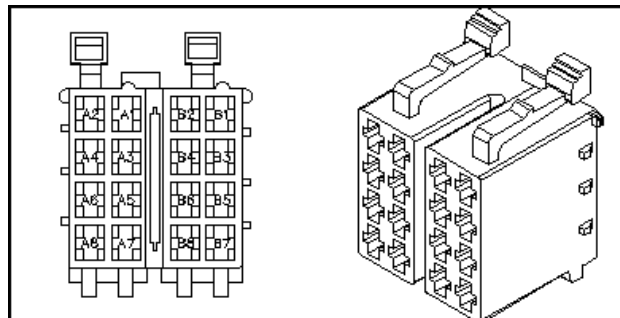

84163395 16

## Wire connectors - Component diagram 04

### CONNECTOR X-040 - Air-conditioning system – ON/OFF indicator light

CONNECTOR X-040 - Air-conditioning system – ON/OFF indicator light			
PIN NUMBER	WIRE NUMBER	CIRCUIT REFERENCE	ELECTRICAL SCHEMATIC FRAME
1	RF-057TK (BK)	SP-057T ROOF GROUND LH1 X-040 Air-conditioning system – ON/OFF indicator light	Wiring harnesses - Electrical schematic sheet 17 (55.100)
2	RF-9215C (BL)	X-040 Air-conditioning system – ON/OFF indicator light SP-9215	

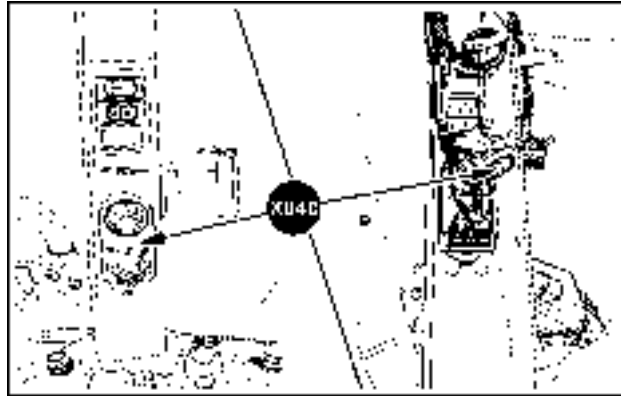

SS13J063 1

**Right-hand B-pillar**

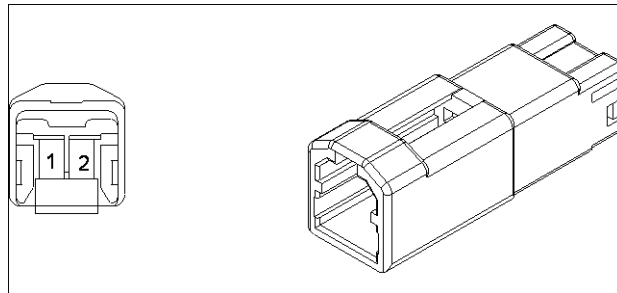

84278792 2

**CONNECTOR X-041 - Temperature control potentiometer**

CONNECTOR X-041 - Temperature control potentiometer			
PIN NUMBER	WIRE NUMBER	CIRCUIT REFERENCE	ELECTRICAL SCHEMATIC FRAME
1	RF-984 (VT)	X-041 Temperature control potentiometer X-050 Cab main harness to roof harness 1	<b>Wiring harnesses - Electrical schematic sheet 17 (55.100)</b>
2	RF-986 (VT)	X-041 Temperature control potentiometer X-050 Cab main harness to roof harness 1	

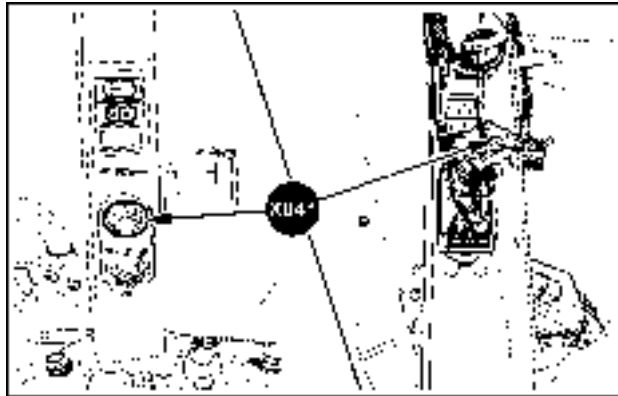

SS13J062 3

**Right-hand B-pillar**

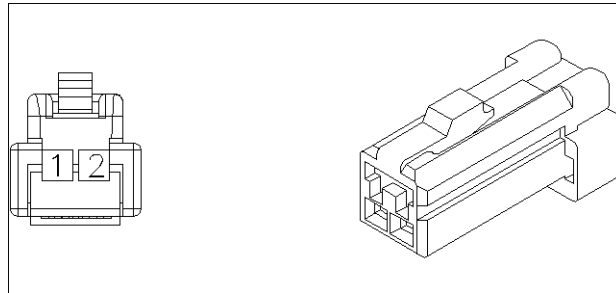

87493513 4

**CONNECTOR X-042 - Air-conditioning system – Pressure switch**

CONNECTOR X-042 - Air-conditioning system – Pressure switch			
PIN NUMBER	WIRE NUMBER	CIRCUIT REFERENCE	ELECTRICAL SCHEMATIC FRAME
1	EN-9219 (BL)	X-042 Air-conditioning system – Pressure switch X-001 Cab main harness to engine harness 1	<b>Wiring harnesses - Electrical schematic sheet 17 (55.100)</b>
2	EN-9220 (BL)	X-042 Air-conditioning system – Pressure switch X-001 Cab main harness to engine harness 1	

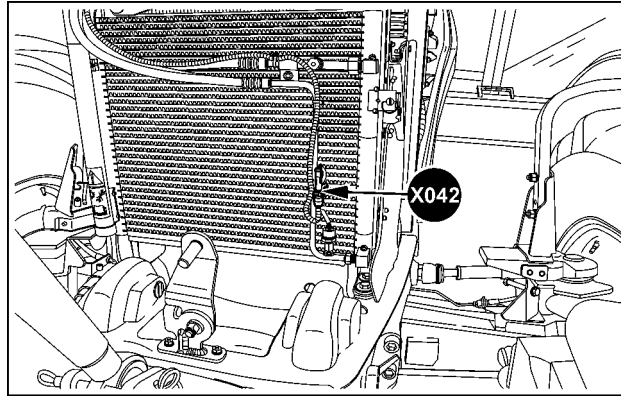

SVIL13TR00714AB 5

**Front of engine**

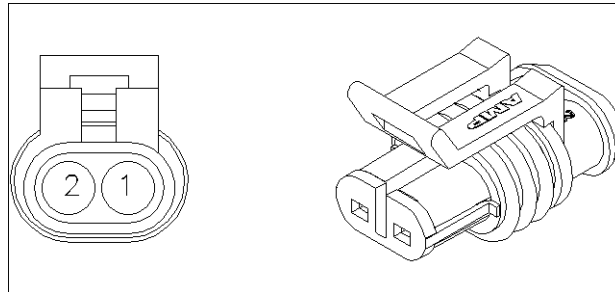

82012083 6

**CONNECTOR X-043 - Heating control valve**

CONNECTOR X-043 - Heating control valve			
PIN NUMBER	WIRE NUMBER	CIRCUIT REFERENCE	ELECTRICAL SCHEMATIC FRAME
1	CM-985C (VT)	X-045 Heating control unit X-043 Heating control valve	<b>Wiring harnesses - Electrical schematic sheet 17 (55.100)</b>
2	CM-010MB (GN)	X-043 Heating control valve SP-010M	
3	CM-985B (VT)	X-043 Heating control valve X-045 Heating control unit	
4	CM-985 (VT)	X-045 Heating control unit X-043 Heating control valve	
6	CM-985A (VT)	X-043 Heating control valve X-045 Heating control unit	

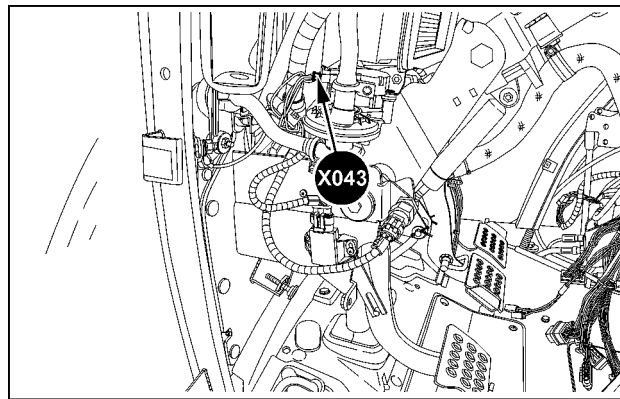

SVIL13TR00734AC 7

**Front left-hand cab**

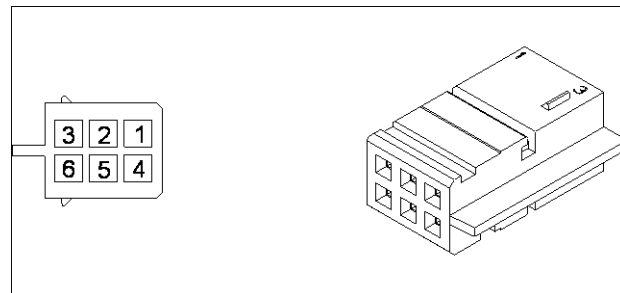

84265223 8

**CONNECTOR X-044 - Antifreeze module**

<b>CONNECTOR X-044 - Antifreeze module</b>			
<b>PIN NUMBER</b>	<b>WIRE NUMBER</b>	<b>CIRCUIT REFERENCE</b>	<b>ELECTRICAL SCHEMATIC FRAME</b>
1	CM-9215B (BL)	X-044 Antifreeze module X-050 Cab main harness to roof harness 1	<b>Wiring harnesses - Electrical schematic sheet 17 (55.100)</b>
2	CM-9220 (BL)	X-001 Cab main harness to engine harness 1 X-044 Antifreeze module	
3	CM-057EP (BK)	X-044 Antifreeze module SP-057E CAB GND 3	



SVIL13TR00718AB 9

**Cab below the instrument cluster**

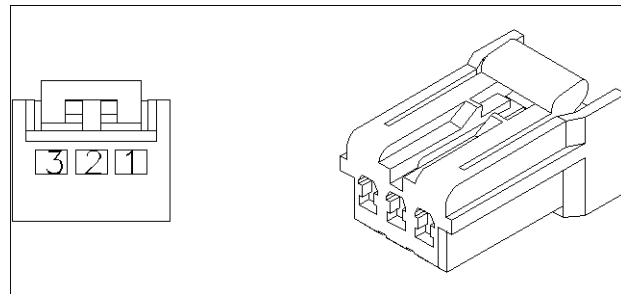

84136442 10



**CONNECTOR X-045 - Heating control unit**

CONNECTOR X-045 - Heating control unit			
PIN NUMBER	WIRE NUMBER	CIRCUIT REFERENCE	ELECTRICAL SCHEMATIC FRAME
2	CM-010MA (GN)	X-045 Heating control unit SP-010M	<b>Wiring harnesses - Electrical schematic sheet 17 (55.100)</b>
3	CM-057EN (BK)	X-045 Heating control unit SP-057E CAB GND 3	
6	CM-984 (VT)	X-045 Heating control unit X-050 Cab main harness to roof harness 1	
7	CM-985 (VT)	X-045 Heating control unit X-043 Heating control valve	
8	CM-985B (VT)	X-043 Heating control valve X-045 Heating control unit	
9	CM-985A (VT)	X-043 Heating control valve X-045 Heating control unit	
13	CM-986 (VT)	X-045 Heating control unit X-050 Cab main harness to roof harness 1	
14	CM-985C (VT)	X-045 Heating control unit X-043 Heating control valve	

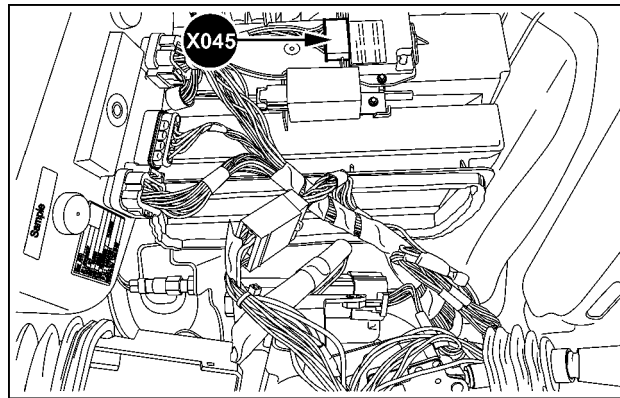

SVIL13TR00718AC 11

**Cab below the instrument cluster**

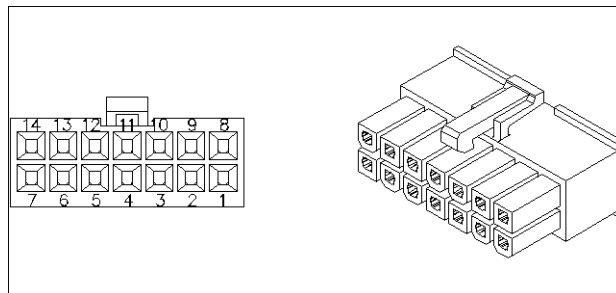

87694702 12

**CONNECTOR X-046 - Cab main harness to blower motor left-hand**

CONNECTOR X-046 - Cab main harness to blower motor left-hand			
PIN NUMBER	WIRE NUMBER	CIRCUIT REFERENCE	ELECTRICAL SCHEMATIC FRAME
1	LF-6300A (BR) CM-6300A (BR)	X-046 Cab main harness to blower motor left-hand X-974 Resistors blower motor SP-6300 X-046 Cab main harness to blower motor left-hand	<b>Wiring harnesses - Electrical schematic sheet 17 (55.100)</b>
2	LF-6301A (BR) CM-6301A (BR)	X-046 Cab main harness to blower motor left-hand X-974 Resistors blower motor SP-6301 X-046 Cab main harness to blower motor left-hand	
3	LF-057AR (BK) CM-057AR (BK)	X-973 Blower motor X-046 Cab main harness to blower motor left-hand SP-057A CAB GND X-046 Cab main harness to blower motor left-hand	
4	LF-6303C (BR) CM-6303C (BR)	SP-062 X-046 Cab main harness to blower motor left-hand X-110 Relay and fuse block (K-004 to K-039 and F-033 to F-036) X-046 Cab main harness to blower motor left-hand	
5	LF-6302C (BR) CM-6302C (BR)	X-046 Cab main harness to blower motor left-hand X-974 Resistors blower motor X-110 Relay and fuse block (K-004 to K-039 and F-033 to F-036) X-046 Cab main harness to blower motor left-hand	

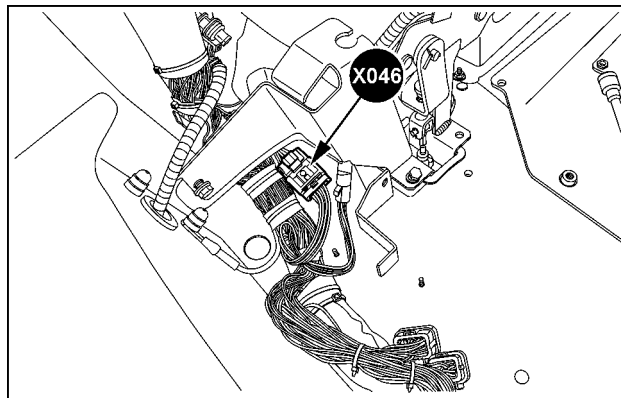

SVIL13TR00768AB 13

**Rear of cab behind left-hand trim**

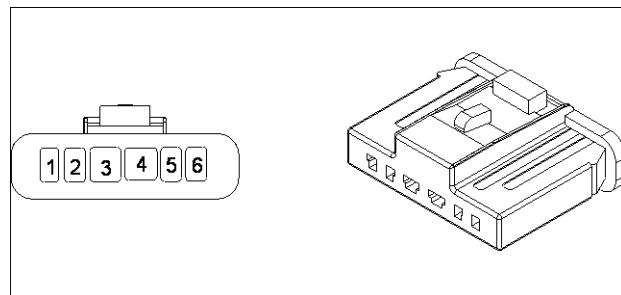

84286809 14

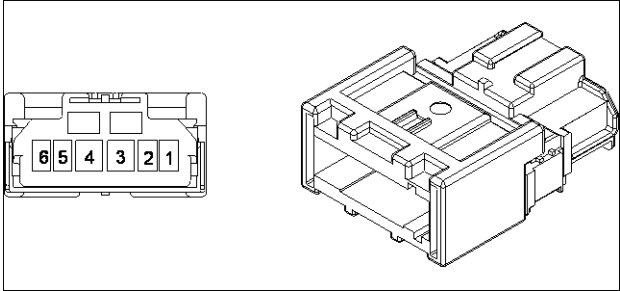

84335033 15

**CONNECTOR X-047 - Cab main harness to blower motor right-hand**

CONNECTOR X-047 - Cab main harness to blower motor right-hand			
PIN NUMBER	WIRE NUMBER	CIRCUIT REFERENCE	ELECTRICAL SCHEMATIC FRAME
1	CM-6300B (BR)	SP-6300 X-047 Cab main harness to blower motor right-hand	Wiring harnesses - Electrical schematic sheet 17 (55.100)
2	CM-6301B (BR)	SP-6301 X-047 Cab main harness to blower motor right-hand	
3	CM-057AS (BK)	SP-057A CAB GND X-047 Cab main harness to blower motor right-hand	
4	CM-6303D (BR)	X-110 Relay and fuse block (K-004 to K-039 and F-033 to F-036) X-047 Cab main harness to blower motor right-hand	
5	CM-6302D (BR)	X-110 Relay and fuse block (K-004 to K-039 and F-033 to F-036) X-047 Cab main harness to blower motor right-hand	

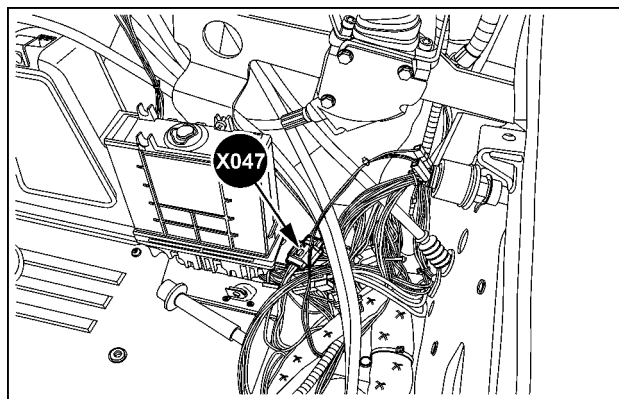

SVIL13TR00769AB 16

**Right-hand bottom rear tractor cab**

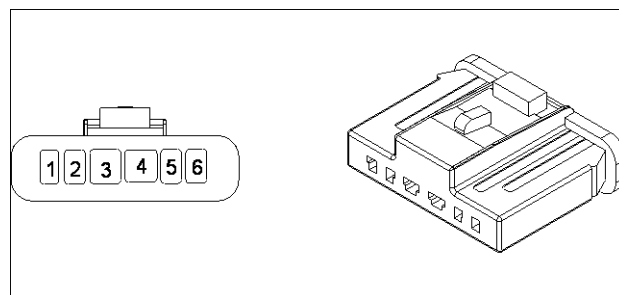

84286809 17

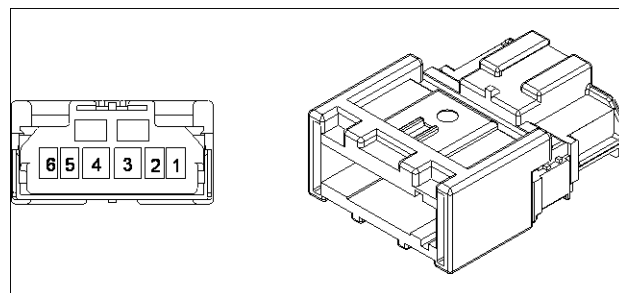

84335033 18

**CONNECTOR X-048 - Intermittent windshield wiper module**

CONNECTOR X-048 - Intermittent windshield wiper module			
PIN NUMBER	WIRE NUMBER	CIRCUIT REFERENCE	ELECTRICAL SCHEMATIC FRAME
1	CM-057AP (BK)	X-048 Intermittent windshield wiper module SP-057A CAB GND	<b>Wiring harnesses - Electrical schematic sheet 22 (55.100)</b>
2	CM-587 (YE)	X-091 Steering column multi-function lever X-048 Intermittent windshield wiper module	
3	CM-097A (LG)	SP-097 X-048 Intermittent windshield wiper module	
4	CM-1019B (GN)	X-048 Intermittent windshield wiper module SP-1019	
5	CM-063 (BL)	X-048 Intermittent windshield wiper module SP-063	
6	CM-1019D (GN)	X-091 Steering column multi-function lever X-048 Intermittent windshield wiper module	

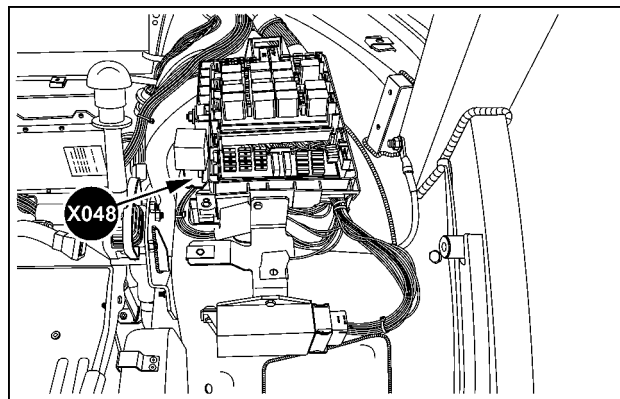

SVIL13TR00717AB 19

**Cab left-hand side**

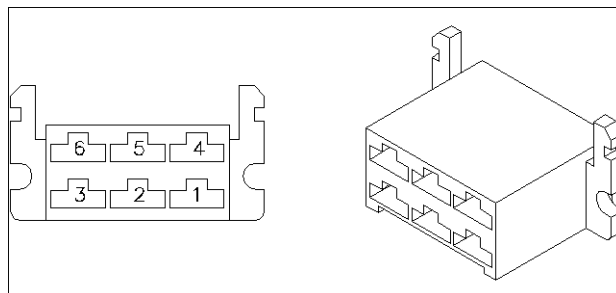

87709659 20

**CONNECTOR X-049 - Power distribution unit**

<b>CONNECTOR X-049 - Power distribution unit</b>			
<b>PIN NUMBER</b>	<b>WIRE NUMBER</b>	<b>CIRCUIT REFERENCE</b>	<b>ELECTRICAL SCHEMATIC FRAME</b>
1	PD-010PC (GN)	SP-002 X-049 Power distribution unit	<b>Wiring harnesses - Electrical schematic sheet 01 (55.100)</b>
2	PD-011G (GN)	X-049 Power distribution unit X-002 Engine harness 1 to power distribution unit	

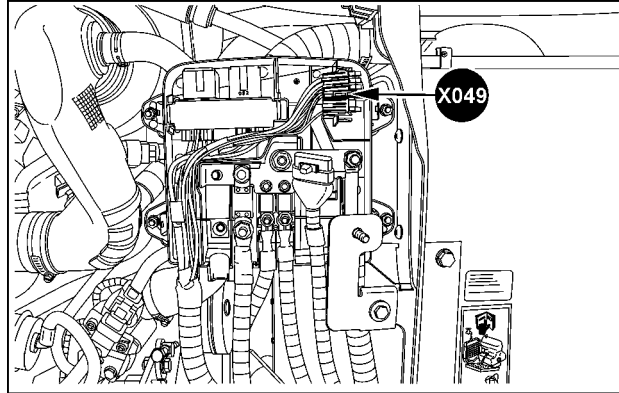

SVIL13TR00798AH 21

**Front top right-hand engine**

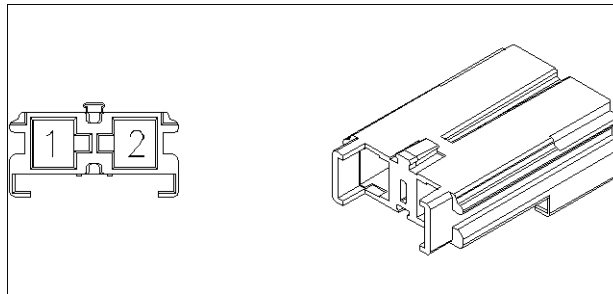

84157160 22

## Wire connectors - Component diagram 05

### CONNECTOR X-050 - Cab main harness to roof harness 1

CONNECTOR X-050 - Cab main harness to roof harness 1			
PIN NUMBER	WIRE NUMBER	CIRCUIT REFERENCE	ELECTRICAL SCHEMATIC FRAME
1	CM-6300 (GN) RF-6300 (BR)	SP-6300 X-050 Cab main harness to roof harness 1 X-030 Blower switch X-050 Cab main harness to roof harness 1	<b>Wiring harnesses - Electrical schematic sheet 02 (55.100)</b> <b>Wiring harnesses - Electrical schematic sheet 17 (55.100)</b>
2	CM-6301 (BR) RF-6301 (BR)	SP-6301 X-050 Cab main harness to roof harness 1 X-030 Blower switch X-050 Cab main harness to roof harness 1	<b>Wiring harnesses - Electrical schematic sheet 18 (55.100)</b> <b>Wiring harnesses - Electrical schematic sheet 21 (55.100)</b>
3	CM-6303 (BR) RF-6303 (BR)	X-050 Cab main harness to roof harness 1 SP-6303 X-030 Blower switch X-050 Cab main harness to roof harness 1	<b>Wiring harnesses - Electrical schematic sheet 22 (55.100)</b>
4	CM-9215B (BL) RF-9215B (BL)	X-044 Antifreeze module X-050 Cab main harness to roof harness 1 X-050 Cab main harness to roof harness 1 SP-9215	
5	CM-6302 (BR) RF-6302 (BR)	SP-6302 X-050 Cab main harness to roof harness 1 X-030 Blower switch X-050 Cab main harness to roof harness 1	
6	CM-984 (VT) RF-984 (VT)	X-045 Heating control unit X-050 Cab main harness to roof harness 1 X-041 Temperature control potentiometer X-050 Cab main harness to roof harness 1	<b>Wiring harnesses - Electrical schematic sheet 02 (55.100)</b> <b>Wiring harnesses - Electrical schematic sheet 17 (55.100)</b> <b>Wiring harnesses - Electrical schematic sheet 18 (55.100)</b>
7	CM-986 (VT) RF-986 (VT)	X-045 Heating control unit X-050 Cab main harness to roof harness 1 X-041 Temperature control potentiometer X-050 Cab main harness to roof harness 1	<b>Wiring harnesses - Electrical schematic sheet 21 (55.100)</b> <b>Wiring harnesses - Electrical schematic sheet 22 (55.100)</b>
8	CM-9305 (BL) RF-9305 (BL)	X-050 Cab main harness to roof harness 1 X-001 Cab main harness to engine harness 1 X-150 Relay and fuse block – Roof X-050 Cab main harness to roof harness 1	
9	CM-9219 (BL) RF-9219 (BL)	X-001 Cab main harness to engine harness 1 X-050 Cab main harness to roof harness 1 X-150 Relay and fuse block – Roof X-050 Cab main harness to roof harness 1	
10	CM-010D (GN) RF-010D (GN)	X-130 Fuse block (F-001 to F-032) X-050 Cab main harness to roof harness 1 X-050 Cab main harness to roof harness 1 SP-010D	

<b>CONNECTOR X-050 - Cab main harness to roof harness 1</b>			
<b>PIN NUMBER</b>	<b>WIRE NUMBER</b>	<b>CIRCUIT REFERENCE</b>	<b>ELECTRICAL SCHEMATIC FRAME</b>
11	CM-1030B (BL) RF-1030B (BL)	X-050 Cab main harness to roof harness 1 SP-1030E SP-1030B X-050 Cab main harness to roof harness 1	<b>Wiring harnesses - Electrical schematic sheet 02 (55.100)</b> <b>Wiring harnesses - Electrical schematic sheet 17 (55.100)</b> <b>Wiring harnesses - Electrical schematic sheet 18 (55.100)</b> <b>Wiring harnesses - Electrical schematic sheet 21 (55.100)</b> <b>Wiring harnesses - Electrical schematic sheet 22 (55.100)</b>
12	CM-1014M (RD) RF-1014M (RD)	SP-1014 X-050 Cab main harness to roof harness 1 X-022 Grab rail light – Right-hand X-050 Cab main harness to roof harness 1	
13	CM-1019C (GN) RF-1019C (GN)	SP-1019 X-050 Cab main harness to roof harness 1 X-050 Cab main harness to roof harness 1 X-075 Roof harness to front window wiper motor (openable front window)	
14	CM-1054 (YE) RF-1054 (YE)	X-110 Relay and fuse block (K-004 to K-039 and F-033 to F-036) X-050 Cab main harness to roof harness 1 X-050 Cab main harness to roof harness 1 X-065 Work light switch panel	
15	CM-1039 (BL) RF-1039 (BL)	SP-1039 X-050 Cab main harness to roof harness 1 X-061 Roof headlight switch X-050 Cab main harness to roof harness 1	
16	CM-9215A (YE) RF-9215A (BL)	X-230 Central Control Unit (CCU) – CN3A X-050 Cab main harness to roof harness 1 SP-9215 X-050 Cab main harness to roof harness 1	
17	CM-098 (LG) RF-098 (LG)	X-077 Rear window washer pump X-050 Cab main harness to roof harness 1 X-036 Rear wiper and washer switch X-050 Cab main harness to roof harness 1	
18	CM-086B (GN) RF-086B (GN)	SP-086 X-050 Cab main harness to roof harness 1 X-075 Roof harness to front window wiper motor (openable front window) X-050 Cab main harness to roof harness 1	
19	CM-1027B (BL) RF-1027B (BL)	X-050 Cab main harness to roof harness 1 SP-1027D SP-1027B X-050 Cab main harness to roof harness 1	
20	CM-3002C (GN) RF-3002C (GN)	X-050 Cab main harness to roof harness 1 SP-3002 X-022 Grab rail light – Right-hand X-050 Cab main harness to roof harness 1	



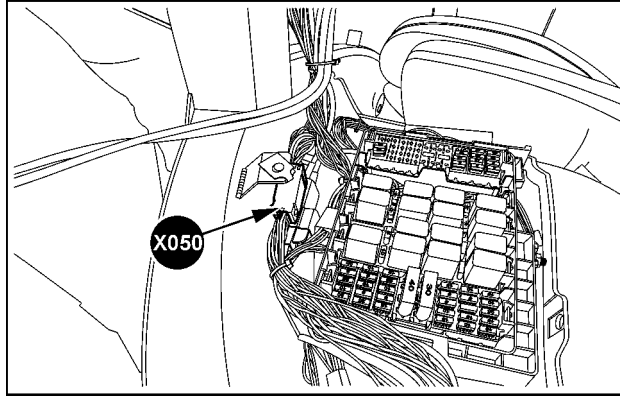

SVIL13TR00716AB 1

**Cab left-hand side**

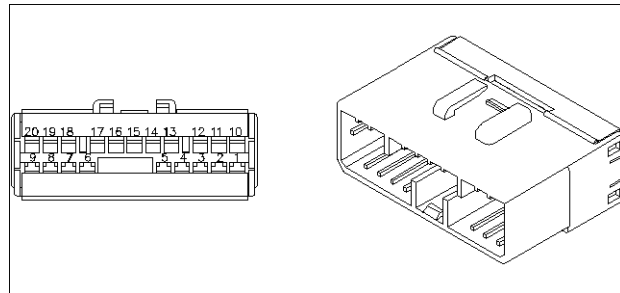

87736513 2

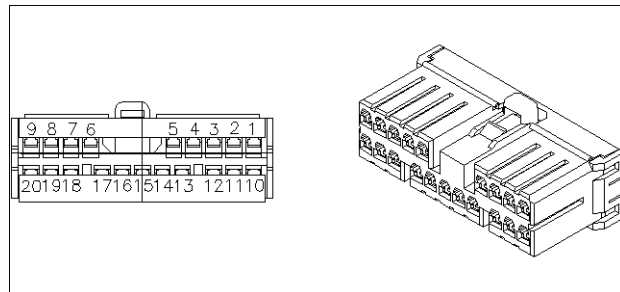

87689502 3

**CONNECTOR X-050A - Cab main harness to roof harness (bridge)**

CONNECTOR X-050A - Cab main harness to roof harness (bridge)			
PIN NUMBER	WIRE NUMBER	CIRCUIT REFERENCE	ELECTRICAL SCHEMATIC FRAME
1	CM-1030F (BL)	SP-1030E X-050A Cab main harness to roof harness (bridge)	Wiring harnesses - Electrical schematic sheet 18 (55.100)
2	CM-1027F (BL)	SP-1027D X-050A Cab main harness to roof harness (bridge)	

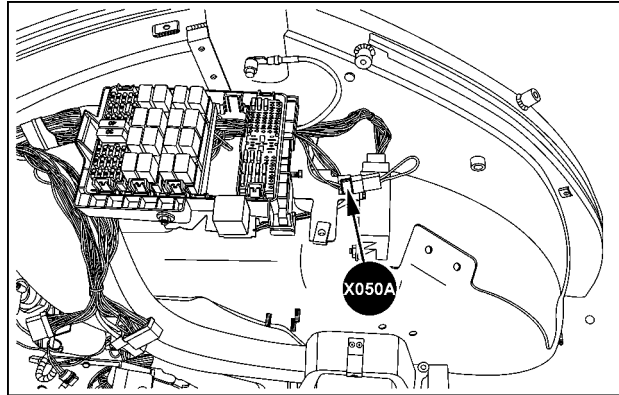

SVIL13TR00695AH 4

**Cab left-hand side**

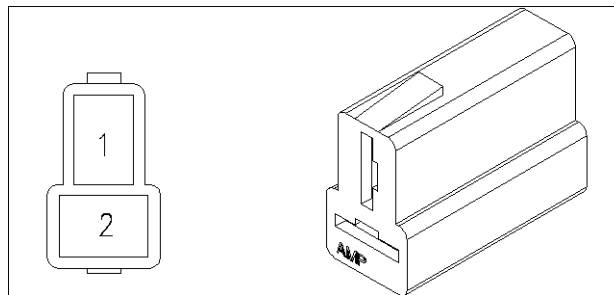

84015523 5

**CONNECTOR X-050B - Cab main harness to roof harness (bridge)**

CONNECTOR X-050B - Cab main harness to roof harness (bridge)			
PIN NUMBER	WIRE NUMBER	CIRCUIT REFERENCE	ELECTRICAL SCHEMATIC FRAME
1	CM-1027G (BL)	X-050B Cab main harness to roof harness (bridge) X-050B Cab main harness to roof harness (bridge)	<b>Wiring harnesses - Electrical schematic sheet 18 (55.100)</b>
2	CM-1027G (BL)	X-050B Cab main harness to roof harness (bridge) X-050B Cab main harness to roof harness (bridge)	

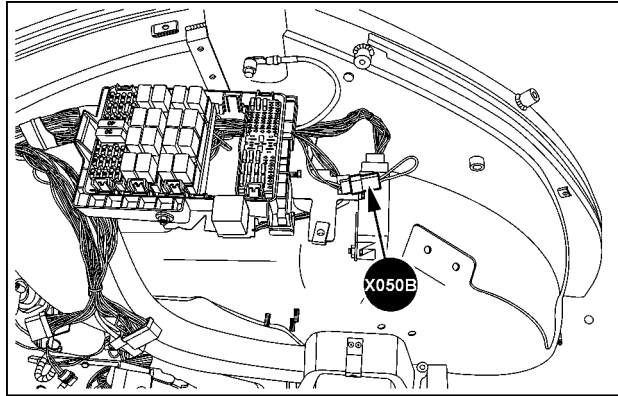

SVIL13TR00695AI 6

**Cab left-hand side**

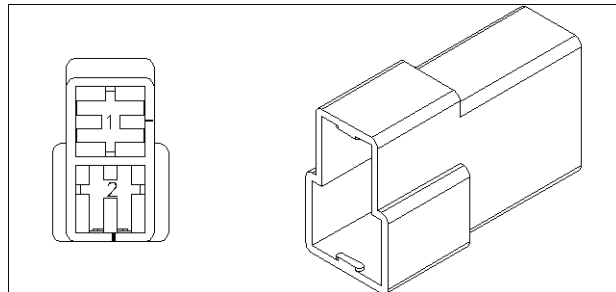

84038366 7

**CONNECTOR X-051 - Cab interior light**

CONNECTOR X-051 - Cab interior light			
PIN NUMBER	WIRE NUMBER	CIRCUIT REFERENCE	ELECTRICAL SCHEMATIC FRAME
1	RF-4012B (VT)	X-051 Cab interior light SP-4012	Wiring harnesses - Electrical schematic sheet 18 (55.100)

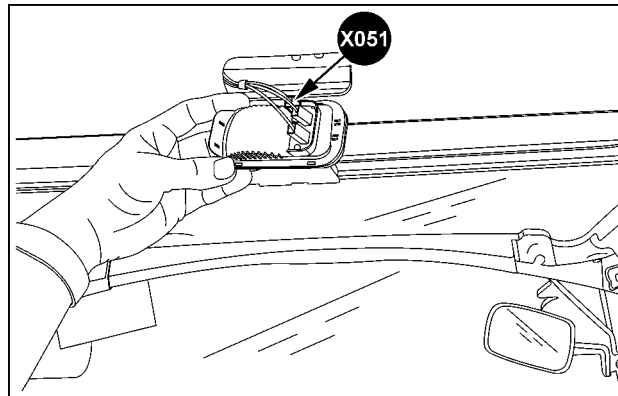

SVIL13TR00730AB 8

**Front inside cab roof**

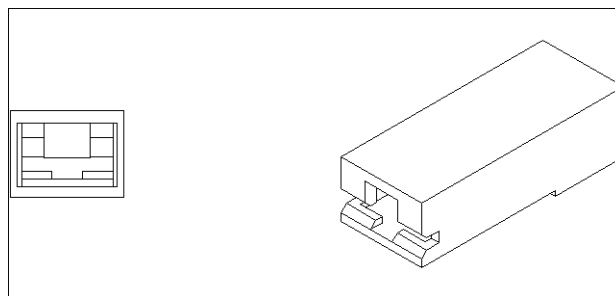

87691425 9

**CONNECTOR X-052 - Cab interior light**

CONNECTOR X-052 - Cab interior light			
PIN NUMBER	WIRE NUMBER	CIRCUIT REFERENCE	ELECTRICAL SCHEMATIC FRAME
1	RF-057TE (BK)	X-052 Cab interior light SP-057T ROOF GROUND LH1	Wiring harnesses - Electrical schematic sheet 18 (55.100)

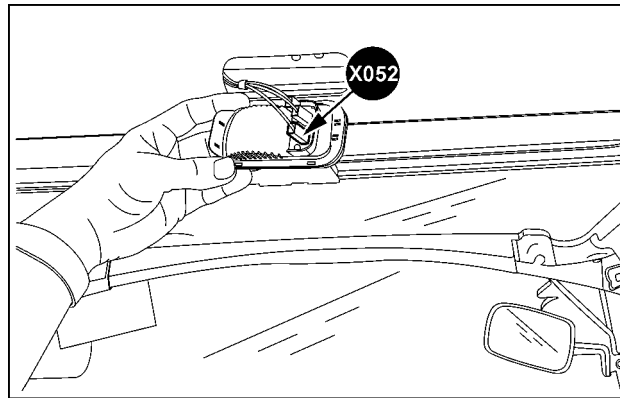

SVIL13TR00730AD 10

**Front inside cab roof**

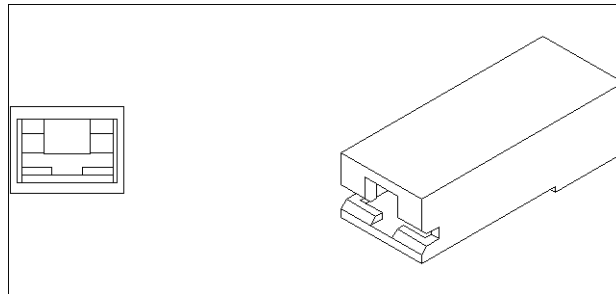

87691425 11

**CONNECTOR X-053 - Cab interior light**

CONNECTOR X-053 - Cab interior light			
PIN NUMBER	WIRE NUMBER	CIRCUIT REFERENCE	ELECTRICAL SCHEMATIC FRAME
1	RF-057JD (BK)	X-053 Cab interior light X-064 Door switch left-hand	Wiring harnesses - Electrical schematic sheet 18 (55.100)

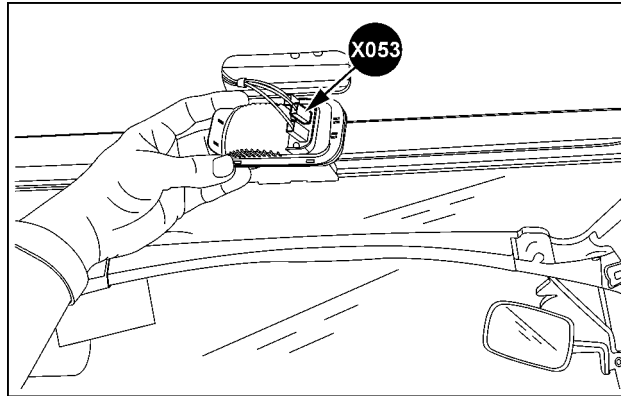

SVIL13TR00730AC 12

**Front inside cab roof**

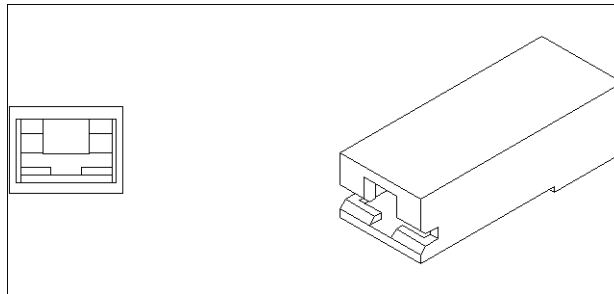

87691425 13

**CONNECTOR X-054 - Console light right-hand**

CONNECTOR X-054 - Console light right-hand			
PIN NUMBER	WIRE NUMBER	CIRCUIT REFERENCE	ELECTRICAL SCHEMATIC FRAME
1	RF-1013LM (BL)	X-054 Console light right-hand SP-1013L	Wiring harnesses - Electrical schematic sheet 20 (55.100)
2	RF-057SG (BK)	SP-057S ROOF GROUND LH2 X-054 Console light right-hand	

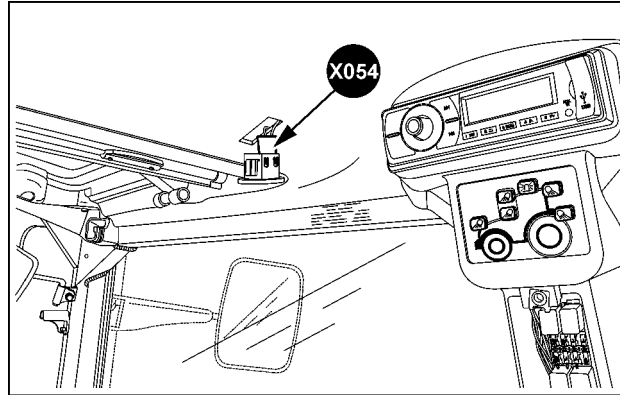

SVIL13TR00721AB 14

**Right-hand inside cab roof**

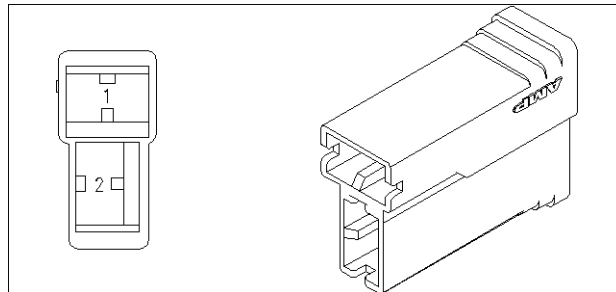

87691950 15

**CONNECTOR X-055 - Rear work light right-hand**

CONNECTOR X-055 - Rear work light right-hand			
PIN NUMBER	WIRE NUMBER	CIRCUIT REFERENCE	ELECTRICAL SCHEMATIC FRAME
1	RF-1076B (VT)	X-055 Rear work light right-hand SP-1076	Wiring harnesses - Electrical schematic sheet 21 (55.100)
2	RF-057SF (BK)	SP-057S ROOF GROUND LH2 X-055 Rear work light right-hand	

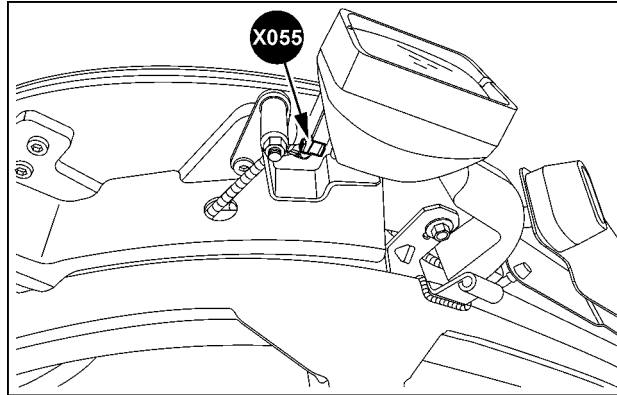

SVIL13TR00722AB 16

**Rear left-hand cab roof**

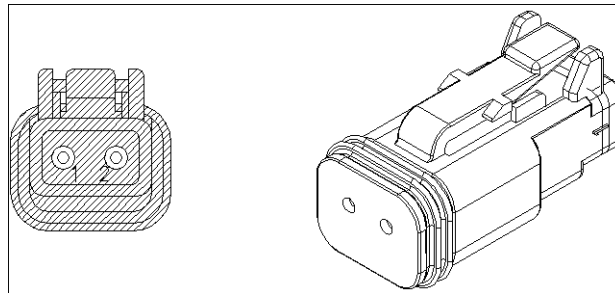

84122124 17



**CONNECTOR X-056 - Rear work light left-hand**

CONNECTOR X-056 - Rear work light left-hand			
PIN NUMBER	WIRE NUMBER	CIRCUIT REFERENCE	ELECTRICAL SCHEMATIC FRAME
1	RF-1076D (VT)	SP-1076 X-056 Rear work light left-hand	<b>Wiring harnesses - Electrical schematic sheet 21 (55.100)</b>
2	RF-057RH (BK)	X-056 Rear work light left-hand SP-057R	

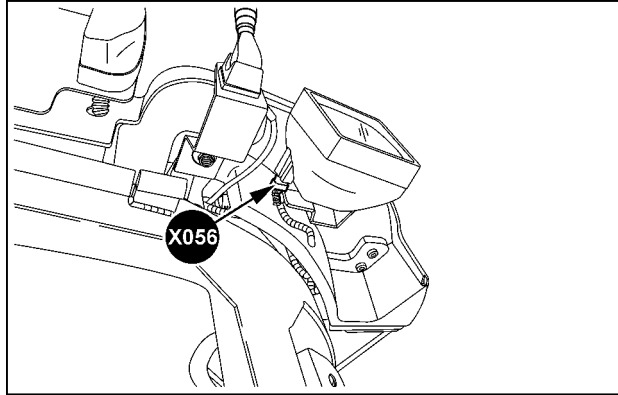

SVIL13TR00726AB 18

**Rear right-hand cab roof**

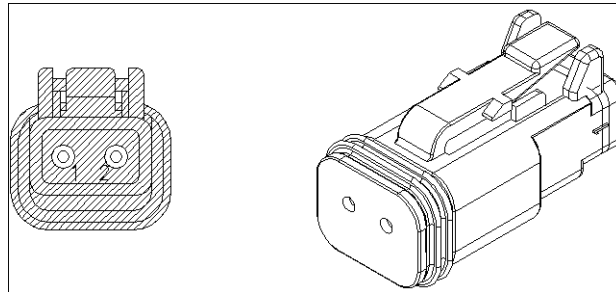

84122124 19

**CONNECTOR X-058\_C - Front work light left-hand**

CONNECTOR X-058_C - Front work light left-hand			
PIN NUMBER	WIRE NUMBER	CIRCUIT REFERENCE	ELECTRICAL SCHEMATIC FRAME
1	RF-1071BD (VT)	SP-1071 X-058_C Front work light left-hand	Wiring harnesses - Electrical schematic sheet 21 (55.100)
2	RF-057FK (BK)	X-058_C Front work light left-hand SP-057R	

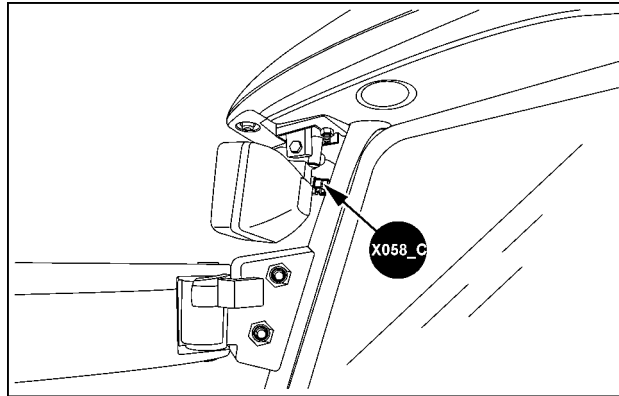

SVIL13TR00728AB 20

**Front left-hand cab roof**

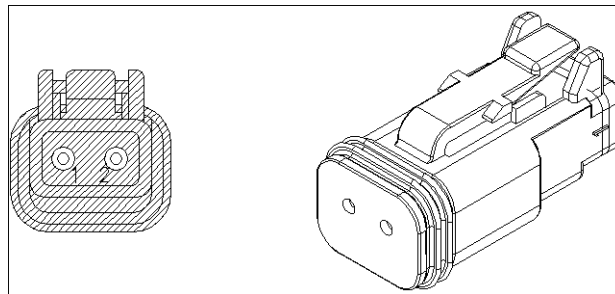

84122124 21

## Wire connectors - Component diagram 06

### CONNECTOR X-060 - Starter motor to power distribution unit

CONNECTOR X-060 - Starter motor to power distribution unit			
PIN NUMBER	WIRE NUMBER	CIRCUIT REFERENCE	ELECTRICAL SCHEMATIC FRAME
B	BT-001F (R)	X-010 Starter motor (battery power supply) X-060 Starter motor to power distribution unit	Wiring harnesses - Electrical schematic sheet 01 (55.100)

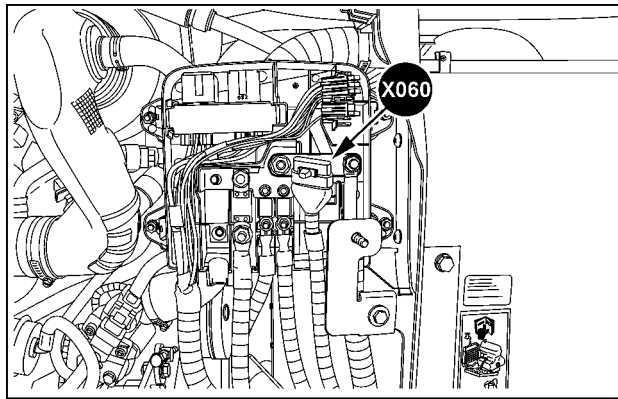

SVIL13TR00798AI 1

Front top right-hand engine

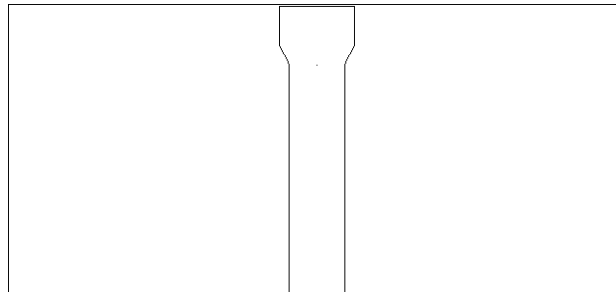

84153306 2

**CONNECTOR X-061 - Roof headlight switch**

CONNECTOR X-061 - Roof headlight switch			
PIN NUMBER	WIRE NUMBER	CIRCUIT REFERENCE	ELECTRICAL SCHEMATIC FRAME
2	RF-1013LJ (BL)	X-061 Roof headlight switch SP-1013L	<b>Wiring harnesses - Electrical schematic sheet 18 (55.100)</b>
3	RF-1039 (BL)	X-061 Roof headlight switch X-050 Cab main harness to roof harness 1	
7	RF-057TL (BK)	X-061 Roof headlight switch SP-057T ROOF GROUND LH1	
8	RF-1013LH (BL)	SP-1013L X-061 Roof headlight switch	

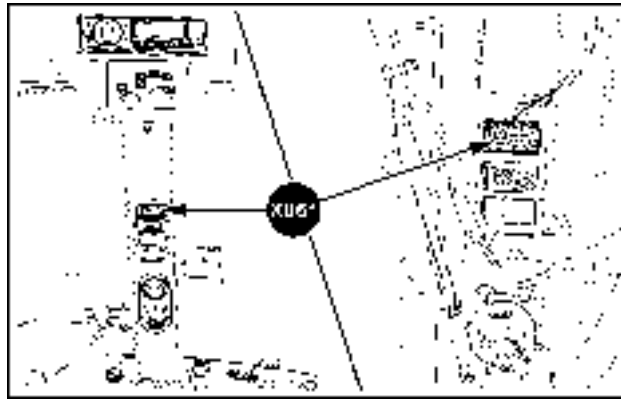

SS13K001 3

**Right-hand B-pillar**

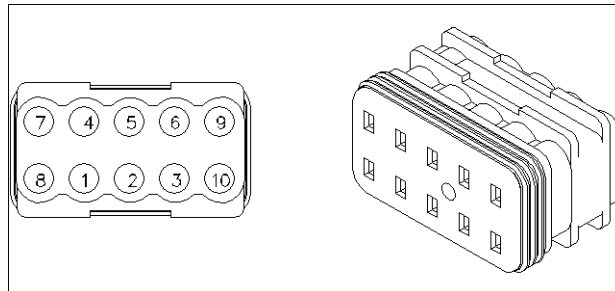

84819781 4

**CONNECTOR X-064 - Door switch left-hand**

CONNECTOR X-064 - Door switch left-hand			
PIN NUMBER	WIRE NUMBER	CIRCUIT REFERENCE	ELECTRICAL SCHEMATIC FRAME
1	RF-057JD (BK)	X-053 Cab interior light X-064 Door switch left-hand	Wiring harnesses - Electrical schematic sheet 18 (55.100)

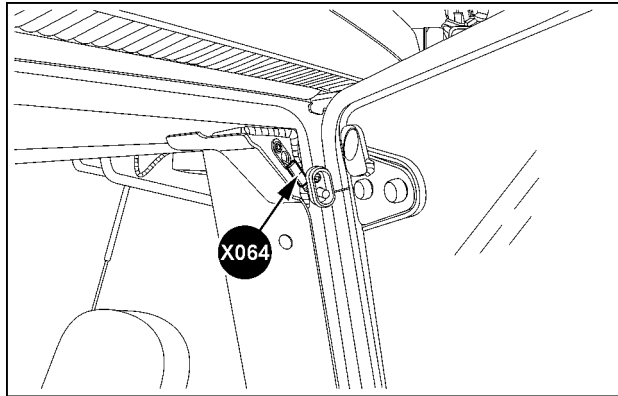

SVIL13TR00736AB 5

**Left-hand B-pillar**

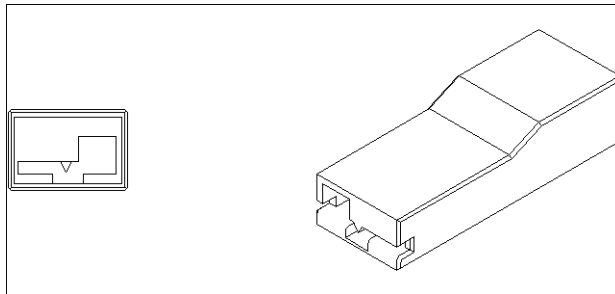

87705127 6

**CONNECTOR X-065 - Work light switch panel**

<b>CONNECTOR X-065 - Work light switch panel</b>				
<b>PIN NUMBER</b>	<b>WIRE NUMBER</b>	<b>CIRCUIT REFERENCE</b>	<b>ELECTRICAL SCHEMATIC FRAME</b>	
B1	RF-4012A (VT)	X-065 Work light switch panel SP-4012	<b>Wiring harnesses - Electrical schematic sheet 21 (55.100)</b>	
B2	RF-1074A (VT)	X-065 Work light switch panel SP-1074		
B3	RF-057TF (BK)	X-065 Work light switch panel SP-057T ROOF GROUND LH1		
B4	RF-1092 (RD)	X-150 Relay and fuse block – Roof X-065 Work light switch panel		
B7	RF-1079 (VT)	X-124 Grab rail work light – Right-hand X-065 Work light switch panel		
B8	RF-1080 (VT)	X-123 Grab rail work light – Left-hand X-065 Work light switch panel		
C1	RF-1090 (VT)	X-150 Relay and fuse block – Roof X-065 Work light switch panel		<b>Wiring harnesses - Electrical schematic sheet 21 (55.100)</b>
C2	RF-4012C (VT)	X-065 Work light switch panel SP-4012C		
C3	RF-1074B (VT)	SP-1074 X-065 Work light switch panel		
C4	RF-1074C (VT)	SP-1074 X-065 Work light switch panel		
C5	RF-1013LK (BL)	SP-1013L X-065 Work light switch panel		
C6	RF-1054 (YE)	X-050 Cab main harness to roof harness 1 X-065 Work light switch panel		
C7	RF-1075A (VT)	SP-1075 X-065 Work light switch panel		
C8	RF-1075B (VT)	SP-1075 X-065 Work light switch panel		

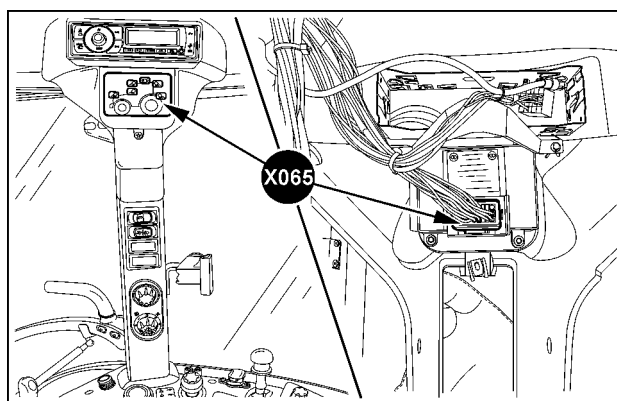

SS13K003 7

**Right-hand B-pillar**

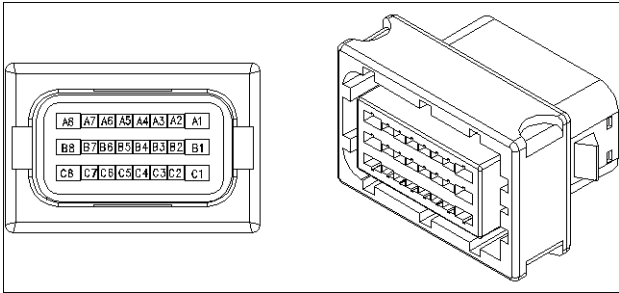

87699386 8

**CONNECTOR X-067 - Diagnostic socket (ZF)**

CONNECTOR X-067 - Diagnostic socket (ZF)			
PIN NUMBER	WIRE NUMBER	CIRCUIT REFERENCE	ELECTRICAL SCHEMATIC FRAME
A	CM-057CB (BK)	X-067 Diagnostic socket (ZF) SP-057C	Wiring harnesses - Electrical schematic sheet 08 (55.100) Wiring harnesses - Electrical schematic sheet 24 (55.100)
B	CM-138DD (VT)	SP-138D X-067 Diagnostic socket (ZF)	
C	CM-191BZ (YE)	SP-191B X-067 Diagnostic socket (ZF)	
D	CM-190BZ (GN)	SP-190B X-067 Diagnostic socket (ZF)	
E	CM-6418A (PK)	X-067 Diagnostic socket (ZF) X-504 Transmission Control Unit (TCU)	
F	CM-291ZF (RD)	X-504 Transmission Control Unit (TCU) X-067 Diagnostic socket (ZF)	
G	CM-290ZF (BL)	X-504 Transmission Control Unit (TCU) X-067 Diagnostic socket (ZF)	
H	-	-	
J	CM-7876 (GN)	X-067 Diagnostic socket (ZF) X-504 Transmission Control Unit (TCU)	

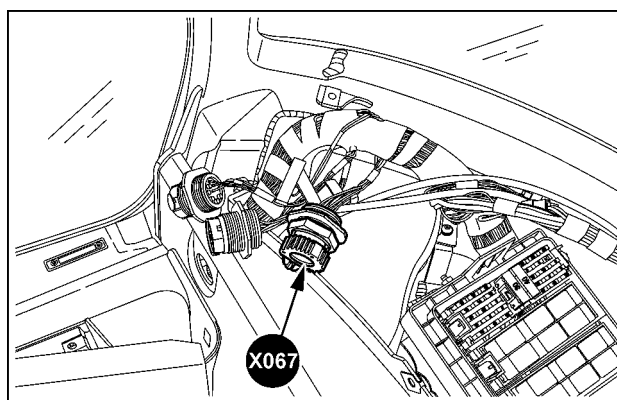

SVIL13TR00739AB 9

**Cab rear left-hand**

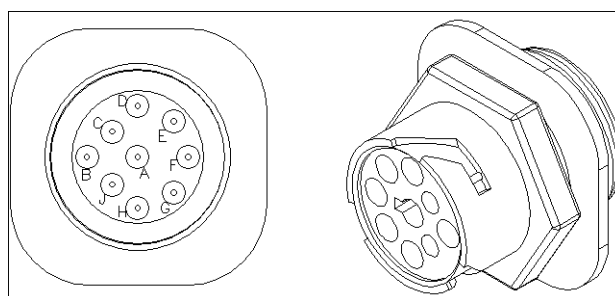

87736919 10



**CONNECTOR X-068\_C - Front work light right-hand**

<b>CONNECTOR X-068_C - Front work light right-hand</b>			
<b>PIN NUMBER</b>	<b>WIRE NUMBER</b>	<b>CIRCUIT REFERENCE</b>	<b>ELECTRICAL SCHEMATIC FRAME</b>
1	RF-1071BC (VT)	SP-1071 X-068_C Front work light right-hand	<b>Wiring harnesses - Electrical schematic sheet 21 (55.100)</b>
2	RF-057SE (BK)	X-068_C Front work light right-hand SP-057S ROOF GROUND LH2	

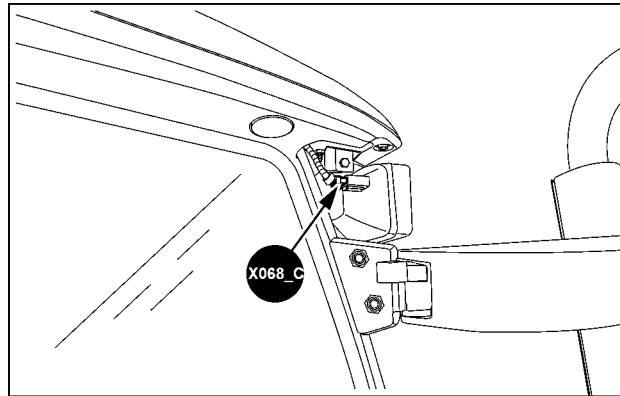

SVIL13TR00727AB 11

**Front right-hand cab roof**

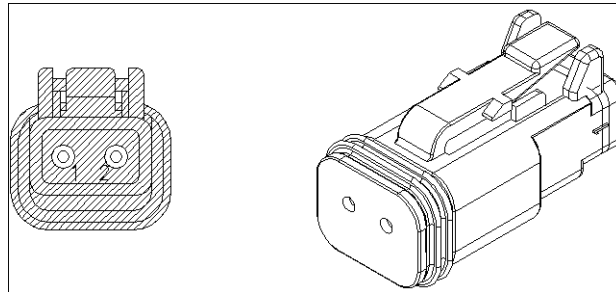

84122124 12



## Wire connectors - Component diagram 07

### CONNECTOR X-070 - Rotating beacon

#### Rotating beacon right-hand

CONNECTOR X-070 - Rotating beacon			
PIN NUMBER	WIRE NUMBER	CIRCUIT REFERENCE	ELECTRICAL SCHEMATIC FRAME
1	BS-057SK (BK)	X-071 Roof harness to rotating beacon right-hand X-070 Rotating beacon	Wiring harnesses - Electrical schematic sheet 21 (55.100)

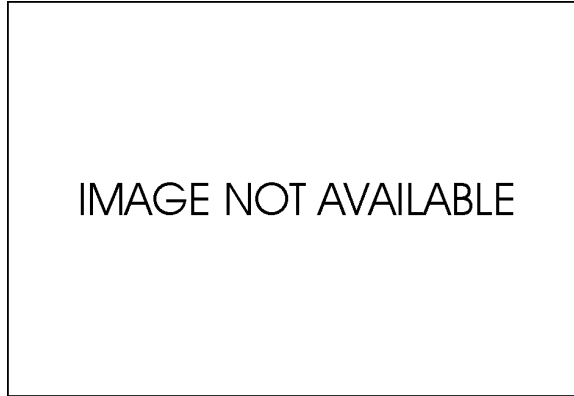

INA 1

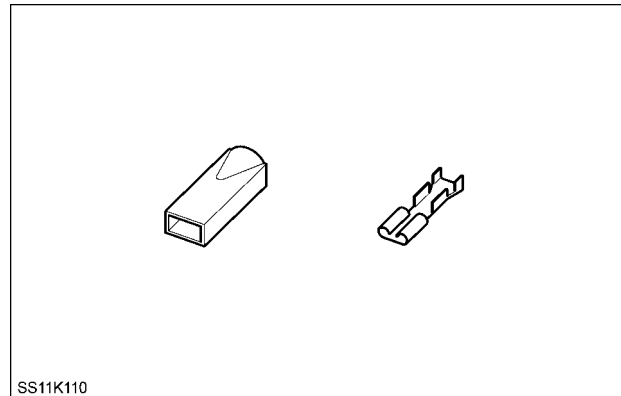

SS11K110

SS11K110 2

**Rotating beacon left-hand**

<b>CONNECTOR X-070 - Rotating beacon</b>			
<b>PIN NUMBER</b>	<b>WIRE NUMBER</b>	<b>CIRCUIT REFERENCE</b>	<b>ELECTRICAL SCHEMATIC FRAME</b>
1	BS-057RC (BK)	X-073 Rotating harness to rotating beacon left-hand X-070 Rotating beacon	<b>Wiring harnesses - Electrical schematic sheet 21 (55.100)</b>

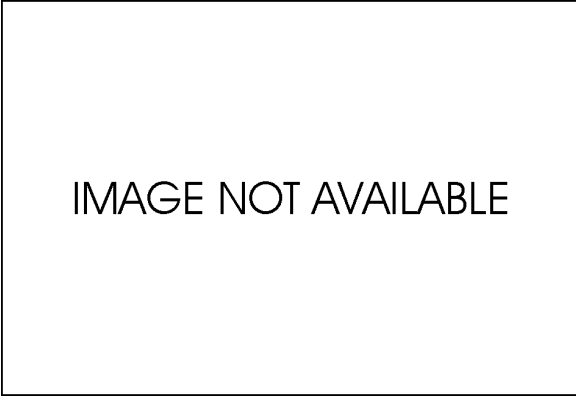

INA 3

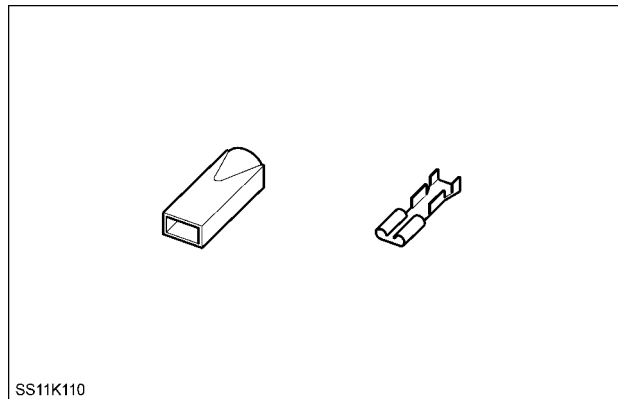

SS11K110

SS11K110 4

**CONNECTOR X-071 - Roof harness to rotating beacon right-hand**

CONNECTOR X-071 - Roof harness to rotating beacon right-hand			
PIN NUMBER	WIRE NUMBER	CIRCUIT REFERENCE	ELECTRICAL SCHEMATIC FRAME
1	BS-057SK (BK) RF-057SK (BK)	X-070 Rotating beacon X-071 Roof harness to rotating beacon right-hand SP-057S ROOF GROUND LH2 X-071 Roof harness to rotating beacon right-hand	<b>Wiring harnesses - Electrical schematic sheet 21 (55.100)</b>
2	BS-4012CA (VT) RF-4012CA (VT)	X-071 Roof harness to rotating beacon right-hand X-390 Rotating beacon X-071 Roof harness to rotating beacon right-hand SP-4012C	

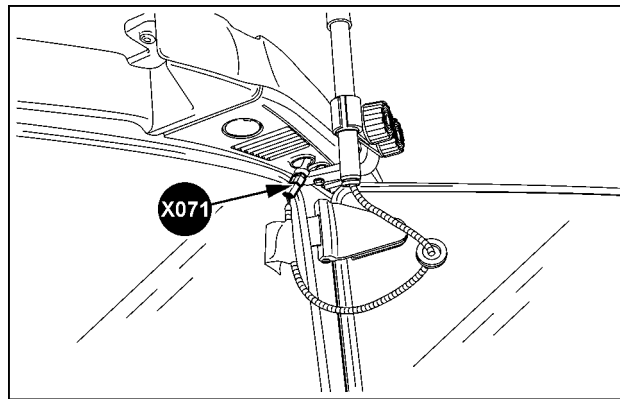

SVIL13TR00851AB 5

**Rear top right-hand cab roof**

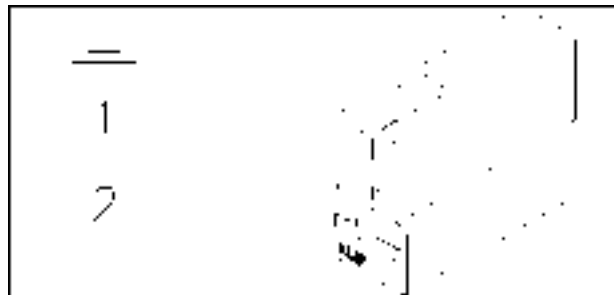

87699736 6

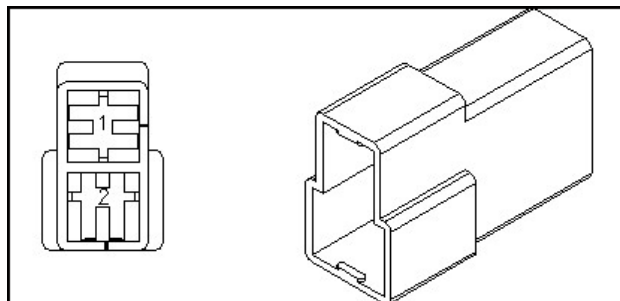

87691951 7

**CONNECTOR X-073 - Roof harness to rotating beacon left-hand**

CONNECTOR X-073 - Roof harness to rotating beacon left-hand			
PIN NUMBER	WIRE NUMBER	CIRCUIT REFERENCE	ELECTRICAL SCHEMATIC FRAME
1	BS-057RC (BK) RF-057RC (BK)	SP-057R X-073 Roof harness to rotating beacon left-hand	Wiring harnesses - Electrical schematic sheet 21 (55.100)
2	BS-4012CB (VT) RF-4012CB (VT)	X-073 Roof harness to rotating beacon left-hand SP-4012C	

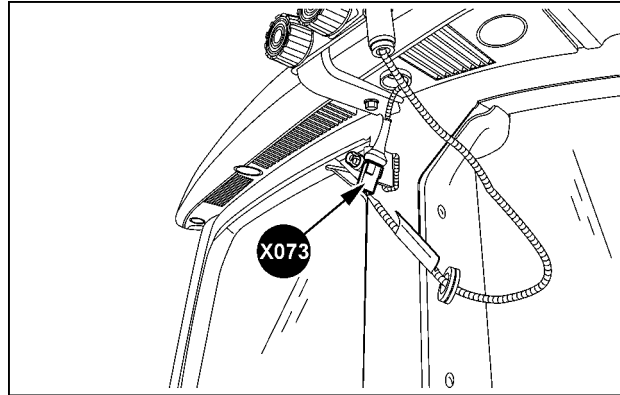

SVIL13TR00805AB 8

**Top rear left-hand cab roof**

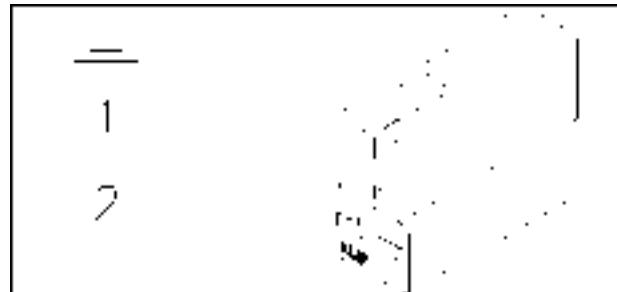

87699736 9

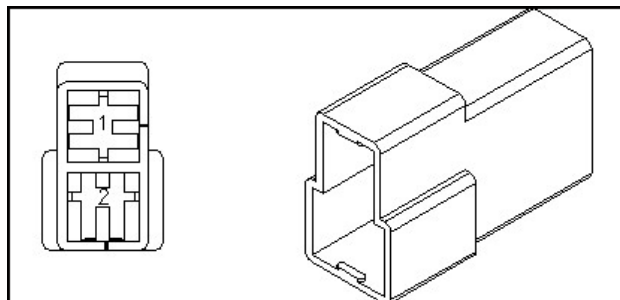

87691951 10

**CONNECTOR X-074 - Front window wiper motor (fixed front window)**

CONNECTOR X-074 - Front window wiper motor (fixed front window)			
PIN NUMBER	WIRE NUMBER	CIRCUIT REFERENCE	ELECTRICAL SCHEMATIC FRAME
1	CM-057EK (BK)	SP-057E CAB GND 3 X-074 Front window wiper motor (fixed front window)	<b>Wiring harnesses - Electrical schematic sheet 22 (55.100)</b>
2	CM-063A (BL)	SP-063 X-074 Front window wiper motor (fixed front window)	
3	CM-063D (BL)	SP-1019 X-074 Front window wiper motor (fixed front window)	
4	-	-	
5	CM-085A (GN)	SP-085 X-074 Front window wiper motor (fixed front window)	
6	CM-086A (GN)	SP-086 X-074 Front window wiper motor (fixed front window)	

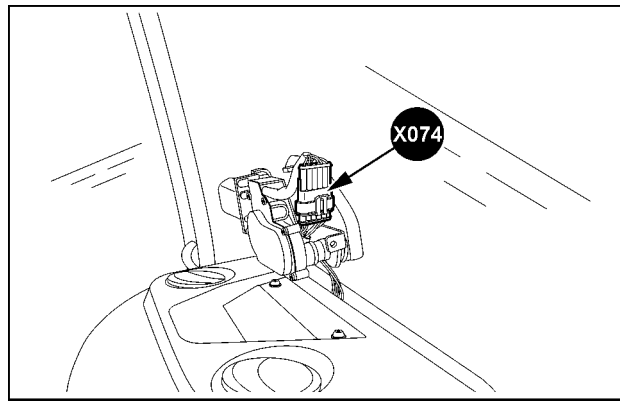

SVIL13TR00741AB 11

**Front inside of cab**

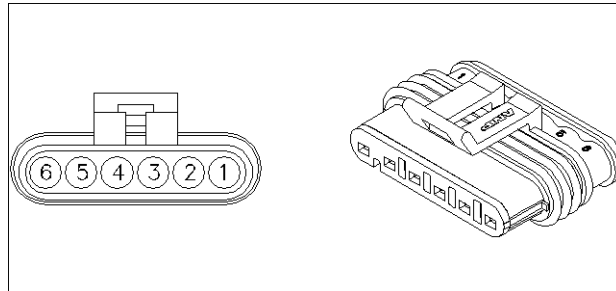

87710588 12

**CONNECTOR X-075 - Roof harness to front window wiper motor (openable front window)**

<b>CONNECTOR X-075 - Roof harness to front window wiper motor (openable front window)</b>			
<b>PIN NUMBER</b>	<b>WIRE NUMBER</b>	<b>CIRCUIT REFERENCE</b>	<b>ELECTRICAL SCHEMATIC FRAME</b>
1	RF-057SM (BK)	X-976 Front window wiper motor (openable front window) X-075 Roof harness to front window wiper motor (openable front window) X-075 Roof harness to front window wiper motor (openable front window) SP-057S ROOF GROUND LH2	<b>Wiring harnesses - Electrical schematic sheet 22 (55.100)</b>
2	RF-063 (BL)	X-976 Front window wiper motor (openable front window) X-075 Roof harness to front window wiper motor (openable front window) X-075 Roof harness to front window wiper motor (openable front window) X-385 Cab main harness to roof harness 2	
3	RF-1019C (GN)	X-976 Front window wiper motor (openable front window) X-075 Roof harness to front window wiper motor (openable front window) X-050 Cab main harness to roof harness 1 X-075 Roof harness to front window wiper motor (openable front window)	
4	-	-	<b>Wiring harnesses - Electrical schematic sheet 22 (55.100)</b>
5	RF-085B (GN)	SP-062 X-046 Cab main harness to blower motor left-hand X-075 Roof harness to front window wiper motor (openable front window) X-385 Cab main harness to roof harness 2	
6	RF-086B (GN)	X-973 Blower motor left-hand X-046 Cab main harness to blower motor left-hand X-075 Roof harness to front window wiper motor (openable front window) X-050 Cab main harness to roof harness 1	

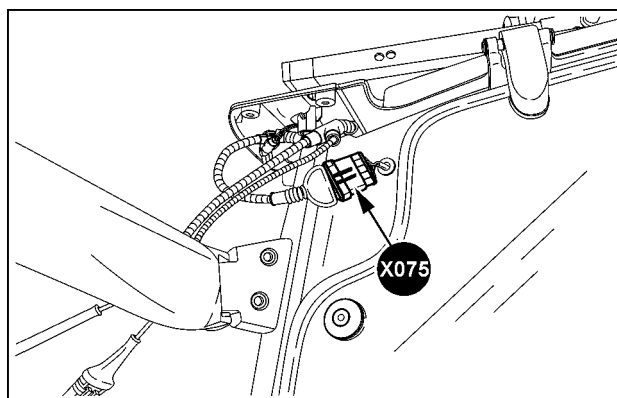

SVIL13TR00852AB 13

**Front right-hand cab**



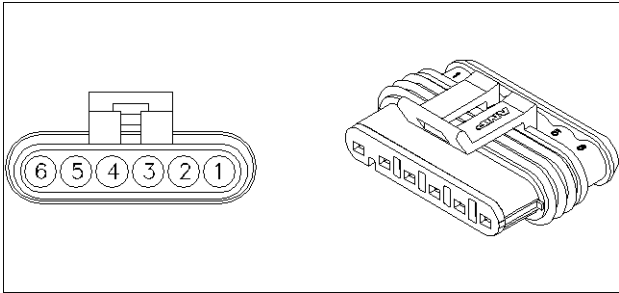

87710588 14

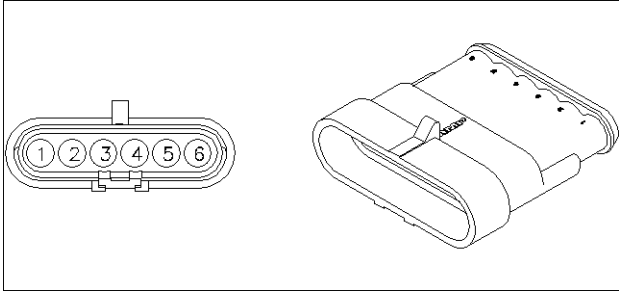

87691968 15

**CONNECTOR X-076 - Front window washer pump**

CONNECTOR X-076 - Front window washer pump			
PIN NUMBER	WIRE NUMBER	CIRCUIT REFERENCE	ELECTRICAL SCHEMATIC FRAME
1	CM-057AN (BK)	X-076 Front window washer pump SP-057A CAB GND	Wiring harnesses - Electrical schematic sheet 22 (55.100)
2	CM-097B (LG)	X-076 Front window washer pump SP-097	

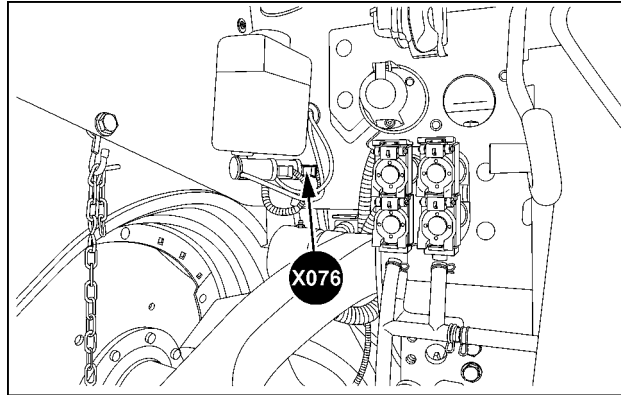

SVIL13TR00742AB 16

**Left-hand rear fender**

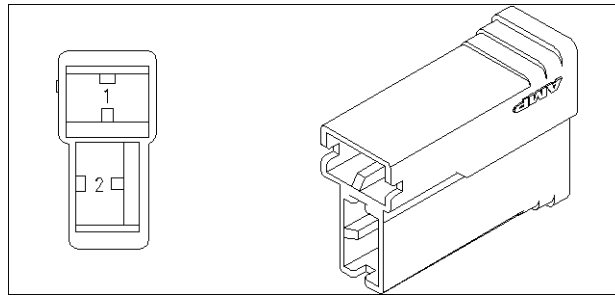

82944110 17

**CONNECTOR X-077 - Rear window washer pump**

CONNECTOR X-077 - Rear window washer pump			
PIN NUMBER	WIRE NUMBER	CIRCUIT REFERENCE	ELECTRICAL SCHEMATIC FRAME
1	CM-057AO (BK)	SP-057A CAB GND X-077 Rear window washer pump	<b>Wiring harnesses - Electrical schematic sheet 22 (55.100)</b>
2	CM-098 (LG)	X-077 Rear window washer pump X-050 Cab main harness to roof harness 1	

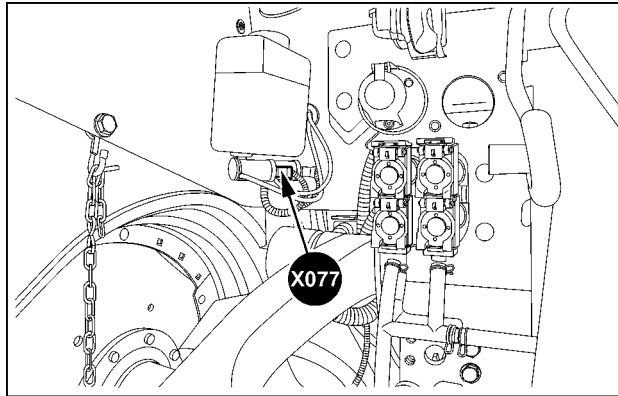

SVIL13TR00742AC 18

**Left-hand rear fender**

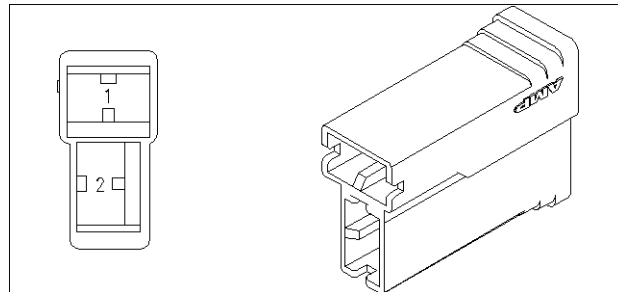

82944110 19

**CONNECTOR X-078 - Power socket 25 A – Cab inside (ground)**

CONNECTOR X-078 - Power socket 25 A – Cab inside (ground)			
PIN NUMBER	WIRE NUMBER	CIRCUIT REFERENCE	ELECTRICAL SCHEMATIC FRAME
1	SP-057AK (BK)	X-078 Power socket 25 A – Cab inside (ground) X-407 Cab main harness to power socket 25 A – Cab inside	Wiring harnesses - Electrical schematic sheet 23 (55.100)

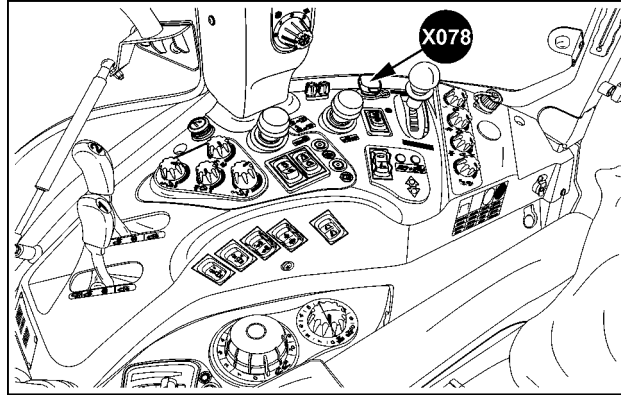

SVIL13TR00706AI 20

**Cab right-hand side**

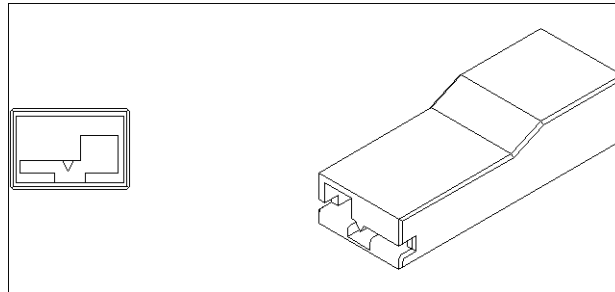

87705127 21

**CONNECTOR X-079 - Power socket 25 A – Cab inside (positive)**

CONNECTOR X-079 - Power socket 25 A – Cab inside (positive)			
PIN NUMBER	WIRE NUMBER	CIRCUIT REFERENCE	ELECTRICAL SCHEMATIC FRAME
1	SP-155 (GN)	X-407 Cab main harness to power socket 25 A – Cab inside X-079 Power socket 25 A – Cab inside (positive)	<b>Wiring harnesses - Electrical schematic sheet 23 (55.100)</b>

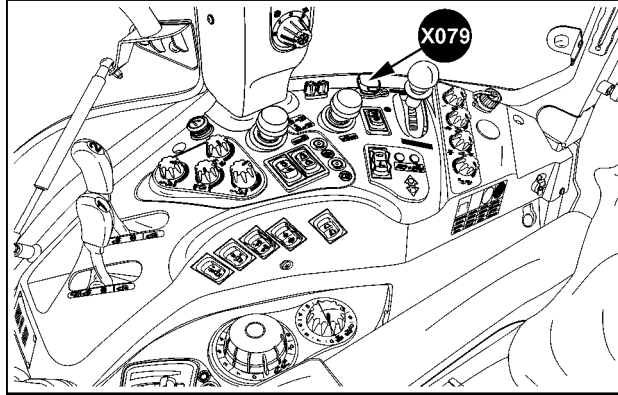

SVIL13TR00706AJ 22

**Cab right-hand side**

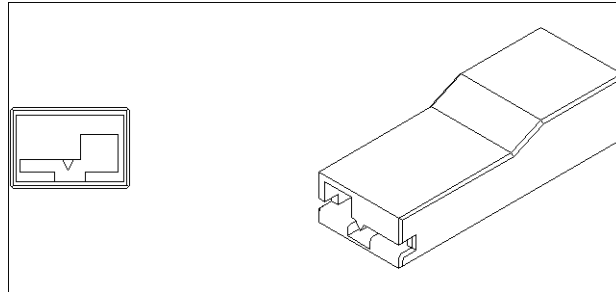

87705127 23

## Wire connectors - Component diagram 08

### CONNECTOR X-080 - Cigarette lighter lighting

CONNECTOR X-080 - Cigarette lighter lighting			
PIN NUMBER	WIRE NUMBER	CIRCUIT REFERENCE	ELECTRICAL SCHEMATIC FRAME
1	SP-1014FP (RD)	SP-1014F POT 58 SWITCH PANEL X-080 Cigarette lighter lighting	Wiring harnesses - Electrical schematic sheet 23 (55.100)

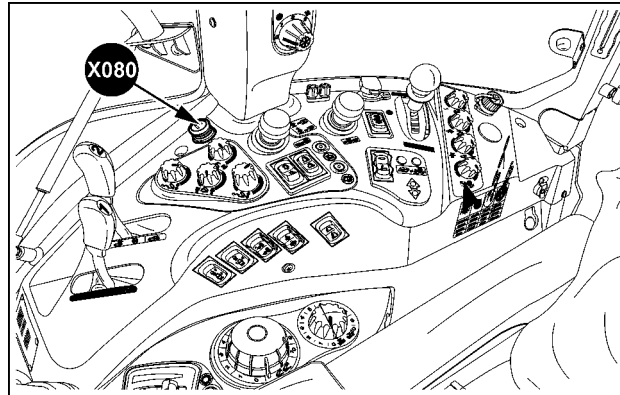

SVIL13TR00706AC 1

**Cab right-hand side**

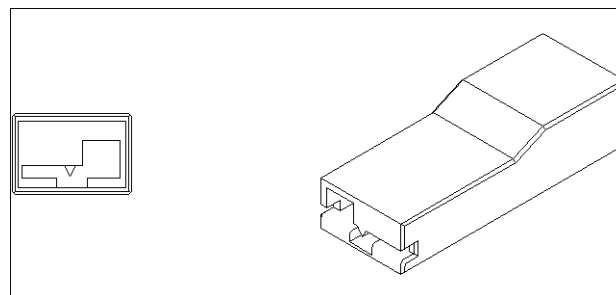

87705127 2

**CONNECTOR X-081 - Cigarette lighter lighting (optional)**

CONNECTOR X-081 - Cigarette lighter lighting (optional)			
PIN NUMBER	WIRE NUMBER	CIRCUIT REFERENCE	ELECTRICAL SCHEMATIC FRAME
1	CM-1013D (RD)	X-081 Cigarette lighter lighting (optional) SP-1013	Wiring harnesses - Electrical schematic sheet 23 (55.100)

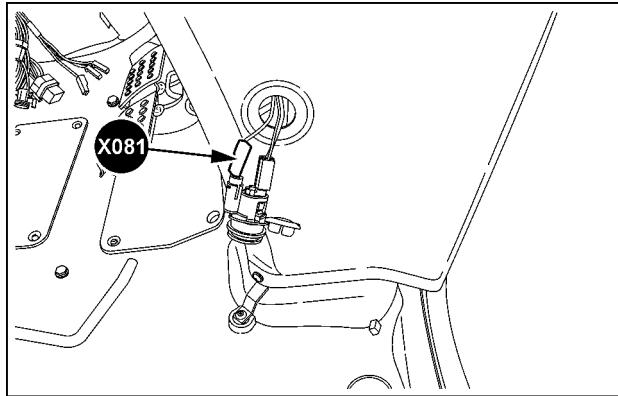

SVIL13TR00745AC 3

**Front right-hand cab floor**

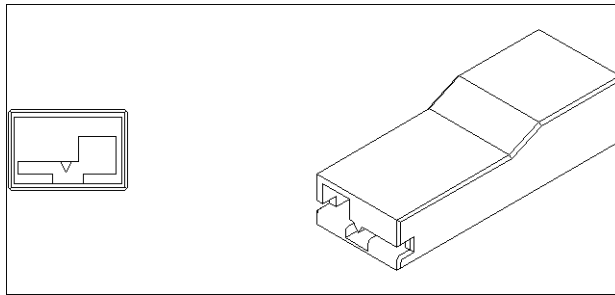

87705127 4

**CONNECTOR X-082 - Speaker rear right-hand**

CONNECTOR X-082 - Speaker rear right-hand			
PIN NUMBER	WIRE NUMBER	CIRCUIT REFERENCE	ELECTRICAL SCHEMATIC FRAME
1	RF-3053 (GY)	X-039 Radio X-082 Speaker rear right-hand	Wiring harnesses - Electrical schematic sheet 19 (55.100)

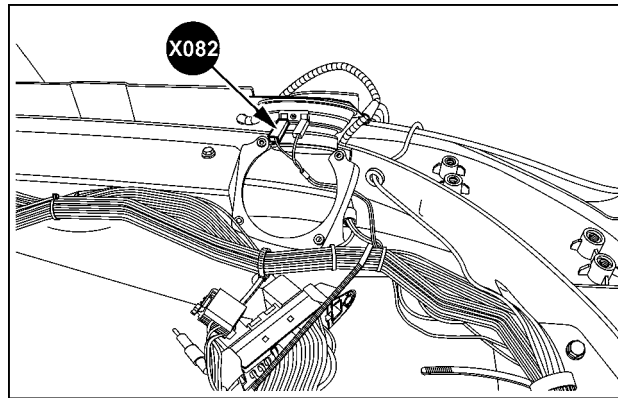

SVIL13TR00809AB 5

**Rear top right-hand cab roof**

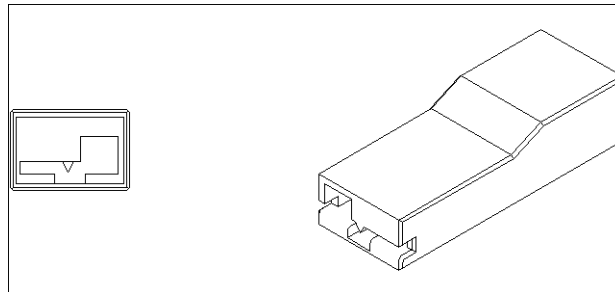

87705127 6



**CONNECTOR X-083 - Speaker rear right-hand**

CONNECTOR X-083 - Speaker rear right-hand			
PIN NUMBER	WIRE NUMBER	CIRCUIT REFERENCE	ELECTRICAL SCHEMATIC FRAME
1	RF-3054 (GY)	X-039 Radio X-083 Speaker rear right-hand	<b>Wiring harnesses - Electrical schematic sheet 19 (55.100)</b>

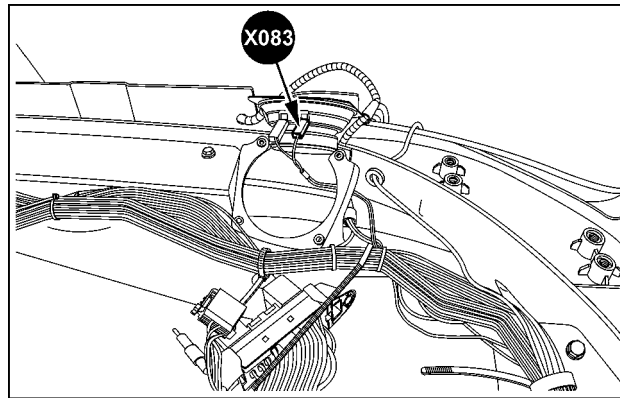

SVIL13TR00809AC 7

**Rear top right-hand cab roof**

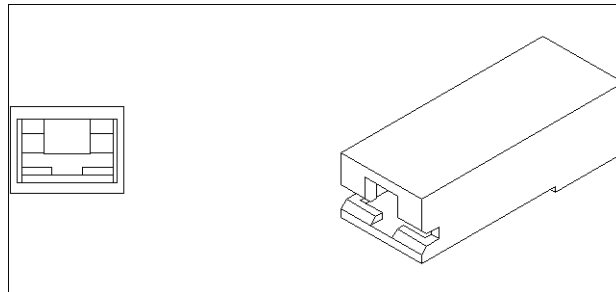

87691425 8

**CONNECTOR X-084 - Speaker rear left-hand**

CONNECTOR X-084 - Speaker rear left-hand			
PIN NUMBER	WIRE NUMBER	CIRCUIT REFERENCE	ELECTRICAL SCHEMATIC FRAME
1	RF-3055 (GY)	X-039 Radio X-084 Speaker rear left-hand	Wiring harnesses - Electrical schematic sheet 19 (55.100)

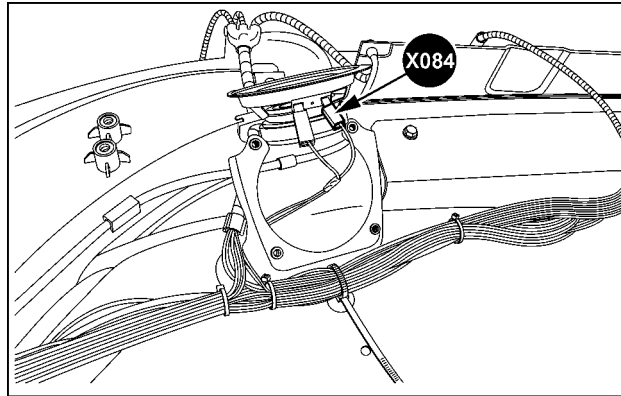

SVIL13TR00810AB 9

**Rear top left-hand cab roof**

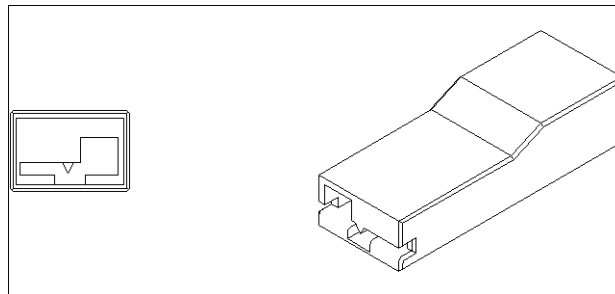

87705127 10

**CONNECTOR X-085 - Speaker rear left-hand**

CONNECTOR X-085 - Speaker rear left-hand			
PIN NUMBER	WIRE NUMBER	CIRCUIT REFERENCE	ELECTRICAL SCHEMATIC FRAME
1	RF-3056 (GY)	X-039 Radio X-085 Speaker rear left-hand	<b>Wiring harnesses - Electrical schematic sheet 19 (55.100)</b>

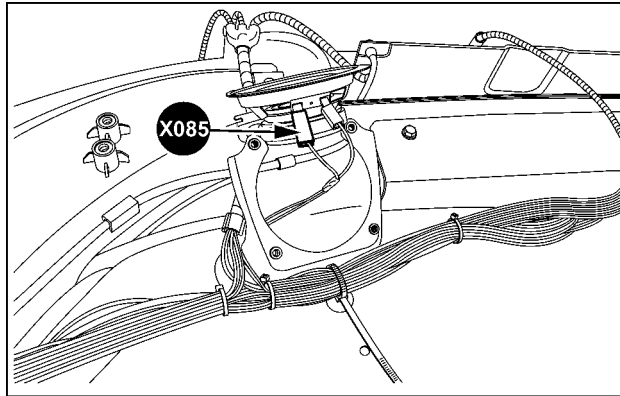

SVIL13TR00810AC 11

**Rear top left-hand cab roof**

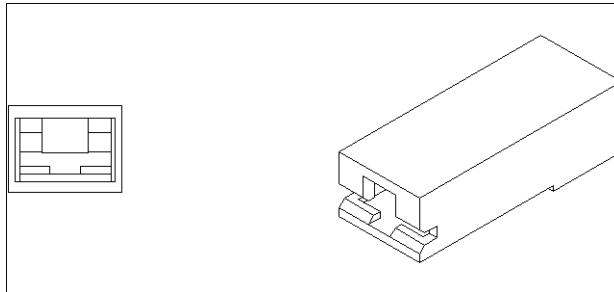

87691425 12

**CONNECTOR X-088 - Air-conditioning compressor – Magnetic clutch**

CONNECTOR X-088 - Air-conditioning compressor – Magnetic clutch			
PIN NUMBER	WIRE NUMBER	CIRCUIT REFERENCE	ELECTRICAL SCHEMATIC FRAME
1	EN-057FB (BK)	X-088 Air-conditioning compressor – Magnetic clutch SP-057F GND - Engine	Wiring harnesses - Electrical schematic sheet 17 (55.100)
2	EN-9305 (BL)	X-088 Air-conditioning compressor – Magnetic clutch X-001 Cab main harness to engine harness 1	

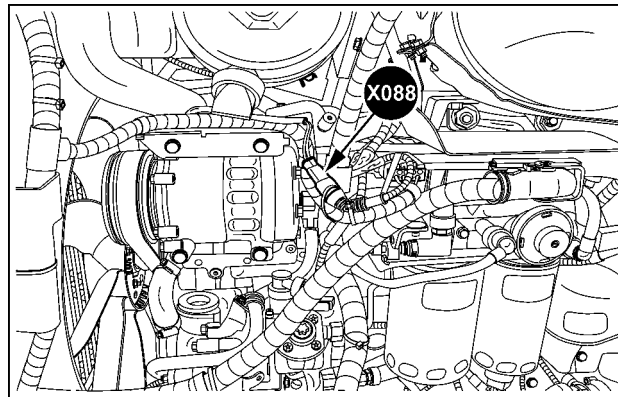

SVIL13TR00811AB 13

**Front top left-hand engine**

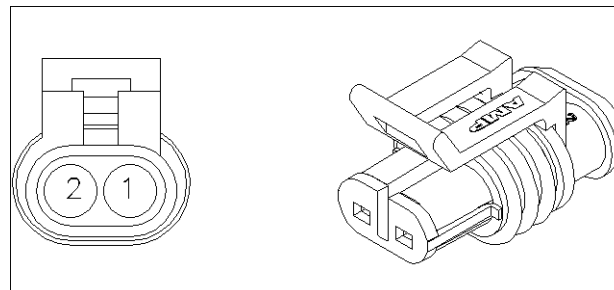

82012083 14

## Wire connectors - Component diagram 09

### CONNECTOR X-090 - Flasher unit

CONNECTOR X-090 - Flasher unit				
PIN NUMBER	WIRE NUMBER	CIRCUIT REFERENCE	ELECTRICAL SCHEMATIC FRAME	
A1	CM-1021B (RD)	X-090 Flasher unit SP-1021 HAZZARD 30	Wiring harnesses - Electrical schematic sheet 20 (55.100)	
A3	CM-3002D (GN)	X-090 Flasher unit X-180 Fuse block (F-070 to F-101)		
A5	CM-3001D (GN)	X-090 Flasher unit X-180 Fuse block (F-070 to F-101)		
A6	CM-3000A (GN)	X-090 Flasher unit X-092 Hazard switch		
A7	CM-3064 (OR)	X-090 Flasher unit X-450 Instrument cluster CN1		
A8	CM-3009A (GN)	X-090 Flasher unit SP-3009		
B1	CM-1021C (GN)	X-090 Flasher unit SP-1021 HAZZARD 30		Wiring harnesses - Electrical schematic sheet 20 (55.100)
B2	CM-3065 (OR)	X-091 Steering column multi-function lever X-090 Flasher unit		
B3	CM-1045 (GN)	X-091 Steering column multi-function lever X-090 Flasher unit		
B4	CM-3000 (GN)	X-090 Flasher unit X-092 Hazard switch		
B5	CM-3063 (OR)	X-090 Flasher unit X-450 Instrument cluster CN1		
B6	CM-3001 (GN)	X-090 Flasher unit SP-3001		
B7	CM-3002 (GN)	X-090 Flasher unit SP-3002		
B8	CM-057AD (BK)	X-090 Flasher unit SP-057A CAB GND		

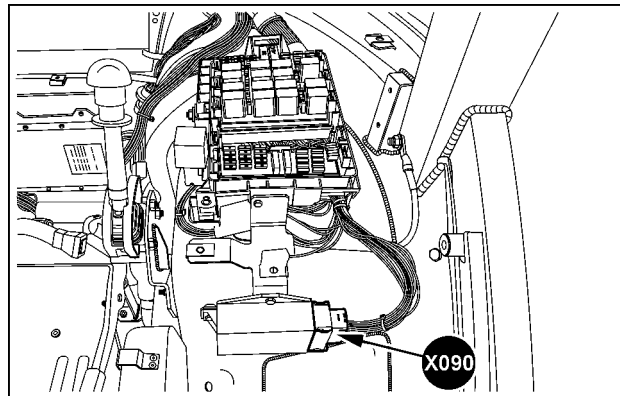

SVIL13TR00717AC 1

Cab left-hand side

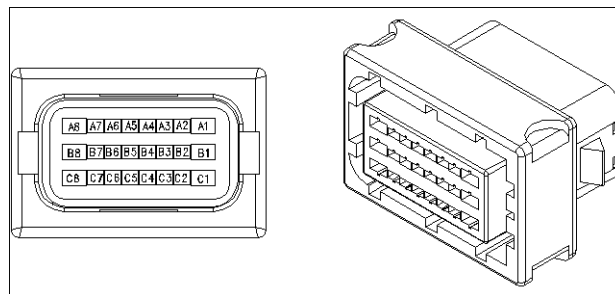

87680366 2

**CONNECTOR X-091 - Steering column multi-function lever**

<b>CONNECTOR X-091 - Steering column multi-function lever</b>			
<b>PIN NUMBER</b>	<b>WIRE NUMBER</b>	<b>CIRCUIT REFERENCE</b>	<b>ELECTRICAL SCHEMATIC FRAME</b>
1	CM-086 (GN)	X-091 Steering column multi-function lever SP-086	<b>Wiring harnesses - Electrical schematic sheet 20 (55.100)</b> <b>Wiring harnesses - Electrical schematic sheet 22 (55.100)</b>
2	CM-097 (LG)	X-091 Steering column multi-function lever SP-097	
3	CM-1052D (YE)	X-180 Fuse block (F-070 to F-101) X-091 Steering column multi-function lever	
4	CM-011D (GN)	X-091 Steering column multi-function lever X-385 Cab main harness to roof harness 2	
5	CM-1030 (BL)	X-120 Relay and diode block (K-007 to K-060 and V-040 to V-044) X-091 Steering column multi-function lever	
6	CM-1027C (BL)	SP-1027C X-091 Steering column multi-function lever	<b>Wiring harnesses - Electrical schematic sheet 20 (55.100)</b> <b>Wiring harnesses - Electrical schematic sheet 22 (55.100)</b>
7	CM-376 (VT)	X-091 Steering column multi-function lever X-001 Cab main harness to engine harness 1	
8	CM-1045 (GN)	X-091 Steering column multi-function lever X-090 Flasher unit	
9	CM-3065 (OR)	X-091 Steering column multi-function lever X-090 Flasher unit	
10	CM-3009B (GN)	X-091 Steering column multi-function lever SP-3009	
11	CM-085 (GN)	X-091 Steering column multi-function lever SP-085	<b>Wiring harnesses - Electrical schematic sheet 20 (55.100)</b> <b>Wiring harnesses - Electrical schematic sheet 22 (55.100)</b>
12	CM-1019D (GN)	X-091 Steering column multi-function lever X-048 Intermittent windshield wiper module	
13	CM-587 (YE)	X-091 Steering column multi-function lever X-048 Intermittent windshield wiper module	
14	CM-084 (GN)	SP-1019 X-091 Steering column multi-function lever	

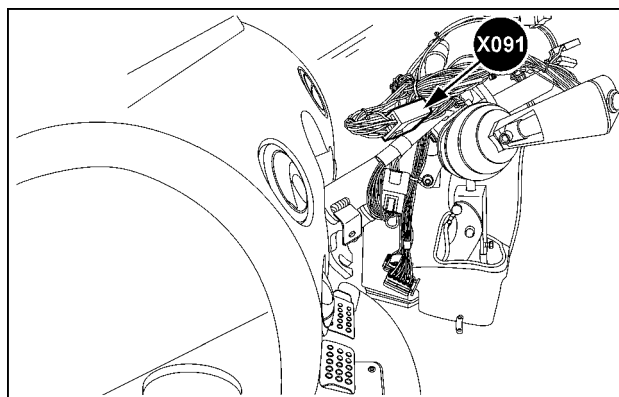

SVIL13TR00747AB 3

**Steering console**

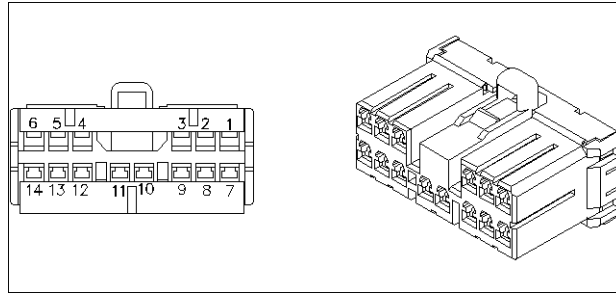

87691878 4

**CONNECTOR X-092 - Hazard switch**

<b>CONNECTOR X-092 - Hazard switch</b>			
<b>PIN NUMBER</b>	<b>WIRE NUMBER</b>	<b>CIRCUIT REFERENCE</b>	<b>ELECTRICAL SCHEMATIC FRAME</b>
30b	CM-1021A (GN)	X-092 Hazard switch SP-1021 HAZZARD 30	<b>Wiring harnesses - Electrical schematic sheet 20 (55.100)</b>
30	CM-3000 (GN)	X-090 Flasher unit X-092 Hazard switch	
49a	CM-057EH (BK)	X-092 Hazard switch SP-057E CAB GND 3	

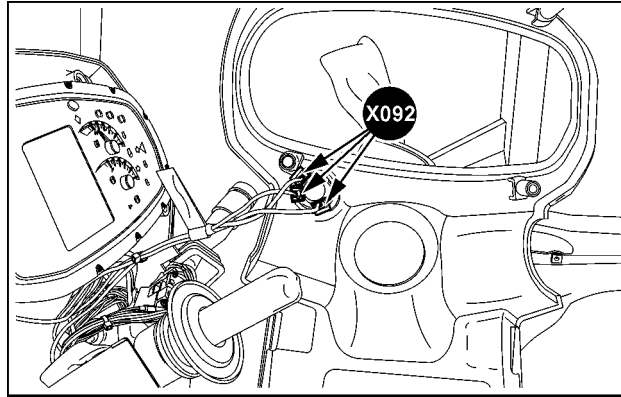

SVIL13TR00812AB 5

**Steering console**

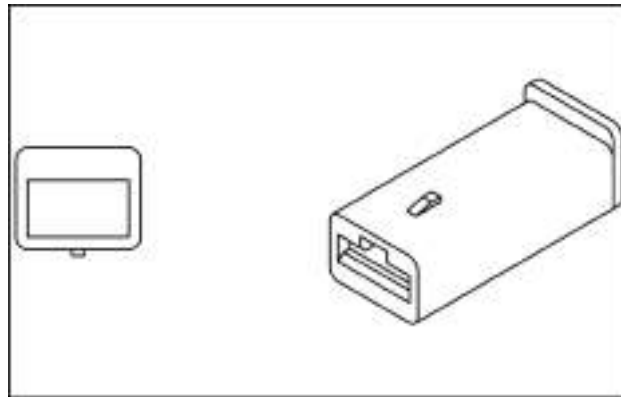

84157166 6

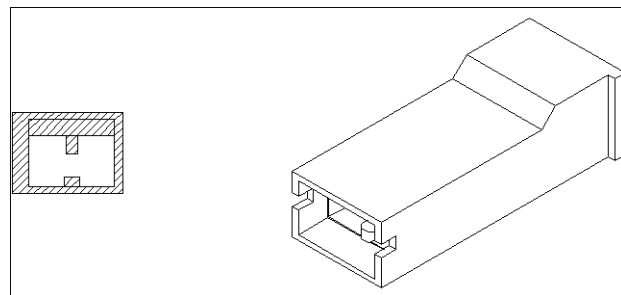

87691062 7



**CONNECTOR X-093 - Brake light switch – Left-hand**

CONNECTOR X-093 - Brake light switch – Left-hand			
PIN NUMBER	WIRE NUMBER	CIRCUIT REFERENCE	ELECTRICAL SCHEMATIC FRAME
1	CM-810K (GN)	SP-810J X-093 Brake light switch – Left-hand	<b>Wiring harnesses - Electrical schematic sheet 18 (55.100)</b>
2	CM-810A (GN)	SP-810 X-093 Brake light switch – Left-hand	
3	CM-810C (GN)	X-093 Brake light switch – Left-hand SP-810C	
4	CM-810M (GN)	X-093 Brake light switch – Left-hand X-210 Central Control Unit (CCU) – CN1B	

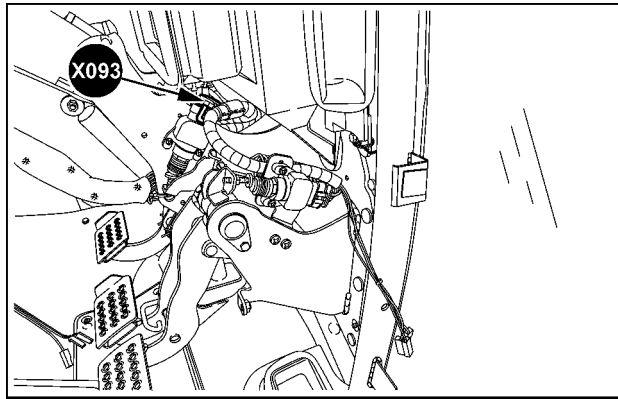

SVIL13TR00748AB 8

**Front right-hand cab**

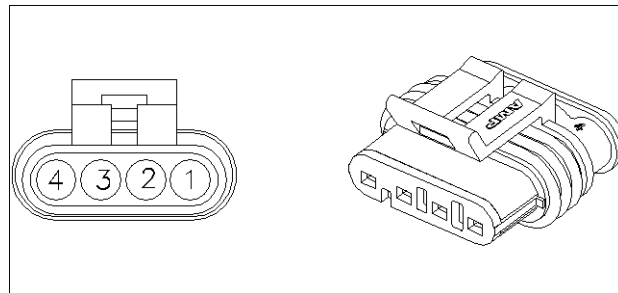

87687242 9

**CONNECTOR X-094 - Brake light switch – Right-hand**

CONNECTOR X-094 - Brake light switch – Right-hand			
PIN NUMBER	WIRE NUMBER	CIRCUIT REFERENCE	ELECTRICAL SCHEMATIC FRAME
1	CM-810L (GN)	X-094 Brake light switch – Right-hand SP-810J	<b>Wiring harnesses - Electrical schematic sheet 18 (55.100)</b>
2	CM-810B (GN)	X-094 Brake light switch – Right-hand SP-810	
3	CM-810H (GN)	X-094 Brake light switch – Right-hand SP-810C	
4	CM-810N (GN)	X-210 Central Control Unit (CCU) – CN1B X-094 Brake light switch – Right-hand	

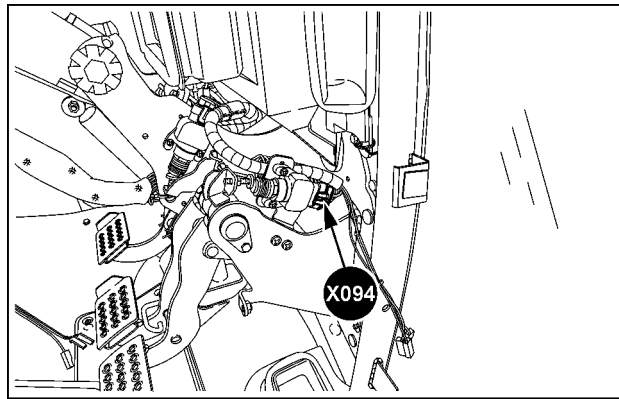

SVIL13TR00748AC 10

**Front right-hand cab**

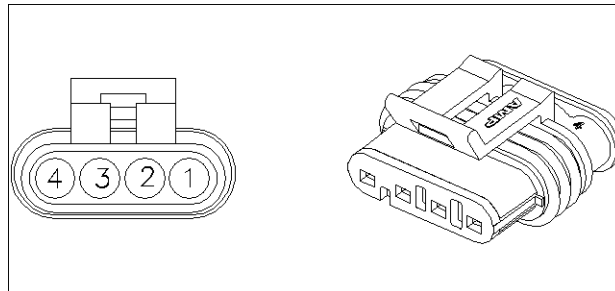

87687242 11

**CONNECTOR X-095 - Cab main harness to license plate light – Cab left-hand (Italy)**

CONNECTOR X-095 - Cab main harness to license plate light – Cab left-hand (Italy)			
PIN NUMBER	WIRE NUMBER	CIRCUIT REFERENCE	ELECTRICAL SCHEMATIC FRAME
1	SL-1109 (YE) CM-1014E (YE)	X-977 License plate light – Cab left-hand (Italy) X-095 Cab main harness to license plate light – Cab left-hand (Italy) SP-1014 X-095 Cab main harness to license plate light – Cab left-hand (Italy)	<b>Wiring harnesses - Electrical schematic sheet 18 (55.100)</b>
2	SL-1110 (WH) CM-057CC (BK)	X-977 License plate light – Cab left-hand (Italy) X-095 Cab main harness to license plate light – Cab left-hand (Italy) SP-057C X-095 Cab main harness to license plate light – Cab left-hand (Italy)	

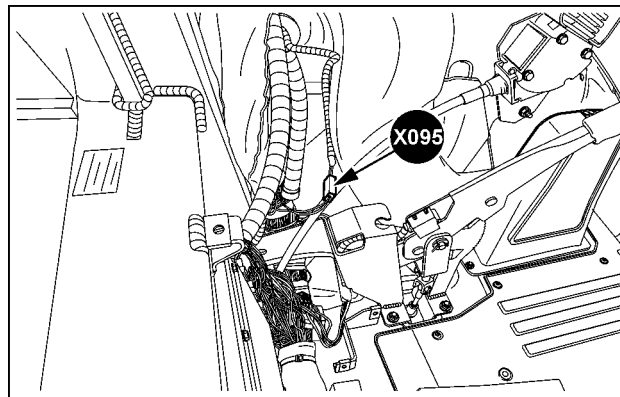

SVIL13TR00857AB 12

**Cab rear left-hand**

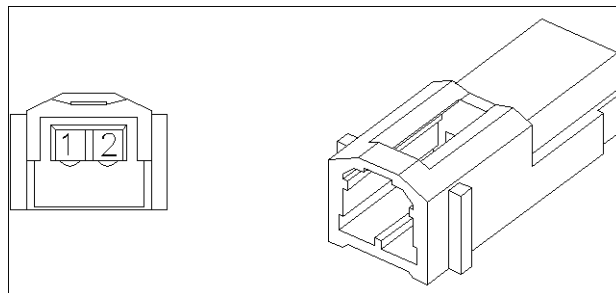

87679493 13

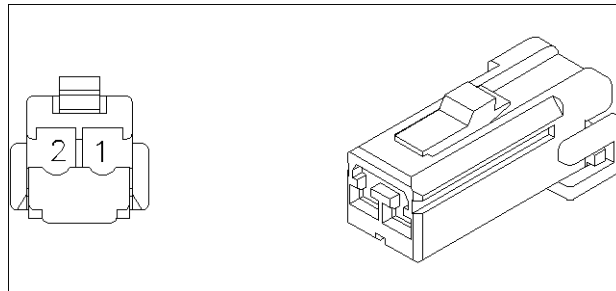

87736475 14

**CONNECTOR X-096 - License plate light – Roof left-hand**

CONNECTOR X-096 - License plate light – Roof left-hand			
PIN NUMBER	WIRE NUMBER	CIRCUIT REFERENCE	ELECTRICAL SCHEMATIC FRAME
1	RF-1013LF (BL)	SP-1013L X-096 License plate light – Roof left-hand	Wiring harnesses - Electrical schematic sheet 20 (55.100)
2	RF-057RP (BK)	X-096 License plate light – Roof left-hand SP-057R	

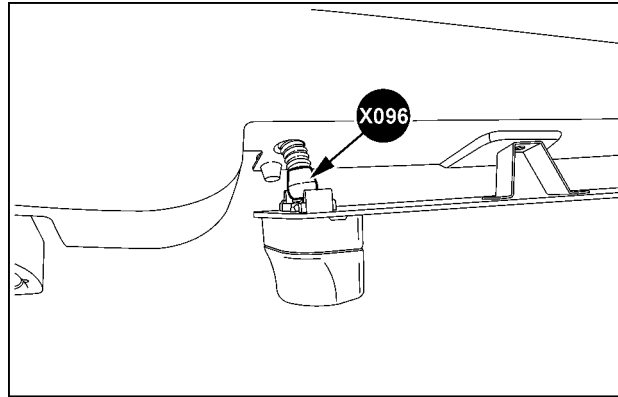

SVIL13TR00750AB 15

**Rear left-hand cab roof**

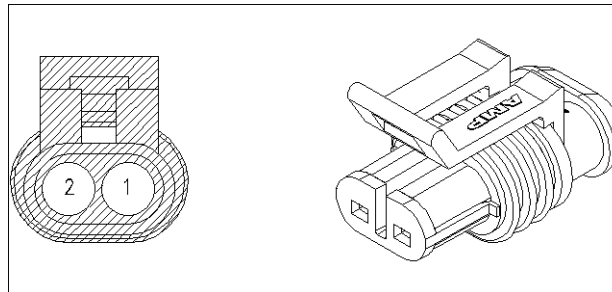

84152155 16

**CONNECTOR X-097 - License plate light – Roof right-hand**

CONNECTOR X-097 - License plate light – Roof right-hand			
PIN NUMBER	WIRE NUMBER	CIRCUIT REFERENCE	ELECTRICAL SCHEMATIC FRAME
1	RF-1013LG (BL)	SP-1013L X-097 License plate light – Roof right-hand	<b>Wiring harnesses - Electrical schematic sheet 20 (55.100)</b>
2	RF-057SL (BK)	X-097 License plate light – Roof right-hand SP-057S ROOF GROUND LH2	

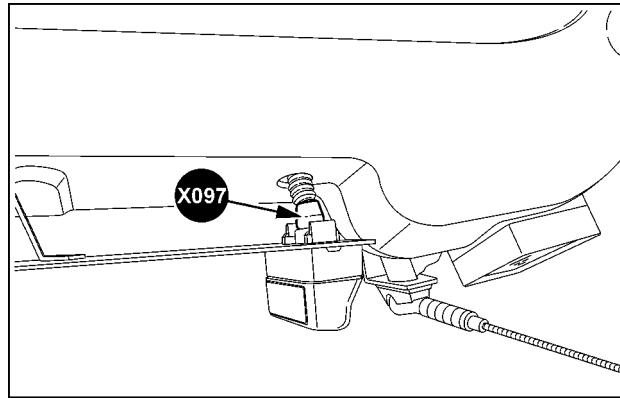

SVIL13TR00752AB 17

**Rear right-hand cab roof**

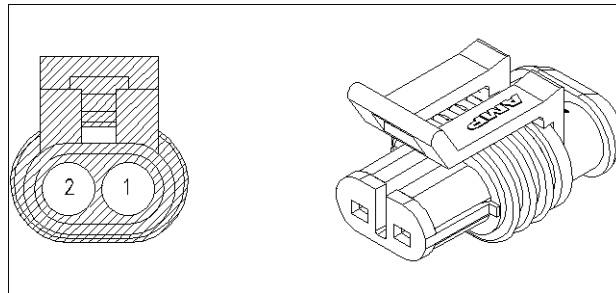

84152155 18

**CONNECTOR X-098 - Trailer socket rear (7-Pin)**

CONNECTOR X-098 - Trailer socket rear (7-Pin)			
PIN NUMBER	WIRE NUMBER	CIRCUIT REFERENCE	ELECTRICAL SCHEMATIC FRAME
1	CM-3001EA (GN)	SP-3001E FLASHER LH socket X-098 Trailer socket rear (7-Pin)	<b>Wiring harnesses - Electrical schematic sheet 23 (55.100)</b>
3	CM-057AM (BK)	X-098 Trailer socket rear (7-Pin) SP-057A CAB GND	
4	CM-3002EA (GN)	X-098 Trailer socket rear (7-Pin) SP-3002E FLASHER RH socket	
5	CM-1013MA (RD)	SP-1013M 58R socket X-098 Trailer socket rear (7-Pin)	
6	CM-810G (GN)	X-098 Trailer socket rear (7-Pin) X-180 Fuse block (F-070 to F-101)	
7	CM-1024DB (RD)	SP-1024D 58L socket X-098 Trailer socket rear (7-Pin)	

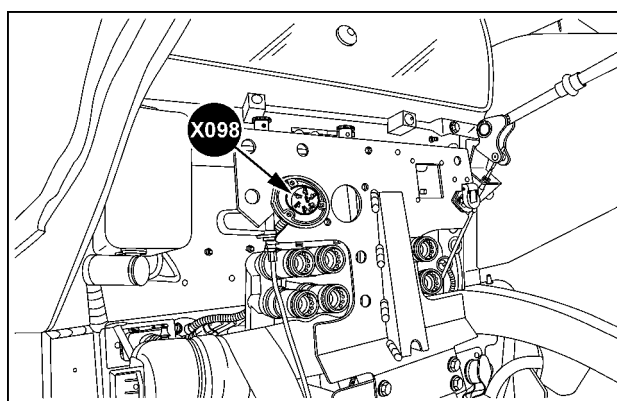

SVIL13TR00770AB 19

**Left-hand side top of transmission**

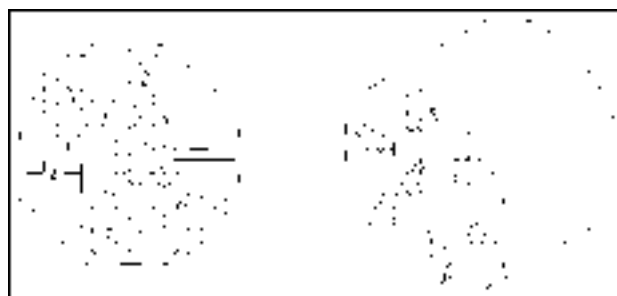

84185564 20

**CONNECTOR X-099 - Trailer socket front (7-Pin)**

<b>CONNECTOR X-099 - Trailer socket front (7-Pin)</b>			
<b>PIN NUMBER</b>	<b>WIRE NUMBER</b>	<b>CIRCUIT REFERENCE</b>	<b>ELECTRICAL SCHEMATIC FRAME</b>
1	SK-3001EB (GN)	X-406 Engine harness 1 to trailer socket front (7-Pin) X-099 Trailer socket front (7-Pin)	<b>Wiring harnesses - Electrical schematic sheet 23 (55.100)</b>
2	SK-010L (GN)	SP-020A +KEY 15 X-099 Trailer socket front (7-Pin)	
3	SK-4023 (BK)	X-099 Trailer socket front (7-Pin) X-433 GND	
4	SK-3002EB (RD)	X-406 Engine harness 1 to trailer socket front (7-Pin) X-099 Trailer socket front (7-Pin)	
5	SK-1013MB (RD)	X-406 Engine harness 1 to trailer socket front (7-Pin) X-099 Trailer socket front (7-Pin)	
7	SK-1024DA (RD)	X-406 Engine harness 1 to trailer socket front (7-Pin) X-099 Trailer socket front (7-Pin)	

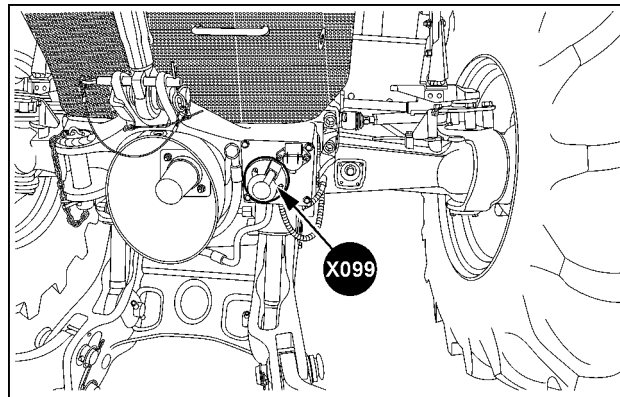

SVIL13TR00753AB 21

**Left-hand front hitch**

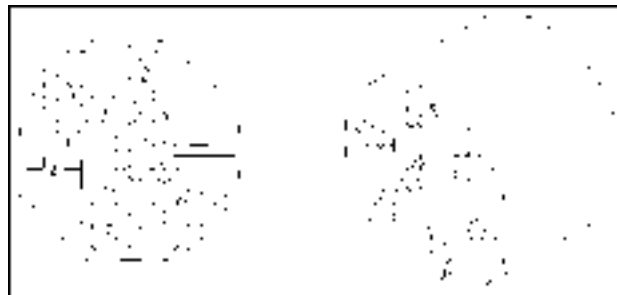

84185564 22

## Wire connectors - Component diagram 10

### CONNECTOR X-100 - Clutch A solenoid valve

CONNECTOR X-100 - Clutch A solenoid valve			
PIN NUMBER	WIRE NUMBER	CIRCUIT REFERENCE	ELECTRICAL SCHEMATIC FRAME
1	TR-7905 (OR)	SP-7900 VPS1 X-100 Clutch A solenoid valve	Wiring harnesses - Electrical schematic sheet 07 (55.100)
2	TR-7900 (VT)	X-100 Clutch A solenoid valve X-300 Cab main harness to transmission harness	

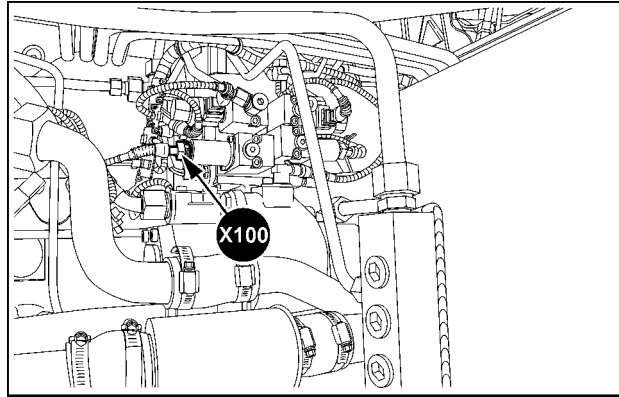

SVIL13TR00754AB 1

**Right-hand of transmission**

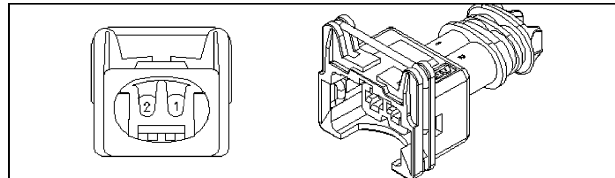

84475258 2



## Wire connectors - Component diagram 11

**CONNECTOR X-110 - Relay and fuse block (K-004 to K-039 and F-033 to F-036)**

<b>CONNECTOR X-110 - Relay and fuse block (K-004 to K-039 and F-033 to F-036)</b>			
<b>PIN NUMBER</b>	<b>WIRE NUMBER</b>	<b>CIRCUIT REFERENCE</b>	<b>ELECTRICAL SCHEMATIC FRAME</b>
F33A	CM-001DQ (RD)	SP-001DM X-110 Relay and fuse block (K-004 to K-039 and F-033 to F-036)	<b>Wiring harnesses - Electrical schematic sheet 05 (55.100)</b> <b>Wiring harnesses - Electrical schematic sheet 14 (55.100)</b>
F33B	CM-001H (RD)	X-028 Cigarette lighter power supply (optional) X-110 Relay and fuse block (K-004 to K-039 and F-033 to F-036)	
F34A	CM-071G (WH)	SP-071 X-110 Relay and fuse block (K-004 to K-039 and F-033 to F-036)	<b>Wiring harnesses - Electrical schematic sheet 17 (55.100)</b> <b>Wiring harnesses - Electrical schematic sheet 20 (55.100)</b>
F34B	CM-010L (GN)	X-110 Relay and fuse block (K-004 to K-039 and F-033 to F-036) X-120 Relay and diode block (K-007 to K-060 and V-040 to V-044)	
F35A	CM-071H (WH)	SP-071 X-110 Relay and fuse block (K-004 to K-039 and F-033 to F-036)	<b>Wiring harnesses - Electrical schematic sheet 21 (55.100)</b> <b>Wiring harnesses - Electrical schematic sheet 22 (55.100)</b> <b>Wiring harnesses - Electrical schematic sheet 23 (55.100)</b>
F35B	CM-1019 (GN)	X-110 Relay and fuse block (K-004 to K-039 and F-033 to F-036) SP-1019	
F36A	CM-001DN (RD)	SP-001DM X-110 Relay and fuse block (K-004 to K-039 and F-033 to F-036)	<b>Wiring harnesses - Electrical schematic sheet 05 (55.100)</b> <b>Wiring harnesses - Electrical schematic sheet 14 (55.100)</b>
F36B	CM-155J (GN)	X-110 Relay and fuse block (K-004 to K-039 and F-033 to F-036) X-385 Cab main harness to roof harness 2	
K15_30	CM-155K (GN)	X-130 Fuse block (F-001 to F-032) X-110 Relay and fuse block (K-004 to K-039 and F-033 to F-036)	<b>Wiring harnesses - Electrical schematic sheet 17 (55.100)</b> <b>Wiring harnesses - Electrical schematic sheet 20 (55.100)</b> <b>Wiring harnesses - Electrical schematic sheet 21 (55.100)</b>
K15_85	CM-057BQ (BK)	X-110 Relay and fuse block (K-004 to K-039 and F-033 to F-036) SP-057B	
K15_86	CM-1054 (YE)	X-110 Relay and fuse block (K-004 to K-039 and F-033 to F-036) X-050 Cab main harness to roof harness 1	<b>Wiring harnesses - Electrical schematic sheet 22 (55.100)</b> <b>Wiring harnesses - Electrical schematic sheet 23 (55.100)</b>
K15_87	CM-1053 (WH)	X-110 Relay and fuse block (K-004 to K-039 and F-033 to F-036) X-001 Cab main harness to engine harness 1	
K4_30	CM-001DY (BL)	X-110 Relay and fuse block (K-004 to K-039 and F-033 to F-036) SP-001DM	<b>Wiring harnesses - Electrical schematic sheet 05 (55.100)</b> <b>Wiring harnesses - Electrical schematic sheet 14 (55.100)</b>
K4_85	CM-057BR (BK)	X-110 Relay and fuse block (K-004 to K-039 and F-033 to F-036) SP-057B	
K4_86	CM-1051 (YE)	X-110 Relay and fuse block (K-004 to K-039 and F-033 to F-036) X-385 Cab main harness to roof harness 2	<b>Wiring harnesses - Electrical schematic sheet 17 (55.100)</b> <b>Wiring harnesses - Electrical schematic sheet 20 (55.100)</b>
K4_87	CM-1024 (RD)	X-110 Relay and fuse block (K-004 to K-039 and F-033 to F-036) SP-1024	
K24_30	CM-155C (GN)	X-130 Fuse block (F-001 to F-032) X-110 Relay and fuse block (K-004 to K-039 and F-033 to F-036)	<b>Wiring harnesses - Electrical schematic sheet 21 (55.100)</b> <b>Wiring harnesses - Electrical schematic sheet 22 (55.100)</b> <b>Wiring harnesses - Electrical schematic sheet 23 (55.100)</b>
K24_85	CM-6570 (GN)	X-110 Relay and fuse block (K-004 to K-039 and F-033 to F-036) X-001 Cab main harness to engine harness 1	

<b>CONNECTOR X-110 - Relay and fuse block (K-004 to K-039 and F-033 to F-036)</b>			
<b>PIN NUMBER</b>	<b>WIRE NUMBER</b>	<b>CIRCUIT REFERENCE</b>	<b>ELECTRICAL SCHEMATIC FRAME</b>
K24_86	CM-071R (WH)	X-110 Relay and fuse block (K-004 to K-039 and F-033 to F-036) SP-071	<b>Wiring harnesses - Electrical schematic sheet 05 (55.100)</b>
K24_87	CM-1246 (RD)	X-110 Relay and fuse block (K-004 to K-039 and F-033 to F-036) SP-1246	<b>Wiring harnesses - Electrical schematic sheet 14 (55.100)</b>
K36_30	CM-155E (GN)	X-130 Fuse block (F-001 to F-032) X-110 Relay and fuse block (K-004 to K-039 and F-033 to F-036)	<b>Wiring harnesses - Electrical schematic sheet 17 (55.100)</b>
K36_85	CM-057BB (BK)	X-110 Relay and fuse block (K-004 to K-039 and F-033 to F-036) SP-057B	<b>Wiring harnesses - Electrical schematic sheet 20 (55.100)</b>
K36_86	CM-6302A (BR)	SP-6302 X-110 Relay and fuse block (K-004 to K-039 and F-033 to F-036)	<b>Wiring harnesses - Electrical schematic sheet 21 (55.100)</b>
K36_87	CM-6302C (BR)	X-110 Relay and fuse block (K-004 to K-039 and F-033 to F-036) X-046 Cab main harness to blower motor left-hand	<b>Wiring harnesses - Electrical schematic sheet 22 (55.100)</b>
K37_30	CM-155F (BL)	X-130 Fuse block (F-001 to F-032) X-110 Relay and fuse block (K-004 to K-039 and F-033 to F-036)	<b>Wiring harnesses - Electrical schematic sheet 05 (55.100)</b>
K37_85	CM-057BA (BK)	X-110 Relay and fuse block (K-004 to K-039 and F-033 to F-036) SP-057B	<b>Wiring harnesses - Electrical schematic sheet 14 (55.100)</b>
K37_86	CM-6302B (BR)	SP-6302 X-110 Relay and fuse block (K-004 to K-039 and F-033 to F-036)	<b>Wiring harnesses - Electrical schematic sheet 17 (55.100)</b>
K37_87	CM-6302D (BR)	X-110 Relay and fuse block (K-004 to K-039 and F-033 to F-036) X-047 Cab main harness to blower motor right-hand	<b>Wiring harnesses - Electrical schematic sheet 20 (55.100)</b>
K38_30	CM-155G (GN)	X-130 Fuse block (F-001 to F-032) X-110 Relay and fuse block (K-004 to K-039 and F-033 to F-036)	<b>Wiring harnesses - Electrical schematic sheet 21 (55.100)</b>
K38_85	CM-057BC (BK)	X-110 Relay and fuse block (K-004 to K-039 and F-033 to F-036) SP-057B	<b>Wiring harnesses - Electrical schematic sheet 22 (55.100)</b>
K38_86	CM-6303A (BR)	X-110 Relay and fuse block (K-004 to K-039 and F-033 to F-036) SP-6303	<b>Wiring harnesses - Electrical schematic sheet 23 (55.100)</b>
K38_87	CM-6303C (BR)	X-110 Relay and fuse block (K-004 to K-039 and F-033 to F-036) X-046 Cab main harness to blower motor left-hand	<b>Wiring harnesses - Electrical schematic sheet 05 (55.100)</b>
K39_30	CM-155H (GN)	X-130 Fuse block (F-001 to F-032) X-110 Relay and fuse block (K-004 to K-039 and F-033 to F-036)	<b>Wiring harnesses - Electrical schematic sheet 14 (55.100)</b>
K39_85	CM-057BD (BK)	X-110 Relay and fuse block (K-004 to K-039 and F-033 to F-036) SP-057B	<b>Wiring harnesses - Electrical schematic sheet 17 (55.100)</b>
K39_86	CM-6303B (BR)	SP-6303 X-110 Relay and fuse block (K-004 to K-039 and F-033 to F-036)	<b>Wiring harnesses - Electrical schematic sheet 20 (55.100)</b>
K39_87	CM-6303D (BR)	X-110 Relay and fuse block (K-004 to K-039 and F-033 to F-036) X-047 Cab main harness to blower motor right-hand	<b>Wiring harnesses - Electrical schematic sheet 21 (55.100)</b>

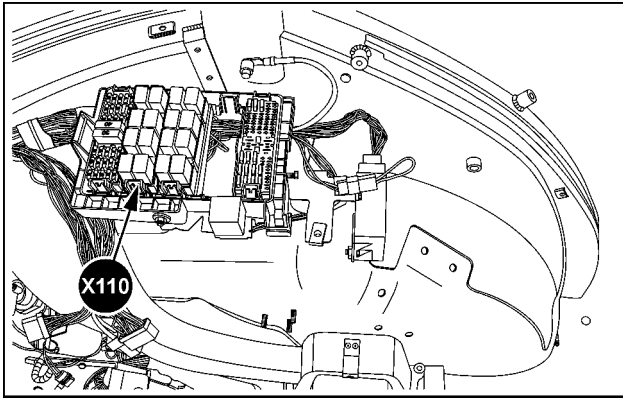

SVIL13TR00695AC 1

**Cab left-hand side**

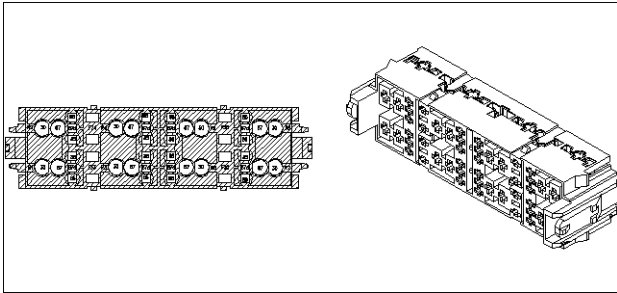

87314762 2

## Wire connectors - Component diagram 12

### CONNECTOR X-120 - Relay and diode block (K-007 to K-060 and V-040 to V-044)

<b>CONNECTOR X-120 - Relay and diode block (K-007 to K-060 and V-040 to V-044)</b>			
<b>PIN NUMBER</b>	<b>WIRE NUMBER</b>	<b>CIRCUIT REFERENCE</b>	<b>ELECTRICAL SCHEMATIC FRAME</b>
F37A	CM-1030CA (BL)	X-120 Relay and diode block (K-007 to K-060 and V-040 to V-044) SP-1030C	<b>Wiring harnesses - Electrical schematic sheet 09 (55.100)</b> <b>Wiring harnesses - Electrical schematic sheet 13 (55.100)</b> <b>Wiring harnesses - Electrical schematic sheet 14 (55.100)</b> <b>Wiring harnesses - Electrical schematic sheet 18 (55.100)</b> <b>Wiring harnesses - Electrical schematic sheet 20 (55.100)</b>
F37B	CM-1030 (BL)	X-120 Relay and diode block (K-007 to K-060 and V-040 to V-044) X-091 Steering column multi-function lever	
F38A	CM-1052BA (BL)	SP-1013K X-120 Relay and diode block (K-007 to K-060 and V-040 to V-044)	
F38B	CM-1052B (YE)	SP-1052 X-120 Relay and diode block (K-007 to K-060 and V-040 to V-044)	
F39A	CM-1013K (BL)	X-120 Relay and diode block (K-007 to K-060 and V-040 to V-044) SP-1013K	
F39B	CM-1013F (RD)	SP-1013 X-120 Relay and diode block (K-007 to K-060 and V-040 to V-044)	
F40A	CM-1052AA (BL)	X-120 Relay and diode block (K-007 to K-060 and V-040 to V-044) SP-1030C	
F40B	CM-1052A (YE)	SP-1052 X-120 Relay and diode block (K-007 to K-060 and V-040 to V-044)	
K7_30	CM-001I (RD)	X-130 Fuse block (F-001 to F-032) X-120 Relay and diode block (K-007 to K-060 and V-040 to V-044)	
K7_85	CM-057BP (BK)	SP-057B X-120 Relay and diode block (K-007 to K-060 and V-040 to V-044)	
K7_86	CM-1030C (BL)	X-120 Relay and diode block (K-007 to K-060 and V-040 to V-044) SP-1030C	<b>Wiring harnesses - Electrical schematic sheet 09 (55.100)</b> <b>Wiring harnesses - Electrical schematic sheet 13 (55.100)</b> <b>Wiring harnesses - Electrical schematic sheet 14 (55.100)</b> <b>Wiring harnesses - Electrical schematic sheet 18 (55.100)</b> <b>Wiring harnesses - Electrical schematic sheet 20 (55.100)</b>
K7_87	CM-1030D (BL)	X-120 Relay and diode block (K-007 to K-060 and V-040 to V-044) X-120 Relay and diode block (K-007 to K-060 and V-040 to V-044)	
K9_30	CM-001J (RD)	X-130 Fuse block (F-001 to F-032) X-120 Relay and diode block (K-007 to K-060 and V-040 to V-044)	

<b>CONNECTOR X-120 - Relay and diode block (K-007 to K-060 and V-040 to V-044)</b>			
<b>PIN NUMBER</b>	<b>WIRE NUMBER</b>	<b>CIRCUIT REFERENCE</b>	<b>ELECTRICAL SCHEMATIC FRAME</b>
K9_85	CM-057BO (BK)	X-120 Relay and diode block (K-007 to K-060 and V-040 to V-044) SP-057B	<b>Wiring harnesses - Electrical schematic sheet 09 (55.100)</b> <b>Wiring harnesses - Electrical schematic sheet 13 (55.100)</b> <b>Wiring harnesses - Electrical schematic sheet 14 (55.100)</b> <b>Wiring harnesses - Electrical schematic sheet 18 (55.100)</b> <b>Wiring harnesses - Electrical schematic sheet 20 (55.100)</b>
K9_86	CM-1027CA (BL)	X-120 Relay and diode block (K-007 to K-060 and V-040 to V-044) SP-1027C	
K9_87	CM-1027 (U)	X-120 Relay and diode block (K-007 to K-060 and V-040 to V-044) X-120 Relay and diode block (K-007 to K-060 and V-040 to V-044)	
K28_30	CM-1030D (BL)	X-120 Relay and diode block (K-007 to K-060 and V-040 to V-044) X-120 Relay and diode block (K-007 to K-060 and V-040 to V-044)	
K28_85	CM-057BK (BK)	SP-057B X-120 Relay and diode block (K-007 to K-060 and V-040 to V-044)	
K28_86	CM-1039A (BL)	X-120 Relay and diode block (K-007 to K-060 and V-040 to V-044) SP-1039	
K28_87A	CM-1030A (BL)	X-001 Cab main harness to engine harness 1 X-120 Relay and diode block (K-007 to K-060 and V-040 to V-044)	
K28_87	CM-1030E (BL)	X-120 Relay and diode block (K-007 to K-060 and V-040 to V-044) SP-1030E	
K29_30	CM-1027 (U)	X-120 Relay and diode block (K-007 to K-060 and V-040 to V-044) X-120 Relay and diode block (K-007 to K-060 and V-040 to V-044)	
K29_85	CM-057BJ (BK)	X-120 Relay and diode block (K-007 to K-060 and V-040 to V-044) SP-057B	
K29_86	CM-1039B (BL)	X-120 Relay and diode block (K-007 to K-060 and V-040 to V-044) SP-1039	
K29_87A	CM-1027A (BL)	X-120 Relay and diode block (K-007 to K-060 and V-040 to V-044) X-001 Cab main harness to engine harness 1	

<b>CONNECTOR X-120 - Relay and diode block (K-007 to K-060 and V-040 to V-044)</b>				
<b>PIN NUMBER</b>	<b>WIRE NUMBER</b>	<b>CIRCUIT REFERENCE</b>	<b>ELECTRICAL SCHEMATIC FRAME</b>	
K29_87	CM-1027D (BL)	X-120 Relay and diode block (K-007 to K-060 and V-040 to V-044) SP-1027D	<b>Wiring harnesses - Electrical schematic sheet 09 (55.100)</b> <b>Wiring harnesses - Electrical schematic sheet 13 (55.100)</b> <b>Wiring harnesses - Electrical schematic sheet 14 (55.100)</b> <b>Wiring harnesses - Electrical schematic sheet 18 (55.100)</b> <b>Wiring harnesses - Electrical schematic sheet 20 (55.100)</b>	
K57_30	CM-010L (GN)	X-110 Relay and fuse block (K-004 to K-039 and F-033 to F-036) X-120 Relay and diode block (K-007 to K-060 and V-040 to V-044)		
K57_85	CM-057BF (BK)	SP-057B X-120 Relay and diode block (K-007 to K-060 and V-040 to V-044)		
K57_86	CM-5210B (BR)	SP-5210 X-120 Relay and diode block (K-007 to K-060 and V-040 to V-044)		
K57_87	CM-011 (GN)	X-120 Relay and diode block (K-007 to K-060 and V-040 to V-044) X-180 Fuse block (F-070 to F-101)		
K14_30	CM-001DW (BL)	SP-001DM X-120 Relay and diode block (K-007 to K-060 and V-040 to V-044)		
K14_85	CM-1052C (YE)	X-120 Relay and diode block (K-007 to K-060 and V-040 to V-044) X-450 Instrument cluster CN1		
K14_86	CM-001DX (BL)	X-120 Relay and diode block (K-007 to K-060 and V-040 to V-044) SP-001DM		<b>Wiring harnesses - Electrical schematic sheet 09 (55.100)</b> <b>Wiring harnesses - Electrical schematic sheet 13 (55.100)</b> <b>Wiring harnesses - Electrical schematic sheet 14 (55.100)</b> <b>Wiring harnesses - Electrical schematic sheet 18 (55.100)</b> <b>Wiring harnesses - Electrical schematic sheet 20 (55.100)</b>
K14_87	CM-1052 (YE)	X-120 Relay and diode block (K-007 to K-060 and V-040 to V-044) SP-1052		
K20_30	CM-5260C (TN)	SP-5260 X-120 Relay and diode block (K-007 to K-060 and V-040 to V-044)		
K20_85	CM-057BE (BK)	SP-057B X-120 Relay and diode block (K-007 to K-060 and V-040 to V-044)		
K20_86	CM-5597C (GY)	SP-5597 X-120 Relay and diode block (K-007 to K-060 and V-040 to V-044)		
K20_87	CM-5260G (TN)	X-120 Relay and diode block (K-007 to K-060 and V-040 to V-044) SP-5260G EHR POWER		
K60_30	CM-010BA (GN)	SP-010B X-120 Relay and diode block (K-007 to K-060 and V-040 to V-044)		
K60_85	CM-1160 (RD)	X-120 Relay and diode block (K-007 to K-060 and V-040 to V-044) X-220 Central Control Unit (CCU) – CN2		
K60_86	CM-010BC (GN)	SP-010B X-120 Relay and diode block (K-007 to K-060 and V-040 to V-044)		
K60_87	CM-1160A (RD)	X-120 Relay and diode block (K-007 to K-060 and V-040 to V-044) X-389 Backup alarm buzzer and backup light		

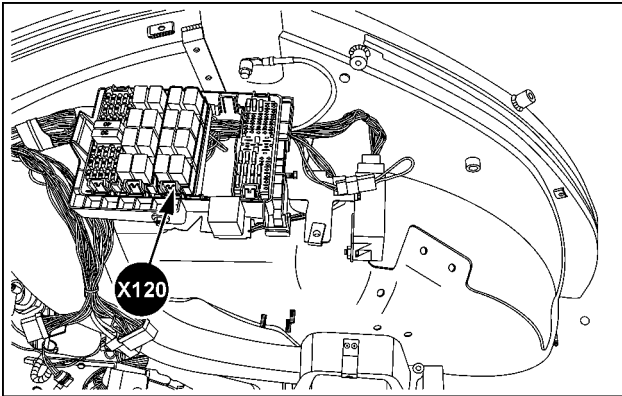

SVIL13TR00695AD 1

**Cab left-hand side**

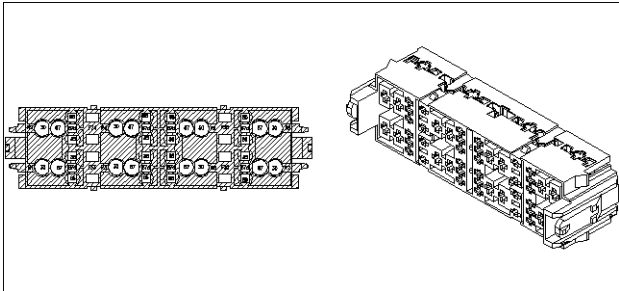

87314762 2

**CONNECTOR X-121 - Grab rail headlight left-hand**

CONNECTOR X-121 - Grab rail headlight left-hand			
PIN NUMBER	WIRE NUMBER	CIRCUIT REFERENCE	ELECTRICAL SCHEMATIC FRAME
1	RF-1030BA (BL)	SP-1030B X-121 Grab rail headlight left-hand	Wiring harnesses - Electrical schematic sheet 18 (55.100)
2	RF-1027BA (BL)	SP-1027B X-121 Grab rail headlight left-hand	
3	RF-057RF (BK)	SP-057R X-121 Grab rail headlight left-hand	

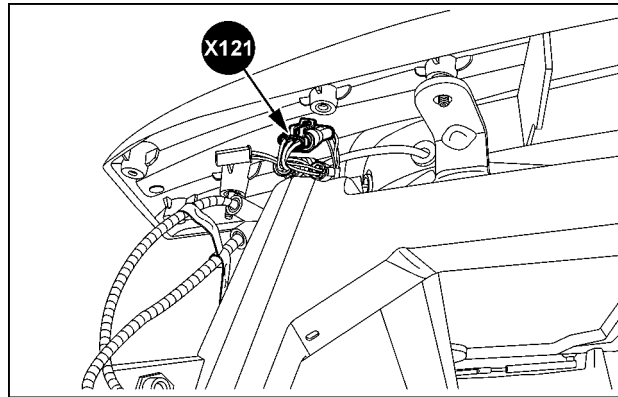

SVIL13TR00806AB 3

**Front left-hand cab roof**

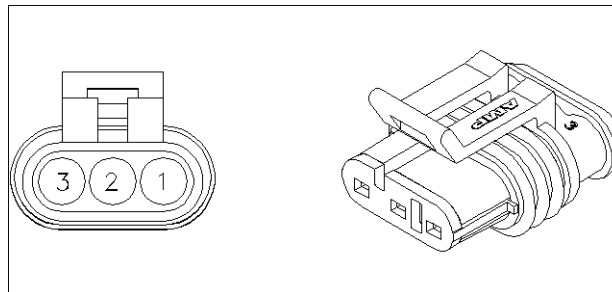

84062580 4



**CONNECTOR X-122 - Grab rail headlight right-hand**

CONNECTOR X-122 - Grab rail headlight right-hand			
PIN NUMBER	WIRE NUMBER	CIRCUIT REFERENCE	ELECTRICAL SCHEMATIC FRAME
1	RF-1030BB (BL)	X-122 Grab rail headlight right-hand SP-1030B	<b>Wiring harnesses - Electrical schematic sheet 18 (55.100)</b>
2	RF-1027BB (BL)	X-122 Grab rail headlight right-hand SP-1027B	
3	RF-057SJ (BK)	X-122 Grab rail headlight right-hand SP-057S ROOF GROUND LH2	

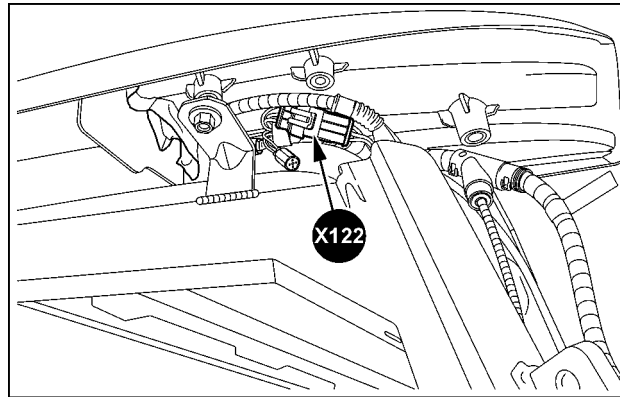

SVIL13TR00702AC 5

**Front right-hand cab roof**

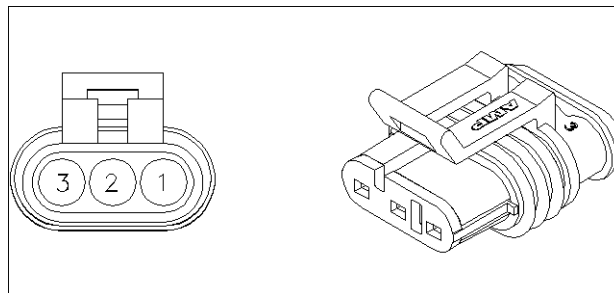

84062580 6

**CONNECTOR X-123 - Grab rail work light – Left-hand**

CONNECTOR X-123 - Grab rail work light – Left-hand			
PIN NUMBER	WIRE NUMBER	CIRCUIT REFERENCE	ELECTRICAL SCHEMATIC FRAME
1	RF-1080 (VT)	X-123 Grab rail work light – Left-hand X-065 Work light switch panel	Wiring harnesses - Electrical schematic sheet 21 (55.100)
2	RF-057RG (BK)	SP-057R X-123 Grab rail work light – Left-hand	

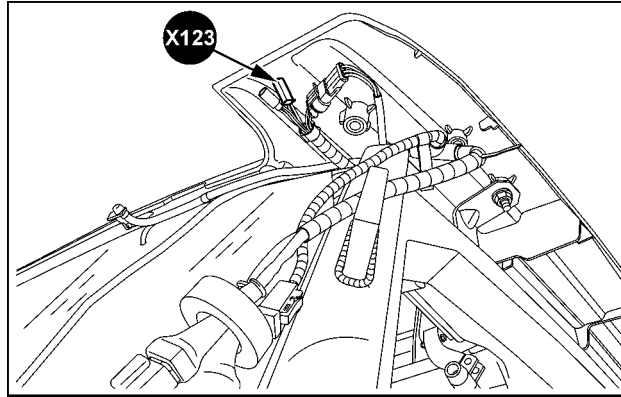

SVIL13TR00701AC 7

**Front left-hand cab roof**

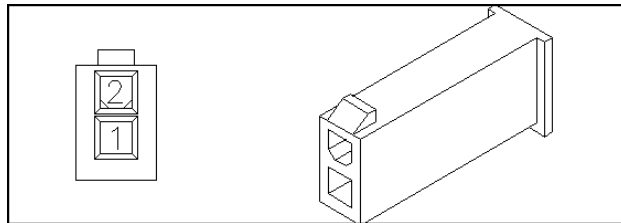

87694708 8

**CONNECTOR X-124 - Grab rail work light – Right-hand**

CONNECTOR X-124 - Grab rail work light – Right-hand			
PIN NUMBER	WIRE NUMBER	CIRCUIT REFERENCE	ELECTRICAL SCHEMATIC FRAME
1	RF-1079 (VT)	X-124 Grab rail work light – Right-hand X-065 Work light switch panel	<b>Wiring harnesses - Electrical schematic sheet 21 (55.100)</b>
2	RF-057SA (BK)	SP-057S ROOF GROUND LH2 X-124 Grab rail work light – Right-hand	

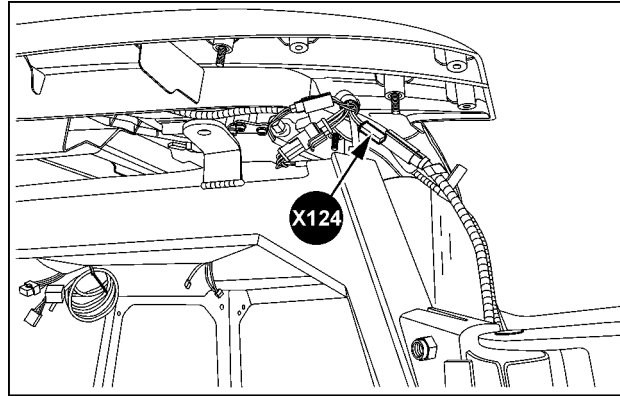

SVIL13TR00807AB 9

**Front right-hand cab roof**

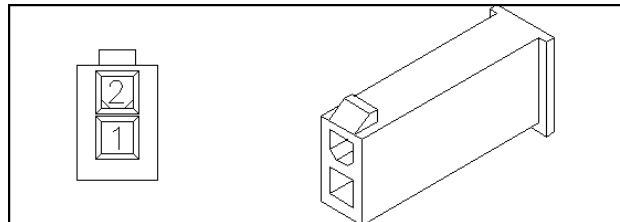

87694708 10

## Wire connectors - Component diagram 13

### CONNECTOR X-130 - Fuse block (F-001 to F-032)

CONNECTOR X-130 - Fuse block (F-001 to F-032)			
PIN NUMBER	WIRE NUMBER	CIRCUIT REFERENCE	ELECTRICAL SCHEMATIC FRAME
1A	CM-001LA (RD)	SP-001DL X-130 Fuse block (F-001 to F-032)	Wiring harnesses - Electrical schematic sheet 02 (55.100)
1B	CM-155E (GN)	X-130 Fuse block (F-001 to F-032) X-110 Relay and fuse block (K-004 to K-039 and F-033 to F-036)	Wiring harnesses - Electrical schematic sheet 05 (55.100) Wiring harnesses - Electrical schematic sheet 07 (55.100)
2A	CM-138C (VT)	SP-138 X-130 Fuse block (F-001 to F-032)	Wiring harnesses - Electrical schematic sheet 09 (55.100)
2B	CM-5001 (VT)	X-130 Fuse block (F-001 to F-032) SP-5001	Wiring harnesses - Electrical schematic sheet 10 (55.100)
3A	CM-001DR (RD)	X-130 Fuse block (F-001 to F-032) SP-001DM	Wiring harnesses - Electrical schematic sheet 11 (55.100)
3B	CM-001I (RD)	X-130 Fuse block (F-001 to F-032) X-120 Relay and diode block (K-007 to K-060 and V-040 to V-044)	Wiring harnesses - Electrical schematic sheet 13 (55.100)
4A	CM-001DJ (RD)	X-130 Fuse block (F-001 to F-032) SP-001DF	Wiring harnesses - Electrical schematic sheet 17 (55.100) Wiring harnesses - Electrical schematic sheet 20 (55.100) Wiring harnesses - Electrical schematic sheet 21 (55.100) Wiring harnesses - Electrical schematic sheet 23 (55.100)
4B	CM-155C (GN)	X-130 Fuse block (F-001 to F-032) X-110 Relay and fuse block (K-004 to K-039 and F-033 to F-036)	Wiring harnesses - Electrical schematic sheet 02 (55.100) Wiring harnesses - Electrical schematic sheet 05 (55.100)
5A	CM-001DT (RD)	SP-001DM X-130 Fuse block (F-001 to F-032)	Wiring harnesses - Electrical schematic sheet 07 (55.100)
5B	CM-155D (GN)	X-130 Fuse block (F-001 to F-032) SP-155D	Wiring harnesses - Electrical schematic sheet 09 (55.100)
6A	CM-071S (WH)	SP-071 X-130 Fuse block (F-001 to F-032)	Wiring harnesses - Electrical schematic sheet 10 (55.100)
6B	CM-5260 (TN)	X-130 Fuse block (F-001 to F-032) SP-5260	Wiring harnesses - Electrical schematic sheet 11 (55.100)
7A	CM-071N (WH)	SP-071 X-130 Fuse block (F-001 to F-032)	Wiring harnesses - Electrical schematic sheet 13 (55.100)
7B	CM-010N (GN)	X-501 Power socket 40 A – Cab outside X-130 Fuse block (F-001 to F-032)	Wiring harnesses - Electrical schematic sheet 17 (55.100) Wiring harnesses - Electrical schematic sheet 20 (55.100) Wiring harnesses - Electrical schematic sheet 21 (55.100) Wiring harnesses - Electrical schematic sheet 23 (55.100)

<b>CONNECTOR X-130 - Fuse block (F-001 to F-032)</b>			
<b>PIN NUMBER</b>	<b>WIRE NUMBER</b>	<b>CIRCUIT REFERENCE</b>	<b>ELECTRICAL SCHEMATIC FRAME</b>
8A	CM-001D0 (RD)	SP-001DM X-130 Fuse block (F-001 to F-032)	<b>Wiring harnesses - Electrical schematic sheet 02 (55.100)</b>
8B	CM-1021 (GN)	X-130 Fuse block (F-001 to F-032) SP-1021 HAZZARD 30	<b>Wiring harnesses - Electrical schematic sheet 05 (55.100)</b>
9A	CM-071P (WH)	SP-071 X-130 Fuse block (F-001 to F-032)	<b>Wiring harnesses - Electrical schematic sheet 07 (55.100)</b>
9B	CM-5005 (TN)	X-130 Fuse block (F-001 to F-032) SP-5005	<b>Wiring harnesses - Electrical schematic sheet 09 (55.100)</b>
10A	CM-071Q (WH)	SP-071 X-130 Fuse block (F-001 to F-032)	<b>Wiring harnesses - Electrical schematic sheet 10 (55.100)</b>
10B	CM-010F (GN)	X-130 Fuse block (F-001 to F-032) SP-010F	<b>Wiring harnesses - Electrical schematic sheet 11 (55.100)</b>
11A	CM-071M (WH)	SP-071 X-130 Fuse block (F-001 to F-032)	<b>Wiring harnesses - Electrical schematic sheet 13 (55.100)</b> <b>Wiring harnesses - Electrical schematic sheet 17 (55.100)</b> <b>Wiring harnesses - Electrical schematic sheet 20 (55.100)</b> <b>Wiring harnesses - Electrical schematic sheet 21 (55.100)</b> <b>Wiring harnesses - Electrical schematic sheet 23 (55.100)</b>
11B	CM-010J (GN)	X-130 Fuse block (F-001 to F-032) SP-010J	<b>Wiring harnesses - Electrical schematic sheet 02 (55.100)</b>
12A	CM-071J (WH)	SP-071 X-130 Fuse block (F-001 to F-032)	<b>Wiring harnesses - Electrical schematic sheet 05 (55.100)</b>
12B	CM-010D (GN)	X-130 Fuse block (F-001 to F-032) X-050 Cab main harness to roof harness 1	<b>Wiring harnesses - Electrical schematic sheet 07 (55.100)</b> <b>Wiring harnesses - Electrical schematic sheet 09 (55.100)</b>
13A	CM-001DV (RD)	SP-001DM X-130 Fuse block (F-001 to F-032)	<b>Wiring harnesses - Electrical schematic sheet 10 (55.100)</b>
13B	CM-155F (BL)	X-130 Fuse block (F-001 to F-032) X-110 Relay and fuse block (K-004 to K-039 and F-033 to F-036)	<b>Wiring harnesses - Electrical schematic sheet 11 (55.100)</b>
14A	CM-071L (BR)	SP-071 X-130 Fuse block (F-001 to F-032)	<b>Wiring harnesses - Electrical schematic sheet 13 (55.100)</b>
14B	CM-010E (GN)	X-130 Fuse block (F-001 to F-032) SP-010E	<b>Wiring harnesses - Electrical schematic sheet 17 (55.100)</b>
15A	CM-001DS (RD)	X-130 Fuse block (F-001 to F-032) SP-001DM	<b>Wiring harnesses - Electrical schematic sheet 20 (55.100)</b> <b>Wiring harnesses - Electrical schematic sheet 21 (55.100)</b> <b>Wiring harnesses - Electrical schematic sheet 23 (55.100)</b>

<b>CONNECTOR X-130 - Fuse block (F-001 to F-032)</b>			
<b>PIN NUMBER</b>	<b>WIRE NUMBER</b>	<b>CIRCUIT REFERENCE</b>	<b>ELECTRICAL SCHEMATIC FRAME</b>
15B	CM-001J (RD)	X-130 Fuse block (F-001 to F-032) X-120 Relay and diode block (K-007 to K-060 and V-040 to V-044)	<b>Wiring harnesses - Electrical schematic sheet 02 (55.100)</b> <b>Wiring harnesses - Electrical schematic sheet 05 (55.100)</b>
16A	CM-001DK (RD)	X-130 Fuse block (F-001 to F-032) SP-001DF	<b>Wiring harnesses - Electrical schematic sheet 07 (55.100)</b> <b>Wiring harnesses - Electrical schematic sheet 09 (55.100)</b>
16B	CM-155K (GN)	X-130 Fuse block (F-001 to F-032) X-110 Relay and fuse block (K-004 to K-039 and F-033 to F-036)	<b>Wiring harnesses - Electrical schematic sheet 10 (55.100)</b> <b>Wiring harnesses - Electrical schematic sheet 11 (55.100)</b>
17A	CM-071T (WH)	X-130 Fuse block (F-001 to F-032) SP-071	<b>Wiring harnesses - Electrical schematic sheet 13 (55.100)</b> <b>Wiring harnesses - Electrical schematic sheet 17 (55.100)</b>
17B	CM-010M (GN)	X-130 Fuse block (F-001 to F-032) SP-010M	<b>Wiring harnesses - Electrical schematic sheet 20 (55.100)</b> <b>Wiring harnesses - Electrical schematic sheet 21 (55.100)</b>
18A	CM-001LB (RD)	X-130 Fuse block (F-001 to F-032) SP-001DL	<b>Wiring harnesses - Electrical schematic sheet 23 (55.100)</b>
18B	CM-155G (GN)	X-130 Fuse block (F-001 to F-032) X-110 Relay and fuse block (K-004 to K-039 and F-033 to F-036)	<b>Wiring harnesses - Electrical schematic sheet 02 (55.100)</b> <b>Wiring harnesses - Electrical schematic sheet 05 (55.100)</b>
19A	CM-138A (VT)	X-130 Fuse block (F-001 to F-032) SP-138	<b>Wiring harnesses - Electrical schematic sheet 07 (55.100)</b> <b>Wiring harnesses - Electrical schematic sheet 09 (55.100)</b>
19B	CM-138D (VT)	X-130 Fuse block (F-001 to F-032) SP-138D	<b>Wiring harnesses - Electrical schematic sheet 10 (55.100)</b> <b>Wiring harnesses - Electrical schematic sheet 11 (55.100)</b>
20A	CM-071E (WH)	SP-071 X-130 Fuse block (F-001 to F-032)	<b>Wiring harnesses - Electrical schematic sheet 13 (55.100)</b> <b>Wiring harnesses - Electrical schematic sheet 17 (55.100)</b>
20B	CM-010C (GN)	X-130 Fuse block (F-001 to F-032) SP-010C	<b>Wiring harnesses - Electrical schematic sheet 20 (55.100)</b> <b>Wiring harnesses - Electrical schematic sheet 21 (55.100)</b>
21A	CM-071K (BR)	SP-071 X-130 Fuse block (F-001 to F-032)	<b>Wiring harnesses - Electrical schematic sheet 23 (55.100)</b>
21B	CM-010I (GN)	X-130 Fuse block (F-001 to F-032) X-001 Cab main harness to engine harness 1	

<b>CONNECTOR X-130 - Fuse block (F-001 to F-032)</b>			
<b>PIN NUMBER</b>	<b>WIRE NUMBER</b>	<b>CIRCUIT REFERENCE</b>	<b>ELECTRICAL SCHEMATIC FRAME</b>
22A	CM-071B (WH)	X-130 Fuse block (F-001 to F-032) SP-071	<b>Wiring harnesses - Electrical schematic sheet 02 (55.100)</b>
22B	CM-3009 (GN)	X-130 Fuse block (F-001 to F-032) SP-3009	<b>Wiring harnesses - Electrical schematic sheet 05 (55.100)</b>
23A	CM-1024C (RD)	X-130 Fuse block (F-001 to F-032) SP-1024	<b>Wiring harnesses - Electrical schematic sheet 07 (55.100)</b>
23B	CM-1024D (RD)	SP-1024D 58L socket X-130 Fuse block (F-001 to F-032)	<b>Wiring harnesses - Electrical schematic sheet 09 (55.100)</b>
24A	CM-1024A (RD)	X-130 Fuse block (F-001 to F-032) SP-1024	<b>Wiring harnesses - Electrical schematic sheet 10 (55.100)</b>
24B	CM-1014 (RD)	X-130 Fuse block (F-001 to F-032) SP-1014	<b>Wiring harnesses - Electrical schematic sheet 11 (55.100)</b>
25A	CM-1024B (RD)	X-130 Fuse block (F-001 to F-032) SP-1024	<b>Wiring harnesses - Electrical schematic sheet 13 (55.100)</b> <b>Wiring harnesses - Electrical schematic sheet 17 (55.100)</b> <b>Wiring harnesses - Electrical schematic sheet 20 (55.100)</b> <b>Wiring harnesses - Electrical schematic sheet 21 (55.100)</b> <b>Wiring harnesses - Electrical schematic sheet 23 (55.100)</b>
25B	CM-1013 (RD)	X-130 Fuse block (F-001 to F-032) SP-1013	<b>Wiring harnesses - Electrical schematic sheet 02 (55.100)</b>
26A	CM-1000 (WH)	X-512 Ignition switch (cranking) X-130 Fuse block (F-001 to F-032)	<b>Wiring harnesses - Electrical schematic sheet 05 (55.100)</b>
26B	CM-1000A (WH)	X-319 Clutch pedal switch – Start interlock X-130 Fuse block (F-001 to F-032)	<b>Wiring harnesses - Electrical schematic sheet 07 (55.100)</b> <b>Wiring harnesses - Electrical schematic sheet 09 (55.100)</b>
27A	CM-071C (WH)	SP-071 X-130 Fuse block (F-001 to F-032)	<b>Wiring harnesses - Electrical schematic sheet 10 (55.100)</b>
27B	CM-010 (GN)	X-130 Fuse block (F-001 to F-032) X-001 Cab main harness to engine harness 1	<b>Wiring harnesses - Electrical schematic sheet 11 (55.100)</b>
28A	CM-071F (BR)	X-130 Fuse block (F-001 to F-032) SP-071	<b>Wiring harnesses - Electrical schematic sheet 13 (55.100)</b>
28B	CM-810 (GN)	SP-810 X-130 Fuse block (F-001 to F-032)	<b>Wiring harnesses - Electrical schematic sheet 17 (55.100)</b> <b>Wiring harnesses - Electrical schematic sheet 20 (55.100)</b> <b>Wiring harnesses - Electrical schematic sheet 21 (55.100)</b> <b>Wiring harnesses - Electrical schematic sheet 23 (55.100)</b>

<b>CONNECTOR X-130 - Fuse block (F-001 to F-032)</b>			
<b>PIN NUMBER</b>	<b>WIRE NUMBER</b>	<b>CIRCUIT REFERENCE</b>	<b>ELECTRICAL SCHEMATIC FRAME</b>
29A	CM-071D (WH)	SP-071 X-130 Fuse block (F-001 to F-032)	<b>Wiring harnesses - Electrical schematic sheet 02 (55.100)</b>
29B	CM-010B (GN)	X-130 Fuse block (F-001 to F-032) SP-010B	<b>Wiring harnesses - Electrical schematic sheet 05 (55.100)</b>
30A	CM-001LC (RD)	SP-001DL X-130 Fuse block (F-001 to F-032)	<b>Wiring harnesses - Electrical schematic sheet 07 (55.100)</b>
30B	CM-155H (GN)	X-130 Fuse block (F-001 to F-032) X-110 Relay and fuse block (K-004 to K-039 and F-033 to F-036)	<b>Wiring harnesses - Electrical schematic sheet 09 (55.100)</b> <b>Wiring harnesses - Electrical schematic sheet 10 (55.100)</b>
31A	CM-001DG (RD)	X-130 Fuse block (F-001 to F-032) SP-001DF	<b>Wiring harnesses - Electrical schematic sheet 11 (55.100)</b>
31B	CM-155 (GN)	X-407 Cab main harness to power socket 25 A – Cab inside X-130 Fuse block (F-001 to F-032)	<b>Wiring harnesses - Electrical schematic sheet 13 (55.100)</b>
32A	CM-001DH (RD)	SP-001DF X-130 Fuse block (F-001 to F-032)	<b>Wiring harnesses - Electrical schematic sheet 17 (55.100)</b>
32B	CM-151M (GN)	X-501 Power socket 40 A – Cab outside X-130 Fuse block (F-001 to F-032)	<b>Wiring harnesses - Electrical schematic sheet 20 (55.100)</b> <b>Wiring harnesses - Electrical schematic sheet 21 (55.100)</b> <b>Wiring harnesses - Electrical schematic sheet 23 (55.100)</b>

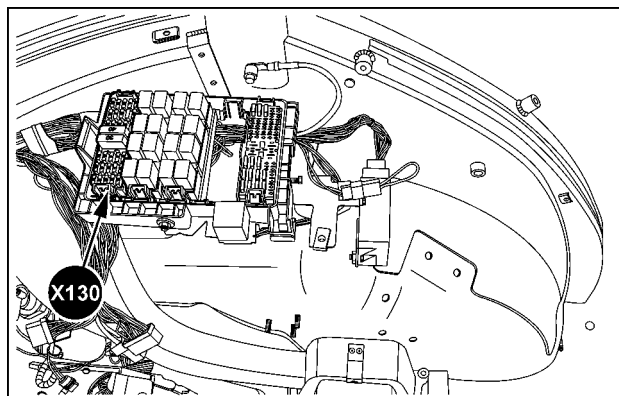

SVIL13TR00695AB 1

**Cab left-hand side**

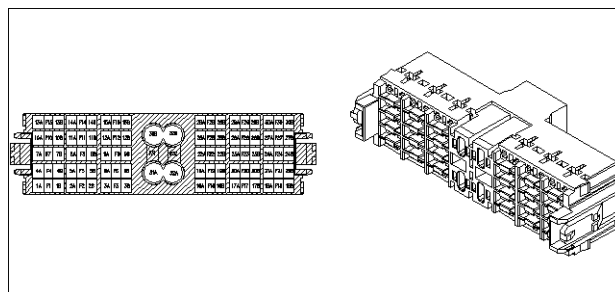

87314761 2



## Wire connectors - Component diagram 15

### CONNECTOR X-150 - Relay and fuse block – Roof

CONNECTOR X-150 - Relay and fuse block – Roof			
PIN NUMBER	WIRE NUMBER	CIRCUIT REFERENCE	ELECTRICAL SCHEMATIC FRAME
F50_9	RF-001DC (RD)	SP-001DA X-150 Relay and fuse block – Roof	<b>Wiring harnesses - Electrical schematic sheet 17 (55.100)</b> <b>Wiring harnesses - Electrical schematic sheet 19 (55.100)</b> <b>Wiring harnesses - Electrical schematic sheet 21 (55.100)</b> <b>Wiring harnesses - Electrical schematic sheet 22 (55.100)</b>
F40_1	RF-010Y (GN)	SP-010Y X-150 Relay and fuse block – Roof	
F40_5	RF-010GB (GN)	SP-010G X-150 Relay and fuse block – Roof	
F62_2	RF-1038 (TN)	X-150 Relay and fuse block – Roof SP-1038	
F62_6	RF-010GA (GN)	X-150 Relay and fuse block – Roof SP-010G	
F60_3	RF-1075 (VT)	X-150 Relay and fuse block – Roof SP-1075	
F60_7	RF-001DI (RD)	SP-001DB X-150 Relay and fuse block – Roof	
F61_4	RF-1074 (VT)	X-150 Relay and fuse block – Roof SP-1074	
F61_8	RF-001DQ (RD)	SP-001DB X-150 Relay and fuse block – Roof	
F50_13	RF-155B (GN)	X-150 Relay and fuse block – Roof X-150 Relay and fuse block – Roof	
F49_10	RF-001DD (RD)	X-150 Relay and fuse block – Roof SP-001DA	
F49_14	RF-155A (GN)	X-150 Relay and fuse block – Roof X-150 Relay and fuse block – Roof	
F48_11	RF-001DE (RD)	X-150 Relay and fuse block – Roof SP-001DB	
F48_15	RF-4012 (VT)	X-150 Relay and fuse block – Roof SP-4012	
F47_12	RF-010GC (GN)	SP-010G X-150 Relay and fuse block – Roof	
F47_16	RF-137 (WH)	X-150 Relay and fuse block – Roof X-039 Radio	
K25_30	RF-155A (GN)	X-150 Relay and fuse block – Roof X-150 Relay and fuse block – Roof	
K25_85	RF-057TB (BK)	X-150 Relay and fuse block – Roof SP-057T ROOF GROUND LH1	
K25_86	RF-1090 (VT)	X-150 Relay and fuse block – Roof X-065 Work light switch panel	
K25_87	RF-1076 (VT)	X-150 Relay and fuse block – Roof SP-1076	
K82_30	RF-001DF (RD)	X-150 Relay and fuse block – Roof SP-001DB	
K82_85	RF-057TC (BK)	X-150 Relay and fuse block – Roof SP-057T ROOF GROUND LH1	
K82_86	RF-010DB (GN)	SP-010D X-150 Relay and fuse block – Roof	
K82_87	RF-010G (GN)	X-150 Relay and fuse block – Roof SP-010G	
K19_30	RF-010DA (GN)	X-150 Relay and fuse block – Roof SP-010D	
K19_85	RF-057TJ (BK)	X-150 Relay and fuse block – Roof SP-057T ROOF GROUND LH1	

<b>CONNECTOR X-150 - Relay and fuse block – Roof</b>			
<b>PIN NUMBER</b>	<b>WIRE NUMBER</b>	<b>CIRCUIT REFERENCE</b>	<b>ELECTRICAL SCHEMATIC FRAME</b>
K19_86	RF-9219 (BL)	X-150 Relay and fuse block – Roof X-050 Cab main harness to roof harness 1	<b>Wiring harnesses - Electrical schematic sheet 17 (55.100)</b> <b>Wiring harnesses - Electrical schematic sheet 19 (55.100)</b> <b>Wiring harnesses - Electrical schematic sheet 21 (55.100)</b> <b>Wiring harnesses - Electrical schematic sheet 22 (55.100)</b>
K19_87	RF-9305 (BL)	X-150 Relay and fuse block – Roof X-050 Cab main harness to roof harness 1	
K26_30	RF-155B (GN)	X-150 Relay and fuse block – Roof X-150 Relay and fuse block – Roof	
K26_85	RF-057TD (BK)	SP-057T ROOF GROUND LH1 X-150 Relay and fuse block – Roof	
K26_86	RF-1092 (RD)	X-150 Relay and fuse block – Roof X-065 Work light switch panel	
K26_87	RF-1071 (VT)	X-150 Relay and fuse block – Roof SP-1071	

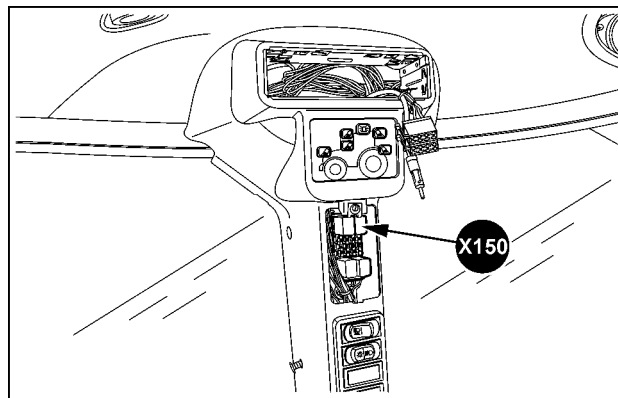

SVIL13TR00771AC 1

**Right-hand B-pillar**

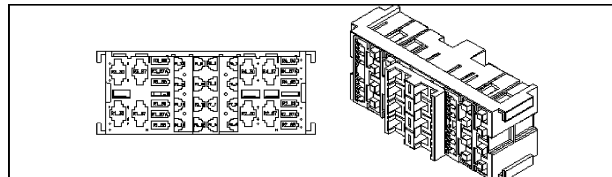

84529039 2

**CONNECTOR X-155 - Front loader relay – Valve 1**

CONNECTOR X-155 - Front loader relay – Valve 1			
PIN NUMBER	WIRE NUMBER	CIRCUIT REFERENCE	ELECTRICAL SCHEMATIC FRAME
30	FS-010HB (GN)	X-155 Front loader relay – Valve 1 SP-010H	<b>Wiring harnesses - Electrical schematic sheet 16 (55.100)</b>
85	FS-3279B (BL)	X-155 Front loader relay – Valve 1 SP-3279A	
86	FS-010HJ (GN)	X-155 Front loader relay – Valve 1 SP-010H	
87	FS-33272 (OR)	X-155 Front loader relay – Valve 1 X-392 Front loader harness (Stoll) to front loader diode (Stoll)	

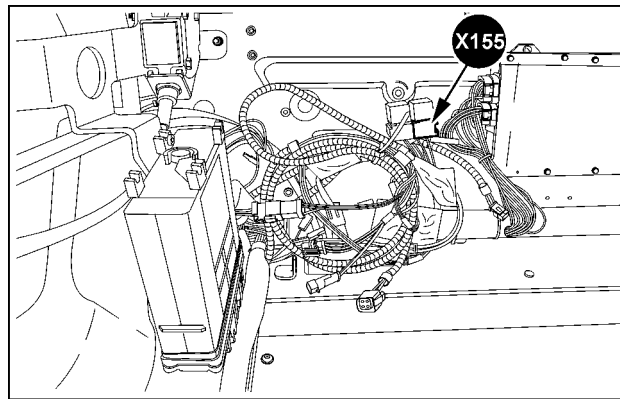

SVIL13TR00865AB 3

**In cab right-hand behind operator's seat**

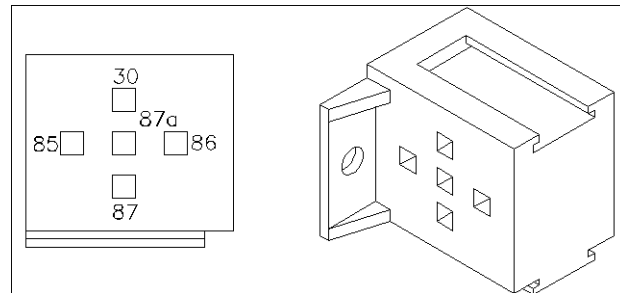

87746018 4

**CONNECTOR X-156 - Front loader relay – Valve 2**

CONNECTOR X-156 - Front loader relay – Valve 2			
PIN NUMBER	WIRE NUMBER	CIRCUIT REFERENCE	ELECTRICAL SCHEMATIC FRAME
30	FS-010HC (GN)	X-156 Front loader relay – Valve 2 SP-010H	<b>Wiring harnesses - Electrical schematic sheet 16 (55.100)</b>
85	FS-3280B (BL)	X-156 Front loader relay – Valve 2 SP-3280A	
86	FS-010HK (GN)	X-156 Front loader relay – Valve 2 SP-010H	
87	FS-3274 (RD)	X-156 Front loader relay – Valve 2 X-380 Front loader harness (Stoll) to front loader socket (Stoll)	

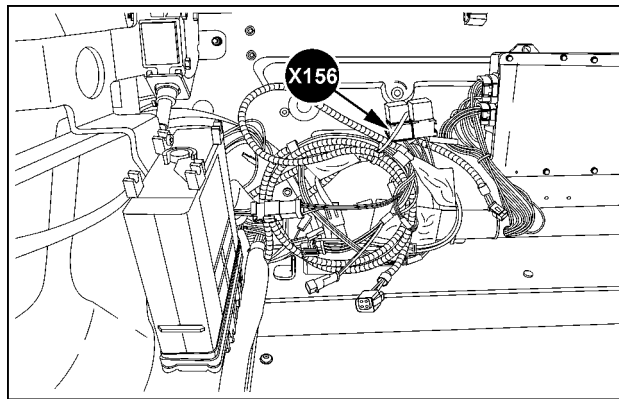

SVIL13TR00865AC 5

**In cab right-hand behind operator's seat**

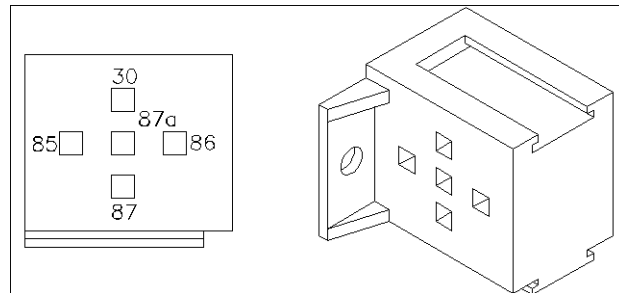

87746018 6

## Wire connectors - Component diagram 16

### CONNECTOR X-160 - Cab main harness to relay and fuse block – Roof

CONNECTOR X-160 - Cab main harness to relay and fuse block – Roof			
PIN NUMBER	WIRE NUMBER	CIRCUIT REFERENCE	ELECTRICAL SCHEMATIC FRAME
A	CM-001DA (RD) RF-001DA (RD)	SP-001D X-160 Cab main harness to relay and fuse block – Roof X-160 Cab main harness to relay and fuse block – Roof SP-001DA	<b>Wiring harnesses - Electrical schematic sheet 21 (55.100)</b>
B	CM-001DB (RD) RF-001DB (RD)	SP-001D X-160 Cab main harness to relay and fuse block – Roof X-160 Cab main harness to relay and fuse block – Roof SP-001DB	

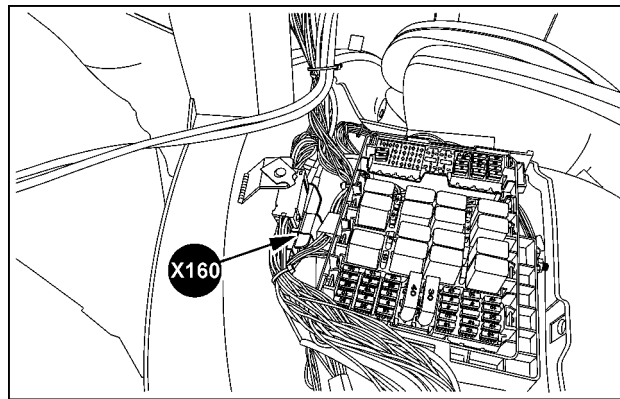

SVIL13TR00716AC 1

**Cab left-hand side**

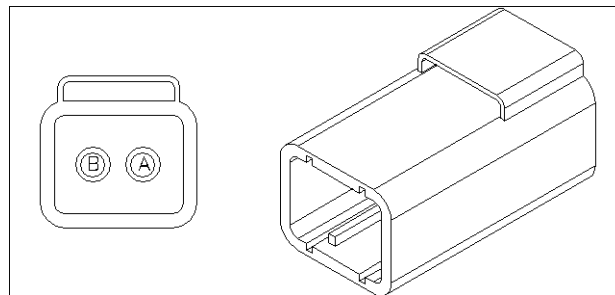

84136444 2

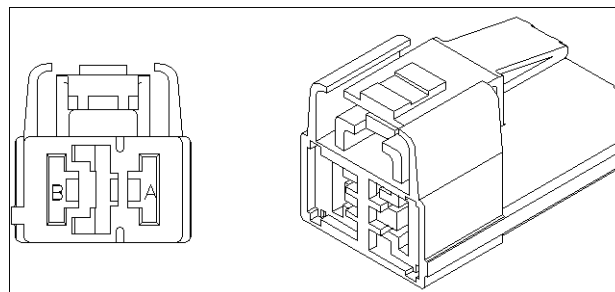

82011938 3

## Wire connectors - Component diagram 17

### CONNECTOR X-170 - Multicontroller

CONNECTOR X-170 - Multicontroller			
PIN NUMBER	WIRE NUMBER	CIRCUIT REFERENCE	ELECTRICAL SCHEMATIC FRAME
1	CM-010EC (GN)	SP-010E X-170 Multicontroller	Wiring harnesses - Electrical schematic sheet 08 (55.100)
2	CM-060FA (BK)	SP-060F X-170 Multicontroller	
3	CM-7210 (PK)	X-170 Multicontroller X-504 Transmission Control Unit (TCU)	
4	CM-7200 (GY)	X-170 Multicontroller X-504 Transmission Control Unit (TCU)	
5	CM-7700 (TN)	X-170 Multicontroller X-504 Transmission Control Unit (TCU)	
6	CM-5560 (YE)	X-170 Multicontroller X-504 Transmission Control Unit (TCU)	
7	CM-7800 (VT)	X-170 Multicontroller X-504 Transmission Control Unit (TCU)	

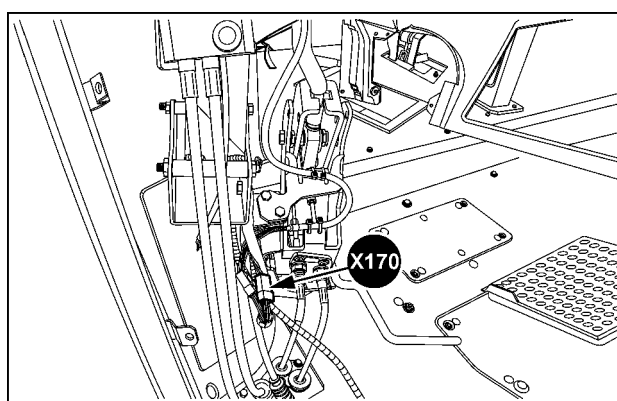

SVIL13TR00757AB 1

Right-hand bottom front tractor cab

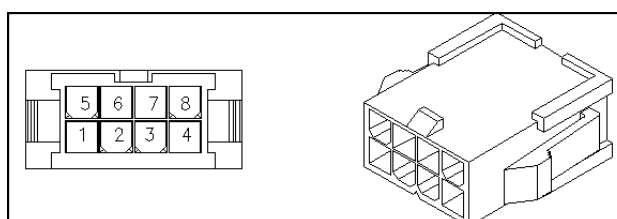

84355097 2

## Wire connectors - Component diagram 18

### CONNECTOR X-180 - Fuse block (F-070 to F-101)

CONNECTOR X-180 - Fuse block (F-070 to F-101)			
PIN NUMBER	WIRE NUMBER	CIRCUIT REFERENCE	ELECTRICAL SCHEMATIC FRAME
1A	CM-5260GA (TN)	SP-5260G EHR POWER X-180 Fuse block (F-070 to F-101)	<b>Wiring harnesses - Electrical schematic sheet 02 (55.100)</b> <b>Wiring harnesses - Electrical schematic sheet 04 (55.100)</b> <b>Wiring harnesses - Electrical schematic sheet 13 (55.100)</b> <b>Wiring harnesses - Electrical schematic sheet 14 (55.100)</b> <b>Wiring harnesses - Electrical schematic sheet 15 (55.100)</b> <b>Wiring harnesses - Electrical schematic sheet 16 (55.100)</b> <b>Wiring harnesses - Electrical schematic sheet 20 (55.100)</b> <b>Wiring harnesses - Electrical schematic sheet 23 (55.100)</b>
1B	CM-5515 (GY)	X-346 Cab main harness to Electro-Hydraulic Remote (EHR) valve harness X-180 Fuse block (F-070 to F-101)	
2A	CM-5260GB (TN)	SP-5260G EHR POWER X-180 Fuse block (F-070 to F-101)	
2B	CM-5515A (GY)	X-180 Fuse block (F-070 to F-101) X-446 Cab main harness (power supply) to Electro-Hydraulic Remote (EHR) valve harness	
3A	CM-5260GC (TN)	SP-5260G EHR POWER X-180 Fuse block (F-070 to F-101)	
3B	CM-5515B (GY)	X-180 Fuse block (F-070 to F-101) X-446 Cab main harness (power supply) to Electro-Hydraulic Remote (EHR) valve harness	
4A	CM-5260GD (TN)	SP-5260G EHR POWER X-180 Fuse block (F-070 to F-101)	
4B	CM-5515C (GY)	X-180 Fuse block (F-070 to F-101) X-446 Cab main harness (power supply) to Electro-Hydraulic Remote (EHR) valve harness	
5A	CM-3001D (GN)	X-090 Flasher unit X-180 Fuse block (F-070 to F-101)	
5B	CM-3001E (GN)	X-180 Fuse block (F-070 to F-101) SP-3001E FLASHER LH socket	
6A	CM-3002D (GN)	X-090 Flasher unit X-180 Fuse block (F-070 to F-101)	
6B	CM-3002E (GN)	SP-3002E FLASHER RH socket X-180 Fuse block (F-070 to F-101)	
7A	CM-810E (RD)	SP-810C X-180 Fuse block (F-070 to F-101)	
7B	CM-810G (GN)	X-098 Trailer socket rear (7-Pin) X-180 Fuse block (F-070 to F-101)	
8A	CM-1013E (RD)	SP-1013 X-180 Fuse block (F-070 to F-101)	
8B	CM-1013M (RD)	X-180 Fuse block (F-070 to F-101) SP-1013M 58R socket	
9A	CM-001DP (RD)	X-180 Fuse block (F-070 to F-101) SP-001DM	
9B	CM-001G (RD)	X-180 Fuse block (F-070 to F-101) X-404 Cab main harness to switch panel harness 1	
10A	CM-001DU (RD)	X-180 Fuse block (F-070 to F-101) SP-001DM	
10B	CM-155L (GN)	X-180 Fuse block (F-070 to F-101) X-944 Cab main harness to Electronic Front Hitch (EFH) control unit harness	
11A	CM-071U (WH)	X-180 Fuse block (F-070 to F-101) SP-071	

<b>CONNECTOR X-180 - Fuse block (F-070 to F-101)</b>			
<b>PIN NUMBER</b>	<b>WIRE NUMBER</b>	<b>CIRCUIT REFERENCE</b>	<b>ELECTRICAL SCHEMATIC FRAME</b>
11B	CM-010H (GN)	X-393 Cab main harness to front loader harness X-180 Fuse block (F-070 to F-101)	<b>Wiring harnesses - Electrical schematic sheet 02 (55.100)</b> <b>Wiring harnesses - Electrical schematic sheet 04 (55.100)</b> <b>Wiring harnesses - Electrical schematic sheet 13 (55.100)</b> <b>Wiring harnesses - Electrical schematic sheet 14 (55.100)</b> <b>Wiring harnesses - Electrical schematic sheet 15 (55.100)</b> <b>Wiring harnesses - Electrical schematic sheet 16 (55.100)</b> <b>Wiring harnesses - Electrical schematic sheet 20 (55.100)</b> <b>Wiring harnesses - Electrical schematic sheet 23 (55.100)</b>
18A	CM-011 (GN)	X-120 Relay and diode block (K-007 to K-060 and V-040 to V-044) X-180 Fuse block (F-070 to F-101)	
18B	CM-011AA (GN)	X-180 Fuse block (F-070 to F-101) X-944 Cab main harness to Electronic Front Hitch (EFH) control unit harness	
21A	CM-001DZ (BL)	X-180 Fuse block (F-070 to F-101) SP-001DM	
21B	CM-1052D (YE)	X-180 Fuse block (F-070 to F-101) X-091 Steering column multi-function lever	
24A	CM-010K (GN)	X-180 Fuse block (F-070 to F-101) X-381 Cab main harness to hydraulic trailer brake harness	
24B	CM-071V (WH)	X-180 Fuse block (F-070 to F-101) SP-071	

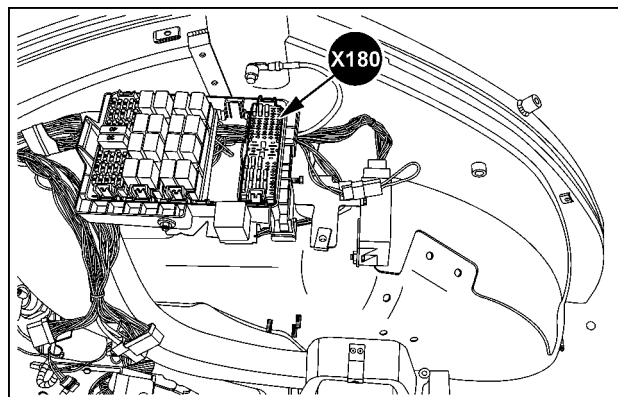

SVIL13TR00695AF 1

**Cab left-hand side**

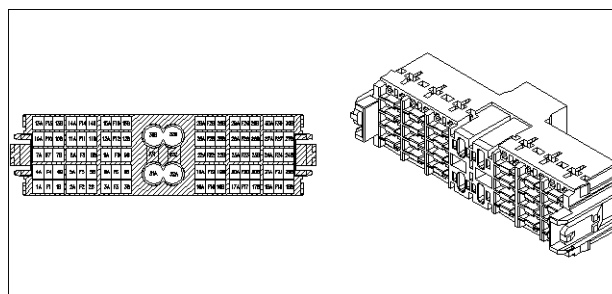

87314761 2



**CONNECTOR X-181 - Clutch pedal switch – Transmission**

CONNECTOR X-181 - Clutch pedal switch – Transmission			
PIN NUMBER	WIRE NUMBER	CIRCUIT REFERENCE	ELECTRICAL SCHEMATIC FRAME
1	CM-9269 (WH)	X-181 Clutch pedal switch – Transmission X-504 Transmission Control Unit (TCU)	<b>Wiring harnesses - Electrical schematic sheet 08 (55.100)</b>
2	CM-010EB (GN)	X-181 Clutch pedal switch – Transmission SP-010E	

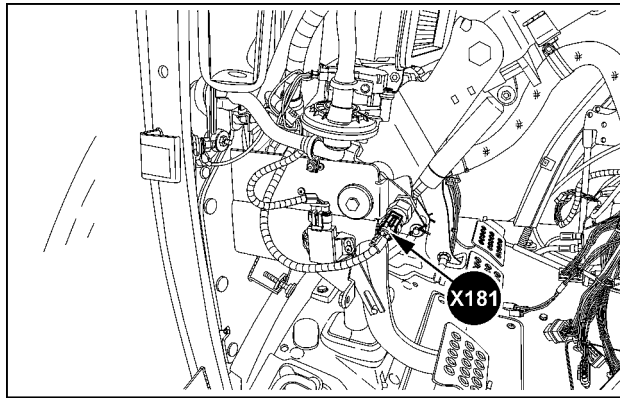

SVIL13TR00734AE 3

**Front left-hand cab**

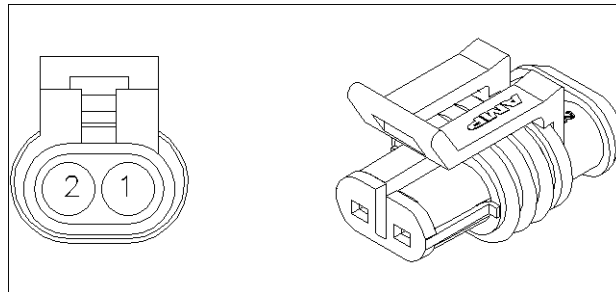

82012083 4

**CONNECTOR X-182 - Auto-shift programming switch**

CONNECTOR X-182 - Auto-shift programming switch			
PIN NUMBER	WIRE NUMBER	CIRCUIT REFERENCE	ELECTRICAL SCHEMATIC FRAME
1	CM-7246 (TN)	X-182 Auto-shift programming switch X-504 Transmission Control Unit (TCU)	Wiring harnesses - Electrical schematic sheet 08 (55.100)
2	CM-010ED (GN)	SP-010E X-182 Auto-shift programming switch	

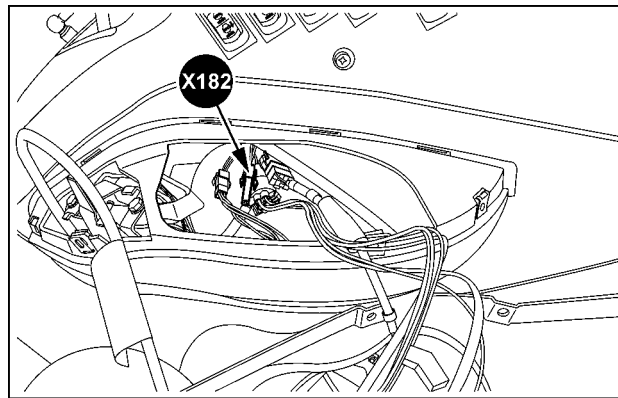

SVIL13TR00732AC 5

**On the right-hand trim behind switch panel**

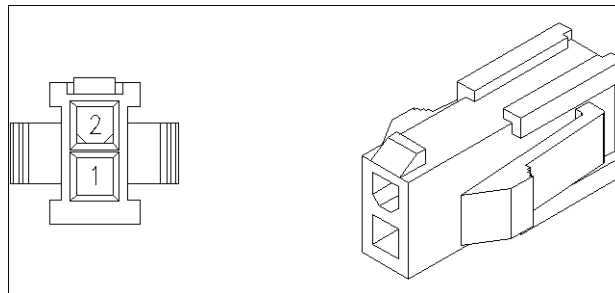

84146426 6

**CONNECTOR X-183 - Ground speed Power Take-Off (PTO) – Stationary operation switch**

CONNECTOR X-183 - Ground speed Power Take-Off (PTO) – Stationary operation switch			
PIN NUMBER	WIRE NUMBER	CIRCUIT REFERENCE	ELECTRICAL SCHEMATIC FRAME
1	CM-2055 (WH)	X-504 Transmission Control Unit (TCU) X-183 Ground speed Power Take-Off (PTO) – Stationary operation switch	<b>Wiring harnesses - Electrical schematic sheet 07 (55.100)</b>
2	CM-010JB (WH)	X-183 Ground speed Power Take-Off (PTO) – Stationary operation switch SP-010J	



SVIL13TR00755AB 7

**Rear of cab behind left-hand trim**

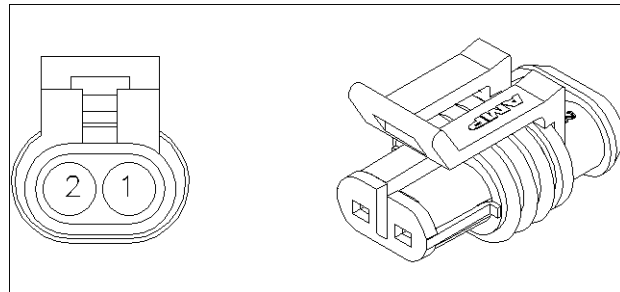

82012083 8

**CONNECTOR X-184 - Air brake pressure sensor (ground)**

CONNECTOR X-184 - Air brake pressure sensor (ground)			
PIN NUMBER	WIRE NUMBER	CIRCUIT REFERENCE	ELECTRICAL SCHEMATIC FRAME
1	CM-060C (BK/WH)	X-184 Air brake pressure sensor (ground) SP-060	Wiring harnesses - Electrical schematic sheet 03 (55.100)

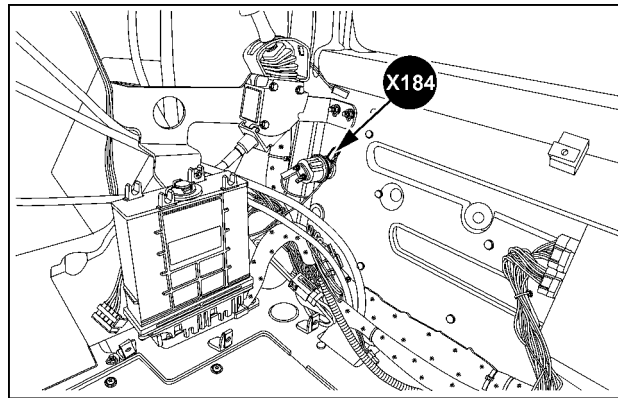

SVIL13TR00756AB 9

**Right-hand bottom rear tractor cab**

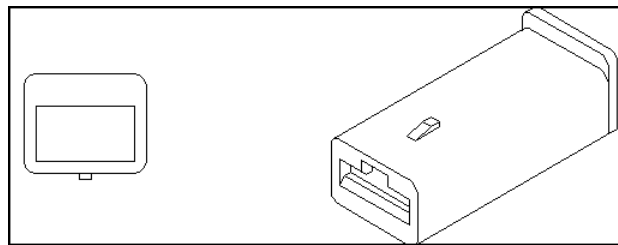

84157166 10

**CONNECTOR X-185 - Air brake pressure sensor (signal)**

CONNECTOR X-185 - Air brake pressure sensor (signal)			
PIN NUMBER	WIRE NUMBER	CIRCUIT REFERENCE	ELECTRICAL SCHEMATIC FRAME
1	CM-8010 (BR)	X-377 Instrument cluster CN3 X-185 Air brake pressure sensor (signal)	<b>Wiring harnesses - Electrical schematic sheet 03 (55.100)</b>

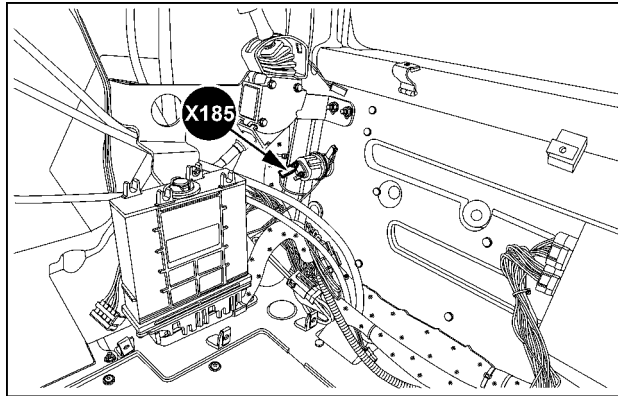

SVIL13TR00756AC 11

**Right-hand bottom rear tractor cab**

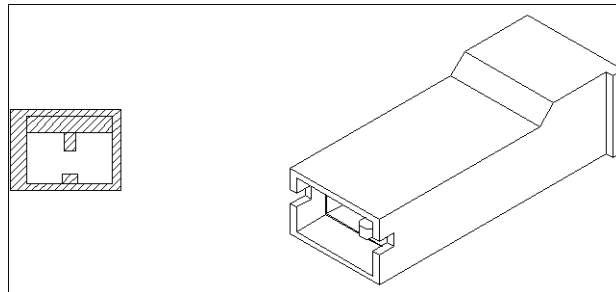

87691062 12

## Wire connectors - Component diagram 19

### CONNECTOR X-197 - Battery isolator control switch

CONNECTOR X-197 - Battery isolator control switch			
PIN NUMBER	WIRE NUMBER	CIRCUIT REFERENCE	ELECTRICAL SCHEMATIC FRAME
1	RF-171B (VT)	X-197 Battery isolator control switch X-385 Cab main harness to roof harness 2	<b>Wiring harnesses - Electrical schematic sheet 01 (55.100)</b>
2	RF-138B (VT)	X-385 Cab main harness to roof harness 2 X-197 Battery isolator control switch	
3	RF-170 (PK)	X-197 Battery isolator control switch X-385 Cab main harness to roof harness 2	
7	RF-057HA (BK)	X-197 Battery isolator control switch SP-057R	
8	RF-1013LD (BL)	X-197 Battery isolator control switch SP-1013L	
9	RF-057RM (BK)	X-197 Battery isolator control switch SP-057R	
10	RF-1013LE (BL)	X-197 Battery isolator control switch SP-1013L	

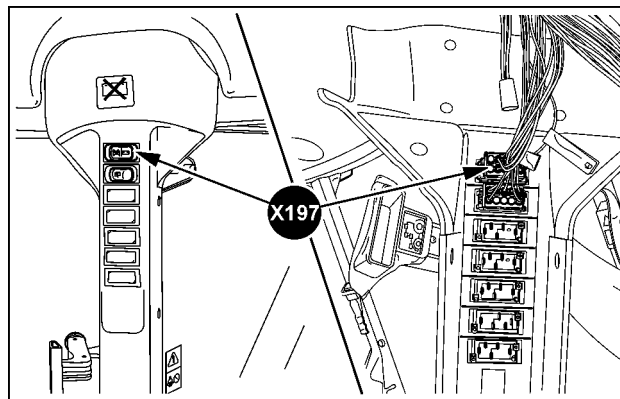

SS13J066 1

**Left-hand B-pillar**

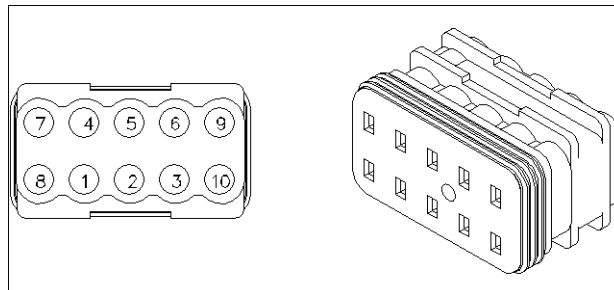

84819781 2

**CONNECTOR X-199 - Powershift input speed sensor**

CONNECTOR X-199 - Powershift input speed sensor			
PIN NUMBER	WIRE NUMBER	CIRCUIT REFERENCE	ELECTRICAL SCHEMATIC FRAME
1	TR-060JB (BK/WH)	X-199 Powershift input speed sensor SP-060J VMG1 ZF Ext	
2	TR-6000 (PK)	X-300 Cab main harness to transmission harness X-199 Powershift input speed sensor	
3	TR-010JC (GN)	X-199 Powershift input speed sensor SP-010JA ZF Trans Sensor 12V	

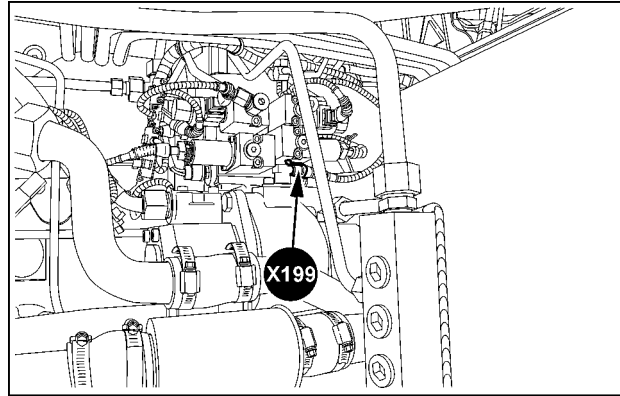

SVIL13TR00754AC 3

**Right-hand of transmission**

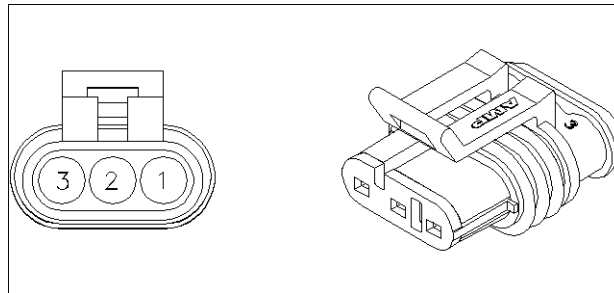

84062580 4

## Wire connectors - Component diagram 20

### CONNECTOR X-200 - Central Control Unit (CCU) – CN1A

CONNECTOR X-200 - Central Control Unit (CCU) – CN1A				
PIN NUMBER	WIRE NUMBER	CIRCUIT REFERENCE	ELECTRICAL SCHEMATIC FRAME	
2	CM-010FB (GN)	SP-010F X-200 Central Control Unit (CCU) – CN1A	Wiring harnesses - Electrical schematic sheet 09 (55.100) Wiring harnesses - Electrical schematic sheet 10 (55.100) Wiring harnesses - Electrical schematic sheet 11 (55.100) Wiring harnesses - Electrical schematic sheet 12 (55.100) Wiring harnesses - Electrical schematic sheet 24 (55.100)	
3	CM-010FC (GN)	SP-010F X-200 Central Control Unit (CCU) – CN1A		
4	CM-8073 (VT)	X-300 Cab main harness to transmission harness X-200 Central Control Unit (CCU) – CN1A		
5	CM-5030 (TN)	X-200 Central Control Unit (CCU) – CN1A X-300 Cab main harness to transmission harness		
7	CM-7081 (LG)	X-300 Cab main harness to transmission harness X-200 Central Control Unit (CCU) – CN1A		
8	CM-5001B (VT)	X-200 Central Control Unit (CCU) – CN1A SP-5001		
10	CM-8071 (VT)	X-300 Cab main harness to transmission harness X-200 Central Control Unit (CCU) – CN1A		
12	CM-5025 (TN)	X-200 Central Control Unit (CCU) – CN1A X-300 Cab main harness to transmission harness		
13	CM-2043 (OR)	X-200 Central Control Unit (CCU) – CN1A X-001 Cab main harness to engine harness 1		Wiring harnesses - Electrical schematic sheet 09 (55.100) Wiring harnesses - Electrical schematic sheet 10 (55.100) Wiring harnesses - Electrical schematic sheet 11 (55.100) Wiring harnesses - Electrical schematic sheet 12 (55.100) Wiring harnesses - Electrical schematic sheet 24 (55.100)
14	CM-5001A (VT)	SP-5001 X-200 Central Control Unit (CCU) – CN1A		
15	CM-191DZ (YE)	SP-191D X-200 Central Control Unit (CCU) – CN1A		
16	CM-190DZ (GN)	SP-190D X-200 Central Control Unit (CCU) – CN1A		
19	CM-057DA (BK)	X-200 Central Control Unit (CCU) – CN1A SP-057D CAB GND		
20	CM-5005C (TN)	X-200 Central Control Unit (CCU) – CN1A SP-5005		
21	CM-291 (RD)	X-200 Central Control Unit (CCU) – CN1A SP-291		
22	CM-290 (BL)	X-200 Central Control Unit (CCU) – CN1A SP-290		
23	CM-060G (BK/WH)	X-200 Central Control Unit (CCU) – CN1A SP-060G		
25	CM-057DB (BK)	X-200 Central Control Unit (CCU) – CN1A SP-057D CAB GND		
26	CM-057DC (BK)	X-200 Central Control Unit (CCU) – CN1A SP-057D CAB GND		



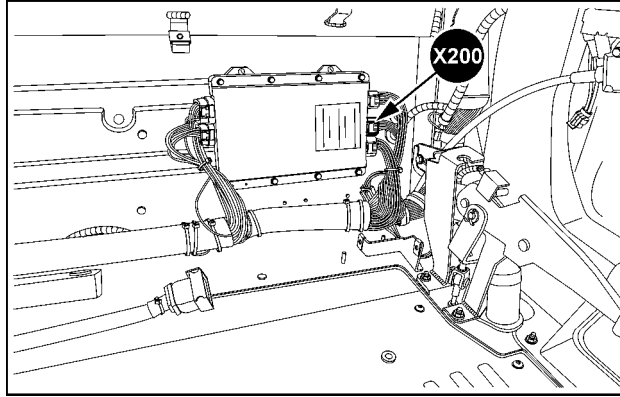

SVIL13TR00860AB 1

**In cab left-hand behind operator's seat**

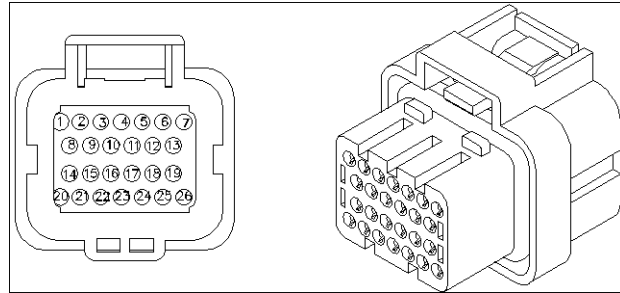

82028493 2

## Wire connectors - Component diagram 21

### CONNECTOR X-210 - Central Control Unit (CCU) – CN1B

CONNECTOR X-210 - Central Control Unit (CCU) – CN1B			
PIN NUMBER	WIRE NUMBER	CIRCUIT REFERENCE	ELECTRICAL SCHEMATIC FRAME
1	CM-5545 (RD)	X-388 Cab main harness to armrest components X-210 Central Control Unit (CCU) – CN1B	<b>Wiring harnesses - Electrical schematic sheet 09 (55.100)</b> <b>Wiring harnesses - Electrical schematic sheet 11 (55.100)</b> <b>Wiring harnesses - Electrical schematic sheet 12 (55.100)</b> <b>Wiring harnesses - Electrical schematic sheet 13 (55.100)</b>
2	CM-5080 (PK)	X-210 Central Control Unit (CCU) – CN1B X-300 Cab main harness to transmission harness	
3	CM-5040D (TN)	X-326 Hitch position control potentiometer X-210 Central Control Unit (CCU) – CN1B	
4	CM-5122 (PK)	X-404 Cab main harness to switch panel harness 1 X-210 Central Control Unit (CCU) – CN1B	
5	CM-5120 (PK)	X-404 Cab main harness to switch panel harness 1 X-210 Central Control Unit (CCU) – CN1B	
6	CM-5123 (PK)	X-404 Cab main harness to switch panel harness 1 X-210 Central Control Unit (CCU) – CN1B	
7	CM-5121 (PK)	X-404 Cab main harness to switch panel harness 1 X-210 Central Control Unit (CCU) – CN1B	
8	CM-5040F (TN)	X-037 Hitch draft control potentiometer X-210 Central Control Unit (CCU) – CN1B	
9	CM-5040A (GN)	X-210 Central Control Unit (CCU) – CN1B X-300 Cab main harness to transmission harness	<b>Wiring harnesses - Electrical schematic sheet 09 (55.100)</b> <b>Wiring harnesses - Electrical schematic sheet 11 (55.100)</b> <b>Wiring harnesses - Electrical schematic sheet 12 (55.100)</b> <b>Wiring harnesses - Electrical schematic sheet 13 (55.100)</b>
10	CM-5040 (TN)	X-210 Central Control Unit (CCU) – CN1B X-300 Cab main harness to transmission harness	
14	CM-7500A (TN)	X-382 Hydraulic oil temperature sensor X-210 Central Control Unit (CCU) – CN1B	
17	CM-5520 (LG)	X-210 Central Control Unit (CCU) – CN1B SP-5520	
18	CM-5555 (BL)	X-210 Central Control Unit (CCU) – CN1B X-001 Cab main harness to engine harness 1	
19	CM-2018 (RD)	X-210 Central Control Unit (CCU) – CN1B X-300 Cab main harness to transmission harness	
20	CM-5557 (BL)	X-032 Remote valve switch – Fender left-hand X-210 Central Control Unit (CCU) – CN1B	
21	CM-5558 (RD)	X-032 Remote valve switch – Fender left-hand X-210 Central Control Unit (CCU) – CN1B	
22	CM-810M (GN)	X-093 Brake light switch – Left-hand X-210 Central Control Unit (CCU) – CN1B	

<b>CONNECTOR X-210 - Central Control Unit (CCU) – CN1B</b>			
<b>PIN NUMBER</b>	<b>WIRE NUMBER</b>	<b>CIRCUIT REFERENCE</b>	<b>ELECTRICAL SCHEMATIC FRAME</b>
23	CM-810N (GN)	X-210 Central Control Unit (CCU) – CN1B X-094 Brake light switch – Right-hand	<b>Wiring harnesses - Electrical schematic sheet 09 (55.100)</b> <b>Wiring harnesses - Electrical schematic sheet 11 (55.100)</b> <b>Wiring harnesses - Electrical schematic sheet 12 (55.100)</b> <b>Wiring harnesses - Electrical schematic sheet 13 (55.100)</b>
24	CM-5730 (WH)	X-388 Cab main harness to armrest components X-210 Central Control Unit (CCU) – CN1B	
25	CM-7520 (GN)	X-210 Central Control Unit (CCU) – CN1B X-300 Cab main harness to transmission harness	
26	CM-7171 (WH)	X-290 Front axle differential lock – Switch X-210 Central Control Unit (CCU) – CN1B	
28	CM-5556 (RD)	X-210 Central Control Unit (CCU) – CN1B X-001 Cab main harness to engine harness 1	
29	CM-5100A (PK)	X-210 Central Control Unit (CCU) – CN1B SP-5100	
30	CM-5095A (PK)	X-210 Central Control Unit (CCU) – CN1B SP-5095	
33	CM-2028 (GN)	X-210 Central Control Unit (CCU) – CN1B X-300 Cab main harness to transmission harness	

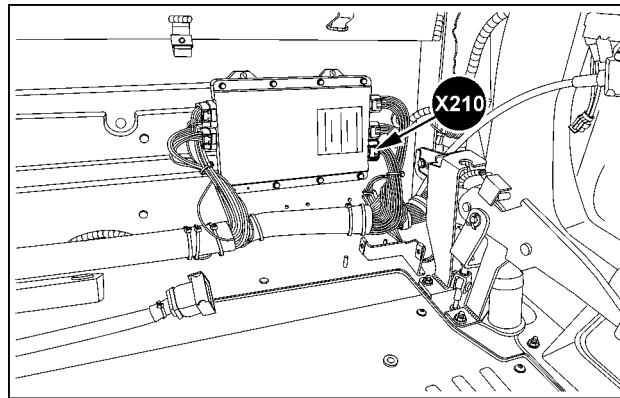

SVIL13TR00860AC 1

**In cab left-hand behind operator's seat**

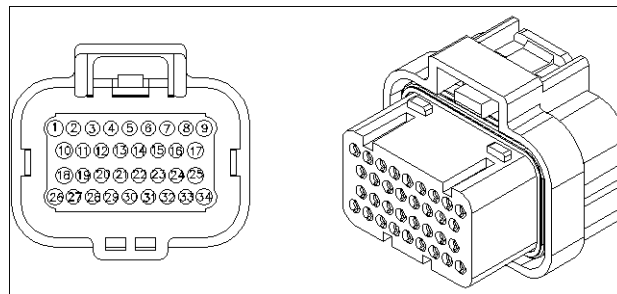

82028495 2

## Wire connectors - Component diagram 22

### CONNECTOR X-220 - Central Control Unit (CCU) – CN2

CONNECTOR X-220 - Central Control Unit (CCU) – CN2			
PIN NUMBER	WIRE NUMBER	CIRCUIT REFERENCE	ELECTRICAL SCHEMATIC FRAME
4	CM-5035 (TN)	X-220 Central Control Unit (CCU) – CN2 X-300 Cab main harness to transmission harness	<b>Wiring harnesses - Electrical schematic sheet 09 (55.100)</b> <b>Wiring harnesses - Electrical schematic sheet 10 (55.100)</b> <b>Wiring harnesses - Electrical schematic sheet 11 (55.100)</b> <b>Wiring harnesses - Electrical schematic sheet 12 (55.100)</b> <b>Wiring harnesses - Electrical schematic sheet 13 (55.100)</b>
5	CM-5035A (TN)	X-220 Central Control Unit (CCU) – CN2 X-300 Cab main harness to transmission harness	
7	CM-2044 (OR)	X-220 Central Control Unit (CCU) – CN2 X-001 Cab main harness to engine harness 1	
8	CM-8074 (VT)	X-300 Cab main harness to transmission harness X-220 Central Control Unit (CCU) – CN2	
11	CM-5220 (YE)	X-405 Cab main harness to switch panel harness 2 X-220 Central Control Unit (CCU) – CN2	
12	CM-1160 (RD)	X-120 Relay and diode block (K-007 to K-060 and V-040 to V-044) X-220 Central Control Unit (CCU) – CN2	
13	CM-8072 (VT)	X-300 Cab main harness to transmission harness X-220 Central Control Unit (CCU) – CN2	
14	CM-5546 (BR)	X-388 Cab main harness to armrest components X-220 Central Control Unit (CCU) – CN2	
15	CM-5271 (BR)	X-220 Central Control Unit (CCU) – CN2 X-388 Cab main harness to armrest components	
17	CM-5272 (BR)	X-220 Central Control Unit (CCU) – CN2 X-388 Cab main harness to armrest components	
19	CM-5105 (GY)	X-405 Cab main harness to switch panel harness 2 X-220 Central Control Unit (CCU) – CN2	
20	CM-5547 (OR)	X-388 Cab main harness to armrest components X-220 Central Control Unit (CCU) – CN2	
21	CM-057DD (BK)	X-220 Central Control Unit (CCU) – CN2 SP-057D CAB GND	
22	CM-2058 (WH)	X-220 Central Control Unit (CCU) – CN2 X-504 Transmission Control Unit (TCU)	
24	CM-5180 (VT)	X-405 Cab main harness to switch panel harness 2 X-220 Central Control Unit (CCU) – CN2	
25	CM-5230 (YE)	X-405 Cab main harness to switch panel harness 2 X-220 Central Control Unit (CCU) – CN2	
26	CM-057DE (BK)	X-220 Central Control Unit (CCU) – CN2 SP-057D CAB GND	

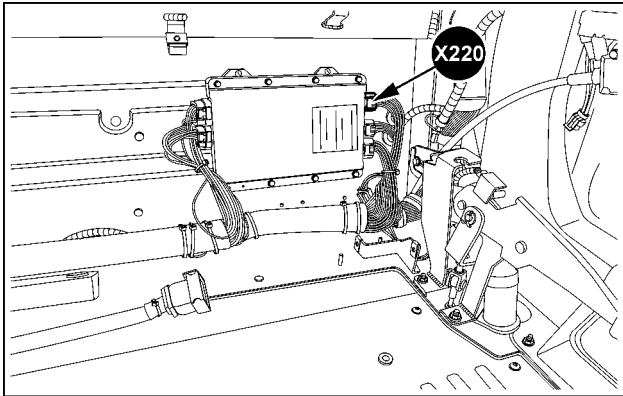

SVIL13TR00860AD 1

In cab left-hand behind operator's seat

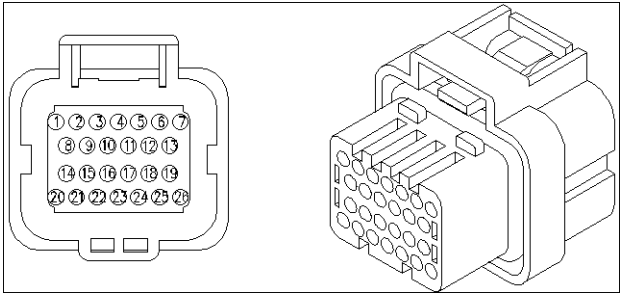

87694552 2

## Wire connectors - Component diagram 23

### CONNECTOR X-230 - Central Control Unit (CCU) – CN3A

CONNECTOR X-230 - Central Control Unit (CCU) – CN3A			
PIN NUMBER	WIRE NUMBER	CIRCUIT REFERENCE	ELECTRICAL SCHEMATIC FRAME
1	CM-3024A (YE)	X-405 Cab main harness to switch panel harness 2 X-230 Central Control Unit (CCU) – CN3A	<b>Wiring harnesses - Electrical schematic sheet 09 (55.100)</b> <b>Wiring harnesses - Electrical schematic sheet 10 (55.100)</b> <b>Wiring harnesses - Electrical schematic sheet 11 (55.100)</b> <b>Wiring harnesses - Electrical schematic sheet 12 (55.100)</b> <b>Wiring harnesses - Electrical schematic sheet 13 (55.100)</b> <b>Wiring harnesses - Electrical schematic sheet 14 (55.100)</b>
3	CM-5597 (GY)	X-230 Central Control Unit (CCU) – CN3A SP-5597	
4	CM-5578 (VT)	X-320 Multicontroller X-230 Central Control Unit (CCU) – CN3A	
5	CM-5210 (BR)	X-230 Central Control Unit (CCU) – CN3A SP-5210	
7	CM-5575 (WH)	X-320 Multicontroller X-230 Central Control Unit (CCU) – CN3A	
9	CM-2085 (OR)	X-405 Cab main harness to switch panel harness 2 X-230 Central Control Unit (CCU) – CN3A	
12	CM-2068 (TN)	X-405 Cab main harness to switch panel harness 2 X-230 Central Control Unit (CCU) – CN3A	
14	CM-1001E (WH)	X-230 Central Control Unit (CCU) – CN3A SP-1001A	
15	CM-5565 (OR)	X-388 Cab main harness to armrest components X-230 Central Control Unit (CCU) – CN3A	
16	CM-6500A (BR)	X-320 Multicontroller X-230 Central Control Unit (CCU) – CN3A	
17	CM-5579 (GY)	X-320 Multicontroller X-230 Central Control Unit (CCU) – CN3A	
19	CM-5577 (VT)	X-320 Multicontroller X-230 Central Control Unit (CCU) – CN3A	
20	CM-2059 (WH)	X-349 Power Take-Off (PTO) ON/OFF switch – Fender right-hand X-230 Central Control Unit (CCU) – CN3A	
21	CM-2056B (WH)	X-230 Central Control Unit (CCU) – CN3A SP-2056	
22	CM-2246 (PK)	X-405 Cab main harness to switch panel harness 2 X-230 Central Control Unit (CCU) – CN3A	
23	CM-2578 (GN)	X-320 Multicontroller X-230 Central Control Unit (CCU) – CN3A	
24	CM-3024B (YE)	X-405 Cab main harness to switch panel harness 2 X-230 Central Control Unit (CCU) – CN3A	
25	CM-9215A (YE)	X-230 Central Control Unit (CCU) – CN3A X-050 Cab main harness to roof harness 1	

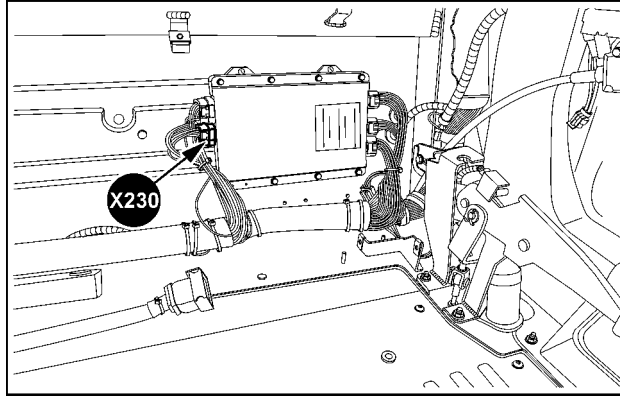

SVIL13TR00860AE 1

**In cab left-hand behind operator's seat**

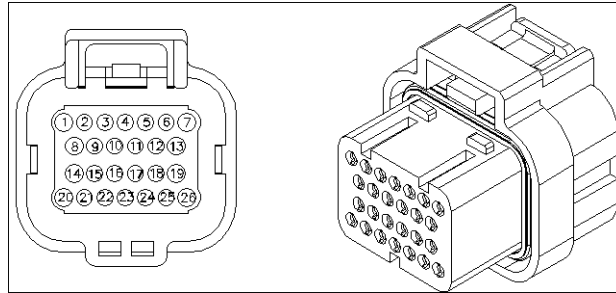

82016219 2

## Wire connectors - Component diagram 24

### CONNECTOR X-240 - Central Control Unit (CCU) – CN3B

CONNECTOR X-240 - Central Control Unit (CCU) – CN3B			
PIN NUMBER	WIRE NUMBER	CIRCUIT REFERENCE	ELECTRICAL SCHEMATIC FRAME
8	CM-7151 (BR)	X-240 Central Control Unit (CCU) – CN3B X-310 Hydraulic oil heating – Solenoid valve	<b>Wiring harnesses - Electrical schematic sheet 09 (55.100)</b> <b>Wiring harnesses - Electrical schematic sheet 10 (55.100)</b> <b>Wiring harnesses - Electrical schematic sheet 13 (55.100)</b> <b>Wiring harnesses - Electrical schematic sheet 14 (55.100)</b> <b>Wiring harnesses - Electrical schematic sheet 15 (55.100)</b> <b>Wiring harnesses - Electrical schematic sheet 16 (55.100)</b>
9	CM-2585 (TN)	X-944 Cab main harness to Electronic Front Hitch (EFH) control unit harness X-240 Central Control Unit (CCU) – CN3B	
11	CM-2235 (PK)	X-240 Central Control Unit (CCU) – CN3B X-405 Cab main harness to switch panel harness 2	
17	CM-2586 (TN)	X-944 Cab main harness to Electronic Front Hitch (EFH) control unit harness X-240 Central Control Unit (CCU) – CN3B	
23	CM-2236 (PK)	X-405 Cab main harness to switch panel harness 2 X-240 Central Control Unit (CCU) – CN3B	
24	CM-3155 (WH)	X-358 Hand brake position switch X-240 Central Control Unit (CCU) – CN3B	
26	CM-5273 (BR)	X-240 Central Control Unit (CCU) – CN3B X-388 Cab main harness to armrest components	
27	CM-3279 (BL)	X-393 Cab main harness to front loader harness X-240 Central Control Unit (CCU) – CN3B	
28	CM-3280 (BL)	X-240 Central Control Unit (CCU) – CN3B X-393 Cab main harness to front loader harness	
29	CM-5274 (BR)	X-240 Central Control Unit (CCU) – CN3B X-388 Cab main harness to armrest components	
30	CM-7170 (WH)	X-405 Cab main harness to switch panel harness 2 X-240 Central Control Unit (CCU) – CN3B	<b>Wiring harnesses - Electrical schematic sheet 09 (55.100)</b> <b>Wiring harnesses - Electrical schematic sheet 10 (55.100)</b> <b>Wiring harnesses - Electrical schematic sheet 13 (55.100)</b> <b>Wiring harnesses - Electrical schematic sheet 14 (55.100)</b> <b>Wiring harnesses - Electrical schematic sheet 15 (55.100)</b> <b>Wiring harnesses - Electrical schematic sheet 16 (55.100)</b>
31	CM-7175 (YE)	X-405 Cab main harness to switch panel harness 2 X-240 Central Control Unit (CCU) – CN3B	
32	CM-2245 (PK)	X-240 Central Control Unit (CCU) – CN3B X-405 Cab main harness to switch panel harness 2	
33	CM-5566 (OR)	X-388 Cab main harness to armrest components X-240 Central Control Unit (CCU) – CN3B	
34	CM-5260A (TN)	SP-5260 X-240 Central Control Unit (CCU) – CN3B	



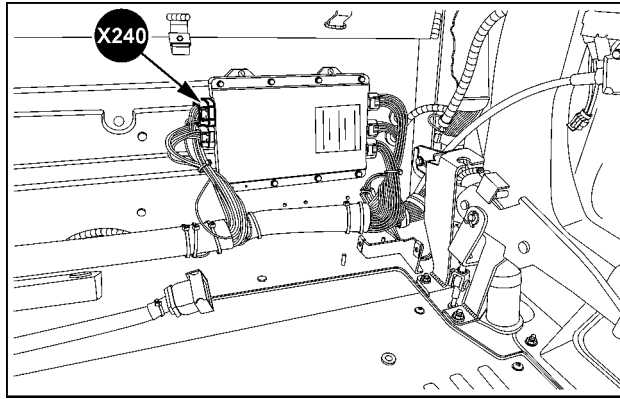

SVIL13TR00860AF 1

**In cab left-hand behind operator's seat**

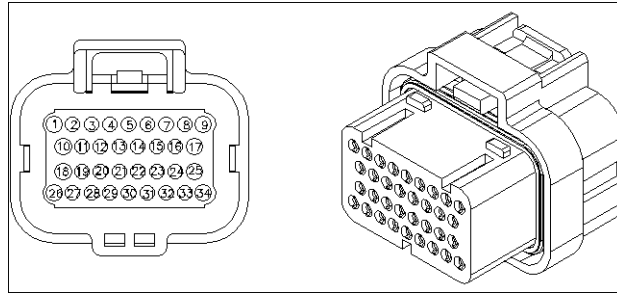

87410946 2

## Wire connectors - Component diagram 25

### CONNECTOR X-250 - Home/enter switch

CONNECTOR X-250 - Home/enter switch			
PIN NUMBER	WIRE NUMBER	CIRCUIT REFERENCE	ELECTRICAL SCHEMATIC FRAME
1	CM-7281 (WH)	X-250 Home/enter switch X-450 Instrument cluster CN1	Wiring harnesses - Electrical schematic sheet 04 (55.100)
2	CM-057EB (BK)	X-250 Home/enter switch SP-057E CAB GND 3	
3	CM-7280 (WH)	X-250 Home/enter switch X-450 Instrument cluster CN1	
4	-	-	
5	-	-	
6	-	-	
7	CM-057EC (BK)	X-250 Home/enter switch SP-057E CAB GND 3	
8	CM-1014K (RD)	SP-1014 X-250 Home/enter switch	
9	CM-057EA (BK)	X-250 Home/enter switch SP-057E CAB GND 3	
10	CM-1014L (RD)	SP-1014 X-250 Home/enter switch	

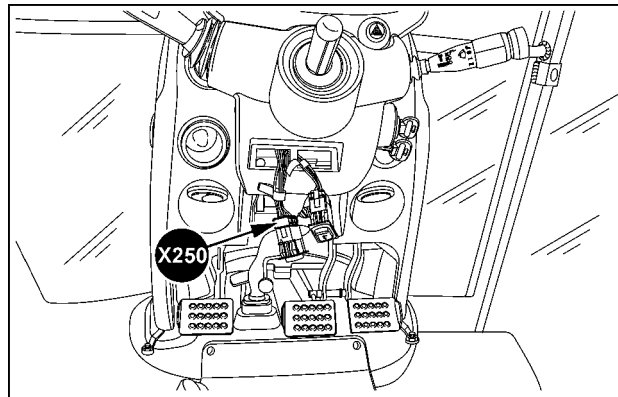

SVIL13TR00761AB 1

**Steering console**

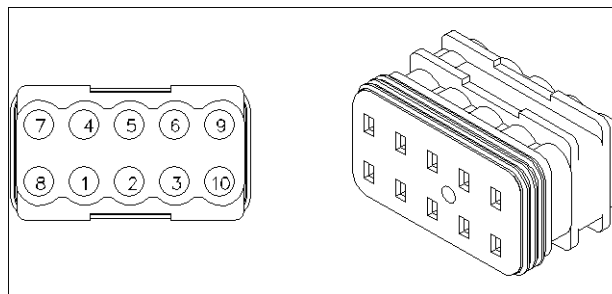

84819781 2

## Wire connectors - Component diagram 26

### CONNECTOR X-260 - Up/down menu switch

CONNECTOR X-260 - Up/down menu switch			
PIN NUMBER	WIRE NUMBER	CIRCUIT REFERENCE	ELECTRICAL SCHEMATIC FRAME
1	CM-2591 (BR)	X-260 Up/down menu switch X-450 Instrument cluster CN1	<b>Wiring harnesses - Electrical schematic sheet 04 (55.100)</b>
2	CM-057EF (BK)	X-260 Up/down menu switch SP-057E CAB GND 3	
3	CM-2590 (BL)	X-260 Up/down menu switch X-450 Instrument cluster CN1	
7	CM-057EG (BK)	X-260 Up/down menu switch SP-057E CAB GND 3	
8	CM-1014H (RD)	SP-1014 X-260 Up/down menu switch	
9	CM-057ED (BK)	X-260 Up/down menu switch SP-057E CAB GND 3	
10	CM-1014J (RD)	SP-1014 X-260 Up/down menu switch	

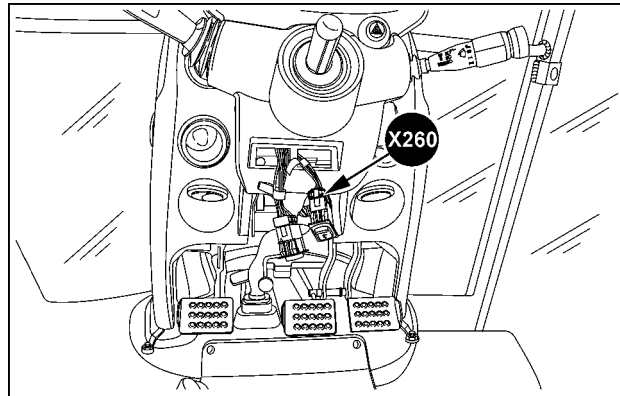

SVIL13TR00761AC 1

**Steering console**

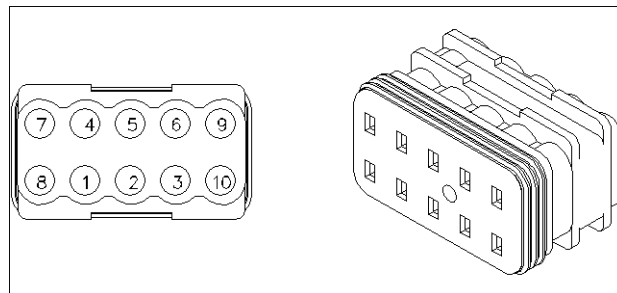

84819781 2

## Wire connectors - Component diagram 28

**CONNECTOR X-280 - Ground connection Central Control Unit (CCU) and Transmission Control Unit (TCU)**

CONNECTOR X-280 - Ground connection Central Control Unit (CCU) and Transmission Control Unit (TCU)			
PIN NUMBER	WIRE NUMBER	CIRCUIT REFERENCE	ELECTRICAL SCHEMATIC FRAME
1	CM-057D (BK)	SP-057D CAB GND X-280 Ground connection Central Control Unit (CCU) and Transmission Control Unit (TCU)	Wiring harnesses - Electrical schematic sheet 25 (55.100)

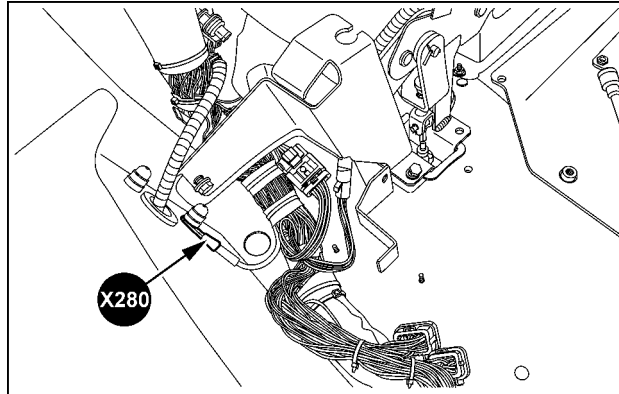

SVIL13TR00768AC 1

**Rear of cab behind left-hand trim**

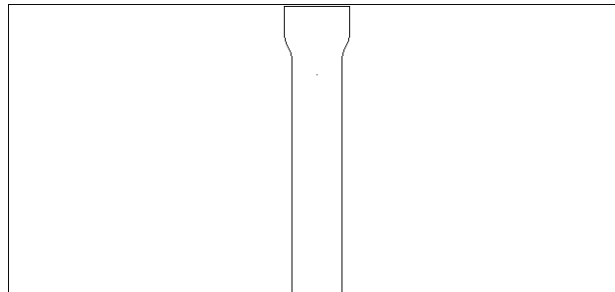

84153309 2

## Wire connectors - Component diagram 29

### CONNECTOR X-290 - Front axle differential lock – Switch

CONNECTOR X-290 - Front axle differential lock – Switch			
PIN NUMBER	WIRE NUMBER	CIRCUIT REFERENCE	ELECTRICAL SCHEMATIC FRAME
1	-	-	Wiring harnesses - Electrical schematic sheet 09 (55.100)
2	CM-010FG (GN)	X-290 Front axle differential lock – Switch SP-010F	
3	CM-7171 (WH)	X-290 Front axle differential lock – Switch X-210 Central Control Unit (CCU) – CN1B	
4	-	-	
5	-	-	
6	-	-	
7	CM-057CH (BK)	X-290 Front axle differential lock – Switch SP-057C	
8	CM-1014G (RD)	X-290 Front axle differential lock – Switch SP-1014	
9	-	-	
10	-	-	

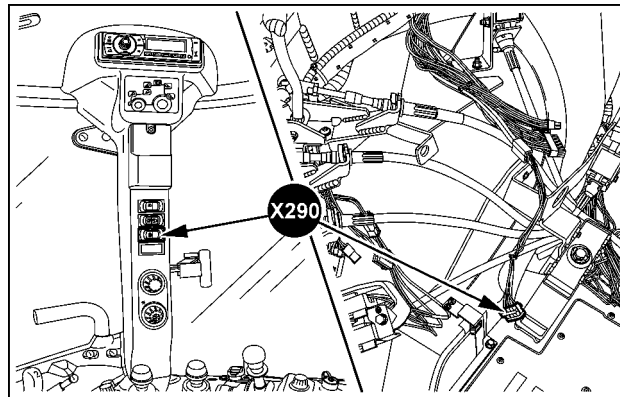

SS13K025 1

Right-hand B-pillar

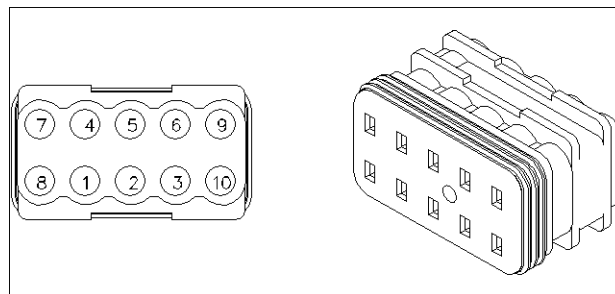

84819781 2

**CONNECTOR X-295 - Front loader diode (Stoll)**

CONNECTOR X-295 - Front loader diode (Stoll)			
PIN NUMBER	WIRE NUMBER	CIRCUIT REFERENCE	ELECTRICAL SCHEMATIC FRAME
1	LR-3281 (BL)	X-392 Front loader harness (Stoll) to front loader diode (Stoll) X-295 Front loader diode (Stoll)	
2	LR-3282A (GN)	X-295 Front loader diode (Stoll) SA1	

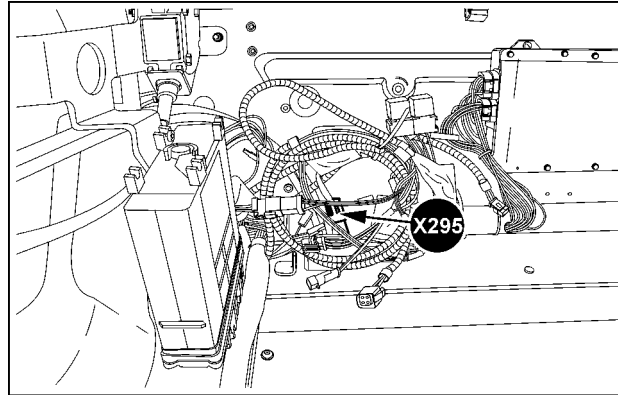

SVIL13TR00865AD 3

**In cab right-hand behind operator's seat**

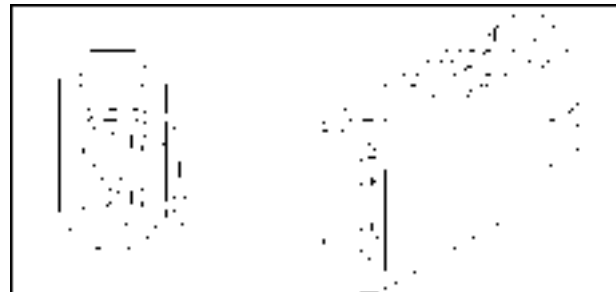

84121648 4

## Wire connectors - Component diagram 30

### CONNECTOR X-300 - Cab main harness to transmission harness

CONNECTOR X-300 - Cab main harness to transmission harness			
PIN NUMBER	WIRE NUMBER	CIRCUIT REFERENCE	ELECTRICAL SCHEMATIC FRAME
1	CM-7920 (VT) TR-7920 (VT)	X-504 Transmission Control Unit (TCU) X-300 Cab main harness to transmission harness X-383 Clutch C solenoid valve X-300 Cab main harness to transmission harness	<b>Wiring harnesses - Electrical schematic sheet 03 (55.100)</b> <b>Wiring harnesses - Electrical schematic sheet 04 (55.100)</b> <b>Wiring harnesses - Electrical schematic sheet 07 (55.100)</b>
2	CM-7900 (VT) TR-7900 (VT)	X-504 Transmission Control Unit (TCU) X-300 Cab main harness to transmission harness X-100 Clutch A solenoid valve X-300 Cab main harness to transmission harness	<b>Wiring harnesses - Electrical schematic sheet 08 (55.100)</b> <b>Wiring harnesses - Electrical schematic sheet 09 (55.100)</b> <b>Wiring harnesses - Electrical schematic sheet 11 (55.100)</b>
3	CM-7930 (VT) TR-7930 (VT)	X-504 Transmission Control Unit (TCU) X-300 Cab main harness to transmission harness X-301 Clutch D solenoid valve X-300 Cab main harness to transmission harness	<b>Wiring harnesses - Electrical schematic sheet 12 (55.100)</b>
4	CM-5520DC (LG) TR-5520DC (LG)	SP-5520 X-300 Cab main harness to transmission harness X-328 Hitch position sensor X-300 Cab main harness to transmission harness	
5	CM-7910 (VT) TR-7910 (VT)	X-504 Transmission Control Unit (TCU) X-300 Cab main harness to transmission harness X-364 Clutch B solenoid valve X-300 Cab main harness to transmission harness	

<b>CONNECTOR X-300 - Cab main harness to transmission harness</b>			
<b>PIN NUMBER</b>	<b>WIRE NUMBER</b>	<b>CIRCUIT REFERENCE</b>	<b>ELECTRICAL SCHEMATIC FRAME</b>
6	CM-7904 (VT) TR-7904 (VT)	X-300 Cab main harness to transmission harness X-504 Transmission Control Unit (TCU) X-300 Cab main harness to transmission harness X-365 Clutch G solenoid valve	<b>Wiring harnesses - Electrical schematic sheet 03 (55.100)</b> <b>Wiring harnesses - Electrical schematic sheet 04 (55.100)</b> <b>Wiring harnesses - Electrical schematic sheet 07 (55.100)</b> <b>Wiring harnesses - Electrical schematic sheet 08 (55.100)</b> <b>Wiring harnesses - Electrical schematic sheet 09 (55.100)</b> <b>Wiring harnesses - Electrical schematic sheet 11 (55.100)</b> <b>Wiring harnesses - Electrical schematic sheet 12 (55.100)</b>
7	CM-7902 (VT) TR-7902 (BK/WH)	X-504 Transmission Control Unit (TCU) X-300 Cab main harness to transmission harness X-300 Cab main harness to transmission harness X-806 Clutch F solenoid valve	
8	CM-8072 (VT) TR-8072 (VT)	X-300 Cab main harness to transmission harness X-220 Central Control Unit (CCU) – CN2 X-300 Cab main harness to transmission harness X-368 Parking brake engagement – Solenoid valve	
9	CM-8071 (VT) TR-8071 (VT)	X-300 Cab main harness to transmission harness X-200 Central Control Unit (CCU) – CN1A X-300 Cab main harness to transmission harness X-368 Parking brake engagement – Solenoid valve	
10	CM-8074 (VT) TR-8074 (VT)	X-300 Cab main harness to transmission harness X-220 Central Control Unit (CCU) – CN2 X-300 Cab main harness to transmission harness X-315 Parking brake disengagement – Solenoid valve	



<b>CONNECTOR X-300 - Cab main harness to transmission harness</b>			
<b>PIN NUMBER</b>	<b>WIRE NUMBER</b>	<b>CIRCUIT REFERENCE</b>	<b>ELECTRICAL SCHEMATIC FRAME</b>
11	CM-060GD (BK/WH) TR-060GD (BK/WH)	SP-060G X-300 Cab main harness to transmission harness SP-060GD Sensor Ground Ext XCM X-300 Cab main harness to transmission harness	<b>Wiring harnesses - Electrical schematic sheet 03 (55.100)</b> <b>Wiring harnesses - Electrical schematic sheet 04 (55.100)</b> <b>Wiring harnesses - Electrical schematic sheet 07 (55.100)</b> <b>Wiring harnesses - Electrical schematic sheet 08 (55.100)</b> <b>Wiring harnesses - Electrical schematic sheet 09 (55.100)</b> <b>Wiring harnesses - Electrical schematic sheet 11 (55.100)</b> <b>Wiring harnesses - Electrical schematic sheet 12 (55.100)</b>
12	CM-7400 (YE) TR-7400 (YE)	X-504 Transmission Control Unit (TCU) X-300 Cab main harness to transmission harness X-309 Transmission output speed sensor X-300 Cab main harness to transmission harness	
13	CM-8073 (VT) TR-8073 (VT)	X-300 Cab main harness to transmission harness X-200 Central Control Unit (CCU) – CN1A X-300 Cab main harness to transmission harness X-315 Parking brake disengagement – Solenoid valve	
14	CM-010CC (GN) TR-010CC (GN)	SP-010C X-300 Cab main harness to transmission harness X-300 Cab main harness to transmission harness X-371 Steering pressure switch	
15	CM-2145 (OR) TR-2145 (OR)	X-504 Transmission Control Unit (TCU) X-300 Cab main harness to transmission harness X-300 Cab main harness to transmission harness X-807 Powershift output speed sensor	
16	CM-6000 (PK) TR-6000 (PK)	X-504 Transmission Control Unit (TCU) X-300 Cab main harness to transmission harness X-300 Cab main harness to transmission harness X-199 Powershift input speed sensor	<b>Wiring harnesses - Electrical schematic sheet 03 (55.100)</b> <b>Wiring harnesses - Electrical schematic sheet 04 (55.100)</b> <b>Wiring harnesses - Electrical schematic sheet 07 (55.100)</b> <b>Wiring harnesses - Electrical schematic sheet 08 (55.100)</b> <b>Wiring harnesses - Electrical schematic sheet 09 (55.100)</b> <b>Wiring harnesses - Electrical schematic sheet 11 (55.100)</b> <b>Wiring harnesses - Electrical schematic sheet 12 (55.100)</b>
17	CM-4002 (RD) TR-4002 (RD)	X-504 Transmission Control Unit (TCU) X-300 Cab main harness to transmission harness X-300 Cab main harness to transmission harness X-308 Transmission oil pressure switch	
18	CM-7907 (OR) TR-7907 (OR)	X-300 Cab main harness to transmission harness X-504 Transmission Control Unit (TCU) SP-7900 VPS1 X-300 Cab main harness to transmission harness	
19	CM-7901 (OR) TR-7901 (OR)	X-300 Cab main harness to transmission harness X-504 Transmission Control Unit (TCU) X-300 Cab main harness to transmission harness SP-7901 VPS2	
20	CM-7500 (GN) TR-7500 (GN)	X-504 Transmission Control Unit (TCU) X-300 Cab main harness to transmission harness X-316 Transmission oil temperature sensor X-300 Cab main harness to transmission harness	

<b>CONNECTOR X-300 - Cab main harness to transmission harness</b>			
<b>PIN NUMBER</b>	<b>WIRE NUMBER</b>	<b>CIRCUIT REFERENCE</b>	<b>ELECTRICAL SCHEMATIC FRAME</b>
21	-	-	<b>Wiring harnesses - Electrical schematic sheet 03 (55.100)</b>
22	-	-	
23	CM-5030 (TN) TR-5030 (TN)	X-200 Central Control Unit (CCU) – CN1A X-300 Cab main harness to transmission harness X-334 Raise solenoid valve X-300 Cab main harness to transmission harness	
24	CM-029 (GN) TR-029 (GN)	X-450 Instrument cluster CN1 X-300 Cab main harness to transmission harness X-354 Fuel level sensor X-300 Cab main harness to transmission harness	<b>Wiring harnesses - Electrical schematic sheet 09 (55.100)</b> <b>Wiring harnesses - Electrical schematic sheet 11 (55.100)</b> <b>Wiring harnesses - Electrical schematic sheet 12 (55.100)</b>
25	CM-010JA (GN) TR-010JA (GN)	X-300 Cab main harness to transmission harness SP-010J SP-010JA ZF Trans Sensor 12V X-300 Cab main harness to transmission harness	
26	CM-2042 (OR) TR-2042 (OR)	X-300 Cab main harness to transmission harness X-504 Transmission Control Unit (TCU) X-300 Cab main harness to transmission harness X-344 Rear Power Take-Off (PTO) – Solenoid valve	<b>Wiring harnesses - Electrical schematic sheet 03 (55.100)</b> <b>Wiring harnesses - Electrical schematic sheet 04 (55.100)</b> <b>Wiring harnesses - Electrical schematic sheet 07 (55.100)</b> <b>Wiring harnesses - Electrical schematic sheet 08 (55.100)</b>
27	CM-7520 (GN) TR-7520 (GN)	X-210 Central Control Unit (CCU) – CN1B X-300 Cab main harness to transmission harness X-300 Cab main harness to transmission harness SP-7520 Draft Sensor	<b>Wiring harnesses - Electrical schematic sheet 09 (55.100)</b> <b>Wiring harnesses - Electrical schematic sheet 11 (55.100)</b> <b>Wiring harnesses - Electrical schematic sheet 12 (55.100)</b>
28	CM-5040A (GN) TR-5040A (GN)	X-210 Central Control Unit (CCU) – CN1B X-300 Cab main harness to transmission harness X-332 Draft pin sensor right-hand X-300 Cab main harness to transmission harness	
29	CM-2018 (RD) TR-2018 (RD)	X-210 Central Control Unit (CCU) – CN1B X-300 Cab main harness to transmission harness X-333 Radar sensor X-300 Cab main harness to transmission harness	
30	CM-2028 (GN) TR-2028 (GN)	X-210 Central Control Unit (CCU) – CN1B X-300 Cab main harness to transmission harness X-333 Radar sensor X-300 Cab main harness to transmission harness	

<b>CONNECTOR X-300 - Cab main harness to transmission harness</b>			
<b>PIN NUMBER</b>	<b>WIRE NUMBER</b>	<b>CIRCUIT REFERENCE</b>	<b>ELECTRICAL SCHEMATIC FRAME</b>
31	CM-2027 (TN) TR-2027 (TN)	X-300 Cab main harness to transmission harness SP-5005 X-333 Radar sensor X-300 Cab main harness to transmission harness	<b>Wiring harnesses - Electrical schematic sheet 03 (55.100)</b> <b>Wiring harnesses - Electrical schematic sheet 04 (55.100)</b>
32	CM-3501 (WH) TR-3501 (WH)	X-300 Cab main harness to transmission harness X-460 Instrument cluster CN2 X-353 Steering pressure switch X-300 Cab main harness to transmission harness	<b>Wiring harnesses - Electrical schematic sheet 07 (55.100)</b> <b>Wiring harnesses - Electrical schematic sheet 08 (55.100)</b> <b>Wiring harnesses - Electrical schematic sheet 09 (55.100)</b>
33	CM-5035 (TN) TR-5035 (TN)	X-220 Central Control Unit (CCU) – CN2 X-300 Cab main harness to transmission harness X-334 Raise solenoid valve X-300 Cab main harness to transmission harness	<b>Wiring harnesses - Electrical schematic sheet 11 (55.100)</b> <b>Wiring harnesses - Electrical schematic sheet 12 (55.100)</b>
34	CM-5035A (TN) TR-5035A (TN)	X-220 Central Control Unit (CCU) – CN2 X-300 Cab main harness to transmission harness X-335 Lower solenoid valve X-300 Cab main harness to transmission harness	
35	CM-7081 (LG) TR-7081 (LG)	X-300 Cab main harness to transmission harness X-200 Central Control Unit (CCU) – CN1A X-300 Cab main harness to transmission harness X-340 Front axle differential lock – Solenoid valve	
36	CM-5040 (TN) TR-5040 (TN)	X-210 Central Control Unit (CCU) – CN1B X-300 Cab main harness to transmission harness X-331 Draft pin sensor left-hand X-300 Cab main harness to transmission harness	<b>Wiring harnesses - Electrical schematic sheet 03 (55.100)</b> <b>Wiring harnesses - Electrical schematic sheet 04 (55.100)</b> <b>Wiring harnesses - Electrical schematic sheet 07 (55.100)</b>
37	CM-060J (BK/WH) TR-060J (BK/WH)	X-504 Transmission Control Unit (TCU) X-300 Cab main harness to transmission harness SP-060J VMG1 ZF Ext X-300 Cab main harness to transmission harness	<b>Wiring harnesses - Electrical schematic sheet 08 (55.100)</b> <b>Wiring harnesses - Electrical schematic sheet 09 (55.100)</b> <b>Wiring harnesses - Electrical schematic sheet 11 (55.100)</b>
38	-	-	<b>Wiring harnesses - Electrical schematic sheet 12 (55.100)</b>
39	-	-	
40	CM-060FB (BK/WH) TR-060FB (BK/WH)	SP-060F X-300 Cab main harness to transmission harness X-316 Transmission oil temperature sensor X-300 Cab main harness to transmission harness	

<b>CONNECTOR X-300 - Cab main harness to transmission harness</b>			
<b>PIN NUMBER</b>	<b>WIRE NUMBER</b>	<b>CIRCUIT REFERENCE</b>	<b>ELECTRICAL SCHEMATIC FRAME</b>
41	CM-7080 (LG) TR-7080 (LG)	X-300 Cab main harness to transmission harness X-504 Transmission Control Unit (TCU) X-300 Cab main harness to transmission harness X-343 Rear axle differential lock – Solenoid valve	<b>Wiring harnesses - Electrical schematic sheet 03 (55.100)</b> <b>Wiring harnesses - Electrical schematic sheet 04 (55.100)</b> <b>Wiring harnesses - Electrical schematic sheet 07 (55.100)</b>
42	CM-3024 (YE) TR-3024 (YE)	X-300 Cab main harness to transmission harness X-504 Transmission Control Unit (TCU) X-300 Cab main harness to transmission harness X-342 Four-Wheel Drive (4WD) – Solenoid valve	<b>Wiring harnesses - Electrical schematic sheet 08 (55.100)</b> <b>Wiring harnesses - Electrical schematic sheet 09 (55.100)</b> <b>Wiring harnesses - Electrical schematic sheet 11 (55.100)</b> <b>Wiring harnesses - Electrical schematic sheet 12 (55.100)</b>
43	-	-	
44	-	-	
45	CM-5080 (PK) TR-5080 (PK)	X-210 Central Control Unit (CCU) – CN1B X-300 Cab main harness to transmission harness X-328 Hitch position sensor X-300 Cab main harness to transmission harness	
46	CM-2140 (OR) TR-2140 (OR)	X-504 Transmission Control Unit (TCU) X-300 Cab main harness to transmission harness X-300 Cab main harness to transmission harness X-341 Rear Power Take-Off (PTO) – Speed sensor	<b>Wiring harnesses - Electrical schematic sheet 03 (55.100)</b> <b>Wiring harnesses - Electrical schematic sheet 04 (55.100)</b> <b>Wiring harnesses - Electrical schematic sheet 07 (55.100)</b> <b>Wiring harnesses - Electrical schematic sheet 08 (55.100)</b>
47	CM-5025 (TN) TR-5025 (TN)	X-200 Central Control Unit (CCU) – CN1A X-300 Cab main harness to transmission harness X-335 Lower solenoid valve X-300 Cab main harness to transmission harness	<b>Wiring harnesses - Electrical schematic sheet 09 (55.100)</b> <b>Wiring harnesses - Electrical schematic sheet 11 (55.100)</b> <b>Wiring harnesses - Electrical schematic sheet 12 (55.100)</b>
48	CM-060A (BK/WH) TR-060A (BK/WH)	SP-060 X-300 Cab main harness to transmission harness X-354 Fuel level sensor X-300 Cab main harness to transmission harness	
49	-	-	
50	CM-057DH (BK) TR-057DH (BK)	X-300 Cab main harness to transmission harness SP-057D CAB GND X-300 Cab main harness to transmission harness SP-057DH Ground	



SVIL13TR00763AB 1

**Rear left-hand underside of cab**

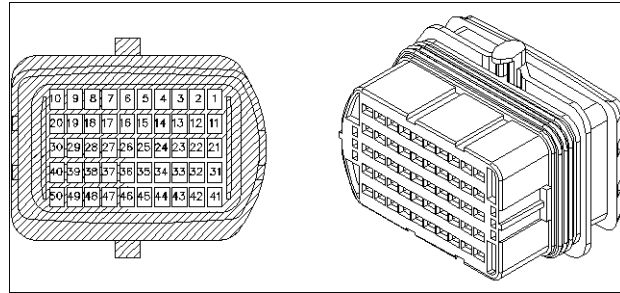

87708538 2

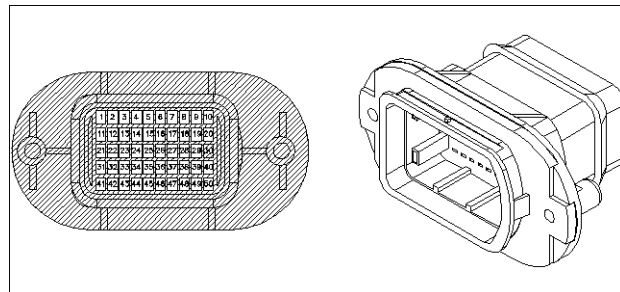

87708541 3

**CONNECTOR X-301 - Clutch D solenoid valve**

<b>CONNECTOR X-301 - Clutch D solenoid valve</b>			
<b>PIN NUMBER</b>	<b>WIRE NUMBER</b>	<b>CIRCUIT REFERENCE</b>	<b>ELECTRICAL SCHEMATIC FRAME</b>
1	TR-7901E (OR)	SP-7901 VPS2 X-301 Clutch D solenoid valve	<b>Wiring harnesses - Electrical schematic sheet 08 (55.100)</b>
2	TR-7930 (VT)	X-301 Clutch D solenoid valve X-300 Cab main harness to transmission harness	

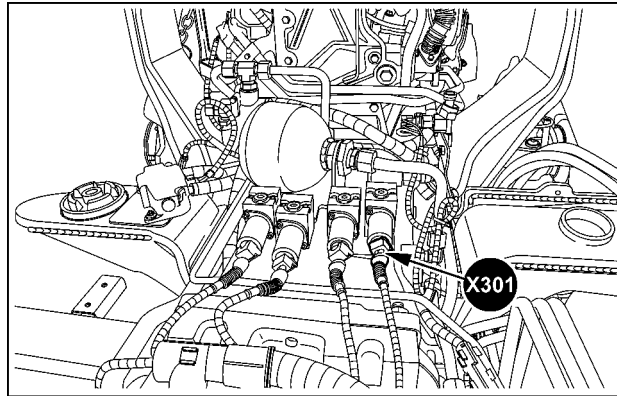

SVIL13TR00764AB 4

**Front top of transmission**

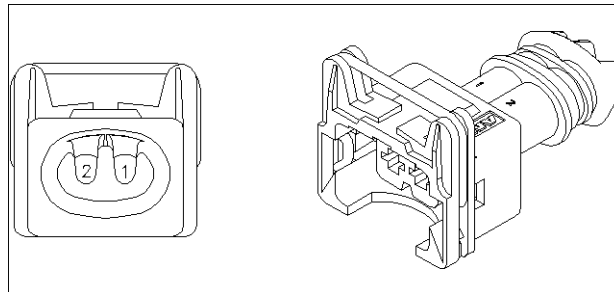

84607243 5

**CONNECTOR X-303 - Constant engine speed – Selector switch**

CONNECTOR X-303 - Constant engine speed – Selector switch			
PIN NUMBER	WIRE NUMBER	CIRCUIT REFERENCE	ELECTRICAL SCHEMATIC FRAME
1	SP-6515 (BR)	X-405 Cab main harness to switch panel harness 2 X-303 Constant engine speed – Selector switch	<b>Wiring harnesses - Electrical schematic sheet 04 (55.100)</b>
2	SP-010CF (GN)	X-303 Constant engine speed – Selector switch SP-010CE POT 15	
3	SP-6500 (BR)	X-405 Cab main harness to switch panel harness 2 X-303 Constant engine speed – Selector switch	
4	-	-	
5	-	-	
6	-	-	
7	SP-057GJ (BK)	X-303 Constant engine speed – Selector switch SP-057G POT GND SWITCH PANEL	
8	SP-1014FH (RD)	X-303 Constant engine speed – Selector switch SP-1014F POT 58 SWITCH PANEL	
9	SP-057GK (BK)	X-303 Constant engine speed – Selector switch SP-057G POT GND SWITCH PANEL	
10	SP-1014FG (RD)	X-303 Constant engine speed – Selector switch SP-1014F POT 58 SWITCH PANEL	

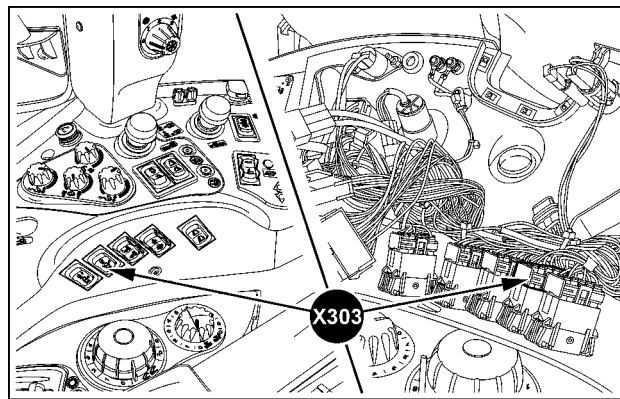

SS13K009 6

**Cab right-hand side**

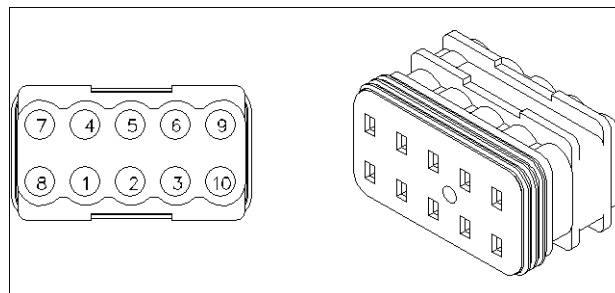

84819781 7

**CONNECTOR X-304 - Starter motor**

<b>CONNECTOR X-304 - Starter motor</b>			
<b>PIN NUMBER</b>	<b>WIRE NUMBER</b>	<b>CIRCUIT REFERENCE</b>	<b>ELECTRICAL SCHEMATIC FRAME</b>
1	BT-001A (RD)	X-304 Starter motor X-013 Alternator B+	<b>Wiring harnesses - Electrical schematic sheet 01 (55.100)</b>

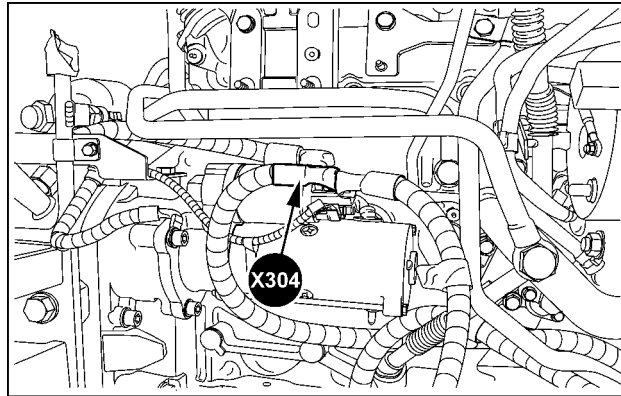

SVIL13TR00699AC 8

**Rear right-hand engine**

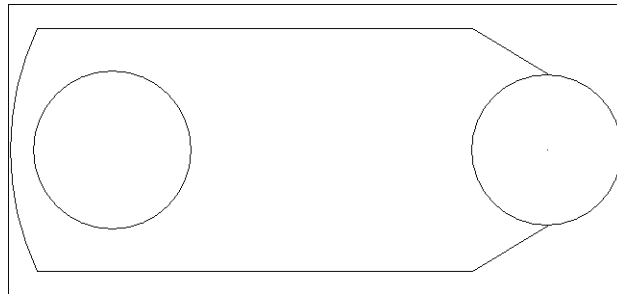

84138841 9



**CONNECTOR X-308 - Transmission oil pressure switch**

CONNECTOR X-308 - Transmission oil pressure switch			
PIN NUMBER	WIRE NUMBER	CIRCUIT REFERENCE	ELECTRICAL SCHEMATIC FRAME
1	TR-4002 (RD)	X-300 Cab main harness to transmission harness X-308 Transmission oil pressure switch	<b>Wiring harnesses - Electrical schematic sheet 07 (55.100)</b>
2	TR-010JF (GN)	SP-010JA ZF Trans Sensor 12V X-308 Transmission oil pressure switch	

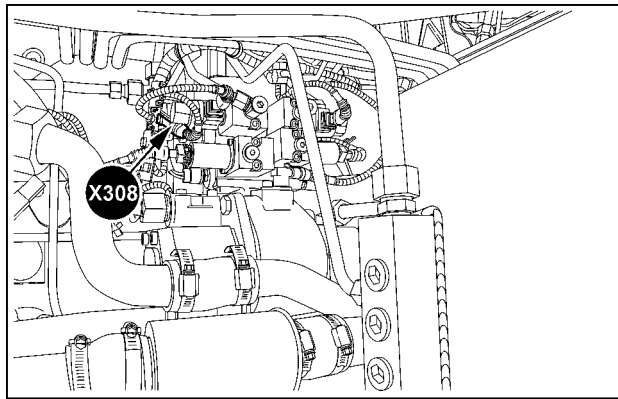

SVIL13TR00754AD 10

**Right-hand of transmission**

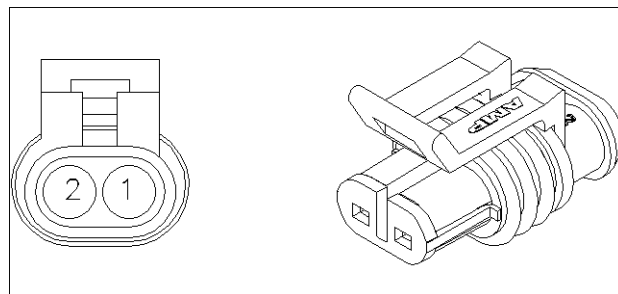

82012083 11

**CONNECTOR X-309 - Transmission output speed sensor**

CONNECTOR X-309 - Transmission output speed sensor			
PIN NUMBER	WIRE NUMBER	CIRCUIT REFERENCE	ELECTRICAL SCHEMATIC FRAME
1	TR-060JA (BK/WH)	X-309 Transmission output speed sensor SP-060J VMG1 ZF Ext	Wiring harnesses - Electrical schematic sheet 07 (55.100)
2	TR-7400 (YE)	X-309 Transmission output speed sensor X-300 Cab main harness to transmission harness	
3	TR-010JB (GN)	SP-010JA ZF Trans Sensor 12V X-309 Transmission output speed sensor	

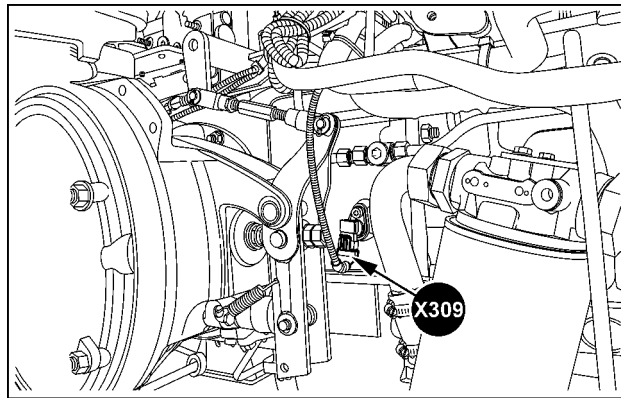

SVIL13TR00765AB 12

**Right-hand rear axle**

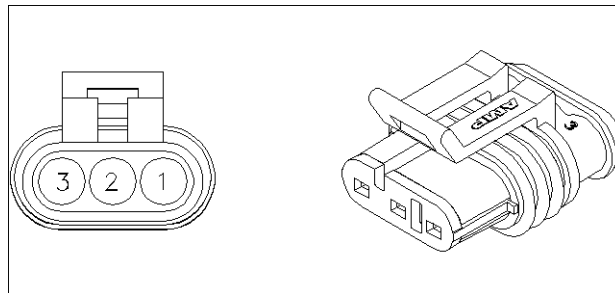

84062580 13

## Wire connectors - Component diagram 31

### CONNECTOR X-310 - Hydraulic oil heating – Solenoid valve

CONNECTOR X-310 - Hydraulic oil heating – Solenoid valve			
PIN NUMBER	WIRE NUMBER	CIRCUIT REFERENCE	ELECTRICAL SCHEMATIC FRAME
1	CM-7151 (BR)	X-240 Central Control Unit (CCU) – CN3B X-310 Hydraulic oil heating – Solenoid valve	<b>Wiring harnesses - Electrical schematic sheet 13 (55.100)</b>
2	CM-057DJ (BK)	SP-057D CAB GND X-310 Hydraulic oil heating – Solenoid valve	



SVIL13TR00772AB 1

**Rear left-hand cab roof**

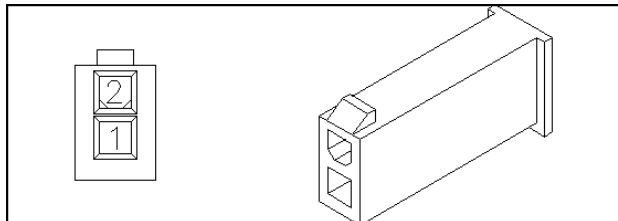

87694708 2

**CONNECTOR X-314 - Hitch up/down switch – Cab inside**

<b>CONNECTOR X-314 - Hitch up/down switch – Cab inside</b>			
<b>PIN NUMBER</b>	<b>WIRE NUMBER</b>	<b>CIRCUIT REFERENCE</b>	<b>ELECTRICAL SCHEMATIC FRAME</b>
1	SP-5095 (PK)	X-314 Hitch up/down switch – Cab inside X-405 Cab main harness to switch panel harness 2	<b>Wiring harnesses - Electrical schematic sheet 11 (55.100)</b>
2	SP-5005AF (TN)	SP-5005A POT 15 EDC X-314 Hitch up/down switch – Cab inside	
3	SP-5100 (PK)	X-314 Hitch up/down switch – Cab inside X-405 Cab main harness to switch panel harness 2	
4	-	-	
5	-	-	
6	-	-	
7	SP-057GS (BK)	X-314 Hitch up/down switch – Cab inside SP-057G POT GND SWITCH PANEL	
8	SP-1014FU (RD)	X-314 Hitch up/down switch – Cab inside SP-1014F POT 58 SWITCH PANEL	
9	SP-057GR (BK)	X-314 Hitch up/down switch – Cab inside SP-057G POT GND SWITCH PANEL	
10	SP-1014FT (RD)	X-314 Hitch up/down switch – Cab inside SP-1014F POT 58 SWITCH PANEL	

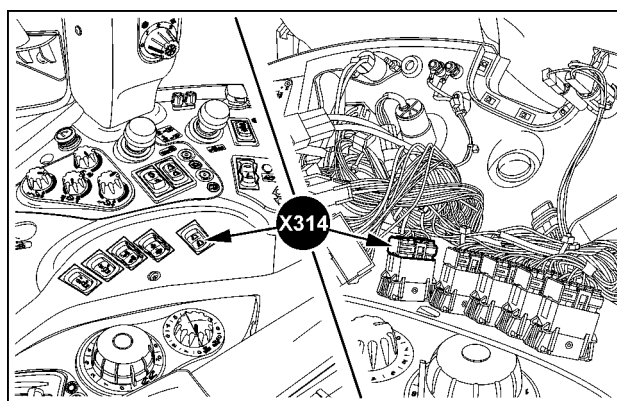

SS13K006 3

**Behind right-hand switch panel**

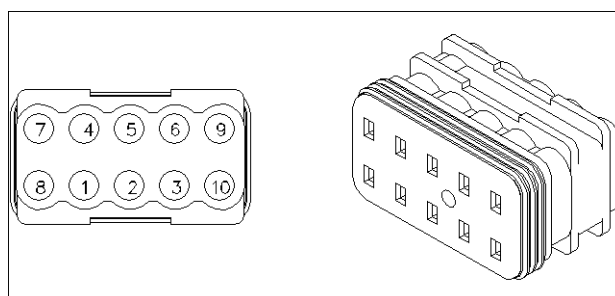

84819781 4

**CONNECTOR X-315 - Parking brake disengagement – Solenoid valve**

CONNECTOR X-315 - Parking brake disengagement – Solenoid valve			
PIN NUMBER	WIRE NUMBER	CIRCUIT REFERENCE	ELECTRICAL SCHEMATIC FRAME
1	TR-8073 (VT)	X-300 Cab main harness to transmission harness X-315 Parking brake disengagement – Solenoid valve	<b>Wiring harnesses - Electrical schematic sheet 09 (55.100)</b>
2	TR-8074 (VT)	X-300 Cab main harness to transmission harness X-315 Parking brake disengagement – Solenoid valve	

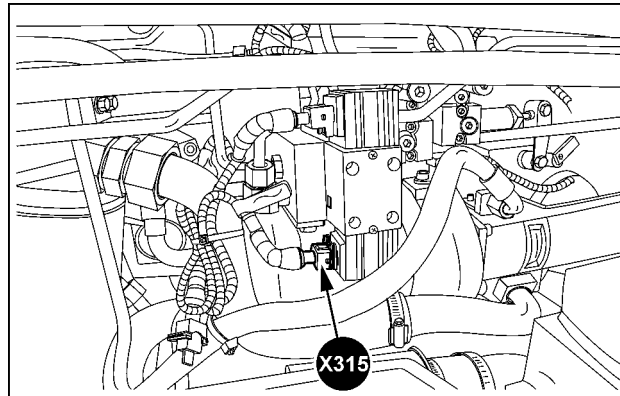

SVIL13TR00814AB 5

**Right-hand of transmission**

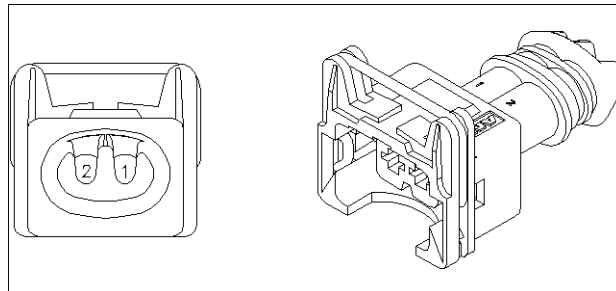

84607243 6

**CONNECTOR X-316 - Transmission oil temperature sensor**

CONNECTOR X-316 - Transmission oil temperature sensor			
PIN NUMBER	WIRE NUMBER	CIRCUIT REFERENCE	ELECTRICAL SCHEMATIC FRAME
1	TR-7500 (GN)	X-316 Transmission oil temperature sensor X-300 Cab main harness to transmission harness	<b>Wiring harnesses - Electrical schematic sheet 08 (55.100)</b>
2	TR-060FB (BK/WH)	X-316 Transmission oil temperature sensor X-300 Cab main harness to transmission harness	

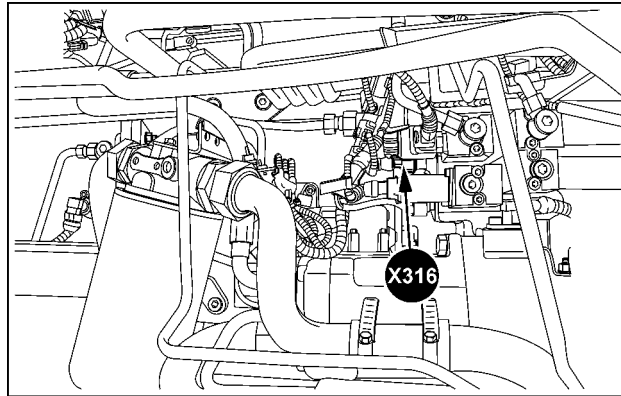

SVIL13TR00774AB 7

**Right-hand of transmission**

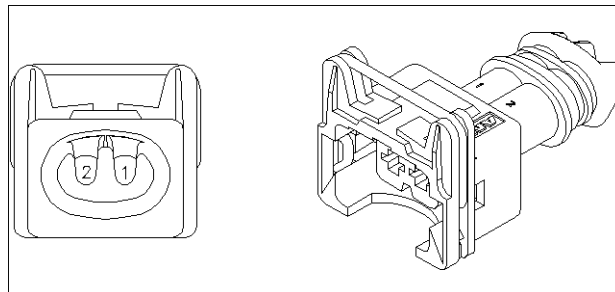

84607243 8

**CONNECTOR X-318 - Shuttle lever**

CONNECTOR X-318 - Shuttle lever			
PIN NUMBER	WIRE NUMBER	CIRCUIT REFERENCE	ELECTRICAL SCHEMATIC FRAME
1	CM-7525A (GN)	X-318 Shuttle lever SP-7525	<b>Wiring harnesses - Electrical schematic sheet 08 (55.100)</b>
2	CM-7250A (GY)	X-318 Shuttle lever SP-7250	
3	CM-7260A (GY)	X-318 Shuttle lever SP-7260	
4	-	-	
5	-	-	
6	CM-7245A (TN)	X-504 Transmission Control Unit (TCU) X-318 Shuttle lever	
7	-	-	
8	CM-060FC (BK/WH)	X-318 Shuttle lever SP-060F	
9	-	-	
10	-	-	
11	CM-7265A (PK)	X-318 Shuttle lever SP-7265	
12	-	-	
13	-	-	

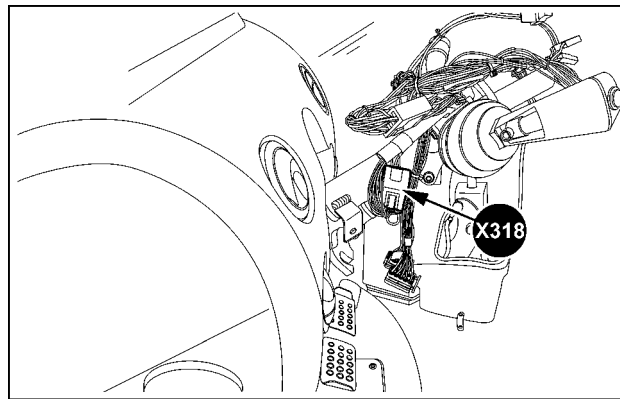

SVIL13TR00747AC 9

**Steering console**

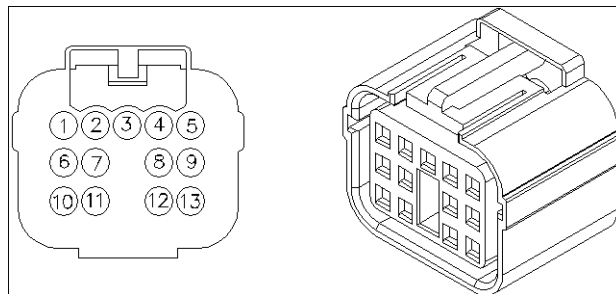

82862752 10

**CONNECTOR X-319 - Clutch pedal switch – Start interlock**

CONNECTOR X-319 - Clutch pedal switch – Start interlock			
PIN NUMBER	WIRE NUMBER	CIRCUIT REFERENCE	ELECTRICAL SCHEMATIC FRAME
1	CM-1000A (WH)	X-319 Clutch pedal switch – Start interlock X-130 Fuse block (F-001 to F-032)	<b>Wiring harnesses - Electrical schematic sheet 08 (55.100)</b>
2	CM-9269A (WH)	X-504 Transmission Control Unit (TCU) X-319 Clutch pedal switch – Start interlock	
3	CM-010EE (GN)	X-319 Clutch pedal switch – Start interlock SP-010E	
4	CM-1001A (WH)	X-319 Clutch pedal switch – Start interlock SP-1001A	

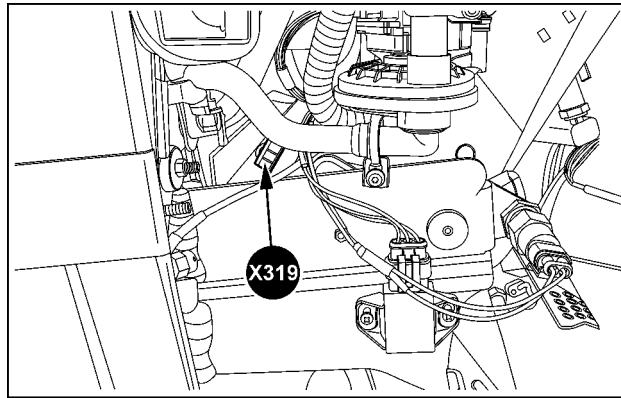

SVIL13TR00775AB 11

**Front left-hand cab**

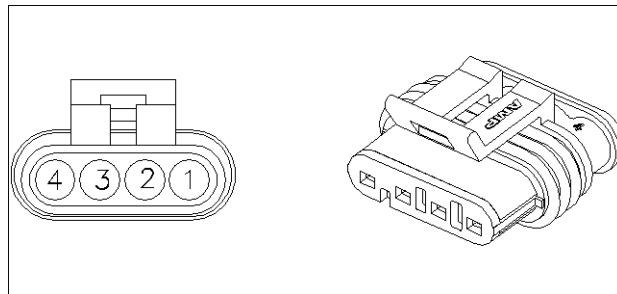

87687242 12



## Wire connectors - Component diagram 32

### CONNECTOR X-320 - Multicontroller

CONNECTOR X-320 - Multicontroller			
PIN NUMBER	WIRE NUMBER	CIRCUIT REFERENCE	ELECTRICAL SCHEMATIC FRAME
1	CM-5520DE (LG)	SP-5520 X-320 Multicontroller	Wiring harnesses - Electrical schematic sheet 12 (55.100) Wiring harnesses - Electrical schematic sheet 13 (55.100) Wiring harnesses - Electrical schematic sheet 14 (55.100)
2	CM-060GF (BK/WH)	SP-060G X-320 Multicontroller	
3	CM-5575 (WH)	X-320 Multicontroller X-230 Central Control Unit (CCU) – CN3A	
4	CM-5577 (VT)	X-320 Multicontroller X-230 Central Control Unit (CCU) – CN3A	
5	CM-2578 (GN)	X-320 Multicontroller X-230 Central Control Unit (CCU) – CN3A	
6	CM-5578 (VT)	X-320 Multicontroller X-230 Central Control Unit (CCU) – CN3A	
7	CM-5579 (GY)	X-320 Multicontroller X-230 Central Control Unit (CCU) – CN3A	
8	CM-6500A (BR)	X-320 Multicontroller X-230 Central Control Unit (CCU) – CN3A	
9	CM-1013C (RD)	SP-1013 X-320 Multicontroller	
10	CM-057AB (BK)	SP-057A CAB GND X-320 Multicontroller	

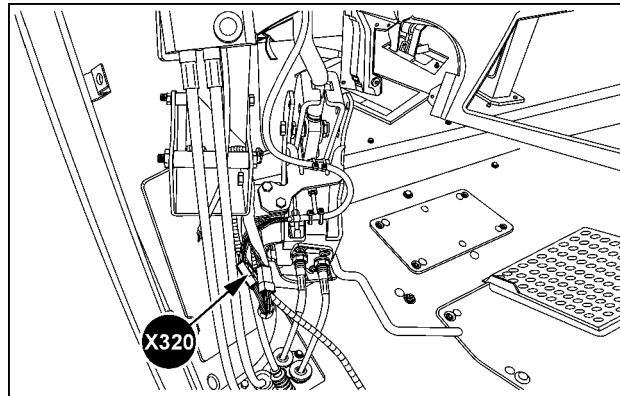

SVIL13TR00757AC 1

**Right-hand bottom front tractor cab**

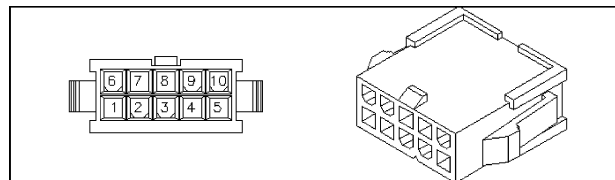

87694699 2

**CONNECTOR X-321 - Foot throttle position sensor**

CONNECTOR X-321 - Foot throttle position sensor			
PIN NUMBER	WIRE NUMBER	CIRCUIT REFERENCE	ELECTRICAL SCHEMATIC FRAME
2	CM-6402 (GN)	X-321 Foot throttle position sensor X-450 Instrument cluster CN1	<b>Wiring harnesses - Electrical schematic sheet 03 (55.100)</b>
3	CM-010CH (GN)	SP-010C X-321 Foot throttle position sensor	
4	CM-6401 (GN)	X-460 Instrument cluster CN2 X-321 Foot throttle position sensor	
5	-	-	
6	CM-6404 (GN)	X-321 Foot throttle position sensor X-450 Instrument cluster CN1	
7	CM-060E (BK/WH)	X-321 Foot throttle position sensor SP-060	
8	CM-060D (BK/WH)	X-321 Foot throttle position sensor SP-060	

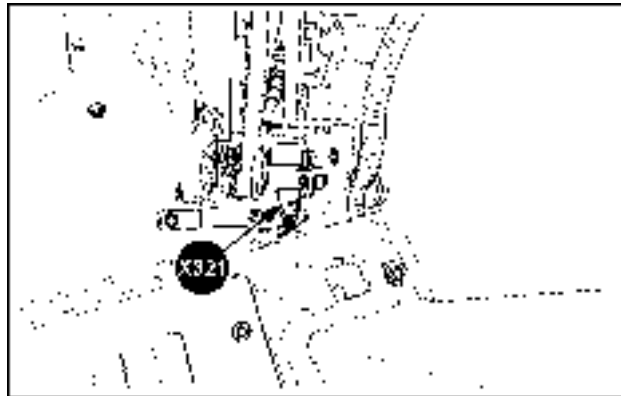

SVIL13TR00776AB 3

**Right-hand bottom front tractor cab**

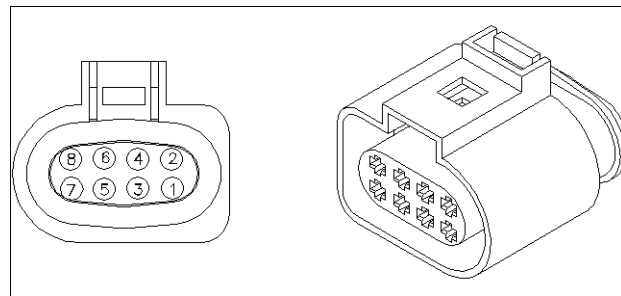

87702265 4

**CONNECTOR X-322 - Clutch pedal sensor**

CONNECTOR X-322 - Clutch pedal sensor			
PIN NUMBER	WIRE NUMBER	CIRCUIT REFERENCE	ELECTRICAL SCHEMATIC FRAME
1	CM-060FD (BK)	X-322 Clutch pedal sensor SP-060F	Wiring harnesses - Electrical schematic sheet 08 (55.100)
2	CM-7525B (GN)	X-322 Clutch pedal sensor SP-7525	
3	CM-7430 (BK/WH)	X-322 Clutch pedal sensor X-504 Transmission Control Unit (TCU)	

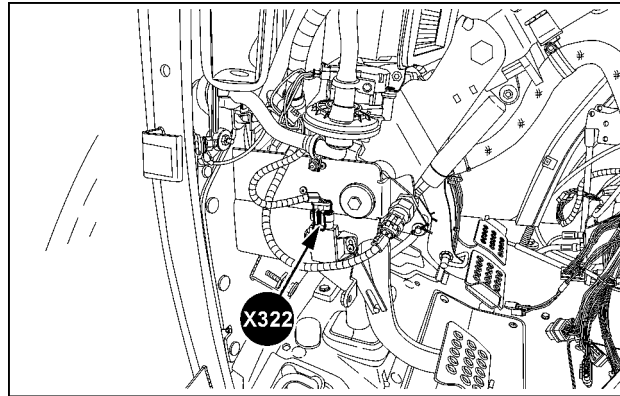

SVIL13TR00734AD 5

**Front left-hand cab**

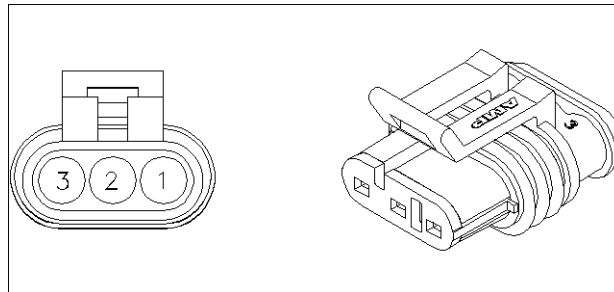

84062580 6

**CONNECTOR X-323 - Front loader switches (mechanical control lever)**

Hydrac

CONNECTOR X-323 - Front loader switches (mechanical control lever)			
PIN NUMBER	WIRE NUMBER	CIRCUIT REFERENCE	ELECTRICAL SCHEMATIC FRAME
1	FS-057CS (BK)	SP-057CM X-323 Front loader switches (mechanical control lever)	<b>Wiring harnesses - Electrical schematic sheet 15 (55.100)</b> <b>Wiring harnesses - Electrical schematic sheet 16 (55.100)</b>
2	FL-3279B (BL)	X-323 Front loader switches (mechanical control lever) SP-3279 X-323 Front loader switches (mechanical control lever) SP-3279A	
3	FL-3280B (BL)	X-323 Front loader switches (mechanical control lever) SP-3280 X-323 Front loader switches (mechanical control lever) SP-3280A	
4	FS-057CR (BK)	SP-057CM X-323 Front loader switches (mechanical control lever)	

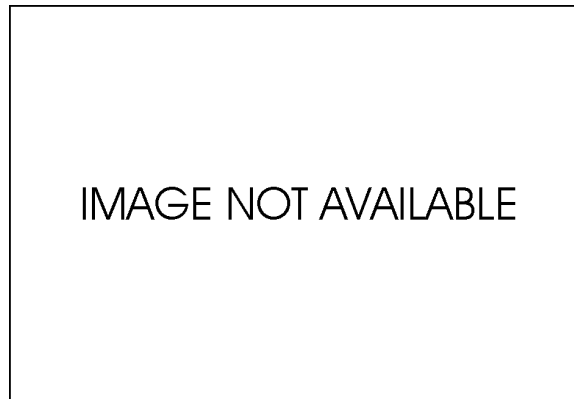

INA 7

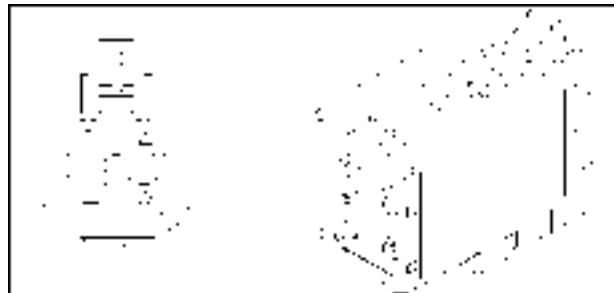

87715977 8

**Stoll**

<b>CONNECTOR X-323 - Front loader switches (mechanical control lever)</b>			
<b>PIN NUMBER</b>	<b>WIRE NUMBER</b>	<b>CIRCUIT REFERENCE</b>	<b>ELECTRICAL SCHEMATIC FRAME</b>
1	FS-057CS (BK)	SP-057CM X-323 Front loader switches (mechanical control lever)	<b>Wiring harnesses - Electrical schematic sheet 15 (55.100)</b> <b>Wiring harnesses - Electrical schematic sheet 16 (55.100)</b>
2	FS-3279A (BL)	X-323 Front loader switches (mechanical control lever) SP-3279 X-323 Front loader switches (mechanical control lever) SP-3279A	
3	FS-3280A (BL)	X-323 Front loader switches (mechanical control lever) SP-3280 X-323 Front loader switches (mechanical control lever) SP-3280A	
4	FS-057CR (BK)	SP-057CM X-323 Front loader switches (mechanical control lever)	

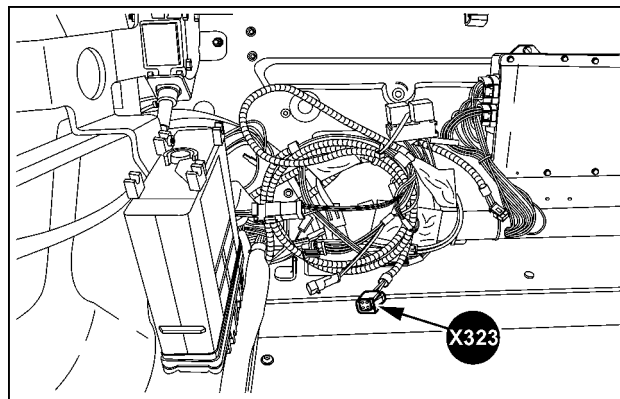

SVIL13TR00865AE 9

**In cab right-hand behind operator's seat**

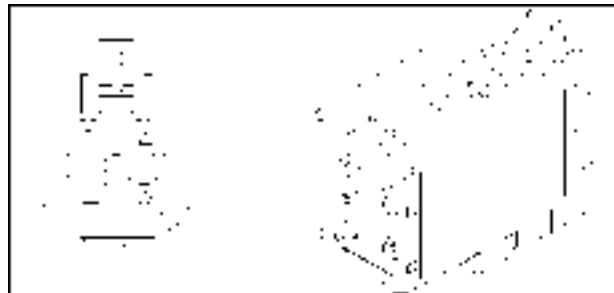

87715977 10

**CONNECTOR X-324 - Hand throttle sensor**

CONNECTOR X-324 - Hand throttle sensor			
PIN NUMBER	WIRE NUMBER	CIRCUIT REFERENCE	ELECTRICAL SCHEMATIC FRAME
1	CM-6450 (GY)	X-450 Instrument cluster CN1 X-324 Hand throttle sensor	<b>Wiring harnesses - Electrical schematic sheet 03 (55.100)</b>
2	CM-6440 (GY)	X-324 Hand throttle sensor X-450 Instrument cluster CN1	
3	CM-060K (BK/WH)	X-324 Hand throttle sensor X-450 Instrument cluster CN1	
4	CM-6445 (BR)	X-324 Hand throttle sensor X-460 Instrument cluster CN2	

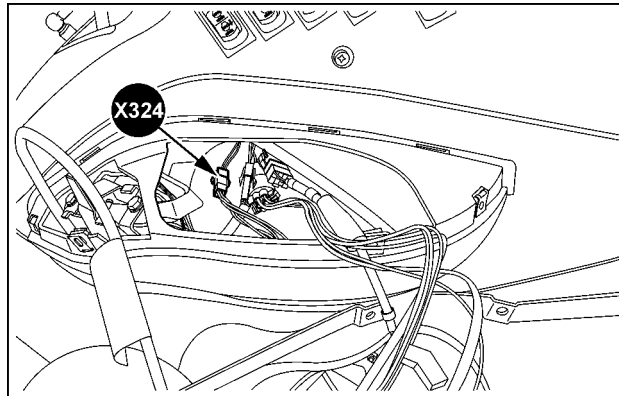

SVIL13TR00732AB 11

**On the right-hand trim behind switch panel**

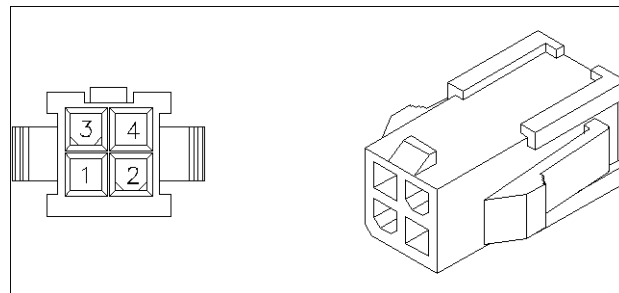

87694694 12

**CONNECTOR X-326 - Hitch position control potentiometer**

CONNECTOR X-326 - Hitch position control potentiometer			
PIN NUMBER	WIRE NUMBER	CIRCUIT REFERENCE	ELECTRICAL SCHEMATIC FRAME
1	CM-5520A (LG)	SP-5520 X-326 Hitch position control potentiometer	<b>Wiring harnesses - Electrical schematic sheet 12 (55.100)</b>
2	CM-060GA (BK/WH)	SP-060G X-326 Hitch position control potentiometer	
3	CM-5040D (TN)	X-326 Hitch position control potentiometer X-210 Central Control Unit (CCU) – CN1B	
4	-	-	
5	CM-1014C (YE)	X-326 Hitch position control potentiometer SP-1014	
6	CM-057CG (BK)	SP-057C X-326 Hitch position control potentiometer	

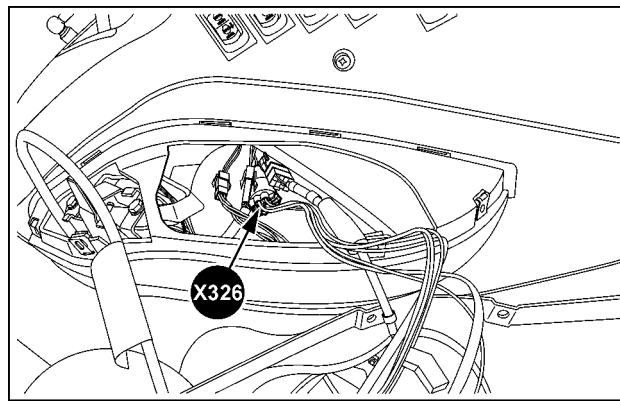

SVIL13TR00732AE 13

**On the right-hand trim behind switch panel**

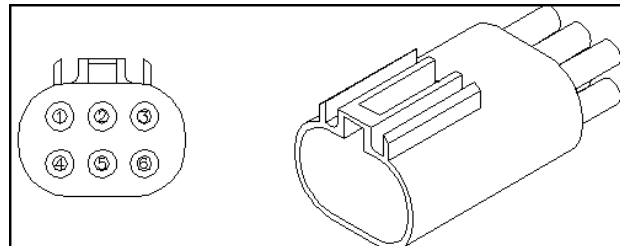

82028842 14

**CONNECTOR X-327 - Hitch electronic control panel**

<b>CONNECTOR X-327 - Hitch electronic control panel</b>			
<b>PIN NUMBER</b>	<b>WIRE NUMBER</b>	<b>CIRCUIT REFERENCE</b>	<b>ELECTRICAL SCHEMATIC FRAME</b>
3	SP-5120 (PK)	X-404 Cab main harness to switch panel harness 1 X-327 Hitch electronic control panel	<b>Wiring harnesses - Electrical schematic sheet 12 (55.100)</b>
4	SP-5122 (PK)	X-404 Cab main harness to switch panel harness 1 X-327 Hitch electronic control panel	
5	SP-5520DD (LG)	X-404 Cab main harness to switch panel harness 1 X-327 Hitch electronic control panel	
6	SP-060GC (BK/WH)	X-404 Cab main harness to switch panel harness 1 X-327 Hitch electronic control panel	
7	SP-5121 (PK)	X-404 Cab main harness to switch panel harness 1 X-327 Hitch electronic control panel	
8	SP-5123 (RD)	X-404 Cab main harness to switch panel harness 1 X-327 Hitch electronic control panel	

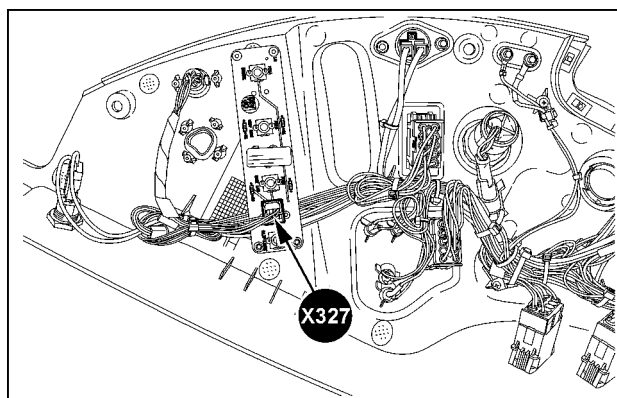

SVIL13TR00743AD 15

**Behind right-hand switch panel**

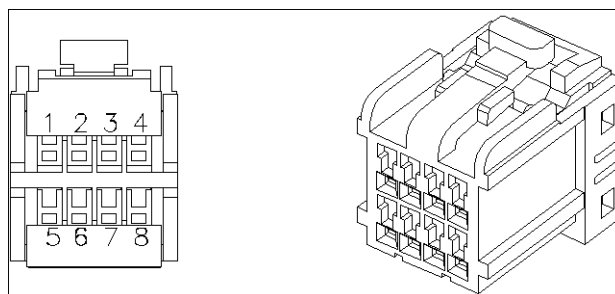

87680680 16



**CONNECTOR X-328 - Hitch position sensor**

CONNECTOR X-328 - Hitch position sensor			
PIN NUMBER	WIRE NUMBER	CIRCUIT REFERENCE	ELECTRICAL SCHEMATIC FRAME
1	TR-5520DC (LG)	X-328 Hitch position sensor X-300 Cab main harness to transmission harness	<b>Wiring harnesses - Electrical schematic sheet 12 (55.100)</b>
2	TR-5080 (PK)	X-328 Hitch position sensor X-300 Cab main harness to transmission harness	
3	TR-060GG (BK/WH)	X-328 Hitch position sensor SP-060GD Sensor Ground Ext XCM	

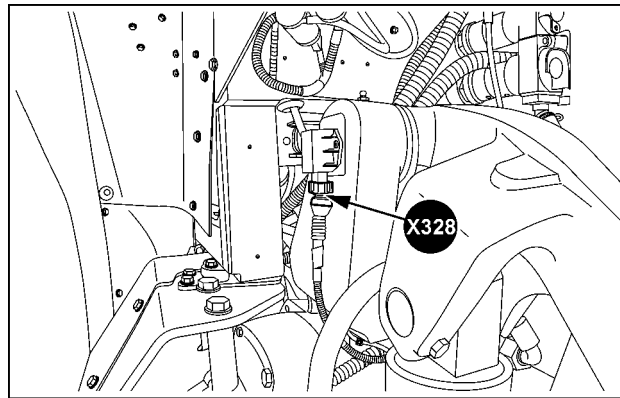

SVIL13TR00777AB 17

**Left-hand side top of rear axle**

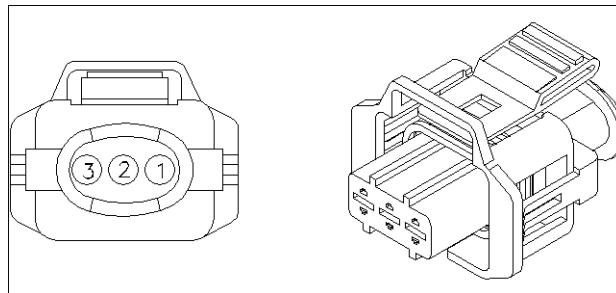

87747172 18

**CONNECTOR X-329 - Hitch up/down switch – Fender left-hand**

CONNECTOR X-329 - Hitch up/down switch – Fender left-hand			
PIN NUMBER	WIRE NUMBER	CIRCUIT REFERENCE	ELECTRICAL SCHEMATIC FRAME
1	CM-5100C (PK)	X-329 Hitch up/down switch – Fender left-hand SP-5100	Wiring harnesses - Electrical schematic sheet 11 (55.100)
2	CM-5005E (TN)	SP-5005 X-329 Hitch up/down switch – Fender left-hand	
3	CM-5095C (PK)	X-329 Hitch up/down switch – Fender left-hand SP-5095	

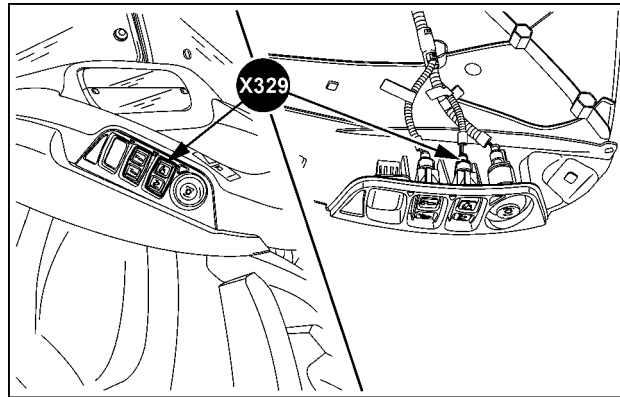

SS13.069 19

**Left-hand rear fender**

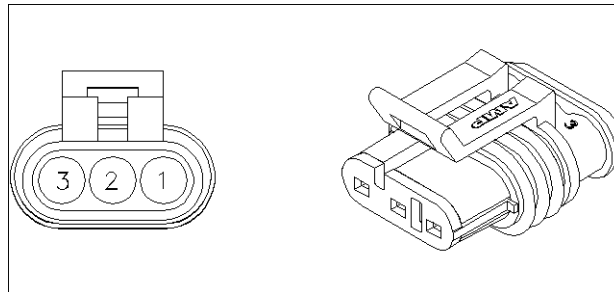

84062580 20

## Wire connectors - Component diagram 33

### CONNECTOR X-330 - Hitch up/down switch – Fender right-hand

CONNECTOR X-330 - Hitch up/down switch – Fender right-hand			
PIN NUMBER	WIRE NUMBER	CIRCUIT REFERENCE	ELECTRICAL SCHEMATIC FRAME
1	CM-5100B (PK)	X-330 Hitch up/down switch – Fender right-hand SP-5100	<b>Wiring harnesses - Electrical schematic sheet 11 (55.100)</b>
2	CM-5005D (TN)	X-330 Hitch up/down switch – Fender right-hand SP-5005	
3	CM-5095B (PK)	X-330 Hitch up/down switch – Fender right-hand SP-5095	

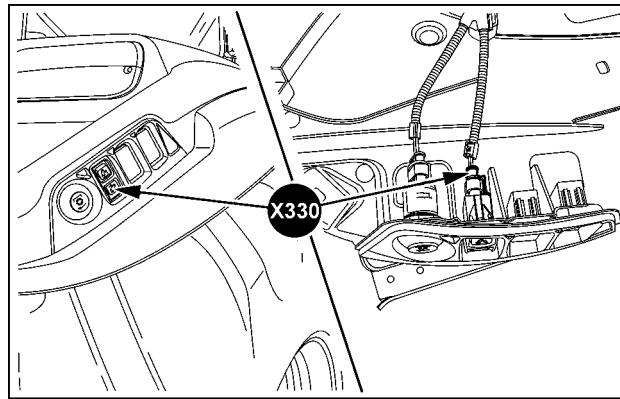

SS13K015 1

**Right-hand rear fender**

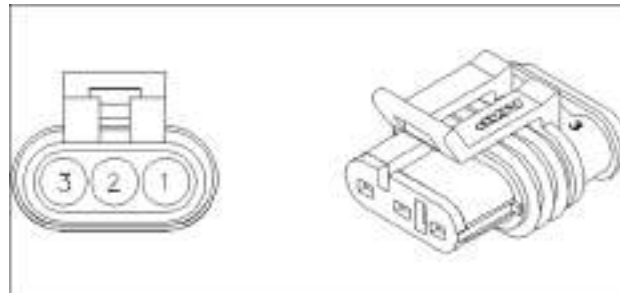

84062580 2

**CONNECTOR X-331 - Draft pin sensor left-hand**

CONNECTOR X-331 - Draft pin sensor left-hand			
PIN NUMBER	WIRE NUMBER	CIRCUIT REFERENCE	ELECTRICAL SCHEMATIC FRAME
1	TR-060GJ (BK/WH)	X-331 Draft pin sensor left-hand SP-060GD Sensor Ground Ext XCM	Wiring harnesses - Electrical schematic sheet 12 (55.100)
2	TR-5040 (TN)	X-331 Draft pin sensor left-hand X-300 Cab main harness to transmission harness	
3	TR-7520A (GN)	SP-7520 Draft Sensor X-331 Draft pin sensor left-hand	

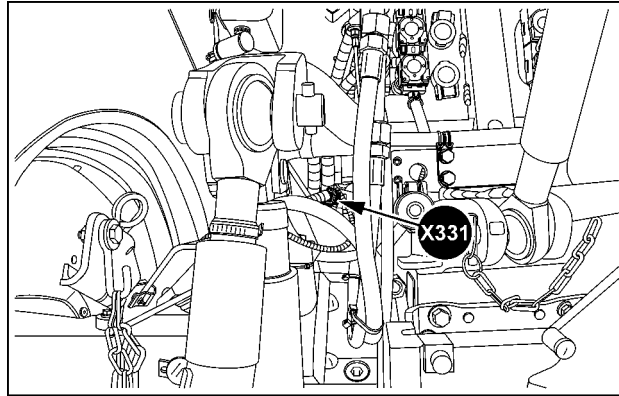

SVIL13TR00779AB 3

**Left-hand side top of rear axle**

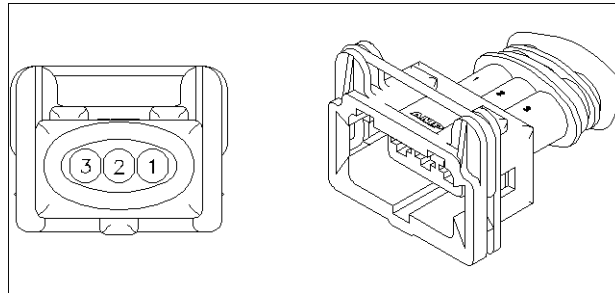

84806091 4

**CONNECTOR X-332 - Draft pin sensor right-hand**

CONNECTOR X-332 - Draft pin sensor right-hand			
PIN NUMBER	WIRE NUMBER	CIRCUIT REFERENCE	ELECTRICAL SCHEMATIC FRAME
1	TR-060GH (BK/WH)	SP-060GD Sensor Ground Ext XCM X-332 Draft pin sensor right-hand	<b>Wiring harnesses - Electrical schematic sheet 12 (55.100)</b>
2	TR-5040A (GN)	X-332 Draft pin sensor right-hand X-300 Cab main harness to transmission harness	
3	TR-7520B (GN)	X-332 Draft pin sensor right-hand SP-7520 Draft Sensor	

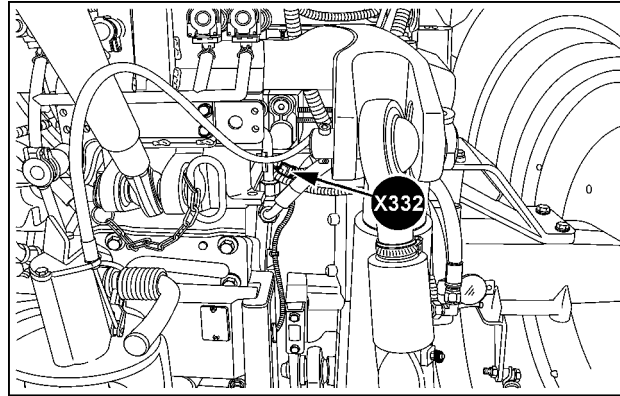

SVIL13TR00780AB 5

**Right-hand side top of rear axle**

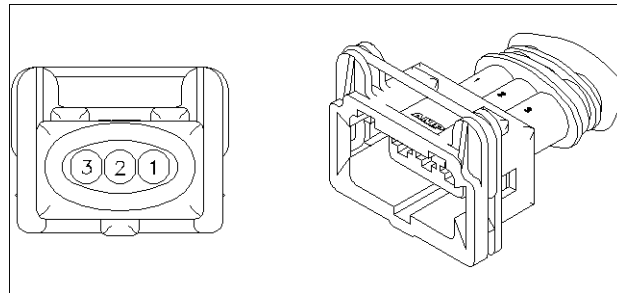

84806091 6

**CONNECTOR X-333 - Radar sensor**

<b>CONNECTOR X-333 - Radar sensor</b>			
<b>PIN NUMBER</b>	<b>WIRE NUMBER</b>	<b>CIRCUIT REFERENCE</b>	<b>ELECTRICAL SCHEMATIC FRAME</b>
1	TR-2028 (GN)	X-333 Radar sensor X-300 Cab main harness to transmission harness	<b>Wiring harnesses - Electrical schematic sheet 11 (55.100)</b>
2	TR-057DM (BK)	X-333 Radar sensor SP-057DH Ground	
3	TR-2027 (TN)	X-333 Radar sensor X-300 Cab main harness to transmission harness	
4	TR-2018 (RD)	X-333 Radar sensor X-300 Cab main harness to transmission harness	

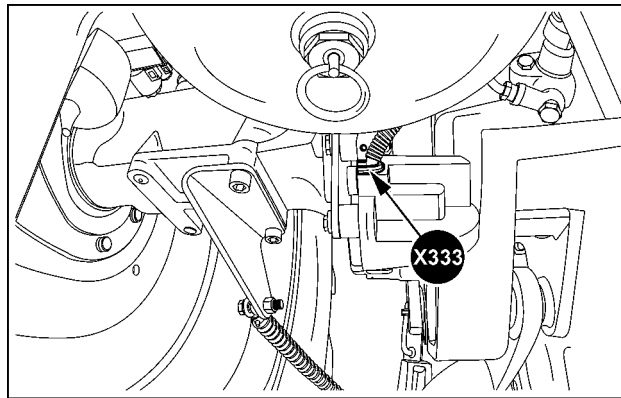

SVIL13TR00815AB 7

**Right-hand underside of rear axle**

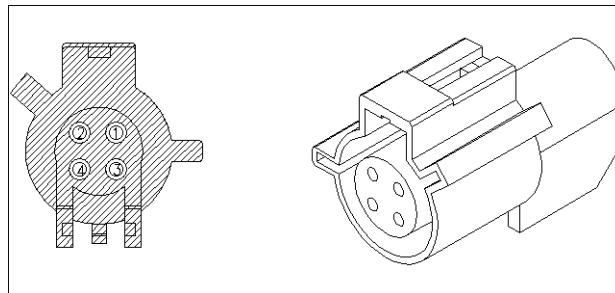

87712738 8

**CONNECTOR X-334 - Raise solenoid valve**

CONNECTOR X-334 - Raise solenoid valve			
PIN NUMBER	WIRE NUMBER	CIRCUIT REFERENCE	ELECTRICAL SCHEMATIC FRAME
1	TR-5030 (TN)	X-334 Raise solenoid valve X-300 Cab main harness to transmission harness	<b>Wiring harnesses - Electrical schematic sheet 12 (55.100)</b>
2	TR-5035 (TN)	X-334 Raise solenoid valve X-300 Cab main harness to transmission harness	

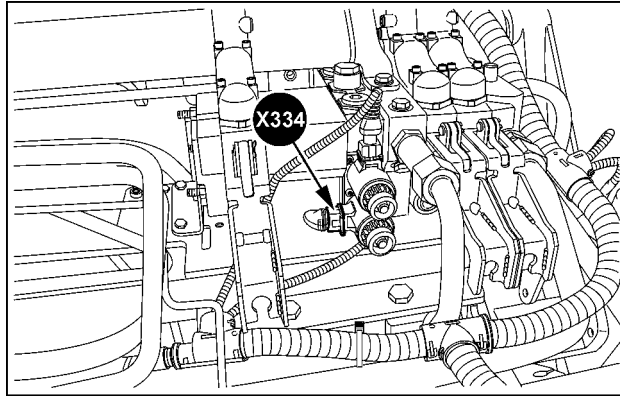

SVIL13TR00782AB 9

**Top of rear axle**

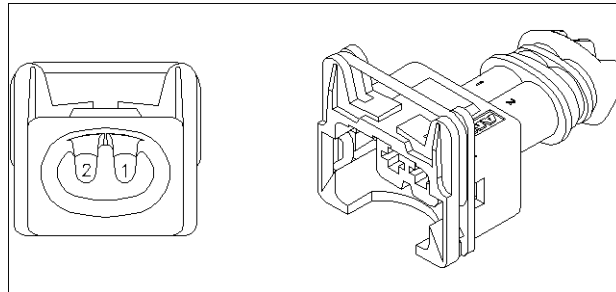

84607243 10

**CONNECTOR X-335 - Lower solenoid valve**

<b>CONNECTOR X-335 - Lower solenoid valve</b>			
<b>PIN NUMBER</b>	<b>WIRE NUMBER</b>	<b>CIRCUIT REFERENCE</b>	<b>ELECTRICAL SCHEMATIC FRAME</b>
1	TR-5025 (TN)	X-335 Lower solenoid valve X-300 Cab main harness to transmission harness	<b>Wiring harnesses - Electrical schematic sheet 12 (55.100)</b>
2	TR-5035A (TN)	X-335 Lower solenoid valve X-300 Cab main harness to transmission harness	

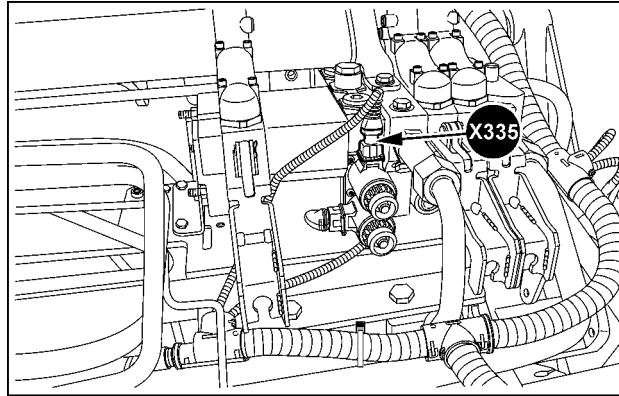

SVIL13TR00782AC 11

**Top of rear axle**

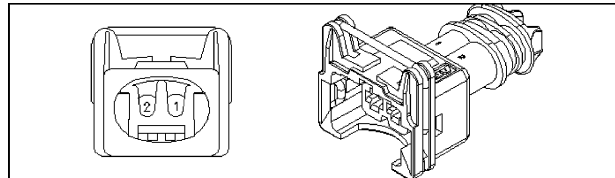

84475258 12



**CONNECTOR X-336 - Diagnostic socket (CAN bus 2)**

CONNECTOR X-336 - Diagnostic socket (CAN bus 2)			
PIN NUMBER	WIRE NUMBER	CIRCUIT REFERENCE	ELECTRICAL SCHEMATIC FRAME
A	CM-057CA (BK)	X-336 Diagnostic socket (CAN bus 2) SP-057C	<b>Wiring harnesses - Electrical schematic sheet 24 (55.100)</b>
B	CM-138DC (VT)	SP-138D X-336 Diagnostic socket (CAN bus 2)	
C	CM-291AZ (RD)	X-336 Diagnostic socket (CAN bus 2) SP-291A	
D	CM-290AZ (BL)	SP-290A X-336 Diagnostic socket (CAN bus 2)	
E	-	-	
F	-	-	
G	-	-	
H	-	-	
J	-	-	

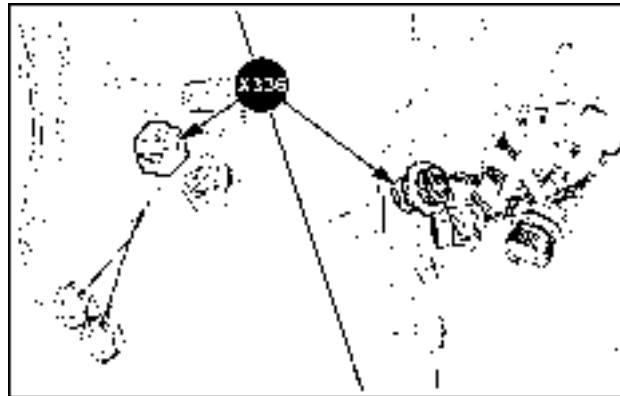

SS13K004 13

**Cab rear left-hand**

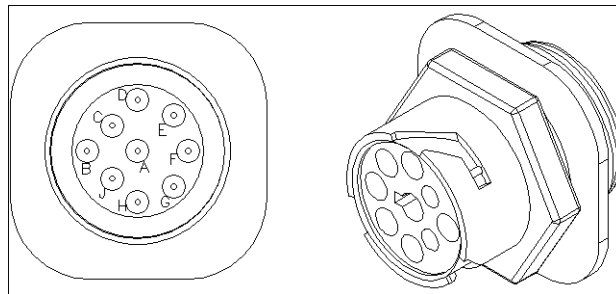

87736919 14

**CONNECTOR X-337 - Hydraulic master switch**

CONNECTOR X-337 - Hydraulic master switch			
PIN NUMBER	WIRE NUMBER	CIRCUIT REFERENCE	ELECTRICAL SCHEMATIC FRAME
1	SP-5210A (BR)	X-405 Cab main harness to switch panel harness 2 X-337 Hydraulic master switch	<b>Wiring harnesses - Electrical schematic sheet 11 (55.100)</b>
2	SP-5005AA (TN)	X-337 Hydraulic master switch SP-5005A POT 15 EDC	
3	-	-	
4	SP-5597BA (GY)	SP-5597B EHR-MASTER X-337 Hydraulic master switch	
5	SP-5260F (TN)	X-337 Hydraulic master switch X-405 Cab main harness to switch panel harness 2	
6	SP-5597BB (GY)	X-337 Hydraulic master switch SP-5597B EHR-MASTER	
7	SP-057GM (BK)	X-337 Hydraulic master switch SP-057G POT GND SWITCH PANEL	
8	SP-1014FM (RD)	X-337 Hydraulic master switch SP-1014F POT 58 SWITCH PANEL	
9	SP-057GL (BK)	X-337 Hydraulic master switch SP-057G POT GND SWITCH PANEL	
10	SP-1014FS (RD)	SP-1014F POT 58 SWITCH PANEL X-337 Hydraulic master switch	

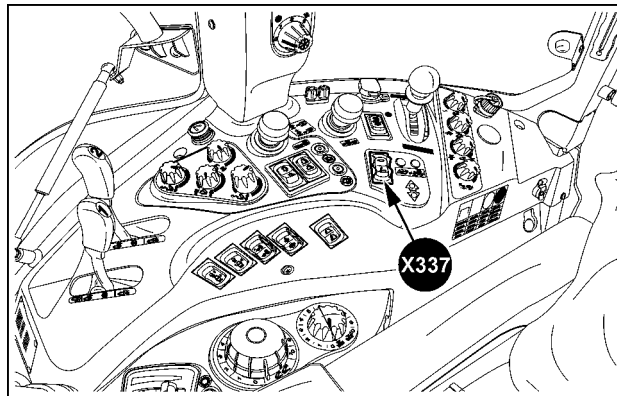

SVIL13TR00706AM 15

**Cab right-hand side**

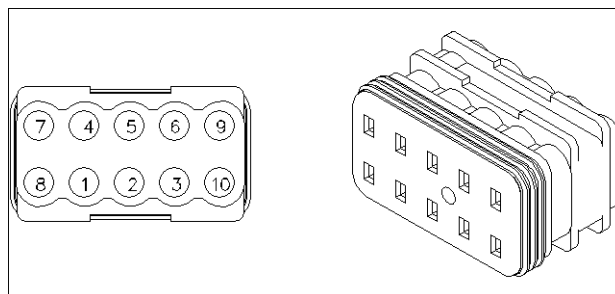

84819781 16

**CONNECTOR X-338 - Remote valve encoder**

CONNECTOR X-338 - Remote valve encoder			
PIN NUMBER	WIRE NUMBER	CIRCUIT REFERENCE	ELECTRICAL SCHEMATIC FRAME
1	24 (WH/GN)	X-388 Cab main harness to armrest components X-338 Remote valve encoder	<b>Wiring harnesses - Electrical schematic sheet 13 (55.100)</b>
2	1 (WH/GN)	X-388 Cab main harness to armrest components X-338 Remote valve encoder	
3	2 (WH/YE)	X-388 Cab main harness to armrest components X-338 Remote valve encoder	
4	22 (WH/BK)	X-388 Cab main harness to armrest components X-338 Remote valve encoder	
5	3 (WH/RD)	X-388 Cab main harness to armrest components X-338 Remote valve encoder	

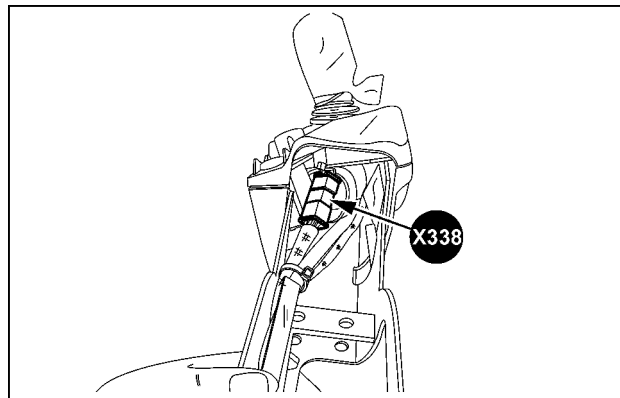

SVIL13TR00867AB 17

**Armrest**

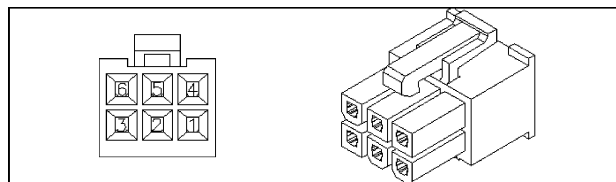

87694706 18

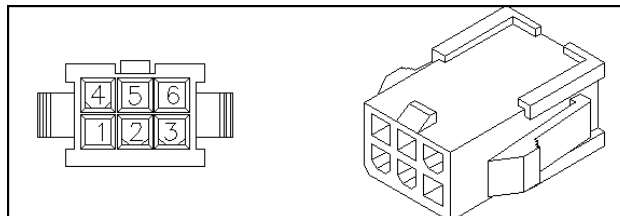

87694696 19

## Wire connectors - Component diagram 34

### CONNECTOR X-340 - Front axle differential lock – Solenoid valve

CONNECTOR X-340 - Front axle differential lock – Solenoid valve			
PIN NUMBER	WIRE NUMBER	CIRCUIT REFERENCE	ELECTRICAL SCHEMATIC FRAME
1	TR-7081 (LG)	X-300 Cab main harness to transmission harness X-340 Front axle differential lock – Solenoid valve	Wiring harnesses - Electrical schematic sheet 09 (55.100)
2	TR-057DN (BK)	SP-057DH Ground X-340 Front axle differential lock – Solenoid valve	

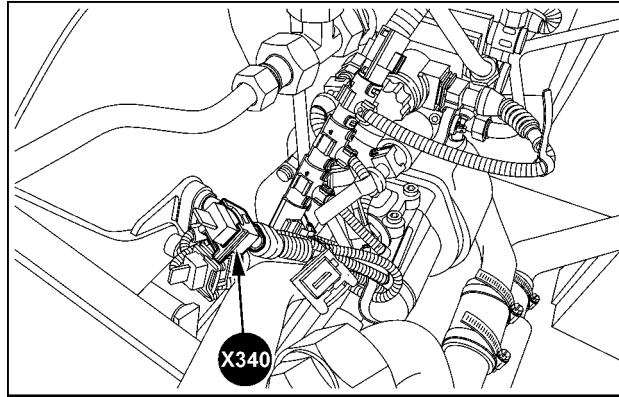

SVIL13TR00773AB 1

**Right-hand of transmission**

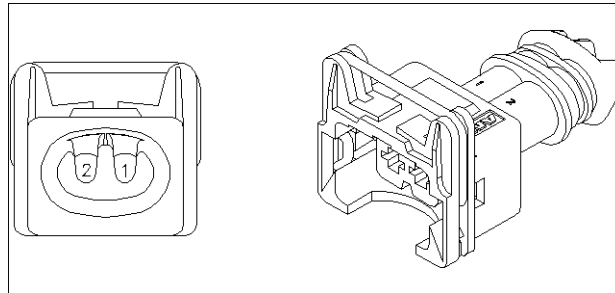

84607243 2

**CONNECTOR X-341 - Rear Power Take-Off (PTO) – Speed sensor**

CONNECTOR X-341 - Rear Power Take-Off (PTO) – Speed sensor			
PIN NUMBER	WIRE NUMBER	CIRCUIT REFERENCE	ELECTRICAL SCHEMATIC FRAME
1	TR-060JD (BK/WH)	X-341 Rear Power Take-Off (PTO) – Speed sensor SP-060J VMG1 ZF Ext	<b>Wiring harnesses - Electrical schematic sheet 07 (55.100)</b>
2	TR-2140 (OR)	X-300 Cab main harness to transmission harness X-341 Rear Power Take-Off (PTO) – Speed sensor	
3	TR-010JE (GN)	X-341 Rear Power Take-Off (PTO) – Speed sensor SP-010JA ZF Trans Sensor 12V	

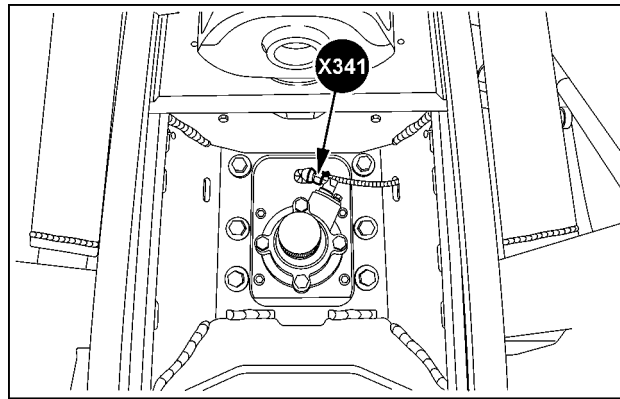

SVIL13TR00783AB 3

**Behind of rear axle**

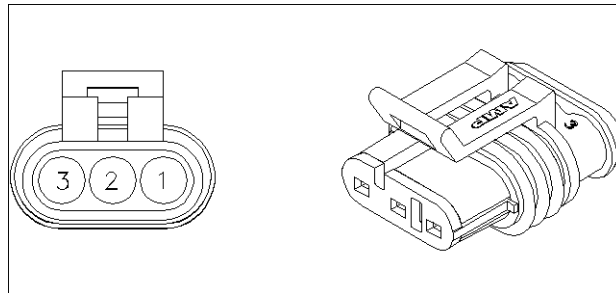

84062580 4

**CONNECTOR X-342 - Four-Wheel Drive (4WD) – Solenoid valve**

CONNECTOR X-342 - Four-Wheel Drive (4WD) – Solenoid valve			
PIN NUMBER	WIRE NUMBER	CIRCUIT REFERENCE	ELECTRICAL SCHEMATIC FRAME
1	TR-3024 (YE)	X-300 Cab main harness to transmission harness X-342 Four-Wheel Drive (4WD) – Solenoid valve	Wiring harnesses - Electrical schematic sheet 08 (55.100)
2	TR-7901C (OR)	X-342 Four-Wheel Drive (4WD) – Solenoid valve SP-7901 VPS2	

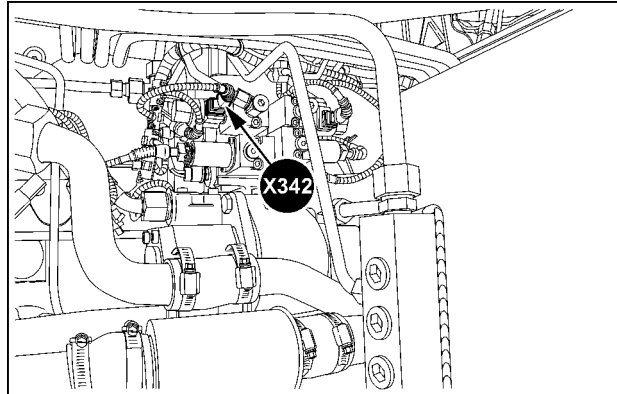

SVIL13TR00754AG 5

**Right-hand of transmission**

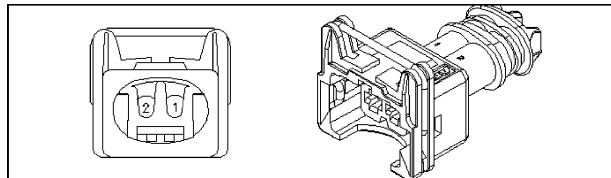

84475258 6

**CONNECTOR X-343 - Rear axle differential lock – Solenoid valve**

<b>CONNECTOR X-343 - Rear axle differential lock – Solenoid valve</b>			
<b>PIN NUMBER</b>	<b>WIRE NUMBER</b>	<b>CIRCUIT REFERENCE</b>	<b>ELECTRICAL SCHEMATIC FRAME</b>
1	TR-7080 (LG)	X-300 Cab main harness to transmission harness X-343 Rear axle differential lock – Solenoid valve	<b>Wiring harnesses - Electrical schematic sheet 08 (55.100)</b>
2	TR-7901B (OR)	X-343 Rear axle differential lock – Solenoid valve SP-7901 VPS2	

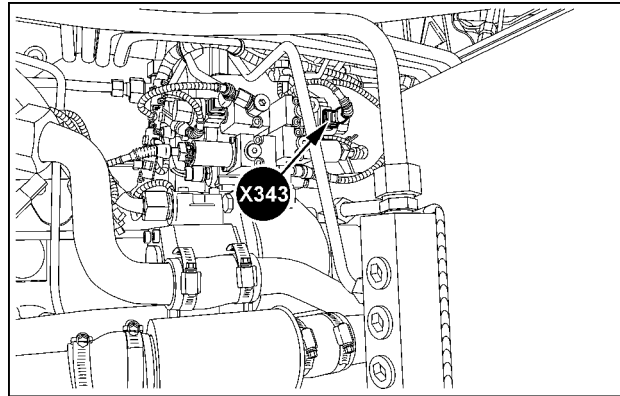

SVIL13TR00754AE 7

**Right-hand of transmission**

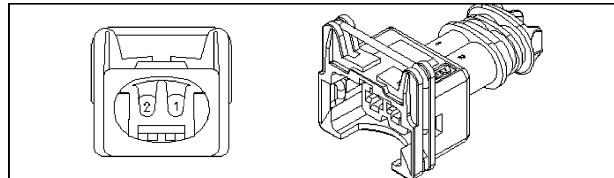

84475258 8

**CONNECTOR X-344 - Rear Power Take-Off (PTO) – Solenoid valve**

CONNECTOR X-344 - Rear Power Take-Off (PTO) – Solenoid valve			
PIN NUMBER	WIRE NUMBER	CIRCUIT REFERENCE	ELECTRICAL SCHEMATIC FRAME
1	TR-2042 (OR)	X-300 Cab main harness to transmission harness X-344 Rear Power Take-Off (PTO) – Solenoid valve	Wiring harnesses - Electrical schematic sheet 08 (55.100)
2	TR-7901A (OR)	X-344 Rear Power Take-Off (PTO) – Solenoid valve SP-7901 VPS2	

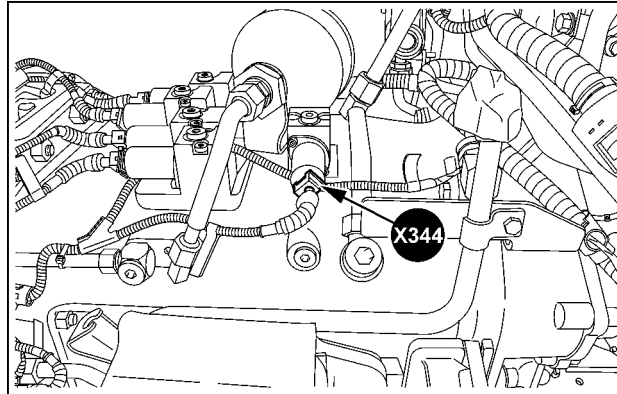

SVIL13TR00784AB 9

**Front right-hand side top of transmission**

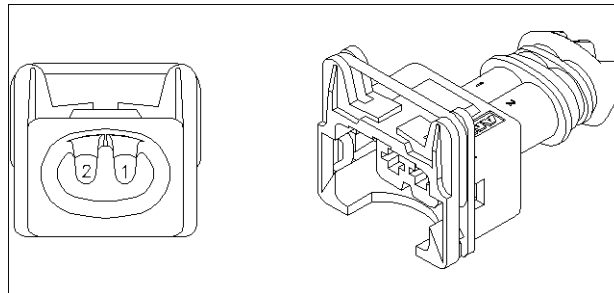

84607243 10



**CONNECTOR X-345 - Front/rear selector switch – Remote valve joystick**

CONNECTOR X-345 - Front/rear selector switch – Remote valve joystick			
PIN NUMBER	WIRE NUMBER	CIRCUIT REFERENCE	ELECTRICAL SCHEMATIC FRAME
1	11 (WH)		
2	5 (WH)		
3	8 (WH)		
7	17 (WH)		
8	14 (WH)		
9	19 (WH)		
10	20 (WH)		

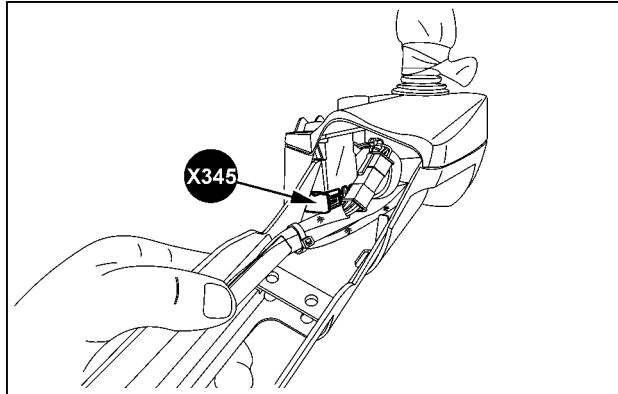

SVIL13TR00869AB 11

**Armrest**

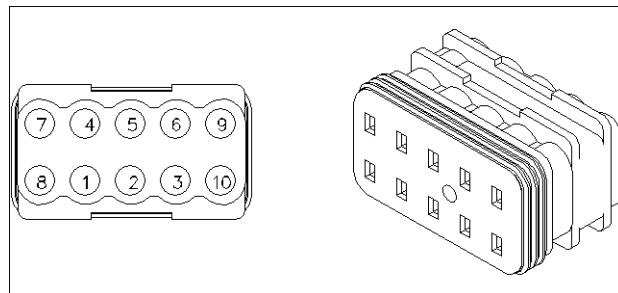

84819781 12

**CONNECTOR X-346 - Cab main harness to Electro-Hydraulic Remote (EHR) valve harness**

CONNECTOR X-346 - Cab main harness to Electro-Hydraulic Remote (EHR) valve harness			
PIN NUMBER	WIRE NUMBER	CIRCUIT REFERENCE	ELECTRICAL SCHEMATIC FRAME
1	CM-5515 (GY) EH-5515 (GY)	X-346 Cab main harness to Electro-Hydraulic Remote (EHR) valve harness X-180 Fuse block (F-070 to F-101) X-346 Cab main harness to Electro-Hydraulic Remote (EHR) valve harness X-700 Electro Hydraulic Remote (EHR) valve 4 – Rear implement	Wiring harnesses - Electrical schematic sheet 13 (55.100) Wiring harnesses - Electrical schematic sheet 24 (55.100)
2	CM-290B (BL) EH-290B (BL)	SP-290A X-346 Cab main harness to Electro-Hydraulic Remote (EHR) valve harness SP-290B X-346 Cab main harness to Electro-Hydraulic Remote (EHR) valve harness	
3	CM-291B (RD) EH-291B (RD)	SP-291A X-346 Cab main harness to Electro-Hydraulic Remote (EHR) valve harness SP-291B X-346 Cab main harness to Electro-Hydraulic Remote (EHR) valve harness	
4	CM-057AE (BK) EH-057AE (BK)	SP-057A CAB GND X-346 Cab main harness to Electro-Hydraulic Remote (EHR) valve harness SP-057AE X-346 Cab main harness to Electro-Hydraulic Remote (EHR) valve harness	

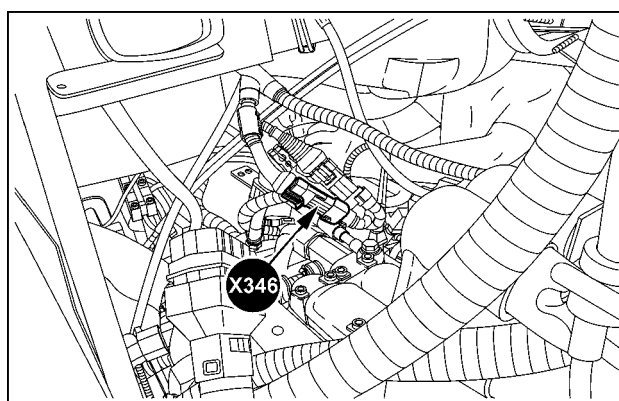

SVIL13TR00785AB 13

**Rear top of transmission**

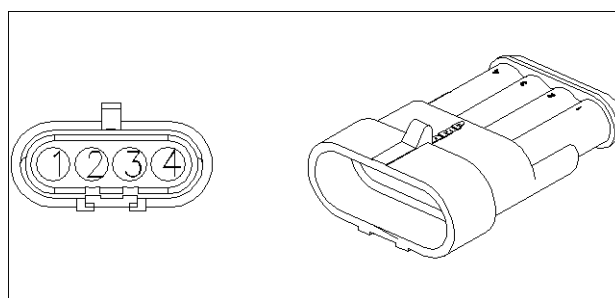

87680652 14

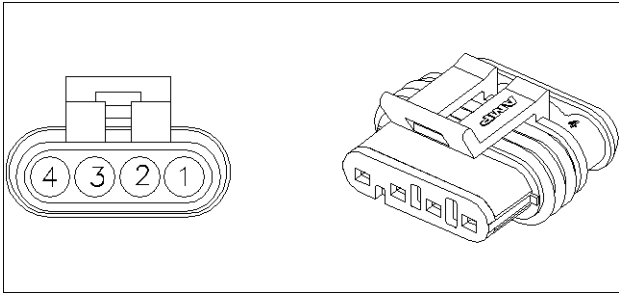

87687242 15

**CONNECTOR X-346\_M - Cab main harness to CAN bus termination resistor**

CONNECTOR X-346_M - Cab main harness to CAN bus termination resistor			
PIN NUMBER	WIRE NUMBER	CIRCUIT REFERENCE	ELECTRICAL SCHEMATIC FRAME
1	-	-	Wiring harnesses - Electrical schematic sheet 25 (55.100)
2	CM-290T (GN)	X-346_M Cab main harness to CAN bus termination resistor ST246	
3	CM-291T (YE)	X-346_M Cab main harness to CAN bus termination resistor ST245	
4	-	-	

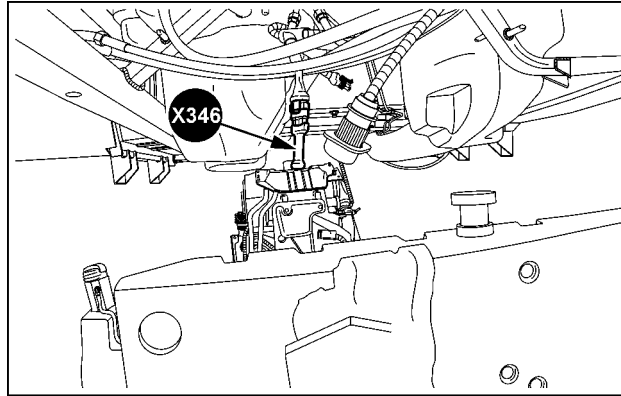

SVIL13TR00816AB 16

**Rear top of transmission**

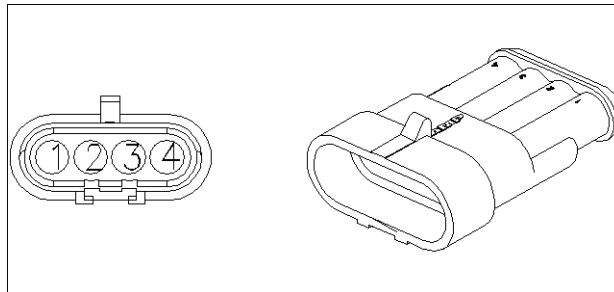

87680652 17

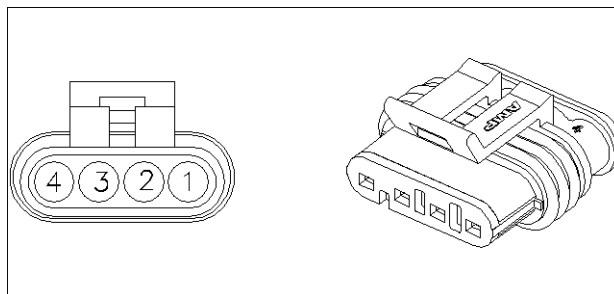

87687242 18

**CONNECTOR X-347 - Power Take-Off (PTO) ON/OFF switch – Fender left-hand**

CONNECTOR X-347 - Power Take-Off (PTO) ON/OFF switch – Fender left-hand			
PIN NUMBER	WIRE NUMBER	CIRCUIT REFERENCE	ELECTRICAL SCHEMATIC FRAME
1	CM-010FA (GN)	X-347 Power Take-Off (PTO) ON/OFF switch – Fender left-hand SP-010F	<b>Wiring harnesses - Electrical schematic sheet 10 (55.100)</b>
2	CM-2057 (WH)	X-347 Power Take-Off (PTO) ON/OFF switch – Fender left-hand X-349 Power Take-Off (PTO) ON/OFF switch – Fender right-hand	
3	CM-2056 (WH)	X-347 Power Take-Off (PTO) ON/OFF switch – Fender left-hand SP-2056	

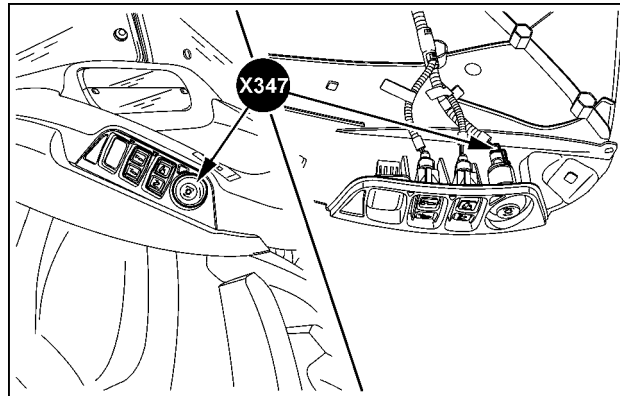

SS13J070 19

**Left-hand rear fender**

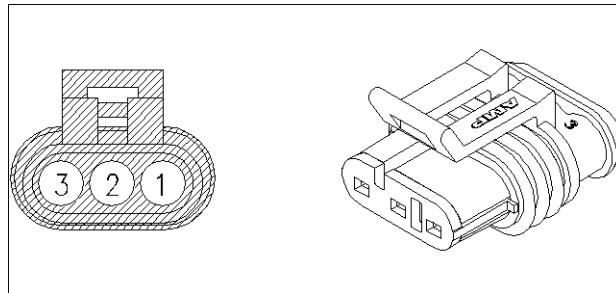

87691928 20

**CONNECTOR X-348 - Front Power Take-Off (PTO) – ON/OFF switch**

CONNECTOR X-348 - Front Power Take-Off (PTO) – ON/OFF switch			
PIN NUMBER	WIRE NUMBER	CIRCUIT REFERENCE	ELECTRICAL SCHEMATIC FRAME
1	SP-011FP (GN)	SP-011FF XCM 5V X-348 Front Power Take-Off (PTO) – ON/OFF switch	Wiring harnesses - Electrical schematic sheet 10 (55.100)
2	SP-2245 (PK)	X-405 Cab main harness to switch panel harness 2 X-348 Front Power Take-Off (PTO) – ON/OFF switch	
3	SP-2246 (WH)	X-405 Cab main harness to switch panel harness 2 X-348 Front Power Take-Off (PTO) – ON/OFF switch	

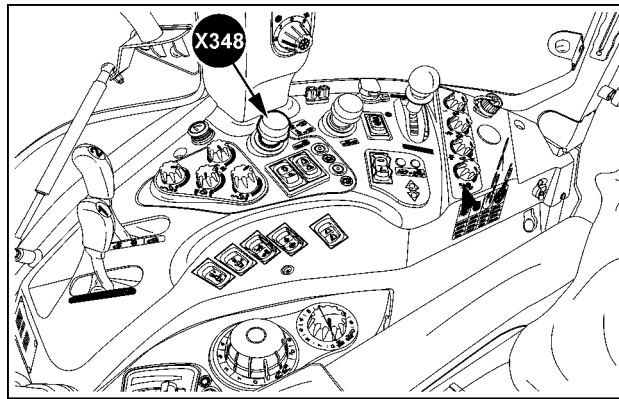

SVIL13TR00706AD 21

**Cab right-hand side**

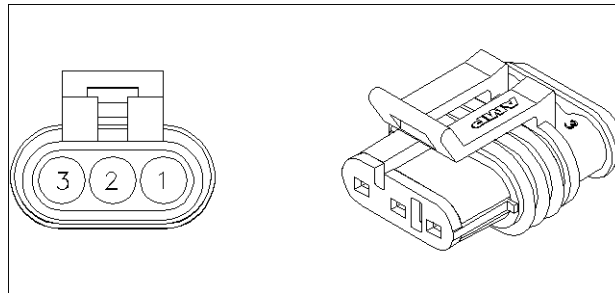

84062580 22

**CONNECTOR X-349 - Power Take-Off (PTO) ON/OFF switch – Fender right-hand**

CONNECTOR X-349 - Power Take-Off (PTO) ON/OFF switch – Fender right-hand			
PIN NUMBER	WIRE NUMBER	CIRCUIT REFERENCE	ELECTRICAL SCHEMATIC FRAME
1	CM-2057 (WH)	X-347 Power Take-Off (PTO) ON/OFF switch – Fender left-hand X-349 Power Take-Off (PTO) ON/OFF switch – Fender right-hand	<b>Wiring harnesses - Electrical schematic sheet 10 (55.100)</b>
2	CM-2059 (WH)	X-349 Power Take-Off (PTO) ON/OFF switch – Fender right-hand X-230 Central Control Unit (CCU) – CN3A	
3	CM-2056A (WH)	X-349 Power Take-Off (PTO) ON/OFF switch – Fender right-hand SP-2056	

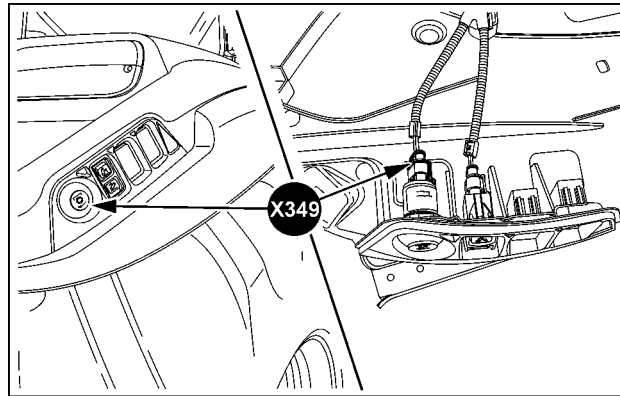

SS13K016 23

**Right-hand rear fender**

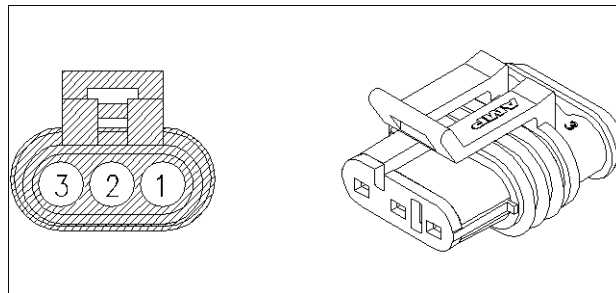

87691928 24

## Wire connectors - Component diagram 35

### CONNECTOR X-350 - Rear Power Take-Off (PTO) – ON/OFF switch

CONNECTOR X-350 - Rear Power Take-Off (PTO) – ON/OFF switch			
PIN NUMBER	WIRE NUMBER	CIRCUIT REFERENCE	ELECTRICAL SCHEMATIC FRAME
1	SP-011FN (GN)	X-350 Rear Power Take-Off (PTO) – ON/OFF switch SP-011FF XCM 5V	Wiring harnesses - Electrical schematic sheet 10 (55.100)
2	SP-2235 (PK)	X-405 Cab main harness to switch panel harness 2 X-350 Rear Power Take-Off (PTO) – ON/OFF switch	
3	SP-2236 (PK)	X-405 Cab main harness to switch panel harness 2 X-350 Rear Power Take-Off (PTO) – ON/OFF switch	

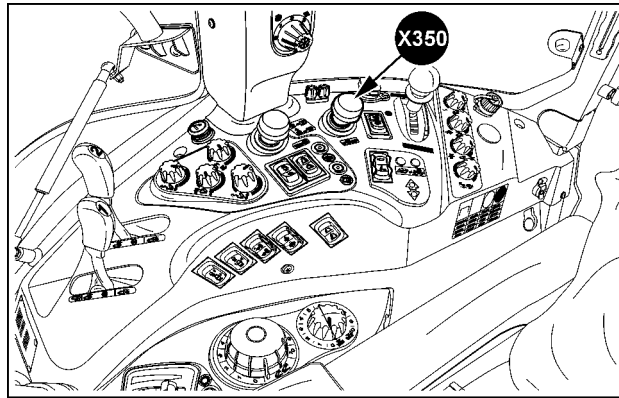

SVIL13TR00706AG 1

**Cab right-hand side**

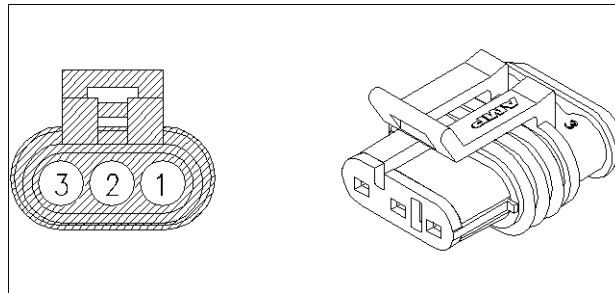

87691928 2



**CONNECTOR X-351 - Rear Power Take-Off (PTO) – Soft-start/auto switch**

CONNECTOR X-351 - Rear Power Take-Off (PTO) – Soft-start/auto switch			
PIN NUMBER	WIRE NUMBER	CIRCUIT REFERENCE	ELECTRICAL SCHEMATIC FRAME
1	-	-	<b>Wiring harnesses - Electrical schematic sheet 10 (55.100)</b>
2	SP-011FK (GN)	X-351 Rear Power Take-Off (PTO) – Soft-start/auto switch SP-011FF XCM 5V	
3	SP-2068 (TN)	X-405 Cab main harness to switch panel harness 2 X-351 Rear Power Take-Off (PTO) – Soft-start/auto switch	
4	SP-2085 (OR)	X-405 Cab main harness to switch panel harness 2 X-351 Rear Power Take-Off (PTO) – Soft-start/auto switch	
5	SP-011FL (GN)	X-351 Rear Power Take-Off (PTO) – Soft-start/auto switch SP-011FF XCM 5V	
6	-	-	
7	SP-057GN (BK)	X-351 Rear Power Take-Off (PTO) – Soft-start/auto switch SP-057G POT GND SWITCH PANEL	
8	SP-1014FE (RD)	SP-1014F POT 58 SWITCH PANEL X-351 Rear Power Take-Off (PTO) – Soft-start/auto switch	
9	SP-057GP (BK)	SP-057G POT GND SWITCH PANEL X-351 Rear Power Take-Off (PTO) – Soft-start/auto switch	
10	SP-1014FF (RD)	SP-1014F POT 58 SWITCH PANEL X-351 Rear Power Take-Off (PTO) – Soft-start/auto switch	

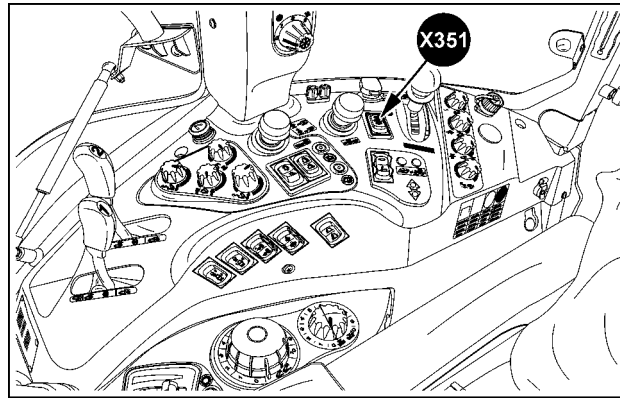

SVIL13TR00706AL 3

**Cab right-hand side**

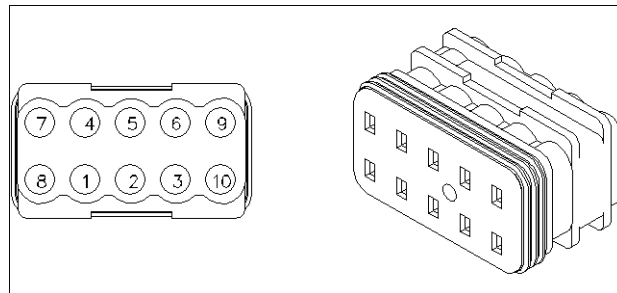

84819781 4

**CONNECTOR X-352 - Front Power Take-Off (PTO) – Solenoid valve**

CONNECTOR X-352 - Front Power Take-Off (PTO) – Solenoid valve			
PIN NUMBER	WIRE NUMBER	CIRCUIT REFERENCE	ELECTRICAL SCHEMATIC FRAME
1	EN-2043 (OR)	X-001 Cab main harness to engine harness 1 X-352 Front Power Take-Off (PTO) – Solenoid valve	<b>Wiring harnesses - Electrical schematic sheet 10 (55.100)</b>
2	EN-2044 (OR)	X-001 Cab main harness to engine harness 1 X-352 Front Power Take-Off (PTO) – Solenoid valve	

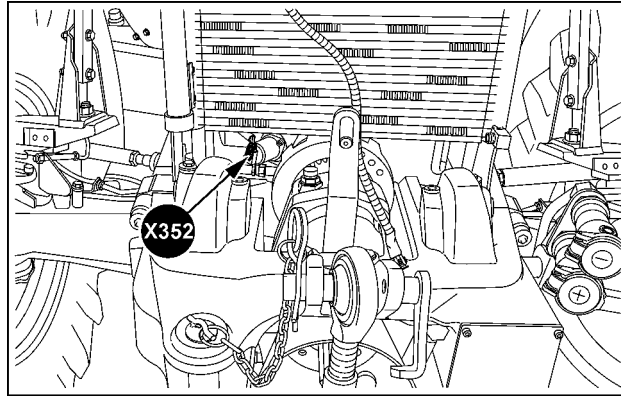

SVIL13TR00787AB 5

**Bottom front right-hand engine**

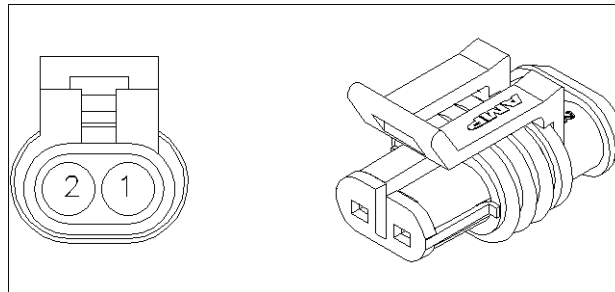

82012083 6

**CONNECTOR X-353 - Steering pressure switch**

CONNECTOR X-353 - Steering pressure switch			
PIN NUMBER	WIRE NUMBER	CIRCUIT REFERENCE	ELECTRICAL SCHEMATIC FRAME
1	TR-3501 (WH)	X-353 Steering pressure switch X-300 Cab main harness to transmission harness	<b>Wiring harnesses - Electrical schematic sheet 04 (55.100)</b>

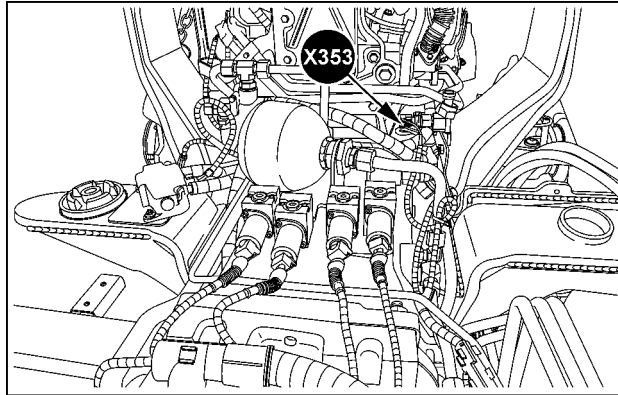

SVIL13TR00764AC 7

**Front top of transmission**

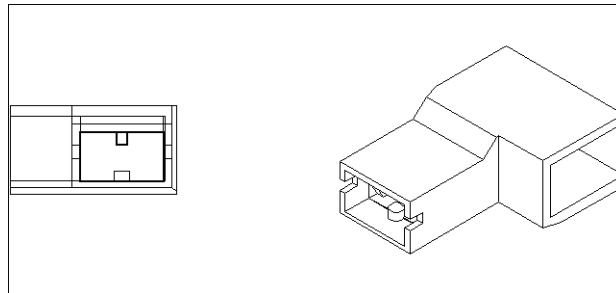

82944111 8

**CONNECTOR X-354 - Fuel level sensor**

CONNECTOR X-354 - Fuel level sensor			
PIN NUMBER	WIRE NUMBER	CIRCUIT REFERENCE	ELECTRICAL SCHEMATIC FRAME
1	TR-060A (BK/WH)	X-354 Fuel level sensor X-300 Cab main harness to transmission harness	<b>Wiring harnesses - Electrical schematic sheet 03 (55.100)</b>
2	TR-029 (GN)	X-354 Fuel level sensor X-300 Cab main harness to transmission harness	

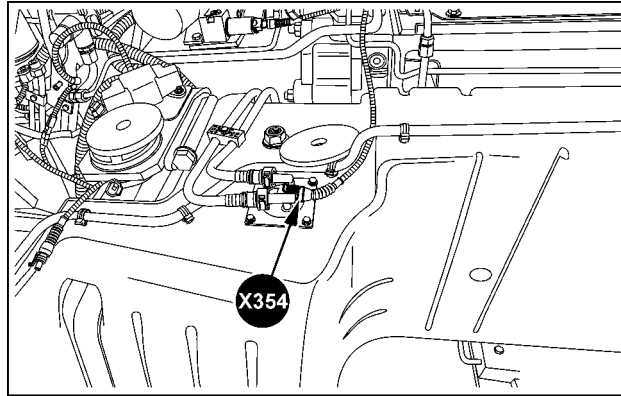

SVIL13TR00788AB 9

**Left-hand behind steps**

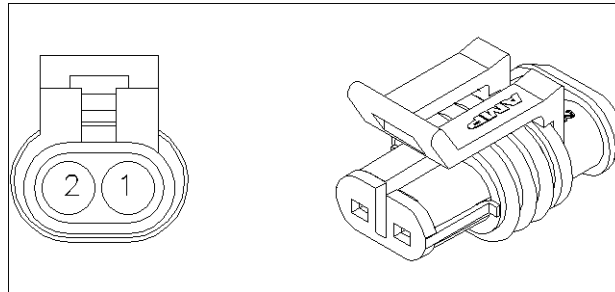

82012083 10

**CONNECTOR X-355 - Seat assembly (seat switch)**

CONNECTOR X-355 - Seat assembly (seat switch)			
PIN NUMBER	WIRE NUMBER	CIRCUIT REFERENCE	ELECTRICAL SCHEMATIC FRAME
1	CM-060B (BK/WH)	SP-060 X-355 Seat assembly (seat switch)	Wiring harnesses - Electrical schematic sheet 03 (55.100)
2	CM-7245 (GN)	X-450 Instrument cluster CN1 X-355 Seat assembly (seat switch)	

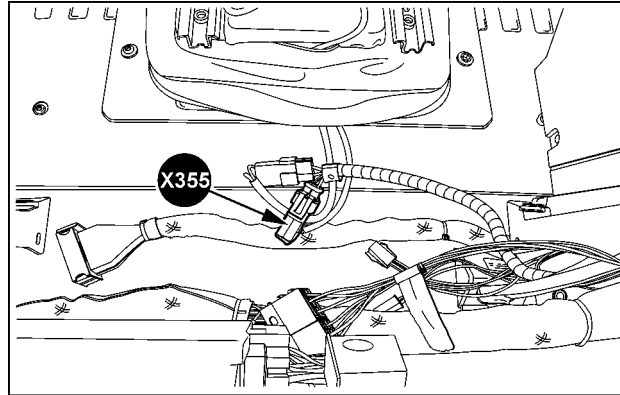

SVIL13TR00710AC 11

**In cab behind operator's seat**

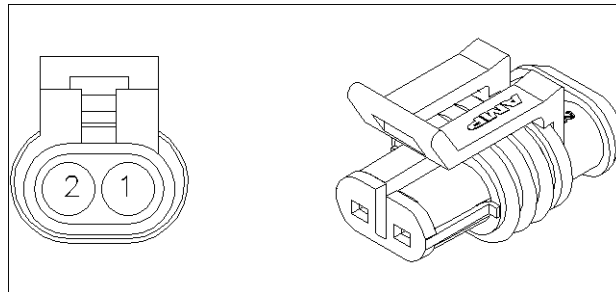

82012083 12

**CONNECTOR X-357 - Air cleaner restriction switch**

<b>CONNECTOR X-357 - Air cleaner restriction switch</b>			
<b>PIN NUMBER</b>	<b>WIRE NUMBER</b>	<b>CIRCUIT REFERENCE</b>	<b>ELECTRICAL SCHEMATIC FRAME</b>
1	EN-9234 (YE)	X-357 Air cleaner restriction switch X-001 Cab main harness to engine harness 1	<b>Wiring harnesses - Electrical schematic sheet 04 (55.100)</b>
2	EN-057FD (BK)	X-357 Air cleaner restriction switch SP-057F GND - Engine	

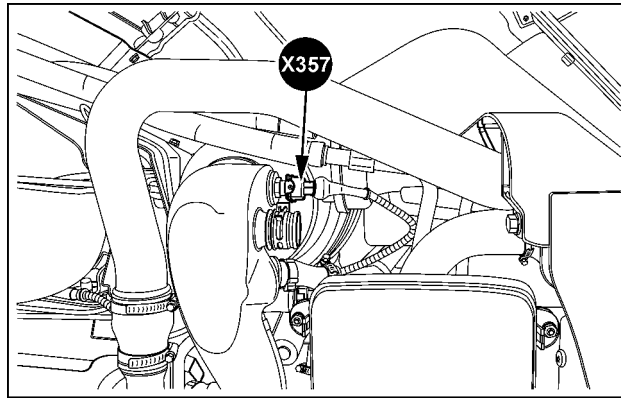

SVIL13TR00789AB 13

**Front top right-hand engine**



87747163 14

**CONNECTOR X-358 - Hand brake position switch**

CONNECTOR X-358 - Hand brake position switch			
PIN NUMBER	WIRE NUMBER	CIRCUIT REFERENCE	ELECTRICAL SCHEMATIC FRAME
1	CM-138DE (VT)	SP-138D X-358 Hand brake position switch	<b>Wiring harnesses - Electrical schematic sheet 04 (55.100)</b>
2	CM-8065 (BL)	X-381 Cab main harness to hydraulic trailer brake harness X-358 Hand brake position switch	
3	CM-057BG (BK)	X-358 Hand brake position switch SP-057B	
4	CM-3155 (WH)	X-358 Hand brake position switch X-240 Central Control Unit (CCU) – CN3B	
5	CM-3012 (RD)	X-358 Hand brake position switch X-460 Instrument cluster CN2	

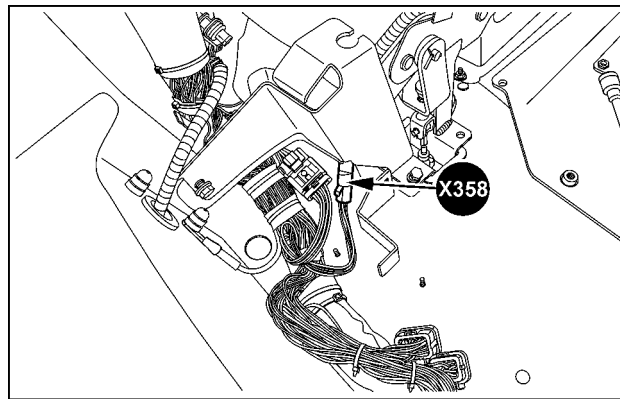

SVIL13TR00768AD 15

**Rear of cab behind left-hand trim**



82867472 16

**CONNECTOR X-359 - Hydraulic trailer brake – Pressure switch**

CONNECTOR X-359 - Hydraulic trailer brake – Pressure switch			
PIN NUMBER	WIRE NUMBER	CIRCUIT REFERENCE	ELECTRICAL SCHEMATIC FRAME
1	TB-057CE (BK)	SP-057CD GND ITALIEN BRAKE X-359 Hydraulic trailer brake – Pressure switch	Wiring harnesses - Electrical schematic sheet 04 (55.100)

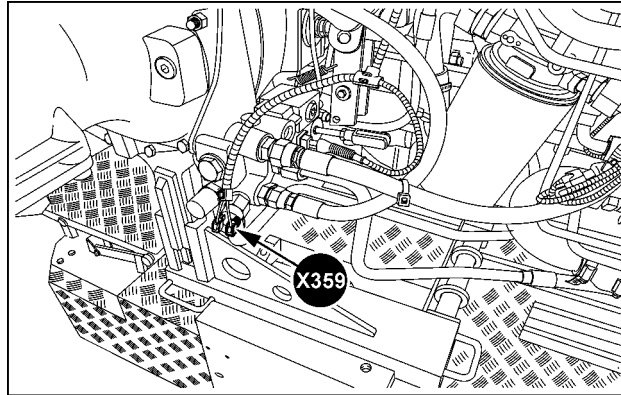

SVIL13TR00871AB 17

**Right-hand on the rear axle**

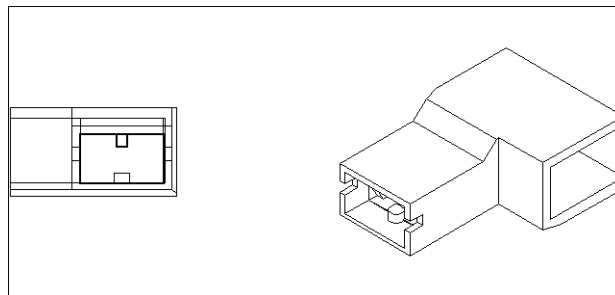

82944111 18



## Wire connectors - Component diagram 36

### CONNECTOR X-360 - Brake fluid level switch

CONNECTOR X-360 - Brake fluid level switch			
PIN NUMBER	WIRE NUMBER	CIRCUIT REFERENCE	ELECTRICAL SCHEMATIC FRAME
1	EN-010CB (GN)	X-360 Brake fluid level switch X-001 Cab main harness to engine harness 1	<b>Wiring harnesses - Electrical schematic sheet 04 (55.100)</b>
2	EN-3016 (GY)	X-360 Brake fluid level switch X-001 Cab main harness to engine harness 1	

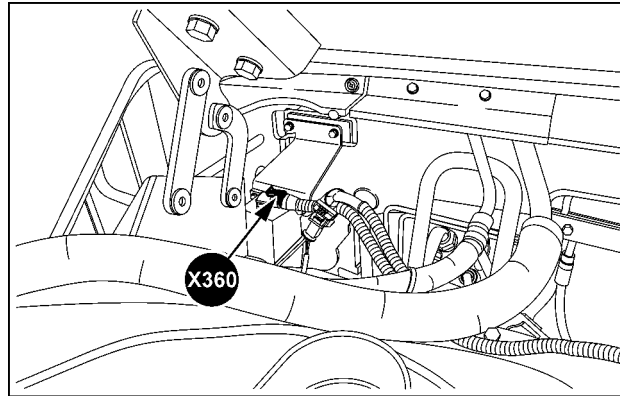

SVIL13TR00790AB 1

**Rear right-hand top of engine**

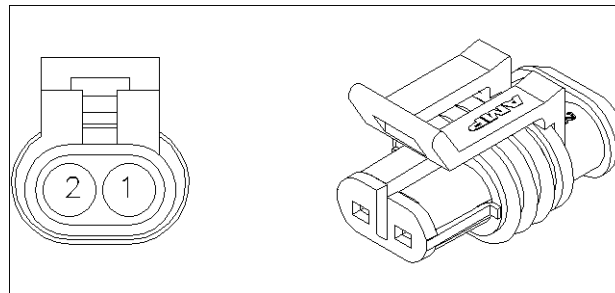

82012083 2

**CONNECTOR X-361 - Hydraulic trailer brake – Solenoid valve**

CONNECTOR X-361 - Hydraulic trailer brake – Solenoid valve			
PIN NUMBER	WIRE NUMBER	CIRCUIT REFERENCE	ELECTRICAL SCHEMATIC FRAME
1	TB-057CF (BK)	X-361 Hydraulic trailer brake – Solenoid valve SP-057CD GND ITALIEN BRAKE	Wiring harnesses - Electrical schematic sheet 04 (55.100)
2	TB-8000A (BR)	X-999 Hydraulic trailer brake relay X-361 Hydraulic trailer brake – Solenoid valve	

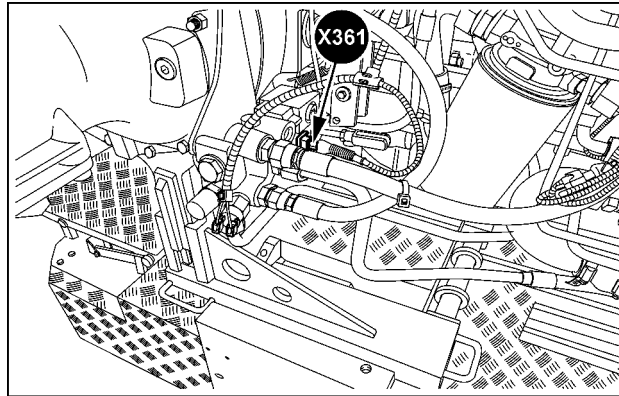

SVIL13TR00871AC 3

**Right-hand on the rear axle**

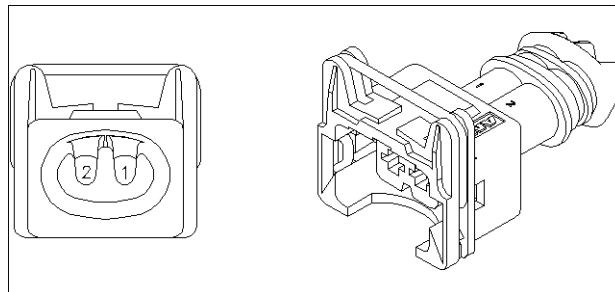

84607243 4

**CONNECTOR X-362 - Fuel heater**

CONNECTOR X-362 - Fuel heater			
PIN NUMBER	WIRE NUMBER	CIRCUIT REFERENCE	ELECTRICAL SCHEMATIC FRAME
1	-	-	Wiring harnesses - Electrical schematic sheet 05 (55.100)
2	-	-	
3	EN-057FE (BK)	X-362 Fuel heater SP-057F GND - Engine	
4	EN-1246C (RD)	X-362 Fuel heater SP-1246A	

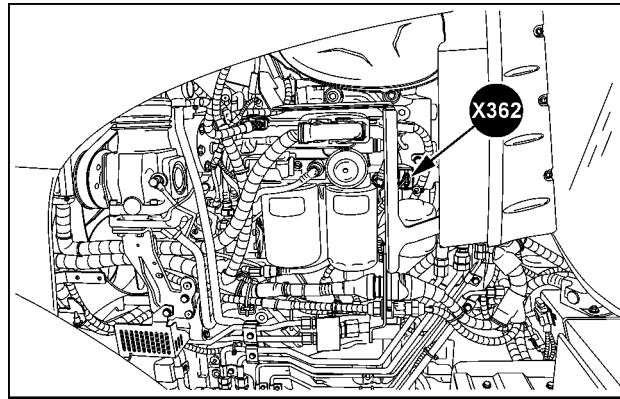

SVIL13TR00700AD 5

**Rear left-hand engine**

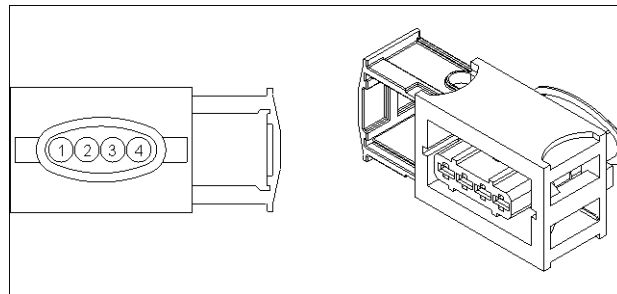

84546837 6

**CONNECTOR X-364 - Clutch B solenoid valve**

<b>CONNECTOR X-364 - Clutch B solenoid valve</b>			
<b>PIN NUMBER</b>	<b>WIRE NUMBER</b>	<b>CIRCUIT REFERENCE</b>	<b>ELECTRICAL SCHEMATIC FRAME</b>
1	TR-7915 (OR)	SP-7900 VPS1 X-364 Clutch B solenoid valve	<b>Wiring harnesses - Electrical schematic sheet 07 (55.100)</b>
2	TR-7910 (VT)	X-364 Clutch B solenoid valve X-300 Cab main harness to transmission harness	

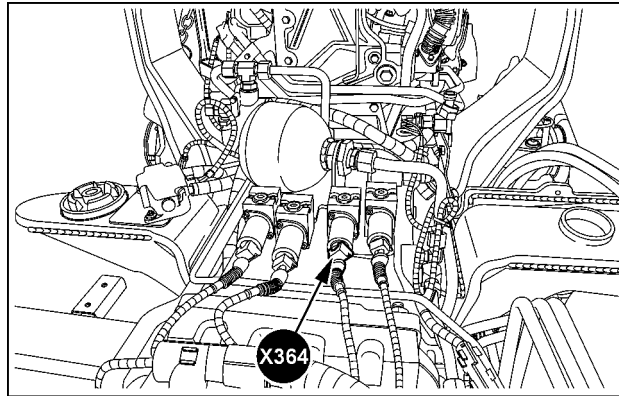

SVIL13TR00764AD 7

**Front top of transmission**

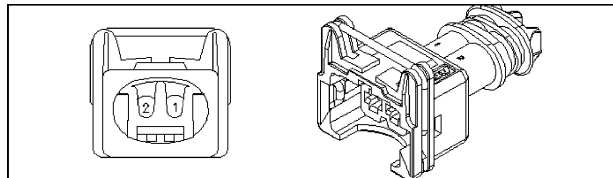

84475258 8

**CONNECTOR X-365 - Clutch G solenoid valve**

<b>CONNECTOR X-365 - Clutch G solenoid valve</b>			
<b>PIN NUMBER</b>	<b>WIRE NUMBER</b>	<b>CIRCUIT REFERENCE</b>	<b>ELECTRICAL SCHEMATIC FRAME</b>
1	TR-7901D (OR)	X-365 Clutch G solenoid valve SP-7901 VPS2	<b>Wiring harnesses - Electrical schematic sheet 08 (55.100)</b>
2	TR-7904 (VT)	X-300 Cab main harness to transmission harness X-365 Clutch G solenoid valve	

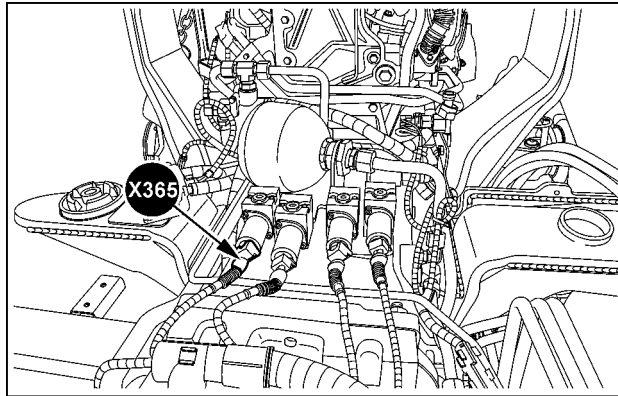

SVIL13TR00764AE 9

**Front top of transmission**

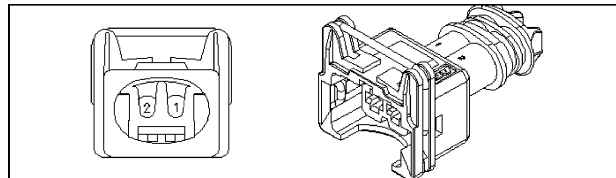

84475258 10

**CONNECTOR X-368 - Parking brake engagement – Solenoid valve**

<b>CONNECTOR X-368 - Parking brake engagement – Solenoid valve</b>			
<b>PIN NUMBER</b>	<b>WIRE NUMBER</b>	<b>CIRCUIT REFERENCE</b>	<b>ELECTRICAL SCHEMATIC FRAME</b>
1	TR-8071 (VT)	X-300 Cab main harness to transmission harness X-368 Parking brake engagement – Solenoid valve	<b>Wiring harnesses - Electrical schematic sheet 09 (55.100)</b>
2	TR-8072 (VT)	X-300 Cab main harness to transmission harness X-368 Parking brake engagement – Solenoid valve	

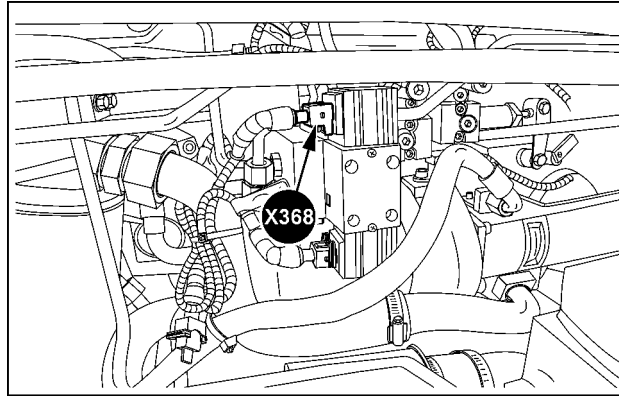

SVIL13TR00814AC 11

**Right-hand of transmission**

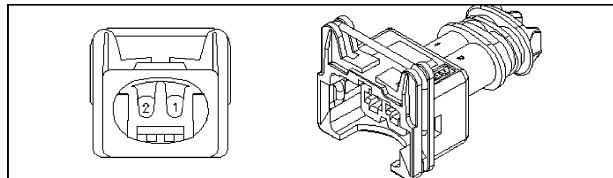

84475258 12

**CONNECTOR X-369 - Constant engine speed – Adjust switch**

CONNECTOR X-369 - Constant engine speed – Adjust switch			
PIN NUMBER	WIRE NUMBER	CIRCUIT REFERENCE	ELECTRICAL SCHEMATIC FRAME
1	SP-6540 (BR)	X-405 Cab main harness to switch panel harness 2 X-369 Constant engine speed – Adjust switch	<b>Wiring harnesses - Electrical schematic sheet 04 (55.100)</b>
2	SP-010CG (RD)	X-369 Constant engine speed – Adjust switch SP-010CE POT 15	
3	SP-6530 (BR)	X-405 Cab main harness to switch panel harness 2 X-369 Constant engine speed – Adjust switch	
4	-	-	
5	-	-	
6	-	-	
7	SP-057GI (BK)	X-369 Constant engine speed – Adjust switch SP-057G POT GND SWITCH PANEL	
8	SP-1014FK (RD)	X-369 Constant engine speed – Adjust switch SP-1014F POT 58 SWITCH PANEL	
9	SP-057GH (BK)	X-369 Constant engine speed – Adjust switch SP-057G POT GND SWITCH PANEL	
10	SP-1014FJ (RD)	X-369 Constant engine speed – Adjust switch SP-1014F POT 58 SWITCH PANEL	

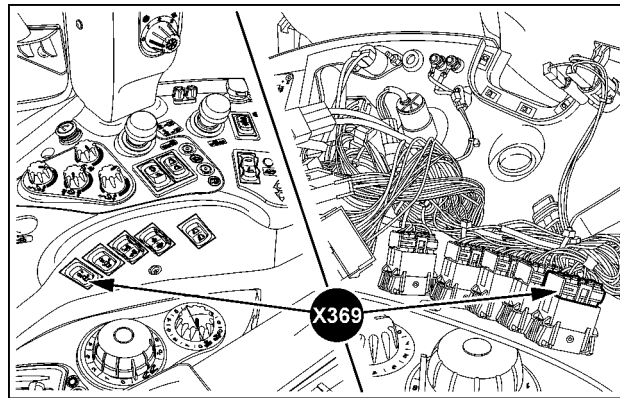

SS13K010 13

**Behind right-hand switch panel**

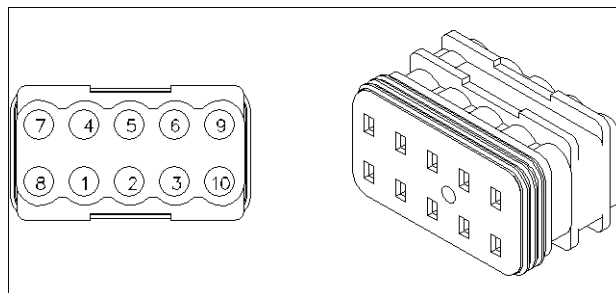

84819781 14

## Wire connectors - Component diagram 37

### CONNECTOR X-370 - Battery harness to cab main harness (battery power supply)

CONNECTOR X-370 - Battery harness to cab main harness (battery power supply)			
PIN NUMBER	WIRE NUMBER	CIRCUIT REFERENCE	ELECTRICAL SCHEMATIC FRAME
1	25 (RD) CM-001D (R)	X-533 Power distribution unit X-002 Engine harness 1 to power distribution unit X-370 Battery harness to cab main harness (battery power supply) SP-001D	Wiring harnesses - Electrical schematic sheet 02 (55.100)

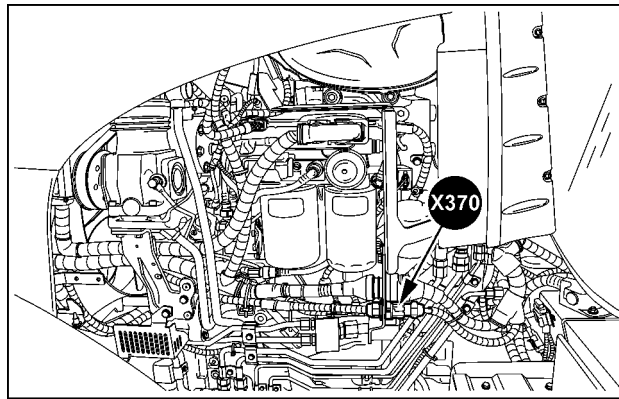

SVIL13TR00700AF 1

Rear left-hand engine

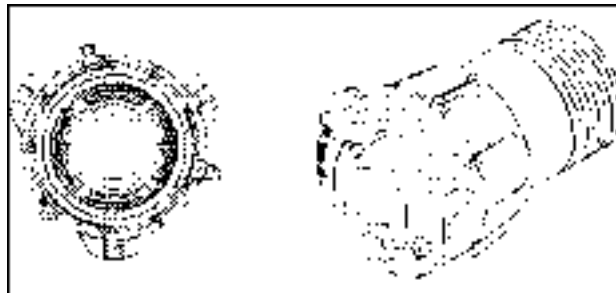

84806654 2



**CONNECTOR X-371 - Steering pressure switch**

CONNECTOR X-371 - Steering pressure switch			
PIN NUMBER	WIRE NUMBER	CIRCUIT REFERENCE	ELECTRICAL SCHEMATIC FRAME
1	TR-010CC (GN)	X-300 Cab main harness to transmission harness X-371 Steering pressure switch	Wiring harnesses - Electrical schematic sheet 04 (55.100)

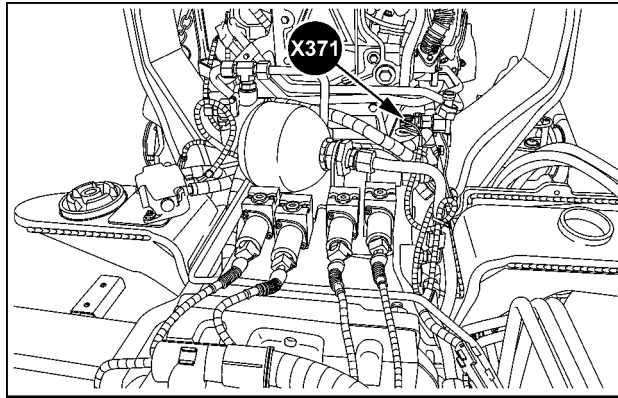

SVIL13TR00764AF 3

**Front top of transmission**

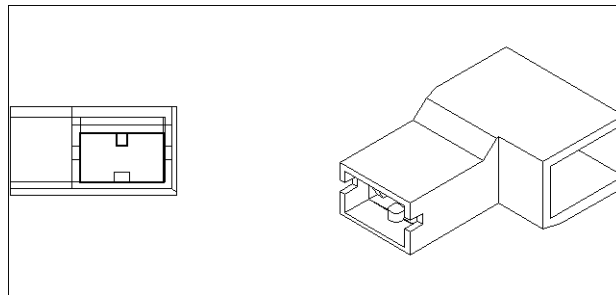

82944111 4

**CONNECTOR X-372 - Roof harness to mirror heater**

CONNECTOR X-372 - Roof harness to mirror heater			
PIN NUMBER	WIRE NUMBER	CIRCUIT REFERENCE	ELECTRICAL SCHEMATIC FRAME
1	RF-010YC (GN)	SP-010Y X-372 Roof harness to mirror heater	Wiring harnesses - Electrical schematic sheet 19 (55.100)
2	RF-057RB (BK)	X-372 Roof harness to mirror heater SP-057R	
3	RF-1013LP (BL)	SP-1013L X-372 Roof harness to mirror heater	

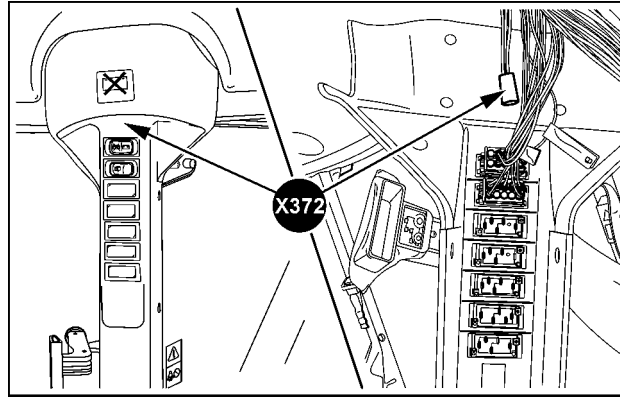

SS13K017 5

**Left-hand B-pillar**



82000578 6

**CONNECTOR X-373 - Electronic Front Hitch (EFH) control unit harness to front hitch harness**

<b>CONNECTOR X-373 - Electronic Front Hitch (EFH) control unit harness to front hitch harness</b>			
<b>PIN NUMBER</b>	<b>WIRE NUMBER</b>	<b>CIRCUIT REFERENCE</b>	<b>ELECTRICAL SCHEMATIC FRAME</b>
1	EF-060LA (BK/WH) FI-060LA (BK/WH)	SP-060L X-373 Electronic Front Hitch (EFH) control unit harness to front hitch harness X-526 Front hitch position sensor X-373 Electronic Front Hitch (EFH) control unit harness to front hitch harness	<b>Wiring harnesses - Electrical schematic sheet 14 (55.100)</b>
2	EF-2594 (OR) FI-2594 (OR)	X-373 Electronic Front Hitch (EFH) control unit harness to front hitch harness X-524 Electronic Front Hitch (EFH) control unit X-526 Front hitch position sensor X-373 Electronic Front Hitch (EFH) control unit harness to front hitch harness	
3	EF-2601B (OR) FI-2601B (VT)	X-373 Electronic Front Hitch (EFH) control unit harness to front hitch harness SP-2601 X-526 Front hitch position sensor X-373 Electronic Front Hitch (EFH) control unit harness to front hitch harness	
4	EF-2588B (VT) FH-2588B (VT)	SP-2588 X-373 Electronic Front Hitch (EFH) control unit harness to front hitch harness X-373 Electronic Front Hitch (EFH) control unit harness to front hitch harness X-521 Front hitch up/down switch – External	<b>Wiring harnesses - Electrical schematic sheet 14 (55.100)</b>
5	EF-2589B (TN) FH-2586B (TN)	SP-2589 X-373 Electronic Front Hitch (EFH) control unit harness to front hitch harness X-373 Electronic Front Hitch (EFH) control unit harness to front hitch harness X-521 Front hitch up/down switch – External	
6	EF-2587B (BR) FH-2587B (BR)	SP-2587 X-373 Electronic Front Hitch (EFH) control unit harness to front hitch harness X-373 Electronic Front Hitch (EFH) control unit harness to front hitch harness X-521 Front hitch up/down switch – External	

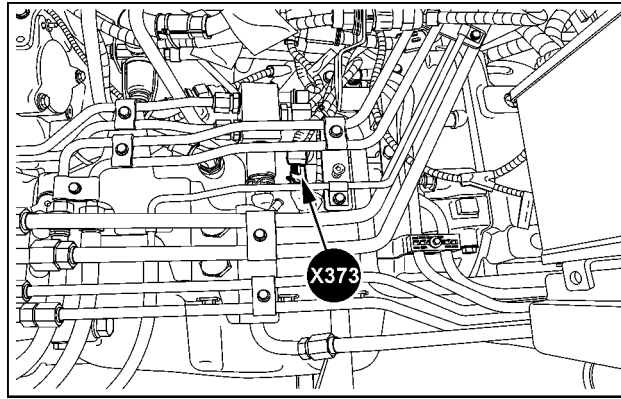

SVIL13TR00872AB 7

**Rear left-hand engine**

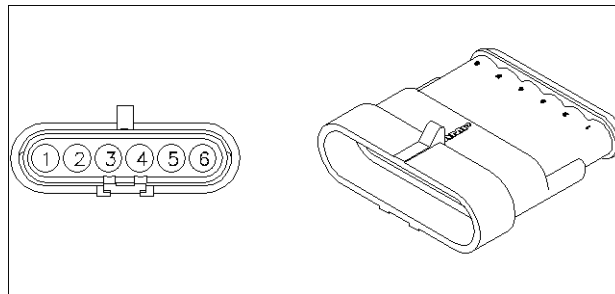

87691968 8

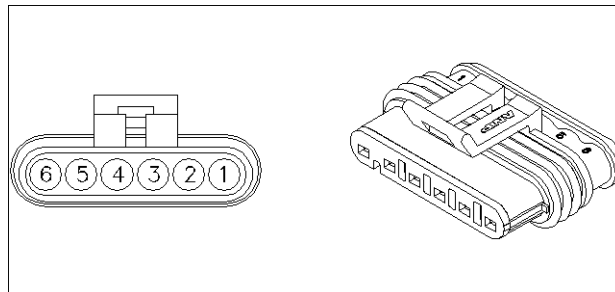

87710588 9

**CONNECTOR X-374 - Four-Wheel Drive (4WD) switch**

CONNECTOR X-374 - Four-Wheel Drive (4WD) switch			
PIN NUMBER	WIRE NUMBER	CIRCUIT REFERENCE	ELECTRICAL SCHEMATIC FRAME
1	SP-3024B (YE)	X-405 Cab main harness to switch panel harness 2 X-374 Four-Wheel Drive (4WD) switch	<b>Wiring harnesses - Electrical schematic sheet 09 (55.100)</b>
2	SP-011FJ (GN)	X-374 Four-Wheel Drive (4WD) switch SP-011FF XCM 5V	
3	SP-3024A (YE)	X-405 Cab main harness to switch panel harness 2 X-374 Four-Wheel Drive (4WD) switch	
4	-	-	
5	-	-	
6	-	-	
7	SP-057GD (BK)	X-374 Four-Wheel Drive (4WD) switch SP-057G POT GND SWITCH PANEL	
8	SP-1014FB (RD)	X-374 Four-Wheel Drive (4WD) switch SP-1014F POT 58 SWITCH PANEL	
9	SP-057GC (BK)	X-374 Four-Wheel Drive (4WD) switch SP-057G POT GND SWITCH PANEL	
10	SP-1014FA (RD)	X-374 Four-Wheel Drive (4WD) switch SP-1014F POT 58 SWITCH PANEL	

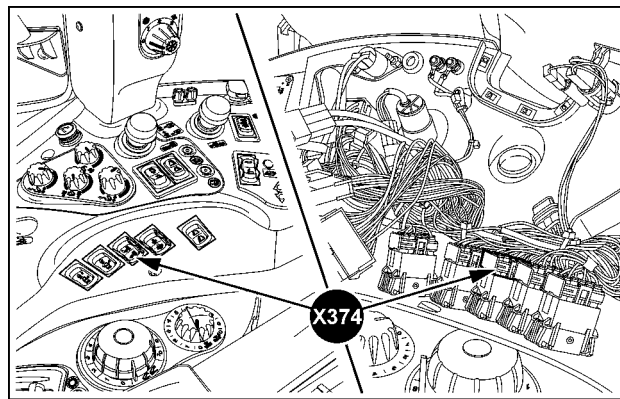

SS13K008 10

**Behind right-hand switch panel**

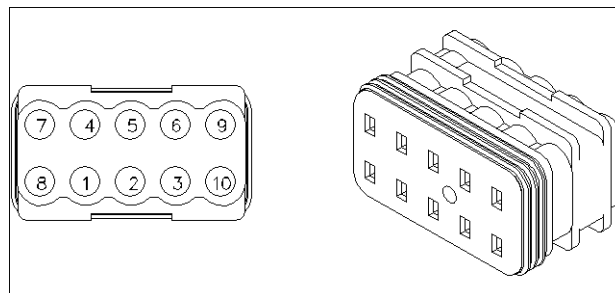

84819781 11

**CONNECTOR X-375 - Rear axle differential lock – Switch**

<b>CONNECTOR X-375 - Rear axle differential lock – Switch</b>			
<b>PIN NUMBER</b>	<b>WIRE NUMBER</b>	<b>CIRCUIT REFERENCE</b>	<b>ELECTRICAL SCHEMATIC FRAME</b>
1	SP-7170 (WH)	X-405 Cab main harness to switch panel harness 2 X-375 Rear axle differential lock – Switch	<b>Wiring harnesses - Electrical schematic sheet 09 (55.100)</b>
2	SP-011FH (GN)	X-375 Rear axle differential lock – Switch SP-011FF XCM 5V	
3	-	-	
4	-	-	
5	SP-011FG (GN)	X-375 Rear axle differential lock – Switch SP-011FF XCM 5V	
6	SP-7175 (YE)	X-405 Cab main harness to switch panel harness 2 X-375 Rear axle differential lock – Switch	
7	SP-057GG (BK)	X-375 Rear axle differential lock – Switch SP-057G POT GND SWITCH PANEL	
8	SP-1014FV (RD)	X-375 Rear axle differential lock – Switch SP-1014F POT 58 SWITCH PANEL	
9	SP-057GF (BK)	X-375 Rear axle differential lock – Switch SP-057G POT GND SWITCH PANEL	
10	SP-1014FC (RD)	X-375 Rear axle differential lock – Switch SP-1014F POT 58 SWITCH PANEL	

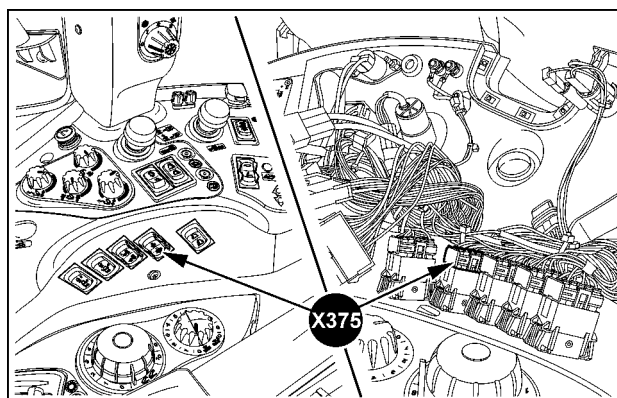

SS13K007 12

**Behind right-hand switch panel**

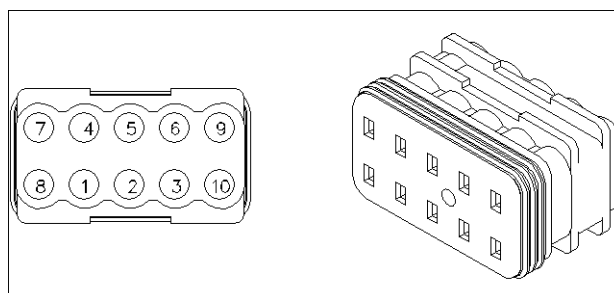

84819781 13

**CONNECTOR X-376 - Diagnostic socket (CAN bus 1)**

CONNECTOR X-376 - Diagnostic socket (CAN bus 1)			
PIN NUMBER	WIRE NUMBER	CIRCUIT REFERENCE	ELECTRICAL SCHEMATIC FRAME
A	CM-057CE (BK)	X-376 Diagnostic socket (CAN bus 1) SP-057C	<b>Wiring harnesses - Electrical schematic sheet 03 (55.100)</b> <b>Wiring harnesses - Electrical schematic sheet 24 (55.100)</b>
B	CM-138DB (VT)	SP-138D X-376 Diagnostic socket (CAN bus 1)	
C	CM-191Z (YE)	SP-191 X-376 Diagnostic socket (CAN bus 1)	
D	CM-190Z (GN)	SP-190 X-376 Diagnostic socket (CAN bus 1)	
E	CM-6418 (PK)	X-376 Diagnostic socket (CAN bus 1) X-001 Cab main harness to engine harness 1	
F	-	-	
G	CM-9253 (WH)	X-450 Instrument cluster CN1 X-376 Diagnostic socket (CAN bus 1)	
H	-	-	
J	-	-	

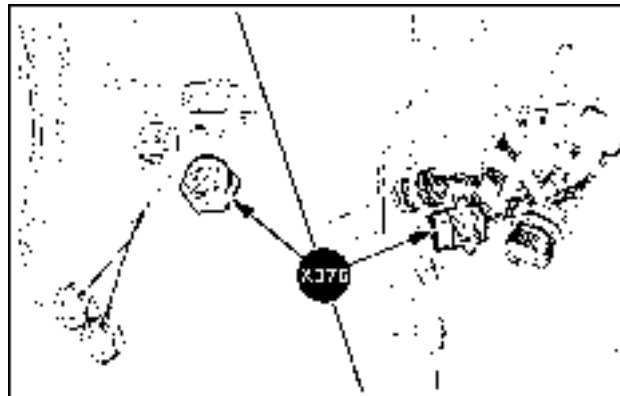

SS13K005 14

**Cab rear left-hand**

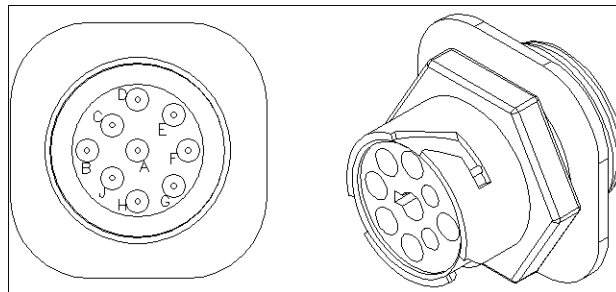

87736919 15

**CONNECTOR X-377 - Instrument cluster CN3**

<b>CONNECTOR X-377 - Instrument cluster CN3</b>			
<b>PIN NUMBER</b>	<b>WIRE NUMBER</b>	<b>CIRCUIT REFERENCE</b>	<b>ELECTRICAL SCHEMATIC FRAME</b>
1	CM-2330 (VT)	X-404 Cab main harness to switch panel harness 1 X-377 Instrument cluster CN3	<b>Wiring harnesses - Electrical schematic sheet 03 (55.100)</b> <b>Wiring harnesses - Electrical schematic sheet 04 (55.100)</b>
2	CM-2320 (VT)	X-404 Cab main harness to switch panel harness 1 X-377 Instrument cluster CN3	
3	CM-2300 (VT)	X-404 Cab main harness to switch panel harness 1 X-377 Instrument cluster CN3	
4	CM-2310 (VT)	X-404 Cab main harness to switch panel harness 1 X-377 Instrument cluster CN3	
5	CM-8010 (BR)	X-377 Instrument cluster CN3 X-185 Air brake pressure sensor (signal)	
6	-	-	

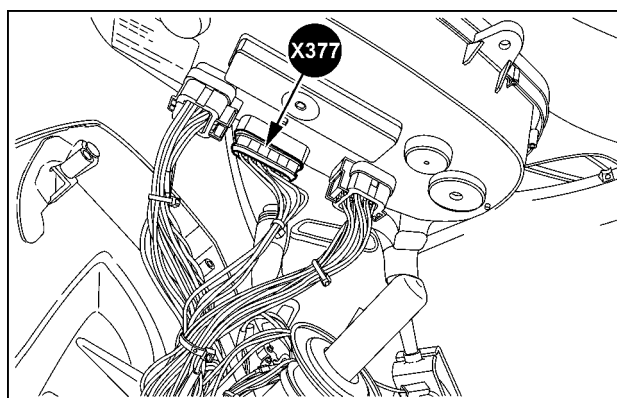

SVIL13TR00791AB 16

**Behind instrument cluster**

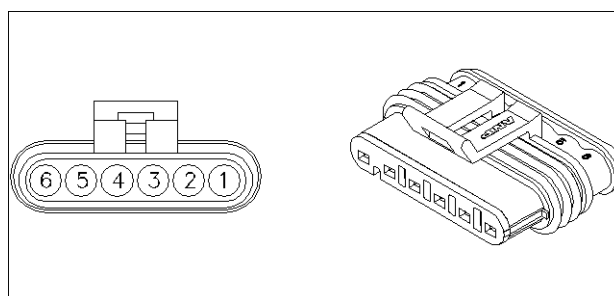

87710588 17



**CONNECTOR X-378 - Implement signal socket (ISO 11786)**

CONNECTOR X-378 - Implement signal socket (ISO 11786)			
PIN NUMBER	WIRE NUMBER	CIRCUIT REFERENCE	ELECTRICAL SCHEMATIC FRAME
1	SP-2320 (VT)	X-404 Cab main harness to switch panel harness 1 X-378 Implement signal socket (ISO 11786)	<b>Wiring harnesses - Electrical schematic sheet 04 (55.100)</b>
2	SP-2300 (VT)	X-404 Cab main harness to switch panel harness 1 X-378 Implement signal socket (ISO 11786)	
3	SP-2330 (VT)	X-404 Cab main harness to switch panel harness 1 X-378 Implement signal socket (ISO 11786)	
4	SP-2310 (VT)	X-404 Cab main harness to switch panel harness 1 X-378 Implement signal socket (ISO 11786)	
5	-	-	
6	SP-010CN (GN)	X-378 Implement signal socket (ISO 11786) SP-010CE POT 15	
7	SP-057GB (BK)	X-378 Implement signal socket (ISO 11786) SP-057G POT GND SWITCH PANEL	

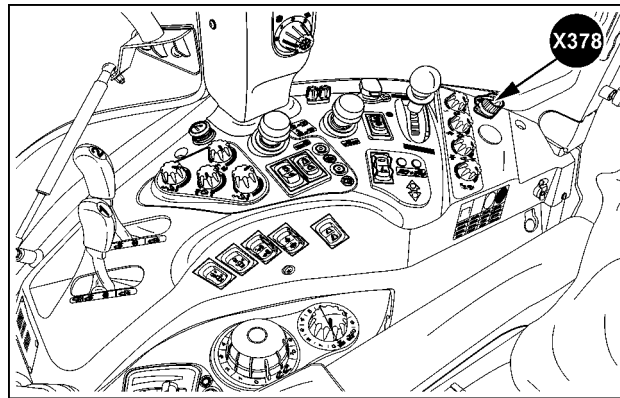

SVIL13TR00706AK 18

**Cab right-hand side**

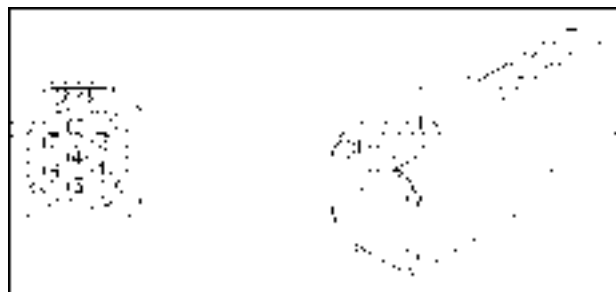

87357892 19

## Wire connectors - Component diagram 38

### CONNECTOR X-380 - Front loader harness (Stoll) to front loader socket (Stoll)

CONNECTOR X-380 - Front loader harness (Stoll) to front loader socket (Stoll)			
PIN NUMBER	WIRE NUMBER	CIRCUIT REFERENCE	ELECTRICAL SCHEMATIC FRAME
1	PS-3281 (BL) FS-3281 (BL)	X-380 Front loader harness (Stoll) to front loader socket (Stoll) X-395 Front loader socket (Stoll) X-380 Front loader harness (Stoll) to front loader socket (Stoll) X-392 Front loader harness (Stoll) to front loader diode (Stoll)	<b>Wiring harnesses - Electrical schematic sheet 16 (55.100)</b>
2	PS-3282 (GN) FS-3282 (GN)	X-380 Front loader harness (Stoll) to front loader socket (Stoll) X-395 Front loader socket (Stoll) X-392 Front loader harness (Stoll) to front loader diode (Stoll) X-380 Front loader harness (Stoll) to front loader socket (Stoll)	
3	PS-3283 (RD) FS-3283 (RD)	X-380 Front loader harness (Stoll) to front loader socket (Stoll) X-395 Front loader socket (Stoll) X-380 Front loader harness (Stoll) to front loader socket (Stoll) X-392 Front loader harness (Stoll) to front loader diode (Stoll)	
4	PS-3274 (RD) FS-3274 (RD)	X-395 Front loader socket (Stoll) X-380 Front loader harness (Stoll) to front loader socket (Stoll) X-156 Front loader relay – Valve 2 X-380 Front loader harness (Stoll) to front loader socket (Stoll)	<b>Wiring harnesses - Electrical schematic sheet 16 (55.100)</b>
5	PS-3284 (YE) FS-3284 (YE)	X-395 Front loader socket (Stoll) X-380 Front loader harness (Stoll) to front loader socket (Stoll) X-394 Front loader switch – Comfort drive (Stoll) X-380 Front loader harness (Stoll) to front loader socket (Stoll)	
6	PS-3285 (BR) FS-3285 (BR)	X-395 Front loader socket (Stoll) X-380 Front loader harness (Stoll) to front loader socket (Stoll) X-396 Front loader switch – Tool locking (Stoll) X-380 Front loader harness (Stoll) to front loader socket (Stoll)	

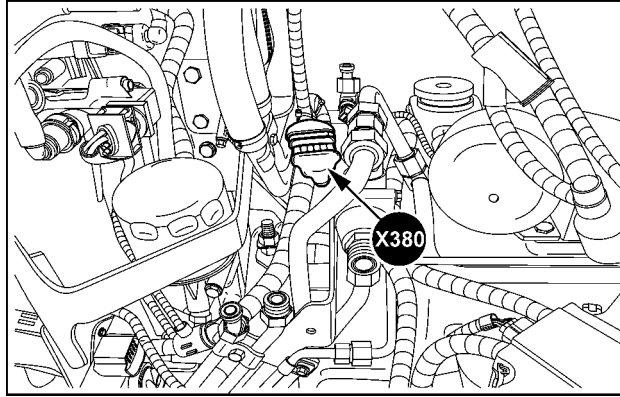

SVIL13TR00873AB 1

**Front top of transmission**

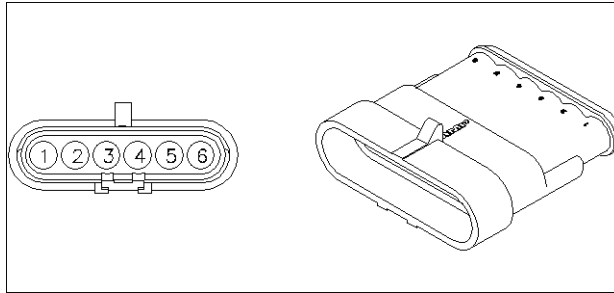

87691968 2

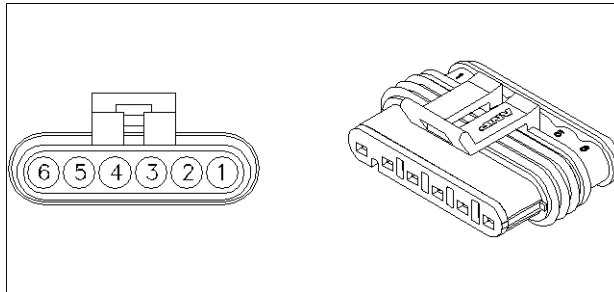

87710588 3

**CONNECTOR X-381 - Cab main harness to hydraulic trailer brake harness**

CONNECTOR X-381 - Cab main harness to hydraulic trailer brake harness			
PIN NUMBER	WIRE NUMBER	CIRCUIT REFERENCE	ELECTRICAL SCHEMATIC FRAME
1	CM-057CD (BK) TB-057CD (BK)	SP-057C X-381 Cab main harness to hydraulic trailer brake harness SP-057CD GND ITALIEN BRAKE X-381 Cab main harness to hydraulic trailer brake harness	<b>Wiring harnesses - Electrical schematic sheet 04 (55.100)</b>
2	CM-8005 (VT) TB-8005 (VT)	X-460 Instrument cluster CN2 X-381 Cab main harness to hydraulic trailer brake harness X-399 Hydraulic trailer brake – Pressure switch X-381 Cab main harness to hydraulic trailer brake harness	
3	CM-010K (GN) TB-010K (GN)	X-180 Fuse block (F-070 to F-101) X-381 Cab main harness to hydraulic trailer brake harness SP-010K IGNITION ITALIEN TRAILER BRAKE X-381 Cab main harness to hydraulic trailer brake harness	
4	CM-8065 (BL) TB-8065 (BL)	X-381 Cab main harness to hydraulic trailer brake harness X-358 Hand brake position switch X-999 Hydraulic trailer brake relay X-381 Cab main harness to hydraulic trailer brake harness	



SVIL13TR00772AC 4

**Right-hand bottom rear tractor cab**

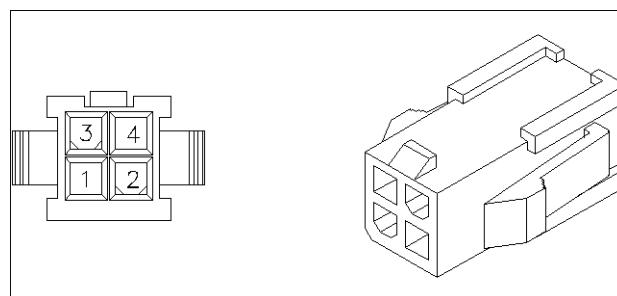

87694694 5

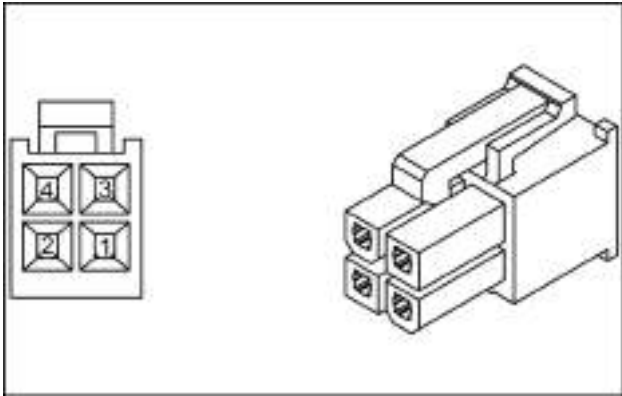

87694704 6

**CONNECTOR X-382 - Hydraulic oil temperature sensor**

CONNECTOR X-382 - Hydraulic oil temperature sensor			
PIN NUMBER	WIRE NUMBER	CIRCUIT REFERENCE	ELECTRICAL SCHEMATIC FRAME
1	CM-7500A (TN)	X-382 Hydraulic oil temperature sensor X-210 Central Control Unit (CCU) – CN1B	<b>Wiring harnesses - Electrical schematic sheet 13 (55.100)</b>
2	CM-060GG (BK/WH)	X-382 Hydraulic oil temperature sensor SP-060G	

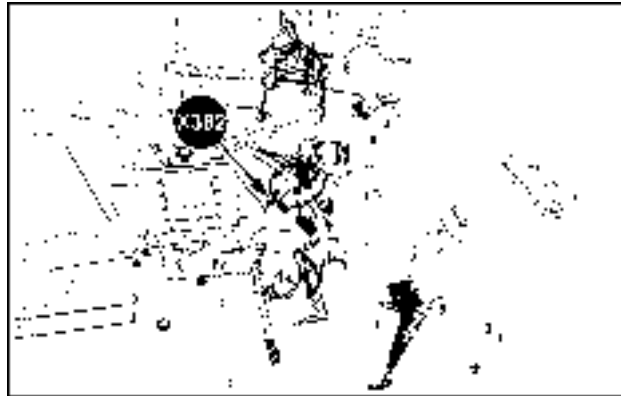

SVIL13TR00772AD 7

**Right-hand bottom rear tractor cab**

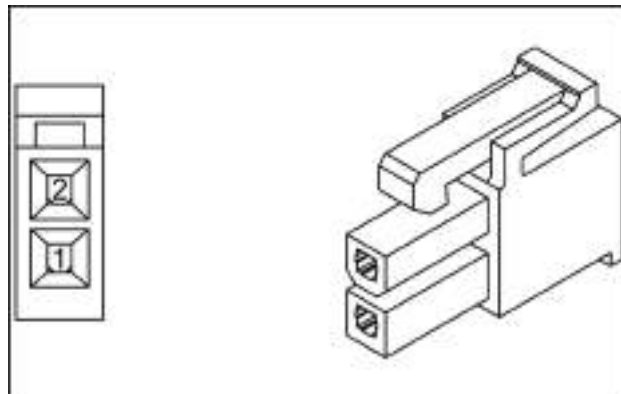

87694692 8

**CONNECTOR X-383 - Clutch C solenoid valve**

<b>CONNECTOR X-383 - Clutch C solenoid valve</b>			
<b>PIN NUMBER</b>	<b>WIRE NUMBER</b>	<b>CIRCUIT REFERENCE</b>	<b>ELECTRICAL SCHEMATIC FRAME</b>
1	TR-7925 (OR)	SP-7900 VPS1 X-383 Clutch C solenoid valve	<b>Wiring harnesses - Electrical schematic sheet 07 (55.100)</b>
2	TR-7920 (VT)	X-383 Clutch C solenoid valve X-300 Cab main harness to transmission harness	

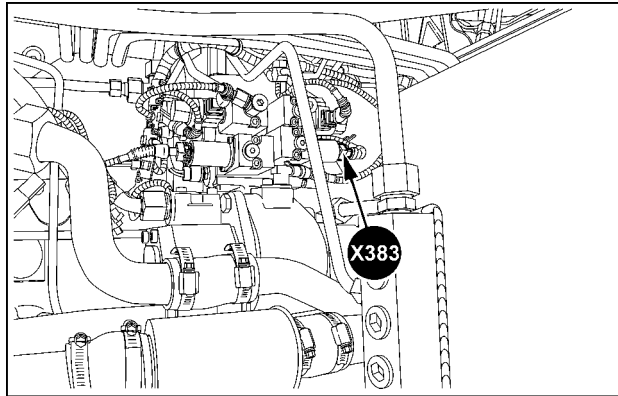

SVIL13TR00754AF 9

**Right-hand of transmission**

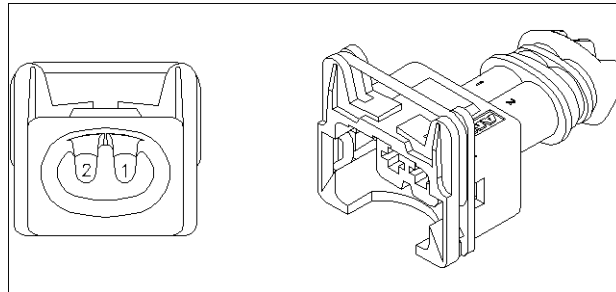

84607243 10

**CONNECTOR X-385 - Cab main harness to roof harness 2**

<b>CONNECTOR X-385 - Cab main harness to roof harness 2</b>			
<b>PIN NUMBER</b>	<b>WIRE NUMBER</b>	<b>CIRCUIT REFERENCE</b>	<b>ELECTRICAL SCHEMATIC FRAME</b>
1	CM-3001B (GN) RF-3001B (GN)	SP-3001 X-385 Cab main harness to roof harness 2 X-021 Grab rail light – Left-hand X-385 Cab main harness to roof harness 2	<b>Wiring harnesses - Electrical schematic sheet 01 (55.100)</b> <b>Wiring harnesses - Electrical schematic sheet 18 (55.100)</b> <b>Wiring harnesses - Electrical schematic sheet 20 (55.100)</b> <b>Wiring harnesses - Electrical schematic sheet 22 (55.100)</b>
2	CM-085B (GN) RF-085B (GN)	SP-085 X-385 Cab main harness to roof harness 2 X-075 Roof harness to front window wiper motor (openable front window) X-385 Cab main harness to roof harness 2	
3	CM-1013L (BL) RF-1013L (BL)	SP-1013K X-385 Cab main harness to roof harness 2 X-385 Cab main harness to roof harness 2 SP-1013L	
4	CM-170 (PK) RF-170 (PK)	X-460 Instrument cluster CN2 X-385 Cab main harness to roof harness 2 X-197 Battery isolator control switch X-385 Cab main harness to roof harness 2	
5	CM-138B (VT) RF-138B (VT)	SP-138 X-385 Cab main harness to roof harness 2 X-385 Cab main harness to roof harness 2 X-197 Battery isolator control switch	
6	CM-1051 (YE) RF-1051 (YE)	X-110 Relay and fuse block (K-004 to K-039 and F-033 to F-036) X-385 Cab main harness to roof harness 2 X-385 Cab main harness to roof harness 2 SP-1051	<b>Wiring harnesses - Electrical schematic sheet 01 (55.100)</b> <b>Wiring harnesses - Electrical schematic sheet 18 (55.100)</b> <b>Wiring harnesses - Electrical schematic sheet 20 (55.100)</b> <b>Wiring harnesses - Electrical schematic sheet 22 (55.100)</b>
7	CM-011D (GN) RF-011D (GN)	X-091 Steering column multi-function lever X-385 Cab main harness to roof harness 2 X-385 Cab main harness to roof harness 2 X-034 Main light switch	
8	CM-171B (VT) RF-171B (VT)	X-385 Cab main harness to roof harness 2 X-001 Cab main harness to engine harness 1 X-197 Battery isolator control switch X-385 Cab main harness to roof harness 2	
9	CM-155J (GN) RF-155J (GN)	X-110 Relay and fuse block (K-004 to K-039 and F-033 to F-036) X-385 Cab main harness to roof harness 2 X-034 Main light switch X-385 Cab main harness to roof harness 2	
10	CM-063B (BL) RF-063 (BL)	SP-063 X-385 Cab main harness to roof harness 2 X-075 Roof harness to front window wiper motor (openable front window) X-385 Cab main harness to roof harness 2	



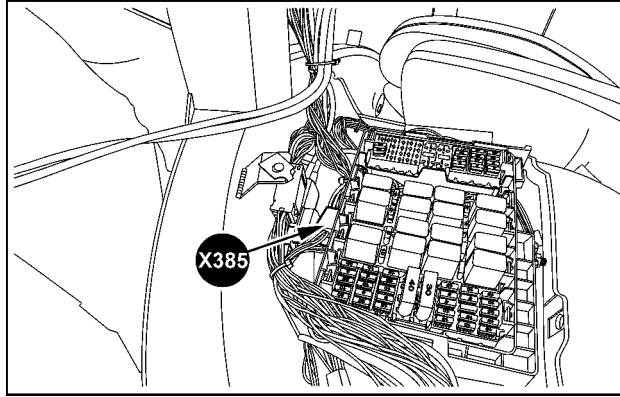

SVIL13TR00716AD 11

**Cab left-hand side**

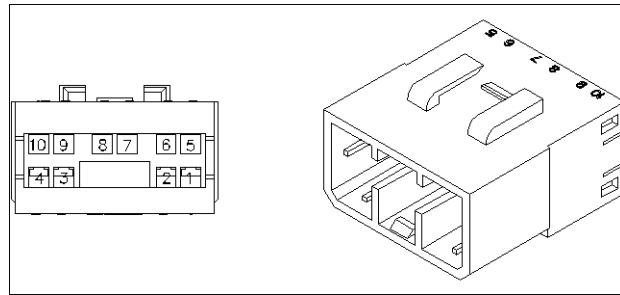

87736504 12

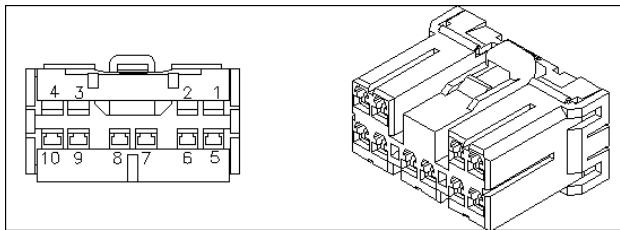

87736477 13

**CONNECTOR X-388 - Cab main harness to armrest components**

<b>CONNECTOR X-388 - Cab main harness to armrest components</b>			
<b>PIN NUMBER</b>	<b>WIRE NUMBER</b>	<b>CIRCUIT REFERENCE</b>	<b>ELECTRICAL SCHEMATIC FRAME</b>
A1	CM-5547 (OR) 1 (WH)	X-388 Cab main harness to armrest components X-220 Central Control Unit (CCU) – CN2	<b>Wiring harnesses - Electrical schematic sheet 13 (55.100)</b> <b>Wiring harnesses - Electrical schematic sheet 24 (55.100)</b>
A2	CM-5597A (GY) 4 (WH)	SP-5597 X-388 Cab main harness to armrest components	
A3	CM-5271 (BR) 7 (WH)	X-220 Central Control Unit (CCU) – CN2 X-388 Cab main harness to armrest components	
A4	CM-5272 (BR) 10 (WH)	X-220 Central Control Unit (CCU) – CN2 X-388 Cab main harness to armrest components	
A5	CM-5273 (BR) 13 (WH)	X-240 Central Control Unit (CCU) – CN3B X-388 Cab main harness to armrest components	
A6	CM-5274 (BR) 16 (WH)	X-240 Central Control Unit (CCU) – CN3B X-388 Cab main harness to armrest components	
A7	CM-057BN (BK) 19 (WH)	X-388 Cab main harness to armrest components SP-057B	
A8	CM-060GE (BK/WH) 22 (WH)	X-388 Cab main harness to armrest components SP-060G	
B1	CM-5546 (BR) 2 (WH)	X-388 Cab main harness to armrest components X-220 Central Control Unit (CCU) – CN2	
B2	CM-5260B (TN) 5 (WH)	SP-5260 X-388 Cab main harness to armrest components	
B3	CM-5565 (OR) 8 (WH)	X-388 Cab main harness to armrest components X-230 Central Control Unit (CCU) – CN3A	
B4	CM-5566 (OR) 11 (WH)	X-388 Cab main harness to armrest components X-240 Central Control Unit (CCU) – CN3B	
B5	CM-1013H (RD) 14 (WH)	SP-1013 X-388 Cab main harness to armrest components	
B6	CM-057BL (BK) 17 (WH)	X-388 Cab main harness to armrest components SP-057B	
B7	CM-1013J (RD) 20 (WH)	X-388 Cab main harness to armrest components SP-1013	
C1	CM-5520DG (LG) 3 (WH)	SP-5520 X-388 Cab main harness to armrest components	

CONNECTOR X-388 - Cab main harness to armrest components			
PIN NUMBER	WIRE NUMBER	CIRCUIT REFERENCE	ELECTRICAL SCHEMATIC FRAME
C2	CM-5597D (GY) (WH)	X-388 Cab main harness to armrest components SP-5597	<b>Wiring harnesses - Electrical schematic sheet 13 (55.100)</b> <b>Wiring harnesses - Electrical schematic sheet 24 (55.100)</b>
C3	CM-057DF (BK) (BR)	X-388 Cab main harness to armrest components SP-057D CAB GND	
C4	CM-291Z (RD) (YE)	SP-291 X-388 Cab main harness to armrest components	
C5	CM-290Z (BL) (GN)	SP-290 X-388 Cab main harness to armrest components	
C6	CM-5260E (TN) 18 (WH)	SP-5260 X-388 Cab main harness to armrest components	
C7	CM-5730 (WH) 21 (WH)	X-388 Cab main harness to armrest components X-210 Central Control Unit (CCU) – CN1B	
C8	CM-5545 (RD) 24 (WH)	X-388 Cab main harness to armrest components X-210 Central Control Unit (CCU) – CN1B	



SVIL13TR00792AB 14

Rear of cab right-hand behind operator's seat

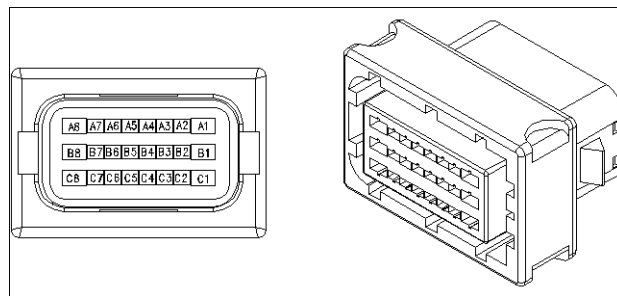

87699386 15

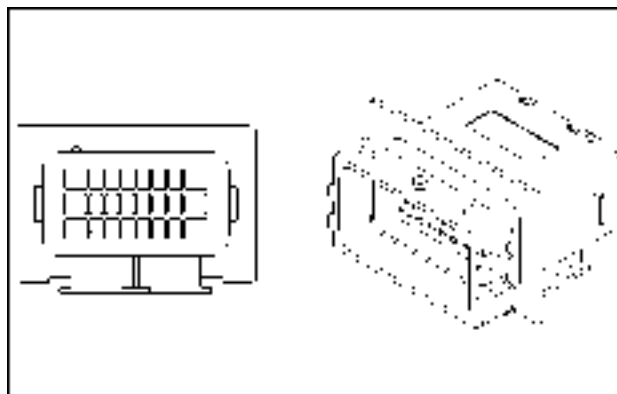

87714265 16

**CONNECTOR X-389 - Backup alarm buzzer and backup light**

CONNECTOR X-389 - Backup alarm buzzer and backup light			
PIN NUMBER	WIRE NUMBER	CIRCUIT REFERENCE	ELECTRICAL SCHEMATIC FRAME
1	CM-1160A (RD)	X-120 Relay and diode block (K-007 to K-060 and V-040 to V-044) X-389 Backup alarm buzzer and backup light	<b>Wiring harnesses - Electrical schematic sheet 09 (55.100)</b>
2	CM-057AC (BK)	SP-057A CAB GND X-389 Backup alarm buzzer and backup light	
3	CM-1014D (YE)	X-389 Backup alarm buzzer and backup light SP-1014	

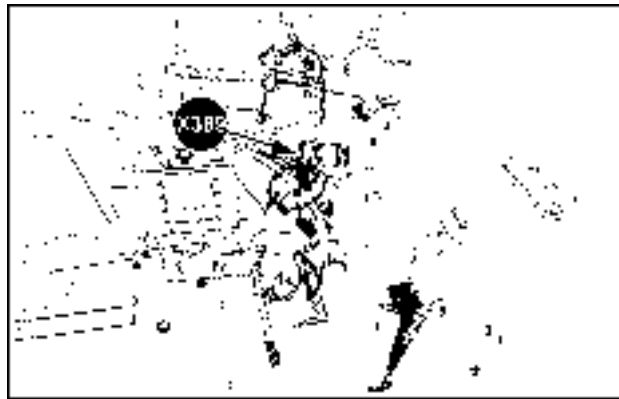

SVIL13TR00772AE 17

**Right-hand bottom rear tractor cab**

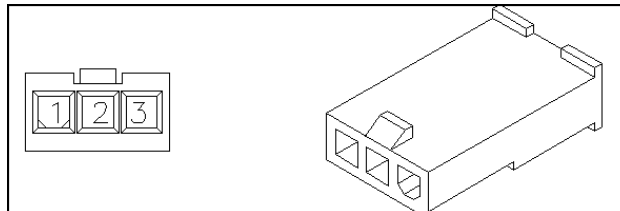

87694695 18

## Wire connectors - Component diagram 39

### CONNECTOR X-390 - Rotating beacon

Rotating beacon right-hand

CONNECTOR X-390 - Rotating beacon			
PIN NUMBER	WIRE NUMBER	CIRCUIT REFERENCE	ELECTRICAL SCHEMATIC FRAME
1	BS-4012CA (VT)	X-390 Rotating beacon X-071 Roof harness to rotating beacon right-hand	Wiring harnesses - Electrical schematic sheet 21 (55.100)

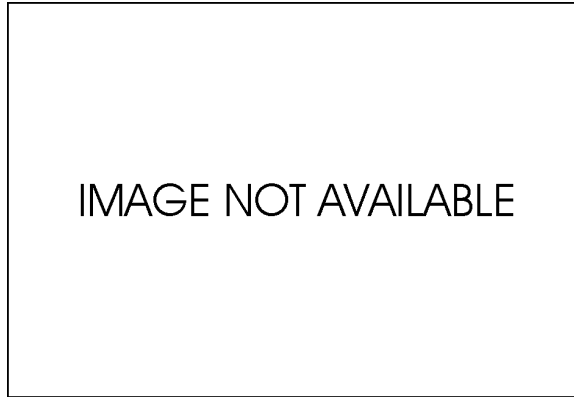

INA 1

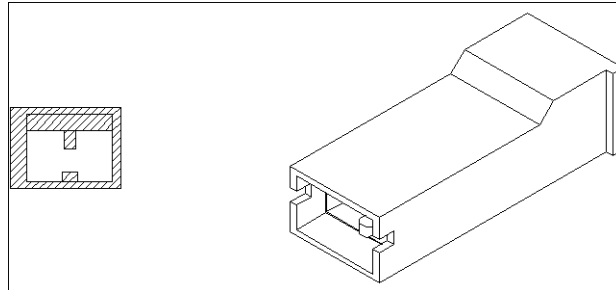

87691062 2

**Rotating beacon left-hand**

<b>CONNECTOR X-390 - Rotating beacon</b>			
<b>PIN NUMBER</b>	<b>WIRE NUMBER</b>	<b>CIRCUIT REFERENCE</b>	<b>ELECTRICAL SCHEMATIC FRAME</b>
1	BS-4012CB (VT)	X-390 Rotating beacon X-073 Roof harness to rotating beacon left-hand	<b>Wiring harnesses - Electrical schematic sheet 21 (55.100)</b>

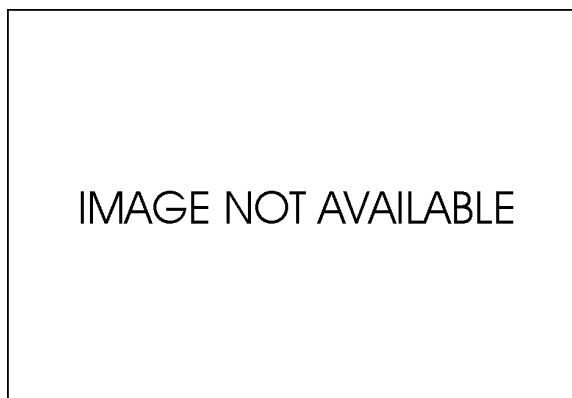

INA 3

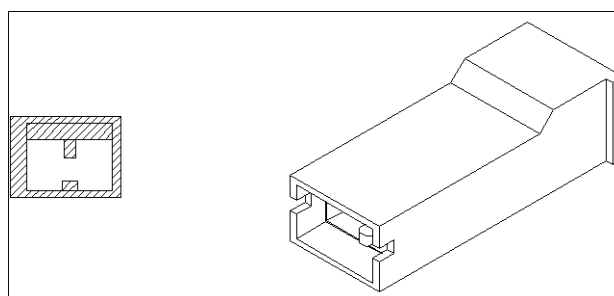

87691062 4

**CONNECTOR X-392 - Front loader harness (Stoll) to front loader diode (Stoll)**

<b>CONNECTOR X-392 - Front loader harness (Stoll) to front loader diode (Stoll)</b>			
<b>PIN NUMBER</b>	<b>WIRE NUMBER</b>	<b>CIRCUIT REFERENCE</b>	<b>ELECTRICAL SCHEMATIC FRAME</b>
1	LR-3281 (BL) FS-3281 (BL)	X-392 Front loader harness (Stoll) to front loader diode (Stoll) X-295 Front loader diode (Stoll) X-380 Front loader harness (Stoll) to front loader socket (Stoll) X-392 Front loader harness (Stoll) to front loader diode (Stoll)	<b>Wiring harnesses - Electrical schematic sheet 16 (55.100)</b>
2	LR-3282 (GN) FS-3282 (GN)	X-392 Front loader harness (Stoll) to front loader diode (Stoll) SA1 X-392 Front loader harness (Stoll) to front loader diode (Stoll) X-380 Front loader harness (Stoll) to front loader socket (Stoll)	
3	FS-3283 (RD)	X-380 Front loader harness (Stoll) to front loader socket (Stoll) X-392 Front loader harness (Stoll) to front loader diode (Stoll)	
4	LR-3272 (GN) FS-33272 (OR)	X-392 Front loader harness (Stoll) to front loader diode (Stoll) SA1 X-155 Front loader relay – Valve 1 X-392 Front loader harness (Stoll) to front loader diode (Stoll)	

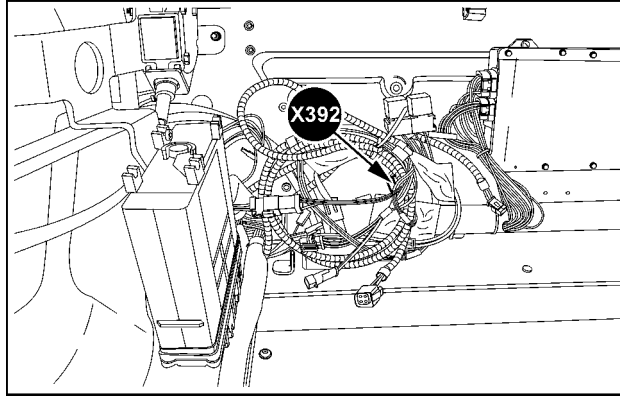

SVIL13TR00865AF 5

**In cab right-hand behind operator's seat**

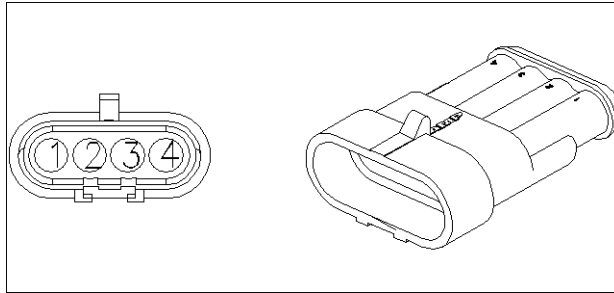

87680652 6

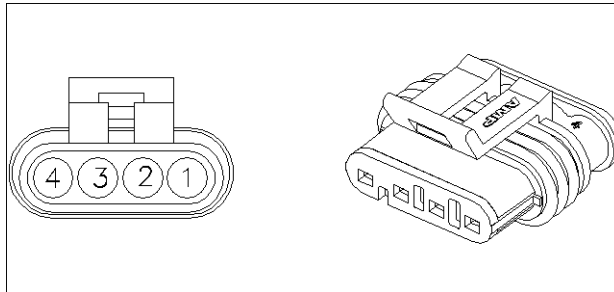

87687242 7

**CONNECTOR X-393 - Cab main harness to front loader harness**

Stoll

CONNECTOR X-393 - Cab main harness to front loader harness			
PIN NUMBER	WIRE NUMBER	CIRCUIT REFERENCE	ELECTRICAL SCHEMATIC FRAME
1	CM-010H (GN) FS-010H (GN)	X-393 Cab main harness to front loader harness X-180 Fuse block (F-070 to F-101) SP-010H X-393 Cab main harness to front loader harness	Wiring harnesses - Electrical schematic sheet 15 (55.100) Wiring harnesses - Electrical schematic sheet 16 (55.100)
3	CM-057CL (BK) FS-057CL (BK)	X-393 Cab main harness to front loader harness SP-057C SP-057CM X-393 Cab main harness to front loader harness	
4	CM-3279 (BL) FS-3279 (BL)	X-393 Cab main harness to front loader harness X-240 Central Control Unit (CCU) – CN3B SP-3279A X-393 Cab main harness to front loader harness	Wiring harnesses - Electrical schematic sheet 15 (55.100) Wiring harnesses - Electrical schematic sheet 16 (55.100)
5	CM-3280 (BL) FS-3280 (BL)	X-240 Central Control Unit (CCU) – CN3B X-393 Cab main harness to front loader harness SP-3280A X-393 Cab main harness to front loader harness	
6	-	-	

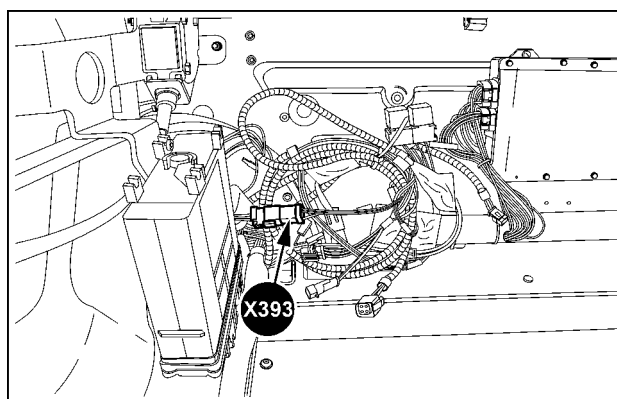

SVIL13TR00865AG 8

**In cab right-hand behind operator's seat**

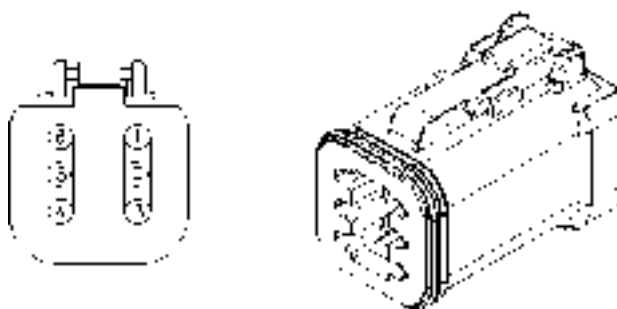

47416268 9



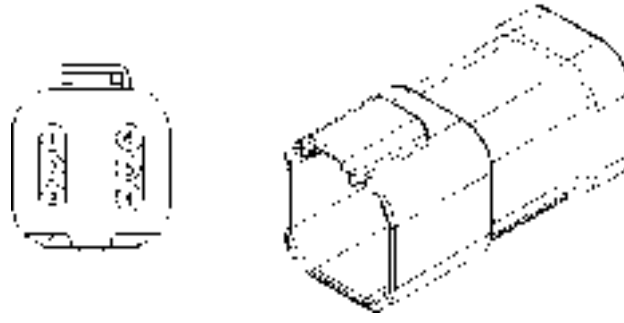

47416275 10

Hydrac

CONNECTOR X-393 - Cab main harness to front loader harness			
PIN NUMBER	WIRE NUMBER	CIRCUIT REFERENCE	ELECTRICAL SCHEMATIC FRAME
1	CM-010H (GN) FL-010HA (GN)	X-393 Cab main harness to front loader harness X-180 Fuse block (F-070 to F-101) SP-010HA X-393 Cab main harness to front loader harness	<b>Wiring harnesses - Electrical schematic sheet 15 (55.100)</b> <b>Wiring harnesses - Electrical schematic sheet 16 (55.100)</b>
2	CM-1013N (RD) FL-1013N (RD)	X-393 Cab main harness to front loader harness SP-1013 X-393 Cab main harness to front loader harness SP-1013N	
3	CM-057CL (BK) FL-057CL (BK)	X-393 Cab main harness to front loader harness SP-057C X-393 Cab main harness to front loader harness SP-057CL	
4	CM-3279 (BL) FL-3279 (BL)	X-393 Cab main harness to front loader harness X-240 Central Control Unit (CCU) – CN3B X-393 Cab main harness to front loader harness SP-3279	<b>Wiring harnesses - Electrical schematic sheet 15 (55.100)</b> <b>Wiring harnesses - Electrical schematic sheet 16 (55.100)</b>
5	CM-3280 (BL) FL-3280 (BL)	X-240 Central Control Unit (CCU) – CN3B X-393 Cab main harness to front loader harness X-393 Cab main harness to front loader harness SP-3280	
6	-	-	

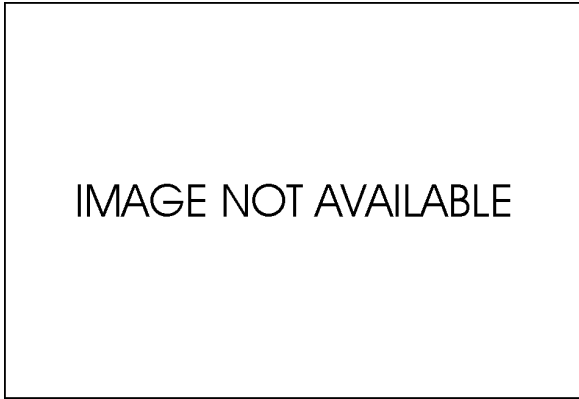

INA 11

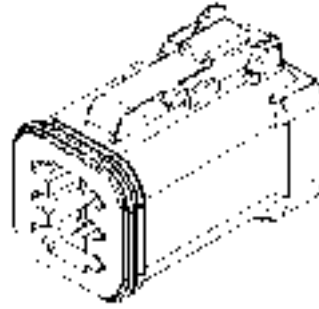
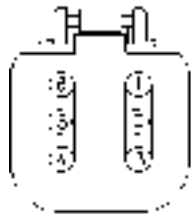

47416268 12

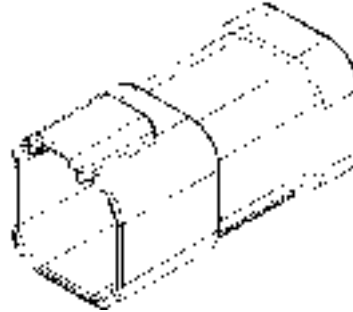

47416275 13

**CONNECTOR X-394 - Front loader switch – Comfort drive (Stoll)**

CONNECTOR X-394 - Front loader switch – Comfort drive (Stoll)			
PIN NUMBER	WIRE NUMBER	CIRCUIT REFERENCE	ELECTRICAL SCHEMATIC FRAME
1	FS-010HA (GN)	SP-010H X-394 Front loader switch – Comfort drive (Stoll)	<b>Wiring harnesses - Electrical schematic sheet 16 (55.100)</b>
2	FS-3284 (YE)	X-394 Front loader switch – Comfort drive (Stoll) X-380 Front loader harness (Stoll) to front loader socket (Stoll)	
3	FS-057CN (BK)	X-394 Front loader switch – Comfort drive (Stoll) SP-057CM	

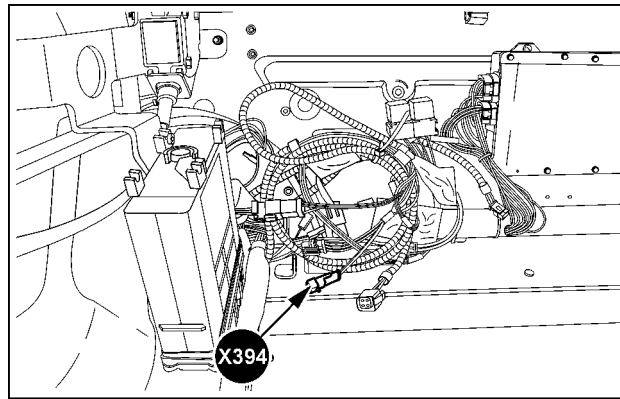

SVIL13TR00865AH 14

**In cab right-hand behind operator's seat**

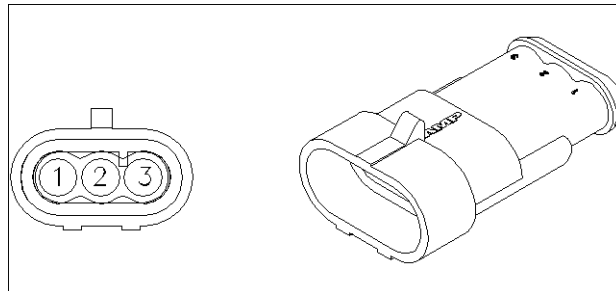

87680689 15

**CONNECTOR X-395 - Front loader socket (Stoll)**

CONNECTOR X-395 - Front loader socket (Stoll)			
PIN NUMBER	WIRE NUMBER	CIRCUIT REFERENCE	ELECTRICAL SCHEMATIC FRAME
1	PS-3281 (BL)	X-380 Front loader harness (Stoll) to front loader socket (Stoll) X-395 Front loader socket (Stoll)	<b>Wiring harnesses - Electrical schematic sheet 16 (55.100)</b>
2	PS-3282 (GN)	X-380 Front loader harness (Stoll) to front loader socket (Stoll) X-395 Front loader socket (Stoll)	
3	PS-3283 (RD)	X-380 Front loader harness (Stoll) to front loader socket (Stoll) X-395 Front loader socket (Stoll)	
4	PS-3274 (GY)	X-395 Front loader socket (Stoll) X-380 Front loader harness (Stoll) to front loader socket (Stoll)	
5	PS-3284 (YE)	X-395 Front loader socket (Stoll) X-380 Front loader harness (Stoll) to front loader socket (Stoll)	
6	PS-3285 (BR)	X-395 Front loader socket (Stoll) X-380 Front loader harness (Stoll) to front loader socket (Stoll)	

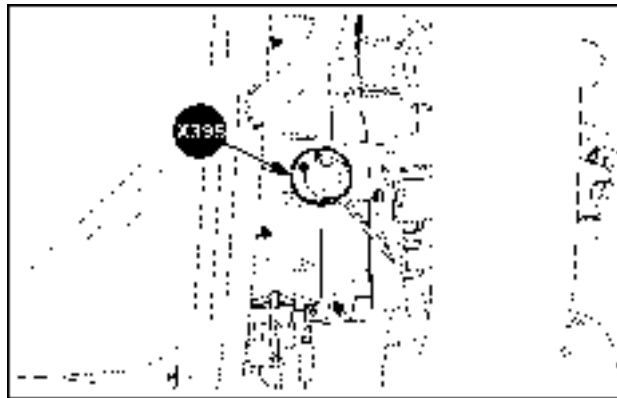

SVIL13TR00875AB 16

**Rear right-hand engine**

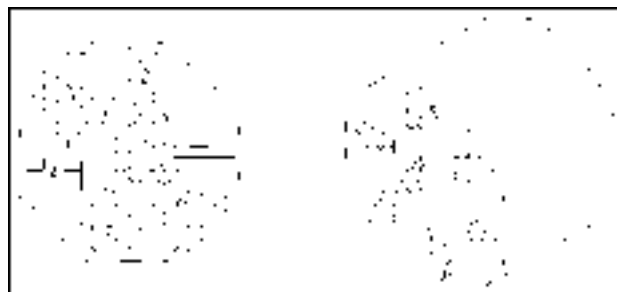

84185564 17

**CONNECTOR X-396 - Front loader switch – Tool locking (Stoll)**

CONNECTOR X-396 - Front loader switch – Tool locking (Stoll)			
PIN NUMBER	WIRE NUMBER	CIRCUIT REFERENCE	ELECTRICAL SCHEMATIC FRAME
1	FS-010HF (GN)	SP-010H X-396 Front loader switch – Tool locking (Stoll)	<b>Wiring harnesses - Electrical schematic sheet 16 (55.100)</b>
2	FS-3285 (BR)	X-396 Front loader switch – Tool locking (Stoll) X-380 Front loader harness (Stoll) to front loader socket (Stoll)	
3	FS-057CP (BK)	X-396 Front loader switch – Tool locking (Stoll) SP-057CM	

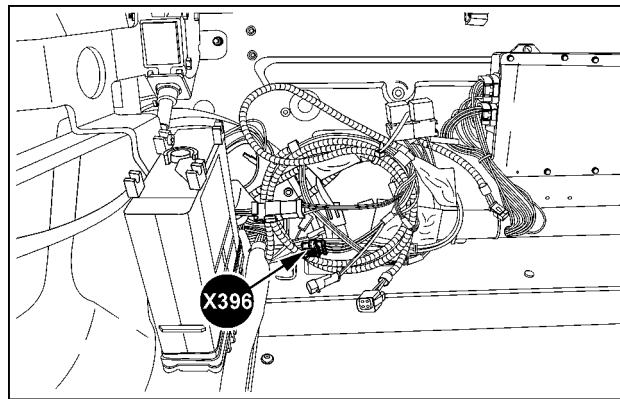

SVIL13TR00865A1 18

**In cab right-hand behind operator's seat**

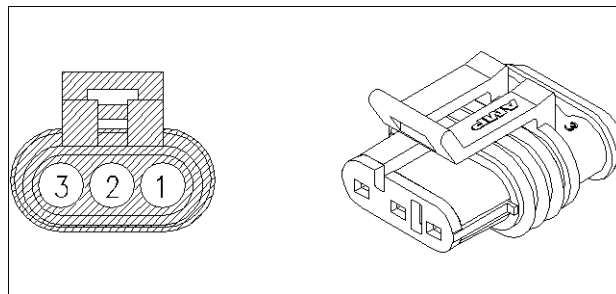

87691928 19

**CONNECTOR X-399 - Hydraulic trailer brake – Pressure switch**

CONNECTOR X-399 - Hydraulic trailer brake – Pressure switch			
PIN NUMBER	WIRE NUMBER	CIRCUIT REFERENCE	ELECTRICAL SCHEMATIC FRAME
1	TB-8005 (VT)	X-399 Hydraulic trailer brake – Pressure switch X-381 Cab main harness to hydraulic trailer brake harness	Wiring harnesses - Electrical schematic sheet 04 (55.100)

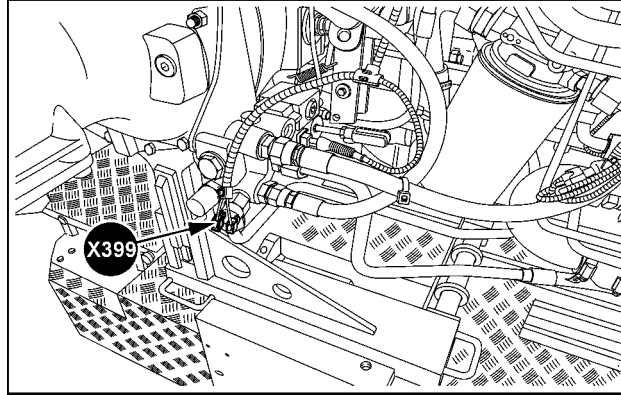

SVIL13TR00871AD 20

**Right-hand on the rear axle**

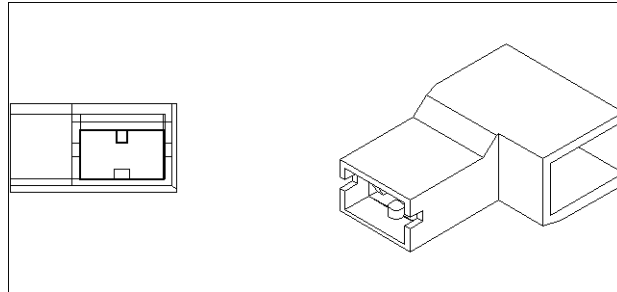

82944111 21

## Wire connectors - Component diagram 40

### CONNECTOR X-400 - Ground connection fuse block

CONNECTOR X-400 - Ground connection fuse block			
PIN NUMBER	WIRE NUMBER	CIRCUIT REFERENCE	ELECTRICAL SCHEMATIC FRAME
1	CM-057A (BK)	SP-057A CAB GND X-400 Ground connection fuse block	Wiring harnesses - Electrical schematic sheet 25 (55.100)

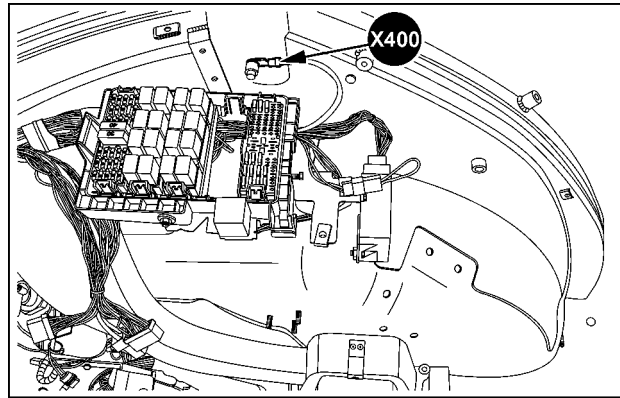

SVIL13TR00695AE 1

**Cab left-hand side**

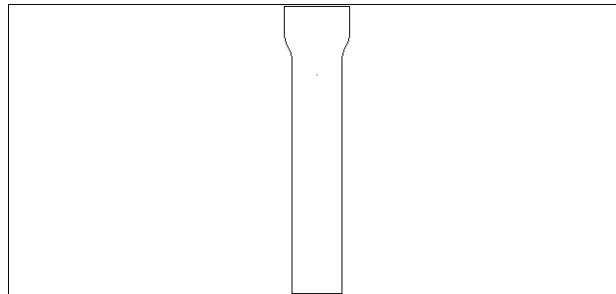

84153309 2

**CONNECTOR X-403\_A - Ground connection roof right-hand**

CONNECTOR X-403_A - Ground connection roof right-hand			
PIN NUMBER	WIRE NUMBER	CIRCUIT REFERENCE	ELECTRICAL SCHEMATIC FRAME
1	RF-057T (BK)	X-403_A Ground connection roof right-hand SP-057T ROOF GROUND LH1	Wiring harnesses - Electrical schematic sheet 25 (55.100)

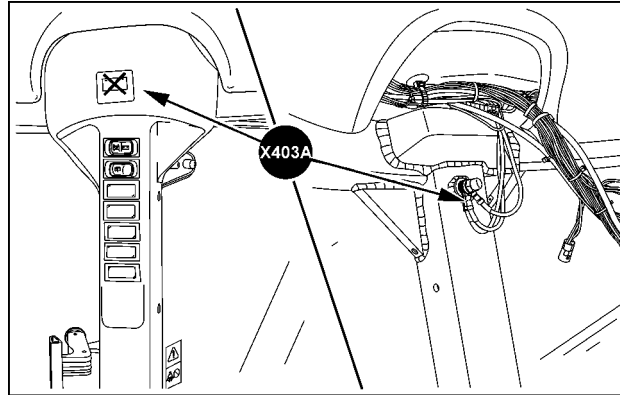

SS13K011 3

**Left-hand B-pillar**

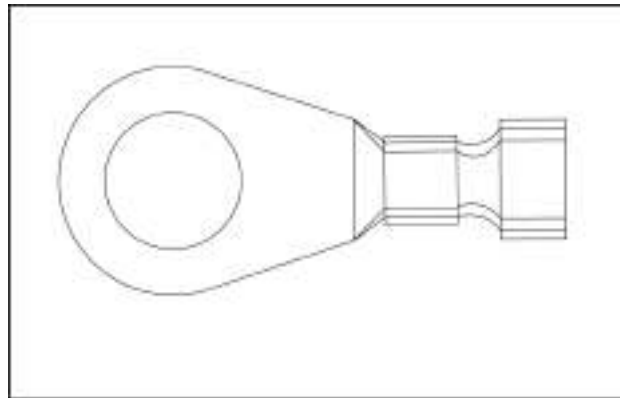

84253168 4



**CONNECTOR X-403\_B - Ground connection roof left-hand 1**

CONNECTOR X-403_B - Ground connection roof left-hand 1			
PIN NUMBER	WIRE NUMBER	CIRCUIT REFERENCE	ELECTRICAL SCHEMATIC FRAME
1	RF-057R (BK)	SP-057R X-403_B Ground connection roof left-hand 1	Wiring harnesses - Electrical schematic sheet 25 (55.100)

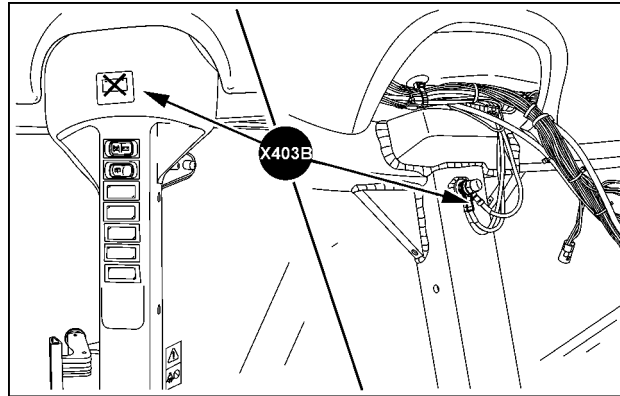

SS13K012 5

**Left-hand B-pillar**

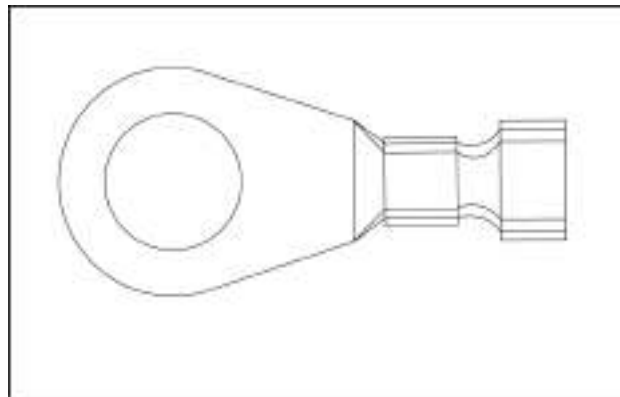

84253168 6

**CONNECTOR X-403\_C - Ground connection roof left-hand 2**

CONNECTOR X-403_C - Ground connection roof left-hand 2			
PIN NUMBER	WIRE NUMBER	CIRCUIT REFERENCE	ELECTRICAL SCHEMATIC FRAME
1	RF-057S (BK)	SP-057S ROOF GROUND LH2 X-403_C Ground connection roof left-hand 2	Wiring harnesses - Electrical schematic sheet 25 (55.100)

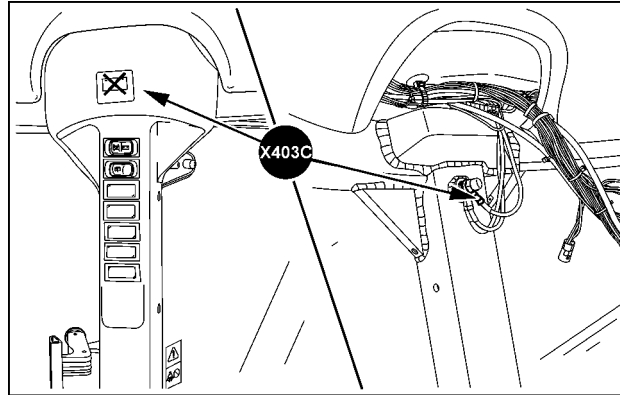

SS13K013 7

**Left-hand B-pillar**

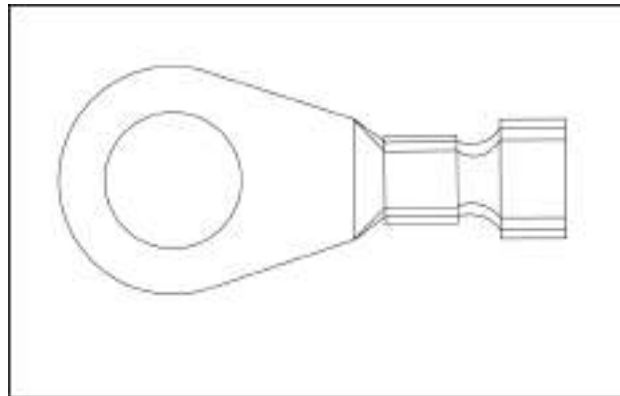

84253168 8

**CONNECTOR X-404 - Cab main harness to switch panel harness 1**

<b>CONNECTOR X-404 - Cab main harness to switch panel harness 1</b>			
<b>PIN NUMBER</b>	<b>WIRE NUMBER</b>	<b>CIRCUIT REFERENCE</b>	<b>ELECTRICAL SCHEMATIC FRAME</b>
1	CM-2320 (VT) SP-2320 (VT)	X-404 Cab main harness to switch panel harness 1 X-377 Instrument cluster CN3 X-404 Cab main harness to switch panel harness 1 X-378 Implement signal socket (ISO 11786)	<b>Wiring harnesses - Electrical schematic sheet 04 (55.100)</b> <b>Wiring harnesses - Electrical schematic sheet 10 (55.100)</b> <b>Wiring harnesses - Electrical schematic sheet 11 (55.100)</b>
2	CM-2300 (VT) SP-2300 (VT)	X-404 Cab main harness to switch panel harness 1 X-377 Instrument cluster CN3 X-404 Cab main harness to switch panel harness 1 X-378 Implement signal socket (ISO 11786)	<b>Wiring harnesses - Electrical schematic sheet 12 (55.100)</b> <b>Wiring harnesses - Electrical schematic sheet 23 (55.100)</b>
3	CM-2330 (VT) SP-2330 (VT)	X-404 Cab main harness to switch panel harness 1 X-377 Instrument cluster CN3 X-404 Cab main harness to switch panel harness 1 X-378 Implement signal socket (ISO 11786)	
4	CM-2310 (VT) SP-2310 (VT)	X-404 Cab main harness to switch panel harness 1 X-377 Instrument cluster CN3 X-404 Cab main harness to switch panel harness 1 X-378 Implement signal socket (ISO 11786)	
5	CM-5120 (PK) SP-5120 (PK)	X-404 Cab main harness to switch panel harness 1 X-210 Central Control Unit (CCU) – CN1B X-404 Cab main harness to switch panel harness 1 X-327 Hitch electronic control panel	<b>Wiring harnesses - Electrical schematic sheet 04 (55.100)</b> <b>Wiring harnesses - Electrical schematic sheet 10 (55.100)</b> <b>Wiring harnesses - Electrical schematic sheet 11 (55.100)</b>
6	CM-5122 (PK) SP-5122 (PK)	X-404 Cab main harness to switch panel harness 1 X-210 Central Control Unit (CCU) – CN1B X-404 Cab main harness to switch panel harness 1 X-327 Hitch electronic control panel	<b>Wiring harnesses - Electrical schematic sheet 12 (55.100)</b> <b>Wiring harnesses - Electrical schematic sheet 23 (55.100)</b>
7	CM-5520DD (LG) SP-5520DD (LG)	X-404 Cab main harness to switch panel harness 1 SP-5520 X-404 Cab main harness to switch panel harness 1 X-327 Hitch electronic control panel	
8	CM-060GC (BK/WH) SP-060GC (BK/WH)	SP-060G X-404 Cab main harness to switch panel harness 1 X-404 Cab main harness to switch panel harness 1 X-327 Hitch electronic control panel	
9	CM-5121 (PK) SP-5121 (PK)	X-404 Cab main harness to switch panel harness 1 X-210 Central Control Unit (CCU) – CN1B X-404 Cab main harness to switch panel harness 1 X-327 Hitch electronic control panel	

<b>CONNECTOR X-404 - Cab main harness to switch panel harness 1</b>			
<b>PIN NUMBER</b>	<b>WIRE NUMBER</b>	<b>CIRCUIT REFERENCE</b>	<b>ELECTRICAL SCHEMATIC FRAME</b>
10	CM-5123 (PK) SP-5123 (RD)	X-404 Cab main harness to switch panel harness 1 X-210 Central Control Unit (CCU) – CN1B X-404 Cab main harness to switch panel harness 1 X-327 Hitch electronic control panel	<b>Wiring harnesses - Electrical schematic sheet 04 (55.100)</b> <b>Wiring harnesses - Electrical schematic sheet 10 (55.100)</b> <b>Wiring harnesses - Electrical schematic sheet 11 (55.100)</b>
11	CM-010FF (GN) SP-011FF (GN)	SP-010F X-404 Cab main harness to switch panel harness 1 SP-011FF XCM 5V X-404 Cab main harness to switch panel harness 1	<b>Wiring harnesses - Electrical schematic sheet 12 (55.100)</b> <b>Wiring harnesses - Electrical schematic sheet 23 (55.100)</b>
12	CM-5005A (TN) SP-5005A (TN)	X-404 Cab main harness to switch panel harness 1 SP-5005 X-404 Cab main harness to switch panel harness 1 SP-5005A POT 15 EDC	
13	CM-5597B (GY) SP-5597B (GY)	X-404 Cab main harness to switch panel harness 1 SP-5597 SP-5597B EHR-MASTER X-404 Cab main harness to switch panel harness 1	
14	CM-010CE (GN) SP-010CE (GN)	SP-010C X-404 Cab main harness to switch panel harness 1 X-404 Cab main harness to switch panel harness 1 SP-010CE POT 15	
15	CM-001G (RD) SP-001G (RD)	X-180 Fuse block (F-070 to F-101) X-404 Cab main harness to switch panel harness 1 X-404 Cab main harness to switch panel harness 1 SP-001G POT 30 SWITCH PANEL 8A	

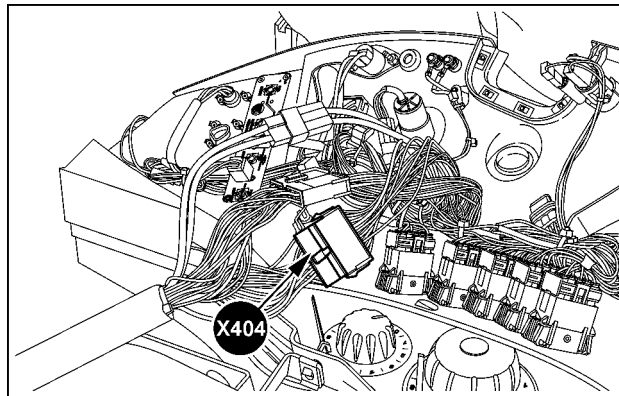

SVIL13TR00744AB 9

**Behind right-hand switch panel**

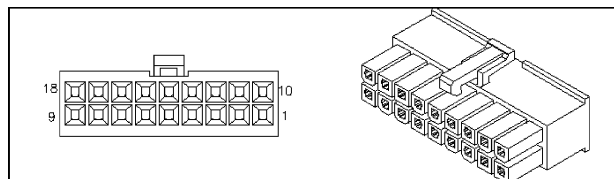

87694700 10

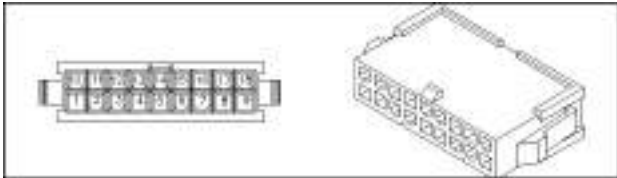

87694698 11

**CONNECTOR X-405 - Cab main harness to switch panel harness 2**

<b>CONNECTOR X-405 - Cab main harness to switch panel harness 2</b>			
<b>PIN NUMBER</b>	<b>WIRE NUMBER</b>	<b>CIRCUIT REFERENCE</b>	<b>ELECTRICAL SCHEMATIC FRAME</b>
1	CM-3024B (YE) SP-3024B (YE)	X-405 Cab main harness to switch panel harness 2 X-230 Central Control Unit (CCU) – CN3A X-405 Cab main harness to switch panel harness 2 X-374 Four-Wheel Drive (4WD) switch	<b>Wiring harnesses - Electrical schematic sheet 04 (55.100)</b> <b>Wiring harnesses - Electrical schematic sheet 09 (55.100)</b> <b>Wiring harnesses - Electrical schematic sheet 10 (55.100)</b>
2	CM-3024A (YE) SP-3024A (YE)	X-405 Cab main harness to switch panel harness 2 X-230 Central Control Unit (CCU) – CN3A X-405 Cab main harness to switch panel harness 2 X-374 Four-Wheel Drive (4WD) switch	<b>Wiring harnesses - Electrical schematic sheet 11 (55.100)</b> <b>Wiring harnesses - Electrical schematic sheet 18 (55.100)</b> <b>Wiring harnesses - Electrical schematic sheet 25 (55.100)</b>
3	CM-6515 (BR) SP-6515 (BR)	X-460 Instrument cluster CN2 X-405 Cab main harness to switch panel harness 2 X-405 Cab main harness to switch panel harness 2 X-303 Constant engine speed – Selector switch	
4	CM-6500 (BR) SP-6500 (BR)	X-405 Cab main harness to switch panel harness 2 X-460 Instrument cluster CN2 X-405 Cab main harness to switch panel harness 2 X-303 Constant engine speed – Selector switch	
5	CM-6540 (BR) SP-6540 (BR)	X-405 Cab main harness to switch panel harness 2 X-450 Instrument cluster CN1 X-405 Cab main harness to switch panel harness 2 X-369 Constant engine speed – Adjust switch	<b>Wiring harnesses - Electrical schematic sheet 04 (55.100)</b> <b>Wiring harnesses - Electrical schematic sheet 09 (55.100)</b> <b>Wiring harnesses - Electrical schematic sheet 10 (55.100)</b>
6	CM-6530 (BR) SP-6530 (BR)	X-405 Cab main harness to switch panel harness 2 X-450 Instrument cluster CN1 X-405 Cab main harness to switch panel harness 2 X-369 Constant engine speed – Adjust switch	<b>Wiring harnesses - Electrical schematic sheet 11 (55.100)</b> <b>Wiring harnesses - Electrical schematic sheet 18 (55.100)</b> <b>Wiring harnesses - Electrical schematic sheet 25 (55.100)</b>
7	CM-5095 (PK) SP-5095 (PK)	SP-5095 X-405 Cab main harness to switch panel harness 2 X-314 Hitch up/down switch – Cab inside X-405 Cab main harness to switch panel harness 2	
8	CM-5100 (PK) SP-5100 (PK)	SP-5100 X-405 Cab main harness to switch panel harness 2 X-314 Hitch up/down switch – Cab inside X-405 Cab main harness to switch panel harness 2	

<b>CONNECTOR X-405 - Cab main harness to switch panel harness 2</b>			
<b>PIN NUMBER</b>	<b>WIRE NUMBER</b>	<b>CIRCUIT REFERENCE</b>	<b>ELECTRICAL SCHEMATIC FRAME</b>
9	CM-7170 (WH) SP-7170 (WH)	X-405 Cab main harness to switch panel harness 2 X-240 Central Control Unit (CCU) – CN3B X-405 Cab main harness to switch panel harness 2 X-375 Rear axle differential lock – Switch	<b>Wiring harnesses - Electrical schematic sheet 04 (55.100)</b> <b>Wiring harnesses - Electrical schematic sheet 09 (55.100)</b> <b>Wiring harnesses - Electrical schematic sheet 10 (55.100)</b>
10	CM-7175 (YE) SP-7175 (YE)	X-405 Cab main harness to switch panel harness 2 X-240 Central Control Unit (CCU) – CN3B X-405 Cab main harness to switch panel harness 2 X-375 Rear axle differential lock – Switch	<b>Wiring harnesses - Electrical schematic sheet 11 (55.100)</b> <b>Wiring harnesses - Electrical schematic sheet 18 (55.100)</b> <b>Wiring harnesses - Electrical schematic sheet 25 (55.100)</b>
11	CM-2245 (PK) SP-2245 (PK)	X-240 Central Control Unit (CCU) – CN3B X-405 Cab main harness to switch panel harness 2 X-405 Cab main harness to switch panel harness 2 X-348 Front Power Take-Off (PTO) – ON/OFF switch	
12	CM-2246 (PK) SP-2246 (WH)	X-405 Cab main harness to switch panel harness 2 X-230 Central Control Unit (CCU) – CN3A X-405 Cab main harness to switch panel harness 2 X-348 Front Power Take-Off (PTO) – ON/OFF switch	
13	CM-2235 (PK) SP-2235 (PK)	X-240 Central Control Unit (CCU) – CN3B X-405 Cab main harness to switch panel harness 2 X-405 Cab main harness to switch panel harness 2 X-350 Rear Power Take-Off (PTO) – ON/OFF switch	<b>Wiring harnesses - Electrical schematic sheet 04 (55.100)</b> <b>Wiring harnesses - Electrical schematic sheet 09 (55.100)</b> <b>Wiring harnesses - Electrical schematic sheet 10 (55.100)</b>
14	CM-2236 (PK) SP-2236 (PK)	X-405 Cab main harness to switch panel harness 2 X-240 Central Control Unit (CCU) – CN3B X-405 Cab main harness to switch panel harness 2 X-350 Rear Power Take-Off (PTO) – ON/OFF switch	<b>Wiring harnesses - Electrical schematic sheet 11 (55.100)</b> <b>Wiring harnesses - Electrical schematic sheet 18 (55.100)</b> <b>Wiring harnesses - Electrical schematic sheet 25 (55.100)</b>
15	CM-2068 (TN) SP-2068 (TN)	X-405 Cab main harness to switch panel harness 2 X-230 Central Control Unit (CCU) – CN3A X-405 Cab main harness to switch panel harness 2 X-351 Rear Power Take-Off (PTO) – Soft-start/auto switch	
16	CM-2085 (OR) SP-2085 (OR)	X-405 Cab main harness to switch panel harness 2 X-230 Central Control Unit (CCU) – CN3A X-405 Cab main harness to switch panel harness 2 X-351 Rear Power Take-Off (PTO) – Soft-start/auto switch	

<b>CONNECTOR X-405 - Cab main harness to switch panel harness 2</b>			
<b>PIN NUMBER</b>	<b>WIRE NUMBER</b>	<b>CIRCUIT REFERENCE</b>	<b>ELECTRICAL SCHEMATIC FRAME</b>
17	CM-5220 (YE) SP-5220 (YE)	X-405 Cab main harness to switch panel harness 2 X-220 Central Control Unit (CCU) – CN2 X-405 Cab main harness to switch panel harness 2 X-534_DIAGN - Hitch indicator lights	<b>Wiring harnesses - Electrical schematic sheet 04 (55.100)</b> <b>Wiring harnesses - Electrical schematic sheet 09 (55.100)</b> <b>Wiring harnesses - Electrical schematic sheet 10 (55.100)</b>
18	CM-5105 (GY) SP-5155 (GY)	X-405 Cab main harness to switch panel harness 2 X-220 Central Control Unit (CCU) – CN2 X-405 Cab main harness to switch panel harness 2 X-534_UP- Hitch indicator lights	<b>Wiring harnesses - Electrical schematic sheet 11 (55.100)</b> <b>Wiring harnesses - Electrical schematic sheet 18 (55.100)</b> <b>Wiring harnesses - Electrical schematic sheet 25 (55.100)</b>
19	CM-5180 (VT) SP-5180 (VT)	X-405 Cab main harness to switch panel harness 2 X-220 Central Control Unit (CCU) – CN2 X-405 Cab main harness to switch panel harness 2 X-534_DOWN- Hitch indicator lights	
20	CM-5230 (YE) SP-5230 (YE)	X-405 Cab main harness to switch panel harness 2 X-220 Central Control Unit (CCU) – CN2 X-405 Cab main harness to switch panel harness 2 X-534_ASR- Hitch indicator lights	
21	CM-5260F (TN) SP-5260F (TN)	X-405 Cab main harness to switch panel harness 2 SP-5260 X-337 Hydraulic master switch X-405 Cab main harness to switch panel harness 2	<b>Wiring harnesses - Electrical schematic sheet 04 (55.100)</b> <b>Wiring harnesses - Electrical schematic sheet 09 (55.100)</b> <b>Wiring harnesses - Electrical schematic sheet 10 (55.100)</b>
22	CM-5210A (BR) SP-5210A (BR)	X-405 Cab main harness to switch panel harness 2 SP-5210 X-405 Cab main harness to switch panel harness 2 X-337 Hydraulic master switch	<b>Wiring harnesses - Electrical schematic sheet 11 (55.100)</b> <b>Wiring harnesses - Electrical schematic sheet 18 (55.100)</b>
23	CM-057AA (BK) SP-057AA (BK)	X-405 Cab main harness to switch panel harness 2 SP-057A CAB GND X-405 Cab main harness to switch panel harness 2 SP-057G POT GND SWITCH PANEL	<b>Wiring harnesses - Electrical schematic sheet 25 (55.100)</b>
24	CM-1014F (RD) SP-1014F (RD)	SP-1014 X-405 Cab main harness to switch panel harness 2 X-405 Cab main harness to switch panel harness 2 SP-1014F POT 58 SWITCH PANEL	



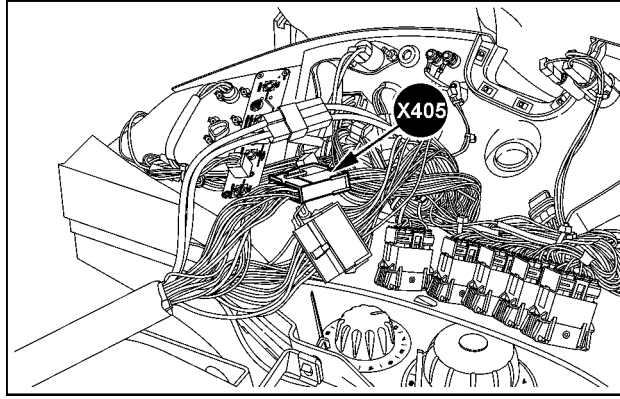

SVIL13TR00744AC 12

**Behind right-hand switch panel**

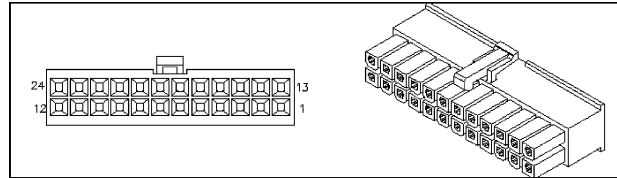

87694705 13

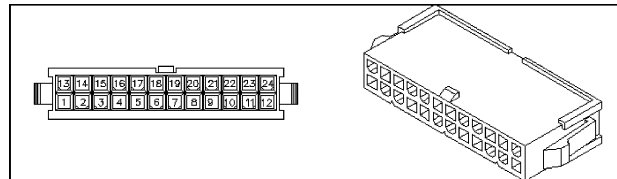

87694693 14

**CONNECTOR X-406 - Engine harness 1 to trailer socket front (7-Pin)**

CONNECTOR X-406 - Engine harness 1 to trailer socket front (7-Pin)			
PIN NUMBER	WIRE NUMBER	CIRCUIT REFERENCE	ELECTRICAL SCHEMATIC FRAME
1	EN-010I (GN) SK-010I (GN)	X-406 Engine harness 1 to trailer socket front (7-Pin) X-001 Cab main harness to engine harness 1 X-406 Engine harness 1 to trailer socket front (7-Pin) SP-020A +KEY 15	<b>Wiring harnesses - Electrical schematic sheet 23 (55.100)</b>
2	EN-1024DA (RD) SK-1024DA (RD)	X-406 Engine harness 1 to trailer socket front (7-Pin) X-001 Cab main harness to engine harness 1 X-406 Engine harness 1 to trailer socket front (7-Pin) X-099 Trailer socket front (7-Pin)	
3	EN-1013MB (RD) SK-1013MB (RD)	X-406 Engine harness 1 to trailer socket front (7-Pin) X-001 Cab main harness to engine harness 1 X-406 Engine harness 1 to trailer socket front (7-Pin) X-099 Trailer socket front (7-Pin)	
4	EN-3001EB (GN) SK-3001EB (GN)	X-406 Engine harness 1 to trailer socket front (7-Pin) X-001 Cab main harness to engine harness 1 X-406 Engine harness 1 to trailer socket front (7-Pin) X-099 Trailer socket front (7-Pin)	
5	EN-3002EB (RD) SK-3002EB (RD)	X-406 Engine harness 1 to trailer socket front (7-Pin) X-001 Cab main harness to engine harness 1 X-406 Engine harness 1 to trailer socket front (7-Pin) X-099 Trailer socket front (7-Pin)	

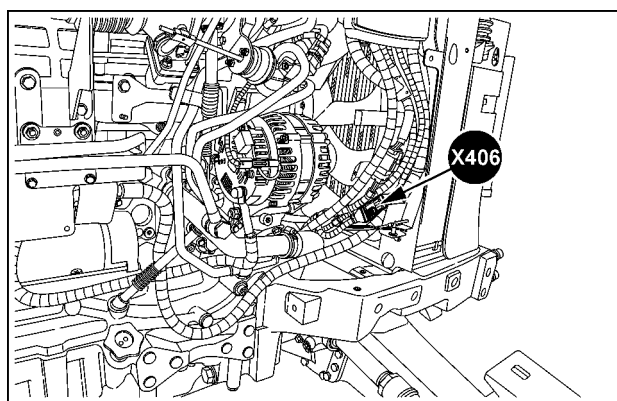

SVIL13TR00794AB 15

**Front right-hand engine**

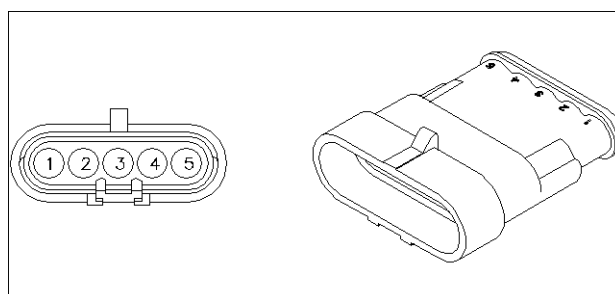

87691924 16

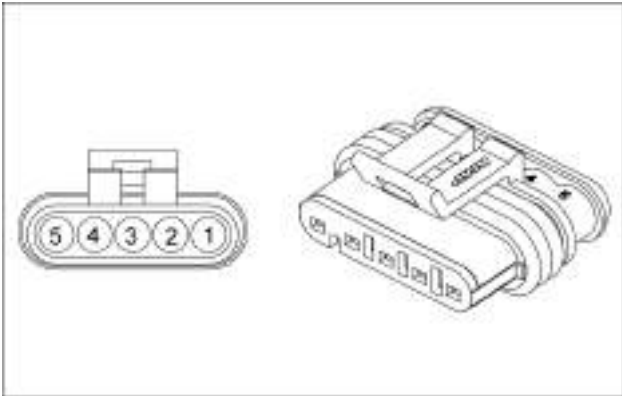

87688719 17

**CONNECTOR X-407 - Cab main harness to power socket 25 A – Cab inside**

CONNECTOR X-407 - Cab main harness to power socket 25 A – Cab inside			
PIN NUMBER	WIRE NUMBER	CIRCUIT REFERENCE	ELECTRICAL SCHEMATIC FRAME
1	CM-057AK (BK) SP-057AK (BK)	X-407 Cab main harness to power socket 25 A – Cab inside SP-057A CAB GND X-078 Power socket 25 A – Cab inside (ground) X-407 Cab main harness to power socket 25 A – Cab inside	<b>Wiring harnesses - Electrical schematic sheet 23 (55.100)</b>
2	CM-155 (GN) SP-155 (GN)	X-407 Cab main harness to power socket 25 A – Cab inside X-130 Fuse block (F-001 to F-032) X-407 Cab main harness to power socket 25 A – Cab inside X-079 Power socket 25 A – Cab inside (positive)	

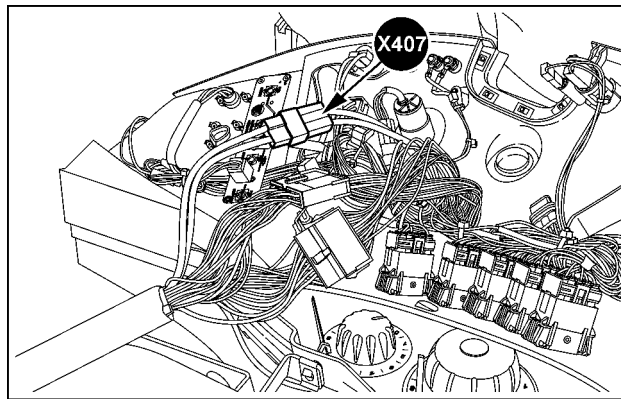

SVIL13TR00744AD 18

**Behind right-hand switch panel**

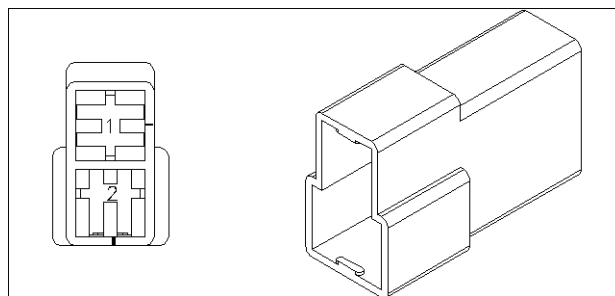

84038366 19

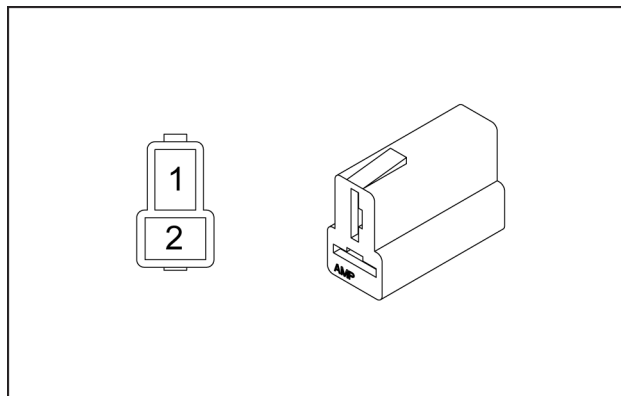

87699736 20

**CONNECTOR X-408 - Power supply pin socket (positive)**

CONNECTOR X-408 - Power supply pin socket (positive)			
PIN NUMBER	WIRE NUMBER	CIRCUIT REFERENCE	ELECTRICAL SCHEMATIC FRAME
1	SP-001GC (RD)	X-408 Power supply pin socket (positive) SP-001G POT 30 SWITCH PANEL 8A	Wiring harnesses - Electrical schematic sheet 23 (55.100)

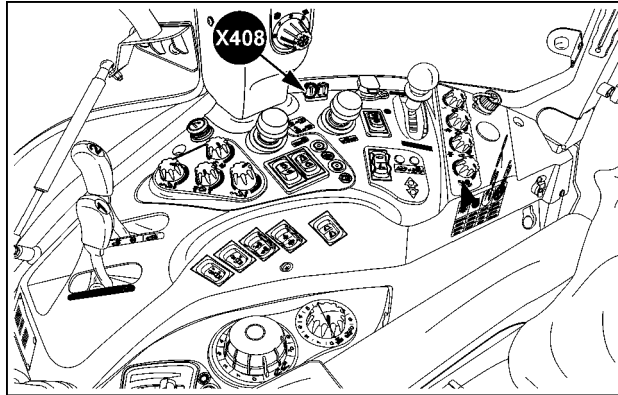

SVIL13TR00706AE 21

**Cab right-hand side**

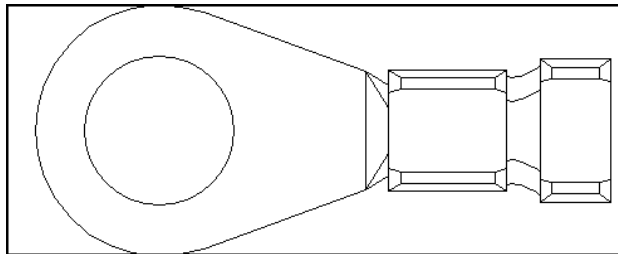

84149205 22

**CONNECTOR X-409 - Power supply pin socket (ground)**

CONNECTOR X-409 - Power supply pin socket (ground)			
PIN NUMBER	WIRE NUMBER	CIRCUIT REFERENCE	ELECTRICAL SCHEMATIC FRAME
1	SP-057G (BK)	X-409 Power supply pin socket (ground) SP-057G POT GND SWITCH PANEL	Wiring harnesses - Electrical schematic sheet 23 (55.100)

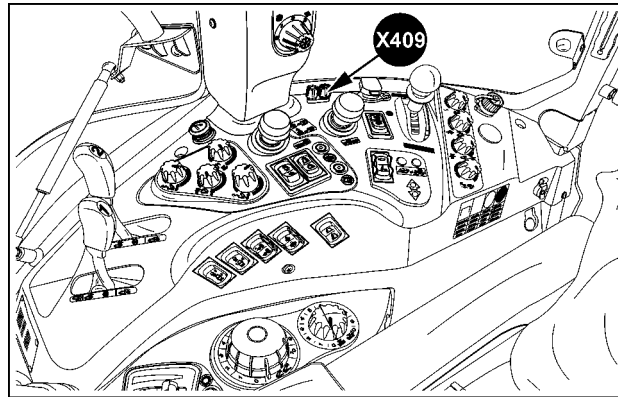

SVIL13TR00706AF 23

**Cab right-hand side**

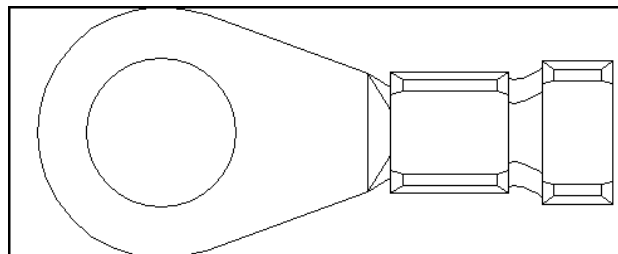

84149205 24

## Wire connectors - Component diagram 41

### CONNECTOR X-410 - Ground connection steering column

CONNECTOR X-410 - Ground connection steering column			
PIN NUMBER	WIRE NUMBER	CIRCUIT REFERENCE	ELECTRICAL SCHEMATIC FRAME
1	CM-057E (BK)	SP-057E CAB GND 3 X-410 Ground connection steering column	Wiring harnesses - Electrical schematic sheet 25 (55.100)

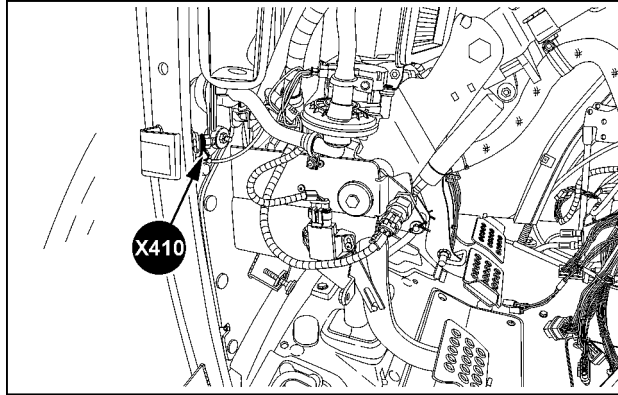

SVIL13TR00734AB 1

Front left-hand cab

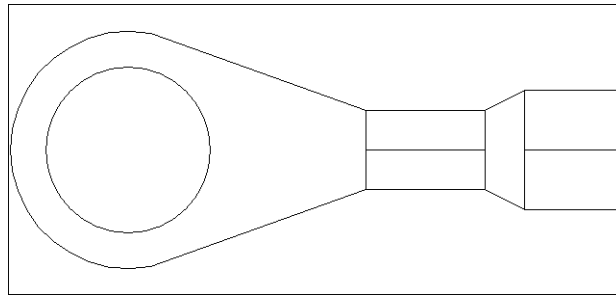

84122130 2

## Wire connectors - Component diagram 42

### CONNECTOR X-420 - Ground connection engine

CONNECTOR X-420 - Ground connection engine			
PIN NUMBER	WIRE NUMBER	CIRCUIT REFERENCE	ELECTRICAL SCHEMATIC FRAME
1	EN-057F (BK)	SP-057F GND - Engine X-420 Ground connection engine	Wiring harnesses - Electrical schematic sheet 05 (55.100)

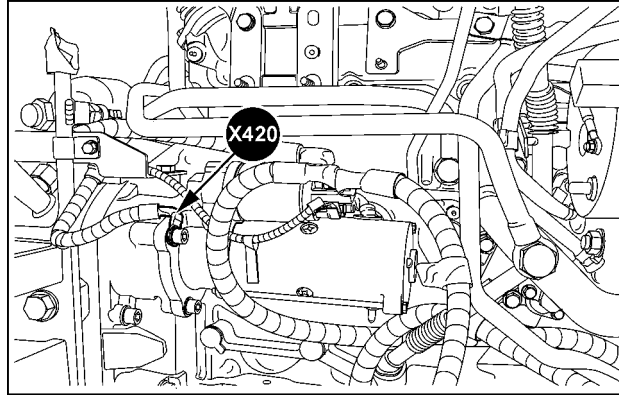

SVIL13TR00699AB 1

Rear right-hand engine

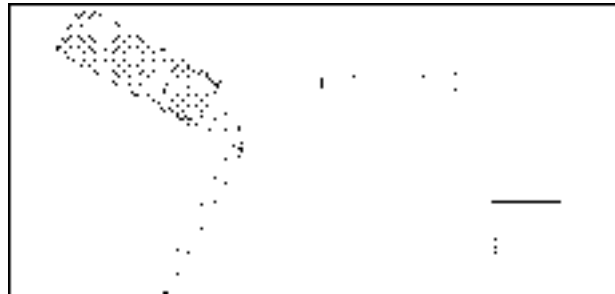

84237741 2



## Wire connectors - Component diagram 43

### CONNECTOR X-431 - Fuse to PDU

CONNECTOR X-431 - Fuse to PDU			
PIN NUMBER	WIRE NUMBER	CIRCUIT REFERENCE	ELECTRICAL SCHEMATIC FRAME
1	SK-2 (RD)	X-432 Power Fuse X-431 Fuse to PDU	

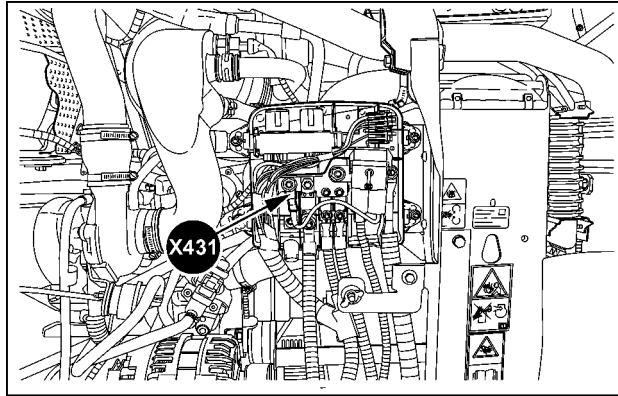

SVIL13TR00795AB 1

**Front top right-hand engine**

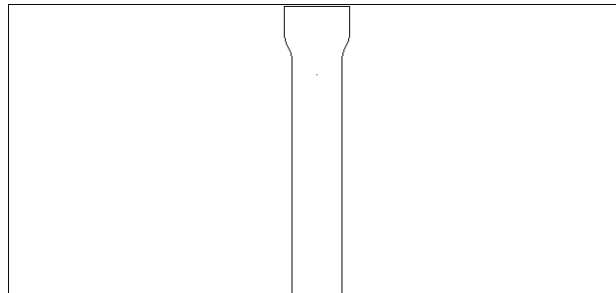

84153309 2

**CONNECTOR X-432 - Power Fuse**

<b>CONNECTOR X-432 - Power Fuse</b>			
<b>PIN NUMBER</b>	<b>WIRE NUMBER</b>	<b>CIRCUIT REFERENCE</b>	<b>ELECTRICAL SCHEMATIC FRAME</b>
1	SK-2 (RD)	X-432 Power Fuse X-431 Fuse to PDU	<b>Wiring harnesses - Electrical schematic sheet 23 (55.100)</b>

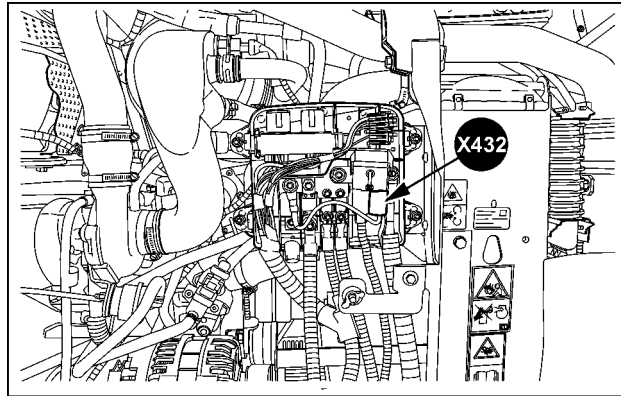

SVIL13TR00795AC 3

**Front top right-hand engine**

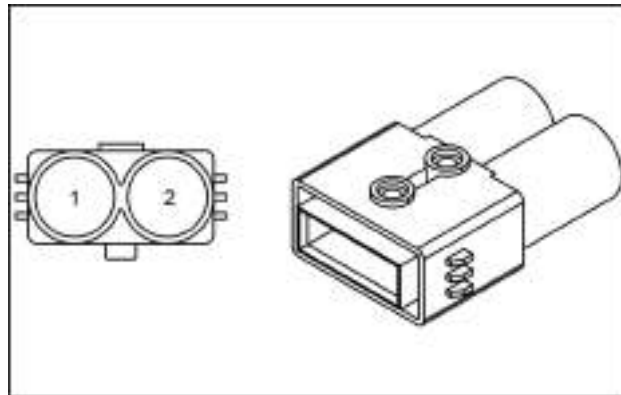

84247654 4

**CONNECTOR X-433 - GND**

<b>CONNECTOR X-433 - GND</b>			
<b>PIN NUMBER</b>	<b>WIRE NUMBER</b>	<b>CIRCUIT REFERENCE</b>	<b>ELECTRICAL SCHEMATIC FRAME</b>
1	SK-4023 (BK)	X-099 Trailer socket front (7-Pin) X-433 GND	<b>Wiring harnesses - Electrical schematic sheet 23 (55.100)</b>

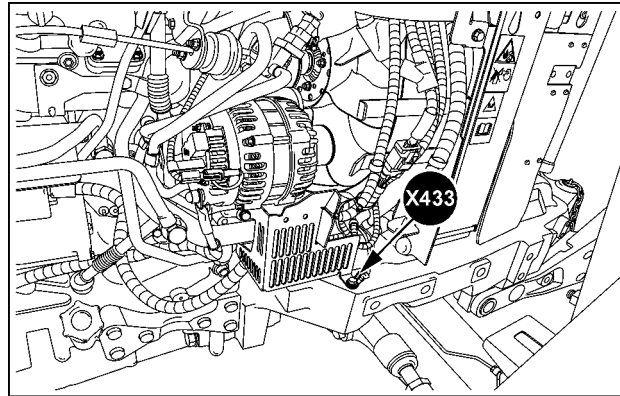

SVIL13TR00698AE 5

**Front right-hand engine**

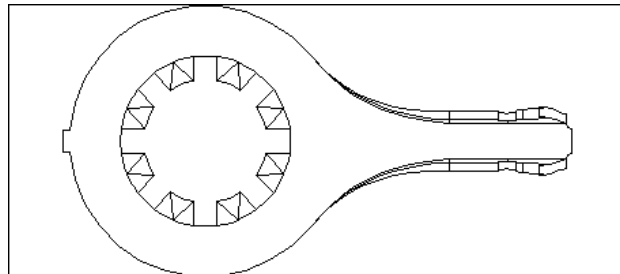

87486317 6

**CONNECTOR X-434 - GND 1**

<b>CONNECTOR X-434 - GND 1</b>			
<b>PIN NUMBER</b>	<b>WIRE NUMBER</b>	<b>CIRCUIT REFERENCE</b>	<b>ELECTRICAL SCHEMATIC FRAME</b>
1	SK-4024 (BK)	X-434 GND 1 X-506 Power socket 40 A – Front	

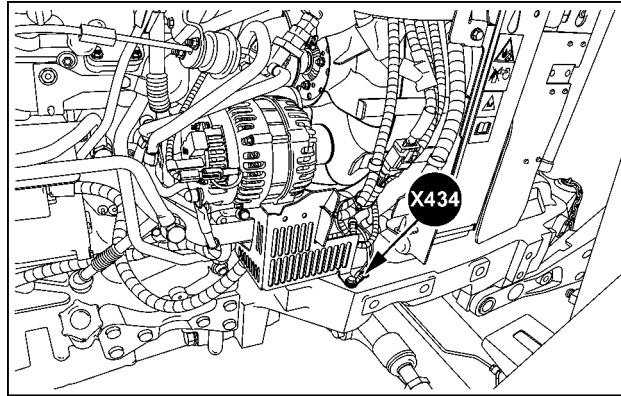

SVIL13TR00698AF 7

**Front right-hand engine**

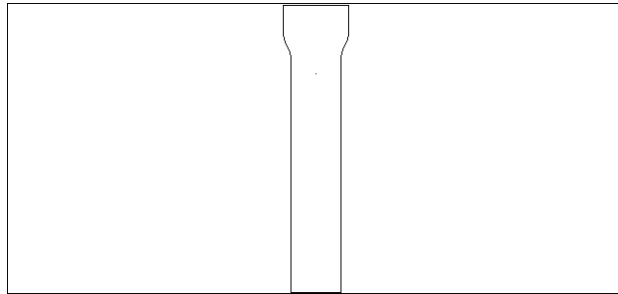

84153309 8

## Wire connectors - Component diagram 44

**CONNECTOR X-446 - Cab main harness (power supply) to Electro-Hydraulic Remote (EHR) valve harness**

<b>CONNECTOR X-446 - Cab main harness (power supply) to Electro-Hydraulic Remote (EHR) valve harness</b>			
<b>PIN NUMBER</b>	<b>WIRE NUMBER</b>	<b>CIRCUIT REFERENCE</b>	<b>ELECTRICAL SCHEMATIC FRAME</b>
1	CM-5515A (GY) EH-5515A (GY)	X-180 Fuse block (F-070 to F-101) X-446 Cab main harness (power supply) to Electro-Hydraulic Remote (EHR) valve harness X-697 Electro Hydraulic Remote (EHR) valve 1 – Front implement X-446 Cab main harness (power supply) to Electro-Hydraulic Remote (EHR) valve harness	<b>Wiring harnesses - Electrical schematic sheet 13 (55.100)</b>
2	CM-5515B (GY) EH-5515B (GY)	X-180 Fuse block (F-070 to F-101) X-446 Cab main harness (power supply) to Electro-Hydraulic Remote (EHR) valve harness X-698 Electro Hydraulic Remote (EHR) valve 2 – Front implement X-446 Cab main harness (power supply) to Electro-Hydraulic Remote (EHR) valve harness	
3	CM-5515C (GY) EH-5515C (GY)	X-180 Fuse block (F-070 to F-101) X-446 Cab main harness (power supply) to Electro-Hydraulic Remote (EHR) valve harness X-699 Electro Hydraulic Remote (EHR) valve 3 – Rear implement X-446 Cab main harness (power supply) to Electro-Hydraulic Remote (EHR) valve harness	



SVIL13TR00785AC 1

**Rear top of transmission**

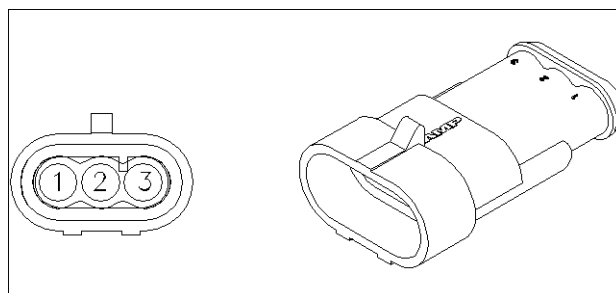

87680689 2

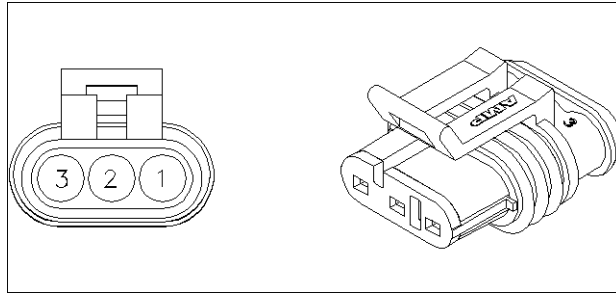

84062580 3

## Wire connectors - Component diagram 45

### CONNECTOR X-450 - Instrument cluster CN1

CONNECTOR X-450 - Instrument cluster CN1				
PIN NUMBER	WIRE NUMBER	CIRCUIT REFERENCE	ELECTRICAL SCHEMATIC FRAME	
1	CM-7245 (GN)	X-450 Instrument cluster CN1 X-355 Seat assembly (seat switch)	<b>Wiring harnesses - Electrical schematic sheet 03 (55.100)</b> <b>Wiring harnesses - Electrical schematic sheet 04 (55.100)</b> <b>Wiring harnesses - Electrical schematic sheet 24 (55.100)</b>	
2	CM-029 (GN)	X-450 Instrument cluster CN1 X-300 Cab main harness to transmission harness		
3	CM-191 (YE)	X-450 Instrument cluster CN1 SP-191		
4	CM-190 (GN)	SP-190 X-450 Instrument cluster CN1		
5	CM-6402 (GN)	X-321 Foot throttle position sensor X-450 Instrument cluster CN1		
6	CM-060 (BK/WH)	SP-060 X-450 Instrument cluster CN1		
7	CM-6404 (GN)	X-321 Foot throttle position sensor X-450 Instrument cluster CN1		
8	CM-6440 (GY)	X-324 Hand throttle sensor X-450 Instrument cluster CN1		
11	CM-6450 (GY)	X-450 Instrument cluster CN1 X-324 Hand throttle sensor		
12	CM-060K (BK/WH)	X-324 Hand throttle sensor X-450 Instrument cluster CN1		
14	CM-1052C (YE)	X-120 Relay and diode block (K-007 to K-060 and V-040 to V-044) X-450 Instrument cluster CN1		<b>Wiring harnesses - Electrical schematic sheet 03 (55.100)</b> <b>Wiring harnesses - Electrical schematic sheet 04 (55.100)</b> <b>Wiring harnesses - Electrical schematic sheet 24 (55.100)</b>
15	CM-6530 (BR)	X-405 Cab main harness to switch panel harness 2 X-450 Instrument cluster CN1		
16	CM-6540 (BR)	X-405 Cab main harness to switch panel harness 2 X-450 Instrument cluster CN1		
17	CM-3063 (OR)	X-090 Flasher unit X-450 Instrument cluster CN1		
18	CM-3064 (OR)	X-090 Flasher unit X-450 Instrument cluster CN1		
20	CM-7281 (WH)	X-250 Home/enter switch X-450 Instrument cluster CN1		
21	CM-7280 (WH)	X-250 Home/enter switch X-450 Instrument cluster CN1		
22	CM-2591 (BR)	X-260 Up/down menu switch X-450 Instrument cluster CN1		
23	CM-2590 (BL)	X-260 Up/down menu switch X-450 Instrument cluster CN1		
25	CM-9253 (WH)	X-450 Instrument cluster CN1 X-376 Diagnostic socket (CAN bus 1)		
26	CM-172 (PK)	X-001 Cab main harness to engine harness 1 X-450 Instrument cluster CN1		

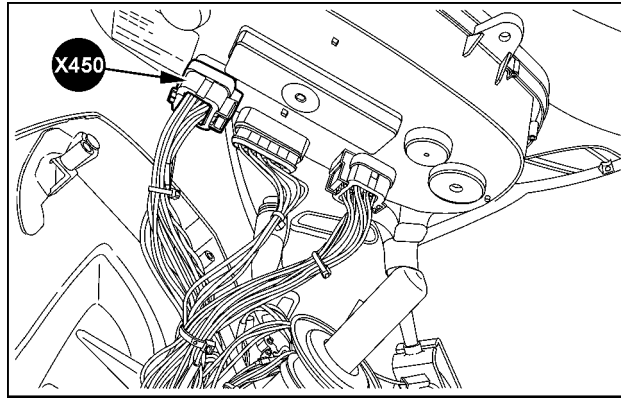

SVIL13TR00791AC 1

**Behind instrument cluster**

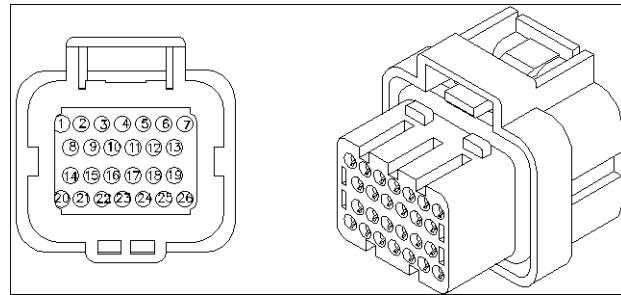

82028493 2



## Wire connectors - Component diagram 46

### CONNECTOR X-460 - Instrument cluster CN2

CONNECTOR X-460 - Instrument cluster CN2				
PIN NUMBER	WIRE NUMBER	CIRCUIT REFERENCE	ELECTRICAL SCHEMATIC FRAME	
1	CM-6401 (GN)	X-460 Instrument cluster CN2 X-321 Foot throttle position sensor	<b>Wiring harnesses - Electrical schematic sheet 03 (55.100)</b> <b>Wiring harnesses - Electrical schematic sheet 04 (55.100)</b>	
2	CM-170 (PK)	X-460 Instrument cluster CN2 X-385 Cab main harness to roof harness 2		
3	CM-9234 (YE)	X-460 Instrument cluster CN2 X-001 Cab main harness to engine harness 1		
6	CM-1027CB (BL)	SP-1027C X-460 Instrument cluster CN2		
7	CM-6515 (BR)	X-460 Instrument cluster CN2 X-405 Cab main harness to switch panel harness 2		
8	CM-3012 (RD)	X-358 Hand brake position switch X-460 Instrument cluster CN2		
9	CM-3001A (GN)	X-460 Instrument cluster CN2 SP-3001		
10	CM-3002A (GN)	X-460 Instrument cluster CN2 SP-3002		
12	CM-8005 (VT)	X-460 Instrument cluster CN2 X-381 Cab main harness to hydraulic trailer brake harness		
13	CM-1006 (BR)	X-460 Instrument cluster CN2 SP-1006		<b>Wiring harnesses - Electrical schematic sheet 03 (55.100)</b> <b>Wiring harnesses - Electrical schematic sheet 04 (55.100)</b>
14	CM-6445 (BR)	X-324 Hand throttle sensor X-460 Instrument cluster CN2		
15	CM-057EM (BK)	X-460 Instrument cluster CN2 SP-057E CAB GND 3		
16	CM-3501 (WH)	X-300 Cab main harness to transmission harness X-460 Instrument cluster CN2		
17	CM-1001C (WH)	SP-1001A X-460 Instrument cluster CN2		
18	CM-3016 (GY)	X-460 Instrument cluster CN2 X-001 Cab main harness to engine harness 1		
19	CM-1014B (RD)	X-460 Instrument cluster CN2 SP-1014		
20	CM-138DA (VT)	X-460 Instrument cluster CN2 SP-138D		
21	CM-010CD (GN)	X-460 Instrument cluster CN2 SP-010C		
26	CM-6500 (BR)	X-405 Cab main harness to switch panel harness 2 X-460 Instrument cluster CN2		

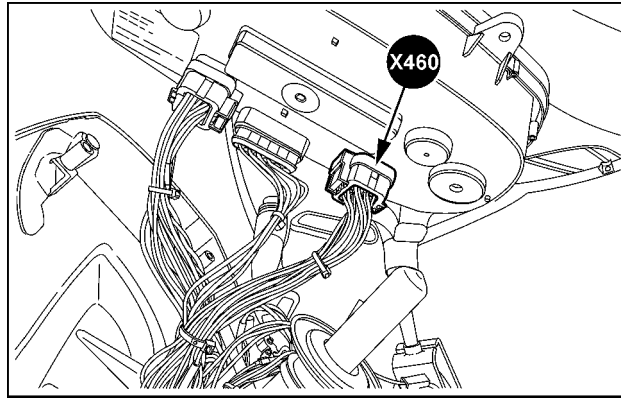

SVIL13TR00791AD 1

**Behind Instrument Cluster**

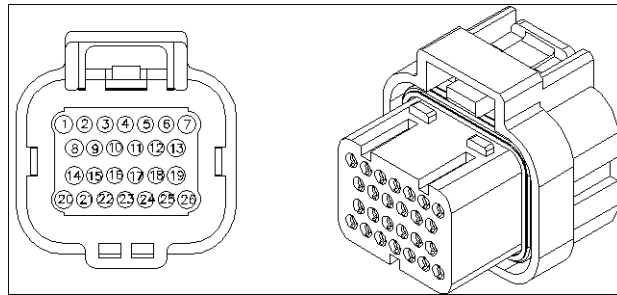

82016219 2

**CONNECTOR X-461 - Front loader diode pack (Hydrac)**

CONNECTOR X-461 - Front loader diode pack (Hydrac)			
PIN NUMBER	WIRE NUMBER	CIRCUIT REFERENCE	ELECTRICAL SCHEMATIC FRAME
A	FL-3277B (GN)	X-461 Front loader diode pack (Hydrac) SP-3277	<b>Wiring harnesses - Electrical schematic sheet 15 (55.100)</b>
B	FL-3276B (GN)	X-461 Front loader diode pack (Hydrac) SP-3276	
C	FL-3275 (BL)	X-461 Front loader diode pack (Hydrac) X-468A Front loader harness (Hydrac) to front loader socket (Hydrac)	
D	FL-3274A (BL)	SP-3274 X-461 Front loader diode pack (Hydrac)	
E	FL-3272A (BL)	SP-3272 X-461 Front loader diode pack (Hydrac)	
F	-	-	

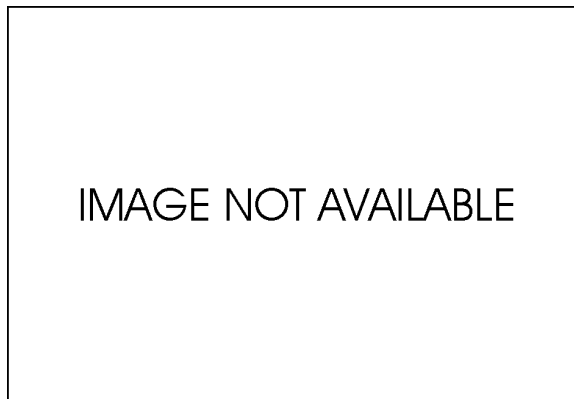

INA 3

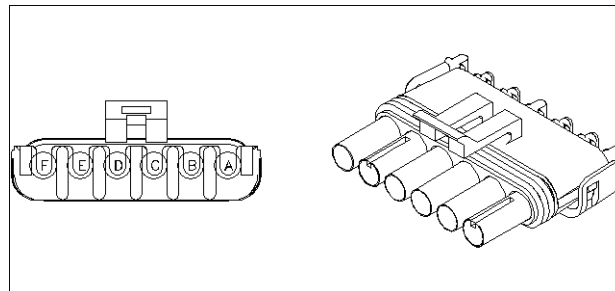

87039236 4

**CONNECTOR X-462 - Front loader switch – Jack support lock (Hydrac)**

CONNECTOR X-462 - Front loader switch – Jack support lock (Hydrac)			
PIN NUMBER	WIRE NUMBER	CIRCUIT REFERENCE	ELECTRICAL SCHEMATIC FRAME
A	FL-010HD (GN)	SP-010HA X-462A Front loader switch – Jack support lock (Hydrac)	Wiring harnesses - Electrical schematic sheet 15 (55.100)
B	FL-3276 (GN)	X-462B Front loader switch – Jack support lock (Hydrac) SP-3276	
C	FL-3277 (GN)	X462C Front loader switch – Jack support lock (Hydrac) SP-3277	

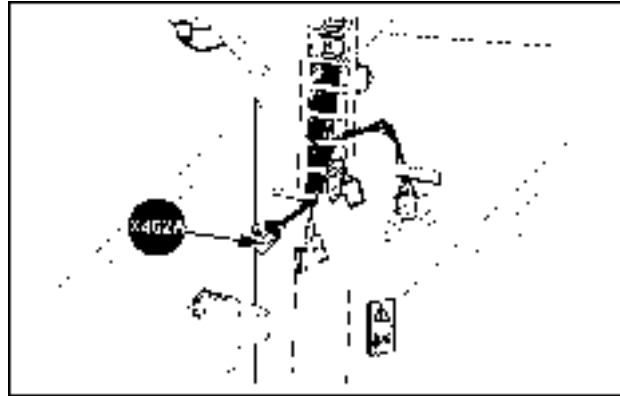

SVIL13TR00877AB 5

**Left-hand B-pillar**

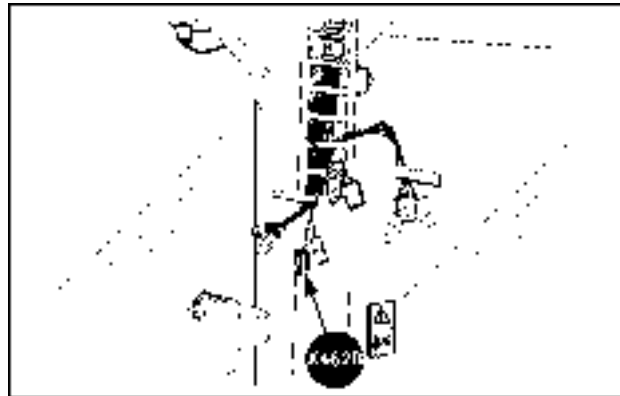

SVIL13TR00877AC 6

**Left-hand B-pillar**

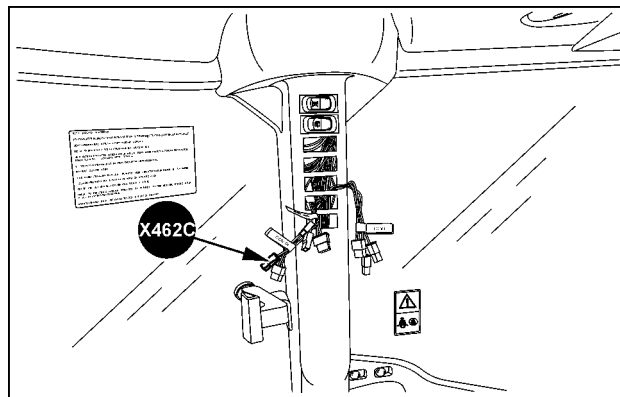

SVIL13TR00878AB 7

**Left-hand B-pillar**

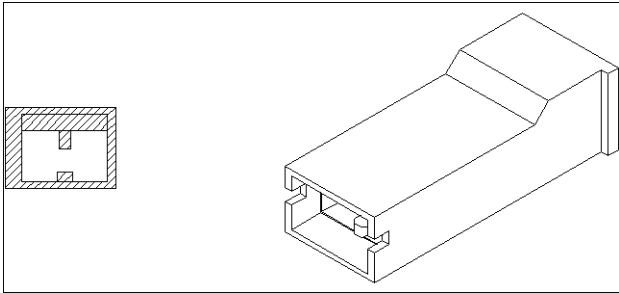

87691062 8

**CONNECTOR X-463 - Front loader switch – Jack support lock lighting (Hydrac)**

CONNECTOR X-463 - Front loader switch – Jack support lock lighting (Hydrac)			
PIN NUMBER	WIRE NUMBER	CIRCUIT REFERENCE	ELECTRICAL SCHEMATIC FRAME
1	FL-1013NA (RD)	SP-1013N X-463 Front loader switch – Jack support lock lighting (Hydrac)	Wiring harnesses - Electrical schematic sheet 15 (55.100)
2	FL-057CN (BK)	SP-057CL X-463 Front loader switch – Jack support lock lighting (Hydrac)	

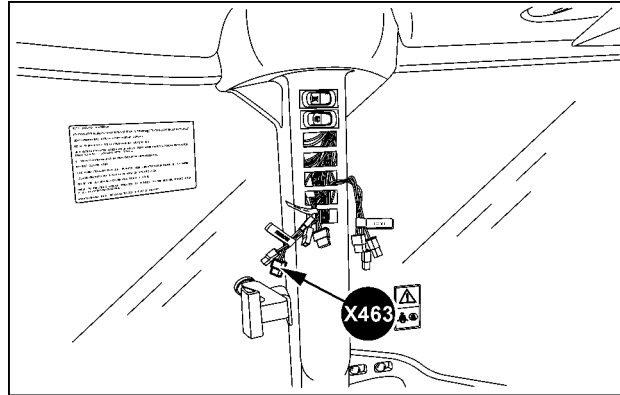

SVIL13TR00878AC 9

**Left-hand B-pillar**

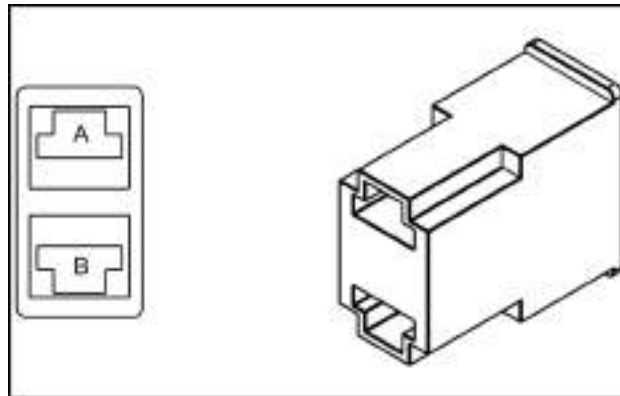

84146684 10

**CONNECTOR X-464 - Front loader switch (Hydrac)**

CONNECTOR X-464 - Front loader switch (Hydrac)			
PIN NUMBER	WIRE NUMBER	CIRCUIT REFERENCE	ELECTRICAL SCHEMATIC FRAME
A	FL-010HC (GN)	SP-010HA X-464A Front loader switch (Hydrac)	Wiring harnesses - Electrical schematic sheet 15 (55.100)
B	FL-3278 (GN)	X464B Front loader switch (Hydrac) X-468 Front loader harness (Hydrac) to front loader socket (Hydrac)	

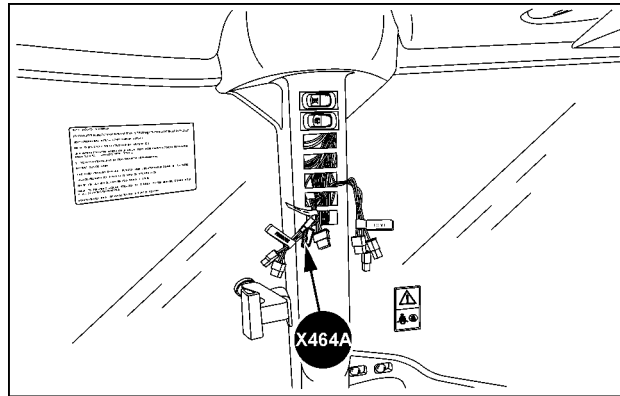

SVIL13TR00878AD 11

**Left-hand B-pillar**

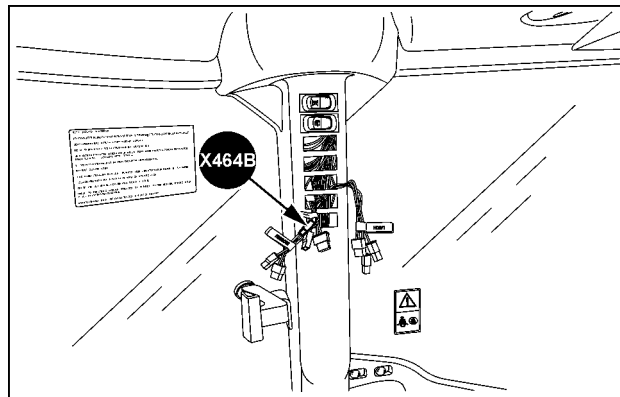

SVIL13TR00878AE 12

**Left-hand B-pillar**

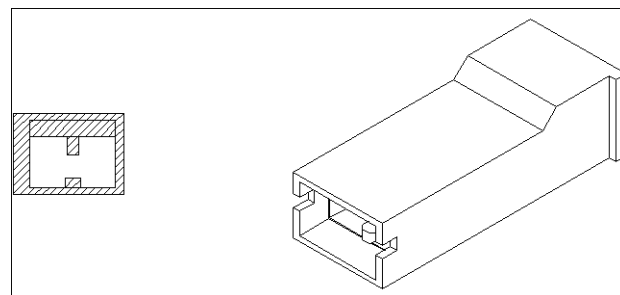

87691062 13

**CONNECTOR X-465 - Front loader switch – Lighting (Hydrac)**

CONNECTOR X-465 - PRESS ACCUM SW ILLUM			
PIN NUMBER	WIRE NUMBER	CIRCUIT REFERENCE	ELECTRICAL SCHEMATIC FRAME
1	FL-1013NB (RD)	SP-1013N X-465 Front loader switch – Lighting (Hydrac)	Wiring harnesses - Electrical schematic sheet 15 (55.100)
2	FL-057CT (BK)	SP-057CL X-465 Front loader switch – Lighting (Hydrac)	

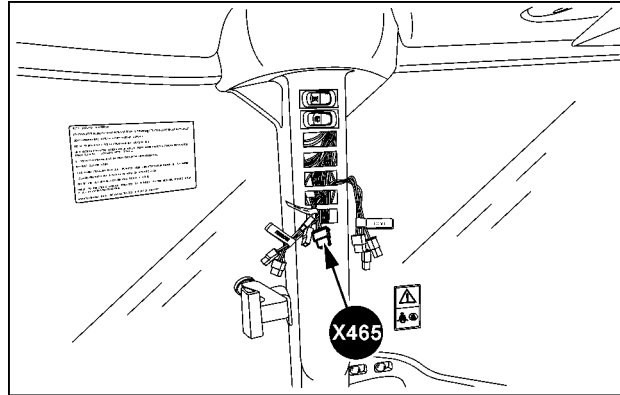

SVIL13TR00878AF 14

**Left-hand B-pillar**

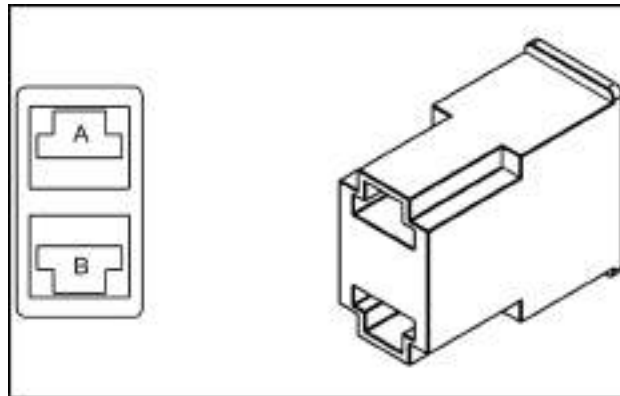

84146684 15



**CONNECTOR X-466 - Front loader latch switch (Hydrac)**

CONNECTOR X-466 - Front loader latch switch (Hydrac)			
PIN NUMBER	WIRE NUMBER	CIRCUIT REFERENCE	ELECTRICAL SCHEMATIC FRAME
A	FL-010HB (GN)	SP-010HA X-466A Front loader latch switch (Hydrac)	Wiring harnesses - Electrical schematic sheet 15 (55.100)
B	FL-3281 (GN)	X466B Front loader latch switch (Hydrac) SP-3281	

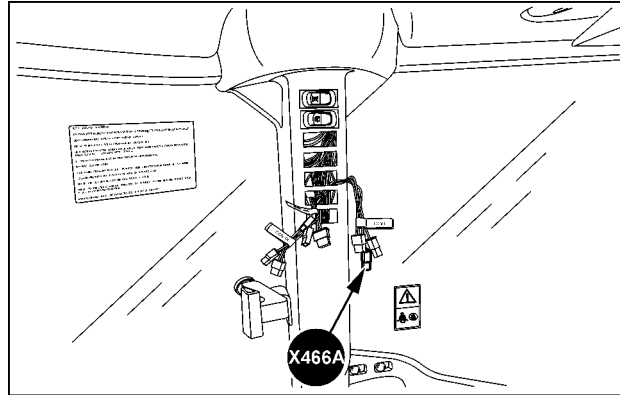

SVIL13TR00878AG 16

**Left-hand B-pillar**

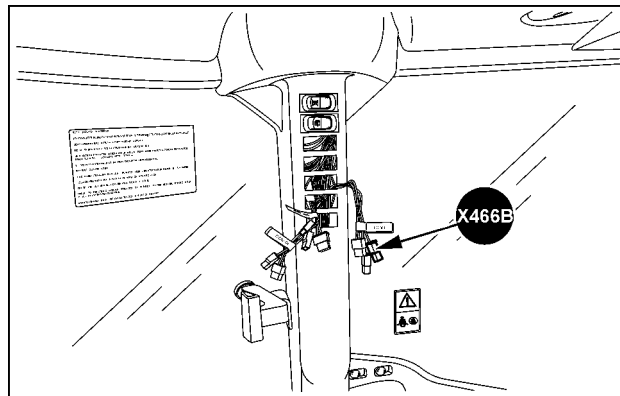

SVIL13TR00878AH 17

**Left-hand B-pillar**

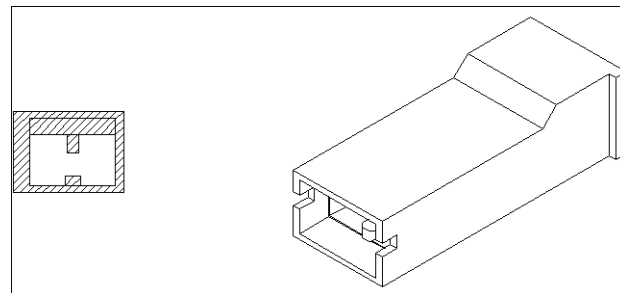

87691062 18

**CONNECTOR X-467 - Front loader latch switch – Lighting (Hydrac)**

CONNECTOR X-467 - Front loader latch switch – Lighting (Hydrac)			
PIN NUMBER	WIRE NUMBER	CIRCUIT REFERENCE	ELECTRICAL SCHEMATIC FRAME
1	FL-1013NC (RD)	SP-1013N X-467 Front loader latch switch – Lighting (Hydrac)	Wiring harnesses - Electrical schematic sheet 15 (55.100)
2	FL-057CP (BK)	SP-057CL X-467 Front loader latch switch – Lighting (Hydrac)	

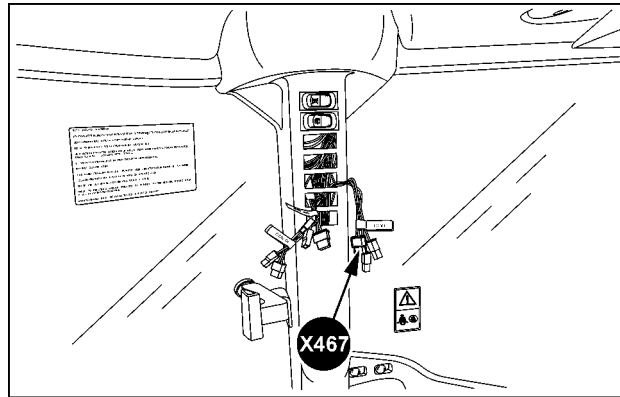

SVIL13TR00878AI 19

**Left-hand B-pillar**

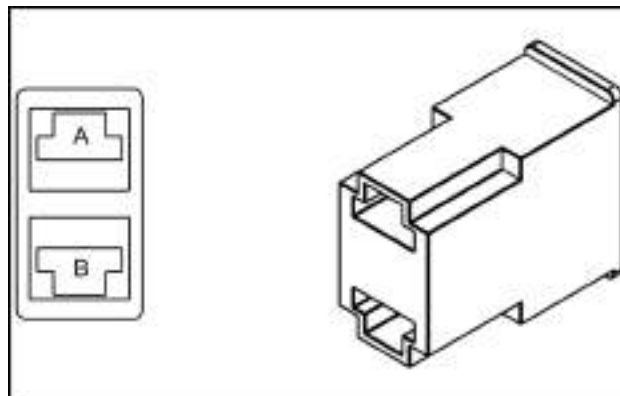

84146684 20

**CONNECTOR X-468 - Front loader harness (Hydrac) to front loader socket (Hydrac)**

CONNECTOR X-468 - Front loader harness (Hydrac) to front loader socket (Hydrac)			
PIN NUMBER	WIRE NUMBER	CIRCUIT REFERENCE	ELECTRICAL SCHEMATIC FRAME
1	FL-3281A (GN)	SP-3281 X-468 Front loader harness (Hydrac) to front loader socket (Hydrac)	<b>Wiring harnesses - Electrical schematic sheet 15 (55.100)</b>
2	FL-3281B (GN)	SP-3281 X-468 Front loader harness (Hydrac) to front loader socket (Hydrac)	
3	FL-3281C (GN)	SP-3281 X-468 Front loader harness (Hydrac) to front loader socket (Hydrac)	
4	FL-3278 (GN)	X-464B Front loader switch (Hydrac) X-468 Front loader harness (Hydrac) to front loader socket (Hydrac)	
5	FL-3274B (RD)	X-468 Front loader harness (Hydrac) to front loader socket (Hydrac) SP-3274	
6	FL-3272B (OR)	X-468 Front loader harness (Hydrac) to front loader socket (Hydrac) SP-3272	

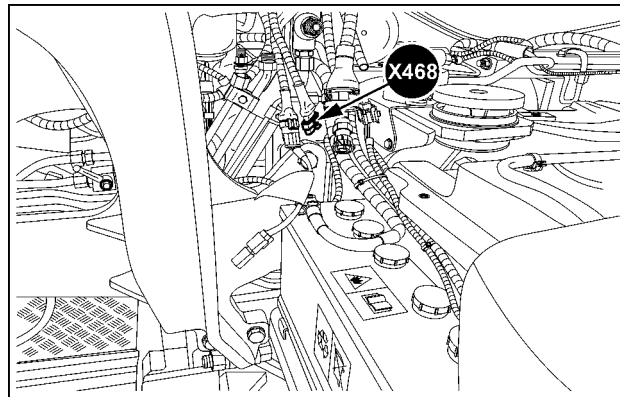

SVIL13TR00879AB 21

**Rear left-hand engine**

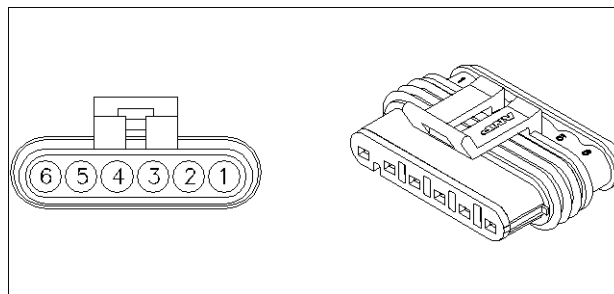

87710588 22

**CONNECTOR X-468A - Front loader harness (Hydrac) to front loader socket (Hydrac)**

CONNECTOR X-468A - Front loader harness (Hydrac) to front loader socket (Hydrac)			
PIN NUMBER	WIRE NUMBER	CIRCUIT REFERENCE	ELECTRICAL SCHEMATIC FRAME
1	FL-3276A (GN)	X-468A Front loader harness (Hydrac) to front loader socket (Hydrac) SP-3276	<b>Wiring harnesses - Electrical schematic sheet 15 (55.100)</b>
2	FL-3277A (GN)	X-468A Front loader harness (Hydrac) to front loader socket (Hydrac) SP-3277	
3	FL-057M (BK)	X-471 Ground connection front loader (Hydrac) X-468A Front loader harness (Hydrac) to front loader socket (Hydrac)	
4	FL-3275 (BL)	X-461 Front loader diode pack (Hydrac) X-468A Front loader harness (Hydrac) to front loader socket (Hydrac)	

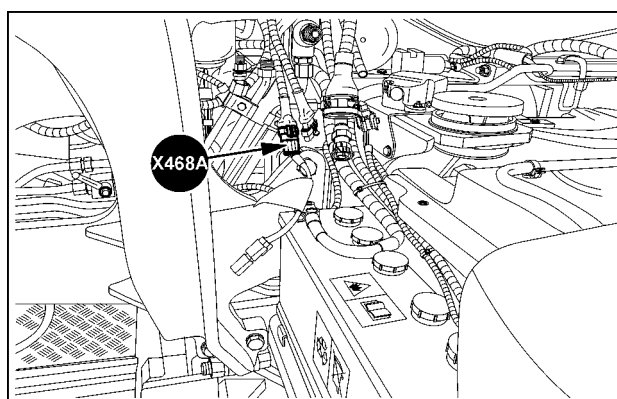

SVIL13TR00879AC 23

**Rear left-hand engine**

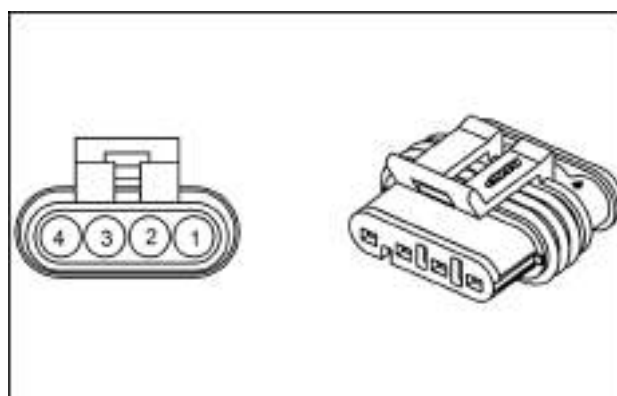

87687242 24

**CONNECTOR X-469 - Front loader relay – Valve 1**

CONNECTOR X-469 - Front loader relay – Valve 1			
PIN NUMBER	WIRE NUMBER	CIRCUIT REFERENCE	ELECTRICAL SCHEMATIC FRAME
30	FL-010HH (GN)	X-469 Front loader relay – Valve 1 SP-010HA	<b>Wiring harnesses - Electrical schematic sheet 15 (55.100)</b>
85	FL-057CS (BK)	X-469 Front loader relay – Valve 1 SP-057CL	
86	FL-3279A (BL)	X-469 Front loader relay – Valve 1 SP-3279	
87	FL-3272 (OR)	X-469 Front loader relay – Valve 1 SP-3272	

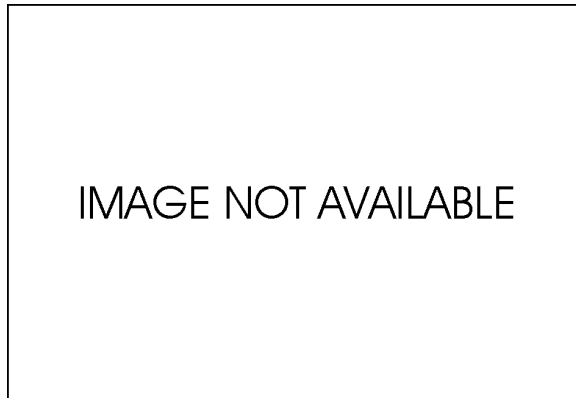

INA 25

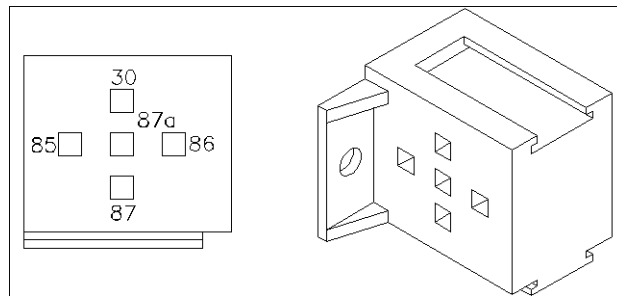

87746018 26

## Wire connectors - Component diagram 47

### CONNECTOR X-470 - Front loader relay – Valve 2

CONNECTOR X-470 - Front loader relay – Valve 2			
PIN NUMBER	WIRE NUMBER	CIRCUIT REFERENCE	ELECTRICAL SCHEMATIC FRAME
30	FL-010HG (GN)	X-470 Front loader relay – Valve 2 SP-010HA	Wiring harnesses - Electrical schematic sheet 15 (55.100)
85	FL-057CR (BK)	X-470 Front loader relay – Valve 2 SP-057CL	
86	FL-3280A (BL)	X-470 Front loader relay – Valve 2 SP-3280	
87	FL-3274 (RD)	X-470 Front loader relay – Valve 2 SP-3274	

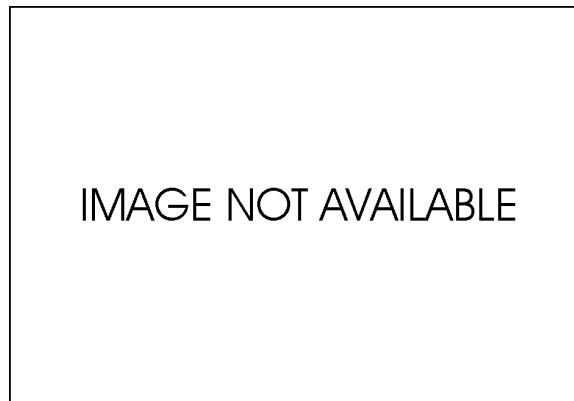

INA 1

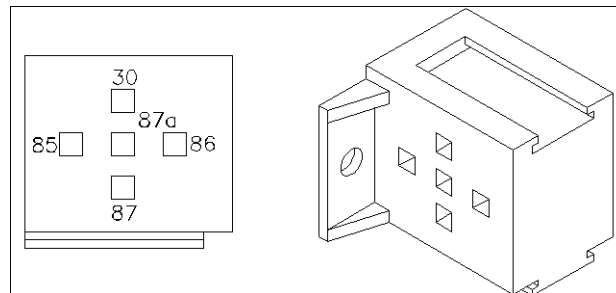

87746018 2

**CONNECTOR X-471 - Ground connection front loader (Hydrac)**

CONNECTOR X-471 - Ground connection front loader (Hydrac)			
PIN NUMBER	WIRE NUMBER	CIRCUIT REFERENCE	ELECTRICAL SCHEMATIC FRAME
1	FL-057M (BK)	X-471 Ground connection front loader (Hydrac) X-468A Front loader harness (Hydrac) to front loader socket (Hydrac)	<b>Wiring harnesses - Electrical schematic sheet 15 (55.100)</b>

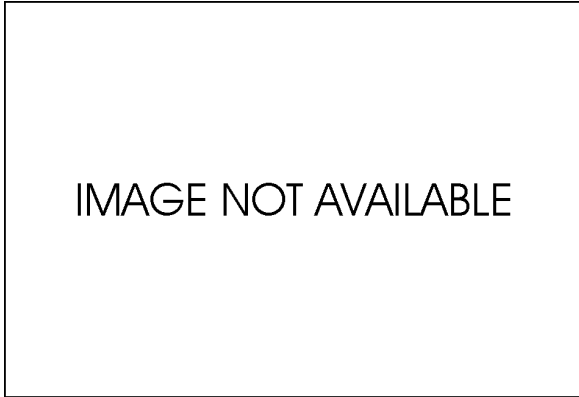

INA 3



REF: 55

BRI4404B 4

## Wire connectors - Component diagram 50

### CONNECTOR X-500 - Battery terminal (positive)

CONNECTOR X-500 - Battery terminal (positive)			
PIN NUMBER	WIRE NUMBER	CIRCUIT REFERENCE	ELECTRICAL SCHEMATIC FRAME
1	BT-001B (BL) BT-001 (BK)	X-500 Battery terminal (positive) X-552 Permanent battery power supply (main fuse) X-009 Battery isolator	Wiring harnesses - Electrical schematic sheet 01 (55.100)

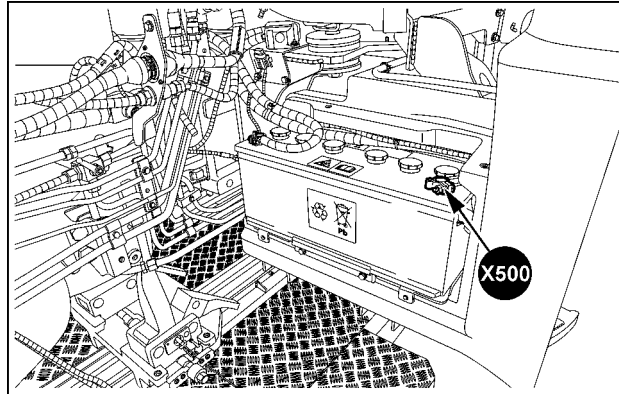

SVIL13TR00796AB 1

Rear left-hand engine

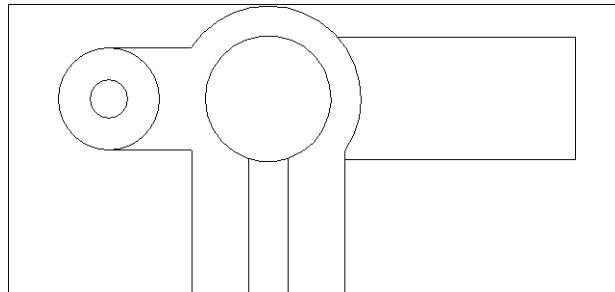

82863787 2



**CONNECTOR X-501 - Power socket 40 A – Cab outside**

CONNECTOR X-501 - Power socket 40 A – Cab outside			
PIN NUMBER	WIRE NUMBER	CIRCUIT REFERENCE	ELECTRICAL SCHEMATIC FRAME
1	CM-010N (GN) IS-010N (GN)	X-501 Power socket 40 A – Cab outside X-130 Fuse block (F-001 to F-032) X-501 Power socket 40 A – Cab outside X-505 Implement Socket Rear	<b>Wiring harnesses - Electrical schematic sheet 23 (55.100)</b>
2	CM-151M (GN) IS-151M (GN)	X-501 Power socket 40 A – Cab outside X-130 Fuse block (F-001 to F-032) X-501 Power socket 40 A – Cab outside X-505 Implement Socket Rear	
4	CM-057DG (BK) IS-057DG (BK)	SP-057D CAB GND X-501 Power socket 40 A – Cab outside X-501 Power socket 40 A – Cab outside X-505 Implement Socket Rear	

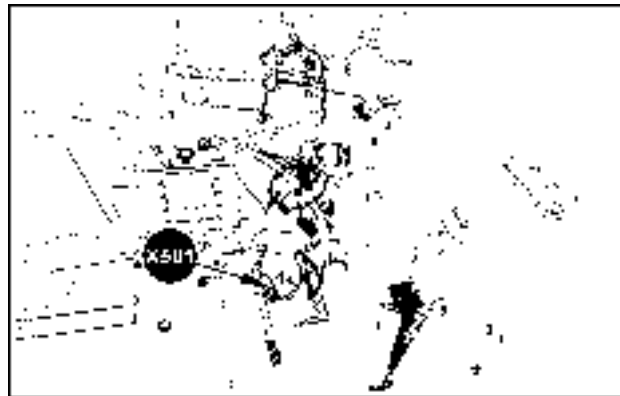

SVIL13TR00772AF 3

**Right-hand bottom rear tractor cab**

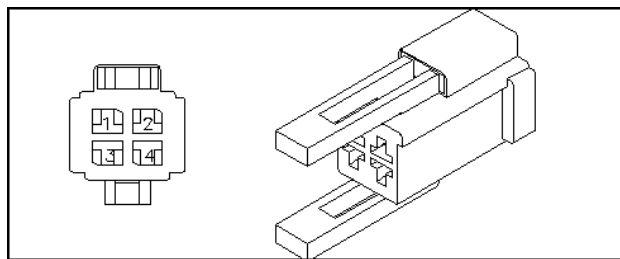

87714267 4

**CONNECTOR X-504 - Transmission Control Unit (TCU)**

<b>CONNECTOR X-504 - Transmission Control Unit (TCU)</b>				
<b>PIN NUMBER</b>	<b>WIRE NUMBER</b>	<b>CIRCUIT REFERENCE</b>	<b>ELECTRICAL SCHEMATIC FRAME</b>	
1	CM-057DK (BK)	X-504 Transmission Control Unit (TCU) SP-057D CAB GND	<b>Wiring harnesses - Electrical schematic sheet 07 (55.100)</b> <b>Wiring harnesses - Electrical schematic sheet 08 (55.100)</b> <b>Wiring harnesses - Electrical schematic sheet 10 (55.100)</b> <b>Wiring harnesses - Electrical schematic sheet 24 (55.100)</b>	
2	CM-057DL (BK)	X-504 Transmission Control Unit (TCU) SP-057D CAB GND		
3	CM-060J (BK/WH)	X-504 Transmission Control Unit (TCU) X-300 Cab main harness to transmission harness		
4	-	-		
5	-	-		
6	-	-		
7	-	-		
8	CM-7901 (OR)	X-300 Cab main harness to transmission harness X-504 Transmission Control Unit (TCU)		
9	-	-		
10	CM-7910 (VT)	X-504 Transmission Control Unit (TCU) X-300 Cab main harness to transmission harness		
11	CM-7080 (LG)	X-300 Cab main harness to transmission harness X-504 Transmission Control Unit (TCU)		
12	-	-		
13	CM-7907 (OR)	X-300 Cab main harness to transmission harness X-504 Transmission Control Unit (TCU)		<b>Wiring harnesses - Electrical schematic sheet 07 (55.100)</b> <b>Wiring harnesses - Electrical schematic sheet 08 (55.100)</b> <b>Wiring harnesses - Electrical schematic sheet 10 (55.100)</b> <b>Wiring harnesses - Electrical schematic sheet 24 (55.100)</b>
14	-	-		
15	CM-6418A (PK)	X-067 Diagnostic socket (ZF) X-504 Transmission Control Unit (TCU)		
16	CM-2140 (OR)	X-504 Transmission Control Unit (TCU) X-300 Cab main harness to transmission harness		
17	CM-6000 (PK)	X-504 Transmission Control Unit (TCU) X-300 Cab main harness to transmission harness		
18	CM-7876 (GN)	X-067 Diagnostic socket (ZF) X-504 Transmission Control Unit (TCU)		
19	CM-7250 (GY)	X-504 Transmission Control Unit (TCU) SP-7250		
20	CM-7260B (GY)	SP-7260 X-504 Transmission Control Unit (TCU)		
21	CM-7210 (PK)	X-170 Multicontroller X-504 Transmission Control Unit (TCU)		
22	CM-9269A (WH)	X-504 Transmission Control Unit (TCU) X-319 Clutch pedal switch – Start interlock		

<b>CONNECTOR X-504 - Transmission Control Unit (TCU)</b>			
<b>PIN NUMBER</b>	<b>WIRE NUMBER</b>	<b>CIRCUIT REFERENCE</b>	<b>ELECTRICAL SCHEMATIC FRAME</b>
23	CM-155DA (GN)	SP-155D X-504 Transmission Control Unit (TCU)	<b>Wiring harnesses - Electrical schematic sheet 07 (55.100)</b>
24	CM-060F (BK/WH)	X-504 Transmission Control Unit (TCU) SP-060F	
25	CM-191CZ (YE)	SP-191C X-504 Transmission Control Unit (TCU)	
26	CM-190CZ (GN)	SP-190C X-504 Transmission Control Unit (TCU)	
27	-	-	
28	-	-	
29	CM-4002 (RD)	X-504 Transmission Control Unit (TCU) X-300 Cab main harness to transmission harness	
30	-	-	
31	CM-2058 (WH)	X-220 Central Control Unit (CCU) – CN2 X-504 Transmission Control Unit (TCU)	
32	CM-7920 (VT)	X-504 Transmission Control Unit (TCU) X-300 Cab main harness to transmission harness	
33	-	-	<b>Wiring harnesses - Electrical schematic sheet 07 (55.100)</b>
34	-	-	
35	CM-7800 (VT)	X-170 Multicontroller X-504 Transmission Control Unit (TCU)	
36	-	-	
37	CM-7525 (GN)	X-504 Transmission Control Unit (TCU) SP-7525	
38	CM-7430 (BK/WH)	X-322 Clutch pedal sensor X-504 Transmission Control Unit (TCU)	
39	CM-7500 (GN)	X-504 Transmission Control Unit (TCU) X-300 Cab main harness to transmission harness	
40	CM-2145 (OR)	X-504 Transmission Control Unit (TCU) X-300 Cab main harness to transmission harness	
41	CM-7265 (PK)	X-504 Transmission Control Unit (TCU) SP-7265	
42	CM-7260 (GY)	X-504 Transmission Control Unit (TCU) SP-7260	
43	CM-5560 (YE)	X-170 Multicontroller X-504 Transmission Control Unit (TCU)	
44	CM-9269 (WH)	X-181 Clutch pedal switch – Transmission X-504 Transmission Control Unit (TCU)	

<b>CONNECTOR X-504 - Transmission Control Unit (TCU)</b>				
<b>PIN NUMBER</b>	<b>WIRE NUMBER</b>	<b>CIRCUIT REFERENCE</b>	<b>ELECTRICAL SCHEMATIC FRAME</b>	
45	CM-010EA (GN)	X-504 Transmission Control Unit (TCU) SP-010E	<b>Wiring harnesses - Electrical schematic sheet 07 (55.100)</b> <b>Wiring harnesses - Electrical schematic sheet 08 (55.100)</b> <b>Wiring harnesses - Electrical schematic sheet 10 (55.100)</b> <b>Wiring harnesses - Electrical schematic sheet 24 (55.100)</b>	
46	-	-		
47	CM-291ZF (RD)	X-504 Transmission Control Unit (TCU) X-067 Diagnostic socket (ZF)		
48	CM-290ZF (BL)	X-504 Transmission Control Unit (TCU) X-067 Diagnostic socket (ZF)		
49	-	-		
50	CM-7930 (VT)	X-504 Transmission Control Unit (TCU) X-300 Cab main harness to transmission harness		
51	CM-2042 (OR)	X-300 Cab main harness to transmission harness X-504 Transmission Control Unit (TCU)		
52	-	-		
53	-	-		
54	CM-7904 (VT)	X-300 Cab main harness to transmission harness X-504 Transmission Control Unit (TCU)		
55	CM-7902 (VT)	X-504 Transmission Control Unit (TCU) X-300 Cab main harness to transmission harness		<b>Wiring harnesses - Electrical schematic sheet 07 (55.100)</b> <b>Wiring harnesses - Electrical schematic sheet 08 (55.100)</b> <b>Wiring harnesses - Electrical schematic sheet 10 (55.100)</b> <b>Wiring harnesses - Electrical schematic sheet 24 (55.100)</b>
56	CM-7900 (VT)	X-504 Transmission Control Unit (TCU) X-300 Cab main harness to transmission harness		
57	CM-3024 (YE)	X-300 Cab main harness to transmission harness X-504 Transmission Control Unit (TCU)		
58	-	-		
59	CM-7700 (TN)	X-170 Multicontroller X-504 Transmission Control Unit (TCU)		
60	-	-		
61	CM-7245A (TN)	X-504 Transmission Control Unit (TCU) X-318 Shuttle lever		
62	CM-7400 (YE)	X-504 Transmission Control Unit (TCU) X-300 Cab main harness to transmission harness		
63	CM-7250B (GY)	SP-7250 X-504 Transmission Control Unit (TCU)		
64	CM-7246 (TN)	X-182 Auto-shift programming switch X-504 Transmission Control Unit (TCU)		
65	CM-7265B (PK)	SP-7265 X-504 Transmission Control Unit (TCU)	<b>Wiring harnesses - Electrical schematic sheet 07 (55.100)</b> <b>Wiring harnesses - Electrical schematic sheet 08 (55.100)</b> <b>Wiring harnesses - Electrical schematic sheet 10 (55.100)</b> <b>Wiring harnesses - Electrical schematic sheet 24 (55.100)</b>	
66	CM-7200 (GY)	X-170 Multicontroller X-504 Transmission Control Unit (TCU)		
67	CM-2055 (WH)	X-504 Transmission Control Unit (TCU) X-183 Ground speed Power Take-Off (PTO) – Stationary operation switch		
68	CM-155DB (GN)	SP-155D X-504 Transmission Control Unit (TCU)		

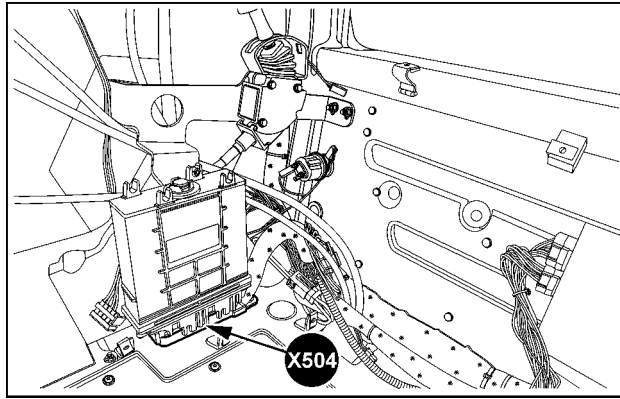

SVIL13TR00756AD 5

**Right-hand bottom rear tractor cab**

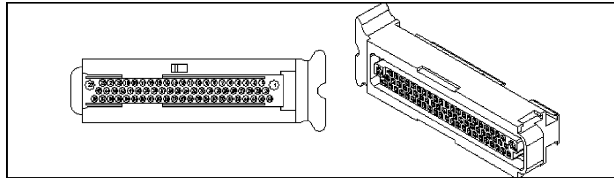

84550089 6

**CONNECTOR X-506 - Power socket 40 A – Front**

<b>CONNECTOR X-506 - Power socket 40 A – Front</b>			
<b>PIN NUMBER</b>	<b>WIRE NUMBER</b>	<b>CIRCUIT REFERENCE</b>	<b>ELECTRICAL SCHEMATIC FRAME</b>
31	SK-4024 (BK)	X-434 GND 1 X-506 Power socket 40 A – Front	<b>Wiring harnesses - Electrical schematic sheet 23 (55.100)</b>
82	SK-010K (GN)	SP-020A +KEY 15 X-506 Power socket 40 A – Front	
15/30	SK-4032 (RD)	X-507 POWER SOCKET + X-506 Power socket 40 A – Front	

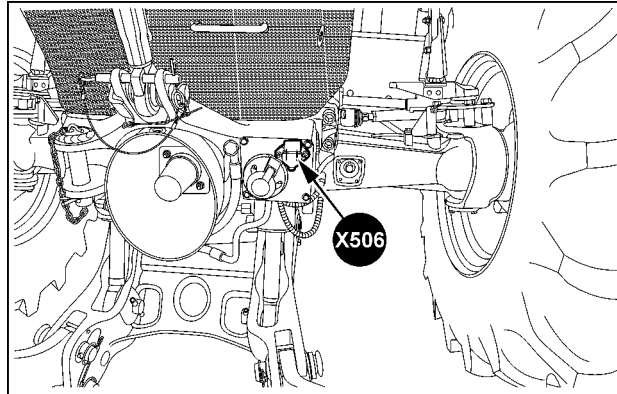

SVIL13TR00753AC 7

**Left-hand front hitch**

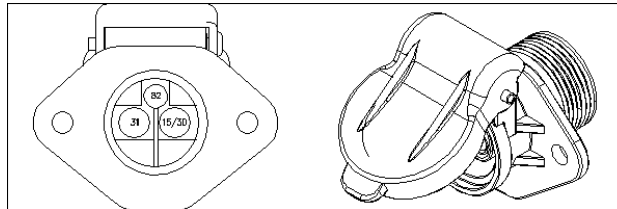

84415676 8

**CONNECTOR X-507 - POWER SOCKET +**

CONNECTOR X-507 - POWER SOCKET +			
PIN NUMBER	WIRE NUMBER	CIRCUIT REFERENCE	ELECTRICAL SCHEMATIC FRAME
2	SK-4032 (RD)	X-507 POWER SOCKET + X-506 Power socket 40 A – Front	

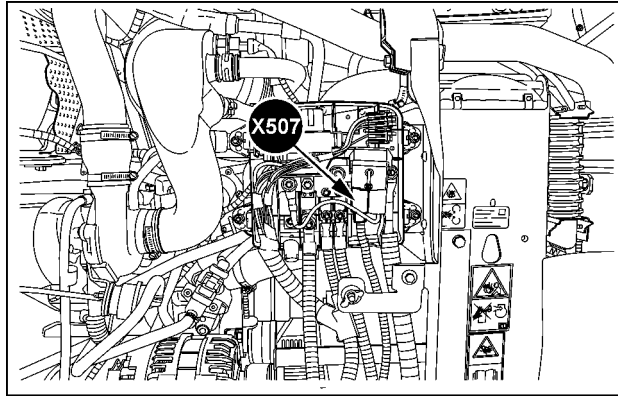

SVIL13TR00795AD 9

**Front top right-hand engine**

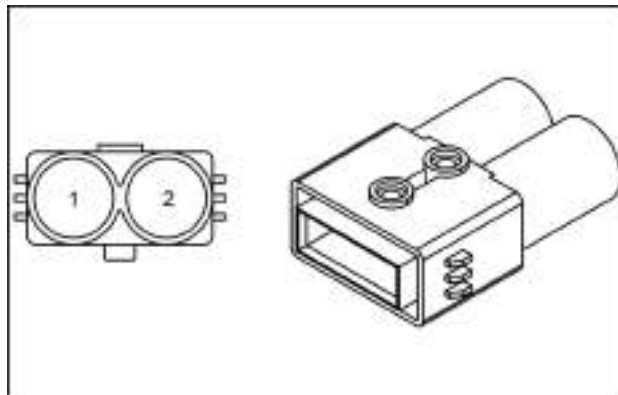

84247654 10

**CONNECTOR X-509 - Ignition switch (battery power supply)**

CONNECTOR X-509 - Ignition switch (battery power supply)			
PIN NUMBER	WIRE NUMBER	CIRCUIT REFERENCE	ELECTRICAL SCHEMATIC FRAME
1	CM-001DD (RD)	SP-001D X-509 Ignition switch (battery power supply)	Wiring harnesses - Electrical schematic sheet 02 (55.100)

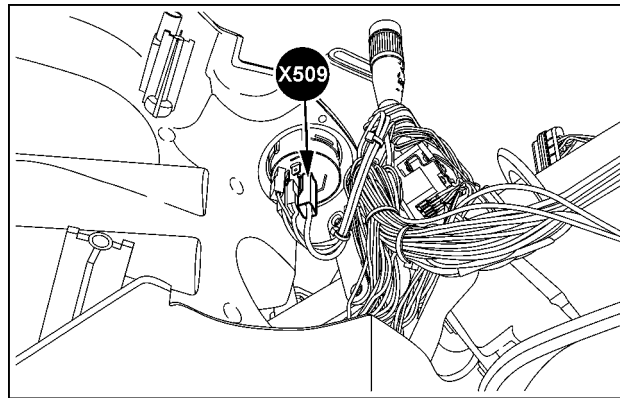

SVIL13TR00797AB 11

**Steering console**

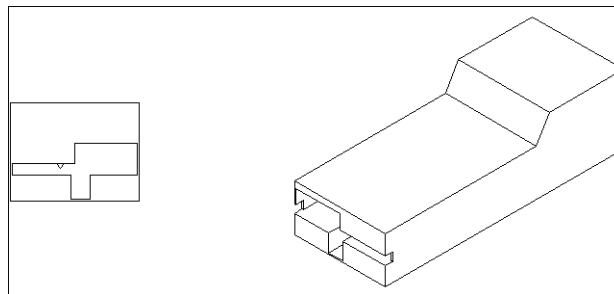

87747155 12



## Wire connectors - Component diagram 51

### CONNECTOR X-510 - Ignition switch (switched battery power supply)

CONNECTOR X-510 - Ignition switch (switched battery power supply)			
PIN NUMBER	WIRE NUMBER	CIRCUIT REFERENCE	ELECTRICAL SCHEMATIC FRAME
1	CM-071A (WH)	X-510 Ignition switch (switched battery power supply) SP-071	Wiring harnesses - Electrical schematic sheet 02 (55.100)

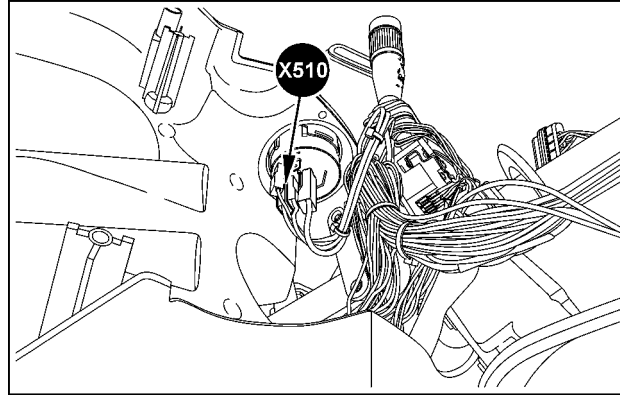

SVIL13TR00797AC 1

**Steering console**

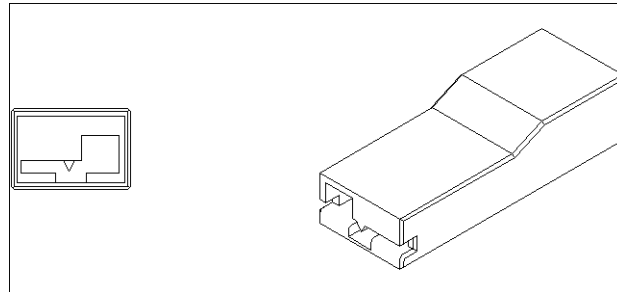

87705127 2

**CONNECTOR X-511 - Ignition switch (switched battery power supply)**

CONNECTOR X-511 - Ignition switch (switched battery power supply)			
PIN NUMBER	WIRE NUMBER	CIRCUIT REFERENCE	ELECTRICAL SCHEMATIC FRAME
1	CM-071 (WH)	X-511 Ignition switch (switched battery power supply) SP-071	Wiring harnesses - Electrical schematic sheet 02 (55.100)

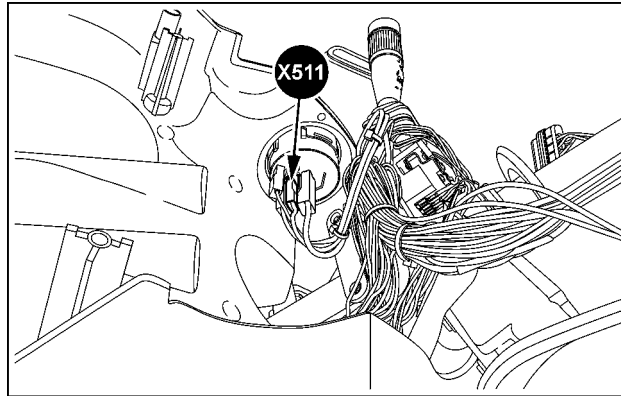

SVIL13TR00797AD 3

**Steering console**

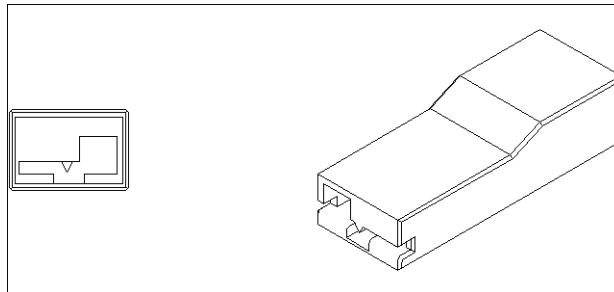

87705127 4

**CONNECTOR X-512 - Ignition switch (cranking)**

CONNECTOR X-512 - Ignition switch (cranking)			
PIN NUMBER	WIRE NUMBER	CIRCUIT REFERENCE	ELECTRICAL SCHEMATIC FRAME
1	CM-1000 (WH)	X-512 Ignition switch (cranking) X-130 Fuse block (F-001 to F-032)	<b>Wiring harnesses - Electrical schematic sheet 02 (55.100)</b>

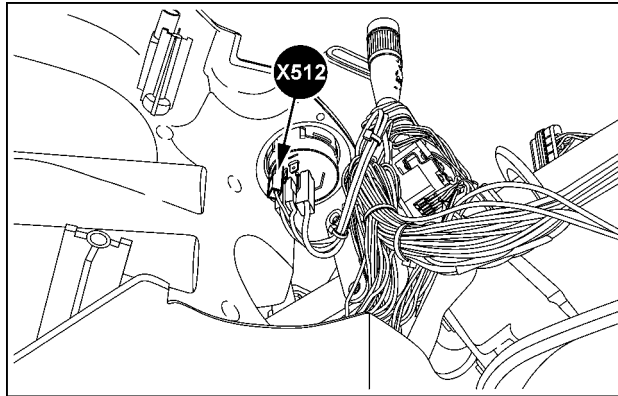

SVIL13TR00797AE 5

**Steering console**

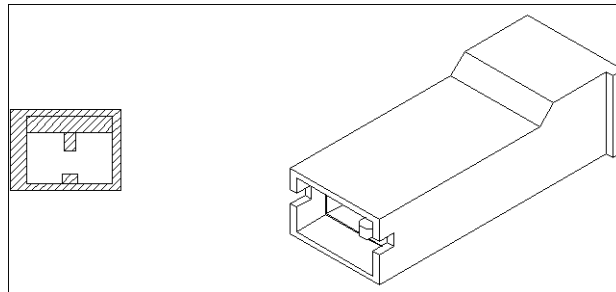

87691062 6

**CONNECTOR X-517 - Front hitch switch – Auto/manual raise mode**

<b>CONNECTOR X-517 - Front hitch switch – Auto/manual raise mode</b>			
<b>PIN NUMBER</b>	<b>WIRE NUMBER</b>	<b>CIRCUIT REFERENCE</b>	<b>ELECTRICAL SCHEMATIC FRAME</b>
1	EF-5597 (GY)	X-525 Front hitch electronic control panel X-517 Front hitch switch – Auto/manual raise mode	<b>Wiring harnesses - Electrical schematic sheet 14 (55.100)</b>
2	EF-2578 (PK)	X-517 Front hitch switch – Auto/manual raise mode X-951 Front hitch raise relay	
3	EF-2800 (VT)	X-517 Front hitch switch – Auto/manual raise mode X-525 Front hitch electronic control panel	
7	EF-057KJ (BK)	X-517 Front hitch switch – Auto/manual raise mode SP-057K GND	
8	EF-1013BF (RD)	SP-1013B BACK LIGHT X-517 Front hitch switch – Auto/manual raise mode	
9	EF-057KN (BK)	SP-057K GND X-517 Front hitch switch – Auto/manual raise mode	
10	EF-1013BE (RD)	SP-1013B BACK LIGHT X-517 Front hitch switch – Auto/manual raise mode	

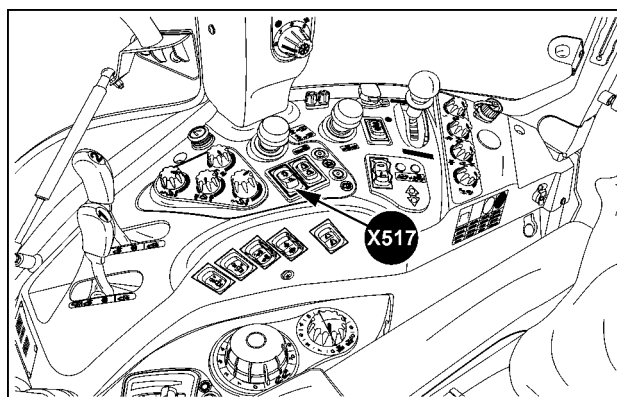

SVIL13TR00706AN 7

**Cab right-hand side**

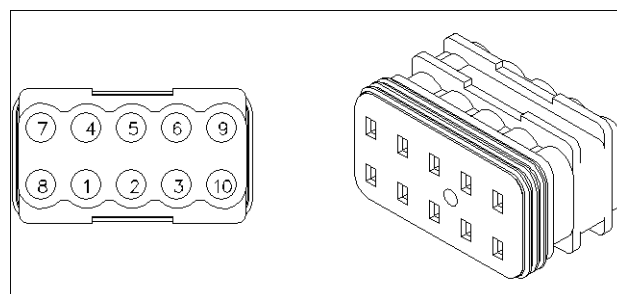

84819781 8

**CONNECTOR X-519 - Front hitch up/down switch – Cab inside**

CONNECTOR X-519 - Front hitch up/down switch – Cab inside			
PIN NUMBER	WIRE NUMBER	CIRCUIT REFERENCE	ELECTRICAL SCHEMATIC FRAME
1	EF-2588A (VT)	SP-2588 X-519 Front hitch up/down switch – Cab inside	<b>Wiring harnesses - Electrical schematic sheet 14 (55.100)</b>
2	EF-2587A (BR)	SP-2587 X-519 Front hitch up/down switch – Cab inside	
3	EF-2589A (TN)	SP-2589 X-519 Front hitch up/down switch – Cab inside	
7	EF-057KA (BK)	SP-057K GND X-519 Front hitch up/down switch – Cab inside	
8	EF-1013BC (RD)	SP-1013B BACK LIGHT X-519 Front hitch up/down switch – Cab inside	
9	EF-057KB (BK)	X-519 Front hitch up/down switch – Cab inside SP-057K GND	
10	EF-1013BB (RD)	SP-1013B BACK LIGHT X-519 Front hitch up/down switch – Cab inside	

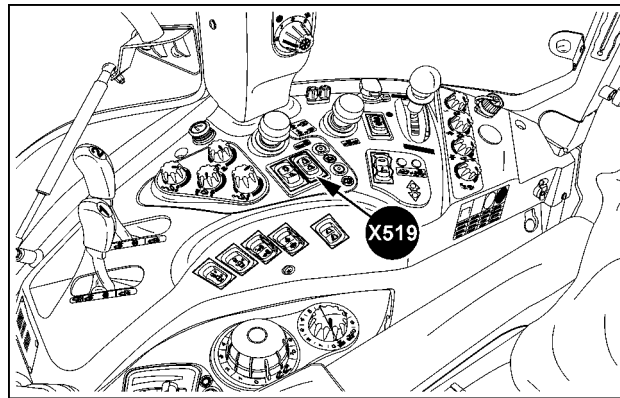

SVIL13TR00706AO 9

**Cab right-hand side**

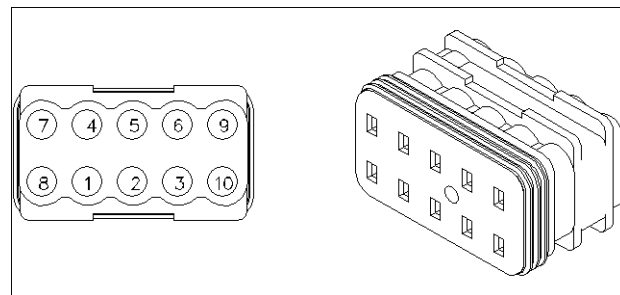

84819781 10

## Wire connectors - Component diagram 52

### CONNECTOR X-520 - Front hitch up/down switch – External

CONNECTOR X-520 - Front hitch up/down switch – External			
PIN NUMBER	WIRE NUMBER	CIRCUIT REFERENCE	ELECTRICAL SCHEMATIC FRAME
1	EN-5555 (BL)	X-001 Cab main harness to engine harness 1 X-520 Front hitch up/down switch – External	<b>Wiring harnesses - Electrical schematic sheet 13 (55.100)</b>
2	EN-5260H (TN)	X-001 Cab main harness to engine harness 1 X-520 Front hitch up/down switch – External	
3	EN-5556 (RD)	X-001 Cab main harness to engine harness 1 X-520 Front hitch up/down switch – External	

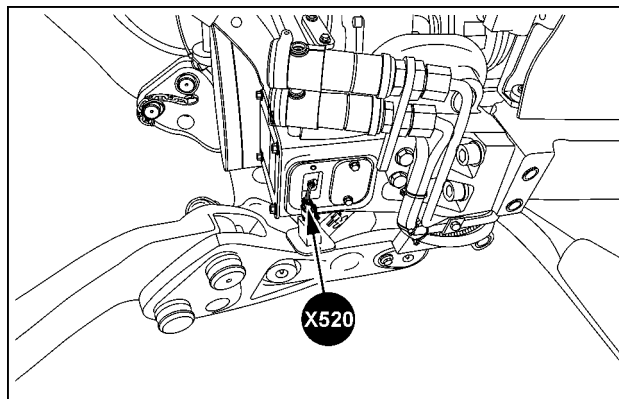

SVIL13TR00818AB 1

**Left-hand front hitch**

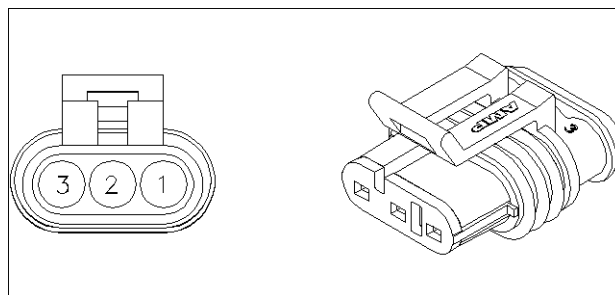

84062580 2

**CONNECTOR X-521 - Front hitch up/down switch – External**

CONNECTOR X-521 - Front hitch up/down switch – External			
PIN NUMBER	WIRE NUMBER	CIRCUIT REFERENCE	ELECTRICAL SCHEMATIC FRAME
1	FH-2588B (VT)	X-373 Electronic Front Hitch (EFH) control unit harness to front hitch harness X-521 Front hitch up/down switch – External	<b>Wiring harnesses - Electrical schematic sheet 14 (55.100)</b>
2	FH-2587B (BR)	X-373 Electronic Front Hitch (EFH) control unit harness to front hitch harness X-521 Front hitch up/down switch – External	
3	FH-2586B (BR)	X-373 Electronic Front Hitch (EFH) control unit harness to front hitch harness X-521 Front hitch up/down switch – External	

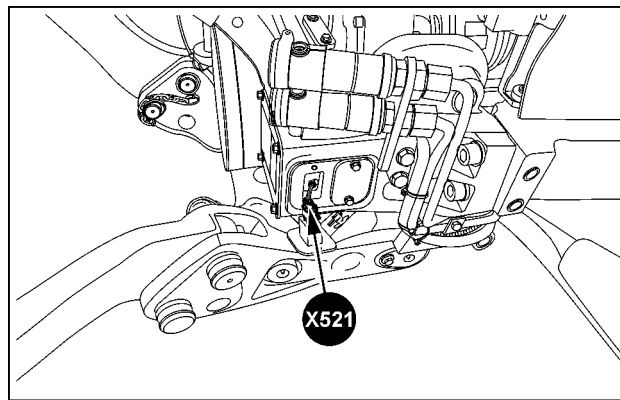

SVIL13TR00818AC 3

**Left-hand front hitch**

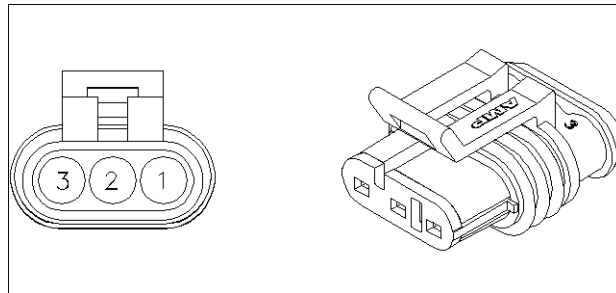

84062580 4

**CONNECTOR X-524 - Electronic Front Hitch (EFH) control unit**

<b>CONNECTOR X-524 - Electronic Front Hitch (EFH) control unit</b>				
<b>PIN NUMBER</b>	<b>WIRE NUMBER</b>	<b>CIRCUIT REFERENCE</b>	<b>ELECTRICAL SCHEMATIC FRAME</b>	
2	EF-2605 (RD)	X-525 Front hitch electronic control panel X-524 Electronic Front Hitch (EFH) control unit	<b>Wiring harnesses - Electrical schematic sheet 14 (55.100)</b> <b>Wiring harnesses - Electrical schematic sheet 24 (55.100)</b>	
3	EF-2604 (GN)	X-525 Front hitch electronic control panel X-524 Electronic Front Hitch (EFH) control unit		
4	EF-2603 (GN)	X-525 Front hitch electronic control panel X-524 Electronic Front Hitch (EFH) control unit		
8	EF-2597 (VT)	X-524 Electronic Front Hitch (EFH) control unit X-527 Front hitch pressure sensor		
9	EF-2587 (BR)	SP-2587 X-524 Electronic Front Hitch (EFH) control unit		
12	EF-2572 (GN)	X-650_EFH+ Front hitch indicator lights X-524 Electronic Front Hitch (EFH) control unit		
13	EF-1006A (BR)	X-944 Cab main harness to Electronic Front Hitch (EFH) control unit harness X-524 Electronic Front Hitch (EFH) control unit		
15	EF-2598 (GY)	X-525 Front hitch electronic control panel X-524 Electronic Front Hitch (EFH) control unit		
16	EF-2599 (GN)	X-525 Front hitch electronic control panel X-524 Electronic Front Hitch (EFH) control unit		<b>Wiring harnesses - Electrical schematic sheet 14 (55.100)</b> <b>Wiring harnesses - Electrical schematic sheet 24 (55.100)</b>
17	EF-2588 (VT)	SP-2588 X-524 Electronic Front Hitch (EFH) control unit		
19	EF-2580 (RD)	X-524 Electronic Front Hitch (EFH) control unit X-529 Front hitch – Lower solenoid valve		
20	EF-060MA (BK/WH)	SP-060M EFH-SENSOR GND X-524 Electronic Front Hitch (EFH) control unit		
21	EF-2602 (PK)	X-953 Front hitch lock relay X-524 Electronic Front Hitch (EFH) control unit		
22	EF-2597A (GN)	X-525 Front hitch electronic control panel X-524 Electronic Front Hitch (EFH) control unit		
23	EF-5405 (GN)	X-524 Electronic Front Hitch (EFH) control unit X-525 Front hitch electronic control panel		
24	EF-011AB (GN)	SP-011AA EFH MASTER X-524 Electronic Front Hitch (EFH) control unit		



<b>CONNECTOR X-524 - Electronic Front Hitch (EFH) control unit</b>			
<b>PIN NUMBER</b>	<b>WIRE NUMBER</b>	<b>CIRCUIT REFERENCE</b>	<b>ELECTRICAL SCHEMATIC FRAME</b>
25	EF-2594 (OR)	X-373 Electronic Front Hitch (EFH) control unit harness to front hitch harness X-524 Electronic Front Hitch (EFH) control unit	<b>Wiring harnesses - Electrical schematic sheet 14 (55.100)</b> <b>Wiring harnesses - Electrical schematic sheet 24 (55.100)</b>
28	EF-057KD (BK)	X-524 Electronic Front Hitch (EFH) control unit SP-057K GND	
29	EF-155LA (GN)	SP-155L X-524 Electronic Front Hitch (EFH) control unit	
31	EF-2577 (VT)	X-524 Electronic Front Hitch (EFH) control unit X-650_DIAG+ Front hitch indicator lights	
35	EF-2571 (GY)	X-524 Electronic Front Hitch (EFH) control unit X-528 Front hitch – Raise solenoid valve	
36	EF-2589 (TN)	X-524 Electronic Front Hitch (EFH) control unit SP-2589	
37	EF-2570 (RD)	X-524 Electronic Front Hitch (EFH) control unit X-528 Front hitch – Raise solenoid valve	<b>Wiring harnesses - Electrical schematic sheet 14 (55.100)</b> <b>Wiring harnesses - Electrical schematic sheet 24 (55.100)</b>
38	EF-060L (BK/WH)	X-524 Electronic Front Hitch (EFH) control unit SP-060L	
39	EF-2601 (OR)	X-524 Electronic Front Hitch (EFH) control unit SP-2601	
46	EF-057KC (BK)	X-524 Electronic Front Hitch (EFH) control unit SP-057K GND	
47	EF-155LB (GN)	SP-155L X-524 Electronic Front Hitch (EFH) control unit	
50	EF-191ZA (YE)	X-944 Cab main harness to Electronic Front Hitch (EFH) control unit harness X-524 Electronic Front Hitch (EFH) control unit	
52	EF-190ZA (GN)	X-944 Cab main harness to Electronic Front Hitch (EFH) control unit harness X-524 Electronic Front Hitch (EFH) control unit	
53	EF-2581 (GY)	X-524 Electronic Front Hitch (EFH) control unit X-529 Front hitch – Lower solenoid valve	

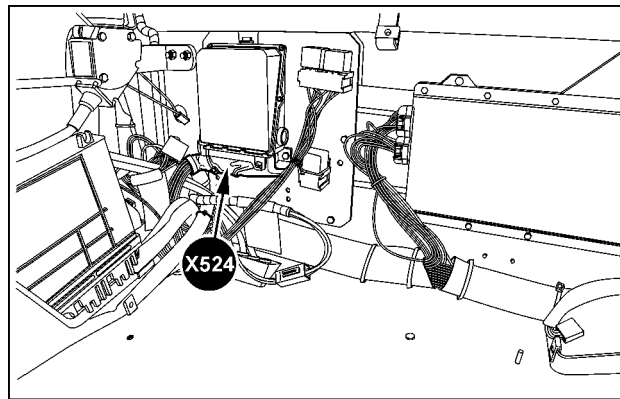

SVIL13TR00882AB 5

**In cab right-hand behind operator's seat**

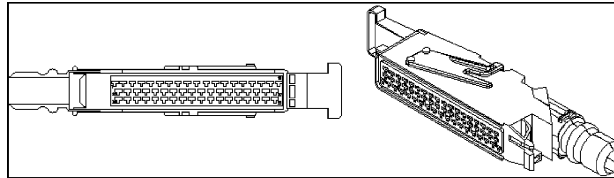

87713934 6

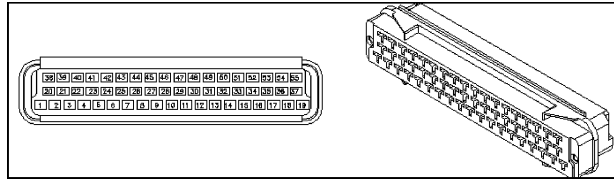

87705965 7

**CONNECTOR X-525 - Front hitch electronic control panel**

<b>CONNECTOR X-525 - Front hitch electronic control panel</b>				
<b>PIN NUMBER</b>	<b>WIRE NUMBER</b>	<b>CIRCUIT REFERENCE</b>	<b>ELECTRICAL SCHEMATIC FRAME</b>	
2	EF-057K (BK)	SP-057K GND X-525 Front hitch electronic control panel	<b>Wiring harnesses - Electrical schematic sheet 14 (55.100)</b>	
3	EF-011AC (GN)	SP-011AA EFH MASTER X-525 Front hitch electronic control panel		
4	EF-1013BD (RD)	SP-1013B BACK LIGHT X-525 Front hitch electronic control panel		
5	EF-2598 (GY)	X-525 Front hitch electronic control panel X-524 Electronic Front Hitch (EFH) control unit		
6	EF-2599 (GN)	X-525 Front hitch electronic control panel X-524 Electronic Front Hitch (EFH) control unit		
7	EF-2599A (BR)	X-525 Front hitch electronic control panel X-531 Front hitch solenoid valve – Accumulator (40 bar)		
8	EF-2598A (GY)	X-525 Front hitch electronic control panel X-530 Front hitch solenoid valve – Accumulator (14 bar)		
9	EF-060M (BK/WH)	X-525 Front hitch electronic control panel SP-060M EFH-SENSOR GND		
10	EF-2574 (WH)	X-525 Front hitch electronic control panel SP-2574 EFH-MODE		
11	EF-2605 (RD)	X-525 Front hitch electronic control panel X-524 Electronic Front Hitch (EFH) control unit		<b>Wiring harnesses - Electrical schematic sheet 14 (55.100)</b>
13	EF-5597 (GY)	X-525 Front hitch electronic control panel X-517 Front hitch switch – Auto/manual raise mode		
14	EF-2800 (VT)	X-517 Front hitch switch – Auto/manual raise mode X-525 Front hitch electronic control panel		
15	EF-2597A (GN)	X-525 Front hitch electronic control panel X-524 Electronic Front Hitch (EFH) control unit		
16	EF-2604 (GN)	X-525 Front hitch electronic control panel X-524 Electronic Front Hitch (EFH) control unit		
17	EF-5405 (GN)	X-524 Electronic Front Hitch (EFH) control unit X-525 Front hitch electronic control panel		
18	EF-2603 (GN)	X-525 Front hitch electronic control panel X-524 Electronic Front Hitch (EFH) control unit		
20	EF-2576 (WH)	X-525 Front hitch electronic control panel X-952 Front hitch lower relay		

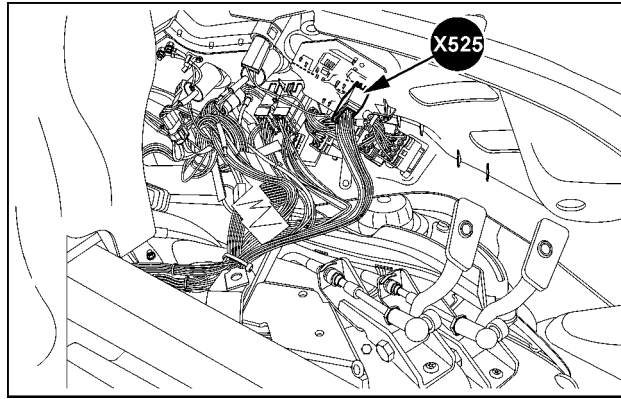

SVIL13TR00819AB 8

**Behind right-hand switch panel**

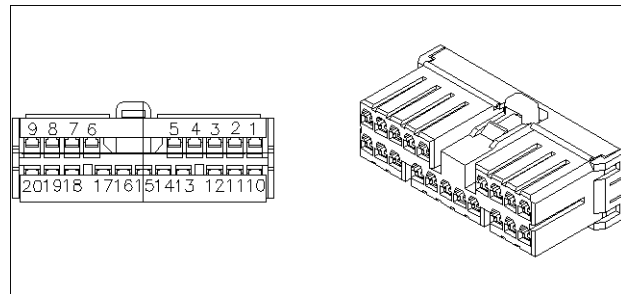

87689502 9

**CONNECTOR X-526 - Front hitch position sensor**

<b>CONNECTOR X-526 - Front hitch position sensor</b>			
<b>PIN NUMBER</b>	<b>WIRE NUMBER</b>	<b>CIRCUIT REFERENCE</b>	<b>ELECTRICAL SCHEMATIC FRAME</b>
1	FI-060LA (BK/WH)	X-526 Front hitch position sensor X-373 Electronic Front Hitch (EFH) control unit harness to front hitch harness	<b>Wiring harnesses - Electrical schematic sheet 14 (55.100)</b>
2	FI-2594 (OR)	X-526 Front hitch position sensor X-373 Electronic Front Hitch (EFH) control unit harness to front hitch harness	
3	FI-2601B (VT)	X-526 Front hitch position sensor X-373 Electronic Front Hitch (EFH) control unit harness to front hitch harness	

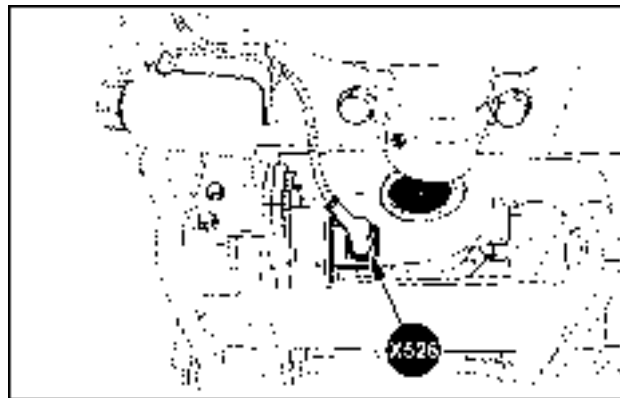

SVIL13TR00820AB 10

**Left-hand underside front hitch**

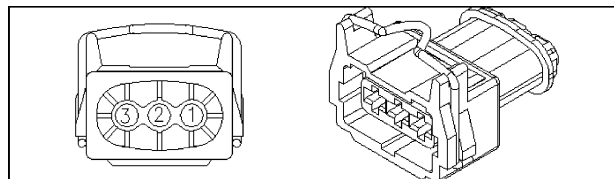

87705966 11

**CONNECTOR X-527 - Front hitch pressure sensor**

CONNECTOR X-527 - Front hitch pressure sensor			
PIN NUMBER	WIRE NUMBER	CIRCUIT REFERENCE	ELECTRICAL SCHEMATIC FRAME
1	EF-060LD (BK/WH)	SP-060L X-527 Front hitch pressure sensor	Wiring harnesses - Electrical schematic sheet 14 (55.100)
2	EF-2597 (VT)	X-524 Electronic Front Hitch (EFH) control unit X-527 Front hitch pressure sensor	
3	EF-2601A (OR)	SP-2601 X-527 Front hitch pressure sensor	

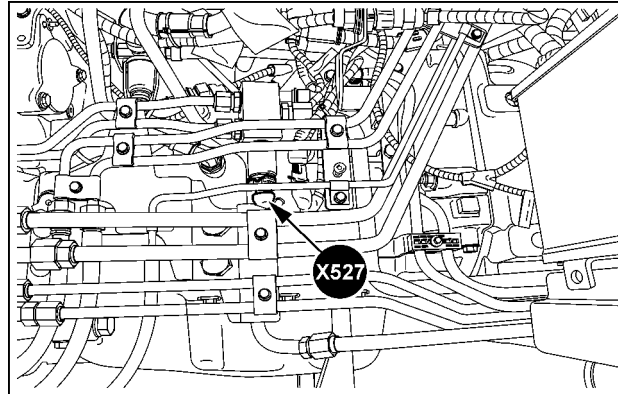

SVIL13TR00872AC 12

**Rear left-hand engine**

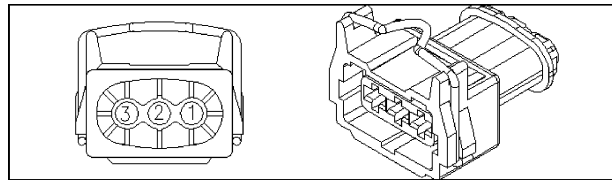

87705966 13

**CONNECTOR X-528 - Front hitch – Raise solenoid valve**

CONNECTOR X-528 - Front hitch – Raise solenoid valve			
PIN NUMBER	WIRE NUMBER	CIRCUIT REFERENCE	ELECTRICAL SCHEMATIC FRAME
1	EF-2570 (RD)	X-524 Electronic Front Hitch (EFH) control unit X-528 Front hitch – Raise solenoid valve	<b>Wiring harnesses - Electrical schematic sheet 14 (55.100)</b>
2	EF-2571 (GY)	X-524 Electronic Front Hitch (EFH) control unit X-528 Front hitch – Raise solenoid valve	

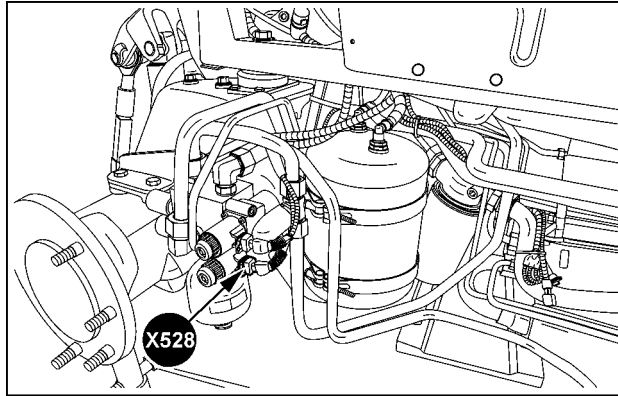

SVIL13TR00821AB 14

**Right-hand rear axle**

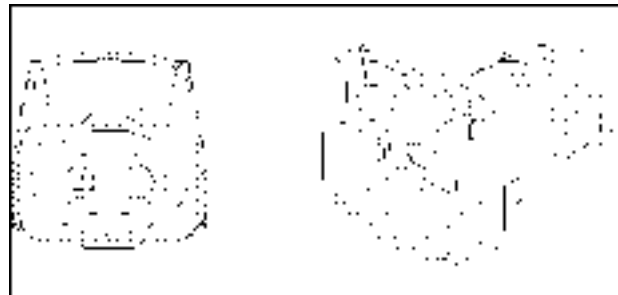

87747163 15

**CONNECTOR X-529 - Front hitch – Lower solenoid valve**

<b>CONNECTOR X-529 - Front hitch – Lower solenoid valve</b>			
<b>PIN NUMBER</b>	<b>WIRE NUMBER</b>	<b>CIRCUIT REFERENCE</b>	<b>ELECTRICAL SCHEMATIC FRAME</b>
1	EF-2580 (RD)	X-524 Electronic Front Hitch (EFH) control unit X-529 Front hitch – Lower solenoid valve	<b>Wiring harnesses - Electrical schematic sheet 14 (55.100)</b>
2	EF-2581 (GY)	X-524 Electronic Front Hitch (EFH) control unit X-529 Front hitch – Lower solenoid valve	

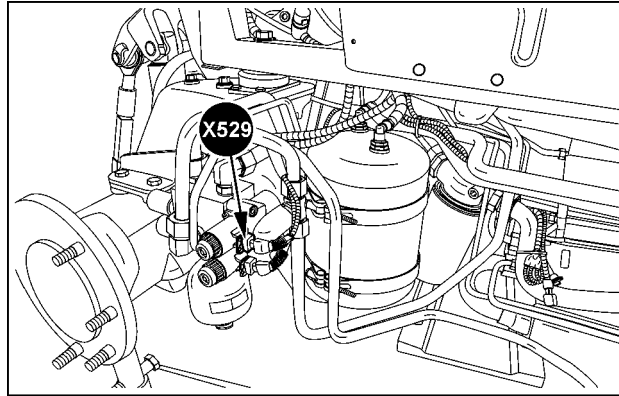

SVIL13TR00821AC 16

**Right-hand rear axle**

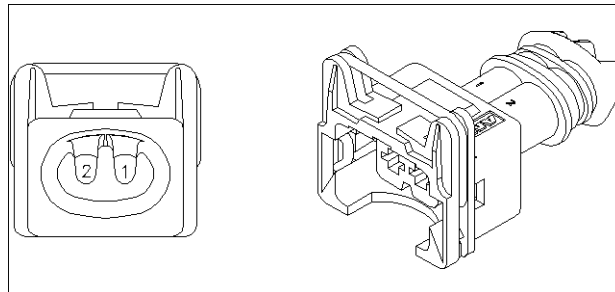

84607243 17



## Wire connectors - Component diagram 53

### CONNECTOR X-530 - Front hitch solenoid valve – Accumulator (14 bar)

CONNECTOR X-530 - Front hitch solenoid valve – Accumulator (14 bar)			
PIN NUMBER	WIRE NUMBER	CIRCUIT REFERENCE	ELECTRICAL SCHEMATIC FRAME
1	EF-2598A (GY)	X-525 Front hitch electronic control panel X-530 Front hitch solenoid valve – Accumulator (14 bar)	<b>Wiring harnesses - Electrical schematic sheet 14 (55.100)</b>
2	EF-060LC (BK/WH)	SP-060L X-530 Front hitch solenoid valve – Accumulator (14 bar)	

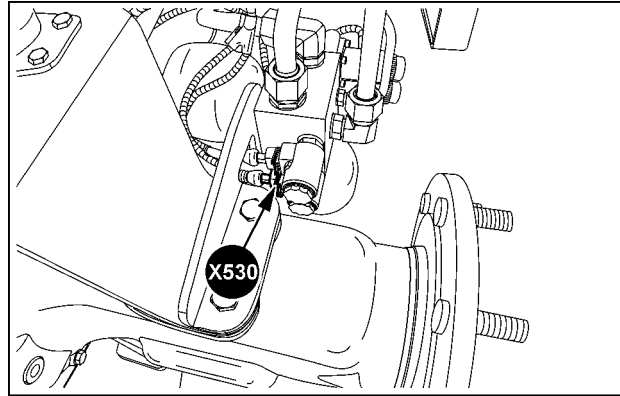

SVIL13TR00885AB 1

**Right-hand on the rear axle**

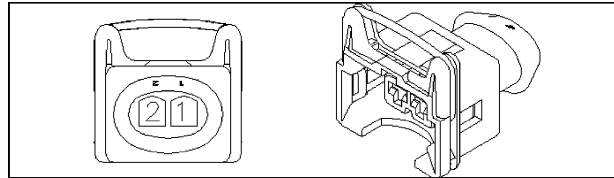

87699762 2

**CONNECTOR X-531 - Front hitch solenoid valve – Accumulator (40 bar)**

CONNECTOR X-531 - Front hitch solenoid valve – Accumulator (40 bar)			
PIN NUMBER	WIRE NUMBER	CIRCUIT REFERENCE	ELECTRICAL SCHEMATIC FRAME
1	EF-2599A (BR)	X-525 Front hitch electronic control panel X-531 Front hitch solenoid valve – Accumulator (40 bar)	<b>Wiring harnesses - Electrical schematic sheet 14 (55.100)</b>
2	EF-060LB (BK/WH)	X-531 Front hitch solenoid valve – Accumulator (40 bar) SP-060L	

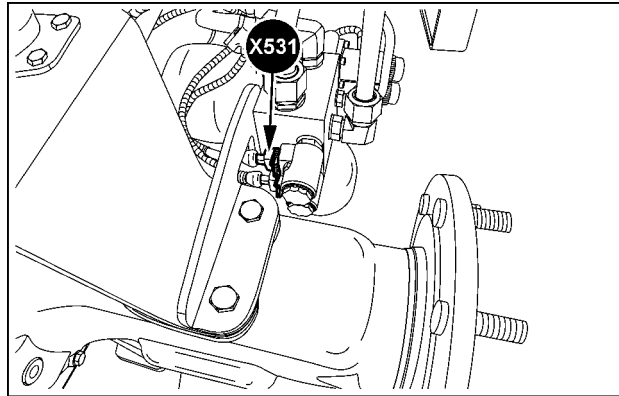

SVIL13TR00885AC 3

**Right-hand on the rear axle**

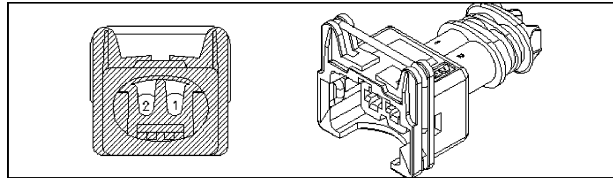

84475264 4

**CONNECTOR X-533 - Power distribution unit**

<b>CONNECTOR X-533 - Power distribution unit</b>			
<b>PIN NUMBER</b>	<b>WIRE NUMBER</b>	<b>CIRCUIT REFERENCE</b>	<b>ELECTRICAL SCHEMATIC FRAME</b>
K5_30	PD-001PA (RD)	SP-001 X-533 Power distribution unit	<b>Wiring harnesses - Electrical schematic sheet 01 (55.100)</b>
K5_85	PD-057FC (BK)	X-533 Power distribution unit X-002 Engine harness 1 to power distribution unit	
K5_86	PD-1001B (WH)	X-533 Power distribution unit X-002 Engine harness 1 to power distribution unit	
K5_87	PD-1001 (WH)	X-002 Engine harness 1 to power distribution unit X-533 Power distribution unit	
K13_30	PD-001PB (RD)	SP-001 X-533 Power distribution unit	
K13_85	PD-2070 (OR)	X-533 Power distribution unit X-002 Engine harness 1 to power distribution unit	
K13_86	PD-001PC (RD)	SP-001 X-533 Power distribution unit	
K13_87	PD-010P (GN)	X-533 Power distribution unit SP-002	

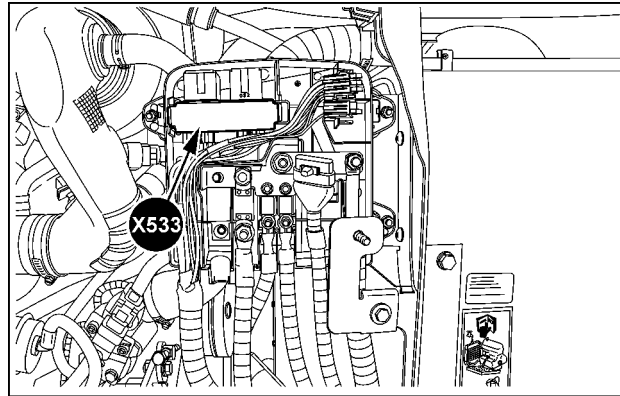

SVIL13TR00798AJ 5

**Front top right-hand engine**

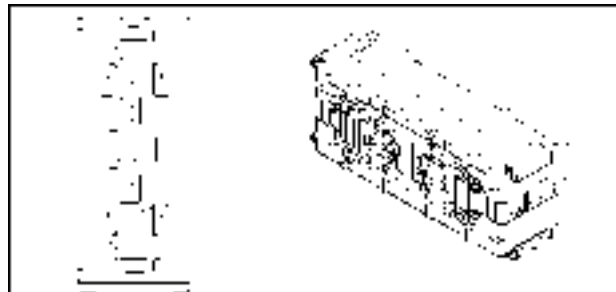

84405124 6

**CONNECTOR X-534 - Hitch indicator lights**

**Hitch lower indicator light**

CONNECTOR X-534 - Hitch indicator lights			
PIN NUMBER	WIRE NUMBER	CIRCUIT REFERENCE	ELECTRICAL SCHEMATIC FRAME
+	SP-5005AE (TN)	X-534 Hitch indicator lights SP-5005A POT 15 EDC	<b>Wiring harnesses - Electrical schematic sheet 11 (55.100)</b>
-	SP-5230 (YE)	X-405 Cab main harness to switch panel harness 2 X-534 Hitch indicator lights	

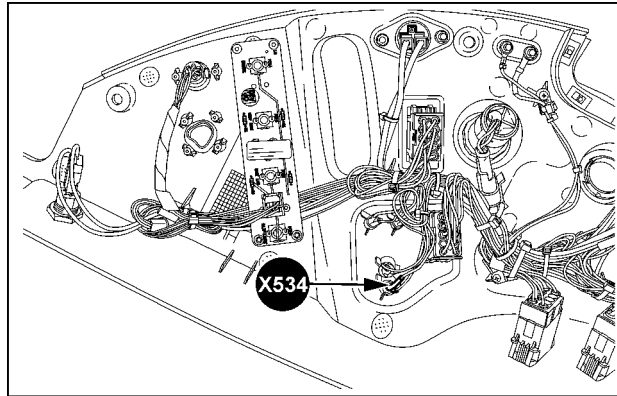

SVIL13TR00743AH 7

**Behind right-hand switch panel**

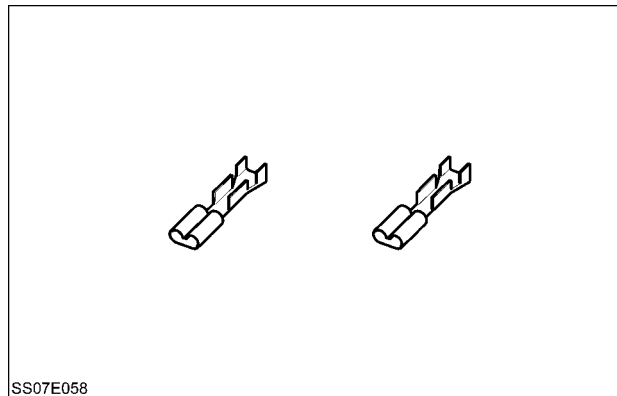

SS07E058 8

Hitch raise indicator light

CONNECTOR X-534 - Hitch indicator lights			
PIN NUMBER	WIRE NUMBER	CIRCUIT REFERENCE	ELECTRICAL SCHEMATIC FRAME
+	SP-5005AD (TN)	X-534 Hitch indicator lights SP-5005A POT 15 EDC	Wiring harnesses - Electrical schematic sheet 11 (55.100)
-	SP-5220 (YE)	X-405 Cab main harness to switch panel harness 2 X-534 Hitch indicator lights	

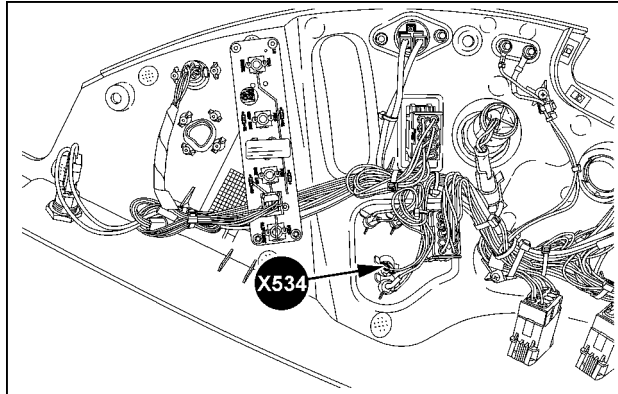

SVIL13TR00743AG 9

Behind right-hand switch panel

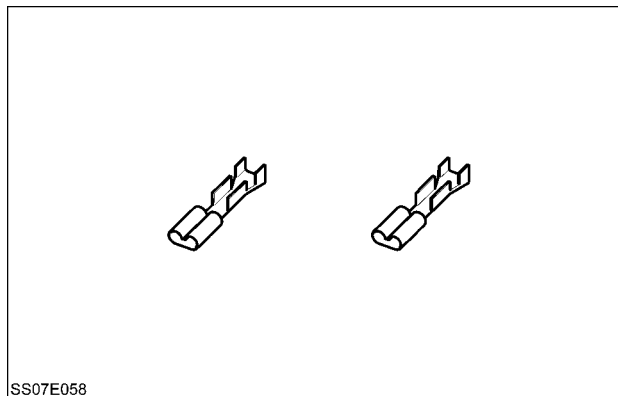

SS07E058

SS07E058 10

Slip control indicator light

CONNECTOR X-534 - Hitch indicator lights			
PIN NUMBER	WIRE NUMBER	CIRCUIT REFERENCE	ELECTRICAL SCHEMATIC FRAME
+	SP-5005AC (TN)	X-534 Hitch indicator lights SP-5005A POT 15 EDC	Wiring harnesses - Electrical schematic sheet 11 (55.100)
-	SP-5180 (VT)	X-405 Cab main harness to switch panel harness 2 X-534 Hitch indicator lights	

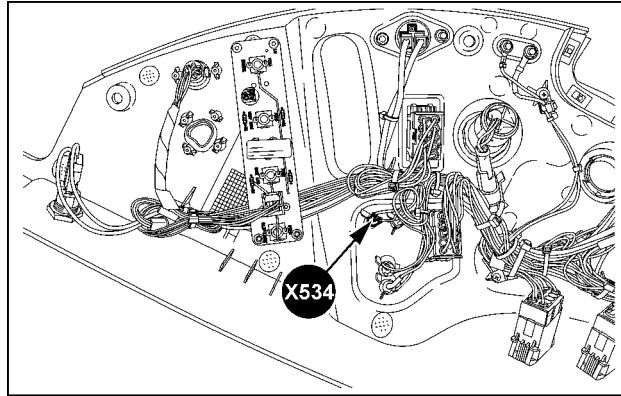

SVIL13TR00743AE 11

Behind right-hand switch panel

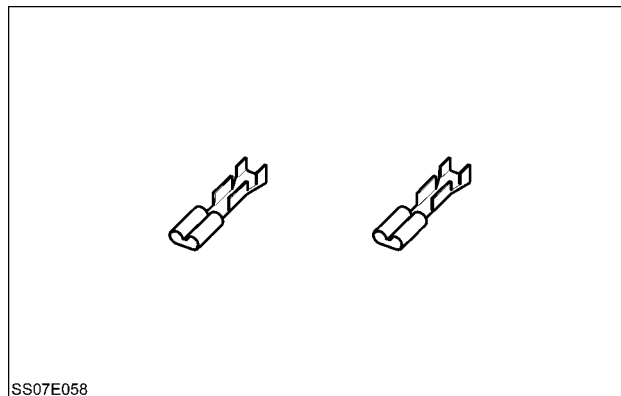

SS07E058

SS07E058 12

Hitch status indicator light

CONNECTOR X-534 - Hitch indicator lights			
PIN NUMBER	WIRE NUMBER	CIRCUIT REFERENCE	ELECTRICAL SCHEMATIC FRAME
+	SP-5005AB (TN)	X534 Hitch indicator lights SP-5005A POT 15 EDC	Wiring harnesses - Electrical schematic sheet 11 (55.100)
-	SP-5155 (GY)	X-405 Cab main harness to switch panel harness 2 X-534 Hitch indicator lights	

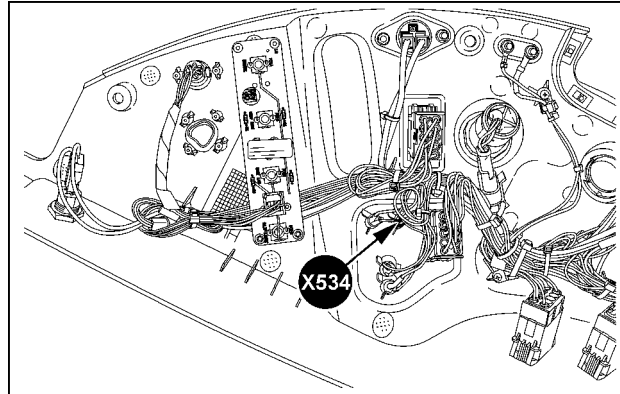

SVIL13TR00743AF 13

Behind right-hand switch panel

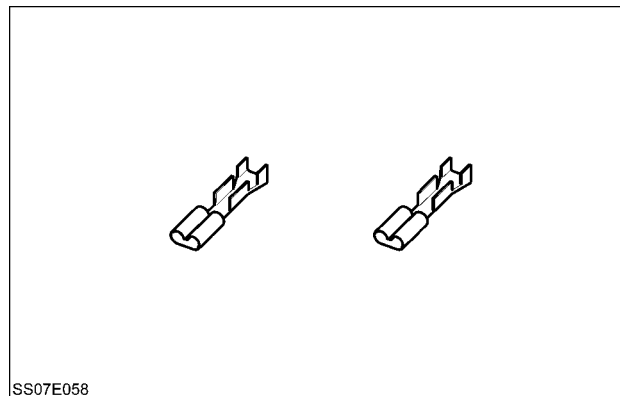

SS07E058

SS07E058 14

## Wire connectors - Component diagram 55

### CONNECTOR X-552 - Permanent battery power supply (main fuse)

CONNECTOR X-552 - Permanent battery power supply (main fuse)			
PIN NUMBER	WIRE NUMBER	CIRCUIT REFERENCE	ELECTRICAL SCHEMATIC FRAME
1	BT-001C (RD)	X-553 Battery harness to engine harness 1 (permanent battery power supply) X-552 Permanent battery power supply (main fuse)	Wiring harnesses - Electrical schematic sheet 01 (55.100)
2	BT-001B (BL)	X-500 Battery terminal (positive) X-552 Permanent battery power supply (main fuse)	

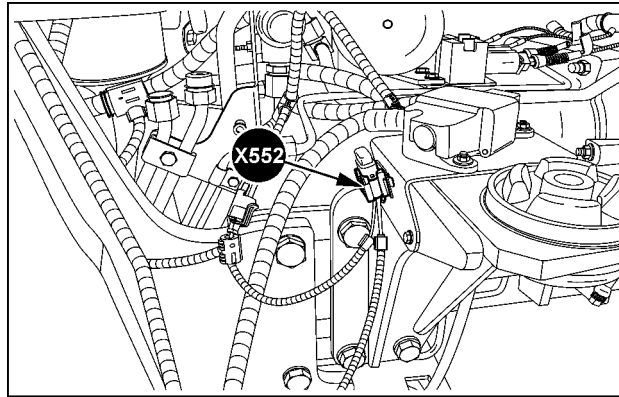

SVIL13TR00694AC 1

Left-hand behind steps

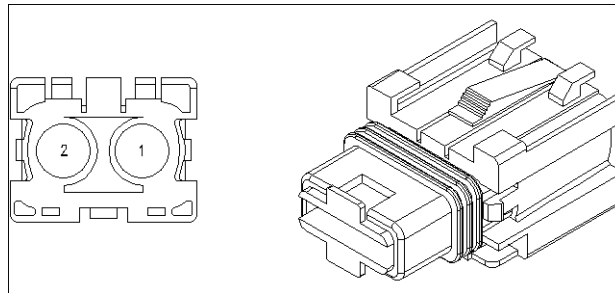

84175724 2



**CONNECTOR X-553 - Battery harness to engine harness 1 (permanent battery power supply)**

CONNECTOR X-553 - Battery harness to engine harness 1 (permanent battery power supply)			
PIN NUMBER	WIRE NUMBER	CIRCUIT REFERENCE	ELECTRICAL SCHEMATIC FRAME
1	BT-001C (RD) EN-001C (RD)	X-553 Battery harness to engine harness 1 (permanent battery power supply) X-552 Permanent battery power supply (main fuse) X-553 Battery harness to engine harness 1 (permanent battery power supply) X-001 Cab main harness to engine harness 1	<b>Wiring harnesses - Electrical schematic sheet 01 (55.100)</b>

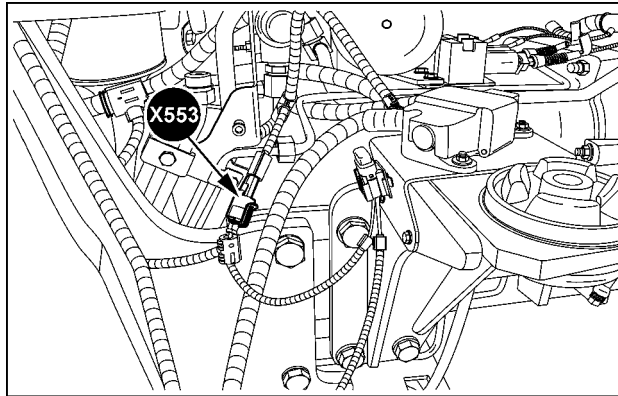

SVIL13TR00694AB 3

**Left-hand behind steps**

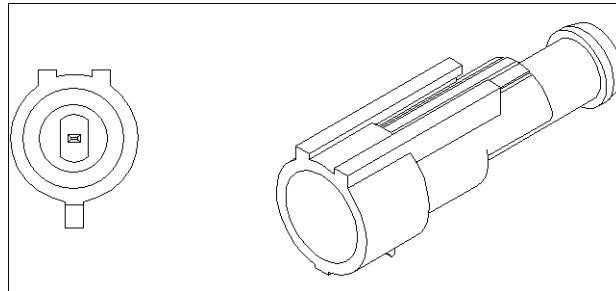

87679525 4

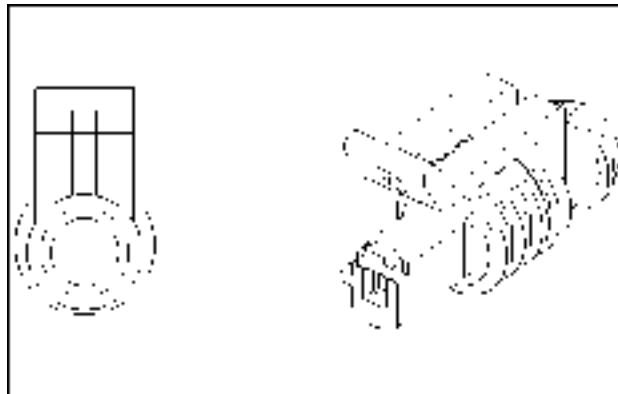

87687239 5

## Wire connectors - Component diagram 57

### CONNECTOR X-570 - Ground connection battery

CONNECTOR X-570 - Ground connection battery			
PIN NUMBER	WIRE NUMBER	CIRCUIT REFERENCE	ELECTRICAL SCHEMATIC FRAME
1	BT-057 (BK)	X-600 Battery terminal (ground) X-570 Ground connection battery	Wiring harnesses - Electrical schematic sheet 01 (55.100)

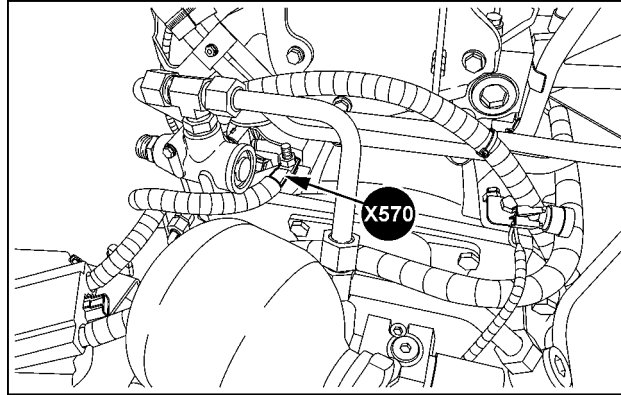

SVIL13TR00799AB 1

**Rear left-hand engine**

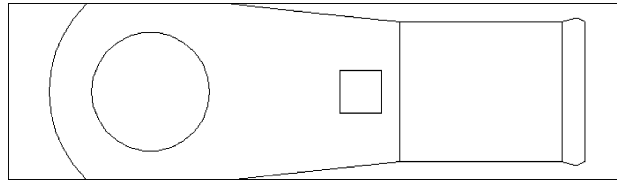

84278805\_1 2

## Wire connectors - Component diagram 60

### CONNECTOR X-600 - Battery terminal (ground)

CONNECTOR X-600 - Battery terminal (ground)			
PIN NUMBER	WIRE NUMBER	CIRCUIT REFERENCE	ELECTRICAL SCHEMATIC FRAME
1	BT-057 (BK)	X-600 Battery terminal (ground) X-570 Ground connection battery	Wiring harnesses - Electrical schematic sheet 01 (55.100)

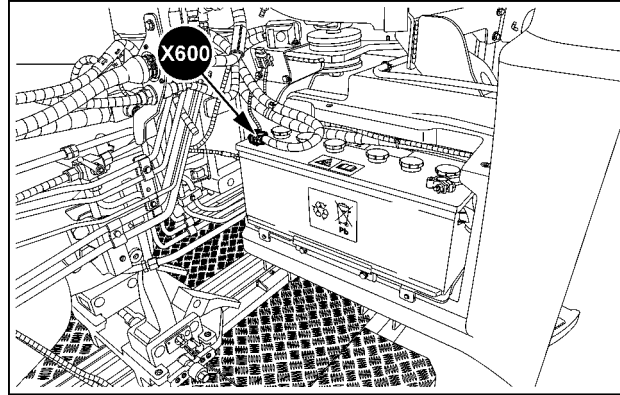

SVIL13TR00796AC 1

Rear left-hand engine

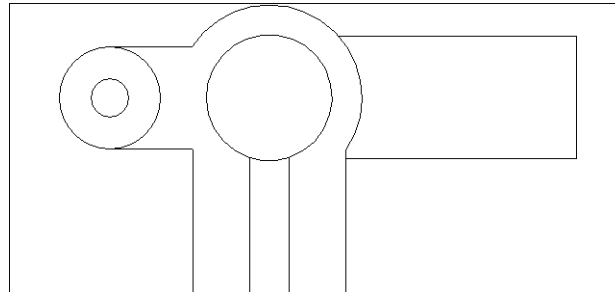

82032329 2

## Wire connectors - Component diagram 65

### CONNECTOR X-650 - Front hitch indicator lights

#### Front hitch diagnostic light

CONNECTOR X-650 - Front hitch indicator lights			
PIN NUMBER	WIRE NUMBER	CIRCUIT REFERENCE	ELECTRICAL SCHEMATIC FRAME
+	EF-2577 (VT)	X-524 Electronic Front Hitch (EFH) control unit X-650 Front hitch indicator lights	<b>Wiring harnesses - Electrical schematic sheet 14 (55.100)</b>
-	EF-060MB (BK/WH)	SP-060M EFH-SENSOR GND X-650 Front hitch indicator lights	

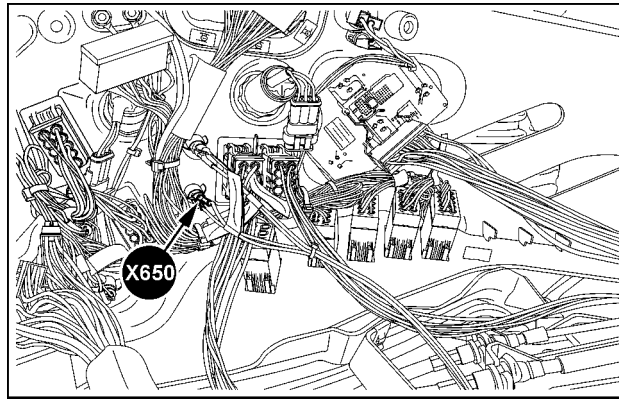

SVIL13TR00881AJ 1

On the right-hand trim behind switch panel

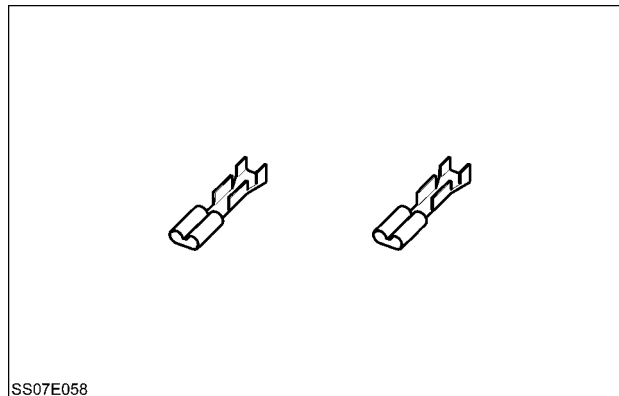

SS07E058

SS07E058 2

**Front hitch relief pressure – indicator light**

<b>CONNECTOR X-650 - Front hitch indicator lights</b>			
<b>PIN NUMBER</b>	<b>WIRE NUMBER</b>	<b>CIRCUIT REFERENCE</b>	<b>ELECTRICAL SCHEMATIC FRAME</b>
+	EF-2572 (GN)	X-650 Front hitch indicator lights X-524 Electronic Front Hitch (EFH) control unit	<b>Wiring harnesses - Electrical schematic sheet 14 (55.100)</b>
-	EF-060MC (BK/WH)	SP-060M EFH-SENSOR GND X-650 Front hitch indicator lights	

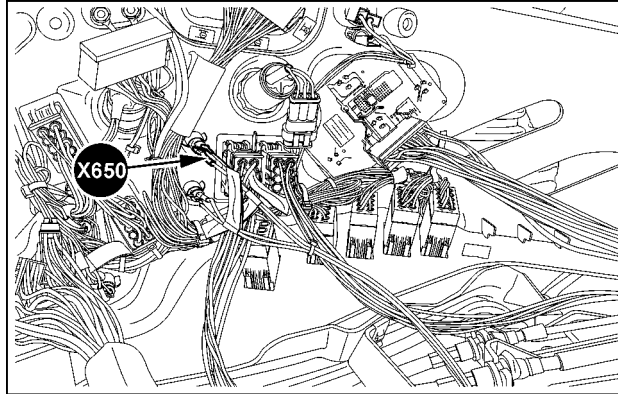

SVIL13TR00881AI 3

**On the right-hand trim behind switch panel**

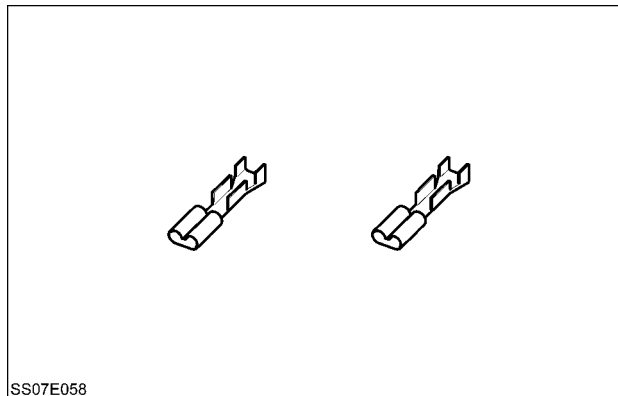

SS07E058 4

## Wire connectors - Component diagram 69

### CONNECTOR X-697 - Electro Hydraulic Remote (EHR) valve 1 – Front implement

CONNECTOR X-697 - Electro Hydraulic Remote (EHR) valve 1 – Front implement			
PIN NUMBER	WIRE NUMBER	CIRCUIT REFERENCE	ELECTRICAL SCHEMATIC FRAME
1	EH-5515A (GY)	X-697 Electro Hydraulic Remote (EHR) valve 1 – Front implement X-446 Cab main harness (power supply) to Electro-Hydraulic Remote (EHR) valve harness	<b>Wiring harnesses - Electrical schematic sheet 13 (55.100)</b> <b>Wiring harnesses - Electrical schematic sheet 24 (55.100)</b>
2	EN-290BZ (BL)	X-697 Electro Hydraulic Remote (EHR) valve 1 – Front implement SP-290B	
3	EH-291BZ (RD)	X-697 Electro Hydraulic Remote (EHR) valve 1 – Front implement SP-291B	
4	EH-057AU (BK)	SP-057AE X-697 Electro Hydraulic Remote (EHR) valve 1 – Front implement	

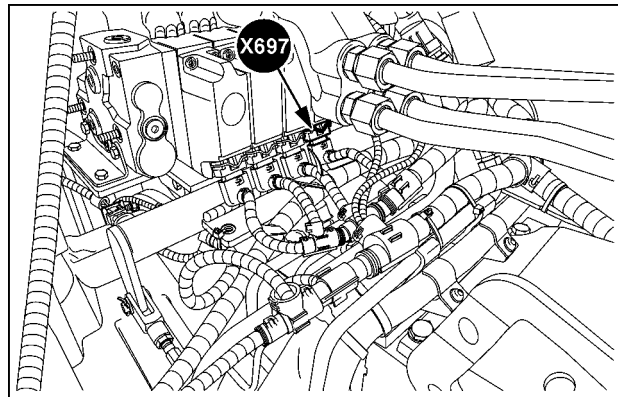

SVIL13TR00822AB 1

Top of rear axle

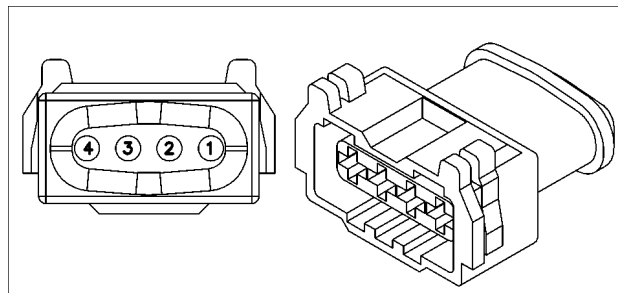

87696713X 2

**CONNECTOR X-698 - Electro Hydraulic Remote (EHR) valve 2 – Front implement**

CONNECTOR X-698 - Electro Hydraulic Remote (EHR) valve 2 – Front implement			
PIN NUMBER	WIRE NUMBER	CIRCUIT REFERENCE	ELECTRICAL SCHEMATIC FRAME
1	EH-5515B (GY)	X-698 Electro Hydraulic Remote (EHR) valve 2 – Front implement X-446 Cab main harness (power supply) to Electro-Hydraulic Remote (EHR) valve harness	<b>Wiring harnesses - Electrical schematic sheet 13 (55.100)</b> <b>Wiring harnesses - Electrical schematic sheet 24 (55.100)</b>
2	EN-290CZ (BL)	SP-290C X-698 Electro Hydraulic Remote (EHR) valve 2 – Front implement	
3	EN-291CZ (RD)	SP-291C X-698 Electro Hydraulic Remote (EHR) valve 2 – Front implement	
4	EH-057EV (BK)	SP-057AE X-698 Electro Hydraulic Remote (EHR) valve 2 – Front implement	

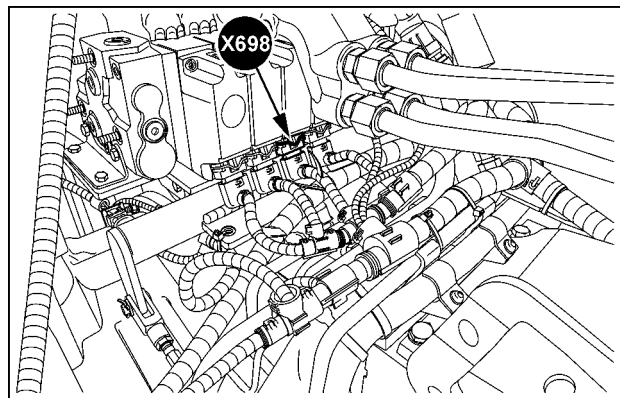

SVIL13TR00822AC 3

**Top of rear axle**

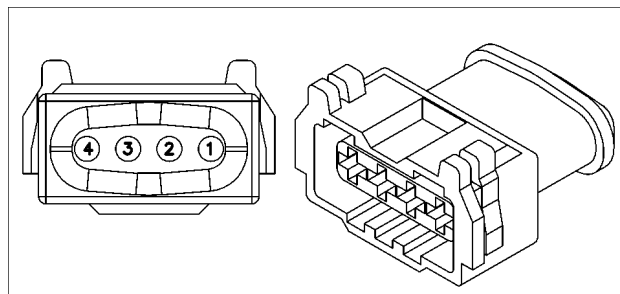

87696713X 4

**CONNECTOR X-699 - Electro Hydraulic Remote (EHR) valve 3 – Rear implement**

CONNECTOR X-699 - Electro Hydraulic Remote (EHR) valve 3 – Rear implement			
PIN NUMBER	WIRE NUMBER	CIRCUIT REFERENCE	ELECTRICAL SCHEMATIC FRAME
1	EH-5515C (GY)	X-699 Electro Hydraulic Remote (EHR) valve 3 – Rear implement X-446 Cab main harness (power supply) to Electro-Hydraulic Remote (EHR) valve harness	<b>Wiring harnesses - Electrical schematic sheet 13 (55.100)</b> <b>Wiring harnesses - Electrical schematic sheet 24 (55.100)</b>
2	EN-290DZ (BL)	X-699 Electro Hydraulic Remote (EHR) valve 3 – Rear implement SP-290D	
3	EN-291DZ (RD)	X-699 Electro Hydraulic Remote (EHR) valve 3 – Rear implement SP-291D	
4	EH-057AT (BK)	SP-057AE X-699 Electro Hydraulic Remote (EHR) valve 3 – Rear implement	

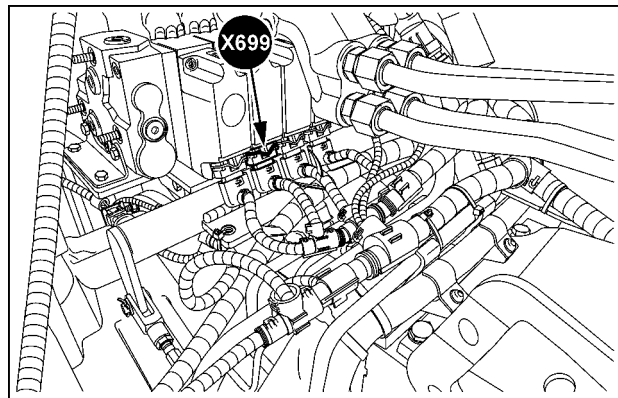

SVIL13TR00822AD 5

**Top of rear axle**

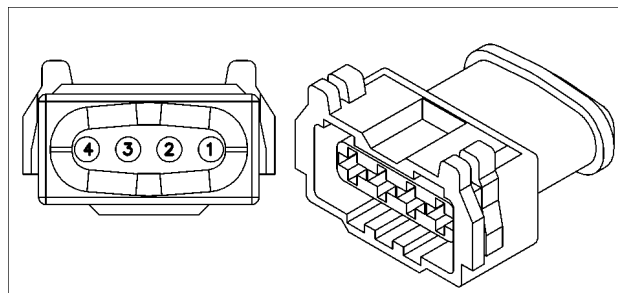

87696713X 6



## Wire connectors - Component diagram 70

### CONNECTOR X-700 - Electro Hydraulic Remote (EHR) valve 4 – Rear implement

CONNECTOR X-700 - Electro Hydraulic Remote (EHR) valve 4 – Rear implement			
PIN NUMBER	WIRE NUMBER	CIRCUIT REFERENCE	ELECTRICAL SCHEMATIC FRAME
1	EH-5515 (GY)	X-346 Cab main harness to Electro-Hydraulic Remote (EHR) valve harness X-700 Electro Hydraulic Remote (EHR) valve 4 – Rear implement	<b>Wiring harnesses - Electrical schematic sheet 13 (55.100)</b> <b>Wiring harnesses - Electrical schematic sheet 24 (55.100)</b>
2	EH-290EZ (BL)	SP-290E X-700 Electro Hydraulic Remote (EHR) valve 4 – Rear implement	
3	EH-291EZ (RD)	SP-291E X-700 Electro Hydraulic Remote (EHR) valve 4 – Rear implement	
4	EH-057AV (BK)	SP-057AE X-700 Electro Hydraulic Remote (EHR) valve 4 – Rear implement	

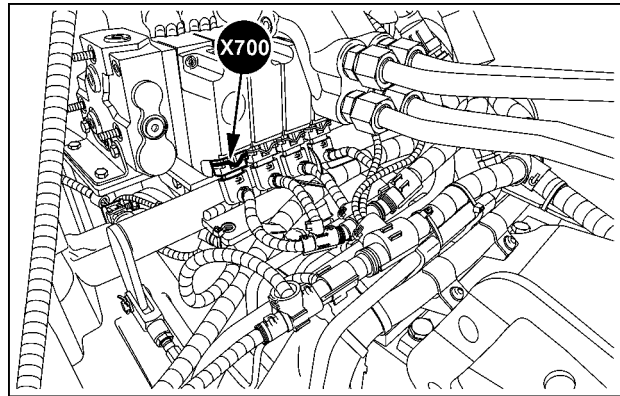

SVIL13TR00822AE 1

Top of rear axle

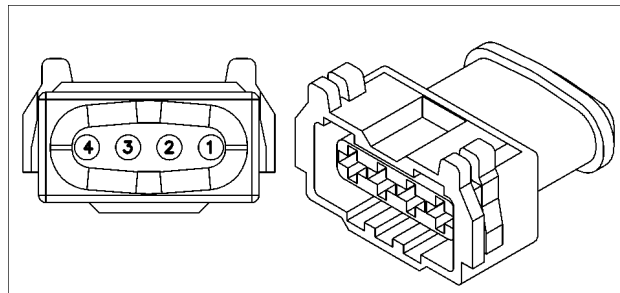

87696713X 2

**CONNECTOR X-702 - CAN bus termination resistor**

CONNECTOR X-702 - CAN bus termination resistor			
PIN NUMBER	WIRE NUMBER	CIRCUIT REFERENCE	ELECTRICAL SCHEMATIC FRAME
1	-	-	Wiring harnesses - Electrical schematic sheet 24 (55.100)
2	EH-290F (BL)	X-702 CAN bus termination resistor SP-290E	
3	EH-291F (RD)	X-702 CAN bus termination resistor SP-291E	
4	-	-	

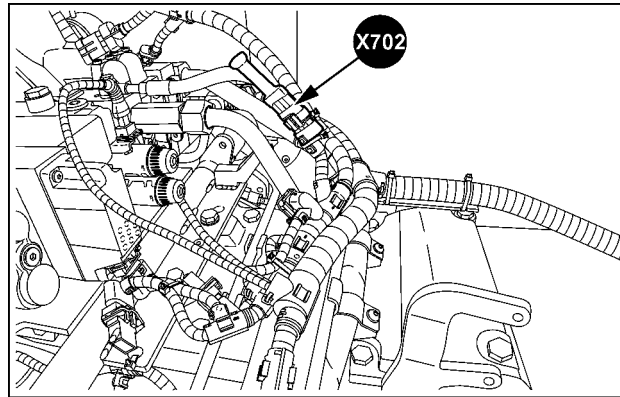

SVIL13TR00801AB 3

**Left-hand side top of rear axle**

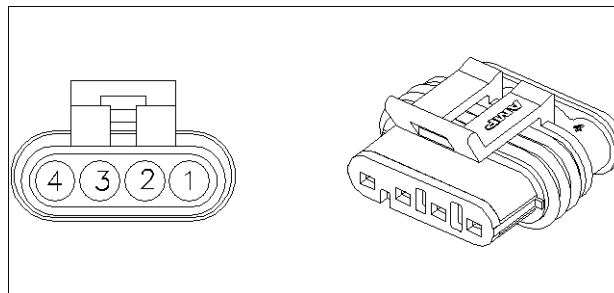

87687242 4

## Wire connectors - Component diagram 80

### CONNECTOR X-806 - Clutch F solenoid valve

CONNECTOR X-806 - Clutch F solenoid valve			
PIN NUMBER	WIRE NUMBER	CIRCUIT REFERENCE	ELECTRICAL SCHEMATIC FRAME
1	TR-7906 (OR)	SP-7900 VPS1 X-806 Clutch F solenoid valve	Wiring harnesses - Electrical schematic sheet 07 (55.100)
2	TR-7902 (BK/WH)	X-300 Cab main harness to transmission harness X-806 Clutch F solenoid valve	

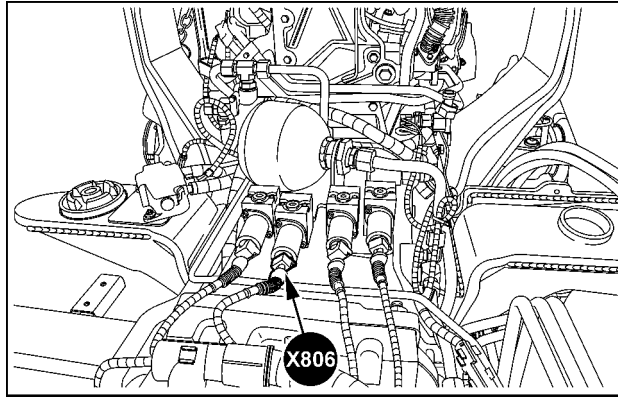

SVIL13TR00764AG 1

Front top of transmission

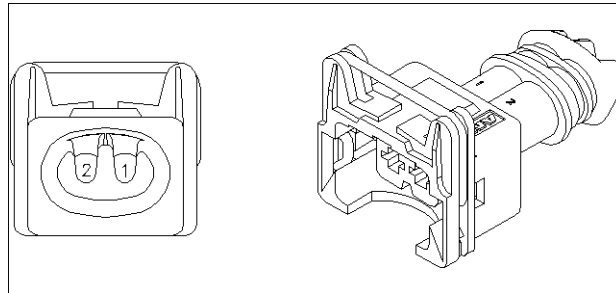

84607243 2

**CONNECTOR X-807 - Powershift output speed sensor**

CONNECTOR X-807 - Powershift output speed sensor			
PIN NUMBER	WIRE NUMBER	CIRCUIT REFERENCE	ELECTRICAL SCHEMATIC FRAME
1	TR-060JC (BK/WH)	X-807 Powershift output speed sensor SP-060J VMG1 ZF Ext	Wiring harnesses - Electrical schematic sheet 07 (55.100)
2	TR-2145 (OR)	X-300 Cab main harness to transmission harness X-807 Powershift output speed sensor	
3	TR-010JD (GN)	X-807 Powershift output speed sensor SP-010JA ZF Trans Sensor 12V	

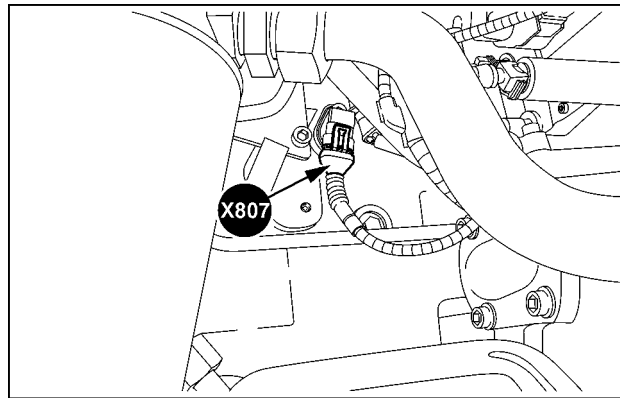

SVIL13TR00802AB 3

**Right-hand of transmission**

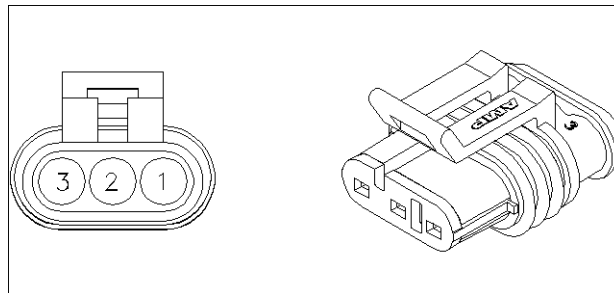

84062580 4

## Wire connectors - Component diagram 93

### CONNECTOR X-937 - Engine Control Unit (ECU)

CONNECTOR X-937 - Engine Control Unit (ECU)			
PIN NUMBER	WIRE NUMBER	CIRCUIT REFERENCE	ELECTRICAL SCHEMATIC FRAME
1	EN-011EC (GN)	X-937 Engine Control Unit (ECU) X-002 Engine harness 1 to power distribution unit	<b>Wiring harnesses - Electrical schematic sheet 05 (55.100)</b> <b>Wiring harnesses - Electrical schematic sheet 24 (55.100)</b>
2	EN-057FF (BK)	SP-057F GND - Engine X-937 Engine Control Unit (ECU)	
3	EN-011EB (GN)	X-937 Engine Control Unit (ECU) X-002 Engine harness 1 to power distribution unit	
4	EN-057FG (BK)	SP-057F GND - Engine X-937 Engine Control Unit (ECU)	
5	EN-011EA (GN)	X-937 Engine Control Unit (ECU) X-002 Engine harness 1 to power distribution unit	
6	EN-057FH (BK)	SP-057F GND - Engine X-937 Engine Control Unit (ECU)	
7	EN-9290 (YE)	X-937 Engine Control Unit (ECU) X-943 Lambda sensor	
8	EN-6418 (PK)	X-937 Engine Control Unit (ECU) X-001 Cab main harness to engine harness 1	
9	-	-	
10	-	-	
11	-	-	
12	-	-	
13	-	-	
14	EN-9339 (OR)	X-937 Engine Control Unit (ECU) X-947 Differential pressure sensor	
15	-	-	<b>Wiring harnesses - Electrical schematic sheet 05 (55.100)</b> <b>Wiring harnesses - Electrical schematic sheet 24 (55.100)</b>
16	-	-	
17	-	-	
18	-	-	
19	EN-9330 (OR)	X-937 Engine Control Unit (ECU) X-942 Inlet air temperature sensor	
20	EN-9331 (OR)	X-937 Engine Control Unit (ECU) X-942 Inlet air temperature sensor	
21	-	-	
22	EN-9320 (RD)	X-937 Engine Control Unit (ECU) X-949 Engine harness 1 to engine harness 2	
23	-	-	
24	EN-191F (YE)	SP-191E X-937 Engine Control Unit (ECU)	
25	EN-190F (GN)	SP-190E X-937 Engine Control Unit (ECU)	
26	-	-	
27	-	-	
28	EN-2070 (OR)	X-937 Engine Control Unit (ECU) X-002 Engine harness 1 to power distribution unit	
29	-	-	
30	EN-2040 (LG)	X-950 Water in fuel sensor X-937 Engine Control Unit (ECU)	

<b>CONNECTOR X-937 - Engine Control Unit (ECU)</b>			
<b>PIN NUMBER</b>	<b>WIRE NUMBER</b>	<b>CIRCUIT REFERENCE</b>	<b>ELECTRICAL SCHEMATIC FRAME</b>
31	-	-	<b>Wiring harnesses - Electrical schematic sheet 05 (55.100)</b> <b>Wiring harnesses - Electrical schematic sheet 24 (55.100)</b>
32	-	-	
33	-	-	
34	-	-	
35	-	-	
36	EN-9340 (OR)	X-937 Engine Control Unit (ECU) X-947 Differential pressure sensor	
37	-	-	
38	-	-	
39	-	-	
40	-	-	
41	EN-9322 (BK)	X-937 Engine Control Unit (ECU) X-949 Engine harness 1 to engine harness 2	
42	-	-	
43	-	-	
44	-	-	
45	-	-	
46	EN-191G (YE)	X-937 Engine Control Unit (ECU) SP-191E	
47	EN-190G (GN)	X-937 Engine Control Unit (ECU) SP-190E	
48	-	-	
49	-	-	
50	-	-	

Electrical systems - Harnesses and connectors

<b>CONNECTOR X-937 - Engine Control Unit (ECU)</b>			
<b>PIN NUMBER</b>	<b>WIRE NUMBER</b>	<b>CIRCUIT REFERENCE</b>	<b>ELECTRICAL SCHEMATIC FRAME</b>
51	-	-	<b>Wiring harnesses - Electrical schematic sheet 05 (55.100)</b> <b>Wiring harnesses - Electrical schematic sheet 24 (55.100)</b>
52	EN-9321 (RD)	X-937 Engine Control Unit (ECU) X-949 Engine harness 1 to engine harness 2	
53	-	-	
54	EN-010AA (WH)	X-937 Engine Control Unit (ECU) SP-010A	
55	-	-	
56	-	-	
57	-	-	
58	EN-9341 (OR)	X-937 Engine Control Unit (ECU) X-947 Differential pressure sensor	
59	-	-	
60	-	-	
61	-	-	
62	-	-	
63	EN-9293 (YE)	X-937 Engine Control Unit (ECU) X-943 Lambda sensor	
64	EN-9288 (YE)	X-937 Engine Control Unit (ECU) X-943 Lambda sensor	
65	-	-	
66	-	-	
67	-	-	
68	-	-	
69	-	-	
70	EN-6570 (BL)	X-001 Cab main harness to engine harness 1 X-937 Engine Control Unit (ECU)	
71	-	-	
72	-	-	
73	-	-	
74	-	-	

<b>CONNECTOR X-937 - Engine Control Unit (ECU)</b>			
<b>PIN NUMBER</b>	<b>WIRE NUMBER</b>	<b>CIRCUIT REFERENCE</b>	<b>ELECTRICAL SCHEMATIC FRAME</b>
75	-	-	<b>Wiring harnesses - Electrical schematic sheet 05 (55.100)</b> <b>Wiring harnesses - Electrical schematic sheet 24 (55.100)</b>
76	-	-	
77	-	-	
78	-	-	
79	EN-9335 (BR)	X-937 Engine Control Unit (ECU) X-946 Diesel Oxidation Catalyst (DOC) – Inlet temperature sensor	
80	EN-9334 (BR)	X-937 Engine Control Unit (ECU) X-946 Diesel Oxidation Catalyst (DOC) – Inlet temperature sensor	
81	EN-9332 (BK)	X-937 Engine Control Unit (ECU) X-949 Engine harness 1 to engine harness 2	
82	EN-9333 (BK/WH)	X-937 Engine Control Unit (ECU) X-949 Engine harness 1 to engine harness 2	
83	EN-9338 (BR)	X-937 Engine Control Unit (ECU) X-945 Diesel Particulate Filter (DPF) – Inlet temperature sensor	
84	EN-9337 (BR)	X-937 Engine Control Unit (ECU) X-945 Diesel Particulate Filter (DPF) – Inlet temperature sensor	
85	EN-9289 (YE)	X-937 Engine Control Unit (ECU) X-943 Lambda sensor	
86	EN-9292 (YE)	X-937 Engine Control Unit (ECU) X-943 Lambda sensor	
87	-	-	
88	-	-	
89	-	-	
90	-	-	
91	-	-	
92	-	-	
93	-	-	
94	-	-	

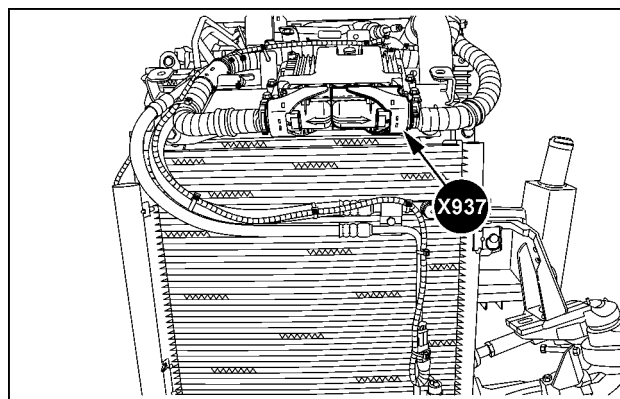

SVIL13TR00803AB 1

**Front top of engine**



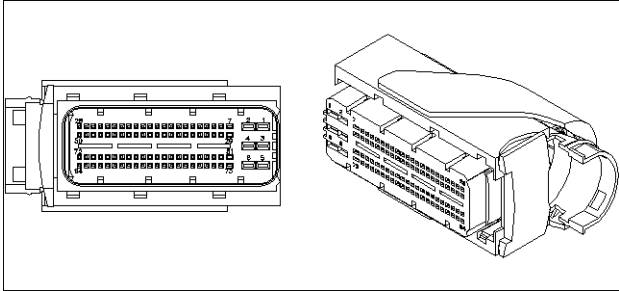

87745798 2

**CONNECTOR X-938 - Glow plug control module**

CONNECTOR X-938 - Glow plug control module			
PIN NUMBER	WIRE NUMBER	CIRCUIT REFERENCE	ELECTRICAL SCHEMATIC FRAME
1	EN2-9325 (RD)	X-938 Glow plug control module X-941 Engine harness 2 to engine components	<b>Wiring harnesses - Electrical schematic sheet 06 (55.100)</b>
2	EN2-9327 (RD)	X-938 Glow plug control module X-941 Engine harness 2 to engine components	
3	EN2-9320 (RD)	X-938 Glow plug control module X-949 Engine harness 1 to engine harness 2	
4	EN2-9923 (RD)	X-938 Glow plug control module X-006 Power distribution unit	
5	EN2-9322A (BK)	X-938 Glow plug control module SP-9322	
6	EN2-9324 (RD)	X-938 Glow plug control module X-941 Engine harness 2 to engine components	
7	EN2-9326 (RD)	X-941 Engine harness 2 to engine components X-938 Glow plug control module	
8	EN2-9321 (RD)	X-938 Glow plug control module X-949 Engine harness 1 to engine harness 2	

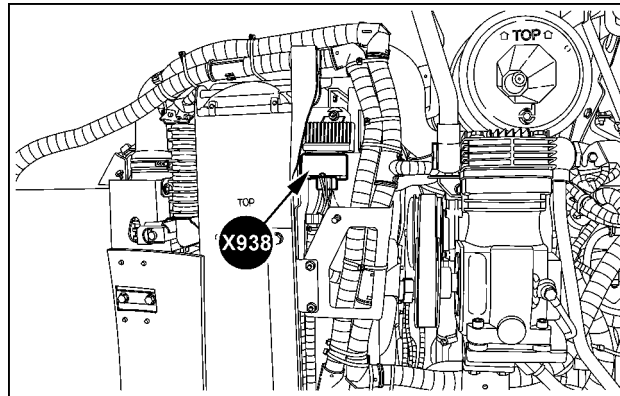

SVIL13TR00804AB 3

**Top left-hand engine**

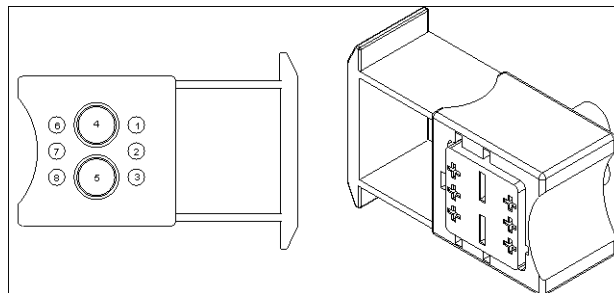

84356962 4

**CONNECTOR X-939 - Engine Control Unit (ECU)**

<b>CONNECTOR X-939 - Engine Control Unit (ECU)</b>			
<b>PIN NUMBER</b>	<b>WIRE NUMBER</b>	<b>CIRCUIT REFERENCE</b>	<b>ELECTRICAL SCHEMATIC FRAME</b>
1	EN2-9331 (VT)	X-939 Engine Control Unit (ECU) X-940 Engine harness 2 to injectors	<b>Wiring harnesses - Electrical schematic sheet 06 (55.100)</b>
2	EN2-9335 (VT)	X-939 Engine Control Unit (ECU) X-940 Engine harness 2 to injectors	
3	-	-	
4	EN2-9337 (BK)	X-939 Engine Control Unit (ECU) X-941 Engine harness 2 to engine components	
5	-	-	
6	EN2-9336 (GY)	X-939 Engine Control Unit (ECU) X-941 Engine harness 2 to engine components	
7	-	-	
8	EN2-9356 (GN)	X-939 Engine Control Unit (ECU) X-941 Engine harness 2 to engine components	
9	EN2-9353 (GN)	X-939 Engine Control Unit (ECU) X-941 Engine harness 2 to engine components	
10	EN2-6670 (OR)	X-939 Engine Control Unit (ECU) X-941 Engine harness 2 to engine components	
11	EN2-9363 (GN)	X-939 Engine Control Unit (ECU) X-941 Engine harness 2 to engine components	<b>Wiring harnesses - Electrical schematic sheet 06 (55.100)</b>
12	EN2-9346 (GN)	X-939 Engine Control Unit (ECU) X-941 Engine harness 2 to engine components	
13	EN2-9345 (BR)	X-939 Engine Control Unit (ECU) X-941 Engine harness 2 to engine components	
14	EN2-9344 (BR)	X-939 Engine Control Unit (ECU) X-941 Engine harness 2 to engine components	
15	EN2-9366 (BR)	X-939 Engine Control Unit (ECU) X-941 Engine harness 2 to engine components	
16	EN2-9328 (VT)	X-939 Engine Control Unit (ECU) X-940 Engine harness 2 to injectors	
17	EN2-9332 (VT)	X-939 Engine Control Unit (ECU) X-940 Engine harness 2 to injectors	
18	-	-	
19	-	-	
20	-	-	

<b>CONNECTOR X-939 - Engine Control Unit (ECU)</b>			
<b>PIN NUMBER</b>	<b>WIRE NUMBER</b>	<b>CIRCUIT REFERENCE</b>	<b>ELECTRICAL SCHEMATIC FRAME</b>
21	-	-	<b>Wiring harnesses - Electrical schematic sheet 06 (55.100)</b>
22	-	-	
23	EN2-9355 (BR)	X-939 Engine Control Unit (ECU) X-941 Engine harness 2 to engine components	
24	EN2-9351 (BR)	X-939 Engine Control Unit (ECU) X-941 Engine harness 2 to engine components	
25	EN2-6650 (OR)	X-939 Engine Control Unit (ECU) X-941 Engine harness 2 to engine components	
26	EN2-9361 (OR)	X-939 Engine Control Unit (ECU) X-941 Engine harness 2 to engine components	
27	EN2-9347 (OR)	X-939 Engine Control Unit (ECU) X-941 Engine harness 2 to engine components	
28	EN2-9343 (BR)	X-939 Engine Control Unit (ECU) X-941 Engine harness 2 to engine components	
29	-	-	
30	-	-	
31	EN2-9330 (YE)	X-939 Engine Control Unit (ECU) X-940 Engine harness 2 to injectors	<b>Wiring harnesses - Electrical schematic sheet 06 (55.100)</b>
32	EN2-9329 (YE)	X-939 Engine Control Unit (ECU) X-940 Engine harness 2 to injectors	
33	-	-	
34	EN2-9357 (OR)	X-939 Engine Control Unit (ECU) X-941 Engine harness 2 to engine components	
35	EN2-9352 (VT)	X-939 Engine Control Unit (ECU) X-941 Engine harness 2 to engine components	
36	-	-	
37	EN2-9358 (VT)	X-939 Engine Control Unit (ECU) X-941 Engine harness 2 to engine components	
38	EN2-9354 (VT)	X-939 Engine Control Unit (ECU) X-941 Engine harness 2 to engine components	
39	EN2-9350 (RD)	X-939 Engine Control Unit (ECU) X-941 Engine harness 2 to engine components	
40	EN2-6680 (OR)	X-939 Engine Control Unit (ECU) X-941 Engine harness 2 to engine components	

<b>CONNECTOR X-939 - Engine Control Unit (ECU)</b>			
<b>PIN NUMBER</b>	<b>WIRE NUMBER</b>	<b>CIRCUIT REFERENCE</b>	<b>ELECTRICAL SCHEMATIC FRAME</b>
41	EN2-9362 (RD)	X-939 Engine Control Unit (ECU) X-941 Engine harness 2 to engine components	<b>Wiring harnesses - Electrical schematic sheet 06 (55.100)</b>
42	-	-	
43	EN2-9348 (RD)	X-939 Engine Control Unit (ECU) X-941 Engine harness 2 to engine components	
44	EN2-9364 (WH)		
45	-	-	
46	EN2-9334 (YE)	X-939 Engine Control Unit (ECU) X-940 Engine harness 2 to injectors	
47	-	-	
48	EN2-9333 (YE)	X-939 Engine Control Unit (ECU) X-940 Engine harness 2 to injectors	
49	EN2-9360 (RD)	X-939 Engine Control Unit (ECU) X-941 Engine harness 2 to engine components	
50	EN2-9349 (GY)	X-939 Engine Control Unit (ECU) X-941 Engine harness 2 to engine components	
51	-	-	<b>Wiring harnesses - Electrical schematic sheet 06 (55.100)</b>
52	-	-	
53	EN2-9359 (GY)	X-939 Engine Control Unit (ECU) X-941 Engine harness 2 to engine components	
54	-	-	
55	EN2-6660 (OR)	X-939 Engine Control Unit (ECU) X-941 Engine harness 2 to engine components	
56	-	-	
57	EN2-93688 (GY)	X-939 Engine Control Unit (ECU) X-941 Engine harness 2 to engine components	
58	EN2-9369 (GY)	X-939 Engine Control Unit (ECU) SP-9369	
59	EN2-9365 (RD)		
60	EN2-9367 (GY)	X-939 Engine Control Unit (ECU) X-941 Engine harness 2 to engine components	

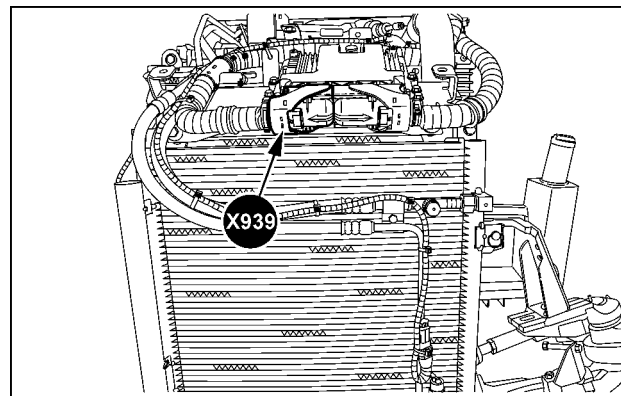

SVIL13TR00803AC 5

**Front top of engine**

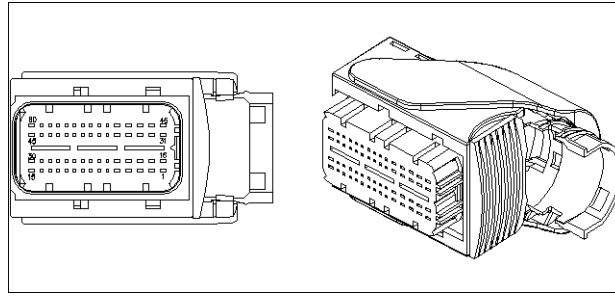

84130269 6

## Wire connectors - Component diagram 94

### CONNECTOR X-940 - Engine harness 2 to injectors

CONNECTOR X-940 - Engine harness 2 to injectors			
PIN NUMBER	WIRE NUMBER	CIRCUIT REFERENCE	ELECTRICAL SCHEMATIC FRAME
A	EN2-9328 (VT) / (BL)	X-939 Engine Control Unit (ECU) X-940 Engine harness 2 to injectors	<b>Wiring harnesses - Electrical schematic sheet 06 (55.100)</b>
B	EN2-9329 (YE) / (BR)	X-939 Engine Control Unit (ECU) X-940 Engine harness 2 to injectors	
C	EN2-9330 (YE) / (WH)	X-939 Engine Control Unit (ECU) X-940 Engine harness 2 to injectors	
D	EN2-9331 (VT) / (VT)	X-939 Engine Control Unit (ECU) X-940 Engine harness 2 to injectors	
E	EN2-9332 (VT) / (OR/BL)	X-939 Engine Control Unit (ECU) X-940 Engine harness 2 to injectors	
F	EN2-9333 (YE) / (GN/VT)	X-939 Engine Control Unit (ECU) X-940 Engine harness 2 to injectors	
G	EN2-9334 (YE) / (GY)	X-939 Engine Control Unit (ECU) X-940 Engine harness 2 to injectors	
H	EN2-9335 (VT) / (YE/OR)	X-939 Engine Control Unit (ECU) X-940 Engine harness 2 to injectors	
J	-	-	
K	-	-	

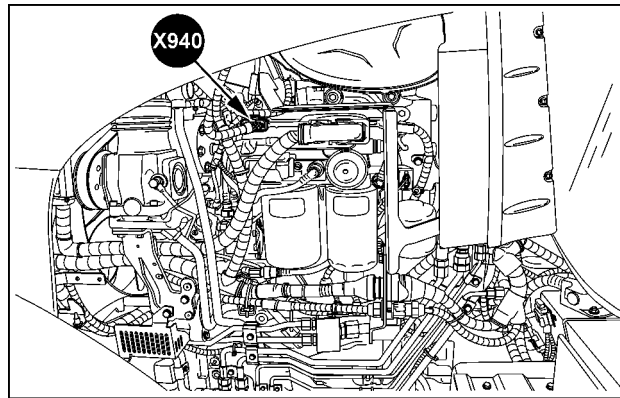

SVIL13TR00700AB 1

**Top left-hand engine**

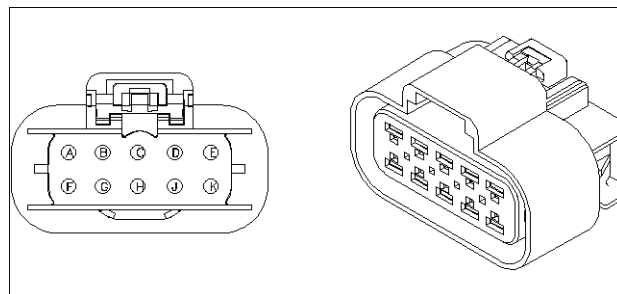

87698252 2

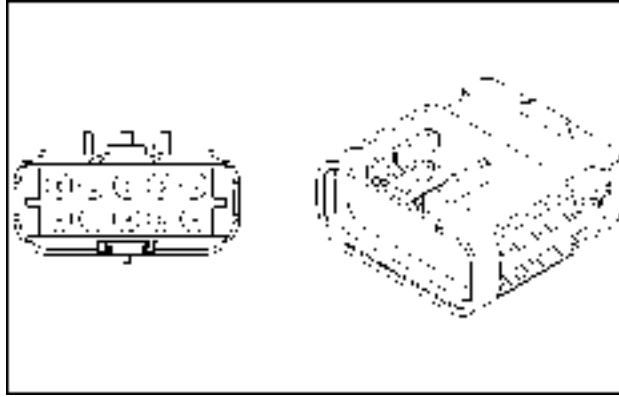

87698254 3



**CONNECTOR X-941 - Engine harness 2 to engine components**

<b>CONNECTOR X-941 - Engine harness 2 to engine components</b>			
<b>PIN NUMBER</b>	<b>WIRE NUMBER</b>	<b>CIRCUIT REFERENCE</b>	<b>ELECTRICAL SCHEMATIC FRAME</b>
1	EN2-9366 (BR) / (VT/WH)	X-939 Engine Control Unit (ECU) X-941 Engine harness 2 to engine components	<b>Wiring harnesses - Electrical schematic sheet 05 (55.100)</b> <b>Wiring harnesses - Electrical schematic sheet 06 (55.100)</b>
2	EN2-9367 (GY) / (OR/WH)	X-939 Engine Control Unit (ECU) X-941 Engine harness 2 to engine components	
3	EN2-9336 (GY) / (GY/BL)	X-939 Engine Control Unit (ECU) X-941 Engine harness 2 to engine components	
4	EN2-9344 (BR) / (GY)	X-939 Engine Control Unit (ECU) X-941 Engine harness 2 to engine components	
5	EN2-9361 (OR) / (GN/BR)	X-939 Engine Control Unit (ECU) X-941 Engine harness 2 to engine components	
6	EN2-9362 (RD) / (YE/BK)	X-939 Engine Control Unit (ECU) X-941 Engine harness 2 to engine components	
7	EN2-9363 (GN) / (GY/GN)	X-939 Engine Control Unit (ECU) X-941 Engine harness 2 to engine components	
8	EN2-9343 (BR) / (VT/GN)	X-939 Engine Control Unit (ECU) X-941 Engine harness 2 to engine components	
9	EN2-9365 (RD) / (BL)		
10	EN2-9364 (WH) / (VT)		
11	EN2-9372 (BK) / (WH)	SP-9372 X-941 Engine harness 2 to engine components	<b>Wiring harnesses - Electrical schematic sheet 05 (55.100)</b> <b>Wiring harnesses - Electrical schematic sheet 06 (55.100)</b>
12	EN2-9345 (BR) / (WH)	X-939 Engine Control Unit (ECU) X-941 Engine harness 2 to engine components	
13	EN2-9369A (GY) / (GN)	X-941 Engine harness 2 to engine components SP-9369	
14	EN2-93688 (GY) / (YE)	X-939 Engine Control Unit (ECU) X-941 Engine harness 2 to engine components	
15	EN2-9355 (BR) / (BR)	X-939 Engine Control Unit (ECU) X-941 Engine harness 2 to engine components	
16	EN2-9354 (VT) / (BR/WH)	X-939 Engine Control Unit (ECU) X-941 Engine harness 2 to engine components	
17	EN2-6670 (OR) / (VT/BR)	X-939 Engine Control Unit (ECU) X-941 Engine harness 2 to engine components	
18	EN2-6680 (OR) / (BL/BR)	X-939 Engine Control Unit (ECU) X-941 Engine harness 2 to engine components	
19	EN2-6650 (OR) / (BR/VT)	X-939 Engine Control Unit (ECU) X-941 Engine harness 2 to engine components	
20	EN2-6660 (OR) / (YE/BK)	X-939 Engine Control Unit (ECU) X-941 Engine harness 2 to engine components	

<b>CONNECTOR X-941 - Engine harness 2 to engine components</b>				
<b>PIN NUMBER</b>	<b>WIRE NUMBER</b>	<b>CIRCUIT REFERENCE</b>	<b>ELECTRICAL SCHEMATIC FRAME</b>	
21	EN2-9346 (GN) / (YE/BK)	X-939 Engine Control Unit (ECU) X-941 Engine harness 2 to engine components	<b>Wiring harnesses - Electrical schematic sheet 05 (55.100)</b> <b>Wiring harnesses - Electrical schematic sheet 06 (55.100)</b>	
22	EN2-9347 (OR) / (BL/WH)	X-939 Engine Control Unit (ECU) X-941 Engine harness 2 to engine components		
23	EN2-9348 (RD) / (BR)	X-939 Engine Control Unit (ECU) X-941 Engine harness 2 to engine components		
24	-	-		
25	EN2-9371 (BK) / (YE/BR)	X-949 Engine harness 1 to engine harness 2 X-941 Engine harness 2 to engine components		
26	EN2-9370 (BK/WH) / (GN/WH)	X-949 Engine harness 1 to engine harness 2 X-941 Engine harness 2 to engine components		
27	EN2-9337 (BK) / (BR/WH)	X-939 Engine Control Unit (ECU) X-941 Engine harness 2 to engine components		
28	EN2-9338 (GN) / (RD)	X-949 Engine harness 1 to engine harness 2 X-941 Engine harness 2 to engine components		
29	EN2-9349 (GY) / (OR/WH)	X-939 Engine Control Unit (ECU) X-941 Engine harness 2 to engine components		
30	EN2-9352 (VT) / (GY/OR)	X-939 Engine Control Unit (ECU) X-941 Engine harness 2 to engine components		
31	-	-		
32	-	-		<b>Wiring harnesses - Electrical schematic sheet 05 (55.100)</b>
33	EN2-9353 (GN) / (BL)	X-939 Engine Control Unit (ECU) X-941 Engine harness 2 to engine components		<b>Wiring harnesses - Electrical schematic sheet 06 (55.100)</b>
34	EN2-9350 (RD) / (BL/WH)	X-939 Engine Control Unit (ECU) X-941 Engine harness 2 to engine components		
35	EN2-9351 (BR) / (VT)	X-939 Engine Control Unit (ECU) X-941 Engine harness 2 to engine components		
36	-	-		
37	EN2-9360 (RD) / (OR/GN)	X-939 Engine Control Unit (ECU) X-941 Engine harness 2 to engine components		
38	EN2-9357 (OR) / (OR/BL)	X-939 Engine Control Unit (ECU) X-941 Engine harness 2 to engine components		
39	-	-		
40	-	-		

<b>CONNECTOR X-941 - Engine harness 2 to engine components</b>			
<b>PIN NUMBER</b>	<b>WIRE NUMBER</b>	<b>CIRCUIT REFERENCE</b>	<b>ELECTRICAL SCHEMATIC FRAME</b>
41	EN2-9356 (GN) / (BL/BR)	X-939 Engine Control Unit (ECU) X-941 Engine harness 2 to engine components	<b>Wiring harnesses - Electrical schematic sheet 05 (55.100)</b> <b>Wiring harnesses - Electrical schematic sheet 06 (55.100)</b>
42	EN2-9359 (GY) / (BL/BK)	X-939 Engine Control Unit (ECU) X-941 Engine harness 2 to engine components	
43	EN2-9358 (VT) / (OR/WH)	X-939 Engine Control Unit (ECU) X-941 Engine harness 2 to engine components	
44	-	-	
45	-	-	
46	-	-	
47	-	-	
48	-	-	
49	-	-	
50	-	-	
51	-	-	
52	-	-	
53	-	-	
54	-	-	
55	-	-	
56	-	-	
57	EN2-9324 (RD) / (BL)	X-938 Glow plug control module X-941 Engine harness 2 to engine components	
58	EN2-9325 (RD) / (VT)	X-938 Glow plug control module X-941 Engine harness 2 to engine components	
59	-	-	
60	EN2-9326 (RD) / (YE)	X-941 Engine harness 2 to engine components X-938 Glow plug control module	
61	EN2-9327 (RD) / (GN/WH)	X-938 Glow plug control module X-941 Engine harness 2 to engine components	
62	-	-	

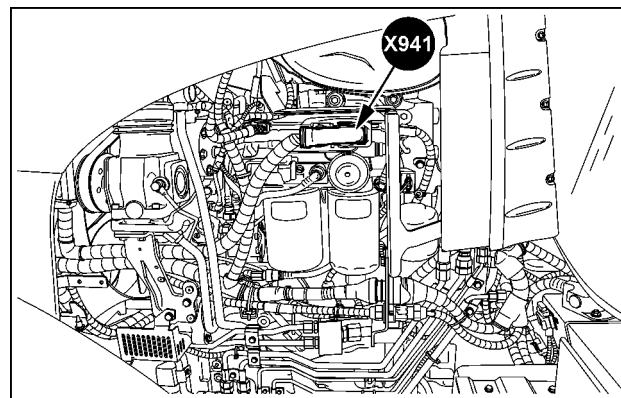

SVIL13TR00700AC 4

**Top left-hand engine**

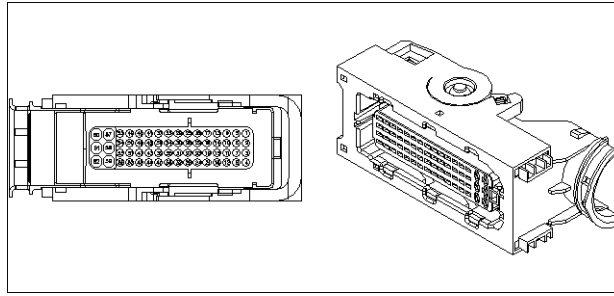

84154706 5

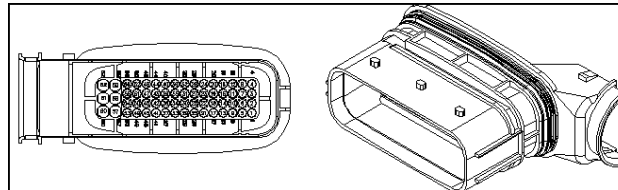

84154701 6

**CONNECTOR X-942 - Inlet air temperature sensor**

CONNECTOR X-942 - Inlet air temperature sensor			
PIN NUMBER	WIRE NUMBER	CIRCUIT REFERENCE	ELECTRICAL SCHEMATIC FRAME
1	EN-9330 (OR)	X-937 Engine Control Unit (ECU) X-942 Inlet air temperature sensor	<b>Wiring harnesses - Electrical schematic sheet 05 (55.100)</b>
2	EN-9331 (OR)	X-937 Engine Control Unit (ECU) X-942 Inlet air temperature sensor	

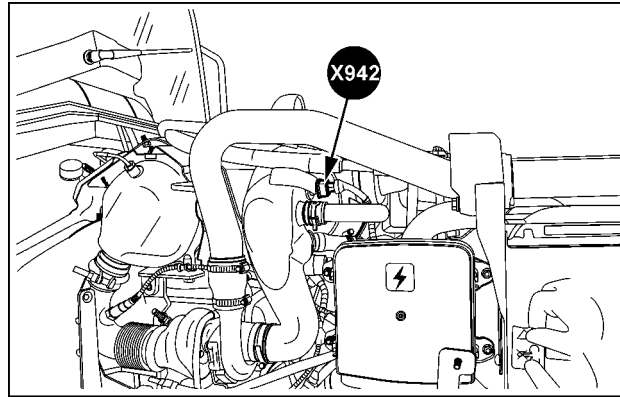

SVIL13TR00823AB 7

**Front top right-hand engine**

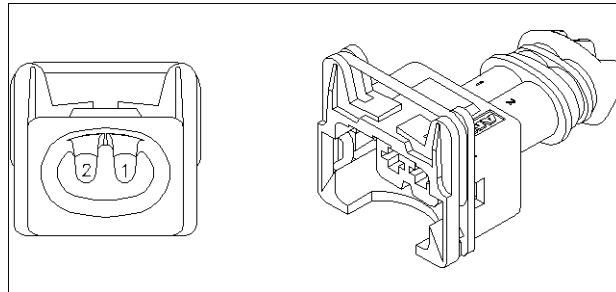

84607243 8

**CONNECTOR X-943 - Lambda sensor**

CONNECTOR X-943 - Lambda sensor			
PIN NUMBER	WIRE NUMBER	CIRCUIT REFERENCE	ELECTRICAL SCHEMATIC FRAME
1	EN-9288 (YE)	X-937 Engine Control Unit (ECU) X-943 Lambda sensor	<b>Wiring harnesses - Electrical schematic sheet 05 (55.100)</b>
2	EN-9289 (YE)	X-937 Engine Control Unit (ECU) X-943 Lambda sensor	
3	EN-9290 (YE)	X-937 Engine Control Unit (ECU) X-943 Lambda sensor	
4	EN-9291 (GN)	X-943 Lambda sensor SP-011G	
5	EN-9292 (YE)	X-937 Engine Control Unit (ECU) X-943 Lambda sensor	
6	EN-9293 (YE)	X-937 Engine Control Unit (ECU) X-943 Lambda sensor	

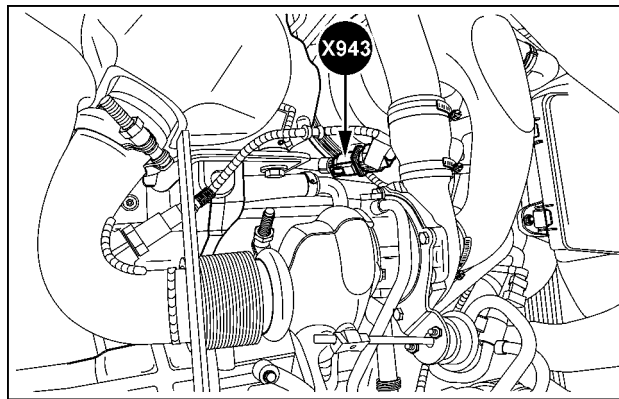

SVIL13TR00824AB 9

**Front top right-hand engine**

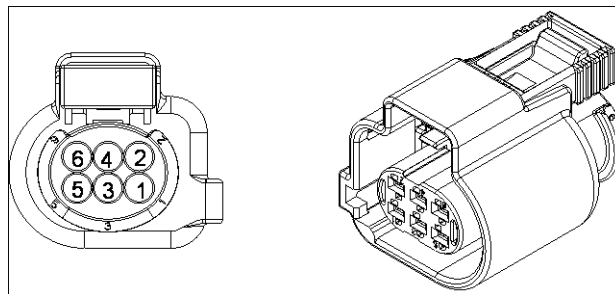

84301132 10

**CONNECTOR X-944 - Cab main harness to Electronic Front Hitch (EFH) control unit harness**

<b>CONNECTOR X-944 - Cab main harness to Electronic Front Hitch (EFH) control unit harness</b>			
<b>PIN NUMBER</b>	<b>WIRE NUMBER</b>	<b>CIRCUIT REFERENCE</b>	<b>ELECTRICAL SCHEMATIC FRAME</b>
1	CM-191AZ (YE) EF-191ZA (YE)	SP-191A X-944 Cab main harness to Electronic Front Hitch (EFH) control unit harness X-944 Cab main harness to Electronic Front Hitch (EFH) control unit harness X-524 Electronic Front Hitch (EFH) control unit	<b>Wiring harnesses - Electrical schematic sheet 14 (55.100)</b> <b>Wiring harnesses - Electrical schematic sheet 24 (55.100)</b> <b>Wiring harnesses - Electrical schematic sheet 25 (55.100)</b>
2	CM-190AZ (GN) EF-190ZA (GN)	SP-190A X-944 Cab main harness to Electronic Front Hitch (EFH) control unit harness X-944 Cab main harness to Electronic Front Hitch (EFH) control unit harness X-524 Electronic Front Hitch (EFH) control unit	
3	CM-2585 (TN) EF-2585 (TN)	X-944 Cab main harness to Electronic Front Hitch (EFH) control unit harness X-240 Central Control Unit (CCU) – CN3B X-944 Cab main harness to Electronic Front Hitch (EFH) control unit harness X-951 Front hitch raise relay	
4	CM-2586 (TN) EF-2586 (TN)	X-944 Cab main harness to Electronic Front Hitch (EFH) control unit harness X-240 Central Control Unit (CCU) – CN3B X-944 Cab main harness to Electronic Front Hitch (EFH) control unit harness X-952 Front hitch lower relay	
5	CM-057AJ (BK) EF-057AJ (BK)	X-944 Cab main harness to Electronic Front Hitch (EFH) control unit harness SP-057A CAB GND SP-057K GND X-944 Cab main harness to Electronic Front Hitch (EFH) control unit harness	<b>Wiring harnesses - Electrical schematic sheet 14 (55.100)</b> <b>Wiring harnesses - Electrical schematic sheet 24 (55.100)</b> <b>Wiring harnesses - Electrical schematic sheet 25 (55.100)</b>
6	CM-057AH (BK) EF-057AH (BK)	X-944 Cab main harness to Electronic Front Hitch (EFH) control unit harness SP-057A CAB GND SP-057K GND X-944 Cab main harness to Electronic Front Hitch (EFH) control unit harness	
7	CM-155L (GN) EF-155L (GN)	X-180 Fuse block (F-070 to F-101) X-944 Cab main harness to Electronic Front Hitch (EFH) control unit harness X-944 Cab main harness to Electronic Front Hitch (EFH) control unit harness SP-155L	
8	CM-011AA (GN) EF-011AA (GN)	X-180 Fuse block (F-070 to F-101) X-944 Cab main harness to Electronic Front Hitch (EFH) control unit harness X-944 Cab main harness to Electronic Front Hitch (EFH) control unit harness SP-011AA EFH MASTER	

<b>CONNECTOR X-944 - Cab main harness to Electronic Front Hitch (EFH) control unit harness</b>			
<b>PIN NUMBER</b>	<b>WIRE NUMBER</b>	<b>CIRCUIT REFERENCE</b>	<b>ELECTRICAL SCHEMATIC FRAME</b>
9	CM-1013B (RD) EF-1013B (RD)	SP-1013 X-944 Cab main harness to Electronic Front Hitch (EFH) control unit harness X-944 Cab main harness to Electronic Front Hitch (EFH) control unit harness SP-1013B BACK LIGHT	<b>Wiring harnesses - Electrical schematic sheet 14 (55.100)</b> <b>Wiring harnesses - Electrical schematic sheet 24 (55.100)</b> <b>Wiring harnesses - Electrical schematic sheet 25 (55.100)</b>
10	CM-1006A (BR) EF-1006A (BR)	SP-1006 X-944 Cab main harness to Electronic Front Hitch (EFH) control unit harness X-944 Cab main harness to Electronic Front Hitch (EFH) control unit harness X-524 Electronic Front Hitch (EFH) control unit	

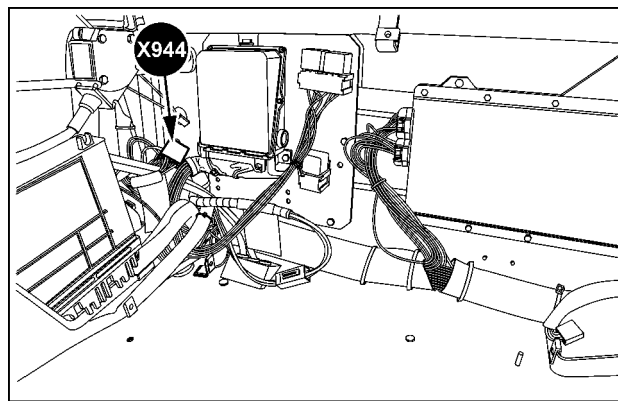

SVIL13TR00882AC 11

**In cab right-hand behind operator's seat**

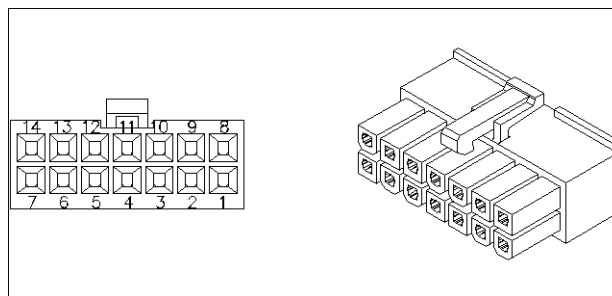

87694702 12

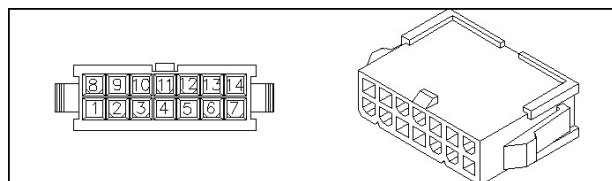

87694701 13



**CONNECTOR X-945 - Diesel Particulate Filter (DPF) – Inlet temperature sensor**

CONNECTOR X-945 - Diesel Particulate Filter (DPF) – Inlet temperature sensor			
PIN NUMBER	WIRE NUMBER	CIRCUIT REFERENCE	ELECTRICAL SCHEMATIC FRAME
1	EN-9337 (BR)	X-937 Engine Control Unit (ECU) X-945 Diesel Particulate Filter (DPF) – Inlet temperature sensor	<b>Wiring harnesses - Electrical schematic sheet 05 (55.100)</b>
2	EN-9338 (BR)	X-937 Engine Control Unit (ECU) X-945 Diesel Particulate Filter (DPF) – Inlet temperature sensor	

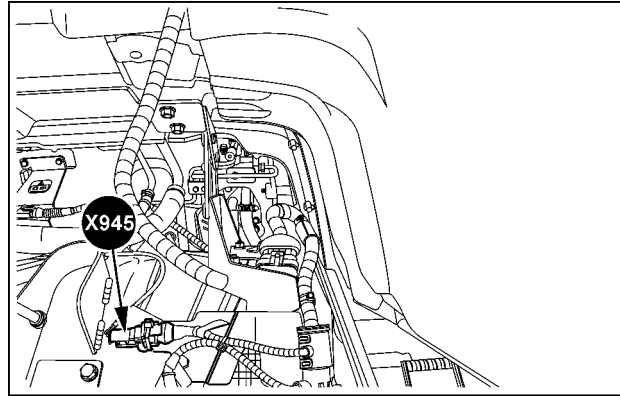

SVIL13TR00705AC 14

**Top left-hand engine**

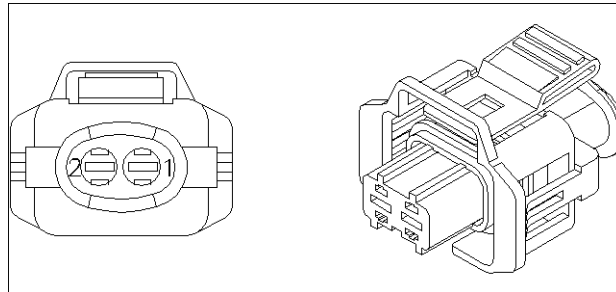

87709793 15

**CONNECTOR X-946 - Diesel Oxidation Catalyst (DOC) – Inlet temperature sensor**

CONNECTOR X-946 - Diesel Oxidation Catalyst (DOC) – Inlet temperature sensor			
PIN NUMBER	WIRE NUMBER	CIRCUIT REFERENCE	ELECTRICAL SCHEMATIC FRAME
1	EN-9334 (BR)	X-937 Engine Control Unit (ECU) X-946 Diesel Oxidation Catalyst (DOC) – Inlet temperature sensor	Wiring harnesses - Electrical schematic sheet 05 (55.100)
2	EN-9335 (BR)	X-937 Engine Control Unit (ECU) X-946 Diesel Oxidation Catalyst (DOC) – Inlet temperature sensor	

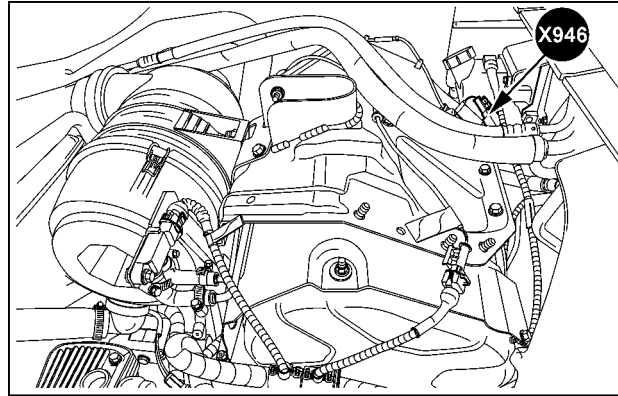

SVIL13TR00825AC 16

**Top left-hand engine**

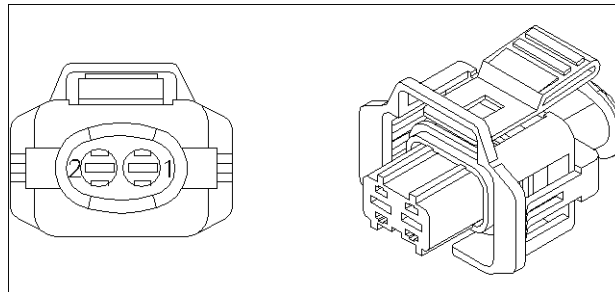

87709793 17

**CONNECTOR X-947 - Differential pressure sensor**

CONNECTOR X-947 - Differential pressure sensor			
PIN NUMBER	WIRE NUMBER	CIRCUIT REFERENCE	ELECTRICAL SCHEMATIC FRAME
1	EN-9339 (OR)	X-937 Engine Control Unit (ECU) X-947 Differential pressure sensor	<b>Wiring harnesses - Electrical schematic sheet 05 (55.100)</b>
2	EN-9340 (OR)	X-937 Engine Control Unit (ECU) X-947 Differential pressure sensor	
3	EN-9341 (OR)	X-937 Engine Control Unit (ECU) X-947 Differential pressure sensor	

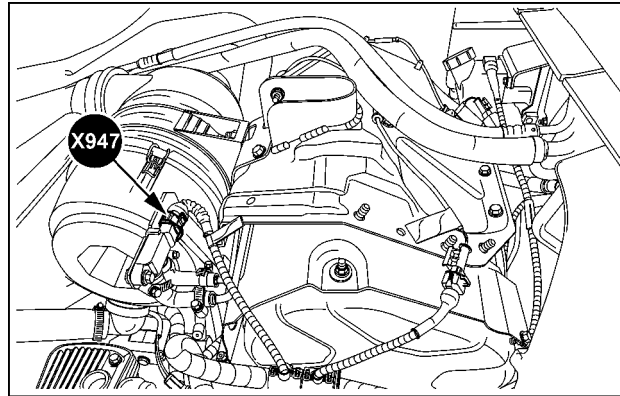

SVIL13TR00825AD 18

**Top left-hand engine**

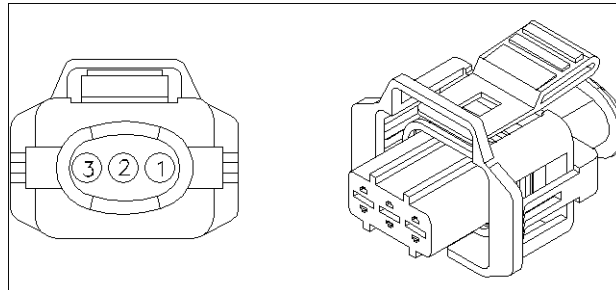

87747172 19

**CONNECTOR X-949 - Engine harness 1 to engine harness 2**

<b>CONNECTOR X-949 - Engine harness 1 to engine harness 2</b>			
<b>PIN NUMBER</b>	<b>WIRE NUMBER</b>	<b>CIRCUIT REFERENCE</b>	<b>ELECTRICAL SCHEMATIC FRAME</b>
1	EN-9332 (BK) EN2-9371 (BK)	X-937 Engine Control Unit (ECU) X-949 Engine harness 1 to engine harness 2 X-949 Engine harness 1 to engine harness 2 X-941 Engine harness 2 to engine components	<b>Wiring harnesses - Electrical schematic sheet 05 (55.100)</b>
2	EN-9333 (BK/WH) EN2-9370 (BK/WH)	X-937 Engine Control Unit (ECU) X-949 Engine harness 1 to engine harness 2 X-949 Engine harness 1 to engine harness 2 X-941 Engine harness 2 to engine components	
3	EN-011GA (GN) EN2-9338 (GN)	SP-011G X-949 Engine harness 1 to engine harness 2 X-949 Engine harness 1 to engine harness 2 X-941 Engine harness 2 to engine components	
4	EN-9320 (RD) EN2-9320 (RD)	X-937 Engine Control Unit (ECU) X-949 Engine harness 1 to engine harness 2 X-938 Glow plug control module X-949 Engine harness 1 to engine harness 2	<b>Wiring harnesses - Electrical schematic sheet 05 (55.100)</b>
5	EN-9321 (RD) EN2-9321 (RD)	X-937 Engine Control Unit (ECU) X-949 Engine harness 1 to engine harness 2 X-938 Glow plug control module X-949 Engine harness 1 to engine harness 2	
6	EN-9322 (BK) EN2-9322 (BK)	X-937 Engine Control Unit (ECU) X-949 Engine harness 1 to engine harness 2 SP-9322 X-949 Engine harness 1 to engine harness 2	

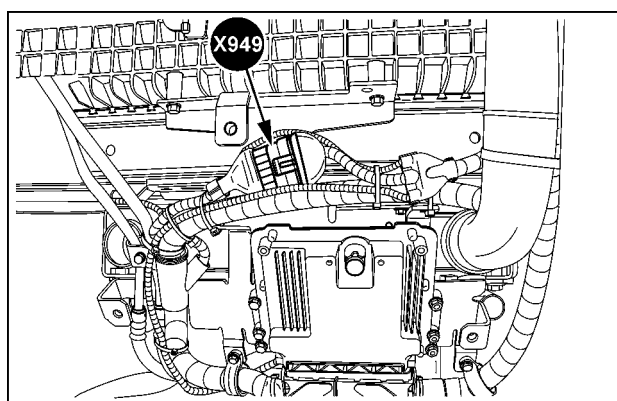

SVIL13TR00826AB 20

**Front top of engine**

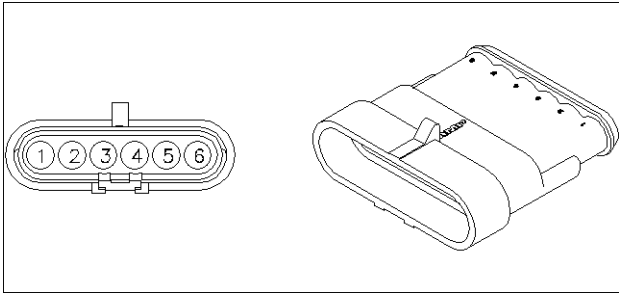

87691968 21

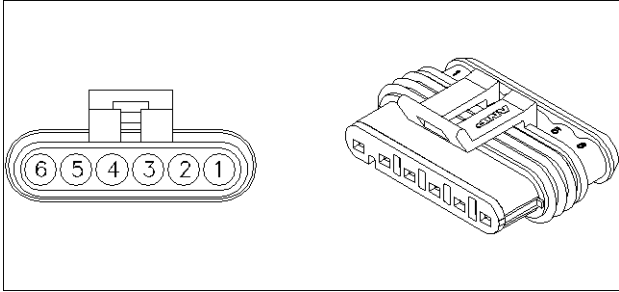

87710588 22

## Wire connectors - Component diagram 95

### CONNECTOR X-950 - Water in fuel sensor

CONNECTOR X-950 - Water in fuel sensor			
PIN NUMBER	WIRE NUMBER	CIRCUIT REFERENCE	ELECTRICAL SCHEMATIC FRAME
1	EN-2040 (LG)	X-950 Water in fuel sensor X-937 Engine Control Unit (ECU)	Wiring harnesses - Electrical schematic sheet 05 (55.100)
2	EN-057FA (BK)	X-950 Water in fuel sensor SP-057F GND - Engine	
3	EN-010AB (WH)	X-950 Water in fuel sensor SP-010A	

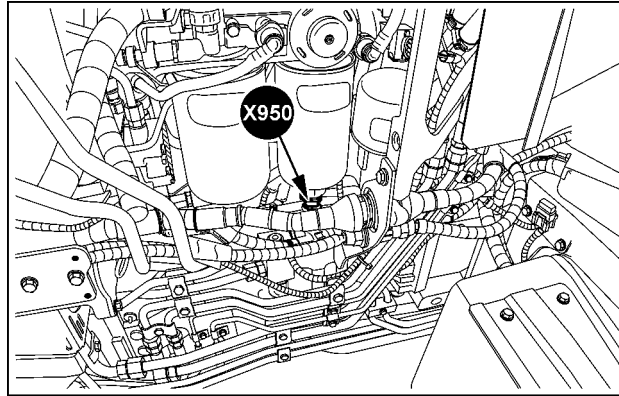

SVIL13TR00827AB 1

Rear left-hand engine

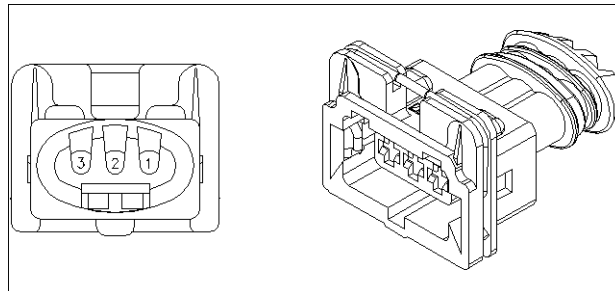

87709663 2

**CONNECTOR X-951 - Front hitch raise relay**

CONNECTOR X-951 - Front hitch raise relay			
PIN NUMBER	WIRE NUMBER	CIRCUIT REFERENCE	ELECTRICAL SCHEMATIC FRAME
30	EF-2574A (WH)	SP-2574 EFH-MODE X-951 Front hitch raise relay	<b>Wiring harnesses - Electrical schematic sheet 14 (55.100)</b>
85	EF-2585 (TN)	X-944 Cab main harness to Electronic Front Hitch (EFH) control unit harness X-951 Front hitch raise relay	
86	EF-011AD (GN)	X-951 Front hitch raise relay SP-011AA EFH MASTER	
87	EF-2578 (PK)	X-517 Front hitch switch – Auto/manual raise mode X-951 Front hitch raise relay	

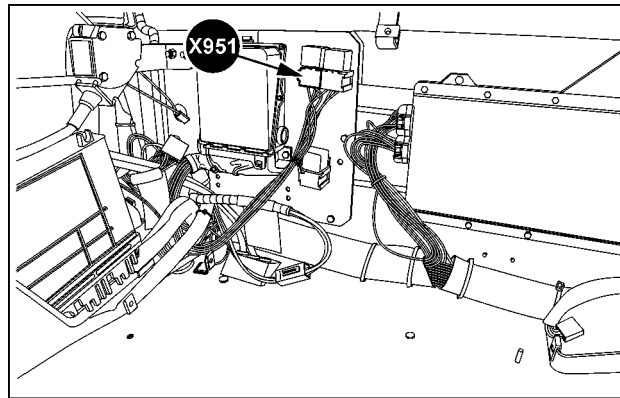

SVIL13TR00882AD 3

**In cab right-hand behind operator's seat**

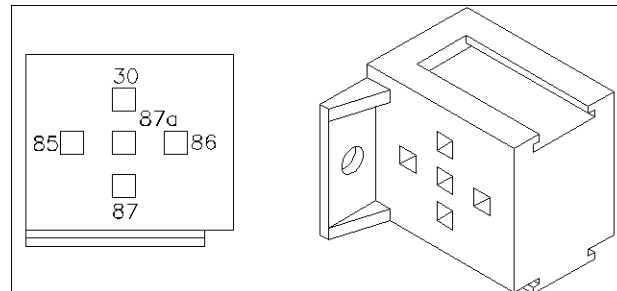

87746018 4

**CONNECTOR X-952 - Front hitch lower relay**

CONNECTOR X-952 - Front hitch lower relay			
PIN NUMBER	WIRE NUMBER	CIRCUIT REFERENCE	ELECTRICAL SCHEMATIC FRAME
30	EF-2574B (WH)	SP-2574 EFH-MODE X-952 Front hitch lower relay	Wiring harnesses - Electrical schematic sheet 14 (55.100)
85	EF-2586 (TN)	X-944 Cab main harness to Electronic Front Hitch (EFH) control unit harness X-952 Front hitch lower relay	
86	EF-011AE (GN)	X-952 Front hitch lower relay SP-011AA EFH MASTER	
87	EF-2576 (WH)	X-525 Front hitch electronic control panel X-952 Front hitch lower relay	

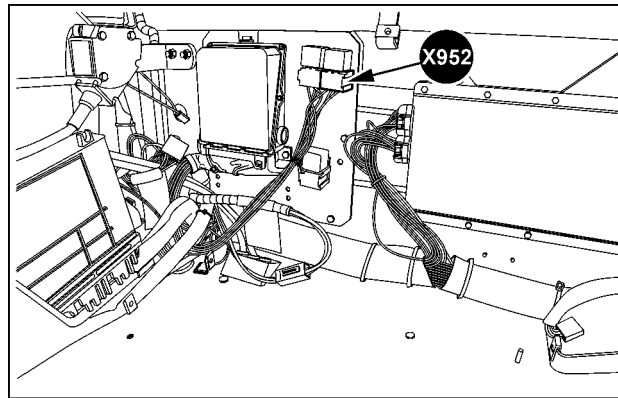

SVIL13TR00882AE 5

**In cab right-hand behind operator's seat**

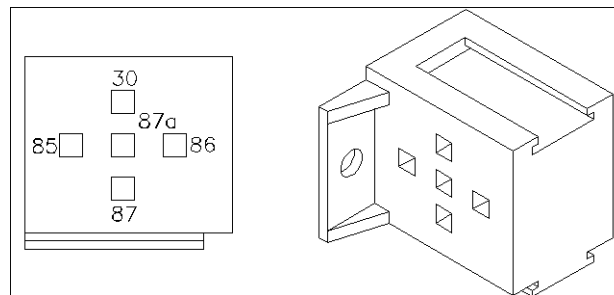

87746018 6



**CONNECTOR X-953 - Front hitch lock relay**

CONNECTOR X-953 - Front hitch lock relay			
PIN NUMBER	WIRE NUMBER	CIRCUIT REFERENCE	ELECTRICAL SCHEMATIC FRAME
30	EF-2574C (WH)	SP-2574 EFH-MODE X-953 Front hitch lock relay	<b>Wiring harnesses - Electrical schematic sheet 14 (55.100)</b>
85	EF-057KM (BK)	X-953 Front hitch lock relay SP-057K GND	
86	EF-011AF (GN)	X-953 Front hitch lock relay SP-011AA EFH MASTER	
87	EF-2602 (PK)	X-953 Front hitch lock relay X-524 Electronic Front Hitch (EFH) control unit	

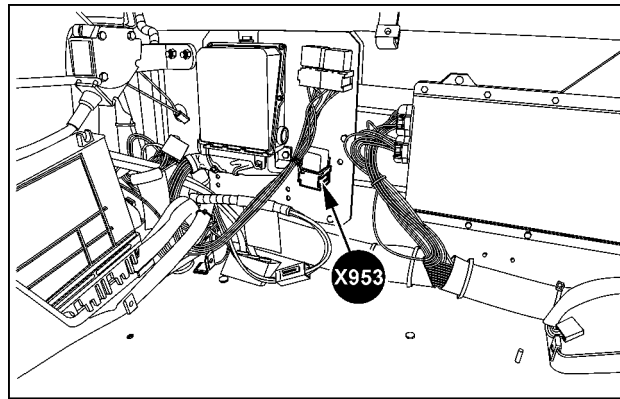

SVIL13TR00882AF 7

**In cab right-hand behind operator's seat**

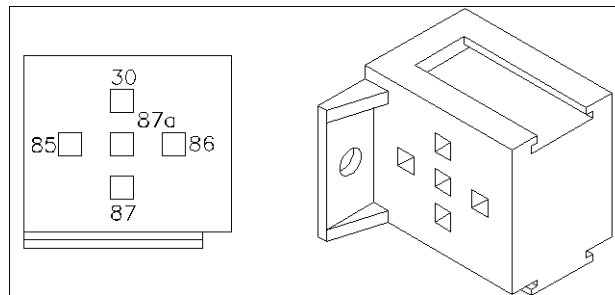

87746018 8

**CONNECTOR X-955 - Glow plug (cylinder 1)**

CONNECTOR X-955 - Glow plug (cylinder 1)			
PIN NUMBER	WIRE NUMBER	CIRCUIT REFERENCE	ELECTRICAL SCHEMATIC FRAME
1	GN/WH	X-941 Engine harness 2 to engine components X-955 Glow plug (cylinder 1)	Wiring harnesses - Electrical schematic sheet 06 (55.100)

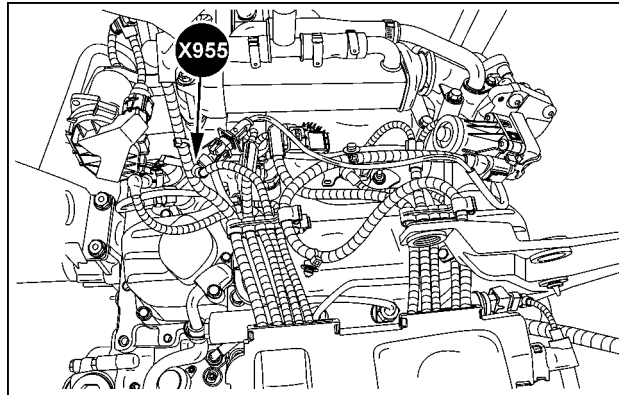

SVIL13TR00828AB 9

**Top of engine**

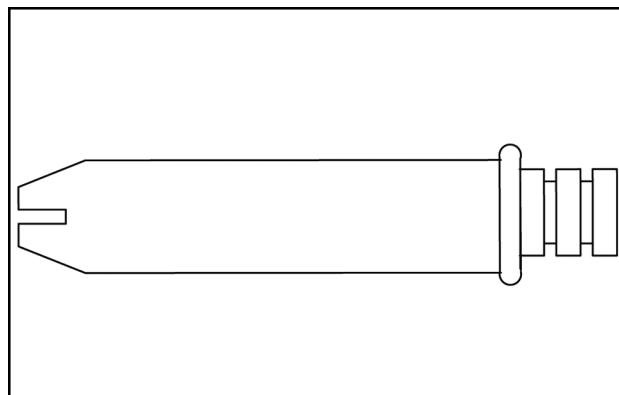

X-955\_X-958OK 10

**CONNECTOR X-956 - Glow plug (cylinder 2)**

CONNECTOR X-956 - Glow plug (cylinder 2)			
PIN NUMBER	WIRE NUMBER	CIRCUIT REFERENCE	ELECTRICAL SCHEMATIC FRAME
1	YE	X-941 Engine harness 2 to engine components X-956 Glow plug (cylinder 2)	<b>Wiring harnesses - Electrical schematic sheet 06 (55.100)</b>

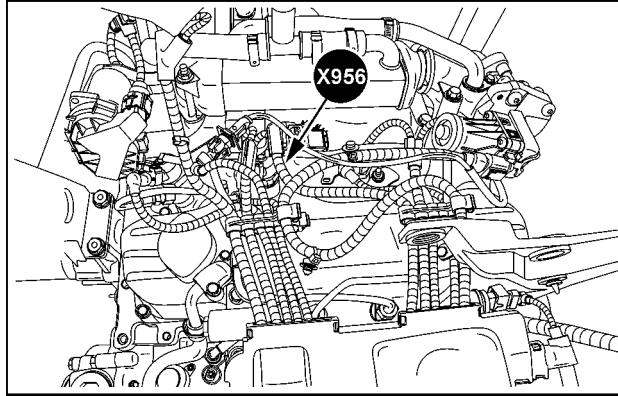

SVIL13TR00828AC 11

**Top of engine**

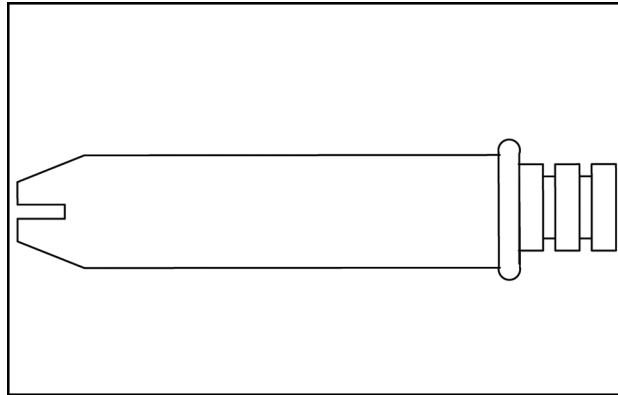

X-955\_X-958OK 12

**CONNECTOR X-957 - Glow plug (cylinder 3)**

CONNECTOR X-957 - Glow plug (cylinder 3)			
PIN NUMBER	WIRE NUMBER	CIRCUIT REFERENCE	ELECTRICAL SCHEMATIC FRAME
1	VT	X-941 Engine harness 2 to engine components X-957 Glow plug (cylinder 3)	Wiring harnesses - Electrical schematic sheet 06 (55.100)

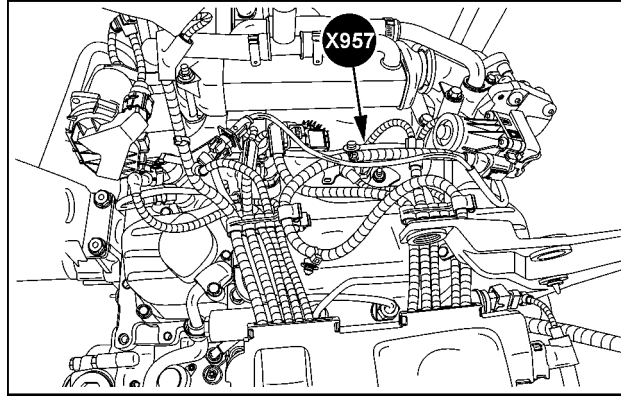

SVIL13TR00828AD 13

**Top of engine**

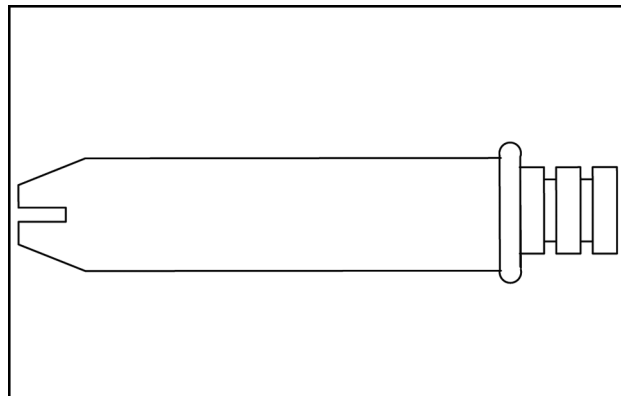

X-955\_X-958OK 14

**CONNECTOR X-958 - Glow plug (cylinder 4)**

CONNECTOR X-958 - Glow plug (cylinder 4)			
PIN NUMBER	WIRE NUMBER	CIRCUIT REFERENCE	ELECTRICAL SCHEMATIC FRAME
1	BL	X-941 Engine harness 2 to engine components X-958 Glow plug (cylinder 4)	Wiring harnesses - Electrical schematic sheet 06 (55.100)

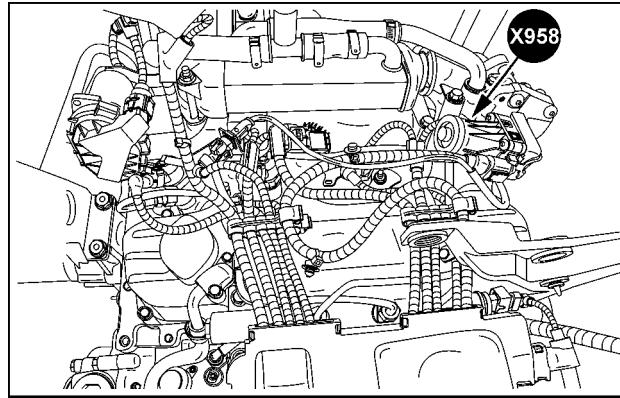

SVIL13TR00828AE 15

**Top of engine**

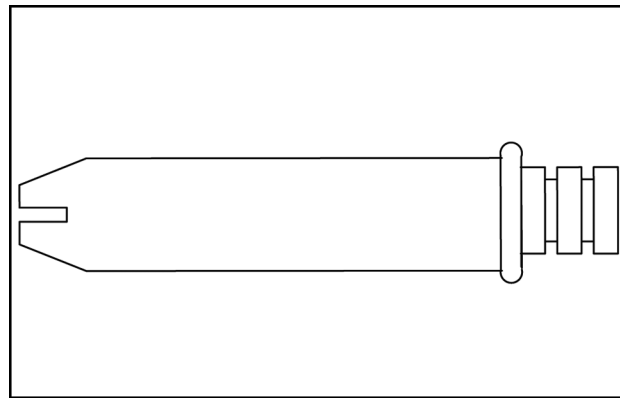

X-955\_X-958OK 16

**CONNECTOR X-959 - Engine oil pressure switch**

CONNECTOR X-959 - Engine oil pressure switch			
PIN NUMBER	WIRE NUMBER	CIRCUIT REFERENCE	ELECTRICAL SCHEMATIC FRAME
1	GY/BL	X-941 Engine harness 2 to engine components X-959 Engine oil pressure switch	Wiring harnesses - Electrical schematic sheet 06 (55.100)

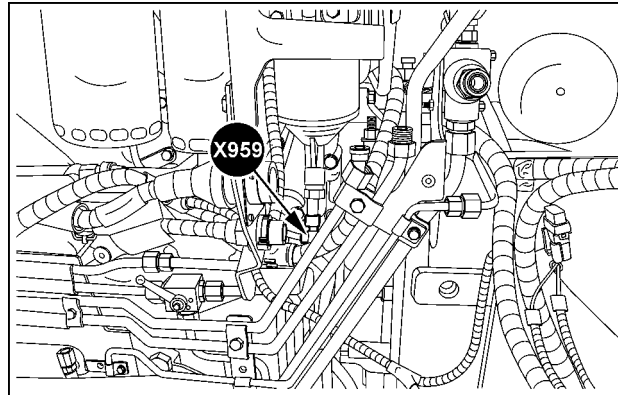

SVIL13TR00829AB 17

**Rear left-hand engine**

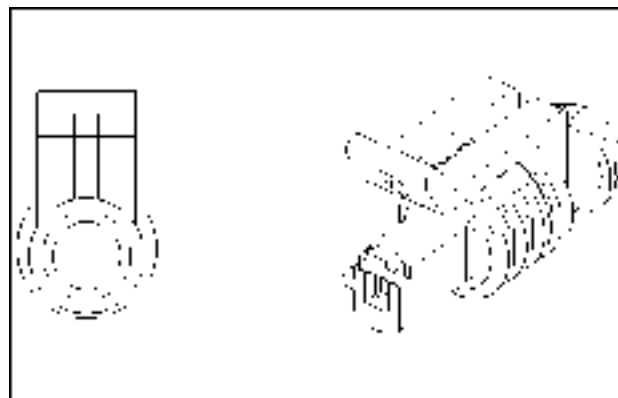

87687239 18

## Wire connectors - Component diagram 96

### CONNECTOR X-960 - Waste gate modulation solenoid

CONNECTOR X-960 - Waste gate modulation solenoid			
PIN NUMBER	WIRE NUMBER	CIRCUIT REFERENCE	ELECTRICAL SCHEMATIC FRAME
1	RD	X-941 Engine harness 2 to engine components X-960 Waste gate modulation solenoid	<b>Wiring harnesses - Electrical schematic sheet 06 (55.100)</b>
2	BR/WH	X-941 Engine harness 2 to engine components X-960 Waste gate modulation solenoid	

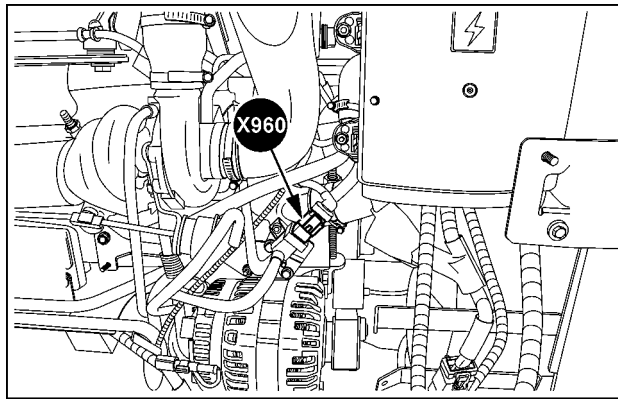

SVIL13TR00830AB 1

**Front right-hand engine**

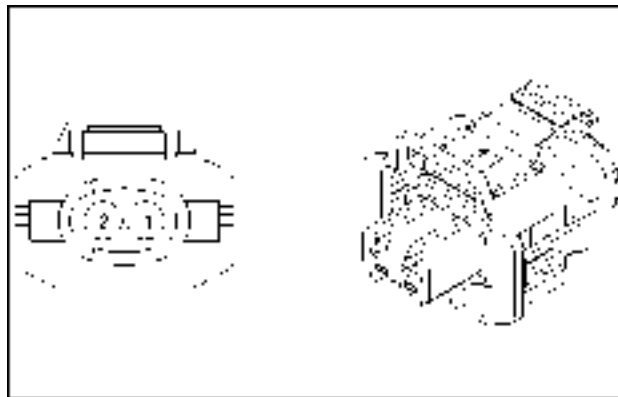

87709793 2

**CONNECTOR X-961 - Intake air pressure and temperature sensor**

CONNECTOR X-961 - Intake air pressure and temperature sensor			
PIN NUMBER	WIRE NUMBER	CIRCUIT REFERENCE	ELECTRICAL SCHEMATIC FRAME
1	BR/VT	X-941 Engine harness 2 to engine components X-961 Intake air pressure and temperature sensor	<b>Wiring harnesses - Electrical schematic sheet 06 (55.100)</b>
2	YE/BK	X-941 Engine harness 2 to engine components X-961 Intake air pressure and temperature sensor	
3	BR/VT	X-941 Engine harness 2 to engine components X-961 Intake air pressure and temperature sensor	
4	BR/BL	X-941 Engine harness 2 to engine components X-961 Intake air pressure and temperature sensor	

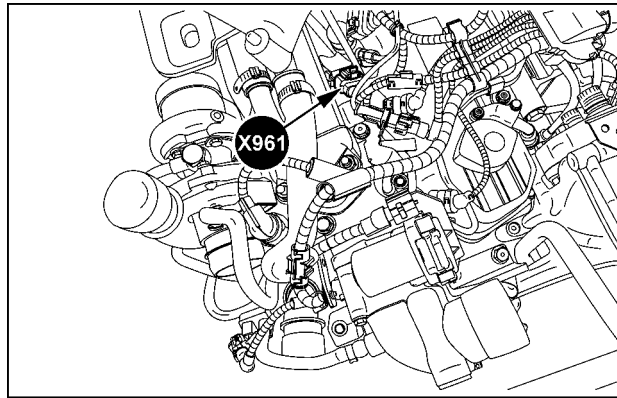

SVIL13TR00831AB 3

**Top of engine**

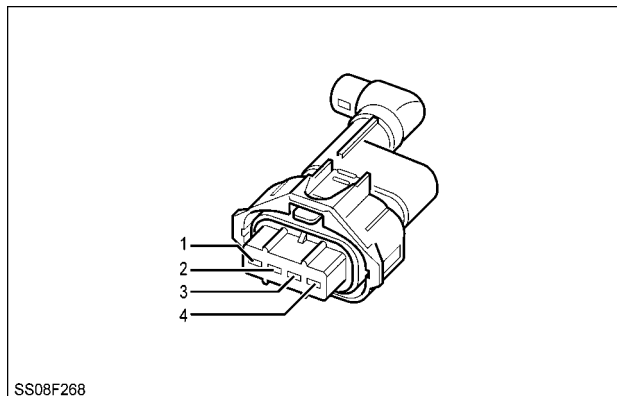

SS08F268

SS08F268 4



**CONNECTOR X-962 - Camshaft sensor**

<b>CONNECTOR X-962 - Camshaft sensor</b>			
<b>PIN NUMBER</b>	<b>WIRE NUMBER</b>	<b>CIRCUIT REFERENCE</b>	<b>ELECTRICAL SCHEMATIC FRAME</b>
1	VT/GN	X-941 Engine harness 2 to engine components X-962 Camshaft sensor	<b>Wiring harnesses - Electrical schematic sheet 06 (55.100)</b>
2	GY	X-941 Engine harness 2 to engine components X-962 Camshaft sensor	
3	WH	X-941 Engine harness 2 to engine components X-962 Camshaft sensor	

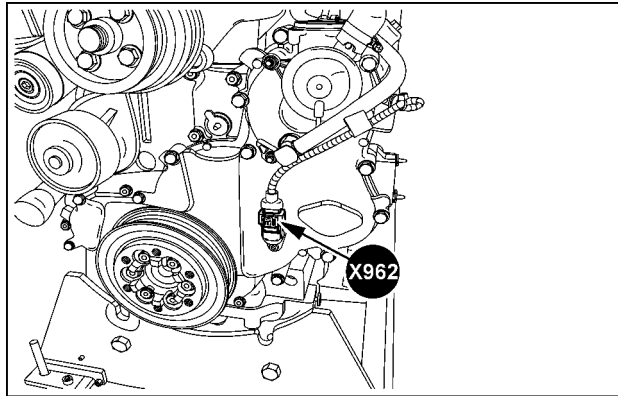

SVIL13TR00832AB 5

**Front left-hand engine**

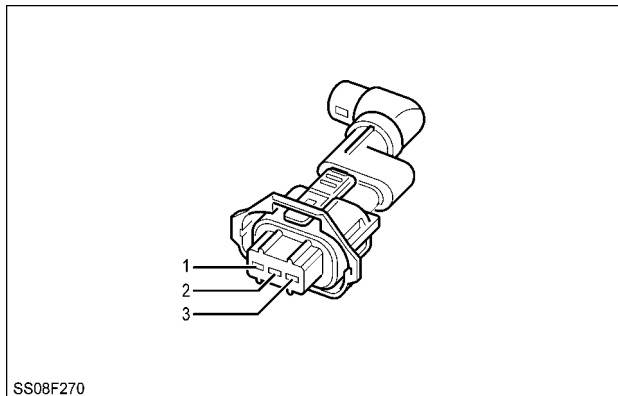

SS08F270

SS08F270 6

**CONNECTOR X-963 - Exhaust manifold pressure sensor**

<b>CONNECTOR X-963 - Exhaust manifold pressure sensor</b>			
<b>PIN NUMBER</b>	<b>WIRE NUMBER</b>	<b>CIRCUIT REFERENCE</b>	<b>ELECTRICAL SCHEMATIC FRAME</b>
1	YE/BK	X-941 Engine harness 2 to engine components X-963 Exhaust manifold pressure sensor	<b>Wiring harnesses - Electrical schematic sheet 06 (55.100)</b>
2	BL/WH	X-941 Engine harness 2 to engine components X-963 Exhaust manifold pressure sensor	
3	BR	X-941 Engine harness 2 to engine components X-963 Exhaust manifold pressure sensor	

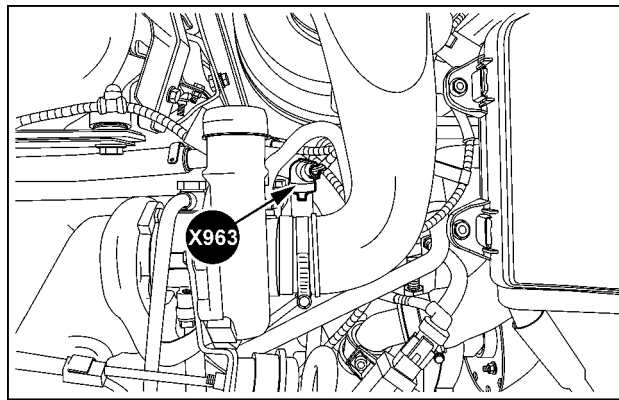

SVIL13TR00833AB 7

**Front top right-hand engine**

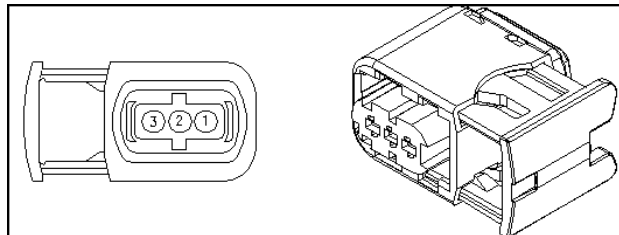

84146685 8

**CONNECTOR X-964 - Exhaust Gas Recirculation (EGR) – Valve actuator**

CONNECTOR X-964 - Exhaust Gas Recirculation (EGR) – Valve actuator			
PIN NUMBER	WIRE NUMBER	CIRCUIT REFERENCE	ELECTRICAL SCHEMATIC FRAME
1	OR/WH	X-941 Engine harness 2 to engine components X-964 Exhaust Gas Recirculation (EGR) – Valve actuator	<b>Wiring harnesses - Electrical schematic sheet 06 (55.100)</b>
2	BL/WH	X-941 Engine harness 2 to engine components X-964 Exhaust Gas Recirculation (EGR) – Valve actuator	
3	-	-	
4	VT	X-941 Engine harness 2 to engine components X-964 Exhaust Gas Recirculation (EGR) – Valve actuator	
5	GY/OR	X-941 Engine harness 2 to engine components X-964 Exhaust Gas Recirculation (EGR) – Valve actuator	
6	BL	X-941 Engine harness 2 to engine components X-964 Exhaust Gas Recirculation (EGR) – Valve actuator	

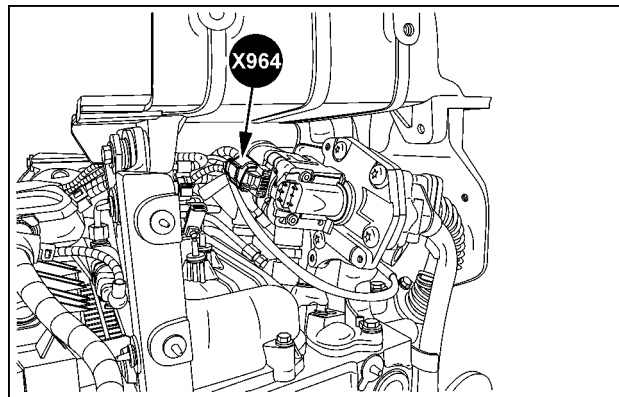

SVIL13TR00834AB 9

**Rear top of engine**

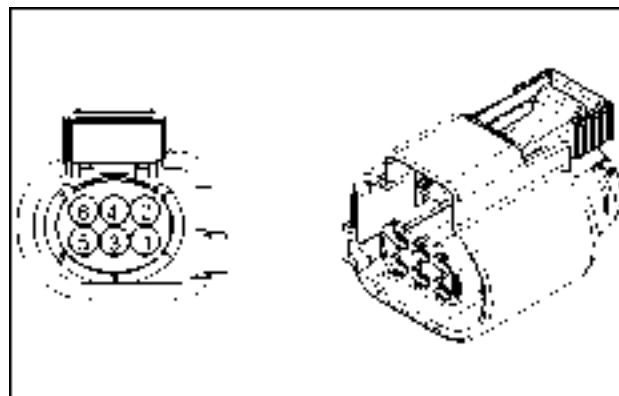

84301132 10

**CONNECTOR X-965 - Crankshaft sensor**

<b>CONNECTOR X-965 - Crankshaft sensor</b>			
<b>PIN NUMBER</b>	<b>WIRE NUMBER</b>	<b>CIRCUIT REFERENCE</b>	<b>ELECTRICAL SCHEMATIC FRAME</b>
1	BL	X-941 Engine harness 2 to engine components X-965 Crankshaft sensor	<b>Wiring harnesses - Electrical schematic sheet 06 (55.100)</b>
2	VT	X-941 Engine harness 2 to engine components X-965 Crankshaft sensor	
3	WH	X-941 Engine harness 2 to engine components X-965 Crankshaft sensor	

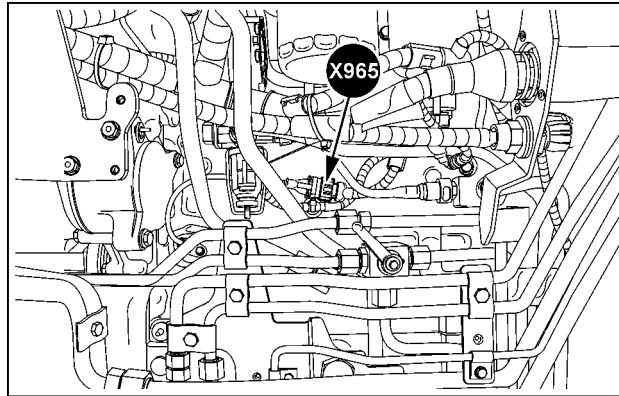

SVIL13TR00835AB 11

**Left-hand engine**

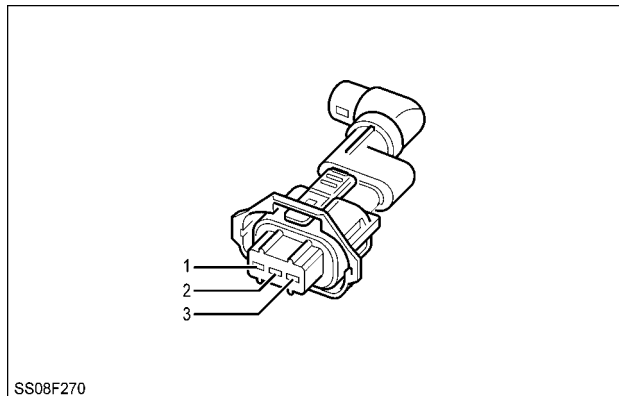

SS08F270

SS08F270 12

**CONNECTOR X-966 - Throttle Valve Actuator (TVA)**

CONNECTOR X-966 - Throttle Valve Actuator (TVA)			
PIN NUMBER	WIRE NUMBER	CIRCUIT REFERENCE	ELECTRICAL SCHEMATIC FRAME
1	BR/BL	X-941 Engine harness 2 to engine components X-966 Throttle Valve Actuator (TVA)	<b>Wiring harnesses - Electrical schematic sheet 06 (55.100)</b>
2	BL/OR	X-941 Engine harness 2 to engine components X-966 Throttle Valve Actuator (TVA)	
3	WH/OR	X-941 Engine harness 2 to engine components X-966 Throttle Valve Actuator (TVA)	
4	-	-	
5	BL/BK	X-941 Engine harness 2 to engine components X-966 Throttle Valve Actuator (TVA)	
6	OR/GN	X-941 Engine harness 2 to engine components X-966 Throttle Valve Actuator (TVA)	

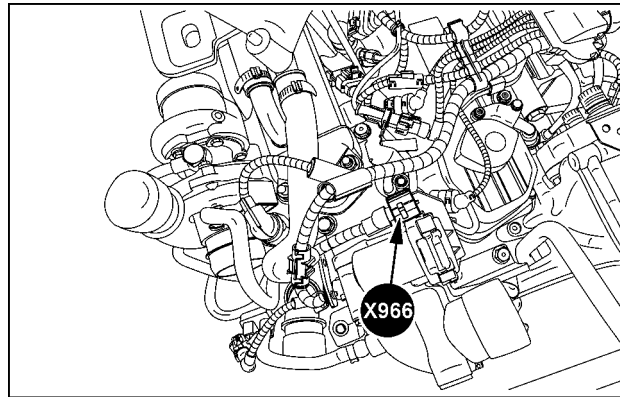

SVIL13TR00831AC 13

**Top of engine**

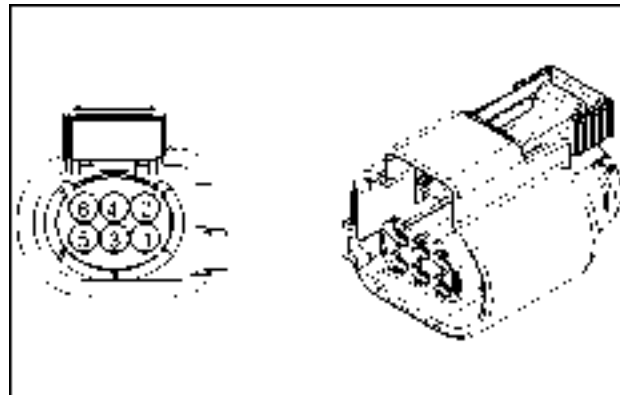

84301132 14

**CONNECTOR X-967 - Common rail pressure sensor**

CONNECTOR X-967 - Common rail pressure sensor			
PIN NUMBER	WIRE NUMBER	CIRCUIT REFERENCE	ELECTRICAL SCHEMATIC FRAME
1	GN/BR	X-941 Engine harness 2 to engine components X-967 Common rail pressure sensor	Wiring harnesses - Electrical schematic sheet 06 (55.100)
2	YE/BK	X-941 Engine harness 2 to engine components X-967 Common rail pressure sensor	
3	GY/GN	X-941 Engine harness 2 to engine components X-967 Common rail pressure sensor	

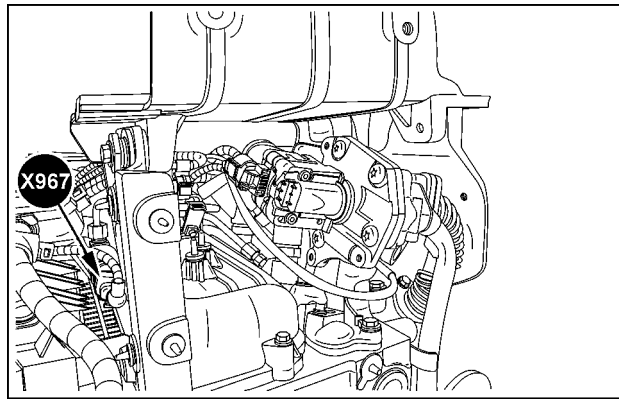

SVIL13TR00834AC 15

**Rear top of engine**

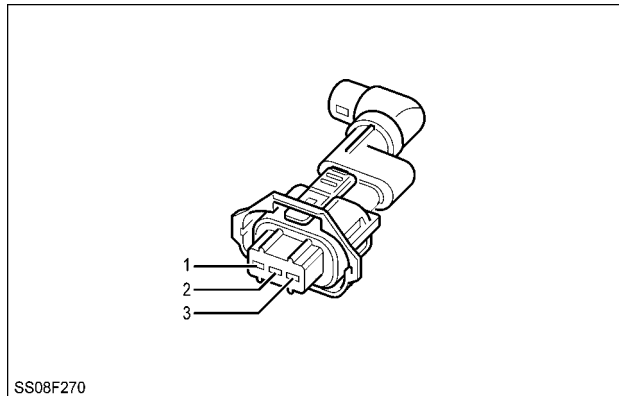

SS08F270

SS08F270 16

**CONNECTOR X-968 - Fuel temperature sensor**

CONNECTOR X-968 - Fuel temperature sensor			
PIN NUMBER	WIRE NUMBER	CIRCUIT REFERENCE	ELECTRICAL SCHEMATIC FRAME
1	BR/WH	X-941 Engine harness 2 to engine components X-968 Fuel temperature sensor	<b>Wiring harnesses - Electrical schematic sheet 06 (55.100)</b>
2	BR	X-941 Engine harness 2 to engine components X-968 Fuel temperature sensor	

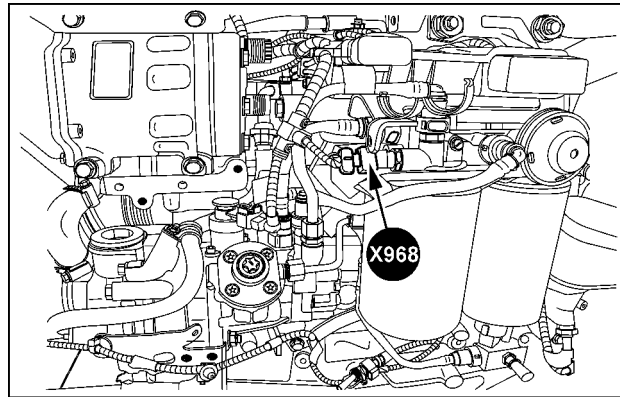

SVIL13TR00836AB 17

**Front left-hand engine**

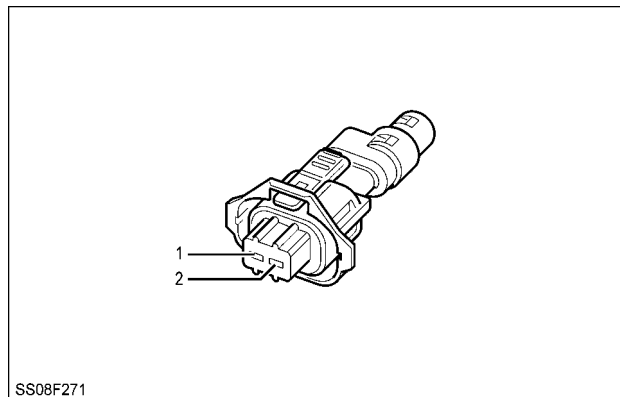

SS08F271

SS08F271 18

**CONNECTOR X-969 - Engine coolant temperature sensor**

CONNECTOR X-969 - Engine coolant temperature sensor			
PIN NUMBER	WIRE NUMBER	CIRCUIT REFERENCE	ELECTRICAL SCHEMATIC FRAME
1	YE	X-941 Engine harness 2 to engine components X-969 Engine coolant temperature sensor	Wiring harnesses - Electrical schematic sheet 06 (55.100)
2	GN	X-941 Engine harness 2 to engine components X-969 Engine coolant temperature sensor	

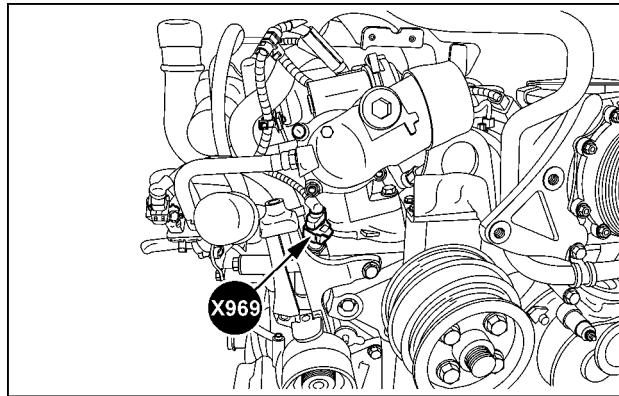

SVIL13TR00837AB 19

**Front right-hand engine**

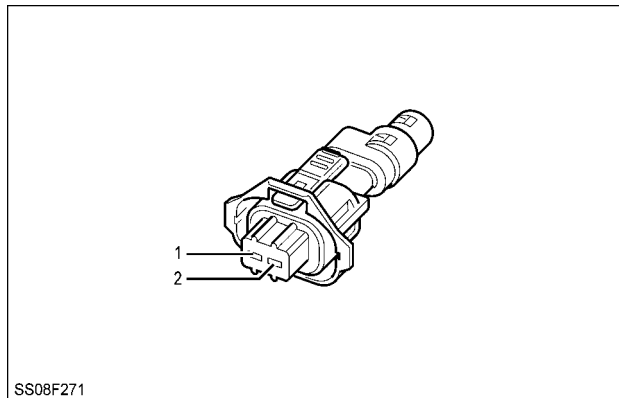

SS08F271

SS08F271 20



## Wire connectors - Component diagram 97

### CONNECTOR X-970 - High pressure pump – Solenoid valve

CONNECTOR X-970 - High pressure pump – Solenoid valve			
PIN NUMBER	WIRE NUMBER	CIRCUIT REFERENCE	ELECTRICAL SCHEMATIC FRAME
1	VT/WH	X-941 Engine harness 2 to engine components X-970 High pressure pump – Solenoid valve	<b>Wiring harnesses - Electrical schematic sheet 06 (55.100)</b>
2	OR/WH	X-941 Engine harness 2 to engine components X-970 High pressure pump – Solenoid valve	

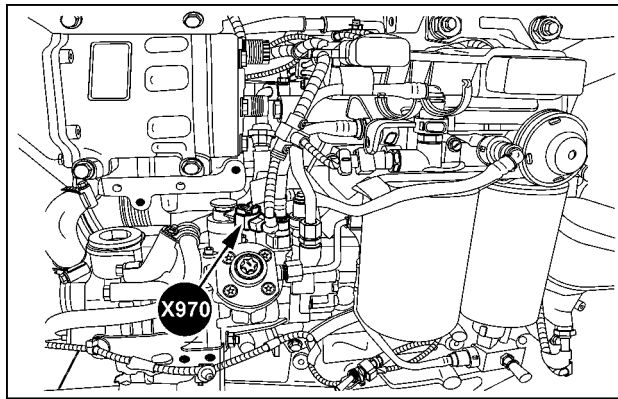

SVIL13TR00836AC 1

**Front left-hand engine**

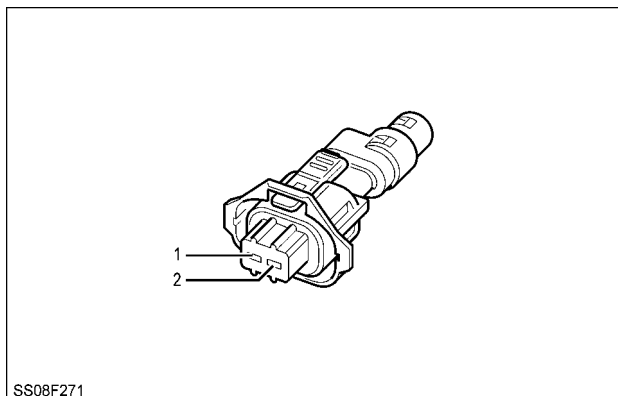

SS08F271

SS08F271 2

**CONNECTOR X-971 - Exhaust manifold temperature sensor**

CONNECTOR X-971 - Exhaust manifold temperature sensor			
PIN NUMBER	WIRE NUMBER	CIRCUIT REFERENCE	ELECTRICAL SCHEMATIC FRAME
1	GN/WH	X-941 Engine harness 2 to engine components X-971 Exhaust manifold temperature sensor	<b>Wiring harnesses - Electrical schematic sheet 05 (55.100)</b>
2	YE/BR	X-941 Engine harness 2 to engine components X-971 Exhaust manifold temperature sensor	

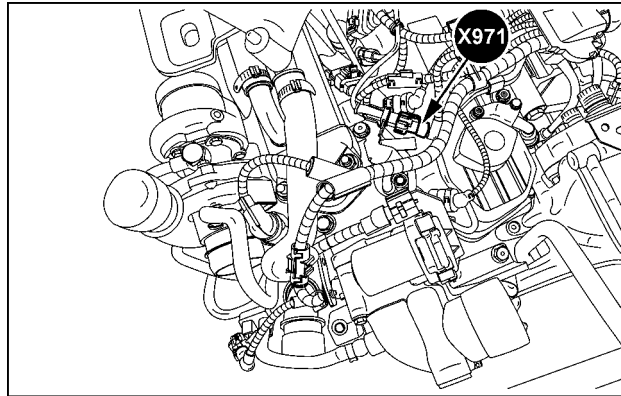

SVIL13TR00831AD 3

**Top of engine**

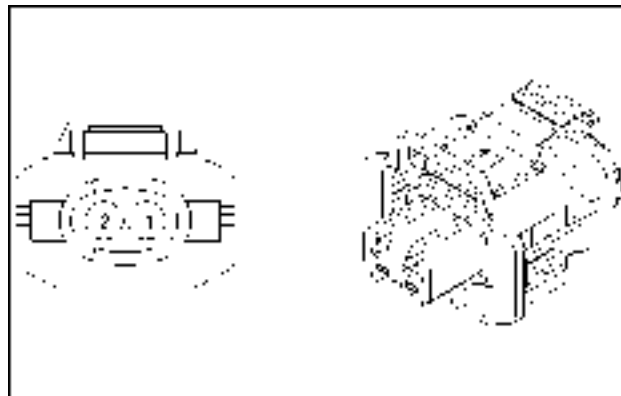

87709793 4

**CONNECTOR X-973 - Blower motor**

**Blower motor left-hand**

CONNECTOR X-973 - Blower motor			
PIN NUMBER	WIRE NUMBER	CIRCUIT REFERENCE	ELECTRICAL SCHEMATIC FRAME
1	LF-057AR (BK)	X-973 Blower motor X-046 Cab main harness to blower motor left-hand	<b>Wiring harnesses - Electrical schematic sheet 17 (55.100)</b>
2	1 (BR)	X-973 Blower motor SP-062	

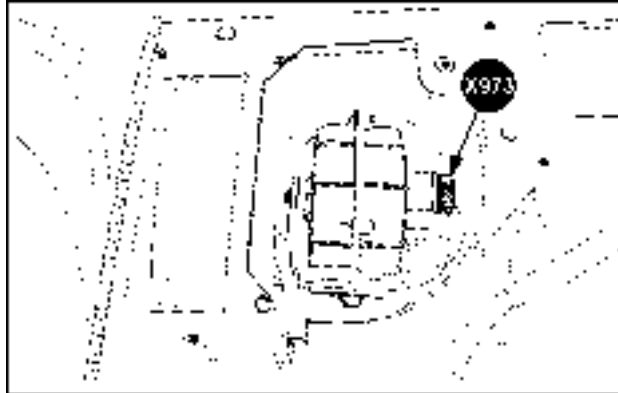

SVIL13TR00838AB 5

**In cab left-hand below operator's seat**

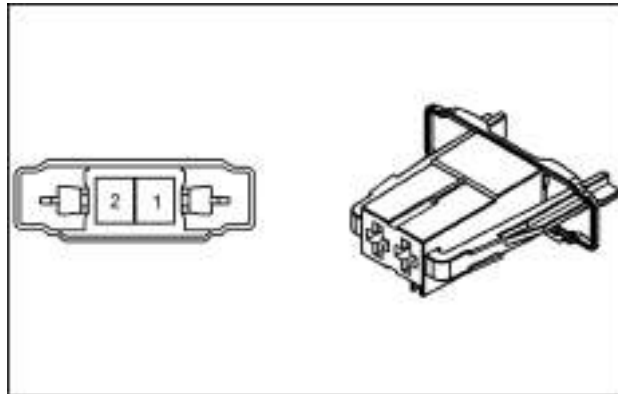

84335034 6

**Blower motor right-hand**

<b>CONNECTOR X-973 - Blower motor</b>			
<b>PIN NUMBER</b>	<b>WIRE NUMBER</b>	<b>CIRCUIT REFERENCE</b>	<b>ELECTRICAL SCHEMATIC FRAME</b>
1	RF-057AS (BK)	X-973 Blower motor X-047 Cab main harness to blower motor right-hand	<b>Wiring harnesses - Electrical schematic sheet 17 (55.100)</b>
2	2 (BR)	X-973 Blower motor SP-062	

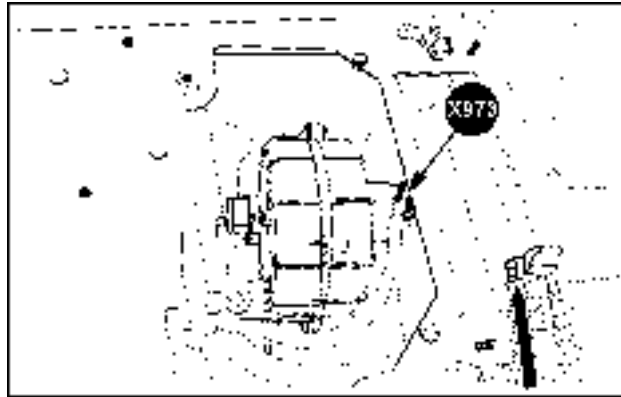

SVIL13TR00839AB 7

**In cab right-hand below operator's seat**

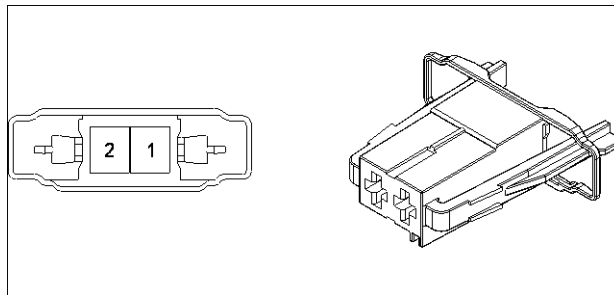

84335034 8

**CONNECTOR X-974 - Resistors blower motor**

**Resistors blower motor left-hand**

<b>CONNECTOR X-974 - Resistors blower motor</b>			
<b>PIN NUMBER</b>	<b>WIRE NUMBER</b>	<b>CIRCUIT REFERENCE</b>	<b>ELECTRICAL SCHEMATIC FRAME</b>
1	LF-6300A (BR)	X-974 Resistors blower motor X-046 Cab main harness to blower motor left-hand	<b>Wiring harnesses - Electrical schematic sheet 17 (55.100)</b>
2	LF-6301A (BR)	X-974 Resistors blower motor X-046 Cab main harness to blower motor left-hand	
3	LF-6302C (GN)	X-046 Cab main harness to blower motor left-hand X-974 Resistors blower motor	
4	LF-6303C (BR)	X-974 Resistors blower motor SP-062	

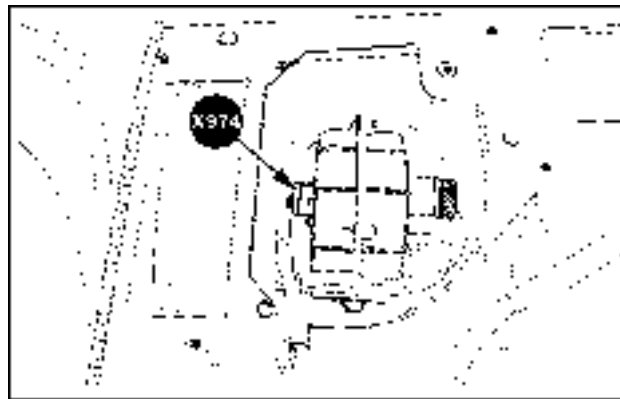

SVIL13TR00838AC 9

**In cab left-hand below operator's seat**

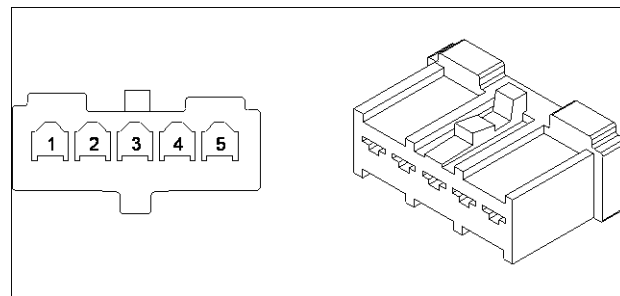

84279647 10

**Resistors blower motor right-hand**

<b>CONNECTOR X-974 - Resistors blower motor</b>			
<b>PIN NUMBER</b>	<b>WIRE NUMBER</b>	<b>CIRCUIT REFERENCE</b>	<b>ELECTRICAL SCHEMATIC FRAME</b>
1	RF-057AS (BK)	X-974 Resistors blower motor X-047 Cab main harness to blower motor right-hand	<b>Wiring harnesses - Electrical schematic sheet 17 (55.100)</b>
2	RF-6301 (BR)	X-974 Resistors blower motor X-047 Cab main harness to blower motor right-hand	
3	RF-6302D (BR)	X-047 Cab main harness to blower motor right-hand X-974 Resistors blower motor	
4	RF-6303D (BR)	X-974 Resistors blower motor SP-062	

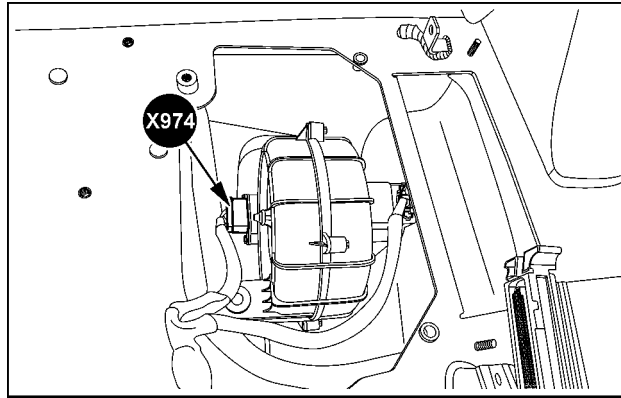

SVIL13TR00839AC 11

**In cab right-hand below operator's seat**

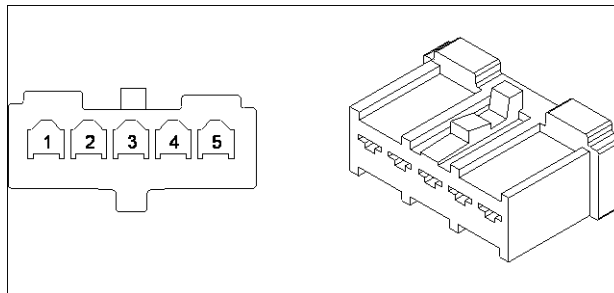

84279647 12

**CONNECTOR X-976 - Front window wiper motor (openable front window)**

CONNECTOR X-976 - Front window wiper motor (openable front window)			
PIN NUMBER	WIRE NUMBER	CIRCUIT REFERENCE	ELECTRICAL SCHEMATIC FRAME
1	(BK)	X-976 Front window wiper motor (openable front window) X-075 Roof harness to front window wiper motor (openable front window)	<b>Wiring harnesses - Electrical schematic sheet 22 (55.100)</b>
2	(GN)	X-976 Front window wiper motor (openable front window) X-075 Roof harness to front window wiper motor (openable front window)	
3	(YE)	X-976 Front window wiper motor (openable front window) X-075 Roof harness to front window wiper motor (openable front window)	
4	-	-	
5	(RD)	X-976 Front window wiper motor (openable front window) X-075 Roof harness to front window wiper motor (openable front window)	
6	(BL)	X-976 Front window wiper motor (openable front window) X-075 Roof harness to front window wiper motor (openable front window)	

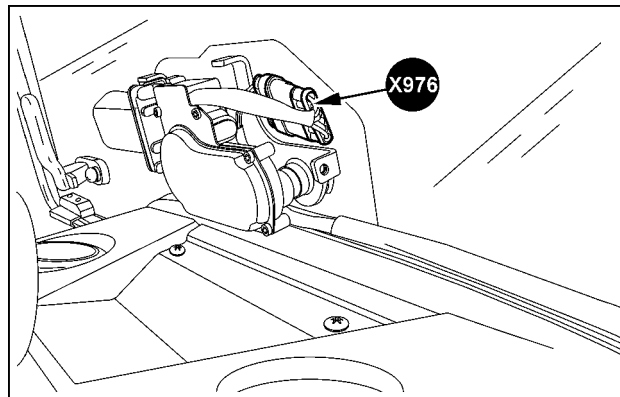

SVIL13TR00891AB 13

**Front inside of cab**

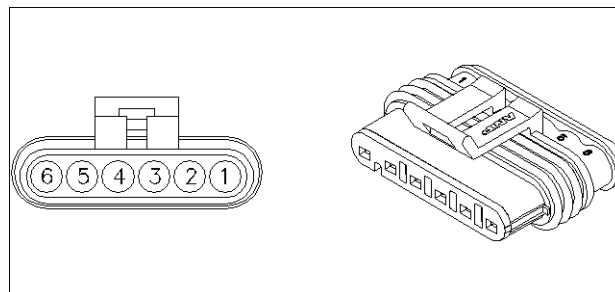

87710588 14

**CONNECTOR X-977 - License plate light – Cab left-hand (Italy)**

CONNECTOR X-977 - License plate light – Cab left-hand (Italy)			
PIN NUMBER	WIRE NUMBER	CIRCUIT REFERENCE	ELECTRICAL SCHEMATIC FRAME
1	SL-1109 (YE)	X-977 License plate light – Cab left-hand (Italy) X-095 Cab main harness to license plate light – Cab left-hand (Italy)	Wiring harnesses - Electrical schematic sheet 18 (55.100)
2	SL-1110 (WH)	X-977 License plate light – Cab left-hand (Italy) X-095 Cab main harness to license plate light – Cab left-hand (Italy)	

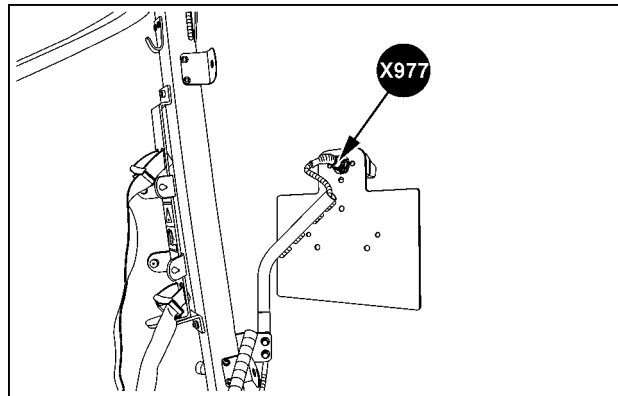

SVIL13TR00840AB 15

**Left-hand C-pillar**

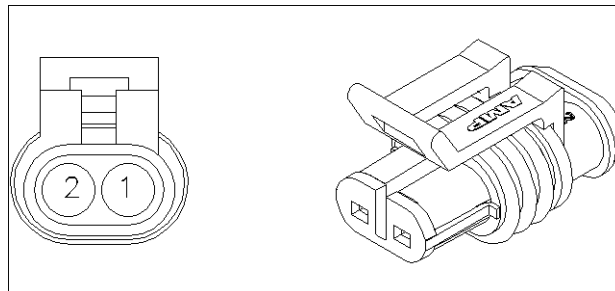

82012083 16



**CONNECTOR X-978 - Headlight left-hand**

CONNECTOR X-978 - Headlight left-hand			
PIN NUMBER	WIRE NUMBER	CIRCUIT REFERENCE	ELECTRICAL SCHEMATIC FRAME
A	HD-1030AA (BL)	X-978 Headlight left-hand SP-049	<b>Wiring harnesses - Electrical schematic sheet 18 (55.100)</b>
B	HD-1027AA (BL)	SP-046 X-978 Headlight left-hand	
C	HD-057ES (BK)	SP-048 X-978 Headlight left-hand	

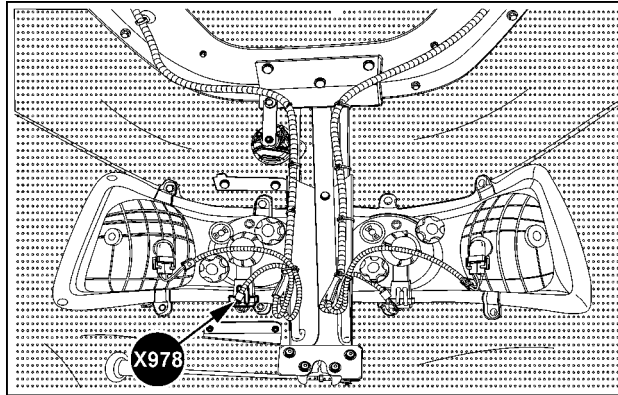

SVIL13TR00729AE 17

**Front hood**

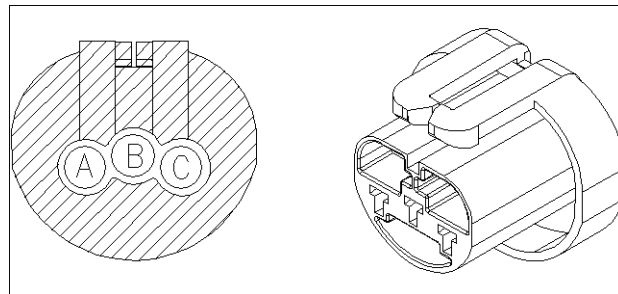

87697641 18

**CONNECTOR X-979 - Headlight right-hand**

CONNECTOR X-979 - Headlight right-hand			
PIN NUMBER	WIRE NUMBER	CIRCUIT REFERENCE	ELECTRICAL SCHEMATIC FRAME
A	HD-1030A (BL)	SP-049 X-979 Headlight right-hand	Wiring harnesses - Electrical schematic sheet 18 (55.100)
B	HD-057EW (BK)	SP-046 X-979 Headlight right-hand	
C	HD-1027AB (BL)	SP-048 X-979 Headlight right-hand	

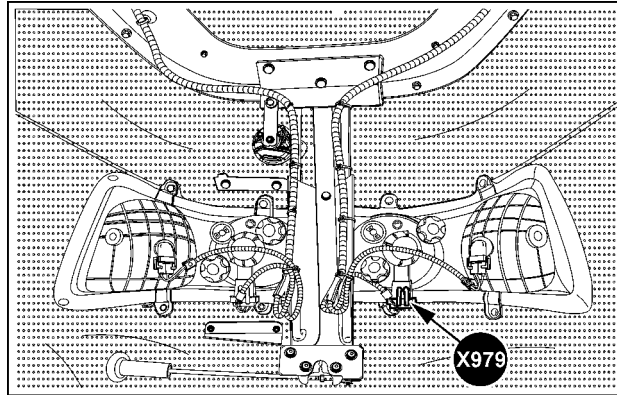

SVIL13TR00729AF 19

**Front hood**

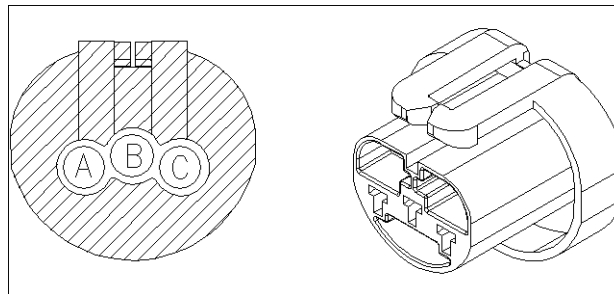

87697641 20

## Wire connectors - Component diagram 98

### CONNECTOR X-980 - Injector cylinder 1

CONNECTOR X-980 - Injector cylinder 1			
PIN NUMBER	WIRE NUMBER	CIRCUIT REFERENCE	ELECTRICAL SCHEMATIC FRAME
1	BL	X-940 Engine harness 2 to injectors X-980 Injector cylinder 1	Wiring harnesses - Electrical schematic sheet 06 (55.100)
2	BR	X-940 Engine harness 2 to injectors X-980 Injector cylinder 1	

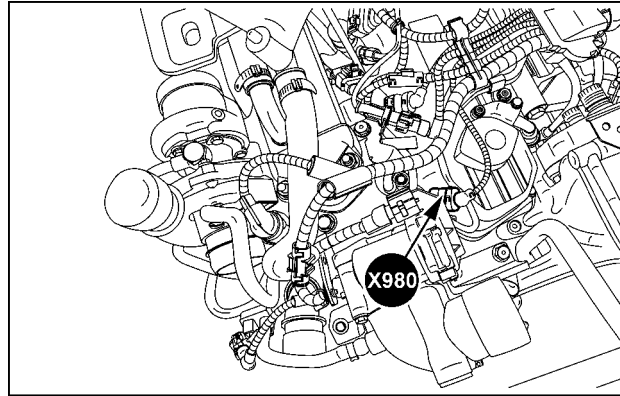

SVIL13TR00831AE 1

**Top of engine**

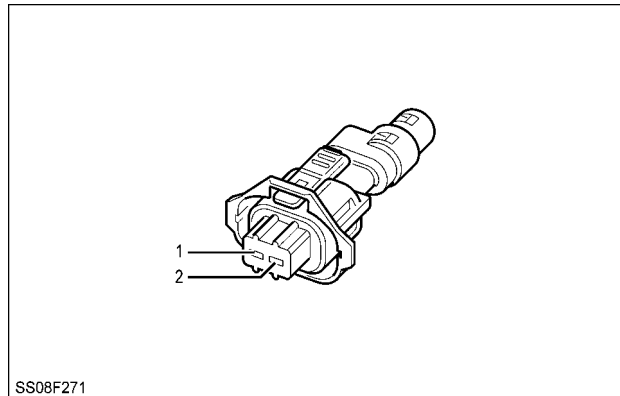

SS08F271

SS08F271 2

**CONNECTOR X-981 - Injector cylinder 2**

CONNECTOR X-981 - Injector cylinder 2			
PIN NUMBER	WIRE NUMBER	CIRCUIT REFERENCE	ELECTRICAL SCHEMATIC FRAME
1	YE/OR	X-940 Engine harness 2 to injectors X-981 Injector cylinder 2	Wiring harnesses - Electrical schematic sheet 06 (55.100)
2	GY	X-940 Engine harness 2 to injectors X-981 Injector cylinder 2	

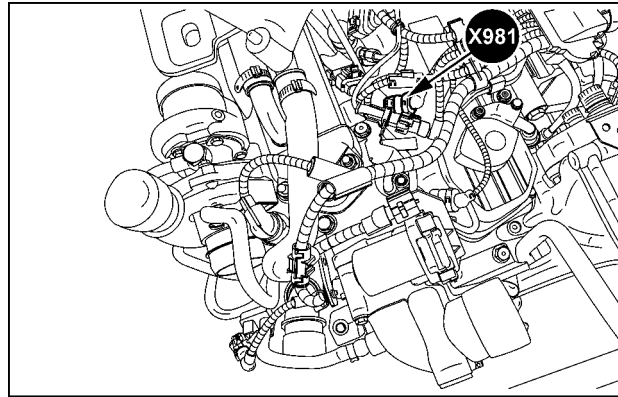

SVIL13TR00831AF 3

**Top of engine**

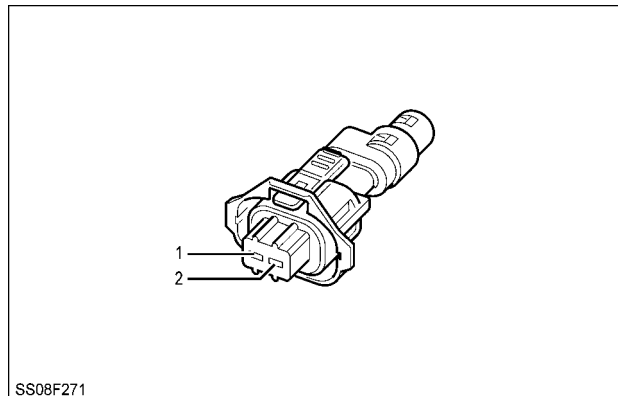

SS08F271

SS08F271 4

**CONNECTOR X-982 - Injector cylinder 3**

CONNECTOR X-982 - Injector cylinder 3			
PIN NUMBER	WIRE NUMBER	CIRCUIT REFERENCE	ELECTRICAL SCHEMATIC FRAME
1	VT	X-940 Engine harness 2 to injectors X-982 Injector cylinder 3	<b>Wiring harnesses - Electrical schematic sheet 06 (55.100)</b>
2	WH	X-940 Engine harness 2 to injectors X-982 Injector cylinder 3	

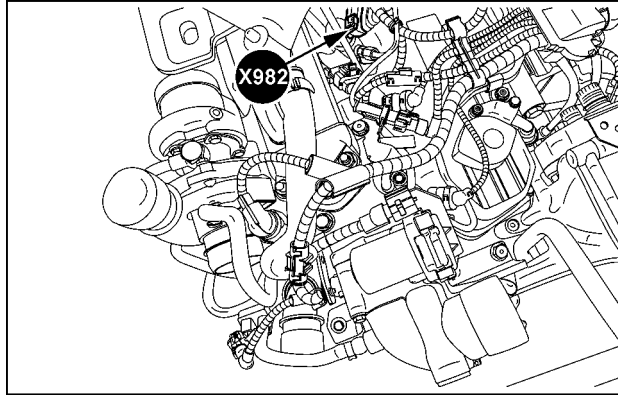

SVIL13TR00831AG 5

**Top of engine**

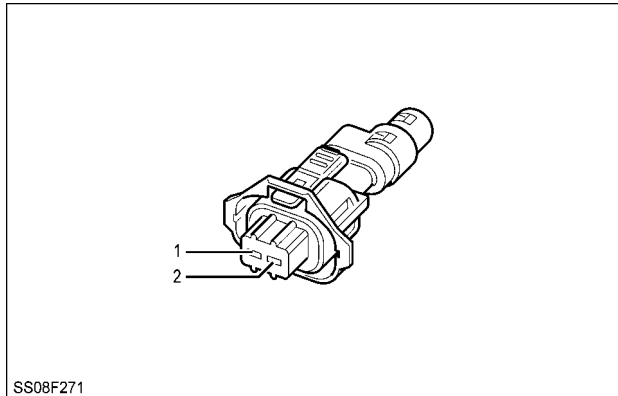

SS08F271

SS08F271 6

**CONNECTOR X-983 - Injector cylinder 4**

<b>CONNECTOR X-983 - Injector cylinder 4</b>			
<b>PIN NUMBER</b>	<b>WIRE NUMBER</b>	<b>CIRCUIT REFERENCE</b>	<b>ELECTRICAL SCHEMATIC FRAME</b>
1	OR/BL	X-940 Engine harness 2 to injectors X-983 Injector cylinder 4	<b>Wiring harnesses - Electrical schematic sheet 06 (55.100)</b>
2	GN/VT	X-940 Engine harness 2 to injectors X-983 Injector cylinder 4	

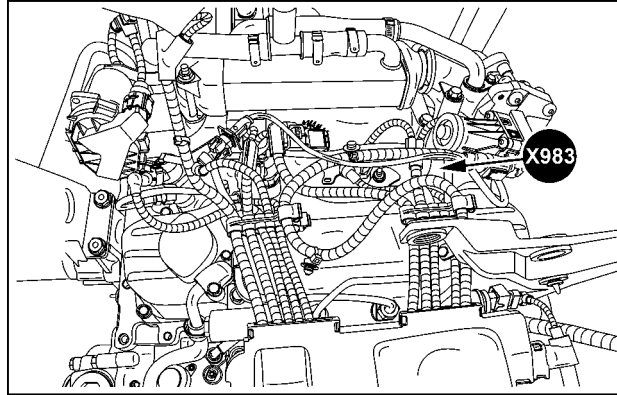

SVIL13TR00828AF 7

**Top of engine**

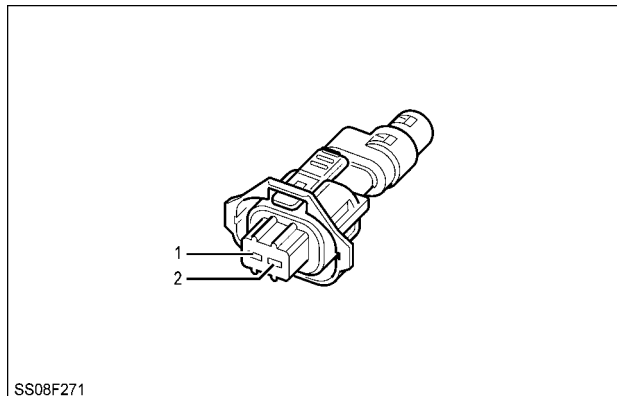

SS08F271

SS08F271 8

## Wire connectors - Component diagram 99

### CONNECTOR X-999 - Hydraulic trailer brake relay

CONNECTOR X-999 - Hydraulic trailer brake relay			
PIN NUMBER	WIRE NUMBER	CIRCUIT REFERENCE	ELECTRICAL SCHEMATIC FRAME
30	TB-010KB (GN)	X-999 Hydraulic trailer brake relay SP-010K IGNITION ITALIEN TRAILER BRAKE	Wiring harnesses - Electrical schematic sheet 04 (55.100)
85	TB-8065 (BL)	X-999 Hydraulic trailer brake relay X-381 Cab main harness to hydraulic trailer brake harness	
86	TB-010KA (GN)	SP-010K IGNITION ITALIEN TRAILER BRAKE X-999 Hydraulic trailer brake relay	
87A	TB-8000A (BR)	X-999 Hydraulic trailer brake relay X-361 Hydraulic trailer brake – Solenoid valve	

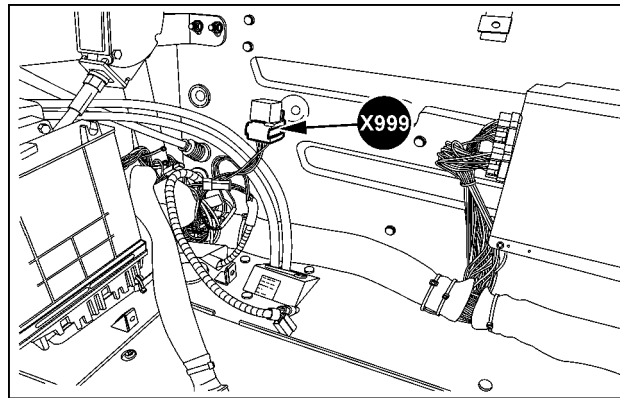

SVIL13TR00893AC 1

Rear of cab right-hand behind operator's seat

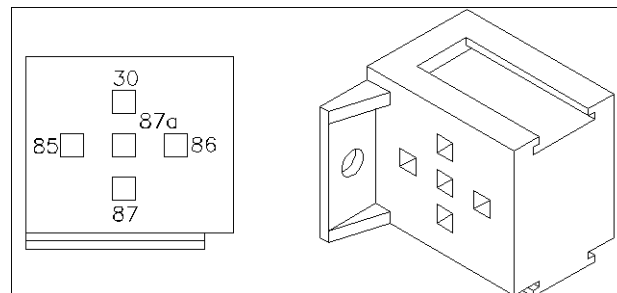

87746018 2

## Wiring harnesses - Repair

### Temporary wire harness repair

**NOTE:** This is a temporary repair only. Ensure the damaged cable is replaced as soon as possible to prevent ingress of water or chemicals.

**NOTE:** When you repair a cable it is important that you use only resin cored solder. The use of other types of solder may result in further cable damage.

The following procedure is intended for the temporary repair of defective wiring.

1. Locate the damaged portion of cable.
2. Cut away the outer protective cover on both sides of the damaged area.
3. Peel back the cable from both ends of the damaged area.
4. Carefully cut away the inner cable cover at the damaged area.
5. Remove approximately **13.0 mm (0.5 in)** of insulation from each wire. Do not cut away any wire strands.
6. Using a suitable solvent, clean approximately **50.0 mm (2.0 in)** from each outer protective cover end. Clean the inner cable cover and the individual wires.
7. Twist together two bare wire ends for each damaged wire, being careful to match the wire color.
8. Solder the wires using resin cored solder.
9. Tape each repaired wire with vinyl insulation tape.
10. Wind a layer of vinyl insulation tape up to the inner cable cover at each end of the repair section.
11. Make a paper trough and apply silicone rubber compound (non hardening sealant) over the repaired section up to the cover ends. Sufficient sealant must be used to fill the ends of the cut away area.
12. Allow the sealant to cure.

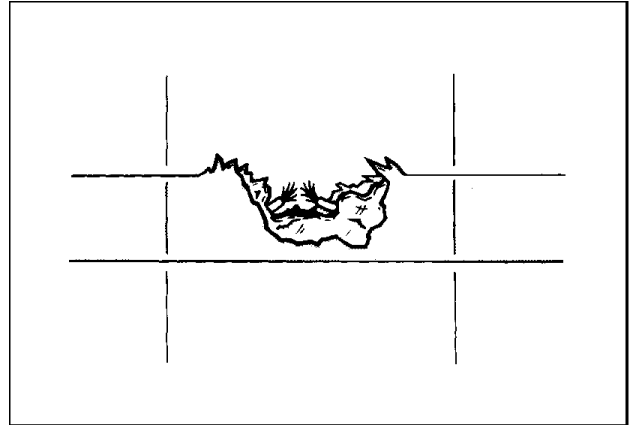

1Z0O2004112111 1

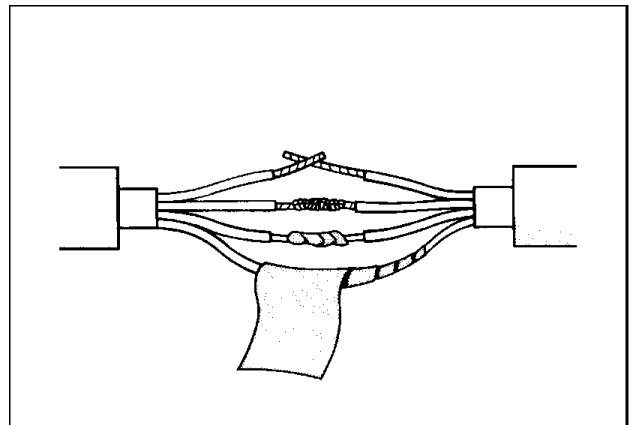

1Z0O2004112112 2

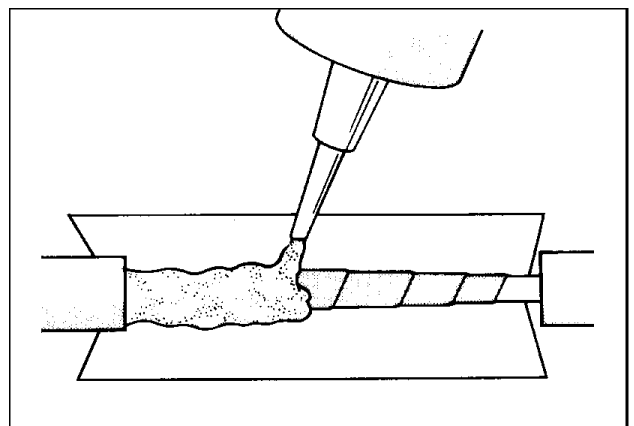

1Z0O2004112113 3



13. Cover the area with insulating tape taking the tape well over each end of the repair. An overlap of at least **50.0 mm (2.0 in)** of tape at each end is necessary.
14. Ensure that the repair is satisfactory. Secure the repaired cable so that repeat damage can be avoided.

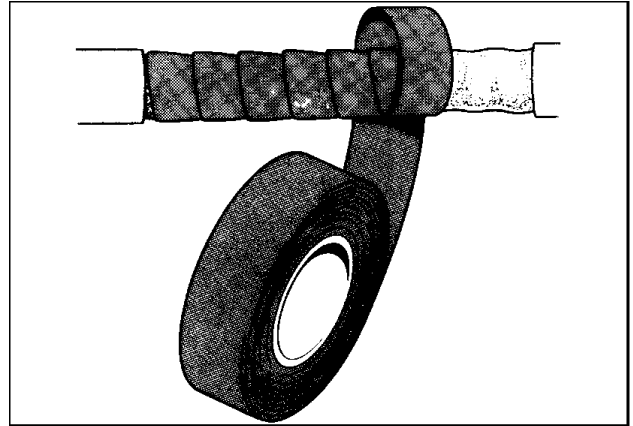

1Z002004112114 4

## Wiring harnesses - Rewire

**380040089:** Electrical repair kit

**380050010:** Test probe kit

### Temporary wire replacement

**NOTE:** This is a temporary repair only. Ensure the damaged cable is replaced as soon as possible to prevent ingress of water or chemicals.

If a wire within the wire harness is found to be beyond repair or is open circuit, a jumper wire may be installed. A jumper wire is a temporary repair until a new harness assembly can be installed. Use the following procedure to install an additional wire.

1. Locate the faulty wire.
2. Disconnect the affected connector.
3. If fitted, carefully roll back the seal between the connector and the cable outer covering.
4. Remove the pins from the connector of the affected wire using the appropriate removal tool found in the harness repair kit.

**NOTE:** Follow the instructions supplied with the harness repair kit to ensure the correct pin removal.

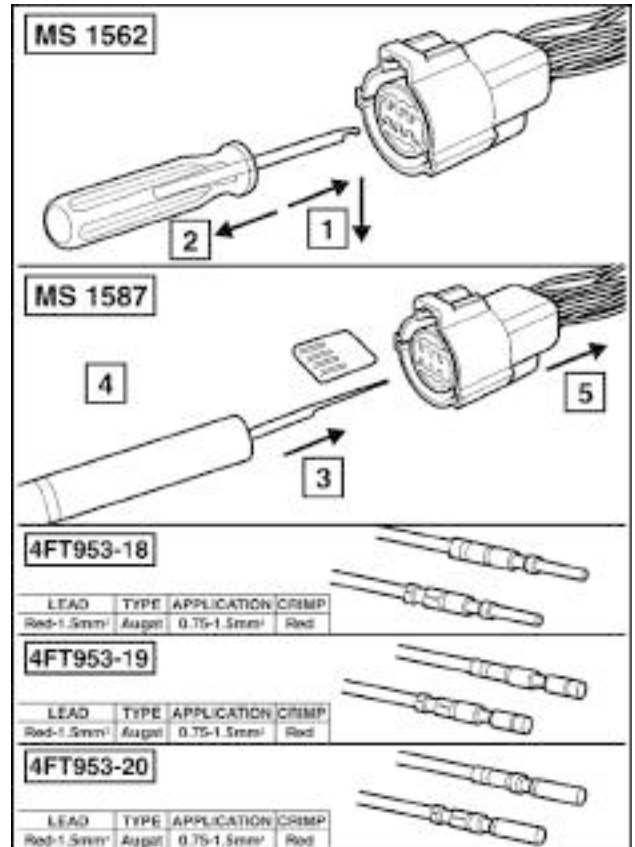

SEZ55CAP9B-5 1

5. From the harness repair kit select the correct pin for the affected connector. Obtain locally the correct cross-sectional size wire and measure out the length required by following the harness routing.
6. Join the new wire to the new pins as described in the harness repair kit and install the pins into its connector.
7. If possible attempt to run the new wire within the existing cable outer covering. If this is not possible, run the wire along the cable, securing regularly with suitable ties. With the wire correctly routed, install the second terminal into its connector. Replace the connector seal if removed.
8. To ensure that the repair has been effective, check for continuity of the new wire using a suitable multimeter.

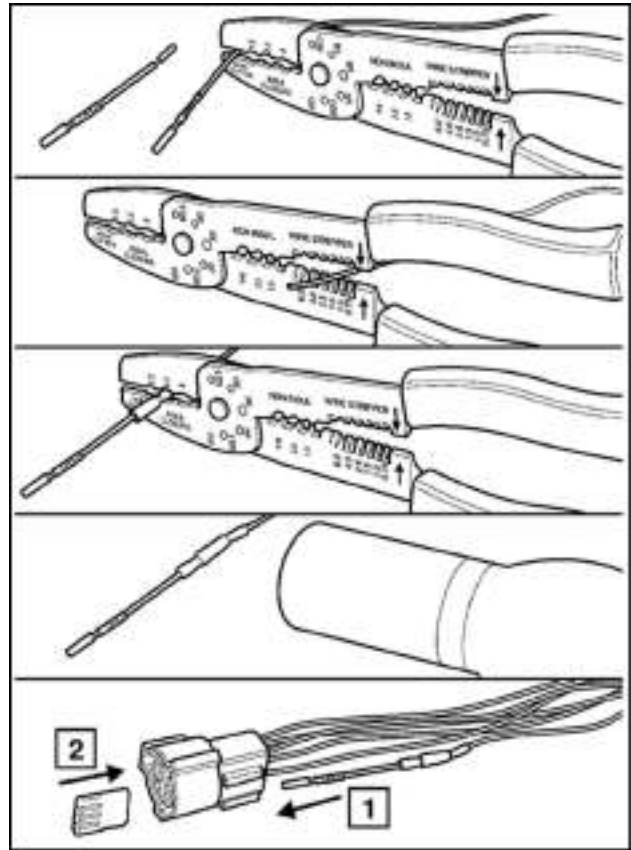

SEZ55CAP9B-17 2

# Index

---

## Electrical systems - 55

### Harnesses and connectors - 100

Wiring harnesses - Electrical schematic sheet 02 - IGNITION SWITCH and FUSES .....	16
Wiring harnesses - Electrical schematic sheet 03 - INSTRUMENT CLUSTER 1 .....	18
Wiring harnesses - Electrical schematic sheet 04 - INSTRUMENT CLUSTER 2 .....	20
Wiring harnesses - Electrical schematic sheet 05 - ENGINE CONTROL UNIT 1 .....	22
Wiring harnesses - Electrical schematic sheet 06 - ENGINE CONTROL UNIT 2 .....	24
Wiring harnesses - Electrical schematic sheet 07 - TRANSMISSION CONTROL UNIT 1 .....	26
Wiring harnesses - Electrical schematic sheet 08 - TRANSMISSION CONTROL UNIT 2 .....	28
Wiring harnesses - Electrical schematic sheet 09 - CENTRAL CONTROL UNIT (four-wheel drive, differential lock and backup alarm) .....	30
Wiring harnesses - Electrical schematic sheet 10 - CENTRAL CONTROL UNIT (front and rear power take-off) .....	32
Wiring harnesses - Electrical schematic sheet 11 - CENTRAL CONTROL UNIT (electronic draft control 1) ....	34
Wiring harnesses - Electrical schematic sheet 12 - CENTRAL CONTROL UNIT (electronic draft control 2) ....	36
Wiring harnesses - Electrical schematic sheet 13 - ELECTRO HYDRAULIC REMOTE VALVES (front and rear) .....	38
Wiring harnesses - Electrical schematic sheet 14 - ELECTRONIC FRONT HITCH .....	40
Wiring harnesses - Electrical schematic sheet 15 - FRONT LOADER (Hydrac) .....	42
Wiring harnesses - Electrical schematic sheet 16 - FRONT LOADER (Stoll) .....	44
Wiring harnesses - Electrical schematic sheet 17 - HEATING, VENTILATION and AIR-CONDITIONING .....	46
Wiring harnesses - Electrical schematic sheet 18 - LIGHTING (headlights, side lights, cab interior light) .....	48
Wiring harnesses - Electrical schematic sheet 19 - RADIO and MIRRORS (electrically adjustable and heated) .....	50
Wiring harnesses - Electrical schematic sheet 20 - LIGHTING (flasher, hazard light switch and follow me home) .....	52
Wiring harnesses - Electrical schematic sheet 21 - WORK LIGHT and ROTATING BEACON .....	54
Wiring harnesses - Electrical schematic sheet 22 - WIPER and WASHER (front and rear) .....	56
Wiring harnesses - Electrical schematic sheet 23 - POWER SOCKETS .....	58
Wiring harnesses - Electrical schematic sheet 24 - CAN bus 1 and ELECTRO HYDRAULIC REMOTE VALVES – CAN bus .....	60
Wiring harnesses - Electrical schematic sheet 25 - GROUND DISTRIBUTION .....	62
Fuse and relay box - Identification .....	7
Fuse and relay box - Static description .....	5
Wire connectors - Component Diagram 00 .....	86
Wire connectors - Component diagram 01 .....	102
Wire connectors - Component diagram 02 .....	112
Wire connectors - Component diagram 03 .....	123
Wire connectors - Component diagram 04 .....	131
Wire connectors - Component diagram 05 .....	142
Wire connectors - Component diagram 06 .....	154

Wire connectors - Component diagram 07	162
Wire connectors - Component diagram 08	173
Wire connectors - Component diagram 09	180
Wire connectors - Component diagram 10	191
Wire connectors - Component diagram 11	192
Wire connectors - Component diagram 12	195
Wire connectors - Component diagram 13	203
Wire connectors - Component diagram 15	208
Wire connectors - Component diagram 16	212
Wire connectors - Component diagram 17	213
Wire connectors - Component diagram 18	214
Wire connectors - Component diagram 19	221
Wire connectors - Component diagram 20	223
Wire connectors - Component diagram 21	225
Wire connectors - Component diagram 22	227
Wire connectors - Component diagram 23	229
Wire connectors - Component diagram 24	231
Wire connectors - Component diagram 25	233
Wire connectors - Component diagram 26	234
Wire connectors - Component diagram 28	235
Wire connectors - Component diagram 29	236
Wire connectors - Component diagram 30	238
Wire connectors - Component diagram 31	250
Wire connectors - Component diagram 32	256
Wire connectors - Component diagram 33	266
Wire connectors - Component diagram 34	275
Wire connectors - Component diagram 35	287
Wire connectors - Component diagram 36	296
Wire connectors - Component diagram 37	303
Wire connectors - Component diagram 38	313
Wire connectors - Component diagram 39	324
Wire connectors - Component diagram 40	334
Wire connectors - Component diagram 41	350
Wire connectors - Component diagram 42	351
Wire connectors - Component diagram 43	352
Wire connectors - Component diagram 44	356
Wire connectors - Component diagram 45	358
Wire connectors - Component diagram 46	360
Wire connectors - Component diagram 47	373
Wire connectors - Component diagram 50	375
Wire connectors - Component diagram 51	384
Wire connectors - Component diagram 52	389

Wire connectors - Component diagram 53 .....	400
Wire connectors - Component diagram 55 .....	407
Wire connectors - Component diagram 57 .....	409
Wire connectors - Component diagram 60 .....	410
Wire connectors - Component diagram 65 .....	411
Wire connectors - Component diagram 69 .....	413
Wire connectors - Component diagram 70 .....	416
Wire connectors - Component diagram 80 .....	418
Wire connectors - Component diagram 93 .....	420
Wire connectors - Component diagram 94 .....	430
Wire connectors - Component diagram 95 .....	445
Wire connectors - Component diagram 96 .....	454
Wire connectors - Component diagram 97 .....	464
Wire connectors - Component diagram 98 .....	474
Wire connectors - Component diagram 99 .....	478
Wiring harnesses - Electrical schema – Symbols .....	12
Wiring harnesses - Electrical schematic sheet 01 - STARTING, CHARGING, POWER DISTRIBUTION and FUSES .....	14
Wiring harnesses - Identification .....	67
Wiring harnesses - Repair .....	479
Wiring harnesses - Rewire .....	481
Wiring harnesses - Static description .....	65





## **Electrical systems - 55**

### **Engine control system - 015**

**Farmall 105U Pro EP  
Farmall 115U Pro EP  
Farmall 95U Pro EP**



# Contents

---

## Electrical systems - 55

### Engine control system - 015

#### FUNCTIONAL DATA

Engine Control Unit (ECU)	
Electronic schema .....	4
Engine timing sensors	
Crankshaft sensor - Overview .....	7



## Engine Control Unit (ECU) - Electronic schema

Component identification	
1.	Engine Control Unit (ECU)
2.	Engine Control Unit (ECU) – Power supply relay
3.	Lambda sensor
4.	Inlet air temperature sensor
5.	Differential pressure sensor
6.	Diesel Oxidation Catalyst (DOC) – Inlet temperature sensor
7.	Diesel Particulate Filter (DPF) – Inlet temperature sensor
8.	Exhaust manifold temperature sensor
9.	Exhaust manifold pressure sensor
10.	Waste gate modulation solenoid
11.	Fuel heater relay
12.	Exhaust Gas Recirculation (EGR) – Valve actuator
13.	Throttle Valve Actuator (TVA)
14.	Water in fuel sensor
15.	Intake air pressure and temperature sensor
16.	Engine oil pressure switch
17.	Common rail pressure sensor
18.	Engine coolant temperature sensor
19.	Crankshaft sensor
20.	Fuel temperature sensor
21.	Camshaft sensor
22.	Glow plug control module
23.	High pressure pump solenoid valve
24.	Injector cylinder 1
25.	Injector cylinder 2
26.	Injector cylinder 3
27.	Injector cylinder 4
28.	Sensors ground
29.	Chassis ground
30.	Supply ground

Electrical systems - Engine control system

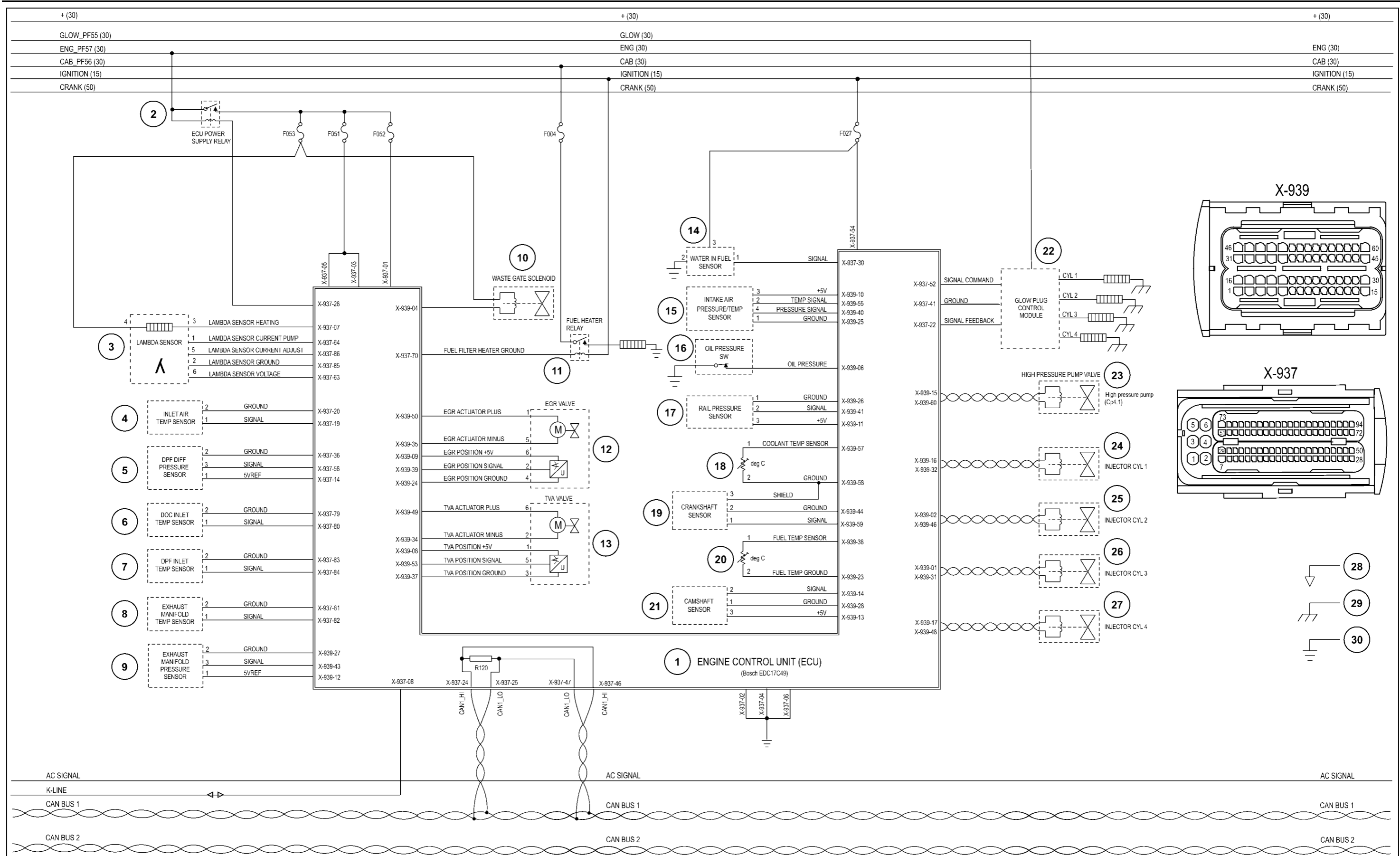

SS13A213 1



## Engine timing sensors Crankshaft sensor - Overview

It is an inductive type sensor placed on the front left side of the engine. It generates signals obtained by the magnetic flow lines closing up through the openings of a tone wheel splined on the engine crankshaft. The same signal is used to pilot the tachometer fitted on the vehicle instrument panel. It is connected to the Electronic Control Unit pins 25C (signal) and 24C (signal). The third pin is for shielding. The Sensor's resistance value is nearly **900  $\Omega$** .

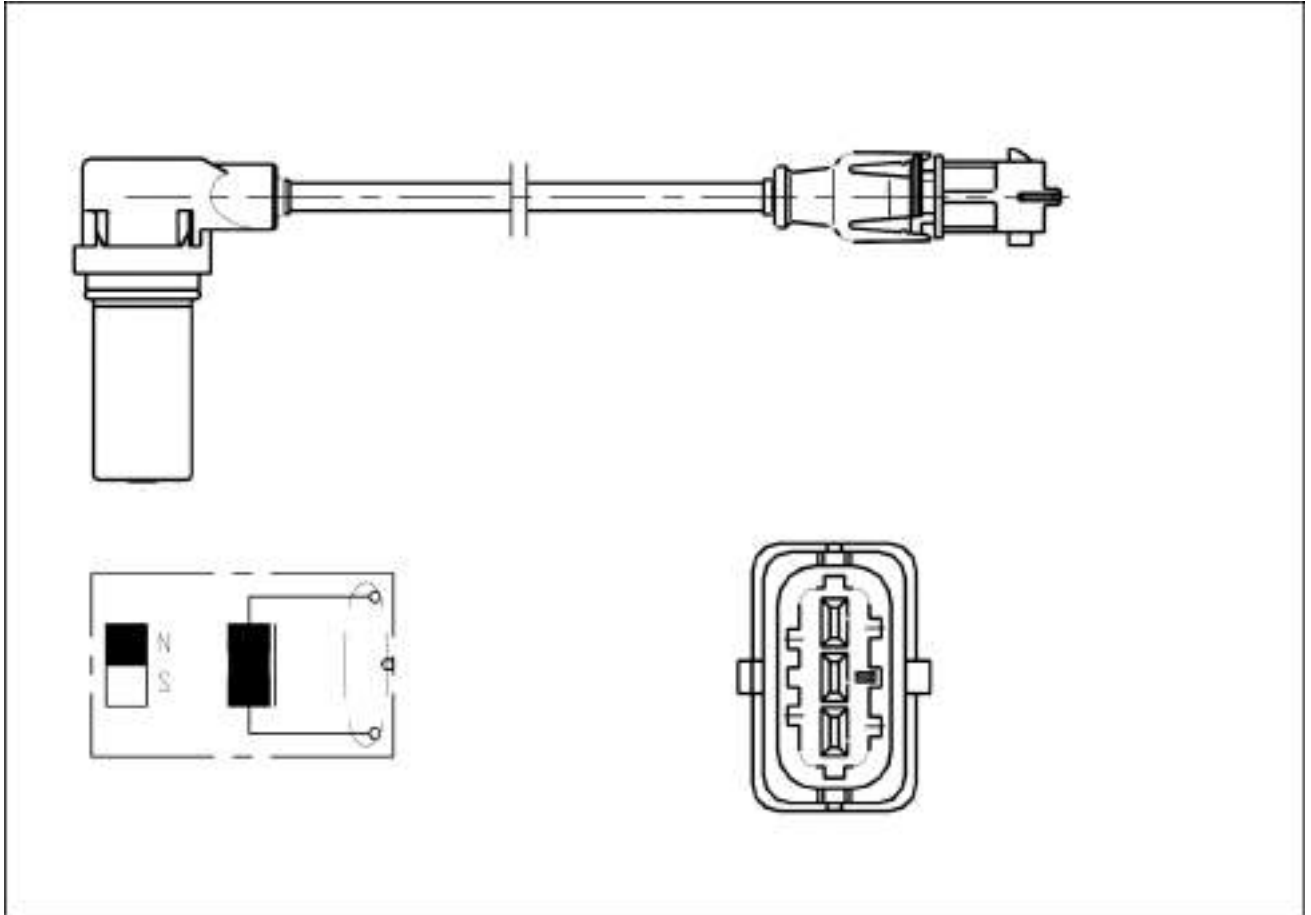

73092812 1

# Index

---

## Electrical systems - 55

### Engine control system - 015

Engine Control Unit (ECU) - Electronic schema .....	4
Engine timing sensors Crankshaft sensor - Overview .....	7



## **Electrical systems - 55**

### **Alternator - 301**

**Farmall 105U Pro EP  
Farmall 115U Pro EP  
Farmall 95U Pro EP**



# Contents

---

## Electrical systems - 55

### Alternator - 301

#### TECHNICAL DATA

Alternator	
Torque .....	3
General specification .....	3

#### FUNCTIONAL DATA

Alternator	
Static description .....	4
Dynamic description .....	6

#### SERVICE

Alternator	
Remove – 120 A alternator .....	7
Install – 120 A alternator .....	8
Remove – 200 A alternator .....	9
Install – 200 A alternator .....	10
Inspect .....	11

## Alternator - Torque

	Alternator 120 A (Iskra)	Alternator 200 A (Letrika)
Pulley retaining nut	<b>90.0 - 100.0 Nm (66.4 - 73.8 lb ft)</b>	<b>85.0 - 95.0 Nm (62.7 - 70.1 lb ft)</b>
Retaining nut for terminal (B+)	<b>7.5 - 8.0 Nm (5.5 - 5.9 lb ft)</b>	<b>9.0 - 13.0 Nm (6.6 - 9.6 lb ft)</b>
Retaining nut for terminal (D+)	<b>2.7 - 3.8 Nm (2.0 - 2.8 lb ft)</b>	<b>2.7 - 3.8 Nm (2.0 - 2.8 lb ft)</b>
Pivot bolt (alternator to engine mounting bracket)	<b>50.0 Nm (36.9 lb ft)</b>	<b>50.0 Nm (36.9 lb ft)</b>
Mounting bolt (alternator to belt tensioner)		<b>45.0 Nm (33.2 lb ft)</b>

## Alternator - General specification

	Alternator 120 A (Iskra)	Alternator 200 A (Letrika)
Polarity	Negative ground	Negative ground
Nominal output voltage	<b>14 V</b>	<b>14 V</b>
Nominal output current	<b>120 A</b>	<b>200 A</b>
Maximum speed (continuous)	<b>12000 RPM</b>	<b>15000 RPM</b>
Maximum speed (short time, max. <b>15 min</b> )	<b>13500 RPM</b>	<b>18000 RPM</b>
Excitation winding resistance at <b>20 °C (68.0 °F)</b>	<b>2.75 Ω</b>	<b>2.90 Ω</b>
Weight	<b>5.5 kg (12.1 lb)</b>	<b>7.8 kg (17.2 lb)</b>

## Alternator - Static description

There is an Iskra alternator ( **120 A** ) or optional a Letrika alternator ( **200 A** ) fitted on the vehicle. Both alternator types incorporate a built-in regulator unit. The Iskra alternator incorporates a cooling fan. The alternator is located at the front on the right-hand side of the engine. The alternator is driven by a pulley ( **1** ) and an elastic poly V-belt ( **2** ).

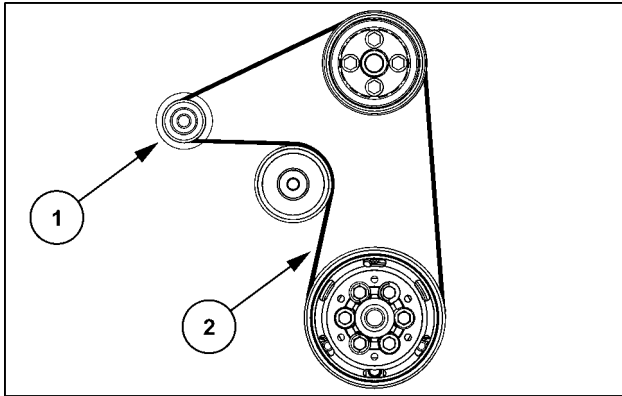

SS13A810 1

Course of the poly V-belt with the **120 A** alternator.

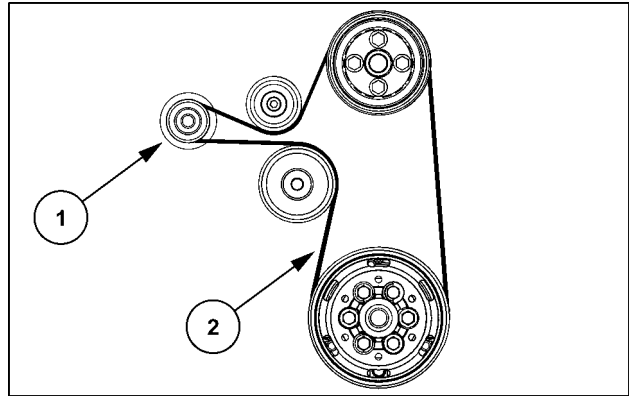

SS13A809 2

Course of the poly V-belt with the **200 A** alternator.

The belt tensioner type depends on the alternator type. Because of the elastic poly V-belt, for both belt tensioner types is only a single setting option for the belt tensioning provided.

The alternators offer the following terminals:

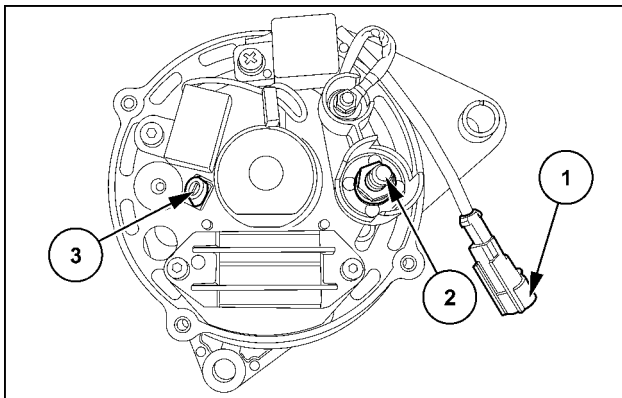

SVIL13TR00173AB 3

Terminals of the **120 A** alternator (Iskra):

- Terminal D+: Charge indicator light ( **1** ).
- Terminal B+: Battery connection ( **2** ).
- Terminal W: Alternator speed information ( **3** ) ( not used ).

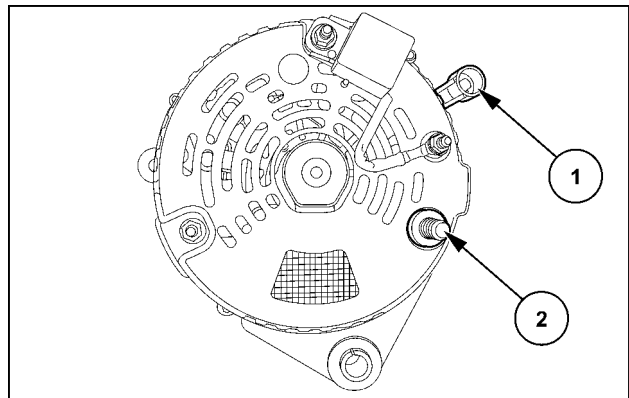

SVIL13TR00172AB 4

Terminals of the **200 A** alternator (Letrika):

- Terminal D+: Charge indicator light ( **1** ).
- Terminal B+: Battery connection ( **2** ).

## General structure of an alternator

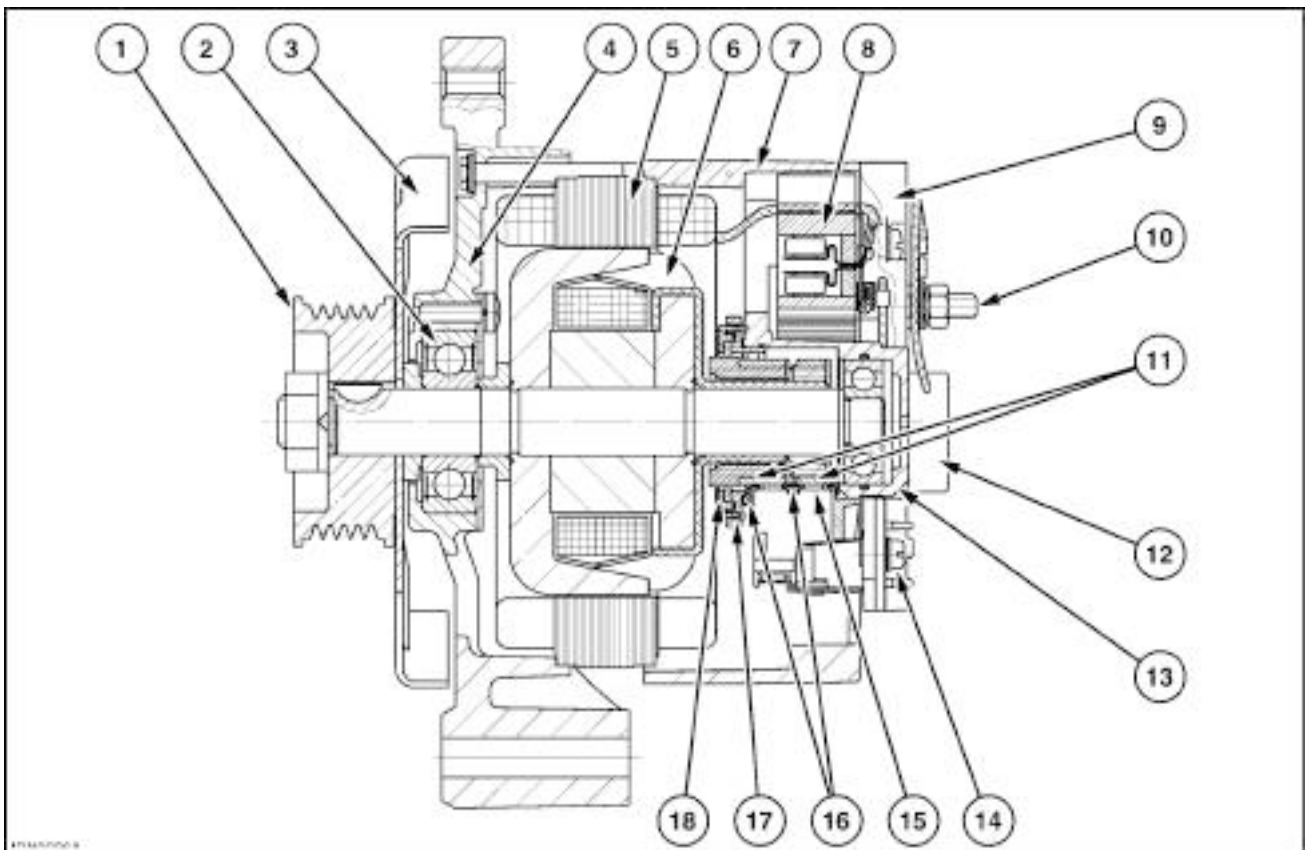

SEZ55CAP4F-2 5

- |                         |                     |
|-------------------------|---------------------|
| (1) Pulley              | (10) Terminal       |
| (2) Bearing             | (11) Gaskets        |
| (3) Cooling fan         | (12) Capacitor      |
| (4) Front support plate | (13) Rear bearing   |
| (5) Stator              | (14) Brush holder   |
| (6) Rotor               | (15) Brushes        |
| (7) Rear support plate  | (16) Rubber seal    |
| (8) Rectifier           | (17) Retaining ring |
| (9) Cover               | (18) Felt gasket    |

## Alternator - Dynamic description

When the ignition key is turned to the ON position, low current flows from the battery through the rotor field winding of the alternator. The electrical circuit closes between the charge indicator light, the alternator terminal D+, the rotor field winding, the regulator unit and ground.

At this point the charge indicator light illuminates and the rotor is partially magnetized. When the engine starts, the partially magnetized rotor rotates inside the stator windings and a three-phase alternating current is generated. A constant quantity of the generated current gets transformed to direct current by the three field diodes of the rectifier.

The direct current is then reintroduced into the electrical circuit to increase the current flow through the rotor field winding. This process causes the gain of the magnetic field in the rotor along with an increase of the output current and the output voltage. The output voltage continues to increase until it reaches the regulated voltage level of approximately **14.4 V** (reflected by the terminal D+).

The charge indicator light is ON until the completion of the alternator excitation phase. After the alternator excitation phase the charge indicator light is switched OFF.

The charge indicator light will remain ON if one of the following failure conditions is present:

- The voltage at the terminal D+ sinks below **9.8 V**. Possible causes for this are a teared poly V-belt or an defective alternator.
- The voltage at the terminal D+ rises above **16 V**. A possible cause for this is an defective alternator.

## Charging circuit

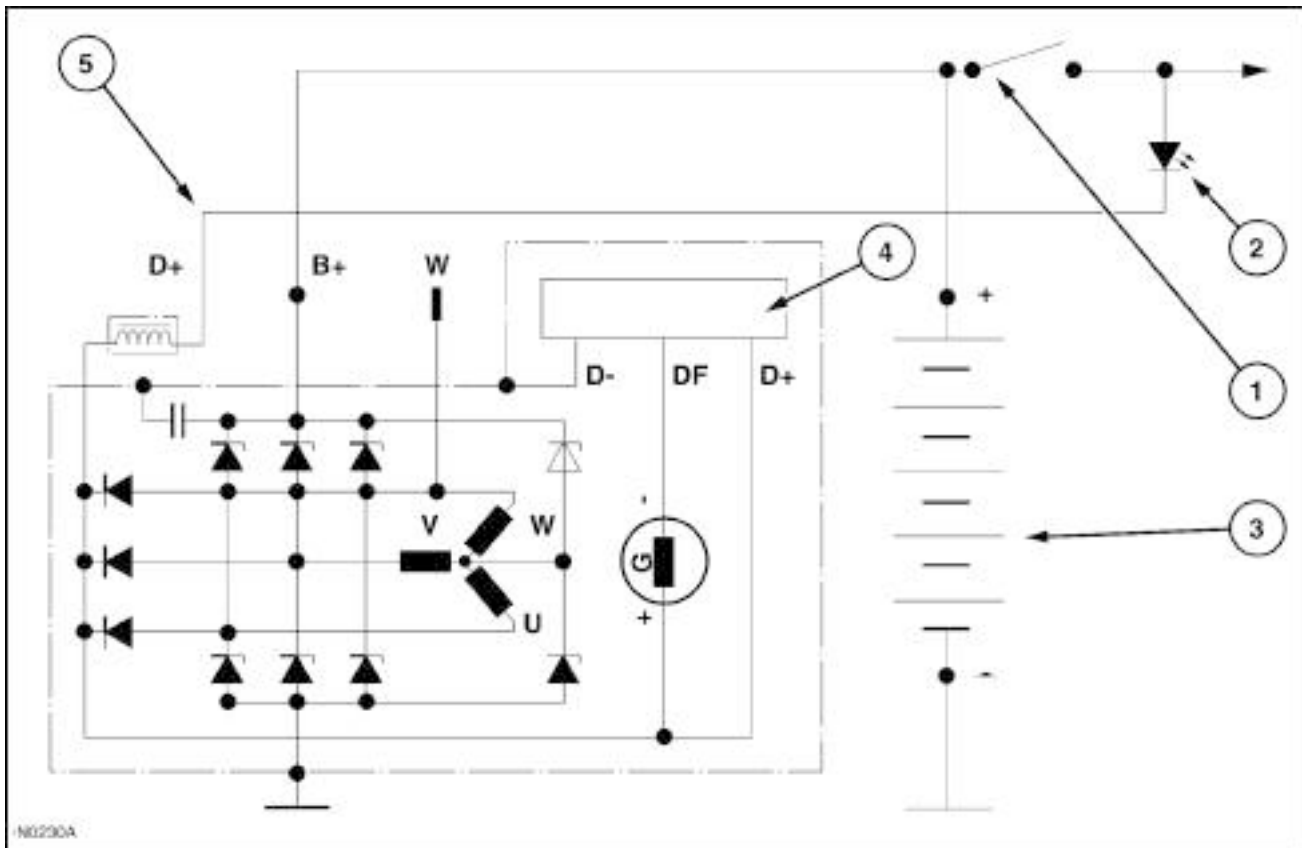

SEZ56CAP4F-1 1

Ignition switch (1)  
 Charge indicator light (2) of the instrument cluster  
 Battery (3)  
 Regulator unit of the alternator (4)  
 Alternator (5)

Terminal B+: Battery connection  
 Terminal D+: Charge indicator light  
 Terminal W (not used): Alternator speed information

## Alternator - Remove – 120 A alternator

### Prior operation:

**Battery - Disconnect (55.302)**

**Belt - Remove – 120 A alternator (10.414)**

1. Disconnect the cable for the charge indicator light (1) from the terminal D+.
2. Remove the retaining nut of the terminal B+.
3. Disconnect the cable for the battery charging (2) from the terminal B+.

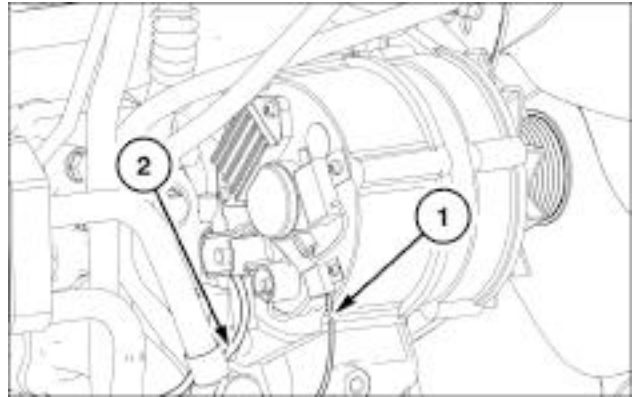

WLAPL4S56C305A 1

4. Remove the retaining nut (1).
5. Remove the pivot bolt (2), the retaining nut, and the two washers. Remove the alternator.

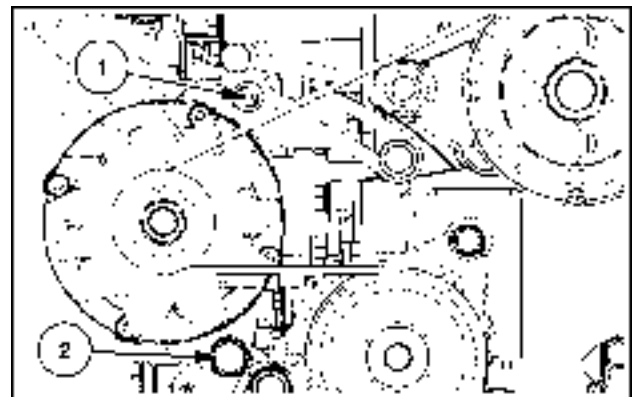

SS13A812 2

### Next operation:

**Alternator - Install – 120 A alternator (55.301)**

## Alternator - Install – 120 A alternator

### Prior operation:

#### Alternator - Remove – 120 A alternator (55.301)

1. Install the alternator to the engine mounting bracket with the pivot bolt (2), the retaining nut, and two washers.
2. Slightly tighten the pivot bolt (2) with the retaining nut.
3. Slightly tighten the retaining nut (1).

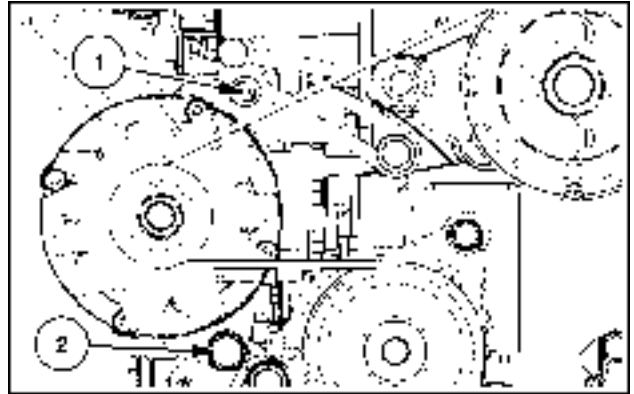

SS13A812 1

4. Connect the cable for the charge indicator light (1) to the terminal D+.
5. Connect the cable for the battery charging (2) to the terminal B+.
6. Tighten the retaining nut of the terminal B+ to a torque between 7.5 - 8.0 Nm (5.5 - 5.9 lb ft).

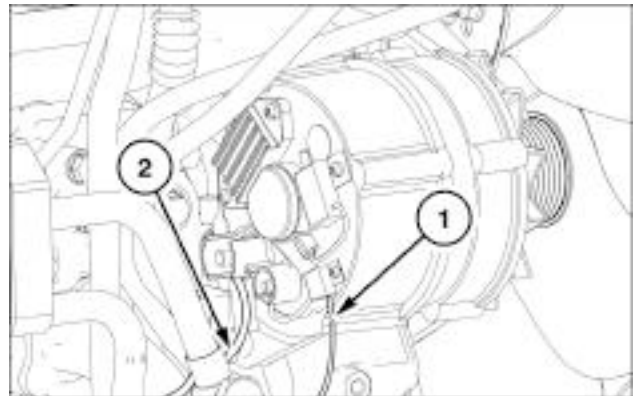

WLAPL4S55C305A 2

7. Install the poly V-belt. Refer to **Belt - Install – 120 A alternator (10.414)**.

### Next operation:

#### Battery - Connect (55.302)

## Alternator - Remove – 200 A alternator

### Prior operation:

**Battery - Disconnect (55.302)**

**Belt - Remove – 200 A alternator (10.414)**

1. Disconnect the cable for the charge indicator light from the terminal D+ (2).
2. Remove the retaining nut of the terminal B+ (1).
3. Disconnect the cable for the battery charging from the terminal B+ (1).

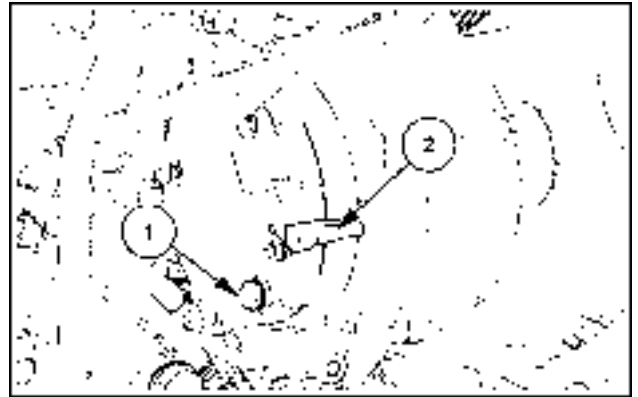

SS13A818 1

4. Remove the mounting bolt (1).
5. Remove the pivot bolt (2), the retaining nut, and the two washers. Remove the alternator.

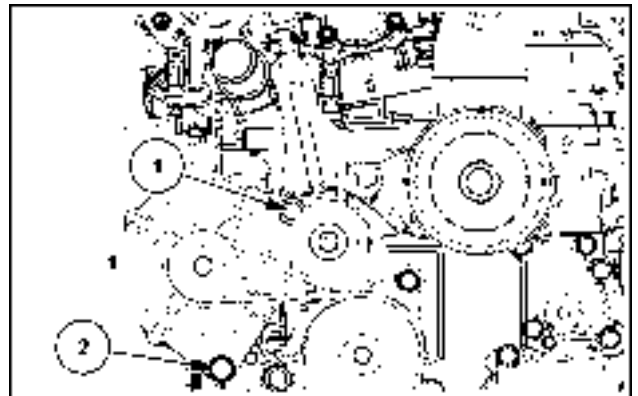

SS13A817 2

### Next operation:

**Alternator - Install – 200 A alternator (55.301)**



## Alternator - Install – 200 A alternator

### Prior operation:

#### Alternator - Remove – 200 A alternator (55.301)

1. Install the alternator to the belt tensioner with the mounting bolt (1).
2. Install the alternator to the engine mounting bracket with the pivot bolt (2), the retaining nut, and two washers.
3. Tighten the mounting bolt (1) to a torque of **45.0 Nm (33.2 lb ft)**.
4. Tighten the pivot bolt (2) with the retaining nut to a torque of **50.0 Nm (36.9 lb ft)**.

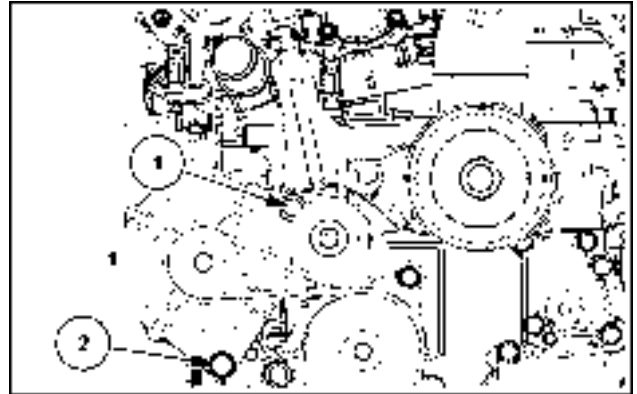

SS13A817 1

5. Connect the cable for the charge indicator light to the terminal D+ (2).
6. Connect the cable for the battery charging to the terminal B+ (1).
7. Tighten the retaining nut of the terminal B+ (1) to a torque between **9.0 - 13.0 Nm (6.6 - 9.6 lb ft)**.

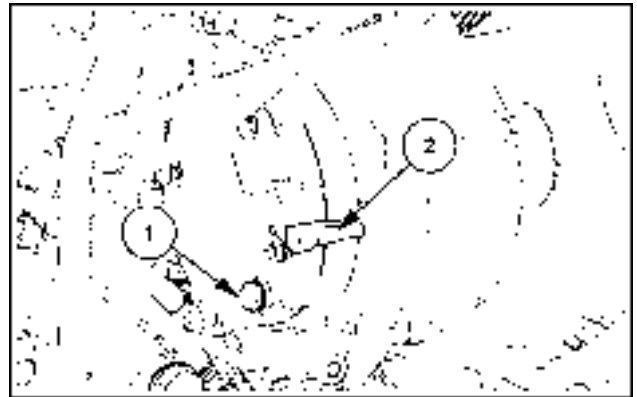

SS13A818 2

8. Install the poly V-belt. Refer to **Belt - Install – 200 A alternator (10.414)**.

### Next operation:

#### Battery - Connect (55.302)

## Alternator - Inspect

### Precautions during the operation

To avoid damage to the components of the alternator charging system, the following precautions must be observed:

- Never connect or disconnect an electrical connection of the alternator charging system including the battery, when the engine is running.
- Never short circuit the positive terminal of the alternator to check if the alternator is working.
- Always disconnect the battery from the vehicle before you charge the battery. Refer to **Battery - Disconnect (55.302)**.
- Always check the battery polarity when you install a battery or when you perform a jump start.
- Do not short circuit an input terminal or an output terminal of the alternator regulator unit when the alternator is working.
- Always connect positive to positive and negative to negative.

### Preliminary inspection of the alternator charging system

- Before you carry out electrical tests on the alternator charging system, check the state of charge of the battery. The battery must be at least 70% charged and in good condition. Refer to **Battery - Testing – State of charge test (specific gravity) (55.302)** or to **Battery - Testing – State of charge test (open circuit voltage) (55.302)**.
- Check the wiring of the alternator charging system for continuity.
- Check if the appropriate connectors of the alternator charging system are connected and in good condition.

### Inspection of the belt drive for the alternator

- There are two different belt tensioner types available for the tractor. Refer to **Alternator - Static description (55.301)**. Because of the elastic poly V-belt, for both belt tensioner types is only a single setting option for the belt tensioning provided.
- Inspect the poly V-belt and the alternator pulley. Make sure that they are both clean and in good condition with no traces of oil or grease.

### Inspection of the charge indicator light

Check the function of the charge indicator light. Refer to **Alternator - Dynamic description (55.301)**.

- Turn the ignition key to the ON position and start the engine. Check if the charge indicator light is ON during the excitation phase of the alternator (a few seconds). If the charge indicator light is OFF after turning the ignition key and starting the engine, the instrument cluster or the charge indicator light is defective.
- If the charge indicator light is ON after turning the ignition key, run the engine above idle speed. If the charge indicator light remains ON after the excitation phase of the alternator a failure is present. Refer to **Alternator - Dynamic description (55.301)**.

# Index

---

## Electrical systems - 55

### Alternator - 301

Alternator - Dynamic description .....	6
Alternator - General specification .....	3
Alternator - Inspect .....	11
Alternator - Install – 120 A alternator .....	8
Alternator - Install – 200 A alternator .....	10
Alternator - Remove – 120 A alternator .....	7
Alternator - Remove – 200 A alternator .....	9
Alternator - Static description .....	4
Alternator - Torque .....	3



## **Electrical systems - 55**

### **Battery - 302**

**Farmall 105U Pro EP  
Farmall 115U Pro EP  
Farmall 95U Pro EP**

# Contents

---

## Electrical systems - 55

### Battery - 302

#### TECHNICAL DATA

Battery	
General specification .....	3

#### FUNCTIONAL DATA

Battery	
Static description .....	4

#### SERVICE

Battery	
Electrical test – General information .....	5
Disconnect .....	7
Connect .....	9
Remove .....	10
Install .....	12

#### DIAGNOSTIC

Battery	
Testing – Visual check .....	14
Testing – Heavy load discharge test .....	15
Testing – State of charge test (specific gravity) .....	15
Testing – State of charge test (open circuit voltage) .....	16
Testing – Charging overview .....	17

## Battery - General specification

Characteristics	Specifications
Capacity (Ampere hour at 20 hour rate)	<b>132 A·h</b>
Cold cranking ampere rating (CCA)	960
Output voltage	<b>12 V</b>
Number of cells	6
Ground terminal	Negative
Weight	<b>35 kg (77.2 lb)</b>

### State of charge determination

State of charge	Corrected specific gravity at 15 °C (59.0 °F)	Corrected specific gravity at 25 °C (77.0 °F)	Average battery voltage
<b>100 %</b>	1.295	1.287	<b>12.60 V</b>
<b>75 %</b>	1.253	1.246	<b>12.40 V</b>
<b>50 %</b>	1.217	1.210	<b>12.20 V</b>
<b>25 %</b>	1.177	1.170	<b>12.00 V</b>
Discharged	1.137	1.130	<b>11.80 V</b>

Temperature	Efficiency of a fully charged battery
<b>25.0 °C ( 77.0 °F)</b>	<b>100 %</b>
<b>-4.5 °C ( 23.9 °F)</b>	<b>82 %</b>
<b>-24.0 °C ( -11.2 °F)</b>	<b>64 %</b>
<b>-27.5 °C ( -17.5 °F)</b>	<b>58 %</b>
<b>-31.0 °C ( -23.8 °F)</b>	<b>50 %</b>
<b>-34.5 °C ( -30.1 °F)</b>	<b>40 %</b>
<b>-37.5 °C ( -35.5 °F)</b>	<b>33 %</b>

	<b>132 A·h (960 CCA)</b>
Slow charge program	30 hours at <b>5 A</b> 15 hours at <b>10 A</b>
Fast charge program (use only in emergencies)	8.5 hours at <b>18 A</b>

## Battery - Static description

All models use a single low maintenance battery with negative ground. The battery consists of six cells. The battery is located under the tool box on the left-hand side of the tractor.

**NOTE:** "Low maintenance" means that under normal charging conditions the battery may lose a small amount of water from the electrolyte. Conditions that may cause water loss include prolonged charging above **14.4 V** where gassing occurs as it approaches full charge. This can be caused by a faulty charging system, a faulty boost charging equipment, or a faulty recovery charging equipment.

The four main functions of the battery are:

- to provide a power supply for the starting, the illumination, and the instrumentation of the vehicle.
- to help control the voltage in the electrical system.
- to supply the system when the required power exceeds the alternator output.
- to supply the radio and the micro processor memories in quiescent state.

Each cell of the battery consists of positive and negative plates positioned alternatively one next to the other. Each positive plate is separated from the adjacent negative plate by means of a porous insulating spacer. If one of the positive plates touches a negative plate in the cell, the cell will be shorted and will be irreversibly damaged. All of the positive plates are welded to a bus bar, forming the positive terminal. Also all of the negative plates are welded to a bus bar, forming the negative terminal.

The positive plates consist of a lead grid with lead peroxide pasted to the grid holes. The negative plates consist of a lead grid with lead sponge pasted to the grid holes.

The plates are submerged in a liquid electrolyte solution of diluted sulphuric acid.

## Battery - Electrical test – General information

### ⚠ WARNING

**Battery gas can explode!**

To prevent an explosion: 1. Always disconnect the negative (-) battery cable first. 2. Always connect the negative (-) battery cable last. 3. Do not short circuit the battery posts with metal objects. 4. Do not weld, grind, or smoke near a battery.

Failure to comply could result in death or serious injury.

W0011A

### ⚠ WARNING

**Battery acid causes burns. Batteries contain sulfuric acid.**

Avoid contact with skin, eyes or clothing. Antidote (external): Flush with water. Antidote (eyes): flush with water for 15 minutes and seek medical attention immediately. Antidote (internal): Drink large quantities of water or milk. Do not induce vomiting. Seek medical attention immediately.

Failure to comply could result in death or serious injury.

W0111A

## General guidelines for handling batteries

- Ensure that you wear appropriate safety equipment (safety goggle, rubber gloves, or apron).
- Ensure that you wear appropriate footwear when you transport the battery manually.
- Always disconnect the battery from the vehicle before you charge the battery. Refer to **Battery - Disconnect (55.302)**.
- Always disconnect the negative battery cable first.
- Always connect the negative battery cable last.
- When you charge the battery, remove the vent caps and work in a well-ventilated environment.
- When a battery is being charged, an explosive gas is produced.
- To avoid sparks ensure that the charging system is switched OFF before you connect or disconnect the battery. Sparks could ignite the gas.
- Wash your hands after working on a battery. There is a risk of poisoning due to the presence of lead and sulphuric acid in the battery cells.
- It is recommended to charge the battery not below an ambient temperature of **20 °C (68 °F)**.

## Maintenance of batteries

- Maintain the battery electrolyte to the recommended fluid level of **17.00 mm (0.67 in)** above the plates.
- Add only distilled or de-mineralized water to the battery electrolyte. Do not use tap water or rain water.
- Avoid over-charging of the battery.
- When you use a fast charge program (high charging current) ensure that the battery temperature does not exceed **50 °C (122 °F)**.
- Excessive charging creates high internal battery temperatures. High internal battery temperatures cause the deterioration of the plate grid and also produce water loss of the battery electrolyte.
- Do not add sulphuric acid to the cell unless the battery electrolyte has been lost through spilling.
- Before you add fluid ensure that the specific gravity is correct.
- A fast charge program is used to quickly boost the battery capacity. A fast charge program must be followed by a slow charge program (low charging current) to bring the battery to full capacity.
- A slow charge program is the only method to be employed to fully charge the battery.

## Common causes for battery failures

### Internal open circuit

Defective internal cell components can cause an internal open circuit.



### **Internal short circuit**

Excessive crystal growth in the battery electrolyte may cause a short circuit. Crystal growth occurs when a battery is left discharged. High temperatures and extended discharged periods increase the growth of crystals in the battery electrolyte.

### **Loss of the battery electrolyte**

Excessive charging (fast charge program, charging system malfunction, or operation of the battery in high temperatures) creates high internal temperature. High internal temperatures cause water loss of the battery electrolyte.

### **Separation of active materials from the battery grids**

Separation destroys the chemical function of the battery. A cause for separation of active materials from the battery grids is the freezing of the battery electrolyte. The battery electrolyte of a fully charged battery does not freeze until **-65 °C (-85 °F)**. The battery electrolyte of a **50 %** charged battery freezes between **-17 - -27 °C (1 - -17 °F)**. The battery electrolyte of a fully discharged battery freezes between **-3 - -11 °C (27 - 12 °F)**. Excessively high boost charging and gassing also causes the separation of active materials from the battery grids.

### **State of charge of batteries**

To determine the state of charge of a battery you can use two information sources. You can use either the specific gravity of the battery electrolyte or the open circuit voltage of the battery. The reference values for these procedures are listed in the appropriate table in **Battery - General specification (55.302)**.

Refer to the following procedures:

- **Battery - Testing – State of charge test (specific gravity) (55.302)**
- **Battery - Testing – State of charge test (open circuit voltage) (55.302)**

### **Charging the battery**

For charging the battery, start with the procedure that is described in **Battery - Testing – Charging overview (55.302)**.

## Battery - Disconnect

### ⚠ WARNING

**Battery gas can explode!**

To prevent an explosion: 1. Always disconnect the negative (-) battery cable first. 2. Always connect the negative (-) battery cable last. 3. Do not short circuit the battery posts with metal objects. 4. Do not weld, grind, or smoke near a battery.

Failure to comply could result in death or serious injury.

W0011A

The battery is located under the tool box on the left-hand side of the tractor.



SS12G299 1

1. To gain access to the battery remove the tool box. The tool box is fixed by a securing pin (1) which is located inside the tool box.

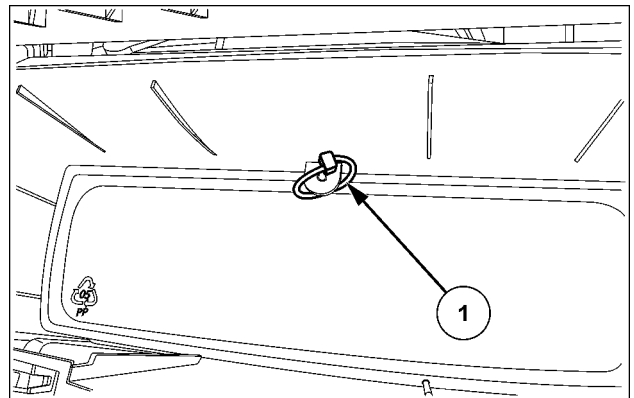

SS12G300 2

2. Unscrew the screws (2) and remove the battery cover.

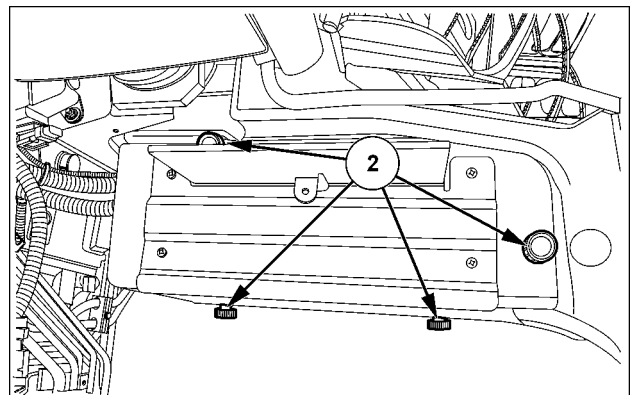

SS12G301 3

3. Disconnect the negative battery cable **(3)** from the battery terminal. Position the negative battery cable to one side.

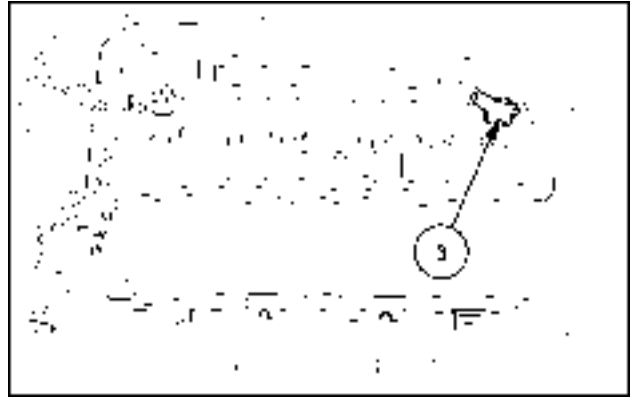

SS13A645 4

**Next operation:**  
**Battery - Connect (55.302)**

## Battery - Connect

### ⚠ WARNING

**Battery gas can explode!**

To prevent an explosion: 1. Always disconnect the negative (-) battery cable first. 2. Always connect the negative (-) battery cable last. 3. Do not short circuit the battery posts with metal objects. 4. Do not weld, grind, or smoke near a battery.

Failure to comply could result in death or serious injury.

W0011A

### Prior operation:

#### Battery - Disconnect (55.302)

1. Connect the negative battery cable (3) to the battery terminal.

**NOTICE:** Ensure that the battery cables are positioned so they do not become trapped or chafed on sharp edges.

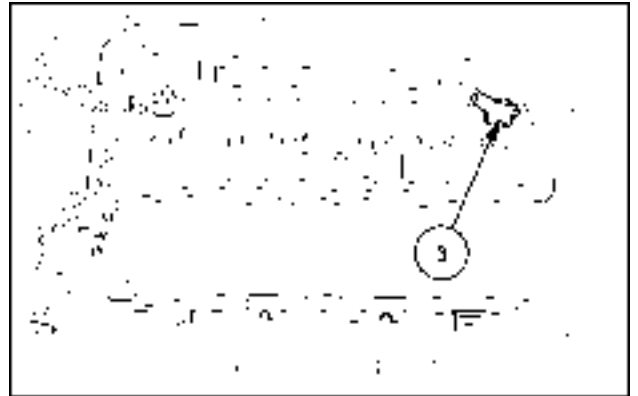

SS13A645 1

2. Add the battery cover and tighten the screws (2).

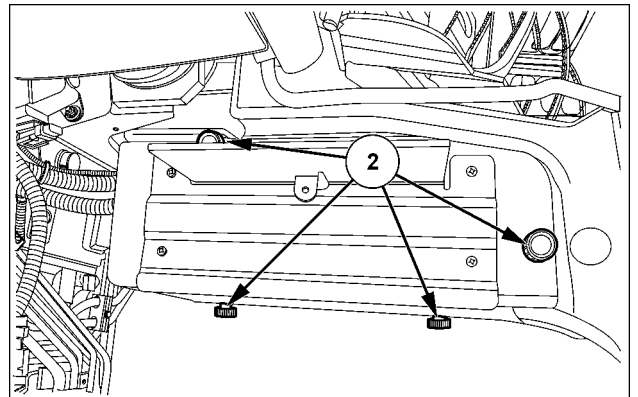

SS12G301 2

3. Place the tool box on the battery. Fix the tool box with the securing pin (1) inside the tool box.

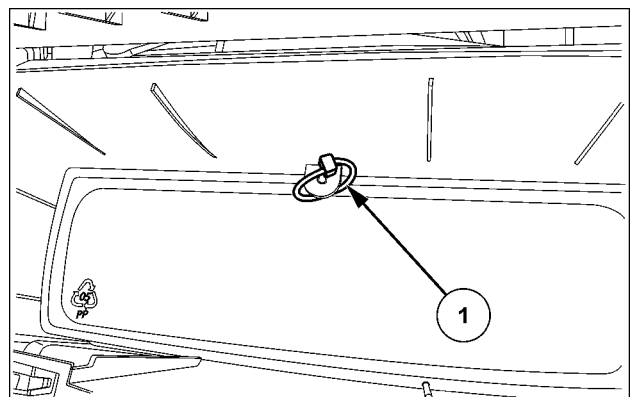

SS12G300 3

## Battery - Remove

### ⚠ WARNING

Battery gas can explode!

To prevent an explosion: 1. Always disconnect the negative (-) battery cable first. 2. Always connect the negative (-) battery cable last. 3. Do not short circuit the battery posts with metal objects. 4. Do not weld, grind, or smoke near a battery.

Failure to comply could result in death or serious injury.

W0011A

### ⚠ CAUTION

Heavy parts!

Machine batteries are extremely heavy. Make sure the battery is supported safely during the removal process.

Failure to comply could result in minor or moderate injury.

C0050A

The battery is located under the tool box on the left-hand side of the tractor.



SS12G299 1

1. To gain access to the battery remove the tool box. The tool box is fixed by a securing pin (1) which is located inside the tool box.

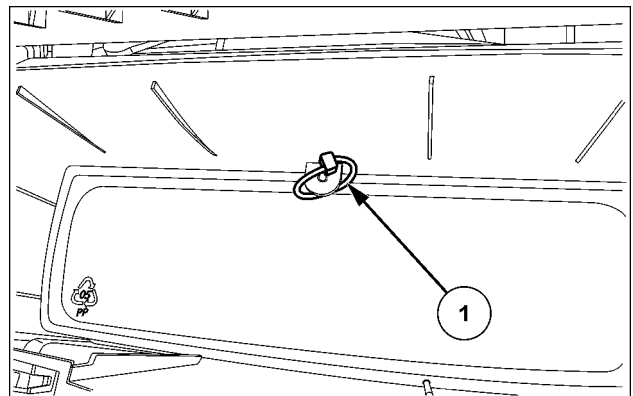

SS12G300 2

2. Unscrew the screws (2) and remove the battery cover.

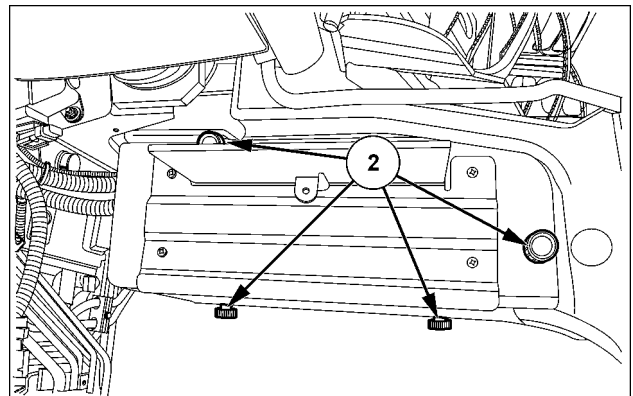

SS12G301 3

3. Disconnect the negative battery cable **(3)** from the battery terminal. Position the negative battery cable to one side.
4. Disconnect the positive battery cable **(4)** from the battery terminal. Position the positive battery cable to one side.
5. Loosen the retaining screws **(5)**.
6. Carefully put the battery out of the carrier.

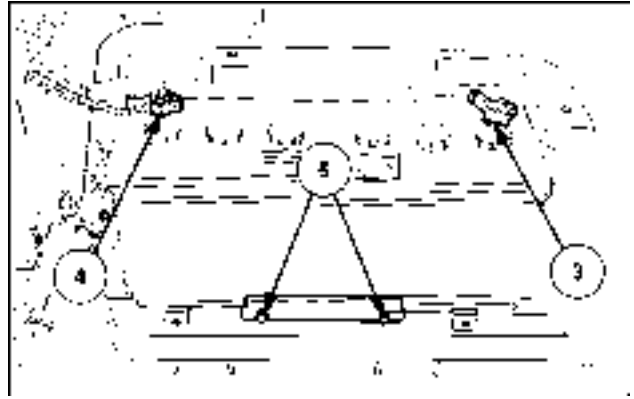

SS12N179 4

**Next operation:**  
**Battery - Install (55.302)**

## Battery - Install

### ⚠ WARNING

Battery gas can explode!

To prevent an explosion: 1. Always disconnect the negative (-) battery cable first. 2. Always connect the negative (-) battery cable last. 3. Do not short circuit the battery posts with metal objects. 4. Do not weld, grind, or smoke near a battery.

Failure to comply could result in death or serious injury.

W0011A

### ⚠ CAUTION

Heavy parts!

Machine batteries are extremely heavy. Make sure the battery is supported safely during the removal process.

Failure to comply could result in minor or moderate injury.

C0050A

### Prior operation:

#### Battery - Remove (55.302)

1. Carefully put the battery into the carrier.
2. Connect the positive battery cable (4) to the battery terminal.
3. Connect the negative battery cable (3) to the battery terminal.
4. Tighten the retaining screws (5).

**NOTICE:** Ensure that the battery cables are positioned so they do not become trapped or chafed on sharp edges.

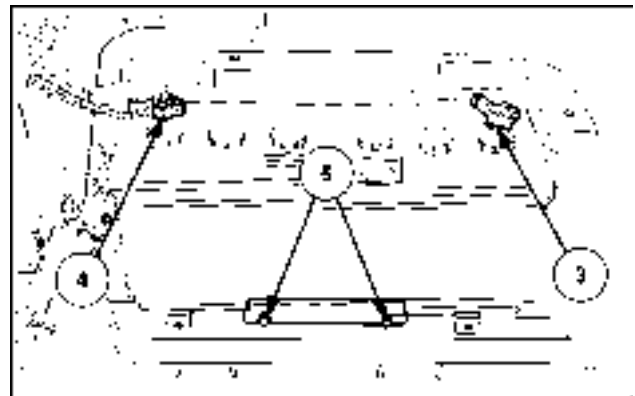

SS12N179 1

5. Add the battery cover and tighten the screws (2).

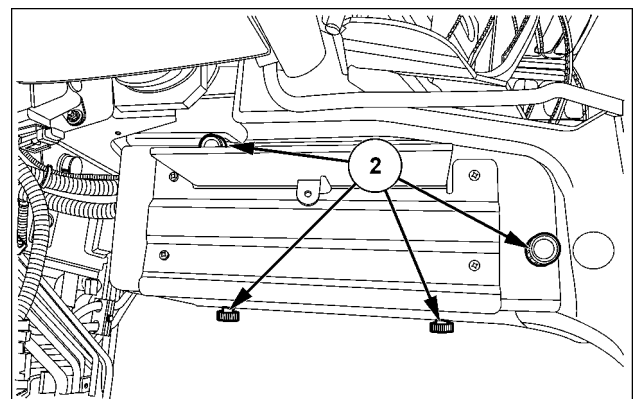

SS12G301 2

6. Place the tool box on the battery. Fix the tool box with the securing pin **(1)** inside the tool box.

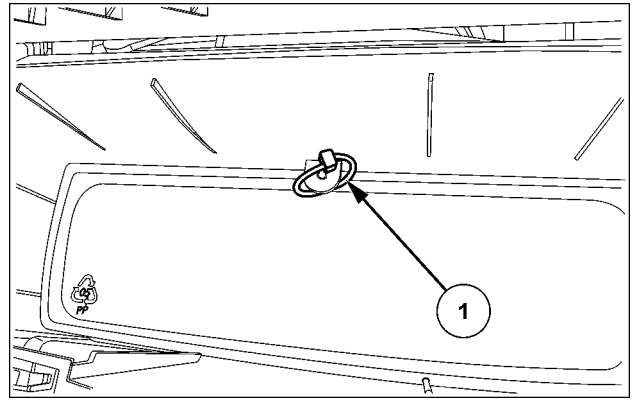

SS12G300 3



## Battery - Testing – Visual check

### ⚠ WARNING

**Battery gas can explode!**

**To prevent an explosion: 1. Always disconnect the negative (-) battery cable first. 2. Always connect the negative (-) battery cable last. 3. Do not short circuit the battery posts with metal objects. 4. Do not weld, grind, or smoke near a battery.**

**Failure to comply could result in death or serious injury.**

W0011A

N°	Test Point	Expected Result	Other Result (Possible Cause)
1	<p><b>Check</b> Visually check the battery case and the battery terminals for any damage.</p>	<p><b>Result</b> The battery is visually in good condition. <b>Action</b> Continue to step 2.</p>	<p><b>Result</b> The battery case is cracked or a battery terminal is defective. This may lead to electrolyte leakage. <b>Action</b> Replace the battery.</p>
2	<p><b>Check</b></p> <ul style="list-style-type: none"> <li>• Check if the battery cables are damaged.</li> <li>• Check if the connections to the battery terminals are damaged, dirty, or loose.</li> <li>• Check if the battery terminals are corroded.</li> </ul>	<p><b>Result</b> The battery cables and the connections to the battery terminals are in good condition. <b>Action</b> Continue to step 3.</p>	<p><b>Result</b> The battery cables or the connections to the battery terminals are not okay. <b>Action</b></p> <ul style="list-style-type: none"> <li>• Repair or replace the battery cables as necessary.</li> <li>• Clean and tighten the connections to the battery terminals.</li> <li>• Clean the battery terminals using warm water and sodium bicarbonate (baking soda). Use a wire brush to remove heavy corrosion. Dry the battery.</li> <li>• Continue to step 3.</li> </ul>
3	<p><b>Check</b> Check if the battery fixing is loose.</p>	<p><b>Result</b> The battery fixing is okay. <b>Action</b> Continue to step 4.</p>	<p><b>Result</b> The battery fixing is loose. <b>Action</b> Tighten the battery fixing as necessary and continue to step 4.</p>
4	<p><b>Check</b> Check the fluid level of the battery electrolyte. The fluid level should be approximately <b>17 mm (0.7 in)</b> above the plates.</p>	<p><b>Result</b> The fluid level is correct in each cell. <b>Action</b> Continue to step 5.</p>	<p><b>Result</b> The fluid level of the battery electrolyte is low. <b>Action</b> Add distilled or de-mineralized water. Do not use tap or rain water. Continue to step 5.</p>
5	<p><b>Check</b> Visually check the battery electrolyte using a hydrometer.</p>	<p><b>Result</b> The battery electrolyte is clear. <b>Action</b> Proceed a state of charge test. Refer to <b>Battery - Testing – State of charge test (open circuit voltage) (55.302)</b> or to <b>Battery - Testing – State of charge test (specific gravity) (55.302)</b>.</p>	<p><b>Result</b> The battery electrolyte is cloudy or discolored. The reasons for this are maybe overcharging of the battery or high vibrations. A bad battery electrolyte can cause a high self-discharge of the battery. <b>Action</b> Correct the cause.</p>

## Battery - Testing – Heavy load discharge test

### ⚠ WARNING

**Battery gas can explode!**

To prevent an explosion: 1. Always disconnect the negative (-) battery cable first. 2. Always connect the negative (-) battery cable last. 3. Do not short circuit the battery posts with metal objects. 4. Do not weld, grind, or smoke near a battery.

Failure to comply could result in death or serious injury.

W0011A

N°	Test Point	Expected Result	Other Result (Possible Cause)
1	<p><b>Condition</b></p> <ul style="list-style-type: none"> <li>Confirm that the state of charge of the battery is at least <b>75 % (&gt; 12.4 V)</b>. Refer to <b>Battery - Testing – State of charge test (open circuit voltage) (55.302)</b> or to <b>Battery - Testing – State of charge test (specific gravity) (55.302)</b>.</li> <li>Determine the capacity rating of the battery as stated on the battery label. It should be a <b>132 Ah (960 CCA)</b> battery installed. Connect the heavy load tester to the battery terminals, observing the correct polarity.</li> <li>To remove the surface charge, load the battery for <b>15 s</b> with the heavy load tester. Adjust the discharge current to a rate equal to three times the Ampere hour (Ah) rating or half of the cold cranking ampere rating (CCA) of the battery.</li> <li>Then disconnect the heavy load tester and then let the battery rest for <b>5 min</b>.</li> </ul> <p><b>Check</b></p> <ul style="list-style-type: none"> <li>Perform the heavy load discharge test. Apply the heavy load tester to the battery for no more than <b>15 s</b>.</li> <li>Note the voltage reading during the test.</li> </ul>	<p><b>Result</b></p> <p>The voltage was greater than <b>9.6 V</b>. The battery has an acceptable output capacity.</p> <p><b>Action</b></p> <p>The battery is suitable for operation. Charge the battery.</p>	<p><b>Result</b></p> <p>The voltage was less than <b>9.6 V</b>. The battery has an unacceptable output capacity.</p> <p><b>Action</b></p> <p>Perform a test charge before attempting a full recharge. Replace the battery if necessary.</p>

## Battery - Testing – State of charge test (specific gravity)

### ⚠ WARNING

**Battery gas can explode!**

To prevent an explosion: 1. Always disconnect the negative (-) battery cable first. 2. Always connect the negative (-) battery cable last. 3. Do not short circuit the battery posts with metal objects. 4. Do not weld, grind, or smoke near a battery.

Failure to comply could result in death or serious injury.

W0011A

**NOTE:** A state of charge test determines if there is sufficient charge in the battery to perform a heavy load discharge test. A state of charge test does not verify the ability of a battery to crank the engine.

N°	Test Point	Expected Result	Other Result (Possible Cause)
1	<p><b>Condition</b></p> <ul style="list-style-type: none"> <li>• Check the fluid level of the battery electrolyte. The fluid level should be approximately <b>17 mm (0.7 in)</b> above the plates. If necessary add distilled or de-mineralized water.</li> <li>• Recharge the battery for <b>2 h</b> and then let the battery rest for <b>15 min</b> before testing.</li> <li>• Shake the battery to mix the battery electrolyte.</li> </ul> <p><b>Check</b></p> <p>Determine the state of charge of the battery.</p> <ul style="list-style-type: none"> <li>• Remove the vent caps. Use a hydrometer to extract battery electrolyte.</li> <li>• Determine the specific gravity for each cell. Begin with the cell closest to the positive terminal. Adjust the hydrometer readings for any temperature variations (<math>\pm 0.004</math> specific gravity for every <math>\pm 5.5\text{ }^{\circ}\text{C}</math> (<math>\pm 41.9\text{ }^{\circ}\text{F}</math>)) related to the calibration temperature.</li> </ul>	<p><b>Result</b></p> <p>The variance of the specific gravity between two cells is below 0.025.</p> <p><b>Action</b></p> <p>Refer to the specific gravity table in <b>Battery - General specification (55.302)</b>. The corrected specific gravity value gives information about the state of charge of the battery.</p>	<p><b>Result</b></p> <p>The variance of the specific gravity between two cells is greater than 0.025. This result indicates a defective cell.</p> <p><b>Action</b></p> <p>Replace the battery.</p>

## Battery - Testing – State of charge test (open circuit voltage)

### **WARNING**

**Battery gas can explode!**

To prevent an explosion: 1. Always disconnect the negative (-) battery cable first. 2. Always connect the negative (-) battery cable last. 3. Do not short circuit the battery posts with metal objects. 4. Do not weld, grind, or smoke near a battery.

Failure to comply could result in death or serious injury.

W0011A

**NOTE:** A state of charge test determines if there is sufficient charge in the battery to perform a heavy load discharge test. A state of charge test does not verify the ability of a battery to crank the engine.

N°	Test Point	Expected Result	Other Result (Possible Cause)
1	<p><b>Condition</b></p> <ul style="list-style-type: none"> <li>To remove any surface charge from the battery, switch ON all electrical consumers (lights, seat heating, etc.) of the vehicle for <b>1 min.</b></li> <li>Switch OFF the electrical consumers and let the vehicle rest for <b>5 min.</b></li> </ul> <p><b>Check</b></p> <p>Determine the state of charge of the battery.</p> <ul style="list-style-type: none"> <li>Measure the open circuit voltage by connecting a digital voltmeter across the battery terminals.</li> <li>Refer to the voltages in the specific gravity table in <b>Battery - General specification (55.302).</b></li> </ul>	<p><b>Result</b></p> <p>The state of charge of the battery is sufficient.</p> <p><b>Action</b></p> <p>The battery is suitable for operation.</p>	<p><b>Result</b></p> <p>The state of charge of the battery is not sufficient.</p> <p><b>Action</b></p> <p>Charge the battery.</p>

## Battery - Testing – Charging overview

### **WARNING**

**Battery gas can explode!**

To prevent an explosion: **1. Always disconnect the negative (-) battery cable first. 2. Always connect the negative (-) battery cable last. 3. Do not short circuit the battery posts with metal objects. 4. Do not weld, grind, or smoke near a battery.**

Failure to comply could result in death or serious injury.

W0011A

**NOTE:** It is recommended to charge the battery not below an ambient temperature of **20 °C (68.0 °F).**

N°	Test Point	Expected Result	Other Result (Possible Cause)
1	<p><b>Check</b></p> <p>Before charging the battery, visually check the battery. Refer to <b>Battery - Testing – Visual check (55.302).</b></p>	<p><b>Result</b></p> <p>The battery is ready for charging.</p> <p><b>Action</b></p> <p>Continue to step 2.</p>	<p><b>Result</b></p> <p>The battery is defective.</p> <p><b>Action</b></p> <p>Replace the battery.</p>
2	<p><b>Check</b></p> <p>Perform a state of charge test. Refer to <b>Battery - Testing – State of charge test (open circuit voltage) (55.302)</b> or to <b>Battery - Testing – State of charge test (specific gravity) (55.302).</b></p>	<p><b>Result</b></p> <p>The state of charge of the battery is above 75%.</p> <p><b>Action</b></p> <p>Continue to step 3.</p>	<p><b>Result</b></p> <p>The state of charge of the battery is below 75%.</p> <p><b>Action</b></p> <p>Charge the battery and continue to step 3.</p>
3	<p><b>Check</b></p> <p>Perform a heavy load discharge test. Refer to <b>Battery - Testing – Heavy load discharge test (55.302).</b></p>	<p><b>Result</b></p> <p>The result of the heavy load discharge test is positive.</p> <p><b>Action</b></p> <p>Continue to step 5.</p>	<p><b>Result</b></p> <p>The result of the heavy load discharge test is not positive.</p> <p><b>Action</b></p> <p>Continue to step 4.</p>
4	<p><b>Check</b></p> <p>Perform a test charge. Charge the battery for approximately <b>2 min</b> with a charging current of approximately <b>40 A</b>. Measure the battery voltage.</p>	<p><b>Result</b></p> <p>The battery voltage is between <b>11 - 16 V.</b></p> <p><b>Action</b></p> <p>The battery will accept a full recharge. Continue to step 5.</p>	<p><b>Result</b></p> <p>The battery voltage is not between <b>11 - 16 V.</b></p> <p><b>Action</b></p> <p>Replace the battery if necessary.</p>

Electrical systems - Battery

N°	Test Point	Expected Result	Other Result (Possible Cause)
5	<b>Check</b> Charge the battery. Use the slow charge program.	<b>Result</b> The charging of the battery was successful. <b>Action</b> Perform the heavy load discharge test. Refer to <b>Battery - Testing – Heavy load discharge test (55.302)</b> .	<b>Result</b> The charging of the battery was not successful. <b>Action</b> Replace the battery.

# Index

---

## Electrical systems - 55

### Battery - 302

Battery - Connect .....	9
Battery - Disconnect .....	7
Battery - Electrical test – General information .....	5
Battery - General specification .....	3
Battery - Install .....	12
Battery - Remove .....	10
Battery - Static description .....	4
Battery - Testing – Charging overview .....	17
Battery - Testing – Heavy load discharge test .....	15
Battery - Testing – State of charge test (open circuit voltage) .....	16
Battery - Testing – State of charge test (specific gravity) .....	15
Battery - Testing – Visual check .....	14





## **Electrical systems - 55**

### **Cold start aid - 202**

**Farmall 105U Pro EP  
Farmall 115U Pro EP  
Farmall 95U Pro EP**



# Contents

---

## Electrical systems - 55

### Cold start aid - 202

#### FUNCTIONAL DATA

##### Glow plug system

Overview .....	3
----------------	---

## Glow plug system - Overview

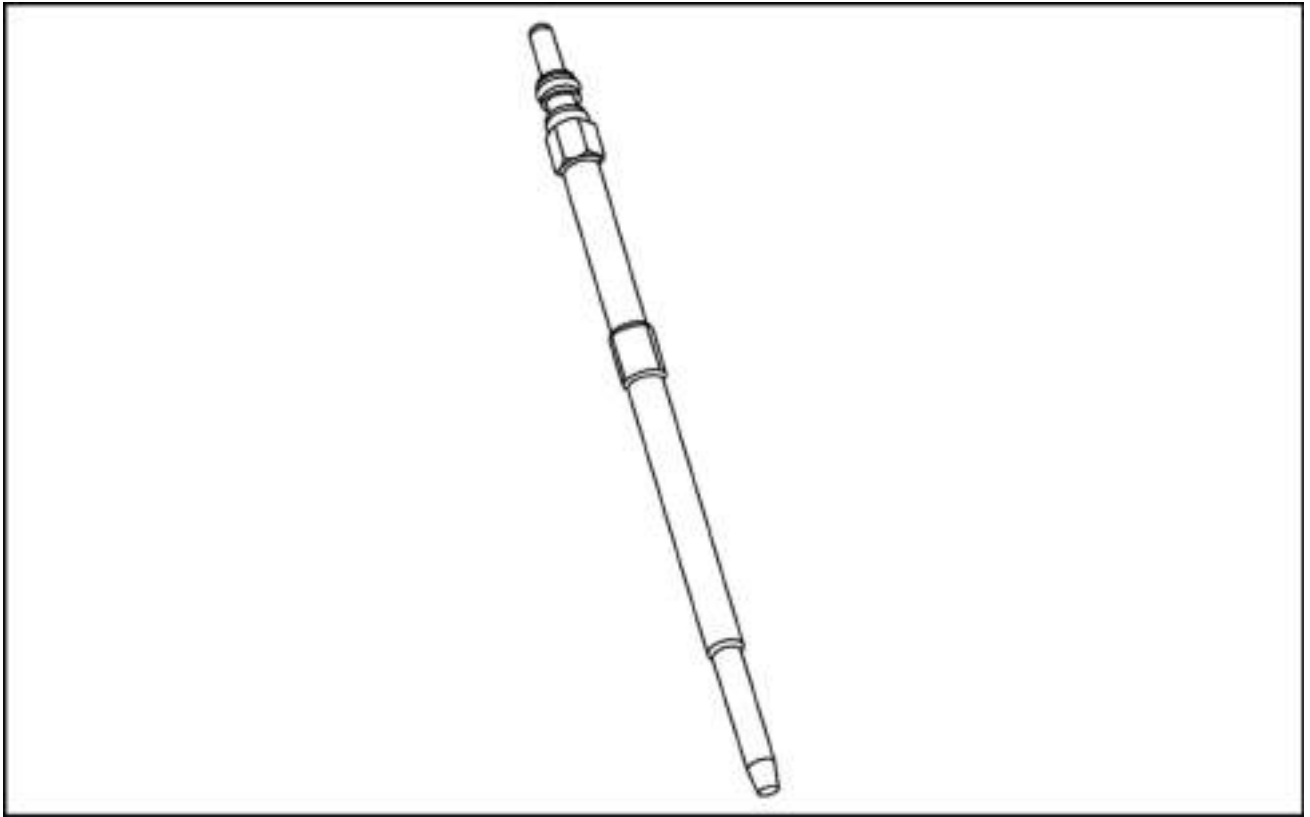

93111647 1

A glow plug is typically comprised of a heating coil in a metal tube closed at one end and filled with electrically insulating ceramic powder. The closed end of the metal tube with the heating coil protrudes through a hole in the cylinder head into the combustion chamber. When the glow plug is electrically energized, its heated portion reaches a surface temperature of more than **1000 °C (1832 °F)** within a few seconds. The air-fuel spray generated by the injection ignites close to the glow plug and initiates combustion.

<b>Specifications</b>	
Protrusion length	<b>30.4 mm +/- 0.25 mm</b>
Diameter of heating element	<b>4 mm +/- 0.1 mm</b>
Heat up time to <b>850 °C (1562 °F)</b>	Less than <b>5 s</b>
Temperature T60	<b>950 - 1010 °C (1742 - 1850 °F)</b>
Switch on current at <b>11 V</b>	Less than <b>19 A</b>
Operating current at <b>11 V</b> after <b>20 s</b>	<b>5 A +/- 1.0 A</b>
Runout heating element	<b>0.4 mm</b>

# Index

---

## Electrical systems - 55

### Cold start aid - 202

Glow plug system - Overview .....	3
-----------------------------------	---



## **Electrical systems - 55**

### **Fuel tank system - 011**

**Farmall 105U Pro EP  
Farmall 115U Pro EP  
Farmall 95U Pro EP**

# Contents

---

## Electrical systems - 55

### Fuel tank system - 011

#### FUNCTIONAL DATA

Fuel level sensor	
Overview .....	3

#### SERVICE

Fuel level sensor	
Replace .....	4

## Fuel level sensor - Overview

### Fuel level sensor (B-024)

The fuel level sensor (1) is located in the fuel tank.

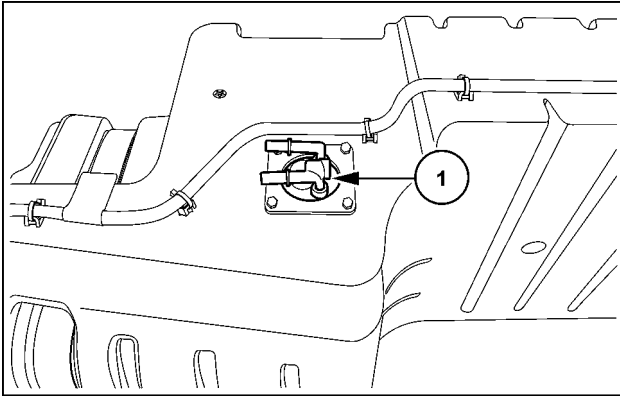

SVIL13TR00913AC 1

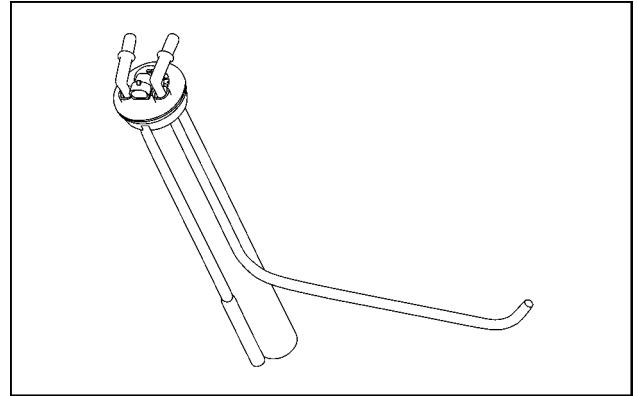

SS13K026 2

Specifications	
Pin 1	Ground
Pin 2	Signal
Maximum current	70 mA

Resistance test values	
full fuel tank	20.5 Ω +/- 2
half-full fuel tank	160 Ω +/- 4
empty fuel tank	276 Ω +/- 5

## Fuel level sensor - Replace

### Prior operation:

Remove the fuel tank. See **Fuel tank - Remove (10.216)**.

1. Remove the four bolts (1).
2. Remove the fuel tank sensor.

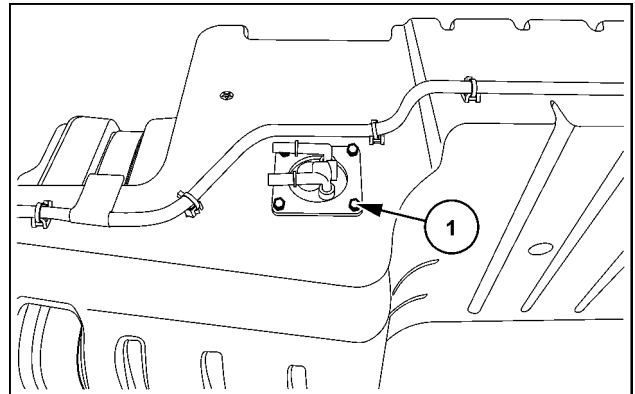

SVIL13TR00913AB 1

3. Install the fuel tank sensor with a new ring seal (1).

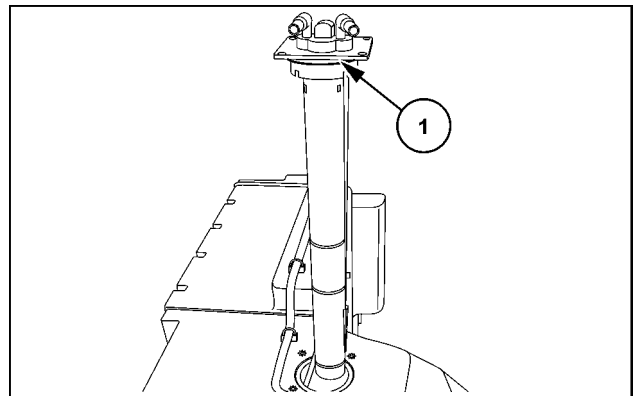

SVIL13TR00912AB 2

4. Install the four bolts (1).

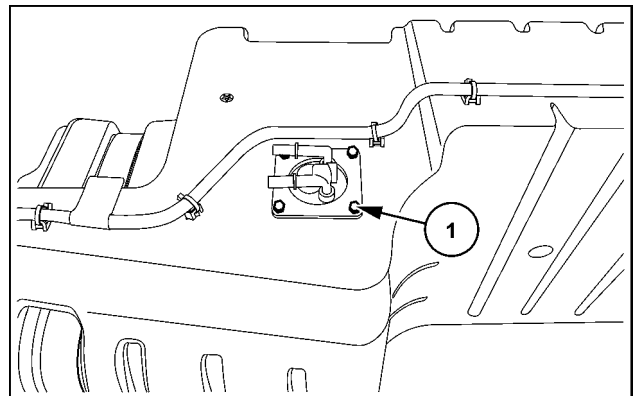

SVIL13TR00913AB 3

### Next operation:

Install the fuel tank. See **Fuel tank - Install (10.216)**.

# Index

---

## Electrical systems - 55

### Fuel tank system - 011

Fuel level sensor - Overview .....	3
Fuel level sensor - Replace .....	4







## **Electrical systems - 55**

### **Engine intake and exhaust system - 014**

**Farmall 105U Pro EP  
Farmall 115U Pro EP  
Farmall 95U Pro EP**

# Contents

---

## Electrical systems - 55

### Engine intake and exhaust system - 014

#### FUNCTIONAL DATA

##### Intake air pressure and temperature sensor

Overview .....	3
----------------	---

## Intake air pressure and temperature sensor - Overview

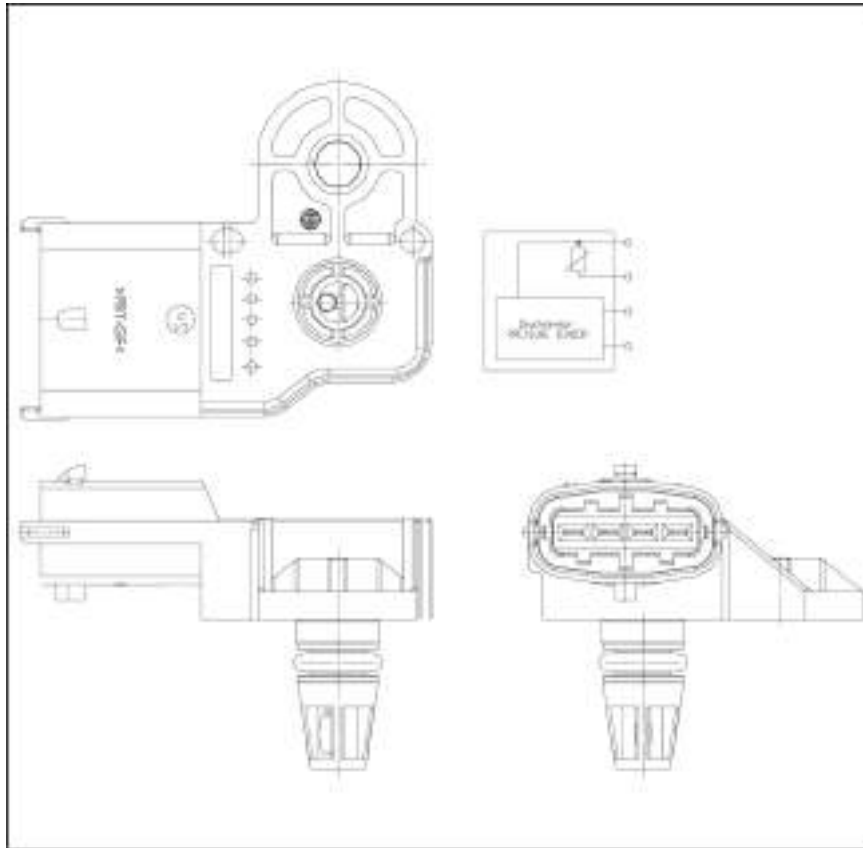

73092811 1

The air pressure temperature sensor, located on the intake manifold, is used to measure intake manifold pressure and temperature after the turbocharger.

# Index

---

## Electrical systems - 55

### Engine intake and exhaust system - 014

Intake air pressure and temperature sensor - Overview .....	3
---	---



## **Electrical systems - 55**

### **Engine cooling system - 012**

**Farmall 105U Pro EP  
Farmall 115U Pro EP  
Farmall 95U Pro EP**

# Contents

---

## Electrical systems - 55

## Engine cooling system - 012

### FUNCTIONAL DATA

#### Engine coolant temperature sensor

Overview .....	3
----------------	---

## Engine coolant temperature sensor - Overview

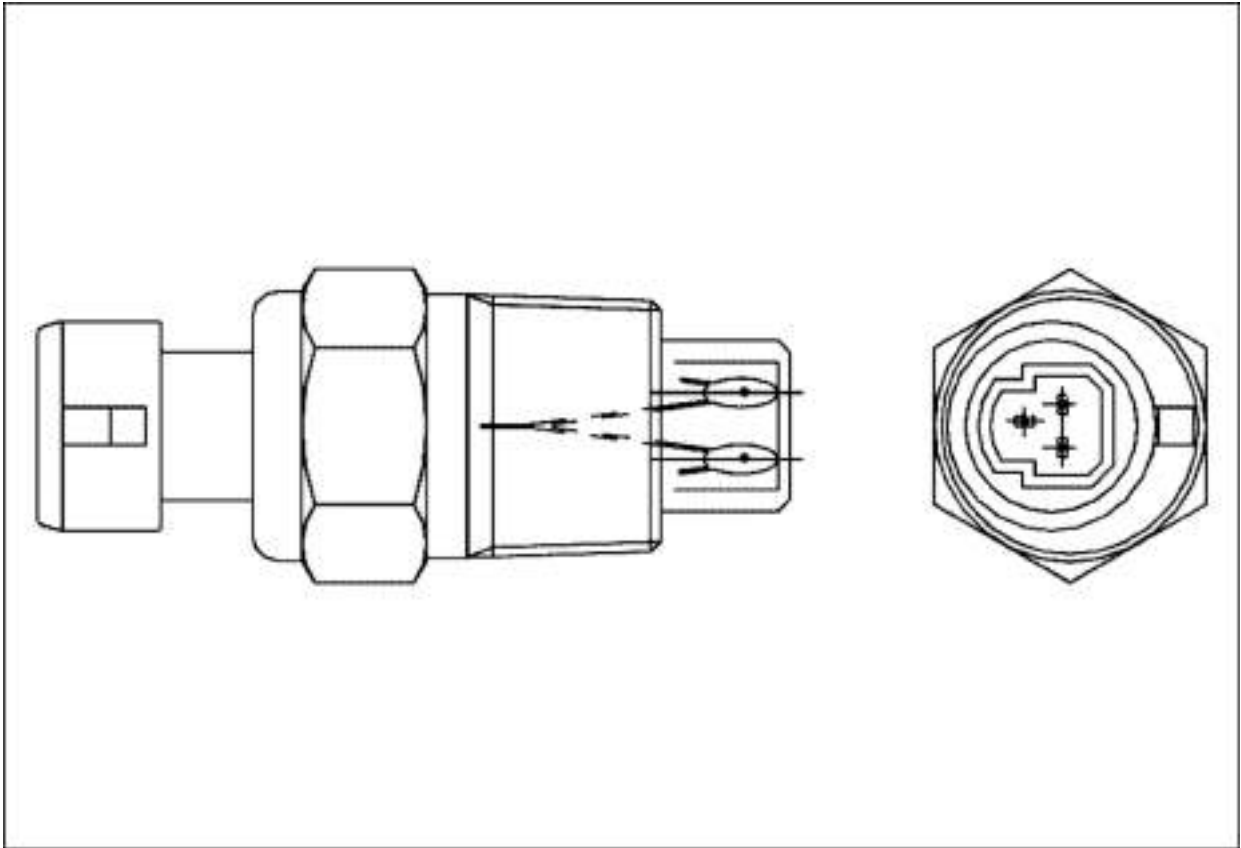

73092808 1

<b>Specifications</b>	
Voltage	<b>6 - 28 V</b>
Working temperature range	
- Connector's side	<b>-40 - 130 °C (-40 - 266 °F)</b>
- Engine side	<b>-40 - 140 °C (-40 - 284 °F)</b>

The coolant temperature sensor measures the temperature of the coolant circulating through the engine. The data is then sent to the Engine Control Unit (ECU).



# Index

---

## Electrical systems - 55

### Engine cooling system - 012

Engine coolant temperature sensor - Overview .....	3
--	---



## **Electrical systems - 55**

### **Engine oil system - 013**

**Farmall 105U Pro EP  
Farmall 115U Pro EP  
Farmall 95U Pro EP**

# Contents

---

## Electrical systems - 55

### Engine oil system - 013

#### FUNCTIONAL DATA

##### Engine oil pressure sensor and switch

Overview .....	3
----------------	---

## Engine oil pressure sensor and switch - Overview

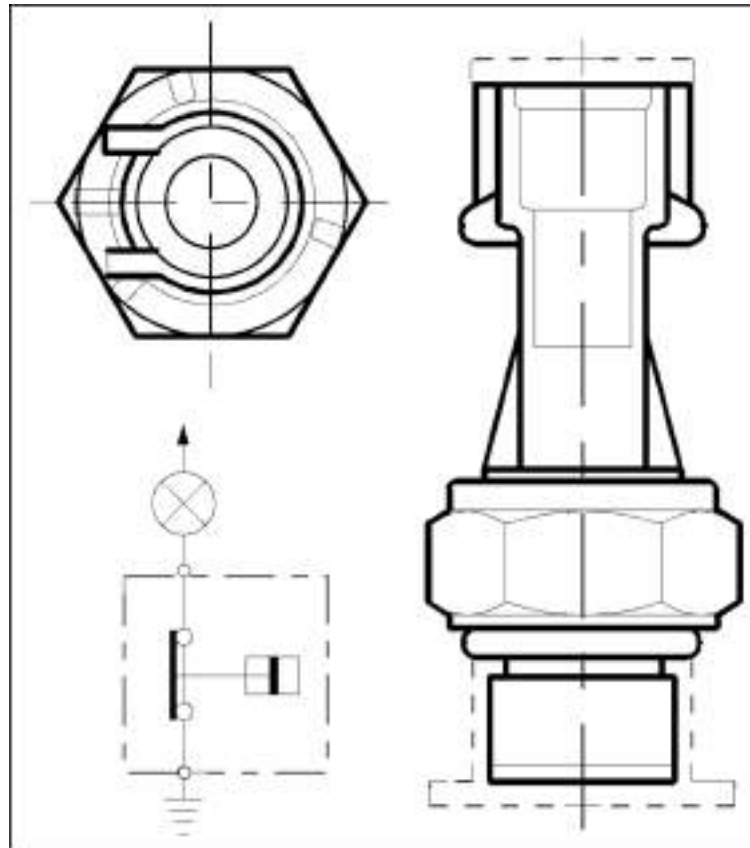

73092809 1

<b>Specifications</b>	
Contact closure with decreasing pressure	<b>0.2 bar (3 psi)</b>
Contact opening with increasing pressure	<b>0.9 bar (13 psi)</b>

The oil pressure sensor is located on the top of the oil filter base.

# Index

---

## Electrical systems - 55

### Engine oil system - 013

Engine oil pressure sensor and switch - Overview .....	3
--	---



## **Electrical systems - 55**

**Electronic modules - 640**

**Farmall 105U Pro EP  
Farmall 115U Pro EP  
Farmall 95U Pro EP**

# Contents

---

## Electrical systems - 55

### Electronic modules - 640

#### TECHNICAL DATA

Electronic module Configure - HH-Menu overview .....	4
---	---

#### FUNCTIONAL DATA

Electronic modules Overview .....	11
Overview – Fault finding .....	12
Electronic module Fault code index .....	13
Instrument control unit - Electronic schema .....	26
Central Control Unit (CCU) - Electronic schema .....	28

#### SERVICE

Electronic module Instrument control unit - H3 - Configurations and options .....	31
Instrument control unit - H4 - View software revision level .....	40
Instrument control unit - H5 - Switch operation test .....	42
Instrument control unit - H8 - Clear stored calibration information (EEPROM) .....	45
Instrument control unit - H9 - Voltmeter diagnostic .....	49
Instrument control unit - HB - Display stored fault codes .....	51
Instrument control unit - HC - Clear all stored fault codes .....	53
Instrument control unit - HF - View controller hardware information .....	55
Central Control Unit (CCU) - H1 - Calibration procedures .....	57
Central Control Unit (CCU) - H2 - View stored calibration values .....	62
Central Control Unit (CCU) - H3 - Configurations and options .....	64
Central Control Unit (CCU) - H4 - View software revision level .....	74
Central Control Unit (CCU) - H5 - Switch operation test .....	76
Central Control Unit (CCU) - H8 - Clear stored calibration information (EEPROM) .....	79
Central Control Unit (CCU) - H9 - Voltmeter diagnostic .....	82
Central Control Unit (CCU) - HB - Display stored fault codes .....	85
Central Control Unit (CCU) - HC - Clear all stored fault codes .....	88
Central Control Unit (CCU) - HE - Display frequency inputs .....	90

Central Control Unit (CCU) - HF - View controller hardware information . . . . .	92
Central Control Unit (CCU) - HJ - Electronic hydraulic remote control valve number programming . . . . .	94
ISO bus interface controller - H4 - View software revision level . . . . .	100
ISO bus interface controller - HF - View controller hardware information . . . . .	101



## Electronic module - Configure - HH-Menu overview

### Electronic control units: names and identifiers

Each of the electronic control units fitted to the vehicle has an associated identifier that is used by the instrument cluster during the H-Menu diagnostics procedures. Throughout this document the units are referred to use these identifiers. The following table lists all the units accessible from the H-Menu diagnostics, its function and the corresponding identifier used by the instrument cluster.

Identifier	Controller name	Controller functions
RA	Central Control Unit (CCU)	Transmission, Electronic Draft Control (EDC), Front Hitch, Rear Power Take-Off (PTO), Front Power Take-Off (PTO), Four-Wheel Drive (4WD), Differential Lock, Electronic Parking Brake, Rear Electro Hydraulic Remote valve, Front Electronic Hydraulic Remote valve
TC	Transmission Control Unit (TCU)	Transmission, Four-Wheel Drive (4WD), Differential Lock, Rear Power Take-Off (PTO)
ZE	Analog-Digital Instrument Cluster (ADIC)	Analog-Digital Instrument Cluster
OA	Isobus interface controller (TECU)	Isobus interface controller

### INTRODUCTION

The H-Menu mode is part of the on-board diagnostics providing configuration and diagnostic support through the resources available on the system.

To gain access to the diagnostic H-Menu mode routine, it is necessary to use the diagnostic test plug (special tool **380000843**) in the tractor diagnostic main connector number 1 (number **(1)** is vehicle bus and number **(2)** is Electro Hydraulic Remote valve (EHR) bus). The main diagnostics connector is located in the cab on the rear left-hand side.

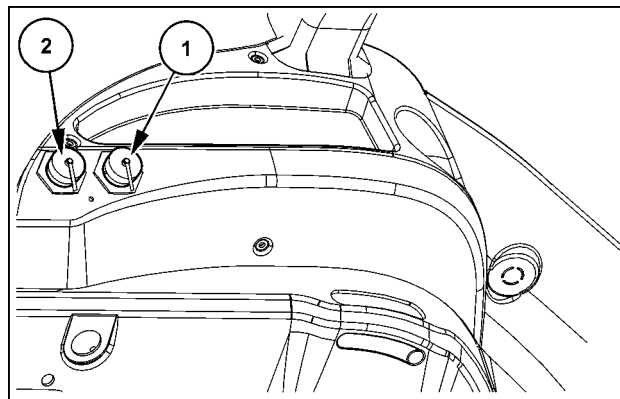

SS12N534 1

The Analog-Digital Instrument Cluster (ADIC) Dot Matrix Display (DMD) (1) and the upper display (2) are used to indicate the information for the HH-Menus.

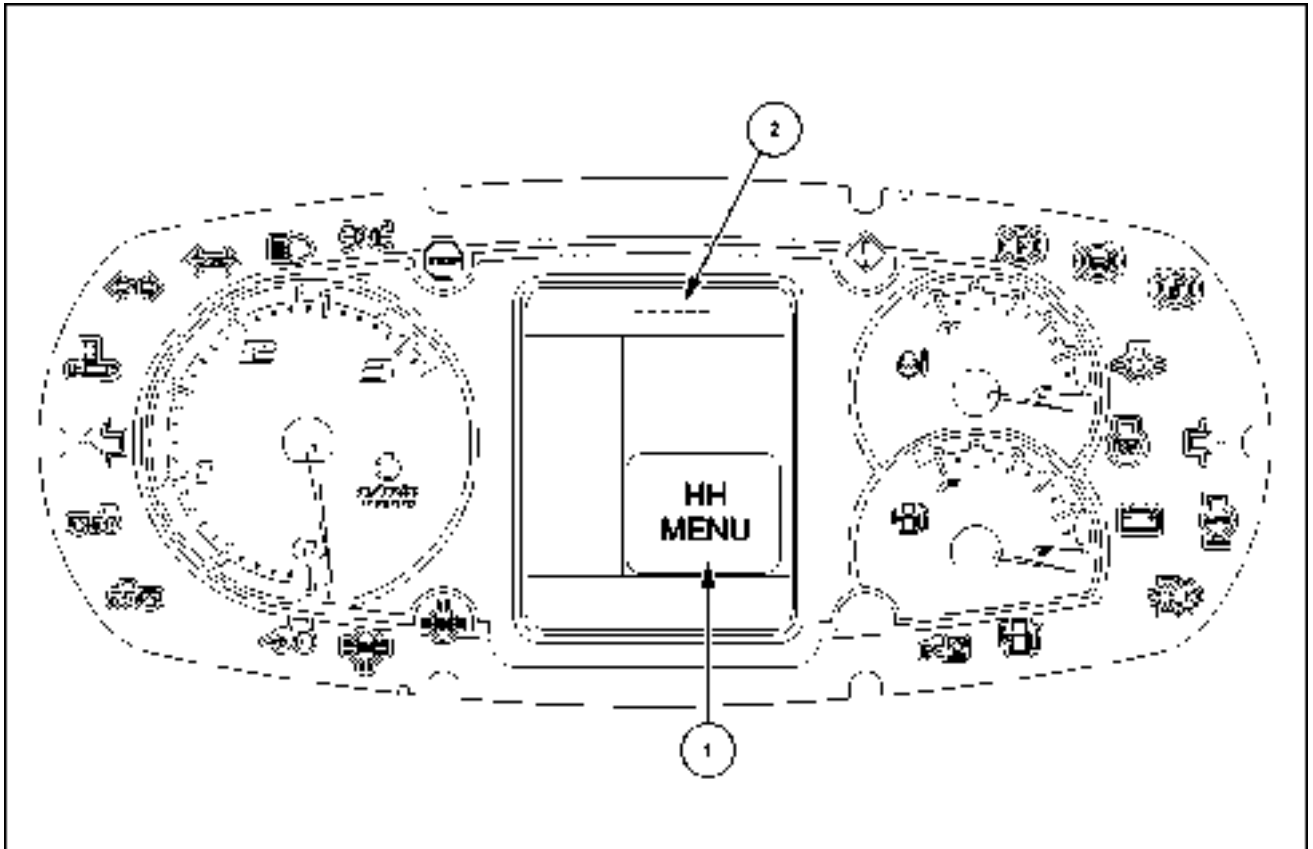

SS12N536 2

### H-Menu navigation procedure

Connect the special tool **380000843** to the diagnostic connector. Turn the ignition switch ON. When the ignition switch is ON, the ADIC will automatically build a list of the controllers connected on the Controller Area Network (CAN), and will store it in the Electrically Erasable Programmable Read Only Memory (EEPROM). The Dot Matrix Display (DMD) will show "HH-MENU" to indicate that the HH-Menu has been activated.

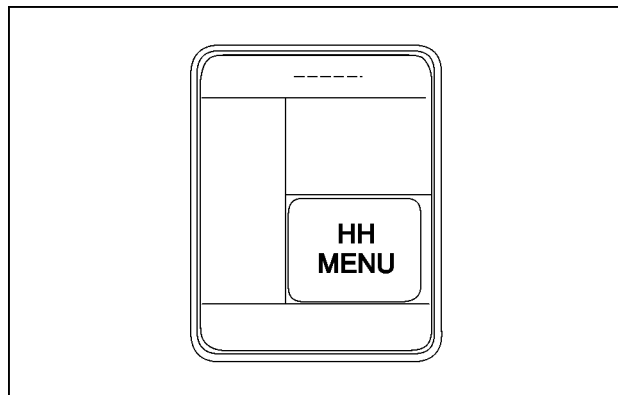

SS12N537 3

To navigate through the HH-Menu, use the two service switches, associated to two double momentary rocker switches. The two service switches are placed near the steering wheel:

- (1) HOME switch: press this switch to close or cancel the setting and programming modes without saving.
- (2) ENTER switch: press this switch to select the setting and programming modes.
- (3) UP switch: press this switch several times to scroll the menu and change submenu options.
- (4) DOWN switch: press this switch several times to scroll the menu and change submenu options.

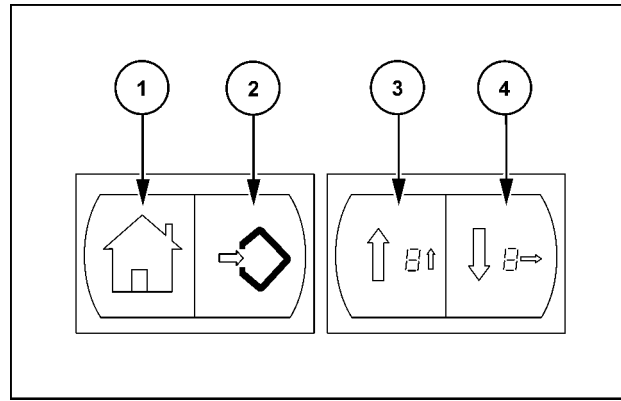

SS12N538 4

By pressing DOWN or UP rocker switches, the DMD will show the identifier code of the current unit listed above. Arrows on the screen indicate that there are other selections available at the same level.

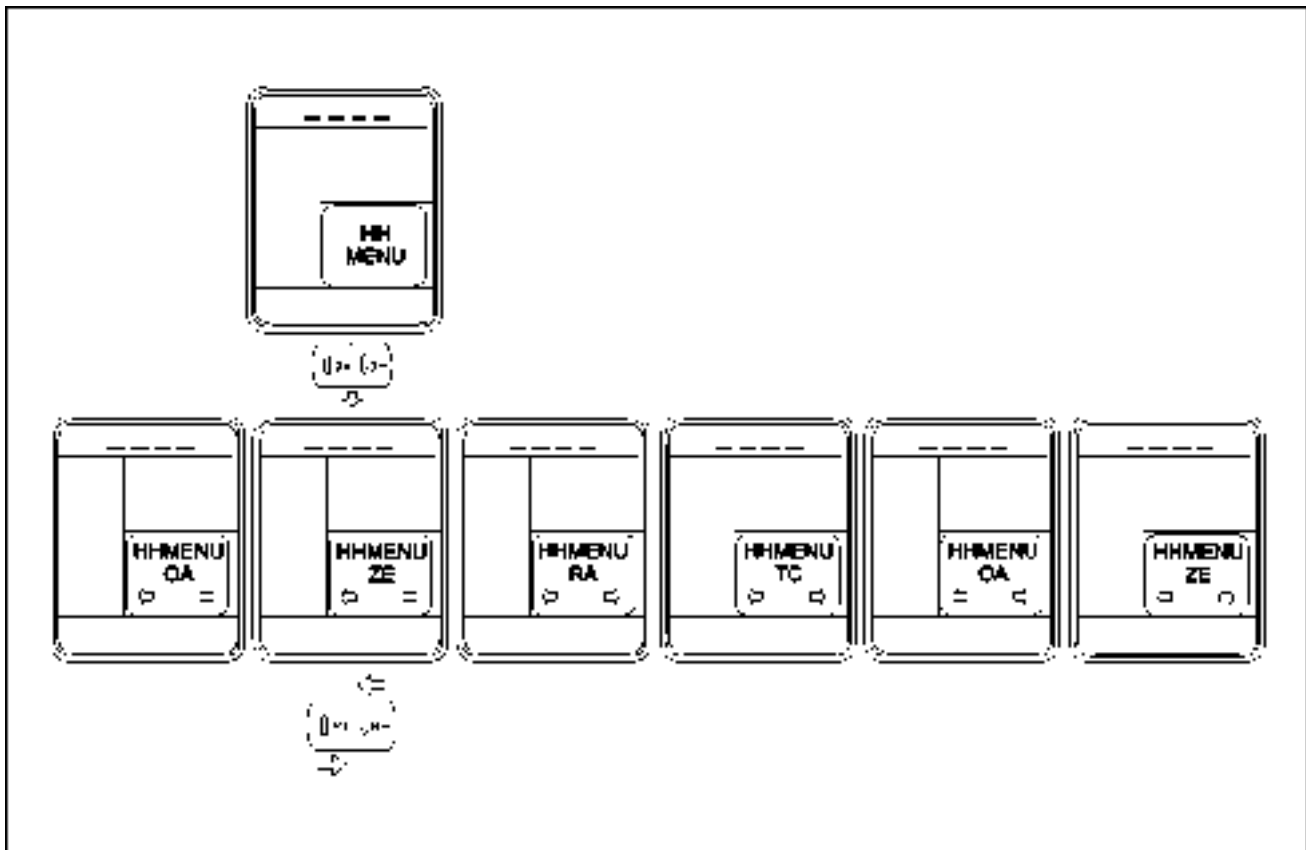

SS12N539 5

When the selection has been done, press the ENTER switch. At this point, the visualization on the DMD will change to one of the following:

- (1) The HH-Menu for this unit is in the diagnostic mode.
- (2) The HH-Menu for this unit cannot be displayed.

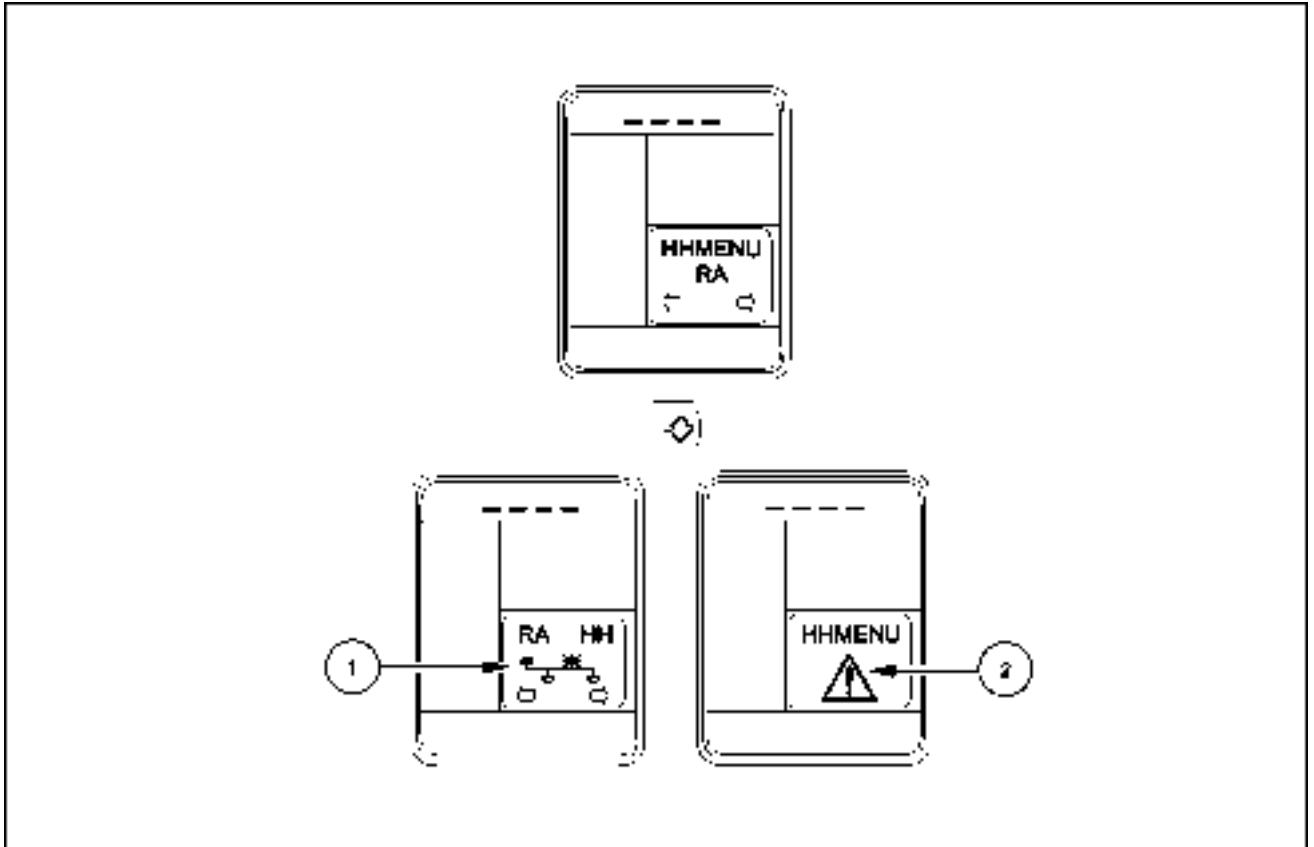

SS12N540 6

To select the H-Menu number: arrows on the screen mean that the operator can choose other HH-Menus.

Using the UP switch, you can scroll options selecting H1, H2, H3, H4, H5, H6, H7, H8, H9, HA, HB, HC, HD, HE, HF, HJ, H1.

Using the DOWN switch you can scroll options selecting HJ, HF, HE, HD, ..... H1.

When passing through the HH-Menus, the DMD will display two different formats, as shown below:

- (1) The unit selection will be displayed in the top left-hand corner of the DMD.
- (2) The H-Menu number will be displayed in the top right-hand corner of the DMD.
- (3) Three arrows will be displayed: the left and right arrows move to another H-Menu. The downward arrow means that there is more than one subsystem that uses this menu.
- (4) Two arrows will be displayed: the left and right arrows move to another H-Menu. When the downward arrow is missing, there is no further subsystem in this menu.

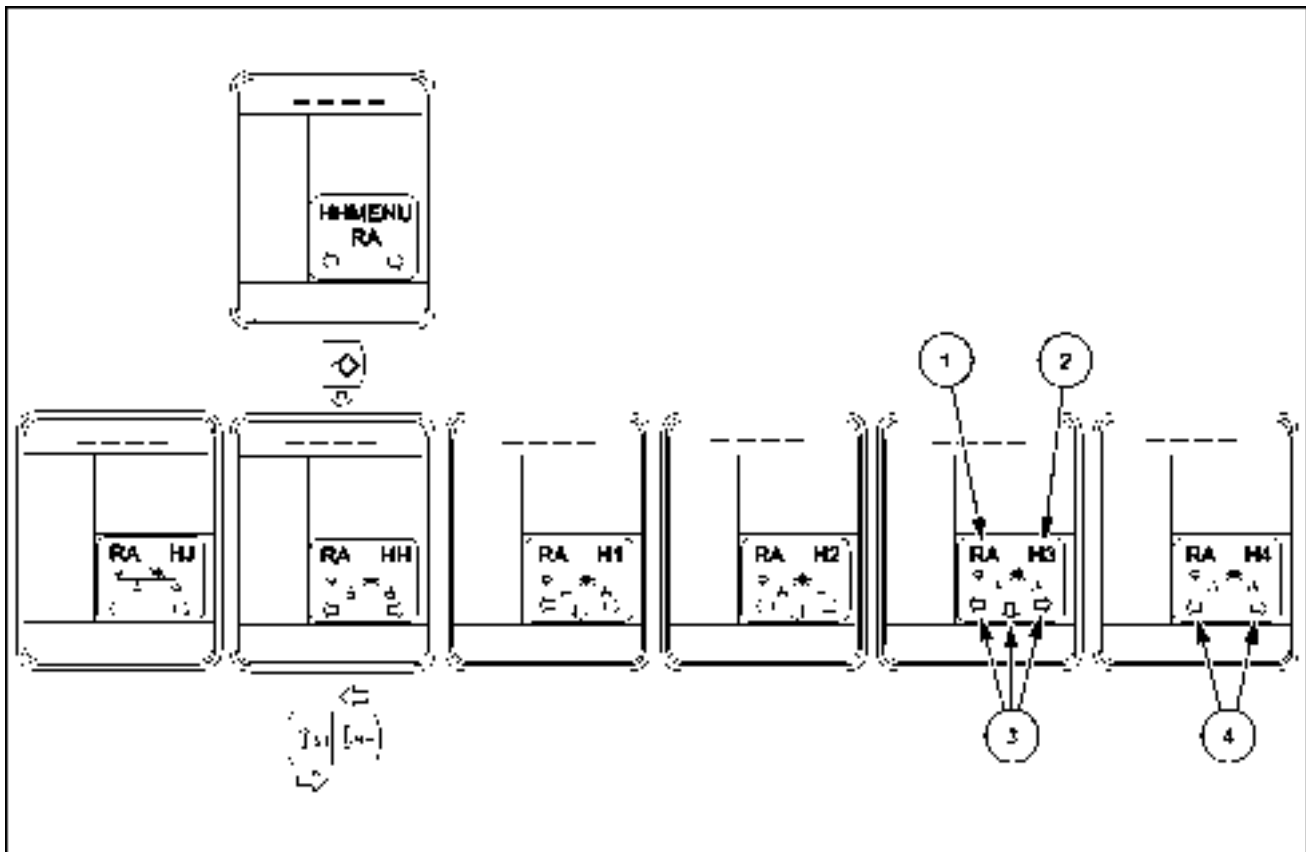

SS12N541 7

The table below shows functions performed by each H-Menu and the menus applicable to each controller.

**NOTE:** Not all H-Menus could be available on every controller. If a controller does not have a particular H-Menu, it will not be shown when scrolling through the menu. See table below.

Menu	Function	ZE	RA	OA	TC
HH	Not supported	-	-	-	-
H1	Calibration procedures	-	X	-	X
H2	View calibration values	-	X	-	X
H3	Configurations and options	X	X	-	X
H4	View software revision number	X	X	X	X
H5	Switch diagnostics	X	X	-	X
H6	Vehicle information view	-	-	-	-
H7	Vehicle test	-	-	-	-
H8	Clear nonvolatile memory	X	X	-	X
H9	Voltmeter diagnostics	X	X	-	X
HA	Demonstration mode	-	-	-	-
HB	Display stored fault codes	X	X	-	X







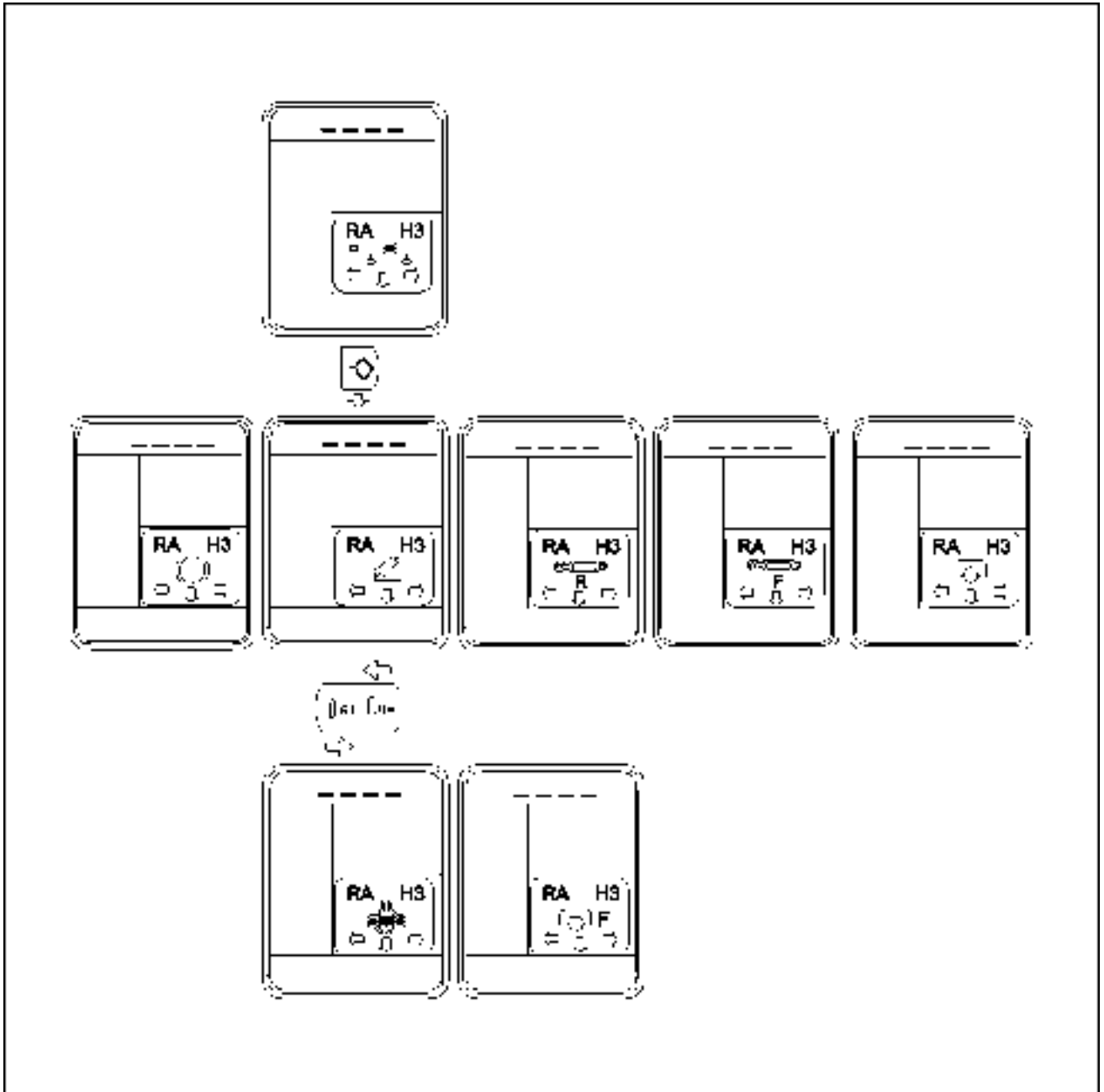

Menu	Function	ZE	RA	OA	TC
HC	Clear stored fault codes	X	X	-	X
HD	Set diagnostic fault mode	-	-	-	-
HE	Frequency inputs	-	X	-	X
HF	View hardware version information	X	X	X	X
HJ	EHR valve number programming	-	X	-	-

### Submenu navigation procedure

Press the ENTER switch to access the “submenu”. The display shows the subsystems that this HH-Menu has. You can use the UP or DOWN switches to scroll between the available subsystems for this level.



All available vehicle subsystems are identified through the icons shown in the table below.

Function	Icon
Rear hitch control	
Rear EHR	
Front EHR	
Transmission	
Differential lock	
Four-Wheel Drive (4WD)	
Rear Power Take-Off (PTO)	
Front Power Take-Off (PTO)	
Electronic parking brake	

Press the ENTER switch to access the “channels”. The display shows the channel level (1) that this subsystem uses. Use the UP or DOWN switches to scroll between the available channel numbers.

**NOTE:** To return back to the controller select screen and press the HOME switch again.

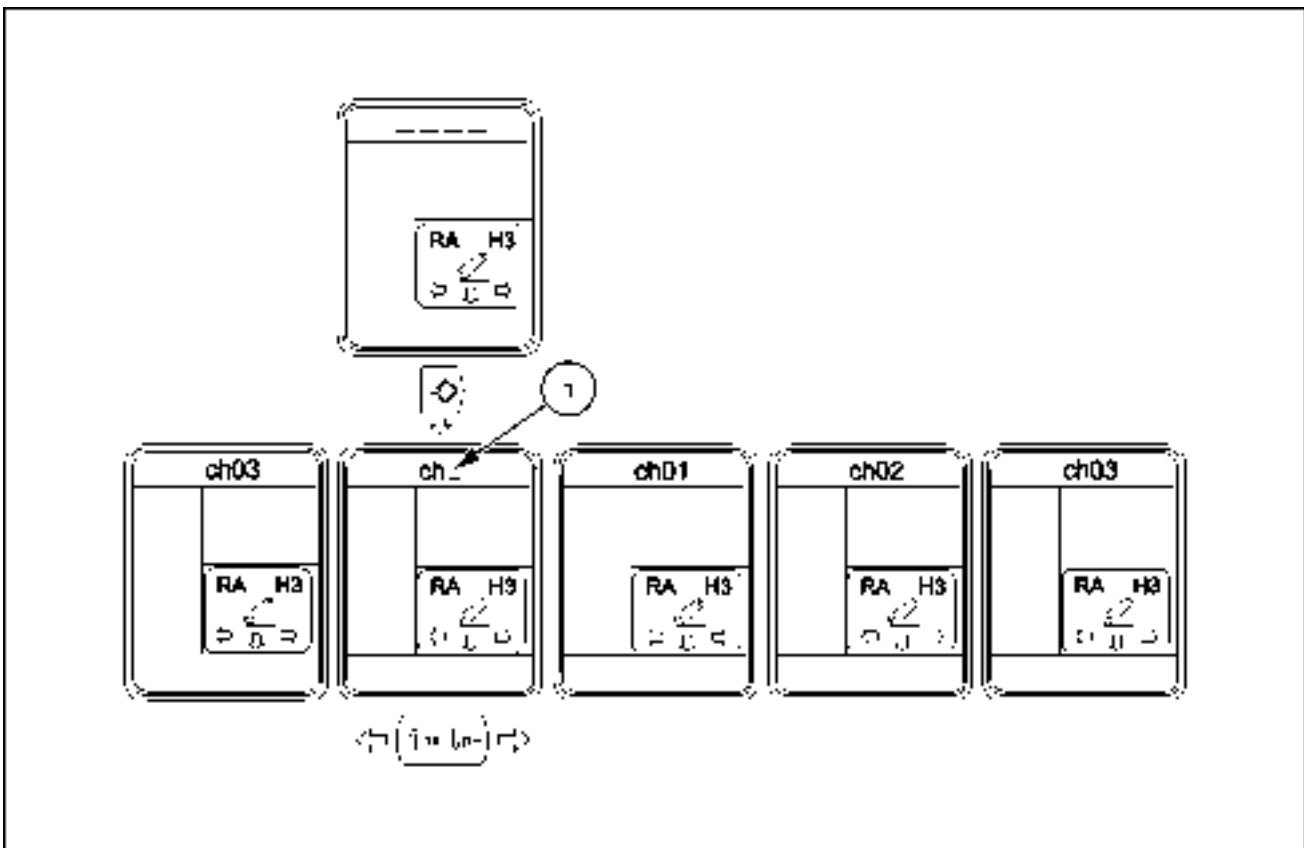

## Electronic modules - Overview

The electronic modules are the "black boxes" that provide control on many of the functions of the tractor. These functions may vary according to the options that are fitted on the tractor.

Inside these "black boxes" there is a processor, the "thinking part" of the module, and inside some of them there is one or more memories, which may allow the module to store calibration values, the configuration of the vehicle (which optional tools or devices have been installed) and the fault codes.

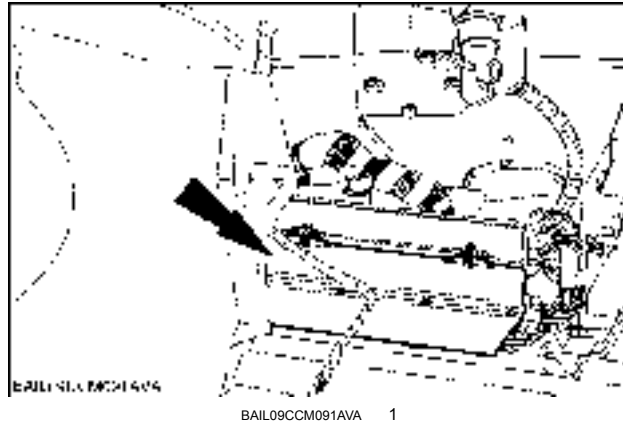

A processor has a series of pins, which are electrical contacts (see image 2). There are three main types of pins: for the inputs of the signals, for the outputs and for the processor supply.

The processor, the memories and the link between them form the hardware of the module, its "physical" part.

Then some software is needed, to handle the communication between the processor and the memories and to manage the various signals going into and out of the processor. The software is designed to operate in a different way for every module, and is called functional code.

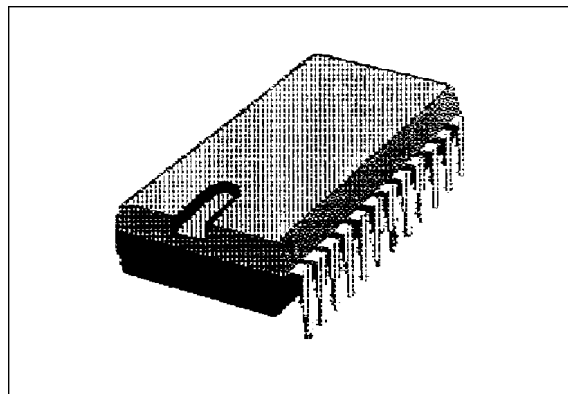

A serial data link is a kind of communication where data is sent along a single wire, so the information regarding different functions of the same processor are sent to the instrument cluster in different moments.

To provide a continuous control on components, the processor continuously scans all the inputs in a time-sharing mode, with a cycle lasting **10 ms**. This means that all the components controlled by the processor are checked one by one, and that every component is checked 100 times per second.

The electronic modules are often blamed as responsible for most of the problems of the modern tractors, while they are for certain among the most protected parts of the tractor. In fact, the pins of the module are protected against spikes (high pulses) of current, and the signals are filtered by the hardware and by the software in input and in output to give the best handling of information.



---

## Electronic modules - Overview – Fault finding

The tractors have a self diagnostic facility. This facility utilizes the digital display of the Instrument cluster to indicate, in coded format, malfunctions in the electrical and electronic circuitry and in the microprocessor. It should be noted that the self diagnostic capability is generally limited to diagnosis of the electrical and electronic circuitry and related components. However, there are some codes, which can be generated if pressure switch circuits are not closed because of an actual lack of hydraulic pressure. Any malfunction of the mechanical and hydraulic components must be diagnosed using conventional techniques, performance characteristics and tooling, such as pressure testing equipment.

Troubleshooting and fault finding should always be carried out in a logical and planned sequence, many apparent faults associated with electronic components are often hastily diagnosed and result in the replacement of expensive components. An extra few minutes confirming the apparent fault will result in a more positive and cost effective repair.

With the use of microprocessors it is often that this item is blamed for any malfunction but the real truth is that this item is usually sound and that the fault is due to poor contacts in the associated connectors.

Each electrical connector illustrated and identified in the wiring diagrams and referred to in the following fault finding procedures, has the same identification reference. For example, one of the processor connectors is referred to as connector X-095 ( C095 identification on older wiring diagrams) in the illustration and also referred to as X-095 the fault finding procedure. In the fault finding procedure the connector, pin and wire color are shown as, X-095 pin 17 (Y,3024). This is broken down as follows:

X-095: Connector number

Y or YE: Wire color

3024: Circuit reference

All tests are carried out on the harness side of the connector, unless otherwise stated.

Refer to the relevant chapter for complete wiring diagrams and how to use them .

Where the fault finding procedure requires checks for continuity a visual inspection of the wiring should be made prior to conducting tests to ensure that obvious 'mechanical' damage has not occurred to the harness or the connectors.

### Fault code displays

A good quality multimeter is an essential item to perform fault finding. It should be capable of measuring resistance of at least **20 kΩ** and measuring voltage and current. When using the multimeter it is good practice to select a high range and work downwards to avoid damaging the instrument.

**NOTICE:** Care should be used when using the multimeter, only use the instrument as instructed to avoid damage to the internal elements of the microprocessor. When checking the continuity of wiring, sensors or switches it is necessary to isolate the electronic microprocessor and ensure the ignition switch is turned off to prevent possible further damage. The ignition switch should only be switched on and the processor connected where specifically instructed in the fault finding procedure.

**NOTICE:** If it is found necessary to clean the connectors a contact spray should be used. Do not use any other method for cleaning terminals. Do not use a cleaner that contains Trichloroethylene. This solvent will damage the plastic body of the connector.

All fault codes are displayed on the instrument cluster. Only disabling faults will be displayed on the Dot-Matrix-Display (DMD) and will be visible to the operator. Less serious faults are stored and can be retrieved via the H-Menu.

## Electronic module - Fault code index

The following table contains all fault codes ("U" codes) which could appear on the Dot Matrix Display (DMD) during the calibration procedures.

Code	Description	Possible failure
Err	A fatal error has occurred during the calibration - the calibration procedure cannot continue	<ul style="list-style-type: none"> <li>Operator not present or seat switch signal failure</li> <li>The calibration pressure is out of range: Clutch C and D: <b>2.5 - 6 bar (36 - 87 psi)</b> Clutch A, B, F and G: <b>0.5 - 2 bar (7 - 29 psi)</b></li> <li>The clutches cannot transmit the required torque during the calibration. The reason can be mechanical problems, valve problems or hydraulic problems.</li> </ul>
U15	Insufficient engine speed deceleration	The clutches cannot transmit the required torque during the calibration
U17	Seat switch not activated	The seat switch is defect or the operator is not present
U19	Invalid transmission oil temperature	Oil temperature is < <b>15 °C (59 °F)</b> (absolute lower limit) (The optimal oil temperature is between <b>30 - 50 °C (86 - 122 °F)</b> )
U20	Invalid hand brake state	The hand brake switch is defect or not activated
U23	Shuttle lever not in FORWARD position	The shuttle lever is defect
U51	Engine speed error	The engine speed is < <b>1150 RPM</b> or > <b>1250 RPM</b> (during drive clutch calibration)
U51	Engine speed error or wrong Power Take-Off (PTO) gear selected	<ul style="list-style-type: none"> <li>Engine speed &lt;<b>1550 RPM</b> or &gt;<b>1650 RPM</b> (during PTO clutch calibration)</li> <li>Wrong PTO gear selected (correct PTO gear is 1000 and in NORMAL position)</li> </ul>
U57	Power Take-Off (PTO) speed sensor error	<ul style="list-style-type: none"> <li>The PTO speed sensor is defect</li> <li>The gear PTO levers are in NEUTRAL position</li> </ul>
U67	Invalid Power Take-Off (PTO) signal	The PTO sensor signal is invalid
U90	No Power Take-Off (PTO) rotation detected	No PTO speed during the PTO calibration
U151	Invalid system pressure	System pressure < <b>14 bar (203 psi)</b>
U167	Clutch pedal actuated	Clutch pedal is not in rest position
U168	Clutch pedal adjustment upper limit	Clutch pedal adjustment is > <b>4.1 V</b>
U169	Clutch pedal adjustment lower limit	Clutch pedal adjustment is < <b>0.7 V</b>
U170	Clutch pedal adjustment switch-point	The switch-point must be between <b>2.8 - 3.5 V</b>
U171	Clutch pedal adjustment invalid rotation direction of the position sensor	The clutch pedal sensor signal during the operation is decreasing (must be increasing)
U172	Invalid transmission output speed during the clutch pedal sensor calibration	The tractor is moving during the clutch pedal sensor calibration
U172	Invalid transmission output speed during the PTO clutch calibration	The tractor is moving during the PTO clutch calibration
U173	Transmission output speed sensor error	The transmission output speed sensor is defect
U174	Transmission output speed above limit	The tractor is moving during the calibration (> <b>0.5 km/h (0.3 mph)</b> )
U176	Shuttle lever actuated during Power Take-Off (PTO) calibration	The shuttle lever is not in RESTING position or defect
U177	Shuttle lever is in FORWARD position	The shuttle lever is not in RESTING position or defect
U178	Shuttle lever is in REVERSE position	The shuttle lever is not in RESTING position or defect
U181	Invalid power shuttle switch state	The forward or reverse switch on the Multicontroller is defect or activated during the calibration
U182	Clutch pedal sensor error	The clutch pedal sensor is defect

Code	Description	Possible failure
U183	Tolerance range exceeded	The tolerance kissing point ranges for A-G and the PTO clutches exceeded
U184	Degraded operation mode	Active fault codes are present which affect the calibration

The following tables contain all fault codes from the vehicle control units.

#### Electronic Draft Control (EDC)

Fault code	Description	Control unit
1002	Radar sensor - disconnected or speed too low	CCU
1003	Radar sensor and transmission output speed sensor – speed difference too high	CCU
1004	Transmission output speed sensor - signal too high	CCU
1006	Hitch slip control potentiometer - signal too low	CCU
1007	Hitch slip control potentiometer - signal too high	CCU
1009	Hitch position control switches - implausible signals or signal at key ON	CCU
1010	Hitch height limit potentiometer - signal too low	CCU
1011	Hitch height limit potentiometer - signal too high	CCU
1012	Hitch drop rate potentiometer - signal too low	CCU
1013	Hitch drop rate potentiometer - signal too high	CCU
1014	Right-hand draft pin sensor - signal too low	CCU
1015	Right-hand draft pin sensor - signal too high	CCU
1016	Left-hand draft pin sensor - signal too low	CCU
1017	Left-hand draft pin sensor - signal too high	CCU
1018	Draft pin sensors - both signals too low	CCU
1019	8 V reference voltage for draft pin sensors - voltage too low	CCU
1020	8 V reference voltage for draft pin sensors - voltage too high	CCU
1021	Hitch sensitivity control potentiometer - signal too low	CCU
1022	Hitch sensitivity control potentiometer - signal too high	CCU
1023	Hitch electronic control panel - disconnected	CCU
1024	Hitch position sensor - not calibrated	CCU
1025	Hitch position control potentiometer - signal too low	CCU
1026	Hitch position control potentiometer - signal too high	CCU
1027	Hitch position sensor - signal too low	CCU
1028	Hitch position sensor - signal too high	CCU
1029	Hitch control solenoid valves - disconnected	CCU
1030	Hitch electronic control panel - ground disconnected	CCU
1031	Chassis harness - disconnected	CCU
1032	Hitch draft control potentiometer - signal too high	CCU
1033	Hitch draft control potentiometer - signal too low	CCU
1049	CAN bus signal fault – TCU1 signal (transmission output speed) from TCU	CCU
1053	5 V reference voltage for Electronic Draft Control (EDC) - voltage too high	CCU
1054	5 V reference voltage for Electronic Draft Control (EDC) - voltage too low	CCU
1063	Lower solenoid valve - open circuit	CCU
1064	Raise solenoid valve - open circuit	CCU
1065	Lower solenoid valve - short circuit to battery	CCU
1066	Raise solenoid valve - short circuit to battery	CCU
1067	Supply voltage for hitch control solenoid valves - voltage too low	CCU
1068	Electronic Draft Control (EDC) - calibration fault	CCU
1070	Electronic Draft Control (EDC) - ram configuration not set	CCU
1072	Hitch raise and lower switches - signal too high	CCU
1073	Hitch raise and lower switches - signal too low	CCU

**Transmission**

<b>Fault code</b>	<b>Description</b>	<b>Control unit</b>
2006	Radar sensor - no signal	CCU
2011	Clutch pedal sensor - signal too low	TCU
2012	Clutch pedal sensor - signal too high	TCU
2013	Forward/reverse switches - invalid signal	TCU
2035	Transmission output speed sensor - speed limit exceeded	TCU
2049	Transmission output speed sensor - signal too low	TCU
2050	Transmission output speed sensor - signal too high	TCU
2051	Transmission oil temperature sensor - signal too high	TCU
2052	Transmission oil temperature sensor - signal too low	TCU
2053	<b>5 V</b> reference voltage – voltage too high	CCU
2054	<b>5 V</b> reference voltage – voltage too low	CCU
2055	Transmission output speed sensor - implausible speed drop detected	TCU
2059	Shuttle lever - implausible signals	TCU
2089	CAN-Bus - invalid engine speed	CCU
2090	CAN-Bus - ADIC absent	CCU
2092	Comfort shift switch - signal too high	TCU
2095	Comfort shift switch - invalid signal	TCU
2323	Powershift output speed sensor - signal too high	TCU
2324	Powershift output speed sensor - signal too low	TCU
2328	Powershift output speed sensor - implausible speed drop detected	TCU
2342	Clutch A solenoid valve - open circuit	TCU
2343	Clutch B solenoid valve - open circuit	TCU
2344	Clutch C solenoid valve - open circuit	TCU
2345	Clutch D solenoid valve - open circuit	TCU
2347	Clutch F solenoid valve - open circuit	TCU
2348	Clutch G solenoid valve - open circuit	TCU
2352	Clutch A solenoid valve - short circuit to battery	TCU
2353	Clutch B solenoid valve - short circuit to battery	TCU
2354	Clutch C solenoid valve - short circuit to battery	TCU
2355	Clutch D solenoid valve - short circuit to battery	TCU
2357	Clutch F solenoid valve - short circuit to battery	TCU
2358	Clutch G solenoid valve - short circuit to battery	TCU
2362	Clutch A solenoid valve - invalid contact pressure calibration data	TCU
2363	Clutch B solenoid valve - invalid contact pressure calibration data	TCU
2364	Clutch C solenoid valve - invalid contact pressure calibration data	TCU
2365	Clutch D solenoid valve - invalid contact pressure calibration data	TCU
2367	Clutch F solenoid valve - invalid contact pressure calibration data	TCU
2368	Clutch G solenoid valve - invalid contact pressure calibration data	TCU
2385	Engine speed and powershift input speed - speed difference too high	TCU
2392	Clutch A solenoid valve - short circuit to ground	TCU
2393	Clutch B solenoid valve - short circuit to ground	TCU
2394	Clutch C solenoid valve - short circuit to ground	TCU
2395	Clutch D solenoid valve - short circuit to ground	TCU
2397	Clutch F solenoid valve - short circuit to ground	TCU
2398	Clutch G solenoid valve - short circuit to ground	TCU
2416	Forward/reverse switches - signal too low	TCU
2417	Forward/reverse switches - signal too high	TCU
2418	Comfort shift switch - signal too low	TCU
2441	CAN-Bus - TCU absent	CCU
2555	Transmission oil pressure switch – no pressure signal	TCU
2602	Clutch A solenoid valve - invalid filling time calibration data	TCU
2603	Clutch B solenoid valve - invalid filling time calibration data	TCU

## Electrical systems - Electronic modules

<b>Fault code</b>	<b>Description</b>	<b>Control unit</b>
2604	Clutch C solenoid valve - invalid filling time calibration data	TCU
2605	Clutch D solenoid valve - invalid filling time calibration data	TCU
2607	Clutch F solenoid valve - invalid filling time calibration data	TCU
2608	Clutch G solenoid valve - invalid filling time calibration data	TCU
2612	Powershift input speed sensor - signal too high	TCU
2613	Powershift input speed sensor - signal too low	TCU
2614	Powershift input speed sensor - implausible speed drop detected	TCU
2616	Forward switch - pressed too long or stuck	TCU
2617	Reverse switch - pressed too long or stuck	TCU
2620	Shuttle lever forward switch - invalid signal	TCU
2621	Shuttle lever reverse switch - invalid signal	TCU
2622	Shuttle lever neutral switch - invalid signal	TCU
2623	Shuttle lever deadman switch - invalid signal	TCU
2624	Internal check – safety warning	TCU
2625	Internal check – critical failure	TCU
2944	Internal check – engine speed protection failure	TCU
2948	<b>5 V</b> reference voltage - voltage too high	TCU
2949	<b>5 V</b> reference voltage - voltage too low	TCU
2950	TCU supply voltage - voltage too high	TCU
2951	TCU supply voltage - voltage too low	TCU
2952	Valve supply voltage 1 - implausible voltage	TCU
2953	Valve supply voltage 2 - implausible voltage	TCU
2955	CAN bus message timeout – TSC1 from ADIC	TCU
2956	CAN bus signal fault – TSC1 signal (speed request) from ADIC	TCU
2957	CAN bus message fault – ADIC3 from ADIC	TCU
2958	CAN bus message fault – ECU1 from CCU	TCU
2959	State change plausibility signal - stays high too long	TCU
2960	State change plausibility signal - plausibility fault	TCU
2961	CAN-Bus message timeout - message from CCU	TCU
2962	CAN-Bus signal fault - engine torque (EEC1) from ECU	TCU
2963	CAN-Bus signal fault - engine speed (EEC1) from ECU	TCU
2964	CAN-Bus signal fault - requested torque (EEC1) from ECU	TCU
2965	CAN-Bus message timeout - ADIC1 from ADIC	TCU
2966	CAN-Bus signal fault - operator presence (ADIC1) from ADIC	TCU
2967	CAN-Bus signal fault - hand brake status (ADIC1) from ADIC	TCU
2968	CAN-Bus signal fault - wheel speed (ADIC1) from ADIC	TCU
2969	CAN-Bus message timeout - EEC1 from ECU	TCU
2970	CAN-Bus message timeout - ADIC3 from ADIC	TCU
2971	CAN-Bus signal fault - foot throttle pedal position (ADIC3) from ADIC	TCU
2972	CAN-Bus signal fault - hand throttle lever position (ADIC3) from ADIC	TCU
2973	CAN-Bus signal fault - automatic powershift function potentiometer (ADIC3) from ADIC	TCU
2974	CAN-Bus message timeout - EEC2 from ECU	TCU
2975	CAN-Bus message timeout - EEC3 from ECU	TCU
2976	CAN-Bus message timeout - ECCU1 from CCU	TCU
2977	CAN-Bus signal fault - 4WD switch status (ECCU1) from CCU	TCU
2978	CAN-Bus signal fault - differential lock switch status (ECCU1) from CCU	TCU
2979	CAN-Bus signal fault - PTO switch rear status (ECCU1) from CCU	TCU
2980	CAN-Bus signal fault - PTO soft start functionality (ECCU1) from CCU	TCU
2981	CAN-Bus signal fault - percent engine load (EEC2) from ECU	TCU
2982	CAN-Bus signal fault - desired engine speed (EEC3) from ECU	TCU
2983	CAN-Bus signal fault - nominal friction torque (EEC3) from ECU	TCU
2984	Powershift – invalid slip at gear 1	TCU
2985	Powershift – invalid slip at gear 2	TCU

<b>Fault code</b>	<b>Description</b>	<b>Control unit</b>
2986	Powershift – invalid slip at gear 3	TCU
2987	Powershift – invalid slip at gear 4	TCU
2988	Transmission oil temperature sensor - temperature limit exceeded	TCU
2989	Clutch pedal sensor and clutch pedal switch – signals not plausible	TCU
2990	EEPROM - clutch pedal sensor data not plausible	TCU
2991	EEPROM - invalid clutch pedal sensor calibration data	TCU
2992	EEPROM - invalid configuration data	TCU
2993	EEPROM - invalid checksum of configuration data	TCU
2994	Application fault - improperly programmed application controls	TCU
2995	Configuration fault - customer setting invalid or not existing	TCU
2996	EEPROM - invalid checksum of vehicle configuration data	TCU
2999	Internal check - hardware and software do not match	TCU

**Engine**

<b>Fault code</b>	<b>Description</b>	<b>Control unit</b>
3001	Foot throttle position sensor - signal not plausible	ECU
3002	Foot throttle position sensor - signal too high	ECU
3003	Foot throttle position sensor - signal too low	ECU
3007	Engine coolant temperature sensor - signal too high	ECU
3008	Engine coolant temperature sensor - signal too low	ECU
3010	Intake air pressure and temperature sensor - temperature signal too high	ECU
3011	Intake air pressure and temperature sensor - temperature signal too low	ECU
3015	Fuel temperature sensor - signal too high	ECU
3016	Fuel temperature sensor - signal too low	ECU
3019	Intake air pressure and temperature sensor - pressure signal too high	ECU
3024	Air pressure sensor - signal too high	ECU
3025	Air pressure sensor - signal too low	ECU
3027	Engine oil pressure switch – signal not plausible	ECU
3037	Intake air pressure and temperature sensor - pressure signal too low	ECU
3038	Constant engine speed selector switch – signals not plausible	ECU
3051	ECU supply voltage - voltage too high	ECU
3052	ECU supply voltage - voltage too low	ECU
3059	Main relay ECU - stuck relay fault	ECU
3063	Injector cylinder 1 - short circuit	ECU
3071	Injector cylinder 3 - short circuit	ECU
3079	Injector cylinder 2 - short circuit	ECU
3083	Injector cylinder 4 - short circuit	ECU
3088	Crankshaft sensor - no signal	ECU
3089	Crankshaft sensor - invalid signal	ECU
3090	Camshaft sensor - no signal	ECU
3091	Camshaft sensor - invalid signal	ECU
3093	Crankshaft sensor and camshaft sensor - offset between speed signals too high	ECU
3096	CAN-Bus - ECU in bus-off state or CAN-Bus fault	ECU
3102	Common rail pressure sensor - signal too low	ECU
3104	Common rail relief valve - open	ECU
3105	Common rail relief valve - pressure shock requested	ECU
3106	Common rail relief valve - opening counter reached maximum	ECU
3107	High pressure pump solenoid valve - short circuit to battery	ECU
3108	High pressure pump solenoid valve - short circuit to ground	ECU
3112	Common rail pressure sensor - signal too high	ECU
3126	Hand throttle - signal 1 too high	ECU
3127	Hand throttle - signal 1 too low	ECU
3137	High pressure pump solenoid valve - open circuit	ECU

## Electrical systems - Electronic modules

<b>Fault code</b>	<b>Description</b>	<b>Control unit</b>
3139	High pressure pump solenoid valve - signal too high	ECU
3140	High pressure pump solenoid valve - signal too low	ECU
3141	High pressure pump solenoid valve - fuel delivery quantity too high	ECU
3146	Water in fuel sensor - water detected or faulty sensor	ECU
3157	CAN-Bus - ECU absent or engine dataset not available	ECU
3158	CAN-Bus - invalid engine dataset	ECU
3166	Fuel heater relay - short circuit to battery	ECU
3167	Fuel heater relay - short circuit to ground	ECU
3168	Fuel heater relay - open circuit	ECU
3169	Fuel heater relay - signal not plausible	ECU
3176	High pressure pump solenoid valve - fuel delivery quantity too high in overrun mode	ECU
3177	Engine protection – engine speed is too high	ECU
3179	CAN-Bus message timeout - BC2EDC2 from ADIC	ECU
3180	CAN-Bus message timeout - VCM2EDC from ADIC	ECU
3188	Injector cylinder 1 - open circuit	ECU
3192	Injector cylinder 2 - open circuit	ECU
3196	Injector cylinder 3 - open circuit	ECU
3200	Injector cylinder 4 - open circuit	ECU
3210	Injection bank 1 - short circuit on injection cable	ECU
3218	Injection bank 2 - short circuit on injection cable	ECU
3230	Injection power stages - processor fault	ECU
3235	Injection control - number of injections limited by runtime	ECU
3236	Injection control - number of injections limited by application	ECU
3237	Injection control - number of injections limited by booster capacity	ECU
3238	Internal check - internal communication fault	ECU
3239	EEPROM - read operation fault	ECU
3240	EEPROM - write operation fault	ECU
3241	EEPROM - calibrated parameters cannot be read	ECU
3242	Internal failure - software reset occurred	ECU
3243	Internal failure - software reset occurred	ECU
3244	Internal failure - software reset occurred	ECU
3245	Internal check - internal communication fault	ECU
3252	Internal check - internal communication fault	ECU
3253	Analog digital converter - reference voltage too high	ECU
3255	Analog digital converter - plausibility check fault	ECU
3256	Analog digital converter - plausibility check fault	ECU
3258	Starter relay - short circuit to battery at high side power stage	ECU
3259	Starter relay - short circuit to ground at high side power stage	ECU
3260	Starter relay - open circuit at low side power stage	ECU
3261	Starter relay - short circuit to battery at low side power stage	ECU
3262	Starter relay - short circuit to ground at low side power stage	ECU
3265	Internal check - injection time too long	ECU
3266	Internal check - engine speed signal not plausible	ECU
3283	Sensor supply voltage 2 - voltage out of valid range	ECU
3285	Sensor supply voltage 3 - voltage out of valid range	ECU
3293	High pressure pump solenoid valve - maximum positive rail pressure deviation exceeded	ECU
3301	High pressure pump solenoid valve - maximum negative rail pressure deviation exceeded	ECU
3305	High pressure pump solenoid valve - minimum rail pressure exceeded	ECU
3309	High pressure pump solenoid valve - maximum rail pressure exceeded	ECU
3334	CAN-Bus message timeout - TSC1-PE from CCU (when active)	ECU
3335	CAN-Bus message timeout - TSC1-PE from CCU (when inactive)	ECU
3338	CAN-Bus message timeout - TSC1-VE from CCU (when inactive)	ECU
3339	CAN-Bus message timeout - TSC1-VE from CCU (when active)	ECU

<b>Fault code</b>	<b>Description</b>	<b>Control unit</b>
3350	Terminal 50 switch – defective switch	ECU
3358	CAN-Bus message timeout - transmit EEC1	ECU
3361	EEPROM - general fault	ECU
3362	Internal check - torque to fuel quantity map not plausible	ECU
3368	Engine protection – torque limitation caused by performance limiter	ECU
3369	Engine protection – torque limitation due to smoke limitation	ECU
3370	Engine protection – torque limitation due to engine overload	ECU
3371	Engine protection – torque limitation caused by injection system	ECU
3374	Injector adjustment – adjustment data fault	ECU
3375	Constant engine speed adjust switch – signals not plausible	ECU
3402	Common rail pressure sensor - maximum rail pressure exceeded	ECU
3403	Starter relay – over-temperature at high side power stage	ECU
3405	Turbocharger power stage – open circuit	ECU
3406	Turbocharger power stage – temperature too high	ECU
3408	Lambda sensor - oxygen concentration too high	ECU
3409	Engine oil pressure switch – oil pressure too low	ECU
3410	Throttle Valve Actuator (TVA) - positive position deviation limit exceeded	ECU
3411	Throttle Valve Actuator (TVA) - negative position deviation limit exceeded	ECU
3414	Glow plug of cylinder 1 - short circuit	ECU
3415	Glow plug of cylinder 2 - short circuit	ECU
3416	Glow plug of cylinder 3 - short circuit	ECU
3417	Glow plug of cylinder 4 - short circuit	ECU
3418	Turbocharger power stage - short circuit to battery	ECU
3419	Turbocharger power stage - short circuit to ground	ECU
3420	CAN-Bus - external engine shutdown message	ECU
3421	Fuel filter restriction sensor - signal too high	ECU
3422	Fuel filter restriction sensor - signal too low	ECU
3423	Fuel filter restriction sensor - implausible signal	ECU
3424	Fuel filter restriction sensor - filter clogged	ECU
3425	Turbocharger - boost pressure deviation too high at intake air pressure and temperature sensor	ECU
3426	Diesel Particulate Filter (DPF) - level 1 reached	ECU
3427	Diesel Particulate Filter (DPF) - low flow resistance	ECU
3428	Differential pressure sensor - signal not plausible	ECU
3429	Differential pressure sensor - hose line plausibility fault	ECU
3430	Exhaust Gas Recirculation (EGR) - less severe derating level induced	ECU
3431	Exhaust Gas Recirculation (EGR) - most severe derating level induced	ECU
3432	Exhaust Gas Recirculation (EGR) - inducement warning	ECU
3433	Diesel Particulate Filter (DPF) - less severe derating level induced	ECU
3434	Diesel Particulate Filter (DPF) - most severe derating level induced	ECU
3435	Diesel Particulate Filter (DPF) - inducement warning	ECU
3517	Inlet air temperature sensor - signal too high	ECU
3518	Inlet air temperature sensor - signal too low	ECU
3616	Engine protection – torque limitation due to turbocharger protection	ECU
3648	Turbocharger - boost pressure deviation too high at intake air pressure and temperature sensor	ECU
3650	Battery voltage - voltage too high	ECU
3651	Battery voltage - voltage too low	ECU
3652	CAN-Bus - bus-off state of node A	ECU
3655	Engine protection – general report for active torque limitations	ECU
3656	Engine protection – torque limitation caused by Diesel Particulate Filter (DPF)	ECU
3657	CAN-Bus message timeout - CM1BC from ADIC	ECU
3663	Exhaust Gas Recirculation (EGR) – command saturation over higher limit	ECU
3664	Exhaust Gas Recirculation (EGR) – command saturation over lower limit	ECU



Electrical systems - Electronic modules

<b>Fault code</b>	<b>Description</b>	<b>Control unit</b>
3665	Exhaust Gas Recirculation (EGR) valve actuator - positive position deviation limit exceeded	ECU
3666	Exhaust Gas Recirculation (EGR) valve actuator - negative position deviation limit exceeded	ECU
3667	Exhaust Gas Recirculation (EGR) valve actuator - open circuit at power stage	ECU
3668	Exhaust Gas Recirculation (EGR) valve actuator - over-temperature at power stage	ECU
3669	Exhaust Gas Recirculation (EGR) valve actuator - short circuit to battery on Out1 of power stage	ECU
3670	Exhaust Gas Recirculation (EGR) valve actuator - short circuit to battery on Out2 of power stage	ECU
3671	Exhaust Gas Recirculation (EGR) valve actuator - short circuit to ground on Out1 of power stage	ECU
3672	Exhaust Gas Recirculation (EGR) valve actuator - short circuit to ground on Out2 of power stage	ECU
3673	Exhaust Gas Recirculation (EGR) valve actuator - short circuit at power stage	ECU
3674	Exhaust Gas Recirculation (EGR) valve actuator - under-voltage at power stage	ECU
3675	Exhaust Gas Recirculation (EGR) valve actuator - long time drift at closed position	ECU
3676	Exhaust Gas Recirculation (EGR) valve actuator - position sensor voltage too high	ECU
3677	Exhaust Gas Recirculation (EGR) valve actuator - position sensor voltage too low	ECU
3680	Internal check - injection cut off	ECU
3688	Water in fuel sensor - water in fuel detected or defective sensor	ECU
3689	Glow plug control module - faulty diagnostic data transmission or protocol fault	ECU
3691	Glow plug control module - open circuit at power stage	ECU
3692	Glow plug control module - over-temperature at power stage	ECU
3693	Glow plug control module - short circuit to battery at power stage	ECU
3694	Glow plug control module - short circuit to ground at power stage	ECU
3699	EEPROM - correction values for rail pressure regulation are inaccessible	ECU
3702	Injection control - failed engine start detected	ECU
3703	Injection control - rail pressure too low	ECU
3704	Injector adjustment - invalid adjustment value programming for injector 2	ECU
3705	Injector adjustment - invalid adjustment value programming for injector 3	ECU
3706	Injector adjustment - invalid adjustment value programming for injector 4	ECU
3707	Lambda sensor - open circuit at the nernst cell pin	ECU
3708	Lambda sensor - open circuit at the pump current pin	ECU
3709	Lambda sensor - open circuit at the virtual ground pin	ECU
3710	Lambda sensor - signal not plausible	ECU
3711	Lambda sensor - short circuit to battery at heater power stage	ECU
3712	Lambda sensor - short circuit to ground at heater power stage	ECU
3713	Lambda sensor - open circuit at heater power stage	ECU
3714	Lambda sensor - oxygen ratio signal too high during calibration	ECU
3715	Lambda sensor - oxygen ratio signal too low during calibration	ECU
3716	Lambda sensor - oxygen ratio signal too high	ECU
3720	Lambda sensor - supply voltage too low	ECU
3721	Lambda sensor - SPI chip defective	ECU
3722	Lambda sensor - calculated temperature too high	ECU
3723	Lambda sensor - calculated temperature too low	ECU
3724	Lambda sensor - short circuit to battery	ECU
3725	Lambda sensor - short circuit to ground	ECU
3727	Engine oil check – low viscosity	ECU
3728	Engine oil check – too low viscosity	ECU
3735	High pressure pump metering solenoid valve – over-temperature	ECU
3736	Lambda sensor - oxygen ratio out of range	ECU
3737	Lambda sensor - over-temperature at heater power stage	ECU
3738	Internal check - ROM memory fault	ECU

## Electrical systems - Electronic modules

<b>Fault code</b>	<b>Description</b>	<b>Control unit</b>
3739	Injector power stages - loss of synchronization	ECU
3740	Injector power stages - diagnostic fault check to set torque limitation	ECU
3741	Injector power stages - timeout fault of monitoring module	ECU
3742	Injector power stages - faulty communication detected during shut off path test	ECU
3743	Injector power stages - under-voltage detected during shut off path test	ECU
3744	Injector power stages - over-voltage detected during shut off path test	ECU
3745	Injector power stages - implausible response during shut off path test	ECU
3746	Injector power stages - timeout problem during shut off path test	ECU
3747	Injector power stages - irreversible fault bit set	ECU
3748	Injector power stages - timeout during shut off path test	ECU
3750	Injection control - implausible injection energizing time	ECU
3751	Injection control - implausible start of energizing	ECU
3752	Internal check - invalid energizing times (zero fuel quantity calibration)	ECU
3753	Level 2 monitoring – injection quantity correction fault	ECU
3754	Level 2 monitoring – implausible rail pressure	ECU
3755	Level 2 monitoring – torque comparison fault	ECU
3756	Level 2 monitoring – fault in the post injection 2 quantity	ECU
3757	Level 2 monitoring – fault in the post injection 2 quantity in normal mode	ECU
3758	Level 2 monitoring – implausible post injection 3 efficiencies	ECU
3759	Level 2 monitoring – calculated lead torque too high	ECU
3760	Level 2 monitoring – calculated lead torque too high	ECU
3761	Level 2 monitoring – calculated inner engine torque too high	ECU
3762	Level 2 monitoring – supply voltage too high	ECU
3763	Level 2 monitoring – supply voltage too low	ECU
3764	Main relay ECU - early opening fault	ECU
3766	Differential pressure sensor - differential pressure value too high	ECU
3767	Internal check - faults in query/response communication	ECU
3768	Internal check - internal communication fault due to under-voltage detection	ECU
3769	Internal check - internal communication fault due to over-voltage detection	ECU
3770	Internal check - internal communication fault	ECU
3773	Turbocharger - positive boost pressure deviation too high	ECU
3786	Diesel Particulate Filter (DPF) - flow resistance exceeded first limit	ECU
3787	Diesel Particulate Filter (DPF) - flow resistance exceeded second limit	ECU
3789	Diesel Particulate Filter (DPF) - regeneration duration too long	ECU
3790	Diesel Particulate Filter (DPF) - flow resistance exceeded maximum limit	ECU
3791	Diesel Particulate Filter (DPF) - flow resistance too high	ECU
3794	Intake air pressure and temperature sensor - signal not plausible	ECU
3795	Intake air pressure and temperature sensor - signal not plausible	ECU
3796	Differential pressure sensor - hose line fault	ECU
3797	Differential pressure sensor - signal too high	ECU
3798	Differential pressure sensor - signal too low	ECU
3799	Common rail relief valve - forced to open due to pressure shock	ECU
3800	Common rail relief valve - pressure shock rejected	ECU
3801	Exhaust manifold pressure sensor – signal too high	ECU
3802	Exhaust manifold pressure sensor – signal too low	ECU
3803	Internal check - internal communication fault	ECU
3808	High pressure pump solenoid valve - set point not plausible	ECU
3810	Common rail pressure sensor - intermittent signal	ECU
3811	Internal check - sensor supply fault	ECU
3812	Temperature sensor ECU – high temperature	ECU
3813	Temperature sensor ECU – low temperature	ECU
3814	Temperature sensor ECU – communication fault	ECU
3818	Throttle Valve Actuator (TVA) - open circuit	ECU
3819	Throttle Valve Actuator (TVA) - over-current at power stage	ECU

<b>Fault code</b>	<b>Description</b>	<b>Control unit</b>
3820	Throttle Valve Actuator (TVA) - over-temperature at power stage	ECU
3821	Throttle Valve Actuator (TVA) - short circuit to battery at Out1 of power stage	ECU
3822	Throttle Valve Actuator (TVA) - short circuit to battery at Out2 of power stage	ECU
3823	Throttle Valve Actuator (TVA) - short circuit to ground at Out1 of power stage	ECU
3824	Throttle Valve Actuator (TVA) - short circuit to ground at Out2 of power stage	ECU
3825	Throttle Valve Actuator (TVA) - short circuit at power stage	ECU
3826	Throttle Valve Actuator (TVA) - temperature dependent over-current at power stage	ECU
3827	Throttle Valve Actuator (TVA) - under-voltage at power stage	ECU
3830	Throttle Valve Actuator (TVA) - position signal too high	ECU
3831	Throttle Valve Actuator (TVA) - position signal too low	ECU
3834	Throttle Valve Actuator (TVA) - position signal too high	ECU
3835	Throttle Valve Actuator (TVA) - position signal too low	ECU
3838	Diesel Oxidation Catalyst (DOC) inlet temperature sensor - signal too high	ECU
3839	Diesel Oxidation Catalyst (DOC) inlet temperature sensor - signal too low	ECU
3840	Diesel Particulate Filter (DPF) inlet temperature sensor - signal too high	ECU
3841	Diesel Particulate Filter (DPF) inlet temperature sensor - signal too low	ECU
3842	Exhaust manifold temperature sensor – signal too high	ECU
3843	Exhaust manifold temperature sensor – signal too low	ECU
3844	Injector cylinder 1 - energizing time too high	ECU
3845	Injector cylinder 2 - energizing time too high	ECU
3846	Injector cylinder 3 - energizing time too high	ECU
3847	Injector cylinder 4 - energizing time too high	ECU
3848	Injector cylinder 1 - energizing time too low	ECU
3849	Injector cylinder 2 - energizing time too low	ECU
3850	Injector cylinder 3 - energizing time too low	ECU
3851	Injector cylinder 4 - energizing time too low	ECU
3852	Lambda sensor - insufficient heater performance	ECU
3870	CAN-Bus message timeout - BC2EDC1 from ADIC	ECU
3899	Engine protection – engine temperature exceeded prewarning level	ECU
3900	Engine protection – engine temperature exceeded warning level	ECU
3906	Injection control - number of injections limited by quantity balance of high pressure pump	ECU
3910	High pressure pump solenoid valve - intermittent connection to ECU	ECU
3915	Common rail relief valve - averaged pressure out of valid range	ECU
3916	Common rail relief valve - maximum open time exceeded	ECU

**Electro-Hydraulic Remote (EHR) valves for rear implements**

<b>Fault code</b>	<b>Description</b>	<b>Control unit</b>
4128	Electro Hydraulic Remote valve (EHR) rear 3 - no control message received	CCU
4129	Electro Hydraulic Remote valve (EHR) rear 3 - control message not plausible	CCU
4130	Electro Hydraulic Remote valve (EHR) rear 3 - EEPROM fault	CCU
4131	Electro Hydraulic Remote valve (EHR) rear 3 - switched to failsafe	CCU
4132	Electro Hydraulic Remote valve (EHR) rear 3 - under-voltage	CCU
4133	Electro Hydraulic Remote valve (EHR) rear 3 - over-voltage	CCU
4134	Electro Hydraulic Remote valve (EHR) rear 3 - spool movement too low	CCU
4135	Electro Hydraulic Remote valve (EHR) rear 3 - spool movement too high	CCU
4136	Electro Hydraulic Remote valve (EHR) rear 3 - float position not reached	CCU
4137	Electro Hydraulic Remote valve (EHR) rear 3 - manually operated	CCU
4138	Electro Hydraulic Remote valve (EHR) rear 3 - driver faulty	CCU
4139	Electro Hydraulic Remote valve (EHR) rear 3 - potentiometer faulty	CCU
4140	Electro Hydraulic Remote valve (EHR) rear 3 - unable to reach neutral	CCU
4141	Electro Hydraulic Remote valve (EHR) rear 3 - spool not in neutral at key on	CCU
4142	Electro Hydraulic Remote valve (EHR) rear 4 - no control message received	CCU
4143	Electro Hydraulic Remote valve (EHR) rear 4 - control message not plausible	CCU

<b>Fault code</b>	<b>Description</b>	<b>Control unit</b>
4144	Electro Hydraulic Remote valve (EHR) rear 4 - EEPROM fault	CCU
4145	Electro Hydraulic Remote valve (EHR) rear 4 - switched to failsafe	CCU
4146	Electro Hydraulic Remote valve (EHR) rear 4 - under-voltage	CCU
4147	Electro Hydraulic Remote valve (EHR) rear 4 - over-voltage	CCU
4148	Electro Hydraulic Remote valve (EHR) rear 4 - spool movement too low	CCU
4149	Electro Hydraulic Remote valve (EHR) rear 4 - spool movement too high	CCU
4150	Electro Hydraulic Remote valve (EHR) rear 4 - float position not reached	CCU
4151	Electro Hydraulic Remote valve (EHR) rear 4 - manually operated	CCU
4152	Electro Hydraulic Remote valve (EHR) rear 4 - driver faulty	CCU
4153	Electro Hydraulic Remote valve (EHR) rear 4 - potentiometer faulty	CCU
4154	Electro Hydraulic Remote valve (EHR) rear 4 - unable to reach neutral	CCU
4155	Electro Hydraulic Remote valve (EHR) rear 4 - spool not in neutral at key on	CCU
4192	Electro Hydraulic Remote valve (EHR) rear 3 - no communication	CCU
4193	Electro Hydraulic Remote valve (EHR) rear 4 - no communication	CCU
4221	Electro Hydraulic Remote (EHR) - oil bypass solenoid fault	CCU
4222	Extend/Retract switches remote valve 3 – signal too low	CCU
4223	Extend/Retract switches remote valve 3 – signal too high	CCU
4224	Extend/Retract switches remote valve 4 – signal too low	CCU
4225	Extend/Retract switches remote valve 4 – signal too high	CCU
4226	Front/rear selector switch for the remote valve joystick – signal disagreement	CCU
4227	Control valve joystick - communication fault	CCU
4228	Finger wheel – signal too low	CCU
4229	Finger wheel – signal too high	CCU
4230	Hydraulic oil temperature sensor – signal too high	CCU
4231	Hydraulic oil temperature sensor – signal too low	CCU

**Electro-Hydraulic Remote (EHR) valves for front implements**

<b>Fault code</b>	<b>Description</b>	<b>Control unit</b>
4500	Electro Hydraulic Remote valve (EHR) front 1 - no control message received	CCU
4501	Electro Hydraulic Remote valve (EHR) front 1 - control message not plausible	CCU
4502	Electro Hydraulic Remote valve (EHR) front 1 - EEPROM fault	CCU
4503	Electro Hydraulic Remote valve (EHR) front 1 - switched to failsafe	CCU
4504	Electro Hydraulic Remote valve (EHR) front 1 - under-voltage	CCU
4505	Electro Hydraulic Remote valve (EHR) front 1 - over-voltage	CCU
4506	Electro Hydraulic Remote valve (EHR) front 1 - spool movement too low	CCU
4507	Electro Hydraulic Remote valve (EHR) front 1 - spool movement too high	CCU
4508	Electro Hydraulic Remote valve (EHR) front 1 - float position not reached	CCU
4509	Electro Hydraulic Remote valve (EHR) front 1 - manually operated	CCU
4510	Electro Hydraulic Remote valve (EHR) front 1 - driver faulty	CCU
4511	Electro Hydraulic Remote valve (EHR) front 1 - potentiometer faulty	CCU
4512	Electro Hydraulic Remote valve (EHR) front 1 - unable to reach neutral	CCU
4513	Electro Hydraulic Remote valve (EHR) front 1 - spool not in neutral at key on	CCU
4514	Electro Hydraulic Remote valve (EHR) front 2 - no control message received	CCU
4515	Electro Hydraulic Remote valve (EHR) front 2 - control message not plausible	CCU
4516	Electro Hydraulic Remote valve (EHR) front 2 - EEPROM fault	CCU
4517	Electro Hydraulic Remote valve (EHR) front 2 - switched to failsafe	CCU
4518	Electro Hydraulic Remote valve (EHR) front 2 - under-voltage	CCU
4519	Electro Hydraulic Remote valve (EHR) front 2 - over-voltage	CCU
4520	Electro Hydraulic Remote valve (EHR) front 2 - spool movement too low	CCU
4521	Electro Hydraulic Remote valve (EHR) front 2 - spool movement too high	CCU
4522	Electro Hydraulic Remote valve (EHR) front 2 - float position not reached	CCU
4523	Electro Hydraulic Remote valve (EHR) front 2 - manually operated	CCU

<b>Fault code</b>	<b>Description</b>	<b>Control unit</b>
4524	Electro Hydraulic Remote valve (EHR) front 2 - driver faulty	CCU
4525	Electro Hydraulic Remote valve (EHR) front 2 - potentiometer faulty	CCU
4526	Electro Hydraulic Remote valve (EHR) front 2 - unable to reach neutral	CCU
4527	Electro Hydraulic Remote valve (EHR) front 2 - spool not in neutral at key on	CCU
4556	Front hitch up/down switch (external) – active at key ON	CCU
4557	Remote valve switch (rear fender) – active at key ON	CCU
4560	Electro Hydraulic Remote valve (EHR) front 1 - communication fault	CCU
4561	Electro Hydraulic Remote valve (EHR) front 2 - communication fault	CCU

**Rear Power Take-Off (PTO)**

<b>Fault code</b>	<b>Description</b>	<b>Control unit</b>
5006	Power Take-Off (PTO) solenoid valve rear - short circuit to battery	TCU
5007	Power Take-Off (PTO) solenoid valve rear - open circuit	TCU
5008	Power Take-Off (PTO) solenoid valve rear - short circuit to ground	TCU
5024	Rear Power Take-Off (PTO) – invalid or no contact pressure in EEPROM	TCU
5025	Rear Power Take-Off (PTO) – invalid or no filling time in EEPROM	TCU
5026	Rear Power Take-Off (PTO) speed sensor – implausible speed drop detected	TCU
5027	Power Take-Off (PTO) speed sensor rear - short circuit to battery or open circuit	TCU
5032	Rear Power Take-Off (PTO) – clutch slip exceeded limit	TCU
5033	Rear Power Take-Off (PTO) ON/OFF switch – normally closed switch fault	CCU
5034	Rear Power Take-Off (PTO) fender switches – short circuit to ground or open circuit	CCU
5035	Rear Power Take-Off (PTO) fender switches – short circuit to battery	CCU
5037	Rear Power Take-Off (PTO) ON/OFF switch – normally open switch fault	CCU
5043	Rear Power Take-Off (PTO) fender switches – stuck on fault	CCU
5044	Power Take-Off (PTO) speed sensor rear - short circuit to ground	TCU
5098	Rear Power Take-Off (PTO) fender switches – option not enabled	CCU
5099	Rear Power Take-Off (PTO) – auto mode not enabled	CCU

**Four-Wheel Drive (4WD)**

<b>Fault code</b>	<b>Description</b>	<b>Control unit</b>
6023	Four-Wheel Drive (4WD) solenoid valve - interrupted line	TCU
6024	Four-Wheel Drive (4WD) solenoid valve - short circuit to battery	TCU
6027	Four-Wheel Drive (4WD) solenoid valve - short circuit to chassis	TCU

**Differential lock**

<b>Fault code</b>	<b>Description</b>	<b>Control unit</b>
7017	Differential lock solenoid valve rear - short circuit to ground or open circuit	TCU
7018	Differential lock solenoid valve rear - short circuit to battery	TCU
7019	Differential lock solenoid valve rear - short circuit to chassis	TCU
7022	Differential lock solenoid valve front - short circuit to ground or open circuit	CCU

**Front Power Take-Off (PTO)**

<b>Fault code</b>	<b>Description</b>	<b>Control unit</b>
8007	Power Take-Off (PTO) solenoid valve front - stuck on	CCU
8008	Power Take-Off (PTO) solenoid valve front - open circuit	CCU
8033	Front Power Take-Off (PTO) ON/OFF switch – normally closed contact is stuck closed	CCU
8037	Front Power Take-Off (PTO) ON/OFF switch – normally open contact is stuck open	CCU
8099	Front Power Take-Off (PTO) – option not enabled	CCU

**Parking brake**

<b>Fault code</b>	<b>Description</b>	<b>Control unit</b>
12590	Parking brake – supply voltage too low	CCU
12591	Hand brake position switch - signal not plausible	CCU
12592	Parking brake engagement solenoid valve – short circuit to ground or open circuit	CCU
12593	Parking brake engagement solenoid valve – short circuit to battery	CCU
12594	Parking brake disengagement solenoid valve – short circuit to ground or open circuit	CCU
12595	Parking brake disengagement solenoid valve – short circuit to battery	CCU

**Analog-Digital Instrument Cluster (ADIC)**

<b>Fault code</b>	<b>Description</b>	<b>Control unit</b>
14015	<b>5 V</b> reference voltage - too high	ADIC
14016	<b>5 V</b> reference voltage - too low	ADIC
14021	Cranking line – short circuit to battery	ADIC
14022	Cranking line – short circuit to ground	ADIC
14051	Fuel level sensor - short circuit to supply voltage or open circuit	ADIC
14052	Fuel level sensor - short circuit to ground	ADIC
14058	Seat switch - closed too long	ADIC
14061	Air brake pressure sensor – short circuit to supply voltage or open circuit	ADIC
14093	Seat switch - short circuit to supply voltage or open circuit	ADIC
14094	Seat switch - short circuit to ground	ADIC
14100	Air brake pressure sensor - present but not configured	ADIC
14107	Front hitch - present but not configured	ADIC
14200	Battery main switch - closed to battery too long at key on	ADIC
14901	CAN-Bus - ECU absent	ADIC
14918	CAN-Bus - CCU absent	ADIC
14919	CAN-Bus - TCU absent	ADIC

**Electronic module Instrument control unit - Electronic schema**

<b>Component identification</b>	
1.	Analog-Digital Instrument Cluster (ADIC)
2.	Battery
3.	Battery isolator
4.	Ignition switch
5.	Clutch pedal switch – Start interlock
6.	Start relay
7.	Air brake pressure sensor
8.	Fuel level sensor
9.	Implement signal socket (ISO 11786)
10.	Diagnostic socket (CAN bus 1)
11.	Work light switch panel
12.	Hand throttle sensor (signal 1 = hand throttle, signal 2 = auto-shift functionality)
13.	Alternator
14.	Flasher unit
15.	Hand brake position switch
16.	Hydraulic trailer brake relay
17.	Sensor ground 1
18.	Sensor ground 2
19.	Chassis ground
20.	Power ground

Electrical systems - Electronic modules

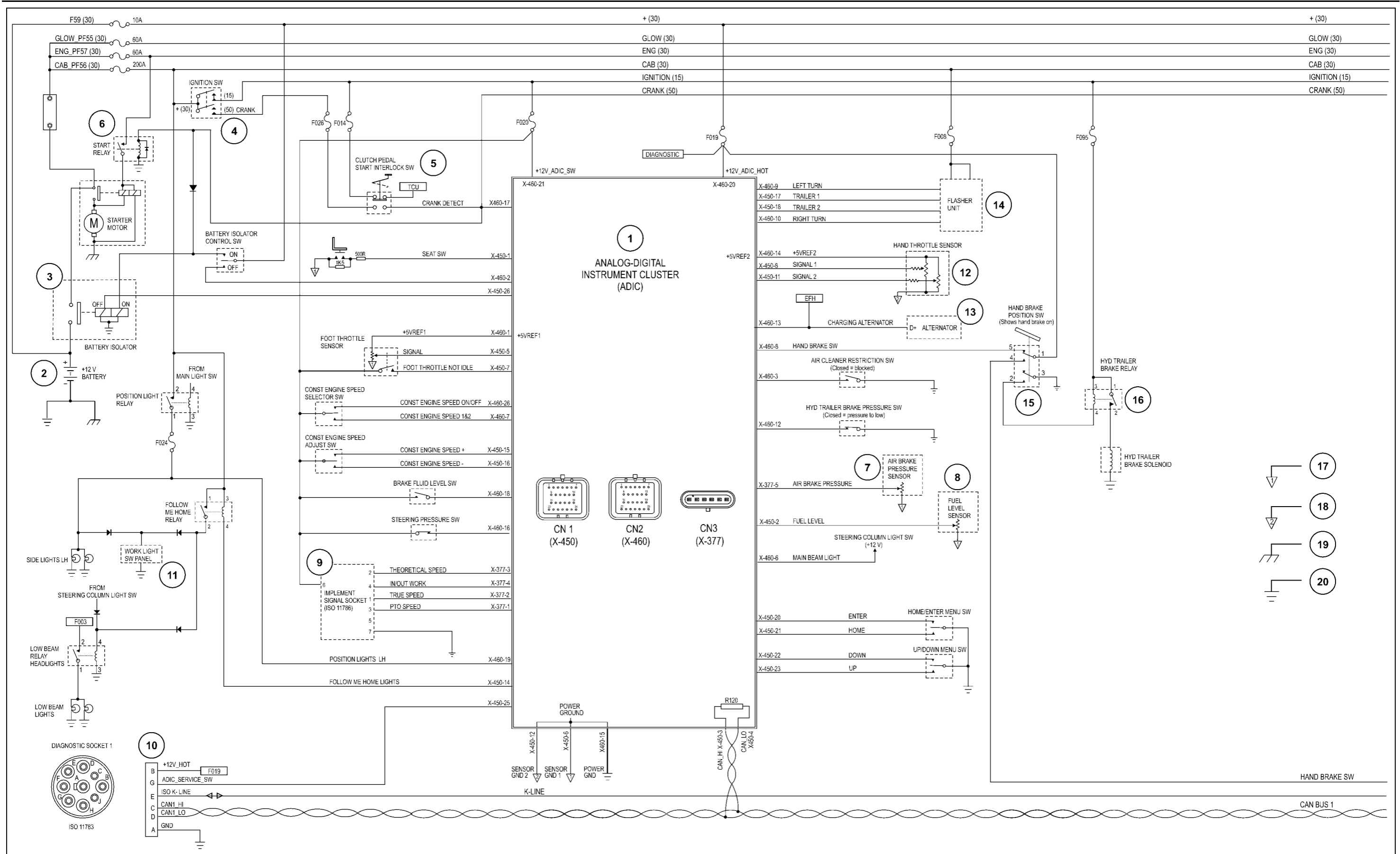



**Electronic module Central Control Unit (CCU) - Electronic schema**

Component identification	
1.	Central Control Unit (CCU)
2.	Electronic Draft Control (EDC)
3.	Hydraulic master switch
4.	Draft pin sensor left-hand and draft pin sensor right-hand
5.	Multicontroller ( EDC control)
6.	Hitch electronic control panel
7.	Raise solenoid valve and lower solenoid valve (EDC)
8.	EDC indicator light panel
9.	Electro Hydraulic Remote (EHR) valve control
10.	Multicontroller (EHR valve control and constant engine speed functionality)
11.	Remote valve encoder
12.	Front loader relay – valve 1 and front loader relay – valve 2
13.	Backup alarm buzzer relay
14.	Rear Power Take-Off (PTO) control
15.	Front Power Take-Off (PTO) control
16.	Four-Wheel Drive (4WD) control and differential lock control
17.	Parking brake control
18.	Sensor ground
19.	Chassis ground
20.	Power ground

Electrical systems - Electronic modules

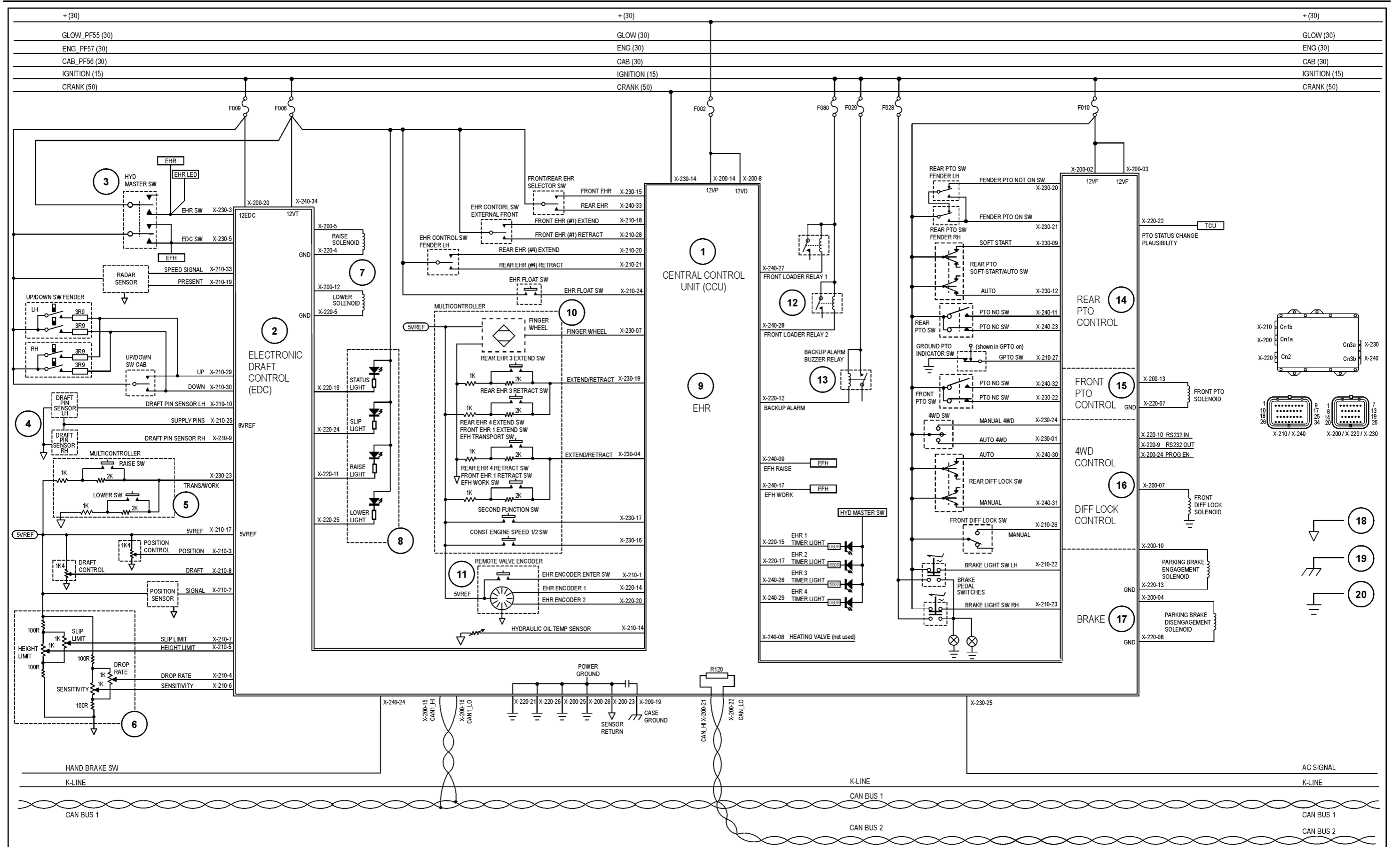









## Electronic module Instrument control unit - H3 - Configurations and options

### Analog-Digital Instrument Cluster (ADIC) controller identification (ZE)

This H-Menu level is used by the service technician to set up any options or configurations available with the instrument cluster.

The table below displays the functions and the belonging symbols for the submenu.

Function	Icon
Fault codes management	
Cab selection	CAB
Air brake	
Front Power Take-Off (PTO)	
Power Take-Off (PTO) overspeed protection <b>NOTE:</b> This configuration option is removed from the H3 menu with the software update 2.0.0.0. With introduction of software 2.0.0.0., the setting of the Power Take-Off (PTO) overspeed protection is only possible with the Electronic Service Tool (EST). Factory setting is YES (active).	PTO OVS
Electronic Front Hitch (EFH) option	
Fuel heater	FUEL HEATER
Electronic Draft Control (EDC) option	
Engine shutdown	
Low idle engine speed	LOW IDLE

**NOTE:** After using the H8 menu, all configurations are on default settings.

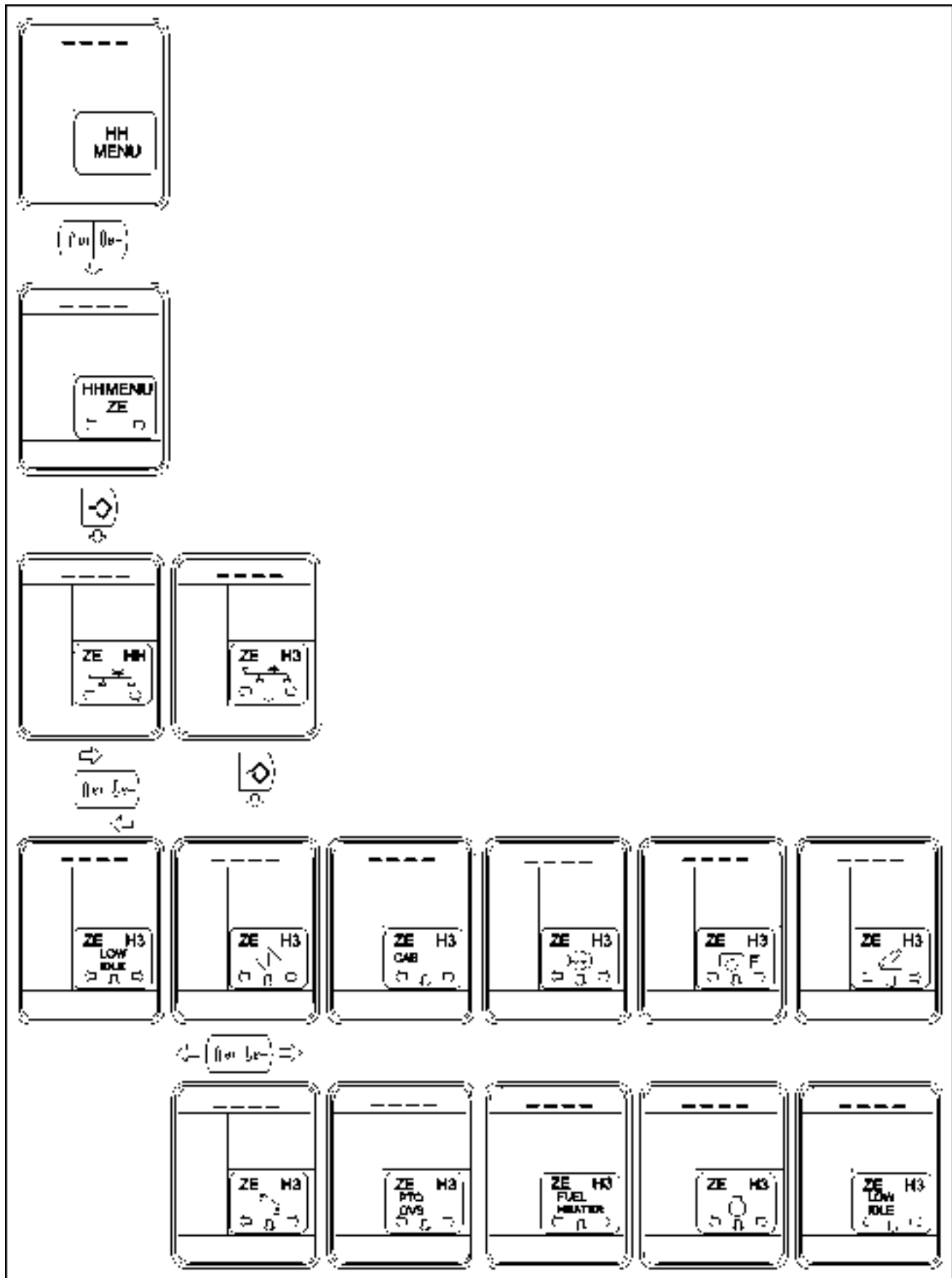

## FAULT CODES MANAGEMENT

This section is used to describe the procedure that allows the technician to set up the fault codes display options.

1. Enter the mode, using the diagnostic test plug special tool **380000843** and navigate to ZE controller H3 menu. See **Electronic module - Configure - HH-Menu overview (55.640)**.
2. Select product code, fault codes management option. The Dot Matrix Display (DMD) displays the fault code management options and an arrow. The arrow indicates the option which is currently set.
3. Use the UP or DOWN switch to select the fault state required:
  - “LIVE”: Live fault code mode: displays all fault codes.
  - “FACTORY”: Factory fault mode: displays all fault codes after ignition “ON for **6 min**”, then it automatically change in error code reduction: default setting.
  - “ECR”: Error Code Reduction: displays only critical errors.
4. Hold down the UP or DOWN switch for **1 s**. The cluster will beep and the setting is stored.
5. Press HOME switch to go back to the H-Menu.

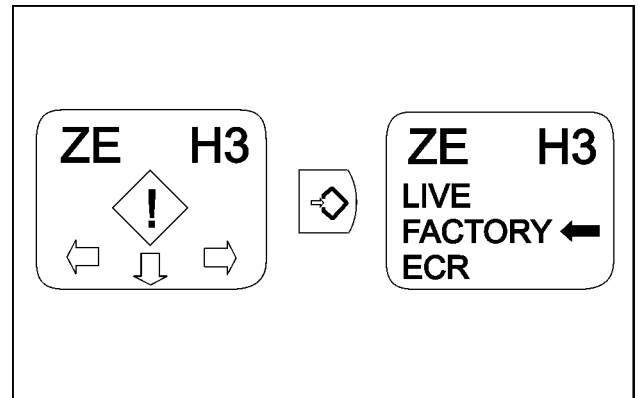

SS12N560 2

## WITH OR LESS CABINE

This section is used to describe the procedure that allows the technician to set up the cab options.

1. Enter the mode, using the diagnostic test plug special tool **380000843** and navigate to ZE controller H3 menu, cab option. See **Electronic module - Configure - HH-Menu overview (55.640)**. Press the ENTER switch. The DMD displays the cab options and an arrow. The arrow indicates the option which is currently set.
2. Use the UP or DOWN switch to move the arrow to the required settings:
  - “YES” (with cab): buzzer volume is reduced: default setting
  - “NO” (less cab): buzzer volume is increased
3. Hold down the UP or DOWN switch for **1 s**. The cluster will beep and then the setting is stored.
4. Press HOME switch to go back to the H-Menu.

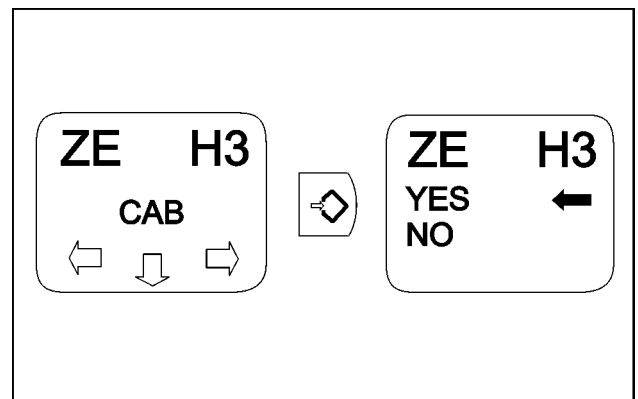

SS12N561 3

## AIR BRAKE

This section is used to describe the procedure that allows the technician to set up the air brake options.

1. Enter the mode, using the diagnostic test plug special tool **380000843** and navigate to ZE controller H3 menu, air brake option. See **Electronic module - Configure - HH-Menu overview (55.640)**. Press the ENTER switch. The DMD displays the air brake options and an arrow. The arrow indicates the option which is currently set.
2. Use the UP or DOWN switch to move the arrow to the required settings:  
 "YES" (present)  
 "NO" (not present): default setting
3. Hold down the UP or DOWN switch for **1 s**. The cluster will beep and then the setting is stored.
4. Press the HOME switch to go back to the H-Menu.

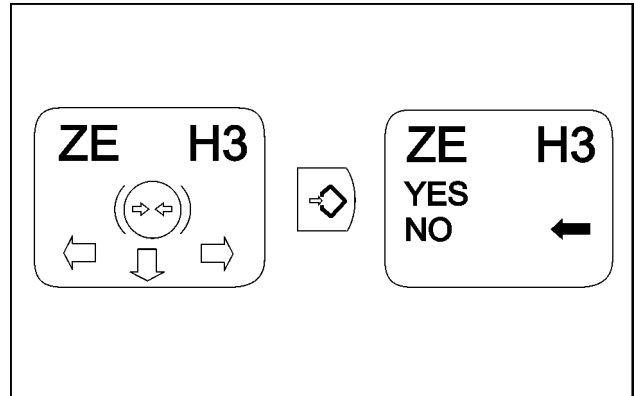

SS12N562 4

## FRONT POWER TAKE-OFF (PTO)

This section is used to describe the procedure that allows the technician to use the visualization of the Front Power Take-Off (PTO) speed, to show if it is selected or not.

1. Enter the mode, using the diagnostic test plug special tool **380000843** and navigate to ZE controller H3 menu, Front Power Take-Off (PTO) option. See **Electronic module - Configure - HH-Menu overview (55.640)**. Press the ENTER switch. The DMD displays the Front Power Take-Off (PTO) options and an arrow. The arrow indicates the option which is currently set.
2. Use the UP or DOWN switch to move the arrow to the required settings:  
 "YES" (enabled)  
 "NO" (disabled): default setting
3. Hold down the UP or DOWN switch for **1 s**. The cluster will beep and then the setting is stored.
4. Press the HOME switch to go back to the H-Menu.

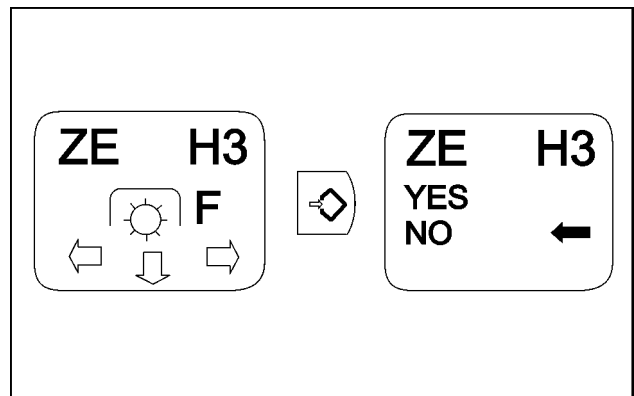

SS12N563 5

**NOTE:** The Front Power Take-Off (PTO) control function must also be activated in the RA central control unit H3 menu. See **Electronic module Central Control Unit (CCU) - H3 - Configurations and options (55.640)**.

## POWER TAKE-OFF (PTO) OVERSPEED PROTECTION

**NOTE:** This configuration option is removed from the H3 menu with the software update 2.0.0.0. With introduction of software 2.0.0.0., the setting of the Power Take-Off (PTO) overspeed protection is only possible with the Electronic Service Tool (EST). Factory setting is YES (active).

This section is used to describe the procedure that allows the technician to use the Power Take-Off (PTO) overspeed protection option.

1. To enter the mode, use the diagnostic test plug special tool **380000843** and navigate to ZE controller H3 menu, Power Take-Off (PTO) overspeed protection option. See **Electronic module - Configure - HH-Menu overview (55.640)**. Press the ENTER switch. The DMD displays the Power Take-Off (PTO) overspeed protection options and an arrow. The arrow indicates the option which is currently set.
2. Use the UP or DOWN switch to move the arrow to the required settings:  
 "YES" (enabled): default setting  
 "NO" (disabled)
3. Hold down the UP or DOWN switch for **1 s**. The cluster will beep and then the setting is stored.
4. Press the HOME switch to go back to the H-Menu.

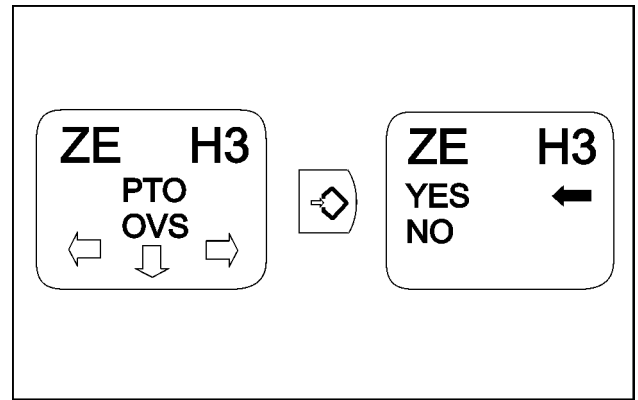

SS12N564 6

### Power Take-Off (PTO) overspeed protection setting 'NO':

When the Power Take-Off (PTO) shaft speed is greater than the selected speed by **17 %**, the PTO light will flash to indicate the over speeding (540 PTO > **630 RPM** or 1000 PTO > **1170 RPM**). The flashing will continue as long as the over speeding is present. After the speed is decreasing (540 PTO < **630 RPM** or 1000 PTO < **1170 RPM**) the light will go back to constant illumination.

### Power Take-Off (PTO) over speed protection setting 'YES':

When the Power Take-Off (PTO) shaft speed has reached the selected speed plus **17 %** (540 PTO **630 RPM** or 1000 PTO **1170 RPM**). The engine speed is limited, it is impossible to overcome these threshold.

### ELECTRONIC FRONT HITCH (EFH) OPTION

This section is used to describe the procedure that allows the technician to use the EFH option and to include EFH position and pressure visualization.

1. Enter the mode, using the diagnostic test plug special tool **380000843** and navigate to ZE controller H3 menu, EFH option. See **Electronic module - Configure - HH-Menu overview (55.640)**. Press the ENTER switch. The DMD displays the EFH options and an arrow. The arrow indicates the option which is currently set.
2. Use the UP or DOWN switch to move the arrow to the required settings:  
 "YES" (enabled)  
 "NO" (disabled): default setting
3. Hold down the UP or DOWN switch for **1 s**. The cluster will beep and then the setting is stored.
4. Press the HOME switch to go back to the H-Menu.

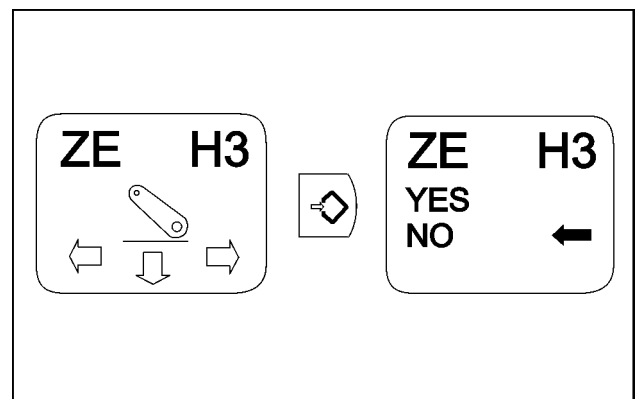

SS12N565 7



## FUEL HEATER

This section is used to describe the procedure that allows the technician to use the fuel heater option.

1. Enter the mode, using the diagnostic test plug special tool **380000843** and navigate to ZE controller H3 menu, fuel heater option. See **Electronic module - Configure - HH-Menu overview (55.640)**. Press the ENTER switch. The DMD displays the fuel heater options and an arrow. The arrow indicates the option which is currently set.
2. Use the UP or DOWN switch to move the arrow to the required settings:  
 "YES" (enabled): default setting  
 "NO" (disabled)
3. Hold down the UP or DOWN switch for **1 s**. The cluster will beep and then the setting is stored.
4. Press the HOME switch to go back to the H-Menu.

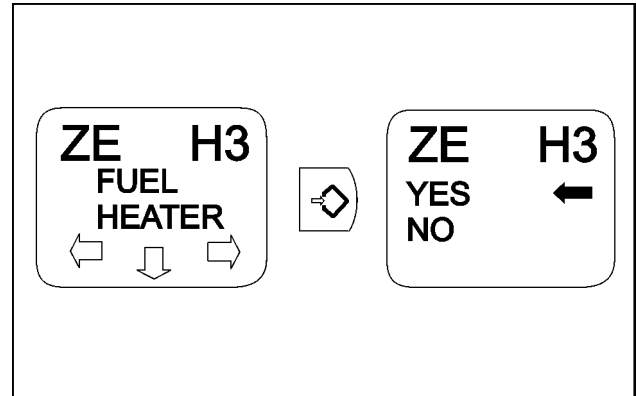

SS12N566 8

**NOTE:** The fuel filter heating system is controlled by the engine controller. Heating starts when the fuel temperature is below **-3 °C** and switched off above **+5 °C**.

## ELECTRONIC DRAFT CONTROL (EDC) OPTION

This section is used to describe the procedure that allows the technician to use the visualization of the rear hitch position, to show if it is selected or not.

1. Enter the mode, using the diagnostic test plug special tool **380000843** and navigate to ZE controller H3 menu, rear hitch option. See **Electronic module - Configure - HH-Menu overview (55.640)**. Press the ENTER switch. The DMD displays the rear hitch options and an arrow. The arrow indicates the option which is currently set.
2. Use the UP or DOWN switch to move the arrow to the required settings:  
 "YES" (enabled): default setting  
 "NO" (disabled)
3. Hold down the UP or DOWN switch for **1 s**. The cluster will beep and then the setting is stored.
4. Press the HOME switch to go back to the H-Menu.

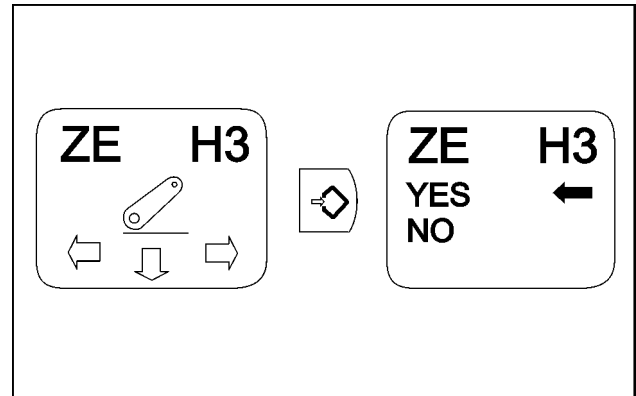

SS12N567 9

**NOTE:** For further setup options, see the RA central control unit H3 menu. See **Electronic module Central Control Unit (CCU) - H3 - Configurations and options (55.640)**.

## ENGINE SHUTDOWN

This section is used to describe the procedure that allows the technician to use the engine shutdown option.

1. Enter the mode, using the diagnostic test plug special tool **380000843** and navigate to ZE controller H3 menu, engine shutdown option. See **Electronic module - Configure - HH-Menu overview (55.640)**.

Press the ENTER switch. The DMD displays the engine shutdown options and an arrow. The arrow indicates the option which is currently set.

2. Use the UP or DOWN switch to move the arrow to the required settings:

“YES1” (always engine shutdown)

“YES2” (stationary engine shutdown): default setting

“NO” (no engine shutdown)

3. Hold down the UP or DOWN switch for **1 s**. The cluster will beep and then the setting is stored.

4. Press the HOME switch to go back to the H-Menu.

Option “NO”, the engine will never be requested to shut down.

Option “YES1” (always engine shutdown), the engine will always be requested to shut down if at least one of the following conditions is detected:

- Engine oil pressure is too low. (If the operator is present or the tractor is not moving, shut down in **30 s**. If the operator is not present and the tractor is not moving, shut down in **5 s**)
- Engine coolant temperature is too high. (If the operator is present or the tractor is not moving, shut down in **30 s**. If the operator is not present and the tractor is not moving, shut down in **5 s**)
- Driveline oil temperature is too high. (If the operator is not present and the tractor is not moving, shut down in **5 s**)
- Driveline oil pressure is too low. (If the operator is not present and the tractor is not moving, shut down in **5 s**)
- Hydraulic oil temperature is too high. (If the operator is not present and the tractor is not moving, shut down in **5 s**)

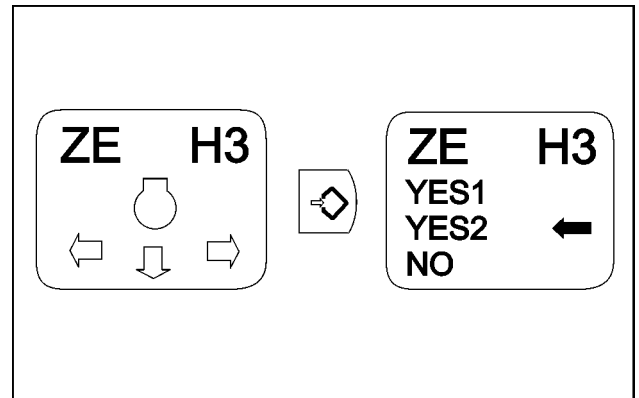

SS12N568 10

Option "YES2" (stationary engine shutdown), the engine will be requested to shut down if at least one of the following conditions is detected:

- Engine oil pressure is too low. (If the operator is not present and the tractor is not moving, shut down in **5 s**)
- Engine coolant temperature is too high.
- Driveline oil temperature is too high. (If the operator is not present and the tractor is not moving, shut down in **5 s**)
- Driveline oil pressure is too low. (If the operator is not present and the tractor is not moving, shut down in **5 s**)
- Hydraulic oil temperature is too high. (If the operator is not present and the tractor is not moving, shut down in **5 s**)

## LOW IDLE ENGINE SPEED OPTION

This section is used to describe the procedure that allows the technician to use the low idle engine speed option.

1. Enter the mode, using the diagnostic test plug special tool **380000843** and navigate to ZE controller H3 menu, low idle engine speed option. See **Electronic module - Configure - HH-Menu overview (55.640)**.  
Press the ENTER switch. The DMD displays the low idle engine options and an arrow. The arrow indicates the option which is currently set.
2. Use the UP or DOWN switch to move the arrow to the required settings:  
"YES" (enabled low idle strategy): default setting  
"NO" (disabled low idle strategy)
3. Hold down the UP or DOWN switch for **1 s**. The cluster will beep and then the setting is stored.
4. Press the HOME switch to go back to the H-Menu.

The low idle engine speed will be able to reduce from **800 RPM** to **700 RPM** when the following conditions are met:

- The operator is not present
- The transmission is in neutral position and the clutch released
- Vehicle speed = **0 km/h (0 mph)**
- Both hand and foot throttle at minimum position (low idle request)
- The actual engine percentage torque is between **18 %** and **20 %** (in order to take into account hydraulic load, fan request, alternator)
- The CRPM is not activated
- The coolant temperature is between **60 - 95 °C (140 - 203 °F)**
- The Power Take-Off (PTO) is not engaged
- The electronic remotes are not active (where fitted)
- The hitch is not rising
- The battery voltage is over **11 V**
- The transmission oil temperature is **>40 °C (>104 °F)**
- The engine oil temperature is **>60 °C (>140 °F)**
- The engine oil pressure is not too low
- The air-conditioning system is disabled

## Increased idle engine speed 1000 RPM

This engine speed option will be able to increase the engine from **700 RPM** to **1000 RPM**. To avoid problems on the electrical system, the low idle engine speed option is in operation for **60 min**.

The engine speed option remains active for **5 min** before returning back to **700 RPM**.

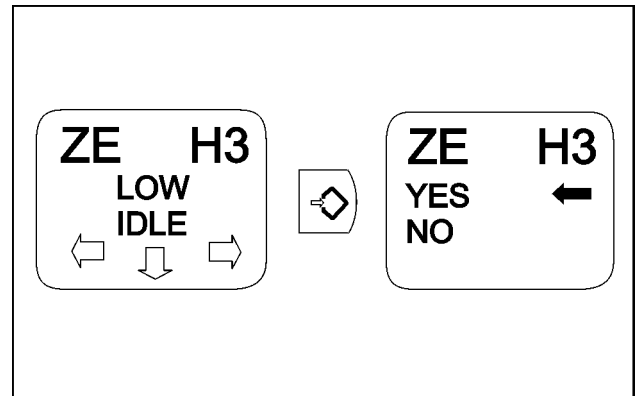

SS12N569 11

## Electronic module Instrument control unit - H4 - View software revision level

### Analog-Digital Instrument Cluster (ADIC) controller identification (ZE)

This menu displays the software version of the ADIC unit.

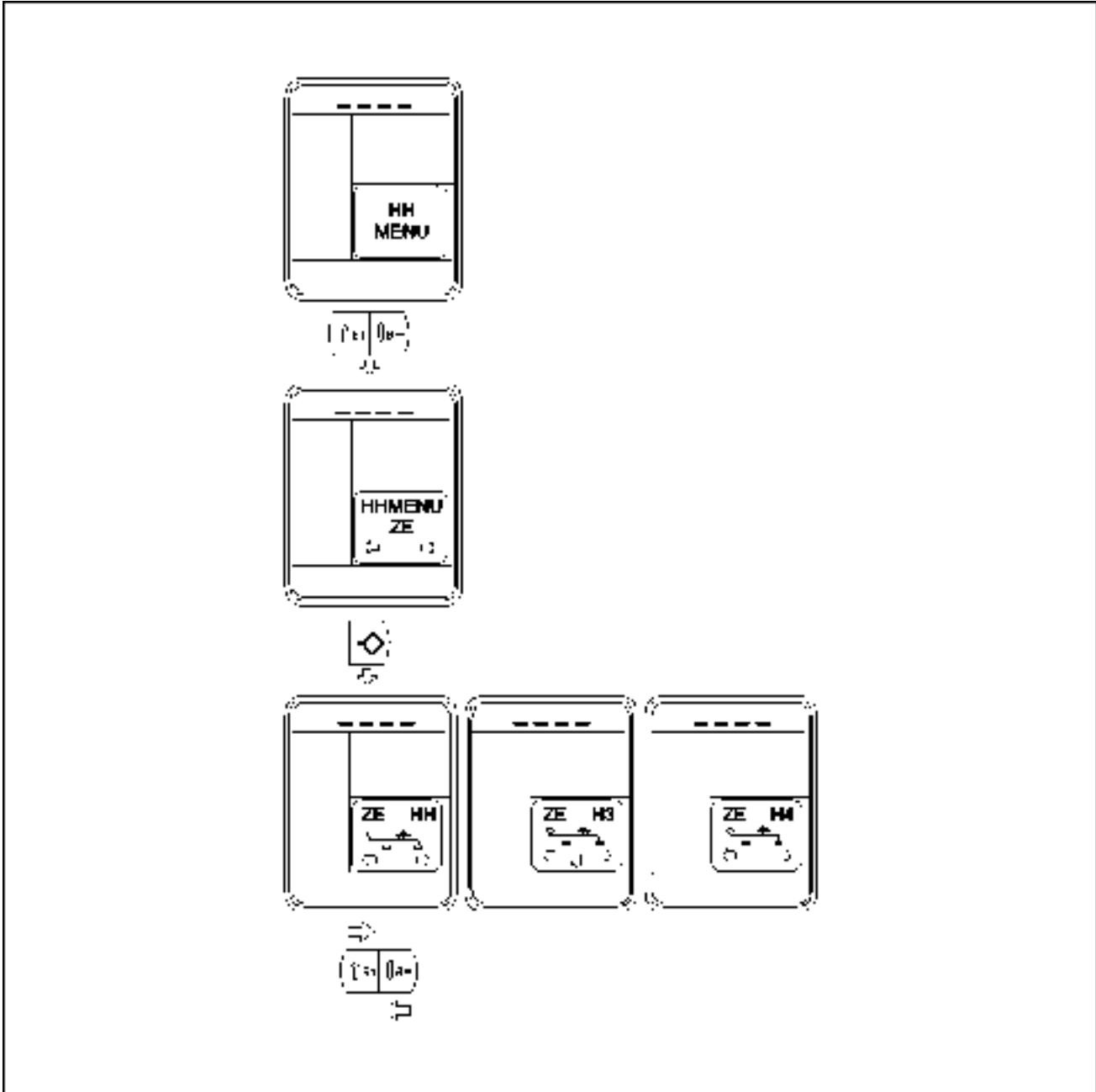

SS12N570 1

1. Enter the mode, using the diagnostic test plug (special tool **38000843**). Navigate to the ZE controller H4 menu. See **Electronic module - Configure - HH-Menu overview (55.640)**.

- Press the ENTER switch. The Dot Matrix Display (DMD) displays on the top a sequence of numbers **(1)**, representing the software identifier and the software version.

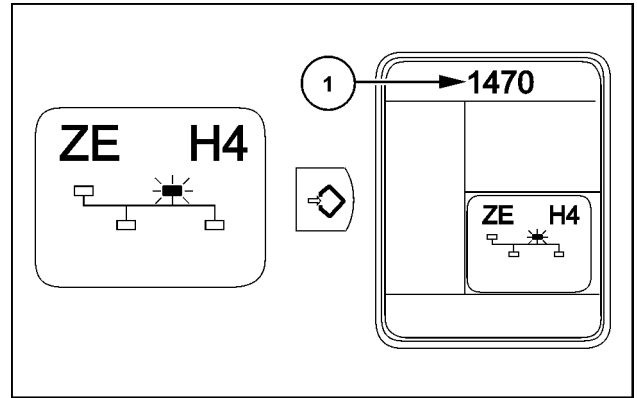

SS12N571 2

- The first **(1)** set of 4 digits indicates the software identifier. The second **(2)** and third **(3)** set of 4 digits displayed define the release version of the application software.

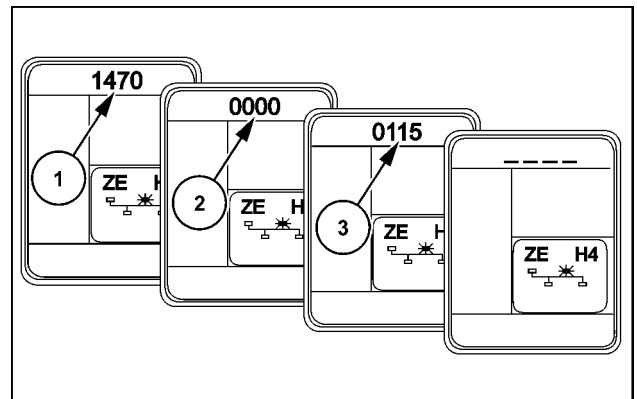

SS12N595 3

- At the end of the routine, the display returns to H4. It is possible to start with the ENTER switch the routine again or navigate further to the H-Menus.

## Electronic module Instrument control unit - H5 - Switch operation test

### Analog-Digital Instrument Cluster (ADIC) controller identification (ZE)

This menu displays a designated code when a switch transition is detected.

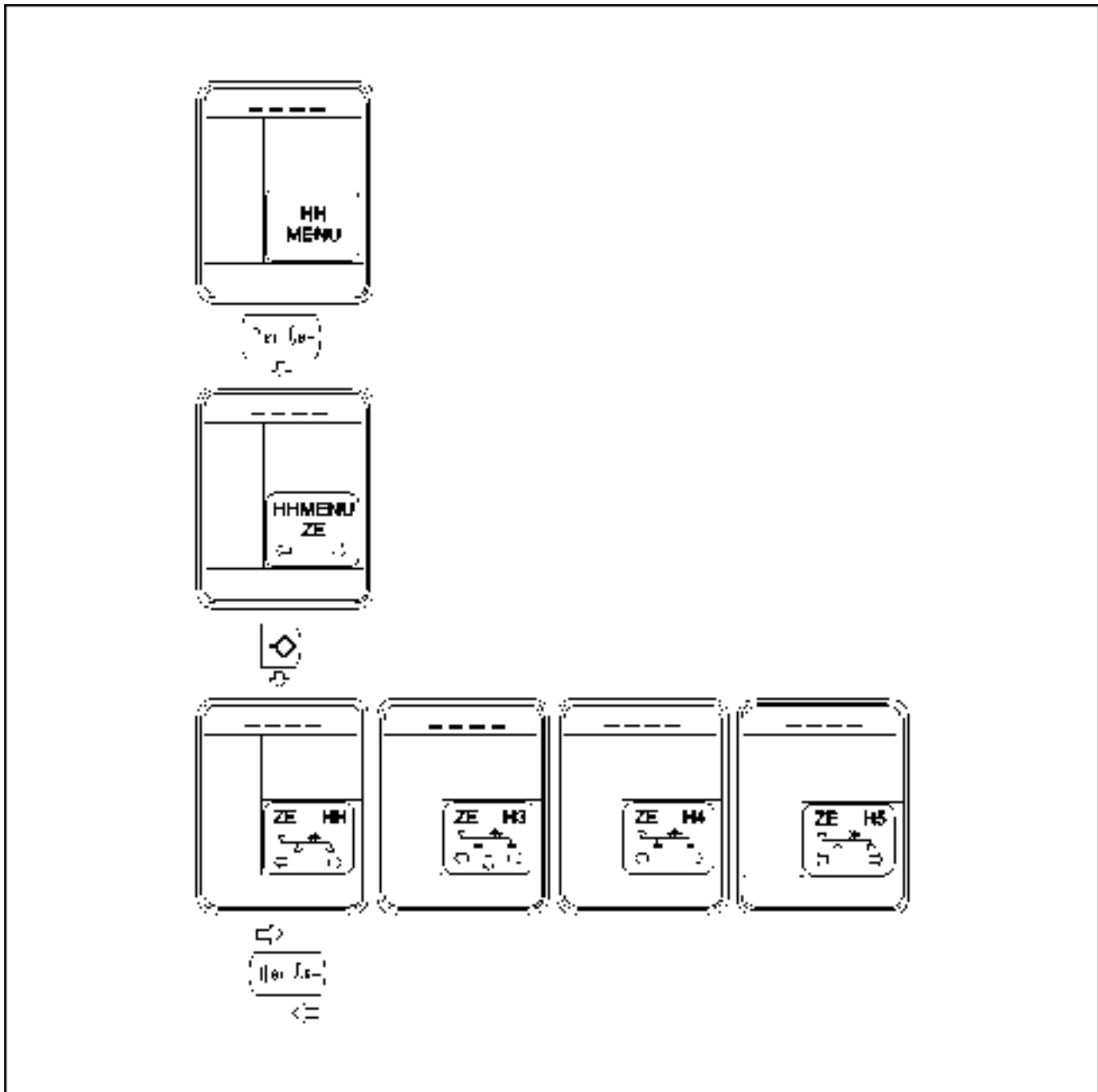

SS12N573 1

1. Enter the mode, using the diagnostic test plug (special tool **380000843**). Navigate to the ZE controller H5 menu. See **Electronic module - Configure - HH-Menu overview (55.640)**.

2. Press the ENTER switch. The Dot Matrix Display (DMD) displays on the top the letter “d\_ \_” (1).

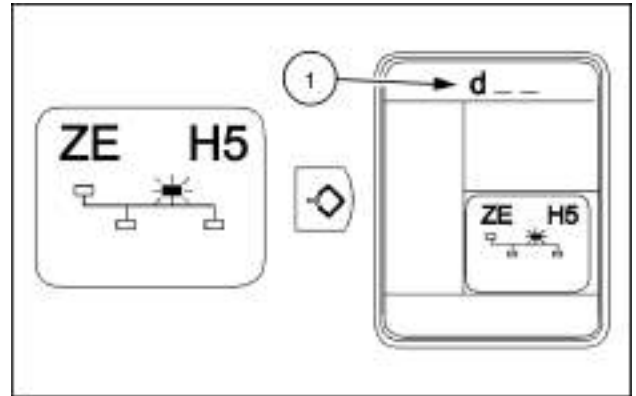

SS12N574 2

3. When the operator presses the switch, the appropriate switch code is displayed and an audible tone can be heard to indicate the correct function. If the appropriate switch code is not displayed and there is no audible tone, a fault is present. The operator can locate the fault trough wiggling the related wiring and simultaneously watching the display.
4. With the H5 menu the operator can check if a switch is open or closed, for example:
- The hand brake switch (1) is open or closed.
  - The foot throttle switch (2) is open or closed.
  - The battery isolator switch (3) is open or closed.

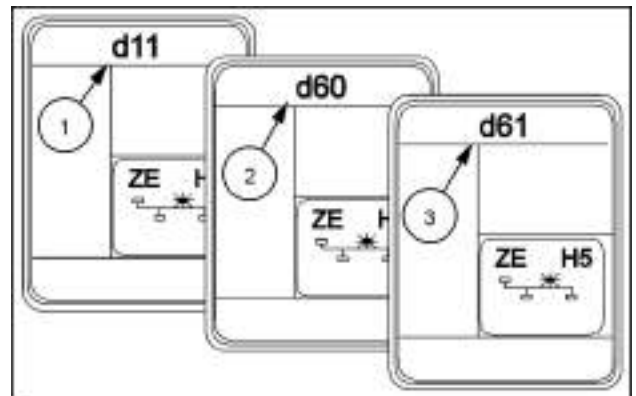

SS12N575 3

Name	Channel	Connector and Pin number
Hand brake	d11	X460-8
Foot throttle switch	d60	X450-7
Battery isolator input	d61	X460-2
Main high beam light	d66	X460-6
Side lights	d67	X460-19
Brakes not latched	d68	X450-9
Turn left-hand indicator	d70	X460-9
Turn right-hand indicator	d71	X460-10
Trailer brake	d72	X460-12
Brake fluid level	d73	X460-18
Engine intake air filter	d103	X460-3
Steering oil pressure switch	d106	X460-16
Display navigation: ENTER	d110	X450-20
Indicator trailer 1	d111	X450-17
Indicator trailer 2	d112	X450-18
CRPM setting +	d115	X450-15
CRPM setting -	d116	X450-16
Cranking detection	d121	X460-17
CRPM ON and OFF	d122	X460-26
CRPM 1 and 2	d123	X460-7
Display navigation: HOME	d131	X450-21



---

<b>Name</b>	<b>Channel</b>	<b>Connector and Pin number</b>
Display navigation: UP	d132	X450-23
Display navigation: DOWN	d133	X450-22

At the end of the switches check, it is required to key OFF to exit the H5 menu.

## **Electronic module Instrument control unit - H8 - Clear stored calibration information (EEPROM)**

### **Analog-Digital Instrument Cluster (ADIC) controller identification (ZE)**

This menu clears calibration values and stored fault codes by resetting all EEPROM values back to the default settings. EEPROM is where all calibration values and fault codes are stored. This memory is retained even if there is no power to the controller, for example: the battery is disconnected. There are two options available: "CLEAR NET CONFIG" and "CLEAR SETTINGS".

"CLEAR NET CONFIG" is used to erase the stored network configuration. This option clears the current configuration stored in the instrument cluster and rebuild the configuration at the next key ON. This should be used if the cluster has been changed or if the HH-Menus are showing units which are not fitted to the machine.

"CLEAR SETTINGS" returns all instrument cluster settings back to their default setting.

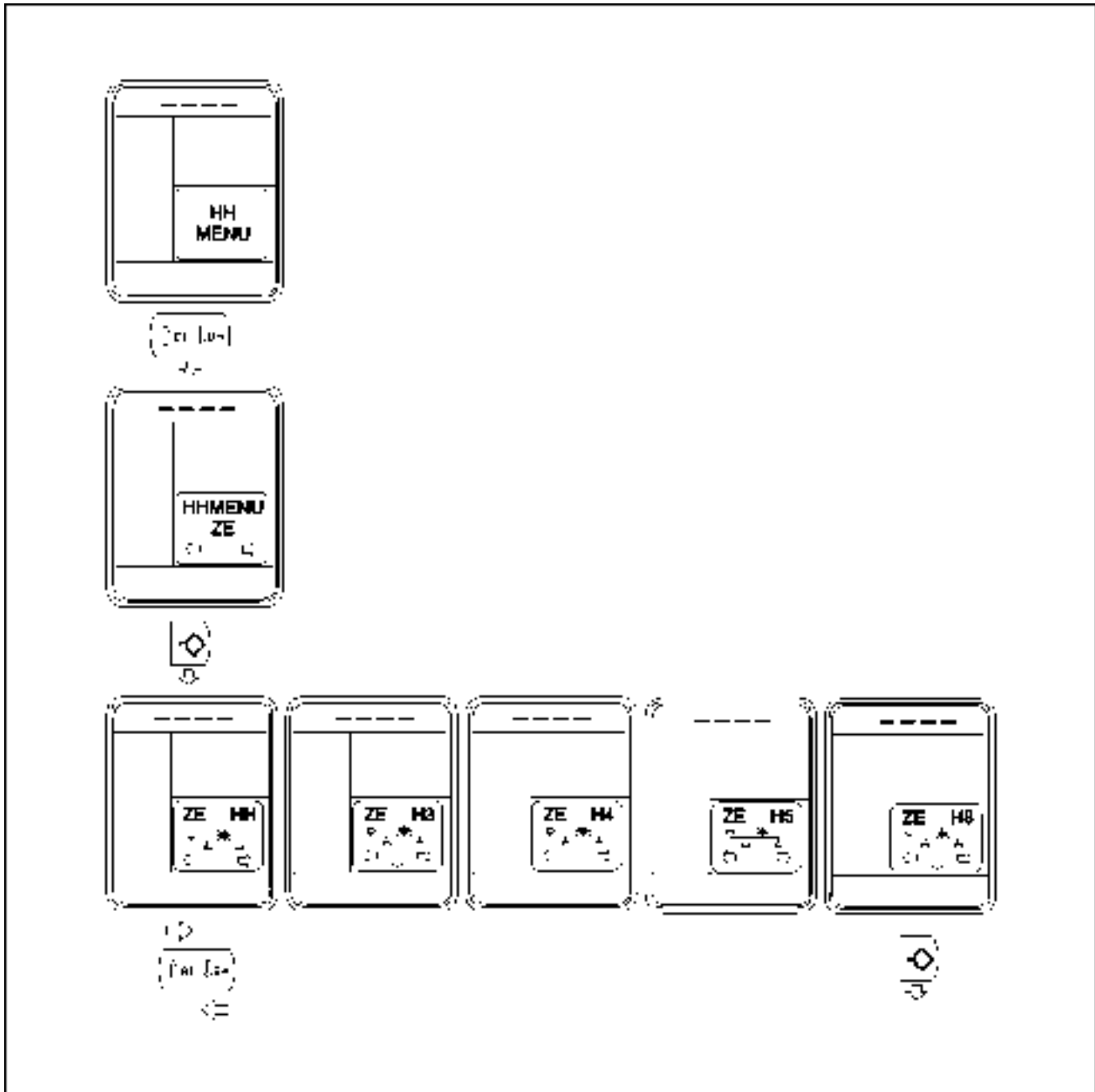

SS12N576 1

1. Enter the mode, using the diagnostic test plug (special tool **380000843**). Navigate to the ZE controller H8 menu. See **Electronic module - Configure - HH-Menu overview (55.640)**.

2. Press the ENTER switch. The DMD displays “CLEAR NET CONFIG”.

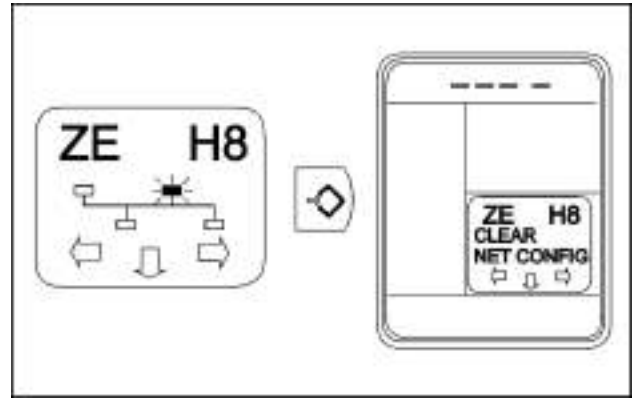

SS12N577 2

3. Use the UP or DOWN switch to select “CLEAR NET CONFIG” (1) or “CLEAR SETTINGS” (2).

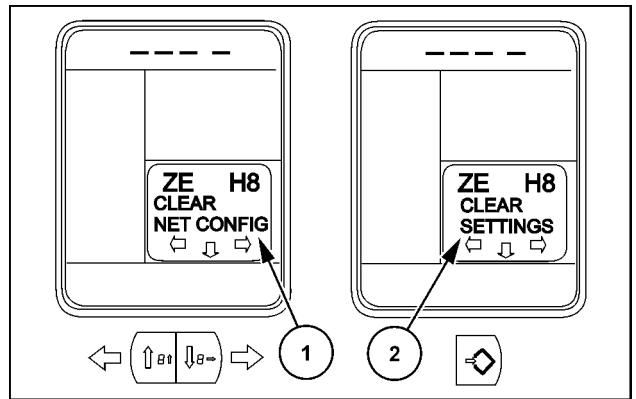

SS12N578 3

4. Press the ENTER switch to access the desired program.
5. Press and hold down the DOWN switch to confirm the resetting of the EEPROM. The DMD will countdown from 5 to 1. Then “EE” will be displayed to indicate that the EEPROM has been cleared.

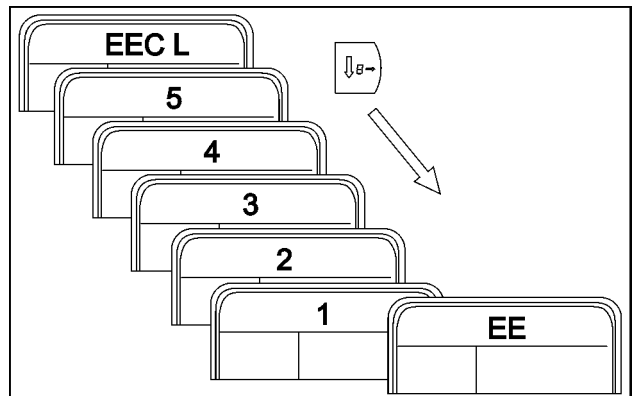

SS12N579 4

**NOTE:** If the DOWN switch is released before the countdown finishes, the procedure will be aborted.

**NOTE:** The “CLEAR NET CONFIG” procedure is carried out in the same way as “CLEAR SETTINGS”.

6. It is not possible to continue through the H-Menu after a H8 procedure. The only possible action is to turn the ignition switch OFF to allow the reset values to be stored.

PARAMETER	FACTORY VALUES
Implement width	0
Maintenance	OFF
Fault codes	No fault
Fault Code Management	FACTORY
Cabin	YES
Air brake	NO

Electrical systems - Electronic modules

PARAMETER	FACTORY VALUES
Front Power Take-Off (PTO)	NO
Power Take-Off (PTO) overspeed	YES
Electro Hydraulic Remote valve (EHR)	NO
Fuel heater	YES
Rear Electronic Draft Control (EDC) position visualization	YES
Engine shutdown	YES2
Low idle engine speed	YES
Unit of measurement	Metric
Area worked	0
Odometer	0
Dimming	50 %

**NOTE:** After using the H8 menu, all H3 configurations are on default setting. See **Electronic module Instrument control unit - H3 - Configurations and options (55.640)**.

## Electronic module Instrument control unit - H9 - Voltmeter diagnostic

### Analog-Digital Instrument Cluster (ADIC) controller identification (ZE)

This menu is used to verify the operation of various potentiometers, voltage supplies, and solenoid current circuits. If an intermittent fault is detected, the operator can locate the fault through wiggling the related wiring and simultaneously watching the display for sudden changes in values.

**NOTE:** The vehicle may be driven while working in this menu.

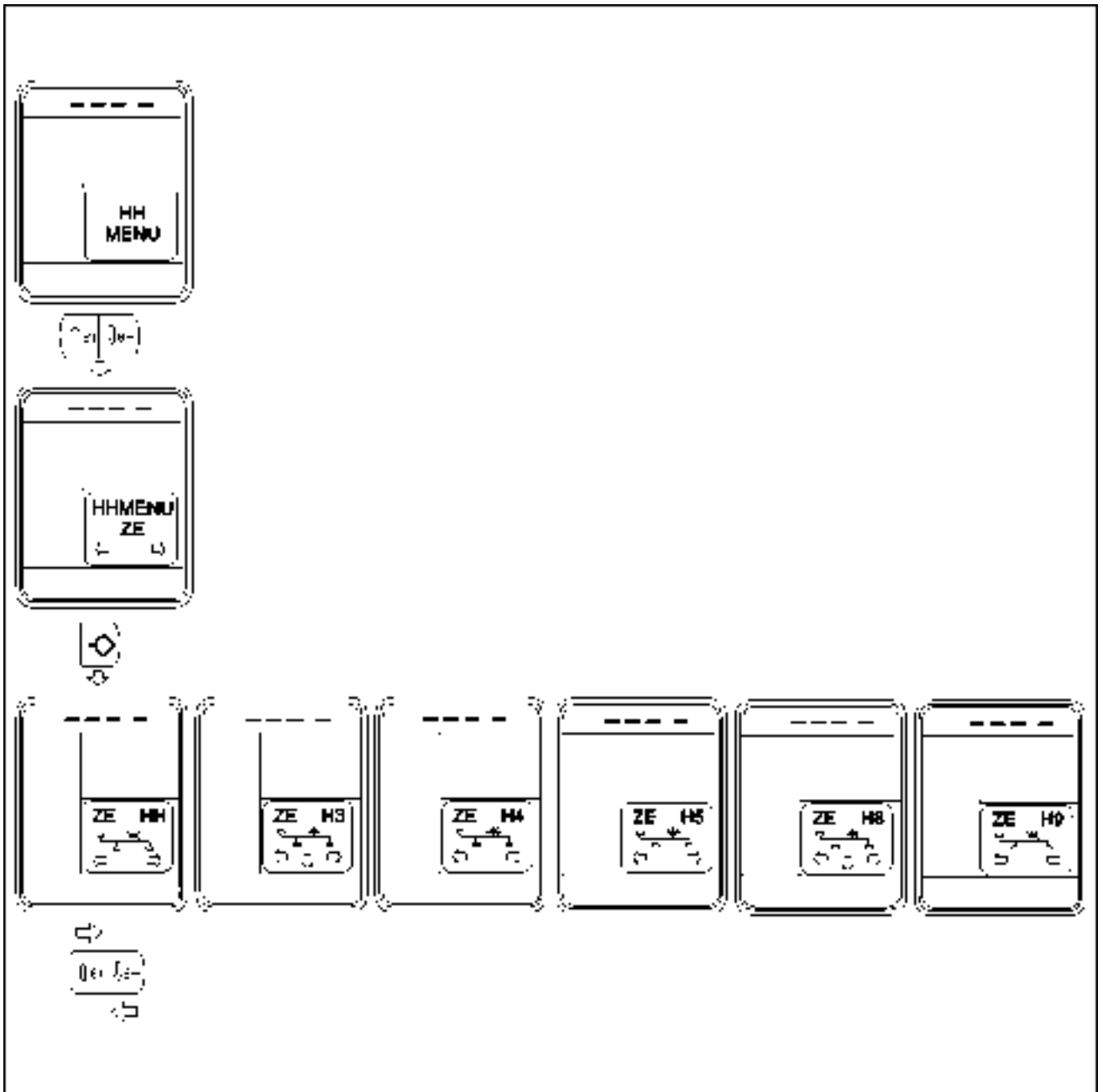

SS12N580 1

1. Enter the mode, using the diagnostic test plug (special tool **380000843**). Navigate to the ZE controller H9 menu. See **Electronic module - Configure - HH-Menu overview (55.640)**.

2. Press the ENTER switch. The Dot Matrix Display (DMD) displays on the top the letter "ch \_" (1).

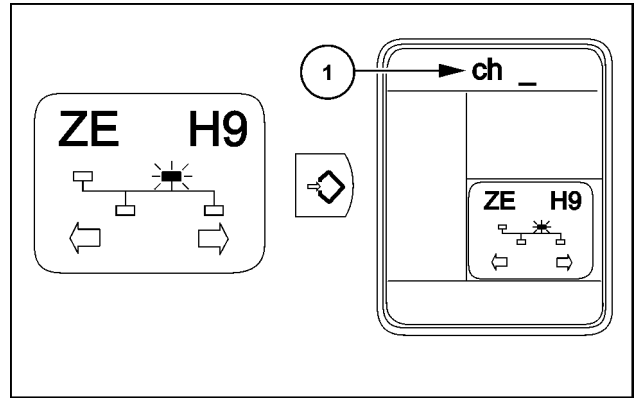

SS12N581 2

3. The required channel can be selected by using the UP and DOWN switches.

After a delay the value will be displayed, for example:

- (1) Channel number (with 3 digits)
- (2) After a delay, the display changes automatically
- (3) Alternator voltage (mV)

**NOTE:** The voltage values displayed in this menu are represented in millivolts, the current values in milliamperes. Compare the displayed value with the typical reading shown in the table below.

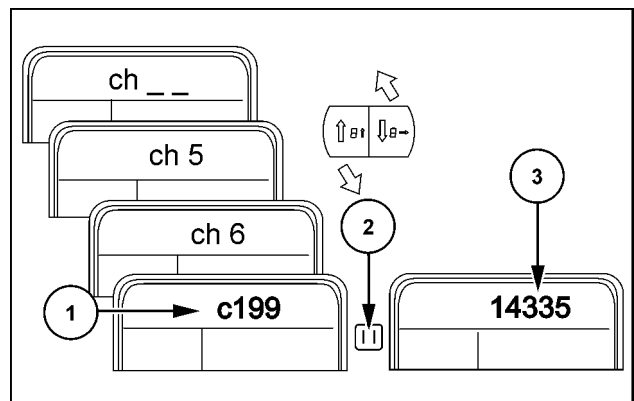

SS12N582 3

Name	Channel	Connector/Pin number	Typical reading
5 V reference 1	ch5	X460-1	4500 - 5500 mV
5 V reference 2	ch6	X460-14	4500 - 5500 mV
Foot throttle position sensor	ch8	X450-5	250 - 4500 mV
Permanent battery power supply	ch10	X460-20	9000 - 16000 mV
Trailer brake pressure sensor	ch24	X377-5	376 - 4536 mV
Fuel level sensor	ch25	X450-2	850 - 3670 mV
Operator presence switch	ch26	X450-1	1430 - 2870 mV
Hand throttle sensor 2	ch89	X450-11	200 - 4800 mV
Hand throttle sensor 1	ch90	X450-8	200 - 4800 mV
Alternator charging	c199	X460-13	9800 - 16000 mV

4. Press the HOME switch to exit the menu.

## Electronic module Instrument control unit - HB - Display stored fault codes

### Analog-Digital Instrument Cluster (ADIC) controller identification (ZE)

This function is used to display the fault codes from the engine controller and the ADIC controller, which have been stored in EEPROM of the ADIC.

**NOTE:** The vehicle may be driven while working in this menu.

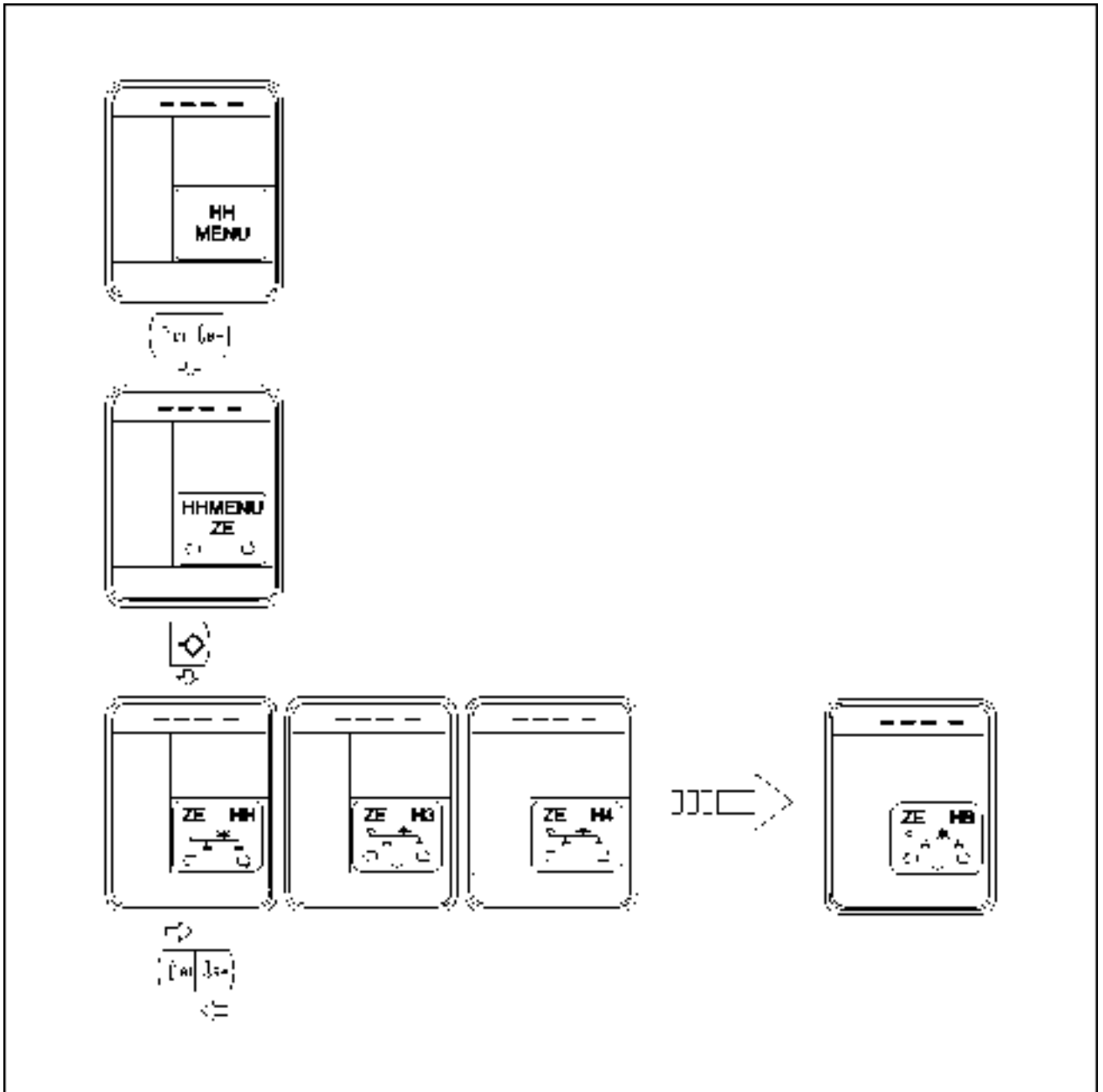

SS12N583 1

1. Enter the mode, using the diagnostic test plug (special tool **380000843**). Navigate to the ZE controller HB menu. See **Electronic module - Configure - HH-Menu overview (55.640)**.



2. Press the ENTER switch.

1. If there is no fault, the DMD will display "NO ERROR".
2. If a fault is present, the DMD shows as follows:
  - "#" Fault number
  - "FIRST" Absolute hour of the first occurrence
  - "LAST" Absolute hour of the last occurrence
  - "CONT" Number of occurrences of the fault

Press the UP or DOWN switch to scroll between the fault codes.

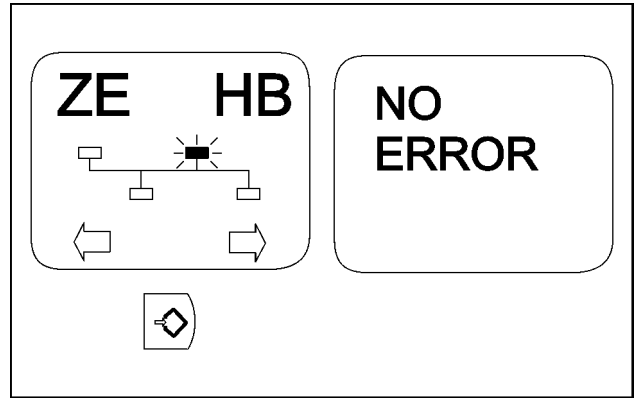

SS12N584 2

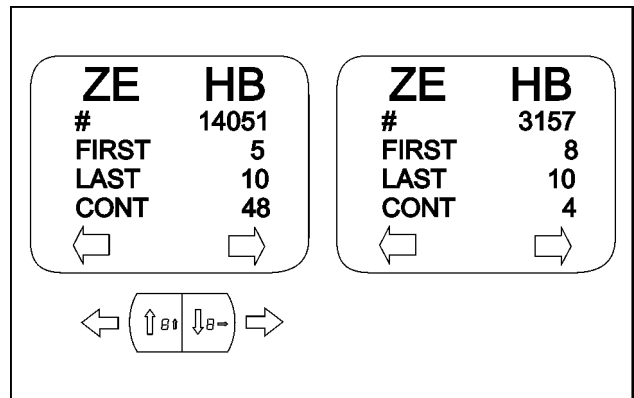

SS12N585 3

3. Press the HOME switch to exit the menu.

**NOTE:** If you would like to erase the fault codes see HC menu. See **Electronic module Instrument control unit - HC - Clear all stored fault codes (55.640)**.

## Electronic module Instrument control unit - HC - Clear all stored fault codes

### Analog-Digital Instrument Cluster (ADIC) controller identification (ZE)

This menu is used to delete all fault codes which have been stored in EEPROM of the control unit.

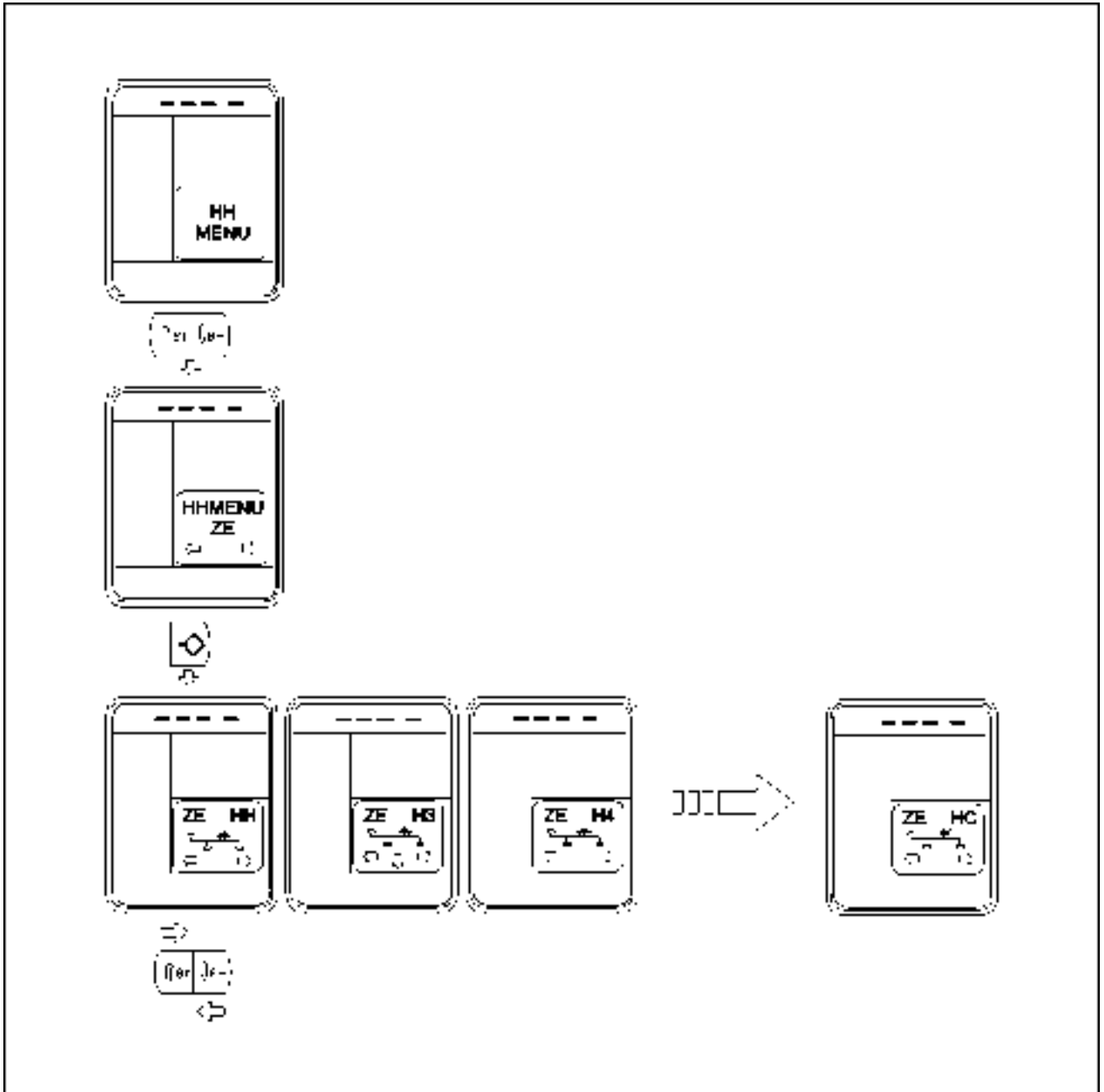

SS12N586 1

1. Enter the mode, using the diagnostic test plug (special tool **380000843**). Navigate to the ZE controller, HC menu. See **Electronic module - Configure - HH-Menu overview (55.640)**.

- Press the ENTER switch. The Dot Matrix Display (DMD) displays "CLEAR ERRORS".

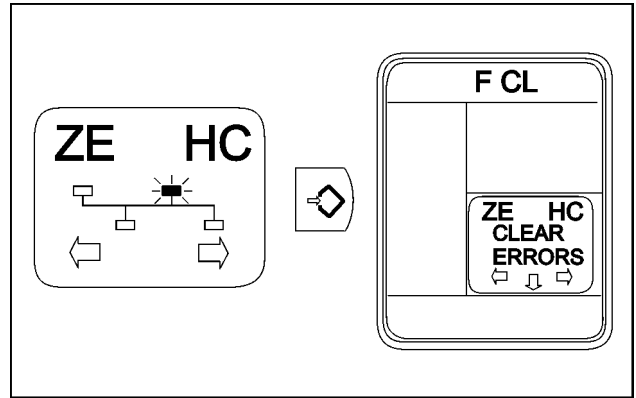

SS12N587 2

- Press the DOWN switch to delete the stored fault codes from the EEPROM. The DMD will countdown from 5 to 1. "EE" will be displayed to indicate that the stored fault codes have been deleted.
- It is not possible to continue through the H-Menu after a HC procedure. The only possible action is to turn the ignition switch OFF to allow the reset values to be stored.

**NOTE:** If the DOWN switch is released before the countdown finishes, the procedure will return and the DMD displays "F CL".

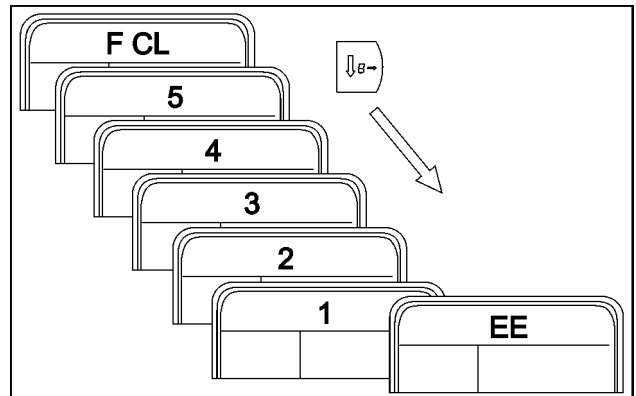

SS12N588 3

## Electronic module Instrument control unit - HF - View controller hardware information

### Analog-Digital Instrument Cluster (ADIC) controller identification (ZE)

This menu is used to show a sequence of numbers, representing the hardware identifier, the hardware version and in some cases the hardware serial number, which are stored in EEPROM of the control unit.

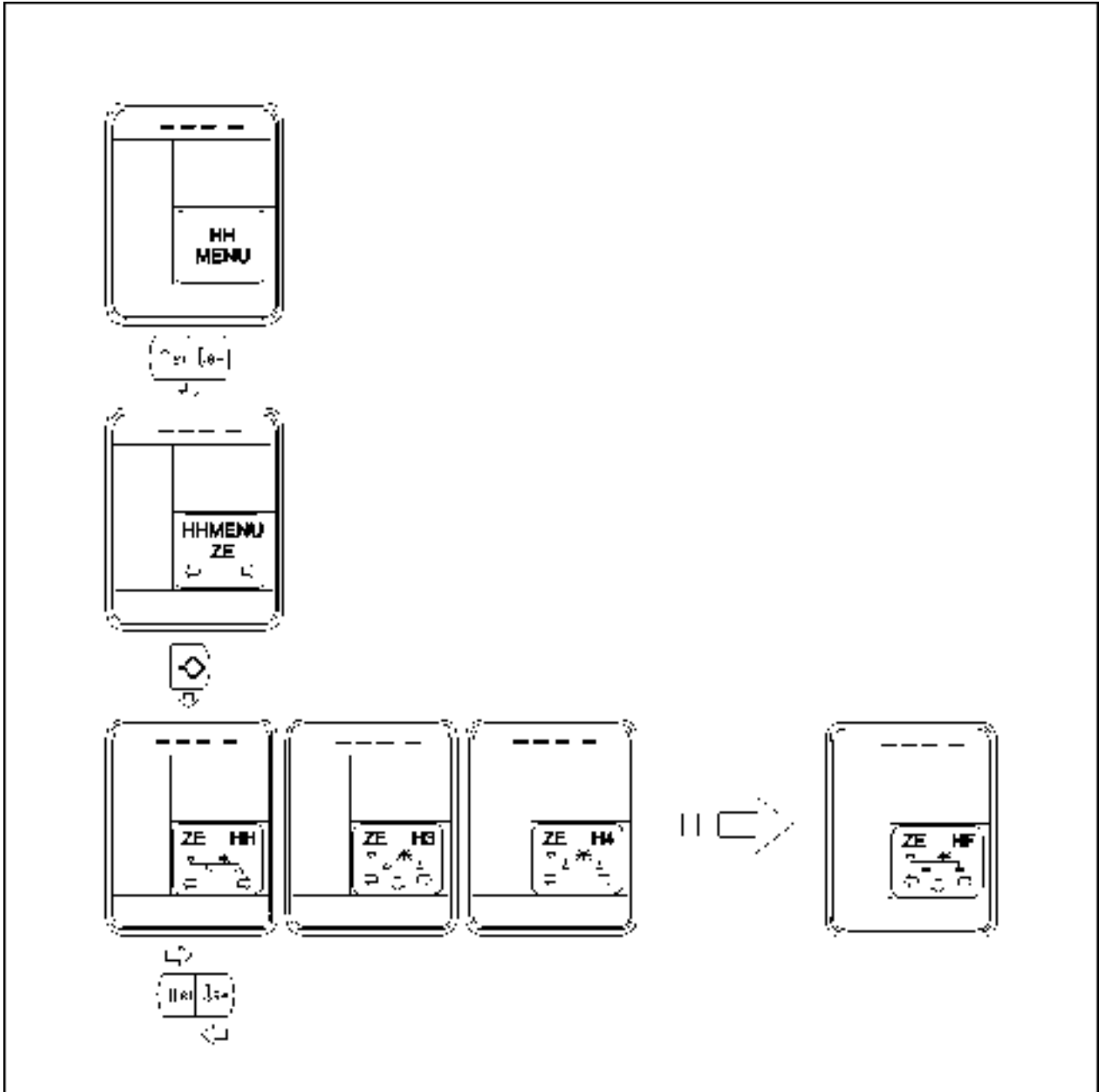

SS12N589 1

1. Enter the mode, using the diagnostic test plug (special tool **38000843**). Navigate to the ZE controller, HF menu. See **Electronic module - Configure - HH-Menu overview (55.640)**.

- Press the ENTER switch. The Dot Matrix Display (DMD) displays the first sequence of numbers "0790" (1).

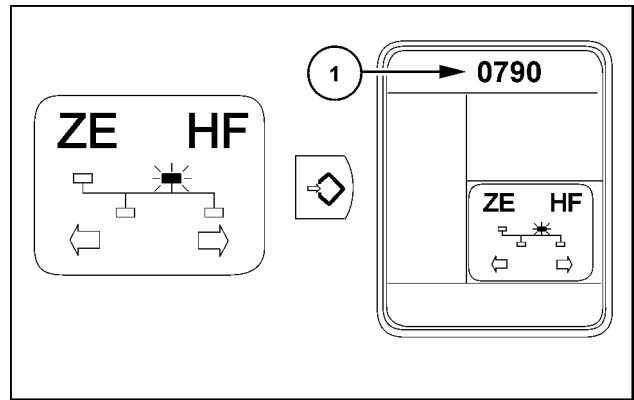

SS12N596 2

- The DMD shows a sequence of numbers, representing the hardware version and hardware serial number:  
 "0790" Hardware identifier ZE  
 "0100" Release number of the unit hardware  
 "0000" Release number of the unit hardware  
 "0000" Unit serial number  
 "0000" Unit serial number  
 "5336" Unit serial number  
 "----" Finished

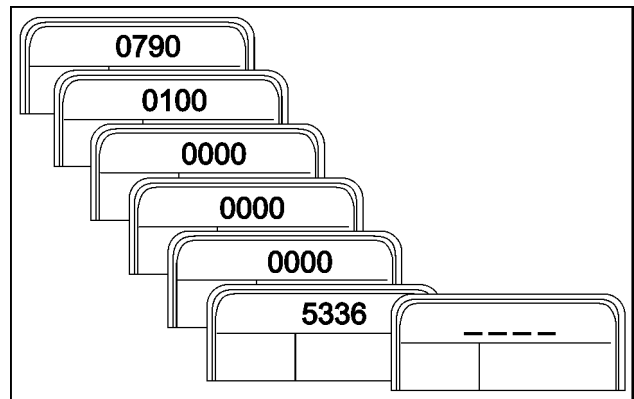

SS12N598 3

- Press the HOME switch to exit the menu.

## Electronic module Central Control Unit (CCU) - H1 - Calibration procedures

### Central Control Unit (CCU) controller identification (RA)

This sections explains the calibration procedure for the Electronic Draft Control (EDC).

- EDC position sensor calibration
- EDC valve calibration

**NOTE:** Before the EDC valve calibration is performed, it is important that the EDC position sensor has been calibrated first.

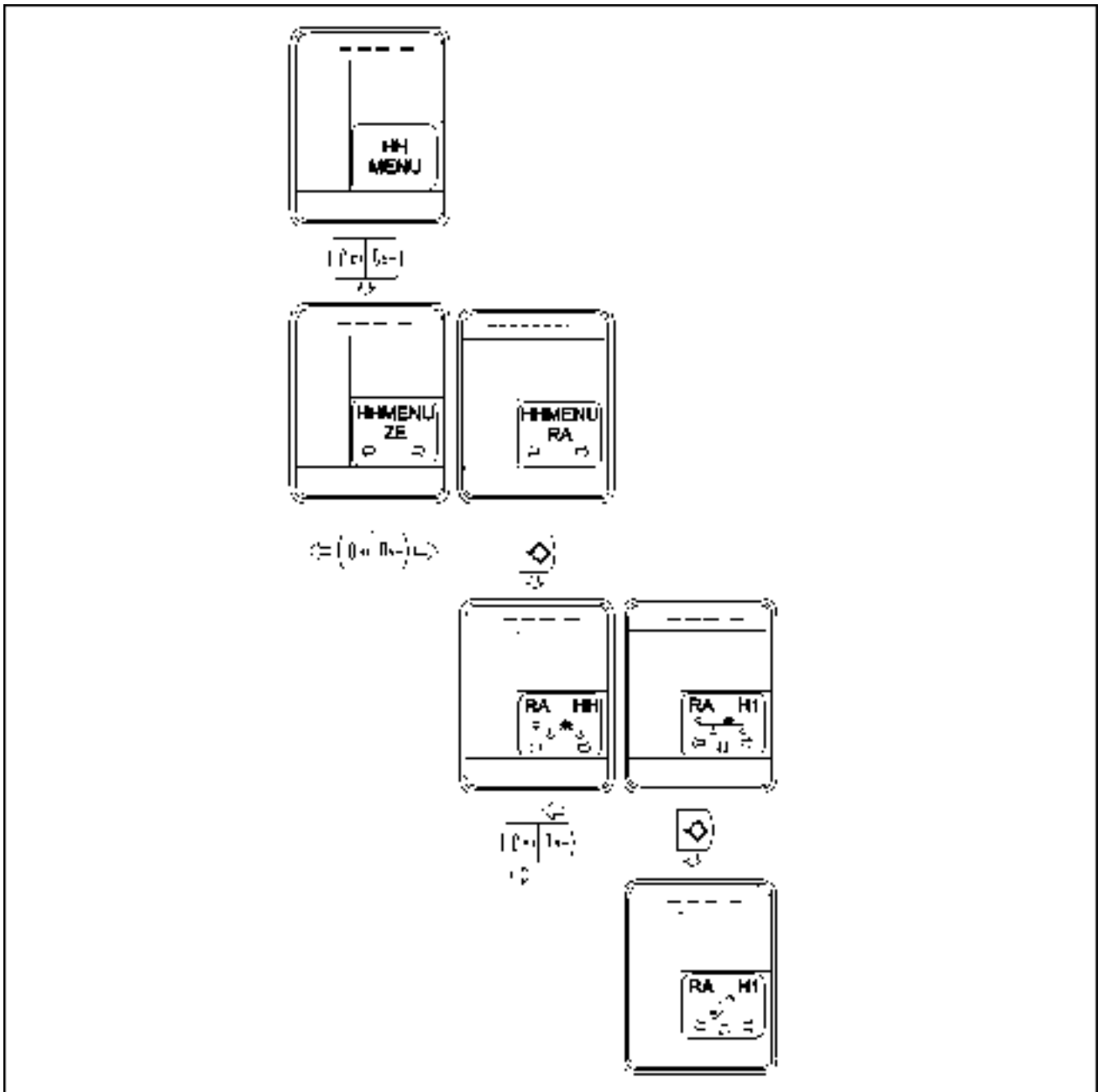

SS12N823 1

## EDC position sensor calibration

**NOTE:** If the fault code 1024 is displayed, the EDC position sensor calibration has not been performed.

1. Set all EDC potentiometers on the EDC panel fully clockwise at maximum value.

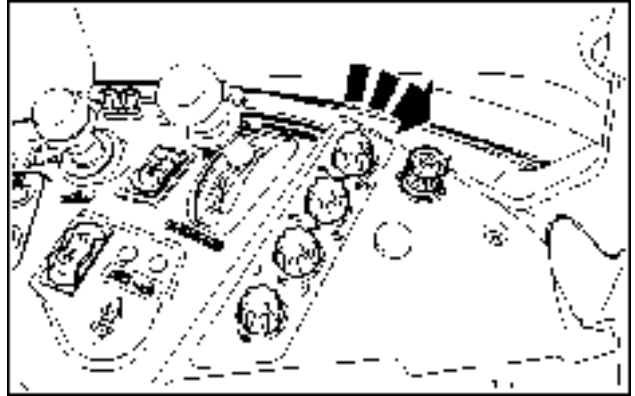

SS12N895 2

2. Set the position control potentiometers and the draft control potentiometers fully counterclockwise at minimum value.

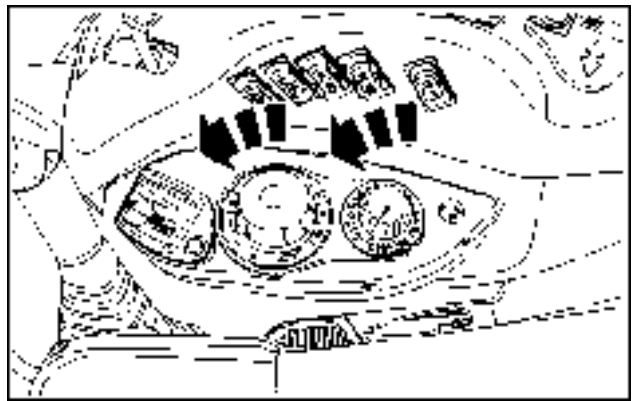

SS12N870 3

3. Hold down the raise switch (1) on the Multicontroller and start the engine. Release the raise switch when the EDC status light (2) starts flashing (there is a 10 s window in which the raise switch must be released). This causes the clearing of the calibrations for: top and bottom of the hitch travel, and minimum and maximum for the position control potentiometer.

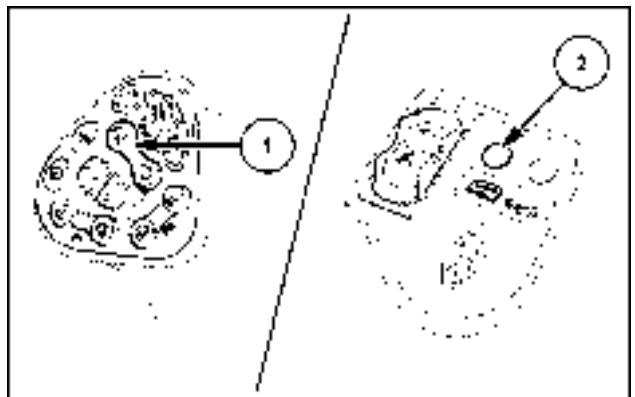

SS12N826 4

4. Raise the hitch by turning the position control potentiometer fully clockwise.

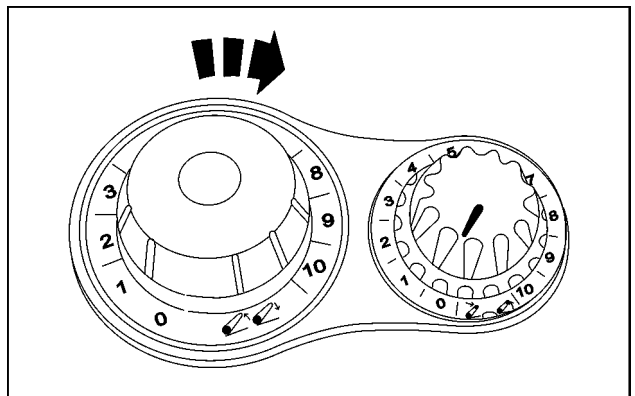

SS12N867 5

- When the hitch stops moving, the rockshaft sensor value is stored as the calibrated value for the rockshaft top.

Then the hitch lowers slightly, as the top 4 % of travel is not used in normal operation, to protect the hitch system from mechanical damage. This position at 96 % of total travel is regarded as 100 % hitch position.

- The low value is calibrated by lowering the hitch, turning the position control potentiometer fully counter-clockwise until it stops moving at the bottom.

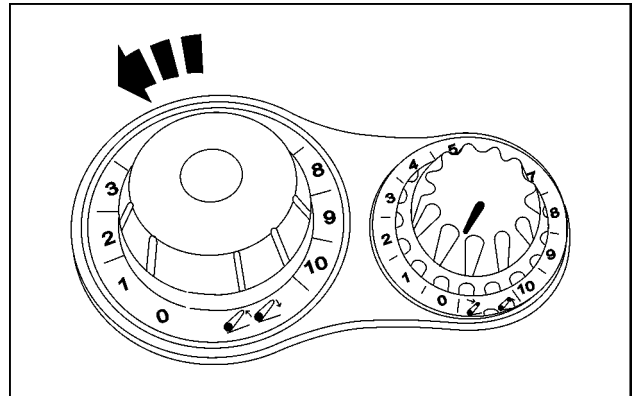

SS12N868 6

- Switch OFF to store the calibration values.

### EDC valve calibration

#### **⚠ WARNING**

##### **Unexpected machine movement!**

The machine could move automatically during calibration. Park on a flat surface, engage the parking brake, and be sure that the area around the machine is clear before starting the calibration process. Failure to comply could result in death or serious injury.

W0300A

**NOTE:** This procedure is required when either the new EDC valves or the Central Control Unit (CCU) are fitted or if the previous calibration has been erased by using the H8 procedure.

Disconnect all implements from the rear hitch. Lower the linkage and connect test weights.

**NOTE:** The test weights must be sufficient to overcome any friction in the hydraulic lift assembly and enable the lift arms to lower without binding. The standard test weights of 1111 - 1542 kg (2449 - 3400 lb) are recommended.

- Stop the engine.
- Set all EDC potentiometers on the EDC panel fully clockwise at maximum value.

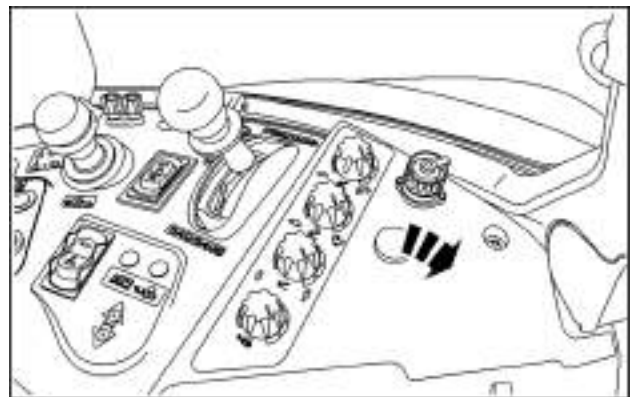

SS12N824 7



10. Set the position control potentiometers and the draft control potentiometers fully counterclockwise at minimum value.

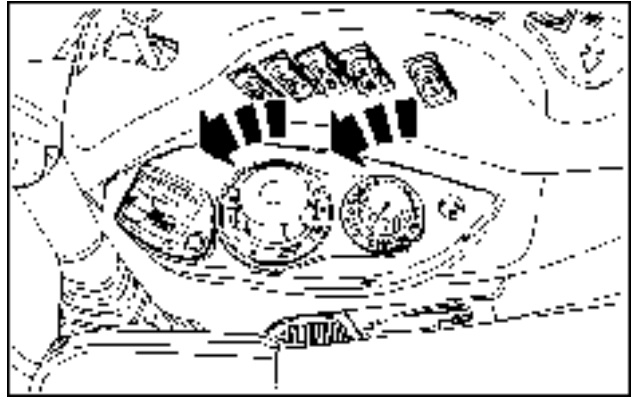

SS12N870 8

11. To enter the mode, you have two choices:

- Diagnostic test plug: Enter the mode, using the diagnostic test plug (special tool **380000843**). Navigate to the RA controller, H1 menu, rear hitch symbol. See **Electronic module - Configure - HH-Menu overview (55.640)**.
- Quick entry: Hold down the lower switch (1) on the Multicontroller and start the engine.

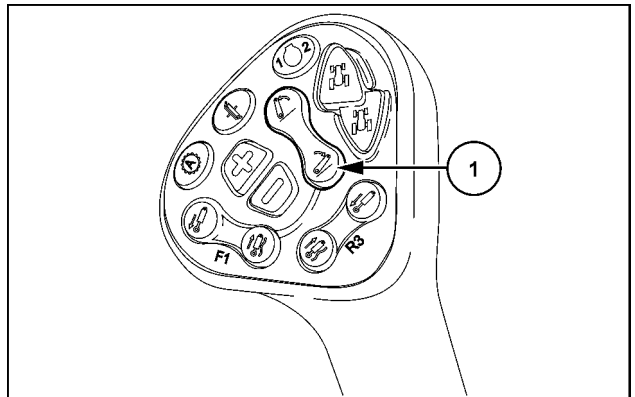

SS12N830 9

12. The system to be calibrated will be shown on the Dot Matrix Display (DMD) and "CAL" will be displayed in the upper side of the display.

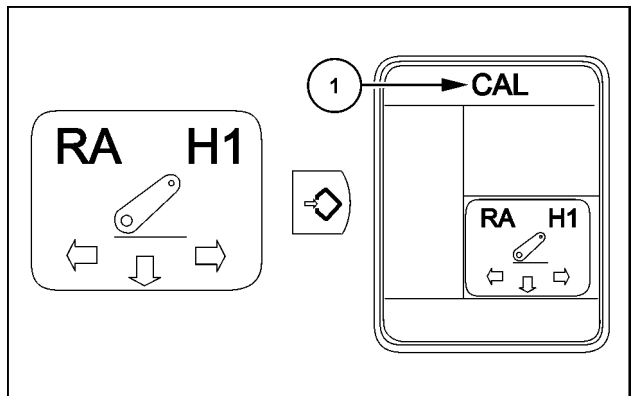

SS12N831 10

13. Set with the hand throttle potentiometer the engine RPM to **1200 RPM +/- 100**. The engine speed must be stable.
14. Turn the position control potentiometer between 7 to 9 to start the calibration sequence.

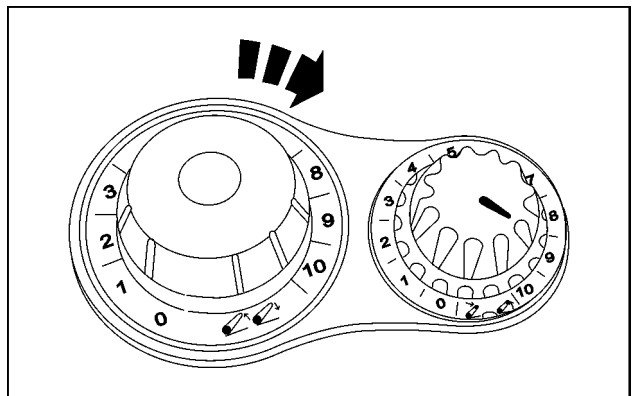

SS12N869 11

15. The upper side of the display changes from "CAL" to "0" to indicate the start of the calibration. During calibration the linkage is automatically raised and lowered for 3 times, which takes **2 - 3 min.**

Each raising and lowering is accompanied by a count on the display from 0 to 2.

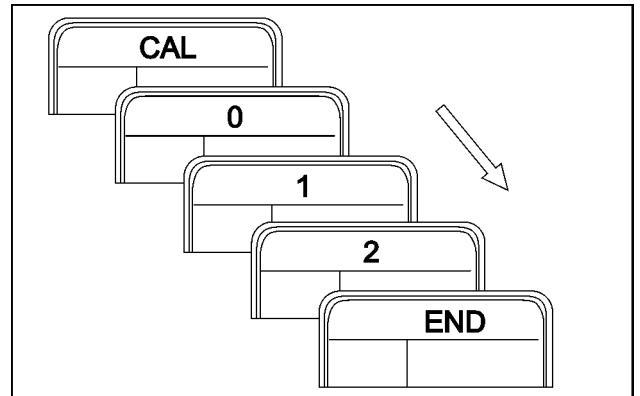

SS12N833 12

16. The calibration is complete when the display indicates "END".
17. Switch OFF to store the calibration values.

**NOTE:** There are no "U" codes defined for the EDC calibration procedure. However, the fault code **1068-Electronic Draft Control (EDC) - calibration fault (55.640)** may be displayed during the procedure.

## Electronic module Central Control Unit (CCU) - H2 - View stored calibration values

### Central Control Unit (CCU) controller identification (RA)

This section is used to view the Electronic Draft Control (EDC) valve calibration values currently stored in the CCU.

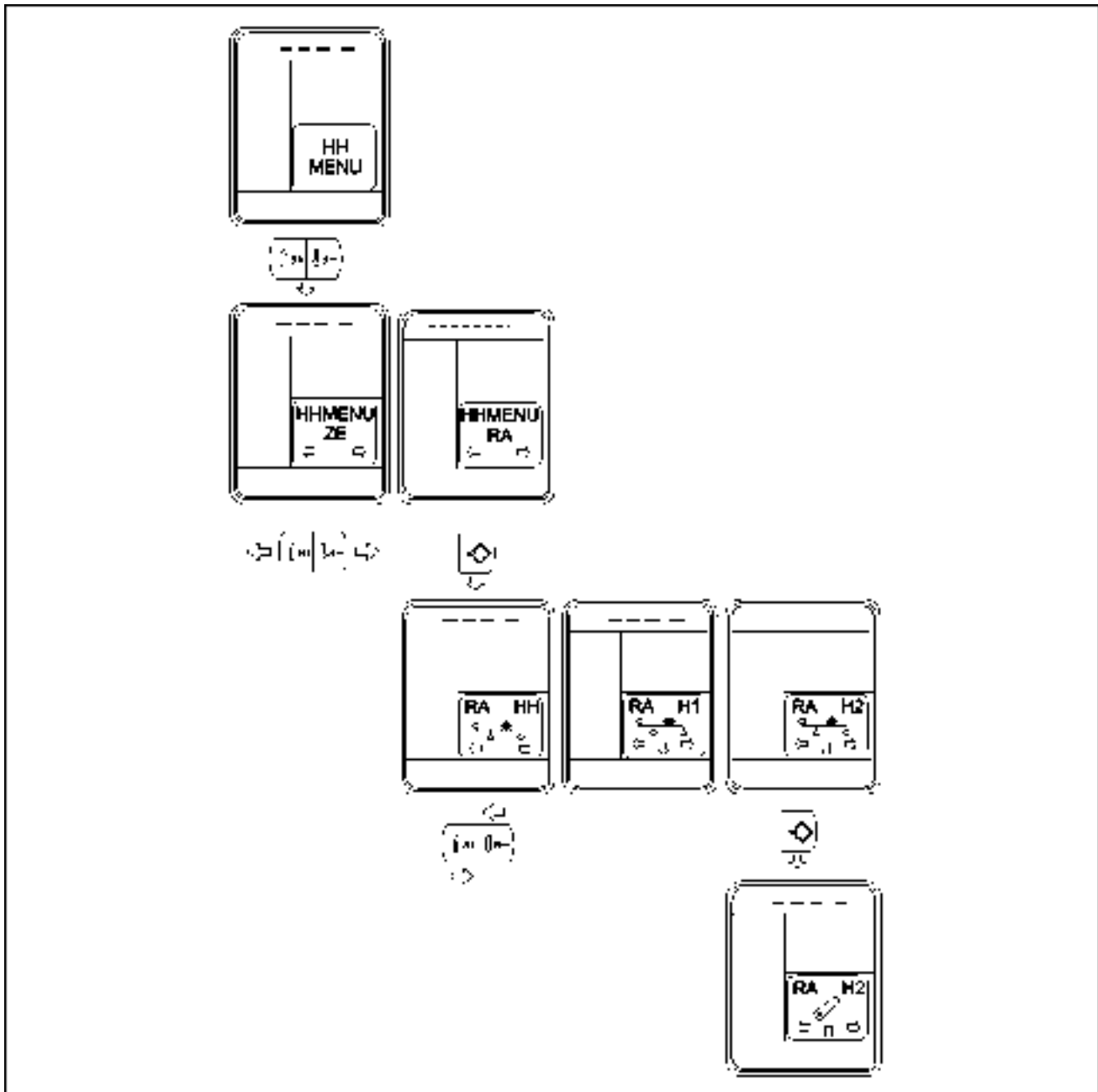

SS12N822 1

1. Enter the mode, using the diagnostic test plug (special tool **380000843**). Navigate to the RA controller H2 menu. See **Electronic module - Configure - HH-Menu overview (55.640)**.

- Press the ENTER switch. The Dot Matrix Display (DMD) displays on the top the letters "ch \_ \_" (1).

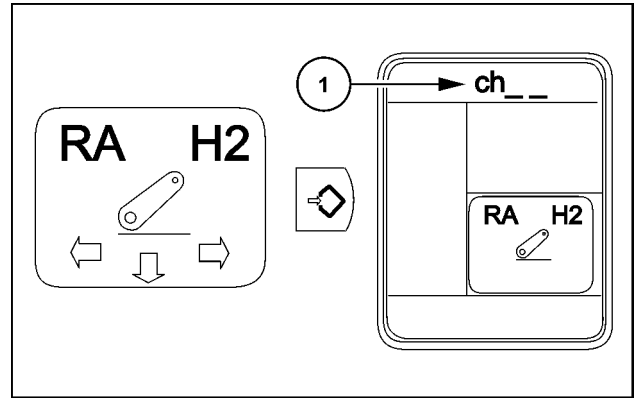

SS12N820 2

- Use the UP or DOWN switch to select the required channel. After a delay a value will be displayed. Compare the displayed value with the typical reading shown in the table below.

**NOTE:** If the value "50" is displayed for both solenoid valves, then the EDC valve is not calibrated.

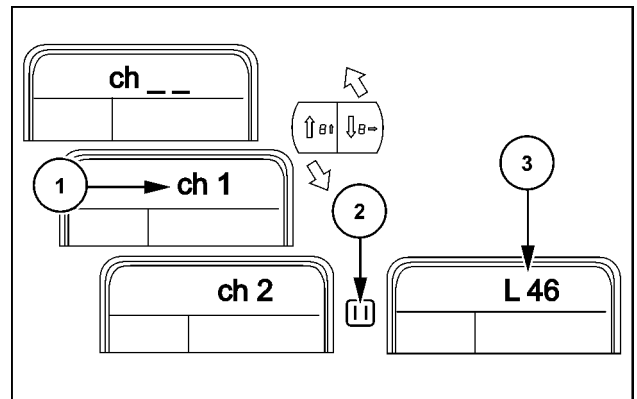

SS12N821 3







Channel	Item	Calibration value
1	Raise solenoid calibration valve	20 - 80 mA
2	Lower solenoid calibration valve	20 - 80 mA

- Press the HOME switch to exit the menu.

## Electronic module Central Control Unit (CCU) - H3 - Configurations and options

### Central Control Unit (CCU) controller identification (RA)

The table below displays the functions and the belonging symbols for this submenu.

Function	Icon
Electronic Draft Control (EDC)	
Electronic parking brake	
Front Power Take-Off (PTO)	
Differential lock	
Rear Power Take-Off (PTO)	
Front Electro Hydraulic Remote valves (EHR)	
Rear Electro Hydraulic Remote valves (EHR)	

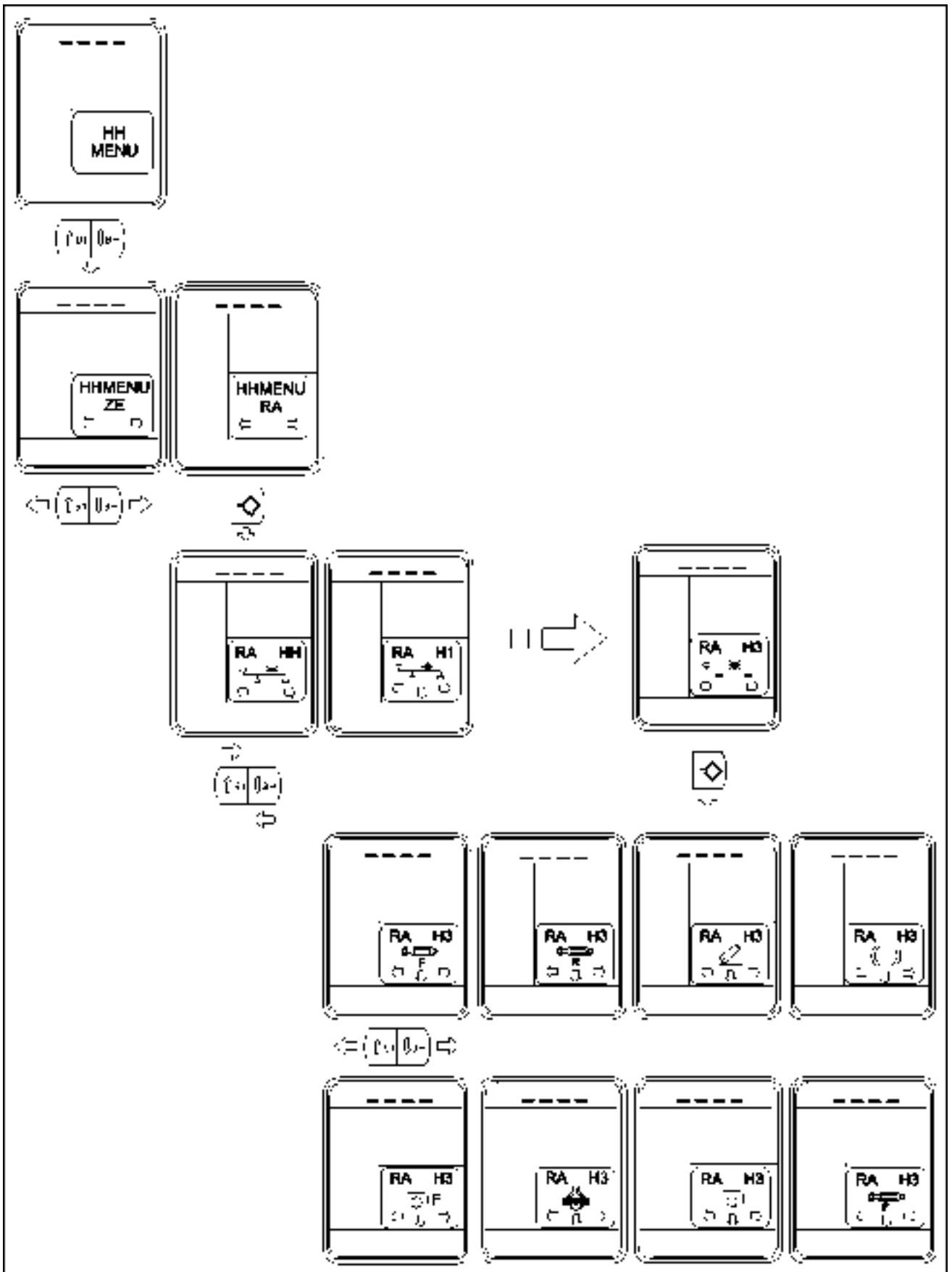

SS12N815 1

**NOTE:** After using the H8 menu, all configurations are on default settings.

## ELECTRONIC DRAFT CONTROL (EDC)

This section is used to allow the service technician to set up any options on the Electronic Draft Control (EDC) system.

1. Enter the mode, using the diagnostic test plug (special tool **380000843**). Navigate to the RA controller H3 menu. See **Electronic module - Configure - HH-Menu overview (55.640)**.
2. Select the symbol, Electronic Draft Control (EDC) option.
3. Press the ENTER switch. The Dot Matrix Display (DMD) displays on the top the letters "ch \_" (1).
4. Use the UP or DOWN switch to select the required channel number.

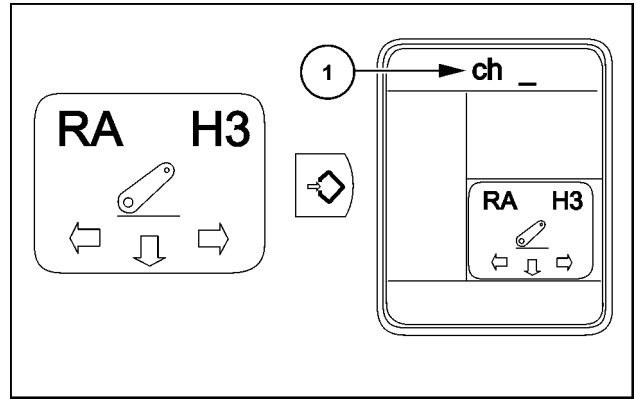

SS12N817 2

### Channel 1 – Electronic Draft Control (EDC) hydraulic section

The DMD can change between 2 settings: "Ar80" and "br80".

1. Use the UP or DOWN switch to toggle the settings and indicate which pump option is selected. Press the UP or DOWN switch for **1 s**. The cluster will beep and then the setting is stored.
2. Press the HOME switch to go back to the H-Menu.

**NOTE:** The default setting for this option is "def". If "def" is displayed, then this channel must be used to select the appropriate configuration. Otherwise the fault code 1070 will be shown.

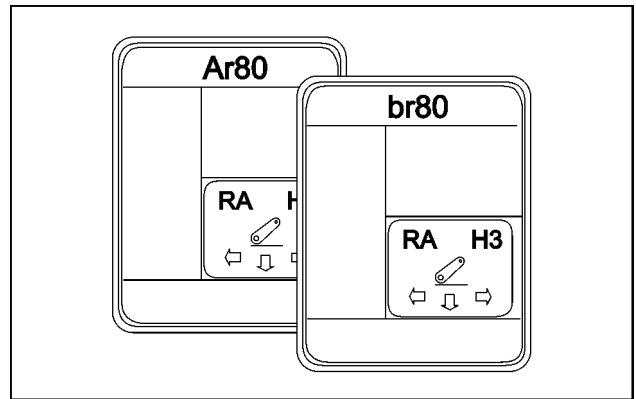

SS12N834 3

Hydraulic systems	Pump	Option
OCLS	60 l (16 US gal)	"Ar80"
CCLS	100 l (26 US gal)	"br80"

### Channel 2 – Enable or disable the Electronic Draft Control (EDC) system

This channel is used to enable or disable the Electronic Draft Control (EDC) system.

1. Use the UP or DOWN switch to select the required setting:
  - "YES" (enabled)
  - "NO" (disabled)
  - (automatic detection)
2. Hold down the UP or DOWN switch for **1 s**. The cluster will beep and then the setting is stored.
3. Press the HOME switch to go back to the H-Menu.

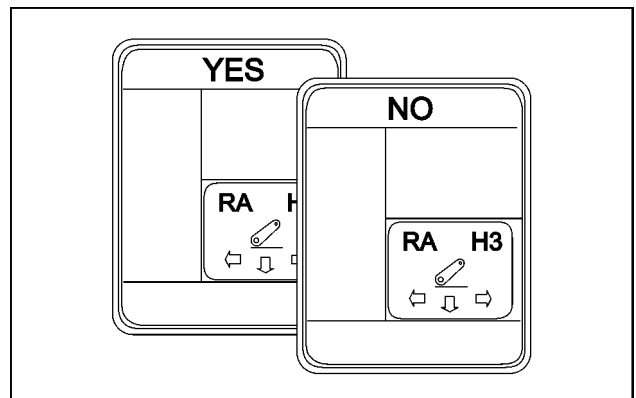

SS12N835 4

### Channel 3 – Enable or disable the slip control

This feature is available if the radar option is fitted.

1. Use the UP or DOWN switch to select the required setting:  
 “YES”: the slip control is present  
 “NO”: the slip control is absent (default setting)
2. Hold down the UP or DOWN switch for **1 s**. The cluster will beep and then the setting is stored.
3. Press the HOME switch to go back to the H-Menu.

**NOTE:** If the “Enable or disable the Electronic Draft Control (EDC) system” option is disabled by using the channel 2 or by an automatic detection, as default the slip control will also be disabled.

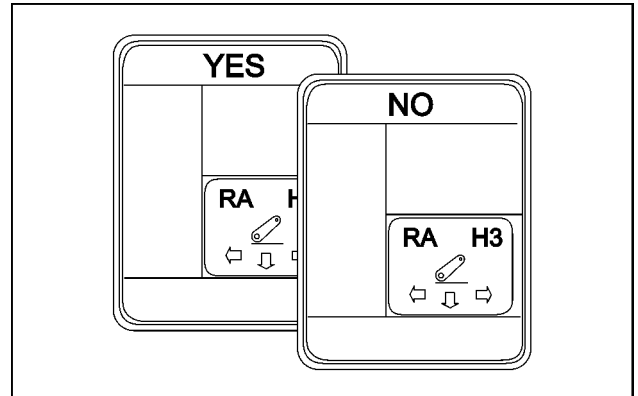

SS12N835 5

### ELECTRONIC PARKING BRAKE

This section is used to allow the service technician to set up any options or configurations available with the electronic parking brake functionalities.

1. Enter the mode, using the diagnostic test plug (special tool **380000843**). Navigate to the RA controller H3 menu. See **Electronic module - Configure - HH-Menu overview (55.640)**.
2. Select the symbol, electronic parking brake option.
3. Press the ENTER switch. The Dot Matrix Display (DMD) displays on the top the letters “ch \_” (1).
4. Use the UP or DOWN switch to select the required channel number.

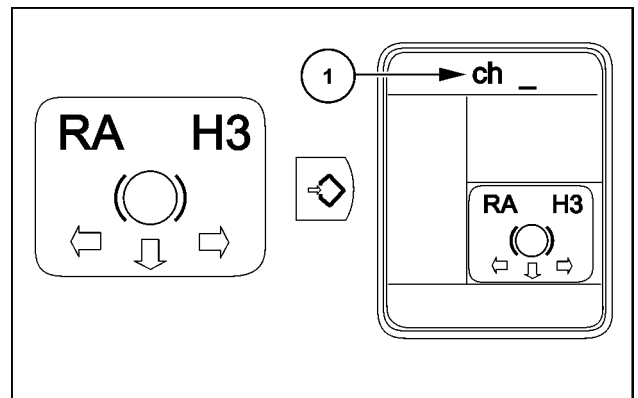

SS12N836 6

### Channel 1 – Enable or disable the electronic parking brake

This channel is used to select whether the electronic parking brake is enabled or disabled.

1. Use the UP or DOWN switch to select the required setting:  
 “YES”: the electronic parking brake is enabled  
 “NO”: the electronic parking brake is disabled (default setting)
2. Hold down the UP or DOWN switch for **1 s**. The cluster will beep and then the setting is stored.
3. Press the HOME switch to go back to the H-Menu.

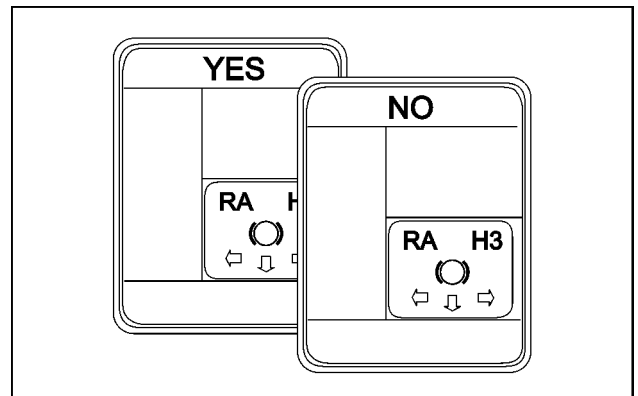

SS12N837 7



## FRONT POWER TAKE-OFF (PTO)

This section is used to allow the service technician to set up any options or configurations available with the front Power Take-Off (PTO) control system.

1. Enter the mode, using the diagnostic test plug (special tool **380000843**). Navigate to the RA controller H3 menu. See **Electronic module - Configure - HH-Menu overview (55.640)**.
2. Select the symbol, front Power Take-Off (PTO) option.
3. Press the ENTER switch. The Dot Matrix Display (DMD) displays on the top the letters "ch \_" **(1)**.
4. Use the UP or DOWN switch to select the required channel number.

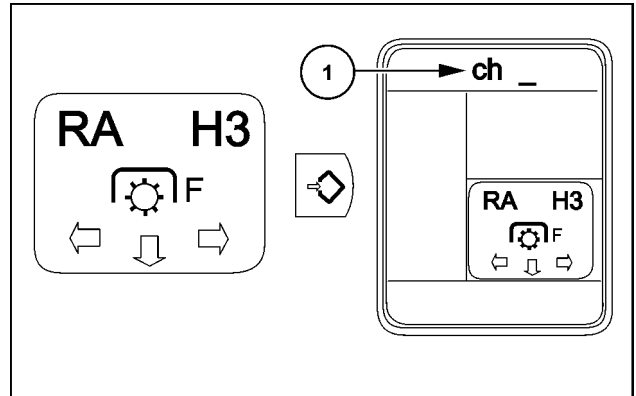

SS12N838 8

## Channel 1 – Front Power Take-Off (PTO) selection

This channel is used to select whether the front Power Take-Off (PTO) selection is enabled or disabled.

1. Use the UP or DOWN switch to select the required setting:  
 "YES": the front PTO is enabled  
 "NO": the front PTO is disabled (default setting)
2. Hold down the UP or DOWN switch for **1 s**. The cluster will beep and then the setting is stored.
3. Press the HOME switch to go back to the H-Menu.

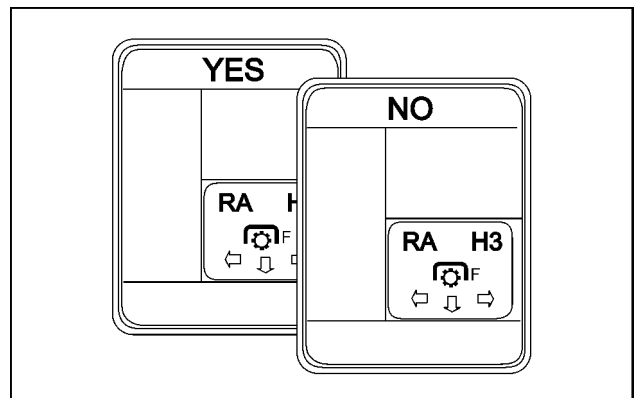

SS12N839 9

## DIFFERENTIAL LOCK AND FOUR-WHEEL DRIVE (4WD)

This section is used to allow the service technician to set up any options or configurations available with the Four-Wheel Drive (4WD) control system.

1. Enter the mode, using the diagnostic test plug (special tool **380000843**). Navigate to the RA controller H3 menu. See **Electronic module - Configure - HH-Menu overview (55.640)**.
2. Select the symbol, differential lock option.
3. Press the ENTER switch. The Dot Matrix Display (DMD) displays on the top the letters "ch \_" **(1)**
4. Use the UP or DOWN switch to select the required channel number.

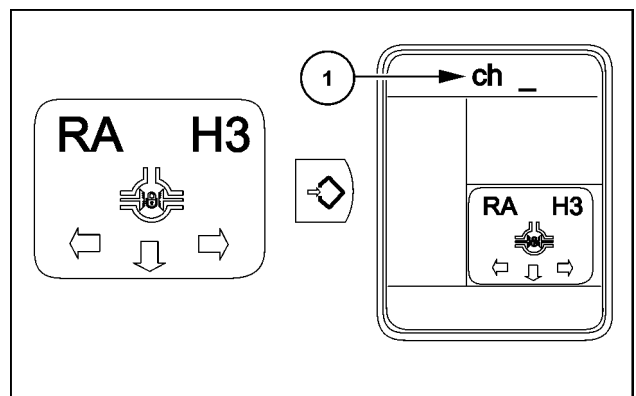

SS12N840 10

### Channel 1, channel 2, and channel 3 – Not used

**NOTE:** These channels are not used and “\_ \_ \_ \_” (1) will be displayed.

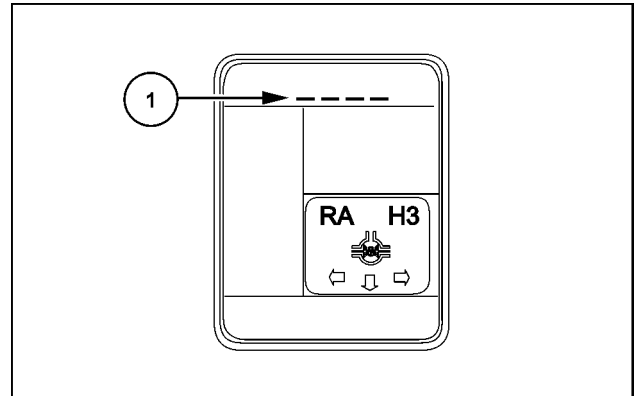

SS12N841 11

### Channel 4 – Four-Wheel Drive (4WD) speed selection

This channel is used to select the ground speed below, where the Four-Wheel Drive will not be activated. To provide Four-Wheel Drive, the 4WD clutch should be engaged whenever both brake pedals are pressed: this activation should be subjected to a minimum vehicle speed for four-wheel drive to be set in this channel.

1. Use the UP or DOWN switch to select the required option:

**NOTE:** The default setting for this option is “4”.

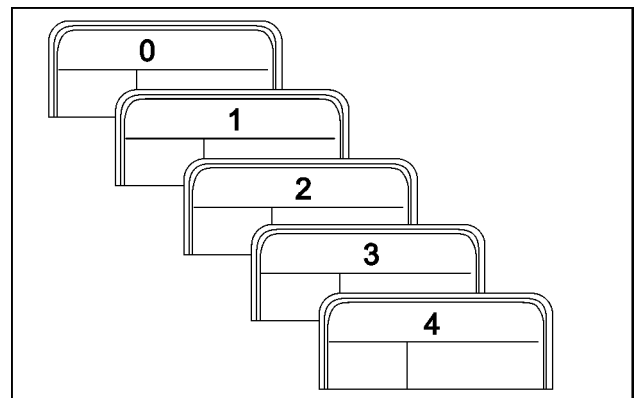

SS12N898 12

Option	4WD disengage speed
“0”	0 km/h (0 mph)
“1”	1.6 km/h (1.0 mph)
“2”	3.2 km/h (2.0 mph)
“3”	4.8 km/h (3.0 mph)
“4”	6.4 km/h (4.0 mph)

2. Hold down the UP or DOWN switch for **1 s**. The cluster will beep and then the setting is stored.
3. Press the HOME switch to go back to the H-Menu.

### Channel 5 – Enable or disable the front differential lock

In this channel you can actuate the rear differential lock and the front differential lock together or separate.

1. Use the UP or DOWN switch to select the required setting:  
 “YES”: the rear differential lock and the front differential lock are actuated separate (enabled)  
 “NO”: the rear differential lock and the front differential lock are actuated together (disabled – default setting)
2. Hold down the UP or DOWN switch for **1 s**. The cluster will beep and then the setting is stored.
3. Press the HOME switch to go back to the H-Menu.

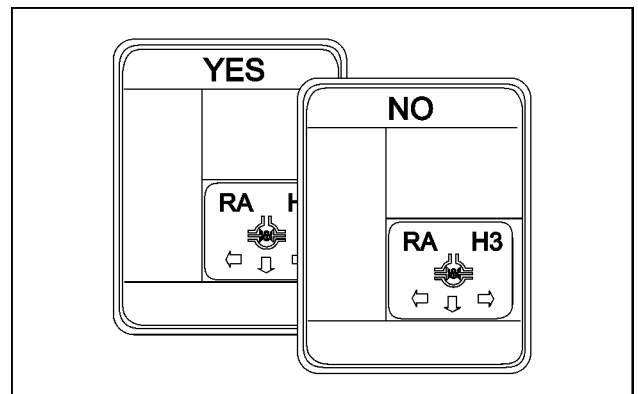

SS12N843 13

## REAR POWER TAKE-OFF (PTO)

This section is used to allow the service technician to set up any options or configurations available with the rear Power Take-Off (PTO) control system.

1. Enter the mode, using the diagnostic test plug (special tool **380000843**). Navigate to the RA controller H3 menu. See **Electronic module - Configure - HH-Menu overview (55.640)**.
2. Select the symbol, rear Power Take-Off (PTO) option.
3. Press the ENTER switch. The Dot Matrix Display (DMD) displays on the top the letters "ch \_" (1).
4. Use the UP or DOWN switch to select the required channel number.

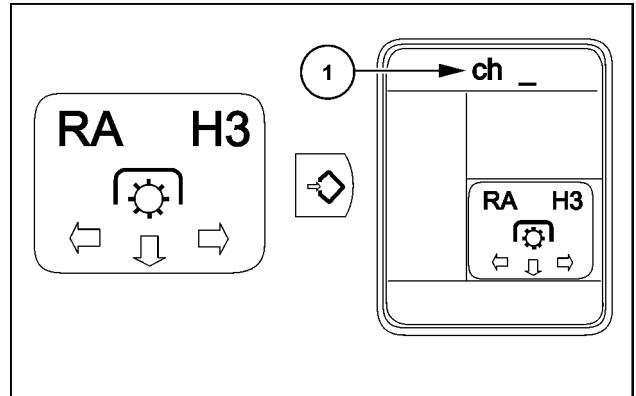

SS12N844 14

## Channel 1 – Enable or disable the automatic Power Take-Off (PTO)

This channel is used to select whether the automatic Power Take-Off (PTO) enabling option is enabled or disabled.

1. Use the UP or DOWN switch to select the required setting:  
 "YES": the automatic PTO is enabled  
 "NO": the automatic PTO is disabled (default setting)
2. Hold down the UP or DOWN switch for **1 s**. The cluster will beep and then the setting is stored.
3. Press the HOME switch to go back to the H-Menu.

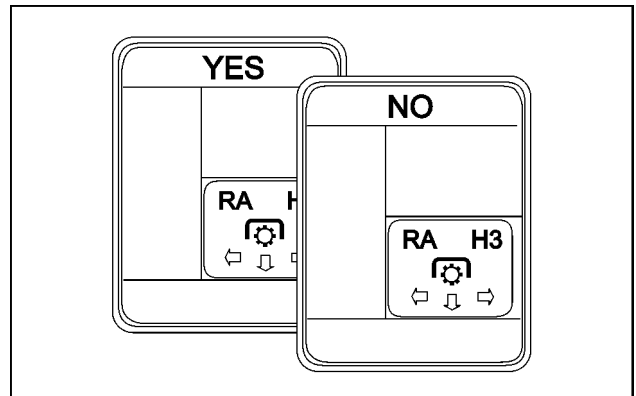

SS12N845 15

## Channel 2 – Rear Power Take-Off (PTO) fender switches configuration

This channel is used to select whether the rear Power Take-Off (PTO) fender switch option is enabled or disabled.

1. Use the UP or DOWN switch to select the required setting:  
 "YES": the rear PTO fender switches are enabled  
 "NO": the rear PTO fender switches are disabled (automatic detection)
2. Hold down the UP or DOWN switch for **1 s**. The cluster will beep and then the setting is stored.
3. Press the HOME switch to go back to the H-Menu.

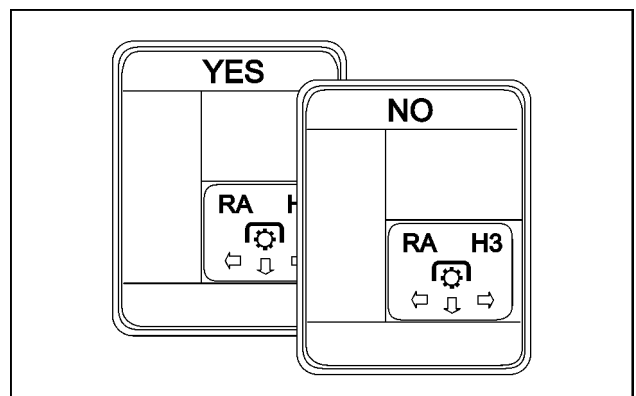

SS12N845 16

## FRONT ELECTRO HYDRAULIC REMOTE VALVES (EHR)

This section is used to allow the service technician to set up any options or configurations available with the front EHR control system.

1. Enter the mode, using the diagnostic test plug (special tool **380000843**). Navigate to the RA controller H3 menu. See **Electronic module - Configure - HH-Menu overview (55.640)**.
2. Select the symbol, front EHR option.
3. Press the ENTER switch. The Dot Matrix Display (DMD) displays on the top the letters "ch \_" (1).
4. Use the UP or DOWN switch to select the required channel number.

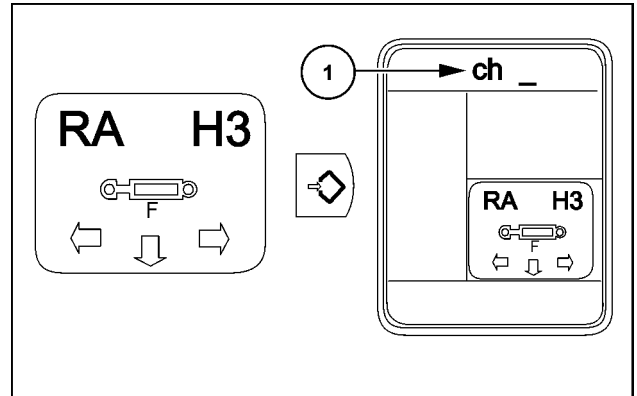

SS12N846 17

### Channel 1 – Enable or disable the front EHR

This channel is used to select whether the front EHR is enabled or disabled.

1. Use the UP or DOWN switch to select the required setting:  
 "YES": the front EHR is enabled  
 "NO": the front EHR is disabled (automatic detection)
2. Hold down the UP or DOWN switch for **1 s**. The cluster will beep and then the setting is stored.
3. Press the HOME switch to go back to the H-Menu.

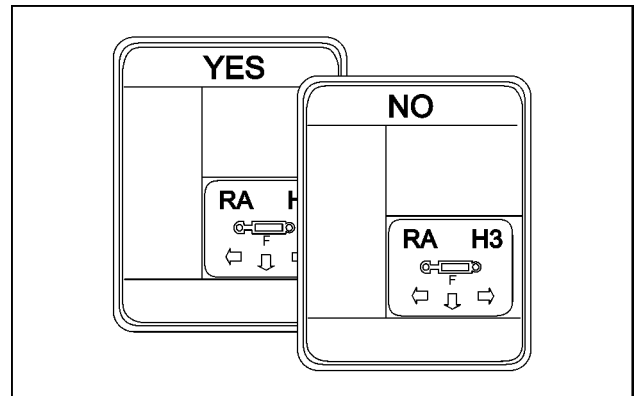

SS12N847 18

### Channel 2 – Front loader, Electronic Front Hitch (EFH), none selection

This channel is used to select whether the front EHR valves are used in conjunction with the EFH or the front loader.

1. Use the UP or DOWN switch to select the required setting:  
 "LOAd"  
 "EFH"  
 "nonE": If this option is selected, then all rear EHR valves and front EHR valves will be available for use.
2. Hold down the UP or DOWN switch for **1 s**. The cluster will beep and then the setting is stored.
3. Press the HOME switch to go back to the H-Menu.

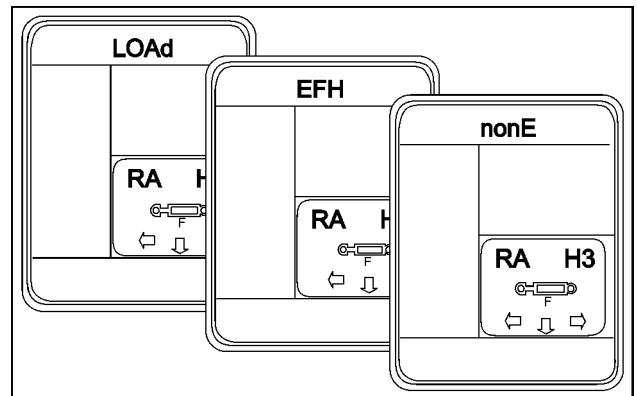

SS12N899 19

**NOTE:** If "LOAd" is selected, then the front EHR valves 1 and 2 will be reserved for the front loader operation. If "nonE" or "EFH" is selected, then all front EHR valves will be available for use.

**NOTE:** The Front hitch up/down switch – External is only working when the option "nonE" is selected.

### Channel 3 – Not used

**NOTE:** This channel is not used and “\_ \_ \_ \_” (1) will be displayed.

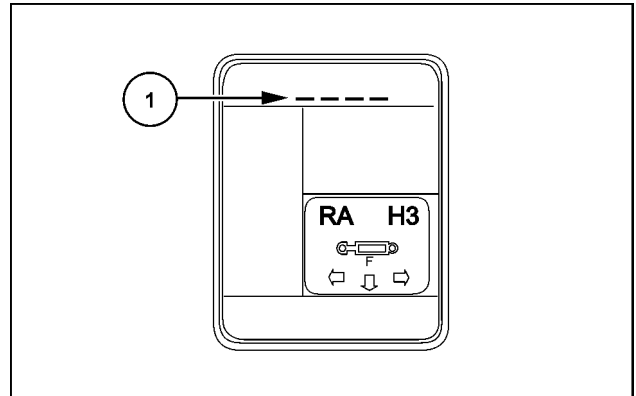

SS12N849 20

### Channel 4 – Number of EHR valves present

When the CCU controller is new or the H8 procedure is completed, an automatic detection for the number of remotes is used. If at any time the number of fitted remote valves needs to be changed, then this setup channel is used. After the selection of channel 4, the current number of remote valves stored is displayed (“1” or “2”).

1. Use the UP or DOWN switch to select the required setting:  
“1”  
“2”
2. Hold down the UP or DOWN switch for **1 s**. The cluster will beep and then the setting is stored.
3. Press the HOME switch to go back to the H-Menu.

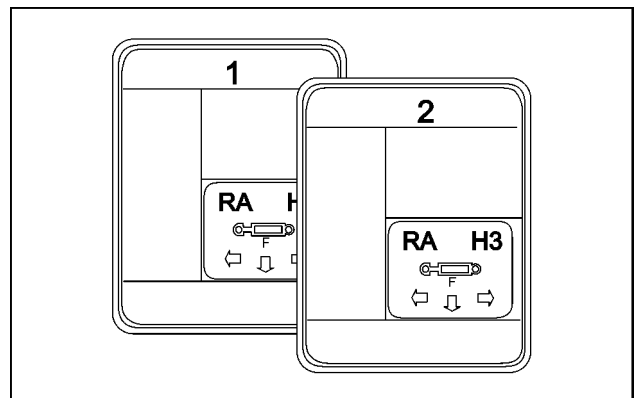

SS12N850 21

**NOTE:** In channel 4 the valve numbers 3 and 4 are also visible but not available.

### REAR ELECTRO HYDRAULIC REMOTE VALVES (EHR)

This section is used to allow the service technician to set up any options or configurations available with the rear EHR control system.

1. Enter the mode, using the diagnostic test plug (special tool **380000843**). Navigate to the RA controller H3 menu. See **Electronic module - Configure - HH-Menu overview (55.640)**.
2. Select the symbol, rear EHR option.
3. Press the ENTER switch. The Dot Matrix Display (DMD) displays on the top the letters “ch \_” (1).
4. Use the UP or DOWN switch to select the required channel number.

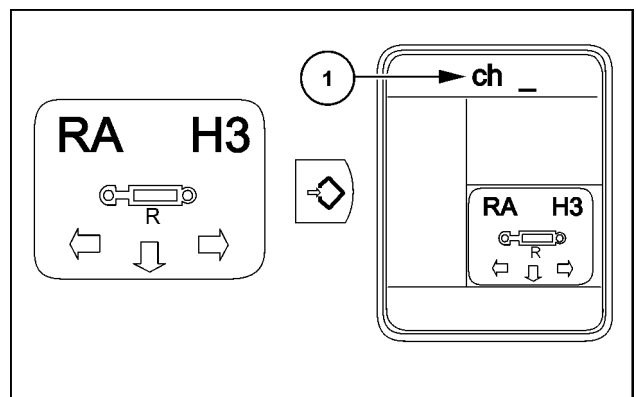

SS12N851 22

### Channel 1 – Enable or disable the rear EHR

This channel is used to select whether the rear EHR is enabled or disabled.

1. Use the UP or DOWN switch to select the required setting:  
 “YES”: the rear EHR is enabled  
 “NO”: the rear EHR is disabled
2. Hold down the UP or DOWN switch for **1 s**. The cluster will beep and then the setting is stored.
3. Press the HOME switch to go back to the H-Menu.

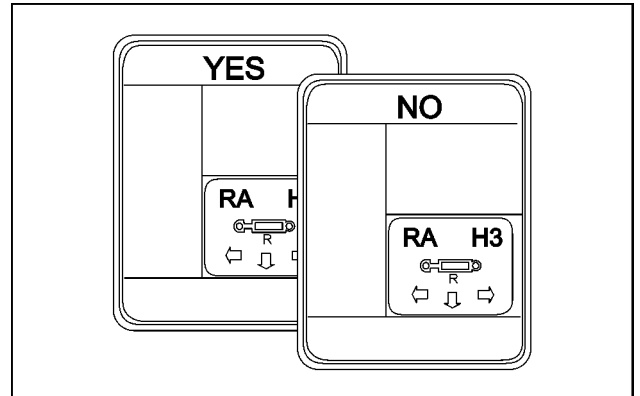

SS12N852 23

### Channel 2, channel 3, channel 5 – Not used

**NOTE:** These channels are not used and “\_ \_ \_ \_” (1) will be displayed.

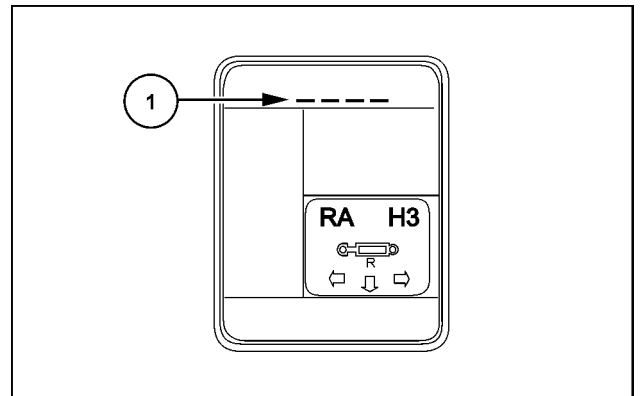

SS12N853 24

### Channel 4 – Number of EHR valves present

When the unit is new or the H8 procedure is completed, an automatic detection for the number of remotes is used. If at any time the number of fitted remote valves needs to be changed, then this setup channel is used. After the selection of channel 4, the current number of remote valves stored is displayed (“3” or “4”).

1. Use the UP or DOWN switch to select the required setting:  
 “3”  
 “4”
2. Hold down the UP or DOWN switch for **1 s**. The cluster will beep and then the setting is stored.
3. Press the HOME switch to go back to the H-Menu.

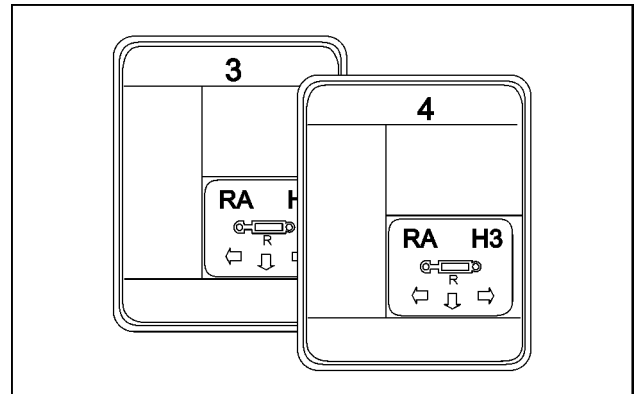

SS12N854 25

### Channel 6 – Heating valve present

This setup channel is used to select whether the optional heating valve (used to heat the cold hydraulic oil) is present or not present.

**NOTE:** Channel 6 is available only for future expansions.

## Electronic module Central Control Unit (CCU) - H4 - View software revision level

### Central Control Unit (CCU) controller identification (RA)

This menu displays the software version of the CCU unit.

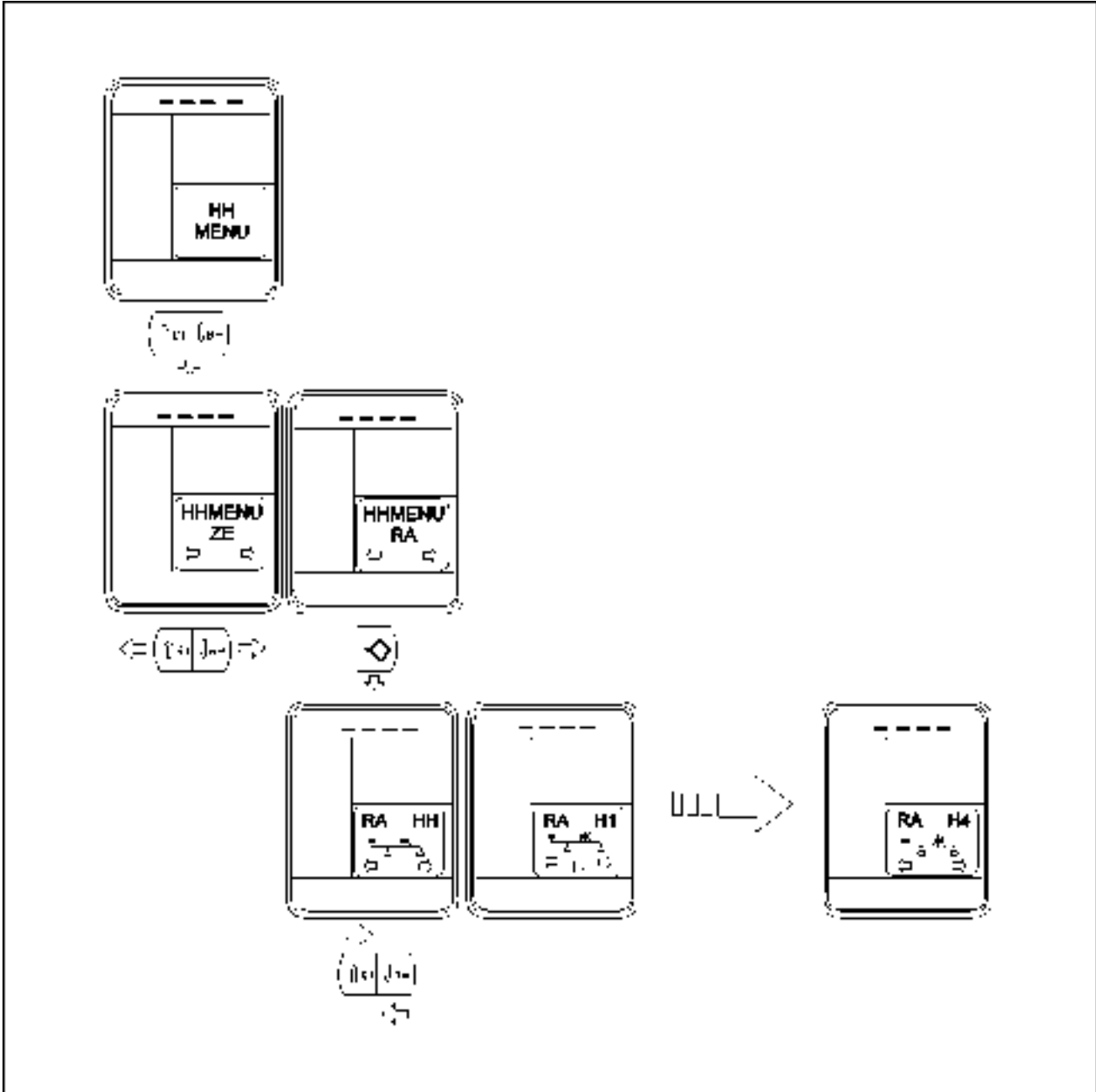

SS12N855 1

1. Enter the mode, using the diagnostic test plug (special tool **380000843**). Navigate to the RA controller H4 menu. See **Electronic module - Configure - HH-Menu overview (55.640)**.

- Press the ENTER switch. The Dot Matrix Display (DMD) displays on the top a sequence of numbers **(1)**, representing the software identifier and the software version.

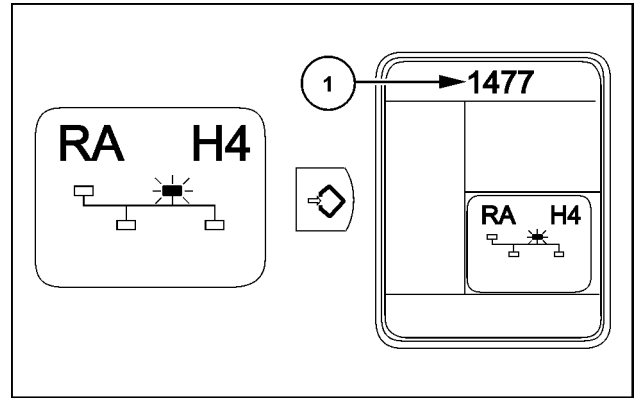

SS12N856 2

- The first **(1)** set of 4 digits indicates the software identifier. The second **(2)** and third **(3)** set of 4 digits displayed define the release version of the application software.

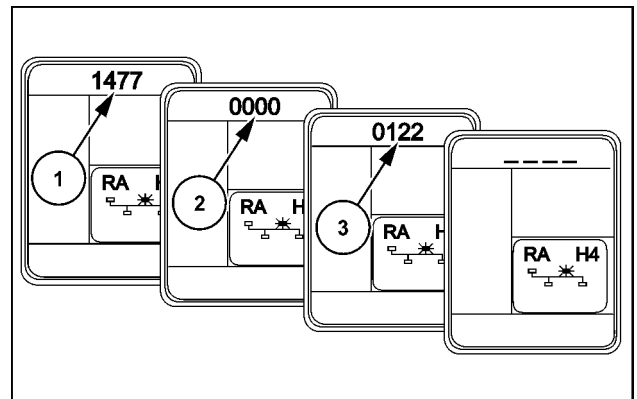

SS12N857 3

- At the end of the routine, the display returns to H4. It is possible to start with the ENTER switch the routine again or navigate further to the H-Menus.



## Electronic module Central Control Unit (CCU) - H5 - Switch operation test

### Central Control Unit (CCU) controller identification (RA)

This menu displays a designated code when a switch transition is detected.

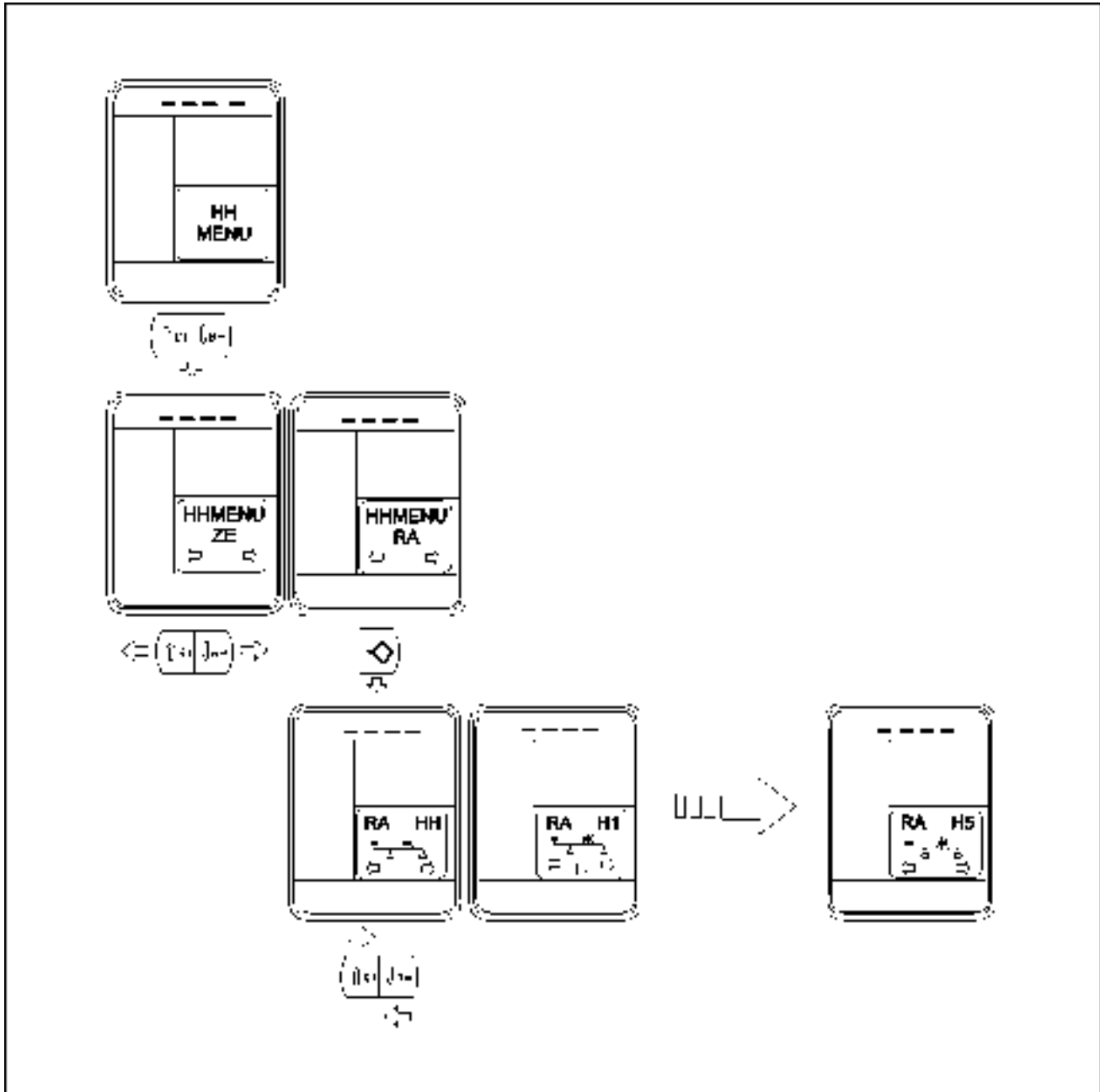

SS12N812 1

1. Enter the mode, using the diagnostic test plug (special tool **380000843**). Navigate to the RA controller H5 menu. See **Electronic module - Configure - HH-Menu overview (55.640)**.

- Press the ENTER switch. The Dot Matrix Display (DMD) displays on the top the letter “d\_ \_” (1).

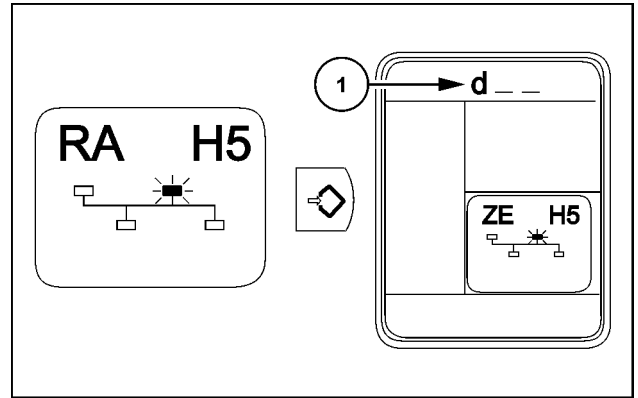

SS12N813 2

- When the operator presses the switch, the appropriate switch code is displayed and an audible tone can be heard to indicate the correct function. If the appropriate switch code is not displayed and there is no audible tone, a fault is present. The operator can locate the fault trough wiggling the related wiring and simultaneously watching the display.
- With the H5 menu the operator can check if a switch is open or closed, for example:
  - The hand brake switch (1) is open or closed.
  - The air-conditioning switch (2) is open or closed.
  - The hydraulic master switch (3) is open or closed.

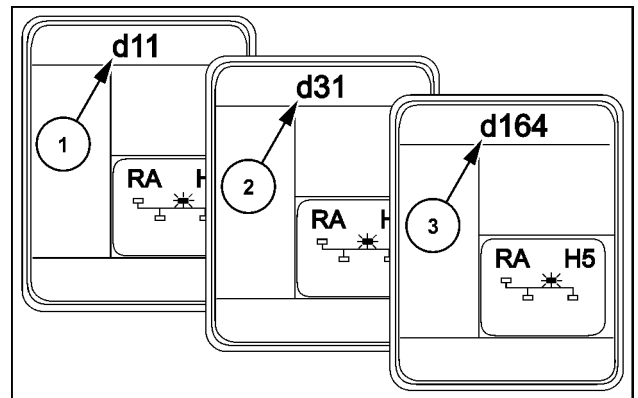

SS12N814 3

Name	Channel	Connector and Pin number
Fender Electronic Draft Control (EDC) lower switch	d1	X210-30
Fender Electronic Draft Control (EDC) raise switch	d2	X210-29
Crank switch	d8	X230-14
Hand brake	d11	X240-24
Left brake switch	d12	X210-22
Right brake switch	d13	X210-23
Second function switch Multicontroller	d19	X230-17
Air-conditioning switch	d31	X230-25
Radar presence signal	d33	X210-19
Manual differential lock switch	d38	X240-31
Automatic differential lock switch	d39	X240-30
Manual Four-Wheel Drive (4WD)	d41	X230-24
Automatic Four-Wheel Drive (4WD)	d42	X230-1
Rear Power Take-Off (PTO) normally open (NO) switch	d44	X240-11
Rear Power Take-Off (PTO) normally closed (NC) switch	d45	X240-23
Rear Power Take-Off (PTO) automatic switch	d49	X230-12
Rear Power Take-Off (PTO) fender normally open (NO) switch	d63	X230-21
Rear Power Take-Off (PTO) fender normally closed (NC) switch	d64	X230-20
Power Take-Off (PTO) soft start switch	d65	X230-9
Front Power Take-Off (PTO) normally open (NO) switch	d90	X240-32
Front Power Take-Off (PTO) normally closed (NC) switch	d91	X230-22

Name	Channel	Connector and Pin number
Electronic Draft Control (EDC) enabling switch	d124	X230-5
Electro Hydraulic Remote valve (EHR) front switch	d128	X230-15
Electro Hydraulic Remote valve (EHR) rear switch	d129	X240-33
CRPM toggle Multicontroller switch	d130	X230-16
Front Electro Hydraulic Remote valve (EHR) external switch (extend)	d140	X210-18
Front Electro Hydraulic Remote valve (EHR) external switch (retract)	d141	X210-28
Manual front differential lock switch	d145	X210-26
Electronic Draft Control (EDC) transport Multicontroller switch	d151	X230-23
Electronic Draft Control (EDC) work Multicontroller switch	d152	X230-23
Joystick switch 1 (black)	d153	CAN
Joystick switch 2 (yellow)	d154	CAN
Joystick switch 3 (green)	d155	CAN
Electro Hydraulic Remote valve (EHR) encoder enter switch	d159	X210-01
Hydraulic master switch	d164	X230-3
Electro Hydraulic Remote valve (EHR) float control switch	d165	X210-24
Electro Hydraulic Remote valve (EHR) extended Multicontroller switch	d178	X230-19
Electro Hydraulic Remote valve (EHR) retract Multicontroller switch	d179	X230-19
Second Electro Hydraulic Remote valve (EHR) extended Multicontroller switch	d180	X230-4
Second Electro Hydraulic Remote valve (EHR) retract Multicontroller switch	d181	X230-4
Electro Hydraulic Remote valve (EHR) rear fender switch (extend)	d183	X210-20
Electro Hydraulic Remote valve (EHR) rear fender switch (retract)	d184	X210-21





At the end of the switches check, it is required to key OFF to exit the H5 menu.

## Electronic module Central Control Unit (CCU) - H8 - Clear stored calibration information (EEPROM)

### Central Control Unit (CCU) controller identification (RA)

This menu clears calibration values and stored fault codes by resetting all EEPROM values back to the default settings. EEPROM is where all calibration values and fault codes are stored. This memory is retained even if there is no power to the controller, for example: the battery is disconnected.

The table below displays the functions and the belonging symbols for this submenu.

Function	Icon
Electronic Draft Control (EDC)	
Rear Electro Hydraulic Remote valve (EHR)	
Front Electro Hydraulic Remote valve (EHR)	
Differential lock	

**NOTE:** The differential lock icon works for both subsystems: differential lock and Four-Wheel Drive (4WD).

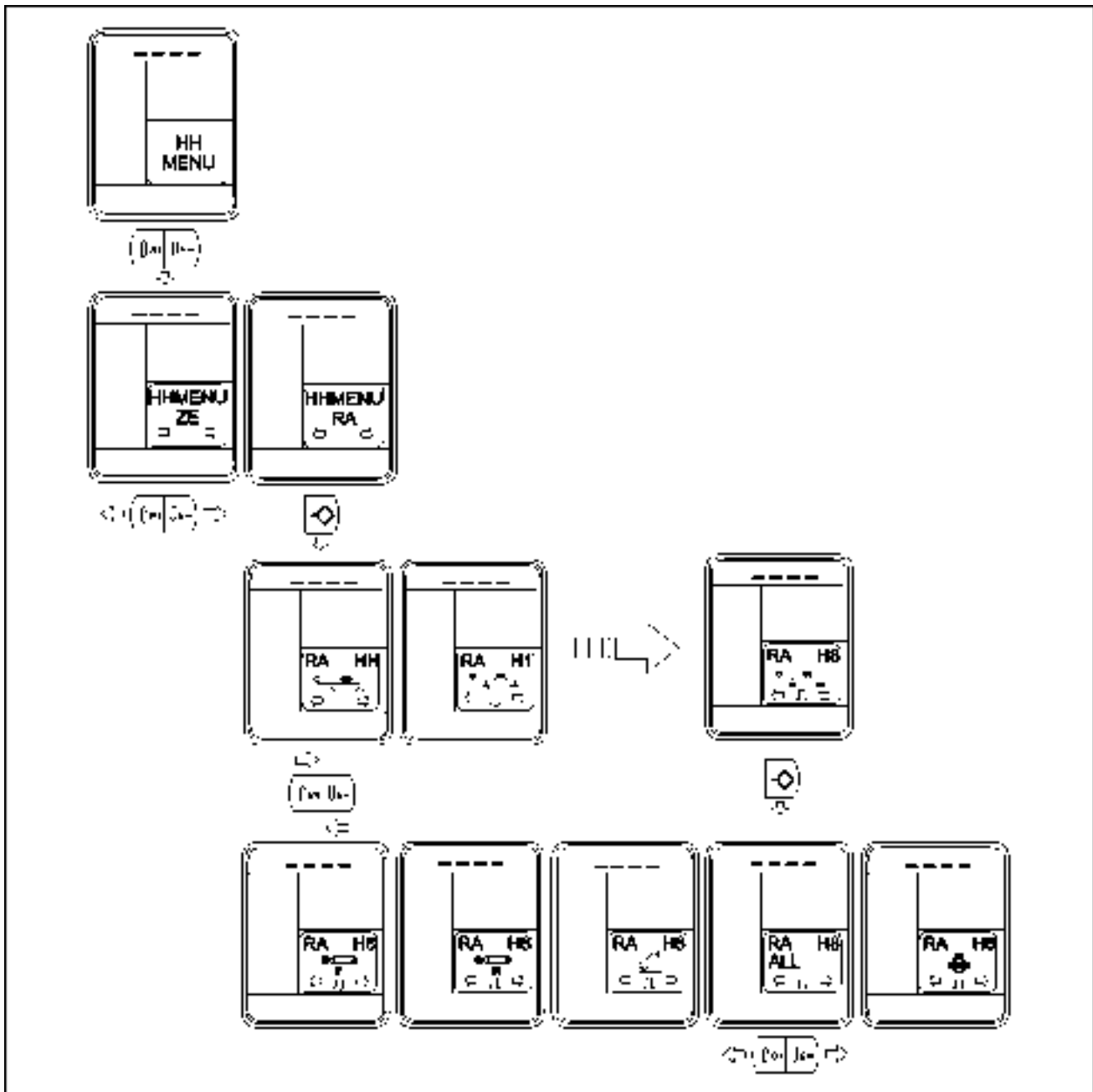

SS12N896 1

1. Enter the mode, using the diagnostic test plug (special tool **380000843**). Navigate to the RA controller H8 menu. See **Electronic module - Configure - HH-Menu overview (55.640)**.

- Press the ENTER switch. The Dot-Matrix-Display (DMD) displays "ALL".

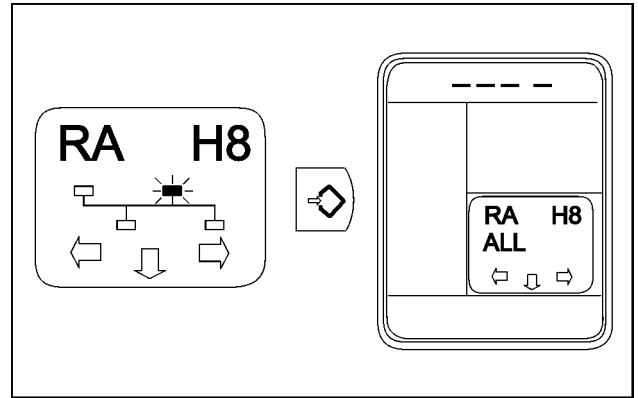

SS12N860 2

- Use the UP or DOWN switch to select either one subsystem, for example EDC. Or you select "ALL", for all subsystems ( EDC, front EHR, rear EHR, and differential lock).

If you want to delete all stored calibration information of all subsystems, you have to select "ALL".

If you just want to delete the stored calibration information of one subsystem, you have to select the required subsystem.

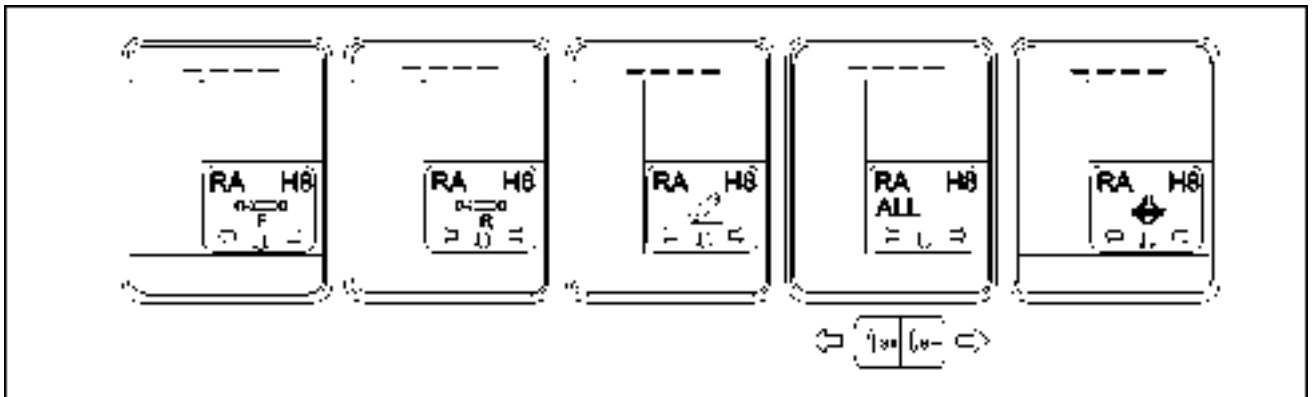

SS12N897 3

- Press the ENTER switch to access the desired program.
- Press the DOWN switch to confirm the resetting of the EEPROM. The DMD will countdown from 5 to 1. Then "EE" will be displayed to indicate that the EEPROM has been cleared.

**NOTE:** If the DOWN switch is released before the countdown finishes, the procedure will be aborted.

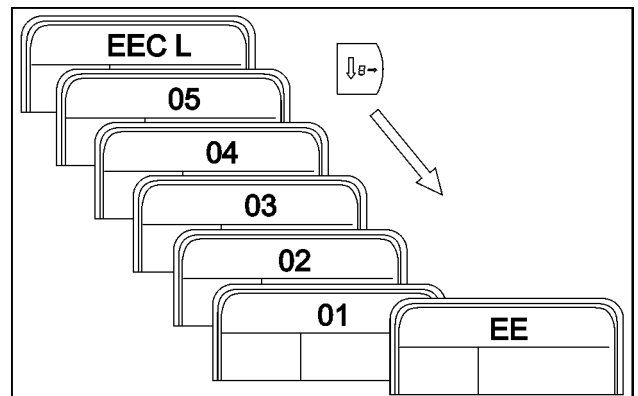

SS12N898 4

- It is not possible to continue through the H-Menu after a H8 procedure. The only possible action is to turn the ignition switch OFF to allow the reset values to be stored.

**NOTE:** After using the H8 menu, all H3 configurations are on default setting. See **Electronic module Central Control Unit (CCU) - H3 - Configurations and options (55.640)**.

## Electronic module Central Control Unit (CCU) - H9 - Voltmeter diagnostic

### Central Control Unit (CCU) controller identification (RA)

This menu is used to verify the operation of various potentiometers, voltage supplies, and solenoid current circuits. If an intermittent fault is detected, the operator can locate the fault through wiggling the related wiring and simultaneously watching the display for sudden changes in values.

**NOTE:** The vehicle may be driven while working in this menu.

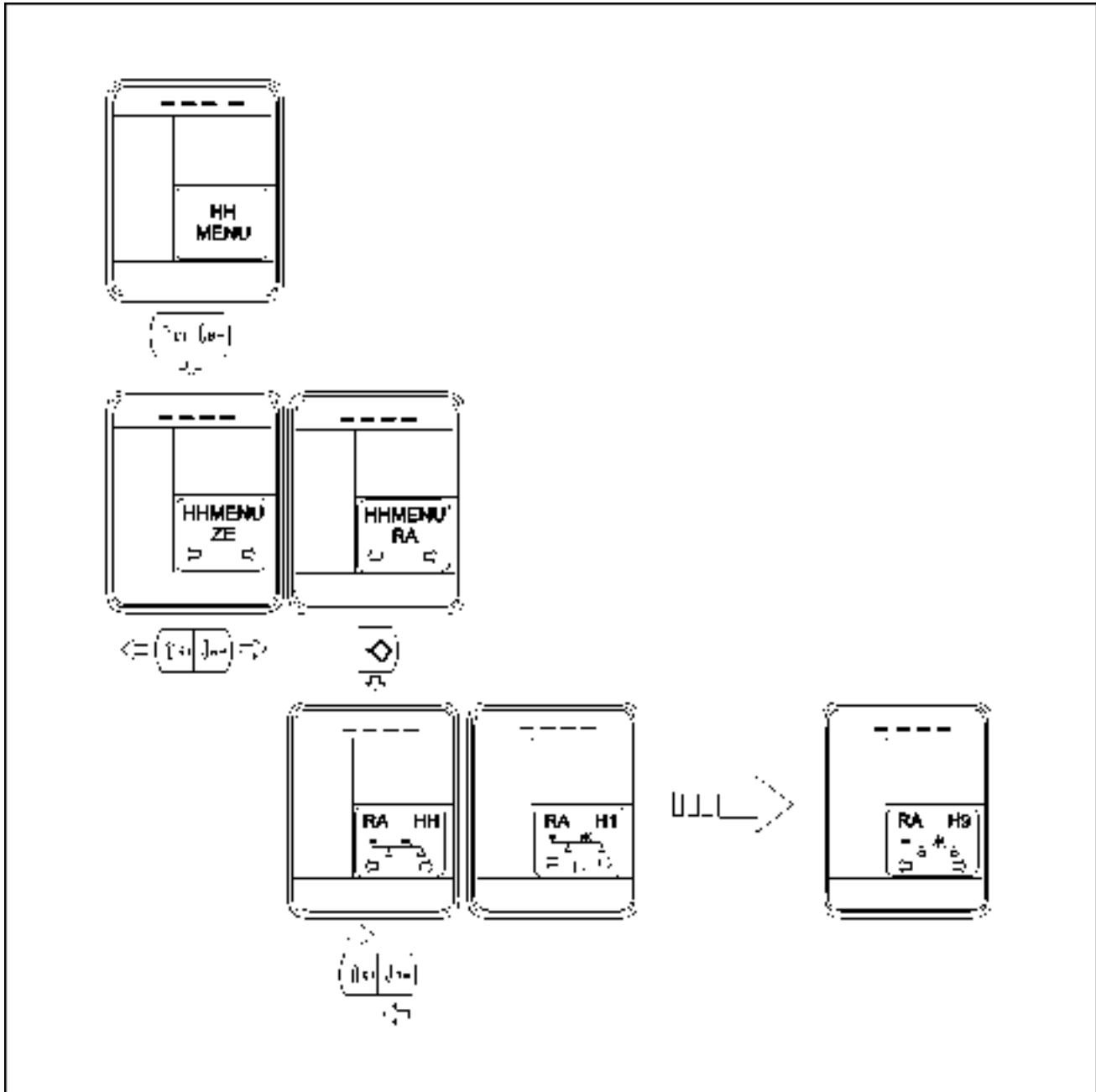

SS12N871 1

1. Enter the mode, using the diagnostic test plug (special tool **380000843**). Navigate to the RA controller H9 menu. See **Electronic module - Configure - HH-Menu overview (55.640)**.

2. Press the ENTER switch. The Dot Matrix Display (DMD) displays on the top the letter “c 10” (1).

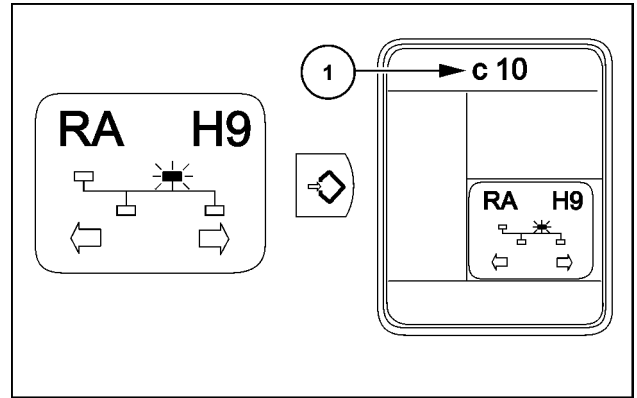

SS12N872 2

3. The required channel can be selected by using the UP and DOWN switches.

After a delay the value will be displayed, for example:

- (1) Channel number (with 3 digits)
- (2) After a delay, the display changes automatically
- (3) Alternator voltage (mV)

**NOTE:** The voltage values displayed in this menu are represented in millivolts, the current values in milliamperes. Compare the displayed value with the typical reading shown in the table below.

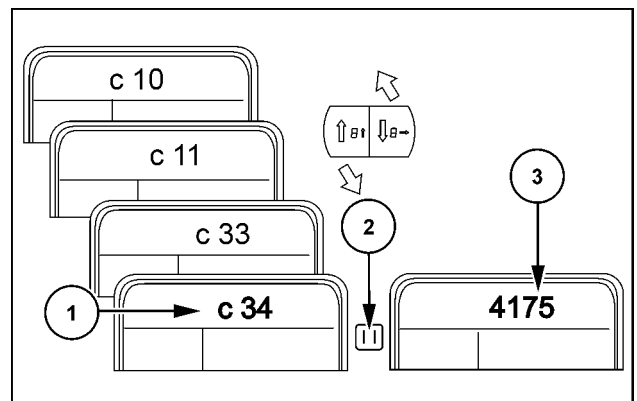

SS12N873 3

Name	Channel	Connector/Pin number	Typical reading
Left-hand draft pin sensor	c10	X210-10	830 - 7680 mV
Right-hand draft pin sensor	c11	X210-9	830 - 7680 mV
Position control potentiometer	c33	X210-3	400 - 4600 mV
Drop rate control potentiometer	c34	X210-4	400 - 4600 mV
Height limit potentiometer	c35	X210-5	400 - 4600 mV
Sensitivity control potentiometer	c36	X210-6	400 - 4600 mV
Maximal slip control potentiometer	c37	X210-7	570 - 4430 mV
Draft control potentiometer	c40	X210-8	400 - 4600 mV
Rockshaft position sensor	c91	X210-2	125 - 4640 mV
Joystick – X-position	c97	CAN	0-100
Joystick – Y-position	c98	CAN	0-100
EDC raiser solenoid valve (current)	c121	X220-4	0 - 3350 mA
EDC lower solenoid valve (current)	c122	X220-5	0 - 3350 mA
Front Power Take-Off (PTO) solenoid valve (current)	c124	X220-7	0 - 750 mA
Electro Hydraulic Remote valve (EHR) extend and retract (Multicontroller)	c131	X230-19	500 - 4500 mV
EDC transport and work (Multicontroller)	c132	X230-23	500 - 4500 mV
Electro Hydraulic Remote valve (EHR) encoder 1 sensor	c164	X220-14	50 - 4950 mV
Electro Hydraulic Remote valve (EHR) encoder 2 sensor	c166	X220-20	50 - 4950 mV
Finger-wheel (Multicontroller)	c180	X230-7	300 - 4700 mV
Parking brake engagement solenoid valve (current)	c181	X220-13	0 - 4000 mA
Parking brake disengagement solenoid valve (current)	c182	X220-6	0 - 4000 mA



Name	Channel	Connector/Pin number	Typical reading
Extend and retract switch remote valve 4 (Multicontroller)	c189	X230-4	500 - 4500 mV
Hydraulic oil temperature sensor	c190	X210-14	1032 mV (warm)
12VD*	c203	X200-8	9000 - 16000 mV
12VF*	c204	X200-2, X200-3	9000 - 16000 mV
12VH*	c207	X200-20	9000 - 16000 mV
12VT*	c213	X240-34	9000 - 16000 mV
8 V sensor supply	c216	X210-25	7000 - 9000 mV
5 V sensor supply	c217	X210-17	4200 - 5800 mV

*	Definition
12VD	Permanent battery power supply
12VF	Switched battery power supply
12VH	Switched battery power supply
12VT	Switched battery power supply

4. Press the HOME switch to exit the menu.







## Electronic module Central Control Unit (CCU) - HB - Display stored fault codes

### Central Control Unit (CCU) controller identification (RA)

This function is used to display the fault codes from the engine controller and the CCU controller, which have been stored in EEPROM of the CCU.

**NOTE:** The vehicle may be driven while working in this menu.

The table below displays the functions and the belonging symbols for this submenu.

Function	Icon
Electronic Draft Control (EDC) option	
Electronic parking brake	
Front Power Take-Off (PTO)	
Differential lock	
Rear Power Take-Off (PTO)	
Front Electro Hydraulic Remote valves (EHR)	
Rear Electro Hydraulic Remote valves (EHR)	

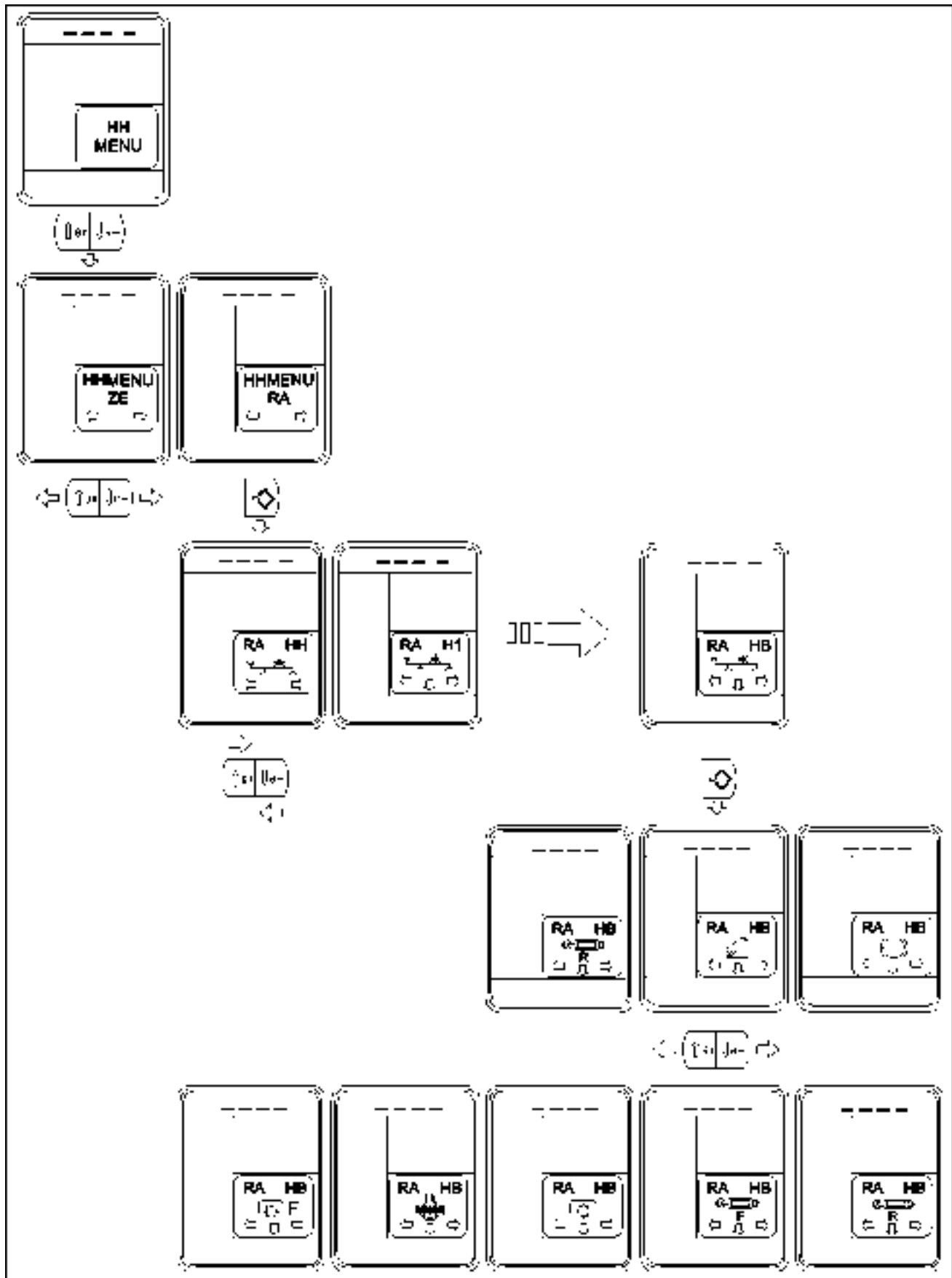

1. Enter the mode, using the diagnostic test plug (special tool **380000843**). Navigate to the RA controller HB menu. See **Electronic module - Configure - HH-Menu overview (55.640)**.
2. Press the ENTER switch.
  1. If there is no fault, the DMD displays “\_ \_ \_ \_” (1)
  2. If a fault is present, the DMD shows as follows:

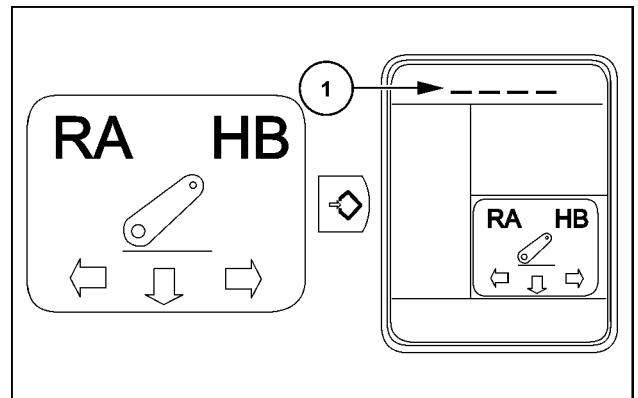

SS12N602 2

Example: first stored fault code (image 3):

- “F”
- “1027”: Fault code number
- “4”: Absolute hour of the first occurrence
- “20”: Absolute hour of the last occurrence
- “14”: Number of occurrences of the fault
- “1027”: Fault code number

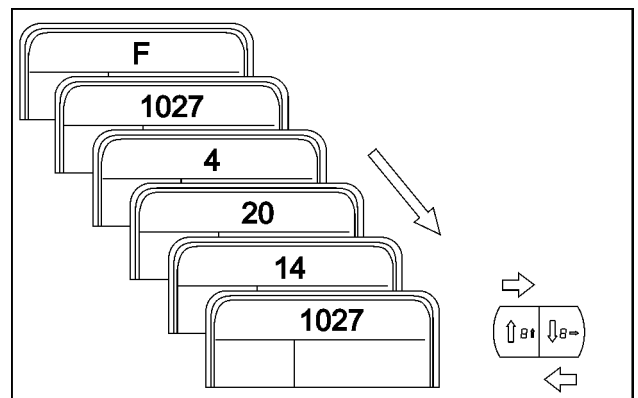

SS12N863 3

Press the UP or DOWN switch to scroll between the stored fault codes.

Example: second stored fault code (image 4):

- “1014”: Fault code number
- “16”: Absolute hour of the first occurrence
- “20”: Absolute hour of the last occurrence
- “4”: Number of occurrences of the fault
- “1014”: Fault code number

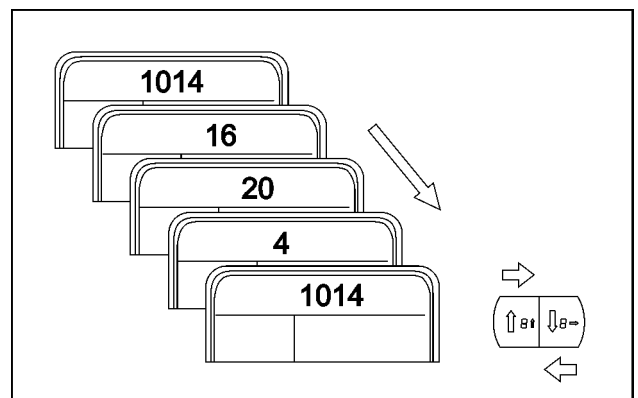

SS12N865 4

**NOTE:** Up to 10 fault codes for each subsystem can be stored.

3. Press the HOME switch to exit the menu.

**NOTE:** If you would like to erase the fault codes see HC menu. See **Electronic module Central Control Unit (CCU) - HC - Clear all stored fault codes (55.640)**.

## Electronic module Central Control Unit (CCU) - HC - Clear all stored fault codes

### Central Control Unit (CCU) controller identification (RA)

This menu is used to delete all fault codes which have been stored in EEPROM of the control unit.

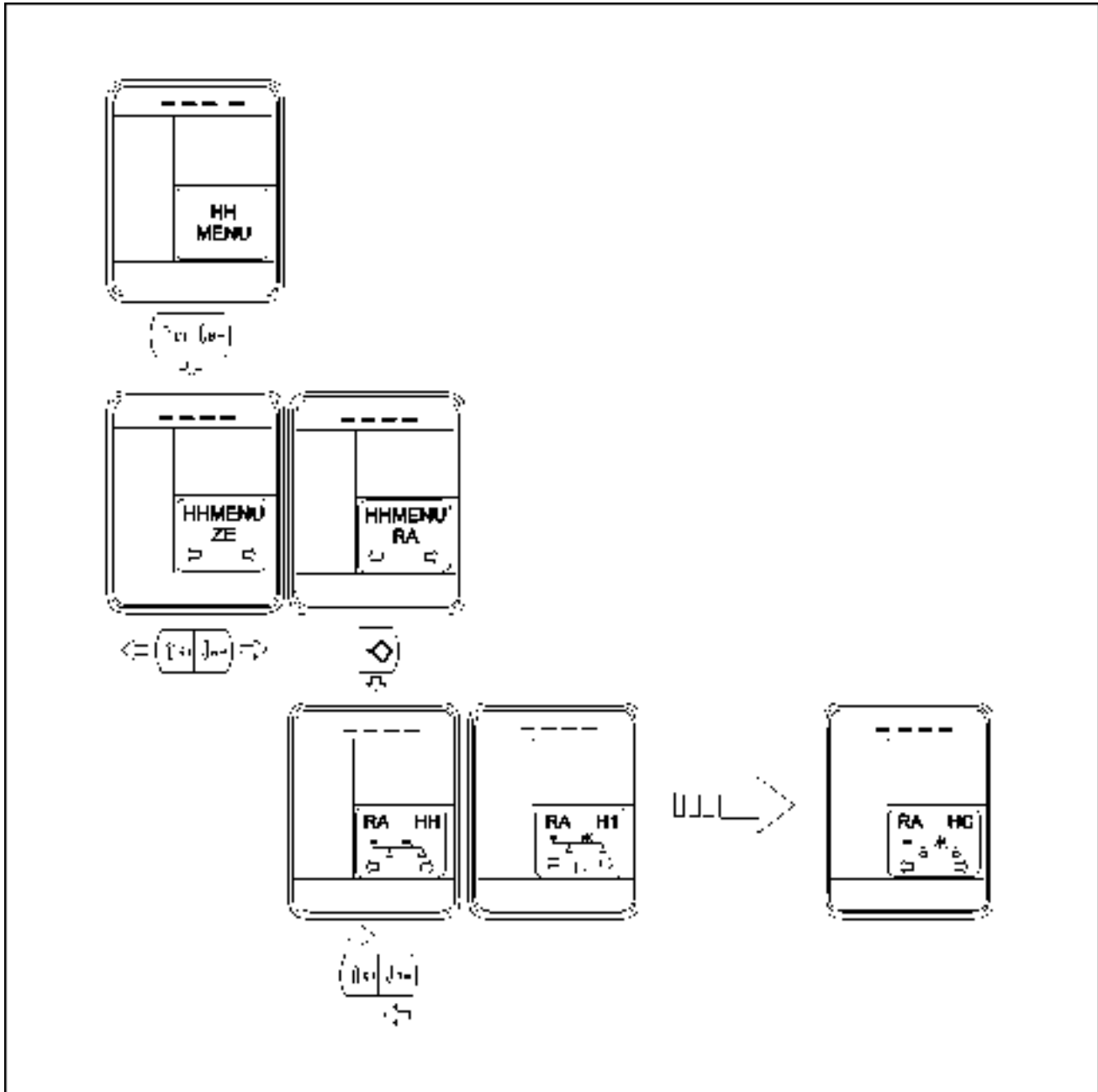

SS12N599 1

1. Enter the mode, using the diagnostic test plug (special tool **380000843**). Navigate to the RA controller, HC menu. See **Electronic module - Configure - HH-Menu overview (55.640)**.

- Press the ENTER switch. The Dot Matrix Display (DMD) displays "FCL".

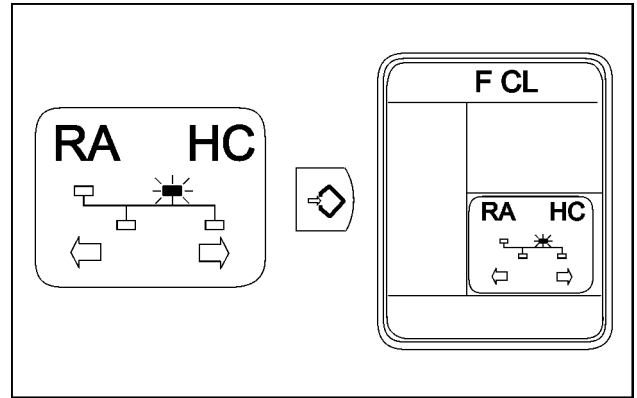

SS12N600 2

- Press the DOWN switch to delete the stored fault codes from the EEPROM. The DMD will countdown from 5 to 1. "EE" will be displayed to indicate that the stored fault codes have been deleted.

**NOTE:** If the DOWN switch is released before the countdown finishes, the procedure will return and the DMD displays "F CL".

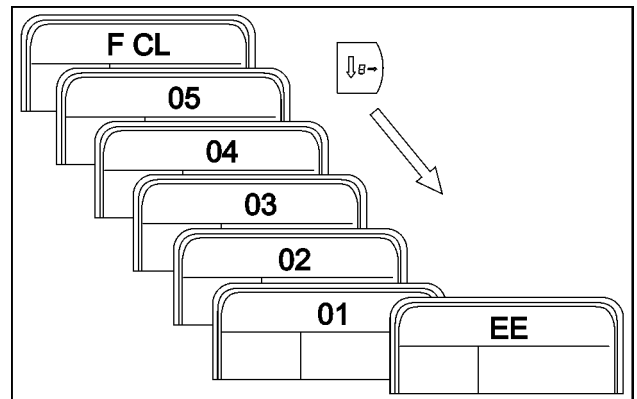

SS12N678 3

- It is not possible to continue through the H-Menu after a HC procedure. The only possible action is to turn the ignition switch OFF to allow the reset values to be stored.

## Electronic module Central Control Unit (CCU) - HE - Display frequency inputs

### Central Control Unit (CCU) controller identification (RA)

This H-Menu level is used by the service technician to verify the operation of various frequency inputs.

**NOTE:** In this mode, the vehicle is operable.

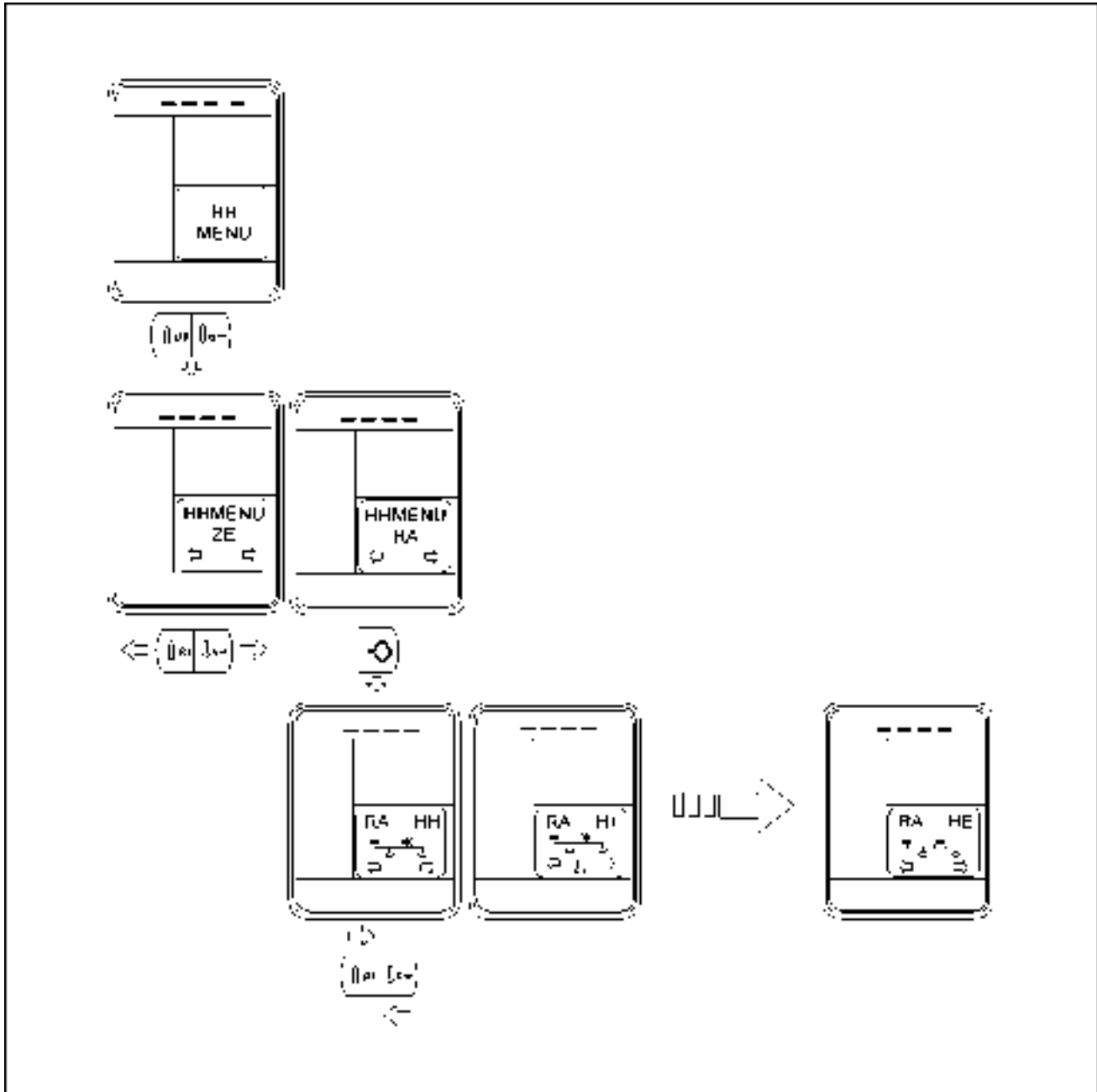

SS12N900 1

1. Enter the mode, using the diagnostic test plug (special tool **380000843**). Navigate to the RA controller HE menu. See **Electronic module - Configure - HH-Menu overview (55.640)**.

2. Press the ENTER switch. The Dot Matrix Display (DMD) displays on the top “ch \_” (1).

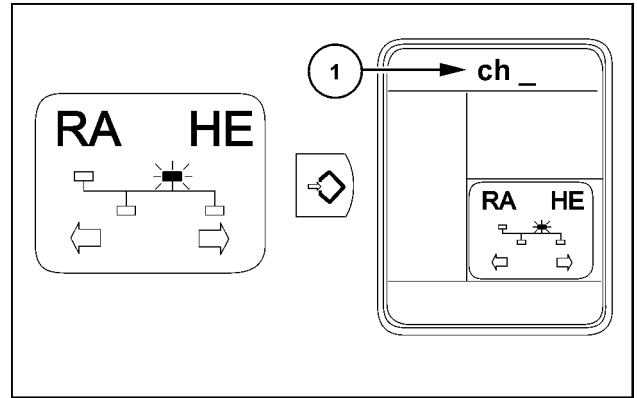

SS12N901 2

3. Press the UP or DOWN switch to select the required channel number.  
 (1) Channel number  
 (2) After a delay, the display changes automatically  
 (3) Displayed value

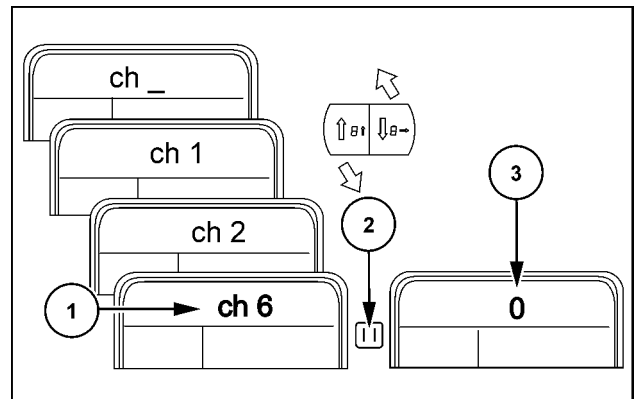

SS12N902 3

Name	Channel	Connector and pin number	Typical reading
Not used	ch1	-	-
Not used	ch2	-	-
Not used	ch3	-	-
Not used	ch4	-	-
Not used	ch5	-	-
Radar sensor	ch6	X210-33	<b>0 - 14720 Hz</b>

4. Press the HOME switch to go back to the H-Menu.



## Electronic module Central Control Unit (CCU) - HF - View controller hardware information

### Central Control Unit (CCU) controller identification (RA)

This menu is used to show a sequence of numbers, representing the hardware identifier, the hardware version and in some cases the hardware serial number, which are stored in EEPROM of the control unit.

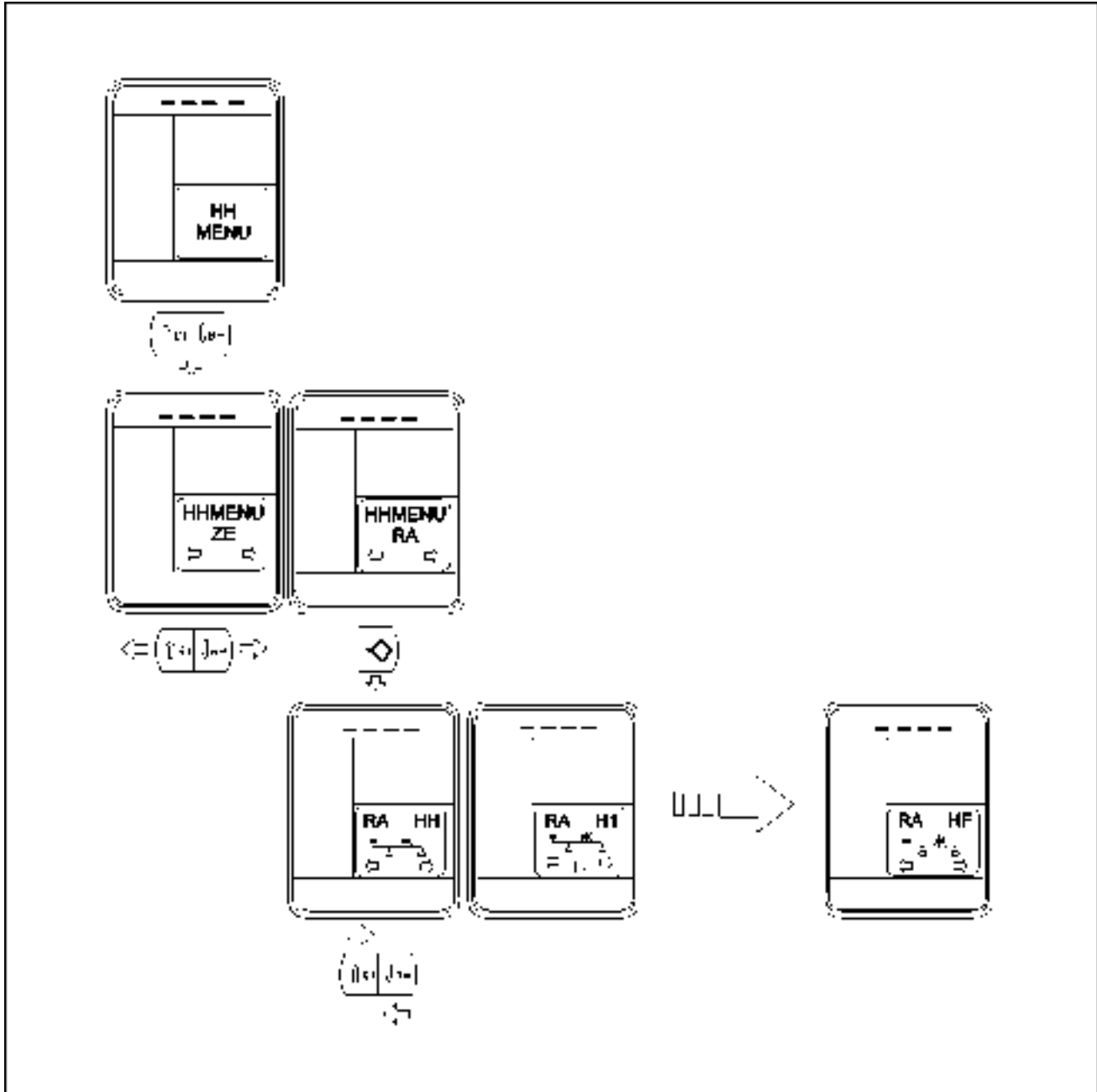

SS12N874 1

1. Enter the mode, using the diagnostic test plug (special tool **380000843**). Navigate to the RA controller, HF menu. See **Electronic module - Configure - HH-Menu overview (55.640)**.

- Press the ENTER switch. The Dot Matrix Display (DMD) displays the first sequence of numbers "0796" (1).

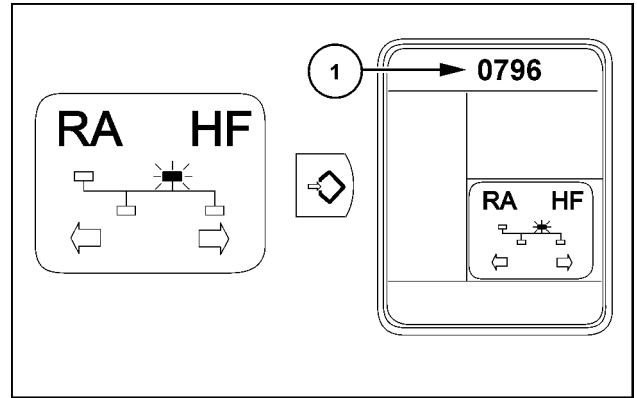

SS12N875 2

- The DMD shows a sequence of numbers, representing the hardware version and hardware serial number:

- " -- -- "
- "0100" Release number of the unit hardware
- "0000" Release number of the unit hardware
- "0000" Unit serial number
- "2011" Unit serial number
- "5220" Unit serial number
- " -- -- " Finished

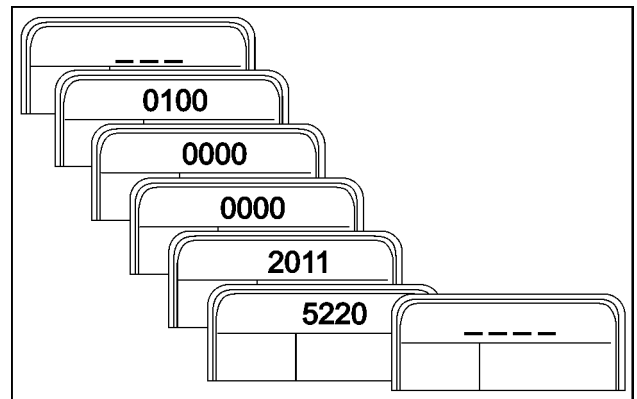

SS12N876 3

- Press the HOME switch to exit the menu.

## Electronic module Central Control Unit (CCU) - HJ - Electronic hydraulic remote control valve number programming

### Central Control Unit (CCU) controller identification (RA)

The processor stores in its memory the Electro Hydraulic Remote (EHR) valve number, within the EHR stack, i.e. whether it is valve number 1, 2, 3 or 4. If it is necessary to replace a valve assembly, then you must reprogram the number of each valve within the complete valve assembly. The replacement valve assemblies are supplied with no number assigned.

**NOTE:** *It is essential that the renumbering procedure for a complete set of valves, for example all rear valves, must be completed in its entirety before continuing the procedure for the other set of valves.*

HJ-Menu for RA unit will be capable of numbering:

- The rear EHR valves: EHR number 3 and number 4 (the system will never assign rear EHR number 1 and/or number 2)
- The front EHR valves: EHR number 1 and number 2

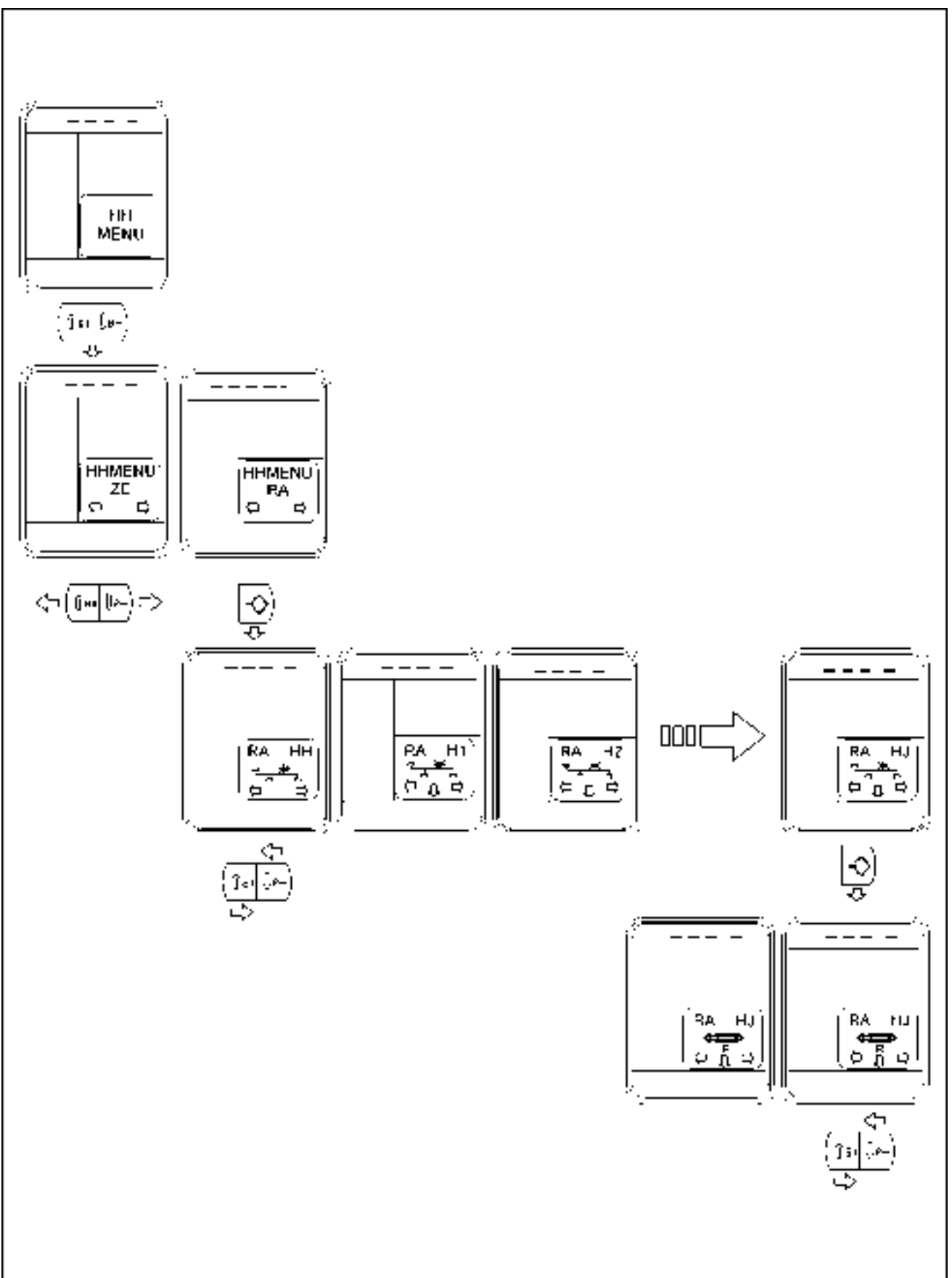

## REAR EHR RENUMBERING

1. Enter the mode, using the diagnostic test plug (special tool **380000843**). Navigate to the RA controller HJ menu. Select the rear EHR symbol. See **Electronic module - Configure - HH-Menu overview (55.640)**.
2. Press the ENTER switch. The Dot Matrix Display (DMD) displays "CEhr" (1).

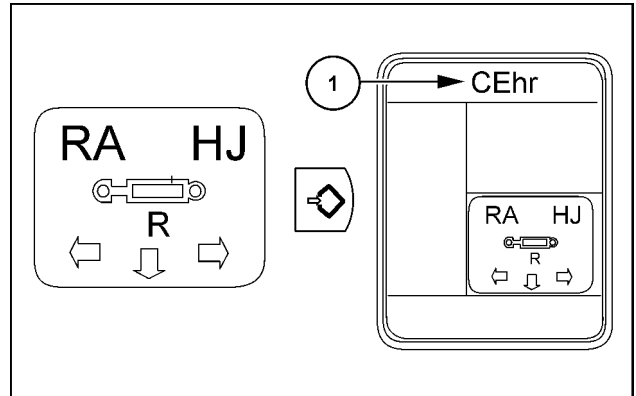

SS13A263 2

3. Press and hold down the DOWN switch. The DMD countdowns from 5 to 1, then the DMD displays "CEhr". This means that the valve numbers have been cleared.

**NOTE:** If the DOWN switch is released before the countdown finishes, the procedure will be aborted.

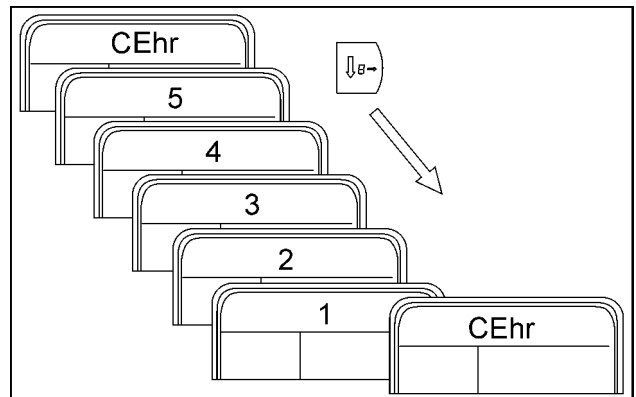

SS13A264 3

4. Turn the ignition switch OFF.
5. Remove the fuse F70 for the rear EHR4. Leave the fuse F73 in the fuse box, because it is responsible for the rear EHR3.

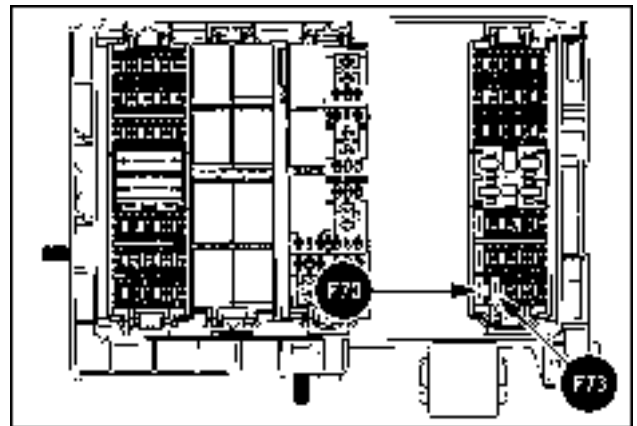

SS13A265 4

6. Turn the ignition switch ON. Enter the mode once again, using the diagnostic test plug. Navigate to the RA controller HJ menu. Select the rear EHR symbol.

7. The instrument cluster displays “Ehr\_” (1) followed by “Ehr3” (2). An audible beep will be heard, indicating that the first valve has been recognized and renumbered. Then the display shows “Ehr4” (3).

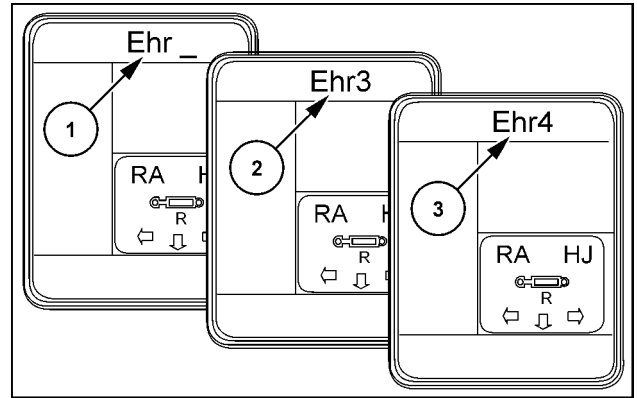

SS13A266 5

8. Put the fuse F70 in the correct fuse holder.

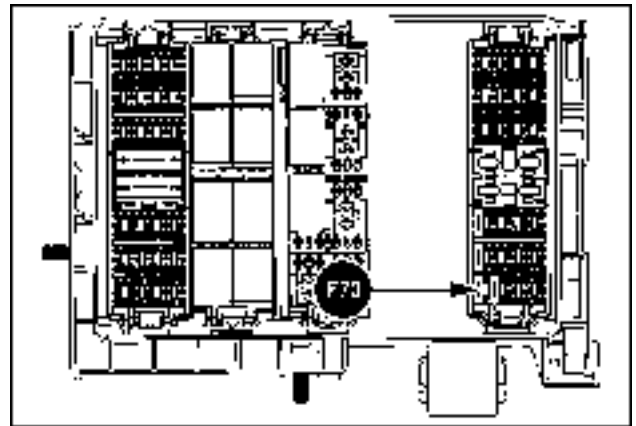

SS13A274 6

9. When the EHR4 valve is energized, an audible beep will signify that the valve is recognized. The display changes automatically and shows “End”.
10. If there is only one rear EHR valve mounted, then the procedure must be finished by pressing the DOWN switch. The display changes to “End” to signify that the programming is complete.

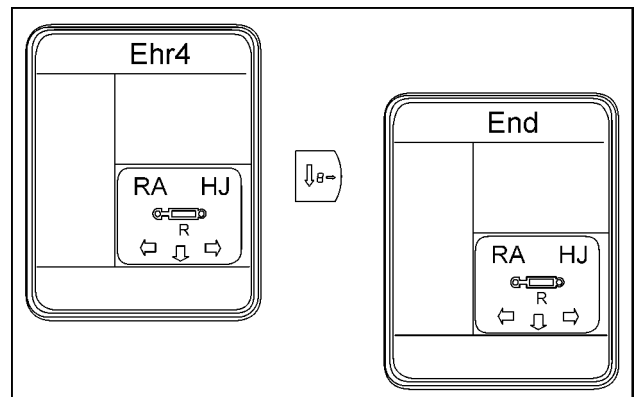

SS13A267 7

11. Turn the ignition switch OFF to store the new valve numbers.

**NOTE:** The following “U” code may be displayed if a problem is encountered during the procedures:

**U160:** Incorrect sequence detected when renumbering the rear EHR valves

**Possible causes:** The renumbering procedure for the rear valves has not been completed correctly. Pay particular attention to ensure that step 10 in the renumbering procedure has been completed.

## FRONT EHR RENUMBERING

12. Enter the mode, using the diagnostic test plug (special tool **380000843**). Navigate to the RA controller HJ menu. Select the front EHR symbol. See **Electronic module - Configure - HH-Menu overview (55.640)**.
13. Press the ENTER switch. The Dot Matrix Display (DMD) displays "CEhr" (1).

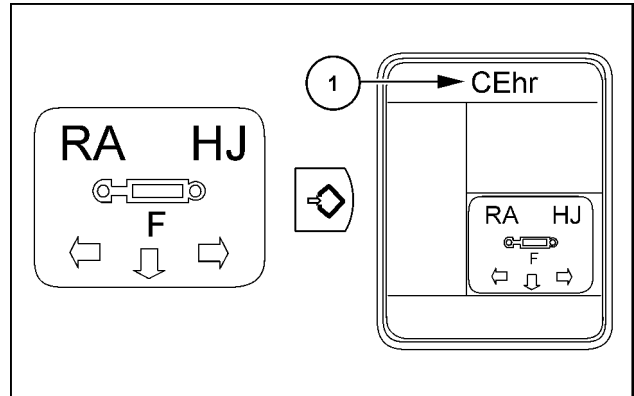

SS13A268 8

14. Press and hold down the DOWN switch. The DMD countdowns from 5 to 1, then the DMD displays "CEhr". This means that the valve numbers have been cleared.

**NOTE:** If the DOWN switch is released before the count-down finishes, the procedure will be aborted.

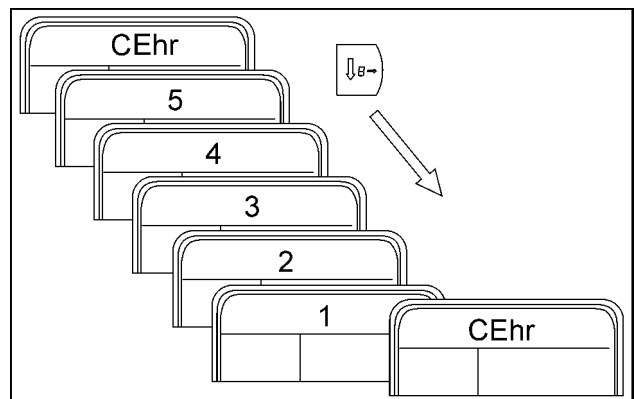

SS13A264 9

15. Turn the ignition switch OFF.
16. Remove the fuse F72 for the front EHR2. Leave the fuse F71 in the fuse box, because it is responsible for the front EHR1.

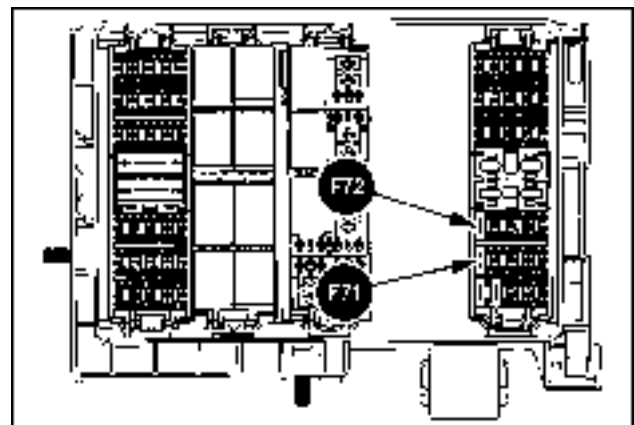

SS13A270 10

17. Turn the ignition switch ON. Enter the mode once again, using the diagnostic test plug. Navigate to the RA controller HJ menu. Select the front EHR symbol.

18. The instrument cluster displays “Ehr\_” **(1)** followed by “Ehr1” **(2)**. An audible beep will be heard, indicating that the first valve has been recognized and renumbered. Then the display shows “Ehr2” **(3)**.

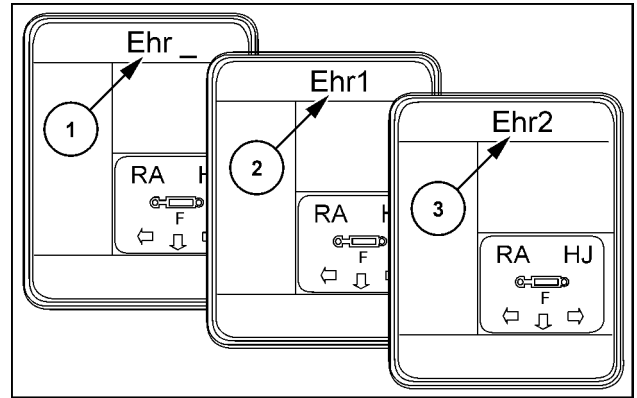

SS13A271 11

19. Put the fuse F72 in the correct fuse holder.

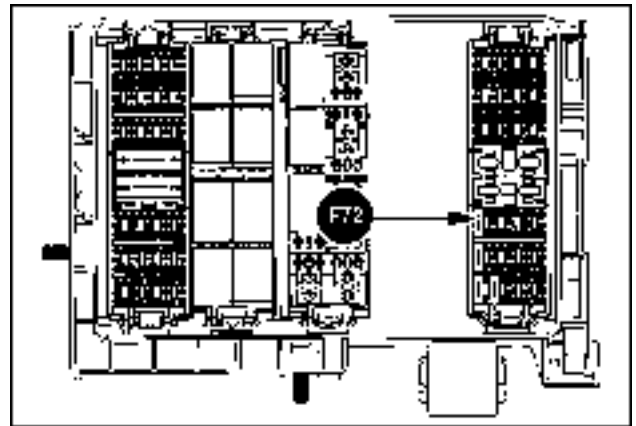

SS13A272 12

20. When the EHR2 valve is energized, an audible beep will signify that the valve is recognized. The display changes automatically and shows “End”.
21. If there is only one front EHR valve mounted, then the procedure must be finished by pressing the DOWN switch. The display changes to “End” to signify that the programming is complete.

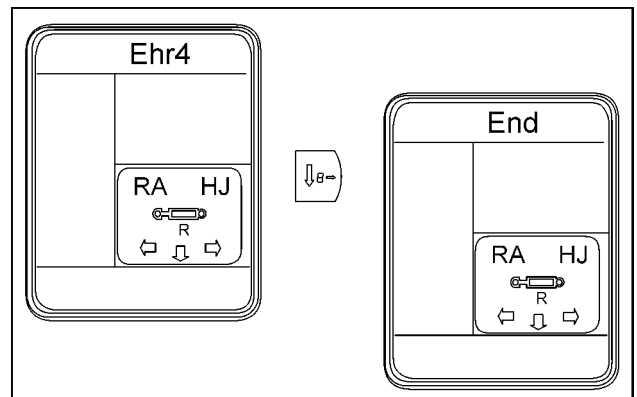

SS13A267 13

22. Turn the ignition switch OFF to store the new valve numbers.

**NOTE:** The following “U” code may be displayed if a problem is encountered during the procedures:

*U161: Incorrect sequence detected when renumbering the front EHR valves*

*Possible causes: The renumbering procedure for the front valves has not been completed correctly. Pay particular attention to ensure that step 21 in the renumbering procedure has been completed.*



---

## **Electronic module ISO bus interface controller - H4 - View software revision level**

### **Isobus interface controller (TECU) controller identification (OA)**

This menu displays the software version of the TECU unit.

---

## **Electronic module ISO bus interface controller - HF - View controller hardware information**

### **Isobus interface controller (TECU) controller identification (OA)**

This menu is used to show a sequence of numbers, representing the hardware identifier, the hardware version and in some cases the hardware serial number, which are stored in EEPROM of the control unit.

# Index

---

## Electrical systems - 55

### Electronic modules - 640

Electronic module Central Control Unit (CCU) - Electronic schema .....	28
Electronic module - Configure - HH-Menu overview .....	4
Electronic module - Fault code index .....	13
Electronic module Central Control Unit (CCU) - H1 - Calibration procedures .....	57
Electronic module Central Control Unit (CCU) - H2 - View stored calibration values .....	62
Electronic module Central Control Unit (CCU) - H3 - Configurations and options .....	64
Electronic module Central Control Unit (CCU) - H4 - View software revision level .....	74
Electronic module Central Control Unit (CCU) - H5 - Switch operation test .....	76
Electronic module Central Control Unit (CCU) - H8 - Clear stored calibration information (EEPROM) .....	79
Electronic module Central Control Unit (CCU) - H9 - Voltmeter diagnostic .....	82
Electronic module Central Control Unit (CCU) - HB - Display stored fault codes .....	85
Electronic module Central Control Unit (CCU) - HC - Clear all stored fault codes .....	88
Electronic module Central Control Unit (CCU) - HE - Display frequency inputs .....	90
Electronic module Central Control Unit (CCU) - HF - View controller hardware information .....	92
Electronic module Central Control Unit (CCU) - HJ - Electronic hydraulic remote control valve number programming .....	94
Electronic module ISO bus interface controller - H4 - View software revision level .....	100
Electronic module ISO bus interface controller - HF - View controller hardware information .....	101
Electronic module Instrument control unit - Electronic schema .....	26
Electronic module Instrument control unit - H3 - Configurations and options .....	31
Electronic module Instrument control unit - H4 - View software revision level .....	40
Electronic module Instrument control unit - H5 - Switch operation test .....	42
Electronic module Instrument control unit - H8 - Clear stored calibration information (EEPROM) .....	45
Electronic module Instrument control unit - H9 - Voltmeter diagnostic .....	49
Electronic module Instrument control unit - HB - Display stored fault codes .....	51
Electronic module Instrument control unit - HC - Clear all stored fault codes .....	53
Electronic module Instrument control unit - HF - View controller hardware information .....	55
Electronic modules - Overview .....	11
Electronic modules - Overview – Fault finding .....	12



## **Electrical systems - 55**

### **Transmission control system - 024**

**Farmall 105U Pro EP  
Farmall 115U Pro EP  
Farmall 95U Pro EP**

# Contents

---

## Electrical systems - 55

### Transmission control system - 024

#### FUNCTIONAL DATA

Transmission electronic control module	
Transmission Control Unit (TCU) - Electronic schema .....	4

#### SERVICE

Transmission electronic control module	
Transmission Control Unit (TCU) - H1 - Calibration procedures .....	7
Transmission Control Unit (TCU) - H2 - View stored calibration values .....	15
Transmission Control Unit (TCU) - H3 - Configurations and options .....	18
Transmission Control Unit (TCU) - H4 - View software revision level .....	20
Transmission Control Unit (TCU) - H5 - Switch operation test .....	22
Transmission Control Unit (TCU) - H8 - Clear stored calibration information (EEPROM) .....	24
Transmission Control Unit (TCU) - H9 - Voltmeter diagnostic .....	26
Transmission Control Unit (TCU) - HB - Display stored fault codes .....	29
Transmission Control Unit (TCU) - HC - Clear all stored fault codes .....	32
Transmission Control Unit (TCU) - HE - Display frequency inputs .....	34
Transmission Control Unit (TCU) - HF - View controller hardware information .....	36



## Transmission electronic control module Transmission Control Unit (TCU) - Electronic schema

Component identification	
1.	Transmission Control Unit (TCU)
2.	Clutch pedal switch – Transmission
3.	Clutch pedal sensor
4.	Shuttle lever
5.	Multicontroller (transmission control)
6.	Reverse switch
7.	Forward switch
8.	Comfort shift switch
9.	Powershift range increase switch
10.	Powershift range decrease switch
11.	Auto-shift select switch
12.	Auto-shift programming switch
13.	Clutch A solenoid valve
14.	Clutch B solenoid valve
15.	Clutch C solenoid valve
16.	Clutch F solenoid valve
17.	Transmission output speed sensor
18.	Powershift output speed sensor
19.	Powershift input speed sensor
20.	Transmission oil pressure switch
21.	Ground speed Power Take-Off (PTO) – Stationary operation switch
22.	Transmission oil temperature sensor
23.	Rear Power Take-Off (PTO) – Speed sensor
24.	Controlled by the Central Control Unit (CCU) via CAN bus.
25.	Clutch D solenoid valve
26.	Clutch G solenoid valve
27.	Rear axle differential lock – Solenoid valve
28.	Four-Wheel Drive (4WD) – Solenoid valve
29.	Rear Power Take-Off (PTO) – Solenoid valve
30.	Rear PTO status change plausibility
31.	Sensor ground 1
32.	Sensor ground 2
33.	Chassis ground
34.	Power ground

Electrical systems - Transmission control system

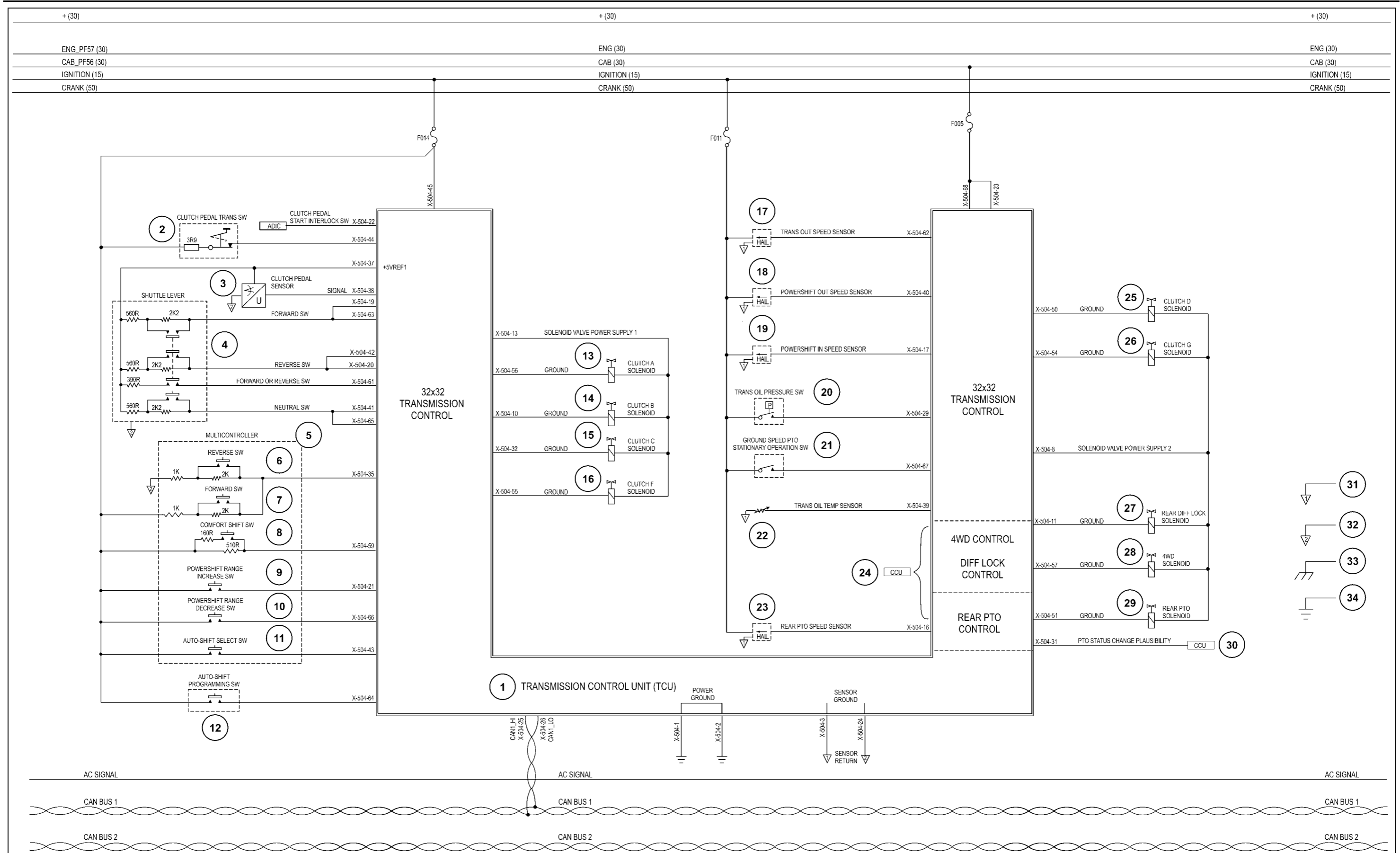





## Transmission electronic control module Transmission Control Unit (TCU) - H1 - Calibration procedures

### **▲ WARNING**

#### **Unexpected machine movement!**

The machine could move automatically during calibration. Park on a flat surface, engage the parking brake, and be sure that the area around the machine is clear before starting the calibration process. Failure to comply could result in death or serious injury.



W0300A

### Transmission Control Unit (TCU) controller identification (TC)

#### TRANSMISSION CALIBRATIONS

The following procedures calibrate the clutch pedal and the driving clutches. For each case, certain environmental conditions need to be respected and maintained. Violations of any environment condition will immediately cause the calibration to abort. Calibration routines can also be aborted by intentionally violating the environment conditions (for example selecting an improper driving direction or performing an incorrect operation on the clutch pedal). In this case it is necessary to recycle the TCU (ignition switch ON and/or OFF) before the next calibrations attempt.

**NOTE:** Before performing the calibration procedure, pay attention that no "U-Codes" are shown. It is also possible that during the calibration procedures a "U-Code" appears. This "U-Code" is a standard fault code. If a "U-Code" is shown, repair this fault or delete the stored "U-Code".

Icon	Channels	Procedure
	Channel 1	Calibration of the clutch pedal sensor
	Channel 2	Calibration of the driving clutches
	Channel 1	Calibration of the rear Power Take-Off (PTO) clutch

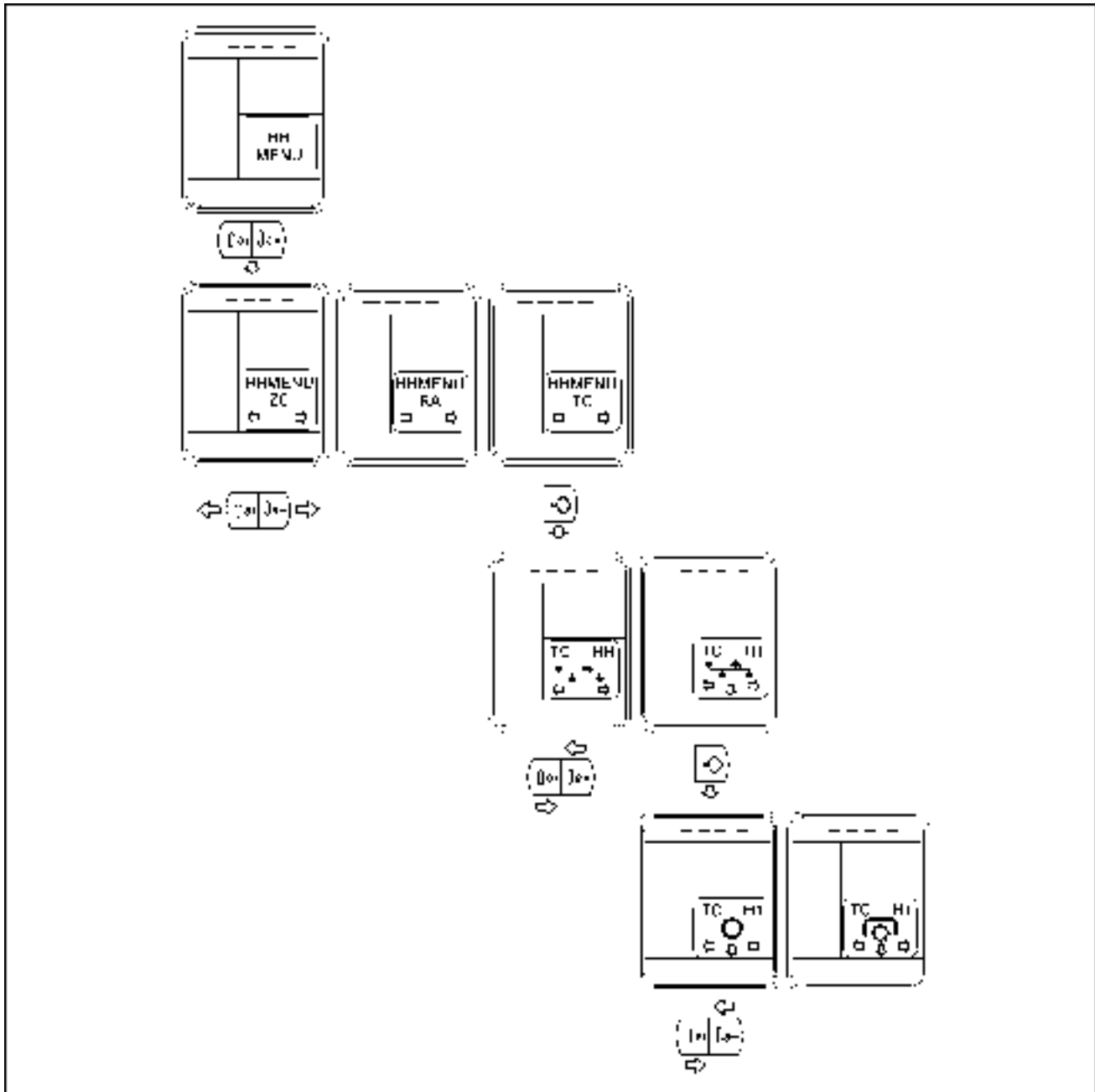

SS12N879 1

## Channel 1 – Calibration of the clutch pedal sensor

**NOTE:** This procedure is required when either the Transmission Control Unit (TCU) has been replaced, the clutch pedal switches have been replaced, the sensor have been replaced, settings have changed or if the previous calibration has been erased by using the “H8” procedure.

This calibration procedure requires following conditions:

- Clutches: in OPEN (NEUTRAL) position
- Engine speed: engine in OFF position
- Shuttle lever: in NEUTRAL position
- Clutch pedal: in RESTING position

1. To enter the mode, you have two choices:

- Diagnostic test plug (image 2): Enter the mode, using the diagnostic test plug (special tool **380000843**). Navigate to the TC controller, H1 menu, transmission symbol. See **Electronic module - Configure - HH-Menu overview (55.640)**.
- Quick entry (image 3): Turn the ignition switch “ON” and wait **10 s**, within a minute. Press the “COMFORT SHIFT switch” (1) and the “MINUS switch” (2) on the Multicontroller as well as the “NEUTRAL switch” (3) on the shuttle lever simultaneously for **3 s**.

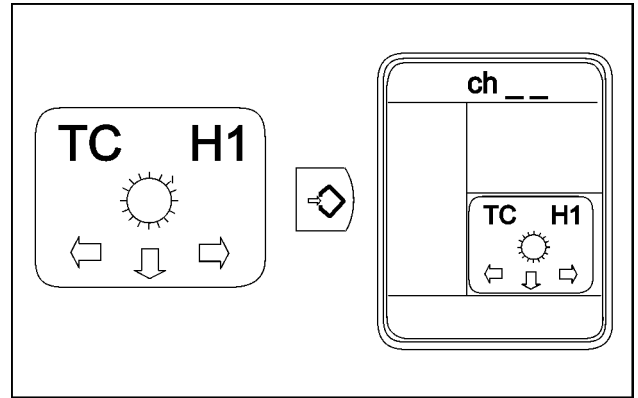

SS12N880 2

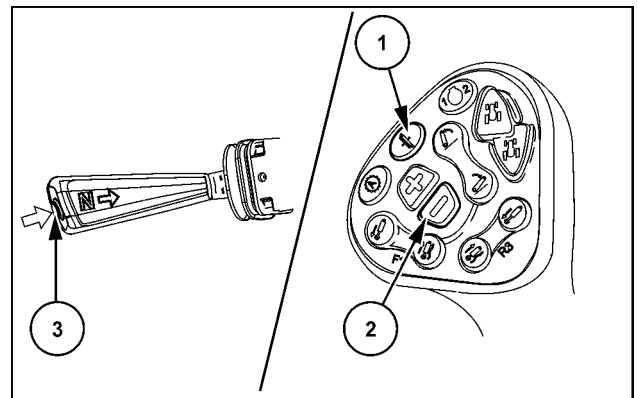

SS12N882 3

2. Use the UP or DOWN switch to move to the required channel 1 (1).

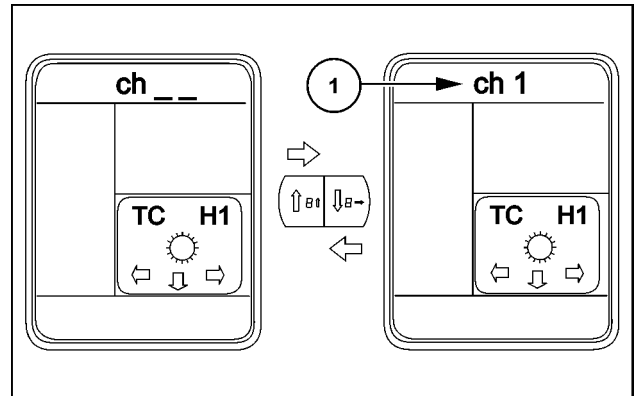

SS12N881 4

3. Press the ENTER switch. The transmission oil temperature is displayed on the Dot Matrix Display (DMD) for nearly **5 s**. Then “OPE” appears.

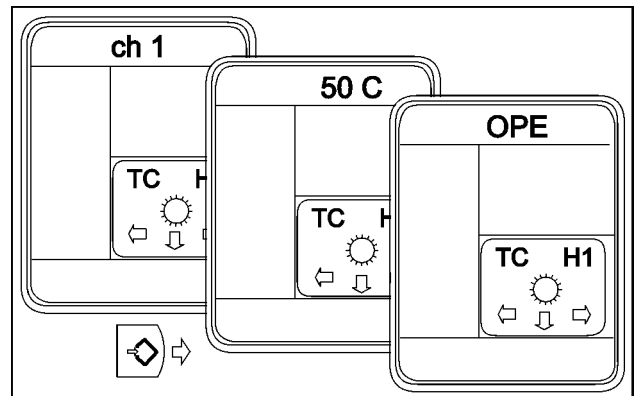

SS12N883 5

4. When "OPE" appears, it is required to slowly press the clutch pedal to the end position. Then slowly release it.

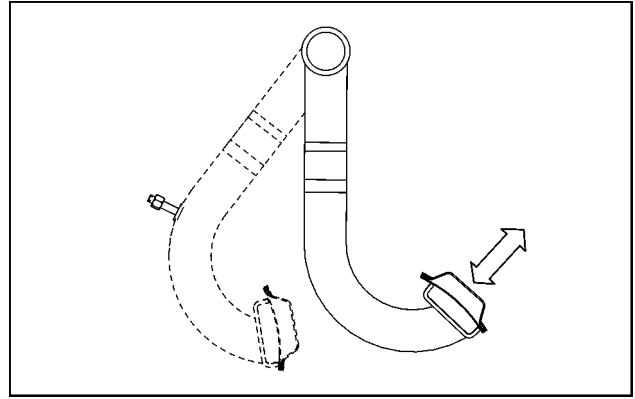

SS12N884 6

**NOTE:** During the clutch pedal calibration, the DMD is indicating "OPE". When the calibration is successfully finished, the DMD indicates "END".

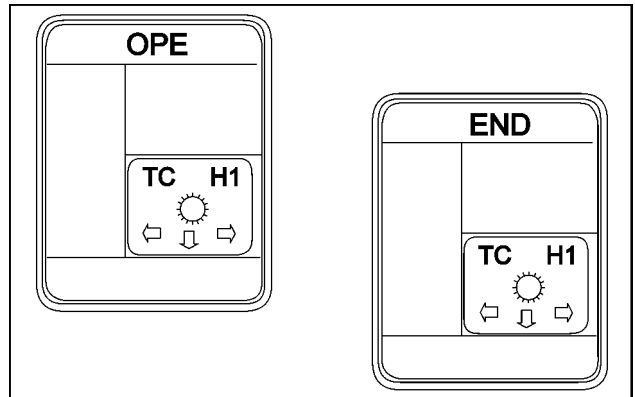

SS12N885 7

5. Switch OFF to store the calibration values.

**NOTE:** It is possible that during the calibration procedure a "U-Code" appears. See **Electronic module - Fault code index (55.640)**.

## Channel 2 – Calibration of the driving clutches

**NOTE:** This procedure is required when either the Transmission Control Unit (TCU) has been replaced, the calibration values has been erased by using the H8 procedure or the power shuttle-shifting quality is not satisfying.

**NOTE:** This procedure is only possible when a valid calibration from the clutch pedal has been done before.

This calibration procedure requires following conditions:

- Clutches: in OPEN (NEUTRAL) position
- Synchronizer gear: in NEUTRAL position
- Engine speed: **1200 RPM +/- 100**
- Shuttle lever: in NEUTRAL position
- Clutch pedal: in RESTING position
- Hand brake: activated
- Hydraulic consumer: deactivated
- Air-conditioning system: deactivated
- Transmission oil temperature: **45 - 50 °C (113 - 122 °F)**

6. To enter the mode, you have two choices:

- Diagnostic test plug (image 8): Enter the mode, using the diagnostic test plug (special tool **380000843**). Navigate to the TC controller, H1 menu, transmission symbol. See **Electronic module - Configure - HH-Menu overview (55.640)**.
- Quick entry (image 9): Start the engine and wait **10 s**, within a minute. Press the “PLUS switch” (1) and the “MINUS switch” (2) on the Multicontroller as well as the “NEUTRAL switch” (3) on the shuttle lever simultaneously for **3 s**.

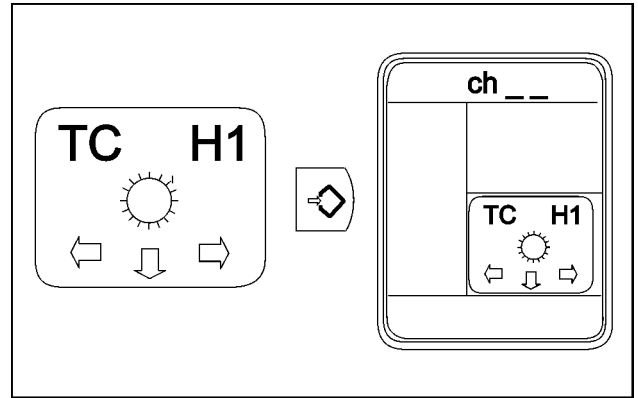

SS12N880 8

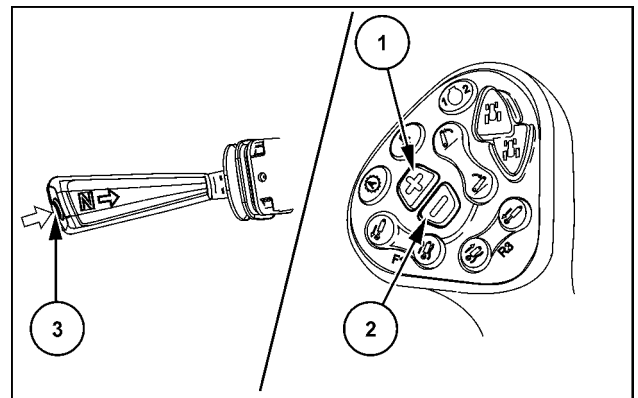

SS12N903 9

7. Use the UP or DOWN switch to move to the required channel 2 (1).

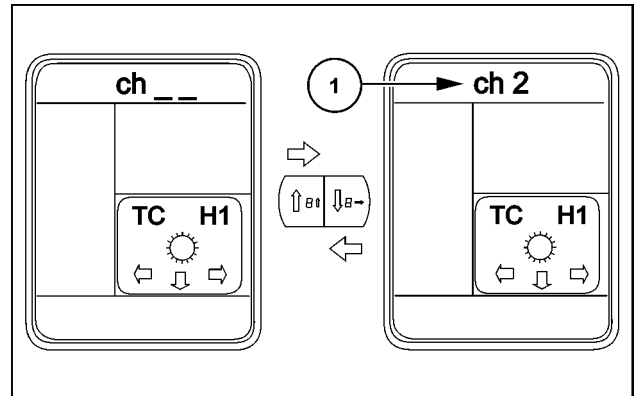

SS12N886 10

8. Press the ENTER switch. The transmission oil temperature is displayed on the Dot Matrix Display (DMD) for nearly **5 s**. Then “OPE” appears.

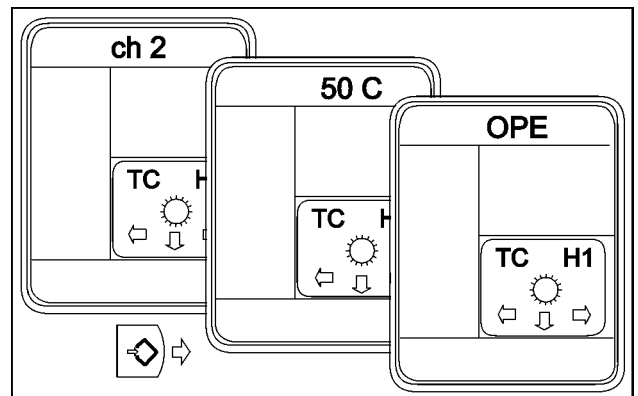

SS12N887 11

9. When "OPE" is displayed it is required to select the forward direction with the shuttle lever.

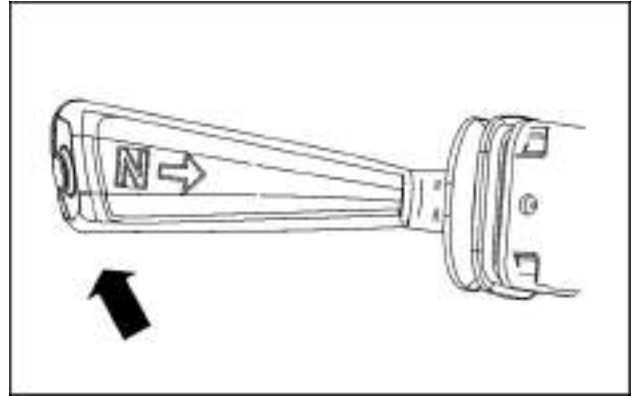

SS12N888 12

**NOTE:** The automatic calibration of all driving clutches starts as soon as "CAL" is displayed on the DMD. During the driving clutch calibration, the DMD is indicating "CAL". The procedure could require up to **10 min**. When the calibration is successfully finished, the DMD indicates "END".

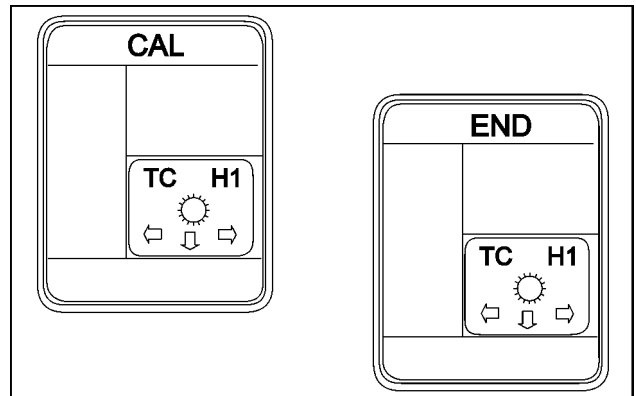

SS12N889 13

10. Switch OFF to store the calibration values.

**NOTE:** It is possible that during the calibration procedure a "U-Code" appears. See **Electronic module - Fault code index (55.640)**.

## REAR POWER TAKE-OFF (PTO) CLUTCH CALIBRATION

**NOTE:** This procedure is required when either the Transmission Control Unit (TCU) is replaced, the calibration values has been erased by using the H8 procedure or the PTO clutch run up quality is not satisfying.

**NOTE:** This procedure is only possible when a valid calibration from the clutch pedal and the driving clutches has been done before.

This calibration procedure requires following conditions:

- Clutches: in OPEN (NEUTRAL) position
- Synchronizer gear: in NEUTRAL position
- Engine speed: **1600 RPM +/- 100**
- Shuttle lever: in NEUTRAL position
- Clutch pedal: in RESTING position
- PTO gear lever: 1000
- PTO gear lever: in NORMAL position
- Hand brake: activated
- Transmission oil: **>35 °C (>95 °F)**

11. To enter the mode, you have two choices:

- Diagnostic test plug (image 14): Enter the mode, using the diagnostic test plug (special tool **380000843**). Navigate to the TC controller, H1 menu, PTO symbol. See **Electronic module - Configure - HH-Menu overview (55.640)**.
- Quick entry (image 15): Start the engine and wait **10 s**, within a minute. Press the “COMFORT SHIFT switch” (1) and the “PLUS switch” (2) on the Multi-controller as well as the “NEUTRAL switch” (3) on the shuttle lever simultaneously for **3 s**.

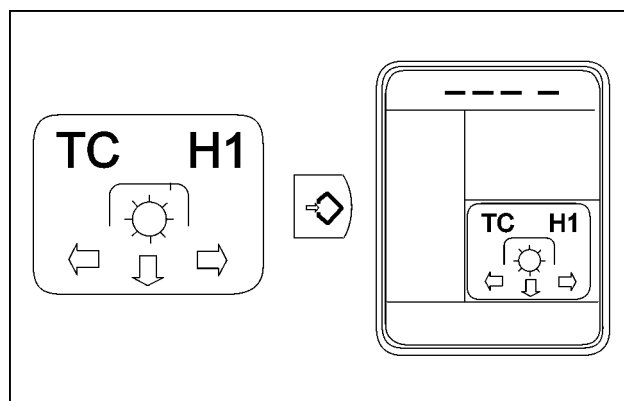

SS12N890 14

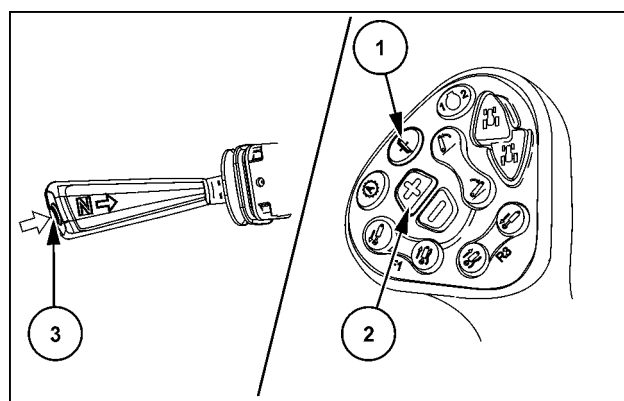

SS12N904 15

12. Use the UP or DOWN switch to move to the required channel 1 (1).

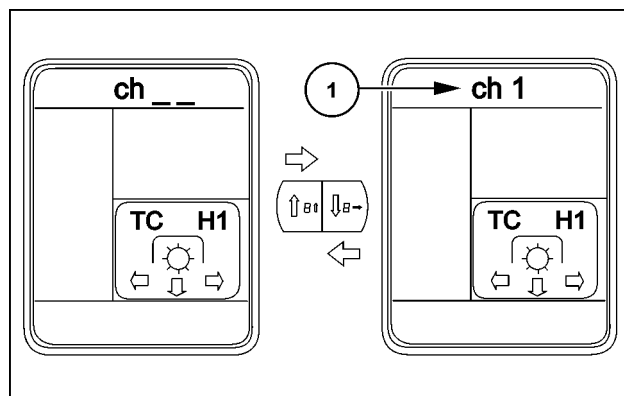

SS12N891 16

13. Press the ENTER switch. The transmission oil temperature is displayed on the Dot Matrix Display (DMD) for nearly **5 s**. Then “OPE” appears.

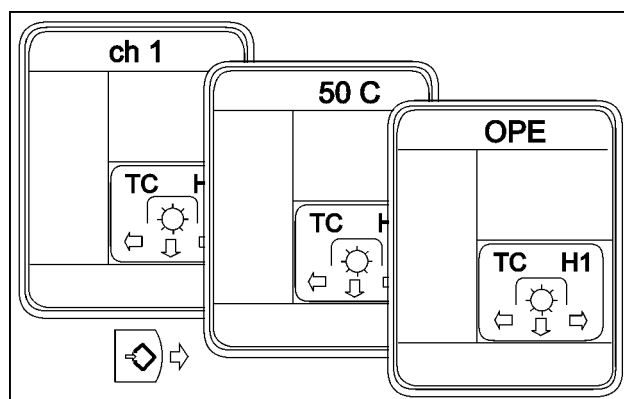

SS12N892 17



14. When "OPE" is displayed it is required to pull the rear PTO switch (1) in the ON position.

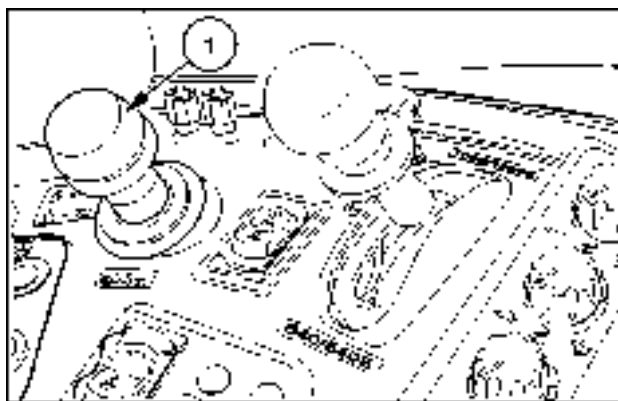

SS12N893 18

**NOTE:** During the PTO clutch calibration, the DMD is indicating "CAL". When the calibration is successfully finished, the DMD indicates "END"

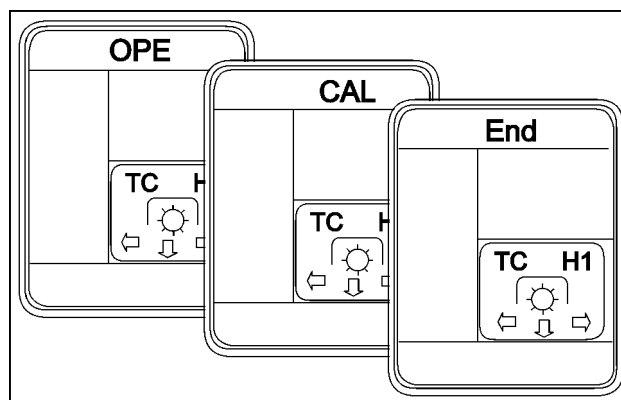

SS12N894 19

**NOTE:** The running calibration routine can always be aborted by intentionally switching OFF the PTO.

15. Switch OFF to store the calibration values.

**NOTE:** It is possible that during the calibration procedure a "U-Code" appears. See **Electronic module - Fault code index (55.640)**.

## Transmission electronic control module Transmission Control Unit (TCU) - H2 - View stored calibration values

### Transmission Control Unit (TCU) controller identification (TC)

This section is used to view the transmission calibration values (calibration current with the calibration temperature) and the clutch pedal calibration values.

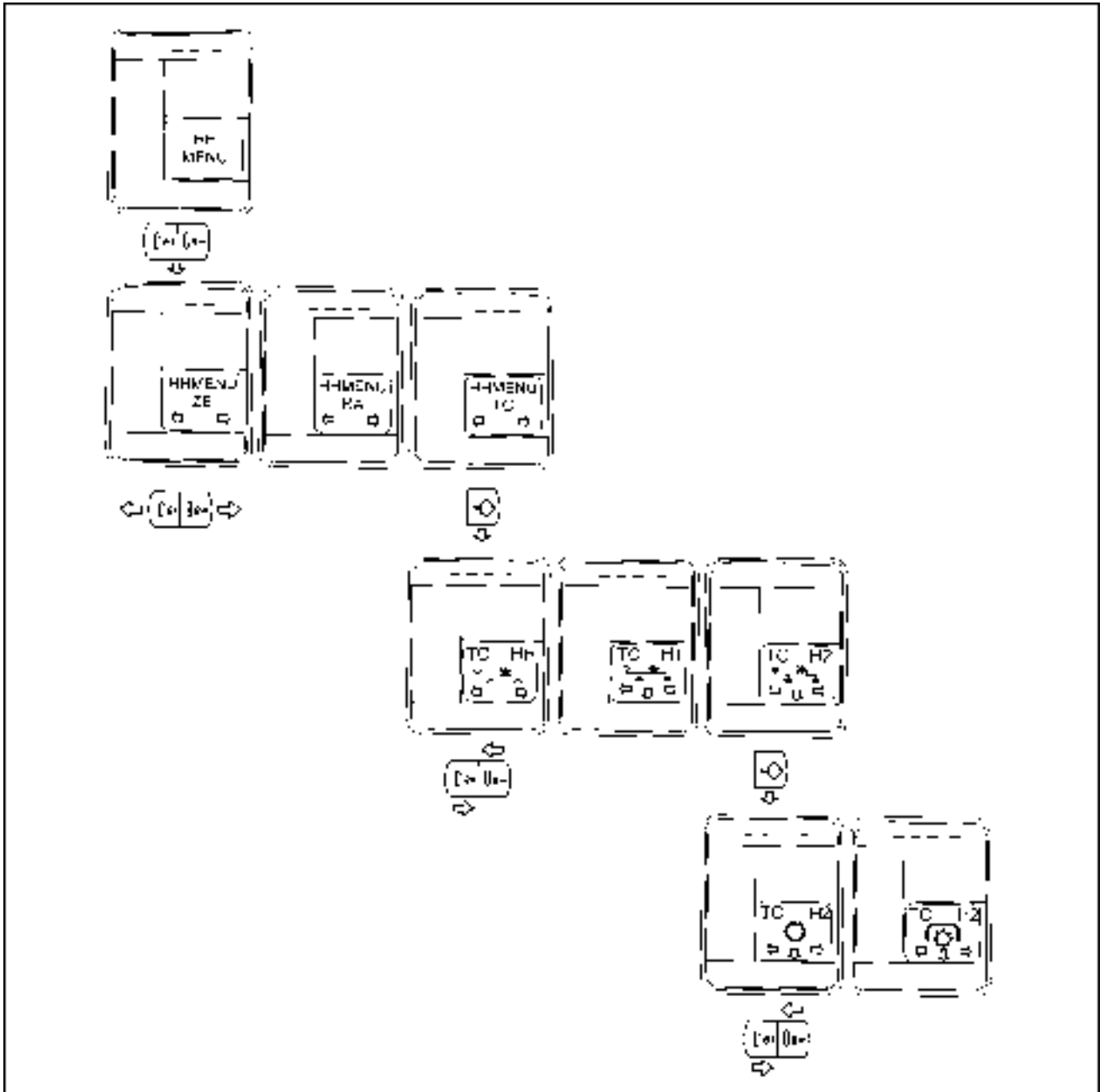

SS13A275 1

### Transmission calibration values and clutch pedal calibration values

1. Enter the mode, using the diagnostic test plug (special tool **380000843**). Navigate to the TC controller H2 menu. Select the transmission symbol. See **Electronic module - Configure - HH-Menu overview (55.640)**

2. Press the ENTER switch. The Dot Matrix Display (DMD) displays on the top the letters "ch \_\_" (1).

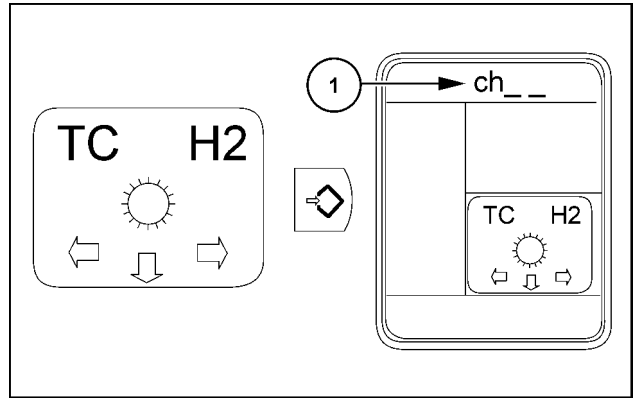

SS13A276 2

3. Use the UP or DOWN switch to select the required channel.  
After a delay ( 1.5 s ), the clutch name and the calibration value will be displayed. Look for the required channel number and clutch name in the table below.

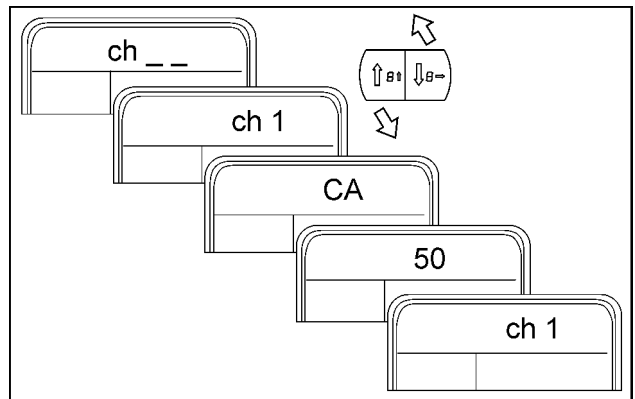

SS13A277 3

Example:

- (1): Channel number
- (2): After a delay the display changes automatically to "P2" (see table below)
- (3): Clutch pedal sensor calibration value in the unit mV
- (4): Channel number

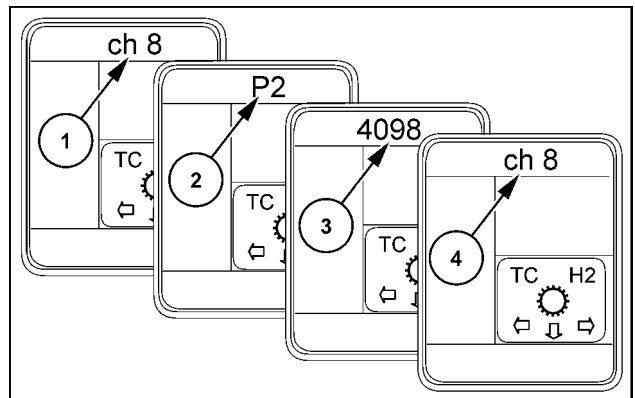

SS13A278 4

Channel	Display	Item	Calibration value
ch1	CA	Clutch A calibration current	mA
ch2	Cb	Clutch B calibration current	mA
ch3	CC	Clutch C calibration current	mA
ch4	Cd	Clutch D calibration current	mA
ch5	CF	Clutch F calibration current	mA
ch6	CG	Clutch G calibration current	mA
ch7	P1	Voltage for pedal at switching point	mV
ch8	P2	Voltage for pedal fully depressed	mV
ch9	P3	Voltage for pedal fully released	mV

4. Press the HOME switch to exit the menu.

### Power Take-Off (PTO) clutch calibration value

5. Enter the mode, using the diagnostic test plug (special tool **380000843**). Navigate to the TC controller H2 menu. Select the Power Take-Off (PTO) symbol. See **Electronic module - Configure - HH-Menu overview (55.640)**
6. Press the ENTER switch. The Dot Matrix Display (DMD) displays on the top the letters "ch \_\_" (1).

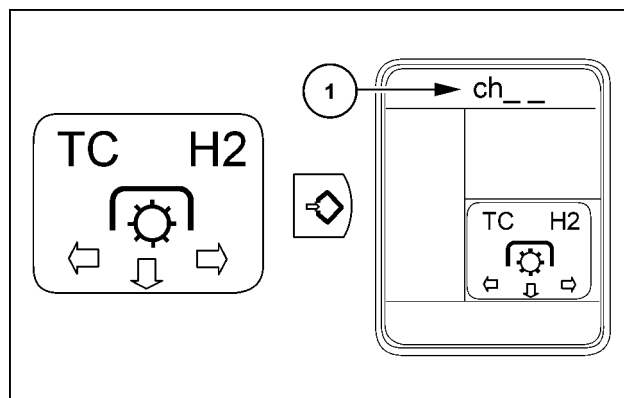

SS13A290 5

7. Use the UP or DOWN switch to select the required channel.

After a delay ( **1.5 s** ), the clutch name and the clutch calibration value will be displayed. Look for the required channel number and clutch name in the table below.

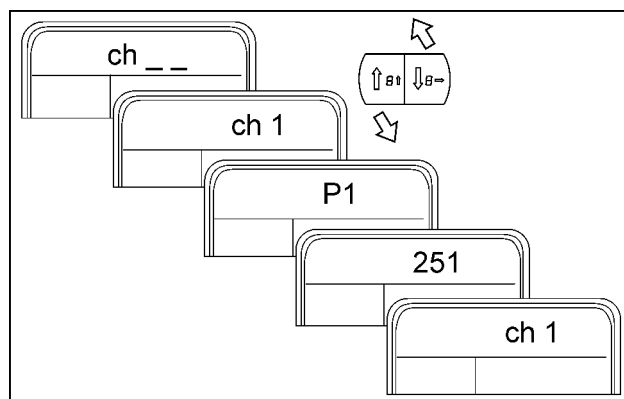

SS13A292 6

Channel	Display	Item	Calibration value
ch1	P1	Power Take-Off (PTO) clutch solenoid valve calibration value	<b>251 mA</b>

8. Press the HOME switch to exit the menu.

# Transmission electronic control module Transmission Control Unit (TCU) - H3 - Configurations and options

## Transmission Control Unit (TCU) controller identification (TC)

The table below displays the function and the belonging symbol for this submenu.

Function	Icon
Rear Power Take-Off (PTO)	

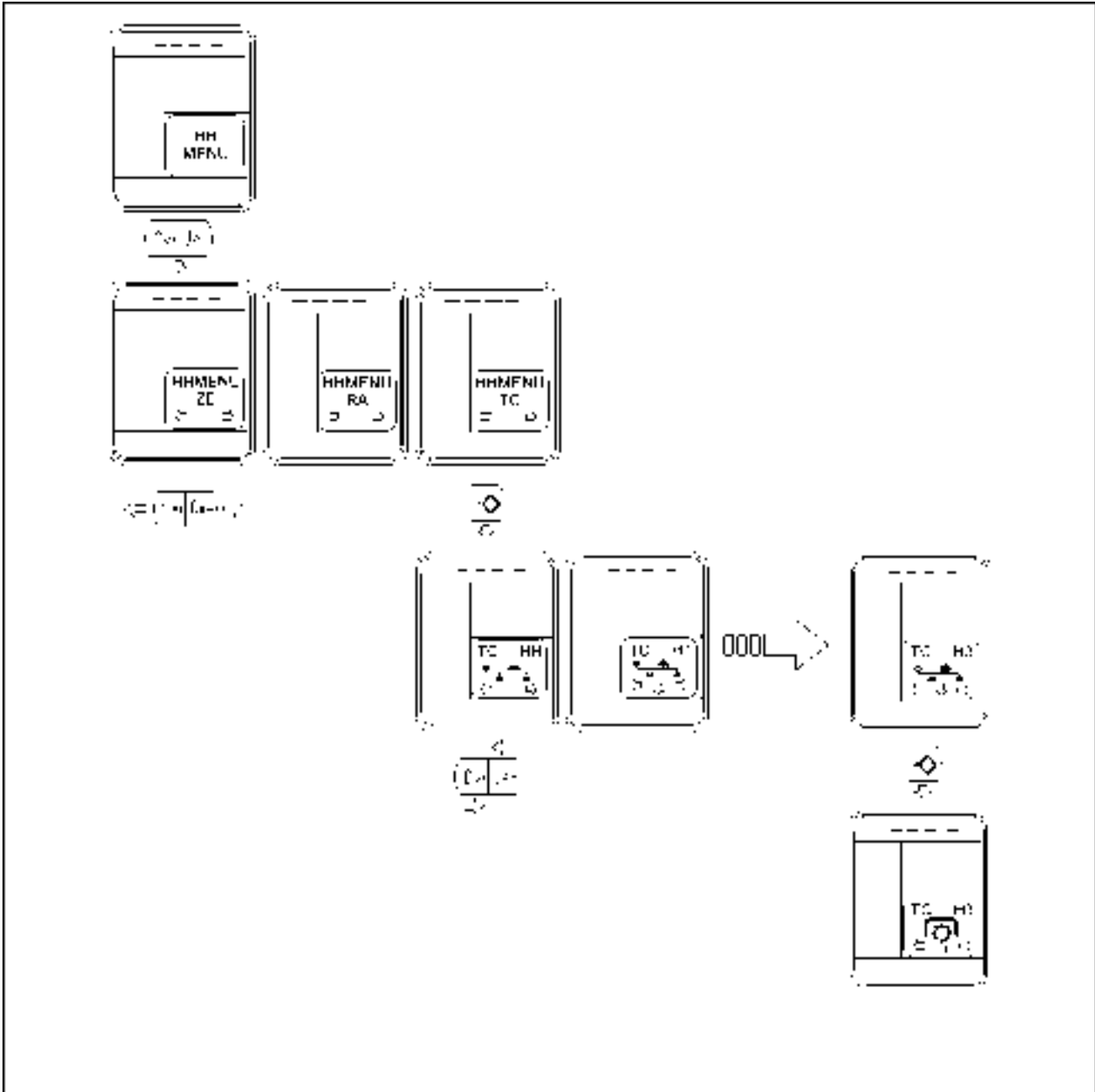

SS12N905 1

**NOTE:** After using the H8 menu, all configurations are on default settings.

## REAR POWER TAKE-OFF (PTO)

This H-Menu level is used by the service technician to set up any options or configurations available with the rear Power Take-Off (PTO) control system.

1. Enter the mode, using the diagnostic test plug (special tool **380000843**). Navigate to the TC controller H3 menu. See **Electronic module - Configure - HH-Menu overview (55.640)**.
2. Select the symbol, rear PTO symbol.
3. Press the ENTER switch. The Dot Matrix Display (DMD) displays on the top the letters "ch \_ \_" (1).
4. Use the UP or DOWN switch to select the required channel number.

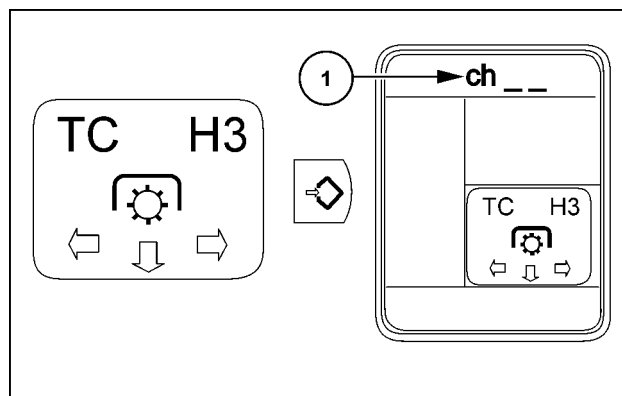

SS13A256 2

### Channel 1 – Rear PTO drop out speed option

This channel is used to select the engine speed below, where the PTO will drop out.

1. Use the UP or DOWN switch to increase or decrease the engine speed in **10 RPM**-steps in the range **0 - 550 RPM**.
2. When the desired speed is displayed, press the UP or DOWN switch for **1 s**. The cluster will beep and then the setting is stored.
3. Press the HOME switch to go back to the H-Menu.

**NOTE:** This adjustment refers to the actual motor speed at which the Power Take-Off clutch is opened automatically (this protects the transmission and the attachments if the engine is stalled)

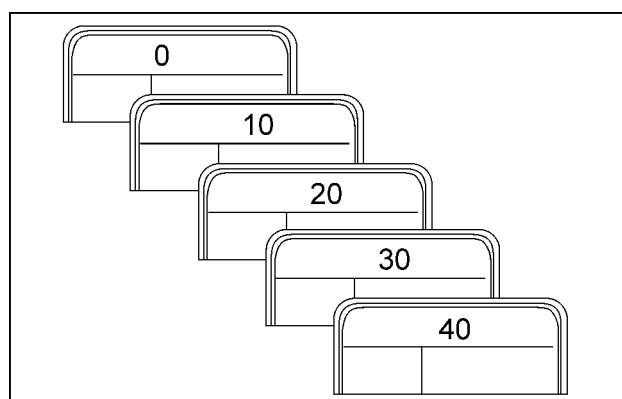

SS13A257 3

## Transmission electronic control module Transmission Control Unit (TCU) - H4 - View software revision level

### Transmission Control Unit (TCU) controller identification (TC)

This menu displays the software version of the TCU unit.

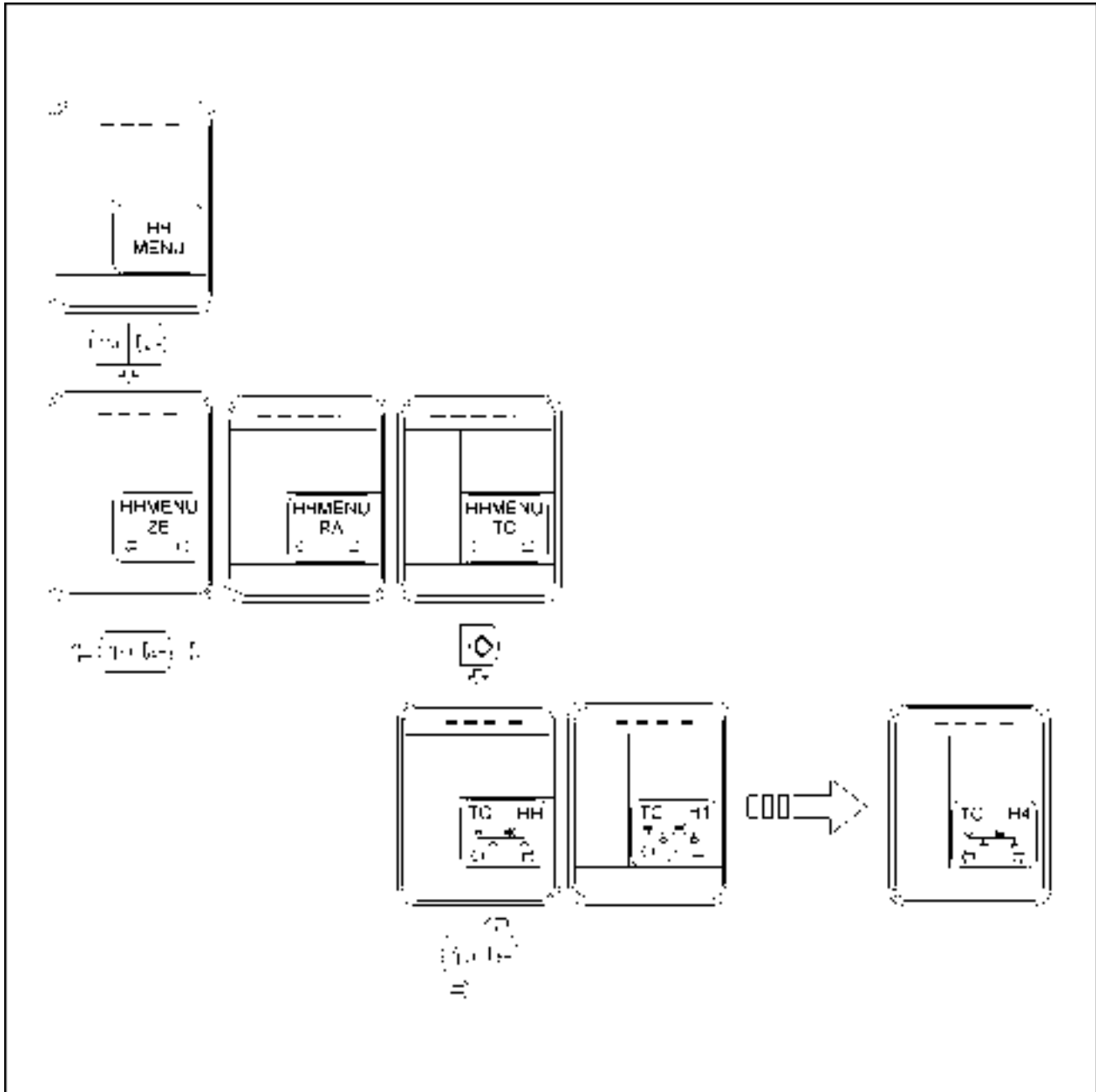

SS12N906 1

1. Enter the mode, using the diagnostic test plug (special tool **380000843**). Navigate to the TC controller H4 menu. See **Electronic module - Configure - HH-Menu overview (55.640)**.

- Press the ENTER switch. The Dot Matrix Display (DMD) displays on the top a sequence of numbers **(1)**, representing the software identifier and the software version.

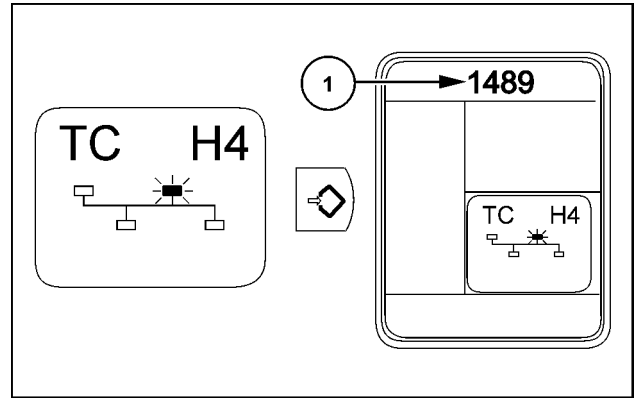

SS12N909 2

- The first **(1)** set of 4 digits indicates the software identifier. The second **(2)** and third **(3)** set of 4 digits displayed define the release version of the application software.

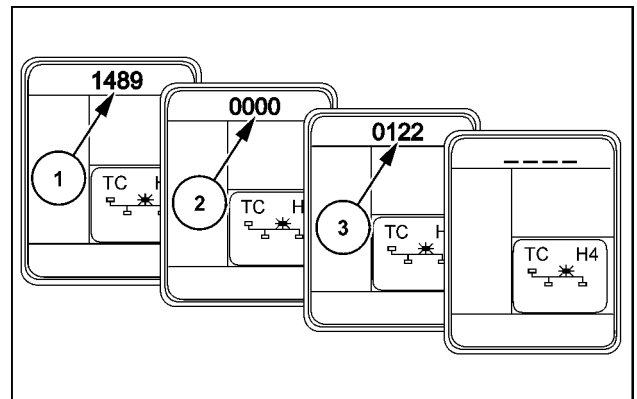

SS12N910 3

- At the end of the routine, the display returns to H4. It is possible to start with the ENTER switch the routine again or navigate further to the H-Menus.



## Transmission electronic control module Transmission Control Unit (TCU) - H5 - Switch operation test

### Transmission Control Unit (TCU) controller identification (TC)

This menu displays a designated code when a switch transition is detected.

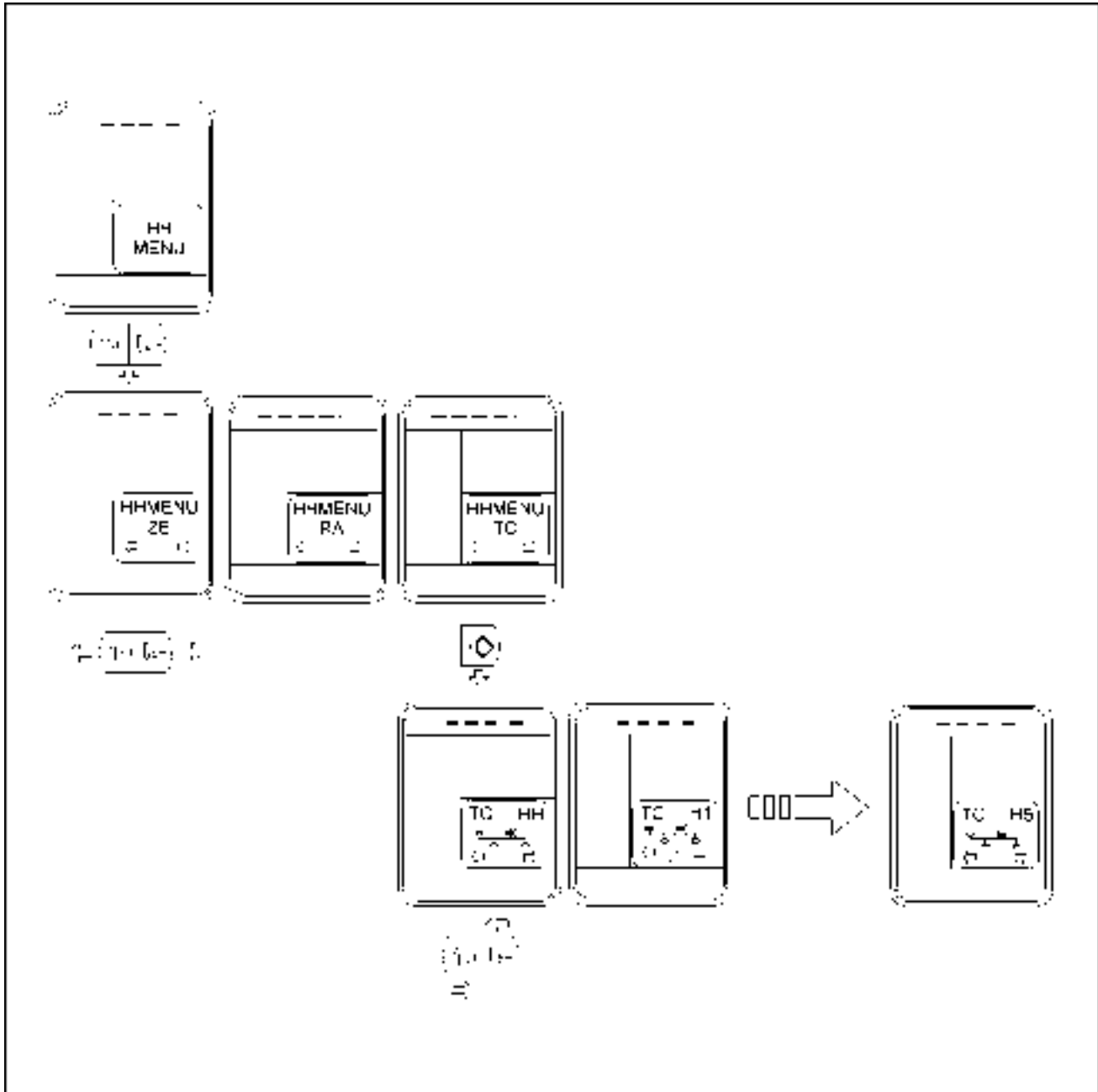

SS12N907 1

1. Enter the mode, using the diagnostic test plug (special tool **380000843**). Navigate to the TC controller H5 menu. See **Electronic module - Configure - HH-Menu overview (55.640)**.

2. Press the ENTER switch. The Dot Matrix Display (DMD) displays on the top the letter “d\_ \_” (1).

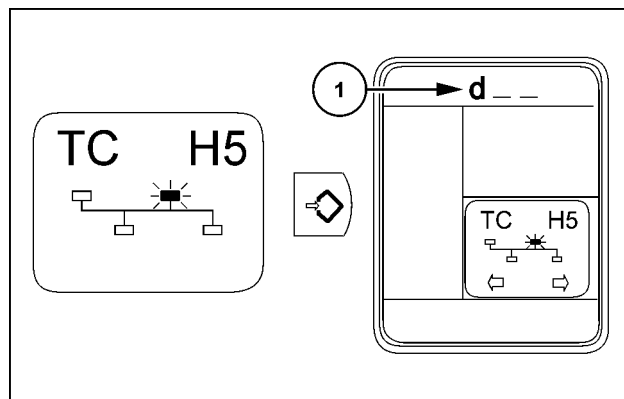

SS13A254 2

3. When the operator presses the switch, the appropriate switch code is displayed and an audible tone can be heard to indicate the correct function. If the appropriate switch code is not displayed and there is no audible tone, a fault is present. The operator can locate the fault trough wiggling the related wiring and simultaneously watching the display.
4. With the H5 menu the operator can check if a switch is open or closed, for example:
- The clutch pedal switch (1) is open or closed.
  - The power switch (downshift) (2) is open or closed.
  - The power switch (upshift) (3) is open or closed.

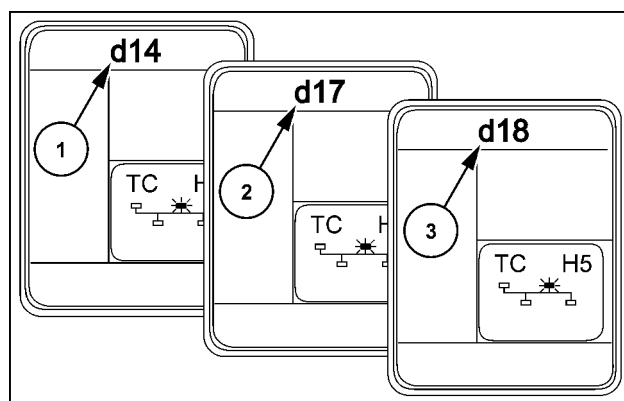

SS13A255 3

Name	Channel	Pin number
Clutch pedal switch – Transmission	d14	X504-44
Powershift range decrease	d17	X504-66
Powershift range increase	d18	X504-21
Ground speed Power Take-Off (PTO) – Stationary operation switch	d48	X504-67
Auto power shift programming	d99	X504-64
Auto power shift select	d102	X504-43
Transmission oil pressure switch	d148	X504-29

At the end of the switches check, it is required to switch OFF the ignition switch to exit the H5 menu.

## Transmission electronic control module Transmission Control Unit (TCU) - H8 - Clear stored calibration information (EEPROM)

### Transmission Control Unit (TCU) controller identification (TC)

This menu clears calibration values and stored fault codes by resetting all EEPROM values back to the default settings. EEPROM is where all calibration values and fault codes are stored. This memory is retained even if there is no power to the controller, for example: the battery is disconnected.

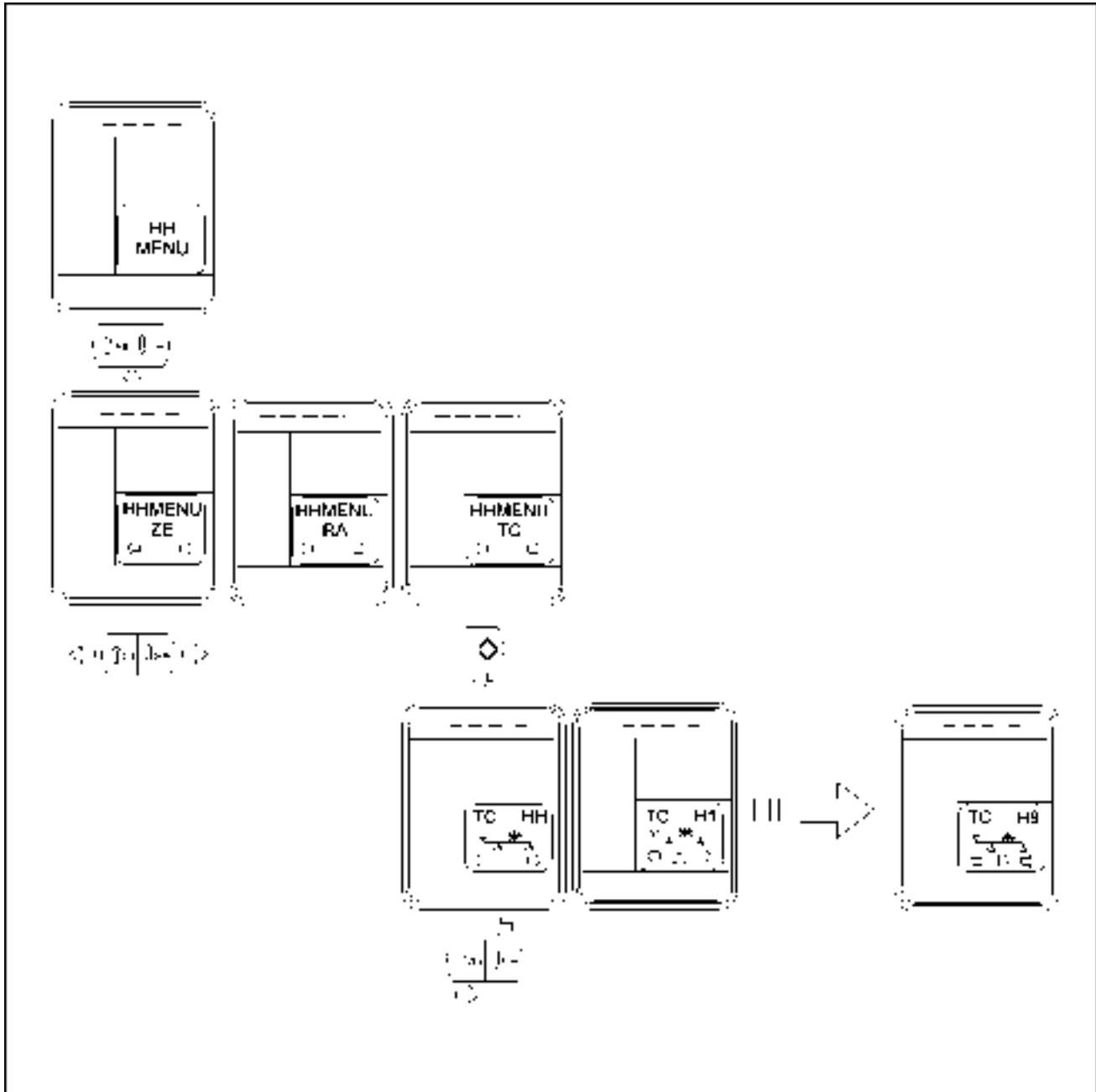

SS12N908 1

1. Enter the mode, using the diagnostic test plug (special tool **380000843**). Navigate to the TC controller H8 menu. See **Electronic module - Configure - HH-Menu overview (55.640)**.

- Press the ENTER switch. The Dot-Matrix-Display (DMD) displays "EECL" (1).

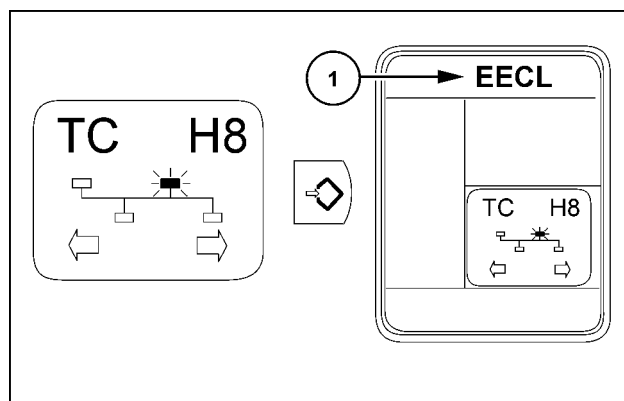

SS13A258 2

- Press the ENTER switch.
- Press the DOWN switch to confirm the resetting of the EEPROM. The DMD will countdown from 5 to 1. Then "EE" will be displayed to indicate that the EEPROM has been cleared.

**NOTE:** If the DOWN switch is released before the countdown finishes, the procedure will be aborted.

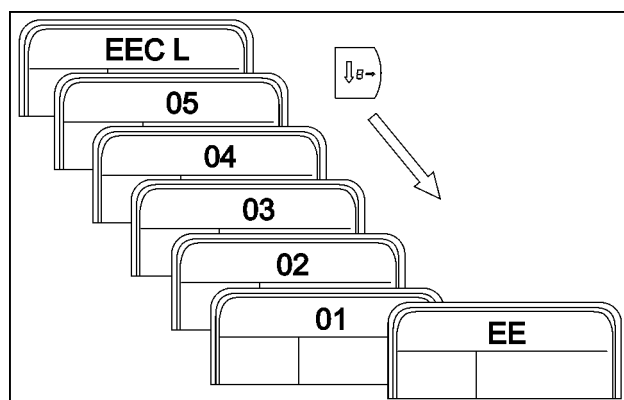

SS12N698 3

- It is not possible to continue through the H-Menu after a H8 procedure. The only possible action is to turn the ignition switch OFF to allow the reset values to be stored.

**NOTE:** After using the H8 menu, all H3 configurations are on default setting. See **Transmission electronic control module Transmission Control Unit (TCU) - H3 - Configurations and options (55.024)**.

## Transmission electronic control module Transmission Control Unit (TCU) - H9 - Voltmeter diagnostic

### Transmission Control Unit (TCU) controller identification (TC)

This menu is used to verify the operation of various potentiometers, voltage supplies, and solenoid current circuits. If an intermittent fault is detected, the operator can locate the fault through wiggling the related wiring and simultaneously watching the display for sudden changes in values.

**NOTE:** The vehicle may be driven while working in this menu.

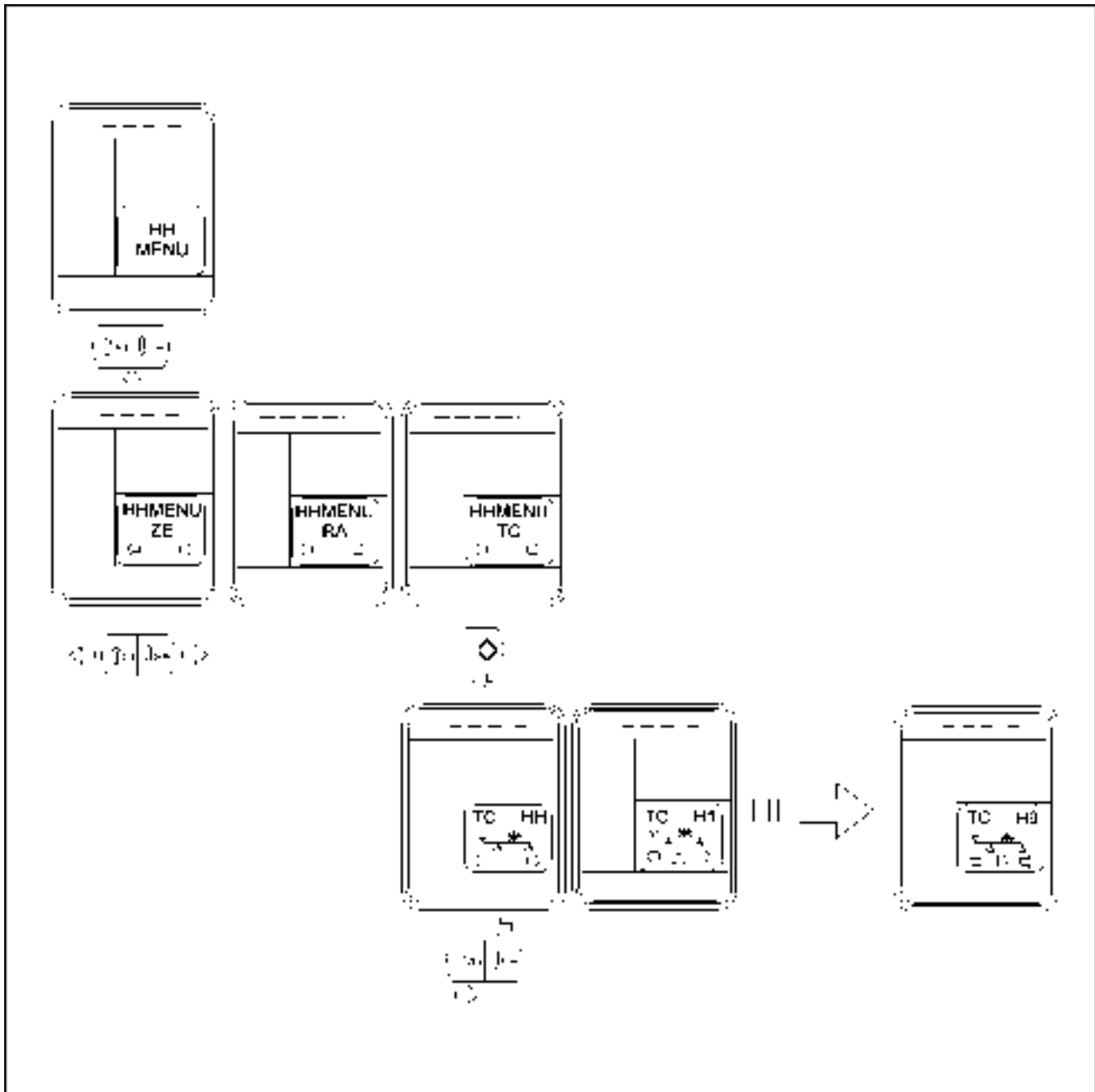

SS13A259 1

1. Enter the mode, using the diagnostic test plug (special tool **380000843**). Navigate to the TC controller H9 menu. See **Electronic module - Configure - HH-Menu overview (55.640)**.

2. Press the ENTER switch. The Dot Matrix Display (DMD) displays on the top the letters "ch \_\_" (1).

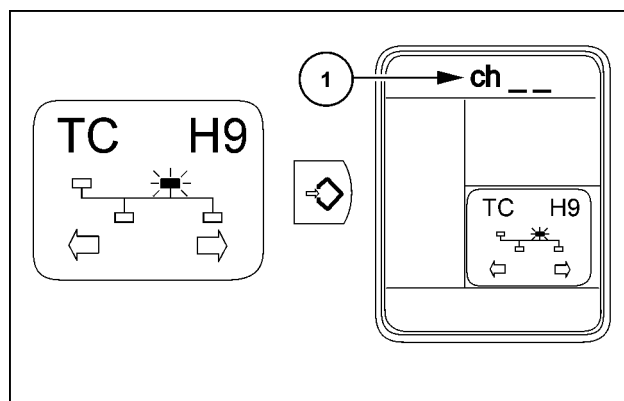

SS13A260 2

3. The required channel can be selected by using the UP and DOWN switches.

After a delay the value will be displayed, for example:

- (1) Channel number
- (2) After a delay, the display changes automatically
- (3) Alternator voltage (mV)

**NOTE:** The voltage values displayed in this menu are represented in millivolts, the current values in milliamperes. Compare the displayed value with the typical reading shown in the table below.

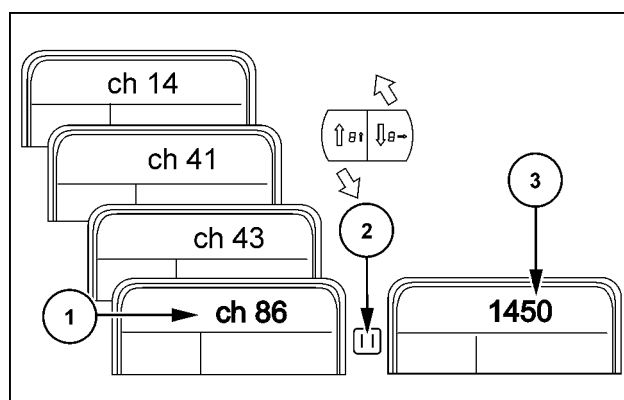

SS13A261 3

Name	Channel	Connector and pin number	Typical reading
Oil temperature sensor	ch14	X504-39	500 - 4500 mV
Direction selector neutral: inactive active	ch41	X504-41	1250 - 1750 mV 2750 - 3250 mV
Direction selector deadman: inactive active	ch43	X504-61	0 - 500 mV 4500 - 5000 mV
Direction selector backward: neutral backward	ch86	X504-42	1250 - 1750 mV 2750 - 3250 mV
Direction selector forward: neutral forward	ch87	X504-19	1250 - 1750 mV 2750 - 3250 mV
Power shuttle clutch A current sense	c100	X504-56	150 - 1200 mA
Power shuttle clutch B current sense	c101	X504-10	150 - 1200 mA
Power shuttle clutch C current sense	c102	X504-32	150 - 1200 mA
Power shuttle clutch D current sense	c103	X504-50	150 - 1200 mA
PTO valve current sense	c123	X504-51	150 - 1200 mA
Shuttle switch: forward backward inactive	c133	X504-35	6500 - 7500 mV 1700 - 2700 mV 3200 - 4200 mV
Comfort shift switch: inactive active	c134	X504-50	7000 - 8000 mV 8300 - 11000 mV
Clutch pedal position sensor	c188	X504-38	700 - 4100 mV

Name	Channel	Connector and pin number	Typical reading
Differential lock valve current sense	c192	X504-11	<b>150 - 1200 mA</b>
4WD valve current sense	c193	X504-57	<b>150 - 1200 mA</b>
<b>12 V PS2*</b>	c195	X504-8	<b>12000 mV</b>
<b>12 V PS1*</b>	c196	X504-12, X504-13	<b>12000 mV</b>
<b>12 V PE*</b>	c197	X504-23, X504-68	<b>12000 mV</b>
<b>12 V PI*</b>	c198	X504-45	<b>12000 mV</b>
<b>5 V sensor supply</b>	c217	X504-37	<b>5000 mV</b>
Power shuttle clutch F current sense	c223	X504-55	<b>150 - 1200 mA</b>
Power shuttle clutch G current sense	c224	X504-54	<b>150 - 1200 mA</b>

*	Definition
<b>12 V PS2</b>	Solenoid valve power supply 2
<b>12 V PS1</b>	Solenoid valve power supply 1
<b>12 V PE</b>	Permanent power supply
<b>12 V PI</b>	Switched battery power supply

4. Press the HOME switch to exit the menu.

---





## Transmission electronic control module Transmission Control Unit (TCU) - HB - Display stored fault codes

### Transmission Control Unit (TCU) controller identification (TC)

This function is used to display the fault codes from the TCU controller, which have been stored in EEPROM of the TCU.

**NOTE:** The vehicle may be driven while working in this menu.

The table below displays the functions and the belonging symbols for this submenu.

Function	Icon
Transmission	
Differential lock	
Four-Wheel Drive (4WD)	
Rear Power Take-Off (PTO)	



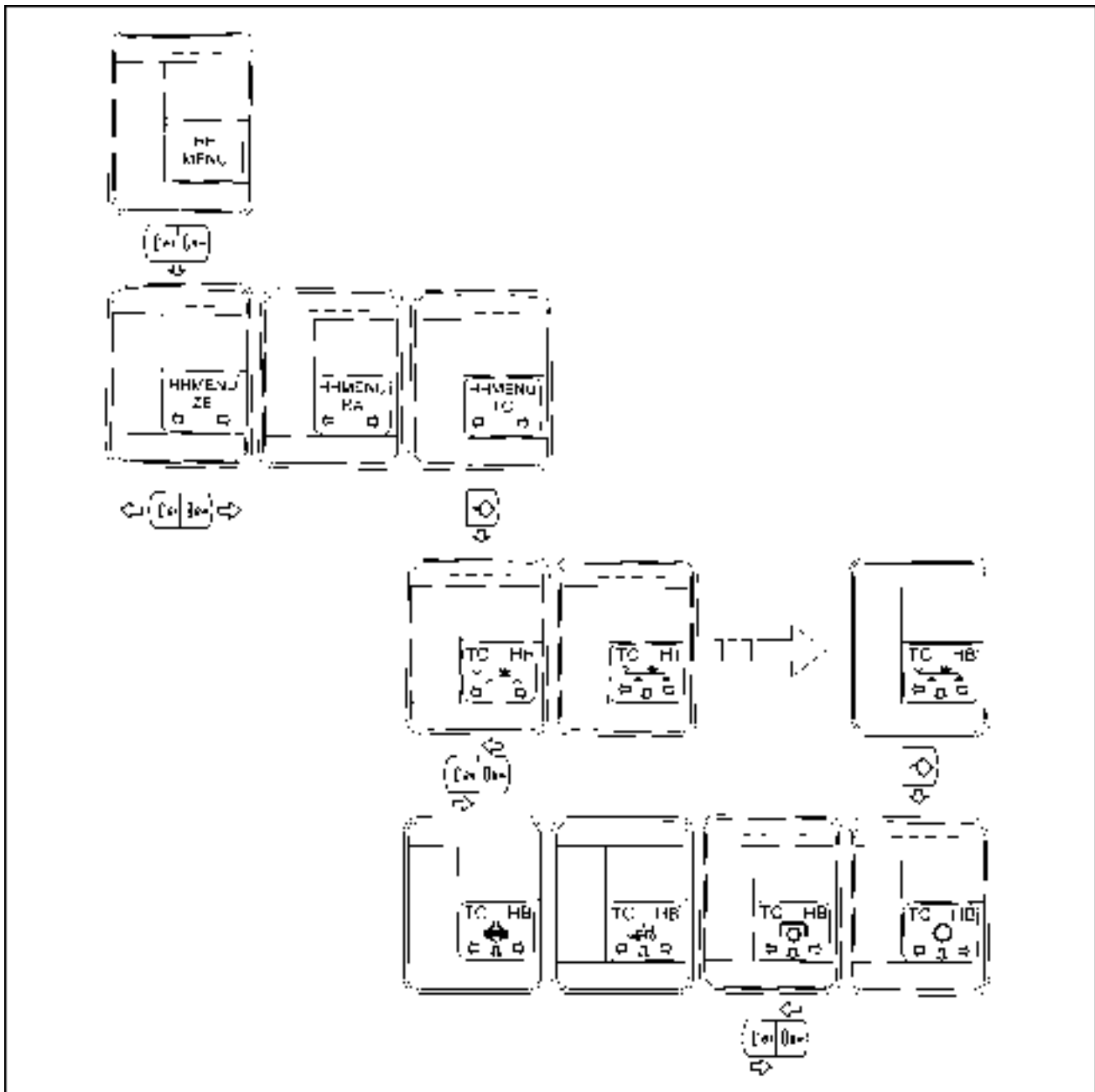

SS13A281 1

1. Enter the mode, using the diagnostic test plug (special tool **380000843**). Navigate to the TC controller HB menu. See **Electronic module - Configure - HH-Menu overview (55.640)**.

2. Press the ENTER switch.

1. If there is no fault, the DMD displays “\_ \_ \_ \_” (1)
2. If a fault is present, the DMD shows as follows:

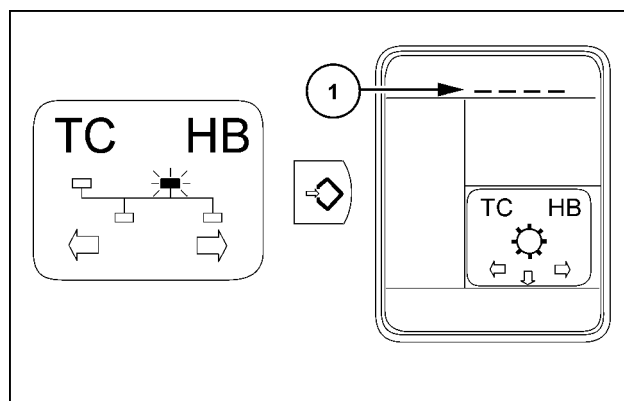

SS13A293 2

Example: first stored fault code (image 3):

“F”

“2602”: Fault code number

“0”: Absolute hour of the first occurrence

“72”: Absolute hour of the last occurrence

“2”: Number of occurrences of the fault

“2602”: Fault code number

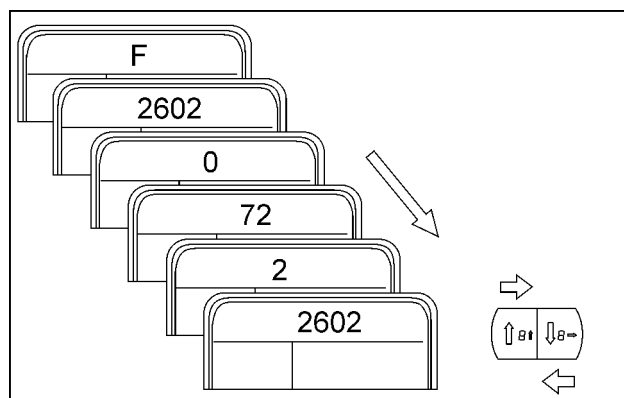

SS13A294 3

Press the UP or DOWN switch to scroll between the stored fault codes.

Example: second stored fault code (image 4):

“2363”: Fault code number

“0”: Absolute hour of the first occurrence

“70”: Absolute hour of the last occurrence

“21”: Number of occurrences of the fault

“2363”: Fault code number

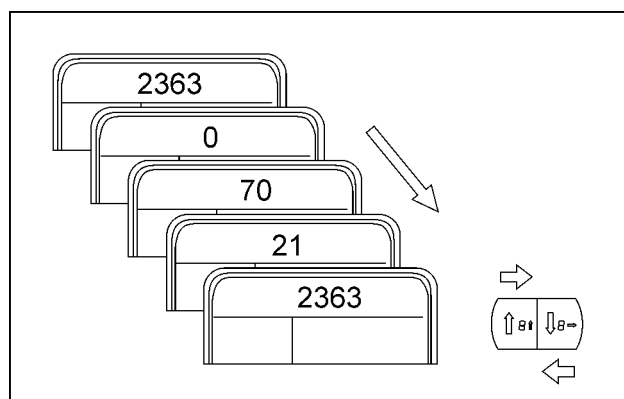

SS13A295 4

3. Press the HOME switch to exit the menu.

**NOTE:** If you would like to erase the fault codes see HC menu. See **Transmission electronic control module Transmission Control Unit (TCU) - HC - Clear all stored fault codes (55.024)**.

## Transmission electronic control module Transmission Control Unit (TCU) - HC - Clear all stored fault codes

### Transmission Control Unit (TCU) controller identification (TC)

This menu is used to delete all fault codes which have been stored in EEPROM of the control unit.

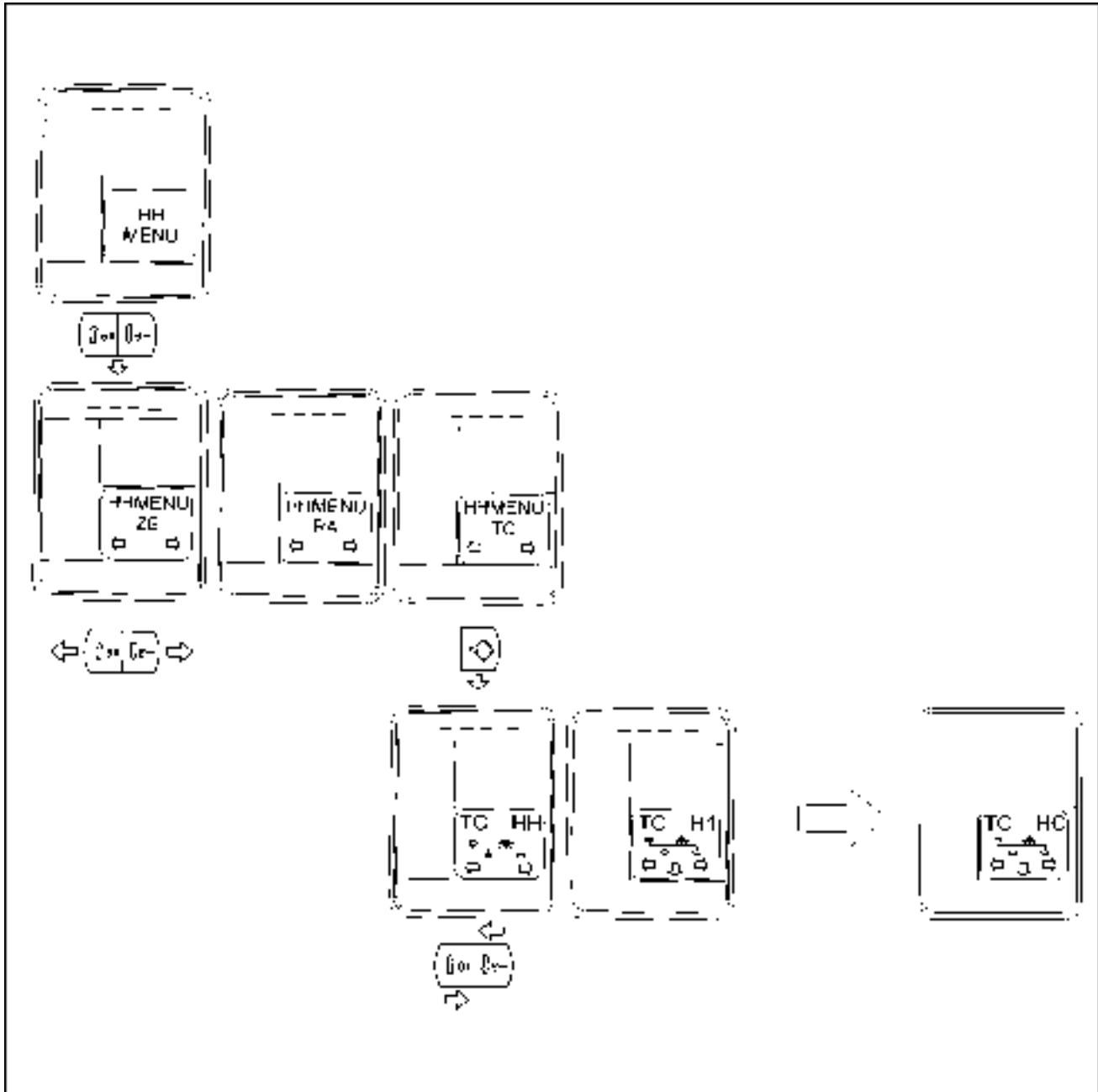

SS13A282 1

1. Enter the mode, using the diagnostic test plug (special tool **380000843**). Navigate to the TC controller, HC menu. See **Electronic module - Configure - HH-Menu overview (55.640)**.

- Press the ENTER switch. The Dot Matrix Display (DMD) displays "FCL".

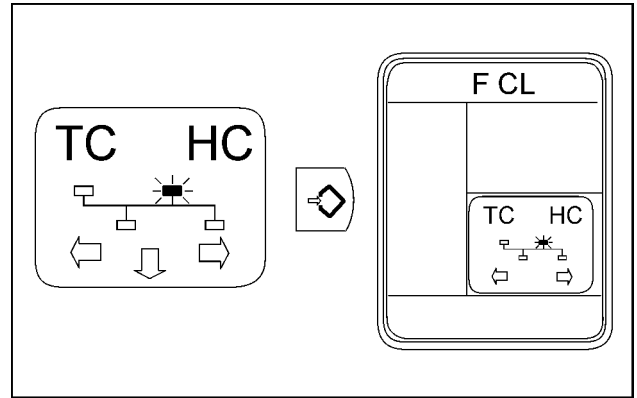

SS13A283 2

- Press and hold down the DOWN switch to delete the stored fault codes from the EEPROM. The DMD will countdown from 5 to 1. "EE" will be displayed to indicate that the stored fault codes have been deleted.

**NOTE:** If the DOWN switch is released before the countdown finishes, the procedure will return and the DMD displays "F CL".

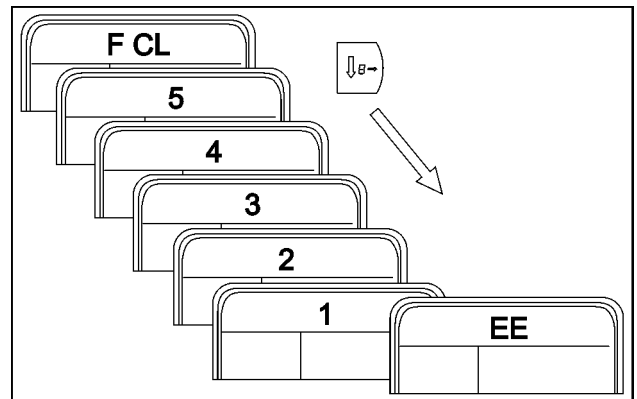

SS12N588 3

- It is not possible to continue through the H-Menu after a HC procedure. The only possible action is to turn the ignition switch OFF to allow the reset values to be stored.

## Transmission electronic control module Transmission Control Unit (TCU) - HE - Display frequency inputs

### Transmission Control Unit (TCU) controller identification (TC)

This H-Menu level is used by the service technician to verify the operation of various frequency inputs.

**NOTE:** In this mode, the vehicle is operable.

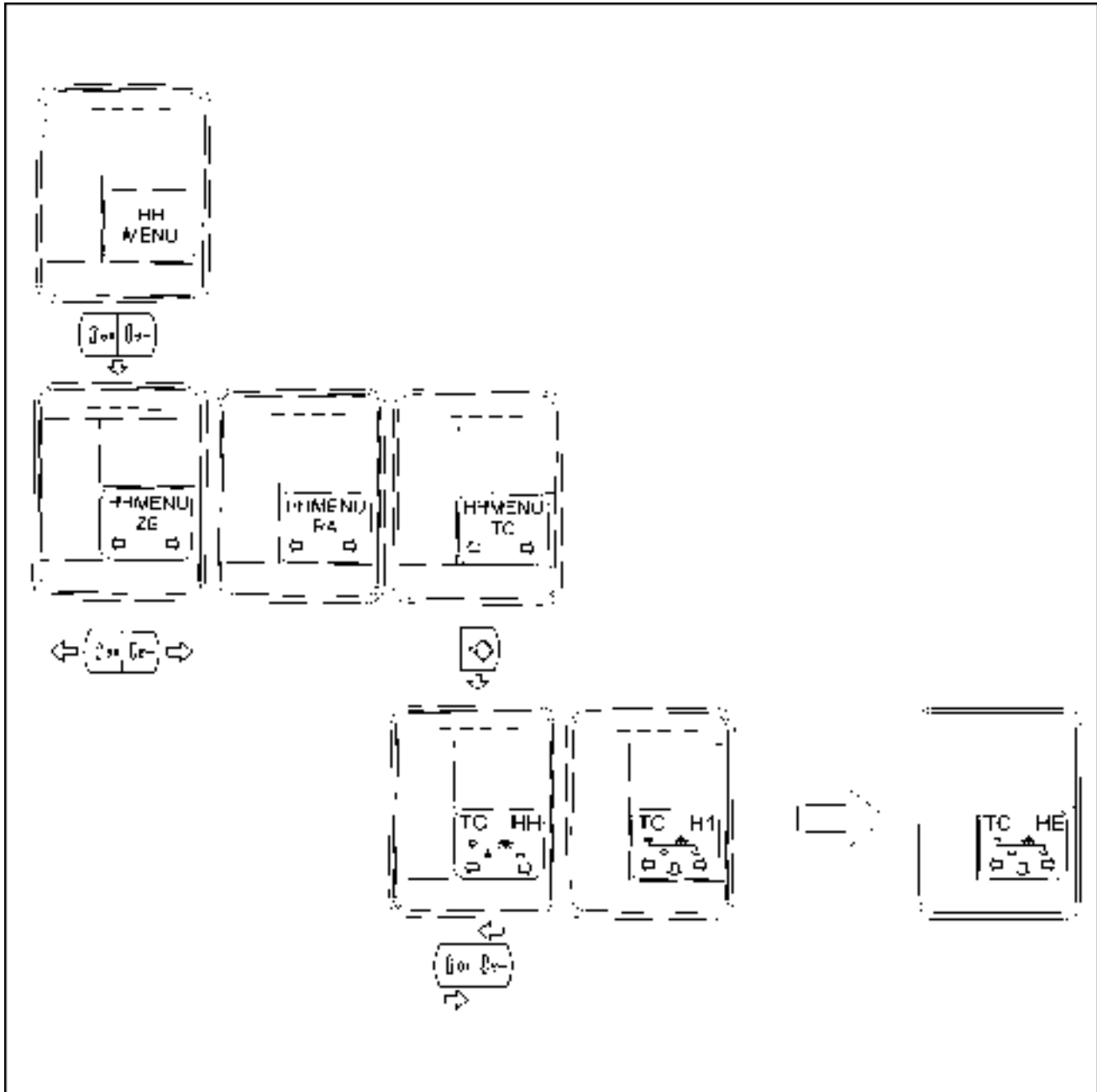

SS13A284 1

1. Enter the mode, using the diagnostic test plug (special tool **380000843**). Navigate to the TC controller HE menu. See **Electronic module - Configure - HH-Menu overview (55.640)**.

2. Press the ENTER switch. The Dot Matrix Display (DMD) displays on the top the letters "ch \_\_" (1).

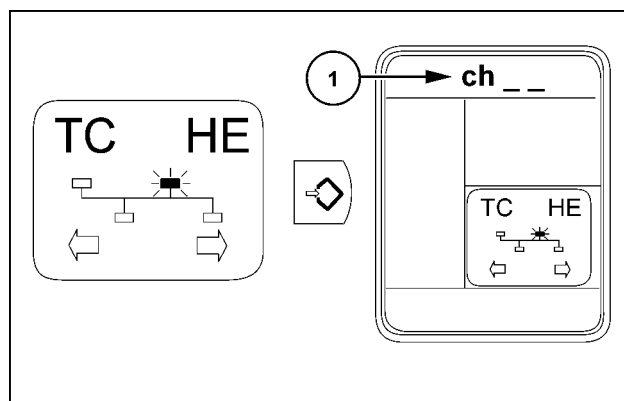

SS13A285 2

3. Press the UP or DOWN switch to select the required channel number.  
 (1) Channel number  
 (2) After a delay, the display changes automatically  
 (3) Displayed value

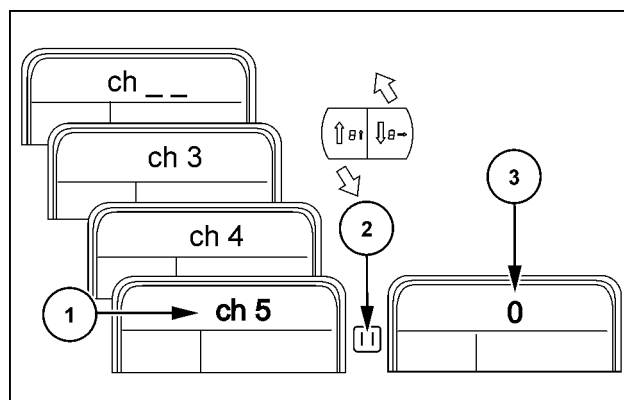

SS13A286 3

Name	Channel	Connector and pin number	Typical reading
Powershift input speed	ch3	X504-17	0 - 3000 RPM
Power Take-Off (PTO) speed	ch4	X504-16	0 - 1500 RPM
Output shaft speed	ch5	X504-62	0 - 5000 RPM
Powershift output speed	ch10	X504-40	0 - 3000 RPM

4. Press the HOME switch to go back to the H-Menu.

## Transmission electronic control module Transmission Control Unit (TCU) - HF - View controller hardware information

### Transmission Control Unit (TCU) controller identification (TC)

This menu is used to show a sequence of numbers, representing the hardware identifier, the hardware version and in some cases the hardware serial number, which are stored in EEPROM of the control unit.

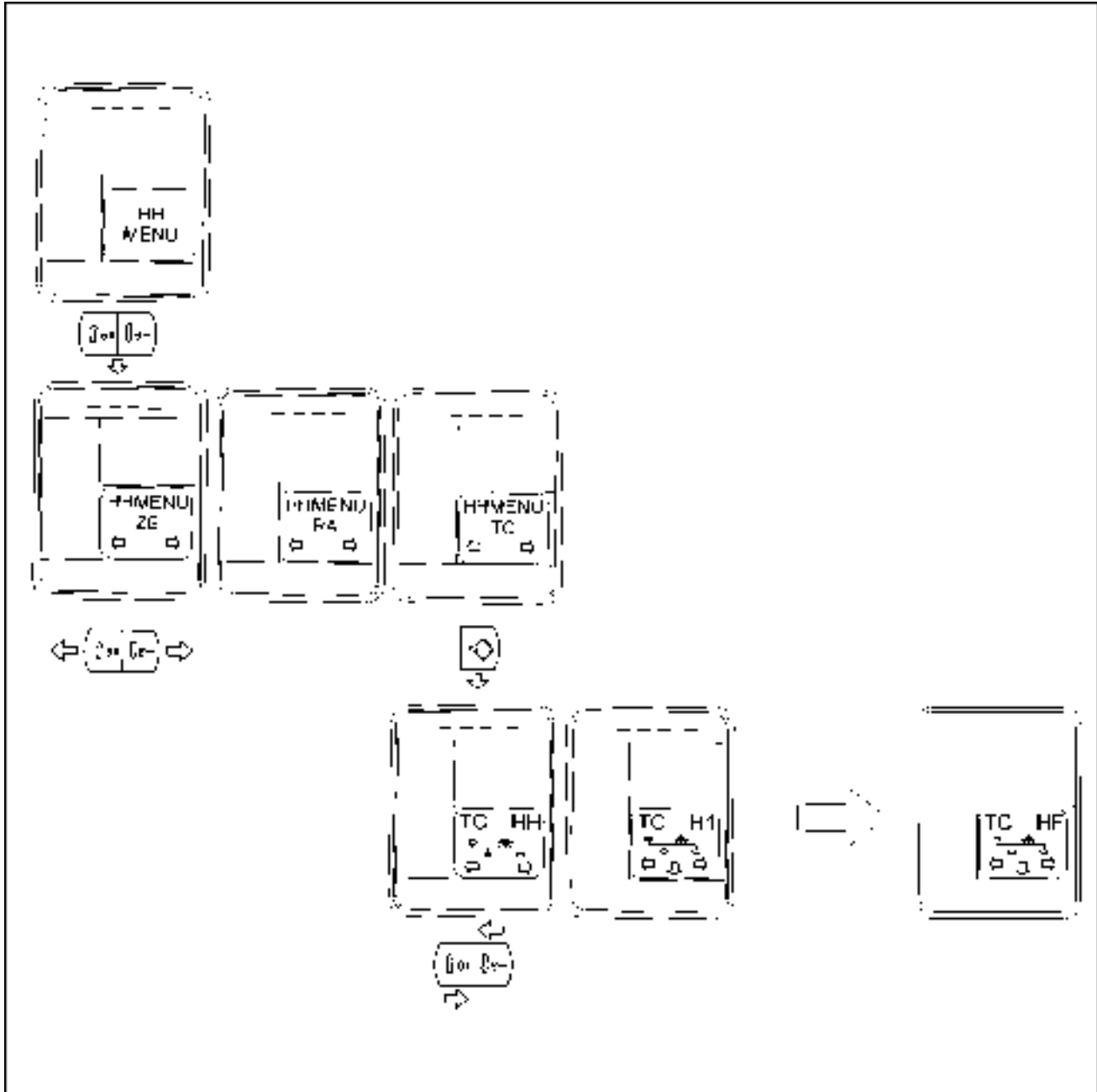

SS13A287 1

1. Enter the mode, using the diagnostic test plug (special tool **380000843**). Navigate to the TC controller, HF menu. See **Electronic module - Configure - HH-Menu overview (55.640)**.

- Press the ENTER switch. The Dot Matrix Display (DMD) displays the first sequence of numbers "0809" (1).

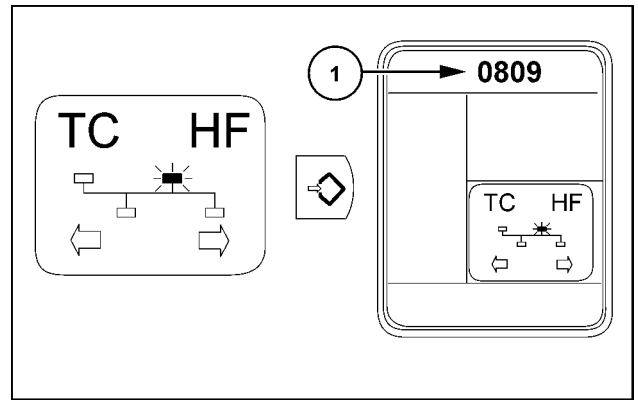

SS13A288 2

- The DMD shows a sequence of numbers, representing the hardware version and hardware serial number:
  - " -- -- "
  - "0809" Hardware identifier
  - "0100" Release number of the unit hardware
  - "0000" Unit serial number
  - " -- -- " Finished

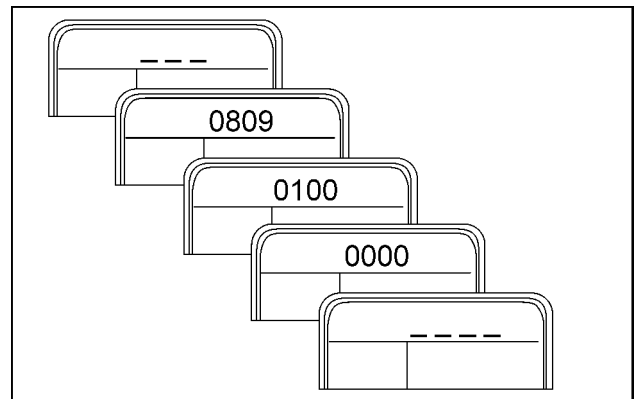

SS13A289 3

- Press the HOME switch to exit the menu.



# Index

---

## Electrical systems - 55

### Transmission control system - 024

Transmission electronic control module Transmission Control Unit (TCU) - Electronic schema . . . . .	4
Transmission electronic control module Transmission Control Unit (TCU) - H1 - Calibration procedures . . . . .	7
Transmission electronic control module Transmission Control Unit (TCU) - H2 - View stored calibration values	15
Transmission electronic control module Transmission Control Unit (TCU) - H3 - Configurations and options . . .	18
Transmission electronic control module Transmission Control Unit (TCU) - H4 - View software revision level . .	20
Transmission electronic control module Transmission Control Unit (TCU) - H5 - Switch operation test . . . . .	22
Transmission electronic control module Transmission Control Unit (TCU) - H8 - Clear stored calibration information (EEPROM) . . . . .	24
Transmission electronic control module Transmission Control Unit (TCU) - H9 - Voltmeter diagnostic . . . . .	26
Transmission electronic control module Transmission Control Unit (TCU) - HB - Display stored fault codes . . . .	29
Transmission electronic control module Transmission Control Unit (TCU) - HC - Clear all stored fault codes . . .	32
Transmission electronic control module Transmission Control Unit (TCU) - HE - Display frequency inputs . . . . .	34
Transmission electronic control module Transmission Control Unit (TCU) - HF - View controller hardware information . . . . .	36



## **Electrical systems - 55**

### **Transmission speed sensors - 020**

**Farmall 105U Pro EP  
Farmall 115U Pro EP  
Farmall 95U Pro EP**

# Contents

---

## Electrical systems - 55

### Transmission speed sensors - 020

#### FUNCTIONAL DATA

Output speed sensor	
Overview .....	3
Powershift - Overview .....	4
Transmission input speed sensor	
Powershift - Overview .....	5

## Output speed sensor - Overview

### Transmission output speed sensor (B-034)

The transmission output speed sensor (1) is located on the right-hand side of the transmission housing.



SS13E047 1

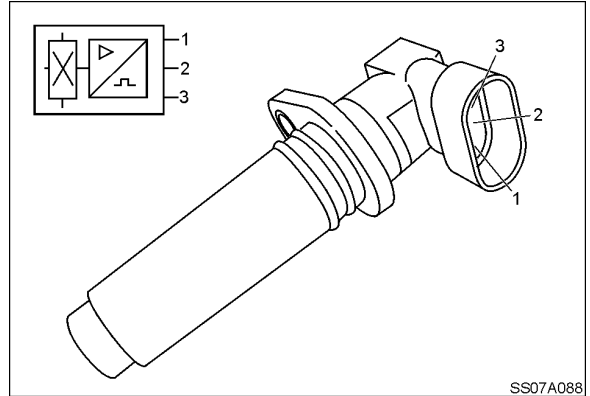

SS07A088 2

SS07A088

<b>Specifications</b>	
Sensor type	Hall-effect sensor
Sensor length (sensor mounting plate to sensor tip)	<b>77.75 mm (3.06 in)</b>
Supply voltage	<b>12 V</b>
Operating current (maximum)	<b>40 mA</b>
Operating temperature	<b>-40 - 125 °C (-40 - 257 °F)</b>
Working range	<b>2 - 6500 Hz</b>
Tightening torque	<b>25 - 30 Nm (18 - 22 lb ft)</b>
Pin 1 (supply)	Ground
Pin 2	Sensor signal (square wave)
Pin 3 (supply)	<b>12 V</b>

## Output speed sensor Powershift - Overview

### Powershift output speed sensor (B-101)

The powershift output speed sensor (1) is located on the right-hand side of the transmission housing.

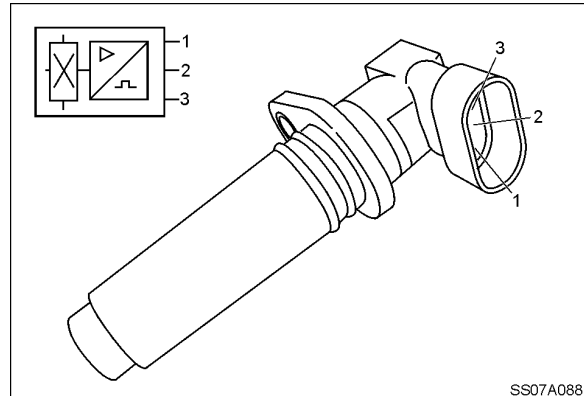

Specifications	
Sensor type	Hall-effect sensor
Sensor length (sensor mounting plate to sensor tip)	<b>77.75 mm (3.06 in)</b>
Supply voltage	<b>12 V</b>
Operating current (maximum)	<b>40 mA</b>
Operating temperature	<b>-40 - 125 °C (-40 - 257 °F)</b>
Working range	<b>2 - 6500 Hz</b>
Tightening torque	<b>25 - 30 Nm (18 - 22 lb ft)</b>
Pin 1 (supply)	Ground
Pin 2	Sensor signal (square wave)
Pin 3 (supply)	<b>12 V</b>

## Transmission input speed sensor Powershift - Overview

### Powershift input speed sensor (B-090)

The powershift input speed sensor (1) is located on the right-hand side of the transmission housing.



SS13E046 1

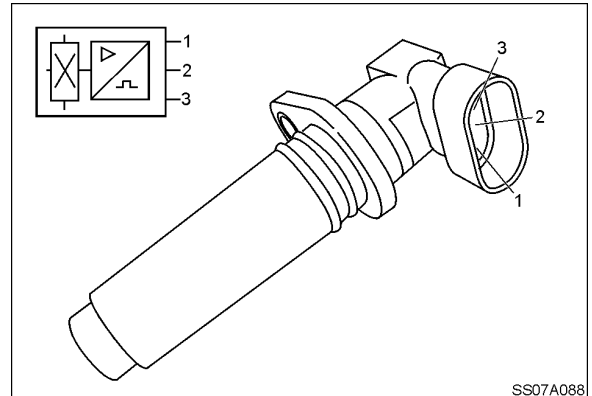

SS07A088 2

SS07A088

Specifications	
Sensor type	Hall-effect sensor
Sensor length (sensor mounting plate to sensor tip)	<b>40.0 mm (1.6 in)</b>
Supply voltage	<b>12 V</b>
Operating current (maximum)	<b>40 mA</b>
Operating temperature	<b>-40 - 125 °C (-40 - 257 °F)</b>
Working range	<b>2 - 6500 Hz</b>
Tightening torque	<b>25 - 30 Nm (18 - 22 lb ft)</b>
Pin 1 (supply)	Ground
Pin 2	Sensor signal (square wave)
Pin 3 (supply)	<b>12 V</b>

# Index

---

## Electrical systems - 55

### Transmission speed sensors - 020

Output speed sensor - Overview .....	3
Output speed sensor Powershift - Overview .....	4
Transmission input speed sensor Powershift - Overview .....	5



## **Electrical systems - 55**

### **Transmission pressure sensors - 021**

**Farmall 105U Pro EP  
Farmall 115U Pro EP  
Farmall 95U Pro EP**



# Contents

---

## Electrical systems - 55

### Transmission pressure sensors - 021

#### FUNCTIONAL DATA

Transmission oil pressure sensor and switch

Transmission oil pressure switch - Overview ..... 3

## Transmission oil pressure sensor and switch Transmission oil pressure switch - Overview

### Transmission oil pressure switch (S-036)

The transmission oil pressure switch (1) is located on the right-hand side of the transmission housing.

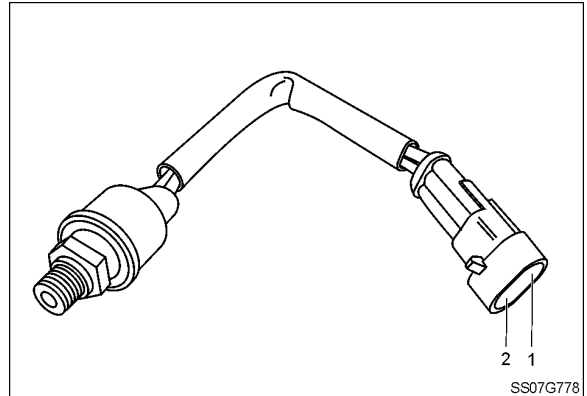
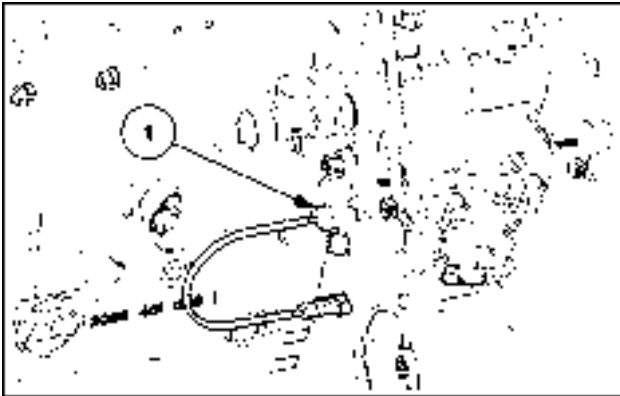

Specifications	
Supply voltage	<b>12 V</b>
Actuation pressure	<b>15.0 bar +/- 0.7 (217.5 psi)</b>
Release pressure	<b>12.5 bar +/- 0.7 (181.2 psi)</b>
Maximum pressure	<b>50.0 bar (725.0 psi)</b>

# Index

---

## Electrical systems - 55

### Transmission pressure sensors - 021

Transmission oil pressure sensor and switch Transmission oil pressure switch - Overview ..... 3



## **Electrical systems - 55**

### **Transmission temperature sensors - 022**

**Farmall 105U Pro EP  
Farmall 115U Pro EP  
Farmall 95U Pro EP**

# Contents

---

## Electrical systems - 55

### Transmission temperature sensors - 022

#### FUNCTIONAL DATA

##### Transmission fluid temperature sensor

Overview .....	3
----------------	---

## Transmission fluid temperature sensor - Overview

### Transmission oil temperature sensor (B-029)

The transmission oil temperature sensor (1) is located on the right-hand side of the transmission housing.



SS13A927 1

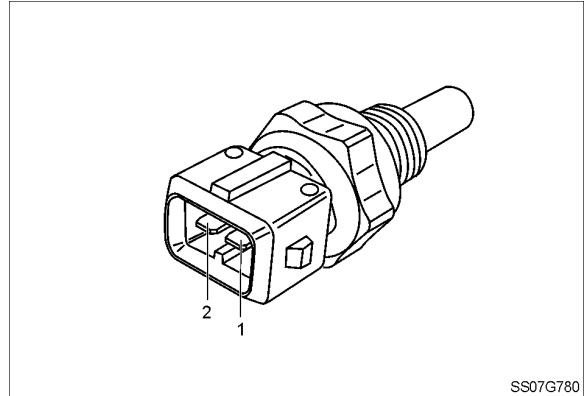

SS07G780 2

Specifications	
Supply voltage	<b>5 V</b>
Operating current (maximum)	<b>2.5 mA</b>
Operating temperature	<b>-50 - 150 °C (-58 - 302 °F)</b>
Tightening torque	<b>25 Nm (18 lb ft)</b>

Resistance test values			
Temperature	Minimum resistance	Nominal resistance	Maximum resistance
20 °C (68 °F)	946.1 Ω	960.9 Ω	975.8 Ω
80 °C (176 °F)	1468.5 Ω	1493.8 Ω	1519.0 Ω
100 °C (212 °F)	1661.0 Ω	1696.0 Ω	1731.0 Ω
120 °C (248 °F)	1854.5 Ω	1903.6 Ω	1952.7 Ω
130 °C (266 °F)	1949.5 Ω	2007.5 Ω	2065.5 Ω

# Index

---

## Electrical systems - 55

### Transmission temperature sensors - 022

Transmission fluid temperature sensor - Overview .....	3
--	---



## **Electrical systems - 55**

**Cab Power Take-Off (PTO) controls - 522**

**Farmall 105U Pro EP  
Farmall 115U Pro EP  
Farmall 95U Pro EP**



# Contents

---

## Electrical systems - 55

### Cab Power Take-Off (PTO) controls - 522

#### FUNCTIONAL DATA

Rear Power Take-Off (PTO) control	
Overview .....	3
Front Power Take-Off (PTO) control	
Overview .....	5

## Rear Power Take-Off (PTO) control - Overview

### Rear Power Take-Off (PTO) – ON/OFF switch (S-012)

The Rear Power Take-Off (PTO) – ON/OFF switch (1) is located on the right-hand console inside the cab.

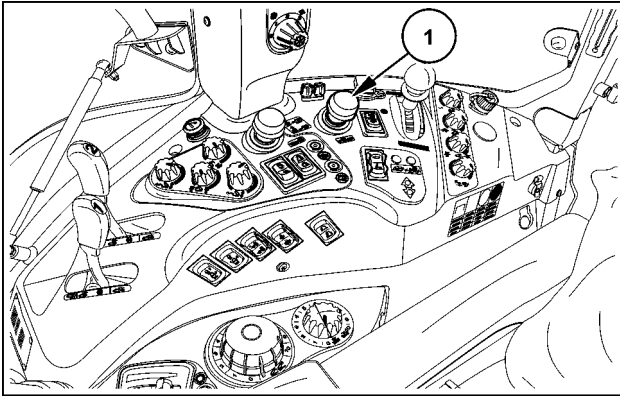

SVIL13TR00706AV 1

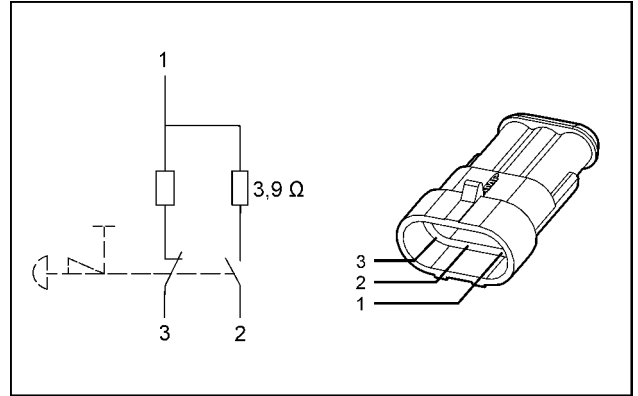

SS13N012 2

Mushroom state	Number in image 3	Input status	
		Normally open	Normally closed
Released	1	0	1
Yellow switch pressed	2	0	0
Collar and switch raised up	3	0	0
Collar up and switch released	4	1	0
Error	5	1	1

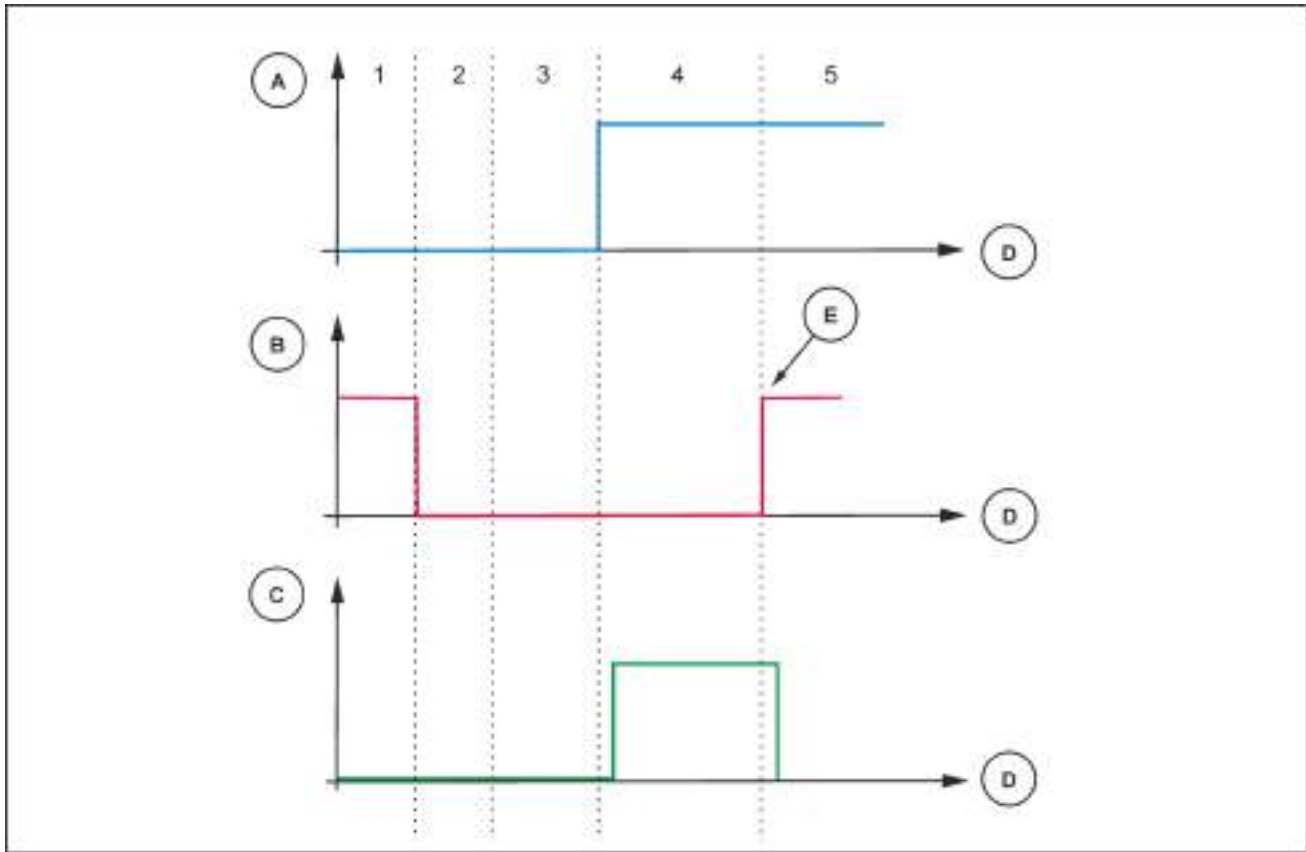

SS13N013 3

(A)	Normally open
(B)	Normally closed
(C)	PTO status
(D)	Time
(E)	Short circuit to <b>12 V</b> injected

## Front Power Take-Off (PTO) control - Overview

### Front Power Take-Off (PTO) – ON/OFF switch (S-002)

The Front Power Take-Off (PTO) – ON/OFF switch (1) is located on the right-hand console inside the cab.

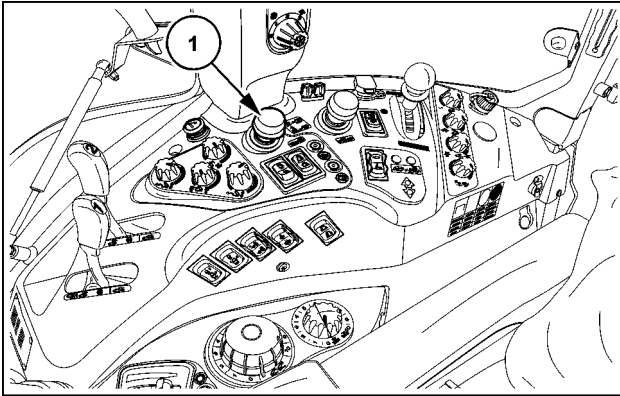

SVIL13TR00706AW 1

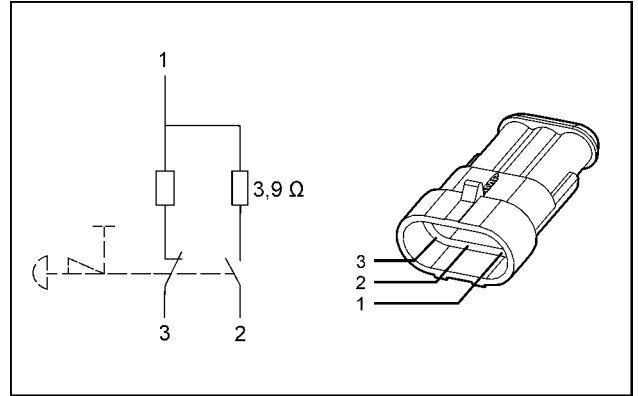

SS13N012 2

Mushroom state	Number in image 3	Input status	
		Normally open	Normally closed
Released	1	0	1
Yellow switch pressed	2	0	0
Collar and switch raised up	3	0	0
Collar up and switch released	4	1	0
Error	5	1	1

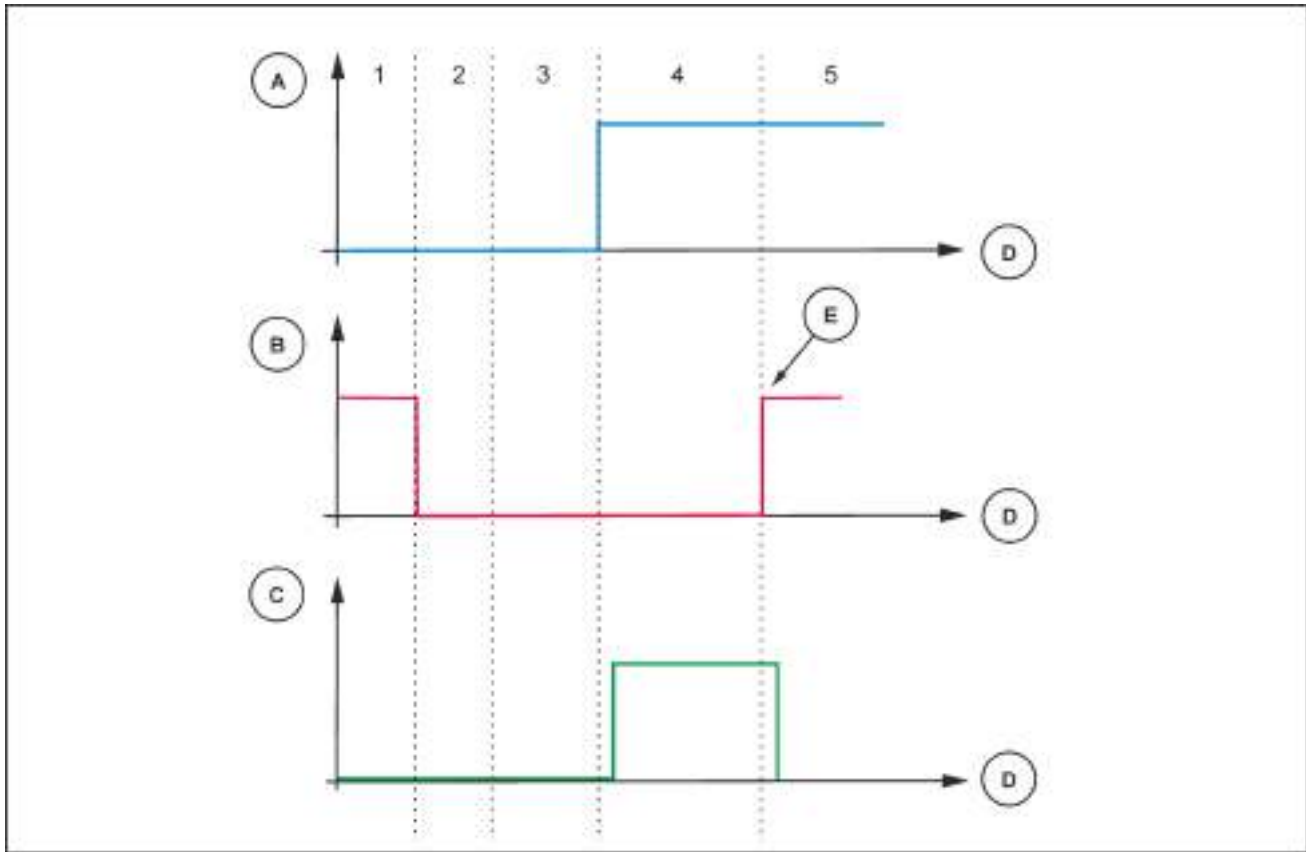

SS13N013 3

(A)	Normally open
(B)	Normally closed
(C)	PTO status
(D)	Time
(E)	Short circuit to <b>12 V</b> injected

# Index

---

## Electrical systems - 55

### Cab Power Take-Off (PTO) controls - 522

Front Power Take-Off (PTO) control - Overview .....	5
Rear Power Take-Off (PTO) control - Overview .....	3





## **Electrical systems - 55**

### **Rear Power Take-Off (PTO) control system - 048**

**Farmall 105U Pro EP  
Farmall 115U Pro EP  
Farmall 95U Pro EP**



# Contents

---

## Electrical systems - 55

### Rear Power Take-Off (PTO) control system - 048

#### FUNCTIONAL DATA

##### Power Take-Off (PTO) speed sensor

Overview .....	3
----------------	---

## Power Take-Off (PTO) speed sensor - Overview

### Rear Power Take-Off (PTO) – Speed sensor (B-026)

The speed sensor (1) is located in the bearing cover of the rear PTO shaft.

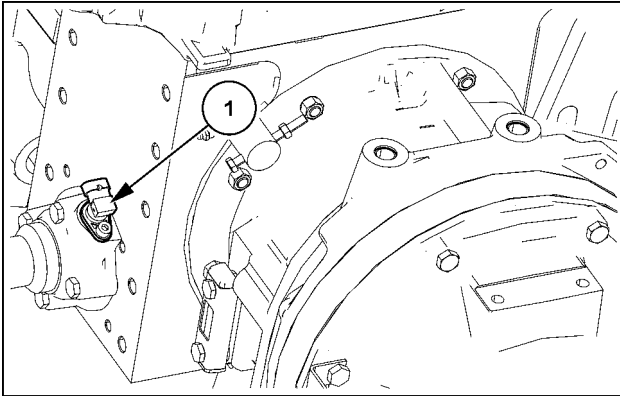

SS13A926 1

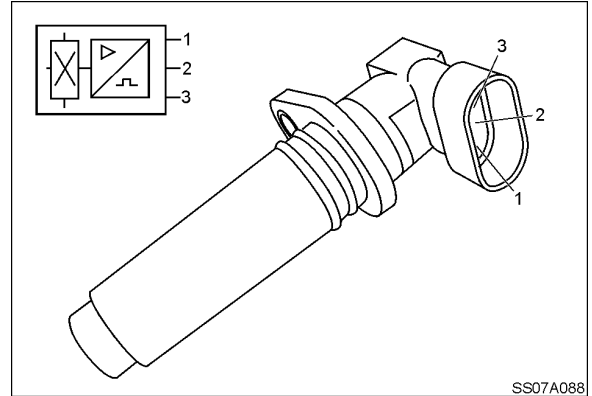

SS07A088 2

Specifications	
Sensor type	Hall-effect sensor
Sensor length (sensor mounting plate to sensor tip)	40.0 mm (1.6 in)
Supply voltage	12 V
Operating current (maximum)	40 mA
Operating temperature	-40 - 125 °C (-40 - 257 °F)
Working range	2 - 6500 Hz
Tightening torque	25 - 30 Nm (18 - 22 lb ft)
Pin 1 (supply)	Ground
Pin 2	Sensor signal (square wave)
Pin 3 (supply)	12 V

# Index

---

## Electrical systems - 55

### Rear Power Take-Off (PTO) control system - 048

Power Take-Off (PTO) speed sensor - Overview .....	3
--	---



## **Electrical systems - 55**

### **Trailer brake electrical system - 032**

**Farmall 105U Pro EP  
Farmall 115U Pro EP  
Farmall 95U Pro EP**

# Contents

---

## Electrical systems - 55

### Trailer brake electrical system - 032

#### FUNCTIONAL DATA

##### Trailer brake pressure switch

Overview ..... 3

Overview ..... 4

##### Trailer brake circuit solenoids

Overview ..... 5

## Trailer brake pressure switch - Overview

### Hydraulic trailer brake – Pressure switch (S-195)

The pressure switch (1) is on the right-hand axle trumpet housing.

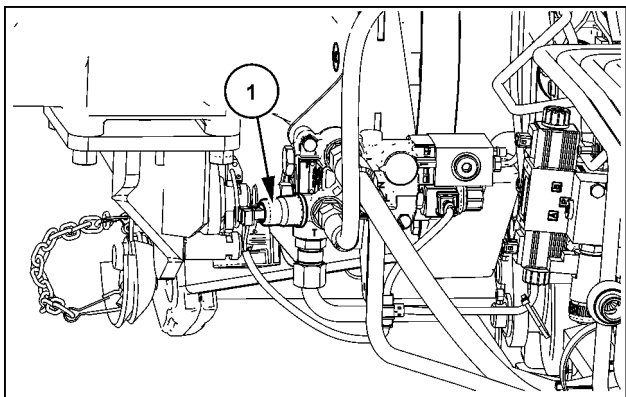

SS13F120 1

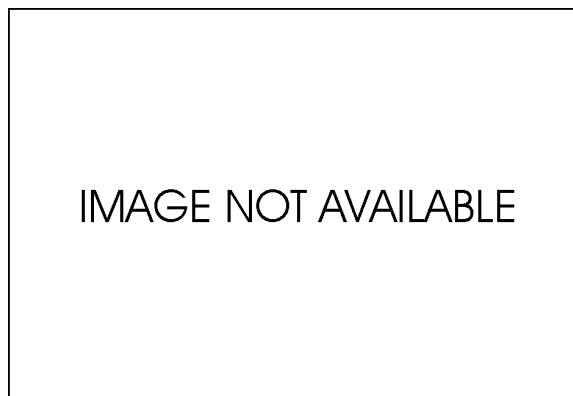

INA 2

Type of switch	Opener
Operating voltage	12VDC
Maximum switched current	<b>0.5 A</b>
The switch opens at	<b>10 bar (145 psi)</b>

## Trailer brake pressure switch - Overview

### Air brake pressure sensor (B-040)

The air brake pressure sensor measures the relative pressure as deviance from the atmospheric pressure.

The air brake pressure sensor (1) is located in the cab behind the operator's seat.

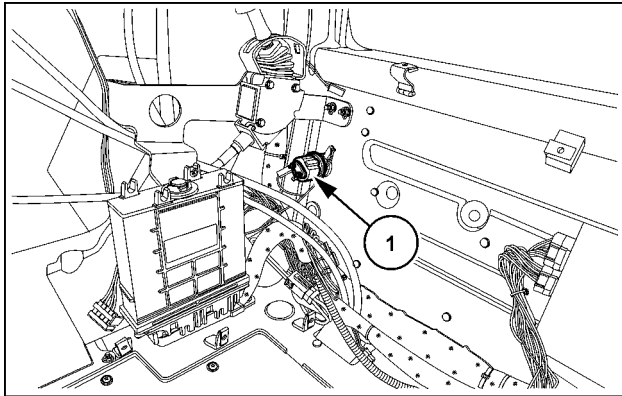

SVIL13TR00756AE 1

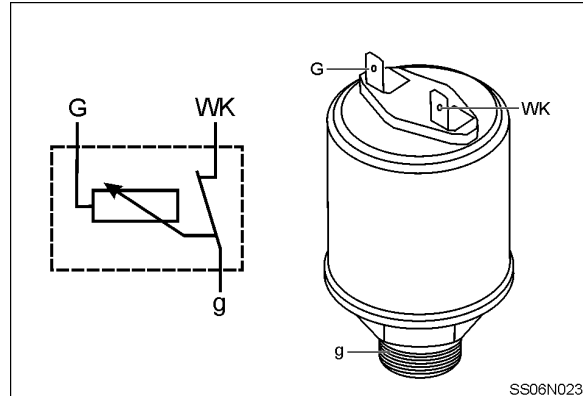

SS06N023 2

Flat pin (G)	<b>6,3 mm</b>
Ground via housing (g)	

Specifications	
Operating temperature	<b>-25 - 100 °C (-13 - 212 °F)</b>

Resistance test values	
<b>0 bar (0 psi)</b>	<b>5 - 13 Ω</b>
<b>2 bar (29 psi)</b>	<b>48 - 56 Ω</b>
<b>4 bar (58 psi)</b>	<b>84 - 92 Ω</b>
<b>6 bar (87 psi)</b>	<b>119 - 129 Ω</b>
<b>8 bar (116 psi)</b>	<b>145 - 170 Ω</b>
<b>10 bar (145 psi)</b>	<b>154 - 214 Ω</b>

## Trailer brake circuit solenoids - Overview

### Hydraulic trailer brake – Solenoid valve (Y-037)

The solenoid valve (1) is on the right-hand axle trumpet housing.

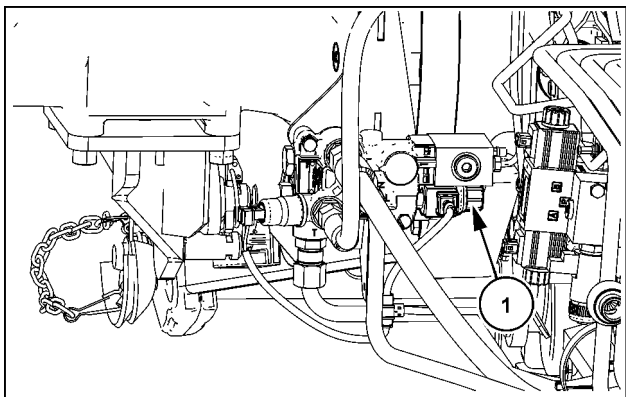

SS13F119 1

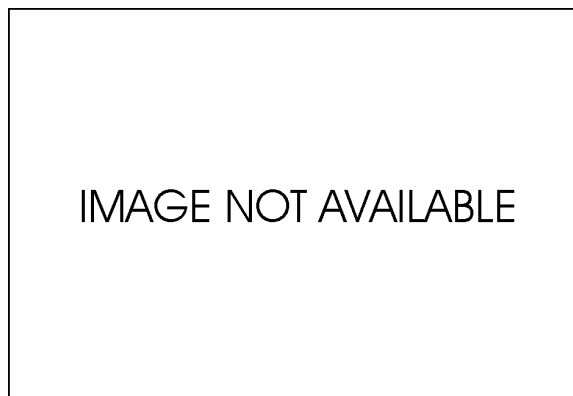

INA 2

Operating voltage	12VDC
Coil resistance at 20 °C (68 °F)	8 Ω
Current consumption (nominal)	1.5 A



# Index

---

## Electrical systems - 55

### Trailer brake electrical system - 032

Trailer brake circuit solenoids - Overview .....	5
Trailer brake pressure switch - Overview .....	3
Trailer brake pressure switch - Overview .....	4



## **Electrical systems - 55**

### **Remote control valve electric control - 035**

**Farmall 105U Pro EP  
Farmall 115U Pro EP  
Farmall 95U Pro EP**

# Contents

---

## Electrical systems - 55

### Remote control valve electric control - 035

#### FUNCTIONAL DATA

Remote control valve control unit	
Electronic schema .....	4
Solenoid valves	
Overview .....	7



## Remote control valve control unit - Electronic schema

Component identification	
1.	Remote valve relay
2.	CAN bus termination resistor
3.	Diagnostic socket (CAN bus 2)
4.	Electro Hydraulic Remote (EHR) valve 1 – Front implement
5.	Electro Hydraulic Remote (EHR) valve 2 – Front implement
6.	Electro Hydraulic Remote (EHR) valve 3 – Rear implement
7.	Electro Hydraulic Remote (EHR) valve 4 – Rear implement
8.	Remote valve joystick
9.	Sensor ground
10.	Chassis ground
11.	Supply ground

Electrical systems - Remote control valve electric control

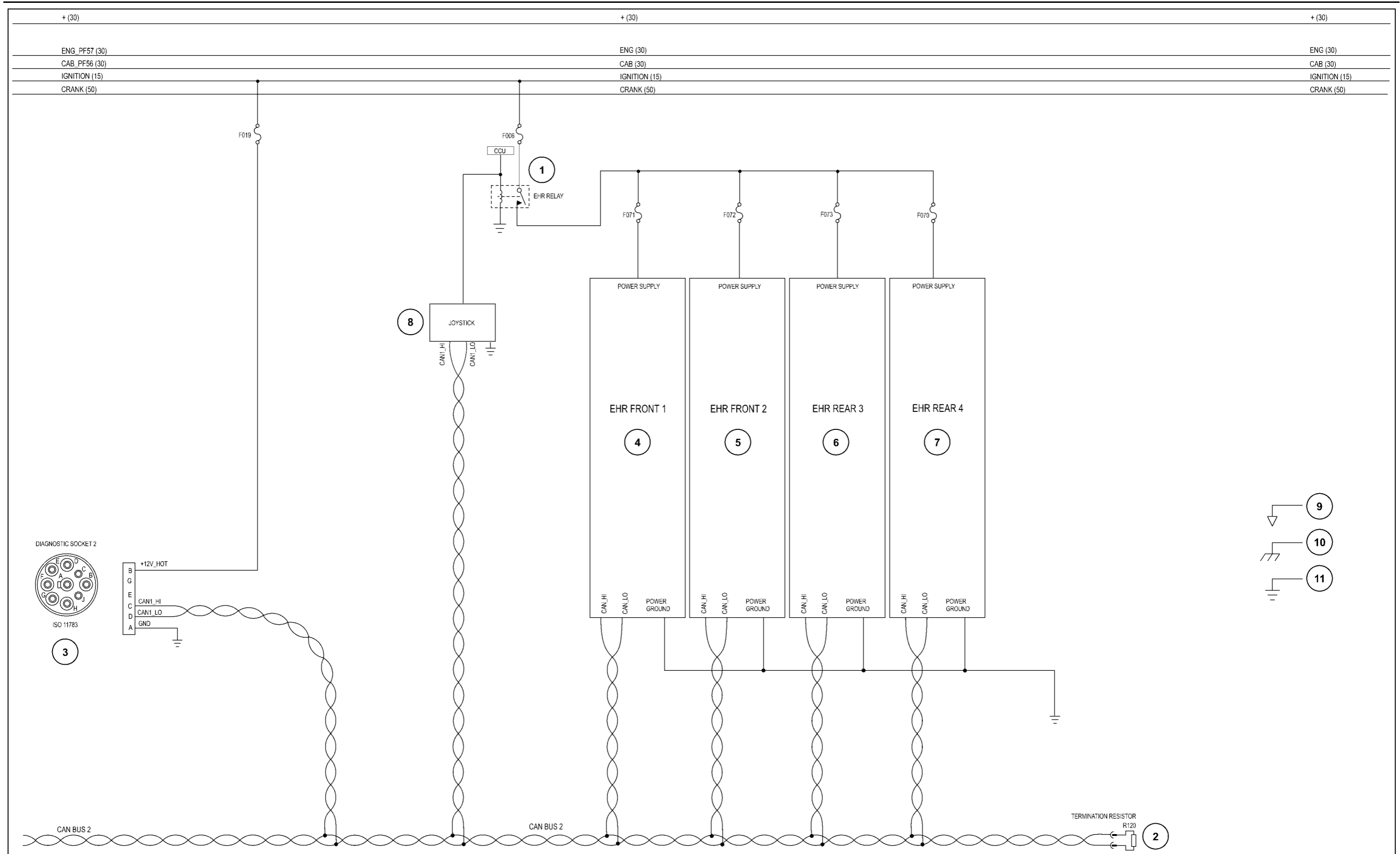

SS13A216 1



## Solenoid valves - Overview

The solenoid valves (1) are located above the rear axle.

**NOTE:** The position of the auxiliary distributors can vary depending on the vehicle version.

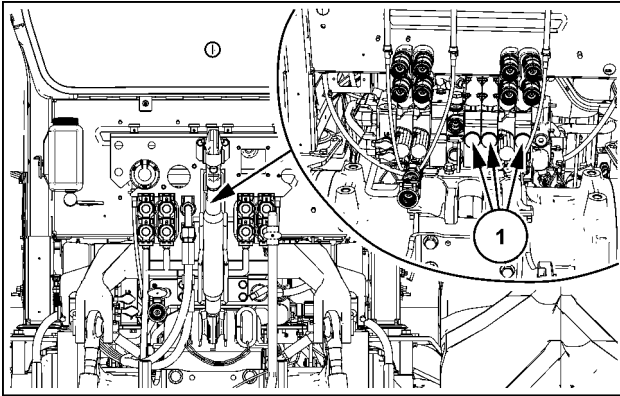

SS13N039 1

Supply voltage	<b>12 V</b>
Duty cycle	<b>100 % to 110 °C (230 °F)</b>
Protection type	IPX6, IPX9K
Electrical power consumption	<b>17 W</b>



# Index

---

## Electrical systems - 55

### Remote control valve electric control - 035

Remote control valve control unit - Electronic schema .....	4
Solenoid valves - Overview .....	7



## **Electrical systems - 55**

### **Hydraulic system control - 036**

**Farmall 105U Pro EP  
Farmall 115U Pro EP  
Farmall 95U Pro EP**

# Contents

---

## Electrical systems - 55

## Hydraulic system control - 036

### FUNCTIONAL DATA

#### Hydraulic fluid temperature control sensor

Overview .....	3
----------------	---

## Hydraulic fluid temperature control sensor - Overview

### Hydraulic oil temperature sensor (B-106)

The hydraulic oil temperature sensor (1) is located at the rear of the hydraulic oil tank.

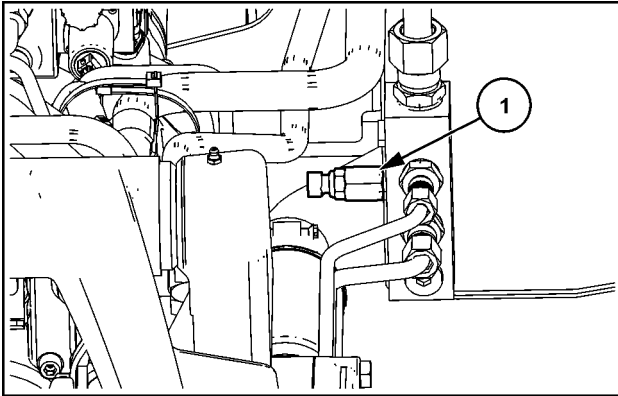

SS13K123 1

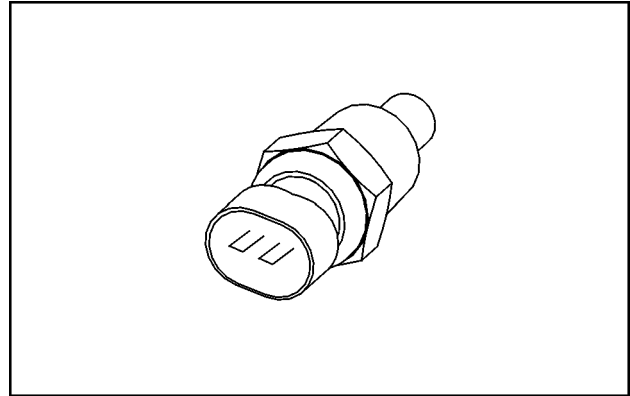

SS13K124 2

Supply voltage	<b>5 V</b>
Operating temperature	<b>-30 - 130 °C (-22 - 266 °F)</b>
Torque	<b>14 - 18 N·m (10 - 13 lb ft)</b>

#### Resistance values

Temperature	Minimum resistance	Maximum resistance
<b>0 °C (32 °F)</b>	<b>1140 Ω</b>	<b>1339 Ω</b>
<b>25 °C (77 °F)</b>	<b>460 Ω</b>	<b>540 Ω</b>
<b>40 °C (104 °F)</b>	<b>285 Ω</b>	<b>335 Ω</b>

# Index

---

## Electrical systems - 55

## Hydraulic system control - 036

Hydraulic fluid temperature control sensor - Overview ..... 3



## **Electrical systems - 55**

**Heating, Ventilation, and Air-Conditioning (HVAC) control system -  
050**

**Farmall 105U Pro EP  
Farmall 115U Pro EP  
Farmall 95U Pro EP**

# Contents

---

## Electrical systems - 55

### Heating, Ventilation, and Air-Conditioning (HVAC) control system - 050

#### FUNCTIONAL DATA

Heating, Ventilation, and Air-Conditioning (HVAC) control system	
Electronic schema .....	4





---

## Heating, Ventilation, and Air-Conditioning (HVAC) control system - Electronic schema

Component identification	
1.	Heating control unit
2.	Cab roof – Power supply relay
3.	Air-conditioning control panel
4.	Blower motor left-hand
5.	Blower motor right-hand
6.	Antifreeze module
7.	Evaporator temperature sensor
8.	Air-conditioning system – Pressure switch
9.	Air-conditioning compressor relay
10.	Air-conditioning compressor – Magnetic clutch
11.	Heating control valve
12.	Sensor ground
13.	Chassis ground
14.	Power ground

Electrical systems - Heating, Ventilation, and Air-Conditioning (HVAC) control system

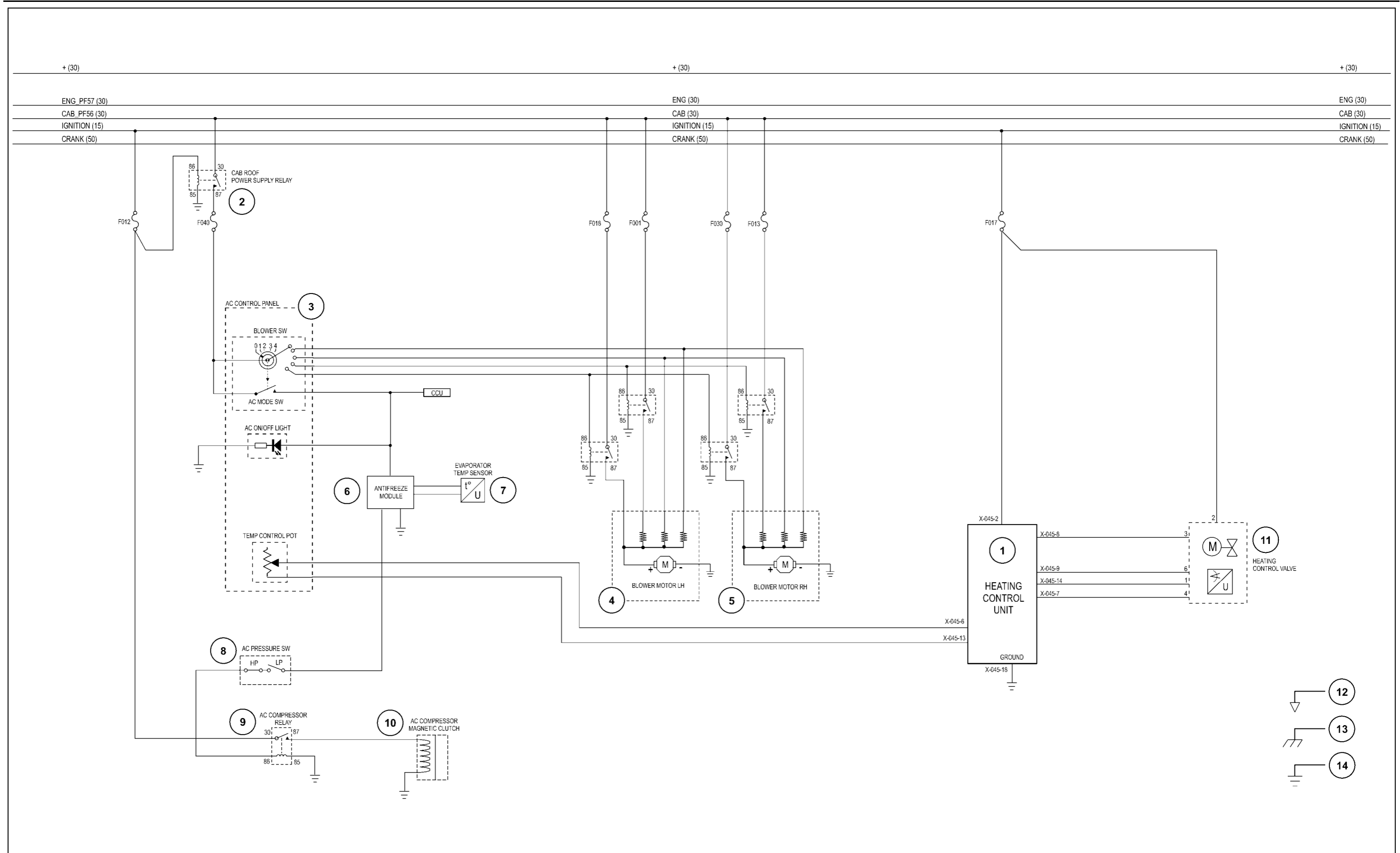

SS13A217 1



# Index

---

## Electrical systems - 55

### Heating, Ventilation, and Air-Conditioning (HVAC) control system - 050

Heating, Ventilation, and Air-Conditioning (HVAC) control system - Electronic schema .....	4
--	---





## **Electrical systems - 55**

**Rear three-point hitch electronic control system - 130**

**Farmall 105U Pro EP  
Farmall 115U Pro EP  
Farmall 95U Pro EP**

# Contents

---

## Electrical systems - 55

### Rear three-point hitch electronic control system - 130

#### FUNCTIONAL DATA

Hitch control solenoids	
Overview – Raise, lower .....	3

## Hitch control solenoids - Overview – Raise, lower

### Raising solenoid valve (Y-012), lowering solenoid valve (Y-013)

The solenoid valves (1) are located above the rear axle.

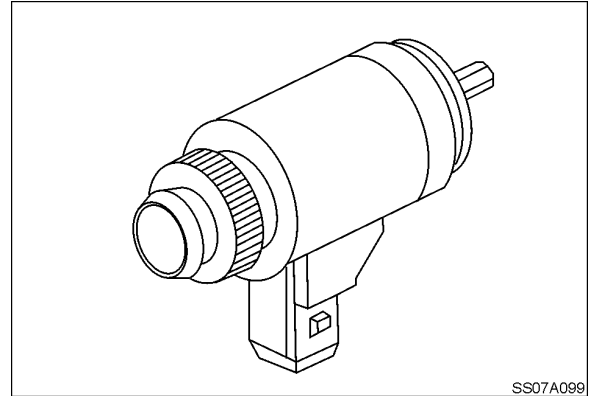
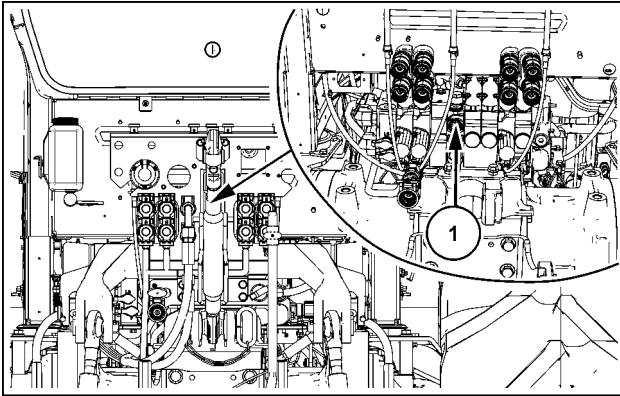

Maximum current consumption	<b>3.35 A</b>
Solenoid coil resistance	<b>1.7 Ω</b>
Permissible duty cycle at an oil temperature of <b>100 °C (212 °F)</b> and <b>2.9 A</b> (maximum current)	<b>100 %</b>



# Index

---

## Electrical systems - 55

### Rear three-point hitch electronic control system - 130

Hitch control solenoids - Overview – Raise, lower .....	3
---	---



## **Electrical systems - 55**

**Front hitch electronic control system - 160**

**Farmall 105U Pro EP  
Farmall 115U Pro EP  
Farmall 95U Pro EP**

# Contents

---

## Electrical systems - 55

### Front hitch electronic control system - 160

#### FUNCTIONAL DATA

##### Front hitch electronic control module

Electronic schema .....	4
-------------------------	---



## Front hitch electronic control module - Electronic schema

Component identification	
1.	Electronic Front Hitch (EFH) control unit
2.	Front hitch up/down switch – Cab inside
3.	Front hitch up/down switch – External
4.	Front hitch electronic control panel
5.	Front hitch position or pressure value – Control potentiometer
6.	Front hitch drop rate – Control potentiometer
7.	Front hitch height limit – Control potentiometer
8.	Front hitch position and/or pressure mix – Control potentiometer
9.	Front hitch switch – Auto/manual raise mode
10.	Front hitch raise relay
11.	Front hitch lower relay
12.	Front hitch pressure sensor
13.	Front hitch position sensor
14.	Front hitch diagnostic light
15.	Front hitch relief pressure – Indicator light
16.	Front hitch solenoid valve – Accumulator ( <b>14 bar (203 psi)</b> )
17.	Front hitch solenoid valve – Accumulator ( <b>40 bar (580 psi)</b> )
18.	Front hitch – Raise solenoid valve
19.	Front hitch – Lower solenoid valve
20.	Electronic Front Hitch (EFH) – Power supply relay
21.	Front hitch lock relay
22.	Sensor ground
23.	Chassis ground
24.	Supply ground

Electrical systems - Front hitch electronic control system

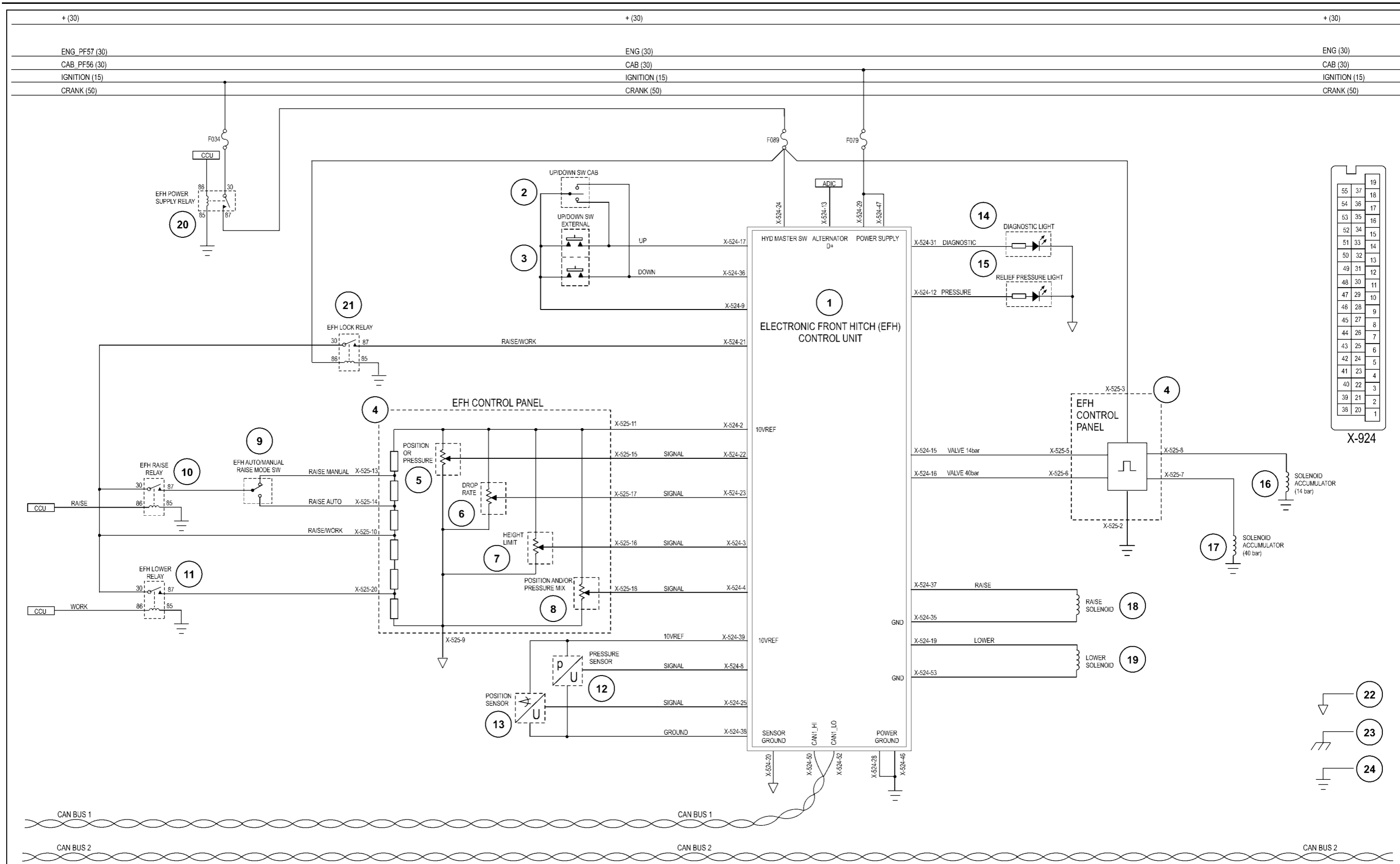

55	37	19
54	36	17
53	35	16
52	34	15
51	33	14
50	32	13
49	31	12
48	30	11
47	29	10
46	28	9
45	27	8
44	26	7
43	25	6
42	24	5
41	23	4
40	22	3
39	21	2
38	20	1

X-924



# Index

---

## Electrical systems - 55

### Front hitch electronic control system - 160

Front hitch electronic control module - Electronic schema .....	4
---	---







## **Electrical systems - 55**

**Warning indicators, alarms, and instruments - 408**

**Farmall 105U Pro EP  
Farmall 115U Pro EP  
Farmall 95U Pro EP**

# Contents

---

## Electrical systems - 55

### Warning indicators, alarms, and instruments - 408

#### FUNCTIONAL DATA

##### Instrument cluster

Overview .....	3
Dynamic description Speed calibration .....	6
Dynamic description programming maintenance work .....	8
Dynamic description setting units of measurement .....	10
Dynamic description oil change counter reset .....	11
Dynamic description .....	12
Dynamic description – setting hours worked .....	19
Dynamic description – Hour meter reset .....	21
Dynamic description fault codes display .....	22
Static description alarms .....	23

## Instrument cluster - Overview

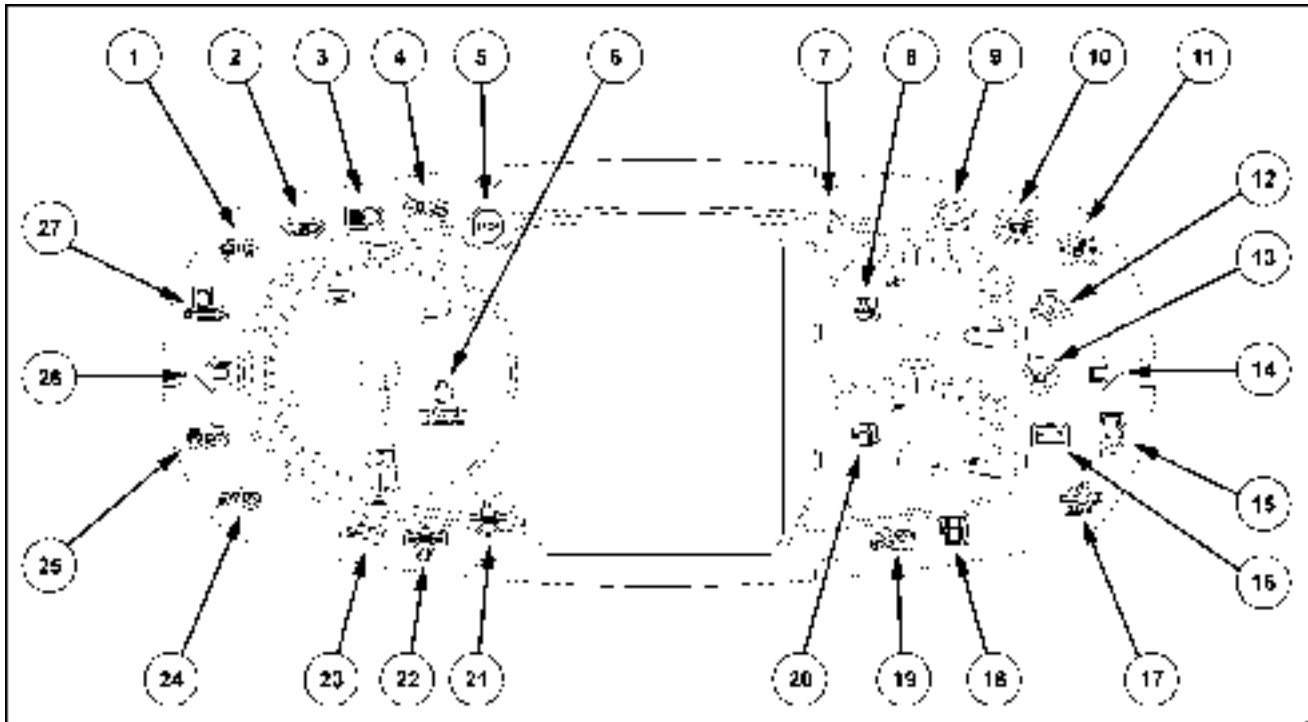

SS12M019 1

The indicator lights on the control panel provide information of the operational condition of the machine. Some of these indicate errors arising during operation. An indicator light coming on may be followed by a continuous or intermittent buzzer. Depending on the severity of the trouble, the alarm will sound.

No.	Description	Signal/Connector pin		
		CAN	Ground	+ 12 V
(1)	<b>Trailer turn signal (green)</b> The light will illuminate with tractor/trailer turn signals when a trailer is attached.			X-450-17
(2)	<b>Trailer turn signal (green)</b> The light will illuminate with tractor/trailer turn signals when a second trailer is attached.			X-450-18
(3)	<b>Headlight high beam (blue)</b> The light illuminate when the tractor lights are switched to high beam.			X-460-6
(4)	<b>Parking lights (green)</b> The light will illuminate when the tractor lights are switched on.			X-460-19
(5)	<b>Stop light (red)</b> If stop light comes on stop the tractor immediately and investigate the cause. A warning symbol will appear in the DMD to confirm the location of the error.	ECU CCU TCU		
(6)	<b>Engine tachometer</b> Indicates the engine rpm. Each subdivision of the graduated scale represents 100 revs/minute.	ECU		

No.	Description	Signal/Connector pin		
		CAN	Ground	+ 12 V
(7)	<b>Warning light (amber)</b> Illumination of this light will be accompanied by a warning symbol in the DMD.	ECU CCU TCU		
(8)	<b>Engine coolant temperature gauge</b> This light will illuminate when the engine coolant temperature is very high.	ECU		
(9)	<b>Parking brake (red)</b> This light will illuminate with ignition key on and parking brake applied. If the ignition key is turned off and the parking brake not applied, or the operator leaves the seat without applying the parking brake, a warning buzzer will sound and the parking brake lamp will flash for approximately <b>10 s</b> or until the parking brake has been applied.			X-460-8
(10)	<b>Trailer brake pressure (red)</b> This light will illuminate to indicate that the pressure to the trailer brake circuit is low. Stop the tractor and investigate the cause.		X-460-12	
(11)	<b>Brake pedals not latched (red)</b> The light will illuminate to show when pedal latch is unlocked (Japan only).			X-450-9
(12)	<b>Engine oil pressure low (red)</b> This light will illuminate when the engine oil pressure is low. Stop the engine and investigate the cause.	ECU		
(13)	<b>Cold start device (amber)</b> This light will illuminate when the grid heater is activated using the ignition key.	ECU		

No.	Description	Signal/Connector pin		
		CAN	Ground	+ 12 V
(14)	<b>Right turn indicator (green)</b> The light will flash with tractor right-hand turn signal. Continuous alarm will sound if indicator is not cancelled after <b>20 s</b> (tractor moving) or <b>5 min</b> (tractor stationary).			X-460-10
(15)	<b>Constant engine speed (amber)</b> The light will illuminate when constant engine speed is engaged	ECU		
(16)	<b>Alternator (red)</b> The light continuously illuminated indicates that the alternator is not charging the battery.			X-460-13
(17)	<b>Filter clogging warning light (DPF) (green)</b> The warning light is on steady with automatic regeneration of the Diesel Particulate Filter (DPF). It flashes during the phase of particulate filter regeneration.	ECU		
(18)	<b>Fuel level low (amber)</b> The light will be illuminated when the tractor requires refueling.			X-450-2
(19)	<b>Rear auto Power Take-Off (PTO) (amber)</b> The light will illuminate when the Auto PTO function is enabled. Each time the implement is raised and the PTO is stopped, the light will flash. When the implement is lowered into work and the PTO engages, the light will cease to flash and become steady.	CCU		
(20)	<b>Fuel level gauge</b> This instrument shows the fuel level in the tank.			X-450-2
(21)	<b>Rear differential lock (amber)</b> The light will illuminate when the differential lock is engaged.	TCU		
(22)	<b>Front differential lock (amber)</b> The light will illuminate when the differential lock is engaged.	CCU		
(23)	<b>Four wheel drive (amber)</b> The light will illuminate when the drive to the front wheels is engaged.	TCU		

(24)	<p><b>Rear Power Take–Off (PTO) warning light (amber)</b>                  The light will illuminate when the engine is running and the rear Power Take–Off is engaged. The warning light, from being on steady, starts blinking when the Power Take–Off exceeds the maximum permissible number of revs.</p>	TCU		
(25)	<p><b>Front Power Take–Off (PTO) warning light (amber)</b>                  The light will illuminate when the engine running and the front Power Take–Off is engaged.</p>	CCU		
(26)	<p><b>Left turn indicator (green)</b>                  The light will flash with tractor left-hand turn signal. Intermittent alarm will sound if indicator is not cancelled after <b>20 s</b> (tractor moving) or <b>5 min</b> (tractor stationary).</p>			X-460-9
(27)	<p><b>Timer for Electro Hydraulic Remotes (EHR's) (amber)</b>                  The light will illuminate whenever one of the EHR timer is active.</p>	CCU		

## Instrument cluster - Dynamic description Speed calibration

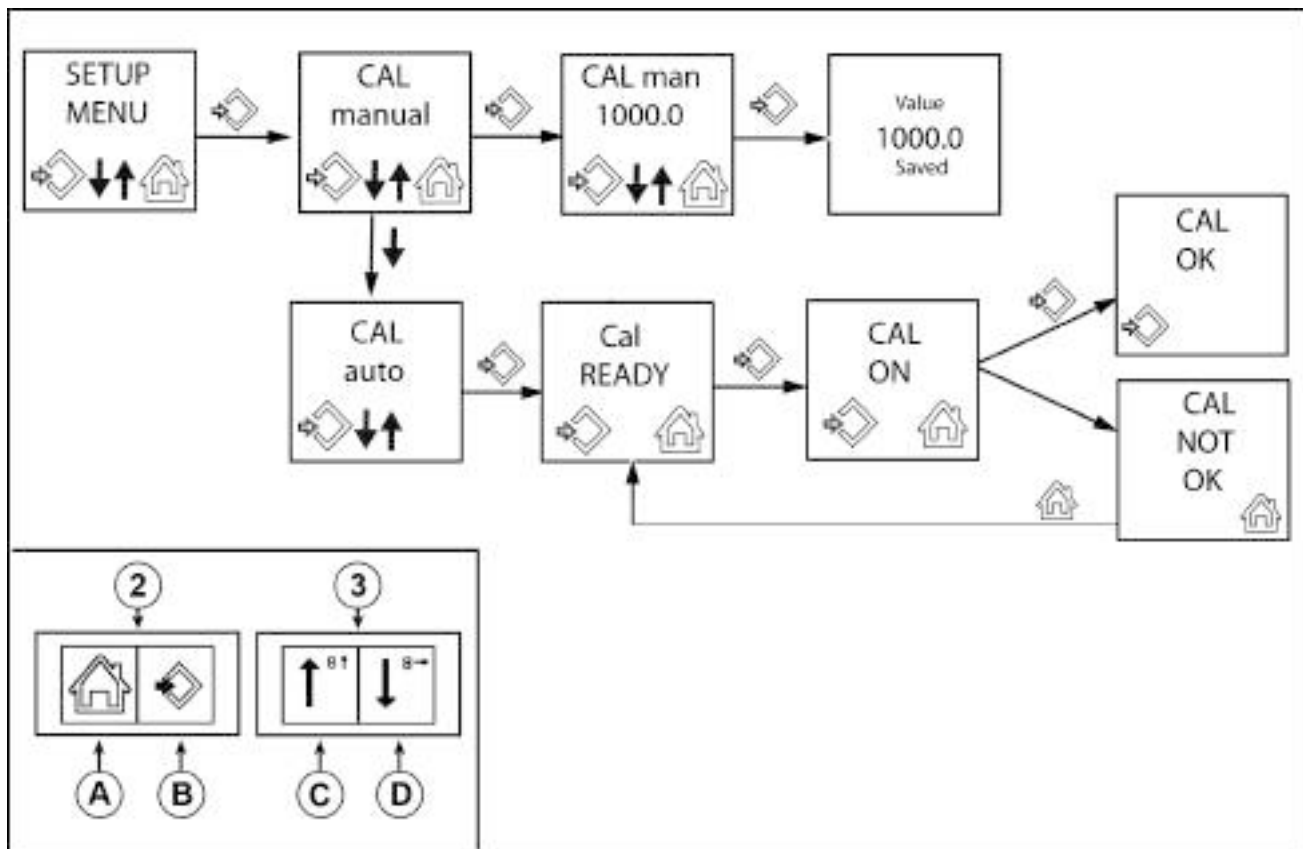

DCAPLT5NE067S3F 1

**NOTE:** This setting is not present if the radar unit is installed.

Check that the circumference of the fitted tyres is as shown on the “CAL manual” screen, otherwise it will be necessary to recalibrate the electronic control module to display the precise exact ground speed. It is possible to recalibrate the module, manually or automatically.

### Manual Calibration

- To calibrate the module manually, it is indispensable to know the rolling circumference (RC) of the new tyre.
- Press the switch (2) on the symbol (B) for more than three seconds to enter the programming menu. The central monitor will show “SETUP MENU”. Release the symbol (B); the display will show “CAL”.
- Press and release the switch (2) on the symbol (B); the monitor will show “CAL manual”.
- Press and release the switch (2) on the symbol (B).
- Press the switch (3) on the symbol (C) to change the flashing value, press the symbol (D) to move to the next digit. In this way you enter the rolling circumference of the new tyre.
- Press the switch (2) on the symbol (B) to save the new added measurement.

If you want to stop the display, press the switch (2) on the symbol (A) . Press the same symbol again to exit the programming menu.

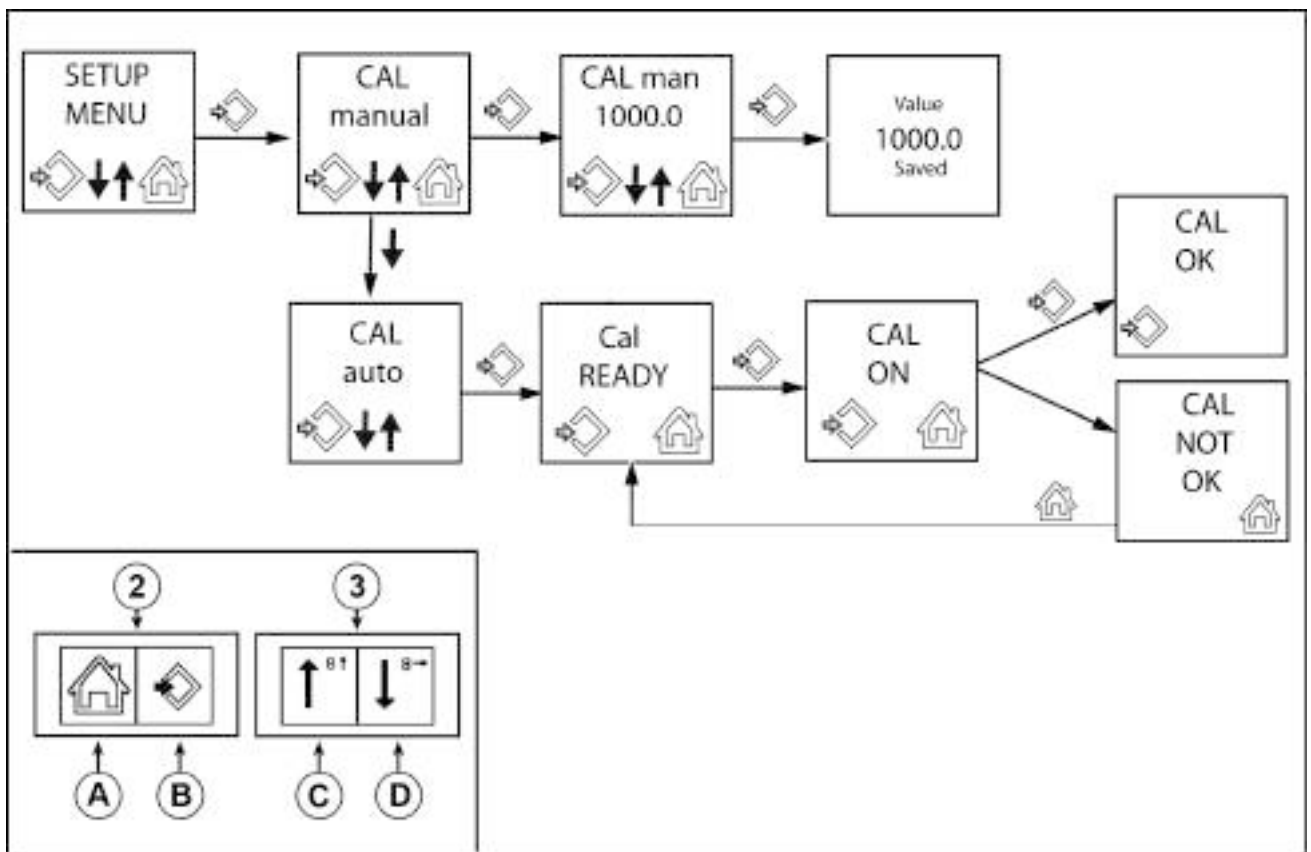

DCAPLT5NE067S3F 2

## Auto Calibration

- Select a stretch of dry, firm, level ground (preferably concrete) and carefully measure out a distance of exactly **100 m (328 ft)** . Mark the start and finish of this measured distance with a bold chalk line.
- Press the switch **(2)** on the symbol **(B)** for more than three seconds to enter the programming menu. The central monitor will show "SETUP MENU" . Release the symbol **(B)**; the display will show "CAL".
- Press and release the switch **(2)** on the symbol **(B)**; the monitor will show "CAL manual".
- Press and release the switch **(3)** on the symbol **(D)**; the monitor will show "CAL auto".
- Press and release the switch **(2)** on the symbol **(B)**; the monitor will show "CAL READY".
- Now select a suitable gear to give a constant speed greater than **2 km/h (1.2 mph)** , and, at the start of the drawn line, press and release the switch **(2)** on the symbol **(B)**; the display will flash "CAL ON".

**NOTE:** The ground speed must be constant and must not drop under **2 km/h (1.2 mph)**. If the speed is less than as prescribed, calibration will not be successful.

- When the middle of the front tyres goes over the end line, press the switch **(2)** again on the symbol **(B)** and, if the procedure has been performed correctly, the monitor will show "CAL OK". Now press the switch **(2)** on the symbol **(B)** again to save the setting. If on the contrary the procedure has not been performed correctly the monitor will display "CAL NOT OK" and the procedure must be repeated.

If you want to stop the procedure and quit the programming menu, repeatedly press the switch **(2)** on the symbol **(A)**

If on the contrary you want to repeat the calibration, press the switch **(2)** on the symbol **(A)** until the display shows "CAL auto". From this position, repeat the procedure, taking care that the tractor speed is constant and greater than **2 km/h (1.2 mph)**.



## Instrument cluster - Dynamic description programming maintenance work

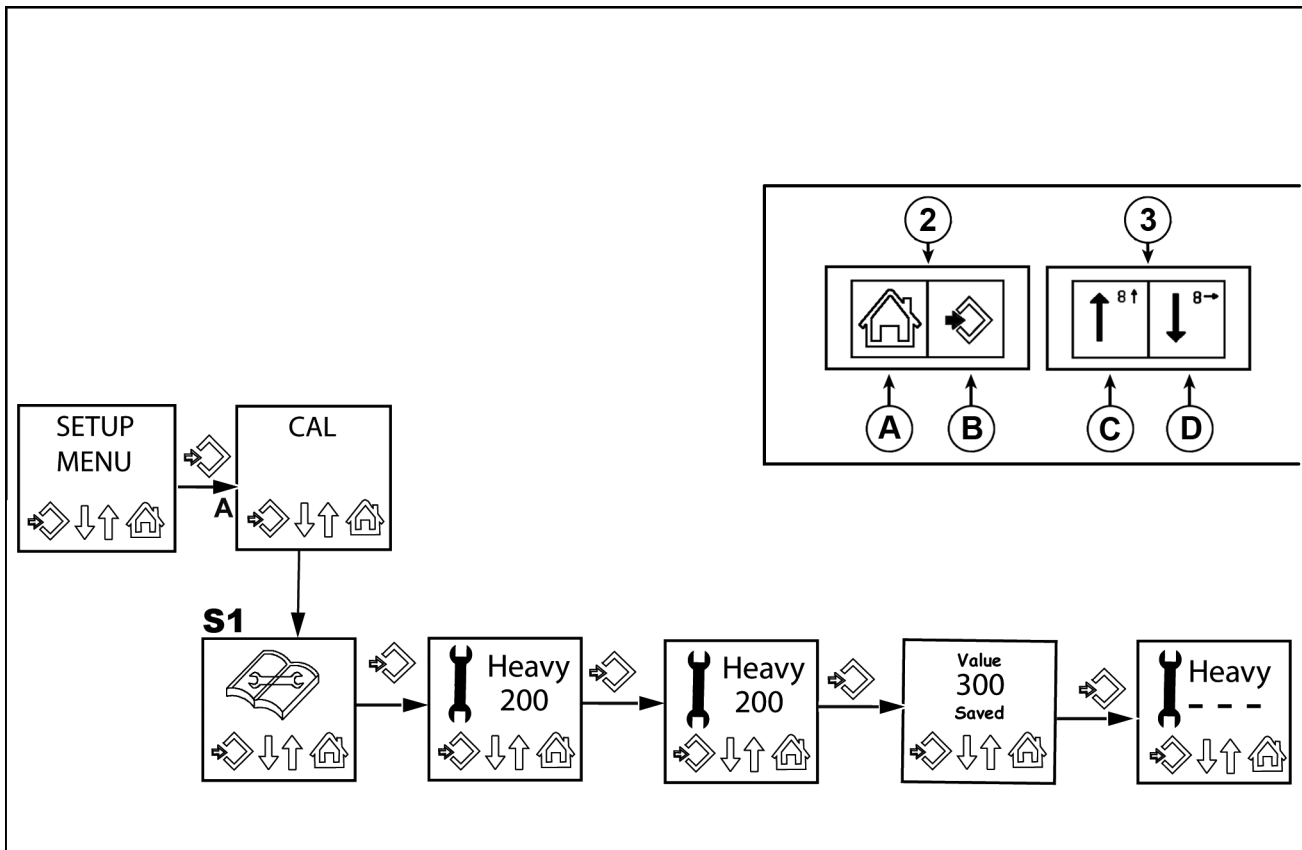

DCAPLT5NE069S3F 1

This function enables the operator to schedule the maintenance work for two levels of importance: "routine (LIGHT)" or "important (HEAVY)". Proceed as follows:

- Press the switch **(2)** on the symbol **(B)** for more than three seconds to enter the programming menu. The central monitor will show "SETUP MENU". Release the symbol **(B)**.
- Press the switch **(3)** on the symbol **(D)** a number of times until the monitor shows the symbol for programming the maintenance frequency **(S1)**.
- Press the switch **(2)** on the symbol **(B)**; The monitor will show the screen "Heavy" with the hours remaining till the time for maintenance. The setting cannot be changed at this stage.
- Press the switch **(2)** on the symbol **(B)** to change the setting of the first flashing digit (in the above example, the number "2").
- Press the switch **(3)** on the symbol **(C)** to increase the value. Press on the symbol **(D)** to move onto the next digit.
- If you do not want to save the new setting and go back to the start of programming, repeatedly press switch **(2)** on the symbol **(A)**.
- To save the new maintenance schedule, press the switch **(2)** on the symbol **(B)**. The monitor will display confirmation on saving the new value.
- After two seconds you exit the maintenance work programming menu.

**NOTE:** Near the time for the programmed work, the monitor will show the warning in hours of work remaining till maintenance. At the end of the count the monitor will show "Heavy" followed by a warning message to indicate that the time has expired. At the end of the count, in the maintenance work programming menu, the counter will show three dashes and must be re-programmed as described above.

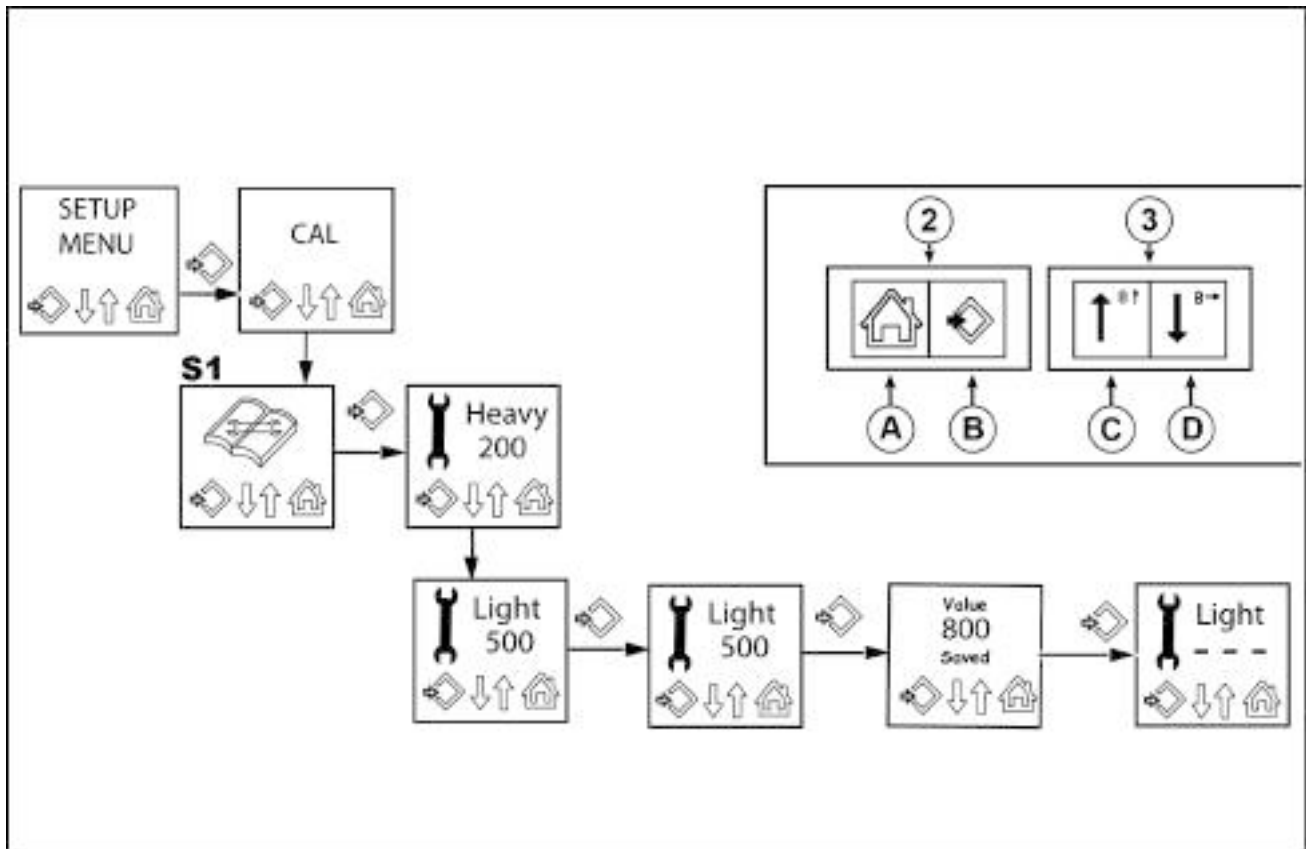

DCAPLT5NE070S3F 2

### Setting routine maintenance work

- Press the switch **(2)** on the symbol **(B)** for longer than three seconds to enter the programming menu. Release the symbol **(B)**.
- Press the switch **(3)** on the symbol **(D)** a number of times until the monitor shows the symbol for programming the maintenance frequency **(S1)**.
- Press the switch **(2)** on the symbol **(B)**; The monitor will show the screen “Heavy” with the hours remaining till the time for maintenance.
- Press the switch **(3)** on the symbol **(D)**; The monitor will show the screen “Light” with the hours remaining till the time for maintenance. The setting cannot be changed at this stage.
- Press the switch **(2)** on the symbol **(B)** to change the setting of the first flashing digit (in the above example, the number “5”).
- Press the switch **(3)** on the symbol **(C)** to increase the value. Press on the symbol **(D)** to move onto the next digit.
- If you do not want to save the new setting and go back to the start of programming, repeatedly press switch **(2)** on the symbol **(A)**.
- To save the new maintenance schedule, press the switch **(2)** on the symbol **(B)**. The monitor will display confirmation on saving the new value.

**NOTE:** Near the time for the programmed work, the monitor will show the warning in hours of work remaining till maintenance. At the end of the count the monitor will show “Light” followed by a warning message to indicate that the time has expired. At the end of the count, in the maintenance work programming menu, the counter will show three dashes and must be re-programmed as described above.

## Instrument cluster - Dynamic description setting units of measurement

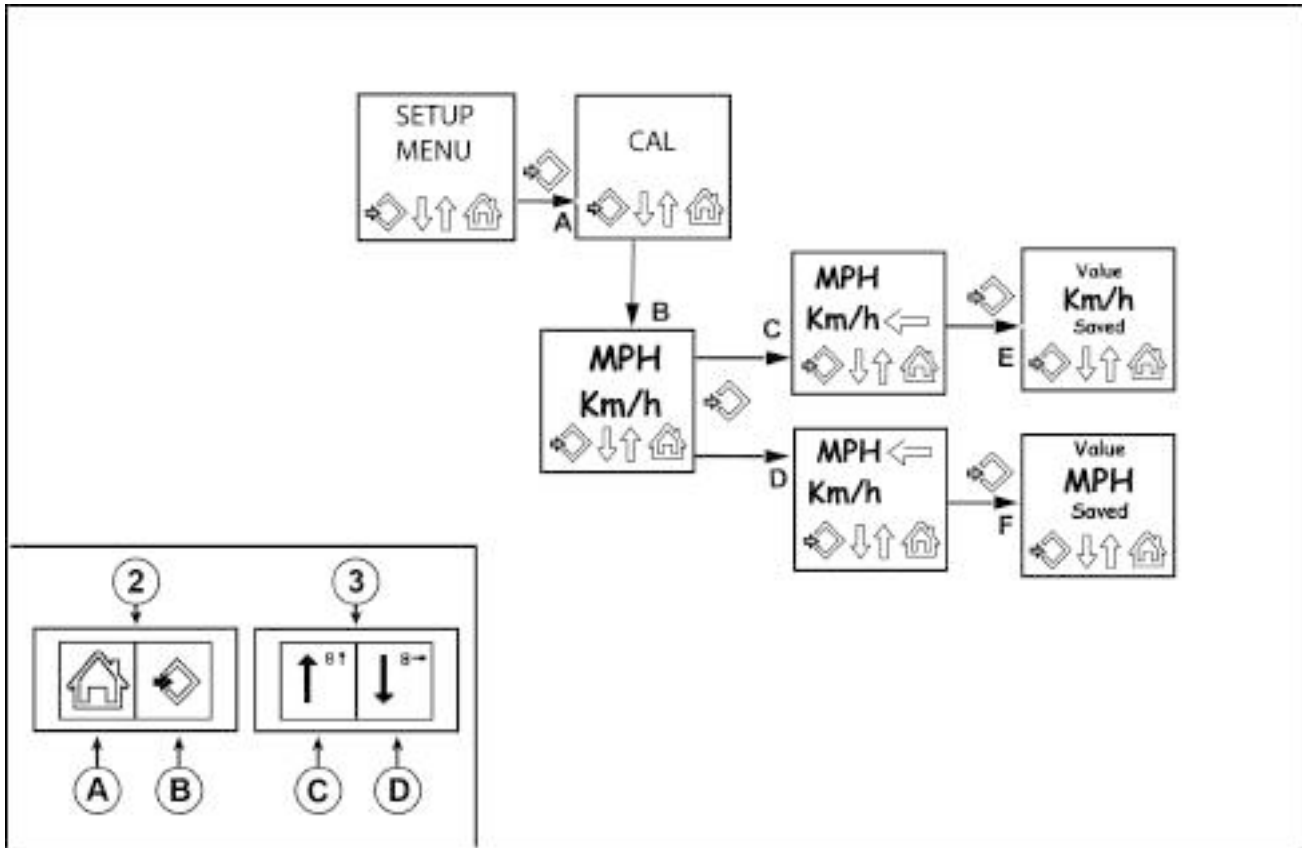

DCAPLT5NE053S3A 1

If you want to change the unit of measurement, proceed as follows:

- Press the switch (2) on the symbol (B) for more than three seconds to enter the programming menu. The central monitor will show "SETUP MENU". Release the symbol (B).
- Press the switch (3) on the symbol (D) a number of consecutive times until the monitor shows "MPH/km/h".
- Press the switch (2) on the symbol (B); the monitor will show the last setting made, "MPH" or "km/h". Press the switch (3) on the symbol (D) or (C) to change the setting.
- After selecting the desired unit of measurement, press the switch (2) on the symbol (B). The monitor will show "Value MPH Saved" or "Value km/h Saved" to confirm the selected unit of measurement.

**NOTE:** If you want to stop the display, press the switch (2) on the symbol (A). This will automatically take you back to viewing the initial page "MPH/km/h". Press the same symbol again to exit the programming menu.

**NOTICE:** This selection procedure changes all the units of measurement for the instrument panel, not just the speed.

## Instrument cluster - Dynamic description oil change counter reset

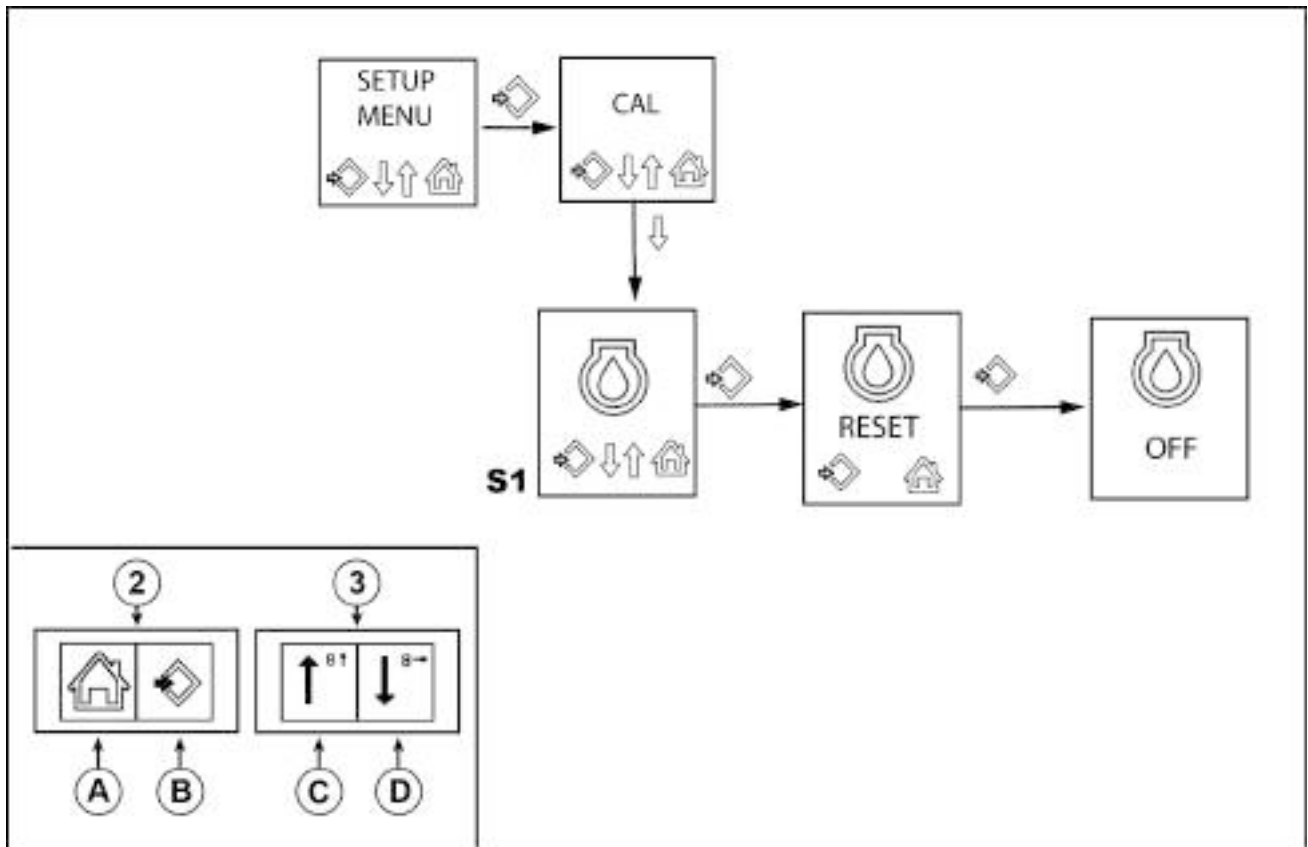

DCAPLT5NE073S3F 1

**NOTICE:** Whenever changing oil it is indispensable to reset the engine oil working hours counter, as described below:

**NOTE:** For this procedure the engine must be switched off.

- Press the switch **(2)** on the symbol **(B)** for more than three seconds to enter the programming menu  
The central monitor will show "SETUP MENU". Release the symbol **(B)**.
- Press the switch **(3)** on the symbol **(D)** a number of consecutive times until the monitor shows "OIL RESET" S1.
- Press the switch **(2)** on the symbol **(B)** for the monitor to display "RESET".
- Press the switch **(2)** on the symbol **(B)** to reset the hour meter; the monitor will display "OFF".
- After two seconds the monitor automatically returns to the initial situation. Now press the switch **(2)** on the symbol **(A)** a number of times until you exit the programming menu.

















**NOTE:** If the hour meter has been reset correctly, the engine oil pressure warning on the instrument panel must blink for two seconds too.

## Instrument cluster - Dynamic description















There are a number of warning/advisory symbols that may appear in the displays. The symbols can be categorized into four main groups.



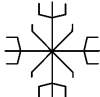









- **Warning.** These symbols advise of a fault that is critical to the operation of the tractor. Stop the tractor as soon as possible, investigate the cause and rectify the fault.
- **Maintenance.** These symbols tell the operator there is a concern relating to the basic functions of the tractor, for example water contamination in the fuel, alternator not charging etc.
- **System Fault.** The system fault symbols relate to an operational fault in one or more of the tractors main components, either electrical or mechanical. Maybe accompanied by a four digit fault code.
- **Advisory.** The advisory symbols are not detrimental to the operation of the tractor but should not be ignored. Take appropriate action where necessary.

### Brake and steering





Display	Panel light	Warning light	Alarm	Cause	Action
		 flashing	continuous for <b>4 s</b>	Hand brake engaged during driving (Drive speed > <b>0.8 km/h (0.5 mph)</b> )	Release hand brake. Check the hand brake switch.
		 flashing	continuous for <b>4 s</b>	Operator leaves seat without applying the hand brake or if there is a fault with the seat switch,	Apply the hand brake. Check the hand brake switch. Check the seat switch.
		-	<b>1 s</b> two pulses	Hand brake engaged during auto drive off.	Release the hand brake before auto drive off.
-		-	continuous for <b>4 s</b>	Hand brake not applied. The signal is only made with the ignition OFF and the hand brake is not engaged.	Apply the hand brake. Check the hand brake switch.
		 flashing <b>4 s</b> / continuous	two pulses/ second for pulsating <b>4 s</b>	Air brake pressure is too low. (Air brake pressure is < <b>5.3 bar</b> )	Stop the engine as soon as possible. Check air pressure with a gauge. Check the air pressure sensor.
	-	 flashing <b>4 s</b> / continuous	-	Brake fluid level too low.	Top up the brake fluid level. Check the level switch.
	-	 flashing	pulsating	Steering oil pressure too low. (Oil pressure < <b>1 bar</b> )	Stop the tractor as soon as possible. Check the transmission oil level. Check the steering system functionality. Check the steering pressure switch.













## Transmission and hydraulic

Display	Panel light	Warning light	Alarm	Cause	Action
	-	-	1 s (two pulses)	The manoeuvre performed is incorrect or dangerous.	Operate the clutch pedal.
	-	-	1 s (two pulses)	Direction is selected.	Press the neutral switch.
	-	 flashing	1 s two pulses	Speed too high when changing direction of travel. (Speed > <b>14.0 km/h (8.7 mph)</b> )	Operate the brake pedal.
	-	 flashing 1 s / continuous	pulsating	Driveline oil pressure too low. (Oil pressure < <b>12.5 bar</b> ). Auto shut off is deactivated or operator is present or speed is <b>0.0 km/h (0.0 mph)</b> .	Stop the engine immediately. Check the oil level. Check the transmission oil pressure switch.
 STOP	-	 flashing	pulsating	Driveline oil pressure too low. (Oil pressure < <b>12.5 bar</b> ). Auto shut off is activated, operator is absent and speed is <b>0.0 km/h (0.0 mph)</b> . The engine will shut off automatically in <b>5 s</b> .	Stop the engine immediately. Check the oil level. Check the transmission oil pressure switch.
	-	-	-	Transmission oil temperature too low. (Oil temperature < <b>10.0 °C (50.0 °F)</b> )	Operate the tractor. During the cold warning the engine speed is reduced. < <b>-10.0 °C (14.0 °F)</b> engine speed is maximal <b>1500 RPM</b> . > <b>-10.0 - 10.0 °C (14.0 - 50.0 °F)</b> engine speed is maximum <b>1900 RPM</b> .
	-	 flashing	pulsating	Driveline oil temperature too high. (Oil temperature > <b>107.0 °C (224.6 °F)</b> ) Auto shut off is deactivated or the operator is present or drive speed is <b>0.0 km/h (0.0 mph)</b> .	Stop the engine immediately. Check the oil level. Clean the oil cooler. Check the thermostat.
 STOP	-		pulsating	Driveline oil temperature too high. (Oil temperature > <b>107.0 °C (224.6 °F)</b> ) Auto shut off is activated or the operator is present or drive speed is <b>0.0 km/h (0.0 mph)</b> . The engine will shut off automatically in <b>5 s</b>	Stop the engine immediately. Check the oil level. Clean the oil cooler. Check the thermostat.
	-	 flashing	continuous for 4 s	The hydraulic oil temperature low level warning is activate. (Oil temperature > <b>107.0 °C (224.6 °F)</b> for > <b>30 s</b> ).	Low warning only. Keep an eye on this warning.

Display	Panel light	Warning light	Alarm	Cause	Action
	-		pulsating	The hydraulic oil temperature high level warning is activate. (Oil temperature > <b>107.0 °C (224.6 °F)</b> for > <b>5 min</b> ). Auto shut off is deactivated or operator is present or drive speed is <b>0.0 km/h (0.0 mph)</b> . The warning disappears. (Oil temperature < <b>105 °C (221 °F)</b> for > <b>10 s</b> ).	Stop the engine immediately. Check the oil level. Clean the transmission oil cooler (if an optional hydraulic oil cooler is fitted). Check the thermostat on the transmission oil cooler (if an optional hydraulic oil cooler is fitted). Check the hydraulic devices and the adjustments.
 STOP	-		pulsating	The hydraulic oil temperature high level warning is activate. (Oil temperature > <b>107.0 °C (224.6 °F)</b> for > <b>5 min</b> ). Auto shut off is activated, operator is absent and speed is <b>0.0 km/h (0.0 mph)</b> . The engine will shut off automatically in <b>5 s</b> .	Stop the engine immediately. Check the oil level. Clean the transmission oil cooler (if an optional hydraulic oil cooler is fitted). Check the thermostat on the transmission oil cooler (if an optional hydraulic oil cooler is fitted). Check the hydraulic devices and the adjustments.
	-	 flashing	continuous for <b>4 s</b>	Rear Power Take-Off engaged without the operator.	Operator leaves the seat. Check the seat switch.
	-	 flashing	continuous for <b>4 s</b>	Front Power Take-Off engaged without the operator.	Operator leaves the seat. Check the seat switch.
	-	 flashing for <b>4 s</b> / continuous	two pulses/ sec for <b>4 s</b>	Internal and external push switches activated simultaneously.	Operation of the Power Take-Off is prevented for a few seconds. Check the push switches.
	-	 flashing for <b>4 s</b> / continuous	two pulses/ sec for <b>4 s</b>	PTO system anti-stall. The anti-stall function disengages the Power Take-Off.	Operation of the Power Take-Off is prevented for a few seconds, then back to normal function.











**Engine**

Display	Panel light	Warning light	Alarm	Cause	Action
 STOP	-	 flashing	pulsating	Engine error state. The tractor will be stopped automatically in a short time.	Stop the engine immediately. Check the fault codes.
			pulsating	Engine oil pressure too low. (Engine oil pressure < <b>0.6 bar</b> ) Auto shut off is deactivated or auto shut off YES2 is activated and operator is present or drive speed is <b>0.0 km/h (0.0 mph)</b> .	Stop the engine immediately. Check the oil level. Check the oil pressure. Check the oil pressure switch.









Display	Panel light	Warning light	Alarm	Cause	Action
 STOP		 flashing	pulsating	Engine oil pressure too low. (Engine oil pressure < <b>0.6 bar</b> ) Auto shut off YES1 is activated and the operator is present or drive speed is <b>0.0 km/h (0.0 mph)</b> . The engine will shut off automatically in <b>30 s</b> . Auto shut off is activated and the operator is absent and drive speed is <b>0.0 km/h (0.0 mph)</b> . The engine will shut off automatically in <b>5 s</b> .	Stop the engine immediately. Check the oil level. Check the oil pressure. Check the oil pressure switch.
	-	 flashing	pulsating	Engine coolant temperature too high. (Coolant temperature > <b>108.0 °C (226.4 °F)</b> ) Auto shut off is deactivated or YES2 and operator is present or drive speed is <b>0.0 km/h (0.0 mph)</b> .	Stop the engine immediately. Check the coolant level. Check the radiator. Check the belt. Check the thermostat. Check the visco-fan.
 STOP	-	 flashing	pulsating	Engine coolant temperature too high. (Coolant temperature > <b>108.0 °C (226.4 °F)</b> ) Auto shut off YES1 is activated and operator is present or drive speed is <b>0.0 km/h (0.0 mph)</b> . The engine will shut off automatically in <b>30 s</b> . Auto shut off is activated and operator is absent and drive speed is <b>0.0 km/h (0.0 mph)</b> . The engine will shut off automatically in <b>5 s</b> .	Stop the engine immediately. Check the coolant level. Check the radiator. Check the belt. Check the thermostat. Check the visco-fan.
 SERV	-		two pulses/sec for <b>4 s</b>	Engine oil change warning.	Change the engine oil. (See oil change counter reset <b>Instrument cluster - Dynamic description (55.408)</b> ).
	-	 flashing <b>4 s/continuous</b>	-	Engine Intake Air Filter Blocked	Clean the air filter. Check the maintenance switch on the air filter.
	-	 flashing <b>4 s/continuous</b>	two pulses/sec for <b>4 s</b>	Water in fuel.	Clean the fuel filter. Check the maintenance switch on the fuel filter.







## Diesel Particulate Filter (DPF)

Display	Panel light	Warning light	Alarm	Cause	Action
		 flashing 4 s/ continuous	two pulses/ sec for 4 s	Request for regeneration of the Diesel Particulate Filter (DPF).	It is possible, proceed with the work, the automatic regeneration will start automatically, if the conditionals are fulfilled. Or you can start the regeneration manual in the setup menu or with the EST. <b>Diesel Particulate Filters (DPF) - Dynamic description (10.501)</b>
 ON every 5 min	-	-	Single beep every 5 min	Automatic regeneration on. It lights up when automatic regeneration of the diesel particulate filter is started.	Continue to work during the regeneration, until OFF appear on the DMD.
 OFF	-	-	-	It lights up when automatic regeneration of the diesel particulate filter has ended.	At the end of the procedure the icon goes out and the display returns to its normal functions. <b>Instrument cluster - Dynamic description (55.408)</b>
 every 5 min	 steady	-	Single beep every 5 min	Automatic regeneration is prevent by the operator. Reminder every 5 min.	If it is no longer necessary to prevent the automatic regeneration of the particular filter, you should activate the automatic regeneration again. Use the setup menu or switch off the ignition key for more than 20 s. <b>Instrument cluster - Dynamic description (55.408)</b>
	-	 flashing 4 s/ continuous	two pulses/ sec for 4 s	Exhaust system failure. The soot load accumulation in the particular filter has a determined level reached.	Engine power loss occurring. Start the manual filter regeneration with the setup menu or with the EST. (Look for the fault code number). <b>NOTE: During forced regeneration it is not possible to move the machine.</b> <b>Instrument cluster - Dynamic description (55.408)</b>
	-	 flashing 4 s/ continuous	pulsating	Exhaust system failure. The soot load accumulation in the particular filter has a determined level reached.	Massive engine power loss occurring. Start the manual filter regeneration with the setup menu or with the EST. (Look for the fault code number). <b>NOTE: During forced regeneration it is not possible to move the machine.</b> <b>Instrument cluster - Dynamic description (55.408)</b>



**Charging system**

Display	Panel light	Warning light	Alarm	Cause	Action
	-	-	-	Battery cut-off request. The warning appears for a time of <b>60 s</b> when the engine is shut down.	Battery is disconnected from the tractor harness.
	-	 flashing 4 s/ continuous	two pulses/ sec for 4 s	Battery voltage is too low (< <b>9 V</b> for more than <b>60 s</b> )	Check the belt. Recharge the battery. Check the alternator.
	-	 flashing 4 s/ continuous	-	Battery voltage too high (> <b>16 V</b> for more than <b>5 s</b> )	Check the alternator.
		 flashing 4 s/ continuous	-	Battery voltage is too low during the engine is running. (< <b>9 V</b> for more than <b>5 s</b> )	Check the belt. Check the alternator.





**Electro Hydraulic Remote (EHR) control valves**

Display	Panel light	Warning light	Alarm	Cause	Action
F 		 flashing 4 s/ continuous	1 s two pulses	Wrong operation	Joystick back in neutral position and then press the black switch again, now you can move the joystick.
R 		 flashing 4 s/ continuous	1 s two pulses	Wrong operation	Joystick back in neutral position and then press the black switch again, now you can move the joystick.



**CAN Bus system**

Display	Panel light	Warning light	Alarm	Cause	Action
	-	 flashing 4 s/ continuous	two pulses/ sec for 4 s	Module configuration. This warning light comes on when a new module is added, with the ignition key ON.	Turn the ignition key OFF and then turn the ignition key ON. The new controller is now added to configurations list.

**Service**

Display	Panel light	Warning light	Alarm	Cause	Action
	-	 flashing 4 s/ continuous	-	Request for "light" maintenance in two hours.	Carry out the programmed type of maintenance at the scheduled time. <b>Instrument cluster - Dynamic description (55.408)</b>
	-	 flashing 4 s/ continuous	-	Request for "heavy duty" maintenance in ten hours.	Carry out the programmed type of maintenance at the scheduled time. <b>Instrument cluster - Dynamic description (55.408)</b>

**Service**

Display	Panel light	Warning light	Alarm	Cause	Action
-	 flashing	-	continuous	Direction indicators	Turn off the direction indicators
-		-	<b>4 s</b> (4 pulses)	Position lights ON with ignition key OFF.	Switch off the side lights.

## Instrument cluster - Dynamic description – setting hours worked

### Setting hours counter on a new Instrument Cluster

1. Turn the ignition switch onto OFF and connect the test plug **380000843** to the relevant diagnostics socket (**1**).

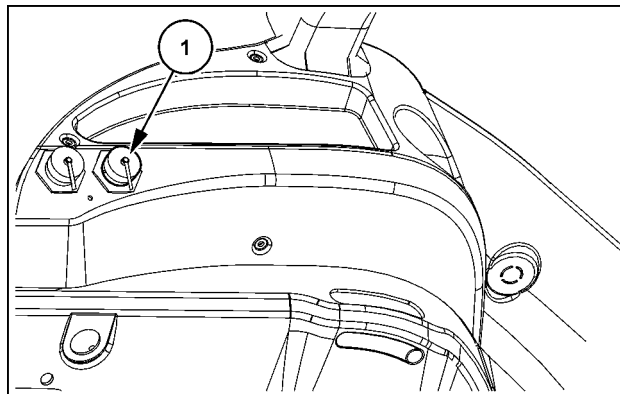

SS14A005 1

2. Turn the ignition switch onto ON. The display will show the "HH-Menu" icon. See image 3.
3. Press and hold down the ENTER button (**B**), after **5 s**, the display will show the number of hours worked and the symbol of hours will flash.
4. In this case you can proceed in two different ways:  
Press the HOME button (**A**) to end the operation without changing the value and go back to the "HH-Menu" screen.

OR

Use the UP button (**C**) (or DOWN button (**D**)) to increase the number of hours. Afterwards press the ENTER button (**B**) for **15 s** to save and exit the "HH-Menu" screen.

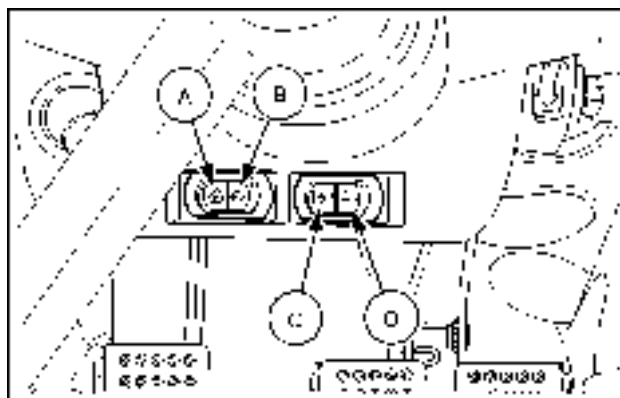

SVIL13TR00059AA 2

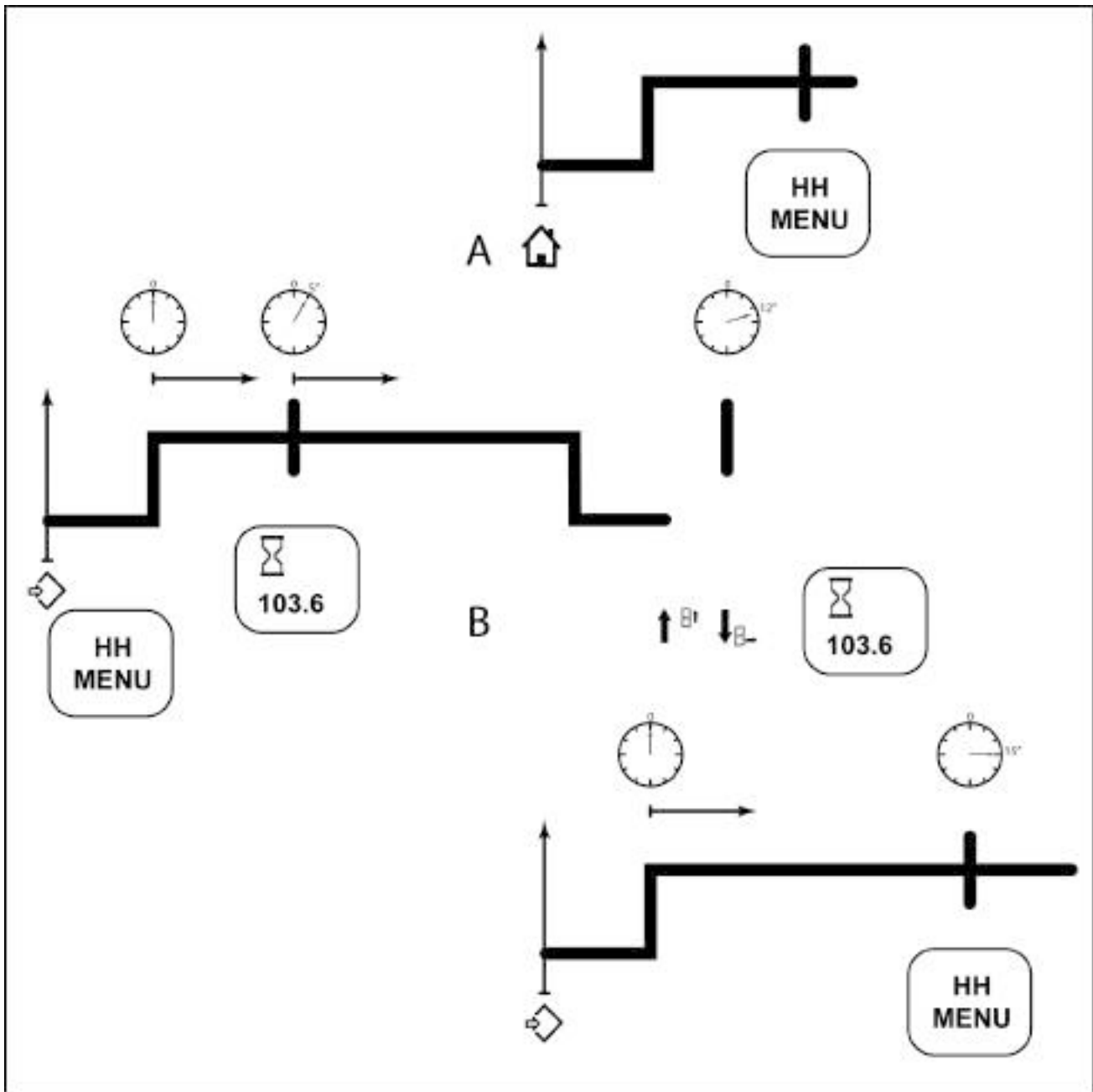

WLAPL4S55C101G 3

## Instrument cluster - Dynamic description – Hour meter reset

You can reset the hours displayed if the value does not exceed **20 h** from a maximum of 3 times in the life of the instrument cluster.

Once the ENTER switch has been depressed for **12 s**, the Dot Matrix Display (DMD) shows one of the following letters:

- H: three resets are available
  - F: two resets are available
  - L: one reset is available
  - -: no reset is available
1. Enter the HH-Menu, using the diagnostic test plug special tool **380000843** and switch on the ignition switch. The DMD will display “HH-Menu”.
  2. Hold down the ENTER switch for **12 s**. At this point, the operator can abort the procedure if he release the ENTER switch.
  3. When the operator hold the ENTER switch for additional **3 s** (for a total of **15 s**), the reset will be performed. The letter corresponding to the number of the remaining reset available shall be displayed and the DMD has to return at HH-Menu enter icon.
  4. Switch off the ignition switch and remove the diagnose plug to leave the HH-Menu.

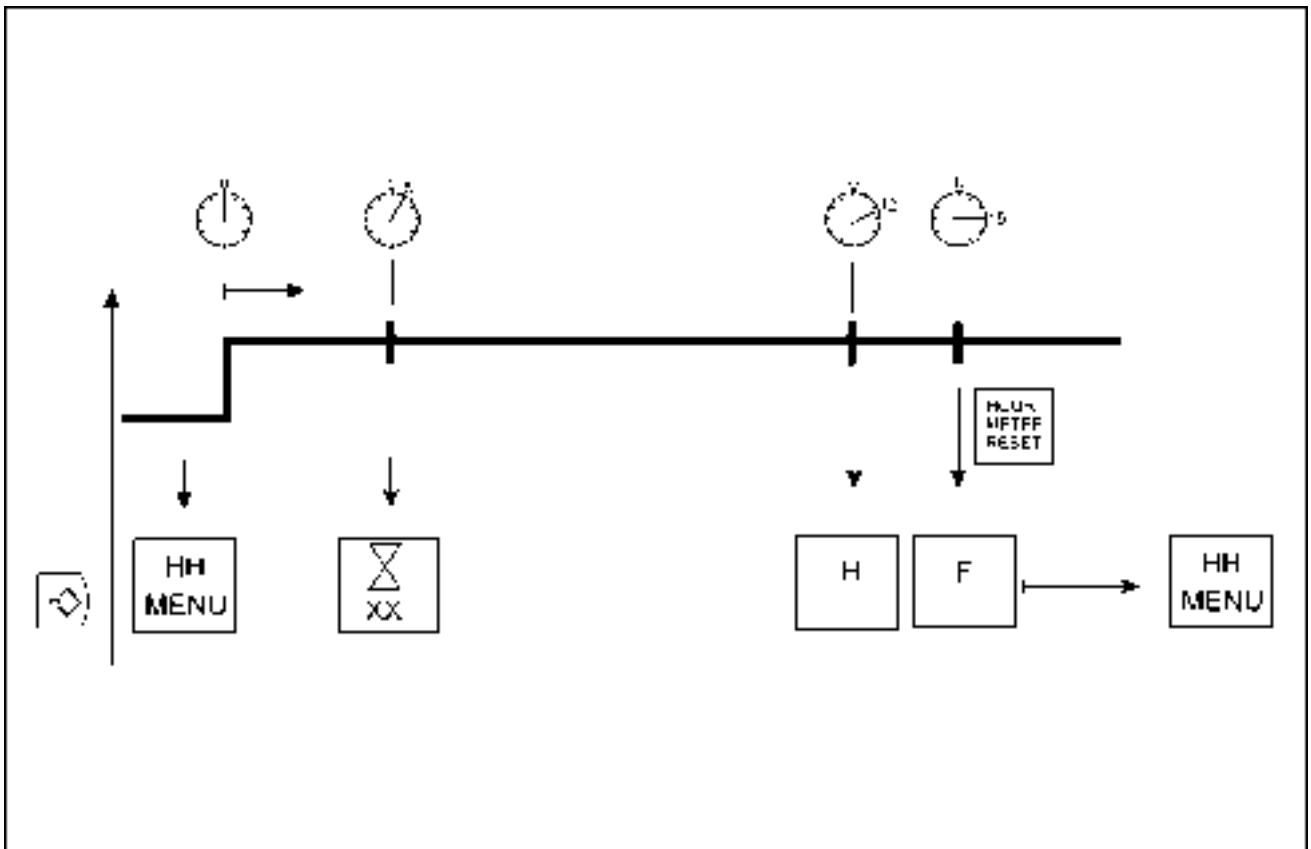

SS14A006 1

## Instrument cluster - Dynamic description fault codes display

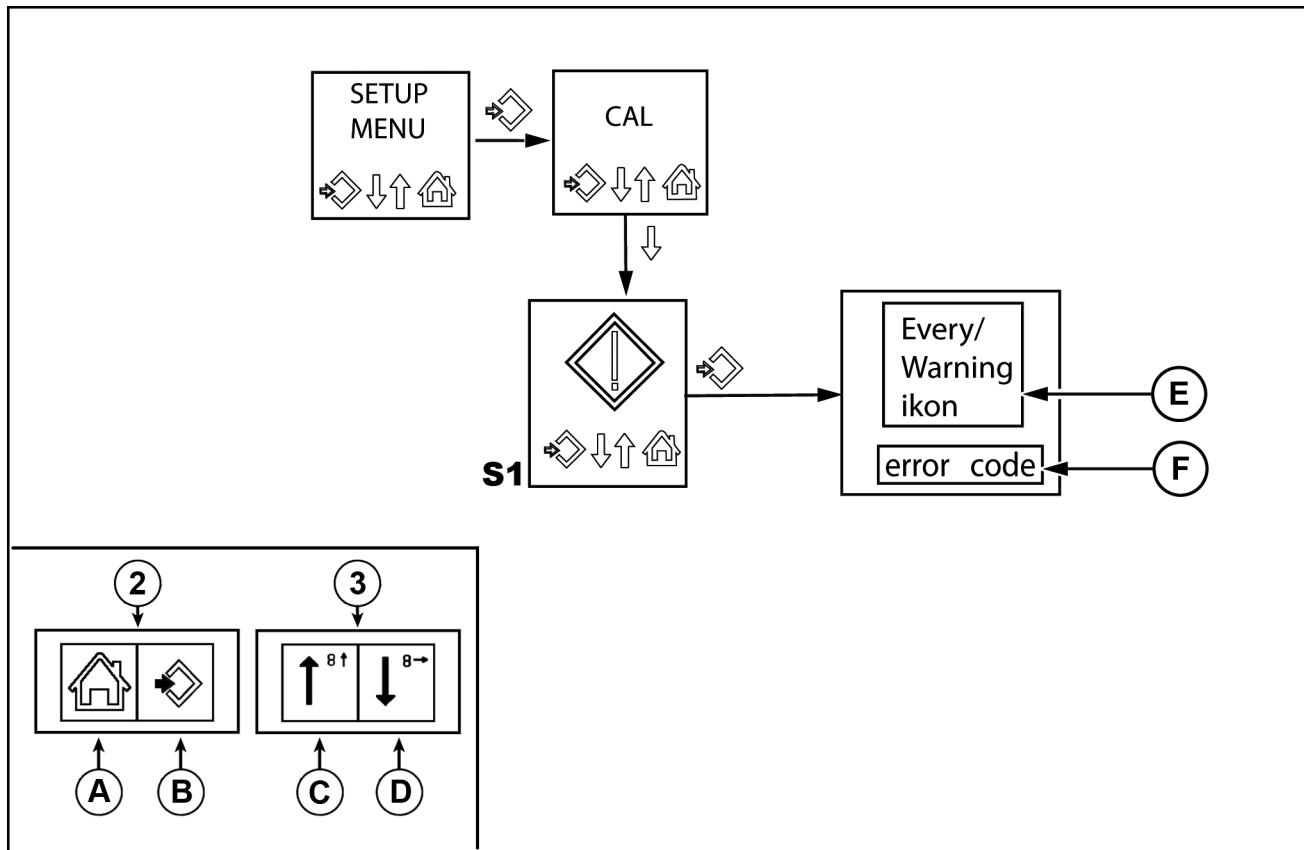

DCAPLT5NE074S3F 1

If it is necessary to know the list of error codes or warnings saved by the control unit and not permanently visible, proceed as described below:

- Press the switch (2) on the symbol (B) for more than three seconds to enter the programming menu. The central monitor will show "SETUP MENU". Release the symbol (B).
- Press the switch (3) on the symbol (D) a number of consecutive times until the monitor shows the symbol for the error codes (S1).
- Press the switch (2) on the symbol (B) to view the error codes in memory..

The error codes or warnings are displayed in two different ways:

- At the top (2) of the monitor the symbol of the failed component appears combined with its error code at the bottom (1). System error symbols refer to an electrical or mechanical malfunction of the tractor's main components. May be accompanied by a four digit fault code. Stop work and call an authorized dealer.
- The monitor will show only the symbol with no error code. When only the symbol is displayed, it is a warning. The advisory symbols are not detrimental to the operation of the tractor but should not be ignored. Take appropriate action where necessary.
- Press the switch (1) on the symbol (A) to quit viewing error codes..

**NOTE:** The current fault codes are displayed in sequence. Each code is displayed three times blinking for 4 seconds.

## Instrument cluster - Static description alarms

The illumination of a warning light may be accompanied by an audible alarm. Depending on the severity of the malfunction, one of the following alarms may be heard.

### Red indicator lamp

Illumination of the red warning light **(1)** is normally associated with a critical alarm. Stop the tractor immediately when this warning light comes on. The warning light will stay on until the fault is corrected or the engine is switched off.

### Amber indicator lamp

Illumination of the amber warning light **(2)** is normally associated with a non-critical alarm. When this indicator light comes on, the operator can continue working. The fault should be rectified as soon as possible.

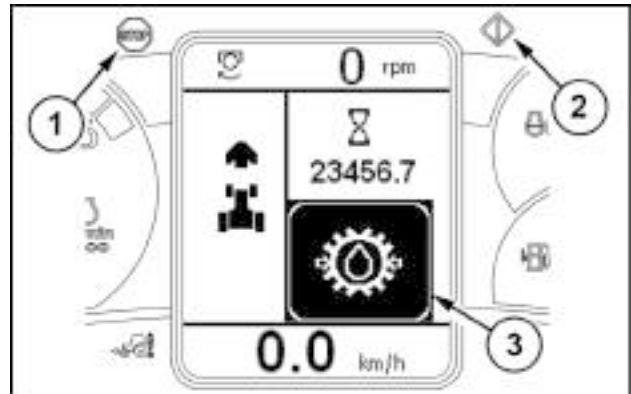

### Action Required

A two pulse alarm will sound for 1 second to advise the operator that a certain action is required. The alarm will continue to be displayed until the operator carries out the appropriate action or the tractor engine is switched off.

### Safety and General Alarms

A general continuous audible warning is emitted if the operator tries to perform inappropriate operations, for instance driving the tractor with the parking brake engaged.

### Parking Lights

A pulse alarm will sound for a short period if the engine is switched off and the parking lights are left on.



## Warning and advisory symbols

There are a number of warning/advisory symbols that may appear on the display **(3)**. This display may be accompanied by the warning lights **(1)** or **(2)** coming on and by an audible warning, depending on the severity of the fault. The symbols can be categorised into four main groups.

1. **Warning.**  
These symbols advise of a fault that is critical to the operation of the tractor. Stop the tractor as soon as possible, investigate the cause and rectify the fault.
2. **Maintenance.**  
These symbols tell the operator there is a concern relating to the basic functions of the tractor, ie. water contamination in the fuel, alternator not charging etc.
3. **System malfunction warning.**  
The system fault symbols relate to an operational fault in one or more of the tractors main components, either electrical or mechanical. Maybe accompanied by a fault code.
4. **Advisory.**  
The advisory symbols are not detrimental to the operation of the tractor but should not be ignored. Take appropriate action where necessary.

# Index

---

## Electrical systems - 55

### Warning indicators, alarms, and instruments - 408

Instrument cluster - Dynamic description Speed calibration .....	6
Instrument cluster - Dynamic description fault codes display .....	22
Instrument cluster - Dynamic description oil change counter reset .....	11
Instrument cluster - Dynamic description programming maintenance work .....	8
Instrument cluster - Dynamic description setting units of measurement .....	10
Instrument cluster - Dynamic description .....	12
Instrument cluster - Dynamic description – Hour meter reset .....	21
Instrument cluster - Dynamic description – setting hours worked .....	19
Instrument cluster - Overview .....	3
Instrument cluster - Static description alarms .....	23





**Electrical systems - 55**

**Autopilot/Autoguidance - 680**

**Farmall 105U Pro EP  
Farmall 115U Pro EP  
Farmall 95U Pro EP**

# Contents

---

**Electrical systems - 55**

**Autopilot/Autoguidance - 680**

## FUNCTIONAL DATA

Radar

Overview ..... 3

## Radar - Overview

### Radar sensor (B-042)

The radar sensor provides for the Central Control Unit (CCU) a sensor present signal and a speed signal (real ground speed). The radar sensor uses a microwave signal to measure the real ground speed and provides a standard square wave output.

**NOTE:** Before working in the sensor's beam area, the ignition key must be turned into the OFF position.

**NOTE:** The instrument cluster displays the radar speed between **2.0 - 18.0 km/h (1.2 - 11.2 mph)**. Outside this range, the instrument cluster shows the transmission output speed.

**NOTE:** Make sure that the radar sensor is mounted with the proper angle of **35 °** related to the ground surface.

The radar sensor (1) is located below the rear axle on the right-hand side.

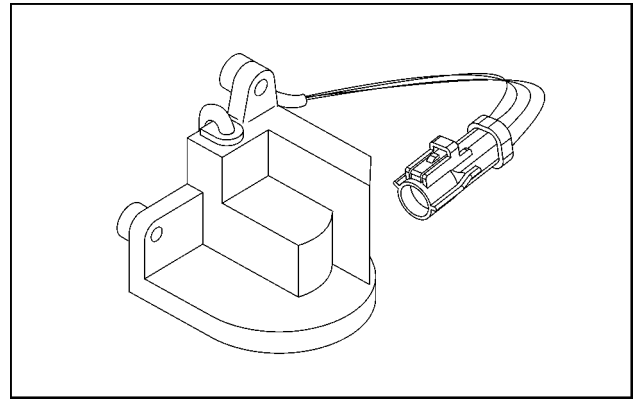
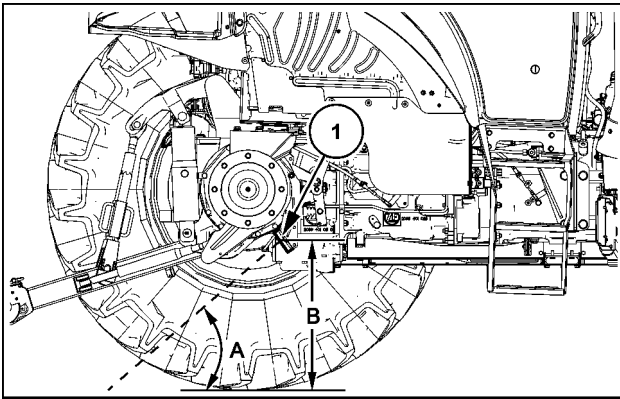

Specifications	
Velocity range	<b>0.5 - 70 km/h (0.3 - 43 mph)</b>
Voltage supply	<b>9 - 16 V</b>
Maximum current	<b>120 mA (at 12 V)</b>
Output signal	<b>505 Hz at 14 km/h (9 mph)</b>
Operating temperature	<b>-40 - 85 °C (-40 - 185 °F)</b>
Mounting angle (A)	<b>35 °</b>
Mounting height related to the ground surface (B)	<b>61 - 122 cm (24 - 48 in)</b>
Pin 1 (speed signal)	square wave
Pin 2 (supply)	Ground
Pin 3 (supply)	<b>12 V</b>
Pin 4 (present signal)	<b>12 V when present</b>

The speed signal sequence of the radar sensor was recorded with the DATAR. The tractor was driven with approximately **2.20 km/h (1.37 mph)**.

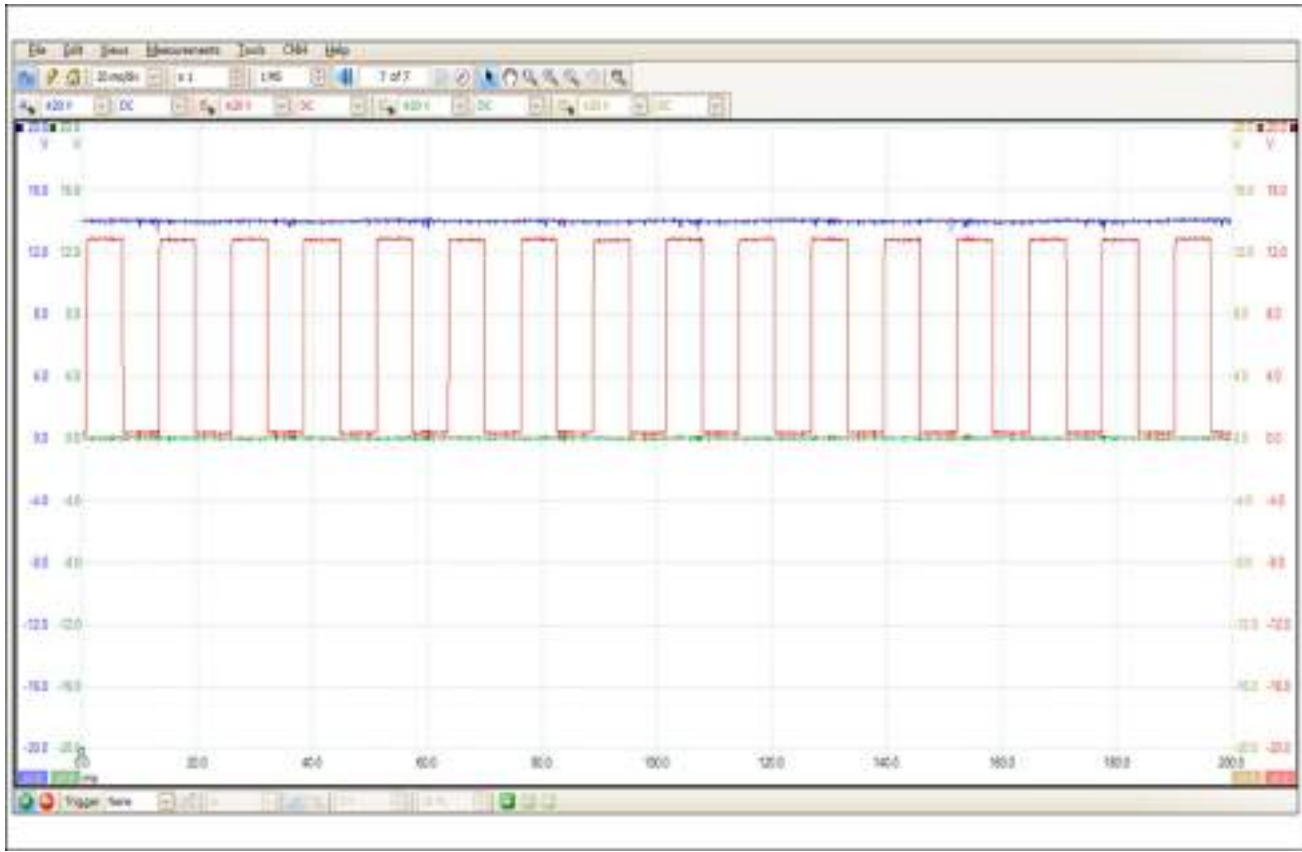

SS13N011 3

# Index

---

**Electrical systems - 55**

**Autopilot/Autoguidance - 680**

Radar - Overview ..... 3







## **Electrical systems - 55**

### **FAULT CODES - DTC**

**Farmall 105U Pro EP  
Farmall 115U Pro EP  
Farmall 95U Pro EP**

# Contents

---

## Electrical systems - 55

### FAULT CODES - DTC

#### FUNCTIONAL DATA

Fault code index .....	3
------------------------	---

## Fault code index

Message	Description	Controller
14015	5V reference voltage - too high	ADIC
14016	5V reference voltage - too low	ADIC
14021	Cranking line – short circuit to battery	ADIC
14022	Cranking line – short circuit to ground	ADIC
14051	Fuel level sensor - short circuit to supply voltage or open circuit	ADIC
14052	Fuel level sensor - short circuit to ground	ADIC
14058	Seat switch - closed too long	ADIC
14061	Air brake pressure sensor – short circuit to supply voltage or open circuit	ADIC
14093	Seat switch - short circuit to supply voltage or open circuit	ADIC
14094	Seat switch - short circuit to ground	ADIC
14100	Air brake pressure sensor - present but not configured	ADIC
14107	Front hitch - present but not configured	ADIC
14200	Battery main switch - closed to battery too long at key on	ADIC
14901	CAN-Bus - ECU absent	ADIC
14915	CAN bus – EFH control unit absent	ADIC
14918	CAN-Bus - CCU absent	ADIC
14919	CAN-Bus - TCU absent	ADIC
1002	Radar sensor - disconnected or speed too low	CCU
1003	Radar sensor and transmission output speed sensor - speed difference too high	CCU
1004	Transmission output speed sensor - signal too high	CCU
1006	Hitch slip control potentiometer - signal too low	CCU
1007	Hitch slip control potentiometer - signal too high	CCU
1009	Hitch position control switches - implausible signals or signal at key ON	CCU
1010	Hitch height limit potentiometer - signal too low	CCU
1011	Hitch height limit potentiometer - signal too high	CCU
1012	Hitch drop rate potentiometer - signal too low	CCU
1013	Hitch drop rate potentiometer - signal too high	CCU
1014	Right-hand draft pin sensor - signal too low	CCU
1015	Right-hand draft pin sensor - signal too high	CCU
1016	Left-hand draft pin sensor - signal too low	CCU
1017	Left-hand draft pin sensor - signal too high	CCU

Electrical systems - FAULT CODES

Message	Description	Controller
1018	Draft pin sensors - both signals too low	CCU
1019	8 V reference voltage for draft pin sensors - voltage too low	CCU
1020	8 V reference voltage for draft pin sensors - voltage too high	CCU
1021	Hitch sensitivity control potentiometer - signal too low	CCU
1022	Hitch sensitivity control potentiometer - signal too high	CCU
1023	Hitch electronic control panel - disconnected	CCU
1024	Hitch position sensor - not calibrated	CCU
1025	Hitch position control potentiometer - signal too low	CCU
1026	Hitch position control potentiometer - signal too high	CCU
1027	Hitch position sensor - signal too low	CCU
1028	Hitch position sensor - signal too high	CCU
1029	Hitch control solenoid valves - disconnected	CCU
1030	Hitch electronic control panel - ground disconnected	CCU
1031	Chassis harness - disconnected	CCU
1032	Hitch draft control potentiometer - signal too high	CCU
1033	Hitch draft control potentiometer - signal too low	CCU
1049	CAN bus signal fault – TCU1 signal (transmission output speed) from TCU	CCU
1053	5 V reference voltage for Electronic Draft Control (EDC) - voltage too high	CCU
1054	5 V reference voltage for Electronic Draft Control (EDC) - voltage too low	CCU
1063	Lower solenoid valve - open circuit	CCU
1064	Raise solenoid valve - open circuit	CCU
1065	Lower solenoid valve - short circuit to battery	CCU
1066	Raise solenoid valve - short circuit to battery	CCU
1067	Supply voltage for hitch control solenoid valves - voltage too low	CCU
1068	Electronic Draft Control (EDC) - calibration fault	CCU
1070	Electronic Draft Control (EDC) - ram configuration not set	CCU
1072	Hitch raise and lower switches - signal too high	CCU
1073	Hitch raise and lower switches - signal too low	CCU
12590	Parking brake – supply voltage too low	CCU
12591	Hand brake position switch - signal not plausible	CCU
12592	Parking brake engagement solenoid valve – short circuit to ground or open circuit	CCU

Electrical systems - FAULT CODES

Message	Description	Controller
12593	Parking brake engagement solenoid valve – short circuit to battery	CCU
12594	Parking brake disengagement solenoid valve – short circuit to ground or open circuit	CCU
12595	Parking brake disengagement solenoid valve – short circuit to battery	CCU
2006	Radar sensor - no signal	CCU
2053	5V reference voltage – voltage too high	CCU
2054	5V reference voltage – voltage too low	CCU
2089	CAN-Bus - invalid engine speed	CCU
2090	CAN-Bus - ADIC absent	CCU
2441	CAN-Bus - TCU absent	CCU
4128	Electro Hydraulic Remote valve (EHR) rear 3 - no control message received	CCU
4129	Electro Hydraulic Remote valve (EHR) rear 3 - control message not plausible	CCU
4130	Electro Hydraulic Remote valve (EHR) rear 3 - EEPROM fault	CCU
4131	Electro Hydraulic Remote valve (EHR) rear 3 - switched to failsafe	CCU
4132	Electro Hydraulic Remote valve (EHR) rear 3 - under-voltage	CCU
4133	Electro Hydraulic Remote valve (EHR) rear 3 - over-voltage	CCU
4134	Electro Hydraulic Remote valve (EHR) rear 3 - spool movement too low	CCU
4135	Electro Hydraulic Remote valve (EHR) rear 3 - spool movement too high	CCU
4136	Electro Hydraulic Remote valve (EHR) rear 3 - float position not reached	CCU
4137	Electro Hydraulic Remote valve (EHR) rear 3 - manually operated	CCU
4138	Electro Hydraulic Remote valve (EHR) rear 3 - driver faulty	CCU
4139	Electro Hydraulic Remote valve (EHR) rear 3 - potentiometer faulty	CCU
4140	Electro Hydraulic Remote valve (EHR) rear 3 - unable to reach neutral	CCU
4141	Electro Hydraulic Remote valve (EHR) rear 3 - spool not in neutral at key on	CCU
4142	Electro Hydraulic Remote valve (EHR) rear 4 - no control message received	CCU
4143	Electro Hydraulic Remote valve (EHR) rear 4 - control message not plausible	CCU
4144	Electro Hydraulic Remote valve (EHR) rear 4 - EEPROM fault	CCU

Electrical systems - FAULT CODES

Message	Description	Controller
4145	Electro Hydraulic Remote valve (EHR) rear 4 - switched to failsafe	CCU
4146	Electro Hydraulic Remote valve (EHR) rear 4 - under-voltage	CCU
4147	Electro Hydraulic Remote valve (EHR) rear 4 - over-voltage	CCU
4148	Electro Hydraulic Remote valve (EHR) rear 4 - spool movement too low	CCU
4149	Electro Hydraulic Remote valve (EHR) rear 4 - spool movement too high	CCU
4150	Electro Hydraulic Remote valve (EHR) rear 4 - float position not reached	CCU
4151	Electro Hydraulic Remote valve (EHR) rear 4 - manually operated	CCU
4152	Electro Hydraulic Remote valve (EHR) rear 4 - driver faulty	CCU
4153	Electro Hydraulic Remote valve (EHR) rear 4 - potentiometer faulty	CCU
4154	Electro Hydraulic Remote valve (EHR) rear 4 - unable to reach neutral	CCU
4155	Electro Hydraulic Remote valve (EHR) rear 4 - spool not in neutral at key on	CCU
4192	Electro Hydraulic Remote valve (EHR) rear 3 - no communication	CCU
4193	Electro Hydraulic Remote valve (EHR) rear 4 - no communication	CCU
4221	Electro Hydraulic Remote (EHR) - oil bypass solenoid fault	CCU
4222	Extend/Retract switches remote valve 3 – signal too low	CCU
4223	Extend/Retract switches remote valve 3 – signal too high	CCU
4224	Extend/Retract switches remote valve 4 – signal too low	CCU
4225	Extend/Retract switches remote valve 4 – signal too high	CCU
4226	Front/rear selector switch for the remote valve joystick – signal disagreement	CCU
4227	Control valve joystick - communication fault	CCU
4228	Finger wheel – signal too low	CCU
4229	Finger wheel – signal too high	CCU
4230	Hydraulic oil temperature sensor – signal too high	CCU
4231	Hydraulic oil temperature sensor – signal too low	CCU
4500	Electro Hydraulic Remote valve (EHR) front 1 - no control message received	CCU
4501	Electro Hydraulic Remote valve (EHR) front 1 - control message not plausible	CCU

Electrical systems - FAULT CODES

Message	Description	Controller
4502	Electro Hydraulic Remote valve (EHR) front 1 - EEPROM fault	CCU
4503	Electro Hydraulic Remote valve (EHR) front 1 - switched to failsafe	CCU
4504	Electro Hydraulic Remote valve (EHR) front 1 - under-voltage	CCU
4505	Electro Hydraulic Remote valve (EHR) front 1 - over-voltage	CCU
4506	Electro Hydraulic Remote valve (EHR) front 1 - spool movement too low	CCU
4507	Electro Hydraulic Remote valve (EHR) front 1 - spool movement too high	CCU
4508	Electro Hydraulic Remote valve (EHR) front 1 - float position not reached	CCU
4509	Electro Hydraulic Remote valve (EHR) front 1 - manually operated	CCU
4510	Electro Hydraulic Remote valve (EHR) front 1 - driver faulty	CCU
4511	Electro Hydraulic Remote valve (EHR) front 1 - potentiometer faulty	CCU
4512	Electro Hydraulic Remote valve (EHR) front 1 - unable to reach neutral	CCU
4513	Electro Hydraulic Remote valve (EHR) front 1 - spool not in neutral at key on	CCU
4514	Electro Hydraulic Remote valve (EHR) front 2 - no control message received	CCU
4515	Electro Hydraulic Remote valve (EHR) front 2 - control message not plausible	CCU
4516	Electro Hydraulic Remote valve (EHR) front 2 - EEPROM fault	CCU
4517	Electro Hydraulic Remote valve (EHR) front 2 - switched to failsafe	CCU
4518	Electro Hydraulic Remote valve (EHR) front 2 - under-voltage	CCU
4519	Electro Hydraulic Remote valve (EHR) front 2 - over-voltage	CCU
4520	Electro Hydraulic Remote valve (EHR) front 2 - spool movement too low	CCU
4521	Electro Hydraulic Remote valve (EHR) front 2 - spool movement too high	CCU
4522	Electro Hydraulic Remote valve (EHR) front 2 - float position not reached	CCU
4523	Electro Hydraulic Remote valve (EHR) front 2 - manually operated	CCU
4524	Electro Hydraulic Remote valve (EHR) front 2 - driver faulty	CCU
4525	Electro Hydraulic Remote valve (EHR) front 2 - potentiometer faulty	CCU



Electrical systems - FAULT CODES

Message	Description	Controller
4526	Electro Hydraulic Remote valve (EHR) front 2 - unable to reach neutral	CCU
4527	Electro Hydraulic Remote valve (EHR) front 2 - spool not in neutral at key on	CCU
4556	Front hitch up/down switch (external) – active at key ON	CCU
4557	Remote valve switch (rear fender) – active at key ON	CCU
4560	Electro Hydraulic Remote valve (EHR) front 1 - communication fault	CCU
4561	Electro Hydraulic Remote valve (EHR) front 2 - communication fault	CCU
5033	Rear Power Take-Off (PTO) ON/OFF switch – normally closed switch fault	CCU
5034	Rear Power Take-Off (PTO) fender switches – short circuit to ground or open circuit	CCU
5035	Rear Power Take-Off (PTO) fender switches – short circuit to battery	CCU
5037	Rear Power Take-Off (PTO) ON/OFF switch – normally open switch fault	CCU
5043	Rear Power Take-Off (PTO) fender switches – stuck on fault	CCU
5098	Rear Power Take-Off (PTO) fender switches – option not enabled	CCU
5099	Rear Power Take-Off (PTO) – auto mode not enabled	CCU
7022	Differential lock solenoid valve front - short circuit to ground or open circuit	CCU
8007	Power Take-Off (PTO) solenoid valve front - stuck on	CCU
8008	Power Take-Off (PTO) solenoid valve front - open circuit	CCU
8033	Front Power Take-Off (PTO) ON/OFF switch – normally closed contact is stuck closed	CCU
8037	Front Power Take-Off (PTO) ON/OFF switch – normally open contact is stuck open	CCU
8099	Front Power Take-Off (PTO) – option not enabled	CCU
3001	Foot throttle position sensor - signal not plausible	ECU
3002	Foot throttle position sensor - signal too high	ECU
3003	Foot throttle position sensor - signal too low	ECU
3007	Engine coolant temperature sensor - signal too high	ECU
3008	Engine coolant temperature sensor - signal too low	ECU
3010	Intake air pressure and temperature sensor - temperature signal too high	ECU
3011	Intake air pressure and temperature sensor - temperature signal too low	ECU

## Electrical systems - FAULT CODES

Message	Description	Controller
3015	Fuel temperature sensor - signal too high	ECU
3016	Fuel temperature sensor - signal too low	ECU
3019	Intake air pressure and temperature sensor - pressure signal too high	ECU
3024	Air pressure sensor - signal too high	ECU
3025	Air pressure sensor - signal too low	ECU
3027	Engine oil pressure switch – signal not plausible	ECU
3037	Intake air pressure and temperature sensor - pressure signal too low	ECU
3038	Constant engine speed selector switch - signals not plausible	ECU
3051	ECU supply voltage - voltage too high	ECU
3052	ECU supply voltage - voltage too low	ECU
3059	Main relay ECU - stuck relay fault	ECU
3063	Injector cylinder 1 - short circuit	ECU
3071	Injector cylinder 3 - short circuit	ECU
3079	Injector cylinder 2 - short circuit	ECU
3083	Injector cylinder 4 - short circuit	ECU
3088	Crankshaft sensor - no signal	ECU
3089	Crankshaft sensor - invalid signal	ECU
3090	Camshaft sensor - no signal	ECU
3091	Camshaft sensor - invalid signal	ECU
3093	Crankshaft sensor and camshaft sensor - offset between speed signals too high	ECU
3096	CAN-Bus - ECU in bus-off state or CAN-Bus fault	ECU
3102	Common rail pressure sensor - signal too low	ECU
3104	Common rail relief valve - open	ECU
3105	Common rail relief valve - pressure shock requested	ECU
3106	Common rail relief valve - opening counter reached maximum	ECU
3107	High pressure pump solenoid valve - short circuit to battery	ECU
3108	High pressure pump solenoid valve - short circuit to ground	ECU
3112	Common rail pressure sensor - signal too high	ECU
3126	Hand throttle - signal 1 too high	ECU
3127	Hand throttle - signal 1 too low	ECU
3137	High pressure pump solenoid valve - open circuit	ECU
3139	High pressure pump solenoid valve - signal too high	ECU
3140	High pressure pump solenoid valve - signal too low	ECU
3141	High pressure pump solenoid valve - fuel delivery quantity too high	ECU
3146	Water in fuel sensor - water detected or faulty sensor	ECU
3157	CAN-Bus - ECU absent or engine dataset not available	ECU

Electrical systems - FAULT CODES

Message	Description	Controller
3158	CAN-Bus - invalid engine dataset	ECU
3166	Fuel heater relay - short circuit to battery	ECU
3167	Fuel heater relay - short circuit to ground	ECU
3168	Fuel heater relay - open circuit	ECU
3169	Fuel heater relay - signal not plausible	ECU
3176	High pressure pump solenoid valve - fuel delivery quantity too high in overrun mode	ECU
3177	Engine protection – engine speed is too high	ECU
3179	CAN-Bus message timeout - BC2EDC2 from ADIC	ECU
3180	CAN-Bus message timeout - VCM2EDC from ADIC	ECU
3188	Injector cylinder 1 - open circuit	ECU
3192	Injector cylinder 2 - open circuit	ECU
3196	Injector cylinder 3 - open circuit	ECU
3200	Injector cylinder 4 - open circuit	ECU
3210	Injection bank 1 - short circuit on injection cable	ECU
3230	Injection power stages - processor fault	ECU
3235	Injection control - number of injections limited by runtime	ECU
3236	Injection control - number of injections limited by application	ECU
3237	Injection control - number of injections limited by booster capacity	ECU
3238	Internal check - internal communication fault	ECU
3239	Engine Control Unit (ECU) Electrically Erasable Programmable Read-Only Memory (EEPROM) - Read operation failure	ECU
3240	EEPROM - write operation fault	ECU
3241	EEPROM - calibrated parameters cannot be read	ECU
3242	Internal failure - software reset occurred	ECU
3243	Internal failure - software reset occurred	ECU
3244	Internal failure - software reset occurred	ECU
3245	Internal check - internal communication fault	ECU
3252	Internal check - internal communication fault	ECU
3253	Analog digital converter - reference voltage too high	ECU
3255	Analog digital converter - plausibility check fault	ECU
3256	Analog digital converter - plausibility check fault	ECU
3265	Internal check - injection time too long	ECU
3266	Internal check - engine speed signal not plausible	ECU

Electrical systems - FAULT CODES

Message	Description	Controller
3283	Sensor supply voltage 2 - voltage out of valid range	ECU
3285	Sensor supply voltage 3 - voltage out of valid range	ECU
3301	High pressure pump solenoid valve - maximum negative rail pressure deviation exceeded	ECU
3305	High pressure pump solenoid valve - minimum rail pressure exceeded	ECU
3309	High pressure pump solenoid valve - maximum rail pressure exceeded	ECU
3334	CAN-Bus message timeout - TSC1-PE from CCU (when active)	ECU
3335	CAN-Bus message timeout - TSC1-PE from CCU (when inactive)	ECU
3338	CAN-Bus message timeout - TSC1-VE from CCU (when inactive)	ECU
3339	CAN-Bus message timeout - TSC1-VE from CCU (when active)	ECU
3358	CAN-Bus message timeout - transmit EEC1	ECU
3361	EEPROM - general fault	ECU
3362	Internal check - torque to fuel quantity map not plausible	ECU
3368	Engine protection - torque limitation caused by performance limiter	ECU
3369	Engine protection – torque limitation due to smoke limitation	ECU
3370	Engine protection – torque limitation due to engine overload	ECU
3371	Engine protection – torque limitation caused by injection system	ECU
3374	Injector adjustment – adjustment data fault	ECU
3375	Constant engine speed adjust switch – signals not plausible	ECU
3402	Common rail pressure sensor - maximum rail pressure exceeded	ECU
3405	ECU Power stages: Open load temperature error on the turbocharger PWM output power stage	ECU
3406	Turbocharger power stage - temperature too high	ECU
3408	Lambda sensor - oxygen concentration too high	ECU
3409	Engine oil pressure switch - oil pressure too low	ECU
3410	Throttle Valve Actuator (TVA) - positive position deviation limit exceeded	ECU
3411	Throttle Valve Actuator (TVA) - negative position deviation limit exceeded	ECU
3414	Glow plug of cylinder 1 - short circuit	ECU
3415	Glow plug of cylinder 2 - short circuit	ECU
3416	Glow plug of cylinder 3 - short circuit	ECU
3417	Glow plug of cylinder 4 - short circuit	ECU

Electrical systems - FAULT CODES

Message	Description	Controller
3418	Turbocharger power stage - short circuit to battery	ECU
3419	Turbocharger power stage - short circuit to ground	ECU
3420	CAN-Bus - external engine shutdown message	ECU
3425	Turbocharger - boost pressure deviation too high at intake air pressure and temperature sensor	ECU
3426	Diesel Particulate Filter (DPF) - level 1 reached	ECU
3427	Diesel Particulate Filter (DPF) - low flow resistance	ECU
3428	Differential pressure sensor - signal not plausible	ECU
3429	Differential pressure sensor - hose line plausibility fault	ECU
3430	Exhaust Gas Recirculation (EGR) - less severe derating level induced	ECU
3431	Exhaust Gas Recirculation (EGR) - most severe derating level induced	ECU
3432	Exhaust Gas Recirculation (EGR) - inducement warning	ECU
3433	Diesel Particulate Filter (DPF) - less severe derating level induced	ECU
3434	Diesel Particulate Filter (DPF) - most severe derating level induced	ECU
3435	Diesel Particulate Filter (DPF) - inducement warning	ECU
3616	Engine protection – torque limitation due to turbocharger protection	ECU
3650	Battery voltage - voltage too high	ECU
3651	Battery voltage - voltage too low	ECU
3652	CAN-Bus - bus-off state of node A	ECU
3655	Engine protection – general report for active torque limitations	ECU
3656	Engine protection – torque limitation caused by Diesel Particulate Filter (DPF)	ECU
3657	CAN-Bus message timeout - CM1BC from ADIC	ECU
3663	Exhaust Gas Recirculation (EGR) - command saturation over higher limit	ECU
3664	Exhaust Gas Recirculation (EGR) - command saturation over lower limit	ECU
3665	Exhaust Gas Recirculation (EGR) valve actuator - positive position deviation limit exceeded	ECU
3666	Exhaust Gas Recirculation (EGR) valve actuator - negative position deviation limit exceeded	ECU
3667	Exhaust Gas Recirculation (EGR) valve actuator - open circuit at power stage	ECU
3668	Exhaust Gas Recirculation (EGR) valve actuator - over-temperature at power stage	ECU

Electrical systems - FAULT CODES

Message	Description	Controller
3669	Exhaust Gas Recirculation (EGR) valve actuator - short circuit to battery on Out1 of power stage	ECU
3670	Exhaust Gas Recirculation (EGR) valve actuator - short circuit to battery on Out2 of power stage	ECU
3671	Exhaust Gas Recirculation (EGR) valve actuator - short circuit to ground on Out1 of power stage	ECU
3672	Exhaust Gas Recirculation (EGR) valve actuator - short circuit to ground on Out2 of power stage	ECU
3673	Exhaust Gas Recirculation (EGR) valve actuator - short circuit at power stage	ECU
3674	Exhaust Gas Recirculation (EGR) valve actuator - under-voltage at power stage	ECU
3675	Exhaust Gas Recirculation (EGR) valve actuator - long time drift at closed position	ECU
3676	Exhaust Gas Recirculation (EGR) valve actuator - position sensor voltage too high	ECU
3677	Exhaust Gas Recirculation (EGR) valve actuator - position sensor voltage too low	ECU
3680	Internal check - injection cut off	ECU
3688	Water in fuel sensor - water in fuel detected or defective sensor	ECU
3689	Glow plug control module - faulty diagnostic data transmission or protocol fault	ECU
3691	Glow plug control module - open circuit at power stage	ECU
3692	Glow plug control module - over-temperature at power stage	ECU
3693	Glow plug control module - short circuit to battery at power stage	ECU
3694	Glow plug control module - short circuit to ground at power stage	ECU
3699	EEPROM - correction values for rail pressure regulation are inaccessible	ECU
3702	Injection control - failed engine start detected	ECU
3703	Injection control - rail pressure too low	ECU
3704	Injector adjustment - invalid adjustment value programming for injector 2	ECU
3705	Injector adjustment - invalid adjustment value programming for injector 3	ECU
3706	Injector adjustment - invalid adjustment value programming for injector 4	ECU
3707	Lambda sensor - open circuit at the nernst cell pin	ECU

Electrical systems - FAULT CODES

Message	Description	Controller
3708	Lambda sensor - open circuit at the pump current pin	ECU
3709	Lambda sensor - open circuit at the virtual ground pin	ECU
3710	Lambda sensor - signal not plausible	ECU
3711	Lambda sensor - short circuit to battery at heater power stage	ECU
3712	Lambda sensor - short circuit to ground at heater power stage	ECU
3713	Lambda sensor - open circuit at heater power stage	ECU
3714	Lambda sensor - oxygen ratio signal too high during calibration	ECU
3715	Lambda sensor - oxygen ratio signal too low during calibration	ECU
3716	Lambda sensor - oxygen ratio signal too high	ECU
3720	Lambda sensor - supply voltage too low	ECU
3721	Lambda sensor - SPI chip defective	ECU
3722	Lambda sensor - calculated temperature too high	ECU
3723	Lambda sensor - calculated temperature too low	ECU
3724	Lambda sensor - short circuit to battery	ECU
3725	Lambda sensor - short circuit to ground	ECU
3727	Engine oil check – low viscosity	ECU
3728	Engine oil check – too low viscosity	ECU
3736	Lambda sensor - oxygen ratio out of range	ECU
3737	Lambda sensor - over-temperature at heater power stage	ECU
3738	Internal check - ROM memory fault	ECU
3739	Injector power stages - loss of synchronization	ECU
3740	Injector power stages - diagnostic fault check to set torque limitation	ECU
3741	Injector power stages - timeout fault of monitoring module	ECU
3742	Injector power stages - faulty communication detected during shut off path test	ECU
3743	Injector power stages - under-voltage detected during shut off path test	ECU
3744	Injector power stages - over-voltage detected during shut off path test	ECU
3745	Injector power stages - implausible response during shut off path test	ECU
3746	Injector power stages - timeout problem during shut off path test	ECU
3747	Injector power stages - irreversible fault bit set	ECU
3748	Injector power stages - timeout during shut off path test	ECU

Electrical systems - FAULT CODES

Message	Description	Controller
3750	Injection control - implausible injection energizing time	ECU
3751	Injection control - implausible start of energizing	ECU
3752	Internal check - invalid energizing times (zero fuel quantity calibration)	ECU
3753	Level 2 monitoring – injection quantity correction fault	ECU
3754	Level 2 monitoring – implausible rail pressure	ECU
3755	Level 2 monitoring – torque comparison fault	ECU
3756	Level 2 monitoring – fault in the post injection 2 quantity	ECU
3757	Level 2 monitoring – fault in the post injection 2 quantity in normal mode	ECU
3758	Level 2 monitoring – implausible post injection 3 efficiencies	ECU
3759	Level 2 monitoring – calculated lead torque too high	ECU
3760	Level 2 monitoring – calculated lead torque too high	ECU
3761	Level 2 monitoring – calculated inner engine torque too high	ECU
3762	Level 2 monitoring - sensor supply voltage too high	ECU
3763	Level 2 monitoring - sensor supply voltage too low	ECU
3764	Main relay ECU - early opening fault	ECU
3766	Differential pressure sensor - differential pressure value too high	ECU
3767	Internal check - faults in query/response communication	ECU
3768	Internal check - internal communication fault due to under-voltage detection	ECU
3769	Internal check - internal communication fault due to over-voltage detection	ECU
3770	Internal check - internal communication fault	ECU
3773	Turbocharger - positive boost pressure deviation too high	ECU
3786	Diesel Particulate Filter (DPF) - flow resistance exceeded first limit	ECU
3787	Diesel Particulate Filter (DPF) - flow resistance exceeded second limit	ECU
3789	Diesel Particulate Filter (DPF) - regeneration duration too long	ECU
3790	Diesel Particulate Filter (DPF) - flow resistance exceeded maximum limit	ECU
3794	Intake air pressure and temperature sensor - signal not plausible	ECU
3795	Intake air pressure and temperature sensor - signal not plausible	ECU
3797	Differential pressure sensor - signal too high	ECU



Electrical systems - FAULT CODES

Message	Description	Controller
3798	Differential pressure sensor - signal too low	ECU
3799	Common rail relief valve - forced to open due to pressure shock	ECU
3800	Common rail relief valve - pressure shock rejected	ECU
3801	Exhaust manifold pressure sensor - signal too high	ECU
3802	Exhaust manifold pressure sensor - signal too low	ECU
3803	Internal check - internal communication fault	ECU
3808	High pressure pump solenoid valve - set point not plausible	ECU
3810	Common rail pressure sensor - intermittent signal	ECU
3811	Internal check - sensor supply fault	ECU
3812	Temperature sensor Engine Control Unit (ECU) – high temperature	ECU
3813	Temperature sensor Engine Control Unit (ECU) – low temperature	ECU
3814	Temperature sensor Engine Control Unit (ECU) – communication fault	ECU
3818	Throttle Valve Actuator (TVA) - open circuit	ECU
3819	Throttle Valve Actuator (TVA) - over-current at power stage	ECU
3820	Throttle Valve Actuator (TVA) - over-temperature at power stage	ECU
3821	Throttle Valve Actuator (TVA) - short circuit to battery at Out1 of power stage	ECU
3822	Throttle Valve Actuator (TVA) - short circuit to battery at Out2 of power stage	ECU
3823	Throttle Valve Actuator (TVA) - short circuit to ground at Out1 of power stage	ECU
3824	Throttle Valve Actuator (TVA) - short circuit to ground at Out2 of power stage	ECU
3825	Throttle Valve Actuator (TVA) - short circuit at power stage	ECU
3827	Throttle Valve Actuator (TVA) - under-voltage at power stage	ECU
3830	Throttle Valve Actuator (TVA) - position signal too high	ECU
3831	Throttle Valve Actuator (TVA) - position signal too low	ECU
3834	Throttle Valve Actuator (TVA) - position signal too high	ECU
3835	Throttle Valve Actuator (TVA) - position signal too low	ECU
3838	Diesel Oxidation Catalyst (DOC) inlet temperature sensor - signal too high	ECU
3839	Diesel Oxidation Catalyst (DOC) inlet temperature sensor - signal too low	ECU

Electrical systems - FAULT CODES

Message	Description	Controller
3840	Diesel Particulate Filter (DPF) inlet temperature sensor - signal too high	ECU
3841	Diesel Particulate Filter (DPF) inlet temperature sensor - signal too low	ECU
3842	Exhaust manifold temperature sensor - signal too high	ECU
3843	Exhaust manifold temperature sensor - signal too low	ECU
3844	Injector cylinder 1 - energizing time too high	ECU
3845	Injector cylinder 2 - energizing time too high	ECU
3846	Injector cylinder 3 - energizing time too high	ECU
3847	Injector cylinder 4 - energizing time too high	ECU
3848	Injector cylinder 1 - energizing time too low	ECU
3849	Injector cylinder 2 - energizing time too low	ECU
3850	Injector cylinder 3 - energizing time too low	ECU
3851	Injector cylinder 4 - energizing time too low	ECU
3852	Lambda sensor - insufficient heater performance	ECU
3870	CAN-Bus message timeout - BC2EDC1 from ADIC	ECU
3899	Engine protection – engine temperature exceeded prewarning level	ECU
3900	Engine protection – engine temperature exceeded warning level	ECU
3906	Injection control - number of injections limited by quantity balance of high pressure pump	ECU
3910	High pressure pump solenoid valve - intermittent connection to ECU	ECU
3915	Common rail relief valve - averaged pressure out of valid range	ECU
3916	Common rail relief valve - maximum open time exceeded	ECU
2011	Clutch pedal sensor - signal too low	TCU
2012	Clutch pedal sensor - signal too high	TCU
2013	Forward/reverse switches - invalid signal	TCU
2035	Transmission output speed sensor - speed limit exceeded	TCU
2049	Transmission output speed sensor - signal too low	TCU
2050	Transmission output speed sensor - signal too high	TCU
2051	Transmission oil temperature sensor - signal too high	TCU
2052	Transmission oil temperature sensor - signal too low	TCU

Electrical systems - FAULT CODES

Message	Description	Controller
2055	Transmission output speed sensor - implausible speed drop detected	TCU
2059	Shuttle lever - implausible signals	TCU
2092	Comfort shift switch - signal too high	TCU
2095	Comfort shift switch - invalid signal	TCU
2323	Powershift output speed sensor - signal too high	TCU
2324	Powershift output speed sensor - signal too low	TCU
2328	Powershift output speed sensor - implausible speed drop detected	TCU
2342	Clutch A solenoid valve - open circuit	TCU
2343	Clutch B solenoid valve - open circuit	TCU
2344	Clutch C solenoid valve - open circuit	TCU
2345	Clutch D solenoid valve - open circuit	TCU
2347	Clutch F solenoid valve - open circuit	TCU
2348	Clutch G solenoid valve - open circuit	TCU
2352	Clutch A solenoid valve - short circuit to battery	TCU
2353	Clutch B solenoid valve - short circuit to battery	TCU
2354	Clutch C solenoid valve - short circuit to battery	TCU
2355	Clutch D solenoid valve - short circuit to battery	TCU
2357	Clutch F solenoid valve - short circuit to battery	TCU
2358	Clutch G solenoid valve - short circuit to battery	TCU
2362	Clutch A solenoid valve - invalid contact pressure calibration data	TCU
2363	Clutch B solenoid valve - invalid contact pressure calibration data	TCU
2364	Clutch C solenoid valve - invalid contact pressure calibration data	TCU
2365	Clutch D solenoid valve - invalid contact pressure calibration data	TCU
2367	Clutch F solenoid valve - invalid contact pressure calibration data	TCU
2368	Clutch G solenoid valve - invalid contact pressure calibration data	TCU
2385	Engine speed and powershift input speed - speed difference too high	TCU
2392	Clutch A solenoid valve - short circuit to ground	TCU
2393	Clutch B solenoid valve - short circuit to ground	TCU
2394	Clutch C solenoid valve - short circuit to ground	TCU
2395	Clutch D solenoid valve - short circuit to ground	TCU
2397	Clutch F solenoid valve - short circuit to ground	TCU
2398	Clutch G solenoid valve - short circuit to ground	TCU
2416	Forward/reverse switches - signal too low	TCU

## Electrical systems - FAULT CODES

Message	Description	Controller
2417	Forward/reverse switches - signal too high	TCU
2418	Comfort shift switch - signal too low	TCU
2555	Transmission oil pressure switch – no pressure signal	TCU
2602	Clutch A solenoid valve - invalid filling time calibration data	TCU
2603	Clutch B solenoid valve - invalid filling time calibration data	TCU
2604	Clutch C solenoid valve - invalid filling time calibration data	TCU
2605	Clutch D solenoid valve - invalid filling time calibration data	TCU
2607	Clutch F solenoid valve - invalid filling time calibration data	TCU
2608	Clutch G solenoid valve - invalid filling time calibration data	TCU
2612	Powershift input speed sensor - signal too high	TCU
2613	Powershift input speed sensor - signal too low	TCU
2614	Powershift input speed sensor - implausible speed drop detected	TCU
2616	Forward switch - pressed too long or stuck	TCU
2617	Reverse switch - pressed too long or stuck	TCU
2620	Shuttle lever forward switch - invalid signal	TCU
2621	Shuttle lever reverse switch - invalid signal	TCU
2622	Shuttle lever neutral switch - invalid signal	TCU
2623	Shuttle lever deadman switch - invalid signal	TCU
2624	Internal check – safety warning	TCU
2625	Internal check – critical failure	TCU
2944	Internal check – engine speed protection failure	TCU
2948	5V reference voltage - voltage too high	TCU
2949	5V reference voltage - voltage too low	TCU
2950	TCU supply voltage - voltage too high	TCU
2951	TCU supply voltage - voltage too low	TCU
2952	Valve supply voltage 1 - implausible voltage	TCU
2953	Valve supply voltage 2 - implausible voltage	TCU
2955	CAN bus message timeout – TSC1 from ADIC	TCU
2956	CAN bus signal fault – TSC1 signal (speed request) from ADIC	TCU
2957	CAN bus message fault – ADIC3 from ADIC	TCU
2958	CAN bus message fault – ECU1 from CCU	TCU
2959	State change plausibility signal - stays high too long	TCU

Electrical systems - FAULT CODES

Message	Description	Controller
2960	State change plausibility signal - plausibility fault	TCU
2961	CAN-Bus message timeout - message from CCU	TCU
2962	CAN-Bus signal fault - engine torque (EEC1) from ECU	TCU
2963	CAN-Bus signal fault - engine speed (EEC1) from ECU	TCU
2964	CAN-Bus signal fault - requested torque (EEC1) from ECU	TCU
2965	CAN-Bus message timeout - ADIC1 from ADIC	TCU
2966	CAN-Bus signal fault - operator presence (ADIC1) from ADIC	TCU
2967	CAN-Bus signal fault - hand brake status (ADIC1) from ADIC	TCU
2968	CAN-Bus signal fault - wheel speed (ADIC1) from ADIC	TCU
2969	CAN-Bus message timeout - EEC1 from ECU	TCU
2970	CAN-Bus message timeout - ADIC3 from ADIC	TCU
2971	CAN-Bus signal fault - foot throttle pedal position (ADIC3) from ADIC	TCU
2972	CAN-Bus signal fault - hand throttle lever position (ADIC3) from ADIC	TCU
2973	CAN-Bus signal fault - automatic powershift function potentiometer (ADIC3) from ADIC	TCU
2974	CAN-Bus message timeout - EEC2 from ECU	TCU
2975	CAN-Bus message timeout - EEC3 from ECU	TCU
2976	CAN-Bus message timeout - ECCU1 from CCU	TCU
2977	CAN-Bus signal fault - 4WD switch status (ECCU1) from CCU	TCU
2978	CAN-Bus signal fault - differential lock switch status (ECCU1) from CCU	TCU
2979	CAN-Bus signal fault - PTO switch rear status (ECCU1) from CCU	TCU
2980	CAN-Bus signal fault - PTO soft start functionality (ECCU1) from CCU	TCU
2981	CAN-Bus signal fault - percent engine load (EEC2) from ECU	TCU
2982	CAN-Bus signal fault - desired engine speed (EEC3) from ECU	TCU
2983	CAN-Bus signal fault - nominal friction torque (EEC3) from ECU	TCU
2984	Powershift – invalid slip at gear 1	TCU
2985	Powershift – invalid slip at gear 2	TCU
2986	Powershift – invalid slip at gear 3	TCU
2987	Powershift – invalid slip at gear 4	TCU
2988	Transmission oil temperature sensor - temperature limit exceeded	TCU
2989	Clutch pedal sensor and clutch pedal switch – signals not plausible	TCU

Electrical systems - FAULT CODES

Message	Description	Controller
2990	EEPROM - clutch pedal sensor data not plausible	TCU
2991	EEPROM - invalid clutch pedal sensor calibration data	TCU
2992	EEPROM - invalid configuration data	TCU
2993	EEPROM - invalid checksum of configuration data	TCU
2994	Application fault - improperly programmed application controls	TCU
2995	Configuration fault - customer setting invalid or not existing	TCU
2996	EEPROM - invalid checksum of vehicle configuration data	TCU
2999	Internal check - hardware and software do not match	TCU
5006	Power Take-Off (PTO) solenoid valve rear - short circuit to battery	TCU
5007	Power Take-Off (PTO) solenoid valve rear - open circuit	TCU
5008	Power Take-Off (PTO) solenoid valve rear - short circuit to ground	TCU
5024	Rear Power Take-Off (PTO) – invalid or no contact pressure in EEPROM	TCU
5025	Rear Power Take-Off (PTO) – invalid or no filling time in EEPROM	TCU
5026	Rear Power Take-Off (PTO) speed sensor – implausible speed drop detected	TCU
5027	Power Take-Off (PTO) speed sensor rear - short circuit to battery or open circuit	TCU
5032	Rear Power Take-Off (PTO) – clutch slip exceeded limit	TCU
5044	Power Take-Off (PTO) speed sensor rear - short circuit to ground	TCU
6023	Four-Wheel Drive (4WD) solenoid valve - interrupted line	TCU
6024	Four-Wheel Drive (4WD) solenoid valve - short circuit to battery	TCU
6027	Four-Wheel Drive (4WD) solenoid valve - short circuit to chassis	TCU
7017	Differential lock solenoid valve rear - short circuit to ground or open circuit	TCU
7018	Differential lock solenoid valve rear - short circuit to battery	TCU
7019	Differential lock solenoid valve rear - short circuit to chassis	TCU

# Index

---

## Electrical systems - 55

### FAULT CODES - DTC

Fault code index .....	3
------------------------	---







© 2014 CNH Industrial Österreich GmbH

All rights reserved. No part of the text or illustrations of this publication may be reproduced.

CASE IH policy is one of continuous improvement and the right to change prices, specification or equipment at any time without notices is reserved.

All data given in this publication is subject to production variations. Dimensions and weight are approximate only and the illustrations do not necessarily show products in standard condition. For exact information about any particular product, please consult your CASE IH Dealer.



## **SERVICE MANUAL**

**Platform, cab, bodywork, and decals**

**Farmall 105U Pro EP  
Farmall 115U Pro EP  
Farmall 95U Pro EP**

# Contents

---

## Platform, cab, bodywork, and decals - 90

[90.150] Cab.....	90.1
-------------------	------



## **Platform, cab, bodywork, and decals - 90**

### **Cab - 150**

**Farmall 105U Pro EP  
Farmall 115U Pro EP  
Farmall 95U Pro EP**

# Contents

---

## Platform, cab, bodywork, and decals - 90

### Cab - 150

#### SERVICE

##### Cab

Remove .....	3
Install .....	13

## Cab - Remove

### Prior operation:

Discharging the air-conditioning system. See **Air conditioning - Discharging (50.200)**.

Remove the battery. See **Battery - Remove (55.302)**.

Remove the rear wheels. See **Rear wheels - Remove (44.520)**.

**NOTICE:** Avoid open pipes or hoses to be sure that they are free of debris.

1. Remove the bolts (1).
2. Remove the cover of the air operated trailer brake (where fitted).

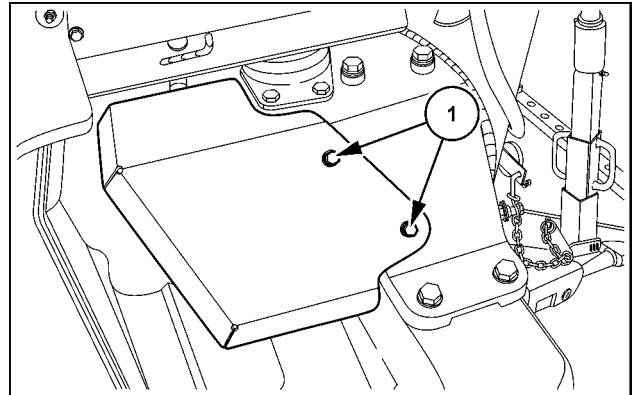

3. Remove the bolts (1) on both sides of the cab.
4. Remove the covers on both sides.

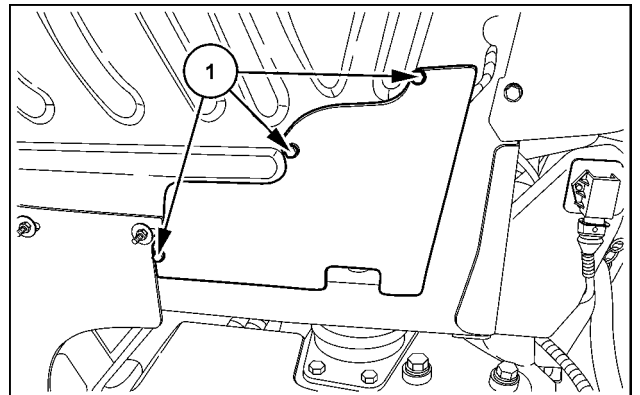

5. Remove the bolts (1) and the nuts (2) on both sides of the cab.
6. Remove the rubber covers on both sides.

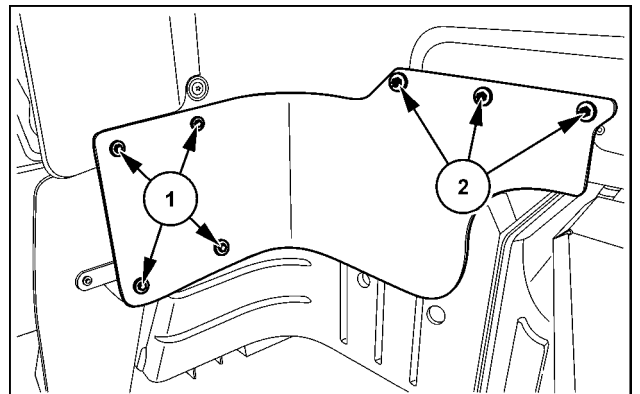

7. Remove the rubber cover (1).

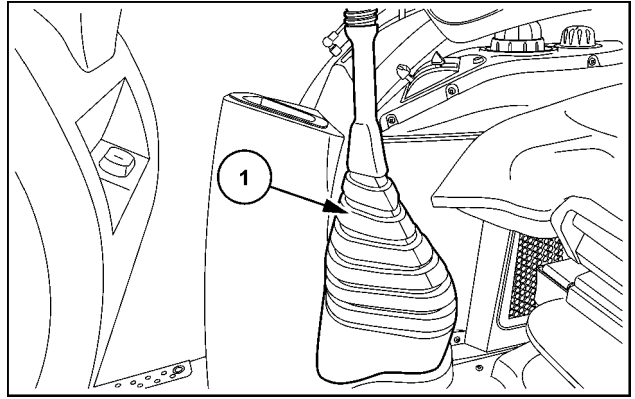

SVIL13TR00648AB 4

8. Install a fixing bolt into the hole on the gear lever.

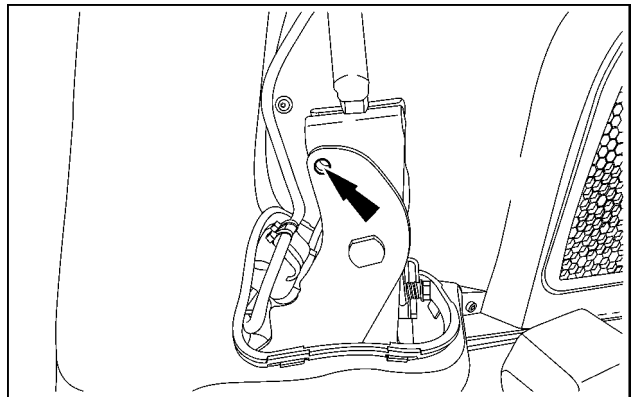

SVIL13TR00647AB 5

9. Remove the bolts (1) on both sides of the cab.  
10. Remove the fixing plates.  
11. Remove the floor mat.

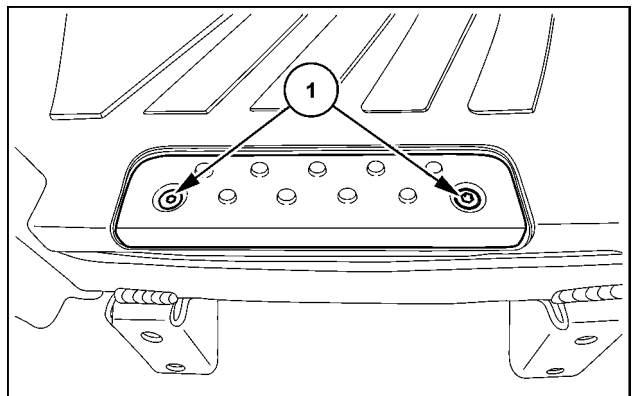

SVIL13TR00636AB 6

12. Remove the bolts (1).  
13. Remove the steps on the right-hand side.

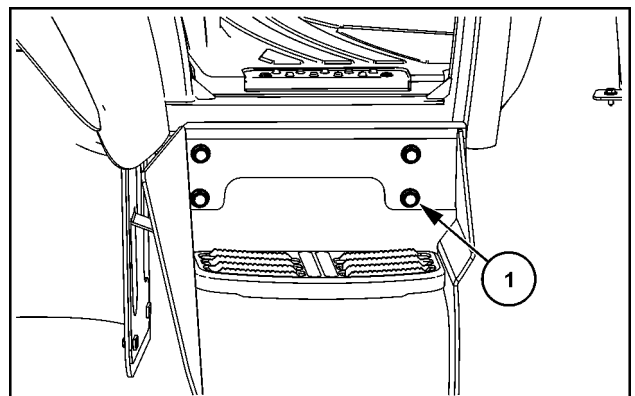

SS13K074 7

14. Remove the fuel tank. See **Fuel tank - Remove (10.216)**.

15. Remove the five bolts (1).
16. Remove the covers on both sides.

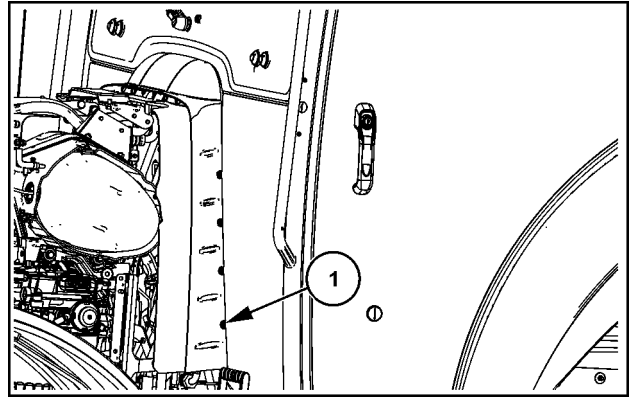

SS13K076 8

17. Open the clamps.
18. Remove the heating hoses (1).

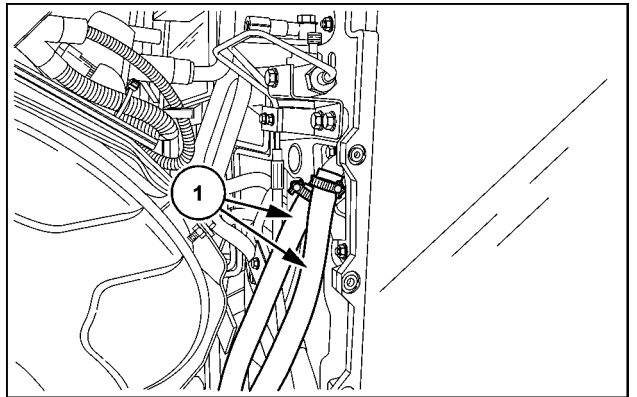

SVIL13TR00641AB 9

19. Disconnect the electrical connector (1) from the brake reservoir.

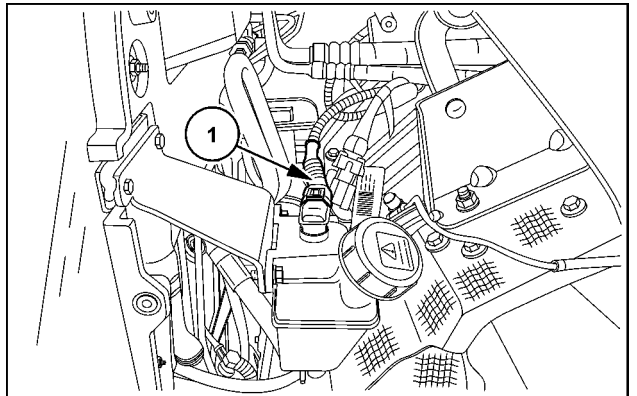

SVIL13TR00639AB 10

20. Remove the bolts (1).
21. Remove the middle cover.

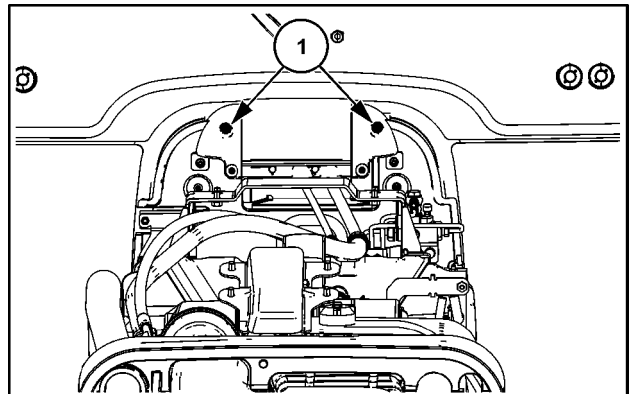

SS13K075 11



22. Remove the nuts (1).
23. Remove the cover.

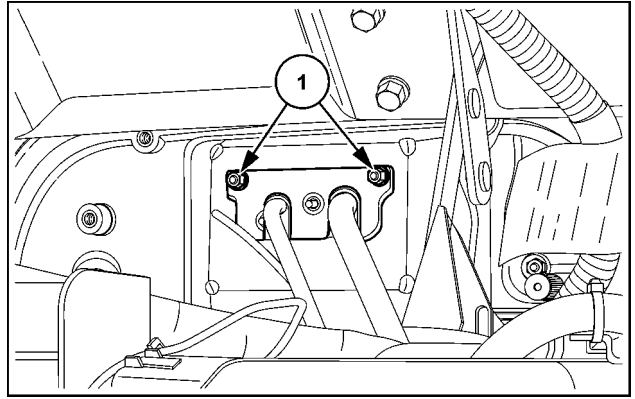

SVIL13TR00638AB 12

24. Remove the nuts (1) (where fitted).
25. Remove the air-conditioning pipes (where fitted).

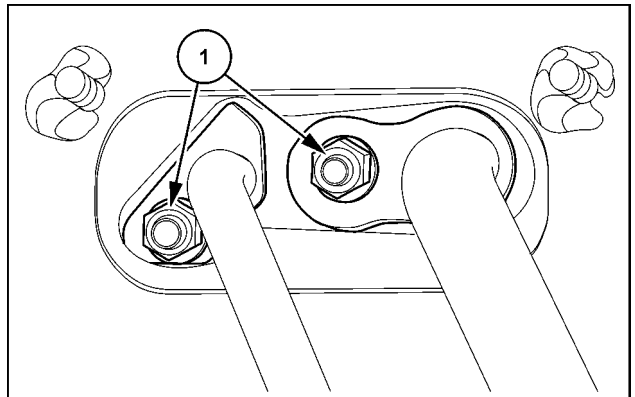

SVIL13TR00642AB 13

26. Disconnect the steering hoses (1).
27. Disconnect the hose (2) from the steering valve to the thermostat.
28. Disconnect the front axle brake hose (3) (where fitted).

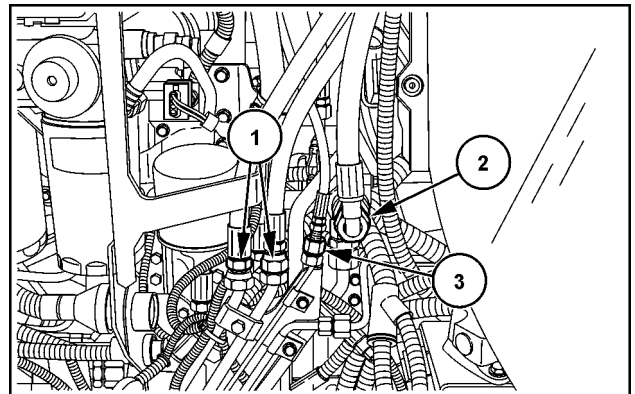

SVIL13TR00637AB 14

29. Disconnect the steering hose (1) on the right-hand side.

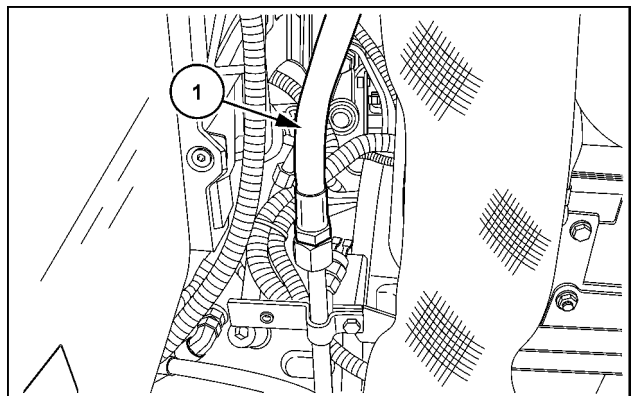

SVIL13TR00635AB 15

30. Remove the bolts (1) from the front cab support on both sides.

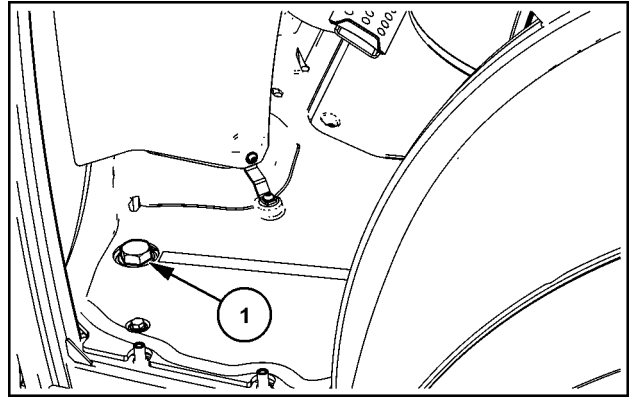

SS13K073 16

### Cab support (standard cab)

31. Remove the nuts (1) on both sides.

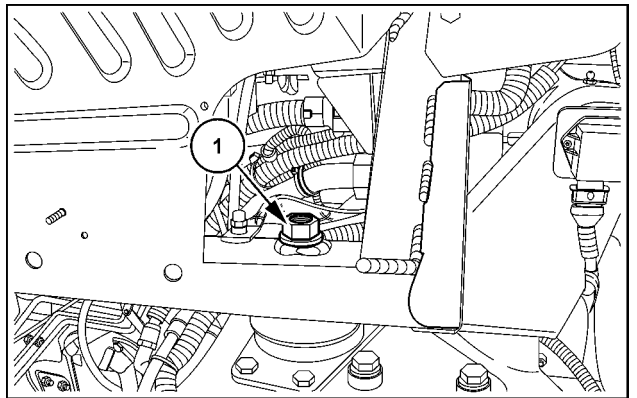

SVIL13TR00634AB 17

### Cab support (suspended cab)

32. Remove the bolts (1) on both sides.

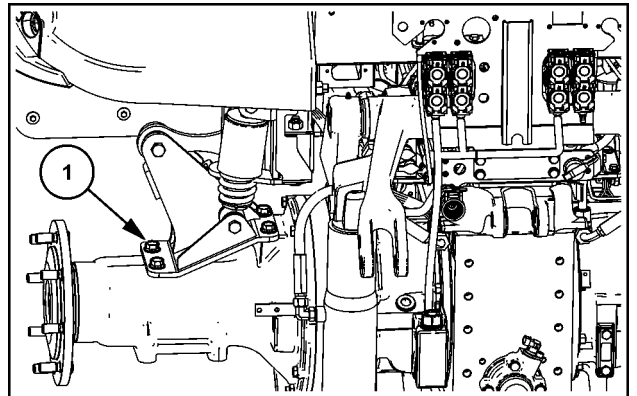

SS13K115 18

33. Remove the clip (1) and the remote flow control (first control unit).

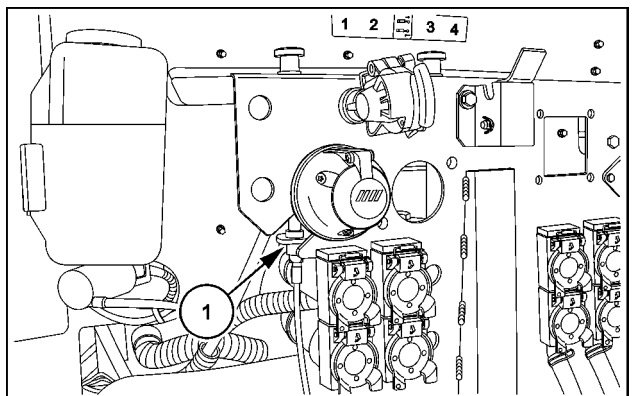

SVIL13TR00632AC 19

34. Remove the trailer socket (1).

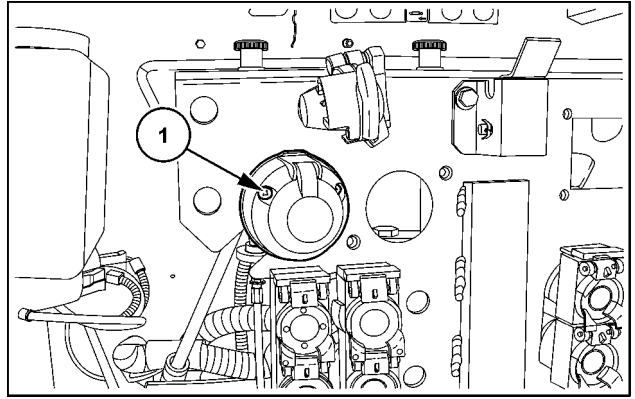

SVIL13TR00633AB 20

35. Remove the power socket (1).

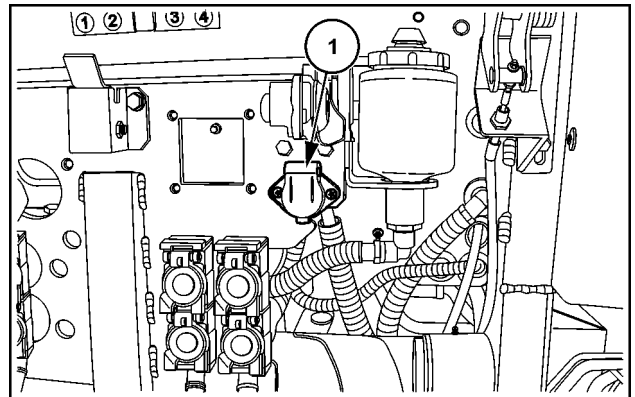

SVIL13TR00631AC 21

36. Remove the Bowden cable (1) for the hitch (where fitted).

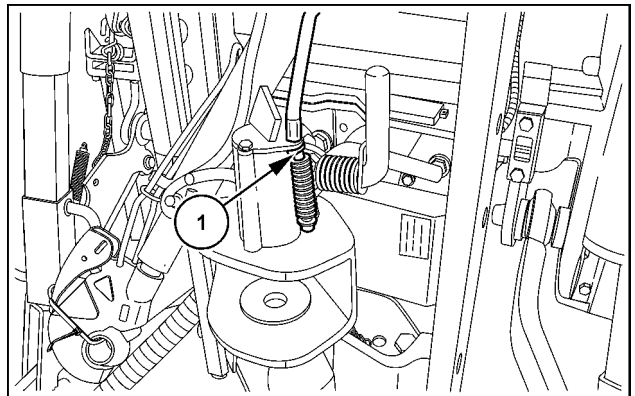

SVIL13TR00629AB 22

37. Disconnect all the electrical connectors for the Electronic Front Hitch (EFH) (where fitted).

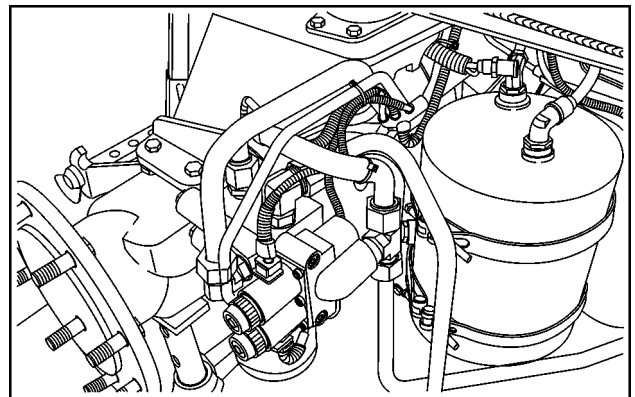

SVIL13TR00630AA 23

38. Remove the pipe (1) for the compressed air sensor (where fitted).

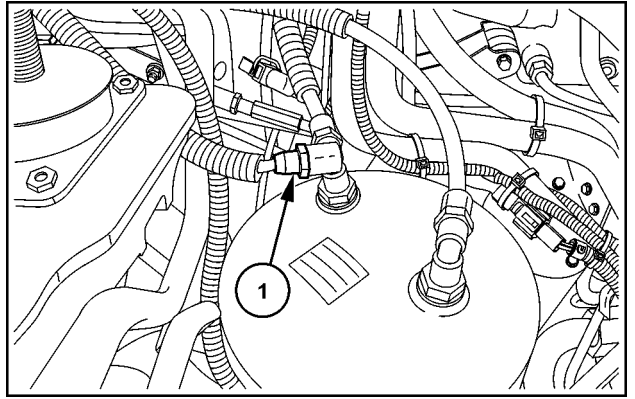

SVIL13TR00624AB 24

39. Remove the Bowden cable (1) for the Power Take-Off (PTO) (540/1000).

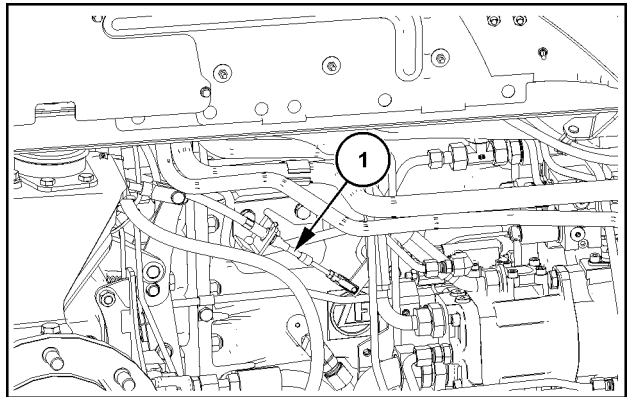

SS13K092 25

40. Remove the ground cable (1).

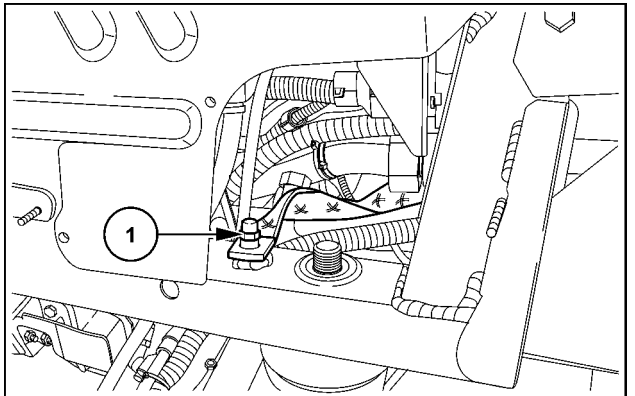

SVIL13TR00626AB 26

41. Remove the Bowden cable (1) for the hand brake.

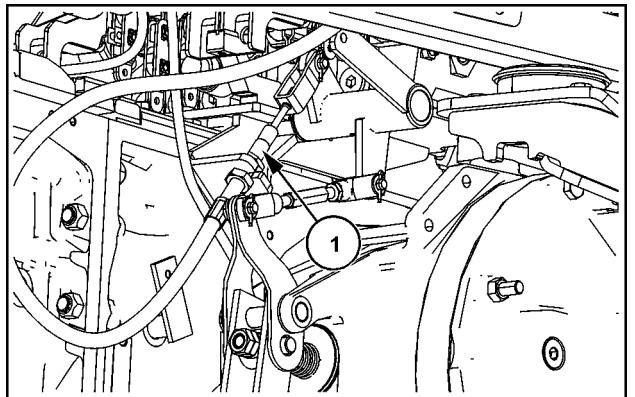

SS13K090 27

42. Disconnect the brake fluid hoses (1).

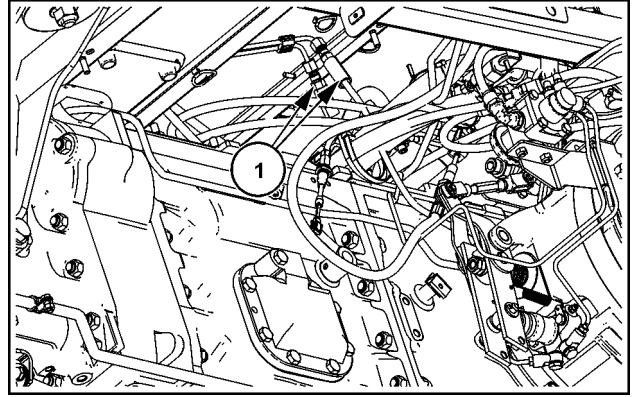

SS13K091 28

43. Remove the Bowden cable (1) for the field/road group.

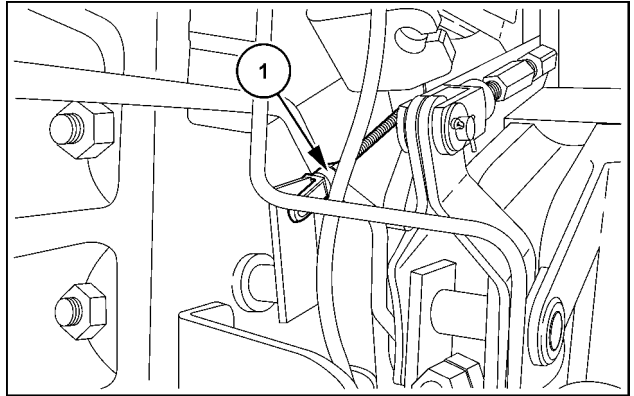

SVIL13TR00627AB 29

44. **▲ WARNING**

**Heavy objects!**

Lift and handle all heavy components using lifting equipment with adequate capacity. Always support units or parts with suitable slings or hooks. Make sure the work area is clear of all bystanders.

Failure to comply could result in death or serious injury.

W0398A

Position tool inside the cab, hitch to a hoist using ropes and lightly take up the slack.

Raise the cab carefully approximately **10.0 cm (3.9 in)**.

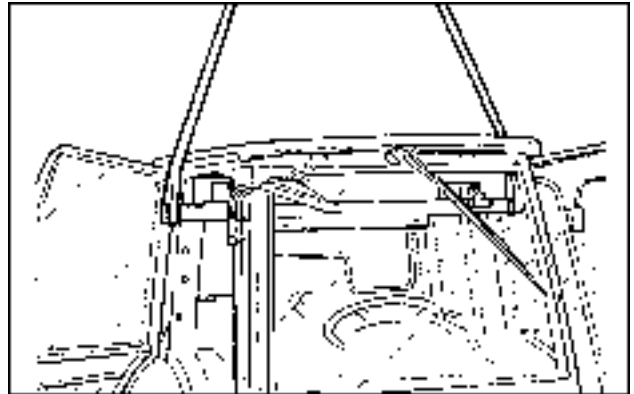

WLAPL4S90C128A 30

**NOTICE:** Pay attention to cables and pipes.

45. Disconnect the electrical connectors (1) for the Electro Hydraulic Remote (EHR) valves (where fitted).

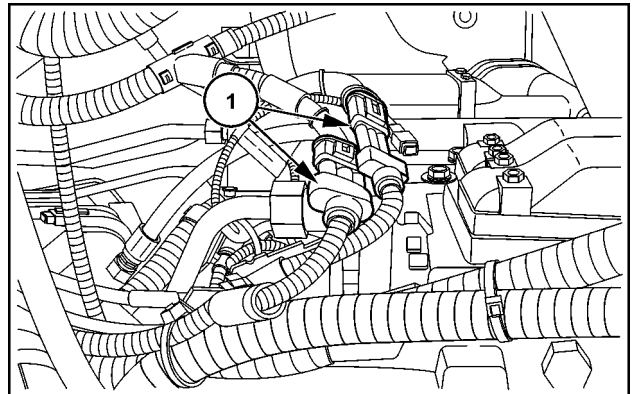

SVIL13TR00625AB 31

46. Remove the Bowden cable (1) for the ground speed Power Take-Off (PTO) (where fitted).

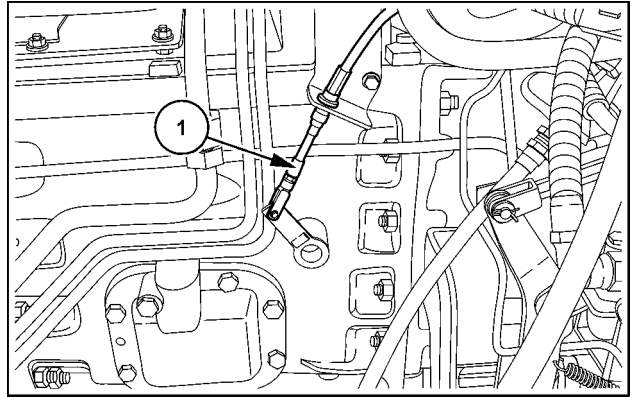

SVIL13TR00628AB 32

47. Disconnect the cab main connector (1) on the rear of the cab.

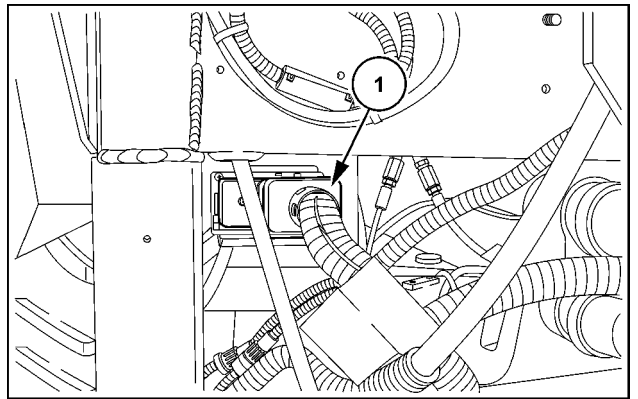

SVIL13TR00623AB 33

48. Remove the Bowden cable (1) for the Power Take-Off (PTO) (NORMAL/ECONOMIC).

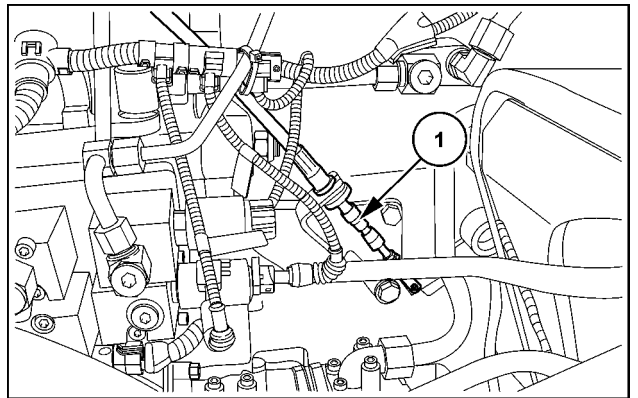

SVIL13TR00622AB 34

49. Remove the bolts (1).  
50. Remove the shifting Bowden cables.

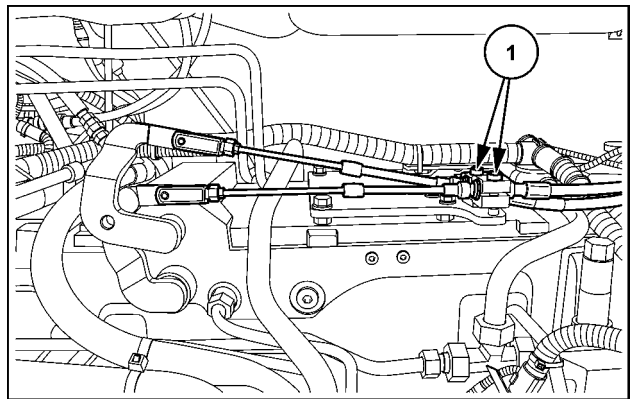

SVIL13TR00621AB 35

51. Remove the bolt (1).
52. Remove the Bowden cables for the remote valves.

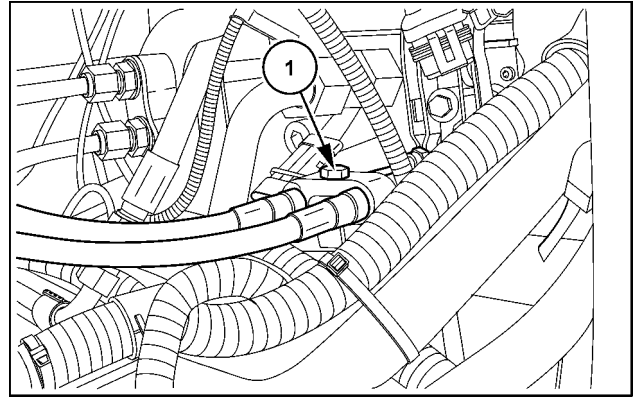

SVIL13TR00620AB 36

53. **▲ WARNING**

**Heavy objects!**

**Lift and handle all heavy components using lifting equipment with adequate capacity. Always support units or parts with suitable slings or hooks. Make sure the work area is clear of all bystanders.**

**Failure to comply could result in death or serious injury.**

W0398A

Carefully raise the cab. Position the cab on a secure place.

**NOTICE:** Pay attention to cables and pipes.

**Next operation:**  
**Cab - Install (90.150)**

## Cab - Install

### Prior operation:

#### Cab - Remove (90.150)

1. Position the cab above the drive line.

**NOTE:** There should be approximately **10.0 cm (3.9 in)** space between the fixing points and the cab.

2. Install the Bowden cables for the remote valves.

**NOTE:** The lever have to be in middle position.

3. Tighten the bolt (1) with **23 N·m (17 lb ft)**.

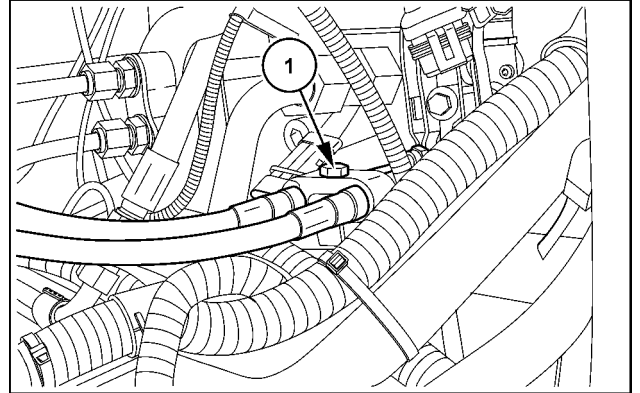

SVIL13TR00620AB 1

4. Install a fixing bolt into the holes of the gear selector levers.

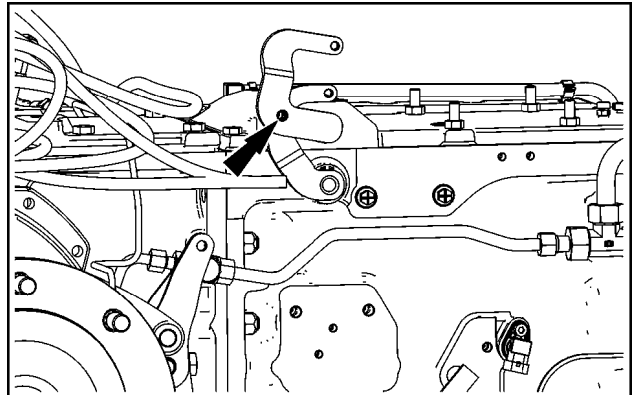

SS13K086 2

5. Install the shifting Bowden cables.

**NOTE:** Ensure the gear lever is fixed with a bolt.

6. Tighten the bolts (1) with **23 N·m (17 lb ft)**.

**NOTE:** Remove the fixing bolt from the gear selector levers.

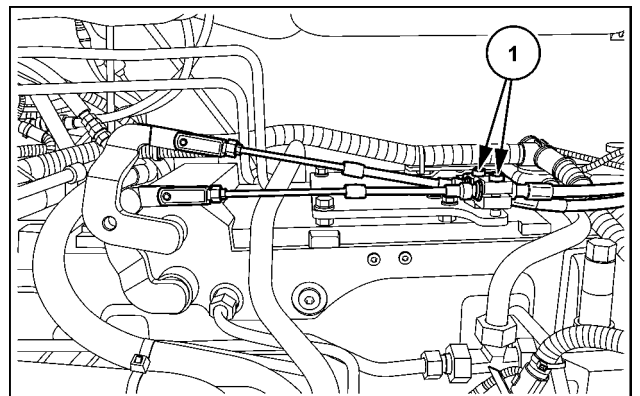

SVIL13TR00621AB 3



7. Install the Bowden cable (1) for the Power Take-Off (PTO) (NORMAL/ECONOMIC).

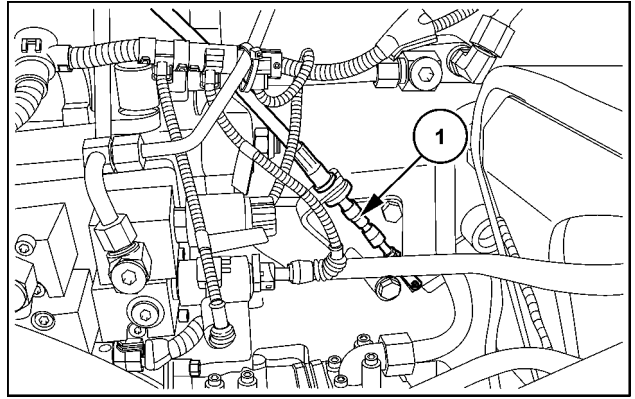

SVIL13TR00622AB 4

8. Connect the cab main connector (1) on the rear of the cab.

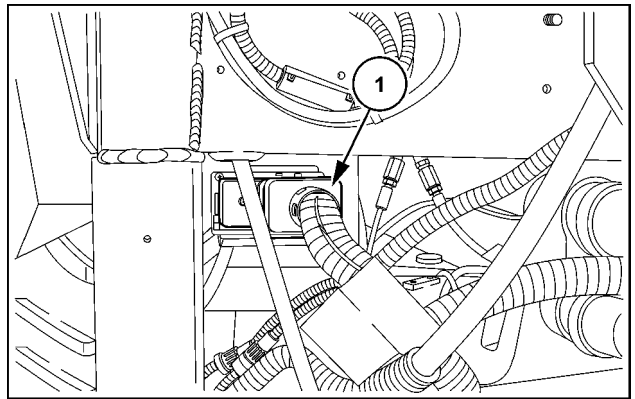

SVIL13TR00623AB 5

9. Install the Bowden cable (1) for the ground speed Power Take-Off (PTO) (where fitted).

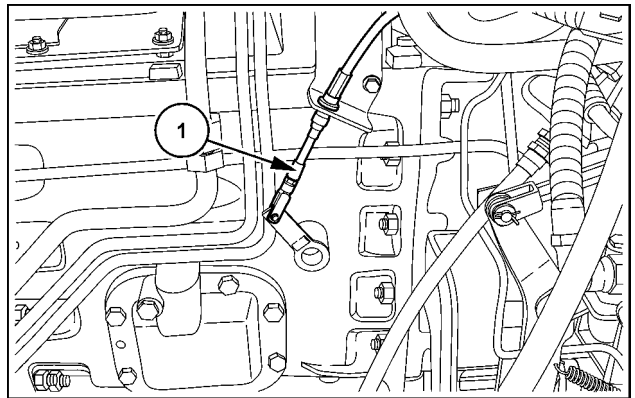

SVIL13TR00628AB 6

10. Connect the electrical connectors (1) for the Electro Hydraulic Remote (EHR) valves (where fitted).

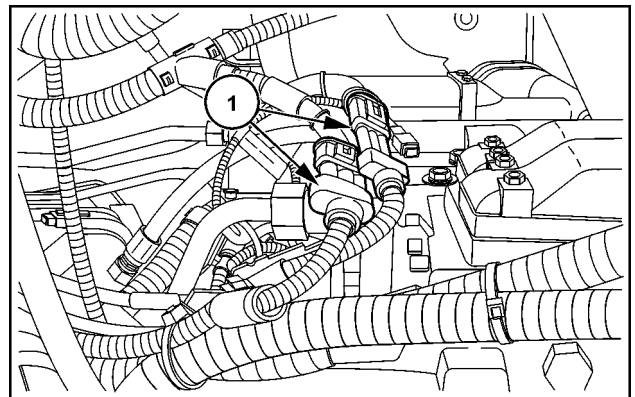

SVIL13TR00625AB 7

11. Install the pipe (1) for the compressed air sensor (where fitted).

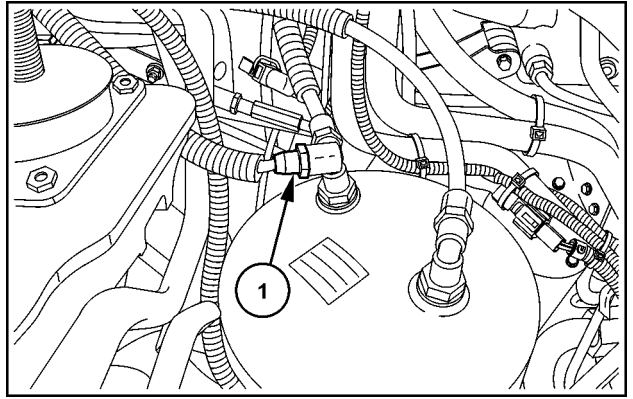

SVIL13TR00624AB 8

12. Lower the cab carefully.

**NOTICE:** Pay attention to cables and pipes.

### Cab support (standard cab)

13. Install the nuts (1) on both sides.
14. Tighten the nuts to **200 N·m +/- 10 (148 lb ft +/- 7.4)**.

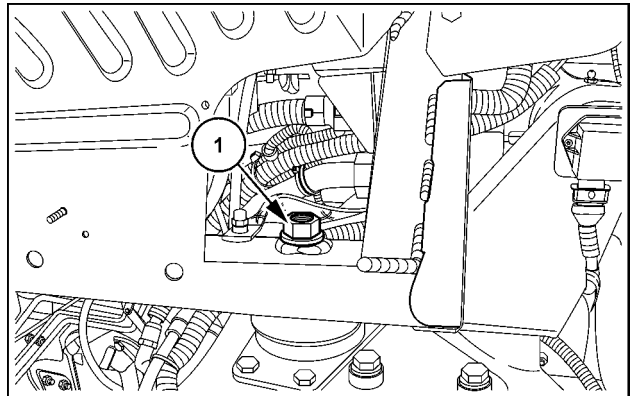

SVIL13TR00634AB 9

### Cab support (suspended cab)

15. Install the bolts (1) on both sides.

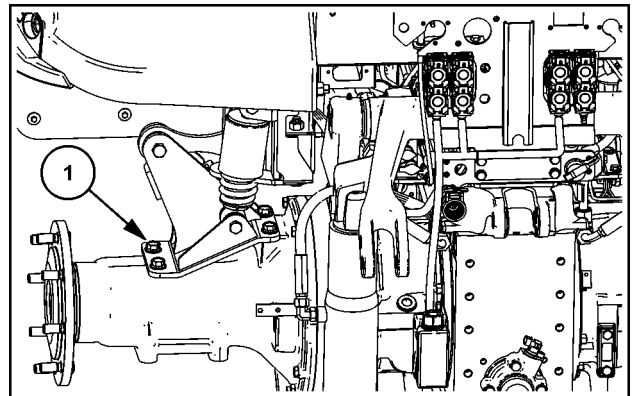

SS13K115 10

16. Install the bolts (1) on both sides.
17. Tighten the bolts to **200 N·m +/- 10 (148 lb ft +/- 7.4)**.

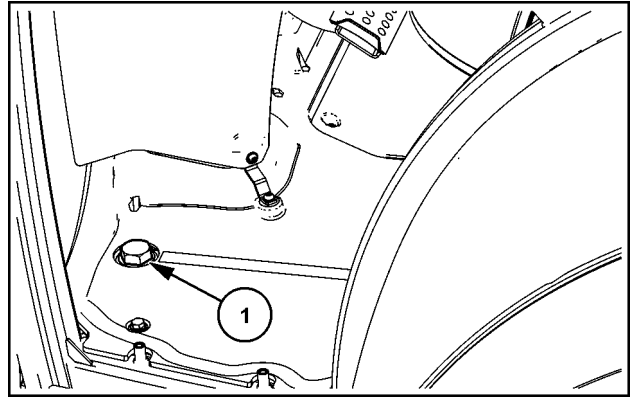

SS13K073 11

18. Install the Bowden cable (1) for the field/road group.

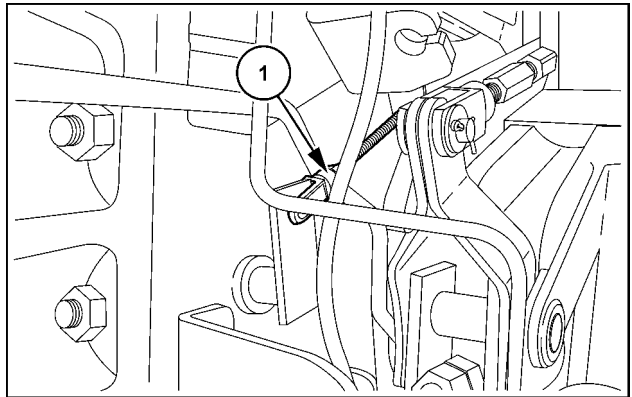

SVIL13TR00627AB 12

19. Connect the brake fluid hoses (1).

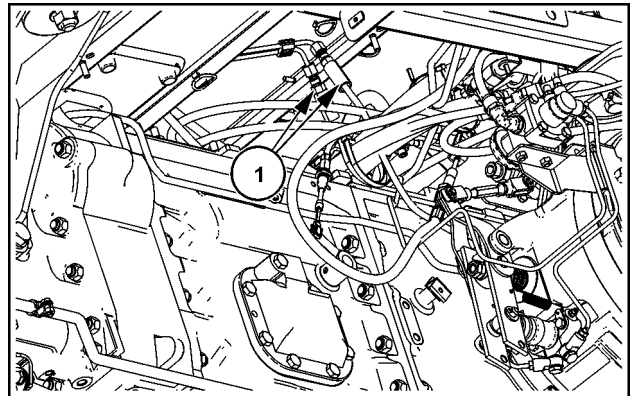

SS13K091 13

20. Install the Bowden cable (1) for the hand brake.
21. Adjust the hand brake. See **Parking brake or parking lock - Adjust (33.110)**.

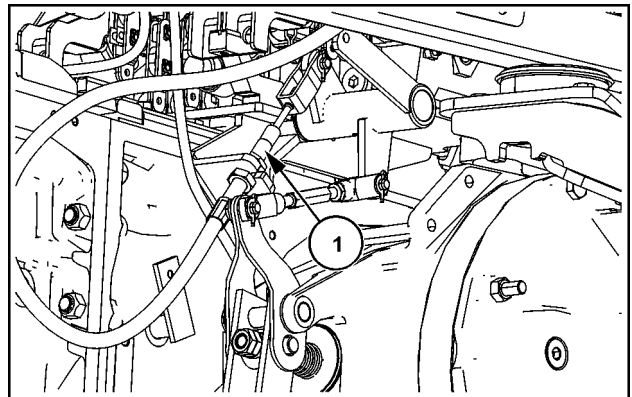

SS13K090 14

22. Install the ground cable.
23. Install the nut **(1)**.

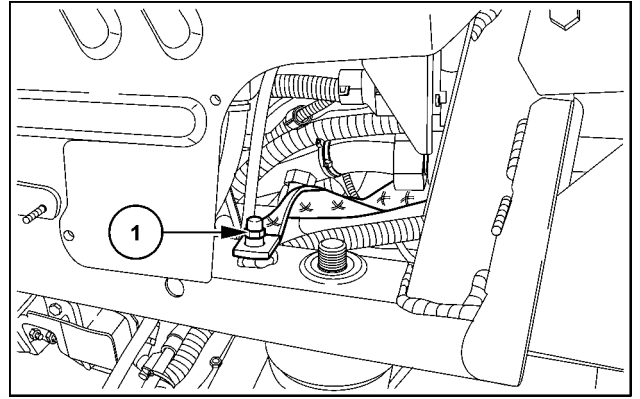

SVIL13TR00626AB 15

24. Install the Bowden cable **(1)** for the Power Take-Off (PTO) (540/1000).

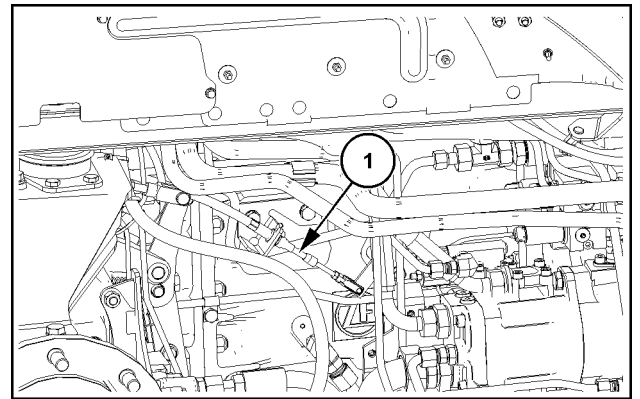

SS13K092 16

25. Connect all the electrical connectors for the Electronic Front Hitch (EFH) (where fitted).

**NOTE:** Fix the cables with cable ties.

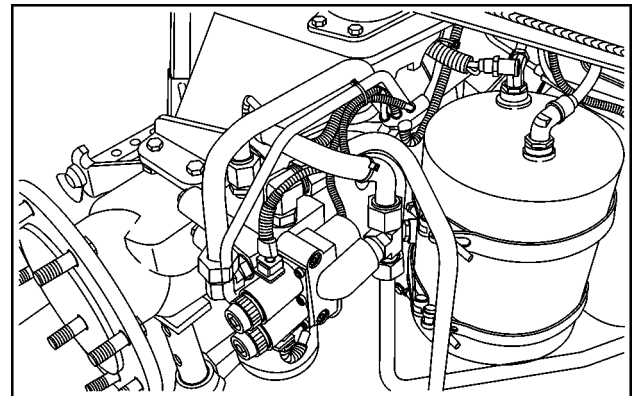

SVIL13TR00630AA 17

26. Install the Bowden cable **(1)** for the hitch.

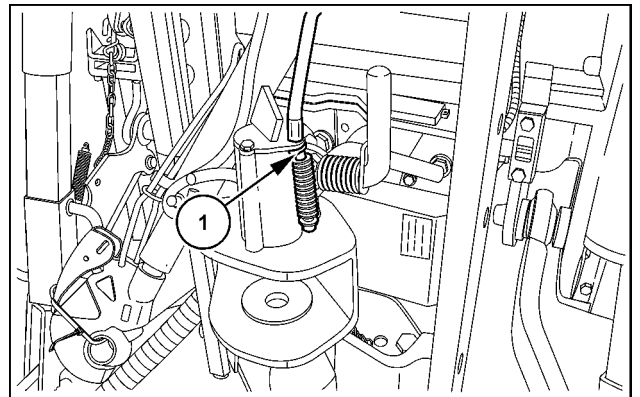

SVIL13TR00629AB 18

27. Install the power socket (1).

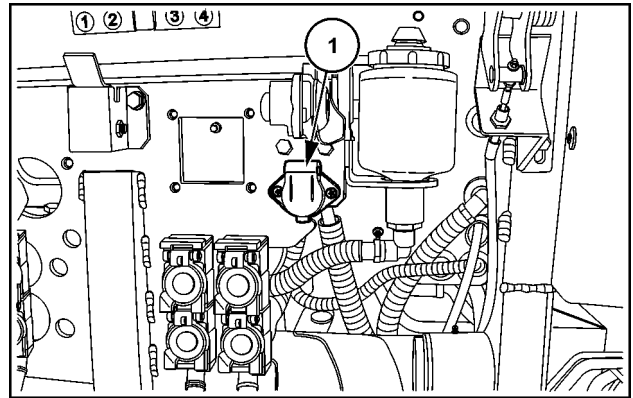

SVIL13TR00631AC 19

28. Install the trailer socket (1).

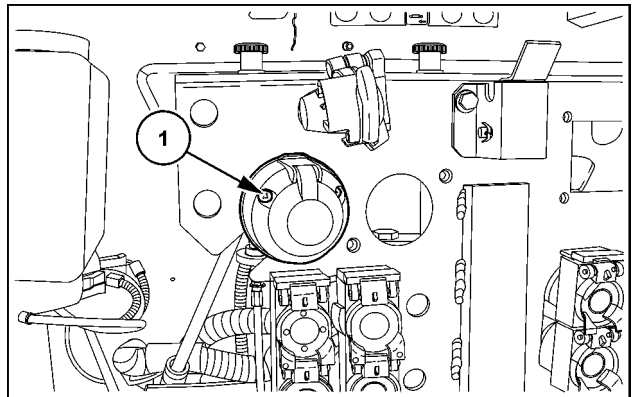

SVIL13TR00633AB 20

29. Install the remote flow control (first control unit). Install the clip (1).

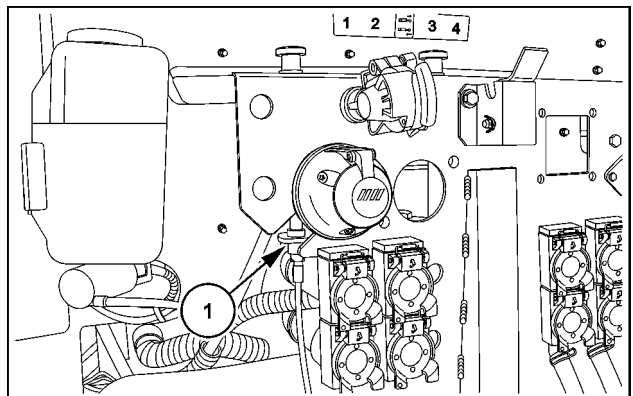

SVIL13TR00632AC 21

30. Install the floor mat.  
31. Install the fixing plates.  
32. Install the bolts (1).

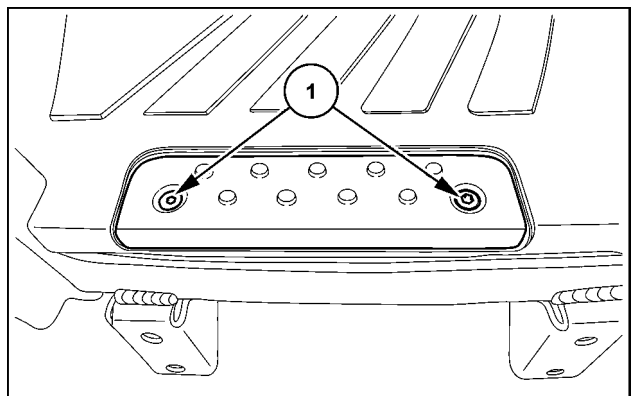

SVIL13TR00636AB 22

33. Connect the steering hose (1) on the right-hand side.

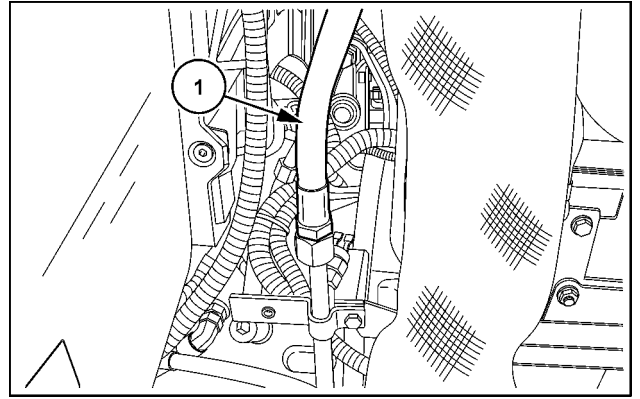

SVIL13TR00635AB 23

34. Connect the steering hoses (1) on the left-hand side.  
35. Connect the hose (2) from the steering valve to the thermostat.  
36. Connect the front axle brake hose (3) (where fitted).

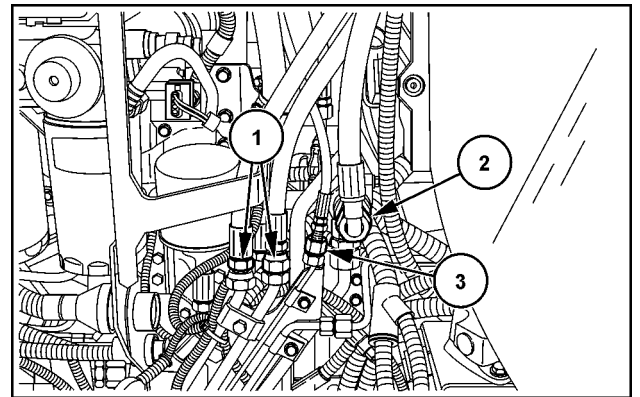

SVIL13TR00637AB 24

37. Install the air-conditioning pipes (where fitted).  
38. Install the nuts (1).

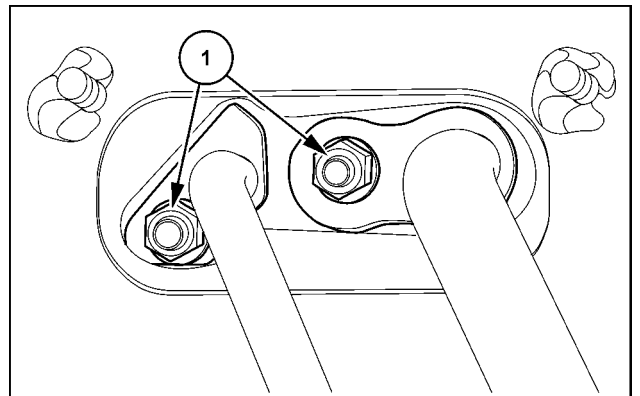

SVIL13TR00642AB 25

39. Install the cover.  
40. Install the nuts (1).

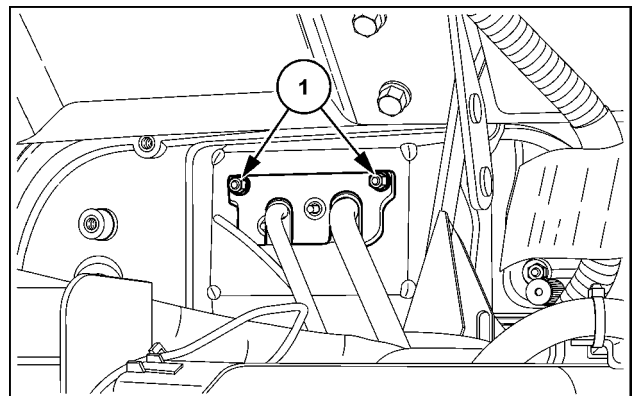

SVIL13TR00638AB 26

41. Connect the electrical connector (1) from the brake reservoir.

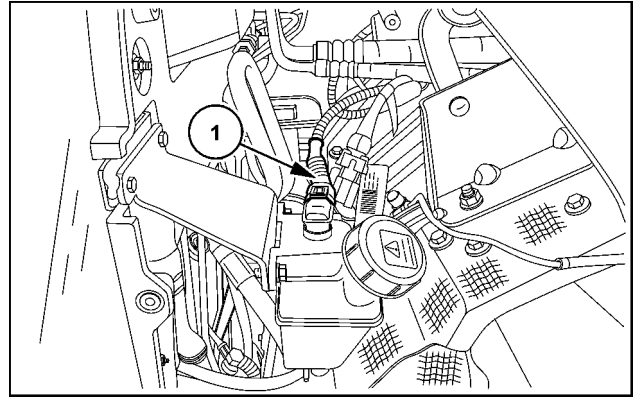

SVIL13TR00639AB 27

42. Install the steps on the right-hand side.  
43. Install the bolts (1).

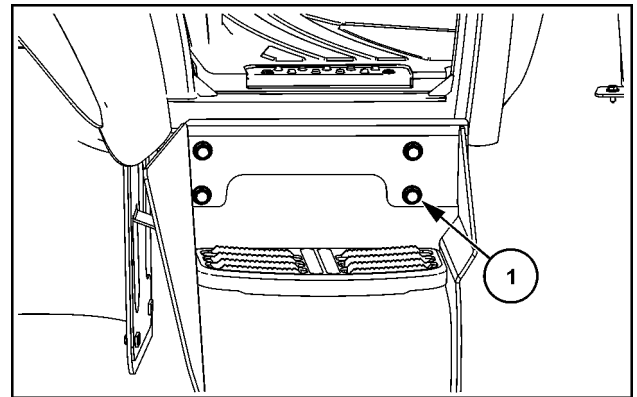

SS13K074 28

44. Install the middle cover.  
45. Install the bolts (1).

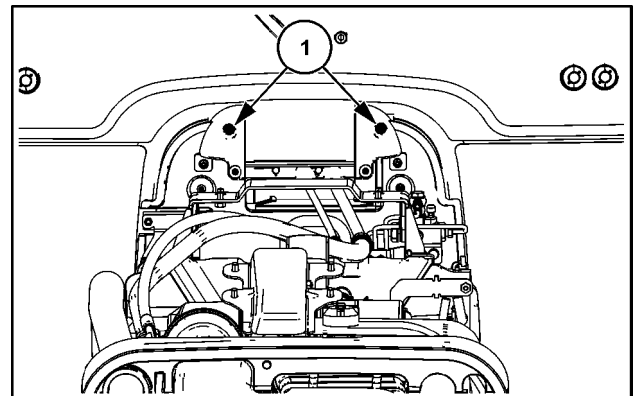

SS13K075 29

46. Install the heating hoses (1).  
47. Fix the heating hoses (1) with the clamps.

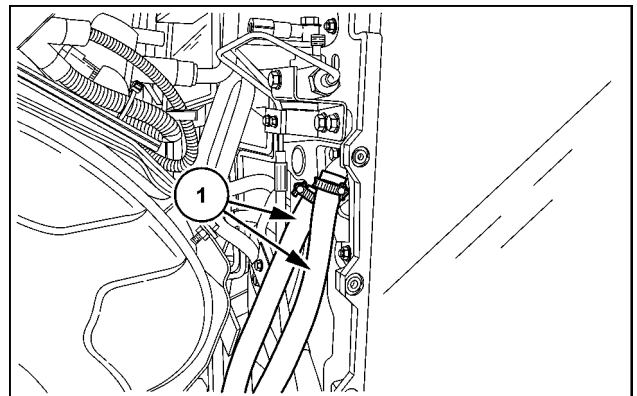

SVIL13TR00641AB 30

48. Bleed the hydraulic service brake. See **Hydraulic service brakes - Bleed (33.202)**.  
49. Install the fuel tank. See **Fuel tank - Install (10.216)**.

50. Install the battery. See **Battery - Install (55.302)**.
51. Bleed the fuel system. See Operator's Manual.
52. Remove the fixing bolt from the hole on the gear lever.

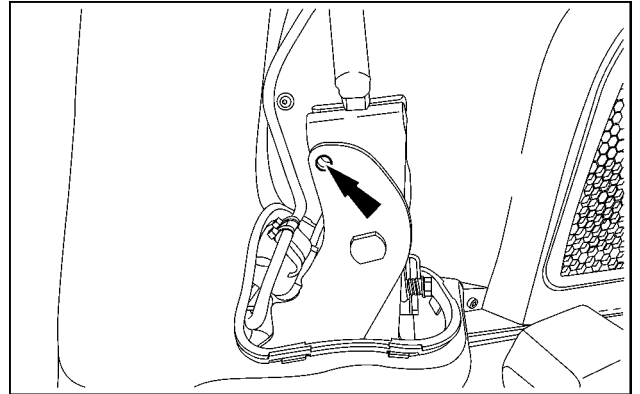

SVIL13TR00647AB 31

53. Install the rubber cover (1).

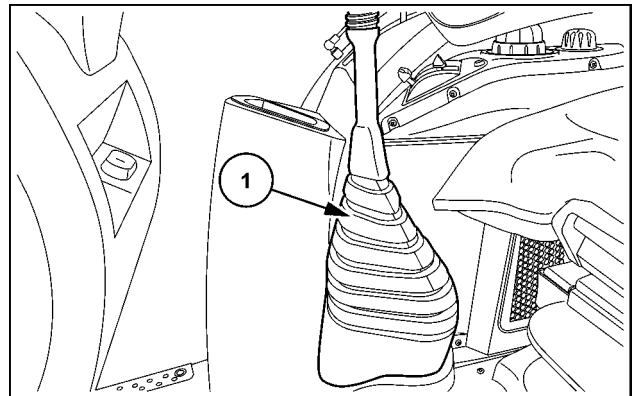

SVIL13TR00648AB 32

54. Install the covers on both sides.
55. Install the five bolts (1) on both sides.

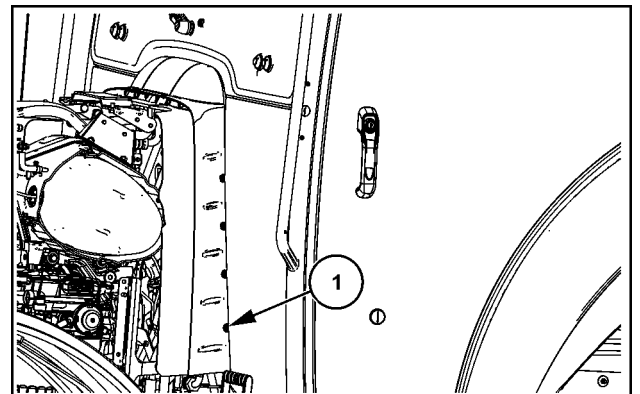

SS13K076 33

56. Install the rubber covers on both sides of the cab.
57. Install the bolts (1) and the nuts (2) on both sides.

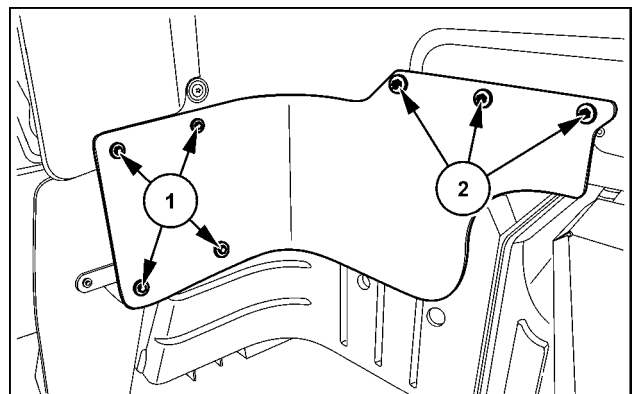

SVIL13TR00650AB 34



58. Install the covers on both sides of the cab.
59. Install the bolts (1).

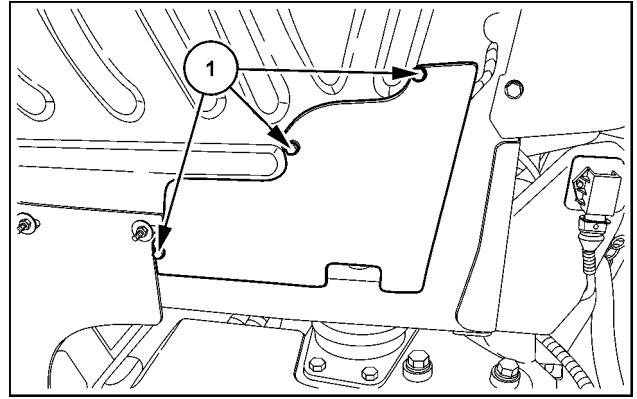

SVIL13TR00652AB 35

60. Install the cover of the air operated trailer brake (where fitted).
61. Install the bolts (1).

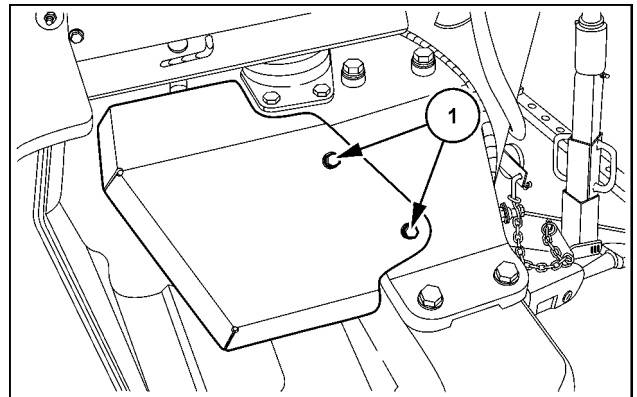

SVIL13TR00653AB 36

62. Check all fluids. If necessary top up. For the correct specification see **Consumables Lubrications and Coolants ()**.

**Next operation:**

Evacuate the air-conditioning system. See **Air conditioning - Evacuate (50.200)**.  
Install the rear wheels. See **Rear wheels - Install (44.520)**.

# Index

---

## Platform, cab, bodywork, and decals - 90

### Cab - 150

Cab - Install .....	13
Cab - Remove .....	3



© 2014 CNH Industrial Österreich GmbH

All rights reserved. No part of the text or illustrations of this publication may be reproduced.

CASE IH policy is one of continuous improvement and the right to change prices, specification or equipment at any time without notices is reserved.

All data given in this publication is subject to production variations. Dimensions and weight are approximate only and the illustrations do not necessarily show products in standard condition. For exact information about any particular product, please consult your CASE IH Dealer.

# SPECIAL TOOL INDEX

Genuine	Reference	PAGE
380200021 [Special Tool]	Semi-Powershift transmission - Special tools	21.1 / 3
380000078 [PTO Drive Shaft Bearing Play Slotted Nut Wrench]	Semi-Powershift transmission - Special tools	21.1 / 3
380000815 [Drive Shaft Nut Socket]	Semi-Powershift transmission - Special tools	21.1 / 3
380001733 [Powershift Castle Nut Socket With Degree Scale]	Semi-Powershift transmission - Special tools	21.1 / 3
380200374 [Sleeve for disassembly / assembly the disk springs of the transmission clutches]	Semi-Powershift transmission - Special tools	21.1 / 3
380200445 [Clutch shafts - Lifting tool]	Semi-Powershift transmission - Special tools	21.1 / 3
380200445 [Clutch shafts - Lifting tool]	Clutch - Remove	21.4 / 11
380200445 [Clutch shafts - Lifting tool]	Clutch - Install	21.4 / 12
380000078 [PTO Drive Shaft Bearing Play Slotted Nut Wrench]	Transmission drive and driven shaft - Remove – Countershaft	21.4 / 68
380000815 [Drive Shaft Nut Socket]	Transmission drive and driven shaft - Remove – Countershaft	21.4 / 68
380001733 [Powershift Castle Nut Socket With Degree Scale]	Transmission drive and driven shaft - Remove – Main shaft	21.4 / 72
380000815 [Drive Shaft Nut Socket]	Transmission drive and driven shaft - Remove – Main shaft	21.4 / 72
380001733 [Powershift Castle Nut Socket With Degree Scale]	Transmission drive and driven shaft - Install – Main shaft	21.4 / 77
380000815 [Drive Shaft Nut Socket]	Transmission drive and driven shaft - Install – Main shaft	21.4 / 77
380000078 [PTO Drive Shaft Bearing Play Slotted Nut Wrench]	Transmission drive and driven shaft - Install – Countershaft	21.4 / 85
380000815 [Drive Shaft Nut Socket]	Transmission drive and driven shaft - Install – Countershaft	21.4 / 85
380000813 [Bearing Outer And Inner Ring Extractor Front Axle Drive]	Front-Wheel Drive	23.1 / 3
380000816 [Tensioner For Cup Springs]	Front-Wheel Drive	23.1 / 3
380000813 [Bearing Outer And Inner Ring Extractor Front Axle Drive]	Front-Wheel Drive	23.1 / 11
380000813 [Bearing Outer And Inner Ring Extractor Front Axle Drive]	Front-Wheel Drive	23.1 / 12
380000816 [Tensioner For Cup Springs]	Front-Wheel Drive	23.1 / 12
380000813 [Bearing Outer And Inner Ring Extractor Front Axle Drive]	Front-Wheel Drive	23.1 / 13
380000816 [Tensioner For Cup Springs]	Front-Wheel Drive	23.1 / 18

<b>Genuine</b>	<b>Reference</b>	<b>PAGE</b>
380000268 [Bevel Pinion Ring Nut Wrench]	Powered front axle - Special tools	25.1 / 5
380000257 [Bevel Gear Pinion Splined Retainer Deep Socket]	Powered front axle - Special tools	25.1 / 5
380000252 [Front Axle Ring Nut Wrench]	Powered front axle - Special tools	25.1 / 5
380000269 [Wheel Hub Bearing Ring Socket]	Powered front axle - Special tools	25.1 / 6
380000270 [Wheel Hub Bearing Pull Grips - Set Of Two]	Powered front axle - Special tools	25.1 / 6
380000265 [Swivel Housing Pin Pivot Puller]	Powered front axle - Special tools	25.1 / 6
380000234 [Swivel Pin Bearing Outer Race Puller]	Powered front axle - Special tools	25.1 / 6
380000235 [Swivel Housing Torque Check Adapter]	Powered front axle - Special tools	25.1 / 6
380200017 [Sunken Seal Key on Hub (without brakes)]	Powered front axle - Special tools	25.1 / 6
380200018 [Sunken seal Key on Spindle (with brakes)]	Powered front axle - Special tools	25.1 / 6
380200019 [Sunken Seal Key on Spindle for Axle Shafts]	Powered front axle - Special tools	25.1 / 6
380200041 [Differential Pinion Shaft Oil Seal Protection Shield Installer]	Powered front axle - Special tools	25.1 / 6
380200042 [Differential Pinion Shaft Oil Seal Installer]	Powered front axle - Special tools	25.1 / 6
380000269 [Wheel Hub Bearing Ring Socket]	Four-Wheel Drive	25.1 / 20
380000268 [Bevel Pinion Ring Nut Wrench]	Four-Wheel Drive	25.1 / 24
380000257 [Bevel Gear Pinion Splined Retainer Deep Socket]	Four-Wheel Drive	25.1 / 24
380200041 [Differential Pinion Shaft Oil Seal Protection Shield Installer]	Four-Wheel Drive	25.1 / 25
380200042 [Differential Pinion Shaft Oil Seal Installer]	Four-Wheel Drive	25.1 / 25
380000257 [Bevel Gear Pinion Splined Retainer Deep Socket]	Bevel gear set and differential carrier - Adjust Ring/Pinion Gears	25.2 / 11
380000268 [Bevel Pinion Ring Nut Wrench]	Bevel gear set and differential carrier - Adjust Ring/Pinion Gears	25.2 / 11
380000252 [Front Axle Ring Nut Wrench]	Bevel gear set and differential carrier - Adjust	25.2 / 13
380000257 [Bevel Gear Pinion Splined Retainer Deep Socket]	Bevel gear set and differential carrier - Adjust	25.2 / 14
380000255 [Differential Overhaul Support]	Differential lock Dog clutch - Overhaul	25.2 / 20
380000251 [Front Axle Overhaul Stand]	Planetary drive and hub - Disassemble	25.3 / 5
380000251 [Front Axle Overhaul Stand]	Planetary drive and hub - Disassemble	25.3 / 5
380000269 [Wheel Hub Bearing Ring Socket]	Planetary drive and hub - Disassemble	25.3 / 6
380200017 [Sunken Seal Key on Hub (without brakes)]	Planetary drive and hub - Assemble	25.3 / 7

<b>Genuine</b>	<b>Reference</b>	<b>PAGE</b>
380200019 [Sunken Seal Key on Spindle for Axle Shafts]	Planetary drive and hub - Assemble	25.3 / 7
380000269 [Wheel Hub Bearing Ring Socket]	Planetary drive and hub - Assemble	25.3 / 7
380000269 [Wheel Hub Bearing Ring Socket]	Planetary drive and hub - Assemble	25.3 / 8
380000251 [Front Axle Overhaul Stand]	Planetary drive and hub - Disassemble	25.3 / 9
380000251 [Front Axle Overhaul Stand]	Planetary drive and hub - Disassemble	25.3 / 9
380000235 [Swivel Housing Torque Check Adapter]	Steering knuckle and king pin - Adjust	25.3 / 12
380000235 [Swivel Housing Torque Check Adapter]	Steering knuckle and king pin - Adjust	25.3 / 12
380200018 [Sunken seal Key on Spindle (with brakes)]	Wheel hub - Replace	25.3 / 14
380200018 [Sunken seal Key on Spindle (with brakes)]	Wheel hub - Replace	25.3 / 14
380200018 [Sunken seal Key on Spindle (with brakes)]	Wheel hub - Replace	25.3 / 14
380000050 [Final Drive Half-Shaft Seal Guide]	Powered rear axle - Special tools	27.1 / 3
380000051 [Final Drive Half-Shaft Seal Installer]	Powered rear axle - Special tools	27.1 / 3
380001730 [Grooved Nut Wrench]	Powered rear axle - Special tools	27.1 / 3
380001731 [Bevel Pinion Shaft Socket]	Powered rear axle - Special tools	27.1 / 3
380001746 [Final Drive Half Shaft Seal Installer]	Powered rear axle - Special tools	27.1 / 3
380001731 [Bevel Pinion Shaft Socket]	Bevel pinion - Remove	27.2 / 14
380001731 [Bevel Pinion Shaft Socket]	Bevel pinion - Install	27.2 / 24
380001730 [Grooved Nut Wrench]	Planetary final drive - Disassemble – Axle trumpet housing and planetary drive	27.3 / 4
380000051 [Final Drive Half-Shaft Seal Installer]	Planetary final drive - Assemble – Axle trumpet housing and planetary drive	27.3 / 6
380000050 [Final Drive Half-Shaft Seal Guide]	Planetary final drive - Assemble – Axle trumpet housing and planetary drive	27.3 / 6
380001746 [Final Drive Half Shaft Seal Installer]	Planetary final drive - Assemble – Axle trumpet housing and planetary drive	27.3 / 6
380001730 [Grooved Nut Wrench]	Planetary final drive - Assemble – Axle trumpet housing and planetary drive	27.3 / 7
380200021 [Special Tool]	Four-speed rear Power Take-Off	31.2 / 4
380200021 [Special Tool]	Power Take-Off	31.2 / 44
380040089 [Electrical Repair Kit]	Wiring harnesses - Rewire	55.2 / 481
380050010 [Test Probe Kit]	Wiring harnesses - Rewire	55.2 / 481
380000843 [Diagnostic Test Switch]	Electronic module - Configure - HH-Menu overview	55.11 / 4
380000843 [Diagnostic Test Switch]	Electronic module - Configure - HH-Menu overview	55.11 / 5
380000843 [Diagnostic Test Switch]	Electronic module Instrument control unit - H3 - Configurations and options	55.11 / 33
380000843 [Diagnostic Test Switch]	Electronic module Instrument control unit - H3 - Configurations and options	55.11 / 33
380000843 [Diagnostic Test Switch]	Electronic module Instrument control unit - H3 - Configurations and options	55.11 / 34
380000843 [Diagnostic Test Switch]	Electronic module Instrument control unit - H3 - Configurations and options	55.11 / 34

<b>Genuine</b>	<b>Reference</b>	<b>PAGE</b>
380000843 [Diagnostic Test Switch]	Electronic module Instrument control unit - H3 - Configurations and options	55.11 / 35
380000843 [Diagnostic Test Switch]	Electronic module Instrument control unit - H3 - Configurations and options	55.11 / 35
380000843 [Diagnostic Test Switch]	Electronic module Instrument control unit - H3 - Configurations and options	55.11 / 36
380000843 [Diagnostic Test Switch]	Electronic module Instrument control unit - H3 - Configurations and options	55.11 / 36
380000843 [Diagnostic Test Switch]	Electronic module Instrument control unit - H3 - Configurations and options	55.11 / 37
380000843 [Diagnostic Test Switch]	Electronic module Instrument control unit - H3 - Configurations and options	55.11 / 39
380000843 [Diagnostic Test Switch]	Electronic module Instrument control unit - H4 - View software revision level	55.11 / 40
380000843 [Diagnostic Test Switch]	Electronic module Instrument control unit - H5 - Switch operation test	55.11 / 42
380000843 [Diagnostic Test Switch]	Electronic module Instrument control unit - H8 - Clear stored calibration information	55.11 / 46
380000843 [Diagnostic Test Switch]	Electronic module Instrument control unit - H9 - Voltmeter diagnostic	55.11 / 49
380000843 [Diagnostic Test Switch]	Electronic module Instrument control unit - HB - Display stored fault codes	55.11 / 51
380000843 [Diagnostic Test Switch]	Electronic module Instrument control unit - HC - Clear all stored fault codes	55.11 / 53
380000843 [Diagnostic Test Switch]	Electronic module Instrument control unit - HF - View controller hardware information	55.11 / 55
380000843 [Diagnostic Test Switch]	Electronic module Central Control Unit	55.11 / 60
380000843 [Diagnostic Test Switch]	Electronic module Central Control Unit	55.11 / 62
380000843 [Diagnostic Test Switch]	Electronic module Central Control Unit	55.11 / 66
380000843 [Diagnostic Test Switch]	Electronic module Central Control Unit	55.11 / 67
380000843 [Diagnostic Test Switch]	Electronic module Central Control Unit	55.11 / 68
380000843 [Diagnostic Test Switch]	Electronic module Central Control Unit	55.11 / 68
380000843 [Diagnostic Test Switch]	Electronic module Central Control Unit	55.11 / 70
380000843 [Diagnostic Test Switch]	Electronic module Central Control Unit	55.11 / 71
380000843 [Diagnostic Test Switch]	Electronic module Central Control Unit	55.11 / 72
380000843 [Diagnostic Test Switch]	Electronic module Central Control Unit	55.11 / 74
380000843 [Diagnostic Test Switch]	Electronic module Central Control Unit	55.11 / 76
380000843 [Diagnostic Test Switch]	Electronic module Central Control Unit	55.11 / 80
380000843 [Diagnostic Test Switch]	Electronic module Central Control Unit	55.11 / 82
380000843 [Diagnostic Test Switch]	Electronic module Central Control Unit	55.11 / 87
380000843 [Diagnostic Test Switch]	Electronic module Central Control Unit	55.11 / 88
380000843 [Diagnostic Test Switch]	Electronic module Central Control Unit	55.11 / 90
380000843 [Diagnostic Test Switch]	Electronic module Central Control Unit	55.11 / 92
380000843 [Diagnostic Test Switch]	Electronic module Central Control Unit	55.11 / 96

<b>Genuine</b>	<b>Reference</b>	<b>PAGE</b>
380000843 [Diagnostic Test Switch]	Electronic module Central Control Unit	55.11 / 98
380000843 [Diagnostic Test Switch]	Transmission electronic control module Transmission Control Unit	55.12 / 9
380000843 [Diagnostic Test Switch]	Transmission electronic control module Transmission Control Unit	55.12 / 11
380000843 [Diagnostic Test Switch]	Transmission electronic control module Transmission Control Unit	55.12 / 13
380000843 [Diagnostic Test Switch]	Transmission electronic control module Transmission Control Unit	55.12 / 15
380000843 [Diagnostic Test Switch]	Transmission electronic control module Transmission Control Unit	55.12 / 17
380000843 [Diagnostic Test Switch]	Transmission electronic control module Transmission Control Unit	55.12 / 19
380000843 [Diagnostic Test Switch]	Transmission electronic control module Transmission Control Unit	55.12 / 20
380000843 [Diagnostic Test Switch]	Transmission electronic control module Transmission Control Unit	55.12 / 22
380000843 [Diagnostic Test Switch]	Transmission electronic control module Transmission Control Unit	55.12 / 24
380000843 [Diagnostic Test Switch]	Transmission electronic control module Transmission Control Unit	55.12 / 26
380000843 [Diagnostic Test Switch]	Transmission electronic control module Transmission Control Unit	55.12 / 30
380000843 [Diagnostic Test Switch]	Transmission electronic control module Transmission Control Unit	55.12 / 32
380000843 [Diagnostic Test Switch]	Transmission electronic control module Transmission Control Unit	55.12 / 34
380000843 [Diagnostic Test Switch]	Transmission electronic control module Transmission Control Unit	55.12 / 36
380000843 [Diagnostic Test Switch]	Instrument cluster - Dynamic description – setting hours worked	55.24 / 19
380000843 [Diagnostic Test Switch]	Instrument cluster - Dynamic description – Hour meter reset	55.24 / 21





© 2014 CNH Industrial Österreich GmbH

All rights reserved. No part of the text or illustrations of this publication may be reproduced.

CASE IH policy is one of continuous improvement and the right to change prices, specification or equipment at any time without notices is reserved.

All data given in this publication is subject to production variations. Dimensions and weight are approximate only and the illustrations do not necessarily show products in standard condition. For exact information about any particular product, please consult your CASE IH Dealer.