

Solar 130LC-V

Shop Manual

2023-7117E

Serial Number 0001 and Up

Solar 130LC-V

Serial No. 0001 and Up

Pub.No. 2023-7117E



Product Label



Instructions

**Trim Out The Label Along
The Lines And Insert Into
Pocket On The Binder Spine**

TABLE OF CONTENTS

Safety

Track Excavator Safety.....	S0102000
-----------------------------	----------

Specifications

Specifications for Solar 130LC-V.....	S0206000
---------------------------------------	----------

General Maintenance

General Maintenance Procedures.....	S0302000
Standard Torques.....	S0309000

Upper Structure

Cab.....	S0402000
Counterweight.....	S0403000
Fuel Tank.....	S0405000
Swing Bearing.....	S0407000
Swing Reduction Gearbox.....	S0408020

Lower Structure and Chassis

Track Assembly.....	S0505050
---------------------	----------

Engine and Drive Train

Air-Conditioner.....	S0605010
----------------------	----------

Hydraulics

Hydraulic System Troubleshooting, Testing and Adjustment.....	S0702050
Accumulator.....	S0703000
Center Joint (Swivel).....	S0704020
Cylinders.....	S0705000
Swing Motor.....	S0707220
Travel Motor (With Gearbox).....	S0707340

Main Pump (With Regulator)	S0708340
Main Control Valve	S0709420
Remote Control Valve (Work Lever / Joystick)	S0709450
Travel Control Valve (RCV8C4015A)	S0709800
Hydraulic Schematic (S130LC-V)	S0792040

Electrical System

Electrical System	S0802060
Electrical Schematic (S130LC-V)	S0892040

Attachments

Boom and Arm.....	S0902030
Bucket.....	S0904000

SAFETY



TRACK EXCAVATOR SAFETY



CAUTION!

Follow all safety recommendations and safe shop practices outlined in the front of this manual or those contained within this section.

Always use tools and equipment that is in good working order.

Use lifting and hoisting equipment capable of safely handling load.

Remember, that ultimately safety is your own personal responsibility.

MODEL	SERIAL NUMBER RANGE
Solar 130LC-V	0001 and Up
Solar 220LC-V	0001 and Up
Solar 220N-V	1001 and Up
Solar 290LC-V	0001 and Up
Solar 330LC-V	1001 and Up
Solar 400LC-V	1001 and Up

TABLE OF CONTENTS

To the Operator of a Daewoo Excavator 3

General Safety Essentials 5

Location of Safety Labels 5

Summary of Safety Precautions for Lifting in Digging Mode 6

Work-site Precautions 7

Operation..... 9

Equipment 14

Maintenance..... 18

Shipping and Transportation 21

Lifting With Sling..... 21

TO THE OPERATOR OF A DAEWOO EXCAVATOR



Unsafe use of the excavator could lead to serious injury or death. Operating procedures, maintenance and equipment practices or traveling or shipping methods that do not follow the safety guidelines on the following pages could cause serious, potentially fatal injuries or extensive damage to the machine or nearby property.

Please respect the importance of taking responsibility for your own safety, and that of other people who may be affected by your actions.

The safety information on the following pages is organized into the following sections:

1. "General Safety Essentials" on page 5
2. "Location of Safety Labels" on page 5
3. "Summary of Safety Precautions for Lifting in Digging Mode" on page 6
4. "Work-site Precautions" on page 7
5. "Operation" on page 9
6. "Equipment" on page 14
7. "Maintenance" on page 18
8. "Shipping and Transportation" on page 21



Be Prepared - Get To Know All Operating and Safety Instructions.

This is the Safety Alert Symbol. Wherever it appears in this manual or on safety signs on the machine you should be alert to the potential for personal injury or accidents. Always observe safety precautions and follow recommended procedures.

LEARN THE SIGNAL WORDS USED WITH THE SAFETY ALERT SYMBOL

The words "**CAUTION**", "**WARNING**", and "**DANGER**" used throughout this manual and on decals on the machine indicate degree of risk of hazards or unsafe practices. All three degrees of risk indicate that safety is involved. Observe precautions indicated whenever you see the Safety Alert "Triangle," no matter which signal word appears next to the "Exclamation Point" symbol.



Indicates potential of a hazardous situation that, if not avoided, could result in minor or moderate injury. It may also be used to alert against a generally unsafe practice.



WARNING!

Indicates potential of a hazardous situation that, if not avoided, could result in serious injury or death. It may also be used to alert against a highly unsafe practice.



DANGER!

Indicates imminent hazard of a situation that, if not avoided, is very likely to cause death or extremely serious injury. It may also be used to alert against equipment that may explode or detonate if handled or treated carelessly.

GENERAL SAFETY ESSENTIALS

ACCESSORY APPLICATIONS

The excavator has been primarily designed for moving earth with a bucket. For use as a grapple or for other object handling, contact Daewoo for proper installation and application. Lifting-work applications (unless restricted or prohibited by local regulations) are permitted in approved lift configuration, to rated capacity only, with no side-loading. DO NOT use the machine for activities for which it was not intended. DO NOT use the bucket for lifting work, unless lift slings are used in the approved configuration.

Use of an accessory hydraulic hammer (breaker), work in rough terrain, demolition applications or other hazardous operation may require installation of additional protective structures to safeguard the operator.

LIFTING CAPACITY RATING CONFIGURATION

Lifting capacity ratings that are printed at the end of this safety section are based on the machine being level, on a firm supporting surface, with hooks and slings attached in approved configuration. Loads must be balanced and supported evenly. Use taglines to keep the load steady if wind conditions and large surface area are a problem. Work crew hand signals, individual tasks and safe procedures should all be universally understood before the lift is made.

IMPORTANT

Before using the excavator to make lifts check municipal and regional regulations or statutes that could apply. Governing ordinances may require that all heavy lifting be done with single purpose equipment specifically designed for making lifts, or other local restrictions may apply. Making heavy lifts with a general purpose excavator that can be used for digging, loading, grading or other work may be expressly forbidden by a regional injunction or other legal prohibition. Always follow all of the other instructions, guidelines and restrictions for Safe Lifting in the Operation and Maintenance Manuals.

LOCATION OF SAFETY LABELS

Location of safety labels (decals) can vary from unit to unit. Refer to appropriate Operation and Maintenance Manual, and parts manual for your unit.

Always replace damaged or faded decals.

SUMMARY OF SAFETY PRECAUTIONS FOR LIFTING IN DIGGING MODE



DANGER!

Unsafe use of the excavator while making rated lifts could cause serious, potentially fatal injuries or extensive damage to the machine or nearby property. Do not let anyone operate the machine unless they've been properly trained and understand the information in the Operation and Maintenance Manual.

To lift safely while in Digging Mode, the following items must be evaluated by the operator and the work-site crew.

- Condition of ground support
- Excavator configuration and attachments
- Weight, lifting height and lifting radius
- Safe rigging of the load
- Proper handling of the suspended load

Taglines on opposite sides of the load can be very helpful in keeping a suspended load secure, if they are anchored safely to control points on the ground.



WARNING!

NEVER wrap a tagline around your hands or body.

NEVER rely on taglines or make rated lifts when wind gusts are in excess of 48.3 km/hr (30 mi/h). Be prepared for any type of wind gust when working with loads that have a large surface area.

Always engage the "Digging Mode" control on the Instrument Panel before using the excavator for lifting work.



WARNING!

If you need more information or have any questions or concerns about safe operating procedures or working the excavator correctly in a particular application or in the specific conditions of your individual operating environment, please consult your local Daewoo representative.

UNAUTHORIZED MODIFICATIONS

Any modification made without authorization or written approval from Daewoo can create a safety hazard, for which the machine owner must be held responsible.

For safety's sake, replace all OEM parts with the correct authorized or genuine Daewoo part. For example, not taking the time to replace fasteners, bolts or nuts with the correct replacement parts could lead to a condition in which the safety of critical assemblies is dangerously compromised.

WORK-SITE PRECAUTIONS

ATTACHMENT PRECAUTIONS

Options kits are available through your dealer. Contact Daewoo for information on available on-e-way (single-acting) and two-way (double-acting) piping/valving/auxiliary control kits. Because Daewoo cannot anticipate, identify or test all of the attachments that owners may wish to install on their machines, please contact Daewoo for authorization and approval of attachments, and their compatibility with options kits.

AVOID HIGH-VOLTAGE CABLES

Serious injury or death can result from contact or proximity to high-voltage electric lines. The bucket does not have to make physical contact with power lines for current to be transmitted.

Use a spotter and hand signals to stay away from power lines not clearly visible to the operator.

VOLTAGE	MINIMUM SAFE DISTANCE
6.6kV	3.0 m (9' - 10")
33.0kV	4.0 m (13' - 1")
66.0kV	5.0 m (16' - 5")
154.0kV	8.0 m (26' - 3")
275.0kV	10.0 m (32' - 10")

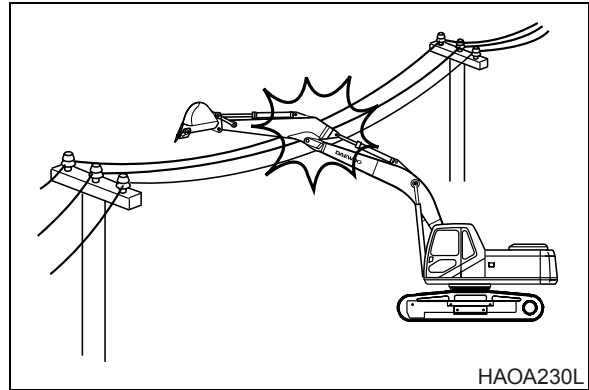

Figure 1

Use these minimum distances as a guideline only. Depending upon the voltage in the line and atmospheric conditions, strong current shocks can occur with the boom or bucket as far away as 4 - 6 m (13 - 20 ft) from the power line. Very high voltage and rainy weather could further decrease that safety margin.

NOTE: *Before starting any type of operation near power lines (either above ground or buried cable-type), you should always contact the power utility directly and work out a safety plan with them.*

BEFORE STARTING TO DIG, CONTACT AUTHORITIES

Below ground hazards also include natural gas lines, water mains, tunnels and buried foundations. Know what's underneath the work-site before starting to dig.

BE AWARE OF HEIGHT OBSTACLES

Any type of object in the vicinity of the boom could represent a potential hazard, or cause the operator to react suddenly and cause an accident. Use a spotter or signal person working near bridges, phone lines, work-site scaffolds, or other obstructions.

USE CARE ON LOOSE SUPPORT

Working heavy loads over loose, soft ground or uneven, broken terrain can cause dangerous side load conditions and possible tipover and injury. Travel without a load or balanced load may also be hazardous.

If temperatures are changing, be cautious of dark and wet patches when working or traveling over frozen ground. Stay away from ditches, overhangs and all other weak support surfaces. Halt work and install support mats or blocking if work is required in an area of poor track support.

USE SOLID SUPPORT BLOCKING

Never rely on lift jacks or other inadequate supports when work is being done. Block tracks fore and aft to prevent any movement.

OVERHANGS ARE DANGEROUS

Digging the workface under an overhang – the work area beneath a cliff or under the edge of a ditch – is dangerous. Know the height and reach limits of the excavator and plan ahead while working. Avoid creating dangerous situations by moving around the work-site while making excavations. Go on to another digging area before steep overhangs are formed. Working around deep pits or a long high walls or trenching may require support blocks, especially after heavy rainfalls or during spring thaws. Park the excavator away from overhangs before work shutdown.

SLOPING TERRAIN REQUIRES CAUTION

Dig evenly around the work-site whenever possible, trying to gradually level any existing slope. If it's not possible to level the area or avoid working on a slope, reducing the size and cycling rate of the workload is recommended.

On sloping surfaces, use caution when positioning the excavator prior to starting a work cycle. Stay alert for instability situations in order to avoid getting into them. For example, you should always avoid working the bucket over downhill crawler tracks when parked perpendicular to the slope. Slow all downhill swing movements and avoid full extensions of the bucket in a downhill direction. Lifting the bucket too high, too close to the machine, while the excavator is turned uphill can also be hazardous.

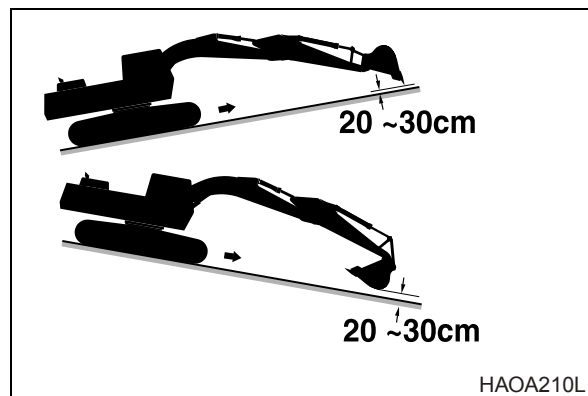

Figure 2

STAY ALERT FOR PEOPLE MOVING THROUGH THE WORK AREA

When loading a truck you should always know where the driver is.

Avoid loading over the cab of a truck even if the driver is in a safe spot. Someone else could have gone inside, for any number of reasons. Avoid working where unseen passersby might be.

Slow down the work cycle and use slower travel speeds in congested or populated areas. Use a commonly understood signal so that other members of the work crew can warn the operator to slow or halt work in an impending hazard situation.

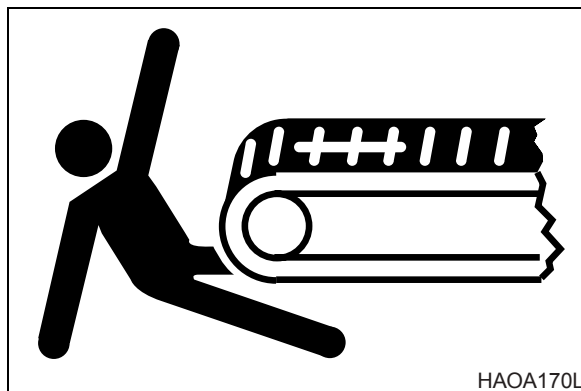

Figure 3

BE AWARE OF AND CONFORM TO LOCAL REGULATIONS

Minimum levels of insurance coverage, work permits or certification, physical barriers around the work-site or restricted hours of operation may be mandated by governing authorities. There may also be guidelines, standards or restrictions on equipment that may be used to perform certain kinds of work. Check and follow all local requirements, which may also be related to below ground hazards and power lines.

OPERATION

OPERATE WHILE SEATED AT THE OPERATOR'S STATION ONLY

Never reach in through a window to work a control. Do not operate the excavator unless you're in the command position stay alert and focused on your work at all times but DO NOT twist out of the seat if job activity behind you (or to the side) requires your attention.

Use a spotter or signal person if you can't see clearly and something is happening behind you.

Replace damaged safety labels and lost or damaged owner's manuals.

Do not let anyone operate the machine unless they've been fully and completely trained, in safety and in the operation of the machine.

BEFORE STARTING THE ENGINE

Do a "pre-start" safety check:



Figure 4

- Walk around your machine before getting in the operator's cab. Look for evidence of leaking fluid, loose fasteners, misaligned assemblies or any other indications of possible equipment hazard.
- All equipment covers and machinery safety guards must be in place, to protect against injury while the machine is being operated.
- Look around the work-site area for potential hazards, or people or property that could be at risk while operation is in progress.
- NEVER start the engine if there is any indication that maintenance or service work is in progress, or if a warning tag is attached to controls in the cab.
- A machine that has not been used recently, or is being operated in extremely cold temperatures, could require a warm-up or maintenance service prior to start-up.
- Check gauges and monitor displays for normal operation prior to starting the engine. Listen for unusual noises and remain alert for other potentially hazardous conditions at the start of the work cycle.

NEVER USE ETHER STARTING AIDS

An electric-grid type manifold heater is used for cold starting. The glowing heater element can cause ether or other starting fluid to detonate, causing injury.



Figure 5

MOUNTING AND DISMOUNTING

NEVER get on or off a moving machine. Do not jump on/off. The entry/egress paths should be clear of mud, oil and spills and mounting hardware must be kept tight and secure.

Always use handholds, steps or track shoes and maintain at least 3-point contact of hands and feet. Never use controls as handholds.

NEVER get up from the operator's seat or leave the operator's station and dismount the machine if the engine is running.

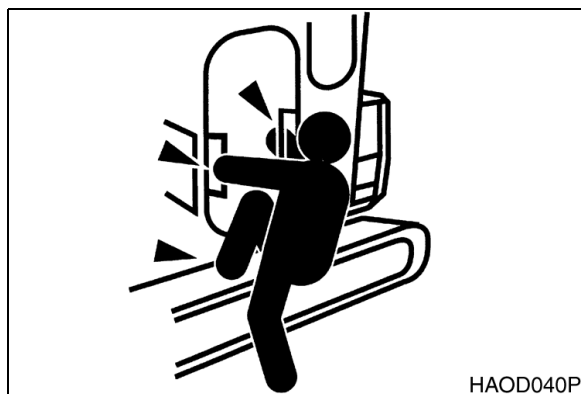

Figure 6

OBSERVE GENERAL SAFETY RULES

Only trained and authorized personnel, with a good knowledge and awareness of safe procedures, may be allowed to operate or perform maintenance or service on the excavator.

All personnel at the work-site should be aware of assigned individual responsibilities and tasks. Communication and hand signals used should be understood by everyone.

Terrain and soil conditions at the job site, approaching traffic, weather-related hazards and any above or below ground obstacles or hazards should be observed and monitored by all work crew members.

ENGINE VENTILATION

Engine exhaust gases can cause fatal accidents, as well as unconsciousness, loss of alertness, judgement and motor control and serious injury.

Make sure of adequate ventilation before starting the engine in any enclosed area.

You should also be aware of open windows, doors or ductwork into which exhaust may be carried, or blown by the wind, exposing others to danger.

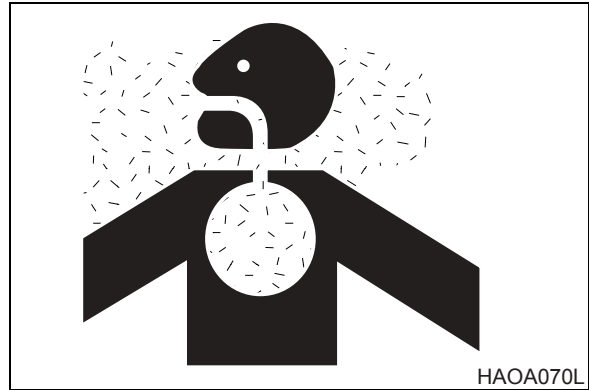

Figure 7

ASBESTOS DUST HAZARD PREVENTION

Asbestos dust can be HAZARDOUS to your health if it is inhaled.

If you handle materials containing asbestos fibers, follow these guidelines as given below:

- Never use compressed air for cleaning
- Use water for cleaning to keep down the dust.
- Work on the machine or component with the wind at your back whenever possible.
- Use an approved respirator with proper filtration.

TAKE TIME TO PROVIDE GOOD VISIBILITY

Halt work if visibility is poor. Strong rains, snow, fog and extremely dusty conditions can all obscure visibility so badly that it is best to wait for weather to change or dust to settle before continuing operation.

Night work in areas of limited visibility should be halted if installation of extra work lights on the machine (or work area) is necessary.

Keep dirt and dust off of windows and off the lens surfaces of work lights. Stop working if lights, windows or mirrors need cleaning or adjustment.

FUEL, OIL AND HYDRAULIC FLUID FIRE HAZARDS

Add fuel, oil, antifreeze and hydraulic fluid to the machine only in a well ventilated area. The machine must be parked with controls, lights and switches turned off. The engine must be off and any flames, glowing embers, auxiliary heating units or spark-causing equipment must be doused, turned off and/or kept well clear of the machine.

Static electricity can produce dangerous sparks at the fuel filling nozzle. In every cold, dry weather or other conditions that could produce static discharge, keep the tip of the fuel nozzle in constant contact with the neck of the fuel filling nozzle, to provide a ground.

Keep fuel and other fluid reservoir caps tight and do not start the engine until caps have been secured.

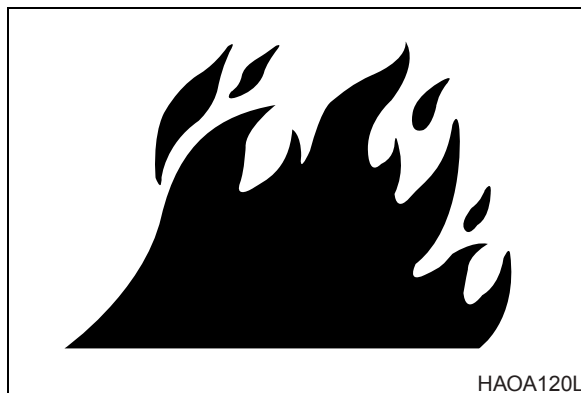

Figure 8

BOOST STARTING OR CHARGING ENGINE BATTERIES

Turn off all electrical equipment before connecting leads to the battery. This includes electrical switches on the battery charger or boost starting equipment.

When boost-starting from another machine or vehicle do not allow the two machines to touch. Wear safety glasses or goggles while required parallel battery connections – positive to positive and negative to negative – are made.

24 volt battery units consisting of two series-connected twelve volt batteries have a cable connecting one positive terminal on one of the 12 volt batteries to a negative terminal on the other battery. Booster or charger cable connections must be made between the non-series-connected positive terminals and between the negative terminal of the booster battery and the metal frame of the machine being boosted or charged. Refer to the procedure and illustration in Operation and Maintenance Manual.

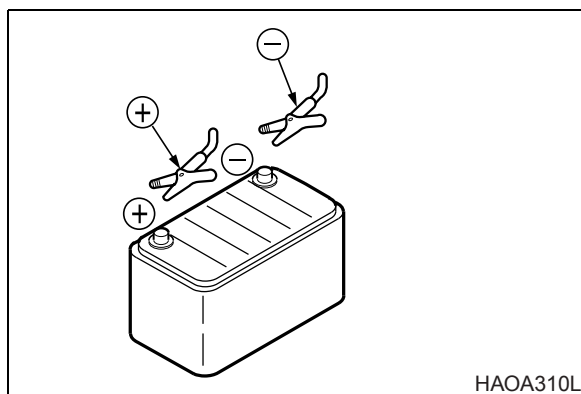

Figure 9

Connect positive cable first when installing cables and disconnect the negative cable first when removing them. The final cable connection, at the metal frame of the machine being charged or boost-started, should be as far away from the batteries as possible.

TRAVEL CONTROLS MAY PRODUCE REVERSED OPERATIONS

Before starting the machine you should always check to see which end of the track frame is under the operator's cab. In the normal travel configuration, track frame travel motors are at the rear of the machine, under the engine and counterweight. If the operator swings the cab 180°, travel motors will be underneath the operator's cab, toward the front of the track frame and operating travel will be reversed.

When traveling the excavator always keep lights on; make sure that you are in compliance with all state and local regulations concerning warning flags and signs and keep the operator's cab positioned over the

idler end of the track frame. That will keep travel controls in their intended configuration and at the same time, maintain the proper orientation of lights on the machine and posted flags and signs.

KEEP "PINCH POINT" AREAS CLEAR - USE CAUTION IN REVERSE & SWING

Use a signal person in high traffic areas and whenever the operator's view is not clear, such as when traveling in reverse. Make sure that no one comes inside the swing radius of the machine.

Anyone standing near the track frames, or working assemblies of the attachment, is at risk of being caught between moving parts of the machine.

Never allow anyone to ride on any part of the machine or attachment, including any part of the turntable or operator's cab.

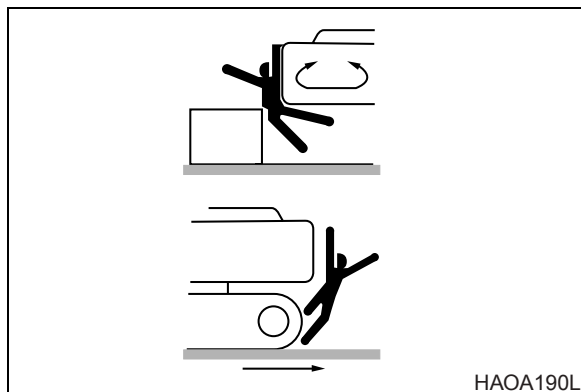

Figure 10

TRAVEL PRECAUTIONS

Attachment control levers should not be operated while traveling.

Do not change selected travel mode (FAST/SLOW) while traveling.

Fold in work equipment so that the outer end of the boom is as close to the machine as possible, and is 203 mm – 304 mm (8" – 12") above ground.

Never travel over obstacles or slopes that will cause the machine to tilt severely. Travel around any slope or obstacle that causes 10 degrees tilt, or more.

OPERATE CAREFULLY ON SNOW AND ICE AND IN VERY COLD TEMPERATURES

In icy cold weather avoid sudden travel movements and stay away from even very slight slopes. The machine could skid off to one side very easily.

Snow accumulation could hide or obscure potential hazards. Use care while operating or while using the machine to clear snow.

Warming up the engine for a short period may be necessary, to avoid operating with sluggish or reduced working capacity. The jolting shocks and impact loads caused by bumping or bottoming the boom or attachment are more likely to cause severe stress in very cold temperatures. Reducing work cycle rate and work load may be necessary.

PARKING THE MACHINE

Avoid making sudden stops, or parking the machine wherever it happens to be at the end of the work day. Plan ahead so that the excavator will be on a firm, level surface away from traffic and away from high walls, cliff edges and any area of potential water accumulation or runoff. If parking on inclines is unavoidable, block the crawler tracks to prevent movement. Lower the bucket or other working attachment completely to the ground, or to an overnight support saddle. There should be no possibility of unintended or accidental movement.

SHUTDOWN CONTROL FUNCTIONS

After the machine has been lowered to the overnight storage position and all switches and operating controls are in the OFF position, the control stand lock lever must be engaged. Release the left console to disable all pilot circuit control functions.

Insert the swing lock pin and engage all brakes and lock-down security equipment that may have been installed on the machine.

IMPORTANT

When hydraulic system maintenance or service work must be performed, you should be aware that an accumulator in the system stores fluid under pressure after system lock down, even after the control stand is raised. Release this energy by working controls with the engine off, until pressure in the pilot circuit has been completely bled away.

EQUIPMENT

ROUGH OPERATION MAY REQUIRE USE OF CERTIFIED SAFETY EQUIPMENT

Working in mines, tunnels, deep pits or on loose or wet surfaces could produce danger of falling rock or hazardous flying objects. Additional protection for the operator's cab could be required in the form of a FOG / Falling Object Guard or windows guards.

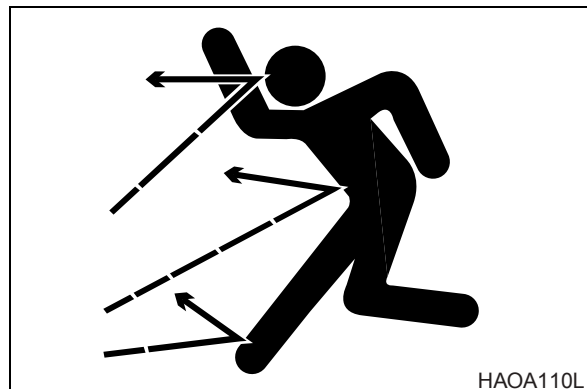

Figure 11

Any reinforcement system that is installed on the machine must pass safety and certification standards and carry appropriate labeling and rating information. For example, the most often added type of reinforcement system, FOG, must meet or exceed International Standard ISO10262, Laboratory Tests and Performance Requirements Earth-Moving Machinery.

Never attempt to alter or modify any type of protective structure reinforcement system, by drilling holes, welding, remounting or relocating fasteners. Any serious impact or damage to the system requires a complete integrity reevaluation. Reinstallation, recertification and/or replacement of the system may be necessary.



Figure 12

INSTALL ADDITIONAL SAFETY EQUIPMENT IF CONDITIONS REQUIRE

When working with a breaker or in some shear work applications, a front guard over the windshield may be required. The windshield guard may or may not be OPS/certified, depending upon the specific application and working situation.

Laminate glass protection for the front, side or rear windows may also be recommended depending upon particular site conditions.

Contact your Daewoo distributor for available safety guards and/or recommendations if there is any danger of getting hit by objects that could strike the operator's cab. Make sure that all other work-site crew members are kept well away from the excavator and safe from potential hazards.

MOVEMENT ALARMS

If the excavator is equipped with an audible travel movement alarm or visible swing movement alarm (strobe light), test the alarm on a daily basis. The audible alarm should sound as soon as the travel system is engaged. The strobe light should begin to flash as soon as the swing system is engaged.

SEAT BELTS SHOULD BE USED AT ALL TIMES

Whenever the engine is running, the operator should be seated at the control station with the seat belt properly engaged.



HAOD060P

Figure 13

WINDOW GLASS BREAKING TOOL

This excavator is equipped with a glass breaking tool. It is located behind the operator seat in the upper right corner of the cab. This tool can be used in case of an emergency situation which requires the breaking of glass to exit from the operator's cabin. Grip the handle firmly and use the sharp point to break the glass.



HAOM590S

Figure 14

KEEP A FIRE EXTINGUISHER AT HAND

It is recommended that an appropriately sized (2.27 kg [5 lb.] or larger) multi-purpose "A/B/C" fire extinguisher be mounted in the cab. Check and service the fire extinguisher at regular intervals and make sure that all work-site crew members are adequately trained in its use.

MAINTAIN STANDARD SAFETY EQUIPMENT IN GOOD CONDITION

Machinery guards and body panel covers must be in place at all times. Keep well clear of rotating parts. Pinch point hazards such as cooling fan and alternator drive belts could catch hair, jewelry or oversize or very loose clothing.

Safety labels must be replaced if they are damaged or become unreadable. The information on labels gives work crew members an important safety reminder exactly where it will do the most good. Part numbers for each label and required mounting locations are shown in Operation and Maintenance Manual.

SAFETY-CRITICAL PARTS MUST BE REPLACED PERIODICALLY

Replace the following fire-related components as soon as they begin to show any sign of wear, or at regular periodic intervals, whether or not deterioration is visible:

- Fuel system flexible hoses, the tank overflow drain hose and the fuel fill cap.
- Hydraulic system hoses, especially the pump outlet lines and front and rear pump branch hoses.
- Keep mounting brackets and hose and cable routing straps tight. Hose routing should have gradual bends.

HYDRAULIC CYLINDER SEALS REQUIRE PERIODIC REPLACEMENT

Check cylinder drift rate at regular intervals. Maximum allowable rates are included in the in this manual. Overhaul seal kits are available through Daewoo.

HIGH PRESSURE HYDRAULIC LINES CAN STORE A GREAT DEAL OF ENERGY

Exposed hydraulic hoses on the arm or boom could react with explosive force if struck by a falling rock, overhead obstacle or other jobsite hazard. *Extra safety guards may be required.* NEVER allow hoses to be hit, bent or interfered with during operation.

THE OPERATOR'S CAB AND TURNTABLE DECK SHOULD BE KEPT CLEAN

Cleaning off accumulations of grease and dirt helps extend equipment service life. Cleaning also provides an opportunity to inspect equipment. Minor damage can be repaired or corrected before major problems result.

Keep the cab floor and consoles free of tools and personal items.

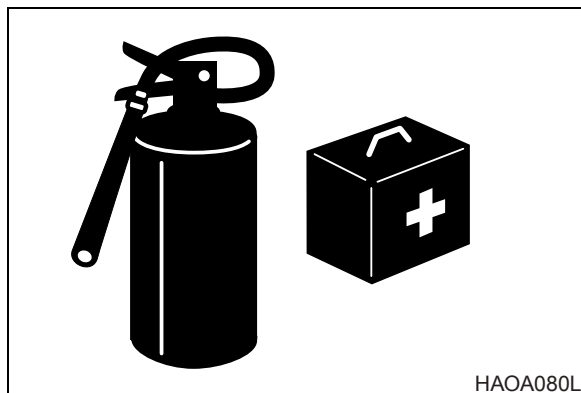

Figure 15

HAOA080L

WEAR EYE PROTECTION AND SAFETY CLOTHING

Full eye protection, a hard hat, safety shoes and gloves may be required at the job site.

While working on the machine, never use inadequate tools. They could break or slip, causing injury, or they may not adequately perform intended functions.

BREATHING MASKS, EAR PROTECTION MAY BE REQUIRED

Don't forget that some risks to your health may not be immediately apparent. Exhaust gases and noise pollution may not be visible, but these hazards can cause disabling or permanent injuries.

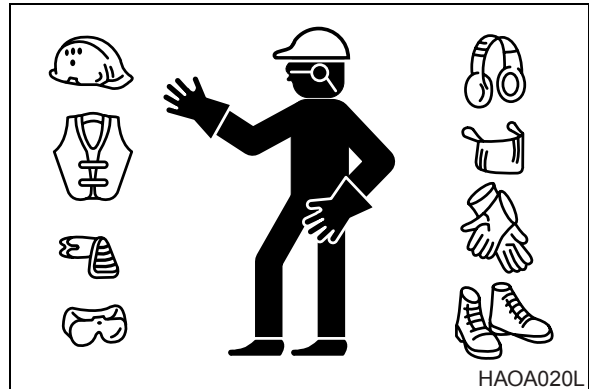

Figure 16

BATTERY ELECTROLYTE AND EXPLOSIVE GASES CAN BE LETHAL

Flush eyes with water for 10-15 minutes if acid is splashed in the face. Anyone who swallows acid must have **immediate** medical aid. *Call the Poison Control listing in the front cover of the telephone directory.* Water, a popsicle or ice cream are likely better than old remedies that try to induce vomiting (which would expose tissue to damage twice).

Explosive battery gas can be set off by sparks from incidental contact or static discharge. Turn off all switches and the engine when working on batteries. Keep battery terminals tight. Contact between a loose terminal and post can create an explosive spark.

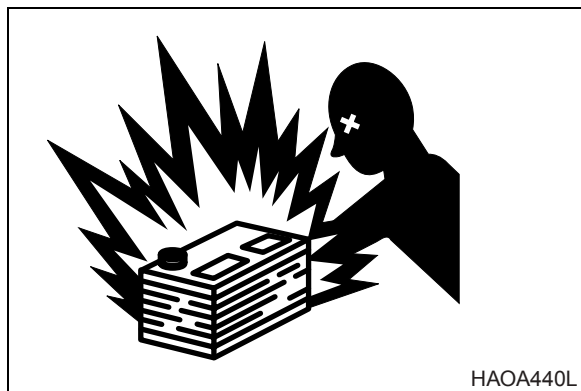

Figure 17

DISCONNECT BATTERIES FOR ELECTRICAL SERVICE BEFORE ELECTRICAL WELDING

Remove cable to negative terminal first, when disconnecting cable. **Connect positive terminal cables first when installing a battery.**

USE LOW HEAT PORTABLE LIGHTING

Hot surfaces on trouble lights or portable work lights can set off fuel or battery explosive gases.

MAINTENANCE

USE WARNING TAG CONTROL LOCKOUT PROCEDURES DURING SERVICE

Alert others that service or maintenance is being performed and tag operator's cab controls – and other machine areas if required – with a warning notice. OSHA-mandated control lever lockout can be made with any OSHA certified lockout device and a length of chain or cable to keep the left-hand control console in the fully raised, non-active position.

Warning tags for controls are available from Daewoo distributors.



Figure 18

DO NOT RUN THE ENGINE IF REPAIRS OR WORK IS BEING PERFORMED ALONE

You should always have at least two people working together if the engine must be run during service. One person needs to remain in the operator's seat, ready to work the controls or stop the machine and shut off the engine.

ALWAYS USE ADEQUATE EQUIPMENT SUPPORTS AND BLOCKING

Do not allow weight or equipment loads to remain suspended. Lower everything to the ground before leaving the operator's seat. Do not use hollow, cracked or unsteady, wobbling weight supports. Do not work under any equipment supported solely by a lift jack.

DO NOT WORK ON HOT ENGINES OR HOT COOLING OR HYDRAULIC SYSTEMS

Wait for the engine to cool off after normal operation. Park the excavator on a firm, level surface and lower all equipment before shutting down and switching off controls. When engine lube oil, gearbox lubricant or other fluids require change, wait for fluid temperatures to decrease to a moderate level before removing drain plugs.

NOTE: *Oil will drain more quickly and completely if it is warm. Do not drain fluids at 95° C (203° F) temperatures but don't allow full cool-down.*

COOL-DOWN IS REQUIRED PRIOR TO RADIATOR OR RESERVOIR CHECKS

Stop the engine and allow heat to dissipate before performing service on the engine radiator or hydraulic fluid reservoir. Both assemblies have air vent levers at or near the fill cap for venting built-up air pressure. Release the levers before trying to take off fill caps and LO OSENCAPS SLOWLY, prior to removal.

PRESSURIZED HYDRAULIC OIL FLUID LEAKS CAN BE DANGEROUS

Fluid leaks from hydraulic hoses or pressurized components can be difficult to see but pressurized oil has enough force to pierce the skin and cause serious injury.

Always use a piece of wood or cardboard to check for suspected hydraulic leaks. Never use your hands or expose your fingers.

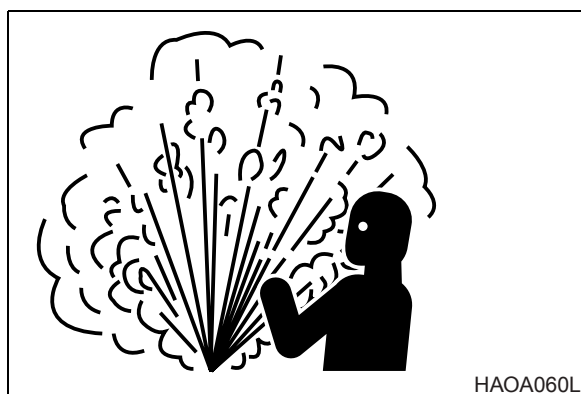

Figure 19

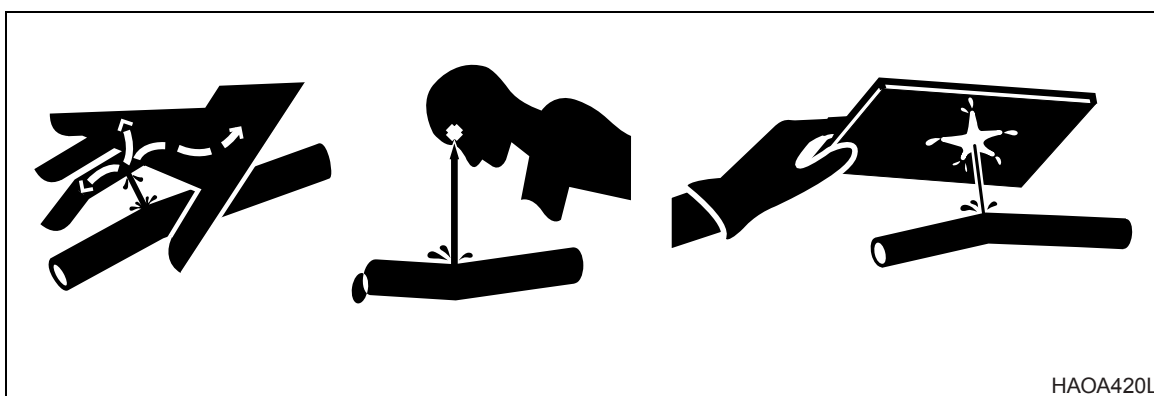

Figure 20

OBTAIN IMMEDIATE MEDICAL ATTENTION IF PRESSURIZED OIL PIERCES THE SKIN.



Failure to obtain prompt medical assistance could result in gangrene or other serious damage to tissue.

USE CORRECT REPLACEMENT FASTENERS TIGHTENED TO PROPER TORQUE

Refer to the "General Maintenance" section of this manual for information on tightening torques and recommended assembly compounds and always use the correct part.

Poor or incorrect fastener connections can dangerously weaken assemblies.

DISPOSE OF ALL PETROLEUM-BASED OILS AND FLUIDS PROPERLY

Physical contact with used motor oil may pose a health risk. Wipe oil from your hands promptly and wash off any remaining residue.

Used motor oil is an environmental contaminant and may only be disposed of at approved collection facilities. Never drain any petroleum-based product on the ground or dispose of old oil in municipal waste collection containers, or in metropolitan sewer systems or rural landfills.

Check state and local regulations for other requirements.

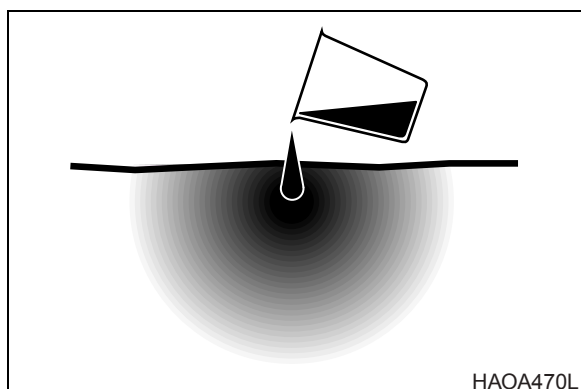

Figure 21

TRACK TENSION ADJUSTMENTS REQUIRE CAUTION

NEVER turn out the track tension grease fitting nut. To release pressure from the crawler frame track tension assembly, you should NEVER attempt to disassemble the track adjuster or attempt to remove the grease fitting or valve assembly.

Keep your face and body away from the valve. Refer to the track adjustment procedure in the Operation and Maintenance Manual or this manual.

SHIPPING AND TRANSPORTATION

OBEDI STATE AND LOCAL OVER-THE-ROAD REGULATIONS

Check state and local restrictions regarding weight, width and length of a load prior to making any other preparation for transport.

The hauling vehicle, trailer and load must all be in compliance with local regulations governing the intended shipping route.

Partial disassembly or tear-down of the excavator may be necessary to meet travel restrictions or particular conditions at the job site. See this manual for information on partial disassembly.

Refer to the Transportation and Shipping section of the Operation and Maintenance Manual for information on loading, unloading and towing.

LIFTING WITH SLING



WARNING!

Improper lifting can allow load to shift and cause injury or damage.

1. Refer to Specification section of Operation and Maintenance Manual for information on weight and dimensions.
2. Use properly rated cables and slings for lifting.
3. Position machine for a level lift.
4. Lifting cables should have a long enough length to prevent contact with the machine. Spreader bars may be required.

NOTE: *If spreader bars are used, be sure that cables are properly secured to them and that the angle of the cables is factored into the lift strength.*

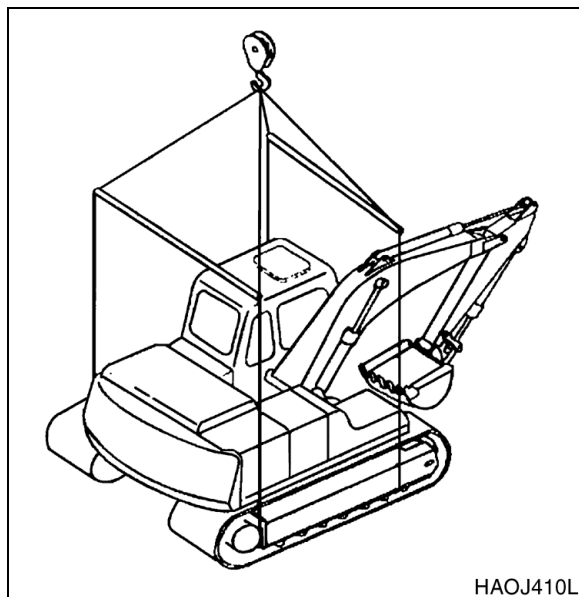

HAOJ410L

Figure 22

SPECIFICATIONS



SPECIFICATIONS FOR SOLAR 130LC-V



CAUTION!

Follow all safety recommendations and safe shop practices outlined in the front of this manual or those contained within this section.

Always use tools and equipment that is in good working order.

Use lifting and hoisting equipment capable of safely handling load.

Remember, that ultimately safety is your own personal responsibility.

MODEL	SERIAL NUMBER RANGE
Solar 130LC-V	0001 and UP

TABLE OF CONTENTS

- General Description..... 3
- General Dimensions..... 6
- Dimensions and Working Range..... 7
- General Specifications 9
- Engine Performance Curves (Per KS-R1004 Standard) 11
- Approximate Weight of Workload Materials 12
- Performance Tests..... 15
- Excavator Performance Standards..... 16
 - Test Conditions..... 16
 - Travel Speed and Travel Motor Balance (Steering Deviation) Tests..... 16
 - Cylinder Performance Tests 20

GENERAL DESCRIPTION

The excavator has three main component sections:

- The Upper Turntable
- The Lower Undercarriage and Track Frames
- The Excavator Front-end Attachment

The following illustration identifies main components and their locations. (See Figure 1 on page -4.)

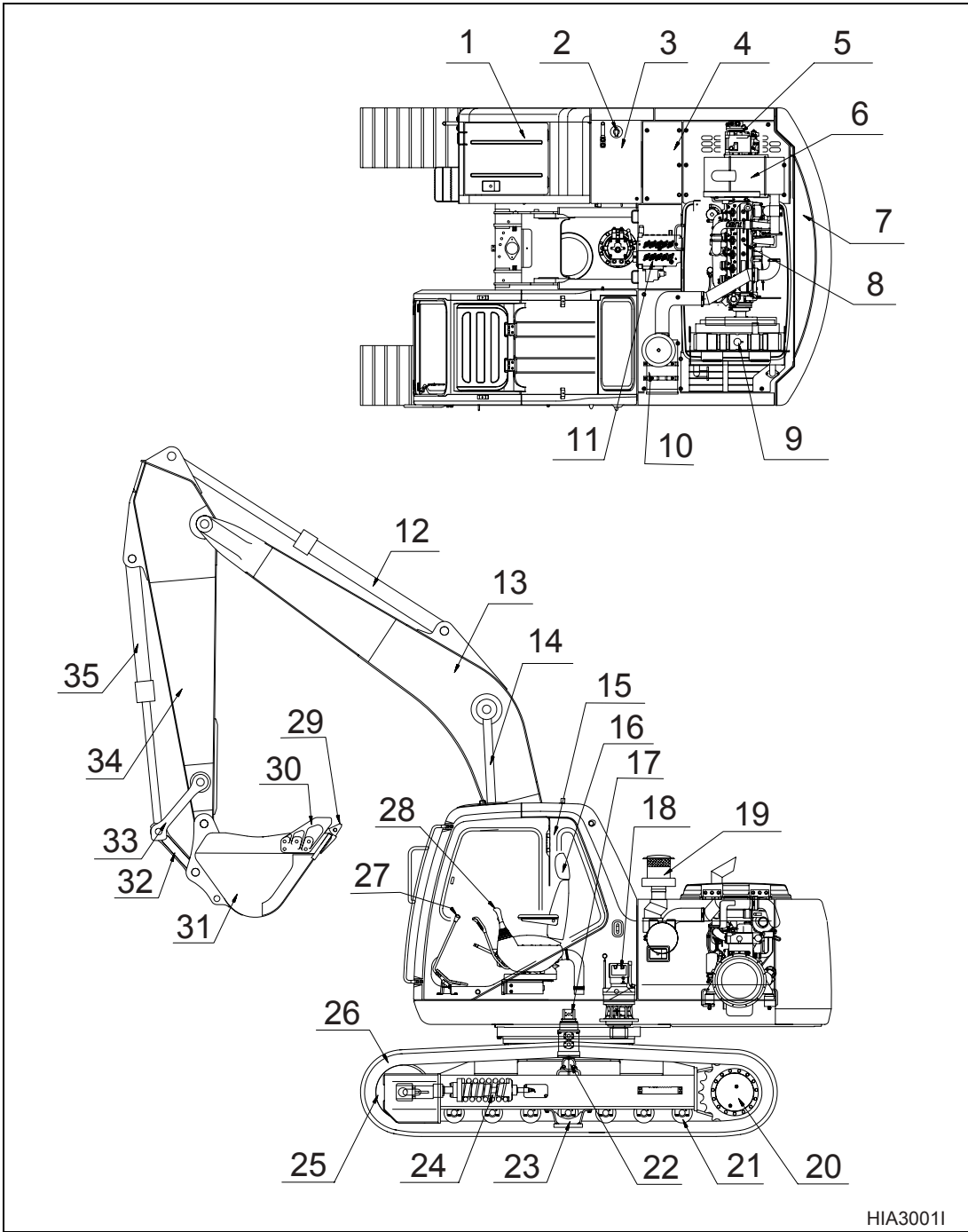

HIA30011

Figure 1

Reference Number	Description
1	Battery
2	Fuel Filler
3	Fuel Tank
4	Hydraulic Oil Tank
5	Pumps
6	Muffler
7	Counterweight
8	Engine
9	Radiator & Oil Cooler
10	Air Cleaner
11	Control Valves
12	Arm Cylinder
13	Boom
14	Boom Cylinder
15	Cab
16	Seat
17	Center Joint
18	Swing Motor

Reference Number	Description
19	Precleaner
20	Travel Motor
21	Lower Roller
22	Upper Roller
23	Track Guide
24	Track Adjuster
25	Idler
26	Track Link & Shoe
27	Travel Lever
28	Joystick Controls
29	Tooth Point
30	Side Cutter
31	Bucket
32	Push Link
33	Guide Link
34	Arm
35	Bucket Cylinder

GENERAL DIMENSIONS

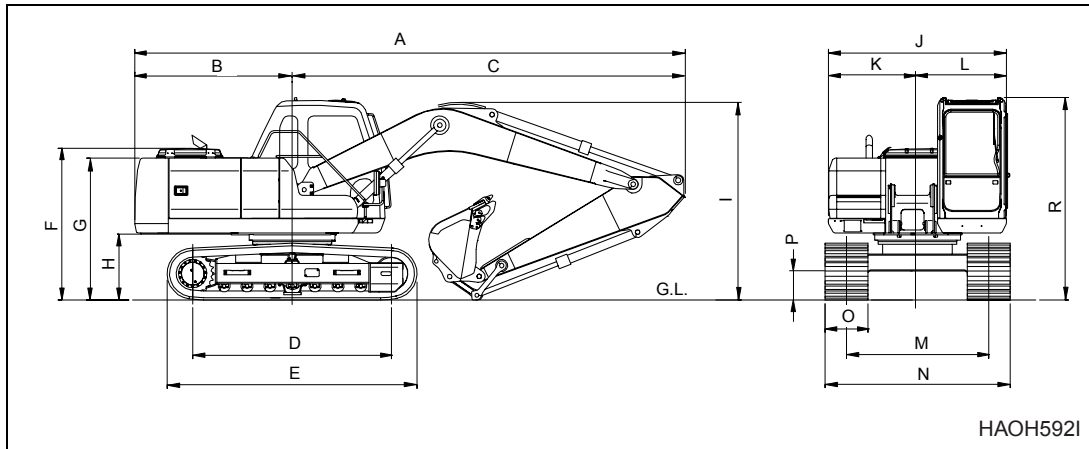

Figure 2

DIMENSION	4.6 M (15.09 FT) BOOM WITH 2.5 M (8.20 FT) ARM	4.6 M (15.09 FT) BOOM WITH 3.0 m (9.84 ft)
A	7700 mm (303.15 in.)	7630 mm (300.39 in.)
B	2200 mm (86.61 in.)	2200 mm (86.61 in.)
C	5500 mm (216.54 in.)	5430 mm (213.78 in.)
D	3,035 mm (119.49 in.)	3,035 mm (119.49 in.)
E	3,750 mm (147.64 in.)	3,750 mm (147.64 in.)
F	2120 mm (83.46 in.)	2120 mm (83.46 in.)
G	1990 mm (78.35 in.)	1990 mm (78.35 in.)
H	920 mm (36.22 in.)	920 mm (36.22 in.)
I	2760 mm (108.66 in.)	3160 mm (124.41 in.)
J	2490 mm (98.03 in.)	2490 mm (98.03 in.)
K	1245 mm (49.02 in.)	1245 mm (49.02 in.)
L	1245 mm (49.02 in.)	1245 mm (49.02 in.)
M	2000 mm (78.74 in.)	2000 mm (78.74 in.)
N	2600 mm (102.36 in.)	2600 mm (102.36 in.)
O	600 mm (23.62 in.)	600 mm (23.62 in.)
P	410 mm (16.14 in.)	410 mm (16.14 in.)
R	2830 mm (11.42 in.)	2830 mm (11.42 in.)

DIMENSIONS AND WORKING RANGE

WARNING!

The actual value for dimension “L” Digging Reach, depends on the stability and support provided by ground conditions. Digging too far underneath the excavator if soil conditions are wet, loose or unstable can collapse ground support, which could cause injury and/or equipment damage.

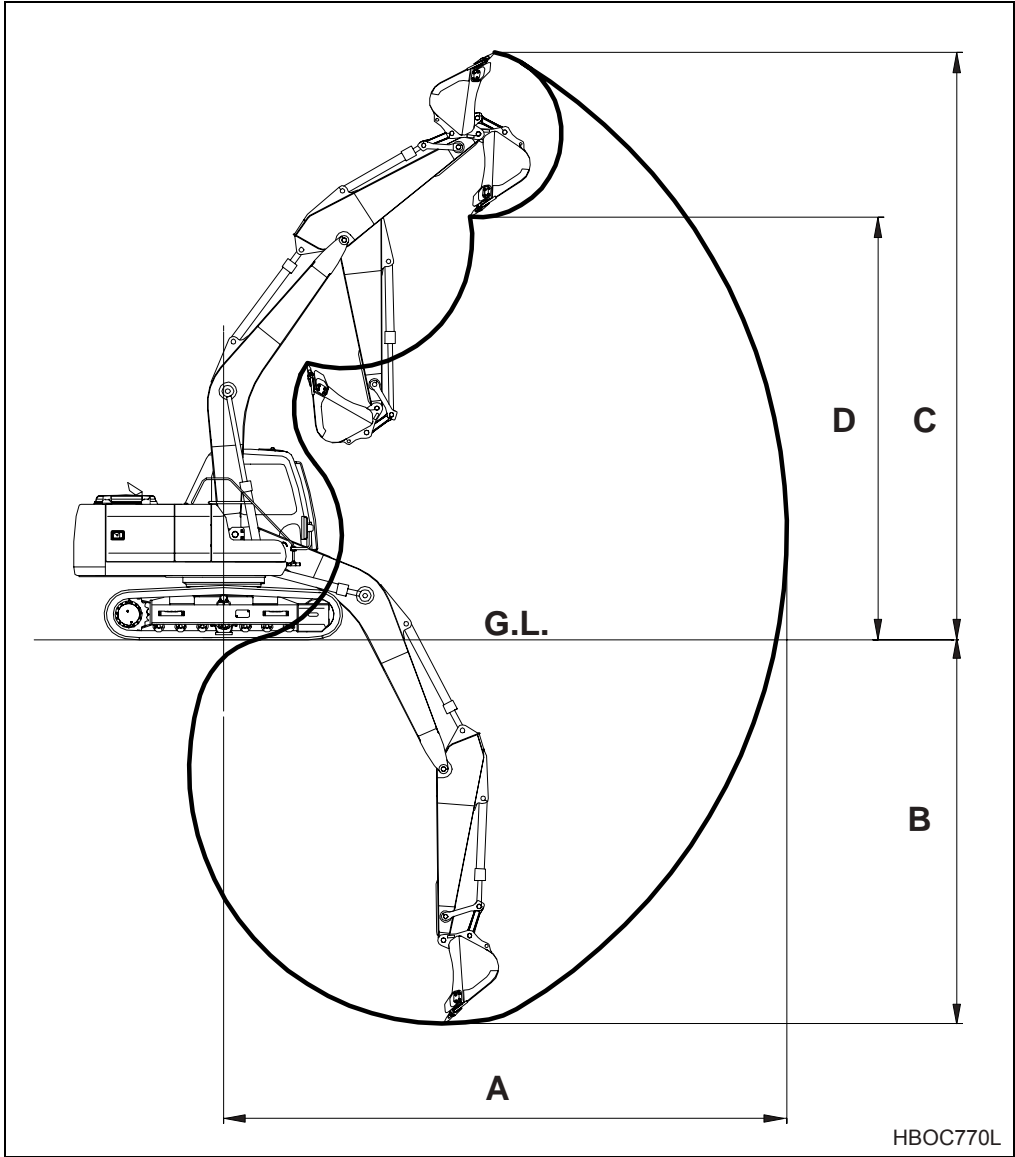

Figure 3

DIM.	Description	4.0 M (157.48 in.) BOOM WITH 1.9 M (74.8 in.) ARM	4.6 M (181.10 in.) BOOM WITH 2.5 M (98.42 in.) ARM	4.6 M (181.10 in.) BOOM WITH 3.0 M (118.11 in.) ARM
A	Maximum Digging Radius	7,020 mm (276.37 in.)	8,260 mm (325.19 in.)	8,740 mm (344.09 in.)
B	Maximum Digging Depth	4,670 mm (183.85 in.)	5,630 mm (221.65 in.)	6,120 mm (240.94 in.)
C	Maximum Digging Height	7,350 mm (289.37 in.)	8,620 mm (339.37 in.)	8,950 mm (352.36 in.)
D	Maximum Dump Height	4,990 mm (196.46 in.)	6,200 mm (244.09 in.)	6,530 mm (257.09 in.)

GENERAL SPECIFICATIONS

Shipping Weight	13.90 metric tons (15.32 tons), includes 10% fuel, boom, 2,500 mm (8' - 2") arm, standard bucket and standard shoes
Operating Weight	Add weight of full fuel tank and operator.
Shipping Weights With Optional Track Shoes	13.9 ton for 600 mm (24") shoes
	13.7 ton for 500 mm (19.7") shoes
	14.1 ton for 700 mm (28") shoes
Major Component Weights	Standard Boom 4,600.0 mm (181.10 in.) 872.0 kg (1,922.43 lbs.)
	2,100.0 mm (82.68 in.) Arm 483.0 kg (1,064.83 lbs.)
	2,500.0 mm (98.43 in.) Arm 534.0 kg (1,177.27 lbs.)
	3,000.0 mm (118.11 in.) Arm 587.0 kg (1,294.11 lbs.)
	Boom Cylinders 105.0 kg (231.49 lbs.) each
	Arm Cylinder 146.0 kg (321.87 lbs.)
	Bucket Cylinder 88.0 kg (194.01 lbs.)
	Counterweight 2,100.0 kg (4,629.71 lbs.)
	Upper Turntable 5,100.0 kg (11,243.57 lbs.) (Including counter weight, w/o front)
Lower - 6,400.0 kg (14,109.58 lbs.) (Including swing bearing)	
Digging Forces:	
Bucket Cylinder	8,300.0 kg (18,298.37 lbs.) with 1,900 mm (6' 3") arm
Arm Cylinder	7,100.0 kg (15,652.82 lbs.) with 1,900 mm (6' 3") arm
	6,300.0 kg (13,889.12 lbs.) with 2,500 mm (8' - 2") arm
	5,000.0 kg (11,023.11 lbs.) with 3,000 mm (9' - 10") arm
Fuel Tank Capacity	230.0 liters (60.72 U.S. gal.)
Hydraulic Reservoir Capacity	89.0 liters (23.50 U.S. gal.)
Bucket Heaped Capacity Range	PCSA 0.50 - 1.18 m ³ (0.65 - 1.54 yd ³)
	IMPORTANT: Refer to the Load Weight, Bucket and Arm Length Compatibility Table for information on which bucket sizes may be used safely with which arm length, for load material weights.
Shoe Type	Triple Grouser
Shoe Width and Optional Sizes	600 mm (24") - standard
	500 mm (19.7") - optional
	700 mm (28") - optional
Ground Pressure Ratings:	
Standard 600 m m (24") shoe -	0.35 bar (5.08 psi)
Optional 500 m m (19.7") shoe -	0.42 bar (6.14 psi)
Optional 700 m m (28") shoe -	0.31 bar (4.50 psi)
Transport Dimensions	

Overall Shipping Length (standard 4.60 m (15' - 1") boom and 2.50 m (8' - 2") arm)	7,700 mm (25' - 3")
Overall Shipping Width (standard 600 mm (23.62 in.) shoes)	2,600 mm (8' - 6")
Overall Shipping Height (to top of cylinder hose)	2,830 mm (9' - 3") for 2.50 m (8' - 2") arm 3,160 mm (10' - 4") for 3.0 m (9' - 10") arm
Track Shipping Length	3,750 mm (12' - 4")
Transport Trailer Capacity	30 tons (33 short tons), minimum load capacity
Transport Loading Ramp Allowable Slope	15° angle CAUTION: Refer to Transport Maximum Procedure for Safe Shipping Instructions.

ENGINE PERFORMANCE CURVES (PER KS-R1004 STANDARD)

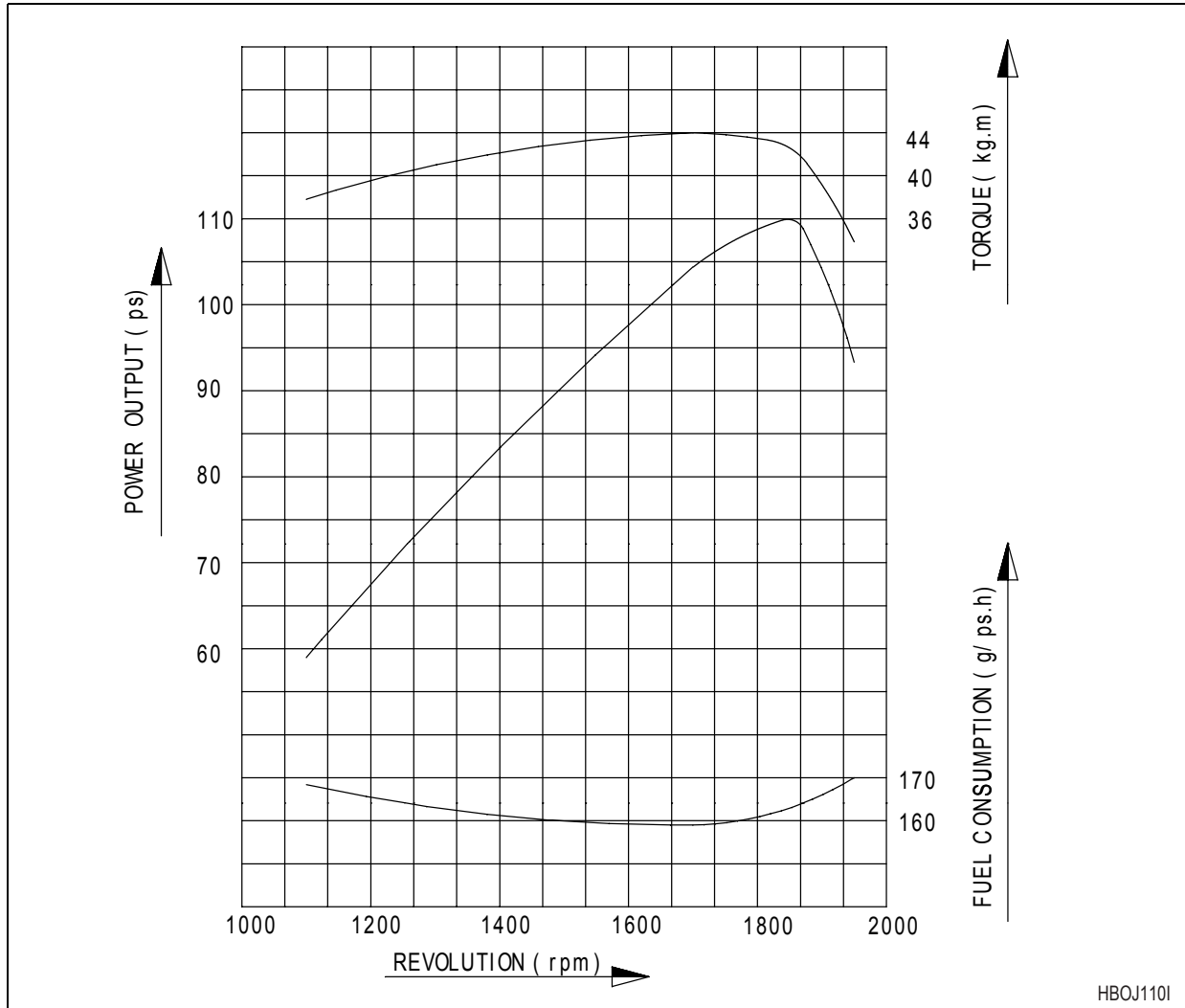

Figure 4

Maximum Output	110.0 ps (108.50 hp) @ 1,850 rpm
Maximum Torque	44.0 kg/m (318.25 ft lbs) @ 1,700 rpm
Fuel Use	163 g/ps h (5.7 oz./ps h)

NOTE: *Barometric Pressure: 760 mm (30") Mercury*
Temperature: 20° C (68° F)
Cooling Fan: 590mm (23.2") sucker fan
Alternator: 24 V, 50 amp
Exhaust System: None

APPROXIMATE WEIGHT OF WORKLOAD MATERIALS

IMPORTANT

Weights are approximations of estimated average volume and mass. Exposure to rain, snow or ground water; settling or compaction due to overhead weight, chemical or industrial processing or changes due to thermal or chemical transformations could all increase the value of weights listed in the table.

MATERIAL	LOW WEIGHT OR DENSITY, 1,100 KG/M ³ (1,850 LB/YD ³), OR LESS	MEDIUM WEIGHT OR DENSITY, 1,600 KG/M ³ (2,700 LB/YD ³), OR LESS	HIGH WEIGHT OR DENSITY, 2,000 KG/M ³ (3,370 LB/YD ³), OR LESS
Charcoal	401 kg/m ³ (695 lb/yd ³)	-----	-----
Coke, blast furnace size	433 kg/m ³ (729 lb/yd ³)	-----	-----
Coke, foundry size	449 kg/m ³ (756 lb/yd ³)	-----	-----
Coal, bituminous slack, piled	801 kg/m ³ (1,350 lb/yd ³)	-----	-----
Coal, bituminous r. of m., piled	881 kg/m ³ (1,485 lb/yd ³)	-----	-----
Coal, anthracite	897 kg/m ³ (1,512 lb/yd ³)	-----	-----
Clay, DRY, in broken lumps	1,009 kg/m ³ (1,701 lb/yd ³)	-----	-----
Clay, DAMP, natural bed	-----	1,746 kg/m ³ (2,943 lb/yd ³)	-----
Cement, Portland, DRY granular	-----	1,506 kg/m ³ (2,583 lb/yd ³)	-----
Cement, Portland, DRY clinkers	-----	1,362 kg/m ³ (2,295 lb/yd ³)	-----

MATERIAL	LOW WEIGHT OR DENSITY, 1,100 KG/M³ (1,850 LB/YD³), OR LESS	MEDIUM WEIGHT OR DENSITY, 1,600 KG/M³ (2,700 LB/YD³), OR LESS	HIGH WEIGHT OR DENSITY, 2,000 KG/M³ (3,370 LB/YD³), OR LESS
Dolomite, crushed	-----	1,522 kg/m ³ (2,565 lb/yd ³)	-----
Earth, loamy, DRY, loose	-----	1,202 kg/m ³ (2,025 lb/yd ³)	-----
Earth, DRY, packed	-----	1,522 kg/m ³ (2,565 lb/yd ³)	-----
Earth, WET, muddy	-----	-----	1,762 kg/m ³ (2,970 lb/yd ³)
Gypsum, calcined, (heated, powder)	961 kg/m ³ (1,620 lb/yd ³)	-----	-----
Gypsum, crushed to 3 inch size	-----	1,522 kg/m ³ (2,565 lb/yd ³)	-----
Gravel, DRY, packed fragments	-----	-----	1,810 kg/m ³ (3,051 lb/yd ³)
Gravel, WET, packed fragments	-----	-----	1,922 kg/m ³ (3,240 lb/yd ³)
Limestone, graded above 2	-----	1,282 kg/m ³ (2,160 lb/yd ³)	-----
Limestone, graded 1-1/2 or 2	-----	1,362 kg/m ³ (2,295 lb/yd ³)	-----
Limestone, crushed	-----	1,522 kg/m ³ (2,565 lb/yd ³)	-----
Limestone, fine	-----	-----	1,602 kg/m ³ (2,705 lb/yd ³)
Phosphate, rock	-----	1,282 kg/m ³ (2,160 lb/yd ³)	-----

MATERIAL	LOW WEIGHT OR DENSITY, 1,100 KG/M ³ (1,850 LB/YD ³), OR LESS	MEDIUM WEIGHT OR DENSITY, 1,600 KG/M ³ (2,700 LB/YD ³), OR LESS	HIGH WEIGHT OR DENSITY, 2,000 KG/M ³ (3,370 LB/YD ³), OR LESS
Salt	929 kg/m ³ (1,566 lb/yd ³)	-----	-----
Snow, light density	529 kg/m ³ (891 lb/yd ³)	-----	-----
Sand, DRY, loose	-----	1,522 kg/m ³ (2,565 lb/yd ³)	-----
Sand, WET, packed	-----	-----	1,922 kg/m ³ (3,240 lb/yd ³)
Shale, broken	-----	1,362 kg/m ³ (2,295 lb/yd ³)	-----
Sulphur, broken	529 kg/m ³ (1,620 lb/yd ³)	-----	-----

PERFORMANCE TESTS

1. Main Relief Pressure

Normal Operation: 330 kg/cm² (4,689 psi)

With "Pressure Up": 350 kg/cm² (4,970 psi)

2. Actuator Speeds

Operation	Serial Number		Unit	Power Mode II	Power Mode III
Boom	All	Up	sec	3.1 ±0.3	2.8 ±0.3
		Down	sec	2.5 ±0.3	2.5 ±0.3
Arm	All	Dump	sec	2.3 ±0.3	2.1 ±0.3
		Crowd	sec	3.1 ±0.3	2.9 ±0.3
Bucket	All	Dump	sec	2.1 ±0.3	2.0 ±0.3
		Crowd	sec	3.9 ±0.3	3.5 ±0.3
Swing (3 Revolutions)	All		sec	16.2 ±0.7	15.0 ±0.7
Jack-Up Speed (3 Turns)	#1 ~ Up	High	sec	17.9 ±0.8	17.9 ±0.8
		Low	sec	26.3 ±0.8	26.3 ±0.8
Travel Speed 20 m (65.6 ft)	#1 ~ Up	High	sec	16.3 ±1.0	15.0 ±1.0
		Low	sec	23.7 ±1.0	21.5 ±1.0
Travel Deviation 20 m (65.6 ft)	All		mm	100 (Speed 1)	150 (Speed 2)

EXCAVATOR PERFORMANCE STANDARDS

Evaluation of equipment performance and operating condition can be made by running the excavator through a series of different tests, and recording results with a stop watch and tape measure.

Compare results of performance tests against the specifications and standards that follow, which are for equipment in new or renewed condition.

TEST CONDITIONS

1. All tests should be performed on a flat, level, firmly supporting ground surface.
2. All recommended, applicable maintenance and adjustment services should be completed prior to testing.
3. Hydraulic fluid and engine oil should be of appropriate viscosity for ambient weather conditions. Warm up hydraulic oil to standard operating temperature, between 45° to 55°C (112° to 135°F).
4. Run all tests with the engine speed control set to maximum RPM.
5. Repeat tests with Power Mode engine control settings at both Power Mode II (standard work mode) and Power Mode III (high speed mode). Travel speed tests should also be repeated at both high and low speed.

TRAVEL SPEED AND TRAVEL MOTOR BALANCE (STEERING DEVIATION) TESTS

Speed Test

Prepare the excavator for travel speed tests by extending all hydraulic cylinders – boom, arm and bucket – to the fully extended position, shown in Figure 5.

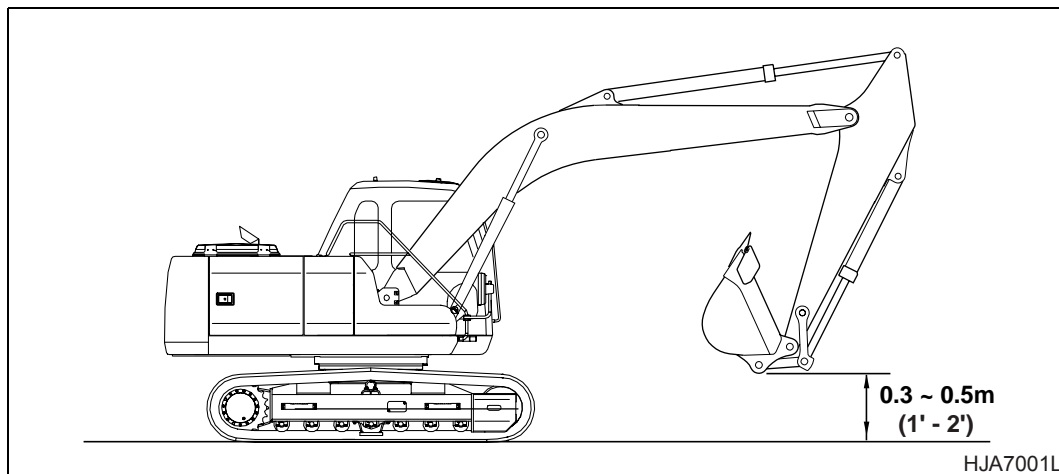

Figure 5

The lowest part of the bucket linkage should be 0.3 m to 0.5 m (1' to 2') off the ground.

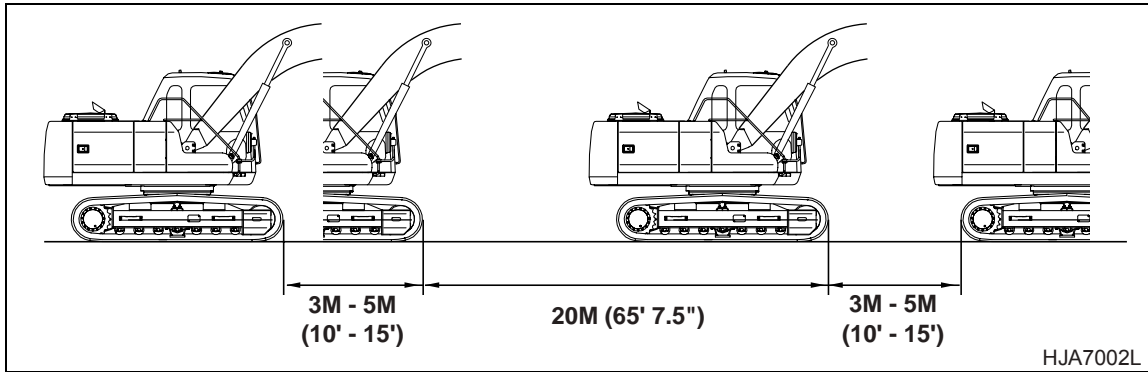

Figure 6

Mark off a 20 m (65' 7-1/2") test distance, with a 3 m to 5 m (10' to 15') run-up area, and a 3 m to 5 m (10' to 15', or longer) speed run-off distance.

Travel the excavator back and forth to be sure steering is centered and side frames are perfectly parallel with the test course.

Operate both travel levers at the fully engaged position and measure the time it takes to cross 20 m (65' 7-1/2"). Compare measured results against the standard for new machines:

RATE OF TRAVEL	TIME	
	MODE II	MODE III
High Speed	16.3 ±1.0 seconds	15.0 ±1.0 seconds
Low Speed	23.7 ±1.0 seconds	21.5 ±1.0 seconds

Rotate the turntable 180°. Both tests should be repeated three times. Average all results to obtain a final value.

Travel Deviation

To check steering deviation (travel motor balance), use a long tape or rope, or the edge of an undeviating straight road curb or other marker to verify side-to-side travel motor uniformity.

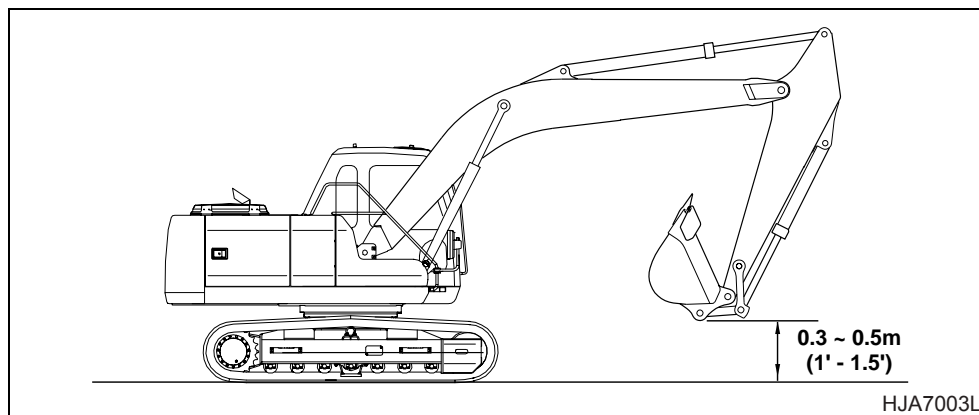

Figure 7

Deviation distance should always be measured at the 20 m (65' 7-1/2") "finish line." Repeat the test in reverse to measure in both directions, with starting point becoming the finish line, and vice versa. (Figure 6) A greater amount of deviation is allowed with the travel control set for high speed.

RATE OF TRAVEL	MAX. DISTANCE
High Speed	150.0 mm (5.91 in.)
Low Speed	100.0 mm (3.94 in.)

Swing Speed Test

Extend the bucket cylinder completely and retract the arm cylinder, as shown in Figure 8, to test swing speed. The lowest point of the bucket will be approximately 1.0 m (3.3') off the ground.

Use paint marks at the same point on the turntable and undercarriage, or select alternate measuring locations and use a stopwatch to time 3 full 360° rotations. The time required for 3 revolutions should be between 14.0 and 16.0 seconds in Power Mode II, 13.0 and 15.0 seconds in Power Mode III.

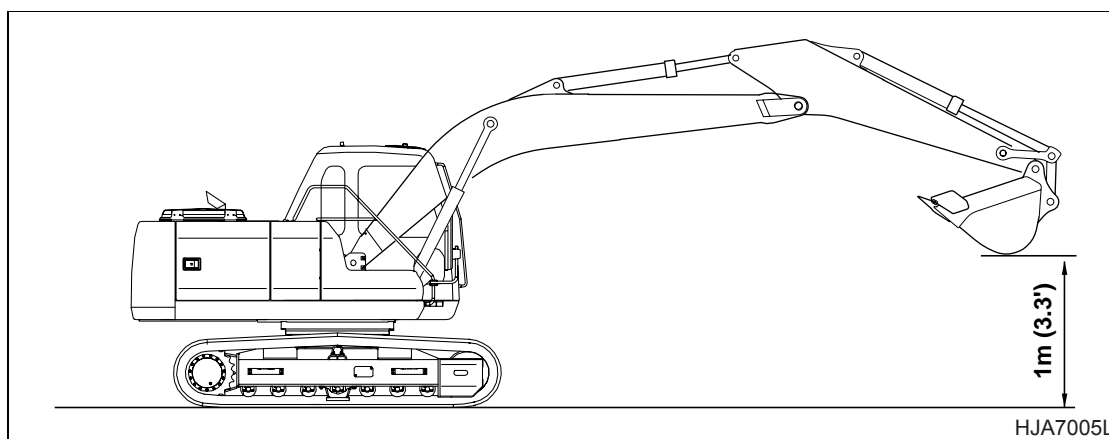

Figure 8

Mode II	16.2 ±0.7 seconds
Mode III	15.0 ±0.7 seconds

Swing Force Test

Reference Number	Description
1	Start Swing
2	90° wing
3	Swing force
4	Swing Stop

With the boom, arm and bucket in the same position as for the swing speed test, rotate the turntable so that the boom is evenly centered between the side frames, pointing straight ahead. Locate the 90° reference point, perpendicular to the boom. Mark the turntable and undercarriage with paint at the 90° point.

Make several attempts to rotate the turntable exactly 90°, starting from the boom straight ahead position. Engage the swing lever and brake at the 90° point, shown as “swing stop” in Figure 9.

Record how far the turntable drifts past the stop point, measuring the distance between paint marks. Maximum distance should be less than 700 mm (27.56 in.), in both Power Mode III and Power Mode II.

Maximum Distance	Less than 700.0 mm (27.56 in.)
-------------------------	-----------------------------------

S
F

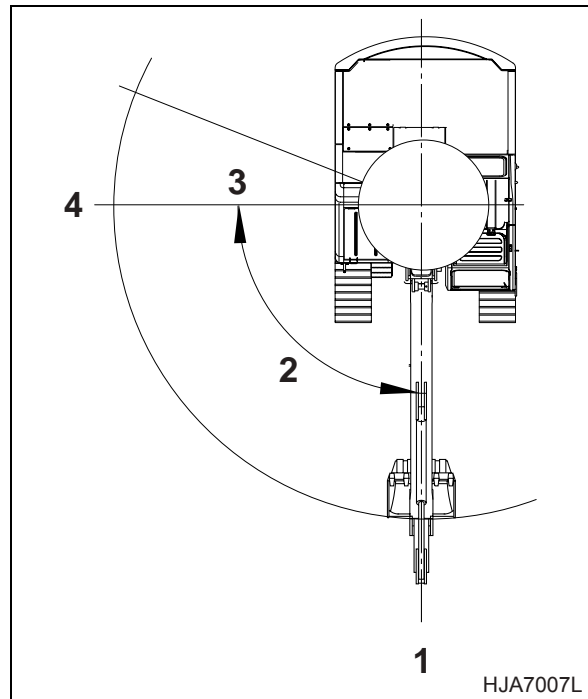

Figure 9

CYLINDER PERFORMANCE TESTS

NOTE: *All tests are performed with standard boom, arm and bucket configuration. The bucket should be empty.*

Boom Cylinders Test

The starting points for the test are with the boom and arm extended away from the excavator, and the bucket curled inward. The arm cylinders should be fully retracted; boom and bucket cylinders must be extended. Test movement in both directions, several times, and average results for both Power Mode II and Power Mode III.

Arm Cylinder Test

Start with the boom up and the arm cylinder fully retracted. Test movement in both directions several times, between the "crowd" and "dump" positions, and average the results of both tests, in both standard and extra-duty power modes.

Bucket Cylinder Test

Start with the boom up and the teeth of the bucket hanging vertically, 500 mm (1-1/2' to 2') above the ground. Dump and crowd the bucket several times, and average results, for both standard and extra-duty power modes.

OPERATION	MODE II	MODE III
Boom Up	2.8 - 3.4 seconds	2.5 - 3.1 seconds
Boom Down	2.2 - 2.8 seconds	2.2 - 2.8 seconds
Arm Dump	2.0 - 2.6 seconds	1.8 - 2.4 seconds
Arm Crowd	2.8 - 3.4 seconds	2.6 - 3.2 seconds
Bucket Dump	1.8 - 2.4 seconds	1.7 - 2.3 seconds
Bucket Crowd	3.6 - 4.2 seconds	3.2 - 3.8 seconds

Hydraulic Cylinder Natural Drop Test

To check boom and arm cylinder tightness against the specified performance standard for new cylinders, put a full load of dirt in the bucket and move the attachment cylinders so that the arm cylinder is extended 20 mm to 50 mm (1" to 2") and boom cylinders are retracted the same amount, 20 mm to 50 mm (1" to 2"). The top of the bucket should be approximately 2 m (6' to 7') off the ground.

Turn off the engine and measure cylinder drop after 5 minutes. Bucket cylinder should not show more than 20 mm (0.8") change, while the arm and boom cylinders should not fall more than 5 mm (0.2").

Cylinder Location	Maximum Drop
Boom Cylinder	Less Than 5.0 mm (0.20 in.)
Arm Cylinder	Less Than 5.0 mm (0.20 in.)
Bucket Cylinder	Less Than 20.0 mm (0.79 in.)

Travel Motor Jack-up Test

Test travel motor operation on each side by painting or chalking a mark on one crawler shoe, with a corresponding mark on the travel frame. Use the attachment to jack up one side of the machine and operate the raised travel motor. Record the number of seconds it takes the crawler shoe to make 3 full rotations, during both high speed and low speed operation.

Serial Number	OPERATION		MODE II	MODE III
#1 ~ Up	High Speed	seconds	17.9 ±0.8	17.9 ±0.8
	Low Speed	seconds	26.3 ±0.8	26.3 ±0.8

GENERAL MAINTENANCE



GENERAL MAINTENANCE PROCEDURES

 **CAUTION!**

Follow all safety recommendations and safe shop practices outlined in the front of this manual or those contained within this section.

Always use tools and equipment that is in good working order.

Use lifting and hoisting equipment capable of safely handling load.

Remember, that ultimately safety is your own personal responsibility.

MODEL	SERIAL NUMBER RANGE
ALL MODELS	ALL RANGES

TABLE OF CONTENTS

- Welding Precautions and Guidelines 3
- Hydraulic System - General Precautions 4
- Maintenance Service and Repair Procedure 5
 - General Precautions 5
- Hydraulic System Cleanliness And Oil Leaks 6
 - Maintenance Precautions for Hydraulic System Service 6
 - Oil Leakage Precautions 6
- Cleaning and Inspection 7
 - Genral Guidelines 7
 - Bearing inspection 8

WELDING PRECAUTIONS AND GUIDELINES

IMPORTANT

To avoid accidents, personal injury and the possibility of causing damage to the excavator or to components, welding must only be performed by properly trained and qualified personnel, who possess the correct certification (when required) for the specific welding fabrication or specialized repair being performed.

WARNING!

Structural elements of the excavator may be built from a variety of steels. These could contain unique alloys or may have been heat treated to obtain particular strength characteristics. It is extremely important that welding repairs on these types of steel are performed with the proper procedures and equipment. If repairs are performed incorrectly, structural weakening or other damage to the excavator (that is not always readily visible) could be caused. Always consult Daewoo After Sales Service before welding on integral components (car body, track frames, turntable, attachment) of the excavator. It is possible that some types of structurally critical repairs may require Magnetic Particle or Liquid Penetrant testing, to make sure there are no hidden cracks or damage, before the excavator can be returned to service.

CAUTION!

Always perform welding procedures with the proper safety equipment on hand. Adequate ventilation and a dry work area are absolutely essential. Keep a fire extinguisher nearby and always wear protective clothing and the recommended type of eye protection.

CAUTION!

Observe the following safety precautions:

1. Use extra caution and adequate safety shielding when welding near fuel and oil tanks, batteries, hydraulic piping lines or other fire hazards.
2. Never weld when the engine is running. Battery cables must be disconnected before the welding procedure is started.
3. Never weld on a wet or damp surface. The presence of moisture causes hydrogen embrittlement and structural weakening of the weld.
4. If welding procedures are being performed near cylinder rods, operator's cab window areas or any other assemblies that could be damaged by weld spatters, use adequate shielding protection in front of the assembly.
5. During equipment setup, always attach ground cables directly to the area or component being welded to prevent arcing through bearings, bushings, or spacers.
6. Always use correct welding rods for the type of weld being performed and observe recommended precautions and time constraints. AWS Class E7018 welding rods for low alloy to medium carbon steel must be used within two hours after removal from a freshly opened container. Class E11018G welding rods for T-1 and other higher strength steel must be used within 1/2 hour.

HYDRAULIC SYSTEM - GENERAL PRECAUTIONS

Always maintain oil level in the system at recommended levels. Assemblies that operate under heavy loads, at high speed, with extremely precise dimensional tolerances between moving parts – pistons and cylinders, or shoes and swash plates, for example – can be severely damaged if oil supply runs dry.

Assemblies can be run dry and damaged severely in a very short time when piping or hoses are disconnected to repair leaks and/or replace damaged components. Hoses that are inadvertently switched during disassembly (inlet for outlet and vice versa), air introduced into the system or assemblies that are low on oil due to neglect or careless maintenance, could all produce sufficient fluid loss to cause damage.

When starting the engine (particularly after long layoff or storage intervals), make sure that all hydraulic controls and operating circuits are in neutral, or "OFF." That will prevent pumps or other components that may be temporarily oil-starved from being run under a load.

Replacement of any hydraulic system component could require thorough cleaning, flushing, and some amount of pre-filling with fresh, clean oil if the protective seal on replacement parts has obviously been broken or if seal integrity may have been compromised. When protective seals are removed prior to installation and reassembly, inspect all replacement parts carefully, before they are installed. If the replacement part is bone dry (with no trace of factory pre-lube) or has been contaminated by dirt or by questionable oils, flushing and pre-filling with clean hydraulic fluid is recommended.

Vibration, irregular or difficult movement or unusual noise from any part of the hydraulic system could be an indication of air in the system (as well as many other types of problems). As a general precaution (and to help minimize the risk of potential long-term damage), allow the engine to run at no-load idle speed immediately after initial start-up. Hydraulic fluid will circulate, releasing any air that may have been trapped in the system before load demands are imposed.

A daily walk-around pre-start equipment safety inspection, including a quick visual scan for any exterior evidence of leaking hydraulic fluid, can help extend the service life of system components.

IMPORTANT

Hydraulic system operating conditions (repetitive cycling, heavy work loads, fluid circulating under high pressure) make it extremely critical that dust, grit or any other type of contamination be kept out of the system. Observe fluid and filter change maintenance interval recommendations and always pre-clean any exterior surface of the system before it is exposed to air. For example, the reservoir filler cap and neck area, hoses that have to be disassembled, and the covers and external surfaces of filter canisters should all be cleaned before disassembly.

MAINTENANCE SERVICE AND REPAIR PROCEDURE

GENERAL PRECAUTIONS

Fluid level and condition should always be checked whenever any other type of maintenance service or repair is being performed.

NOTE: *If the unit is being used in an extreme temperature environment (in sub-freezing climates or in high temperature, high humidity tropical conditions), frequent purging of moisture condensation from the hydraulic reservoir drain tap should be a regular and frequent part of the operating routine. In more moderate temperature climates, draining reservoir sediment and moisture may not be required more than once or twice every few months.*

Inspect drained oil and used filters for signs of abnormal coloring or visible fluid contamination at every oil change. Abrasive grit or dust particles will cause discoloration and darkening of the fluid. Visible accumulations of dirt or grit could be an indication that filter elements are overloaded (and will require more frequent replacement) or that disintegrating bearings or other component failures in the hydraulic circuit may be imminent or have already occurred. Open the drain plugs on the main pump casings and check and compare drain oil in the pumps. Look for evidence of grit or metallic particles.

Vibration or unusual noise during operation could be an indication of air leaking into the circuit (Refer to the appropriate Troubleshooting section for component or unit for procedures.), or it may be evidence of a defective pump. The gear-type pilot pump could be defective, causing low pilot pressure, or a main pump broken shoe or piston could be responsible.

NOTE: *If equipped, indicated operating pressure, as shown on the multi-display digital gauge on the Instrument Panel ("F-Pump" and "R-Pump") will be reduced as a result of a mechanical problem inside the pump. However, pressure loss could also be due to cavitation or air leakage, or other faults in the hydraulic system.*

Check the exterior case drain oil in the main pumps. If no metallic particles are found, make sure there is no air in the system. Unbolt and remove the tank return drain line from the top part of the swing motor, both travel motors and each main pump. If there is air in any one of the drain lines, carefully pre-fill the assembly before bolting together the drain line piping connections. Run the system at low RPM.

HYDRAULIC SYSTEM CLEANLINESS AND OIL LEAKS

MAINTENANCE PRECAUTIONS FOR HYDRAULIC SYSTEM SERVICE

Whenever maintenance, repairs or any other type of troubleshooting or service is being performed, it's important to remember that the hydraulic system – including both the interior and exterior surfaces of assemblies, and every drop of operating fluid – must be protected from contamination.

Dust and other foreign contaminants are major contributors to premature wear in hydraulic circuits. The narrow tolerances, rapidly moving parts and high operating pressures of the system require that fluid be kept as clean as possible. The performance and dependability of the machine (and the service life of individual components) can be noticeably reduced if proper precautions are not observed:

- Use a safe, non-combustible, evaporative-type, low-residue solvent and thoroughly clean exterior surfaces of assemblies before any part of the circuit is opened up or disassembled.

NOTE: *It's just as important to clean the cap and reservoir top before routine fluid changes or quick checks as it is before major repairs. (Accumulated dirt attracts moisture, oil and other fluids – as well as more dirt.)*

- Keep dismantled parts covered during disassembly. Use clean caps, plugs or tape to protect the disconnected openings of flanges, manifolds and piping.
- Do not allow cleaning solvents or other fluids to mix with the oil in the system. Use clean oil to flush any traces of solvent or other residue before reassembly.
- If metal or rubber fragments are found in the system, flush and replace all fluid in the system and troubleshoot the circuit to identify the source of contamination.

IMPORTANT

Make sure that cleaning solvents will be compatible with rubber materials used in the hydraulic system. Many petroleum based compounds can cause swelling, softening, or other deterioration of system sealing elements, such as O-rings, caps and other seals.

OIL LEAKAGE PRECAUTIONS

Oil that is visibly seeping from joints or seals should always serve as a “red flag” alarm.

Leaks must alert the machine operator and maintenance crew that air, water and dirt have an open, free passageway through which to enter the circuit. Harsh, corrosive salt air, freezing and thawing condensation cycles and working environments that are full of fine dust are especially hazardous. Clogging of valve spools or external piping (especially pilot circuit piping) can gradually diminish or very suddenly put a complete stop to normal hydraulic function. You can prevent having to make these types of repairs by following recommended assembly procedures:

1. Use new O-rings and oil seals whenever hydraulic assemblies are rebuilt.
2. Prepare joint surfaces prior to assembly by checking alignment and flatness. Clean and repair corrosion or any other damage.
3. Follow bolt torque recommendations and all other assembly requirements.

NOTE: Grease lips seals prior to assembly.

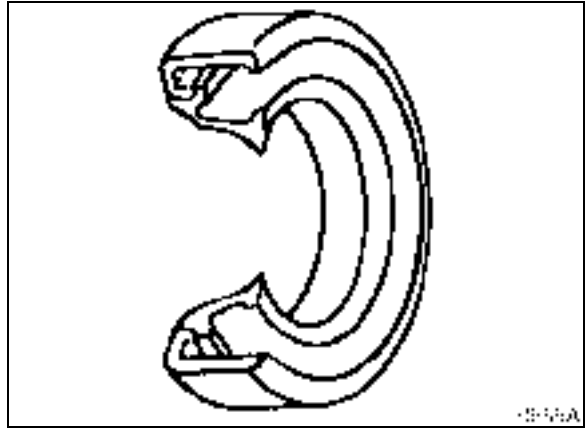

Figure 1

CLEANING AND INSPECTION

GENERAL GUIDELINES

All parts must be clean to permit an effective inspection. During assembly, it is very important that no dirt or foreign material enters unit being assembled. Even minute particles can cause malfunction of close fitting parts such as thrust bearing, matched parts, etc.



WARNING!

Care should be exercised to avoid inhalation of vapors, exposure to skin and creating fire hazards when using solvent type cleaners.

1. Clean all metal parts thoroughly using a suitable cleaning fluid. It is recommended that parts be immersed in cleaning fluid and moved up and down slowly until all oils, lubricants, and/or foreign materials are dissolved and parts are thoroughly clean.
2. For bearings that can be removed, soak them in a suitable cleaning fluid for a minute or two, then remove bearings from cleaning fluid and strike flat against a block of wood to dislodge solidified particles of lubricant. Immerse again in cleaning fluid to flush out particles. Repeat above operation until bearings are thoroughly clean. To dry bearings, use moisture-free compressed air. Be careful to direct air stream across bearing to avoid spinning bearings that are not lubricated. **DO NOT SPIN BEARINGS WHEN DRYING;** bearings may be rotated slowly by hand to facilitate drying process.
3. Carefully inspect all bearing rollers, cages and cups for wear, chipping or nicks to determine condition. Do not replace a bearing cone or cup individually without replacing mating cup or cone at the same time. After inspection, dip bearings in light weight oil and wrap in clean lintless cloth or paper to protect them until installation.

For those bearings that are to be inspected in place; inspect bearings for roughness of rotation, scoring, pitting, cracked or chipped races. If any of these defects are found, replace bearings. Also inspect defective bearing housing and/or shaft for grooved, galled or burred conditions that indicate bearing has been turning in its housing or on its shaft.

4. It is more economical to replace oil seals, O-rings, sealing rings, gaskets and snap rings when unit is disassembled than waiting for premature failures; refer to latest Micro Fiche and/or Parts Book for replacement items. Be extremely careful when installing sealing members, to avoid cutting or

scratching. Curling under of any seal lip will seriously impair its efficiency. Apply a thin coat of Loctite #120 to outer diameter, of metal casing, on oil seals to assure an oil tight fit into retainer. Use extreme care not to get Loctite on lips of oil seals. If this happens, that portion of the seal will become brittle and allow leakage.

When replacing lip type seals, make sure spring loaded side is towards oil to be sealed.

5. If available, use magna-flux or similar process for checking for cracks that are not visible to the eye. Examine teeth on all gears carefully for wear, pitting, chipping, nicks, cracks or scores. Replace all gears showing cracks or spots where case hardening has worn through. Small nicks may be removed with suitable hone. Inspect shafts and quills to make certain they have not been sprung, bent, or splines twisted, and that shafts are true.

NOTE: *Spline wear is not considered detrimental except where it affects tightness of splined parts.*

Inspect thrust washers for distortion, scores, burs, and wear. Replace thrust washer if defective or worn.

6. Inspect bores and bearing surfaces of cast parts and machined surfaces for scratches, wear, grooves and dirt. Remove any scratches and burrs with crocus cloth. Remove foreign matter. Replace any parts that are deeply grooved or scratched which would affect their operation.

BEARING INSPECTION

The conditions of the bearing are vital to the smooth and efficient operation of the machinery. When any component containing bearings is disassembled, always carefully examine the condition of the bearings and all of its components for wear and damage.

Once the bearing is removed, clean all parts thoroughly using a suitable cleaning solution. If the bearing is excessively dirty soak the bearing assembly in a light solution and move the bearing around until all lubricants and or foreign materials are dissolved and the parts are thoroughly clean.

When drying bearings, moisture free compressed air can be used. Be careful not to direct the air in a direction which will force the bearing to dry spin while not being properly lubricated.

After the bearings have been cleaned and dried, carefully inspect all bearing rollers, cages and cups for wear, chipping or nicks. If the bearing can not be removed and is to be inspected in place, check for roughness of rotation, scoring, pitting, cracked or chipped races. If any of these defects are found replace the whole bearing assembly. NEVER replace the bearing alone without replacing the mating cup or the cone at the same time.

After inspection lightly coat the bearing and related parts with oil and wrap in a clean lintless cloth or paper and protect them from moisture and other foreign materials until installation.

It is also important to inspect the bearing housing and/or shaft for grooved, galled or burred conditions that indicate that the bearing has been turning in its housing or on its shaft.

If available, use magna-flux or similar process for checking for cracks that are not visible to the naked eye.

The following illustrations will aid in identifying and diagnosing some of the bearing related problems.

NOTE: *The illustrations will only show tapered roller bearings, but the principles of identifying, diagnosing and remedying the defects are common to all styles and types of bearings.*

Normal Bearing

Smooth even surfaces with no discoloration or marks

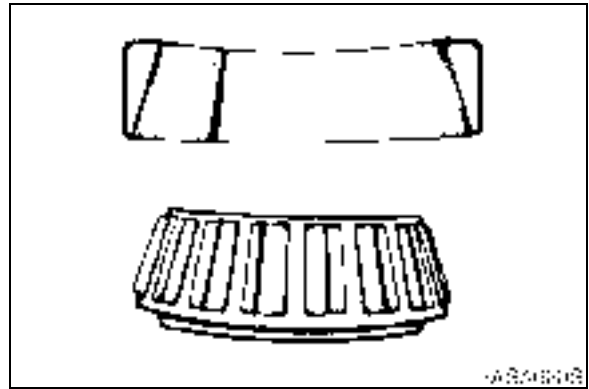

Figure 2

Bent Cage

Cage damage due to improper handling or tool usage.

Replace bearing

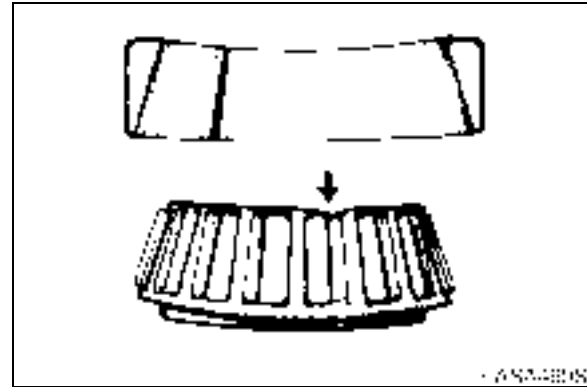

Figure 3

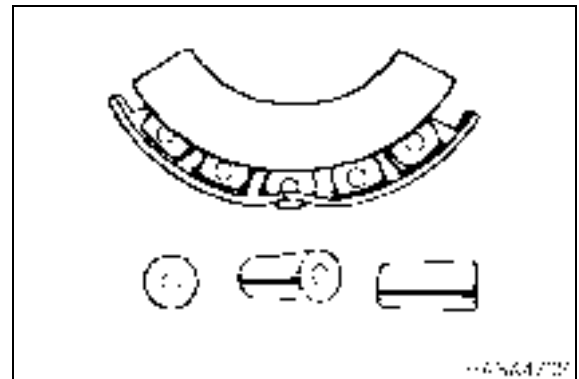

Figure 4

Galling

Metal smears on roller ends due to overheat, lubricant failure or overload.

Replace bearing - check seals and check for proper lubrication.

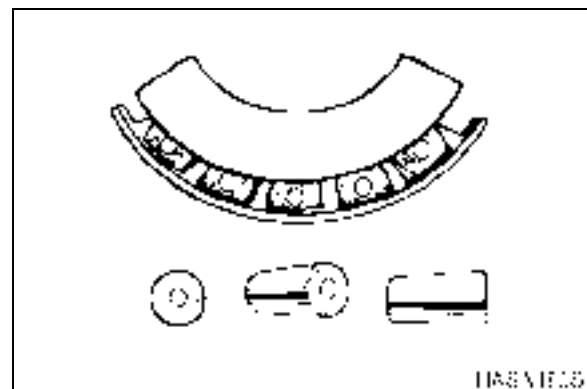

Figure 5

Abrasive Step Wear

Pattern on roller ends caused by fine abrasives.

Clean all parts and housings, check all parts and housings, check seals and bearings and replace if leaking, rough or noisy.

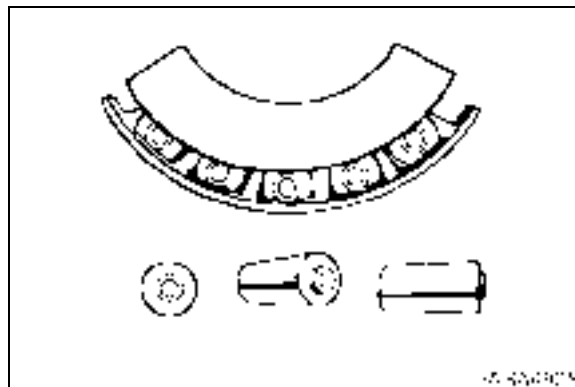

Figure 6

Etching

Bearing surfaces appear gray or grayish black in color with related etching away of material usually at roller spacing.

Replace bearings - check seals and check for proper lubrication.

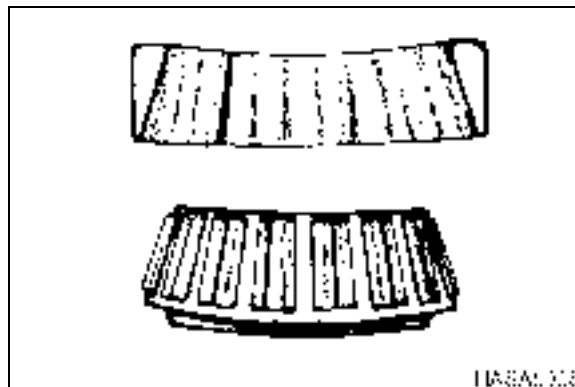

Figure 7

Misalignment

Outer race misalignment due to foreign object.

Clean related parts and replace bearing. Make sure races are properly seated.

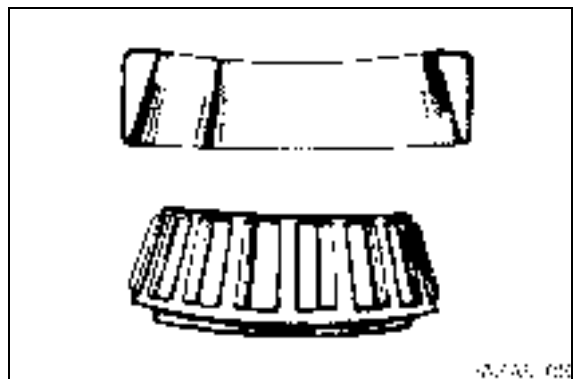

Figure 8

Indentations

Surface depressions on race and rollers caused by hard particles of foreign materials.

Clean all parts and housings, check seals and replace bearings if rough or noisy.

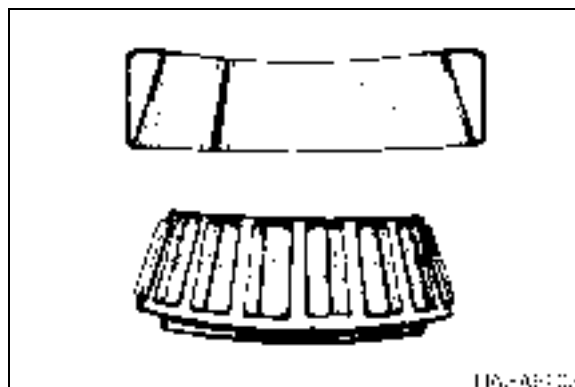

Figure 9

Fatigue Spalling

Flaking of surface metal resulting from fatigue.

Replace bearing - clean all related parts.



Figure 10

Brinelling

Surface indentations in raceway caused by rollers either under impact loading or vibration while the bearing is not rotating.

Replace bearing if rough or noisy.

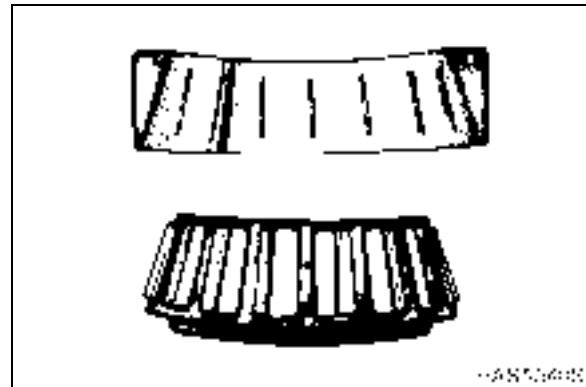

Figure 11

Cage Wear

Wear around outside diameter of cage and roller pockets caused by abrasive material and inefficient lubrication.

Replace bearings - check seals.

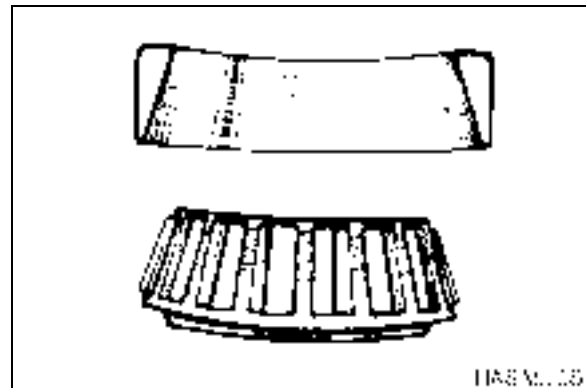

Figure 12

Abrasive Roller Wear

Pattern on races and rollers caused by fine abrasives.

Clean all parts and housings, check seals and bearings and replace if leaking, rough or noisy.

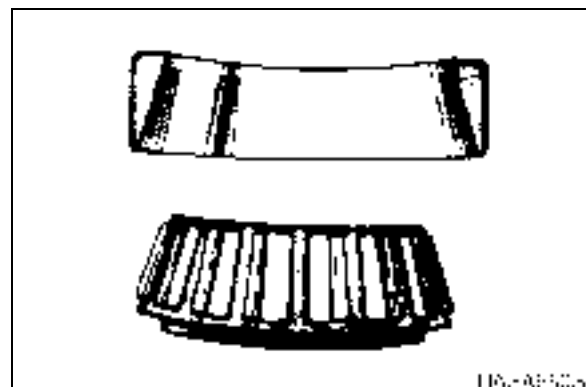

Figure 13

Cracked Inner Race

Race cracked due to improper fit, locking or poor bearing seat.

Replace all parts and housings, check seals and bearings and replace if leaking.

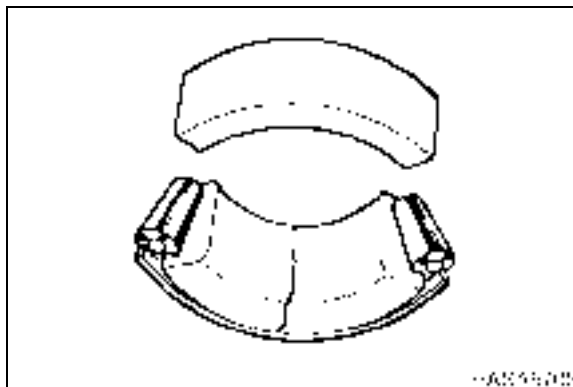

Figure 14

Smears

Smearing of metal due to slippage caused by poor fitting, lubrication, overheating, overloads or handling damage.

Replace bearings, clean related parts and check for proper fit and lubrication.

Replace shaft if damaged.

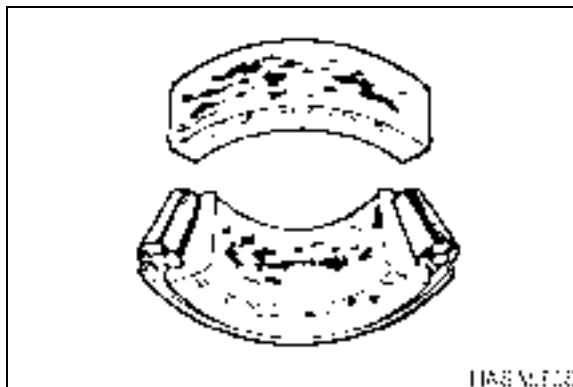

Figure 15

Fretting

Corrosion set up by small relative movement of parts with no lubrication.

Replace bearing. Clean all related parts. Check seals and check for proper lubrication.

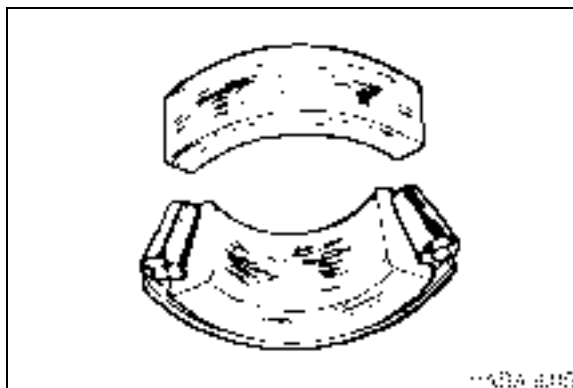

Figure 16

Heat Discoloration

Heat discoloration can range from faint yellow to dark blue resulting from overload or incorrect lubrication.

Excessive heat can cause softening of races or rollers.

To check for loss of temper on races or rollers, a simple file test may be made. A file drawn over a tempered part will grab and cut metal, whereas a file drawn over a hard part will glide readily with no metal cutting.

Replace bearings if over heating damage is indicated. Check seals and other related parts for damage.

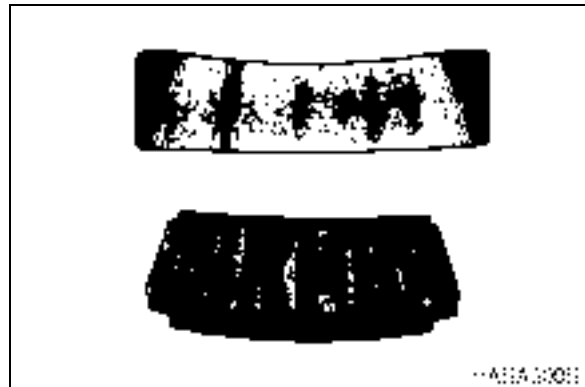

Figure 17

Stain Discoloration

Discoloration can range from light brown to black caused by incorrect lubrication or moisture.

If the stain can be removed by light polishing or if no evidence of overheating is visible, the bearing can be reused.

Check seals and other related parts for damage.

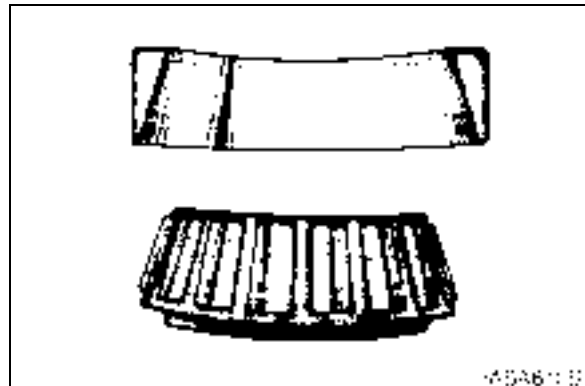

Figure 18



STANDARD TORQUES

 **CAUTION!**

Follow all safety recommendations and safe shop practices outlined in the front of this manual or those contained within this section.

Always use tools and equipment that is in good working order.

Use lifting and hoisting equipment capable of safely handling load.

Remember, that ultimately safety is your own personal responsibility.

MODEL	SERIAL NUMBER RANGE
ALL MODELS	ALL RANGES

TABLE OF CONTENTS



- Torque Values for Standard Metric Fasteners 3
- Torque Values for Standard U.S. Fasteners 4
- Type 8 Phosphate Coated Hardware 6
- Torque Values for Hose Clamps 7
- Torque Values for Split Flanges 8
- Torque Wrench Extension Tools 9
 - Torque Multiplication 9
 - Other Uses for Torque Wrench Extension Tools 10
 - Tightening Torque Specifications (Metric) 10

TORQUE VALUES FOR STANDARD METRIC FASTENERS

NOTE: *The units for the torque values are kg m (ft lb)*

Grade Dia. x Pitch (mm)	3.6 (4A)	4.6 (4D)	4.8 (4S)	5.6 (5D)	5.8 (5S)	6.6 (6D)	6.8 (6S)	6.9 (6G)	8.8 (8G)	10.9 (10K)	12.9 (12K)
M5 x Std.	0.15 (1.08)	0.16 (1.15)	0.25 (1.80)	0.22 (1.59)	0.31 (2.24)	0.28 (2.02)	0.43 (3.11)	0.48 (3.47)	0.50 (3.61)	0.75 (5.42)	0.90 (6.50)
M6 x Std.	0.28 (2.02)	0.30 (2.16)	0.45 (3.25)	0.40 (2.89)	0.55 (3.97)	0.47 (3.39)	0.77 (5.56)	0.85 (6.14)	0.90 (6.50)	1.25 (9.04)	1.50 (10.84)
M7 x Std.	0.43 (3.11)	0.46 (3.32)	0.70 (5.06)	0.63 (4.55)	0.83 (6.00)	0.78 (5.64)	1.20 (8.67)	1.30 (9.40)	1.40 (10.12)	1.95 (14.10)	2.35 (16.99)
M8 x Std.	0.70 (5.06)	0.75 (5.42)	1.10 (7.95)	1.00 (7.23)	1.40 (10.12)	1.25 (9.04)	1.90 (13.74)	2.10 (15.18)	2.20 (15.91)	3.10 (22.42)	3.80 (27.48)
M8 x 1	0.73 (5.28)	0.80 (5.78)	1.20 (8.67)	1.00 (7.23)	1.50 (10.84)	1.35 (9.76)	2.10 (15.18)	2.30 (16.63)	2.40 (17.35)	3.35 (24.23)	4.10 (29.65)
M10 x Std.	1.35 (9.76)	1.40 (10.12)	2.20 (15.91)	1.90 (13.74)	2.70 (19.52)	2.35 (19.99)	3.70 (26.76)	4.20 (30.37)	4.40 (31.18)	6.20 (44.84)	7.20 (52.07)
M10 x 1	1.50 (10.84)	1.60 (11.57)	2.50 (18.08)	2.10 (15.18)	3.10 (22.42)	2.80 (20.25)	4.30 (31.10)	4.90 (35.44)	5.00 (36.16)	7.00 (50.63)	8.40 (60.75)
M12 x Std.	2.40 (17.35)	2.50 (18.08)	3.70 (26.76)	3.30 (23.86)	4.70 (33.99)	4.20 (30.37)	6.30 (45.56)	7.20 (52.07)	7.50 (54.24)	10.50 (75.94)	12.50 (90.41)
M12 x 1.5	2.55 (18.44)	2.70 (19.52)	4.00 (28.93)	3.50 (25.31)	5.00 (36.16)	4.50 (32.54)	6.80 (49.18)	7.70 (55.69)	8.00 (57.86)	11.20 (81.00)	13.40 (96.92)
M14 x Std.	3.70 (26.76)	3.90 (28.20)	6.00 (43.23)	5.20 (37.61)	7.50 (54.24)	7.00 (50.63)	10.00 (72.33)	11.50 (83.17)	12.00 (86.79)	17.00 (122.96)	20.00 (144.66)
M14 x 1.5	4.10 (29.65)	4.30 (31.10)	6.60 (47.73)	5.70 (41.22)	8.30 (60.03)	7.50 (54.24)	11.10 (80.28)	12.50 (90.41)	13.00 (94.02)	18.50 (132.26)	22.00 (158.12)
M16 x Std.	5.60 (40.50)	6.00 (43.39)	9.00 (65.09)	8.00 (57.86)	11.50 (83.17)	10.50 (75.94)	15.50 (112.11)	17.90 (129.47)	18.50 (133.81)	26.00 (188.05)	31.00 (224.22)
M16 x 1.5	6.20 (44.84)	6.50 (47.01)	9.70 (70.16)	8.60 (62.20)	12.50 (90.41)	11.30 (81.73)	17.00 (122.96)	19.50 (141.04)	20.00 (144.66)	28.00 (202.52)	35.50 (256.77)
M18 x Std.	7.80 (56.41)	8.30 (60.03)	12.50 (90.41)	11.00 (79.56)	16.00 (115.72)	14.50 (104.87)	21.00 (151.89)	27.50 (198.90)	28.50 (206.14)	41.00 (296.55)	43.00 (311.01)
M18 x 1.5	9.10 (65.82)	9.50 (68.71)	14.40 (104.15)	12.50 (90.41)	18.50 (133.81)	16.70 (120.79)	24.50 (177.20)	27.50 (198.90)	28.50 (206.14)	41.00 (296.55)	49.00 (354.41)
M20 x Std.	11.50 (83.17)	12.00 (86.79)	18.00 (130.19)	16.00 (115.72)	22.00 (159.12)	19.00 (137.42)	31.50 (227.83)	35.00 (253.15)	36.00 (260.38)	51.00 (368.88)	60.00 (433.98)
M20 x 1.5	12.80 (92.58)	13.50 (97.64)	20.50 (148.27)	18.00 (130.19)	25.00 (180.82)	22.50 (162.74)	35.00 (253.15)	39.50 (285.70)	41.00 (296.55)	58.00 (419.51)	68.00 (491.84)
M22 x Std.	15.50 (112.11)	16.00 (115.72)	24.50 (177.20)	21.00 (151.89)	30.00 (216.99)	26.00 (188.05)	42.00 (303.78)	46.00 (332.71)	49.00 (354.41)	67.00 (484.61)	75.00 (542.47)
M22 x 1.5	17.00 (122.96)	18.50 (133.81)	28.00 (202.52)	24.00 (173.59)	34.00 (245.92)	29.00 (209.75)	47.00 (339.95)	52.00 (44.76)	56.00 (405.04)	75.00 (542.47)	85.00 (614.80)
M24 x Std.	20.50 (148.27)	21.50 (155.50)	33.00 (238.68)	27.00 (195.29)	40.00 (289.32)	34.00 (245.92)	55.00 (397.81)	58.00 (419.51)	63.00 (455.67)	82.00 (593.10)	92.00 (655.43)
M24 x 1.5	23.00 (166.35)	35.00 (253.15)	37.00 (267.62)	31.00 (224.22)	45.00 (325.48)	38.00 (202.52)	61.00 (441.21)	67.00 (484.61)	74.00 (535.24)	93.00 (672.66)	103.00 (744.99)

TORQUE VALUES FOR STANDARD U.S. FASTENERS

TYPE	S.A.E. GRADE	DESCRIPTION	BOLT HEAD MARKING
1	1 R	WILL HAVE NO MARKINGS IN THE CENTER OF THE HEAD Low or Medium Carbon Steel Not Heat Treated	
5	5	WILL HAVE THREE RADIAL LINES Quenched and Tempered Medium Carbon Steel	
8	8	WILL HAVE 6 RADIAL LINES Quenched and Tempered Special Carbon or Alloy Steel	

Recommended torque, in foot pounds, for all Standard Application Nuts and Bolts, provided:

1. All thread surfaces are clean and lubricated with SAE-30 engine oil (See Note.)
2. Joints are rigid, that is, no gaskets or compressible materials are used.
3. When reusing nuts or bolts, use minimum torque values.

NOTE: *Multiply the standard torque by:*

0.65 when finished jam nuts are used.

0.70 when Molykote, white lead or similar mixtures are used as lubricants.

0.75 when parkerized bolts or nuts are used.

0.85 when cadmium plated bolts or nuts and zinc bolts w/waxed zinc nuts are used

0.90 when hardened surfaces are used under the nut or bolt head.

NOTE: *When reusing bolts and nuts in service, use minimum torque values.*

The following General Torque Values must be used in all cases where **SPECIAL TORQUE VALUES** are not given

NOTE: TORQUE VALUES LISTED THROUGHOUT THIS MANUAL ARE LUBRICATED (WET) THREADS; VALUES SHOULD BE INCREASED 1/3 FOR NON-LUBRICATED (DRY) THREADS.				
THREAD SIZE	HEAT TREATED MATERIAL GRADE 5 & GRADE 8			
	GRADE 5 (3 RADIAL DASHES ON HEAD)		GRADE 8 (6 RADIAL DASHES ON HEAD)	
	FOOT POUNDS (Ft. Lbs.)	NEWTON METER (N.m)	FOOT POUNDS (Ft. Lbs.)	NEWTON METER (N.m)
1/4" - 20	6	8	9	12
1/4" - 28	7	9	11	15
5/16" - 18	13	18	18	24
5/16" - 24	15	20	21	28
3/8" - 16	24	33	34	46
3/8" - 24	27	37	38	52
7/16" - 14	38	52	54	73
7/16" - 20	42	57	60	81
1/2" - 13	58	79	82	111
1/2" - 20	65	88	90	122
9/16" - 12	84	114	120	163
9/16" - 18	93	126	132	179
5/8" - 11	115	156	165	224
5/8" - 18	130	176	185	251
3/4" - 10	205	278	290	393
3/4" - 16	240	312	320	434
7/8" - 9	305	414	455	617
7/8" - 14	334	454	515	698
1" - 8	455	617	695	942
1" - 14	510	691	785	1064
1 1/8" - 7	610	827	990	1342
1 1/8" - 12	685	929	1110	1505
1 1/4" - 7	860	1166	1400	1898
1 1/4" - 12	955	1295	1550	2102
1 3/8" - 6	1130	1532	1830	2481
1 3/8" - 12	1290	1749	2085	2827
1 1/2" - 6	1400	2034	2430	3295
1 1/2" - 12	1690	2291	2730	3701
1 3/4" - 5	2370	3213	3810	5166
2" - 4 1/2	3550	4813	5760	7810

NOTE: If any bolts and nuts are found loose or at values less than what the chart states, it is recommended that the loose bolt and/or nut be replaced with a new one.

TYPE 8 PHOSPHATE COATED HARDWARE

This chart provides tightening torque for general purpose applications using original equipment standard hardware as listed in the Parts Manual for the machine involved. **DO NOT SUBSTITUTE.** In most cases, original equipment standard hardware is defined as Type 8, coarse thread bolts and nuts and threaded hardened flat washers (Rockwell "C" 38-45), all phosphate coated and assembled without supplemental lubrication (as received) condition.

The torques shown below also apply to the following:

1. Phosphate coated bolts used in tapped holes in steel or gray iron.
2. Phosphate coated bolts used with phosphate coated prevailing torque nuts (nuts with distorted threads or plastic inserts).
3. Phosphate coated bolts used with copper plated weld nuts.

Markings on bolt heads or nuts indicate material grade ONLY and are NOT to be used to determine required torque.

NOMINAL THREAD DIAMETER	STANDARD TORQUE ± 10%	
	KILOGRAM METER (kg m)	FOOT POUNDS (Ft. Lbs.)
1/4"	1.1	8
5/16"	2.2	16
3/8"	3.9	28
7/16"	6.2	45
1/2"	9.7	70
9/16"	13.8	100
5/8"	19.4	140
3/4"	33.2	240
7/8"	53.9	390
1"	80.2	580
1 - 1/8"	113.4	820
1 - 1/4"	160.4	1160
1 - 3/8"	210.2	1520
1 - 1/2"	279.4	2020
1 - 3/4"	347.1	2510
2"	522.8	3780

TORQUE VALUES FOR HOSE CLAMPS

The following chart provides the tightening torques for hose clamps used in all rubber applications (radiator, air cleaner, operating lever boots, hydraulic system, etc.).

CLAMP TYPE AND SIZE	TORQUE PLUS OR MINUS 5 lbf in (0.1 kg m)			
	RADIATOR, AIR CLEANER, BOOTS, ETC.		HYDRAULIC SYSTEM	
	KILOGRAM METER (kg m)	INCH POUNDS (In. Lbs.)	KILOGRAM METER (kg m)	INCH POUNDS (In. Lbs.)
U-T Bolt (Any Diameter)	0.6 - 0.7	55 - 65	-----	-----
Worm Drive - 1-3/4 in. Open Diameter & Under	0.2 - 0.3	20 - 30	0.5 - 0.6	40 - 50
Worm Drive - Over 1-3/4 in. Open Diameter	0.5 - 0.6	40 - 50	-----	-----
Worm Drive - All "Ultra-Tite"	1.1 - 1.2	95 - 105	0.5 - 0.6	40 - 50

TORQUE VALUES FOR SPLIT FLANGES

The following chart provides the tightening torques for split flange connections used in hydraulic systems. Split flanges and fitting shoulders should fit squarely. Install all bolts, finger tight and then torque evenly.

NOTE: *Overtorquing bolts will damage the flanges and/or bolts, which may cause leakage.*

FLANGE SIZE (*)	BOLT SIZE	BOLT TORQUE	
		KILOGRAM METER (kg m)	FOOT POUNDS (Ft. Lbs.)
1/2"	5/16"	2.1 - 2.5	15 - 18
3/4"	3/8"	3.0 - 3.7	22 - 27
1"	3/8"	3.7 - 4.8	27 - 35
1 - 1/4"	7/16"	4.8 - 6.2	35 - 45
1 - 1/2"	1/2"	6.4 - 8.0	46 - 58
2"	1/2"	7.6 - 9.0	55 - 65
2 - 1/2"	1/2"	10.9 - 12.6	79 - 91
3"	5/8"	19.1 - 20.7	138 - 150
3 - 1/2"	5/8"	16.2 - 18.4	117 - 133

(*) - Inside diameter of flange on end of hydraulic tube or hose fitting.

NOTE: *Values stated in chart are for Standard Pressure Series (Code 61) Split Flanges.*

TORQUE WRENCH EXTENSION TOOLS

Very large diameter, high grade fasteners (nuts, bolts, cap screws, etc.) require a great deal of turning force in order to achieve recommended tightening torque values.

Common problems that could occur as a result are:

- Recommended torque exceeds the measuring capacity of the torque wrench.
- Specialized sockets do not fit the adapter on the front end (nose) of the torque wrench.
- Generating adequate force on the back end (handle) of the wrench is difficult or impossible.
- Restricted access or an obstruction may make use of the torque wrench impossible.
- A unique application requires fabrication of an adapter or other special extension.

Most standard torque wrenches can be adapted to suit any one of the proceeding needs or situations, if the right extension tool is used or fabricated.

TORQUE MULTIPLICATION

A wrench extension tool can be used to increase the tightening force on a high capacity nut or bolt.

For example, doubling the distance between the bolt and the back (handle) end of the torque wrench doubles the tightening force on the bolt. It also halves the indicated reading on the scale or dial of the torque wrench. To accurately adjust or convert indicated scale or dial readings, use the following formula:

$I = A \times T / A + B$ where:

I = Indicated force shown on the torque wrench scale or dial.

T = Tightening force applied to the nut or bolt (actual Torque).

A = Length of the torque wrench (between the center of the nut or bolt and the center of the handle).

B = Length of the extension.

As an example, if a 12" extension is added to a 12" torque wrench, and the indicated torque on the dial reads "150 ft lb," the real force applied to the bolt is 300 ft lb:

$$I = \frac{A \times T}{A + B} = \frac{12 \times 300}{12 + 12} = \frac{3600}{24} = 150$$

NOTE: *The formula assumes that there is no added deflection or "give" in the joint between the extension and torque wrench. Readings may also be inaccurate:*

- If the extension itself absorbs some of the tightening force and starts to bend or bow out.
- If an extension has to be fabricated that is not perfectly straight (for example, an extension made to go around an obstruction, to allow access to a difficult to tighten fastener), the materials and methods used must be solid enough to transmit full tightening torque.

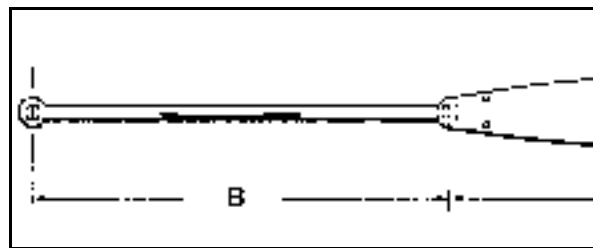

Figure 1

OTHER USES FOR TORQUE WRENCH EXTENSION TOOLS

Torque wrench extensions are sometimes made up for reasons other than increasing leverage on a fastener.

For example, a torque wrench and extension can be used to measure adjustment “tightness” of a linkage or assembly. Specially fabricated extensions can be used to make very precise checks of the force required to engage or disengage a clutch mechanism, release a spring-applied brake assembly, or “take up” free play in most any movable linkage.

Once the value of the adjustment force is established, repeated checks at regular intervals can help to monitor and maintain peak operating efficiency. These types of adjustment checks are especially useful if physical measurements of linkage travel are difficult to make or will not provide the needed degree of precision and accuracy.

To allow the assembly or mechanism to accept a torque wrench, welding a nut or other adapter on the end of a linkage shaft or other leverage point will allow turning the shaft or assembly manually.

TIGHTENING TORQUE SPECIFICATIONS (METRIC)

(For coated threads, prelubricated assemblies)



Disassembly, overhaul and replacement of components on the excavator, installation of new or replacement parts and/or other service-related maintenance may require the use of thread or flange sealing assembly compound.

Use the information on this page as a general guide in selecting specific formulas that will meet the particular requirements of individual assembly installations. Daewoo does not specifically endorse a specific manufacturer or brand name but the following table of “Loctite” applications is included for which cross-references to other makers’ products should also be widely available.

IMPORTANT

Use primer “T” or “N” for all cold weather assembly of fastener adhesives, with Thread locker sealers 222, 242/243, 262, 271, 272, or 277.

I. "Loctite" Fastener Adhesives

Product	Application	Color	Removal	Break-away Cure Strength (In/lb) Of Sealer Alone
222	Low strength for 6 mm (1/4") or smaller fasteners.	Purple	Hand tools	45
242 or 243	Medium strength for 6 mm (1/4") and larger fasteners.	Blue	Hand tools	80
262	High strength for high grade fasteners subject to shock, stress and vibration.	Red	Heat/260°C (500°F) Remove HOT (NO solvent)	160
271	Extra high strength for fine thread fasteners up to 25 mm (1") diameter.	Red	Heat/260°C (500°F) Remove HOT	160
272	High temperature/high strength for hostile environments to 232° C (450°F).	Red	Heat/316°C (600°F) Remove HOT	180
277	Extra high strength for coarse thread fasteners 25 mm (1") diameter and larger.	Red	Heat/260°C (500°F) Remove HOT	210

II. "Loctite" Pipe Thread Sealant

Product	Application	Color	Removal	Required Setup
545	"No-filler/non-clog" formula for high-pressure hydraulic systems. Over-application will not restrict or foul system components.	Purple	Hand tools	4 Hours (or 1/2 hour with Locquic "T" Primer)
656	Solvent-resistant, higher viscosity tapered thread sealer.	White	Hand tools	4 Hours (or 1/2 hour with Locquic "T" Primer)

III. "Loctite" gasket/flange sealer

Product	Application	Color	Notes
518	Gasket eliminator specifically made for aluminum flanges/surfaces. For hydraulic systems to 34,475 kPa (5,000 psi).	Red	Use Locquic "N" primer for fast (1/2 to 4 hours) setup. Unprimed setup 4-24 hours.
504	Low pressure/wide-gap gasket eliminator compound. Fills gaps to 0.0012 mm (0.030"), cures to rigid seal.	Orange	Use Locquic "N" primer for faster (1/2 to 4 hours) setup. Unprimed setup 4-24 hours.
515	General purpose, fast setup, flexible-cure gasket eliminator. For non-rigid assemblies subject to shock, vibration or deflection.	Purple	Use Locquic "N" primer for faster (1/4 to 2 hours) setup. Unprimed setup 1-12 hours.

IV. "Loctite" retaining compounds

Product	Application	Color	Notes
609	For bushings, sleeves, press-fit bearings, splines and collars. For gaps to 0.0002 mm (0.005"), temperatures to 121°C (250°F).	Green	Use Locquic "N" primer for increased bond strength and all cold temperature applications.
620	For high temperatures to 232°C (450°F).	Green	Same as 609, above.
680	For high strength bonds and tight clearance gaps, to 0.00008 mm (0.002").	Green	Same as 609, above.

V. "Loctite" Adhesives

Product	Application	Color	Notes
380	Black Max instant adhesive for shock and vibration-resistant bonds.	Black	May take 120 hours to reach full cure strength.
454	Adhesive for porous surfaces.	Clear	Full strength in 24 hours.
480	Increased strength (+50%), shock and vibration-resistant.	Black	Full strength in 24 hours.

UPPER STRUCTURE



S0402000
R1

CAB

 **CAUTION!**

Follow all safety recommendations and safe shop practices outlined in the front of this manual or those contained within this section.

Always use tools and equipment that is in good working order.

Use lifting and hoisting equipment capable of safely handling load.

Remember, that ultimately safety is your own personal responsibility.

MODEL	SERIAL NUMBER RANGE
Solar 130LC-V	0001 and Up
Solar 220LC-V	0001 and Up
Solar 220LL	1001 and Up
Solar 220N-V	1001 and Up
Solar 290LC-V	0001 and Up
Solar 290LL	1001 and Up
Solar 330LC-V	1001 and Up
Solar 400LC-V	1001 and Up

Copyright 1999 Daewoo

March 1999

Cab

S0402000
Page 1

TABLE OF CONTENTS

Removal 3
Installation 5
Window and Gasket Replacement 8
Falling Object Protective Structures (F.O.P.S.) 9

REMOVAL

CAUTION!

Avoid disassembling cab if there are strong wind gusts, which could catch large surface area of cab shell and push it sideways during lift.

1. Park on firm and level ground.
2. Lower bucket to ground.
3. Shut engine down and remove key from starter switch.

WARNING!

If engine must be run while performing maintenance, use extreme care. Always have one person in the cab at all times. Never leave the cab with the engine running.

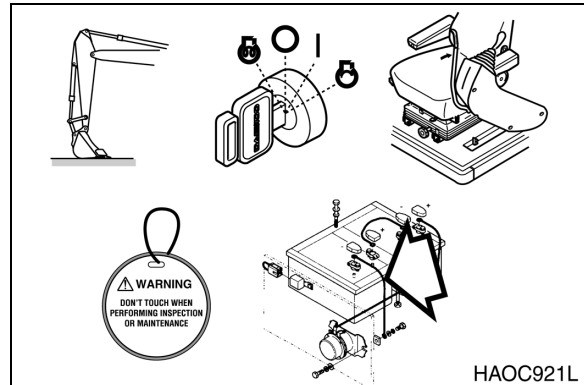

Figure 1

4. Set safety lever on "LOCK" position.
5. Hang maintenance warning tag on controls.
6. Disconnect negative (-) battery cable leading to frame from battery.
7. Prepare cab shell for removal by disconnecting wiring connectors for:
 - A. Cab interior lighting.
 - B. External light wiring.
 - C. Radio antenna and connections.
 - D. Wiper/washer connections.

NOTE: Control console wiring harnesses and hydraulic piping lines that pass through the floor of the cab do not need to be disassembled.

NOTE: If unit is equipped with a cab protective structure (for forestry, or hazardous working conditions), it must be removed.

8. Remove floor mat.
9. Remove operator's seat (1, Figure 2).
NOTE: *Be careful not to damage seat covering.*
10. Remove duct covers (5, 6, 7 and 9, Figure 2). When removing duct cover (7), disconnect hour meter connector.
11. Remove air duct (3, 4 and 8, Figure 2) located at right side of cab. Disconnect duct wiring connector before removing air duct (3).
12. Disconnect wire motor connector and front window washer hose located at floor plate bottom.

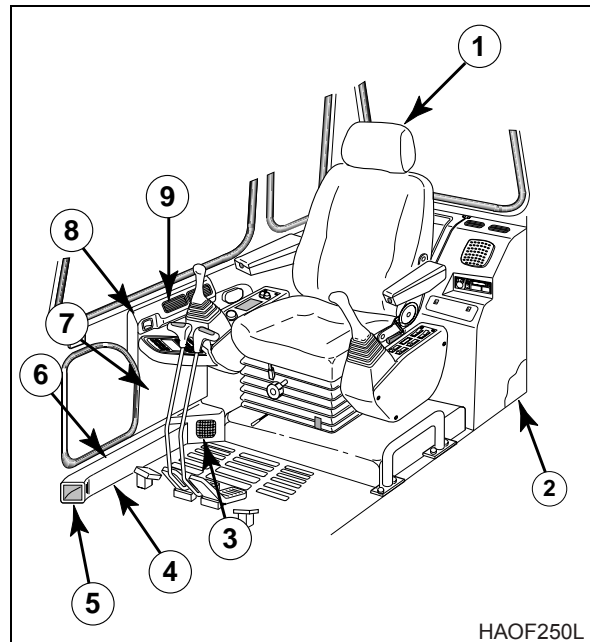

Figure 2

13. Remove two rubber tops (2, Figure 3) used in storing the front lower glass. Remove bolts (1) from the rear left and right dash covers. Lift left side cover (3) slightly and disconnect speaker wire, stereo wire and antenna wire connector. Remove left cover (3).
14. Lift right side cover (4, Figure 3) and disconnect speaker wire. Remove right side cover.
15. Disconnect cab lamp wiring connector.
16. Disconnect cabin ground cable (2, Figure 2).

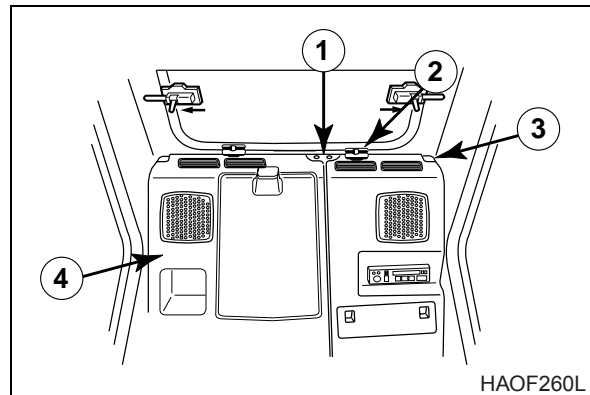

Figure 3

17. Remove four mounting nuts from four corners of cabin floor (2, Figure 4).
18. Remove four hex bolts (3, Figure 4) from door side of cabin floor.
19. Remove two hex bolts (1, Figure 4) from right side of cabin floor and one bolt (4) under front window of cab floor.

Quantity	Description
4	16 mm hex nuts at each corner of the cab
4	10 mm x 1.5 hex bolts at the door side of the cab
3	10 mm x 1.5 mm hex head bolts, 2 on the right side of the cab and 1 under the front window.

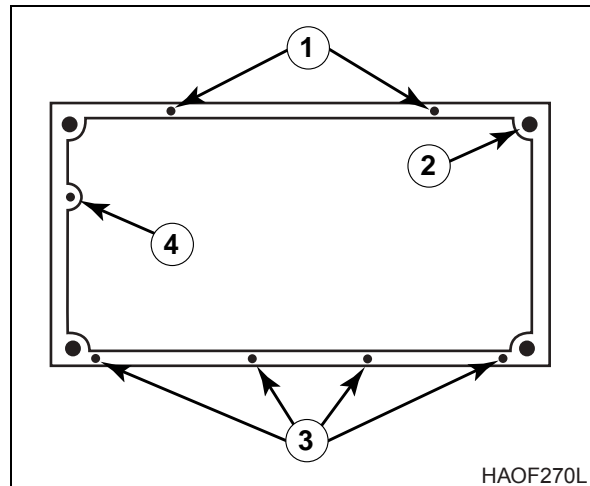

Figure 4

20. Using a suitable lifting device, attach slings to four lift points on top of cab (Figure 5).

NOTE: Cab weighs approximately 290 kg (639 lb).

21. Lift cab from 25 - 50 mm (1" - 2") above deck height. Check that all electrical connections have been disconnected and all other items unbolted.
22. Continue lifting with the assist crane to remove the cab shell. Lower the shell to a pre-prepared safe blocking support.

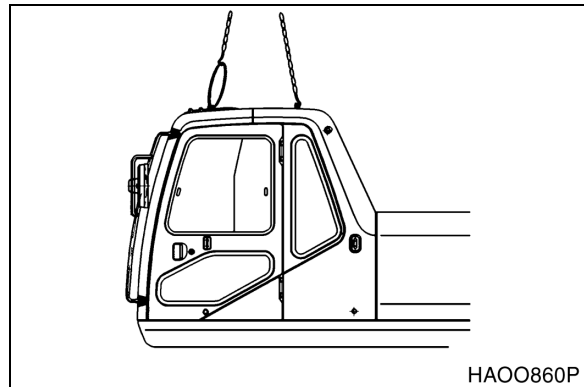

Figure 5

INSTALLATION

1. Using a suitable lifting device, attach slings to four lift points on top of cab (Figure 5).

NOTE: Cab weighs approximately 290 kg (639 lb).

2. Lower cab into position on cab floor

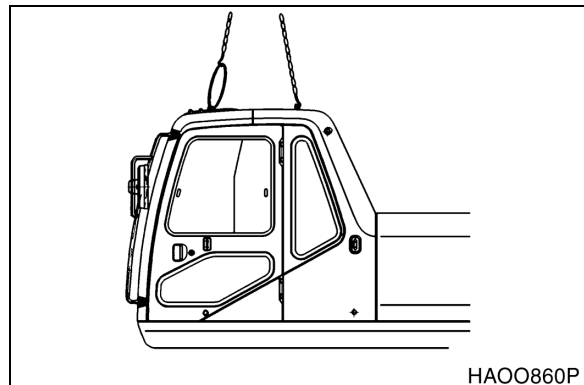

Figure 6

3. Install four mounting nuts on four corners of cabin floor (2, Figure 4).

NOTE: *Mounting nut torque 20.2 kg·m (146 ft lbs)*

4. Install four hex bolts (3, Figure 4) in door side of cabin floor.
5. Install two hex bolts (1, Figure 4) in right side of cabin floor and one bolt (4) under front window of cab floor.

Quantity	Description
4	16 mm hex nuts at each corner of the cab
4	10 mm x 1.5 hex bolts at the door side of the cab
3	10 mm x 1.5 mm hex head bolts, 2 on the right side of the cab and 1 under the front window.

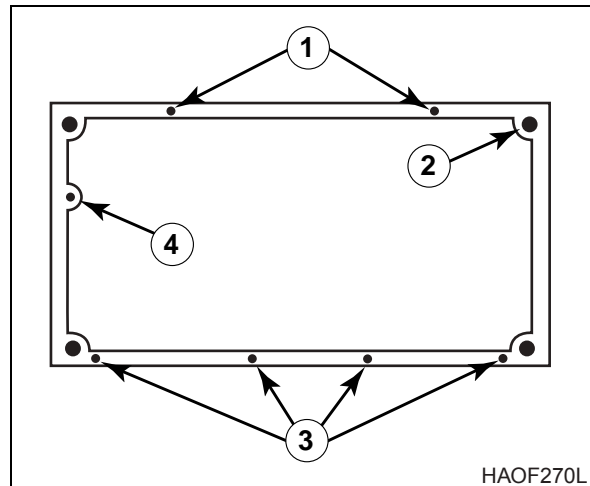

Figure 7

6. Once cab is mounted to floor unhook lifting device
7. Connect cabin ground cable (2, Figure 2).
8. Connect cab lamp wiring connector.
9. Connect speaker wire to right side cover (4, Figure 3).
10. Connect speaker wire, stereo wire and antenna wire connector to left side cover (3).
11. Install bolts (1) to hold rear left and right dash covers (3 and 4) in place.
12. Install two rubber stops (2, Figure 3) used in storing the front lower glass.

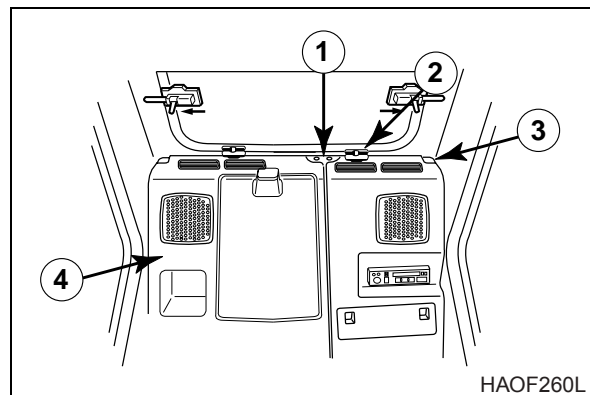

Figure 8

13. Connect wiper motor connector and front window washer hose located at floor plate bottom.
14. Install air duct (3, 4 and 8, Figure 2) located at right side of cab.

NOTE: *Connect duct wiring connector before installing air duct (3).*

15. Connect hour meter connector and install duct covers (5, 6, 7 and 9, Figure 2).
16. Install operator's seat (1, Figure 2).

NOTE: *Be careful not to damage seat covering.*

17. Install floor mat.
18. Disconnect negative (-) battery cable leading to frame from battery.

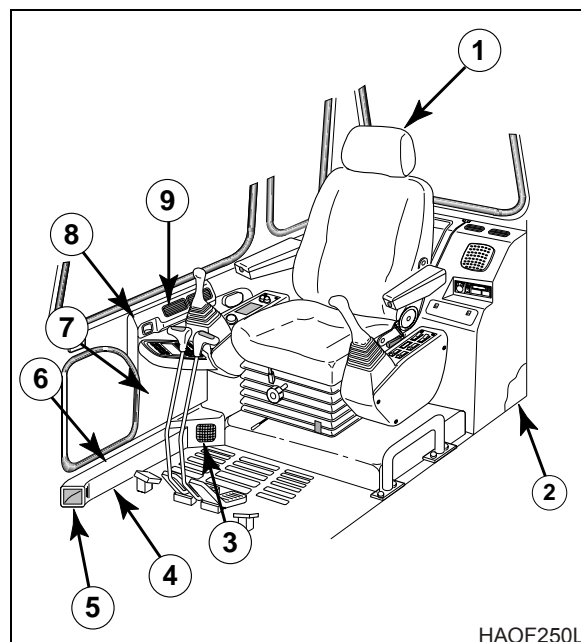

Figure 9

**Thank you very much
for your reading.**

Please Click Here

**Then Get More
Information.**