

SJ009/830T-2009

www.yuchaihi.com

中国最大的、具有中国民族品牌的小型工程机械生产和出口基地

玉柴工程机械



YC35-8 液压挖掘机

# 零部件图册

SPARE PARTS BOOK FOR YC35-8  
HYDRAULIC EXCAVATOR

## **欢迎使用玉柴机器，并衷心感谢对玉柴业务上的大力合作！**

本机的大修和调整工作，请委托本公司的维修站或代理机构进行，并使用本公司提供的配件、备件。当使用非纯正的配件或部件，当时可能对机器没有明显影响。日后肯定会引起机器一系列不良的后果。

### **并敬请用户注意：**

**如果因为使用非纯正的配件、部件或由未经本公司授权的公司维修而造成的机器故障，即使在三包期内也恕我公司不承担保修业务！**

玉柴产品本着用户至上的原则，不断地改进产品，以尽可能把最好的产品推向市场，为此改进可能随时实施，对于当时正销售的产品，我们不更换资料，不作预先通知。

**注：本图册适用于YC35-8(适用830T04 机型)**

## 目录 1 (INDEX 1)

01.1.1	底盘总成 (适用830T04机型)	CHASSIS ASSEMBLY (APPLY TO 830T04 TYPE)	1
02.1.1	平台 (适用830T04机型)	PLATFORM (APPLY TO 830T04 TYPE)	5
03.1.1	推土装置 (适用830T04机型)	DOZER EQUIPMENT (APPLY TO 830T04 TYPE)	11
04.1.1	工作装置 1 (适用830T04机型)	WORKING EQUIPMENT 1 (APPLY TO 830T04 TYPE)	13
04.2.1	工作装置 2 (适用830T04机型)	WORKING EQUIPMENT 2 (APPLY TO 830T04 TYPE)	15
04.3.1	工作装置 3 (适用830T04机型)	WORKING EQUIPMENT 3 (APPLY TO 830T04 TYPE)	17
04.4.1	工作装置 4 (适用830T04机型)	WORKING EQUIPMENT 4 (APPLY TO 830T04 TYPE)	19
04.5.1	工作装置 5 (适用830T04机型)	WORKING EQUIPMENT 5 (APPLY TO 830T04 TYPE)	21
05.1.1	平台部分液压系统 1 (适用830T04机型)	HYDRAULIC SYSTEM FOR PLATFORM 1 (APPLY TO 830T04 TYPE)	23
05.2.1	平台部分液压系统 2 (适用830T04机型)	HYDRAULIC SYSTEM FOR PLATFORM 2 (APPLY TO 830T04 TYPE)	27
05.3.1	平台部分液压系统 3 (适用830T04机型)	HYDRAULIC SYSTEM FOR PLATFORM 3 (APPLY TO 830T04 TYPE)	29
05.4.1	平台部分液压系统 4 (适用830T04机型)	HYDRAULIC SYSTEM FOR PLATFORM 4 (APPLY TO 830T04 TYPE)	31
05.5.1	平台部分液压系统 5 (适用830T04机型)	HYDRAULIC SYSTEM FOR PLATFORM 5 (APPLY TO 830T04 TYPE)	33
05.6.1	平台部分液压系统 6 (适用830T04机型)	HYDRAULIC SYSTEM FOR PLATFORM 6 (APPLY TO 830T04 TYPE)	35
05.7.1	平台部分液压系统 7 (适用830T04机型)	HYDRAULIC SYSTEM FOR PLATFORM 7 (APPLY TO 830T04 TYPE)	37
05.8.1	平台部分液压系统 8 (适用830T04机型)	HYDRAULIC SYSTEM FOR PLATFORM 8 (APPLY TO 830T04 TYPE)	39
05.9.1	平台部分液压系统 9 (适用830T04机型)	HYDRAULIC SYSTEM FOR PLATFORM 9 (APPLY TO 830T04 TYPE)	41
05.10.1	中央回转接头 10 (适用830T04机型)	CENTRE SLEWING JOINT 10 (APPLY TO 830T04 TYPE)	43
65.1.1	附属装置液压系统 (适用830T04机型)	AUXILIARY EQUIPMENT HYDRAULIC SYSTEM (APPLY TO 830T04 TYPE)	45
65.1.2	附属装置液压系统 (适用830T04机型)	AUXILIARY EQUIPMENT HYDRAULIC SYSTEM (APPLY TO 830T04 TYPE)	47
75.1.1	行走装置液压系统 (适用830T04机型)	TRAVEL EQUIPMENT HYDRAULIC SYSTEM (APPLY TO 830T04 TYPE)	49
75.1.2	行走装置液压系统 (适用830T04机型)	TRAVEL EQUIPMENT HYDRAULIC SYSTEM (APPLY TO 830T04 TYPE)	51
85.1.1	先导控制液压系统 1 (适用830T04机型)	PILOT EQUIPMENT HYDRAULIC SYSTEM 1 (APPLY TO 830T04 TYPE)	53
85.2.1	先导控制液压系统 2 (适用830T04机型)	PILOT EQUIPMENT HYDRAULIC SYSTEM 2 (APPLY TO 830T04 TYPE)	57
85.3.1	先导控制液压系统 3 (适用830T04机型)	PILOT EQUIPMENT HYDRAULIC SYSTEM 3 (APPLY TO 830T04 TYPE)	61

## 目录 2 (INDEX 2)

85.4.1	先导控制液压系统 4 (适用830T04机型)	PILOT EQUIPMENT HYDRAULIC SYSTEM 4 (APPLY TO 830T04 TYPE)	63
85.5.1	先导控制液压系统 5 (适用830T04机型)	PILOT EQUIPMENT HYDRAULIC SYSTEM 5 (APPLY TO 830T04 TYPE)	65
95.1.1	工作装置液压系统 1 (适用830T04机型)	HYDRAULIC SYSTEM FOR WORKING EQUIPMENT 1 (APPLY TO 830T04 TYPE)	67
06.1.1	操纵机构(适用830T04机型)	CONTROL FRAMEWORK(APPLY TO 830T04 TYPE)	71
06.2.1	行走操纵(适用830T04机型)	HOOF FRAMEWORK(APPLY TO 830T04 TYPE)	77
07.1.1	驾驶室组件 1 (适用830T04机型)	CAB SUBASSEMBLY 1 (APPLY TO 830T04 TYPE)	81
07.2.1	驾驶室组件 2 (适用830T04机型)	CAB SUBASSEMBLY 2 (APPLY TO 830T04 TYPE)	83
07.3.1	驾驶室组件 3 (适用830T04机型)	CAB SUBASSEMBLY 3 (APPLY TO 830T04 TYPE)	85
07.4.1	驾驶室组件 4 (适用830T04机型)	CAB SUBASSEMBLY 4 (APPLY TO 830T04 TYPE)	87
07.5.1	驾驶室组件 5 (适用830T04机型)	CAB SUBASSEMBLY 5 (APPLY TO 830T04 TYPE)	89
07.6.1	驾驶室组件 6 (适用830T04机型)	CAB SUBASSEMBLY 6 (APPLY TO 830T04 TYPE)	93
07.7.1	驾驶室组件 7 (适用830T04机型)	CAB SUBASSEMBLY 7 (APPLY TO 830T04 TYPE)	95
08.1.1	空调系统(适用830T04机型)	AIR-CONDITION SYSTEM (APPLY TO 830T04 TYPE)	97
09.1.1	罩框组件(适用830T04机型)	COVER FRAME MODULE (APPLY TO 830T04 TYPE)	101
10.1.1	发动机罩(适用830T04机型)	ENGINE HOOD (APPLY TO 830T04 TYPE)	105
10.2.1	发动机罩锁装置 (适用于830T04 机型)	ENGINE HOOD LOCK EQUIPMENT (APPLY TO 830T04 TYPE)	107
11.1.1	回转机构(适用830T04机型)	SLEWING SUPPORT (APPLY TO 830T04 TYPE)	111
12.1.1	冷却系统(适用830T04机型)	COOLING SYSTEM (APPLY TO 830T04 TYPE)	113
12.2.1	进气系统(适用830T04机型)	AIR INLET SYSTEM (APPLY TO 830T04 TYPE)	117
12.3.1	排气系统(适用830T04机型)	EXHAUST SYSTEM (APPLY TO 830T04 TYPE)	119
12.4.1	动力输出系统(适用830T04机型)	POWER OUTPUT SYSTEM (APPLY TO 830T04 TYPE)	121
12.5.1	支承(适用830T04机型)	SUPPORT (APPLY TO 830T04 TYPE)	123
12.6.1	油门操纵系统(适用830T04机型)	THROTTLE CONTROL SYSTEM (APPLY TO 830T04 TYPE)	125
12.7.1	燃油系统(适用830T04机型)	FUEL SYSTEM (APPLY TO 830T04 TYPE)	127
13.1.1	电气系统-电气总装(适用830T04机型)	ELECTRICAL SYSTEM-ELECTRICAL ASSEMBLY (APPLY TO 830T04 TYPE)	129
13.2.1	电气系统-开关总成(适用830T04机型)	ELECTRICAL SYSTEM-SWITCH ASSEMBLY(APPLY TO 830T04 TYPE)	131
13.3.1	电气系统-继电器安装总成(适用830T04机型)	ELECTRICAL SYSTEM-RELAY ASSEMBLY (APPLY TO 830T04 TYPE)	135
13.4.1	电气系统-电池安装组(适用830T04机型)	ELECTRICAL SYSTEM-BATTERY ASSEMBLY (APPLY TO 830T04 TYPE)	137
13.5.1	电气系统-接线系 (适用830T04机型)	ELECTRICAL SYSTEM-WIRING DIAGRAM(APPLY TO 830T04 TYPE)	139

01.1.1 底盘总成(适用830T04机型) CHASSIS ASSEMBLY (APPLY TO 830T04 TYPE)

序号 No.	数量 Quantity	代号 Code	名称 Description		备注 Remark
1	24	M12 35 GB/T5783	六角头螺栓	Bolt	12.9-达克罗
2	24	12 GB/T7244	重型弹簧垫圈	Spring washer	达克罗
3	2	830D-0100001	驱动轮	Driving wheel	
4			行走马达	Traveling motor	
5	1	830D-0101000A	车架总成	Chassis assembly	
6	2	820-0108000	行走马达盖板	Traveling motor's cover plate	
7	18	10 GB/T97.1	平垫圈	Washer	达克罗
8	18	10 GB/T93	弹簧垫圈	Spring washer	达克罗
9	18	M10 20 GB/T5783	六角头螺栓	Bolt	8.8-达克罗
10	4	12 GB/T97.1	平垫圈	Washer	Zn. D
11	4	12 GB/T93	弹簧垫圈	Spring washer	Zn. D
12	4	M12 25 GB/T5783	六角头螺栓	Bolt	8.8-Zn. D
13	1	820-0107000	封底板	Chassis cover plate	
14	1	820-0100002	螺塞	Screw plug	
15	8	820-0104000	支重轮总成	Idler assembly	
16	16	M14 30 GB/T5783	六角头螺栓	Bolt	10.9-达克罗
17	18	14 GB/T93	弹簧垫圈	Spring washer	达克罗
18	2	820-0100004	侧盖板	Side cover plate	
19	18	12 GB/T7244	重型弹簧垫圈	Spring washer	Zn. D
20	18	M12 35 GB/T5783	六角头螺栓	Bolt	12.9-氧化
21	2	820-0103000	托轮总成	Carrier roller assembly	
22	2	M14 80 GB/T5784	六角头螺栓	Bolt	8.8-达克罗
22	2	M14 GB/T 6170	1型六角螺母	Nut	8-达克罗
24	2	30 GB/T894.1	轴用弹性挡圈	Stopper	达克罗
25	2	820-0109000	侧盖板II	Side cover plate II	
26	2	820-0102210A	单向阀总成	Check valve assembly	
27	2	820-0102200	张紧装置总成	Tension unit assembly	23
28	2	820-0102230	密封组件	Sealed ring assembly	

01.1.1 底盘总成(适用830T04机型) CHASSIS ASSEMBLY (APPLY TO 830T04 TYPE)

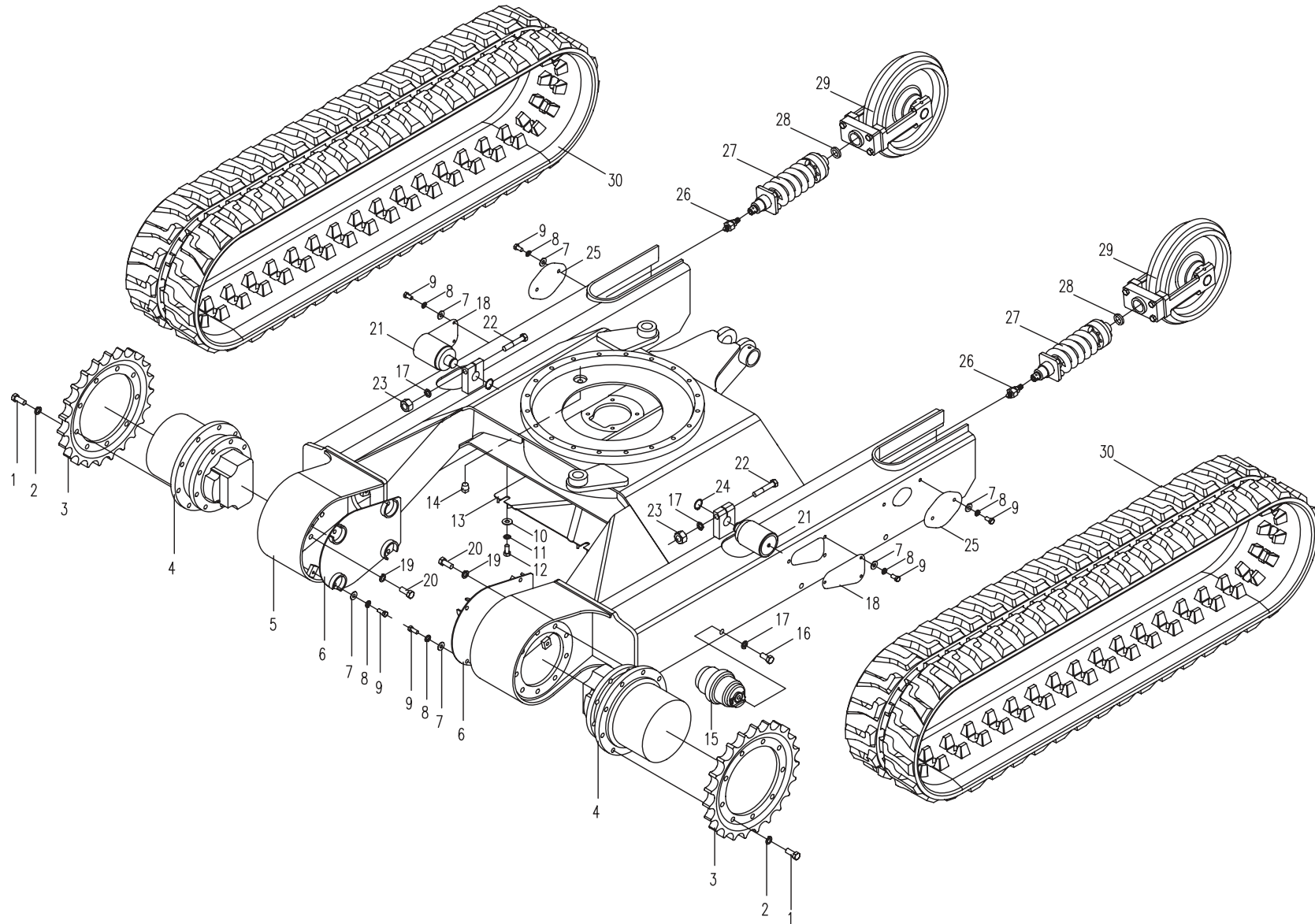



01.1.1 底盘总成(适用830T04机型) CHASSIS ASSEMBLY (APPLY TO 830T04 TYPE)

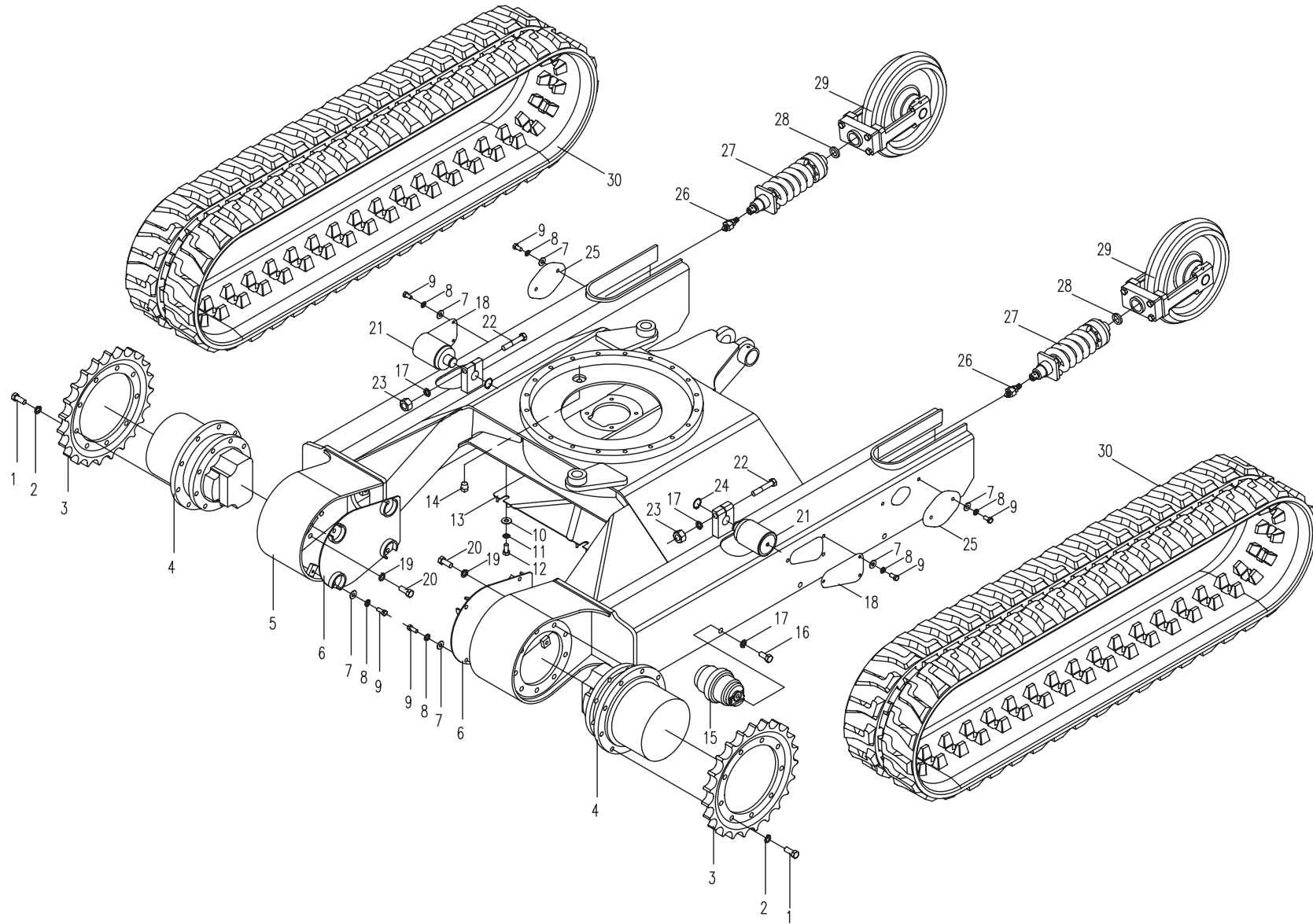



02.1.1 平台(适用830T04机型) PLATFORM(APPLY TO 830T04 TYPE)

序号 No.	数量 Quantity	代号 Code	名称 Description		备注 Remark
1	1	830T-0202000	平台	Platform	装KYB回转马达
2	5	853D-0200012	螺母块	Screw block	
3	1	820-0200004	上销轴	Upper pin	
4	1	820-0200005	衬套	Bush	
5	1	820-0200001A	动臂销轴	Boom Shaft pin	
6	1	820-0200015	偏转缸前销轴	Pin	
7	3	M10×90 GB/T31.1	六角头螺杆带孔螺栓	Bolt	8. 8-Zn. D
8	4	M10 GB/T6170	1型六角螺母	Nut	8-Zn.D
9	4	M10 GB/T6179	1型六角开槽螺母	Nut	8-Zn. D
10	4	2.5×24 GB/T91	开口销	Cotter pin	Zn.D
11	1	830E-0250000	转向头总成	Steering Head Assembly	
12	1	M10×100 GB/T31.1	六角头螺杆带孔螺栓	Bolt	8.8-Zn.D
13	1	820-0200009A	动臂缸销轴	Shaft pin	
14	1	820-0200011	限位块	Position block	
15	1	820-0204000	下销轴	Lower pin	
16	1	820-0200012	压板	Plank	
17	6	12 GB/T97.1	平垫圈	Washer	Zn. D
18	6	12 GB/T 93	弹簧垫圈	Spring washer	Zn.D
19	6	M12×25 GB/T5783	六角头螺栓	Bolt	8. 8-Zn. D
20	2	M10×80 GB/T70.1	内六角圆柱头螺钉	Bolt	8.8-Zn.D
21	5	10 GB/T97.1	平垫圈	Washer	Zn. D
22		T0804-01012	隔垫片	Spacer	
23	5	M10×1 JB/T7940.1	直通式压注油杯	Grease cup	Zn. D
24	5	801-0400001	油杯盖	Grease cup cap	
25	1	M10×125 GB/T5783	六角头螺栓	Bolt	8. 8-Zn. D
26	1	820-0200007	挡板	Baffle	
27	6	8 GB/T93	弹簧垫圈	Spring washer	Zn. D
28	6	M8×16 GB/T5783	六角头螺栓	Bolt	8.8-Zn.D

02.1.1 平台(适用830T04机型) PLATFORM(APPLY TO 830T04 TYPE)

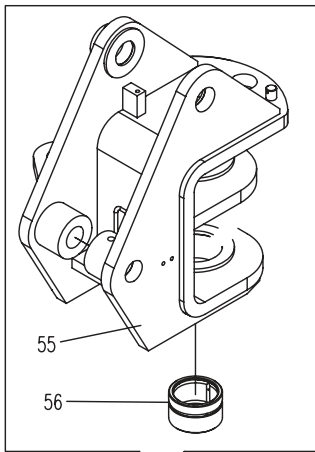
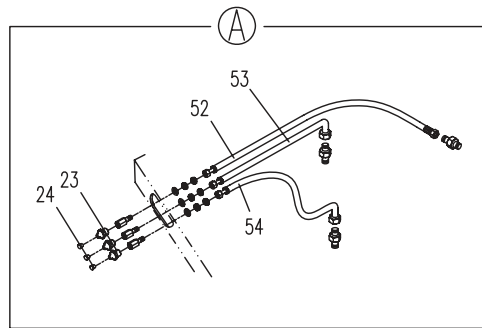

11

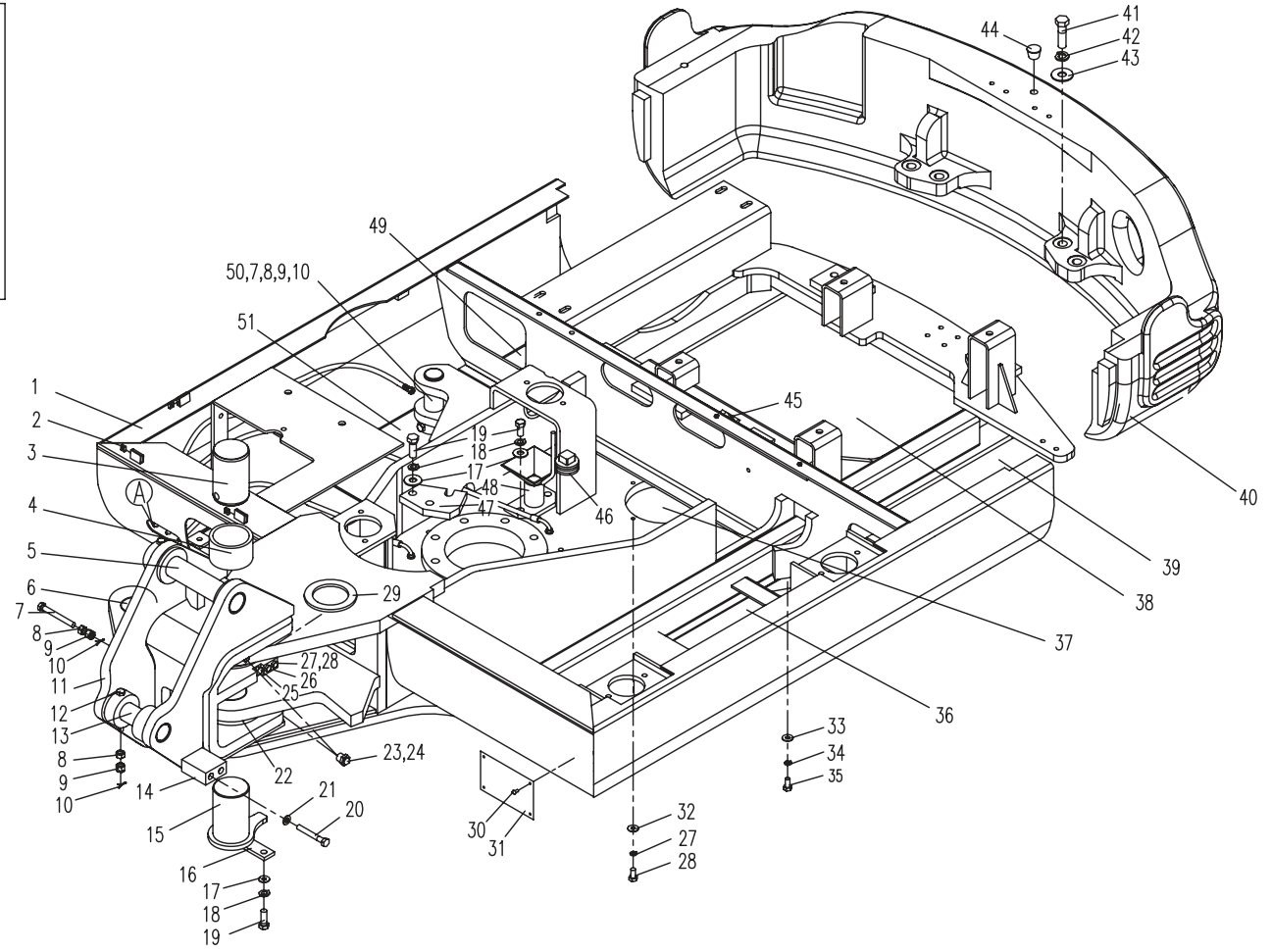

6

02.1.1 平台(适用830T04机型) PLATFORM(APPLY TO 830T04 TYPE)

序号 No.	数量 Quantity	代号 Code	名称 Description		备注 Remark
29	1	820-0200003	承重垫圈	Washer	
30	4	4×12 GB/T12618	开口型扁圆头抽芯铆钉	Rivet	
31	1	T0802-01002	标牌（英文）	Scutcheon(English)	选配
	1	T0802-01003	标牌（法文）	Scutcheon(French)	选配
	1	T0802-01004	标牌（意大利文）	Scutcheon(Italian)	选配
32	4	8 GB/T96	大垫圈	Washer	Zn.D
33	26	10 GB/T96	大垫圈	Washer	Zn. D
34	26	10 GB/T93	弹簧垫圈	Spring washer	Zn.D
35	26	M10×25 GB/T5783	六角头螺栓	Bolt	8. 8-Zn. D
36	1	830D-0200005A	左前封底板	Left-ahead cover	
37	1	830D-0200002	圆封底板	Round cover plate	
38	1	830T-0200005	左后封底板	Left-hind cover plate	
39	1	830T-0200004	中后封底板	Middle-hind cover plate	
40	1	830T-0200001	平衡重	Counter weight	
41	4	M16×70 GB/T5783	六角头螺栓	Bolt	10. 9-达克罗
42	4	16 GB/T 93	弹簧垫圈	Spring washer	Zn.D
43	4	16 GB/T 97.1	平垫圈	Washer	Zn. D
44	3	830P-0200005A	螺堵	Plug	
45	1	830D-0210003	平台横梁海绵	Sponge	
46	1	820-0200013	螺塞	Screw plug	
47	1	820-0200016	拔叉板	Locking-plate	
48	1	820-0208000	漏斗	Filler	
49	1	830T-0200003	右后封底板组件	Right-hind cover plate	
50	1	820-0200014	偏转缸后销轴	Pin	
51	1	830L-0200001	右前封底板	Right-ahead cover plate	
52	1	820-0205100	连接管	Connective pipe	
53	1	820-0206100	连接管	Connective pipe	
54	1	820-0207100	连接管	Connective pipe	

02.1.1 平台(适用830T04机型) PLATFORM(APPLY TO 830T04 TYPE)

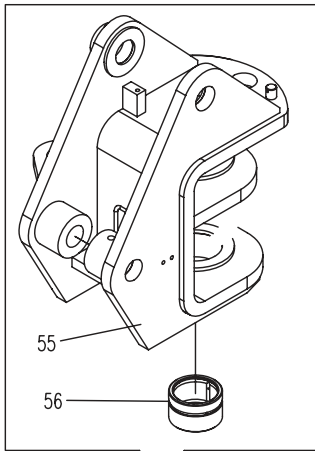
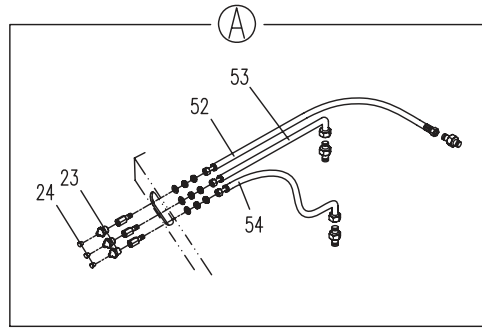

11

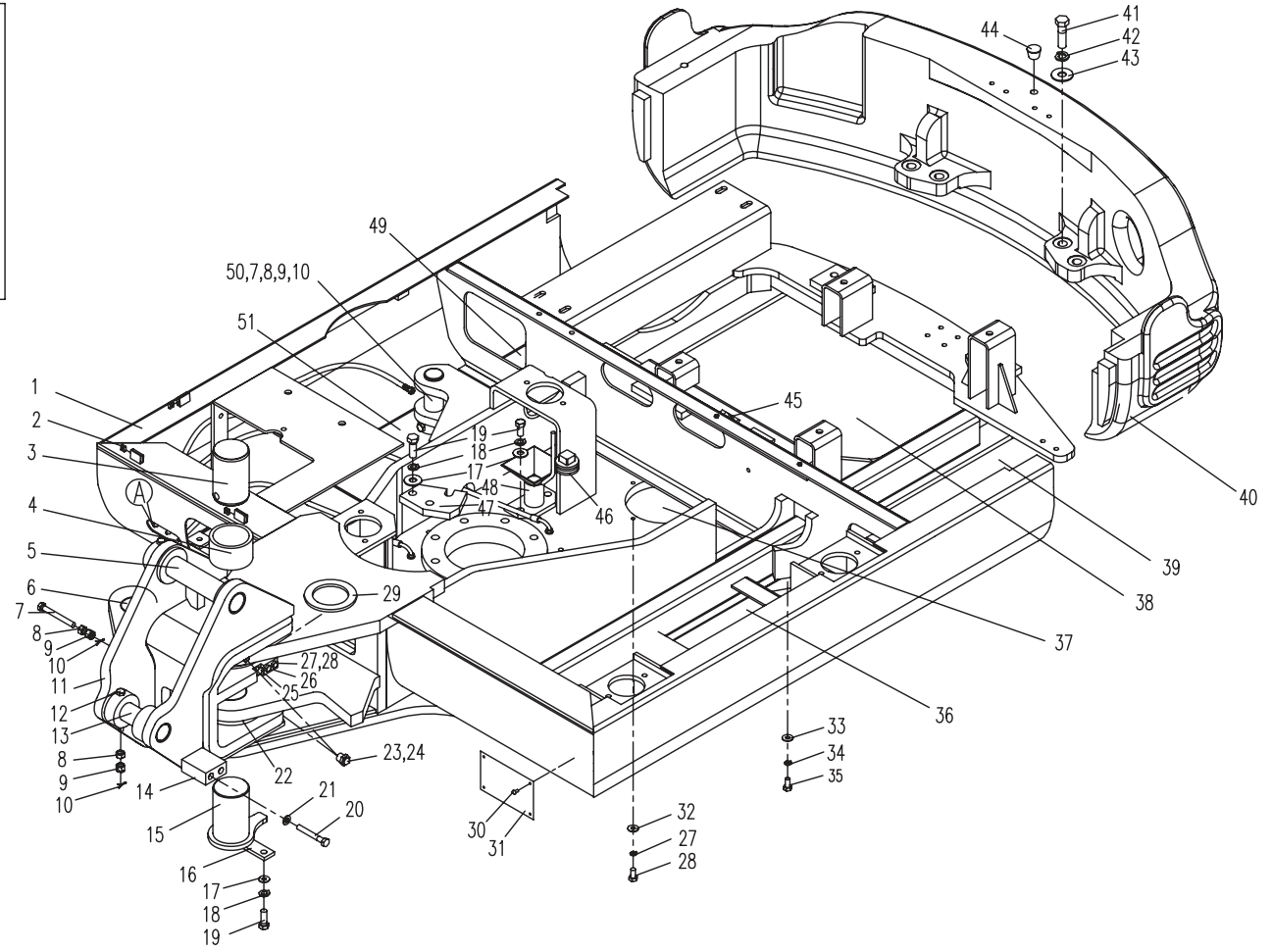



02.1.1 平台(适用830T04机型) PLATFORM(APPLY TO 830T04 TYPE)

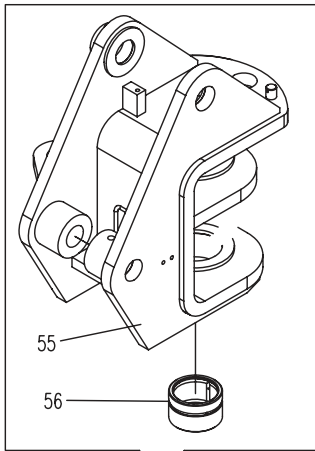
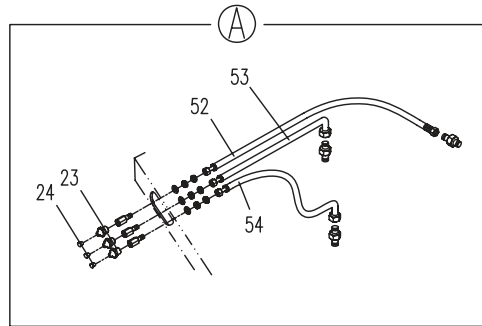

11

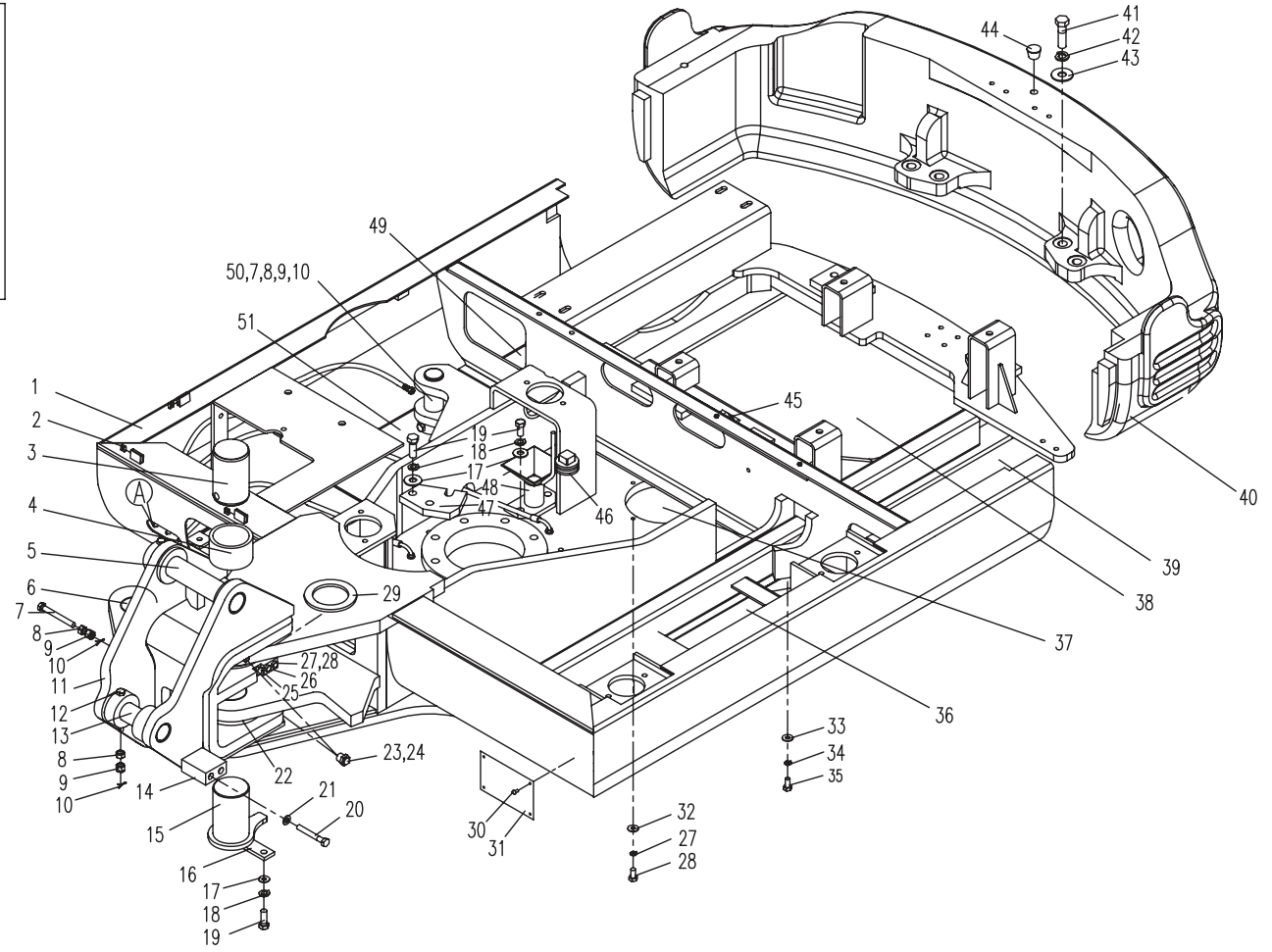



03.1.1 推土装置(适用830T04机型) DOZER EQUIPMENT (APPLY TO 830T04 TYPE)

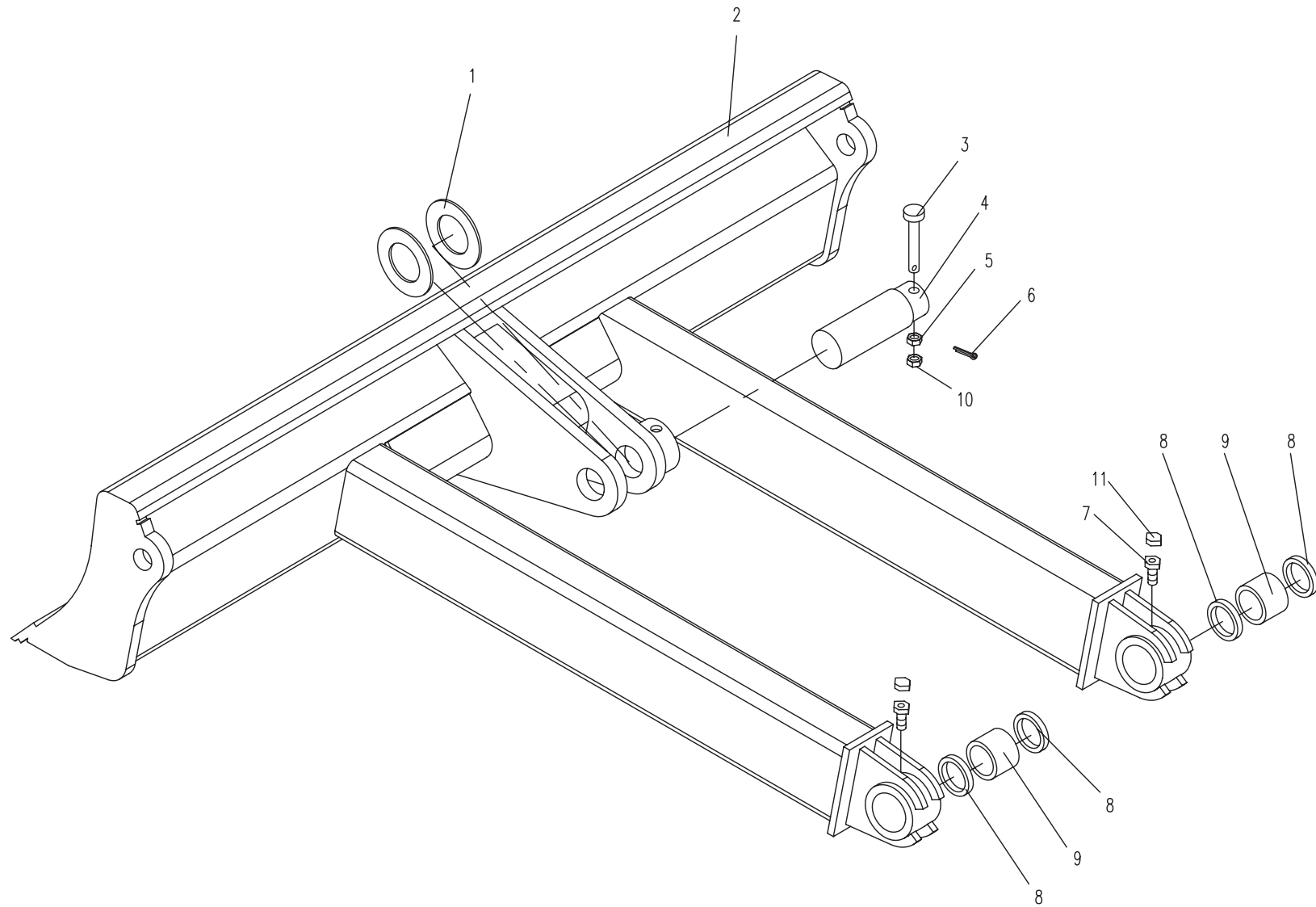



04.1.1 工作装置 1(适用830T04机型) WORKING EQUIPMENT 1 (APPLY TO 830T04 TYPE)

序号 No.	数量 Quantity	代号 Code	名称 Description		备注 Remark
	1	820-0401000A	动臂	Boom	含序号1, 2, 3, 4(Include No. 1, 2, 3, 4)
1	2	820-0401005	防尘圈	Dust-proof seal	
2	2	820-0401004A	铜衬套	Bush	
3	1	820-0401100C	动臂体	Boom body	
4	1	820-0401003A	中间衬套	Middle bush	
5	2	T0804-01003	隔垫片	Spacer washer	
6	2	M10 GB/T6170	1型六角螺母	Nut	8-Zn. D
7	2	2.5 20 GB/T91	开口销	Cotter pin	Zn.D
8	2	M10 90 GB/T31.1	六角头螺杆带孔螺栓	Bolt	8. 8-Zn. D
9	1	820-0400018	垫圈	Washer	
10	2	T0804-01004	隔垫片	Spacer	
11	1	820-0406000A	销轴总成	Shaft pin	
12	1	M10 1 JB/T7940.2	接头式压注油杯	Grease cup	Zn. D
13	2	T0804-01004	隔垫片	Spacer	
14	1	820-0400012A	销轴	Shaft pin	
15	1	820-0400013A	销轴	Shaft pin	
16	1	M36 GB/T6178	1型六角开槽螺母	Nut	8-Zn. D
17	1	6.3 60 GB/T91	开口销	Cotter pin	Zn. D
18	1	801-0400001	油杯盖	Grease cup cap	
19	2	M10 GB/T6178	1型六角开槽螺母	Nut	8-Zn. D

04.1.1 工作装置 1(适用830T04机型) WORKING EQUIPMENT 1 (APPLY TO 830T04 TYPE)

---

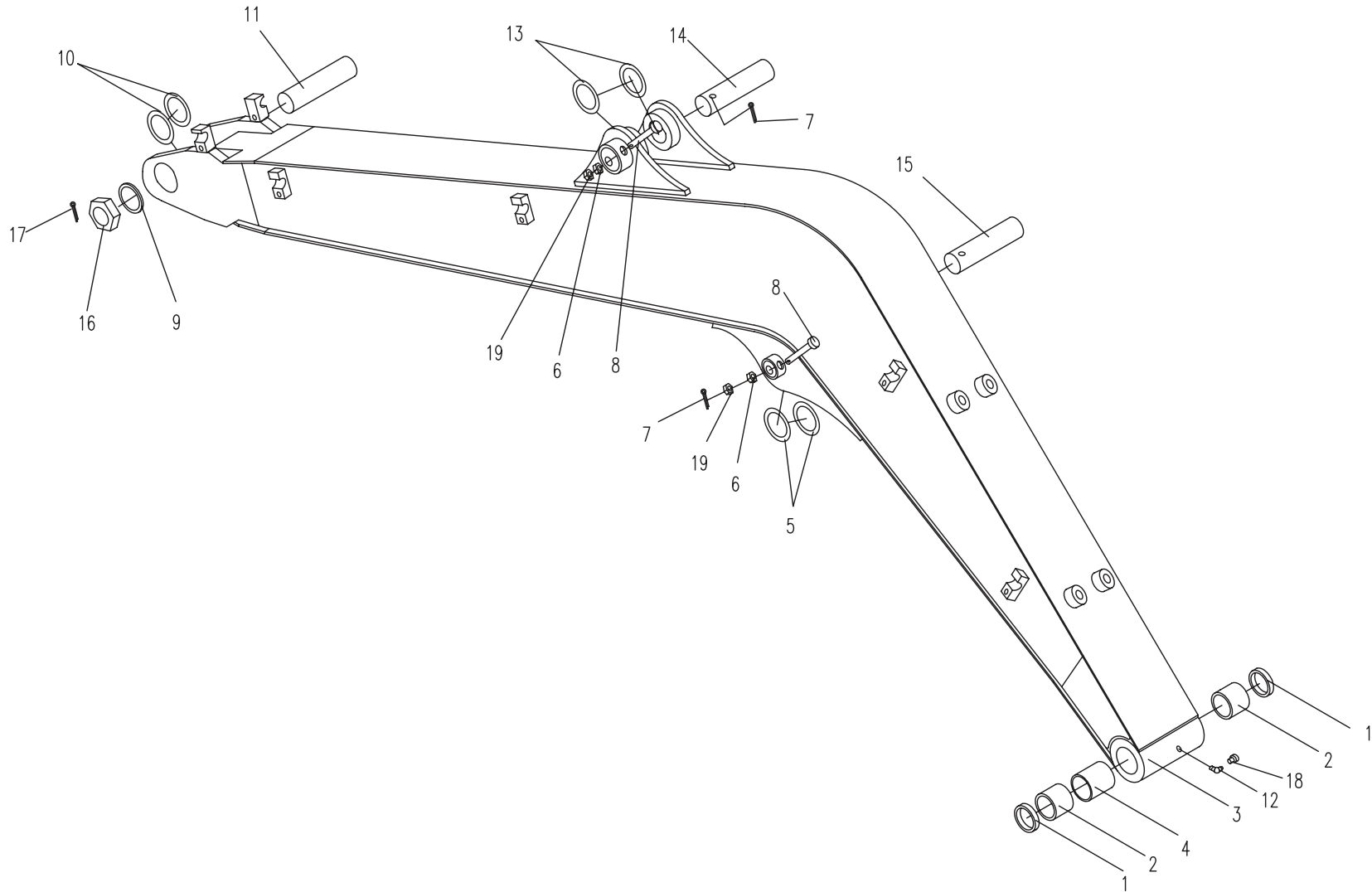

04.2.1 工作装置 2 (适用830T04机型) WORKING EQUIPMENT 2 (APPLY TO 830T04 TYPE)

序号 No.	数量 Quantity	代号 Code	名称 Description		备注 Remark
1	1	820-0402000A	斗杆	Arm	展开见04. 4. 1
2	2	T0804-01004	隔垫片	Spacer washer	
3	6	M10 90 GB/T31. 1	六角头螺杆带孔螺栓	Bolt	8. 8-Zn. D
4	6	2. 5 20 GB/T91	开口销	Cotter pin	Zn.D
5	6	M10 GB/T6178	1型六角开槽螺母	Nut	8-Zn. D
6	6	M10 GB/T6170	1型六角螺母	Nut	8-Zn. D
7	1	820-0400011A	销轴	Shaft pin	
8	2	820-0400001B	销轴	Shaft pin	
9	1	820-0404000A	连杆	Connecting	展开见04. 5. 1
10	1	820-0405000A	左摇杆	Left linkage	
11	5	M10 1 JB/T7940. 1	直通式压注油杯	Grease cup	Zn. D
12	5	801-0400001	油杯盖	Grease cup cap	
13	1	820-0400007A	销轴	Shaft pin	
14	2	T0804-01003	隔垫片	Spacer	
15	1	820-0400006B	销轴	Shaft pin	
16	1	820-0407000	右摇杆	Right linkage	
17	8	T0804-01003	隔垫片	Spacer washer	
18	1	820-0400003B	销轴	Shaft pin	

04.2.1 工作装置 2 (适用830T04机型) WORKING EQUIPMENT 2 (APPLY TO 830T04 TYPE)

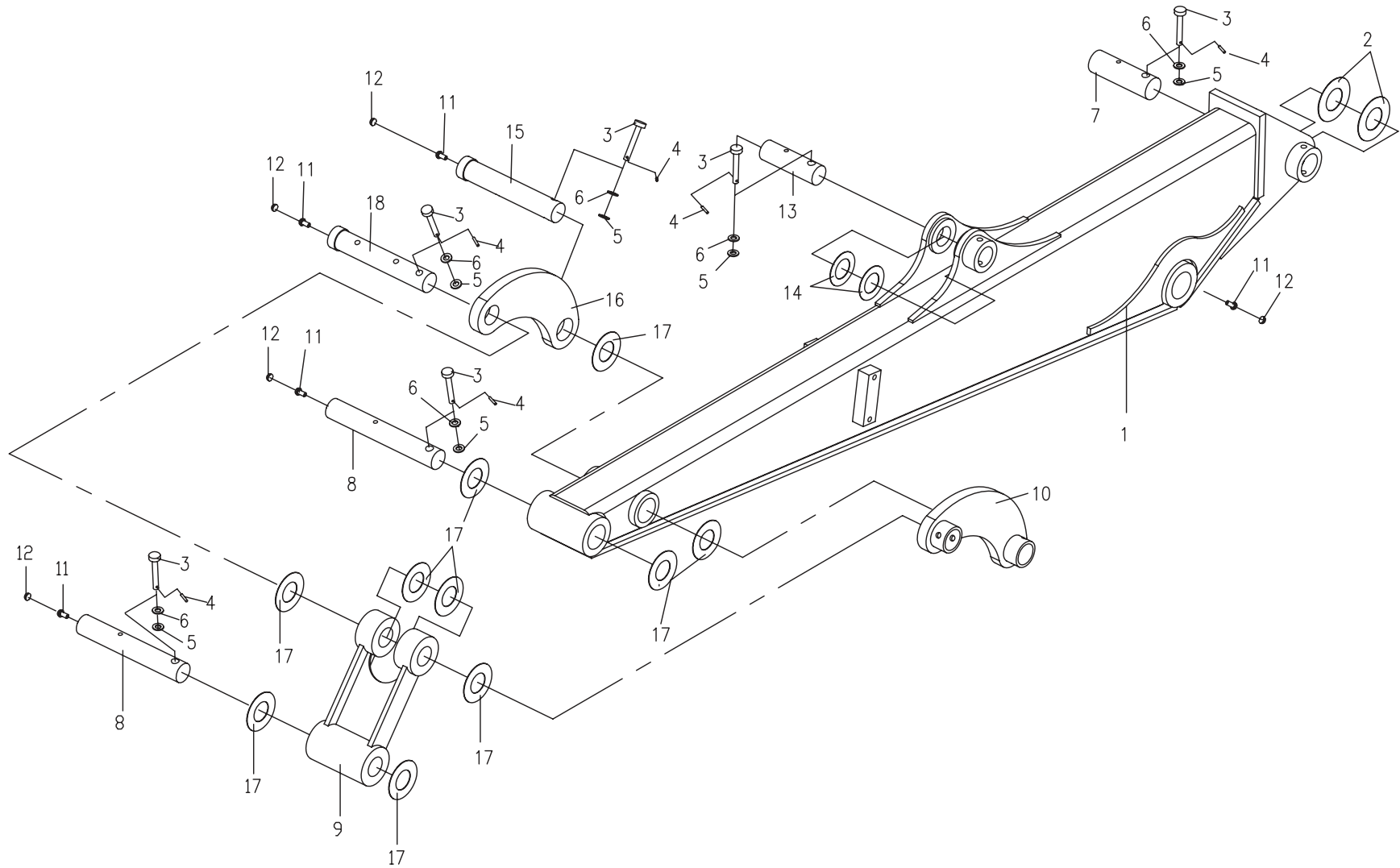



04.3.1 工作装置 3 (适用830T04机型) WORKING EQUIPMENT 3 (APPLY TO 830T04 TYPE)

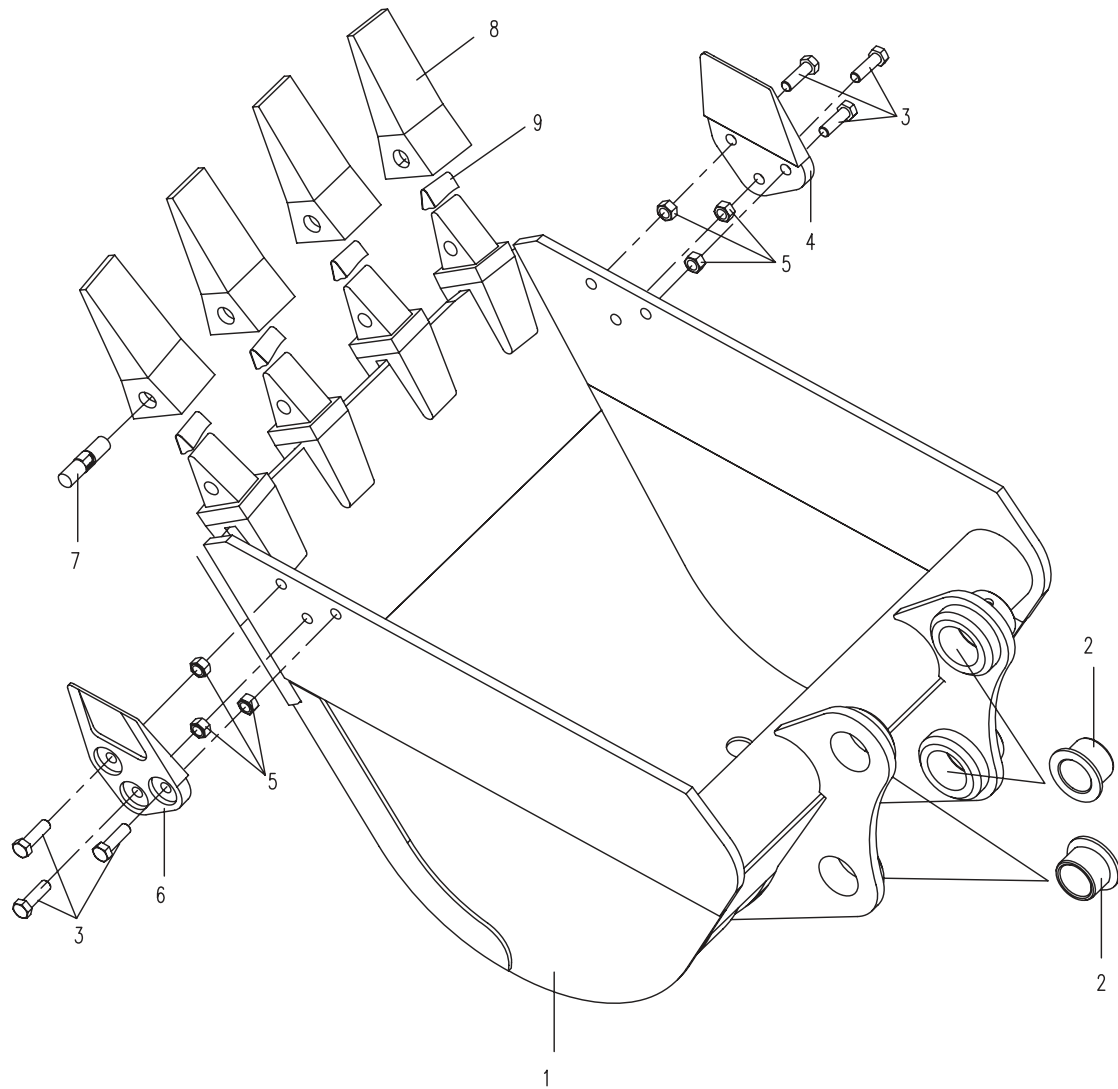



04.4.1 工作装置 4 (适用830T04机型) WORKING EQUIPMENT 4 (APPLY TO 830T04 TYPE)

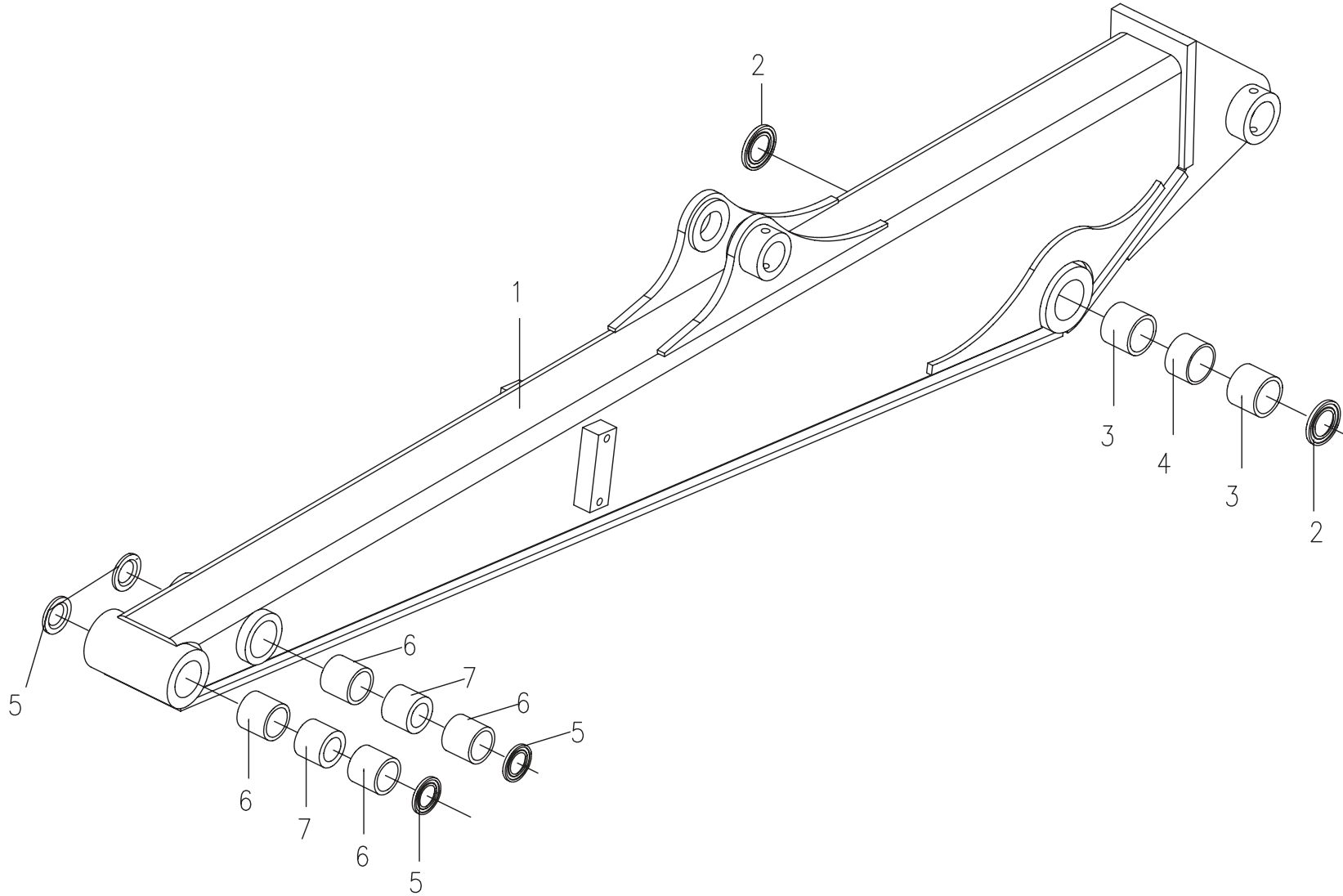





04.5.1 工作装置 5 (适用830T04机型) WORKING EQUIPMENT 5 (APPLY TO 830T04 TYPE)

---

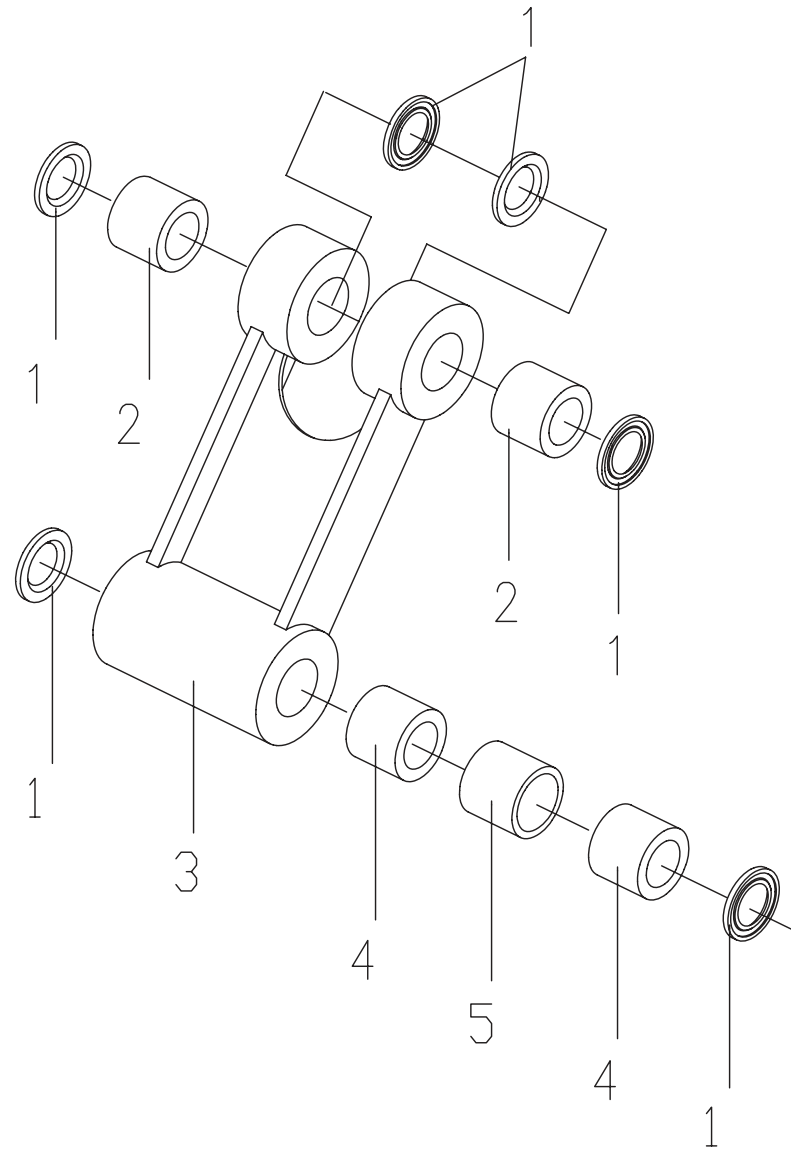

05.1.1 平台部 液压系统 1 (适用830T04机型) HYDRAULIC SYSTEM FOR PLATFORM 1 (APPLY TO 830T04 TYPE)

序号 No.	数量 Quantity	代号 Code	名称 Description	备注 Remark
1	1	830P-0501300	油箱（焊接件） Gasoline tank	
2	5	5 GB/T97. 1	平垫圈 Washer	
3	5	5 GB/T93	弹簧垫圈 Spring washer	
4	5	M5 16 GB/T5783	六角头螺栓 Bolt	
5	1	801-1205400	滤网 Filter sieve	
6	1	801-1205300	燃油箱补气阀 Air-filling valve	
7	1	801-1205002	注油口盖 Fuel-filling cover	
8	1	B8 26 GB/T882	销轴 Shaft pin	
9	1	830P-0501100	盖 Cover	
10	1	830D-0501006	弹性销 Cotter pin	
11	1	820-0502400	吸油滤油器总成 Oil -intake flange assembly	
12	1	280 5.3 GB/T3452. 1	O形橡胶密封圈 O seal ring	丁腈橡胶
13	1	830P-0501400	盖板总成 Cover assembly	
14	16	8 GB/T93	弹簧垫圈 Spring washer	
15	16	M8 16 GB/T70. 1	内六角圆柱头螺钉 Bolt	
16	1	835-0501400	空气滤清器 Air cleaner	PAF1-0. 035-0. 55-20L
17	1	27 BS/A 27. 7X36X2 ISO	组合密封垫圈 Combination washer	
18	1	835-0501300	法兰盖总成 Flange assembly	
19	1	132 2. 65 GB/T3452. 1	O形橡胶密封圈 O seal ring	丁腈橡胶
20	1	820-0502002	弹簧 Spring	
21	1	830P-0501200	回油滤油器总成 Oil -return filter assembly	
22	1	835-0501001A	液位计总成 Content gauge	YWZ-80
23	2	M10 30 GB/T5783	六角头螺栓 Bolt	
24	12	10 GB/T93	弹簧垫圈 Spring washer	
25	2	10 GB/T97. 1	平垫圈 Washer	
26	1	75 5.3 GB/T3452. 1	O形橡胶密封圈 O seal ring	丁腈橡胶
27	1	830H-0501100	吸油口法兰总成 Oil -intake flange assembly	

05.1.1 平台部分液压系统 1 (适用830T04机型) HYDRAULIC SYSTEM FOR PLATFORM 1 (APPLY TO 830T04 TYPE)

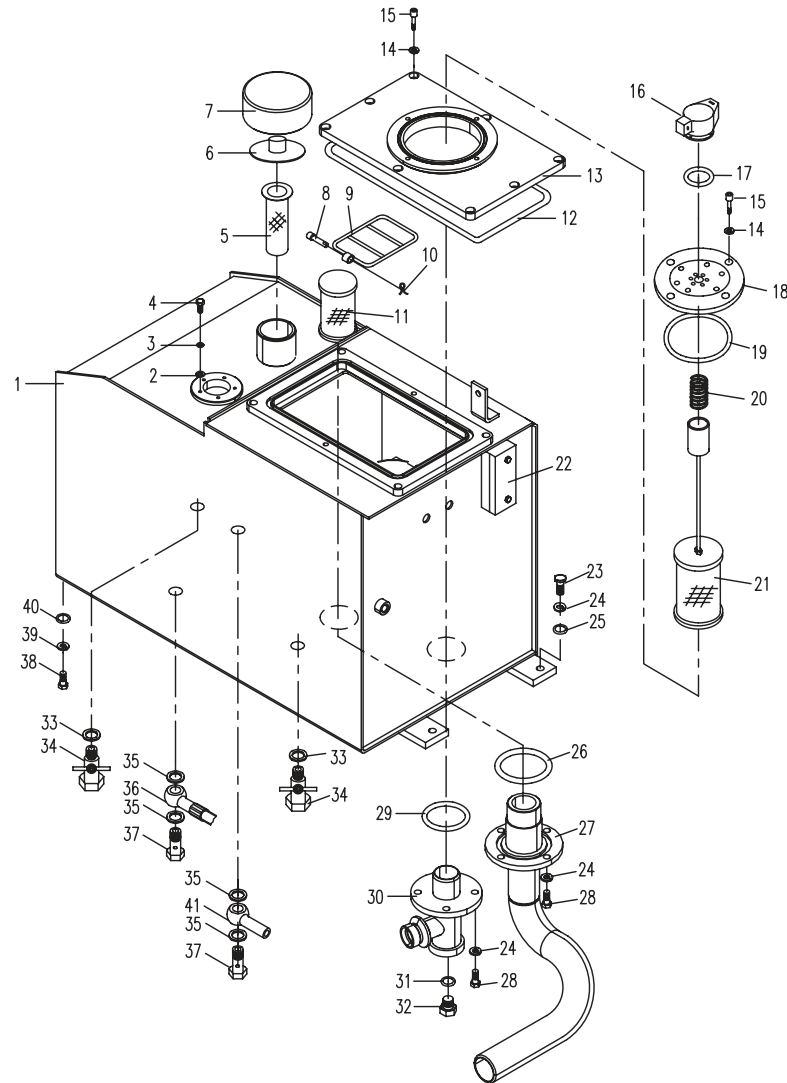



05.1.1 平台部分液压系统 1 (适用830T04机型) HYDRAULIC SYSTEM FOR PLATFORM 1 (APPLY TO 830T04 TYPE)

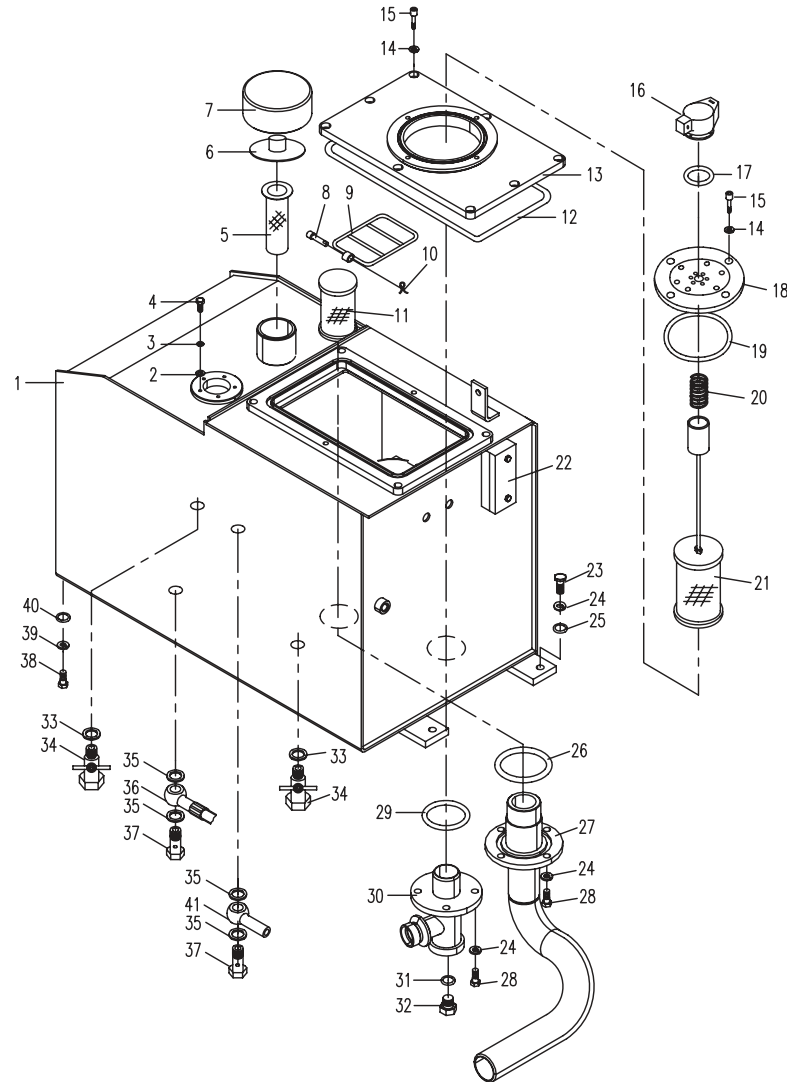



05.2.1 平台部分液压系统 2 (适用830T04机型) HYDRAULIC SYSTEM FOR PLATFORM 2 (APPLY TO 830T04 TYPE)

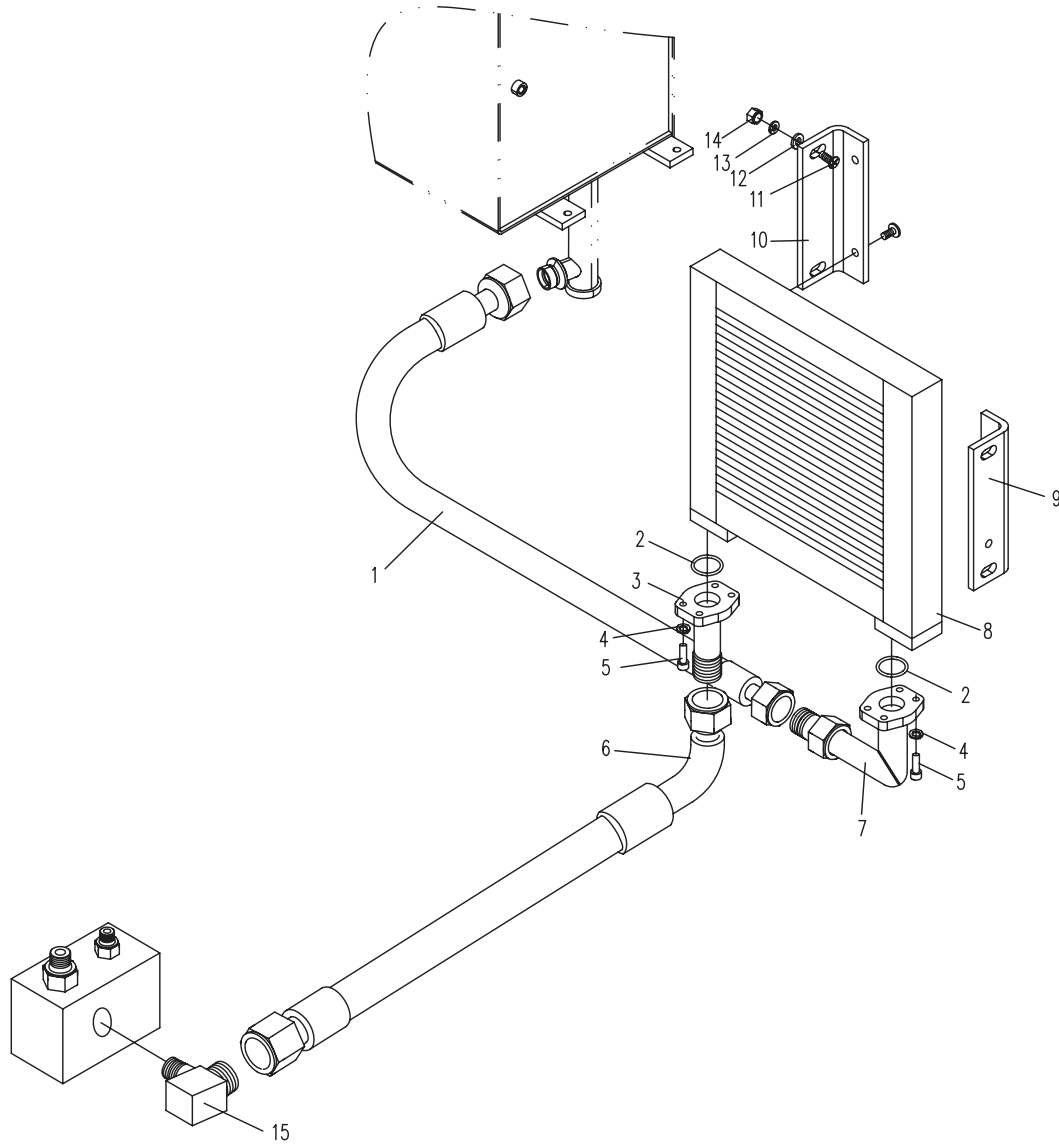



05.3.1 平台部 液压系统 3 (适用830T04机型) HYDRAULIC SYSTEM FOR PLATFORM 3 (APPLY TO 830T04 TYPE)

序号 No.	数量 Quantity	代号 Code	名称 Description	备注 Remark
1	4	M8x16 GB/T5783	六角头螺栓	Bolt
2	4	8 GB/T93	弹簧垫圈	Spring washer
3	4	8 GB/T97.1	平垫圈	Washer
4	1	830E-0501003	支板	Support
5	1	830E-0501001	接头体	Joint body
6	4	22 BS/A22.7x30x2 ISO	组合密封垫圈	Combinatory washer
7	1	838B-0500002	直接头	Bolt joint
8	1	18 BS/A18.7x27x2 ISO	组合密封垫圈	Combinatory washer
9	1	820-0500031	直接头	Bolt joint
10	1	818B-0500063	90°弯接头	Square joint
11	1	830B-0507001	管接头	Joint
12	1	830D-0518000	卡套式组合三通接头	Tree joint
13	1	830D-0555000	胶管总成	Hose assembly
14	1	830H-0516000	阀T2回油钢管	Return pipe
15	1	830H-0511000	阀T1回油胶管	Hose assembly
16	1	820-0500023	直接头	Bolt joint
17	1	820-0500041	直接头	Bolt joint
18	1	13.8x2.4 NBR-90	O形橡胶密封圈	O seal ring
19	1	830E-0500004	直通管接头	Bolt joint
20	1	830E-0501004	内外螺纹弯接头	Adapter
21	1	830D-0505000	胶管总成	Hose assembly

05.3.1 平台部分液压系统 3 (适用830T04机型) HYDRAULIC SYSTEM FOR PLATFORM 3 (APPLY TO 830T04 TYPE)

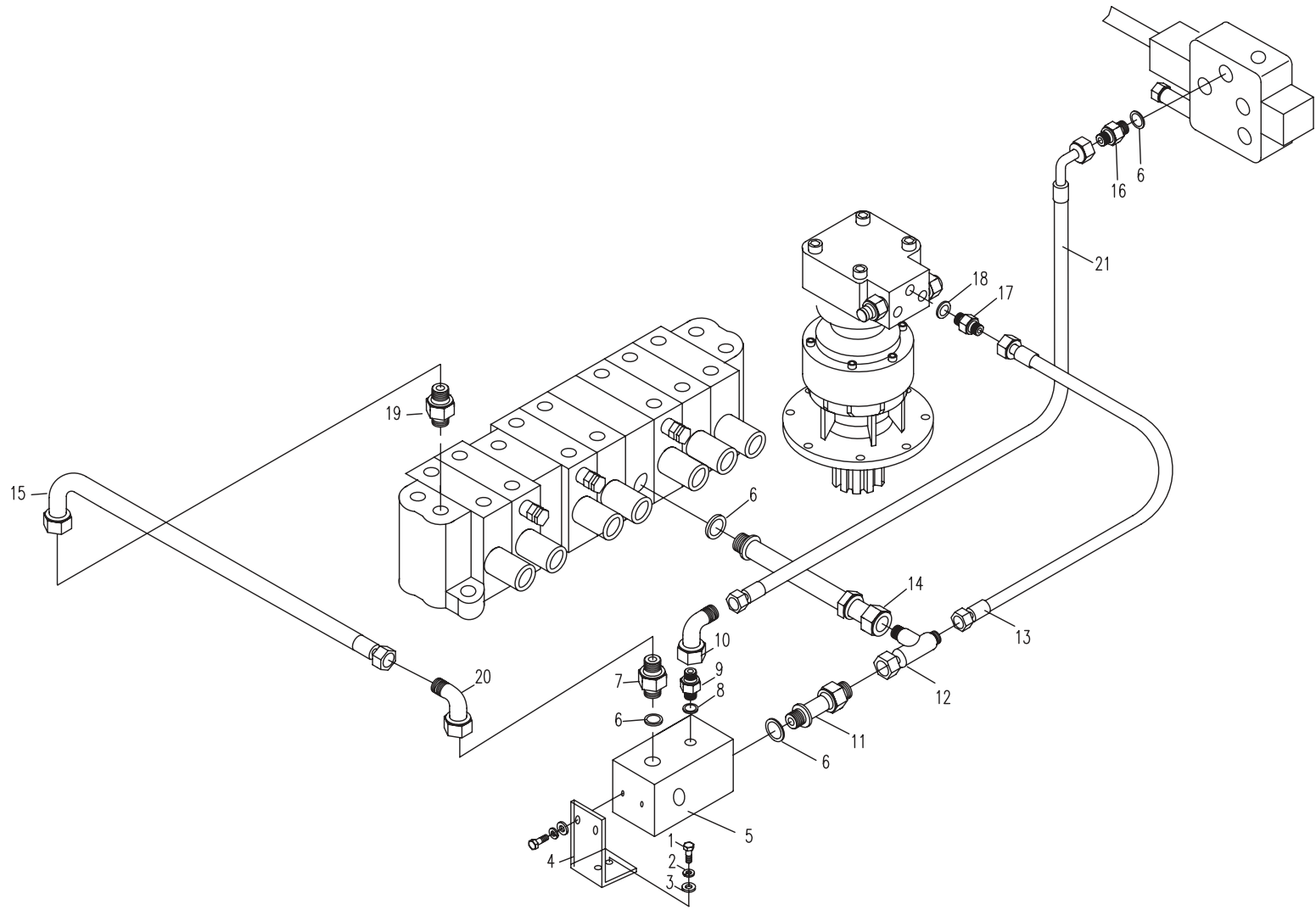

05.4.1 平台部 液压系统 4 (适用830T04机型) HYDRAULIC SYSTEM FOR PLATFORM 4 (APPLY TO 830T04 TYPE)

序号 No.	数量 Quantity	代号 Code	名称 Description		备注 Remark
1	1	830E-0513000A	胶管总成	Hose assembly	
2	1	830E-0512000A	胶管总成	Hose assembly	
3	1	830D-0535000	胶管总成	Hose assembly	
4	3	10 BS/A10.7x16x1.5 ISO	组合密封垫圈	Combinatory washer	
5	3	820-0510000	测压接头	Bolt joint	
6	1	830E-0500006	带测压口接头	Bolt joint	
7	1	830E-0500009	内外螺纹直接头	Bolt joint	
8	2	830E-0500003	内外螺纹弯接头	Bend joint	
9	2	830E-0500008	带测压口接头	Bolt joint	
10	2	830E-0500007	内外螺纹直接头	Bolt joint	
11	1	830H-0509000A	变量柱塞泵	variable plunger pump	NACHI泵
12	2	12 GB/T97.1	平垫圈	Washer	
13	2	M12x30 GB/T5783	六角头螺栓	Bolt	
14	1	820-0500023	直接头	Bolt joint	
15	2	22 BS/A 22.7x30x2 ISO	组合密封垫圈	Combinatory washer	
16	1	820-0500009	直接头	Bolt joint	
17	1	830D-0500001	直接头	Bolt joint	
18	1	830D-0509000	多路阀	Multi-change valve	(5000-G53) HUSCO
19	4	M10 GB/T6170	1型六角螺母	Nut	
20	4	10 GB/T93	弹簧垫圈	Spring washer	
21	4	10 GB/T97.1	平垫圈	Washer	
22	4	M10x40 GB/T5783	六角头螺栓	Bolt	

05.4.1 平台部分液压系统 4 (适用830T04机型) HYDRAULIC SYSTEM FOR PLATFORM 4 (APPLY TO 830T04 TYPE)

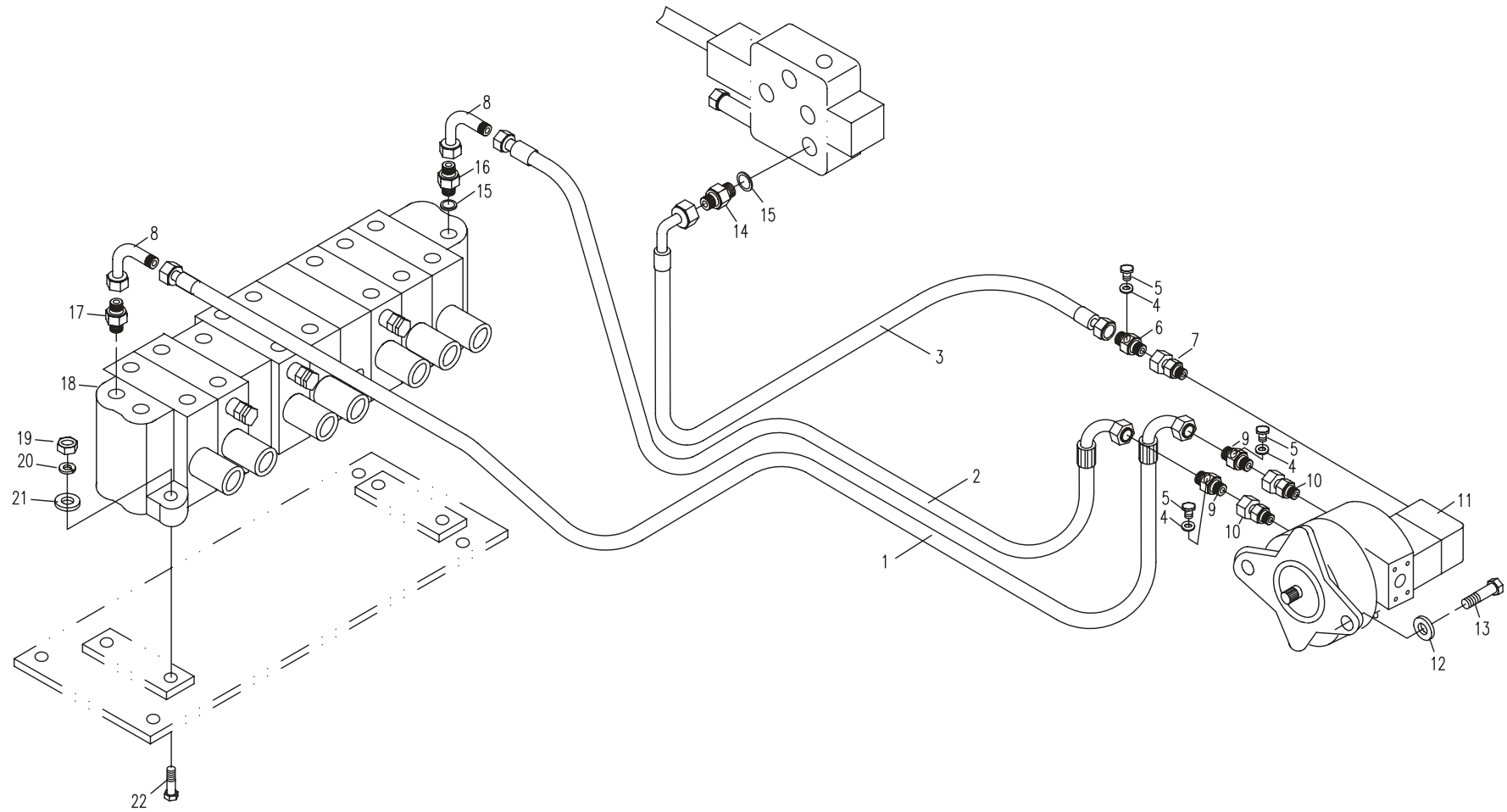



05.5.1 平台部分液压系统 5 (适用830T04机型) HYDRAULIC SYSTEM FOR PLATFORM 5 (APPLY TO 830T04 TYPE)

---

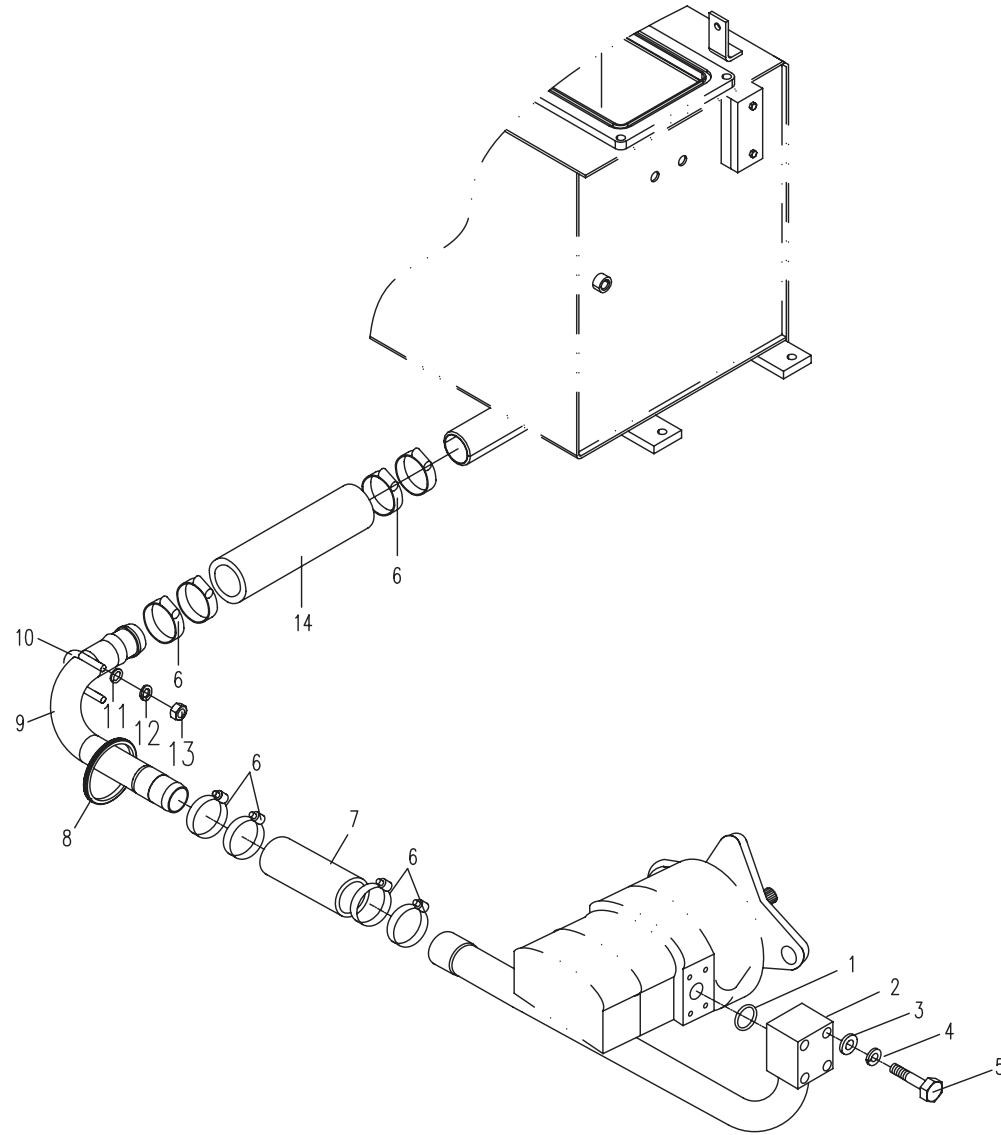



05.6.1 平台部分液压系统 6 (适用830T04机型) HYDRAULIC SYSTEM FOR PLATFORM 6 (APPLY TO 830T04 TYPE)

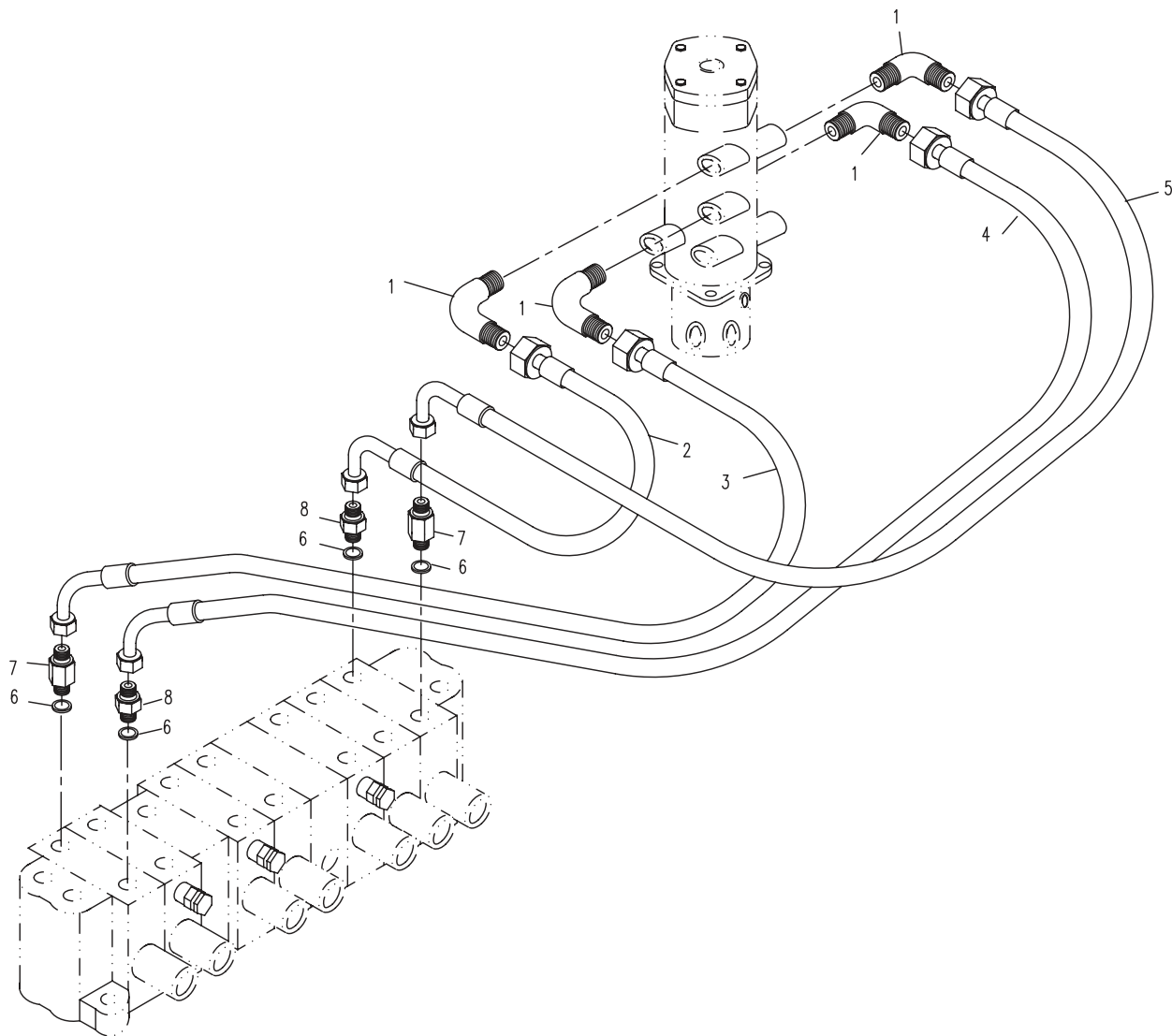





05.7.1 平台部分液压系统 7 (适用830T04机型) HYDRAULIC SYSTEM FOR PLATFORM 7 (APPLY TO 830T04 TYPE)

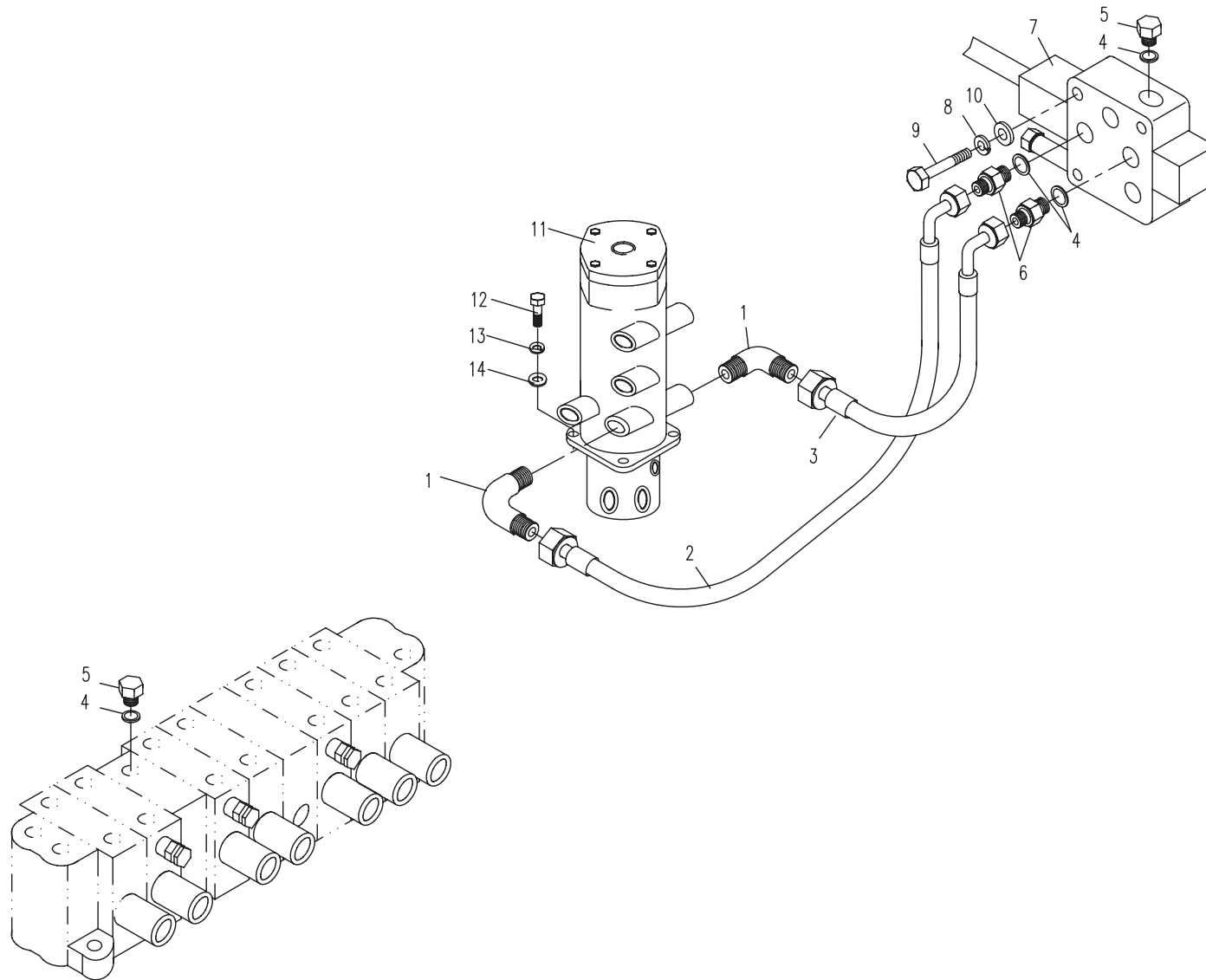

05.8.1 平台部 液压系统 8 (适用830T04机型) HYDRAULIC SYSTEM FOR PLATFORM 8 (APPLY TO 830T04 TYPE)

序号 No.	数量 Quantity	代号 Code	名称 Description		备注 Remark
1	8	22 BS/A 22.7x30x2 ISO	组合密封垫圈	Combinatory washer	
2	8	820-0500023	直接头	Bolt joint	
3	3	830D-0505000	胶管总成	Hose assembly	
4	6	18 BS/A18.7x27x2 ISO	组合密封垫圈	Combinatory washer	
5	4	820-0500031	直接头	Bolt joint	
6	2	818B-0500063	90°弯接头	Square joint	
7	1	820-0531000	偏转油缸	Boom offset cylinder assembly	
8	2	830E-0509000	胶管总成	Hose assembly	
9	2	830E-0502000	胶管总成	Hose assembly	
10	2	820-0500041	直接头	Bolt joint	
11	2	13.8x2.4 NBR-90 ISO	O形橡胶密封圈	O-seal Ring	
12	1	830D-0511000	胶管总成	Hose assembly	
13	1	T0308-01000	两位六通换向阀	Reversing valve	
14	1	830H-0528000	回转减速机	Swing motor	
15	8	M16X40 GB/T5783	六角头螺栓	Bolt	12.9-氧化
16	1	830E-0500013	液压锁支架	Bracket	
17	3	8 GB/T97.1	平垫圈	Washer	
18	3	8 GB/T93	弹簧垫圈	Spring washer	
19	2	M8x20 GB/T5783	六角头螺栓	Bolt	
20	1	830-0504000	液压锁 BYX-95	Hydraulic lock	
21	3	6 GB/T93	弹簧垫圈	Spring washer	
22	3	M6X45 GB/T70.1	内六角圆柱头螺钉	Bolt	
23	2	830E-0526000	单向节流阀	Unilateralism throttle	
24	1	820-0532000	偏转缸保护板	Cover	
25	1	820-0500012	弹簧座	Spring seat	
26	1	820-0500011	碟形弹簧	Belleville spring	
27	1	M8x35 GB/T5783	六角头螺栓	Bolt	

05.8.1 平台部分液压系统 8 (适用830T04机型) HYDRAULIC SYSTEM FOR PLATFORM 8 (APPLY TO 830T04 TYPE)

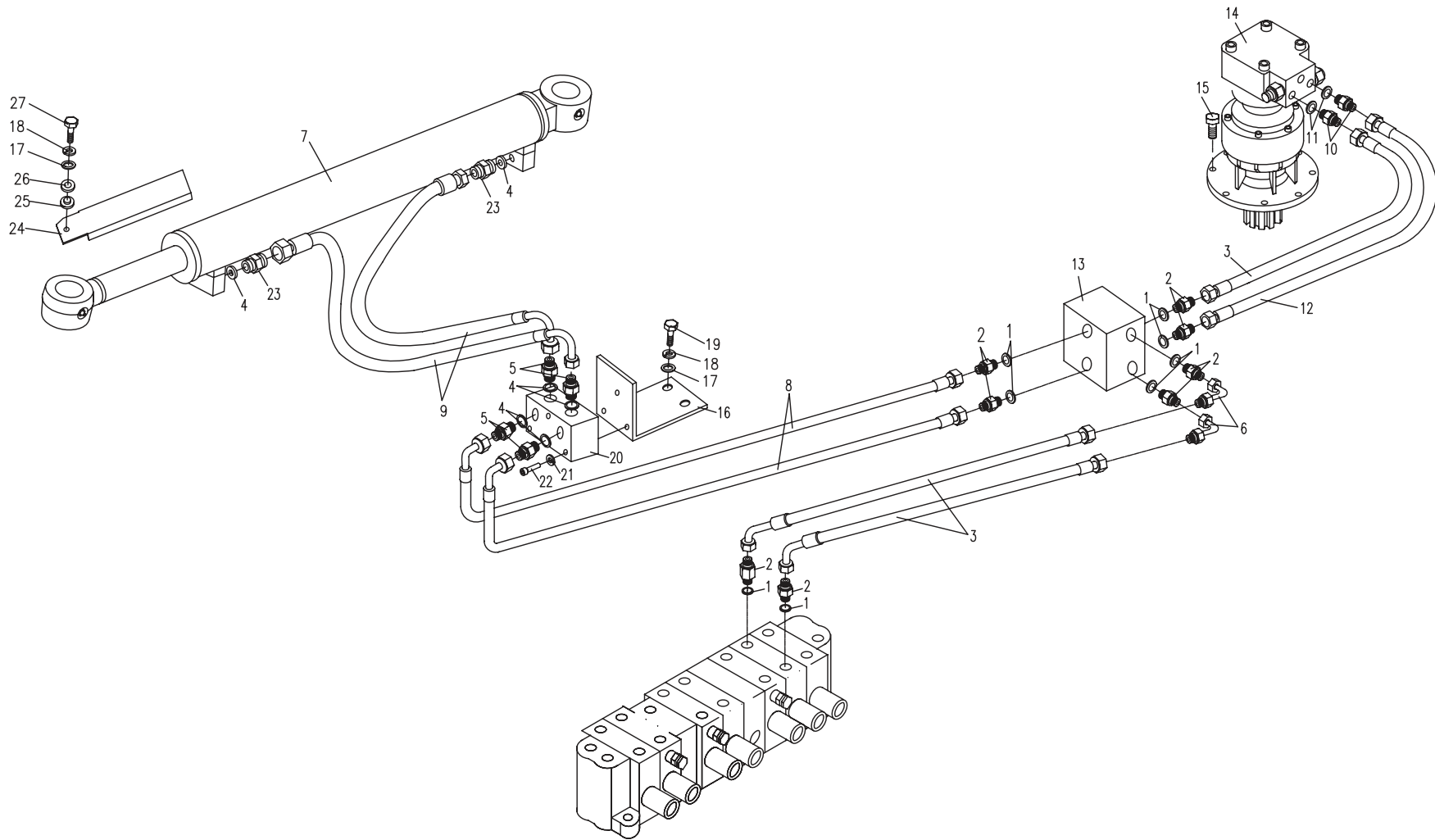



05.9.1 平台部分液压系统 9 (适用830T04机型) HYDRAULIC SYSTEM FOR PLATFORM 9 (APPLY TO 830T04 TYPE)

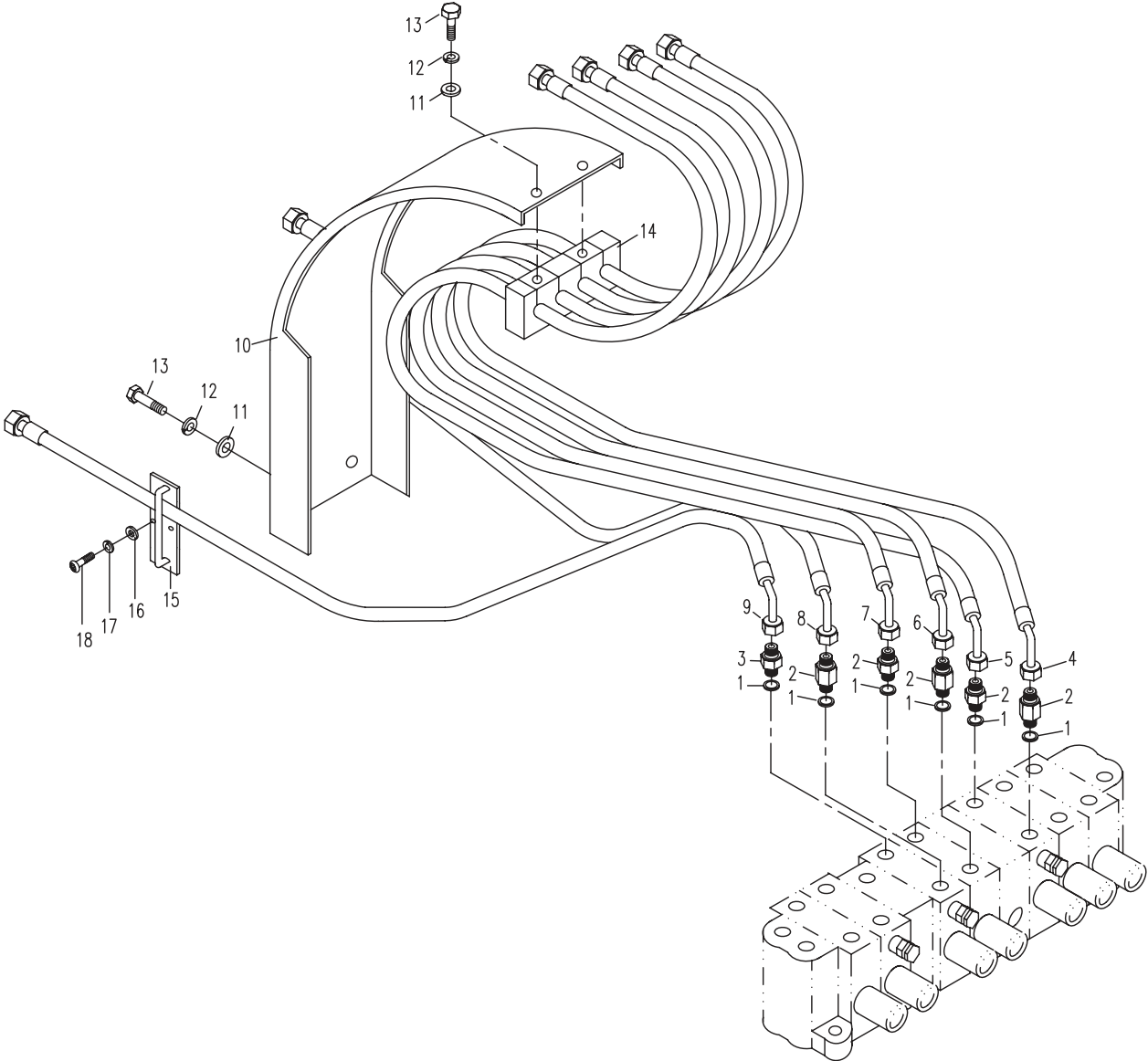



05.10.1 中央回转接头 10 (适用830T04机型) CENTRE SLEWING JOINT 10 (APPLY TO 830T04 TYPE)

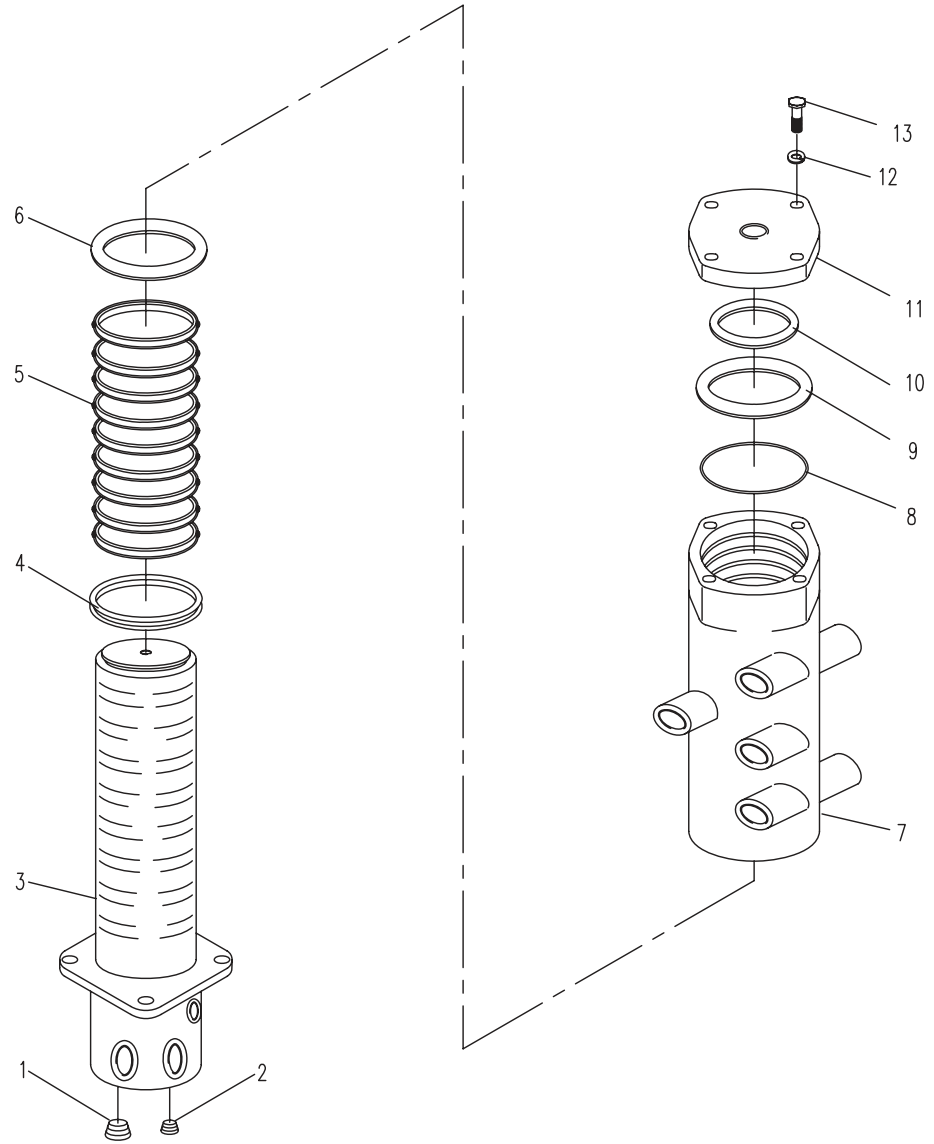





65.1.1 附属装置液压系统 (适用830T04机型) AUXILIARY EQUIPMENT HYDRAULIC SYSTEM (APPLY TO 830T04 TYPE)

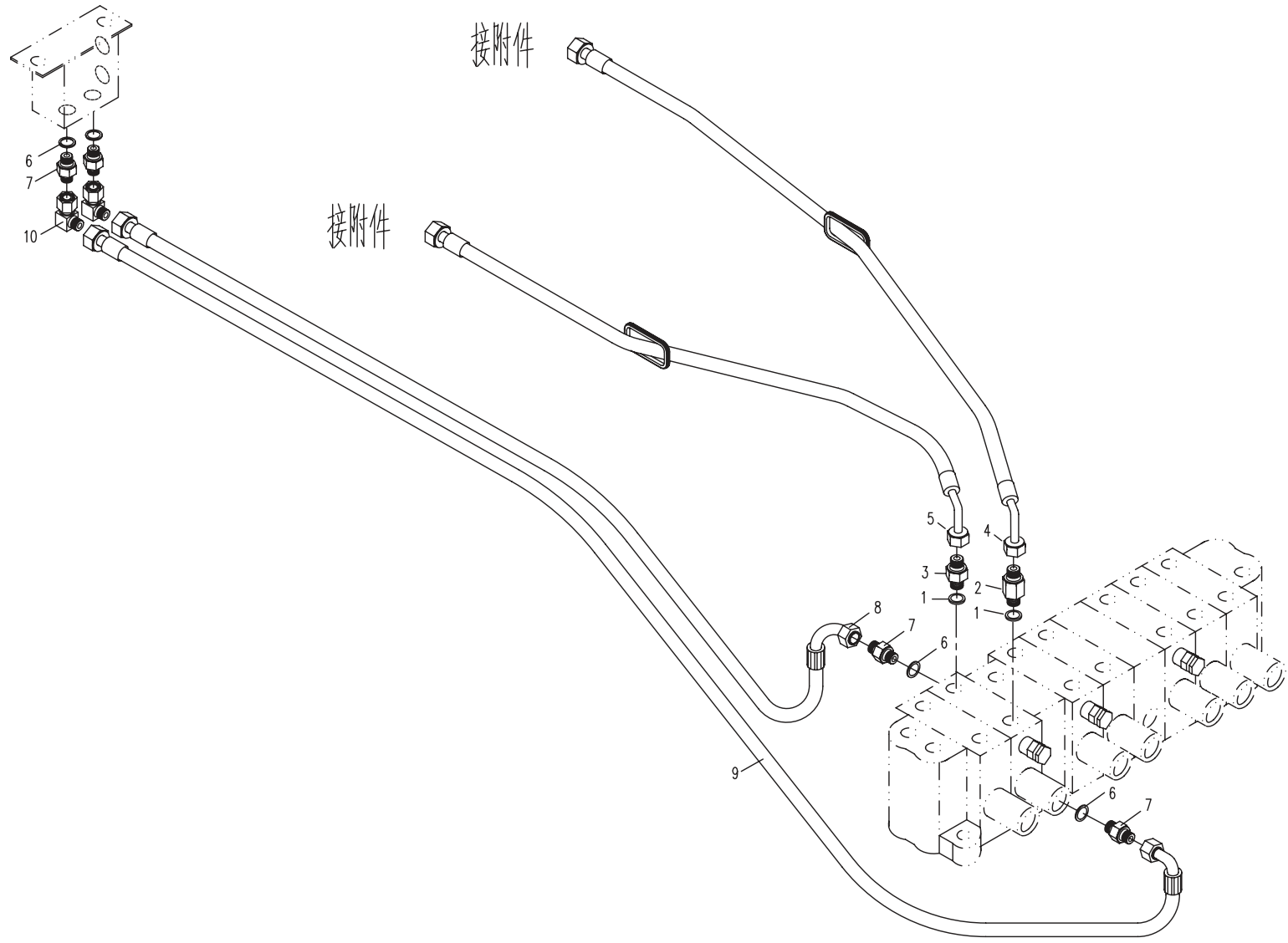

65.1.2 附属装置液压系统 (适用830T04机型) AUXILIARY EQUIPMENT HYDRAULIC SYSTEM (APPLY TO 830T04 TYPE)

序号 No.	数量 Quantity	代号 Code	名称 Description		备注 Remark
1	1	830D-9519000	右辅助钢管总成	Steel tube assembly-RH	
2	1	830D-9517000	左辅助钢管总成	Steel tube assembly-LH	
3	2	820-9504000	胶管总成	Hose assembly	
4	8	M8x35 GB/T5783	六角头螺栓	Bolt	
5	8	8 GB/T93	弹簧垫圈	Spring washer	
6	8	8 GB/T97.1	平垫圈	Washer	
7	8	820-9500005A	管夹	Clamp	
8	8	820-9500006	胶垫	Rubber spacer	
9	4	M10x20 GB/T5783	六角头螺栓	Bolt	
10	4	10 GB/T93	弹簧垫圈	Spring washer	
11	4	10 GB/T97.1	平垫圈	Washer	
12	2	830D-9500003	压板	Clamp	
13	2	830D-9501000	转阀	Valve	
14	2	830D-9500004	垫	Rubber mat	
15	4	22 BS/A22.7x30x2 ISO	组合密封垫圈	Combinatory washer	
16	2	820-7500005	弯头接头	Elbow joint	
17	2	830D-9500001	直接头	Bolt joint	适用液压锤
18	2	830-0500004	螺塞	Plug	
19	1	17.8X2.4 NBR-90	O形橡胶密封圈	O-seal ring	适用液压锤
20	1	830-9522000	单向阀	Retaining valve	适用液压锤

65.1.2 附属装置液压系统 (适用830T04机型) AUXILIARY EQUIPMENT HYDRAULIC SYSTEM (APPLY TO 830T04 TYPE)

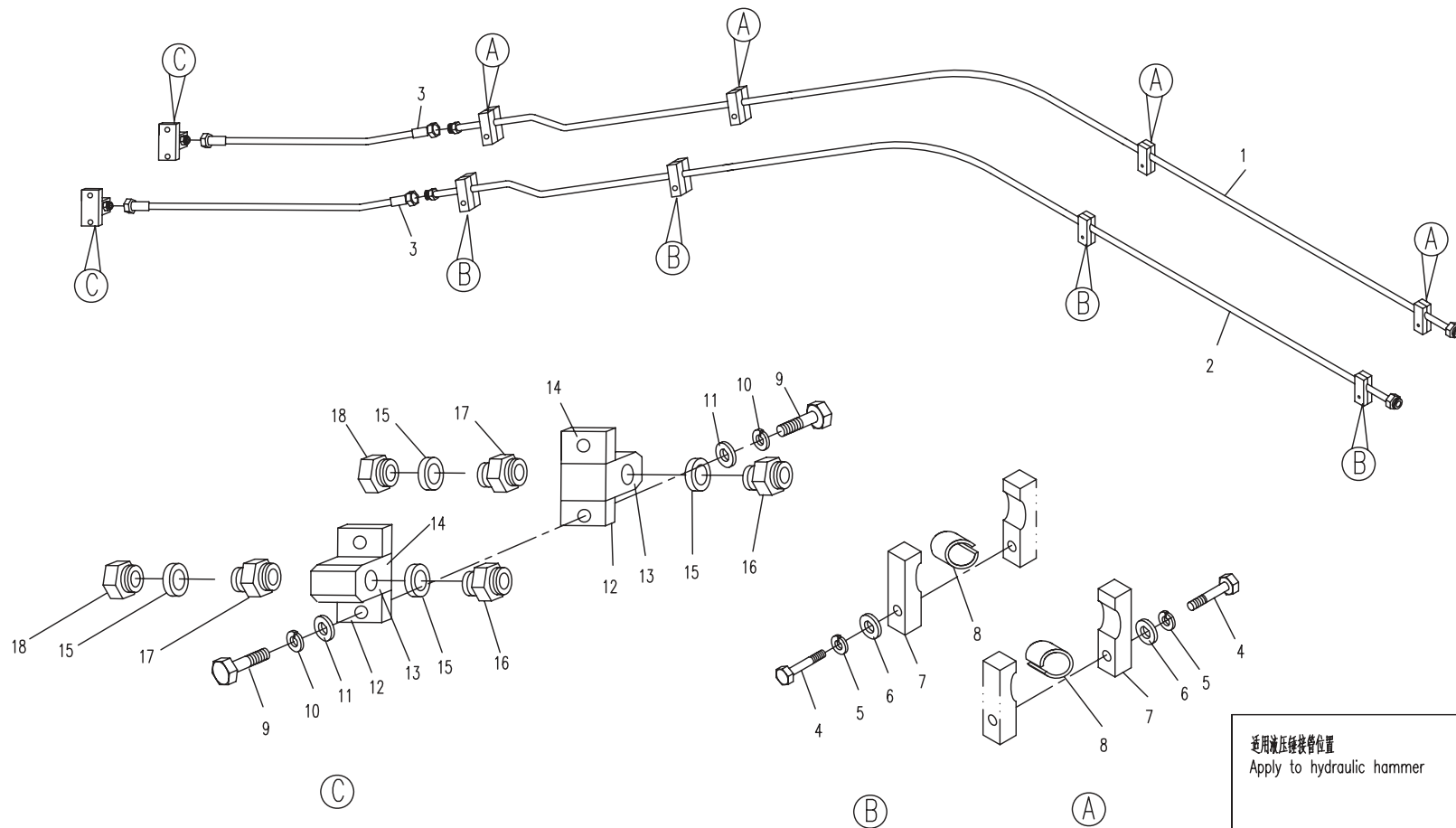

适用液压接管位置  
Apply to hydraulic hammer

高压管 High pressure hose  
低压管 Low pressure hose



75.1.1 行走装置液压系统 (适用830T04机型) TRAVEL EQUIPMENT HYDRAULIC SYSTEM (APPLY TO 830T04 TYPE)

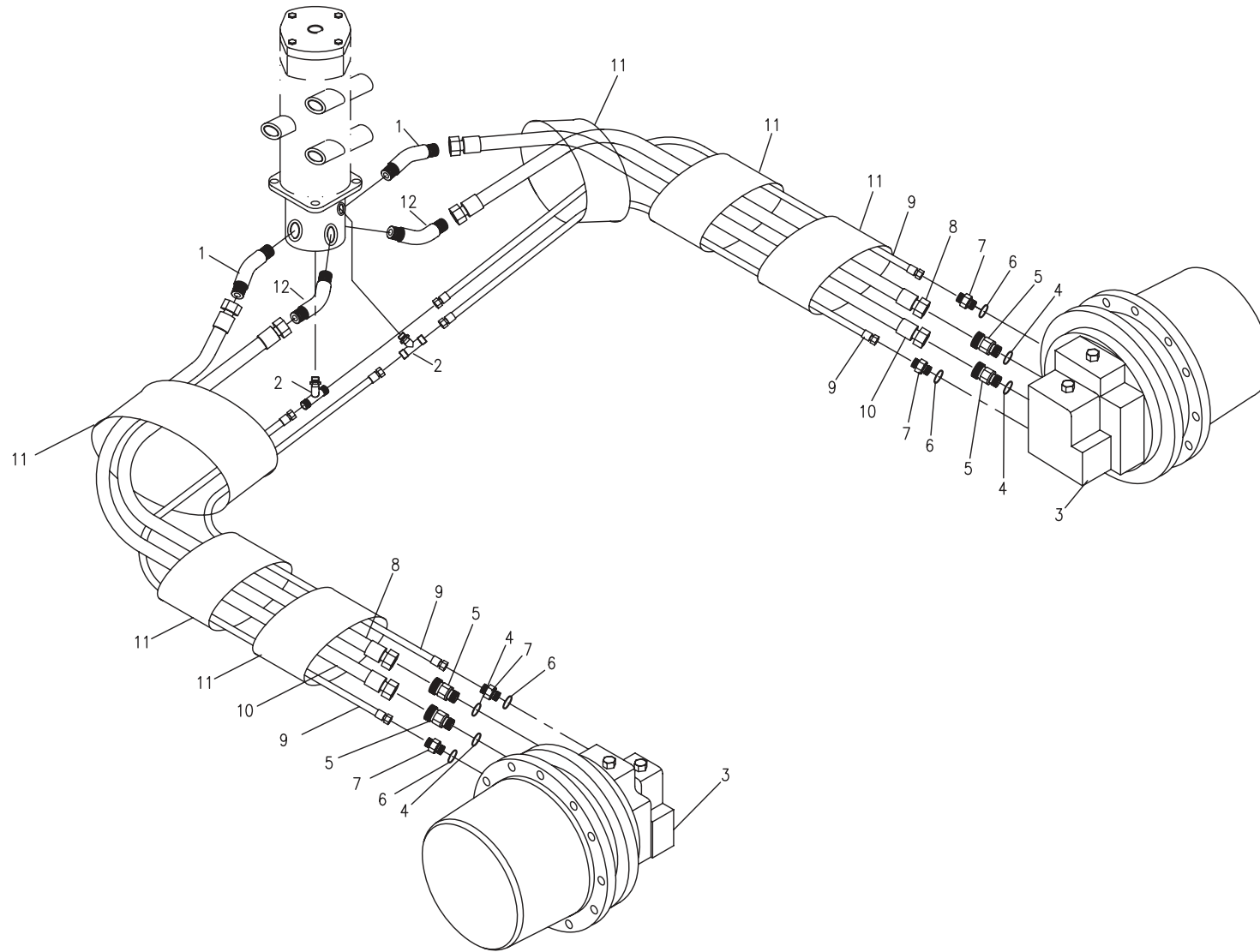



75.1.2 行走装置液压系统 (适用830T04机型) TRAVEL EQUIPMENT HYDRAULIC SYSTEM (APPLY TO 830T04 TYPE)

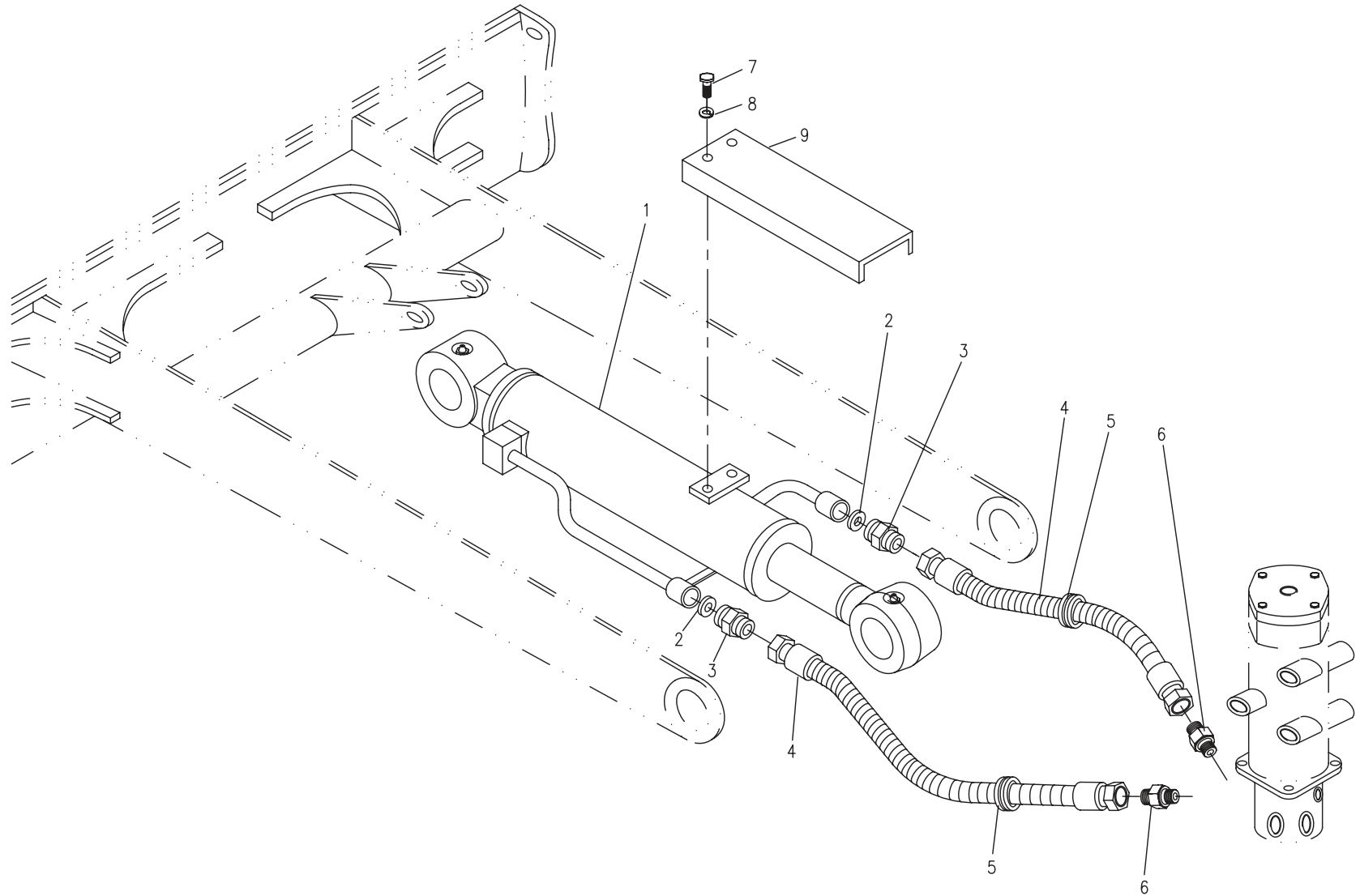



85.1.1 先导控制液压系统 1 (适用830T04机型) PILOT EQUIPMENT HYDRAULIC SYSTEM 1 (APPLY TO 830T04 TYPE)

序号 No.	数量 Quantity	代号 Code	名称 Description		备注 Remark
1	1	13.8×2.4 NBR-90	O形橡胶密封圈	O seal ring	
2	1	820-8500013	直接头	Bolt joint	
3	1	830D-8521000A	胶管总成	Hose assembly	
4	5	820-0500003	直接头	Bolt joint	
5	8	18 BS/A18.7×27×2 ISO	组合密封垫圈	Combinatory washer	
6	1	820-8514000	滤油器	Oil filter	
7	1	830B-8505000	直接头	Bolt joint	
8	1	828-8506000	油源阀总成	Valve	
9	1	830B-8500002	支承弯板	Bracket	
10	3	8 GB/T97.1	平垫圈	Washer	
11	3	8 GB/T93	弹簧垫圈	Spring washer	
12	3	M8×20 GB/T5783	六角头螺栓	Bolt	
13	4	850-8502000	三通接头	Tee joint	
14	1	830D-8522000A	胶管总成	Hose assembly	
15	1	830D-8503000A	胶管总成	Hose assembly	
16	2	14 BS/A14.7×21×1.5 ISO	组合密封垫圈	Combinatory washer	
17	1	830B-8500003	直接头	Bolt joint	
18	1	22 BS/A22.7×30×2 ISO	组合密封垫圈	Combinatory washer	
19	1	820-8544000	蓄能器	Accumulator	
20	1	850D-8500002	直角接头	Square joint	
21	1	828-8505000	胶管总成	Hose assembly	
22	1	10.8×2.4 NBR-90 ISO	O形橡胶密封圈	O seal ring	
23	1	855-7500002	直接头	Bolt joint	
24	1	850-8501000	三通接头	Tee joint	
25	1	830D-8504000	胶管总成	Hose assembly	
26	2	M6×15 GB/T5783	六角头螺栓	Bolt	
27	4	6 GB/T93	弹簧垫圈	Spring washer	
28	1	830-8505000	转阀	Turning vale	

85.1.1 先导控制液压系统 1 (适用830T04机型) PILOT EQUIPMENT HYDRAULIC SYSTEM 1 (APPLY TO 830T04 TYPE)

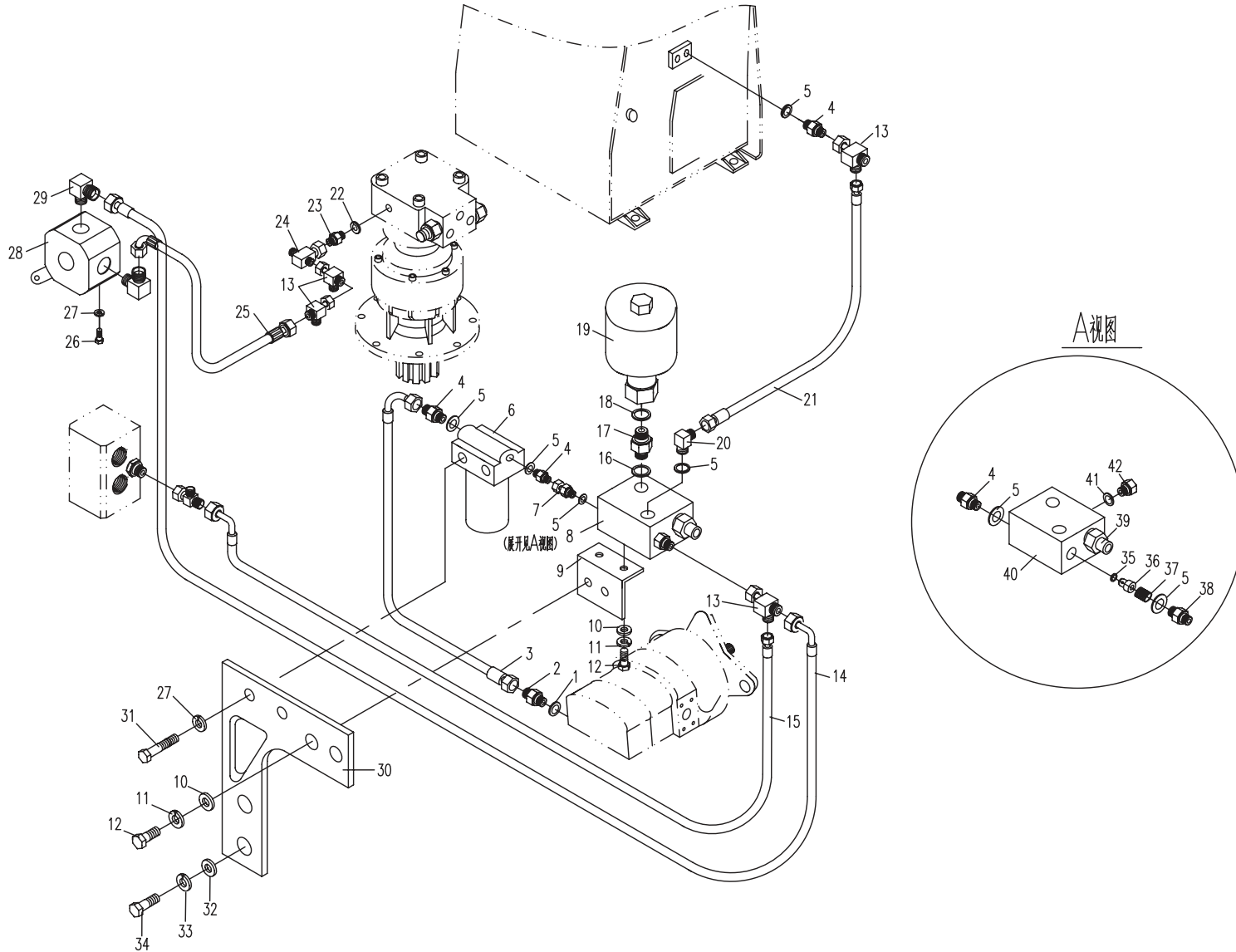



85.1.1 先导控制液压系统 1 (适用830T04机型) PILOT EQUIPMENT HYDRAULIC SYSTEM 1 (APPLY TO 830T04 TYPE)

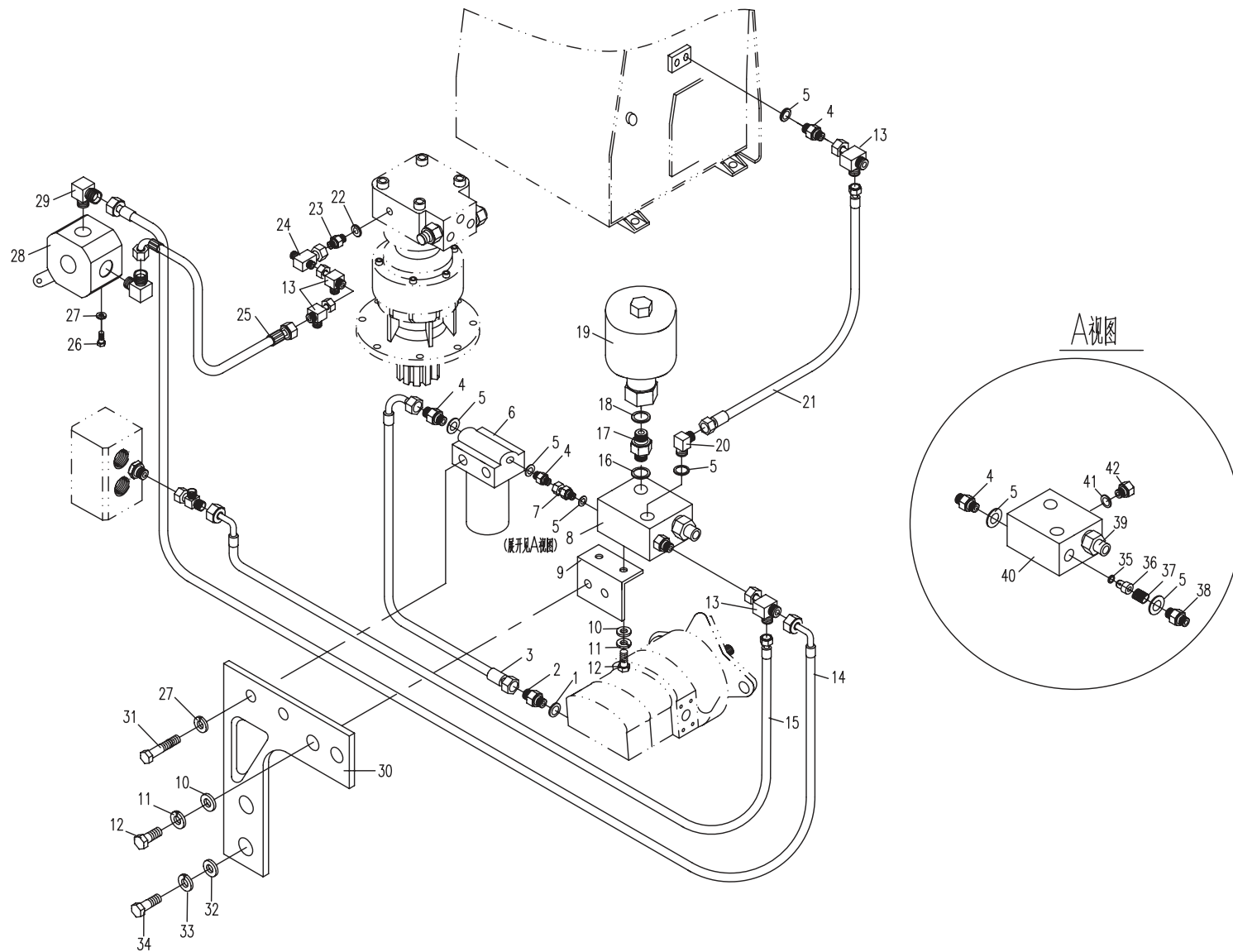

85.2.1 先导控制液压系统 2 (适用830T04机型) PILOT EQUIPMENT HYDRAULIC SYSTEM 2 (APPLY TO 830T04 TYPE)

序号 No.	数量 Quantity	代号 Code	名称 Description		备注 Remark
1	2	M6×25 GB/T70.1	内六角圆柱头螺钉	Bolt	
2	2	6 GB/T93	弹簧垫圈	Spring washer	
3	2	6 GB/T97.1	平垫圈	Washer	
4	1	T0301-12000	踏板先导阀	Dozer pilot valve	
5	7	14 BS/A14.7×21×1.5 ISO	组合密封垫圈	Combinatory washer	
6	7	820-8500004	直接头	Bolt joint	
7	2	830D-8523000A	胶管总成	Hose assembly	
8	1	830D-8519000A	胶管总成	Hose assembly	
9	4	850-8502000	三通接头	Tee joint	
10	3	830D-8521000A	胶管总成	Hose assembly	
11	2	T0309-03000	电磁阀	Solenoid valve	ARGO (电压12V)
12	8	5 GB/T93	弹簧垫圈	Spring washer	
13	8	M5×50 GB/T 70.1	内六角圆柱头螺钉	Bolt	
15	1	828-0520001	阀板	Bracket	
16	3	10 GB/T97.1	平垫圈	Washer	
17	3	10 GB/T93	弹簧垫圈	Spring washer	
18	3	M10×25 GB/T5783	六角头螺栓	Bolt	
19	6	8 GB/T97.1	平垫圈	Washer	
20	6	8 GB/T93	弹簧垫圈	Spring washer	
21	6	M8×20 GB/T5783	六角头螺栓	Bolt	
22	1	820-8500006	直角接头	Square joint	
23	1	820-0500001	三通接头	Tee joint	
24	1	830D-8522000A	胶管总成	Hose assembly	
25	1	10.8×2.4 NBR-90 ISO	O形橡胶密封圈	O-Ring	
26	1	855-7500002	直接头	Bolt joint	
27	1	18 BS/A18.7×27×2 ISO	组合密封垫圈	Combinatory washer	

85.2.1 先导控制液压系统 2 (适用830T04机型) PILOT EQUIPMENT HYDRAULIC SYSTEM 2 (APPLY TO 830T04 TYPE)

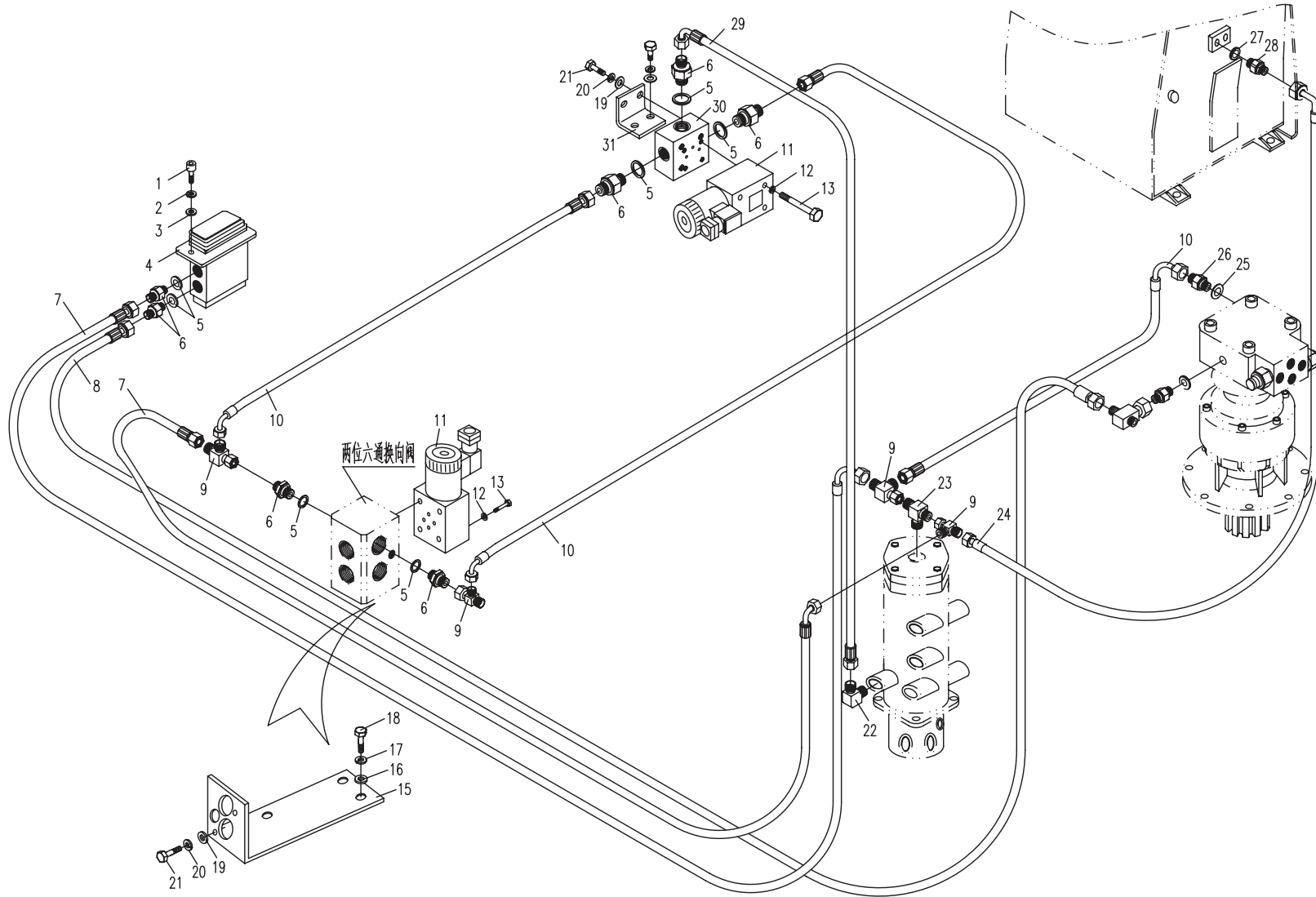







85.3.1 先导控制液压系统 3 (适用830T04机型) PILOT EQUIPMENT HYDRAULIC SYSTEM 3 (APPLY TO 830T04 TYPE)

序号 No.	数量 Quantity	代号 Code	名称 Description		备注 Remark
1	4	M6×25 GB/T70.1	内六角圆柱头螺钉	Bolt	
2	4	6 GB/T93	弹簧垫圈	Spring washer	
3	4	6 GB/T97.1	平垫圈	Washer	
4	1	T0301-01000	左先导阀	Pilot valve-LH	JRCVJ-07C-LH
5	6	10.8×2.4 NBR-90 ISO	O形橡胶密封圈	O-seal ring	
6	4	860A-8500003	直接头	Bolt joint	
7	2	855-7500002	直接头	Bolt joint	
8	1	828-8505000	胶管总成	Hose assembly	
9	1	830D-8518000	胶管总成	Hose assembly	
10	1	830D-8517000	胶管总成	Hose assembly	
11	1	830D-8501000	胶管总成	Hose assembly	
12	1	830D-8512000	胶管总成	Hose assembly	
13	1	830D-8511000	胶管总成	Hose assembly	
14	1	850-8502000	三通接头	Tee joint	
15	1	820-8500004	直接头	Bolt joint	
16	4	14 BS/A14.7×21×1.5 ISO	组合密封垫圈	Combinatory washer	
17	1	830D-8523000A	胶管总成	Hose assembly	
18	1	850-8505000	三通接头	Tee joint	
19	1	830D-8503000A	胶管总成	Hose assembly	
20	2	820-8500003	直接头	Bolt joint	
21	2	830E-8502000	可调接头	Adjustable joint	
22	1	830D-8500002	胶管护套	Rubber pipe sleeve	

85.3.1 先导控制液压系统 3 (适用830T04机型) PILOT EQUIPMENT HYDRAULIC SYSTEM 3 (APPLY TO 830T04 TYPE)

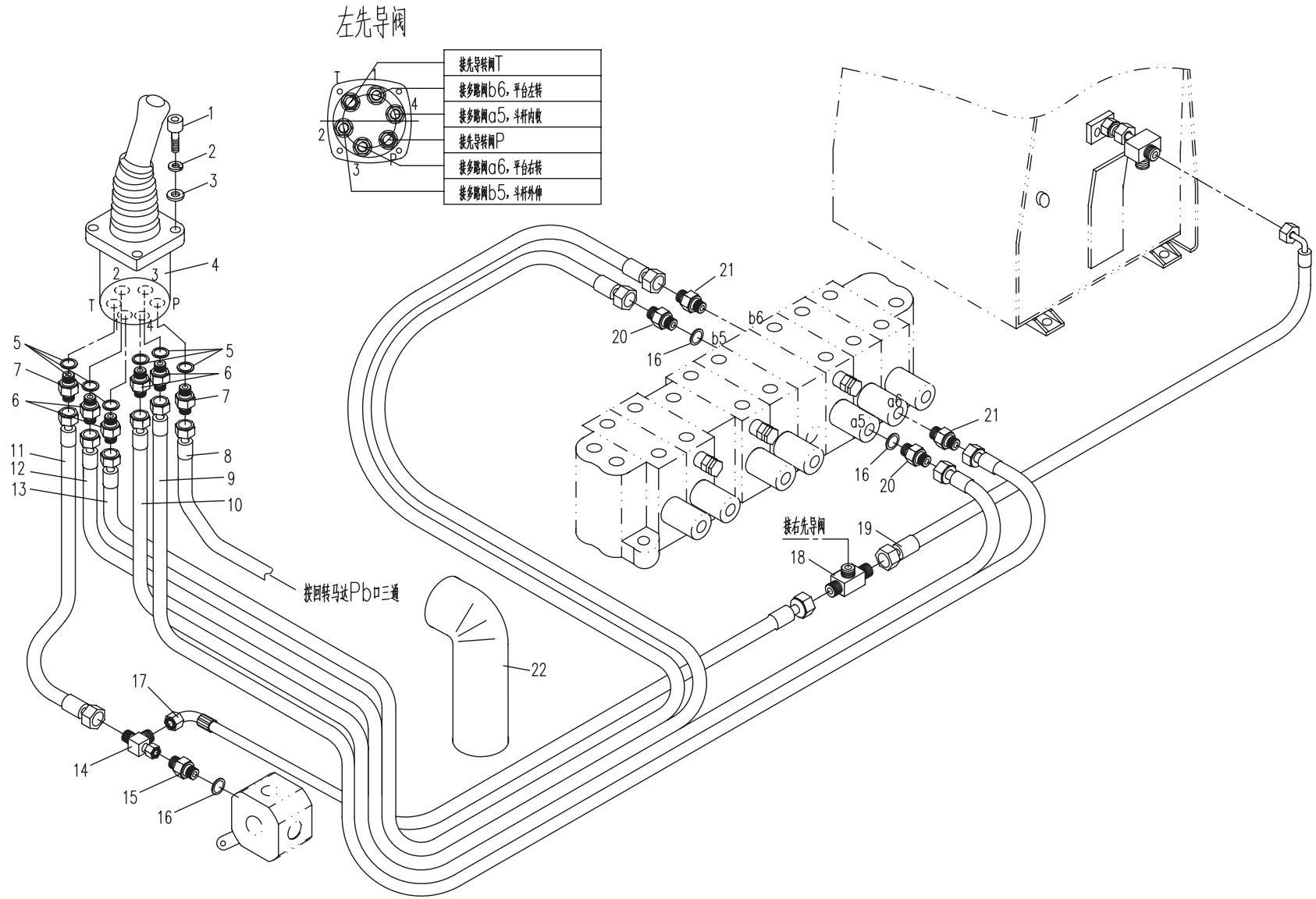



85.4.1 先导控制液压系统 4 (适用830T04机型) PILOT EQUIPMENT HYDRAULIC SYSTEM 4 (APPLY TO 830T04 TYPE)

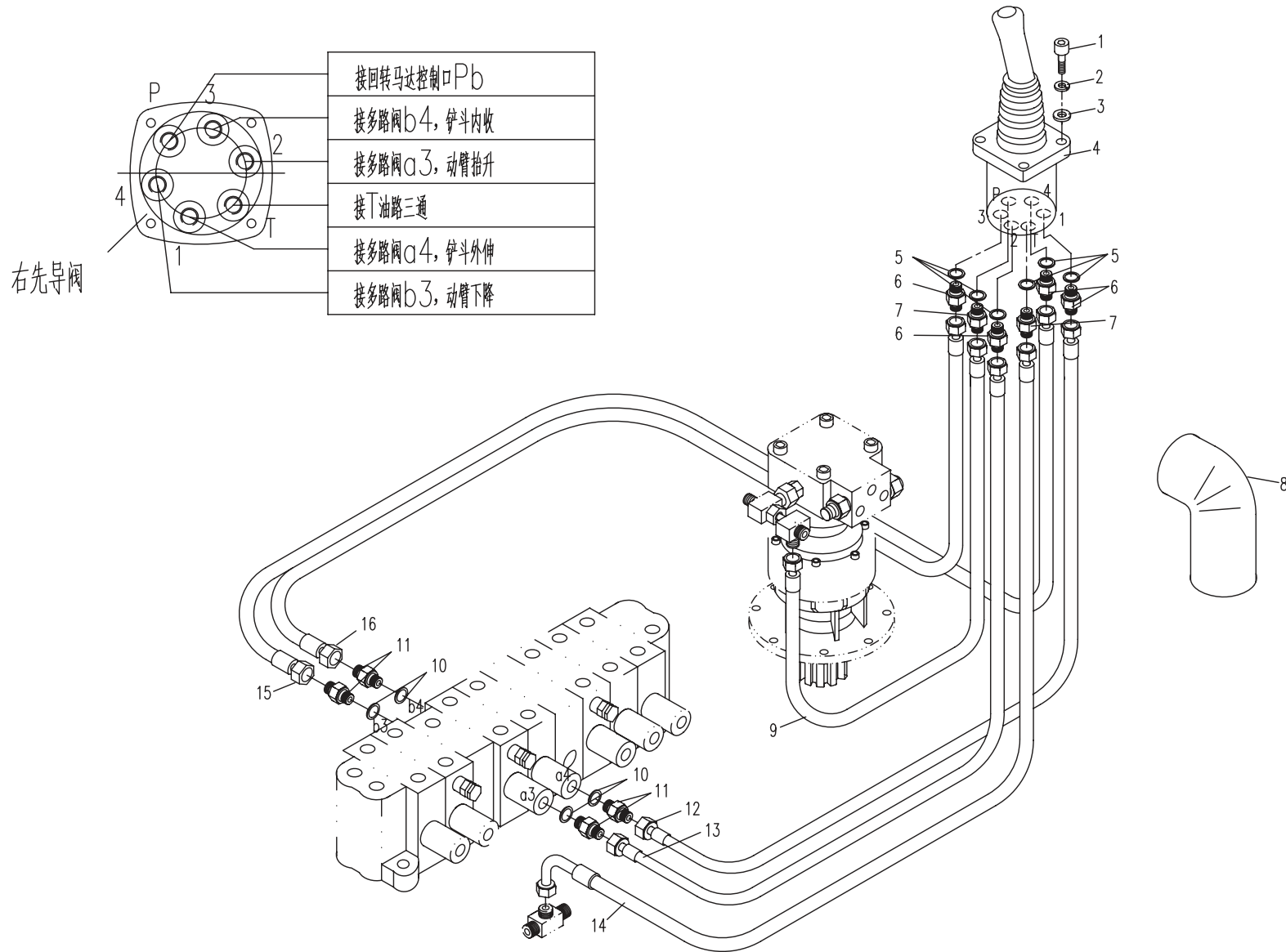



85.5.1 先导控制液压系统5 (适用830T04机型) PILOT EQUIPMENT HYDRAULIC SYSTEM 5 (APPLY TO 830T04 TYPE)

---

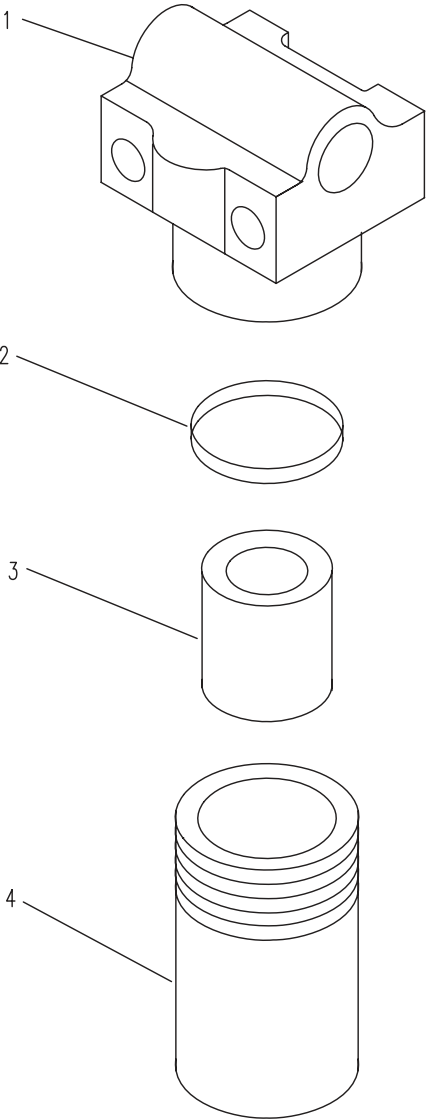

95.1.1 工作装置液压系统 1 (适用830T04机型) HYDRAULIC SYSTEM FOR WORKING EQUIPMENT 1 (APPLY TO 830T04 TYPE)

序号 No.	数量 Quantity	代号 Code	名称 Description		备注 Remark
1	6	M8x1 JB/T7940.1	直通式压注油杯	Grease cup	
2	6	801-0400001	油杯罩盖	Grease cup cover	
3	1	820-9502000	铲 油缸	Bucket cylinder	韩国
	1	830D-9551000	铲 油缸	Bucket cylinder	恒立
4	6	17.8x2.4 NBR-90	O形橡胶密封圈	O-seal ring	
5	3	850-0500005	直接头	Bolt joint	
6	2	820-9503000	胶管总成	Hose assembly	
7	2	M8x30 GB/T5783	六角头螺栓	Bolt	
8	10	8 GB/T93	弹簧垫圈	Spring washer	
9	2	820-9500003A	管夹	Clamp	
10	2	820-9500004	胶垫	Rubber spacer	
11	1	830D-9505000	杆油缸	Arm cylinder	韩国
	1	830D-9552000	杆油缸	Arm cylinder	恒立
12	1	820-9512000	钢管总成	Steel pipe assembly	
13	1	820-9513000	钢管总成	Steel pipe assembly	
14	1	830D-9511000	胶管总成	Hose assembly	
15	2	830D-9514000	钢管总成	Steel pipe assembly	
16	2	820-9500012	下压板	Lower clamping plate	
17	2	820-9500011	管夹	Clamp	
18	2	820-9500009	上压板	Upper clamping plate	
19	2	M8 40 GB/T5783	六角头螺栓	Bolt	
20	1	830D-9530000	单向节流阀	Valve	
21	1	10 GB/T93	弹簧垫圈	Spring washer	
22	1	M10x30 GB/T5783	六角头螺栓	Bolt	
23	1	820-9509100	保护板	Protective plate	
24	4	M8 GB/T6170	1型六角螺母	Nut	
25	14	8 GB/T97.1	平垫圈	Washer	

95.1.1 工作装置液压系统 1 (适用830T04机型) HYDRAULIC SYSTEM FOR WORKING EQUIPMENT 1 (APPLY TO 830T04 TYPE)

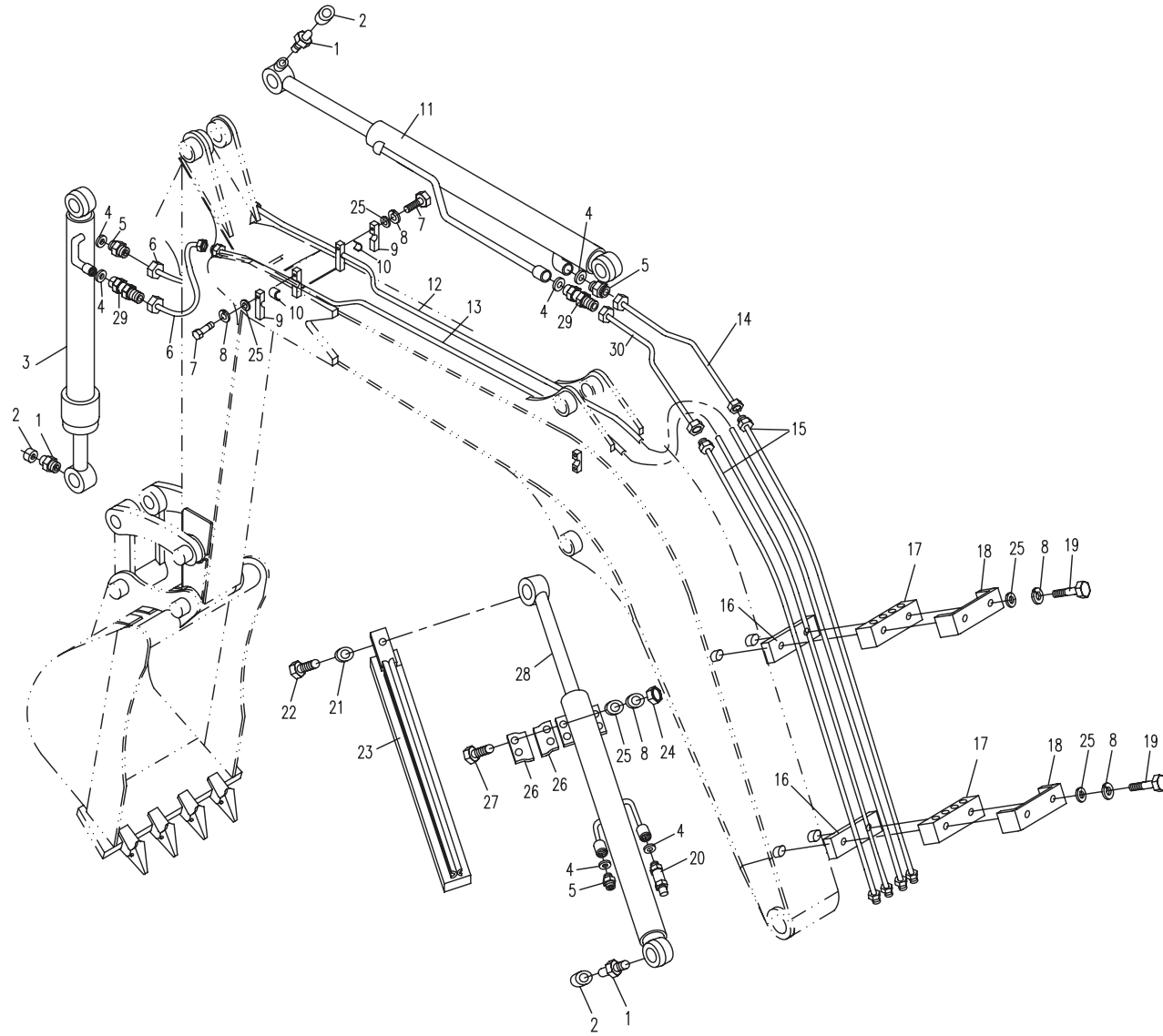





95.1.1 工作装置液压系统 1 (适用830T04机型) HYDRAULIC SYSTEM FOR WORKING EQUIPMENT 1 (APPLY TO 830T04 TYPE)

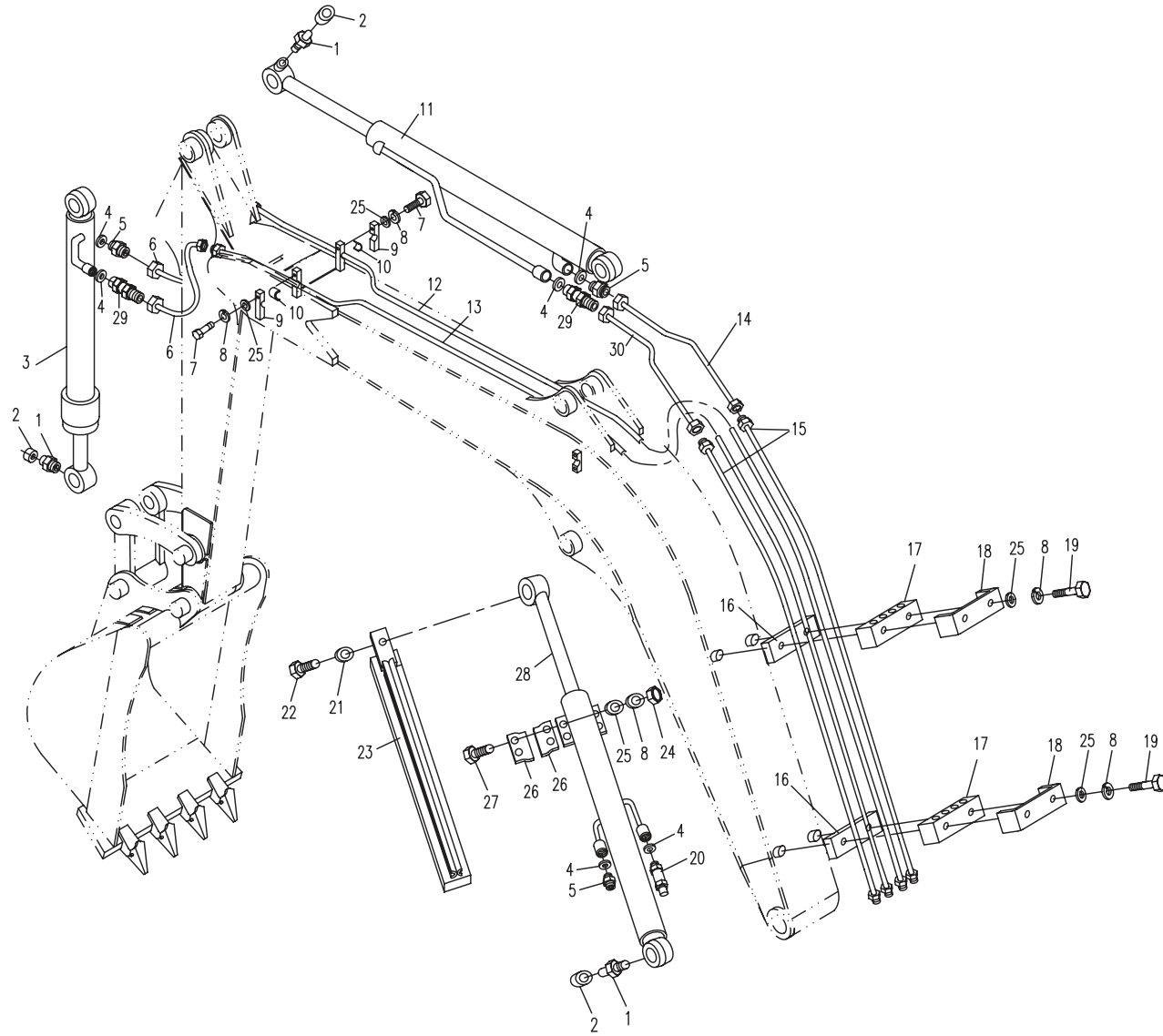

06.1.1 操纵机构(适用830T机型) CONTROL FRAMEWORK(APPLY TO 830T TYPE)

序号 No.	数量 Quantity	代号 Code	名称 Description		备注 Remark
1	14	M6 20 GB/T70.1	内六角圆柱头螺钉	Bolt	8. 8-Zn. D
2	28	6 GB/T93	弹簧垫圈	Spring washer	Zn.D
3	2	830P-0602001	上箱	Upper box	
4	1	830P-0602003	右面板	Right panel	
5	8	5 GB/T93	弹簧垫圈	Spring washer	Zn. D
6	8	M5x10 GB/T818	十字槽盘头螺钉	Bolt	8. 8-Zn. D
7	2	860-0600004	压板	Press plate	
8	1	830P-0602100A	右支架	Right bracket	
9	5	M8x25 GB/T5789	六角法兰面螺栓	Bolt	8. 8-Zn. D
10	2	830P-0602002	下箱	Below box	
11	1	830P-0611000	平台锁定杆	The lock of the platform	
12	1	830D-0600043A	橡胶套	Rubber wrap	
13	1	830P-0604100	阀罩	Valve cover	
14	41	M8x16 GB/T5789	六角法兰面螺栓	Bolt	8. 8-Zn. D
15	1	830P-0604005	后海绵	Rear sponge	
16	1	830P-0604003	右海绵	Right sponge	
17	1	830P-0604004	顶海绵	Upper sponge	
18	1	830P-0604006	前海绵	Front sponge	
19	1	830P-0604001	阀罩盖	Cover	
20	1	830D-0600022	支撑板	Bracket	
21	1	830D-0600038	胶塞	Rubber plug	
22	5	M8 GB/T6170	1型六角螺母	Nut	8-Zn. D
23	1	830D-0600037	防尘套III	Dust wrap III	
24	1	830P-0604002	推土手柄	Handle of dozer valve	
25	2	810S-0604600	手柄头	Handle ball	
26	1	830P-0601000A	框架组件	Frame assembly	
27	4	M14 30 GB/T70.1	内六角圆柱头螺钉	Bolt	8. 8-Zn. D
28	4	14 GB/T97.1	平垫圈	Washer	Zn. D

06.1.1 操纵机构(适用830T04机型) CONTROL FRAMEWORK(APPLY TO 830T04 TYPE)

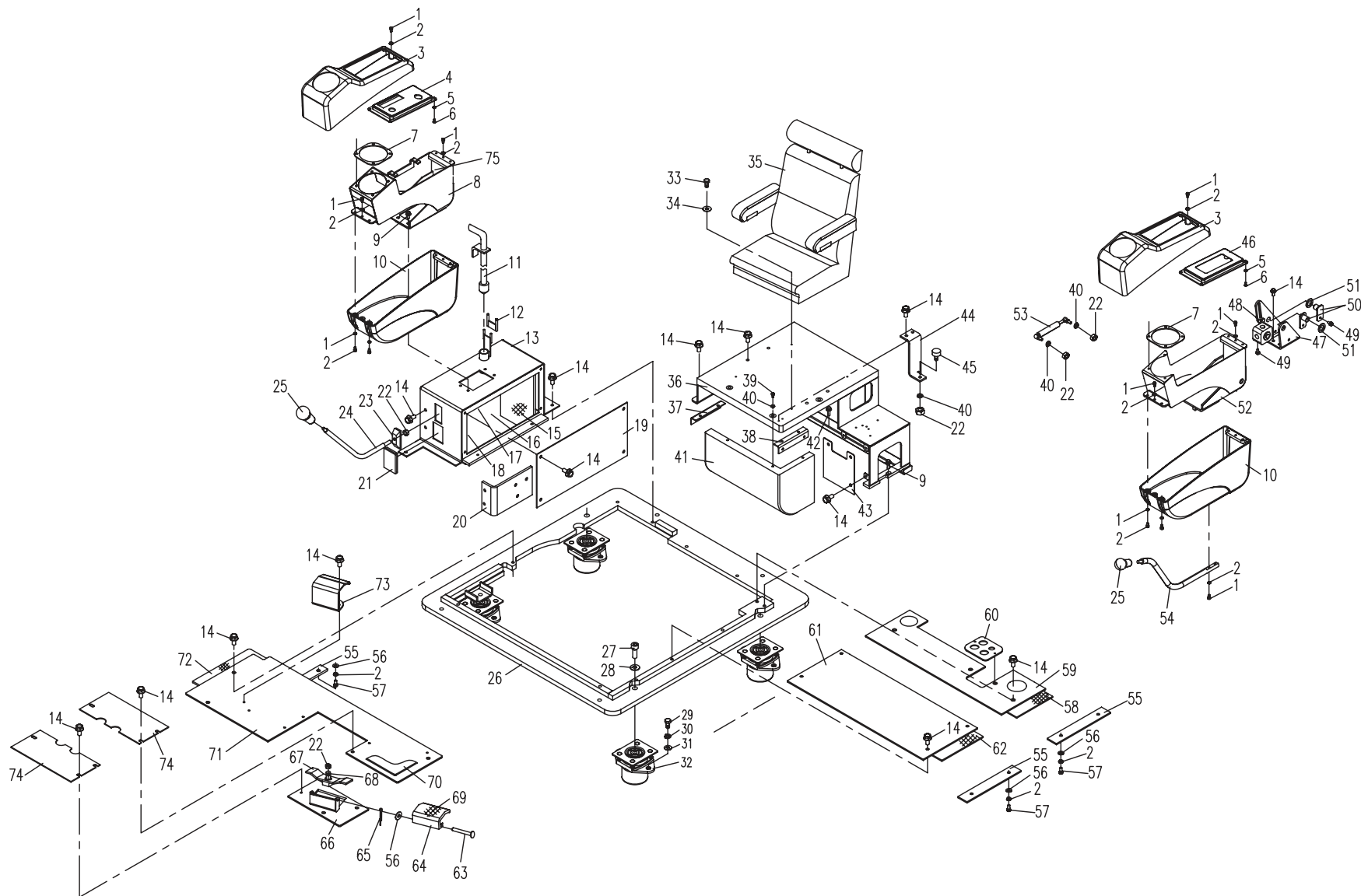

06.1.1 操纵机构(适用830T机型) CONTROL FRAMEWORK(APPLY TO 830T TYPE)

序号 No.	数量 Quantity	代号 Code	名称 Description		备注 Remark
29	8	M10X20 GB/T5783	六角头螺栓	Bolt	8. 8-Zn. D
30	8	10 GB/T93	弹簧垫圈	Spring washer	Zn. D
31	8	10 GB/T97. 1	平垫圈	Washer	Zn. D
32	4	830P-0600001	减震器	Shock absorber	
33	4	M8X16 GB/T5783	六角头螺栓	Bolt	8. 8-Zn. D
34	4	8 GB/T97. 1	平垫圈	Washer	Zn.D
35	1	830D-0600026	座椅	Seat	
36	1	830P-0605100A	座椅架	Supporting plate of seat	
37	1	858-0606000	空调右安装板	Right bracket	
38	1	858-0609000	空调左安装板	Left bracket	
39	3	M8X30 GB/T70. 1	内六角圆柱头螺钉	Bolt	8. 8-Zn. D
40	6	8 GB/T93	弹簧垫圈	Spring washer	Zn.D
41	1	830P-0605200	围罩	Cover	
42	2	M8 35 GB/T5789	六角法兰面螺栓	Bolt	8. 8-Zn. D
43	1	830P-0605001A	挡板	Baffle	
44	1	830P-0605300A	前支撑	Front supporting	
45	1	818B-0608000	螺钉帽	Cap of bolt	
46	1	830P-0603004	左面板	Left panel	
47	1	830P-0603300	后支撑	Rear supporting	
48	1	830D-0615000	安全阀手柄	Handspike of safety valve	
49	4	M6x12 GB/T5789	六角法兰面螺栓	Bolt	8. 8-Zn. D
50	2	830P-0603200	转轴	Axes	
51	2	850-0600002	隔垫片	Washer	
52	1	830P-0603100A	左支架	Left bracket	
53	1	810A-1503000	气弹簧	Gas spring	
54	1	830P-0603001A	拉杆	Draught pole	
55	7	830P-0606001	垫板	Press plate	
56	16	6 GB/T97. 1	平垫圈	Washer	Zn. D

06.1.1 操纵机构(适用830T04机型) CONTROL FRAMEWORK(APPLY TO 830T04 TYPE)

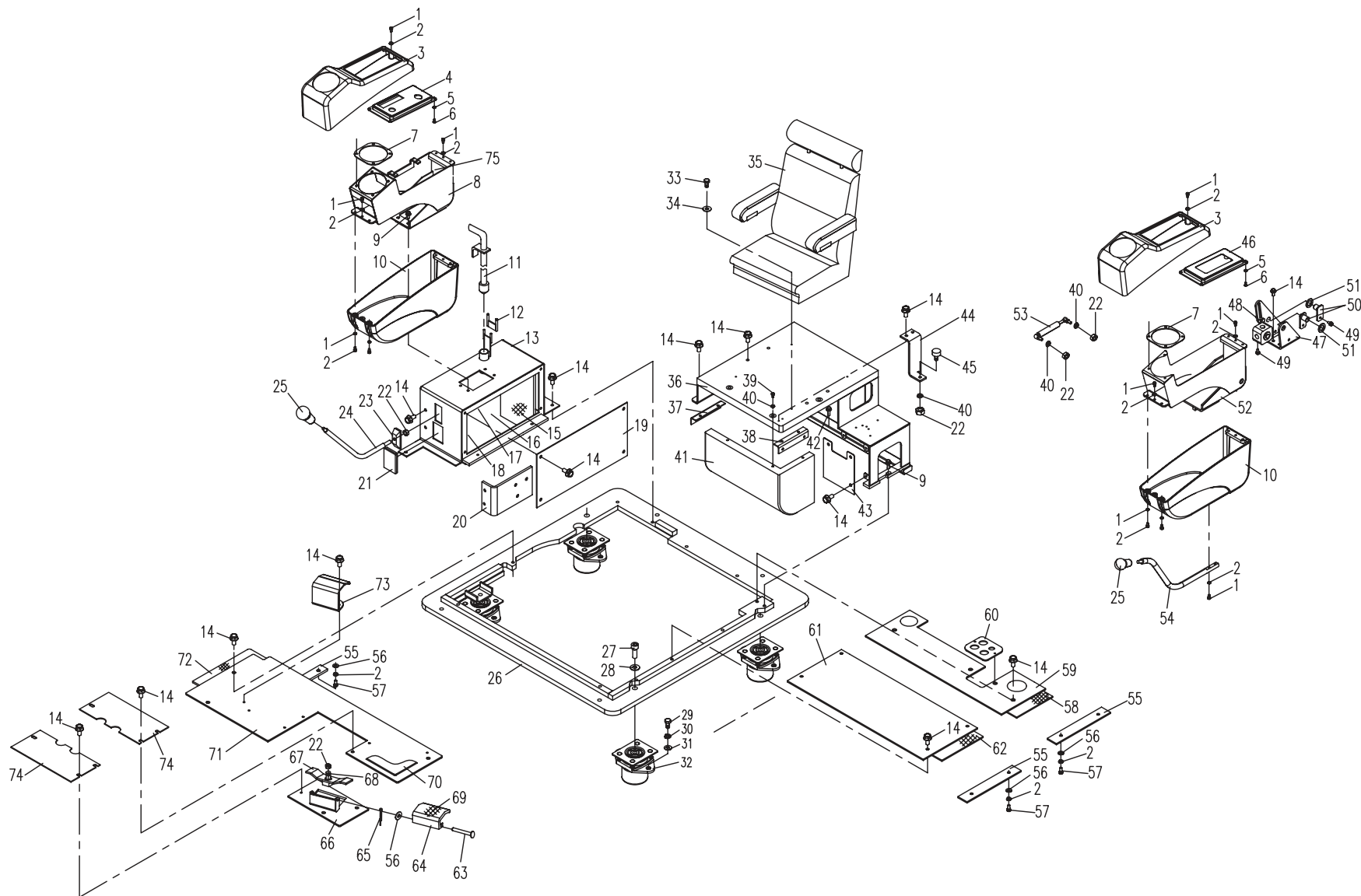

06.1.1 操纵机构(适用830T机型) CONTROL FRAMEWORK(APPLY TO 830T TYPE)

序号 No.	数量 Quantity	代号 Code	名称 Description		备注 Remark
57	14	M6X16 GB/T5783	六角头螺栓	Bolt	8. 8-Zn. D
58	1	830P-0607001A	隔音绵	Sponge	
59	1	830P-0607100A	后底板	Rear motherboard	
60	1	830D-0600015	盖板	Cover	
61	1	830P-0608100	中底板	Middle motherboard	
62	1	830P-0608001A	隔音绵	Sponge	
63	2	6X16 GB/T 882	销轴	Pin	Zn. D
64	1	830P-0609100	脚踏盖板	Cover plate	
65	2	2X12 GB/T 91	开口销	Cotter pin	Zn. D
66	1	830H-0613000	左底板	Left Motherboard	
67	1	830D-0611100	踏板	Footplate	
68	1	830D-0611002	螺杆	Screw	
69	1	860E-0613001	橡胶踏	Rubber footplate	
70	1	830P-0600002B	地板胶	Rubber floorboard	
71	1	830P-0606100A	前底板	Front motherboard	
72	1	830P-0606002A	隔音绵	Sponge	
73	1	835-0614000A	脚踏板组件	Footplate	
74	2	830D-0600016	操纵盖板	Controlling cover plate	
75	1	830P-0602004	海绵板	Sponge	

06.1.1 操纵机构(适用830T04机型) CONTROL FRAMEWORK(APPLY TO 830T04 TYPE)

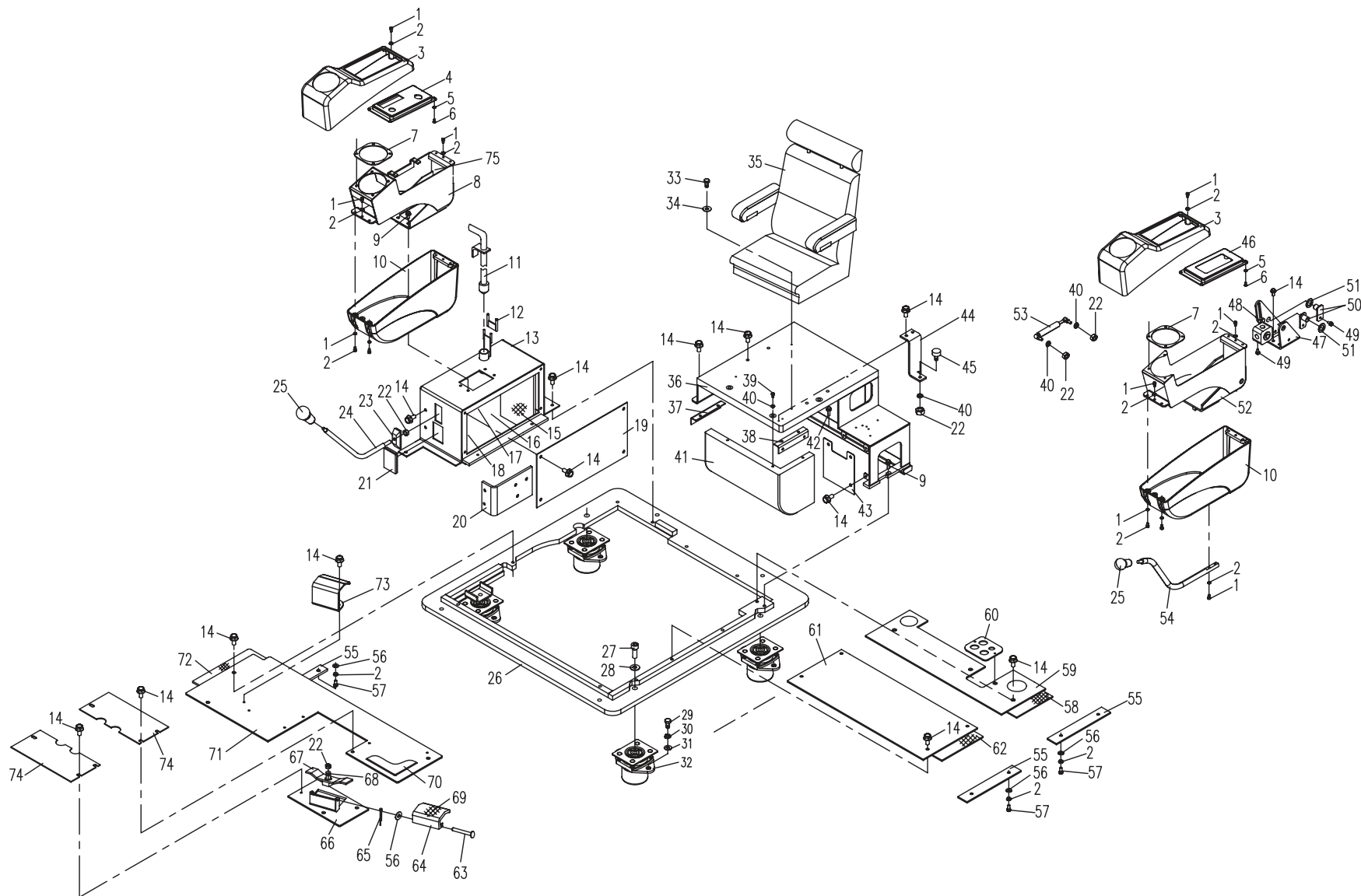



06.2.1 行走操纵(适用830T04机型) HOOF FRAMEWORK(APPLY TO 830T04 TYPE)

序号 No.	数量 Quantity	代号 Code	名称 Description		备注 Remark
1	2	830D-0620006	连接叉IV	Connecting fork IV	
2	6	M8 GB/T6170	1型六角螺母	Nut	8-Zn. D
3	2	830D-0620011	螺杆	Screw	
4	2	830D-0620009	轴套	Bushing	
5	6	6X24 GB/T882	销轴	Pin	Zn. D
6	2	830D-0620003	连接叉II	Connecting fork II	
7	8	6 GB/T97.1	平垫圈	Washer	Zn. D
8	6	2X12 GB/T91	开口销	Cotter pin	Zn. D
9	2	12 GB/T97.1	平垫圈	Washer	Zn. D
10	2	12 GB/T93	弹簧垫圈	Spring washer	Zn. D
11	2	M12X25 GB/T5783	六角头螺栓	Bolt	8. 8-Zn. D
12	11	M8 16 GB/T5783	六角头螺栓	Bolt	8. 8-Zn. D
13	11	8 GB/T93	弹簧垫圈	Spring washer	Zn. D
14	11	8 GB/T97.1	平垫圈	Washer	Zn. D
15	1	830D-0631000	左固定轴	Left stationary shaft	
16	1	830D-0622000	左操纵轴总成	Left sleeve assembly	
17	1	830D-0626000	支架	Supporting plank	
18	2	830D-0620002	连接叉I	Connecting fork I	
19	2	830D-0620004	连接叉III	Connecting fork III	
20	1	830D-0614000	行走固定轴	Stepped stationary shaft	
21	4	M6 GB/T6170	1型六角螺母	Nut	8-Zn. D
22	4	M6X25 GB/T5783	六角头螺栓	Bolt	8. 8-Zn. D
23	2	830D-0620016	卡板	Clip plank	
24	1	830D-0652000	左踏板	Left footplate	
25	2	830D-0620015	胶踏板	Rubber footplate	
26	1	830D-0623000	左操纵总成	Left travelling control assembly	
27	2	810-0620000A	手柄头	Handle ball	
28	2	M12 GB/T6172	六角薄螺母	Nut	8-Zn. D

06.2.1 行走操纵(适用830T04机型) HOOF FRAMEWORK(APPLY TO 830T04 TYPE)

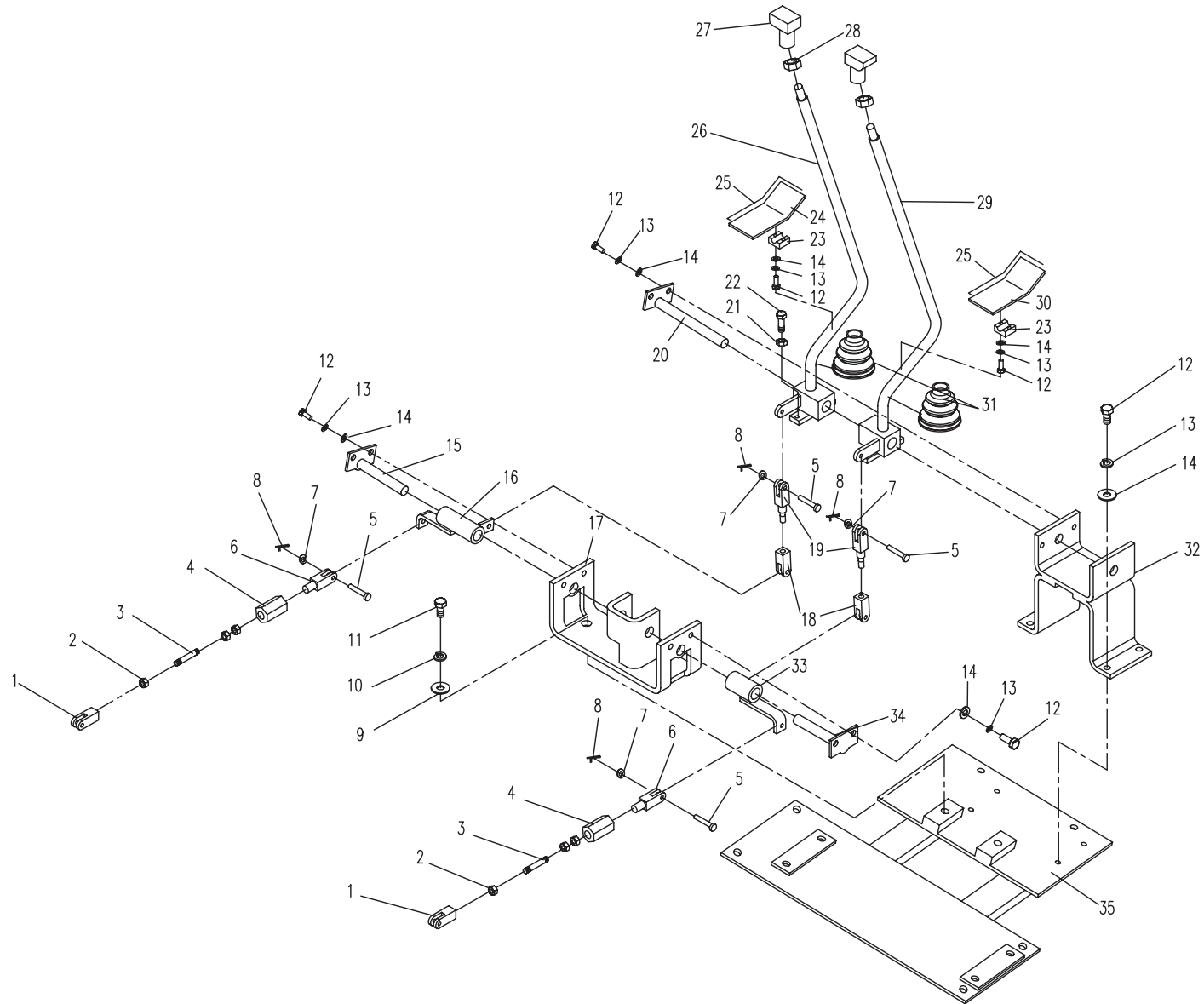



06.2.1 行走操纵(适用830T04机型) HOOF FRAMEWORK(APPLY TO 830T04 TYPE)

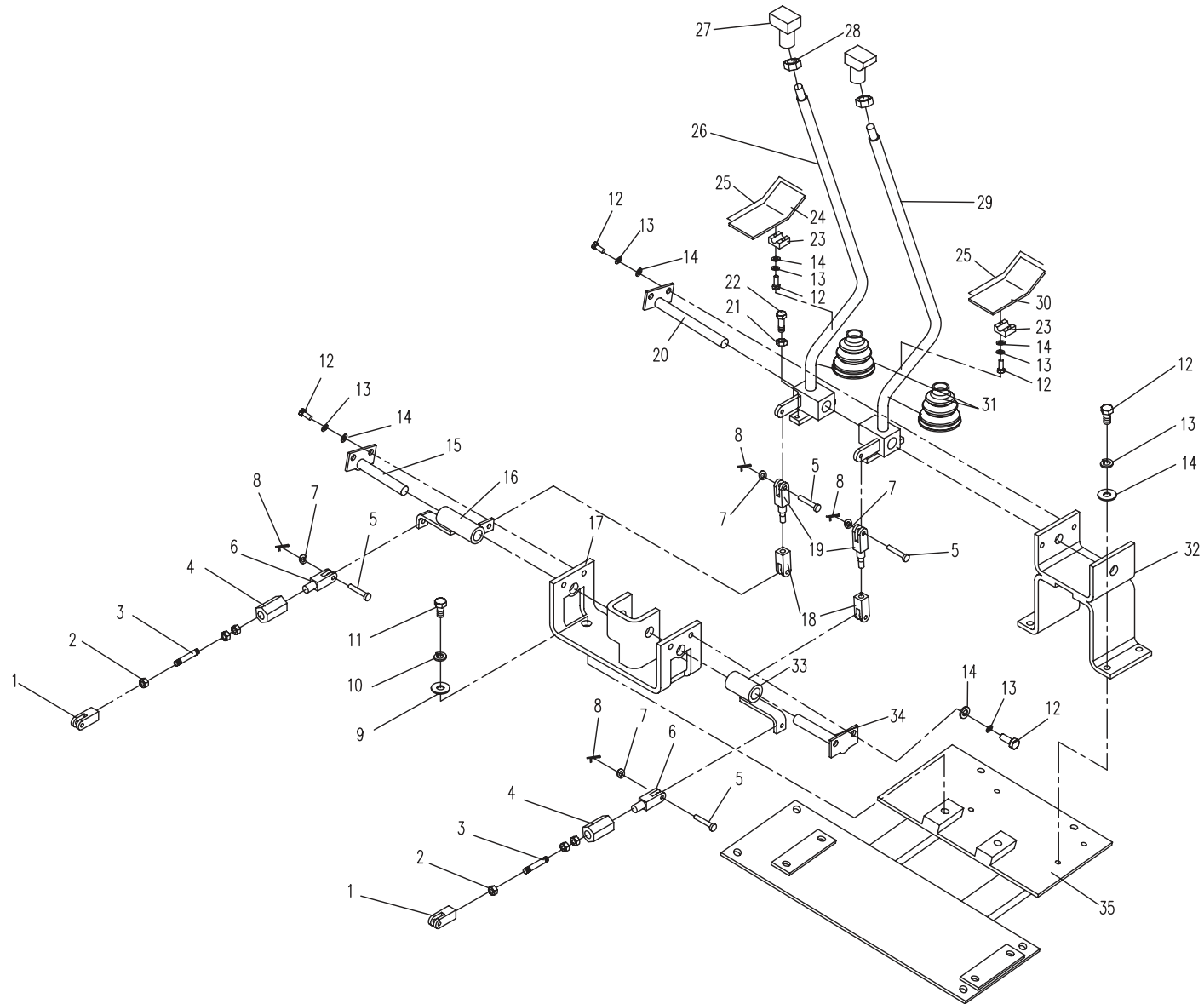

07.1.1 驾驶室组件 1 (适用830T04机型) CAB SUBASSEMBLY 1 (APPLY TO 830T04 TYPE)

序号 No.	数量 Quantity	代号 Code	名称 Description		备注 Remark
	1	830T-2811000	驾驶室	Cab	
1	1	830T-0701000	驾驶室主体	Main body of cab	
2	1	853D-0700006	后窗玻璃	Rear window glass	
3	1	830D-0713000	灭火器	Fire extinguisher	
4	2	5 GB/T97.1	平垫圈	Washer	Zn.D
5	2	ST4.8×22 GB/T845	十字槽盘头自攻螺钉	Bolt	8.8-Zn.D
6	2.2m	830D-0700038	胶条	Rubber seal strip	
7	1	853D-0700009	前顶窗玻璃	Transom window glass	
8	1	830D-0700028A	前密封胶条	Rubber seal strip	
9	1	853D-0700027	右封堵头	Right plug	
10	4	ST4.2×13 GB/T845	十字槽沉头自攻螺钉	Bolt	8.8-Zn.D
11	1	853D-0700028	左封堵头	Left plug	
12	0.87m	801-0700016	密封条	Rubber seal strip	
13	1	853D-0700002	前下窗玻璃	Front-lower window glass	
14	1.07m	830D-0700044	下窗缓冲胶条	Rubber seal strip	
15	4	M16×55 GB/T5783	六角头螺栓	Bolt	10.9-达克罗
16	4	16 GB/T93	弹簧垫圈	Spring washer	达克罗
17	4	16 GB/T96	大垫圈	Washer	达克罗
18	1	830H-0700012	逃生锤	Lifesaving hammer	
19	1	853D-0700001	左后侧窗玻璃	Left-rear window glass	
20	2	M6×12 GB/T5789	六角法兰面螺栓	Bolt	8.8-Zn.D
21	1	830H-0711000	玻璃安装板	Fixing plate	

07.1.1 驾驶室组件 1 (适用830T04机型) CAB SUBASSEMBLY 1 (APPLY TO 830T04 TYPE)

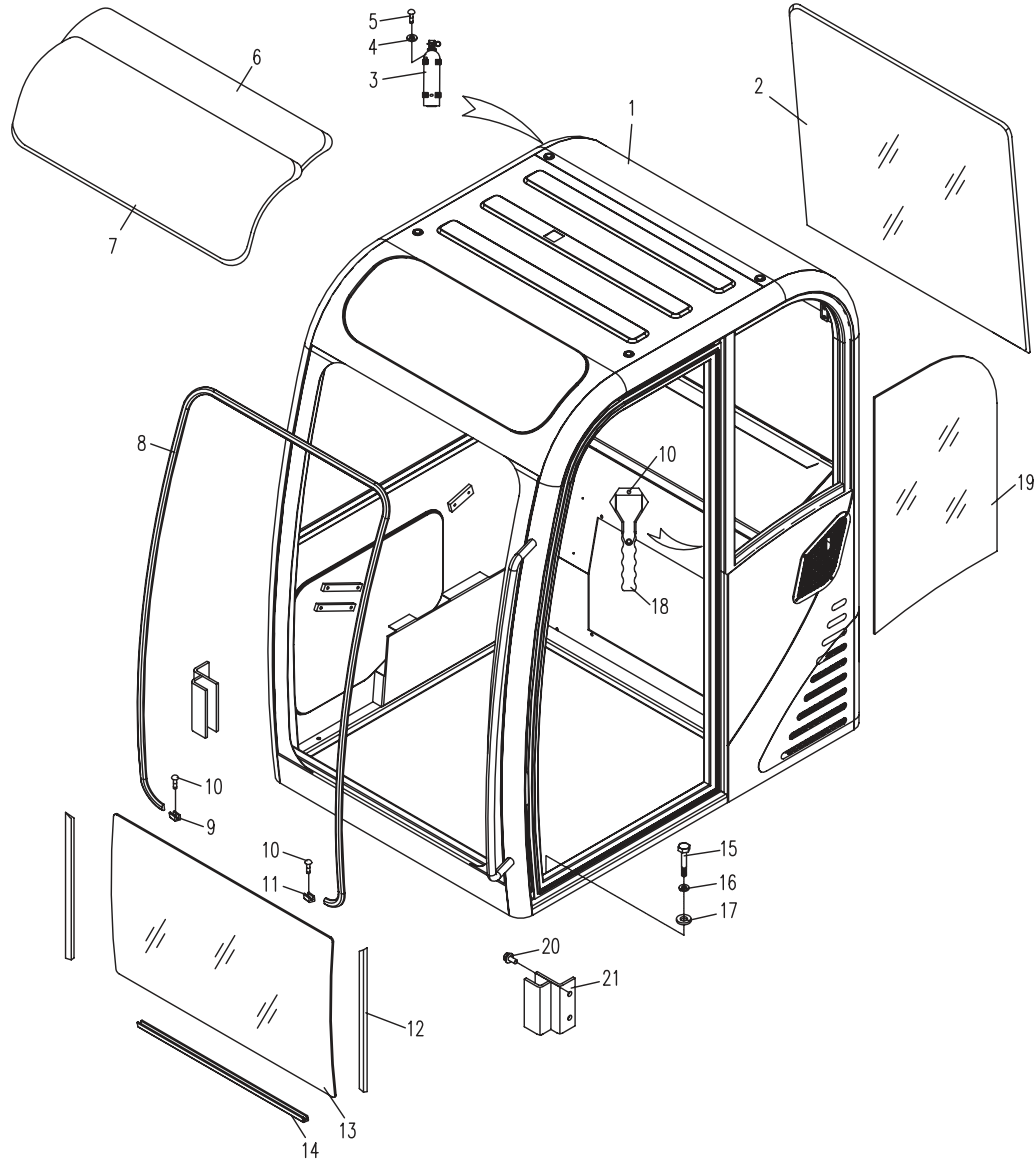

07.2.1 驾驶室组件 2 (适用830T04机型) CAB SUBASSEMBLY 2 (APPLY TO 830T04 TYPE)

序号 No.	数量 Quantity	代号 Code	名称 Description		备注 Remark
	1	853D-0703000	门组件	Cab door	
1	1	830H-0703001	门密封胶条	Rubber seal strip	
2	1	853D-0703100	门主体	Main body-Door	
3	2m	830H-0703008	胶条	Rubber seal strip	
4	1	853D-0703002	门上玻璃	Glass of door	
5	1	853D-0703007	门下玻璃	Glass of door	
6	1	860-0702009	锁钩	Locking knob	
7	2	860-0702011A	圆套	Bush	
8	2	8 GB/T97.1	平垫圈	Washer	Zn.D
9	2	8 GB/T93	弹簧垫圈	Spring washer	Zn.D
10	2	M8 GB/T6170	1型六角螺母	Nut	8.8-Zn.D
11	1	860-0702003	门锁	Door lock	
12	3	M6×10 GB/T818	十字槽盘头螺钉	Bolt	8.8-Zn.D
13	4	M6X25 GB/T5789	六角法兰面螺栓	Bolt	8.8-Zn.D
14	4	830H-0703011	胶塞	Rubber plug	
15	6	M5×10 GB/T819.1	十字槽沉头螺钉	Bolt	8.8-Zn.D
16	1	810S-0700015	限位 I	Bumper I	
17	1	853D-0703012	门内扶手	Inside armrest	
18	2	M8×16 GB/T5789	六角法兰面螺栓	Bolt	8.8-Zn.D
19	1	855-0702005	内拉手	Inside knob	
20	2	M5×16 GB/T70.1	内六角圆柱头螺钉	Bolt	8.8-Zn.D
21	1	830D-0700015A	拉杆 II	Push shaft II	
22	1	830H-0700004	拉杆	Push shaft	
23	1	810S-0700016	限位 II	Bumper	
24	3	M5×8 GB/T819.6	十字槽沉头螺钉	Bolt	8.8-Zn.D

07.2.1 驾驶室组件 2 (适用830T04机型) CAB SUBASSEMBLY 2 (APPLY TO 830T04 TYPE)

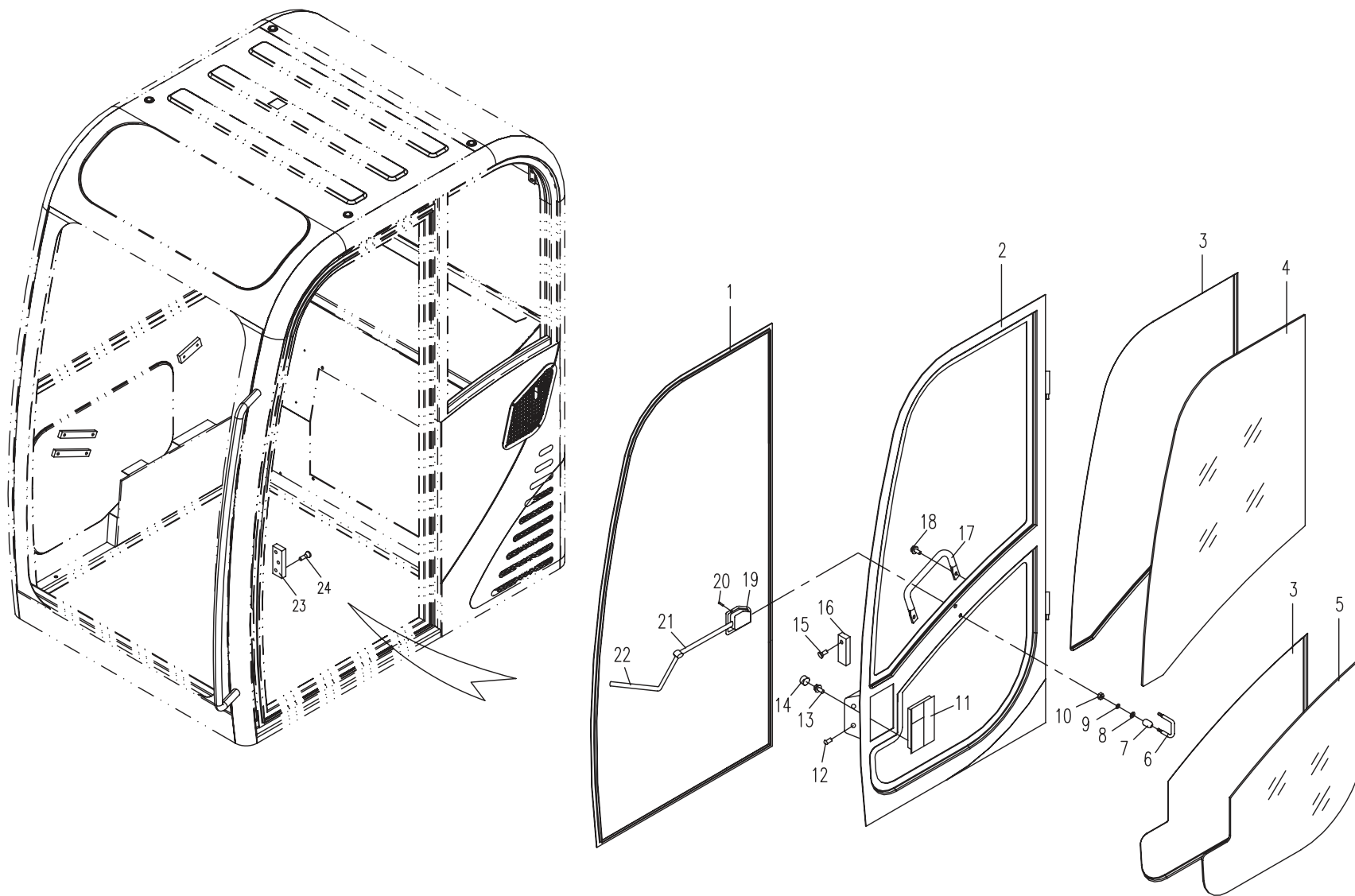





07.3.1 驾驶室组件 3 (适用830T04机型) CAB SUBASSEMBLY 3 (APPLY TO 830T04 TYPE)

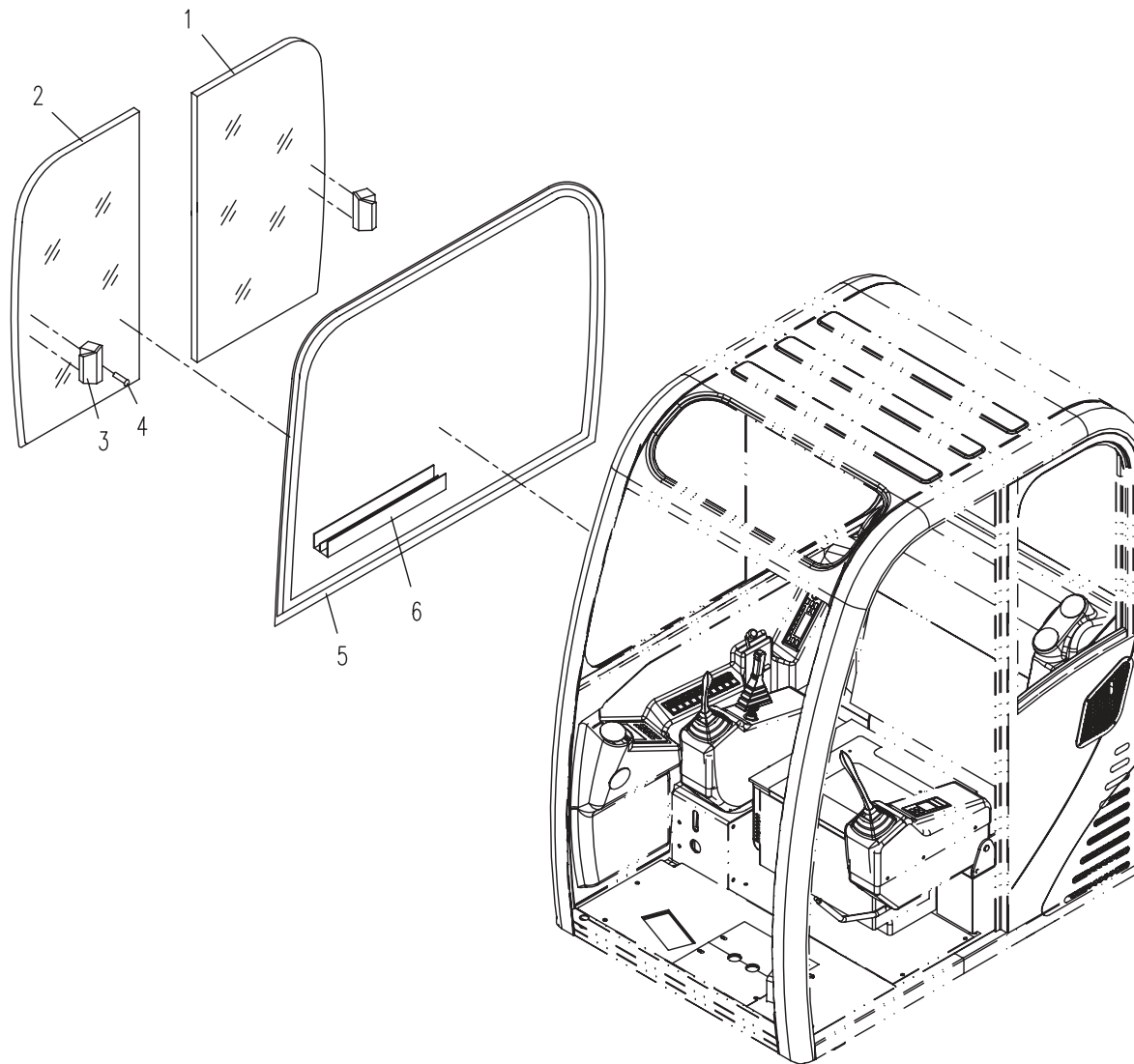

07.4.1 驾驶室组件 4 (适用830T04机型) CAB SUBASSEMBLY 4 (APPLY TO 830T04 TYPE)

序号 No.	数量 Quantity	代号 Code	名称 Description		备注 Remark
1	10	M8X16 GB/T5789	六角法兰面螺栓	Bolt	8. 8-Zn. D
2	1	830H-0702050	右摆杆支架	Bracket-RH	
3	1	830H-0705000	右摆杆	Right sinister	
4	2	8 GB/T96	大垫圈	Bigger washer	
5	2	M8X12 GB/T5789	六角法兰面螺栓	Bolt	8. 8-Zn. D
6	1	830H-0702010	左摆杆支架	Bracket-LH	
7	1	830H-0704000	左摆杆	Lift sinister	
8	2	830H-0700011	翻转窗气弹簧	Pneumatic spring	
9	2	830H-0700013	气弹簧紧固销	Pin	
10	4	M8 GB/T6170	1型六角螺母	Nut	8-Zn. D
11	2	830H-0702003	滑轮	Block	
12	1	830H-0702040	右滑轮支架	Block bracket-RH	
13	1	830H-0702030	左滑轮支架	Block bracket-LH	
14	1	853D-0702100	翻转窗主体	Overturn window frame	
15	1	830D-0700042	右扶手锁	Right handrail lock	
16	6	M6X12 GB/T2671. 1	内六角螺钉	Bolt	8. 8-Zn. D
17	1	830D-0700043	左扶手锁	Left handrail lock	
18	1	830H-0702020	雨刮电机固定板	Fixing plate	
19	1	830H-0702002	电机罩	Cover	
20	2	6 GB/T93	弹簧垫圈	Spring washer	
21	1	853D-0702001	翻转窗玻璃	Glass	
22	1	830H-0702004	翻转窗下胶条	Rubber cushion	

07.4.1 驾驶室组件 4 (适用830T04机型) CAB SUBASSEMBLY 4 (APPLY TO 830T04 TYPE)

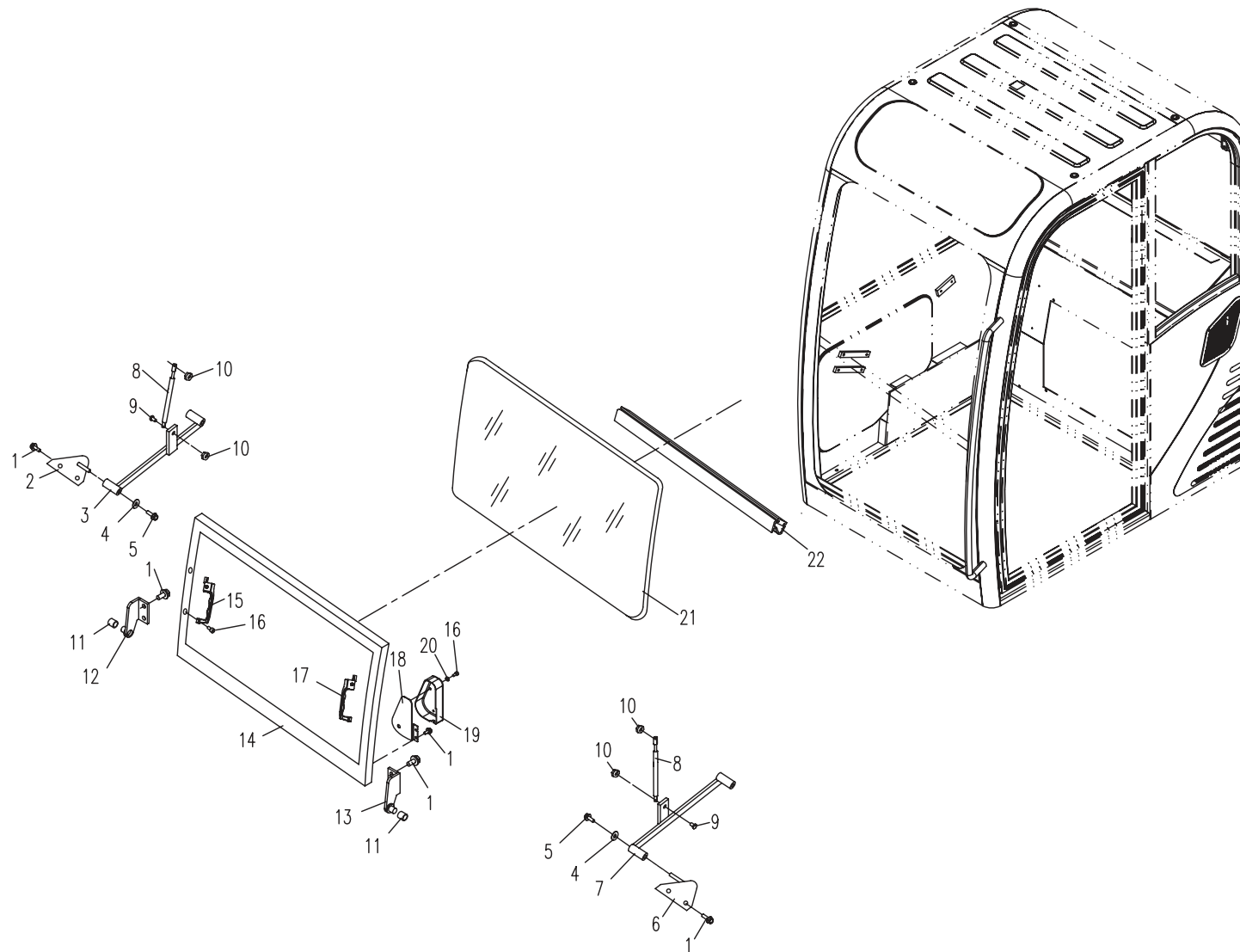

07.5.1 驾驶室组件 5 (适用830T04机型) CAB SUBASSEMBLY 5 (APPLY TO 830T04 TYPE)

序号 No.	数量 Quantity	代号 Code	名称 Description		备注 Remark
1	1	830H-0700019	右侧隔热板	Adiabatic plate-RH	
2	1	830H-0706002	右侧内饰板	Inside plaque-RH	
3	1	830H-0706020	仪表盖板	Appearance cover	
4	1	830H-0706001	电器检修口盖板	Cover	
5	42	5 GB/T97.1	平垫圈	Washer	140HV-Zn.D
6	42	ST4.8×22 GB/T845	十字槽盘头自攻螺钉	Bolt	8.8-Zn.D
7	1	830H-0706003	油门盖板	Cover	
8	1	830H-0706030	收音机安装板	Radiogram bracket	
9	1	830H-0706008	顶棚	Inside plaque-UP	
10	6	830H-0706006	风口	Place with a draught	
11	1	830H-0706005	空调罩饰板	Air-condition cover	
12	1	830H-0706004	检修口封板	Examine and repair cover	
13	1	853D-0710000	后封板组件	Back cover	
14	4	M6×12 GB/T5789	六角法兰面螺栓	Bolt	8.8-Zn.D
15	1	830H-0706007	后窗包板	Back window plaque	
16	1	830H-0706013	铝合金封边	Aluminium alloy plaque	
17	1	853D-0706009	左侧内饰板	Inside plaque-LH	
18	1	830H-0706011	盖板	Cover board	
19	1	830H-0706012	门碰把手	Door handle	
20	1	830H-0700017	左侧隔热板	Adiabatic plate-LH	
21	4	M6×8 GB/T819.1	十字槽沉头螺钉	Bolt	8.8-Zn.D
22	1	853D-0705000	进气滤网	Aiir inlet screen	
23	1	830H-0700015	隔热板	Adiabatic plate	
24	2	830D-0700005A	压板 I	Clamp board I	
25	8	M8×20 GB/T5789	六角法兰面螺栓	Bolt	8.8-Zn.D
26	1	830H-0700018	后侧隔热板	Adiabatic plate	
27	2	830H-0700014	压板	Clamp plate	
28	1	830D-0705000A	隔热盖板	Adiabatic board	

07.5.1 驾驶室组件 5 (适用830T04机型) CAB SUBASSEMBLY 5 (APPLY TO 830T04 TYPE)

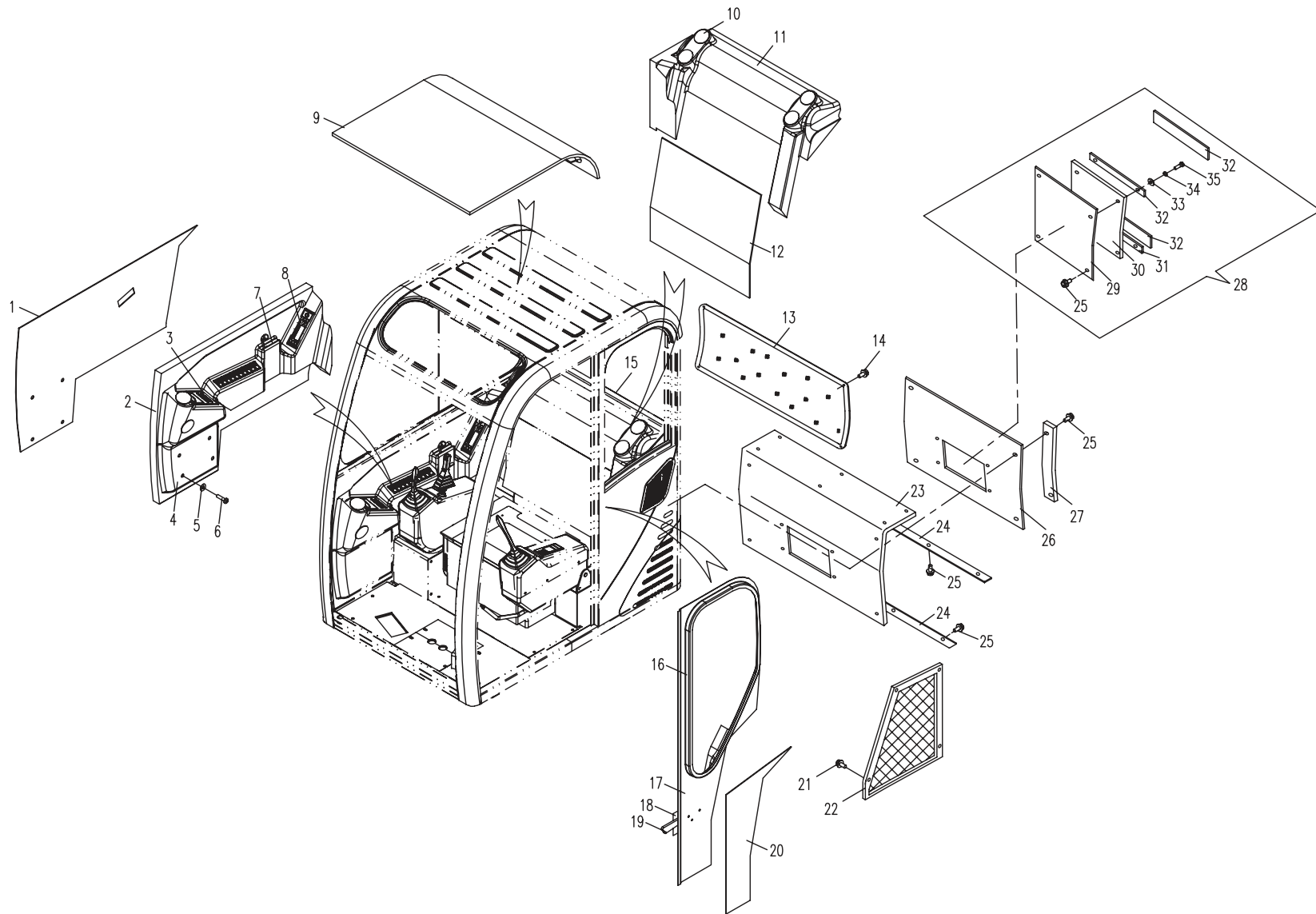



07.5.1 驾驶室组件 5 (适用830T04机型) CAB SUBASSEMBLY 5 (APPLY TO 830T04 TYPE)

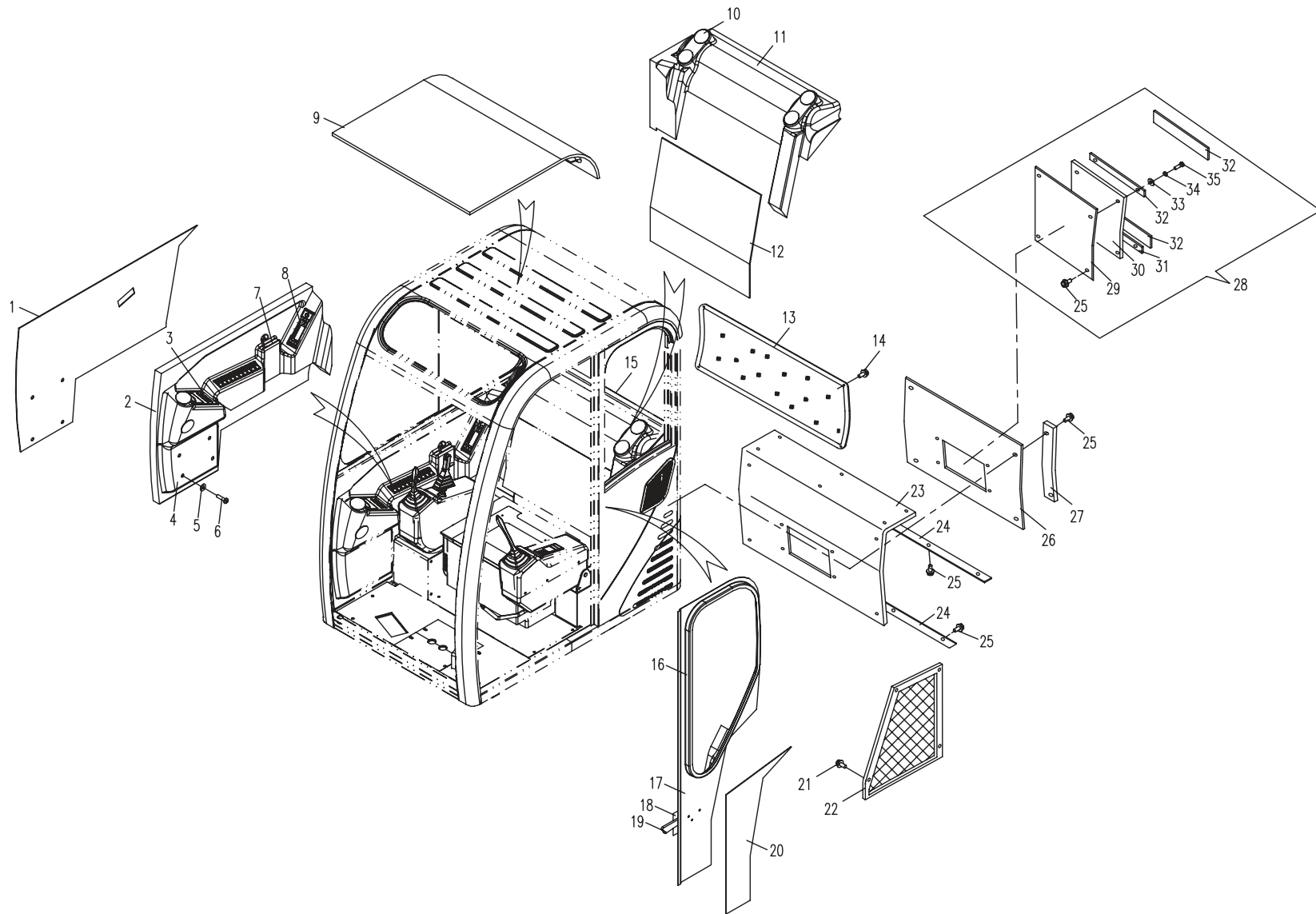



07.6.1 驾驶室组件 6 (适用830T04机型) CAB SUBASSEMBLY 6 (APPLY TO 830T04 TYPE)

序号 No.	数量 Quantity	代号 Code	名称 Description		备注 Remark
1	12	M6X12 GB/T5789	六角法兰面螺栓	Bolt	8. 8-Zn. D
2	1	853D-0707000A	左侧网板组件	Half-tone assembly-LH	
3	1	801-0704000	橡胶座	Rubber pedestal	
4	1	M10 GB/T 6170	1型六角螺母	Nut	8-Zn. D
5	1	830D-0709000A	右侧盖板组件	Right cover assembly	
6	2	820-0703000	橡胶座	Rubber pedestal	
7	2	M12 GB/T 6170	1型六角螺母	Nut	8-Zn. D
8	4	860-0705002	垫片	Washer	
9	4	M16X20 GB/T5789	六角法兰面螺栓	Bolt	8. 8-Zn. D
10	4	M16 GB/T825	吊环螺钉	Eye bolt	8. 8-Zn. D
11	2	830E-0700014	固定杆	Fixing Pole	
12	2	830E-0700012	锁紧螺母	Blocking nut	
13	1	830E-0700013	后视镜右支杆	Right bracket	
14	2	830E-0700003	后视镜	Rearview mirror	
15	1	830E-0700011	后视镜左支杆	Left bracket	
16	1	830H-0700007	内扶手	Armrest	
17	2	M8X35 GB/T5789	六角法兰面螺栓	Bolt	8. 8-Zn. D

07.6.1 驾驶室组件 6 (适用830T04机型) CAB SUBASSEMBLY 6 (APPLY TO 830T04 TYPE)

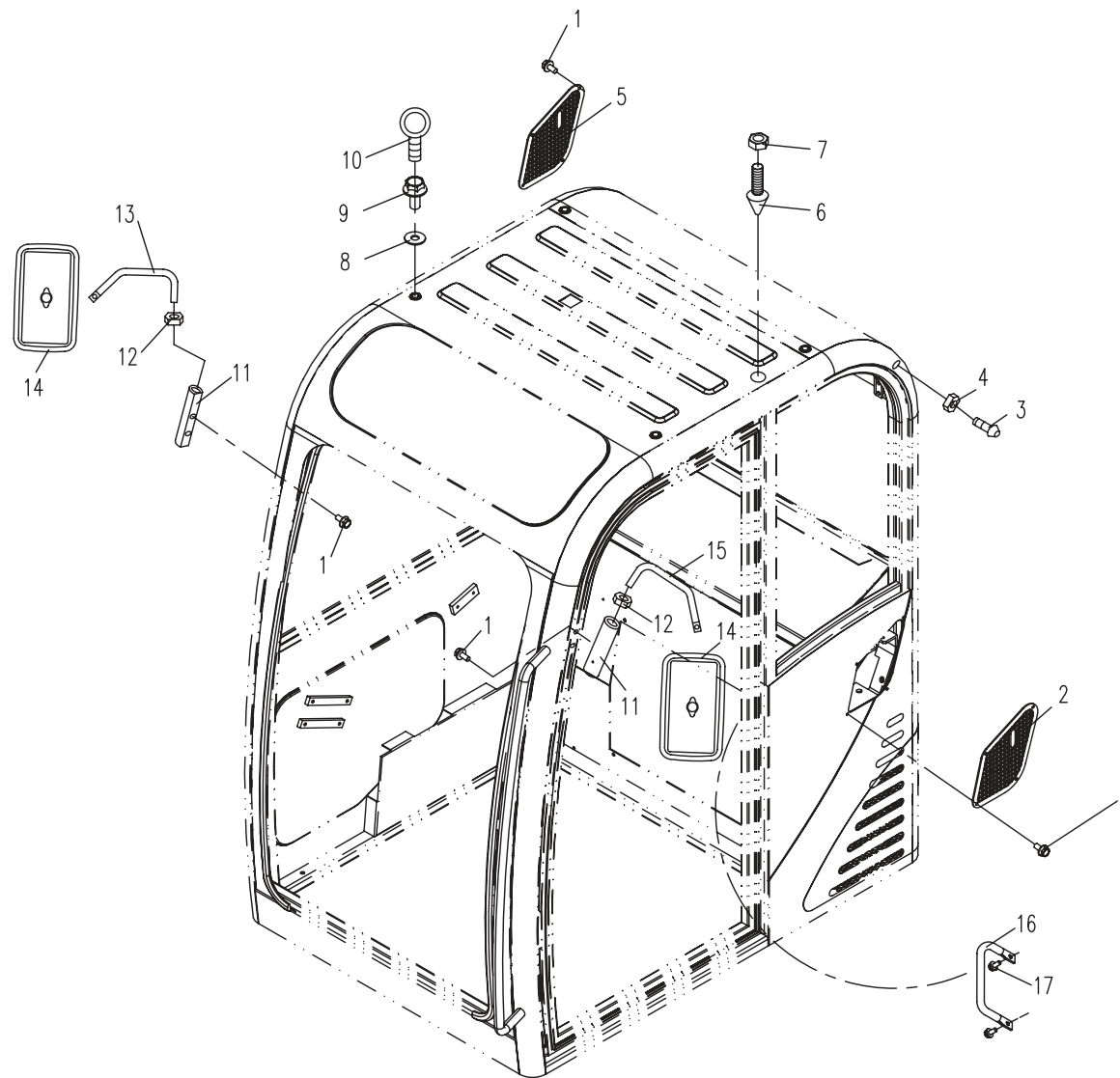



07.7.1 驾驶室组件 7 (适用830T04机型) CAB SUBASSEMBLY 7 (APPLY TO 830T04 TYPE)

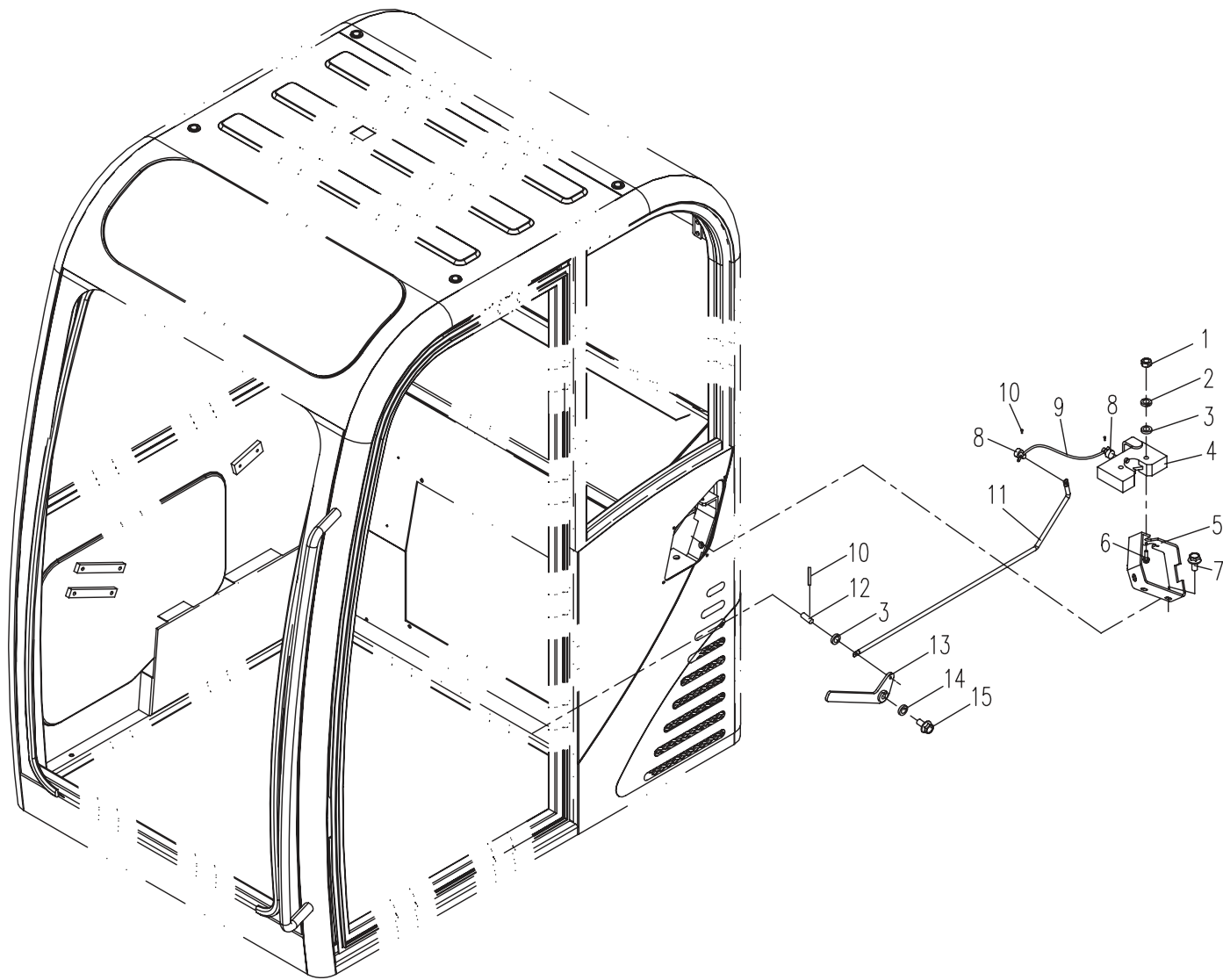

08.1.1 空调系统(适用830T04机型) AIR-CONDITION SYSTEM(APPLY TO 830T04 TYPE)

序号 No.	数量 Quantity	代号 Code	名称 Description		备注 Remark
1	4	M5×16 GB/T5783	六角头螺栓	Bolt	8.8-Zn.D
2	4	5 GB/T 97.1	平垫圈	Washer	
3	4	5 GB/T 93	弹簧垫圈	Spring washer	
4	1	860G-0800002	暖水阀安装板	Bracket	
5	1	850-0800001	暖水管 I	Warm water pipe I	
6	6	d24 Q672	双钢丝式环箍	Hoop	Zn.D
7	1	860G-0801200	热水流量控制器组件	Flux control hot water	
8	2	830H-0820005	暖水管	Water pipe	
9	2	850-0800004	管接头	Joint	
10	1	830H-0820200	压缩机总成	Compressor assembly	
11	2	M8×35 GB/T5789	六角法兰面螺栓	Bolt	8.8-Zn.D
12	1	830T-0820004	吸气软管总成	Inspiration pipe assembly	
13	1	830H-0820002	排气软管总成	Vent-pipe assembly	
14	1	850-0801002	管夹	Pipe clamp	
15	5	M6×30 GB/T5783	六角头螺栓	Bolt	8.8-Zn.D
16	9	6 GB/T 97.1	平垫圈	Washer	
17	9	6 GB/T 93	弹簧垫圈	Spring washer	
18	6	M8×20 GB/T5783	六角头螺栓	Bolt	8.8-Zn.D
19	6	8 GB/T93	弹簧垫圈	Spring washer	Zn.D
20	6	8 GB/T96	大垫圈	Bigger washer	Zn.D
21	1	830H-0802000	支架组件	Bracket	
22	1	830D-0801600	干燥瓶总成	Desiccator assembly	
23	1	850-0801300	干燥瓶出口管总成	Desiccator exit pipe	
24	1	830H-0820003	冷凝器出口管总成	Desiccator exit pipe	
25	5	830D-0801001	大密封圈	Seal ring	
26	1	830D-0801006	胶管密封圈	Seal ring	
27	1	830H-0820500	空调线束总成	Air-condition cable	
28	4	M6×20 GB/T5783	六角头螺栓	Bolt	8.8-Zn.D

08.1.1 空调系统(适用830T04机型) AIR-CONDITION SYSTEM (APPLY TO 830T04 TYPE)

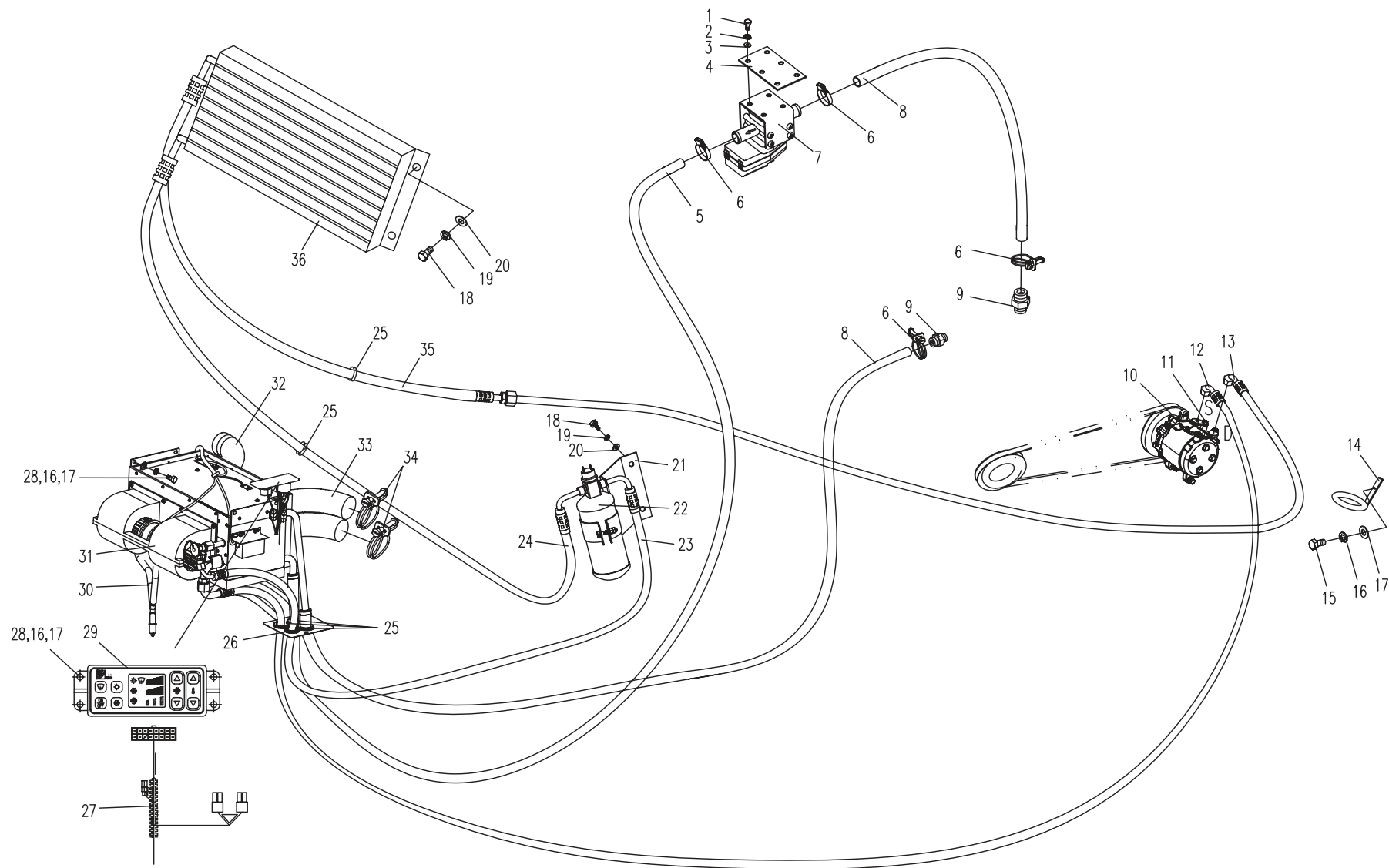



08.1.1 空调系统(适用830T04机型) AIR-CONDITION SYSTEM (APPLY TO 830T04 TYPE)

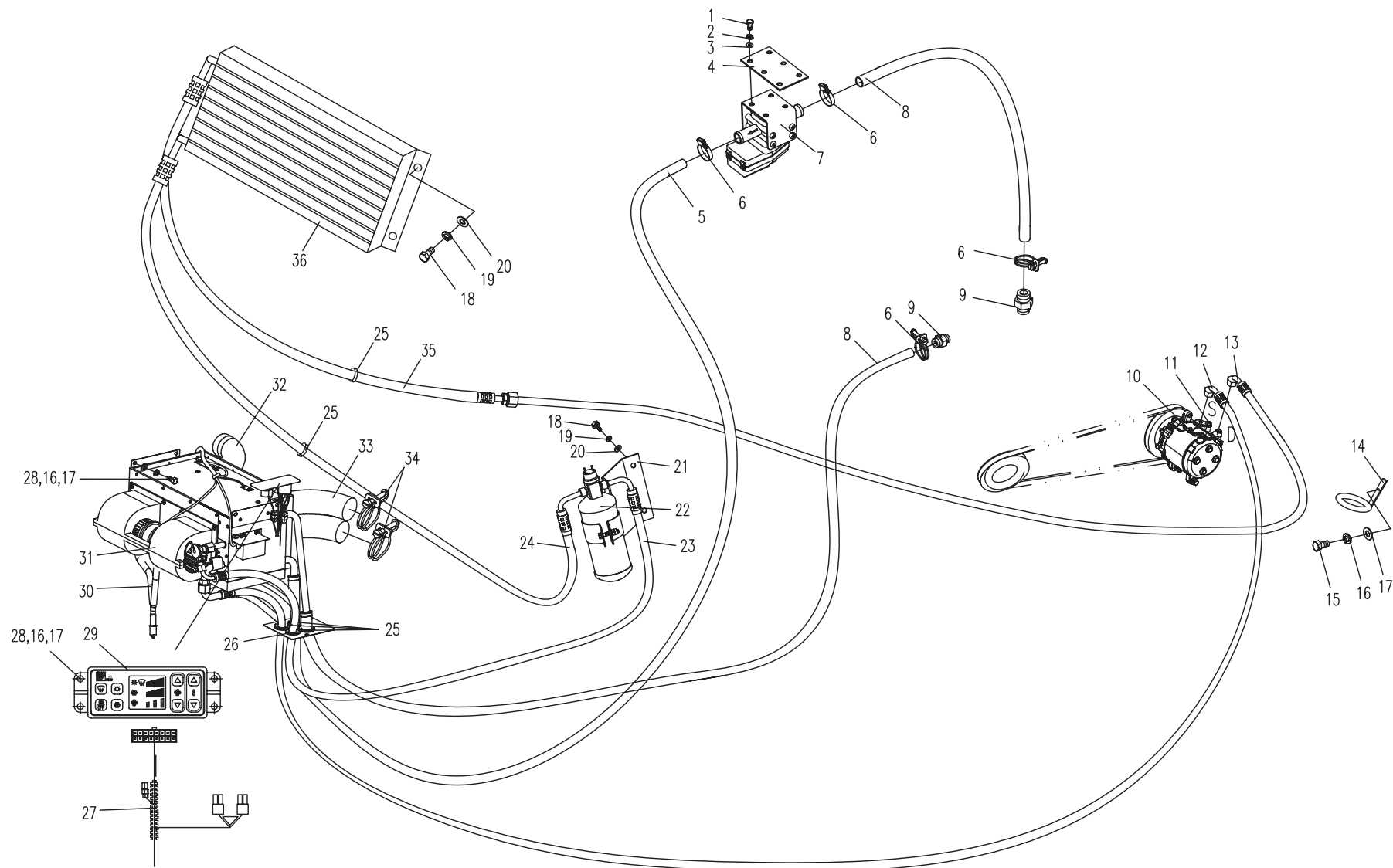



09.1.1 罩框组件(适用830T04机型) COVER FRAME MODULE (APPLY TO 830T04 TYPE)

序号 No.	数量 Quantity	代号 Code	名称 Description		备注 Remark
1	1	858-0901005	罩盖锁	Lock	
2	1	830P-0904000A	前盖板	Front cover	
3	1	853D-0900004	把手	Handle	
4	1	830P-09040001A	前盖板体	Front cover body	
5	2	M8 GB/T6170	1型六角螺母	Nut	8-Zn.D
6	1	830P-0900001A	气弹簧	Air spring	
7	2	M6×16 GB/T5783	六角头螺栓	Bolt	8.8-Zn.D
8	2	6 GB/T 93	弹簧垫圈	Spring washer	Zn.D
9	13	6 GB/T 97.1	平垫圈	Washer	Zn.D
10	1	830P-0900002A	支撑	Support	
11	7	M8×20 GB/T5789	六角法兰面螺栓	Bolt	8.8-Zn.D
12	1	830P-0903001A	右盖板体	Right cover	
13	1	830P-0906000A	锁扣	Lock buckle	
14	21	8 GB/T 97.1	平垫圈	Washer	Zn.D
15	21	8 GB/T 93	弹簧垫圈	Spring washer	Zn.D
16	17	M8×20 GB/T5783	六角头螺栓	Bolt	8.8-Zn.D
17	2	810-1500003	螺钉帽	Bolt cap	
18	2	853D-0900005	弯板	Curve plate	
19	2	818B-0608000	螺钉帽	Bolt cap	
20	1	830P-0900005B	挡板	Baffle	
21	1	830P-0901000B	罩框焊件	Cover frame	
22	8	10 GB/T 97.1	平垫圈	Washer	Zn.D
23	8	10 GB/T 93	弹簧垫圈	Spring washer	Zn.D
24	8	M10×25 GB/T5783	六角头螺栓	Bolt	8.8-Zn.D
25	1	830P-0905000B	铰链	Gemel	
26	2	M8×20 GB/T 70.1	内六角圆柱头螺钉	Bolt	8.8-Zn.D
27	1	830P-0903100A	筛网组件	Screen assembly	
28	12	ST3.5×13 GB/T845	十字槽盘头自攻螺钉	Bolt	8.8-Zn.D

09.1.1 罩框组件(适用830T04机型) COVER FRAME MODULE (APPLY TO 830T04 TYPE)

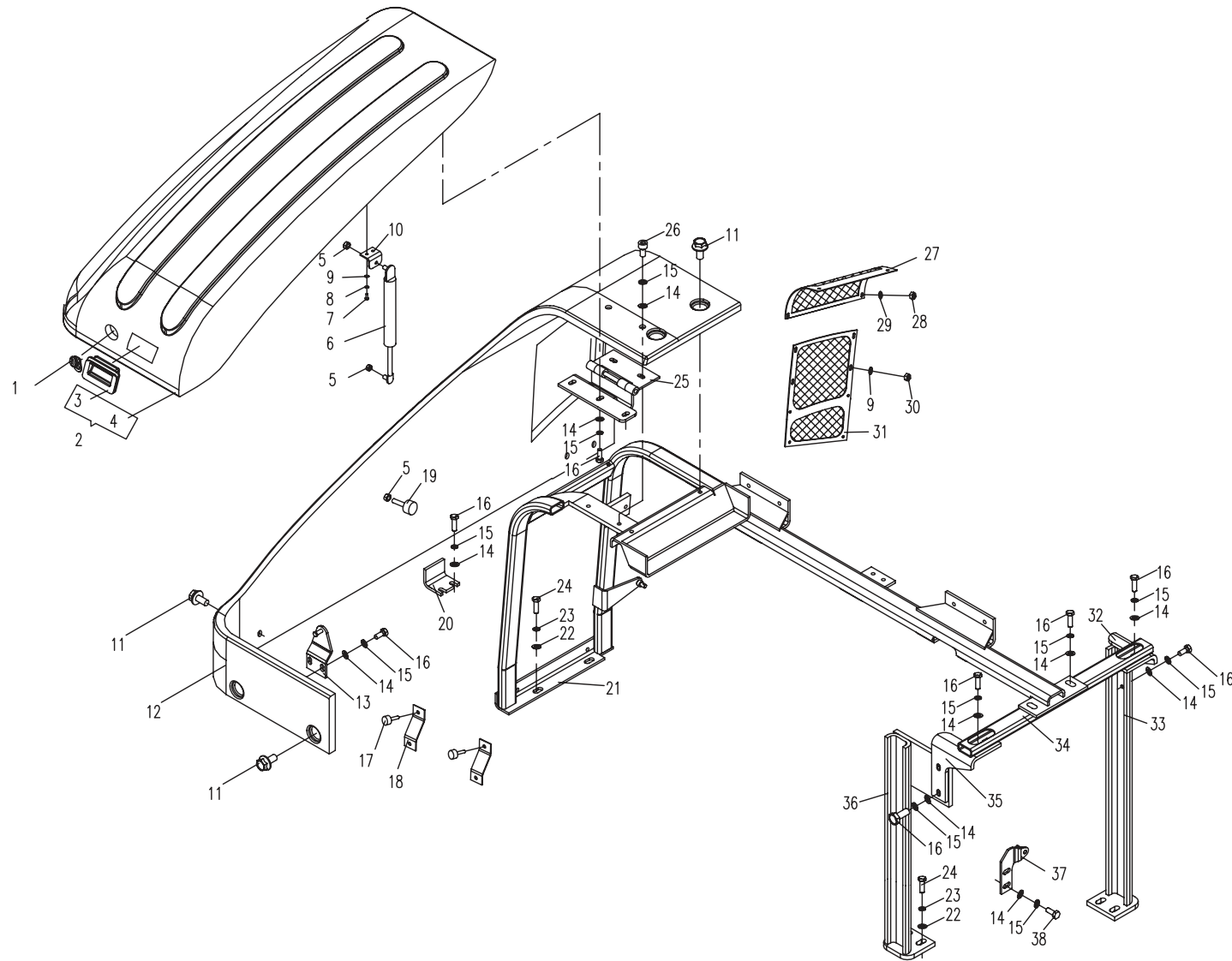



09.1.1 罩框组件(适用830T04机型) COVER FRAME MODULE (APPLY TO 830T04 TYPE)

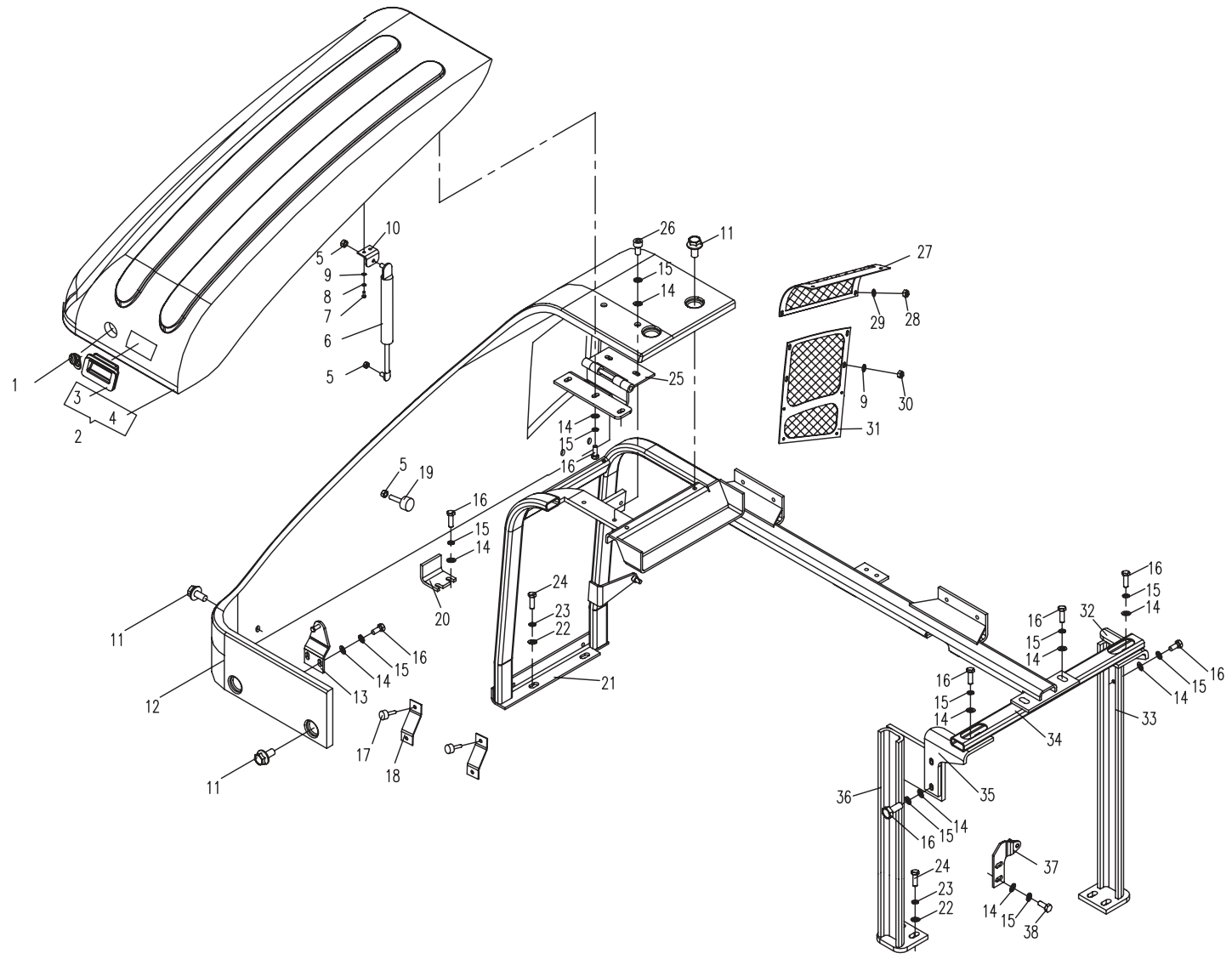

10.1.1 发动机罩(适用830T04机型) ENGINE HOOD (APPLY TO 830T04 TYPE)

1 No.	数 量 Quantity	代 号 Code	名 称 Description		备 注 Remark
1	1	830P-1001001A	壳体	Engine hood body	
2	4.5m	830P-1001002A	密封胶条	Airproof rubber	
3	12	M8X25 GB/T 5783	六角头螺栓	Bolt	8. 8-Zn. D
4	12	8 GB/T93	弹簧垫圈	Spring washer	Zn.D
5	16	8 GB/T 97. 1	平垫圈	Washer	Zn.D
6	2	830P-1003000A	支撑	Support	
7	2	830P-1000001A	气弹簧	Air spring	
8	4	2. 5X16 GB/T 91	开口销	Cotter pin	Zn. D
9	2	830P-1002000B	铰链	Gemel	
10	1	830P-1001004A	吸音棉	Anechoic sponge	
11	10	830D-1010001	塑料卡钉	Plastic tack	
12	1	830P-1001300A	右上滤网组件	Top sieve-RH	
13	1	830P-1001500A	右下滤网组件	Lower sieve-RH	
14	32	4 GB/T96	大垫圈	Washer	Zn.D
15	32	ST3. 5 13 GB/T845	十字槽盘头自攻螺钉	Bolt	8. 8-Zn. D
16	16	M8X16 GB/T5789	六角法兰面螺栓	Bolt	8. 8-Zn. D
17	1	830P-1001200A	左上滤网组件	Top sieve-LH	
18	1	830P-1001400A	左下滤网组件	Lower sieve-LH	
19	1	830P-101100A	板金组件	Sheet plate assembly	

10.1.1 发动机罩(适用830T04机型) ENGINE HOOD (APPLY TO 830T04 TYPE)

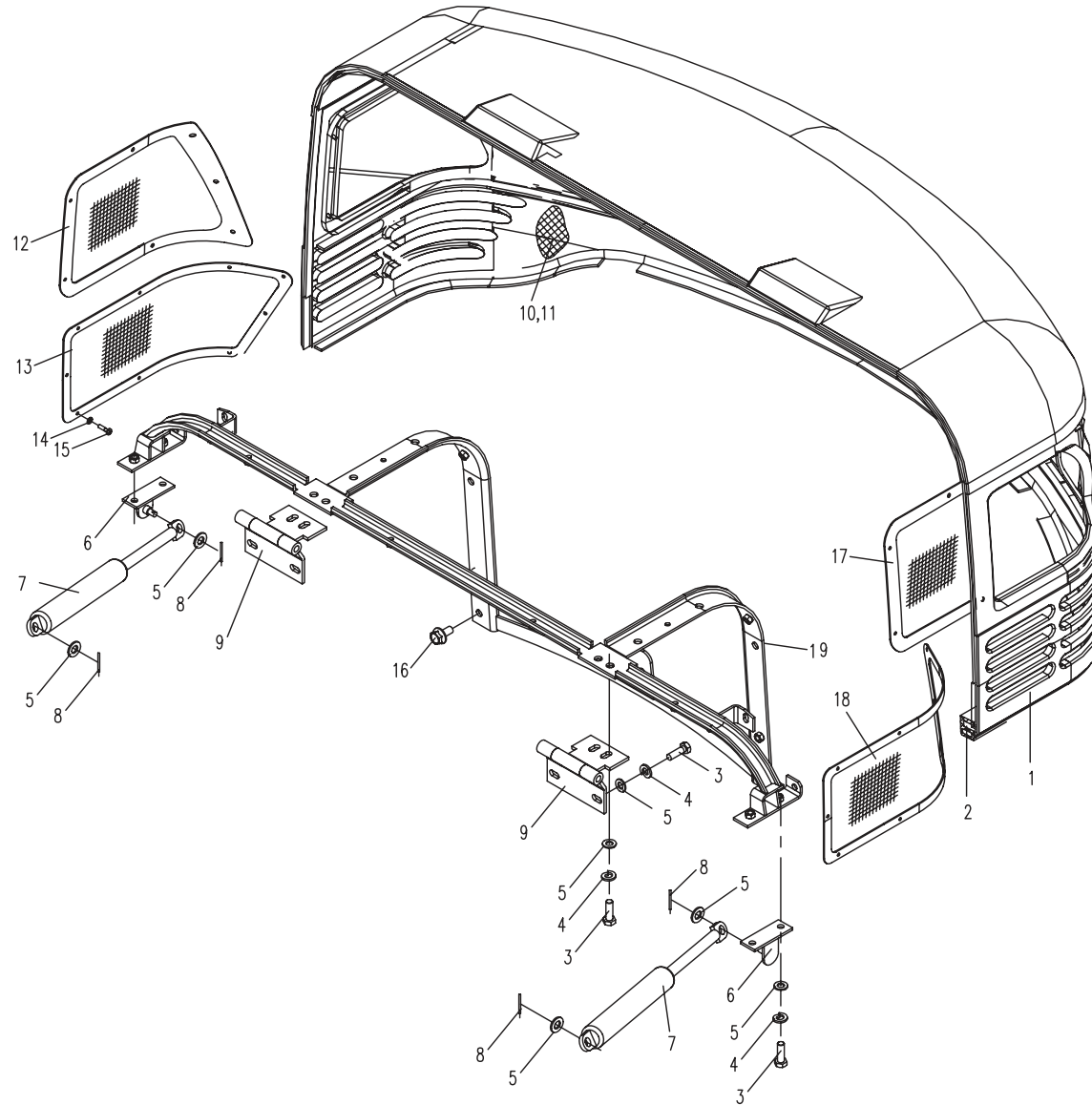

10.2.1 发动机罩锁装置（适用于830T04 机型） ENGINE HOOD LOCK EQUIPMENT (APPLY TO 830T04 TYPE)

序号 No.	数量 Quantity	代号 Code	名称 Description		备注 Remark
1	1	M12 GB/T6170	1型六角螺母	Nut	8-Zn.D
2	1	830D-1014200	锁销座	Lock pin pedestal	
3	5	10 GB/T97.1	平垫圈	Washer	Zn.D
4	5	10 GB/T93	弹簧垫圈	Spring washer	Zn.D
5	5	M10×20 GB/T5783	六角头螺栓	Bolt	8.8-Zn.D
6	1	830D-1014003	螺母	Nut	
7	1	830D-1014004	弹簧	Spring	
8	1	830D-1014005	弹簧座	Spring pedestal	
9	1	830D-1014002	锁销	Lockpin	
10	1	830D-1014001	拉簧	Tension spring	
11	1	830D-1014103	销轴	Shaft pin	
12	1	830D-1014104	右卡板	Right check plate	
13	1	830D-1014101	软轴固定销	Immobile pin	
14	1	M5 GB/T6170	1型六角螺母	Nut	8-Zn.D
15	1	M5×16 GB/T5783	六角头螺栓	Bolt	8.8-Zn.D
16	1	830D-1014105	左卡板	Left check plate	
17	2	M10×1 GB/T 6172.1	六角薄螺母	Nut	8-Zn.D
18	2	830D-1014102	转轴	Rotational pin	
19	1	830D-1014110	座	Pedestal	
20	1	830D-1015200	软管组件	Soft-pipe subassembly	
21	5	8 GB/T97.1	平垫圈	Washer	Zn.D
22	5	8 GB/T93	弹簧垫圈	Spring washer	Zn.D
23	2	M8 GB/T6170	1型六角螺母	Nut	8-Zn.D
24	1	830D-1015003	手柄	Handle	
25	1	801-1206200	手柄头	Handle ball	
26	1	830D-1015001A	扭簧	Torsion spring	
27	1	830P-1004100	转盘座	Turntable pedestal	
28	1	9 GB/T894.1	轴用弹性挡圈	Closing ring	

10.2.1 发动机罩锁装置（适用于830T04 机型）ENGINE HOOD LOCK EQUIPMENT (APPLY TO 830T04 TYPE)

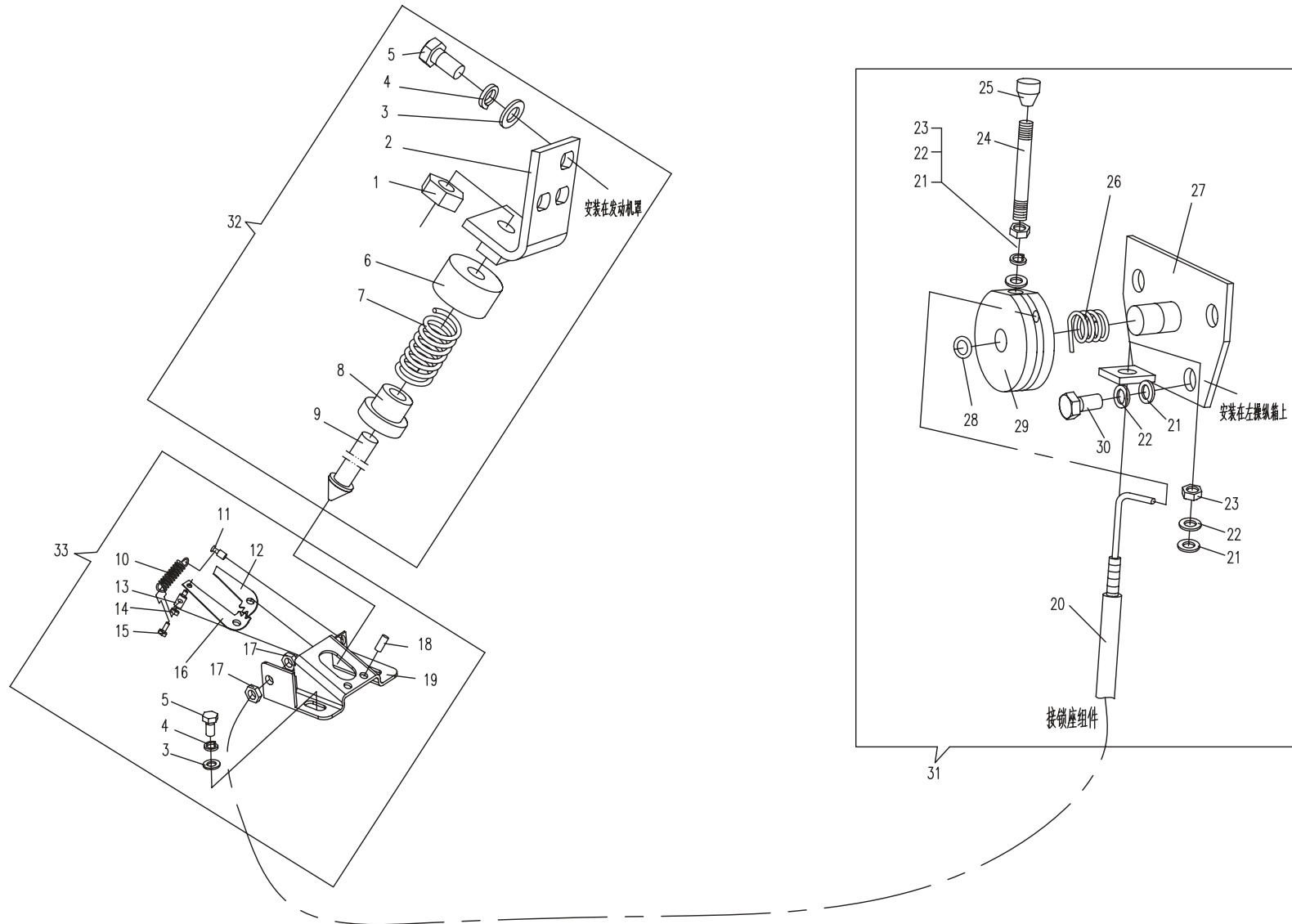





10.2.1 发动机罩锁装置（适用于830T04 机型）ENGINE HOOD LOCK EQUIPMENT (APPLY TO 830T04 TYPE)

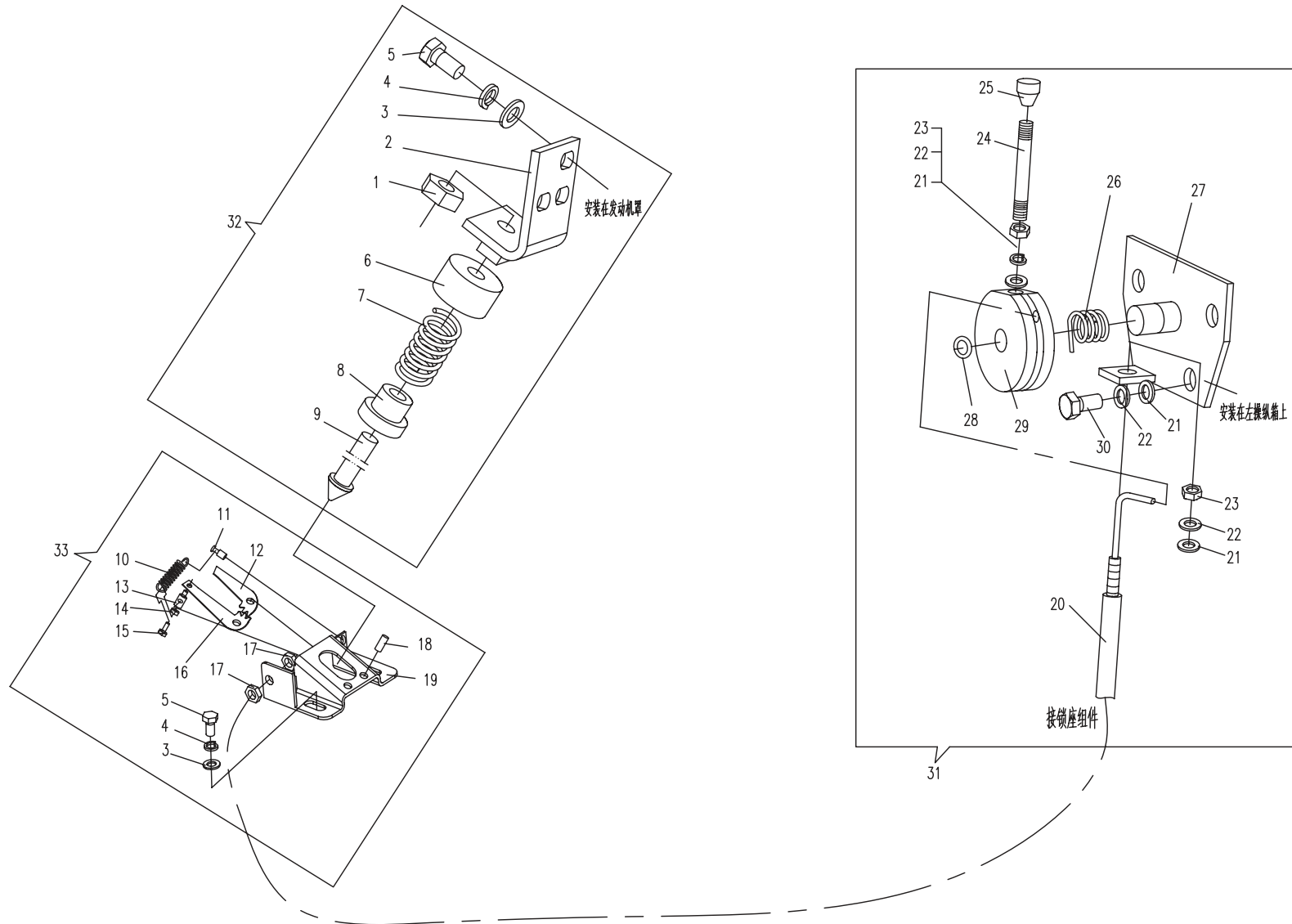



11.1.1 回转机构(适用830T04机型) SLEWING SUPPORT (APPLY TO 830T04 TYPE)

---

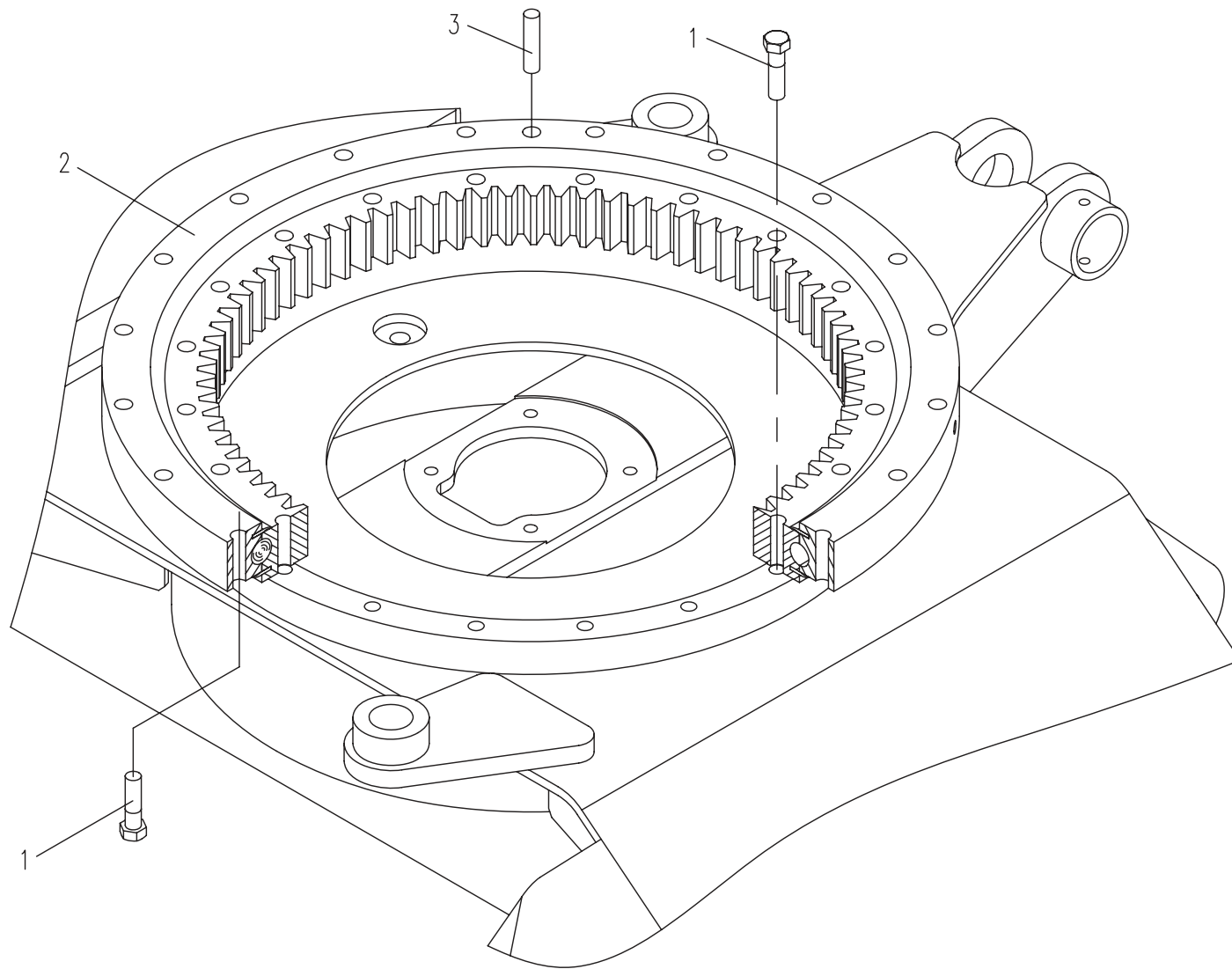

12.1.1 冷却系统(适用830T04机型) COOLING SYSTEM (APPLY TO 830T04 TYPE)

序号 No.	数量 Quantity	代号 Code	名称 Description		备注 Remark
1	4	M10X35 GB/T5783	六角头螺栓	Bolt	
2	4	10 GB/T93	弹簧垫圈	Spring washer	
3	4	10 GB/T97.1	平垫圈	Washer	
4	2	839-1211009	橡胶垫	Rubber spacer	
5	1	839-1211300	水箱左支架	Radiator bracket-LH	
6	14	M8X20 GB/T5783	六角头螺栓	Bolt	
7	15	8 GB/T93	弹簧垫圈	Spring washer	
8	15	8 GB/T97.1	平垫圈	Washer	
9	8	4X45 GB/T882	销轴	Pin shaft	
10	1	830T-1201003	左隔风板	Separate plate-LH	
11	4	d45 Q672	双钢丝式喉箍	Hoop	
12	1	830L-1201005	下隔热垫	Lower heat-insulation spacer	
13	1	835-1201002	下水管	Lower water pipe	
14	1	830T-1221007	右隔热垫	Right heat-insulation spacer	
15	8	830-1201013	垫片	Washer	
16	8	1.6X16 GB/T91	开口销	Cotter pin	
17	1	830T-1201100	导风罩	Fan guide	
18	8	M6x16 GB/T5783	六角头螺栓	Bolt	
19	8	6 GB/T93	弹簧垫圈	Spring washer	
20	10	6 GB/T97.1	平垫圈	Washer	
21	2	830H-1201013	密封条	Airproof bar	
22	1	828-1201100	护网	Fender	
23	1	830T-1201002	上隔风板	Upper separate plate	
24	1	830T-1221006	左隔热垫	Left heat-insulation spacer	
25	1	830T-1201001	上水管	Upper water pipe	
26	1	830T-1201006	上隔热垫	Upper heat-insulation spacer	
27	1	830T-1201004	右隔风板	Separate plate-RH	
28	1	839-1211400	水箱右支架	Radiator bracket-RH	
29	1	830T-1201200	水箱	Radiator	

12.1.1 冷却系统(适用830T04机型) COOLING SYSTEM (APPLY TO 830T04 TYPE)

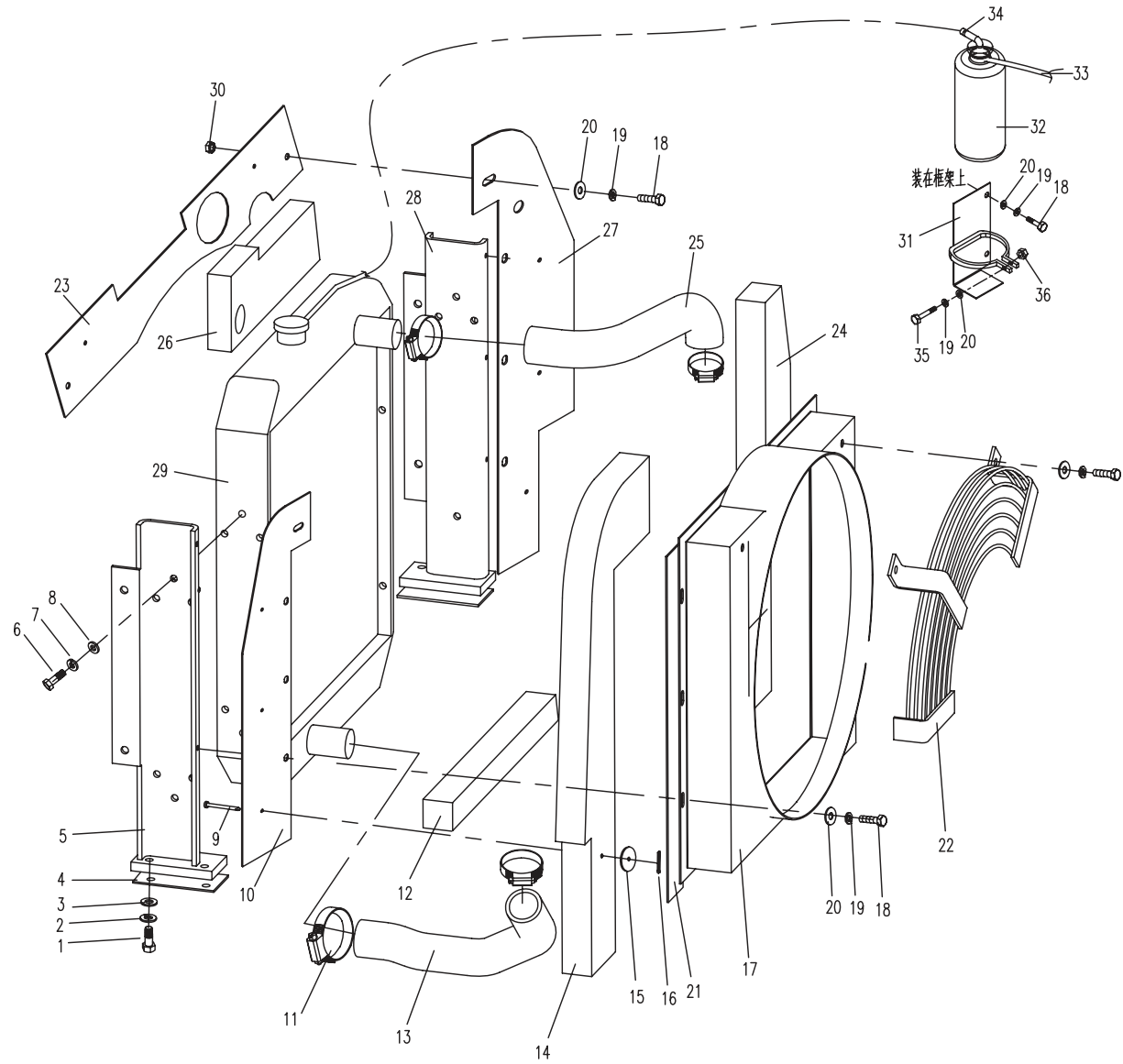



12.1.1 冷却系统(适用830T04机型) COOLING SYSTEM (APPLY TO 830T04 TYPE)

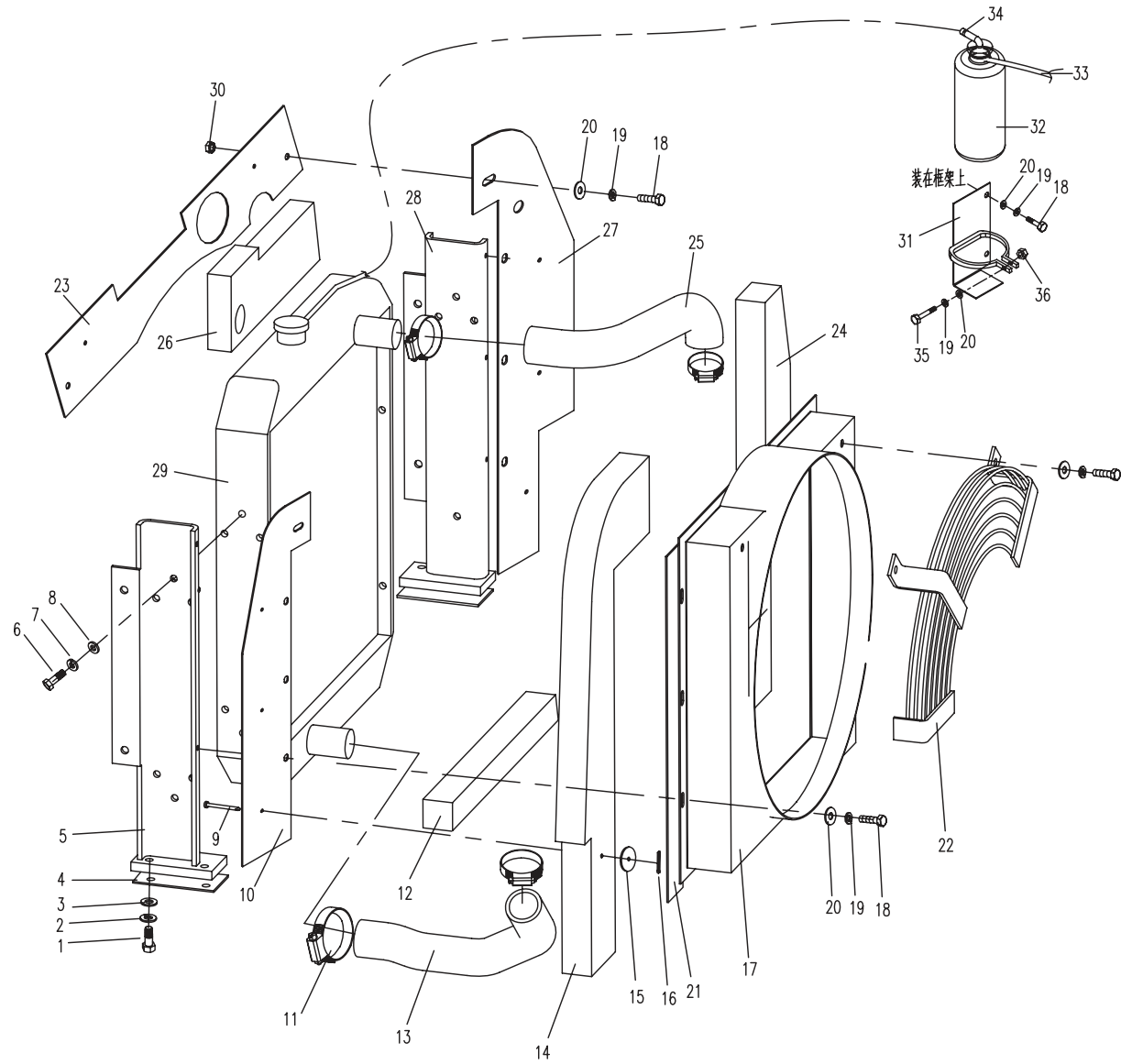





12.2.1 进气系统(适用830T04机型) AIR INLET SYSTEM (APPLY TO 830T04 TYPE)

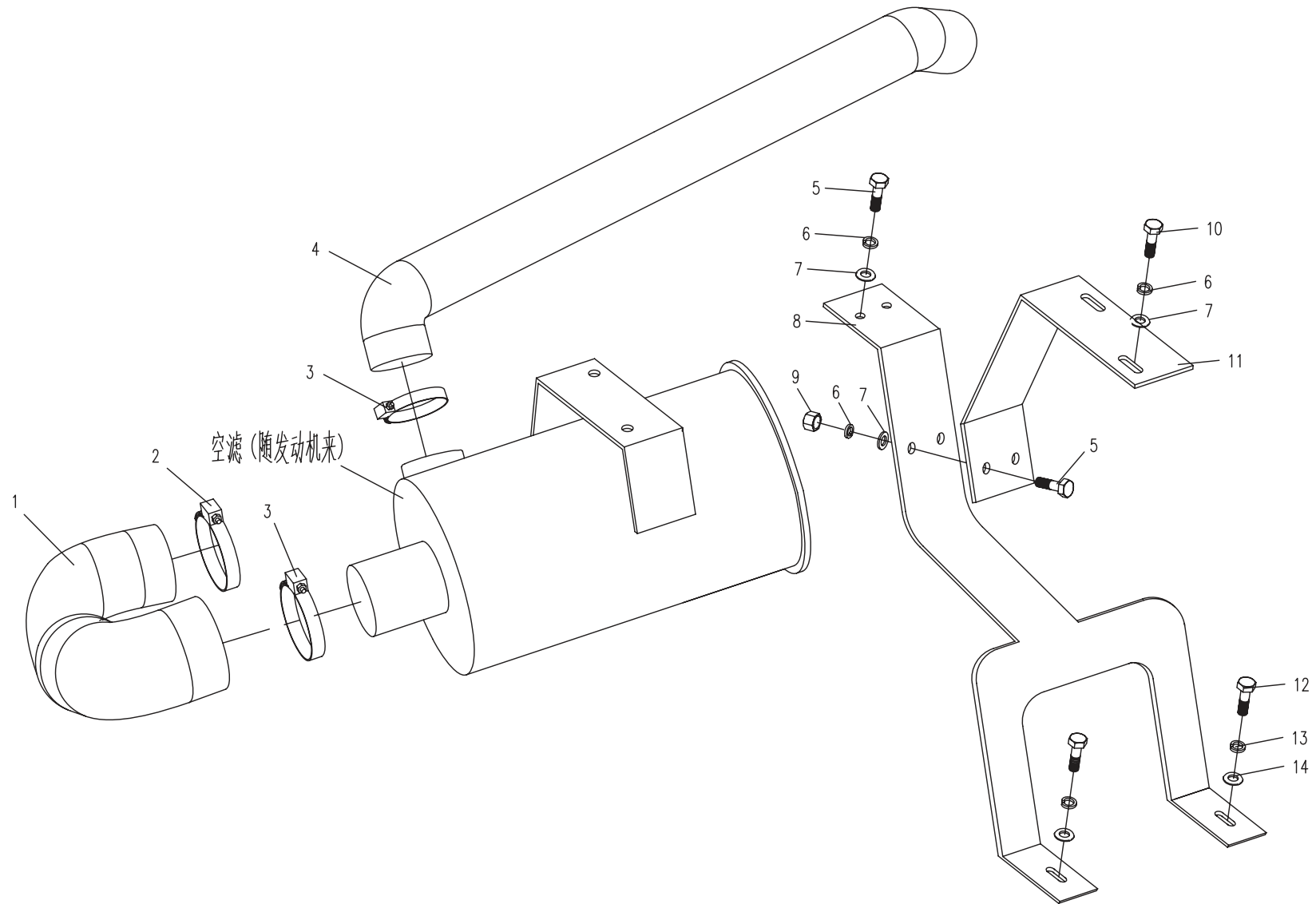

12.3.1 排气系统(适用830T04机型) EXHAUST SYSTEM (APPLY TO 830T04 TYPE)

序号 No.	数量 Quantity	代号 Code	名称 Description		备注 Remark
1	5	M8X25 GB/T5783	六角头螺栓	Bolt	8. 8-Zn. D
2	9	8 GB/T93	弹簧垫圈	Spring washer	Zn. D
3	5	8 GB/T97. 1	平垫圈	Washer	Zn. D
4	2	835-1204400	侧固定箍	Cirque hoop	8. 8-Zn. D
5	2	M6X30 GB/T5783	六角头螺栓	Bolt	8. 8-Zn. D
6	2	6 GB/T93	弹簧垫圈	Spring washer	Zn. D
7	2	6 GB/T97. 1	平垫圈	Washer	Zn. D
8	1	830T-1206100	消声器	Muffler	
9	2	835-1204200	固定箍	Cirque hoop	
10	1	835-1204002	消声器包裹材料	Muffler heat-insulation material	
11	1	835-1214300	消声器支架	Muffler support	
12	2	M10X40 GB/T5783	六角头螺栓	Bolt	10. 9-达克罗
13	2	10 GB/T93	弹簧垫圈	Spring washer	Zn. D
14	2	10 GB/T97. 1	平垫圈	Washer	Zn. D
15	4	8 GB/T96	大垫圈	Washer	Zn. D
16	4	M8 GB/T6170	1型六角螺母	Nut	8-Zn. D
17	2	M12 25 GB/T5783	六角头螺栓	Bolt	10.9-达克罗
18	2	12 GB/T93	弹簧垫圈	Spring washer	Zn. D
19	2	12 GB/T97. 1	平垫圈	Washer	Zn. D
20	2	835-1204003	侧面包裹材料	Muffler heat-insulation material	

12.3.1 排气系统(适用830T04机型) EXHAUST SYSTEM (APPLY TO 830T04 TYPE)

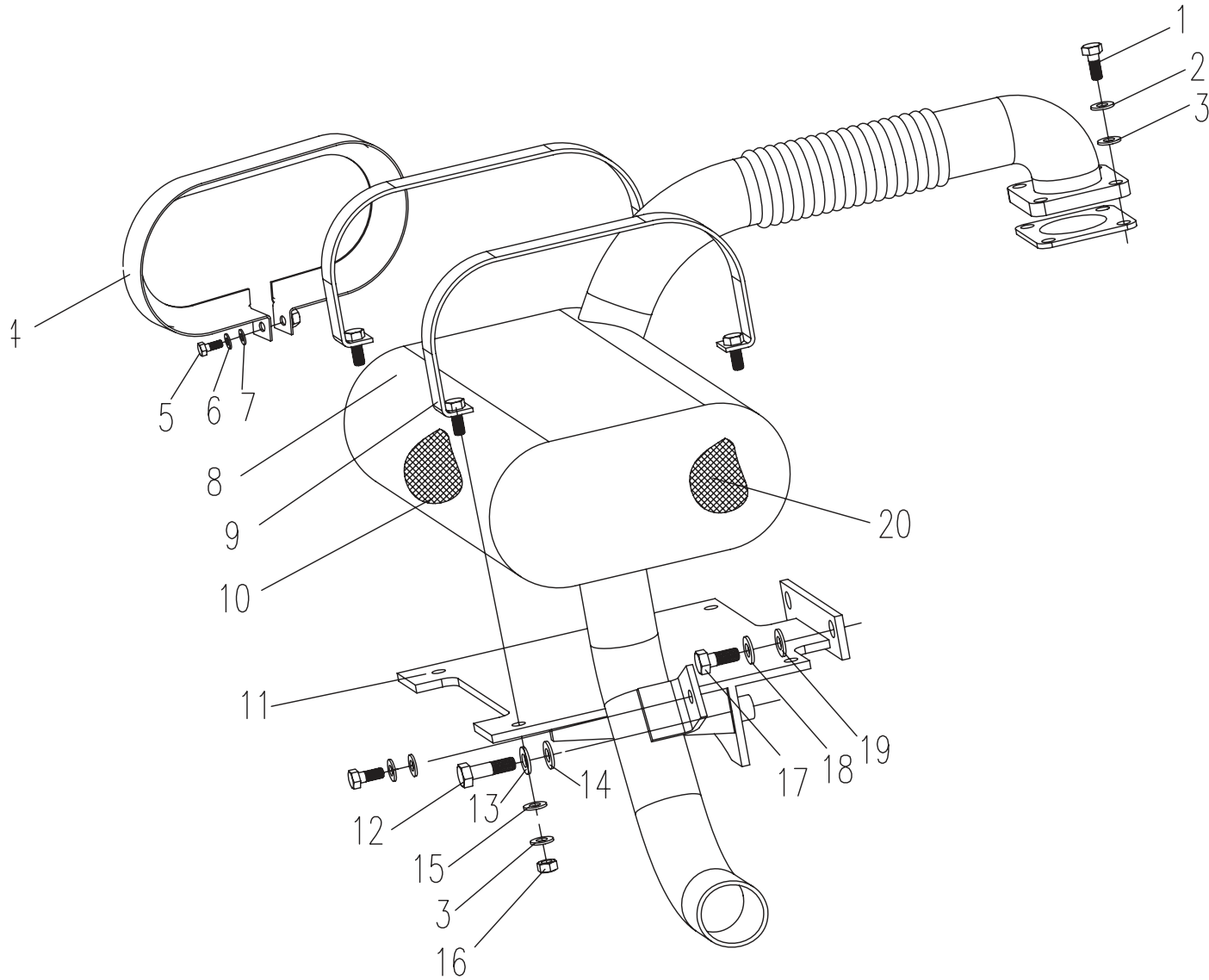



12.4.1 动力输出系统(适830T04机型) POWER OUTPUT SYSTEM (APPLY TO 830T04 TYPE)

---

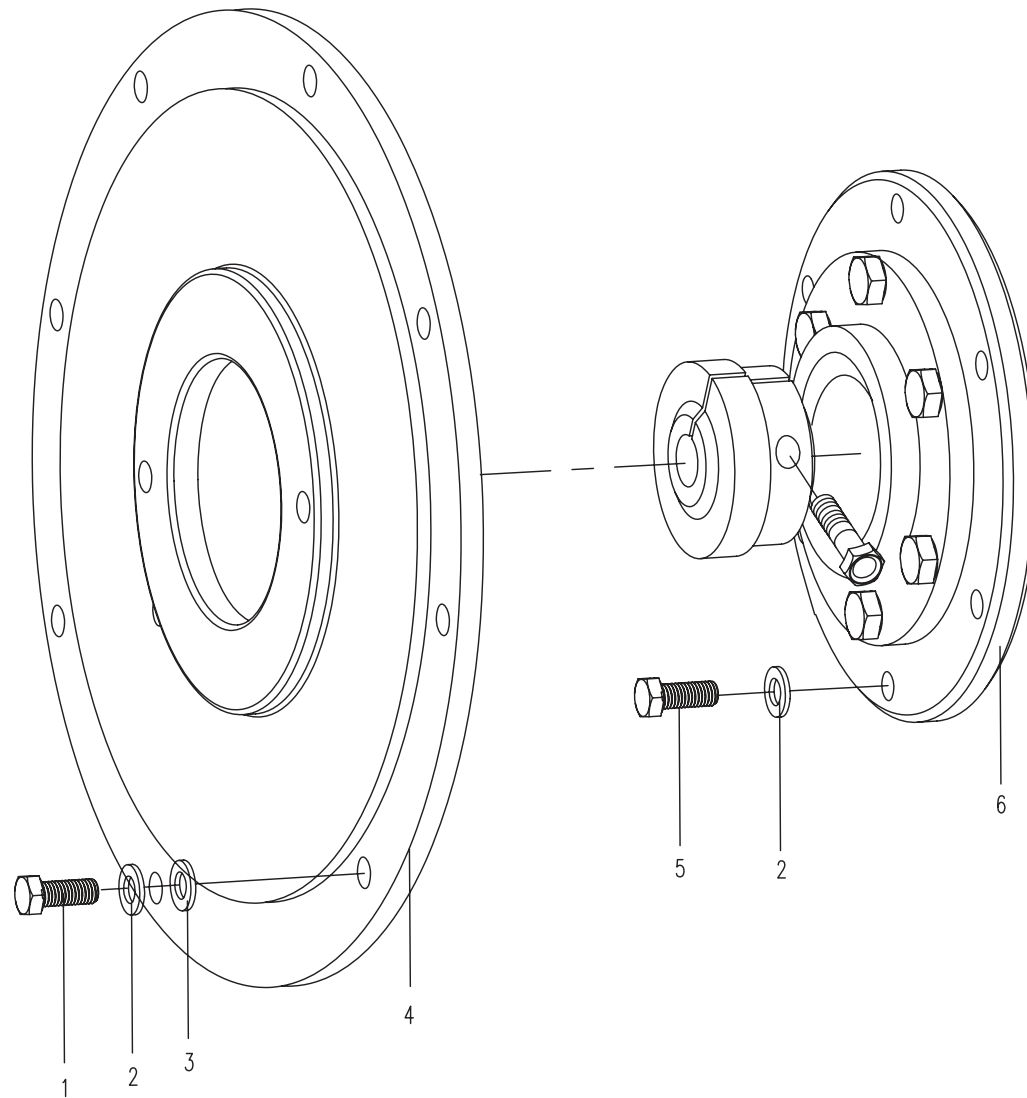

12.5.1 支承(适用830T04机型) SUPPORT (APPLY TO 830T04 TYPE)

序号 No.	数量 Quantity	代号 Code	名称 Description		备注 Remark
1	2	M12X110 GB/T5782	六角头螺栓	Bolt	10.9-达克罗
2	8	828-1206001	减震器	Shock absorber	
3	1	830T-1204200A	右后支架	Rear support-RH	
4	4	810K-1208003	圆垫	Washer	
5	10	12 GB/T 97.1	平垫圈	Washer	Zn. D
6	2	12 GB/T6182	嵌件六角锁紧螺母	Nut	8-Zn. D
7	4	14 GB/T 97.1	平垫圈	Washer	Zn. D
8	4	14 GB/T 93	弹簧垫圈	Spring washer	Zn. D
9	4	M14×1.5×35 GB/T5786	六角头螺栓	Bolt	10.9-达克罗
10	1	830T-1204100A	左后支架	Rear support-LH	
11	1	M8×40 GB/T5783	六角头螺栓	Bolt	10.9-达克罗
12	4	8 GB/T93	弹簧垫圈	Spring washer	Zn. D
13	4	8 GB/T97.1	平垫圈	Washer	Zn. D
14	1	M10×1.25×30 GB/T5786	六角头螺栓	Bolt	10.9-达克罗
15	1	10 GB/T93	弹簧垫圈	Spring washer	Zn. D
16	1	10 GB/T97.1	平垫圈	Washer	Zn. D
17	6	M12×1.25×35 GB/T5786	六角头螺栓	Bolt	10.9-达克罗
18	6	12 GB/T93	弹簧垫圈	Spring washer	Zn. D
19	2	M12×100 GB/T5782	六角头螺栓	Bolt	10.9-达克罗
20	1	M8×30 GB/T5783	六角头螺栓	Bolt	10.9-达克罗
21	2	M8×25 GB/T5783	六角头螺栓	Bolt	10.9-达克罗
22	1	830T-1207001	张紧杆	Tightening bolt	
23	1	830T-1207002	空调皮带	Strap	
24	1	830T-1203200	右前支架	Front support-RH	
25	1	830T-1203100	左前支架	Front support-LH	

12.5.1 支承(适用830T04机型) SUPPORT (APPLY TO 830T04 TYPE)

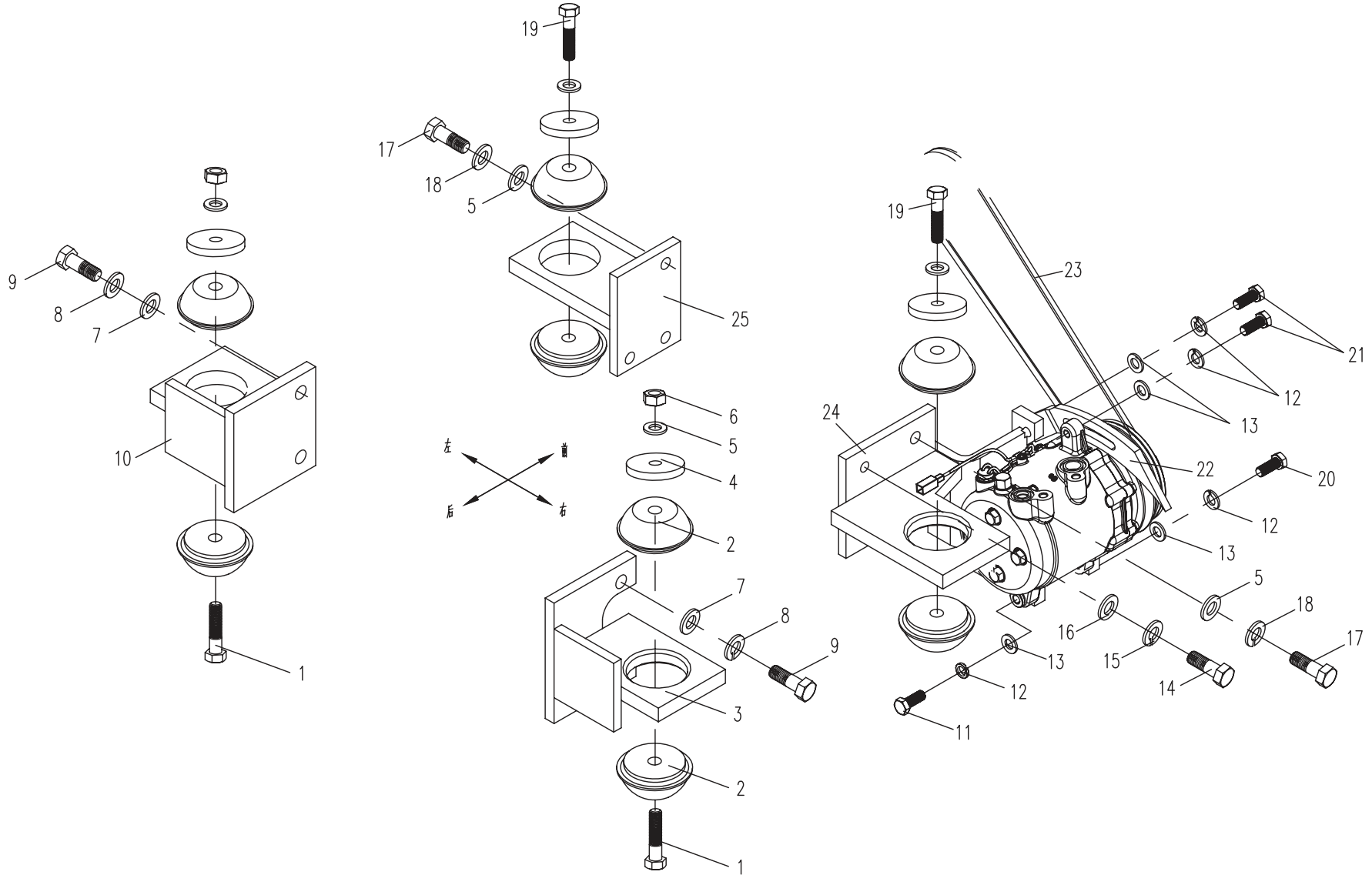





12.6.1 油门操纵系统(适用830T04机型) THROTTLE CONTROL SYSTEM (APPLY TO 830T04 TYPE)

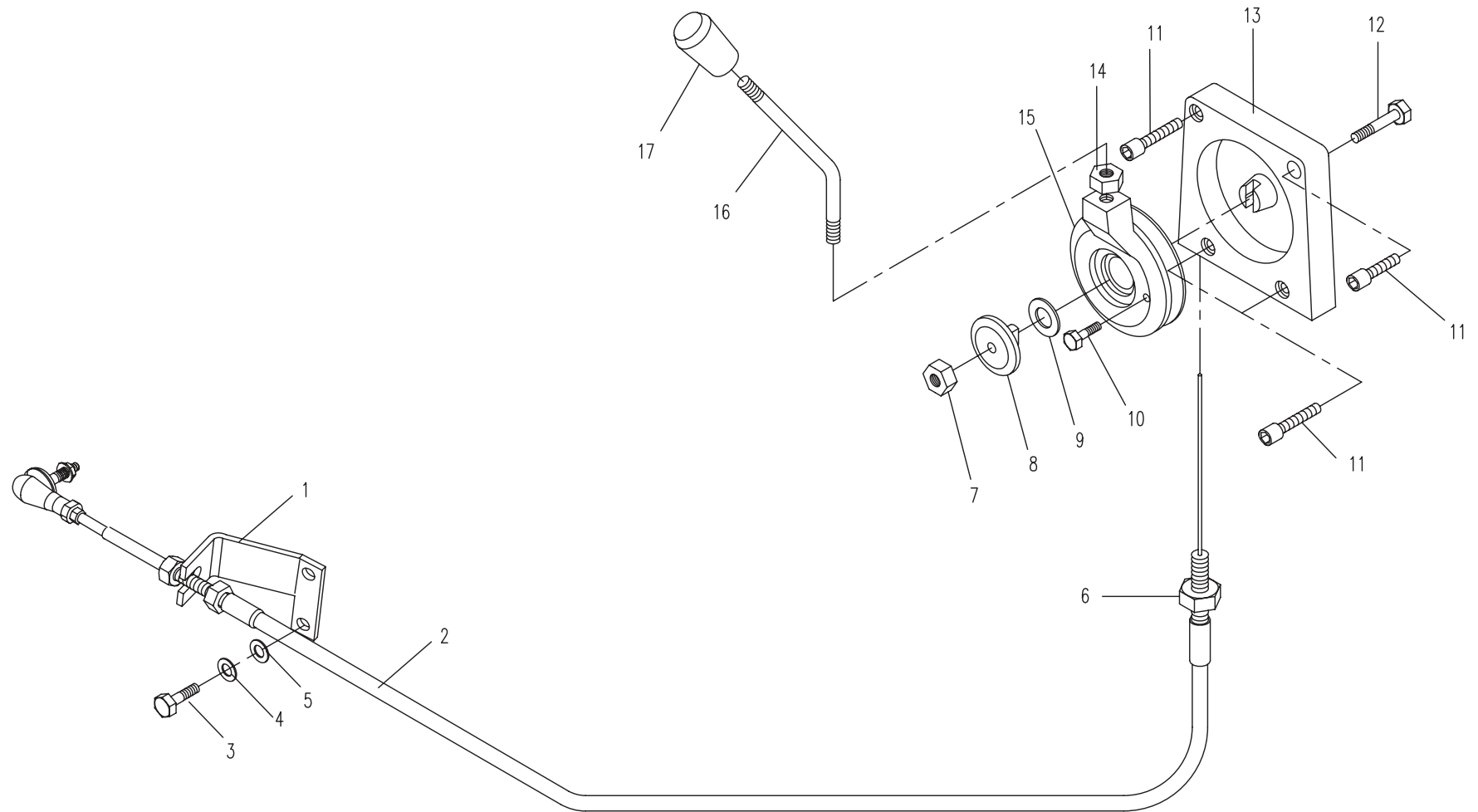



12.7.1 燃油系统(适用830T04机型) FUEL SYSTEM (APPLY TO 830T04 TYPE)

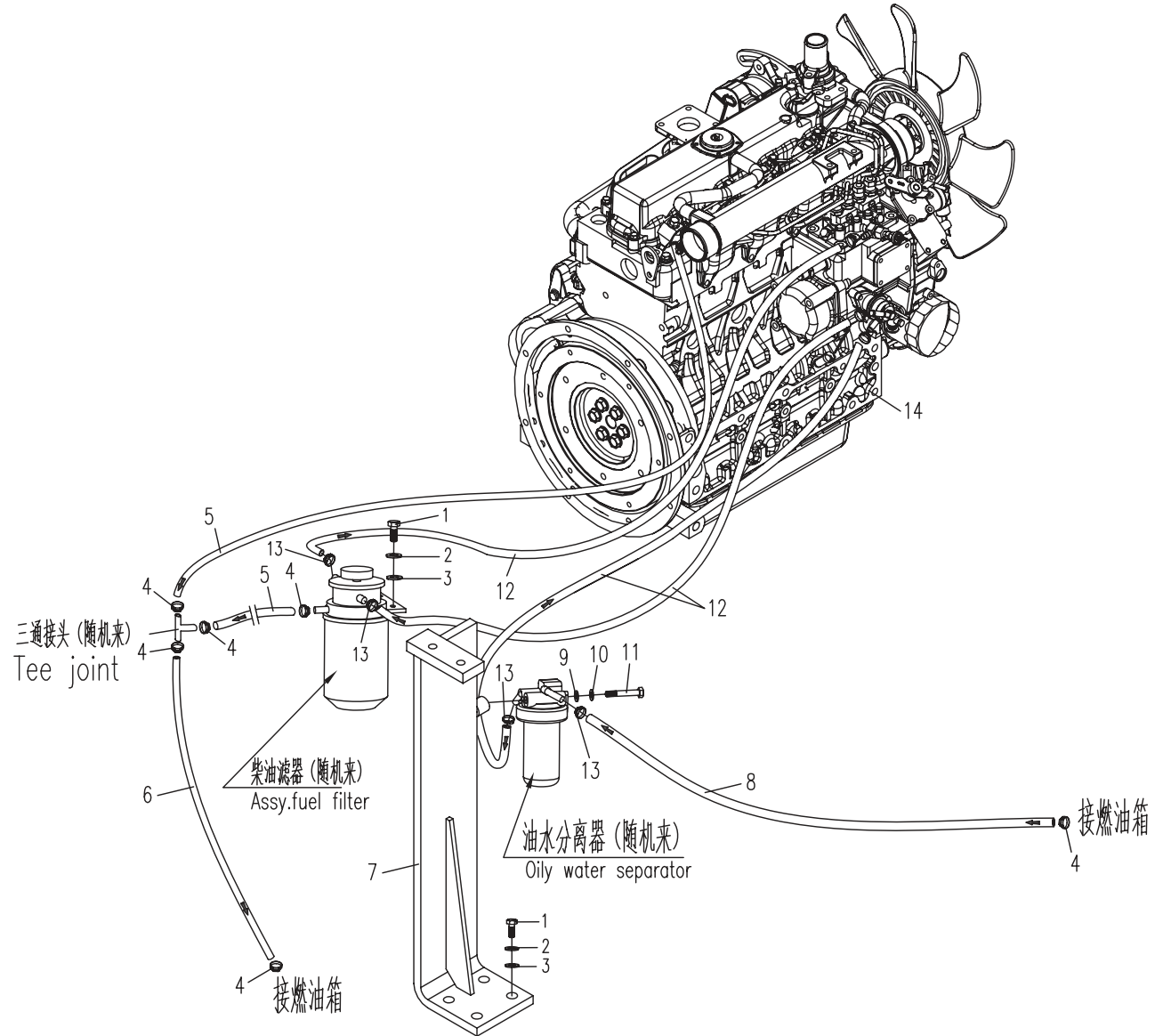

13.1.1 电气系统-电气总装(适用830T04机型) ELECTRICAL SYSTEM-ELECTRICAL ASSEMBLY (APPLY TO 830T04 TYPE)

序号 No.	数量 Quantity	Code	名称 Description		备注 Remark
1	1	T0401-01112	电磁式电源总开关	Main switch	12V
2	3	M10X20 GB/T5783	六角头螺栓	Bolt	8. 8-Zn. D
3	3	10 GB/T93	弹簧垫圈	Spring washer	Zn. D
4	3	10 GB/T97. 1	平垫圈	Washer	Zn. D
5	1	T0416-02102	电喇叭	Horn	12V
6	3	M8X20 GB/T5783	六角头螺栓	Bolt	8. 8-Zn. D
7	5	8 GB/T93	弹簧垫圈	Spring washer	Zn. D
8	5	8 GB/T97. 1	平垫圈	Washer	Zn. D
9	1	830D-1300200	电池搭铁线		
10	1	M12x45 GB/T5783	六角头螺栓	Bolt	8. 8-Zn. D
11	2	12 GB/T93	弹簧垫圈	Spring washer	Zn. D
12	2	12 GB/T97. 1	平垫圈	Washer	Zn.D
13	1	T0405-02211	工作灯	Work lamp	12V
14	1	830E-1301100	动臂灯框架	Bracket	
15	5	T0416-06001	线束安装块	Clamp	
16	1	830T-1340100	主线束	Main cable	
17	15	6 GB/T97. 1	平垫圈	Washer	Zn. D
18	15	6 GB/T93	弹簧垫圈	Spring washer	Zn. D
19	5	M6x12 GB/T818	十字槽盘头螺钉	Bolt	8. 8-Zn. D
20	1	830H-1310600	驾驶室线束	Cable-Cab	
21	1	T0406-12111	雨刮器	Wiper	
22	1	T0411-15212	液位传感器	Fuel level sensor	L=380
23	1	T0411-01201	温度传感器	Temperature sensor	
24	1	T0409-02101	收音机天线	Antenna	
25	1	T0405-13211	顶灯	Cab lamp	
26	3	T0405-12111	工作灯	Work lamp	
27	1	T0405-04211	警示灯	Caution light	
28	1	T0416-04002	警示灯支架	Bracket	

13.1.1 电气系统-电气总装(适用830T04机型) ELECTRICAL SYSTEM-ELECTRICAL ASSEMBLY (APPLY TO 830T04 TYPE)

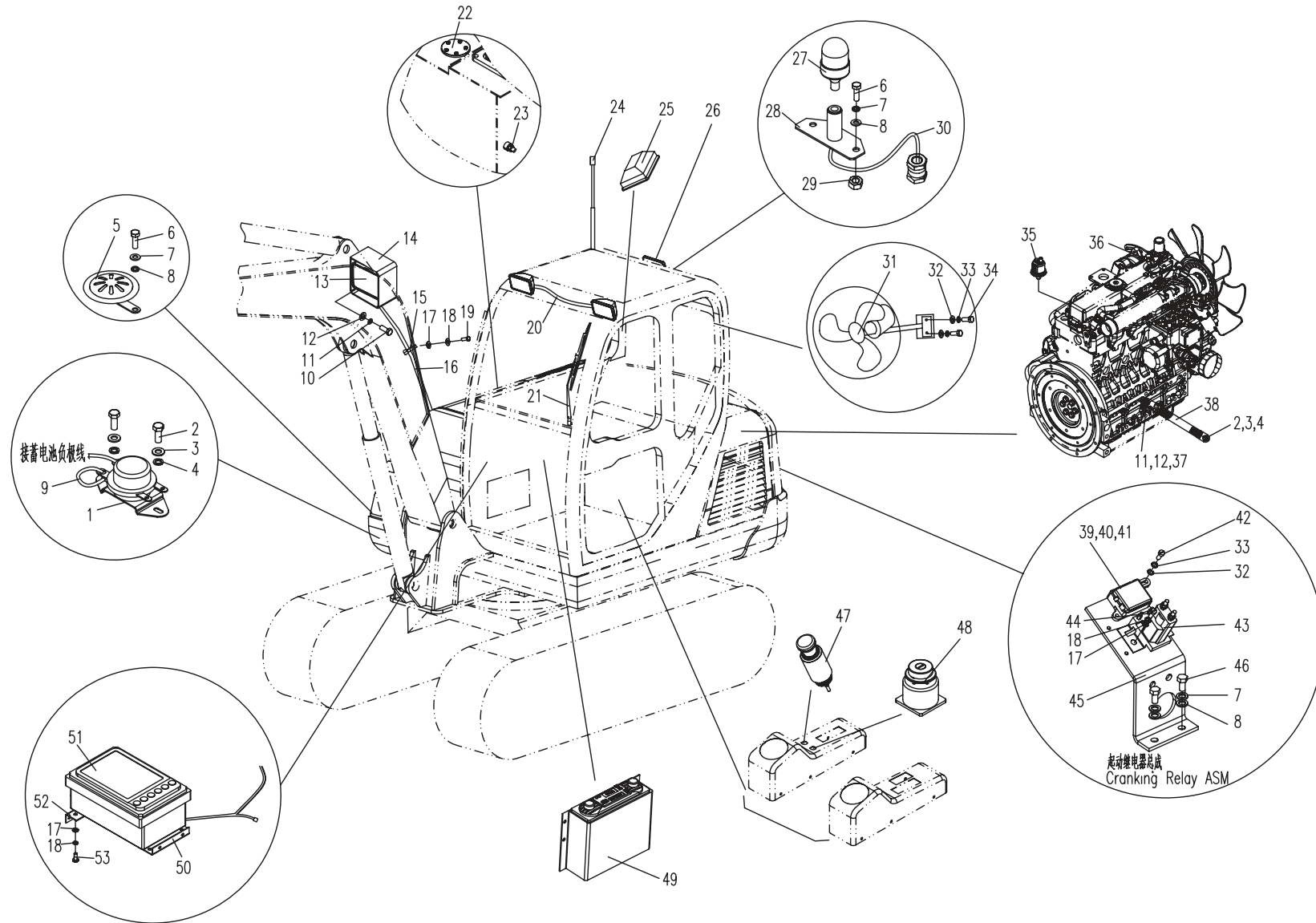

13.1.1 电气系统-电气总装(适用830T04机型) ELECTRICAL SYSTEM-ELECTRICAL ASSEMBLY (APPLY TO 830T04 TYPE)

序号 No.	数量 Quantity	Code	名称 Description		备注 Remark
29	2	M8 GB/T6170	1型六角螺母	Nut	8-Zn. D
30	1	830E-1310500	驾驶室灯线束	Cable-Lamp	
31	1	T0407-11111	电风扇	Fanner	
32	4	5 GB/T97. 1	平垫圈	Washer	Zn. D
33	4	5 GB/T93	弹簧垫圈	Spring washer	Zn. D
34	2	M5X16 GB/T70. 1	内六角圆柱头螺钉	Bolt	8. 8-Zn. D
35	1	T0411-03101	压力传感器	Pressure Sensor	1/8 NPTF
36	1	T0411-01101	温度传感器	Temperature sensor	3/8 NPTF
37	1	M12 1.25 25 GB/T5786	六角头螺栓	Bolt	8. 8-Zn. D
38	1	835-1324001	发动机搭铁线	Earthing wire	
39	1	T0402-01105	二路熔断器盒	Two place fuse box	
40	1	T0402-04104	2路熔断器保险片	50A Fuse	50A
41	1	T0402-04102	2路熔断器保险片	30A Fuse	30A
42	2	M5X12 GB/T65	开槽圆柱头螺钉	Bolt	8. 8-Zn. D
43	1	T0404-01211	起动继电器	Starter relay	
44	2	M6X10 GB/T65	开槽圆柱头螺钉	Bolt	8. 8-Zn. D
45	1	830H-1300101A	安装板	Fixing plank	
46	2	M8X16 GB/T5783	六角头螺栓	Bolt	8. 8-Zn. D
47	1	T0408-01111	点烟器	Cigaret lighter	
48	1	838A-1302000	起动开关总成	Starter switch	
49	1	T0409-01110	收音机	Radio	
50	1	830H-1300610	仪表安装板II	Bracket	
51	1	T0412-04212	小挖专用监控器	Controller	DC038D-H
52	1	830H-1300601	仪表安装板	Bracket	
53	8	M6x12 GB/T5783	六角头螺栓	Bolt	8. 8-Zn. D

13.1.1 电气系统-电气总装(适用830T04机型) ELECTRICAL SYSTEM-ELECTRICAL ASSEMBLY (APPLY TO 830T04 TYPE)

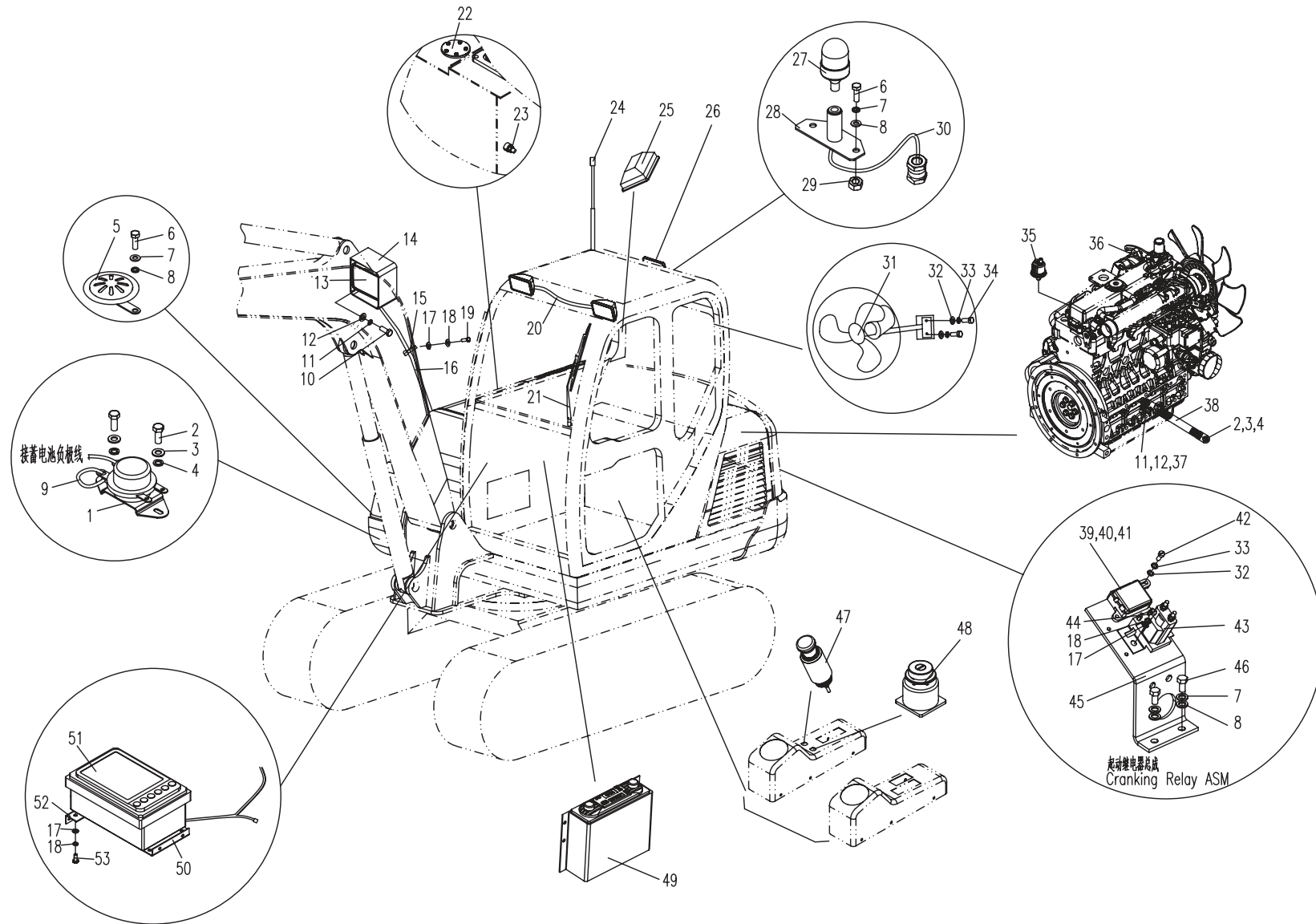





13.2.1 电气系统-开关总成(适用830T04机型) ELECTRICAL SYSTEM-SWITCH ASSEMBLY(APPLY TO 830T04 TYPE)

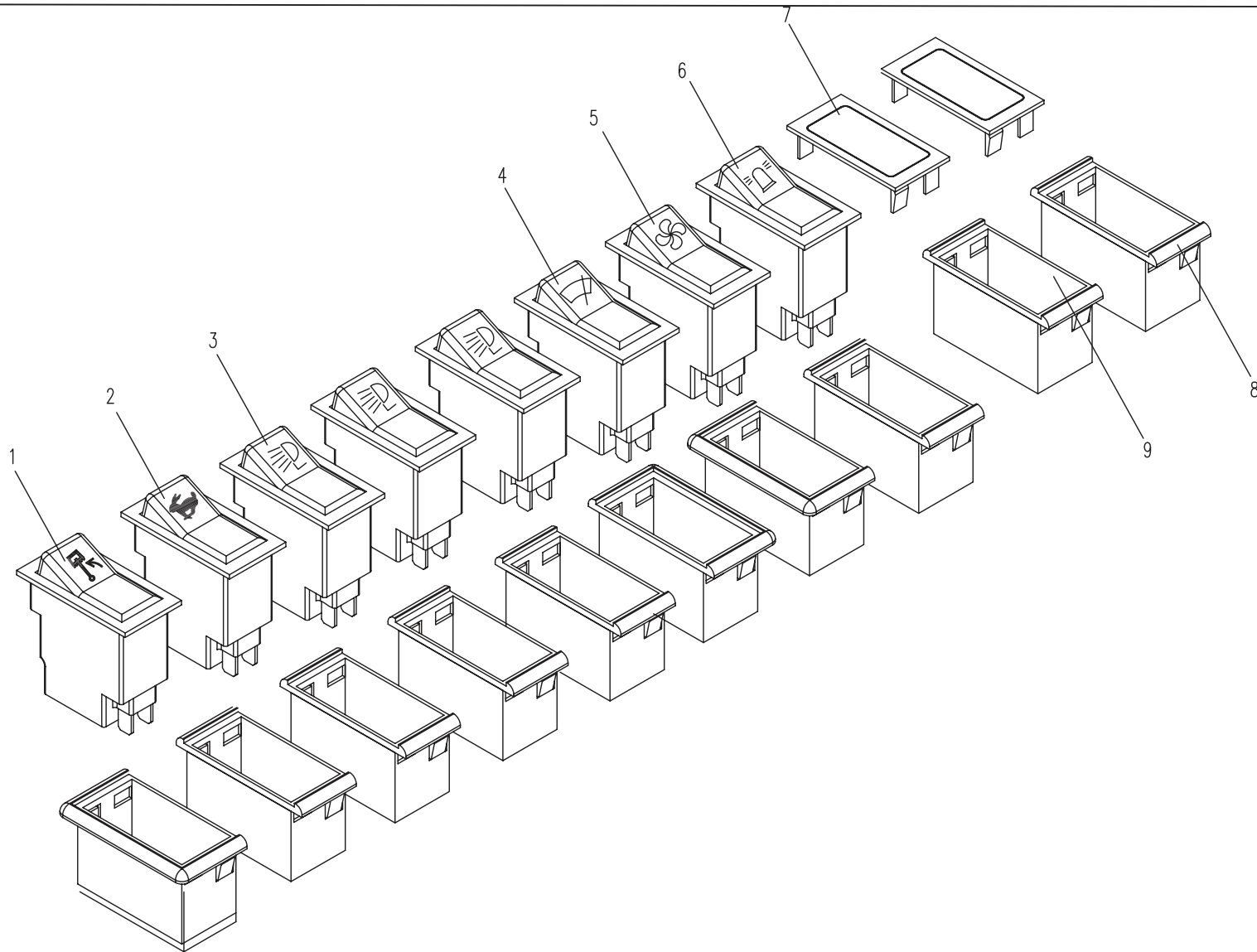



13.3.1 电气系统-继电器安装总成(适用830T04机型) ELECTRICAL SYSTEM-RELAY ASSEMBLY (APPLY TO 830T04 TYPE)

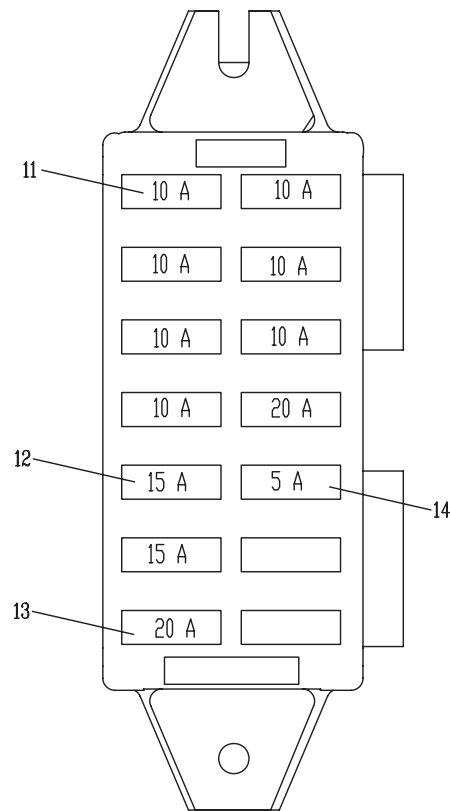
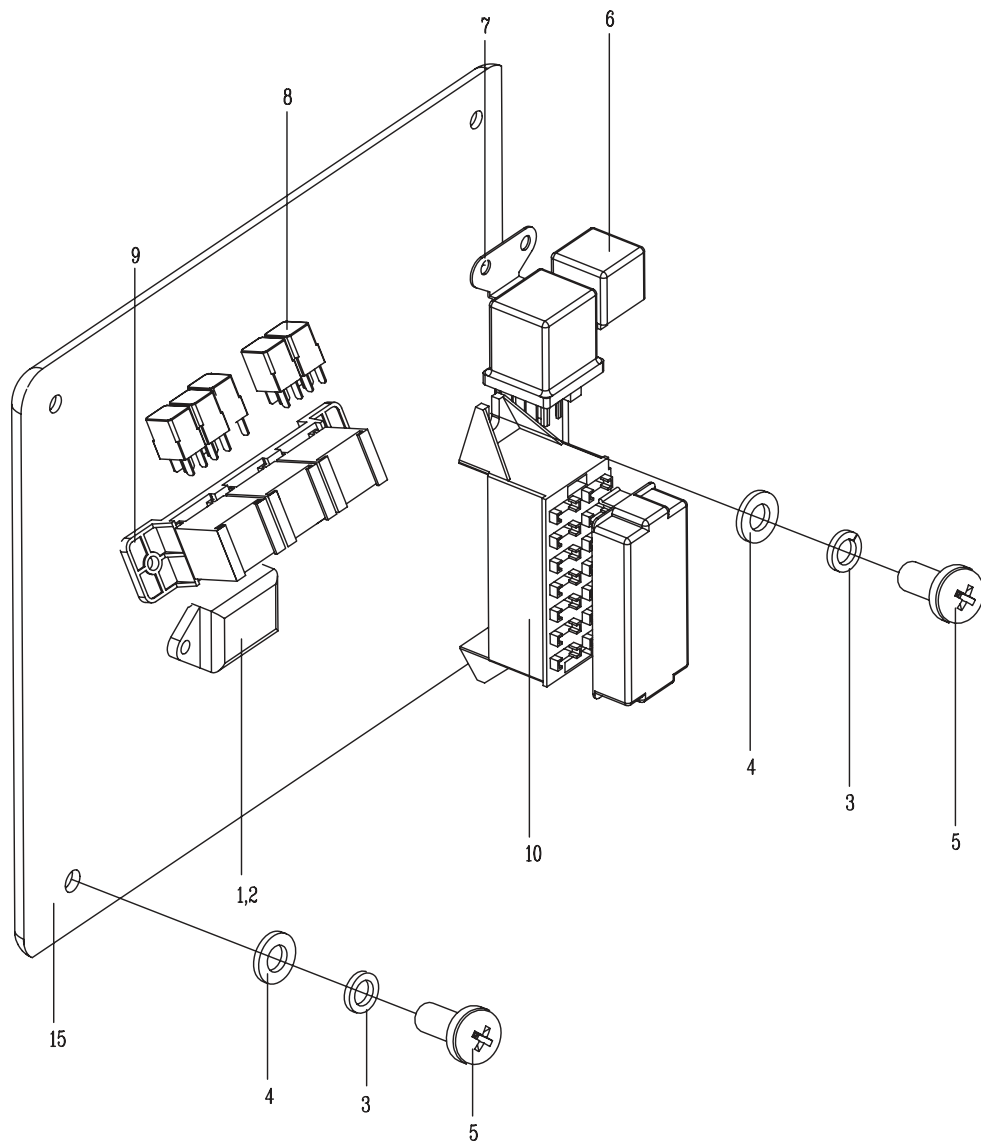



13.4.1 电气系统-电池安装组(适用830T04机型) ELECTRICAL SYSTEM-BATTERY ASSEMBLY (APPLY TO 830T04 TYPE)

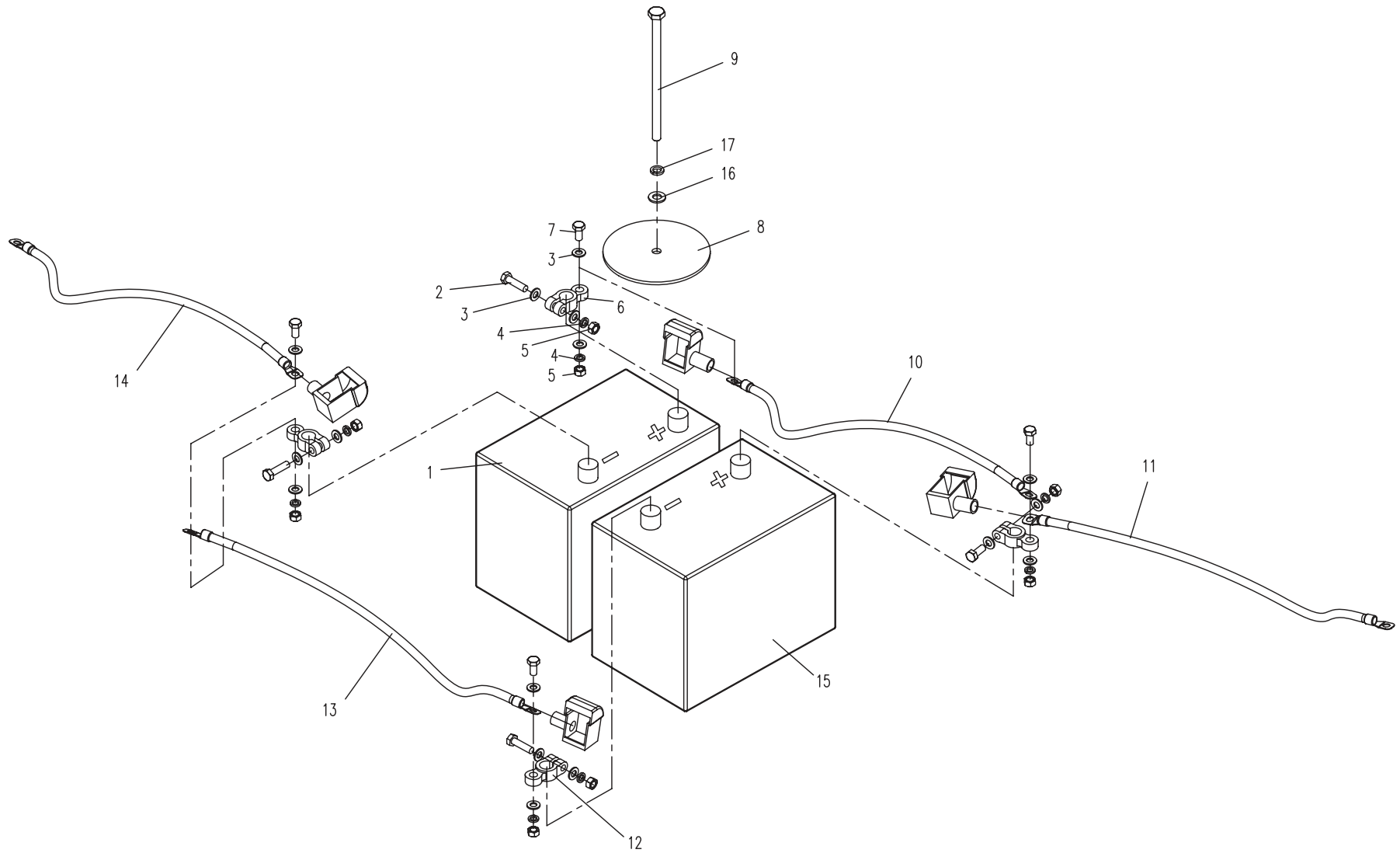

13.5.1 电气系统-接线系 (适用830T04机型) ELECTRICAL SYSTEM-WIRING DIAGRAM(APPLY TO 830T04 TYPE)

