

Hydraulic Digger

USER MANUAL



CAUTION

Not correct operation could cause the damage. Before the machine can be used, it should be done as follow:

- Remember the operation manual and the use criterion
- Read & understand the content of the user manual about the safety operation
- Understand & know the safety sign of the machine
- Let the person leave the workplace who not the operator
- It should have a safety operation training before you operates the machine

You have the duty to observance the ordinance & laws, follow the relevant direction about machine operation & maintain from YUCHAI.

Contents

I 、 Prolegomena

To user-----	1-2
Product Information -----	1-3
Direction of The Machine -----	1-5
Machine Form-----	1-6
Technical Parameters -----	1-7

II 、 Safety Rule

General rules-----	2-2
Safety Prompt -----	2-3
Safety Equipment -----	2-4
Safety Sign -----	2-5
Safety of The Workplace -----	2-13
Safety Operation -----	2-14
Transport &Load and Unload -----	2-24
Maintain -----	2-25
Fire-proof、Explosion-proof& Antigas -----	2-26
Accumulator -----	2-27
Hydraulic System -----	2-28

III、 Parts Introduction

Pandect for Operation Device(Cab Type) -----	3-2
Pandect for Operation Device(Canopy Type) -----	3-3
Panel Switch of Left Controlling Box(Switch group)-----	3-4
Panel Switch of Right Controlling Box(Panel meter and Switch)-----	3-5
Safety Lock Part -----	3-7
Operate The Operation Device& Rotating Device -----	3-8
Driving Operation -----	3-10

Hydraulic Digger

throttle grip -----	3-11
driver's chair -----	3-12
safety belt -----	3-13
Air-condition Control -----	3-14
Radio -----	3-18
Door and Window -----	3-20

IV、 Operation Manual

Prepare for Running Machine -----	4-2
Engine Operation -----	4-3
In&Out Machine -----	4-7
Moving The Machine -----	4-8
Turning The machine -----	4-10
Rotating The Machine -----	4-11
Operate The Operating Device -----	4-12
Working On The Slope or In The Water -----	4-14
Out of The Muddy Condition -----	4-15
Operating Manual -----	4-16
Take-down & Installing The Bucket -----	4-19
Place The Machine -----	4-20
After The Operation -----	4-22
Takedown &Transport The Machine -----	4-23
Operate The Machine Under The Cold/Hot Weather -----	4-28
Deposit The Machine -----	4-29
Reason for the Technical Trouble& Resolve -----	4-31

V、 Maintenance

General Knowledge of Maintenance -----	5-2
Maintenance Summary -----	5-4
Easy Broken Part -----	5-6

Hydraulic Digger

Forced Changing Part -----	5-7
Choose List of the Oil Plants-----	5-8
The Tighten Moment -----	5-9
Maintenance List of Time-check -----	5-12
Routine Check -----	5-14
Fuel System of the Engine -----	5-15
Cooling System of the Engine -----	5-19
Lubricating System of the Engine -----	5-22
Air Intake System of The Engine -----	5-24
Other Maintenances of The Engine -----	5-26
Hydraulic System -----	5-27
Accumulator -----	5-33
The Reducer -----	5-35
Pedrail-----	5-37
Support Roller,Carrier Roller& Leading Roller -----	5-38
Lubricating -----	5-39
Air-condition(If the machine have) -----	5-40
Replace The Gear of The Bucket -----	5-43
Washing The Plastic Cushion of the floor -----	5-44
Fuse -----	5-45

VI、 Attachment Manual

Safety Item-----	6-2
Installing & take-down step of the attachment -----	6-3
Operation Manual of the attachment -----	6-4
Daily Check of Hydraulic Crush Hammer -----	6-9

Attachment:

Black Manual of The Certification

TO USER

Dear users,

You are welcome to use YUCHAI excavator, thank you for your support to our business.

This manual is for the operator and the service man of YUCHAI excavator. Hope you can read this manual carefully before operating and maintaining, and work strictly as the regulations of safety measures, operating guides, lubrication and periodic maintenance.

Correctly handle the operating method and maintain frequently are the necessary measures for the machine work reliably and efficiently, and also can lengthen machine use life.

Please send the machine to our company's service office or agent for important servicing and adjustment, and use the original parts supplied by our company. It will cause many problems if you install other parts on our machines even it is not clear effect for beginning.

We will not supply the warranty service if the machine broken as Used the unoriginal parts or repaired by the service department which is not authorized by Yuchai even it is during the warranty period.

According to the principle of "The customer is god", we will keep improving the machine for supplying the product to the user as best as we can. The improvement will be take in any minute, we will not responsible for sending the new manuals for the selling products and giving the notice in advance.

Hope this machine can supply the comfortable operating condition.

1

Prolegomena

Hydraulic Digger

Product Information

When you want to know the informations of the machine, please view the picture as follow:

- Overall Information(The nameplate is on the nearside of the platform)

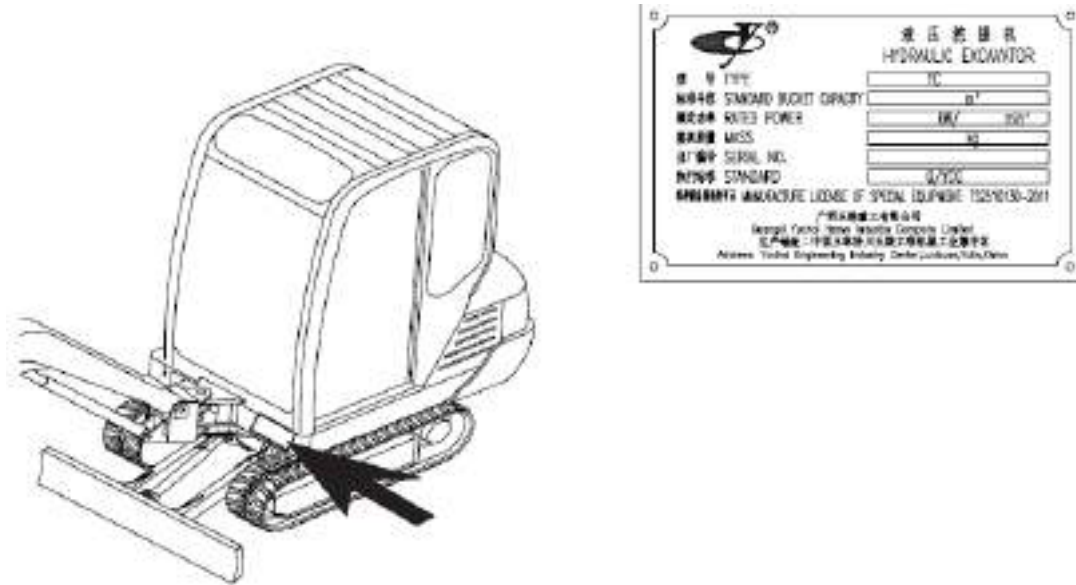

液压挖掘机 HYDRAULIC EXCAVATOR	
型号 TYPE	TC
额定斗容 STANDARD BUCKET CAPACITY	m ³
额定功率 RATED POWER	kW / HP
额定质量 MASS	kg
出厂编号 SERIAL NO.	
执行标准 STANDARD	GB/T202
特种设备制造许可证特种设备制造许可 10210130-2011	
生产厂家 三一重工股份有限公司 Georgi Yangxi Heavy Industry Company Limited 生产地址：中国湖南省长沙县星沙工业园三一总部	
Address: Yantai Engineering Industry Center, Luoyuan/Tian, China	

- Engine Information(The nameplate is in the top of the cylinder cover)

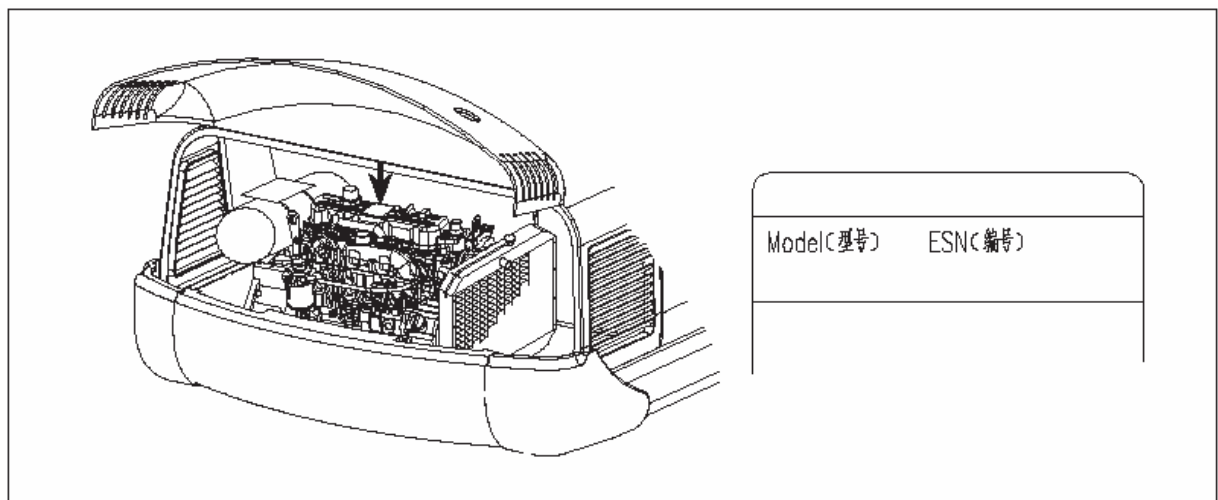

Model(型号) ESN(编号)

Hydraulic Digger

- Running Information(The timer of the engine is in the digital combination instrument which in the cab)

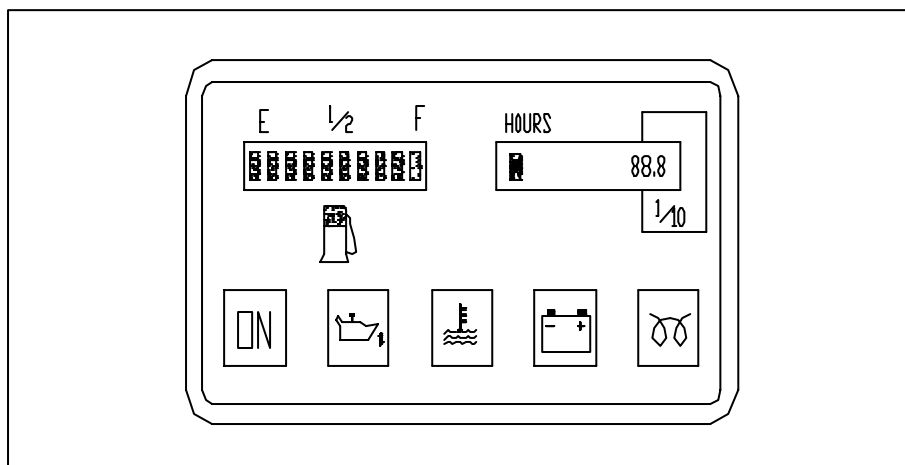

Machine File

Please fill the machine and engine's series No. in the table. When you need to buy the spare parts or the relational informations, you can tell us the No..

	● 机器型号 _____
	● 产品整机系列号 _____
	● 发动机系列号 _____
	● 经销商信息 _____

Direction of The Machine

Hydraulic Digger

Front, back, left, right, top, underside in the manual same as the direction as follow:

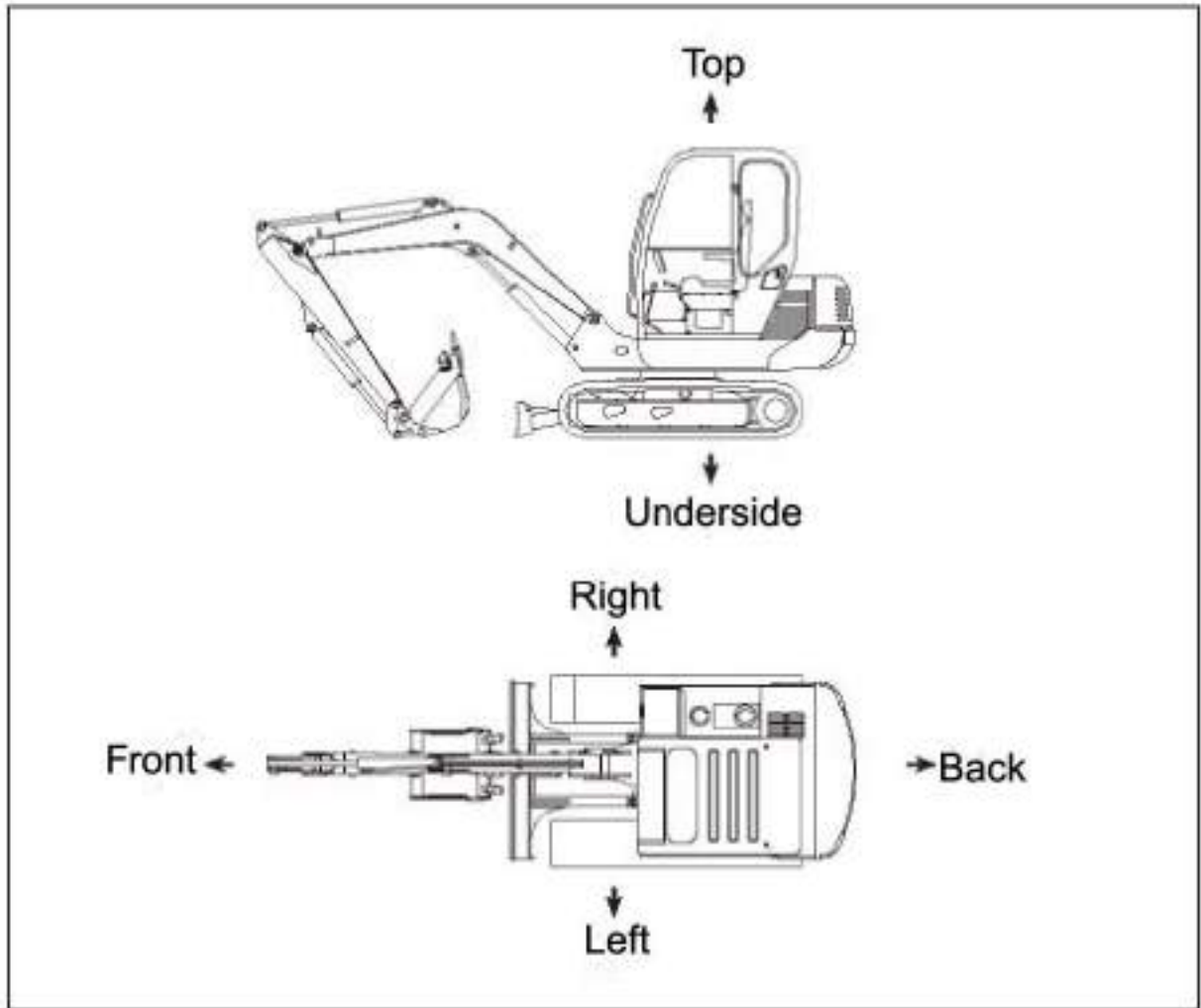

Hydraulic Digger

Machine Form (The Moving-arm Un-deflecting Type)

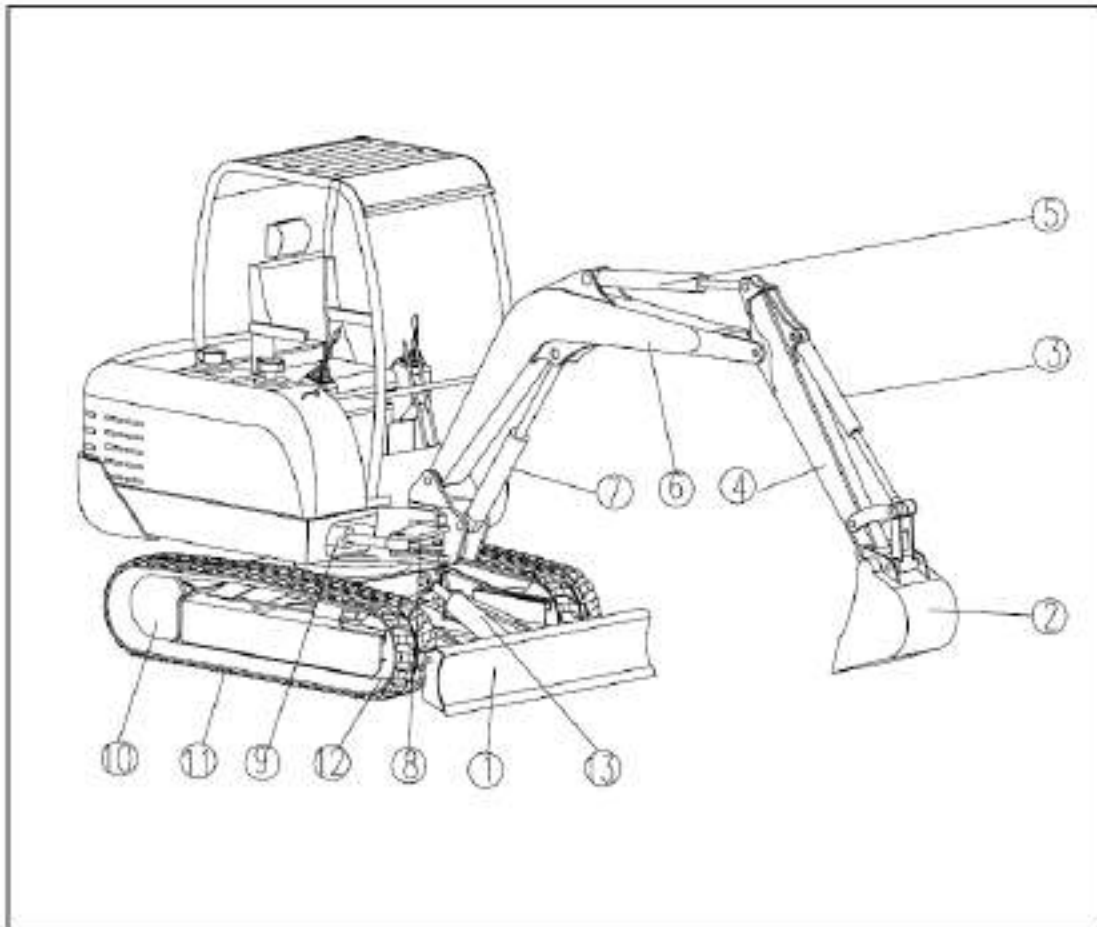

- | | | |
|-----------------------------------|-----------------------------|------------------------|
| 1. Bulldozer | 2. Bucket | 3. Bucket oil cylinder |
| 4. Lever | 5. Lever oil cylinder | 6. Moving-arm |
| 7. Moving-arm oil cylinder | 8. Rotating platform | |
| 9. Rotating platform oil cylinder | 10. Driving wheel | |
| 11. Pedrail | 12. guide deflection sheave | |
| 13. Bulldozer oil cylinder | | |

Note: The lookum is optional equipment. It only used in the better condition.

Technical Parameters

Hydraulic Digger

1. Frame dimension parameter

Code	Item	Unit	YC25-8	
			825E	
	Operating Weight	Kg	3080	
	Standard bucket capacity	M ³	0.07	
	Name of engine		Kubota D1803	Cummins A1700
	Power of engine	Kw/rpm	22.8/2200	24/2200
A	Length	Mm	4508	
B	Height	Mm	2400	
C	Overall width	Mm	1450	
D	Width of pedrail	Mm	300(steel/rubber)	
E	Rotating radii of platform	Mm	1351	
F	Length of pedrail	Mm	1935	
G	Distance of roller	Mm	1455	
H	Height from floor	Mm	320	
I	Height of Boom end	Mm	1409	
J	Width of the platform	Mm	1420	
K	Height of engine cover	Mm	1384	
L	Height from floor of platform	Mm	563	
	Width of bucket	Mm	517	
	Driving speed(low/hight)	Km/h	2.4/4.2	
	Rotating speed of platform	Rpm	10~12	
	Cab		●	
	Canopy		●	
	Deflection angle(left/right)	°	80/50	

Note: Technical parameters are subject to change without prior notice!

Hydraulic Digger

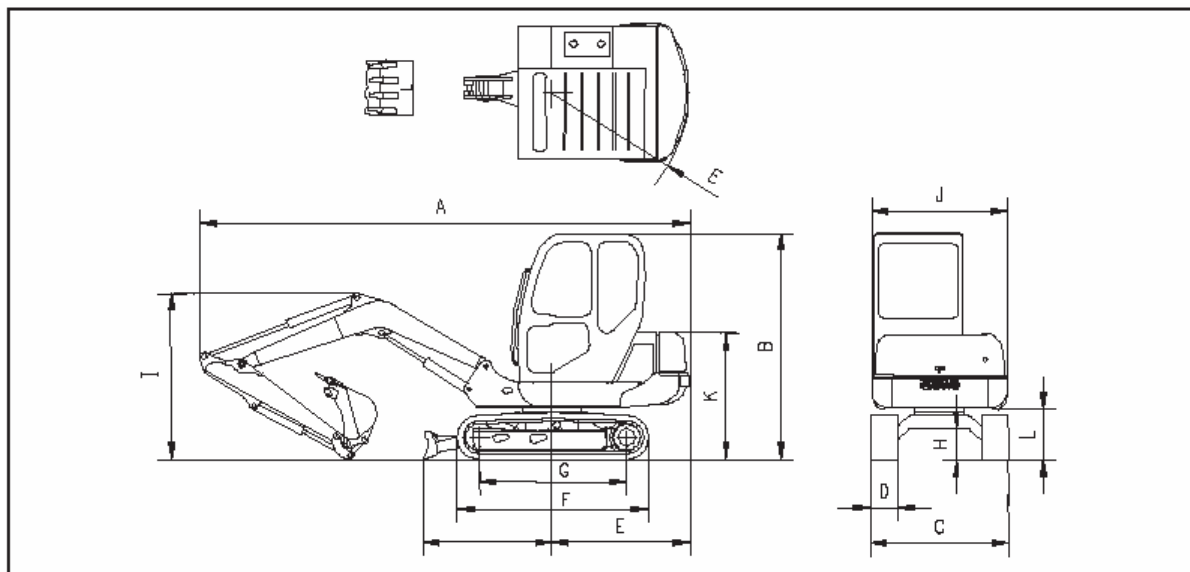

2. Operating parameters

Code	Item	Unit	YC25-8
			825E
A	Max. digging height	Mm	4205
B	Max.height of load&unload	Mm	2840
C	Max. digging depth	Mm	2610
D	Max. digging radii	Mm	4610
D1	Max.digging distance of level floor	Mm	4487
E	Digging radii of Max.digging height	Mm	2957
F	Min. rotating radii	Mm	1856
G	Max. bucket depth of Bulldozer	Mm	372
H	Max. uplift height of Bulldozer	Mm	262
	Max.dig power	KN	17.4

Note: Technical parameters are subject to change without prior notice!

Hydraulic Digger

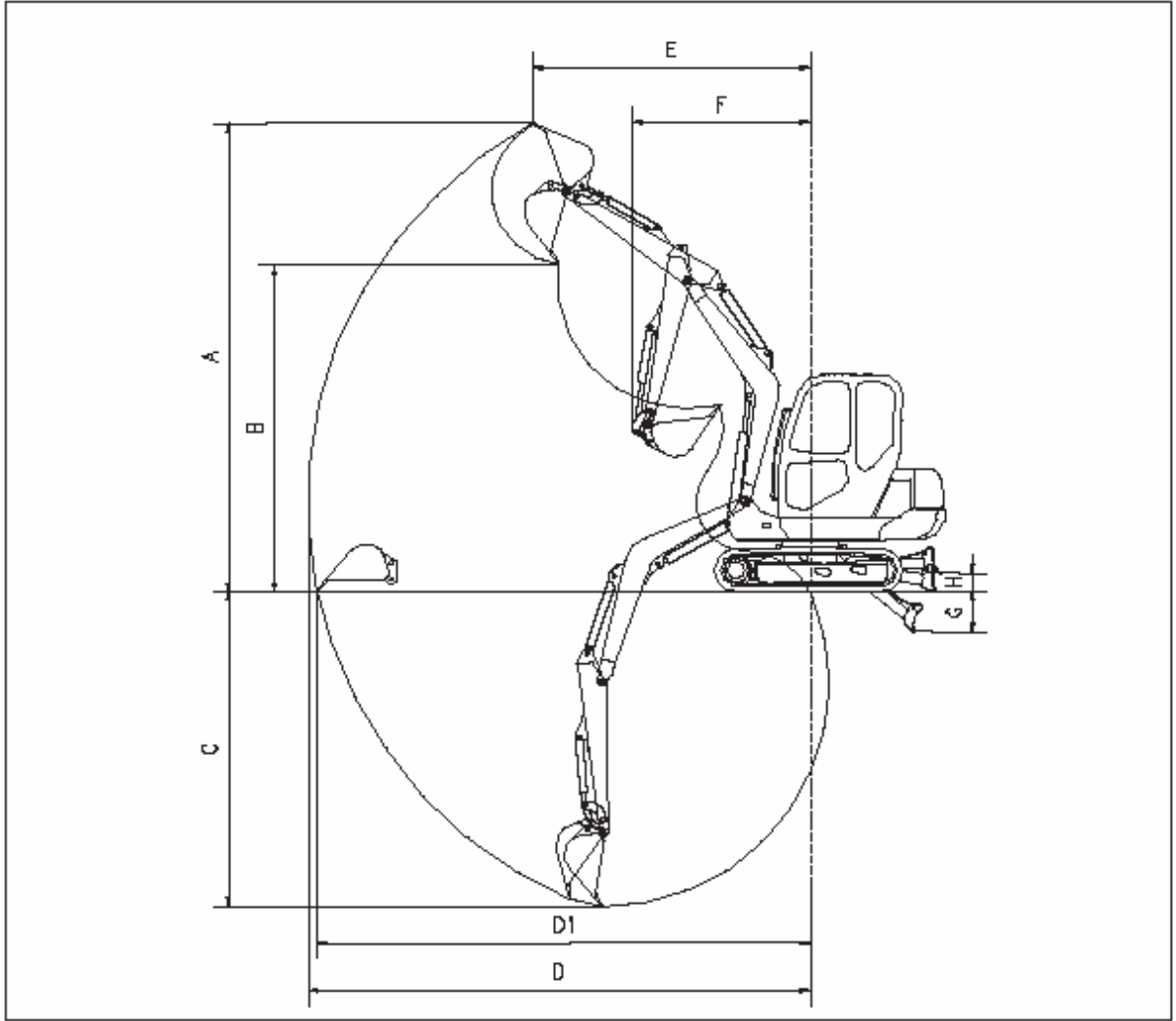

3. Bucket series (black area is standard collocate)

铲斗类型		反铲斗								清沟斗		
铲斗斗容		0.044	0.044	0.068	0.07	0.08	0.08	0.10	0.12	0.25	0.30	0.35
铲斗宽度		300	300	400	517	462	546	517	626	1000	1200	1433
铲斗重量		74	78	86	76	91	82	102	115	107	122	137
铲斗斗齿数		2	3	3	4	3	4	4	4	—	—	—
标准 动臂	1.134m 标准斗杆	⊙	⊙	⊙	⊙	⊙	⊙	⊙	⊙	○	○	○
	1.358m 标准斗杆	⊙	⊙	⊙	⊙	⊙	⊙	⊙	⊙	○	○	○

⊙ 适用于普通挖掘(物料比重不大于1.8t/m³) ○ 适用于平整斜坡
 ☆ 适用于轻负载挖掘(物料比重不大于1.2t/m³) X 不可用

Hydraulic Digger

4. Driving machine

It adopts the hydraulic motor through the multilevel epicycle reducer to become independent drive. The reducer is inside of the padrail.

	Driving speed(km/h)	Max.pull(kN)	Power of make the grade
High speed	4.3	12.36	58%(30°)
Low speed	2.4	22.94	

5. Hydraulic system

First enter to the throttle hydraulic system

Main valve: Intake multiple valve

Variable plunger pump: Flux of 2 plunger pump(L/min) 52.8

Pressure(Mpa) 21

Flux of 1 gear pump(L/min) 15.4

Pressure(Mpa) 21

Flux of lead gear pump(L/min) 7.7

Pressure(Mpa) 3.9

Return oil filter: paper material with 10micron

Oil absorbent filter: gridding filter

7. Electric system

Voltage: 12V

Accumulator: 60 x 2AH

Safety Prompt



1. Warning sign



In the user manual, the sign shows the important information about the safety. When you see the sign, you need to read the information behind the sign carefully.

2. Safety prompting word

The machine includes "Danger", "Warning", "Notice" etc. The safety prompting word. Explain them as follows:

-  Danger: If not elude, the result may be lead die or hurt. It only use in the condition which have the most dangerous.
-  Warning: If not elude, the potential danger may be lead die or hurt.
-  Notice: If not elude, the potential danger may be lead hurt. Or it can prompt the operation which can hurt the body.

Safety Equipment

1.The safeguard for the operator

- 1) The operator need put on the interrelated safeguard: sheathy work clothes、 motorcycle safety helmet、 work shoe and so on(safety glass、 safety earplug、 glove、 safe belt)

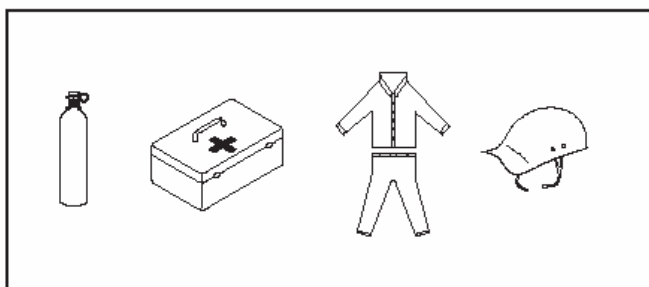

- 2) IF the operator has long hair, please tie it and wear the motorcycle safety helmet. It can protect your hair not into the machine.
- 3) The user need put some first-aid medicines in the machine, and routine check them.
- 4) Before operating or examining, please check the function of the safeguards are ok.

2.Flee hammer & fire extinguisher

Flee hammer & fire extinguisher installing on the wall of the cab.

When you couldn't out or into the cab, need escape the cab, you can use the flee hammer break the glass. But when you break the glass, please protect you eye and face.

When the machine burning, please use the fire extinguisher.

Please read the user manual of the fire extinguisher carefully.

Routine check and maintenance the fire extinguisher.

Hydraulic Digger

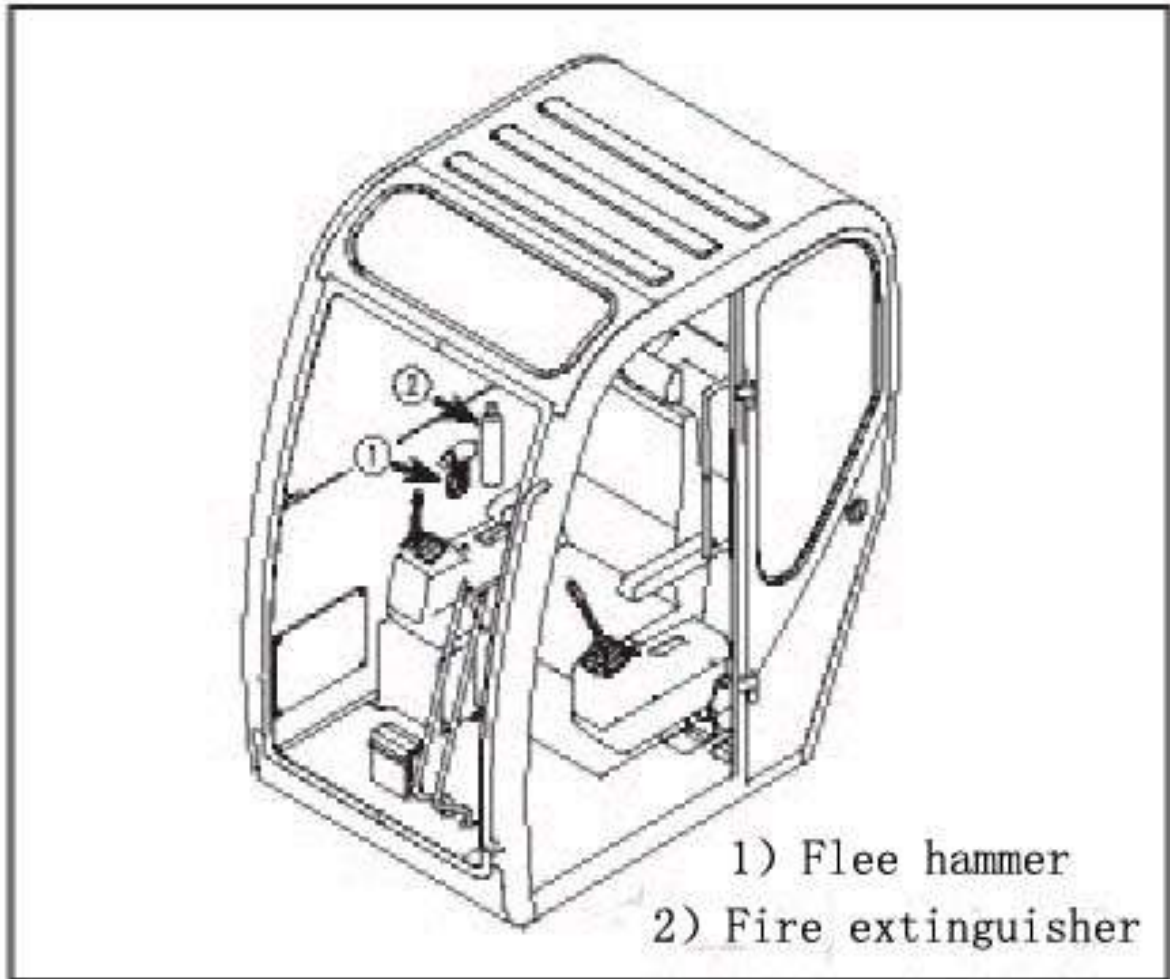

Safety Sign



Warning: if you don't know the safety sign or the safety sign loses, it may be make some casualty. Please replace the lose or broken sign timely, and make the safety sign cleanness and easy to see.

Please read the user manual and the safety sign carefully before operation、 maintenance、 maintain the machine.

Check the sign before running the machine every day. If they not see clear, please clean them.

When cleaning the sign, it only use the calico、 water、 soap. Don't use the organic solvent、 gas, etc. They many are make the sign lose.

1.Sort of safety sign

In the user manual, the safety sign adopts "Glossary safety sign" and "Graphic safety sign".

A. Graphic safety sign

It use the picture to show the Safety warning information. Simple and easy to understand.



B. Glossary safety sign

It used the picture and word to show the safety warning information. It use for the way which the picture couldn't show the infofrmtn,and need the word to explain.



2. The place of the safety sign

The sign is the picture only show the “Safety sign” part of the sign, other will show in next section

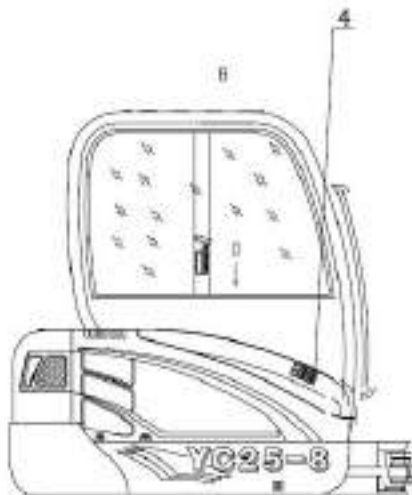
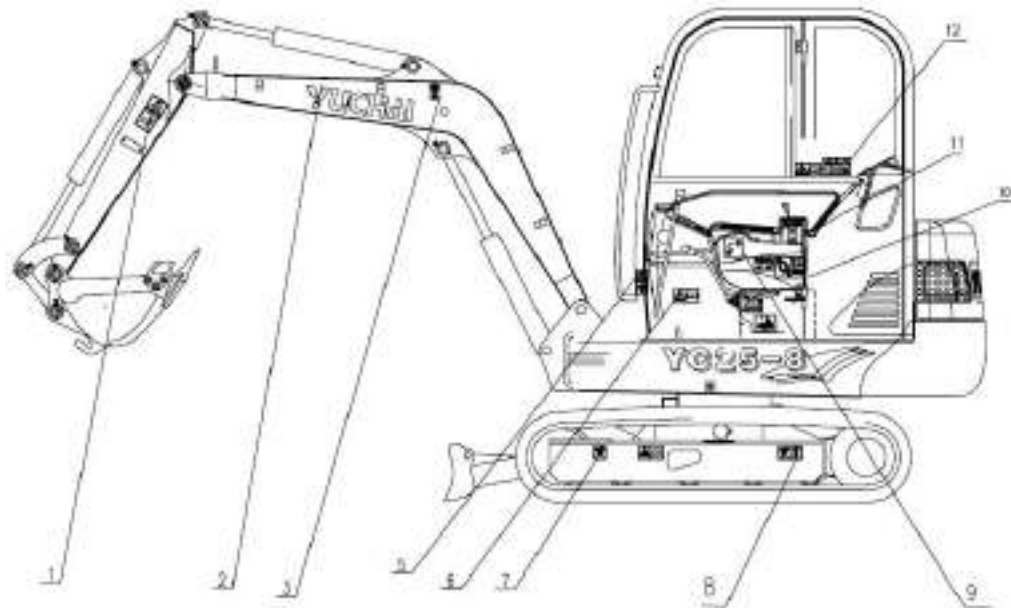

3. Graphic& instruction of the safety sign

1) Care and remoteness the operating device



2) Tail Trade Mark



3) Hoisting Mark

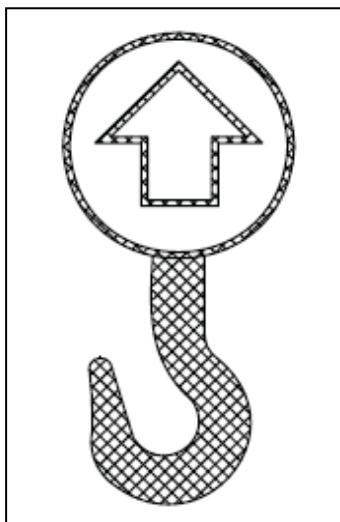

4) No treading

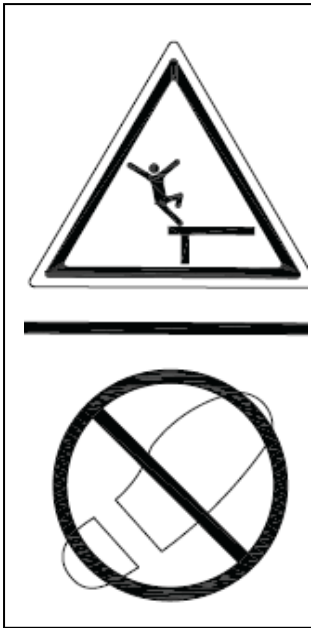

5) Pay attention to the safety when up & down the machine



Up& down the machine, please slow, and fist the handrail, face to the machine, use the ladder and the pedrail.

5) Reading the manual

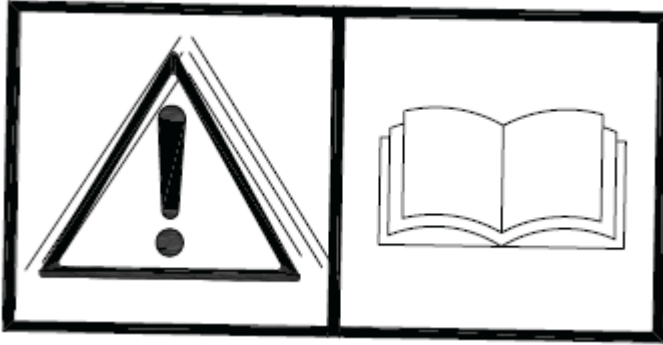

7) Binding Mark

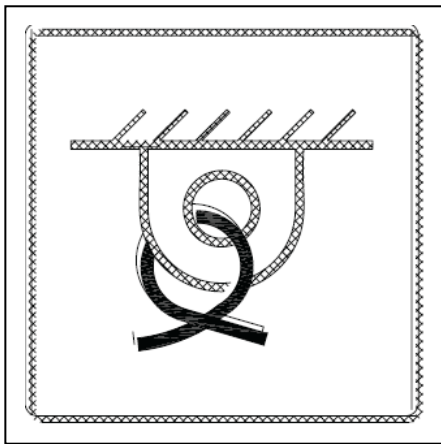

8) Hoisting and Binding mark

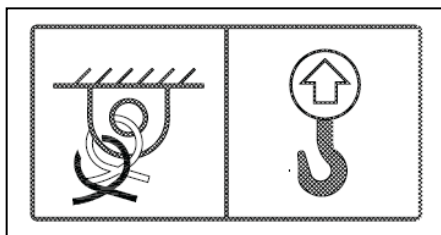

9) Locked mark

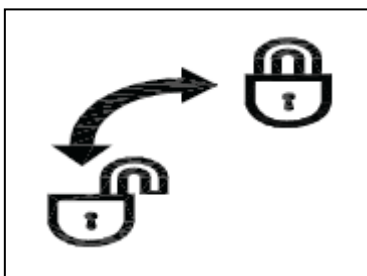

Left control box locked

10) Long arm warning mark

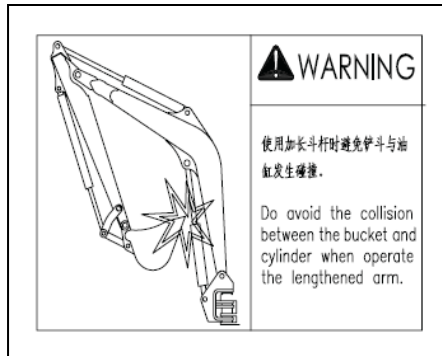

11) Left locked mark

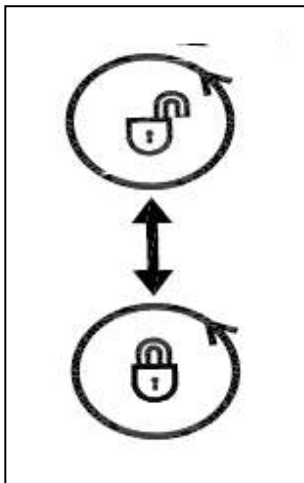

12) Warning marks

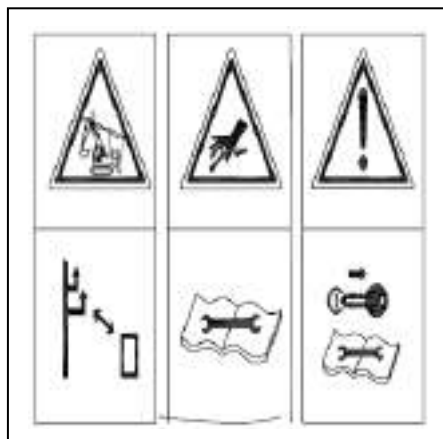

13) When maintain electric please read the manual

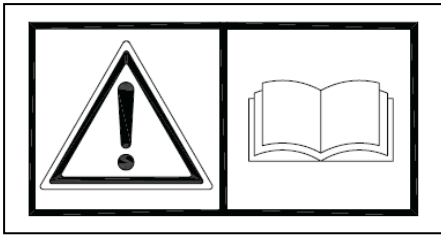

Electric system can easy to shock hazard. It should read the manual when it maintain.

14) Warning mark on Left control box

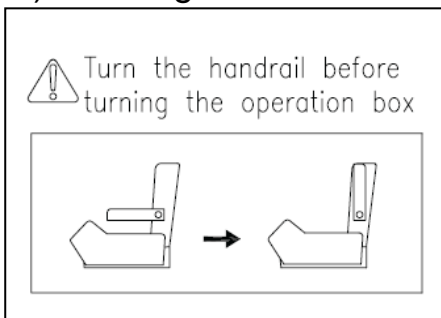

15) Do not start the engine through short circuit of the starting motor



16) Excavator electric shock mark

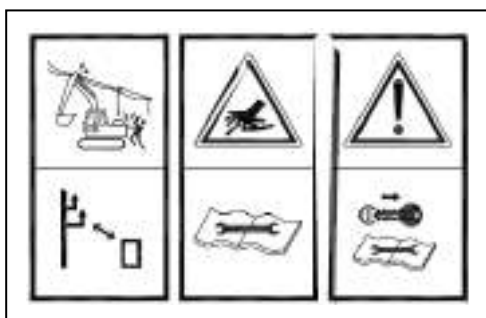

17) System warning mark

 WARNING	
<p>PLEASE CHECK THE HYDRAULIC OIL LEVEL, ENGINE OIL LEVEL, COOLANT LEVEL BEFORE STARTING THE ENGINE.</p> <p>DRAIN THE WATER AND DEPOSIT IN THE WATER SEPARATOR EVERY DAY.</p>	<p>EVERY OIL CHANGING OR ENGINE OUT OF START WITHIN 30 DAYS, THE INITIAL ENGINE STARTING SHOULD BE NOTED:</p> <ol style="list-style-type: none"> 1. DISCONNECTED THE WIRE FROM THE FUEL INJECTING PUMP ELECTROMAGNETIC VALVE; 2. TURNING THE CRANKSHAFT BY STARTING MOTOR TILL THE COMPRESSING WAS SHOWED ON THE INSTRUMENT OR THE ENGINE OIL WARNING LAMP WAS OFF; 3. CONNECT THE WIRE WHICH IS LED TO THE FUEL INJECTING PUMP ELECTROMAGNETIC VALVE; 4. START THE ENGINE BY USING THE STARTING MOTOR.
<p style="text-align: center;">LUBRICATING SYSTEM WARNING</p> <ol style="list-style-type: none"> 1. USE THE STANDARD ENGINE OIL THAT WAS NOT LOWER THAN CF. 2. SUGGEST TO CHANGE ENGINE OIL AND ENGINE OIL FILTER PER 200 WORKING HOURS. 	<p style="text-align: center;">AIR-INTAKE SYSTEM WARNING</p> <ol style="list-style-type: none"> 1. CHECK THE AIR-INTAKE SYSTEM PIPE AND HOOP, RUBBER SEAL AND FILTER PAPER, ENSURE THAT ALL KEEP IN GOOD STATE. 2. CLEAN THE AIR FILTER ELEMENT PROPERLY ACCORDING TO THE STATUS OF AMBIENT CONDITION AND AIR FILTER BLOCK ALARM.
<p style="text-align: center;">COOLANT SYSTEM WARNING</p> <ol style="list-style-type: none"> 1. PLEASE USE THE COOLANT AT ANY WEATHER. 2. FILL IN THE WATER TANK WITH COOLANT TILL IT WAS REACHED THE BOTTOM OF INTAKE TANK COVER. 3. MAKE SURE THAT THE WATER TANK COVER IS FIXED WHEN USING THE ENGINE. 	

18) Hydraulic oil filling mark

 <p style="font-size: 8pt; margin-top: 5px;">HYDRAULIC OIL</p>	<p style="text-align: center; font-weight: bold;">NOTICE</p> <ol style="list-style-type: none"> 1. PLEASE REPLACE THE HYDRAULIC OIL AND CLEAN THE FILTER EVERY 800 HOURS. 2. PLEASE REPLACE THE FILTER ELEMENT FOR OIL RETURN EVERY 400 HOURS. 3. PLEASE SELECT L-HM68 TYPE HYDRAULIC OIL.
--	---

19) Sign of transfuse the fuel oil

 <p style="font-size: 8pt; margin-top: 5px;">FUEL OIL</p>	<p style="text-align: center; font-weight: bold;">THE FUEL SYSTEM NOTICE</p> <ol style="list-style-type: none"> 1. PLEASE CLEAN THE FUEL TANK EVERY 200 HOURS. 2. PLEASE CLEAN OR REPLACE THE FILTER ELEMENT OF DIESEL FILTER. 3. SELECT FUEL: <ul style="list-style-type: none"> A)- SELECT NO. 0 LIGHT DIESEL OIL WHEN THE AIR TEMPERATURE(°C) >0°C. B)- SELECT NO. -10 LIGHT DIESEL OIL WHEN THE AIR TEMPERATURE (°C) 0°C ~ -5°C. C)- SELECT NO. -20 LIGHT DIESEL OIL WHEN THE AIR TEMPERATURE(°C) 0°C ~ -15°C.
--	--

20) Sign of Lubrication

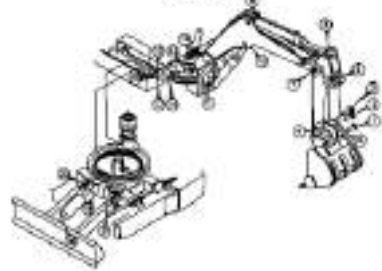
<p style="font-weight: bold; font-size: 12pt;">NOTE</p> 

21) Sign of sling

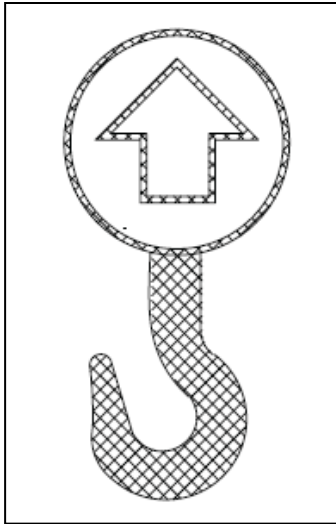

22) Accelerograph mark

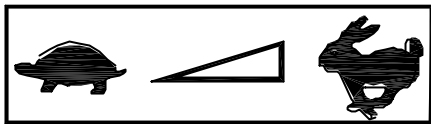

23) Pay attention to lock it after open the window of the cab.

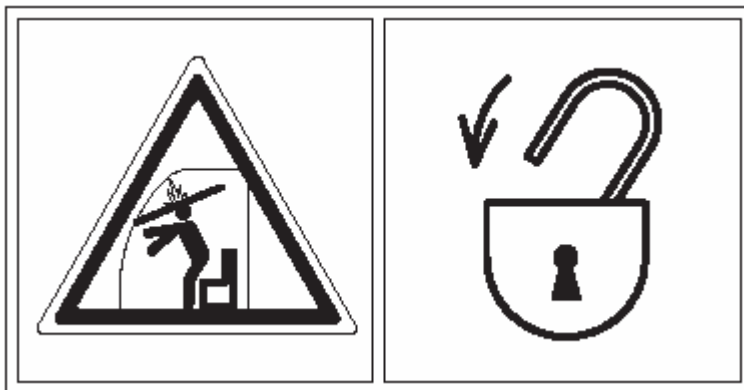

If it doesn't lock the window, it will close because of the outside force or the vibration, may be hurt the body.

24) Sign of noise

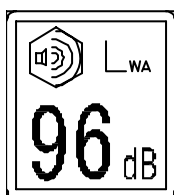

25)CE mark



26)Safety sign

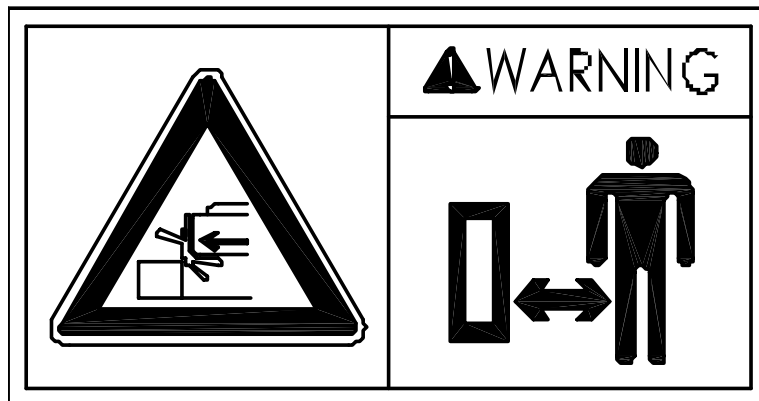

27)The sign of center of rotating

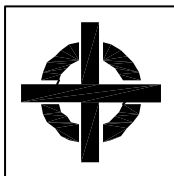

28) Dozer blade and Chassis adjusting sign

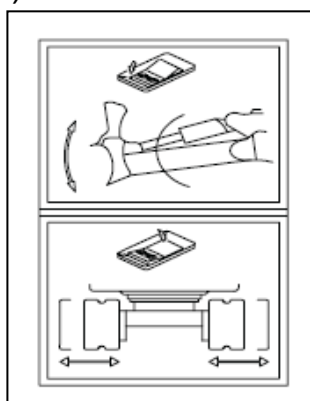

30) Don't allow to split、 drill、 cut and hit the accumulator、 the high-pressure of the air spring,and need keep way from the fire or the high temperature.

Hydraulic Digger

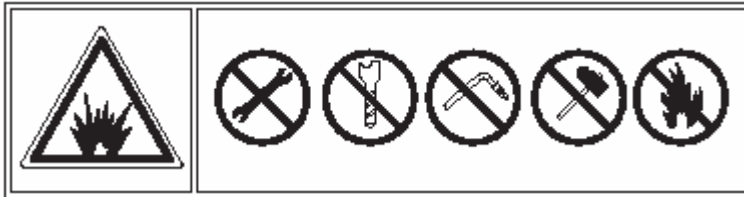

The parts have the high-pressure air. The wrong way to dispose it can lead some hurts. Please let the person who has more experiences to dispose it.

30) Binding sign

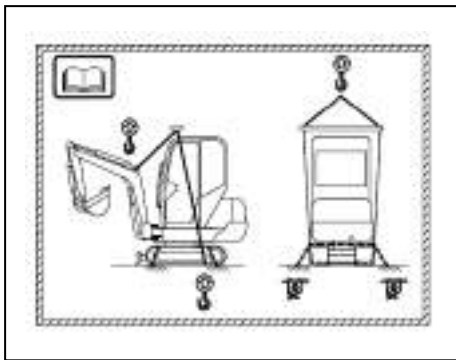

31) Sign of Door latch

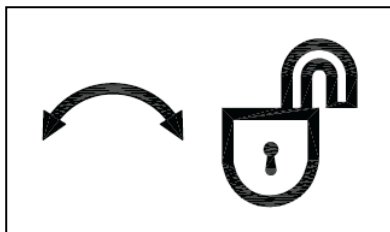

32) Use notice of the flee hammer

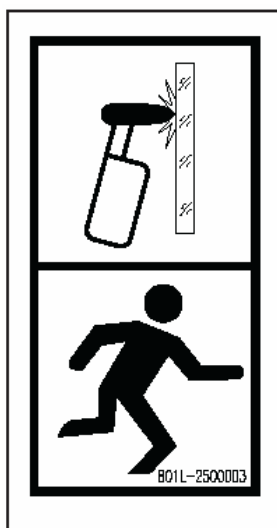

33) Sign of oil draining port on the fuel tank

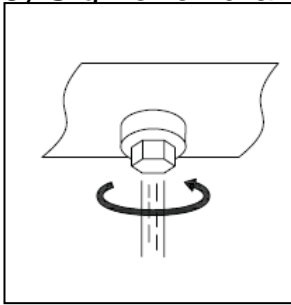

34) Sign of traveling direction

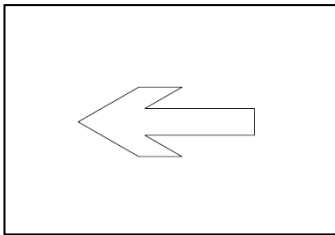

35) Servicing warning sign



36) Glisten sign

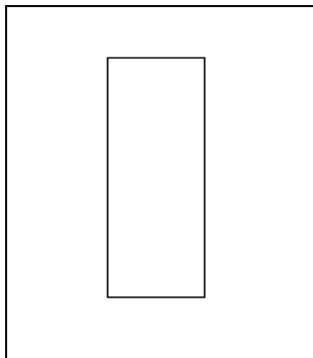

37) Shift sign

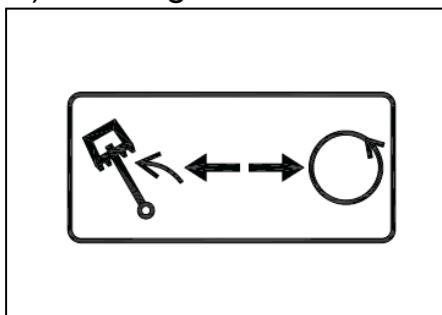

Safety of The Workplace

As far as possible to know the workplace, please check as follow:

1. The place of slope
2. The open drain
3. The suspender
4. The agrotyp (soft or hard)
5. The plash or the fenland
6. The rock or stub
7. The groundsill which buried, the limit of the stub or wall.
8. The garbage which buried or the limit of the filling
9. The hole、the roadblock、the mud、the water
10. The traffic
11. The dust、the smother、the fog
12. The place of the electric、gas、phone、water、sewage or the other public conduit which hang or buried

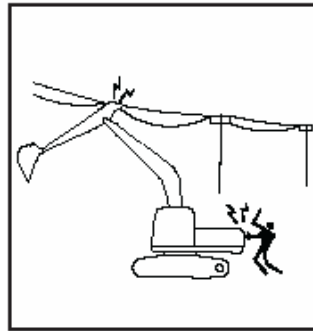

Warning: Before digging, please contact the public establishment service system or sector

13. When operating the machine in the building, you need to know the space of the door, aisle, the bearing capability of the floor.
14. Know the distance of the wire、the line & the machine、the machine & the floor. If possible, it's better to cut off the power.



Warning: Touch or close the power or close the machine which connect the power will shock. No let any part of the machine close the power line except have the preventive

15. Keep the min.legal distance of the gas-main、the cable、the line、

water pipe.



Warning: If you see the end of the broken cable, the cutting cable will hurt your eye.

Safety Operation



Warning: Before running the machine, please tie the safety belt, ring the trumpet, and confirm nobody in the workplace.

1. Start the machine

A. Safety detailed rules of start engine

- 1) Before to start the engine, it need to ring the trumpet.
- 2) Except the operator, it doesn't allow somebody to hitching
- 3) It only allow the operator sit on the seat to operate the machine
- 4) It's not allow to start the engine by short start motor.
- 5) In the cold day, the machine need to warm-up
- 6) Make sure have enough engine oil, fuel and hydraulic oil



Warning: If the operation handle hangs the sign: no start the engine, it doesn't allow to start the engine

B. After start the engine

After start the engine, it needs to check the things as follow:

- 1) Whether tie the safety belt
- 2) Whether the part running well, like the operation device、the bulldozer、the driving device、the rotating device、the operation device deflecting

Hydraulic Digger

- 3) Whether the sound、the liberation、the smell、the instrument are well
- 4) Whether the machine oil or the fuel leak
- 5) Check engine oil pressure and water temperature
- 6) Warm-up 2-3 minute

2. Travelling and rotating

- 1) Before the machine driving, please turn the top of the platform to the right way, make the operating device and the bulldozer to the same direction. If they don't the same direction, the operation will opposite
- 2) Before the machine driving & rotating, please ring the trumpet to warn the people
- 3) The digger operated on the hand ground which the width must more than 1.5 times.
- 4) Before driving, please lock the cab's door. The cab's window allows to open, but it needs to lock.
- 5) Before back off or rotating, if it can not see the back, it need arrange the signal compere

● Safety rules of driving

- 1) when the machine drives on the flat road, it need to reduce the moving-arm, retract the lever, keep the best way for the barycenter, keep 40-50mm distance for the bucket with the ground.
- 2) When the machine drives on

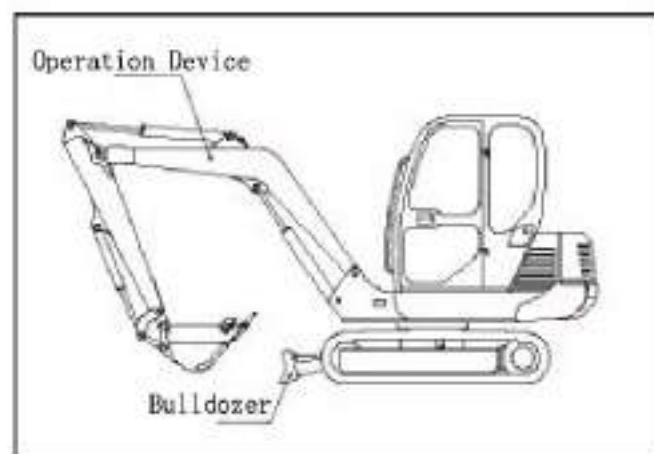

Hydraulic Digger

- 5) When the machine drives on the area which have the underpass、the bridge、the cable, it need have the sign command, keep a distance
- 6) Upgrade or downgrade, it need lock the platform
- 7) When the machine overpass the bridge、the building、the bearing, it should confirm whether they can bear the weight of the digger.
- 8) If the machine needs to drive on the calzada, it need to ask the local traffic section.

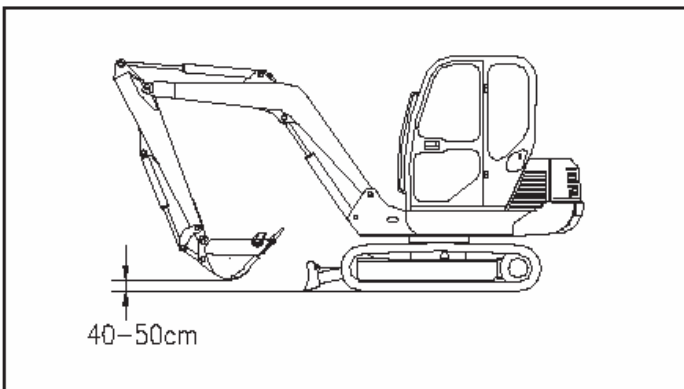

the uneven road,it adopts the low speed driving,and not allow to turn the machine.If do it,may be lead the machine overturn.

- 3) The machine doesn't drive on the roadblock which lopsided,it will lead the machine overturn.
- 4) When the machine drives or operates, it must keep a distance with the people、the building and other machines

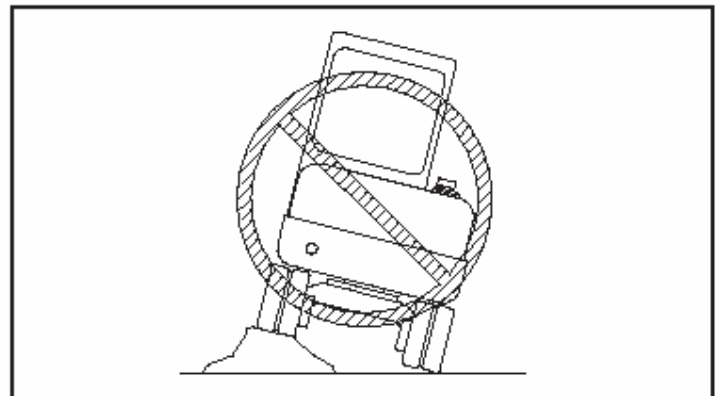

3. Driving or operating on the slope

It is dangerous to driving、operating on the slope. Be care!

1) It suggests not upgrade or downgrade on the slope which the gradient more than 20°

2) When the machine works, it need to tie the safety belt especially on the upgrade or downgrade and the danger area

3) When the digger upgrades, the drive wheel need towards the direction which under the slope. It should let the moving-arm、lever with the slope parallel, the gear of the bucket have 20-30cm distance from the ground. And lock the platform then upgrade low speed.

4) When the digger downgrade, it locks the platform. The drive wheel need towards the direction which up the slope. Elongate the moving-arm、lever , and the gear of bucket have 20-30cm distance from the ground, then downgrade low

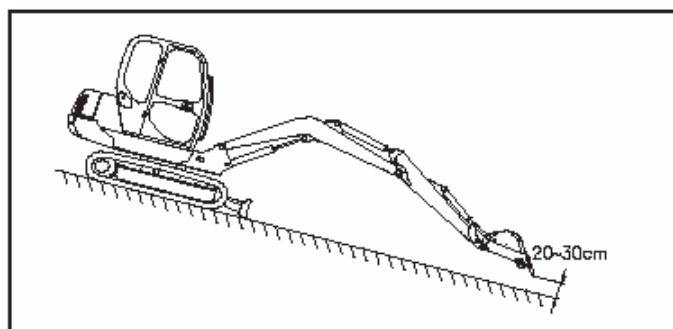

speed.

5) No allow to swerve on the slope or pass the slope, it must replace the machine's place on the next flat place, then upgrade.

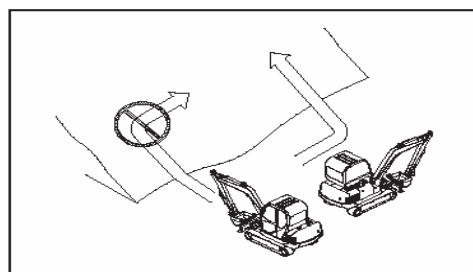

Hydraulic Digger

- 6) When the machine operates on the slope, it must start the high first ,then towards the direction of the downgrade. The Bulldozer backs it, and press the ground, the place for remove the soil on the direction of the upgrade.
- 7) It need drives low speed on the lea、the shatter 、the wet armor plate
- 8) No allow to swerve when the machine upgrade or downgrade. Otherwise, the machine maybe overturn.
- 9) When the machine stops on the slope, it must make the bulldozer into the ground, and make the bucket into the ground, too. After it stop placidly, and then stop the engine, and the operator out.

the slope which the portrait gradient more than 25°

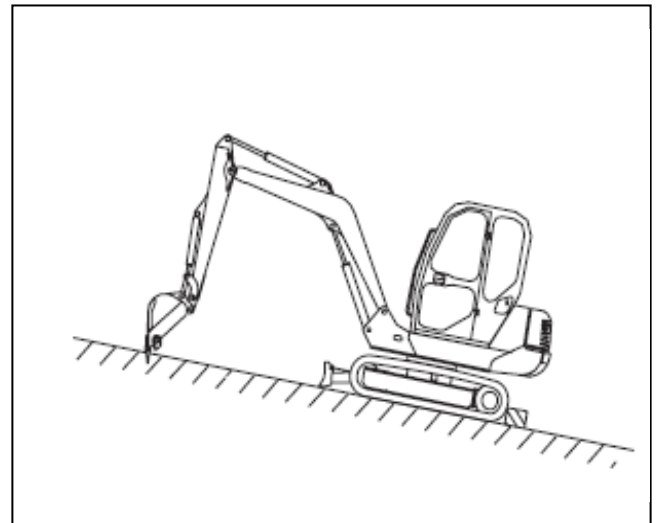
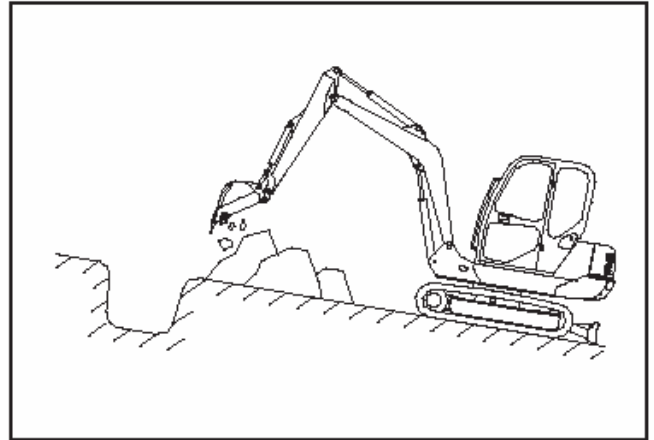

Danger

It is very dangerous to stop the machine on the slope, please do as follows if have to be:

Please put the dozer blade and the bucket on ground immediately if the engine is stop running on the slope, and pull the control handle to middle position before restarting. Even the machine is stop on the slop temporary, please also lower the bucket and dozer blade on the ground, pull the control handle to middle position and put the block to fix the machine at lower end of the tracks.

Hydraulic Digger

driving on the rock or over the roadblock.

10) Don't driving or operating on the slope which the lengthways orientation gradient is more than 25°

11) Don't driving or operating on the slope which the landscape orientation gradient is more than 15°

12) Keep machine balance, do not travel on the rock or want over roadblock

13) Don't swerve on the slope.

14) On the slope, the engine and the hydraulic oil must warn-up.

15) When the pedrail and the slope is 90° , the machine is very dangerous if it rotating. If the machine must rotating, it should make the bucket close the ground, near the machine body, the pedrail towards the top of the slope, and rotating low speed.

16) When the machine operates on the slope, operating the rotating or

17) operation device, the machine maybe overturn

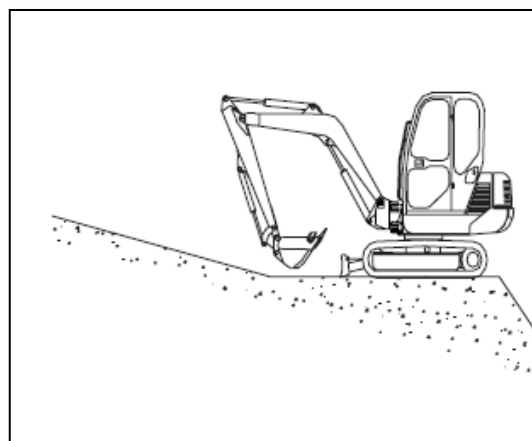
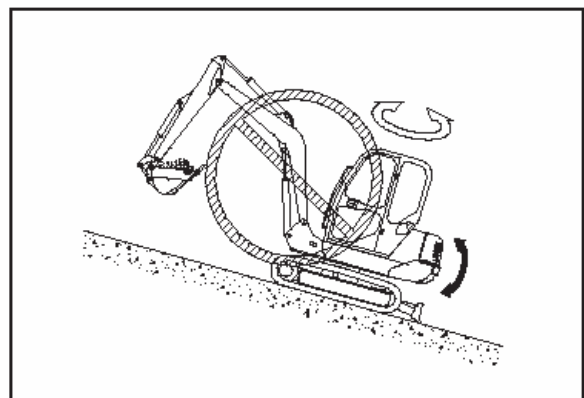
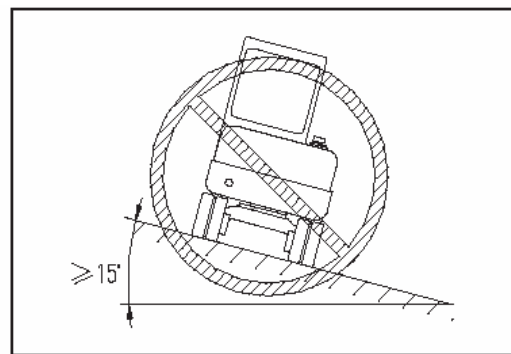
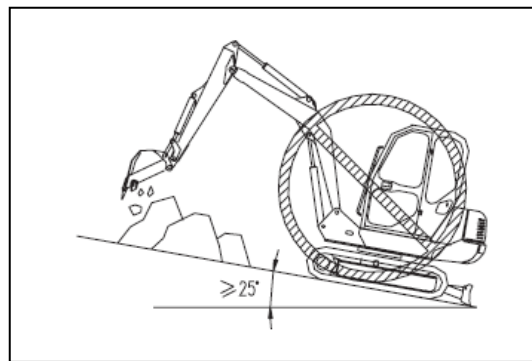

operation device, the machine maybe overturn

4.Safe to operation



Warning: the operation must remember the operation handles to avoid the wrong operation.



Warning: the wrong operation will make the machine overture. Remember the information can make a right guide to protect the body.

- 1) Before operating, it should remove all the things and the people.
- 2) To confirm the workplace can bear the machine, then let the machine enter.
- 3) As far as possible the two pedrail in the same plane, then it can operate.
- 4) To confirm the workplace no cable、no windpipe、no water pipe, the machine starts
- 5) When the machine back off, it should observe whether the moving line regular, whether it has the roadblock
- 6) When the bucket has the special resistance, it doesn't allow to driving or rotating. Otherwise, the machine broken.

Hydraulic Digger

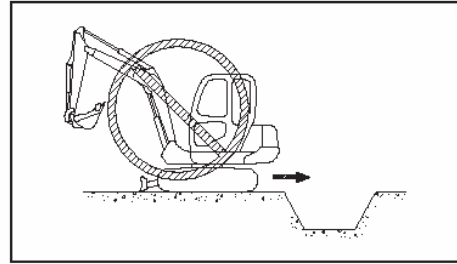
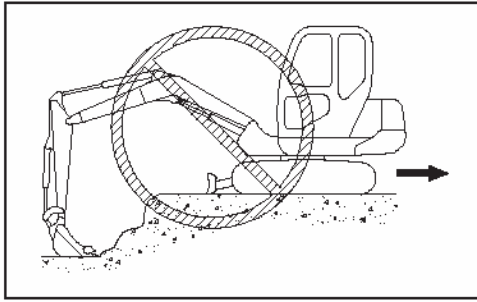

- 7) When the machine operated, if the hydraulic oil tank reach the end-point of the driving, the power will act on the limit ring of the oil tank. It will reduce the use life of the machine. To avoid the case, when the hydraulic oil tank operated, it should have a little value.
- 8) When the machine digs deep, It need to avoid the bottom of the moving-arm or the oil tank's soft pipe of the bucket touch the ground.
- 9) When the machine operated, it need to avoid the moving-arm、the lever、the bucke、the cab(lookum) touch the nonego.
- 10) When the machine rotated, it needs to avoid it touch the cover of the engine.
- 11) When the moving-arm reduced, it doesn't stop unexpected

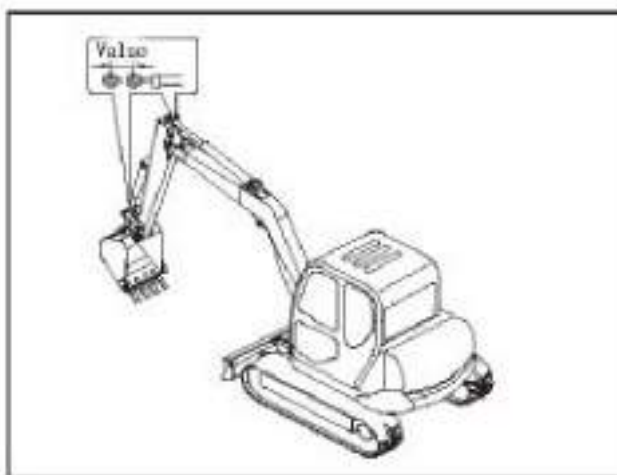

Hydraulic Digger

- 12) Not dig to the machine body.
- 13) When the pedrail leave the ground, it doesn't dig. Otherwise, the machine and the frame will break.
- 14) Not use the deadweight of the machine to increase the digging power
- 15) Not use the falling power of the bucket regard the handle, the knapper, the monkey. It will make the back of the machine bear over weight.
- 16) Not use the bucket to dig the road surface more. Otherwise, the parts will over load and break.

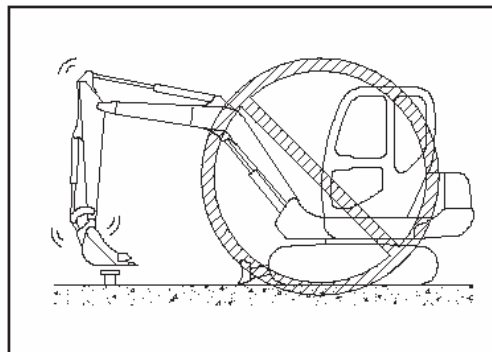
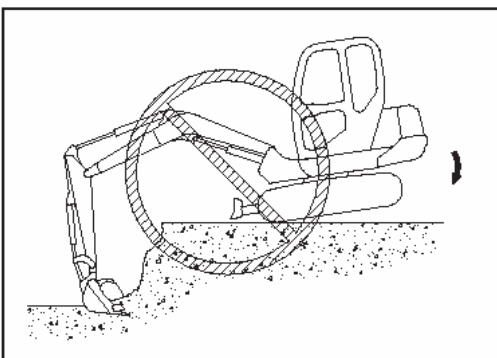
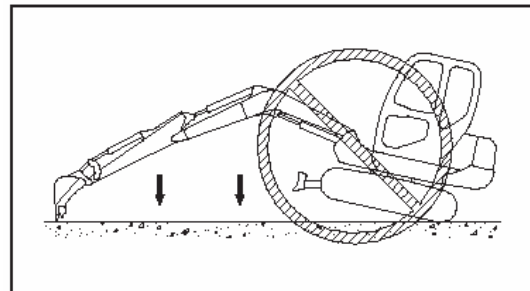
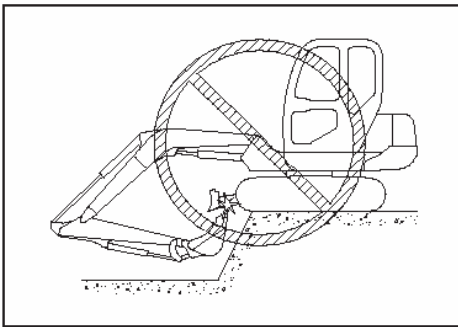

Hydraulic Digger

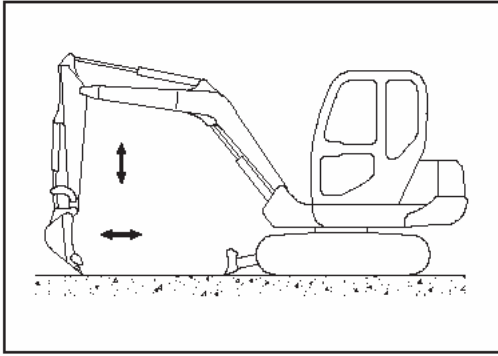

17) Not use the falling power of the machine. Otherwise, the machine broken.

18) Not use the power of rotating to press the soil or destroy the ridge and the wall. When the machine rotates, it doesn't make the gear of the bucket into the soil.

19) Not make the bucket into the soil, and not use the driving power to dig. It makes the back of the machine bear over weight.

20) Not dig the working plane which under the hanging part. It may have the danger of the rockfall or the hanging part collapse.

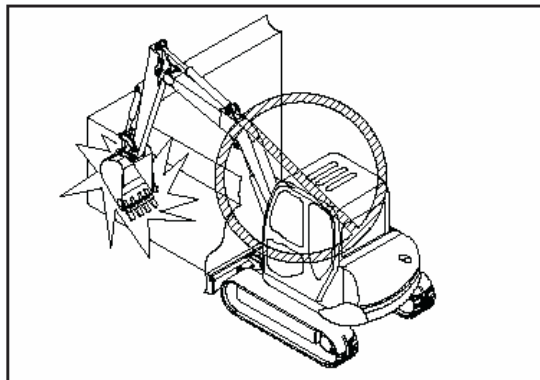
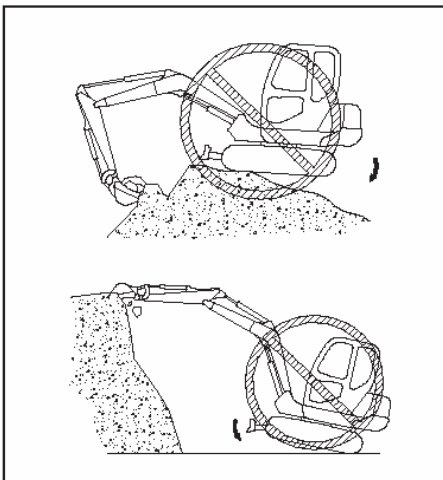

Hydraulic Digger

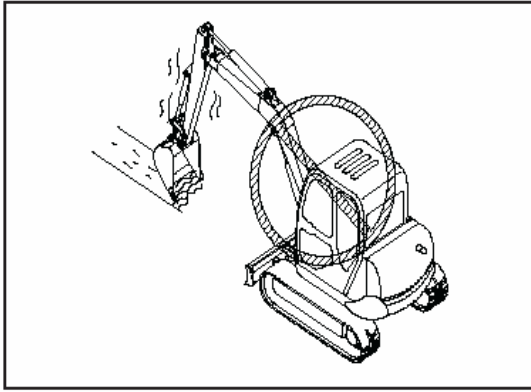

21) Not dig the working plane which under the hanging part. It may have the danger of the rockfall or the hanging part collapse.

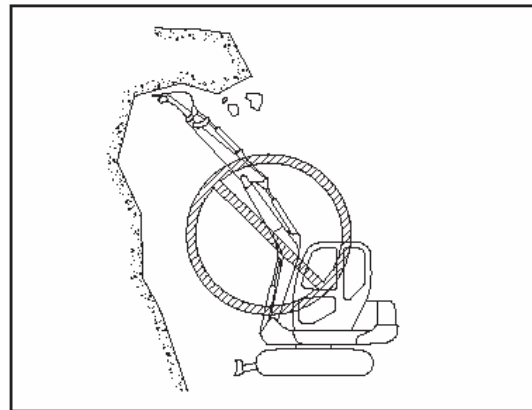

22) Please install the cabin protecting device
If the working area is dangerous for rockfall

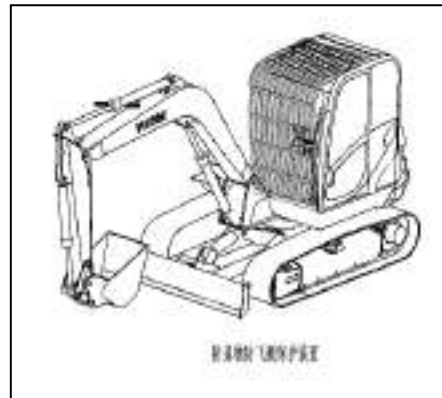

23) Do not travelling or working on the soft surface and swampland

24) Don't use excavator to draw other device or object

5. Prevent dumpage、 Antiskid and the resolvent



Warning:1)If it need to swerve on the slope, it only use the big radian swerve. When the machine turn right, turn the lever of the moving-arm to left. The distance to the ground about 30cm, lock the platform.

2) When the machine slips, it need press the bulldozer and the bucket to the ground.

3) When the machine dumpage, the operator mustn't jump off .It must to fist the handrail or the pillar of the lookum.

Following, the machine is easy to overturn:

- 1) The machine moves on the uneven road, the two pedrail one side high one side low or half of the pedrail hangs.
- 2) One of the pedrail touches the soft soil, another touch the hard soil.
- 3) One side of the machine is Limestone cave or the slime
- 4) The machine operates on the slope which the portrait gradients more than 250, the thing towards the downgrade.
- 5) The machine operates on the slope which the landscape orientation Gradient more than 15° , the thing towards the downgrade

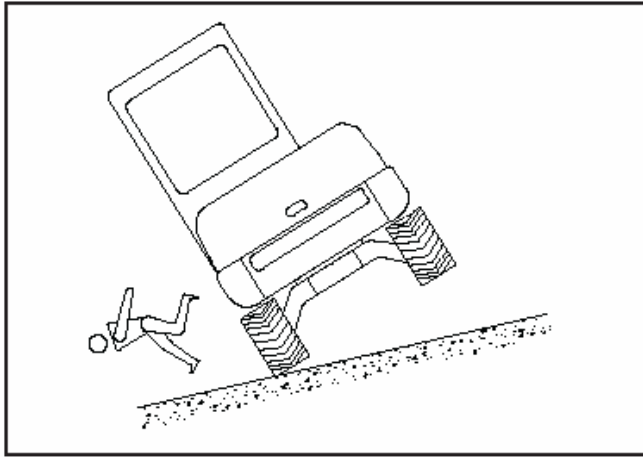

- 6) On the slope, it is 90° for the two pedrail and the gradient, the rotating platform more than 90°
- 7) The machine operates on the slope, it swerves, the platform rotates fast or no power
- 8) When the machine turn adown about 180°
- 9) It is the uneven road for the back operation
- 10)The machine dig the underside of the body when it depth digging
- 11)The machine moves on the frost road
- 12)The two pedrail have the machine oil or the lube.

6. Stop the machine

See it at the chapter 4

Transport & Load and Unload

Transport (unload) the digger must strict obey the safety rules

- When the digger transported, it must obey the safety transport rules of the country (local) trade or the good habit
- When the digger transported, the cab doesn't allow to hitching anybody and anything.
- When the digger loaded & unloaded, it mustn't have anything or anybody in the moving radii area of the sling
- When the digger loaded & unloaded, it mustn't have anybody or anything in the traveling area of the loaded & unloaded digger
- Except the digger uses the sling or drives it from the port, it can uses two lath which enough strong to put in the transporter. The gradient of the lath should less than 15° , The length of the gradient is 3.5 times of the height. The width of the lath is 1.2-1.5times of the pedrail.

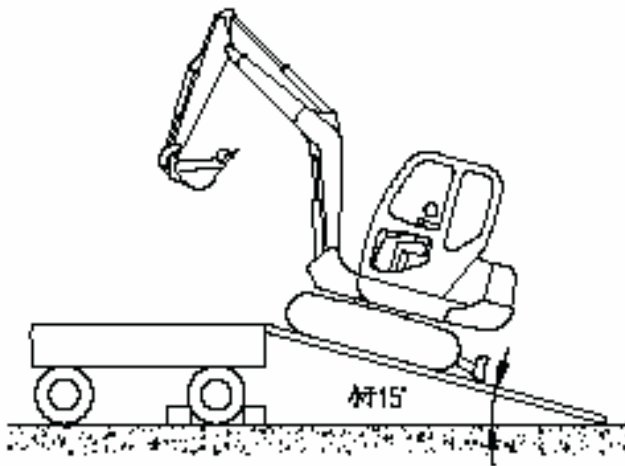

- Up or down the slide, it should put down the orientation handle to avoid the platform rotates.
- When the machine up or down the slide, it doesn't allow to operate any handle, except the driving handle
- The machine unloaded the smooth road.
- It should have the flag, the light, the warning sign when the

Hydraulic Digger

machine drives on the road. And make sure the people can see them. And make sure the car which after can see the sign of “Drive slow”

- The pedrail type machines maybe destroy the road. It needs the truck to transport.

Maintain



Warning: When the machine is maintained, it should hang the warning sign “No operation” on the operation handle.

- It must stop the machine on the smooth and hard road
- After stop the digger, it must put down the bucket, and run the engine 3 minutes with low speed, then stop it and pull out the key.
- Release all the power of the hydraulic system
- It be forced to stop the machine on the slope, it should have the enough roadblock on the underside of the pedrail
- It makes sure have enough distance with other machines when the machine stops
- When it maintains the electric system or electric welding, it should take-down the cathode cable of the accumulator. To avoid the current moves
- After start the machine, it doesn't lubricate or maintain. It doesn't let the motion touch the running part
- If it wants to maintain when the engine runs, it need someone to see the machine

Hydraulic Digger

- Don't put some small parts into the placket
- The high-pressure liquid can hurt the eye or the skin, it need to avoid when the machine maintains
- Clean all the sundries of the interior machine, it maybe hurt the operator or destroy the machine

Fire-proof、Explosion-proof& Antigas

- When the digger transported、drived、digged, it doesn't touch the wire.Otherwise,it leads the casualty
- The wiring and the line need to check frequently.If fined the broken、aging part,it must replace them to avoid the fire
- Keep the line linker clean,and fix it fastness.Check the line everyday
- It doesn't to put the thing which flammability、explosive into the digger
- When it need oiling,it must stop the engine,and keep away from the fire and not leave the machine
- When it oiling ,it not allow the fuel overflow to the surface of the superheater or the parts part of the electric system
- After add the oil,it should clean the fuel or machine oil which overflow,and screw



down the cover of the fuel or the machine oil

Hydraulic Digger

- Clean out the slip、 the spill、 the lamina and other flammability thing which in the engine、 the vent-pipe、 the muffler、 the engine room
- It doesn't have to put the dishcloth which have the oil into the cab.
- It should have the fire extinguisher in the cab,and put it where can easy to take
- When the machine electric welding,it doesn't allow to do when the pipeline of the hydraulic oil and the fuel not segregate
- Avoid the fire because of the hydraulic pipeline:check all the soft pipe and the fastener、 the cover、 the dead block whether they fixed fastness
- Accumulator needs far from the fire,to avoid the high temperature.Otherwise,it explodes
- If the digger with the sealed cab,it needs to check the sealed center clapboard,to avoid the exhaust gas into the cab make the operator poisoning
- No operating the machine on the are which the airiness system not good
- When it happens the fire,it doesn't use the water to put out the fire,it should use the powder fire extinguisher or the sand,or use the slipcover

Accumulator

Safety rules of the accumulator

The electrolyte of the accumulator has the vitriol and the hydrogen which flammability、explosive.The wrong operation leads the hurt or

fire. It must do as follow:

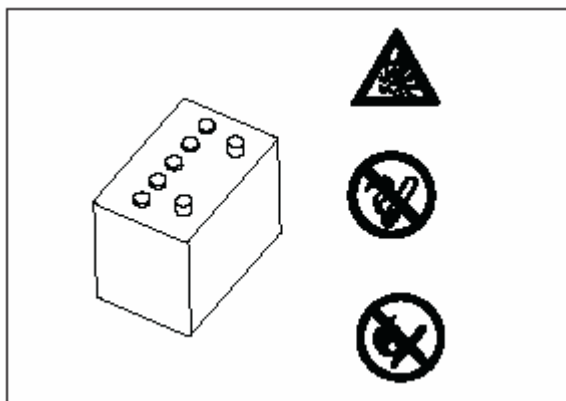

- Check the level of the electrolyte timely, and supply the distilled water to make the level of the electrolyte between the “top level” and the “low level” line. If the electrolyte of the accumulator lower than the “low level” line, it doesn’t have to use the accumulator
- Operating the accumulator, it need wear the safety glass and the rubber glove
- It doesn’t allow have the fire near the accumulator
- If the eye、 the cloth、 the skin have the vitriol, it must use the lots of water to wash and go to the hospital
- Before operating the accumulator, it should turn the key to “OFF”
- Use the electric torch to check the electrolyte of the accumulator, it should stop the antichattering system.
- The end of the sealed accumulator dilates, it show the accumulator freezed. When the accumulator freezed, it doesn’t electricize or connect and start the engine. The temperature doesn’t more than 15⁰C when heat up the freezed accumulator. Otherwise, it explodes

Explosion-proof of the accumulator



Warning: the electric spark or the flame can make the hydrogen of the accumulator explodes. Avoid

Hydraulic Digger

explode please caution as follow:

- 1) Cut off the cable of the accumulator, it should cut the cathode cable first
- 2) Connect the cable, it should connect the cathode cable first
- 3) Don't use the metal element to connect the port of the accumulator
- 4) Don't welding 、 grind 、 smoking near the accumulator

Because it has danger of spark,do as follow:

- Please fix the accumulator to the right place
- No make the tool or other metal touch the port of the accumulator.No fall the tool or other metal near it
- Connect or cut off the sign of the accumulator as the right order.The port of the accumulator should fix fastness
- When the accumulator electricizes,it produces flammability hydrogen.So before electricize,it should unload the accumulator from the machine,and put it to the draughty place and remove the cover
- Screw down the cover of the accumulator

Caution:When it maintains the electric system or electric welding,it should remove the cathode port to avoid the current moves

Hydraulic System

1.Safety rule of high-pressure oil

The inside of the hydraulic system always have the pressure. When it checks or replaces the pipeline or the soft pipe, it must to check whether the pressure has release or not. If it has the pressure, it will make a serious hurt or destroy. Do as follow:

- 1) When the hydraulic system has the pressure, it doesn't check or replace
- 2) If the pipeline of the soft pipe has leak and around the area wet. Please check the pipeline or the soft pipe whether it broken, and the soft pipe whether it dilates. When the operator checks, it should wear the safety glass and the glove

If the high-pressure touch the eye, it will have the danger of the ablepsia. It need use the clean water to wash the eye or the skin which touch the high-pressure, and go to the hospital

3)





2.Safety operation of the high-pressure soft pipe

If the high-pressure leaks, it will make the fire or the operation trouble. And lead the serious hurt or destroy. If it finds the bolt become less crowded, it should stop the machine, and screw down it. No welding the machine when the hydraulic oil pipeline (soft pipe) not separate. If it finds the soft pipe has any broken, it need to stop operate, and contact us.

If it finds the problems, it needs to replace the soft pipe:

- 1) The tie-in of hydraulic pipe has leaked or destroyed
- 2) The envelope broken or cut off, or the steel wire of the reinforcement out
- 3) Some parts of the envelope dilates
- 4) The moving part contorts
- 5) The envelope has the impurity

3.Safety rule of the high-temperature oil

The hydraulic oil doesn't cooling on the working or after working, it is high-temperature and high-pressure. To avoid the oil squirted or touch the hot part make scald when it checks or lets the oil. it should wait the oil cooling and the temperature can touch before do it. It need undo the cover or the bolt slow before unload the cover or the bolt even if the oil cooled.

Hydraulic Digger

4. Release the pressure of the hydraulic system

When the digger operates, the hydraulic oil of the hydraulic pipeline in the state of high-temperature and high-pressure. When it take-down the gun, the oil maybe squirts. So it needs to turn the cover of the gun before take-down the gun and release the pressure.

- 1) If the operation device doesn't locate the state as like the picture, it needs to start the engine and runs low speed, hold out the oil tank of the bucket. Draw back the oil tank of the lever. Then down the bucket, put the bulldozer on the ground, stop the engine.

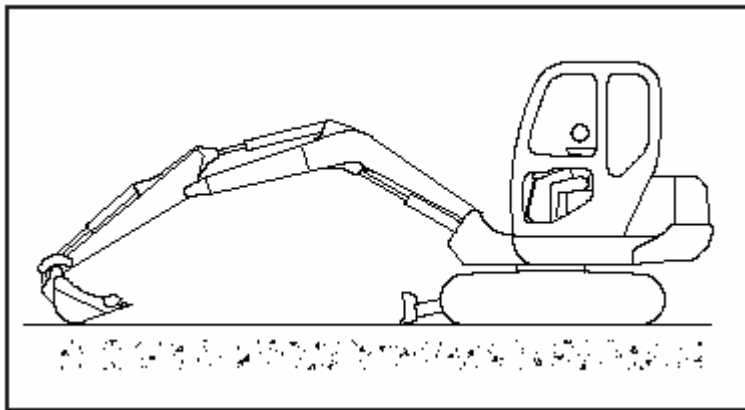

- 2) Within 15 seconds after stop the engine, it turns the switch to "ON" and operates the joy stick to all the direction(operation device、 driving),to release the pressure.

5. Safety operation of the stored energy device



Warning: The stored energy device is the part which full of the high-pressure nitrogen gas. If it's wrong to use, it will explode. No take-down the stored energy device, no drilling and welding. No close the fire, no hit and impact.

Hydraulic Digger

It deals it ,it need the professional.

The machine have the stored energy device in the control pipeline, it is a device which stores the pressure. When the machine has the device, after stop the engine, it can operate the control pipeline short time.

It operates the joy stick; it can down the operation device by the deadweight.

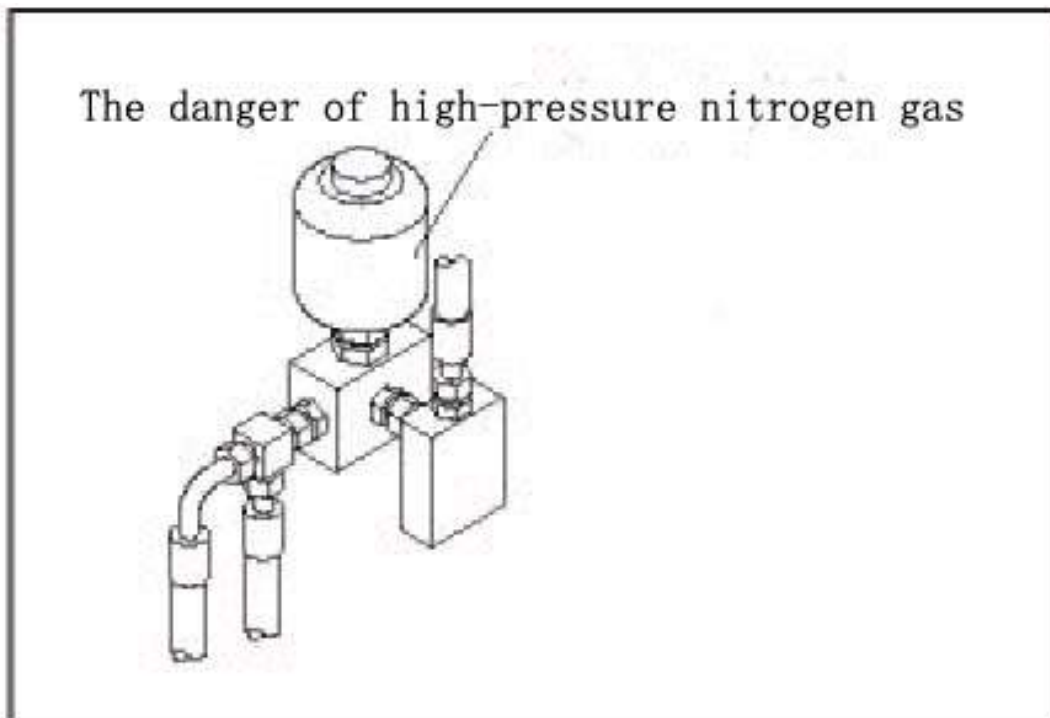

The way of the control pipeline to release the pressure which has the stored energy device:

- 1) Downing the operation device to the ground, and stop the hydraulic crush or other attachment.
- 2) Stopping the engine
- 3) Turning the start key to "ON" to make the current of the circuit moves
- 4) Turning the safety lock joy stick to the free place, driving the joy stick of the operation device to front、back、left、right and the attachment control pedal, to release the pressure of the control

Hydraulic Digger

pipeline.

- 5) Turning the safety lock joy stick to the lock place to lock the job stick and the attachment control pedal.

3

Parts Introduction

Pandect for Operation Device(Cab Type)

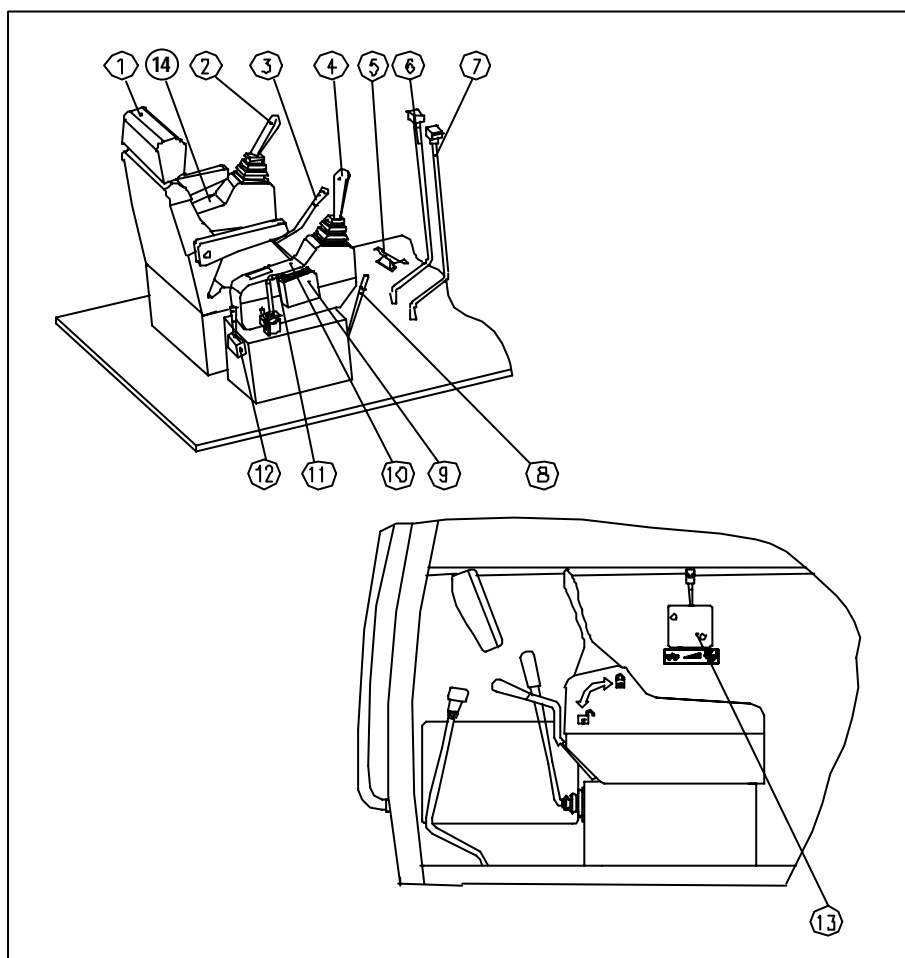

1. the seat
2. Joy stick of the left operation device
3. Safety lock handle
4. Joy stick of the right operation device
5. Pedal cover of the assistant control valve
6. Joy stick of the left driving
7. Joy stick of the right driving
8. Joy stick of the bulldozer
9. Radio
10. Plane assembly of the right control box
11. Lock pin of the platform
12. Plane assembly of the left control box
13. The gun handle of the engine

14. Left control panel

Pandect for Operation Device(Canopy Type)

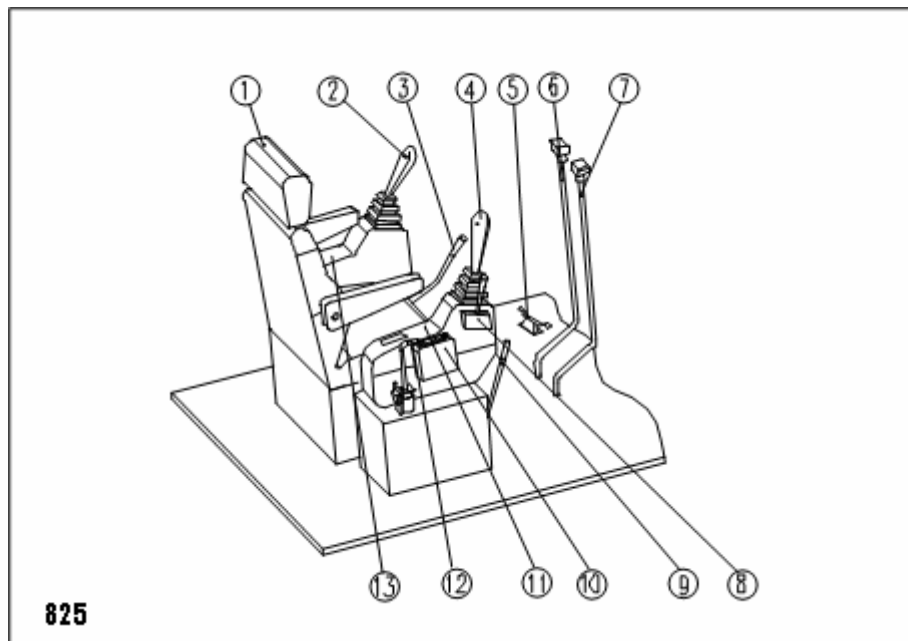

1. The seat
2. Joy stick of the left operation device
3. Safety lock handle
4. Joy stick of the right operation device
5. Pedal cover of the assistant control valve
6. Joy stick of the left driving
7. Joy stick of the right driving
8. The gun handle of the engine
9. Joy stick of the bulldozer
10. Radio
11. Plane assembly of the right control box
12. Lock pin of the platform
13. Plane assembly of the left control box

Panel Switch of Left Controlling Box

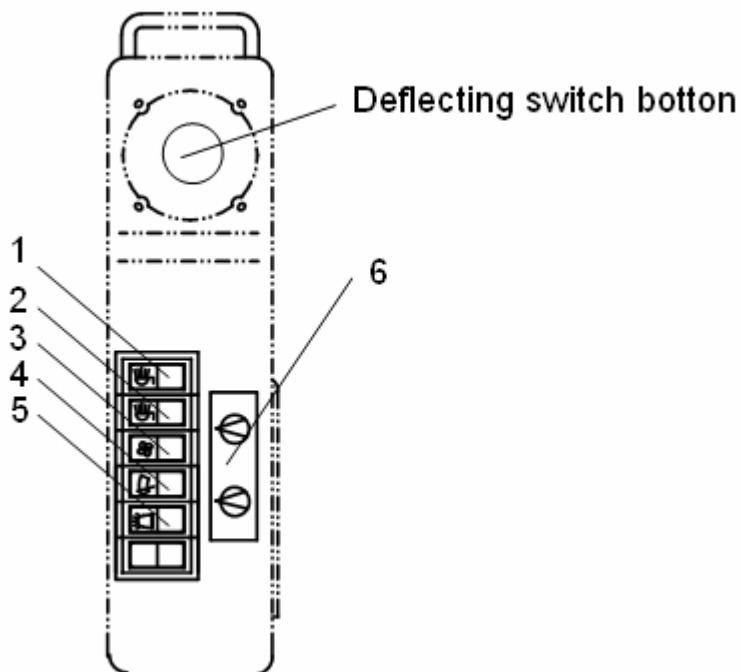

1. Switch of the fore light

It is open which has the switch sign.

2. Switch of the rear light

It is open which has the switch sign.

3. Fan switch

It is open which has the switch sign.

4. Switch of windscreen wiper

It controls the windscreen wiper of the fore window. It has two station:

OFF: the windscreen wiper doesn't move

ON: the windscreen wiper moves

5. Switch of the caution light

It for the caution light of the top cab. It is open which has the switch

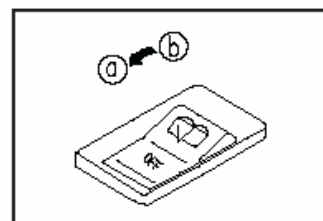

sign

6. Air-condition switch

Panel Switch of Right Controlling Box

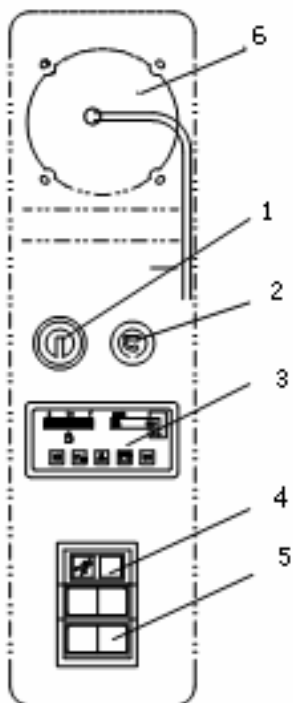

1. Start switch

It uses for start or stop the engine. It has four stations.

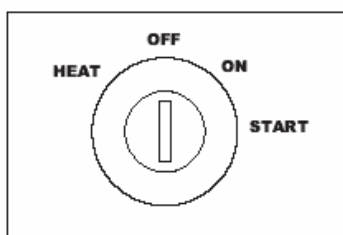

OFF station

It can insert or draw the key, all the switch of the electric system are close, and the engine stops

ON station

When the engine runs, it should keep the switch key on the ON station

START station

It is the start station of the engine. When the engine starts, it should keep the key on this station. After start the engine, it need loosen the key immediately, it will back ON station by itself.

HEAT station

When it starts the engine in the winter, it should keep the key on this station. When the key on the HEAT station, the warn-up light lights. After warn-up, loosen the key, it will back OFF station by itself. And turn the key to START station to start the engine.

2. Igniter

It can connect the element of the igniter, and it also can connect the cable of the igniter.

Note: the total capacity of the current under 10A.

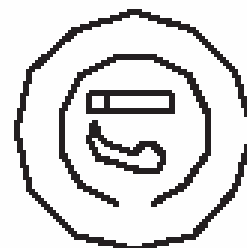

3. Digital Combination Instruction Sheet

4. Deflecting indicator light

If the light lights, it indicates the machine on the operation mode which the moving-arm deflecting type. And when it switches to the platform rotating mode, the light off.

5. High-speed driving switch

It uses for replace the speed of high or low driving

High (high-speed) station: high-speed driving

Low (low-speed) station: low-speed driving

6. Button switch of the electric trumpet

Hydraulic Digger

Press the switch, the trumpet rings, when the machine will start or act, to remind of safety who around the machines.

Instruction Sheet

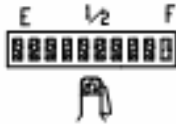

meter of fuel

It indicates the fuel quantity of the fuel tank. When the oil under 1/5, the sign sparks. When the oil under 1/10, the sign sparks and the buzzer rings

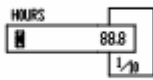

Working hour meter

It indicates the working time which accumulative total.

Alarming indicate



Power supply

When the switch in the working location, it lights means switch on.



Machine oil low-pressure alarming of engine

If the machine oil pressure of the engine under 0.1Mpa, the annunciator lights.



Water high-temperature alarming of engine

If the water temperature is higher than the standard value, the annunciator light.



Charge indicator light

After the engine start, it lights. When the engine is working, the light crushes out. If the engine has already working but it light, means the dynamo

Hydraulic Digger

have not worked.



Warm-up state indication

When the engine warm up, the sign light

Safety Lock Part

1. Safety lock handle



Warning: The safety lock part is the important part of the safety system. When the operator leaves the cab, it must safety lock. If the safety lock handle doesn't stay the lock stations, the handle maybe moves and makes the operation device or the platform move.

Put the safety lock handle and the left operation box to the lock station. The lead system control not supply the oil, the operation device、 the platform rotating not work(except driving to left、 right、 the bulldozer),it can safe protect.

Put the safety lock handle and the left operation box to the free station. The lead system control connects the oil pressure, the machine works.

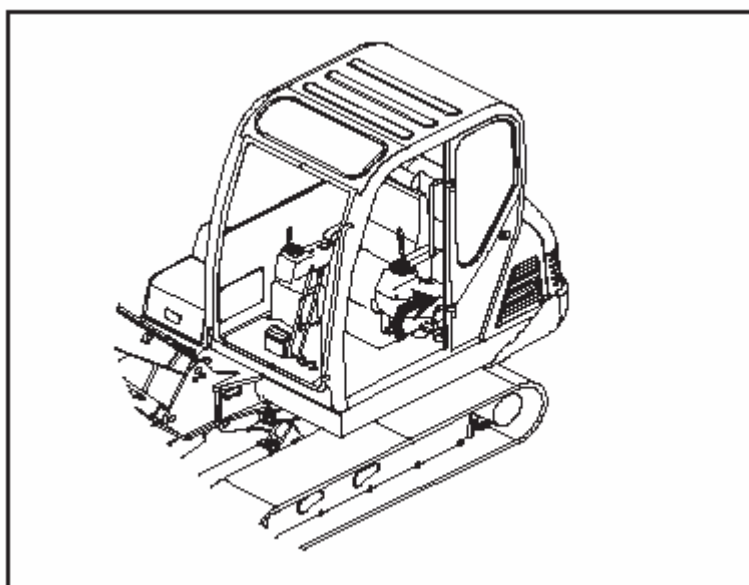

2. Platform lock machine

Hydraulic Digger



Warning: The platform lock part is the important part of the safety system. When the machine transport、driving、lay or stop on the ramp, it must platform lock.

Platform locks and unlock

Lift the pin of the platform lock (see the picture).The bending block (a) of the pin hang on the box(c), unlock the platform and the bottom frame. Put down the lock pin, put the bending block on the station (d).The pin bearing (b)will lock with the platform and the bottom frame.

When it locks, it should the platform and the lock pin hole in one line.

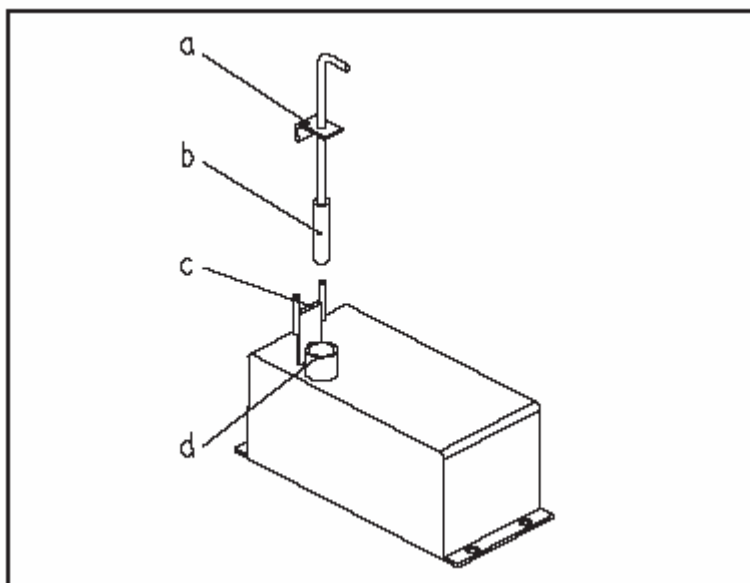

Operate The Operation Device & Rotating Device

1. Operate the operation device & rotating device

Use the joy stick direction of the left & right operation device. See the picture.

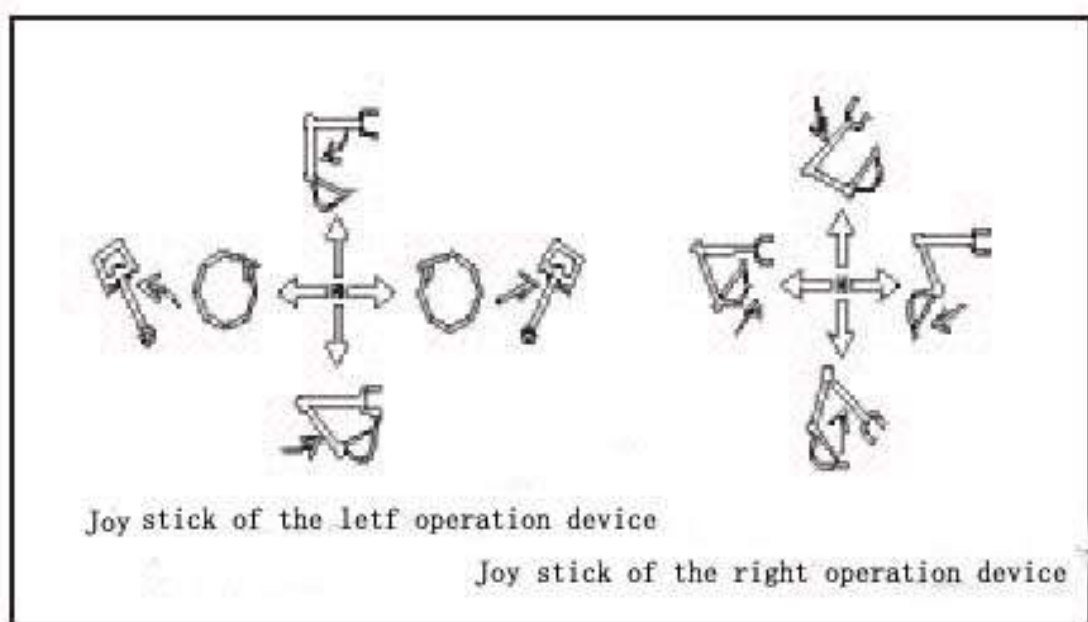

A. Joy stick of the left operation device

Operating the bucket lever: fore push the joy stick, the bucket lever overhang, rear pulls the joy stick, the bucket lever draw-in

Rotating the platform: Turn the joy stick right, the platform turn right. Turn the joy stick left, the platform left.

Rotating the moving-arm: Turn the joy stick right, the moving-arm return .Turn the joy stick left, the moving-arm left

B. Joy stick of the right operation device

Operating the moving-arm: fore push the joy stick, the moving-arm down. Rear pulls the joy stick, the moving-arm lift.

Operating the bucket: turns the joy stick right, the bucket exstrophy, turn the joy stick left, the bucket introversive

●Replace and operate the rotating and deflecting

The moving-arm deflecting Type with the rotary head need use the

switch button of the left operation device joy stick to replace the platform rotating function or moving-arm deflecting function.

On the working order, the machine is the mode of the platform rotating.

When it presses the button, it makes the turning head of the joy stick deflects, and presses the replacement button of the joy stick, it can return the mode of the platform rotating.

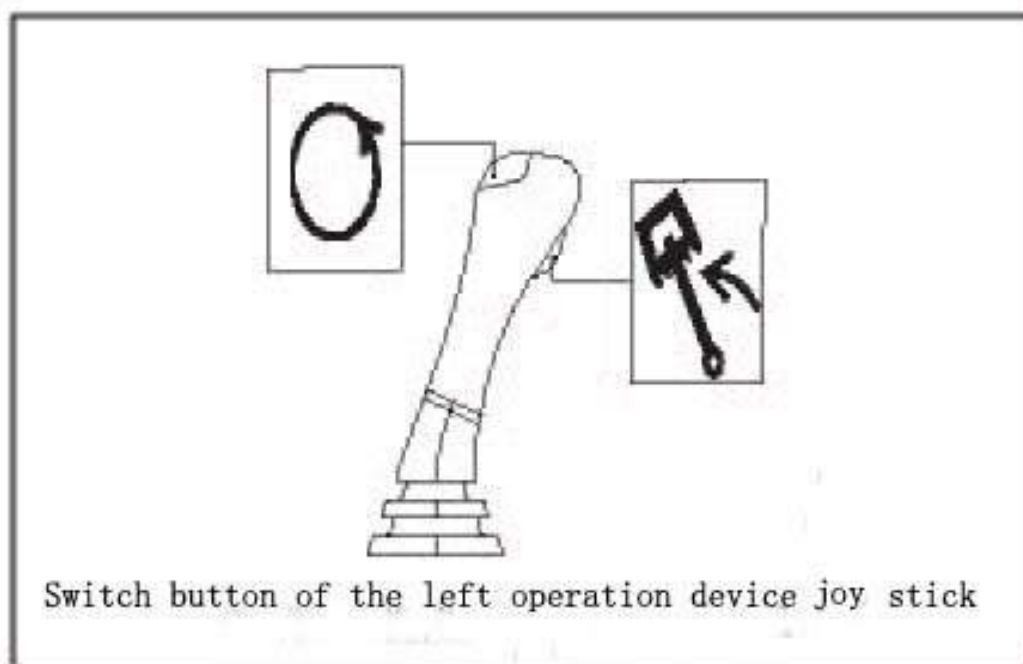

2. Operate the bulldozer

Push-down the joy stick, the bulldozer into the soil. Pull-up it, the bulldozer lift.

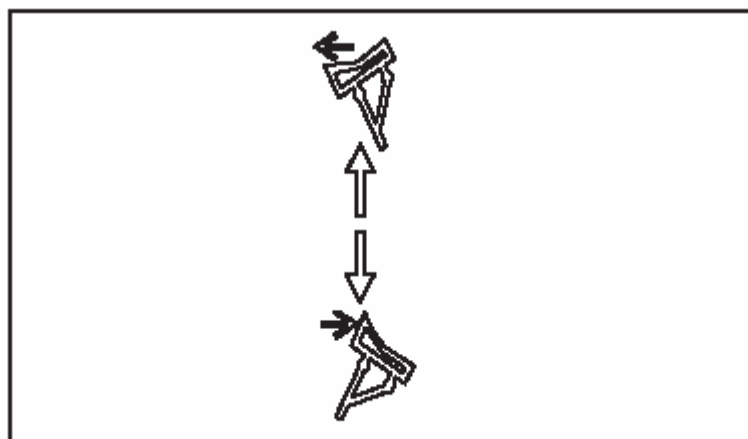

3. Operating the assistant operation device

When the machine has the assistant operation device, it opens the shift fore、 pedal cover of the assistant operation lead valve, and step the pedal of the lead valve, it can connect the assistant oil.

Driving Operation

1. Control the direction

Operate the left、 right driving joy stick to control the pedrail of the machine.

Operating one side of the joy stick, it can make machine to turn one side.

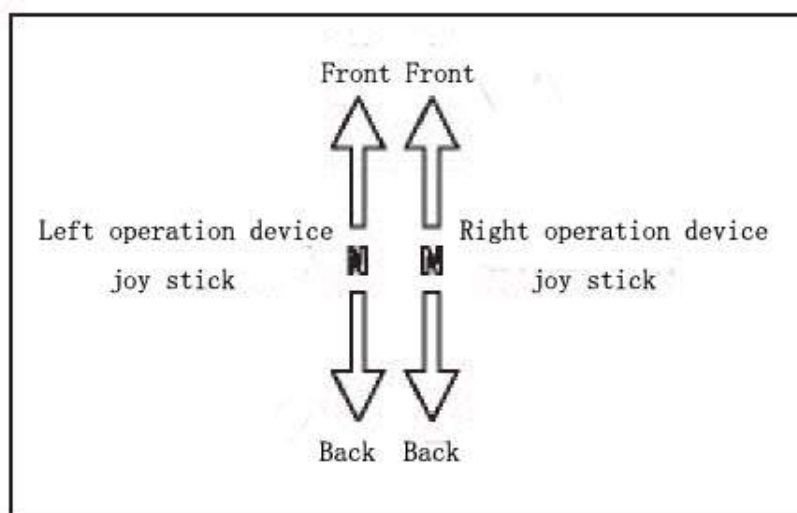

2. Control the speed

- 1) To the standard configuration: it uses the assistant operate lead valve to control the speed. It opens pedal cover of the assistant operation lead valve, and step the pedal of the lead valve to make the machine driving high-speed.
- 2) To the electric and aptitude control: it uses the high\low control button of the left operation box to control the driving speed.

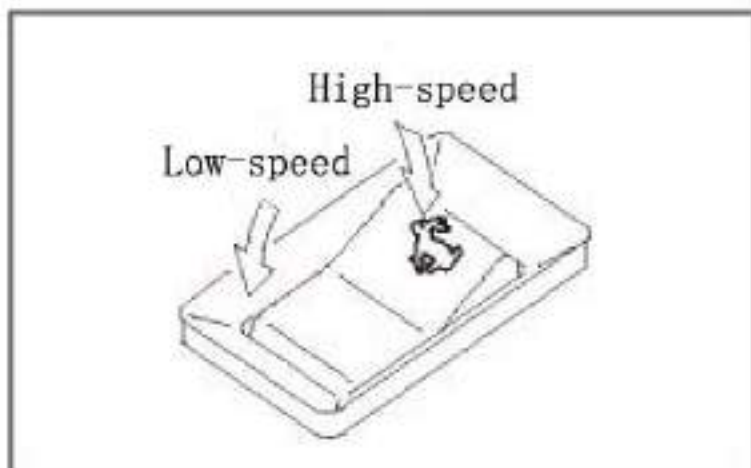

Gun Handle

1. Gun handle

A. Gun handle(Cab type)

Pull behind the gun handle of the engine. The gun increases. Before stop the engine, pushed ago the handle to the end. After stop the machine, the handle replaces.

B. Gun handle(Lookum type)

Pull behind the gun handle of the engine. The gun increases. Before stop the engine, pushed age the handle to the end. After stop the machine, the handle replaces.

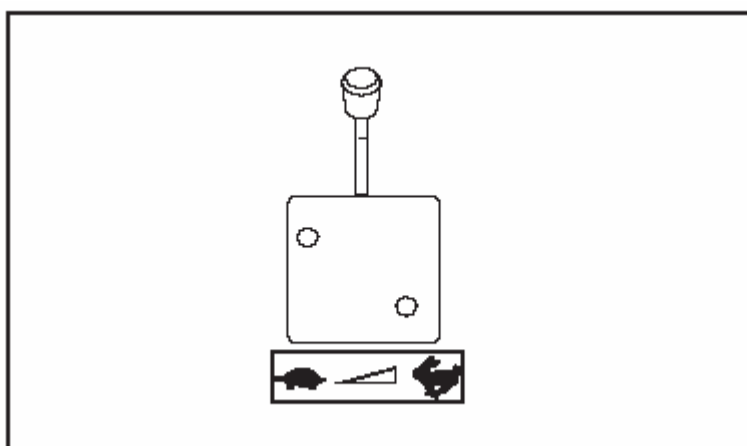

Driver's Seat



Warning:If the machine to turn over or move

Hydraulic Digger

suddenness, it will lead to hurt. Remember to tie the safety belt and adjust the seat before starting the machine.

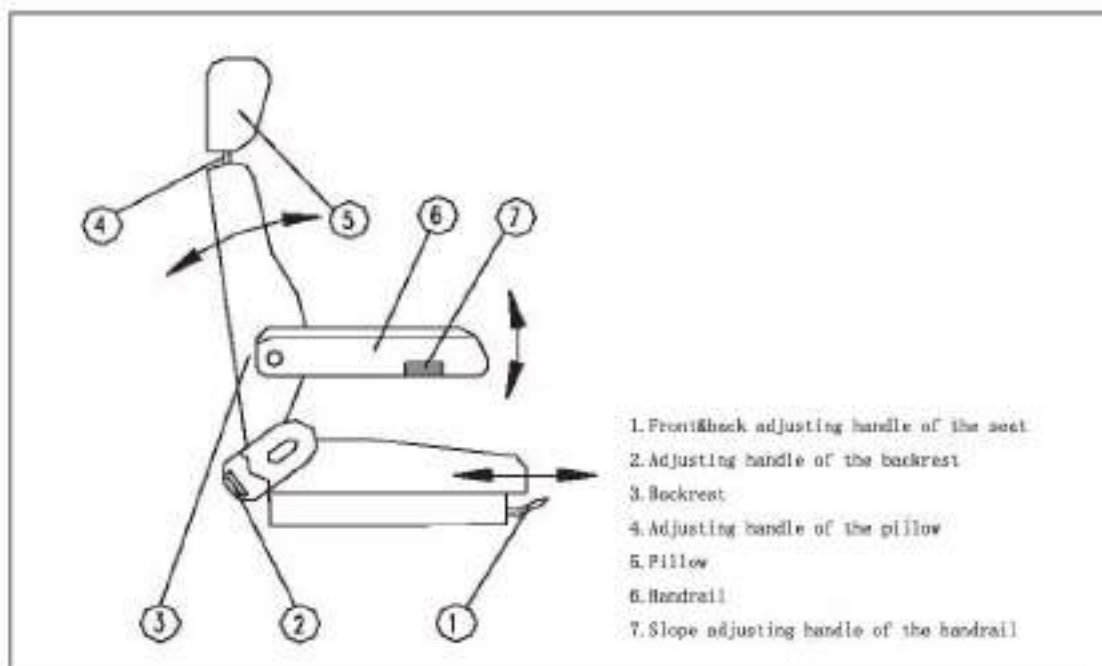

- Front & back adjusting the seat: twist the front & back adjusting handle of the seat, it allows to move about 0-75mm. Loosen the handle, the seat locked.
- Adjusting the backrest: pull-up the adjusting handle of the backrest, the backrest can adjust about 5 grade, loosen the handle, the backrest lock perchs.
- Adjusting the pillow: Moving the adjusting handle of the pillow back, and push & pull the pillow to the right place.
- Adjusting the slope of the handrail: turn the slope adjusting handle of the handrail, it adjusts the slope.

Caution: When it needs to adjust the seat, it stops the machine. After adjusting, jiggle the seat to make sure the seat locked.

Safety Belt



Warning: The safety belt is the important part of the

safety system. Before the operation, it must tie the safety belt. If the operator doesn't tie it, it will hurt him when the machine to turn over.



Warning: Before tie the safety belt, it need to check whether the safety belt unconventionality. If it fray or destroy, it need to replace it.

- If the safety belt doesn't have any unconventionality, it need replace the belt every three year. The product date indicates in the leave factory label
- Operating the machine, it must tie the safety belt.
- When the operator tie the safety belt, it doesn't make the belt twist.

1. Fix the safety belt

Holds the safety belt and checks the belt whether twists. Adjusts the length of the belt. Then puts it into the button. And pulls the belt lightly. Last checks the safety belt whether locked right.

2. Ravel the safety belt

Press the red button, it can ravel the safety belt.

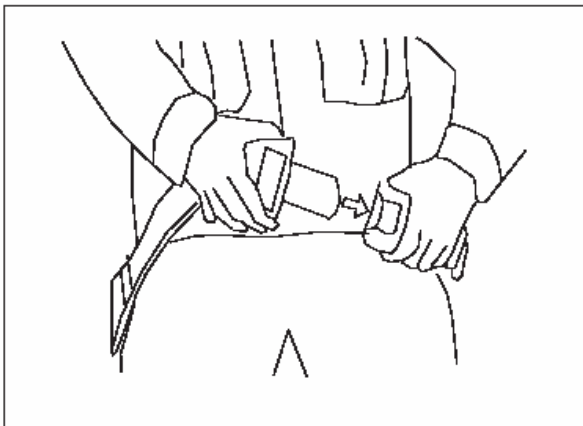

Air-condition Control

The plane of the air-condition lies on the plane switch ground of the left joy stick.

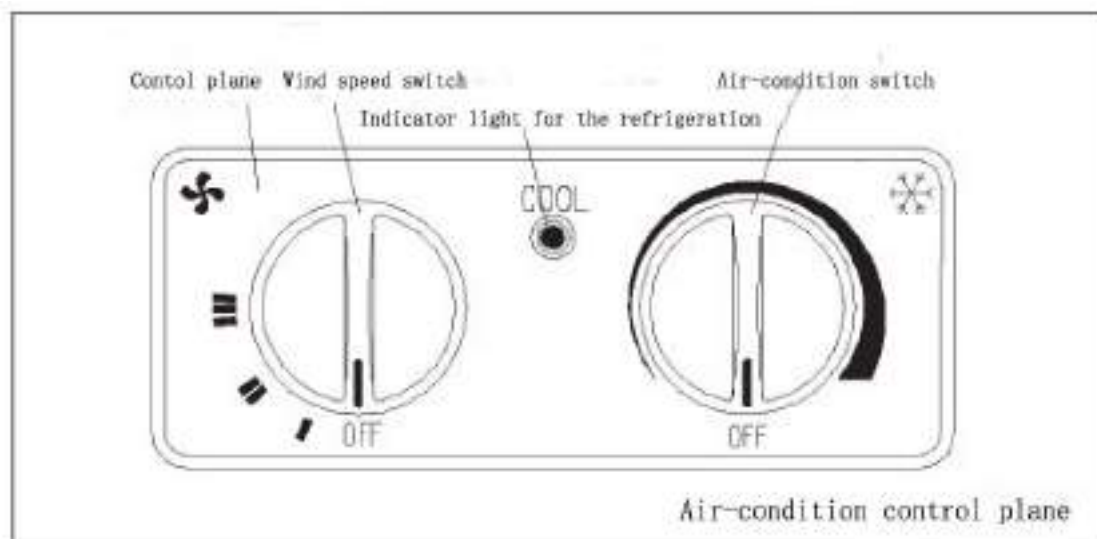

1. Basic operation of the aeration

- 1) Turn the air-condition switch to "OFF" anticlockwise;
- 2) Turn the wind speed switch to I、II、III deasil as need.
- 3) See the picture a、b, turn the wind direction t the right place.
- 4) Turn the wind speed switch to "OFF" anticlockwise, it stop the air-condition.

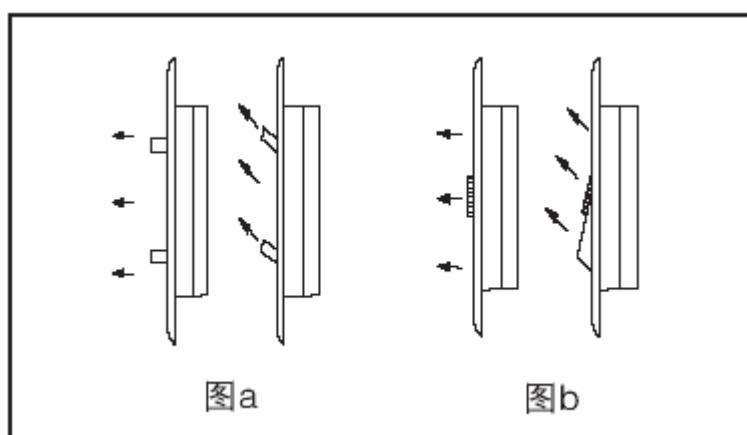

2. Basic operation of the refrigeration

- 1) Press "Basic operation of the refrigeration" to replace the wind

speed and wind direction.

- 2) Turn the air-condition switch to the right place
 - 3) Adjust the wind speed、wind direction、cooling to make a comfortable condition.
 - 4) Turn the air-condition switch to “OFF “anticlockwise, and Turn the wind speed switch to “OFF “anticlockwise, it stop the refrigeration.
3. Basic operation of the warming

According to “Basic operation of the aeration”, when the warm water valve open.

Radio

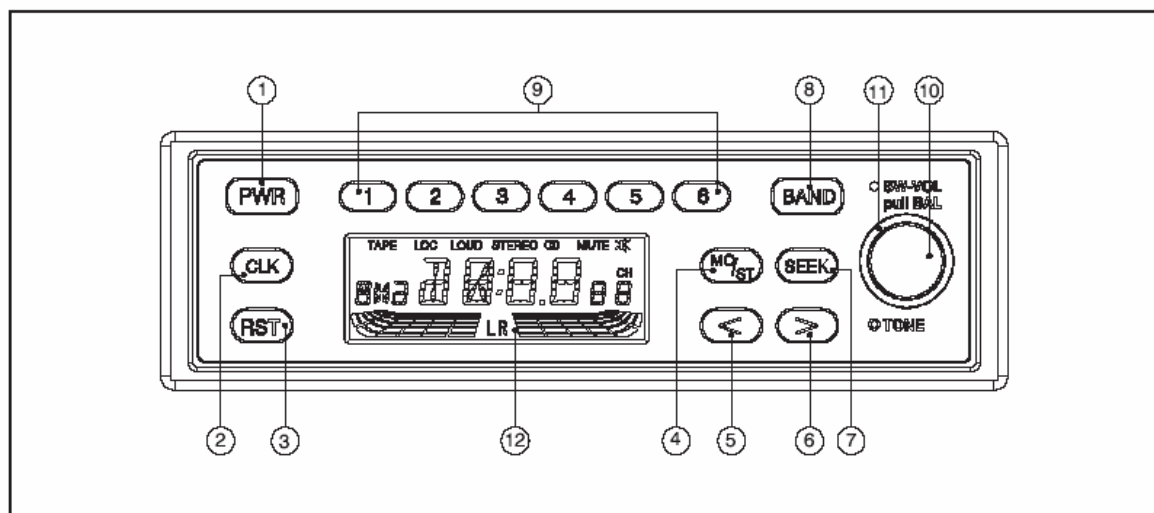

- | | |
|---|-----------------------------|
| 1. Power | 9. Channel preset key |
| 2. Time/ frequency switch | 10. Volume/balance adjuster |
| 3. Replace key | 11. Volume adjuster |
| 4. Stereo/mono mix switcher | 12. Display |
| 5. Manual downwards channel selection/time adjuster | |
| 6. Manual upwards channel selection/time adjuster | |
| 7. Automatic channel selection key | |
| 8. wave band switcher | |

Operation Manual of The Radio

1. Start & Stop

Press 1.PWR key, the electrical source open, the radio starts. Press it again, the electrical source close, the radio stops.(If the radio is the automatic electrical source, press any key to start the radio, press 1.PWR key stop it.)

2. Switch the wave band

Press 8.BAND key to switch the wave band, the order of the wave band:FM1-FM2-FM3-AM1-AM2

3. Channel selection by automatic

Press 7.SEEK key one time, the radio will select channel from low to high by itself. When it selects the channel, it will lock and play.

4. Channel selection by manual

When the radio's signal weak, it adopts channel selection by manual.Press5.<key or 6.>key to downwards or upwards channel selection.Press5.<key or 6.>key long time, it can downwards or upwards channel selection fast.

5. Memory channel by manual

When it selects the channel by automatic or by manual, press the preset key of memory channel long time (more than 3 seconds).

6. Stereo/mono mix switcher

Press 4.MO/ST to switch the stereo mix and mono mix. When the display "STEREO" lights, it is the stereo mix mode. If the display " ∞" light, it means the stereo channel. If the signal of the stereo mixes weak, please switch to the mono mix mode to improve the effect.

7. Time/frequency switcher

Press 3.CLK key to switch the time/frequency mode. When it is the time mode, press other key (except PWR key), it will return the frequency mode. It will return the time mode by automatic after 5 seconds

8. Time adjusting

Press 2.CL key long time(more than 3seconds),the time sparks. It mean it enter the time adjusting mode. Now press 5.< key to adjust the minute, press 6.>key to adjust the time. After adjusting, it will return the natural display mode in 5seconds.

9. Volume adjusting

Turn 10.to adjust the volume.

10. Tonality adjusting

Turn 11.to adjust the tonality.

11. Left & right balance adjusting

12. System replace

If the radio doesn't work good, please press 3.RST,it will renew the status when it produced.

Caution: 1.The digger doesn't have the time function of the radio.

2. Because of the different radio, it has the different operation plane.

Door and Window

1. Door of the cab

It is the only way to enter the digger for the operator. When the operator leaves the cab, he needs to lock the door.

When open the door, it should the lock blocks to the lockpin. When it needs to close the door, it should press the door pull rod. The lockpin open, and the door open.

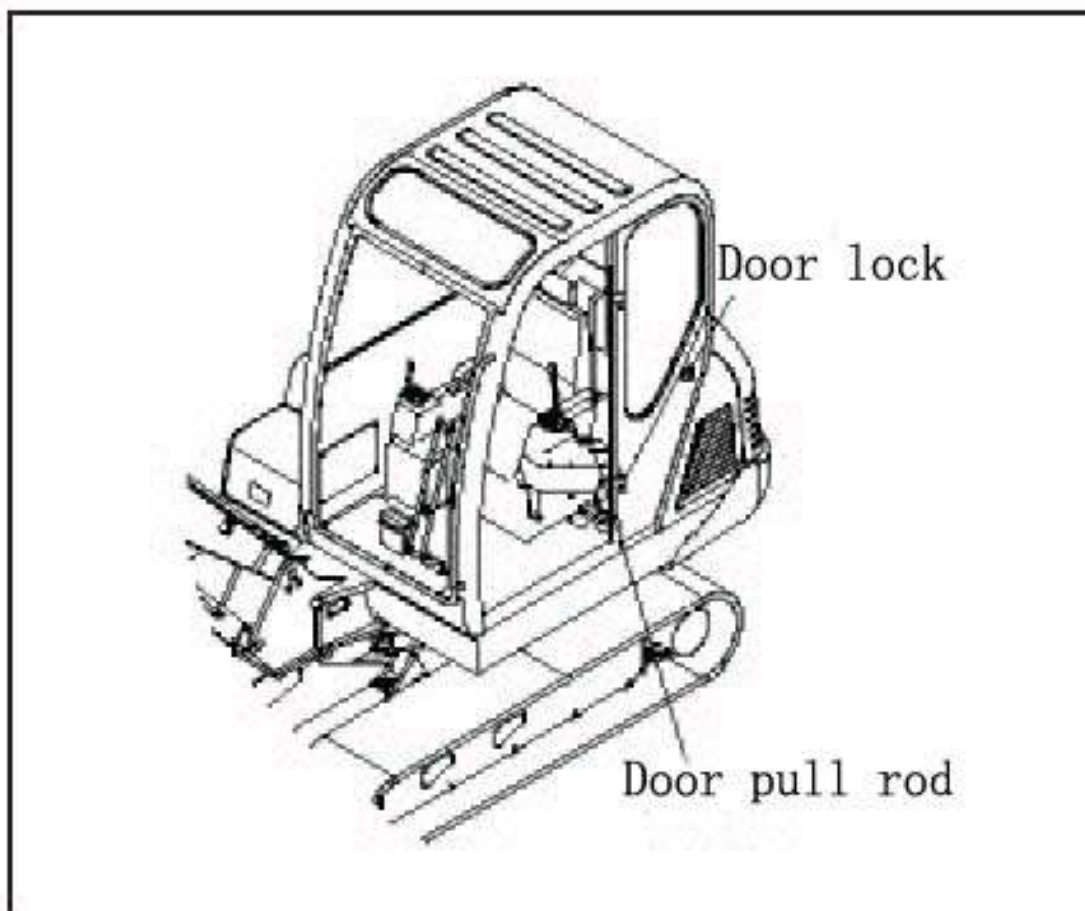

2. Rear window

The rear window can as an exit. When the door couldn't open, and the operator couldn't out and need get away from the cab, it can use the flee hammer to smash the rear window.

3. Fore window(Turnover window)

If it opens the turnover window, the operator can have a good condition.

Hydraulic Digger

If it wants to open the turnover window (fore window), it needs to pull the two commode handles of the turnover window. Operating the commode handles to glide the turnover window. When the turnover window glide to the right place, and push-up the turnover window to the lock place, loosen the commode handle lock, the turnover window locked. Whereas, the turnover lets down.

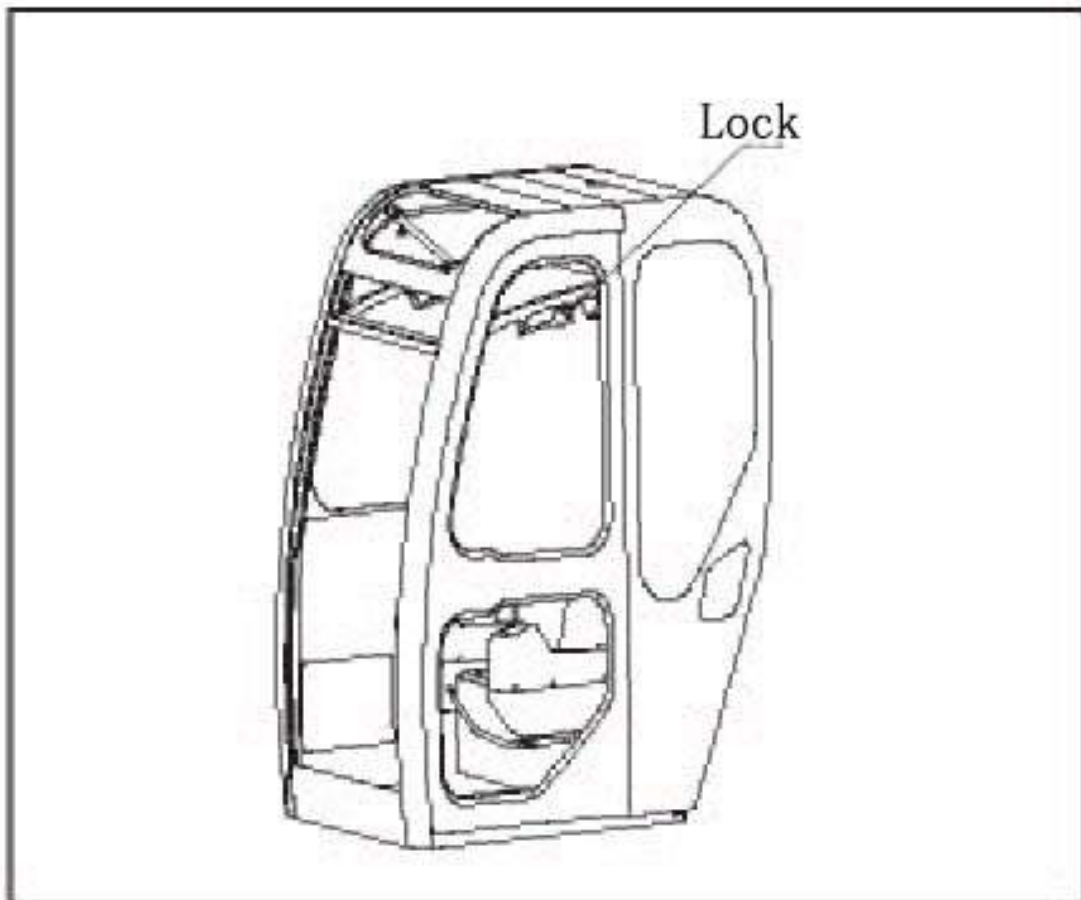

Prepare for Running Machine

- 1) The digger is operated by the driver who trained.
- 2) Don't operating the machine before the operator perusal the user manual.
- 3) The operator need put on the interrelated safeguard: sheathy work clothes、 motorcycle safety helmet、 work shoe and so on(safety glass、 safety earplug、 glove、 safe belt)
- 4) It needs to check the machine before running the machine every day.
- 5) Check whether the operation device、 the oil tank、 the rubber pipe destroy.
- 6) Clear the dust which around the engine、 the radiator、 the accumulator.
- 7) Check whether the hydraulic device、 the oil tank、 the rubble pipe、 the tie-in leak.
- 8) Check whether the infrastructure destroys, whether the bolt loosens, whether the bolt loosens which connect the frame and the platform.
- 9) Check whether the instrument destroys.
- 10)Clean the rearview mirror, check whether destroys and adjust the angle.
- 11)Check whether the safety belt destroys.
- 12)Make sure to do the maintenance with the right way.

Engine Operation



Warning: Before start the engine, please reading the safety detail of the user manual. Reading the safety sign of the machine.

1. Check the machine before start the engine

- 1) Check whether ties the safety belt, rings the trumpet, make sure nobody on the workplace and the top/bottom of the machine.
- 2) Check whether the rearview mirror and the widow can supply good view.
- 3) Clear the dust which around the engine、the radiator、the accumulator
- 4) Check whether the operation device、the oil tank、the rubber pipe destroy
- 5) Check whether the hydraulic device、the hydraulic oil tank、the rubble pipe、the tie-in leak
- 6) Check whether the infrastructure destroys, whether the bolt loosens or whether leaks.
- 7) Check whether the instrument destroys
- 8) Check whether the oil level of the hydraulic oil、the fuel、the electrolyte of the accumulator、the machine oil of the engine between the upper limit and the lower limit.
- 9) In the cold day, it need to check whether the hydraulic oil、the fuel、the electrolyte of the accumulator、the machine oil、the lube freeze. If they freeze, it should start the engine after thaw.
- 10) Check whether the left joy stick on the lock state.
- 11) Check what the state、the direction、the station of the machine.

2. Start the engine

Hydraulic Digger



Warning: When the joy stick hangs the safety sign "No start engine", it doesn't allow to start the engine.



Warning: Before start the engine, it must to make sure the safety lock handle on the lock state.



Warning: In the cold day to start the engine, it need to warm-up. If it doesn't warm-up, the joy stick will slowness, and may be lead the accident.



Warning: If the electrolyte of the accumulator thaw, it doesn't electrifies or use the different power to start the engine. Where as ,it will fire. Before the electrification or use the different power to start the engine, it makes the electrolyte of the accumulator unfreeze.

Before start the engine, it should the key insert the start switch, and turn to "ON", check the display state of the indicate alarming light of the digital combination instruction sheet. If it has the alarming, it need to deal the trouble and then start the engine.

A. Normal temperature to start the engine

When the temperature of the condition exceeds 5 degree, turn the key to "ON", the indicator light wink, and it mean the machine can start. Then turn to "START", it keep the key on the place not

exceed 10seconds.After starting the engine and loose the key, it will return to “ON” by itself. If it finds the engine not start, it should start the engine again after 30 seconds.

B. Cold temperature to start the engine

When the temperature of the condition under 5 degree, turn the key to “HEAT” to warm-up. About 6 seconds after warm-up finish, the warm-up indicator light wink. Then turn to “START”, and start the engine

Caution: the time of the warm-up not exceed 30 seconds.

Caution: continuous start it not exceed 10 second; the time for start it again not under 1 minute. If it doesn't start the engine three time, it needs to check whether the system ok.



Warning:1)When the engine runs, it hadn't to turn the key.2) When it drags the digger, it haven't to start the engine.3)Haven't to use the way to start the engine which start the motor short circuit

● **Use the assistant cable to start the engine**



Warming: When the electrolyte of the battery freezes, if (1) it electrifies or(2) use the different power to start the engine, the battery will explode. To avoid the electrolyte of the battery r freeze, it keeps it have full electricity.



Warning: The battery can produce the explode air. It must keep away from the fire、the spark. Electricize it in thesealing area or it keeps ventilated area when use the battery. Working need the battery, it need wear the eyepatch.

If the way for connect the assistant cable wrong, it will lead explode. It must do as follow:

- 1) When it uses the assistant cable to start, it need two persons to operate(one sit on the operator' seat, another operates the accumulator)
- 2) When it uses another machine to start, it hasn't to the two machine touch.
- 3) When it connect the assistant cable, It need to turn the keys of the normal machine and the trouble machine to "OFF". Whereas, when it has the power, the machine will move.
- 4) When it installs the assistant cable, it must connect the cathode (-) of the accumulator at last; When it removes the cable, it must off the cathode (-) of the accumulator first.
- 5) When it removes the assistant cable, it doesn't let the nip of the assistant cable touch one another or the nip of the cable touch the machine.
- 6) When it uses the assistant cable to start the engine, it must to wear the eyepatch and the rubber glove.
- 7) When the use the assistant cable to connect the normal machine and the trouble machine, it needs to use the normal machine which has the same volt with the trouble machine.

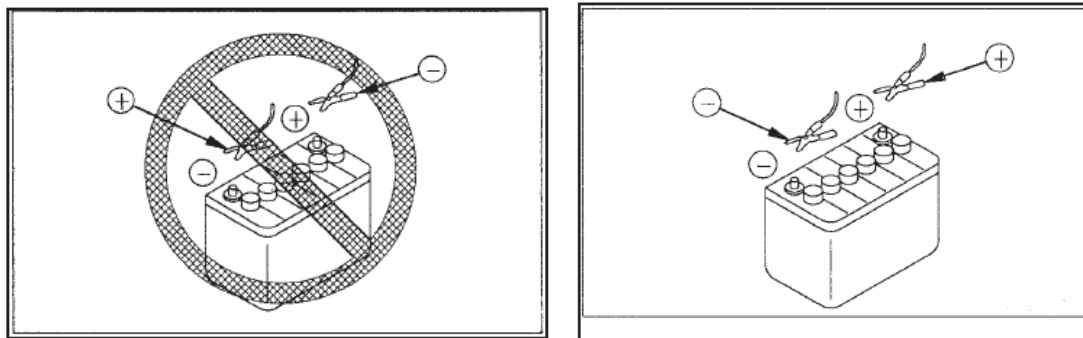

3. After start the engine

A. Warning the engine and warn-up the machine

The normal temperature of the hydraulic oil is 50°C - 80°C . If it operates the hydraulic oil under 20°C , it will destroy the hydraulic element. So before start to working, if the temperature under 20°C , it must warn-up as follow:

- 1) The engine runs 5 min with the **Idle-speed** .
- 2) Put the gun of the engine to the median to run 5-10 min
- 3) Under the speed, flex each oil tank, operate the rotating device and the driving motor to warn-up. When the oil temperature arrive 20°C , it can run. If it needs, it can flex the oil tank of the bucket to the travel end-point, warn-up the hydraulic oil. But the time for it not exceed 30 seconds. It can repeat till arrive the request of the oil temperature.

B. Examining after start the engine

- 1) Check whether the indicator light wink.
- 2) Check whether leak oil(the lube、 the fuel) and leak water
- 3) Check whether the sound、 the librations、 the calefaction、 the smell、 the instrument have the unconventionality, stop machine immediately if there are any unusual.

4. Stop the engine

Caution: If you shut down the engine before it cooling, it will shorten the use life. Except urgent, no stop the engine suddenly.

If the engine superheat, don't stop the engine, it need cooling the engine with the Idle-speed running, then stop the engine.

- 1) Push the gun goes ahead to the end.
- 2) Make it cooling with the low-speed running about 5min.
- 3) Turn the key switch to "OFF", stop the engine, and the indicator lights wink.
- 4) Take the key.

5. Examining after stop the engine.

- 1) Check whether the machine leaks oil or water.
- 2) Add the oil to the fuel tank
- 3) Check whether the engine cab has the wastepaper or the scrap.
Clean the wastepaper and the scrap to avoid the fire.
- 4) Clear the soil of the underpan.

In & Out Machine

- 1) Make sure to grasp the handrail of the cab's door (see the arrowhead of the picture)
- 2) Make sure the feet step on the pedrail placidly.
- 3) In & out the machine, it haven't to use the joy stick instead of the handrail
- 4) Before in & out the machine, it makes sure whether the handrail、the pedrail have the soil、the oil. If they have, please clean them.
- 5) No jump up or down the machine, when the machine moves ,it doesn't allow to jump up or down the machine.
- 6) Before leave the machine, it must let the operation device down and use the safety lock handle to pull-up the control box, make the machine in the lock state, and stop the

engine, and keep the state to the next operation.

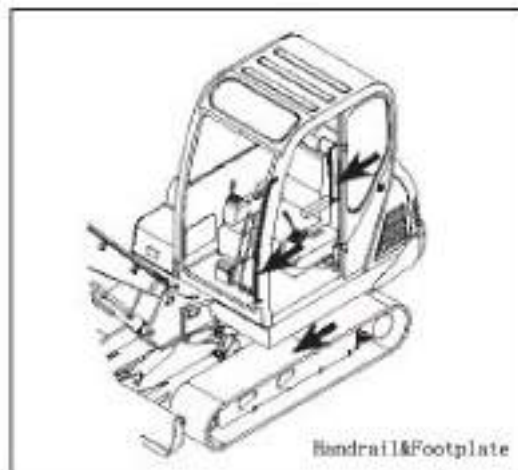

Caution: When the operator leaves the cab, please take out the key and lock the door and the window.

No allow climb up the oil tank、 the cover of the engine、 the top of the cab.

Under any state, the operation devices (the bucket、 the lever、 the moving-arm、 the attachment) don't allow have the person.

Moving Of The Machine

1. Safety rules for moving the machine

- 1) Before start the digger, you need know the condition, know whether it has the passerby or the roadblock and know the bearing power of the ground.
- 2) Before start the digger, you need to ring the alarming to caution the passerby.
- 3) No start or operate the machine when the operator on the ground.
- 4) The digger must drive、 operate on the hard ground which the width must more than 1.5 times
- 5) When the machine drives on the area which have the underpass、 the bridge、 the cable, you need have the sign command.
- 6) When the machine drives, you must fall the moving-arm、 the lever, and keep the best station of the barycenter.
- 7) When the machine drives, it only allow the operator in, don't hitchhiking other persons.
- 8) When the machine drives on the smooth road long time, it can't lock the platform. But it up & down slope, it has to lock the platform.
- 9) Before turn the joy stick, it should check the direction of the pedrail frame. If the bucket in the back, operate the joy stick of the driving reverse.
- 10) Don't allow the person in the area which the machine around
- 11) Clear the roadblock when the machine drives.
- 12) It is a blind spot which behind the machine, when it is back a car, and need caution.



Warning: When it is high-speed driving, it is dangerous to turn the joy stick suddenly.

- 1) No turn the joy stick suddenly, otherwise, it will make the machine starts suddenly.
- 2) Avoid to replace the joy stick from go ahead to back off suddenly(or from back off to go ahead)
- 3) Avoid the joy stick replaces suddenly, for example from the high-speed and stop suddenly(loosen the joy stick)

2. Prepare for moving the machine

- 1) Put down the lock pin of the platform; lock the rotating of the platform.

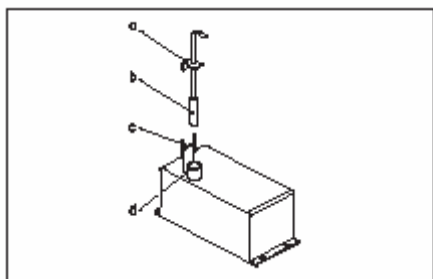

- 2) Make the gun handle run to the hi-speed, to increase the rotate speed.

3. Moving the machine forward

- 1) Adjust the safety lock handle and the control box to the free station, lift the operation device and off the ground 40cm to 50cm

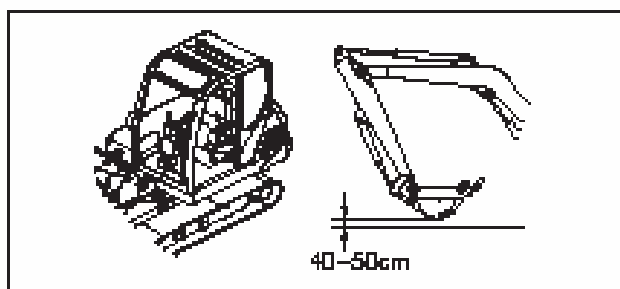

Hydraulic Digger

2) Operate the left & right driving joy stick as follow:

When the bulldozer in front, pushes the foreside of the joy stick forward slowly, and make the machine moves.

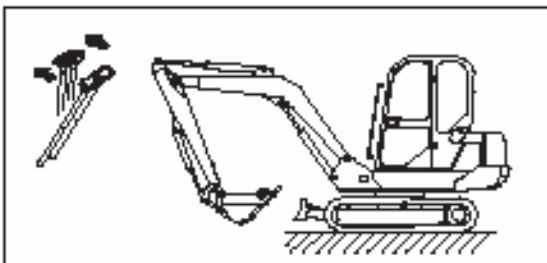

When the bulldozer in back, pull the joy stick backward slowly, and make the machine moves.

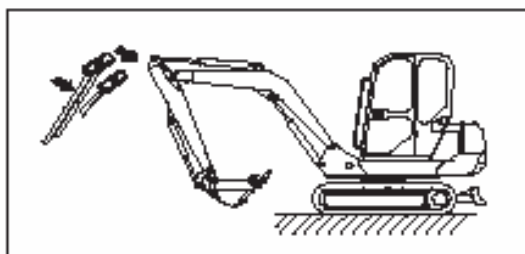

Caution: When it is the lower temperature, the driving speed of the machine doesn't right, it need to warm-up. Otherwise, if the bottom of the machine has the soil, the driving speed doesn't right, it need to clear the soil.

4. Moving the machine backward

1) Adjust the safety lock handle and the control box to the free station, lift the operation device and off the ground 40cm to 50cm

2) The operation is opposition forward

5. Stop the machine

Make the left & right joy stick to the middle, it stops the machine.

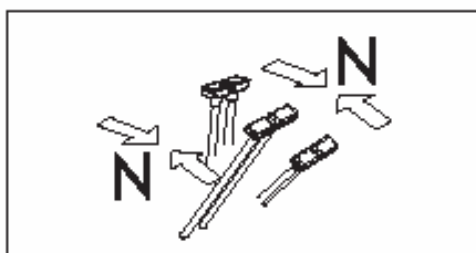

Hydraulic Digger

Caution: Avoid the machine stop suddenly, it need have enough space.

Turning The machine

Caution: Before operate the joy stick, it need to check the station of the bulldozer. If the bulldozer in back, the operation reverse

Use the left& right driving joy stick to replace the direction of the driving.

Avoid to replace the direction sudden as far as possible.

1. Turn the direction when the machine stops

Turn left:

Driving forward, pull the right driving joy stick, the machine will turn left. Driving backward, push the right driving joy stick, the machine will turn left.

Turn right: the mode same as turn left.

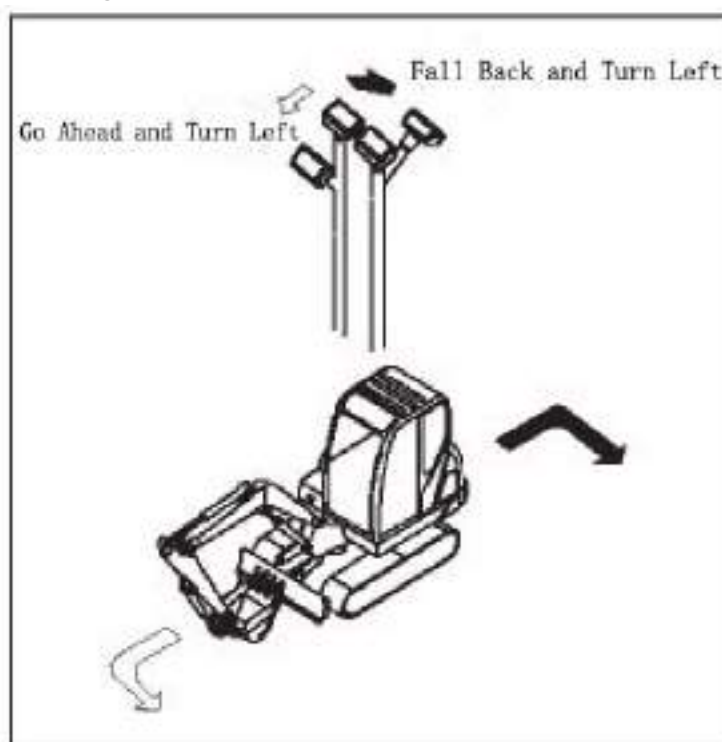

2. Turn the direction at the same place.

When the machine is turn left at the same place, push the left driving joy stick and pull the right driving joy stick.

When the machine is turn right at the same place, push the right driving joy stick and pull the left driving joy stick

Hydraulic Digger

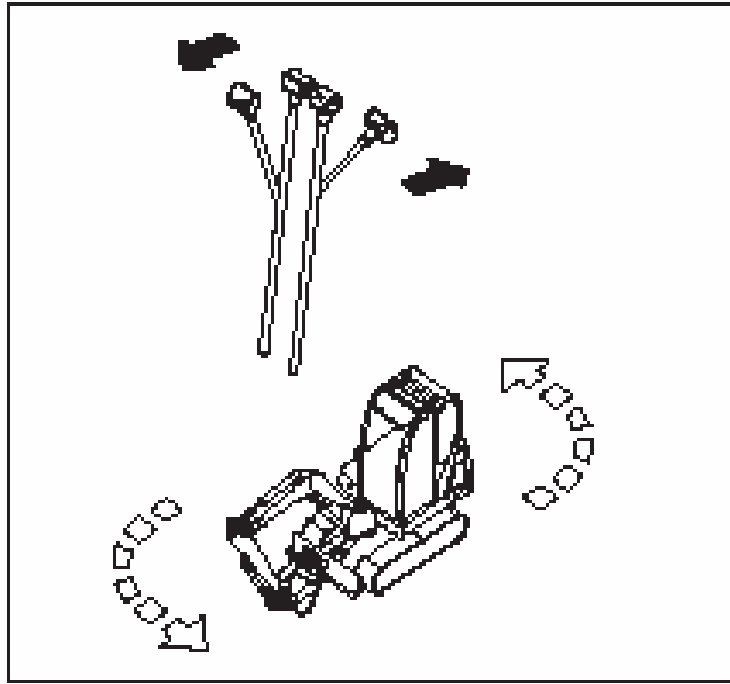

Rotating The Machine

- Before rotate the top frame, it need to check whether the area safe.
 - Make sure already to lift up the lock pin of the platform, unlock the platform and the chassis.
 - If it operates the rotating joy stick fast, the top frame turns fast, too. If it operates the rotating joy stick slowly, the top frame turns slowly, too.
- 1) Before do rotating operation, it needs to lift up the lock pin of the platform, unlock the platform and the chassis.
 - 2) If the machine has the rotation head, it need to operate the choice button of the left operation device joy stick, to make sure the machine stay the station of the platform rotating.
 - 3) Operate the left operation device joy stick to do the rotating operation

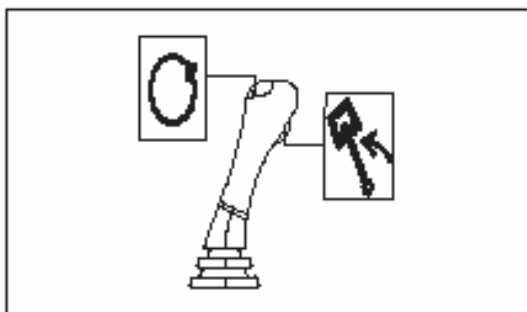

- 4) If it doesn't do the rotating operation, it needs to insert the orientation pin of the platform, lock the platform rotate.

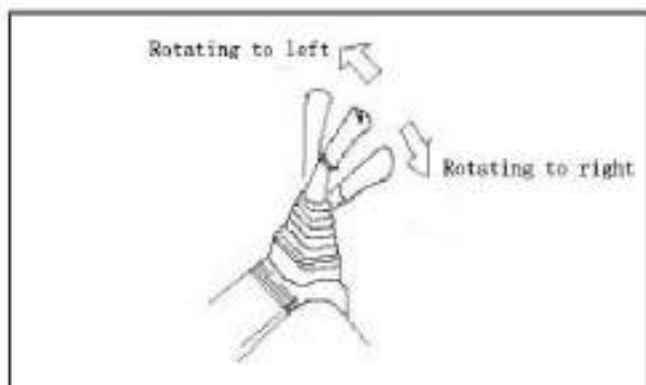

Operate The Operating Device

If it operates the joy stick of the operation device fast, the operation device moves fast, too. If it operates the joy stick of the operation device slowly, the operation device moves slowly ,too

The operation device operated by the left/right operation control valve. The left operation control valve operates the lever and the rotating (if it has the rotation head, the left operation control valve can operate the head move).The right operation control valve operates the moving-arm and the bucket.

Loosen the joy stick, they will return the middle by automatic. The operation device keep on the original.

If it operates the control valve in 15 seconds when stop the engine, it can down the operation device.

And it also can operate the control valve to release the rest power of the hydraulic oil line and down the moving-arm after the machine has the trailer.

1.Control the lever

Operate the left operation control valve, push forward, the lever extends. Pull backward, the lever draw in

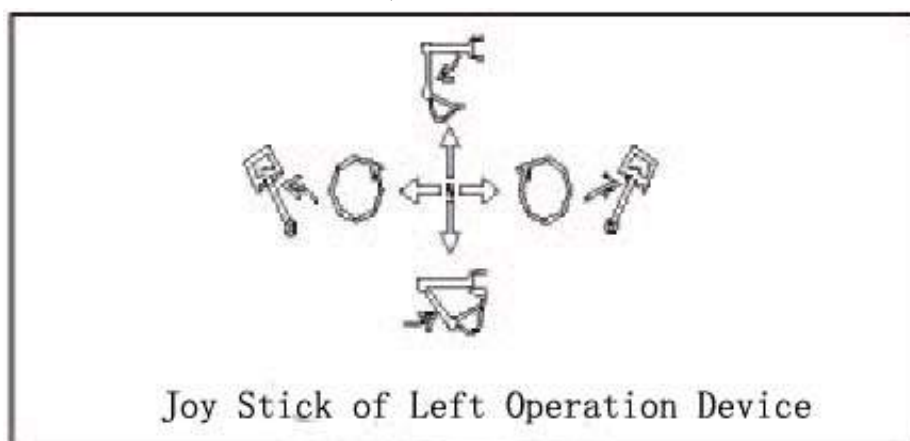

2.Control the rotating

Operate the left operation control valve, deflect to left, the platform turn left. Deflect to right t, the platform turn right.

If the moving arm has the deflecting function, it must make sure the machine stay the rotating state before it rotating.

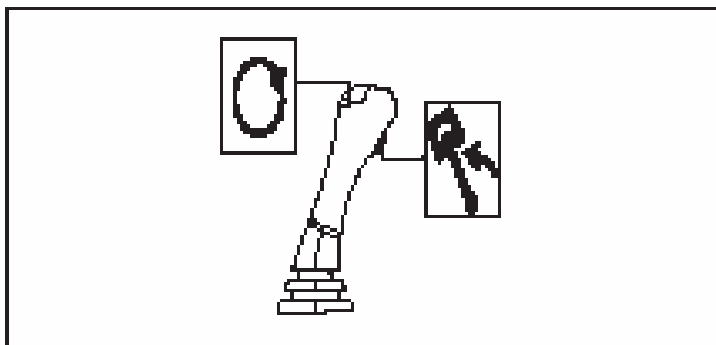

3. Control the moving-arm

Operate the right operation control valve, push forward, the moving-arm down; Pull backward, the moving-arm up.

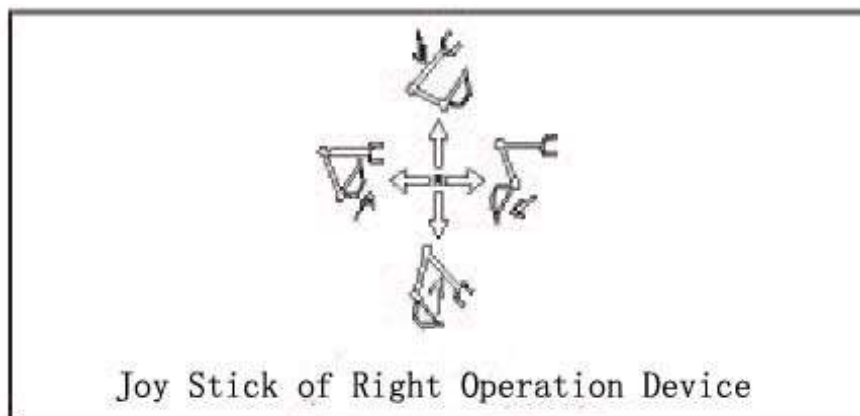

4. Control the bucket

Operate the right operation control valve, deflect to left, the bucket eversion. Deflect to right, it draw in

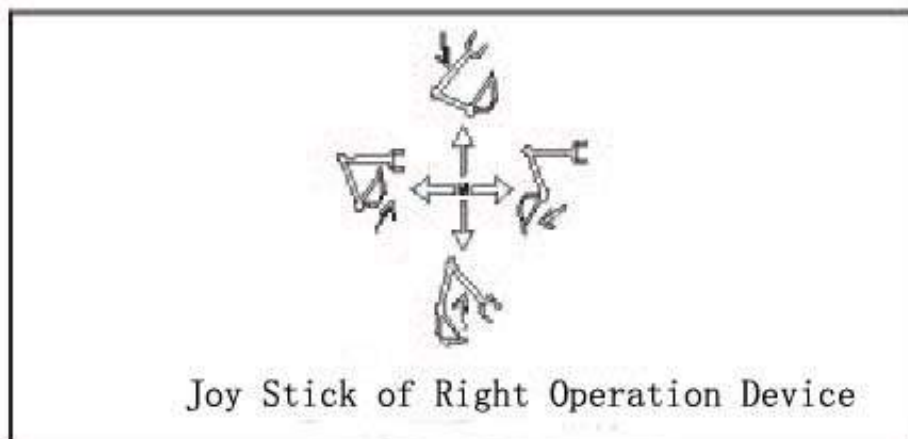

5. Control the moving-arm deflecting (the rotation head)

Operate the left operation control valve, deflect to left, the rotation head turn left. Deflect to right, the rotation head turn right.

If the moving arm has the deflecting function, it must make sure the machine stay the moving-arm deflecting mode before it rotating

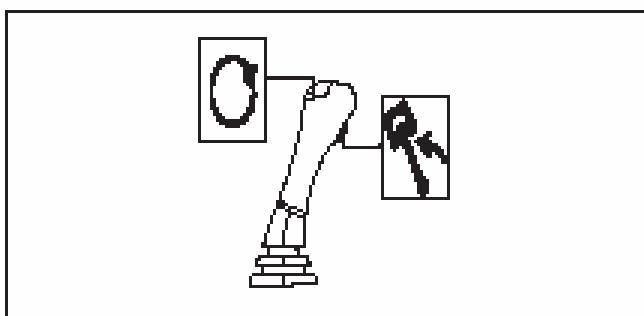

6. Control the bulldozer

Push-down the joy stick of the bulldozer, the bulldozer into the soil. And pull-up the joy stick, the bulldozer lift up.

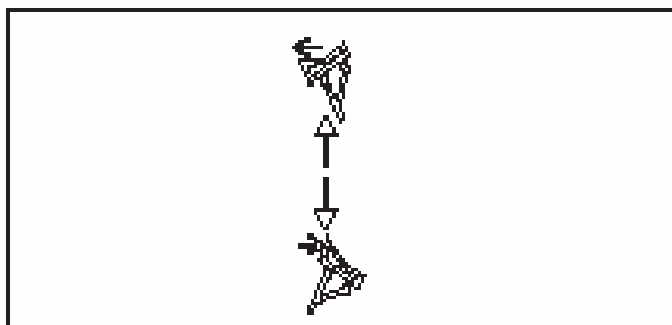

Caution: When the lever operated, it maybe pauses. It doesn't the trouble, it is the normal phenomenon. When the lever moves, it maybe lacks the oil because of the deadweight to make it move fast.

Working On The Slope or In The Water



Warning: It is dangerous to work near the slope of the piedmont.

- When the machine drives, the bucket should away the ground 20-30cm
- No back up on the slope.
- When the machine drives on the roadblock, it should make the operation device close the ground and drives slowly.
- No swerve on the slope or cross the slope. It can turn the direction on the smooth ground.
- It will overturn when the machine swerves or operates the operation device on the slope. When the bucket overload, it's very dangerous to rotate to the direction of the downgrade. If it must to do, it needs use the soil to stack a flat roof and to make the machine keeps the balance.
- No up& down the slope, it maybe has the danger.
- When the machine is upgrade, if the pedrail skids or the power of the pedrial not enough to upgrade, no use the pull power of the lever to help it. Maybe the machine will overturn.
- When the machine upgrade, it needs to make sure the engine and the hydraulic oil warm-up.

The depth of the water which it allows

No drives the machine when the depth of the water exceed the center line of the bracket.

It needs to lubricate the butter when the parts in the water long time, till the butter which used all out.

Hydraulic Digger

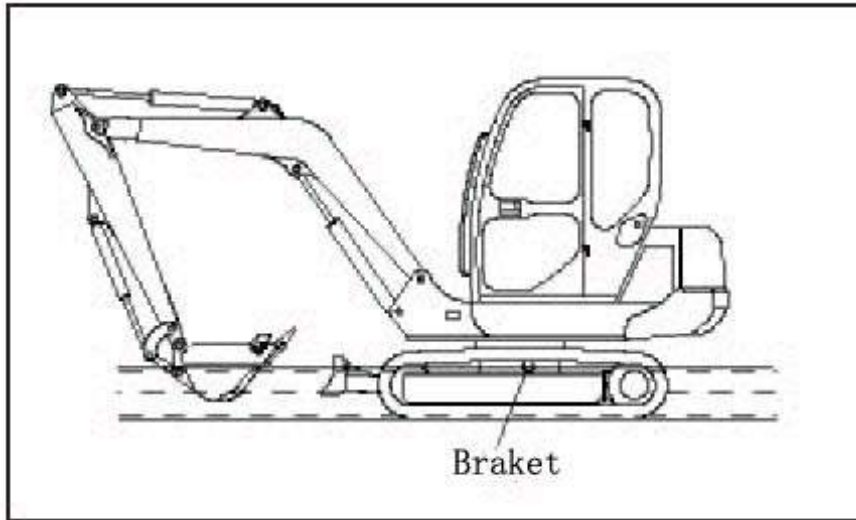

Out of The Muddy Condition

It needs to operate the machine careful to avoid get into the mud. If the machine gets into the mud, please do as follow:

A. One side of the pedrail gets into the mud

Caution: When it uses the moving-arm or the lever to uplift the machine, it must make the bottom of the bucket touch the ground.(No use the gear of the bucket to push).The angle of the moving-arm and lever is 90° to 110°

When it only one side of the pedrail gets into the mud, it uses the bucket to uplift the pedrail, and underlay the stow-wood, make the machine drive out. If it necessary ,it can underlay the board under the bucket.

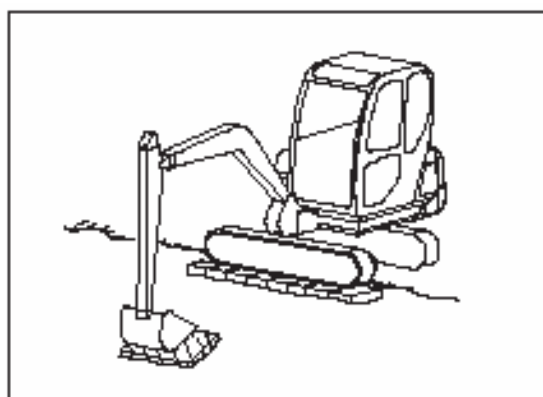

B. Double sides of the pedrail get into the mud

If the double sides of the pedrail get into the mud, and skip not to move. It can adopt the way which as A to underlay the stow-wood. It makes the bucket dig into the ground, and operate the joy stick same as the way which it digs. And adjust the joy stick of the driving to the station which goes ahead to pull out the machine

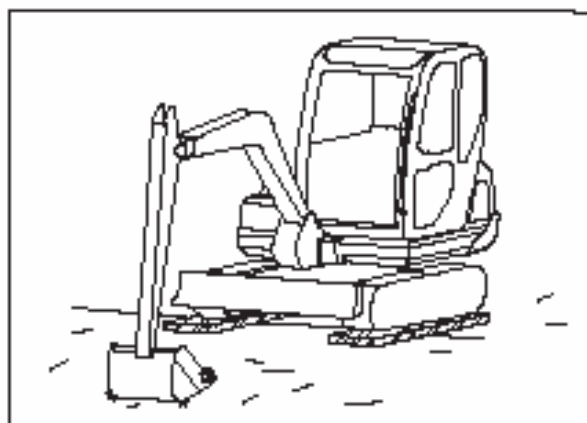

Operating Manual

1. Operation when the bucket in reverse

The bucket in reverse suit for the station under the machine

When the machine stay the state which like the picture, when the angle is 90° for the oil tank of the bucket and the lever, the oil tank of the lever and the lever, it can have the max. digging power of the bucket.

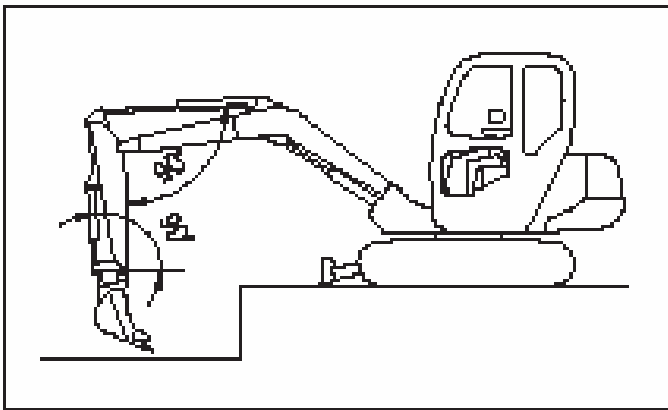

If it uses the angel effective when it digs, it has the best efficiency. The dig area of the lever is 45° away the machine to 30° towards the machine.

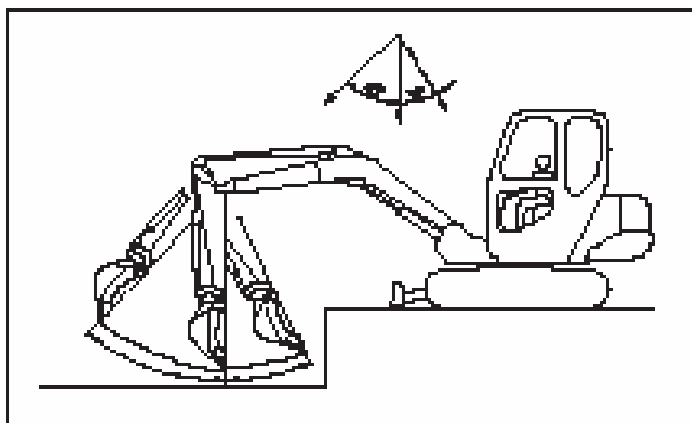

Caution: If the machine digs the hard ground, it is the best way to use other tools crash it then digs.

2. Operation when the machine loading

On the place which the angle of the rotating small, it let the truck stop the place which the operator can see easy.

If the truck loads from the back easier than from the side, the loadage is more,

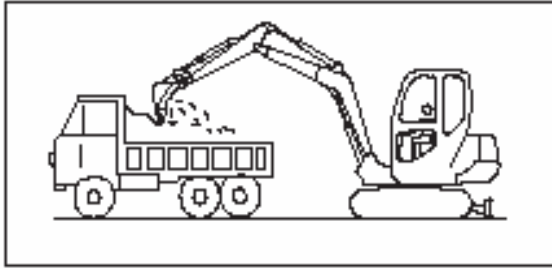

3. Operation of dig the ditch

Make the bulldozer back and anchor into the ground.

Throw out the moving-arm and the lever, and make the gear of the bucket into the ground.

Use the oil tank of the lever to dig. It needs to adjust the angle of cut-in and load the soil when it digs or choice the oil tank of the bucket to digs. It doesn't make the gear of the bucket into the soil too deep, lest should the hydraulic system overload and not have the power to dig. If it doesn't have the power to dig, it can uplift the moving-arm. After full of the bucket, lift up the moving-arm and the lever, make the bucket higher than the ground, and turn the platform the right place to unload the soil.

Caution:

- 1) No touch the wire**
- 2) After make clear the under-pipe、 the cable, then start dig.**
- 3) If it gets an electric shock, the driver doesn't leave the seat, and warn the person not close. After the machine on the safety area and cut off the electricity, then leave.**

4. Backfill

For backfill the ditch, the driving direction of the digger should plumb the ditch. And after the bulldozer cut-in the soil to the certain depth, loosen the joy stick of the bulldozer, start the driving, and use the bulldozer push the soil into the ditch.

5. Shake down the sandy and the soil which in the bucket

Make the lever stay the level state, the bucket stay the unload state. If the sandy and the soil don't down, and operate the operation handle of the bucket some time with left & right, the sandy will shake down. Avoid use the end of the bucket's oil tank to percussive to shake down them.

6. Use proceeding of the correlation parts

A. Use proceeding of the pedrail

- 1) More sundries into the pedrail, it increases the intensity to make the machine destroy
- 2) Avoid to swerve on the road which has the strong friction
- 3) Avoid to touch the brine, it can corrupt the pedrail
- 4) If the pedrail doesn't use long time, it should keep it on the area where shady and cool、dry
- 5) When one pedrail and the foreside device are withstended, no use another pedrail to driving, it makes them fray
- 6) When the machine driving. the pedrail not flab, otherwise, the pedrail maybe down or destroy.

B. Caution proceeding of the bulldozer

- 1) It only uses the bulldozer to move the soil, not use it dig the soil. Otherwise, it can destroy the bulldozer or the pedrail system(see the picture)

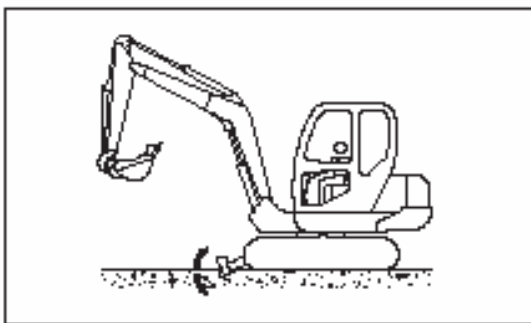

- 2) The bulldozer bear the big thing or the thing which the barycenter flabby. Otherwise, it can destroy the bulldozer or the

Hydraulic Digger

pedrail system

- 3) When the machine driving, the bulldozer doesn't hang anything. Otherwise, it can destroy the bulldozer or the pedrail system
- 4) When the bulldozer lift up the machine, it should make sure the smooth road, the bucket can touch the ground.

Take-down & Installing The Bucket

Safety rule

- When it uses the hammer to knock the pin bearing, the slug maybe into the eye to make the hurt. When the person deal the operation, it need wear the safety glass、 motorcycle safety helmet、 the glove.
- When it take-down the bucket, it need to put it steady.
- When it uses the hammer to knock the pin bearing, it maybe fly off and hurt the person who in the around area. So before knock the pin bearing, it should make sure they are safe.
- When it take-down the pin bearing, no stand under the bucket, no let the foot or other parts of the body under the bucket.
- When it take-down or installing the pin bearing, caution no hurt the hand.
- When it make the hole in line, no put the finger into the pin bearing.

Installing

Stop the machine on the ground which hard and smooth. When it do the connect work, it should know the signal and work careful.

Make the digger stay the operation state, envisage the bucket, operate the lever till the hole of the lever and the bucket in line, and inset one steel stick(Φ 30mm,①)into the hole

Lift up the moving-arm and the lever to make the bucket hang on the lever vertical.

Operate the oil tank of the lever to make the holes of the connect lever and the connect hole of the bucket in line. Installing the bearing②,take out the steel stick①and installing the bearing③。

Hydraulic Digger

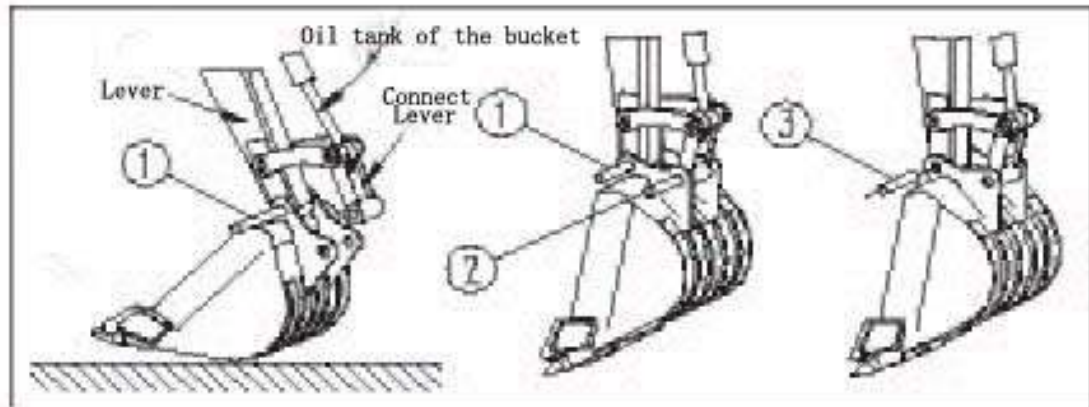

Take-down

Stop the machine on the ground which hard and smooth. It requests to put the bucket to the place which can touch the ground. If the bucket fall down heavy, it will increase the resistance and difficult to take-down the pin bearing.

Take-down the double nuts of the lock bolt which connect the lever and the connect lever, and take-down the bolts, then take-down the pin bearing③and the pin bearing of the connect lever②and take-down the bucket

Place The Machine

Safe rule

- 1) Avoid to stopping the machine suddenly. When it places the machine, it need have enough space.
- 2) Place the machine on the ground which hard and smooth. No place it on the slope. If it must places the machine on the slope, it need put the stow-wood under the pedrail ,make the operation device inset the ground.

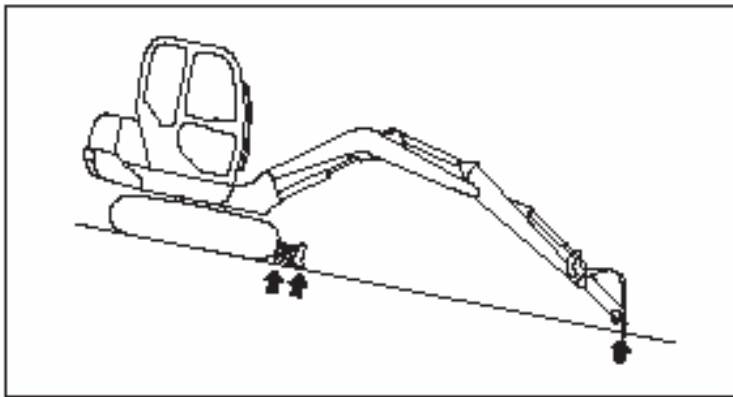

- 3) If it touches the joy stick of the operation device incautious, the operation device or the machine moves, it will lead the accident. So before leave the seat, it must to lock the joy stick of the safety lock.

Place the machine

- 1) Make the left/right driving joy stick stay the middle. Stop the machine.

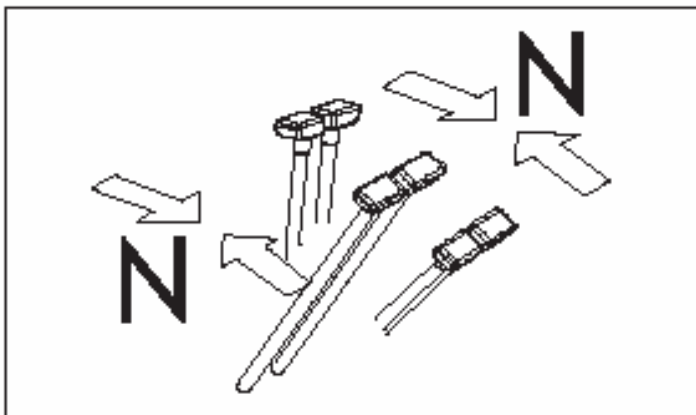

Hydraulic Digger

- 2) After overload work when the engine is, no stop the machine immediately. It needs let the engine to run 5 minutes with low-speed, clear over-heat then stop the machine
- 3) Fall down the bucket and the bulldozer.
- 4) Push the gun to the end, pull the stop handle to the end(if the machine have)
- 5) Start the key and turn to "OFF"
- 6) After stop the engine, and replace the stop handle
- 7) Lock the platform

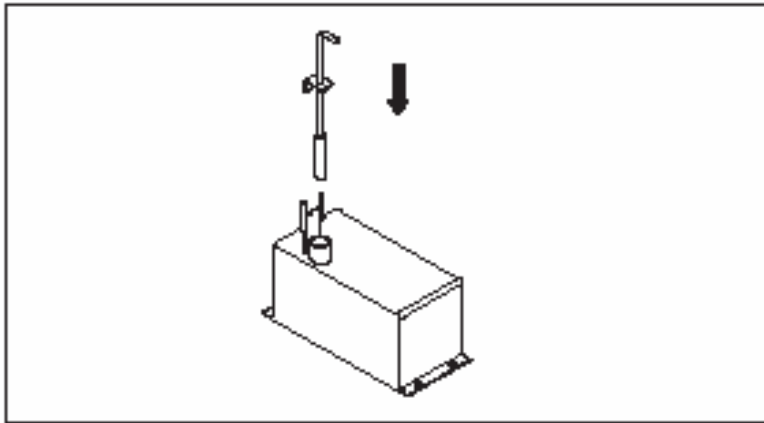

- 8) Lift up the safety lock handle

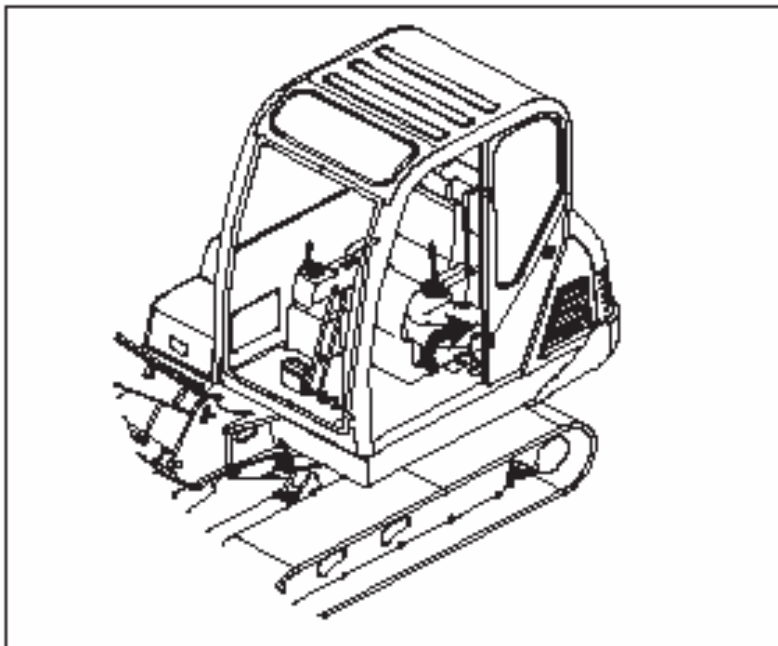

After The Operation

1.Examining

Check the digital combination instruction sheet: the water temperature of the engine、 the pressure of the machine oil、 the pressure of the machine oil、 the oil level of the fuel and so on.

2.Locking

Please lock all the things as follow:

1) The cab(don't forget to close the window、 turnover window).

At any time, if it wants to open the turnover window (fore window), it needs to pull the two commode handles of the turnover window. Operating the commode handles to glide the turnover window. When the turnover window glide to the right place, and push-up the turnover window to the lock place, loosen the commode handle lock, the turnover window locked.

Whereas, the turnover lets down.

2) The sprue of the fuel

3) The sprue of the hydraulic oil tank

4) The cover of the accumulator

5) The cover of the engine

Use the operation handle③(under the left control box) to make the①、 ②come away, and open the cover of the engine.

Use the proper power to close the cover to make①clip②,lock the cover of the engine

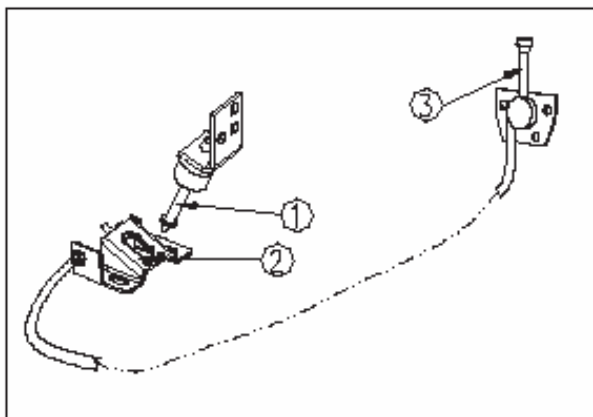

Caution: When it opens the cover of the engine, the back of the engine don't stand the person.

Take-down & Transport The Machine

1. Safety rule for shipping the machine

- 1) Running the engine with low-speed, load/unload the machine slowly.
- 2) When it warm-up the machine by automatic, no load/unload the machine
- 3) If it cancel the operation of the warm-up when it load/unload, the speed will replace sudden.
- 4) It needs to choice the hard 、 smooth road when it load/unload. It needs to keep a safe distance with the edge of the road.
- 5) It needs to use the ramp which enough width、 length、 thickness、 strong. The width of the ramp is as 1.2-1.5times as the pedrail. Avoid the accident, it suggest the load/unload gradient under 15° or the length of the slope as 3.5time as the height.
- 6) Avoid the machine slip on the slope, it needs to clean the soil in the pedrail before starting. Make sure the surface of the slope clean, no water、 no snow、 no ice、 no lube、 no oil
- 7) No correct the turning on the ramp. Otherwise, the machine turnover. If it must to turning, it should drive out the ramp. After correct, and then drive into the ramp.
- 8) No use the operation device to do the take-down operation.
- 9) No operate any joy stick except the driving joy stick when it on the ramp
- 10) The barycenter of the machine maybe replace when the machine touch the joint of the transport vehicle on the ramp, and the machine maybe lose the balance. So it needs to do slowly.

Hydraulic Digger

- 11) When the machine rotate the superstructure in the transport vehicle, the transport vehicle unstable. So it needs to rotate slowly and draw back the operation device.
- 12) It needs to wedge the wheels of the transport vehicle whether up/down the transport vehicle.
- 13) It uses the wood to make the digger keep the fix place in the transport vehicle when the machine transported. And use the rope to tie the digger.
- 14) Before the drive leaves the seat after finish the operation, he need to uplift the left control box first and cut off the lead operate oil line.
- 15) It must put down the orientation commode handle of the rotating platform before up/down the ramp. Avoid the platform rotate.

2. Loading the machine

- 1) Need choice the hard、smooth road to load the machine and keep a safe distance with the edge of the road.
- 2) Braking the transport vehicle, and put he stow-wood under the wheels to make sure the transport vehicle doesn't move.
- 3) Install the ramp between the transport vehicle and the machine, and make sure the ramps in one plane. The max. gradient not exceed 15° . And adjust the distance of the ramps match with the center of the pedrail.

Hydraulic Digger

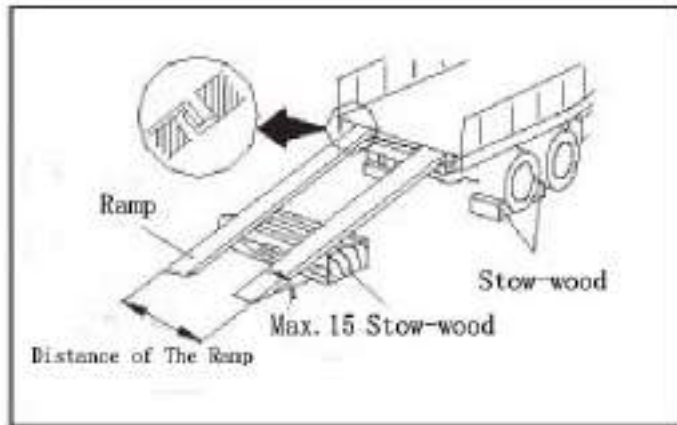

- 4) Lock the rotating platform
- 5) Let the digger and the ramp in the line, the bulldozer stay the backside.

Caution: It only operates the driving joy stick on the ramp, no operate other joy sticks or the footplate.

- 6) Stop driving and hold out the lever (B), and make the foreside of the pedrail declination to the soleplate of the transport vehicle. No allow the operation device touch the frame of the transport vehicle when the machine declination, and driving the machine to the stated place of the transport vehicle.

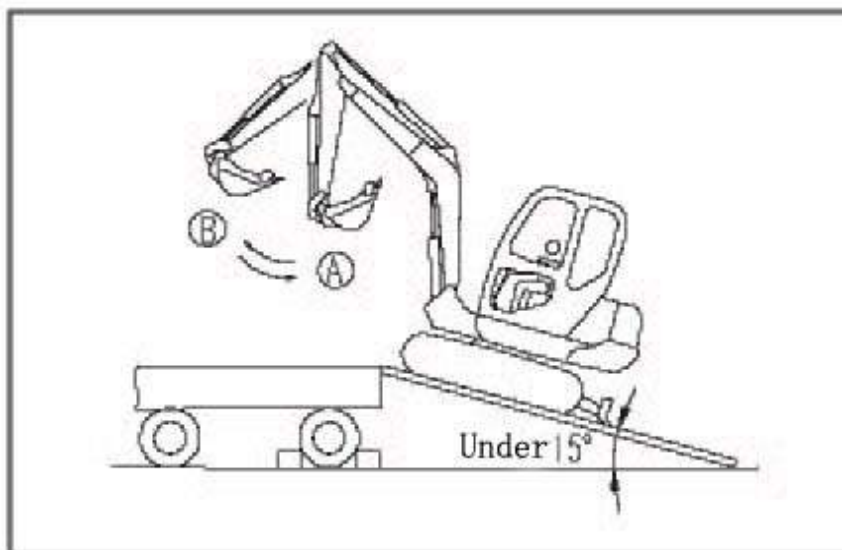

- 7) Put down the lever, and fall the bucket on the ground, put down the bulldozer, make the machine on the stated place

of the transport vehicle.



Warning: Before the drive leaves the seat after finish the operation, he need to uplift the left control box first and cut off the lead operate oil line.

3. Fix the machine in the transport vehicle

- 1) Put the operation device
- 2) Stop the the engine, and take out the key
- 3) Uplift the safety lock handle and the control box
- 4) Lock the cab and the cover of the engine

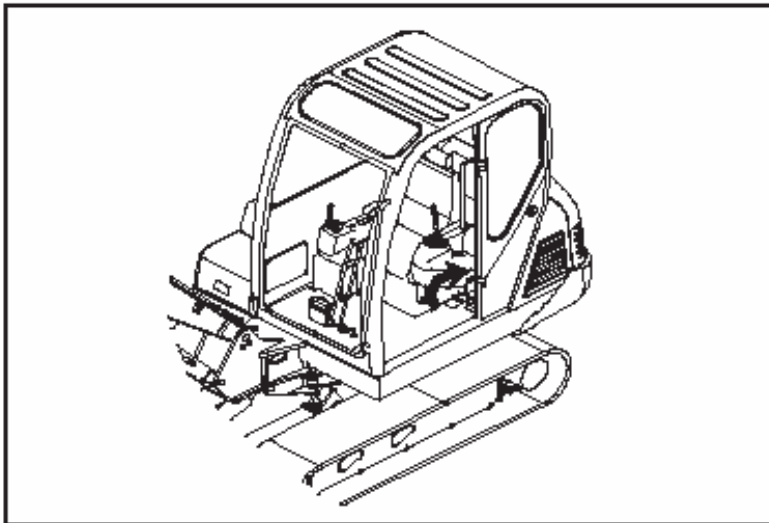

- 5) Put the stow-wood under the pedrails to avoid the machine moves when it transported. And use the steel wire to tie the machine not slip to one side.

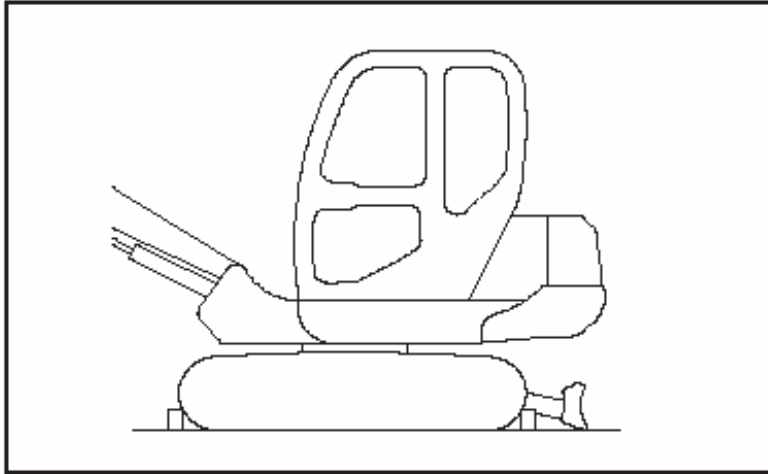

4. Unload the machine from the transport vehicle

- 1) Need to choice the hard 、 smooth road when it load/unload. It needs to keep a safe distance with the edge of the road
- 2) Braking the transport vehicle, and put he stow-wood under the wheels to make sure the transport vehicle doesn't move
- 3) Install the ramp between the transport vehicle and the machine, and make sure the ramps in one plane. The max. gradient not exceed 15° . And adjust the distance of the ramps match with the center of the pedrail
- 4) Take-down the steel wire which fix the machine
- 5) Start the machine. It need to warm-up the machine in the winter
- 6) Put down the safety lock handle
- 7) Upgrade the lever and the bucket, uplift the bulldozer
- 8) Check the area not have the roadblock
- 9) Pull up the lock pin of the platform make the platform rotate 180° , the dig device to the slope, and the digger to the direction which go ahead.
- 10) The digger go ahead slowly to the top of the ramp, let the

lever hold out, and make the pedrail of the digger declination to the ramp, then drives to the ground.

5. Hoisting the machine

A. Safety rule

- 1) No hoisting the machine when it has the people
- 2) Make sure the steel wire has the enough stronger to bear the weight of the machine.
- 3) No use any way to hoist the machine except the way which mention hereinafter. Otherwise, the machine will lose the balance
- 4) No hoisting the machine which the upside frame turn on side. Before hoisting the machine, it need to turn the operation device to the port of the sprocket wheel, and make the bottom of the pedrail parallel to the upside frame
- 5) Keep the machine level when it lift up
- 6) It dangerous to walk under the machine when it hoisted

B. Hoisting program- standard technical parameter

Caution: The hoisting program suit for the machine which is the standard technical parameter.

It should do the process as follow on the smooth road when the machine hoisted:

- 1) Turn the operation device to the port of the sprocket wheel
- 2) Hold out the oil tank of the bucket and the lever. Then use the oil tank of the moving-arm to fall down the operation device to the ground, see the picture.

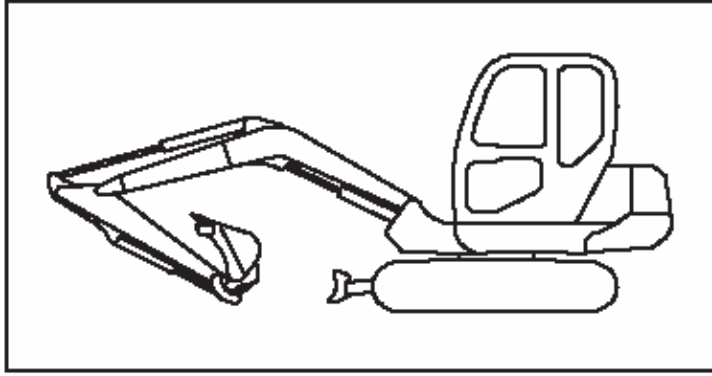

- 3) Stop the engine, make sure not have anything around the cab, then leave the machine. Close the door of the cab and the window.
- 4) Use the steel wire thrill through the guided wheel and the return wheel of the pedrail, the drive wheel and the return wheel of the pedrail. And it also can thrill through the steel wire under the pedrail.
- 5) Adjust the uplift angle of the steel wire to 30° - 40° , then hoist the machine slowly.

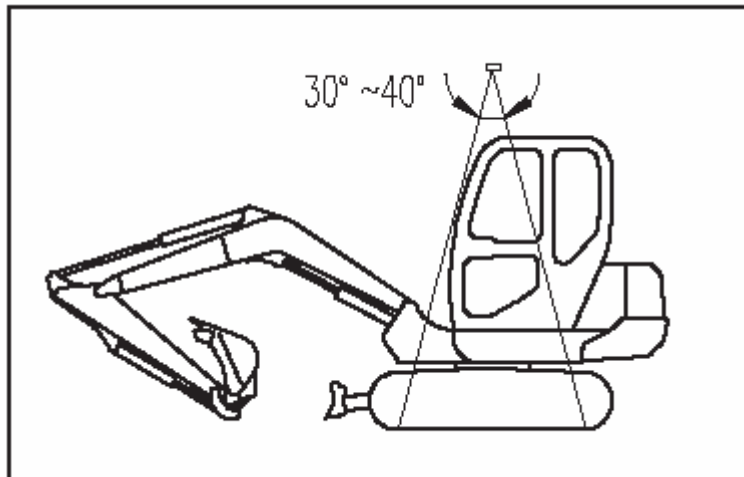

- 6) After the machine leave the ground, it need to check whether it balance, then hoist slowly.

C. Hoisting program-the machine has the hoisting hole

If the machine has the hoisting hole, it should do as follow:

- 1) Start the engine and adjust the operation device to the pose like the picture. Uplift the moving-arm. Take back the lever

Hydraulic Digger

and the bucket. Adjust the upside frame face to the port of the guided wheel

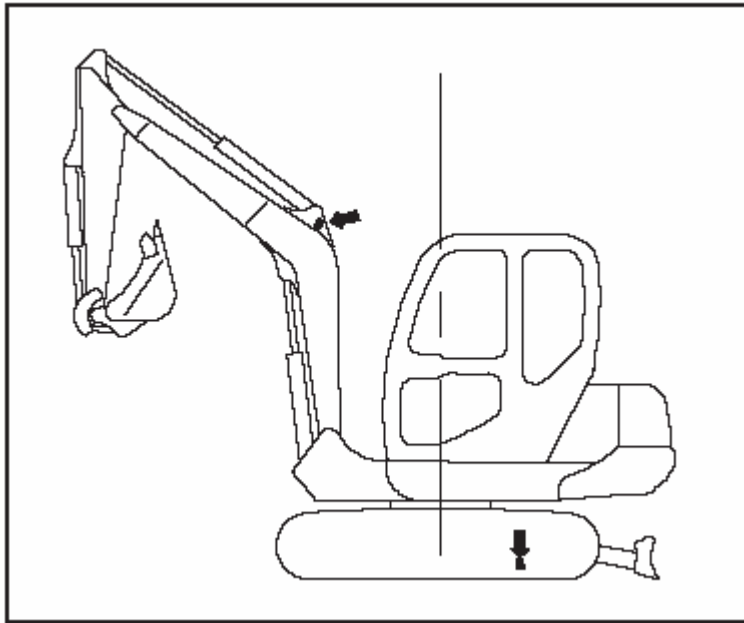

- 2) Take back the safety lock handle
- 3) Stop the engine, check whether the area safe. then leave the machine. Close the door and the widow of the cab and the cover of the engine
- 4) Make the cargo hook to hook the hoist hole of the moving arm(It has the sign near the hoist hole),then use the steal wire thrill through the drive wheel and the first return wheel
- 5) Choice the position for uplift. make it stay the barycenter of the machine(the barycenter of the machine stay top of the rotating center),see the picture

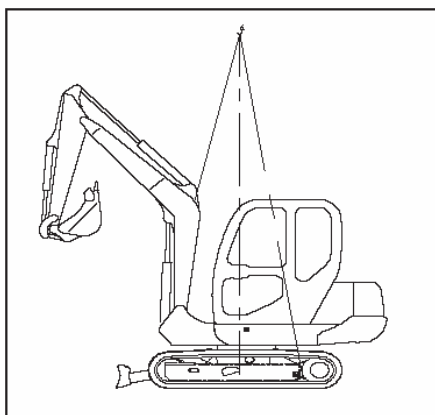

Hydraulic Digger

- 6) Check whether it can replace the pose when the hydraulic oil line of the moving-arm oil tank leaks oil.
- 7) Stopping operate uplift when the machine leave the ground, and check whether the machine keep the balance. Operate uplift when the machine steady.

Operate The Machine under The Cold/Hot Weather

1. Operate the machine under the cold weather

It has the special problems because of the cold weather. It need to protect the machine not destroy.

- 1) Electric system: Keep the accumulator cleaning, full with the power. Check the cable and the tie-in of the accumulator, clean the tie-in and wipe the axunge to avoid rust
- 2) Lube: Use the lube to the joint.
- 3) Fuel system: Whether the oil match with the cold weather. Use the low viscosity fuel.

Check the moisture of the fuel system. Because of the cold weather, it makes the moisture in the oil tank. It need check the moisture of the fuel filter every 50hours.If it doesn't have the moisture, it can delay the check period. If it has the moisture, it needs to check the oil tank.

- 4) Cooling system: Check the coolant before operate the machine in the cold weather. Adjust the mix rate
- 5) Operation device: Before operate the machine, start the machine with low-end. Then stop the machine and operate the operation device 10minutes.

2. Operate the machine under the hot weather

Avoid the machine destroy, please do as follow:

- 1) Make sure the coolant of the radiator well-balanced
- 2) Check the radiator before starting in the hot weather. If it need to replace the coolant.
- 3) Clear the dunghill of the radiator and the engine
- 4) Check the fan running the belt
- 5) Use the suit viscosity lube
- 6) Use the suit rate of the coolant for the cooling system
- 7) Check the air filter when the condition has more dust.

Deposit The Machine

1. Preparative before the machine deposited

Please do as follow when the machine deposited long time:

- 1) Clearing and washing all the parts, then put the machine into the inside. If it has to put the machine outside, it need to choice the smooth ground and use the mantle to cover the machine
- 2) Wipe the lube to the metal surface of the piston. Lubricate all the place which need lubricate
- 3) Take out the accumulator, and after electrification, put it in the area which dry
- 4) Ejectment the machine oil of the engine with the hot mode, and immit the machine oil which corrosion resistance.MIL-L-21260 type of the machine oil for the engine. Use 1or2 grade SEA10W in winter, use SAS30 grade in summer
- 5) Immit the same anti-cauterization machine oil with 4-6% to the fuel. Make them mix better. The oil tank need to immit the mix fuel to avoid has the condensate
- 6) Check the antifreeze performance of the coolant. It can reduce the antifreeze performance to -20°C if it use the way which immit the antifreeze. Because of the weather, the coolant doesn't have the anti-cauterant, it need immit the anti-cauterant.
- 7) Start the engine, and make it running exceed 15minutes.It can adopt different speed no overload. Ejectment the lube of the hydraulic part and the reducer, it should run and then immit the new machine oil to deposit.
- 8) It suggest to use the film and the adhesive tape to seal the air intake of the air filter and the vent of the vent-pipe.
- 9) Lock the platform, uplift the safety lock handle(uptift the left control box).Make all the joy stick and the footplate stay the

lock state.

10) Lock the cut-off valve which for install the attachment. And installing a bolt in the elbow.

11) Keep the machine cleaning, and deposit the area which dry

Caution: When the machine deposited, it need to adjust the pose of the machine to protect the piston of the oil tank.

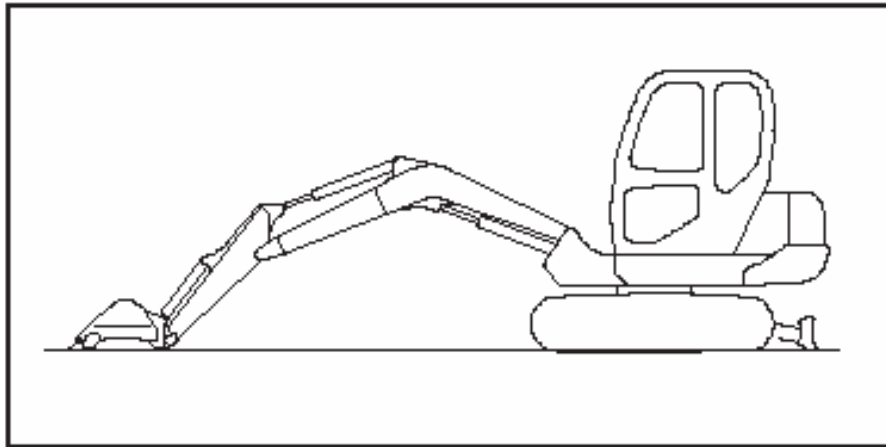

2. The period of the machine deposited

1) It need to operate the machine once every month in the period of the machine deposited to make the surface of the parts have a new lube. It need to electricize the accumulator.

2) Need to run the air-condition if the machine has

3) Run the pedrail



Warning:If it must do the anticorrosive operation inside,it should open the door and the window.

3. Desterilize after the machine deposited

Pleas do as follow before use the machine when the machine deposited long time:

1) Rub away the lube which in the surface of the piston

- 2) Immit the machine oil and lube to all the parts.
- 3) The moisture into the oil when the machine deposited long time. Before /after start the engine, it needs to check the oil of all the parts. If the oil includes the water, it needs to replace it.

Caution:1)The deposit way which introduced can make the digger deposit one year under normal condition of the weather. But after about 6 months, it needs to run the parts 15 minutes without overload. An immit the lube to the parts.

- 3) **It needs to do the required work and check the parts before use the machine which deposited long time. After the digger deposited one year, it need to ejectment the oil of the hydraulic loop and the reducer, and replace them.**

Reason for the Technical Trouble& Resolve

Trouble	Reason	Resolve
<p>1.The engine couldn't start or start difficult</p>	<ul style="list-style-type: none"> ● Problem for start the engine ● Lack electrification of the battery ● Error use for the line or the piston of the warm-up ● Error of the oil injection positive ● The pipe laying obstructed ● The filter of the fuel obstructed ● The fuel system has the water、 the dust or the air. ● The nozzle dirty or the pressure of oil injection lower ● The trouble of the fuel injection pump ● The fuel lacks ● The intake/vent system obstructed 	<ul style="list-style-type: none"> ● Replace or check the engine ● Electrification or replace the battery ● Mend or replace the warm-up piston ● Check the oil injection positive ● Clean the pipe laying ● Clean or replace the filter of the fuel ● Ejectment the air, clean the pipe laying ● Maintain the nozzle ● Contact assistant service ● Immit the oil ● Ejectment the trouble
<p>2.The engine knocking 、 running irregularly or stop</p>	<ul style="list-style-type: none"> ● It have many air ● The filter of the fuel obstructed ● The fuel system has the dust or the air. ● The filter obstructed,the nozzle dirty or trouble ● The high-pressure oil pipe destroyed ● The fuel lacks ● The velometer couldn't adjust ● The trouble of the fuel injection pump ● Error of spurt oil positive or the nozzle clip 	<ul style="list-style-type: none"> ● Contact assistant service ● Clean the filter ● Vent and clean the oil line ● Check them ● Replace the high-pressure oil pipe ● Immit the oil ● Contact assistant service ● Contact assistant service ● Check them
Trouble	Reason	Resolve

Hydraulic Digger

<p>3.The power of the engine descend</p>	<ul style="list-style-type: none"> ●The fuel has the air ● The pipe laying obstructed which supply the oil ●The oil injection positive replaces ●The oil injection work not good ●The air filter obstructed ●Error of the intake/vent or they not seal ●The cylinder cushion bad or leak ●The oil injection pump work not good ●The engine overheat 	<ul style="list-style-type: none"> ●Ejectment the air ●Check and clean it ●Adjust it with the ordain value ●Check the working pressure or the oil injection and the pulverization of the nozzle ●Clean the core of the filter ●Adjust the gap of the intake/vent ●Replace the cylinder cushion ●Contact assistant service ● Check whether use the coolant right.whether the water pump and the belt loose .If they have,it need to mend or replace them,and clear the choker of the flume
<p>4.The engine overheat</p>	<ul style="list-style-type: none"> ●The level of the coolant low ● The temperature sensor has the trouble ●The air filter obstructed ●The belt of the fan looses or trouble ●The pipe of the cooling system has the dust ●Bad machine oil or much the machine oil 	<ul style="list-style-type: none"> ●Immit the coolant ●Replace the sensor ●Clean the filter ●Screw down it again or replace ●Clean the pipe ●Replace the machine oil
<p>5.The pressure of the engine low</p>	<ul style="list-style-type: none"> ●The level of the machine oil low ●The filter of the machine oil obstructed ●The pipe leaks oil ●The coolant of the engine exorbitant 	<ul style="list-style-type: none"> ●Immit the oil ●Clean the filter of the machine oil ●Screw down or replace ●Mix the coolant with the right rate or

Hydraulic Digger

Trouble	Reason	Resolve
		contact assistant service
6.The engine emit the black smoke	<ul style="list-style-type: none"> ●Bad fuel ●The air filter obstructed ●Error of the oil injection positive ●The pulverization of the nozzle not good 	<ul style="list-style-type: none"> ●Use the better fuel ●Replace the core of the filter ●Adjust it with the ordain value ●Check and replace the parts
7.The engine emit the withe smoke	<ul style="list-style-type: none"> ●Bad fuel ●The machine oil of the engine more ●Error of the oil injection positive ●The oil tank &the fuel have the water 	<ul style="list-style-type: none"> ●Use the better fuel ●Renew the level of the oil ●Adjust it with the ordain value ●Check and replace the fuel
8.The battery not electricize	<ul style="list-style-type: none"> ●The tie-in looses or rusts ●The belt of the engine loose or trouble ●The engine not electricize 	<ul style="list-style-type: none"> ●Clean or screw down ●Screw down or replace ●contact assistant service
9.The engine not run or run slow	<ul style="list-style-type: none"> ●The tie-in looses or rusts ●The battery undercharge ●The line destroy 	<ul style="list-style-type: none"> ●Clean or screw down ●Replace ●Contact assistant service
10.The engine runs,but the alarming light lights	<ul style="list-style-type: none"> ●The engine has trouble ●The electron adjuster has the trouble ●The line has the trouble 	<ul style="list-style-type: none"> ●Contact assistant service ●Replace ●Check and repair
11.The part of the hydraulic system runs slow	<ul style="list-style-type: none"> ●The hydraulic oil cool ●The pressure of the guide system low ●Error use of the hydraulic oil ●The speed of the engine too slow 	<ul style="list-style-type: none"> ●Warm-up ●Contact assistant service ●Use the hydraulic oil which right ●contact assistant service
Trouble	Reason	Resolve

Hydraulic Digger

<p>12.The temperature of the hydraulic oil too high</p>	<ul style="list-style-type: none"> ●Error use of the hydraulic oil ●The pipe laying obstructed ● The oil filter of the hydraulic oil obstructed ●The oil pump attrite ●The oil cooler obstructed ●The oil cooler has trouble ●The pressure of the main safety valve or the spill valve too high ●The oil too dirty ●The sensor has trouble 	<ul style="list-style-type: none"> ●Use the hydraulic oil which right ●contact assistant service ●Clean or replace ●contact assistant service ●Clean the oil cooler ●contact assistant service ●Contact assistant service ●Replace the oil ●Replace
<p>13.The hydraulic emulsification or has the foam</p>	<ul style="list-style-type: none"> ●The pipe which from the oil tank to the oil pump leak ●Error use of the hydraulic oil ●The hydraulic oil includes the water ●The level of the oil too low 	<ul style="list-style-type: none"> ●Check and repair,and screw down ●Use the hydraulic oil which right ●Replace the oil ●Check the level of the oil
<p>14.The pressure of the oil too low or not</p>	<ul style="list-style-type: none"> ●The hydraulic pump destroy ●The oil lacks ●The safety valve has trouble. 	<ul style="list-style-type: none"> ●contact assistant service ●Immit the oil ●contact assistant service
<p>15.All parts no work</p>	<ul style="list-style-type: none"> ●The hydraulic pump destroy 	<ul style="list-style-type: none"> ●Contact assistant service
<p>A.The oil pump has the noise</p>	<ul style="list-style-type: none"> ●The hydraulic oil lacks ●The oil suction pipe leaks 	<ul style="list-style-type: none"> ●Immit the oil ●Repair or replace
<p>B.The noise of the oil pump not replace</p>	<ul style="list-style-type: none"> ●The donkey pump destroy ●The operation device of the hydraulic safety not working 	<ul style="list-style-type: none"> ●Replace ●Check and repair,

Hydraulic Digger

Trouble	Reason	Resolve
16.The oil tanks or the motor no working or no power to working	<ul style="list-style-type: none"> ●The hydraulic pump destroy ●The pressure of the main safety valve become low ●The level of the oil low ●The oil suction filter obstructed ●The oil sealer destroy ●The piston lever destroy and leak oil ●The guide valve trouble ●The guide pipe rupture and leak oil 	<ul style="list-style-type: none"> ●contact assistant service ●Adjust the pressure ●Immit the oil ●Clean the filter ●Repair or replace ●Repair or replace ●Replace ●Repair or replace
17.Double driving device not working	<ul style="list-style-type: none"> ●The joint of the central rotating series oil 	<ul style="list-style-type: none"> ●Contact assistant service
18.One driving device not working	<ul style="list-style-type: none"> ●The driving device destroy ●The control machine destroy 	<ul style="list-style-type: none"> ●Contact assistant service ●Check and repair
19.Driving deviant	<ul style="list-style-type: none"> ●The pedrail too tight or too loose ●The performance of the oil pump reduce ●The pedrail frame metamorphosed ●The chain of the pedrail has the scree ●The control valve leaks oil ●The performance of the motor reduce 	<ul style="list-style-type: none"> ●Adjust it again ●contact assistant service ●Repair or replace ●Repair ●contact assistant service ●contact assistant service
20.The rotating deviant	<ul style="list-style-type: none"> ●The performance of the oil pump reduce ●The rotating motor destroy ●The guide valve not working 	<ul style="list-style-type: none"> ●contact assistant service ●contact assistant service ●contact assistant service
21.The rotating discrete	<ul style="list-style-type: none"> ●The rotating gear attrite ●The rotating bearing or ball bearing attrite 	<ul style="list-style-type: none"> ●contact assistant service ●contact assistant service

Hydraulic Digger

Trouble	Reason	Resolve
	<ul style="list-style-type: none"> ●The axunge lacks ●The control valve leaks oil 	<ul style="list-style-type: none"> ●contact assistant service ●contact assistant service
22.The air-condition system has the nosie	<ul style="list-style-type: none"> ●The joint of the electron looses,to lead the clutch not good ●The belt looses ●The fan of the blower looses ●The blower works deviant ●The electric fan works deviant ● The bearing of the decrement machine destroy ●The tension bearing destroy 	<ul style="list-style-type: none"> ●Inter the joint tight or repaire ●Adjust it ,replace it if it broken ●Screw down agin ●Repair or replace ●Repair or replace ●Replace ●Replace
23.The air-condition couldn't refrigeration	<ul style="list-style-type: none"> ●The line trouble ●The switch of the air-condition trouble ●Not have the cryogen ●The system obstructed ●The belt looses or rupture ●The expansion valve trouble ●The decrement machine runs deviant ●The switch of the pressure trouble 	<ul style="list-style-type: none"> ●Repair or replace ●Repair or replace ●Check、 repair、 immit the cryogen ●Clean or replace ●Adjust or replace ●Clean or replace ●Repair or replace ●Replace
	<ul style="list-style-type: none"> ●The line touch not good ●The belt loose ●The temperature of the air-condition switch adjust unsuitable ●The system includes much water,the inside has the ice ● The electron fan or other relays destroy 	<ul style="list-style-type: none"> ●Check and repair ●Adjust the belt ●Adjust ●Replace the dryer ●Repair or replace

5

Maintenance

General Knowledge of Maintenance

New machine's break-in

The incunabulum 100 hours is the break-in period. It need to use the machine careful in the period. No let the machine do the works which overload and the work intensity too high. First 50hours,it only allow to bear overload work about 80%.

After the first 50hours,it should to do the first Check & repair as the list of the Check& maintenance, replace the oil and the filter. And the Check the pollute grade, too. The value not exceed NAS9 grade. Otherwise, it needs to replace the hydraulic oil.

When the hydraulic system doesn't work, it doesn't allow the engine run with the high-speed. It could operate the operation device when the temperate of the hydraulic oil exceed 20⁰.

Operation at the place which has much dust

When the machine operated at the place which has mush dust, please do as follow:

- Use the air obstruct sensor to Check whether the air filter obstructed regular. It requests to clean the core the filter
- Clean the core of the radiator regular to avoid obstruct
- Clean and replace the core of the fuel filter regular
- Clean the electric part, especially the start motor and the AC engine
- It need to move the machine to the place where not have the dust when it Checked or replace the oil

Hydraulic oil and the filter core

Please use the clean machine oil and lube, don't allow the impurity into the container of the machine oil

After replace the oil and the filter core, it need to check whether the old oil and the filter core have the metal scraps or the impurity. If it finds have many the metal scraps or the impurity, it should tell the

director and deal them.

No mix the oils which have the different trademark. If it needs to immit the oil with the different trademark, it should ventment the old oil and replace the new trademark

Reading the calculagraph

Check the calculagraph which in the instruction sheet. See the value whether the machine need to maintenance

Using the purity spare parts

Use the purity spare parts of Yuchai is the important factor to ensure the machine working and delay the use life.

Disposing the castoff

- Put the oil which vent from the machine into the container. No vent to the ground direct or into the cloacae, the drain, the river, the sea or the lake
- When it dispose the insurants (the machine oil, the fuel, the coolant, plastic spare parts, the solvent, the filter core, the accumulator and so on),it need to observe the rules.

Avoid the things into the inside of the machine

- It doesn't drop the bolt, the nut, the cushion or other tools into the inside of the machine when it opens the intake of the oil tank to Check. If the things drop into the machine, it will make the machine destroy or trouble. May be leading the accident. It must take out when the things drop into the machine.
- It needs to check the amount the tools and the parts before/after checks. It makes sure nothing into the machine.

Time-Check and maintenance

Time-Check and maintenance the item which the list of time-Check and maintenance has is the important reason to ensure the machine working and delay the use life. It must observe Check and maintenance period.

Countercheck the machine after Check and maintenance

If it doesn't countercheck the machine after Check and maintenance every time, it can happen the accident and lead the serious hurt or destroy. Check as follow:

- Whether miss some parts which need Check and maintenance
- Whether it is right to do all the items which need Check and maintenance
- Check whether the tools or parts drop into the machine. It is dangerous if the parts drop into the machine and clip the connect lever
- Check whether the machine leaks water or oil, whether the bolts screw down.

Maintenance Summary

The lube

- Use the lube which the choose list of the oil plants shows. In the stated time, it needs to replace the lube.
- Avoid the impurity(water、 metal grain、 dust and so on) into the lube. Many problems of the machine because of the impurity.
- No mix the lube which are the different trademark or the grade
- Immit the lube as the stated value. It has the trouble because of too much or too little
- When it replaces the lube, it needs to replace the filter core. Especially, it replaces the filter core for the machine oil. It should immit the new、 clean machine oil into the filer core before installing

The fuel

- Place or immit the fuel, no allow the impurity
- Use the fuel which the choose list of the oil plants shows. It chooses the fuel as the temperature of the condition when it uses the fuel. Otherwise, it is easy to freeze (especially under 15⁰C) when it is the low temperature.
- Avoid the moisture of the air freezes in the fuel tank, it immit full of the oil tank after finish work
- It need vent the water and the impurity before start the engine or after immit the fuel 10 minutes.
- It must vent the air of the pipe laying when the fuel of the engine over or replace the filter core.

The lubricating oil

- The lubricating oil use for avoid the joint twists and sounds
- It need to use the lubricating oil when the parts runs long time and they unskillful and have the noise
- Wipe the old lubricating oil when it extruded

- Wipe the old lubricating oil

The coolant

- It must use the coolant under any weather
- Check the level of the coolant. If it lacks, it need to immit. Lack of the coolant will lead the engine overheat
- It mix the suitable rate of the coolant and antifreeze solution as the temperature of the condition
- No append the coolant when the engine overheat and not cooling

The filter core

- Need to time-replace the filter core. It need to replace it in short time as the lube and fuel (includes the sulfur) when it operates in the bad condition.
- No use the filter core which cleaned again. It must use the new one
- Check whether it has the metal grain in the old filter core when replace the filter core. If it find the metal grain, please contact the dealer
- No open the filter core's package before use

Hydraulic system

- In & after working, the hydraulic system is high-temperature. And it is stay the high-temperature state when it operates
- No stand in the front of the parts when loose the bolt、 the nut or the tie-in of the soft pipe. Before take-down, it need to loose them slow and release the pressure
- It must vent the air and release the pressure when the hydraulic system has been Checked or been maintained
- Check or maintenance for the hydraulic system includes Check the level of the hydraulic oil、 replace the filter core、 append the hydraulic oil

Hydraulic Digger

- Check whether the “O” loop destroyed when take-down the high-pressure of the soft pipe. Replaces it if it broken
- It need clean the surface of the installation and use the new parts when it take-down the parts which has the “O” loop or the sealer
- No allow to twist the soft pipe or bend to the loop when it installs the soft pipe.

Electric system

- It very dangerous that the electric system is affected with damp or the insulator of the wire destroyed. It will make the creepage lead the machine has trouble. Don't use the water washing the inside of the cab. Don't let the water into the electric parts when washing the machine
- Maintenance of the electric system: Check and maintenance the hydraulic level of the accumulator、replace the lights、replace the fuse and the relay, and so on
- No install other electron element except Yuchai allow
- Need clean the electric system careful when it operated in the beach. Avoid to rust
- It should connect the special tie-in of the power when it installs the cooler or other electron device. The power doesn't connect the fuse、 the start switch 、 the relay of the accumulator

Hydraulic Digger

Easy Broken Part

The seal ring、the filter core、the gear of the bucket and the blade are the easy broken parts. They need time-Check/maintenance or replace.

Please order the parts from the agent of Yuchai as the following list which show the part No.

Item	Part No.	Name of The Part	Qty.	Period of Changing
Bucket	820-0413001	Gear Cover	As the different body, they different	
	820-0413002	Axes Tray		
	820-0413005	Left Blade	1	
	820-0413004	Right Blade	1	
	GB/T 5782A	Bolt M12*40	6	
	GB/T 6182	Nut 12	6	
YC25-2 Type	830D-0501500	The filter core for oil return	1	Every 500 hours
	GB3452.1	“O” loop 38.7*2.65	1	
	GB3452.1	“O” loop 10.3*2.4	3	
	GB3452.1	“O” loop 11*1.8	6	
	GB3452.1	“O” loop 6.5*1.5	4	
	GB3452.1	“O” loop 8*1.5	4	
	GB3452.1	“O” loop 10*1.5	4	
	JB982	Combination Gasket 14	4	
	JB982	Combination Gasket 18	4	
	JB982	Combination Gasket 22	4	
	JB982	Combination Gasket 27	2	
	820-0502400	The filter for absorbed oil	1	Every 500 hours
	830H-1502100(AF4991)	The core of the air filter	1	Every 500 hours

Hydraulic Digger

830H-1502300(FS1235)	The core of the diesel oil	1	
830H-1502400(FS16034)	The filter of the machine oil	1	Every 250 hours
830H-1502600(FS1242)	Segregator of (core)	1	
T0405-01211	The bulb for working light	4	

Forced Changing Part

Some parts are important for the machine about the safety. They are the soft pipes of the oil/ liquid. The material will replace and easy to aging, fret or metamorphose when the machine used long time. They will effect the function and maybe have the danger. It need replace the parts in the stated period.

If the parts don't arrive the period, but the parts have some unconventionality, it must repair and replace them. It should replace the sealer when replace the soft pipe.

Hydraulic Digger

Choose List of the Oil Plants

As the temperature of the condition , the using fact to choose the oil plants. But the oil plants must pass muster:

	Lube or Fuel	Use temperature	Viscosity	Fill-in
Lube of the engine	Chilliness area:CH15W/40 General area:CH5W/30	-15 ⁰ upwards -25 ⁰ upwards		
Hydraulic oil	HS46+	-35 ⁰ upwards	41.5-50.5 centipoise (When it is 40 ⁰ C)	
Lube of the driving reducer	Overload use the gear oil(GL-5)	Winter/summer		SAE80W/90
Lube of the rotating reducer	Overload use the gear oil(GL-5)	Winter/summer		
Lube of the guide wheel/carrier wheel	Vehicle oil Hz-23	All the temperatures	20-25 centipoise (When it is 50 ⁰ C)	
Lubricating oil	lubricating grease	-20 ⁰ C--160 ⁰ C		
Fuel	Summer:0# light diesel oil Winter:-10# light diesel oil -20# light diesel oil	>0 ⁰ C 0 ⁰ C-5 ⁰ C -5 ⁰ C-15 ⁰ C -15 ⁰ C-28 ⁰ C		
Coolant (Glycol engine)	-25# -35# -45#	>-15 ⁰ C >-25 ⁰ C >-35 ⁰ C		

● The capacity of the Oil

Sort	Unit	Value
Fuel tank	L	36
Machine oil of the engine	L	7
Total of the hydraulic system	L	62
Hydraulic oil tank	L	40
Rotating reducer	L	0.9

Hydraulic Digger

Driving reducer	L	1.4(Every side)
-----------------	---	-----------------

The Tighten Moment

Refer to the value to install the bolts、the nuts.

The tighten moment of the general parts

Intensity Grade of The Bolt	Bend Intensity N/mm ²	Diameter of The Bolt mm							
		6	8	10	12	14	16	18	20
		The Tighten Moment Nm							
8.8	640	9-12	22-30	45-59	78-104	124-165	193-257	264-354	376-502
10.9	900	13-16	30-36	65-78	110-130	180-210	280-330	380-450	540-650
12.9	1080	16-21	38-51	75-100	131-175	209-278	326-434	448-697	635-847

Intensity Grade of The Bolt	Bend Intensit y N/mm ²	Diameter of The Bolt mm						
		22	24	27	30	33	36	39
		The Tighten Moment Nm						
8.8	640	512-683	651-868	952-1269	1293-1723	1759-2345	2259-3012	2923-3898
10.9	900	740-880	940-1120	1400-1650	1700-2000	2473-3298	2800-3350	4111-5481
12.9	1080	864-1152	1098-1461	1606-2142	2181-2908	2968-3958	3812-5082	4933-6577

The tighten moment of hydraulic soft pipe

Rotating Nut with The Metric System Thread			
Metric System Thread	Outside diameter of steel tube	Nm	
		Moment	Min./max
M12*1.5	6	20	15-25
M14*1.5	8	38	30-45
M16*1.5	8/10	45	38-52
M18*1.5	10/12	51	43-85
M20*1.5	12	58	50-65
M22*1.5	14/15	74	60-88
M24*1.5	16	74	60-88
M26*1.5	18	105	85-25
M30*2	20/22	135	115-155
M36*2	25/28	166	140-192
M42*2	30	240	210-270
M45*2	35	290	255-325
M52*2	38/42	330	280-380

Hydraulic Digger

The tighten moment of hydraulic soft pipe

BSP Thread and Rotating Nut		
Nm		
BSP Thread	Metric System Moment	Min./max
G1/4	20	15-25
G3/8	34	27-41
G1/2	60	42-76
G5/8	69	44-94
G3/4	115	95-135
G1	140	115-165
G1.1/4	210	140-280
G1.1/2	290	215-365
G2	400	300-500

ORFS Rotating Nut			
Nm			
UNF Thread	Specs of the lineation	Min	Max
9/16-18	-4	14	19
11/16-16	-6	24	27
13/16-16	-8	43	47
1-14	-10	60	68
1.3/16-12	-12	90	95
1.3/16-12	-14	90	95
1.7/16-12	-16	125	135
1.11/16-12	-20	170	190
2-12	-24	200	225

Hydraulic Digger

Maintenance List of Time-Check

Refer to the list and the calculagraph, time-Check and maintenance to the machine. If the condition of the machine bad or the working intensity strong, or it hast the hydraulic crash hammer and so on, the period of some parts maybe reduce.

No.	Item	Period of Maintenance (Total of the Working Hour)					
		10	50	100	250	500	1000
1	General Check						
	●Whether the machine oil、 water、 fuel leak	▲					
	●Parts of the machine and the appearance of the soft pipe	▲					
	●Fix circs of bolt and hydraulic joint	▲					
	●Circs of the operation device、 light 、 indicator light	▲					
	●Working circs of the diesel engine	▲					
2	Fuel System of The Engine						
	●Check the level of the oil and supply	▲					
	●Vent the water and the impurity			▲			
	●Clean the oil tank				▲		
	●Check the pressure of oil injection					▲	
	●Replace the filter core					▲	
3	Cooling System of The Engine						
	●Check soft pipe and cutting sleeve	▲					
	●Check the level of the coolant	▲					
	●Clean the vane of the radiator					▲	
	●Replace the coolant		☆				■
	●Check the consistence of the coolant	▲					

Hydraulic Digger

No.	Item	Period of Maintenance (Total of the Working Hour)						
		10	50	100	250	500	1000	2000
4	Lubricate System of The Engine&Other							
	●Check the level of the machine oil	▲						
	●Replace the machine oil		☆		▲			
	●Replace the filter core of the machine oil		☆		▲			
	●Check belt of the fan		☆	▲				
	●Check the gap of the valve					☆	▲	
	●Check fastening circs of the cylinder					☆	▲	
	●Check fastening circs of the engine bearing		☆			▲		
5	Air Intake System of The Engine							
	●Break out the deposit tank	▲						
	●Replace the core of the air filter					▲		
6	Hydraulic System							
	●Check the level of the machine oil	▲						
	●Vent the water and dust of the oil tank				▲			
	●Replace the hydraulic oil,clean the filter							▲
	●Replace the return oil of the hydraulic oil and the core of the guide loop filter		☆			▲		
	●Check the pressure of the system					▲		
7	Accumulator							
	●Check the level of the electrolyte		▲					
	● Check the acidity and the state of the electrification					▲		
8	Pedrail							
	●Check and adjust the tension state of the pedrial	▲						

Hydraulic Digger

No.	Item	Period of Maintenance (Total of the Working Hour)						
		10	50	100	250	500	1000	2000
9	Reducer							
	● Check the level of the oil and immit				▲			
	● Replace the machine oil						▲	
	● Check the tighten moment of the reducer which connect the bolt		☆			▲		
10	Bear wheel、 carrier wheel、 guide wheel							
	● Check the tighten moment		☆			▲		
	● Check the level oil of the guide wheel/carrier wheel						▲	
11	Lubricate							
	● Immit lube to the point which need		▲					

▲: Routine period to do

☆: Maintenance of the first time to do

■: Every spring and Autumn

Routine Check

It need do the routine Check to the machine everyday or every 10hours.

- 1) Check whether the machine leak oil、 water or the fuel leaks
- 2) Check whether the parts and the attachment have the rupture、 the nick or the distortion
- 3) Check the hydraulic device's fix and connect
- 4) Check the appearance of the parts
- 5) Check the working circs of the operation device、 light 、 indicator light
- 6) Check the working circs of the engine.

Fuel System of the Engine

Maintenance manual

Capacity of the oil tank-----40L

Check the level of the oil-----10h

Vent the water and the impurity from the oil tank-----100h

Clean the oil tank-----250h

Check the pressure of the oil injection-----500h

Replace the filter core of the fuel-----500h

1. Check the level of the oil and immit

It can see the instruction sheet of the combination instruction sheet to check the level of the oil. Do it everyday or every 10 hours.

It should immit the oil tank after working to avoid have the hydrometeor. The gun stay front of the fuel-hydraulic oil tank

2. Vent the water and the impurity from the oil tank

Vent the condensation water and the impurity every 100 hours.

Loose the oil drain plug to make the condensation water and the impurity out. When the fuel out, please install the oil drain plug again. According to the quality of the fuel, the user can adjust the period to vent the condensation water.

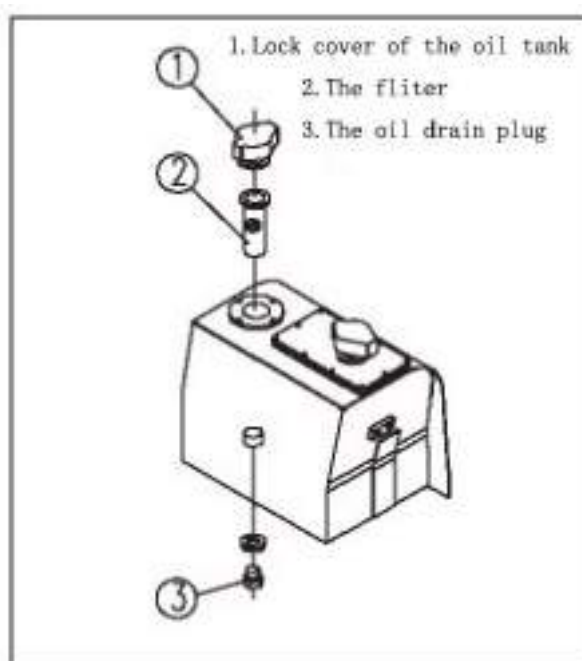

3. Clean the oil tank

Clean it every 250hours

- 1) Vent the fuel to the container
- 2) Take-down the oil drain plug, take out the filter. Top up half of the oil tank, and vent it again.
- 3) Clean the filter and replace.
- 4) Install the oil drain plug again. Through the filter top up the fuel
- 5) Vent the air of the pipe laying

Caution: Don't use the trichlene to washing the inside of the oil tank, it only use the diesel oil

4. Exhaust of the fuel loop

It need to exhaust the air before start the engine when it replaces filter core of the fuel、 cut off the pipe of the fuel、 clean the filter of the fuel and make the air into the fuel loop.

Exhaust of YC25-2 type fuel loop

- 1) Open the vent nut of the base of the fuel filter
- 2) Run and press the pump piston till no air pour from the fuel
- 3) Close the vent nut.

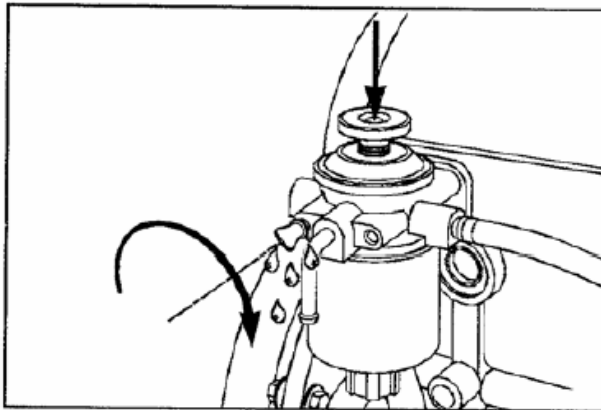

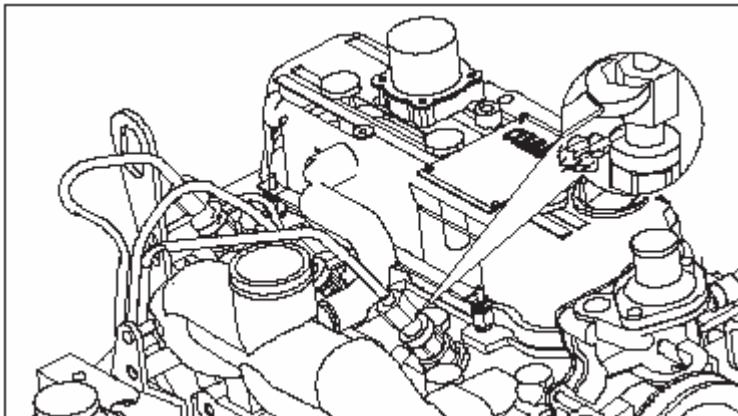
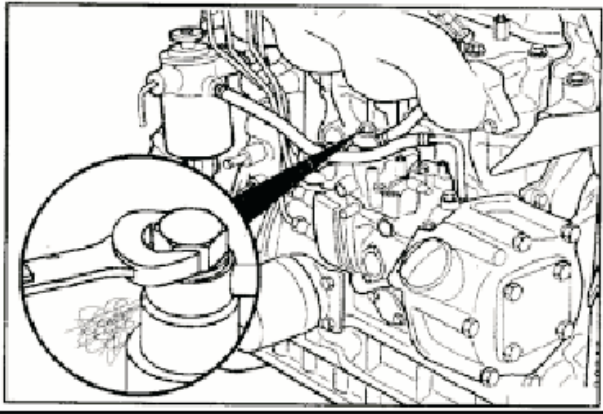

Warning:The pressure of fuel which from the high-pressure oil pipe can penetrate the skin and hurt the body.It should put on the glove and the sheathy work clothes before operating.

4. Pre-filter of the diesel oil

Chang the filter core every 500hours

Vent the water and the dust of the separator everyday.

- 1) Stop the engine,open the outlet valve,and turn the valve about half and three circle counterclockwise till the valve drop down about 25.4mm(1 inch) and start to vent
- 2) Vent the water of the separator till see the cleanly fuel.
- 3) Screw down the valve clockwise when close the valve.

Caution: Don't screw the valve too tight. It will destroy the thread.

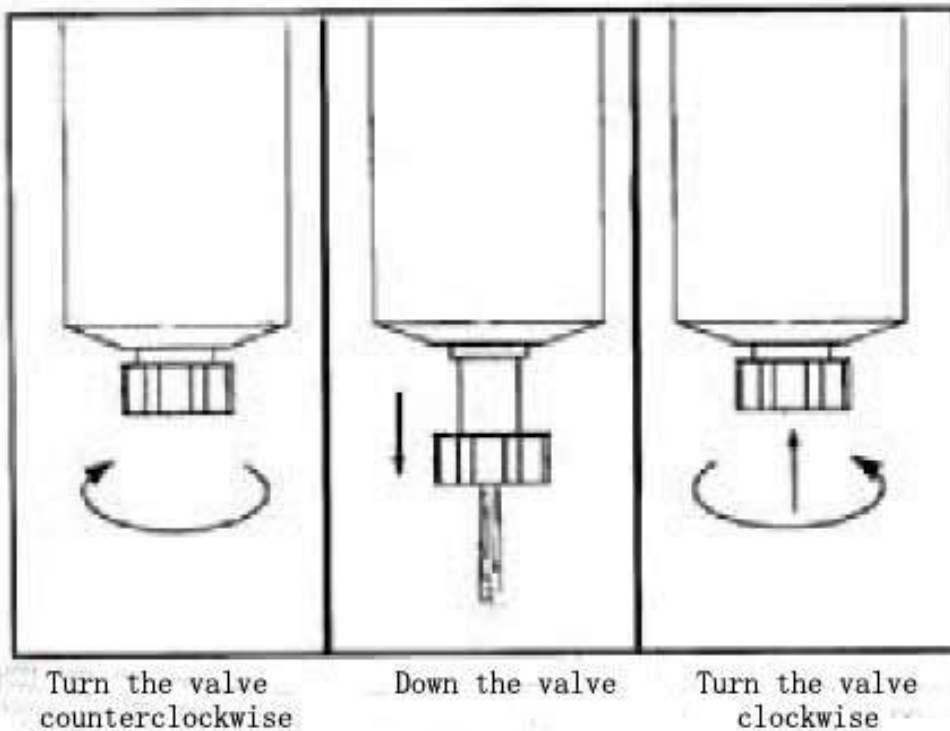

5. Replace the filter core of the fuel

Replace it every 200hours or every 3 months. It must use the sterling filter core

- 1) Take-down the filter of the fuel
- 2) Use the cloth which not cottony to clean the surface of the sealing gasket.
- 3) Disuse the "O" loop
- 4) Install the new "O" loop

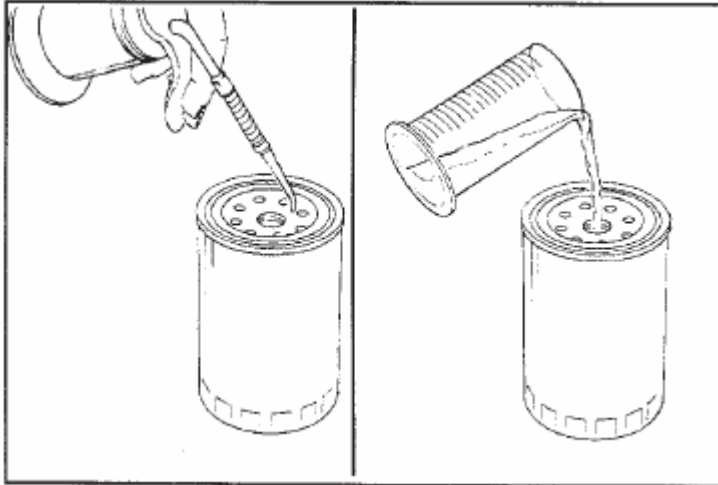

Caution: Check whether the base of the filter core has the old sealing gasket. If it has the old sealing water, it will leak oil.

5) Use the new fuel top up the new filter, and use the cleanly machine oil to lubricate the “O” seal ring.

6) Install the filter as the manufacturer’s order

Caution: For reduce the feasibility of the fuel leaks, it make sure to install the filter fix but on too tight. Too tight will destroy the filter of the fuel.

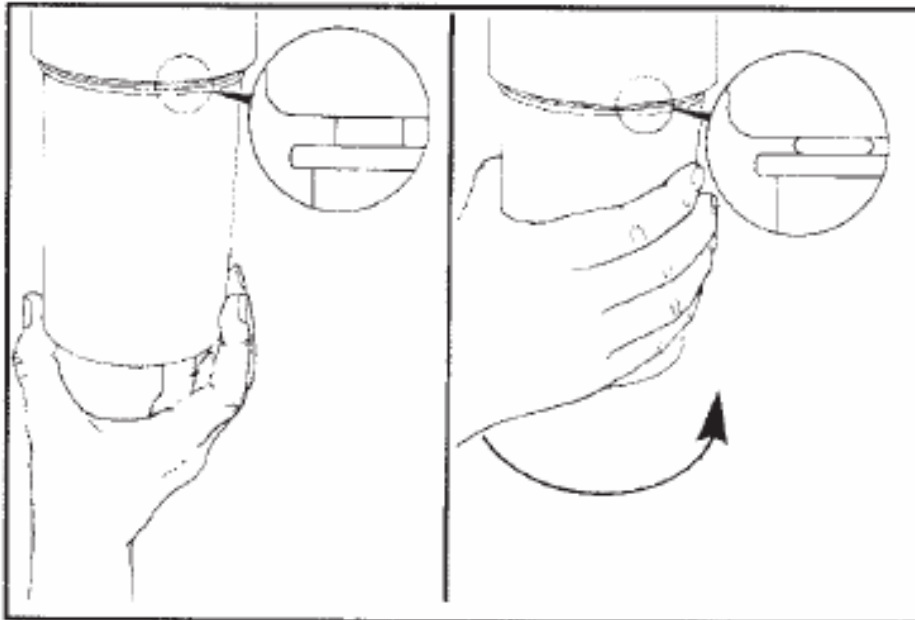

7) After replace the filter core,start the engine and Check whether the surface of the seal ring leaks the oil

Cooling System of the Engine

Maintenance manual

Capacity of the radiator-----5.7L

Check the level of the coolant-----Everyday or 10h

Check the rubber soft pipe and the clip-----Everyday or 10h

Clean the vane of the radiator-----500h

Replace the coolant-----Spring and Autumn

Check the consistency of the coolant -----Everyday or 10h

1. Check the level of the coolant

When a new machine has been started, you must check the level of the coolant first. And check the level of the coolant everyday or every 10hours.

Take out the cover of the radiator (water tank), check the level of the coolant.

The level of the coolant should under the sprue about 20mm

Observe the position of the level in the balance tank.

- The level of the coolant should lie in between the highest and the lowest level when the engine cooling.

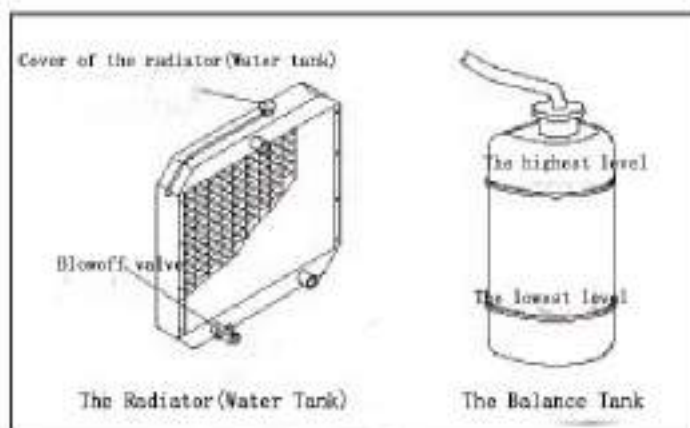



Warning: The hot coolant will spurt when open the cover of the radiator.

The way to open the cover: Open the cover little after the system cooled .Then wait it release the pressure.

2. Check the rubber soft pipe and the clip

Check it everyday or every 10 hours.

It needs replace the soft pipe if it has the flaw or become hard because of the aging.

Check whether the clip locked, if it becomes less crowded or destroy ,it need replace it in time.

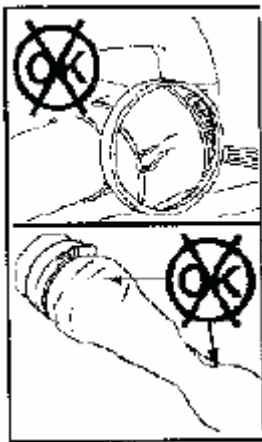

3. Clean and Check the vane of the radiator

Clean it every 500 hours.

It need clean it in time. Because the dust of the radiator (water tank) will affect the effect of the cooling.

Open the cover, and use the high-pressure water or the compress air to blow the dust or the leaves and so on. Meantime, it need clean the cleading which front of the cooler .If the machine has the air-condition, it need clean the condenser.



Warning: It is dangerous when the compressed air, the high-pressure water, the steam hit the body. It must use the glasses, the veil and so on

Caution: Avoid shatter the vane of the radiator, the distance should exceed 500mm between the nozzle of the high-pressure water or the compressed air and the surface of the radiator (water tank). The vane of the radiator which destroyed lead leak water or overheat. It need check the radiator everyday when the pace has much dust.

4. Replace the coolant

After work 50 hours, the coolant will replace first time. Then it need replace it two times in one year, Spring and Autumn.

- 1) Take down the cover of the radiator (water tank), open the vent valve to make the coolant out.
- 2) Clean the cooling loop, close the vent valve. Immit the coolant, then start the engine to make the engine run about 10 minutes with the low-speed. Then stop the machine and blow off the coolant.
- 3) Close the vent valve again
- 4) Immit the coolant, let the engine run several minutes with the low-speed to make the coolant permeated the loop.
- 5) Check the level of the coolant and supply the coolant.

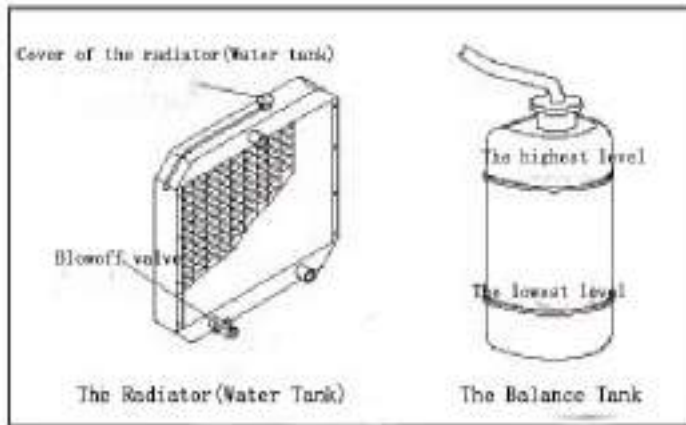

Warning: Don't open the cover of the radiator (water tank) with the hot engine except the temperature of the coolant under 50°C .

5. Check the consistency of the coolant

It need to check the consistency of the coolant before the beginning of the cold weather. The coolant can use under 20°C . If the temperature of the condition lower, it should increase the proportion of the coolant.



Warning: The coolant is the toxicant. Avoid the children and the pet touch the coolant. If the coolant doesn't used, it need deal it as the rule.



Warning: It must use the coolant in any weather.

No use the water instead of the coolant.

The water from the river includes much autunite and other

impurity. If it uses this water, it will become the scale and adhesive to the radiator or the pipe of the cooling water. No use the drinking-water, too.

The coolant is easy to burn. No close the fire.

If the coolant into the eye, it should use the water to clean and to the hospital in time.

Lubricating System of the Engine

Maintenance manual

Capacity of the radiator-----7L

Check the level of the oil-----Everyday or 10h

Replace the oil or replace the filter core-----Every 250 hours

1. Check the level of the oil

Check the level of the oil before start the new machine. Then Check it every 10 hours.

- 1) Place the digger to the level road, and stop the engine.
- 2) Open the cover of the engine, and take out the staff gauge of the machine oil. Observe the value which has the oil. The level of the oil should lie in the value between the lowest (L) and the highest (H).

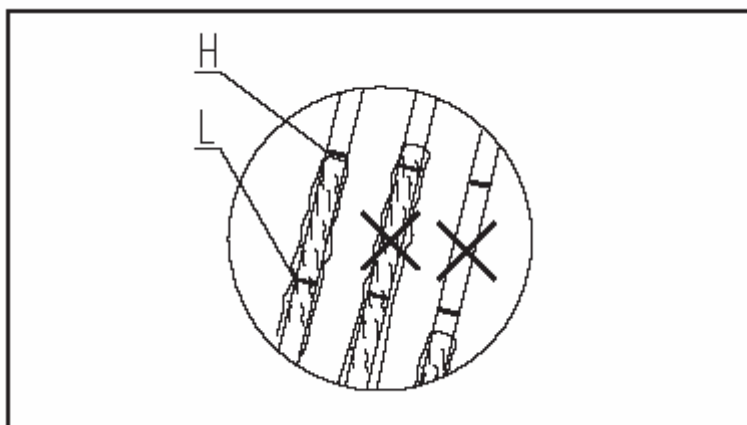

- 3) It can immit the oil through the sprue to make the level of the oil

arrive the ordain value.



Warning: After stop the engine, the parts and the oil are the high-temperature. They will hurt the body. It need wait the temperature reduce when it start to maintenance.

2. Replace the machine oil of the engine

Replace the machine oil of the engine after the new machine runs 50 hours. Then replace it every 250 hours

- 1) Place the digger to the level road, and stop the engine, and remove the machine oil.
- 2) Take-down the vent bolt to make all the machine oil removed.

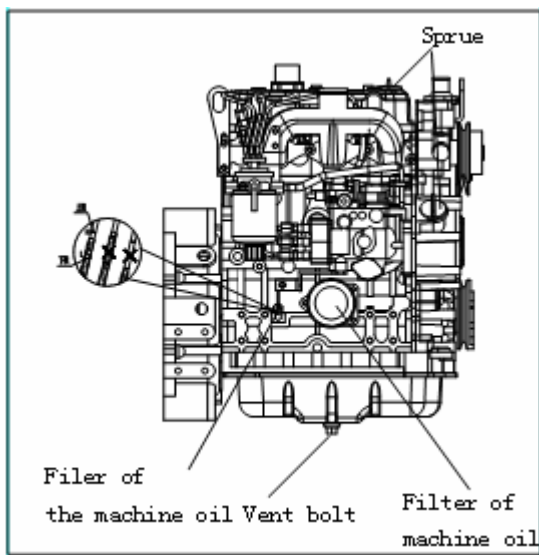

Warning: Avoid inhale the oil steam、eat or touch the machine oil long time

- 3) Clean the vent bolts and install, if the seal ring has broken, it need replace it.
- 4) Open the sprue.

- 5) Immit the new machine oil till the oil arrive the “Max” of the oil leveler
- 6) Close the cover of the sprue, and run the engine about 5 minutes.
- 7) After stop the engine about 10-20 minutes, check the level of the machine oil. It immits the machine oil if it necessary.

3. Replace the filter core which for the machine oil of the engine

The first cleaning after the new machine runs 50 hours. Then clean or replace it every 250 hours.

Replace the filter of the machine oil for YC25-2 type

- 1) Clean the area which around the base of the filter, take-down the filter of the machine oil, clean the surface of the base.
- 2) Lubricate two seal gaskets which lie in the right of the filter
- 3) Before install the filter, it need wipe the machine oil on the surface of the seal gasket.
- 4) Install the filter as the manufacturer’s request
- 5) Run the engine with the low-speed, check whether the filter leaks the oil
- 6) Stop the engine and wait 15 minutes to make the machine oil return
- 7) Check the level of the oil. Immit the machine oil to the”H” sign if it necessary.

Air Intake System of The Engine

Maintenance manual

Cleaning period of the dust tank-----Every 10hours or everyday

Replace period of the filer core-----Every 500h

1. Clean the dust tank

Clean the dust tank every 10 hours or everyday.

- 1) Take out the dust tank
- 2) Clean the dust tank

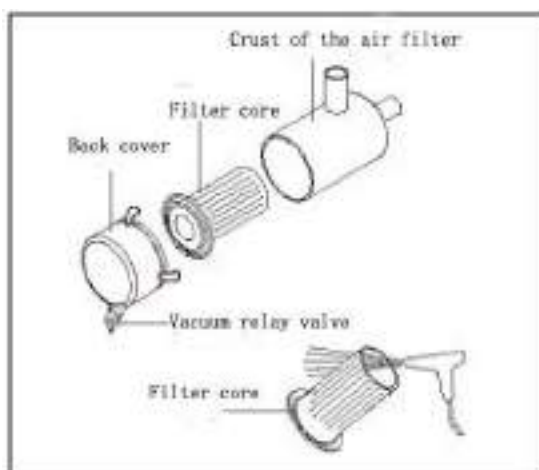

Warning: The dust will enter the engine if it checked, cleaned or replaced when the engine running and destroy the engine. Stop the engine before do the operations. It is dangerous when it use the compressor and the dust fly out. It need wear the glasses, the veil and so on.

2. Replace the filter core

It need replace when the core cleaned exceed 6 times or used 500hours.

- 1) Open the cover of the engine, take-down the back cover of the air filter, take down the core.
- 2) Install the new core, and close the cover.

3. Check the air intake pipe

Check whether it has the things which the intake pipe has the fray、the pipe destroy、the clip loose or the pipe break and so on Replace the pipe and the clip if it necessary,to make sure the intake system not leak.

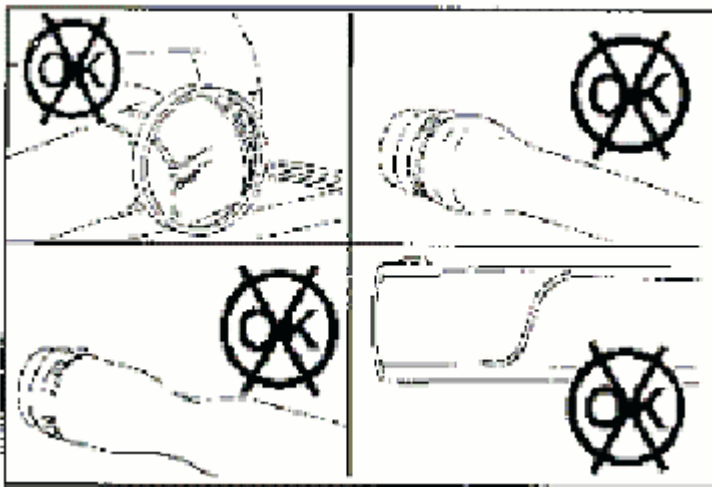

Other Maintenances of The Engine



Warning: No maintenance when the engine runs. If it must do the maintenance before the engine runs, it needs more than two persons to operate and operate as follows:

Must have one person sit on the operator's seat and prepare to stop

the engine at any moment. And all the persons must keep in touch. It maybe has the danger-winded when it near the fan、 the belt of the fan and so on to operate.

No insert the tools or other things into the fan or the belt of the fan. Otherwise, the part rupture or fly out



Warning: It has the audition problem with temporary overduration if the machine has the noise too big. It need wear the earplug when do the maintenance and in the noise long time.

● Check the belt of the fan' tension

After 50 hours do the first checking. Then check it every 100 hours. It must use the right tension of the belt to assure the engine working and the belt's use life

About the right tension of the belt, between the belt wheel of the fan and belt wheel of the engine, it throw 110N to the belt by upright, the sinkage of the belt about 10mm or the deflexion of the belt wheel 's center exceed the thickness

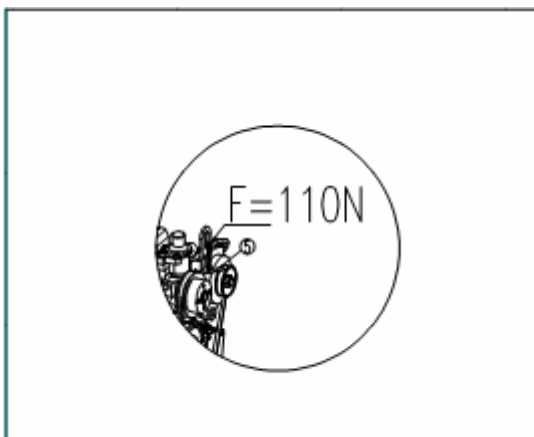

● Please see the attachment——《User Manual for The Diesel Engine》 for the maintenance period of the other element and the ways

Hydraulic System

Maintenance manual

Capacity of the hydraulic oil tank-----	40L
Check the level of the oil-----	10h
Replace the filter-----	500h
Replace the hydraulic oil-----	1000—1500 h
Check the pressure system-----	500h



warning: It brings the serious hurt and death if the hydraulic oil or the axunge rip into the skin. Avoid your hand or body close the leaking area. It should use the paper to check it.



Warning: For avoid hurt, it does the maintenance only after the hydraulic oil cool or before working everyday. When Take-down the flange cover of the sprue, it need turn the cover slow and release the pressure to avoid the oil spurt out.

1. Check the level of the oil of hydraulic pressure tank

Check it every 10 hours.

- 1) Stop the machine on the road.
- 2) Start the engine and make the oil tanks reciprocation moving
- 3) Draw back the oil tank of the level, and throw out the oil tank of the bucket, then down the bucket. Lie the bulldozer to the ground, then stop. See the picture.

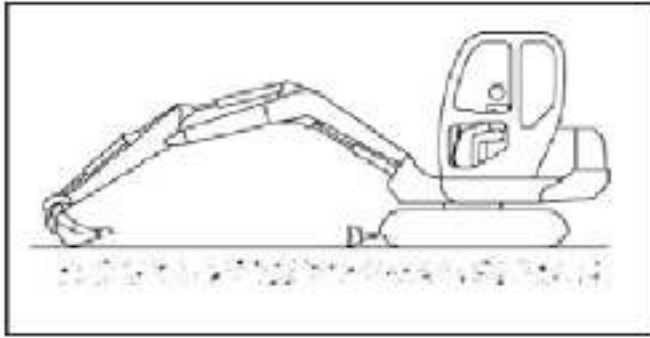

4) Observe the level of the oil through the oil leveler of the hydraulic oil tank (see ①)

It requests the level can see in the area of the oil leveler. No immerse too much to see the oil leveler.

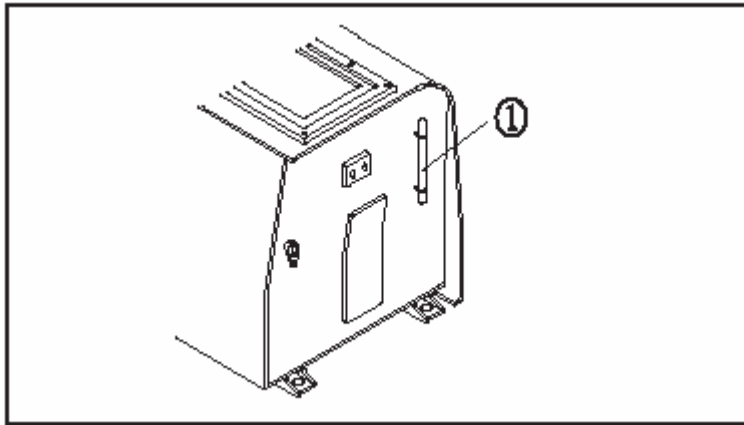

Caution: The level of the hydraulic oil will change when the temperature up. Before operate, the level lie the middle of the oil leveler, and when the temperature up, the level will arrive the top of the oil leveler.

2. Vent the water and the dust of the oil tank

Vent the water and the dust of the oil tank every 250 hours.

- 1) Vent the air of the oil tank after stop the machine and the temperature down or before start the machine everyday.
- 2) Loose the oil drain valve which lie in the bottom of the oil tank or the oil drain cock (see the picture)
- 3) Vent the water or the dust till the limpid hydraulic oil. Close the oil drain valve or screw down the bolt.

4) If the oil lacks, it should supply it.

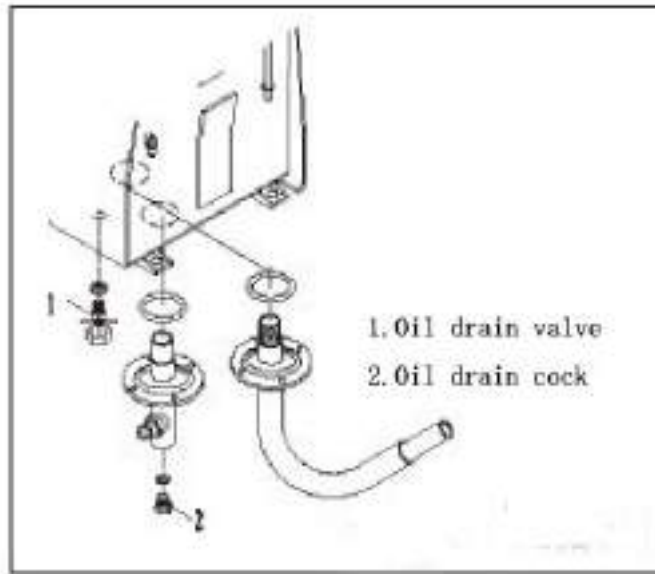

3. Replace the hydraulic oil and clean the filter

Replace and clean it every 1000 hours.



Warning:1) Avoid the scald, it vents the oil only after the hydraulic oil cool or before start the machine everyday.

2) When Take-down the flange cover of the sprue, it needs turn the cover slow and release the pressure to avoid the oil spurt out.

3) No allow the water, the dust, the soil into the oil tank when it replaces the oil.

Steps for replace the oil:

- 1) Stop the digger to the level road
- 2) Loose the nut of the oil tank cover assembly (see ①). Open the flange and the air filter(see ②) together, don't drop the filter of the oil return.
- 3) Prepare a container which the capacity is 60L. the pump for take out the oil or the clean pipe to draw out the hydraulic oil
- 4) Same as the way which vent the water and the dust, loose the

oil drain valve of the oil tank or the oil drain cock to vent the surplusage

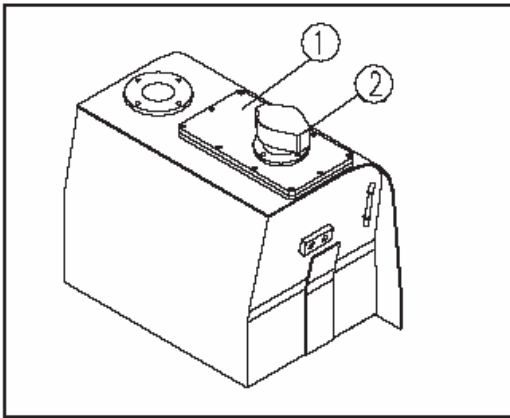

5) Take down the oil absorbent filter(see ③)

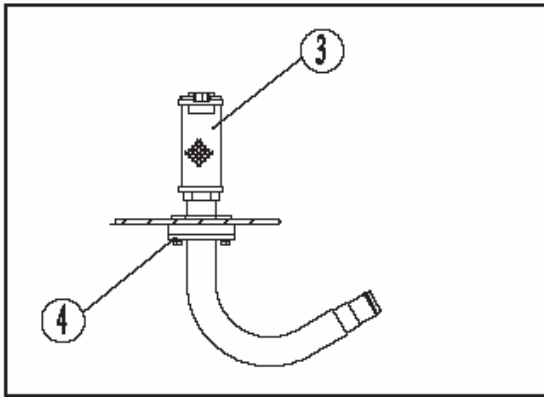

6) Clean the inside of the oil tank

7) Clean the vent cock and the vent valve, install it again.

8) Clean the oil absorbent filter. Take out the oil absorbent filter③ from the sprue (No let the dust drop into the inside of the oil tank).Take-down the parts of the filter, clear the impurity of the inside, and clean the parts with the diesel oil, then install it again.

9) Install the oil absorbent filter into the flange(see ④),then immit the new oil which as the hydraulic oil choose request and the Cleanness not exceed NAS6 grade, arrive the view area of the oil leveler. Cover the cover assembly and screw sown the nut last.

4. Vent the air which in the hydraulic system

A. Vent the air which in the pump

- 1) Loose the drain bolt of the vent, and check whether it has the oil out. Over the exhaust.
- 2) Over the exhaust, screw down the bolt.

Caution: If it run the pump without the oil, the pump will have the high temperature and make the pump break prematurely.

B. Vent the air which between the pump and the hydraulic oil tank

- 1) Start the engine, and keep it run with the mid-speed
- 2) Operate the operation device slow about 5 minutes to vent the air

Caution: If the engine runs with the high speed if it didn't vent the air which between the pump and the hydraulic oil, the pump also has the high-temperature

C. Vent the air which in the oil tank

- 1) Under the engine runs with the low-speed, draw/throw out the oil tank to the part 4-5 times which the end of the driving about 100mm(It mustn't draw/throw out to the end)
- 2) Then operate the oil tank to the end of the driving 3-4 times
- 3) Last, operate the oil tank to the end of the driving 4-5 times, and vent the air

Caution: If starts the machine and runs the engine with high-speed at once or the operate the oil tank to the end of the driving, the air which in the oil tank can destroy the piston airproof, and destroy the oil tank.

D. Vent the air which in the rotating motor(when it vent the oil from the shell of the rotating motor)

Caution :No rotating the machine at any time during vent the air

- 1) Run the engine with low-speed, loose the blowoff cock, examine whether the oil outflow from the drain bolt
- 2) If it doesn't have the oil outflow, take-down the drain bolt, then immit the hydraulic oil into the crust of the motor
- 3) After vent the air, screw down the drain bolt
- 4) Last runs the engine with the low-speed, and turn the frame of the machine to left/right about two times.

Caution: If it doesn't vent the air which in the motor, it maybe destroy the bearing of the rotating motor.

E. Vent the air which in the driving motor(when it vent the oil from the shell of the driving motor)

- 1) Run the engine with low-speed, loose the blowoff cock. If the right oil outflow, screw the bolt.
- 2) Run the engine with low-speed, make the operation device rotating 90° , and let it lie in one side of the pedrail.(See the picture)
- 3) Use the operation device uplift the machie, make one side of the pedrail away the ground litter, and run the pedrail 2 minute. Repeat do for the left/right pedrial, and turn the pedrail forwards and backwards

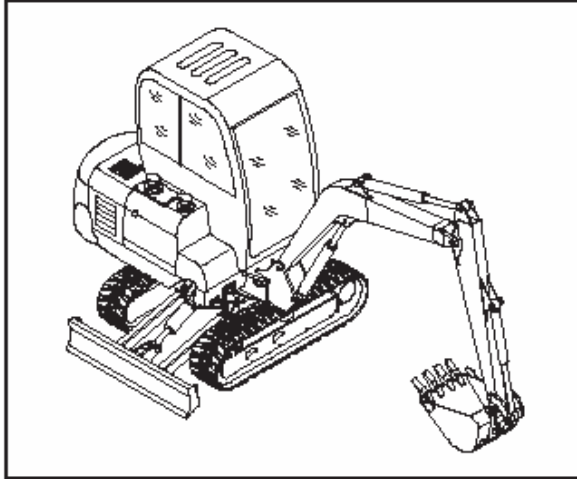

F. Vent the air which in the attachment

If the machine has the attachment, it need run the engine with low-speed, and operate the footplate of the attachment (about 10 times), till the air vented from the pipe laying of the attachment.

Caution:

- 1. If the manufacturer has the way for vent the air, it should do it as the way**
- 2. After finish the operation, stop the engine. It need lay up the machine 5 minutes before start the operation to clear the air bubble of the oil tank**
- 3. It shouldn't leak when checking. Wipe the oil which spill over.**
- 4. After the operation, check the level of the oil. If the level of the oil low, it need supply it.**

5. Replace the filter core of the oil return

Replace it every 500 hours. The filter of the oil return in the hydraulic oil tank, so:

- 1) Take-down the cover of the flange② with the air filter① together.**
- 2) Take down the "O" seal ring③of the flange cover**

- 3) Take down the spring④
- 4) Take down the filter element⑨ from the flange of the oil return⑩
- 5) Screw down the core⑦ from the lever⑥
- 6) Replace "O" ring⑧ of the core, after it install with the lever⑥, wipe the hydraulic oil to "O" ring, then insert the nozzle of the flange⑩
- 7) Install the spring④ on the top of the lever⑤
- 8) Adjust the base of the spring, make the gap which the base of the spring with the cover of the flange② not exceed 10mm, and use the nut which under it lock and fix
- 9) Install the "O" seal ring③
- 10) Install the cover of the flange②. Press the convexity into the hole which in the top of the lever⑤, screw down the nut

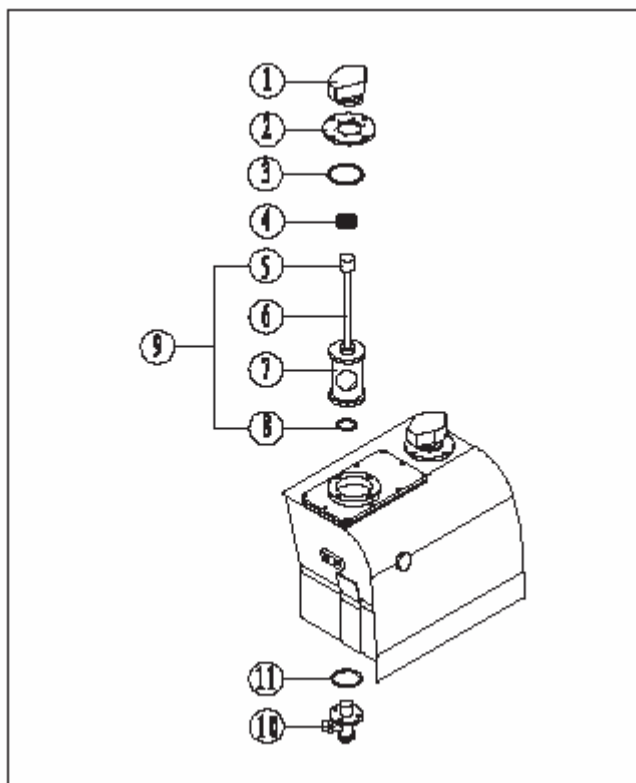

6. Replace the filter core of the guide pipe laying

Replace it every 500 hours.

Caution: It must vent the pressure of the hydraulic oil tank before take-down the filter core

- 1) Screw down the filter shell⑤
- 2) Take-down the filter core③
- 3) Install the new "O" ring ②into the groove of the filter head
- 4) Before install the new core ,it need wipe the hydraulic oil on the surface of the sealer, and put the core into the filter head
- 5) Clean the filter shell⑤ and soft magnet. No allow the dust and the water into the filter shell.
- 6) Screw down the filter shell and the filter head with the moment 25-35Nm
- 7) Connect the pipeline, and start the engine slow. And run 3-5 minutes vent the air
- 8) Place the machine on the level road, stop and check the level of the oil. It can supply the oil if it necessary. No let the oil over the highest limit

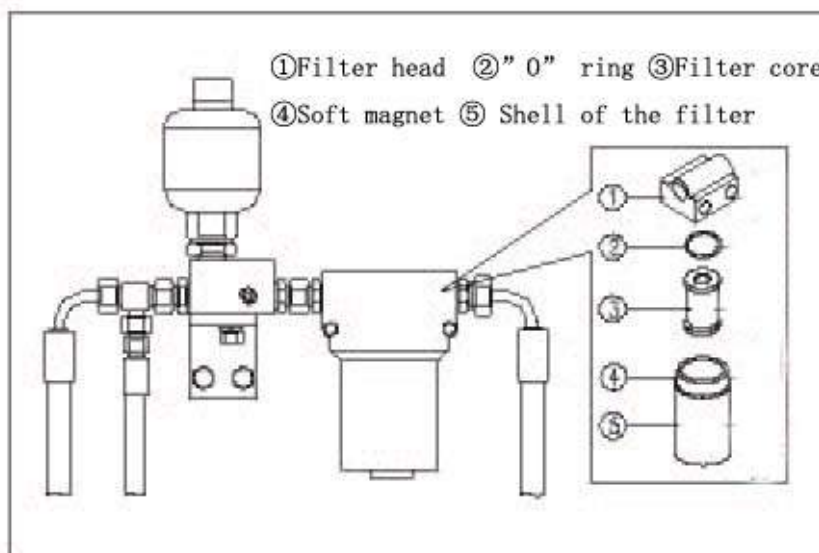

■ **The replace period of the hydraulic oil and the filter core when it the attachment (Crush hammer, etc.)**

It increase the pollution of the hydraulic system when use the hydraulic hammer. The replace period of the hydraulic oil and the

Hydraulic Digger

filter core reduces,too.Avoid destroy the hydraulic pump and other hydraulic elements,it suggest the periods as follow:(Unit:Hour)

Working rate of the hydraulic hammer	Replace period of the hydraulic oil	Replace period of the filter core
50%	500	500
100%	250	250

Caution: It adjust the pressure of the system as the hydraulic hammer' request when use the hydraulic hammer

7. Check the pressure of the system

Check it every 500 hours

- 1) It adjusts and checks the pressure after the temperature of the hydraulic oil arrive 50°C
- 2) Use the manometer with the flexible pipe. The measurement of the manometer is 0-30Mpa.
- 3) Connect the manometer with the direct head,M10*1 to the piston pump(see the picture ①②)

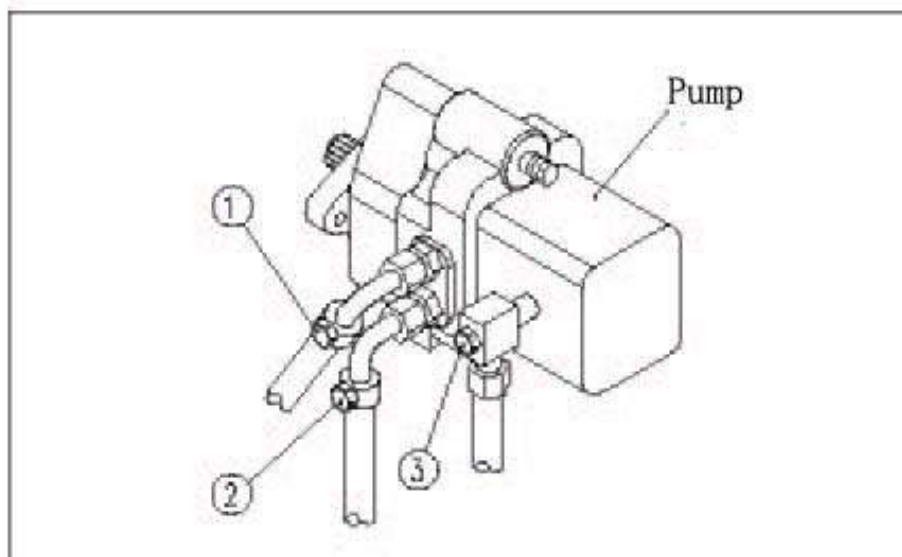

- 4) Detect the pressure adjust value of the main loop safety valve. The value is $3.5\text{Mpa}\pm 0.2\text{Mpa}$. If the value doesn't arrive the request, it need adjust the main safety valve of the

Hydraulic Digger

main safety adjust multi-valve which in the adjust multi-valve, till the value arrive the ordain value.

Detect the guide pressure:

- 1) Screw the bolt of the export tie-in which for the supply valve of the guide oil(see the picture: the accumulator①),connect the manometer with the direct head and M10*1. The measurement of the manometer is 0-6Mpa.
- 2) Check the pressure value of the guide oil. the value is 3.5 Mpa+/-0.2Mpa. If the value doesn't arrive the request, it need adjust the safety valve of the oil valve till arrive the value.

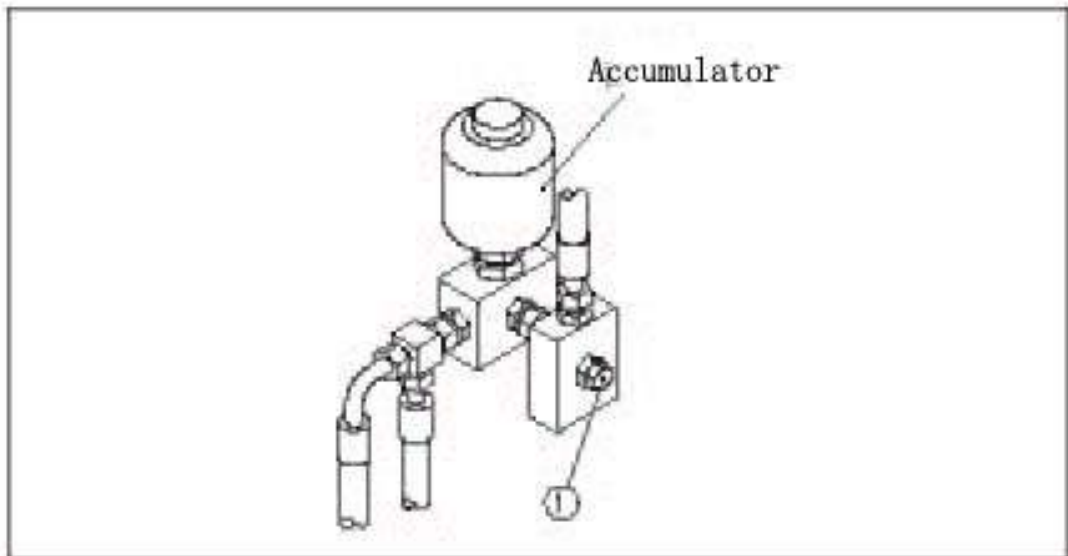

Caution: Please contact the service agent when the pressure of the main loop、 the bulldozer loop and the guide oil loop fall short of the request.

Accumulator

1. Check the level of the electrolyte



Warning:1)If the level of the electrolyte under the low-order level, no use the accumulator. Otherwise, it will expedite the inside metamorphose and reduce the use life .Maybe it brings explode

2)The electrolyte is dangerous. It needs lot of water to wash and go the hospital when the eye or the skin touch it.

3)No let the level of the electrolyte higher than the perch when it append the distilled water to the accumulator. If the level of the electrolyte too high, it could leak.

Check the level of the electrolyte every 50hour.If it lack, it need append the distilled water.

A. Check the level of the electrolyte from the profile of the accumulator

- 1) Open the door of the accumulator, take-down the cover board of the accumulator.
- 2) Use a wet and cleaning cloth to clean the around area of the level. Check whether the level of the electrolyte between the perch (UL)and the low-order(L.L). If it uses the dry cloth to clean the accumulator, the static can lead the fire or explode.

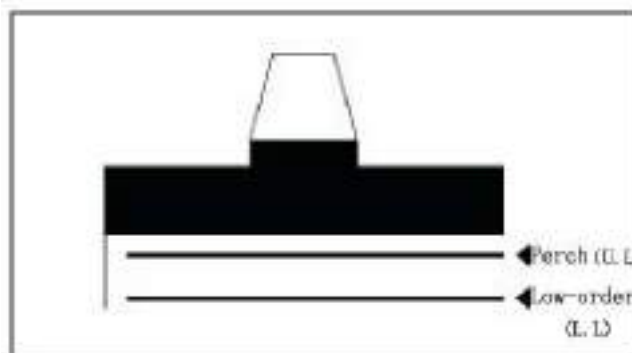

3) If the electrolyte under the middle between the perch(UL) and the low-order(L.L),take-down the cover and append the distilled water to the perch(U.L)

4) After append the distilled water, screw down the cover

Caution: It need append the distilled water before the operation in the morning when it is the cold day. Avoid the electrolyte freeze.

Caution: If it append the distilled water higher than the perch(U.L),it uses the straw to down the level under he perch(U.L).And it can use the saleratus to counteract the liquid, then use lot of the water to wash it or contact the agent or Yuchai or the manufacturer of the accumulator.

B. When it couldn't Check the level of the electrolyte from the profile of the accumulator

- 1) Open the door of the accumulator, take-down the cover board of the accumulator.
- 2) Take-down the cover of the accumulator, check the level of the electrolyte thought the sprue. If the electrolyte doesn't arrive the sleeve, it need append the distilled water and make sure the level arrive the bottom of the sleeve(U.L)
- 3) After append the distilled water, screw down the cover

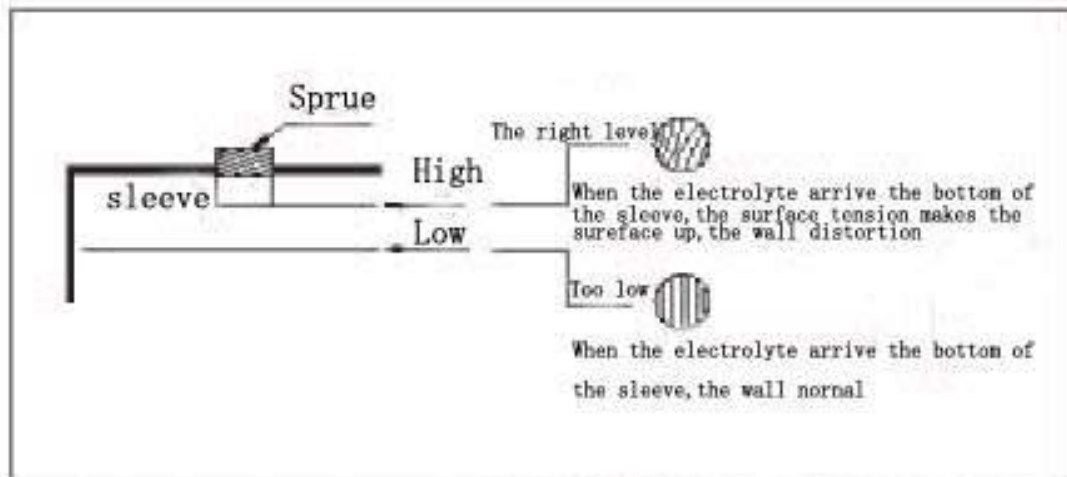

Check whether the electrolyte arrive the bottom of the sleeve

Caution: If it append the distilled water under the bottom of the sleeve, it uses the straw to down the level under the bottom of the sleeve. And it can use the saleratus to counteract the liquid, then use lot of the water to wash it or contact the agent or Yuchai or the manufacturer of the accumulator

C. Use the indicator to check the level of the electrolyte

As the instruction to check when it use the indicator to check the level of the electrolyte

2. Check the acidity of the accumulator and the electrification state

- The content of the acid is 1.28g/cm^3 in 20°C when the accumulator in the right state of the electrification
- For make sure to start the engine has a good working condition, it need the accumulator in the protect electrification state. Avoid the accumulator freeze when it used in the cold area.
- The intensity of the current should be $1/10$ the capacitor of the accumulator. It means it uses 6A current within 8 hours for the electrification time(The specific gravity of the electrolyte is

Hydraulic Digger

1.16, the electrification time is 2 hours; the specific gravity of the electrolyte is 1.1, the electrification time is 3 hours. Lower the specific gravity, longer the electrification time). Then use the above value of the current to electricize 15 hours. If the specific gravity of the 6 single-electrolyte between 1.24-1.29, over the electrification.

- For make sure to connect the accumulator and the cable, it need fixing better, and use the acidproof Vaseline to wipe the electrode

Caution: Fix too loose or too tight will destroy the accumulator.

No close the fire.

The Reducer

Maintenance manual

Lube capacity of the rotating reducer -----0.9L

Lube capacity of the driving reducer -----1.4L(each side)

Check the level of the lube and append the oil ----- 250h

Replace the lube ----- 500h

Check the tighten moment for the connect bolt of the reducer -500h

1. Check the level of the lube for the driving reducer and put on steam



Warning: The oil of the reducer will heat when the machine drives. The driving reducer and the oil in the high-temperature after stop the engine. It will make scald.

It must wait the oil cool before start. Loose the vent bolt two or three, it can take-down the bolt after release the air pressure. It is dangerous to take-down the bolt fast.

Check it every 250 hours

- 1) Prepare a **inside hexagon** spanner.
- 2) Stop the digger on the level road.
- 3) Turn the driving reducer make the two bolt of the outboard in "a" position(see the picture),then stop the machine
- 4) After the oil cooling, open the bolt①
- 5) After release the air pressure, use 12-15Nm the moment to screw down the bolt①
- 6) Open the bolt②,check the position of the level. The height of the level should arrive the bottom of the bolt hole.
- 7) It can supply the machine oil if it necessary(as the way to

append the oil)

- 8) Clean the bolt ②, install to the reducer again. The tighten moment is 12-15Nm.

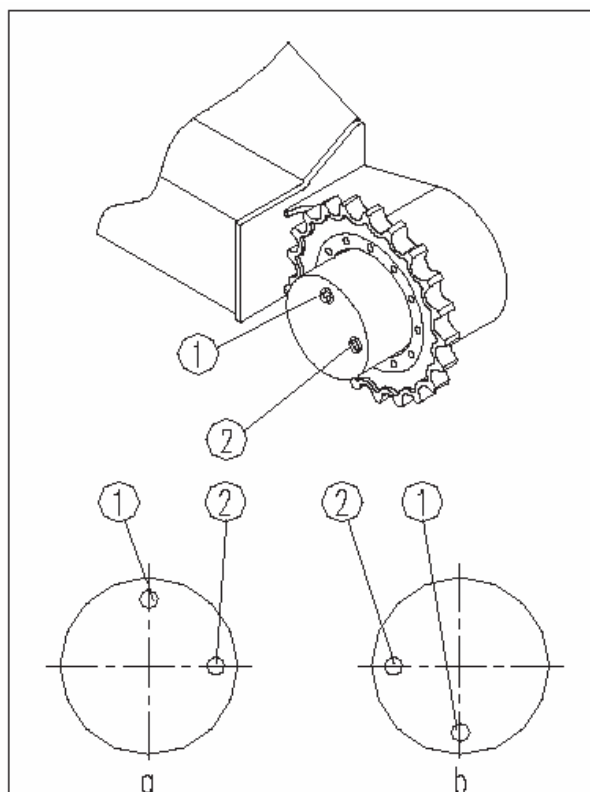

2. Replace the lube (For each reducer)

Replace it every 1000 hours

- 1) Stop the digger on the level road.
- 2) Turn the driving reducer make the bolt ① in "b" position (see the picture)
- 3) Vent the oil when the oil of the reducer is in the hot state.

Caution: Don't let the hot oil scald

- 4) Loosen the bolt ① and vent the oil, and loosen the bolt ② to make vent the oil complete
- 5) Turn the driving reducer to make the bolt in "a" position
- 6) Append the operation lube through the sprue until the check hole ② of the level has the oil out.
- 7) Screw down ① and ②, the tighten moment is 12-15Nm.

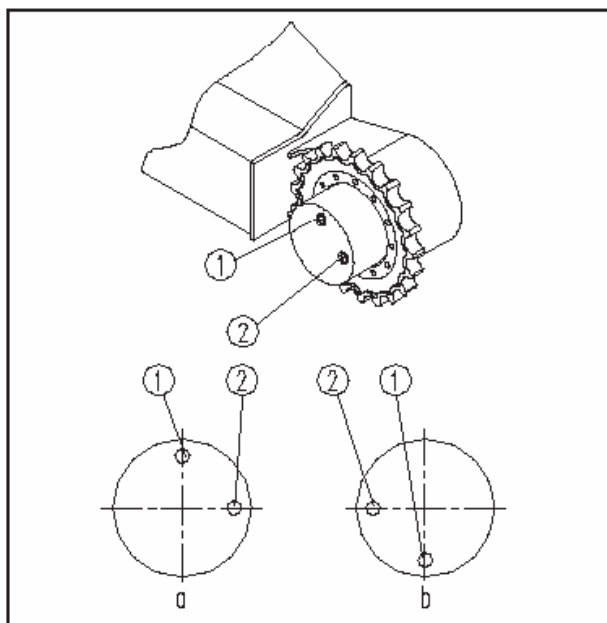

3. Check the tighten moment for the driving reducer with the connect bolt of the rotating reducer

A .Fixing check for the connect bolt of the driving reducer

After runs 50 hours check it the first time. Then check it every 500 hours.

The tighten moment is $150 \pm 10\text{Nm}$ for the bolt which connect the reducer、 the base and the drive wheel.

B. Fixing check for the connect bolt of the rotating reducer

After runs 50 hours check it the first time. Then check it every 500 hours.

The tighten moment is 195-250Nm for the reducer and the bolt of the platform.

Support Roller, Carrier Roller & Leading Roller

1. Check the tighten moment of the support roll

After runs 50 hours check it the first time. Then check it every 500 hours.

The tighter moment of the bolt② is $195 \pm 15 \text{ Nm}$

If it finds the bolt looses, it need screw it down and clean the thread additive which for lock and fix of the bolt. And wipe the additive again, then screw down it with the tighten moment which requested.

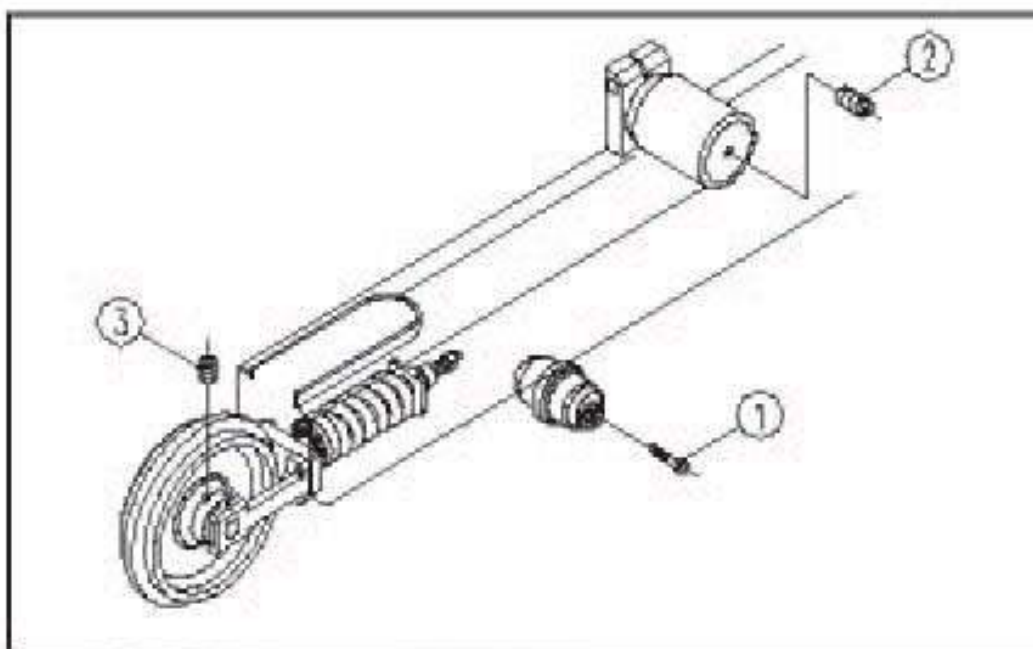

1. Bolt of the support roller

2. Carried roller cock

3. Guide roller cock

If it need to replace the bolt, it must use the same bolt.

2. Check the level of the machine oil for the carrier roller and leading roller

Check it every 1000 hours.

1) Take out the nut②、③ of the carrier roller and leading roller

2) Immit the oil

- 3) When the sprue has the oil out, screw down the nut②、③ again.

Pedrail

Check and adjust the tension state of the pedrail

Check it every 10 hours.

- 1) Place the digger on the smooth and hared road.
- 2) Put the bulldozer back, and draw out the piston level of the oil tank till the pedrail uplift.
- 3) Put the bucket on the ground, operate the moving-arm oil tank to uplift the foreside of the digger(a of the picture 1).
- 4) Adjust the tension of the pedrail to make the A which between the middle part of the support roll, and the flexibility is 10-15mm
- 5) Take down each cover① of the pedrail frame(b of the picture 1),show up the sprue of the tension device(③ of the picture 2)
- 6) For loose the pedrail, first loose the tie-in②(picture 2),to make the lube out till the tension screw down again.
- 7) For adjust the pedrail, connet the tie-in of the butter gun and the tie-in③(picture 2).Then use the butter gun immit till the right tension.

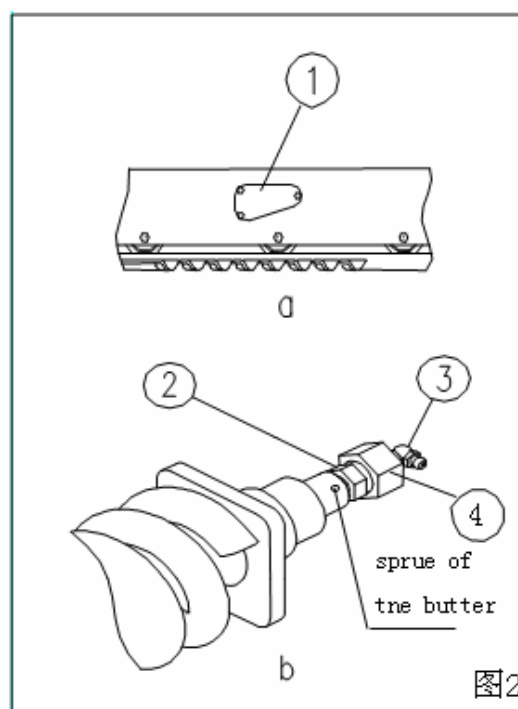
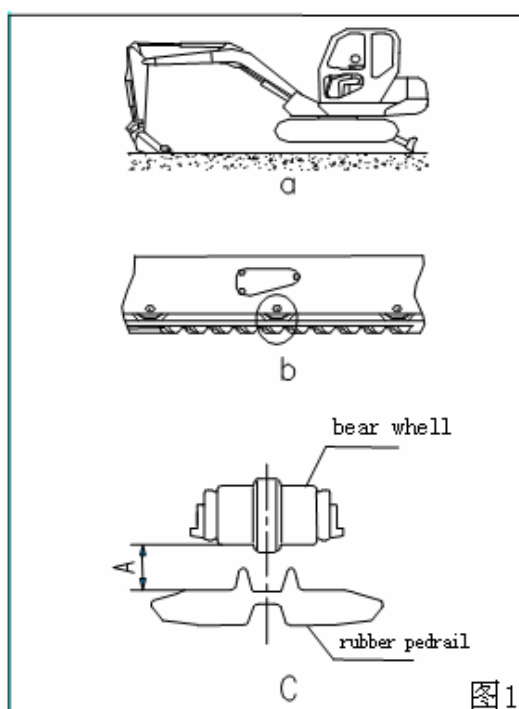

Hydraulic Digger



Warning: Don't knock the tension spring of the pedrail. The spring will rupture when it bear the large pressure. And hurt the person. Don't take-down the spring when it in pull state.



Warning: Don't take-down the screw of 4. It can hurt the valve and somebody.

Lubricating

Lubricating the parts which need every 50 hours

The step:

- 1) Start the operation device, and put the bucket to the ground
- 2) Put the bulldozer to the ground
- 3) Stop the engine
- 4) Clean the sprue of the oil cup
- 5) Lubricating the parts and wipe the superabundance

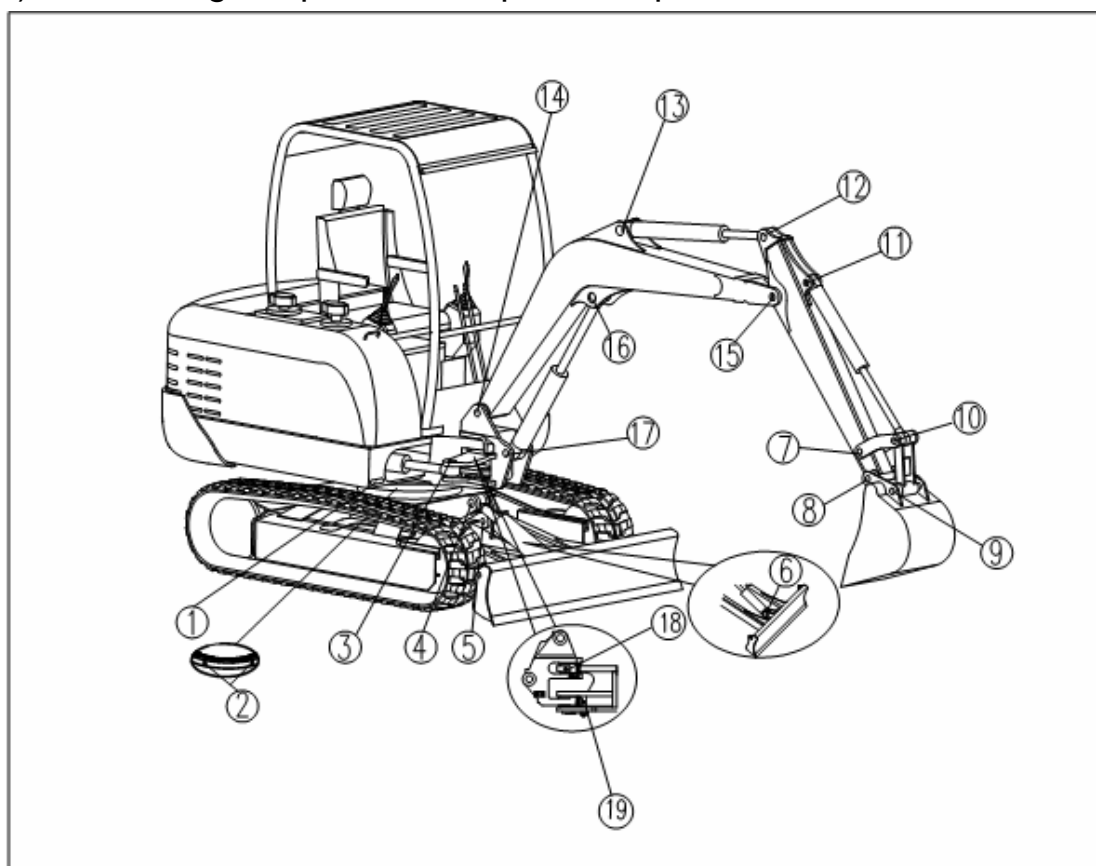

- | | |
|---|---|
| 1.The part of axes from the deflecting oil tank | 12.Joint of the top lever's oil tank |
| 2.The part of the rotating support roller | 13. The parts of the lever's oil tank' end |
| 3. Part of the top deflecting oil tank | 14. Joint of the moving-arm and the platform |
| 4.Joint of the top bulldozer's oil tank | 15. Joint of the lever and the moving-arm |
| 5. Joint of the bulldoze and the support's | 16.Part of the top moving-arm oil tank |
| 6.The parts of the bulldozer's oil tank' end | 17.The parts of the moving-arm's oil tank' end |
| 7. Joint of the rocker and the lever | 18.Top part of the axes from the rotating head |
| 8. Joint of the lever and the bucket | 19.Bottom part of the axes from the rotating head |

Hydraulic Digger

9. Joint of the connect lever and the bucket
10. Joint of the rocker and the connect lever, and joint of the top from the bucket's oil tank
11. The parts of the bucket's oil tank' end

Air-condition (If the machine have)

The main makeup of the air-condition as the following picture. The operation switch in the plane of the control box.

About the operation and the maintenance of the air-condition, please see the user manual and the air-condition user manual.

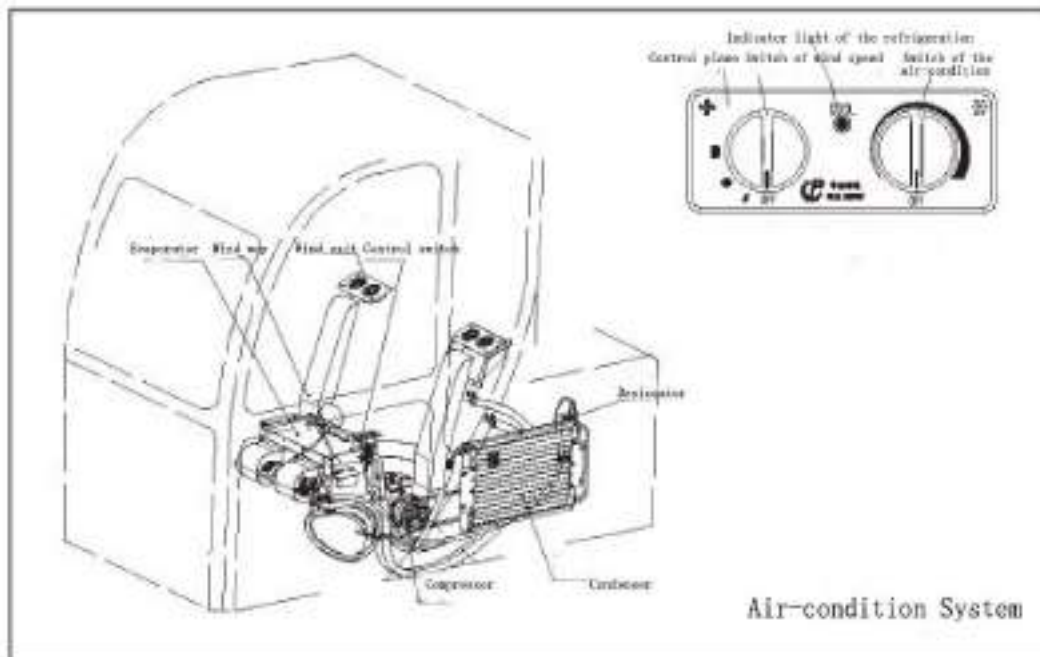

1. Caution items of the air-condition maintenance

- 1) If the air-condition assembly has the dust screen. The dust screen must clean often. Otherwise, the dust will stop the dust screen and make the air not thought the heat exchanger
- 2) It should close the water warming valve, when it uses the refrigeration system in summer and use the draft system in spring and autumn. When it use the warming-up system, it should open the water warming and turn the air-condition's switch to "OFF"
- 3) The core of the caliduct connect to the water tank of the engine, if the core leaks, it will lead the water of the water tank lack, and make the engine overheat. In winter, it same to protect core not freeze as the water tank. Avoid the coolant

freeze to make the core or the water tank freeze, please use the coolant which the manufacture requests, which produce the main machine. Please let out the coolant if the machine stops long time in winter when it maybe freezes.

- 4) Please run the thermantidote every 15 days if it doesn't use it long time. And run about 5-10 minutes every time.

2. Check the value of the refrigeration



The refrigerating agent is easy to frostbite the skin.

And

it emit the poisonous gas and light when the refrigerating agent near the fire. It need make sure the refrigerating agent no spray to the skin and the eyes when it need to take-down the refrigeration system. It should let it out then take-down it. No fire.

If the machine short of the refrigeration agent, that the cooling performance will worse. Check the value every month or every 250 hours.

According the view mirror of the desiccators whether has the air bubble to judge the value when the engine runs high-speed and air-condition stay the refrigeration state.

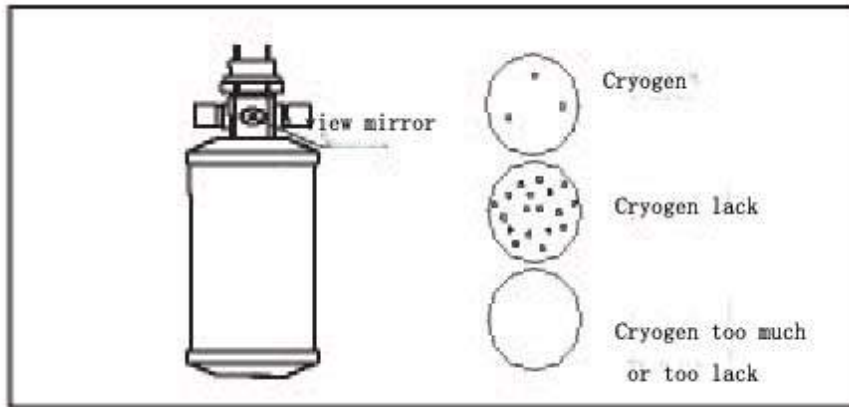

3. Check, adjust the belt tension of the compressor

Check it every 250hours

A. Check

Use the finger about 12N power to press the middle part which between the drive belt wheel and the compressor belt wheel and check the deflexion about 4-5 mm

Check whether the belt destroys .It need to replace when the belt pulled, no adjust value or the belt has the rift.

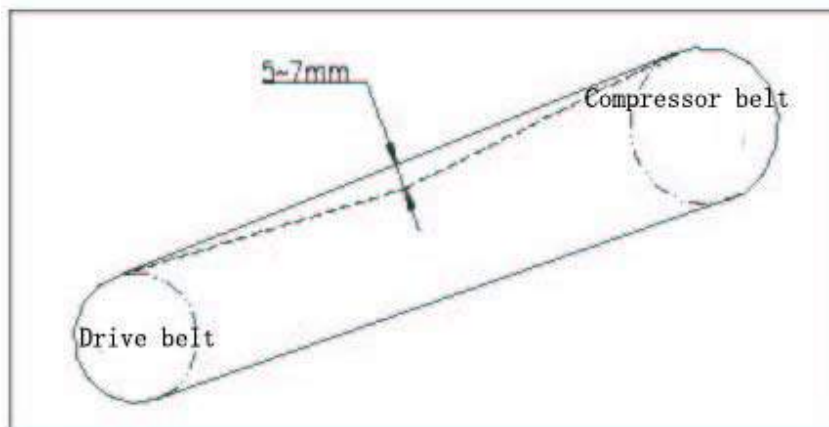

B. Adjust

Loose the bolt (see the picture),use the tommy bar to open the compressor, adjust the belt to the suitable tension. And screw down the bolt.(If it necessary, it can loose the two bolts which for fix the compressor)

Hydraulic Digger

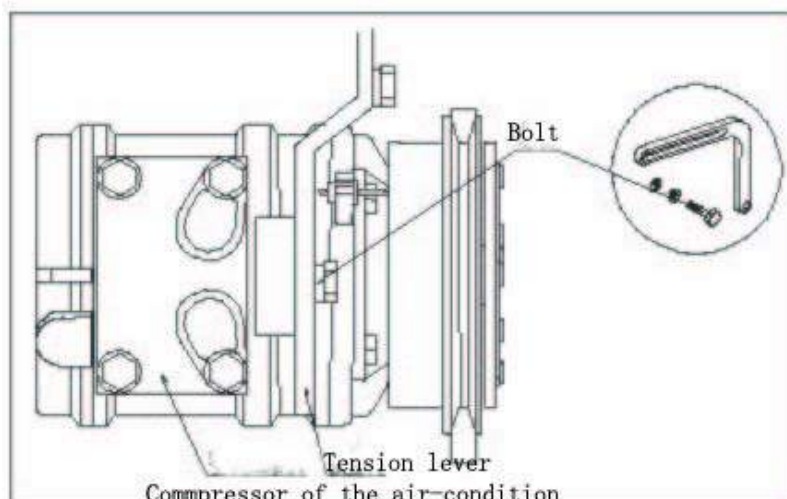

4. Items of the time-check

No.	Check Item	Check Content	Check Periods	
			Every Month	Every Quarter
1	Fastener	If loose、fall off	★	
2	Belt of air-condition	The tension and fray	★	
3	Pipeline	If fray or rupture	★	
4	Tie-in	If fray of leak		★
5	Electric fan	Whether run normal	★	
6	Line	If fray、burn	★	
7	Condensator	If has the dust stop		★
8	Electromagnetism clutch	If slip	★	
9	Compressor	If has the noise		★
10	Value of refrigeration agent	If the view mirror has the air bubble	★	
11	dust screen	If stop	★	

Replace The Gear of The Bucket

It replaces the gear of the bucket before the base of the gear fray.



Warning: If the operation device because of the wrong operation and lead it moving, it very dangerous when replace the gear. Before replace the gear, it should make the operation device locked, then stop the engine and let all the joy stick locked. It need use the guard to avoid the axes out.

Replace the gear

- 1) Make the base device of the bucket on the stow-wood for take-down the axes. Check whether the operation device stay the tranquilization state and the bucker place level. Then push up the safety lock of the left control box, then stop the engine.

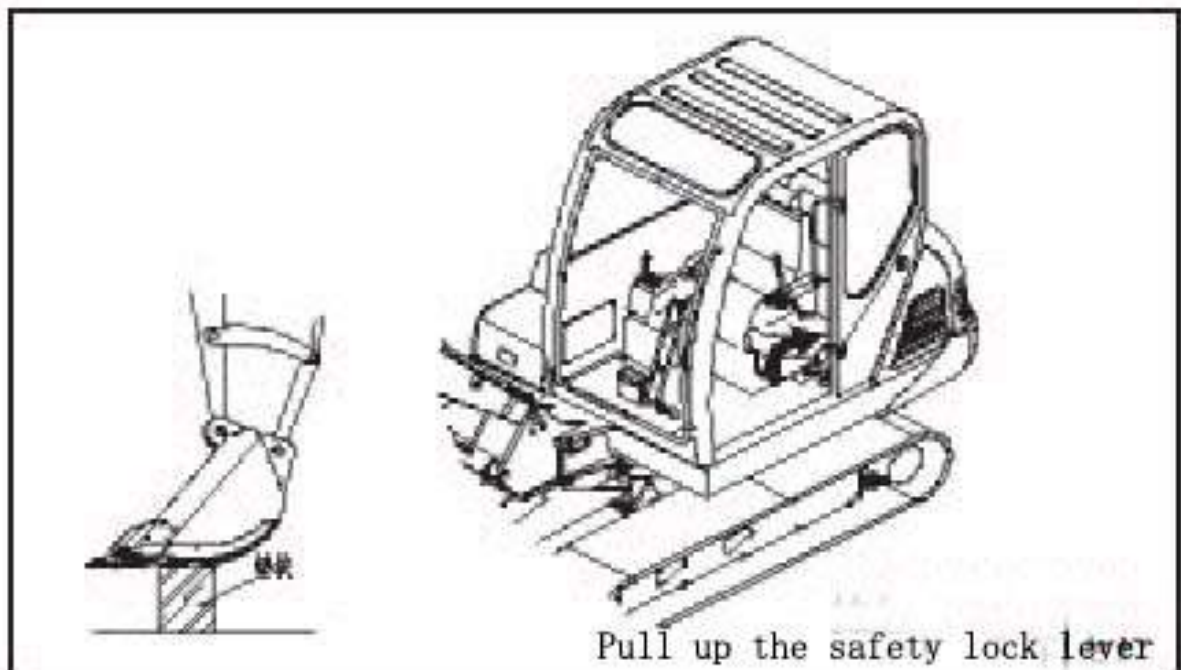

- 2) Put the metal stick which the diameter smaller than the axes on the axe's head, use the hammer knock the stick to knock out the axes, and take-down the gear.

- 3) Clean the installing surface. Install the new gear into the base of the gear, use the hand push the axes into it, then use the hammer knock the axes into the lock to make the gear into the base of the gear.

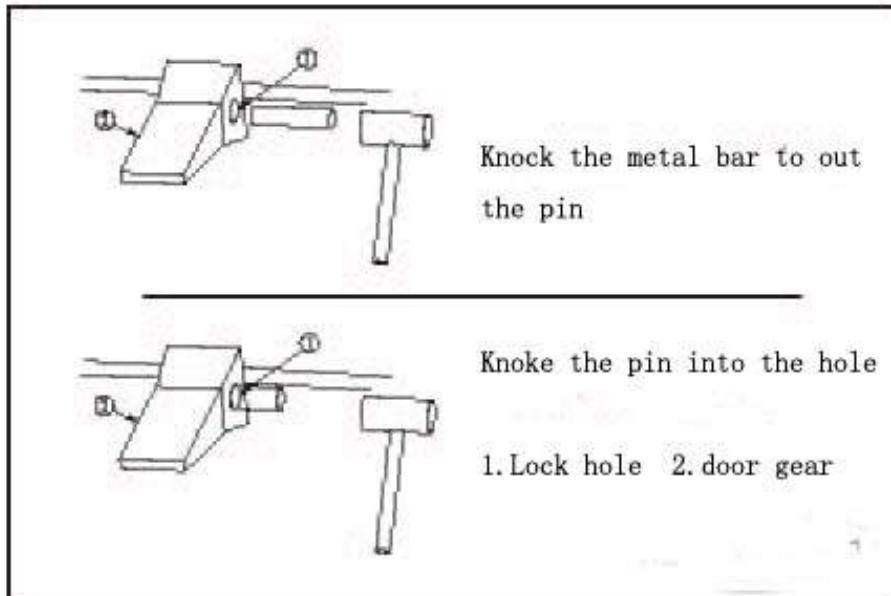

Washing The Plastic Cushion of the floor

Avoid the floor slip、tumble to make the accident, please wash it at any moment if it dirty.



Warming: If it touches the joy stick unguarded, the operation device or the machine will move, and lead the accident. So it must place the machine on the hard and smooth road before take down the plastic cushion. It must uplift the guide safety handle and the top control box to lock the guide system before the operator leaves the seat.

The step for washing the plastic cushion:

- 1) Take the plastic cushion out the cab
- 2) Use the brush to washing the dunghill or use the water washing it.

Hydraulic Digger

- 3) Use the clean mop to clean the floor
- 4) After the plastic cushion dry take back.

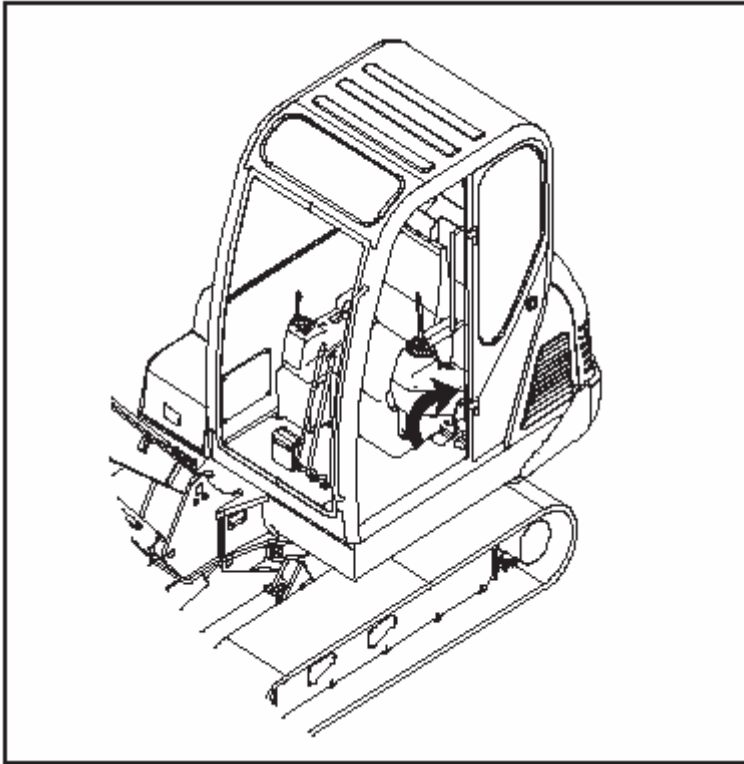

Replace Fuse

The fuse used for avoid the electric device and the wire burn. It need to replace the fuse when the fuse rust or cam see the white powder、 or the fuse loose in the base of the fuse

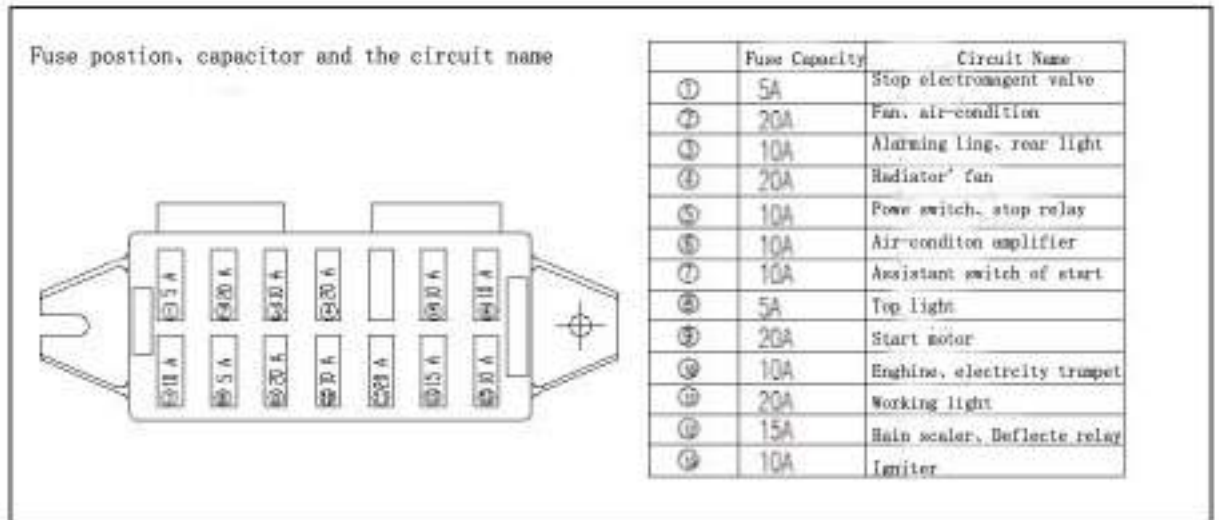

Caution:1)It must close the switch of the power supply and the start switch of the engine before replace the fuse;2)Need the fuse with the same capacity to replace.

Safety Item

It will affect the service life of the machine and bring some safety problems, if the machine has been installed some attachment which not authorized by Yuchai. If it need install the attachment, it must contact Yuchai.

If you don't contact us, we haven't to bear any duty about the accident or damage.

1. The attachment of safe operate

- The attachment has the strong assistant function. It need to use the attachment with right way to avoid hurt or damage.
- Read the attachment user manual. Don't use the attachment before you don't know the content of the manual. If the user manual has been lost, please let the manufacturer or the attachment sale company supply new one.
- It need install the necessary foreside mantle that according to the circs of the attachment.
- The libration noise cause the colleague difficult communicates the operation purpose. It needs to seed a compere and fix on the signal before operating.
- Don't rotate the machine when the attachment has overload. It is very dangerous that doing this operation on the slop.
- The foreside of the operation device has overload and unstable when the machine has the hammer. For avoid dangerous overturn, don't operate the machine when the attachment turn to the side.
- The rotating area and the barycenter are different when the machine installs the attachment, the machine can move suddenness. It must realize the machine's instance.
- It need to set a warning line near the machine avoid the person enter before operated. Don't operate the machine when it has

the person near it.

- Avoid the wrong operating that lead the accident, don't put the foot on the footplate except operate the footplate.

2. Take down or install the attachment

- Take down and install operation on the hard and smooth road
- Fix on the signal when it has two persons do the operation or above. And abide the signal
- It must use the chain block when upgrade or carry the heavy object(exceed 25kg)
- Need support the part when take down the heavy parts.Caution the barycenter when use the chain block
- It is dangerous to use the chain block for overload. It need have a plank to make sure the state safe
- Make sure the steady state that can not overturn when place the attachment which take down or install
- Don't walk under the chain block when it overload.



Warning: It needs the qualification certificate to operate the chain block. About the details of take-down and installation ,please contact Yuchai

The steps of the attachment Installing & take down

1. Step for take down

- 1) Put the attachment on the ground and stop the engine
- 2) Turn the start switch to "ON" and push the left control box to the free position
- 3) Turn the jot stick of the operation device to front、back、left、right and operate the attachment controlling footplate 2-3 times to release the pressure of the hydraulic pipe laying.
- 4) Lock the rotary valve which connect to the leading-in tube and outlet pipe of the lever' side after make sure the oil temperature down.
- 5) Take down the soft pipe which in the side of the attachment, twist the combination gasket of the bulkhead cover to the leading-in tube and the outlet pipe.
- 6) Take down the attachment thought take down the axes, and then install the bucket.
- 7) Use the clean plastic bag to pack the end of the rubber pipe from the hydraulic hammer. Deposit the attachment

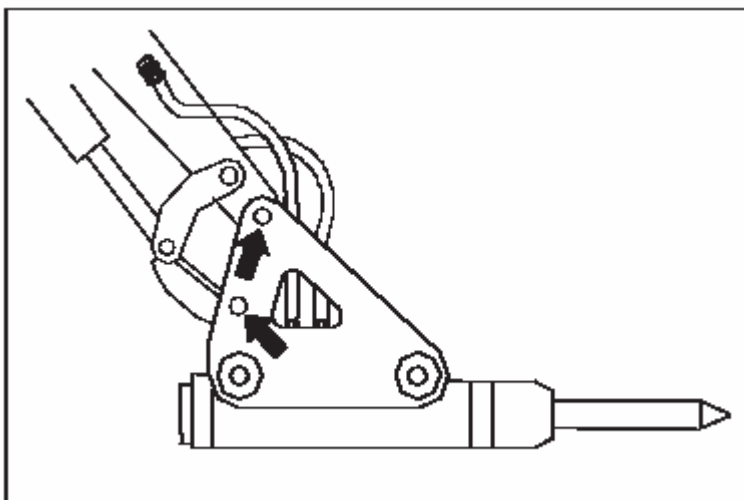

2. Step for installing

- 1) Take down the bucket

Hydraulic Digger

- 2) Put the attachment to a smooth area, use the axes A and axes B connect the lever with the hydraulic and the connect lever with the hydraulic one by on
- 3) Take down the bolt from the leading-in tube and outlet pie after the oil temperature down. No let the dust、 soil touch the tie-in of the soft pipe. If the combination gasket destroy, replace the new one
- 4) Connect the soft pipe of the side on the attachment. Check the flux of the oil and don't connect it in a wrong way
- 5) Unlock the rotary valve which connect to the leading-in tube and outlet pipe of the lever' side
- 6) After install the attachment, it need make sure the oil level in the hydraulic oil tank to the suitable position.

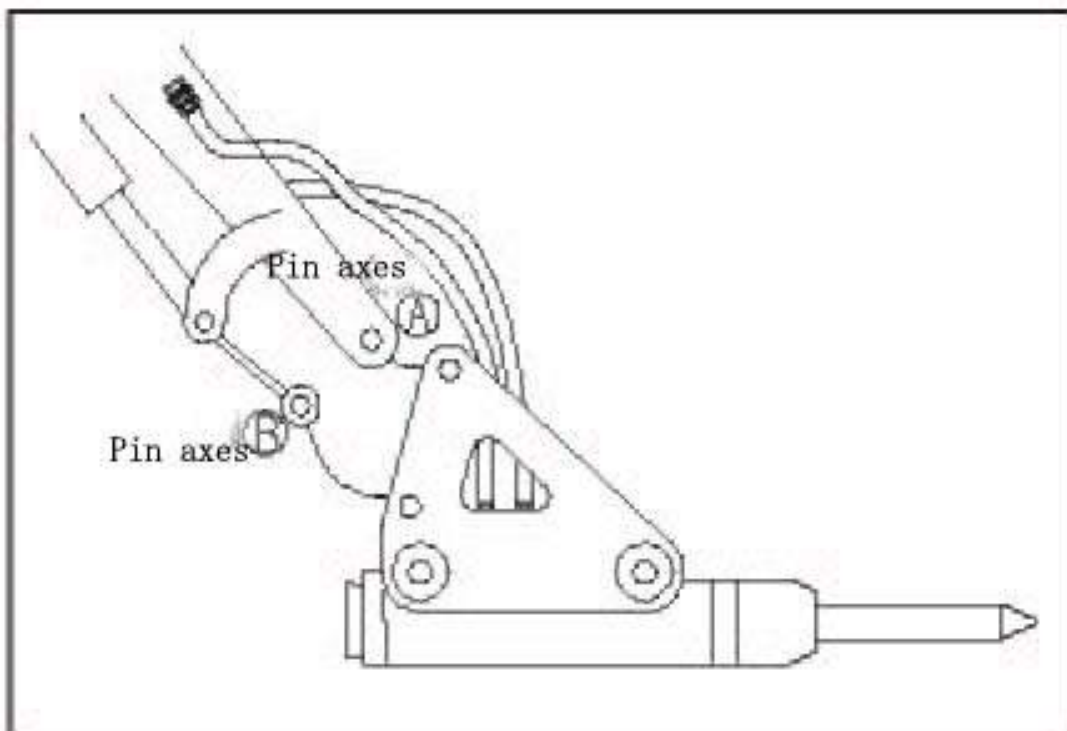

Operation Manual of the attachment

The parts introduce the caution when operate the digger which install the attachment.

Caution: Choose the attachment which is the best one of the main machine. The type of machine is different which can install the attachment. About the attachment and the type's choosing, please contact Yuchai.

Hydraulic crush hammer

penetrate direction of the

1. User manual of the hydraulic crush hammer

The hydraulic crush hammer is the familiar attachment.

1) Make sure the direction of the hammer top plumbs the surface of the object when the machine do the crush operation, and keep it at any moment. If it has the gradient with the surface of the object, the hammer maybe slips by itself. And will lead the hammer mangle and affect the piston.

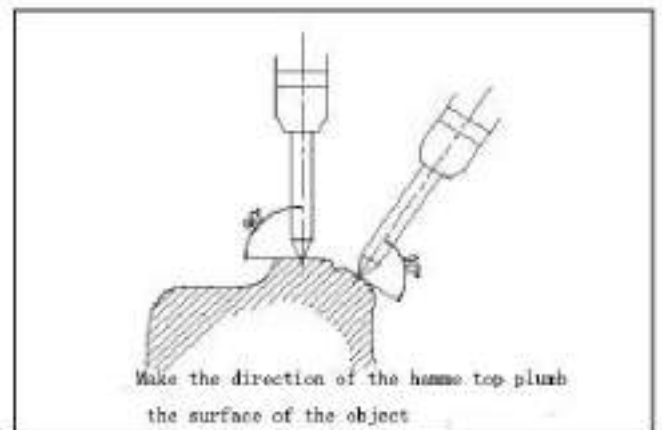

Please choose the best point to crush.

And make sure the hammer steady then knock.

Request to adjust the oil tank of the bucket to keep the

Caution: No operate the oil tank to the end of the driving

hammer and the body of the hammer in on line.

2) Press the hammer to surface of the object, and make the underpan about 5cm from the ground. When inflict the wallop. No let the machine away the ground too much.

3) If the hammer doesn't penetrate or crush the surface within one minute when inflict the wallop on one surface continuous, it need to change the impact part and near the edge of the object to crush.

4) Use the hammer to impact the surface suitable, avoid no resistance use the wallop. Stop use the crush hammer to impact when the rock or the object crushed. If not stop, it will lead the bolt of the main body loose and mangle.

2. Operate tabu of the hydraulic crush hammer

For the machine has long use life and the safety operation, no operate as follow:

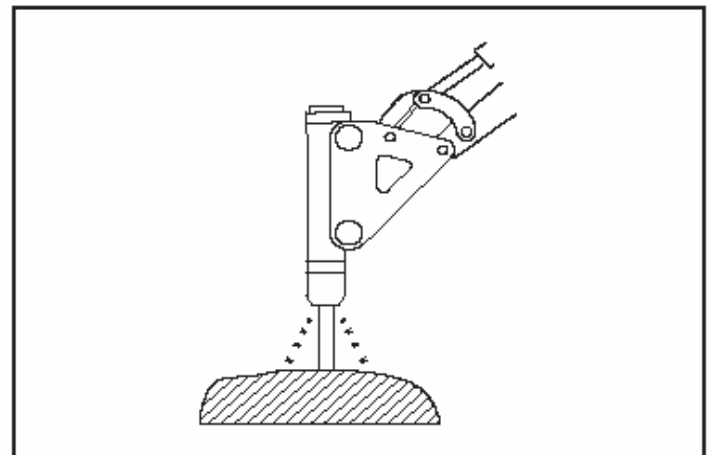
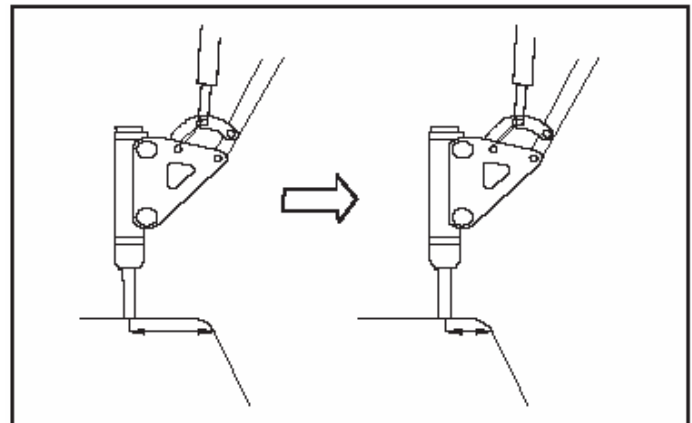
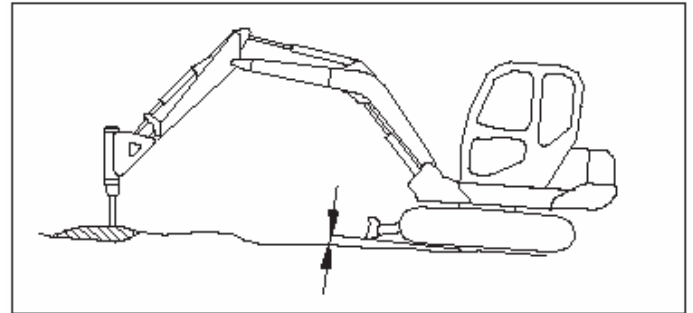

it should keep the rest about
5cm

- 1) Push the heavy thing or the big block use the crush hammer

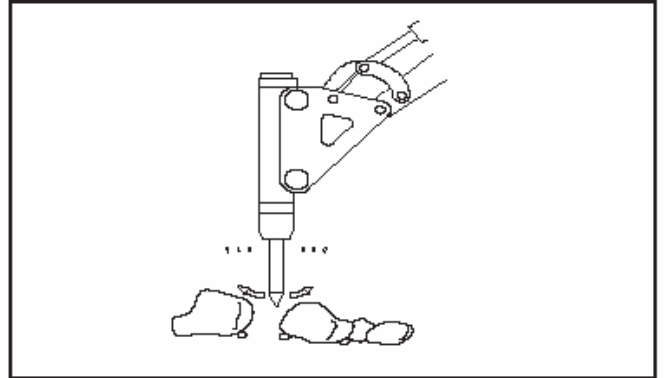

- 2) Use the rotating operation

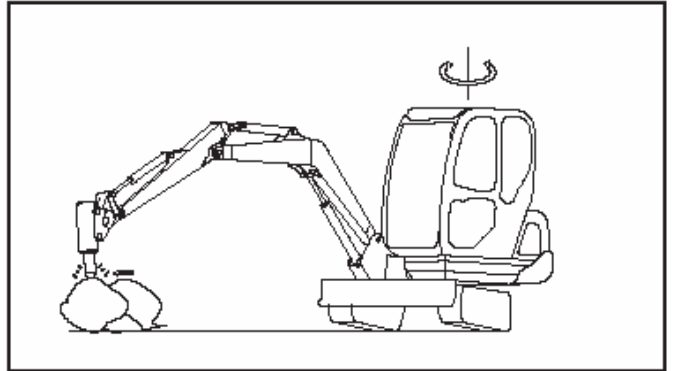

- 3) Move the hammer when do the impact operation

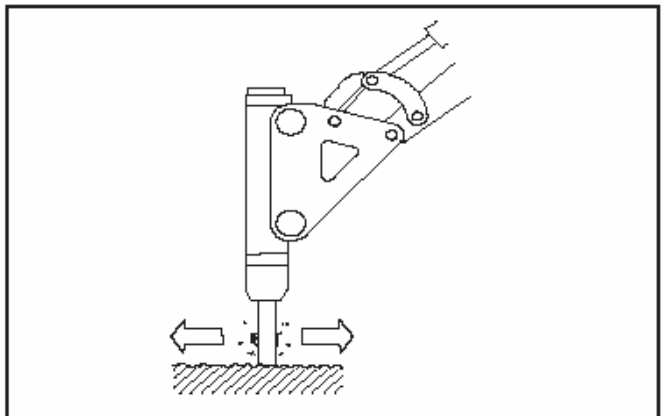

- 4) Inflict the wallop on the level ground or upwards

Hydraulic Digger

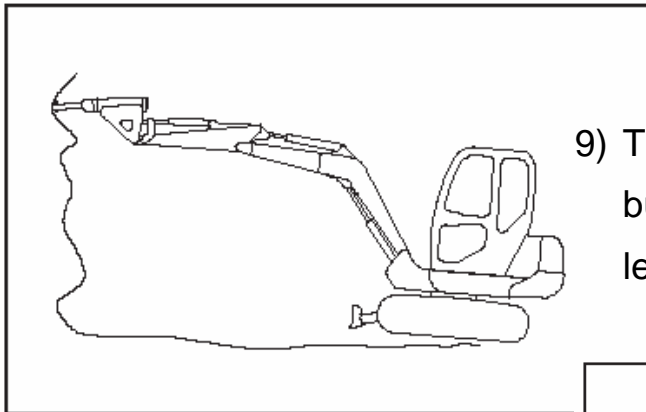

9) Throw out the oil tank of the bucket to make the machine leave the ground

5) Waver the crush hammer when it penetrate the rock

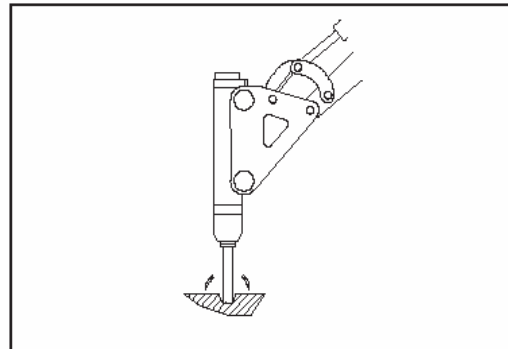

6) Peck operation

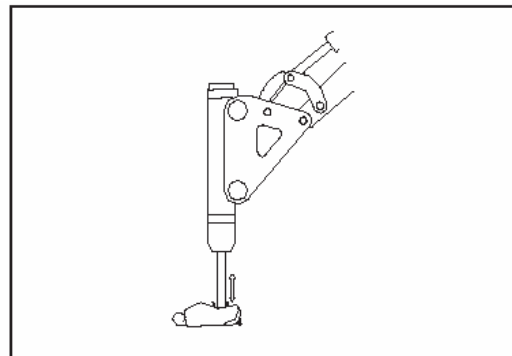

7) Operate it in the water or the muddy ground

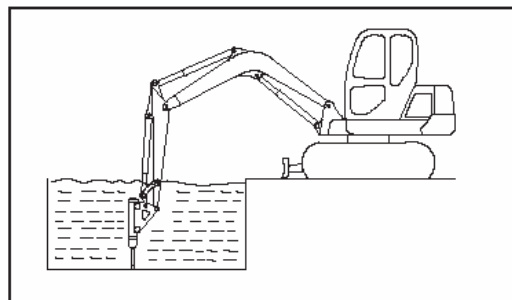

8) Use the crush hammer hang the heavy thing

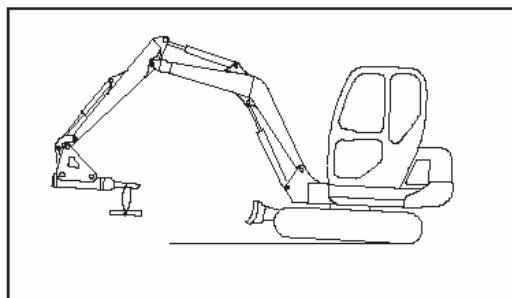

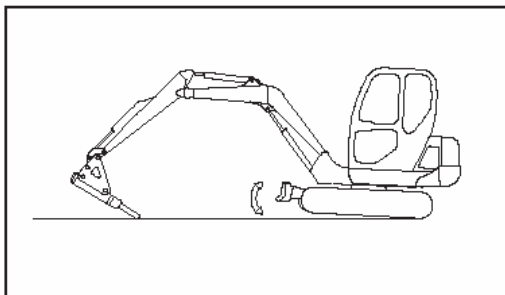

Fast-replace tie-in

1. Install the bucket

- 1) Use the tommy bar to prize ①

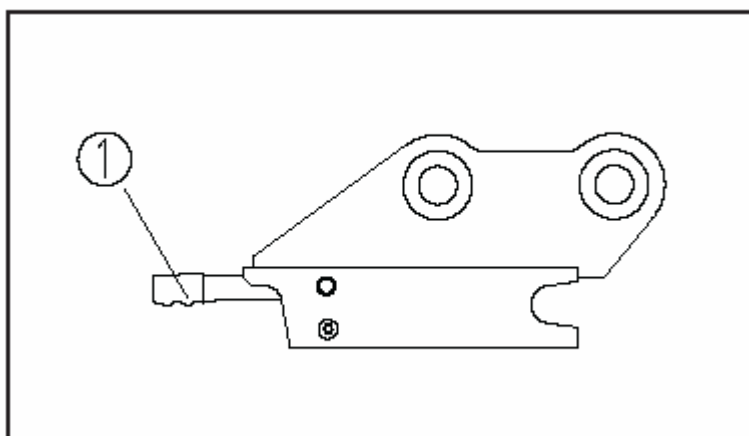

- 2) Put the axes of the bucket into the ②③, down the tommy bar and the bucket installed.

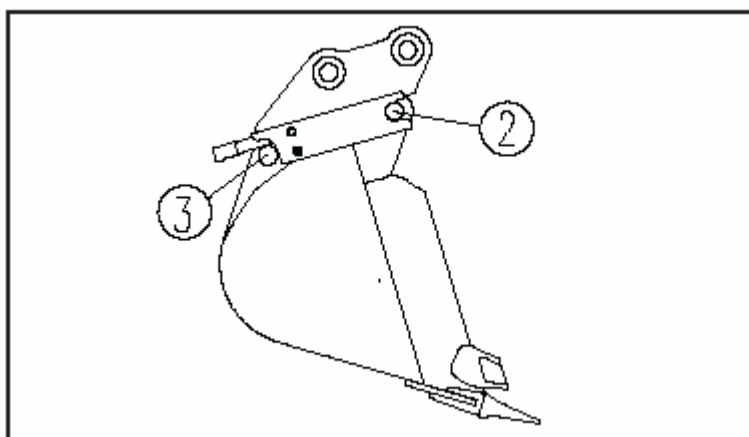

2. Take down the bucket

- 1) Use the tommy bar to prize ①
- 2) Take down the bucket.

Daily Check of Hydraulic Crush Hammer

Do the daily check and the maintenance as the following list:

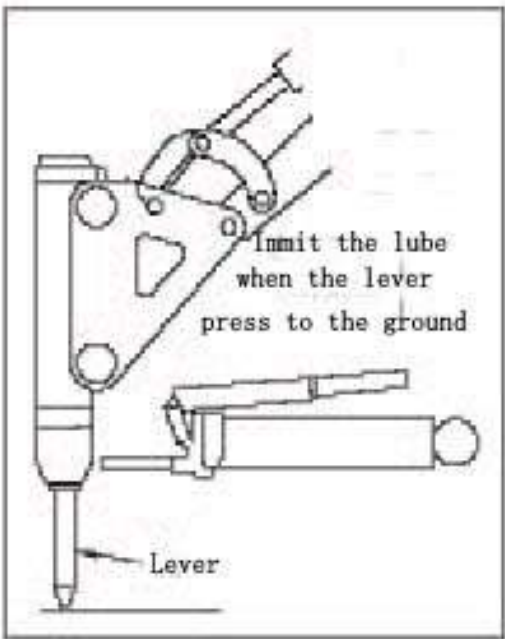
No.	Check or maintain item	Check point	Resolve
1	Check whether the bolt/nut loose or lose	Bolt of the main body and the side of the bolt	Screw down the bolt or install the new bolt again
2	Check whether the parts of the soft pipe loose and the soft pipe break or leaks oil	Hydraulic pipeline of the crush hammer High-pressure vitta	Screw down the part which loose Replace the broken part
3	Lubricate 	Use the lube 10ml/t before the operation and after operate 2-3hours Immit the lube 5-10times	Immit the lube thought the sprue which in the foreside of the crush hammer.
4	Check the capacity of the hydraulic oil and the pollution circs	The circs of the hydraulic oil	The change circs of the hydraulic oil is different as the different condition. The simple way to judge the oil is

Hydraulic Digger

			observe whether the color changes If the oil worse, please vent the oil and clean the oil tank, Immit the new oil
--	--	--	--