

CASTLOADERS

800 SERIES



800 SERIES



DIMENSIONS AND LOADING DIAGRAMS*

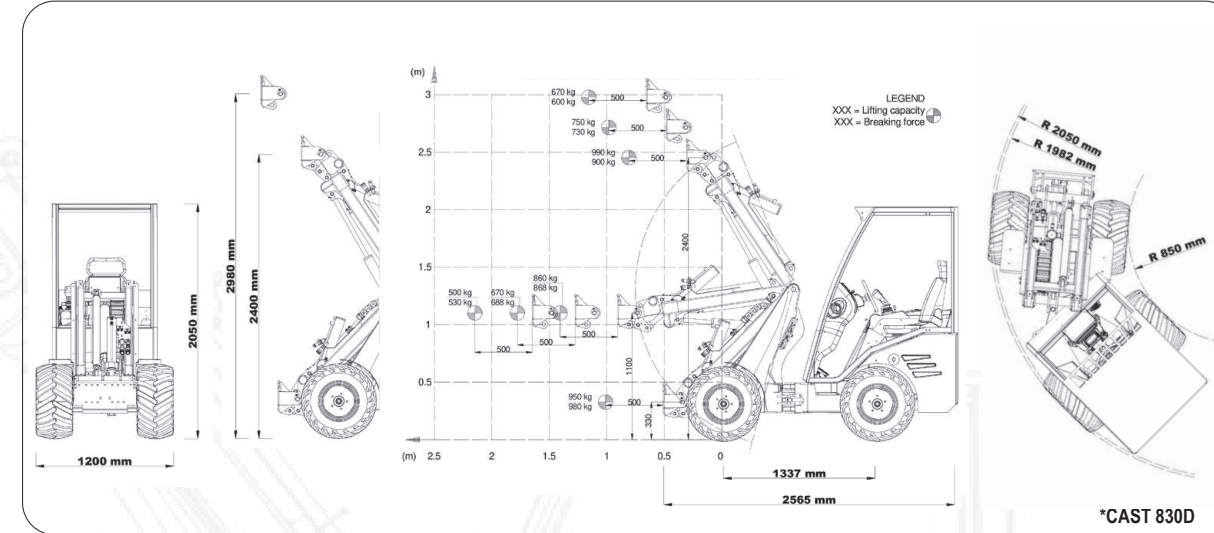

WHEELS

| SKID | TRAC MASTER | TRACTOR | TURF |
|--|------------------|--|--|
| 23X8.50-12 23X10.50-12 26X12.00-12 | 8PR 300/60X12 | 23X8.50-12 23X10.50-12 26X12.00-12 | 23X8.50-12 23X10.50-12 24X13.00-12 26X12.00-12 26.5X14.00-12 |

800 SERIES MODELS

| | LIFTING CAPACITY | ENGINE POWER | HYDRAULIC SYSTEM | BOOM HEIGHT |
|------------------|------------------------------|-----------------|------------------|-------------|
| CAST 820D | 750 Kg (with counterweights) | 20 Hp / 14,9 kw | 30 l/min | 2980 mm |
| CAST 825D | 850 Kg (with counterweights) | 25 Hp / 18,6 kw | 42 l/min | 2980 mm |
| CAST 830D CARBON | 950 Kg (with counterweights) | 25 Hp / 18,6 kw | 46 l/min | 2980 mm |



CASTGROUP
WWW.CASTLOADERS.IT

CAST GROUP SRL
Via A. Meucci, 18 I-30035 MIRANO VE
ph. +39041 5701827 fx +39041 5726786
info@cast-group.it

LEAF_800 SERIES_ENG_09/2021

Data contained in this document is subject to change without notice and/or modification. Cast Group reserves the right to modify its products without obligation to communications. The images in this document are the only a demonstrative purpose.

800 SERIES

- >>> 820D
- >>> 825D
- >>> 830D



EN

CASTLOADERS.IT





800 SERIES

The 800 series is characterized by a design with a strong personality. Thanks to its low structure center of gravity the vehicle remains stable on all types of ground and offers the operator excellent visibility and maneuverability. Heated cabin available upon request.



STEER ADJ

Tilt adjustment of the steering column.

SAFETY GATE

The side gate is supplied as an option and is available for all models of the 800 series. A very useful accessory for enhanced operator safety.



SILENT BLOCK

820D

Lifting capacity 750 Kg
Engine power 20 Hp
Hydraulic system 30 l / min
Telescopic boom height 2980 mm

Cast 820D is equipped with a Kubota D722 diesel engine, liquid cooled, 4WD hydrostatic transmission and 10km / h speed. Electric differential lock, 5-function joystick, silent block, tractor tires 23x8.50-12.



- Agriculture
- Breeding
- Green maintenance
- Building
- Road maintenance



The uniqueness of a machine built for demanding professionals.

Cast 830D is equipped with a liquid-cooled Kubota D1305 diesel engine. 4WD hydrostatic transmission and speed of 16 km / h. It is equipped with an electric differential lock and a double cylinder selflevelling system. Standard equipment includes the ergonomic 10-function joystick, adjustable steering column, 12V auxiliary socket, front led work lights, comfortable heated seat with safety belt, metal hoods, silent block, minimum size in width 920 mm, tractor tires 26x12.00-12.

830D CARBON

Lifting capacity 950 Kg
Engine power 25 Hp
Hydraulic system 46 l / min
Telescopic boom height 2980 mm

Compactness and solidity.

825D

Lifting capacity 850 Kg
Engine power 25 Hp
Hydraulic system 42 l / min
Telescopic boom height 2980 mm

Cast 825D features a Kubota D1105 diesel engine, liquid cooled. The transmission is 4WD hydrostatic and its speed reaches 12 km / h. It is equipped with an electric differential lock, double cylinder selflevelling system. Standard features include the 5-function joystick, adjustable steering column, 12V auxiliary socket, led work lights, comfortable and adjustable seat with safety belt, metal hoods, silent block, tractor tires 23x10.50-12.