

BOMAG

FAYAT GROUP

Operating instructions Maintenance instructions

Original operating instructions

BMP 8500

S/N 101 720 11 1082 bis 101 720 11 1091 S/N 101 720 11 1112 bis 101 720 11 1116
S/N 101 720 11 1121 >

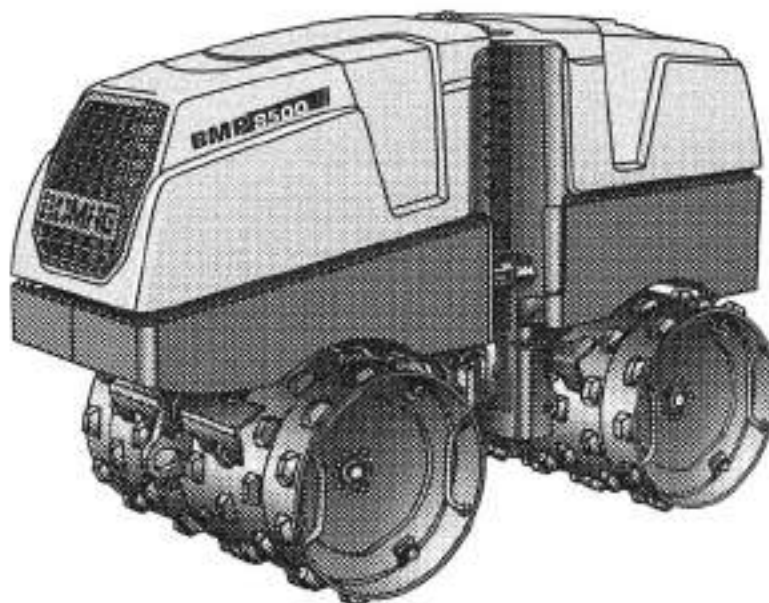

Multi-purpose compactor

If the machine is equipped with a battery -

CALIFORNIA
Proposition 65 Warning

Battery posts, terminals and related accessories contain lead and lead compounds, chemicals known to the State of California to cause cancer and birth defects or other reproductive harm.
Wash hands after handling.

If the machine is equipped with a diesel engine :

CALIFORNIA
Proposition 65 Warning

The engine exhaust and some of its constituents are known to the state of California to cause cancer, birth defects, and other reproductive harm.

BOMAG machines are products from the wide range of BOMAG compaction equipment.

BOMAG's vast experience in connection with state-of-the-art production and testing methods, such as lifetime tests of all important components and highest quality demands guarantee maximum reliability of your machine.

This manual comprises:

- Safety regulations
- Operating instructions
- Maintenance instructions
- Trouble shooting

Using these instructions will

- help you to become familiar with the machine.
- avoid malfunctions caused by unprofessional operation.

Compliance with the maintenance instructions will

- enhance the reliability of the machine on construction sites,
- prolong the lifetime of the machine,
- reduce repair costs and downtimes.

BOMAG GmbH will not assume liability for the function of the machine

- if it is handled in a way that does not comply with the usual modes of use,
- if it is used for purposes other than the ones it is intended for (see safety regulations).

No warranty claims can be lodged in case of damage resulting from

- operating errors,
- insufficient maintenance and
- wrong fuels and lubricants.

Please note!

This manual was written for operators and maintenance personnel on construction sites.

Always keep this manual close at hand, e.g. in the tool compartment of the machine or in a specially provided container. These operating and maintenance instructions are part of the machine.

You should only operate the machine after you have been instructed and in compliance with these instructions.

Strictly observe the safety regulations.

Please observe also the guidelines of the Civil Engineering Liability Association "Safety Rules for the Operation of Road Rollers and Soil Compactors" and all relevant accident prevention regulations.

For your own personal safety you should only use original spare parts from BOMAG.

In the course of technical development we reserve the right for technical modifications without prior notification.

These operating and maintenance instructions are also available in other languages.

Furthermore, the spare parts catalogue is available from your BOMAG dealer against the serial number of your machine.

Your BOMAG dealer will also supply you with information about the correct use of our machines in soil and asphalt construction.

The above notes do not constitute an extension of the warranty and liability conditions specified in the general terms of business of BOMAG GmbH.

We wish you successful work with your BOMAG machine.

BOMAG GmbH

Printed in Germany

Copyright by BOMAG

Please fill in

.....

Machine type (Fig. 1)

.....

Serial-number (Fig. 1 and 2)

.....

Motor type (Fig. 3)

.....

Motor number (Fig. 3)

i Note

Supplement the above data together with the commissioning protocol.

During commissioning our organisation will instruct you in the operation and maintenance of the machine.

Please observe strictly the safety regulations and all notes on risks and dangers!

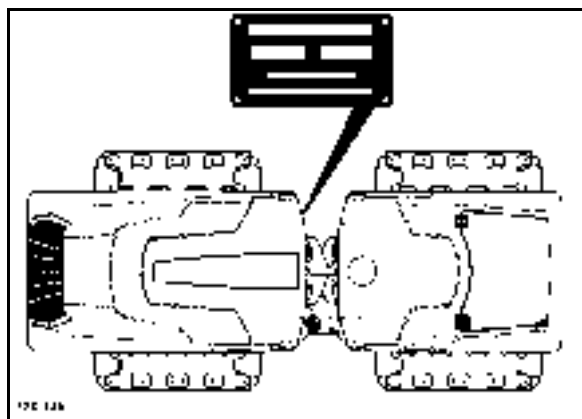

Fig. 1

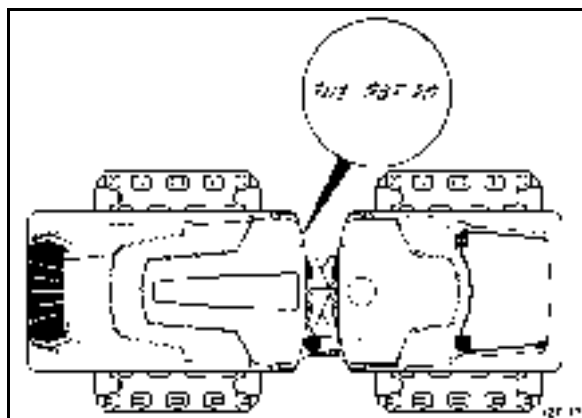

Fig. 2

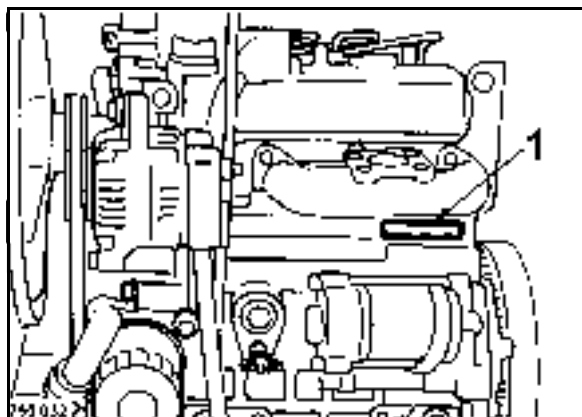

Fig. 3

| | |
|---|-----------|
| Technical Data | 7 |
| Safety regulations | 13 |
| Indicators and Controls | 23 |
| 3.1 General notes | 26 |
| 3.2 Description of indicators and control elements | 26 |
| Operation | 33 |
| 4.1 General | 34 |
| 4.2 Tests before taking into operation | 34 |
| 4.3 BOSS safety system | 35 |
| 4.4 Electronic immobilizer | 36 |
| 4.5 Starting the engine | 36 |
| 4.6 Driving the machine (cable remote control) | 39 |
| 4.7 Safety inspection for the cable remote control | 42 |
| 4.8 Switching the vibration on and off | 42 |
| 4.9 Shut down the engine | 44 |
| 4.10 Shutting down the engine manually | 45 |
| 4.11 Starting operation of the radio remote control | 46 |
| 4.12 Replacing, recharging the radio remote control power pack | 50 |
| 4.13 Safety inspection for the radio remote control | 52 |
| 4.14 Switching off of the radio remote control in case of radio interferences | 53 |
| 4.15 Entering the machine type code into the display module | 53 |
| 4.16 Teaching the BOSS safety system transponder | 55 |
| 4.17 Assembling/removing the drum extension | 56 |
| 4.18 Loading and transport | 56 |
| Maintenance | 59 |
| 5.1 General notes on maintenance | 60 |
| 5.2 Fuels and lubricants | 61 |
| 5.3 Table of fuels and lubricants | 64 |
| 5.4 Running-in instructions | 65 |
| 5.5 Maintenance table | 66 |
| 5.6 Check the engine oil level | 69 |
| 5.7 Check the hydraulic oil level | 69 |
| 5.8 Check the fuel level | 70 |
| 5.9 Fuel filter, draining off water | 70 |
| 5.10 Check the coolant level | 71 |
| 5.11 Check the air intake hose | 73 |
| 5.12 Changing engine oil and oil filter | 73 |
| 5.13 Checking, tensioning, replacing the V-belt | 75 |
| 5.14 Clean the cooling fins on engine and hydraulic oil cooler | 76 |
| 5.15 Change the oil in the vibrator shaft housing | 77 |
| 5.16 Checking the central screw of the drive hub | 79 |

Table of Contents

| | | |
|-------------------------|--|-----------|
| 5.17 | Draining the fuel tank sludge | 81 |
| 5.18 | Changing the fuel pre-cleaner, bleeding the fuel system | 81 |
| 5.19 | Battery service, checking the main battery switch | 83 |
| 5.20 | Check the rubber buffers | 84 |
| 5.21 | Checking, adjusting the valve clearance | 85 |
| 5.22 | Safety field measurement of the Boss safety system | 86 |
| 5.23 | Change hydraulic oil and filter | 87 |
| 5.24 | Change the coolant | 88 |
| 5.25 | Change the fuel lines | 90 |
| 5.26 | Checking the injection pressure | 90 |
| 5.27 | Checking the fuel injection pump | 91 |
| 5.28 | Checking the fuel injection timing | 91 |
| 5.29 | Check, clean, replace the combustion air filter | 93 |
| 5.30 | Adjust the scrapers | 96 |
| 5.31 | Tightening torques for screws with metric unified thread | 96 |
| 5.32 | Engine conservation | 97 |
| Trouble shooting | | 99 |
| 6.1 | General notes | 100 |
| 6.2 | Engine problems | 101 |
| 6.3 | Problems with remote control Hetronic with spiral cable | 103 |
| 6.4 | Problems with radio remote control Hetronic in radio operation | 107 |
| 6.5 | Faults in BOSS safety system | 109 |
| 6.6 | Fault indicator | 110 |
| 6.7 | Fault code | 111 |
| 6.8 | Input codes for BLM control | 124 |

1 Technical Data

Technical Data

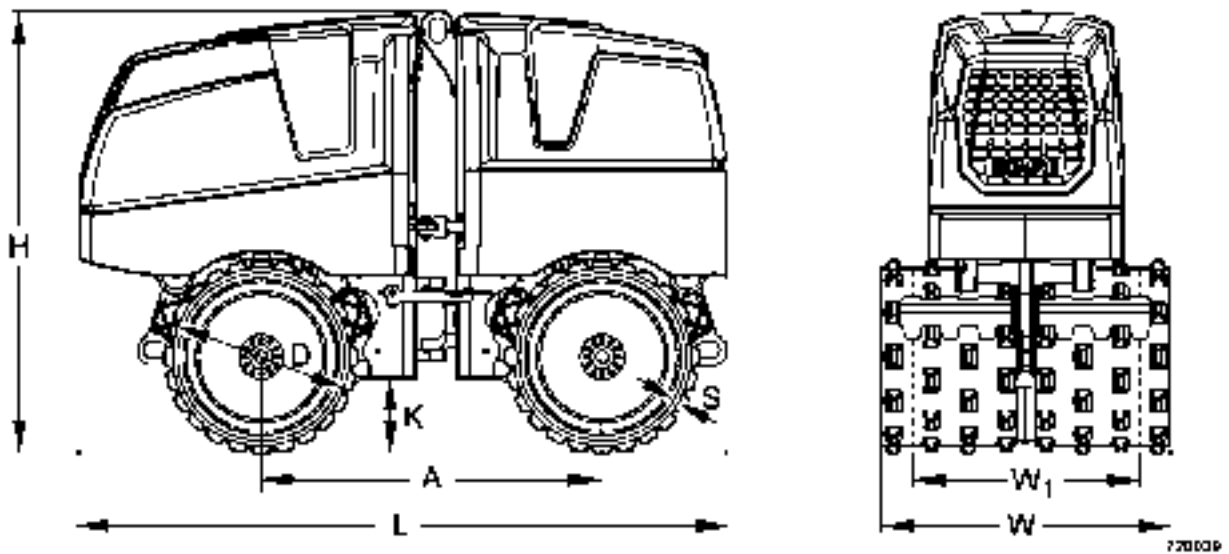

| Dimensions in mm | A | D | H | K | L | S | W | W ₁ |
|------------------|------|-----|------|-----|------|----|-----|----------------|
| BMP 8500 | 1000 | 520 | 1275 | 222 | 1897 | 25 | 850 | 610) |

*

BMP 8500

Weights

| | | |
|-------------------------|----|------|
| Operating weight (CECE) | kg | 1595 |
| Basic weight | kg | 1585 |
| Mean axle load (CECE) | kg | 775 |

Travel characteristics

| | | |
|--|------|----------|
| Travel speed (1) forward/reverse | km/h | 0 to 1.3 |
| Travel speed (2) forward/reverse | km/h | 0 to 2.5 |
| Max. gradability without/with vibration (soil dependent) | % | 55/45 |

Drive

| | | |
|----------------------|-----|--------------|
| Engine manufacturer | | Kubota |
| Type | | D 1005 |
| Cooling | | Water |
| Number of cylinders | | 3 |
| Rated power ISO 9249 | kW | 14.5 |
| Rated speed | rpm | 2600 |
| Drive system | | hydrostatic |
| Driven drums | | front + rear |

Brake

| | | |
|---------------|--|-------------|
| Service brake | | hydrostatic |
| Parking brake | | mechanical |

Steering

| | | |
|--|-----|-------------------|
| * | | BMP 8500 |
| Type of steering | | Articulated joint |
| Steering operation | | hydrostatic |
| Vibration system | | |
| Vibrating drum | | front + rear |
| Drive system | | hydrostatic |
| Frequency | Hz | 42 |
| Amplitude | mm | 1.12/0.56 |
| Centrifugal force | kN | 72/36 |
| Filling capacities | | |
| Fuel (diesel) | l | 24 |
| Hydraulic oil | l | 17 |
| Engine oil | l | 4.7 |
| Coolant | l | 4.5 |
| Vibration housing | l | 2x 1,7 |
| Safety field system | | |
| Performance level | | PL c |
| Reach of the safety field in front of/behind the machine | m | > 1.20 |
| Safety field control | | |
| Voltage | V | 8 ... 30 |
| Current consumption @ 12 V | A | 1.5 |
| Protection class | | IP 55 |
| Safety field frequency | kHz | 125 |
| Operating temperature | °C | -20 ... +80 |
| Storage temperature | °C | -40 ... +85 |
| Transponder (in remote control) | | |
| Voltage (cable operation) | V | 9 ... 30 |
| Voltage (battery operation) | V | 3.6 |
| Transmitting frequency range | MHz | 868/916 |
| Operating temperature | °C | -20 ... +80 |
| Storage temperature | °C | -40 ... +85 |
| Safety field antenna | | |
| Protection class | | IP 55 |
| Operating temperature | °C | -20 ... +85 |
| Storage temperature | °C | -40 ... +85 |
| Radio remote control | | |
| Manufacturer | | HETRONIC |
| Transmitter | | |
| Frequency band | | F-band |
| Transmitting frequency range | MHz | 868 / 916 |
| Number of channels | | 1 |
| Reach, depending on environment | m | approx. 30 |

Technical Data

| | | | |
|-------------------------------|--------|--|-----------------|
| * | | | |
| | | | BMP 8500 |
| Current draw | mA | | approx. 10 |
| Weight | kg | | approx. 1,6 |
| Receiver | | | |
| Receiver frequency range | MHz | | 868 / 916 |
| Current draw | mA | | approx. 10 |
| Transmitter power pack | | | |
| Voltage | V | | 3.6 |
| Capacity | Ah | | 1.2 |
| Battery charger | | | |
| Operating voltage | V (AC) | | 110/230 |
| | V (DC) | | 12 - 24 |

* The right for technical modifications remains reserved

The following noise and vibration data acc. to

- EC Machine Regulation edition 2006/42/EC
- the noise regulation 2000/14/EG, noise protection guideline 2003/10/EC
- Vibration Protection Regulation 2002/44/EC

were determined during conditions typical for this type of equipment and by application of harmonized standards.

During operation these values may vary because of the existing operating conditions.

Noise value

Sound pressure level on the place of the operator:

$L_{pA} = 85 \text{ dB(A)}$, determined acc. to ISO 11204 and EN 500

Guaranteed sound power level:

$L_{WA} = 103 \text{ dB(A)}$, determined acc. to ISO 3744 and EN 500

Danger

Wear your personal noise protection means (ear defenders) before starting operation.

2 Safety regulations

General

This BOMAG machine has been built in compliance with the latest technical standard and complies with the applicable regulations and technical rules. However, dangers for persons and property may arise from this machine, if:

- it is used for purposes other than the ones it is intended for,
- it is operated by untrained personnel,
- it is changed or converted in an unprofessional way,
- the safety instructions are not observed.

Each person involved in the operation, maintenance and repair of the machine must therefore read and comply with these safety regulations. If necessary, this must be confirmed by obtaining the signature of the customer.

Furthermore, the following obviously also applies:

- applicable accident prevention instructions,
- generally accepted safety and road traffic regulations,
- country specific safety regulations. It is the duty of the operator to be acquainted with these instructions and to apply these accordingly. This applies also for local regulations concerning different types of handling work. Should the recommendations in these instructions be different from the regulations valid in your country, you must comply with the safety regulations valid in your country.

Intended use

This machine must only be used for:

- Compaction of cohesive soils in trench construction
- Construction backfills
- Earthwork in sewer and pipeline construction
- Earthwork in railway and dam construction
- Earthwork in sanitary landfill construction
- Subbase and foundation work

The place of the operator is behind the machine.

When operating the machine from the opposite side, actuation of travel controls will cause ma-

chine movements, which are not in compliance with the movement of the control elements.

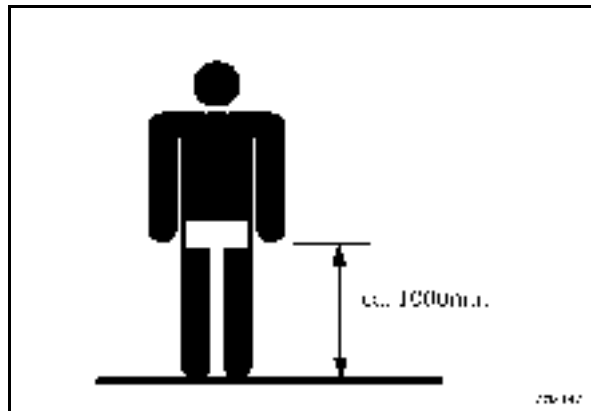

Fig. 4

- The remote control must be carried in front of the body, as intended (Fig. 4).

Unintended use

Danger may arise from the machine if it is used for purposes other than the one it is intended for.

Any danger caused by unintended use is the sole responsibility of the customer or driver/operator, the manufacturer cannot be made liable.

Examples for unintended use are:

- work with vibration on hard concrete, cured bitumen layers or extremely frozen ground
- driving on unstable subbases or insufficient grip or too small contact area (danger of tipping over)
- using the machine on for towing
- operating the machine without visual contact

The transport of persons is prohibited.

Starting and operation of the machine in explosive environments and in underground mining is prohibited.

Remaining dangers, remaining risks

Despite careful work and compliance with standards and regulations it cannot be ruled out that further dangers may arise when working with and handling the machine.

Both the machine as well as all other system components comply with the currently valid safety regulations. Nevertheless, remaining risks cannot be ruled out completely, even when using the ma-

chine for the purpose it is intended for and following all information given in the operating instructions.

A remaining risk can also not be excluded beyond the actual danger zone of the machine. Persons remaining in this area must pay particular attention to the machine, so that they can react immediately in case of a possible malfunction, an incident or failure etc.

All persons remaining in the area of the machine must be informed about the dangers that arise from the operation of the machine.

Regular safety inspections

Have the machine inspected by an expert (properly trained person) once every year.

Who is allowed to operate the machine?

Only trained, instructed and authorized persons of at least 18 years of age are permitted to drive and operate this machine. For operation of the machine the responsibilities must be clearly specified and complied with.

Persons under the influence of alcohol, medicine or drugs are not allowed to operate, service or repair the machine.

Maintenance and repair work requires specific knowledge and must therefore only be performed by trained specialists.

Conversions and alterations to the machine

Unauthorized conversions to the machine are prohibited for safety reasons.

Original parts and accessories have been specially designed for this machine. We wish to make expressly clear that we have not tested or authorized any original parts or special equipment not supplied by us. The installation and/or use of such products can impair the active and/or passive driving safety. The manufacturer expressly excludes any liability for damage resulting from the use of non-original parts or accessories.

Damage, deficiencies, misuse of safety installations

Machines which are not safe to operate or in traffic must be immediately taken out of service and shall not be used, until these deficiencies have been properly rectified.

Safety installations and switches must neither be removed nor must they be made ineffective.

Safety notes in the operating and maintenance instructions:

Danger

Sections marked like this point out possible dangers for persons.

Caution

Sections marked like this point out possible dangers for the machine or for parts of the machine.

Note

Sections marked like this provide technical information concerning the optimal economical use of the machine.

Environment

Sections marked like this highlight activities for the safe and environmental disposal of fuels and lubricants as well as replaced parts.

Observe all environment protection regulations.

Loading the machine

Check the fastening of the central lifting hook before each use.

Use only stable loading ramps of sufficient load bearing capacity. The ramp inclination must be less than the gradability of the machine.

Secure the machine against tipping or slipping off.

Secure the machine on the transport vehicle against rolling, slipping and turning over.

Persons are highly endangered if

Safety regulations

- they step or stand under loads being lifted
- they remain in the drive range of the machine during an instruction and during loading.

The machine must not swing about when being lifted.

Use only safe lifting gear of sufficient load bearing capacity

Fasten the lifting gear only at the specified lifting points.

Recovering/towing the machine

The machine can be recovered by lifting it out of the danger area.

▲ Danger

Life hazard!

Lift the machine only with suitable lifting gear.

Weight: see chapter "Technical Data".

Starting the machine

Before starting

When operating several machines with radio remote controls the system numbers of the individual control units must be checked.

Use only machines which are serviced at regular intervals.

Become acquainted with the equipment, the control elements, the working principle of the machine and the working area.

Wear your personal protective outfit (hard hat, safety boots, etc.).

Before starting the machine check whether:

- persons or obstructions are near the machine
- the machine shows any obvious faults
- all guards and safety elements are in place
- brakes, control elements and horn are working
- engine hood is closed and locked

Do not start the machine with defective gauges, control lights or control elements.

Do not take any loose objects with you or fasten them to the machine.

Starting

For starting set all control levers to 'neutral position'.

Do not use any starting aids like start pilot or ether.

After starting check all gauges and control lights.

Starting with jump wires

Connect positive with positive and negative with negative (ground cable) – always connect the ground strap last and disconnect it first! A wrong connection will cause severe damage in the electric system.

Do not start the engine by shorting the electric terminals on the starter motor, because the machine may start to drive immediately.

Do not use any starting aids like start pilot or ether.

Starting and operation of the machine is closed rooms and trenches

Exhaust gases are highly dangerous! Always ensure an adequate supply of fresh air when starting and operating in closed rooms and trenches!

Driving the machine

Persons in the danger area

Before taking up work, also after breaks, you should always convince yourself that the danger zone is free of persons or obstructions, especially when driving in reverse.

Give warning signals, if necessary. Stop work immediately if persons remain in the danger zone, despite the warning.

Driving

Do not use the machine to transport persons.

In case of unusual noises and development of smoke perform trouble shooting and have the fault corrected.

Always keep a sufficient distance to excavation walls and embankments and do not use working methods that could impair the stability of the machine.

Do not work with vibration on hard concrete, cured bitumen layers or extremely frozen ground.

Driving on inclinations and slopes

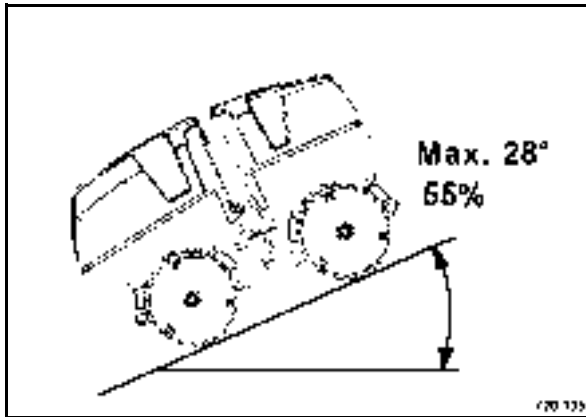

Fig. 5

Do not drive on gradients exceeding the maximum gradability of the machine.

On slopes drive extremely careful and always directly up or down the slope. Change to a lower gear before starting to drive.

Wet and loose soils considerably reduce the ground adhesion of the machine on inclinations and slopes. Higher risk of accident!

Inclination

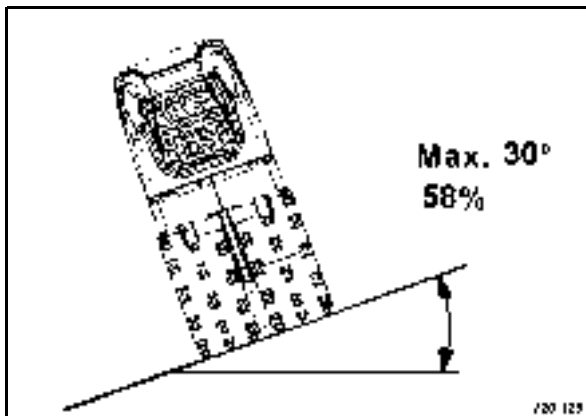

Fig. 6

The tipping angle was measured in static condition on level, hard ground with the machine stopped, no steering and without vibration.

With loose soil, acceleration/deceleration, running vibration, steering or attached accessories the tipping angle may be considerably lower.

Driving across slopes should therefore be strictly avoided, because of the high risk of tipping over and the related risk of severe or even fatal accidents.

You should therefore always drive straight up or down a slope.

Behaviour in traffic

Match the speed to the working conditions.

Always give way to loaded transport vehicles.

Keep away from edges and embankments.

Checking the effect of vibration

When compacting with vibration you must check the effect on nearby buildings and underground supply lines (gas, water, sewage, electric power), if necessary stop compaction work with vibration.

Do not activate the vibration on hard (frozen, concrete) ground. Danger of bearing damage!

Parking the machine

Park the machine on horizontal, level, firm ground.

Before leaving the machine:

- shut the engine down, pull the ignition key off
- secure the machine against unintended use.
- Pull off the main battery switch.

Mark machines, which could be in the way, with a clearly visible sign.

Refuelling

Do not inhale any fuel fumes.

Refuel only with the engine shut down.

Do not refuel in closed rooms.

No open fire, do not smoke.

Monitor the entire refuelling process.

Do not spill any fuel. Catch running out fuel, do not let it seep into the ground.

Wipe off spilled fuel. Keep dirt and water away from the fuel.

A leaking fuel tank can cause an explosion. Ensure tight fit of the fuel tank cover, if necessary replace immediately.

Fire protection measures

Familiarise yourself with the location and the operation of fire fighting equipment. Observe all fire reporting and fire fighting possibilities.

Maintenance work

Comply with the maintenance work described in the operating and maintenance instructions, including the information concerning the replacement of parts.

Maintenance work must only be performed by qualified and authorized persons.

Keep unauthorized persons away from the machine.

Do not perform maintenance work while the machine is driving or the engine is running.

Park the machine on horizontal, level, firm ground.

Pull off the ignition key and switch off the main battery switch.

Work on hydraulic lines

Relieve hydraulic pressures before working on hydraulic lines. Hydraulic oil escaping under pressure can penetrate the skin and cause severe injury. When being injured by hydraulic oil consult a medical doctor immediately, as otherwise this may cause severe infections.

Do not step in front of or behind the drums when performing adjustment work in the hydraulic system.

Do not change the setting of pressure relief valves.

Drain the hydraulic oil at operating temperature – danger of scalding!

Catch running out hydraulic oil and dispose of environmentally.

Always catch and dispose of hydraulic oils separately.

Do not start the engine after draining the hydraulic oil.

Once all work is completed (with the system still depressurized!) check all connections and fittings for leaks.

Changing hydraulic hoses

Hydraulic hoses must be visually inspected at regular intervals.

Hydraulic hoses must be immediately replaced if:

- the outer layer is damaged down to the inlay (e.g. chafing, cuts, cracks)
- the outer layer is brittle (formation of cracks in the hose material)

- the hose shows deformations in pressurized and depressurized condition, which do not comply with the genuine shape of the hydraulic hose
- the hose shows deformations in bends, e.g. squeezing, buckling, layer separation, formation of blisters
- parts of the hose are leaking.
- hoses are not correctly installed.
- the hydraulic hose has separated from the fitting
- the fitting shows corrosion that impairs both function and strength.
- hoses are mixed up by mistake.
- fittings are damaged or deformed, whereby the function and strength of the hose/hose connection is impaired.

Only genuine BOMAG replacement hydraulic hoses ensure that the correct hose type (pressure range) is used at the right location.

Working on the engine

Shut the engine down before opening the engine hood.

Drain the engine oil at operating temperature – danger of scalding!

Wipe off spilled oil, catch running out oil and dispose of environmentally.

Store used filters and other oil contaminated materials in a separate, specially marked container and dispose of environmentally.

Do not leave any tools or other objects, that could cause damage, in the engine compartment.

Working on electric parts of the machine

Caution

Disconnect the minus pole first and the plus pole after.

Connect the battery in reverse order. Connect the plus pole first and the minus pole after.

Before starting to work on electric parts of the machine disconnect the battery and cover it with insulating material.

Do not use fuses with higher ampere ratings and do not repair fuses with a piece of wire. Fire hazard!

Working on the battery

When working on the battery do not smoke, do not use open fire!

Do not let acid come in contact with hands or clothes! When injured by acid flush off with clear water and seek medical advice.

Metal objects (e.g. tools, rings, watch straps) must not come in contact with the battery poles – danger of short circuit and burning!

When recharging non-serviceable batteries remove all plugs, to avoid the accumulation of explosive gases.

Observe the applicable instructions when starting with an auxiliary battery.

Dispose of old batteries according to regulations.

Switch off the charging current before removing the charging clamps.

Ensure sufficient ventilation, especially if the battery is to be charged in a closed room.

Working on the fuel system

Do not inhale any fuel fumes.

Avoid open fire, do not smoke, do not spill any fuel.

Catch running out fuel, do not let it seep into the ground and dispose off environmentally.

Cleaning work

Do not perform cleaning work while the motor is running.

Do not use gasoline or other easily inflammable substances for cleaning.

When cleaning with steam cleaning equipment do not subject electrical parts and insulation material to the direct jet of water, or cover it beforehand.

- Do not guide the water jet into the exhaust and into the air filter.

After maintenance work

After all maintenance work is completed reinstall all guards and safety installations.

Repair

Mark a defective machine by attaching a warning tag to the dashboard.

Before starting electric welding work on the machine, all electrical components must be disconnected from the power supply.

Repair work must only be performed by qualified and authorized persons. Use our repair instructions for this work.

Exhaust gases are highly dangerous! Always ensure an adequate supply of fresh air when starting in closed rooms!

Test

The safety of compaction equipment must be checked by a specialist as required in dependence on the application and the operating conditions, however at least once every year.

Radio remote control

The machine must only be operated within the field of vision of the operator.

The radio remote control must only be used by trained and authorized persons.

The safety features incorporated in the radio remote control must be checked at regular intervals.

A defective radio remote control must no longer be used.

In case of radio interferences watch the fault code display and switch to cable remote control, if necessary

The machine will stop when the reach of the radio remote control is exceeded.

In case of defects the radio remote control must be immediately taken out of service. The transmitter must be switched off via the emergency stop function. The connecting cable must be disconnected from the machine related socket on the receiver. The radio remote control must only be repaired by the manufacturer or specialists authorized by the manufacturer.

When working on plug connections the machine battery must be disconnected or the connecting cable of the receiver pulled off.

All work related with the initial installation of a system or with repair work must only be performed by qualified personnel.

The person performing the work is fully liable for professional execution of repair and maintenance work in compliance with the regulations of the manufacturer.

Warranty on spare parts can only be granted if these parts were installed in compliance with our regulations and instructions and by personnel au-

Safety regulations

thorized by us. We will not assume liability for changes and modifications not performed by us.

Information and safety stickers/decals on the machine

Keep safety stickers in good and legible condition (see parts manual) and comply with their meaning.

Replace damaged and illegible stickers/decals.

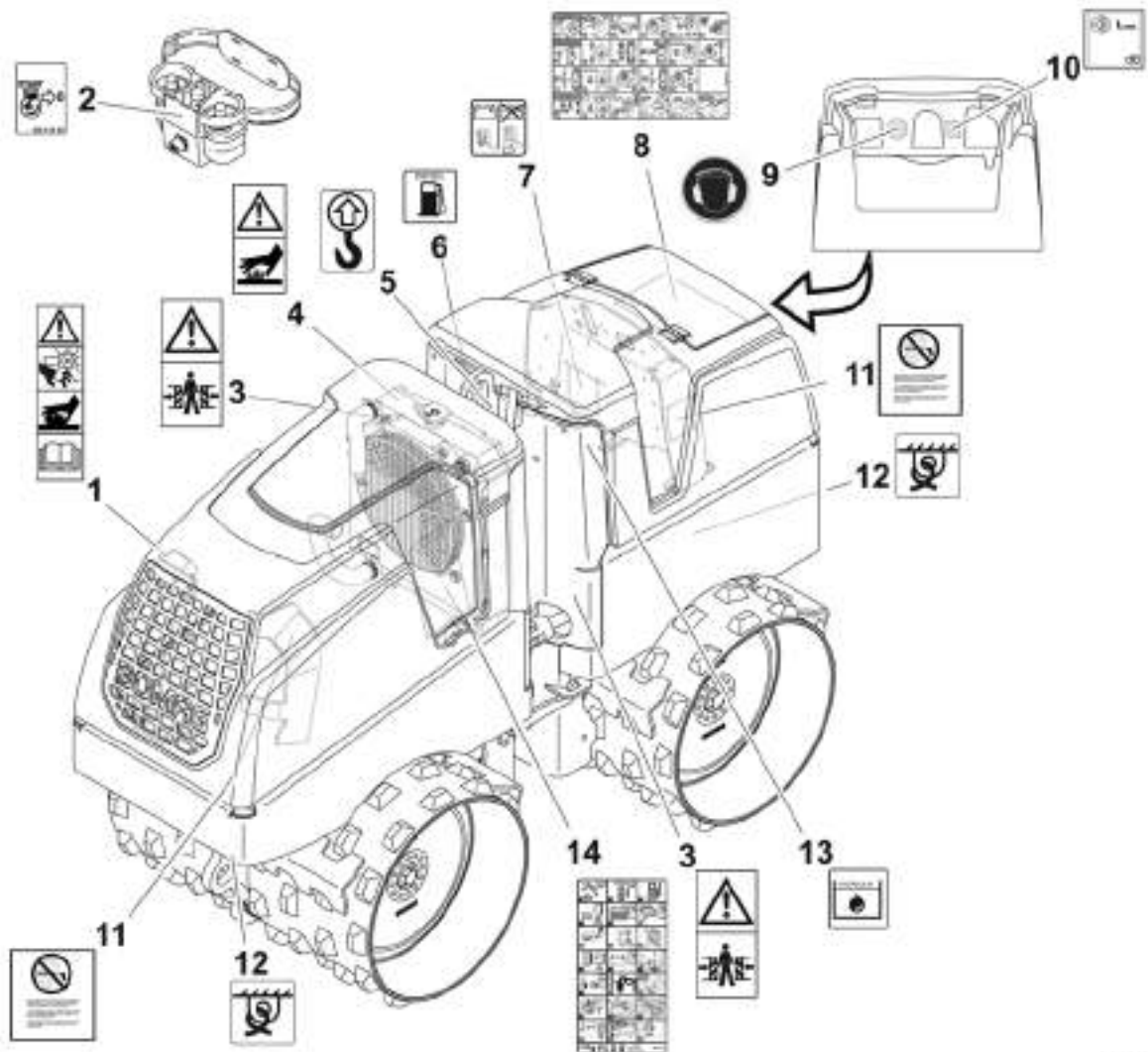

720068

Fig. 7

Stickers and decals

- | | |
|--|---|
| <ul style="list-style-type: none"> 1 Warning sticker: Hand injuries and hot surface, read operating instructions 2 Information sticker "Engine start" 3 Warning sticker "Danger of crushing" 4 Warning sticker "Hot surface" 5 Information sticker "Lifting point" 6 Information sticker "Diesel" 7 Information sticker "Battery disconnecting switch" 8 Brief operating instructions 9 Instruction sticker: "Wear ear defenders" | <ul style="list-style-type: none"> 10 Information sticker "Guaranteed sound capacity level" 11 Maintenance sticker "High pressure cleaner" 12 Information sticker "Lashing points" 13 Information sticker "Hydraulic oil" 14 Maintenance sticker |
|--|---|



Fig. 8

Information sticker "Bio Hydraulic Oil"*

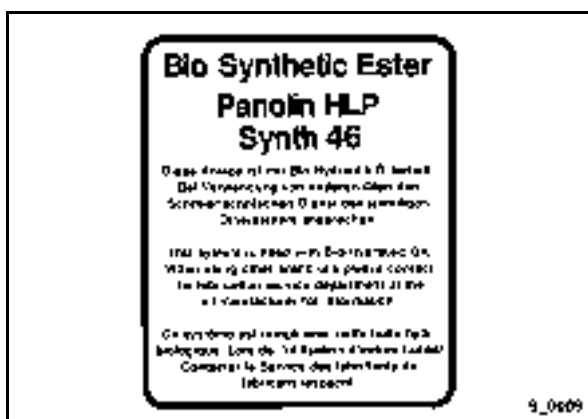

Fig. 9

Information sticker "Panolin 46"**

* Optional equipment

** Optional equipment

3 Indicators and Controls

Indicators and Controls

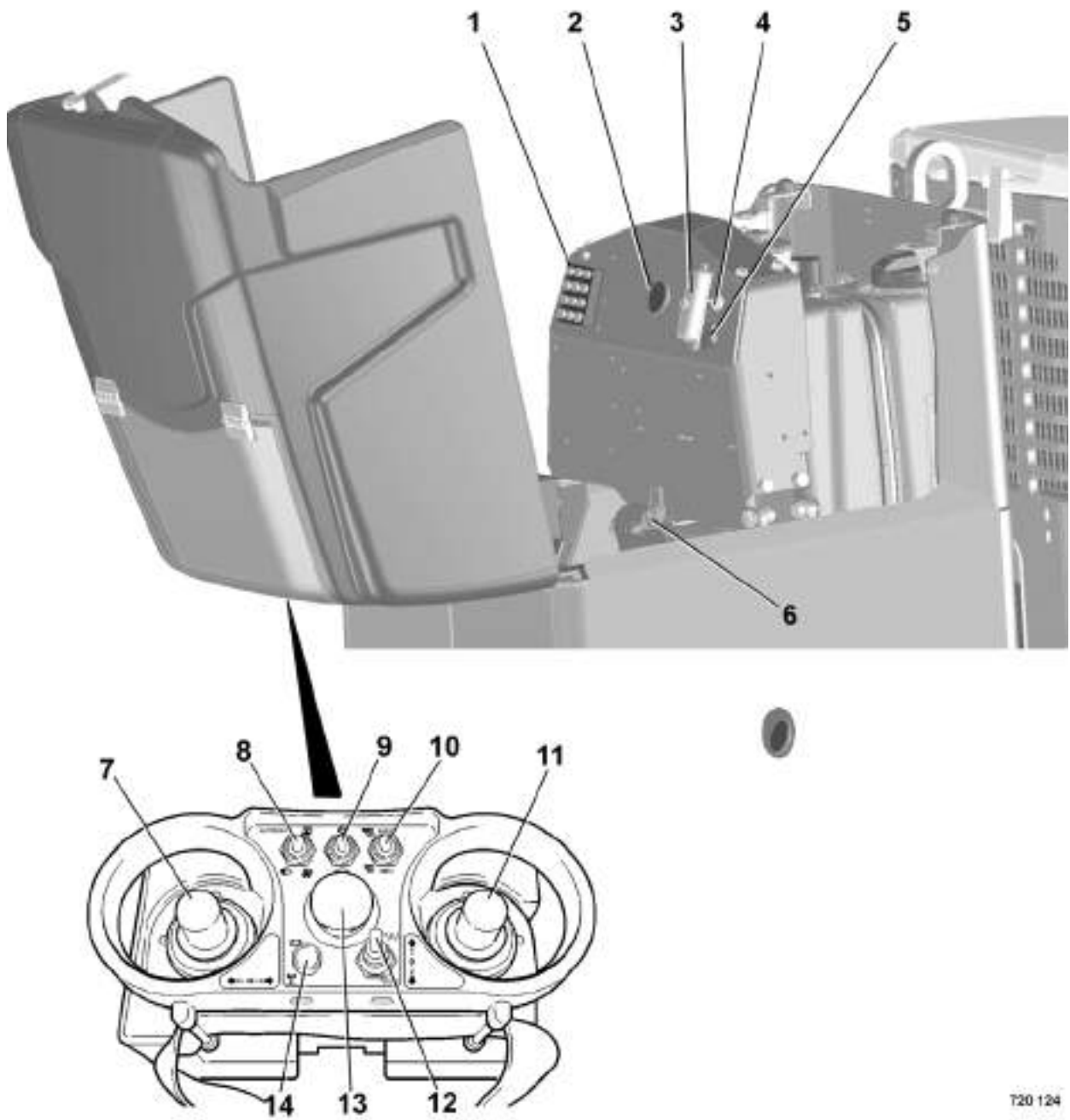

T20 124

Fig. 10

- 1 Electronic immobilizer*
 - 2 Display module
 - 3 Fuse box
 - 4 Toggle switch for cable remote control/radio remote control
 - 5 Socket
 - 6 Main battery switch
 - 7 Steering control lever
 - 8 Toggle switch, vibration automatic/manual
 - 9 Toggle switch, travel ranges
 - 10 Toggle switch, engine speed
 - 11 Travel direction control lever
 - 12 Toggle switch for vibration high/low amplitude
 - 13 Emergency stop switch
 - 14 Control light data transfer/power pack radio remote control
- * Optional equipment

3.1 General notes

If you are not yet familiar with the control and display elements on this machine you should read this section thoroughly before starting any operation on the machine. Here all functions are described in detail.

Section 4 "Operation" contains only brief descriptions of the individual control steps.

3.2 Description of indicators and control elements

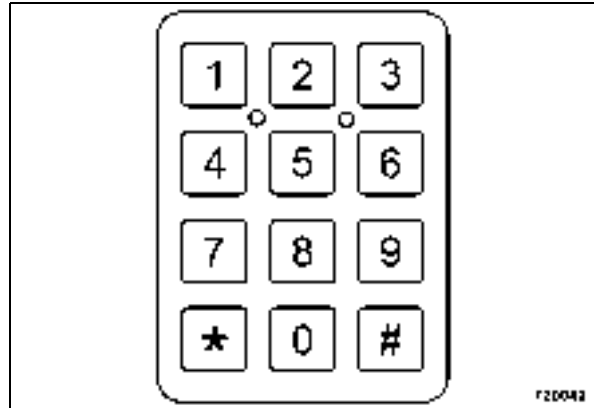

Fig. 11

No. 1 = Electronic immobilizer*

Before starting the engine the anti-theft protection* must be disarmed by entering a code.

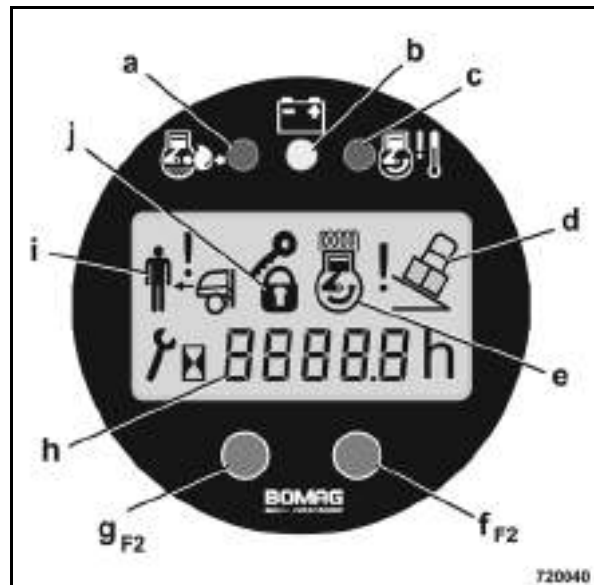

Fig. 12

No. 2 = Display module

- a red** = Warning light, engine oil pressure
Lights if the engine oil pressure is too low
Check engine oil level, repair the engine if necessary.
- b yellow** = Charge control light
Lights if the battery is not being

* Optional equipment

- charged.
Check V-belt, if necessary repair the generator.
- c red** = Coolant temperature warning light
Lights red if the temperature of the engine coolant is too high
 - d** = Tipping angle warning indicator
Lights when the tipping angle of the machine is > 45°.
The machine will stop, vibration is shut down.
Restart the machine and move it carefully out of the danger area.
 - e** = Preheating control
Preheating for starting at low temperatures.
 - f** = Function key F1
To enter code numbers in connection with function key F2
 - g** = Function key F2
To enter code numbers in connection with function key F1
 - h** = Operating hour meter
Counts the operating hours while the engine is running.
All maintenance work must be performed according to the indicated operating hours.
Display of machine type code, remote control code and fault codes.
 - i** = Display of safety field system
Lights when the operator is within the safety field. The machine stops.
Move the travel lever accordingly to free the machine from the obstruction.
 - j** = Indication that the electronic immobilizer is active*.
Enter the required code to deactivate.

* Optional equipment

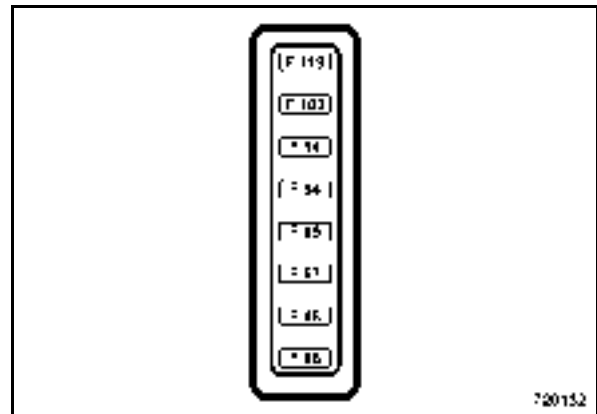

Fig. 13

No. 3 = Fuse box

- F119 = (20A) Fuse for starter motor
- F103 = (10A) Fuse potential 15
- F14 = (25A) Fuse for engine solenoid
- F54 = (5A) Fuse for cable remote control
- F05 = (10A) Fuse for utility socket
- F67 = (25A) Fuse control (potential 30)
- F48 = (30A) Preheating
- F68 = (5A) Immobilizer**

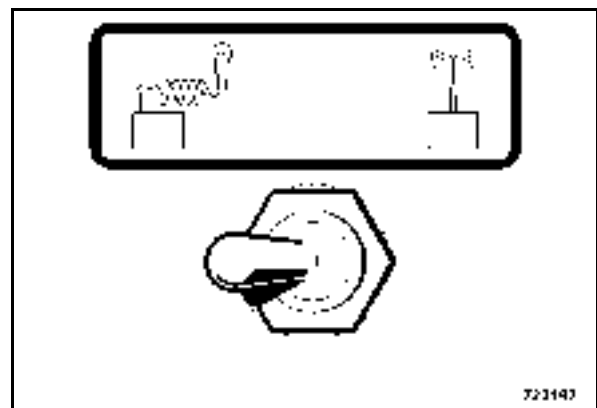

Fig. 14

No. 4 = Toggle switch for cable remote control/radio remote control

- Position left = Cable remote control
- Position right = Radio remote control*

** Optional equipment

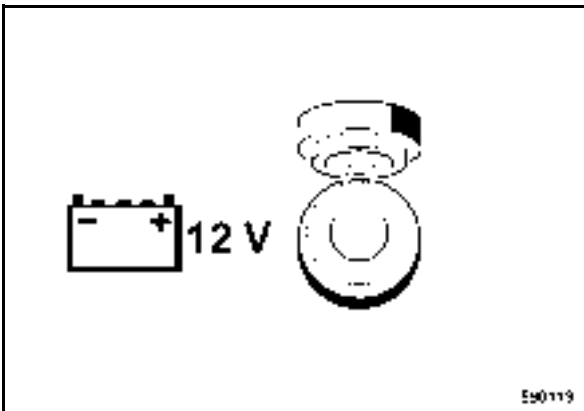

Fig. 15

No. 5 = 12 V socket

12 V vehicle voltage when main battery switch is switched on.

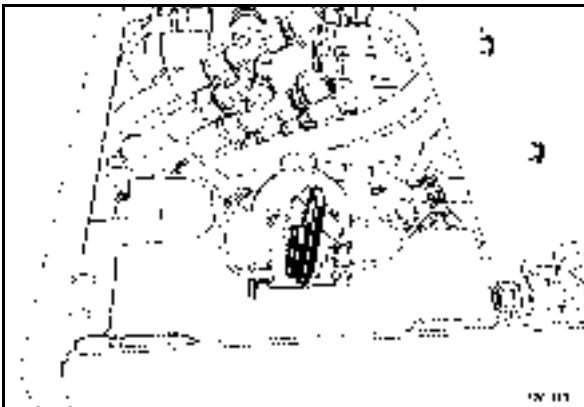

Fig. 16

No. 6 = Main battery switch

Disconnects the ground contact in the electric circuit of the machine.

i Note

If the power pack of the radio remote control is to be charged, the main battery switch must remain switched on when the engine is shut down.

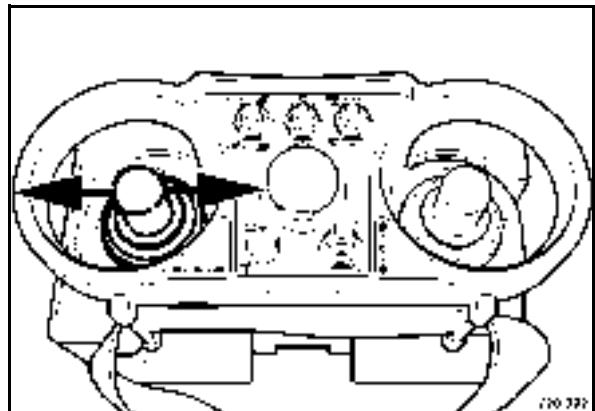

Fig. 17

No. 7 = Steering control lever

Middle position = Straight ahead

Position left = Driving to the left

Position right = Driving to the right

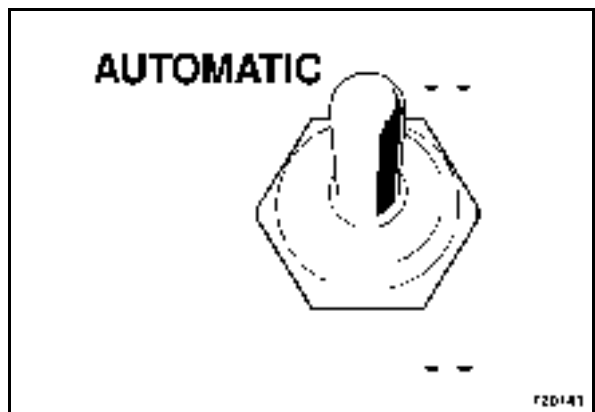

Fig. 18

No. 8 = Toggle switch, vibration automatic / manual

Position "Manual"

= Vibration switches on when shifting the control lever for high/low amplitude.

i Note

Machine switches automatically to speed range 1

Position "Automatic"

= Vibration comes on: when moving the travel lever to forward/reverse after the control lever for high/low amplitude has been actuated to any desired position.

= Vibration switches off: with travel lever in position "0".

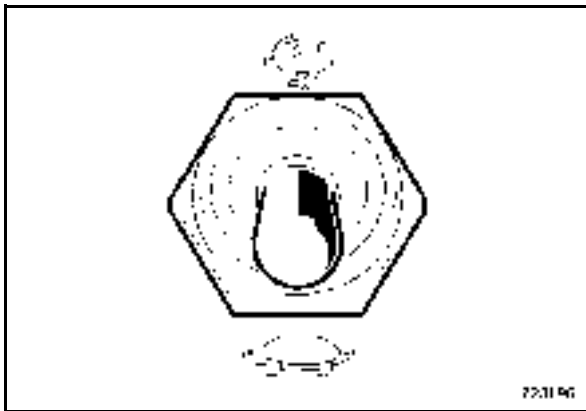

Fig. 19

No. 9 = Toggle switch, travel ranges

Position "turtle" = 1. Travel speed range: 0 ... 1.3 km/h

Position "rabbit" = 2nd travel speed range: 0 ... 2.7 km/h, driving with vibration not possible

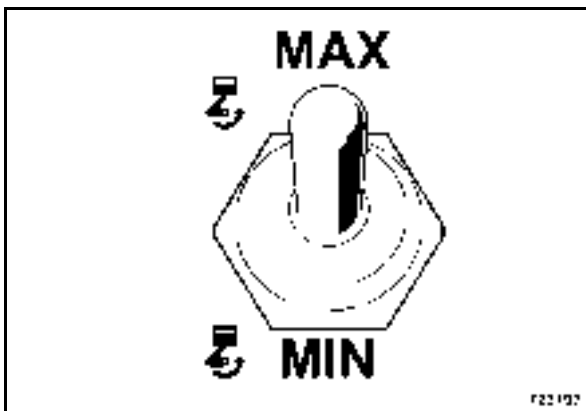

Fig. 20

No. 10 = Toggle switch, engine speed

Position "MIN" = idle speed of engine
Position "MAX" = maximum engine speed

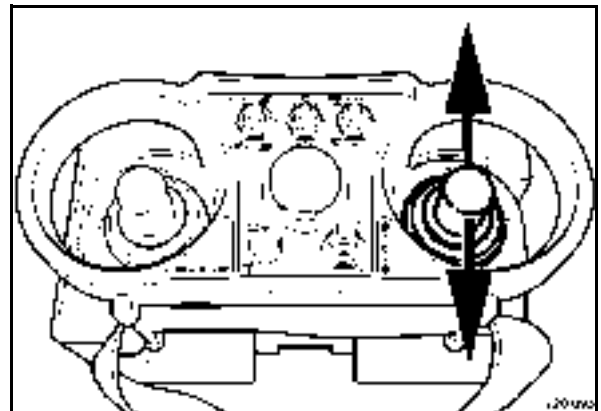

Fig. 21

No. 11 = Travel direction control lever

Middle position = Stop position

Position front = Forward travel

Position rear = Backwards travel

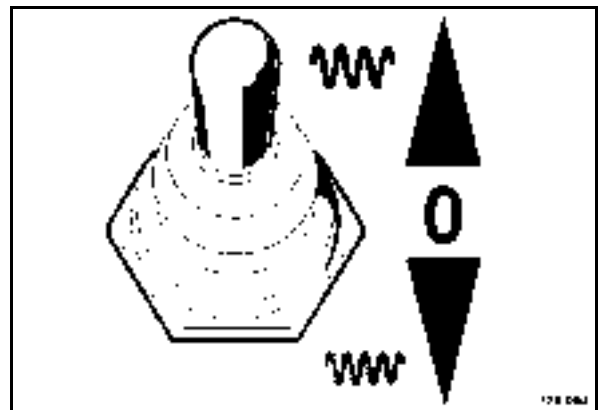

Fig. 22

No. 12 = Toggle switch for vibration high/low amplitude

Position "front" = high amplitude

Position "middle" = vibration switched off

Position "rear" = low amplitude

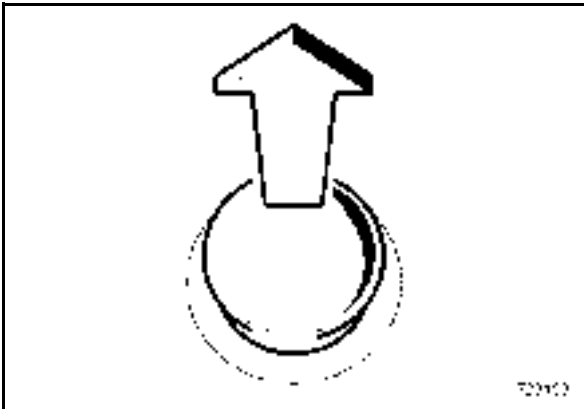

Fig. 23

No. 13 = Emergency stop push button

actuated = transmitter and diesel engine will be switched off.

unlocked = switches the transmitter on when the ignition is switched on.

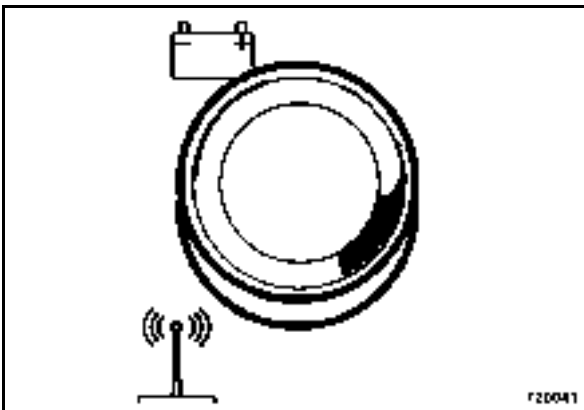

Fig. 24

No. 14 = Control light data transfer/power pack radio remote control

Flashes green when the transmitter is switched on.

Lights red when the accumulator voltage drops too low.

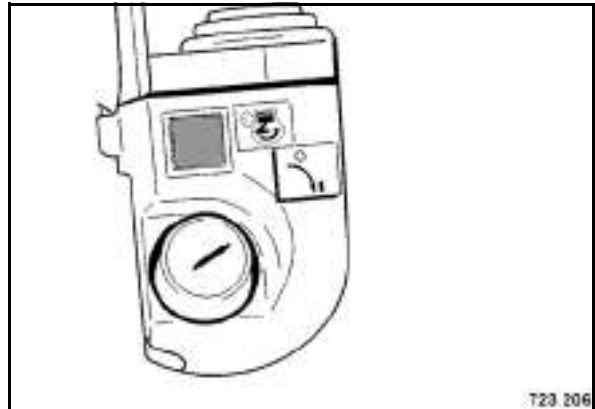

Fig. 25

No. 15 = Start button

to start the engine.

i Note

Perform the starting process for maximum 15 to 20 seconds without interruption and pause for about 1 minute between starting attempts. Should the engine not start in this time, perform trouble shooting and rectify the cause.

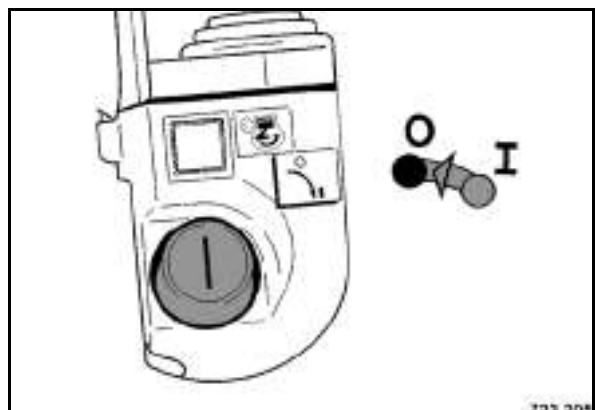

Fig. 26

No. 16 = Ignition switch

Position 0 = Insert or pull out key, ignition/engine off

Position I = Ignition on, charge and oil pressure control lamps light up

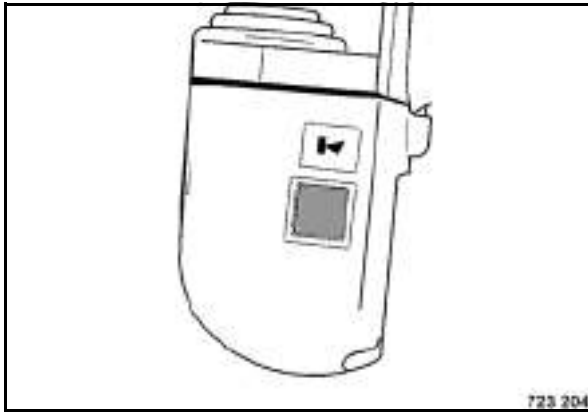

Fig. 27

No. 17 = Horn button

to signalize a danger situation.

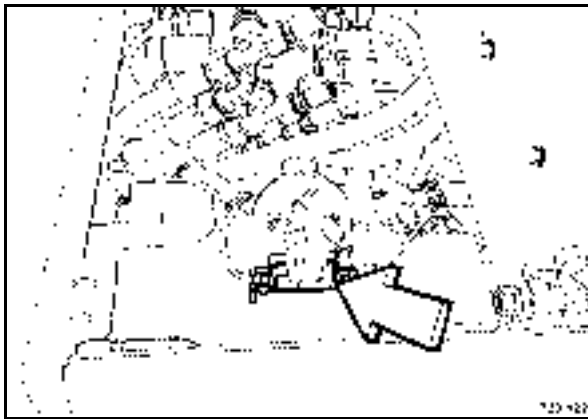

Fig. 28

No. 18 = Main fuse for battery

80A = (F00)



4 Operation

4.1 General

If you are not yet acquainted with the controls and indicating elements on this machine you should thoroughly read chapter 3 "Indicators and control elements" before starting work.

All indicators and control elements are described in detail in this chapter.

4.2 Tests before taking into operation

Before the everyday use or before a longer working period the following tests and inspections must be performed.

Danger

Danger of injury!

Please observe strictly the safety regulations in chapter 2 of these operating and maintenance instructions.

- Park the machine on ground as level as possible.
- The operator must become acquainted with the size of the safety field.

Check:

- fuel tank and fuel lines for leaks
- engine, radiator and hydraulic system for leaks
- screw joints for tight fit
- Machine for condition, cleanliness, damage
- Function of remote control and emergency stop.
- presence of the appropriate operating and maintenance instructions
- proper maintenance of the machine
- Air pressure in rubber tires (only AC machines)

Note

For a description of the following tasks refer to the chapter "maintenance every 10 operating hours".

- Engine oil level, top up if necessary
- Hydraulic oil level, top up if necessary.
- Fuel level, top up if necessary.
- Coolant level, top up if necessary
- Water level, top up if necessary.

4.3 BOSS safety system

Function

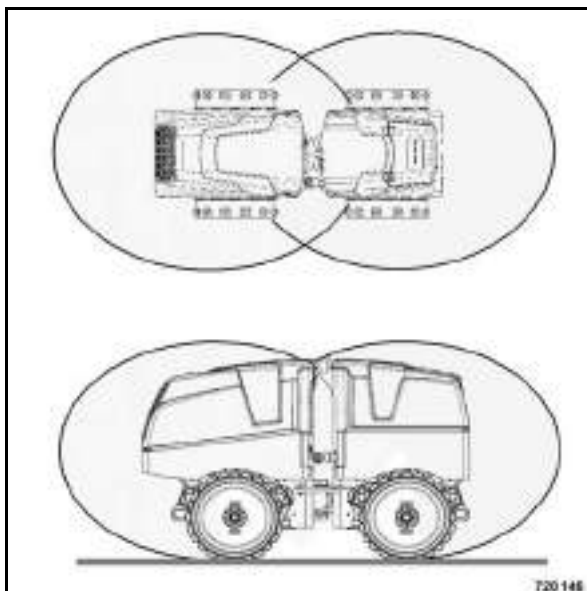

Fig. 29

The machine is surrounded by 2 spherical electromagnetic safety fields (Fig. 29). If the machine operator with the remote control enters into the field, which stretches in travel direction, the machine will stop immediately.

- Shift the travel lever to neutral position and exit the field, which corresponds with the travel direction.
- Operate the machine to the opposite direction (picture), so that the operator is no longer in the safety field of the machine.

⚠ Caution

The operator must become acquainted with the size of the safety field before he starts operation.

If an operator is between 2 machines in both safety fields, both corresponding travel directions of the associated machines will be stopped. The operator must leave the safety field to be able to move the machine again.

The minimum distance between operator and machine must be 2 m. When falling short of a distance of 1.2 m, the corresponding travel direction will be stopped.

⚠ Danger

Danger of squashing!

Only operators carrying the associated remote control are protected.

There is no protection for persons laying on the ground.

4.4 Electronic immobilizer*

Before starting the engine the anti-theft protection* must be disarmed by entering a code.

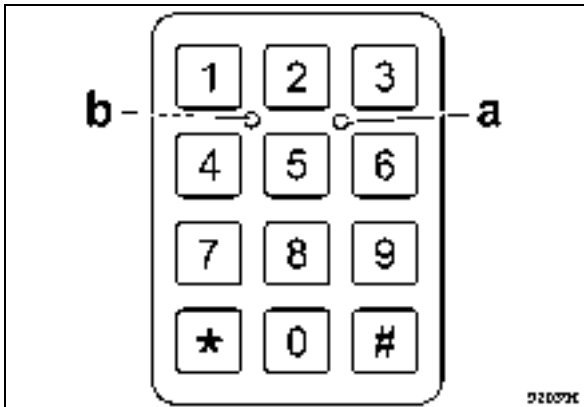

Fig. 30

i Note

With the electronic immobilizer armed, the light emitting diode (a) (Fig. 30) flashes slowly.

- Slowly enter the six-digit user code.

i Note

When entering the code, the light emitting diode (6) lights up with every digit.

- Press the diamond button.
- The electronic immobilizer is now disarmed and the engine can be started within the next 30 seconds.

i Note

After entering the service code (for maintenance work) the electronic immobilizer remains switched off.

* Optional equipment

4.5 Starting the engine

⚠ Danger

Wear your personal noise protection means (ear defenders) before starting operation.

⚠ Danger

Exhaust gases are highly dangerous!

Always ensure an adequate supply of fresh air when starting and operating in closed rooms and trenches!

⚠ Caution

In this chapter it is assumed that the operator is fully acquainted with the function of the different control elements on the machine.

- Open the rear hood.

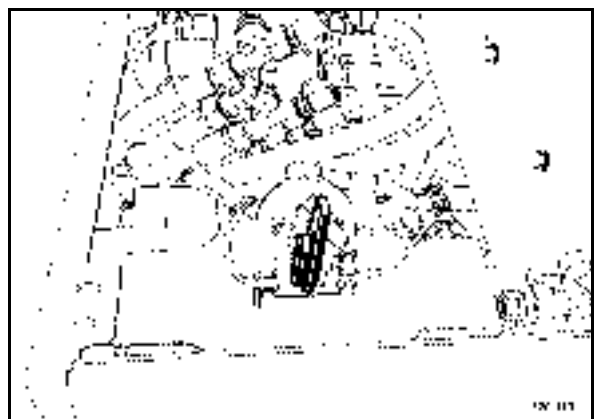

Fig. 31

- Switch on the main battery switch (Fig. 31).
- Strap the control to your body and plug the spiral cable into the remote control, if required.

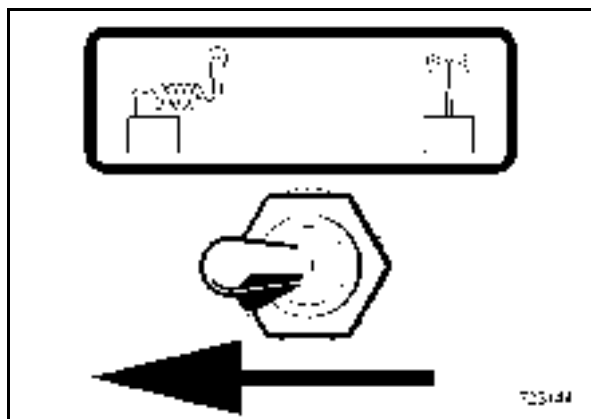

Fig. 32

- For cable operation of the machine switch the toggle switch (Fig. 32) to the left.

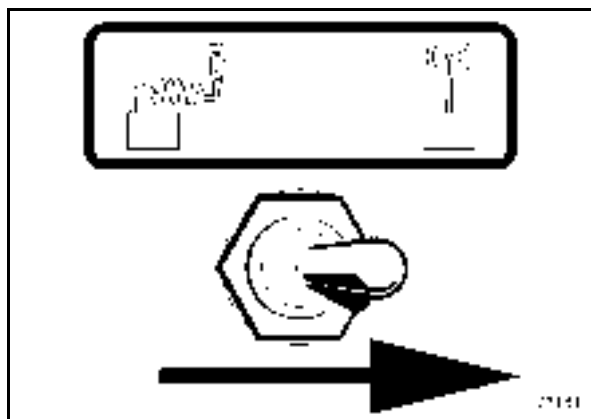

Fig. 33

- For radio operation of the machine switch the toggle switch (Fig. 33) to the right.

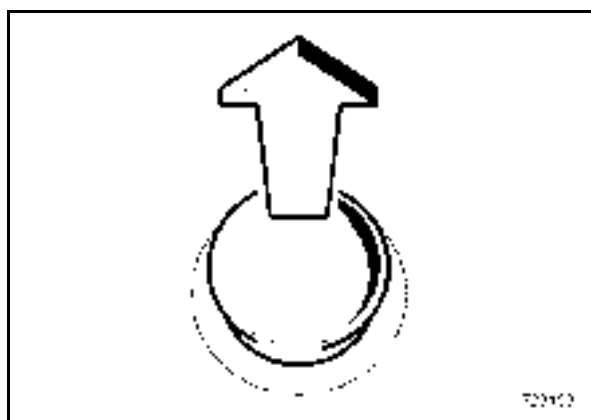

Fig. 34

- If necessary unlock the emergency stop switch (Fig. 34).

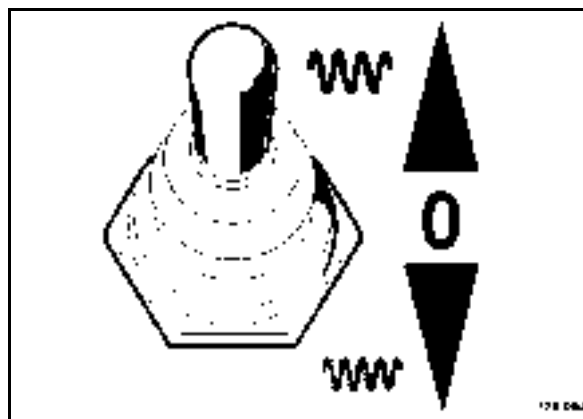

Fig. 35

- Set the vibration toggle switch (Fig. 35) to position "0".

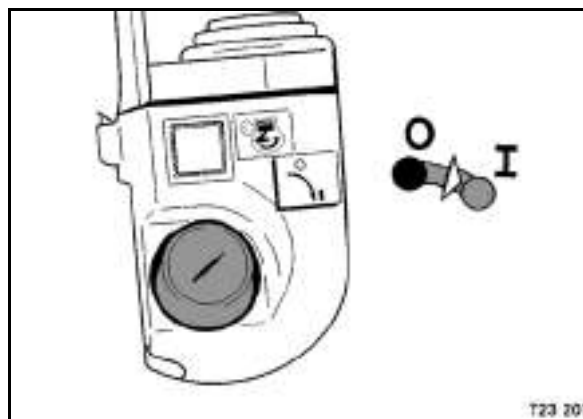

Fig. 36

- Switch on the ignition (Fig. 36).

i Note

With the ignition key in position "1" the machine type code will appear in the display module for a few seconds.

The machine will emit a short horn signal. This indicates that the machine is ready for operation.

i Note

If the horn does not sound, there must be fault on the machine.

The control emits two short buzzer signals. This indicates that the control is ready for operation.

Operation

i Note

If the buzzer does not sound, there must be a fault in the control or the power pack of the control is empty.

i Note

All normal work functions can only be operated from a defined neutral position, i.e. the respective control elements must be in rest position when switching the sender on. If this is not true, the engine cannot be started.

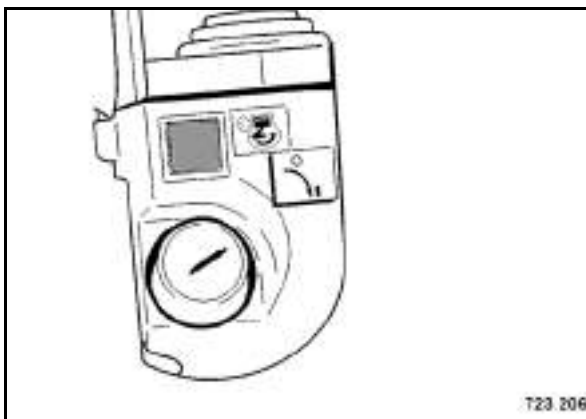

Fig. 37

- Press the start button to start the engine (Fig. 37).

⚠ Caution

Run the engine warm for a short while before starting work. Do not rev up a cold engine to high idle speed/full load speed.

Starting with jump wires

⚠ Caution

A wrong connection will cause severe damage in the electric system.

- Open the rear hood.

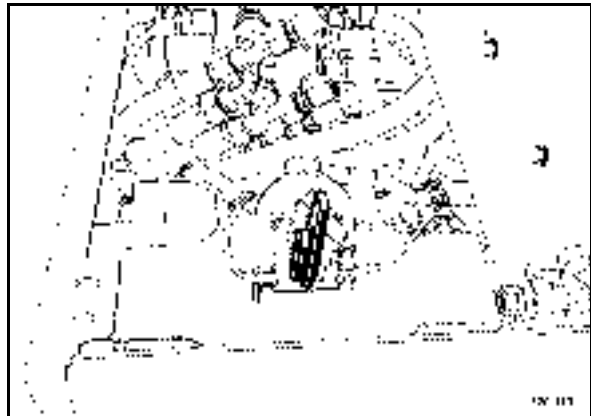

Fig. 38

- Switch on the main battery switch (Fig. 38).

⚠ Caution

Only use a 12 volt battery for jump starting.

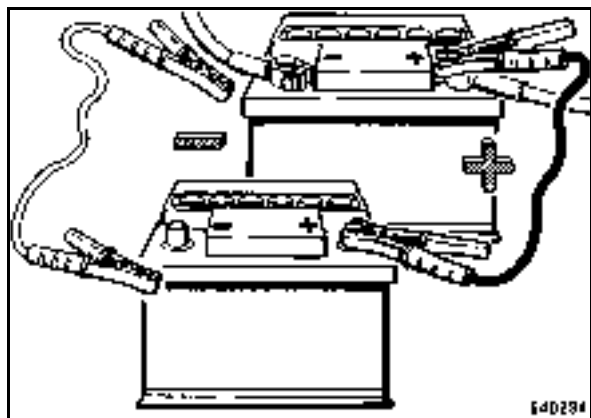

Fig. 39

- When starting with an external battery connect the plus poles (Fig. 39) first and the minus poles (ground cable) after.
- Switch the vibration off
- Start the engine as described above
- After starting disconnect the cable from the minus poles (ground cable) first and from the plus poles last.
- Fold the control box back in and close the hood.

Starting under low temperatures

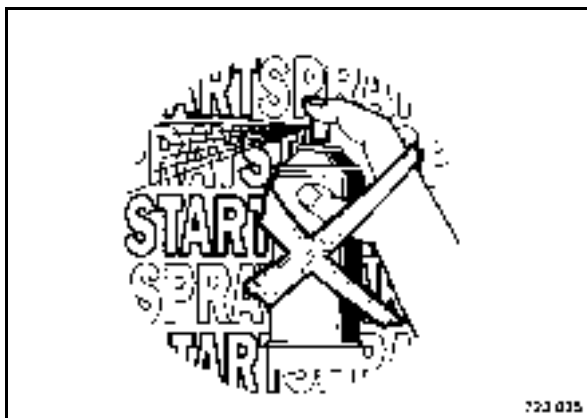

Fig. 40

⚠ Caution

Do not use any starting aid spray (Fig. 40).

4.6 Driving the machine (cable remote control)

⚠ Danger

Danger of accident!

Before starting to drive make sure that the drive range is absolutely safe.

Wet and loose soils considerably reduce the ground adhesion of the machine on inclinations and slopes.

Do not drive up and down inclinations exceeding the maximum gradability of the machine (see technical data).

Slowly return the travel lever towards neutral when driving down slopes.

Before starting to drive check the function of the remote control.

During operation of the machine with remote control the operator must always stay behind or beside the machine. Specified directions apply only if the operator is standing behind the machine. If the operator is standing in front of the machine all machine movements will be opposite to the movement of the control lever.

The machine must only be operated with remote control strapped to the body.

The machine must only be operated within the field of vision of the operator.

The minimum distance between operator and machine must be 2 m.

- Do not overstretch the spiral cable.

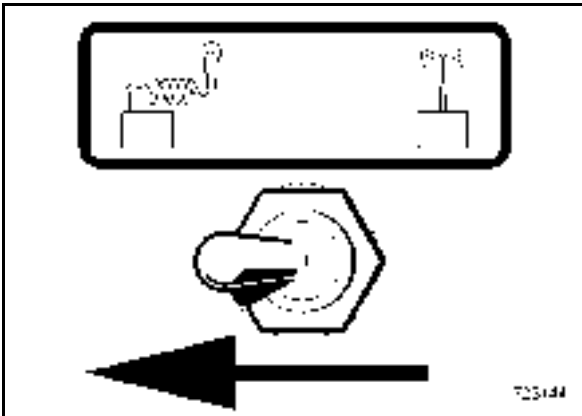

Fig. 41

- Before starting the engine switch the toggle switch (Fig. 41) to the left to position "Cable operation"
- Start the engine (see chapter "Starting the engine").

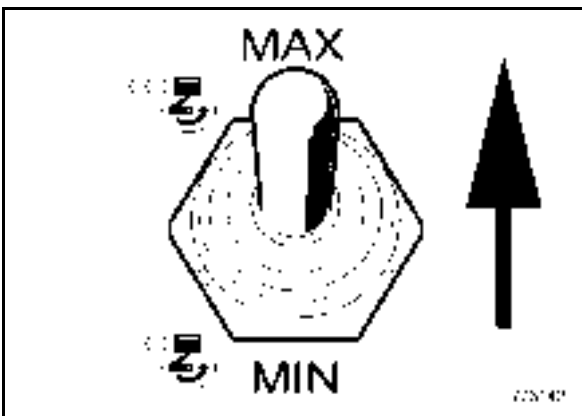

Fig. 42

- Set the toggle switch (Fig. 42) to maximum engine speed.

i Note

If the machine is not operated over a period of 20 seconds, the engine will be switched to "ecomode" (low idle speed).

The engine will return to high idle as soon as either the steering or travel lever is actuated.

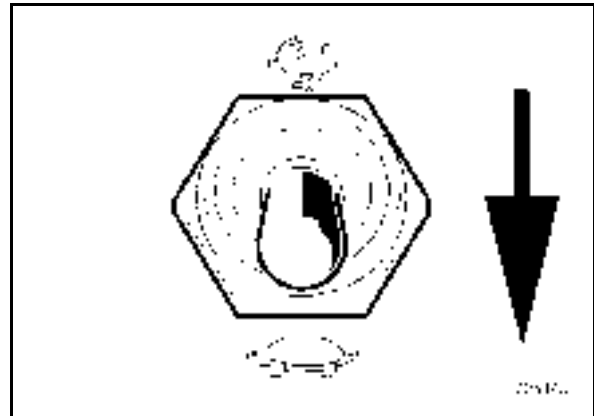

Fig. 43

- Set the toggle switch (Fig. 43) to the desired travel stage.

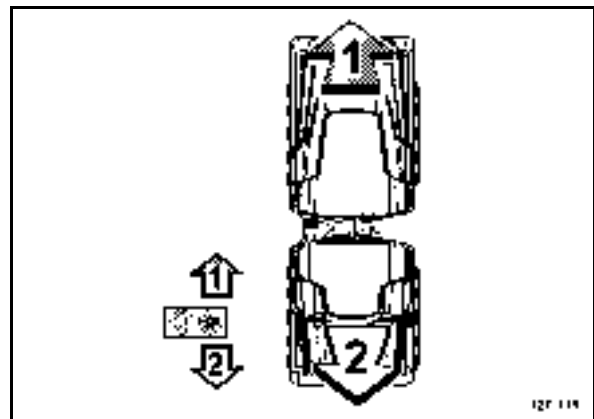

Fig. 44

Actuate the travel lever (Fig. 44). The machine drives with a speed which corresponds with the displacement of the travel control levers.

- Standstill = Travel lever in middle position
- Forward travel 1 = Shift the travel lever forward
- Reverse travel 2 = Pull the travel lever back

Stopping the machine

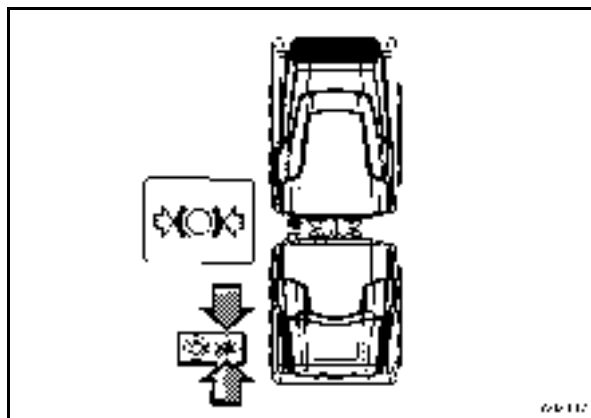

Fig. 45

- Travel lever (Fig. 45) in middle position. The machine will brake.

Steering the machine

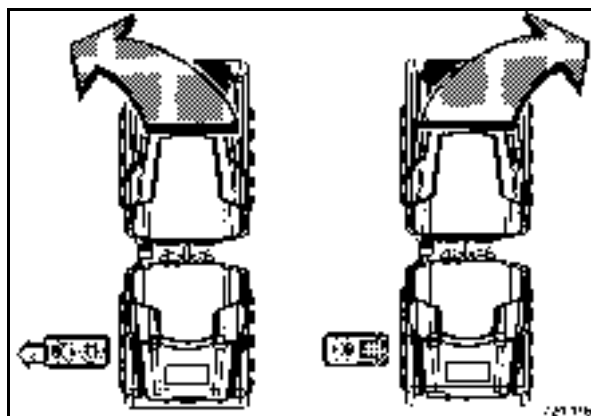

Fig. 46

- Actuate the travel levers (Fig. 46) accordingly.

Straight ahead = Steering lever in middle position

To drive to the right = Move the travel lever to the right

To drive to the left = Move the travel lever to the left

Cleaning after use

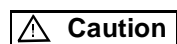

Keep the cable remote control clean.

Rests of concrete, clay or mortar may damage the bellows on travel levers and sealing caps on toggle switches, so that water can enter.

Do not use a water jet or a high pressure or steam cleaner for cleaning.

- After work clean the cable remote control with a clean cloth or brush.
- Check the state of bellows and sealing caps at regular intervals, have replaced by an expert, if necessary.

4.7 Safety inspection for the cable remote control

This safety inspection must be performed regularly once every week, especially after longer breaks.

⚠ Danger

Danger of injury!

Make sure that there are no persons within the danger zone.

⚠ Caution

Rests of mortar or concrete may restrict the movement of the travel control levers. Check from time to time (with the sender switched off!) whether both travel control levers return reliably to their neutral position when being released.

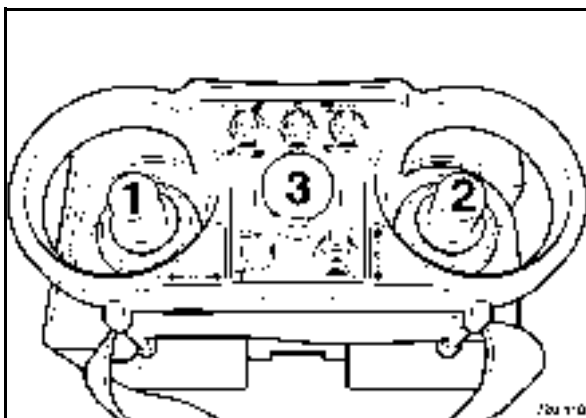

Fig. 47

- With the machine shut down actuate and hold one of the travel levers 1 or 2 (Fig. 47).
- Try to start the diesel engine.

The diesel engine must not start.

- Return the travel lever to neutral position (rest position).
- Start the engine and actuate the control lever again.

The functions must now work as usual.

- Operate the emergency stop switch (3).

The machine must stop and the engine must be shut down.

4.8 Switching the vibration on and off

⚠ Danger

Risk of damage!

When compacting with vibration you must check the effect of nearby buildings and underground supply lines (gas, water, sewage, electric power), if necessary stop compaction with vibration.

Do not activate the vibration on hard (frozen, concrete) ground. Danger of bearing damage!

Automatic

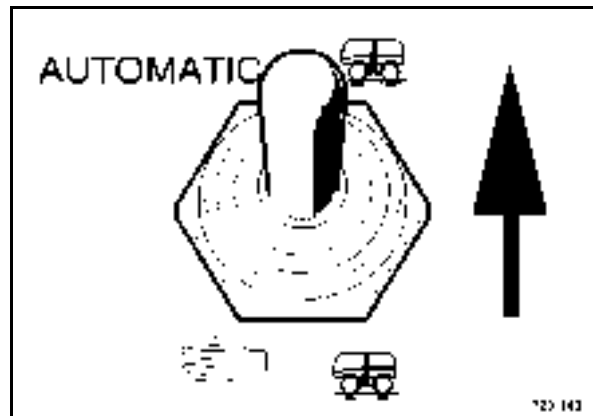

Fig. 48

- Set the vibration switch (Fig. 48) to "Automatic".

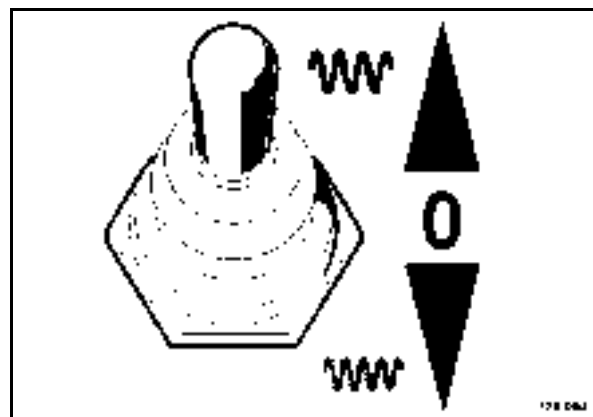

Fig. 49

- Choose the amplitude (Fig. 49).

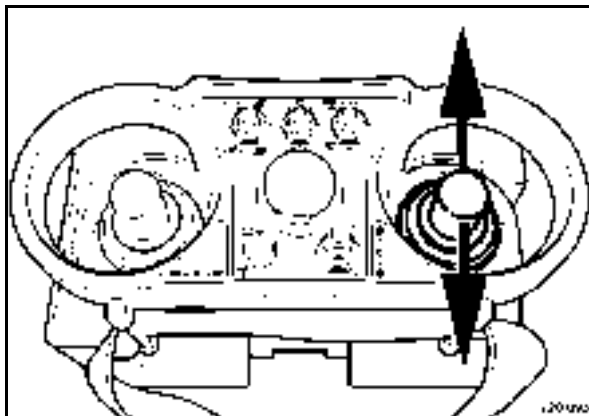

Fig. 50

- Move the travel lever (Fig. 50) forward or back.

The machine starts to move and the vibration switches on automatically.

The vibration will switch off when the machine comes to a halt.

Manual

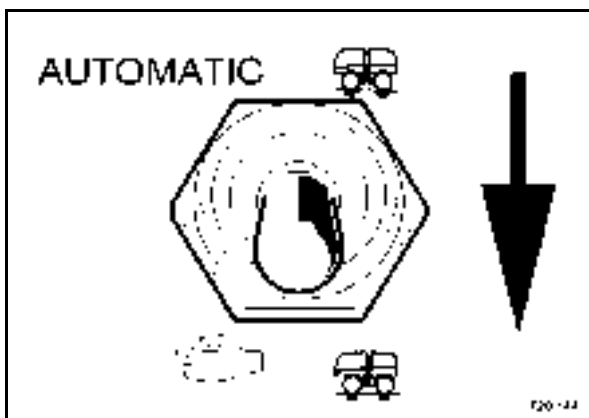

Fig. 51

- Set the vibration switch (Fig. 51) to position "Manual".

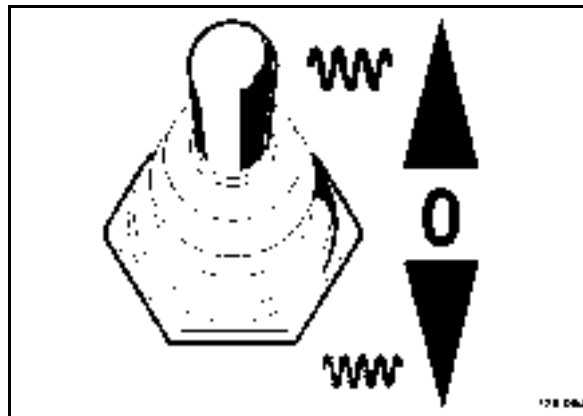

Fig. 52

- Choose the amplitude (Fig. 52).

Vibration switches on.

4.9 Shut down the engine

- Switch the vibration off, if necessary.

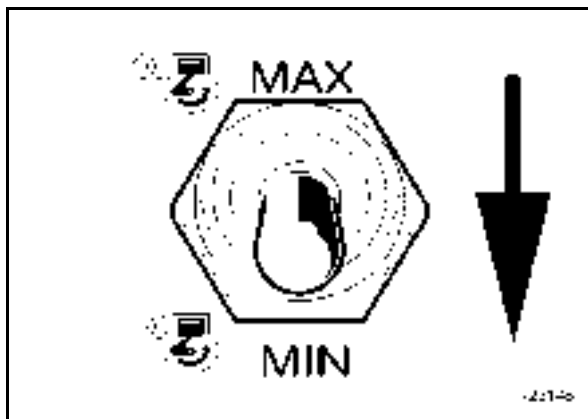

Fig. 53

- Change to idle speed (Fig. 53) and let the engine run for another few minutes for cooling.

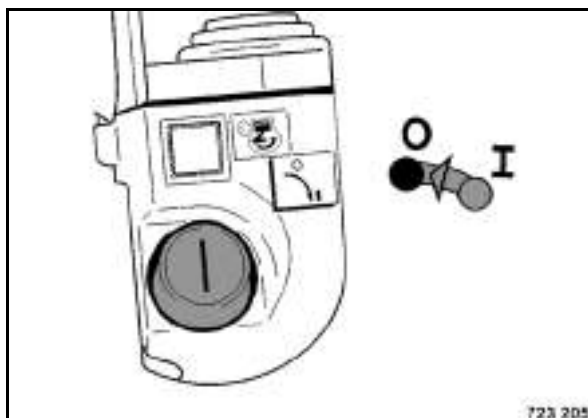

Fig. 54

- Turn the ignition switch (Fig. 54) to position "0".

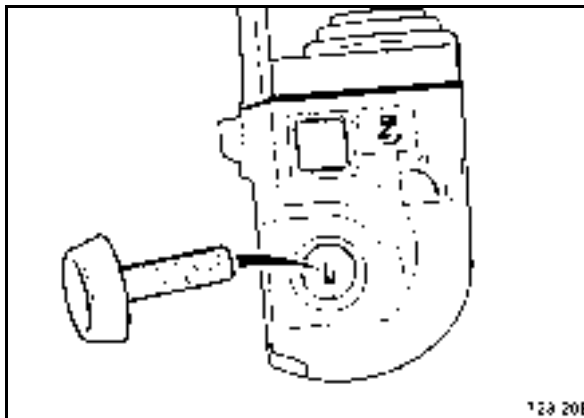

Fig. 55

- Pull off the ignition key (Fig. 55) and store it in a safe place.

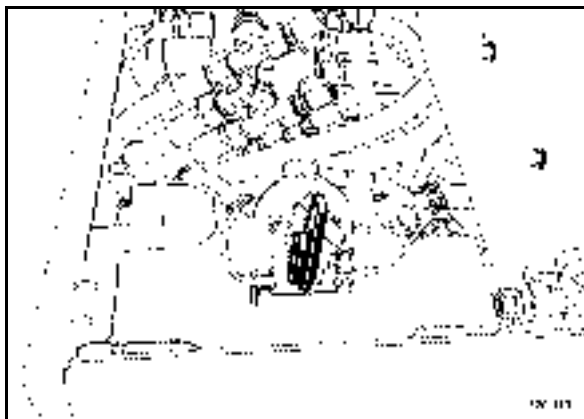

Fig. 56

- Switch off and pull out the main battery switch (Fig. 56).
- Plug the safety cap on the lock.

⚠ Danger

Danger of accident!

Secure the machine against unauthorized use.

4.10 Shutting down the engine manually

⚠ Caution

If the engine is not automatically shut down when turning the ignition switch to position "0", you may switch it off manually.

⚠ Danger

You should immediately investigate the cause for the engine not shutting down and repair the machine accordingly.

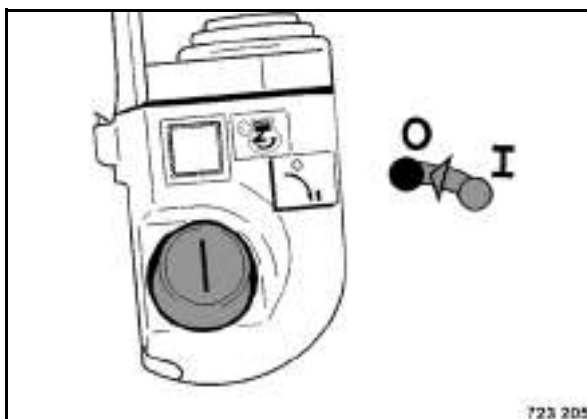

Fig. 57

- Turn the ignition switch (Fig. 57) to position "0".

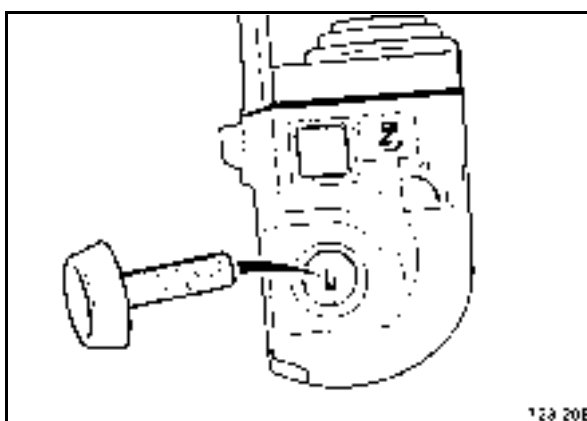

Fig. 58

- Pull off the ignition key (Fig. 58) and store it in a safe place.
- Fold the engine hood open

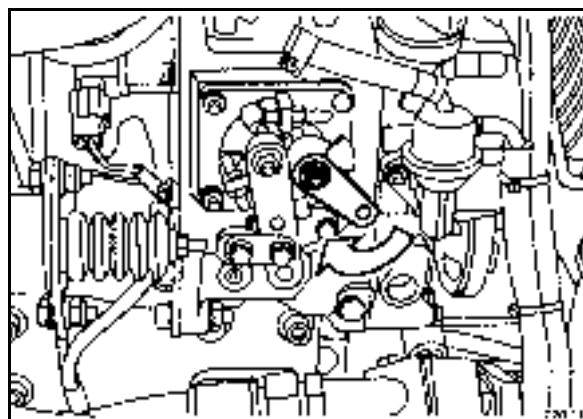

Fig. 59

- Keep the hand lever (Fig. 59) on the engine depressed, until the engine shuts down.
- Open the rear hood.

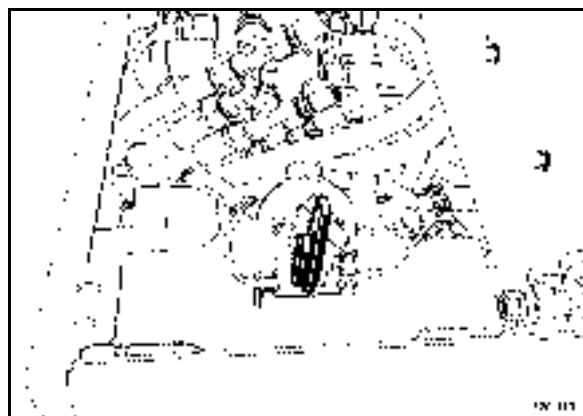

Fig. 60

- Switch off and pull out the main battery switch (Fig. 60).
- Remove the guard.
- Close engine hood and rear hood again.

⚠ Danger

Danger of accident!

Secure the machine against unauthorized use.

4.11 Starting operation of the radio remote control

⚠ Danger

The minimum distance between operator and machine must be 2 m.

⚠ Caution

Use the transmitter only if the type approval has been granted.

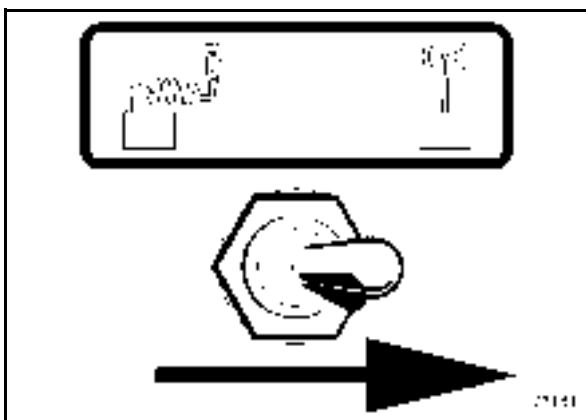

Fig. 61

- Set the toggle switch (Fig. 61) to remote control position.

Inserting the replacement power pack

⚠ Caution

Change the power pack only when the sender is switched off.

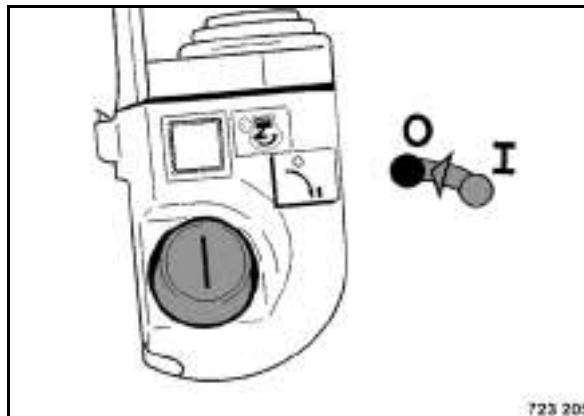

Fig. 62

- Turn the ignition switch to position "O" (Fig. 62) and pull it off.



Fig. 63

- Insert the replacement power pack into the receptacle (Fig. 63) and let it click into place.

i Note

Make sure the power pack clicks into place.

Duty time with a fully charged power pack:

approx. 100 hours

Switching on the transmitter

⚠ Danger

Life hazard!

In order to avoid unauthorized operation of the machine do not leave the activated transmitter unattended.

Operate the transmitter only if the machine is in your field of vision.

i Note

All normal work functions can only be operated from a defined neutral position, i.e. the respective control elements must be in rest position when switching the sender on. If this is not true, the engine cannot be started.

- Strap the transmitter to your body, adjust the belts accordingly.

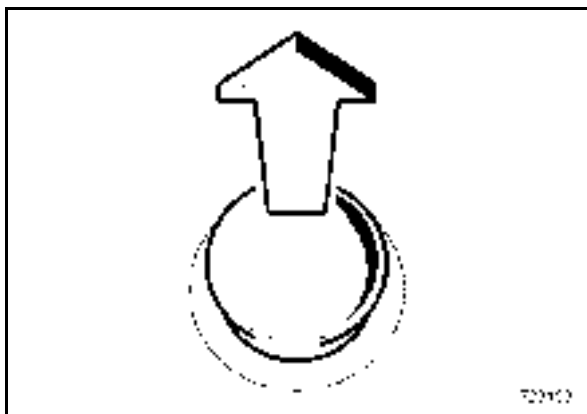

Fig. 64

- If necessary unlock the emergency stop switch (Fig. 64).

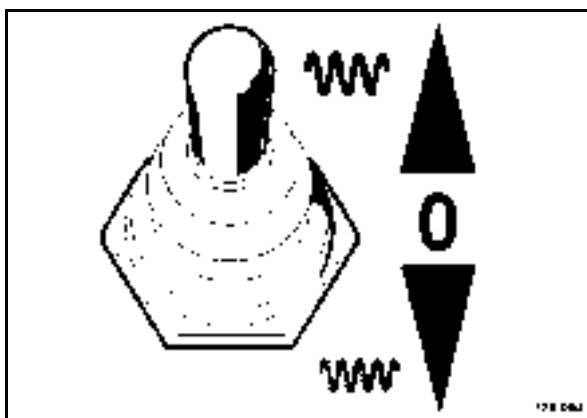

Fig. 65

- Set the vibration toggle switch (Fig. 65) to position "0".

Starting the engine

i Note

Before starting the engine both travel levers and the vibration control lever must be in rest position (neutral).

The radio remote control is equipped with a re-start lock.

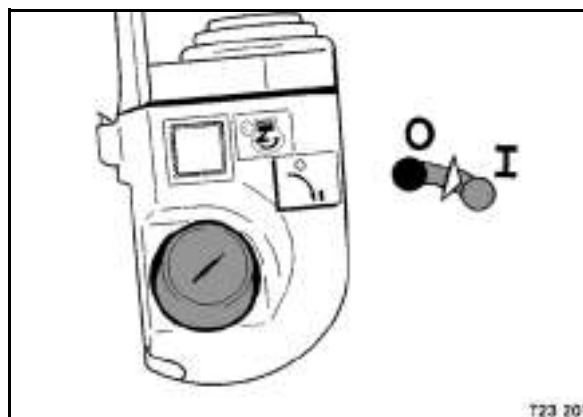

Fig. 66

- Switch on the ignition (Fig. 66).

The green control light on the transmitter starts to flash and a buzzer signal sounds. The transmitter is ready for operation.

After a period of approx. 5 to 10 seconds the signal horn on the machine starts to sound.

The machine is now ready for operation.

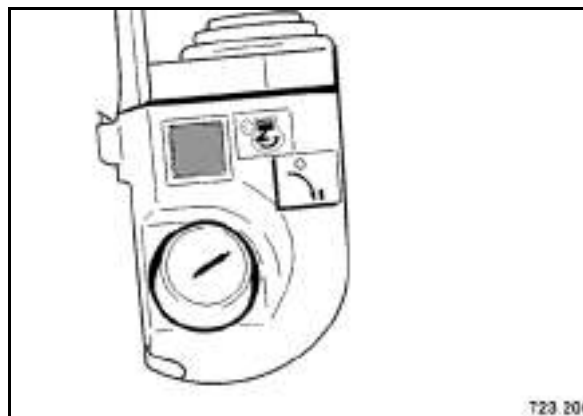

Fig. 67

- Press the start button to start the engine (Fig. 67).

i Note

Run the engine warm for a short while before starting work.

Long distance shut-down

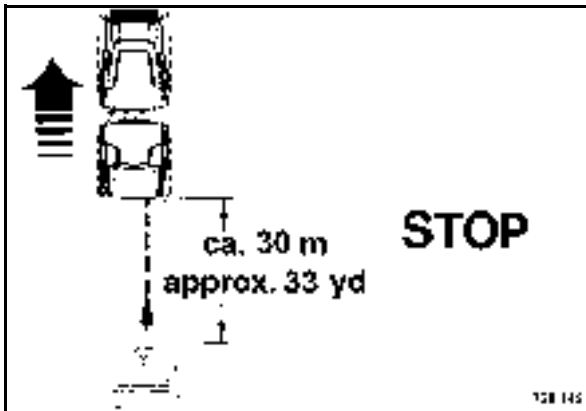

Fig. 68

If the distance (Fig. 68) between transmitter and receiver exceeds 30 m, the machine will stop.

i Note

To continue travelling reduce the distance and restart the machine.

Work function

⚠ Danger

Life hazard!

Move the machine only when it is directly in sight.

The functions of operating elements and controls are identical with the ones for the cable remote control (see previous description).

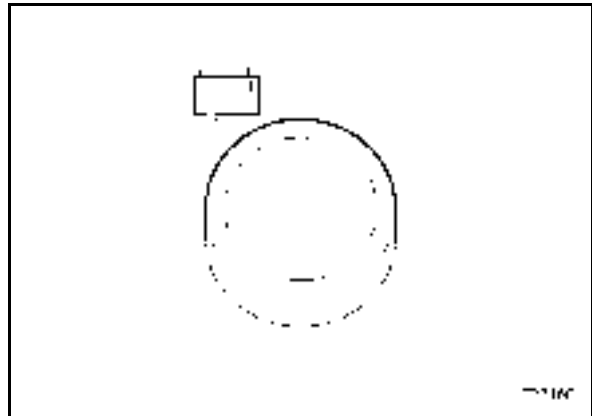

Fig. 69

i Note

If the battery voltage drops down to a too low level during operation (power pack discharged), the red warning light on the control (Fig. 69) will light up approx. 10 minutes before the engine is shut down. The warning buzzer starts to sound approx. 1 minute before the shut down

Drive the machine to a safe place as soon as possible, so that it will not stop all of a sudden.

If necessary switch over to operation with cable remote control and plug the spiral cable into the remote control. During cable operation of the machine the power pack is automatically charged.

Replace or recharge the power pack.

Switching off the transmitter (engine)

⚠ Caution

Do not shut the engine down all of a sudden from full load, but let it idle for a while in position "Min" for temperature equalization.

If the radio remote control is not going to be used for a longer period of time we strictly recommend to take the batteries out of the transmitter and to recharge them approx. every four weeks. This avoids complete discharging and prolongs the lifetime of the power packs.

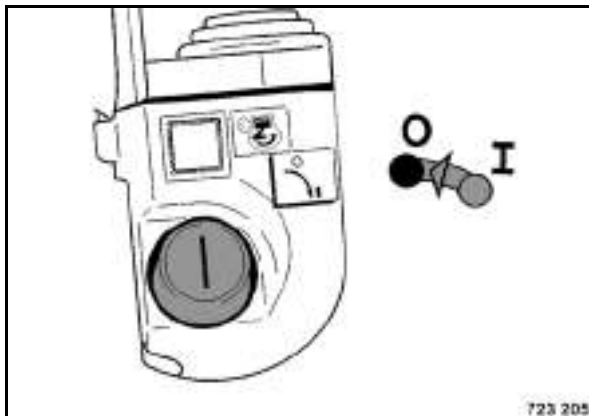

Fig. 70

- Turn the ignition key (Fig. 70) to position "0". Transmitter and engine will be switched off after two seconds, the green control light on the transmitter goes out.

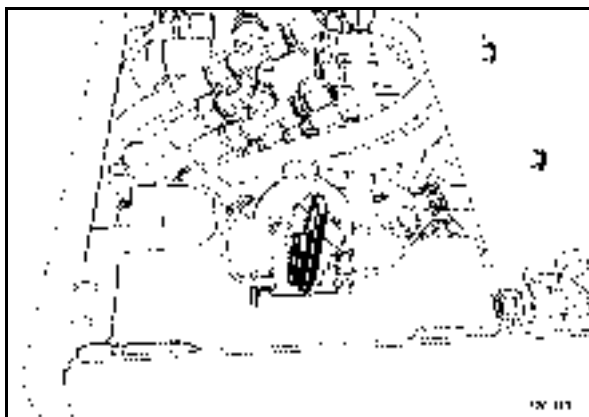

Fig. 71

- Switch off and pull out main battery switch 1 (Fig. 71).
- Plug the safety cap on the lock.

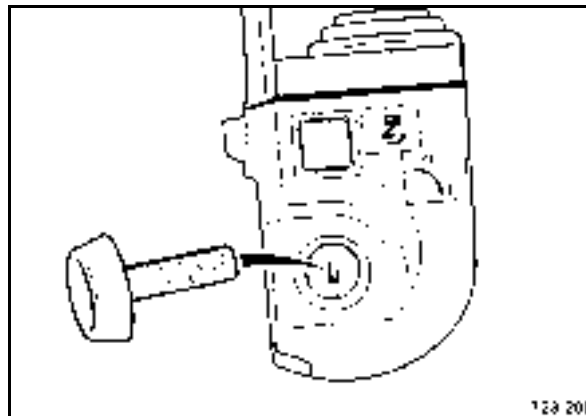

Fig. 72

- Pull off the ignition key (Fig. 72) and store it in a safe place.

i Note

If the power pack of the remote control is to be recharged via the remote control cable, the main battery switch (Fig. 71) must be switched on.

Cleaning after use

⚠ Caution

Keep the radio remote control clean.

Rests of concrete, clay or mortar may damage the bellows on travel levers and sealing caps on toggle switches, so that water can enter.

Do not use a water jet or a high pressure or steam cleaner for cleaning.

- After work clean the transmitter with a clean cloth or brush.
- Check the state of bellows and sealing caps at regular intervals, have replaced by an expert, if necessary.

4.12 Replacing, recharging the radio remote control power pack

i Note

As standard the power pack is recharged in the machine through the spiral cable. A separate battery charger is available as an option. The recharging time is approx. 6 hours.

⚠ Danger

Operate the battery charger only in dry rooms at temperatures of min. 0 °C to max. 40 °C!

A charged power pack is a concentrated energy source! Do not store charged power packs in a tool box or similar, because metal parts may cause a short circuit. Short circuits may also be caused by keys etc. in a trouser pocket.

⚠ Caution

Change the power pack only when the sender is switched off.

Before connecting the battery charger make sure that the mains voltage is in accordance with the specifications mentioned on the battery charger.

Strictly follow the operating instructions for the battery charger.

i Note

Ageing of the power pack reduces the discharging capacity and therefore the operating time of the sender.

The full discharging capacity is only reached after several charging cycles.

i Note

As the charging of the power pack succeeds, the charging current drops, so that overcharging of the power pack is almost impossible. However, if the control is switched off for a couple of days (holidays, bad weather) you should also disconnect the charging unit from the mains supply or switch off the main battery switch.

Charging the power pack in the machine

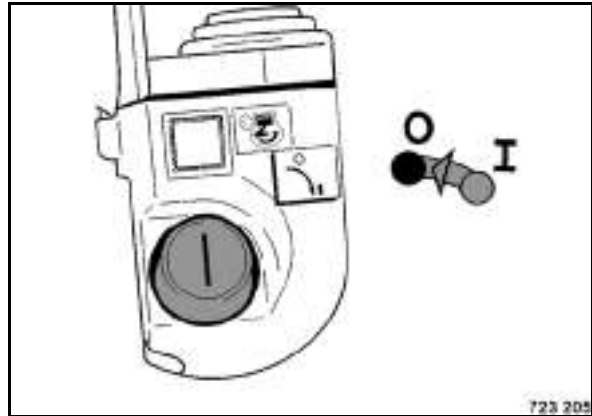

Fig. 73

- Switch off the transmitter (Fig. 73) with the ignition key.
- Plug the spiral cable into the transmitter

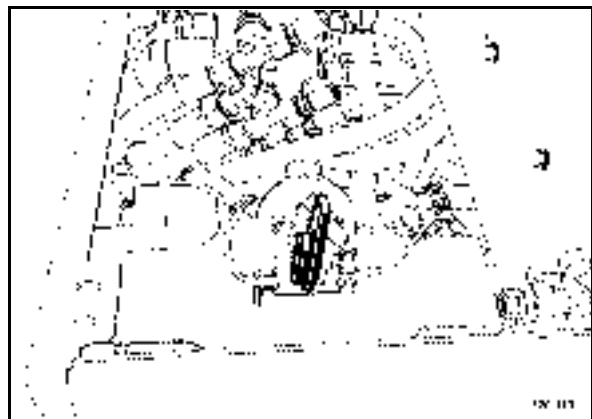

Fig. 74

- The main battery switch (Fig. 74) must be switched on.

i Note

The power pack recharging time is approx. 6 hours.

Charging the power pack with the external battery charger

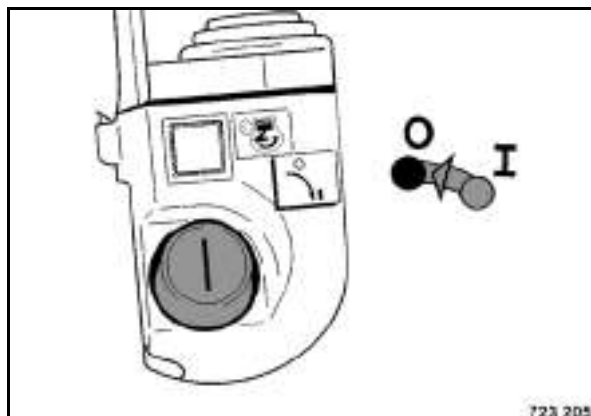

Fig. 75

- Switch off the transmitter (Fig. 75) with the ignition key.

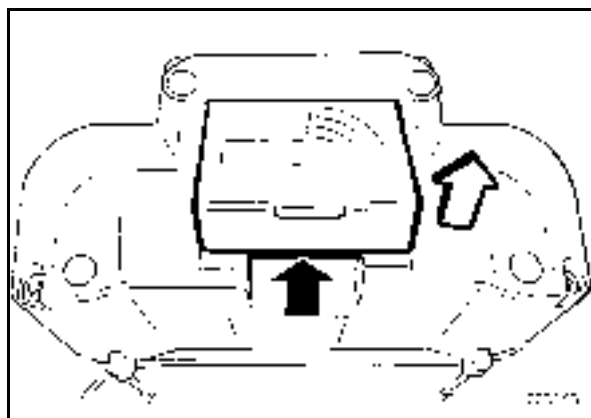

Fig. 76

- Press the power pack forward and lift it out of the housing (Fig. 76).

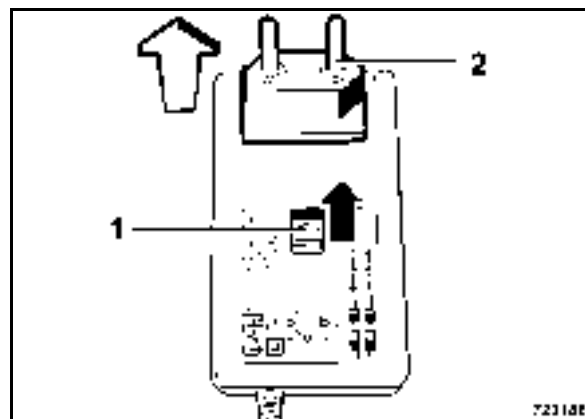

Fig. 77

- Push lock 1 (Fig. 77) on the mains unit of the battery charger forward and pull plug (2) upward out of the mains unit.

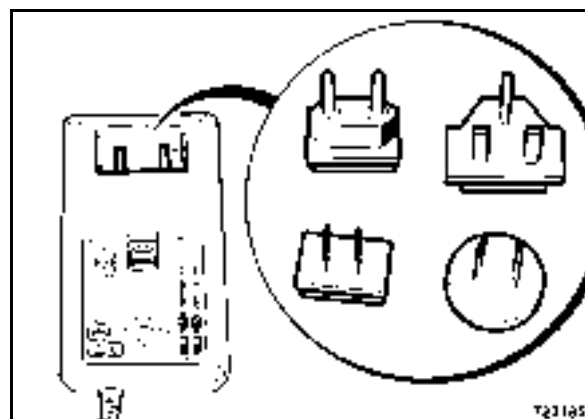

Fig. 78

- Plug the corresponding plug (Fig. 78) onto the mains unit of the battery charger.

i Note

The type of plug to be chosen depends on the country. Observe local conditions and regulations.

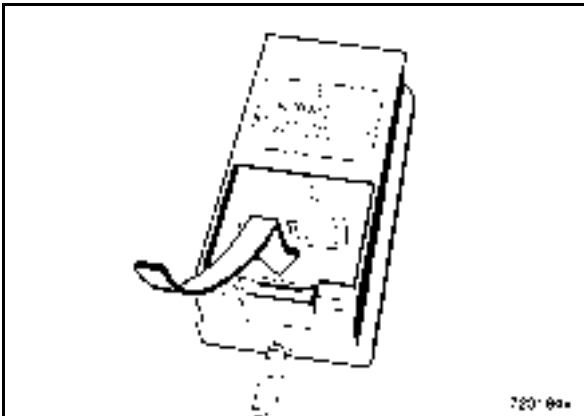

Fig. 79

- Insert the power pack into the battery charger (Fig. 79).

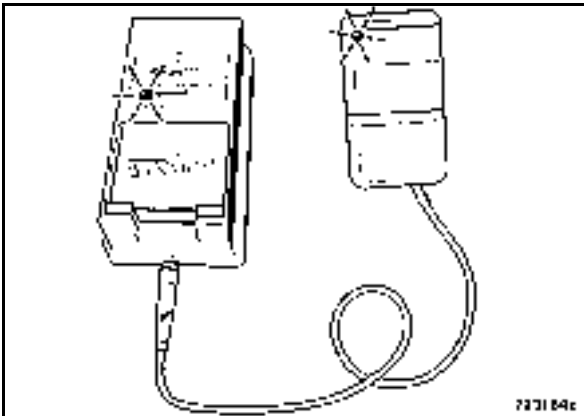

Fig. 80

- Connect the battery charger to a power source (Fig. 80).

The two light emitting diodes on battery charger and mains unit must light up.

i Note

The power pack recharging time is approx. 6 hours.

When charging is completed the green LED on the charger will start to flash.

4.13 Safety inspection for the radio remote control

This safety inspection must be performed regularly once every week, especially after longer breaks.

⚠ Danger

Danger of injury!

Make sure that there are no persons within the danger zone.

⚠ Caution

Rests of mortar or concrete may restrict the movement of the travel control levers. Check from time to time (with the sender switched off!) whether both travel control levers return reliably to their neutral position when being released.

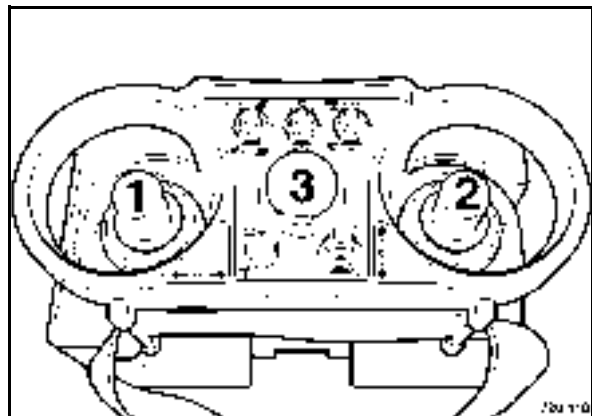

Fig. 81

- With the transmitter switched off actuate and hold one of the travel levers 1 or 2 (Fig. 81).
- Switch on the transmitter and try to start the diesel engine.

The diesel engine must not start.

- Return the travel lever to neutral position (rest position).
- Start the engine and actuate the travel lever again.

The functions must now work as usual.

- Operate the emergency stop switch (3).

The machine must stop and the engine must be shut down.

4.14 Switching off of the radio remote control in case of radio interferences

The radio remote control is automatically switched off whenever the radio connection to the receiver is interrupted or disturbed for more than 2 seconds.

Resetting the control after switching off by radio interference

- Step into the radio transmission range of the machine.

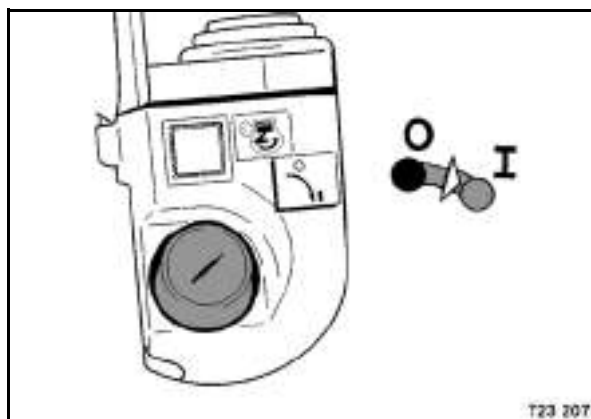

Fig. 82

- Switch on the ignition (Fig. 82) and restart the machine.

Operation can be resumed.

4.15 Entering the machine type code into the display module

⚠ Caution

After replacing the machine control (BLM) the type code must be entered again.

The machine type code for the BMP 8500 is "7104"

The machine must not be operated with a wrong type settings, as otherwise the correct function of the control can no longer be assured.

The code can only be entered when the engine is shut down.

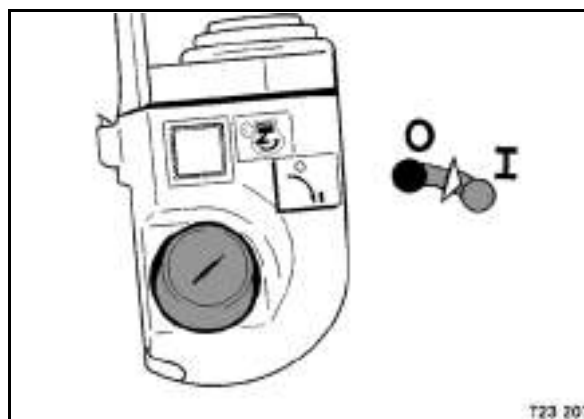

Fig. 83

- Switch on the ignition (Fig. 83).
- Open the rear hood.

Display module input functions

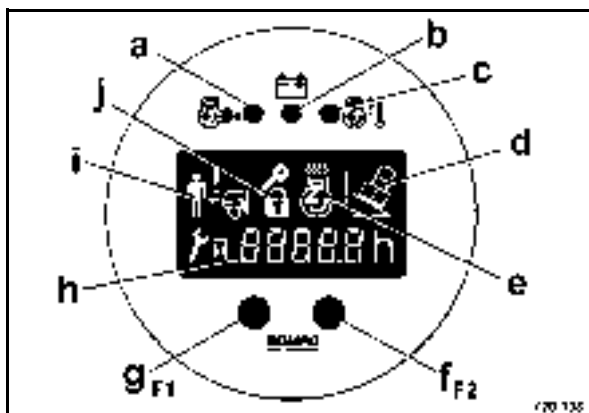

Fig. 84

- Keep both keys (F1/g and F2/f) depressed for two seconds (Fig. 84). The display shows „00000“, whereby the first digit is flashing.
- The value of the flashing digit can be increased by pressing key (F1/g). If the value "9" is displayed and the key (F1/g) is pressed again, the display will jump back to the value "0".
- Pressing key (F2/f) moves the flashing digit one digit to the right. If the fourth digit in the display is flashing, key (F2/f) is pressed again for confirmation.

The desired function is now executed or the desired value is displayed.

- To cancel the display function you must either enter code number "0000" or switch off the ignition.

Entering the machine type code

- Enter code number "7010".

This code number activates the function "Adjusting machine type".

The display module now permanently shows code "7010".

- Enter code "7104".

The display module now permanently shows the entered code.

- Enter code number "7011".

This code number confirms the entered machine type.

After the confirmation of the machine type the control switches off.

The control automatically switches on again is now ready for starting. The display module shows the machine type for 3 seconds.

Whenever switching the ignition on the machine type will appear in the display module for 3 seconds.

i Note

The machine type code can be checked by entering the code "7010".

4.16 Teaching the BOSS safety system transponder

When replacing a defective remote control only units with a completely black housing must be used. Please follow the described procedure when installing new components of the radio system or the safety system (BOSS):

- Shut down the engine,
- switch off the main battery switch,
- replace defective components,
- switch on the main battery switch,
- plug the spiral cable into the remote control.

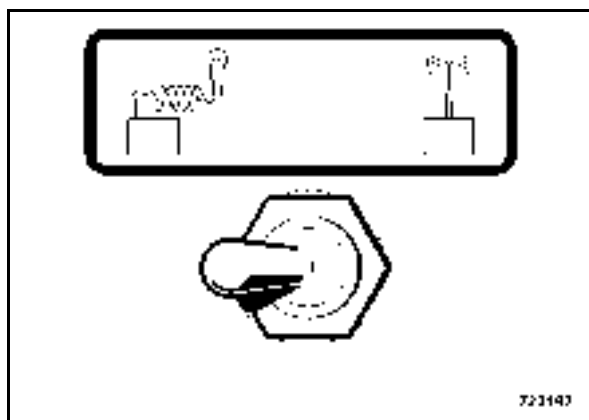

Fig. 85

- Turn the tumbler switch for the cable remote control to position "Left", cable operation (Fig. 85).

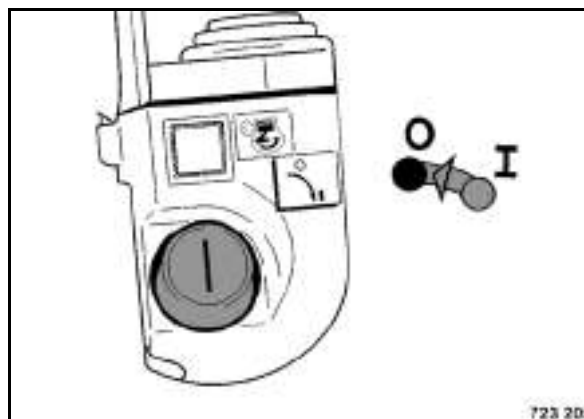

Fig. 86

- Turn the ignition switch to position I (Fig. 86), charge control lamp and oil pressure control lamp come on.
- Move the remote control out of the safety field.
- The safety field control lamp goes out at the latest after 2 seconds.

The machine is now ready for operation.

4.17 Assembling/removing the drum extension

Assembly

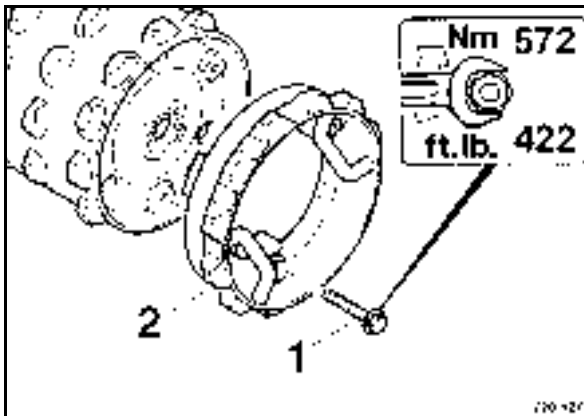

Fig. 87

- Attach drum extensions 2 (Fig. 87) to the drums, turn three fastening screws (1) into each drum and tighten.

Removal

- Unscrew the fastening screws and take off the drum extensions.
- Turn the fastening screws back into the drum and fasten.

⚠ Caution

In order to protect the threads turn the fastening screws into the drums, even after removing the drum extensions.

⚠ Danger

Danger of turning over!

When using drums with a working width of 610 mm the second speed range must not be switched on.

4.18 Loading and transport

⚠ Danger

Danger of accident!

Use only stable loading ramps of sufficient load bearing capacity.

Make sure that persons are not endangered by the machine tipping or sliding off.

Always engage the articulation lock before loading, lifting and transporting the machine.

Lash the machine down so that no persons are endangered by the machine falling off, sliding about or turning over.

Lift the machine only with suitable lifting gear. Weights: see chapter "Technical Data".

Always use shackles on the lifting points for loading, tying or lifting the machine.

Do not step or stand under suspended loads.

The machine must not swing about when being lifted.

Check the lifting eye before lifting the machine. It must be free of cracks.

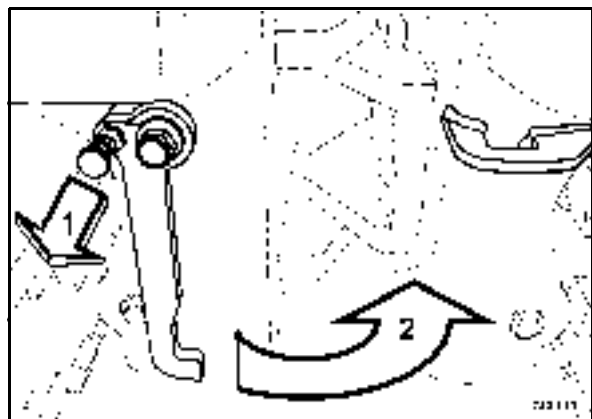

Fig. 88

- After driving the machine on the transport vehicle pull out the locking knob 1 (Fig. 88) and engage the articulation lock in the locking eye (2). Let the locking knob click into place.

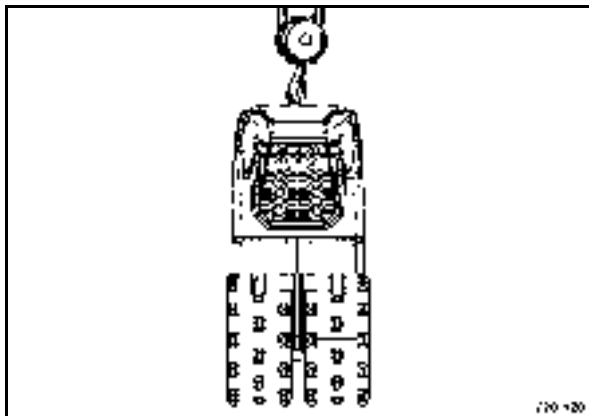

Fig. 89

Use the central lifting facility (Fig. 89) to lift the machine.

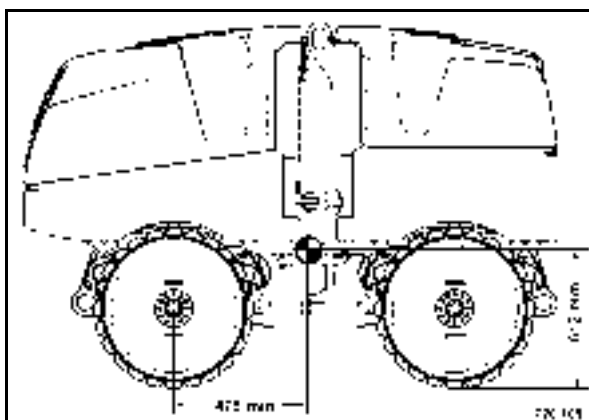

Fig. 90

- Position of centre of gravity (Fig. 90).

Loading weight see technical data.

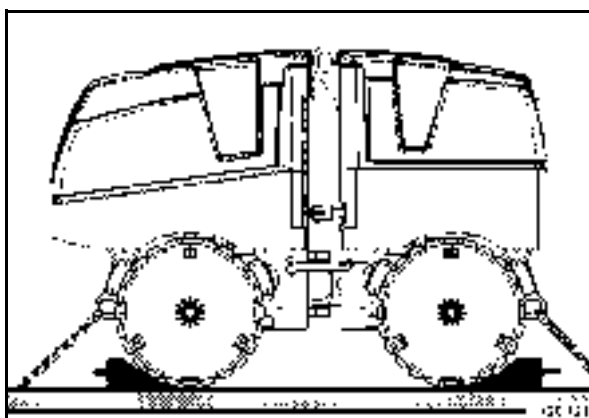

Fig. 91

- Drive the machine onto the transport vehicle and lash it down by the two lashing eyes (Fig. 91).

Weights: See technical data

▲ Danger

Danger of accident!

The machine cannot be steered if the articulation lock is applied.

- After transport release the articulation lock again and store it in the receptacle.



5 Maintenance

5.1 General notes on maintenance

When performing maintenance work always comply with the appropriate safety regulations.

Thorough maintenance of the machine guarantees far longer safe functioning of the machine and prolongs the lifetime of important components. The effort needed for this work is only little compared with the problems that may arise when not observing this rule.

The terms right/left correspond with travel direction forward.

- Always clean machine and engine thoroughly before starting maintenance work.
- For maintenance work stand the machine on level ground.
- Always remove the main battery switch for all maintenance work.
- Perform maintenance work only with the motor switched off.
- Relieve hydraulic pressures before working on hydraulic lines.
- Before working on electric parts of the machine disconnect the battery and cover it with insulation material.
- When working in the area of the articulated joint attach the articulation lock (transport lock).

Environment

During maintenance work catch all oils and fuels and do not let them seep into the ground or into the sewage system. Dispose of oils and fuels environmentally.

Keep used filters in a separate waste container and dispose of environmentally.

Catch biodegradable oils separately.

Notes on the fuel system

The lifetime of the diesel engine depends to a great extent on the cleanliness of the fuel.

- Keep fuel free of contaminants and water, since this will damage the injection elements of the engine.

- Drums with inside zinc lining are not suitable to store fuel.
- When choosing the storage place for fuel make sure that spilled fuel will not harm the environment.
- Do not let the hose stir up the slurry at the bottom of the drum.
- The fuel drum must rest for a longer period of time before drawing off fuel.
- The rest in the drum is not suitable for the engine and should only be used for cleaning purposes.

Notes on the performance of the engine

On diesel engines both combustion air and fuel injection quantities are thoroughly adapted to each other and determine power, temperature level and exhaust gas quality of the engine.

If your engine has to work permanently in "thin air" (at higher altitudes) and under full load, you should consult the customer service of BOMAG or the customer service of the engine manufacturer.

Notes on the cooling system

Prepare and check coolant with highest care, since otherwise the engine may be damaged by corrosion, cavitation and freezing.

The coolant is prepared by mixing a cooling system protection agent (ethylene glycol) into the coolant.

Mixing with cooling system protection agent is necessary in all climatic zones. It prevents corrosion, lowers the freezing point and raises the boiling point of the coolant.

Notes on the hydraulic system

During maintenance work on the hydraulic system cleanliness is of major importance. Make sure that no dirt or other contaminating substances can enter into the system. Small particles can produce flutes in valves, cause pumps to seize, clog nozzles and pilot bores, thereby making expensive repairs inevitable.

- If, during the daily inspection of the oil level the hydraulic oil level is found to have dropped, check all lines, hoses and components for leaks.

- Seal leaks immediately. If necessary inform the responsible customer service.
- We recommend to use the BOMAG filling and filtering unit with fine filter to fill the system. This ensures finest filtration of the hydraulic oil, prolongs the lifetime of the hydraulic oil filter and protects the hydraulic system.
- Clean fittings, filler covers and the area around such parts before disassembly to avoid entering of dirt.
- Do not leave the tank opening unnecessarily open, but cover it so that nothing can fall in.

5.2 Fuels and lubricants

Engine oil

Quality

Lubrication oils are classified according to their performance and quality class. Oils according to other comparable specifications may be used.

If low sulphur fuel (< 0.05%) is used, you must only use engine oils of API^{*}-classification CF, CF-4, CG-4, CH-4 and CI-4.

For operation of an engine with high sulphur fuels it is recommended to use an engine oil of classification CF or higher with a total base number of at least 10.

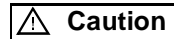

Caution

Engine oils of classification CJ-4 must not be used!

Oil viscosity

Since lubrication oil changes its viscosity with the temperature, the ambient temperature at the operating location of the engine is of utmost importance when choosing the viscosity class (SAE-class) .

Optimal operating conditions can be achieved by using the following oil viscosity chart as a reference.

| Ambient temperature | Viscosity |
|---------------------|-----------------------------------|
| over 25 °C! | SAE 30 SAE10W-30 SAE 15W-40 |
| 0°C to 25°C | SAE 20 SAE10W-30 SAE 15W-40 |
| below 0 °C | SAE 10 SAE10W-30 SAE 15W-40 |

* American Petroleum Institute

Oil change intervals

The longest permissible time a lubrication oil should remain in an engine is 1 year. If the following oil change intervals are not reached over a period of 1 year, the oil change should be performed at least once per year, irrespective of the operating hours reached.

API: CF, CF-4,
CG-4, CH-4 and
CI-4 = 250 operating hours

Fuels

Quality

Cetan index number: The recommended minimum index number for the Cetan value is 45. A Cetan index number higher than 50 should preferably be used, especially at ambient temperatures below -20 °C and when working at altitudes of 1500 m and more.

Diesel fuel specifications: With respect to the percentage (ppm) of sulphur the fuel used in the engine must comply with all relevant exhaust emission regulations in the area of use of the engine.

It is highly recommended to use a fuel with a sulphur content of less than 0,10 % (1000 ppm).

When using a diesel fuel with a high sulphur content of 0.50 % (5000 ppm) to 1.0 % (10.000 ppm), the engine oil change intervals must be observed.

Caution

Do not use any fuels with a sulphur content of more than 1,0 % (10000 ppm).

It is recommended to use diesel fuel that complies with the specifications EN590 or ASTM D975.

Diesel fuel with the designation no. 2-D is a distillate fuel with low volatility, which is especially suitable for industrial engines and heavy-duty commercial vehicles (SAE J313 JUN87).

Since KUBOTA diesel engines with a rated power of less than 56 kW (75 HP) comply with the exhaust emission standard of EPA -stage 4, the use of low or ultra-low sulphur fuel is mandatory for these engines, if the engines are operated within the validity area of the EPA standard. As an alternative to no. 2-D you may also use diesel fuel no. 2-D S500 or S15; with ambient temperatures be-

* United States Environmental Protection Agency

low -10 °C the diesel fuel no. 1-D S500 or S15 should be used for no. 1-D.

The fuel level should always be topped up in due time so that the fuel tank is never run dry, as otherwise filter and injection lines need to be bled.

Winter fuel

Danger

Fire hazard!

Diesel fuels must never be mixed with gasoline.

For winter operation use only winter diesel fuel, to avoid clogging because of paraffin separation. At very low temperatures disturbing paraffin separation can also be expected when using winter diesel fuel.

Coolant

Always use a mixture of anti-freeze agent and clean, dehardened water with a mixing ratio of 1:1.

Under particularly extreme temperature conditions you should consult the service representation of the engine manufacturer with respect to the anti-freeze agent to be used.

There are various types of anti-freeze agents available. For this engine you should use ethylene glycol.

Before filling in the coolant mixed with anti-freeze agent the radiator must be flushed with clean water. This procedure should be repeated two to three times to clean the inside of radiator and engine block.

Mixing the anti-freeze agent: Prepare a mixture of 50 % anti-freeze agent and 50 % low mineral, clean water. Stir well before filling it into the radiator. The method for mixing water and anti-freeze agent depends on the brand of the anti-freeze agent. In this respect see standard SAE J1034 and also the standard SAE J814c.

Add anti-freeze agent: If the coolant level drops because of evaporation, only clean water is to be used for topping up. In case of leakages you must always fill in anti-freeze agents of the same brand and the same mixing ratio.

 **Caution**

Do not mix different coolants and additives of any other kind.

Do not use any radiator cleaning agent after the anti-freeze agent has been mixed in. The anti-freeze agent also contains a corrosion protection agent. If this mixes with cleaning agent it may cause the development of sludge, which could damage the cooling system.

Anti-freeze concentration

50% = -37 °C

 **Environment**

Coolant must be disposed of environmentally.

Mineral oil based hydraulic oil

The hydraulic system is operated with hydraulic oil HV 46 (ISO) with a kinematic viscosity of 46 mm²/s at 40 °C. For topping up or for oil changes use only high-quality hydraulic oil, type HVLP according to DIN 51524, part 3, or hydraulic oils type HV according to ISO 6743/3. The viscosity index (VI) should be at least 150 (observe information of manufacturer).

Bio-degradable hydraulic oil

The hydraulic system can also be operated with a synthetic ester based biodegradable hydraulic oil.

The biologically quickly degradable hydraulic oil Panolin HLP Synth.46 meets all demands of a mineral oil based hydraulic oil according to DIN 51524.

In hydraulic systems filled with Panolin HLP Synth.46 always use the same oil to top up.

When changing from mineral oil based hydraulic oil to an ester based biologically degradable oil, you should consult the lubrication oil service of the oil manufacturer for details.

 **Caution**

Check the filter more frequently after this change.

Perform regular oil analyses for content of water and mineral oil.

Replace the hydraulic oil filter element every 500 operating hours.

5.3 Table of fuels and lubricants

| Assembly | Fuel or lubricant | | Quantity |
|-------------------|---|--|--------------------------------------|
| | Summer | Winter | Attention Observe the level marks |
| Engine | | | |
| - Engine oil | Engine oil API: CF, CF-4, CG-4, CH-4 or CI-4 SAE 10W/30 (-15 °C to +30 °C) SAE 15W/40 (-15 °C to + 40 °C) | | approx. 4.7 litres |
| - Fuel | SAE 30 (+5 °C to +30 °C) Diesel | SAE 10 (-30 °C to -5 °C) Winter diesel fuel (down to -12°C) | approx. 24 litres |
| - Coolant | Mixture of water and anti-freeze agent | | approx. 4.5 litres |
| Hydraulic system | Hydraulic oil (ISO), HV46, kinem. viscosity 46 mm ² /s at 40 °C or ester based biodegradable hydraulic oil | | approx. 17 litres |
| Vibration housing | Engine oil SAE 15W/40 | | 2 x 1.7 l |

5.4 Running-in instructions

i Note

The maintenance plan inside the engine hood of the machine assists you when servicing the machine!

The following maintenance work must be performed when running in new machines or overhauled engines:

⚠ Caution

Up to approx. 250 operating hours check the engine oil level twice every day.

Depending on the load the engine is subjected to, the oil consumption will drop to the normal level after approx. 100 to 250 operating hours.

Maintenance after 50 operating hours

- Change engine oil and filter
- Check the engine for leaks
- Retighten the fastening screws on air filter, exhaust and other attachments.
- Check screw connections on the machine, retighten as necessary.
- Retighten fastening screws of engine mounts
- Check the central screw of the drive hub, retighten if necessary

5.5 Maintenance table

| No. | Maintenance work | Comment | every 10 operating hours, daily | every 250 oper. hours | every 500 oper. hours | every 1000 oper. hours | every 2000 oper. hours | every 3000 oper. hours | as required |
|------|---|---------------------------------------|---------------------------------|-----------------------|-----------------------|------------------------|------------------------|------------------------|-------------|
| 5.6 | Check the engine oil level | Dipstick mark | X | | | | | | |
| 5.7 | Check the hydraulic oil level | Inspection glass | X | | | | | | |
| 5.8 | Check the fuel level | | X | | | | | | |
| 5.9 | Fuel filter, draining off water | | X | | | | | | |
| 5.10 | Check the coolant level | | X | | | | | | |
| 5.11 | Check the air intake hose | | | X | | | | | |
| 5.12 | Change engine oil and oil filter* | at least 1x per year see foot note | | X | | | | | |
| 5.13 | Check, tension, replace the V-belt | | | X | | | | | |
| 5.14 | Clean radiator cooling fins | | | X | | | | | |
| 5.15 | Change the oil in the vibrator shaft housing | min. 1x per year | | X | | | | | |
| 5.16 | Check the central screw of the drive hub** | see foot note | | X | | | | | |
| 5.17 | Drain the fuel tank sludge | | | | X | | | | |
| 5.18 | Change the fuel pre-cleaner, bleed the fuel system | | | | X | | | | |
| 5.19 | Battery service, checking the main battery switch | pole grease | | | X | | | | |
| 5.20 | Check the rubber buffers | | | | X | | | | |
| 5.21 | Check, adjust the valve clearance | 0.145 ... 0.185 mm | | | | X | | | |
| 5.22 | Check the safety field in front of/behind the machine | | | | | X | | | |
| 5.23 | Change hydraulic oil and filter*** | at least every 2 years | | | | | X | | |

| No. | Maintenance work | Comment | every 10 operating hours, daily | every 250 oper. hours | every 500 oper. hours | every 1000 oper. hours | every 2000 oper. hours | every 3000 oper. hours | as required |
|------|--|------------------|---------------------------------|-----------------------|-----------------------|------------------------|------------------------|------------------------|-------------|
| | | | | | | | | | |
| 5.24 | Change the coolant | | | | | | X | | |
| 5.25 | Change the fuel lines | | | | | | X | | |
| 5.26 | Check the injection pressure | | | | | | X | | |
| 5.27 | Check the fuel injection pump | | | | | | | X | |
| 5.28 | Check the fuel injection timing | | | | | | | X | |
| 5.29 | Check, clean, change the combustion air filter | min. 1x per year | | | | | | | X |
| 5.30 | Adjust the scrapers | | | | | | | | X |
| 5.31 | Tightening torques | | | | | | | | X |
| 5.32 | Engine conservation | | | | | | | | X |

* Running-in instructions: Oil change after 50 and 250 operating hours, then every 250 operating hours When using fuels with a sulphur content higher than 0.5% the oil change intervals must be halved.

** Running-in instructions: check tightening torque after 50 and 250 operating hours, then every 250 operating hours

*** Also in case of repair in the hydraulic system.

5.6 Check the engine oil level

i Note

Park the machine on level ground so that the engine is in horizontal position.

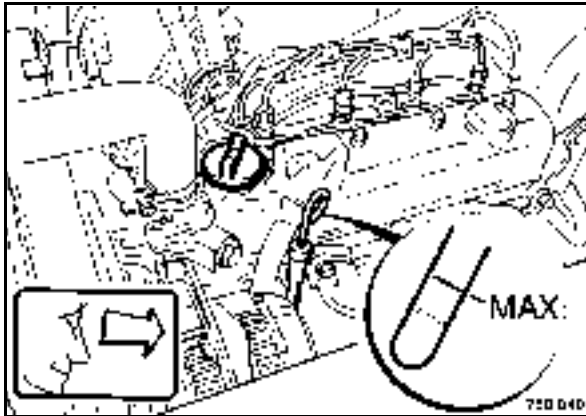

Fig. 92

- Shut down the engine
- Pull the dipstick (Fig. 92) out, wipe it off with a lint-free, clean cloth and reinsert it until it bottoms.
- Pull the dipstick back out again.
- The oil level should reach the upper mark (MAX) on the dipstick.
- If the oil level is too low top up oil immediately.

For quality and quantity of oil refer to the "table of fuels, lubricants and filling capacities".

5.7 Check the hydraulic oil level

⚠ Caution

In hydraulic systems filled with Panolin HLP Synth. 46 always use the same oil to top up. With other ester based oils consult the lubrication oil service of the respective oil manufacturer.

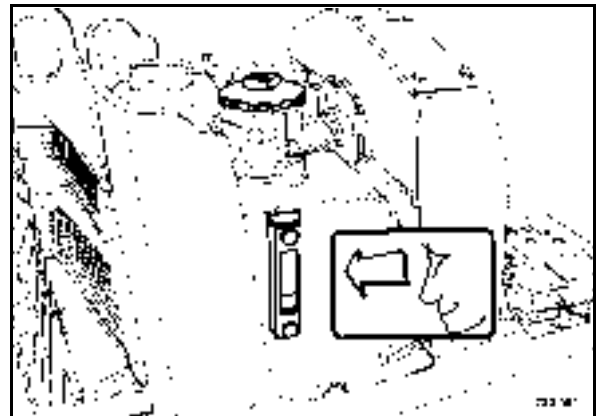

Fig. 93

- Check the hydraulic oil level in the inspection glass (Fig. 93).

⚠ Caution

Hydraulic oil is not consumed like engine oil.

If, during the daily inspection of the oil level the hydraulic oil level is found to have dropped, check all lines, hoses and components for leaks.

- If necessary remove the cover from the filter.
- Fill in hydraulic oil up to the MAX mark of the inspection glass.
- Screw the cover back on.

For quality and quantity of oil refer to the table of fuels and lubricants.

5.8 Check the fuel level

⚠ Danger

Fire hazard!

When working on the fuel system do not use open fire, do not smoke.

Do not refuel in closed rooms.

Do not inhale any fuel fumes.

⚠ Caution

Contaminated fuel can cause malfunction or even damage of the engine.

If necessary, fill in fuel through a funnel with screen filter.

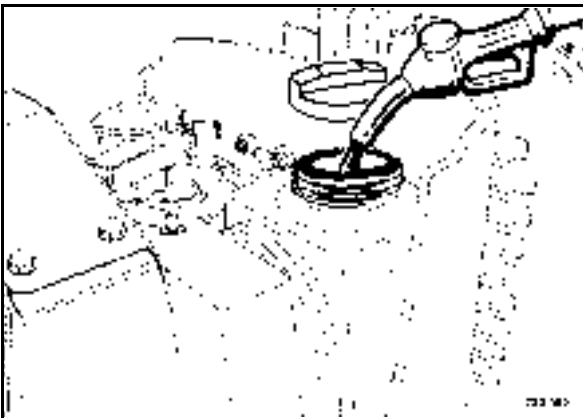

Fig. 94

- Clean the area around the filler opening, unscrew the cover, check the filling level and fill in fuel as necessary (Fig. 94) .

For quality of fuel refer to the table of fuels and lubricants.

5.9 Fuel filter, draining off water

i Note

The service intervals for the water separator depend on the water content in the fuel and can therefore not be determined precisely. After taking the engine into operation you should therefore check the filter bowl initially every day for signs of water.

♻ Environment

Catch running out fuel and dispose of environmentally.

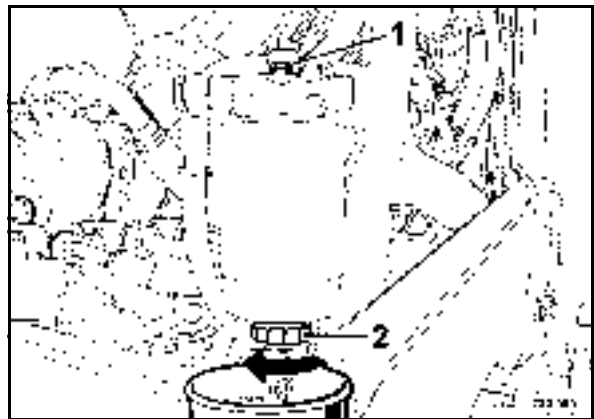



Fig. 95

- Slacken bleeding screw 1 (Fig. 95) for a few turns.
- Slacken drain plug (2) for a few turns and catch running out fuel / water.
- Tighten drain and bleeding plugs again and check for leaks, if necessary replace the seal ring.

5.10 Check the coolant level

 **Caution**

Fill up coolant only when the engine is cold.

If, during the daily inspection the coolant level is found to have dropped, check all lines, hoses and engine for leaks.

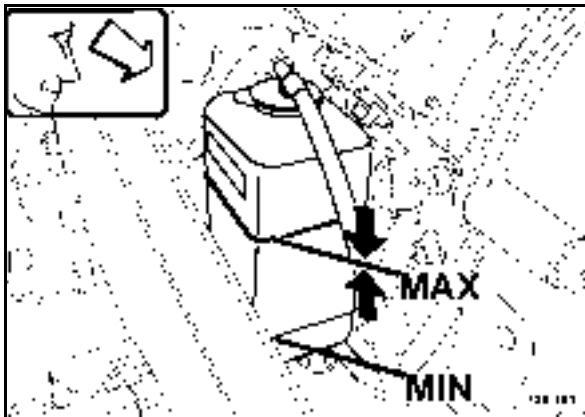

Fig. 96

- Check the coolant level (Fig. 96).
- To top up unscrew the filler cap and fill in coolant up to the MAX-mark.

For quality of coolant refer to the chapter 5.2, fuels and lubricants.

Every 10 operating hours



5.11 Check the air intake hose

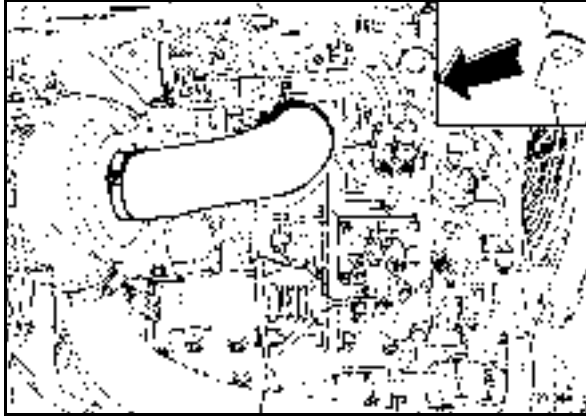

Fig. 97

- Check the fastening of the hose clamps (Fig. 97), tighten if necessary.
- Check the condition of the air intake hose, replace if necessary.

5.12 Changing engine oil and oil filter

▲ Danger

Danger of scalding!

When draining off hot oil.

By hot oil when unscrewing the engine oil filter.

▲ Caution

The oil change at 250 operating hours refers to the use of fuels with a sulphur content of less than 0.5%. When using fuels with a sulphur content higher than 0.5% the oil change intervals must be halved.

Drain the engine oil only when the engine is warm.

For quality and quantity of oil refer to the "table of fuels and lubricants".

Environment

Catch running out oil and dispose of environmentally together with the oil filter cartridge.

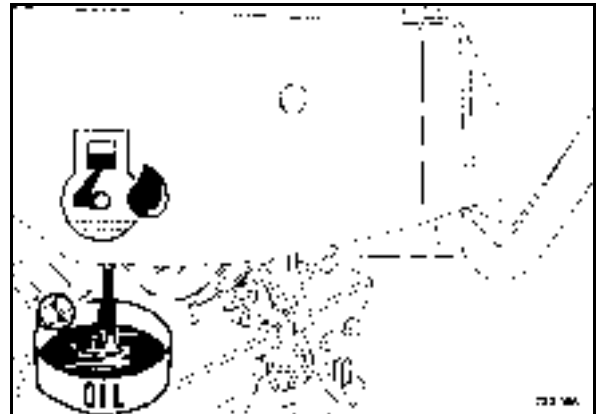

Fig. 98

- Unscrew the drain plug (Fig. 98) and catch running out oil.
- Turn the drain plug tightly back in.

Every 250 operating hours

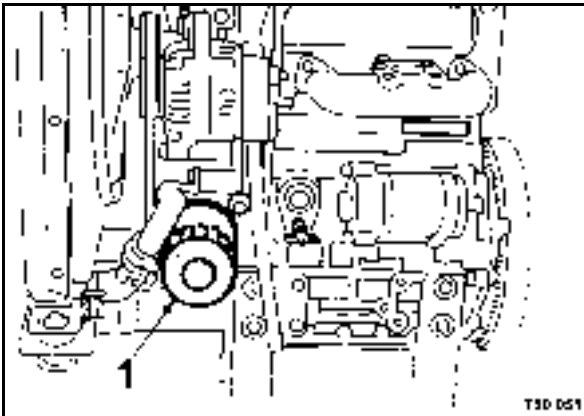

Fig. 99

- Unscrew the filter cartridge (1) (Fig. 99) using an appropriate filter wrench.
- Clean the sealing face on the filter carrier from any dirt.

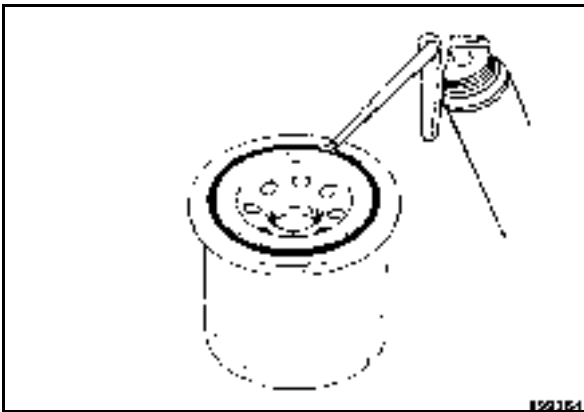

Fig. 100

- Slightly oil the rubber seal on the new filter cartridge (Fig. 100).
- Turn the new filter cartridge on by hand, until the seal contacts.
- Tighten the filter element for another half turn.



Fig. 101

- Fill in new engine oil (Fig. 101).
- Tighten the oil filler cap properly.

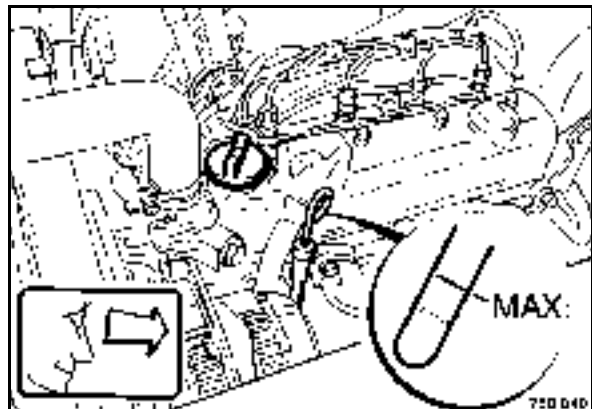

Fig. 102

- After a short test run check the oil level once again (Fig. 102), if necessary top up to the top mark (MAX).

5.13 Checking, tensioning, re- placing the V-belt

▲ Danger

Danger of accident!

Perform this work only with the engine shut down.

Checking the V-belt

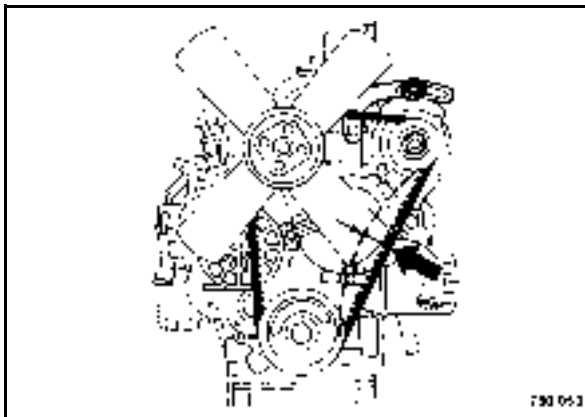

Fig. 103

- Check the entire circumference of the V-belt (Fig. 103) for damage and cracks. Replace damaged or cracked V-belts.
- Check with thumb pressure whether the V-belt can be depressed more than 7 to 9 mm between the V-belt pulleys, retighten if necessary.

Tensioning the V-belt

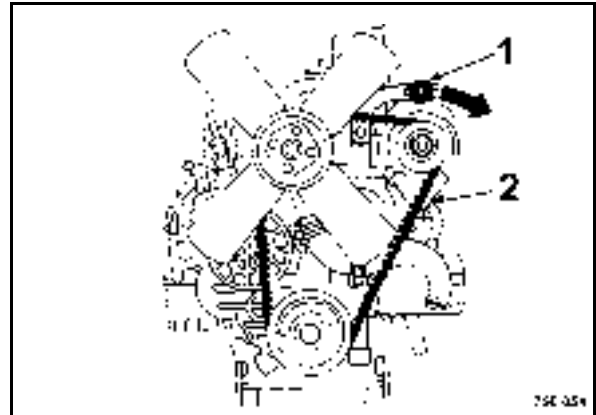

Fig. 104

- Slacken the fastening screws 1 and 2 (Fig. 104) slightly.
- Press the generator in direction outward using a lever, until the correct V-belt tension is reached.
- Retighten all fastening screws and check the V-belt tension once again.

Changing the V-belt

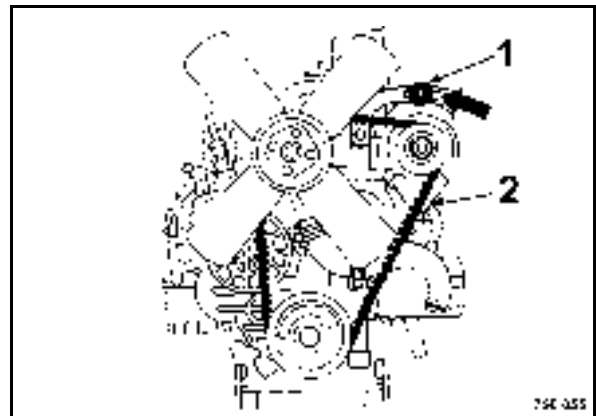

Fig. 105

- Slacken the fastening screws 1 and 2 (Fig. 105) slightly.
- Press the generator completely against the engine.
- Take the old V-belt off.
- Fit the new V-belt to the V-belt pulleys.
- Tension the V-belt as previously described.

⚠ Caution

Check the V-belt tension again after a running time of 30 minutes.

5.14 Clean the cooling fins on engine and hydraulic oil cooler

⚠ Danger

Danger of injury!

Perform cleaning work only after the engine has cooled down and with the engine stopped.

⚠ Caution

Do not damage any cooling fins on the cooler core when cleaning.

i Note

Dirt on fan blades and radiator reduce the cooling effect. Dirt deposits in these areas are substantially supported by oil and fuel on these surfaces. For this reason you should always seal any oil or fuel leaks in the vicinity of the cooling fan or the radiator and clean the cooling surfaces after.

Cleaning with compressed air

i Note

Start to blow out from the exhaust side.

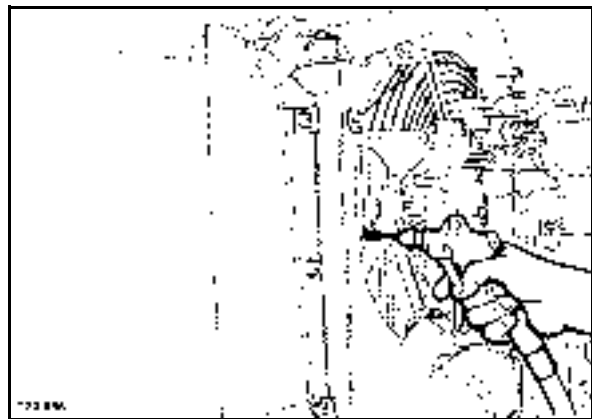

Fig. 106

- Blow the cooler (Fig. 106) out with compressed air from the air discharge side.
- Blow the cooler out with compressed air from the air supply side.

Cleaning with cold cleansing agent

Caution

Protect electrical equipment such as generator and starter against the direct water jet.

- Spray engine and cooler with a suitable cleansing agent, e.g. cold cleanser, let it soak in for a while and spray it off with a strong water jet.
- Run the engine warm for a while to avoid corrosion.

5.15 Change the oil in the vibrator shaft housing

Caution

Change the oil at operating temperature. For this purpose run the machine approx. half an hour with vibration.

Environment

Catch running out oil and dispose of environmentally.

Danger

Danger of injury!

Do not step under suspended loads.

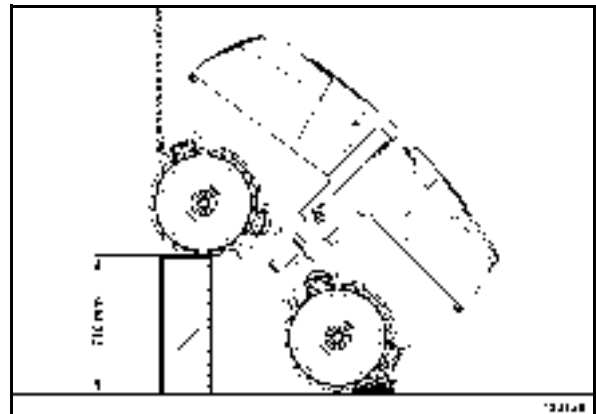

Fig. 107

- Lift the machine up and support it safely (Fig. 107).

Every 250 operating hours

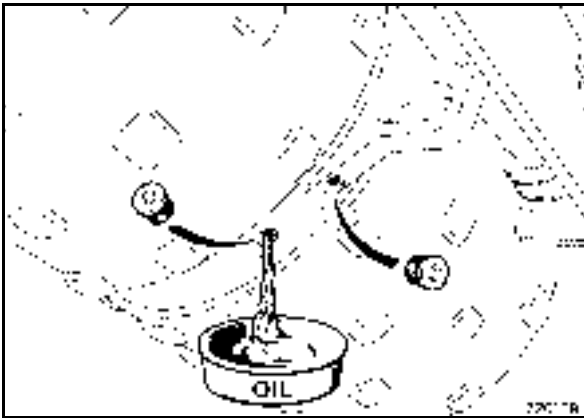

Fig. 108

- Unscrew the drain and filling plug on the front drum (Fig. 108).
- Drain and catch all oil.

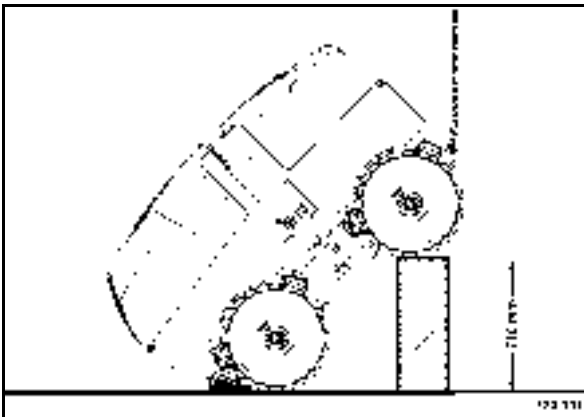

Fig. 109

- Jack up the opposite side of the machine and secure it adequately (Fig. 109).



Fig. 110

- Drain of oil through the oil drain bore in the bottom drum.

For quality and quantity of oil refer to the table of fuels and lubricants.

- Screw the drain and ventilation plugs back in.

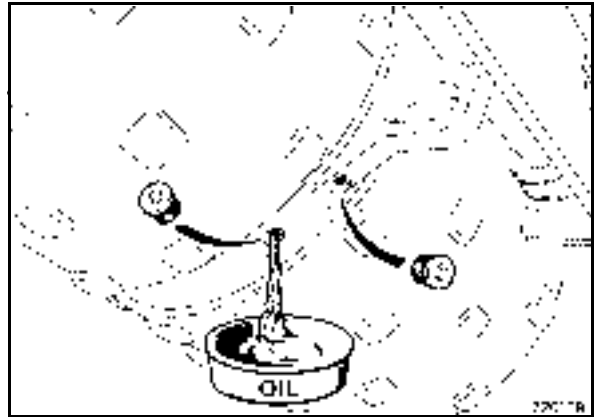

Fig. 111

- Unscrew the drain and ventilation plugs (Fig. 108) from the upper drum.
- Drain and catch all oil.

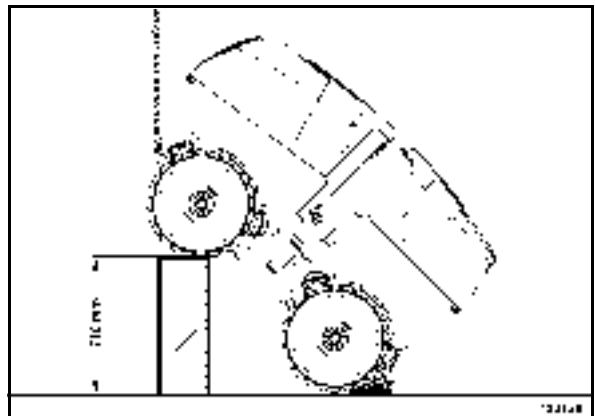

Fig. 112

- Jack up the opposite side of the machine and secure it adequately (Fig. 107).

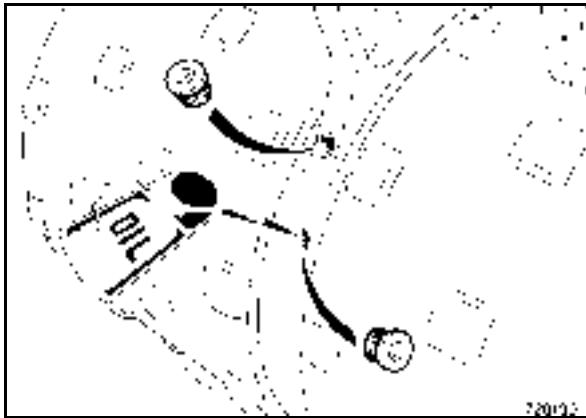

Fig. 113

- Drain of oil through the oil drain bore in the bottom drum.

For quality and quantity of oil refer to the table of fuels and lubricants.

- Screw the drain and ventilation plugs back in.

5.16 Checking the central screw of the drive hub

Caution

Check the tightening torque of the central screw on all 4 drive hubs.

Tightening torque: 900 Nm.

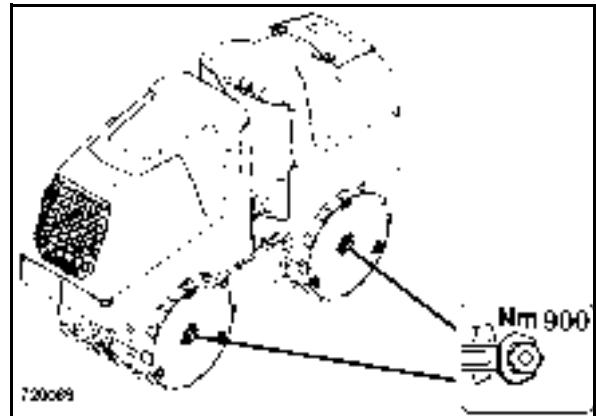

Fig. 114

- Check the tightening torque of the central screw on all 4 drive hubs (Fig. 107).

Every 250 operating hours



5.17 Draining the fuel tank sludge

⚠ Danger

Fire hazard!

When working on the fuel system do not use open fire, do not smoke.

Do not spill any fuel.

⚠ Danger

Health hazard!

Do not inhale any fuel fumes.

♻ Environment

Catch running out fuel, do not let it seep into the ground.

i Note

When performing this work the fuel tank shall only hold max. 5 litres of fuel, pump off if necessary.

- Fold out the rear frame

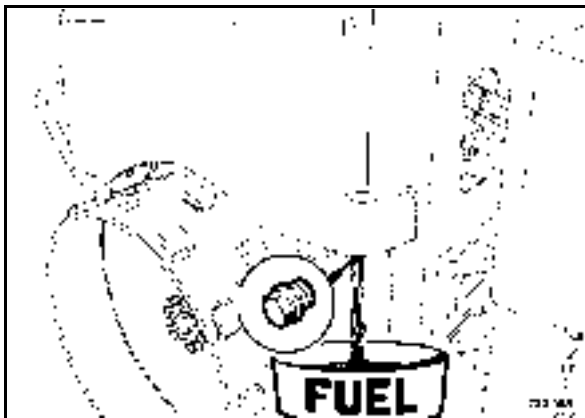

Fig. 115

- Place the suitable container under the fuel tank drain plug(Fig. 115).
- Unscrew the plug and drain off fuel.
- Once all fuel has run out screw the drain plug back in with a new seal ring.
- Fill the fuel tank with clean fuel.

5.18 Changing the fuel pre-cleaner, bleeding the fuel system

⚠ Danger

Fire hazard!

When working on the fuel system do not use open fire, do not smoke.

Do not spill any fuel.

⚠ Danger

Health hazard!

Do not inhale any fuel fumes.

♻ Environment

Catch running out fuel, do not let it seep into the ground.

Dispose of the used fuel filter environmentally.

Change the fuel filter cartridge

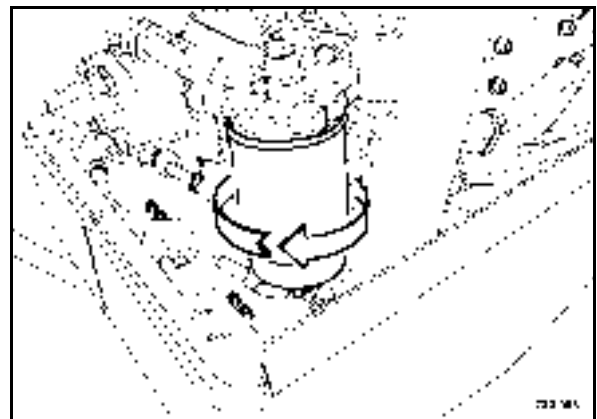

Fig. 116

- Loosen and unscrew the fuel filter cartridge (Fig. 116) using an appropriate filter wrench.
- Cleaning the sealing face on the filter head.

Every 500 operating hours



Fig. 117

- Apply a thin film of fuel to the seals and screw the new filter cartridge (Fig. 117) on hand-tight.

Bleed the fuel system

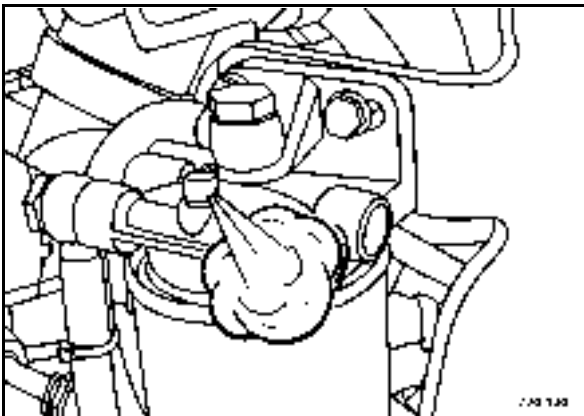

Fig. 118

- Open the bleeding screw on the fuel filter (Fig. 118) and crank the engine with the starter, until fuel runs out without air bubbles.
- Retighten the bleeding screw.



Fig. 119

- Open the bleeding screw on the injection pump (Fig. 119) and crank the engine with the starter, until fuel runs out without air bubbles.
- Retighten the bleeding screw.

5.19 Battery service, checking the main battery switch

⚠ Danger

Danger of cauterisation ! Danger of explosion!

When working on the battery do not use open fire, do not smoke!

The battery contains acid. Do not let acid come in contact with skin or clothes!

Wear protective clothing!

Do not lay any tools on the battery!

For recharging remove the plugs from the battery to avoid the accumulation of highly explosive gases.

♻ Environment

Dispose of the old batteries environmentally.

i Note

Maintenance free batteries also need care. Maintenance free only means that the fluid level does not need to be checked. Each battery suffers under self-discharge, which may, if not checked occasionally, even cause damage to the battery as a result of exhaustive discharge.

The following therefore applies for the service life:

- Switch off all consumers.
- Check open-circuit voltage of the battery at regular intervals. At least once per month.

Reference values: 12.6 V = fully charged; 12.3 V = 50% discharged.

- Recharge the battery immediately after an open-circuit voltage of 12.25 V or less is reached. Do not perform quick charging.

The open-circuit voltage of the battery occurs approx. 10 hours after the last charging process or one hour after the last discharge.

- After each charging process allow the battery to rest for one hour before taking it into service.
- For resting periods of more than one month you should always disconnect the battery. Do

not forget to perform regular open-circuit voltage measurements.

⚠ Caution

Exhausted batteries (batteries with formation of sulphate on the plates) are not covered under warranty!

- Open the maintenance flap and remove the battery cover.

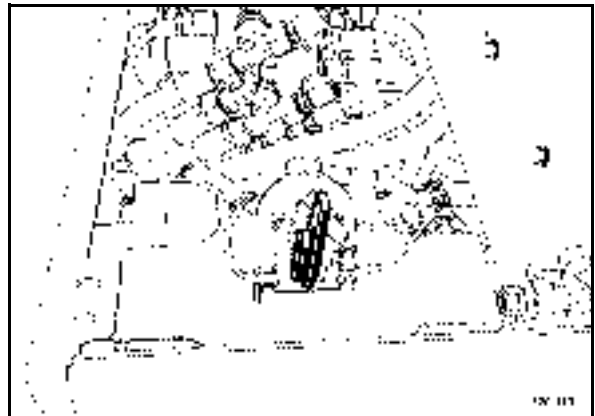

Fig. 120

- Clean the outside of the battery (Fig. 120).
- Clean battery poles and pole clamps and grease them with pole grease (Vaseline).
- Check the fastening of the battery.
- On serviceable batteries check the acid level, if necessary top up to the filling mark with distilled water.

Checking the main battery switch

- Turn the main battery switch to "horizontal" position and check by voltage measurement (ignition key test) whether the batteries are disconnected from the electric system of the machine.

5.20 Check the rubber buffers

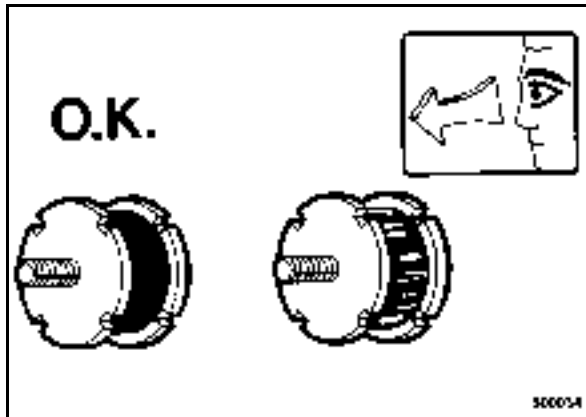

Fig. 121

- Check all rubber buffers (Fig. 121) for tight fit, cracks and damage and replace immediately if damaged.

5.21 Checking, adjusting the valve clearance

Caution

We recommend to have this work carried out by trained personnel or our after sales service.

Check and adjust only when the engine is cold.
Cylinder 1 is on the flywheel side.

- Disassemble cylinder head cover and glow plug.

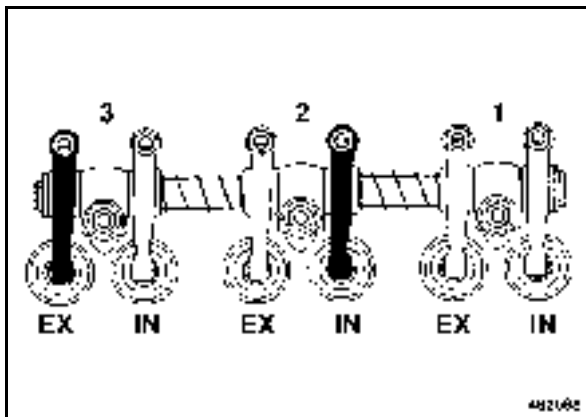

Fig. 122

Crankshaft position 1

IN = Intake valve
EX = Exhaust valve

- Crank the engine until both valves on cylinder 1 are "overlapping".
- Perform the adjustment of the valve by following the adjustment diagram 1" (Fig. 122), black mark.

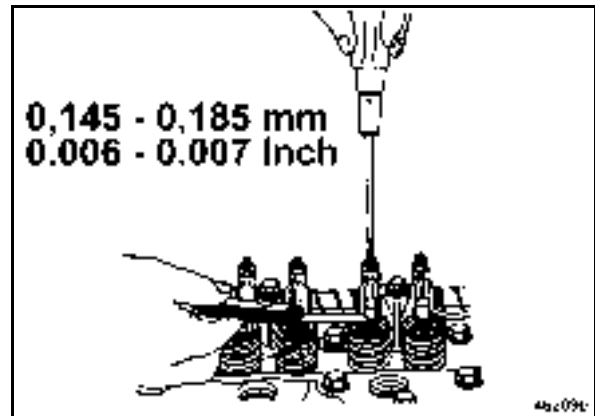

Fig. 123

- Check the gap between rocker arm and valve with a feeler gauge (Fig. 123).

Valve clearance for intake and exhaust valve:
0.145 - 0.185 mm

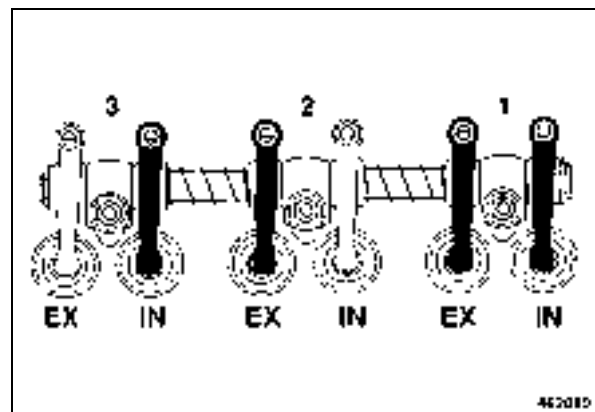

Fig. 124

Crankshaft position 2

IN = Intake valve
EX = Exhaust valve

- Turn the crankshaft one revolution (360 °) further.
- Perform the adjustment of the valve by following the adjustment diagram 2" (Fig. 124), black mark.
- Assemble the cylinder head cover with a new gasket.

Note

After a short test run check the engine for leaks.

5.2.2 Safety field measurement of the Boss safety system

⚠ Danger

Danger of injury!

The safety field of the machine must be measured at a height of one meter, also after maintenance/repair work on the safety system.

A safety field length < 1.20 m is not permitted.

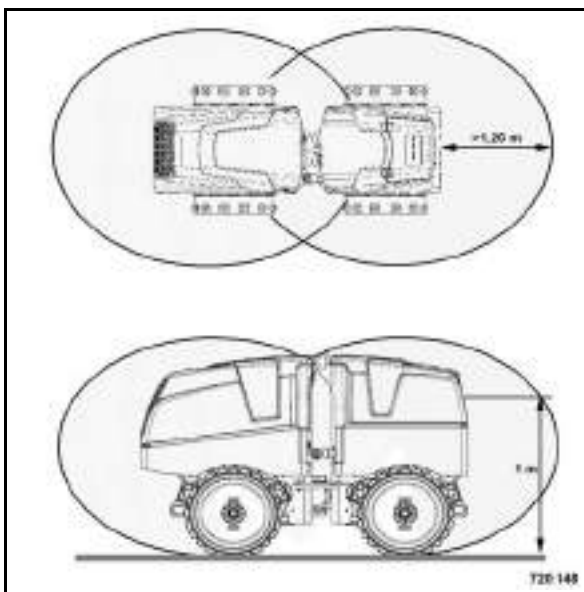

Fig. 125

- Step behind the machine with the remote control and allow the machine to move towards you, until it stops.
- Measure the distance between machine and remote control housing.

Nominal value:

>1.20 m

⚠ Danger

Danger of injury!

If the safety distance is fallen short of stop the machine and have the safety system repaired. It is not permitted to continue operation.

- Repeat this inspection in front of the machine.

5.23 Change hydraulic oil and filter

i Note

See also the notes on the hydraulic system in the chapter "General notes on maintenance".

⚠ Danger

Danger of scalding!

When draining off hot hydraulic oil!

⚠ Caution

The hydraulic oil must also be changed after major repairs in the hydraulic system.

Perform the oil change when the hydraulic oil is warm.

Replace the hydraulic oil filter element with every hydraulic oil change.

Clean the area round hydraulic oil tank, filler opening and breather filter.

Do not start the engine after draining the hydraulic oil.

Do not use any detergents to clean the system.

For quality and quantity of oil refer to the "table of fuels and lubricants".

When changing from mineral oil based hydraulic oil to an ester based biologically degradable oil, you should consult the lubrication oil service of the oil manufacturer for details.

♻ Environment

Catch running out oil and dispose of environmentally.

- Drive the machine, until the hydraulic oil has reached operating temperature.
- Shut down the engine.

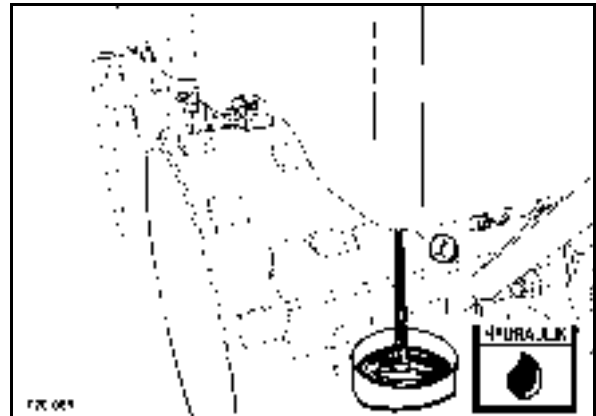

Fig. 126

- Unscrew the plug (Fig. 126) and drain off all hydraulic oil.
- Turn the plug tightly back in.

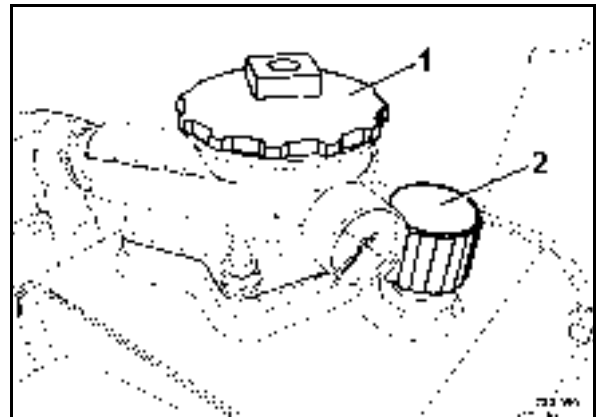

Fig. 127

- Unscrew the filter cover 1 (Fig. 127) and take out the filter element.

i Note

We recommend to use the BOMAG filling and filtering unit with fine filter to fill the system. This ensures finest filtration of the hydraulic oil, prolongs the lifetime of the hydraulic oil filter and protects the hydraulic system.

- Fill in new hydraulic oil.
- Insert a new filter and reassemble the filter cover.
- Replace the breather filter (2).
- Perform a test run and check the system for leaks.

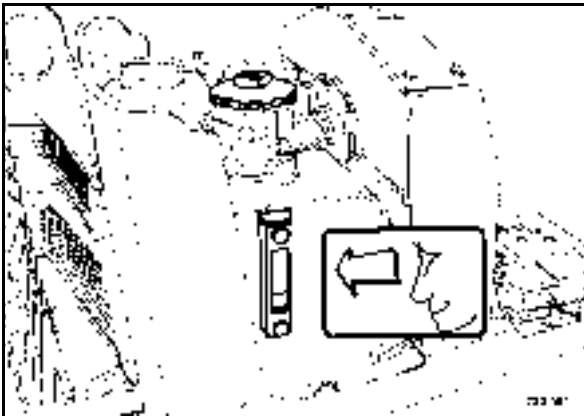

Fig. 128

- Check the oil level in the inspection glass (Fig. 128).

5.24 Change the coolant

Danger

Danger of scalding!

Change the coolant only when the engine is cold.

Do not remove the radiator cap when the engine is still hot.

Always wear gloves when handling anti-freeze agent.

Caution

Always screw the radiator cap tightly back on (second detent).

Always fill the engine cooling system with an anti-freeze mixture (corrosion protection).

Do not use more than 50% anti-freeze.

Do not mix different coolants and additives of any other kind. If necessary flush the cooling system 2-3 times with clear water.

For quality and quantity of coolant refer to the "table of fuels and lubricants".

Environment

Catch running out coolant and dispose of environmentally.

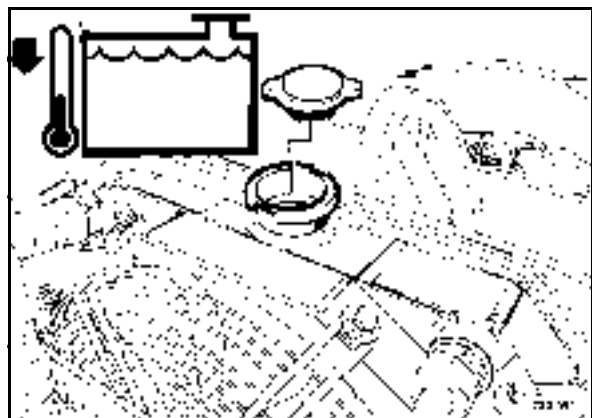

Fig. 129

- Remove the radiator cap (Fig. 129).

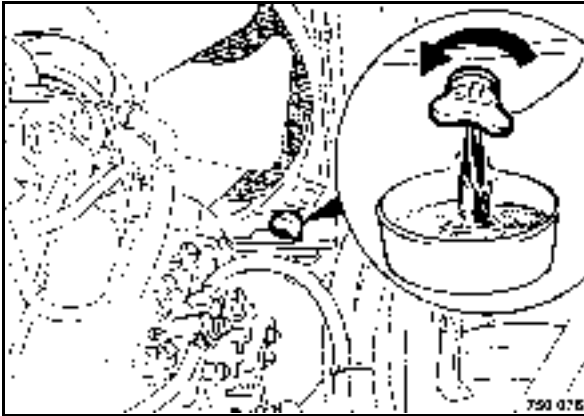

Fig. 130

- Unscrew the drain valve (Fig. 130) from the radiator.
- Drain the coolant completely off and collect it.
- Screw the drain valve back in.
- Check the condition of radiator hoses, if necessary replace all radiator hoses.

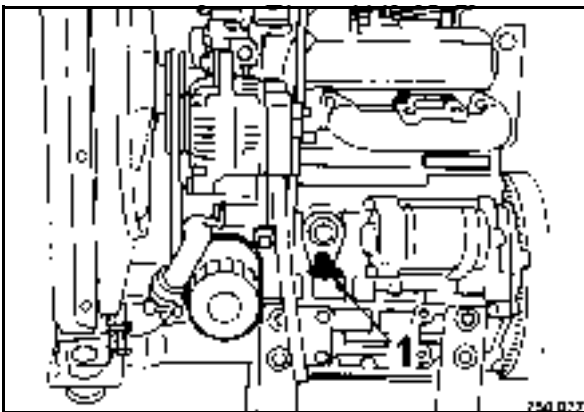

Fig. 131

- Open the drain valve (Fig. 131) on the engine.
- Drain the coolant completely off the engine block and collect it.
- Close the drain tap again.

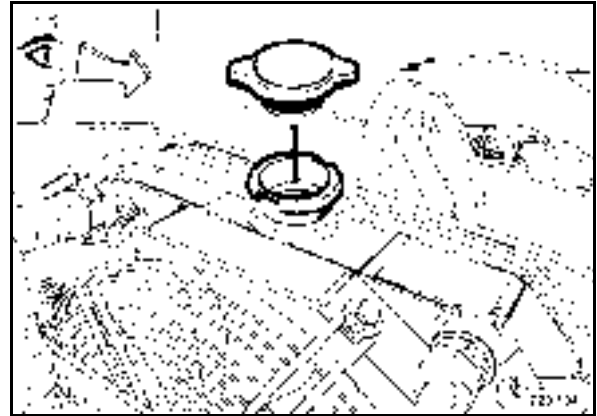

Fig. 132

- Fill in coolant until the level reaches the bottom edge of the radiator filler socket (Fig. 132).

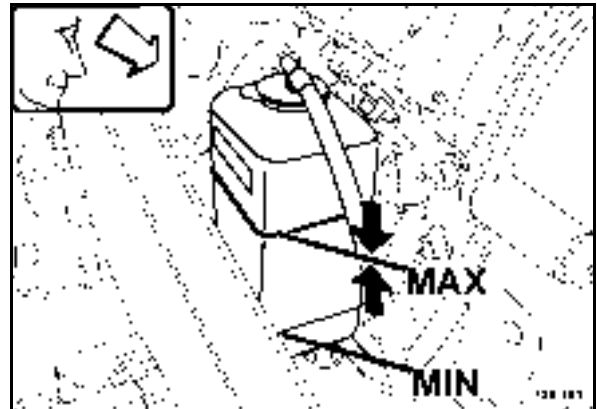

Fig. 133

- Fill in coolant up to the MAX mark (Fig. 133).
- Reattach the radiator cap and the cap of the compensation tank.
- Start the diesel engine and run it warm to operating temperature.
- Let the engine cool down and check the coolant level again, if necessary top up in the compensation tank.

5.25 Change the fuel lines

i Note

For safety reasons this work should be performed every two years.

Hoses consist of rubber or plastic material and age over the course of time.

⚠ Danger

Fire hazard!

When working on the fuel system do not use open fire, do not smoke and do not spill any fuel.

Do not inhale any fuel fumes.

♻ Environment

Catch running out fuel, do not let it seep into the ground.

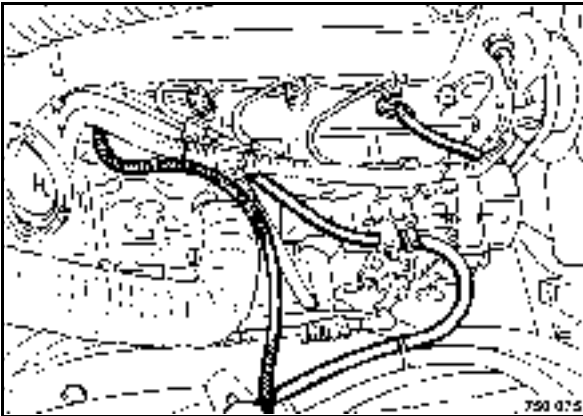

Fig. 134 084

- Replace all fuel hoses (Fig. 134) including their hose clips.

5.26 Checking the injection pressure

i Note

This work must only be performed by authorized service personnel.

5.27 Checking the fuel injection pump

i Note

This work must only be performed by authorized service personnel.

5.28 Checking the fuel injection timing

i Note

This work must only be performed by authorized service personnel.

Every 3000 operating hours



5.29 Check, clean, replace the combustion air filter

Caution

Do not use gasoline or hot fluids to clean the filter cartridge.

After cleaning the filter cartridge must be inspected with a torch for damage.

Dry air filter cartridges with damaged filter element or seal must be replaced in any case.

The dry air filter element must be replaced after 3 times cleaning, but at the latest after one year, irrespective of the operating hours.

Each cleaning interval must be marked with a cross on the cover of the filter element.

Cleaning does not make sense if the cartridge is covered with a sooty deposit. Use a new filter cartridge.

Incorrectly handled filter elements may become ineffective because of damage (e.g.: cracks) and cause engine damage.

When working in dusty environments the filter service may become due considerably earlier. This may be noticed by a drop in engine power and black exhaust fumes.

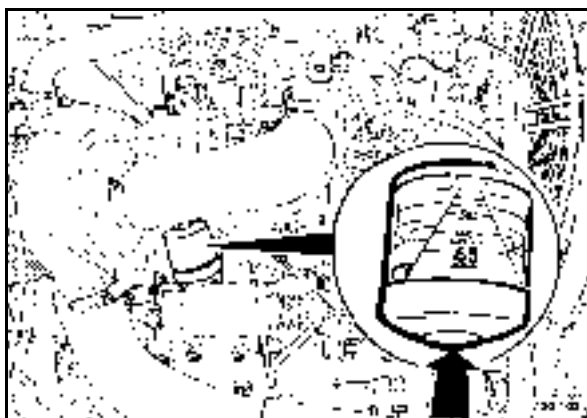

Fig. 135

Servicing of the dry air filter is necessary when the yellow piston (Fig. 135) has reached the inscription "Service", but at the latest after one year.

After completion of the filter service reset the indicator back to "Zero" by pressing the button.

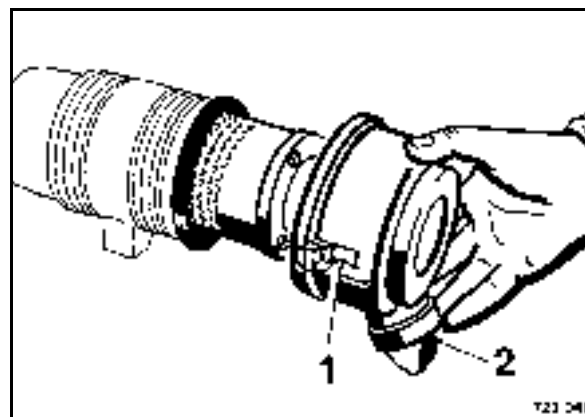

Fig. 136

- Open both clamps 1 (Fig. 136).
- Remove the filter hood.
- Clean filter hood and dust discharge valve (2).



Fig. 137

- Carefully loosen the filter element.

The filter element is located directly on the outlet tube, thereby providing a seal on the inside of the filter cover. Carefully remove the filter element, in order to reduce the released amount of dust. To release the seal pull the filter element carefully up, down and sideways or turn it (Fig. 137).

As required

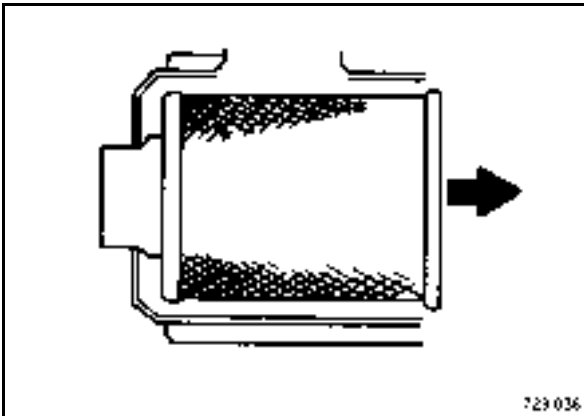
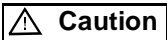

Fig. 138

- Pull the filter element (Fig. 138) carefully out of the housing.



Caution

Avoid contact between filter element and housing.

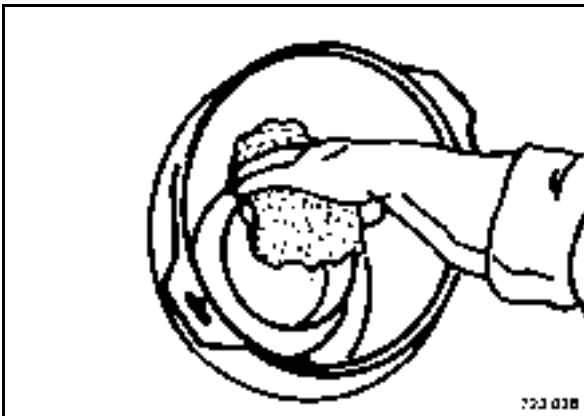

Fig. 139

- Clean the sealing face on the outlet tube (Fig. 139).

Dust on the outer diameter of the outlet tube can impair effective sealing.

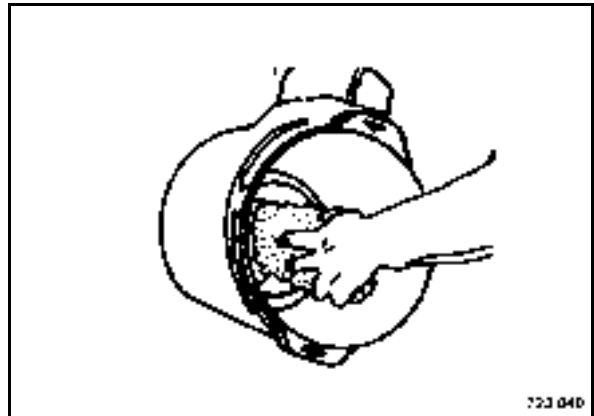

Fig. 140

- Thoroughly clean the inside of the outlet tube (Fig. 140) and the filter housing.

Dirt that may incidentally drop into the outlet tube will reach the engine and cause wear.

- Check the old filter element.

The old filter element can be of help to discover foreign particles on the sealing face, which could lead to leaks. A dust strip on the clean air side of the filter may be a sign for this. Eliminate the problem before installing a new filter element.

- Clean or replace the filter element.
- Examine the filter element thoroughly for damage.

Before installing the new filter element check it for possible damage from transport, cleaning or incorrect handling. Especially on the inside of the open end (sealing area). Do not install a damaged filter element.

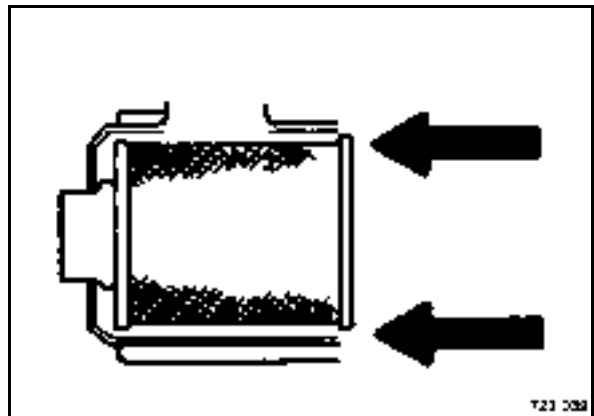

Fig. 141

- Insert the filter element (Fig. 141).

The radial sealing area is located at the inside of the open filter edge. This critical sealing area must be under slight tension after the filter has been installed. In order to achieve a tight seal apply pressure to the outer edge of the filter and not to the moveable centre.

- Reinstall the filter hood with the dust discharge valve.

⚠ Caution

The dust discharge valve must point vertically downwards.

Dry cleaning of the filter cartridge

⚠ Danger

Eye injury!

Wear protective clothing (goggles, gloves).

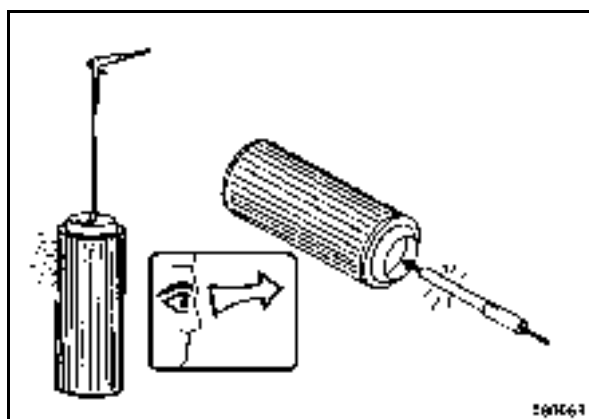

Fig. 142

i Note

For cleaning purposes fit a tube to the compressed air gun (Fig. 142), the end of which should be bent for approx. 90°.

The length should reach down to the bottom of the cartridge.

- Blow the cartridge out with compressed air (max. 5 bar) from inside to outside by moving the tube up and down inside the cartridge, until it is free of dust.
- Examine the filter cartridge with a torch for cracks and holes in the paper bellows.

⚠ Caution

Do not continue to use a damaged filter element. If in doubt use a new filter element.

5.30 Adjust the scrapers

i Note

If the scrapers (2 per drum) are worn, they must be adjusted or replaced.

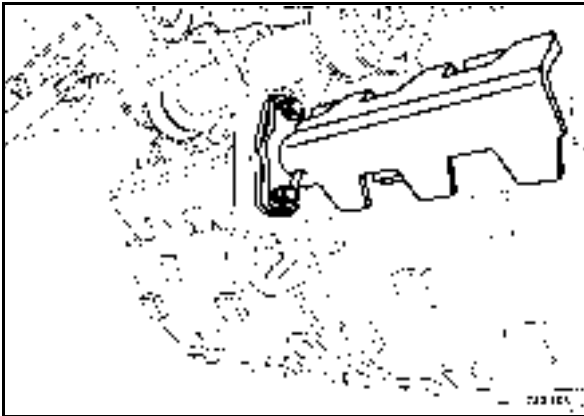

Fig. 143

- Loosen the fastening screws (Fig. 143) on both sides of the machine.
- Adjust the scrapers to a distance of approx. 5 mm to the drum.
- Tighten the fastening screws.

5.31 Tightening torques for screws with metric unified thread

| Bolt dimensions | Tightening torques Nm* | | |
|-----------------|------------------------|------|------|
| | 8.8 | 10.9 | 12.9 |
| M4 | 3 | 5 | 5 |
| M5 | 6 | 9 | 10 |
| M6 | 10 | 15 | 18 |
| M8 | 25 | 35 | 45 |
| M10 | 50 | 75 | 85 |
| M12 | 80 | 120 | 140 |
| M14 | 137 | 195 | 235 |
| M16 | 241 | 308 | 358 |
| M18 | 290 | 412 | 490 |
| M20 | 482 | 578 | 685 |
| M22 | 560 | 785 | 942 |
| M24 | 711 | 1000 | 1208 |
| M27 | 1038 | 1480 | 1774 |
| M30 | 1425 | 2010 | 2400 |

Fig. 144

* Strength classes for screws with untreated, non-lubricated surface. Screw quality designations are stamped on the screw heads.

8.8 = 8G

10.9 = 10K

12.9 = 12K

- Drum extension - drum
= 652 Nm

The values result in a 90% utilization of the screw's yield point at a coefficient of friction total = 0,14. Compliance with the specified tightening torques is checked with torque wrenches. When using MoS₂ lubricants the specified tightening torques do not apply.

i Note

Self-locking nuts must always be replaced once they have been unscrewed.

5.32 Engine conservation

If the engine is to be shut down for a longer period of time (e.g. during winter) we recommend the following conservation measures for the engine to avoid corrosion:

- Clean the engine, including the cooling system with cold cleansing agent and a water jet or, even better, with a steam jet.
- Run the engine warm and shut it down.
- Drain the still warm engine oil and fill in anti-corrosion engine oil.
- Drain the fuel from the fuel tank, mix it well with 10% anti-corrosion oil and fill it in again. Instead of mixing anti-corrosion oil with the fuel it is also possible to fill the tank with injection pump testing oil with anti-corrosive properties (e.g. Calibration Fluid B).
- Run the engine for 10 minutes until all lines, filter, pump and nozzles are filled with the conserving mixture and the new engine oil is distributed to all parts.
- After this test run remove the cylinder head covers and the lateral cover of the injection pump, spray the rocker chambers and the spring chamber in the injection pump with a mixture of diesel fuel with 10% anti-corrosion oil. Reassemble hoods and covers.
- Crank the engine several times by hand (without ignition) in order to spray the combustion chamber.
- Take the V-belt off and spray the grooves in the pulleys with anti-corrosion oil. Remove the anti-corrosion oil before taking the machine into operation.
- Close the air intake opening on the air filter and the exhaust opening.

i Note

Depending on weather conditions, these conserving measures will provide protection for approx. 6 - 12 months.

The conserving oil must be replaced by engine oil according to the API- (MIL) classification before taking the machine into operation. Refer to the section "Fuels and Lubricants".

Anti-corrosion oils are those that comply with the specification MIL-L-21260 B or TL 9150-037/2 or Nato Code C 640/642.

Caution

Mark a machine with a conserved engine by attaching a clearly visible warning tag.



6 Troubleshooting

6.1 General notes

The following work must only be carried out by qualified and trained personnel or by the BOMAG sales service.

Please observe strictly the safety regulations in chapter 2 of these operating and maintenance instructions.

Malfunctions are frequently caused by incorrect operation of the machine or insufficient maintenance. Whenever a fault occurs you should therefore thoroughly read these instruction on correct operation and maintenance. If you cannot locate the cause of a fault or rectify it yourself by following the trouble shooting chart, you should contact the service departments at our branch offices or dealers.

On the following pages you will find a selection of fault remedies. It goes without saying that not all possible reasons for faults could be listed.

⚠ Danger

Danger of injury!

Do not touch rotating parts of the engine.

6.2 Engine problems

| Fault | Possible cause | Remedy |
|---|--|--|
| Engine does not start | Fuel tank empty | Fill fuel tank |
| | Fuel filter clogged, in winter due to paraffin separation | Change the filter, use winter fuel |
| Engine does not start | Fuel lines leaking | Check all line connections for leaks and tighten the fittings |
| | Battery not charged or not connected | Charge the battery, check the pole clamps |
| | Operating error | see section "Starting the engine" |
| | Incorrect valve clearance | Adjust the valve clearance |
| | Inclination switch has switched off | Reduce the inclination |
| Poor starting of engine or engine works irregularly with poor power | Battery power too low | Have battery checked |
| | Battery pole clamps loose or oxidized, causing the starter to turn too slow | Clean the pole clamps, tighten and cover them with acid-free grease |
| | Especially in winter: use of too viscous engine oil | Use an engine oil complying with the ambient temperatures |
| | Fuel supply too low, fuel system clogged by paraffin separation during winter | Change the fuel filter. Check the line connections for leaks and tighten the fittings. Use winter fuel under cold conditions |
| | The specified valve clearance is not correct | Adjust the valve clearance |
| Injection valve or injection pump defective | Have examined by a specialist | |
| Engine loses power and speed, excessive exhaust smoke | Engine oil level too high | Drain the oil down to the top dipstick mark |
| | Air filter dirty | clean, if necessary use a new one |
| | Poor compression due to burned or broken piston rings or incorrect valve clearance | Have piston rings and pistons examined by a specialist, adjust the valve clearance |
| | Injection valve defective | Have examined by a specialist |

Trouble shooting

| Fault | Possible cause | Remedy |
|--|--|---|
| Engine over-heating, engine must be shut down immediately! | Cooling fins heavily soiled Injection valve defective Engine oil level too high Injection pump displacement not correctly adjusted Lack of cooling air | Clean the cooling fins Have examined by a specialist Drain the oil down to the top dipstick mark Have corrected by a specialist Remove any clogging from the cooling air duct |
| Engine has too low oil pressure, engine must be immediately shut down! | Leaks in the lubrication system, oil level too low Engine oil with wrong SAE viscosity class | Check fittings on oil lines and lubrication oil filter for leaks, if necessary tighten all fittings Fill up engine oil up to the mark on the dipstick Change the engine oil |
| Charge control light lights up during operation | The generator does not charge the battery, because of defect on generator or regular | Have examined by a specialist |

6.3 Problems with remote control Hetronic with spiral cable

| Fault | Possible cause | Remedy |
|---------------------------------|--|---|
| Engine stops without any reason | Engine oil pressure too low or engine oil pressure switch defective Does the red oil pressure warning lamp light up when the engine is running? | Check engine oil level or oil pressure switch |
| | Battery | Check battery terminals for tight fit (intermittent contact?) Check the main battery switch Replace the battery |
| | Emergency stop push button | Switch operated? Display off, pull button out Switch defective? replace |
| | Fuses F 54, F 67, F 103 defective | Replace the fuses (may be damaged by vibration) |
| | Toggle switch cable/radio S101 | Check plug connections, bridge switch for testing |
| | Relay K 11 | Replace the relay Check the plug connections in the relay base |
| | Spiral cable | Check the continuity of the individual cables Check the cables for short circuit to the housing Replace the cables |
| | All wiring looms | Check all wiring looms for intermittent contact, to do so wobble all cables, especially close to the plug connections, while the engine is running Check also the plug connections on the regulator and the ground cable between engine and frame. |
| | Transmitter | Replace the transmitter |

Trouble shooting

| Fault | Possible cause | Remedy |
|---|----------------------------------|--|
| | Inclination sensor | Check the sensor signal, input code 1405 Bridge connections 5 and 6 on the plug for the inclination sensor If necessary replace the sensor |
| | Regulator | Pull off the four-pin plug above the regulator, if OK, replace the regulator |
| | A 70 module (BLM) | Replace the module |
| | Main wiring loom | Replace the main wiring loom |
| | Engine wiring harness | Replace the engine wiring loom |
| | Generator | Pull off the two-pin plug coming from the generator and measure the a.c. voltage between the two cables while the engine is running (approx. 26 V at max. speed) Check both cables for continuity and check the ground connection |
| Ignition on, display module on, but starting not possible | Travel lever not in "0"-position | Actuate the travel lever and return it to "0"-position Check with input code 2500 and 2501 |
| | Fuse F 119 | Replace the fuses (may be damaged by vibration) |
| | Battery | A clicking sound on module A 70 indicates that the battery is empty, if necessary replace the battery |
| | Inclination sensor | Check the sensor signal, (input code 1405) Bridge connections 5 and 6 on the plug for the inclination sensor If necessary replace the sensor |
| | Relay K 39 | Check the relay control with code 5070 (start repetition lock!) Replace the relay Check the plug connections in the relay base |
| | Transmitter | Replace the transmitter |
| | A 70 module (BLM) | Replace the module |

| Fault | Possible cause | Remedy |
|--|--|---|
| | All wiring looms | Check all wiring looms for intermittent contact, to do so wobble all cables, especially close to the plug connections, while the engine is running Check also the plug connections on the regulator and the ground cable between engine and frame. |
| After starting still no function | Not waited for horn signal before starting | Press the horn button or wait for the horn signal before starting |
| | Emergency stop push button | Switch operated? Display off, pull button out Switch defective? replace |
| | Transmitter | Replace the transmitter |
| | Spiral cable | Check the continuity of the individual cables Check the cables for short circuit to the housing Replace the cables |
| | A 70 module (BLM) | Replace the module |
| | Main wiring loom | Replace the main wiring loom |
| Display module shows CTO when ignition is on | Spiral cable | Check the continuity of the individual cables Check the cables for short circuit to the housing Replace the cables |
| | Main wiring loom | Check whether plug X3:30 or X3:31 is loose Check for short circuit between X24:6 and 7, or CAN+ und CAN- or 8 and 3 on the display module |
| | A 70 module (BLM) | Replace the module |
| Engine not running at max. speed, otherwise OK | Toggle switch for speed S 134 | Toggle switch in position "max" ? Check with input code 2505 If necessary replace the toggle switch |
| | Fuse F 14 | Replace the fuses (may be damaged by vibration) |
| | Engine solenoid Y 46 (adjustment) | Adjust the engine solenoid if the fuse keeps blowing |

Trouble shooting

| Fault | Possible cause | Remedy |
|--------------|-----------------------|---|
| | Relay K 114 | Check the relay control with code 5050 Replace the relay Check the plug connections in the relay base |
| | A 70 module (BLM) | Replace the module |
| | Main wiring loom | Replace the main wiring loom |
| | Engine wiring harness | Replace the engine wiring loom |

6.4 Problems with radio remote control Hetronic in radio operation

i Note

Assumed that the function is correct when using the spiral cable.

Steel ropes or metal attachments on the frame can disturb the radio connection.

| Fault | Possible cause | Remedy |
|---|---|--|
| Machine does not respond | Incorrect or defective aerial | Replace the aerial (observe the frequency of the aerial) Check the plug connection between aerial and receiver |
| | The receiver is electrically not or not correctly connected | Check the plug connection between receiver and machine |
| | Receiver and transmitter have different system numbers | Installation of transmitter and receiver with identical system-no. |
| | Power pack empty or defective | Charge or replace the power pack |
| | Distance between machine and transmitter more than 30 m | Move closer to the machine |
| | Toggle switch radio/cable (S101) | Check the plug connection Bridge switch for testing |
| | Transmitter or receiver defective | Replace transmitter or receiver |
| Ignition on, display module on, but starting not possible | Power pack empty or defective | Charge or replace the power pack |
| | Transmitter or receiver defective | Replace transmitter or receiver |
| Engine stops without any reason | Power pack empty or defective | Charge or replace the power pack |
| | Disturbance caused by other radio systems | Check whether the problem arises when other radio signals are transmitted nearby (airport, construction crane, etc.) If necessary continue in cable operation |
| | Incorrect or defective aerial | Replace the aerial (observe the frequency of the aerial) Check the plug connection between aerial and receiver |
| | Distance between machine and transmitter more than 30 m | Move closer to the machine |
| | Toggle switch radio/cable (S101) | Check the plug connection Bridge switch for testing |

Trouble shooting

| Fault | Possible cause | Remedy |
|--------------|-----------------------------------|--|
| | Emergency stop push button | Switch operated? Display off, pull button out Switch defective? replace |
| | Transmitter or receiver defective | Replace transmitter or receiver |
| | Main wiring loom | Replace the main wiring loom |

6.5 Faults in BOSS safety system

After maintenance and/or repair work on the safety system the safety field length must be checked again (see "Maintenance every 3000 operating hours").

⚠ Danger

Danger of injury!

| Fault | Possible cause | Remedy |
|---|---|---|
| no travel movements, steering is still possible | The operator is inside the safety field | Leave the safety field |
| | Transponder (in transmitter) has not been taught | see point 4.15 Teaching the transponder |
| | Safety antenna front / rear defective or not plugged in | Replace the antenna, check plug connection |
| | Distance between machine and transmitter more than 30 m | Move closer to the machine |
| | Safety field control defective or not plugged in | Replace the safety field control or check the plug connection |
| | Transmitter defective | Replace the transmitter |
| | Wiring loom for safety field antennas | Replace the wiring loom for safety field antennas |

6.6 Fault indicator

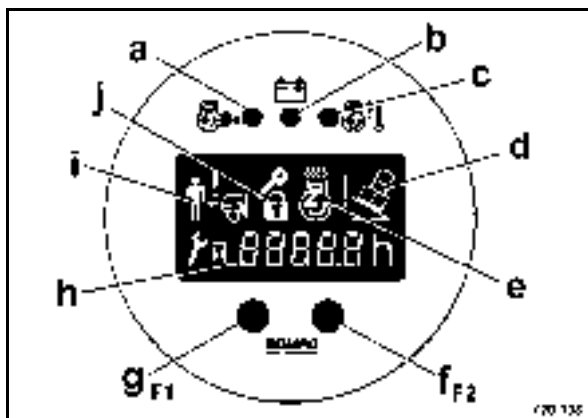

Fig. 145

Faults are displayed in the display module h (Fig. 145) in form of flashing fault codes. If several faults occur at the same time, these will be indicated by flashing codes, one after the other.

6.7 Fault code

Overview

| Fault code | Function group |
|-------------|---|
| 1000 - 1999 | Travel system |
| 2000 - 2499 | Steering |
| 2500 - 2999 | Remote controls |
| 5000 - 5499 | Diesel engine |
| 7000 - 7499 | Input codes for machine parameterization |
| 7500 - 7999 | Operating hour meter, load spectrum (input codes) |
| 8000 - 8999 | Severe software error |
| 9000 - 9998 | external IO-node, joystick, data collector |
| 9999 | Unknown fault, displayed value higher than +/- 10000, automatic output by the BMFSA |

Fault codes of travel functions

| Code | Fault reaction | Description of fault | Possible cause | Terminal on BLM | Input code for diagnose |
|------|---|--|---|-----------------|-------------------------|
| 1030 | Output is switched off, function no longer possible | Output valve travelling forward, Y 16 Too high current flow out of this output Output was switched off! | Excessive current flow in current path, probably because of a defective coil or a short circuit to ground | X3:22 | - |
| 1031 | Output is switched off, function no longer possible | Output valve travelling forward, Y 16 Short-circuit current flow out of this output Output was switched off! | Short circuit to ground in the current path Lines rubbed through Valve defective | X3:22 | - |
| 1032 | Output is switched off, function no longer possible | Output valve travelling forward, Y 16 No or too low current flow out of this output | Wire breakage in current path Current path connected to +12V | X3:22 | 1030 1031 1032 |

Trouble shooting

| Code | Fault reaction | Description of fault | Possible cause | Terminal on BLM | Input code for diagnose |
|------|---|---|---|-----------------|-------------------------|
| 1033 | Engine is shut down | Output valve traveling forward, Y 16 Although the output is switched off, voltage is present | Current path connected to +12V | X3:22 | 1030 1031 1032 |
| 1040 | Output is switched off, function no longer possible | Output valve traveling reverse, Y 17 Too high current flow out of this output Output was switched off! | Excessive current flow in current path, probably because of a defective coil or a short circuit to ground | X3:24 | - |
| 1041 | Output is switched off, function no longer possible | Output valve traveling reverse, Y 17 Short-circuit current flow out of this output Output was switched off! | Short circuit to ground in the current path Lines rubbed through Valve defective | X3:24 | - |
| 1042 | Output is switched off, function no longer possible | Output valve traveling reverse, Y 17 No or too low current flow out of this output | Wire breakage in current path Current path connected to +12V | X3:24 | 1040 1041 1042 |
| 1043 | Engine is shut down | Output valve traveling reverse, Y 17 Although the output is switched off, voltage is present | Current path connected to +12V | X3:24 | 1040 1041 1042 |
| 1050 | Output is switched off, function no longer possible | Output valve 2. gear, Y 03 Too high current flow out of this output Output was switched off! | Excessive current flow in current path, probably because of a defective coil or a short circuit to ground | X3:11 | - |
| 1051 | Output is switched off, function no longer possible | Output valve 2. gear, Y 03 Short-circuit current flow out of this output Output was switched off! | Short circuit to ground in the current path Lines rubbed through Valve defective | X3:11 | - |

| Code | Fault reaction | Description of fault | Possible cause | Terminal on BLM | Input code for diagnose |
|------|--|--|---|-----------------|-------------------------|
| 1052 | Output is switched off, function no longer possible | Output valve 2. gear, Y 03 No or too low current flow out of this output | Wire breakage in current path Current path connected to +12V | X3:11 | 1050 1051 1052 |
| 1053 | Output is switched off, engine runs only with idle speed | Output valve 2. gear, Y 03 Although the output is switched off, voltage is present | Current path connected to +12V | X3:11 | 1050 1051 1052 |
| 1060 | Output is switched off, function no longer possible | Output brake valve, Y 04 Too high current flow out of this output Output was switched off! | Excessive current flow in current path, probably because of a defective coil or a short circuit to ground | X3:40 | - |
| 1061 | Output is switched off, function no longer possible | Output brake valve, Y 04 Short-circuit current flow out of this output Output was switched off! | Short circuit to ground in the current path Lines rubbed through Valve defective | X3:40 | - |
| 1062 | Output is switched off, function no longer possible | Output brake valve, Y 04 No or too low current flow out of this output | Wire breakage in current path Current path connected to +12V | X3:40 | 1060 1061 1062 |
| 1063 | Output is switched off, engine runs only with idle speed | Output brake valve, Y 04 Although the output is switched off, voltage is present | Current path connected to +12V | X3:40 | 1060 1061 1062 |
| 1305 | Output is switched off, function no longer possible | Output valve vibration low ampl., Y 56 Too high current flow out of this output Output was switched off! | Excessive current flow in current path, probably because of a defective coil or a short circuit to ground | X3:12 | - |

Trouble shooting

| Code | Fault reaction | Description of fault | Possible cause | Terminal on BLM | Input code for diagnose |
|------|--|---|---|-----------------|-------------------------|
| 1306 | Output is switched off, function no longer possible | Output valve vibration low ampl., Y 56 Short-circuit current flow out of this output Output was switched off! | Short circuit to ground in the current path Lines rubbed through Valve defective | X3:12 | - |
| 1307 | Output is switched off, function no longer possible | Output valve vibration low ampl., Y 56 No or too low current flow out of this output | Wire breakage in current path Current path connected to +12V | X3:12 | 1305 1306 1307 |
| 1308 | Output is switched off, engine runs only with idle speed 2nd gear is inhibited | Output valve vibration low ampl., Y 56 Although the output is switched off, voltage is present | Current path connected to +12V | X3:12 | 1305 1306 1307 |
| 1310 | Output is switched off, function no longer possible | Output valve vibration high ampl., Y 57 Too high current flow out of this output Output was switched off! | Excessive current flow in current path, probably because of a defective coil or a short circuit to ground | X3:13 | - |
| 1311 | Output is switched off, function no longer possible | Output valve vibration high ampl., Y 57 Short-circuit current flow out of this output Output was switched off! | Short circuit to ground in the current path Lines rubbed through Valve defective | X3:13 | - |
| 1312 | Output is switched off, function no longer possible | Output valve vibration high ampl., Y 57 No or too low current flow out of this output | Wire breakage in current path Current path connected to +12V | X3:13 | 1310 1311 1312 |
| 1313 | Output is switched off, engine runs only with idle speed 2nd gear is inhibited | Output valve vibration high ampl., Y 57 Although the output is switched off, voltage is present | Current path connected to +12V | X3:13 | 1310 1311 1312 |

Fault codes steering

| Code | Fault reaction | Description of fault | Possible cause | Terminal on BLM | Input code for diagnose |
|------|---|---|---|-----------------|-------------------------|
| 2010 | Output is switched off, function no longer possible | Output valve steering left, Y 237 Too high current flow out of this output Output was switched off! | Excessive current flow in current path, probably because of a defective coil or a short circuit to ground | X3:19 | 1010 |
| 2011 | Output is switched off, function no longer possible | Output valve steering left, Y 237 Short-circuit current flow out of this output Output was switched off! | Short circuit to ground in the current path Lines rubbed through Valve defective | X3:19 | - |
| 2012 | Output is switched off, function no longer possible | Output valve steering left, Y 237 No or too low current flow out of this output | Wire breakage in current path Current path connected to +12V | X3:19 | 1010 1011 1012 |
| 2013 | Engine is shut down | Output valve steering left, Y 237 Although the output is switched off, voltage is present | Current path connected to +12V | X3:19 | 1010 1011 1012 |
| 2020 | Output is switched off, function no longer possible | Output valve steering right, Y 238 Too high current flow out of this output Output was switched off! | Excessive current flow in current path, probably because of a defective coil or a short circuit to ground | X3:21 | - |
| 2021 | Output is switched off, function no longer possible | Output valve steering right, Y 238 Short-circuit current flow out of this output Output was switched off! | Short circuit to ground in the current path Lines rubbed through Valve defective | X3:21 | - |
| 2022 | Output is switched off, function no longer possible | Output valve steering right, Y 238 No or too low current flow out of this output | Wire breakage in current path Current path connected to +12V | X3:21 | 1020 1021 1022 |

Trouble shooting

| Code | Fault reaction | Description of fault | Possible cause | Terminal on BLM | Input code for diagnose |
|------|---------------------|--|--------------------------------|-----------------|-------------------------|
| 2023 | Engine is shut down | Output valve steering right, Y 238 Although the output is switched off, voltage is present | Current path connected to +12V | X3:21 | 1020 1021 1022 |

Fault codes of remote control

| Code | Fault reaction | Description of fault | Possible cause |
|------|--|--|--|
| 2500 | Engine is stopped, all functions are locked, horn sounds | Operation of two remote control system at the same time | A remote control with cable and a wireless remote control are operated at the same time. |
| 2600 | Engine stopped, emergency stop relay in the control is switched off, all outputs on control are switched off | Remote control emergency stop | Emergency stop on remote control operated |
| 2601 | Engine stopped, emergency stop relay in the control is switched off, all outputs on control are switched off | Fault in data transfer between remote control sender and receiver | Battery empty Radio or infrared transmission disturbed Distance between sender and machine too big |
| 2605 | Engine stopped, emergency stop relay in the control is switched off, all outputs on control are switched off | Receive signal too weak | Radio or infrared transmission disturbed Distance between sender and machine too big |
| 2611 | Engine is shut down. | CANopen – fault in bus communication | CANopen Slave cable control has not sent a node guarding answer |
| 2612 | Engine is shut down. | CANopen – fault in bus communication | CANopen Slave radio remote control has not sent a node guarding answer |
| 2613 | Engine is shut down | CANopen – fault in bus communication | CANopen Slave infrared remote control has not sent a node guarding answer |

General fault codes diesel engine, machine

| Code | Fault reaction | Description of fault | Possible cause | Terminal on BLM | Input code for diagnose |
|------|---|--|---|-----------------|-------------------------|
| 5015 | Only warning, horn sounds, display module is dark, | Potential 15 missing Control has switched relay K11, no voltage | Fuse F 103 defective Relay K11 defective Cable breakage in wiring loom | X3:20 | not possible |
| 5016 | Output is switched off, function no longer possible | Battery voltage too low Battery voltage already below 11 Volt when switching on | Battery acid level too low Battery defective Battery discharged | | 0561 |
| 5020 | Only warning, horn sounds | Input engine oil pressure, B 06 Oil pressure switch delivers the signal "no engine oil pressure" | The oil pressure switch has measured a too low oil pressure. The engine may be shut down. Should this message be displayed even though the engine is not running, the following faults should be examined: Current path has short circuit to ground Engine oil level not correct Engine oil pump defective Pressure relief valve after engine oil filter soiled Oil pressure switch defective | X3:03 | 5020 |
| 5021 | Engine shut down by too low oil pressure | Input engine oil pressure, B 06 Fault 5 0 2 0 present longer than 8 seconds Engine is shut down | see fault code 5 0 2 0 | X3:03 | 5020 |

Trouble shooting

| Code | Fault reaction | Description of fault | Possible cause | Terminal on BLM | Input code for diagnose |
|------|--------------------------------------|---|---|-----------------|-------------------------|
| 5022 | Oil pressure switch defective | Input engine oil pressure, B 06 The machine had not been started and does not run, however, there is still an oil pressure signal | Engine oil pressure switch defective Cable breakage to oil pressure switch Fault code inactive since version 1.10 | X3:03 | - |
| 5025 | Engine running | No rotary speed signal from the generator regulator Only warning | Generator regulator defective Line between regulator and control interrupted | X3:41 | - |
| 5031 | Machine standing | Engine stops, engine stalled | Lack of fuel Engine stopped even though the BLM control did not submit a corresponding command | | |
| 5040 | Output is switched off, engine stops | Output HW-shutdown solenoid, Y 13 Too high current flow out of this output Output was switched off! | Excessive current flow in current path, probably because of a defective coil or a short circuit to ground | X3:10 | - |
| 5041 | Output is switched off, engine stops | Output HW-shutdown solenoid, Y 13 Short-circuit current flow out of this output Output was switched off! | Short circuit to ground in the current path Lines rubbed through Valve defective | X3:10 | - |
| 5042 | Output is switched off, engine stops | Output HW-shutdown solenoid, Y 13 No or too low current flow out of this output | Wire breakage in current path Current path connected to +12V | X3:10 | 5040 5041 5042 |

| Code | Fault reaction | Description of fault | Possible cause | Terminal on BLM | Input code for diagnose |
|------|---|---|---|-----------------|-------------------------|
| 5043 | Output is switched off, engine stops | Output HW-shut-down solenoid, Y 13 Although the output is switched off, voltage is present | Current path connected to +12V | X3:10 | 5040 5041 5042 |
| 5050 | Output is switched off, engine runs only with idle speed | Output relay K 114, engine speed solenoid Too high current flow out of this output Output was switched off! | Excessive current flow in current path, probably because of a defective coil or a short circuit to ground | X3:09 | - |
| 5051 | Output is switched off, engine runs only with idle speed | Output relay K 114, engine speed solenoid Short-circuit current flow out of this output Output was switched off! | Short circuit to ground in the current path Lines rubbed through | X3:09 | - |
| 5052 | Output is switched off, engine runs only with idle speed | Output HW-shut-down solenoid, Y 13 No or too low current flow out of this output | Wire breakage in current path Current path connected to +12V | X3:10 | 5050 5051 5052 |
| 5053 | Output is switched off, engine runs only with idle speed | Output relay K 114, engine speed solenoid Although the output is switched off, voltage is present | Current path connected to +12V | X3:09 | 5050 5051 5052 |
| 5054 | | Input AUX – signal engine solenoid Y 13 | Wire breakage in current path | X3:04 | - |
| 5060 | Output switched off, no potential 15 on machine, control is working, engine is stopped or cannot be started | Output relay K 11, changeover of potential 15 Too high current flow out of this output Output was switched off! | Excessive current flow in current path, probably because of a defective coil or a short circuit to ground | X3:07 | - |

Trouble shooting

| Code | Fault reaction | Description of fault | Possible cause | Terminal on BLM | Input code for diagnose |
|------|---|---|---|-----------------|-------------------------|
| 5061 | Output switched off, no potential 15 on machine, control is working, engine is stopped or cannot be started | Output relay K 11, changeover of potential 15 Short-circuit current flow out of this output Output was switched off! | Short circuit to ground in the current path Lines rubbed through | X3:07 | - |
| 5062 | Output switched off, no potential 15 on machine, control is working, engine is stopped or cannot be started | Output relay K 11, changeover of potential 15 No or too low current flow out of this output | Wire breakage in current path Current path connected to +12V | X3:07 | 5060 5061 5062 |
| 5063 | Output switched off, no potential 15 on machine, control is working, engine is stopped or cannot be started | Output relay K 11, changeover of potential 15 Although the output is switched off, voltage is present | Current path connected to +12V | X3:07 | 5060 5061 5062 |
| 5070 | Output switched off, engine cannot be started | Output relay K 39, starter Too high current flow out of this output Output was switched off! | Excessive current flow in current path, probably because of a defective coil or a short circuit to ground | X3:06 | - |
| 5071 | Output switched off, engine cannot be started | Output relay K 39, starter Short-circuit current flow out of this output Output was switched off! | Wire breakage in current path Current path connected to +12V Lines rubbed through | X3:06 | - |
| 5072 | Output switched off, engine cannot be started | Output relay K 39, starter No or too low current flow out of this output | Wire breakage in current path Current path connected to +12V | X3:06 | 5070 5071 5072 |
| 5073 | All outputs switched off, engine stopped, safety relay switched off | Output relay K 39, starter Although the output is switched off, voltage is present | Current path connected to +12V | X3:06 | 5070 5071 5072 |

| Code | Fault reaction | Description of fault | Possible cause | Terminal on BLM | Input code for diagnose |
|--------------|---|--|---|-----------------|-------------------------|
| 5080 5085 | Output switched off, horn cannot sound | Output horn, H 07 Too high current flow out of this output Output was switched off! | Excessive current flow in current path, probably because of a defective coil or a short circuit to ground | X3:08 X3:36 | - |
| 5081 5086 | Output switched off, horn cannot sound | Output horn, H 07 Short-circuit current flow out of this output Output was switched off! | Short circuit to ground in the current path Lines rubbed through Horn defective | X3:08 X3:36 | - |
| 5082 5087 | Output switched off, horn cannot sound | Output horn, H 07 No or too low current flow out of this output | Wire breakage in current path Current path connected to +12V | X3:08 X3:36 | 5080 5081 5082 |
| 5083 5088 | Horn may sound continuously | Output horn, H 07 Although the output is switched off, voltage is present | Current path connected to +12V | X3:08 X3:36 | 5080 5081 5082 |
| 5090 | Machine does not start | Input inclination switch B56 The machine cannot be started, because the input does not receive a signal from the inclination switch | Wire breakage in current path Switch defective The switch is in actuated state (incorrect installation position) | X3:23 | 1405 |
| 5091 | Shut down of diesel engine | Input inclination switch B56 The diesel engine is shut down because the input on the control does not receive a signal from the inclination sensor | Wire breakage in current path Switch defective The switch is in actuated state (machine has turned over) The machine must first be shut down after it has been placed in correct position. | X3:23 | 1405 |
| 5100 | Warning horn sounds, only warning! | Input coolant temperature sensor, B53 Coolant temperature too high | Lack of coolant Radiator defective Sensor defective | X3:05 | 5100 |

Trouble shooting

| Code | Fault reaction | Description of fault | Possible cause | Terminal on BLM | Input code for diagnose |
|------|------------------------------------|---|---|-----------------|-------------------------|
| 5101 | Vibration and 2. gear switched off | Input coolant temperature sensor, B53 Coolant temperature too high over a longer period of time | Lack of coolant Radiator defective Sensor defective | X3:05 | 5100 |

Fault in BOSS safety system

| Code | Fault reaction | Description of fault | Possible cause |
|------|--|---|---|
| 6001 | Machine travels for 15min. without activated BOSS safety system. Attention: Only for servicing purposes! | Warning that service mode is active | Service mode activated via input code |
| 6010 | Travel movement not possible, only steering | Fault of front safety field antenna (W12) | Wire breakage in current path, front safety field antenna defective |
| 6011 | Travel movement not possible, only steering | Fault of rear safety field antenna (W13) | Wire breakage in current path, rear safety field antenna defective |
| 6012 | Travel movement not possible, only steering | Transponder fault (no feedback) | Fault in radio link of safety system, transponder of remote control defective |
| 6013 | Travel movement not possible, only steering | Transponder fault | Internal fault in transponder of remote control |
| 6014 | Travel movement not possible, only steering | Fault in safety field control (A115) | Internal fault in safety field control |
| 6015 | Travel movement not possible, only steering | Fault in bus communication between safety field control and transponder | Wire breakage in current path |
| 6016 | | Reception quality safety field control | |

Faults in parameterization

| Code | Fault reaction | Description of fault | Possible cause | Terminal on BLM | Input code for diagnose |
|-------------|---|-----------------------------|--|------------------------|--------------------------------|
| 7010 | Machine cannot be started, module is not completely initialized | No machine type set | Module is new, parameters were deleted | | 0725 |

6.8 Input codes for BLM control

Outputs for travel functions

| Input code | Description of display function | Display values |
|------------|--|---|
| 1010 | Output valve steering left, Y 237 Voltage at output | Display value = output voltage in Volt |
| 1011 | Output valve steering left, Y 237 Current at output | Display value = output current in AmperD® |
| 1012 | Output valve steering left, Y 237 Logic level of control | 0000 = Output not triggered 0001 = Output triggered |
| 1015 | Valve control, right | 0100 = steering to the left 0010 = Valve not triggered 0011 = steering to the right |
| 1020 | Output valve steering right, Y 238 Voltage at output | Display value = output voltage in Volt |
| 1021 | Output valve steering right, Y 238 Current at output | Display value = output current in AmperD® |
| 1022 | Output valve steering right, Y 238 Logic level of control | 0000 = Output not triggered 0001 = Output triggered |
| 1030 | Output valve travelling forward, Y 16 Voltage at output | Display value = output voltage in Volt |
| 1031 | Output valve travelling forward, Y 16 Current at output | Display value = output current in AmperD® |
| 1032 | Output valve travelling forward, Y 16 Logic level of control | 0000 = Output not triggered 0001 = Output triggered |
| 1035 | Valve control, travel system | 0100 = Driving forward 0010 = Drum stopped 0011 = Driving reverse |
| 1040 | Output valve travelling reverse, Y 17 Voltage at output | Display value = output voltage in Volt |
| 1041 | Output valve travelling reverse, Y 17 Current at output | Display value = output current in AmperD® |
| 1042 | Output valve travelling reverse, Y 17 Logic level of control | 0000 = Output not triggered 0001 = Output triggered |

| Input code | Description of display function | Display values |
|-------------------|---|---|
| 1050 | Output valve 2. gear, Y 03 Voltage at output | Display value = output voltage in Volt |
| 1051 | Output valve 2. gear, Y 03 Current at output | Display value = output current in Amper \AA [®] |
| 1052 | Output valve 2. gear, Y 03 Logic level of control | 0000 = Output not triggered 0001 = Output triggered |

Outputs for work functions

| Input code | Description of display function | Display values |
|-------------------|--|--|
| 1305 | Output valve vibration low amplitude, Y 56 Voltage at output | Display value = output voltage in Volt |
| 1306 | Output valve vibration low amplitude, Y 56 Current at output | Display value = output current in Amper \AA [®] |
| 1307 | Output valve vibration low amplitude, Y 56 Logic level of control | 0000 = Output not triggered 0001 = Output triggered |
| 1309 | Vibration valve control | 0100 = Vibration low amplitude 0010 = No vibration 0011 = Vibration high amplitude |
| 1310 | Output valve vibration high amplitude, Y 57 Voltage at output | Display value = output voltage in Volt |
| 1311 | Output valve vibration high amplitude, Y 57 Current at output | Display value = output current in Amper \AA [®] |
| 1312 | Output valve vibration high amplitude, Y 57 Logic level of control | 0000 = Output not triggered 0001 = Output triggered |

Inputs logic and power module

| Input code | Description of display function | Display values |
|-------------------|--|---|
| 1400 | Input signal L from generator regulator | 12 V > Generator stopped Ground, 0 V > Generator running |

Trouble shooting

| Input code | Description of display function | Display values |
|------------|--|---|
| 1401 | Input oil pressure switch, B 06 | 12 V > No oil pressure Ground, 0 V > Oil pressure |
| 1402 | Input limit switch engine speed solenoid, Aux | 12 V > Solenoid retracted 0V Ground > Solenoid not in end position |
| 1405 | Input inclination sensor, B 56 | 12 V > Inclination less than 45→x 0V Ground > Inclination higher than 45→x |
| 1407 | Input limit switch for safety bow rear, B 41 | 12 V > Bow not operated Ground , 0V > Bow operated |
| 1408 | Input limit switch for safety bow front, B 189 | 12 V > Bow not operated Ground , 0V > Bow operated |
| 1409 | Activation input, cable remote control, S 101 | 12 V > Operating mode cable remote control |
| 1410 | Activation input infrared remote control, S 101 | 12 V > Operating mode wireless |

Diesel engine, machine electrics

| Input code | Description of display function | Display values |
|------------|--|--|
| 5010 | Engine speed | Engine speed |
| 5020 | Engine oil pressure, B 06 Shows status of input engine oil pressure | 0000 = No engine oil pressure 0001 = Engine oil pressure OK |
| 5030 | Inclination sensor, B 56 Shows the switching state of the inclination switch | 0000 = No signal, machine inclined more than 45→x, or switch defective 0001 = OK, inclination of machine less than 45→x |
| 5040 | Output bia winding of shut-down solenoid, Y 13 Voltage at output | Display value = output voltage in Volt |
| 5041 | Output bia winding of shut-down solenoid, Y 13 Current at output | Display value = output current in AmperD® |
| 5042 | Output bia winding of shut-down solenoid, Y 13 Logic level of control | 0000 = Output not triggered 0001 = Output triggered |
| 5050 | Output relay K 114, engine speed solenoid Voltage at output | Display value = output voltage in Volt |

| Input code | Description of display function | Display values |
|-------------------|---|---|
| 5051 | Output relay K 114, engine speed solenoid Current at output | Display value = output current in Amper \AA [®] |
| 5052 | Output relay K 114, engine speed solenoid Logic level of control | 0000 = Output not triggered 0001 = Output triggered |
| 5053 | Status diesel engine Shows the status of the diesel engine. The state is determined on basis of signal L from generator, oil pressure and engine speed signal | 0000 = Engine OFF 0001 = Engine ON |
| 5055 | Ecomode diesel engine | Temporary deactivation while the engine is running |
| 5056 | Ecomode diesel engine | Permanent deactivation release/5057 off Permanent deactivation release/5058 on |
| 5060 | Output relay K 11, potential changer Voltage at output | Display value = output voltage in Volt |
| 5061 | Output relay K 11, potential changer Current at output | Display value = output current in Amper \AA [®] |
| 5062 | Output relay K 11, potential changer Logic level of control | 0000 = Output not triggered 0001 = Output triggered |
| 5070 | Output relay K 39, starter Voltage at output | Display value = output voltage in Volt |
| 5071 | Output relay K 39, starter Current at output | Display value = output current in Amper \AA [®] |
| 5072 | Output relay K 39, starter Logic level of control | 0000 = Output not triggered 0001 = Output triggered |
| 5080 | Output horn, H 07 Voltage at output | Display value = output voltage in Volt |
| 5081 | Output horn, H 07 Current at output | Display value = output current in Amper \AA [®] |
| 5082 | Output horn, H 07 Logic level of control | 0000 = Output not triggered 0001 = Output triggered |

Trouble shooting

| Input code | Description of display function | Display values |
|------------|--|---|
| 5085 | Output 2 horn, H 07 Voltage at output | Display value = output voltage in Volt |
| 5086 | Output 2 horn, H 07 Current at output | Display value = output current in Amperes® |
| 5087 | Output 2 horn, H 07 Logic level of control | 0000 = Output not triggered 0001 = Output triggered |
| 5100 | Coolant temperature sensor, B 53 | 0000 = Temperature too high, excessive temperature 0001 = Temperature OK |

Checking the function of the remote controls

With the input codes listed above it is possible to check the transfer of the individual switching signals from the remote controls to the central control unit. For this purpose start the machine and subsequently press the horn button to bring the re-

mote control sender in operating mode for this function test.

For testing the spiral cable switch the operating mode switch to cable operation, connect the spiral cable to the sender and start the machine. If the engine starts, the spiral cable is OK!

| Input code | Description of display function | Display values |
|------------|--|--|
| 2500 | Actuation of travel lever on remote control, S 138 | 0100 = Travel lever shifted forward 0010 = Travel lever not moved 0001 = Travel lever shifted backward |
| 2501 | Actuation of steering joystick on remote control, S 137 | 0100 = Joystick actuated to the left 0010 = Joystick not moved 0001 = Joystick actuated to the right |
| 2502 | Position of switch for vibration, S 36 | 0100 = Switch operated to forward, vibration high amplitude 0010 = Switch not operated 0001 = Switch operated to reversed, vibration low amplitude |
| 2503 | Position of switch for type of vibration, S 132 | 0100 = Switch operated to forward, automatic operation 0010 = Switch not operated, manual operation |
| 2504 | Position of switch for fast speed, S 133 | 0100 = Switch operated to forward, fast speed selected 0010 = Switch not operated, fast speed disabled |

| Input code | Description of display function | Display values |
|-------------------|---|--|
| 2505 | Position of switch for engine speed, S 134 | 0100 = Switch operated to forward, high engine speed 0010 = Switch not operated, idle speed |
| 2506 | Position of button for horn, S 03 | 0000 = Button not operated 0001 = Button operated |

System information

| Input code | Description of display function | Display values |
|-------------------|---|------------------------------|
| 0555 | Software Version Shows the software version number. | 3-digit version number |
| 0561 | Supply voltage Shows the voltage value | Display value = voltage in V |

Setting the remote control type

| Input code | Description of display function | Display values |
|-------------------|--|-----------------------------|
| 0660 | Switches on function "Set remote control type" | See adjustment instructions |
| 0661 | confirms the entered remote control type | See adjustment instructions |
| 0662 | Preselect radio remote control, default setting | See adjustment instructions |

Fault log

| Input code | Description of display function | Display values |
|-------------------|---|-----------------------------|
| 0700 | Switch on function „Show stored faults,“ | See adjustment instructions |
| 0701 | Switch off function "Show stored faults" | See adjustment instructions |
| 0662 | Delete all stored faults | See adjustment instructions |

Safety system

| Input code | Description of display function | Display values |
|-------------------|--|-----------------------|
| 6000 | Enable service mode | 6000 |

Trouble shooting

| Input code | Description of display function | Display values |
|------------|--|----------------------------|
| 6001 | Service mode active, machine travels for 15min. without activated BOSS safety system. Attention: Only for servicing purposes! | 6001 = service mode active |
| 6002 | Service mode inactive | |

Reading out the operating hour meter

| Input code | Description of display function | Display values |
|------------|---|---|
| 7500 | Display of hours, operating hour meter | The full hours are displayed |
| 7501 | Display of minutes, operating hour meter | The minute digits of the operating hour meter are displayed |

Setting the machine type

| Input code | Description of display function | Display values |
|------------|--|-----------------------------|
| 7101 | Preselect machine type BMP 851 | See adjustment instructions |
| 7102 | Preselect machine type BPH 80/65s | See adjustment instructions |
| 7010 | Switches on function "Set machine type" | See adjustment instructions |
| 7011 | Confirms entered machine type | See adjustment instructions |
| 7104 | Preselect machine type BMP 8500 | See adjustment instructions |

We will help you - immediately!

Operating, maintenance, repair instructions and
spare parts catalogues



- in situ:

- Safe and simple trouble shooting
- Secure access to required spare parts
- Easy to understand – from experts for users

Contact us or your BOMAG distributor!

Head Office/Hauptsitz

BOMAG
Hellerwald
56154 Boppard
GERMANY
Tel.: +49 6742 100-0
Fax: +49 6742 3060
e-mail: germany@bomag.com
www.bomag.com

BOMAG
Niederlassung Berlin
Gewerbestraße 3
15366 Hoppegarten
GERMANY
Tel.: +49 3342 369410
Fax: +49 3342 369436
e-mail: nberlin@bomag.de

BOMAG
Niederlassung Hannover
Dieselstraße 44
30627 Garbsen-Berenboedel
GERMANY
Tel.: +49 5131 70060
Fax: +49 5131 6766
e-mail: nihannover@bomag.de

BOMAG
Maschinenhandels-gesellschaft
m.b.H.
Porschestraße 9
1230 Wien
AUSTRIA
Tel.: +43 1 69040-0
Fax: +43 1 69040-20
e-mail: austria@bomag.com

BOMA Equipment Hong Kong LTD
Room 1003, 10/F Charm Centre
700, Castle Peak Road
Kowloon, Hong Kong
Tel.: +852 2721 5363
Fax: +852 2721 3212
e-mail: bomaghk@bomag.com

BOMAG Italia Srl.
Z.I. Via Mella, 6
25015 Desenzano del Garda (BS)
ITALY
Tel.: +39 030 9127263
Fax: +39 030 9127276
e-mail: italy@bomag.com

BOMAG GmbH
300 Beach Road
The Concourse, #18-06
Singapore 199555
SINGAPORE
Tel.: +65 294 1277
Fax: +65 294 1377
e-mail: singapore@bomag.com.sg

BOMAG
Niederlassung Boppard
Hellerwald
56154 Boppard
GERMANY
Tel.: +49 6742 100360
Fax: +49 6742 100392
e-mail: niboppard@bomag.de

BOMAG
Niederlassung München
Otto-Hahn-Ring 3
85301 Schweitenkirchen
GERMANY
Tel.: +49 8444 91840
Fax: +49 8444 918420
e-mail: nmuennen@bomag.de

BOMAG (CANADA), INC.
3455 Semenyk Court
Mississauga, Ontario L5C 4P9
CANADA
Tel.: +1 905 361 9961
Fax: +1 905 361 9962
e-mail: canada@bomag.com

BOMAG S.A.F.
2, avenue du Général de Gaulle
91170 Viry-Chatillon
FRANCE
Tel.: +33 1 69978600
Fax: +33 1 69982660
e-mail: france@bomag.com

BOMAG Polska Sp. z o.o.
Ul. Szyszkowa 52
02 285 Warszawa
Poland
Tel.: +48 22 482 0400
Fax: +48 22 482 04 01
e-mail: poland@bomag.com

BOMAG Americas, Inc.
2000 Kentville Road
Kewanee, Illinois 61443
U.S.A.
Tel.: +1 309 8533571
Fax: +1 309 8520350
e-mail: usa@bomag.com

BOMAG
FAYAT GROUP

BOMAG
Niederlassung Chemnitz
Querstraße 6
09247 Chemnitz
GERMANY
Tel.: +49 3722 51590
Fax: +49 3722 515951
e-mail: nlchemnitz@bomag.de

BOMAG
Niederlassung Stuttgart
Uferstraße 22
73630 Remshalden-Grünbach
GERMANY
Tel.: +49 7151 986293
Fax: +49 7151 9862959
e-mail: nlstuttgart@bomag.de

BOMAG (China)
Compaction Machinery Co. Ltd.
No. 2808 West Huancheng Road
Shanghai Comprehensive Industrial
Zone (Fengxian)
Shanghai 201401
CHINA
Tel.: +86 21 33655588
Fax: +86 21 33655508
e-mail: china@bomag.com

BOMAG (GREAT BRITAIN), LTD.
Sheldon Way, Larkfield
Aylesford
Kent ME20 6SE
GREAT BRITAIN
Tel.: +44 1622 718611
Fax: +44 1622 718385
e-mail: gb@bomag.com

BOMAG RUS OOO
Klyazma block, h 1-g
141400 Khimki
RUSSIA
Tel.: +7 (495) 287 92 90
Fax: +7 (495) 287-82 91
e-mail: russia@bomag.com

Printed in Germany