

Simplicity®

**INSTRUCTIONS
AND PARTS LIST**

**MODEL "W"
WALKING TRACTOR**

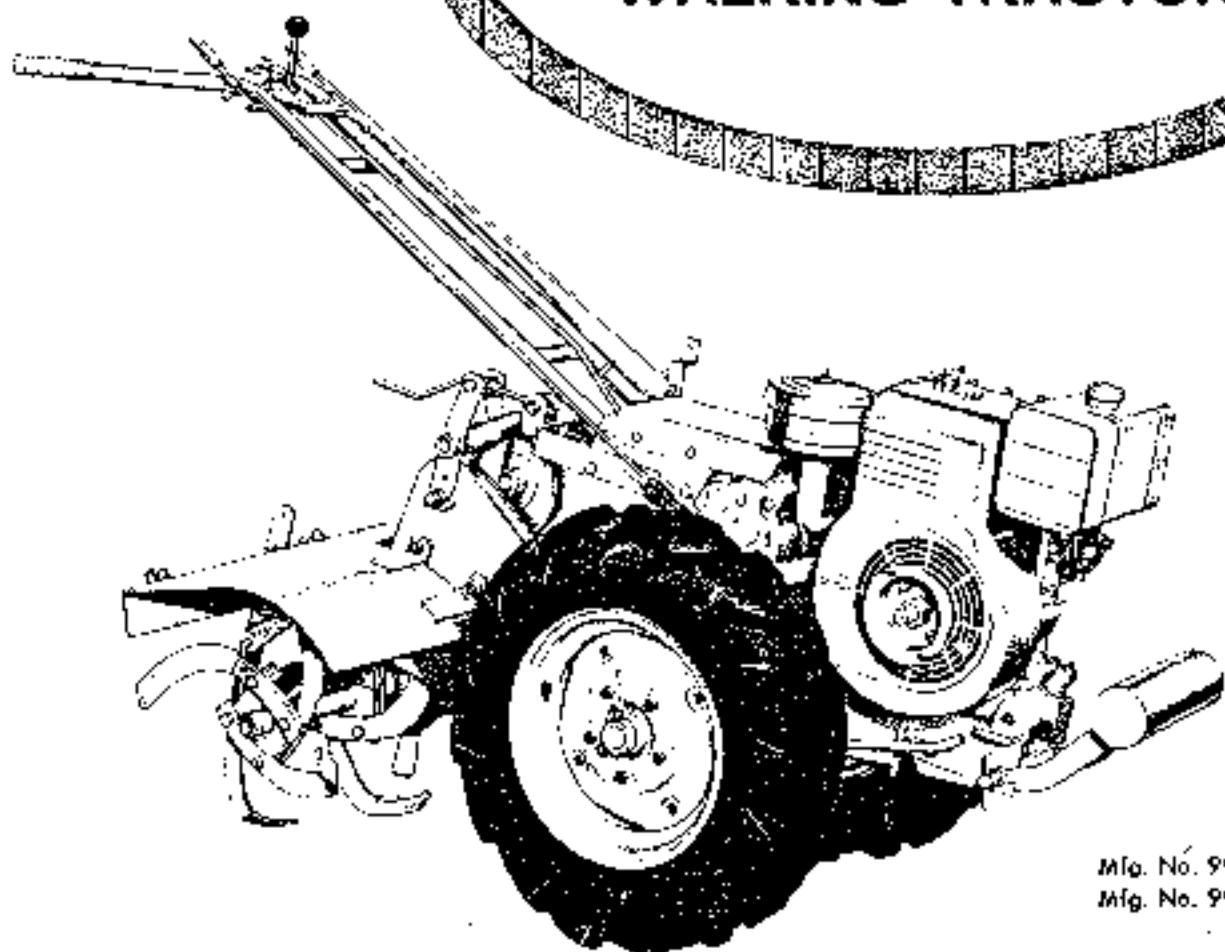

Mfg. No. 990189
Mfg. No. 990214

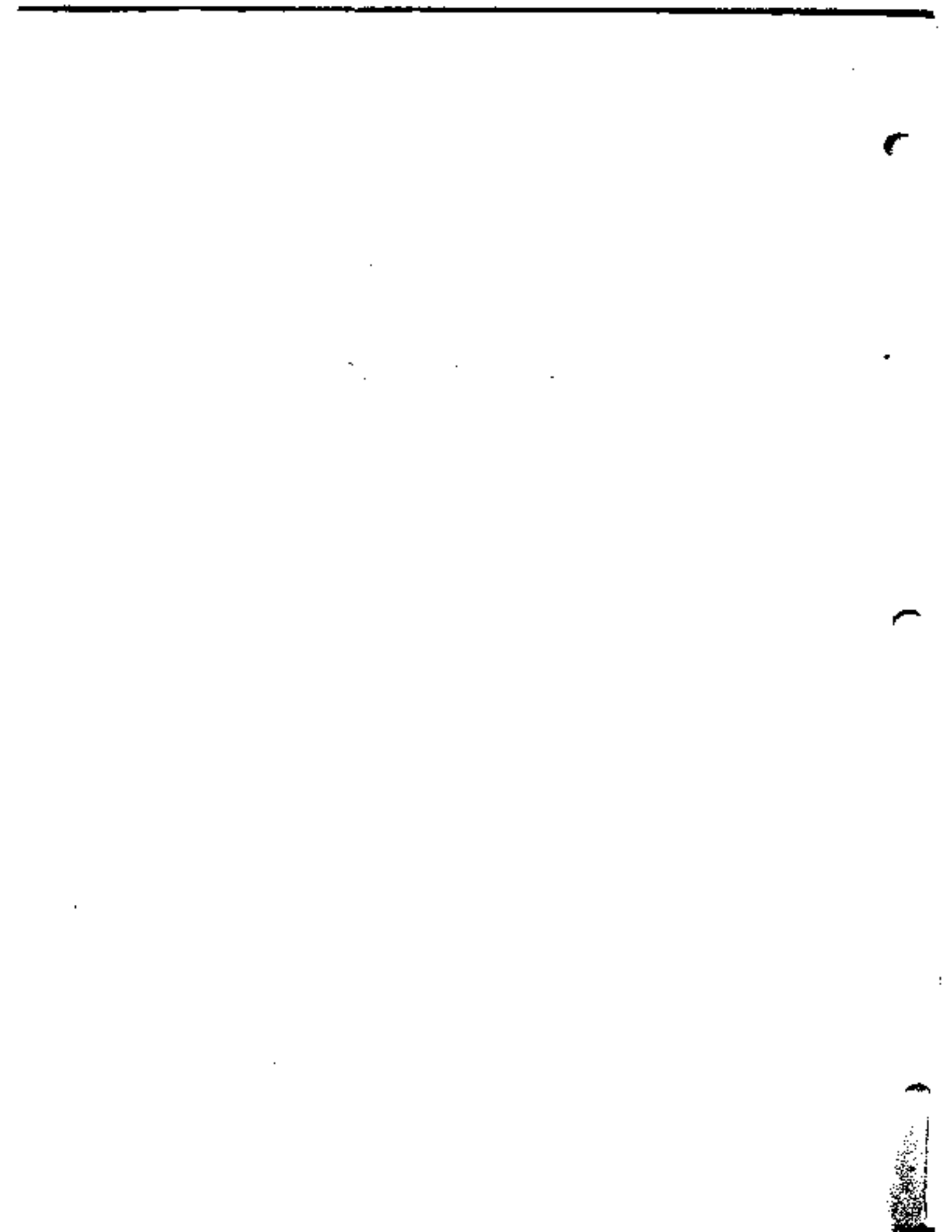

Packing

For ease in shipping, the Model "W" tractor is shipped in two packages. One package contains the engine, tractor frame, wheels, and transmission. The other contains the handles, clutch rods and levers, and the transmission shift lever.

The tractor is equipped with a convenient kick stand which enables the tractor to be kept level when implements are not attached to tractor. When assembling the handles to the tractor, use the kick stand to keep the tractor level.

Assembly

For ease in assembly, follow the sequence of steps as outlined below:

1. The tractor handles attach to the rear frame assembly of the tractor as shown in figure 1. Place the tractor handles inside of the rear frame assembly, line up the holes in the tractor frame with the holes in the handle assembly and insert hex head capscrews. The two front capscrews are held in place with a flat washer, lockwasher, and hex nut. The rear capscrews are held in place with a lockwasher and hex nut. **NOTE:** the end holes of the handle assembly are slotted to allow for adjustment of handle height.

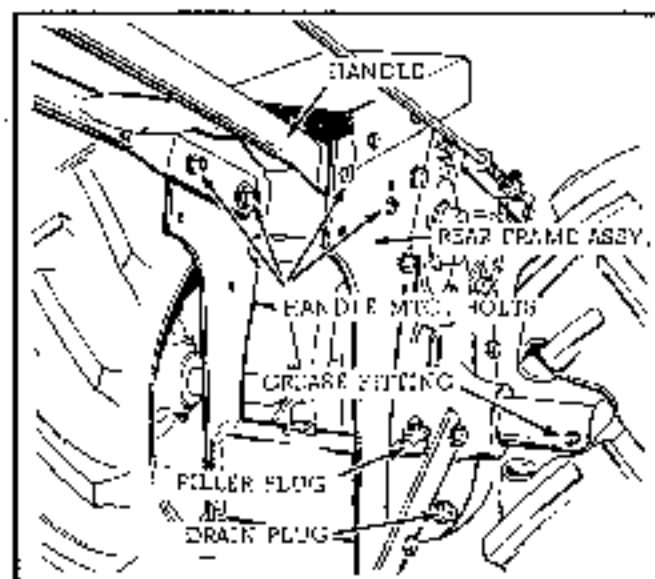

Fig. 1

2. It will be noted that the tractor handle assembly has 3 rods and levers attached to it. These control the tractor clutch, implement clutch, and transmission shifting. The lever on the left hand side controls the implement clutch rod which is to be attached to the clutch rod pivot lever as shown in figure 2. Remove the handle mounting bolt and install the following parts in this sequence; 5 flat washers, pivot lever stop, bushing, pivot lever, 1 flat washer. Retighten the hex head capscrew and check to see that the end of the clutch rod does not hit on the side of the rear frame cover.

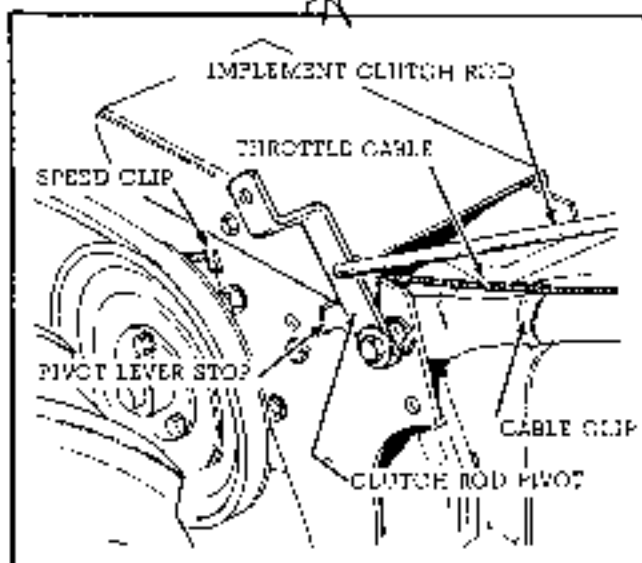

Fig. 2

The right hand lever controls the tractor clutch rod which is to be attached to the idler pivot assembly as shown in figure 3. Place a flat washer and bushing between the idler pivot assembly and the clutch rod guide assembly and bolt the idler pivot assembly and clutch rod guide together with a hex head capscrew, flat washer, lockwasher, and hex nut. Do not tighten excessively, as these parts must be free to pivot.

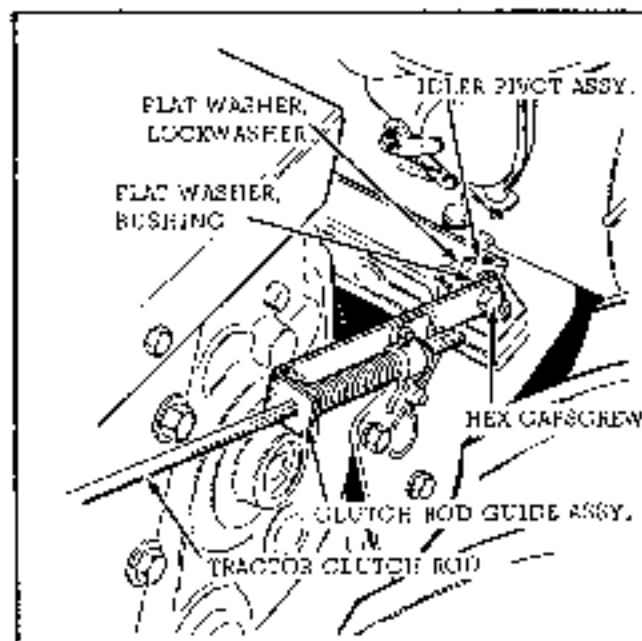

Fig. 3

The center lever is the transmission shift lever and is to be attached to the transmission as shown in figure 4. To attach this lever, retract the kickstand and lower the front end of the tractor until it rests on the ground. Fasten the yoke of the shift lever to the transmission shift rod with a hex capscrew, lockwasher, and hex nut. Tighten securely.

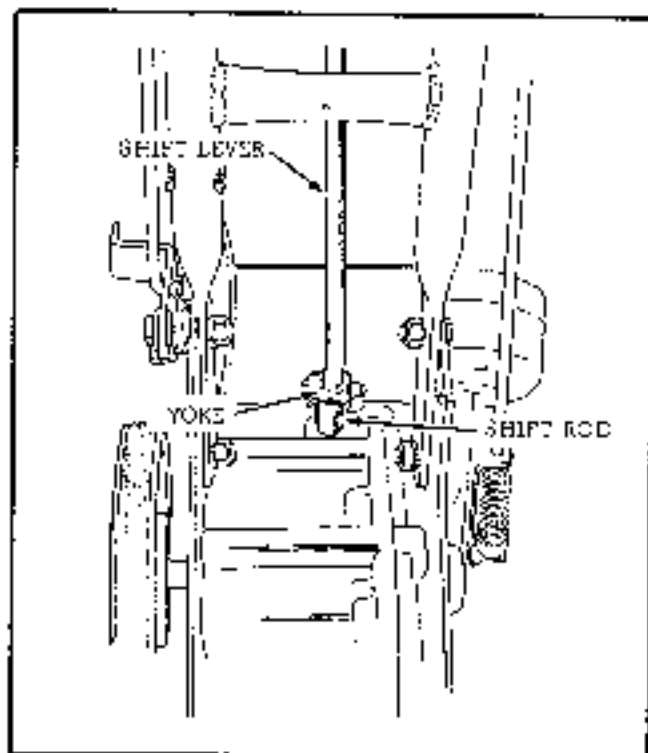

Fig. 4

3. The speed of the engine is regulated by the throttle control lever. This control lever is already assembled to the throttle cable and for shipment is coiled up and fastened to the engine. Uncoil the throttle cable and pass the control lever under the cover of the rear frame. The cable is to be fastened to the rear frame at this point with a speed clip as shown in figure 2. Continue up the length of the left hand side of the handle assembly and clip the cable in place with cable clips. Fasten the throttle control lever to the left hand handle, using 2 self tapping screws as shown in figure 5. When properly mounted, the throttle will open when the lever is raised, and close when the lever is pushed down. Be certain that the throttle wire is held securely by the locking screw in the throttle lever, and that no kinks or sharp bends exist in the cable mounting.

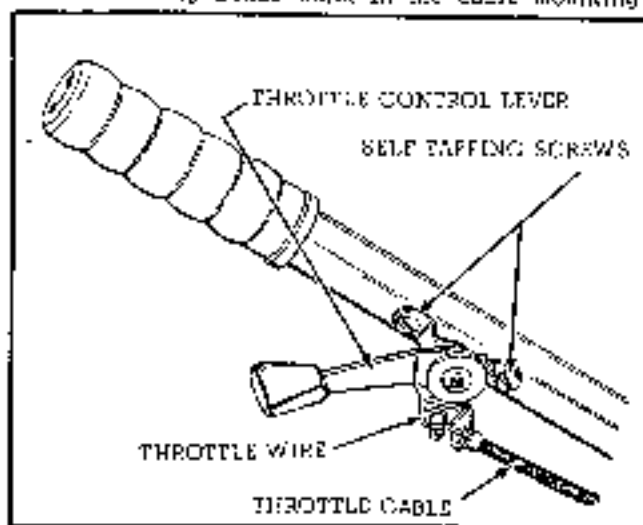

Fig. 5

Belt Tension

For the tractor drive belt to efficiently transmit the power from the engine to the tractor transmission, the tension of the drive belt must be correct. As the idler pulley regulates the tension on the drive belt, the tension will be properly adjusted when a clearance of approximately $5/8$ " exists between the set collar "A" and the projection on the clutch rod guide as shown in figure 6, when the clutch lever is in the engaged position. To alter the tension of the drive belt, release the clutch lever and loosen the set screw on the collar and slide the collar towards the handles to increase tension. To decrease tension, slide the collar toward the front of the tractor. Avoid excessive tension, as this will lead to premature belt failure. Be sure to retighten the set screw in collar before engaging the clutch lever.

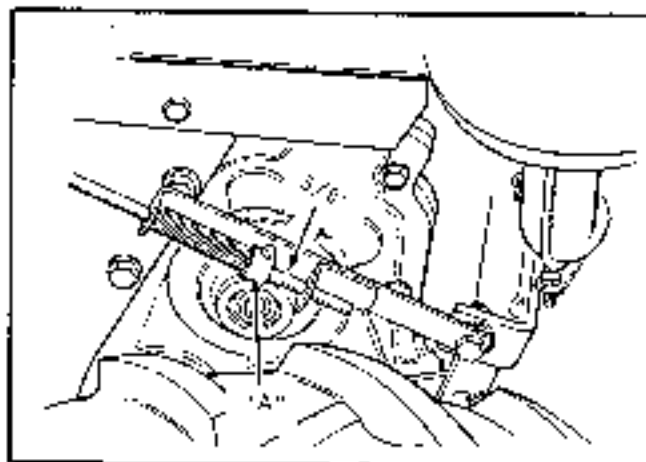

Fig. 6

Belt Stops

On the drive pulley side of the engine you will note a bracket with 3 belt stops or fingers attached to it as shown in figure 7.

Engage the tractor clutch and apply tension to the drive belt and check the clearance between the belt and these belt stops. These belt stops will be properly adjusted when $1/8$ " clearance is visible. To adjust, loosen the hex head capscrews slightly and move belt stops to desired position. Tighten the hex capscrews sufficiently to keep belt stops in position.

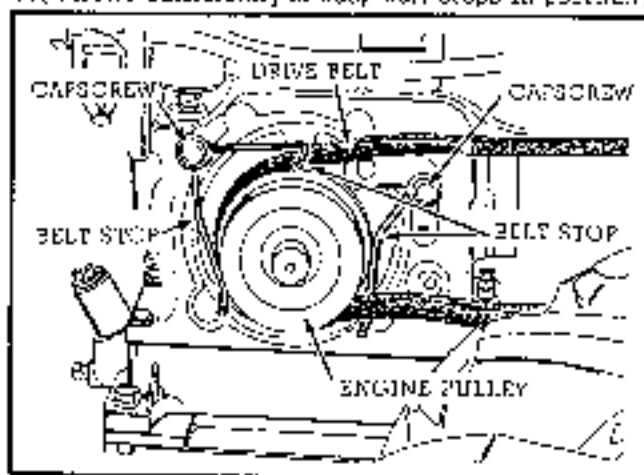

Fig. 7

Tires

For shipping purposes, the tires are inflated to approximately 36 lbs. When tractor is assembled and ready for operation, deflate the tires to 8 to 10 lbs. of pressure.

Lubrication

The tractor, but not the engine, (see engine instruction manual), is fully lubricated and ready for use when received.

The transmission has a capacity of 2 1/2 quarts of SAE 90 oil, and is filled at the factory. It will not normally require replenishment, but occasionally check the drain plug for tightness and axle nuts for leakage. Keep oil up to level of filler plug. Remove vent plug from top of transmission and allow oil to settle to normal level before checking. See figure 1.

The right hand axle tube has 1 grease fitting which should receive general purpose automotive type grease periodically. Use a standard grease gun and be sure to clean the grease fitting before applying grease. See figure 1.

Differential

The Model "W" tractor is equipped with a Controlled Traction Differential. Tightening the top head capscrews in the right hand wheel hub (see figure 3), provides pressure against a nylon plug and sleeve around the track axle and prevents excessive wheel slippage when the tractor is being used under abnormal slippery conditions. The adjusting capscrews are set at the factory to a torque of 20 ft. lbs. As the nylon sets itself through use, it may be necessary to re-adjust the capscrews a few times to maintain 20 ft. lbs. of torque (20 lbs. weight on wrench 1 ft. long). CAUTION: Do not apply more than 30 ft. lbs. to the adjusting capscrews.

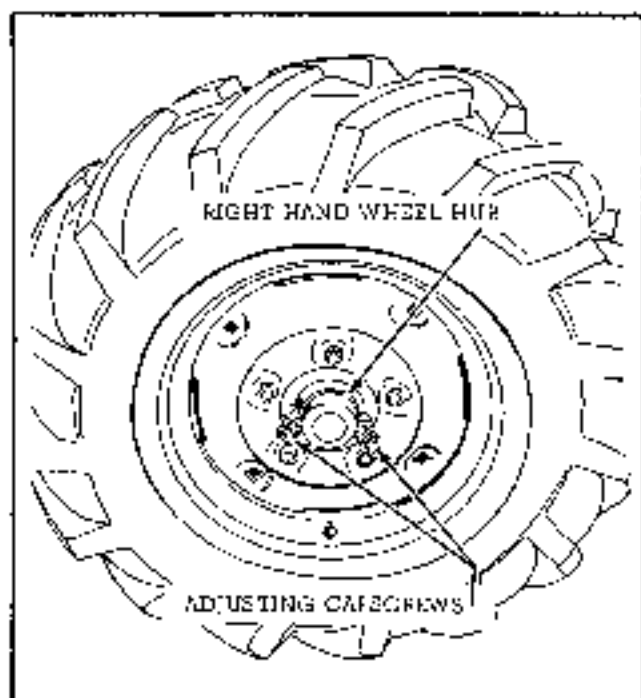

Fig. 3

Operation

STARTING ENGINE...

Rest the tractor on the kick stand and place the transmission in neutral position. Disengage the tractor clutch lever. Open the throttle control lever about half-way and place the carburetor choke lever in choke position as shown in figure 10. Wind the starter rope around the starter pulley in a clockwise direction as shown and pull the rope rapidly and with force. As the engine starts, move the choke lever slowly back to the unchoke position. To stop the engine, disengage the clutch lever and depress the stop lever against the spark plug. Avoid touching the spark plug with finger while depressing the stop lever.

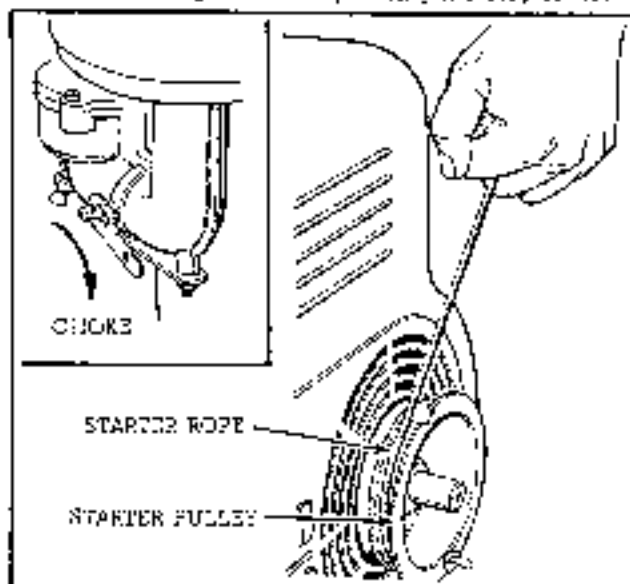

Fig. 10

SHIFTING the TRANSMISSION...

The shift rod guide plate, located between the two handles of the tractor, carries 2 decals which show the relative positions of the shift lever when the transmission is placed in its various gear ranges.

To shift the transmission from one gear to another, disengage the tractor clutch and allow the tractor to come to a stop before moving the shift lever from one position to another as shown in figure 11.

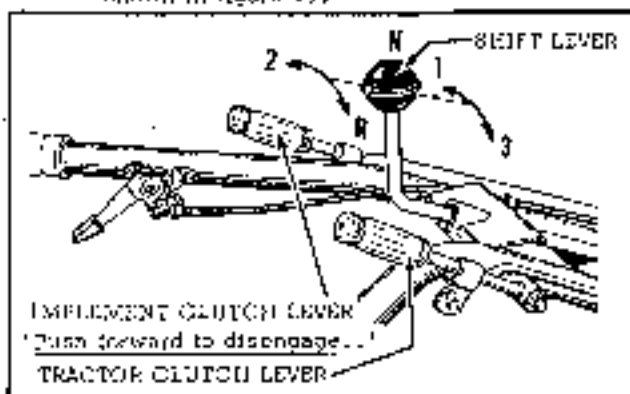
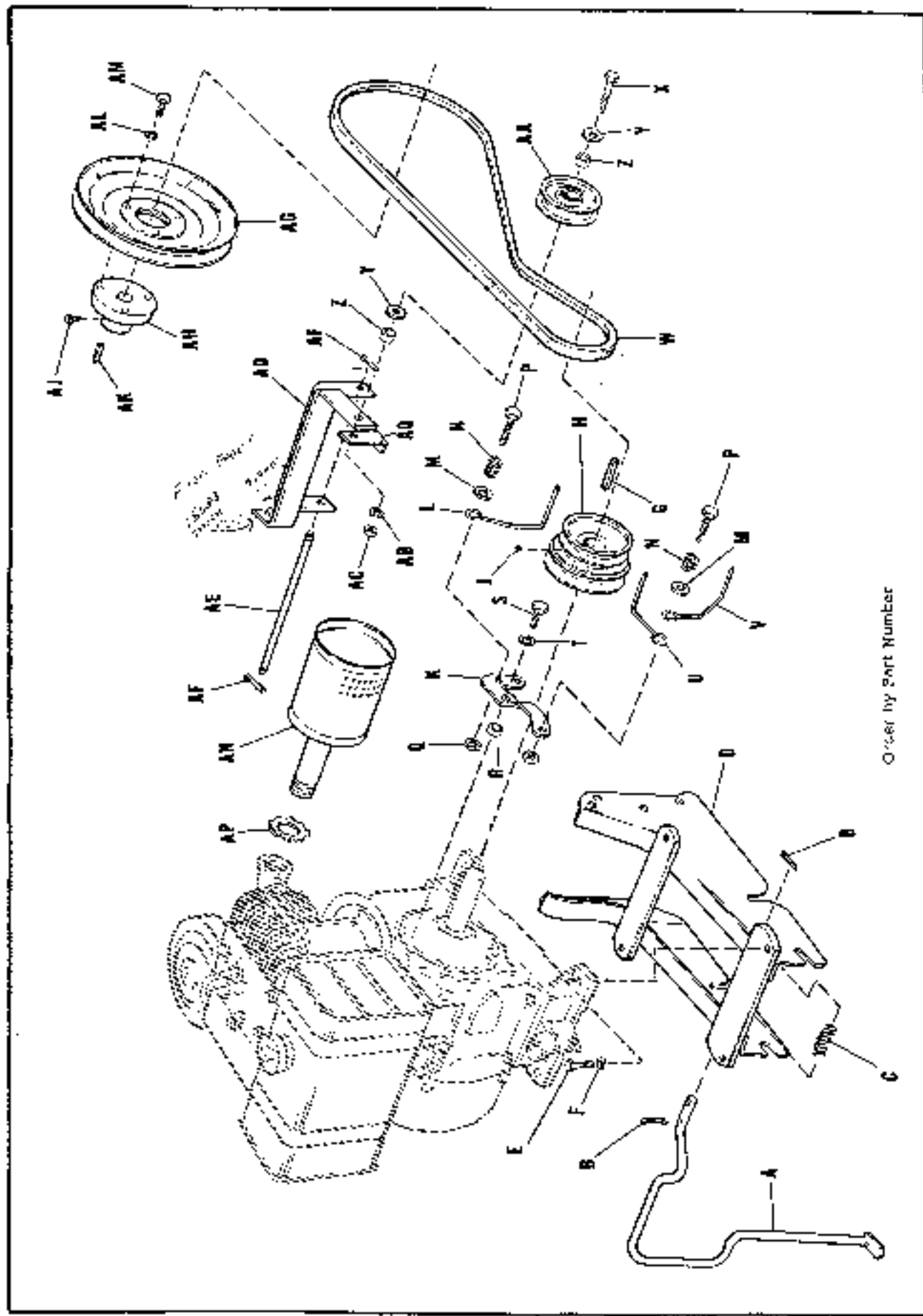

Fig. 11



Order by Part Number

ENGINE BASE & PULLEYS

ENGINE BASE & PULLEYS

Order By Part Number

Reference Letter	Part No.	Description
A	155025	Stand Assembly
B	722000	Pin, Cutter, 1/8" dia. x 1" lg.
C	152006	Spring, Stand
D	155034	Base Assembly, Engine
S	705036	Capcrew, Hex Hd., 3/8"-16 NC x 1 1/4" lg.
F	720032	Washer, Lock, 3/8"
G	806100 159129	Key 159129
H	155021	Pulley, Engine
F	713503	Screw, Set, Cup Pt., 5/16"-18 NC x 5/16" lg.
K	8061089	Holder, Belt Stop
L	8021073	Stop, Belt
M	719002	Washer, Plain, 5/16"
N	8191047	Spring
P	705019	Capcrew, Hex Hd., 3/16"-18 NC x 1 1/4" lg.
Q	717011	Nut, Hex, Jam, 5/16"-18 NC
R	8161215	Bushing
S	705007	Capcrew, Hex Hd., 5/16"-18 NC x 1" lg.
T	720001	Washer, Lock, 5/16"
U	8061089	Stop, Belt
V	8021073	Stop, Belt
W	155004	Belt, "V"
X	705010	Capcrew, Hex Hd., 3/8"-16 NC x 3/4" lg.
Y	719032	Washer, Plain, 5/16"
Z	8171048	Bushing
AA	454510	Pulley, Idler 1 1/2" x 5" 3/4"
AB	720004	Washer, Lock, 3/8"
AC	717003	Nut, Hex, Full, 3/8"-16 NC
AD	155223	Pivot Assembly, Idler
AE	185140	Rod, Pivot
AF	722005	Pin, Cutter, 3/32" dia. x 7/8" lg.
AG	155017	Pulley, Transmission 2"
AH	105205	Hub, Pulley
AJ	713504	Screw, Set, Square Head, 5/16"-18 NC x 3/8" lg.
AK	8061081	Key, Transmission Pulley
AL	720001	Washer, Lock, 5/16"
AM	705001	Capcrew, Hex Hd., 5/16"-18 NC x 7/8" lg.
AN	154373	Muffler, Exhaust 2 1/2" x 2 1/2" on 2 1/2"
AP	154379	Nut, Lock
AQ	9021121	Stop

Starter Rope B/S # 69932 70¢ No Part # for simplicity

WHEELS AND AXLE

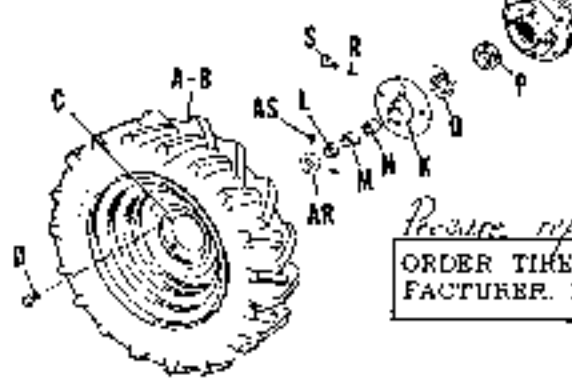
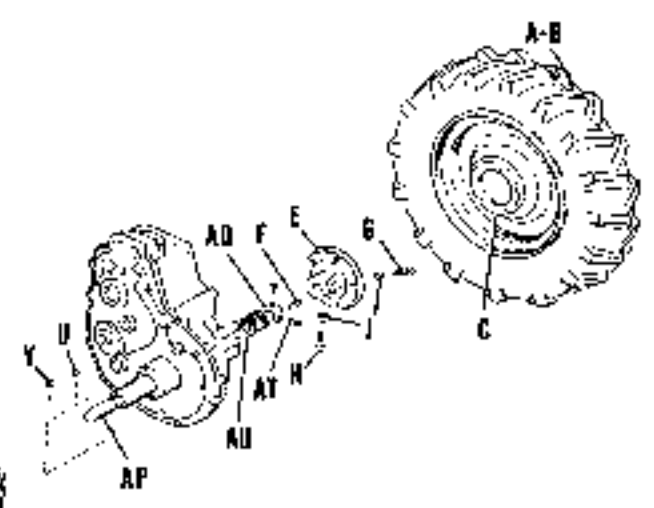
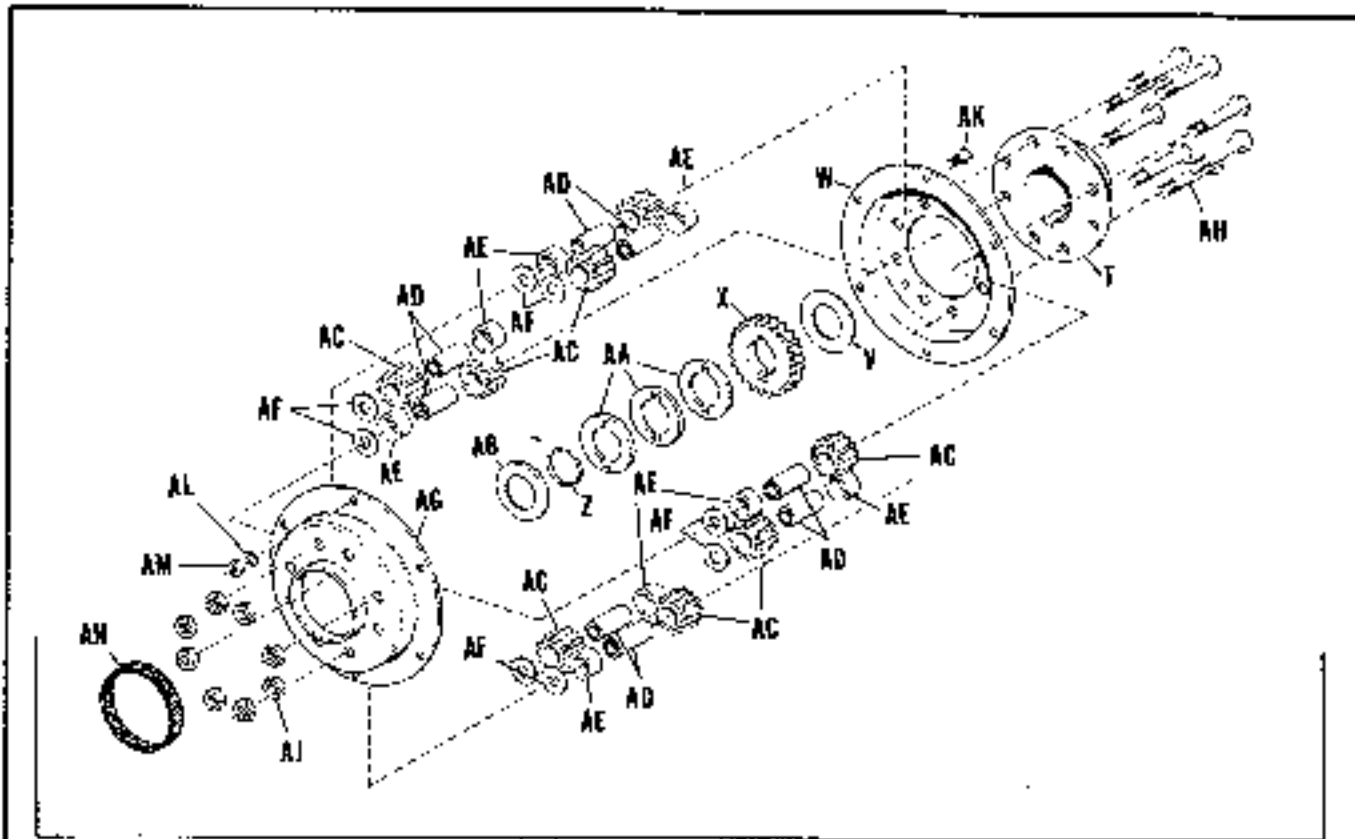

Please replacements every 6 months

ORDER TIRE & TUBE REPLACEMENTS FROM TIRE MANUFACTURER. DO NOT ORDER FROM SIMPLICITY MFG. CO.

Order by Part Number

WHEELS AND AXLE

Order by Part Number

Reference Letter	Part No.	Description
A	151059	Tire
B	151060	Tube
C	8262323	Wheel
D	8261133	Bolt, Hub
E	154208	Hub, Wheel, L. H.
F	8061100	Key
G	715022	Screw, Set, Sq. Hd., Cone, 3/8" - 16 N. C. x 1-1/2" lg.
H	713004	Screw, Set, Sq. Hd., Cup, 3/8" - 16 N. C. x 1" lg.
J	717021	Nut, Hex., Jam, 3/8" - 16 N. C.
K	152052	Hub Assy., (Complete w/ bgs., nylon plugs, gear, etc.)
L	105058	Bearing
M	152041	Bearing, Nylon
N	153060	Bearing
P	154460	Gear, Differential
Q	723003	Pin, Roll
R	152042	Plug
S	8261100	Bolt, Hub
T	154063	Carrier, Differential <i>157119</i>
U	154040	Key, Drive <i>157120</i>
V	154035	Washer, Axle
W	121149	Cover, Differential
X	121312	Gear, Differential
Y	725501	Key, Hi-Pro
Z	154201	Ring, Retaining
AA	152077	Washer, Axle
AB	154277	Washer, Axle
AC	121311	Pinion, Differential
AD	121083	Spindle, Pinion Differential
AE	121084	Spacer, Differential
AF	719002	Washer, Plain
AG	151022	Cover, Differential
AH	705003	Screw, Cap, Hex., 3/8" - 16 N. C. x 2-1/4" lg.
AJ	717510	Nut, Lock, Full Hex., 3/8" - 16 N. C.
AK	705002	Screw, Cap, Hex., 1/4" - 20 N. C. x 1/2" lg.
AL	720003	Washer, Lock, 1/4"
AM	717005	Nut, Full, Hex., 1/4" - 20 N. C.
AN	121190	Seal, Differential Cover
AP	154059	Axle, Rear <i>157026</i>
AQ	154065	Collar, Axle
AR	154065	Collar, Axle
AS	713503	Screw, Set, Cup Point, Hollow Head, 5/16" - 18 N. C. x 5/16" lg.
AT	713006	Screw, Set, Cup Point, Square Head, 5/16" - 18 N. C. x 1/2" lg.
AC	105050	Washers

HANDLE GROUP

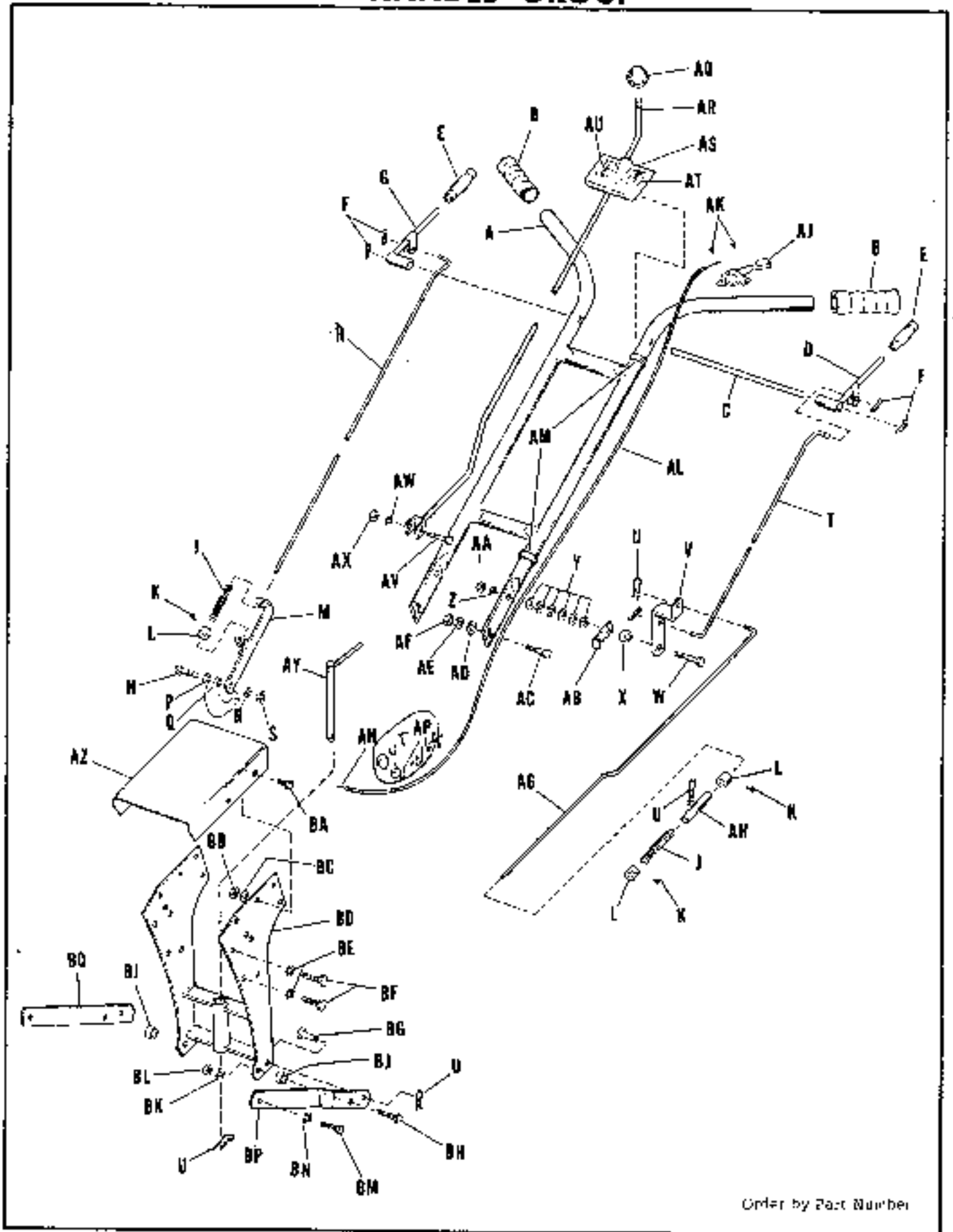

Order by Part Number

Order by Part Number

HANDLE GROUP

Reference Letter	Part No.	Description
A	155030	Handle Assembly
B	155048	Grp, Handle, ^{with} 1/2"
C	155039	Pin, Lever
D	155006	Lever Assembly, L.H.
E	153017	Grp
F	722001	Pin, Cotter, 3/32" dia. x 3/4" lg.
G	155003	Lever Assembly, R.H.
H	155012	Rod, Engine Clutch
J	9191045	Spring, Clutch Rod
K	713001	Screw, Set, Square Head, Cup Point, 1/4"-20 NC x 3/8" lg.
L	8161022	Collar, Set
M	8081503	Guide Assembly, Clutch Rod
N	705005	Capscrew, Hex Hd., 3/8"-16 NC x 1" lg.
P	713001	Washer, Plain, 3/8"
Q	153073	Spacer
R	720002	Washer, Lock, 3/8"
S	717003	Nut, Hex, Full, 1/8"-16 NC
T	8021122	Rod, Upper Idler
U	8161045	Spring, Clp
V	155005	Lever, Lower Clutch
W	705013	Capscrew, Hex Hd., 1/8"-16 NC x 1 3/4" lg.
X	8161215	Bushing
Y	715001	Washer, Plain, 3/8"
Z	720002	Washer, Lock, 3/8"
AA	717003	Nut, Hex, Full, 1/8"-16 NC
AB	8021121	Lever, Stop
AC	705016	Capscrew, Hex Hd., 3/8"-16 NC x 1 1/4" lg.
AD	715011	Washer, Plain, 3/8"
AE	720002	Washer, Lock, 3/8"
AF	717003	Nut, Hex, Full, 1/8"-16 NC
AG	8061030	Rod, Lower Clutch
AH	8161518	Socket Assembly, Rod
AJ	8061087	Control, Throttle Lever
AK	714005	Screw, Round Head, Self Tapping, #10-24 x 1/2" lg.
AL	153080	Throttle Cable
AM	8061138	Clp, Cable
AN	153087	Wire, Throttle
AP	155040	Clp, Guide, Speed
AQ	155044	Ball, Shift Lever
AR	155029	Rod Assembly, Shift
AS	155015	Guide Assembly, Rod
AT	155003	Decal, Shift, L.H.
AU	155002	Decal, Shift, R.H.
AV	705018	Capscrew, Hex Hd., 5/16"-18 NC x 1 1/2" lg.
AW	720001	Washer, Lock, 5/16"
AX	717001	Nut, Hex, Full, 5/16"-18 NC
AY	8061502	Pin Assembly, Hitch
AZ	155027	Cover, Frame
BA	705012	Capscrew, Hex Hd., 5/16"-18 NC x 5/8" lg.
BB	717001	Nut, Hex, Full, 5/16"-18 NC
BC	720001	Washer, Lock, 5/16"
BD	155033	Frame Assembly, Rear
BE	720006	Washer, Lock, 7/16"
BF	705041	Capscrew, Hex Hd., 7/16"-14 NC x 1" lg.
BG	155037	Pin, Round Head
BH	705009	Capscrew, Hex Hd., 3/8"-16 NC x 1 1/4" lg.
BJ	105006	Spacer
BK	720002	Washer, Lock, 3/8"
BL	717003	Nut, Full, Hex, 3/8"-16 NC
BM	705041	Capscrew, Hex Hd., 7/16"-14 NC x 1" lg.
BN	720006	Washer, Lock, 7/16"
BP	155053	Bar, Draw, L.H.
BQ	155011	Bar, Draw, R.H.

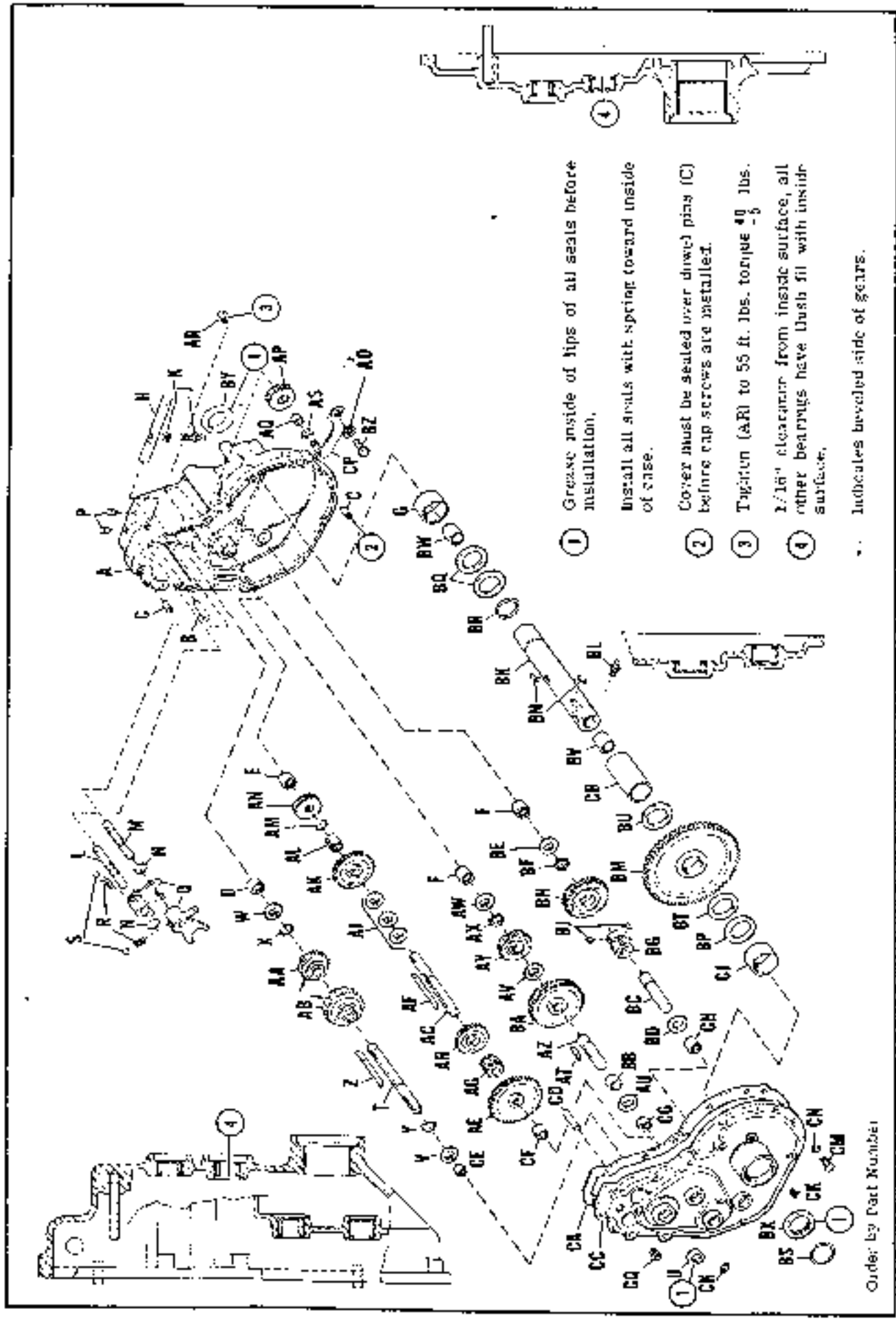

- ① Grease inside of lips of all seals before installation.
 - ② Install all caps with spring toward inside of case.
 - ③ Cover must be sealed over drive pins (C) before cap screws are installed.
 - ④ Tighten (AR) to 55 ft. lbs. torque $\frac{40}{-5}$ lbs. $\frac{1}{16}$ " clearance from inside surface, all other bearings have Dush fill with inside surface.
- • Indicates beveled side of gears.

Order by Part Number

TRANSMISSION GROUP

TRANSMISSION GROUP

About 3 qts of #90 oil

Order by Part Number

Reference Letter	Part No.	Description
A	155045	Case, Gear, Complete w/coverings & dowel pins
B <i>15451E</i>	723007	Pin, Roll <i>Pin 723006 - Ball 15451E</i> 7-18-64
C	723007	Pin, Roll
D	154257	Bearing, Needle
E	154258	Bearing, Needle
F	154259	Bearing, Needle
G	154260	Bearing, Axle Tube
H	154068	Mod. Shift
J	154261	Stem, Shift
K	717010	Nut, Hex., Full, 3/8" - 24 N. F.
L	154067	Shaft, Shifter, Rev., Med.
M	154068	Shaft, Shifter, High, Low
N	8061040	Ring, Retaining
P	715019	Screw, Set, Hollow Head, Conc Point, 5/16" - 18 N. C. x 1/2" lg.
Q	154069	Fork, Shift
R	154323	Spring
S	154262	Ball, Shift Lock
T	154070	Shaft, Pulley
U	154263	Seal, Oil
V	154462	Washer
W	154462	Washer
X	154264	Ring, Retaining
Y	154264	Ring, Retaining
Z	154265	Key
AA	154072	Pinion Assembly, Rev., II
AB	154075	Pinion Assembly, Rev., I and III
AC	155014	Shaft, 1st Intm.
AD	721503	Washer, Lock, 3/8" Internal Shakeproof
AE	154078	Gear, Driven, I
AF	154354	Key
AG	154979	Pinion, 1st Intm.
AH	154980	Pinion, Driven, III
AJ	8061012	Spacer, Trans. Gear
AK	154061	Gear, Driven, II
AL	154962	Spacer
AM	154264	Ring, Retaining
AN	154083	Pinion, Reverse
AP	154067	Gear, Reverse
AQ	154064	Spacer, Rev. Gear
AR	717516	Nut, Lock, 1/2" - 20 N. F.
AS	154325	Washer
AT <i>DZ</i>	154066	Shaft, 2nd. Intm.
AU	154038	Washer
AV	154038	Washer
AW	154038	Washer
AX	154266	Ring, Retaining
AY	154068	Pinion, 2nd. Intm.
AZ <i>AT</i>	154267	Key
BA	154069	Gear, 2nd. Intm.
BB	154090	Spacer
BC	154091	Shaft, 3rd. Intm.
BD	154038	Washer
BE	154038	Washer
BF	154266	Ring, Retaining
BG	154092	Pinion, 3rd. Intm.
BH	154093	Gear, 3rd. Intm.
BJ	735002	Key, Woodruff
BK	154094	Tube, Axle <i>(154094 prior to Serial # 456) 157514</i>

TRANSMISSION GROUP (cont.)

Order by Part Number

Reference Letter	Part No.	Description
BL	727002	Fitting, Grease
BM	154095	Gear, Drive
BN	154096 157120	Key
BP	154097	Washer
BQ	154097	Washer
BR	154268	Ring, Snap
BS	154268	Ring, Snap
BT	154130	Washer, Axle Tube
BU	154130	Washer, Axle Tube
BY	153068	Bearing
BW	153068	Bearing
BX	154269	Seal
BY	154269	Seal
BZ	705011	Screw, Cap, Hex., 3/8" - 16 N. C. x 5/8" lg.
CA	154270	Gasket, Gear Case
CB	154098	Spacer, Axle Tube
CC	155046	Cover, Gear Case, Complete w/bearings
CD	154537 720000	Pin, Roll w/ Ball (Pin 720000 - Davis 154536) 7-18" x 1/4"
CE	154257	Bearing, Needle
CF	154257	Bearing, Needle
CG	154271	Bearing, Needle
CH	154259	Bearing, Needle
CJ	154260	Bearing, Axle Tube
CK	720003	Plug, Pipe, 3/8"
CM	705007	Screw, Cap, Hex., 5/16" - 18 N. C. x 1" lg.
CN	720001	Washer, Lock, 5/16"
CP	154352	Pin Assembly, Rev. Gear
CQ	726003	Plug, Pipe, 3/8"