

# **ILLUSTRATED PARTS LIST**

**MFG. ID NO. 96051015001**

**CUSTOMER CATALOG NO. M145-97TC**

**POWERDRIVE**

**PRODUCT NO. 960 51 01-50**

**TRACTOR - MODEL NO. M145-97TC POWERDRIVE (96051015001), PROD. NO. 960 51 01-50  
DECALS 27**

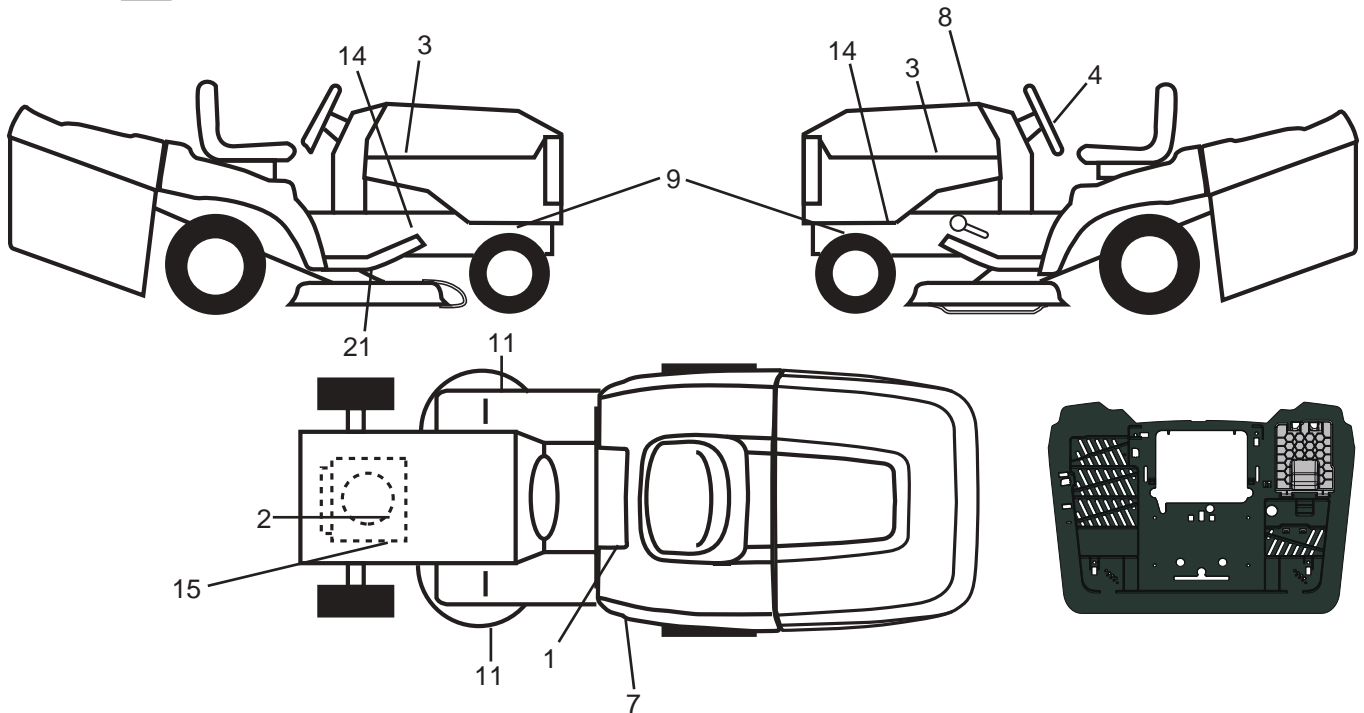

KEY NO.	PART NO.	DESCRIPTION
1	581 57 83-01	Decal, Warning
2	581 57 97-01	Decal, Warning Eng. Sym.
3	581 09 12-01	Decal, Hood RH/LH
4	501 49 43-01	Decal, Stwhl. Stdhrsq
7	581 90 95-01	Decal, Fender
8	596 59 57-01	Decal, Replacement
9	581 57 98-01	Decal, Warning
11	581 57 91-01	Decal, Cutfinger
14	581 57 96-01	Decal, Chassis Hot Muffler

KEY NO.	PART NO.	DESCRIPTION
15	532 43 74-12	Decal, Engine HP
21	592 98 02-01	Decal, Belt Sch CRD
--	583 90 19-01	Decal, Bypass
--	532 42 59-86	Pad Footrest RH
--	532 42 59-76	Pad Footrest LH
--	532 44 27-44	Decal, Battery Door
--	588 91 60-01	Decal, Hood RCG Strip
--	114 07 51-20	Manual Operator's (Euro)
--	114 07 54-10	Manual Operator's (Scan)
--	114 07 53-50	Manual Operator's (E-Bloc)
--	114 07 52-40	Manual Operator's (Baltic)

**WHEELS & TIRES**

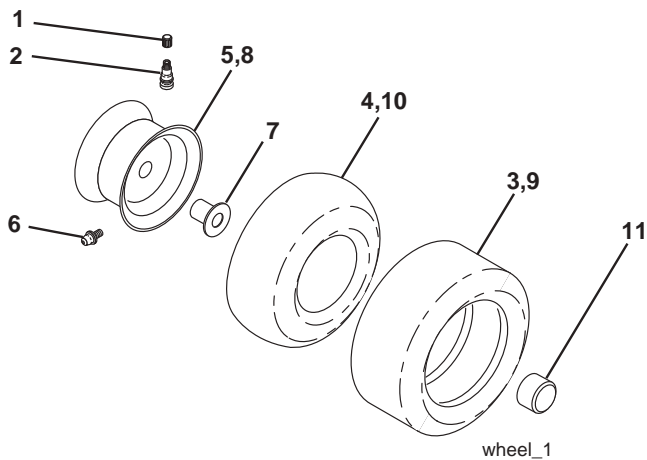

KEY NO.	PART NO.	DESCRIPTION
1	532 05 91-92	Cap Valve Tire
2	532 06 51-39	Stem Valve
3	532 10 62-22	Tire Front 15 x 6-6
4	532 05 99-04	Tube Inner Front #35060
5	532 12 51-21	Rim Asm 6" Front Service
6	532 00 02-78	Fitting, Grease
7	532 00 90-40	Bearing, Flange
8	532 12 51-22	Rim Asm 8" Rear Service
9	532 12 46-35	Tire Rear 18 x 8.5-8
10	532 00 71-52	Tube, Rear, 9.5 x 8 Service
11	532 19 32-68	Cap Axle
--	532 14 43-34	Sealant, Tire (10 oz. Tube)

**NOTE:** All component dimensions given in U.S. inches  
1 inch = 25.4 mm

# TRACTOR - MODEL NO. M145-97TC POWERDRIVE (96051015001), PROD. NO. 960 51 01-50

## SCHEMATIC **38**

SCH17

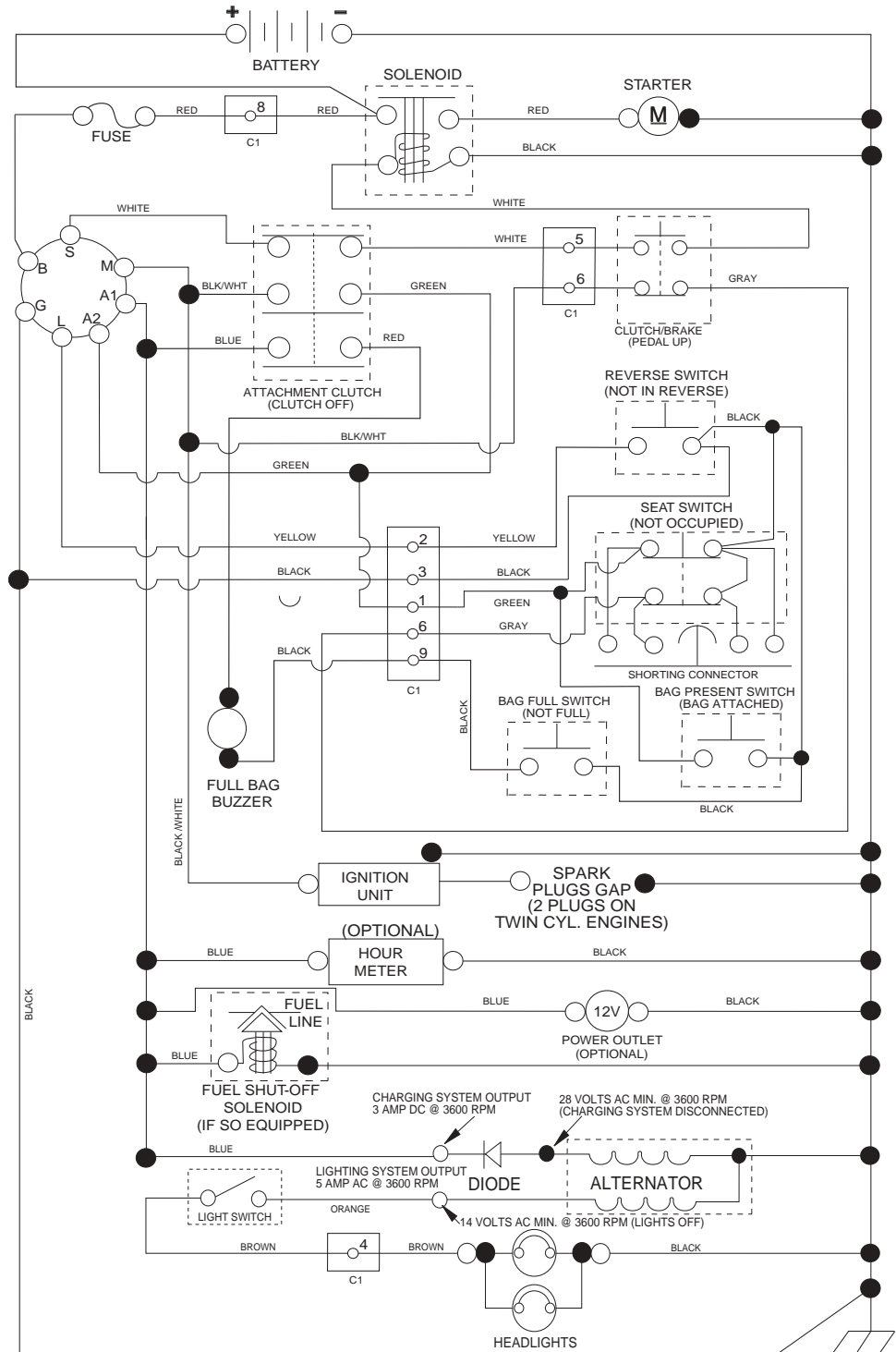

**NOTE**  
 YOUR TRACTOR IS EQUIPPED WITH A SPECIAL ALTERNATOR SYSTEM. THE LIGHTS ARE NOT CONNECTED TO THE BATTERY, BUT HAVE THEIR OWN ELECTRICAL SOURCE. BECAUSE OF THIS, THE BRIGHTNESS OF THE LIGHTS WILL CHANGE WITH ENGINE SPEED. AT IDLE THE LIGHTS WILL DIM. AS THE ENGINE SPEED IS INCREASED, THE LIGHTS WILL BECOME THEIR BRIGHTEST.

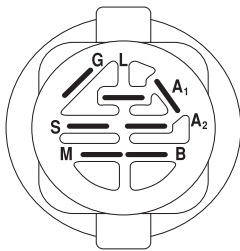

IGNITION SWITCH

POSITION	CIRCUIT	"MAKE"
OFF	M+G+A1	
RUN/OVERRIDE	B+A1	
RUN	B+A1	L+A2
START	B + S + A1	

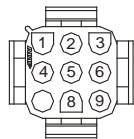

CHASSIS HARNESS CONNECTOR (C1) (MATING SIDE)

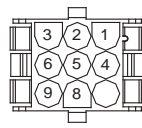

DASH HARNESS CONNECTOR (C1) (MATING SIDE)

**WIRING INSULATED CLIPS**  
 NOTE: IF WIRING INSULATED CLIPS WERE REMOVED FOR SERVICING OF UNIT, THEY SHOULD BE RE-INSTALLED TO PROPERLY SECURE YOUR WIRING.

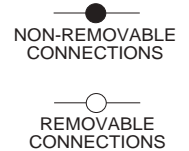

**TRACTOR - MODEL NO. M145-97TC POWERDRIVE (96051015001), PROD. NO. 960 51 01-50**  
**ELECTRICAL 32**

TC03S

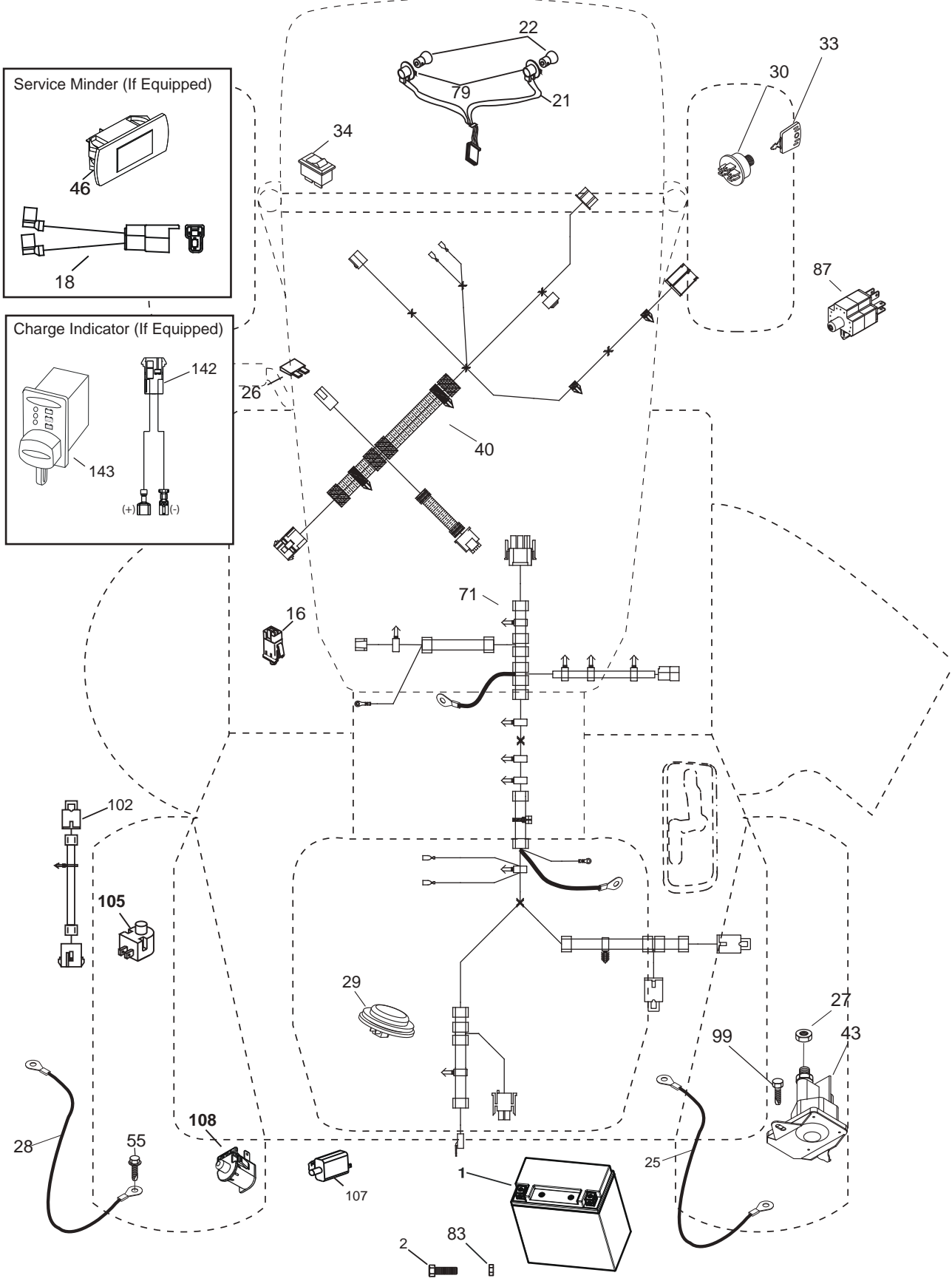
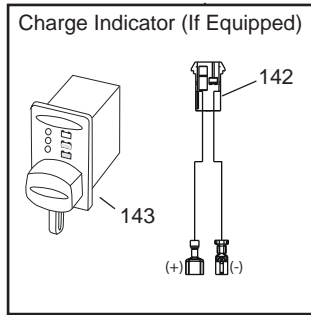
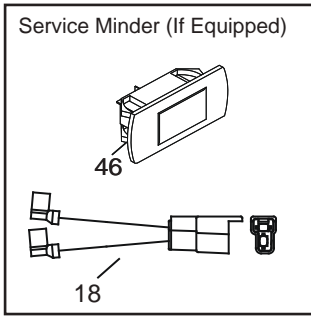

**TRACTOR - MODEL NO. M145-97TC POWERDRIVE (96051015001), PROD. NO. 960 51 01-50  
ELECTRICAL 32**

<b>KEY NO.</b>	<b>PART NO.</b>	<b>DESCRIPTION</b>
1	532 43 71-57	Battery
2	596 32 01-01	Bolt, Hex. M6 x 1 x 12.4 mm 8.8
16	532 17 61-38	Switch Interlock
21	532 40 02-52	Harness Asm Light w/4152J
22	532 00 41-52	Bulb Light #1156
25	581 48 98-01	Cable Battery Red
26	532 17 51-58	Fuse
27	596 13 36-01	Locknut, Keps. 1/4-20
28	581 48 98-02	Cable Ground Black
29	532 40 15-45	Switch Seat
30	532 19 33-50	Switch Ignition
33	532 41 19-35	Key/Chain
34	532 11 07-12	Switch Light
40	532 42 10-02	Harness Ignition Dash
43	582 04 28-02	Solenoid
55	817 06 05-12	Screw 5/16-18 x 3/4
71	581 02 33-01	Harness Chassis
79	532 17 52-42	Socket Asm.
83	594 08 65-01	Nut, Square, M6 x 1
87	532 42 10-60	Switch Railmount
99	817 00 05-12	Screw 5/16-18 x 3/4
102	581 02 35-01	Harness Pigtail
105	532 40 75-68	Switch Reverse
107	532 18 03-79	Switch Full Bagger Indicator
108	532 42 10-62	Switch Snapmount

**NOTE:** All component dimensions given in U.S. inches  
1 inch = 25.4 mm

TRACTOR - MODEL NO. M145-97TC POWERDRIVE (96051015001), PROD. NO. 960 51 01-50  
CHASSIS AND ENCLOSURES **39**

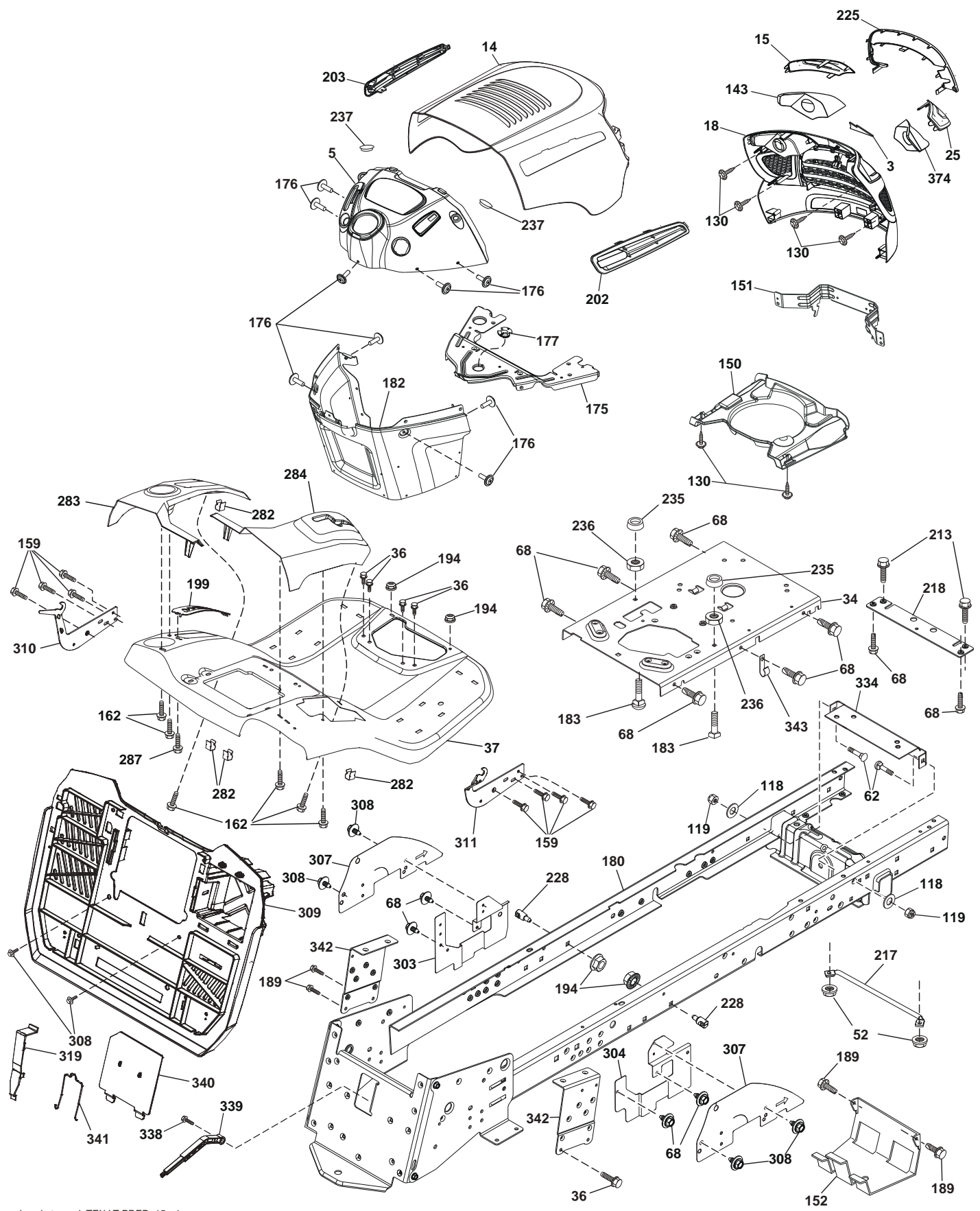

chassis-tex crd\_TEX LT PRED\_15\_r4

**TRACTOR - MODEL NO. M145-97TC POWERDRIVE (96051015001), PROD. NO. 960 51 01-50  
CHASSIS AND ENCLOSURES **39****

<b>KEY NO.</b>	<b>PART NO.</b>	<b>DESCRIPTION</b>	<b>KEY NO.</b>	<b>PART NO.</b>	<b>DESCRIPTION</b>
3	578 89 71-01	Emblem Mount	218	532 19 63-95	X-Piece Hood Stop
5	532 40 95-97	Dash	225	581 05 62-01	Trim Ring
14	581 56 47-01	Hood	228	593 82 40-01	Stud, W/"D" Anti-rotation
15	581 05 58-01	Lens LH	235	596 56 42-01	Spacer, Fender, Clr. Zn
18	581 01 07-01	Grille, Asm. PredLT, Mccul. Logos	236	873 93 05-00	Nut Lock 5/16-18 unc
25	581 05 59-01	Lens RH	237	532 40 37-04	Plug Mount Cargo
34	593 94 44-02	Plate, Engine, Weldedchas. 127"	282	532 41 41-10	Clip Retainer
36	817 06 05-12	Screw 5/16-18 x 3/4	283	532 44 03-61	Console Deck Lift
37	532 44 08-49	Fender	284	532 44 03-60	Console Shift RH
52	596 04 05-01	Nutlock, Hex. Prvl. 5/16-18	287	817 60 04-06	Screw Hex Washead 1/4-20 x 3/8
62	596 72 82-01	Bolt, Carr. 3/8-16 x 1" Gr. 5	303	589 00 76-02	Shield LH
68	596 03 07-01	Screw, Hexagon, 5/16-18 x 1/2	304	589 41 27-02	Shield RH
118	596 56 53-01	Washer 3/8 x 0.08 In. St. Clr. Zinc	307	587 49 45-01	Shield Upper
119	596 32 26-01	Nut. Crownlock 3/8-16 unc.	308	532 17 18-77	Bolt 5/16-18 unc x 3/4
130	596 32 17-01	Screw, #10 x 0.750 BOS Thread	309	501 18 83-01	Backplate Bagger
143	581 05 60-01	Insert Reflective LH	310	532 44 54-28	LH Adjust Hanger
150	532 40 02-67	Duct, Air	311	532 44 54-30	RH Adjust Hanger
151	532 18 75-68	Bracket Pivot Hood	319	532 17 46-62	Lever Bagger
152	532 19 95-35	Shield Browning	334	532 44 25-37	Engine Plate
159	817 00 06-12	Screw Hexwsh Thdr 3/8-16 x 3/4	338	594 09 39-01	Bolt, Shoulder 5/16-18 x .88
162	596 13 41-01	Screw, Hex. Tap. 1/4-15 x 1/2	339	532 43 66-41	Lever Bagger Full
175	532 19 94-72	Crossmember	340	532 44 09-31	Door Battery
176	532 40 07-76	Screw 10-24 x 5/8	341	582 06 08-01	Latch Battery Door
177	532 19 52-28	Bushing Steering	342	582 82 68-02	Support Fender
180	582 74 60-01	Chassis	343	532 44 07-49	Clip
182	532 40 71-76	Dash Lower	374	581 05 60-02	Insert Reflective RH
183	595 30 57-01	Screw, Hexagon, 5/16-18 x 1-1/4			
189	817 00 05-12	Screw 5/16-18 x 3/4			
194	596 13 57-01	Nutlock, Prvl, Torq. 5/16-18 x .68			
199	532 41 87-39	Plate Deck Lift			
202	588 98 86-01	Vent Hood RH			
203	588 98 86-02	Vent Hood LH			
213	596 03 05-01	Bolt, Hex. Hd. 5/16-18 unc x 3/4			
217	532 40 91-67	Rod Pivot Hood			

**NOTE:** All component dimensions given in U.S. inches  
1 inch = 25.4 mm

TRACTOR - MODEL NO. M145-97TC POWERDRIVE (96051015001), PROD. NO. 960 51 01-50  
DRIVE **40**

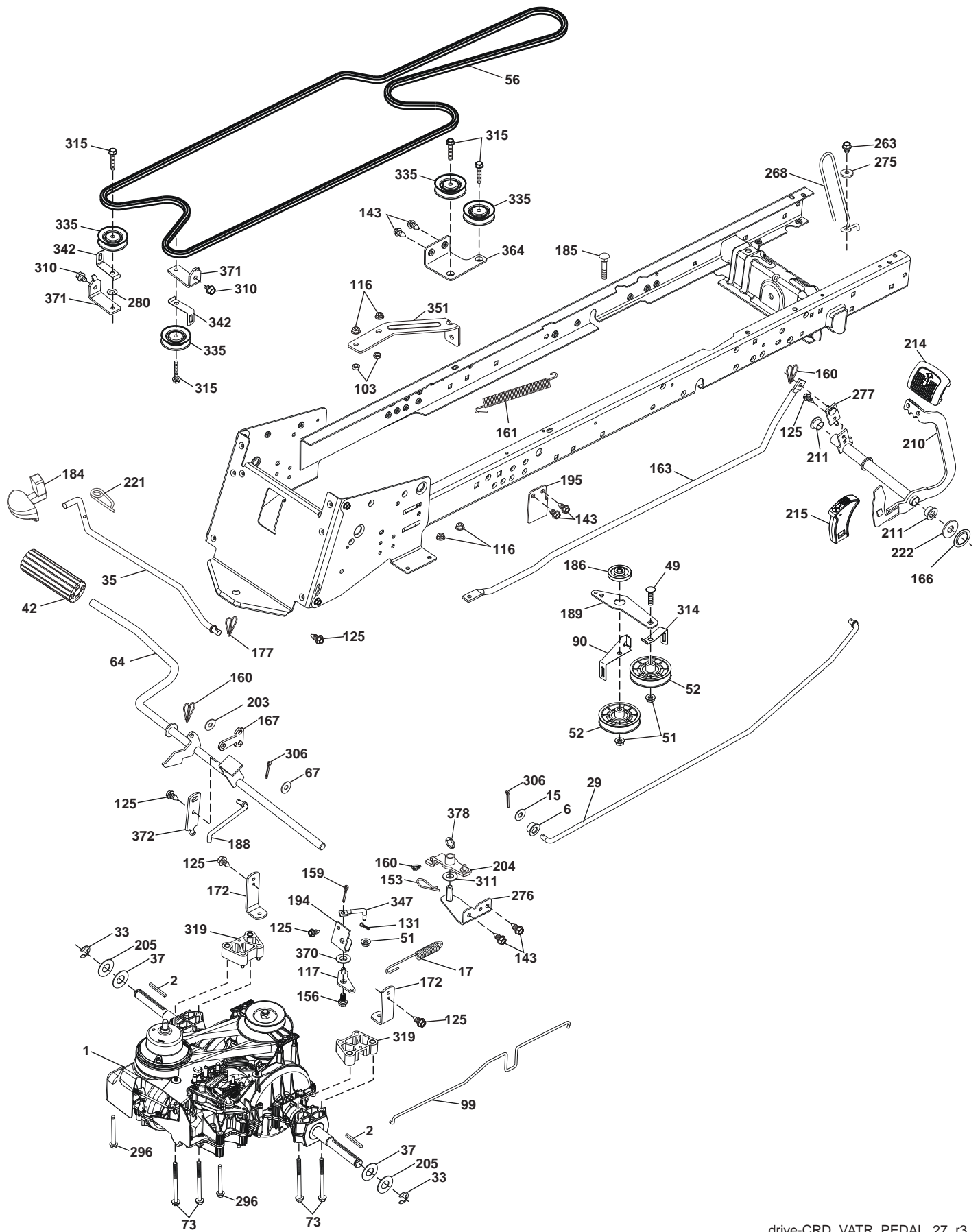



**TRACTOR - MODEL NO. M145-97TC POWERDRIVE (96051015001), PROD. NO. 960 51 01-50  
DRIVE 40**

KEY NO.	PART NO.	DESCRIPTION	KEY NO.	PART NO.	DESCRIPTION
1	-----	Transmission, Gentrans VATR. (590277701) (Order parts from transaxle manufacturer.)	188	582 21 70-01	Link Clutch Ground Drive Long
2	532 12 35-83	Key Square .2.0 x .1845/.1865	189	532 43 36-11	Bellcrank Groundrive
6	532 12 40-28	Bushing Snap	194	583 87 86-01	Bellcrank Brake
15	596 56 53-01	Washer, 3/8 x 0.08 In. St. Clr. Zinc	195	580 45 69-02	Brake Bracket
17	580 32 52-01	Spring Brake	203	596 20 41-01	Washer, 11/32 x 11/16 x 14
29	581 18 74-01	Rod Brake	204	584 99 70-01	Link Pivot Pedal
33	812 00 00-01	E-Ring. #5133-75	205	532 12 17-48	Washer 25/32 x 1-5/8 x 16 Ga.
35	596 87 48-01	Rod, Control, Park Txlt. Clr. Zinc	210	588 92 10-01	Weldment Pedal
37	532 18 89-67	Washer Harden .793 x 1.637 x 060	211	532 12 01-83	Bearing Nylon
42	532 00 88-83	Cover, Pedal, Blk. Round	214	532 42 12-63	Pedal Forward Pad
49	596 13 62-01	Bolt, Cup Head, 3/8-16 x 3/4	215	591 10 01-01	Cap Pedal Reverse
51	873 90 06-00	Nut, Hex, Flangelock 3/8-16	221	532 40 31-87	Retainer Spring Clip Handle
52	532 19 43-26	Idler V-Groove Offset	222	879 21 20-10	Washer 21/32 x 1-1/4 10 Ga.
56	532 44 69-91	Belt Drive	263	817 00 06-12	Screw Hxwsh Thdr 3/8-16 x 3/4
64	589 67 14-01	Shaft Asm. Pedal Brake	268	596 88 78-01	Guard, Muffler, B&S OHV
67	582 58 01-01	Washer Nylon 13/32 x 13/16 x 1.09	275	596 13 54-01	Washer, Plain, 13/32 x 1 Clr. Znc
73	580 83 04-01	Bolt Shoulder Transaxle	276	590 63 01-02	Bracket Control Pedal
90	532 44 36-05	Keeper Belt	277	532 44 85-00	Subasm. Link Rocker Pedal
99	581 28 09-01	Rod Bypass	280	596 03 99-01	Washer, Plain, 11/32 x 5/8 Clr.
103	596 43 63-01	Nut, Hex. 5/16-18 x 0.577" Gr. 5 Zn.	296	532 42 04-71	Screw Thdrol 5/16-18 x 3
116	596 13 57-01	Nutlock, Prvl. Torq. 5/16-18 x .68	306	596 02 96-01	Pin, Cotter 1/8 Dia x 1.00
117	580 38 29-01	Subasm Bellcrank Brake	310	596 56 40-01	Hex. Bolt W/Collar 3/8-16 x 0.53
125	817 00 05-12	Screw 5/16-18 x 3/4 Smgml Tap/Bl	311	585 07 20-01	Washer Nylon
131	596 91 76-01	Pin, Cotter 3/32 x 1/2" Clr. Zn	314	532 44 47-13	Keeper Belt
143	596 03 07-01	Screw, Hexagon, 5/16-18 x 1/2	315	817 58 05-20	Screw Thdrol 5/16-18 x 1.25
153	532 00 49-21	Retainer, Spring	319	580 45 74-02	Spacer Transaxle
159	596 02 95-01	Pin, Cotter, 1/8 Dia. x 3/4	335	532 19 95-34	Pulley V-Idler
160	596 02 94-01	Clip, Retainer, "M-Shape"	342	580 96 10-02	Keeper Belt Idler
161	532 10 57-09	Spring Return Clutch 6.75	347	580 32 51-01	Rod Connecting Brake
163	581 18 73-01	Rod Control Pedal	351	532 43 69-98	Bracket Swaybar
166	532 42 91-64	Nut Push .625	364	532 44 30-32	Bracket Idler
167	532 40 52-57	Latch Brake Parking	370	878 12 16-32	Washer Thrust 3/8 x 1 x .032
172	532 44 82-76	Strap Torque LH/RH	371	580 96 07-03	Bracket Idler
177	587 22 53-01	Pin Cotter, Locking, Bowtie, 1in.	372	581 47 52-01	Arm Control Brake
184	532 41 14-84	Handle Parking Brake	378	584 28 77-01	Nut Push
185	872 11 06-22	Bolt Rdhd.3/8-16 Unc x 2-3/4 Gr.5			
186	532 19 43-21	Spacer Retainer			

**NOTE:** All component dimensions given in U.S. inches  
1 inch = 25.4 mm



**TRACTOR - MODEL NO. M145-97TC POWERDRIVE (96051015001), PROD. NO. 960 51 01-50  
ENGINE 24**

KEY NO.	PART NO.	DESCRIPTION
1	- - - - -	Engine Briggs Model 31Q507-0002-H5 (597389201) (Order parts from engine manufacturer.)
2	532 13 73-52	Muffler
9	583 84 78-01	Keeper Belt Engine
12	586 47 85-01	Pulley Engine
15	581 28 99-01	Tank Fuel
18	532 43 02-20	Cap Fuel
20	532 18 38-97	Control Throttle/Choke
21	596 32 17-01	Screw, #10 x 0.750 BOS Thread
22	532 19 49-81	Control Choke
28	532 13 70-40	Line Fuel
29	532 13 71-80	Kit Spark Arrester (Flat Scrn)
37	532 12 34-87	Clamp Hose Blk
42	596 23 89-01	Washer, 7/16 in. Clr. Zn
45	596 13 36-01	Locknut, Keps. 1/4-20
69	532 16 52-91	Gasket Muffler
79	596 13 42-01	Screw, Hex. Socket, 5/16-18 x 3/4
84	817 06 06-20	Screw 3/8-16 x 1-1/4
85	501 60 65-01	Bolt 7/16-20 x 4 x Gr. 5-1.5 BLU
90	817 00 06-16	Screw 3/8-16 x 1
96	596 13 53-01	Washer, Plain, 9/32 x 7/8 Clr. Zn
97	817 67 04-12	Screw Hexwsh Thdrol 1/4-20 x 3/4
102	593 33 76-01	Screw, 5/16-18 x 1.00 Hwh. Trs
108	587 17 95-10	Cover Pulley Eng. w/SHLD
122	532 42 19-22	Extension Drain Oil

**NOTE:** All component dimensions given in U.S. inches  
1 inch = 25.4 mm

**Engine Power Rating Information**

The gross power rating for individual gas engine models is labeled in accordance with SAE (Society of Automotive Engineers) code J1940 (Small Engine Power & Torque Rating Procedure), and rating performance has been obtained and corrected in accordance with SAE J1995 (Revision 2002-05). Torque values are derived at 3060 RPM; horsepower values are derived at 3600 RPM. Actual gross engine power will be lower and is affected by, among other things, ambient operating conditions and engine-to-engine variability. Given both the wide array of products on which engines are placed and the variety of environmental issues applicable to operating the equipment, the gas engine will not develop the rated gross power when used in a given piece of power equipment (actual "on-site" or net power). This difference is due to a variety of factors including, but not limited to, accessories (air cleaner, exhaust, charging, cooling, carburetor, fuel pump, etc.), application limitations, ambient operating conditions (temperature, humidity, altitude), and engine-to-engine variability. Due to manufacturing and capacity limitations, Briggs & Stratton may substitute an engine of higher rated power for this Series engine.

TRACTOR - MODEL NO. M145-97TC POWERDRIVE (96051015001), PROD. NO. 960 51 01-50  
 STEERING ASSEMBLY **41**

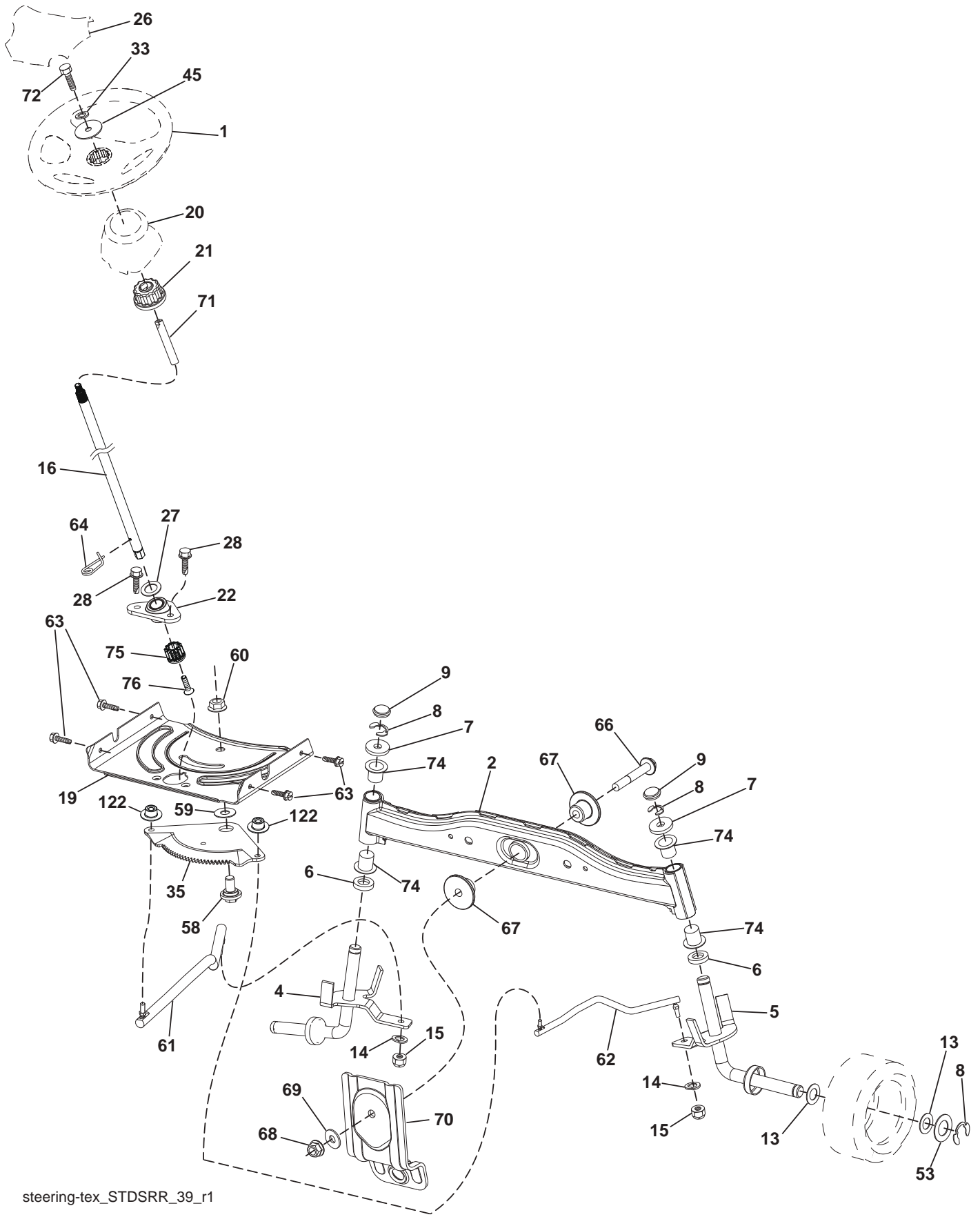

steering-tex\_STDSRR\_39\_r1

**TRACTOR - MODEL NO. M145-97TC POWERDRIVE (96051015001), PROD. NO. 960 51 01-50  
STEERING ASSEMBLY 41**

<b>KEY NO.</b>	<b>PART NO.</b>	<b>DESCRIPTION</b>
1	532 42 45-51	Wheel, Steering
2	532 41 81-68	Axle Asm., Front
4	532 40 30-87	Spindle Asm., LH
5	532 40 30-88	Spindle Asm., RH
6	532 00 62-66	Washer, Thrust, .75 x 1.230
7	532 12 17-48	Washer 25/32 x 1-5/8 x 16 Ga.
8	812 00 00-29	Ring, Klip #T5304-75
9	532 12 12-32	Cap, Spindle
13	532 12 17-49	Washer 25/32 x 1-1/4 x 16 Ga.
14	596 23 87-01	Washer, Spring, Lock, .381 ID x .680
15	873 54 06-00	Nut, Crown Lock 3/8-24 unf
16	585 86 92-02	Steering Shaft
19	532 19 47-29	Plate Steering
20	532 40 97-63	Boot, Steering
21	532 18 67-37	Adapter, Wheel Steering
22	585 02 98-02	Bearing
26	532 42 45-53	Insert, Wheel Steering
27	596 93 34-01	Washer, Plain
28	817 00 06-12	Screw 3/8-16 x 3/4
33	596 23 88-01	Washer, Lock, 5/16 Sqr. End. ZN
35	532 19 47-32	Gear, Sector Plate
45	596 04 00-01	Washer 11/32 x 2-3/8" Clr. Zn.
53	532 18 89-67	Washer Hardened .793 x 1.637 x .060
58	532 19 47-47	Bolt Shoulder Sector Pivot CFM
59	532 19 47-48	Washer Thrust Sector Steering
60	873 97 10-00	Nut Flange Lock 5/8-11
61	597 04 78-02	Draglink, LH. Ballstud, Std.
62	597 04 79-02	Draglink, RH. Ballstud, Std.
63	817 00 05-12	Screw 5/16-18 x 3/4
64	532 19 98-49	Retainer Clip Spring Steering
66	871 02 07-48	Bolt Hex Fghd 7/16-14 x 3 Serr
67	532 19 47-37	Bushing PM Front Axle
68	873 90 07-00	Nut Lock Flange 7/16-14 Gr. 5
69	532 19 91-62	Washer 1.5 x .505 x .118
70	585 33 88-01	Bracket Deck Susp. Front
71	532 19 07-52	Shaft Extension Steering
72	596 03 97-01	Bolt, Hex Head, 5/16-18 unc x 4" Gr. 5
74	532 00 33-66	Bearing, Col. Strg. Blk
75	580 68 37-01	Pinion
76	580 68 36-01	Screw Head Sock
122	532 44 49-62	Cap Gear Sector

**NOTE:** All component dimensions given in U.S. inches  
1 inch = 25.4 mm

TRACTOR - MODEL NO. M145-97TC POWERDRIVE (96051015001), PROD. NO. 960 51 01-50  
MOWER DECK 44

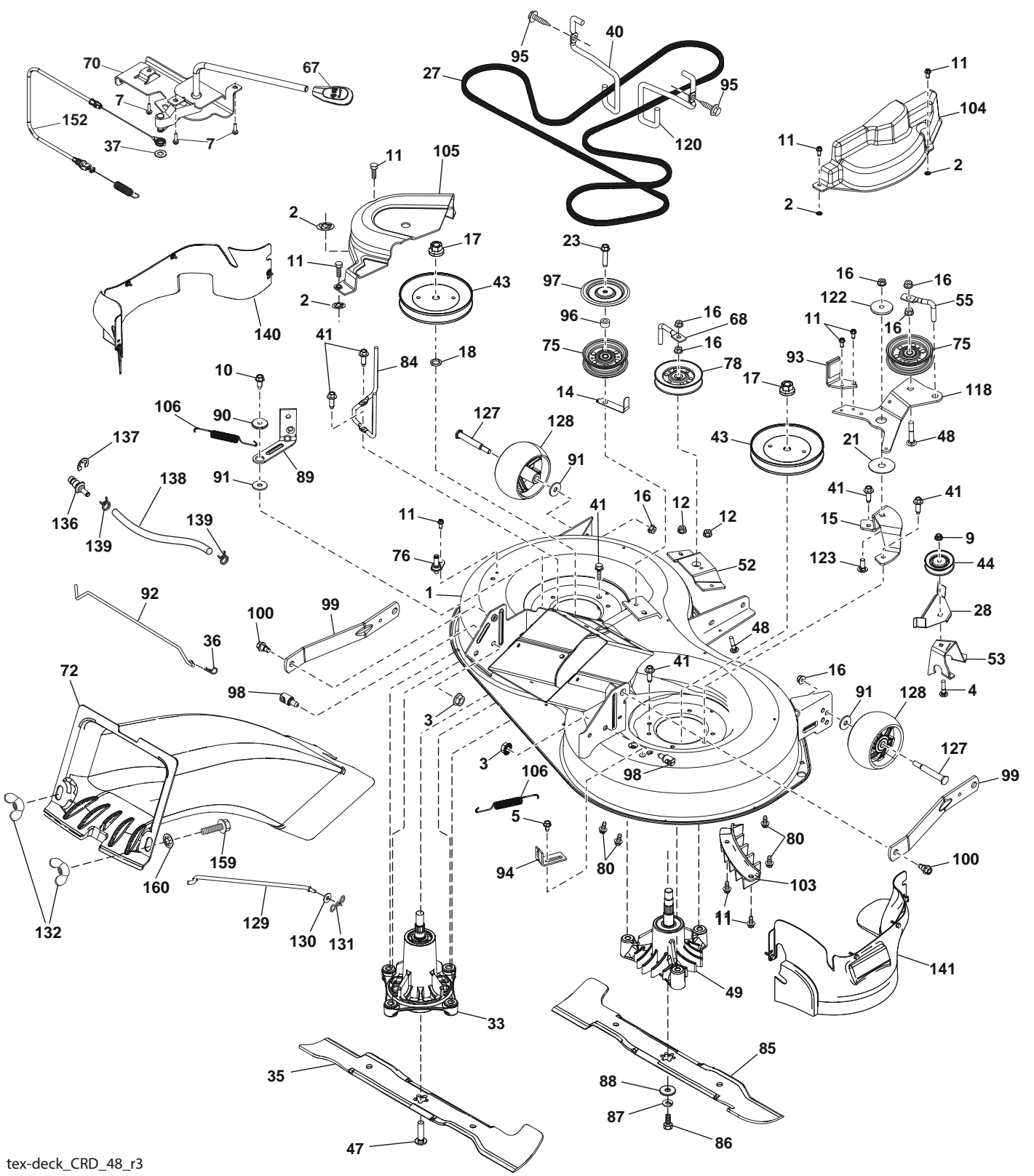

tex-deck\_CRD\_48\_r3

**TRACTOR - MODEL NO. M145-97TC POWERDRIVE (96051015001), PROD. NO. 960 51 01-50  
MOWER DECK 44**

KEY NO.	PART NO.	DESCRIPTION	KEY NO.	PART NO.	DESCRIPTION
1	596 58 21-01	Kit SVC Deck Weldment	84	589 67 61-02	Keeper Belt Mandrel
2	532 42 30-62	Palnut 1/4	85	532 42 79-85	Blade
3	596 13 57-01	Nut, Lock, Prvl, Torq, 5/16-18 x .68	86	532 18 17-13	Bolt 3/8-24 x 1.50
4	872 11 05-10	Bolt Carr 5/16-18 x 1-1/4 Gr. 5	87	596 23 87-01	Washer, Spring, Lock, .381 ID x .680
5	817 00 05-10	Bolt 5/16-18	88	532 14 02-96	Washer Hard Blade
7	596 32 17-01	Screw, #10 x 0.750, BOS Thread	89	532 43 81-24	Arm Brake
9	585 69 13-01	Nut Hex Flg Nylock	90	532 19 90-92	Spacer Retainer
10	817 00 06-16	Screw 3/8-16 x 1	91	596 13 49-01	Washer, Plain 3/8 x 7/8
11	532 13 77-29	Screw 1/4-20 x 5/8	92	592 85 57-01	Rod Brake 97 CRD Link
12	594 94 44-01	Nut, Hex, Flng, 5/16-18, Nyloc Clr	93	592 85 49-02	Arm Brake
14	532 15 60-85	Keeper Belt Idler	94	532 19 72-50	Bracket Clutch Cable
15	592 85 47-02	CRD Idler Arm Mount Bracket	95	817 00 06-12	Screw Hexwsh 3/8-16 x 3/4
16	873 90 06-00	Nut 3/8-16	96	532 40 02-71	Spacer
17	596 13 48-01	Nut, Hex 9/16-18 x 1.010	97	532 18 20-61	Shield Idler Mower
18	532 18 76-90	Washer Spacer Mandrel	98	593 82 40-01	Stud, W/"D" Anti-rotation
21	532 17 85-15	Washer Flat Hardened	99	532 19 51-86	Arm Suspension
23	596 56 40-03	Bolt, Hex 3/8-16 x 1.78 Clrzinc.	100	532 19 65-39	Bolt Shoulder
27	599 36 53-01	Belt, Deck	103	532 43 69-92	Guard Front Vent
28	592 85 56-02	Keeper 97 CRD Angled Idler	104	592 84 81-01	Mandrel Cover RH
33	587 81 97-01	Kit, Mandrel, Nongrease, Tall (includes shaft and bolt)	105	532 43 87-44	Mandrel Cover LH
35	532 42 79-84	Blade	106	532 19 32-16	Spring Brake Return
36	532 00 44-97	Retainer, Spring, 1" Zinc/Cad	118	599 23 63-02	97 CRD. Clutching Arm, MS431
37	596 56 53-01	Washer, 3/8 x 0.08 In. St. Clr. Zinc	120	532 19 72-59	Keeper Belt Engine RH
40	532 19 72-58	Keeper Belt Engine LH	122	532 16 57-23	Retainer Spring
41	584 95 39-01	Bolt Hex Wshrhhd .313-18 x 1.19	123	596 98 75-01	Bolt, 3/8 x 1-1/4" Gr. 5 Clr. Zn.
43	532 19 74-73	Pulley Mandrel	127	596 43 44-04	Bolt, Shoulder, 3/8-16 x 3-5/8
44	532 19 95-34	Pulley V-Idler Grnd Dr Plated	128	589 52 73-01	Wheel Gauge Rally
47	584 30 93-01	Screw LH Blade 7/16 x 1	129	532 40 48-51	Rod Anti-Sway
48	596 13 63-01	Bolt, Cup, Head, 3/8-16 x 2	130	596 13 32-01	Washer 13/32 x 13/16 x 12 Ga.
49	532 16 55-79	Mandrel, Asm. Crd. LH (includes bearing, housing, shaft, felt washer, nut, bolt and washer)	131	532 19 42-08	Pin Cotter 5/16 Bow Tie Lock
52	599 21 07-03	Bracket, 97 CRD. Center, Idler, x431	132	532 17 88-99	Knob Handle
53	595 09 81-03	Bracket V-Idler Bolt Angled	136	532 43 96-39	Washout Port Hookup
55	598 96 92-01	Keeper, 97 CRD. Clutching, Arm	137	812 00 00-29	Ring Klip
67	532 40 30-12	Handle Clutch Cable	138	532 44 07-43	Hose 3/8 Long 12"
68	598 90 38-02	Keeper, Belt	139	596 86 74-01	Clamp, Hose, 3/8 Clear, Zinc
70	532 40 12-46	Clutch Asm Manual	140	501 57 94-01	Guard Asm. LH
72	582 03 56-01	Chute Upper	141	501 57 93-01	Guard Asm. RH
75	597 02 50-01	Pulley, Idler, Flat, Clr. Zn	152	532 44 04-88	Cable Clutch Manual W/Spring
76	532 43 96-40	Washout Port	159	872 14 06-14	Bolt 3/8-16 unc x 1-3/4
78	532 17 39-02	Pulley Idler V-Gr Plated 4.25	160	532 16 89-37	Nut Push
80	595 90 16-01	Bolt, Cup, 5/16-18 x 3/4 Clear, Zin	--	596 58 24-01	Replacement Mower Complete

**NOTE:** All component dimensions given in U.S. inches  
1 inch = 25.4 mm

**TRACTOR - MODEL NO. M145-97TC POWERDRIVE (96051015001), PROD. NO. 960 51 01-50**  
**MOWER LIFT 45**

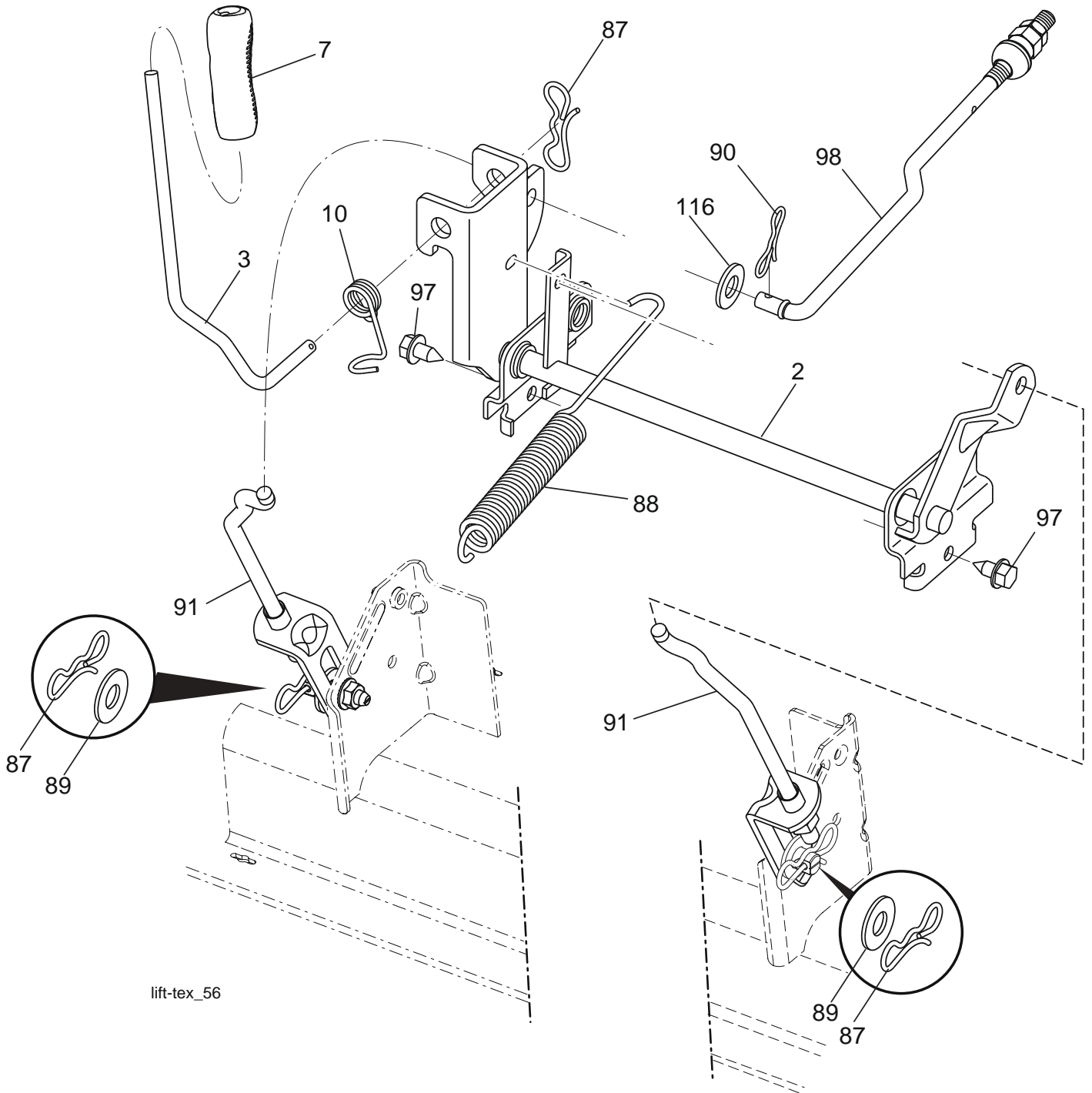

lift-tex\_56

KEY NO.	PART NO.	DESCRIPTION
2	532 43 69-96	Deck Lift
3	594 01 80-01	Lever, Lift, Handle, Clear, Zinc
7	580 96 23-01	Grip, Lever
10	532 19 63-14	Spring Torsion
87	532 19 42-09	Pin Cotter 7/16 Bow Tie Lock
88	532 43 69-95	Spring Lift Assist
89	819 19 19-12	Washer 17/32 x 1-3/16 x 12 Ga.
90	532 19 42-08	Pin Cotter 5/16 Bow Tie Lock

KEY NO.	PART NO.	DESCRIPTION
91	589 46 48-03	Link, Assy. Lift, Rear
97	596 56 40-01	Hex. Bolt W/Collar. 3/8-16 x 0.53
98	581 50 69-04	Link, Assy. Mwr. Front, Susp. 10.400
116	594 97 65-01	Washer, Round 15/32 x 15/16 x .065

**NOTE:** All component dimensions given in U.S. inches  
 1 inch = 25.4 mm



**TRACTOR - MODEL NO. M145-97TC POWERDRIVE (96051015001), PROD. NO. 960 51 01-50  
SEAT ASSEMBLY 42**

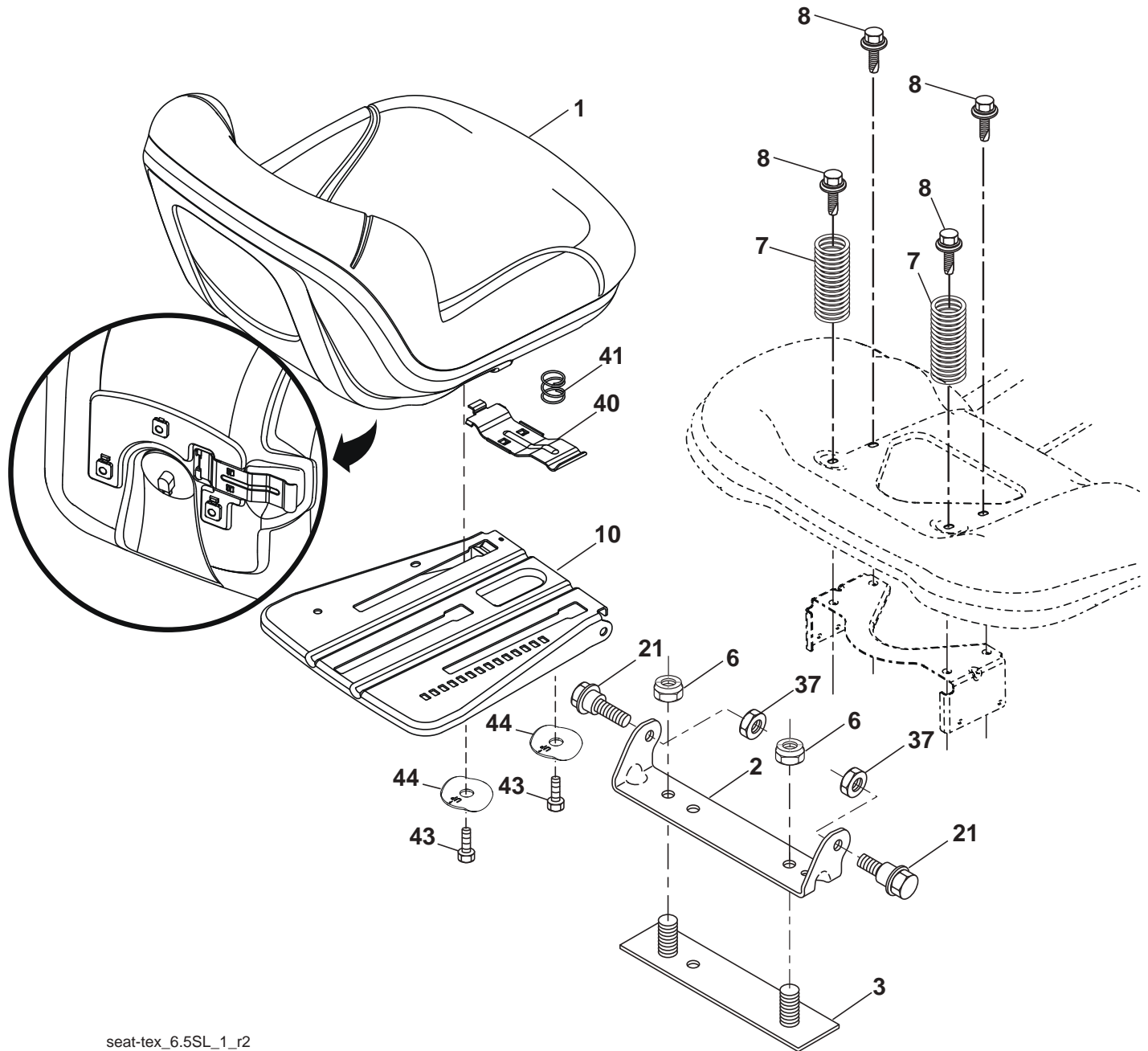

seat-tex\_6.5SL\_1\_r2

KEY NO.	PART NO.	DESCRIPTION
1	581 46 21-01	Seat
2	532 18 01-66	Bracket Pnt Pivot Fender
3	532 14 06-75	Strap
6	873 80 06-00	Nut Lock Hex w/Ins 3/8-16
7	589 48 35-01	Spring Seat Cprsn
8	532 17 18-77	Bolt 5/16-18 unc x 3/4
10	596 65 74-02	Plate, Seat, Slide 3pt. Ms 431
21	587 90 78-01	Bolt Shoulder 5/16-18 x 5/8

KEY NO.	PART NO.	DESCRIPTION
37	596 58 37-02	Nut, W/Nonmetal, Ins. Blk. Zinc
40	595 08 81-02	Handle, Seat, Slide, E-Dip, x 431
41	532 19 82-00	Spring Latch
43	874 76 06-12	Bolt 3/8-16 unc x 3/4
44	501 05 18-01	Washer Winged

**NOTE:** All component dimensions given in U.S. inches  
1 inch = 25.4 mm

TRACTOR - MODEL NO. M145-97TC POWERDRIVE (96051015001), PROD. NO. 960 51 01-50  
BAGGER **46**

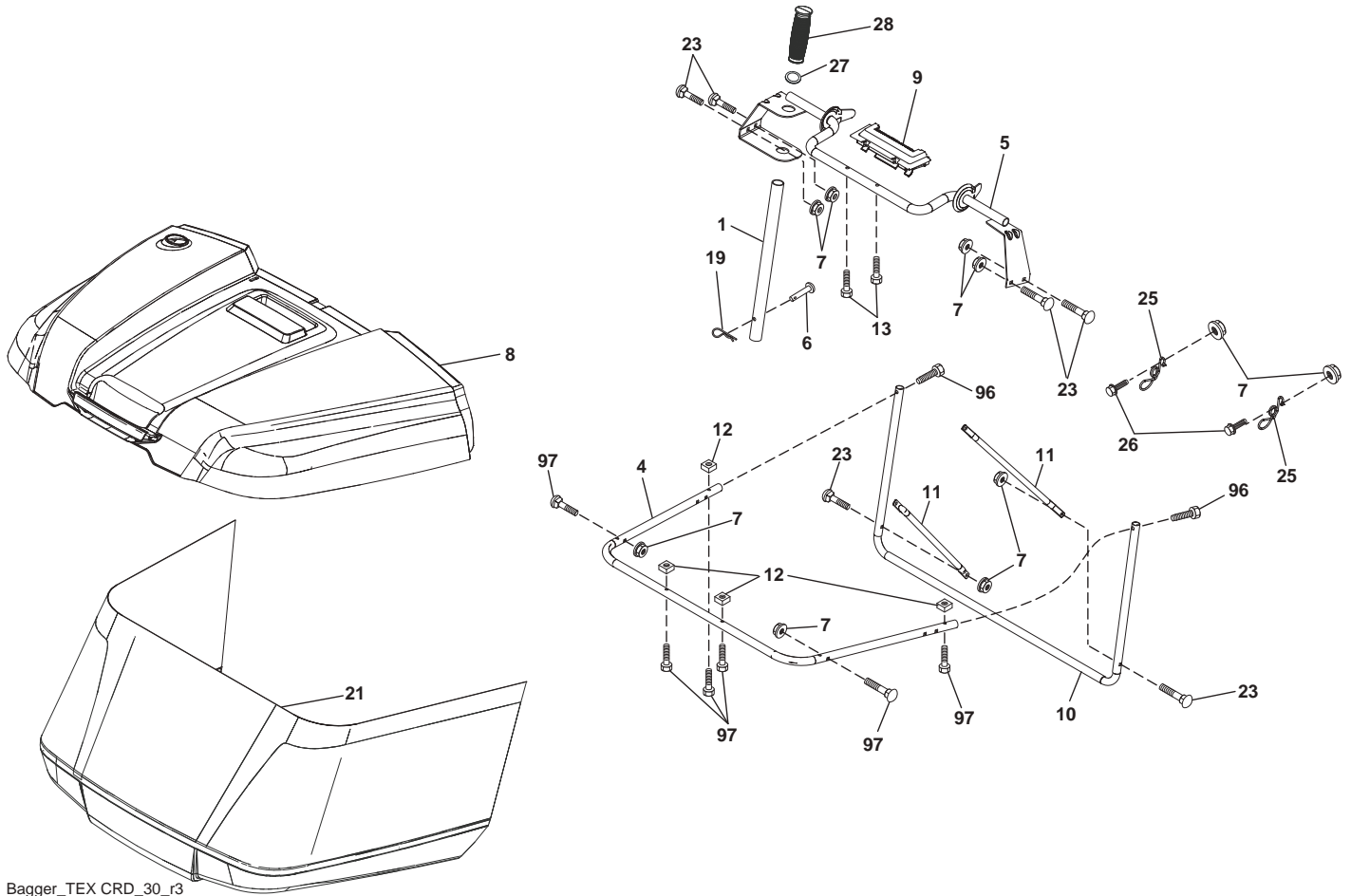

Bagger\_TEX CRD\_30\_r3

**TRACTOR - MODEL NO. M145-97TC POWERDRIVE (96051015001), PROD. NO. 960 51 01-50  
BAGGER 46**

<b>KEY NO.</b>	<b>PART NO.</b>	<b>DESCRIPTION</b>
1	532 42 86-10	Tube Handle Bagger
4	579 78 54-01	Frame Asm Bagger Top
5	532 41 76-32	Frame Asm Top Bagger
6	532 12 68-75	Rivet Drilled
7	873 90 04-00	Nut Hex Flange 1/4-20 unc
8	532 42 59-54	Cover Bagger
9	532 41 76-29	Insert Handle Bagger
10	532 43 67-70	Frame Front
11	532 43 67-71	Tubing Brace Bagger
12	532 42 17-93	Nut Square 1/4
13	532 42 17-80	Screw 1/4 x 1.150
19	532 19 42-08	Cotter Pin 5/16 Bow Tie
21	581 33 70-01	Bag Asm
23	872 04 04-10	Bolt Carr. 1/4-20
25	532 42 16-14	Spring Latch
26	817 49 04-12	Screw 1/4-20
27	532 42 12-62	Grommet Rubber
28	532 16 57-87	Grip Handle Black
96	501 40 66-01	Screw Hex Cap 1/4-20 x 1.500
97	590 10 57-01	Screw Torx Butn HD 1/4-20-1.5"

**NOTE:** All component dimensions given in U.S. inches  
1 inch = 25.4 mm

