

MODEL NOS. 141-760 10 H.P.  
141-860 12 H.P. — 141-960 14 H.P.

# OWNER'S GUIDE

## GARDEN TRACTOR

*Snow Blade 141-763*

*Deck 142-761 - N/A*

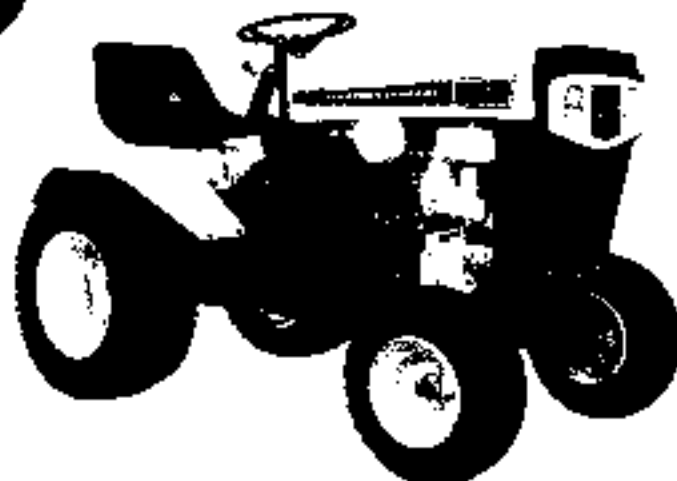
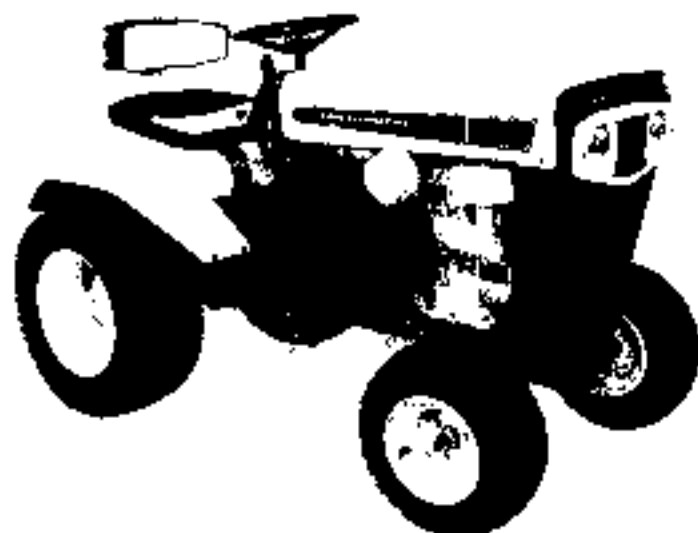

### WARRANTY

For one year from date of purchase, MTD Products Inc. will replace for the original purchaser, free of charge, F.O.B. factory or authorized service firm, any part or parts found to be defective in material or workmanship. All transportation charges on parts submitted for replacement under this warranty must be paid by the purchaser. This warranty does not include replacement of parts which become inoperative through misuse, excessive use, accident, neglect, improper maintenance or alterations by unauthorized persons. This warranty does not include the engine, motor, battery, battery charger or any component parts thereof. For service on these units refer to the applicable manufacturer's warranty.

The above warranty will apply only to the original owner and will be effective only if the warranty card has been properly processed. It will not apply where the unit has been used commercially.

Warranty service is available through your local authorized service dealer or distributor. UNDER NO CIRCUMSTANCES WILL THE RETURN OF A COMPLETE UNIT BE ACCEPTED BY THE FACTORY UNLESS PRIOR WRITTEN PERMISSION HAS BEEN EXTENDED.

MTD PRODUCTS INC • 5389 WEST 130TH ST. • P.O. BOX 2471 • CLEVELAND, OHIO 44111

# BE A PRO! KNOW YOUR MACHINE – HOW TO CONTROL IT SMOOTHLY, AND HOW TO STOP IT QUICKLY! AND – READ THE OWNERS MANUAL

## SAFETY TIPS FOR GARDEN TRACTORS AND ATTACHMENTS

Improper use of riding lawn mowers, garden tractors and attachments on the part of the operator can result in injury. To reduce this possibility, give complete and undivided attention to the job at hand.

1. Know the controls and how to stop quickly – READ THE OWNER'S MANUAL.
2. Do not allow children to operate machine; nor adults to operate it without proper instruction.
3. Clear work area of objects which might be picked up and thrown.
4. Disengage all clutches and shift into neutral before starting motor. Keep hands, feet and clothing away from power driven parts.
5. Do not carry passengers. Keep children and pets a safe distance away.
6. Never direct discharge of any material toward by-standers nor allow anyone near machine while in operation.
7. Disengage power to any attachment and stop motor before leaving operator position.
8. Take precautions when leaving machine unattended. (To avoid accidental starting, rolling away, accidental dropping of any attachment, etc.)
9. Disengage power to any attachment whenever it is not in use or when traveling from one work area to another.
10. Stay alert for holes and other hidden hazards.
11. Know what is behind you before backing up.
12. Beware of steep slopes; reduce speed on all side slopes and sharp turns to prevent tipping or losing control.
13. Don't stop or start suddenly when going uphill or downhill.
14. Use extra care when pulling loads or using heavy equipment. (Refer to your owner's manual)
15. Watch out for traffic when near roadways.
16. Handle gasoline with care – it is highly flammable.
  - A. Use approved gasoline container.
  - B. Never add gasoline to running motor – fill tank out of doors and wipe up spilled gasoline.
  - C. Replace gasoline cap securely.
  - D. Open doors if motor is run in garage – exhaust gases are dangerous.
17. Keep machine in good operating condition and keep safety devices in place. Use guards as instructed in owner's manual.
18. Disengage power to any attachment and stop motor before making repairs or adjustments.
19. While operating the mower, if any foreign object is struck, stop the mower and inspect for damage. Do not restart or operate the mower until all damage has been repaired.

# KNOW YOUR TRACTOR

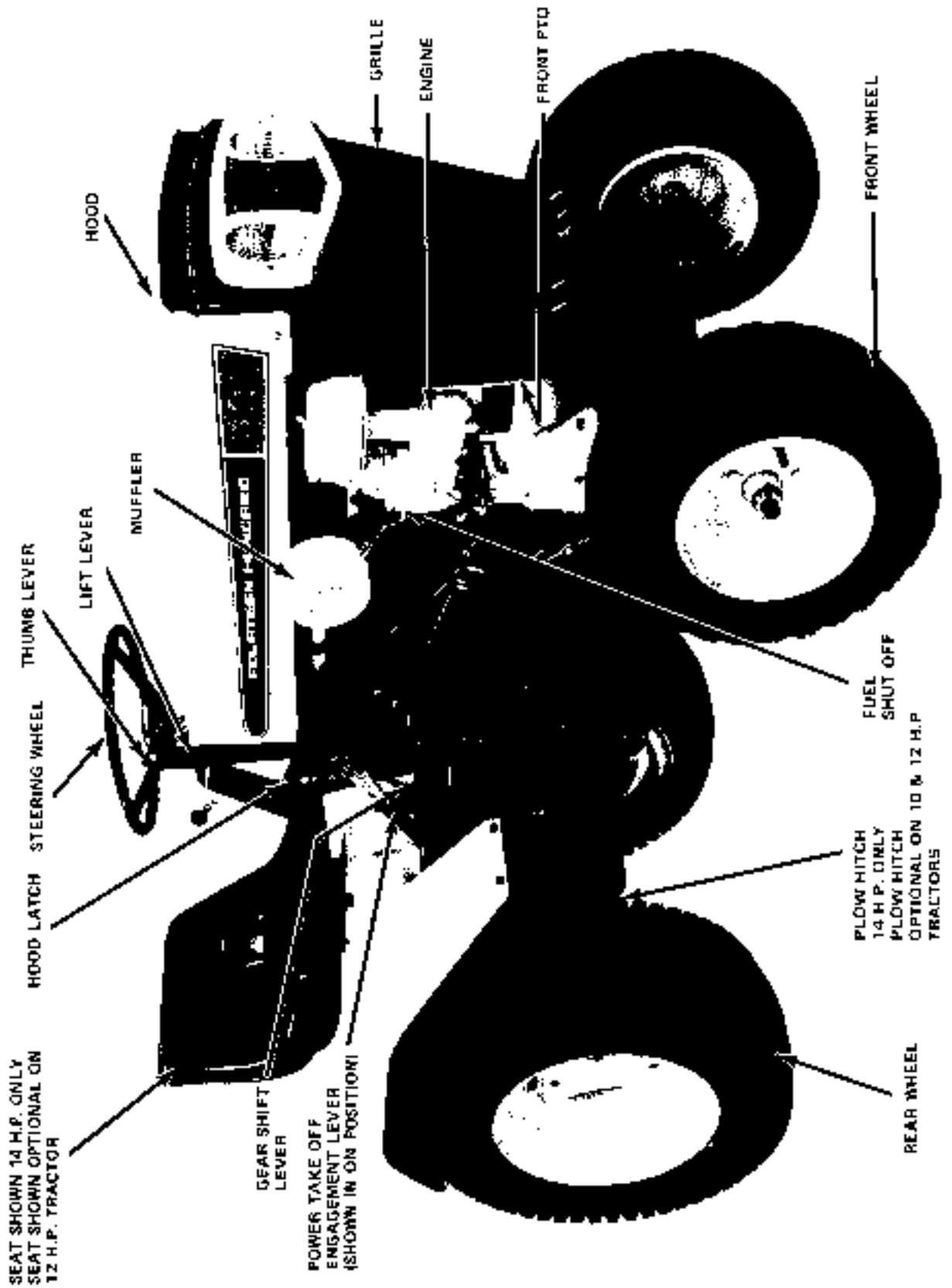

## ASSEMBLY INSTRUCTIONS

1. Place battery to be filled on bench or workbench. Never activate battery in tractor. Remove vent plugs from all cells.
2. Fill each cell carefully using battery grade 1.250-1.265 specific gravity Sulfuric Acid to 3/8" above the top of the separators or to the split ring.
3. Allow battery to set for 20 minutes. Battery can then be installed, however, to have maximum capacity the battery should be placed on a charger after the 20 minutes setting period. Battery can be charged at maximum of 35 amperes until the specific gravity reading is 1.265-1.275.
4. The battery should be checked with a hydrometer after every 25 hours of operation. If the specific gravity is less than 1.225 remove battery and recharge.
5. The battery should be kept clean. Any deposits of acid should be neutralized with soda and water. Be careful not to get this solution in the cells. Coat the terminals with a thin coat of grease.
6. If the battery is not going to be used in the winter, remove the battery and store in a cool, dry place. Do not store directly on a concrete floor as this will drain the battery. Recharge whenever the specific gravity is less than 1.225.

### 725-130 BATTERY SPECIFICATIONS

45 AMP.HRS. at 20 HRS.  
PLATES PER CELL 9  
ASSEMBLY LEFT HAND  
WEIGHT WET 22 LBS.  
WEIGHT DRY 17 LBS.

ELECTROLYTE 2 QUARTS SPLASH  
PROOF VENTS TERMINALS  
REGULAR AUTOMOTIVE TYPE -  
ROUND - ONE LARGE AND  
ONE SMALL

SIZE 8 x 6-3/4 x 7-1/2



#### WARNING

SINCE BATTERY ACID IS CORROSIVE TO METALS, DO NOT POUR INTO ANY SINK OR DRAIN. RINSE EMPTY ELECTROLYTE CONTAINERS AND MUTILATE BEFORE DISCARDING. IF ACID IS ACCIDENTALLY SPILLED ON BATTERY DURING FILLING OR CHARGING, OR ON BENCH OR CLOTHING, ETC., FLUSH OFF WITH CLEAR WATER AND NEUTRALIZE WITH SODA OR AMMONIA SOLUTION.

#### INSTALLING THE BATTERY

Place the battery in the tractor with the negative terminal towards the front of the tractor. Before sliding the battery all the way in, attach the positive battery cable (red) to the positive terminal and attach the negative battery cable (black) to the negative terminal. Slide the battery into the proper position and use the hold down rods and cross rod with the washers and wing nuts to hold the battery in place. Screw wing nuts finger tight. Overtightening can crack the battery case. (see Fig. 2)

#### CHECK TIRE PRESSURE.

Use 10 to 12 pounds pressure for grass cutting. Use 15 to 20 pounds for field work.

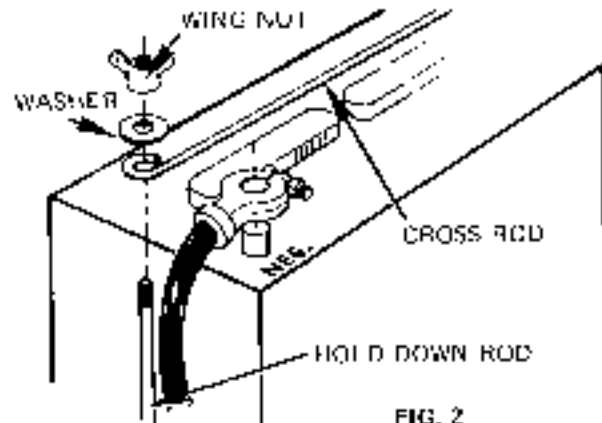

#### BEFORE STARTING

##### FILL FUEL TANK

Use clean, fresh "regular" grade gasoline. Fill tank completely.

DO NOT FILL GASOLINE TANK WHILE ENGINE IS RUNNING. Avoid spilling gasoline on a hot engine. This may cause an explosion and serious injury.

DO NOT MIX OIL WITH GASOLINE

##### OIL RECOMMENDATIONS

WINTER	SUMMER
(Below 40° F.)	(Above 40° F.)
Use SAE 5W-20	Use SAE 30

Any high quality detergent oil having the American Petroleum Institute classification "For Service MS" can be used in your Briggs & Stratton engine. Detergent oils keep the engine cleaner and retard the formation of gum and varnish deposits.

The above oil recommendations are the result of extensive testing. No special additives should be used.

##### FILL CRANKCASE WITH OIL

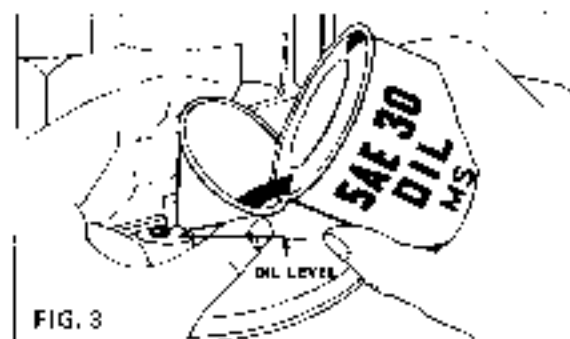

Remove the oil filler plug. Place the engine level. Fill the crankcase to overflowing. POUR SLOWLY. CAPACITY 4 PINTS. Replace the filler plug.

# GENERAL INFORMATION

## ENGINE AND DRIVE TRAIN

Engine — 10 or 14 HP Synchro-Balanced Briggs & Stratton cast iron block with 12 volt electric starter.

Transaxle — Peerless with four forward speeds and reverse. Creeper gear — 3/4 MPH at full throttle. Fourth gear 6-1/2 MPH at full throttle. All speeds variable with throttle.

Clutch — Five and one half inch double faced disc clutch.

## ORIENTATION

Your tractor is right hand (R.H.) or left hand (L.H.) as you operate it. Direction of rotation is clockwise (C.W.) and counterclockwise (C.C.W.) as observed from the operator's position, looking down. Turning the steering wheel C.W. would turn the tractor to the right C.W. and C.C.W. on the vertical plane would be observed facing the R.H. side of the tractor.

## CLUTCH-BRAKE PEDAL

This pedal is operated with your left foot. Depress half way down to declutch, depress all the way down to declutch and brake, coming to a complete stop. Always depress the pedal when shifting gears. Release pedal slowly to engage clutch.

## PARKING BRAKE

The brake is located on the low (L.H.) side of the tractor. To operate, depress the clutch brake pedal completely and lock it by turning the parking brake knob C.W. until it tightens. To release the brake, turn the knob C.C.W. one complete revolution. (See Fig. 5)

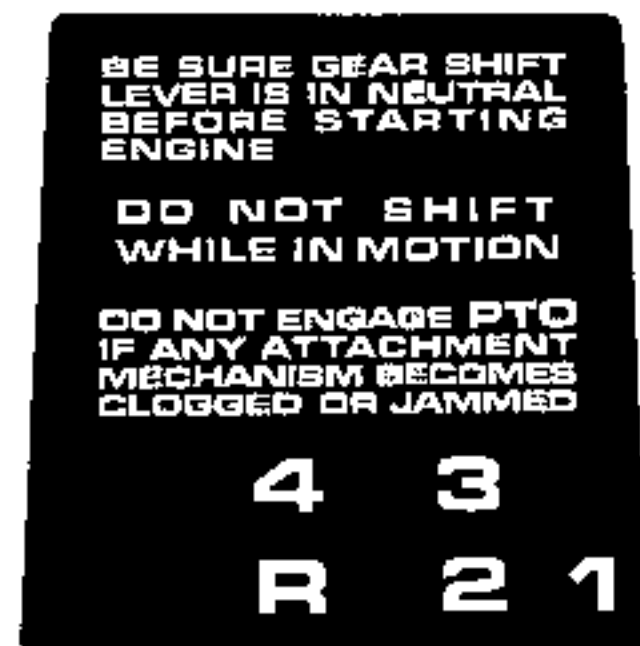

FIG. 4

## GEAR SHIFT LEVER

The selection of the correct gear and throttle setting will be determined by the attachment being used. Generally, anything that uses the tractor engine as a power source should be run at full throttle with the ground speed determined by the gear selection.

A lock is provided to prevent accidentally engaging the creeper (1st gear) gear. (see Fig. 4)

## DASH PANEL CONTROLS

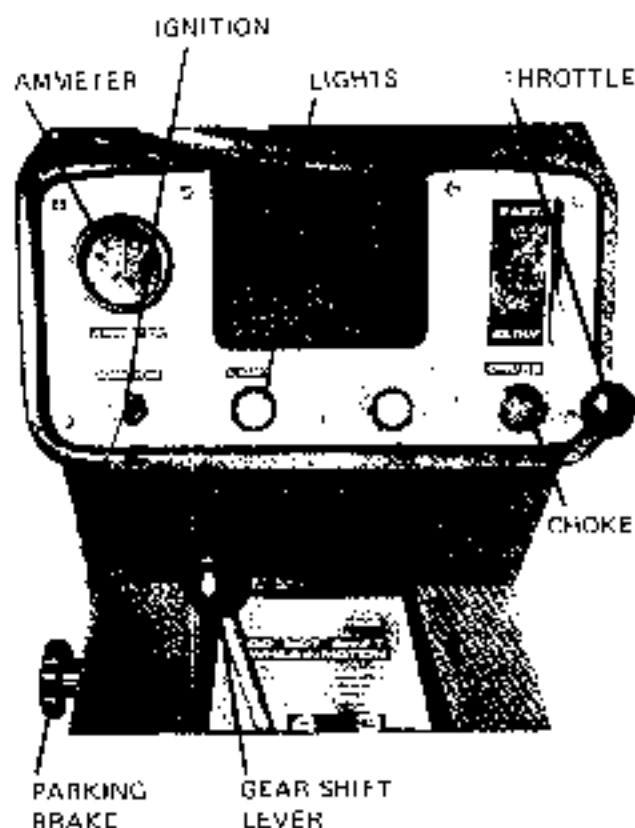

FIG. 5

## LIFT LEVER

The lift lever is used to change the height of the attachments such as the cutting deck, tiller and plow. To operate, depress the thumb button, move to the desired height and release the button.

The plow hitch operates off the lift lever and does not have to be disconnected when attaching the cutting deck or snow blade. (see Fig. 1)

## POWER TAKE OFF (P T O)

There are two PTOs on your tractor. One is located under the frame of the tractor and is to be used for the cutting attachment and rotary tiller. This PTO has a disengagement lever located on the RH side of the tractor. It is shown in the picture in the DIS engaged position. It should be in this position whenever it is not in use. (See Fig. 6)

The second PTO is used to operate equipment attached to the front of the tractor such as the snow thrower. (See Fig. 3)

## IGNITION SWITCH

Turn key to the right (C W) to engage starting motor on engine. Remove key from switch when tractor is not in use. (See Fig. 5)

## THROTTLE CONTROL

Used to regulate engine speed. Move throttle control up to increase engine speed and down to slow down engine. (See Fig. 5)

## CHOKE

To start engine, pull all the way out. After engine starts, move choke in half way. After engine warms up, move choke in gradually until it is completely in. (See Fig. 5)

## LIGHTS

Pull switch button out to turn on head lights. (See Fig. 5)

## WHEELS

Front ..... 16 x 8.50 - 8" High Flotation  
Rear ..... 23 x 8.50 - 12" High Flotation  
Valve stems are to the inside to accommodate wheel weights for the rear wheels. 100 pound (total weight) wheel weights are available.

## HOOD

Hood pivoted at the front for easy access to engine and clutch. To open, release latches on each side of the hood. (See Fig. 1)

## STEERING ASSEMBLY

Segment and union with 2:1 ratio for easy steering. Automatic type adjustable tie rods for toe-in adjustment. Cast iron pivoted front end.

## WHEEL ADJUSTMENT

Each rear wheel can be adjusted out 2" on the axle. Details covered in the adjustment section of this manual. (See Fig. 10)

## TIRE PRESSURE: Front and Rear

Tire pressure for grass cutting is 10 to 12 pounds. For field operation or tilling increase pressure to 15 to 20 pounds.

## AMMETER

The ammeter registers the rate of battery charge or discharge. The ammeter should register on the plus (+) side when the engine is running in the "Fast" position until the battery is completely charged. With a fully charged battery or with the engine idling the ammeter will not show a charge. (See Fig. 5)

## SEAT—TWO PIECE ASSEMBLY (OPTIONAL ON 10 H.P.)

Fully padded for comfort. Back adjustable by loosening hinge knob. Seat adjusts back and forward by loosening the large hex nut under the seat and sliding the seat back or forth.

# OPERATING INSTRUCTIONS

## STARTING YOUR ENGINE

To get the feel of your tractor, operate it in a large open space until you become familiar with the controls.

1. Be sure you have read the manual to acquaint yourself with the controls.
2. Fill engine with oil and gasoline as outlined on page 3 of this manual.
3. Open fuel shut-off valve located under the gasoline tank.
4. Place gear shift lever in neutral position.
5. Depress clutch-brake pedal and lock into disengaged position with the parking brake.
6. Pull choke out all the way.
7. Place throttle lever in 1/2 throttle position.
8. Turn ignition key (C W) to engage starter. When engine starts, move choke in half way. After engine warms up, move choke in gradually until completely in.

### CAUTION

Do NOT run starter for more than 30 seconds at a time. If engine does not start after several tries, place throttle control in "fast" position, wait several minutes and try again without moving the throttle lever from the "fast" position.

## STOPPING YOUR ENGINE

Turn ignition key to the left (C C W). Remove key from ignition when tractor is not in use to prevent accidental starting.

Remove spark plug wire from spark plug when tractor is not in use to prevent accidental starting.

## TO OPERATE THE TRACTOR

1. Move throttle control to 1/2 throttle position.
2. Place left foot on clutch-brake pedal and hold down while you release the parking brake.
3. Place the gear shift lever in second gear. (Use a low gear until you get the feel of your tractor.)
4. Slowly let out the clutch-brake pedal until it is completely released.

### NOTE

When operating attachments such as the cutting unit or tiller that uses the tractor engine as source of power, run the engine at near full or full throttle. Set your ground speed by changing transmission gears.

### CAUTION

Do not force the gear shift lever if the gears do not immediately mesh. Release the clutch-brake pedal and depress again until it shifts easily.

Do not shift while in motion.

Always release the clutch-brake pedal slowly.

## STOPPING YOUR TRACTOR

Disengage the transmission by depressing the clutch-brake pedal and shifting into neutral.

If you park the tractor, set the parking brake and leave the transmission in gear. Before starting the engine again, place gear shift lever in neutral.

## POWER TAKE OFF (PTO)

The PTO should be in the "OFF" position (Handle Down) when starting the engine and when attachments using the PTO are not on the tractor. If, while using the cutting unit or the rotary tiller, they become clogged and will not operate, shut off the engine AND THE PTO before clearing the attachment.

The PTO engagement lever should be engaged fast to prevent wear on the PTO belts.

The cutting unit and the rotary tiller can be raised or lowered while they are operating under full power. For example, the rotary tiller can be tilted from the ground with the left lever in order to turn the tractor around without shutting off the PTO.

# MAINTENANCE

## BELTS

**PTO BELT REMOVAL** To remove the belts: (see Fig. 6)

1. Set the engagement lever in the ENGAGED position.
2. Remove the spring.
3. Remove the belt guard on the PTO by removing 2 bolts and lock washers.
4. Remove hex bolts (Ref. No. 151) and lock washers (Ref. No. 239).
5. Remove hex nut (Ref. No. 191) and lock washer (Ref. No. 246) and hex bolt (Ref. No. 282).
6. Push the entire clutch back as far as it will go by hand and remove the belt between the yoke and clutch.
7. ALWAYS replace both bolts at the same time.

### NOTE

If the lower belt guard is too far away from the PTO belts, it will not "trap-out" the belt on the yoke and the belts will continue to rotate slowly. Adjust the belt guard for minimum clearance (not touching) when the PTO handle is in the engaged position.

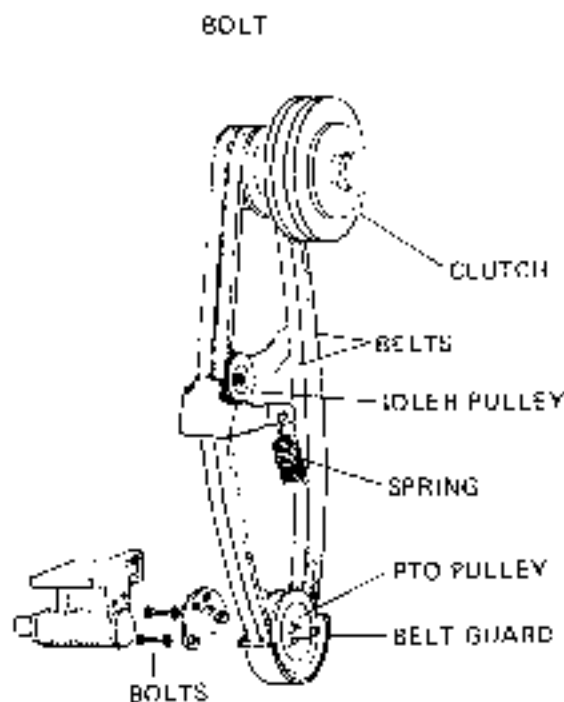

FIG. 6

## TRANSMISSION BELT

**Adjustment** The tension of the belt is increased by UNSCREWING the leveler screw until you obtain a 1/2" deflection on the belt when you apply 10 pounds of force midway between the transmission pulley and the pulley. Lock leveler in place by tightening the lock nut.

**Removal** Screw the leveler screw all the way in until the idler is loose and remove the belt. (See Fig. 8)

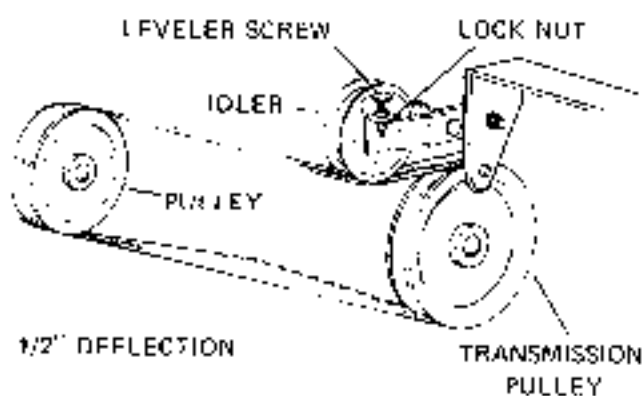

FIG. 8

## POWER TAKE OFF (PTO) (See Fig. 7)

**Adjustment** If the PTO creeps when it is in the disengaged position the belt should be adjusted. To adjust:

1. Set the engagement lever in the ENGAGED position.
2. Remove the cotter pin on the PTO adjusting rod.
3. Remove the nut from the bracket and unscrew it 3 complete turns and insert back into the bracket.
4. Replace the cotter-pin.

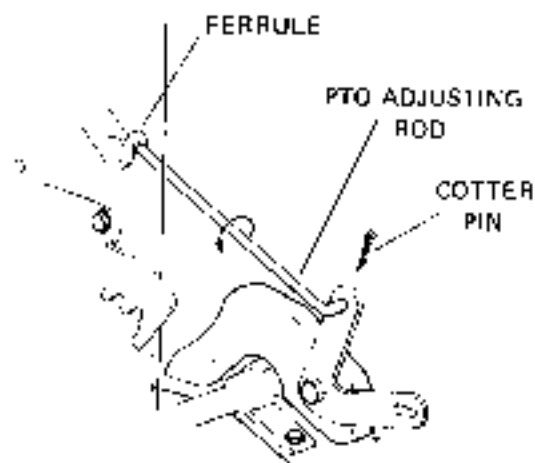

FIG. 7

## STARTER-GENERATOR BELT

If the starter-generator turns over and the engine does not turn over or there is a high pitched squeal when the starter generator is turned on, it is an indication of a loose belt.

**Adjustment** - To tighten, loosen the bolt in the bracket slightly, loosen the belt in the adjusting strap and swing the starter-generator away from the engine until the belt is tight. (Belt should deflect 1/4" when depressed with your thumb.) Tighten all bolts. (See Fig. 9)

**Removal** - Follow same procedure as above except when the bolts on the bracket and adjusting strap are loose, swing the starter-generator towards the engine until the old belt can be removed and replaced. Follow the above procedure for tightening the new belt. (See Fig. 9)

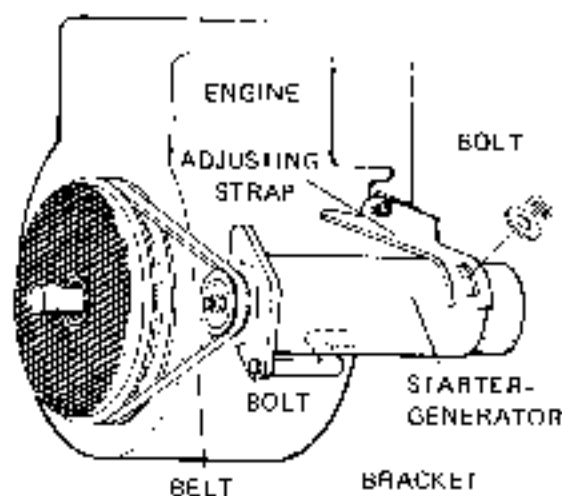

FIG. 9

## WHEEL TREAD ADJUSTMENT

The tread on the rear wheels is adjustable from 29" to 35" by loosening the hex nut on the rear hub and sliding the hub out. Do not extend the hub beyond the 3 inches. Tighten the hex nut. Both wheels should be in the same relative position on the axle. (See Fig. 10)

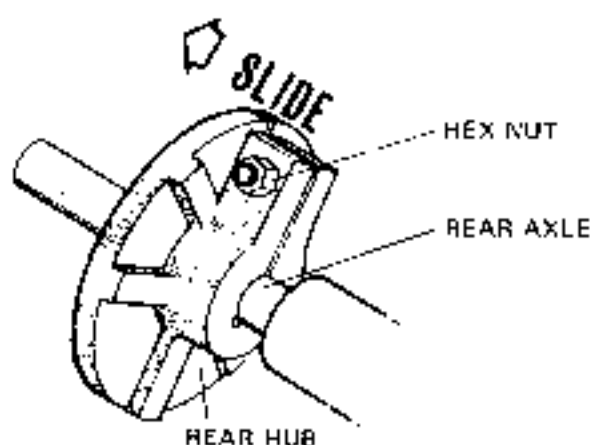

FIG. 10



## LIFT LEVER LOCKOUT

The lift lever can be locked out so it is free floating and the ratchet does not engage. This is done by depressing the thumb button on top of the lift lever and moving the lockout in the direction of the arrow. (See Fig. 11)

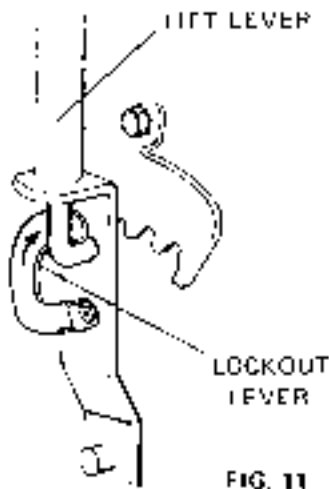

FIG. 11

## CLUTCH AND BRAKE ADJUSTMENT

The clutch and brake should always be adjusted at the same time. To adjust:

1. Loosen the elastic stop nut until the chain is slack.
2. Tighten the elastic stop nut until the SLACK is out of the chain and there is  $1/32$  free play between yoke and bearing when clutch is engaged. Bearing should be free to rotate with shaft.
3. Depress the clutch brake pedal all the way and check the distance between the pressure plate and the clutch disc.
4. The distance should be approximately  $1/16$  of an inch.

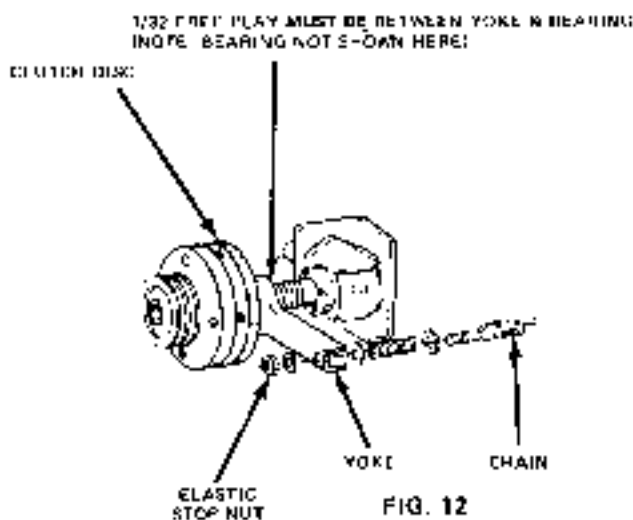

FIG. 12

**FINE BRAKE ADJUSTMENT** — Remove hair pin (C). Turn the castle nut (B) clockwise to tighten one quarter revolution and check brakes. Repeat as necessary to have proper braking power. Replace hair pin (C). (See Fig. 13).

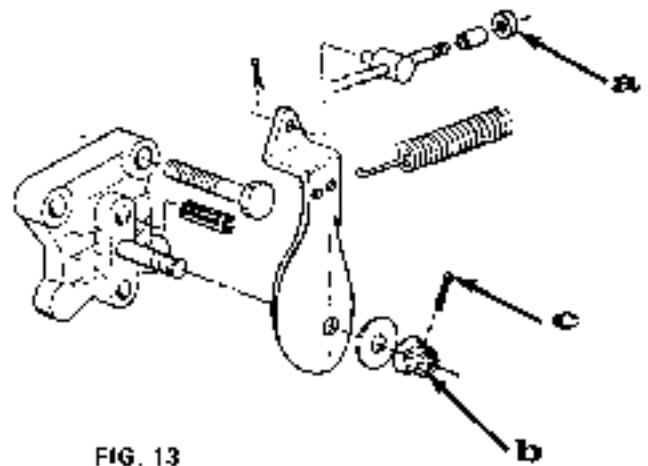

FIG. 13

**PEDAL ADJUSTMENT** To take up the adjustment on the brake linkage, tighten or loosen the hex nut (A) on brake linkage. (See Fig. 13).

## THREE POINT HITCH ASSEMBLY INSTRUCTIONS

### NOTE

Mowing unit must not be on tractor. If so remove mowing unit before assembly of hitch kit.

1. Assemble the lift pull rod assembly (Ref. No. 70) to lift handle assembly (Ref. No. 58) on the right hand side, with clevis pin (Ref. No. 220), flat washer (Ref. No. 264) and hairpin cotter (Ref. No. 199). Assemble the second lift pull rod assembly (Ref. No. 70) to lift arm assembly (Ref. No. 136) on the left hand side, with clevis pin (Ref. No. 220), flat washer (Ref. No. 264) and hairpin cotter (Ref. No. 199).
2. Thread adjustment clevis assembly (Ref. No. 138) on end of pull rod assembly (Ref. No. 70).
3. Move lift lever to full engaged position.
4. Assemble link clevis pins (Ref. No. 226) to frame with lockwashers (Ref. No. 287) and hex nuts (Ref. No. 94) (See Drawing on Page 20).
5. Assemble draft bar assembly—R.H. (Ref. No. 227) to frame & clevis pin (Ref. No. 226) with hairpin cotter (Ref. No. 199). Do the same on the left hand side.
6. Pull the lift pull rods (Ref. No. 70) to the rear of the tractor and line up holes in pull rod and draft bar assembly. Insert clevis pin (Ref. No. 222) and secure with flat washer (Ref. No. 264) and hairpin cotter (Ref. No. 199).
7. Place upper hitch bracket (Ref. No. 224) against rear frame section of tractor, secure in position with spring lockwasher (Ref. No. 285) and hex bolt (Ref. No. 286).
8. Place clevis screw assembly (Ref. No. 223) in upper hitch bracket (Ref. No. 224) secure with clevis pin (Ref. No. 225) and hairpin cotter (Ref. No. 199).
9. Thread on adjustment clevis ass'y (Ref. No. 138).
10. Place draw bar assembly (Ref. No. 69) between draft bars and secure with hairpin cotter (Ref. No. 199).
11. Assemble hitch chain hooks (Ref. No. 288) to draft bar ass'y, (Ref. No. 227) & (Ref. No. 280). Secure with hex nuts (Ref. No. 289).

## TIE ROD ADJUSTMENT (Toe-In)

The caster (forward slant of the kingpin) and the camber (tilt of the wheel's out at the top) requires no adjustment. Automotive steering principles have been used to determine the caster and camber on the tractor.

The front wheels should be toe-in  $1/8"$ . To adjust the toe in, loosen the hex jam nut, remove the elastic locknut, lift the tie rod end out of the hole in the steering arm and screw the tie rod end in or out to make your adjustment. The distance "B" must be less than "A" by  $1/8"$ . (see Figs. 15 & 16)

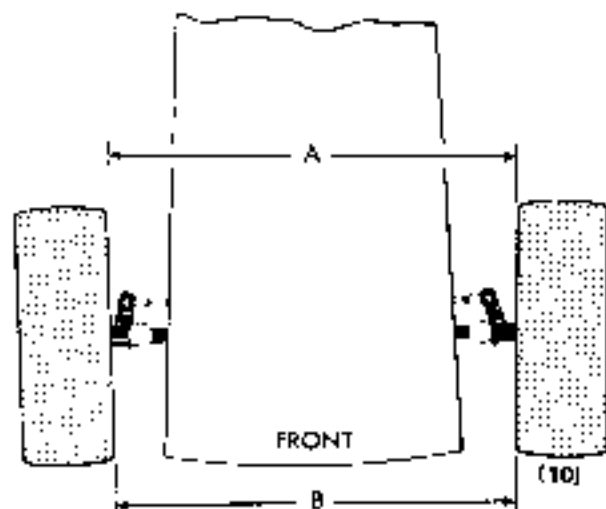

FIG. 15

## TIE ROD END

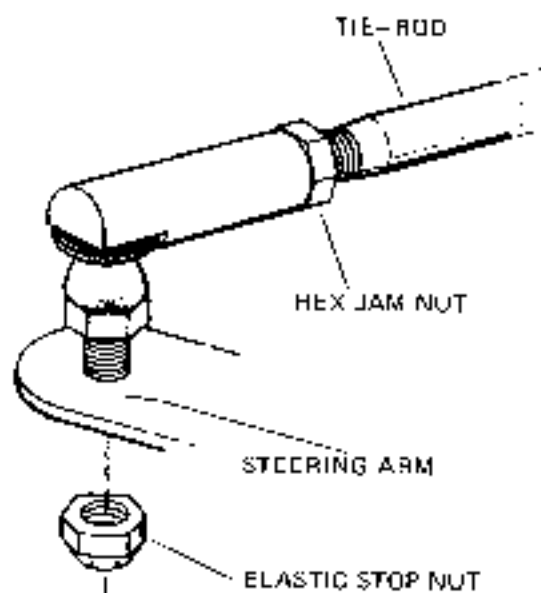

FIG. 16

## BATTERY CARE

**Battery Failure** Many times new batteries are returned for charging within a few days or a week after sale. Before returning the battery to the dealer who sold you the tractor, make these following checks.

1. Was the battery fully charged when installed? The dry pack battery should have been placed on a charger and the specific gravity of the battery should read 1.265 to 1.275 before it was installed in the tractor.
2. Were the battery terminals clean, greased and properly tightened when the battery was installed?
3. Batteries are usually involved in ANY starting failure, however, insufficient hours of driving, worn cables, trouble in the electrical system, corroded connections, slipping drive belt can cause a battery to become discharged without the battery being a fault.

## SERVICING YOUR BATTERY

It is all right to use drinking water in your battery, excluding mineral water.

Adding water to a battery cell will lower the specific gravity of the electrolyte. Water should not be added unless the tractor is going to be run immediately during freezing weather.

Maintain electrolyte level in the battery to the level indicated on the top of the battery.

Keep the terminals clean and coated with grease.

## BATTERY STORAGE

If your tractor is to be stored during an off-season, the battery should be removed from the tractor, placed on a charger until the specific gravity reads 1.265 to 1.275 and stored at approximately  $72^{\circ}\text{F}$ . Batteries should not be placed directly on current as this will drain the battery. Recharge to bring the specific gravity to normal before placing it in the tractor after storage.

## ENGINE REMOVAL

If the engine is removed from the tractor the following steps should be followed for the removal and installation of the engine.

### REMOVAL

1. Follow the steps to remove the Power Take Off belts shown in Fig. 6.
2. Remove the four engine bolts holding the engine to the frame of the tractor.
3. Remove the hood brace from the front grille to the dash board.
4. Remove the three wires to the starter-generator (red wire to the L.H. terminal and small black wire and large black wire to the R.H. terminal)
5. Shut off the gas valve and disconnect the gas hose.
6. Disconnect the throttle and choke wires to the engine.
7. Lift out the engine.

## INSTALLATION

1. Set the engine in position and tighten the four engine bolts finger tight.
2. Attach the Power Take Off belts. (see Fig. 6)
3. Attach hood brace and wiring.
4. Attach choke and throttle wires to engine.
5. Attach gas line and open valve.
6. Tighten engine bolts.

## BRAKE ASSEMBLY

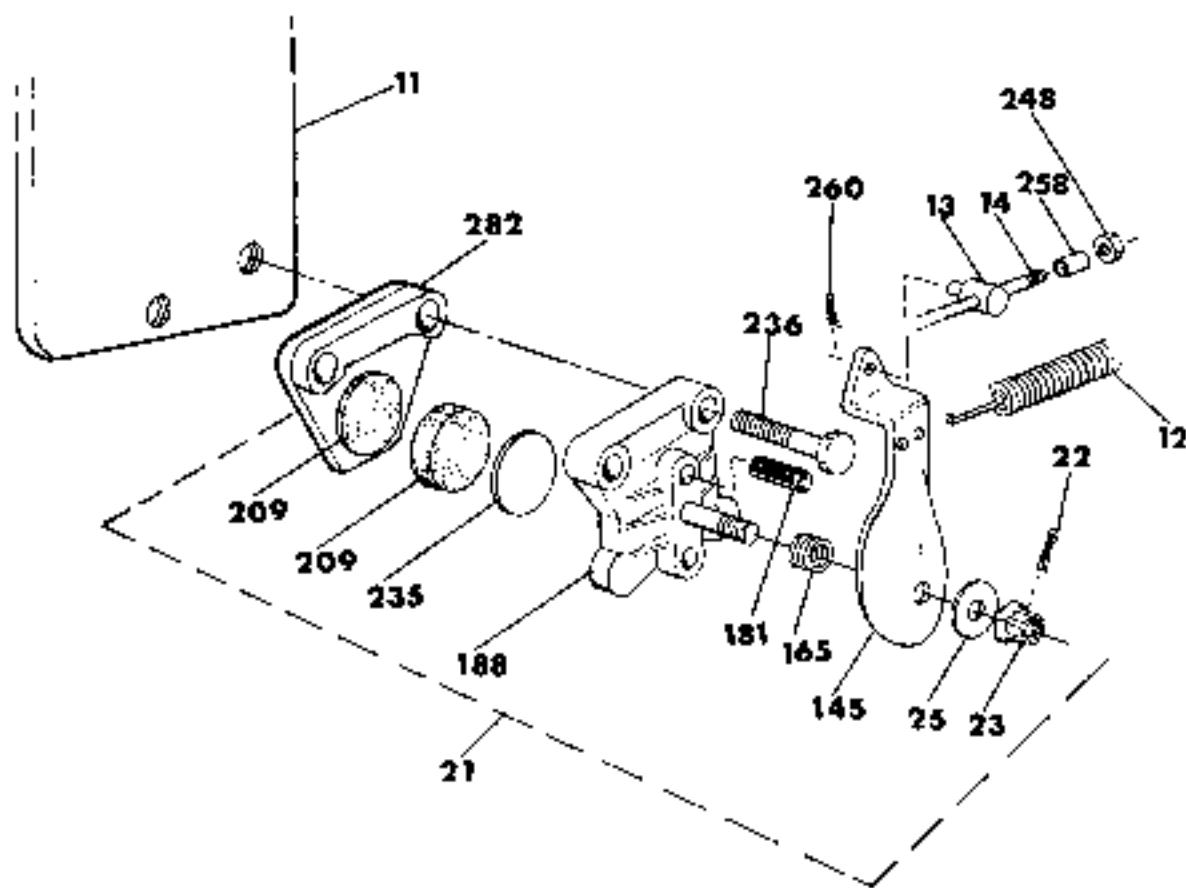

Fig. 17

## CLUTCH REPAIR (Refer to Page 11)

Any repair of the Clutch, Throw Out Assembly, or Right Angle Drive requires removal of the complete assembly from the tractor.

1. Loosen the screw on the Belt Idler Bracket Assembly. Remove the Belt. (Refer to Page 11)
2. Remove the Elastic Stop Nut and Washer on the Clutch Adjustment Rod.
3. Remove the Elastic Stop Nut and Washer on the Clutch Yoke.
4. Four Cap Screws hold the Right Angle Drive Bracket to the Frame. Remove these four screws.
5. Move back the Right Angle Drive and Clutch approximately  $\frac{1}{8}$  inch. Remove entire Assembly from the Tractor.
6. Put Clutch Unit and Right Angle Drive in a vise.
7. Place "C" Clamps over Outer Disc Assembly and bottom of Right Angle Drive mounting plate as shown in Fig. 18.
8. Drive out Spirol Pin, and slowly release "C" Clamps to relieve spring pressure.
9. Removal of the second Spirol Pin will free the other parts for inspection or replacement.

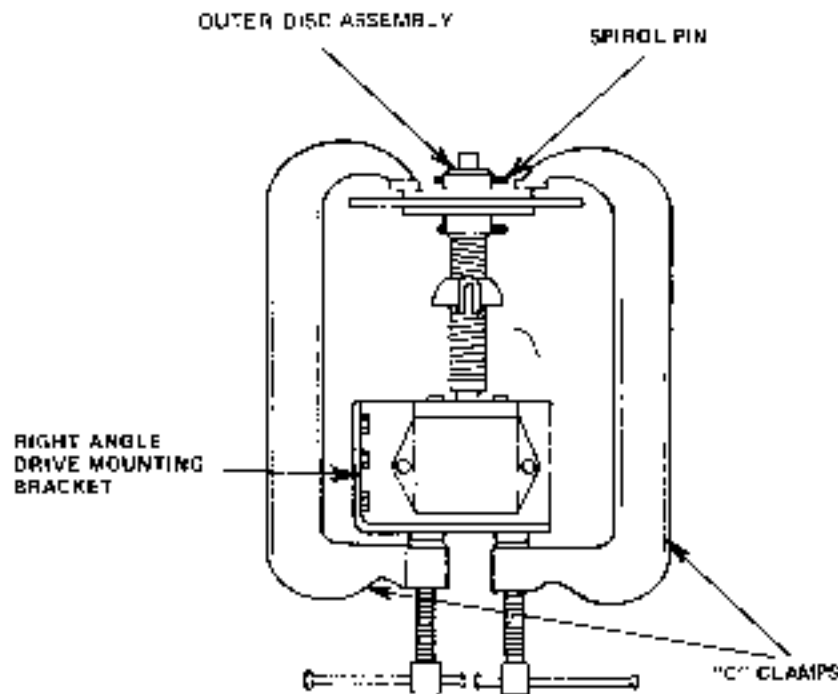

FIG. 18

## CLUTCH INSTALLATION

1. To reassemble the Clutch Assembly, reverse preceding instructions.
2. Mount Clutch Assembly in Tractor. Assemble the Clutch Yoke to the Pivot Bracket and fasten with Shoulder Bolt, Washer and Elastic Stop Nut. Tighten Elastic Stop Nut and then back off one half turn. Clutch Yoke should then move freely.
3. When fastening Right Angle Drive Bracket to Frame, position to obtain correct Spring clearance on Clutch Yoke. Spring should be centrally located in Clutch Yoke, free from all contact with the formed edge. It should remain this way in either Engaged or Disengaged position and with the Engine running.
4. Install the Belt and unscrew the Leveler Screw until you obtain a  $\frac{1}{2}$ " deflection on the Belt when you apply a 10 pound force midway between the Transaxle Pulley and the Right Angle Drive Pulley.
5. Adjust the Clutch and Brake as shown on Page 9 of this manual

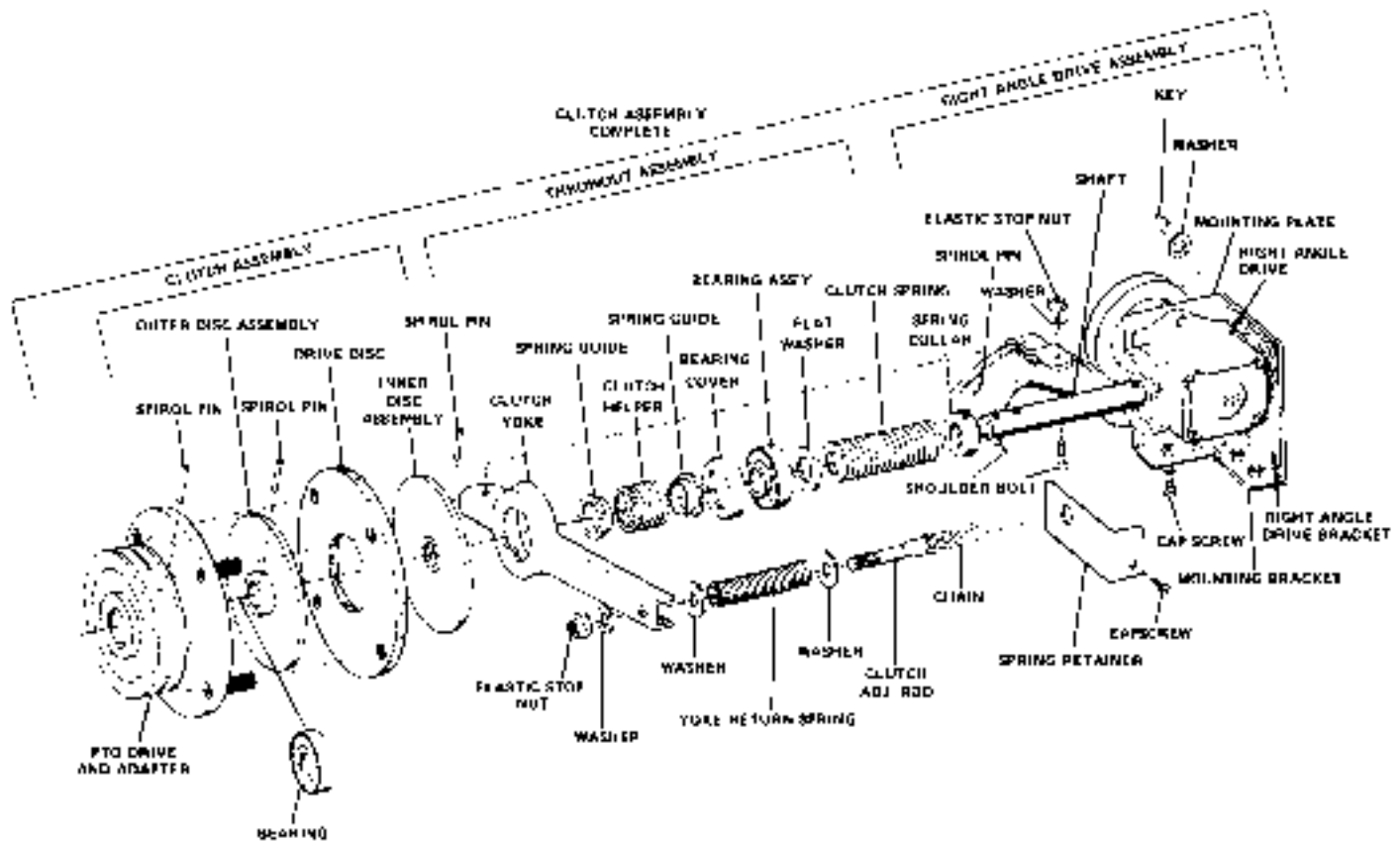

FIG. 19

## LUBRICATION

Your tractor has been engineered to give you years of trouble free service, however, by following these simple lubrication procedures, you can greatly extend the life of your tractor.

Ref. No.	LUBRICATION CHART (SEE FIG. 20-27)	25 Hours	50 Hours	Once a Season
1	Engine - Oil Recommendations Winter (Below 40°F) SAE 5W-20 Summer (Above 40°F) SAE 30	x		
2	Transaxle - Lubricated with 4 pints of SAE E.P. 90 oil. Refill if below upper oil level.		x	
3	Right Angle Drive - Lubricated with 6 oz. of E.P.G. Lithium Grease.			x
<b>GREASE FITTINGS (1) - No. of Fittings</b> Use automotive multi-purpose grease				
4	Pivot Bolt (1)	x		
5	Wheel Bearings (2)	x		
6	King Pins (2)	x		
7	Deck Pivot Bar (2)	x		
8	Steering Arm (1)	x		
9	Clutch (1) †	x		
10	Power Take Off (1)	x		
<b>APPLY GREASE</b> Use automotive multi-purpose grease				
11	Steering and Segment Gears			x
12	Power Take Off Idler Hkts.			x
13	Power Take Off Lever			x
<b>OIL THESE PARTS</b> Use Engine Oil				
14	Lift Lever	x		
15	Chain (on Clutch not shown)	x		
16	Plew Hitch	x		
17	Clutch Plect Point	x		

Oil all other pivot points once a season.

† Change oil after the first five hours of operation and every 25 hours thereafter. Use any high quality detergent oil.

1 To lubricate the clutch, rotate the clutch housing until you can see the grease fitting. Depress the clutch-brake pedal and set the parking brake.

Lubricate with 3 squirts (1 1/2 oz.) of grease with the grease gun provided with your tractor or the equivalent. DO NOT OVER LUBRICATE. Too much grease will go beyond the bearing and on to the face of the clutch.

‡ Check lubricant level only if the drive train is removed from the tractor for repair or if grease leaks from the right angle drive. Remove the four screws holding the cover and fill with E.P.G. Lithium grease so it just covers the spline shaft (6 oz.) See figures 17 and 20.

The following parts are sealed and require no further lubrication:

Idler Bearings  
Power Take Off  
Transaxle Belt

Tie Rod and Drag Link Ends

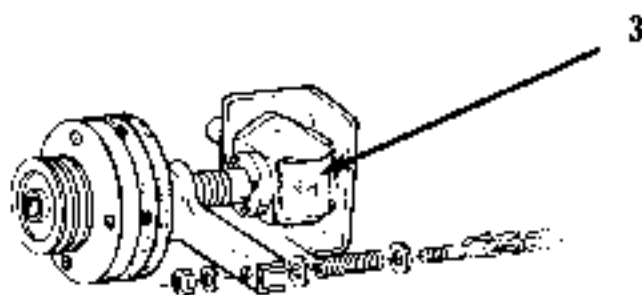

CLUTCH

FIG. 20

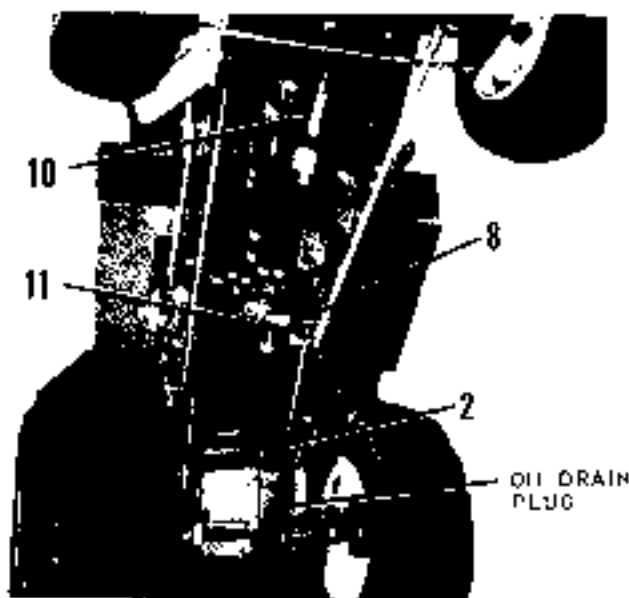

BOTTOM  
OF  
TRACTOR

FIG. 21

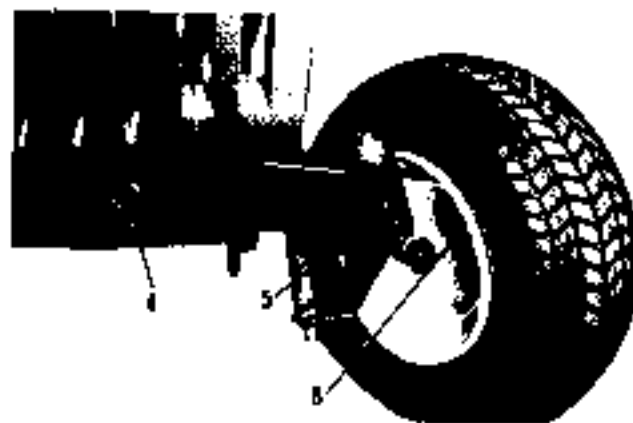
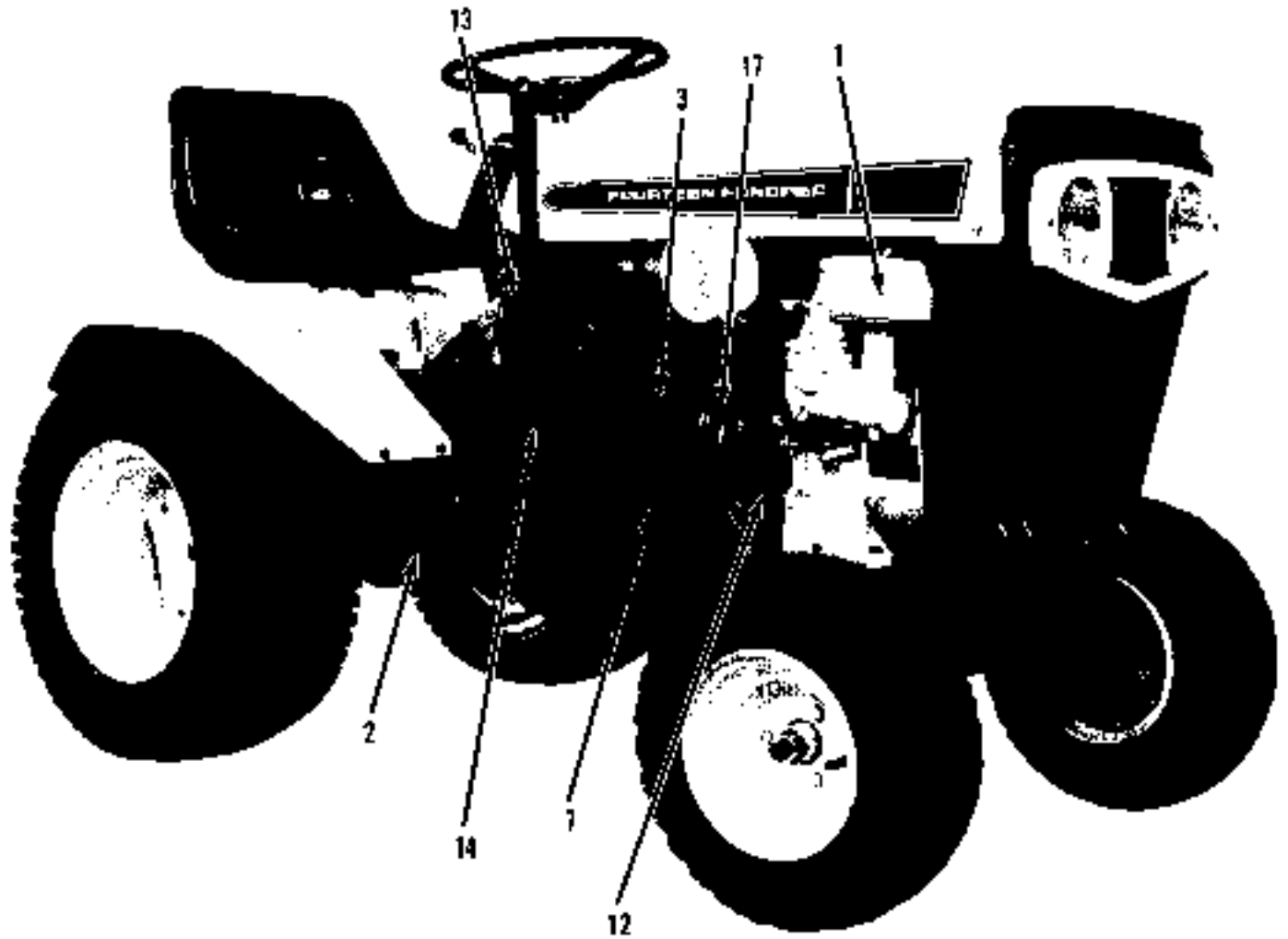

ILLUSTRATED PARTS FOR 141-760, 141-860 AND 141-960 TRACTOR  
 PARTS LIST ON PAGE 23

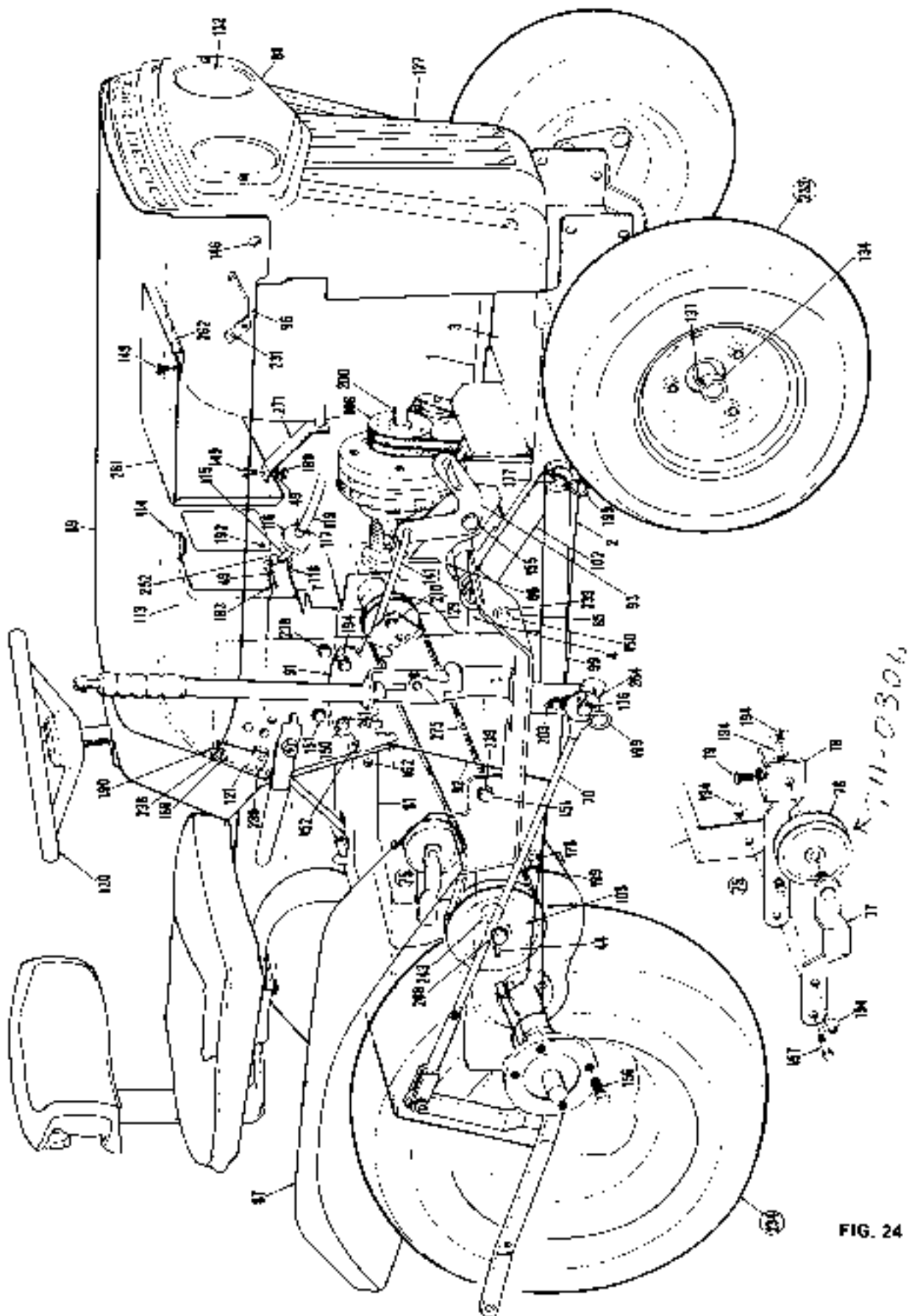

FIG. 24



L.H. FULL VIEW

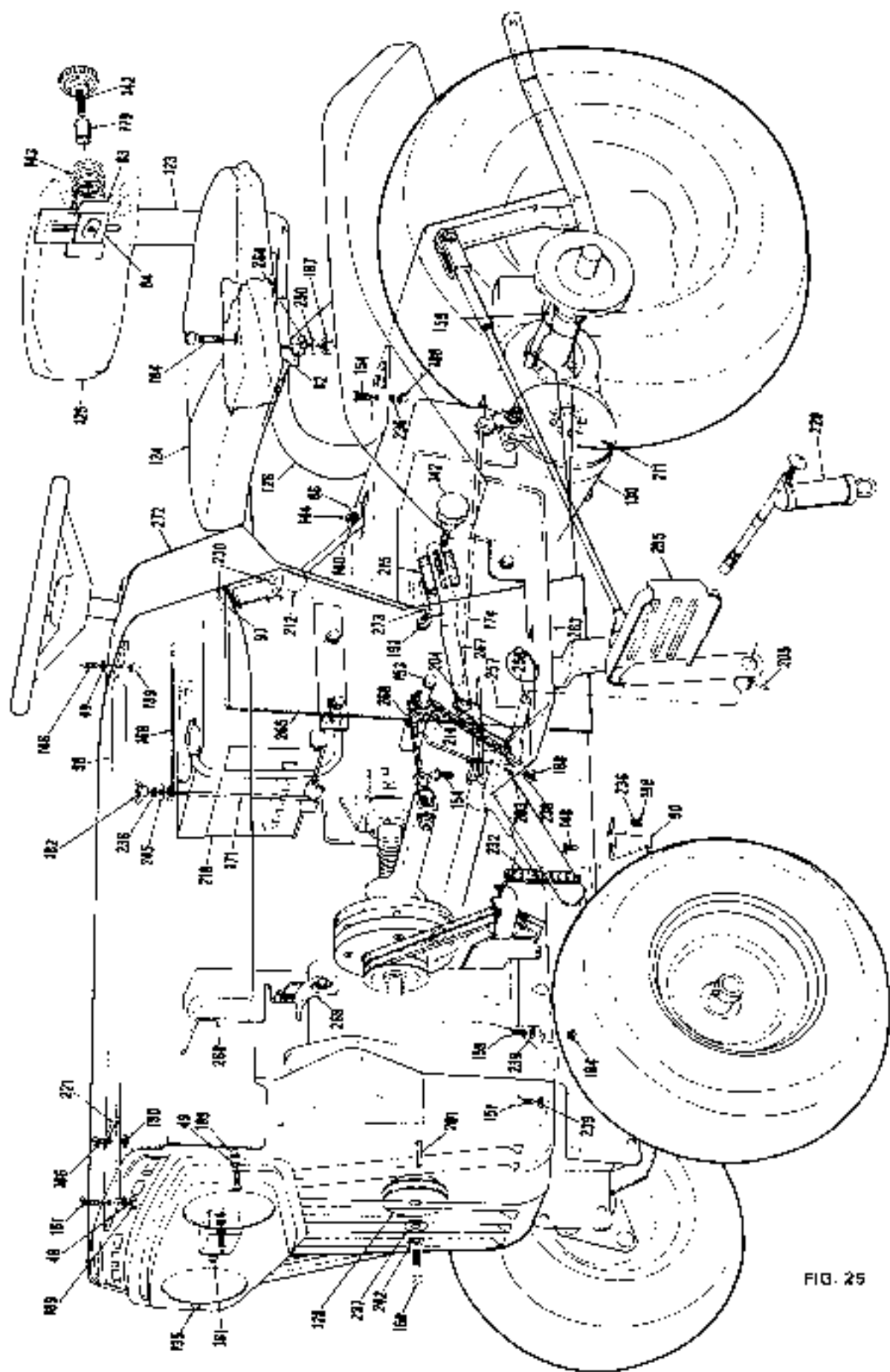

FIG. 25

# STEERING ASSEMBLY

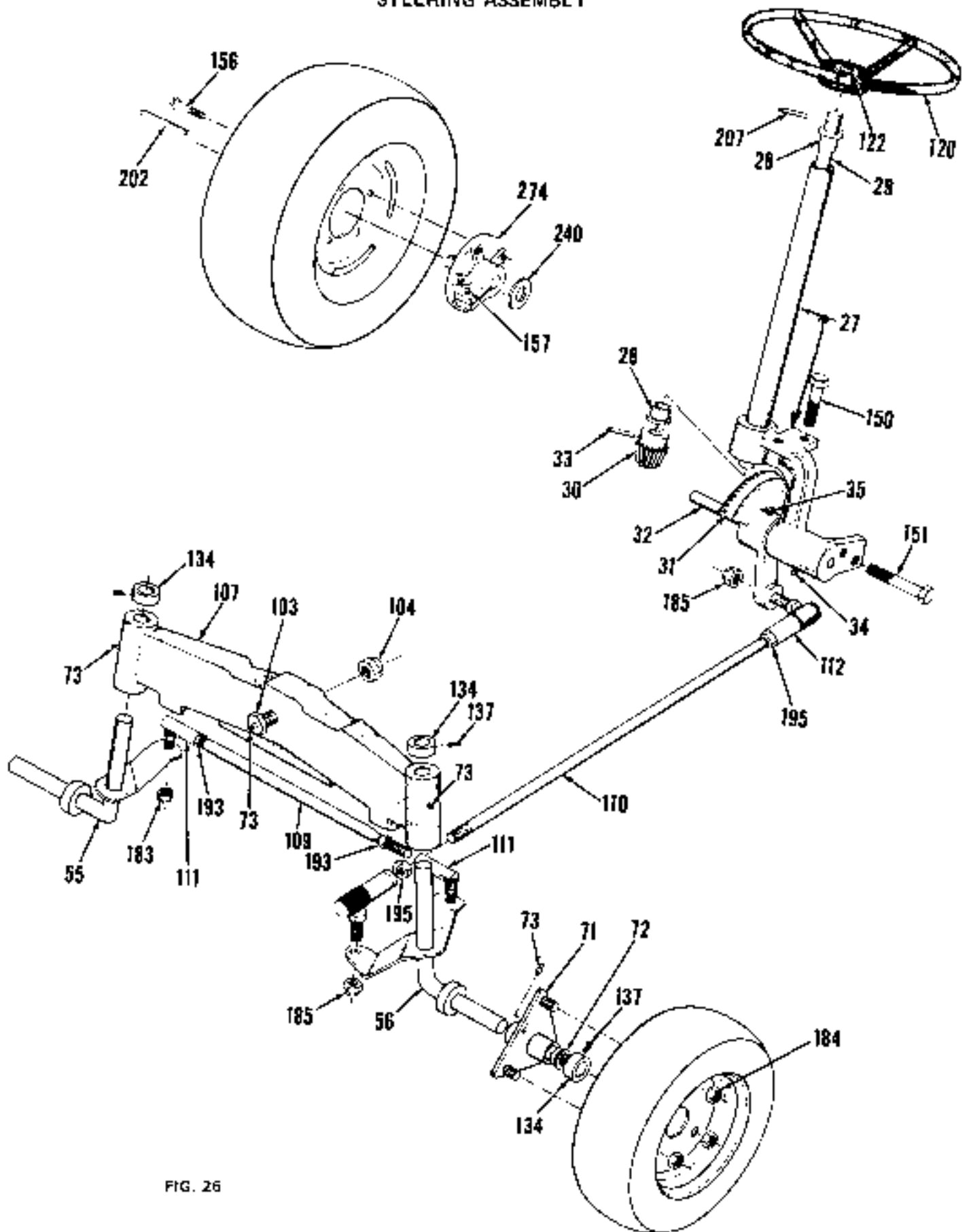

FIG. 26

# LIFT LEVER & PLOW HITCH

**NOTE:** Three Point Hitch Comes on 14 H.P. Tractor. It is optional on the 10 and 12 H.P. Tractors.

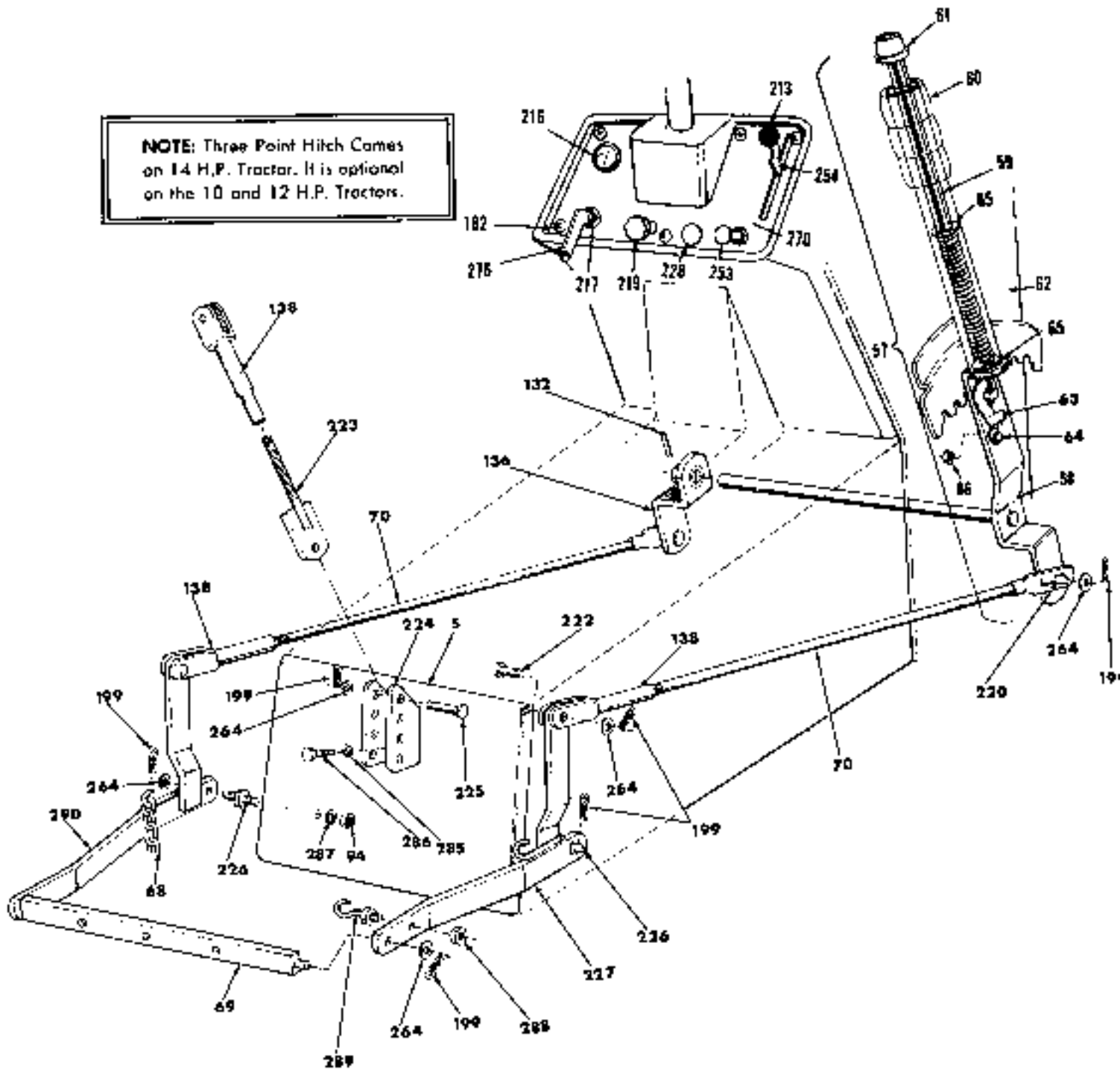

FIG. 27

POWER TAKE OFF

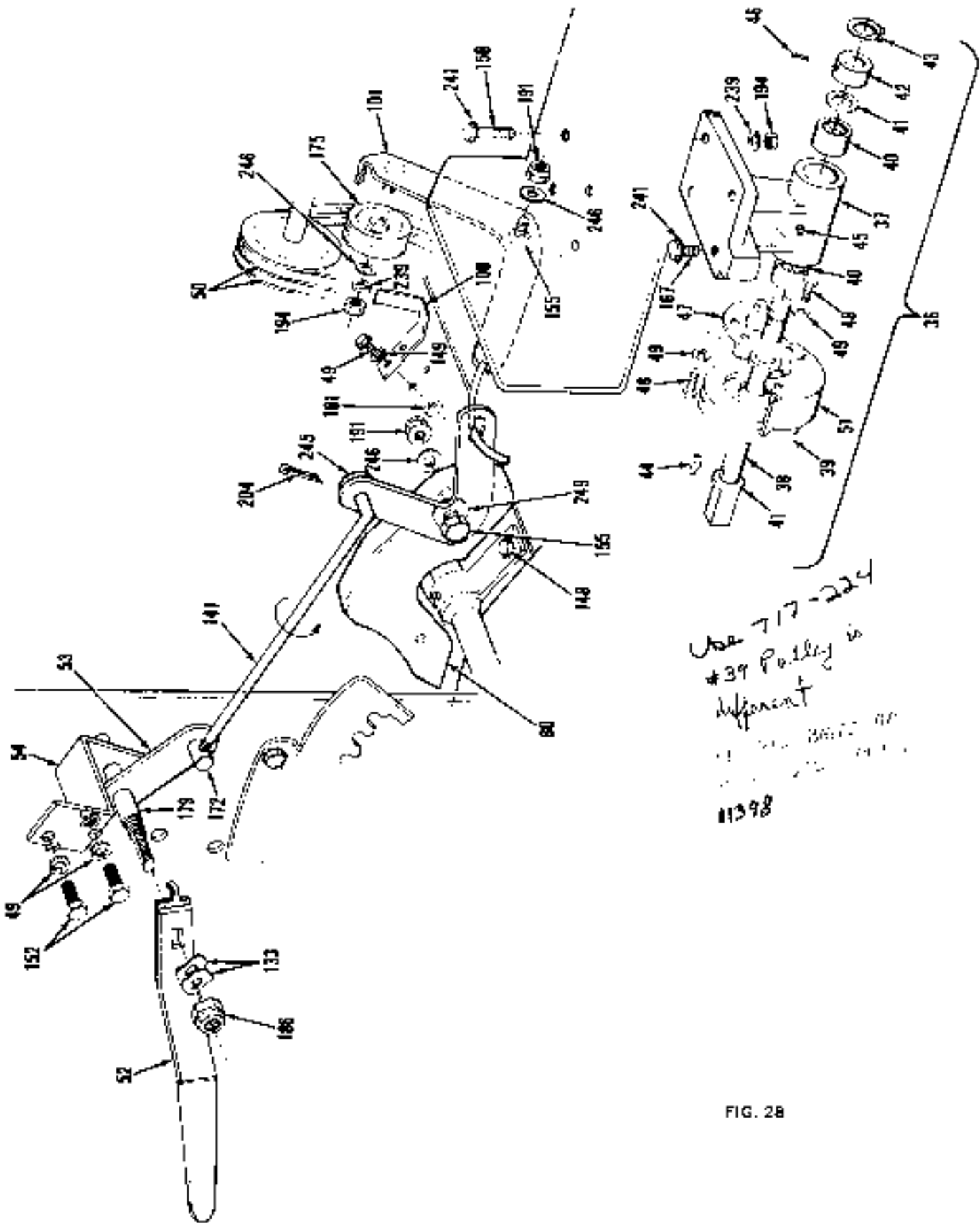

FIG. 28

CLUTCH

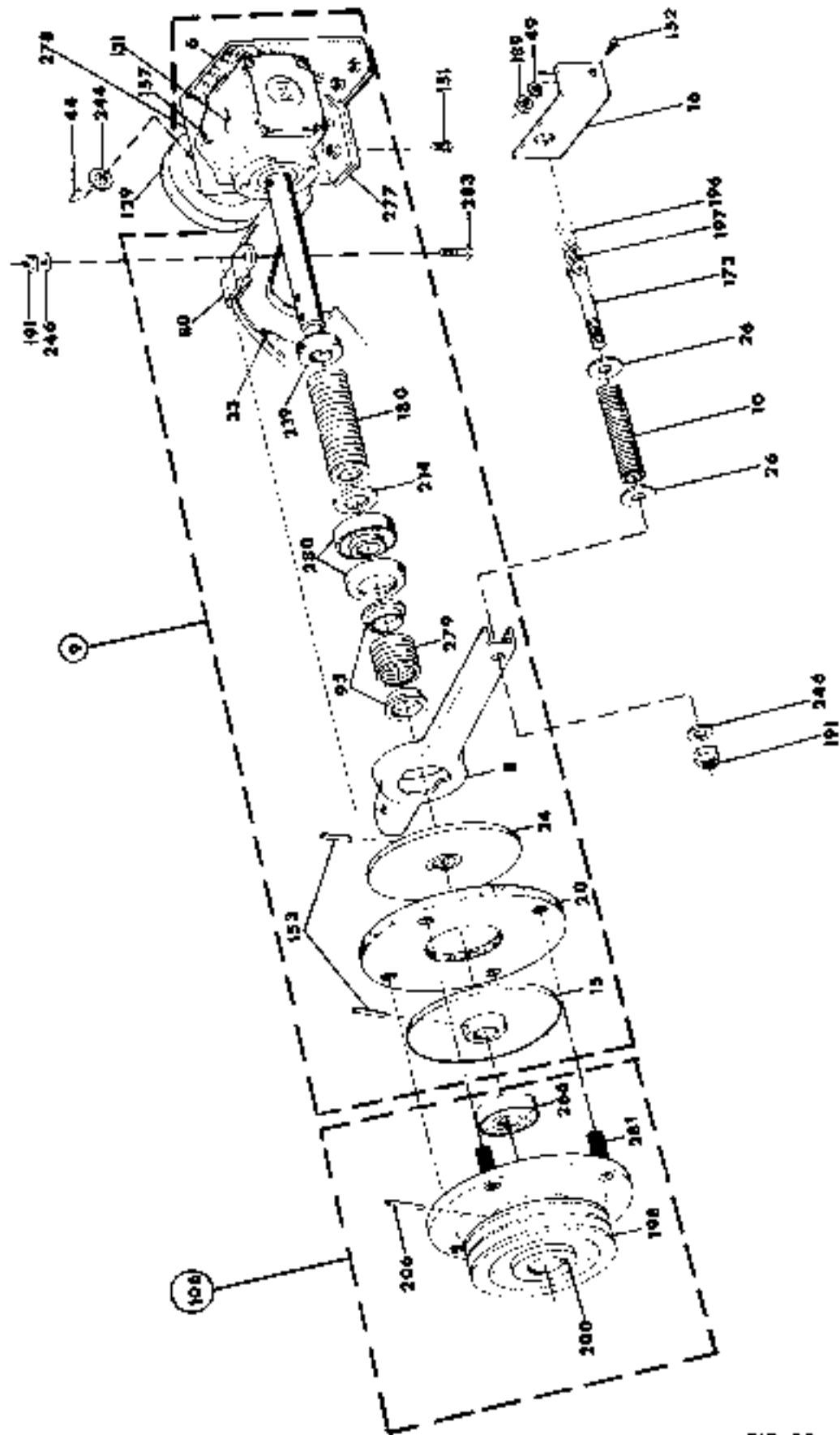

FIG. 29

### DIAGRAM FOR ELECTRICAL SYSTEM

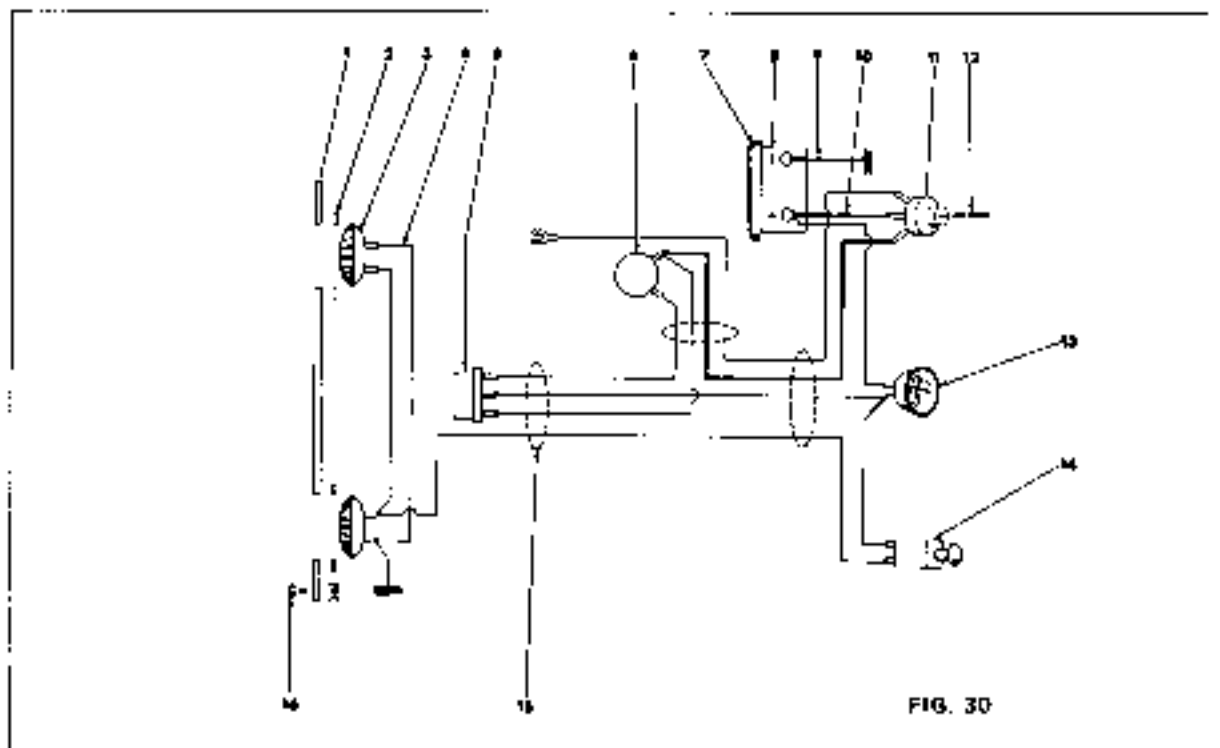

FIG. 30

### PARTS LIST FOR ELECTRICAL SYSTEM

Ref. No.		DESCRIPTION
1	394-9516	Head Lamp Bracket
2	721-112	Gasket
3	725-222	Head Lamp
4	725-204	13' —Head Lamp Ground Wire 18 Ga. B. Gal.
5	725-120	Voltage Regulator
6	725-104	Starter — Generator
7	711-278	Battery Hold Down Rod
	712-113	Wing Nut
	736-264	Flat Washer
	711-284	Battery Hold Down Stud
8	725-130	Battery — 12 Volt
9	725-139	16-3/4' — Battery to Ground Wire 8 Ga. Red
10	725-138	20' — Wtd from battery to starter — sw. to ammeter 18 Ga. Red
11	725-199	Starter Switch — Key operated
12	726-201	Starter Key
13	726-119	Ammeter
14	725-202	Head Lamp Switch
15	725-205	Wire Harness
16	713-346	Hex Head Cap Screw 1/4" 20 x 1 1/2" Lg.
	736-328	Spring Lockwasher 1/4" Screw
	717-267	Hex Nut 1/4-20 Tnc.

\*Common Hardware, purchase locally

**PARTS LIST FOR 141-750, 860 AND 960 TRACTORS**

Ref. No.	Part Number	DESCRIPTION	Ref. No.	Part Number	DESCRIPTION
1.	438-10384	Frame - Rail Assembly - L. H.	65.	738-185	Fuel Washer*
2.	438-8400	Frame - Rail Assembly - Rt. H.	66.	712-107	Hex Locknut 1/4-20 Thd.*
3.	438-8511	Frame - Front Assembly	68.	713-148	Chain
4.	438-9423	Gear Box Mount Assembly	69.	438-10896	Draw Bar Assy
5.	438-9428	Frame - Plate Assembly - Rear	70.	438-10923	1 1/2 Pulley Assy
6.	438-9410	Gear Box Mounting Bracket Assembly	71.	438-10467	Front Hub Assembly
7.	438-9412	Gas Tank & Ret. Mount. Bracket Assembly	72.	741-141	Ball Bearing
8.	310-10453	Clutch Yoke	73.	737-108	Grease Fitting
9.	901-10458	Clutch Assy with Angle Drive	75.	438-3583	Idler Bracket Assembly Complete
10.	732-207	Yoke Return Spring	76.	438-3446	Left Hub Bracket Assembly
11.	438-10385	Transaxle Mounting Br. Assy.	77.	438-10418	Right Hub Bracket
12.	732-202	Brake Tension Spring	79.	710-307	Leveler Screw
13.	711-437	Brake Ferrule	80.	438-10460	Clutch Yoke Pivot Bracket Assy
14.	711-292	Brake Rod	81.	438-9500	Center Console Assembly
15.	310-10443	Disc Assembly - Clutch	82.	312-9522	Seat Assembly 10 & 12 H.P. Only
16.	408-10480	Screw Retainer		757-203	Seat Assembly 14 H.P. Only
17.	310-9498	Bearing Retaining Ring	83.	312-9572	Seat Back Assembly 10 & 12 H.P. Only
18.	710-473	Truss Hd. Washing Screw #10-24 x 1/2 lg.*	84.	312-9569	Seat Back Pinst Assembly 10 & 12 H.P. Only
19.	736-147	External Lockwasher #10 Screw*	85.	438-9682	Foot Ped Assembly - H. H.
20.	717-160	Drive Disc - Clutch	90.	438-9480	Second Gear Shoe
21.	723-231	Caliper Disc Brake Assembly	91.	438-9493	Rear Fender
22.	06-1862-0000	Pin Center	98.	438-9516	Bezel - Head Lamp
23.	82-1011-0000	Nut, Castle	99.	312-9525	Hood
24.	310-10444	Disc Assembly - Clutch	90.	438-9428	PTO Spring Bracket
25.	82-1030-0000	Washer, Thrust 3/16	91.	438-9433	Index Bracket
26.	736-112	Bellefonte Axle	92.	438-9408	Side Plate R. H.
27.	438-9517	Steering Tube Seg. Assembly	93.	438-9477	Idler Chain
28.	746-157	Steering Tube Bushing	94.	712-823	Hex Center Locknut 5/8-18 Thd.*
29.	310-9535	Steering Rod	95.	711-447	Spring Guide - Clutch
30.	719-171	Pinion Gear	96.	438-9538	Head Shoe
31.	710-172	Gear Segment	97.	438-9575	Head Catch
32.	310-9563	Gear Segment Shaft	98.	438-9576	Grille Brace
33.	715-161	Roll Pin 1/4 x 1-1/2 lg.	99.	438-9479	Lift Bar
34.	737-479	Grease Fitting	100.	438-9478	PTO Belt Trapout
35.	716-348	Square Hd. Set Screw 5/16-18 x 3/4 lg.*	101.	438-10480	Clutch Idler Bracket Assembly
36.	901-9578	PTO Shaft Assembly - Complete	102.	438-9457	Pivot Bar Assembly
37.	719-134	PTO Shaft Housing	103.	348-335	Pivot Bush
38.	711-298	PTO Shaft	104.	712-205	Electric Stop Nut 3/4-10 Thd
39.	719-130	PTO Drive Pulley	105.	719-123	Transaxle Drive Shafts
40.	741-123	Needle Bearings 3/4 I.D. x 1.187 O.D.	106.	901-10467	PTO Drive and Adapter Assembly
41.	741-151	Thrust Rod	107.	719-123	Front Axle Support
41.	741-150	Thrust Bearing	108.	711-262	Hitch Pin
42.	711-139	Collar	109.	711-454	Tie Rod
43.	716-110	Snap Ring	110.	711-455	Drag Link
44.	714-314	Key - H.P. #806	111.	723-156	Tie Rod Ends
45.	737-109	Grease Fitting 1/4-28 x 11/16 Thd	112.	723-179	Drag Link Ends
46.	710-356	Sq. Hd. Cut. Pl. Set Screw 5/16-18 x 1/2 lg.*	113.	723-182	Gas Tank w/straps
47.	438-9486	PTO Mounting Bracket	114.	723-165	Gas Gauge
48.	710-289	Hex Head Screw 1/4-20 x 1/2 lg.	115.	723-152	Gas Hose 1/2" O.D. x 1/4" I.D. x 1-1/2" lg
49.	735-328	Spring Lockwasher 1/4 Screw*	116.	723-154	Gas Filter
50.	754-120	PTO Belt 33" lg.*	117.	723-157	Hose Clamps 1/2" O.D.
51.	438-9494	PTO Belt Guard Assembly	118.	723-159	Gas Valve
52.	310-9499	PTO Handle	119.	723-153	Gas Hose 1/2" O.D. x 1-4" I.D. x 10-1/2" lg.
53.	438-10688	PTO Handle Shaft Assembly	120.	723-185	Steering Wheel
54.	402-10690	Hexilia Support Assembly	121.	723-186	Hood Latch
55.	438-8422	Axle Assembly - Front - R. H.	122.	723-188	Steering Wheel Cap
56.	438-9473	Axle Assembly - Front - L. H.	123.	723-189	Seat Back Spring 10 & 12 H.P. Only
57.	901-9468	Lift Handle Assembly Complete	124.	723-190	Seat Cover 10 & 12 H.P. Only
58.	438-9467	Lift Handle Assembly	125.	723-191	Seat Back Rest Cover 10 & 12 H.P. Only
59.	438-9470	Handle Spacer Tube	126.	723-181	Seat Spring
60.	306-8818	Handle Grip	127.	719-139	Grille
61.	726-110	Push Cap	128.	719-137	Front Slings
62.	732-136	Compression Spring	129.	719-140	Gear Box Springs
63.	438-9448	Lift Handle Lockout	130.	- - -	Transaxle w/gear Shift Lever
64.	710-252	Hex Hd. Cap Screw 1/4-20 x 3/4 lg.*			

## PARTS LIST FOR TRACTOR (Continued)

Ref. No.	Part Number	DESCRIPTION	Ref. No.	Part Number	DESCRIPTION
131		Right Angle Gear Box	196	713-136	Clutch Bracket Chain
132	715-707	Spiral Pin 5/16-18 x 1-1/2 lg.*	197	713-116	Master Link
133	736-192	Wave Washer	198	719-188	PTO and Drive Adapter
134	748-386	Axle Collar	199	714-117	Hair Pin Cotter
135	710-346	Ovs. Hd. Screw 1/4-20 x 1-1/2 lg.*	200	714-110	Square Key 1/4 x 1-1/2 lg.*
136	438-10710	Lift Arm Assy.	201	714-119	Square Key 1/4 x 3/4 lg.*
137	710-356	Sq. Hd. Set Screw 5/16-18 x 1/2 lg.*	202	714-120	Square Key 1/4 x 3/4 lg.*
138	438-10991	Adjustment Clevis Assy.	203	714-121	Cotter Pin 3/32 Dia. x 1 lg.*
139	438-9406	Figure - Rear	204	714-474	Cotter Pin 1/8 Dia. x 3/4 lg.*
140	717-145	Spring	205	715-107	Spiral Pin 5/16 x 1 3/8 Heavy Duty*
141	711-290	PTO Clutch Rod	206	715-111	Spiral Pin 5/16 x 2 1/2 Heavy Duty*
142	722-117	Parking Brake Knob 10 & 12 H.P. Only	207	715-101	Spiral Pin 1/4 x 2-1/2
143	732-170	Compression Spring 10 & 12 H.P. Only	208	710-101	Snap Ring Tractor #5100-75
144	715-106	Hex Hd. Cap Screw 1/4-20 x 1-1/2 lg.*	209	15-1070-1029	Pin, Friction
145	18-1759-0000	Cam (Level)	210	15-1070-1049	Pin, Friction
146	710-166	Truss Hd. Machine Screw 1/4-20 x 1 1/8 lg.*	210	710-111	Snap Ring Tractor #5100-87
147	710-182	Hex Hd. Cap Screw 1/2-13 x 3 lg.*	211	723-236	Brake Disc Assembly
148	710-196	Sems Hex Hd. Cap Screw 5/16-18 x 3/4 lg.*	212	722-116	Gear Shift Knob
149	710-211	Sems Hex Hd. Cap Screw 1/4-20 x 3/4 lg.*	213	722-118	Throttle Control Knob
150	710-210	Hex Head Cap Screw 3/8-16 x 3/4 lg.*	214	735-214	Flat Washer
151	710-253	Hex Head Cap Screw 3/8-16 x 1 lg.*	215	723-103	Strainer Plate
152	710-258	Hex Head Cap Screw 1/4-20 x 5/8 lg.*	216	725-119	Ammeter
153	715-121	Spiral Pin 1/4 x 7" lg. Heavy Duty	217	725-129	Ignition Switch
154	710-322	Sems Hex Hd. Cap Screw 5/16-18 x 1 lg.*	218	725-130	Battery 12 volt
155	710-334	Shoulder Screw 3/8-16 x .625 Dia.	219	725-131	Light Switch
156	710-336	Wheel Lug Bolts 7/16-20 x 1-3/16 lg.*	220	711-305	Clevis Pin 5/8 Dia. x 1-1/16" lg.
157	710-342	Hex Hd. Cap Screw 3/8-16 x 1 1/4 lg.*	221	715-157	Cable Ties (Not Shown)
158	710-344	Hex Hd. Cap Screw 3/8-16 x 1 1/2 lg.*	222	711-325	Clevis Pin 5/8 Dia.
159	710-347	Hex Hd. Cap Screw 3/8-16 x 1 3/4 lg.*	223	438-10994	Clevis Screw Assy.
160	710-348	Hex Hd. Cap Screw 7/16-20 x 3/4 lg.*	224	438-10990	Upper Hitch Bracket
161	710-350	Counter Sunk Flat Hd. Screw 1/4-20 x 1 lg.*	225	711-174	Clevis Pin 5/8 Dia.
162	710-351	Phi. Hd. Screw #10-Type Z - 1/2 lg.*	226	711-497	Lift Clevis Pin
163	710-355	Hd. Hd. Screw 1/4-20 x 1-1/4 lg.*	227	438-10886	Crack Bar Assy. - R.H.
164	710-360	Carriage Bolt 1/2-15 x 1-3/4 lg.* 10 & 12 H.P. Only	228	728-119	Button
165	06-1079-0000	Spring, Compression	229	727-193	Grease Gun
166	710-472	Truss Hd. Mach. Screw #10-24 x 1/2 lg.*	230	728-111	Pop Rivet S3 44 B 5
167	710-937	Hex Hd. Cap Screw 3/8-16 x 2-1/2 lg.*	231	728-113	Pop Rivet S3 64 B 3
168	711-225	Clevis Pin	232	732-155	Extension Spring
169	711-278	Battery Hold Down Rod	233	503-9262	Wheel Assembly - Complete**
170	711-280	Brake Spacer Tube		317-9262	Wheel Rim
171	711-284	Battery Hold Down Stud		714-275	Tire - Tubeless 16 x 8.50-8
172	711-288	Ferrule	234	734-262	Wheel Assembly - Complete** 10 H.P. Only
173	711-289	Clutch Stud		734-320	Wheel Assembly - Complete** 12 & 14 H.P.
174	711-292	Brake Rod		734-279	Wheel Rim
175	756-127	Idler PTO		734-278	Tire - Tubeless 23 x 8.50-12
176	711-306	Clevis Pin		734-302	Tire - Tubeless 23 x 8.50-12 (12 & 14 H.P.)
177	711-309	Clevis Pin	235	03-1031-0000	Disc, Back-Up
178	711-310	Clevis Pin	236	710-442	Hex Hd. Cap Screw 5/16-18 x 1-1/2 lg.*
179	711-313	Steve 10 & 12 H.P. Only	237	736-133	Flat Washer*
180	732-205	Clutch Spring	238	736-147	External Lockwasher #10 Screw*
181	06-1023-0000	Pin, Push	239	711-444	Spring Cutter - Clutch
182	712-113	Wing Nut 1/4-20 Thd.*	240	736-163	Flat Washer*
183	712-116	Elastic Stop Nut 3/8-24 Thd.*	241	736-148	External Lockwasher 3/8 Screw*
184	712-193	Lug Nut 3/8-24 Thd.	242	736-171	Spring Lockwasher 7/16 Screw*
185	712-200	Elastic Stop Nut 1/2-20 Thd.*	243	736-180	Flat Washer*
186	712-204	Elastic Stop Nut 1/2-13 Thd.*	244	736-181	Flat Washer*
187	712-206	Hex Nut 1-2 13 Thd.* 10 & 12 H.P. Only	245	736-264	Flat Washer 5/16 SAE*
188	12-1964-0000	Casing, Cam Side	246	736-300	Flat Washer*
189	712-267	Hex Nut 1/4-20 Thd.*	247	736-468	Flat Washer*
190	712-425	Square Nut #10-24 Thd.*	248	712-428	Elastic Stop Nut 5/16-18*
191	712-430	Elastic Stop Nut 3/8-16 Thd.*	249	736-880	Flat Washer*
192	712-492	Square Nut 1/4-20 Thd.*	250	706-921	Spring Lockwasher 1-2 Screw* 10 & 12 H.P. Only
193	712-711	Hex Jam Nut 3/8-24 Thd.*	251	737-111	Muffler Nipple 1" Dia. x 6" lg.* †
194	712-798	Hex Nut 3/8-16 Thd.*	252	737-112	Fuel Tank Nipple 3/8" Dia.*
195	712-922	Hex Nut 1/2-20 Thd.*	253	746-129	Choke Control
			254	746-130	Throttle Control
			255	310-9420-1	Clutch - Brake Pedal Assembly



### PARTS LIST FOR TRACTOR (Continued)

Ref. No.	Part Number	DESCRIPTION	Ref. No.	Part Number	DESCRIPTION
256	438-1092b	Clutch Brake Crank Assembly	274	715-138	Rear Wheel Hub
257	438-9431	Clutch Shaft Bracket Assembly	275	754-424	Belt - Transaxle Drive b7 3/8 lg (Cates 9224-2700)
260	311-318	Shims			
259	310-9627	Brake Link	276	725-128	Key
260	314-117	Hair Pin, Center*	277	438-10551	Gear Box Mounting Washer
261	312-9531	Heat Shield Assembly	278	438-9691	Gear Box Mounting Plate
262	312-9529	Heat Shield Mounting Bracket Assembly	279	739-204	Clutch Helper
263	438-9581	Foot Ped. Assembly L, H	280	310-10477	Bearing Assembly - Clutch
264	310-7287	Flat Washer 10 & 1/2 H.P. Only	281	715-125	Spiral Pin 3/8 x 2 1/4 Heavy Duty
265	438-9409	Side Plate L, H	282	12-1538-2001	Casting, Carrier Side
266	741-140	Ball Bearing	283	710-340	Shoulder Bolt 3/4 dia x 4 1/2 lg
267	438-9445	Parking Brake Link	284	754-139	Starter Generator V-Belt (Spec 1)
268	312-9526	Generator Bracket	285	736-217	Spring Lockwasher 3/8 Spr Heavy Duty*
269	312-9527	Generator Pivot Bracket	286	710-253	Hex Hd. Cap Scr 3/8-16 x 1-11/32**
270	312-9520	Bever - Instrument Panel	287	736-168	Spring Lockwasher*
271	312-9534	Heat Shield Angle Bracket	288	712-347	Hex Jam Nut 3/8-16 Thd.**
272	305-9584	Instrument Panel	289	310-10988	Hook Chain Hook w/3/8 Thd
273	438-9443	Parking Brake Bracket Assembly	290	438-10885	Drag Bar Assy - L, H

\*\* When ordering service parts include all the information on the side wall of the tire such as the size and brand name.

\* For faster service obtain standard nuts, bolts, and washers locally. If these items cannot be obtained locally, order by part number and size as shown on parts list.

† Power Take-Off belts are matched. Always order in pairs.

‡ Not shown. Measure between engine and muffler.

**RIGHT ANGLE DRIVE FOR TRACTOR**  
**PEERLESS**  
**RA-208-P91**

**NOTE:** No Peerless, Tecumseh parts orders will be accepted by the mower manufacturer.  
 All parts **MUST** be ordered through your local authorized Tecumseh service dealer.



**PEERLESS MODEL**

Parts and service available through all authorized Tecumseh, Lauson Power Products Service Dealers. Check the "Yellow Pages" of your telephone directory under "Engines—Gasoline."

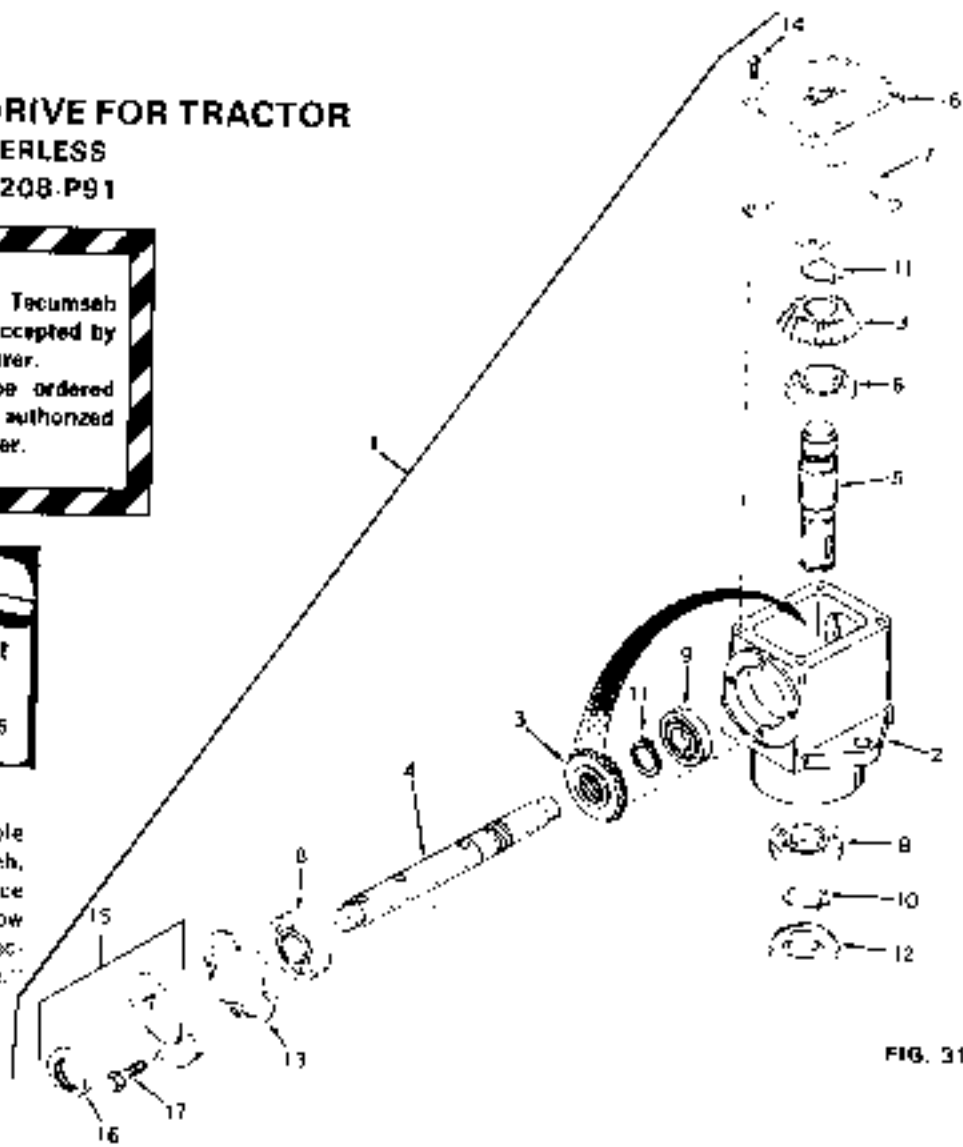

FIG. 31

**RIGHT ANGLE DRIVE MODEL NO. (PEERLESS RA-208-P91)**

REF. NO.	PART NUMBER	DESCRIPTION
1	794077	Head Assy. Right hand (Incl. Nos. 2 thru 15)
2	770026	Housing, Right angle drive
3	778046	Gear, Miter
4	776116	Shaft, Input pinion
5	776060A	Shaft, Output
6	772034	Cover, Right hand
7	788028	Gasket, Cover
8	780034	Bearing, Ball
9	780024	Bearing, Ball
10	788019	Ring, Snap
11	788018	Ring, Snap
12	788029	Seal, Oil
13	788030	Gasket, Cap
14	797025	Screw, Rd. hd. self tap. 10-24 x 1/2
15	786029	Cap & Seal Assy., Retainer (Incl. Nos. 16 & 17)
16	788031	Seal, Oil
17	782026	Screw, Hex hd. 1/4-20 x 7/8

**TRANSAXLE  
PEERLESS  
2315A**

**NOTE:** No Peerless, Tecumseh parts orders will be accepted by the mower manufacturer.

All parts **MUST** be ordered through your local authorized Tecumseh service dealer.

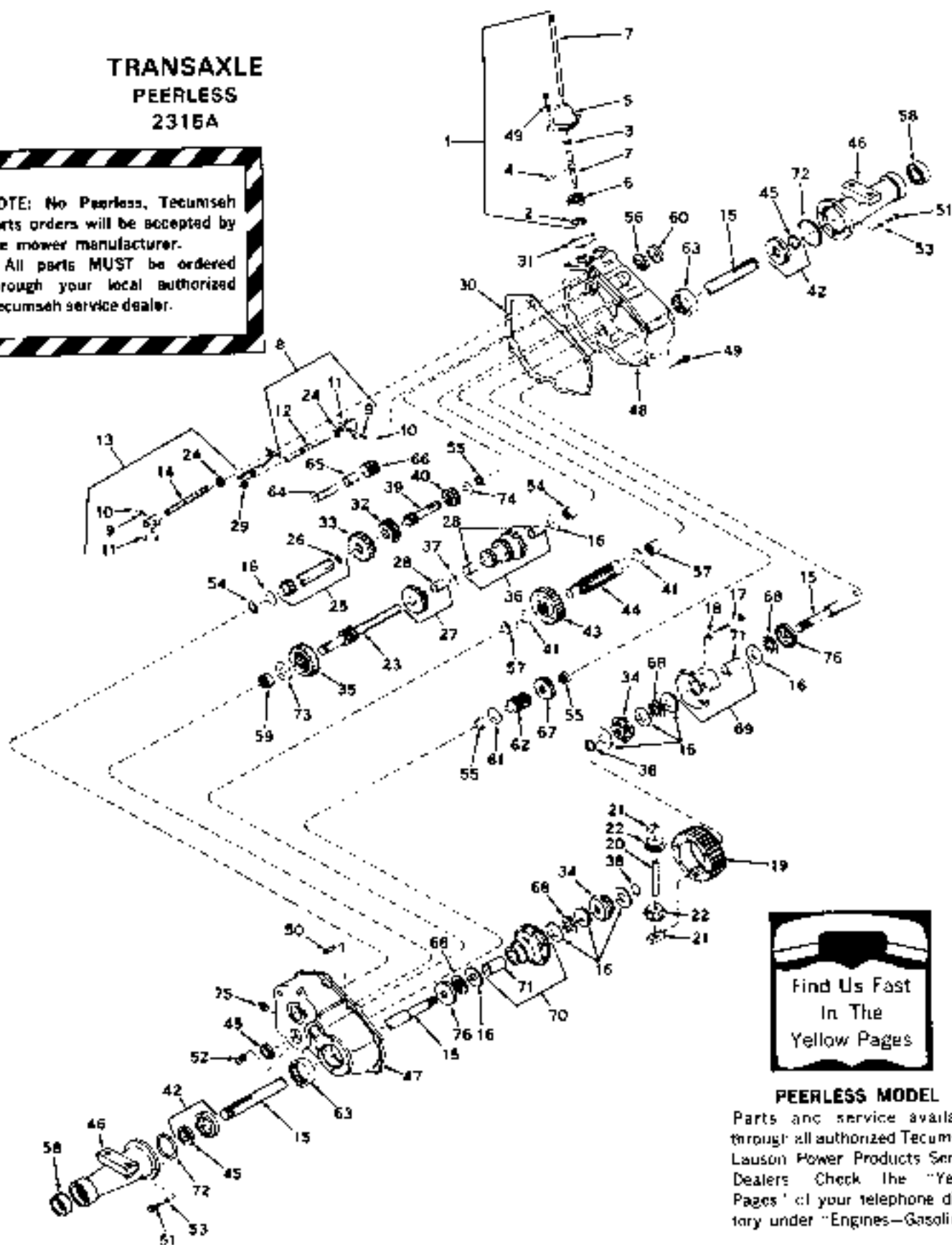

**PEERLESS MODEL**

Parts and service available through all authorized Tecumseh, Lauson Power Products Service Dealers. Check the "Yellow Pages" of your telephone directory under "Engines—Gasoline."

**TRANSAXLE MODEL NO. (PEERLESS 2315-A)**

Ref. No.	Part No.	DESCRIPTION	Ref. No.	Part No.	DESCRIPTION
1	784151	Lever & Housing Assy., Shift (Incl. Nos. 2 thru 7)	39	776015A	Shaft, Input
2	782016	Ring, Snap	40	778024	Spur Gear, Input shaft
3	782001	Ring, Quad	41	780052	Washer, Thrust
4	792002	Pin, Roll	42	788021	Seal & Retainer Assy., Oil (Incl. No. 45)
5	784093	Housing, Shift lever	43	778036	Gear, Output
6	784094	Keeper, Shift lever	44	778028	Pinion, Output
7	784152	Lever, Shift	45	788008	Seal, Oil
8	784054	Rod Assy., Shift (Incl. Nos. 9 thru 12 & 24)	46	782024	Housing, Axle
9	792003	Spring	47	772016A	Cover Assy., Transaxle (Incl. Nos. 54, 56, 57, 59 & 63)
10	792004	Barl. Steel	48	770012	Case Assy., Transaxle (Incl. Nos. 54, 55, 57 & 63)
11	784004	Fork, Shifter	49	792007	Screw, Socket hd. cap, 1/4-20 x 3/4
12	784055	Rod, Shifter (3rd & 4th)	50	786026	Pin, Dowel
13	784056	Rod Assy., Shift (Incl. Nos. 9, 10, 11 & 14)	51	792028	Screw, Hex hd. 5/16-18 x 7/8
14	784057	Rod, Shifter (low)	52	792019	Plug, Magnetic drain
15	774124	Axle	53	792029	Lockwasher, Split 5/16"
16	780042	Washer, Thrust	54	780048	Bearing, Needle
17	792005	Screw, Hex hd. cap, 1/4-20 x 2-1/2	55	780022	Bearing, Needle
18	782006	Lockwasher, 1/4	56	780024	Bearing, Ball
19	778033A	Gear, Ring	57	780047	Bearing, Needle
20	788019	Pin, Drive	58	780050	Bearing, Ball
21	786027	Block, Drive	59	790046	Bearing, Needle
22	778094	Pinion, Bevel	60	788025	Seal, Oil
23	776028A	Shaft & Gear, Brake	61	780001	Washer
24	792017	Ring, Snap	62	776031	Shaft & Pinion
25	776026	Shaft & Bearing Assy., Pinion (Incl. No. 26)	63	780048	Bearing, Needle
26	780018	Bearing	64	776030	Shaft, Reverse idler
27	778034	Gear Cluster Assy., (Incl. No. 28)	65	786025	Spacer, Reverse idler
28	780053	Bushing	68	778016	Idler, Reverse
29	784074	Stop, Shifter	67	778038	Spur gear (22 teeth)
30	788023	Gasket, Case & Cover	68	780039	Bearing, Thrust
31	788022	Gasket, Shift lever housing	69	774072A	Carrier Assy., Differential (Incl. No. 71)
32	778019	Gear, Shifting (3rd & 4th)	70	774071A	Carrier Assy., Differential (Incl. No. 71)
33	778020	Gear, Shifting (1st, 2nd & Rev.)	71	780041	Bushing
34	778095	Gear, Bevel	72	788024	"O" Ring
35	778037	Gear, Idler	73	790007	Washer, Thrust
36	778036	Gear Cluster Assy., (Incl. No. 28)	74	780051	Washer, Thrust
37	786024	Spacer	75	792010	Plug, Pipe
38	792018	Ring, Snap	76	780075	Race, Thrust