

# **T390/T400/T430/T450**

## *SERVICE MANUAL*

---

<b>Chapter 1. Introduction</b>	<b>-----01</b>
<b>Chapter 2. Disassembly and reassembly of major point</b>	<b>-----02</b>
<b>Chapter 3. Engine accessories</b>	<b>-----03</b>
<b>Chapter 4. Clutch system</b>	<b>----- 04</b>
<b>Chapter 5. Transmission</b>	<b>-----05</b>
<b>Chapter 6. Front axle (4WD)</b>	<b>-----06</b>
<b>Chapter 6. Front axle (sheet metal)</b>	<b>-----06</b>
<b>Chapter 7. Rear axle and Brakes</b>	<b>-----07</b>
<b>Chapter 8. Power steering system</b>	<b>----- 08</b>
<b>Chapter 9. Hydraulic system</b>	<b>-----09</b>
<b>Chapter 9. Hydraulic system(old version)</b>	<b>-----09</b>
<b>Chapter 10. Electric accessories and instruments</b>	<b>-----10</b>
<b>Chapter 11. Service standard and other information</b>	<b>-----11</b>

<b>INTRODUCTION</b> -----	<b>1-1</b>
<b>SAFETY INTRODUCTION</b> -----	<b>1-2</b>
<b>WARNING SIGNS IN THIS MANUAL</b> -----	<b>1-5</b>
<b>SAFETY SIGNS</b> -----	<b>1-6</b>
<b>SAFETY DECALS</b> -----	<b>1-11</b>
<b>UNIVERSAL SYMBOLS</b> -----	<b>1-14</b>
<b>SECTION 1. TRACTOR TYPES AND PUNCHED</b>	
<b>IDENTIFICATION MARKS</b> -----	<b>1-15</b>
<b>SECTION 2. SPECIFICATIONS</b> -----	<b>1-17</b>
<b>SECTION 3. GEAR TRAIN DIAGRAMS</b> -----	<b>1-20</b>
<b>SECTION 4. PRECAUTIONS FOR TRACTOR OPERATIONS</b> ---	<b>1-21</b>
<b>1. INSTRUMENTS</b> -----	<b>1-21</b>
<b>2. CONTROLS</b> -----	<b>1-23</b>
<b>3. FILLING DIAGRAM AND CAPACITY TABLE</b> -----	<b>1-24</b>
<b>4. MAINTENANCE CHART</b> -----	<b>1-25</b>

## *Chapter 1 .Introduction*

**This tractor service manual is for qualified service personnel engaged in servicing and overhauling 3510/4110/T390(T400)/T430(T450) tractor. Use of this publication is not recommended for field operators since they usually do not have access to special tools and shop equipment essential for most servicing.**

**Servicing procedures outlined herein contain sufficient information to return all component parts of a tractor to new condition. In discussion of each component parts, it is assumed that a complete overhaul is been performed, consequently, complete disassembly and reassembly are outlined. The mechanic is relied upon to decide how far disassembly must be carried when complete overhaul is not required.**

**Study unfamiliar service procedures thoroughly and clearly understood before attempting disassembly. Specific data essential for proper overhaul, such as running clearances and torque values, have been provided in interline of Inspection and reassembly procedures of each group section.**

**This manual was compiled from latest information available at time of publication. Manufacturer reserves the right to make changes at any time without notice.**

**Whenever the terms "left" and "right" are used, They means as viewed by the operator when seated in the operator's seat.**

## **SAFETY INSTRUCTION**

### **ALWAYS PRACTICE SAFETY BY THINKING BEFORE ACTION**

#### **AVOID FIRE HAZARDS.**

- Keep fire extinguishers easily available and in good operating condition.  
All relevant personnel should know how to operate fire fighting equipment.
- Keep a first aid kit in an easily accessible location.
- Do not smoke while handling fuel, or other highly flammable material.
- Do not use an open pail for transporting fuel.
- Use of an approved fuel container.
- Dispose of all fuel-soaked rags in covered containers where cigarettes cannot be dropped carelessly.
- Do not smoke and avoid open flame when charging, jumping, or boosting batteries.
- Batteries give off gas which is flammable and explosive.
- Do not charge batteries in a closed area. Provide proper ventilation to avoid explosion of accumulated gases.

#### **Avoid acid burns.**

- Wear safety goggles when handling battery electrolyte. It contains sulfuric acid which is a poison and can cause blindness. Avoid it contacting eyes, skin, or clothing. Sulfuric acid will eat through clothing and can cause severe burns to skin.

#### **AVOID HIGH-PRESSURE FLUIDS**

- 1) Before beginning work on hydraulic system components, turn off engine and operate hydraulic control levers to relieve internal hydraulic pressure.
- 2) Oil under pressure can penetrate skin and lead to personal injury. Treat sources of oil pressure with extreme care, wearing safety goggles.
- 3) If hydraulic leak develops, correct immediately. Escaping hydraulic oil can have extremely high pressure. A stream of high pressure oil may easily penetrate skin just like modern needless vaccination equipment, but with the exception that hydraulic fluid may cause blood poisoning. It is imperative that connections are tight and that all lines and pipes should be in good condition. If injured by escaping hydraulic fluid, see a doctor at once.



## **STAY CLEAR OF PTO**

- 1) Entanglement in rotating drive line can cause serious injury or death.
- 2) Keep tractor master shield and drive line shield in place at all times except for special applications as directed in the implement operator's manual.
- 3) Wear fairly tight fitting clothing. Stop the engine and be sure PTO driveline is stopped before making adjustment, connections, or cleaning out PTO drive equipment.

## **SERVICE TIRES SAFELY**



Tire changing can be dangerous and should be done by trained personnel using proper tools and equipment.

Do not re-inflate a tire that has been run flat or seriously under-inflated. Have it checked by qualified personnel.

Use wheel handling equipment adequate for weight involved when removing and installing wheels.

## WARNING SIGNS IN THIS MANUAL

The following warning symbols in this manual draw additional attention to items of importance for the safe and correct operation of the tractor.

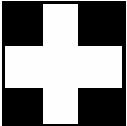
SIGN	MEANING OF SIGN
 DANGER	Serious hazard with a very high level of risk of either serious injury or death
 WARNING	Hazard or unsafe practice that can lead to severe injury or death.
 CAUTION	Hazard or unsafe practice that can lead in injury or death.
 IMPORTANT	Instructions for the correct operation of the machine which, if followed, will ensure that it performs at it's best

# SAFETY SIGNS

## RECOGNIZE SAFETY INFORMATION

This symbol, Safety-Alert Symbol, means **ATTENTION! YOUR SAFETY IS INVOLVED.** The message that follows the symbol contains important information about safety. Carefully read the message



## SIGNAL WORDS.

A signal word—**DANGER, WARNING OR CAUTION**—is used with safety alert symbol. **DANGER** identifies the most serious hazards. Safety signs with signal Word —**DANGER OR WARNING**—are typically near specific hazards. General precautions are listed on **CAUTION** safety signs.



**DANGER**



**WARNING**



**CAUTION**

## READ SAFETY INSTRUCTION

Carefully read all safety instructions given in this manual for your safety. Tempering with any of the safety devices can cause serious injuries or death. Keep all safety signs in good condition. Replace missing or damaged safety signs.

Keep your tractor in proper condition and do not allow any unauthorized modifications to be carried out on the Tractor, which may impair the function/safety and affect Tractor life.



## PROTECTION CHILDREN

Keep children and others away from the Tractor while operating.

### BEFORE YOU REVERSE

- Look behind Tractor for children.
- Do not let children to ride on Tractor or any implement.



### **USE OF ROPS AND SEAT BELT**

The Roll Over Protective Structure (ROPS) has been certified to industry and/or government standards. Any damage or alteration to the ROPS, mounting hardware, or seat belt voids the certification and will reduce or eliminate protection for the operator in the event of a roll-over. The ROPS, mounting hardware, and seat belt should be checked after the first 100 hours of Tractor and every 500 hours thereafter for any evidence of damage, wear or cracks. In the event of damage or alteration, the ROPS must be replaced prior to further operation of the Tractor.

The seat belt must be worn during machine operation when the machine is equipped with a certified ROPS.

Failure to do so will reduce or eliminate protection for the operator in the event of a roll over.



### **PRECAUTION TO AVOID TIPPING**

Do not drive where the Tractor could slip or tip.

Stay alert for holes and rocks in the terrain, and other hidden hazards.

Slow down before you make a sharp turn.

Driving forward out of a ditch or mired condition could cause Tractor to tip over backward. Back out of these situations if possible

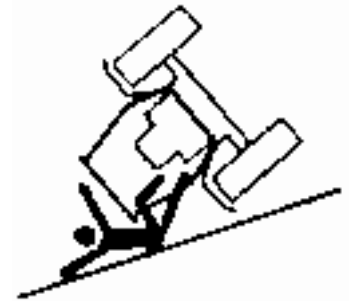

### **PARK TRACTOR SAFELY**

Before working on the Tractor ;

Lower all equipment to the ground.

Stop the engine and remove the key



### **KEEP RIDERS OFF TRACTOR**

Do not allow riders on the Tractor.

Riders on Tractor are subject to injury such as being stuck by foreign objects and being thrown off of the Tractor



### **HANDLE FUEL SAFELY-AVOID FIRES**

Handle fuel with care; it is highly flammable. Do not refuel the Tractor while smoking or near open flame or sparks.

Always stop engine before refueling Tractors.

Always keep your tractor clean of accumulated grease, and debris.

Always clean up spilled fuel.



### **STAY CLEAR OF ROTATING SHAFTS**

Entanglement in rotating shaft can cause serious injury or death.

Keep PTO shield in place at all times.

Wear close fitting clothing. Stop the engine and be sure PTO drive is stopped before making adjustments, connections, or cleaning out PTO driven equipment.



### **ALWAYS USE SAFETY LIGHTS AND DEVICES**

Use of hazard warning lights and turn signals are recommended when towing equipment on public roads unless prohibited by state or local regulations.

Use slow moving vehicle (SMV) sign when driving on public road during both day & night time, unless prohibited by law

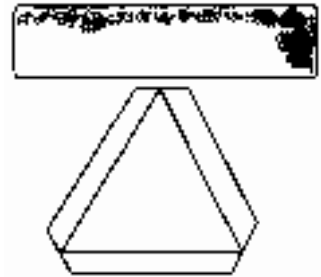

### **PRACTICE SAFE MAINTENANCE**

Understand service procedure before doing work.

Keep the surrounding area of the Tractor clean and dry.

Do not attempt to service Tractor when it is in motion.

Keep body and clothing away from rotating shafts.

Always lower equipment to the ground. Stop the engine.

Remove the key. Allow Tractor to cool before any work repair is caused on it.

Securely support any Tractor elements that must be raised for service work.

Keep all parts in good condition and properly installed.

Replace worn or broken parts. Replace damage/missing decals.

Remove any buildup of grease or oil from the Tractor.

Disconnect battery ground cable(-) before making adjustments on electrical systems or welding on Tractor



### **AVOID HIGH-PRESSURE FLUIDS**

Escaping fluid under pressure can penetrate the skin causing serious injury. Keep hands and body away from pinholes and nozzles, which eject fluids under high pressure. If ANY fluid is injected into the skin. Consult your doctor immediately.



### **PREVENT BATTERY EXPLOSIONS**

Keep sparks, lighted matches, and open flame away from the top of battery. Battery gas can explode.

Never check battery charge by placing a metal object across the poles.



### **PREVENT ACID BURNS**

Sulfuric acid in battery electrolyte is poisonous. It is strong enough to burn skin, cause holes in clothing and cause blindness if found entry into eyes.

For adequate safety always;

1. Fill batteries in a well-ventilated area.
2. Wear eye protection and acid proof hand gloves
3. Avoid breathing direct fumes when electrolyte is added.
4. Do not add water to electrolyte as it may splash off causing severe burns.

If you spill acid on yourself;

1. Flush your skin with water.
2. Flush your eyes with water for 10-15 minutes.

Get medical attention immediately.

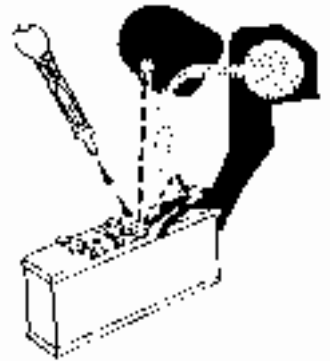

### **SERVICE TRACTOR SAFELY**

Do not wear a necktie, scarf or loose clothing when you work near moving parts. If these items were to get caught, severe injury could result.

Remove rings and other jeweler to prevent electrical shorts and entanglement in moving parts.



### **WORK IN VENTILATED AREA**

Do not start the Tractor in an enclosed building unless the doors & windows are open for proper ventilation, as tractor fumes can cause sickness or death. If it is necessary to run an engine in an enclosed area remove the exhaust fumes by connecting exhaust pipe extension.



## TRACTOR RUNAWAY

**1. The tractor can start even if the transmission is engaged position causing Tractor to runaway and serious injury to the people standing nearby the tractor.**

**For additional safety keep the pull to stop knob (fuel shut off control) in fully pulled out position. Transmission in neutral position, Foot brake engaged and PTO lever in disengaged position while attending to Safety Starter Switch or any other work on Tractor.**

## SAFETY STARTER SWITCH

- 1. Clutch operated safety switch is provided on all Tractors which allow the starting system to become operational only when the Clutch pedal is fully pressed.**
- 2. Do not By-pass this safety starter switch or work on it. Only Authorized Dealers are recommended to work on safety starter switch.**
- 3. On some models Safety Starter switch is provided on transmission High-low shifter lever and in PTO shifter lever. The tractor can be started only if High-low shifter lever is in neutral position.**



**Safety Starter Switch is to be replaced after every 2000 hours/4 years, whichever is earlier**

## SAFETY DECALS

The following safety decals ARE INSTALLED ON THE MACHINE.

If a decal become damaged, illegible or is on the machine, replace it. The decal part number is listed in the parts lists.



## WARNING

- Before starting and operating know the operating and safety instructions in the operators Manual and on the tractor.
- Clear the area of bystanders.
- Locate and know operation of controls.
- Start engine only from Operator's seat with depressed clutch pedal, transmission in the neutral, PTO disengaged and hydraulic control in lower position
- Slow down on turns, rough ground and slopes to avoid upset.
- Do not permit anyone but the operator to ride on the tractor.  
There is no safe place for rider.
- Lock brakes together, use warning lights and SMV emblem while driving on roads.
- Lower equipment, place gear shift levers in neutral, stop engine, remove the key and apply parking brake before leaving the tractor seat.
- Air pressures are specified by the manufacturer.

**FAILURE TO FOLLOW ANY OF THE INSTRUCTIONS ABOVE CAN CAUSE SERIOUS INJURY TO THE OPERATOR.**

**Location: On FENDER RH**

**Part No.: 1260-904-070-1A**



## WARNING

**TO AVOID POSSIBLE  
PERSONAL INJURY, THIS GUARD MUST  
BE KEPT IN PLACE**

**Location: ON PTO guard**

**Part No.: 1260-904-069-0A**



 **CAUTION**

**TO PROTECT ENGINE AND HYDRAULIC COMPONENTS.**

- Idle Engine for 1 minute before shut down or full load operation.
- Do not exceed 1/2 throttle for first 5 minutes of operation

**Location: On Dash cover side RH**

**Part No.: 1260-904-064-0**

 **WARNING**

**KEEP HANDS AND CLOTHING AWAY FROM ROTATING FAN AND BELTS TO PREVENT SERIOUS INJURY**

**Location: On Radiator bracket side LH & RH**

**Part No.: 1260-904-061-0**

 **CAUTION**

**BEFORE OPERATE THE TRACTOR, READ THE OPERATOR'S MANUAL THOROUGHLY, TO UNDERSTAND THE IMPORTANT FUNCTIONS AND CONTROLS.**

**Location: On dash cover side LH**

**Part No.: 1260-904-067-0A**

 **WARNING**

**The cooling system operates under pressure.**

- It is dangerous to remove the radiator cap while the system is hot.
- Always turn the cap slowly to the first stop and allow pressure to escape before removing the cap completely.
- When operating below 32°F, use suitable anti-freeze solution as coolant

**Location: On Radiator bracket side LH&RH**

**Part No.: 1260-904-063-0**



## DANGER

**BLINDNESS CAN  
RESULT FROM  
BATTERY EXPLOSION.  
KEEP SPARKS OR OPEN  
FRAMES AWAY FROM  
BATTERY.**

**DO NOT JUMP START.**

**BURNS CAN RESULT  
FROM BATTERY ACID.**

**IN CASE OF CONTACT  
FLUSH IMMEDIATELY  
WITH WATER**

**Location: On battery bracket RH**

**Part No.: 1260-904-066-0**



## WARNING

- **Pull only from drawbar. Pulling from any other point can cause rear overturn.**
- **Do not operate with unshielded PTO.**
- **Disengage PTO and stop engine before servicing tractor or attaching and detaching implements.**
- **When towing equipment use a Safety chain**

**FAILURE TO FOLLOW ANY OF THE  
INSTRUCTIONS ABOVE CAN CAUSE SERIOUS  
INJURY TO THE OPERATOR OR OTHER  
PERSONS.**

**Location: On rear frame**

**Part No.: 1260-904-065-0A**



## WARNING

- **Start engine only from operators seat. If safety start switch is bypassed engine can start with transmission in gear.**
- **Do not connect or short across terminal on starter solenoid.**

**Attach booster cables as shown on battery decal and operator's manual.**

























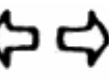





**Starting in gear causing runaway can result in serious injury.**

**Location: On dash over side LH**

**Part no: 1260- 904-062-0A**

# UNIVERSAL SYMBOLS

Some of the universal Symbols have been shown below with an indication of their meaning.

	<b>Engine speed (rev/minX100)</b>		<b>Pressured- open slowly</b>		<b>Corrosive substance</b>
	<b>Hours, recorded</b>		<b>Continuous Variable</b>		<b>”Tortoise” slow or minimum setting</b>
	<b>Engine coolant temperature</b>		<b>Warning</b>		<b>”Hare” fast or maximum setting</b>
	<b>Fuel level</b>		<b>Hazard warning</b>		<b>Transmission oil pressure</b>
	<b>Engine stop control</b>		<b>Neutral</b>		<b>Turn signal</b>
	<b>Lights</b>		<b>Fan</b>		<b>Transmission oil temperature</b>
	<b>Horn</b>		<b>Power take off engaged</b>		<b>parking brake</b>
	<b>Engine oil pressure</b>		<b>Power take off disengaged</b>		<b>Work lamps</b>
	<b>Air filter</b>		<b>Lift arm/raise</b>		<b>Differential lock</b>
	<b>Battery charge</b>		<b>Lift arm/lower</b>		<b>See operator’s manual</b>

# SECTION 1. TRACTOR TYPES AND PUNCHED IDENTIFICATION MARKS

The tractor serial number is shown on the left hand side of the tractor as shown in the picture. The engine number is stamped on the top of the engine block.

## Tractor Serial Number

## Engine Serial Number

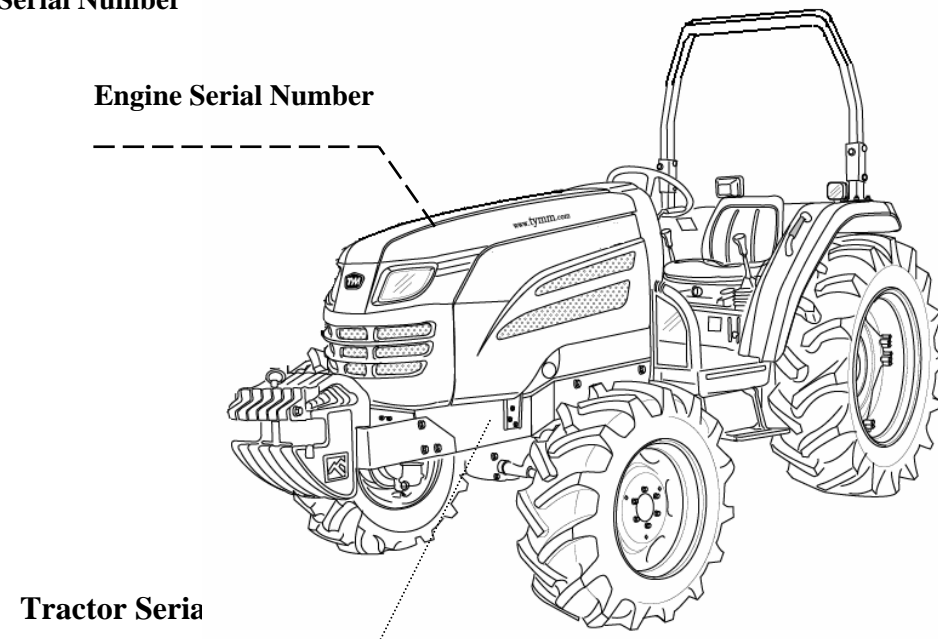

## 1.MODEL NAME PLATE

The plate indicates the model and type of the tractor.

- ① Model name
- ② Production I.D No.

The production I.D reference number is as shown below

39NC W 01 0001

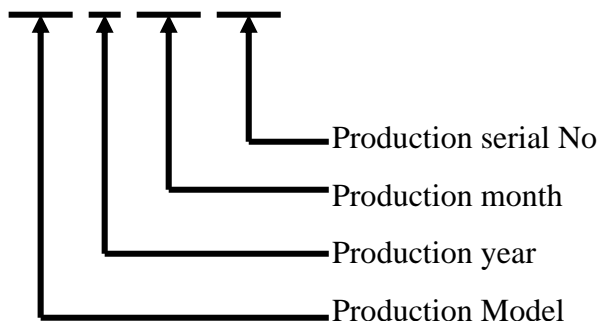

<b>TONG YANG</b>	
MODEL	:AGRICULTURAL TRACTOR T390
TYPE	:4-CYCLE DIESEL
ENGINE: ps/rpm	:39ps/2800 rpm
SERIAL NO.	:39NC W 01 0001
MANUFACTURER:TONG YANG MOOLSAN CO.,LTD	
ADDRESS:#90,NON HYUN 2 DONG,KANGNAM KU	
SEOUL, KOREA	
TEL	:82-2- 3014-2780-86

3.Engine model and engine serial number plate on the head cover.



SECTION 2. SPECIFICATIONS

MODEL		T390/T400	T430/T450
Engine	Maker	KUBOTA	KUBOTA
	Model	V1903	V2203
	Type	Vertical,water cooled 4 cycle Diesel	
	Out put(ps/rpm)	39	43
	Rated Speed	2,800rpm	2600rpm
	Number of Cylinder	4	4
	Displacement(cc)	1,857	2,197
	Bore and Stroke	(80mmX92.4mm)	(87mmX92.4mm)
	Compression ratio	22:1	22:1
	Firing order	1-3-4-2	1-3-4-2
	Injection pump	Throttle type	
	Lubrication type	Forced	
	Cooling system	Water cooled,forced circulation	
	Coolant capacity	1.85US gal (7L)	
	Air cleaner	Dry type with paper element	
	Muffler	Horizontal Round	
	Fuel	Diesel	
	Fuel Tank capacity:litre	8.717 US gal (33L)	
Electrical	Battery	12V110AH	
	Starting system	Electronic with cell motor	
	Starter Capacity	12V-1.7KW	
Drive Train	Alternator	12V50A	
	Transmission	Constant mesh(Synchromeshed 3 <sup>rd</sup> and 4 <sup>th</sup> in main shift in both forward and reverse)	
	MFWD(4WD)	Standard	
	Differential lock	Bevel gears with diff-Lock	
	Brakes	Wet Disk	
	Steering	Hydrostatic Power	

<b>MODEL</b>		<b>T390/T400</b>	<b>T430/T450</b>	
<b>Clutch</b>	<b>Main</b>	<b>Dry single disc,mechanic</b>		
	<b>PTO</b>	<b>Multiple wet disk</b>		
<b>Dimensions</b>	<b>Overall length</b>	<b>3531(139")</b>	<b>3531 (139")</b>	
	<b>Overall width</b>	<b>1475(58.1")</b>	<b>1490(58.7")</b>	
	<b>Overall Height</b>	<b>2228(87.7")</b>	<b>2288(90.1")</b>	
	<b>Wheel base (Distance between shafts)</b>	<b>1800 (70.8")</b>		
	<b>Min. Ground Clearance</b>	<b>308(12.1")</b>	<b>330(13")</b>	
	<b>Tire size</b>	<b>Front</b>	<b>8-16- 4PLY</b>	<b>8-16- 4PLY</b>
		<b>Rear</b>	<b>13.6-24-6PLY</b>	<b>13.6-24-6PLY</b>
	<b>Axle type</b>	<b>Front</b>	<b>Center pin</b>	
<b>Rear</b>		<b>Central axle</b>		

<b>Implement</b>	<b>Operation</b>	<b>Hydraulic</b>
	<b>Mounting method</b>	<b>3-Point hitch</b>
	<b>Drawing method</b>	<b>Draw bar</b>
	<b>3-Point hitch category</b>	<b>Category 1</b>
	<b>Hydraulic-control</b>	<b>Position ,draft control</b>

**Traveling speeds:Km/h (Mile/h)**

<b>Traveling Speed : km/hour</b>					
<b>MODEL</b>		<b>T390/T400</b>		<b>T430/T450</b>	
<b>Range shift</b>	<b>Main shift</b>	<b>Forward</b>	<b>Reverse</b>	<b>Forward</b>	<b>Reverse</b>
<b>L L</b>	<b>1</b>	<b>-</b>	<b>-</b>	<b>0.39</b>	<b>0.36</b>
	<b>2</b>	<b>-</b>	<b>-</b>	<b>0.55</b>	<b>0.50</b>
	<b>3</b>	<b>-</b>	<b>-</b>	<b>0.75</b>	<b>0.68</b>
	<b>4</b>	<b>-</b>	<b>-</b>	<b>0.98</b>	<b>0.89</b>
<b>L</b>	<b>1</b>	<b>1.14</b>	<b>1.09</b>	<b>1.02</b>	<b>0.93</b>
	<b>2</b>	<b>1.60</b>	<b>1.53</b>	<b>1.43</b>	<b>1.30</b>
	<b>3</b>	<b>2.17</b>	<b>2.07</b>	<b>1.93</b>	<b>1.77</b>
	<b>4</b>	<b>2.85</b>	<b>2.71</b>	<b>2.54</b>	<b>2.32</b>
<b>M</b>	<b>1</b>	<b>3.96</b>	<b>3.78</b>	<b>3.28</b>	<b>2.99</b>
	<b>2</b>	<b>5.56</b>	<b>5.30</b>	<b>4.60</b>	<b>4.20</b>
	<b>3</b>	<b>7.54</b>	<b>7.18</b>	<b>6.23</b>	<b>5.69</b>
	<b>4</b>	<b>9.89</b>	<b>9.43</b>	<b>8.18</b>	<b>7.47</b>
<b>H</b>	<b>1</b>	<b>10.63</b>	<b>10.14</b>	<b>9.48</b>	<b>8.66</b>
	<b>2</b>	<b>14.92</b>	<b>14.23</b>	<b>13.30</b>	<b>12.16</b>
	<b>3</b>	<b>20.21</b>	<b>19.27</b>	<b>18.03</b>	<b>16.47</b>
	<b>4</b>	<b>26.52</b>	<b>25.29</b>	<b>23.65</b>	<b>21.62</b>

**PTO shaft**

<b>Model</b>	<b>T390/T400</b>	<b>T430/T450</b>
<b>Speed(PTO rpm/Engine rpm)</b>	<b>599,977/2800</b>	<b>587,705,1057,1321/2600</b>
<b>Shaft Diameter.Spline teeth</b>	<b>1 3/8, 6 spline</b>	



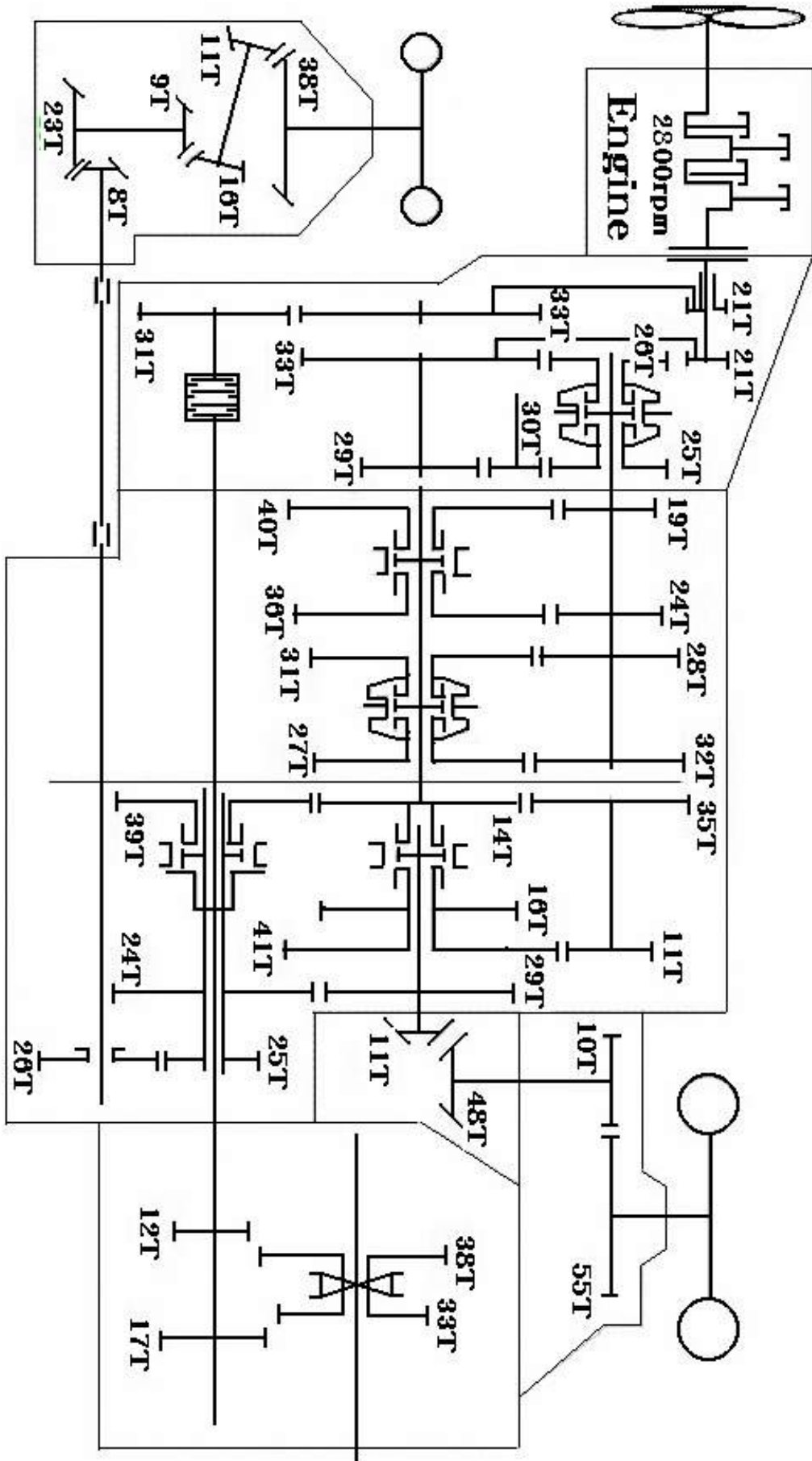

Fig.1-3 GEAR TRAIN DIAGRAM

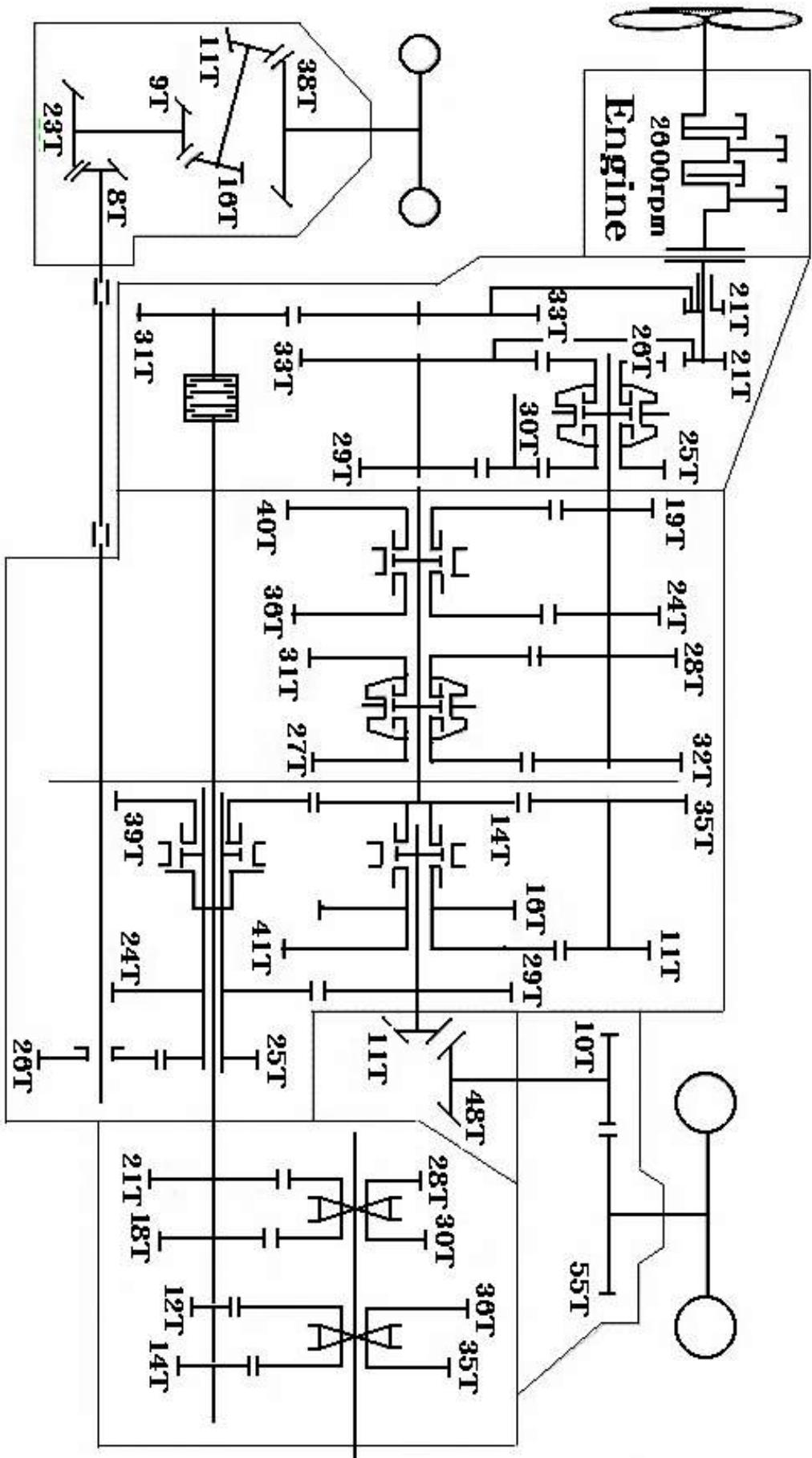
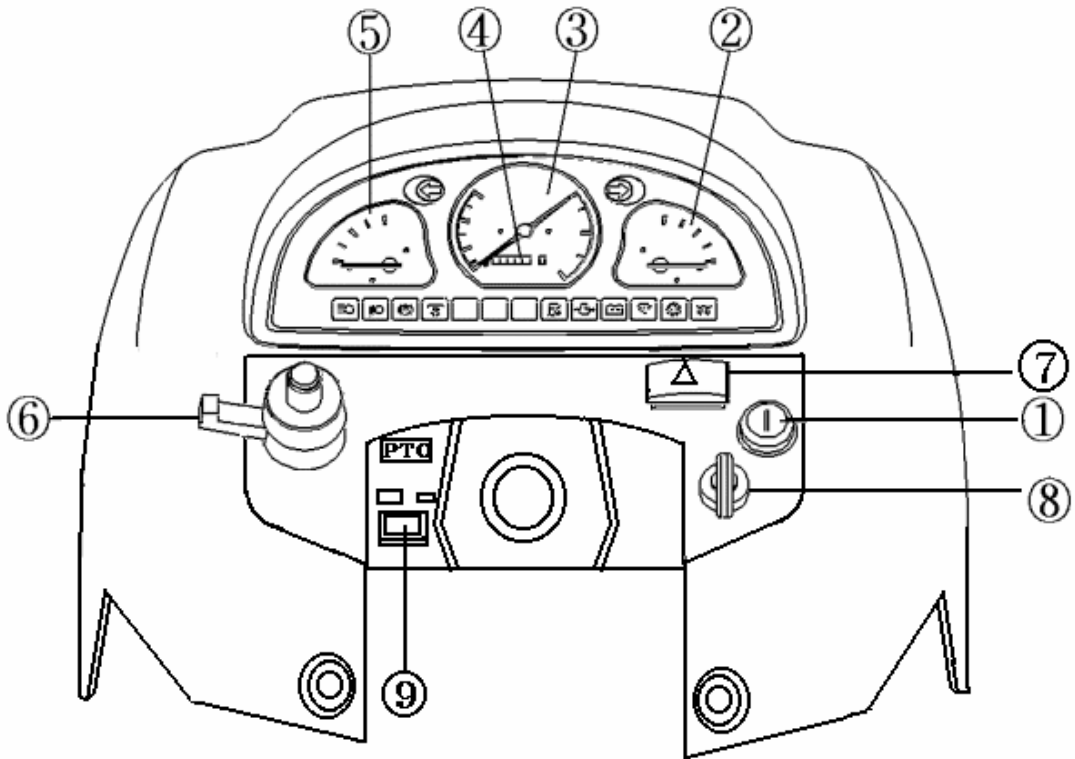

Fig.1-3 GEAR TRAIN DIAGRAM

## SECTION 4. PRECAUTION FOR TRACTOR OPERATION

### 1. INSTRUMENTS



- ①key switch ②temperature gauge ③tachometer ④Hour meter ⑤Fuel gauge  
⑥Light switch,indicators and horn ⑦hazard warning light switch  
⑧ PTO Mode switch ⑨ PTO ON OFF switch

#### Note:

- Oil pressure warning light and charge light on the monitor array will light when the main switch is turned from OFF to ON
- All lights on the panel go out automatically when the engine is started and its speed is increased to a specific level.
- Do not panic if some lights on the monitor light array do not go out while the engine is at idle speed just after its starting.They will go out automatically when the engine speed reaches as a specific level.

# MONITOR LIGHT ARRAY

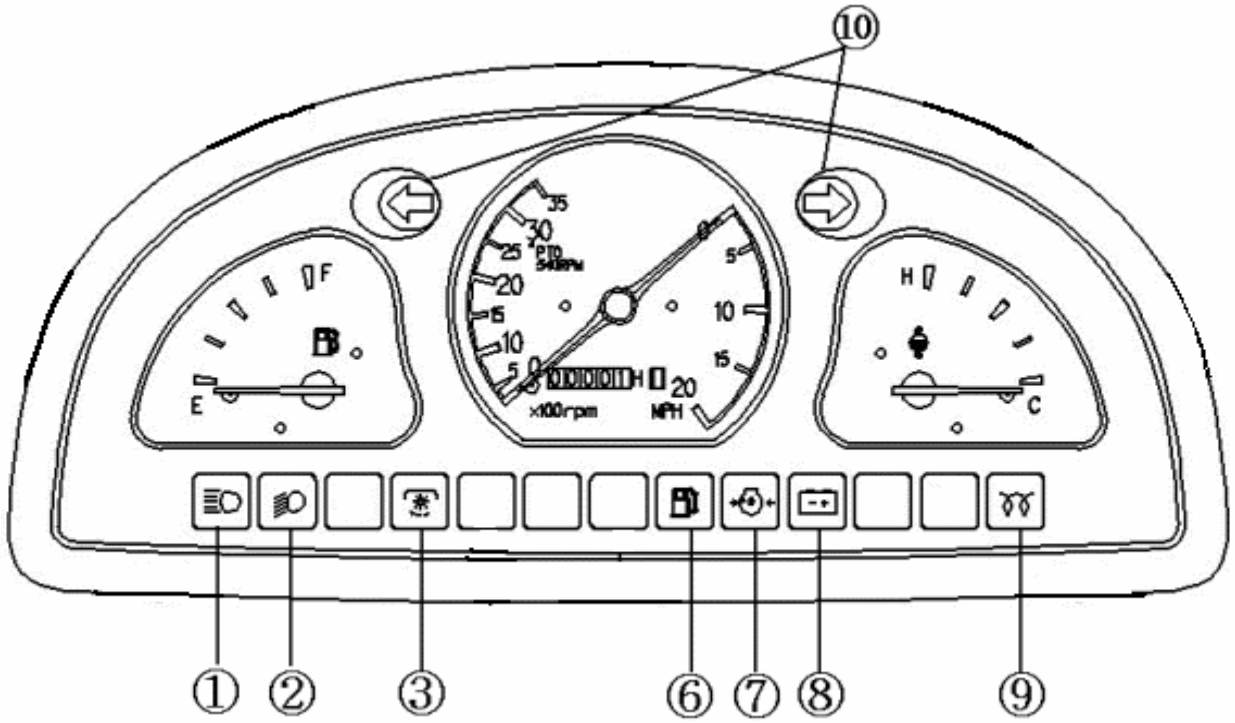

- ① High Beam Lamp
- ② Low Beam Lamp
- ③ PTO Monitor Lamp
- ⑥ Fuel Empty Warning Lamp
- ⑦ Oil pressure lamp
- ⑧ Charge lamp
- ⑨ Glow signal Lamp
- ⑩ Turn Signal Lamp

## 2. CONTROLS

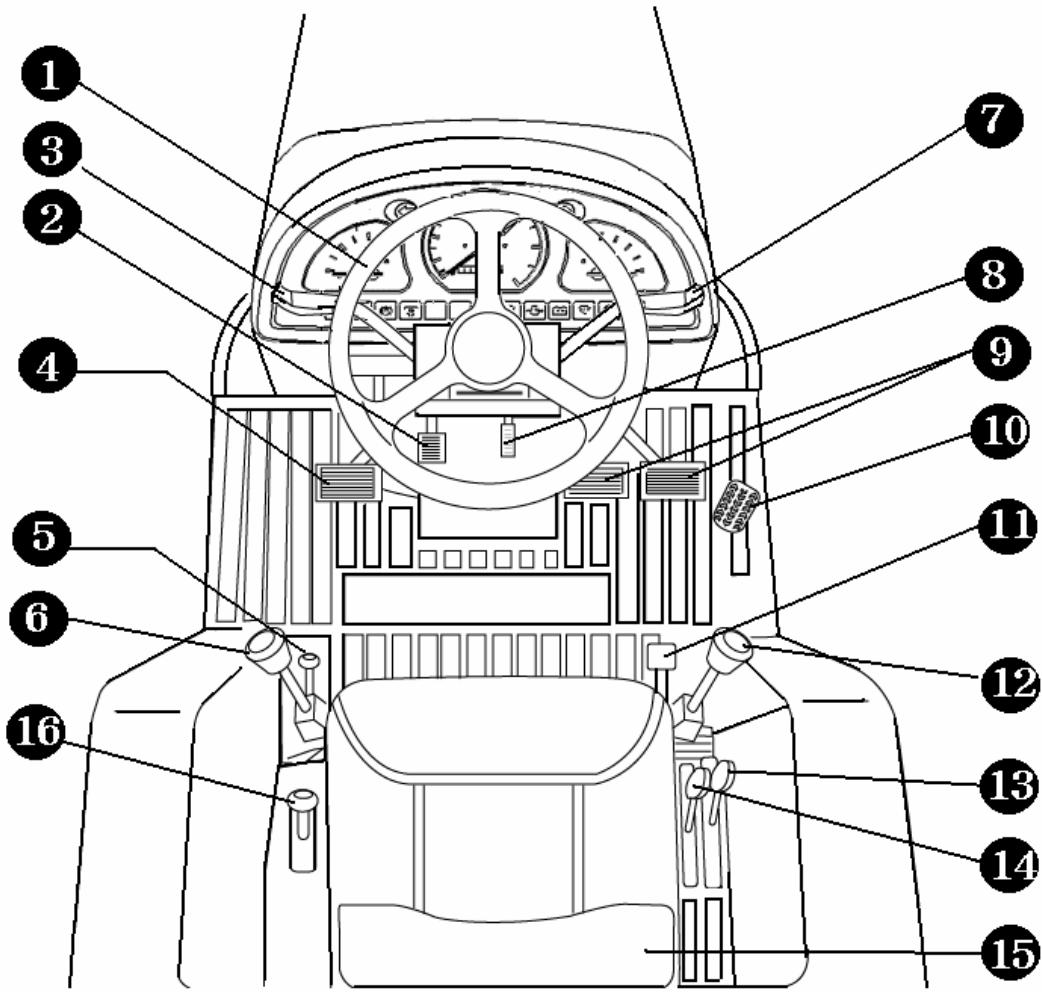

- |  |   |   |                       |                    |                            |
|--|---|---|-----------------------|--------------------|----------------------------|
| 1. Steering wheel                              | 2. parking brake pedal                      | 3. Lear shift lever (Linear shifting between forward and reverse traveling) | 4. Clutch pedal       | 5. PTO shift lever | 6. Speed range shift lever |
| 7. Throttle lever                              | 8. Tilting pedal                            | 9. Brake pedals   | 10. Accelerator pedal | 11. Dif-lock pedal | 12. Main shift lever       |
| 13. Hydraulic control lever (position control) | 14. Hydraulic control lever (Draft control) | 15. Operator's seat   | 16. 4WD lever         |                    |                            |

### 3. FILLING DIAGRAM & CAPACITY TABLE

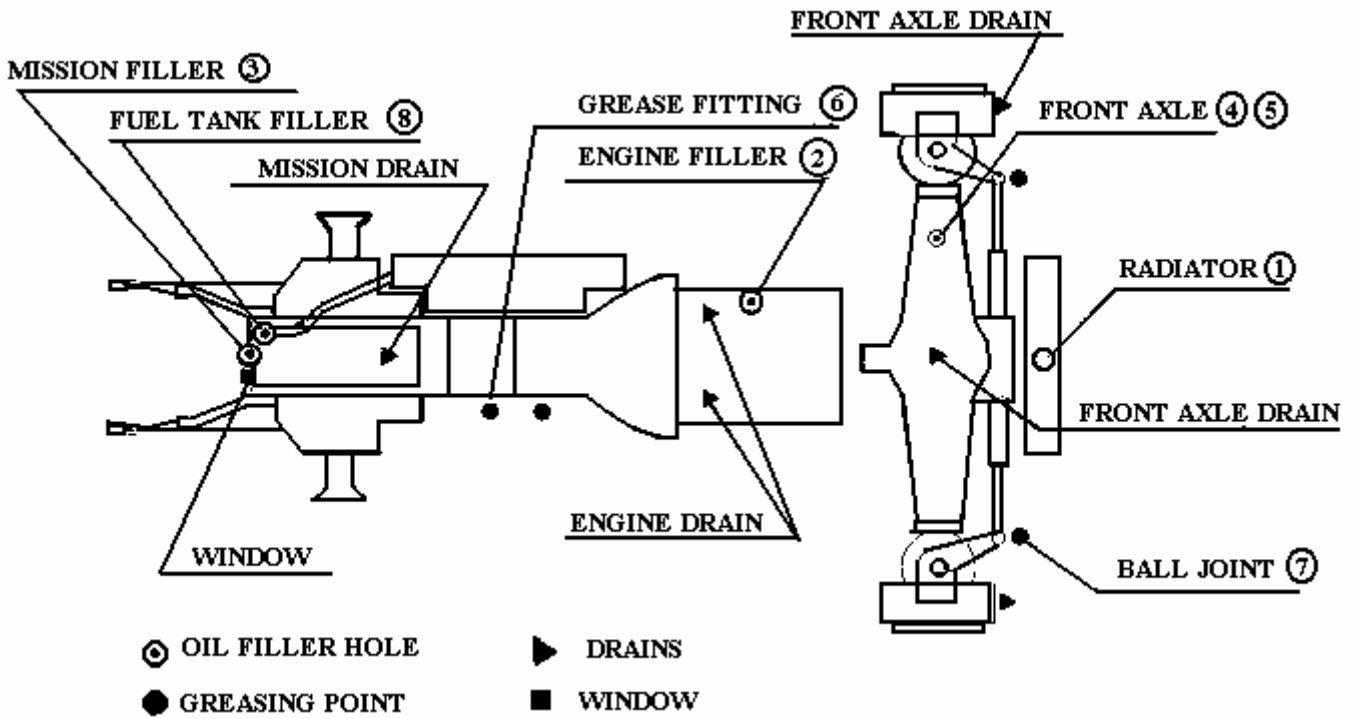

TABLE 1-7

MODEL		T390/T400	T430/T450
No	Filling point	Fillings	Quantity Liter (gal.)
1	RADIATOR	Fresh clean Water(L.L.C)	9ℓ 9ℓ
2	ENGINE	Engine oil	5.8ℓ (1.58 gal) 7.0ℓ (1.90 gal)
3	TRANSMISSION CASE	THF500	34ℓ(9 US gal) 34ℓ(9 US gal)
4	FRONT AXLE	Gear oil #80 or #90	8.8ℓ(2.32US gal) 8.8ℓ(2.32US gal)
5	FINAL DRIVE		
7	CASE(B) BALL JOINT	Grease	As required As required
8	FUEL TANK	Diesel fuel	33ℓ(8.717 US gal) 33 ℓ(8.717 US gal)

#### Tire size and inflation

TABLE 1-8

MODEL	T390/T400		T430/T450	
Wheels	FRONT	REAR	FRONT	REAR
TIRE SIZE	8-16	13.6-24	8-16	13.6-24
INFLATION (kg/cm <sup>2</sup> )	1.6	2.4	1.6	2.4

## 4. MAINTENANCE CHART

○ inspection, replenish, and adjustment

● Replacement △ Cleaning and/or washing

### € ENGINE

★ Consult your Dealer

Inspection items	Daily	Inspection and servicing intervals												Intervals after that	Judgment criteria mm(in)	
		Hour of operation (X10 on hour meter)														
		5 0	1 5	1 0	2 5	2 0	3 5	3 0	4 5	4 0	5 5	5 0	6 0			
Engine oil	○	●		●		●		●		●		●		●	Replace after every 100 hours	Level is between upper and lower limits
Oil filter		●				●				●						
Air cleaner			△		△		△		△		△		●	Clean after every 100 hrs. Replace element that has been washed more than 5 times		
Radiator coolant	○													Replace every year	Fill coolant up to radiator throat	
Radiator	○															
Radiator fin & screen	○				△				△				△			Clean cooling fins and cores
Fuel	○													Everyday and before work	Tank should be full	
Fuel filter	○	△	○	△	○	△	●	○	○	△	○	△	●	Wash after every 100 hrs. and replace after 300 hrs.		
Fan belt	○															About 5(0.20in) deflection pushed with a finger
Hose clamps	○															
Electrolyte level	○		○		○		○		○		○		○	Check after every 100 hrs. and replenish if necessary		

○ inspection, replenish, and adjustment

● Replacement △ Cleaning and/or washing

★ Consult your Dealer

€ TRANSMISSION

Inspection items	Daily	Inspection and servicing intervals												Intervals after that	Judgment criteria mm(in)
		Hour of operation (X10 on hour meter)													
		5	1	1	2	2	3	3	4	4	5	5	6		
		0	5	0	5	0	5	0	5	0	5	0			
Transmission oil	○	●						●						Replace after initial 50 hrs, then after every 300 hrs.	Clean hydraulic suction filter at the same time.
Clutch pedal free play															Free Play: 20 to 30mm
Brake pedal free play															Free Play: 30 to 40mm
Brake performance															Interlocked brakes should work simultaneously
Lever performance															Every lever should work positively
Steering wheel free play	○														Ab. 5.0(1.97) on circumstance
Toe-in							★						★	Check after every 300 hrs	2 to 6 mm (0.08~0.24 in)
Front wheel hub greasing														Inject grease after every 300 hrs	
Retightening ball joints of steering system	○												○	Check after every 300 hrs	
Wheel tightening bolts	○														All should be tighten
Greasing each nipple		○	○	○	○	○	○	○	○	○	○	○	○	Replenish every 50 hrs (Everyday in dusty condition)	
Loose bolts and nuts	○														All should be tighten
Electric wiring	○						○							Check every year	All should work properly.



Inspection items	Daily	Inspection and servicing intervals Hour of operation (X10 on hour meter)												Intervals after that	Judgment criteria mm(in)	
		5	1	1	2	2	3	3	4	4	5	5	6			
Electric apparatuses																All should work properly
Adjusting accelerator pedal and throttle lever								★						★	Check after 300 hours	
Oil leaks in clutch housing															Check every year by removing the plug installed in the front bottom of clutch chamber	
Hydraulic fluid filter		●							●						Replace after initial 100 hrs.and then after every 300 hrs	
4WD front axle housing oil			●		○		○		○		○		○		Check after every 100 hrs.Replace after every 600hrs	
Rubber pipes				○		○		○		○			○		Check after every 100 hrs.	

- 1) Every terminal should be connected securely
- 2) Wiring should not interfere with other parts.
- 3) Fatigued wiring should be replaced.
- 4) Wiring should be held in each clamp properly.

Disassembly and reassembly of major components

**SECTION 1. GENERAL PRECAUTIONS AND SEPARATION**

**AND REINSTALLATION-----2-1**

**1. Before operation-----2-1**

**2. Precautions to be followed when installing standardized parts.**

-----2-1

**SECTION 2. OPERATION CHART FOR DISASSEMBLY**

**AND REASSEMBLY BY MAJOR BLOCKS -----2-4**

**SECTION 3. SEPARATION OF MAJOR COMPONENTS -----2-5**

**1. Separation of the front axle and axle bracket-----2-5**

**2. Separation of the engine and front axle bracket-----2-6**

**3. Separation of the engine and front transmission-----2-7**

**4. Separation of the front transmission and Spacer transmission-----2-10**

**5. Separation of the Spacer transmission and rear trans mission-----2-14**

**6. Separation of the rear transmission and rear axle housing -----2-17**

**7. Separation of the rear transmission and Cylinder case -----2-18**

# Chapter 2

## Disassembly and reassembly of major components

### SECTION 1. GENERAL PRECAUTIONS FOR SEPARATION AND REINSTALLATION

#### 1. BEFORE OPERATION

- 1) Always be safety-conscious in selecting clothes to wear and suitable tools to use.
- 2) Before disassembly, be sure that you familiarize yourself with the assembled condition for subsequence in reassembly.
- 3) Keep parts and tools in proper order during operations.
- 4) When servicing electrically charged parts, be sure to disconnect the negative battery terminal.
- 5) To prevent oil or water leaks, use the liquid gasket as required.
- 6) When lifting up only the front or rear part of the tractor, be sure to wedge the grounded wheels.
- 8) When the tractor is jacked up, be sure to support the entire tractor with something like a stand. Lifting it up with a jack only is dangerously unstable procedure.
- 9) When replacing parts, use authorized, genuine TYM parts only. TYM assumes no responsibility for accidents, operating problems or damage caused by the use of imitation parts.

Also, the use of unauthorized parts will result in relatively poor machine performance.

#### 2. PRECAUTIONS TO BE FOLLOWED WHEN INSTALLING STANDARDIZED PARTS.

- (1) Roller or Ball bearings
  - 1) When a bearing is fitted in by the outer race, use an installer which is a specially designed to push only the outer race and vice versa.
  - 2) The installer must be designed to install the bearing on the shaft in a parallel position.
  - 3) When installing a bearing which appears the same on both sides, install it so that the face which has the identification number faces in a direction for easy visual identification. All the bearings which are to be installed in the transmission case should be placed so that their identification number faces outward.
  - 4) If a shaft or hole where a bearing is to be installed has a stopper, the bearing should be pushed in completely until it is seated against the stopper.
  - 5) Installed bearings should turn smoothly.
- (2) Oil seals
  - 1) Oil seals installer should be designed so as not to deform the oil seals.

- 2) During installation, be careful not to damage the lips, and assure that it is pushed in parallel to the shaft or hole.
- 3) When oil seals are installed, there should be no turnover of the lips nor dislocation of the springs.
- 4) When a multi-lip seal is installed, the grooves between lips should be filed with grease, not adhesive.

### (3) O-rings

- 1) O-rings should be coated with grease before installing.
- 2) Installed O-rings should have no slack or twist.
- 3) Installed O-rings should maintain proper air tightness.

### (4) Snap rings

- 1) Snap ring installers should be designed so as not to permanently deform the snap rings.
- 2) Installed snap rings should be seated securely in the groove.
- 3) Be careful not to overload the snap ring to the extent that it is permanently deformed.

#### 4) How to install the snap ring:

When installing a snap ring, install it as shown in the figure with its round edge side turned toward the part to be retained. This round edge is formed when the snap ring is pressed out.

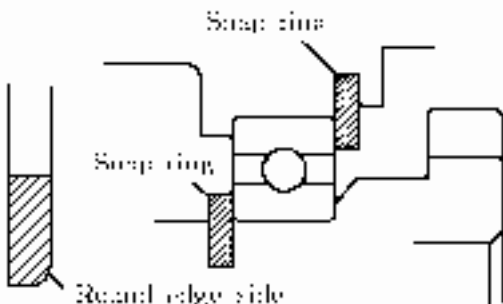

Fig.2-1

### (5) Spring(roll) pins

- 1) Spring pins should be driven in properly as tightly.
- 2) Spring pins should be installed so that their seams should face the direction from which the load is applied.

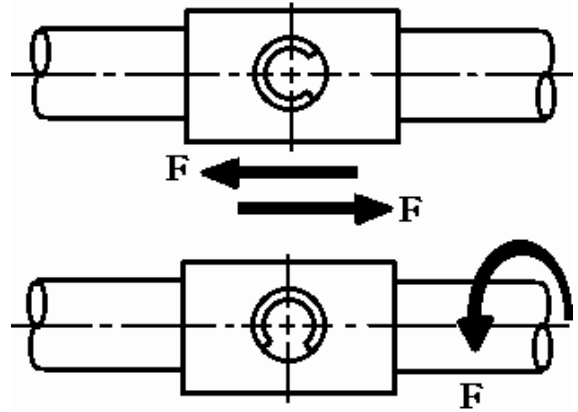

Fig.2-2

- 3) The roll pins installed in the transmission or other parts where much force is applied should be retained with the wire.

### (6) Cotter pins

When installed, cotter pins should be bent securely at the ends as shown in the figure

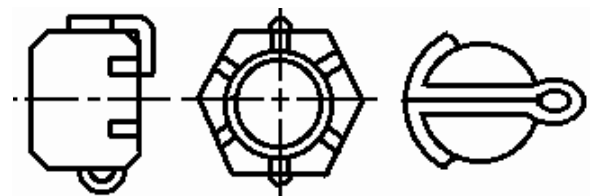

Fig.2-3

### (7) Bolts and nuts

- 1) Special bolts are installed at several locations, so be sure not to interchange them other bolts.
- 2) Bolts and nuts should be tightened to their specified torque wrench.
- 3) When locking the bolts or nuts with wire or a lock washer,

,Be sure to wind the wire paying sufficient attention to its winding direction and bend the lock washer for secure looking.

4) When locking bolts and nuts with an adhesive,apply the adhesive on the thread and tighten securely.

5) Apply an adhesive(THREE BOND TB1104) to parts through which there is any possibility of oil leaks,such as stud bolts and tapped-through parts.

6) Each lock nut must be tightened securely.

7) When tightening bolts and nuts, refer to the tightening torque table.

(8) After installation, each grease fitting should be filled with grease.

1) When installing grease fittings of type B and C,be sure to turn the fitting tips in a direction that will provide easy access for a grease gun.

(9) Other precautions

1) Be sure not to damage any finished surfaces or parts.

2) Always refrain from forcing installation.

3) Each lever knob should be installed coated with an adhesive (SUPER THREE CEMENT TB1702)

4) Each contact surface should be coated with an adhesive(THREE BOND TB 1215) and tightened evenly with bolts.

Adhesive coated surfaces should be installed within 30 minutes after application of the adhesive.

The contact surfaces should be flawless and free from foreign matter,and especially from grease before application of the adhesive.

5) Precautions for applying adhesives.

- The surface or the thread where an adhesive is to be applied should be completely free of chips.

- The surface or the thread where an adhesive is to be applied should be completely free of oil-ness.

## SECTION 2. OPERATION CHART FOR DISASSEMBLY AND REASSEMBLY BY MAJOR BLOCKS

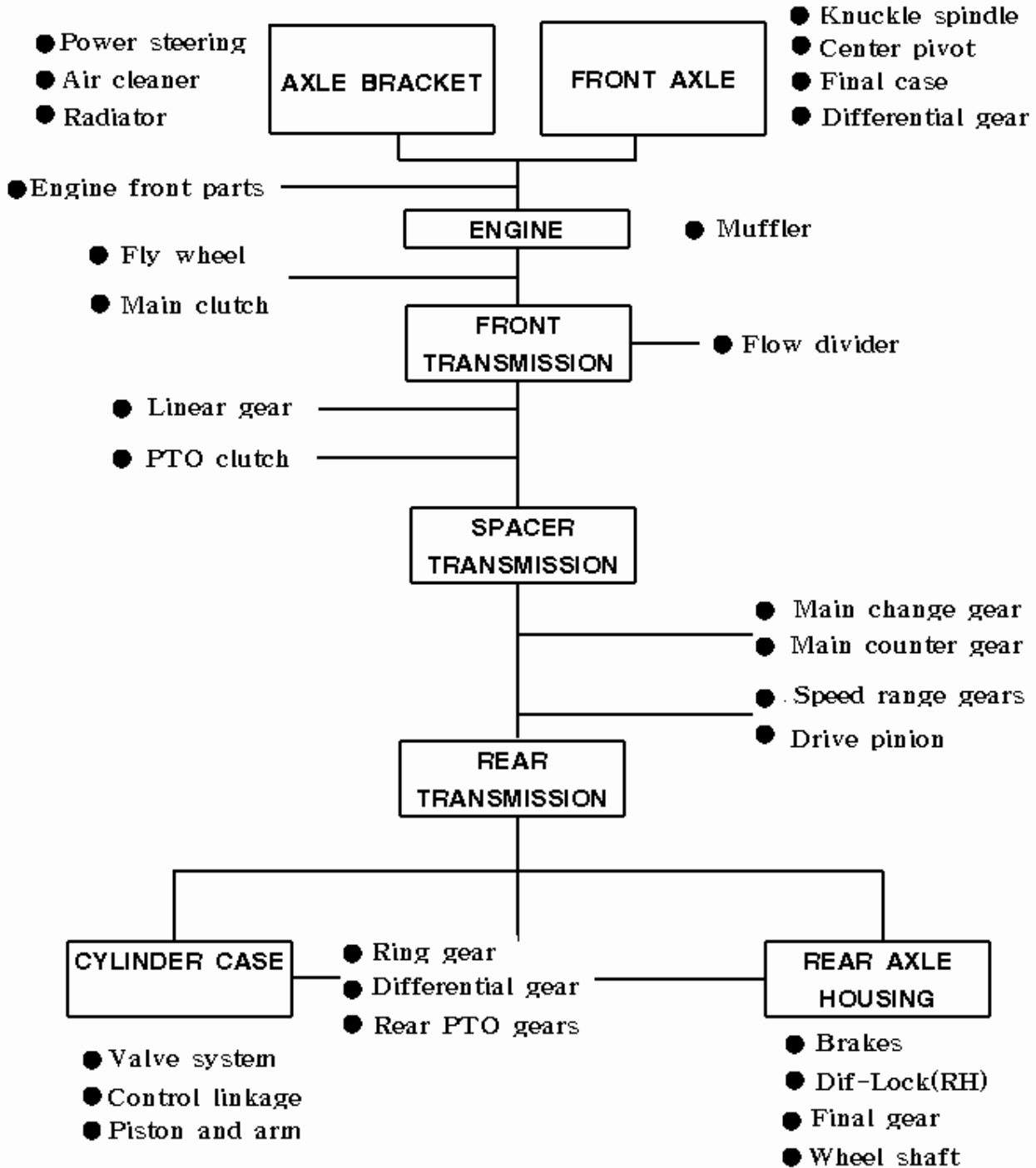

# SECTION 3. SEPARATION OF MAJOR COMPONENTS

## 1. SEPARATION OF THE FRONT AXLE AND AXLE BRACKET

Parts which can be inspected during This operation

- Center pivot
- Final case
- Differential gear

### (1) Removal

- 1) Hold the front hitch or the front bracket securely with a crane or stands.
- 2) Support the front axle with a jack
- 3) Remove both right-hand and left-hand tie rods.
- 4) Remove the pivot metal bolts.
- 5) Remove the front axle assembly forward.



Fig.2-4 Front axle

Note:

When working on the 4WD version, the drive shaft should be removed ahead of time.

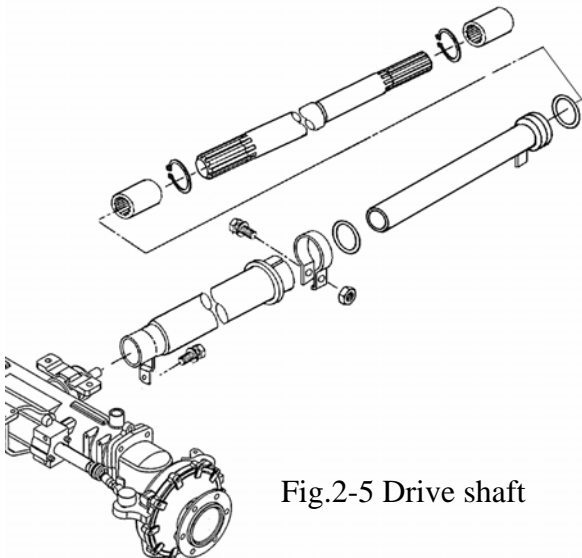

Fig.2-5 Drive shaft

### (2) Installation

- 1) Install the front axle assembly.
- 2) Install both pivot metals(supports)

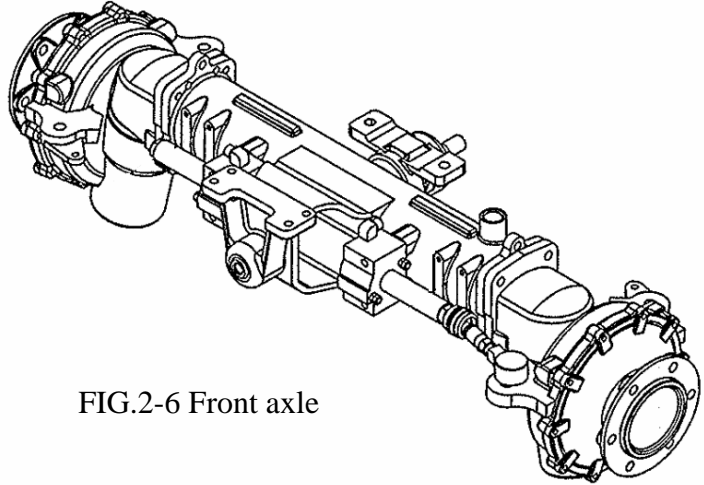

FIG.2-6 Front axle

Note:

Apply grease to the bushing and fill the oil seal with grease ahead of time. Install the oil seal carefully not to allow its lips to turn over.

- 3) install both of the right and left tie rod.

# 1. SEPARATION OF THE ENGINE AND THE FRONT AXLE BRACKET

Parts which can be inspected during This operation

- Air cleaner
- Radiator
- Power steering system
- Engine front part.

## (1) Removal

- 1) Hold or support the engine with a crane or stands.
- 2) Hold or support the front bracket or the axle bracket in a manner that the part other than the engine can be removed if required.
- 3) Remove the side covers (RH and LH) and engine hood.

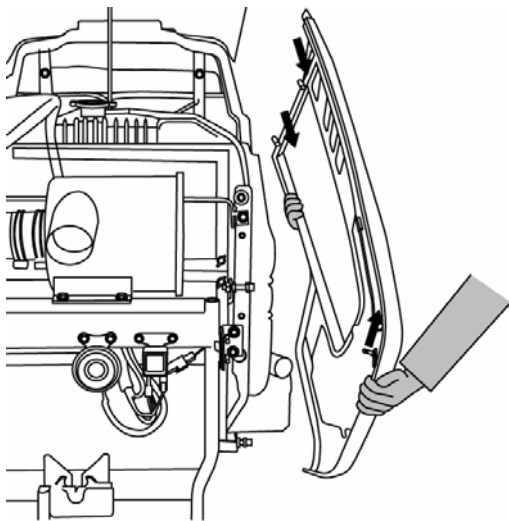

FIG.2-7

- 4) Disconnect the positive and negative battery cables.

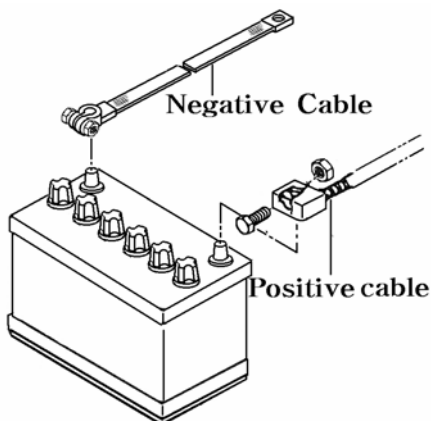

FIG.2-8 Battery

- 5) Open the front grille.
- 6) Detach the head light wiring.
- 7) Remove the other wiring
- 8) Remove the inlet pipe from the air cleaner.
- 9) Remove the air cleaner.

Note:

Here the air cleaner can be moved as an assembly.

- 10) Remove the upper hose, lower hose, and drain hose from the radiator.

Note:

The radiator should be drained of the coolant ahead of time.

- 11) Remove the fuel filter.



Fig.2-9 Fuel filter

- 12) Remove the radiator from the axle bracket



Fig.2-10 Radiator



- 13) Remove the battery and battery bracket.
- 14) Remove the two hoses for the power steering system.
- 15) Remove the mounting bolts of the right hand pivot metal (support) ahead of time.
- 16) At this stage, the power steering unit can be removed by disconnecting both right-hand and left hand tie-rods and removing the unit mounting bolts.

Note:

When the pipes related to the hydraulic system are removed, their openings should be covered with plastic caps or the like to keep out dust or other foreign matter.

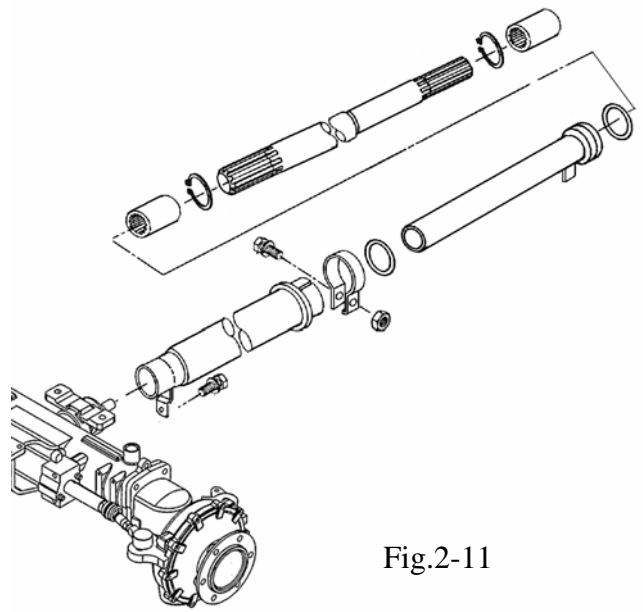

Fig.2-11

## (2) installation

Reassemble in reverse order of removal.

- 1) Install the axle bracket on the engine.
- 2) Retighten the right-hand pivot metal (support) mounting bolts.
- 3) Connect the piping of the power steering system.
- 4) Install the battery bracket and battery.
- 5) Install the radiator and oil cooler on the front axle bracket.
- 6) Connect the upper, lower and drain radiator hoses.
- 7) Install the air cleaner assembly and the inlet pipe of the air cleaner.
- 8) Connect the wiring of the head lights and other harness.
- 9) Connect the ground strap and the battery cables.
- 10) Install the engine hood.
- 11) Install the side covers.
- 12) Fill the radiator with coolant.

- 2) Support the engine on the bottom with a jack or stands.
- 3) Hold the transmission with a garage jack or a crane so that the transmission side can be moved when needed.
- 4) Remove both side covers (RH and LH) and engine hood.

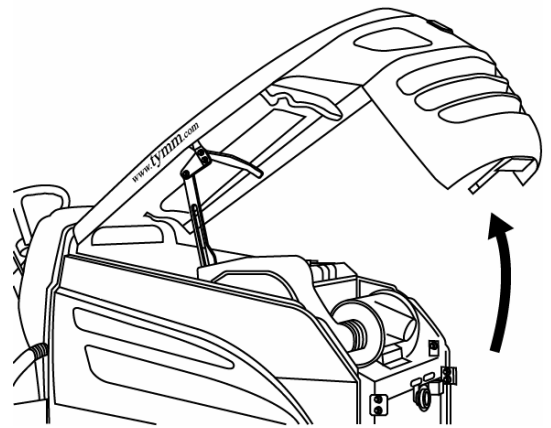

FIG.2-12

## 3. SEPARATION OF THE ENGINE AND THE FRONT TRANSMISSION.

Parts which can be inspected during this operation.

- Fly wheel
- Main clutch

### (1) Removal

- 1) Drain the transmission of the oil (In the case of the 4WD version), remove the front wheel drive shaft.

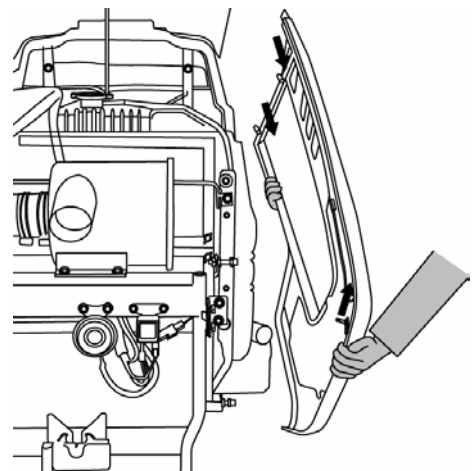

FIG.2-13

5) Disconnect the battery cables.

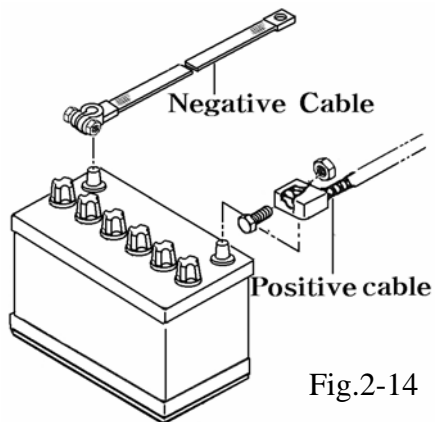

Fig.2-14

6) Disconnect the panel instrument set removing bolts(4 nos.)



Fig.2-15

Note:

- Tilt the steering column rearwards.
- Lift up the panel set and disconnect the wiring couplers.

7) Remove the cover.



Fig.2-16

8) Disconnect the hydraulic hose from the power steering (orbitrol)

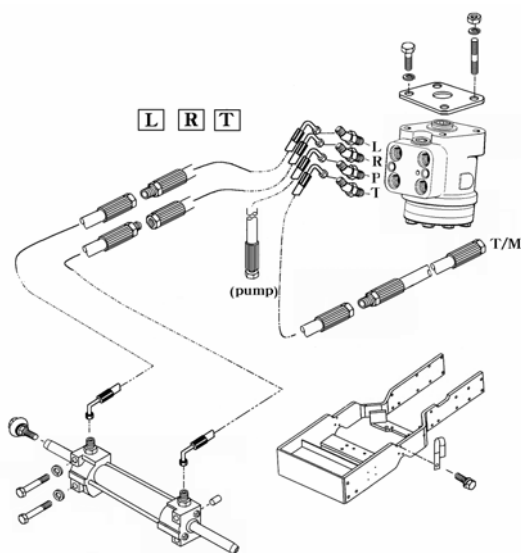

Fig.2-17

Note:

- Disconnect the linear shift control cable
- Disconnect the cable from both the steering lever side and transmission.

10) Remove the mounting bolts and dismounting the dash panel

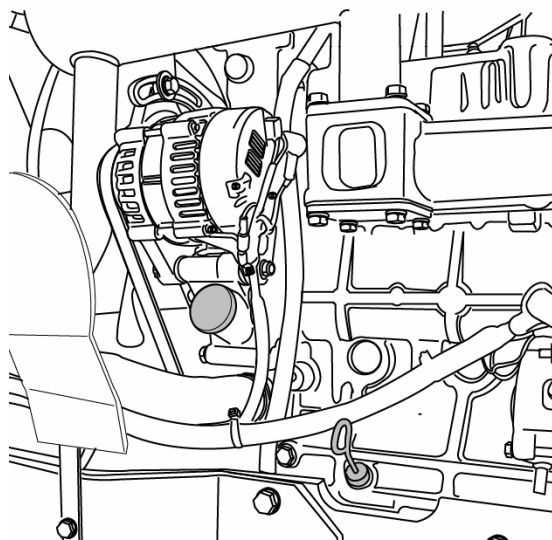
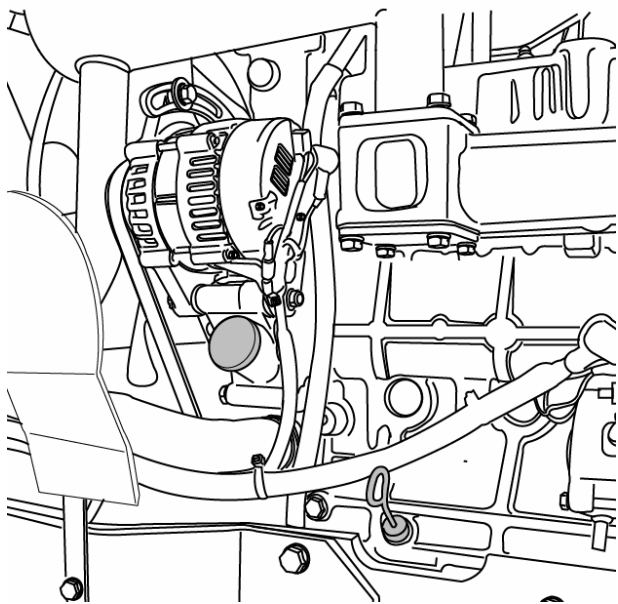

FIG.2-18 hardware Disassembly

11) Disconnect the rubber hose from the suction pipe.



- 12) Wedge both sides of the front axle to prevent the engine from tilting.



FIG.2-19 Wedging

- 13) Remove the clutch housing and engine tightening bolts and move the engine forward.



FIG.2-20 Engine

## (2) Engine separation from the chassis.

When separating the engine from the chassis, the following steps are required as well as the ones mentioned above.

- 1) Lift the engine with the hoist and hold the front axle bracket with a stand or the like.
- 2) Disconnect the upper, Lower, and drain hoses from the radiator.
- 3) Disconnect the two power steering system hoses.
- 4) Remove the fuel hose.
- 5) Disconnect the inlet pipe.
- 6) Loosen the right hand pivot metal tightening bolts beforehand.
- 7) Separate the engine from the front axle bracket.

## (3) INSTALLATION

### REASSEMBLY IN REVERSE ORDER OF REMOVAL.

- 1) Install the engine on the front axle bracket.
- 2) Retighten the right hand pivot metal tightening bolts.
- 3) Connect hoses.
- 4) Assemble the engine and the front transmission.

#### Note:

- Apply small amount of grease to each of the sliding parts. Be careful not to apply excessive amount of grease as this could cause clutch slipping.
- During operation, be sure to avoid any of the reassembly operations that may place load upon the input gear.

- 5) Install the hydraulic system piping.
- 6) Install the dash panel.
- 7) Install the wiring and rods.
- 8) Install the covers.
- 9) Connect the panel set wiring and then install the panel.
- 10) Connect the wiring for the engine.
- 11) Connect the battery terminals.
- 12) Install the engine hood and side cover.

# 4.SEPARATION OF THE FRONT TRANSMISSION AND SPACER TRANSMISSION

Parts which can be inspected during This operation

- PTO clutch
- Linear shift gears and related parts
- Main change gears

## 1) Removal

A:Removal of the whole floor.

1) Remove the side covers(LH and RH).

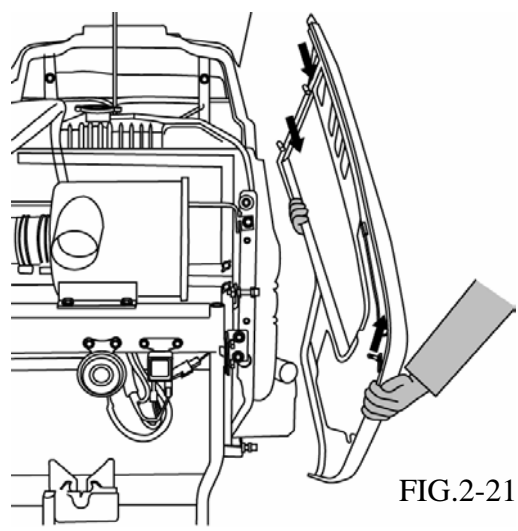

FIG.2-21

2) Disconnect the negative battery cable.

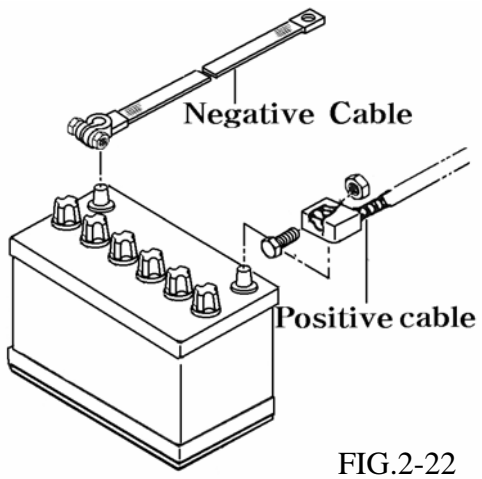

FIG.2-22

3) Detach all the wiring relevant to the removal of the floor.

4) Disconnect the throttle lever cable from the fuel injection pump and accelerator pedal cable from the pedal.

5) Remove the frames(LH and RH)

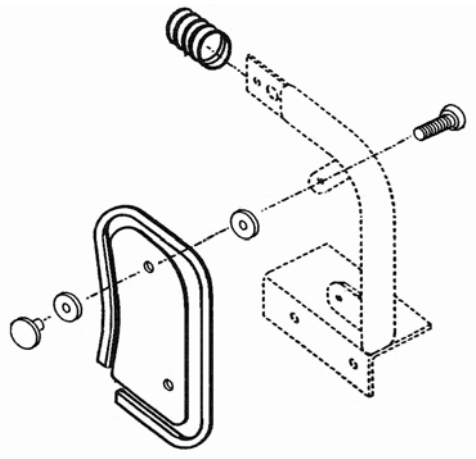

FIG.2-23

6) Disconnect the clutch rod and brake rods under the floor.

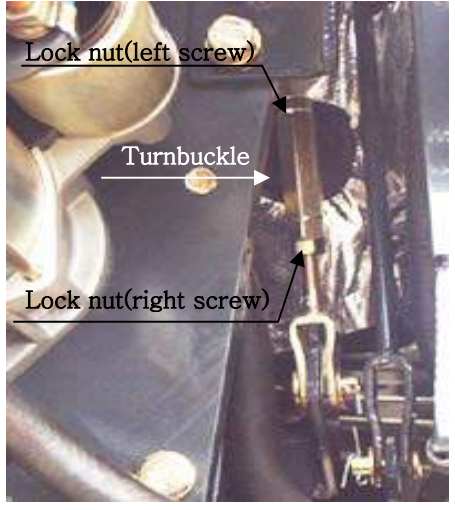

FIG.2-24

7) Remove the slow-return check valve knob.



FIG.2-25 Slow return check valve



8) Remove the dif-Lock pedal



Fig.2-26 Diff-lock pedal

9) Remove the main shift and transmission range shift levers. The levers can be separated in the middle.

10) Remove the control rods of the PTO shift and 4WD shift levers from the transmission.

11) Remove the position and draft control levers.

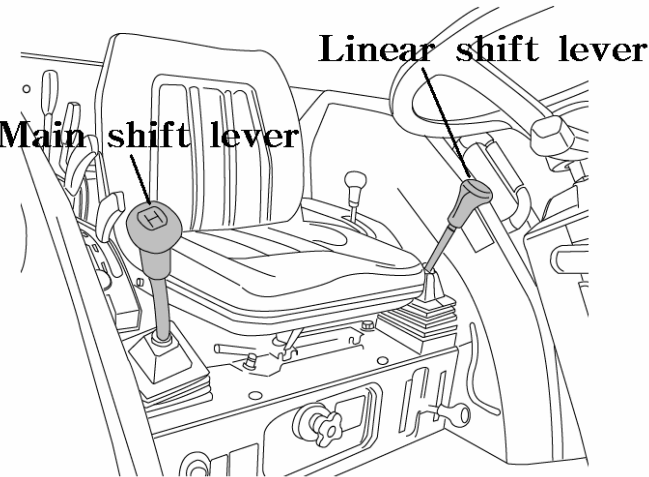

FIG.2-27 Range shift lever

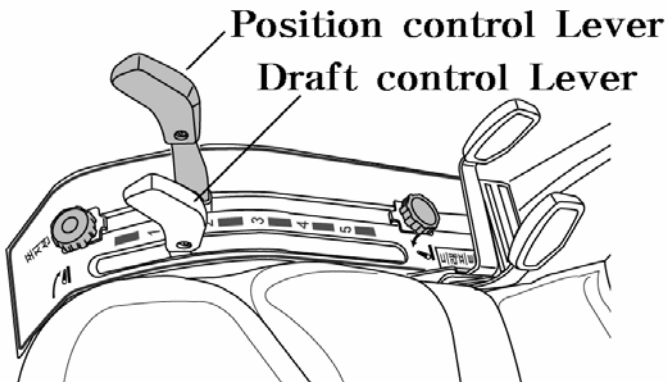

FIG.2-28 position ,Draft control lever

13) When the tractor is equipped with an optional remote control valve, remove the remote control valve link.

14) Drain the fuel system of fuel.

15) Remove four rubber mounts.

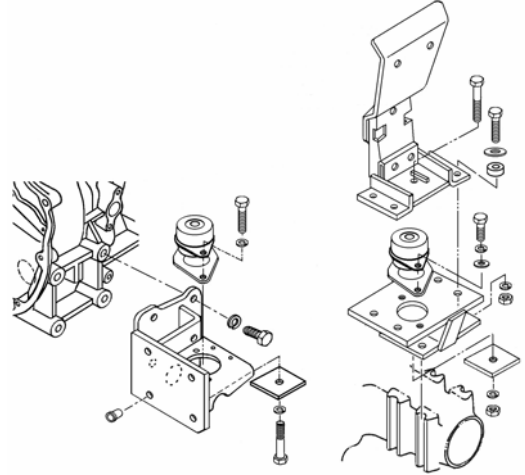

Fig.2-29 Rubber mounting

16) Lift up the floor slightly with a hoist.

17) Disconnect the linear shift control cable, fuel hoses, and gauge coupler between the fuel tank and floor.

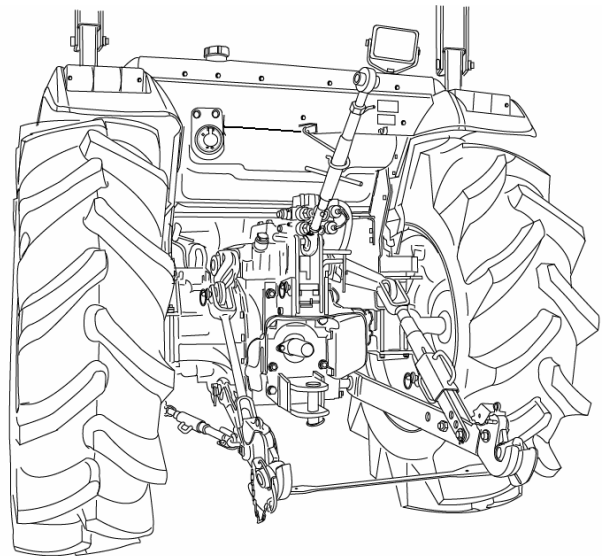

FIG.2-30

18) Lift the floor gradually taking care not to allow the shaft of the slow return check valve and its hole in the floor to interfere with each other.



FIG.2-31 Slow return check valve

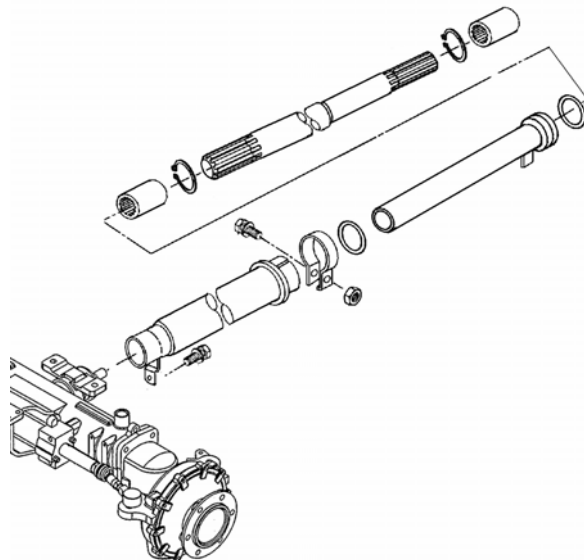

FIG.2-33 Front wheel drive

3) Disconnect the brake rods.

Note:  
Lift up the floor gradually making sure that all relevant wiring, piping, and links are disconnected.

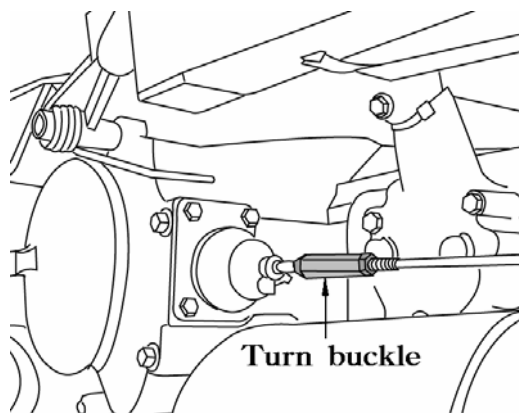

FIG.2-34 Brake rod.



FIG.2-32 Floor

4) When the tractor is equipped with an optional remote control valve, remove the remote control piping.

B: Division of the chassis.

- 1) Drain the transmission of oil
- 2) Remove the front wheel drive shaft

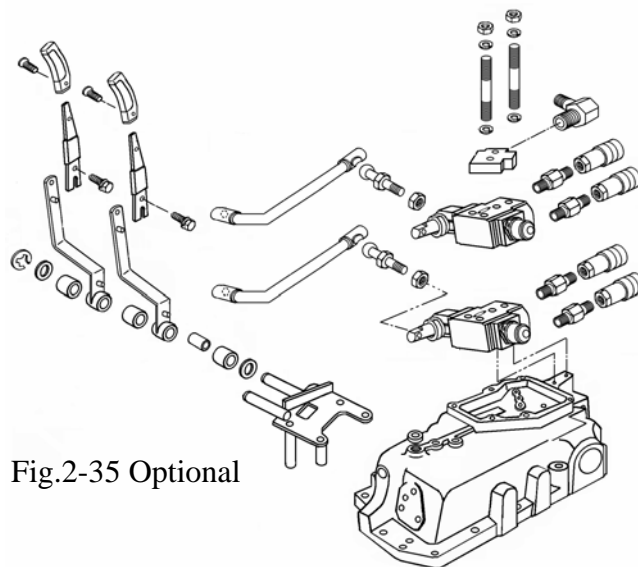

Fig.2-35 Optional

- 5) Remove the suction and delivery pipes.
- 6) Remove the delivery pipe for the PTO clutch.
- 7) Remove the reverse shift metal(support)

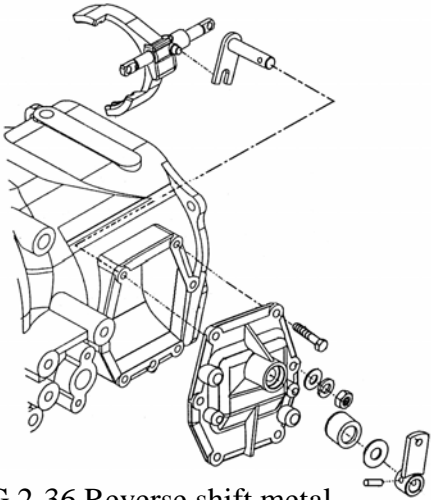

FIG.2-36 Reverse shift metal

- 8) Hold the clutch housing and spacer transmission case with a crane or jack.
- 9) Remove the bolts which tighten the front transmission and spacer transmission cases.
- 10) Move the rear part of the tractor rearwards by turning the rear wheels by hand, and then the spacer and rear transmission assembly will be separated from the front transmission.

**Note:**

When moving the rear part of the tractor, be careful not to allow the garage jack to shift from the spacer transmission case.

**Remarks**

The rear transmission and spacer transmission cases should be separated and the reverse shift metal(support) removed in order to take care out or provide access to the main shift and transmission range shift gears. For further details, refer to Chapter 5. Transmission.

**2.installation**

- Reassemble in reverse order of disassembly.
- (1) Assemble the front and spacer transmission.

**Note:**

Make sure that the turning lock of the PTO clutch is securely seated in the groove in the Front transmission case.

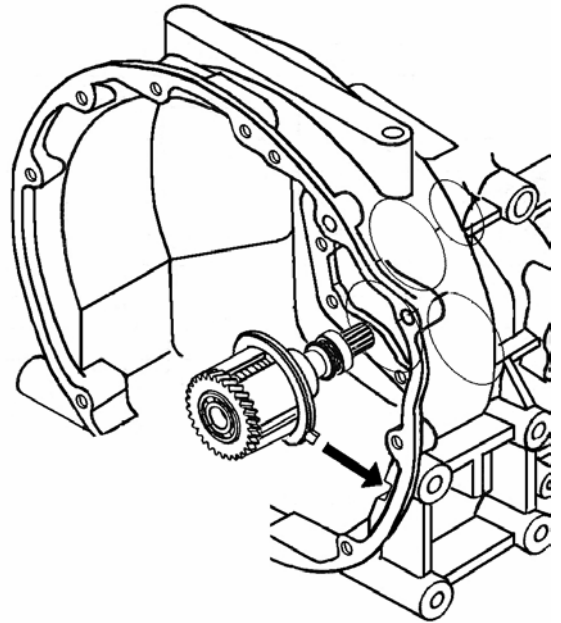

Fig.2-37

- (2) Install the reverse shift metal(support)
- (3) Install the PTO clutch delivery piping.
- (4) Install brake rods.
- (5) Install the front wheel drive shaft.
- (6) Position the floor taking care not to allow wiring or other parts to be pinched under it
- (7) With the floor lifted up a little, install the fuel hose and fuel gauge coupler on the fuel sub-tank and connect the linear shift control cable.
- (8) Fix the floor at the four rubber mounts.
- (9) Install all levers, knobs, and Rods.
- (10) Connect the power steering wheels.
- (11) Connect the accelerator wires.
- (12) Install wiring
- (13) Connect the negative battery cable.
- (14) Install the side covers(RH and LH)
- (15) Fill the transmission case with oil

3510/4110/T390(T400)/T430(T450):34(9 us gal)

## 5.SEPARATION OF THE SPACER TRANSMISSION AND REAR TRANSMISSION

Parts which can be inspected during This operation

- Drive pinion gear
- Speed range gear(Transmission range shift)
- Main change gear.
- 4WD drive gear

### 1) Removal

- (1) remove side cover(LH and RH)
- (2) Disconnect the negative battery cable
- (3) Remove the slow-return check valve knob.



FIG.2-40 slow return check valve knob

- (4) Remove the diff-lock pedal
- (5) Remove the Main speed shift and transmission range shift levers.The lever can be separated in the middle
- (6) Disconnect the PTO change and 4WD change rods from the transmission.
- (7) Remove the operator's seat

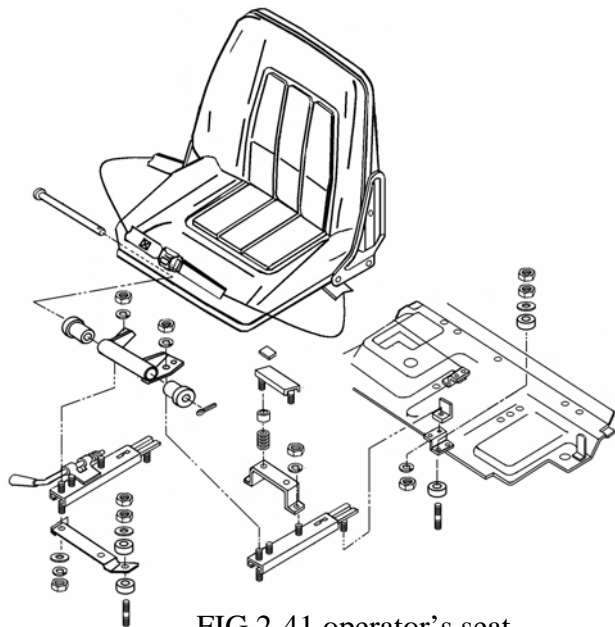

FIG.2-41 operator's seat

- 8) remove the position control lever and draft control lever

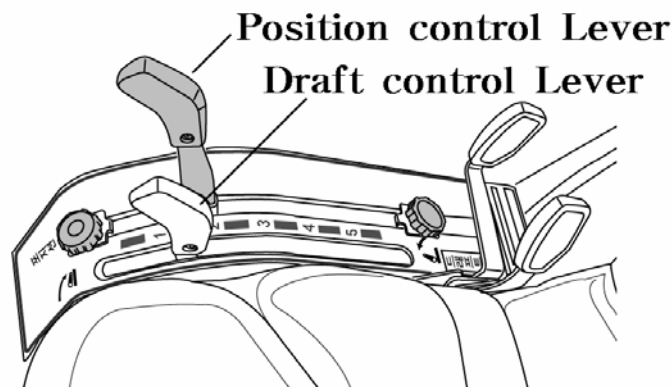

FIG.2-42

- (9) Remove the lever guide.
- (10) When the tractor is equipped with an optional remote control valve,remove the remote control valve and relevant parts from the bracket.
- (11) remove the back panel.
- (12) remove the fuel tank cover
- (13) Drain the fuel of fuel tank.
- (14) Remove the fuel tank and tank stay.
- (15) Remove the floor frame.
- (16) Drive in a chock between the front axle housing and axle bracket.



FIG.2-43.Chock

- (17) Place a jack under the bottom of the spacer transmission case to support
- (18) Lift up the rear transmission and remove the right and left rear wheel



(19) Remove two rubber mounts.

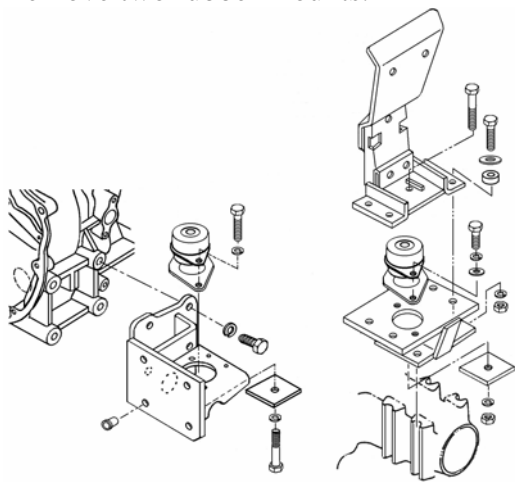

FIG.2-44 Frame rubber mounts.

(20) Lift up the rear end of the floor/fender assembly by about 100 mm, and place wood between the spacer transmission case and floor panel

(21) Drain the transmission of oil

(23) Remove the assembly of the remote control valve and piping.

(24) Remove the suction and delivery pipe

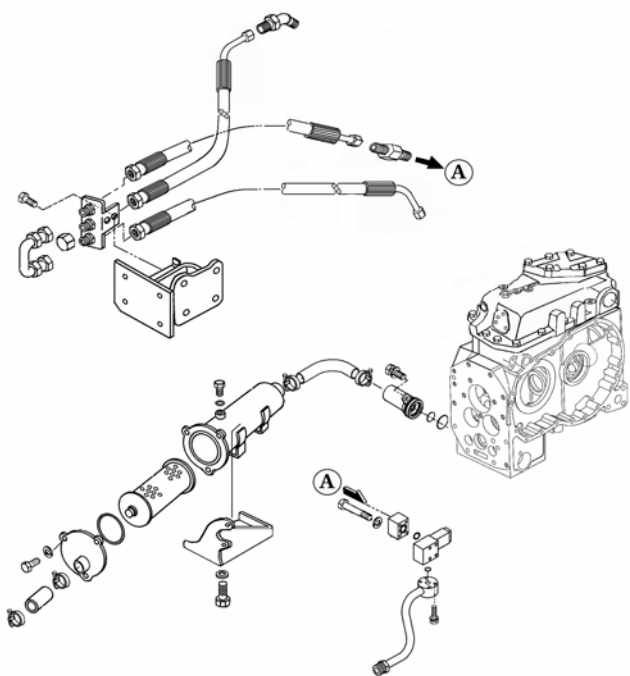

FIG.2-45

(25) Remove the front wheel drive shaft

(26) Remove the brake rods.

(27) Remove the main change metal and sub change metal(Support)

(28) Remove the 4WD shift metal

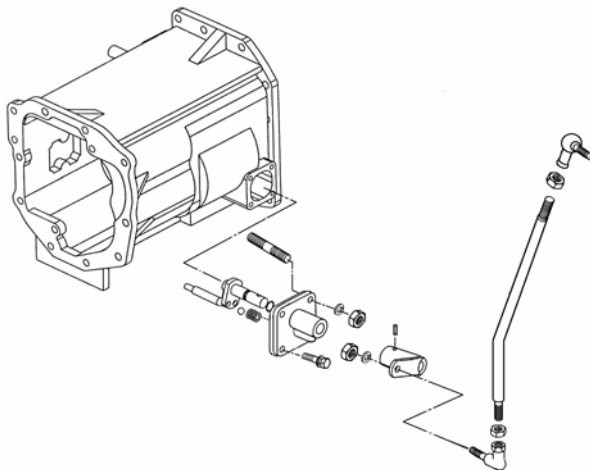

FIG.2-46 sub change metal

(29) Remove all the spacer-rear transmission case tightening bolts and nuts except the bottom bolt.

(30) Install the rear wheels(LH and RH) and the remained bolts. Then turn the rear wheels by hand to move the rear transmission case away from the spacer transmission case.

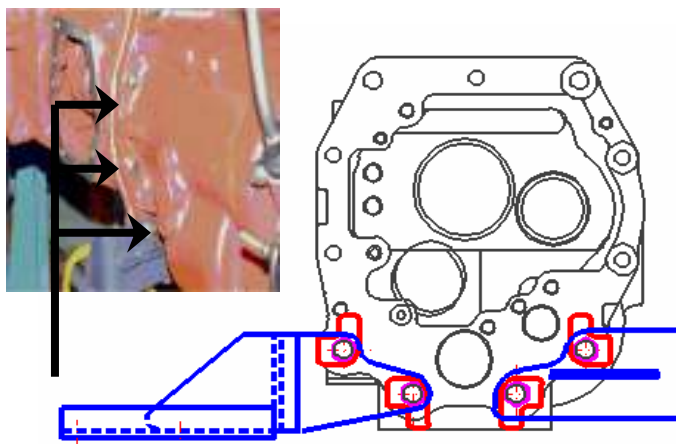

FIG.2-47 space transmission bolt

2) Installation

Reassemble in reverse order of disassembly.

Note:

- The 4WD drive shaft should be installed on the rear transmission ahead of time.

(1) Join the rear and spacer transmission cases.

Note:

During the operation, be careful not to damage needle bearings, the cut-away part in the gear should be turned downward without fail so as to clear the gear to be positioned underneath.

- (2) Install the main change shifter link and each change metal.
- (3) install the brake rods and front drive shaft.
- (4) Install the hydraulic piping.
- (5) Install two rear rubber mounts.
- (6) Install exterior parts.
- (7) Fill the transmission case with oil  
3510/4110/T390(T400)/T430(T450):34(9 us gal)

## 6.SEPARATION OF THE REAR TRANSMISSION AND REAR AXLE HOUSING

Parts which can be inspected during This operation

- Diff Lock
- Brakes
- Final gears

### 1) Removal

As both sides can be disassembled in the same way,only side with the diff-lock installed will be explained here.

- (1) Drain the transmission case of oil
- (2) Lift up the rear transmission and remove the rear wheel on the diff-lock side.

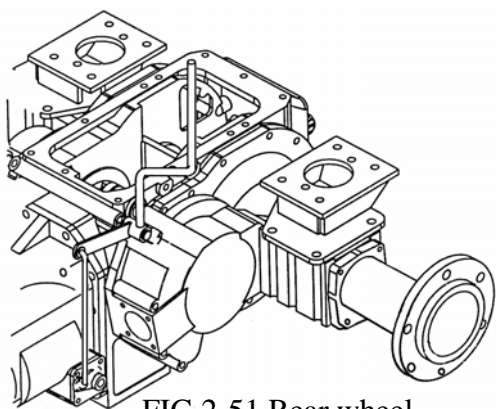

FIG.2-51 Rear wheel

- (3) Remove the diff-lock pedal



FIG.2-52 Diff-lock pedal

- (4) Remove the brake rods.
- (5) Remove the 3-point linkage and related parts.

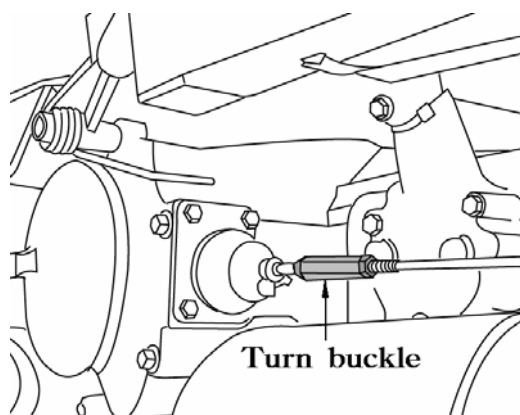

FIG.2-53 Brake rod

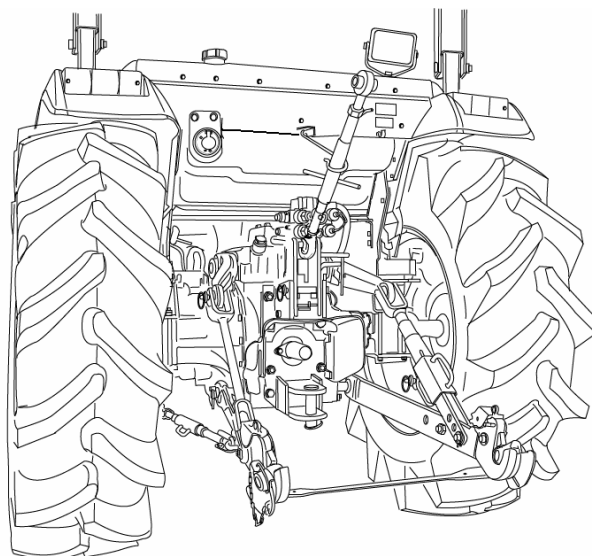

FIG.2-54 3-point linkage

- (6) Support the floor panel with a trestle or the like.
- (7) Remove the rubber mount along with the bracket.

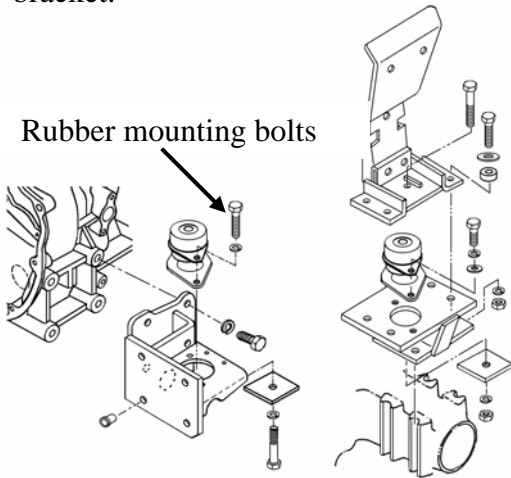

FIG.2-55 Frame rubber mounts.

- (8) Remove the rear axle housing tightening bolts.
- (9) Detach the rear axle housing from the rear transmission case

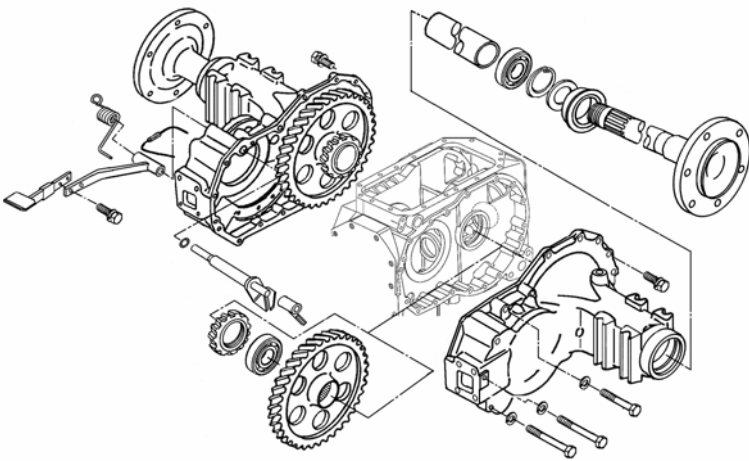

FIG.2-56 Rear axle housing

- 2) Installation
- Reassemble in reverse order of disassembly.
- (1) join the rear axle and rear transmission

Note:

Make sure that the diff-lock shifter is fitted into the groove in the dif-lock metal

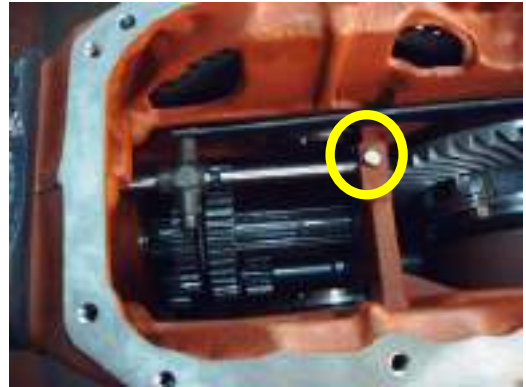

FIG.2-57

- (2) Reinstall the other removed parts.
  - (3) Mount the rear wheel.
  - (4) Refill the transmission with oil up to the specified level
- Level up to fill the oil can be sought from the rear side of rear transmission case(Window)

## 7. SEPARATION OF THE REAR TRANSMISSION AND CYLINDER CASE

Parts which can be inspected during This operation

- Control valve
- Control linkage
- Piston and lift crank linkage
- PTO change gears.

Inspection and service of the rear transmission should be performed following the instructions in the paragraph : 5 SEPARATION OF THE REAR TRANSMISSION AND SPACER TRANSMISSION

### 1) Removal

- (1) Remove the operator's seat.

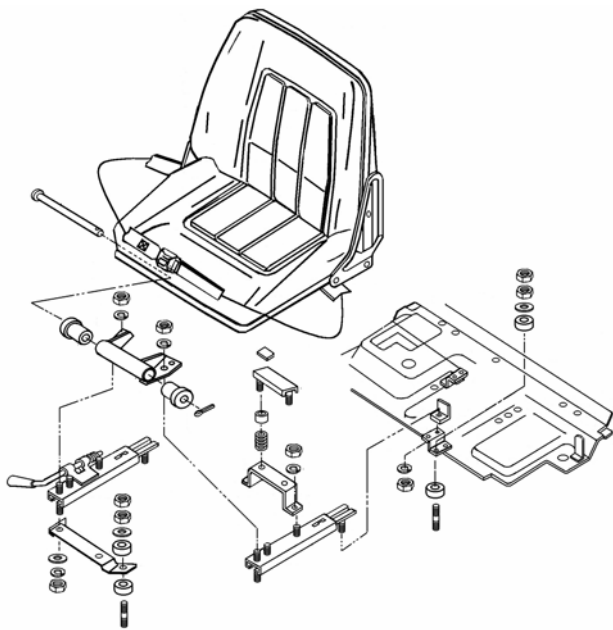

FIG.2-58 operator's seat

- (2) Remove the position lever
- (3) Remove the lever guide(RH)
- (4) When the tractor is equipped with an optional remote control valve, remove the remote control lever and related parts from the bracket.
- (5) Remove the back panel
- (6) Remove the tank cover
- (7) Remove the wiring for the rear combination lamps and trailer socket coupler.
- (8) Drain the fuel of fuel tank.
- (9) Remove the fuel tank and tank stay bracket .

- (10) Detach the delivery pipe from the cylinder case.
- (12) Remove the slow-return check valve along with the shaft.
- (13) Remove the 3-point lift link and related parts from the lift arm.
- (14) Remove the Cylinder case tightening bolts.
- (15) Detach the cylinder case assembly from the rear transmission

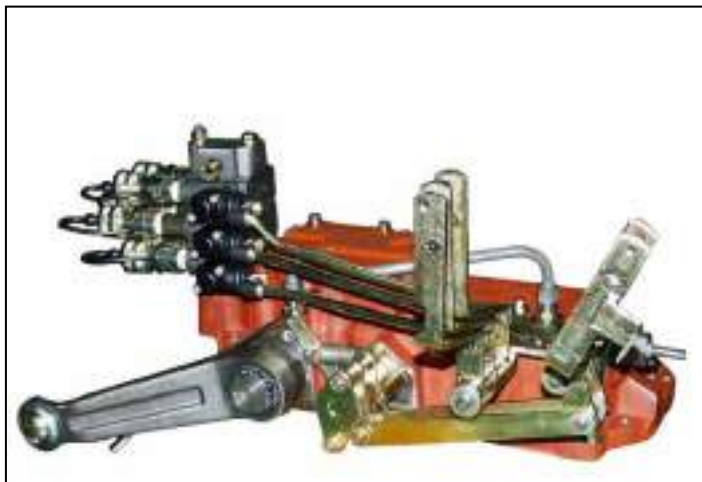

FIG.2-59 cylinder case

### 2) Installation

Reassemble the reverse order of disassemble.

- (1) Tighten the cylinder case on the rear transmission case to the specified torque.

Tightening torque	5.5~7.0 Kgf.m (39.8~50.6lb.ft)
-------------------	-----------------------------------

- (2) After reassembly, make sure that the system functions properly.

**SECTION 1. RADIATOR -----3-1**

**1. General description -----3-1**

**2. Radiator -----3-2**

**3. Specifications-----3-3**

**4. Removal of the radiator-----3-3**

**5. Inspection of each part -----3-3**

**6. Radiator reassembly -----3-5**

**7. Daily inspection -----3-5**

**8. Trouble shooting -----3-6**

**SECTION 2. AIR CLEANER SYSTEM----- 3-7**

**1. General description-----3-7**

**2. Double elementary air-cleaner -----3-8**

**3. Inspection of each part-----3-9**

**4. Cleaning of the air cleaner-----3-9**

**5. Element installation-----3-10**

# Chapter 3.Engine accessories

## SECTION 1. RADIATOR

### 1.General description

The pressure cooling system includes mainly the radiator,water pump,multi-blade fan, and

the thermostat.During the warm-up period,the thermostat remains closed and coolant is directed through by-pass to the suction side of the water pump.

Coolant then circulates through the cylinder block and water pump only to provide a uniform and fast warm-up period. Once the engine has reached operating temperature,the thermostat opens and coolant is pumped from the bottom of the radiator via the lower hose into the cylinder block. Here it circulates through the block and around the cylinders.

From the cylinder block,coolant is directed through the cylinder head and into the thermostat housing.With the thermostat open,coolant passes through the housing and upper radiator hose into the top of the radiator where it is circulated to dissipate heat.

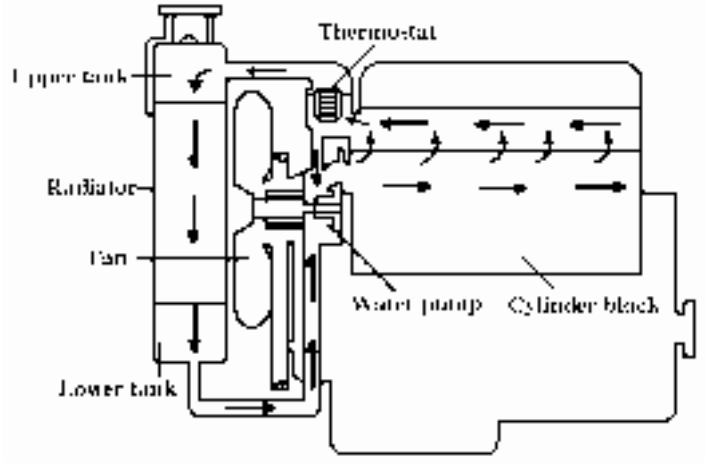

FIG.3-1

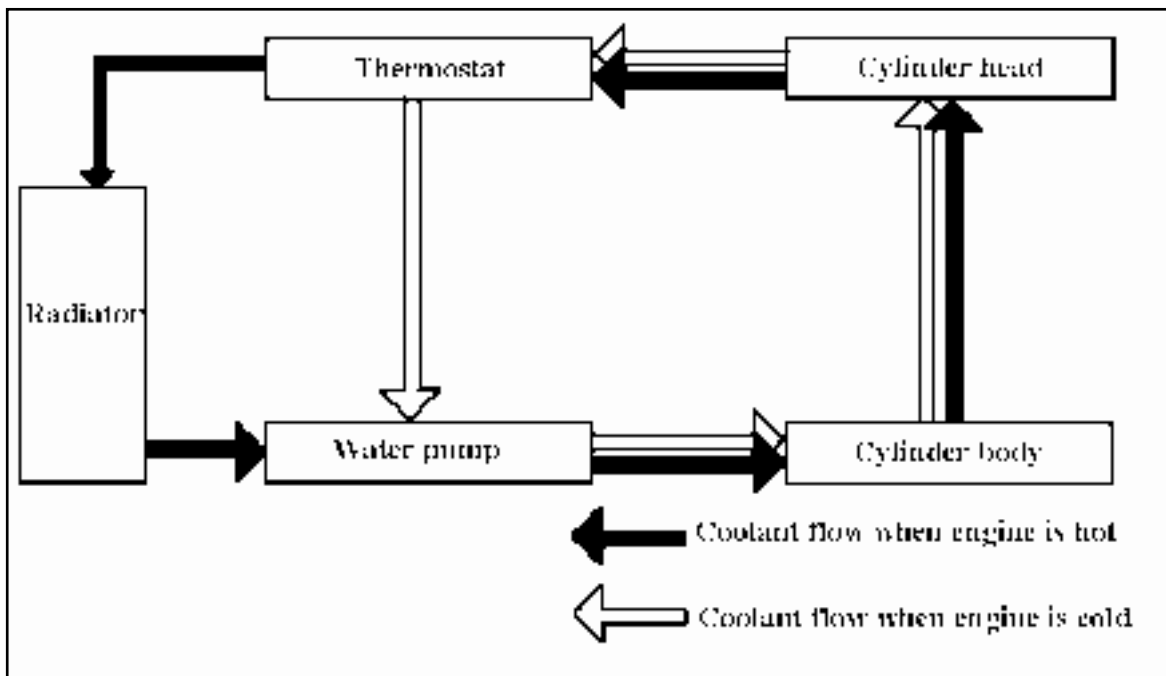

FIG.3-2



## 2. Radiator

The radiator consists of radiator cores, a tank to Flow coolant, side plates to install the radiator, and a fan guide.

Fin-tube type cores are used and the cores and tank is made of anti corrosive copper and Copper alloy.

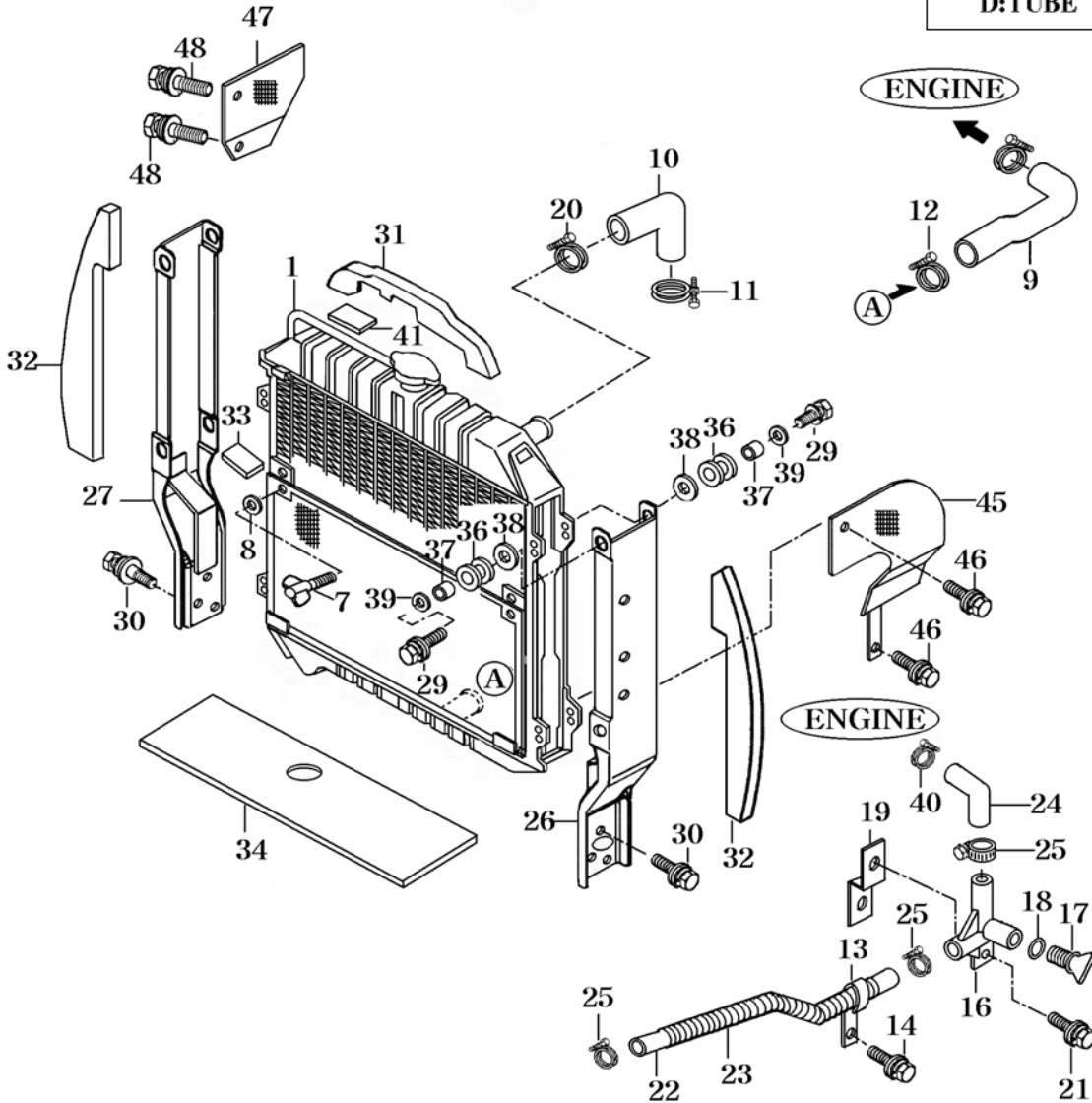
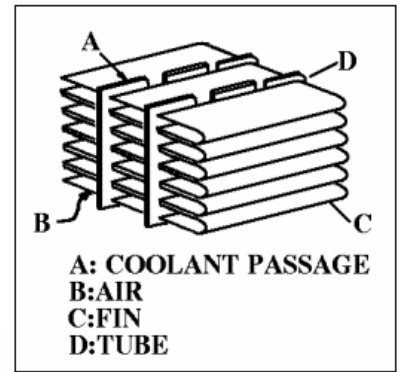

FIG.3-3

- |                 |                          |              |                   |                      |                |
|-----------------|--------------------------|--------------|-------------------|----------------------|----------------|
| 1.Radiator assy | 5.Bolt                   | 6.Net        | 7.Wing bolt       | 8.Washer plain       | 9.Hose(outlet) |
| 10.Hose(Inlet)  | 11. Clip(42)             | 12.Clamp     | 13.Clip           | 14.Bolt(SP)          |                |
| 15.Clip         | 16.Connector             | 17.Plug      | 18.O-ring(P)      | 19.plate             |                |
| 20.Clip(42)     | 21.Bolt(SP)              | 22.Hose(380) | 23.Corrugate      | 24. Hose             |                |
| 25.Hose band    | 26.Bracket               | 27.Bracket   | 28.Bolt(SP)       | 29.Bolt(S)           |                |
| 30.Bolt(SP)     | 31. 32. 33. 34.Insulator | 36.Grommet   | 37.Collar(8X12X8) | 45. Safety cover(LH) |                |
| 38.Collar       | 39.Washer                | 40.Band      | 41.Insulator      |                      |                |
| 46.Bolt(SP)     | 47.Safety cover(RH)      |              | 48.Bolt(SP)       |                      |                |

### 3. SPECIFICATIONS

Description	3510/4110/T390/T430
Radiator core type	Flat water tube with corrugate fins
Core train number	3 trains
Radiator fin pitch	3 mm
Thermal radiator area	18.04m <sup>2</sup>
Pressure valve opening pressure	1.1±0.15Kgf/ cm <sup>2</sup>
Coolant capacity	7 ℓ(contains in cylinder block)
Test pressure	1.5 Kgf/cm <sup>2</sup>

#### 4. REMOVAL OF THE RADIATOR

- 1) Release the clamp and remove the upper hose.
- 2) Release the clamp and remove the lower hose.
- 3) Release the hose clamp and remove the water drain hose.

Note:

- Refer to the paragraph "SEPARATION OF THE ENGINE AND THE FRONT AXLE BRACKET" in chapter 2 for operation up to this step.

-When removing the radiator,take care not to damage the radiator cores and oil cooler.

#### 5. INSPECTION OF EACH PART

##### (1) Inspection for radiator water leaks.

Water leaks are liable to occur at the fitting portion between the upper tank and the core section or between the lower tank and the core section.

If any water leak should occur there,repair the leak by soldering.Besides making a visual check,a more complete inspection should be accomplished as follows:

##### a. Leak test with compressed air.

Place the radiator as shown in the figure. Close the openings for water inlet and with something like a rubber plug and apply compressed air (1kgf/cm<sup>2</sup> or 14.2psi) through the drain pipe into the radiator.

Excessively compressed air may damage the cores, so perform the air delivery carefully,watching the pressure gauge. Water leaks are inspected by watching for rising air bubbles.

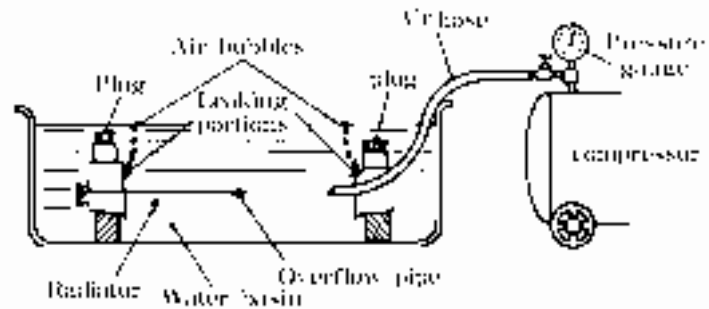

FIG.3-4

##### b.Leak test with a radiator cap tester

With the inlet and outlet pipes plugged up and the radiator filled with water,replace radiator cap with a radiator cap tester as shown in the figure. Pump up the pressure in the radiator to the specified value and check to see if there are any leaks in the radiator.

When the radiator is water-tight,the pressure indicated on the pressure gauge does not increase,but if there are leaks,the pressure decreases.This tester is also applicable for leak tests for the whole cooling system,not only for the radiator.The test method is the same as mentioned above.



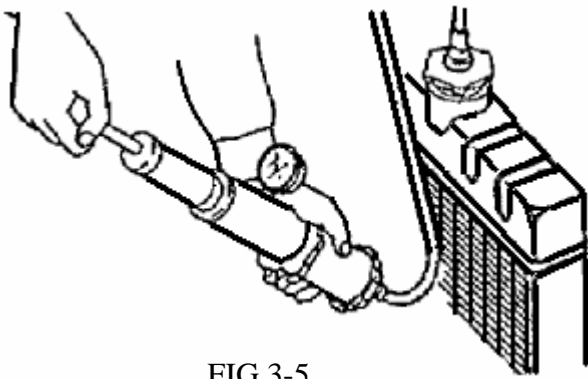

FIG.3-5

Testing Pressure	1.0Kgf/ $cm^2$
------------------	----------------

## 2) Inspection for radiator clogging

To inspect the radiator cores to see if they are clogged with fur or rust, remove the radiator cap and check for transparency of the coolant, and for rust or fur formation around the radiator throat inside the radiator.

If some rust or fur has formed or the coolant transparency is very poor, the radiator should be cleaned.

### a. Cleaning the radiator inside.

-Place the radiator upside down and supply pressurized water from a faucet to the lower tank, draining through the upper tank, as shown in the figure to wash out accumulated deposits.

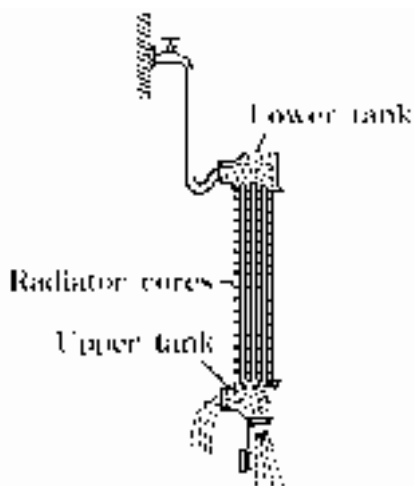

FIG.3-6

-Clean with a detergent

When cleaning the radiator with a detergent, follow the instructions given by its manufacturer. Different detergents have different characteristics.

### b. Cleaning the radiator exterior

- Cleaning the net (wire mesh)

After the tractor has been operated in dusty conditions, check the net daily and clean it if necessary.

-Cleaning the radiator cores

Clean the radiator cores by applying water spray or compressed air so as to for a right angle with the radiator cores, moving water application in parallel.

Note:

When cleaning the radiator cores with pressurized water, be sure to apply it at a right angle to the cores. Slanted application might deform their cooling fins.

## 3) Visual inspection of the exterior parts

When the radiator exterior is corroded, cracked, or badly damaged, replace the radiator. Also replace damaged or fatigued water hoses.

Retighten loose hose clamps securely if water is leaking through the hose clamps securely, or replace them if necessary.

## 4) Inspection of the radiator cap.

Check the radiator cap to see if it functions normally, using a radiator cap tester as following.

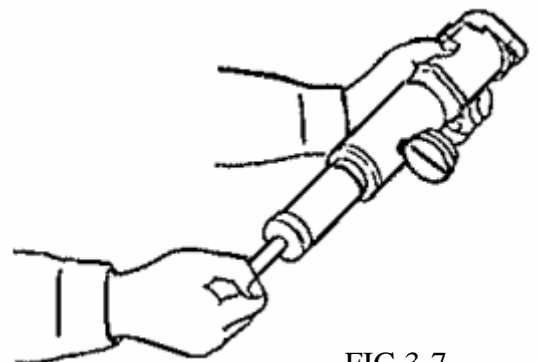

FIG.3-7

Pressure valve Opening pressure	1.05 Kg/ cm <sup>2</sup> (14.93 psi)
Vacuum valve Opening pressure	0.04-0.05 Kg/ cm <sup>2</sup> (0.57-0.71psi)

-Function test:

The pressure type radiator cap has a pressure valve and a vacuum as shown in the figure.

Both valves are held against there seats by springs while the pressure in the cooling system remains within a specified range,thus keeping the cooling system air-tight.

When the pressure in the radiator rises higher than the specified valves,it overcomes the force of the pressure valve spring and open the pressure valve to release excess pressure through the overflow pipe as shown in the figure.

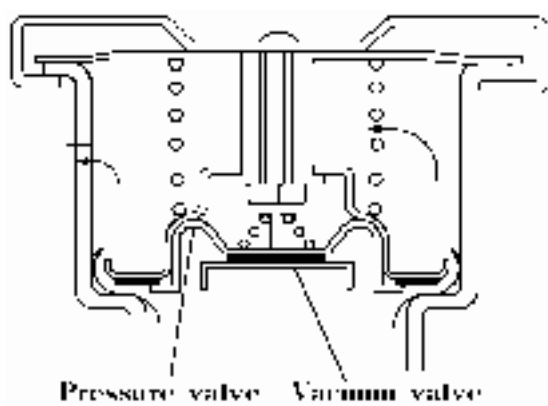

FIG.3-8

When the coolant temperature falls enough to cause the vapor to condense in the cooling system and decrease the coolant volume,the radiator pressure becomes negative.When this occurs,the vacuum valve opens to let outside air into the radiator as shown in the figure,

thus preventing the radiator from being deformed.

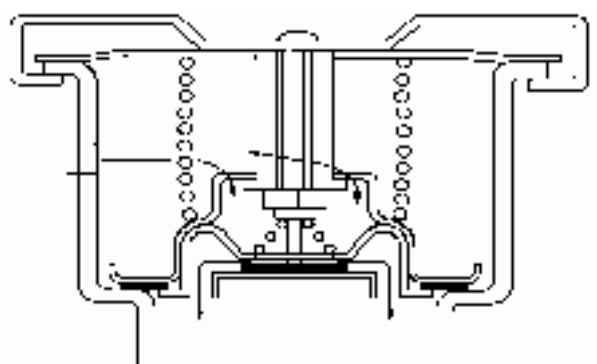

FIG.3-9

## 6. RADIATOR REASSEMBLY

Reassemble the radiator in the reverse order of disassembly.

Note:

- The rubber hoses should be clamped securely and must not interfere with the cooling fan.
- The radiator cores must not interfere with the cooling fan.

## 7. DAILY INSPECTION

### 1) Coolant level inspection and coolant replacement

When the radiator is hot after operation,be sure to wait until the coolant cools down sufficiently before removing the radiator cap.

If this is not done,heated vapor might burst out and cause burns.Use fresh water from a faucet as the coolant. When the coolant is replenished or changed,let the engine idle for a while for the coolant to circulate sufficiently in the cooling system and replenish if necessary after stopping the engine.

### 2)Antifreeze

When The weather is cold,use an antifreeze to prevent the engine from freezing.The freezing point differs according to the mixture ration of water and antifreeze.Therefore,prepare an antifreeze solution which will have a freezing point 5°C lower than the estimated lowest atmospheric temperature in your environment.

### Precaution for filling antifreeze.

- The radiator interior should be washed clean ahead of time.
- As concerns of mixing ratio of an antifreeze, follow its manufacture's instructions.
- Antifreeze should be blended well with water before filling.
- When the coolant level is lowered due to evaporation,maintain the level by adding water, not by using an antifreeze solution.
- When the coolant level is lowered due to leaks, maintain the level by adding an antifreeze solution of the same mixing ratio.
- As antifreeze corrodes point,take care not to spill it on painted parts.
- The tractor is filled with a permanent type antifreeze (Mobile Long Life Coolant) when shipping(mixing ratio:50%)

Problems	Causes	Countermeasures
1) Overheating	(1) Low coolant level	(1) Replenish coolant and inspect water leaks.
	(2) Fatigued pressure valve spring	(2) Replace radiator cap.
	(3) Loose or broken fan belt	(3) Adjust belt tension or replace.
	(4) Oily fan belt	(4) Replace.
	(5) Poor thermostat	(5) Replace.
	(6) Poor water pump or water leaks	(6) Repair or replace.
	(7) Clogged water passages	(7) Clean radiator and water passages.
	(8) Improper injection timing	(8) Adjust injection timing.
	(9) Clogged air ways	(9) Clean radiator exterior.
	(10) Fuel gas enters water jacket due to broken cylinder gasket	(10) Inspect cylinder head and replace cylinder gasket
2) Overcooling	(1) Poor thermostat	(1) Replace
	(2) Excessive low atmospheric temperature	(2) Decrease radiator working area by radiator masking.
3) Lose of coolant	(1) Leaking radiator	(1) Repair or replace
	(2) Loosely clamped or broken water hose	(2) Retighten or replace
	(3) Fatigued pressure valve spring	(3) Replace radiator cap
	(4) Leaking water pump	(4) Repair or replace
	(5) Water leakage through cylinder head gasket	(5) Inspect cylinder head and Replace gasket
	(6) Cracked cylinder head or body	(6) Replace
4) Noisy cooling fan	(1) Poor water pump bearing	(1) Replace
	(2) Loose or bent fan	(2) Retighten or replace
	(3) Unbalanced fan	(3) Replace.
	(4) Poor fan belt	(4) Replace.

# SECTION 2. AIR CLEANING SYSTEM

## 1.GENERAL DESCRIPTION

Unfiltered air contains many particles harmful to the engine such as dust ,sand,or other foreign matter. When such foreign matter have entered in to the engine,They have mixed into the lubricant and promote wear of lubrication parts in addition to damaging the piston cylinders.To eliminate these harmful particles,an air cleaner has been installed.The air cleaner Which is installed on the T series tractor is a dry,cyclone type and is constructed as shown in the figure.

Under the influence of suction generated by the engine,unfiltered air flows through air inlet tube(4) and is forced into a high-speed centrifugal motion.By this circulating action most of the dust and dirt particles are separated from the air and collected in the dust unloading valve(3).The remaining dust is removed as the air flows through the paper element(1) before being drawn into the engine.

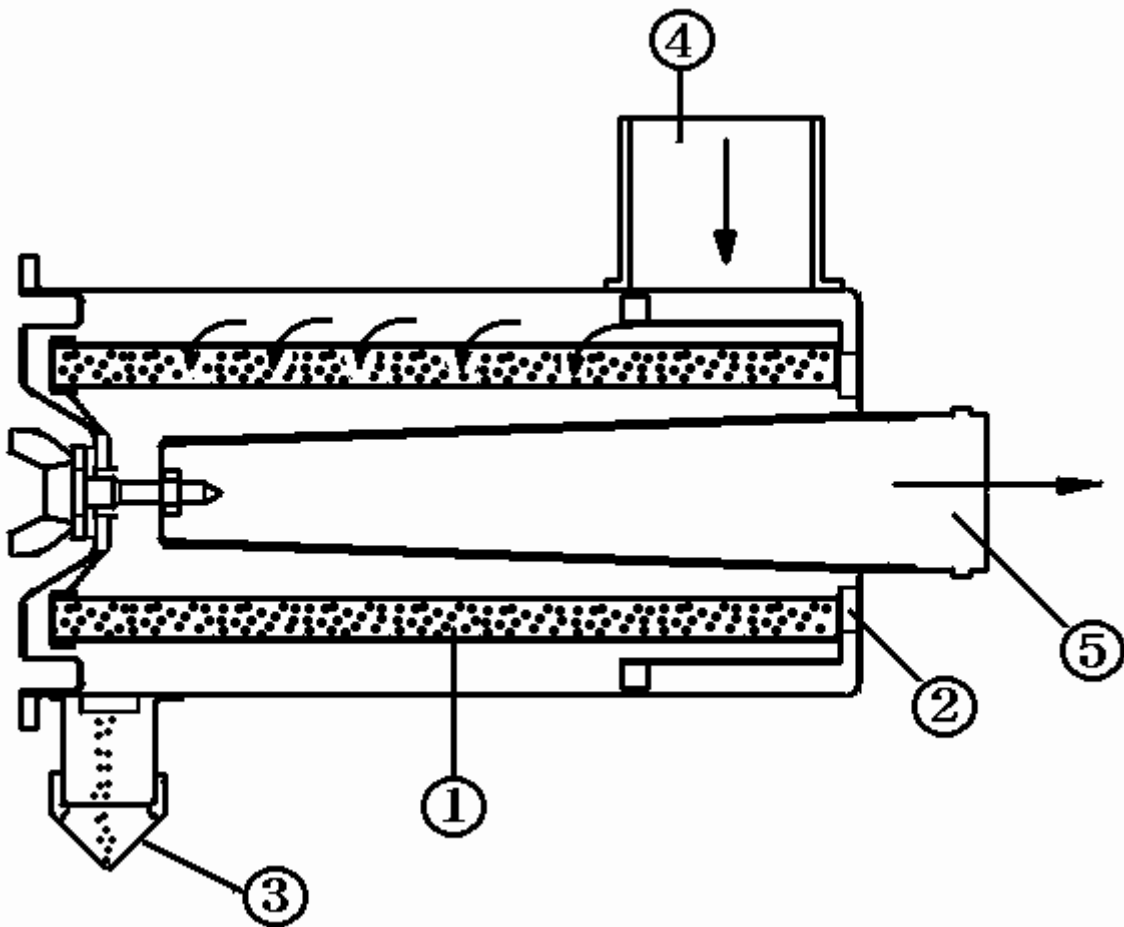

FIG.3-10

- ① Paper element      ② Packing      ③ Dust unloading valve
- ④ Air inlet            ⑤ Air outlet

## 2.ELEMENT AIR CLEANER

### (1) SPECIFICATIONS.

Model		3510/4110/T390/T430
Type		Dry,paper element filtering type
Rated intake air volume (m <sup>3</sup> /min.(cu.ft/min)		2.6(91.8)
air venting resistance (mmAg)		120 or less
Cyclone efficiency (%)		45 or over
Total filtering efficiency (%)		99.9 or over
Dust holding capacity(gr)		700
Filtering area(m <sup>2</sup> )(sq.in)	Outer element	1.32(2046)
	inner element	0.16(248)
Filter material	Outer element	AS 42
	inner element	AS 44
Remarks		Tested dust : SAE FINE Dust density : 1.0 gr/m <sup>2</sup> (0.93gr/sq.ft)

### 2) DISASSEMBLY

#### (1) Element removal

Remove the wing bolt which clamps the paper element and take out the element.

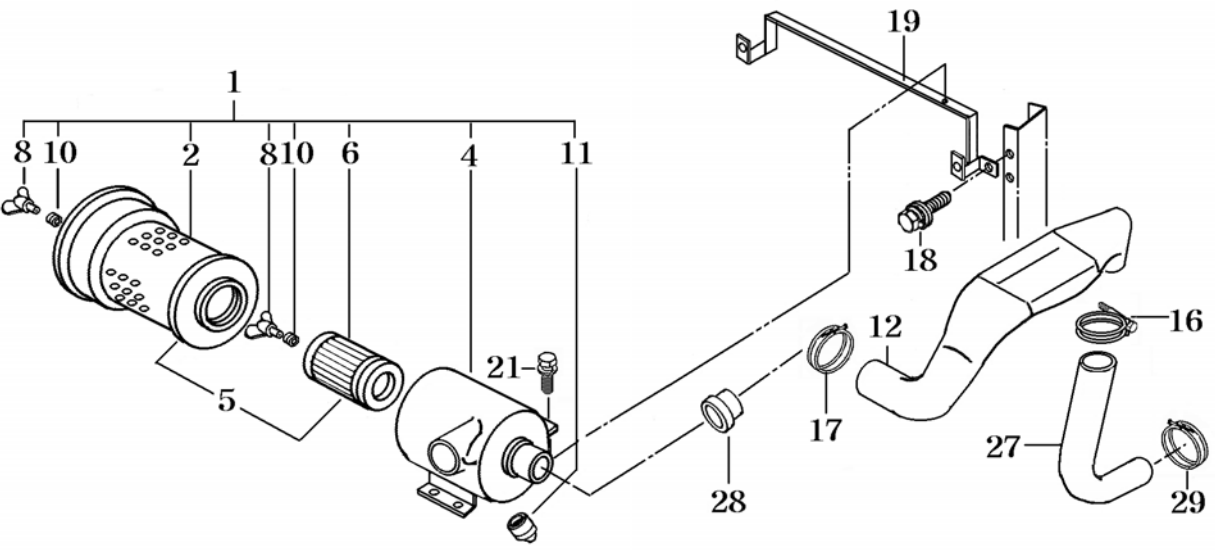

FIG.3-11

- 1.Air cleaner    2.Element(outer)    4. Body    6.Element(Inner)    8.Wing Nut    10.Packing
- 12.Pipe (inlet)    16.Clamp    17.Clamp    18.Bolt(S)    19.Stay    21.Bolt
- 27.Hose(Inlet)    28.Gasket    29.Clamp

### 3. INSPECTION OF EACH PART

- 1) Inspection of the cleaner body
  - (1) Check the cleaner exterior for cracks, deformation, or damage and repair or replace if necessary.
  - (2) Check each packing for fatigue or damage and replace if necessary.

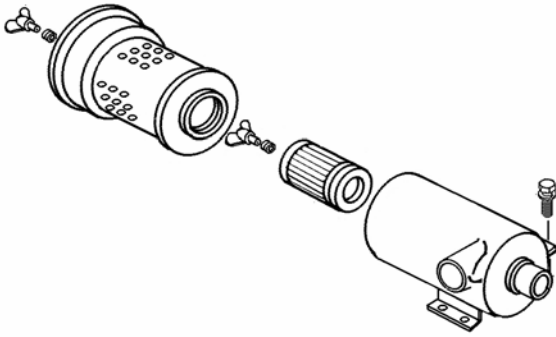

Fig.3-12

- 2) Inspection of rubber hoses  
Check the rubber hoses for fatigue or damage and replace if necessary.
- 3) Inspection of the paper element  
To check the element for damage, Dry it sufficiently after washing and put an electric bulb in to the element and look for damage.

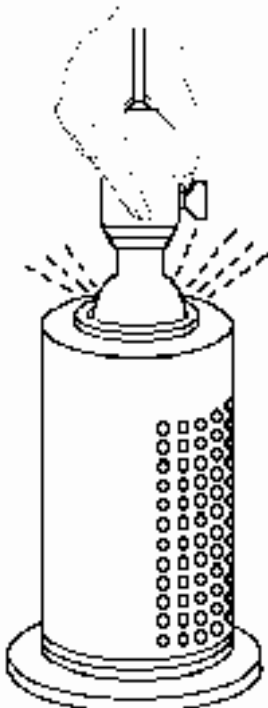

FIG.3-13 Element check

Note:

Especially note the glue portions of the paper and metal parts.

### 4. CLEANING THE AIR CLEANER

Clean the air cleaner after 100 hours of operation or less depending on conditions in the following manner.

1) When the air cleaner is cleaned or the element is replaced, dust accumulated inside the air cleaner body should be removed with a cloth. As inhaled dust causes engine wear, remove dust accumulated inside the inlet pipe, the rubber hose which connects in the inlet pipe and the air cleaner, the inlet manifold, and inlet port.

(1) When accumulated dust is dry.

-When removing the dust in the element, hold the element by a hand and pat the side wall with other hand. Never hit the element against a stone or a concrete wall because that might cause its side wall to peel off.

-apply compressed air from inside of the element to blow dust off while turning the element by hand.

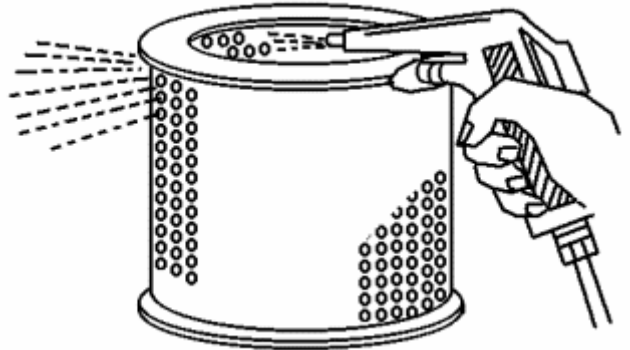

FIG.3-14 Element

Note:

The compressed air to be applied should not have a pressure of more than  $7\text{kg/cm}^2$  (99.6psi) Maintain sufficient distance between the air gun and the element.

(2) When accumulated dust is oily.

-Use a solution of TC 101 element detergent or the quality household neutral detergent. Leave the element in the solution for approximately 30 minutes and then wash it by dipping it in and out of the solution.

-After soaking,rise it in fresh water.

-Let it in a shaded and well ventilated place.  
Forced drying by heat or compressed air is prohibited.

Note:

Water applied to rinse the element should not have a pressure of more than 2.8kgf/cm<sup>2</sup> (39.8psi).

An element which has been washed 5 times must be replaced with a new one.

## 5.ELEMENT INSTALLATION

Install the element in the reverse order of disassembly,but follow these instructions.

- 1) Each tightening bolt must be secured and care must be taken not to miss the packing and washers.
- 2) Before installing the element,clean the rubber packing on the top of the element.

Note:

The wing bolt retaining the element should be tightened sufficiently so that it will not become loose during operation

<b>SECTION 1. GENERAL DESCRIPTION</b>	<b>4-1</b>
<b>SECTION 2. SPECIFICATIONS</b>	<b>4-2</b>
<b>SECTION 3. DISASSEMBLY,INSPECTION,AND REASSEMBLY</b>	<b>4-3</b>
<b>1. Main clutch</b>	<b>4-3</b>
<b>2. Clutch shaft and related parts</b>	<b>4-8</b>
<b>3.Final adjustment of the clutch pedal</b>	<b>4-9</b>
<b>SECTION 4. TROUBLESHOOTING</b>	<b>4-10</b>



## Chapter 4. clutch system

### GENERAL DESCRIPTION.

The clutch is a device to engage and disengage the power of the engine. The construction of the clutch is as shown in the figure. It is composed of the flywheel which holds the clutch disc, the pressure plate, diaphragm springs, the clutch cover, and input gear.

The plate is held against the flywheel by the pressure springs and pushes the clutch disc against the flywheel. The clutch disc, which is sandwiched between the pressure plate and the flywheel, is mounted on the splined part of the input gear. It can move in an axial direction, but is locked in the rotational direction. It transmits engine power to the transmission by means of friction. Twelve coil springs are installed between the clutch cover and the pressure plate along the circumference, which are the pressure springs.

To disengage the engine power, the force of the diaphragm spring acting on the pressure plate must be eliminated. For this purpose the release lever is installed. By depressing the clutch pedal, the release lever pushes off the pressure plate from the clutch disc, thus providing clearance between the friction surfaces of the flywheel, the clutch disc, and the pressure plate. Thus the engine is disengaged.

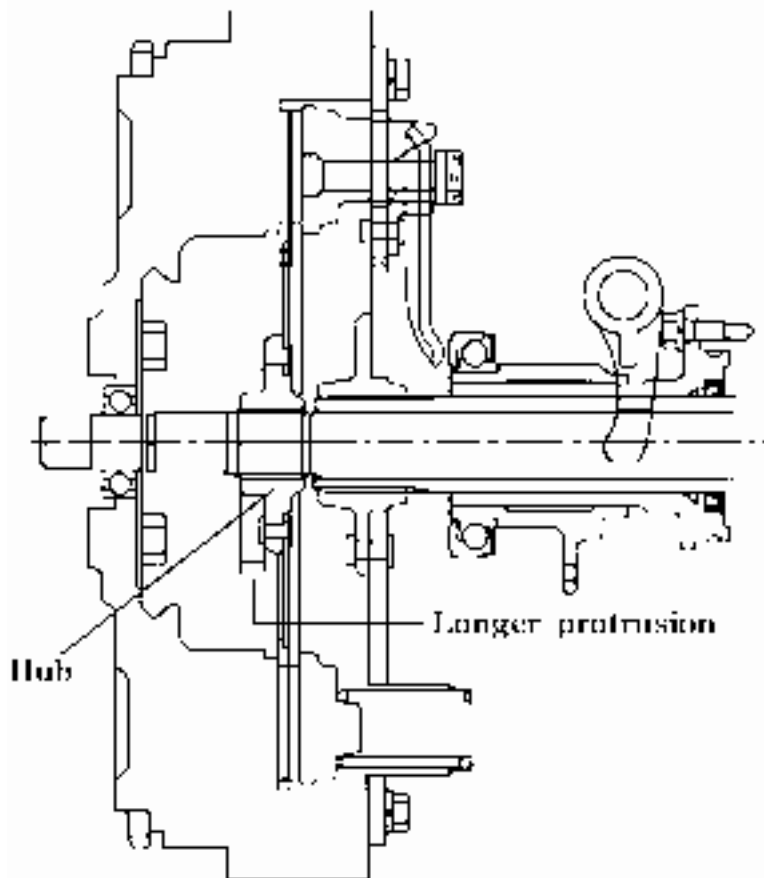

Fig.4-1 Main clutch disc.

## SECTION 2. SPECIFICATIONS

Table 4-1

Parts	Items	Description and assembly standard values	
Clutch cover	Type		
	Springs: shape	Coil spring	
	Quantity	9	
	Free length mm (in)	87.4(3.44)	
	Installed length/Load mm/Kgf(in/lb)	53/64.4(2.09/141.7)	
	Lever plate height(above flywheel surface)mm (in)	65±0.7(2.5590)	
	Lever height difference limit between levers mm(in)	0.7(0.028)or less	
Hub spline:	large dia. mm(in)	35.0(1.378)	
	Small dia.mm(in)	31.7(1.248)	
	No. of splines	19	
Clutch disc	Type	Dry single plate	
	Facing material	Y02	
	Outer dia. ×inner dia. mm(in)	260X170(10.24X6.69)	
	Effective friction area cm <sup>2</sup> (sq.in)	607.6(94.2) in both faces	
	spline hub	Large dia. mm (in)	Ø25.0 (0.984)
		Small dia.mm (in)	Ø21.7 (0.854)
		No.of splines	13
	Disc thickness (free) mm (in)	8.0±0.3 (0.315)	
	Surface deviation mm (in)	0.4 (0.016)or less	
	Lateral deviation mm(in)	0.7 (0.028) or less	
	Vertical deviation mm (in)	1.0 (0.039) or less	
Clutch pedal	Clearance between lever plate and release bearing mm (in)	2.0 (0.079)	
	Clutch pedal free play mm (in)	20 ~ 30 (0.79 ~ 1.18)	

## SECTION 3. DISASSEMBLY, INSPECTION, AND REASSEMBLY

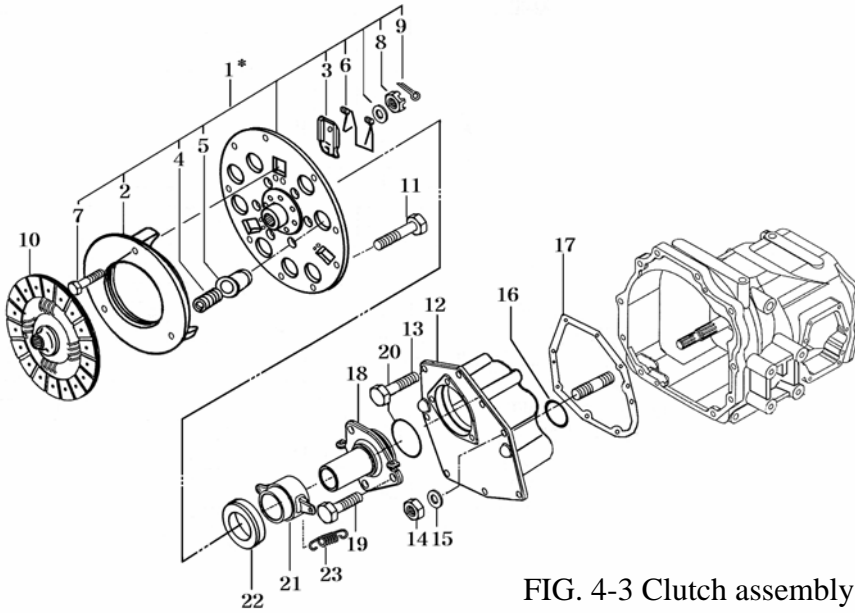

FIG. 4-3 Clutch assembly

- 1.Cover (clutch/260)
2. Pressure plate
- 3.Release lever
- 4.Spring
- 5.Spring Cap
- 6.Return Spring
- 7.Bolt(Lever)
- 8.Lever
- 9.Split pin
- 10.Disc(Clutch/260)
- 11.Bolt(S)
- 12.Metal(Input)
- 13.Bolt(seal)
- 14.Nut
- 15.Washer plain
- 16.Snap ring
- 17.Gasket
- 18.Metal(sleeve)
- 19.Bolt(seal)
- 20.O-ring
- 21.Sleeve
- 22.Clutch release bearing
- 23.Spring tension(31)

### 1.MAIN CLUTCH

#### 1-1.Disassembly

Separate the engine from the front transmission referring to the paragraph "SEPARATION OF MAJOR COMPONENT in chapter 2."

2) Remove the clutch assembly from the flywheel.

3) Remove the cotter pins from the lever nuts.

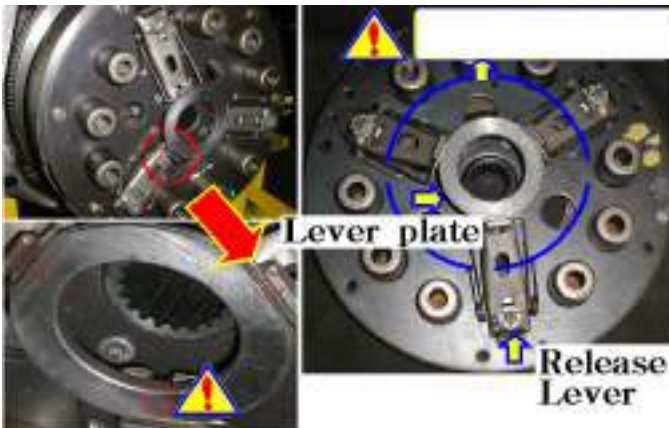

Fig 4-4 cotter pin.

#### Note:

When removing the bolts,loosen them gradually in diagonal sequence.

Take care not to let oil get on the clutch facing.

4) Install a special tool on the clutch cover assembly and screw in the screw until the release levers are freed.

Note:

Ensure that the claw positions are in contact and tighten the center screw gradually.

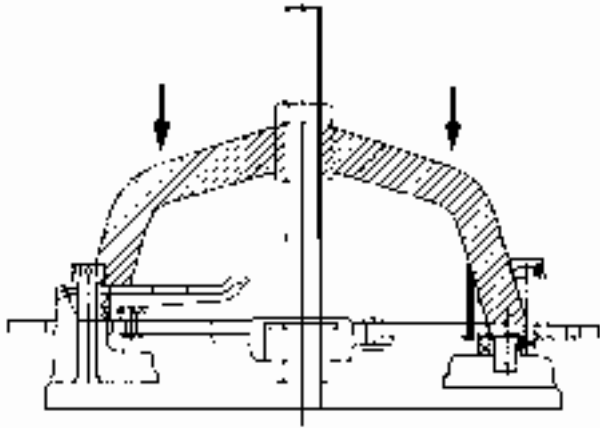

Fig. 4-5

5) Remove the three lever nuts.



Fig. 4-6

Note:

To maintain balance of the clutch, push alignment marks on the clutch cover assembly and the pressure plate before separating them. (Fig. 4-7)



Fig. 4-7

## 1.2. INSPECTION

### (1) Inspection of the clutch disk

Check the clutch disk for wear or cracks on the facing, loose rivets, broken torsion springs, or wear of the hub splines.

1) Measure the suppression of the rivets, if the suppression is 0.2 mm or less and cracks or burnt damage are found on the surface, the disc must be replaced.

Rivet suppression	Usable limit
	0.2mm(0.008in)

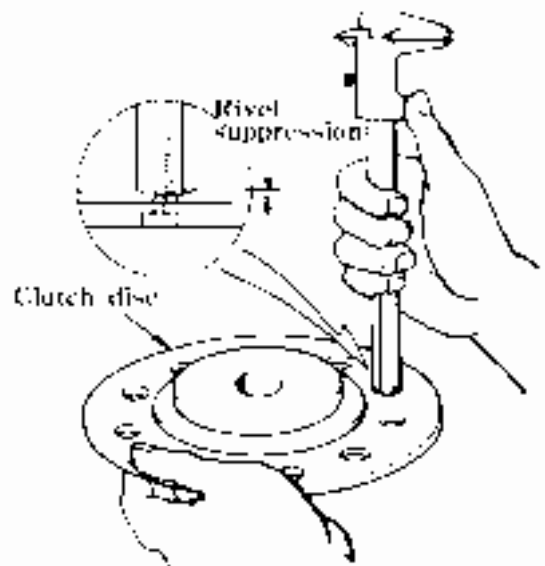

Fig. 4-8

Note:  
 Be sure to replace any clutch disc which has 0.2mm (0.008in) or less in rivet suppression. Use of a insufficient rivet depression disc will result in serious damage to the flywheel and the pressure plate.

2) Any oil stained clutch disc must be replace.  
 However, a very small oil stain may simply be removed by use of a volatile solvent.

Note:  
 The causes of oil stains must be located and necessary corrective measures must be taken.

- 3) Hardened lining surfaces must be repaired by use of a sandpaper, or be replaced with a new ones.
- 4) When loose rivets are found, replace the clutch disc assembly because those of rivets will loosen again even if they are retightened.
- 5) Install the disc on the input gear and inspect the rotational play. If the measurement deviates from the specified value, replace the disc.

Rotational play of the hub spline	Usable limit
	0.3mm(0.012in)

6) Measure the deviations of the clutch disc. If the measurements are beyond the usable limits, replace the clutch disc assembly. (Fig4-9)

	Usable limit
Surface deviation	0.4mm(0.016in) or less
Lateral deviation	0.7mm(0.028in) or less
Vertical deviation	1.0mm(0.039in) or less

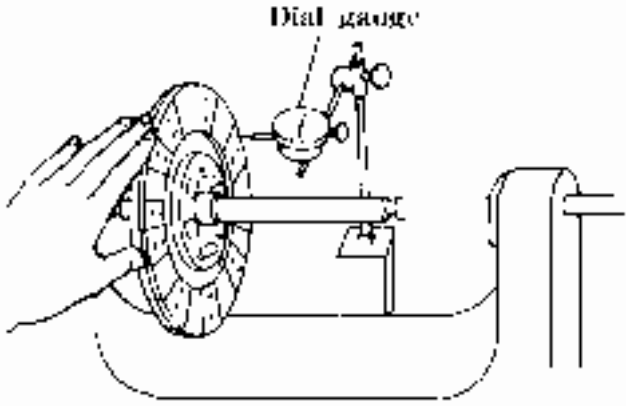

Fig.4-9

(2) Inspection of pressure plate

Inspect the pressure plate friction surface for up-and down, scratches, stepped wear, or oil stains.

- 1) Shallow scratches may be repaired with a sand paper, but excessive wear or damage must be repaired by machining the friction surface.

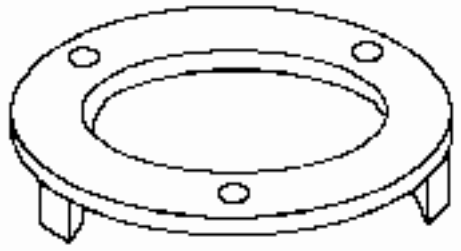

Fig.4-10

2) Repair of friction surface.

The friction surface should be ground down or machined to finish it to 12 μm (4.7X10<sup>-4</sup>) to 25 μm (9.8X10<sup>-4</sup>) in surface smoothness.

The machining limit of the pressure plate surface in thickness is 1.0mm(0.039in)

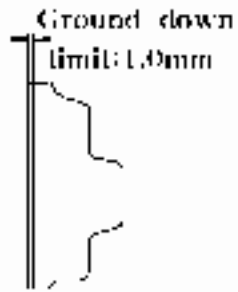

Fig.4-11

### 3) Adjustment of pressure springs.

When the friction surfaces of the pressure plate and the flywheel are repaired by grinding or machining the installation height of the pressure springs increase by the ground-off value both on the flywheel and the friction plate resulting in decreased spring tension. Consequently, adjusting washers equivalent to the ground-off value must be inserted between the spring seat and the pressure spring.

Insert a washer of the same thickness as the ground-down thickness

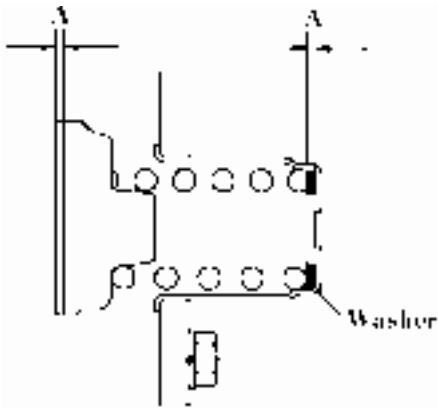

Fig.4-12

### (3) Inspection of the pressure springs

Check the pressure springs for free length, deviation from vertical and tension, and replace them if they are fatigued or deformed.

1) Measure their free length with vernier calipers.

Excessively fatigued ones should be replaced.

Free length:	Usable limit
87.4mm(3.44in)	82mm(3.23)

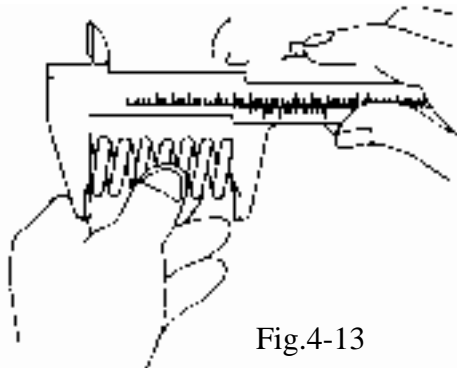

Fig.4-13

2) Measure the deviation from vertical using a square, Replace springs which are slanted more than approximately 2 degrees.

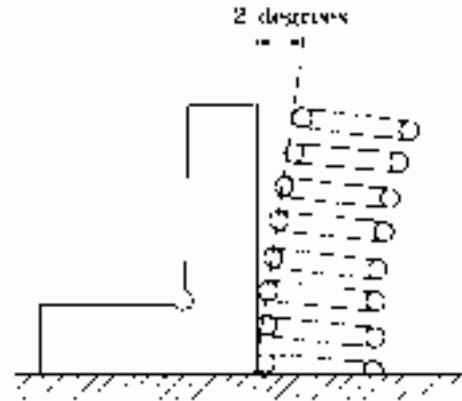

Fig.4-14

3) The coil ends of the springs should be level for More than two thirds of the circumference for proper seating and vertical positioning.

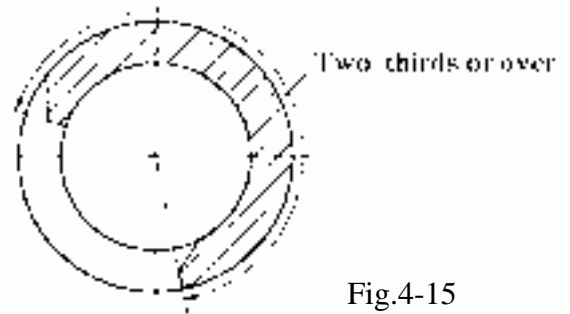

Fig.4-15

(4) Inspection of other parts.

Inspect the release levers, return springs, lever plates, clutch cover assembly, spring cap, and Lever bolts for wear, damage, and deformation, and replace parts which exhibit abnormalities.



Fig.4-16

### 1.3. REASSEMBLY

Reassemble them in reverse order of disassembly in accordance with the following instructions.

- 1) Be sure to keep oil off of the clutch disc, the pressure plate, and the flywheel.
- 2) Apply a thin coat of molybdenum disulfide-based grease to revolving or sliding parts prior to reassembly.

Note:

Be sure not to apply too much grease because this will cause clutch slippage.

- 3) When installing the clutch disc on the flywheel, turn the longer protrusion of the hub towards the flywheel. The reverse installation will damage the clutch cover or the disc. When installing the dual clutch assembly, use a special tool.

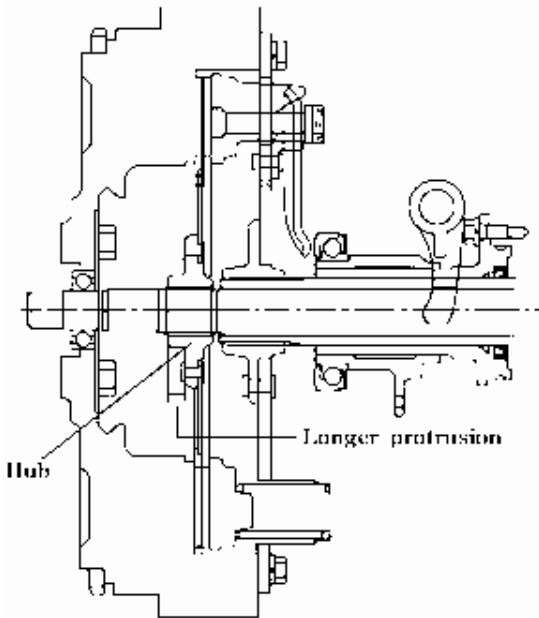

Fig.4-17

Note:

After the release lever height adjustment, be sure to install the cotter pin.

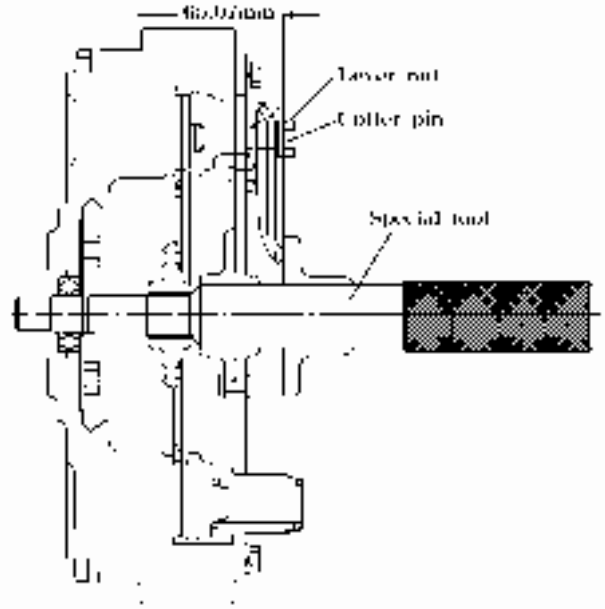

Fig.4-18

- 4) Adjust the release lever height with the centering tool.

Clearance between flywheel surface and release lever	65±0.7mm (2.559 in)
Difference between release lever height	0.7mm (0.023 in) or less

## 2. CLUTCH SHAFT AND RELATED PARTS.

### (1) disassembly

- 1) Remove the tension spring and extract the sleeve
- 2) Remove the wire which is retaining the taper pin.

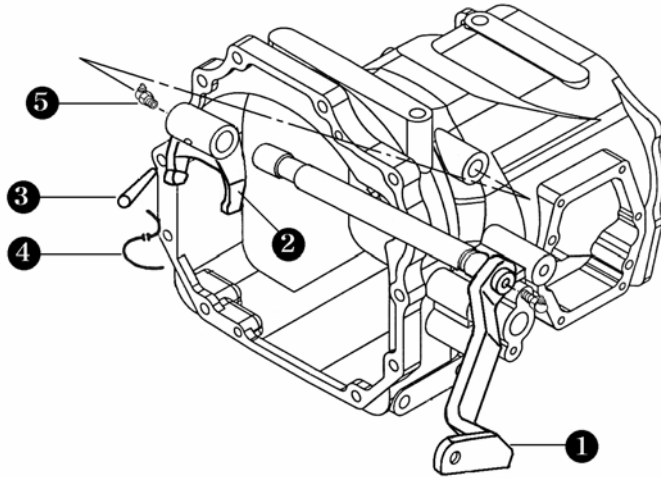

- ①Clutch shaft comp ②Release fork  
③Taper pin ④Wire ⑤Grease fitting

Fig.4-19 Main clutch and related parts

- 3) Remove the grease fittings from the clutch shaft ends.
- 4) Turn the release fork upward and pull out the taper pin. Then draw the clutch shaft.

### (2) Inspection

#### 1) Inspection of release bearing

The release bearing is of the grease-sealed type, but when the grease in the bearing reaches a low level or the bearing does not turn smoothly due to damage or seizure, replace the bearing.

Note:

The release bearing should not be washed.

#### 2) Inspection of sleeve

Ensure smooth movement of the sleeve. If it does not move smoothly, clean and grease it. Use heat-proof grease.

#### 3) Inspection of tension springs.

If there are some broken tension springs, replace them.

#### 4) Inspection of the fork.

Inspect the contact faces of the fork and the sleeve. If there is abnormal wear, make repairs or replace the fork or the sleeve.

#### 5) Inspection of the clutch shaft.

The clutch shaft must revolve smoothly

### (3) Reassembly

Reassemble the disassembled parts in reverse order of disassembly, pursuant to the following instructions.

- 1) Each sliding part should be coated with heat-proof grease.
- 2) The clutch fork taper pin should be locked securely with wire.
- 3) Smooth movement of each part should be conformed.
- 4) The release bearing must be installed in the correct direction.

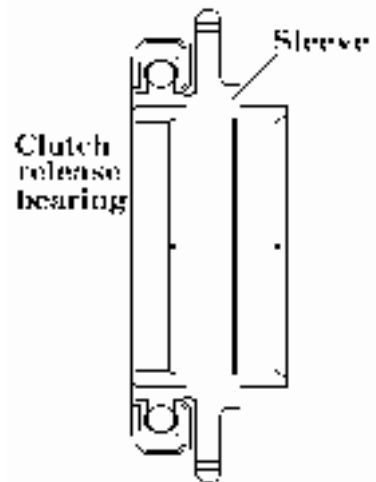

Fig 4-20 Release bearing



### 3.FINAL ADJUSTMENT OF THE CLUTCH PEDAL

#### Clutch pedal play

1) Loosen the lock nuts on the clutch rod and adjust the clutch rod length to achieve 20~30mm (0.79~1.18 in.) pedal play.Retighten the lock nut securely.

Note:  
One lock nut has a right hand thread and the other has left-hand threads,so take care not to interchange them.

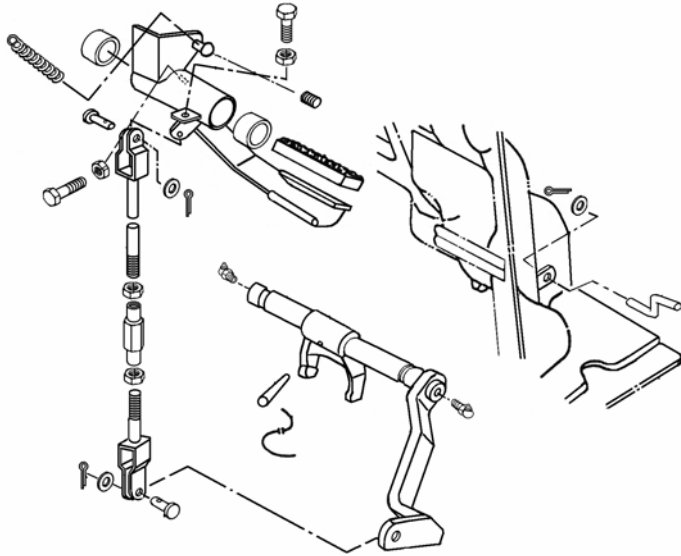

Fig 4-21 Main clutch

Note:

Adjust the turnbuckle through the opening in the panel with the rubber cap removed.

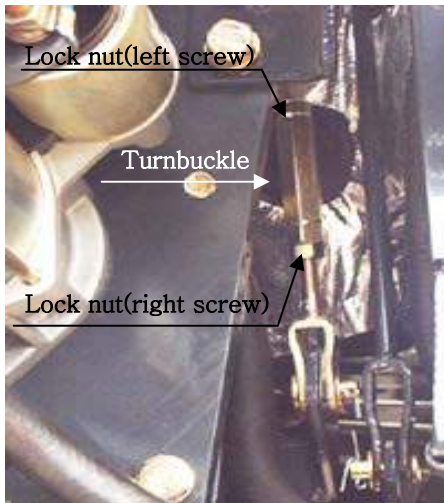

Fig 4-22

2) Adjust the clearance between the safety switch and the bolt head to  $38 \pm 1$  mm(1.496 in.) so that the switch will turn on only when the clutch is disengaged to allow the engine to start.

3) Inspect the clutch action.

-Inspection of clutch action and slippage.

While the engine is running,the transmission gears must be shifted smoothly with the brakes applied.

-Inspection of clutch slippage

While accelerating the engine gradually, the engine must stop when the clutch is engaged gradually with the parking brakes applied and the speed shift levers to 4X4.

## SECTION 4. TROUBLESHOOTING

### 1.PROBLEM :Clutch slippage.

The initial stage of clutch slippage is very hard to notice, but the following symptoms

- 1) The tractor is not generating adequate power when performing heavy duty operations.
- 2) Output is not commensurate to increase in engine speed when the engine is accelerated suddenly during operation.
- 3) Increased fuel consumption.

These symptoms are apt to be mistaken for engine problems. Clutch slippage that is not repaired will result in serious damage such as excessive wear of the clutch facing, the clutch cover, and even flywheel or clutch seizure.

### TEST METHOD

If the parking brakes are applied and the transmission gears shifted to top speed and the engine stops, then the clutch is normal. But if the engine does not stop, it shows that the clutch is slipping.

Probable causes	Countermeasures
-No play in the release bearing	Adjust
-Broken or fatigued pressure spring	Replace
-Excessive wear of clutch facing	Replace
-Oil stained or hardened clutch facing	Repair or replace
-Deviation of flywheel or pressure plate	Repair or replace

### 2.PROBLEM :Poor disengage

When the clutch does not disengage properly, the transmission gears make noise when shifted, or shifting or the gears is difficult.

Probable causes	Countermeasures
-Worn or rusted splined section of the clutch disc hub	Remove rust or replace and apply grease
-Excessive deviation of the clutch disc	Replace
-Insufficient play of the release bearing	Adjust
-Excessive play of the release bearing	Adjust
-Dried pilot bearing	Replace

### 3. PROBLEM :juddering

Probable causes	Countermeasures
-Oil-stained clutch facing	Replace
-Fatigued pressure springs	Replace
-Hardened clutch facing	Replace
-Deviation in clutch facing	Repair or replace.
-Deviation or deflected wear of pressure plate or flywheel	Replace
-Difference in release lever heights	Adjust

4. PROBLEM: Abnormal noises

There are abnormal noises emanating from the clutch.

Probable causes	Countermeasures
-Broken or insufficiently lubricated release bearing	Replace
-Seized or worn pilot bearing	Replace
-Cracked disc plate	Replace

5. PROBLEM: Dashing or shifting

The tractor does not starting moving smoothly but dashes or is likely to stop when the clutch is operated during a operation.

Probable causes	Countermeasures
-Oil stained clutch facing	Replace
-Worn clutch facing or loose rivets	Replace
-Deviation or deflected wear of flywheel or pressure plate	Repair or replace
-Fatigued pressure spring	Replace

<b>SECTION 1.GENERAL DESCRIPTION-----</b>	<b>5-1</b>
<b>1.Wheel driving system-----</b>	<b>5-1</b>
<b>2.PTO drive system-----</b>	<b>5-1</b>
<b>3.Power train diagrams-----</b>	<b>5-2</b>
<b>4.Speed shift patterns and gear train diagrams-----</b>	<b>5-2</b>
<b>5.Construction and function of synchromesh mechanism-----</b>	<b>5-5</b>
<b>SECTION 2. SPECIFICATIONS-----</b>	<b>5-7</b>
<b>1. Wheel drive system-----</b>	<b>5-7</b>
<b>2. PTO drive system-----</b>	<b>5-7</b>
<b>SECTION 3.DISASSEMBLY,INSPECTION,AND REASSEMBLY-----</b>	<b>5-8</b>
<b>1. Input shaft and reverse change gear(Front transmission) -----</b>	<b>5-8</b>
<b>2. PTO clutch -----</b>	<b>5-17</b>
<b>3. Main change,sub-change,and 4WD change gears.-----</b>	<b>5-21</b>
<b>4. Rear transmission -----</b>	<b>5-31</b>
<b>5. Shifters and related parts-----</b>	<b>5-41</b>
<b>SECTION 4. TROUBLESHOOTING-----</b>	<b>5-47</b>
<b>1. Wheel drive system-----</b>	<b>5-47</b>
<b>2. PTO drive system-----</b>	<b>5-48</b>
<b>3. Power train diagrams-----</b>	<b>5-49</b>

# Chapter 5 .Transmission

## SECTION 1.GENERAL DESCRIPTION

### 1. WHEEL DRIVE SYSTEM

The wheel driving system is composed of the following major components:

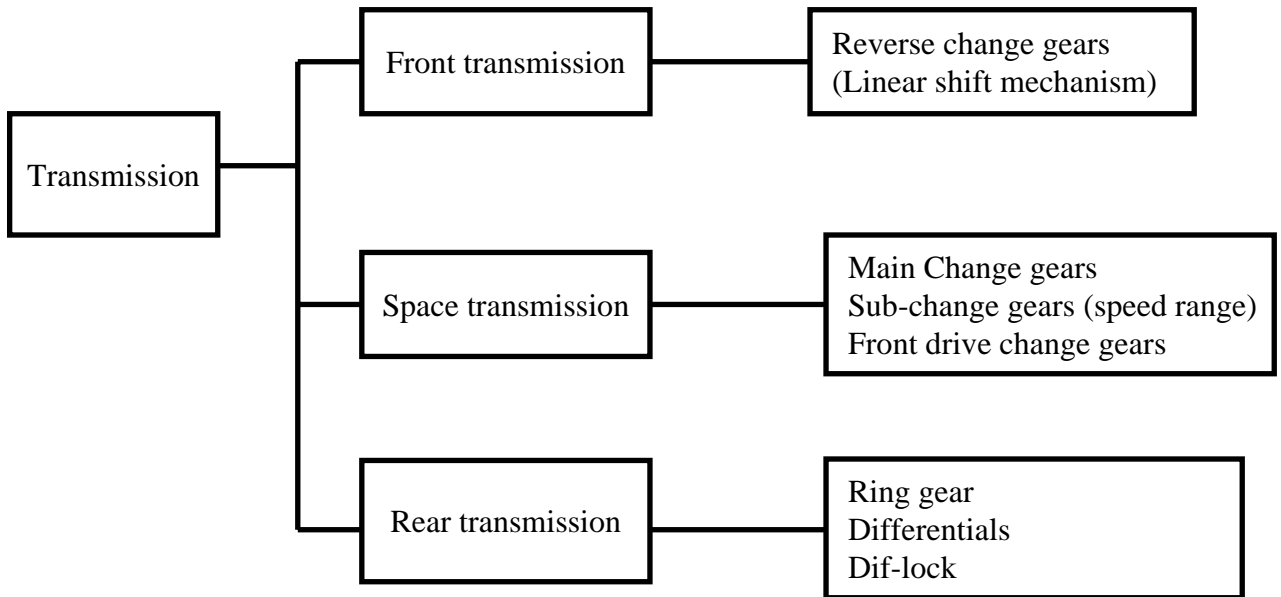

Fig.5-1 Wheel drive system

- 1) The standard transmission produces 12 speeds forward and reverse :F1 and R1 by reverse change gears;4 speeds by main change gears;3 speed by sub-change gears.
- 2) Synchromesh transmission has 3rd and 4th speed stages of the main change gears synchronized. Therefore,between these stages,gear shifting while traveling is possible (synchromesh version)

Note:

1st and 2nd speed stages of main change must be surely stopped traveling.

### 2. PTO DRIVE SYSTEM

- 1) The PTO drive system is composed of the independent PTO clutch and the PTO change gears.
- 2) The PTO change gears are housed behind the ring gear,which produce 1 PTO speed.

### 3. POWER TRAIN DIAGRAMS

Refer to page 5-49 and 50 at the end of this chapter

#### 4.SPEED SHIFT PATTERNS AND GEAR TRAIN DIAGRAMS.

##### 1)Linear shift(reverse change gears)

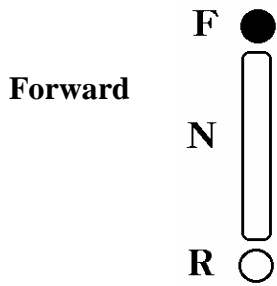

Fig.5-2

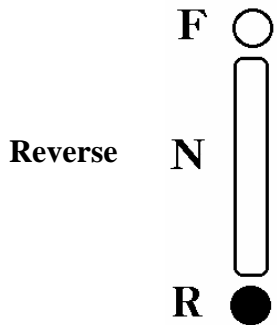
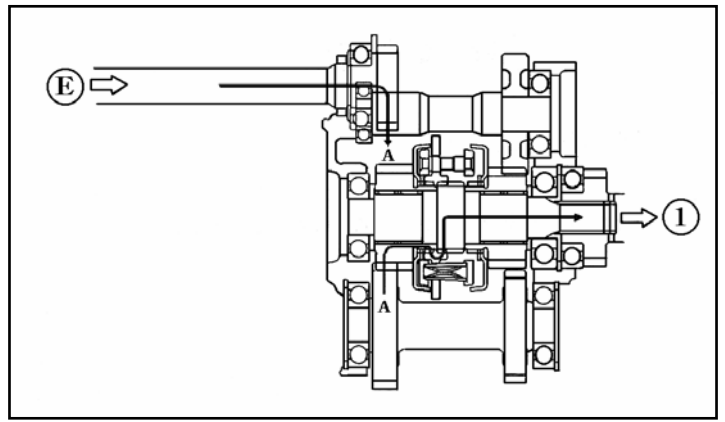
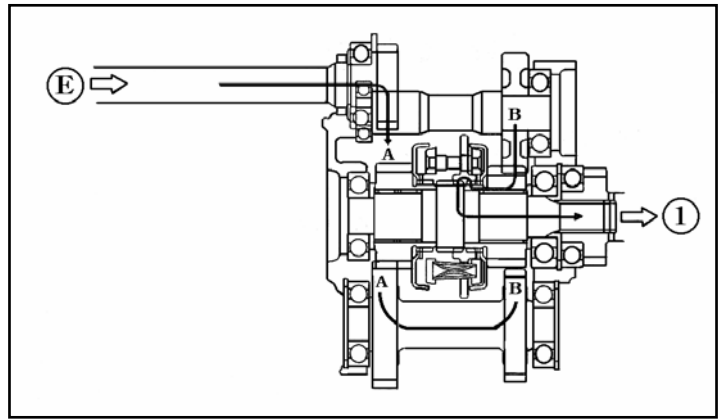

Fig.5-3



##### 2) Main speed shift(Main change gears)

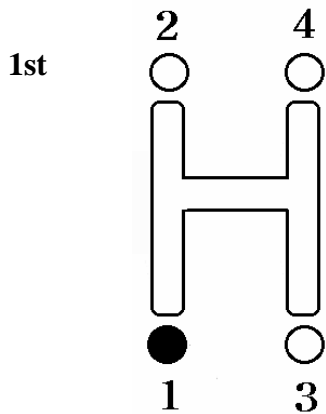

Fig.5-4

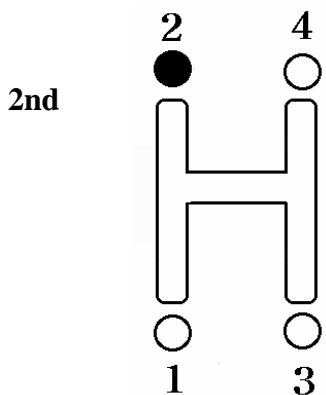
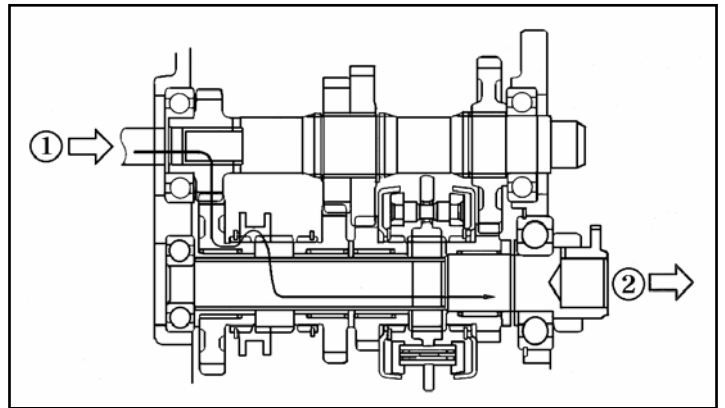
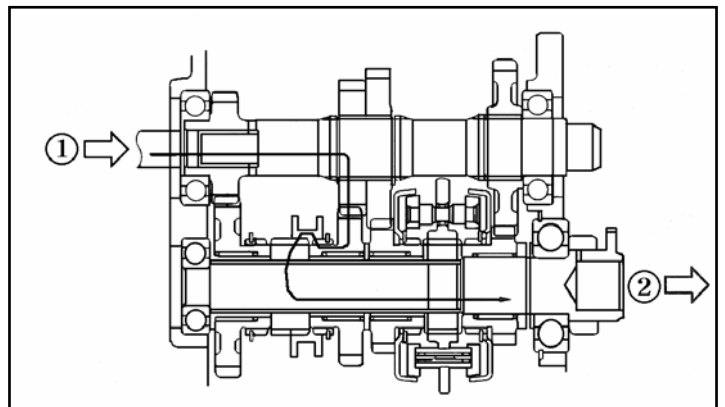

Fig.5-5



3rd

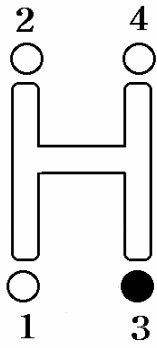
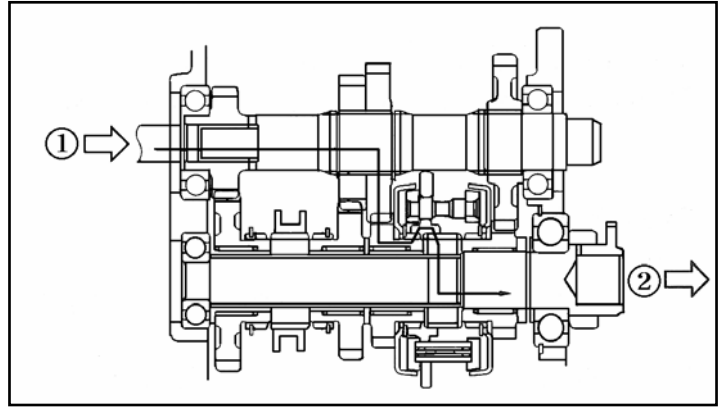

Fig.5-6



4th

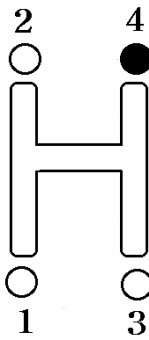
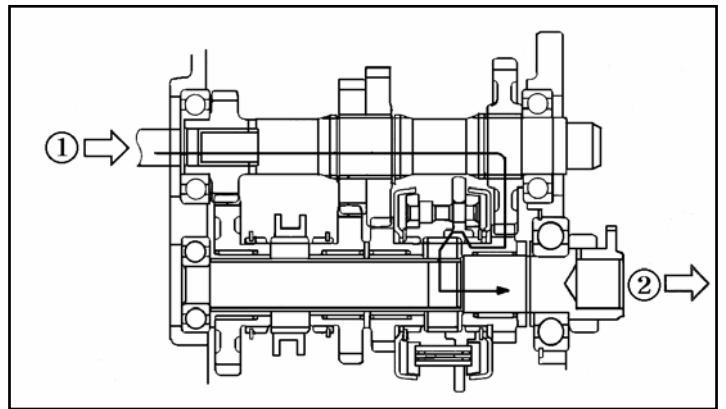

Fig.5-7



3) Speed range shift(Sub-change gears)

1st  
(Low)

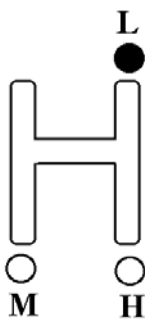
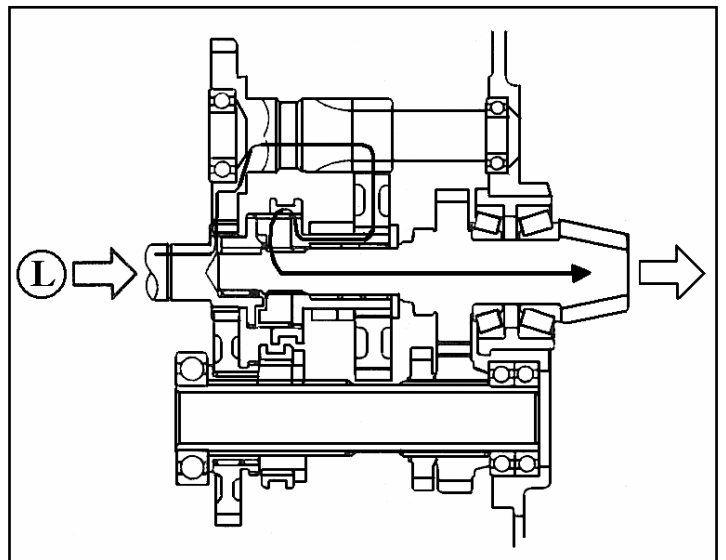

Fig.5-9



2<sup>nd</sup>  
(MID)

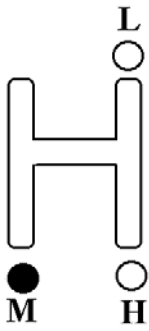
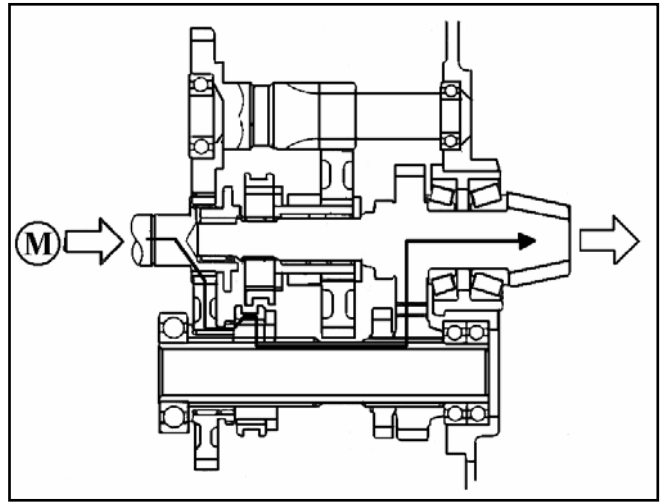

Fig.5-10



3<sup>rd</sup>  
(HIGH)

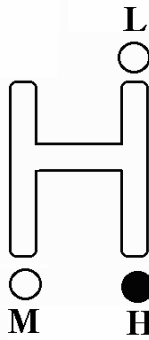
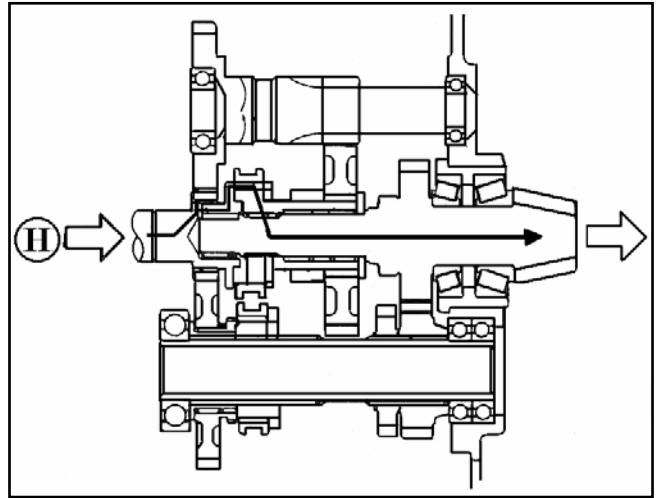

Fig.5-11



4)PTO speed shift(PTO change gear)

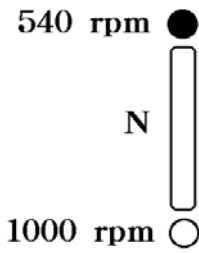

Fig.5-12

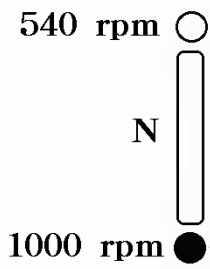
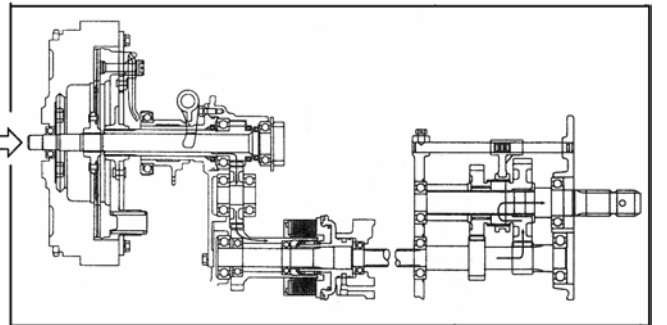
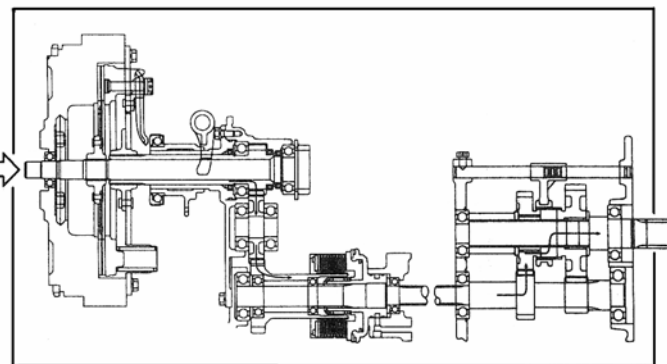

Fig.5-13





## 5.CONSTRUCTION AND FUNCTION OF THE SYNCHROMESH MECHANISM

### 1) Construction

- ① Shifter
- ② Hub
- ③ Block pin
- ④ Synchro-ring
- ⑤ Synchro-cup
- ⑥ Thrust piece
- ⑦ spring
- ⑧ spline of hub(2)
- ⑨ spline of synchro-cup(2)
- ⑩ constant mesh gear
- ⑪ spline of gear(10)
- ⑫ constant mesh gear
- ⑬ Spline of gear(12)
- ⑭ Spline hub
- ⑮ Spline of spline hub(14)
- 16.Snap ring C(for shaft)

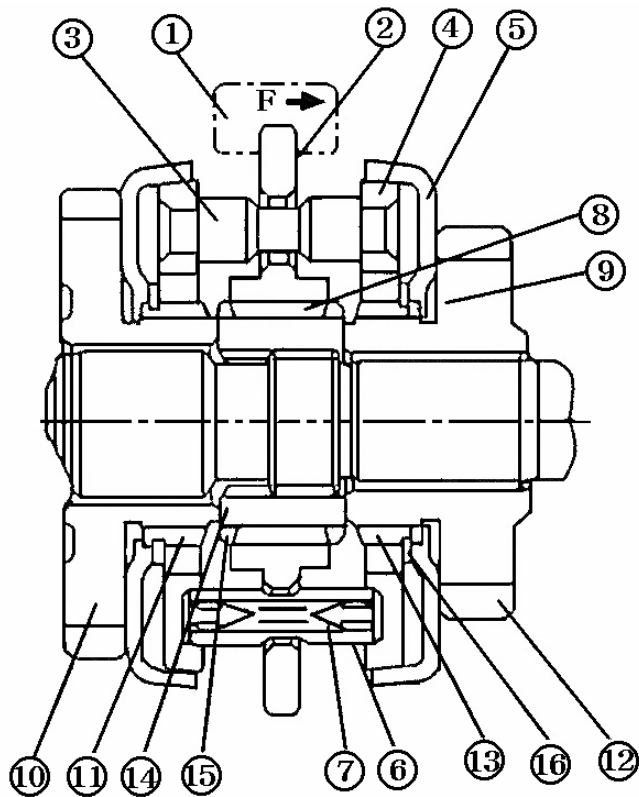

Fig.5-14 Synchromesh

The synchromesh mechanism includes the components staged below

#### Synchro-hub

The synchro-hub is composed of the hub(2), block pin(3),synchro-ring(4),thrust piece(6),and spring(7).Synchro-ring(4)has a conical friction surface on its circumference.Block pin(3) prevents hub(2) from sliding until the torque, imposed upon the pin due to the speed differential caused when shifting gears,disappears. Thrust piece(6)is composed of an outer split pin and an inner and is held together as one unit by the expansion force of the spring.

It has a tapered shape as shown in Fig.5-15

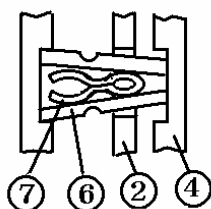

Fig.5-15

when the hub is position to side and also serves as a lock pin to keep the synchro mechanism engage.

#### Synchro-cup

It has a conical friction surface which forms a pair with synchro-ring(4).It meshes with the gears(10) and (11) through the splined part.

### 2) Function principles(operating procedures)

The synchromesh mechanism operates in the 4 stages mentioned below to complete the transmission from NEUTRAL to ENGAGEMENT

**1st stage:**

When force(F) is applied to shifter(1) through the gear shift lever, hub(2) is pushed in the direction of the arrow. Following movement of the hub, other parts such as block pin(3), synchro-ring(4), and thrust piece(6) also move in the same direction by means of spring(7), without allowing the hub to clear the groove in thrust piece(6) until such time as the friction surface of synchro-ring (4) comes into contact with the friction surface of synchro-cup (5).

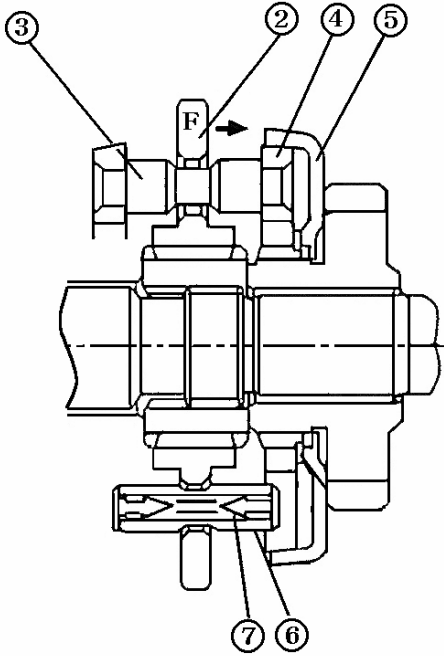

Fig. 5-16 1st stage

**2nd stage:**

At the moment when both the friction surfaces come into contact, the ring turns by as much as the surplus space in hub(2) for block pin(3) as shown in Fig.5-5

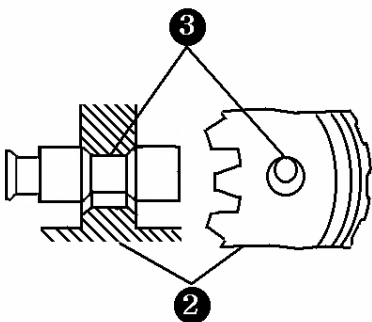
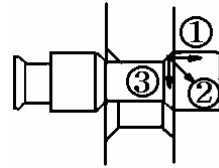

Fig.5-17 Block-pin

**3rd stage:**

When hub(2) is pushed further, the tapered surface in the hole of the hub and the tapered surface on the block pin are pressed tightly against each other, this pushes synchro-ring(4) against synchro-cup(5). Consequently, as shown fig.5-6, the synchro-ring and the synchro-cup are pressed more tightly against each other by the resultant turning force of the rear wheel and the thrust of the shifter. Ultimately, the revolving speeds of the synchro-ring and the synchro-cup become the same.



- (1) Thrust
- (2) Resultant force
- (3) Turning force

Fig. 5-18 Synchro-ring and cup

**4th stage :**

When synchro-ring(4) and synchro-cup(5) reach the same speed, the friction force disappears. Then the resistance between hub(2) and block pin(3) also disappears to allow the hub to clear the groove on the block pin and to sit on the large diameter area of the pin. At the same time, thrust piece(6) which has a tapered shape and hub(2) advance smoothly on the pin to complete the meshing between spline(8) of the hub and spline(13) of the gear.

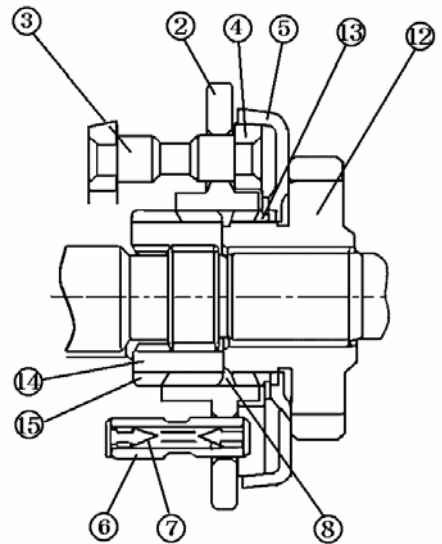

Fig. 5-19 Complete Synchro-ring and cup

## SECTION 2. SPECIFICATIONS

### 1. WHEEL DRIVE SYSTEM

Model		3510/4110	T390	T430/T431
Speed shift range		forward	12	16
		reverse	12	16
Reduction ratios.	Linear shift	forward	1/ 1.238	
		reverse	1/ 1.354	
	Main speed shift	1 <sup>st</sup>	1/ 2.105	
		2 <sup>nd</sup>	1/ 1.5	
		3 <sup>rd</sup>	1/ 1.107	
4 <sup>th</sup>		1/ 0.844		
Speed range shift	LL	-	1/24.191	
	L	1/ 9.318	1/9.318	
	M	1/ 2.683	1/ 2.893	
	H	1	1	
Drive pinion-Ring gear		1/ 4.364		
Final reduction		1/ 5.5		
Operation methods	Linear shift		Column shift	
	Main speed shift		Side shift (RH)	
	Speed range shift		Side shift (RH)	
Oil capacity	Transmission case		34 ℓ(9 gal)	

### 2) PTO DRIVE SYSTEM

MODEL	3510/4110	T390(T400)	T430/T431
Speed shift range	2	2	4
Reduction ratios.	1:1/1/4.675 2:1/2.866	1:1/1/4.675 2:1/2.866	1:1/4.429 2:1/3.690 3:1/2.460 4:1/1.968
PTO shaft speeds	540 @2524 rpm 1000 @2866 rpm	540 @2524 rpm 1000 @2866 rpm	540 @2392 rpm 700 @2582 rpm 1000 @2460rpm 1250 @ 2460rpm
PTO shaft size	∅ 35mm(1 3/8 in) 6-splines		
Rotational direction	Clockwise viewed from the rear		
PTO clutch	Wet,multi-disc,hydraulic-operated clutch		
	No.of clutch plates	9	9
	Oil used	THF500	

## SECTION 3. DISASSEMBLY,INSPECTION,AND REASSEMBLY

### 1. INPUT SHAFT AND REVERSE CHANGE GEARS (FRONT TRANSMISSION)

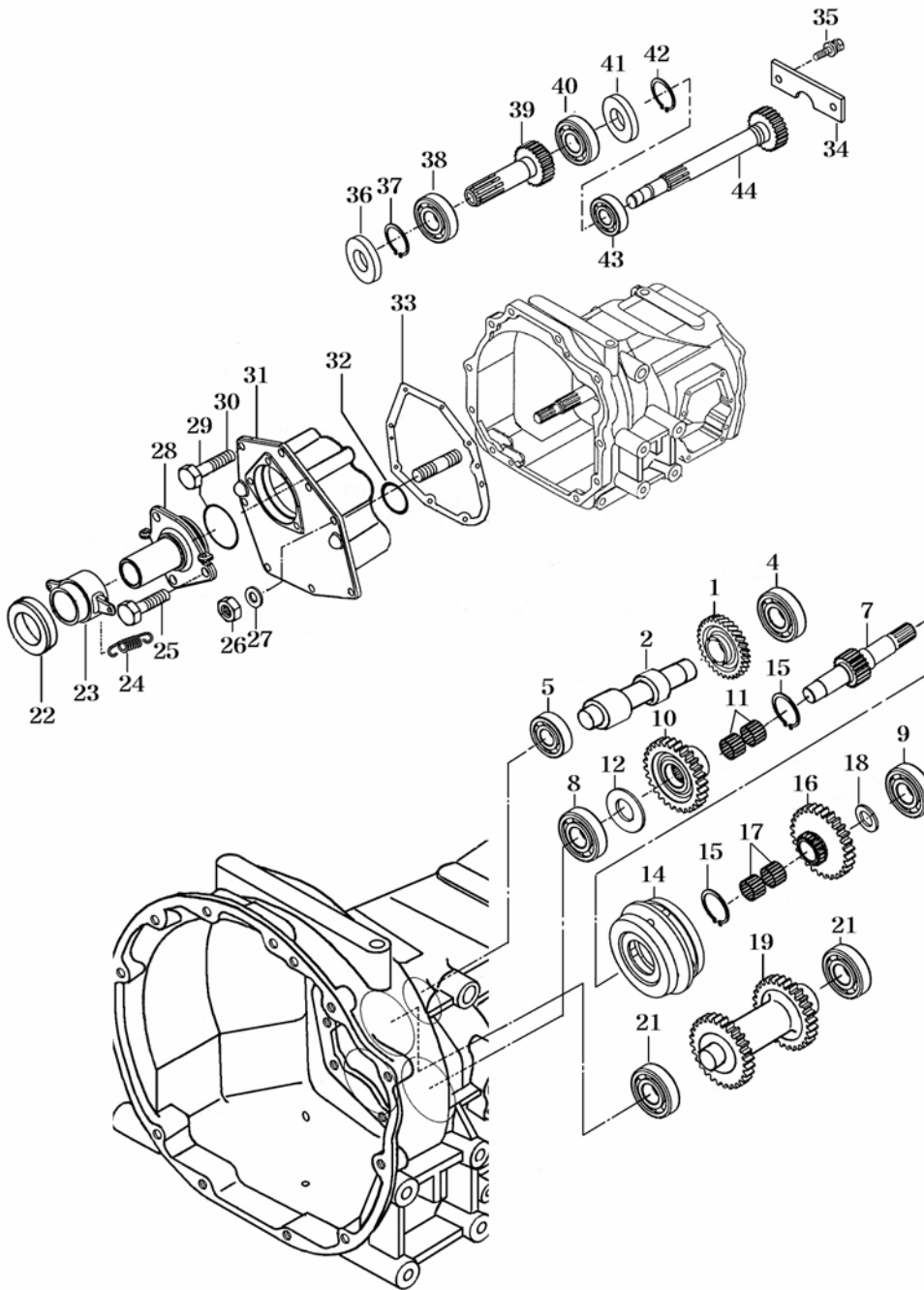

- 1.Gear helical(30)
- 2.Shaft
4. Ball bearing
- 5.Ball bearing
- 7.Reverse shaft
- 8.Ball bearing
- 9.Ball bearing
- 10.Gear helical(26)
- 11.Needle bearing
- 12.Washer(25X46X03)
14. Synchronizer
- 15.Snap ring
- 17.Needle bearing
- 18.Washer(30X46X03)
- 19.Gear(helical/33-29)
- 21.Ball bearing
- 22.Clutch release bearing
- 23.Sleeve
- 24.Tension spring(31)
25. Bolt
- 26.Nut
- 27.Washer spring
- 28.Metal sleeve
- 29.O-ring(G76)
- 30.Bolt
- 31.Metal(input)
- 32.snap ring
- 33.Packing
- 34.Plate
- 35.Bolt(S)
- 36.Oil seal
- 37.Snap ring
- 38.RBB
- 39.Gear helical(21)

Fig.5-20

- 40.Bearing      41.Oil seal      42.Snap ring      43.Ball bearing(HL1)      44. Gear helical

## 1.1 DISASSEMBLY

(1) Removal of input shaft and related parts  
separate the engine from the front transmission  
referring to the paragraph 3.(1) of SECTION 4.  
SEPARATION OF MAJOR COMPONENT in  
Chapter 2.

a. Remove input metal as an assembly using  
two push bolts(M8X2)

Note:

Be sure to screw in the bolts evenly

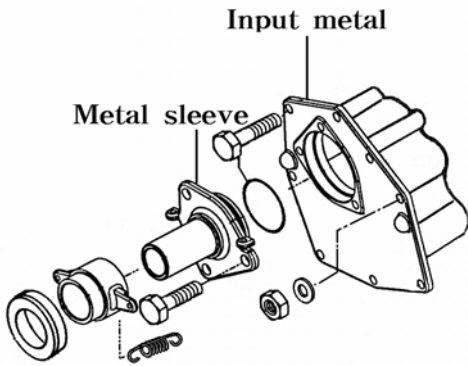

Fig.5-21 Input metal and related parts

b. Remove plate.(The tightening bolts are applied  
with adhesive on their threads.)

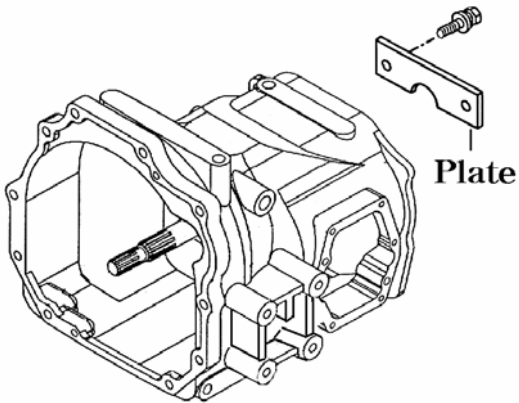

Fig.5-22 Plate

c. Pull out Helical gear(21T) rearwards.

d. Remove the sleeve metal tightening bolts  
and take off sleeve metal.

e. Draw Input gear forwards.

f. Remove snap ring C

g. Pull out idle shaft,using the tapped hole in it

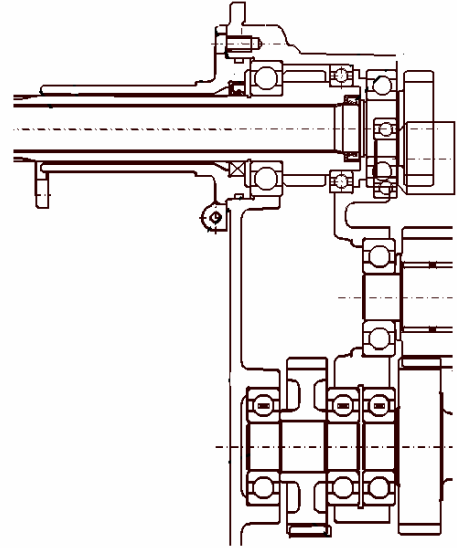

Fig.5-23

## (2) Removal of reverse change gears and PTO clutch assembly

separate the engine from the front transmission  
referring to the paragraph 4.(1) of SECTION 4.  
SEPARATION OF MAJOR COMPONENT in  
Chapter 2.

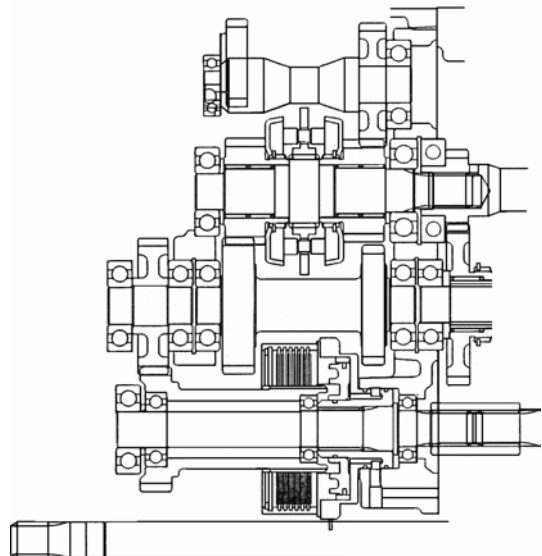

Fig.5-24

a. Draw shaft along with gear(Fig5-24)

b. Draw PTO drive gear;PTO clutch assembly;PTO drive shaft;gear all together as an assembly.

Note:

Be careful not to damage the seal ring of the PTO clutch

c. Extract the assembly of gear,reverse shaft,synchromesh assembly,and gear.

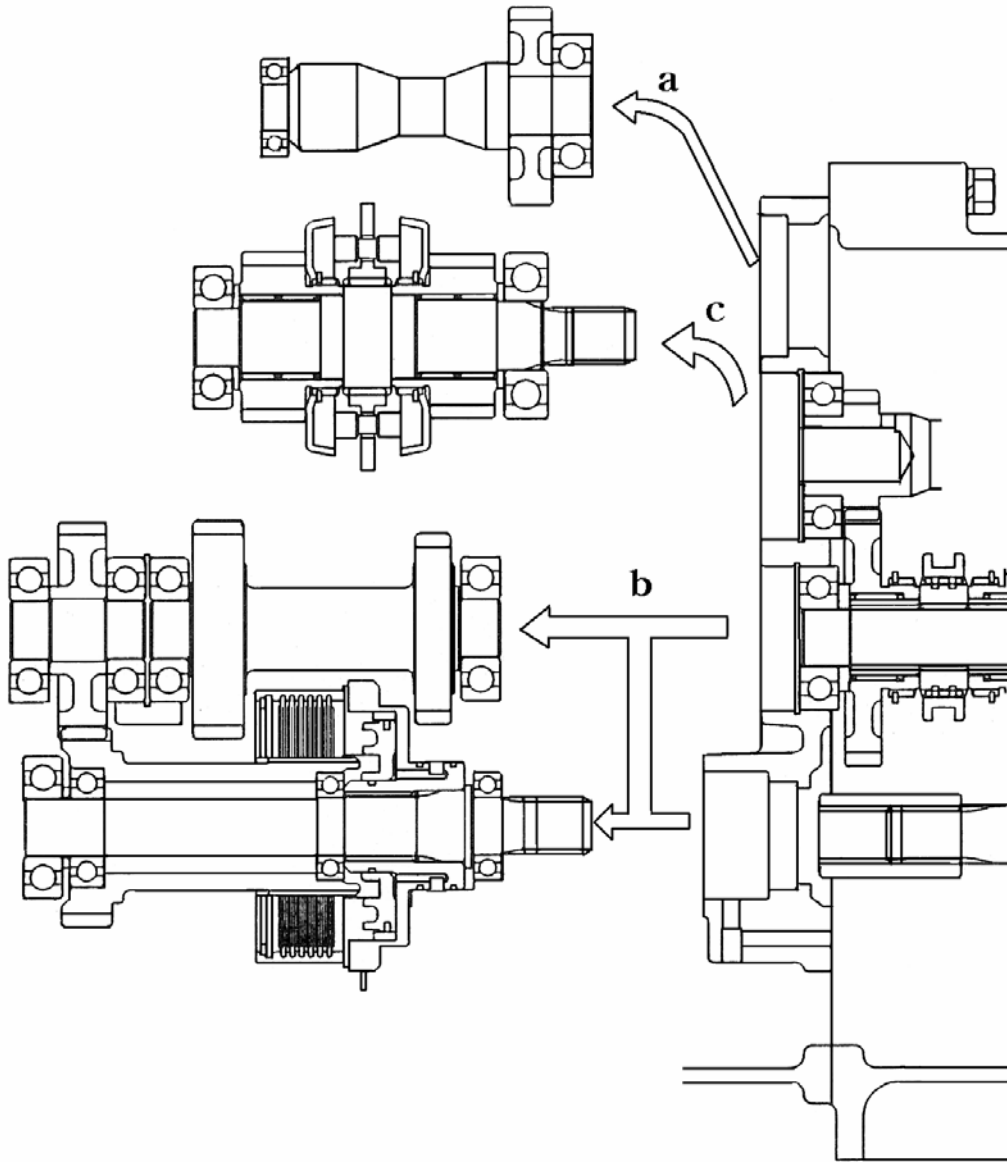

Fig.5-25

Note:

When the PTO clutch assembly is trouble-free,keep it aside,without disassembling it,in a Clean,dust-free place

### (3) Disassembly of reverse shaft and related parts.

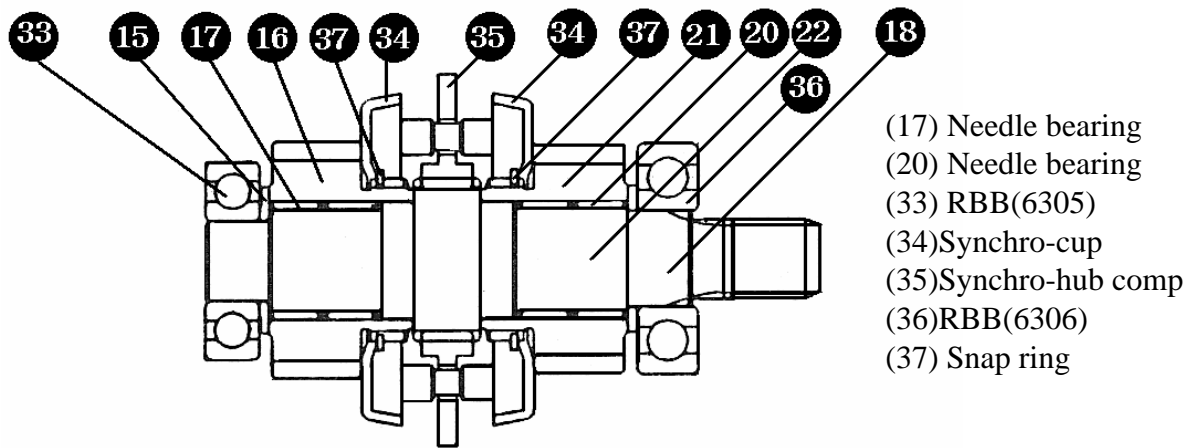

Fig.5-26

- a. Remove bearings(33 and 36)
- b. Remove washers(15 and 22), needle bearings(17 and 20), synchro-hub comp,(35), etc. synchro-cup(34) can be taken off as an assembly with gears(16 and 21).
- c. Remove snap ring(37) and detach the synchro-cup.

## 1.2 INSPECTION

Before and after disassembly, inspect each part for points mentioned below, and replace if necessary.

Inspection items	Standard values	Usable limits
Backlash of each gear (measured in meshed condition)	0.1 - 0.2 mm (0.004-0.008 in)	0.5 mm (0.020 in)
Stepped wear of teeth	0 mm (0 in)	0.3 mm (0.012 in)
Assembled width of synchromesh assembly Dimension A	51.17 mm (2.015 in)	-
Synchro-hub thrust for shifting Neutral-Engaging	13.0-18.8 Kgf (28.7-41.5 lbs)	9.5 Kgf (20.9lbs)

- Inspect bearings such as ball bearings and needle bearings for abnormalities in rotation such as irregularity, hitching, etc. by turning them with pressure applied by hand. Replace defective ones.
- Seriously worn or damaged parts should also be placed.

### 1.3 REASSEMBLY

(1) Sub Assembly of reverse shaft and related parts.

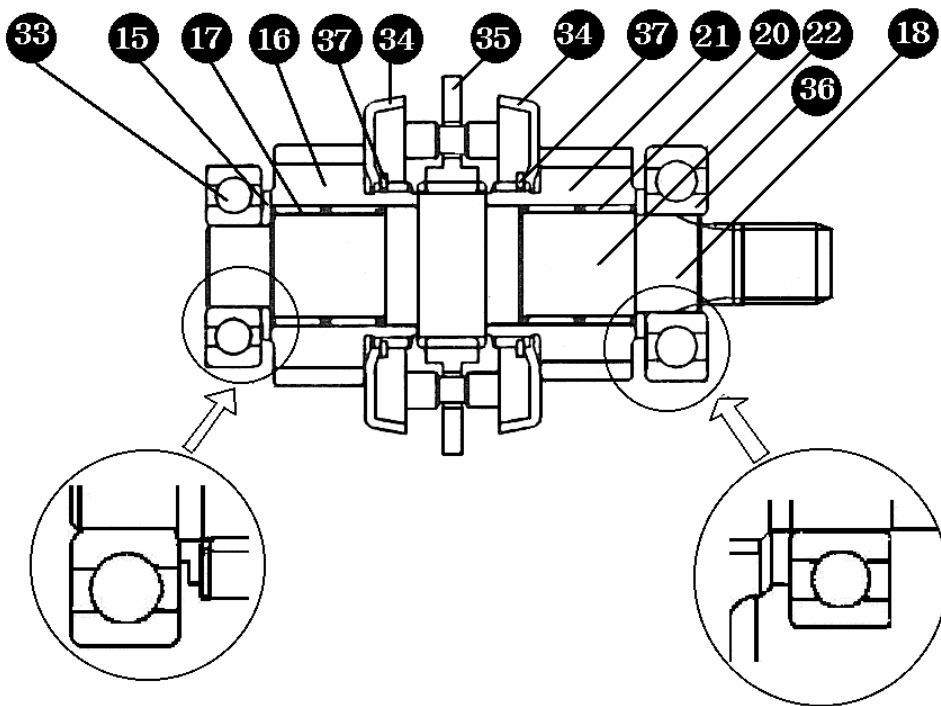

Fig.5-27

- a. Install Synchro-cups(34) on gear(16) and gear(21) respectively and retain them securely with snap rings C
- b. Install synchro-hub comp(35) and above sub- assemblies on reverse shaft(18)

Note:  
As each synchromesh assembly maintains a specified installed width, be sure not to mix different pairs of the synchro-hub comp, and the synchro-cup

- c. Install washers (15 and 22) and install the bearings positively.

Note:  
As these washers have their own directions of installation, be strict to install them correctly.



(2) installation of each sub-assembled shaft.

Install each sub- assembled shift into the reverse metal(Support).

Note:  
When installing the PTO clutch assembly,apply a thin coat of grease to the seal rings and install it taking care not to damage these rings.

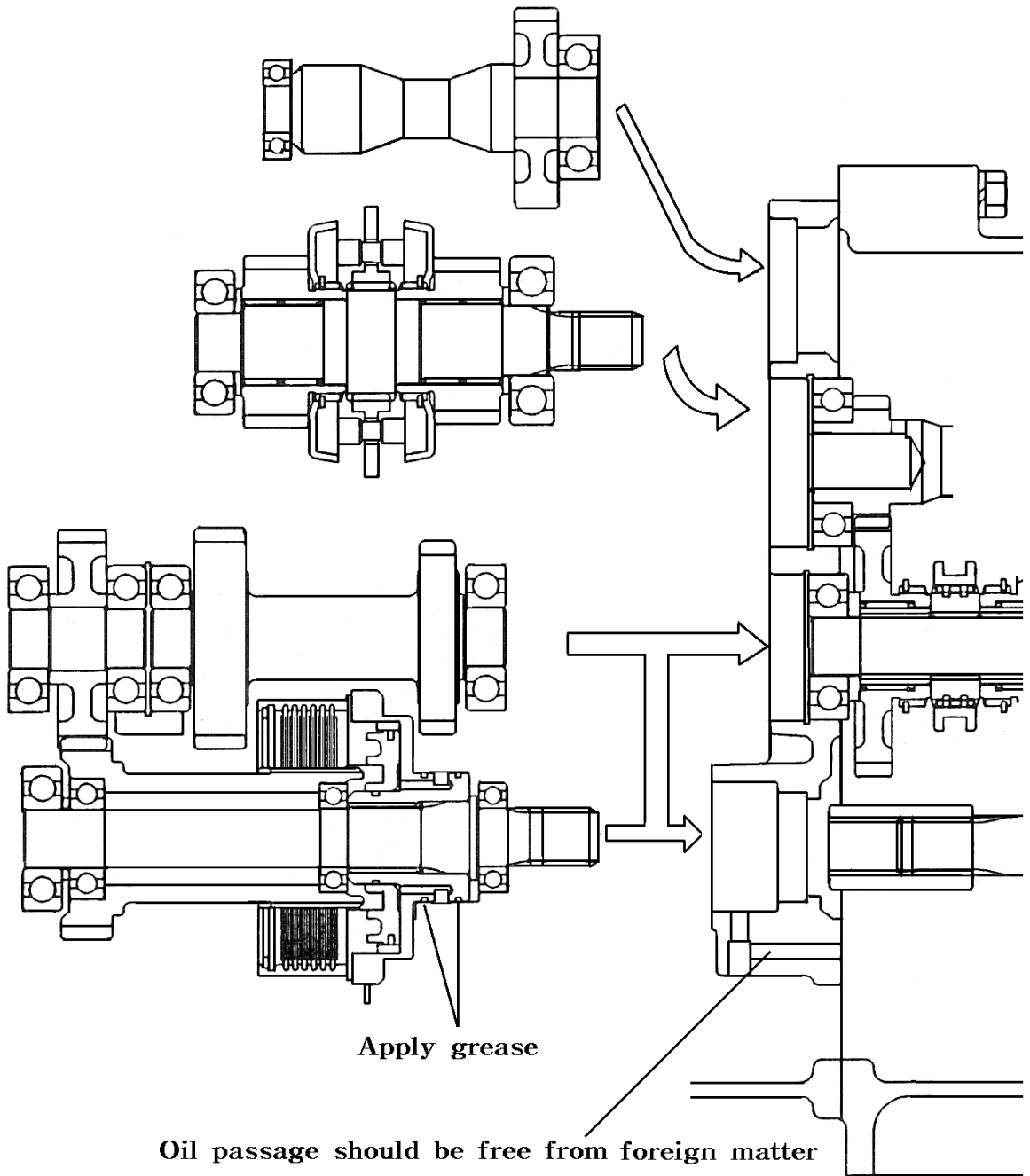

Fig.5-28

**(3) installation of input metal and related parts.**

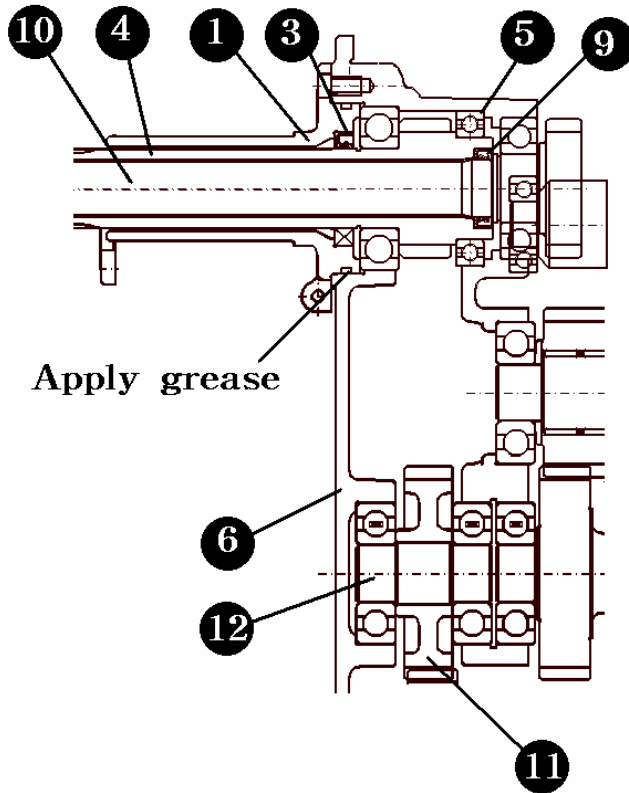

Fig.5-29

Reassemble in reverse order of disassembly, following the next instructions.

- a. Install the idle shaft(12) so that the end with the tapped hole faces rearwards, that is, on the snap ring installed side.
- b. Apply adhesive to the threads of the bolts (M8 × 20) which tighten the bearing retaining plate.
- c. Oil seals should be installed in their correct direction. As an oil seal is a special eccentric seal, be careful not to interchange these seals.
- d. Before installing sleeve metal (support) (1) on input metal (support) (6), apply grease to the O-ring to prevent its damage.

## 2. PTO CLUTCH

### 2-1. DISASSEMBLY

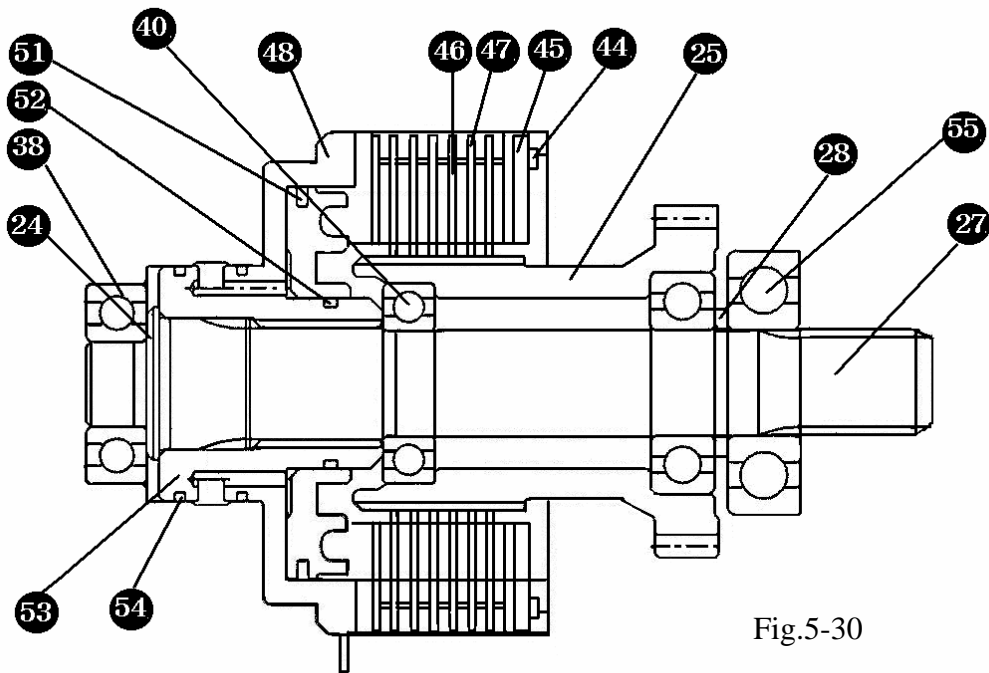

Fig.5-30

(38)RBB (40)RBB (44) Snap ring (45)Back-up plate (46) Disc assembly (47)Driven plate  
 (48) Piston (51) Seal ring (52) Seal ring (53) Cover assembly (54)Seal ring

Note:  
 Disassembly of the PTO clutch assembly should be done in a clean,dust-free place.Exercise special attention to avoid damage of the seal rings,etc

- a. Pull out PTO drive shaft rearwards.
- b.Pull out PTO drive gear forwards.
- c.Remove snap ring (D95 for hole),and take bake-up plate,disc assembly,and driving plates.
- d.While holding return spring(43) compressed with a special tool,remove snap ring

- e. Disassemble into separate parts;piston,return sparing,brake disc,and cover assembly.

### 2.2 INSPECTION

- a. Cover assembly
  - Replace a cover assembly which has a damaged or worn sliding surface.
  - If there is any damage to the cover assembly and the piston seal ring,these parts should also be replaced.
- b. Disc assembly
  - If the thickness of a disc assembly exceeds the usable limit mentioned below or combined width of the disc assembly and driven plate is less than 23.8mm(0.937 in),replace both the disc assembly and driven plate.

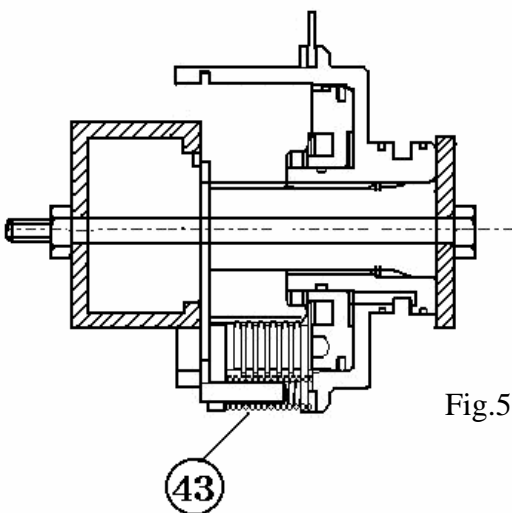

Fig.5-31

-Inspection for disc thickness and serration wear.

Inspection Items	Specified values	Usable limit
Disc thickness	2.2±0.1mm (0.087 in)	1.9mm (0.075 in)
Surface flatness	-	0.2mm (0.008 in)

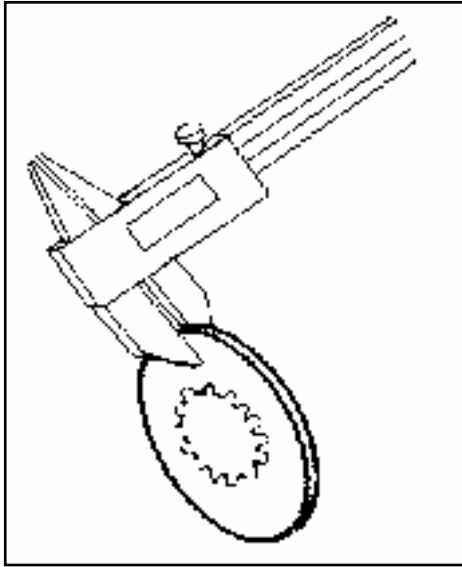

Fig.5-32

c. Driven plate

-Inspection for deformation and burning.  
-A seriously damaged or worn disc should be replaced.

Inspection Items	Specified values	Usable limit
Surface flatness	-	0.2mm (0.008 in)

d. Brake disc

-Inspection for deformation and burning.  
-A seriously damaged or worn disc should be replaced.

Inspection Items	Specified values	Usable limit
Disc thickness	3±0.1mm (0.118 in)	2.5 mm (0.098 in)
Surface flatness	-	0.2mm (0.008 in)

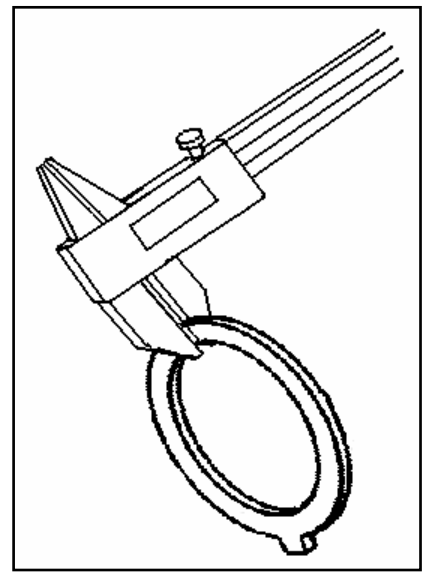

Fig.5-33

e. If the combined thickness of the return plate and brake disc deviates from the specified value, replace both parts.

Inspection Items	Specified values	Usable limit
Combined thickness of return plate and brake disc	5.5 ±0.18 (0.217 in)	5mm (0.2 in)

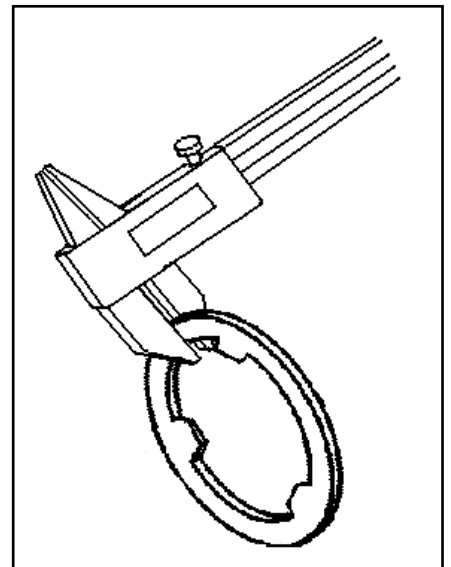

Fig.5-34

f. Also inspect other parts for wear and deformation and replace them if necessary

Note:

Seal ring and the two seal rings should be replaced as a pair

## 2.3 REASSEMBLY

Reassemble the parts in reverse order of disassembly, following these instructions.

Note:

-Each parts should be washed clean before reassembly.

-Apply multi-purpose, quality grease to needle bearings in advance.

-Each bolt and nut should be tightened to the respective specified torque table.

-Every time a gear is installed, its smooth rotation should be checked.

-Every snap ring should be seated securely in its groove.

a. When installing seal rings, apply fresh oil ahead of time and install them carefully so as not to damage them.

b. Install the return plate with the press-processed side turn towards the brake disc.

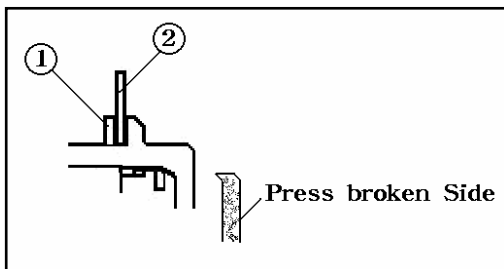

Fig.5-35

① Return plate ② Brake Disc

c. When installing the return spring, use a special tool; the snap ring should be securely seated in the groove.

d. When pushing the RBB's (6205 and 6005) into the gear, be careful only to push their outer races.

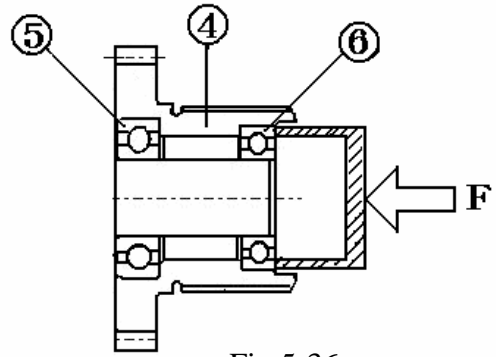

Fig.5-36

4. Bearing ball (6205) 5. Gear, helical 35T  
6. Bearing, ball (6005)

e. Install washer in correct direction.

f. After reassembly, check to see that gear turns smoothly by locking the PTO clutch

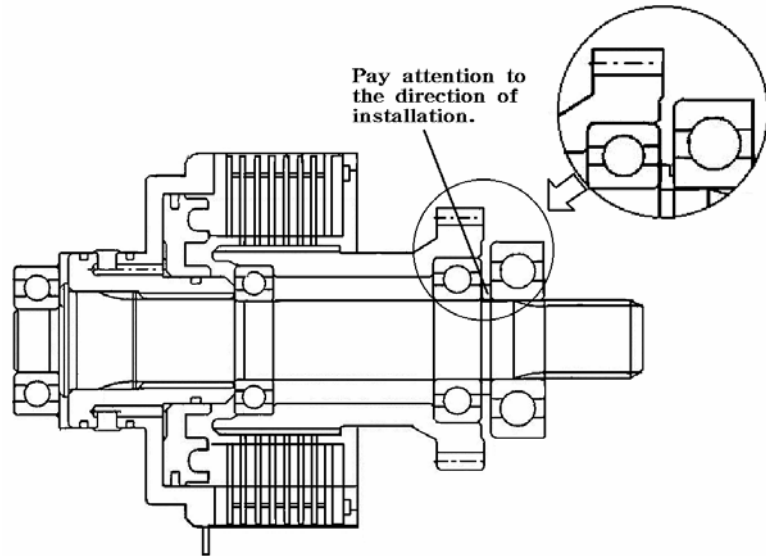

Fig.5-37

### 3.MAIN CHANGE,SUB-CHANGE,AND 4WD CHANGE GEARS.

(1)Synchronesh transmission version.

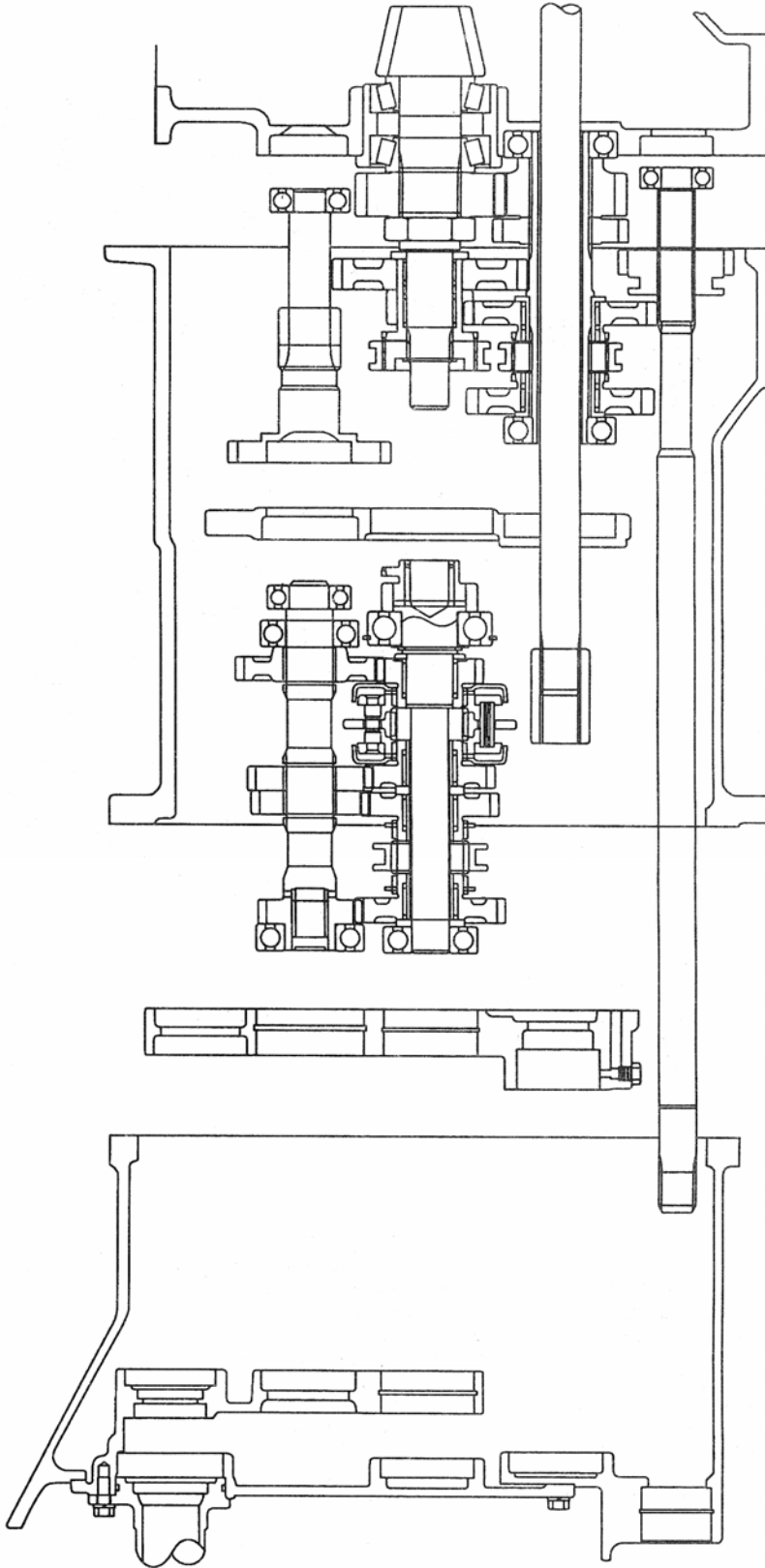

Fig.5-38 Synchronesh transmission version

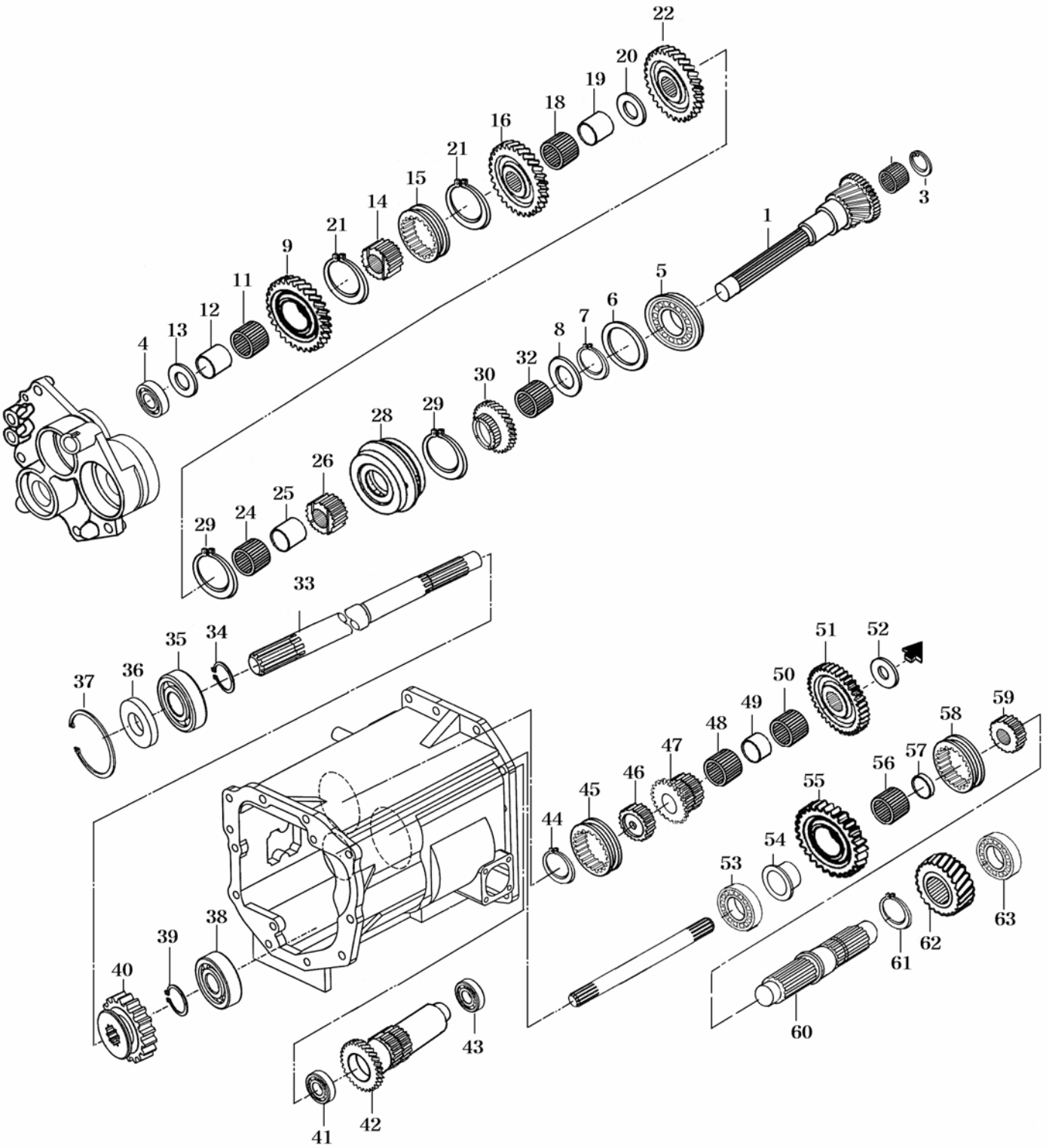

Fig.5-39 Main change gear and related parts.

### 3.1 DISASSEMBLY

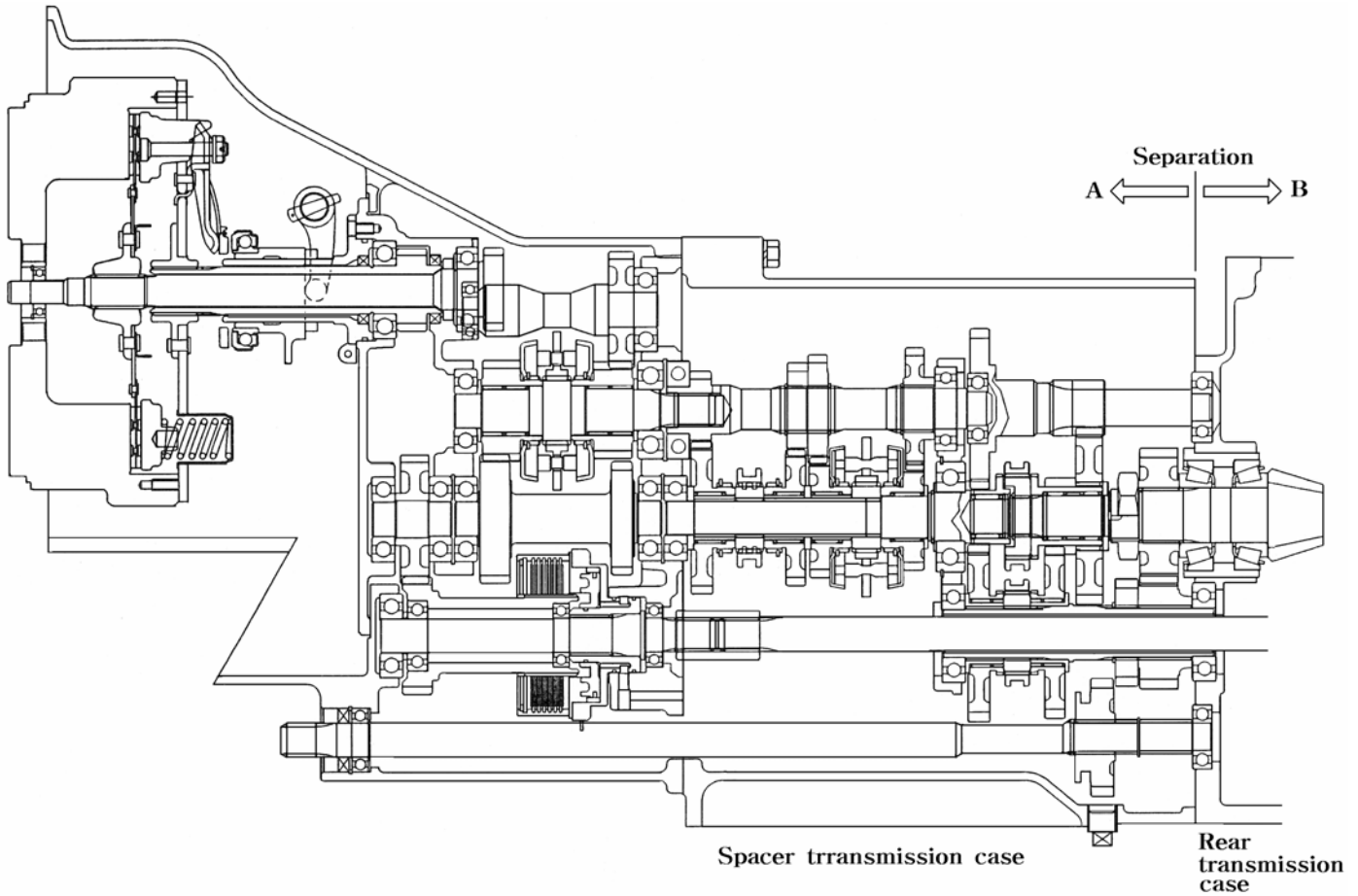

Fig.5-40

Separation the spacer transmission case and rear transmission case from each other referring paragraph 5.(1) in SECTION 4.SEPARATION OF MAJOR COMPONENTS in chapter 2.

With this operation,the transmission is divided into parts A and B part A includes main speed shift and mechanism and part B includes speed shifting and 4WD shifting mechanisms.(fig.5-26)

Note:

The separation of the gears mentioned in the figure is possible without dividing the front transmission and the spacer transmission from each other



(1) Disassembly of main change gears(main speed shift),part of sub-change gears(speed range shift) and shifters.

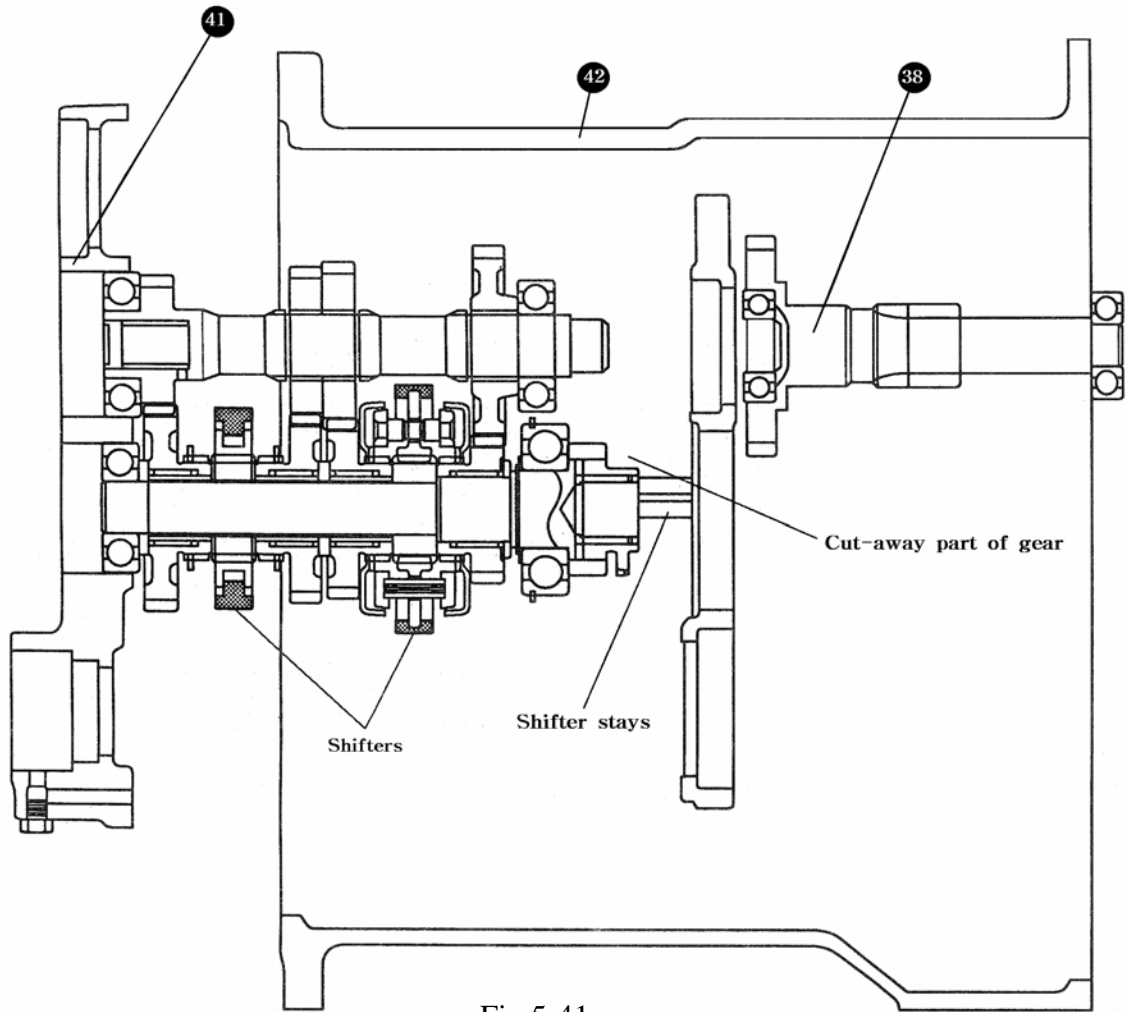

Fig.5-41

a.set the cut away part of the gear so that it clears the gear as shown in fig.5-42



Fig.5-42

- b.Remove the tightening bolts of the reverse metal(support) (two straight pins are installed)
- c.Pull out the assembly of the reverse shifter metal,main speed shift gears,and shifters rearwards by tapping it with a plastic hammer.

Note:

Take care not allow the gear to drop as it is free when the above assemble is removed.

- d.Remove the shift stays from the shift metal and remove the gears assemblies as shown Fig.5-43.
- d. Remove bearings and gears from each shaft.

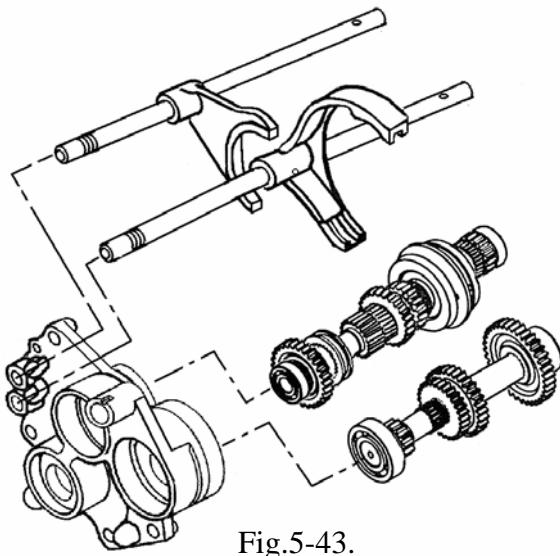

Fig.5-43.

**(2) Disassembly of the sub-change gears  
(Speed range shift)**

- a. Remove the sub-shifter and shifter stay.
- b. Pull out the PTO shaft ,4WD shaft and gear



Fig.5-44

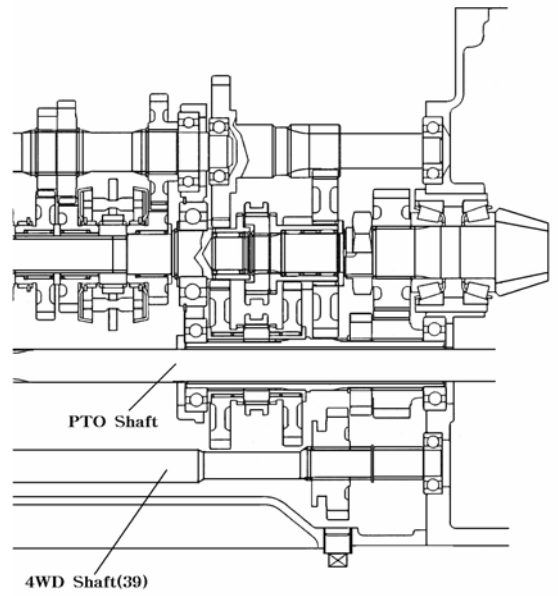

Fig.5-45

- c. Remove the snap ring from the end of the pinion gear shaft
- d. Remove the hub
- e. Remove the sub-change gears.

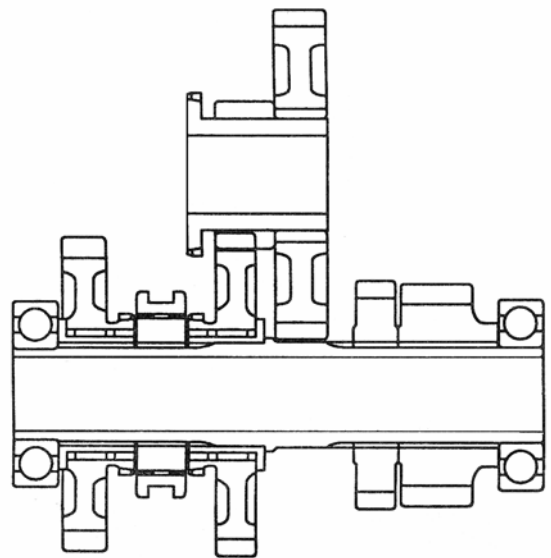
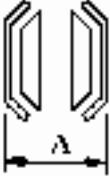

Fig.5-45

### 3.2 INSPECTION

Before and after disassembly, inspect each part for points mentioned below, and replace if necessary.

Inspection Item	Standard Value	Usable limits
Backlash of each gear(measured in meshed condition)	0.1-0.2mm(0.004-0.008in)	0.5mm (0.020 in)
Stepped wear of teeth	0mm	0.3 mm (0.012 in)
Assembled width of synchromesh assembly	Dimension A  51.17 <sup>+0.18</sup> <sub>-0.424</sub> (2.015in)	-
Syncho-hub thrust for shifting Neutral → Engaging	13.0-18.8 Kgf (28.7-41.4lbs)	9.5 Kgf (20.9 lbs)
Thrust play of fixed gears	0 mm	0.5 mm (0.020 in)
Wear in each shifter		0.5 mm (0.020 in)

- Inspect bearings such as ball bearings and needle bearings for abnormalities in rotation such as irregularity, hitching, etc. by turning them with pressure applied by hand. Replace defective ones.

- Serious worn or damaged parts should also be replaced.

### 3.3 REASSEMBLY

Reassemble the parts in reverse order of disassembly, following these instructions.

Note:

- Each part should be washed clean before reassembly.
- Apply multi-purpose, quality grease to needle bearings in advance.
- Each bolt and nuts should be tightened to the respective specified torque in accordance with the tightening torque table.
- Every time a gear installed, its smooth rotation should be checked.
- Every snap ring should be seated securely in its groove.
- As each synchromesh assembly maintains a specified width, be sure not to mix different pairs of the synchro-hub comp. and the synchro-cup.
- Remember to install the snap rings.

#### (1) Installation of main change gears

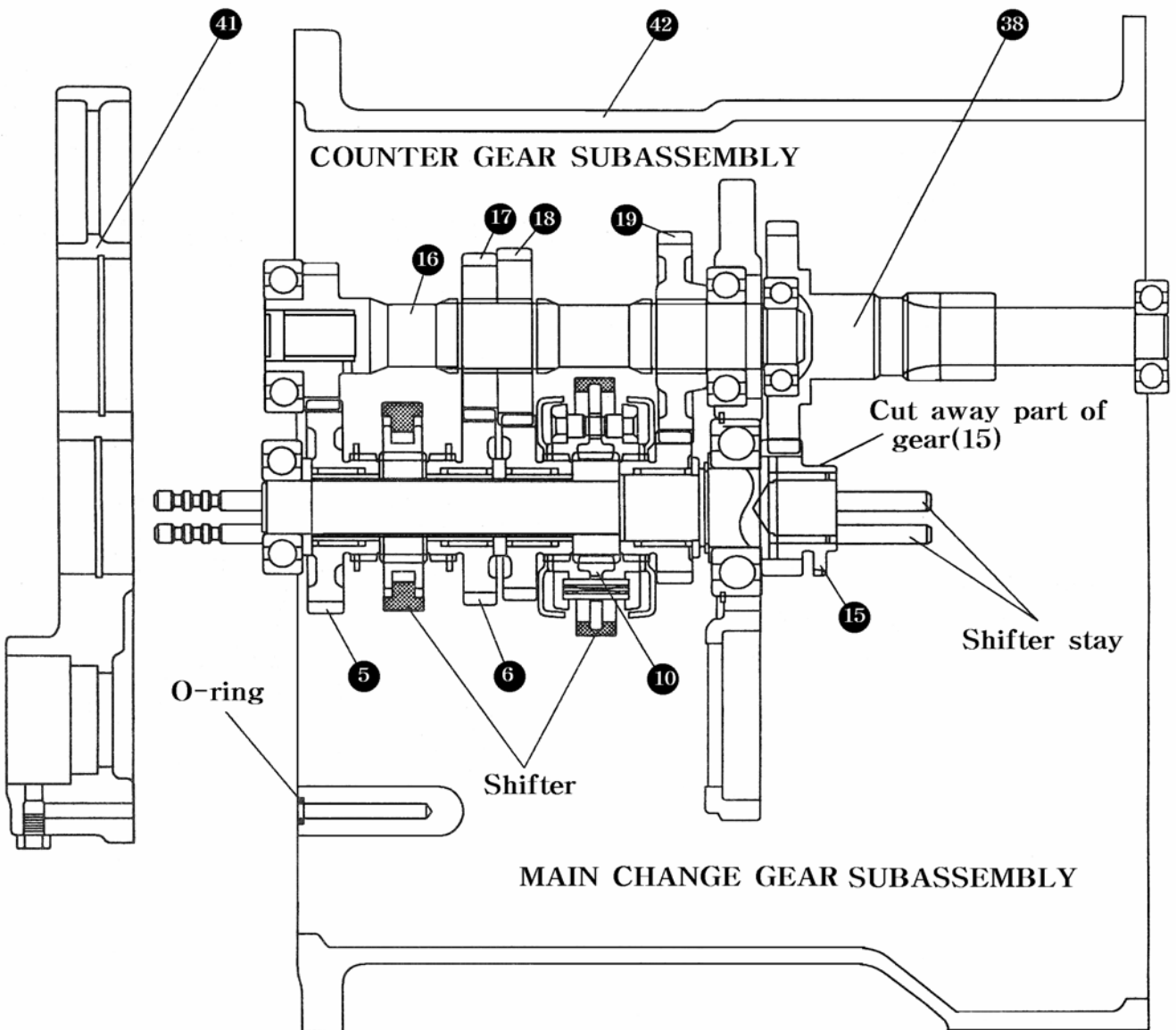

Fig.5-46

- a. While holding the gear in the position shown in the drawing, install the assembly of the main change gears and related parts in position by tapping it slightly on the front of a plastic hammer and then the gears by tapping it on the rear.
- b. Sub assemble the shifter stay, spring, and steel ball (Fig.5-47) on the reverse shift metal (support) and install the sub-assembly on the shift stay
- c. Align the holding parts in the reverse shift metal with RBB's of the sub assemblies of the counter gears and main change gears, straight pins, etc., and install the reverse shift metal on the spacer transmission case.

Note:

- Align the cut-away part of gear to clear the gear
- When installing the O-ring, take care not to damage it or allow it to fall

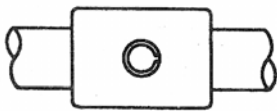
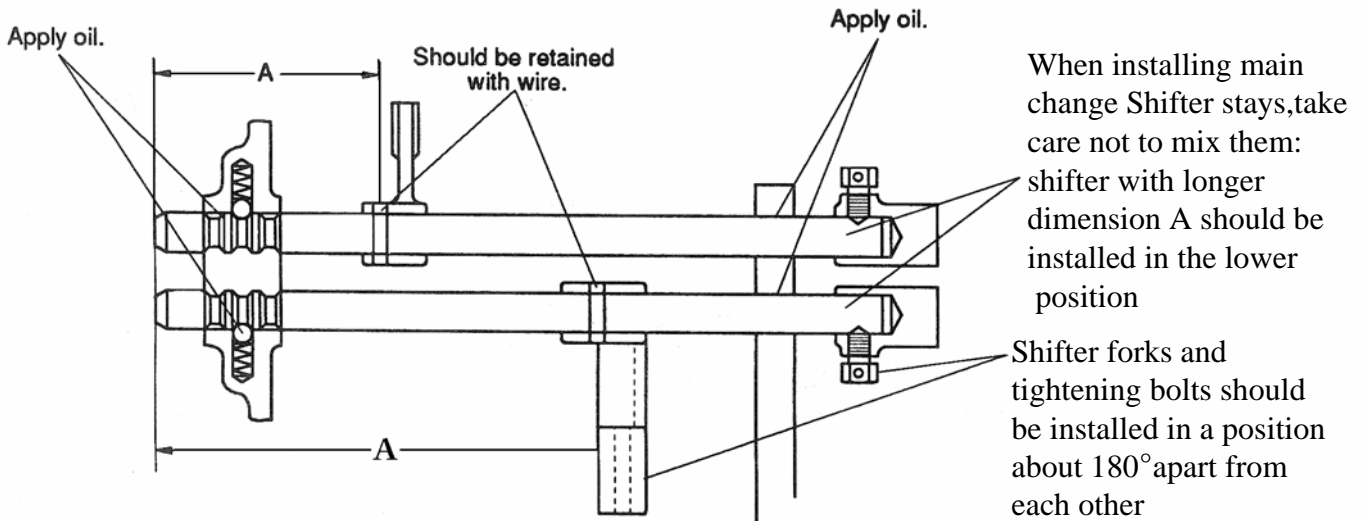

Fig.5-48

Spring pins should be retained with wire and each wire should be twisted in the position illustrated

Spring pin ends should be driven in until their ends become flush with the shifter surfaces

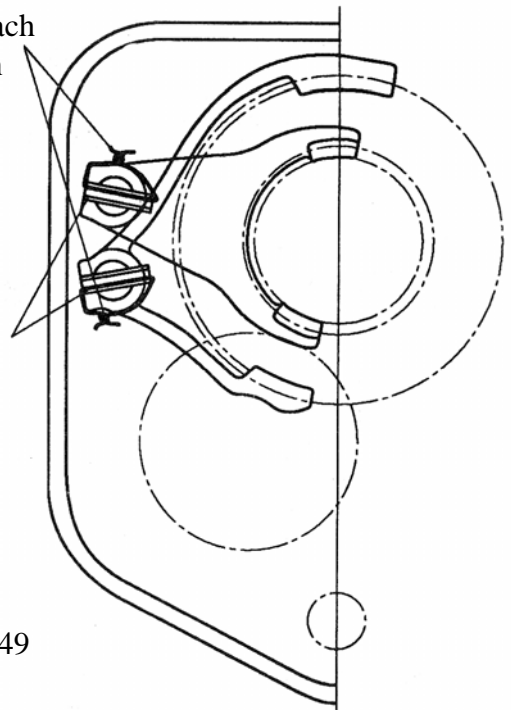

Fig.5-49

Note:

- Install spring (roll) pins so that their seams are positioned as illustrated in Fig.5-49

**(2) Reassembly of sub-change gears  
(speed range shift)**

-Reassemble the parts in reverse order  
of disassembly following next  
precautions.

a. Never forget to install needle roller  
bearing and collar

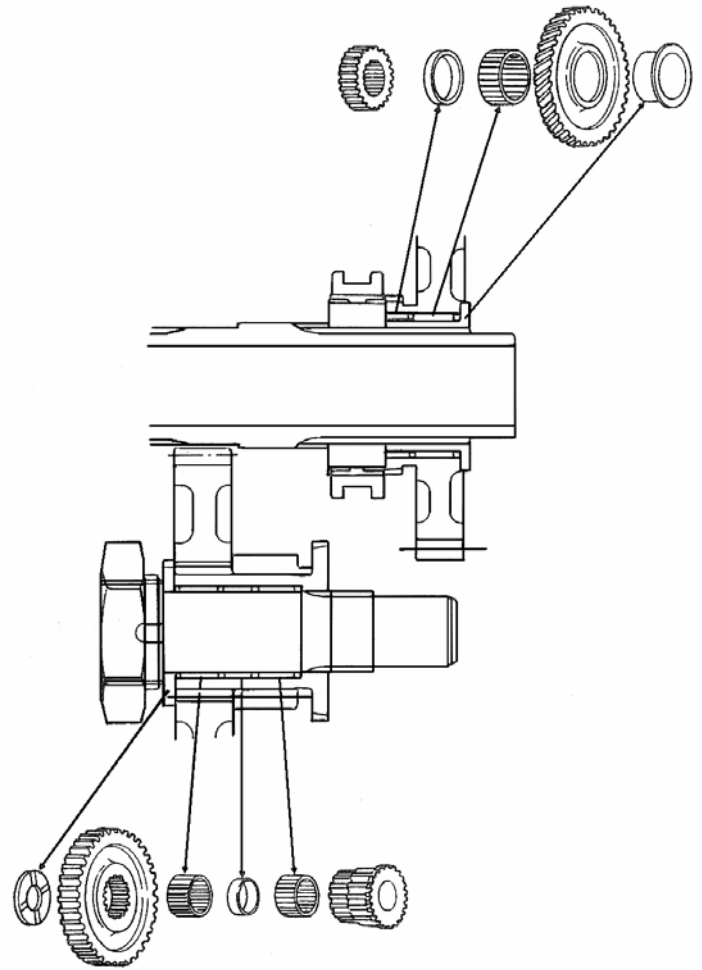

Fig.5-50

b. Pay attention to the installed direction of gear

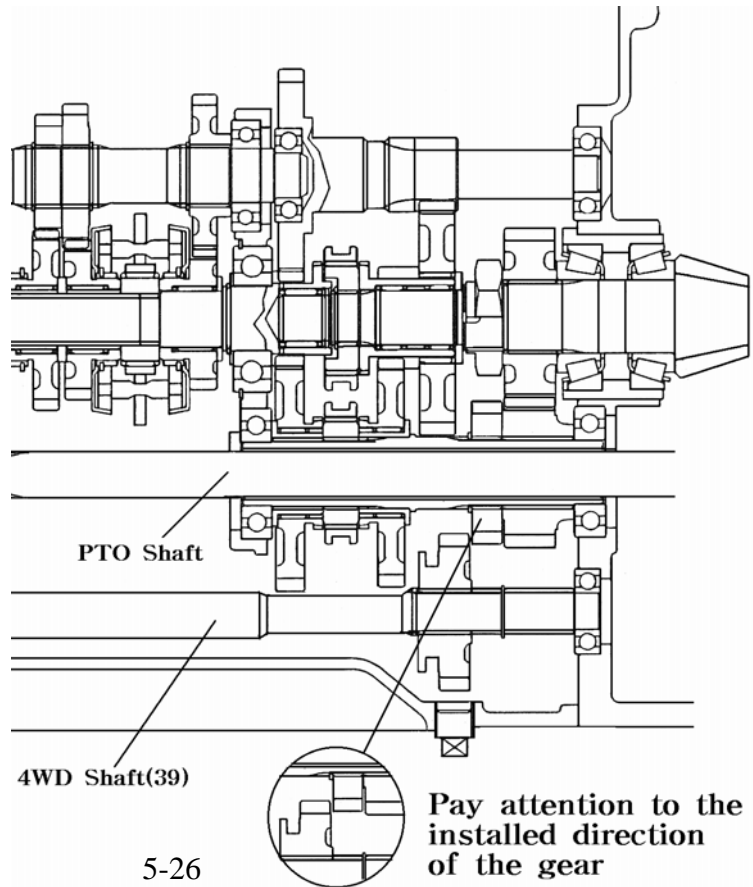

Fig.5-51

c. Be sure to install the sub-change shifter

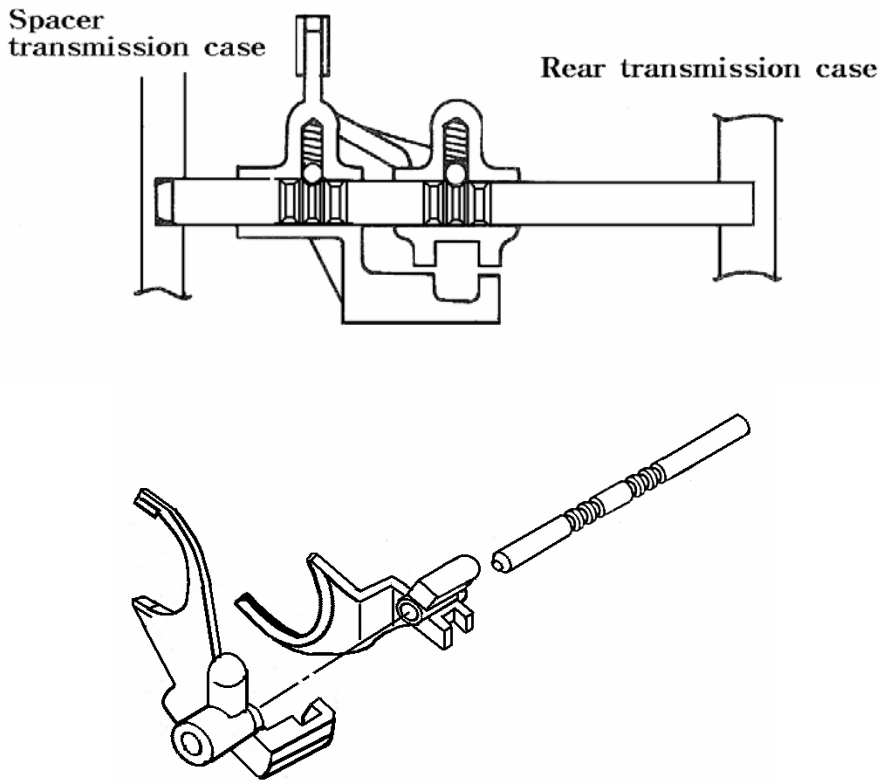

Fig.5-52

## 4. Rear transmission case

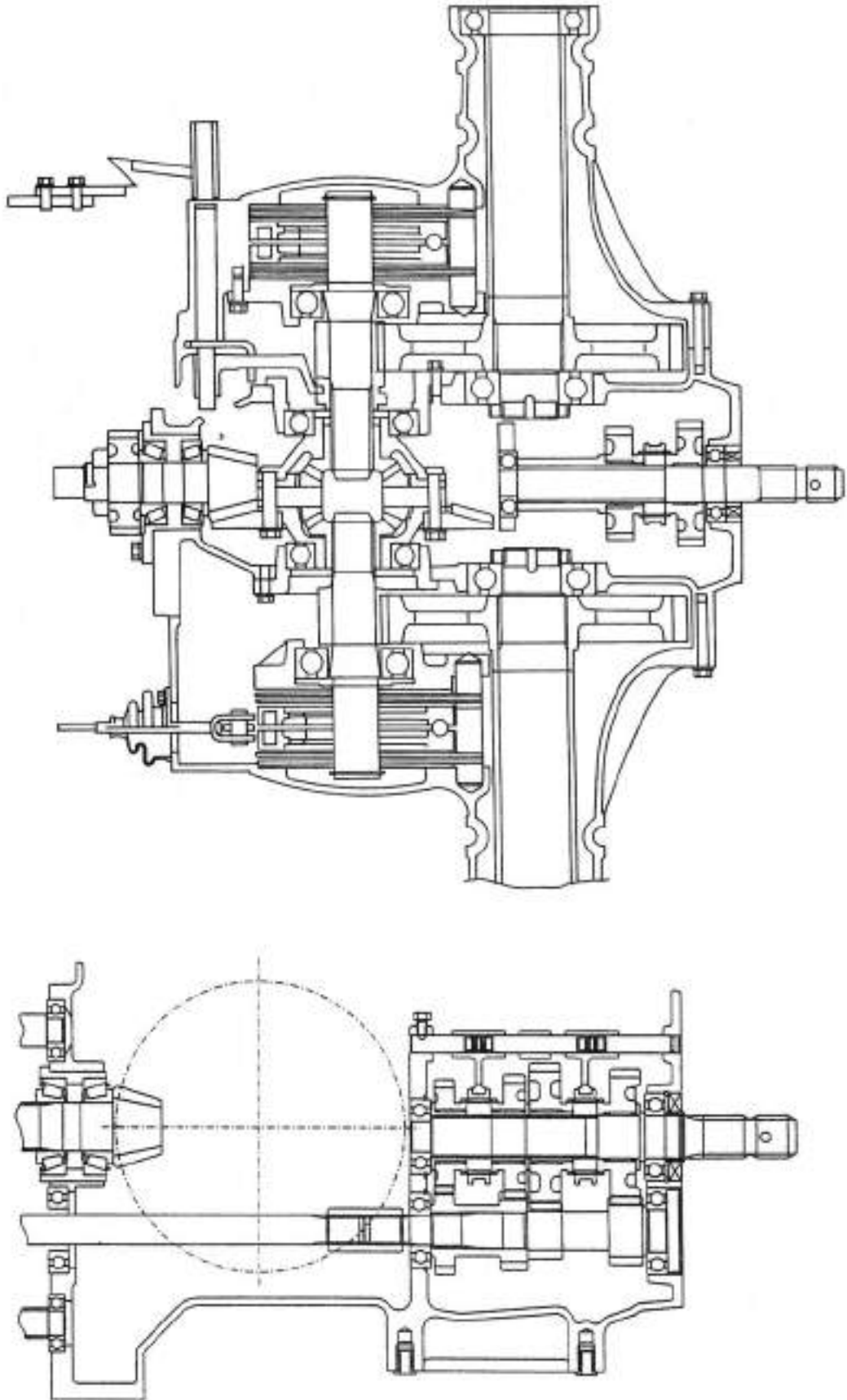

Fig.5-53. 4 speed PTO version



### 3-1. DISASSEMBLY

Separate the spacer transmission and the rear transmission from each other and then remove the hydraulic cylinder case.referring to paragraph 7.(1) of SECTION 4. SEPARATION OF MAJOR COMPONENTS in Chapter 2.

#### (1) Ring gear, Drive pinion, and related parts.

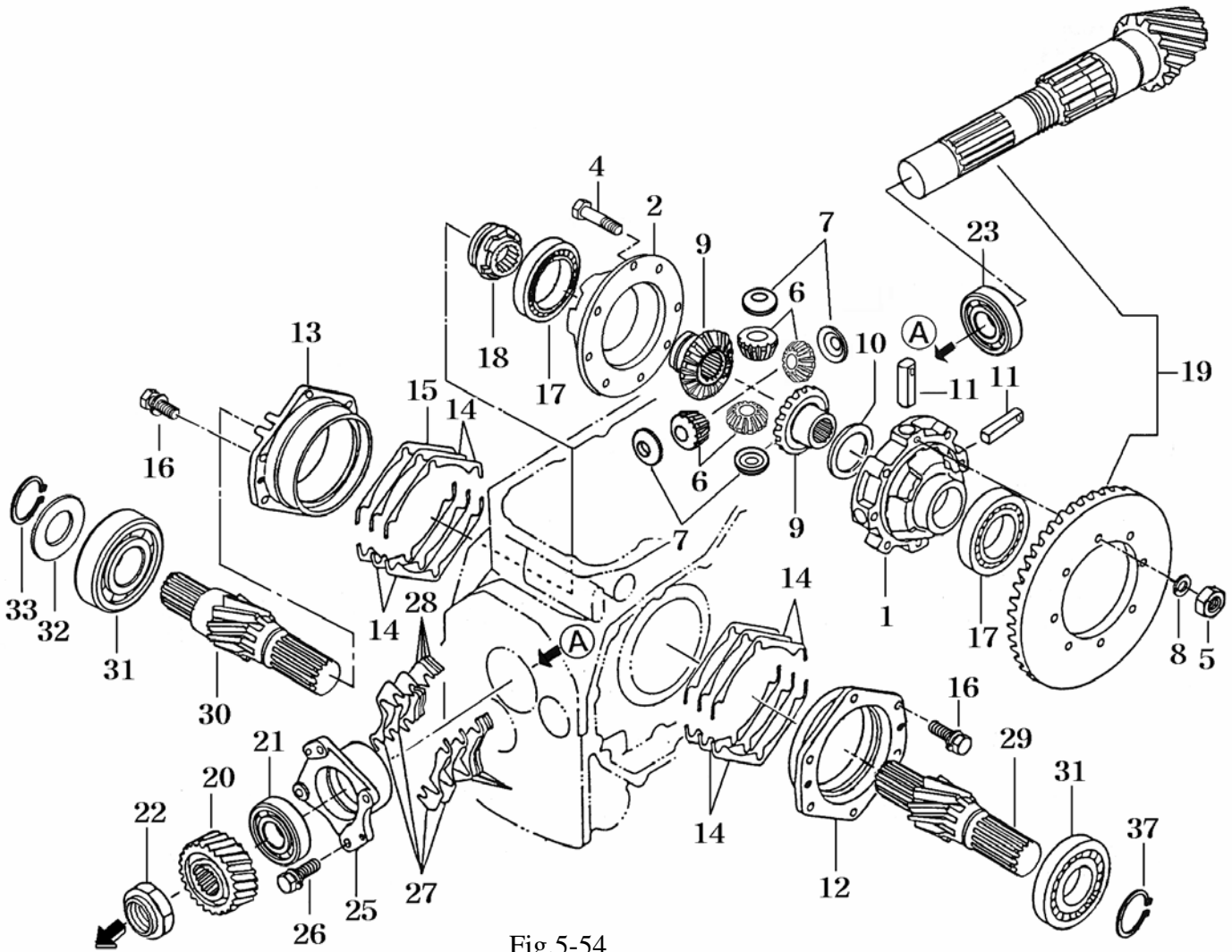

Fig.5-54

- |                         |                           |                       |                        |                        |          |              |
|-------------------------|---------------------------|-----------------------|------------------------|------------------------|----------|--------------|
| 1.Diff case (L)         | 2.Diff case(R)            | 4.Bolt                | 5.Nut                  | 6.Diff pinion(12)      | 7.Collar | 8.Lock plate |
| 9.Bevel gear(20)        | 10.Thrust collar(45X58X1) | 11.Shaft diff pinion  | 12. Metal Diff case(L) |                        |          |              |
| 13.Metal Diff case(R)   | 14.Shim(A)                | 15.Shim(B)            | 16.Bolt(S)             | 17.Ball bearing        |          |              |
| 18.Diff lock clutch     | 19.Bevel (9-52)           | 20.Gear spur/25       | 21.TRB                 | 22.Nut                 | 23.TRB   |              |
| 25. Metal pinion        | 26.Bolts                  | 27.Shim(0.1)          | 28.Shim(0.2)           | 29.Wheel pinion(10/LH) |          |              |
| 30. Wheel pinion(10/RH) | 31.Ball bearing(HL1)      | 32.Collar(39.8X52X04) |                        |                        |          |              |
| 33.Snap ring(Shaft)     | 34.Snap ring(Hole)        |                       |                        |                        |          |              |

- a. Dismount diff-case (RH) and diff-case metal(LH) by installing push bolt as shown in Fig.5-55

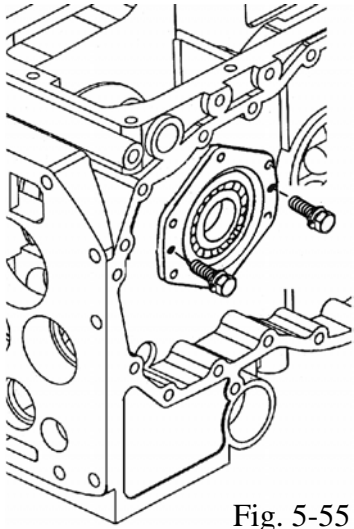

Fig. 5-55

- b. The number of installed shims(14) should be written down or memorized for later reference.

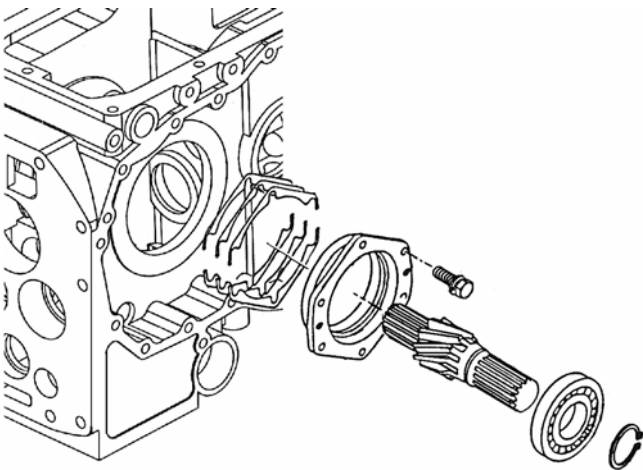

Fig. 5-56

- c. Remove ring gear(2) as a set.  
 d. When disassembling the ring gear set further, remove bearing(31) with a puller.  
 e. Remove the bolts, and the ring gear can then be separated from dif-cases  
 f. Pull out diff pinion shaft(11) and take out dif-pinions(6) and dif-side gears(8).

- g. Remove the pinion metal(support) tightening bolts and take put drive pinion(19) and related parts as an assembly. The number of installed shims should be written down or memorized for later reference.

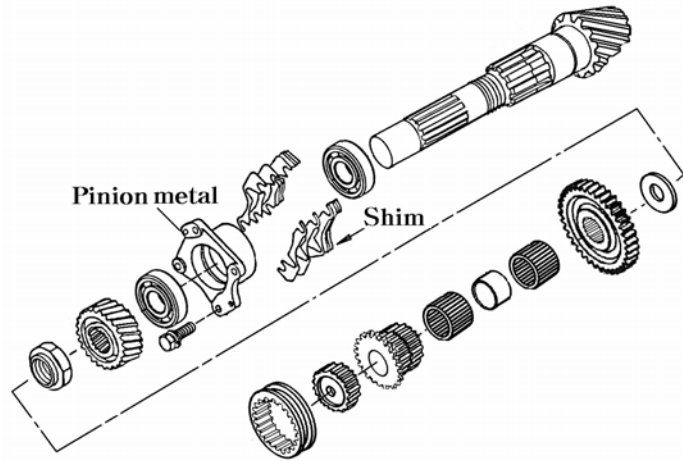

Fig.5-57

- g. Release the lock of nut and remove the nut

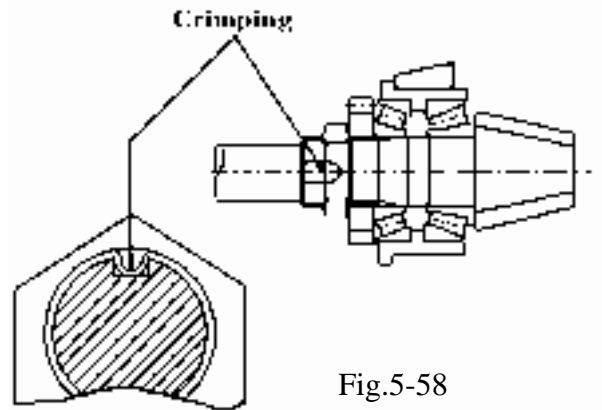

Fig.5-58

- h. Push out drive pinion(19) from drive pinion metal on a press.  
 i. Remove the bearing from the drive pinion with a special tool.

(2) PTO shaft and related parts.

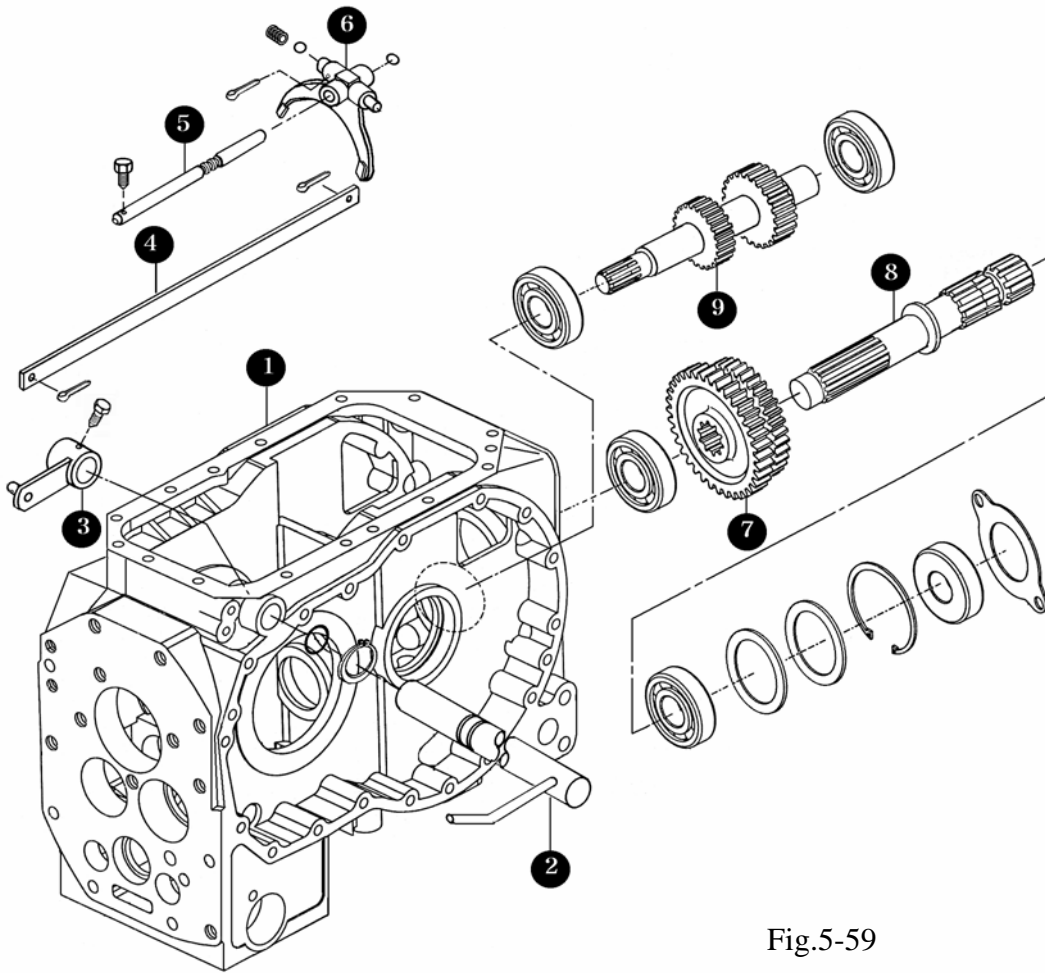

Fig.5-59

- |                          |               |                    |                 |
|--------------------------|---------------|--------------------|-----------------|
| 1.Rear transmission case | 2.Change arm  | 3.Cam.             | 4. Change plate |
| 5.PTO shifter stay       | 6.PTO shifter | 7.Gear spur(38-33) | 8.PTO shaft     |
| 9.Gear spur(12-17)       |               |                    |                 |

- a.Remove the rear hitch and the trailer hitch
- b.Remove change plate(4)
- c.Extract PTO shaft(5) rearwards and take out shifter(6)
- d.Be alert to the steel ball which may spring out of the shifter.Extract PTO shaft(10) rearwards and remove the change gears and related parts.
- e.Remove counter gear

## 4.2. INSPECTION

Before and after disassembly, inspect each part for the items mentioned below. Parts which deviate from the specified values should be replaced.

-Wash clean all disassembled parts and check them for wear, damage, deformation, Burning ,etc. Defective parts should be corrected or replaced.

-As the drive pinion and the ring gear make a pair, they should be replaced together even if only one is found to be defective.

-Backlash between the drive pinion and the ring gear

Backlash	0.1-0.2 mm (0.004-0.008 in)
----------	--------------------------------

-Backlash between the diff-pinion and the dif-side gear.

Backlash	0.1-0.2 mm (0.004-0.008 in)
----------	--------------------------------

-When the backlash exceeds 0.5mm, also inspect the thrust collar for wear, defective collars should be replaced.

-Disengaging the resistance of PTO shifters.

Standard Value	18-22 Kgf (40-49lbs)
Usable limit	17 Kgf (38 lbs)

\* Measured at the shifter

## 4.3. REASSEMBLY

Reassemble the parts in reverse order of disassembly, following these instructions.

### (1) Ring gear, Drive pinion, and related parts.

a. Apply oil to the drive pinion and related parts ahead of time. Then install them and tighten the assembly to the specified torque.

Tightening torque	1.4 Kgf.m (9.36 ft.lbs)
-------------------	-------------------------

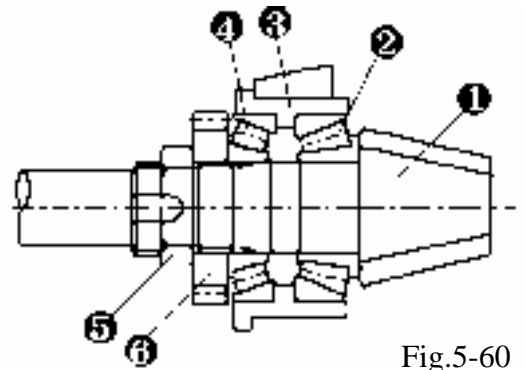

Fig.5-60

- (1) Drive pinion
- (2) Tapered roller bearing
- (3) Drive pinion metal
- (4) Tapered roller bearing
- (5) Nut (M30X1.0)
- (6) Gear

b. Be sure that the starting torque of the drive pinion meets the specified level.

Starting torque	0.11-0.13 Kgf.m (0.792-0.936 ft.lbs)
-----------------	---

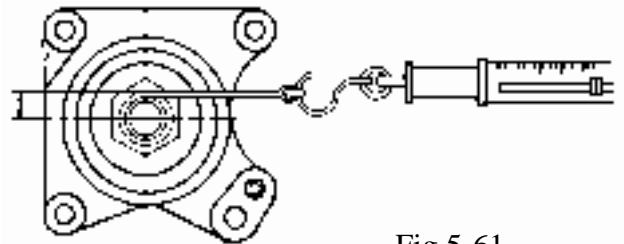

Fig.5-61

c. After the starting torque has been adjusted to the specified level, crimp the lock of the nut at one point as illustrated.

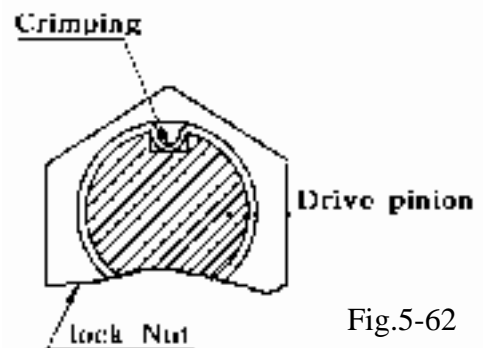

Fig.5-62

d. Tighten the drive pinion metal (support) by providing it with the same shimming thickness that it had when it was disassembled.

When the drive pinion or the ring gear has been replaced, the proper number of shims to be installed should be determined based upon the following procedure:

Drive pinion metal tightening torque	5.5-7 Kgf.m (39.8-69 ft.lbs)
--------------------------------------	---------------------------------

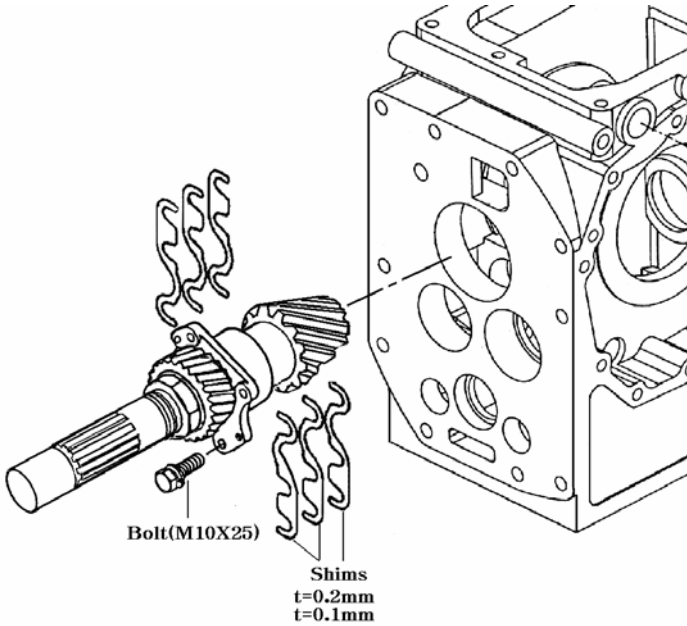

Fig.5-63

Note:

When assembling without replacing the pinion gear and ring gear with new ones, provide the same shimming thickness as that provided before disassembly.

e. Install the differential gears.

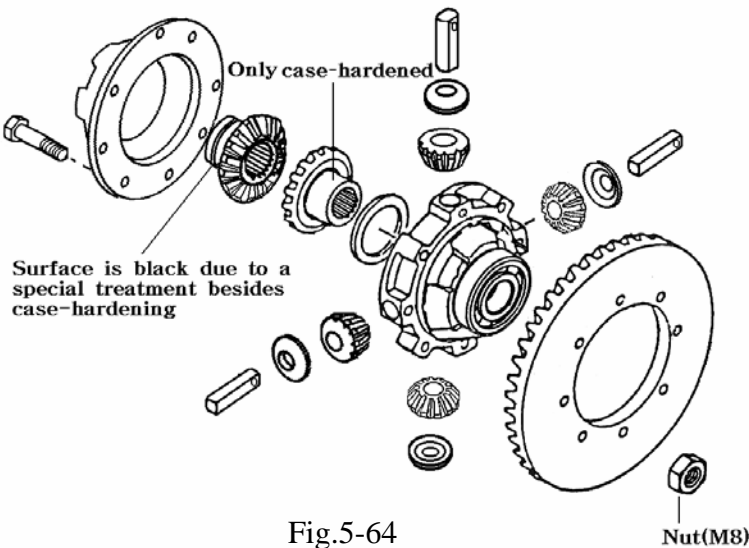

Fig.5-64

Ring gear tightening torque	9.0-11 Kgf.m (39.8-69 ft.lbs)
-----------------------------	----------------------------------

Note:

- As shown in Fig5-64, there are two kinds of differential side gears. Although are case hardened, the one installed on the side of the diff-lock is treated further and colored black. Take care not to mix them when assembling.  
 - Apply multi-purpose, quality grease to the parts mentioned below:

- Tooth surfaces of dif-pinions and dif-side gears
- Friction surfaces of dif-pinion shafts and dif-pinions.

f. The Backlash between dif-pinion and dif-side gear should be within as range of 0.1 to 0.2mm(0.004-0.008 in) and these parts should turn smoothly.

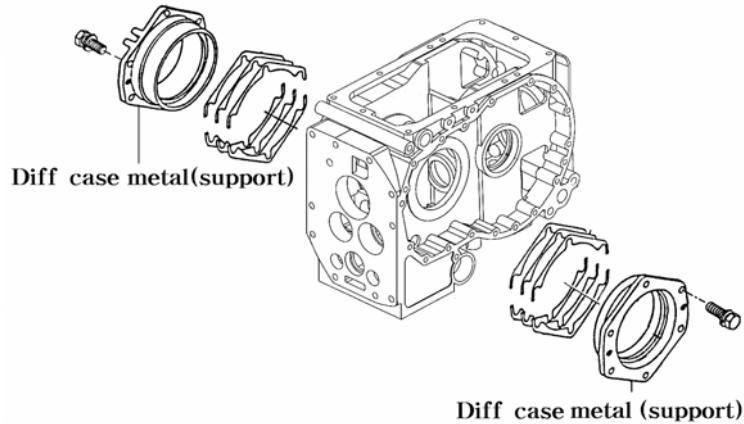

Fig.5-65

g. Install the differential gear assembly.

Diff-case metal tightening torque.	5.5-7 Kgf.m (39.8-69 ft.lbs)
------------------------------------	---------------------------------

Note:

When reassembling the used pinion and ring gear, reinstall the same thickness of shims as was installed before disassembly in each shimming position.

h. Backlash adjustment between the drive pinion and the ring gear (Fig 5-65)

i. As the drive pinion and the ring gear make a pair, be sure not to mate them with other parts from differential tractors.

ii Adjust the shimming to backlash of 0.1-0.2 mm (0.004-0.008 in). The standard shimming is 0.4mm (0.016 in) on both sides.

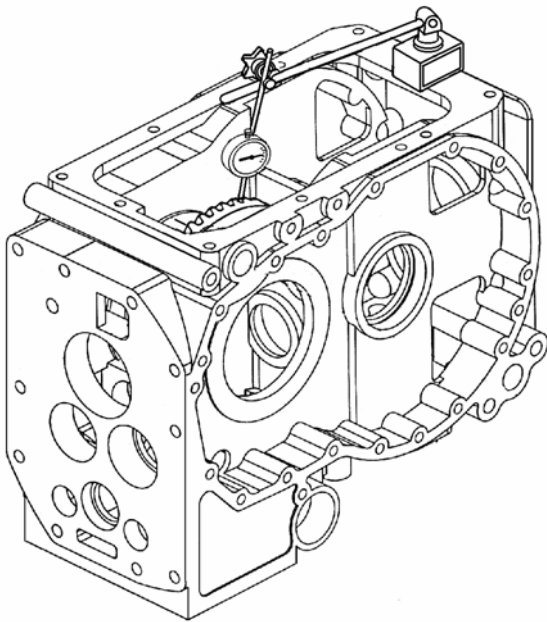





Fig.5-66

**Note:**

Strike the circumference of the ring gear both sides with a copper hammer by turning the ring gear manually, and check to see that the backlash remains unchanged. The backlash should be checked at four points 90 degrees apart to each other.

iii. inspection of the tooth bearing

Apply an even coat of oil-dissolved minimum on the drive pinion teeth and turn the drive pinion on the ring gear to check the tooth bearing by observing the bearing traces on the ring gear.

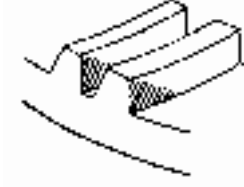
<p><b>Correct Contact</b></p> 	<p>When drive pinion and ring gear are meshed correctly with each other and their backlash is within specified range, contact is in middle of ring gear tooth and is approximately 75% of total tooth width.</p>
<p><b>Tip contact</b></p> 	<p>Excessive backlash. Move differential case and shims from right side to left side. See "Assembly and installation".</p>
<p><b>Root contact</b></p> 	<p>Inadequate backlash. Move differential case shims from left side to right side. See "Assembly and installation".</p>
<p><b>Toe contact</b></p> 	<p>Too little engagement. Remove some drive pinion support shims. See Transmission: REAR TRANSMISSION ASSEMBLY-Setting cone center.</p>
<p><b>Heel contact</b></p> 	<p>Too much engagement. Add some drive pinion support shims. See TRANSMISSION: "REAR TRANSMISSION ASSEMBLY-Setting cone center."</p>

**INSTALLATION OF A NEW PAIR OR RING GEAR AND DRIVE PINION**

1. use a new pair of ring gear and drive pinion delivered from the manufacturer. Never mix its components with those of other pairs.

Note:  
Every ring gear-dive pinion pairs is adjusted and inspected for tooth contact individually at factory.

2. Adjust the backlash between the ring gear and drive pinion to be 0.1-0.2mm(0.004-0.008 in) by shimming the drive pinion metal and right and left dif-case metal and make sure that their tooth contact is proper

## (2) PTO shaft and related parts.

- a. Pushing the PTO counter gear end into the bearing until the stop on the gear is securely seated against the bearing. The seal should be coated with an adhesive (THREE BOND TB1215) on the circumference before installing.
- b. Install the oil seal on the PTO shaft, paying attention to its installed direction.
- c. After installation, the slide coupling should smoothly slide and mesh with the designated gears.

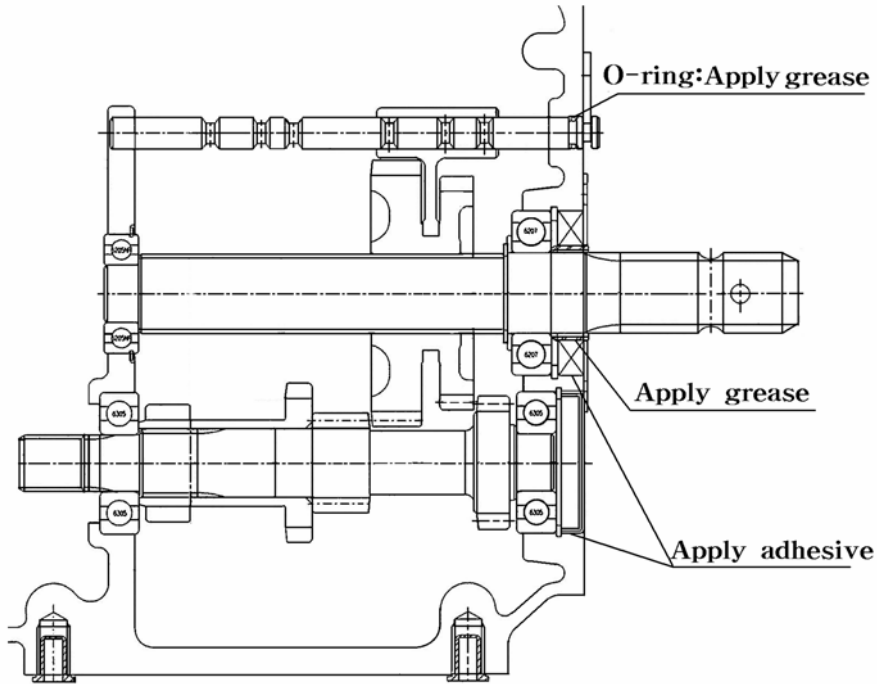

Fig.5-67 PTO 2 speed

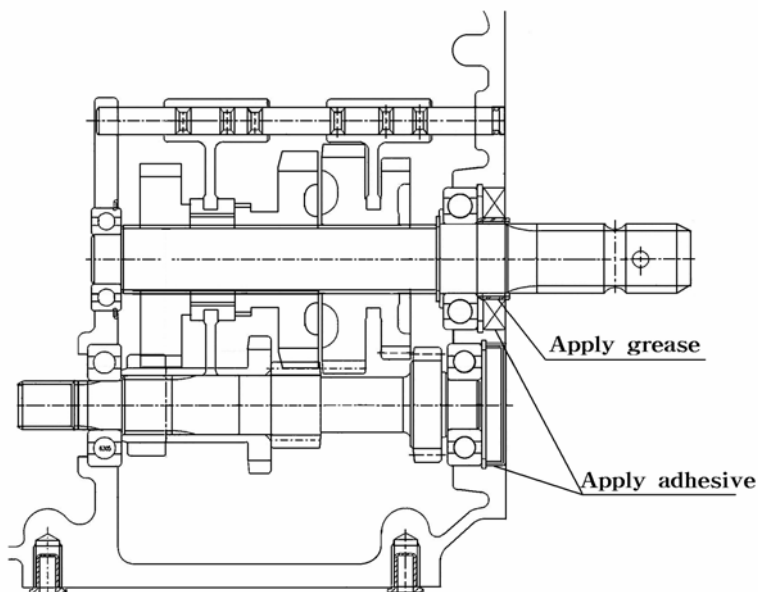

Fig.5-68 PTO 4 speed



## 5. SHIFTERS AND RELATED PARTS.

### 5.1. CONSTRUCTION

(1)Forward and reverse control linkage mechanism(Linear speed shifter)  
(synchromesh transmission version)

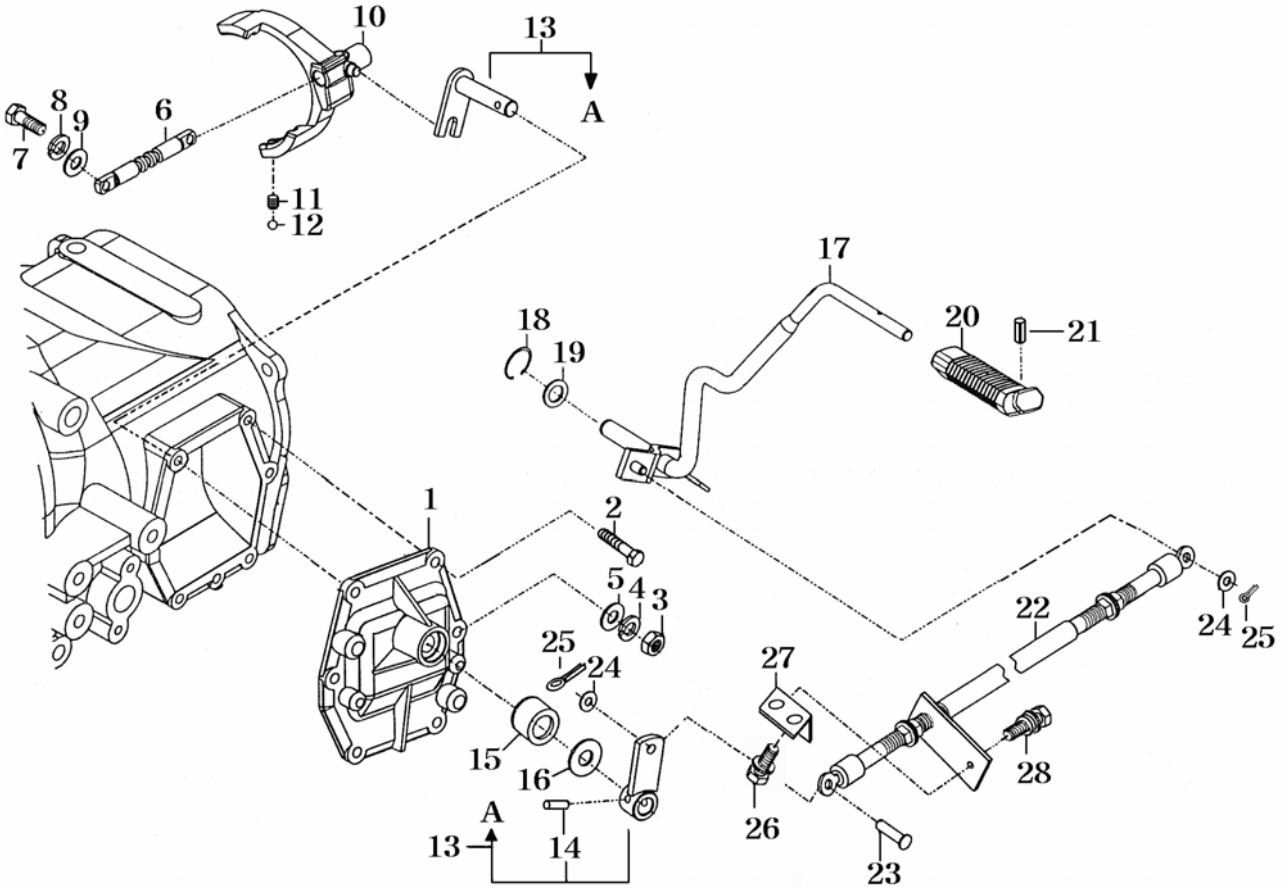

Fig.5-69

1.Metal(shifter,reverse) 2.Bolt(S) 3.Nut 4.Washer spring 5.Washer plain 6. Stay shifter reverse  
7.Reamer bolt 8.Washer spring 9.Washer plain 10. Fork(shift/shuttle) 11. Shifter spring  
12.Steel ball 13.Arm(reverse) 14. Split pin 15. Oil seal 16.Washer 17.Lever(Bar/14) 18.Snap ring  
19.Washer(15X24X2) 20. Grip 21.Pin spring 22.Cable 23.Pin 24.Washer plain 25.pin split  
26.Bolt(S) 27. Plate 28.Bolt(SP)

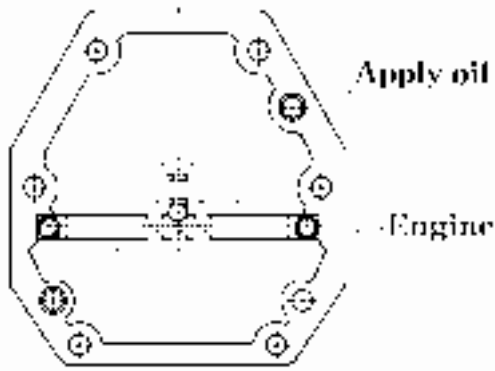

Fig.5-70

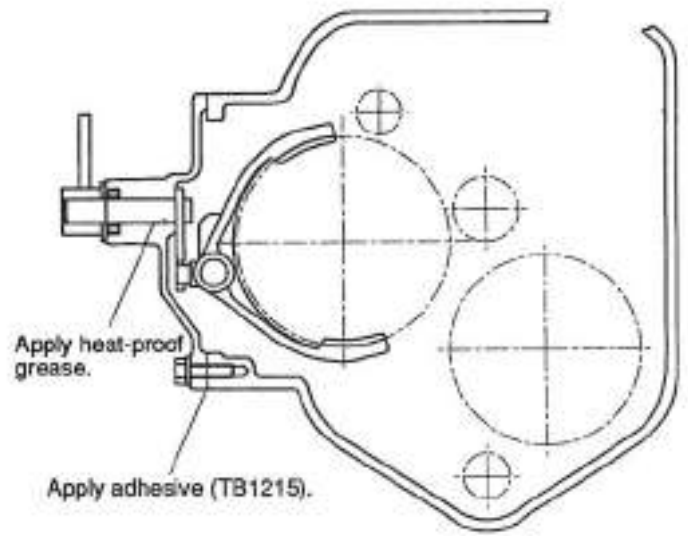

Fig.5-71

(2) Main change mechanism(Main speed shift)  
(Synchromesh transmission version)

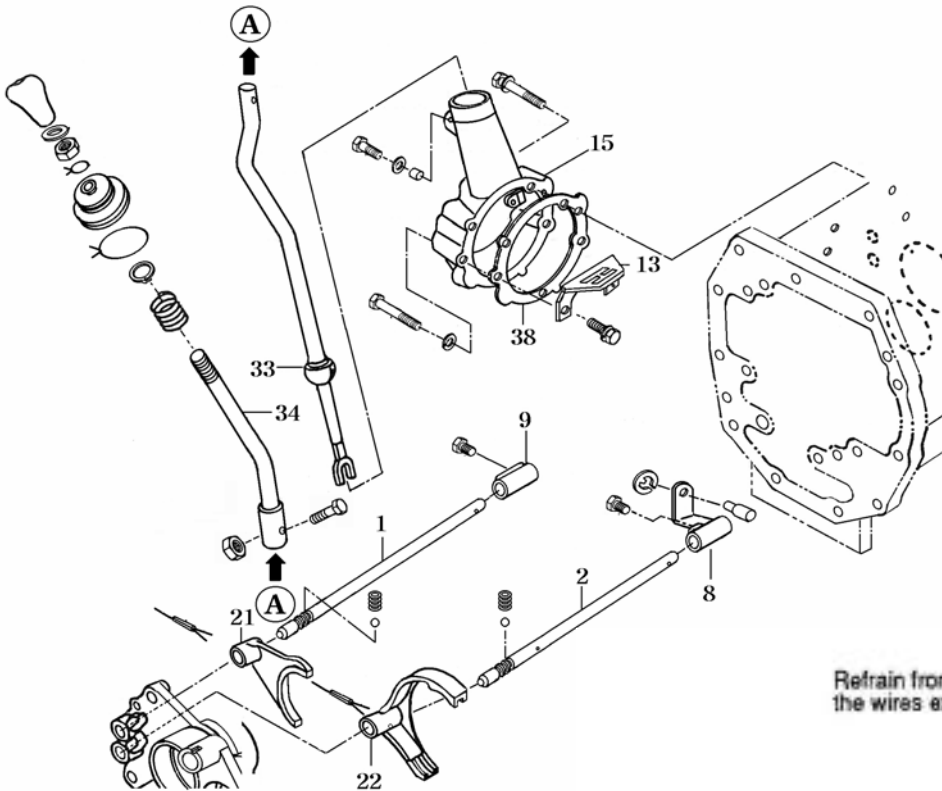

Fig.5-72

- 1.Rail(shifter/1<sup>st</sup> 2<sup>nd</sup>)
- 2.Rail(shifter 3<sup>rd</sup>,4<sup>th</sup>)
- 8.Link
- 9.Link
- 13.Guide
- 15.Metal(Main)
- 21.Fork(shifter/main)  
(1<sup>st</sup>,2<sup>nd</sup>)
- 22..Fork(shifter/main)  
(3<sup>rd</sup>,4<sup>th</sup>)
- 33.Lever(bar/16)lower
- 34.Lever(bar/16)upper
- 38.Gasket(Main metal)

Note:

The bolt tightening the bottom of the metal(Support) should be coated with an adhesive ahead of time

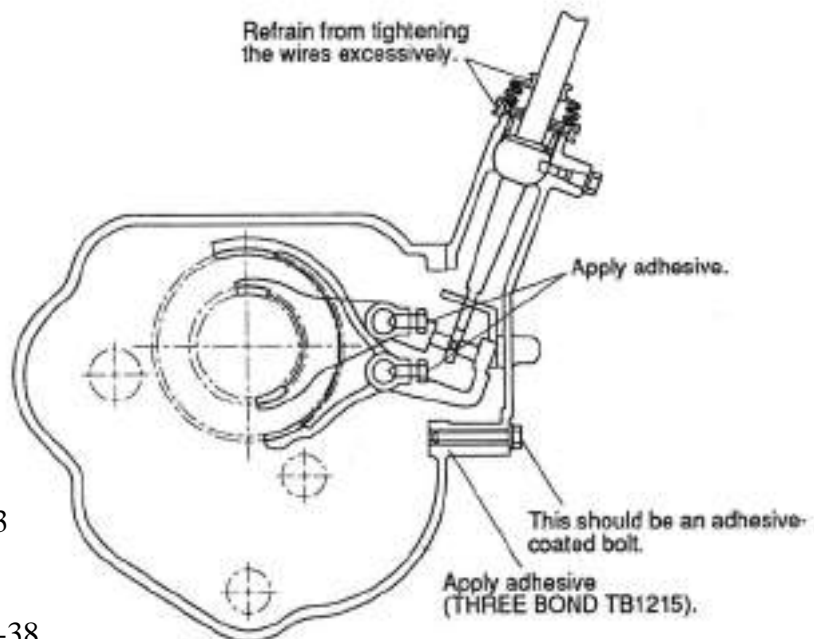

Fig.5-73

### (3) Range shifter (Speed range shift) mechanism

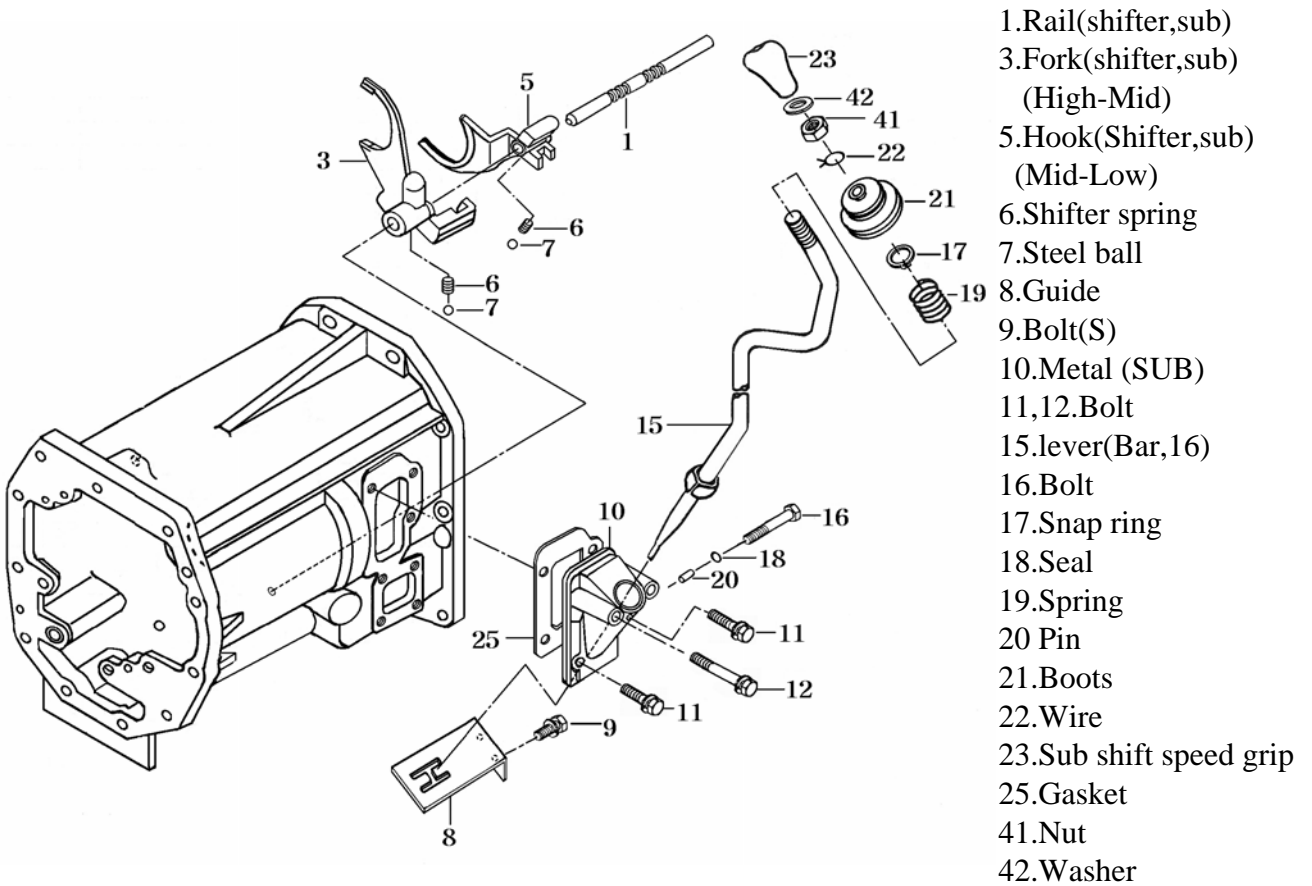

Fig.5-74

Note:

The bottom two tightening bolts should be coated with an adhesive on their threads before being tightened.

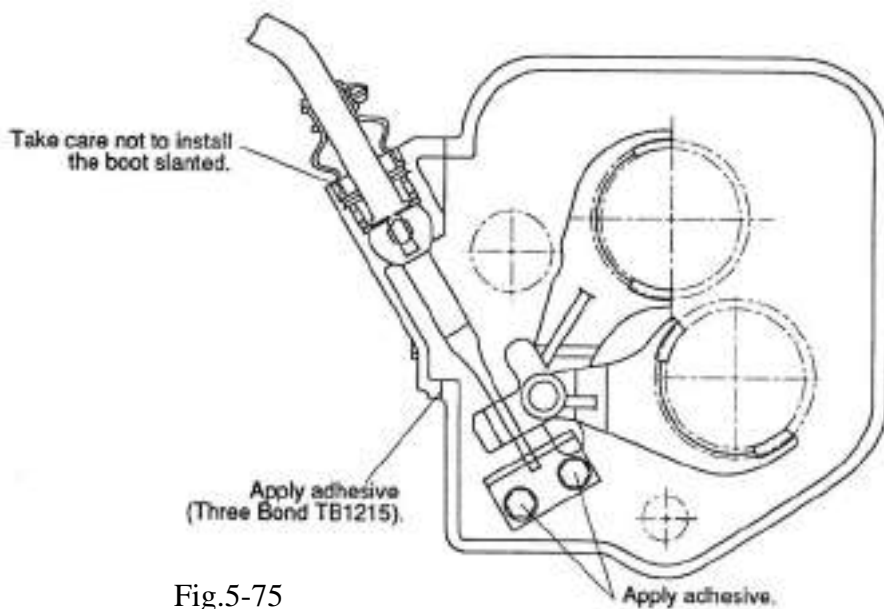

Fig.5-75

#### (4) Front drive change (4 WD shaft) mechanism

- 1.Metal(shifter)
- 2.Shifter spring
- 3.Steel ball
- 4.Bolt
- 5.Nut
- 6.Washer spring
- 7.Arm comp
- 8.O-ring
- 9.Arm(plate)
- 10.Spring pin
- 11.Lever(bar,12)
- 12.Bush
- 14.Knob
- 15.Bracket
- 16.Bolt
- 17.Tension arm washer
- 18.Snap ring
- 19.Rod
- 22.Elbow
- 23.Nut
- 24.Washer spring
- 25.Stud
- 26.Packing

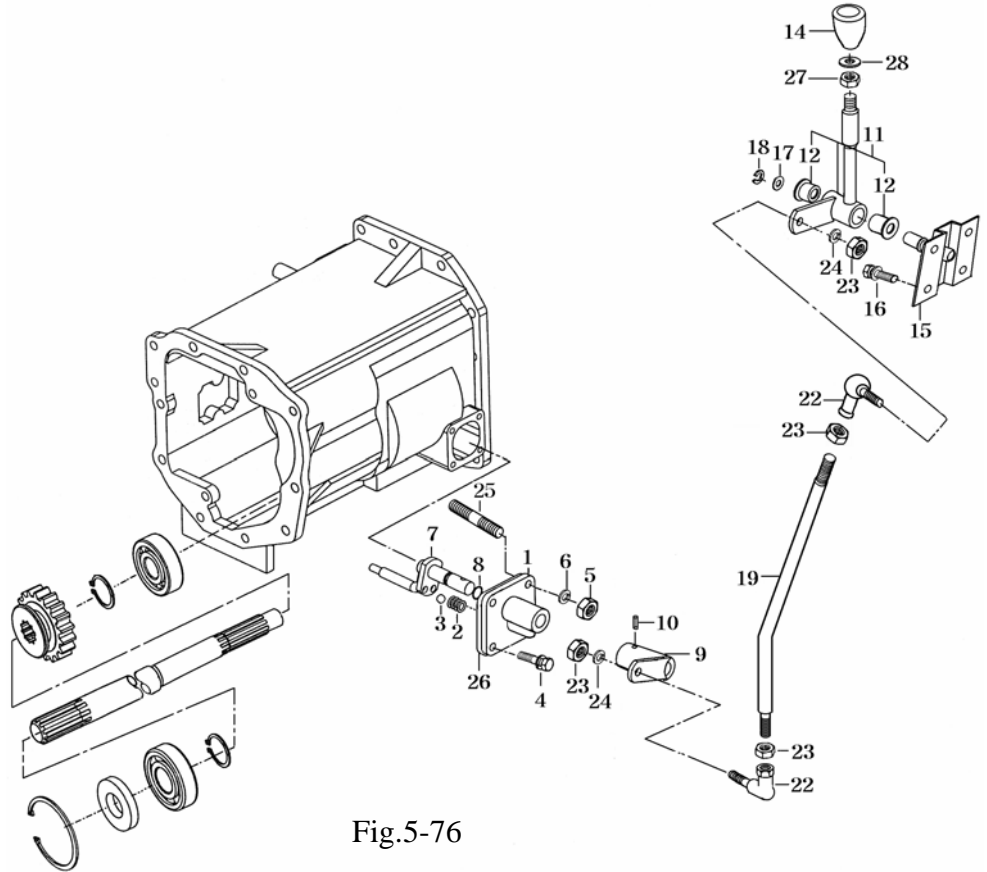

Fig.5-76

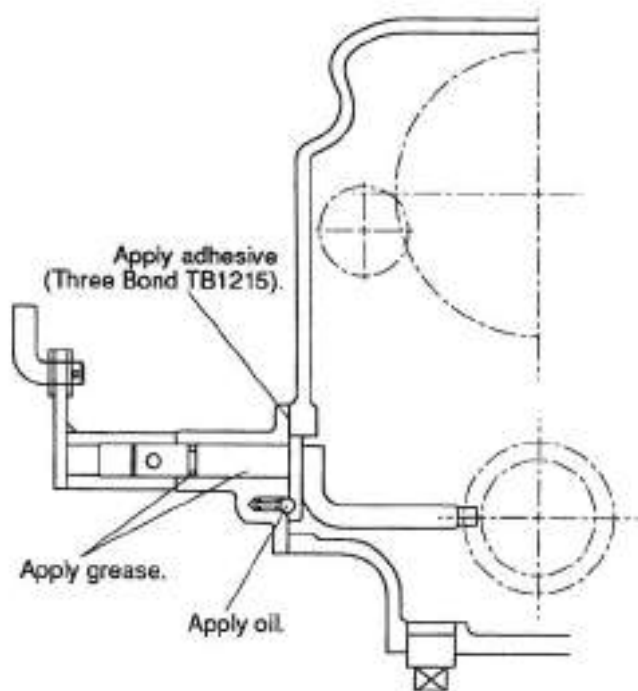
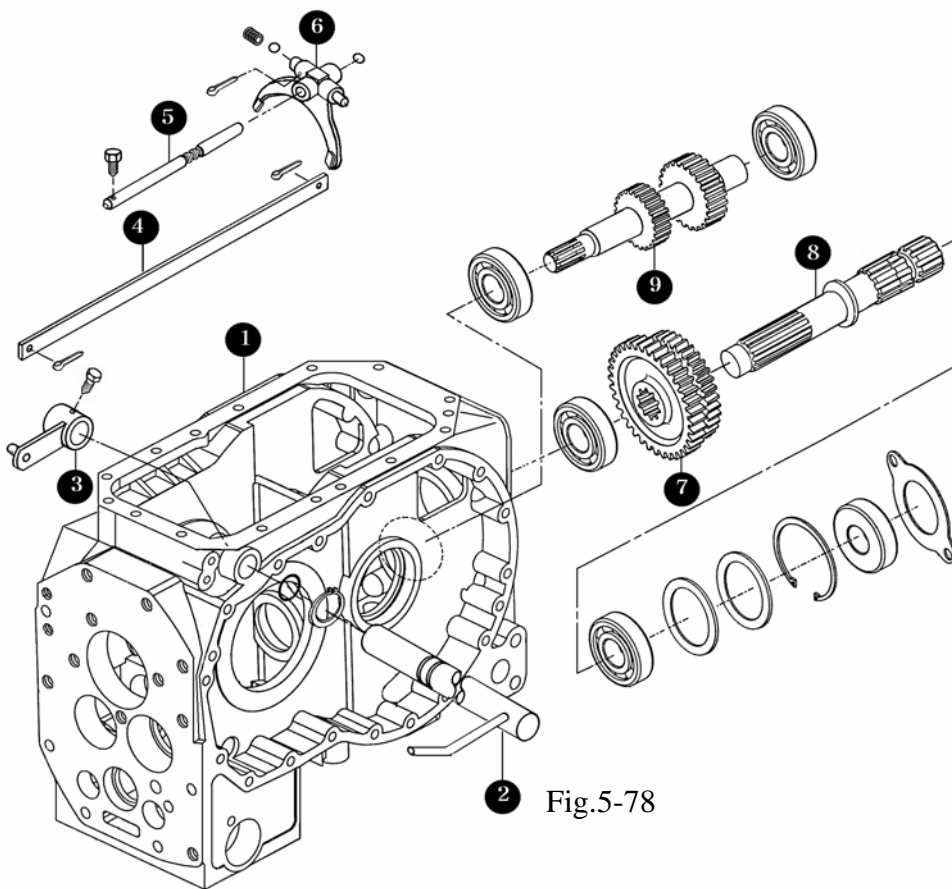

Fig.5-77

**(5) Rear PTO shift mechanism**



- |                          |               |                    |                 |
|--------------------------|---------------|--------------------|-----------------|
| 1.Rear transmission case | 2.Change arm  | 3.Cam.             | 4. Change plate |
| 5.PTO shifter stay       | 6.PTO shifter | 7.Gear spur(38-33) | 8.PTO shaft     |
| 9.Gear spur(12-17)       |               |                    |                 |

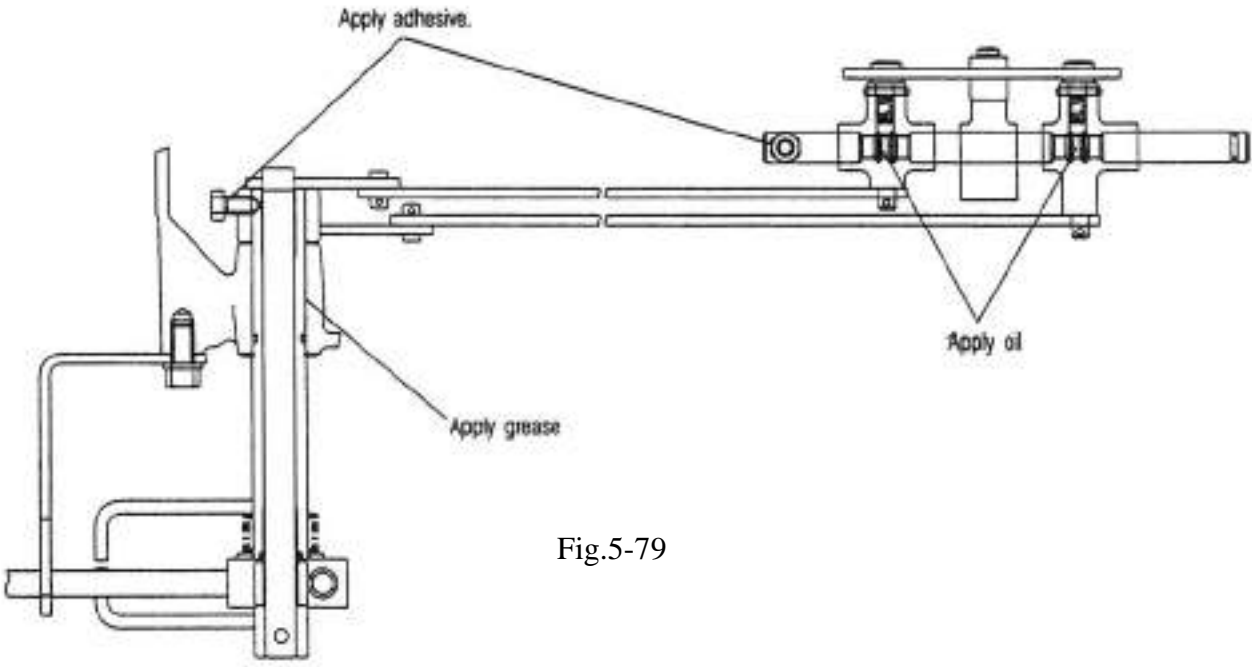

Fig.5-79

(6) REAR PTO counter shaft mechanism

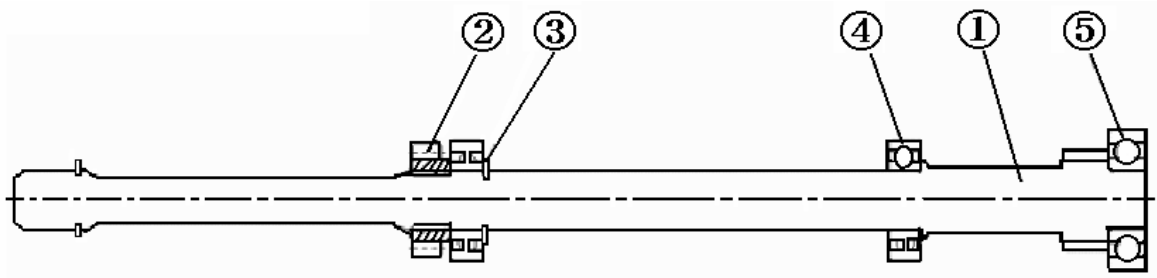

Fig.5-80

1. Gear, spur 12 2. Gear spur 14 3. Snap ring (shaft) 4. Ball bearing (6205) 5. Ball bearing (6305)

Note:

- When pushing the R.B.B's (6305, 6205) into the gear, spur 12, be careful only to push their inner races.
- The snap ring C should be securely seated in the groove and the press-processed side turned towards the outer side.
- Be sure not to mix different pairs of the gear (spur/14).
- Every time a gear is installed, its smooth rotation should be checked.

a. REAR PTO shaft

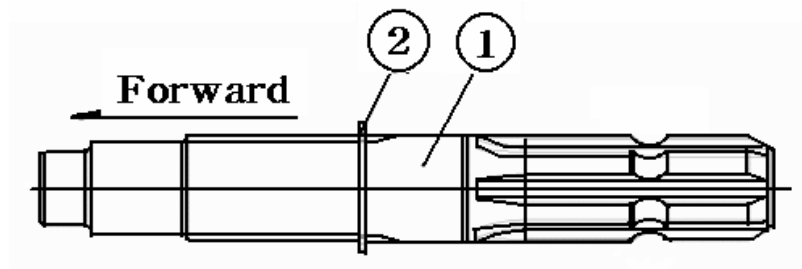

1. Shaft PTO  
2. Snap ring

Fig.5-81

Note:

The snap ring C should be securely seated in the groove and the press-processed side turned towards the outer side.

b. REAR PTO shift stay

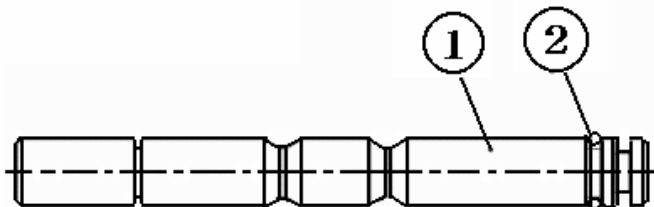

1. Stay PTO shift  
2. O-ring

Fig.5-82

Note:

- When installing the O-ring to rear transmission case, take care not to damage it or allow to fall.

(7) Drive pinion Sub assembly

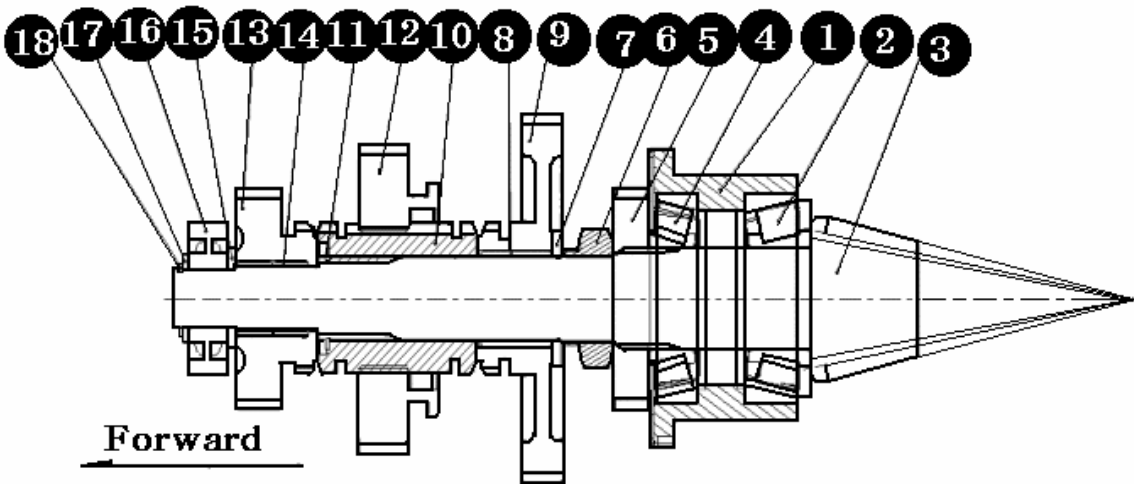

Fig.5-83

- |                       |                         |                       |                          |
|-----------------------|-------------------------|-----------------------|--------------------------|
| 1. Metal pinion       | 2. Taper roller bearing | 3. pinion drive       | 10. Taper roller bearing |
| 5. Gear spur 23T      | 6. Nut(M30X1.5)         | 7. Washer(28X46X03)   | 8. Needle bearing        |
| 9. gear spur 40T      | 10. Hub(28X51X59)       | 11. Snap ring (shaft) | 12. Gear spur 33T        |
| 13. gear helical 22T  | 14. needle bearing      | 15. Washer(20X34X03)  | 16. Ball bearing         |
| 17. Washer(20X30X1.8) | 18. Snap ring (shaft)   |                       |                          |

Note:

- Apply oil to the drive pinion and related parts ahead of time. Then install them and tighten the assembly to the specified torque.
- Be sure that the starting torque of the drive pinion meets the specified level.  
Starting torque is 0.11-0.13 Kgf.m (0.792-0.936ft.lbs)
- After the starting torque has been adjusted to the specified level, crimp the lock of the nut at one point as illustrated.
- Be sure that these parts should turn smoothly

When the drive pinion or the ring gear has been replaced, the proper number of shims to be installed should be determined based upon the following procedure:

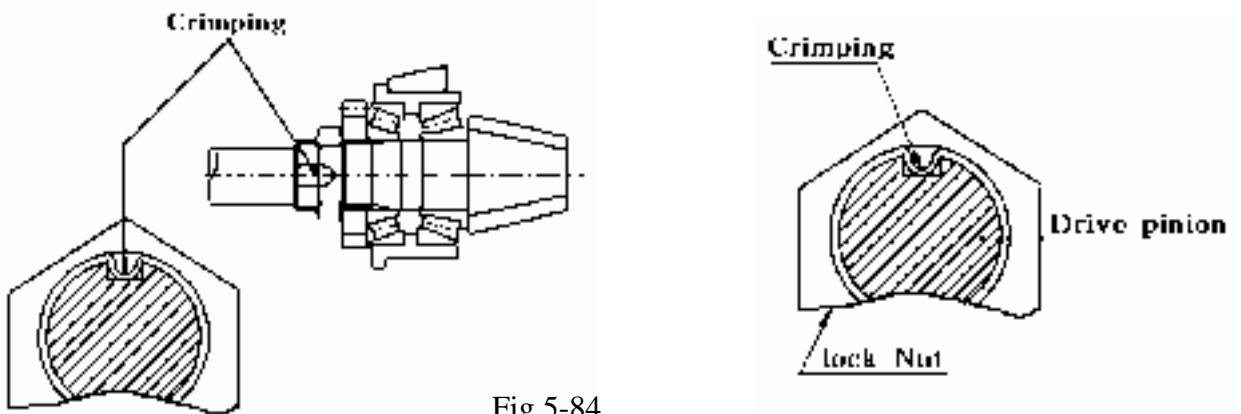
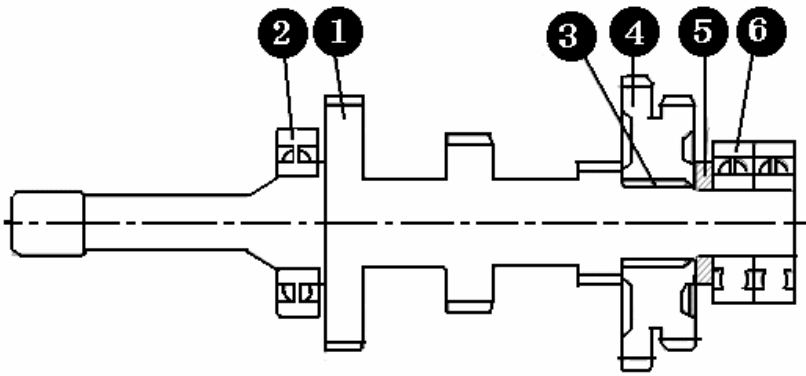

Fig.5-84

## (8). Sub change counter shaft



1. Gear range(13X20X29T)
2. Ball bearing(6207)
3. Needle bearing
4. Gear spur(30X35T)
5. Washer(25X46X07)
6. Ball bearing(6305)

Note:

1. Apply grease when installing Needle bearing
2. pay attention to the installed direction of gear(spur/30-35)
3. After installation, be sure to slide smoothly

## 8. Differential gears.

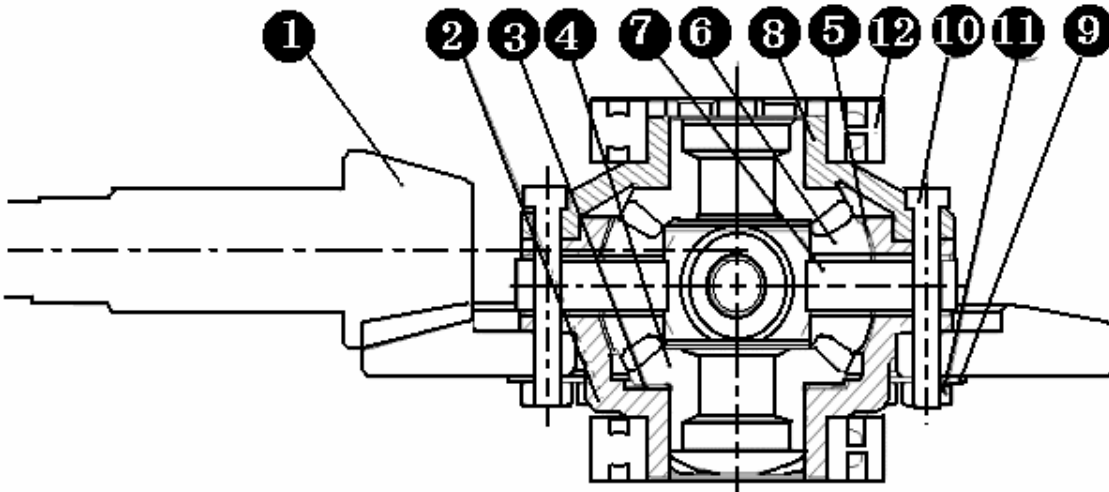

Fig.5-85

- |                        |                      |                        |                          |
|------------------------|----------------------|------------------------|--------------------------|
| 1. Bevel 10X51         | 2. Case Diff(L)      | 3. Gear bevel(20)      | 5. Thrust collar, pinion |
| 6. pinion Diff(12)     | 7. Shaft diff pinion | 8. Case Diff (R)       | 9. plate lock            |
| 10. Bolt, differential | 11. Nut              | 12. Ball bearing(6011) |                          |

Note:

1. When assembling without replacing the pinion gear and ring gear with new ones, provide the same shimming thickness as that provided before disassembly.
2. Backlash between dif-pinion and dif-side gear should be within as range of 0.1 to 0.2mm (0.004-0.008 in) and these parts should turn smoothly.
3. When reassembling the used pinion and ring gear, reinstall the same thickness of shims as was installed before disassembly in each shimming position.
4. Backlash adjustment between the drive pinion and the ring pair(Fig5-8) i. As the drive pinion and the ring gear make a pair, be sure not to mate them with other parts from differential tractors.
5. Adjust the shimming to backlash of 0.1-0.2 mm (0.004-0.008 in). The standard shimming is 0.4mm (0.016 in) on both sides.



## 5-2 PRECAUTIONS FOR DISASSEMBLY, INSPECTION, AND ASSEMBLY

### (1) Disassembly

When drawing a shifter stay from its shifter, be careful not to lose the steel ball. It can jump out of the shifter.

### (2) Inspection

-Shifter –disengaging load:

Main change and sub change: **18-22 Kgf (40-49lbs)**

4WD change: **25-29 kgf (55-64 lbs)**

-Usable limit of shifter-disengaging load:

Main change & Sub-change: **17 Kgf (38lbs)**

4WD change: **24Kgf( 53lbs)**

-Wearing limit of each shifter: **0.5 mm (0.02 in)**

### (3) Reassembly

a. lubricate the grooves in the shifters.

b. Each shifter should be installed in the correct direction.

c. When installing the shifter on the shifter stay, Use the special tool as shown in Fig.5-86

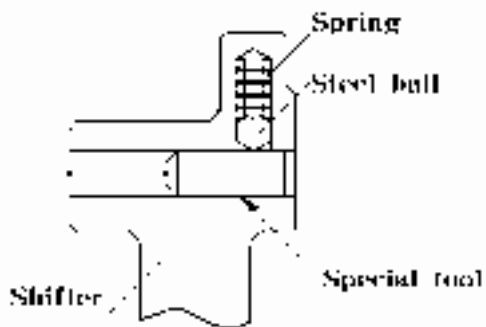

Fig.5-86

## SECTION 4. TROUBLESHOOTING

### 1. WHEEL DRIVE SYSTEM

Problems	Causes	Countermeasures
Transmission makes noise in neutral	Insufficient or improper lubricant	Replenish or replace
	Excessive splines of change shaft,spline hub,etc	Replace
	Worn or broken bearings	Replace
	Slide couplings interfering with the gears due to worn or deformed shifters	Replace
Gears make a noise when shifted.	Improperly disengaged clutch	Repair or replace (Clutch pedal play)
	Wear in width of gears,splined hubs,collars,etc	Replace
	Defective Change shift fork	Replace
Gears disengage by themselves	Broken shifter springs	Replace
	Wear in width of gears,splined hubs,collars,etc	Replace
	Worn shifters	Replace
Gears do not engage or disengage	Improper disengaged shift lever	Repair or replace
	Gears are locked due to foreign matter between them	Remove the foreign matter

## 2. PTO DRIVE SYSTEM

problem	Causes	Counter measures
PTO does not spin with PTO shifted to ON	PTO shift lever is in neutral	Shift lever positively to ON
	Defective PTO switch	replace
	Clogged PTO valve	Wash clean
	Poor Pump	Replace
	Defective solenoid valve	Replace
PTO spins but does not produce sufficient torque.	Worn clutch disc	Replace
	Broken or fatigues seal ring at clutch sleeve	Replace
	Loose joint or broken O-ring of delivery valve	Retighten or replace
	Poor pump	Replace
	Clogged PTO valve	Wash clean
PTO does not stop when PTO switch is shifted to OFF	Defective PTO valve solenoid	Replace
	Poor PTO valve (contamination)	Wash clean
	Broken clutch piston return spring	Replace
	Poor switch	Replace
PTO follows too much when PTO switch is shifted to OFF	Improper oil	Replace
	Insufficient warming up	Let tractor warm up sufficiently
	Poor PTO clutch brake	Replace
	Weak or broken piston return spring	Replace
	Poor PTO valve( contamination)	Wash clean
	Deflected clutch plate	Replace

**Power train diagram**

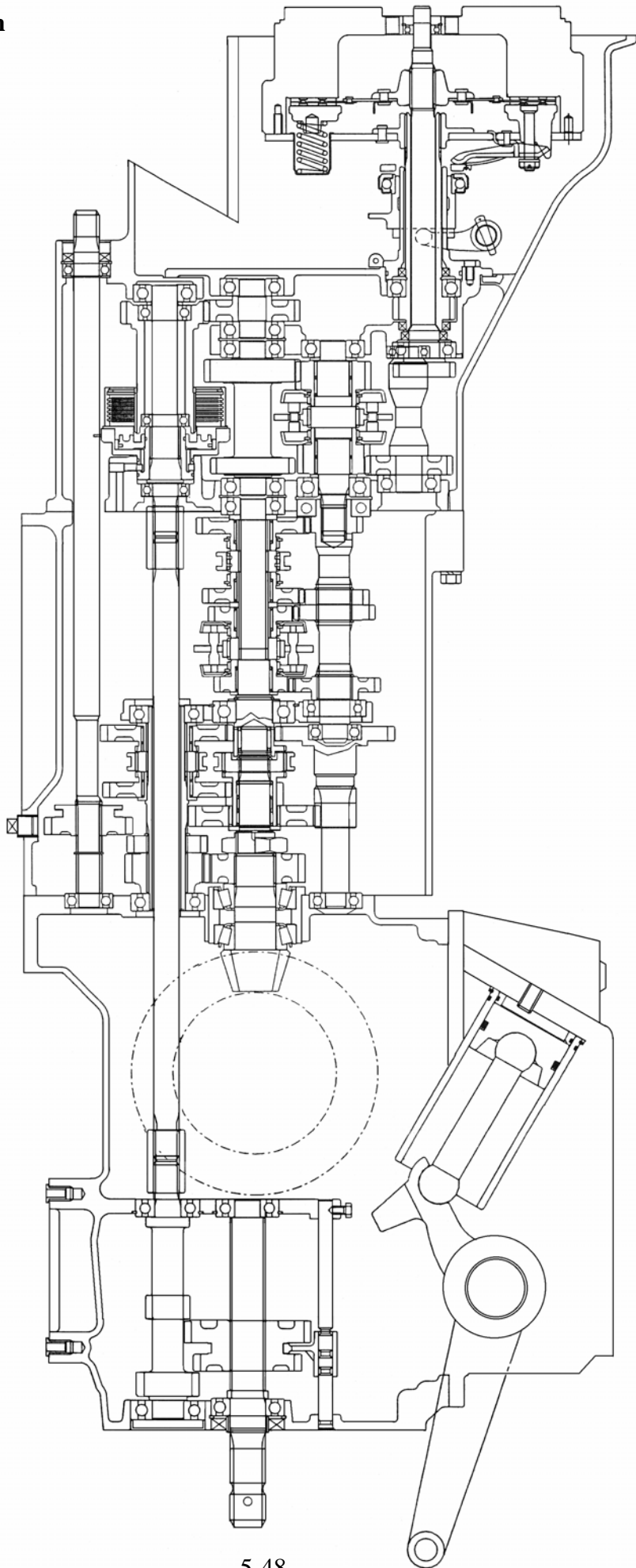

Fig.5-87

**CHAPTER 6. FRONT AXLE(4WD)-----6-1**

**SECTION 1.GENERAL DESCRIPTION-----6-1**

**SECTION 2. SPECIFICATIONS-----6-2**

**SECTION 3.DISASSEMBLY,INSPECTION,AND REASSEMBLY--6-3**

**1. Center pivot-----6-3**

**1-1. Disassembly-----6-4**

**1-2. Inspection-----6-4**

**1-3. Reassembly-----6-4**

**2. Front differential-----6-6**

**2-1. Disassembly-----6-7**

**2-2. Inspection-----6-7**

**2-3. Reassembly-----6-8**

**3. Final case-----6-10**

**3-1. Disassembly-----6-11**

**3-2. Inspection-----6-12**

**3-3. Reassembly-----6-13**

**SECTION 4.TROUBLE SHOOTING-----6-15**

# Chapter 6 Front axle(4WD)

## 1. GENERAL DESCRIPTION

The 4WD front axle is a center pivot type. The front wheel drive mechanism is incorporated as a part of the axle.

The front wheel drive power is taken off the rear transmission and transmitted to the differential in the front axle where the power is divided into right and left and to the respective final cases.

In the final cases, the transmitted revolution is reduced by the bevel gears to drive the front wheel.

The 4WD mechanism with bevel gears provides wider steering angle and greater durability.

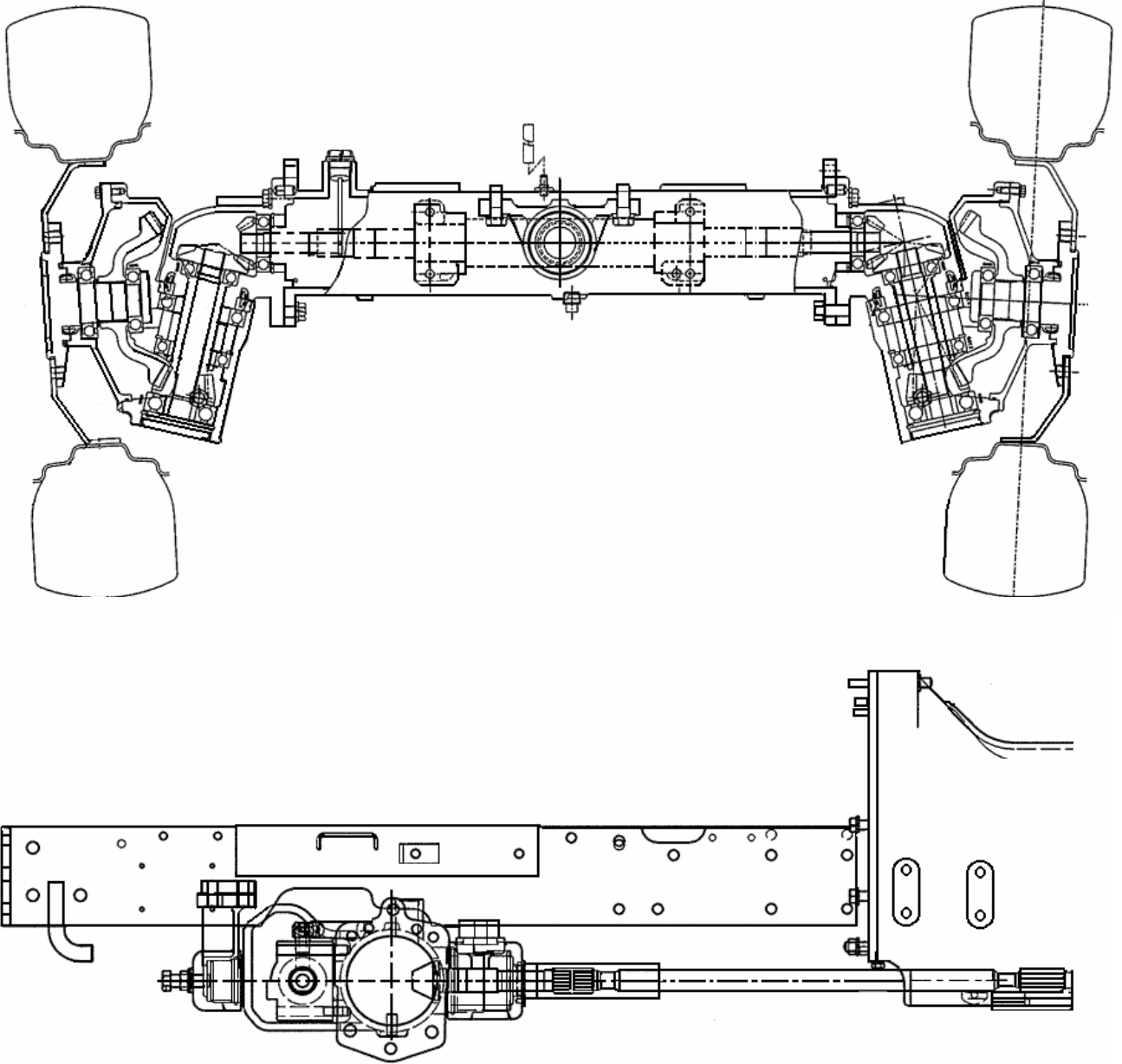

Fig 6-1

## SECTION 2. SPECIFICATIONS

		3510/4110/T400/T450/T451
Wheel alignment	Toe-in (mm)	2~6
	Camber	$3^{\circ} \pm 1^{\circ}$
	Caster	$1^{\circ} \pm 1^{\circ}$
Front axle	Pivot metal (F) bore (mm)	$\Phi 55$
	Pivot metal (R) bore (mm)	$\Phi 80$
	Pivot metal (F) bush (mm)	50X55X20
	Pivot metal (R) bush (mm)	75X80X30
	Housing (F) Diameter (mm)	$\Phi 50$
	Housing (R) Diameter (mm)	$\Phi 75$
	Front wheel steering angles	$52^{\circ}$

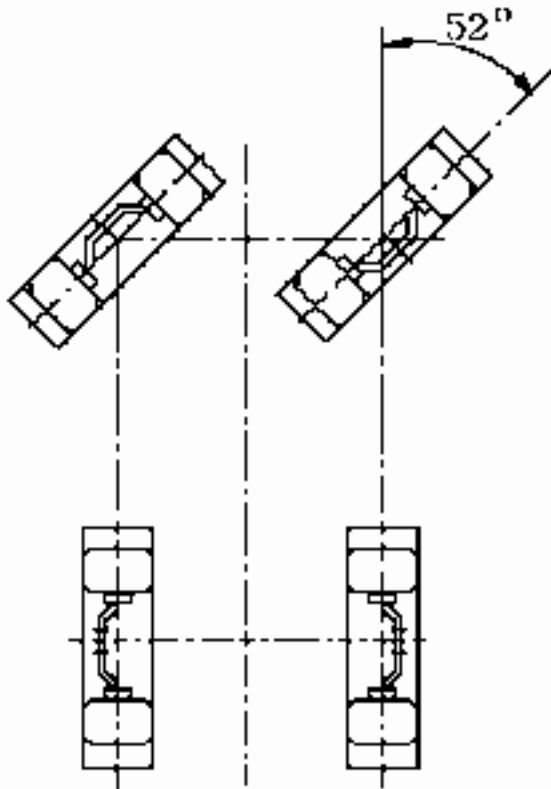

Fig.6-2

# SECTION 3. DISASSEMBLY,INSPECTION,AND REASSEMBLY

## 1. CENTER PIVOT

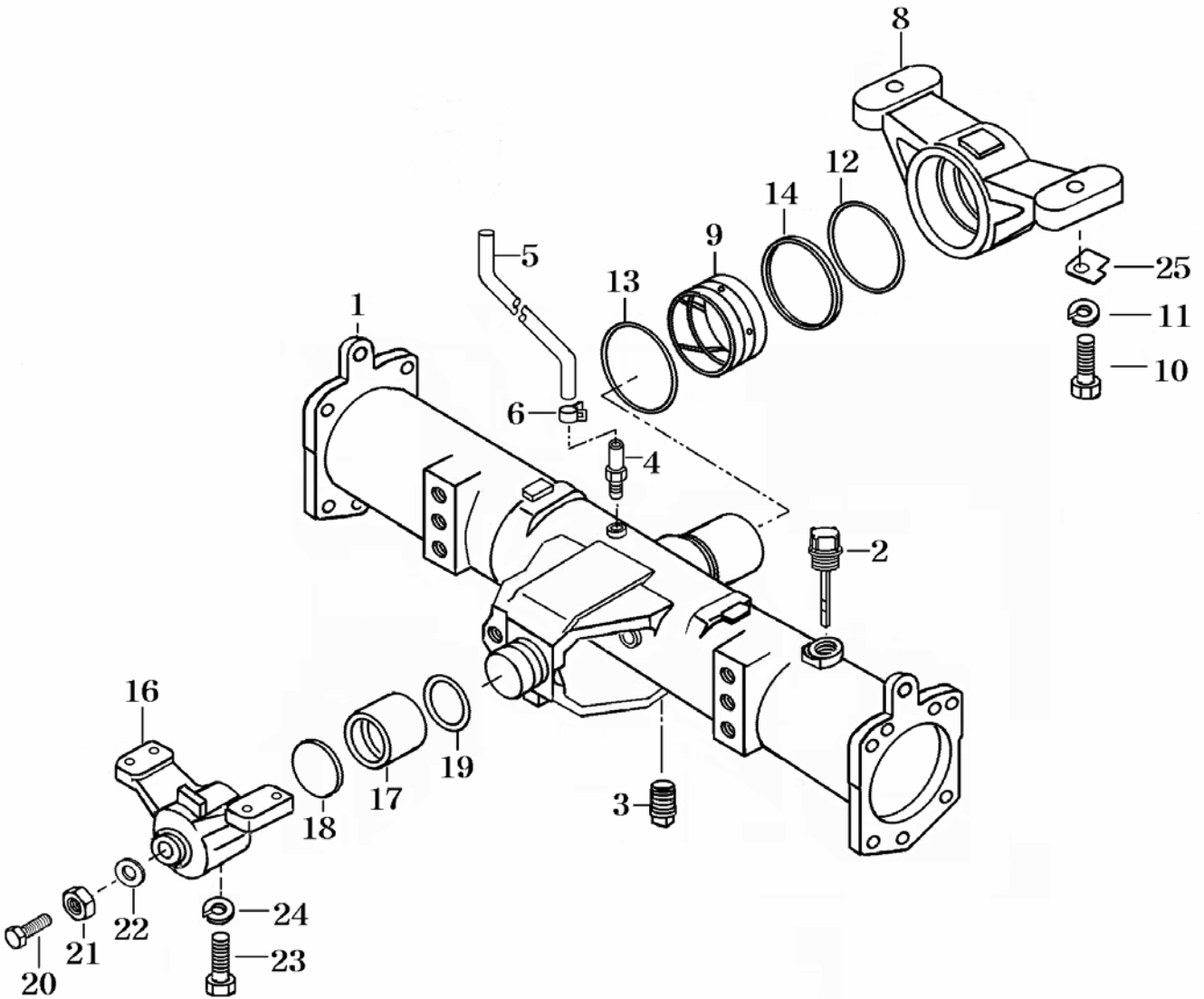

Fig.6-3

- 1.Housing,front axle
- 2.Oil cap
- 3.Plug
- 4.connector
- 5.Hose(820)
- 6.Clamp,(worm/14.5)
- 8.Metal,pivot(R)
- 9.Bush(75X80X30)

- 10.Bolt (M16X40)
- 11.Washer,spring(M16)
- 12.O-ring(P)
- 13.O-ring
- 14.Spacer (R)
- 16.Metal pivot(F)
- 17.Bush(50X55X20)
- 18.Spacer (F)

- 19.O-ring(G 55)
- 20.Bolt
- 21.Nut
- 22.Seal washer
- 23.Bolt(M12X40)
- 24.Washer spring



## 1.1.DISASSEMBLY

- 1) Dismount the front wheel drive shaft, referring to the pertinent paragraph in chapter 2.
- 2) Remove the right and left tie rods.
- 3) Suspend the front axle bracket with a chain.
- 4) Remove the front metal clamping bolts.The front axle can then be separated from the axle bracket.
- 5) Remove the front and rear pivot metals.

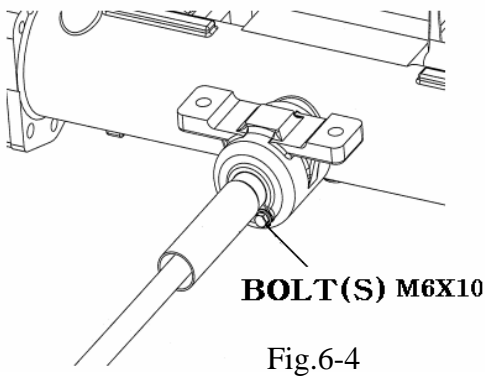

## 1.2.INSPECTION

### 1) FRONT AXLE SHAFT DIAMETER

Measure the diameter at a roll bush contact point with a micro-meter or vernier calipers.If the measured value is less than usable limit,replace the housing front axle or bush in Metal pivot (F)or Metal pivot (R) .

	Front	rear
Standard value as assembled	Ø50	Ø75
Usable limit	Ø49.9	Ø74.9

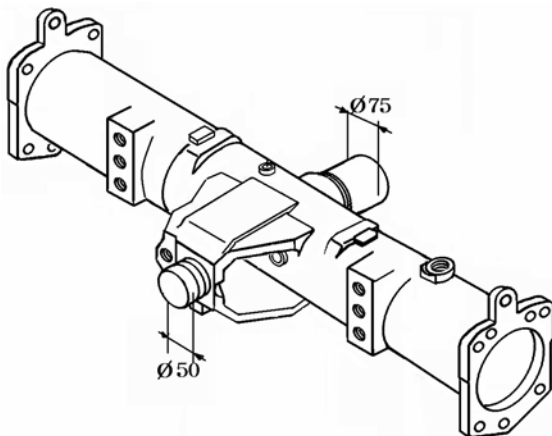

Fig.6-5

## 2) FRONT AXLE BUSH BORE DIAMETER

Measure the bore diameter of the roll bush in the pivot metal(F).If the measured value exceeds the usable limit,replace the bush.

	Front	rear
Standard value as assembled	Ø50	Ø75
Usable limit	Ø50.35	Ø75.35

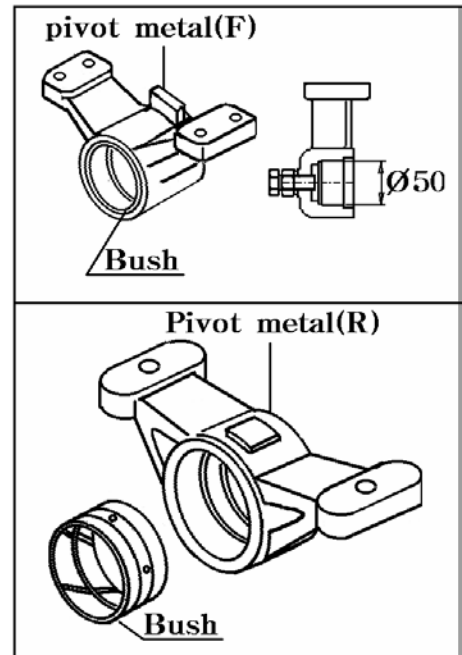

Fig.6-6

- 3) Worn or damaged oil seals,O-rings, bearings,etc.should be replaced.

## 1.3 REASSEMBLY

Reassemble the parts in reverse order of disassembly,following these instructions.

- 1) Lips of the oil seals,bush contact surfaces, and O-rings should be coated with grease in advance.
- 2) When installing the roll bushes,abide by the following precautions.

- Use an installer and press in the bush on a press.
- The bore surface should be coated with grease in advance.
- The shim of the roll bush should reach position as shown Fig.6-7.In other words the seam should be in a position which is free from any load.

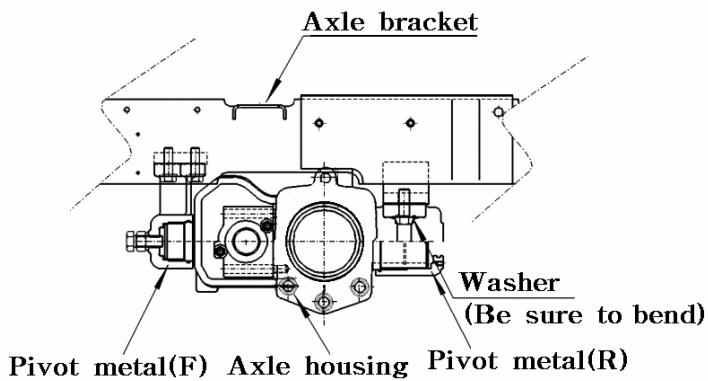

Fig.6-7

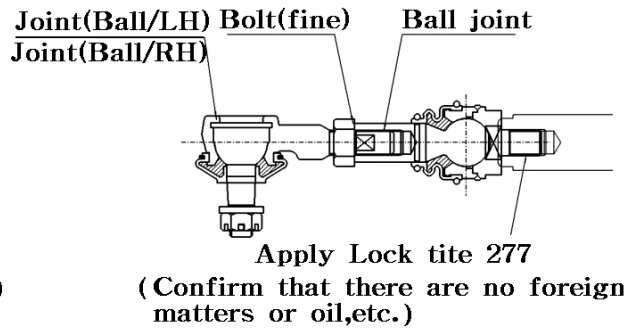

Fig.6-9

Note:

Slanted or forced installation of the bush should be avoided, and the bore surface of the bush should not be damaged.

- 3) Pay particular attention to the installed direction of thrust collar, that is, with the sharply-edged face turned towards the bevel gear case.
- 4) When the thrust collar has been replaced or the fore-and aft play of the front axle exceeds the usable limit, correct play by screwing in the adjust bolt on the top of the pivot metal(F).

Note:

After correcting the pivot metal play, tighten the lock nut of the adjusting bolt to a torque of 11.7~13.7KN-cm(1200~1400 kgf-cm)

- 5) The reassembled front axle should rock smoothly while pivoting.
- 6) When the tie-rods are reinstalled, the toe-in should be adjusted. At the same time, the steering angles of the both wheels should also be adjusted.
- 7) Be sure the dimension C and D is same size and Adjust E and F as same dimension.

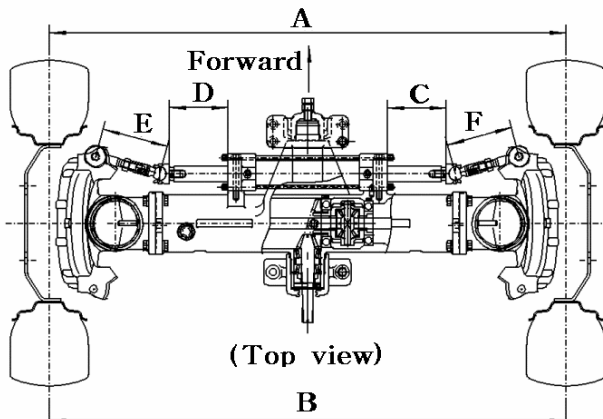

Fig.6-8

## 2. FRONT DIFFERENTIAL

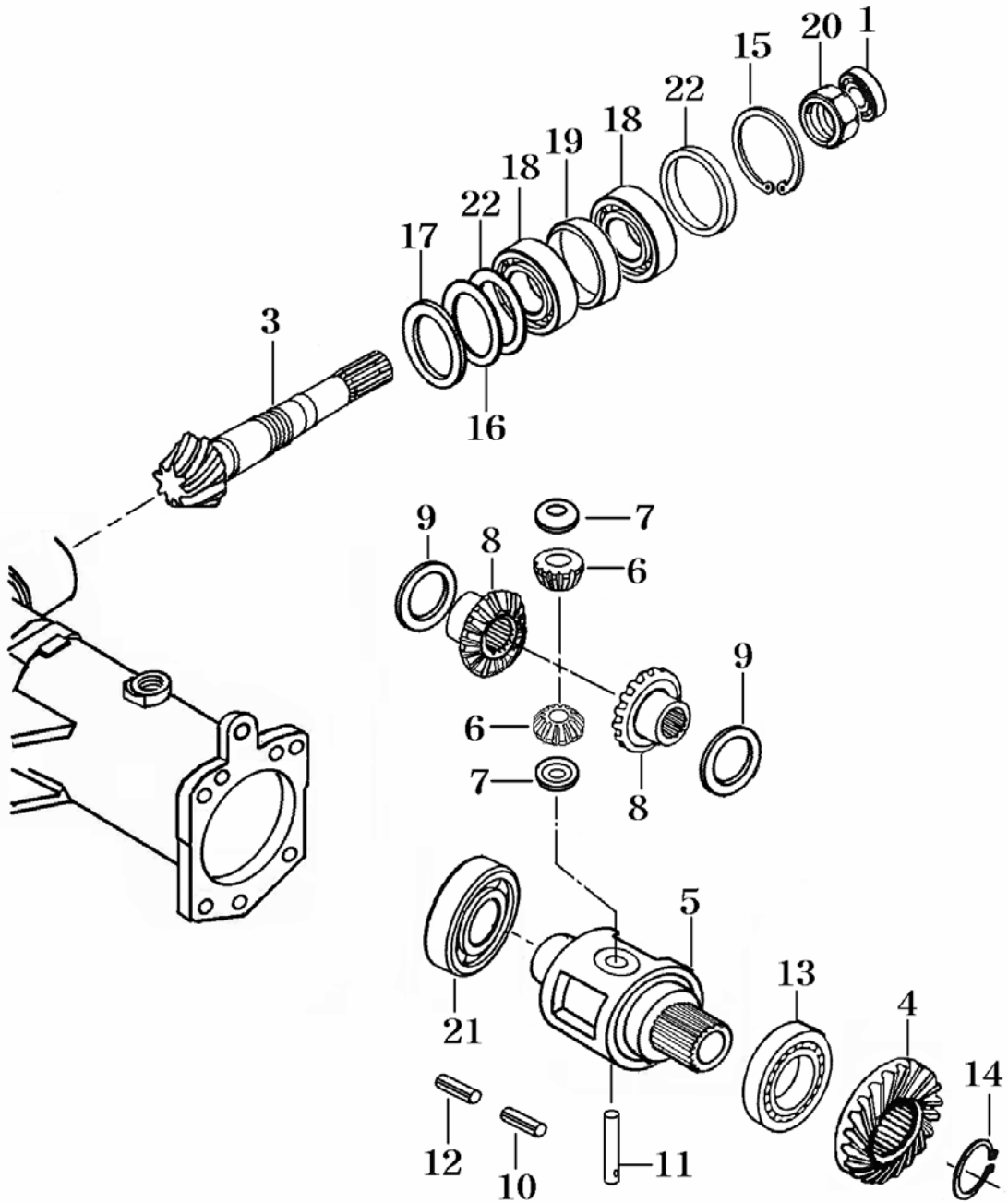

Fig.6-10

- |                 |                         |                  |                     |                        |
|-----------------|-------------------------|------------------|---------------------|------------------------|
| 1.Oil seal      | 3.Pinion bevel 8T       | 4.Gear bevel 23T | 5.Case front Diff   | 6.Pinion Diff (12)     |
| 7.Thrust collar | 8.Gear diff side (20)   | 9.Washer thrust  | 10.Pin spring       | 11.Shaft diff pinion   |
| 12. Pin spring  | 13.Bearing Ball(6212)   | 14.Snap ring     | 15.Snap ring( hole) | 16.Shim(A)             |
| 17.Shim(B)      | 18.Bearing taper roller | 19.collar        | 20.Nut(M30)         | 21. Bearing ball(6211) |
| 22.Shim         |                         |                  |                     |                        |

## 2.1 DISASSEMBLY

- 1) As concerns operation prior to removal of the front axle, refer to the paragraph covering disassembly of the center pivot
- 2) Remove both wheels
- 3) Remove the drain plug from the final case and drain oil from the final case.
- 4) remove both final case assembly (A and B) from the front axle( Fig.6-11)

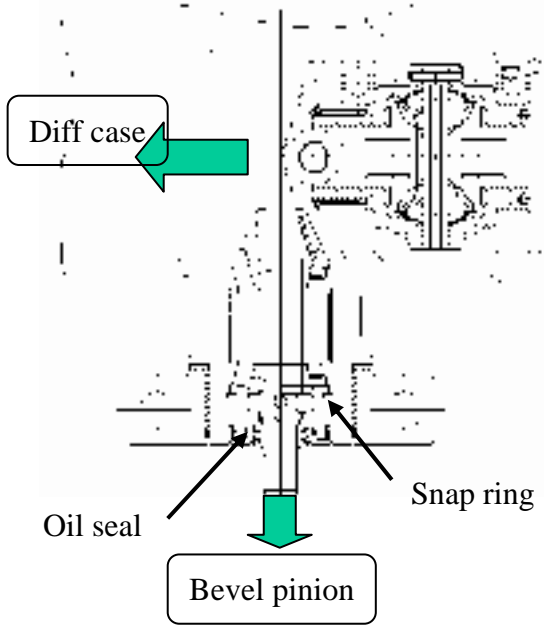

Fig.6-11

- 5) Remove the oil seal, assuring parallelism of the ring gear and bearing

Note:

The number of shims(1) installed and the the shimming thickness should be noted for later reference.



Fig.6-12

- 6) Remove the bearings from the Axle housing And the ring gear, and then the ring gear can be separated from the Axle housing.
- 7) Remove the straight pin(4) which retains the axle housing.

Note: Discard the removed straight pin and oil seal and install a new pin and Oil seal when reassembled, because this pin and oil seal is apt to be damaged when removed.

- 8) Remove the snap ring and the bevel pinion can then be removed together with the TRB's (Fig.6-11)
- 9) When separating the TRB's from the bevel pinion, release the calking of the lock nut and remove the bearings.

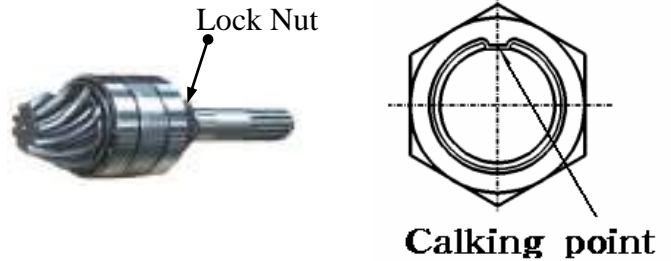

Fig.6-13

Note:

The lock nut should be calked at a point completely apart from the threads may damage the threads of the bevel pinion.

## 2.2 INSPECTION

- 1) visually check the bearing surfaces of the bevel pinion and ring gear teeth.

Note:

The bevel pinion and the ring gear should be replaced as a pair.

- 2) seriously worn or damaged parts should be replaced.

### 2-3.REASSEMBLY

Reassembly the parts in reverse order of disassembly, following these instructions.

- 1) Each friction surface should be coated with grease in advance.
- 2) The bevel pinion and the ring gear make a distinct pair after a mesh adjustment performed at the factory. Consequently, when reassembling the pair, be sure to pair parts with a same reference number.

-Tighten the lock nut to the specified starting torque of the single unit of the bevel pinion.

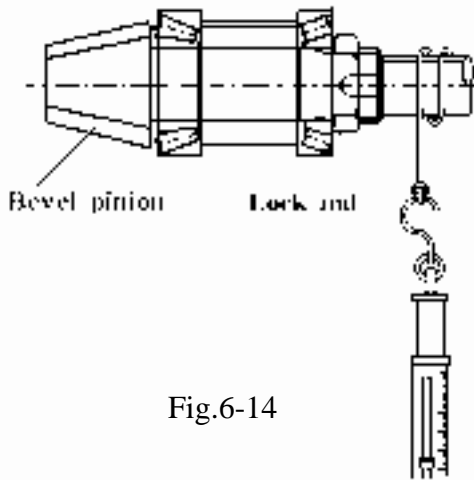

Fig.6-14

Note:

As a general rule, a disassembled lock nut should be replaced and a new one should be installed. However, when there is no alternative but to reuse the disassembled lock nut assure that it can lock securely.

Note:

Measure the starting torque a manner as shown in the figure 6-14.

Specified starting torque	6 -7 Kgf-cm (0.43-0.51 ft.lbs)
---------------------------	-----------------------------------

-When any of the bevel pinion, ring gear, TRB, collar, etc. has been replaced, inspect the bevel pinion assembly for thrust play in the front axle housing.

Specified thrust play mm(in)	0.1-0.3 (0.004-0.011 in)
---------------------------------	-----------------------------

Note:

TRB and collar should be replaced as a pair.

- (1) Bevel pinion (8)

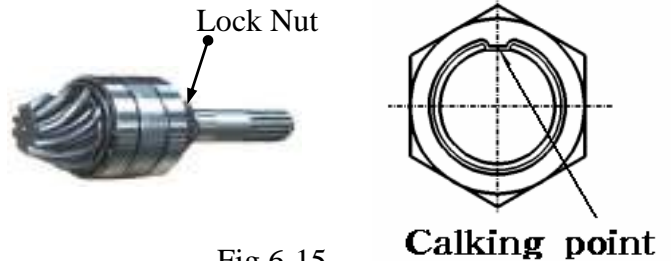

Fig.6-15

- (2) FRONT DIFF CASE

- a. When installing washer and thrust washer, apply fresh Molibdenium grease ahead of time.
- b. Apply fresh Molibdenium grease to teeth of diff-pinion and dif-side gear.
- c. Each parts should be washed clean, and There should be no sharp edge to the surface of thrust washer.
- d. When assemble the spring pin, Be sure the spring pin should be different direction (Ø5 and Ø3)
- e. When any of the bevel pinion, ring gear, TRB, collar, etc. has been replaced, inspect the bevel pinion assembly for thrust play in the front axle housing.

Specified thrust play mm(in)	0.1-0.3 (0.004-0.011 in)
---------------------------------	-----------------------------



Fig.6-16

### 3) DIF CASE AND BEVEL PINION



Fig.6-17

- 1.shim
- 2.shim
- 3.shim
- 4.Parallel pin

- 1) Each friction surface should be coated with grease in advance.
- 2) The bevel pinion and the ring gear make a distinct pair after a mesh adjustment performed at the factory. Consequently, when reassembling the pair, be sure to pair parts with a same reference number.
- 3) When installing the TRB's from the bevel pinion, Be sure the calking of the lock nut and the bearings.
- 4) Install the snap ring and the bevel pinion can then be installed together with the TRB's (Fig.6-17)

- Note: Discard the removed straight pin and oil seal and install a new pin and Oil seal when reassembled, because this pin and oil seal is apt to be damaged when removed.
- 5) Install the bearings from the Axle housing And the ring gear, and then the ring gear can be assembled from the Axle housing.
  - 6) Install the straight pin(4) which retains the axle housing.
  - 7) When any of the bevel pinion, ring gear, TRB, collar, etc. has been replaced, inspect the bevel pinion assembly for thrust play in the front axle housing through drain plug hole.

Specified thrust play mm(in)	0.1-0.2 (0.004-0.008 in)
---------------------------------	-----------------------------

### 3. FINAL CASE

#### 3-1. Front gear case 1.

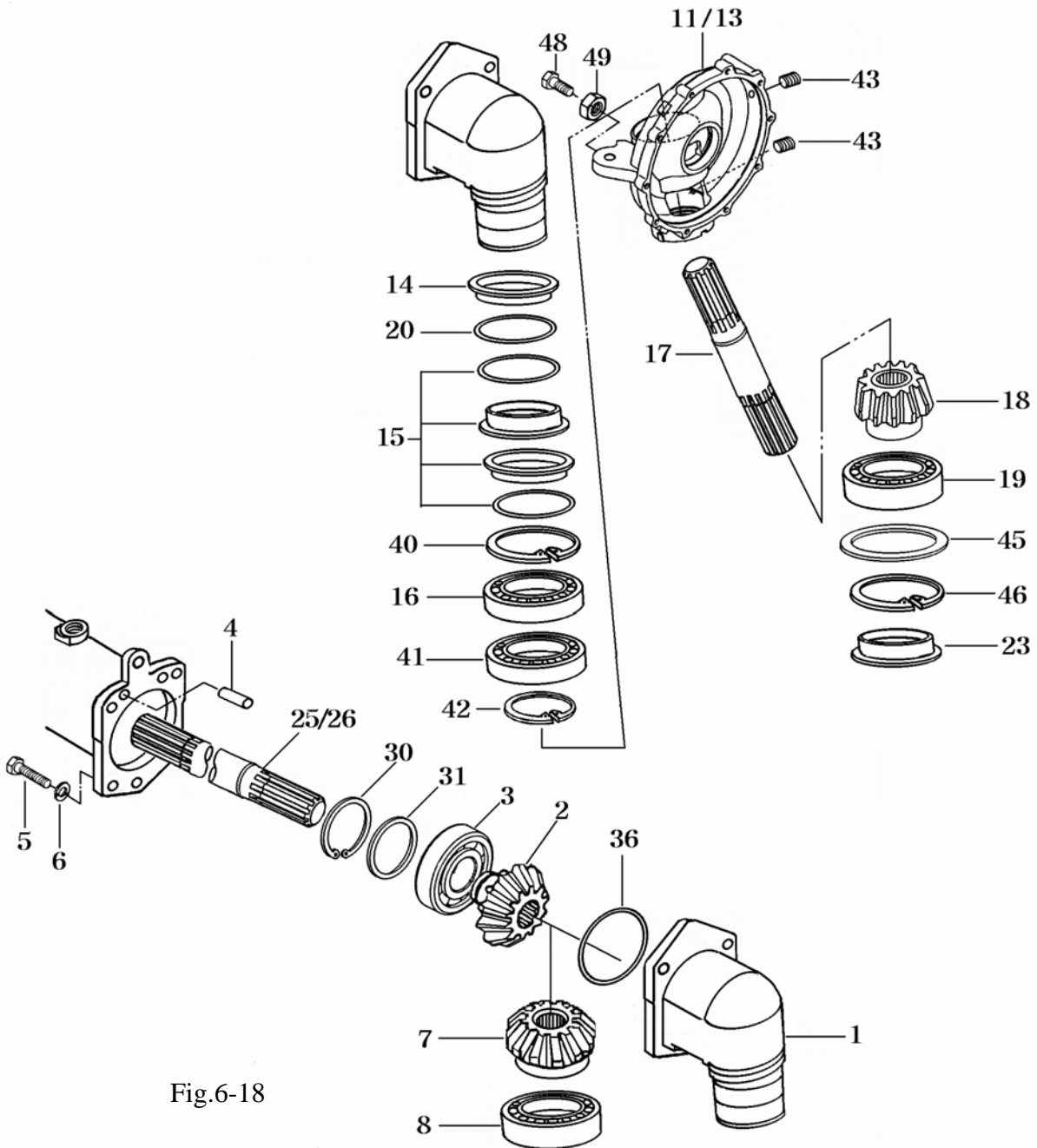

Fig.6-18

- |                       |                 |                           |                           |                   |                 |
|-----------------------|-----------------|---------------------------|---------------------------|-------------------|-----------------|
| 1.Final drive case(A) | 2.Gear bevel(9) | 3.RBB(6208)               | 4.Pin,parallel            | 5.Bolt(fine)      | 6.Washer spring |
| 7.Gear bevel(16)      | 8.RBB(6207)     | 11.Final drive case(B)(L) | 13.Final drive case(B)(R) |                   |                 |
| 14. Housing seal      | 15.Seal         | 16.RBB(6014)              | 17.shaft                  | 18.Gear bevel(11) | 19.RBB(6308)    |
| 20.O-ring             | 23.Cap 90       | 25.Shaft RH(296)          | 26. shaft LH(480)         | 30.C-ring         |                 |
| 31.collar(68X80X2)    | 40.Snap ring    | 41.RBB(6012)              | 42.Snap ring              |                   |                 |
| 43.Plug               | 45.shim         | 46 Snap ring              | 48.Bolt                   | 49.Nut            |                 |



### 3-2. Front gear case 2.

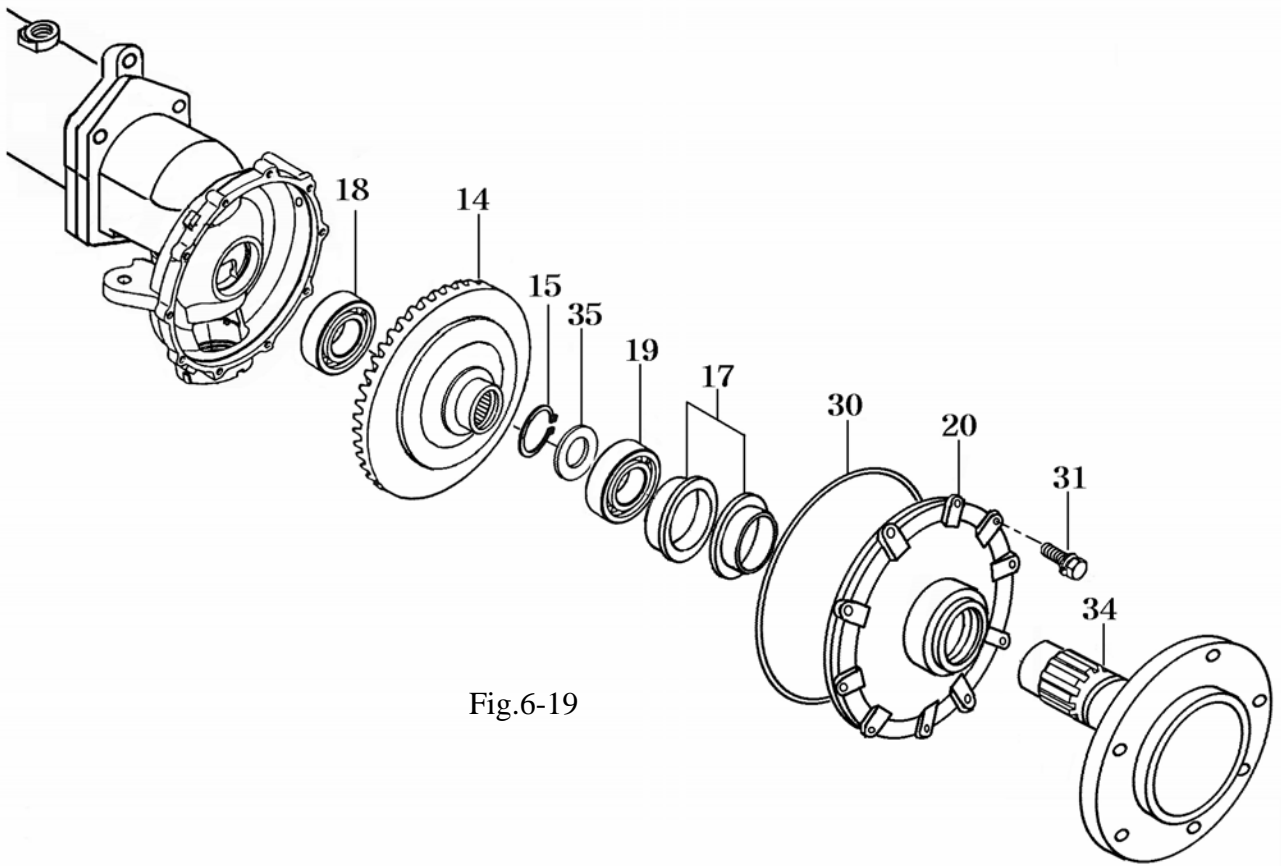

Fig.6-19

- |                      |              |         |                |                    |
|----------------------|--------------|---------|----------------|--------------------|
| 14.Gear bevel 38     | 15.Snap ring | 17.Seal | 18.Bearing     | 19.RBB(6210)       |
| 20.Cover wheel shaft | 30.O-ring    | 31.Bolt | 34.Shaft wheel | 35.Washer(50X60X2) |

### 3.1 Disassembly

- 1) Drain oil from the final case by removing the drain plug.
- 2) Remove the tie rod or the tie rod end.
- 3) Remove the final drive case clamping bolts and take out the assembly of the wheel shaft,
- 4) Remove the wheel shaft cover clamping bolts and cap (90)

- Note: Discard the removed Cap(90) and install a new cap(90) when reassembled, because this cap is apt to be damaged when removed.
- 5) Detach the snap ring C from the bevel gear.
  - 6) Extract the wheel shaft bearing together with the bevel gear, using a bearing puller



Fig.6-20



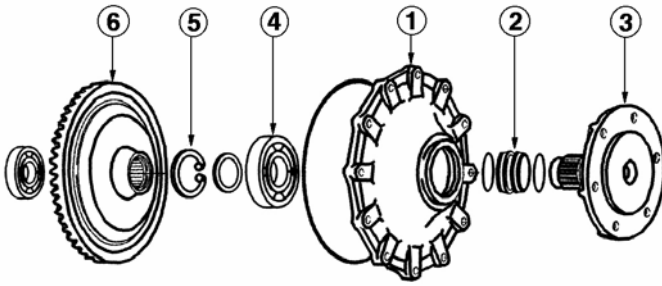

Fig.6-21

7) Remove the stop ring and the wheel shaft can be extracted.

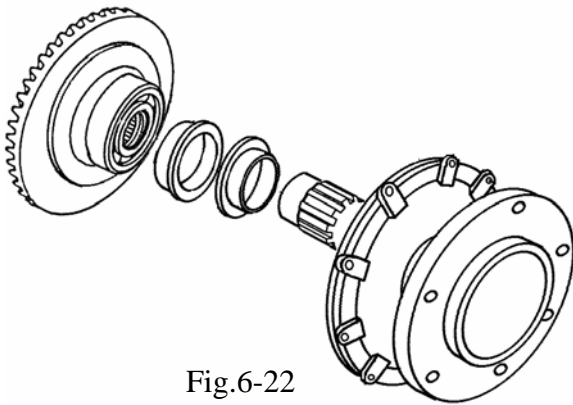

Fig.6-22

8) Remove the seal from the the wheel shaft cover

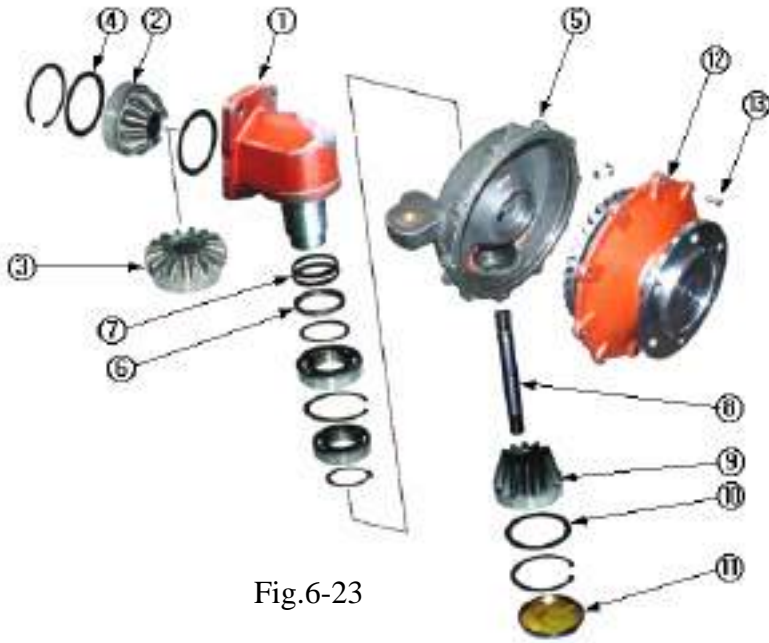

Fig.6-23

9) Remove the cap (11) from the bottom of the final case B and detach the snap ring(hole). Then the counter shaft(8) and RBB can be removed.

Note:

The removed cap(90) (black plug) should be discarded and replaced when reassembled.

### 3.2 INSPECTION

#### 1) Wheel shaft cover

- Inspect mechanical oil seal,O-rings, Gears, cases,etc. and replace them if worn or damaged.
- Measure the diameter the part which makes contact with the wheel shaft,with a micro-meter or vernier-calipers.When the measured value less than the usable limit,replace the wheel shaft cover.

Standard value	62
Usable limit	61.9

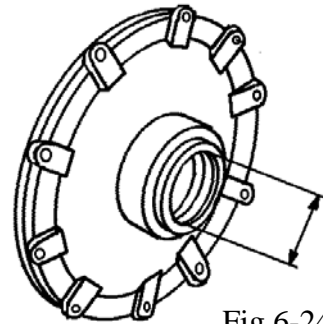

Fig.6-24

#### 2) Final Drive case (B)

- Measure the diameter the part which makes contact with the Final drive case (A),with a micro-meter or vernier-calipers.When the measured value less than the usable limit, replace the wheel shaft cover.

Standard value	110
Usable limit	110.1

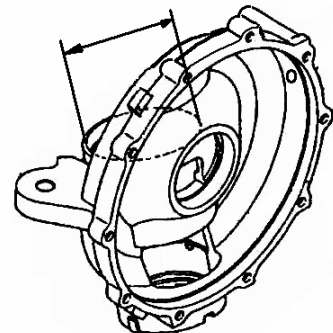

Fig.6-25

### 3.3 REASSEMBLY

Reassemble the parts in reverse order of disassembly, following these instructions.

- 1) Apply an adhesive (THREE BOND TB1215) to the following parts.
  - a. Contact surfaces between the final case B and wheel shaft cover.
  - b. Contact surfaces between the final case A and front axle.
- 2) The installed wheel shaft should turn smoothly.
- 3) When installing unitized seals on the wheel shaft cover and the rotating part between the final cases (A and B), apply force only to the outer circumference of the seal as shown in Fig.6-26 to avoid deformation.

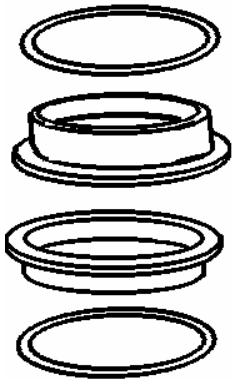

Fig.6-26

- 4) The oil seal should be coated with grease in advance. Then install them carefully, assuring that their lips are not turned over.
- 5) The reassembled final case (B) should turn smoothly until it makes contact the stopper.
- 6) When the wheel(tire) is reinstalled, turn it by hand to make sure that all the mechanism turns smoothly without making any noise.
- 7) After adjustment of the toe-in, perform road tests. There should be no abnormalities such as vibration, abnormal noises, defected steering wheel operation, etc.

### -Wheel shaft cover

- 1) Every snap ring(5) should be seated securely in its groove.
- 2) Be sure the numbers of Bevel gear is correct (teeth numbers are 41)

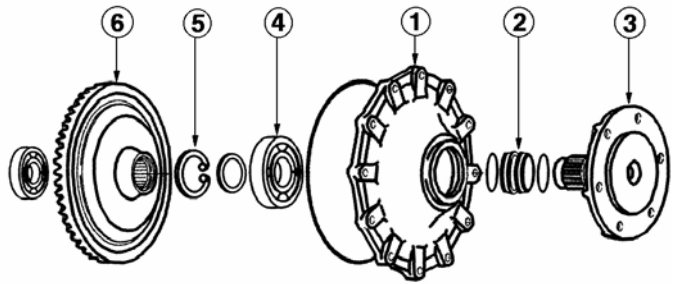

Fig.6-27

### -Final drive case A

- 1) Each parts should be washed clean before reassembly.
- 2) Apply multi-purpose, quality grease to bearings in advance
- 3) Every time a gear and bearings are installed, its smooth rotation should be checked
- 4) Adjust Back lash between bevel gear 9 (2) and bevel gear 16 (3) with collar(4) .

Back lash mm(in)	0.1-0.2 (0.004-0.008 in)
---------------------	-----------------------------

- 5) Apply oil to the housing ahead of time to install the mechanical seal.
- 6) Be sure that the length of shaft (8) is 192 mm.
- 7) Tighten the bolts to the specified torque.

Tightening torque	130-180Kgf.cm
-------------------	---------------

- 8) Adjust backlash between gear bevel 38 and gear bevel 11(9) with collar(10)

Back lash mm(in)	0.1-0.2 (0.004-0.008 in)
---------------------	-----------------------------

- 9) Apply an adhesive to the Cap (90), and be sure not to deform when installing.

Note: Refer to Fig.6-23

## - FINAL DRIVE CASE AND HOUSING



Fig.6-28

- 1) When installing the shaft, Be sure that the gears are not damaged.
- 2) Be sure the differences between the LH and RH shaft.

	LH	RH
Specified length	526mm	342mm

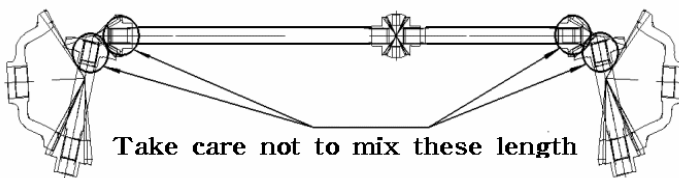

Fig.6-29

- 3) Tighten the bolts to specified torque.

Tightening torque	1300-1500 Kgf.cm
-------------------	------------------

## - STEERING CYLINDER

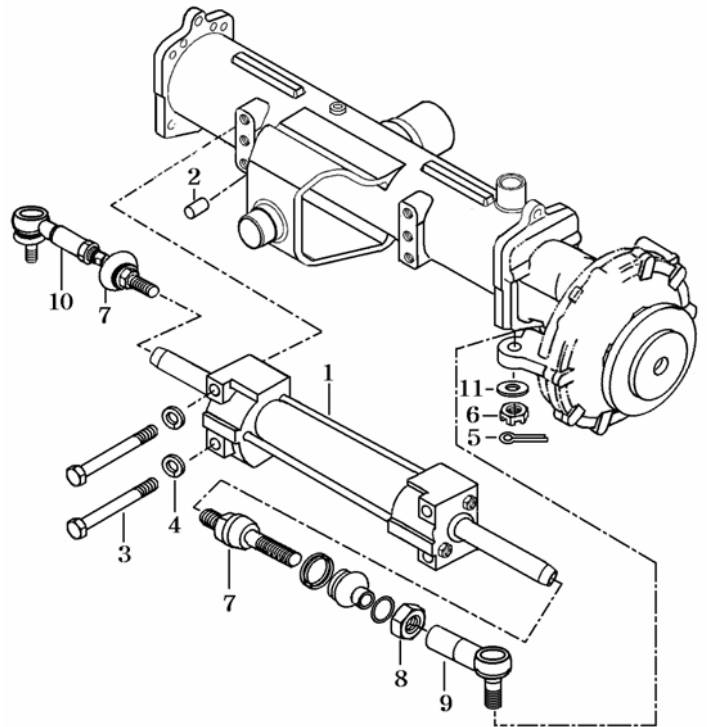

Fig.6-30

- 1) When installing the steering cylinder, Be sure that the rods are not damaged.
- 2) Install the pin (2) before assembling the cylinder.
- 3) Apply an adhesive Locktite and tighten the bolts to specified torque

Tightening torque	900-1100 Kgf.cm
-------------------	-----------------

- 4) Apply an adhesive locktite to the ball joint (7) and tighten the ball joint to specified torque

Tightening torque	1600-1800 Kgf.cm
-------------------	------------------

- 5) Be sure to bend the split pin (5) after installing the ball joint

**CHAPTER 6. FRONT AXLE(4WD)-----6-1**

**SECTION 1.GENERAL DESCRIPTION-----6-1**

**SECTION 2. SPECIFICATIONS-----6-2**

**SECTION 3.DISASSEMBLY,INSPECTION,AND REASSEMBLY--6-3**

**1. Center pivot-----6-3**

**1-1. Disassembly-----6-4**

**1-2. Inspection-----6-4**

**1-3. Reassembly-----6-5**

**2. Front differential-----6-6**

**2-1. Disassembly-----6-7**

**2-2. Inspection-----6-8**

**2-3. Reassembly-----6-8**

**3. Final case-----6-9**

**3-1. Disassembly-----6-10**

**3-2. Inspection-----6-11**

**3-3. Reassembly-----6-12**

**SECTION 4.TROUBLE SHOOTING-----6-14**

# Chapter 6 Front axle(4WD)

## 1. GENERAL DESCRIPTION

The 4WD front axle is a center pivot type. The front wheel drive mechanism is incorporated as a part of the axle.

The front wheel drive power is taken off the rear transmission and transmitted to the differential in the front axle where the power is divided into right and left and to the respective final cases.

In the final cases, the transmitted revolution is reduced by the bevel gears to drive the front wheel.

The 4WD mechanism with bevel gears provides wider steering angle and greater durability.

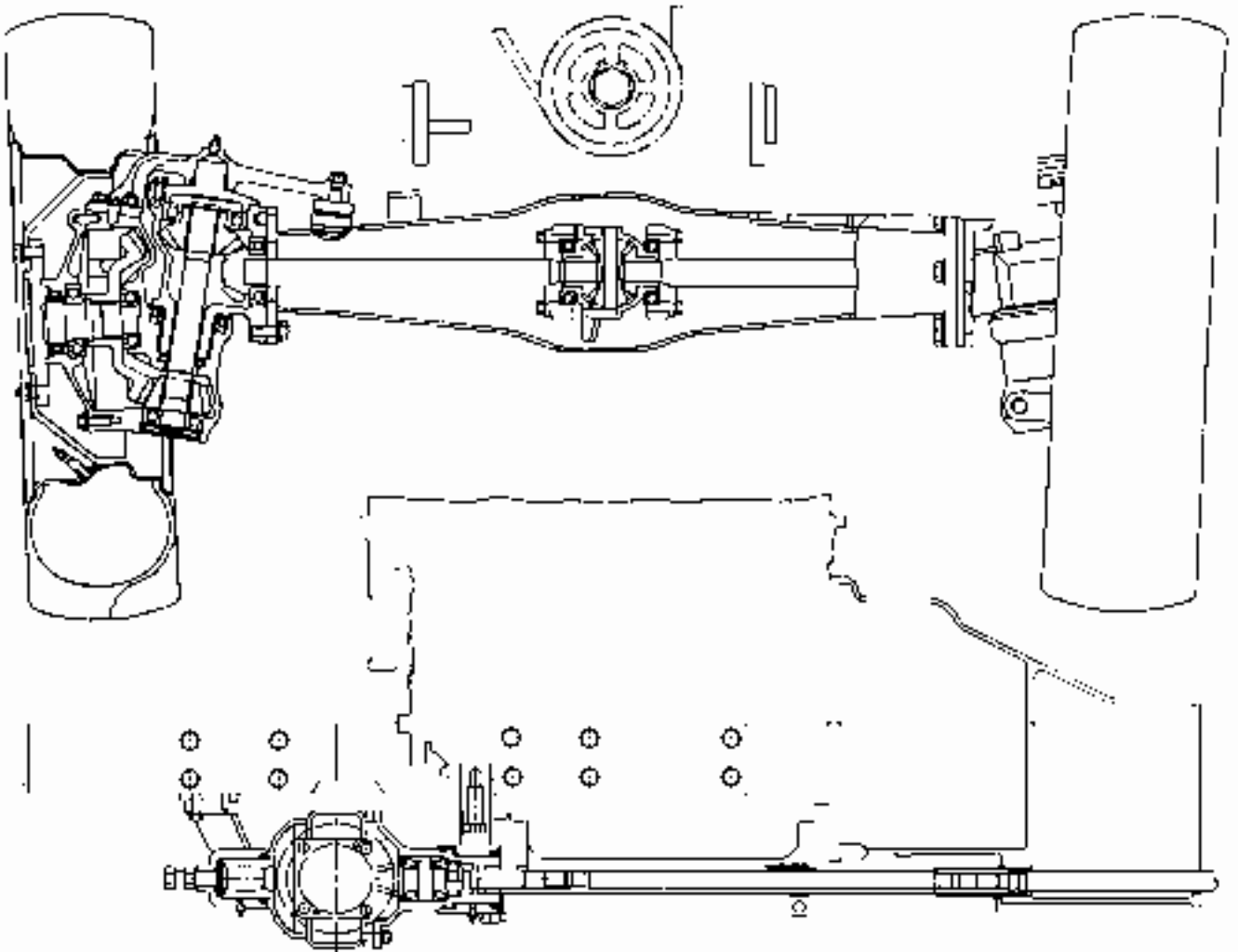

Fig 6-1

## SECTION 2. SPECIFICATIONS

		T390//T430
Wheel alignment	Toe-in (mm)	2~6
Front axle	Center Pivot Axle diameter front axle (mm)	Φ80
	Front diff holder (mm)	
	Pivot metal (F) bush bore (mm)	Φ80
	Bearing cover shaft diameter (mm)	Φ35
	Case shaft Diameter (mm)	Φ55
	Case bush bore (mm)	Φ55
	Front wheel steering angles	55°

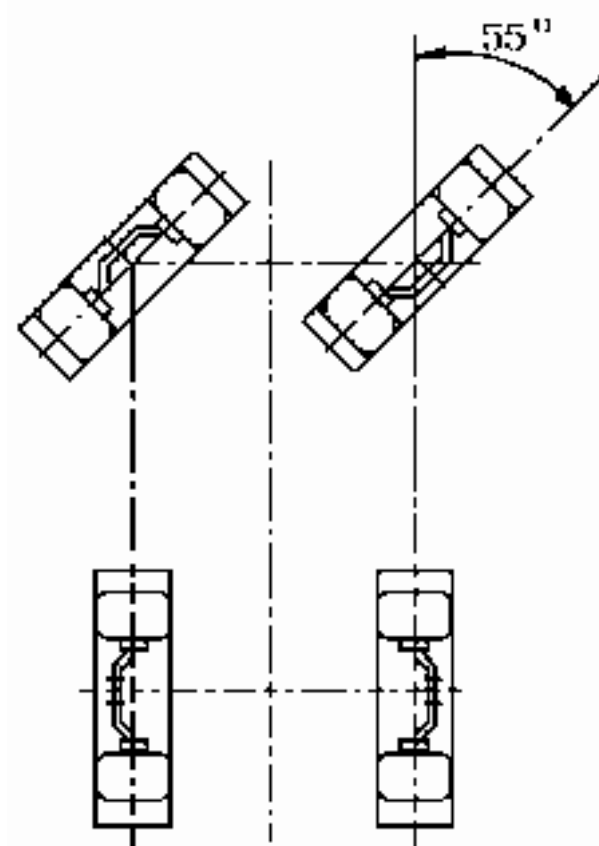

Fig.6-2

# SECTION 3. DISASSEMBLY,INSPECTION,AND REASSEMBLY

## 1.CENTER PIVOT

T390,T430,T431

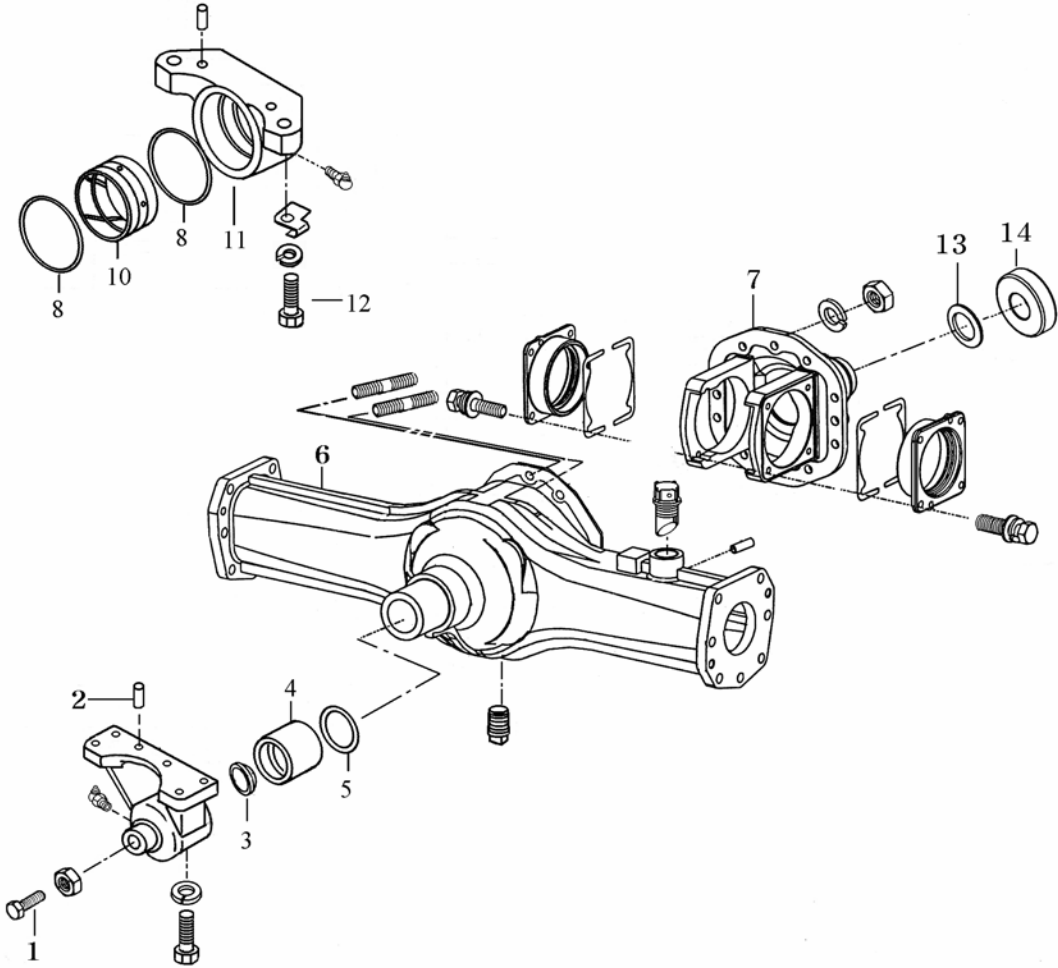

Fig.6-3

- 1.Lock bolt
- 2.Pivot metal (support)
- 3.Spacer
- 4.connector
- 5.Bush(55X60X50)
- 6.Axle housing
- 7.Bevel gear case
- 8.X-ring

- 9.Thrust collar
- 10.Bush(65X70X44)
- 11.Rear pivot metal Support)
- 12.Bolt(M18X1.5X55:7T)
- 13.Oil seal
- 14.Cover

## 1.1.DISASSEMBLY

- 1) Dismount the front wheel drive shaft, referring to the pertinent paragraph in chapter 2.
- 2) Remove the right and left tie rods.
- 3) Suspend the front axle bracket with a chain block.
- 4) Remove the front metal clamping bolts.The front axle can then be separated from the axle bracket.
- 5) Remove the front and rear pivot metals.

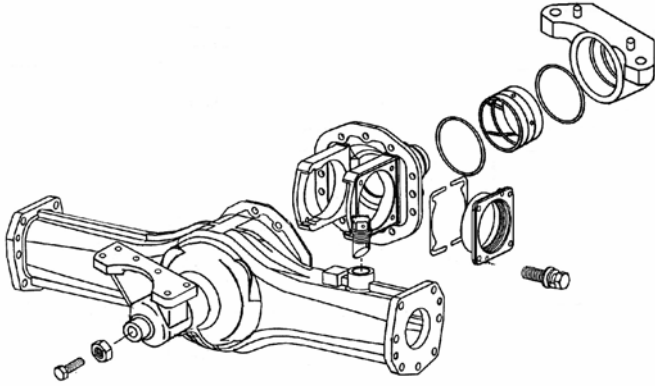

Fig.6-4

## 1.2.INSPECTION

### 1) Bevel case shaft diameter

Measure the diameter at a roll bush contact point with a micro meter or vernier calipers. If the measured value is less than usable limit ,replace the case.

	T390	T430
Standard value as assembled	Ø80	Ø80
Usable limit	Ø79.9	Ø79.9

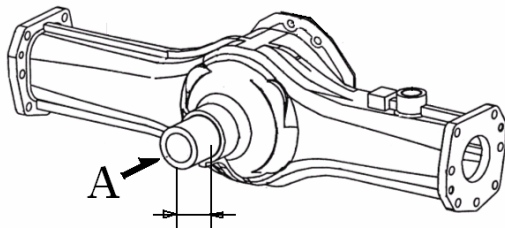

View A

Fig.6-5

### 2) Bevel case bush bore

Measure the bore diameter of the bush for the pivot metal (R) with a cylinder gauge or vernier calipers. If the measured value exceeds the usable limit, replace the bush

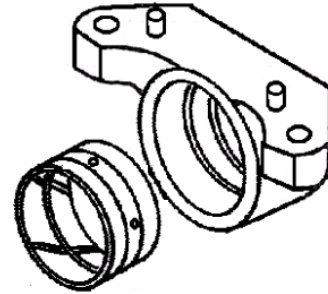

Fig.6-6

### 3) FRONT AXLE SHAFT DIAMETER

Measure the diameter at a bush contact point with a micro-meter or vernier calipers.If the measured value is less than usable limit,replace the case

mm (in)

	T390 /T430
Standard value as assembled	Ø55 (2.165)
Usable limit	Ø59.9

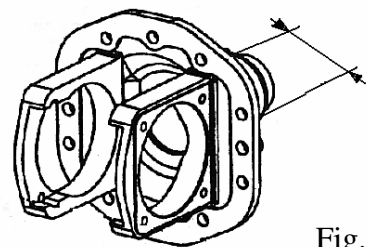

Fig.6-7

### 2) FRONT AXLE BUSH BORE DIAMETER

Measure the bore diameter of the roll bush in the pivot metal(F).If the measured value exceeds the usable limit,replace the bush.

mm (in)

	T390/T430
Standard value as assembled	Ø55 (2.167)
Usable limit	Ø50.2(2.173)



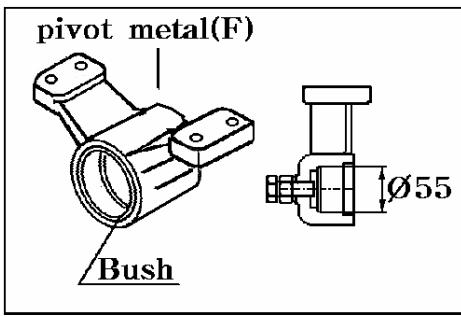

Fig.6-8

3) Worn or damaged oil seals, O-rings, bearings, etc. should be replaced.

### 1.3 REASSEMBLY

Reassemble the parts in reverse order of disassembly, following these instructions.

- 1) Lips of the oil seals, bush contact surfaces, and O-rings should be coated with grease in advance.
- 2) When installing the roll bushes, abide by the following precautions.

- Use an installer and press in the bush on a press.
- The bore surface should be coated with grease in advance.
- The shim of the roll bush should reach position as shown Fig.6-8. In other words the seam should be in a position which is free from any load.

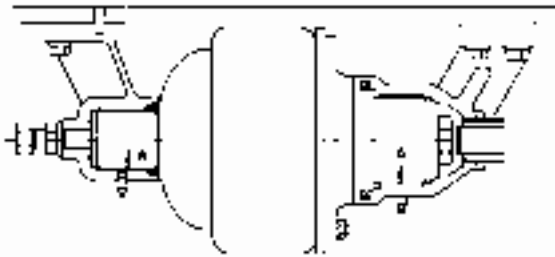

Fig.6-9

#### Note:

Slanted or forced installation of the bush should be avoided, and the bore surface of the bush should not be damaged.

- 3) Pay particular attention to the installed direction of thrust collar, that is, with the sharply-edged face turned towards the bevel gear case.
- 4) When the thrust collar has been replaced or the fore-and aft play of the front axle exceeds the usable limit, correct play by screwing in the adjust bolt on the top of the pivot metal (F).

#### Note:

After correcting the pivot metal play, tighten the lock nut of the adjusting bolt to a torque of 11.7~13.7KN-cm (1200~1400 kgf-cm)

- 5) The reassembled front axle should rock smoothly while pivoting.
- 6) When the tie-rod is reinstalled, the toe-in should be adjusted. At the same time, the steering angles of the both wheels should also be adjusted.

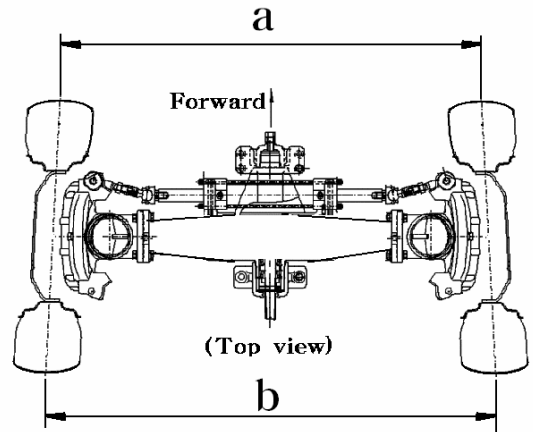

Fig.6-10

Toe-in:mm(in)	
Front wheel steering angle(inner)	2~6(0.08~0.24) 55

- 7) Perform road test and confirm that there are no loose parts or other abnormalities.

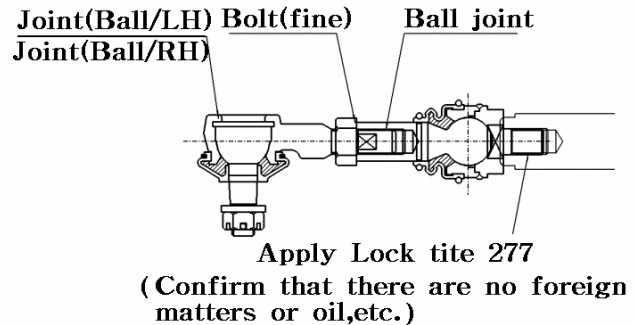

Fig.6-11

## 2. FRONT DIFFERENTIAL

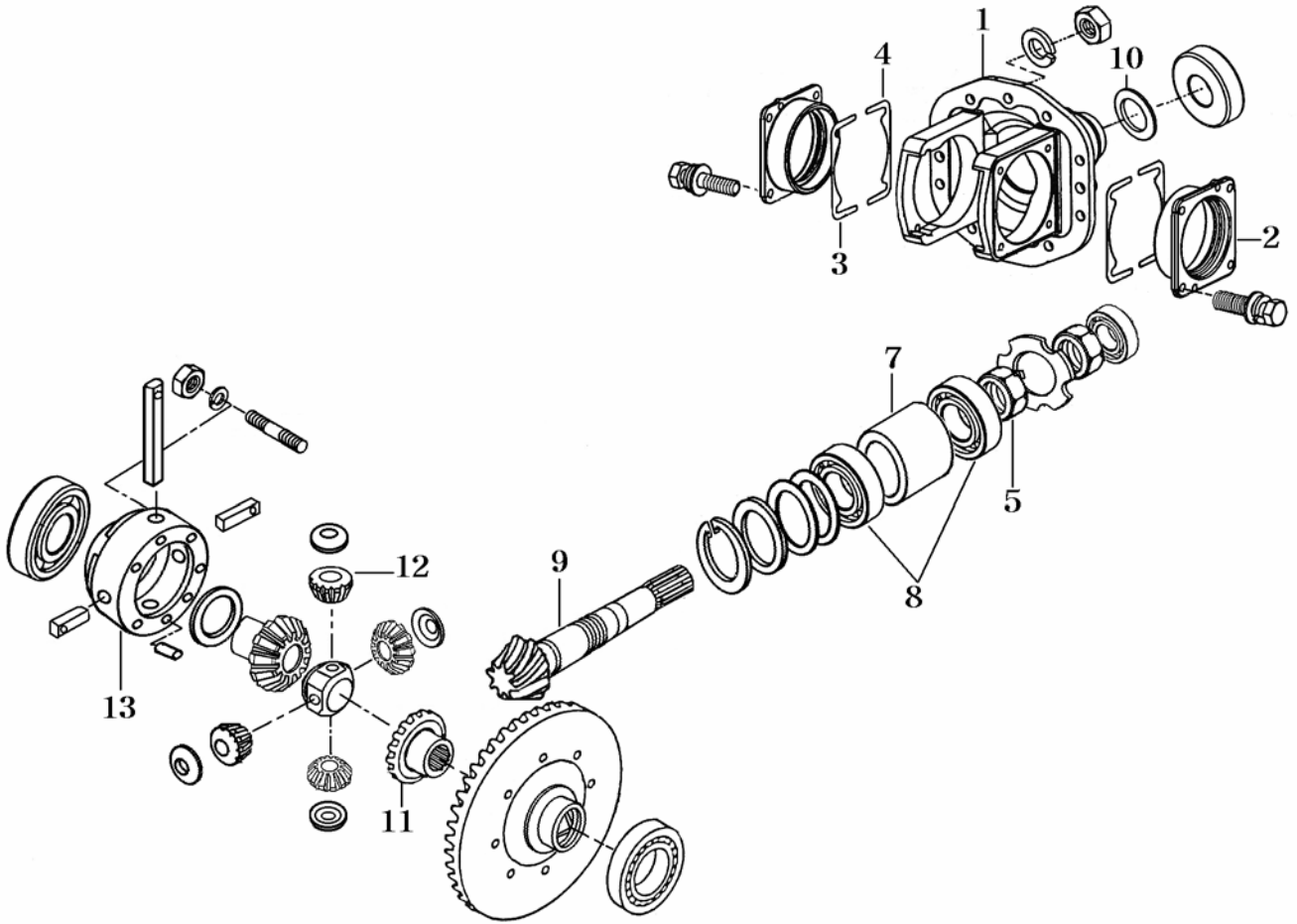

Fig.6-12

- |                         |                           |
|-------------------------|---------------------------|
| 1. Bevel case           | 8. Tapered roller bearing |
| 2. Diff-Metal (support) | 9. Bevel pinion           |
| 3. Shim A               | 10. Washer (85X98X05)     |
| 4. Shim B               | 11. Bevel gear (20 T)     |
| 5. Nut (M28X1.5)        | 12. Bevel pinion (11T)    |
| 6. Sleeve               | 13. Front diff-case       |
| 7. Shims ( A and B)     |                           |

## 2.1 DISASSEMBLY

- 1) As concerns operation prior to removal of the front axle, refer to the paragraph covering disassembly of the center pivot
- 2) Remove both wheels
- 3) Remove the drain plug from the final case and drain oil from the final case.
- 4) remove both final case assembly (A and B) from the front axle( Fig.6-13)

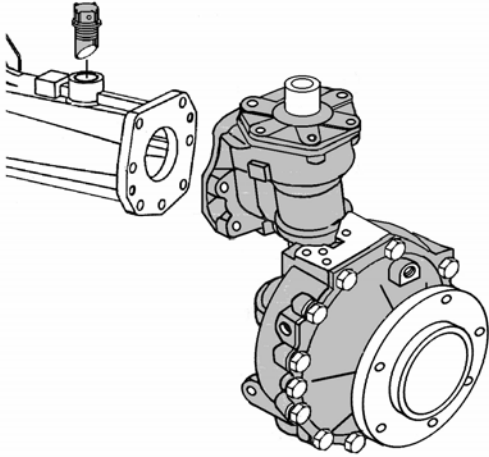

Fig.6-13

- 5) Remove the Bevel case from the front axle after pulling out the right and left drive shafts. (Fig.6-14)

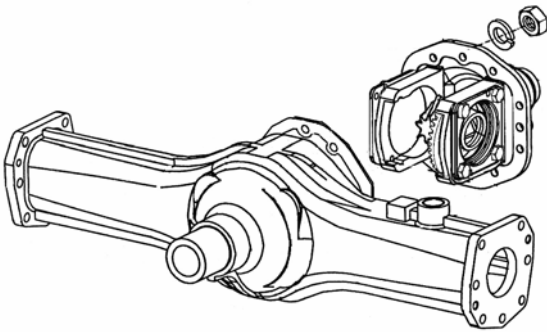

Fig.6-14

- 6) Remove the clamping bolts from both diff-metals( RH and LH) and pull the metals out with push bolts.assuring parallelism of the ring gear and bearing(Fig.6-15)

**Note:**

The number of shims installed and the the shimming thickness should be noted for later reference.

- 7) Remove the bearings from the Diff case And the ring gear, and then remove the bolt. The ring gear can then be separated from the diff-case.
- 8) Remove the straight pin which retains the Dif-pinion shaft and the dif-case can then be disassembled.

**Note:**

- Discard the removed straight pin and oil seal and install a new pin and Oil seal when reassembled, because this pin and oil seal is apt to be damaged when removed.
- 9) Remove the snap ring and the bevel pinion can then be removed together with the TRB's (Fig.6-15)

**Note:**

The thrust play of the bevel pinion should be inspected before disassembly. If the play exceeds the specified value, correct it by shimming.

Specified value	0.2mm or less
Available shims mm(in)	Shim A :0.2(0.008) Shim B: 0.1(0.004)

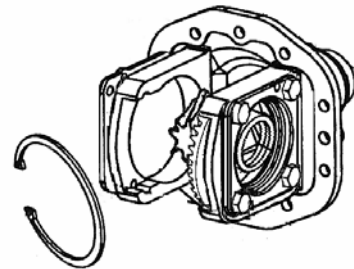

Fig.6-15

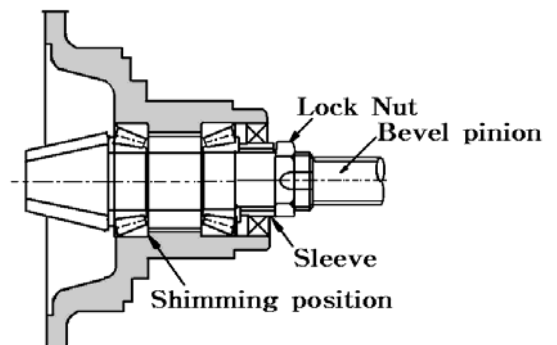

Fig.6-16

10) When separating the TRB's from the bevel pinion, release the calking of the lock nut and remove the bearings.

Note:

The lock nut should be calked at a point completely apart from the threads may damage the threads of the bevel pinion.

## 2.2 INSPECTION

1) visually check the bearing surfaces of the bevel pinion and ring gear teeth.

Note:

The bevel pinion and the ring gear should be replaced as a pair.

2) seriously worn or damaged parts should be replaced.

## 2-3. REASSEMBLY

Reassembly the parts in reverse order of disassembly, following these instructions.

- 1) Each friction surface should be coated with grease in advance.
- 2) The bevel pinion and the ring gear make a distinct pair after a mesh adjustment performed at the factory. Consequently, when reassembling the pair, be sure to pair parts with a same reference number.

-Tighten the lock nut to the specified starting torque of the single unit of the bevel pinion.

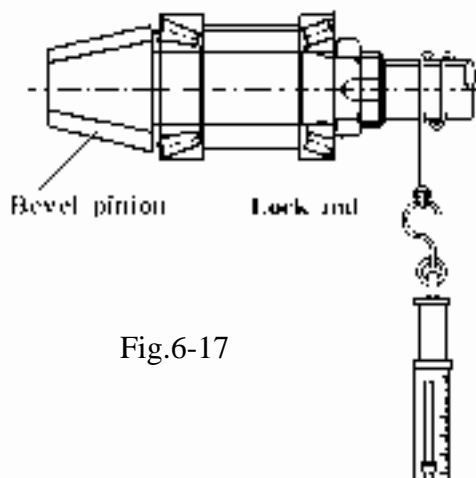

Fig.6-17

Note:

As a general rule, a disassembled lock nut should be replaced and a new one should be installed. However, when there is no alternative but to reuse the disassembled lock nut, assure that it can lock securely.

Note:

Measure the starting torque a manner as shown in the figure

Specified starting torque	6 -7 Kgf-cm (0.43-0.51 ft.lbs)
---------------------------	-----------------------------------

-When any of the bevel pinion, ring gear, TRB, collar, etc. has been replaced, inspect the bevel pinion assembly for thrust play in the front axle housing.

Specified thrust play mm(in)	0 -0.2 (0 -0.008 in)
---------------------------------	-------------------------

Note:

TRB and collar should be replaced as a pair.

### 3. FINAL CASE

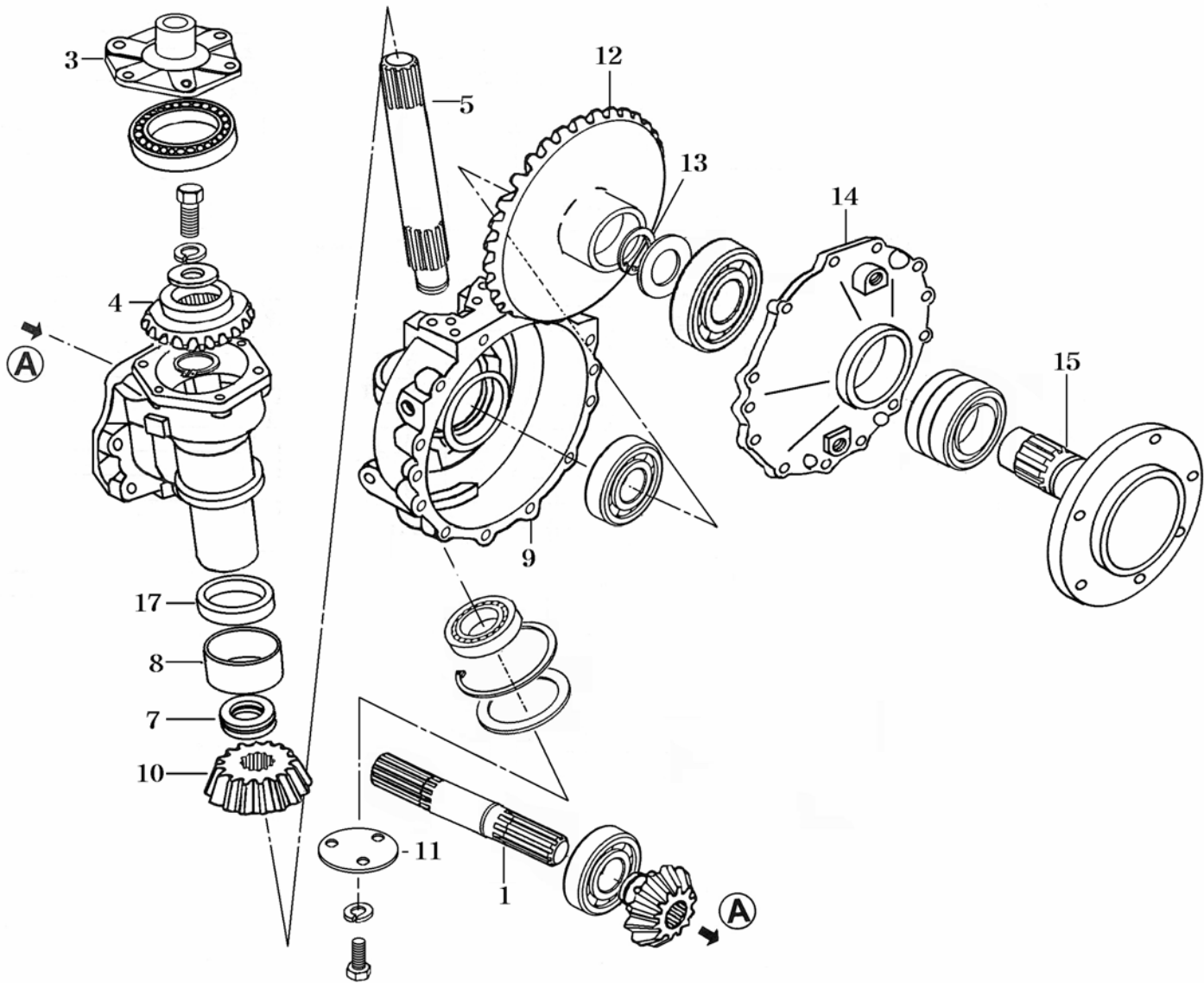

Fig.6-18

- |                     |                            |                  |                      |                 |
|---------------------|----------------------------|------------------|----------------------|-----------------|
| 1.Final drive shaft | 2.bevel gear               | 3.Bearing cove   | 4.bevel gear         | 5.Counter shaft |
| 6.Final case A      | 7.Flat seat thrust bearing | 8.Roll bush      | 9.Final case B       | 10.Bevel gear   |
| 11.Seal(Blank plug) | 12. Bevel gear             | 13. Stop ring    | 14.Wheel shaft cover |                 |
| 15.Wheel shaft      | 16. Axle housing           | 17.Unitized seal |                      |                 |

\*Inspection prior to disassembly

-Try to move the final case B up and down to make sure that there is no play.

Standard value as assembled mm( in)	0~0.2mm (0~0.008)
Usable limit: mm(in)	0.5(0.020)

-When the play exceeds the usable limit,correct it by a shimming adjustment.

Adjustable shims in thickness mm(in)	0.5(0.020) 1.0(0.039)
--------------------------------------	--------------------------

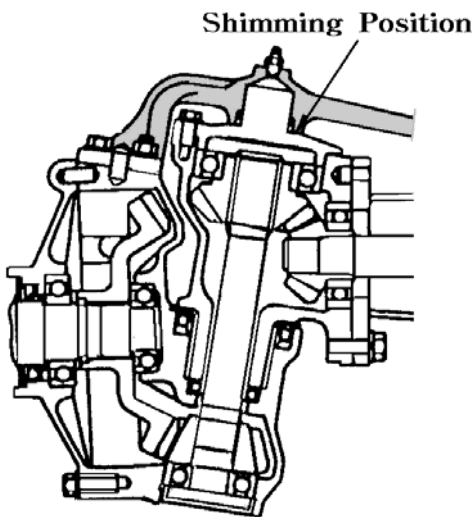

Fig.6-19

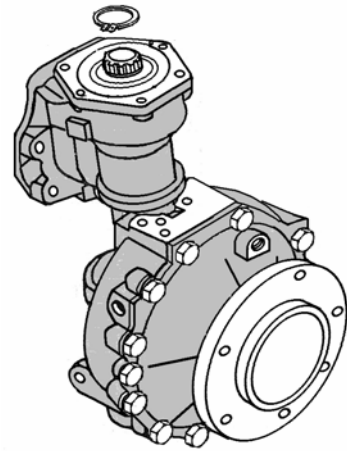

Fig.6-20

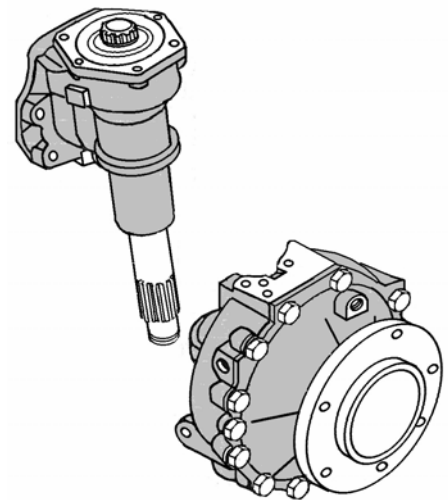

Fig.6-21

### 3.1 Disassembly

- 1) Before disassembly, lift up the front axle and remove the wheel on the side of the final case that is to be disassembled.
- 2) Drain oil from the final case by removing the drain plug.
- 3) Remove the tie rod or the tie rod end.
- 4) Remove the assembly of the final drive cases (A and B) from the front axle.
- 5) Remove the drag arm from the final cases (A and B)
- 6) Remove the bearing cover and then detach snap ring C from the counter shaft. Then the final case B can be separated downwards.

- 7) Remove the wheel shaft cover clamping bolts and take out the assembly of the wheel shaft, wheel shaft cover, and bevel gear.

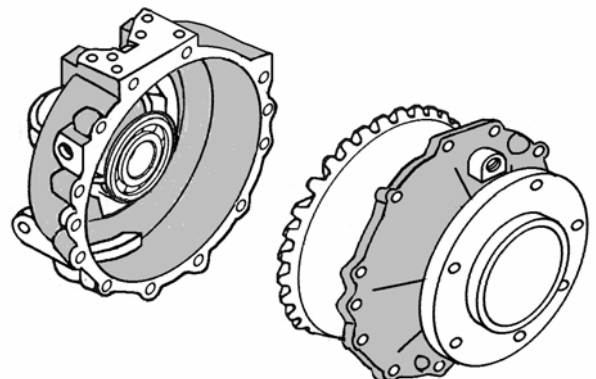

Fig.6-22

8) Extract the wheel shaft bearing together with the bevel gear, using a bearing puller.

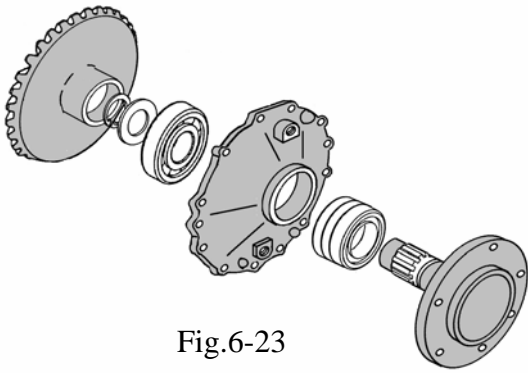

Fig.6-23

9) Remove the stop ring and the wheel shaft can be extracted.

10) Remove the seal from the bottom of the final case B and detach the snap ring(hole) .Then the counter shaft and RBB can be removed.

**Note:**

The removed seal (black plug) should be discarded and replaced when reassembled.

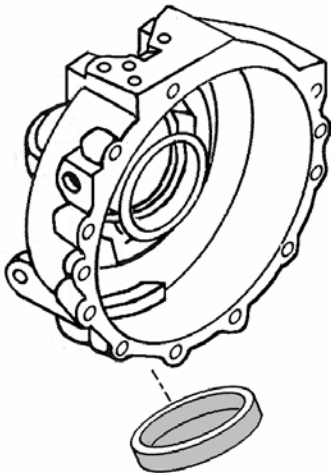

Fig.6-24

**3.2 INSPECTION**

**1) Bearing cover shaft diameter**

Measure the diameter the part which makes contact with the roll bush in the drag arm, with a micro-meter or vernier-calipers. When the measured value less than the usable limit, replace the bearing cover.

Standard value as assembled	Ø55 (2.165)
Usable limit	Ø54.9 (2.161)

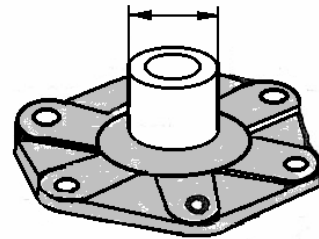

Fig.6-25

**2) Drag arm bush bore diameter**

-Measure the bore diameter of the roll bush in the drag arm with a cylinder gauge or vernier calipers. If the measured value exceeds the usable limit, replace the bush (Fig. 6-26)

Standard value as assembled	Ø35 (1.378)
Usable limit	Ø35.2(1.385)

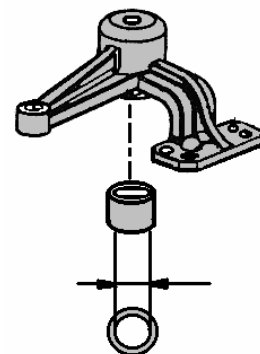

Fig.6-26

### 3) Final case A shaft diameter

Measure the diameter of the shaft part which makes contact with the roll bush with a micrometer or vernier calipers. When the measured value is less than the usable limit, replace the case (Fig. 6-27)

Standard value as assembled	Ø55 (2.165)
Usable limit	Ø54.9 (2.161)

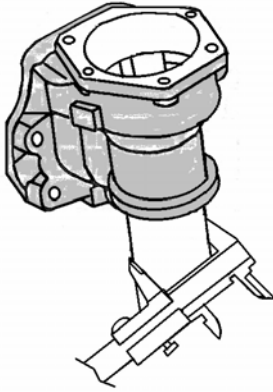

Fig. 6-27

### 4) Final case B bush bore diameter

Measure the bore diameter of the roll bush in the final case B with a cylinder gauge or vernier calipers. When the measured value exceeds the usable limit, replace the bush. (Fig. 6-28)

Standard value as assembled	Ø55 (2.165)
Usable limit	Ø55.2 (2.173)

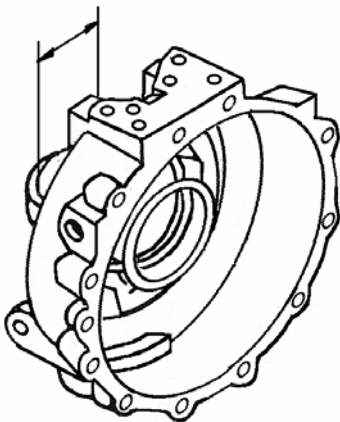

Fig. 6-28

5) Inspect other bearings, oil seals, O-rings, shafts, gears, cases, etc., and replace them if worn or damaged

### 3.3 REASSEMBLY

Reassemble the parts in reverse order of disassembly, following these instructions.

- 1) Apply an adhesive (THREE BOND TB1215) to the following parts.
  - a. Contact surfaces between the final case B and wheel shaft cover.
  - b. Contact surfaces between the final case A and front axle.
- 2) When driving the seal into the bottom of the final case A, Apply an adhesive (TB1215) to the seal in advance.
- 3) When installing unitized seals on the wheel shaft cover and the rotating part between the final cases (A and B), apply force only to the outer circumference of the seal as shown in Fig. 6-29 to avoid deformation.

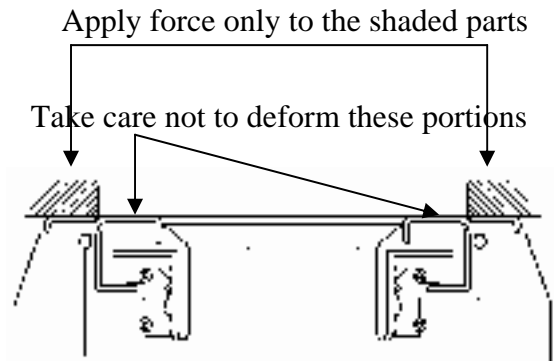

Fig. 6-29

4) The installed wheel shaft should turn smoothly.

5) The flat-seat thrust bearing, as shown in Fig. 6-30, should be installed with the larger bore side turned downwards. Also install the ball-cage assembly as shown in the figure.

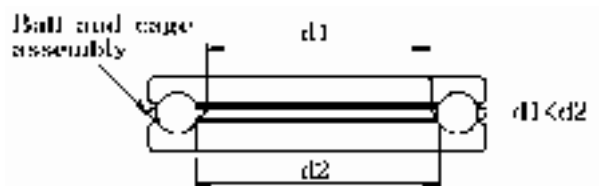

Fig. 6-30



- 6) The oil seal should be coated with grease in advance. Then install them carefully, assuring that their lips are not turned over.
- 7) The reassembled final case (B) should turn smoothly until it makes contact the stopper.
- 8) When the wheel(tire) is reinstalled, turn it by hand to make sure that all the mechanism turns smoothly without making any noise.

---

Wheel clamping torque	9-11Kgf.m (65-80 ft.lbs)
-----------------------	-----------------------------

---

- 9) After adjustment of the toe-in, perform road tests. There should be no abnormalities such as vibration, abnormal noises, defected steering wheel operation, etc.

## SECTION 4. TROUBLE SHOOTING

PROBLEMS AND PROBABLE CAUSES	COUNTERMEASURES
● Steering wheel hard to turn	
1) Too low tire inflation 2) Broken thrust bearing 3) Stuck or broken ball joint of tire-rod end 4) Seizure or poor lubrication of axle end bush	Inflate to specified value Replace Grease or replace Grease or replace
● Vibrating or pulling steering wheel	
1) Unbalanced wheels 2) Wheel deflation 3) Unequal diameter of both tires 4) Loose, worn, or damaged wheel axle bearing 5) Loose, worn, or damaged wheel steering wheel shaft 6) Worn final case bush 7) Loose final case-front axle tightening bolt 8) Loose front wheel(tire)tightening nuts1)	Adjust balance Repair or replace Adjust inflation or replace Repair or replace Retighten or replace Replace Retighten Retighten
● Steering wheel tends to turn to the right or left while traveling on straight paved road.	
1) Deflected wear of tire 2) Different tire diameters 3) Damaged final case bearing	Replace Adjust inflation or replace Replace
● Excessive or eccentric wear of tire	
1) Improper tire inflation 2) Worn front wheel shaft bearing 3) Poorly adjusted toe-in 4) Front wheel drive is always engaged	Adjust Replace Readjust correctly: 2-6mm (0.08-0.24 in) Engage FWD only when required
● Noise	
1) Loose fasteners 2) Worn or damaged final case bearing 3) Worn bush 4) Wear or poor movement of tie-rod end 5) Excessive backlash of differential and bevel gear	Tighten correctly to specified torque Replace Replace Lubricate or replace Adjust
● Different steering angles in both directions	
1) Lengths of RH and LH tie-rods are different	Adjust

**CHAPTER 7**  
**Rear axle and brakes**

---

<b>SECTION 1.GENERAL DESCRIPTION-----</b>	<b>7-1</b>
<b>SECTION 2. SPECIFICATIONS-----</b>	<b>7-2</b>
<b>SECTION 3.DISASSEMBLY,INSPECTION,AND REASSEMBLY--</b>	<b>7-3</b>
<b>1.Rear axle housing and brake system-----</b>	<b>7-3</b>
<b>1.1. Disassembly-----</b>	<b>7-4</b>
<b>1.2. Inspection-----</b>	<b>7-4</b>
<b>1.3. Reassembly-----</b>	<b>7-5</b>
<b>SECTION 4.TROUBLE SHOOTING-----</b>	<b>7-7</b>

# Chapter 7. Rear axle and brakes

## 1. GENERAL DESCRIPTION

The rear axle system is of the central axle type, which contains the final reduction gears, differential gears with diff-lock, and brakes. The power from the engine is transmitted to the right and left wheel pinions through the differential gears, and reduced in the revolution to the rear wheels by the wheel gears. A wet, multi-Disc, mechanical operated brake system is employed. Each of the brakes has 2 friction plates and can produce significant braking force with excellent durability. The two actuators work to push their friction plates in opposite directions, that is, outward, so that stable braking force can be realized in both forward and reverse movements of the tractor. A dif-lock mechanism which is housed in the right-hand rear axle housing is employed to lock the differential gears and is activated by depressing the dif-lock pedal, resulting in the same rotary speeds of both wheels.

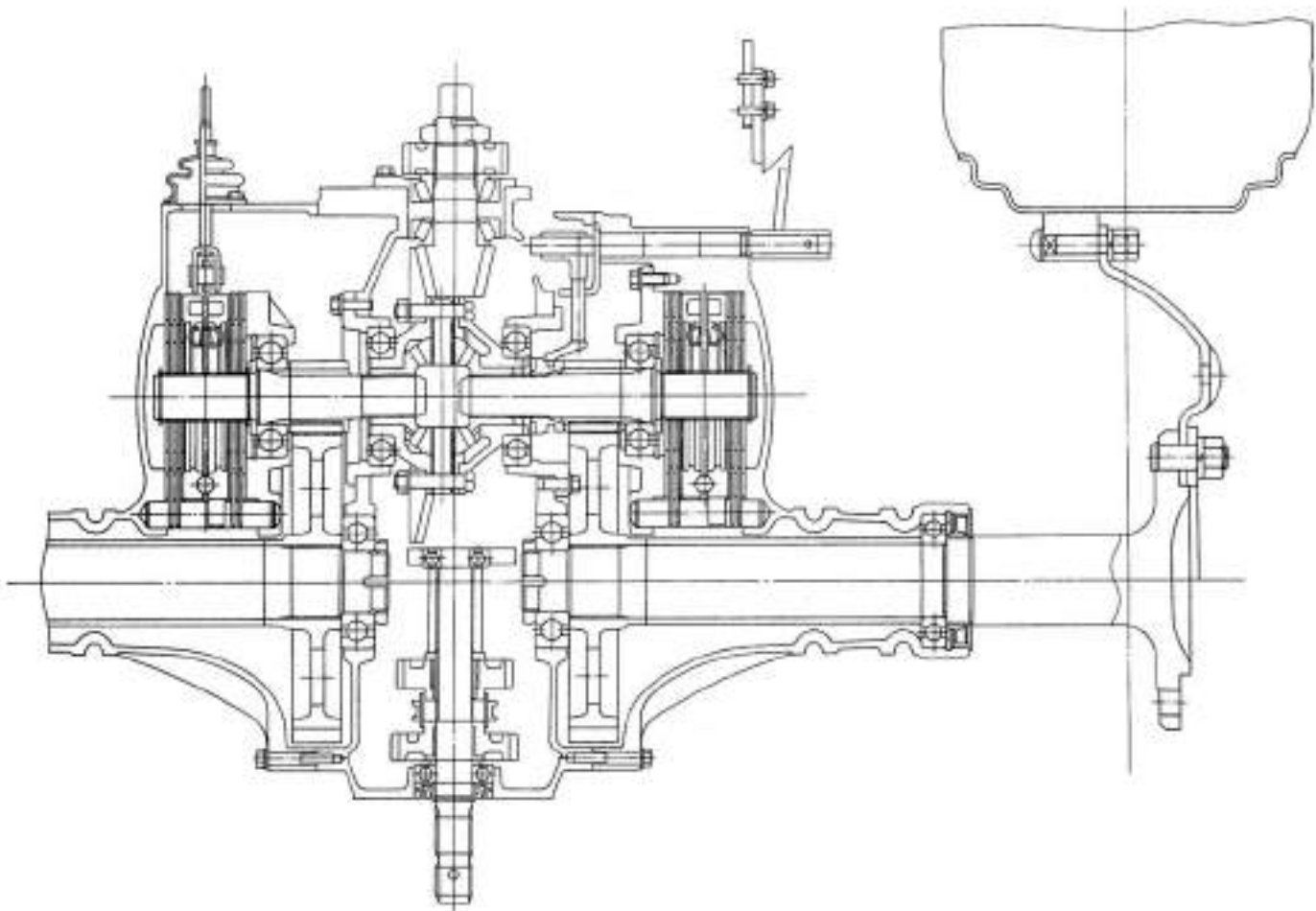

Fig.7-1

## SECTION 2. SPECIFICATIONS

MODEL		3510/4110/T390(T400)/T430(T450)	
Final reduction gears		Type	Helical gears
		Reduction ratio	5.5
Brake system	Friction Plate	Type	Wet,multi-disc,Mechanically operated
		Outer diameter	Φ184mm(Φ7.24 in)
		Thickness	3.4±0.1 mm(0.134 in)
		Lining material	Paper base
		Number of plates	4 on each side
	Separator Plate	Outer diameter	Φ188mm(Φ7.4 in)
		Thickness	2.5±0.09 mm(0.098 in)
		Number of plates	2 on each side
		Metal brake assembly Installed thickness	36 ±0.1 mm(1.417 in)
		Total brake thickness	58.4 mm(2.299 in)

# SECTION 3.DISASSEMBLY,INSPECTION,AND REASSEMBLY

Separate the rear axle housing from the rear transmission referring to paragraph 6.(1) of SECTION 4.

## SEPARATION OF MAJOR BLOCKS in Chapter 2

### 1) REAR AXLE HOUSING AND BRAKE SYSTEM

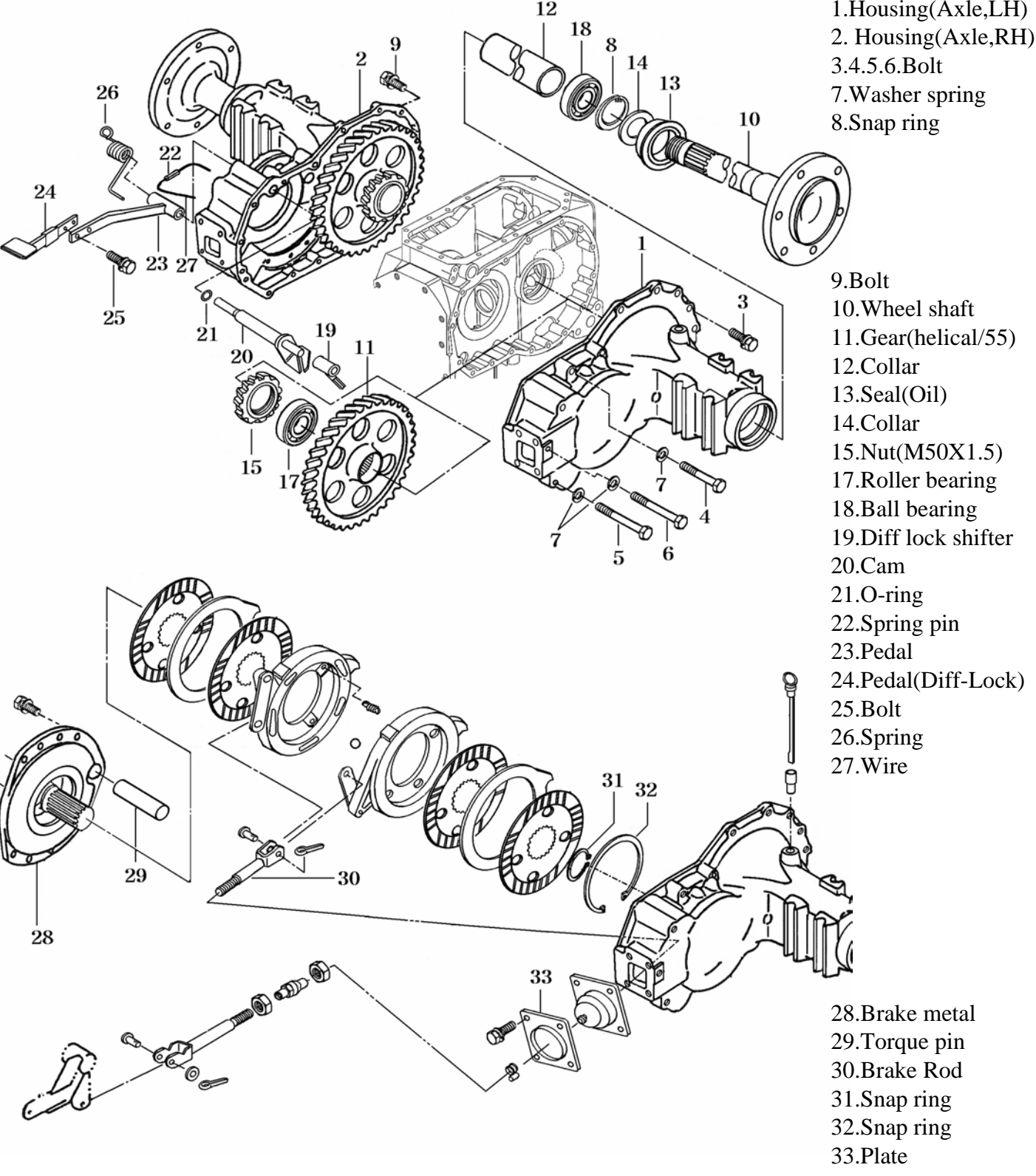

Fig.7-2

## 1.1 Disassembly

- 1) Release the lock of Nut and remove the nut
- 2) Extract the bearing with a puller and remove wheel gear

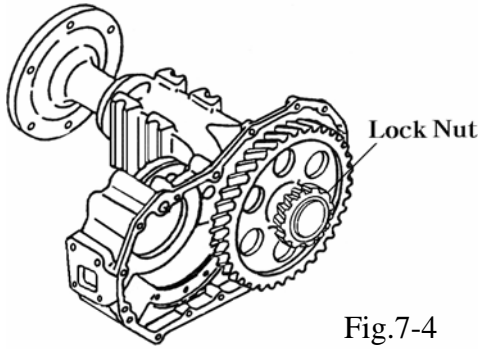

Fig.7-4

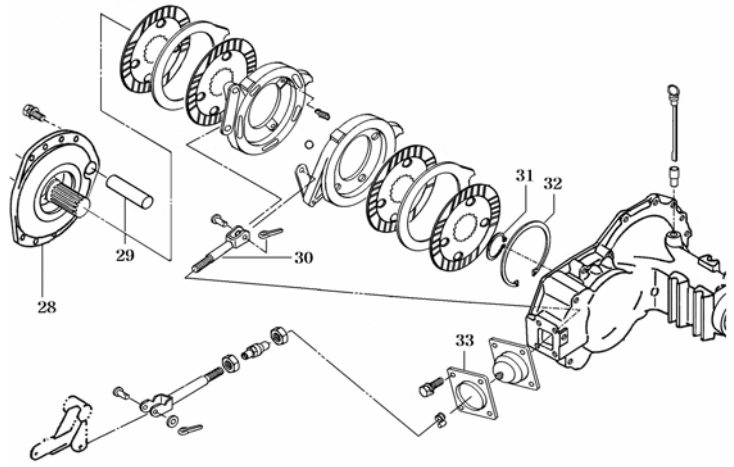

Fig.7-6

- 3) Remove the collar and pull out wheel shaft(3)

Note:

Removed oil seal should be replaced with a new one when reassembled

- 4) Detach the brake rod from actuator
- 5) Remove plate and the rubber boot
- 6) Remove the brake metal tightening bolts and remove brake metal with wheel pinion and the disc brake assembly on it
- 7) Remove the snap ring of wheel pinion (Fig.7-6) And individually separate the friction plates, actuator and separator plates from each other.
- 6) The actuator can be disassembled by removing Spring

Note:

Be careful to keep the friction surfaces of the linings, Actuators and separator plates free from damage and foreign matter.

## 1.2. INSPECTION

### 1) Friction plates.

Replace the plates whose surfaces have been become glossy by carbonization or whose thickness exceeds the usable limit.

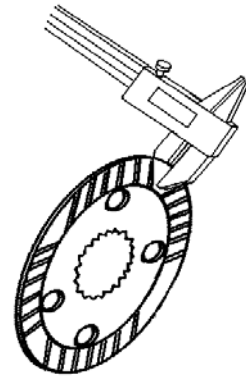

Fig.7-7

Standard	$3.4 \pm 0.1 (0.134)$
thickness:mm(in) Usable limit:mm (in)	3.0 (0.118)

**Note:**

**Also replace those whose grooves have been worn out completely even if only on one side**

## 2) Metal brake

Check the pressure plate, and brake rod for abnormality. Replace defective parts. Replace the metal brake whose thickness exceeds the usable limit.

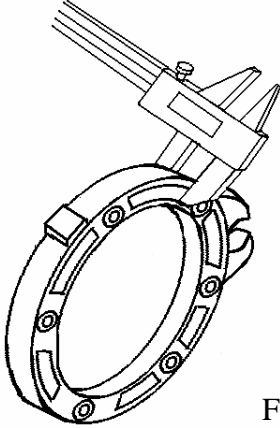

Fig.7-8

Standard	18(0.708)
thickness:mm(in) Usable limit:mm (in)	17.5((0.688)

Note:

Slight scratches on the friction surface can be corrected with sandpaper(#1000)

## 3) Separator plate.

Measure the thickness and replace the plate whose thickness exceeds the usable limit or whose surfaces are damaged (Fig.7-9)



Fig.7-9

Standard thickness:mm(in)	2.5±0.09 (0.098)
Usable limit:mm (in)	2.2(0.087)

## 4) Wheel shaft

Check the shaft for abnormalities like wear, damage, etc, and replace a defective one.

## 5) Bearings

Check them for abnormalities like hitching, irregularity, etc. in rotation after being washed clean. Replace defective ones.

## 6) Oil seals

Removed oil seal should be replaced with a new one when reassembled.

## 1.3 REASSEMBLY.

Reassemble the parts in reverse order of disassembly, follow these precautions.

- 1) Make sure that oil grooves, friction surfaces, etc of the brakes are free from matter such as dust, iron powder, etc. to avoid brake lining damage.
- 2) When installing the brake unit on the wheel pinion, friction plates and separator plates should be arranged in correct order and never forget to retain the unit with the snap ring.
- 3) Brake metal tightening bolts should be tightened to the specified torque with a torque wrench.

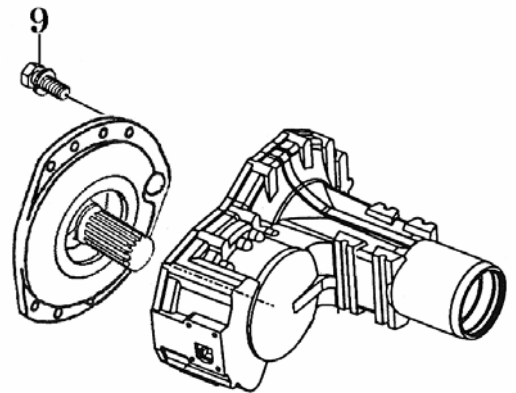

Fig.7-10

Tightening torque	5.5-7 Kgf.m (39.8-50.6ft-lbs)
-------------------	----------------------------------



4) Replace the oil seal.

Install the bearing, snap ring, and collar into the axle housing, and then press in the oil seal by applying force only to the circumference as shown in the figure( Fig.7-11)

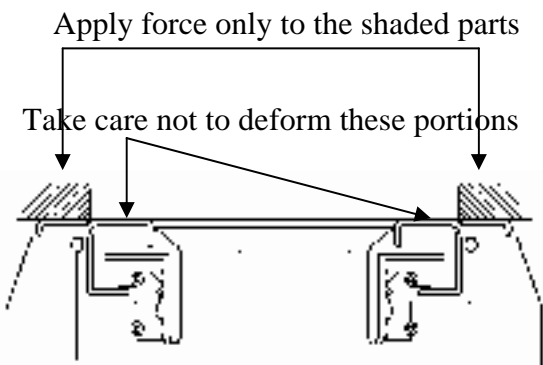

Fig.7-11

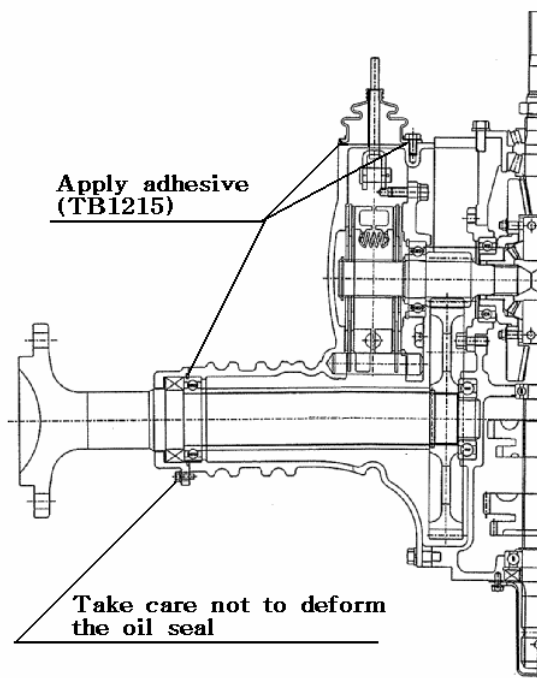

Fig.7-12

5) press in the wheel shaft.

6) Install the wheel gear and bearing on the wheel shaft and retain them with nut.

7) Apply adhesive (THREE BOND 1215) to the contact surfaces of the brake metal and housing and then retain the plates by tightening the nuts to the specified torque.

Tightening torque	0.6-0.8 Kgf.m (4.3-5.8ft-lbs)
-------------------	----------------------------------

## SECTION 4. TROUBLESHOOTING

Problem	Causes	countermeasures
1) Rear axle		
Noises	<ul style="list-style-type: none"> <li>· Worn or damaged bearing</li> <li>· Worn gear or wheel shaft</li> </ul>	Replace Replace
2) Brake system		
(1)Insufficient braking force	<ul style="list-style-type: none"> <li>· Insufficient depressing of brake pedals</li> <li>· Improper pedal free play</li> <li>· Worn friction plates</li> </ul>	Depress pedals positively Adjust Replace
(2)Brake noise	<ul style="list-style-type: none"> <li>· Insufficient brake oil</li> <li>· Broken actuator spring</li> <li>· Eccentric wear of actuator</li> </ul>	Replenish Replace Replace
(3)Brake overheating	<ul style="list-style-type: none"> <li>· Insufficient oil</li> <li>· Excessive pedal free play</li> <li>· Improper operation</li> </ul>	Replenish Adjust Operate brakes properly
(4)Brake cannot be disengaged completely.	<ul style="list-style-type: none"> <li>· Improper brake pedal free play</li> <li>· Broken actuator spring</li> <li>· Broken pedal spring</li> </ul>	Adjust Replace Replace
(5)Not uniform braking	<ul style="list-style-type: none"> <li>· Improper free play adjustment</li> <li>· Worn actuator ball</li> </ul>	Adjust Replace
(6)Excessive pedal play	<ul style="list-style-type: none"> <li>· Improper adjustment of brake rod</li> <li>· Worn actuator-fork tightening bolt</li> <li>· Worn brake shaft or brake arm</li> </ul>	Adjust Replace Replace

# Chapter 8

## Power assisted steering system

---

<b>SECTION 1.GENERAL DESCRIPTION-----</b>	<b>8-1</b>
<b>SECTION 2. SPECIFICATIONS-----</b>	<b>8-2</b>
<b>2.1 Gear pump-----</b>	<b>8-2</b>
<b>2.2 Steering valve-----</b>	<b>8-2</b>
<b>2.3 Oil tank-----</b>	<b>8-2</b>
<b>SECTION 3. FUNCTION-----</b>	<b>8-3</b>
<b>3.1 Open center non load reaction-----</b>	<b>8-3</b>
<b>SECTION 4.DISASSEMBLY,INSPECTION,AND REASSEMBLY</b>	
<b>4.1 major component of steering valve assembly -----</b>	<b>8-7</b>
<b>4.2 Special tools-----</b>	<b>8-8</b>
<b>4.3 Disassembly-----</b>	<b>8-8</b>
<b>SECTION 5. TROUBLESHOOTING-----</b>	<b>8-13</b>

# Chapter 8. Power assisted steering system.

## SECTION 1. GENERAL DESCRIPTION

The hydraulics of this power-assisted steering system are actuated by a specially designed steering valve system.

Non Load reaction valve blocks the L,R cylinder ports in neutral condition and does not transmits the reaction load of the tire to the steering wheel in neutral. Generally the system is used for the vehicles that treat heavy equipment or low speed traveling.

Hydraulic circuit consists of Independent system.

The oil from tank flows into gear pump of orbitrol via filter, and the quantity of oil in the proportion to the rotations of steering wheel flows into steering Cylinder Via "R"-port at right turn and via "L"-port at left turn.

As follow figure shows components composition of power steering system on the vehicle with the Orbitrol

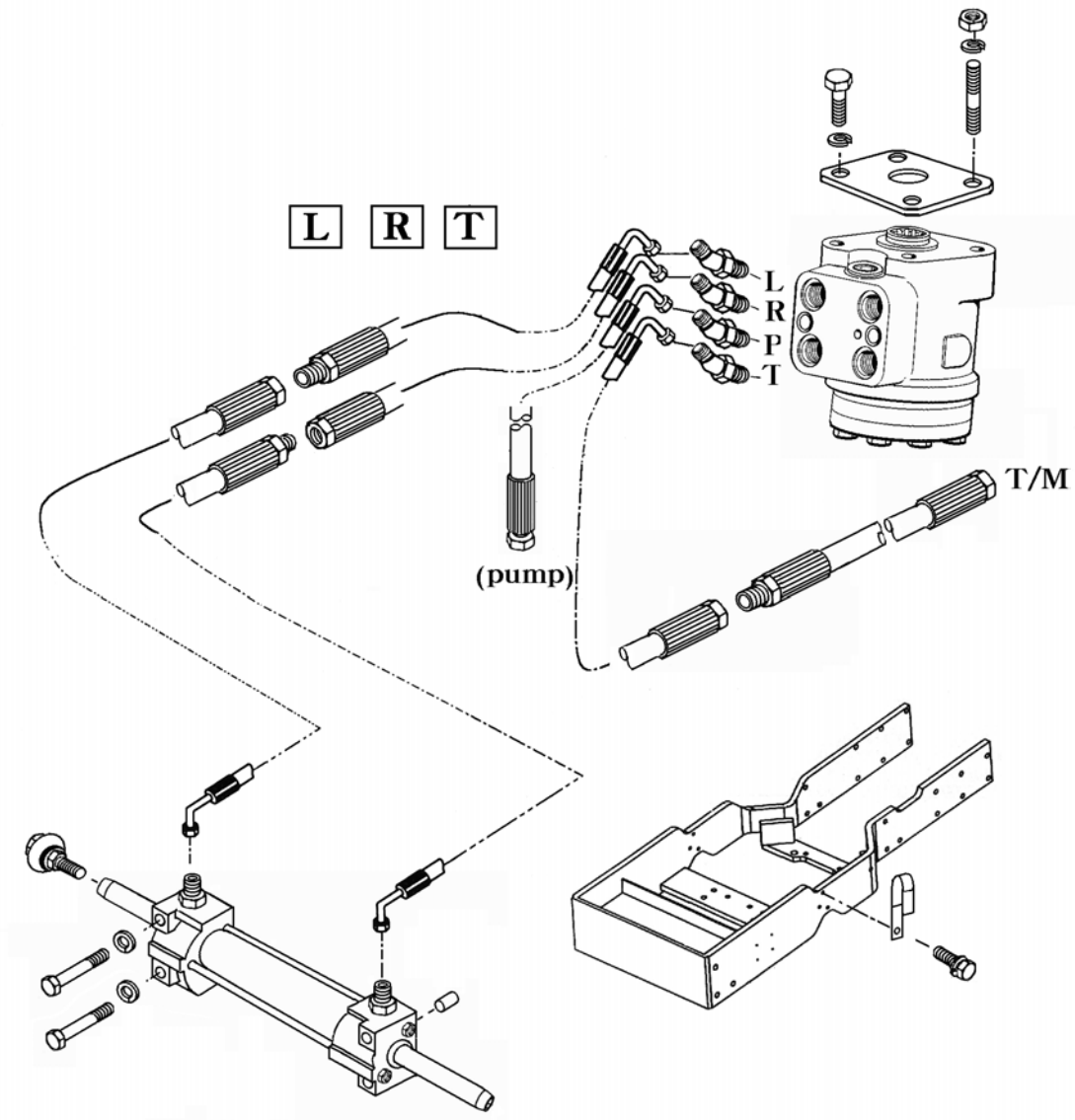

Fig.8-1

## SECTION 2. SPECIFICATIONS

### 1) GEAR PUMP

MODEL	3510	4110	T390	T430/T431
Delivery (cc/rev)	11	6.5	4.778	4.778
Maximum pressure(kgf/cm <sup>2</sup> )	210	210	210	210
Rated operation speed (rpm)	600~3000 rpm	2700 rpm	3062 rpm	2843rpm
Rotation direction	C.C.W as viewed from shaft			

### 2. Power steering valve Unit( orbitrol)

MODEL	3510/4110	T390/T430	T431
Model number	UBS120B08AWD	UBS120B08AWD	UBS120B08AWD
Displacement (cc/rev)	69	69	69
Rated flow (ℓ/min)	16	16	16
Maximum system pressure (kgf/cm <sup>2</sup> )	140	140	140
Max. back pressure(kgf/cm <sup>2</sup> )	10	10	10
Max. temperature(°C)	95	95	95
Input torque (N.m)	0.2	0.2	0.2
Main relief pressure setting (kgf/cm <sup>2</sup> )	120 kgf/cm <sup>2</sup> (at 8ℓ/min)	120 kgf/cm <sup>2</sup> (at 8ℓ/min)	120 kgf/cm <sup>2</sup> (at 8ℓ/min)
Recommended filtration (ISO4406)	22/20/17		22/20/17
Weight (kgf)	5.4(11.9lb)	5.4 (11.9lb)	5.4(11.9lb)

### 3. OIL TANK

MODEL	3510/4110	T390/T430
TANK	Transmission Case	
Fluid volume (ℓ)	33ℓ (8.7 gal)	33ℓ (8.7 gal)
Fluid	THF500	

# SECTION 3. FUNCTION

## 1. Open Center Non Load Reaction

### 1. Neutral Position

When the steering control valve is in the neutral position, inlet flow(P) from the priority valve moves the flow selector spool against its spring. This flow is blocked at the control valve control spool. The signal port is connected to the reservoir(T) through orifices in the control spool. The priority valve will only supply enough oil to the control valve to compensate for internal leakage and maintain low stand-by pressure. The oil at each side of the steering cylinder is connected to each side of the metering pump, this allows a degree of self centering when turning out of a bend.

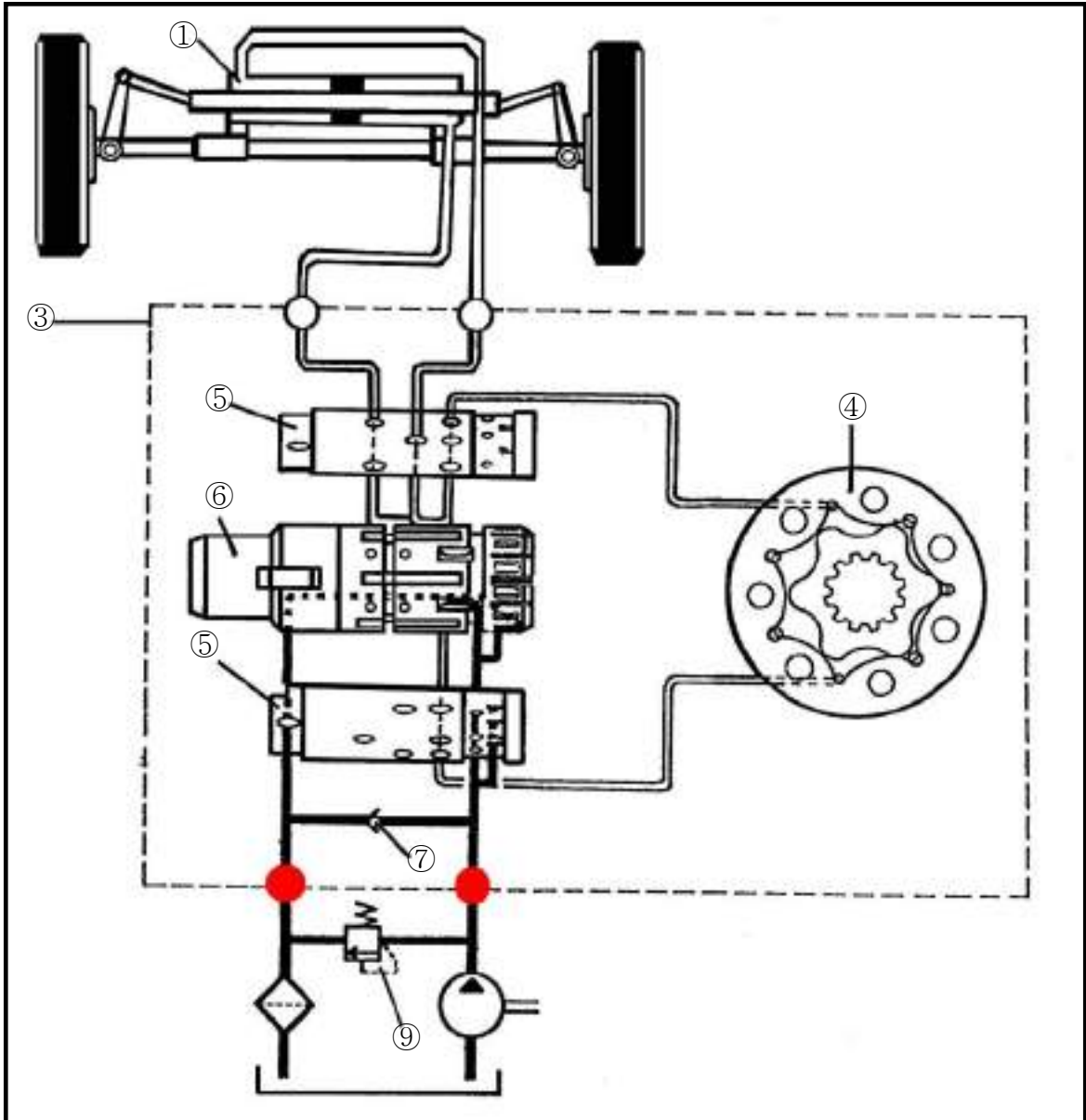

- ① Steering cylinder
- ③ Steering unit
- ④ rotor
- ⑤ sleeve
- ⑥ Main spool
- ⑦ Check valve
- ⑨ Main relief valve

Fig.8-2 Neutral position

## 2)Right Turn

When the steering control valve shaft is rotated to the right, the control valve moves off center. This connects the inlet port (P) to one port of each metering pump section and also connects the other port of each metering pump section to the cylinder. The amount that the spool moves off center depends on how fast the steering wheel is rotated and also how much effort is required to turn the wheel.

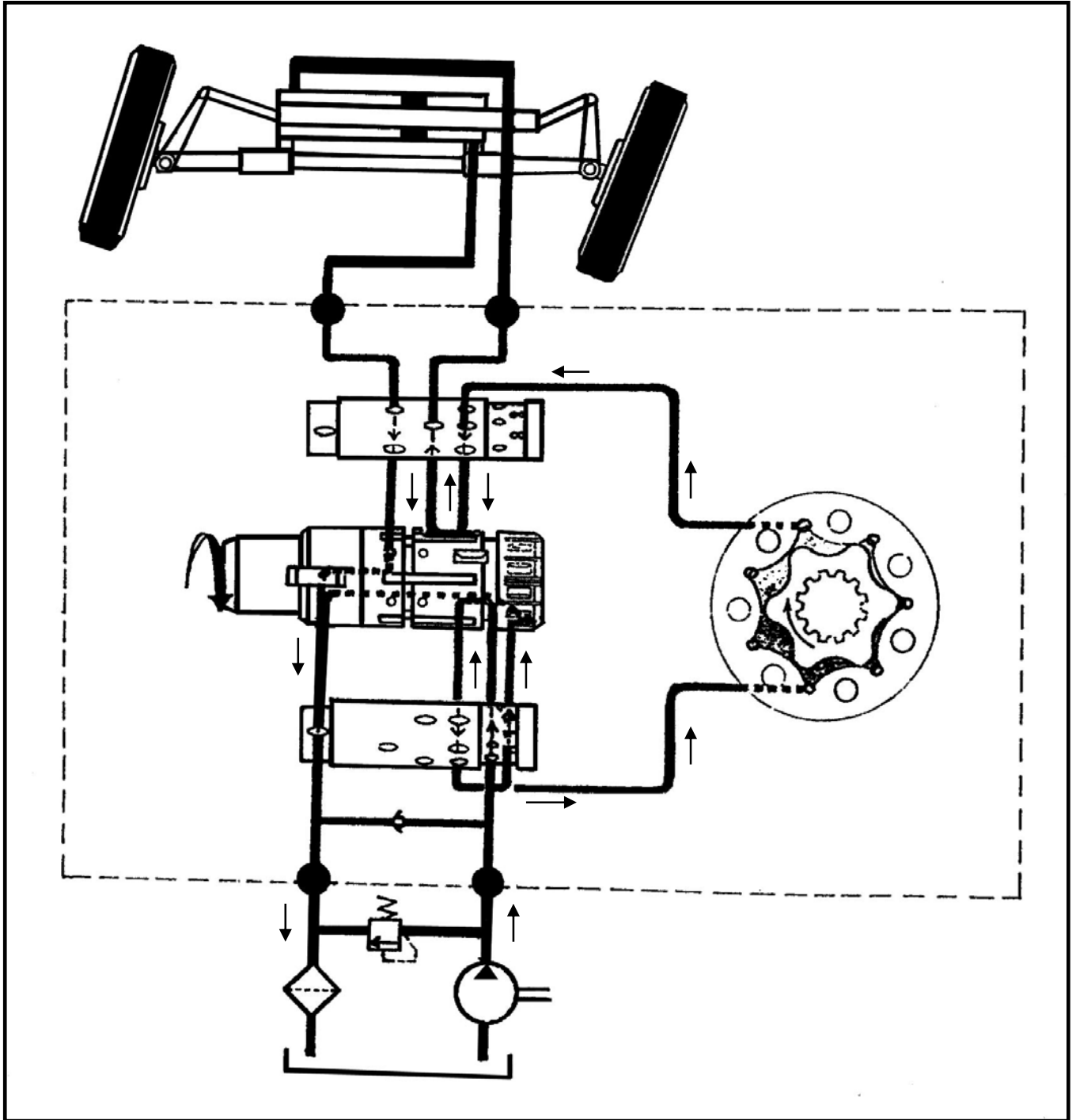

Fig.8-3 Right turn position

### 3)Left turn

When the steering control valve shaft is rotated to the left, the control valve spool moves off center. This connects the inlet port (P) to the one port of each metering pump section and also connects the other port of each metering pump section to the cylinder. The amount that the spool shifts off center depends on how fast the steering wheel is turned and how much effort is required to turn the wheel.

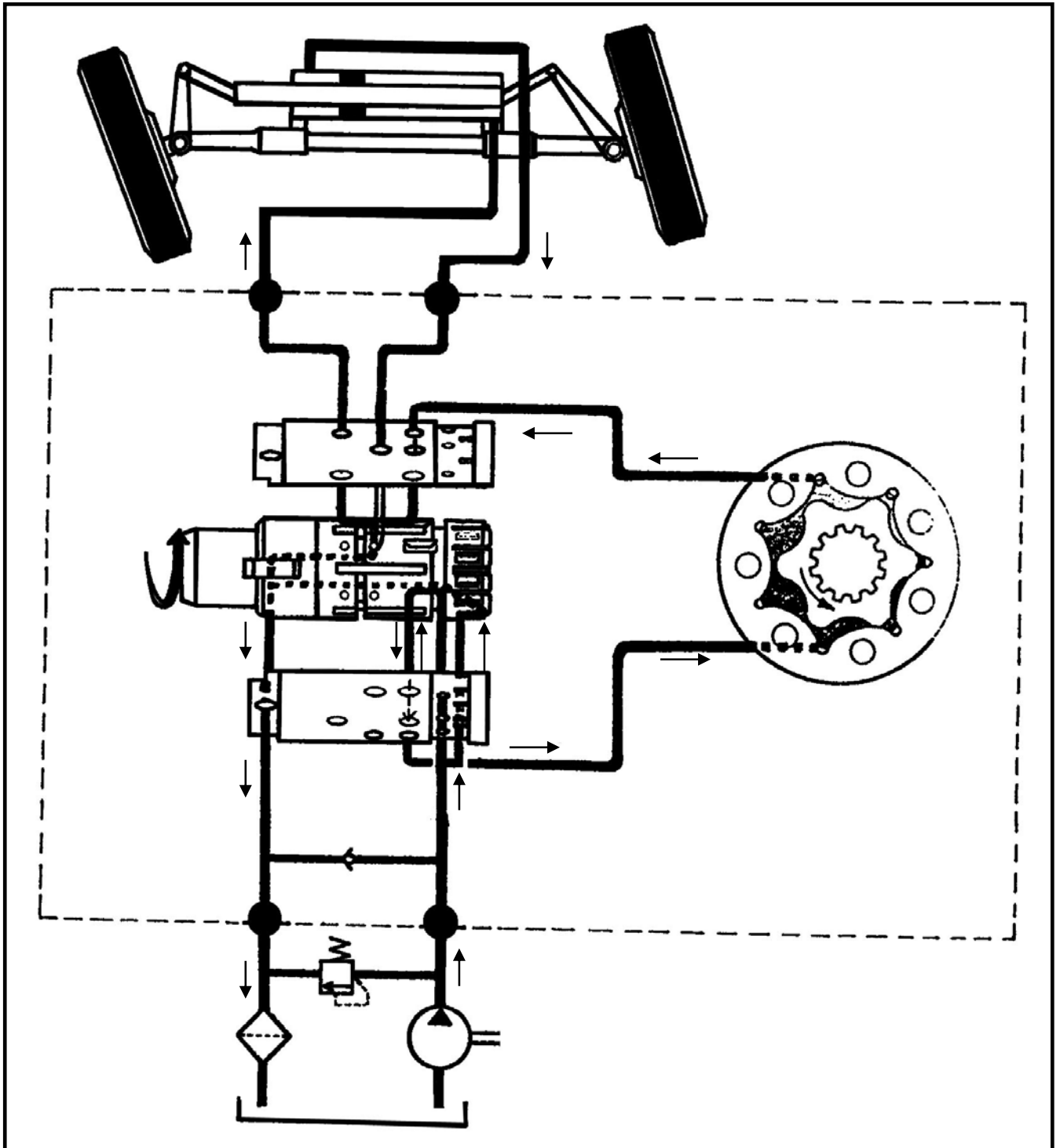

Fig. 8-4 Left turn position



#### 4) Manual steering

When there is no piston pump supply pressure the flow selector is moved to the left by its spring. This connects together the inlet and outlet ports of the lower gyrotor pump and disconnects this pump from the system. When the steering is operated manually, only the upper gyrotor pump section is used to direct flow to the steering cylinder. This reduces operator effort to an acceptable level, however the number of turns from lock to lock is increased.

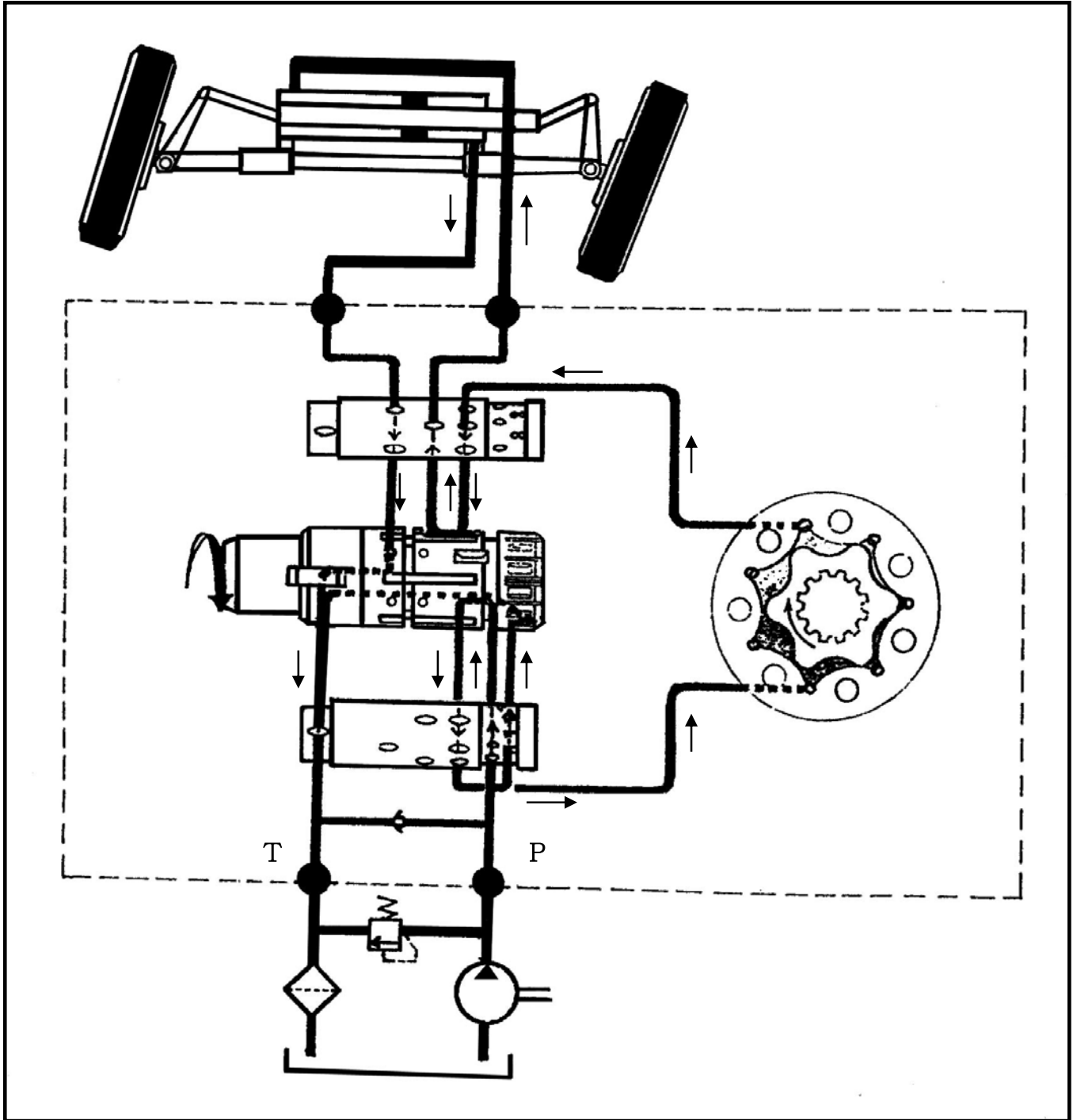

Fig. 8-5 Manual steering

## SECTION 4. Disassembly, Inspection, And Reassembly

### 1. Major component of steering valve (orbitrol)

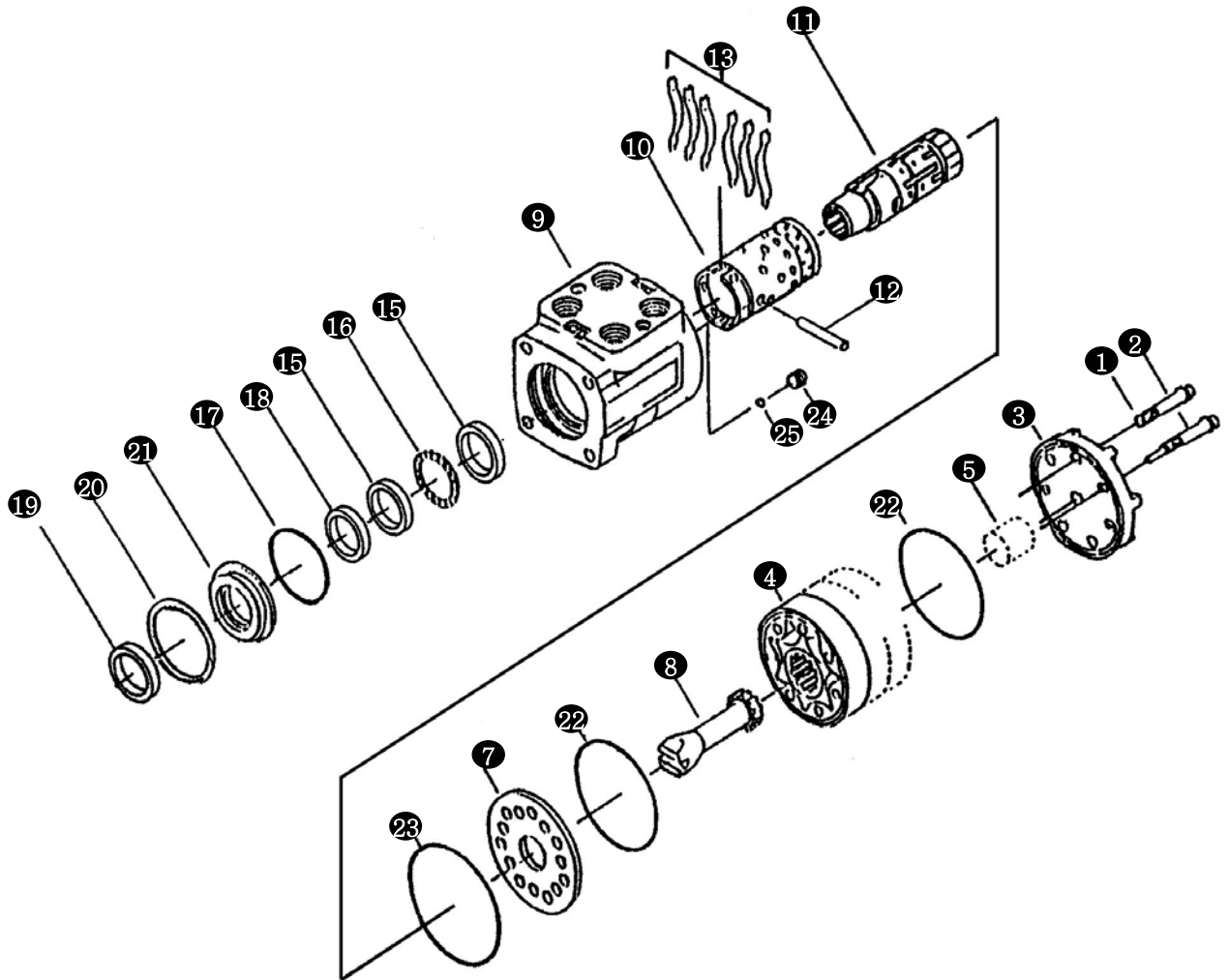

Fig.8-6

- |                      |                       |                       |
|----------------------|-----------------------|-----------------------|
| 1. Cover bolt(6)     | 2. Cover bolt(1)      | 3. End cap(1)         |
| 4. Gyrotor(1)        | 5. Spacer(1)          | 7. Spacer plate(1)    |
| 8. Driver shaft(1)   | 9. Pump body(1)       | 10. Sleeve(1)         |
| 11. Spool(1)         | 12. Pin(1)            | 13. Center springs(6) |
| 15. Thrust washer(2) | 16. Thrust bearing(1) | 17. O-ring(1)         |
| 18. Seal ring(1)     | 19. Dust seal(1)      | 20. Retaining ring(1) |
| 21. Seal bushing(1)  | 22. O-ring(1)         | 23. O-ring(1)         |
| 24. Screw(1)         | 25. Ball(1)           |                       |

## 2.SPECIAL TOOLS

- ①Torque wrench(Torque 5kgf·m) -----1
- ②5/12"-12 socket -----1
- ③“- ”Driver(big) -----1
- ④“- ”Driver(small) -----1
- ⑤Centering spring installer -----1  
(P/N : 600057)
- ⑥plastic hammer -----1
- ⑦grease
- ⑧jaw vice -----1
- ⑨marking pen -----1

## 3.Disassembly

### STEP 1.

secure the steering hand pump body in a clean soft jaw vice.,do not over tighten the vice.Remove the fittings,remove and discard the o-rings.Make a note of the position of the sensing hose fitting.

### STEP 2.

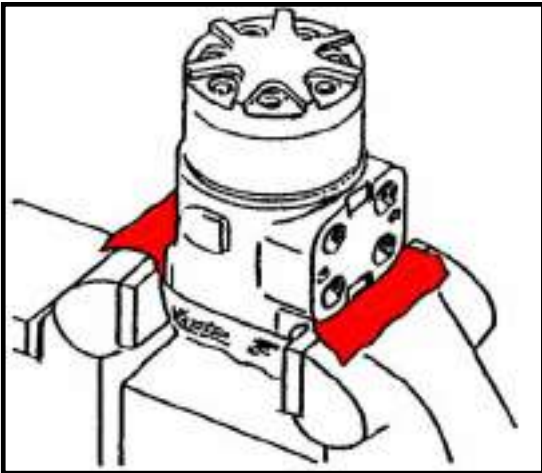

Put alignment marks (A) on body, plate, stator and end cap.Remove bolts and end cap,remove and discard o-ring.

### STEP 3.

Remove spacer,stator and rotor,remove and discard o-ring.Remove drive shaft and plate.Remove and discard o-ring.Remove the pump from the vice and place on a clean work surface.

### STEP 4.

For pumps equipped with cross over check valves,mark position and remove spring, valve pins and balls.

**IMPORTANT:**Do not use a magnet to remove balls.

### STEP 5.

Use a screw driver to release the spiral retaining ring from the groove in the pump body.Remove the spiral retaining ring,seal bushing,o-ring and seal ring.Remove dust seal from seal bushing.

### STEP 6.

Remove thrust washer,thrust bearing and thrust washer.

### STEP 7.

Cover bolt

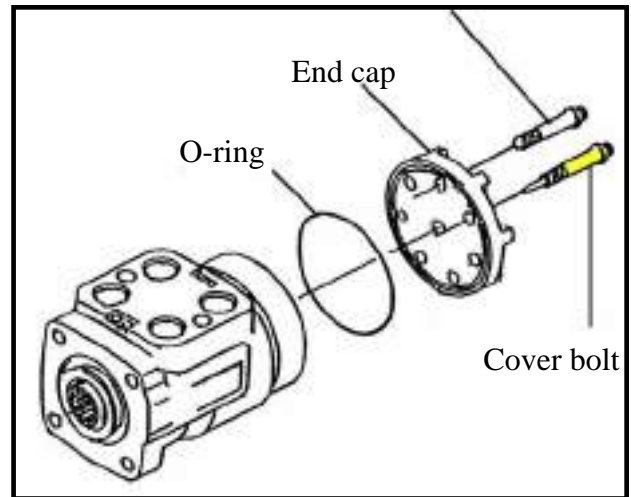

Turn spool and sleeve assembly until pin is parallel to the hydraulic fitting mounting face.Remove spool and sleeve assembly from the body.

### STEP 8.

Remove pin from the spool and sleeve assembly.Remove spool from sleeve and remove centering springs.

STEP 9.

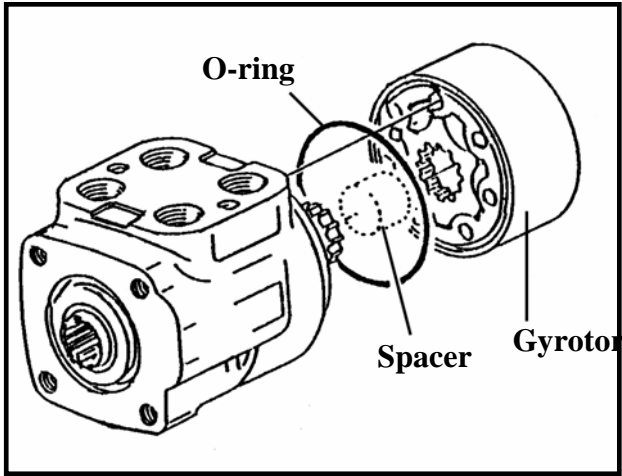

Remove plug and install a machine screw into the threaded end of check valve seat. Pull check valve seat from the pump body and remove and discard o-rings from check valve seat. Remove check valve ball and check ball retainer. DO NOT remove the relief valves (if equipped) from the pump body.

NOTE: DO NOT remove the check valve from the pump body inlet port (D)

Assembly

NOTE: During assembly lubricate at all parts with clean transmission oil.

STEP 10.

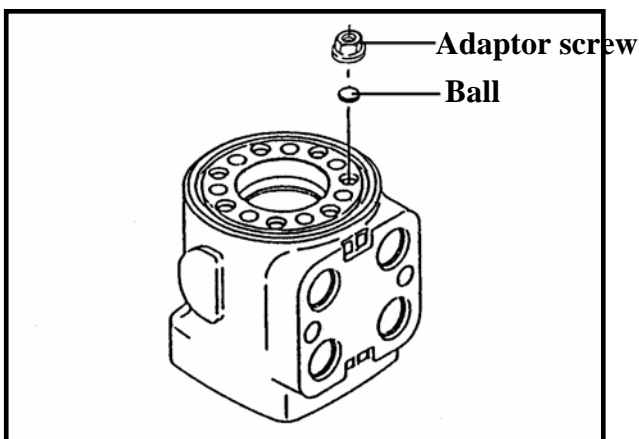

Lubricate and install new o-rings onto check valve seat. Install check ball retainer, check ball and check valve seat into the pump body. Make sure the threaded end of check valve is facing outward. Install and tighten plug to a torque of 11 Nm (100 lb in).

STEP 11.

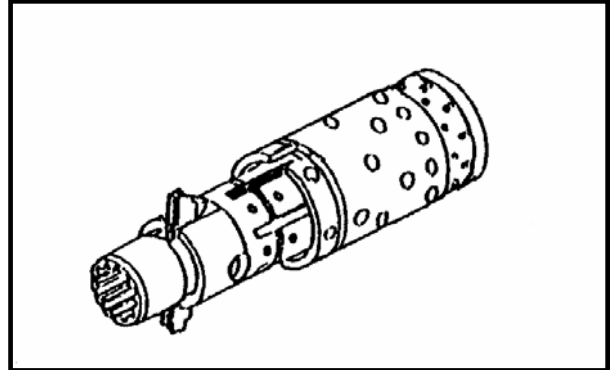

Install spool into sleeve. Make sure the alignment marks are aligned.

IMPORTANT: Heat from your hands may expand spool preventing the spool being installed.

Allow the spool to cool and repeat STEP 11.

STEP 12.

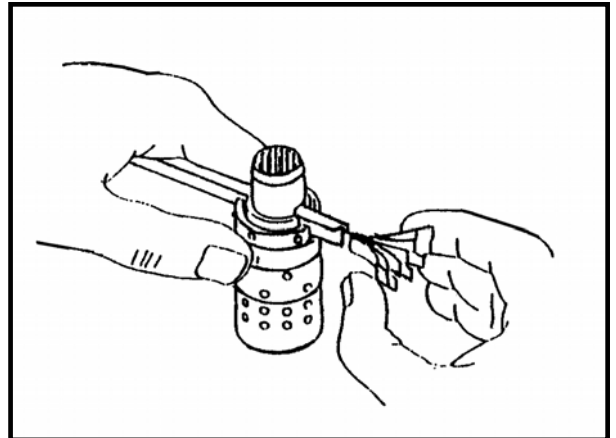

Install the centering spring installer through the slot in the sleeve assembly. Arrange the four centering springs as shown, install one end the springs into the slot in the centering spring installer. Make sure the notched side of the springs is towards the sleeve assembly. Compress by hand the the other end of the springs and push into the sleeve assembly.

NOTE: Make sure the centering spring notches locate correctly into the sleeve.

### STEP 13

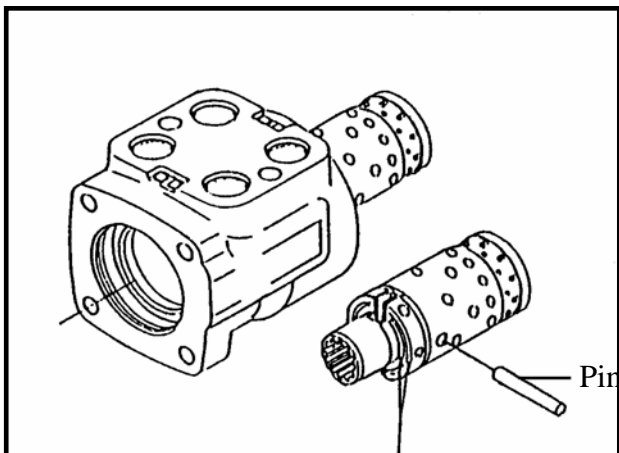

install pin into sleeve assembly and install sleeve into the pump body.

NOTE: Heat from your hands may expand spool and sleeve assembly, preventing the assembly being installed, DO NOT use force to install spool and sleeve assembly. Allow the assembly to cool and repeat STEP 13.

### STEP 14.

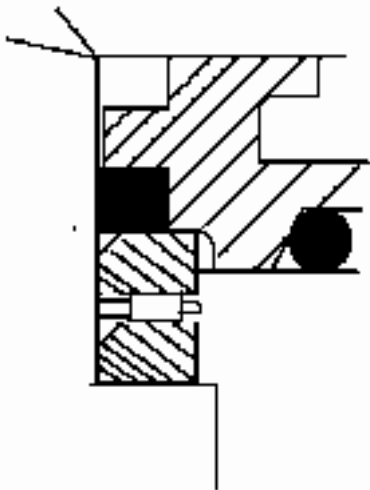

Install thrust washer, thrust bearing and thrust washer onto spool. lubricate a new o-ring and seal ring. install o-ring into the pump body and install seal ring onto spool. Install the seal bushing with a slight twisting motion, use a soft faced hammer and tap the bushing into position against the thrust washer.

### STEP 15.

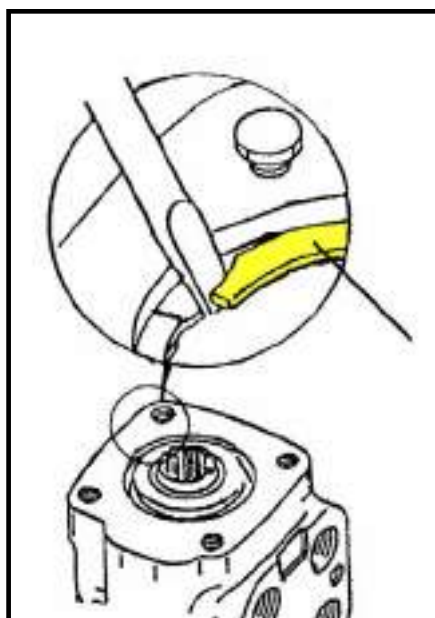

Install spiral retaining ring into the the groove in the pump body. Use a screwdriver to make sure the spiral retaining ring is located correctly into the groove in the pump body.

### STEP 16.

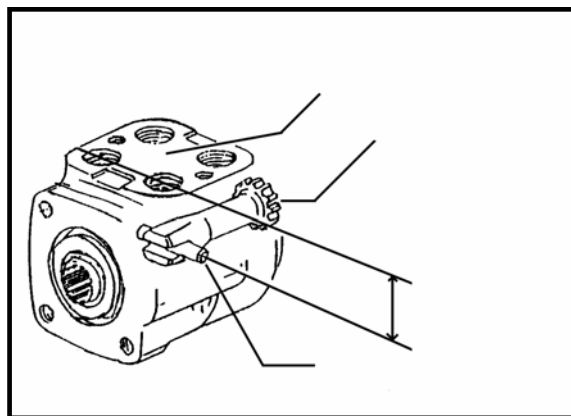

Carefully turn sleeve assembly until pin is parallel to hydraulic fitting mounting face as shown.

### STEP 17

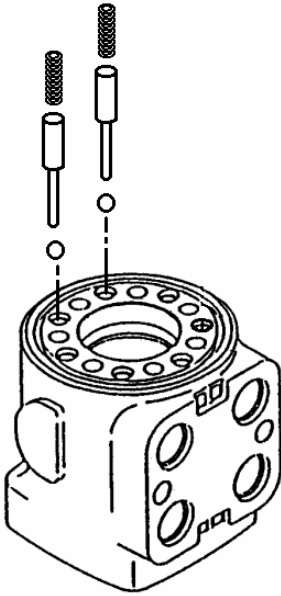

For pumps equipped with cross over check valves,install balls, valve pins and springs in the position noted in STEP 4.

### STEP 18

Lubricate and install new o-ring into the groove in pump body.Install plate,align marks made in STEP 2,make sure the o-ring groove in plate is facing outwards.

### STEP 19

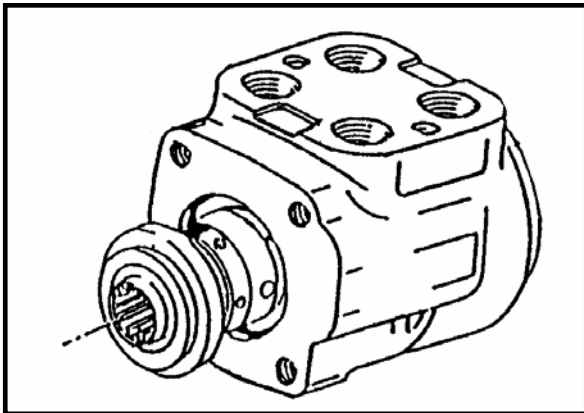

With pin parallel to fitting mounting face.install drive shaft,make sure the slot in drive shaft locates onto pin.

### STEP 20

install rotor onto drive shaft.Make sure one of the rotor teeth is aligned with the connector mounting face.Lubricate and install a new o-ring into the groove in plate.Align the marks made in STEP 2, and install stator.Make sure the o-ring groove in stator is facing outwards.

**NOTE:** Pin must remain parallel with the connector mounting face as shown.

**IMPORTANT:** If rotor is installed incorrectly,the steering hand pump will operate as a motor when installed onto the tractor and the engine is running.The steering wheel will rotate continually which may cause damage and injury.

### STEP 21

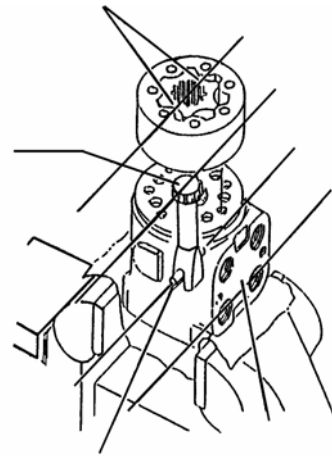

Install spacer into rotor.Lubricate and install a new o-ring into the groove in stator.

### STEP 22

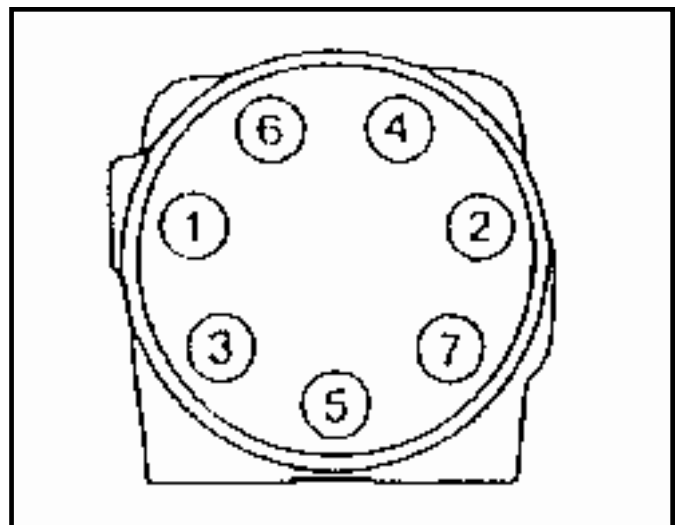

Align the marks made in STEP 2, and install the end cap. Install and evenly tighten the torx hand screws in two stages to a torque of 17 Nm (12 lb ft) then to 25 to 30 Nm (19 to 22 lb ft) in the sequence shown.

NOTE: The torx head bolts must be dry and clean of oil.

STEP 23

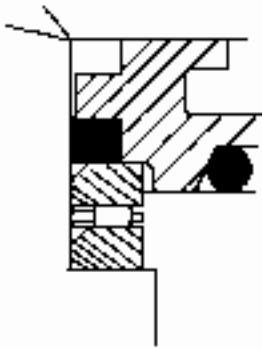

Install a new dust seal into seal bushing.

STEP 24

Install clean transmission oil into the return port and supply port. Cover all the ports with a clean cloth and slowly turn the pump input shaft clockwise and counterclockwise.

STEP 25

Repeat STEP 24 until the steering hand pump is primed of oil.

STEP 26

Lubricate new o-rings with clean transmission oil. Install the o-rings onto the fittings. Install and tighten the fittings.

Volume(cc/rev)	Tighten torque(kgf·m)
51 ~ 230	2.3
277	2.4
369 ~ 737	2.9

## SECTION 5. TROUBLESHOOTING

Problems and probable causes	Counter measures
<b>1. Steering wheel is very heavy to turn</b>	
1) Poor assemble between steering column and unit. (1) Spline of column and unit are assembled tightly. (2) Spool of unit is seized by spline of column (3) Poor rotation of column	-Replace column spline -Check column assembly face and spline length (MAX 6.5mm) -Replenish oil or Exchange
2) Insufficient pump pressure or fluid volume (1) Check pump delivery (Unit volume×120 rpm×1.15) (2) Check oil tank fluid volume (3) Check pump pressure	-Exchange pump -Replenish oil -Adjust relief pressure
3) Trouble internal steering unit valve (1) Low setting pressure of relief valve (2) Ball-nut heavy to work	-Adjust fluid level properly -Wash clean or replace
4) Trouble machine mechanism. (1) Poor link work (2) Excessive sector gear pre-load	-Wash and replenish oil -Adjust backlash
<b>2. Return to neutral is too slow</b>	
1) Poor assemble steering column and unit (1) Poor assemble to center between column and unit (2) Column assembly face depressed unit bushing	-Loosen the bolt and fix again with center -Replace column or repair
2) Depressed control set (spool+sleeve) (1) Excessive fluid volume (2) Excessive pressure (3) Dust	-Adjust fluid level properly -Adjust pressure -Wash
3) High pressure ratio of "T" port (tank port) (1) Tank port hall is small (2) Tank port pipe is linked to other lines	-MAX. Pressure ratio 20 bar -Wash and clean pipe line -Separate unit pipe line and reinstall



Problems and probable causes	Counter measures
<b>3. Free play of steering wheel</b>	
1) Too low elastic of centering spring ( Remove P port pipe line and check left and right turning) (1) Damaged spring or poor elastic	-Replace spring
2) Depressed control set (1) Excessive fluid and pressure (2) Depressed by foreign material (3) Depressed from external when assemble with column	-Adjust fluid level and pressure properly -Wash -Check column and adjust
<b>4. Steering wheel resistance with turning</b>	
(1) Worn of spline gear column (2) Depressed control set (3) Air trapped in cylinder and pipe line (4) Excessive backlash column (5) Poor turning of column, or wear of bearing .	-Replace column -Wash, and Adjust fluid level and pressure properly -Deflate the air -Adjust column -Replace column and replenish oil
<b>5. Too much free play of steering wheel (Rough touching on tire causes vibration)</b>	
(1) Air trapped in steering cylinder and pipe line. (2) Worn ball bearing	-Deflate the air -Replace
<b>6. Free play steering wheel</b>	
(1) Insufficient oil in the tank (2) Worn, damage steering cylinder (3) Loose spacer in unit	-Replenish oil -Replace oil seal and cylinder -assemble spacer parts.
<b>7. Kick-back of steering wheel</b>	
(1) Loose check valve in "P" port or don't operate (2) Trouble in system	-Adjust check valve -consult workshop

Problems and probable causes	Counter measures
------------------------------	------------------

8.Serious kick-back each side

(1)Poor assemble the gyrotor lower the unit	-Reassemble
---	-------------

9. Steering wheel is very heavy to begin turning

(1)Oil density is too high or cool	-Replace oil
------------------------------------	--------------

10. External Oil leakage

(1)column (2)End cap gyrotor (3)Tightening Bolt	-Replace oil seal,slide ring -Replace o-ring -Replace copper washer (Torque 1st:175 kgf·cm. 2nd:280 kgf·cm)
---	--

<b>SECTION 1. GENERAL DESCRIPTION</b> .....	<b>9-1</b>
<b>SECTION 2. SPECIFICATIONS</b> .....	<b>9-2</b>
<b>SECTION 3. DISASSEMBLY AND ADJUSTMENT</b> .....	<b>9-3</b>
<b>1.Hydraulic system</b> .....	<b>9-3</b>
<b>2.Disassembly</b> .....	<b>9-4</b>
<b>3.Reassembly</b> .....	<b>9-5</b>
<b>3.1 General precautions</b> .....	<b>9-5</b>
<b>3.2 Reassembly steps</b> .....	<b>9-7</b>
<b>4.Adjustment of the link mechanism</b> .....	<b>9-8</b>
<b>SECTION 4. MAJOR COMPONENT OF THE HYDRAULIC</b> <b>SYSTEM</b> .....	<b>9-10</b>
<b>1.main control valve</b> .....	<b>9-10</b>
<b>2.Flow-divider</b> .....	<b>9-19</b>
<b>3.Pressure control valve</b> .....	<b>9-22</b>
<b>4.Flow control valve</b> .....	<b>9-25</b>
<b>5.Safety valve</b> .....	<b>9-27</b>
<b>6.Relief valve</b> .....	<b>9-27</b>
<b>7.Gear Pump</b> .....	<b>9-29</b>
<b>8.Filter</b> .....	<b>9-35</b>
<b>SECTION 5.Remote hydraulic control(Optional)</b> .....	<b>9-36</b>
<b>1.General description</b> .....	<b>9-36</b>
<b>2.Functions</b> .....	<b>9-36</b>
<b>3.Specifications</b> .....	<b>9-37</b>
<b>SECTION 6. TROUBLESHOOTING</b> .....	<b>9-38</b>

# Chapter 9 Hydraulic system

## SECTION 1. GENERAL DESCRIPTION

The hydraulic system is composed of a gear pump, valves, oil filter, cylinder (actuator), piping, etc. The implement lift is operated by a control valve which is actuated by the control lever through a link mechanism.

ON and OFF of the PTO is controlled by a hydraulic, wet, multi-disc clutch whose circuit is opened and closed by an electromagnetic valve in the flow-divider.

The construction and circuit of the hydraulic system are shown in Fig.9-1 and 9-2

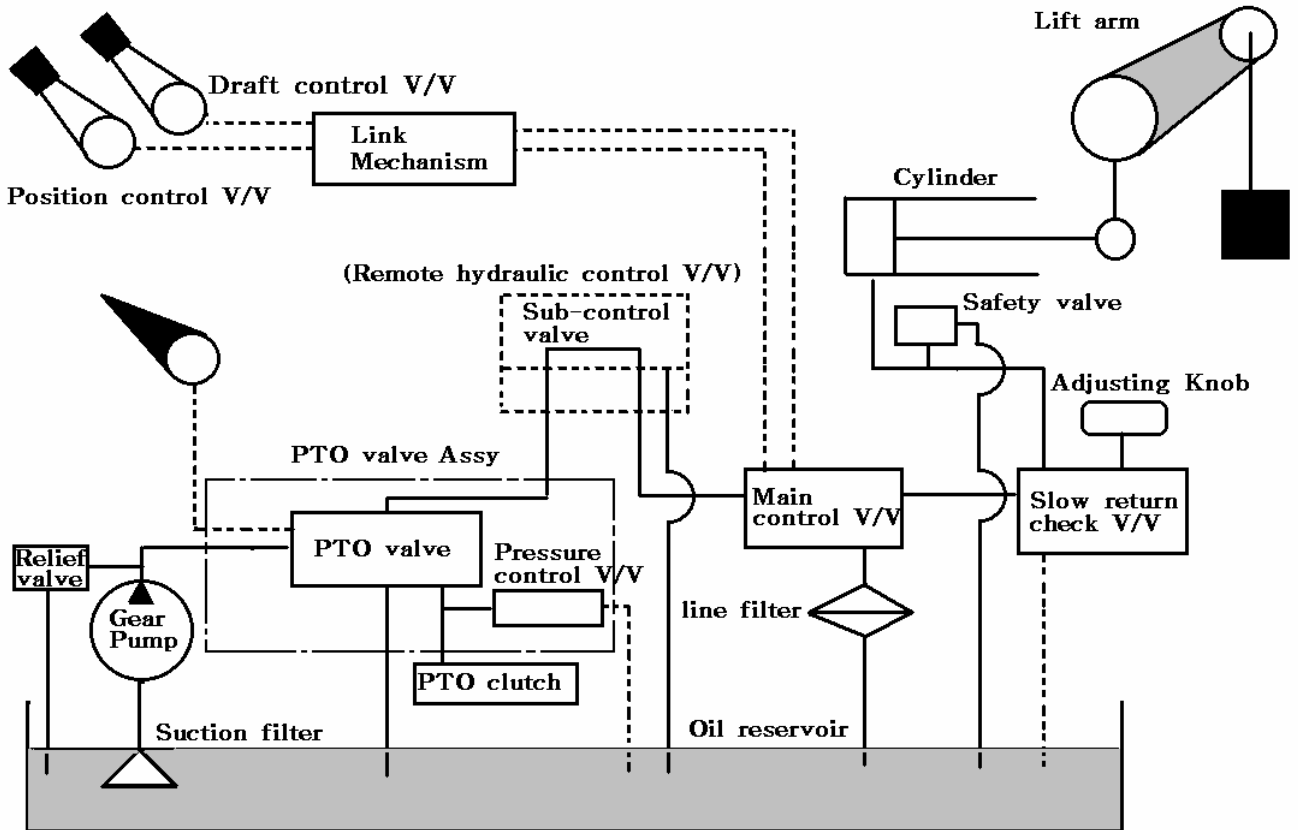

Fig.9-1 hydraulic system construction

SECTION 2.SPECIFICATIONS

MODEL		3510	4110	T390/ T400	T430/ T450	T431/ T451
Piston and cylinder	Lift(at lower link top end)	1300 Kgf				
Control valve	Cylinder port leaks (under a pressure of 9800KPa[(100Kgf/cm <sup>2</sup> ) with gear oil of SAE 80])	5cc(0.305 Cu in)				
Main relief valve	Cracking pressure	135 Kgf/cm <sup>2</sup>				
	Relief pressure	160~165 Kgf/cm <sup>2</sup>				
Gear Pump	Delivery(91% efficiency) : liter(cu.in)mm at 2600rpm	26.026 ℓ	28.39ℓ			
Suction filter	Rated flow: (ℓ /min)	43	57			
	Filtration density	35μm	25 μm			
	Filtration area	6231cm <sup>2</sup>	11000 cm <sup>2</sup>			
Line filter	Rated flow: (ℓ /min)	35				
	Filtration density	150 mesh				
	Filtration area	790 cm <sup>2</sup>				

NOTE: Recommendable Transmission oil

Manufacturer :Product

CALTEX :Textran TDH Premium

Texaco :TDH oil

Chevron :Chevron 1000THF

ESSO :Torque Fluid 56

MOBIL :Mobil fluid 423

SHELL :Donax TD

CASTROL :CASTROL AGRI MULTITRANS

TOTAL :Transmission MP

# SECTION 3. DISASSEMBLY AND ADJUSTMENT

## 1.HYDRAULIC SYSTEM

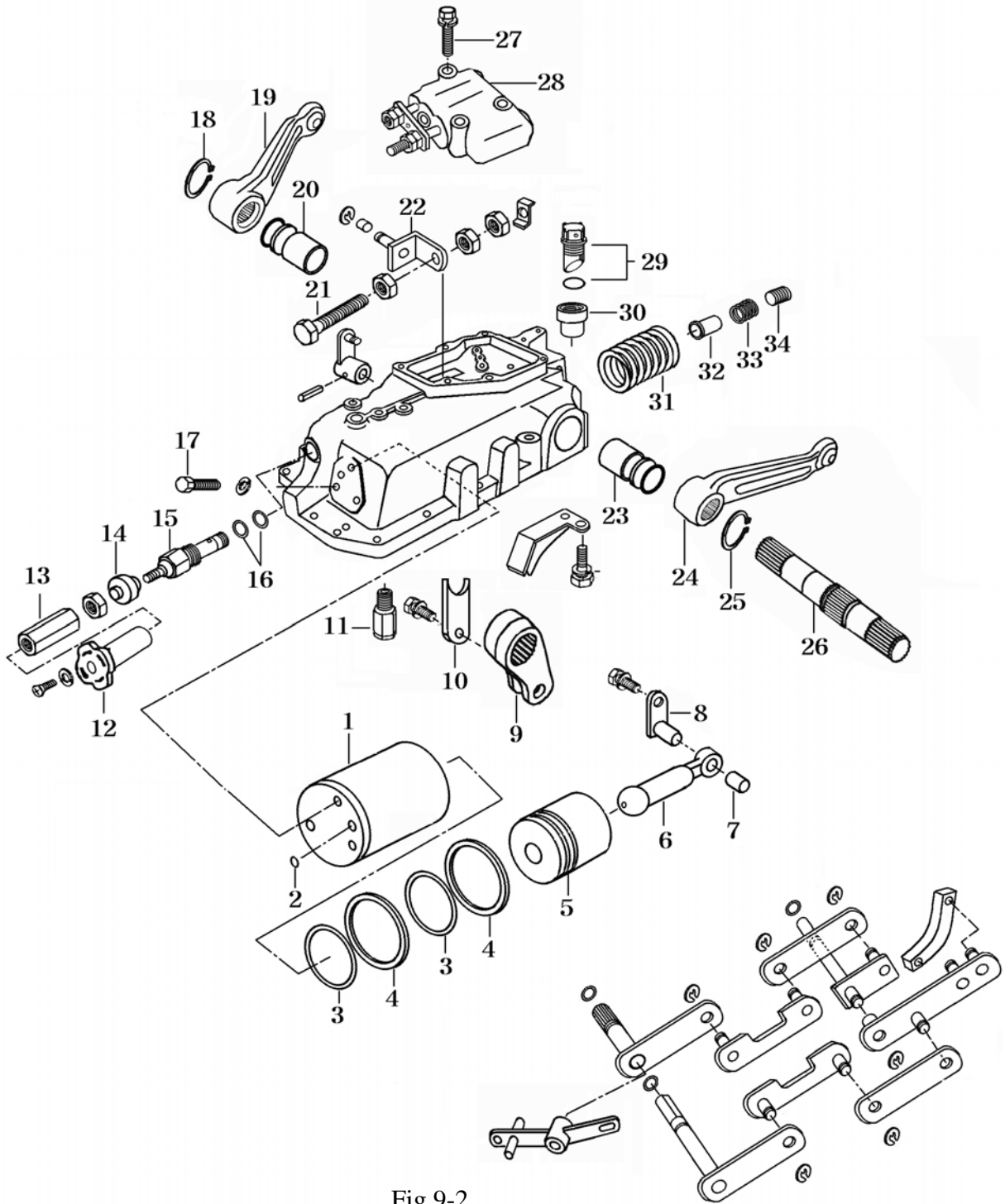

Fig.9-2

- |                       |             |                 |                       |                |                     |                    |              |
|-----------------------|-------------|-----------------|-----------------------|----------------|---------------------|--------------------|--------------|
| 1.Cylinder            | 2. O-ring   | 3.O-ring        | 4.Ring                | 5.Piston,Hyd.  | 6.Rod piston        | 7. Bush            | 8.Pin,Hyd.   |
| 9.Lift crank          | 10.Plate    | 11.Relief valve | 12. Knob              | 13.Shaft       | 14.Seal dust        | 18. C-ring(shaft)  | 19.Arm,Lift  |
| 15.Valve flow control | 16. O-ring  | 17.Bolt(M12)    | 20. Bush(50X55X44)    | 21.Bolt(M8X50) | 22. Clevis          | 23. Bush(50X55X44) | 24. Arm lift |
| 25.C-ring             | 26.Bar      | 27.Bolt(M8X45)  | 28.Valve,Main control | 29.Cap oil     | 30.Collar(24X38X44) | 31.Spring(SC067)   | 32.Filter    |
| 33.Spring             | 34.Plug PTO |                 |                       |                |                     |                    |              |

## 2.DISASSEMBLY

1)Remove the cylinder case assembly,referring to relevant paragraph in Chapter 2.

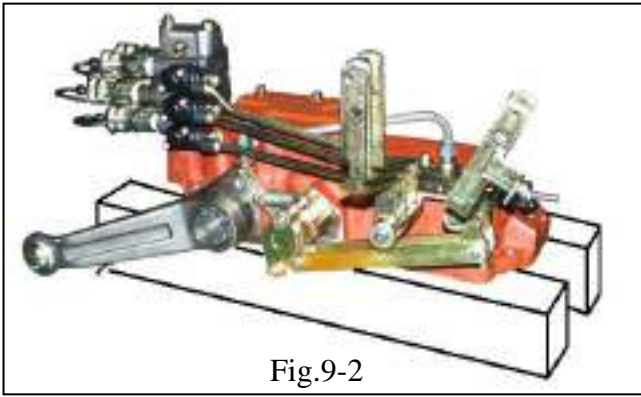

Fig.9-2

Note:

Put the cylinder case on a wooden plank to prevent the surface from damage.

2) Remove the link pin and extract the related Lift link .

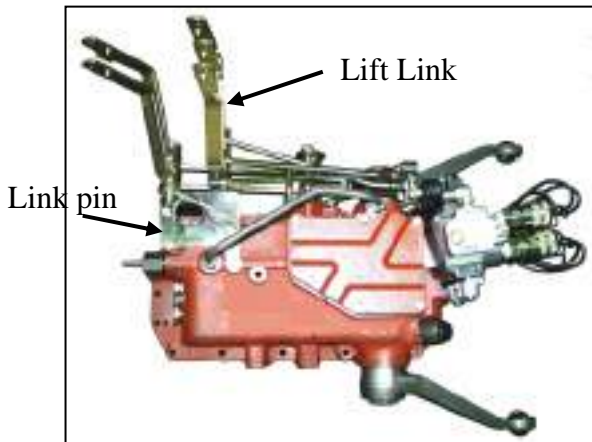

Fig.9-2

3) Remove the cylinder head and extract the cylinder.Then remove the piston from the cylinder.



Fig.9-3



Fig.9-4

4) Applying aligning marks on the Lift shaft(26) and right hand lift arm(19),Then remove the arm

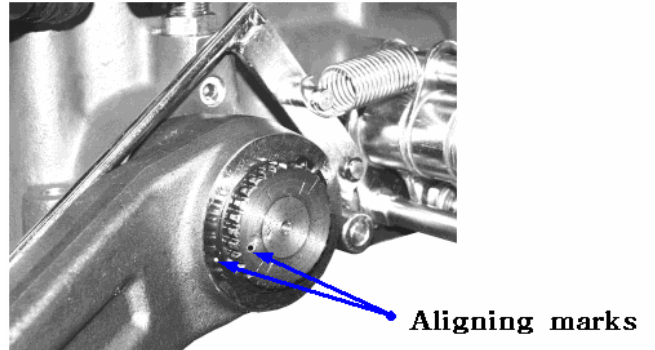

Fig.9-5

5) Applying aligning marks on the Draft shaft And Draft arm ,Then remove the shaft



Fig.9-6

6) Applying aligning marks on the Lift crank And Bar ,Then remove Bar

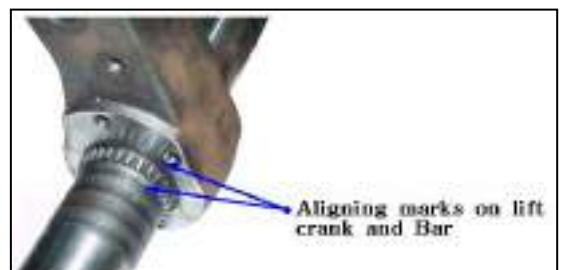

Fig.9-7

7) Remove the set bolt for the lift crank and remove the assembly of the lift shaft and lift arm.



Fig.9-8

8) Remove the assembly of the lift crank and piston rod.

9) Unhook the each link parts and remove the cover main control valve



Fig.9-9

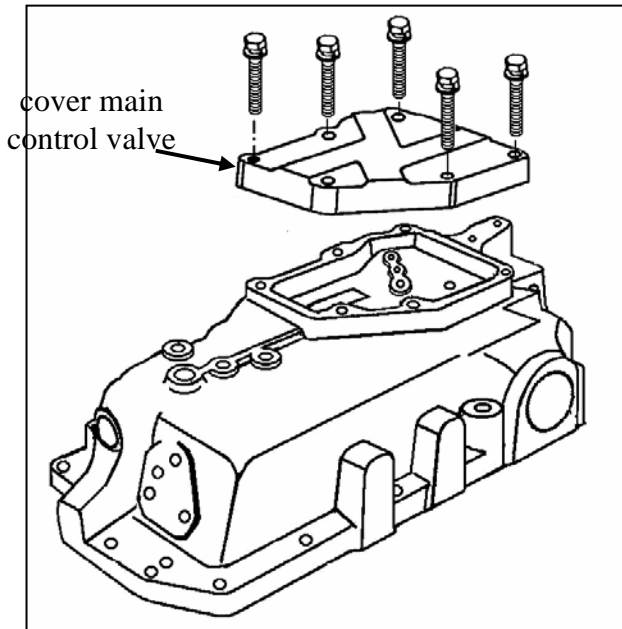

Fig.9-10

10) Remove the bolt and extract the main control valve

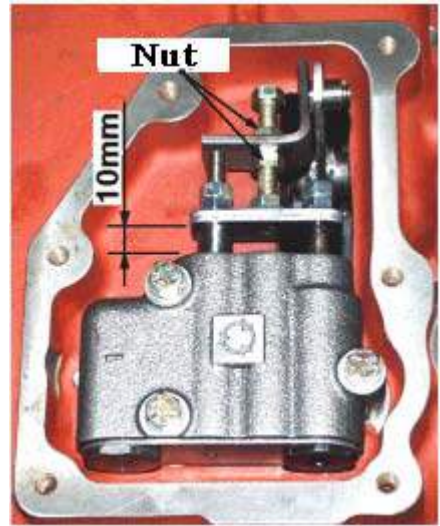

Fig.9-11

11) Remove the following linkages:

- a. Each linkage
- b. position control linkage
- c. Draft control linkage

### 3. REASSEMBLY

Reassemble in reverse order of disassembly.

### 3.1 GENERAL PRECAUTIONS

- 1) Hydraulic system parts should completely be free from dust before reassembly.
- 2) All O-rings should be replaced with new ones, which should be lubricated with grease before installation.
- 3) When the lift shaft is removed, the oil seal should also be replaced with a new one.
- 4) Install the piston from the cylinder bottom side. The O-ring and back up ring should be coated with grease ahead of time. Install with care so as not to damage them.



Fig.9-12



5) When assembling the lift crank on the lift lift shaft, mesh their splines using the alignment marks which were put their before disassembly

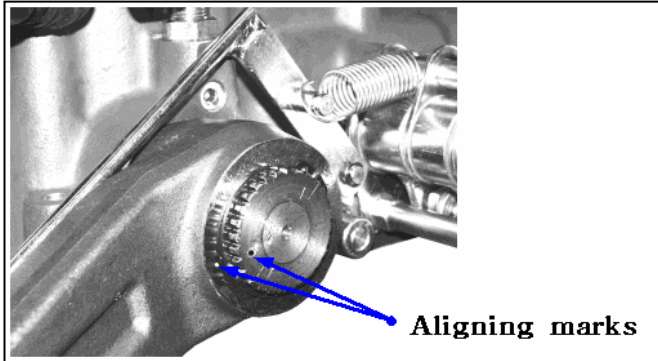

Fig.9-13

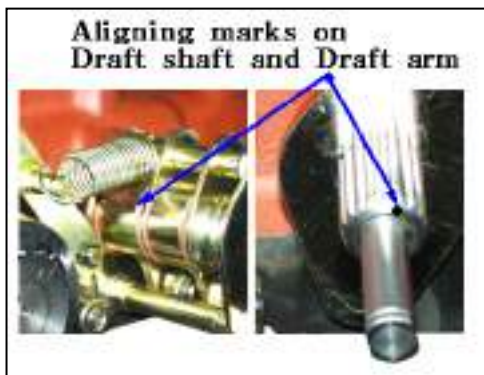

Fig.9-14

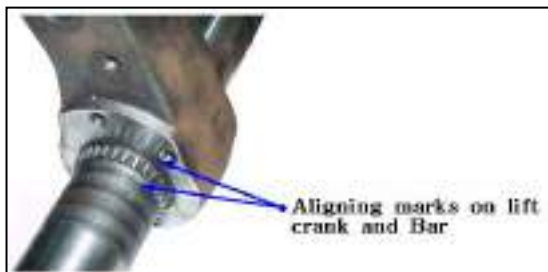

Fig.9-15

6) Tighten the Main valve securely to the specified torque

Tightening torque	130~180 Kg.cm
-------------------	---------------



Fig.9-16

7) When installing the control valve, apply grease to the o-rings and avoid their dislocation or binding during tightening the valve to the specified torque

8) Tighten the slow return check valve to the specified torque

Tightening torque	1000~1200 Kg.cm
-------------------	-----------------

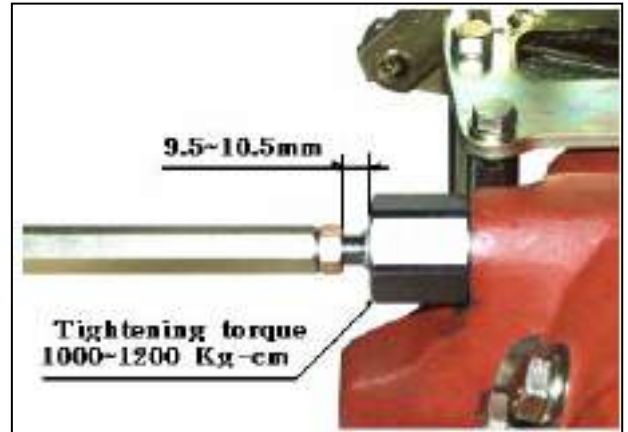

Fig.9-17

9) Tighten the Exterior valve(remote control valve) to the specified torque

Tightening torque	200~250 Kg.cm
-------------------	---------------

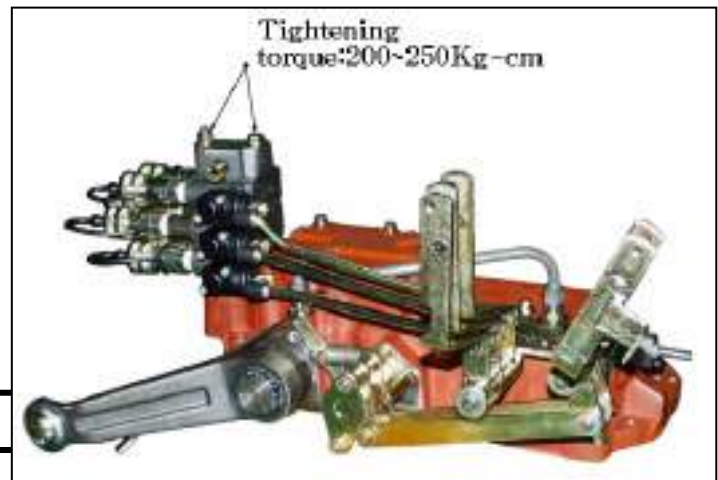

Fig.9-18



Fig.9-19

3.2 REASSEMBLY STEPS.

- 1) Install the main control valve
- 2) Install the clevis comp.

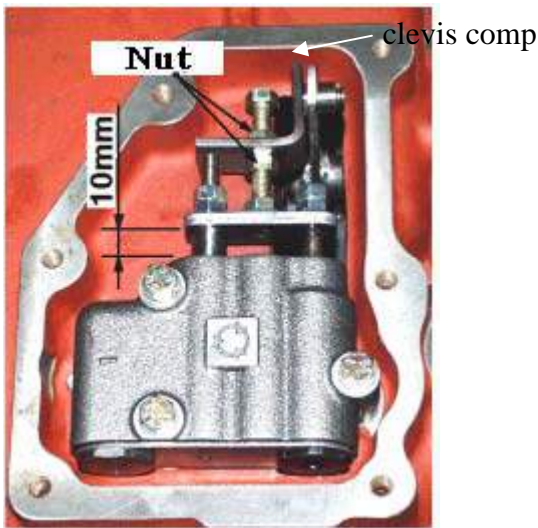

Fig.9-20

Note:  
After installing the clevis to main control valve ,make the installed length of the set the body and plate to be 10mm(Fig.9-20)

- 3) Install the each link parts.



Fig.9-21

- 4) Install the lift crank temporarily along with the feed back link.Install the piston on the lift crank.



Fig.9-22

- 5) Install the lift shaft and lift crank together in accordance with the aligning marks on them. (Fig.9-23).Apply grease to the roll bush.

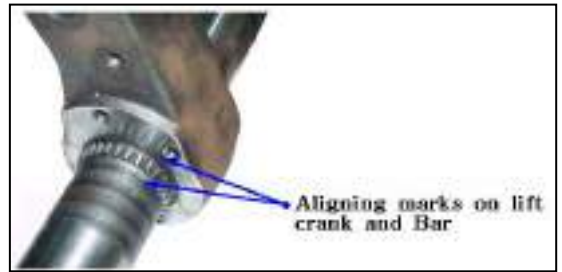

Fig.9-23

- 6) Drive the oil seal onto the lift shaft and install the lift arm.

Note:  
When installing the oil seal,take care not to allow the oil seal lips to be damaged by the splines of the lift shaft.

- 7) Install the cover main control valve and Then install the remote control valve.

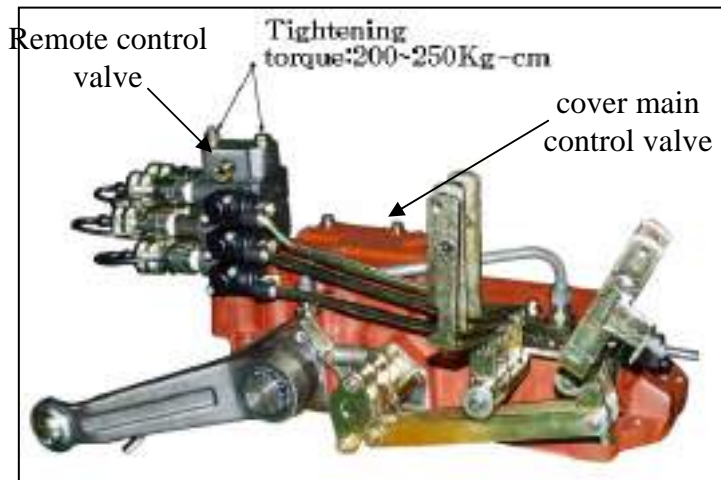

Fig.9-24

#### 4. ADJUSTMENT OF THE LINK MECHANISM.

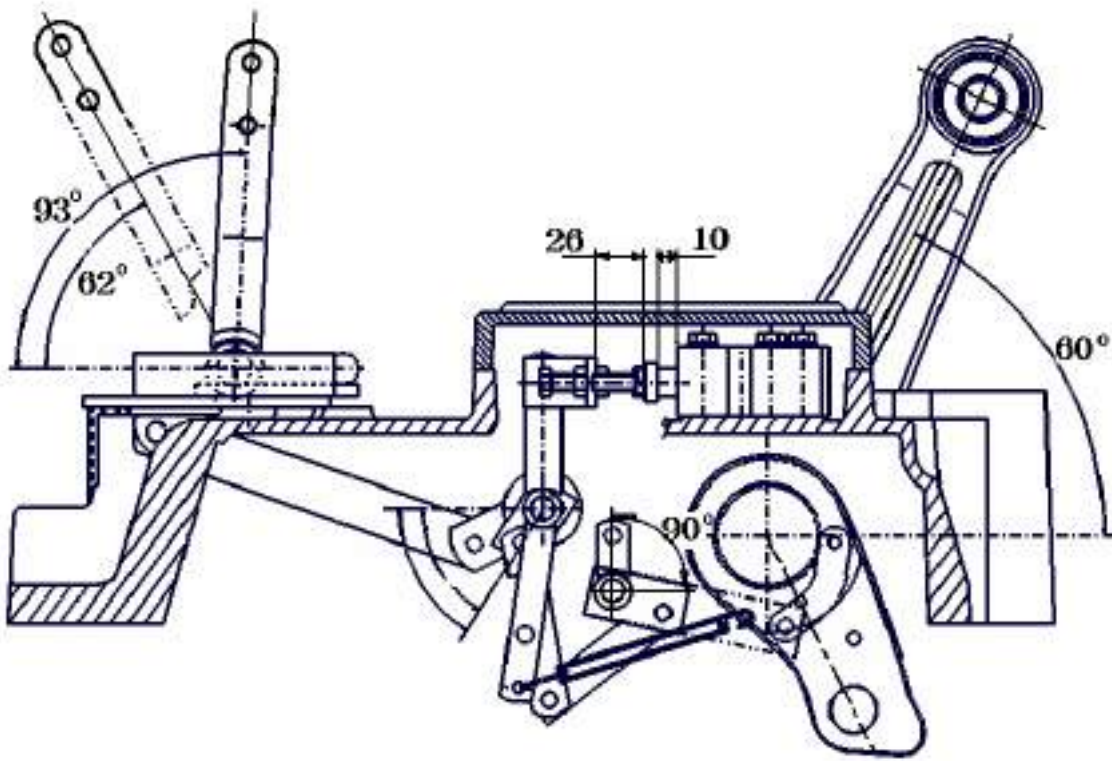

Fig.9-25

#### 1) Adjustment of the position control link mechanism

Place the cylinder case assembly upside so that the lift arm can be moved freely

Point 1. Set the lift crank to the top position. Adjust the top position installed length of the body and plate is about 10mm or determine the position where the angle of the lift arm from horizontal is 60~ 61.5°.

Point 2. Fix the clearance between the body and plate on the control valve and the casing spool to be 10 mm, while the gap A should be 26mm (Fig.9-27), while the main spool is set in the neutral position.

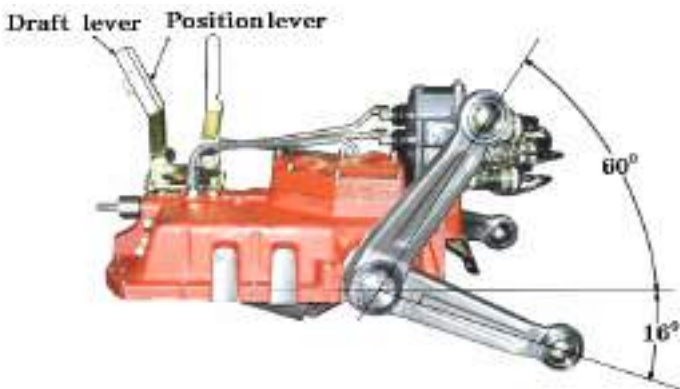

Fig.9-26

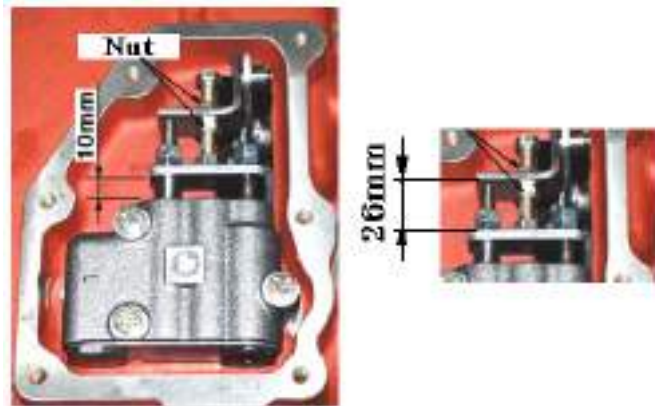

Fig.9-27



Point 3. Set the feed back link so that there is no play by the adjusting nut.

Point 4. Apply an locktite to adjusting Nut.



Fig.9-28

Thus the adjustment of the position control linkage is completed.

## 2) Adjustment of the draft-control link mechanism

Point 1. Shift the draft-control lever to the top position and the position-control lever to the bottom position.

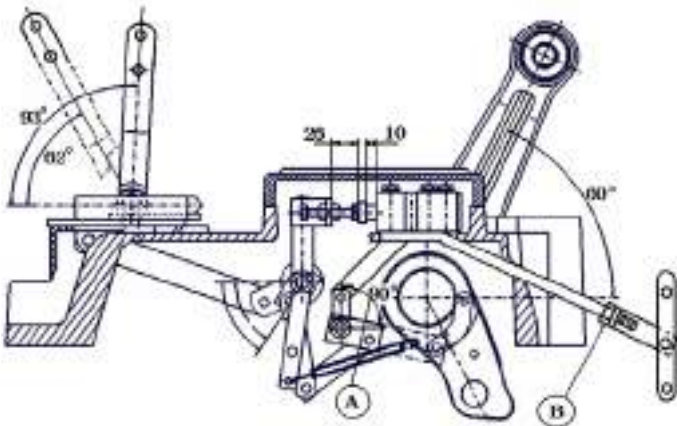

Fig.9-30

Point 2. With position (A) is 90° together in accordance with Shifting the draft-control lever to the top position and the position-control lever to the bottom position.

Adjust by loosening the lock nut.

Thus the adjustment of the draft-control link mechanism is completed.

## SECTION 4. MAJOR COMPONENTS OF THE HYDRAULIC SYSTEM

### 1. MAIN CONTROL VALVE

#### 1.1 GENERAL DESCRIPTION

This valve controls the lifting and lowering operation of the hydraulic cylinder. It has especially been developed to control the working height of the implement. It consists of a feed back valve, direction control valve, flow-control unloading valve, and holding check valve.

#### 1.2 SPECIFICATIONS

Maximum operating pressure	175 Kgf./cm <sup>2</sup>
Maximum flow	45 liters/min
C-port leaks	5 cc/min below (Fluid temp : 50 °C : pressure : 100Kgf.cm(1422 psi))

#### 1.3.CONSTRUCTION

##### 1) Main spool

it consists of a spool, spool head, and snap ring E and has three functions.

- It opens and closes passages P to C and C to T and controls the passage wall area successively.
- It converts unloading pilot pressure to C-port pressure or tank pressure
- It turns the pilot pressure of the pilot spool on or off.

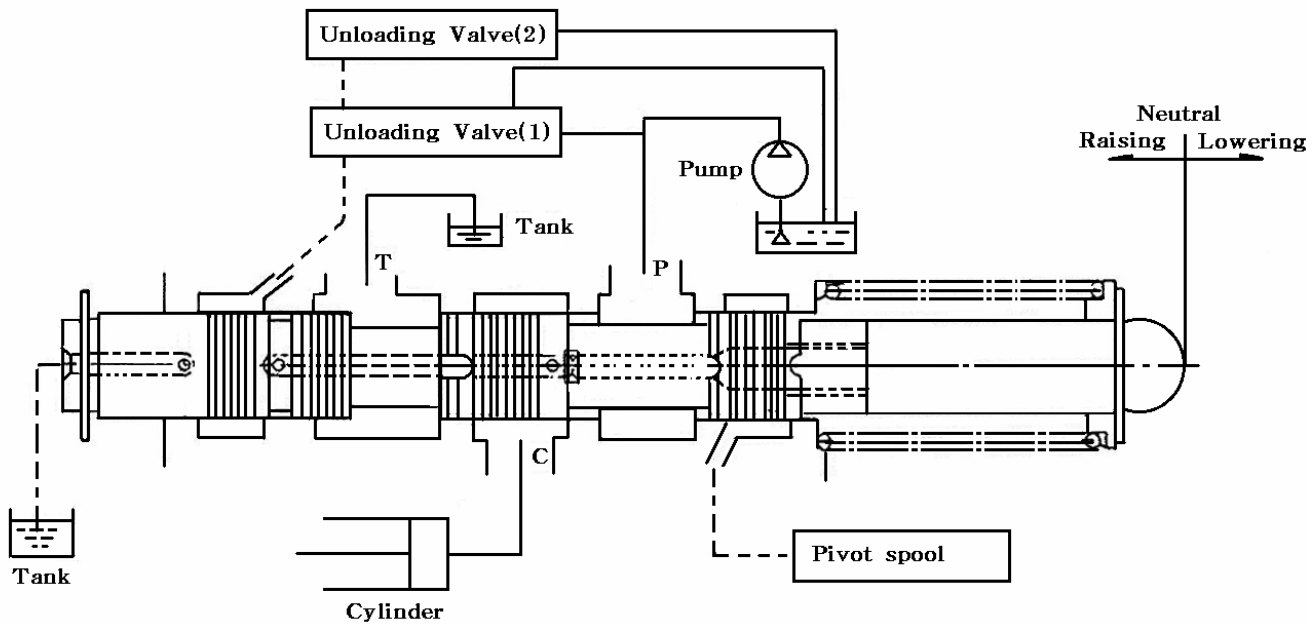

Fig.9-31

## 2) Unloading valve(1) (compensator)

it consists of the spool and spring.

While the main spool is neutral or in the lowering position, it diverts all the fluid from the pump directly to the tank. In this state, the pump delivery pressure is regulated to be  $7-8 \text{ Kg/cm}^2$  ( $100-114 \text{ psi}$ ) To prevent engine power loss and fluid temperature rise.

When the main spool is set in the lifting position, it delivers the fluid whose volume is in proportion to the opening to the port P-to C passage and surplus is diverted to the tank. Consequently only fluid with volume corresponding to main spool displacement is allowed into the cylinder through port C, Independent from fluctuations in cylinder pushing pressure and pump delivery pressure, which making it possible to perform very subtle operations such as inching. Moreover, as the pump delivery Pressure never exceeds the value of cylinder pushing pressure +  $7-8 \text{ Kg/cm}^2$  ( $100-114 \text{ psi}$ ), pump power loss is minimized.

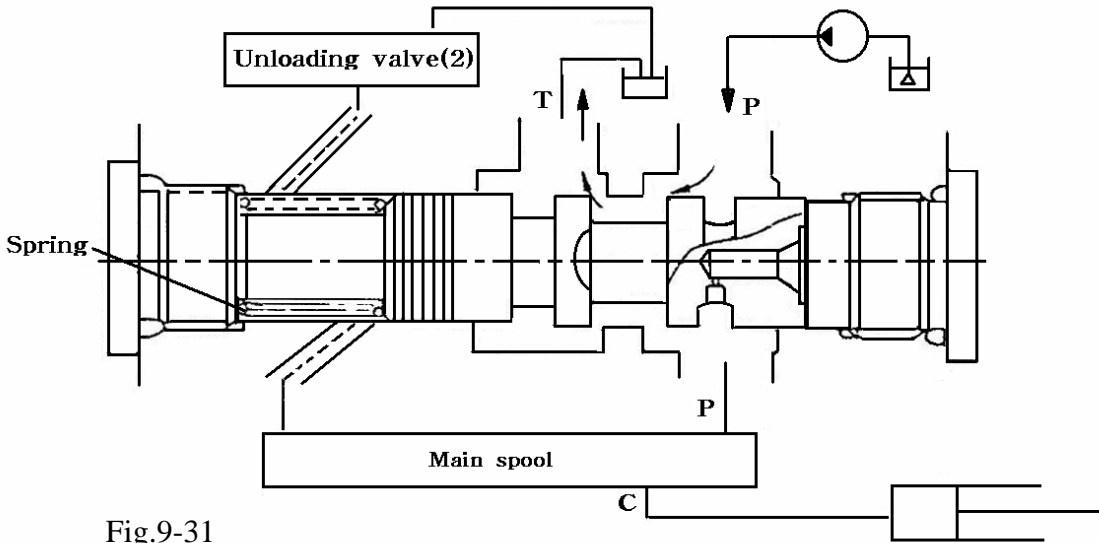

Fig.9-31

## 3) Unloading valve(2)

It consists of a spool, poppet ( $\varnothing 0.5$ ), spring and stopper bolt. This valve is installed to improve unloading efficiency. It works as follows.

When the main spool is shifted from the lifting position to the neutral position, it diverts the unloading pilot pressure to the tank, making use of port-C pressure.

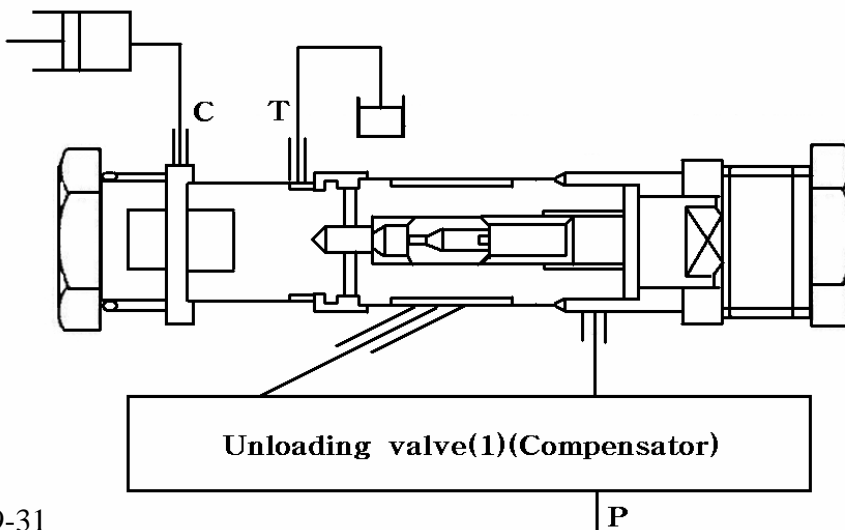

Fig.9-31

#### 4) Holding check valve

It consists of a check poppet and spring, and is installed between the cylinder port and the main spool. It blocks the flow from the cylinder to the valve in the neutral and in the lifting position, thus preventing the cylinder from releasing in the neutral or lifting position when the pump stops. In the lowering position, the pilot spool releases the spring chamber pressure and the check poppet opens the passage from the cylinder to the tank.

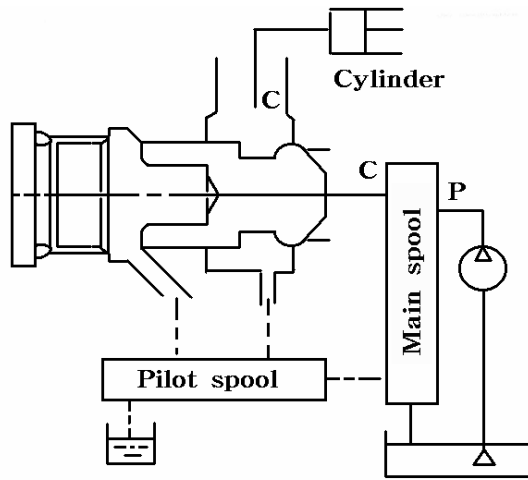

Fig.9-32

#### 5) Pivot spool

It consists of a pilot spool, sleeve, spring, plug, and push rod.

It is activated by the pilot pressure only while the main spool is in the lowering position. It connects the check valve spring chamber and tank to open the check valve. In other cases, that is, in the neutral or lifting position, the holding check valve functions as a check valve because the check valve spring chamber and port C are inter-connected.

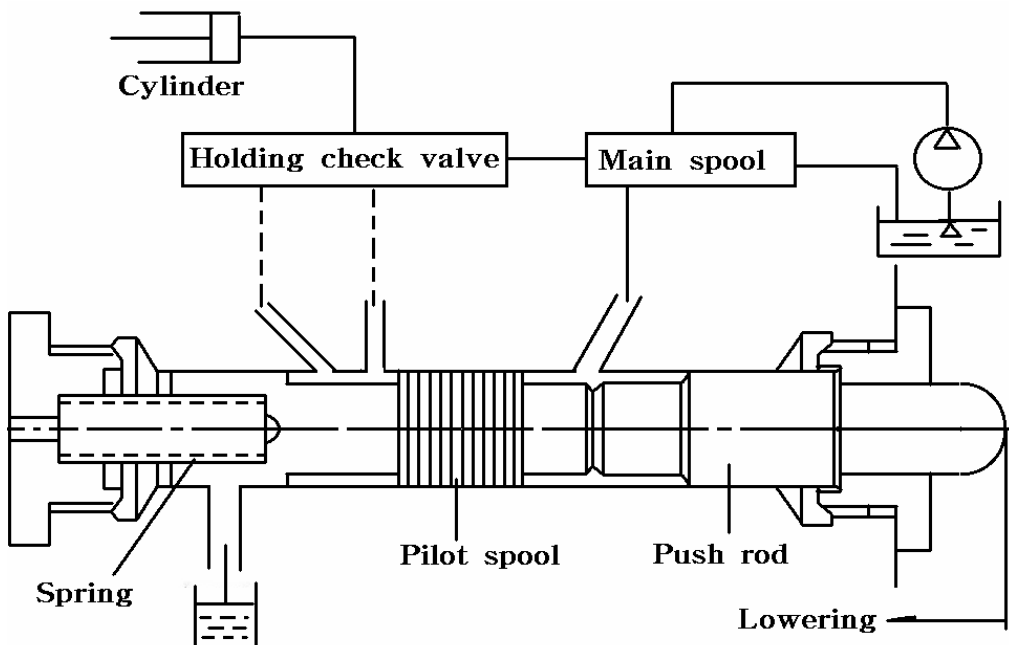

Fig.9-33

## 1.4 OPERATION

Port p means “pump port”, and is connected to the pump, while port C means “Cylinder port”, and is connected to the cylinder. Drain ports T1 to T4 are connected to the tank.

### 1) Neutral position

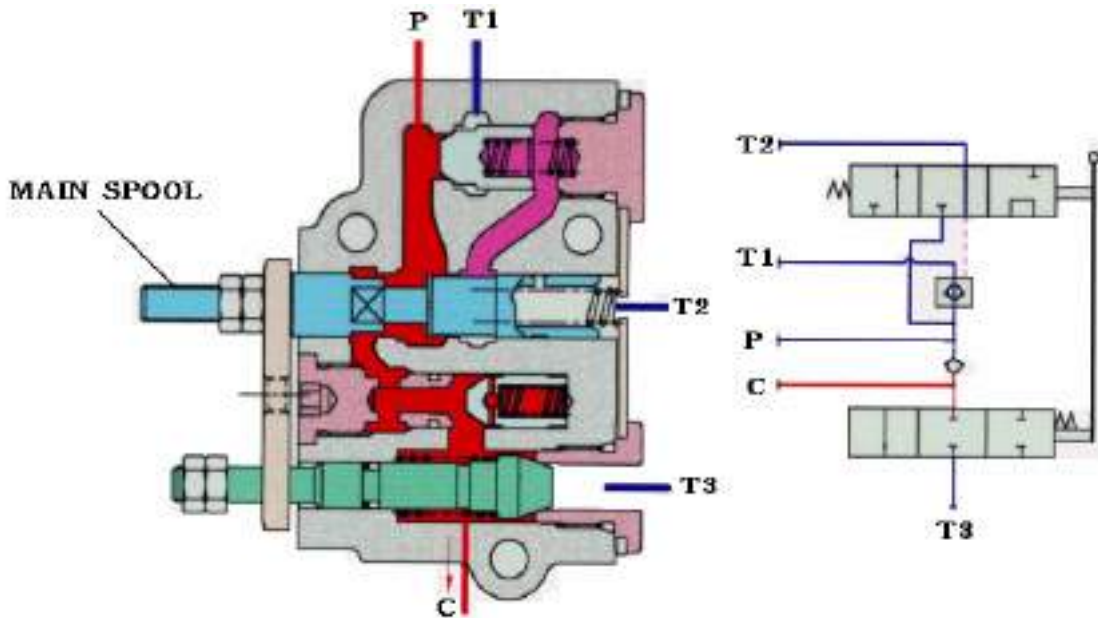

Fig.9-34

In the NEUTRAL position, Spring chamber of unloading valve connected to TANK(T2), Therefore the force imposed upon the right hand side of the unloading valve, then the fluid from the pump flows into TANK(T1).

The pressure in chamber becomes equal to the tank pressure. Consequently the fluid in the C port becomes high, then the check valve and main check valve completely closes the cylinder circuit enough to hold the piston steady.



## 2) Lifting position

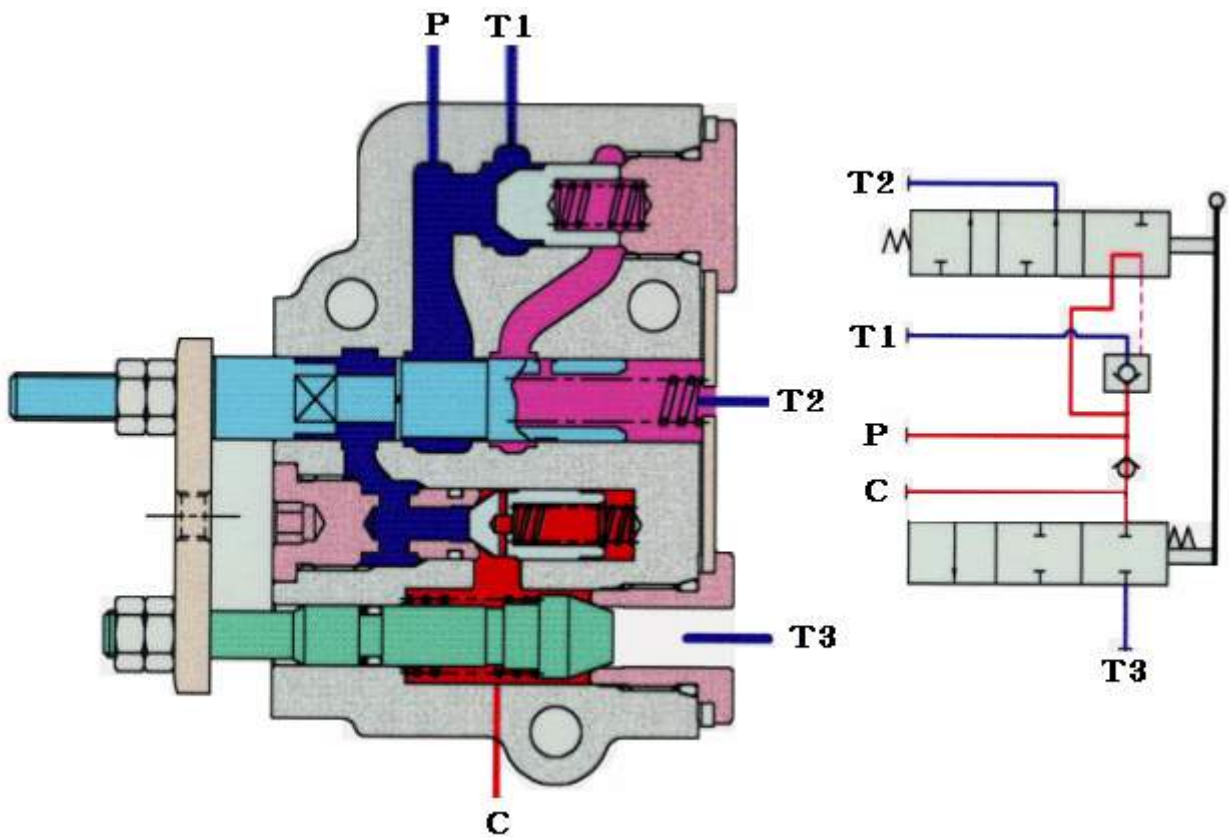

Fig.9-35

When the main spool is shifted to the lifting position, Passages to the Tank(T2) are closed with unloading spring and the Fluid from the pump flows into unloading valve spring., therefore the force imposed up the left-hand side of the unloading check valve, Consequently the fluid in the T1 port becomes to close the unloading.

The pump delivery fluid pressure open the the loading check valve, then through C port the pump pressure flows into hydraulic cylinder to lift up the lift arm.

### 3) Lowering position

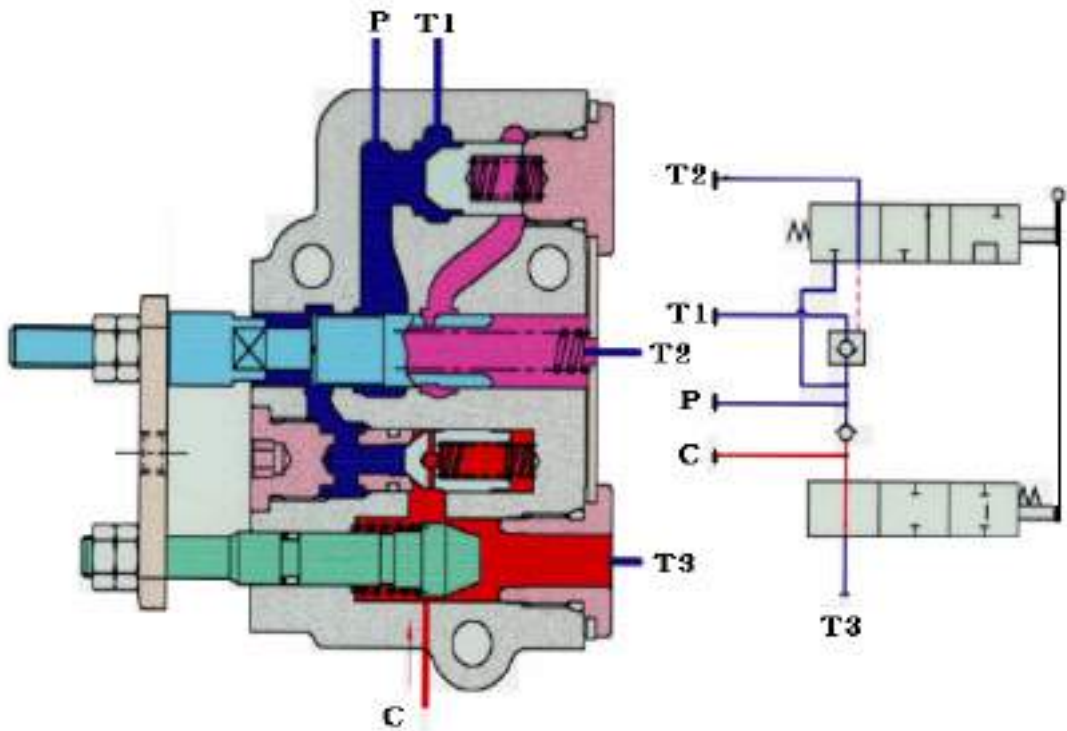

Fig.9-36

When Main spool is shifted to the lowering position, Unloading spring is connected to the Tank(T2), and the force imposed up the right hand side of the unloading check, therefore the fluid from the pump flows into the Tank(T1).

Consequently the force imposed up the left hand side of the main check valve, which is connected with Plate-B to open the T3 port.

By this action, the fluid from the cylinder flows out and into the tank through chamber, so the piston is released

## 1.5. SERVICING INSTRUCTIONS.

### 1) Required tools

- 6mm set screw wrench and torque Wrench
- 19mm spanner and torque wrench
- 22mm spanner and screw wrench
- conventional screw driver[3mm(0.12 in) in blade width]
- plastic rod [Ø10mm(Ø0.394 in)]
- Oil stone,cleanser,tweezers,etc.

### 2) Tightening torque

Description	Size	Tightening torque Kgf.m(ft.lbs)
Plug	M16	3.5 (25.3)
Plug	M14	2.5 (18.1)
Sunk Plug	PT /4	2.5 (18.1)
Spool head	M6	0.8 (5.8)
Stopper bolt	M6	0.8 (5.8)

### 3) Disassembly

#### -Main spool and related parts.

Remove the snap ring E and draw out the main spool carefully.

#### Note:

The main spool and spool head are screw-fitted, so they can be separated from each other. But they are tightened with adhesive applied, so they should not be disassembled unless required.

#### -Holding check valve and related parts.

Remove the plug and take out the spring. The poppet can come out only by slanting the casing, and if not, remove it with pliers.

#### -Unloading valve(1): compensator

Remove the plugs from both sides and take out the spring and spool.

#### -Unloading valve(2)

Remove the plugs from both sides and take out the spring and spool.

#### Note:

The spool and stopper bolt are tightened with each other with adhesive applied to their threads, so they should not be separated unless required. by removing the stopper bolt, the poppet and spring can be taken out of the spool.

#### -Pilot spool and related parts.

Remove the plugs from both sides and take out the spring and push rod.

The pilot spool set can be pushed out from the push rod side with a Ø10 mm(Ø0.394 in) rod. When pushing, put the rod on the sleeve, not the spool.

#### Note:

The spool and sleeve cannot be separated from each other.

### 4) Reassembly

#### -Inspection of the disassembled parts.

Place all the disassembled parts side by side on a clean surface. Check o-rings for damage and replace defective ones. Inspect the friction surfaces of the spools, poppets, and casing for flaws like scratches. Correct slight flaw with an oil stone and wash corrected parts in a cleanser.

#### -Main spool and related parts.

When the head is disassembled, it should be tightened and locked securely using adhesive. Before retaining the spool with the snap ring E, make sure that the spool slides smoothly within the casing.

#### -Holding check valve and related parts

Put the poppet into hole B as shown in the figure and make sure that the poppet slides smoothly. Then put the spring in and tighten the plug, on which the O-ring must be installed, to the specified torque.

-unloading valve(1) and related parts.

Install the spool into hole C(Fig.9-19) in the correct direction. Put the spring in and tighten the plug to the specified torque.

-Unloading valve(2) and related parts.

Install the spool and confirm that it returns smoothly by the spring force after it is compressed by pushing the stopper bolt end and check that it slides smoothly.

-Pilot spool and related parts.

Be careful not to damage the O-ring during pilot spool installation. After assembly, make sure that the spool slides smoothly by pushing the push rod.

## 2.FLOW-DIVIDER( PTO solenoid valve)

### 2.1 GENERAL DESCRIPTION

This valve is installed to bypass working fluid of a specified pressure from the main circuit into the PTO circuit through a fixed orifice. It includes a changeover valve for engaging and disengage the PTO clutch by means of a solenoid and a sequential valve for PTO circuit's over the main circuit.

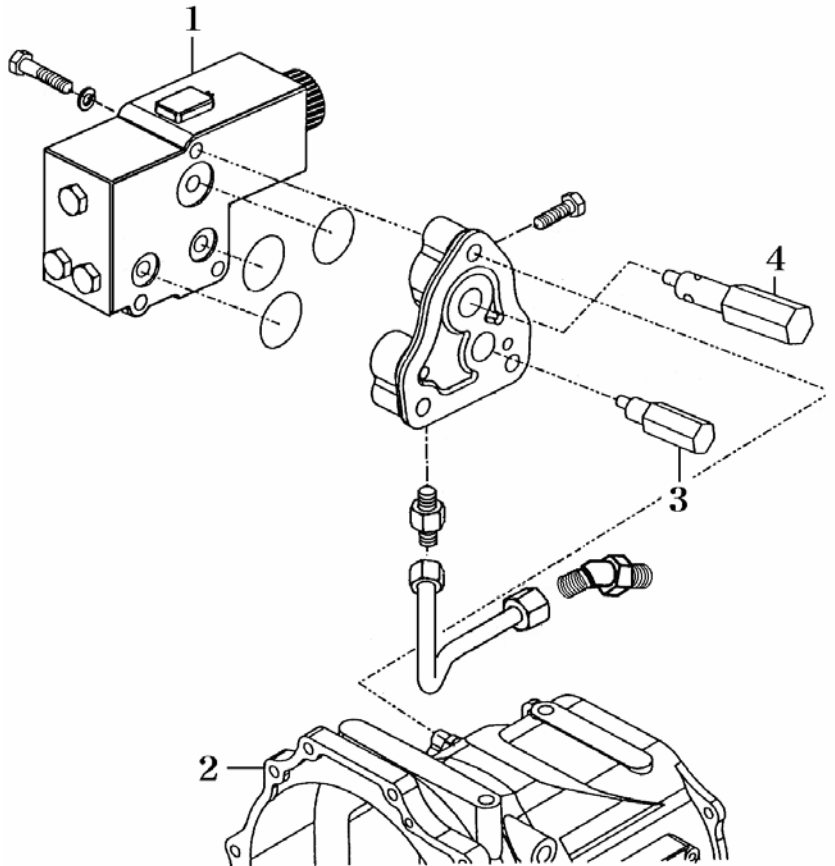

- (1) Flow-divider
- (2) Transmission case
- (3) Relief Valve
- (4) Pressure control valve

Fig.9-37

#### (1) Solenoid

This solenoid is switched on or off by operating the PTO switch. With this lever operation, the solenoid shifts the changeover valve to the left or the right to bypass or block the flow to port B.

#### (2) PTO changeover valve

This valve is composed of the spool and spring. When the solenoid is switched on, the spool is moved to the left by overcoming the spring force and allows the fluid from the pump to flow from port P to port B through the fixed orifice.

-When the solenoid is switched 「ON」

The fluid from the pump flows to port B through port P, the pressure-reducing valve, and the changeover valve.

The pressure of the PTO clutch circuit and that of passage(2) are the same and will be set as  $P_2$ . The pressurized fluid acts on the left-hand side of the valve, passing through port ; its pressure will be set as  $P_1$ .

As passage (1) and passage (2) are interconnected, then  $P_1 = P_2$ .

The force imposed upon the left-hand side of the valve is  $P_1$  whereas the force imposed upon the right side of the valve is  $P_1$  plus the spring force. Consequently the spool is pushed leftwards.

Here port A is blocked, so the fluid from the pump is branched off to the PTO clutch.

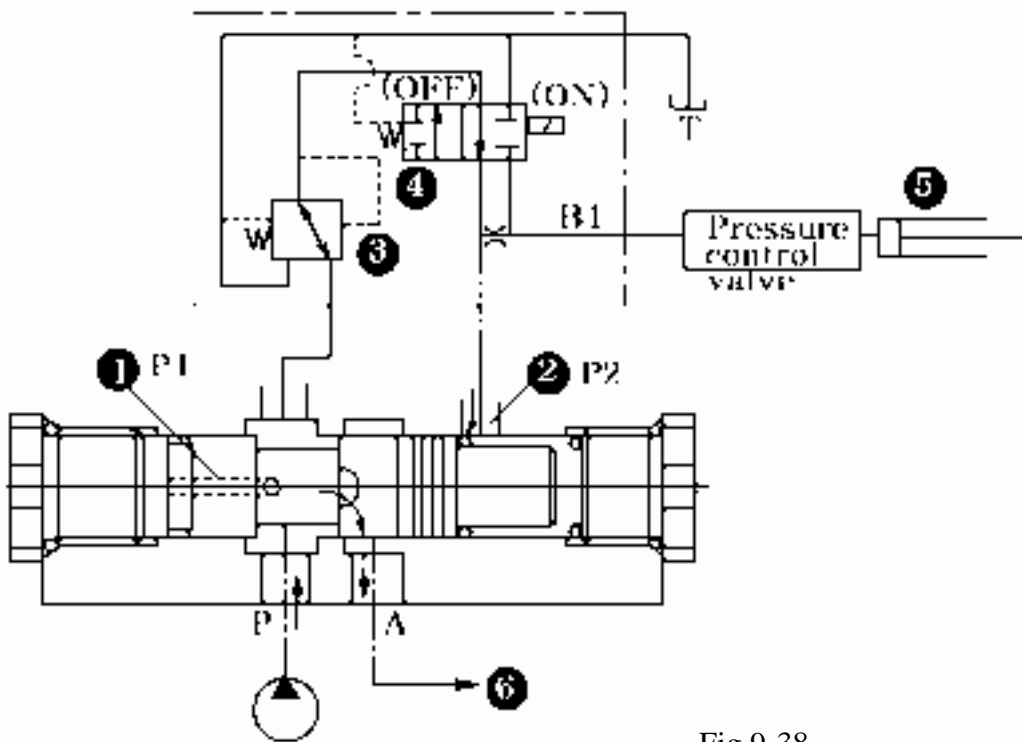

Fig.9-38

- (1) Passage 1
- (2) passage 2
- (3) Pressure-reducing valve
- (4) Changeover valve
- (5) PTO clutch
- (6) To control valve.

-When the solenoid is switched 「OFF」 :

The fluid in the PTO clutch is unloaded to the tank through port B. Consequently pressure  $P_2$  at passage (2) becomes zero, whereas the pressure at passage (1) is  $P_1$ . Then the force imposed upon the left side of spool ( $P_1$ ) overcomes the force imposed upon the right side

( $P_2$ +spring force), so that the spool is pushed rightwards to connect port P and port A. Therefore no fluid from the pump is branched off to the PTO clutch; that is, all fluid flows to the control valve.

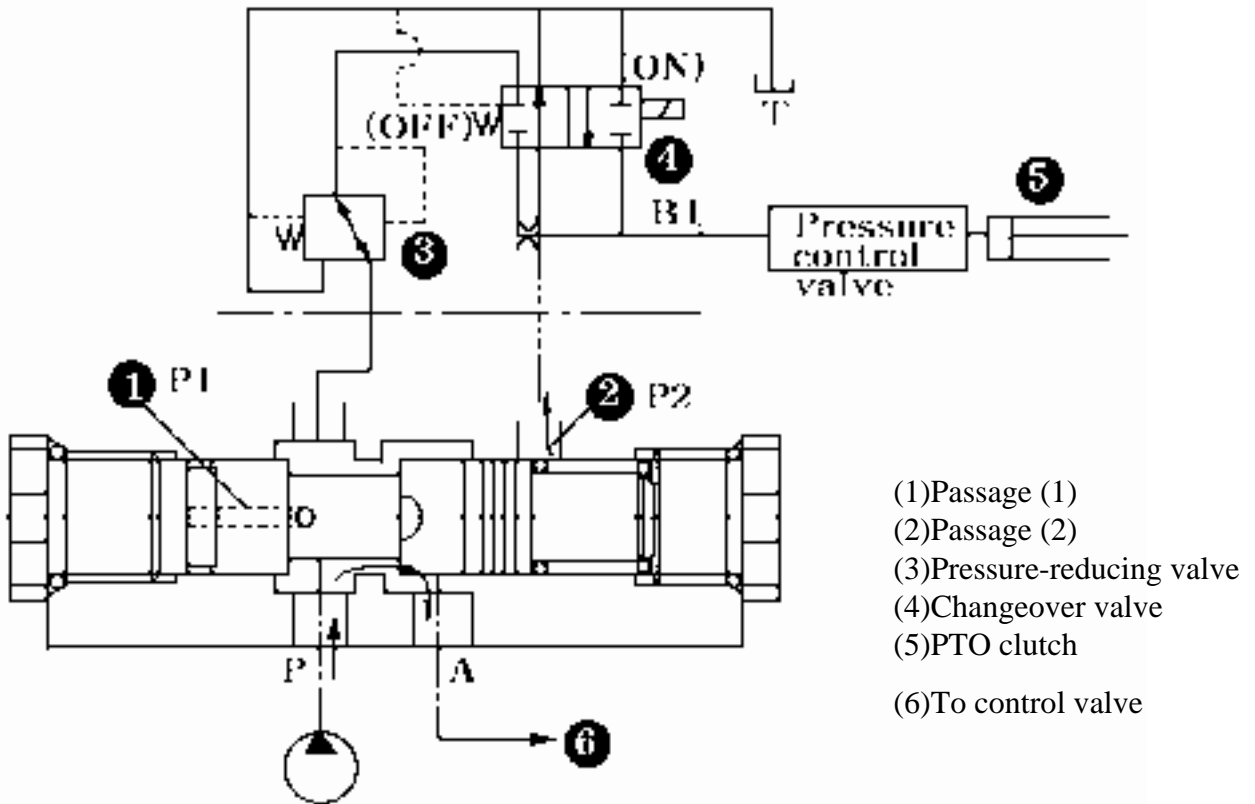

Fig. 9-39 PTO solenoid switch 「OFF」 position

(1) Pressure-reducing valve.

This valve is composed of the spool, spring, and piston and bleeds off the surplus fluid from the pump into the tank by actuating the spool when the fluid pressure exceeds the regulated pressure at port B

(2) Fixed orifice

This orifice controls the fluid flow at B in accordance with the pressure differential between the secondary pressure of the pressure reducing valve and the PTO clutch actuating pressure.

### 3. PRESSURE CONTROL VALVE

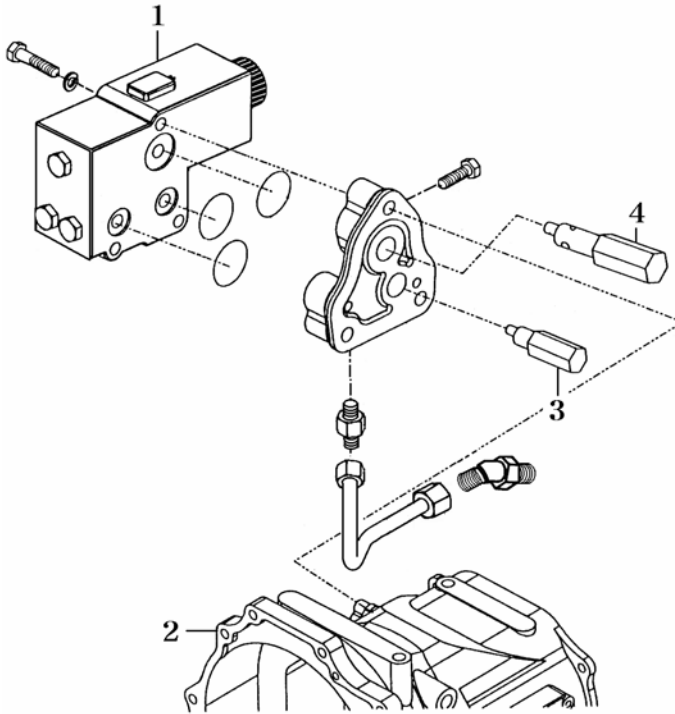

- (1) Flow-divider
- (2) Transmission case
- (3) Relief Valve
- (4) Pressure control valve

Fig.9-40

#### 3.1. GENERAL DESCRIPTION

This valve is composed of the body,plunger,piston,springs,and plug.It serves to absorb shocks which are given when the PTO clutch engages.

#### 3.2. OPERATIONS

1) When the clutch cylinder is achieved:

When the PTO clutch valve is turned on,the cylinder is activated.Consequently the pressure in circuit does not leave the seat of body(4) because the preset force by spring(8) and spring(9) is larger.Therefore there is no flow of fluid from port B to port T,which means all the fluid from the PTO clutch leads to the clutch cylinder.

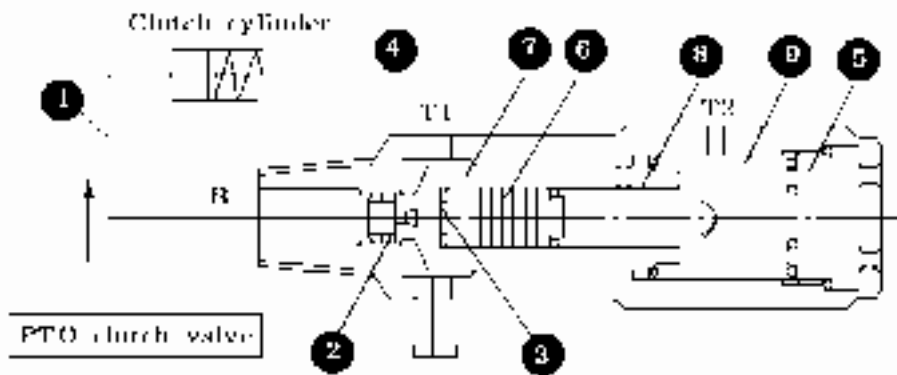

No	Part name	Q'ty
4	Body	1
5	Plug	1
6	Piston	1
7	Plunger	1
8	Spring1	1
9	Spring2	1

Fig.9-41 When the clutch starts engaging



2) When the clutch is in half-engaged state:

When the clutch cylinder is completely activated, the pressure in circuit (1) starts rising at point P1 on the graph in Fig.9-42. When the pressure reaches point P2, the piston starts moving to the right overcoming the force of spring (6 and 7).

Here the flow through chock (2) causes some difference in pressure between circuit (1) and chamber (3). As the effective area of the seat of plunger (7) for circuit (1) pressure and that for chamber (3) pressure are the same, this pressure difference causes the plunger to compress spring (9) to move to the right, which opens the passage from port B to port T1 to prevent the pressure in circuit (1) from rising abruptly. As piston (6) moves to the right, the force of spring (8) increases so much. Both pressures in chamber (3) and circuit (1) also increases gradually, so the clutch engages smoothly without shocks.

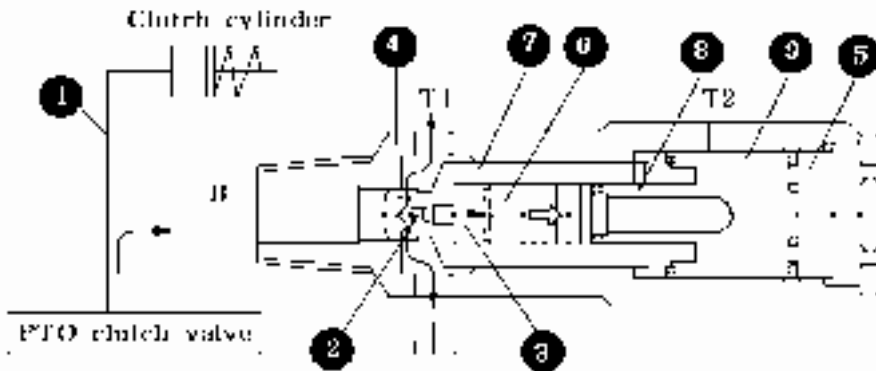

Fig.9-42 When the clutch is in half-engaged state

Dynamic characteristics

Provided  $P1=3\text{Kgf/cm}^2(43\text{psi})$

$P2=3.6\text{ Kgf/cm}^2(51\text{psi})$

$P3=5.9\text{ Kgf/cm}^2(84\text{psi})$

$T=0.4-0.6\text{ sec}$

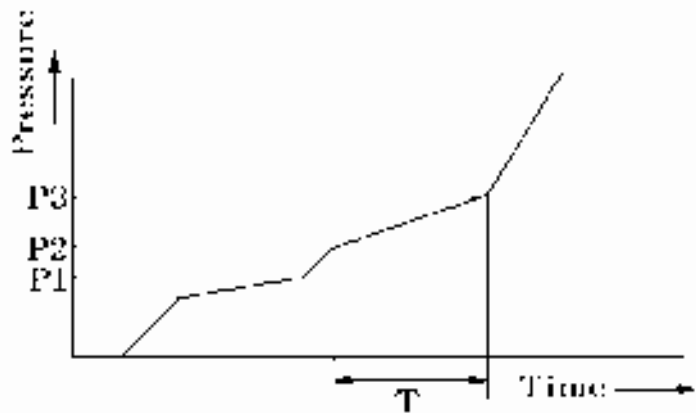

Fig.9-43

2) When the clutch is engaged completely

When the piston(6) moves to the end, there is no flow through chock(2) and the pressures in chamber (3) and circuit(1) become equal, that is, the pressure which the plunger receives on both sides are the same. Consequently, plunger(7) is pushed back to the left by the force of spring(9), which closes the passage from port B to port T. With this, the pressure in circuit(1) starts rising at point P3 up to the supplied pressure. Thus the clutch engagement is maintained.

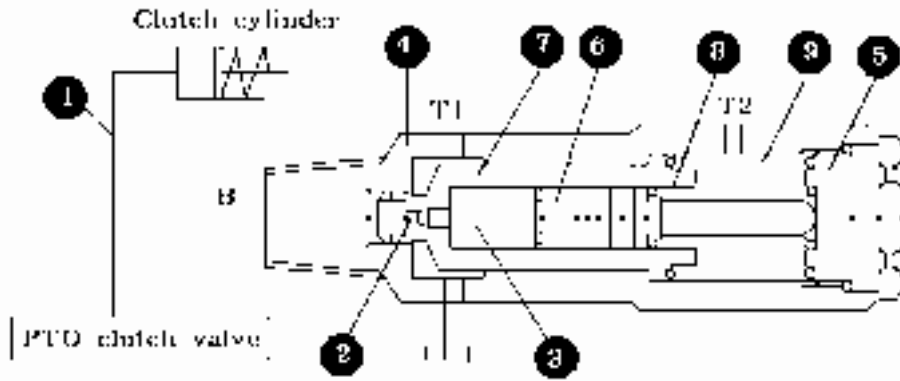

Fig.9-44 When the clutch is completely engaged

### 3.3 DISASSEMBLY AND INSPECTION

1) Required Tools

- 24 mm box type wrench and torque wrench: for valve tightening
- 22 mm box type wrench and torque wrench: for plug(5)
- Other required things:tweezers,sealing tape,rag,and oil stone

2) Disassembly

- a. Detach the change cover and remove this valve assembly
- b. Remove the plug(5) ,Take springs (9 and 8), and then extract piston(6) and plunger(7) by tilting body(4).

3) Inspection of the disassemble parts.

Inspect the plunger and the piston for dents on their friction surfaces.Such flaws must be corrected with oil stone.Wash all parts in fresh cleansing oil

4) Reassembly

a. Tightening torque

Ref.No	Fastener Name	Tightening torque[Kgf.m(ft.lbs)]
(5)	Plug	4.0-5.0(28.9-36.2)
	Valve assembly*	4.5(32.6)

\* The threads should not be wrapped with sealing tape.

- b.Install plunger(7) into body(4) and confirm that the plunger moves smoothly.Then install piston(6),spring(8),and spring(9) in order and tighten plug(5) to the specified torque.

## 4. FLOW-CONTROL VALVE(SLOW-RETURN CHECK VALVE)

### 4.1. GENERAL DESCRIPTION

This valve regulates the lowering speed of the lift by controlling the unloading flow from the lift cylinder to the tank.

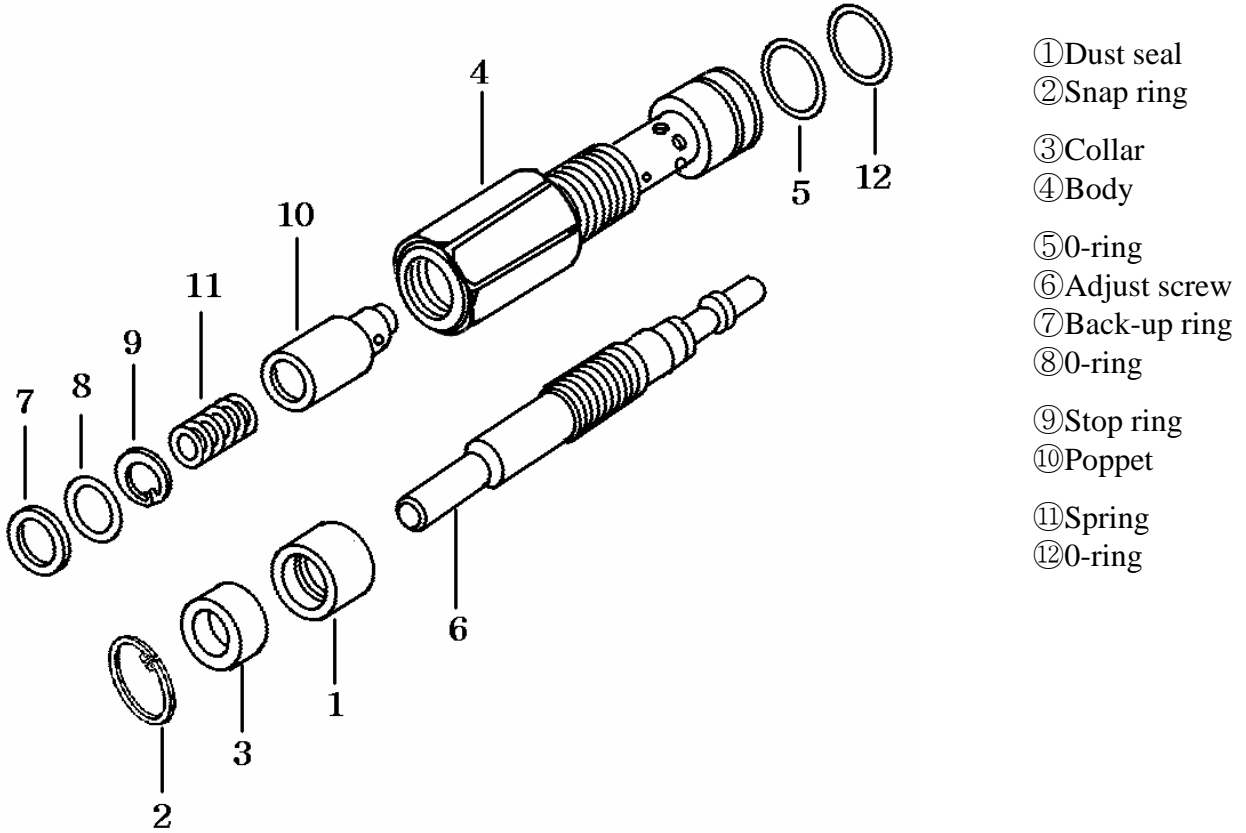

- ①Dust seal
- ②Snap ring
- ③Collar
- ④Body
- ⑤O-ring
- ⑥Adjust screw
- ⑦Back-up ring
- ⑧O-ring
- ⑨Stop ring
- ⑩Poppet
- ⑪Spring
- ⑫O-ring

Fig. 9-45 Slow-return check valve Diagram

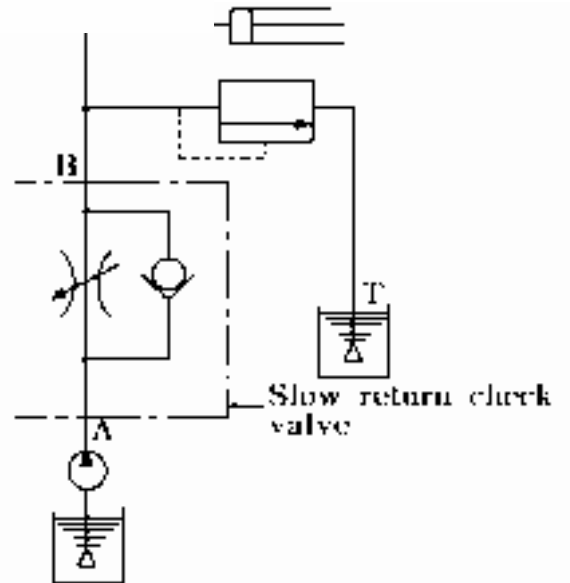

## 4.2 OPERATIONS

### 1) DOWN position

The fluid from port B pushes up stop ring (9) of poppet (10) until the ring comes into contact with adjust screw (6), as it reaches chamber (R). Consequently, the extent choke (C) is opened is determined by the positioning of adjust screw (6): that is, when adjust screw (6) is screwed in clockwise, the opening of chock (C) decreases and the lowering speed of the lift arm slows down; whereas the opening of choke (C) increases and the lowering speed of the lift is accelerated when the adjust screw is unscrewed counterclockwise. When the adjust screw is screwed in completely, the poppet comes into contact with body seat (S) and the choke is closed completely, so the lift arm stops.

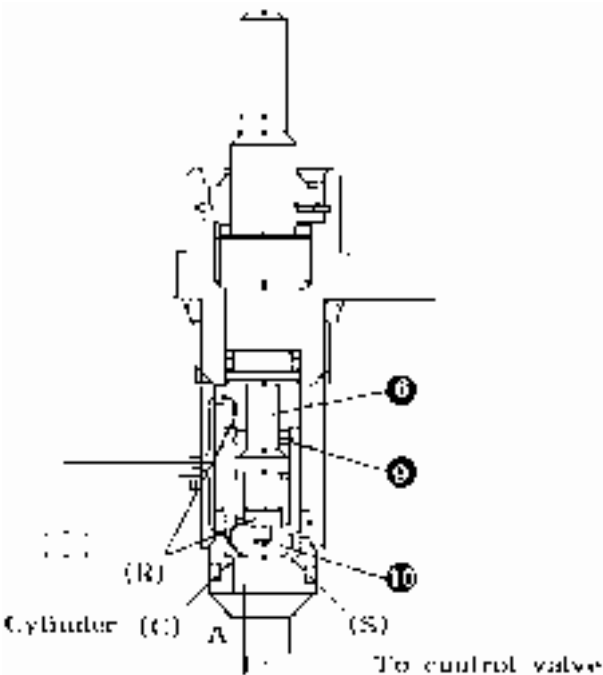

Fig. 9-46 Down position

### 2) Up position

The flow port A, overcoming the force of spring (11), pushes up poppet (10) and choke (C) is fully opened regardless of the position of adjust screw (6). Thus the fluid flows to port B and the cylinder, which results in raising the lift arm.

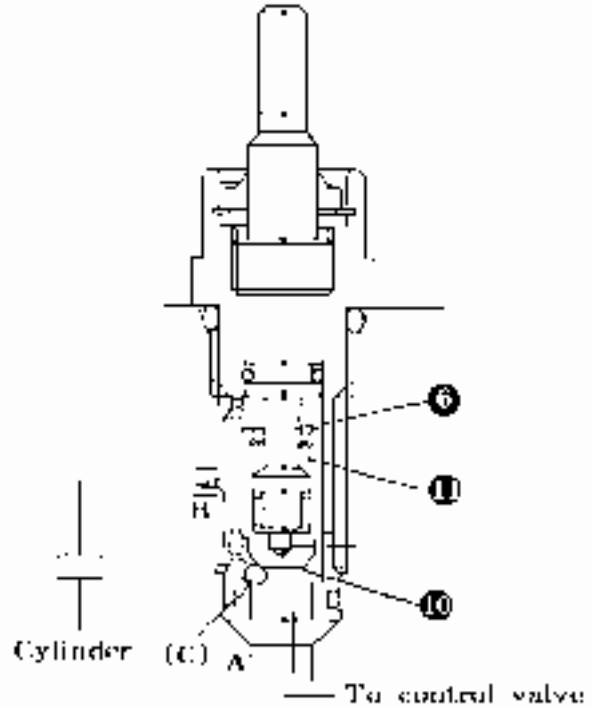

Fig. 9-47 Up position

## 5.SAFETY VALVE( Optional)

### 5.1 GENERAL DESCRIPTION

With the chock closed completely by turning the adjust screw tightly clockwise,the implement mounted on the lift is held at a specified height.While the tractor is traveling on roads in the condition,there is a possibility that the cylinder pressure will rise excessively when the implement bounces.In such a situation the cylinder pressure can rise so high as to break the cylinder.To prevent such an accident,the relief valve works to leak off the fluid in the cylinder to the tank via port P and port T to decrease the cylinder pressure

## 5.2 OPERATION

This valve is installed in the slow return check valve circuit and able to be installed in the cylinder case instead of Bolt.When the adjust screw of the slow return check valve is closed completely,the slow return check valve is completely closed.In this condition,when the cylinder pressure exceeds the regulated pressure of the relief valve: cracking pressure,the fluid pushed up ball(3),overcoming the force of spring(5).Then the surplus fluid is bled off to the tank via port P and Port T.

## 6. RELIEF VALVE

### 1) GENERAL DESCRIPTION

This valve regulates the maximum pressure in the whole hydraulic circuit.The regulated pressure can be set with the adjust screw.

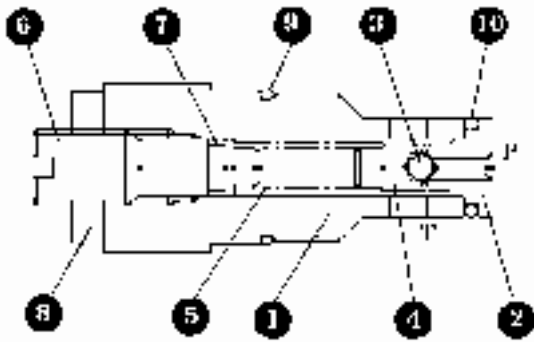

Fig.9-48

- 1.Body 2.seal 3.Ball 4.Spring seat  
5. Spring 6.Adjust screw 7.O-ring  
8.Lock nut 9.O-ring 10.O-ring

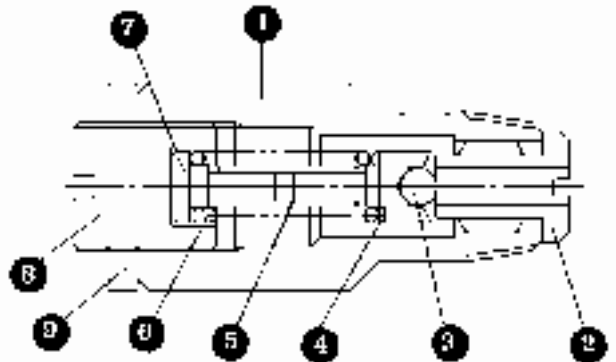

Fig.9-50

- 1.Body 2.seal 3.Ball 4.Spring seat  
5. Sleeve 6.Spring 7.Spring stopper  
8.Adjust screw 9.Lock nut

### 2) PRECAUTIONS FOR DISASSEMBLY AND REASSEMBLY

- (1) Tightening torque of lock nut (9) 5.0 ~ 6.0 kgf·cm<sup>2</sup> (36.2 ~ 43.4 ft.lbs)
- (2) Install seat (2) and then tap ball (3) (5/16) lightly so as to provide tight seating.
- (3) Wrap the valve threads with sealing tape and tighten the valve up to a specified torque of 5-6Kgf.m (36-43 ft.lbs)
- (4) Before disassembly, the current screwing-in depth of the adjust screw should be written down or memorized for later reference.

Circuit diagram

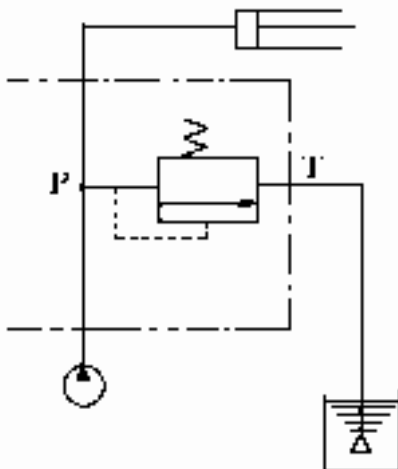

Fig.9-49

### 3) MEASUREMENT OF THE RELIEF PRESSURE

#### (1) 3 POINT TO TEST RELIEF PRESSURE

① Remove the plug in the delivery pipe on the right-hand side of the transmission case and install a compression gauge to measure the pressure.

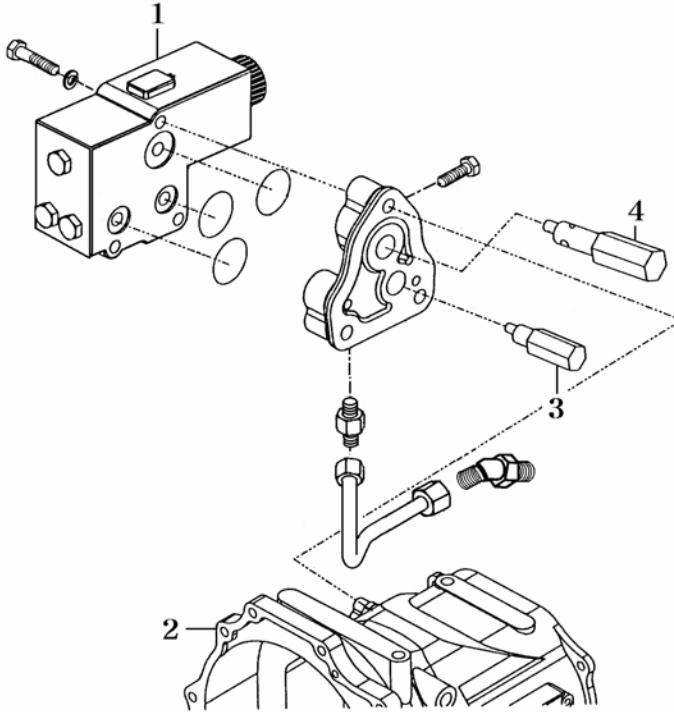

Fig.9-48

Keep the engine speed at 2600 rpm and shift the position control lever at the highest position.

② Control valve coupler.

③ Remove the plug in the hyd. pump flange and engage the pressure gauge and measure it.

Measurement the Pressure must be done 3 times and should be set within specified pressure.

Specified relief pressure	160 ± 5 kgf·cm <sup>2</sup>
---------------------------	-----------------------------

## 7.GEAR PUMP

### 7.1 GENERAL DESCRIPTION

This pump induces fluid from one side and delivers it from the other side, by rotating two gears meshed with each other. The actual delivery is as mentioned below, considering the consequences of fluid temperature and volume efficiency in accordance with revolution speed. That is dual pump system.

#### 7.1.1 Gear pump (Model :3510)

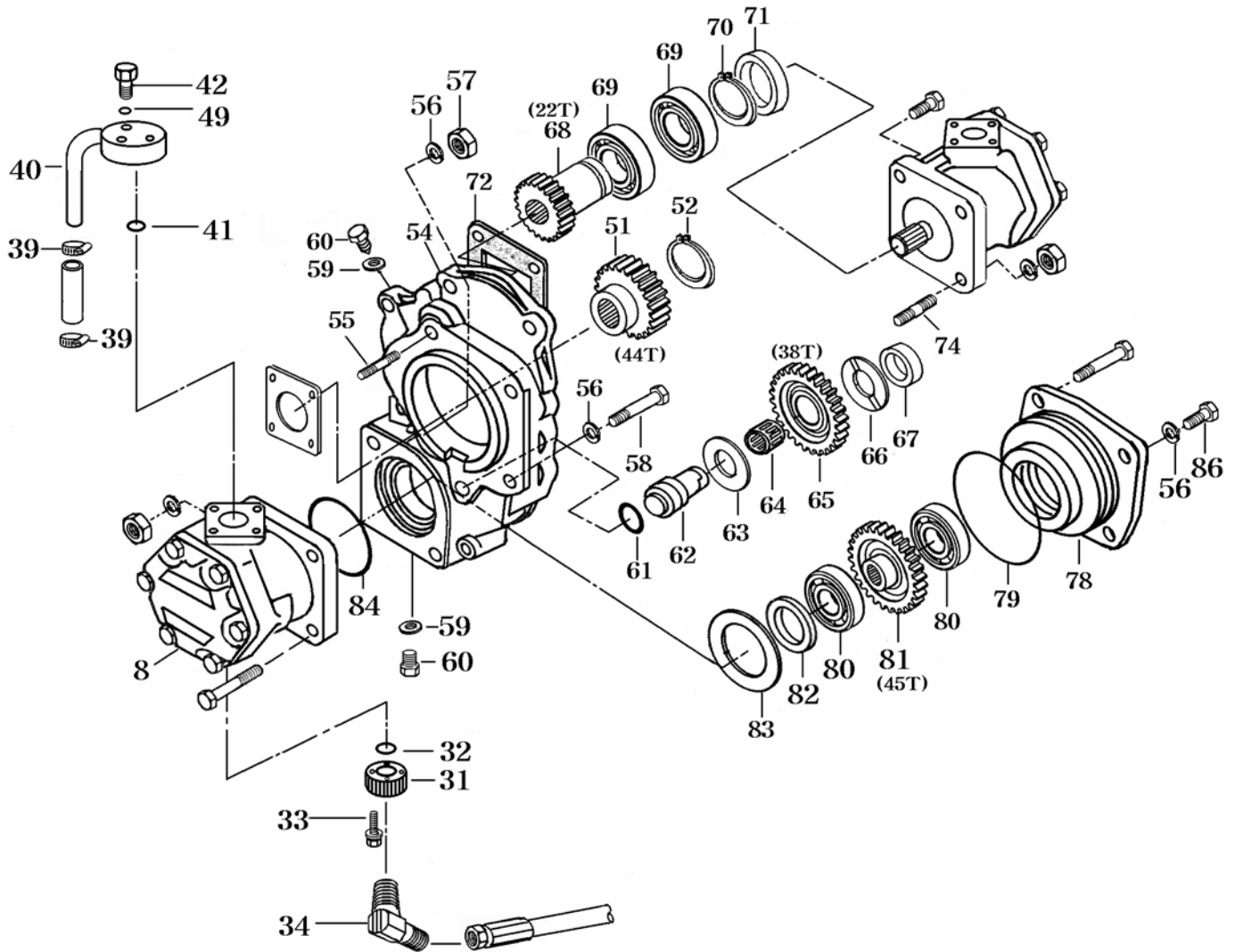

Fig. 9-49 Gear pump (3510)

## 7.1.2 Gear pump (Model: 4110.T390(T400).T430(T450).T431(T451))

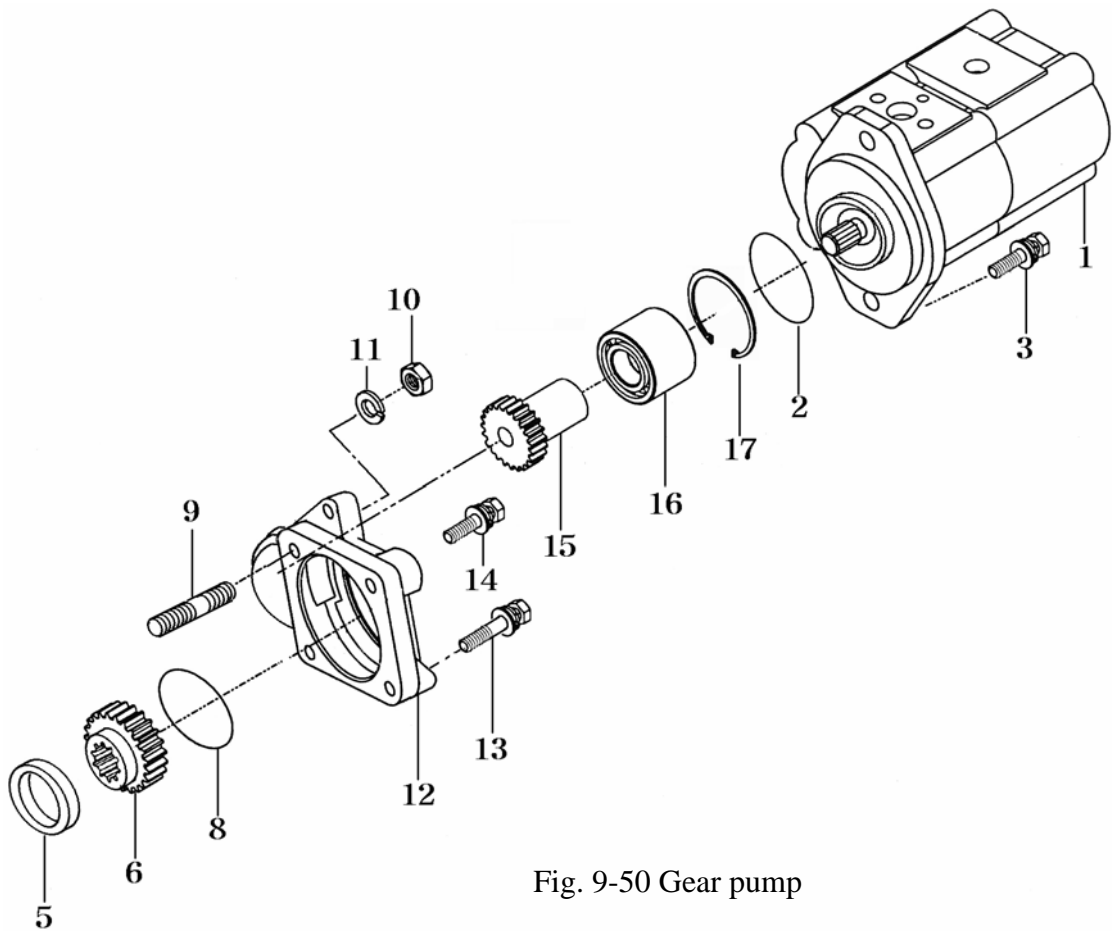

Fig. 9-50 Gear pump

- |             |                         |                         |                |                   |             |
|-------------|-------------------------|-------------------------|----------------|-------------------|-------------|
| 1.Gear pump | 2.O-ring(S)             | 3.Bolt(S)               | 5.Collar       | 6.Drive pump(34T) | 8.O-ring(S) |
| 9.Stud      | 10.Nut                  | 11.Washer spring        | 12.Holder pump | 13.Bolt(S)        |             |
| 14.Bolt(S)  | 15.Drive pump(17T) gear | 16.Angular ball bearing | 17.Snap ring   |                   |             |

## 7.2 OPERATIONS.

This pump induces fluid from one side and delivers it from the other side, by rotating two gears meshed with each other. The actual delivery is as mentioned Fig.9-51, Considering the consequences of fluid Temperature and volume efficiency in accordance with revolution speed.

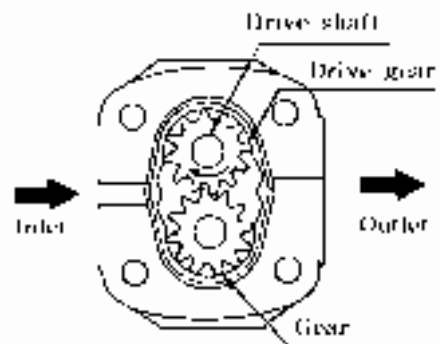

Fig. 9-51 Gear pump



### 7.3 DISASSEMBLY

#### NOTE:

① Before disassembling the pump, wash the outside clean. In the course of disassembling operation, all disassembled parts should be kept aside in a clean place such as on clean paper or cloth and be handled carefully so as to prevent them from becoming dirty or damaged.

Check all disassembled parts for damage and wash undamaged or usable parts in clean diesel fuel or kerosene. Inspect all parts referring to these point, and repair or replace defective parts.

#### (1) DISASSEMBLY

① Remove the key.

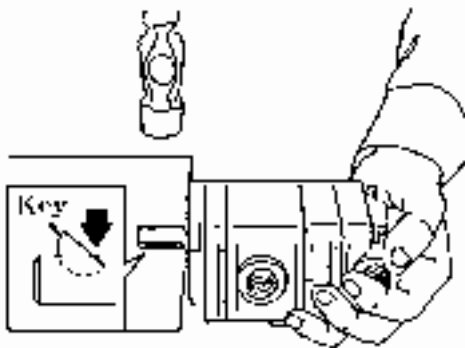

Fig. 9-52 Drive shaft key.

② Hold the pump in a vice with the mounting flange turned downward, and remove the bolts



Fig. 9-53 Cover bolt

③ Remove front and rear pump.

Be sure not to be damaged the o-ring or steel ball

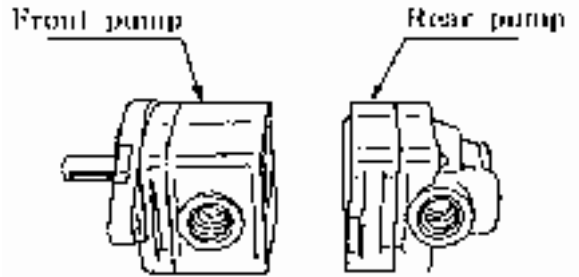

Fig. 9-54 Front and rear pump

④ Remove the rear pump

- ▶ Detach the cover
- ▶ Remove the o-ring
- ▶ Remove the bushing, drive gear, gear and bushing. Take care of removing the bushing which is marked and recorded.
- ▶ Remove the bushing seal from the bushing.

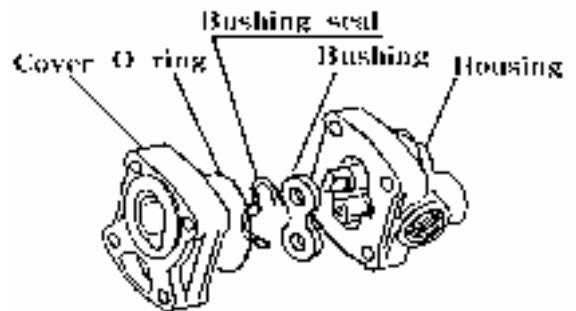

Fig. 9-55 Front and rear pump

⑤ Remove the front pump same as rear pump disassembly.

⑥ Remove the snap ring and extract oil seal from the flange.

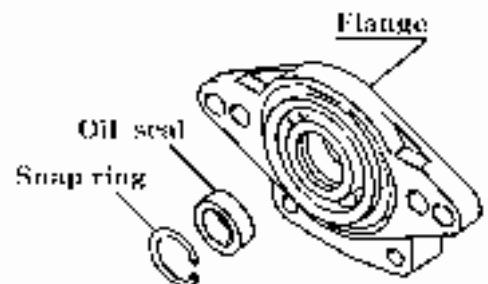

Fig. 9-56 Front and rear pump

### 3) REASSEMBLY

#### ① Install the rear pump.

- ▶ Install the bushing seal to bushing.
- ▶ Install the bushing, drive gear, gear, and bushing to the housing.
- ▶ Install the o-ring to the cover.
- ▶ Install the cover to the housing.

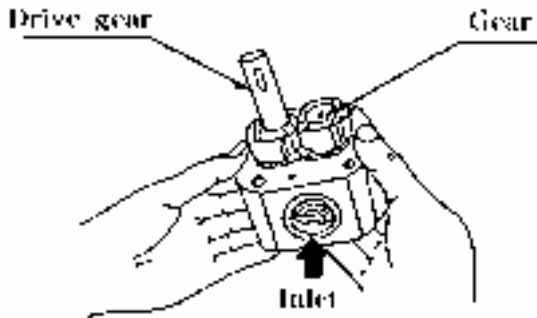
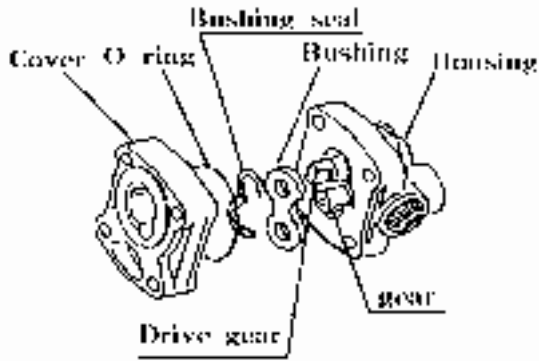

Fig. 9-57 Front and rear pump.

#### ② Install the front pump with rear pump.

#### ③ After installing the cap ring, and O-ring to the front pump, and install the rear pump.

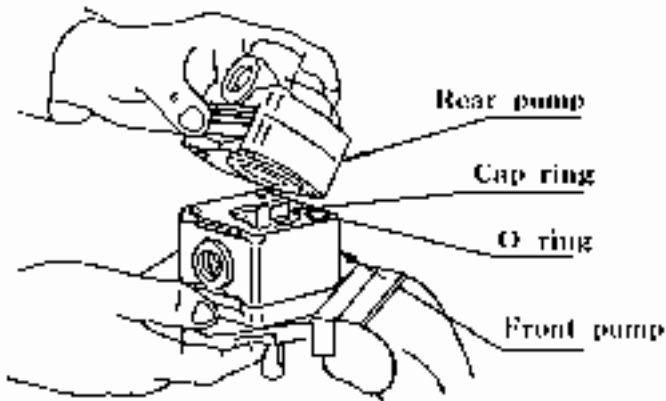

Fig. 9-58 Drive gear, gear, Gasket

#### ④ Tightening sequence and torque of the pump cover tightening bolts.

- ▶ Tightening torque: 2.5 ~ 2.8kgf·m



Fig. 9-59 Cover bolt

#### ⑤ Install the oil seal, snap ring, and key.

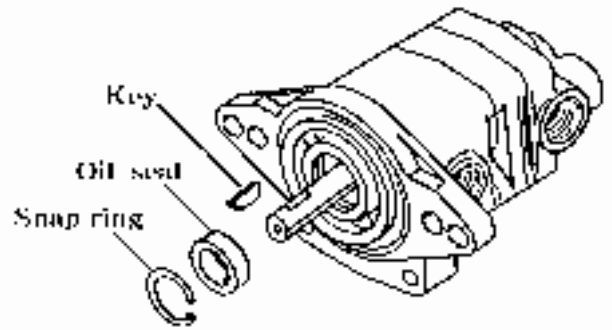

Fig. 9-60 Oil seal, snap ring, key.

#### ⑥ The gears should turn smoothly with a turning torque of less than 30 kgf.cm (2.2ft.lbs)

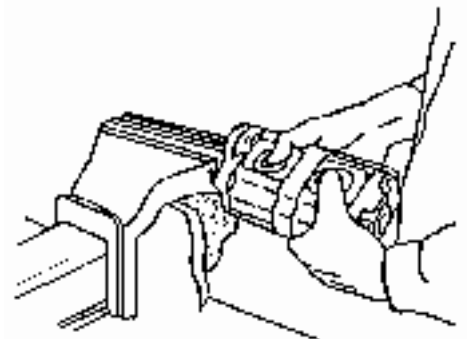

Fig. 9-61 Inspection after reassembly.

#### 4) INSPECTION AND REPAIR

(1) Check all disassembled parts for damage and wash undamaged or usable parts in clean diesel fuel or kerosene except rubber parts. Inspect all parts referring to these points, and repair or replace defective parts.

##### (2) Housing(casing)

- ① The gear pump is originally designed so that the gears come into light contact with the side of the pump body
- ② Therefore some evidence of contact can be found around the intake port of a pump once used.
- ③ The normal contact tracing is less than half the length of the gear housing bore and less than 0.05 mm (0.0020 in) in width. If width A is more than 0.1 mm (0.004 in), replace the gear pump set.

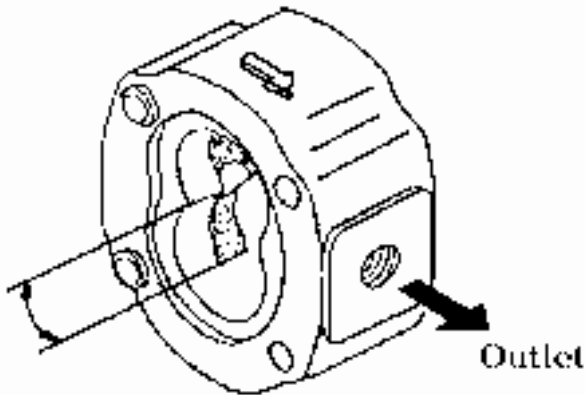

Fig. 9-62 Housing (casing)

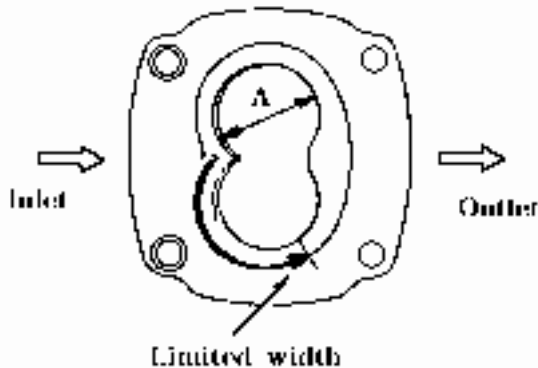

Fig. 9-63 Housing (casing)

##### (3) Bushing

- ① With clean working fluid, surfaces are rarely scratched and should be smooth.
- ② If there are many scratches on the bore walls, or on parts which are in contact with the gears, which can be readily felt or when the latter parts are darkened, the gear pump set should be replaced.

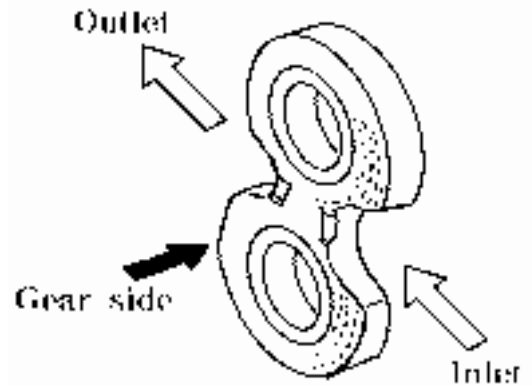

Fig. 9-64 Bushing

Problem and causes are as below

- a. contaminated fluid
- b. overload by relief valve damage
- c. cavitation or aeration
- d. overheat of fluid.
- e. Low density of fluid

④ Some evidence of contact can be found around the intake port of a bushing once used. The normal contact tracing is less than half the length of the bushing bore and less than 0.03 mm (0.0012 in) in width. If width is more than 0.03 mm (0.0012 in). Replace the bushing.

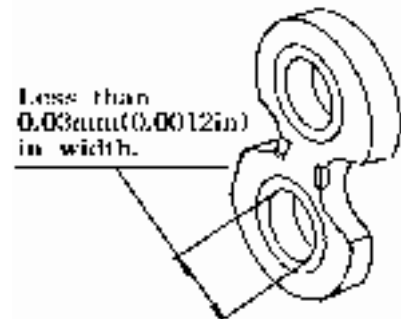
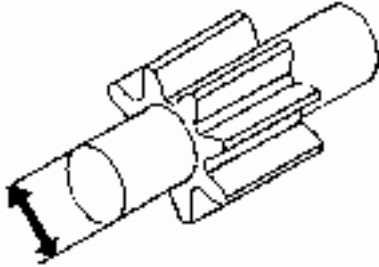

Fig. 9-65 Bushing

#### (4) GEAR

- ① With clean working fluid, surfaces are rarely scratched and should be smooth.
- ② If roughness can be felt by a finger nail, they are darkened, or the shaft diameter is less than 0.03 mm, replace the shaft.
- ③ Usable shaft diameter is as below



Shaft diameter less than 0.03

Fig.9-66 gear shaft

#### (5) Oil seal

The oil seal prevents oil leaks by its inner seal lip and dust from invading by its outer dust lip. Therefore if an oil seal has damaged or deformed lips, it should be replaced.

#### (6) MEASUREMENT OF THE PUMP

The best way to measure for the pump is to use a special tester.

But if it's not available, use installed tractor. Remove the plug in the delivery pipe on the right-hand side of the transmission case and install a compression gauge to measure the pressure.

Keep the engine speed at 2600 rpm and shift the position control lever at the highest position.

## 8. FILTER

- 1.Filter
- 2.O-ring
- 3.Bolt
- 4.Filter
- 5.Spring
- 6.Plug (PT1/10)

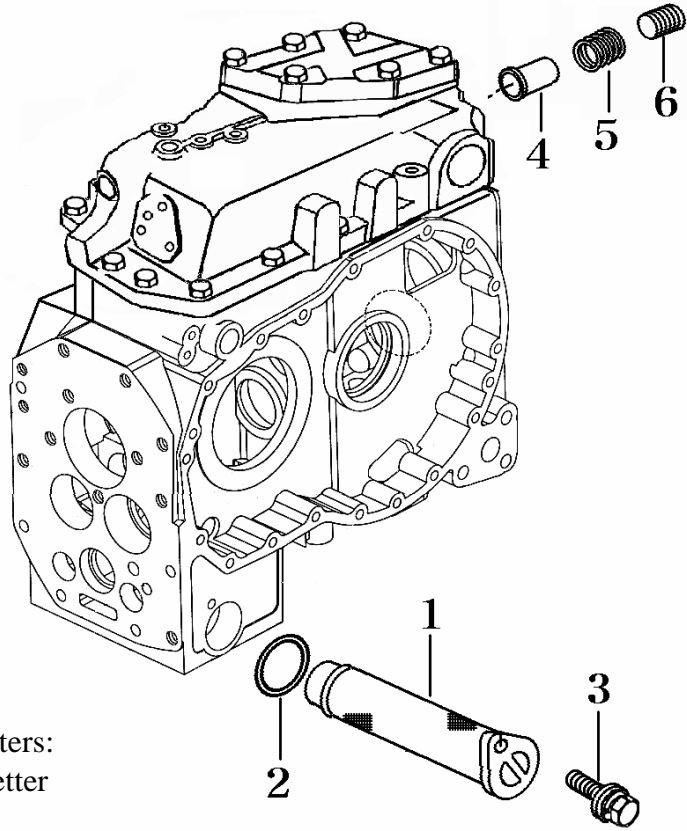

Fig. 9-67 Filter

### 8.1 GENERAL DESCRIPTION

The tractor is equipped with two oil filters: suction filter(1) and line filter(4),for better filtration.

### 8.2 SPECIFICATIONS

#### 1) Suction filter

Model	3510	4110/T390(T400)/T430(T450)/T431(T451)
Applicable oil	DONAX TD or RPM THF 500	
Rated flow rate( $\ell/\text{min.}$ )	43	57
Filtration density	35 $\mu\text{m}$	25 $\mu\text{m}$
Filtration area	6231 $\text{cm}^2$	11000 $\text{cm}^2$
Working oil temperature ( $^{\circ}\text{C}$ )	-30 ~ 130 $^{\circ}\text{C}$	

#### 2) Line filter

Rated flow( $\ell/\text{min.}$ )	35
Filtration density (mesh)	150 mesh
Filtration area	790 $\text{cm}^2$

### 8.3 REPLACEMENT

Check the O-rings for damage or deformation and replace defective ones. When installing the filters, be sure to install the O-rings properly with grease applied.

SECTION 5. REMOTE HYDRAULIC CONTROL

1.GENERAL DESCRIPTION

- A hydraulic operated implement can be driven and controlled with this optional remote hydraulic control valve set.
- The valve is connected between the gear pump and the main control valve and is given a priority to draw hydraulic power.
- The valve is installed on the right-hand side of the hydraulic cylinder case and the connecting ports are provided under the right hand step .

2.FUNCTIONS

Lever position		Circuit diagram
 <p>Raising</p>	<p>Raising</p> <p>A to B</p>	
	<p>Neutral</p> <p>Closed at A and B</p>	
	<p>Lowering</p> <p>B to A</p>	

Fig. 9-68 Remote hydraulic pump

### 3. SPECIFICATIONS

Maximum flow (ℓ/min)	45LPM
Maximum pressure(Kgf/cm <sup>2</sup> )	210
A and B port leak Oil temperature:50°C (122°F) Under a load of 100Kgf/cm <sup>2</sup>	9 cc/min
Recommended fluid	THF 500
Operating temperature range	-20°C~80°C

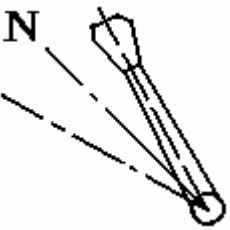
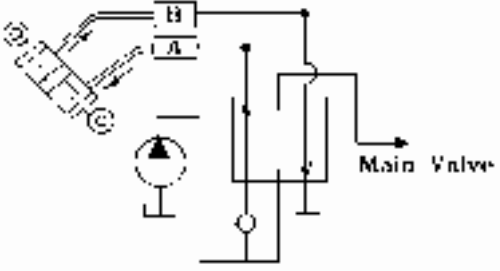
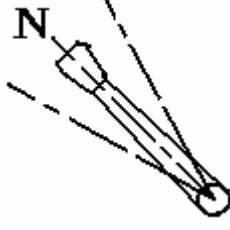
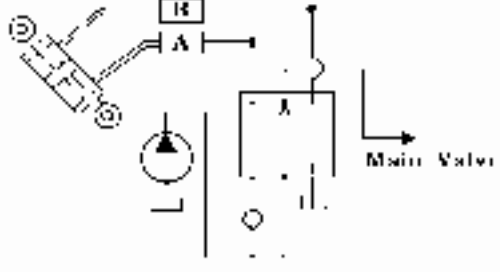
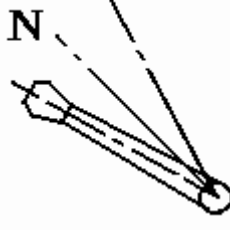
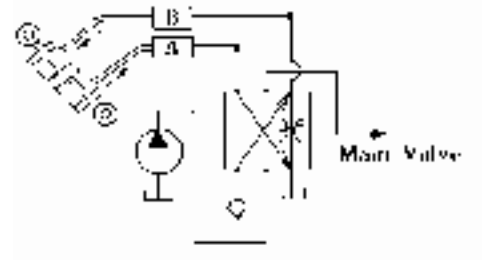
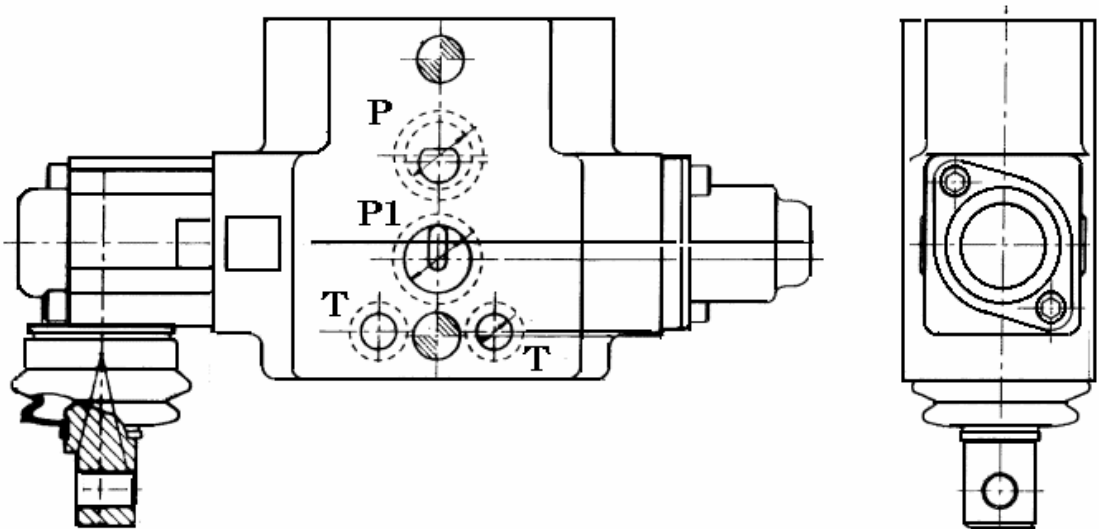

Fig. 9-69 Remote hydraulic pump

#### 3.1 HYDRAULIC CIRCUIT

P:From pump

T:To tank

A:High pressure port

B: Return port

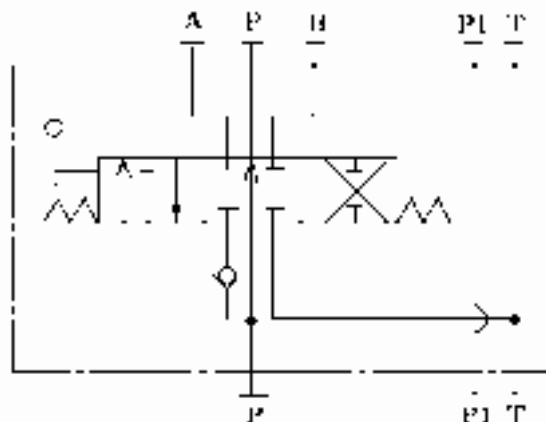

\*This chapter is applied to old version

<b>SECTION 1. GENERAL DESCRIPTION</b>	<b>9-1</b>
<b>SECTION 2. SPECIFICATIONS</b>	<b>9-2</b>
<b>SECTION 3. DISASSEMBLY AND ADJUSTMENT</b>	<b>9-3</b>
1. Hydraulic system	9-4
2. Disassembly	9-5
3. Reassembly	9-5
3.1 General precautions	9-5
3.2 Reassembly steps	9-6
4. Adjustment of the link mechanism	9-8
5. Special jigs for link adjustment	9-11
<b>SECTION 4. MAJOR COMPONENT OF THE HYDRAULIC SYSTEM</b>	<b>9-12</b>
1. main control valve	9-21
2. Flow-divider	9-31
3. Pressure control valve	9-22
4. Flow control valve	9-35
5. Safety valve	9-37
6. Relief valve	9-37
7. Gear Pump	9-39
8. Filter	9-40
<b>SECTION 5. Remote hydraulic control(Optional)</b>	<b>9-41</b>
1. General description	9-41
2. Functions	9-41
3. Specifications	9-43
<b>SECTION 6. TROUBLESHOOTING</b>	<b>9-46</b>



# Chapter 9 Hydraulic system

## SECTION 1. GENERAL DESCRIPTION

The hydraulic system is composed of a gear pump, valves, oil filter, cylinder (actuator), piping, etc. The implement lift is operated by a control valve which is actuated by the control lever through a link mechanism.

ON and OFF of the PTO is controlled by a hydraulic, wet, multi-disc clutch whose circuit is opened and closed by an electromagnetic valve in the flow-divider.

The construction and circuit of the hydraulic system are shown in Fig.9-1 and 9-2

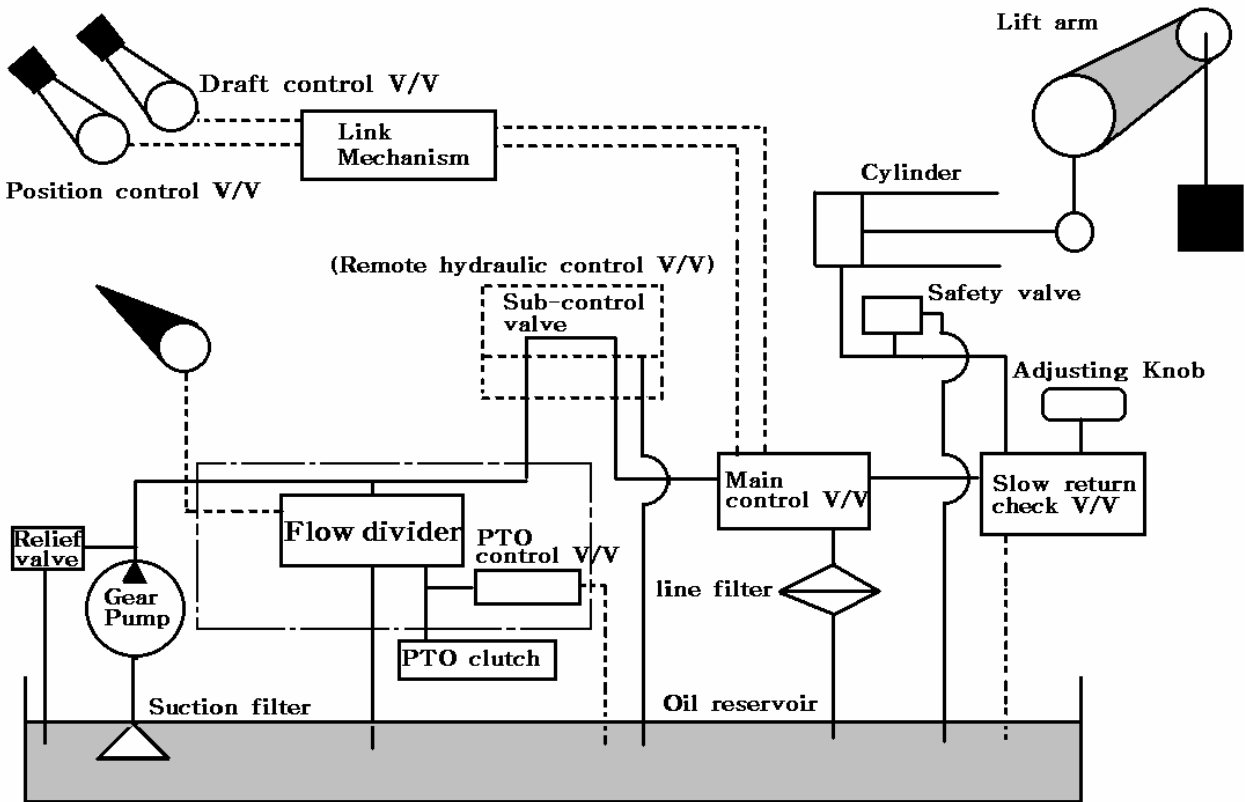
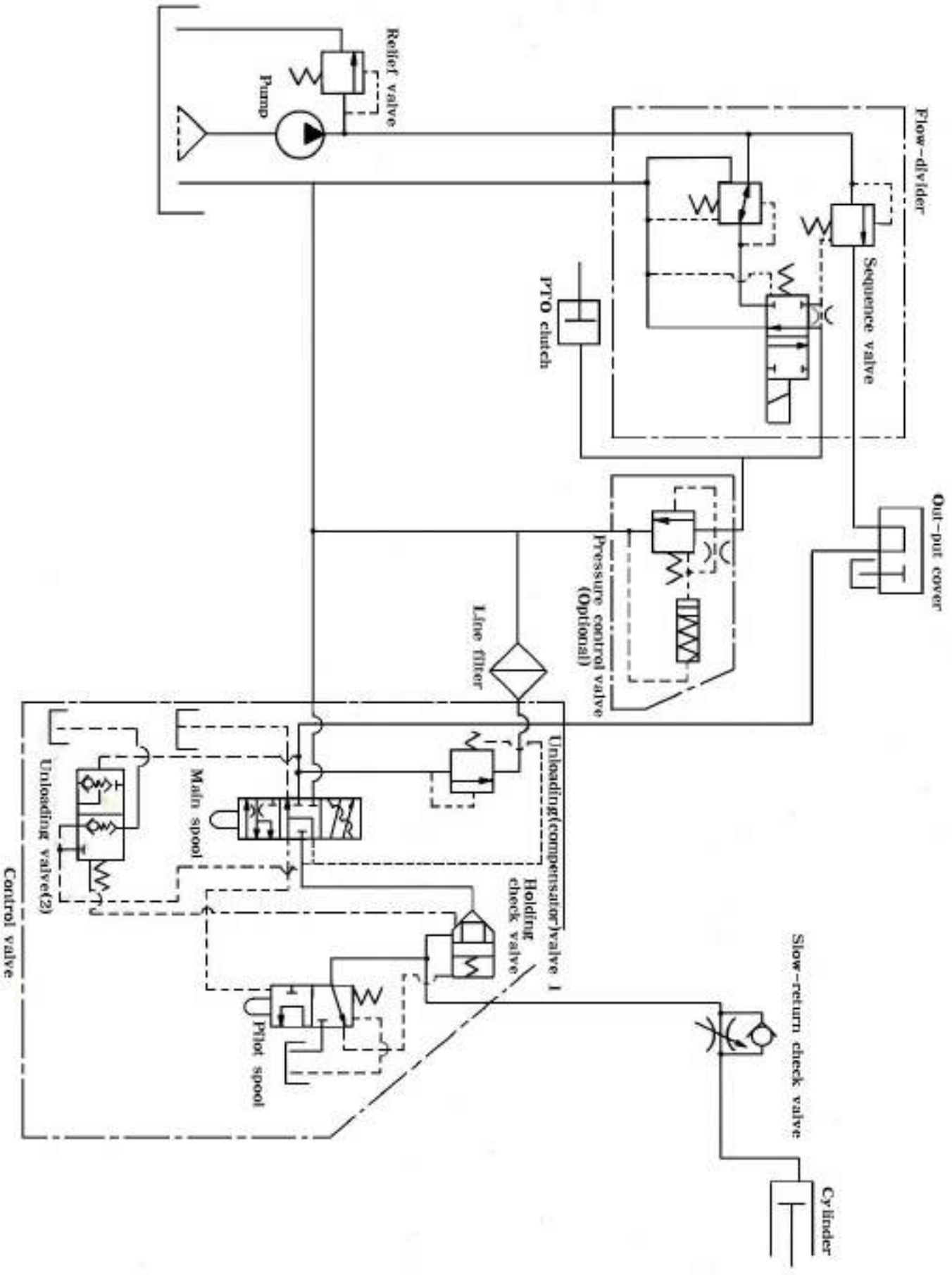

Fig.9-1 hydraulic system construction



SECTION 2.SPECIFICATIONS

MODEL		3510	4110	T390/ T400	T430/ T450	T431/ T451
Piston and cylinder	Lift(at lower link top end)	1300 Kgf				
Control valve	Cylinder port leaks (under a pressure of 9800KPa[(100Kgf/cm <sup>2</sup> ) with gear oil of SAE 80])	5cc(0.305 Cu in)				
Main relief valve	Cracking pressure	136 Kgf/cm <sup>2</sup>				
	Relief pressure	160~165 Kgf/cm <sup>2</sup>				
Gear Pump	Delivery(91% efficiency) : liter(cu.in)mm at 2600rpm	26.026 <i>ℓ</i>		29.8 <i>ℓ</i>		27.7 <i>ℓ</i>
Suction filter	Rated flow: (ℓ /min)	43	57			
	Filtration density	35 μm	25 μm			
	Filtration area	6231 cm <sup>2</sup>	11000 cm <sup>2</sup>			
Line filter	Rated flow: (ℓ /min)	32				
	Filtration density	10 μm				
	Filtration area	3,276 cm <sup>2</sup>				

NOTE: Recommendable Transmission oil

Manufacturer :Product

CALTEX :Textran TDH Premium

Texaco :TDH oil

Chevron :Chevron 1000THF

ESSO :Torque Fluid 56

MOBIL :Mobil fluid 423

SHELL :Donax TD

CASTROL :CASTROL AGRI MULTITRANS

TOTAL :Transmission MP

# SECTION 3. DISASSEMBLY AND ADJUSTMENT

## 1.HYDRAULIC SYSTEM

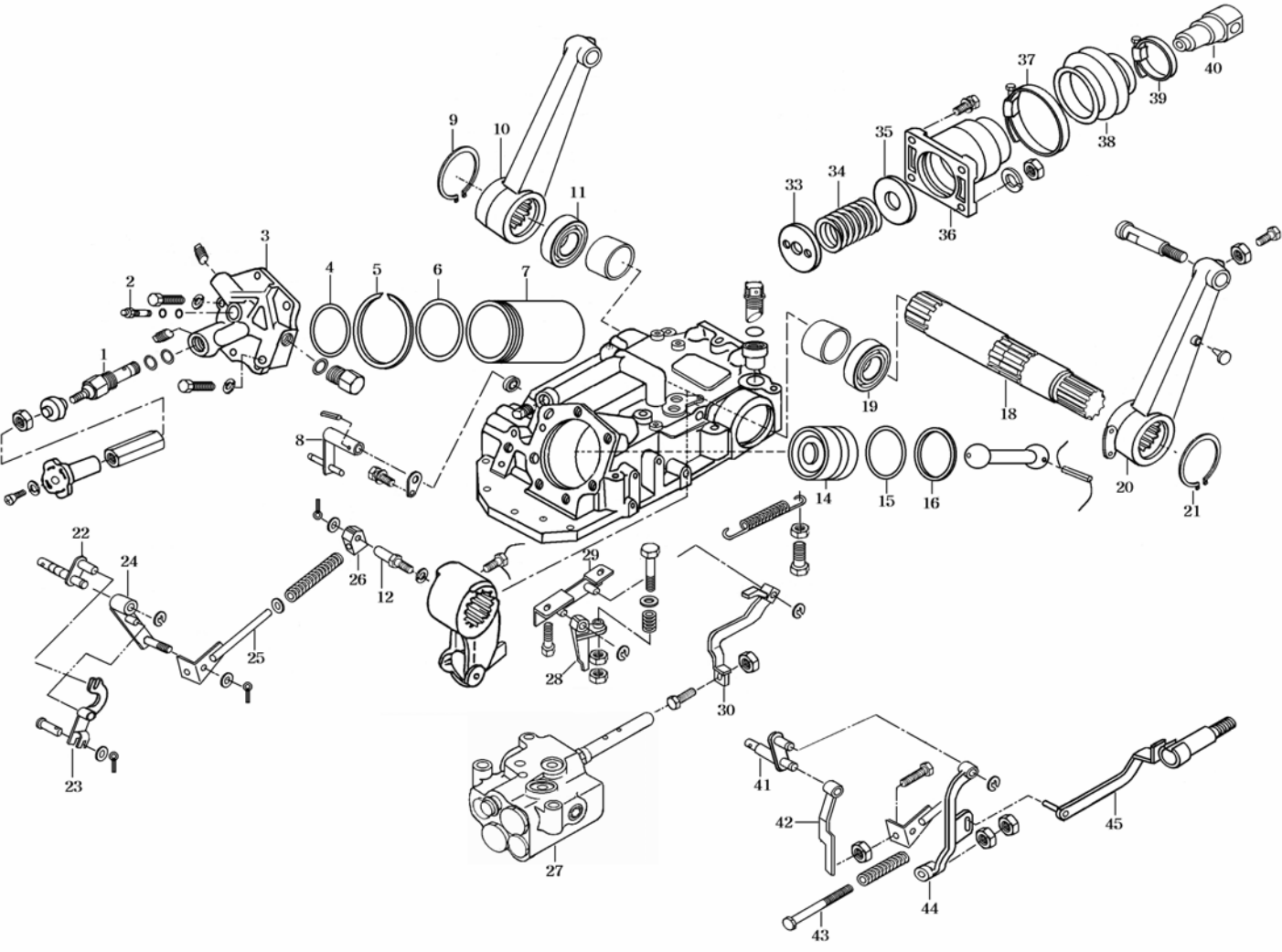

- 1.Flow-control valve (slow-return check valve)
- 2.Safety valve or plug
- 3.Cylinder valve
- 4.O-ring(G80)
- 5.Snap ring
- 6.O-ring(G95)
- 7.Cylinder
- 8.Position control rod
- 9.Snap ring
- 10.Lift arm(RH)
- 11.Oil seal
- 12.Pin(12X45)
- 13.Lift crank
- 14.piston

- 15.O-ring
- 16.Back up ring
- 17.Piston rod
- 18.Lift shaft
- 19.Oil seal
- 20.Lift arm
- 21.Snap ring
- 22.Position control arm
- 23.Arm comp
- 24.Feed back arm comp
- 25.Feed back rod comp
- 26.Feed back link
- 27.Main control valve
- 28.Arm
- 29.Holder comp

- 30.Pilot spool arm comp
- 31.Draft control arm comp
- 32.Stopper
- 33.Spring holder
- 34.Spring
- 35.Washer
- 36.Draft control spring case
- 37.Clamp
- 38.Boot
- 39.Clamp
- 40.Draft control boss link
- 41.Draft control arm comp
- 42.Arm
- 43.Pin
- 44.Arm
- 45.Draft control link comp

Fig.9-2

## 2.DISASSEMBLY

- 1) Remove the cylinder case assembly,referring to relevant paragraph in Chapter 2.

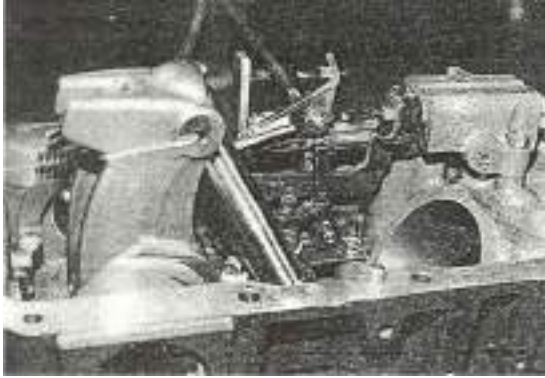

Fig.9-4

### Note:

Put the cylinder case on a wooden plank to prevent the surface from damage.

- 2) Remove the cylinder head and extract the cylinder.Then remove the piston from the cylinder.
- 3) Applying aligning marks on the lift shaft(18) and right hand lift arm(10).Then remove the lift arm.
- 4) Remove the set bolt for the lift crank(13) and remove the assembly of the lift shaft and lift arm(20).
- 5) Remove the assembly of the lift crank(13) and piston rod(17)
- 6) Unhook the spool-return spring and remove the main control valve.
- 7) Remove the following linkage:
  - a.Pilot spool control linkage
  - b.Position control linkage
  - c.Draft control linkage.

## 2.REASSEMBLY

Reassemble in reverse order of disassembly.

### 3.1 GENERAL PRECAUTIONS

- 1) Hydraulic system parts should be completely be free from dust before reassembly.
- 2) All removed O-rings should be replaced with new ones.which should be lubricated with grease before installation.
- 3) When the lift shaft is removed,the oil seal should also be replaced with a new one.
- 4) Install the piston from the cylinder head side. The O-ring and back up ring should be coated with grease ahead of time.Install with care so as not to damage them.
- 5) When assembling the lift crank on the lift shaft, mesh their splines using the alignment marks which were put there before disassembly.
- 6) Wrap the threads of the safety valve with sealing tape and then tighten the valve securely to the specified torque.

Tightening torque	5.0-6.0 Kgf.m (36.2-43.4 ft.lbs)
-------------------	-------------------------------------

- 7) When installing the control valve,apply grease to the O-rings and avoid their dislocation or binding during tightening the valve to the specified torque.

Tightening torque	1.3-1.8 Kgf.m (9.4-13.0 ft.lbs)
-------------------	------------------------------------

- 8) Tighten the slow return check valve to the specified torque.

Tightening torque	10-12 Kgf.m (72-87 ft.lbs)
-------------------	-------------------------------

- 9) Apply rod length L as specified(Fig.9-5)

Length L	114 mm(4.49 in)
----------	-----------------

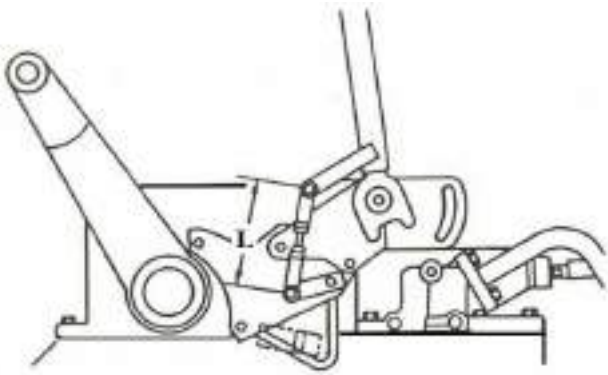

Fig.9-5

### 3.2.REASSEMBLY steps

- 1) Install the draft control linkage.

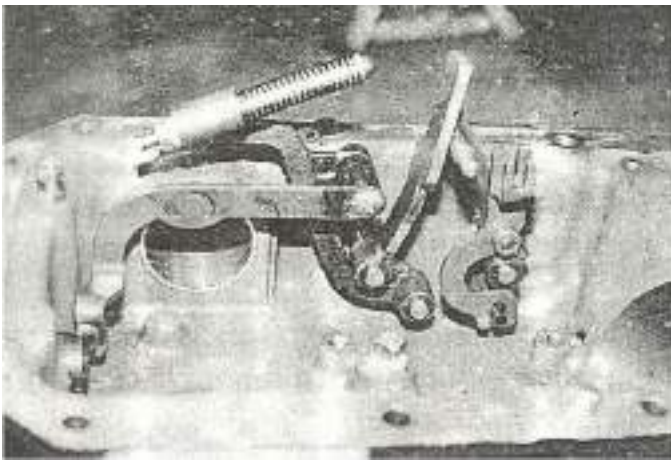

Fig.9-6

- 2) Install the position control linkage.

- 3) Install the pilot spool control linkage.



Fig.9-7

**Note:**

Before installing the linkage, set the load of the pressure spring to be 9.5-9.8Kgf(20.9-21.6 lbs) by making the installed length of the spring 21.5 mm (0.0847 in) (Fig.9-7)

- 4) Install the main control valve and return spring

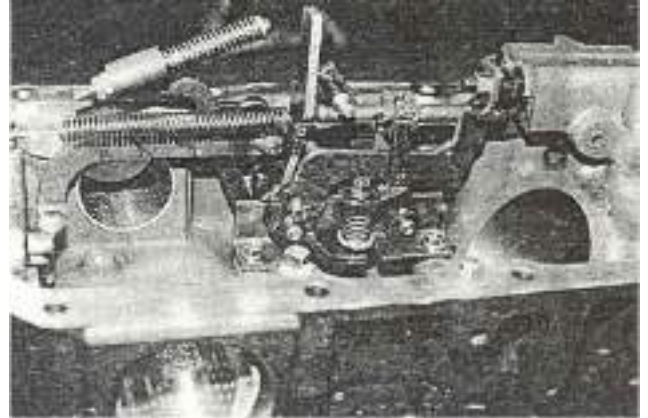

Fig.9-8

- 5) Install the lift crank temporarily along with the feed back link. Install the piston rod on the lift crank.

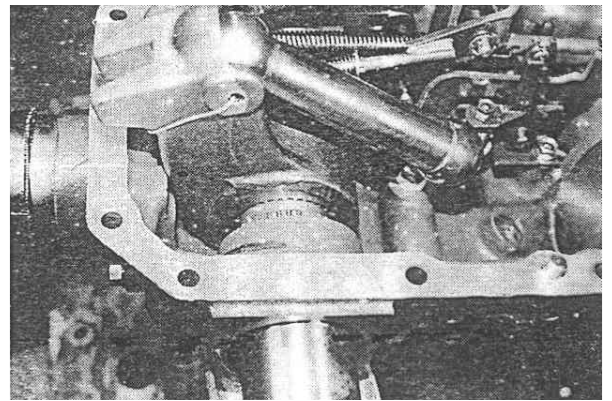

Fig.9-9

**Note:**

Drive the roll pin into the piston pin through the lift crank and lock the pin with wire.

- 6) Install the lift shaft and lift crank together in accordance with the aligning marks on them.



(Fig.9-10).Apply grease to the roll bush.

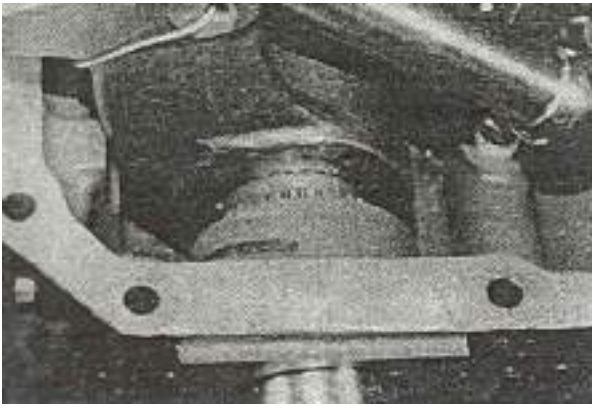

Fig.9-10

7) Drive the oil seal onto the lift shaft and install the lift arm.

**Note:**

When installing the oil seal,take care not to allow the oil seal lips to be damaged by the splines of the lift shaft.

8) Install the cylinder and piston.Then install the cylinder head.

## 4. ADJUSTMENT OF THE LINK MECHANISM

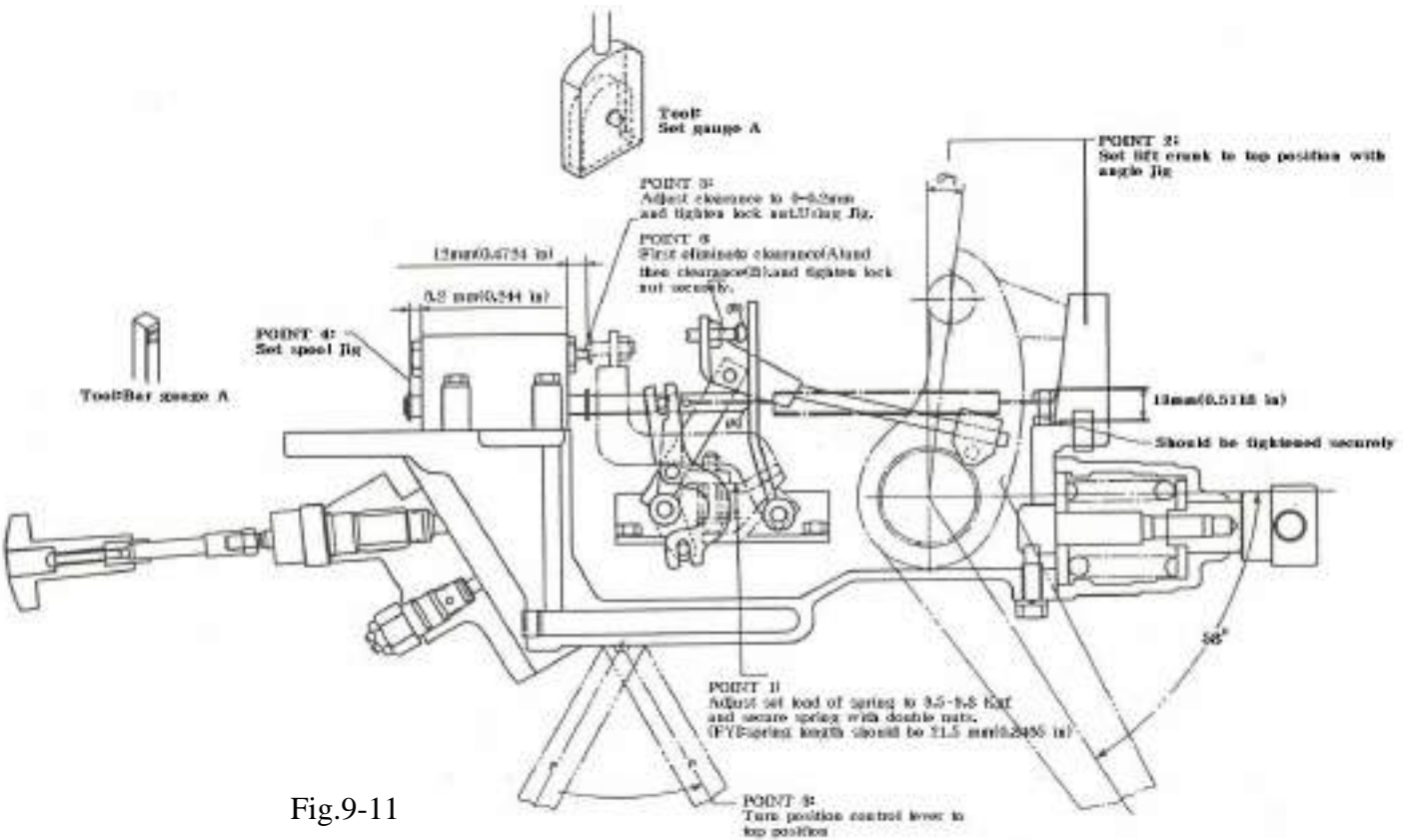

Fig.9-11

### 1) Adjustment of the position-control link mechanism.

Place the cylinder case assembly upside down so that the lift arm can be moved freely.

#### Point 1.

Set the load of the pressure spring of the pilot spool control arm to be 9.5-9.8 Kgf (20.9-21.6 lbs):the installed length of the spring is about 21.5 mm(0.847 in).

#### Note:

The cylinder should be removed ahead of time.

#### Point 2

Set the lift crank to the top position.Adjust the top position using an angle setting tool or determine the position where the angle of the lift arm from horizontal is 58°



#### Point 3

Set the position control lever to the top position.

#### Point 4

Fix the clearance between the back face of the snap ring on the main spool on the control valve front and the casing to be 6.2 mm(0.2444 in) with a setting tool,while the main spool is set in the neutral position.



### Point 5

Set the clearance between the pilot spool and the push rod to be 0-0.2mm(0-0.008in) with the adjusting screw.

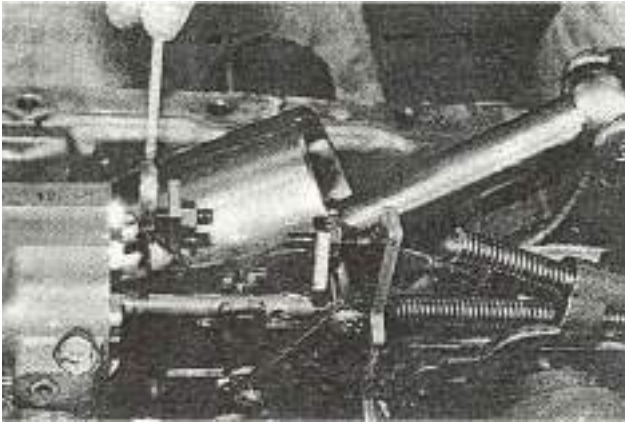

Fig.9-13

Link so that there is no play by the adjusting screw. It is recommended to hold the draft control push rod pushed against the arm for easier adjustment.

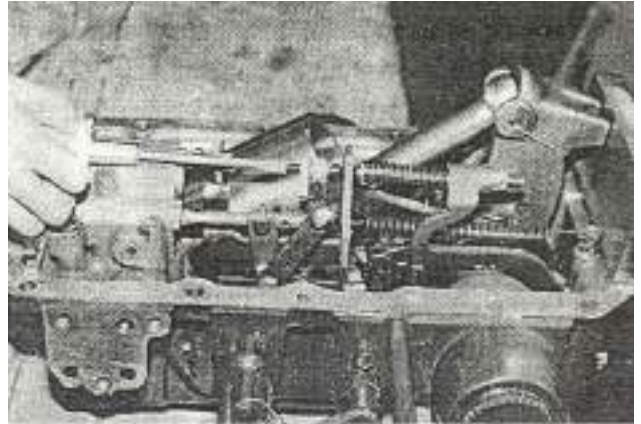
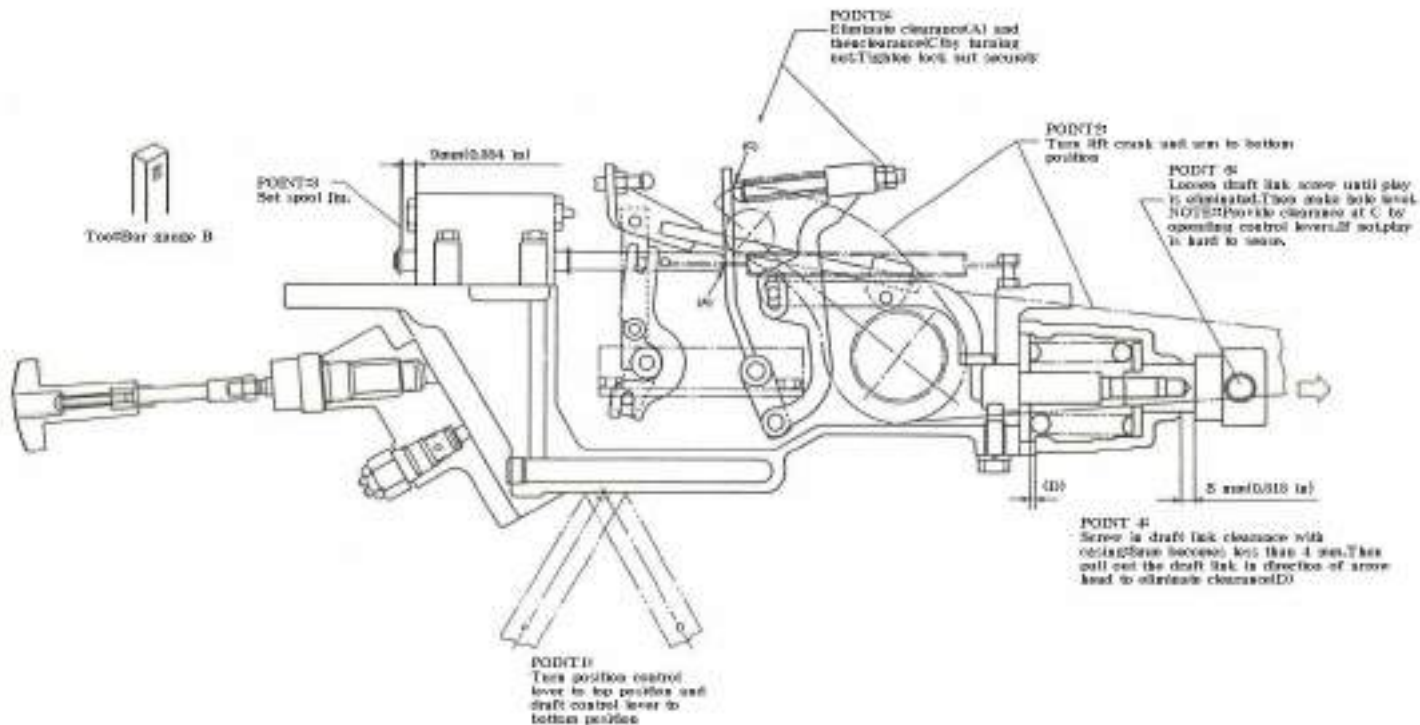

Fig.9-14

### Point 6

With the arm pushed against the main spool( the neutral position of the main spool), set the feed-back

Thus the adjustment of the position control linkage is completed.



## 2) Adjustment of the draft-control link mechanism

### Point 1

Shift the draft control lever to the top position and the position control lever to the bottom position.

**Point 2.**

Turn the lift crank to the bottom position

**Point 3**

Insert a spool jig between the back face of the snap ring on the main spool front and the casing and set the clearance to be 9 mm(0.35 in).The main spool circuit should be set for full open for Lifting

**Point 4.**

Screw in the draft link boss until the clearance with the casing becomes less than 4 mm(0.16 in) and make sure that the boss can be pushed in and out.Then hold the boss pulled out

**Point 6**

Loosen the draft link boss and eliminate its fore and –aft play.Then turn the boss so that the hole in it becomes horizontal.

Thus the adjustment of the draft-control link mechanism is completed.



Fig.9-16

**Point 5**

With the arm pushed against the main spool, eliminate any play of the draft control push rod and arm by loosening the lock nut.

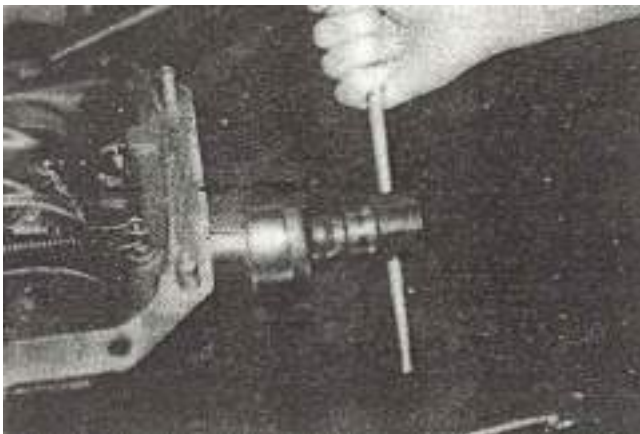
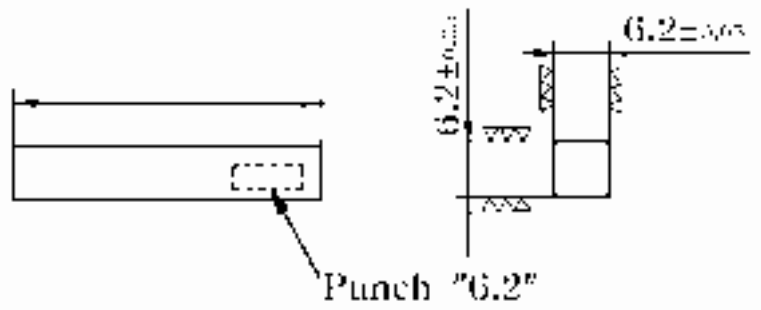

Fig.9-17

## 5.SPECIAL JIGS FOR LINK ADJUSTMENT

### Rod gauge(A)



### Rod gauge(B)

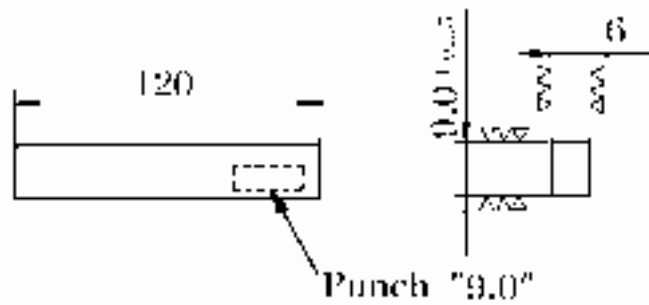
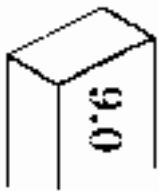

### Set gauge(A)

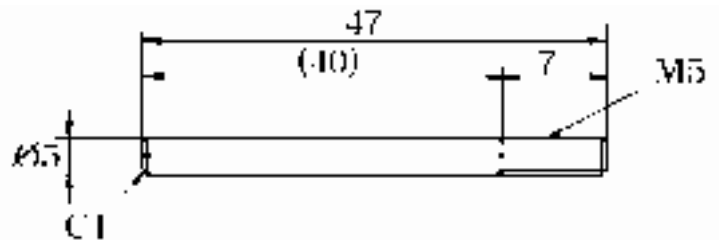
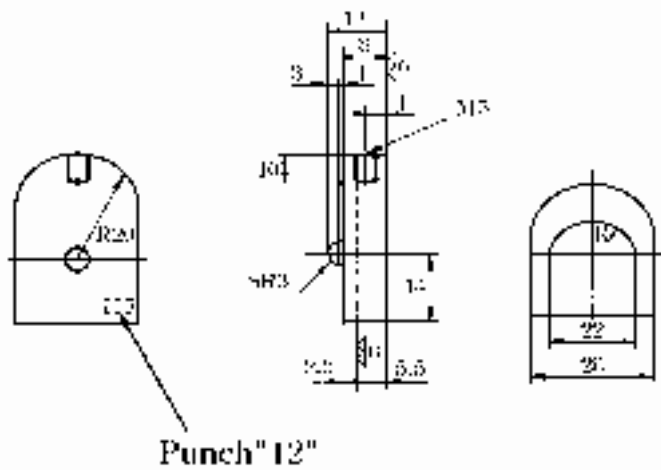
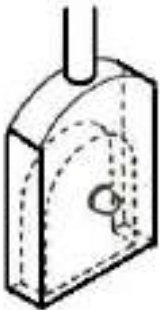

## SECTION 4. MAJOR COMPONENTS OF THE HYDRAULIC SYSTEM

### 1. MAIN CONTROL VALVE

#### 1.1 GENERAL DESCRIPTION

This valve controls the lifting and lowering operation of the hydraulic cylinder. It has especially been developed to control the working height of the implement. It consists of a feed back valve, direction control valve, flow-control unloading valve, and holding check valve.

#### 1.2 SPECIFICATIONS

Maximum operating pressure	250 Kgf./cm <sup>2</sup> (3556 psi)
Maximum flow	50 liters/min(3051 cu.in)
C-port leaks	5 cc/min below (Fluid temp : 50 °C :pressure :100Kgf.cm(1422 psi))

#### 1.3.CONSTRUCTION

##### Main spool

it consists of a spool, spool head, and snap ring E and has three functions.

- It opens and closes passages P to C and C to T and controls the passage wall area successively.
- It converts unloading pilot pressure to C-port pressure or tank pressure
- It turns the pilot pressure of the pilot spool on or off.

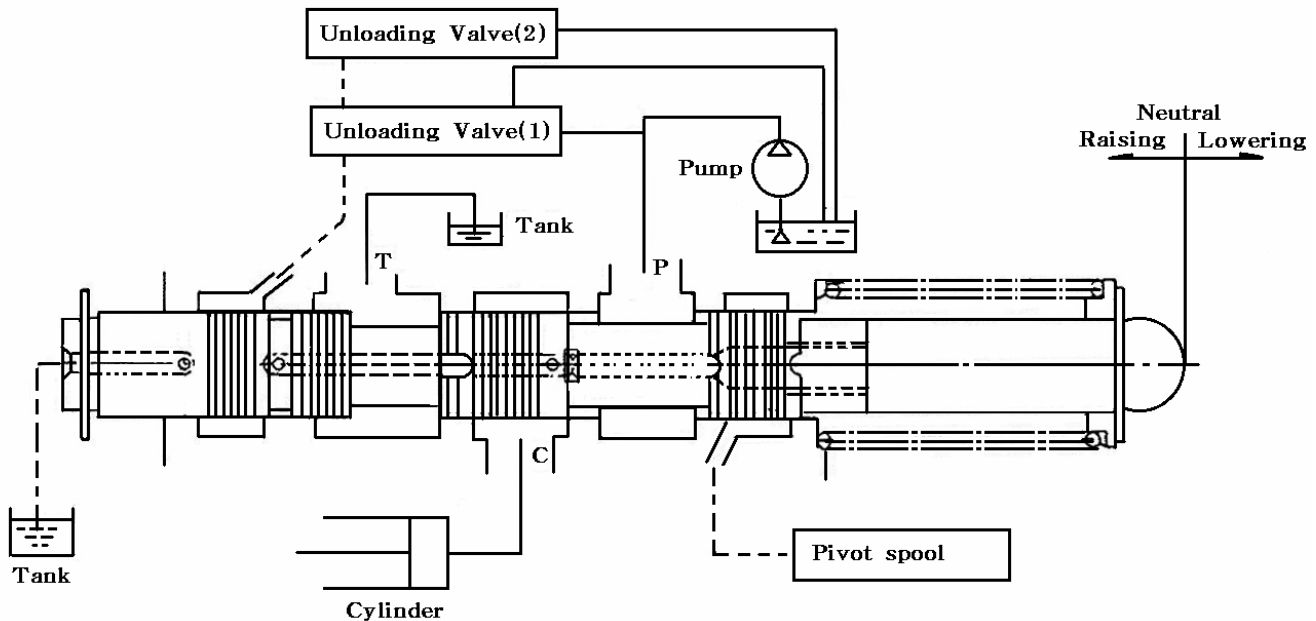

Fig.9-19

## 2) Unloading valve(1) (compensator)

it consists of the spool and spring.

While the main spool is neutral or in the lowering position, it diverts all the fluid from the pump directly to the tank. In this state, the pump delivery pressure is regulated to be  $7-8 \text{ Kg/cm}^2$  ( $100-114 \text{ psi}$ ) To prevent engine power loss and fluid temperature rise.

When the main spool is set in the lifting position, it delivers the fluid whose volume is in proportion to the opening to the port P-to C passage and surplus is diverted to the tank. Consequently only fluid with volume corresponding to main spool displacement is allowed into the cylinder through port C, Independent from fluctuations in cylinder pushing pressure and pump delivery pressure, which making it possible to perform very subtle operations such as inching. Moreover, as the pump delivery Pressure never exceeds the value of cylinder pushing pressure  $+7-8 \text{ Kg/cm}^2$  ( $100-114 \text{ psi}$ ), pump power loss is minimized.

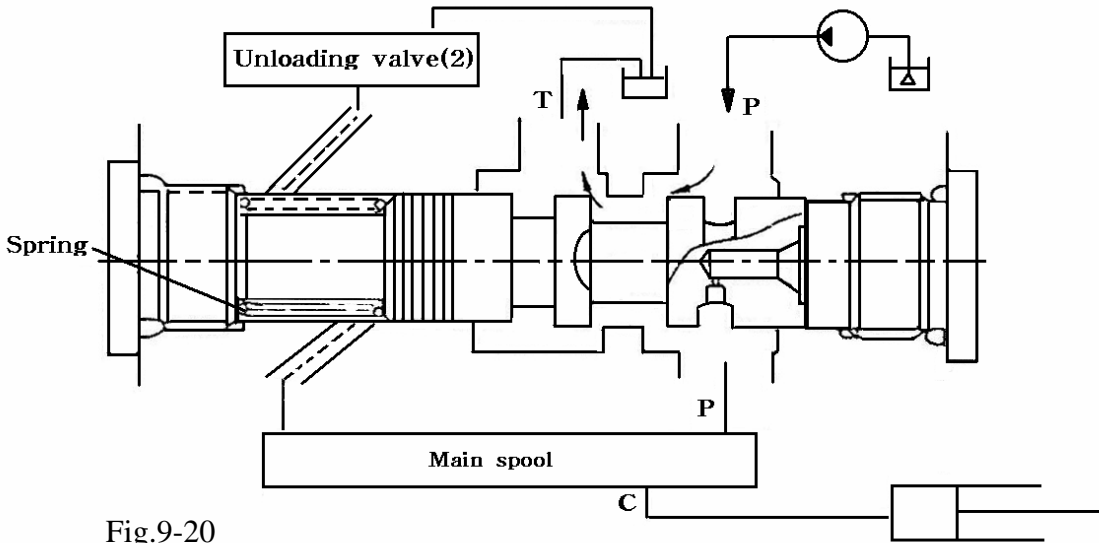

Fig.9-20

## 3) Unloading valve(2)

It consists of a spool, poppet ( $\varnothing 0.5$ ), spring and stopper bolt. This valve is installed to improve unloading efficiency. It works as follows.

When the main spool is shifted from the lifting position to the neutral position, it diverts the unloading pilot pressure to the tank, making use of port-C pressure.

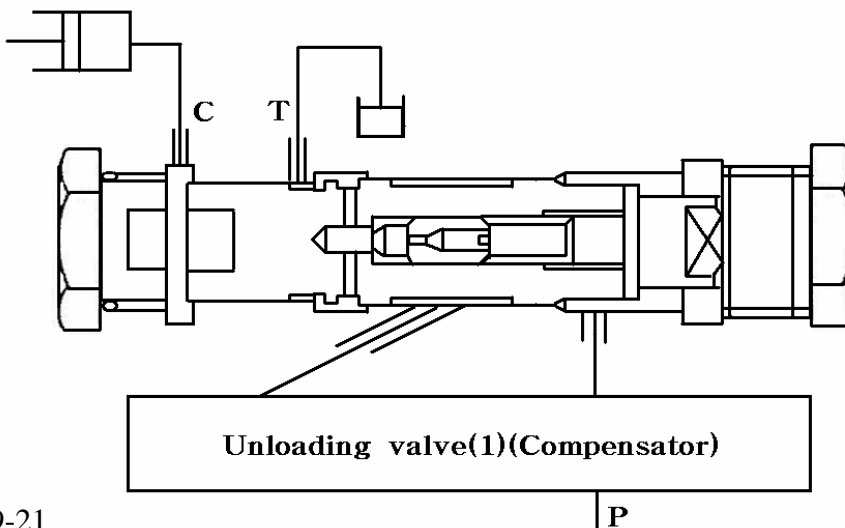

Fig.9-21

#### 4) Holding check valve

It consists of a check poppet and spring, and is installed between the cylinder port and the main spool. It blocks the flow from the cylinder to the valve in the neutral and in the lifting position, thus preventing the cylinder from releasing in the neutral or lifting position when the pump stops. In the lowering position, the pilot spool releases the spring chamber pressure and the check poppet opens the passage from the cylinder to the tank.

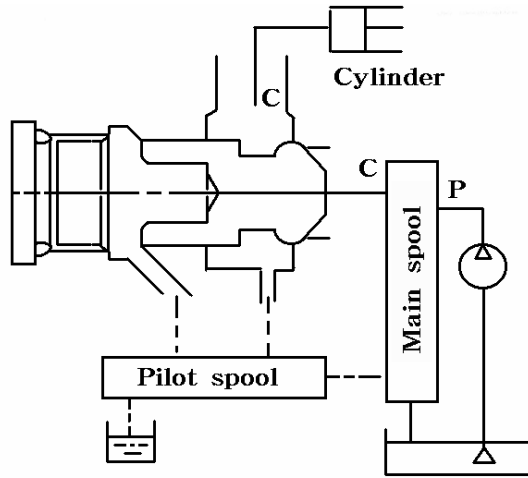

Fig.9-22

#### 5) Pivot spool

It consists of a pilot spool, sleeve, spring, plug, and push rod.

It is activated by the pilot pressure only while the main spool is in the lowering position. It connects the check valve spring chamber and tank to open the check valve. In other cases, that is, in the neutral or lifting position, the holding check valve functions as a check valve because the check valve spring chamber and port C are inter-connected.

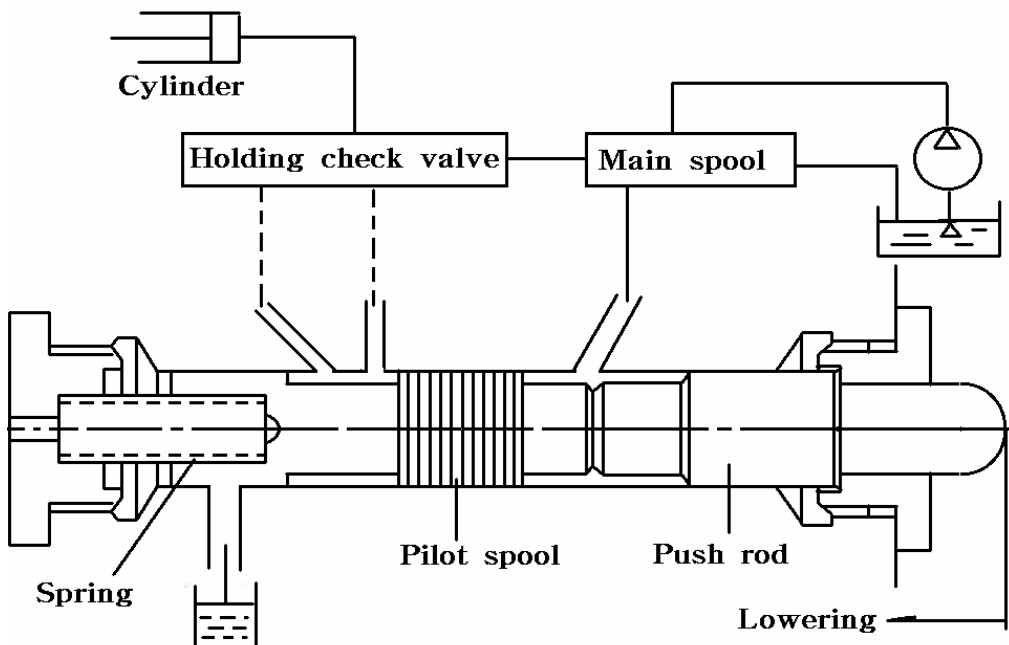

Fig.9-23

## 1-4 OPERATION

The valve operation is explained here referring to Fig.9-16 to 18.

Port P means "pump port" and is concerned to the pump, while port C means "Cylinder port", and is connected to the cylinder. Drain port T1 to T4 are connected to the tank.

### 1) Neutral position

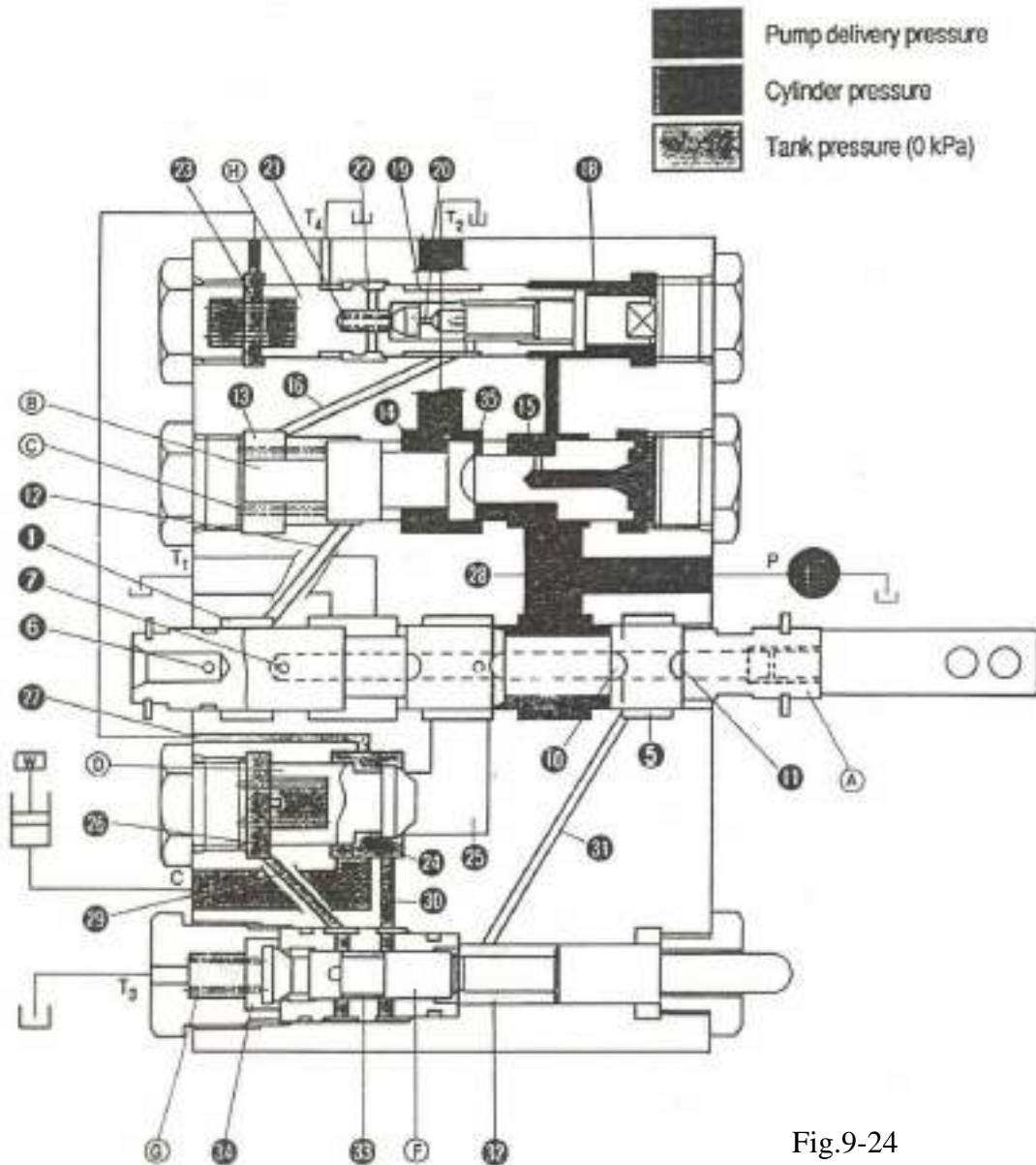

Fig.9-24

In the neutral position, orifice (7) is closed, orifice (16) is open, and chamber (1) is connected to port T4 through passages in the order of passage (12), chamber (13), passage (16), chamber (19), orifice (20), and chambers (21 and 22). As chamber (1) is connected with the unloading valve spring chamber (13) through passage (12), the pressure in the unloading valve spring chamber (unloading pilot pressure) is 0 Kpa (0 Kgf/cm<sup>2</sup>). Therefore the force imposed upon the left-hand side of the unloading valve is only that of the spring (C). Then the fluid from the pump flows into chamber (15) through port P and passage (28) and shifts spool (unloading valve 1) to open orifice (35). Through the orifice it flows out into the tank through chamber (14) and port T2. Its pressure is enough to resist the force of spring (C) : 7-8 Kgf/cm<sup>2</sup> (100-114 psi).



The pressure in chamber(32)(pilot pressure)becomes equal to the tank pressure[ 0 Kgf/cm<sup>2</sup>(0 psi)] because chamber(32) is connected with chamber(5). The pilot spool is then shifted rightward and passages(29 and 30) are connected with each other. Consequently the pressure in check valve spring chamber(26) becomes high enough to hold the piston steady and the check valve poppet (D) completely closes the cylinder circuit. In this state, fluid leaks through port C are prevented by the check valve poppet seat and also by friction surfaces of the pilot spool and the spool (H)(unloading valve 2), because check valve spring chamber (24) and chamber (23) of spool(H)(unloading valve 2) Are connected with each other through passage(27). That is, leaks from chamber(24) to passage (25) are prevented by the check valve poppet seat, those from chamber(33) to chambers(32 and 34) by the friction surface of pilot spool(F), and those from chamber(23) to port T4 by the friction surface of spool (H) (unloading valve 2)

## 2) Lifting position

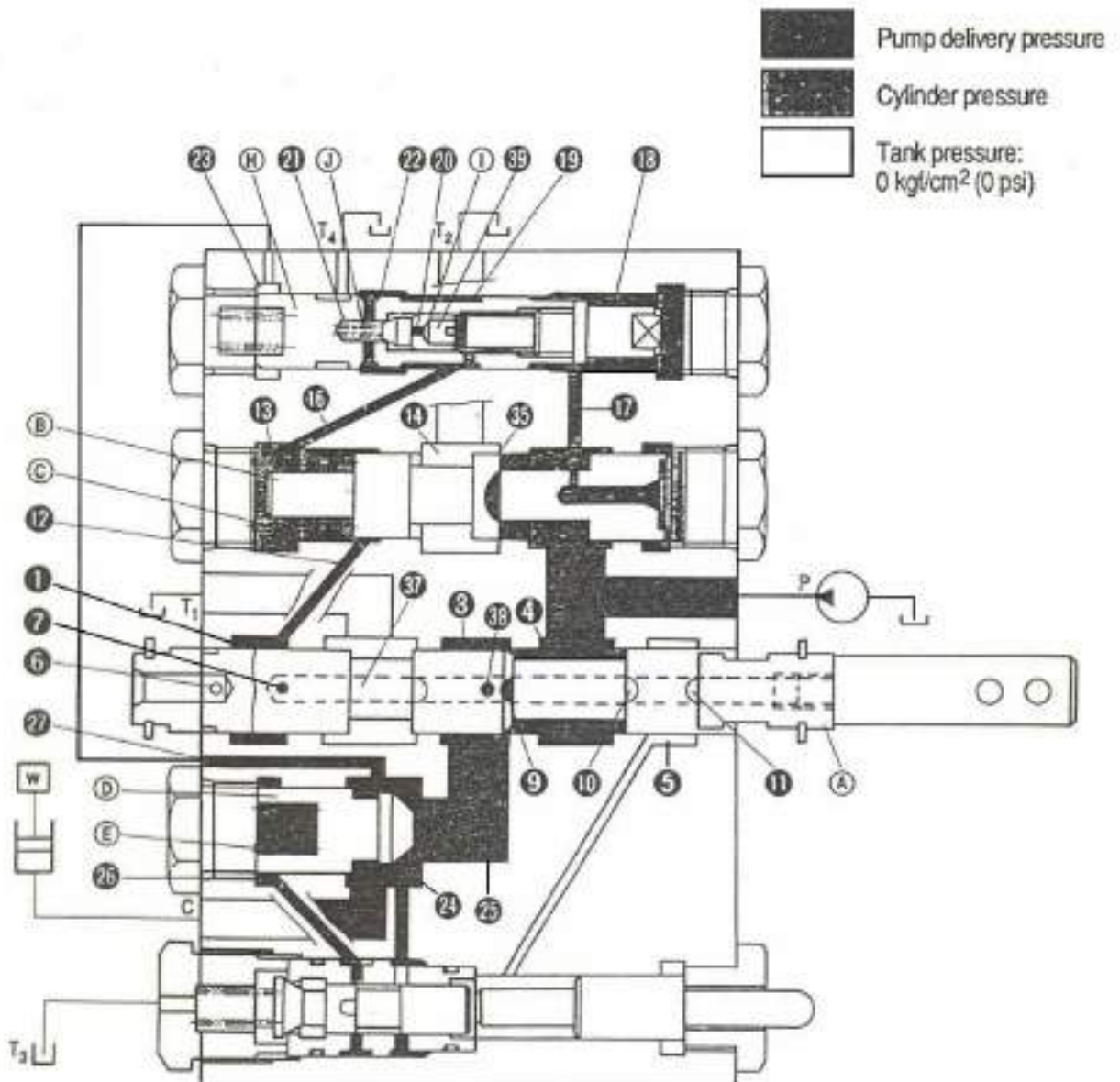

Fig.9-25



When spool (A) is shifted to the lifting position, orifice(6) is closed, and orifice(7) is opened and chamber(1) is connected with chamber(3) through passages(37 and 38): passages to the tank are closed. As orifice (11) is opened and orifice(10) closed, chamber(5) is connected to the tank. Chambers(3 and 4) are connected with each other through orifice(9). Chamber(13) is connected with chamber (3) through passage (12), chamber(7), and passages(37 and 38), so the fluid from the pump flows into chamber(13) from chamber(3) where it comes through chamber(4) and orifice(4) and orifice(9). Through passage(16) and chamber (19) it flows further into orifice(20) in the poppet(I) of spool (H)(unloading valve 2). Then a pressure difference is built up at orifice (20) and poppet (I) is shifted leftwards to disconnect chambers(39 and 21) from each other.

Pump delivery pressure is imposed upon the right-hand side of spool(B)( unloading 1) and combined force of the pump delivery pressure and the force of spring© upon the left-hand side. As pushed areas on both sides are the same, spool(B) is shifted rightwards and closes orifice(35). Consequently pump delivery pressure rises along with the pressure in passage(25)

When the pressure in passage(25) exceeds the combined force of that of spring (E) and the cylinder Holding pressure which holds check valve poppet(D) closed, the poppet is shifted leftwards connecting passage(25) and chamber(24) with each other. Then the pump delivery fluid flows into the cylinder through port C via Chamber(4), orifice(9), chamber(3), passage(25), and chamber (24), and activates the piston. The pump delivery fluid also flows into chamber(18) through passage(17) and shifts spool (H)(unloading valve 2), while chamber(22) is disconnected from port T4 but is connected with chamber(19). Thus pressure difference between chambers(21 and 39) is equalized out and poppet (I) is shifted rightwards, making the pressure in chambers(39, 21, and 22) the same as that in Chamber (13). Suppose that the piston push-up pressure is  $100 \text{ Kgf/cm}^2$  (1422 psi), and the pressure in chambers(24 and 26) is also  $100 \text{ Kgf/cm}^2$  (1422 psi), then the pressure in passage(25) is  $101 \text{ Kgf/cm}^2$  (1437 psi):  $100 \text{ Kgf/cm}^2$  (1422 psi) +  $1 \text{ Kgf/cm}^2$  (14 psi) - the force of spring E converted into hydraulic pressure imposed upon the left-hand side of spool(B)(unloading valve 1) is maintained at the combined pressure of the pressure in chamber(13):  $101 \text{ Kgf/cm}^2$  (1437 psi) and that by spring C:  $7 \text{ Kgf/cm}^2$  (100psi), that is,  $108 \text{ Kgf/cm}^2$  (1563 psi).

In this way, the pump delivery pressure is always maintained at a level higher than the piston push-up pressure by  $7 \text{ Kgf/cm}^2$  (100 psi), so the pressure difference between, in front of, and behind orifice(9): Pressure difference between chambers(4 and 3) is maintained at a constant  $8 \text{ Kgf/cm}^2$  (114psi) Independent from cylinder push-up pressure or fluid volume delivered by the pump. Therefore the fluid volume which passes orifice(9) is constantly controlled at a level conforming to the open area of the orifice. This means that subtle control or damping of shocks at the starting and ending of lifting Operation is easily achieved by adjusting the opening of orifice(9). If the spool is shifted enough to fully open orifice(9), the pressure difference between, in front of, and behind the orifice [between chambers(4 and 3)] is flattened out. So pressure imposed upon both sides of spool(B)( unloading 1) is equalized and the spool is shifted rightwards by the spring force. Then all fluid from the pump flows into the cylinder to push up the piston at full speeds.

If the pump should stop delivering fluid resulting from a stalled engine, pump breakdown, etc., the check valve poppet(D) closes immediately to block the passage from the cylinder, thus lowering of the implement is prevented.

### 3) Lowering position

When spool(A) is shifted to the lowering position, orifice(6) is opened, orifice(7) is closed, and chamber(1) is connected to the tank, while orifice(11) is closed, orifice(10) is opened, chamber(5) is Connected to the tank, while orifice (11) is closed, orifice(10) is opened, chamber(5) is connected to chamber(4), and the passage to the tank is closed. Chamber(3) is connected to chamber (2).

In the same manner as in the neutral position,unloading pilot pressure becomes 0 Kgf/cm<sup>2</sup>(0 psi) And almost all fluid delivered by the pump flows out into the tank through chamber(15), orifice(35), and chamber(14).Pump delivery pressure becomes 7-8 Kgf/cm<sup>2</sup>(100-114psi).Orifice (10) is opened, allowing part of the fluid delivered by the pump to flow into chamber(5) and through passage(31) into chamber(32).

All pump delivery pressure [7-8 Kgf/cm<sup>2</sup>(100-114psi)] is imposed upon the right hand side of pilot spool(F) in this stage,the spool is shifted leftwards overcoming the force of spring(9).By this shifting, passage(30) is closed and chamber(26) is connected to port T3 through passage(29), chamber(33), orifice(36),and chamber(34).consequently the force imposed upon the left hand side of check valve poppet(D) becomes that of spring(E) alone.On the other hand,cylinder holding pressure is imposed upon the right-hand side surface of the poppet except the area covered by the seat,and the poppet is shifted to open.By this action,the fluid from the cylinder flows out and into the tank from port T1 Through chamber(24),chamber(25),orifice(8),chamber(2) and passage(40),so the piston is released. When the opening of orifice(8) is small,some pressure is built up in chamber(3) and works as braking pressure to control the lowering speed of the lift.Of course when the orifice is opened fully,no braking pressure is built up,so the lift lowers at full speed.

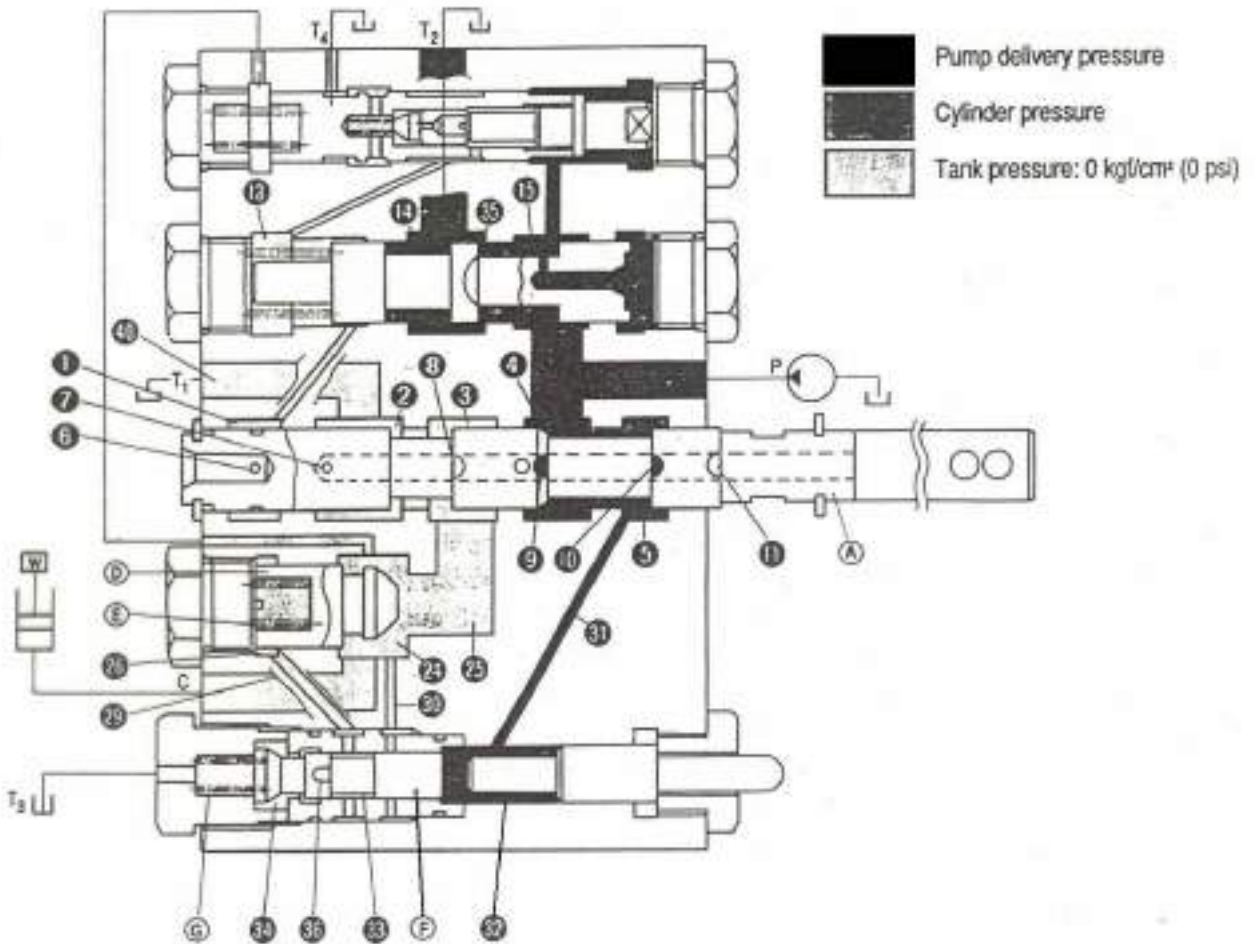

Fig.9-26

#### 4) Lifting to neutral shifting(unloading process)

While the piston is rising,the configuration of the control valve is the same as in the lifting position. But when the piston stops rising at a required position,spool(A) returns to neutral position. In this state,orifice(7) is closed and orifice (6) is opened,so the pressure in chamber(13) becomes lower than that in chamber(15) and spool (B) (unloading valve 1) is shifted leftwards a little to let pump delivery fluid flow out through orifice(35).As pump delivery pressure becomes lower than cylinder holding pressure,passage(27) becomes higher than that in chamber(18).Consequently spool (H) (unloading valve 2) is shifted rightwards and chamber(22) is connected to port T4,Chamber (13) is also connected to port T4 through passage(16),chamber(19),orifice(20),chamber (21),and chamber(22),so the surplus pressure in chamber(13) is released.In short when the control valve is shifted from the lifting position to the neutral position,The pressure in chamber(13) on the right-hand side of spool(B) is forced to release to port T4 and thus unloading operation is performed positively.

### 1.5. SERVICING INSTRUCTIONS.

#### 1) Required tools

- 6mm set screw wrench and torque Wrench
- 19mm spanner and torque wrench
- 22mm spanner and screw wrench
- conventional screw driver[3mm(0.12 in) in blade width]
- plastic rod [Ø10mm(Ø0.394 in)]
- Oil stone,cleanser,tweezers,etc.

#### 2) Tightening torque

Description	Size	Tightening torque Kgf.m(ft.lbs)
Plug	M16	3.5 (25.3)
Plug	M14	2.5 (18.1)
Sunk Plug	PT /4	2.5 (18.1)
Spool head	M6	0.8 (5.8)
Stopper bolt	M6	0.8 (5.8)

#### 3) Disassembly

-Main spool and related parts.

Remove the snap ring E and draw out the main spool carefully.

##### Note:

The main spool and spool head are screw-fitted, so they can be separated from each other. But they are tightened with adhesive applied,so they should not be disassembled unless required.

##### -Holding check valve and related parts.

Remove the plug and take out the spring. The poppet can come out only by slanting the casing, and if not,remove it with pliers.

##### -Unloading valve(1): compensator

Remove the plugs from both sides and take out the spring and spool.

##### -Unloading valve(2)

Remove the plugs from both sides and take out the spring and spool.

##### Note:

The spool and stopper bolt are tightened with each other with adhesive applied to their threads, so they should not be separated unless required. by removing the stopper bolt,the poppet and spring can be taken out of the spool.

##### -Pilot spool and related parts.

Remove the plugs from both sides and take out the spring and push rod.

The pilot spool set can be pushed out from the push rod side with a Ø10 mm(Ø0.394 in) rod. When pushing,put the rod on the sleeve,not the spool.

##### Note:

The spool and sleeve cannot be separated from each other.

#### 4) Reassembly

-Inspection of the disassembled parts.

Place all the disassembled parts side by side on a clean surface. Check o-rings for damage and replace defective ones. Inspect the friction surfaces of the spools, poppets, and casing for flaws like scratches. Correct slight flaw with an oil stone and wash corrected parts in a cleanser.

##### -Main spool and related parts.

When the head is disassembled, it should be tightened and locked securely using adhesive. Before retaining the spool with the snap ring E, make sure that the spool slides smoothly within the casing.

##### -Holding check valve and related parts

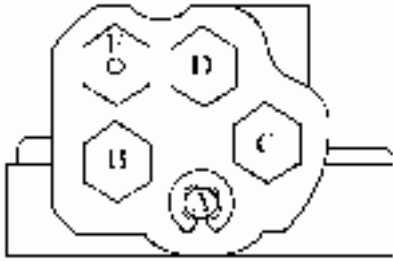

Fig.9-27 (A) Main spool hose  
(B) Check valve's hole  
(C) Unloading valve-1's hole  
(D) Unloading valve-2's hole  
(E) Pilot spool's hole

Put the poppet into hole B as shown in the figure and make sure that the poppet slides smoothly. Then put the spring in and tighten the plug, on which the O-ring must be installed, to the specified torque.

##### -unloading valve(1) and related parts.

Install the spool into hole C (Fig.9-19) in the correct direction. Put the spring in and tighten the plug to the specified torque.

##### -Unloading valve(2) and related parts.

Install the spool and confirm that it returns smoothly by the spring force after it is compressed by pushing the stopper bolt end and check that it slides smoothly.

##### -Pilot spool and related parts.

Be careful not to damage the O-ring during pilot spool installation. After assembly, make sure that the spool slides smoothly by pushing the push rod.

## 2.FLOW-DIVIDER( PTO solenoid valve)

### 2.1 GENERAL DESCRIPTION

This valve is installed to bypass working fluid of a specified pressure from the main circuit into the PTO circuit through a fixed orifice. It includes a changeover valve for engaging and disengage the PTO clutch by means of a solenoid and a sequential valve for PTO circuit's over the main circuit.

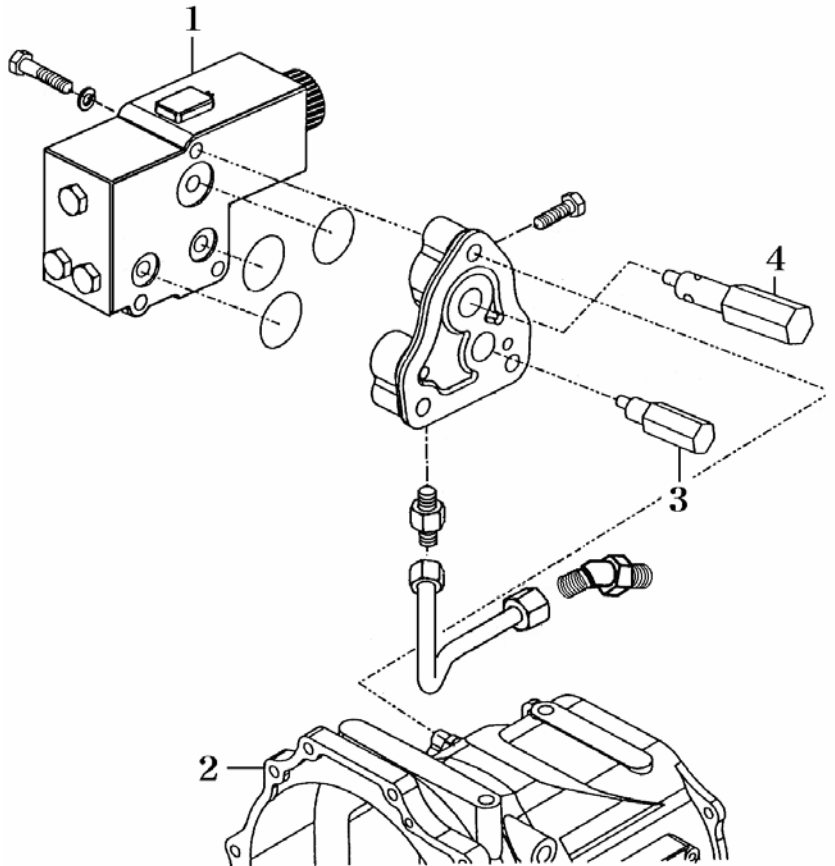

- (1) Flow-divider
- (2) Transmission case
- (3) Relief Valve
- (4) Pressure control valve

Fig.9-28

### 2.2 CONSTRUCTION

#### (1) Solenoid

This solenoid is switched on or off by operating the PTO switch. With this lever operation, the solenoid shifts the changeover valve to the left or the right to bypass or block the flow to port B.

#### (2) PTO changeover valve

This valve is composed of the spool and spring. When the solenoid is switched on, the spool is moved to the left by overcoming the spring force and allows the fluid from the pump to flow from port P to port B through the fixed orifice.

**-When the solenoid is switched 「ON」**

The fluid from the pump flows to port B through port P, the pressure-reducing valve, and the changeover valve.

The pressure of the PTO clutch circuit and that of passage(2) are the same and will be set as  $P_2$ . The pressurized fluid acts on the left-hand side of the valve, passing through port ; its pressure will be set as  $P_1$ .

As passage (1) and passage (2) are interconnected, then  $P_1 = P_2$ .

The force imposed upon the left-hand side of the valve is  $P_1$  whereas the force imposed upon the right side of the valve is  $P_1$  plus the spring force. Consequently the spool is pushed leftwards.

Here port A is blocked, so the fluid from the pump is branched off to the PTO clutch.

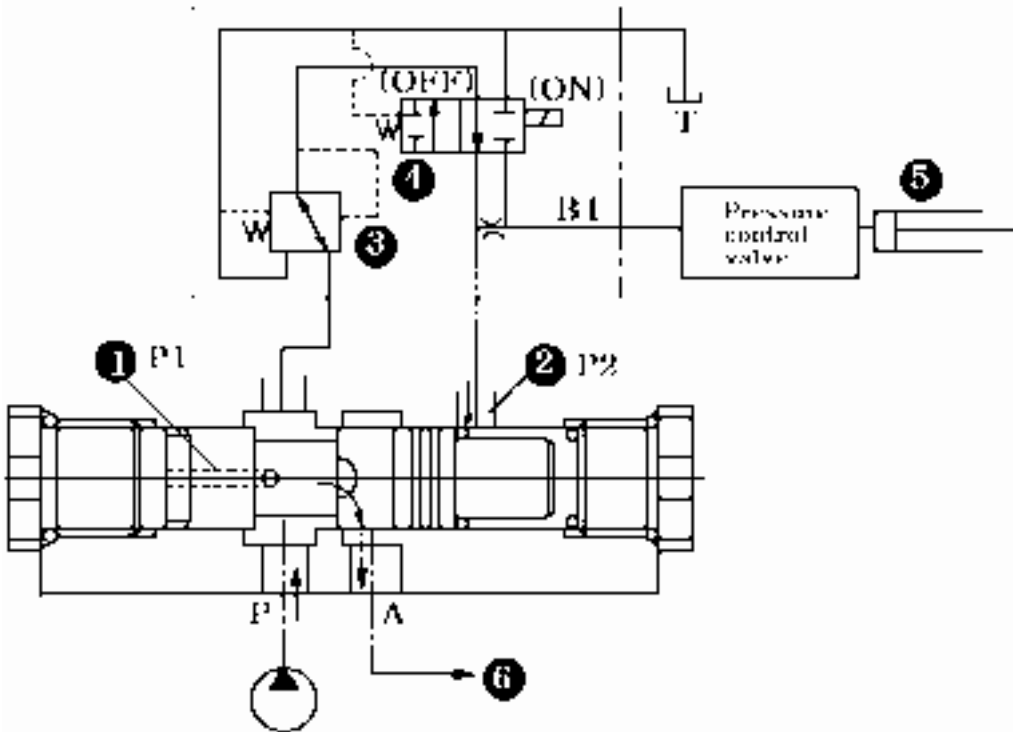

Fig.9-29

- (1) Passage 1
- (2) passage 2
- (3) Pressure-reducing valve
- (4) Changeover valve
- (5) PTO clutch
- (6) To control valve.

**-When the solenoid is switched 「OFF」 :**

The fluid in the PTO clutch is unloaded to the tank through port B. Consequently pressure  $P_2$  at passage (2) becomes zero, whereas the pressure at passage (1) is  $P_1$ . Then the force imposed upon the left side of spool ( $P_1$ ) overcomes the force imposed upon the right side ( $P_2 + \text{spring force}$ ), so that the spool is pushed rightwards to connect port P and part A. Therefore no fluid from the pump is branched off to the PTO clutch; that is, all fluid flows to the control valve.

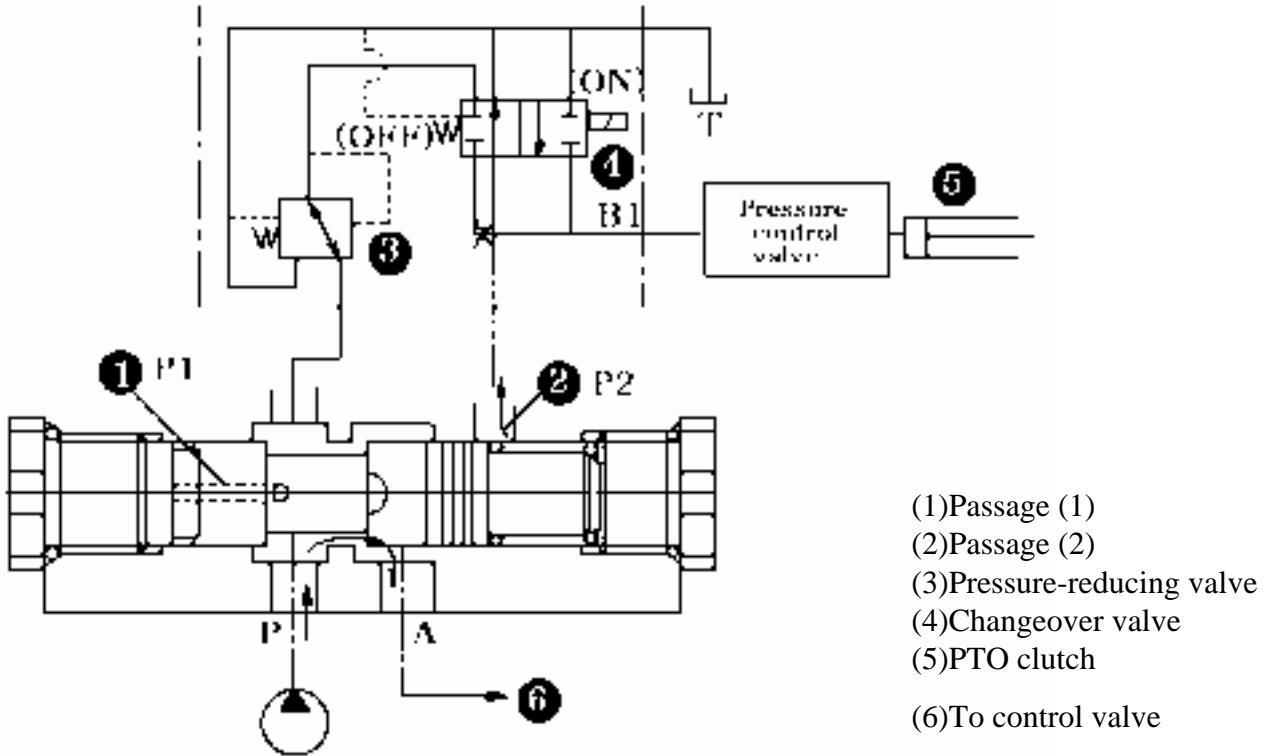

Fig. 9-30 PTO solenoid switch 「OFF」 position

**(1) Pressure-reducing valve.**

This valve is composed of the spool, spring, and piston and bleeds off the surplus fluid from the pump into the tank by actuating the spool when the fluid pressure exceeds the regulated pressure at port B

**(2) Fixed orifice**

This orifice controls the fluid flow at B in accordance with the pressure differential between the secondary pressure of the pressure reducing valve and the PTO clutch actuating pressure.

## 2.3. OPERATIONS

The operations of this valve will be explained by reference to the operation diagrams in Fig.9-31 and 33.

Port P is connected to the pump; port A is connected to the main circuit(port P of the control valve) ; port B is connected to the clutch cylinder; port T is connected to the tank.

### 1) OFF position

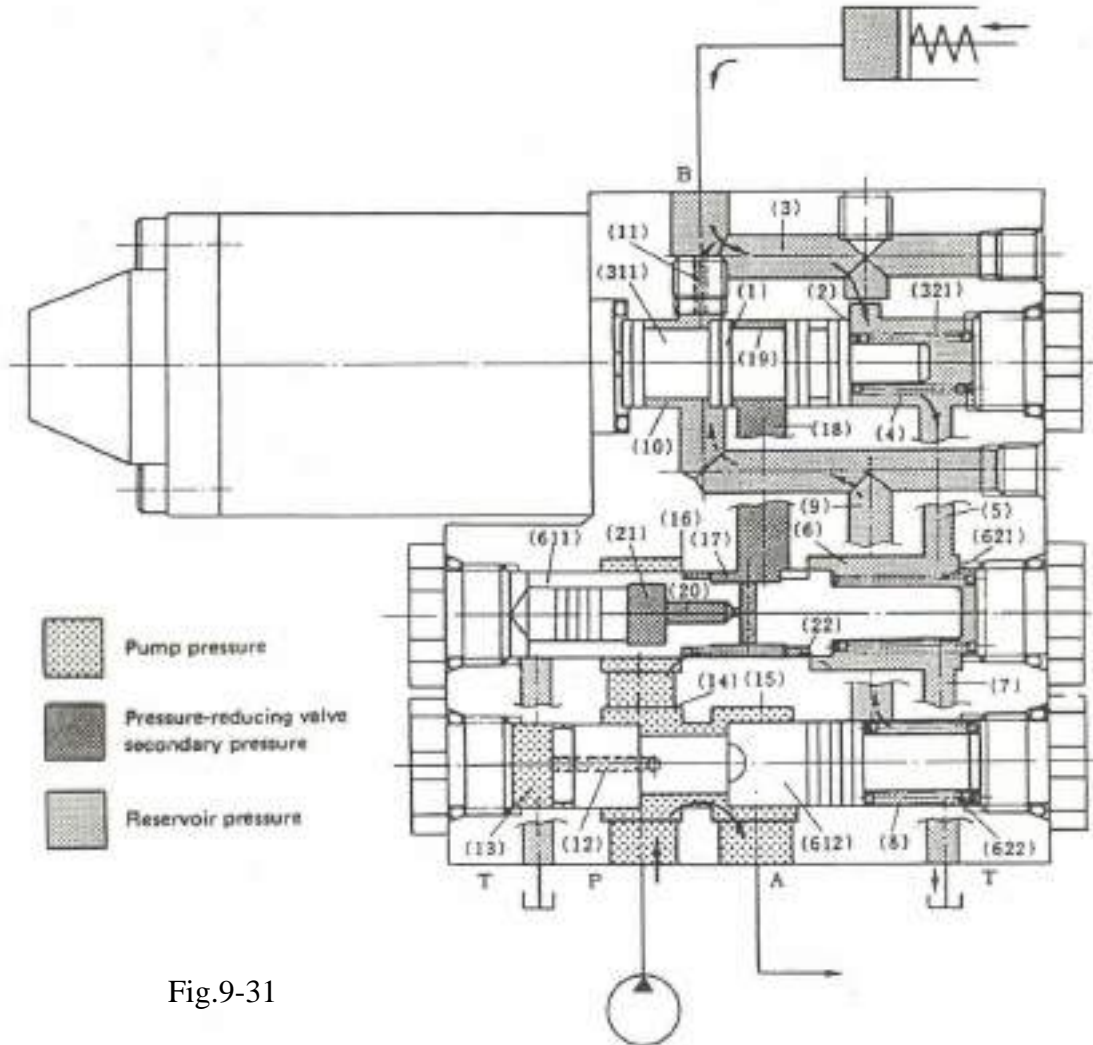

Fig.9-31

While the solenoid is switched off, the fluid in the cylinder is unloaded to the tank and all fluid from the pump flows to the main circuit with no branching. The details of this operation are described below: Changeover spool (311) is pushed leftward by spring(321), so that orifice(1) is closed whereas orifice(2) is opened. Consequently, the fluid in the cylinder flows to the tank from port B, via passage(3), chamber(4), passage(5), chamber(6), and passage(7). As the fluid in sequential valve spring chamber(8) is connected to the tank via passage(9), chamber(10), orifice(11), and passage(3), the pressure in chamber(18) becomes 0 kgf/cm<sup>2</sup> (0 psi) and the force for pushing sequential valve spool(612)leftwards is just the force of spring(622). The pump delivered fluid is led to chamber(14) through passage(12) and pushes the sequential valve spool rightwards and flows to the main circuit from port A via chamber(14 and 15). At this point, if the pressure at port A, that is, the pressure at port P is low because of the unloading of the main circuit, pressure-reducing valve spool(611) is pushed leftwards by the force of spring(621) and orifice(16) is fully opened,



which renders the pressure in chambers(17, 18, and 19) the same as the pressure at port P. When the main circuit pressure is higher than the pressure regulated by spring(621): 15kgf/cm<sup>2</sup>(214 psi), pressure-reducing valve spool(611) works to maintain the pressure in chamber(17), the pressure-reducing valve secondary pressure, at a specified level.

The operation of the pressure-reducing valve with a regulated pressure of 15kgf/cm<sup>2</sup>(213 psi) will now be explained.

The pressure in chamber(17) is led to chamber(21) through passage(20) and pushes the pressure-reducing valve spool rightwards. When the pressure in chamber(17) is higher than 15kgf/cm<sup>2</sup>(213 psi), pressure-reducing valve spool(611) is pushed rightwards, which closes orifice(16) to block the passage from the higher pressure side and at the same time opens orifice(16) leading to the tank, and as a result the pressure in chamber(17) lowers.

**Circuit diagram in the Off position**

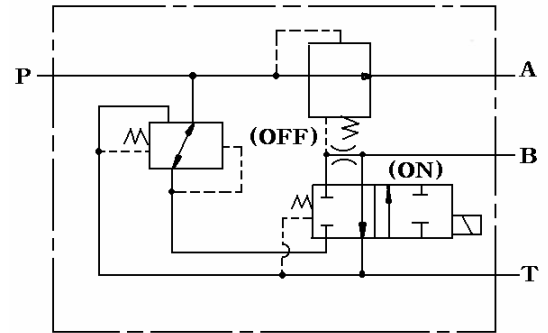

Fig.9-32

Conversely, when the pressure in chamber(17) is lower than the specified pressure, spool(611) is pushed leftwards by the force of spring(621), which results in the closing of orifice(22) and the opening of orifice(16). This leads to a rise in the pressure-reducing valve secondary pressure is maintained at 15kgf/cm<sup>2</sup> (213 psi).

## 2)ON position

When the solenoid is switched on, a specified amount of the fluid from the pump is branched off to the clutch cylinder. When the clutch is engaged and the cylinder pressure rises, the cylinder pressure is maintained at a specified level by reducing the amount of the fluid branched off. The detail of this operation will be explained in two situations: when the main circuit pressure is higher than the port B regulated pressure (pressure-reducing valve secondary pressure) and when the main circuit pressure is lower than the regulated pressure.

### • When the main circuit pressure is higher than the regulated pressure:

When the main circuit pressure is higher than the regulated pressure, the sequential valve(612+622) does not work when sequential valve spool(612) is pushed rightwards.

When the solenoid is switched on, the changeover spool is pushed rightwards and orifice(1) is opened to connect passage(18) to chamber(10) whereas orifice(2) is closed to block the passage to the tank. Some of the fluid delivered from the pump is led to the clutch cylinder from port B via chamber(23), orifice(16), chamber(17), passage(18), chamber(10), and orifice(11). At this point, provided that the orifice(16), chamber(17), passage(18), chamber(10), and orifice(11). At this point, provided that the cylinder actuating pressure is 1 kgf/cm<sup>2</sup> (14 psi): the pressure at port B, the down side pressure of orifice (11) becomes 1 kg/cm<sup>2</sup>(14 psi), whereas the up side pressure: the pressure in chamber(10) is the same as those in chambers(18 and 17): 15 kgf/cm<sup>2</sup>(213 psi), which is maintained by the pressure-reducing valve in the same way as it does in the OFF position. Consequently, the pressure differential across orifice(11) is rendered constant and the fluid flow through orifice(11) remains constant. With this, the engaging time for the clutch is specified.

At the end of the clutch stroke, the pressure at port B rises, but when it reaches 15 kgf/cm<sup>2</sup>(213 psi), the pressure differential across orifice(11) becomes zero and naturally the fluid flow through orifice(11) stops. As this pressure is maintained by the pressure-reducing valve, the clutch pressure is also kept constant.

• **When the main circuit pressure is lower than the regulated pressure:**

when the main circuit pressure is lower than the pressure regulated a port B, the sequential valve work to increase the pressure at port P to maintain the regulated pressure.

When the solenoid is switched on, in the same way as mentioned in the previous paragraph, passage(18) and chamber(10) are interconnected and a part of the fluid delivered from the pump is branched and flows from port B to the cylinder. A the same time, the branched off fluid is let into sequential valve spring chamber(8) through passage(9).

Here, the force imposed upon the left side of sequential valve spool(612) is the pressure in chamber(13), and on the right side of the spool the pressure in chamber(8) and the force of spring(622) are imposed. While chambers(13 and 8) have the same pressure, the spool is pushed leftwards by the force of spring(622) and closes orifice(24). Then the pressure at port P increases. When the pressure at port B reaches 15kgf/cm<sup>2</sup>(213 psi), pressure-reducing valve spool(611) shifts itself to close orifice(16) and the pressure in chamber(8) is also maintained at 15kgf/cm<sup>2</sup> (213 psi) to maintain the pressure-reducing valve secondary pressure at the regulated level. The pressure at port P is balanced at a pressure that is higher by the pressure equivalent to the force of spring(622): approx.3kgf/cm<sup>2</sup>(43 psi), so the pressure at port B becomes approx.18kgf/cm<sup>2</sup>(256 psi).

In this way even when the main circuit pressure is lower than the regulated level , the pressure at port P (the pump delivery pressure) is elevated to the specified level, making it possible for the clutch to be engaged in the same way as mentioned in the previous paragraph.

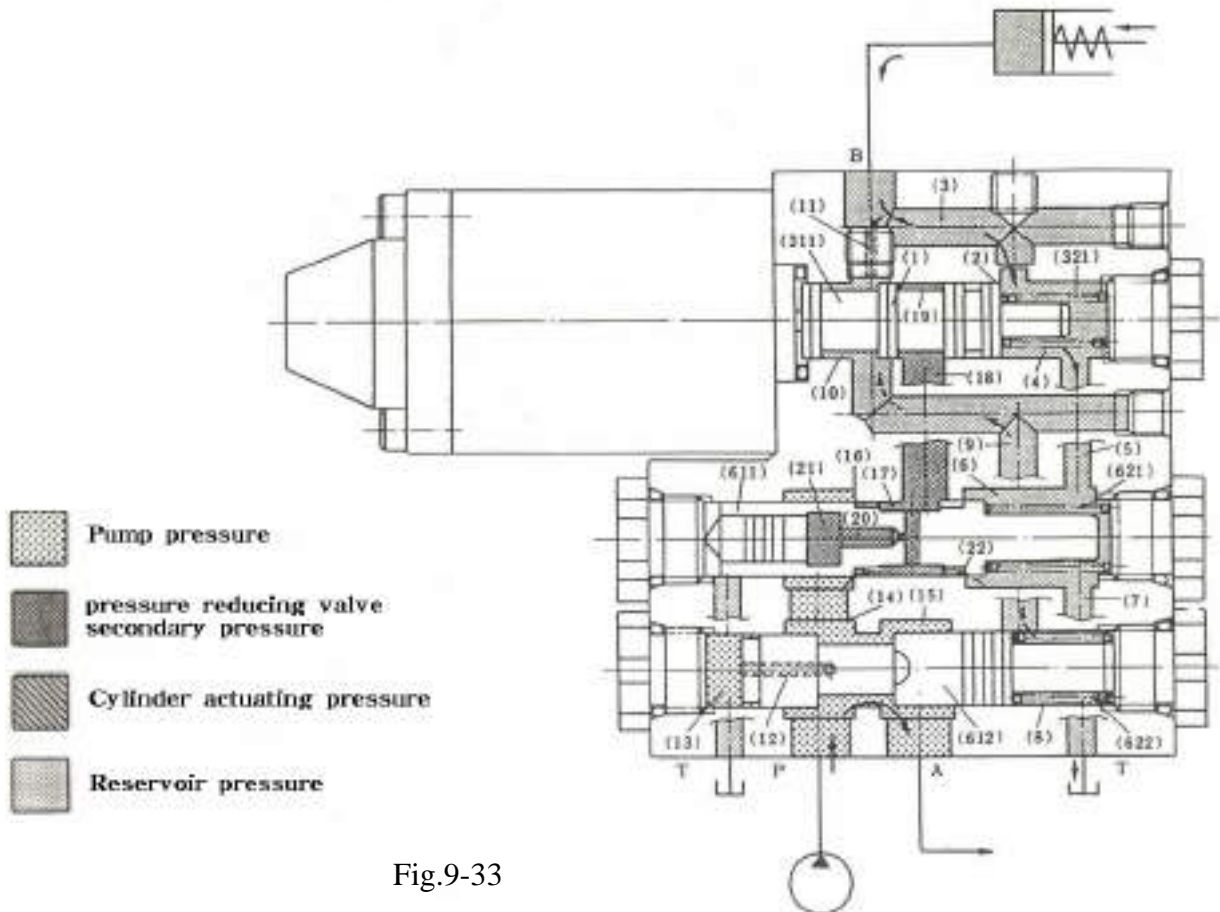

Fig.9-33

**Circuit diagram in the ON position**

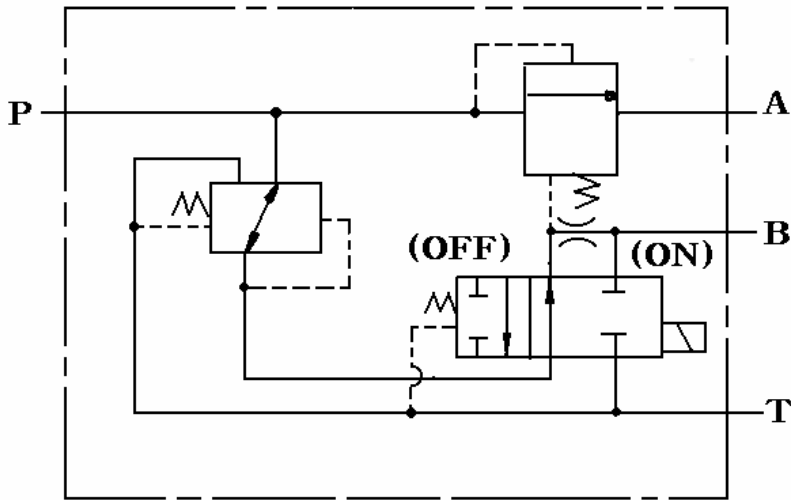

Fig.9-34

## 2.4 DISASSEMBLY AND INSPECTION

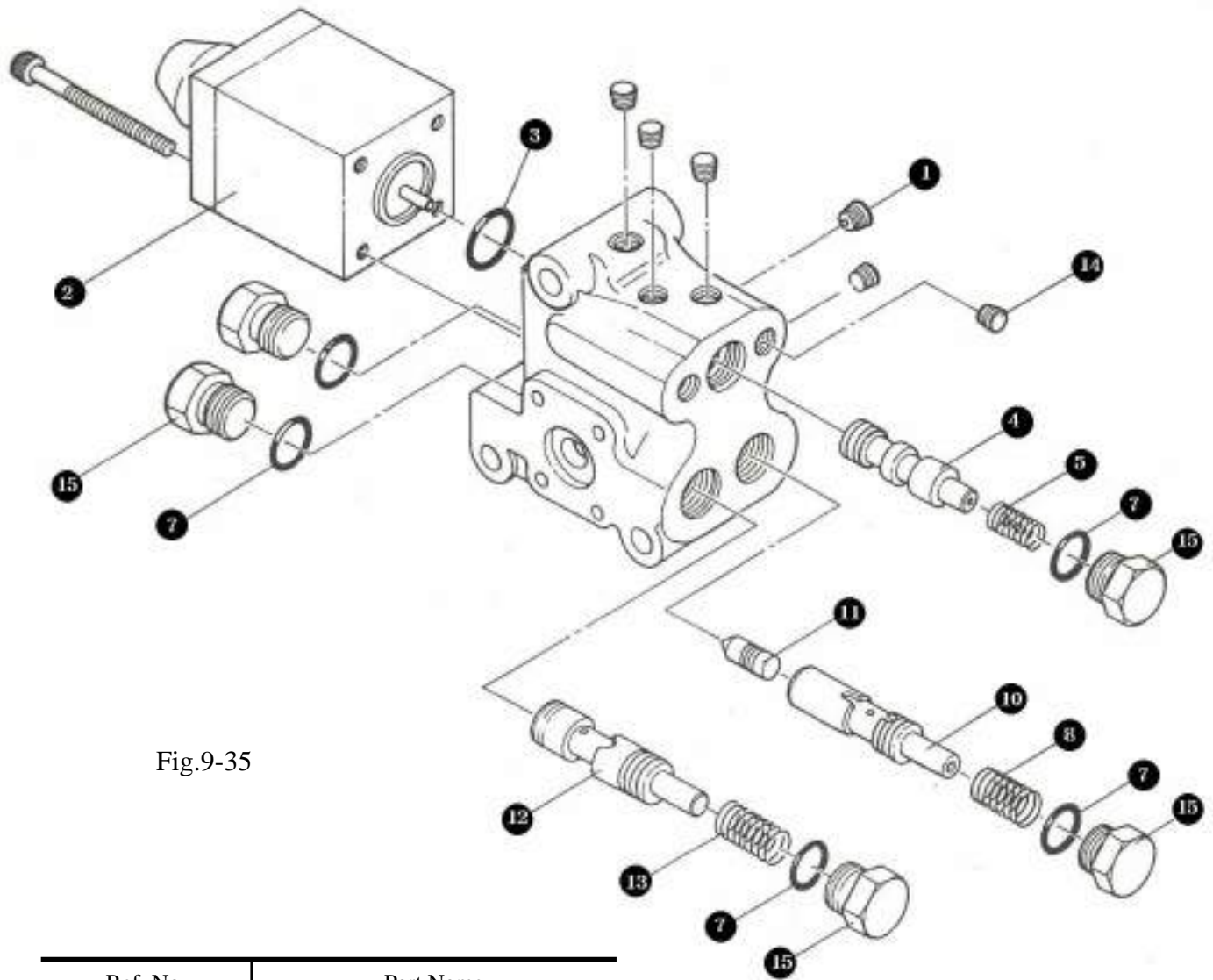

Fig.9-35

Ref. No.	Part Name
1	Orifice(choke)
2	Solenoid
3	O-ring
4	Changeover valve spool
5	Changeover valve spring
6	Casing
7	O-ring
8	Pressure reducing valve spool
9	Shim(optional)
10	Pressure-reducing valve spool
11	Piston
12	Sequential valve spool
13	Sequential valve spring
14	Blank plugs
15	Plugs

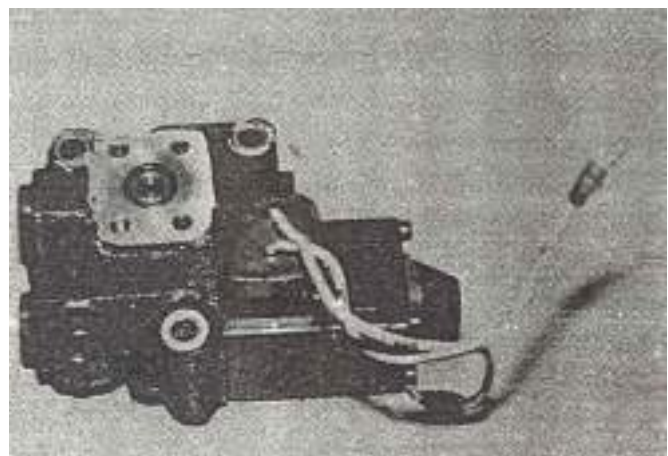

Fig.9-36

- 1) Remove the solenoid clamping bolts with an setscrew wrench and separate the assembly into the solenoid and the valve.
- Inspect the solenoid for open wiring with tester or by drawing current.
  - The solenoid which has any open wiring should be replaced.

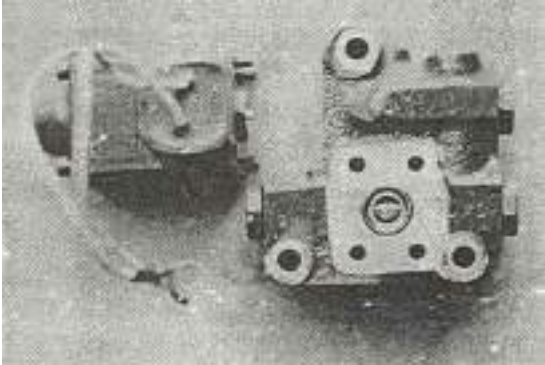

Fig.9-37

- 2) The changeover valve spool can be removed easily by removing the plug in advance.
- A spool which is damaged on the friction surface should be replaced
  - Minor damage to the surface can be corrected with an oil stone.

Clearance between spool and casing mm(in )	Usable limit
	0.025(0.0010)



Fig.9-38

- A changeover valve spring whose free length is less than the specified or which is distorted should be replaced.

Specified free length of changeover valve spring mm(in )	Specified value: 15.5(0.610)
	Usable limit:15(0.59)

- 3) Remove the plugs and extract the pressure reducing valve spool, spring, and piston.
- parts which are seriously damaged on the surface should be replaced.

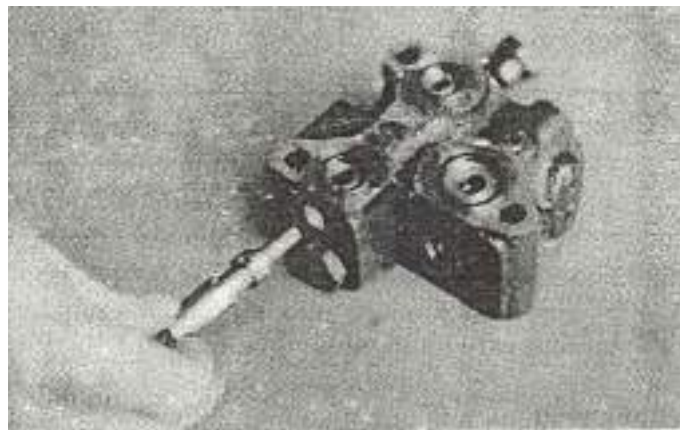

Fig.9-39

- Minor damage to the surface can be corrected with an oil stone.
- There should be no clogged passages in the spool

Clearance between pressure reducing valve spool and casing:mm(in)	Usable limit
	0.021(0.0008)

- A piston which is seriously damaged on the friction surface should be replaced. But minor damage can be corrected with an oil stone

Clearance between piston and pressure reducing valve spool mm(in)	Usable limit
	0.035(0.0014)



- A pressure-reducing valve spring whose free length is less than specified or which is distorted should be replaced.

Free length of pressure reducing valve spring mm(in)	Specified value: 30(1.18)
	Usable limit:29(1.14)

4) Remove the plugs and extract the sequential valve spool and spring

- A spool which is seriously damaged on the friction surface should be replaced.
- Minor damage can be corrected with an oil stone.
- There should be no clogged passages in the spool.

Clearance between sequential valve spring and casing: mm(in)	Usable limit
	0.021(0.0008)

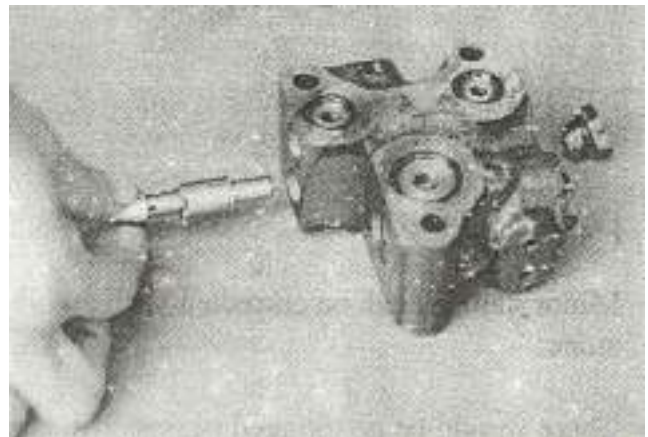

Fig.9-40

- A sequential valve spring with a free length that is less than the usable limit or which is distorted should be replaced.

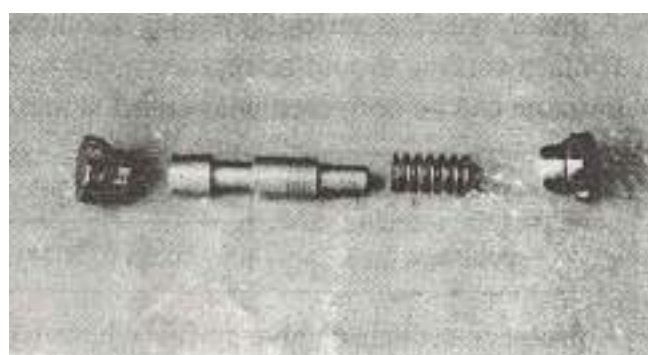

Fig.9-41

Free length of sequential valve spring mm(in)	Specified value: 22(0.87)
	Usable limit:21.5(0.847)

**2.5 REASSEMBLY**

Reassemble the parts in reverse order of disassembly , following these instructions.

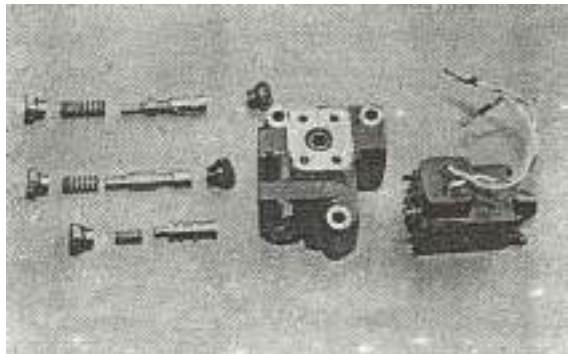

Fig.9-42

- 1) Each part should be washed clean in cleanser.
- 2) Friction parts of each component should be coated with working fluid or oil before installation.
- 3) O-rings should be coated with oil in advance and be careful not to damage them during installation.

Note:

- Each part should be reinstalled correctly by referring to fig.9-35 and fig 9-36.
- When installing the solenoid,do not forget to install the O-ring.

**Tightening torque**

Plugs	3.5-4.0 Kgf.m (25.3-28.9 ft.lbs)
Solenoid clamp bolts	0.3-0.4Kgf.m (2.2-2.9 ft.lbs )

### 3. PRESSURE CONTROL VALVE

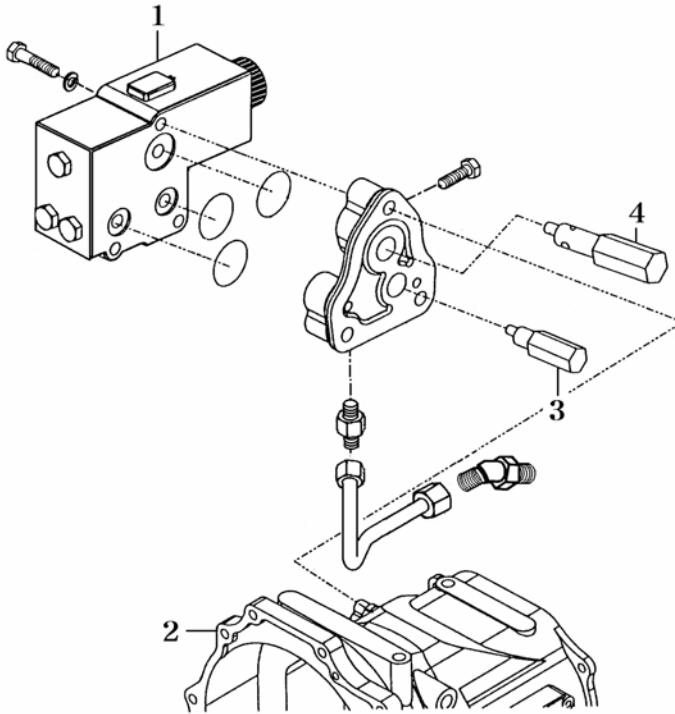

- (1) Flow-divider(PTO clutch valve)
- (2) Front Transmission case
- (3) Relief Valve
- (4) Pressure control valve

Fig.9-43

#### 3.1. GENERAL DESCRIPTION

This valve is composed of the body,plunger,piston,springs,and plug.It serves to absorb shocks which are given when the PTO clutch engages.

#### 3.2. OPERATIONS

##### 1) When the clutch cylinder is activated:

When the PTO clutch valve is turned on,the cylinder is activated.Consequently the pressure in circuit does not leave the seat of body(4) because the preset force by spring(8) and spring(9) is larger.Therefore there is no flow of fluid from port B to port T,which means all the fluid from the PTO clutch leads to the clutch cylinder.

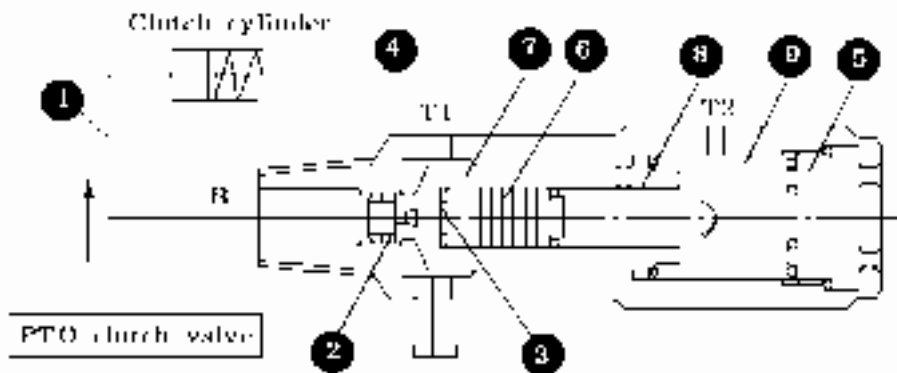

No	Part name	Qn'ty
4	Body	1
5	Plug	1
6	Piston	1
7	Plunger	1
8	Spring1	1
9	Spring2	1

Fig.9-44 When the clutch starts engaging

## 2) When the clutch is in half-engaged state:

When the clutch cylinder is completely activated, the pressure in circuit (1) starts rising at point P1 on the graph in Fig.9-49. When the pressure reaches point P2, the piston starts moving to the right overcoming the force of spring (6 and 7).

Here the flow through chock (2) causes some difference in pressure between circuit (1) and chamber (3). As the effective area of the seat of plunger (7) for circuit (1) pressure and that for chamber (3) pressure are the same, this pressure difference causes the plunger to compress spring (9) to move to the right, which opens the passage from port B to port T1 to prevent the pressure in circuit (1) from rising abruptly. As piston (6) moves to the right, the force of spring (8) increases so much. Both pressures in chamber (3) and circuit (1) also increases gradually, so the clutch engages smoothly without shocks.

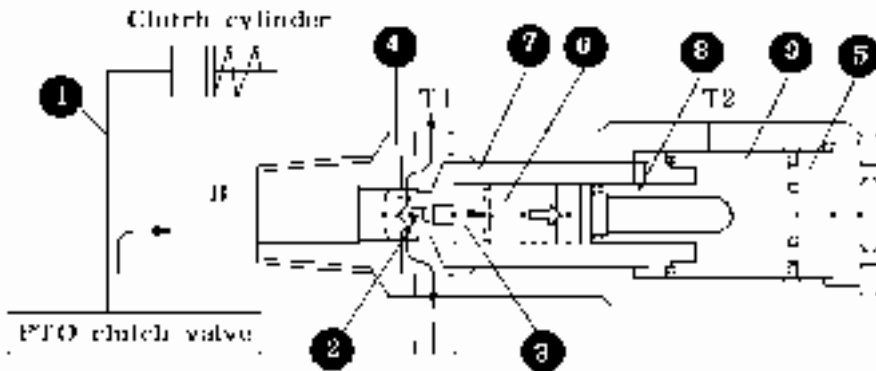

Fig.9-45 When the clutch is in half-engaged state

### Dynamic characteristics

Provided  $P1 = 3 \text{ Kg/cm}^2 (43 \text{ psi})$

$P2 = 3.6 \text{ Kg/cm}^2 (51 \text{ psi})$

$P3 = 5.9 \text{ Kg/cm}^2 (84 \text{ psi})$

$T = 0.4 - 0.6 \text{ sec}$

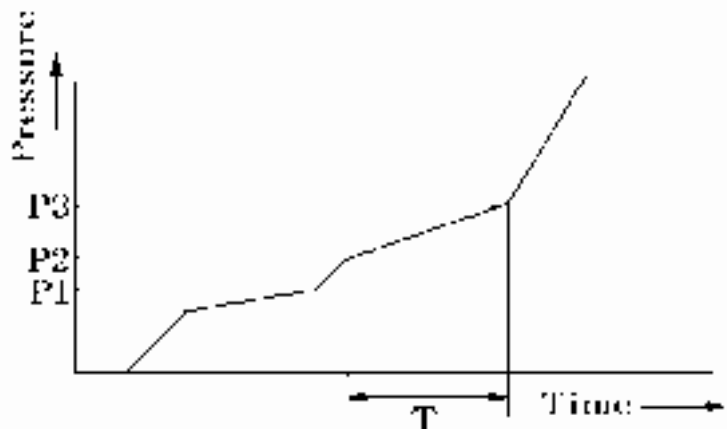

Fig.9-43



**2) When the clutch is engaged completely**

When the piston(6) moves to the end, there is no flow through chock(2) and the pressures in chamber (3) and circuit(1) become equal, that is, the pressure which the plunger receives on both sides are the same. Consequently, plunger(7) is pushed back to the left by the force of spring(9), which closes the passage from port B to port T. With this, the pressure in circuit(1) starts rising at point P3 up to the supplied pressure. Thus the clutch engagement is maintained.

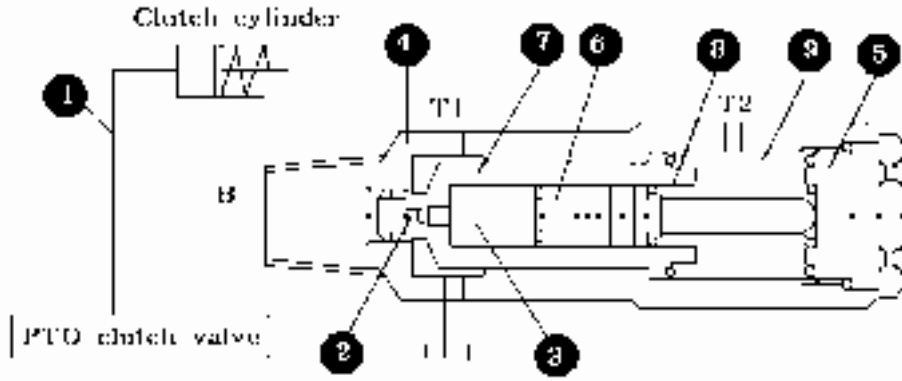

Fig.9-47 When the clutch is completely engaged

**3.3 DISASSEMBLY AND INSPECTION**

**1) Required Tools**

- 24 mm box type wrench and torque wrench: for valve tightening
- 22 mm box type wrench and torque wrench: for plug(5)
- Other required things:tweezers,sealing tape,rag,and oil stone

**2) Disassembly**

- a. Detach the change cover and remove this valve assembly
- b. Remove the plug(5) ,Take springs (9 and 8), and then extract piston(6) and plunger(7) by tilting body(4).

**3) Inspection of the disassemble parts.**

Inspect the plunger and the piston for dents on their friction surfaces.Such flaws must be corrected with oil stone.Wash all parts in fresh cleansing oil

**4) Reassembly**

- a. Tightening torque

Ref.No	Fastener Name	Tightening torque[Kgf.m(ft.lbs)]
(5)	Plug	4.0-5.0(28.9-36.2)
	Valve assembly*	4.5(32.6)

\* The threads should not be wrapped with sealing tape.

- b.Install plunger(7) into body(4) and confirm that the plunger moves smoothly.Then install piston(6),spring(8),and spring(9) in order and tighten plug(5) to the specified torque.

## 4. FLOW-CONTROL VALVE(SLOW-RETURN CHECK VALVE)

### 4.1. GENERAL DESCRIPTION

This valve regulates the lowering speed of the lift by controlling the unloading flow from the lift cylinder to the tank.

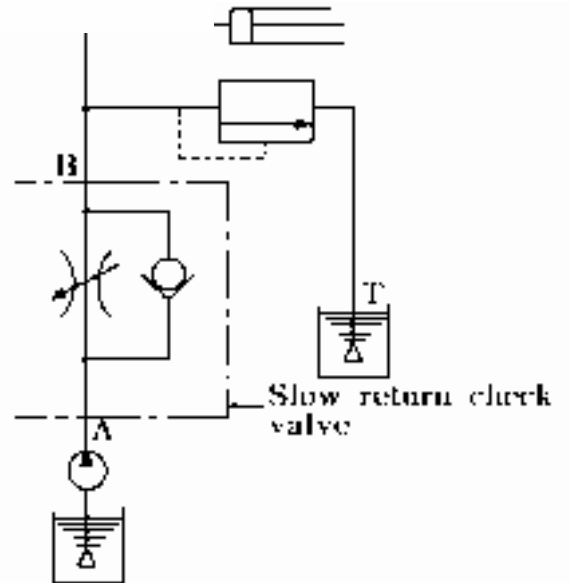
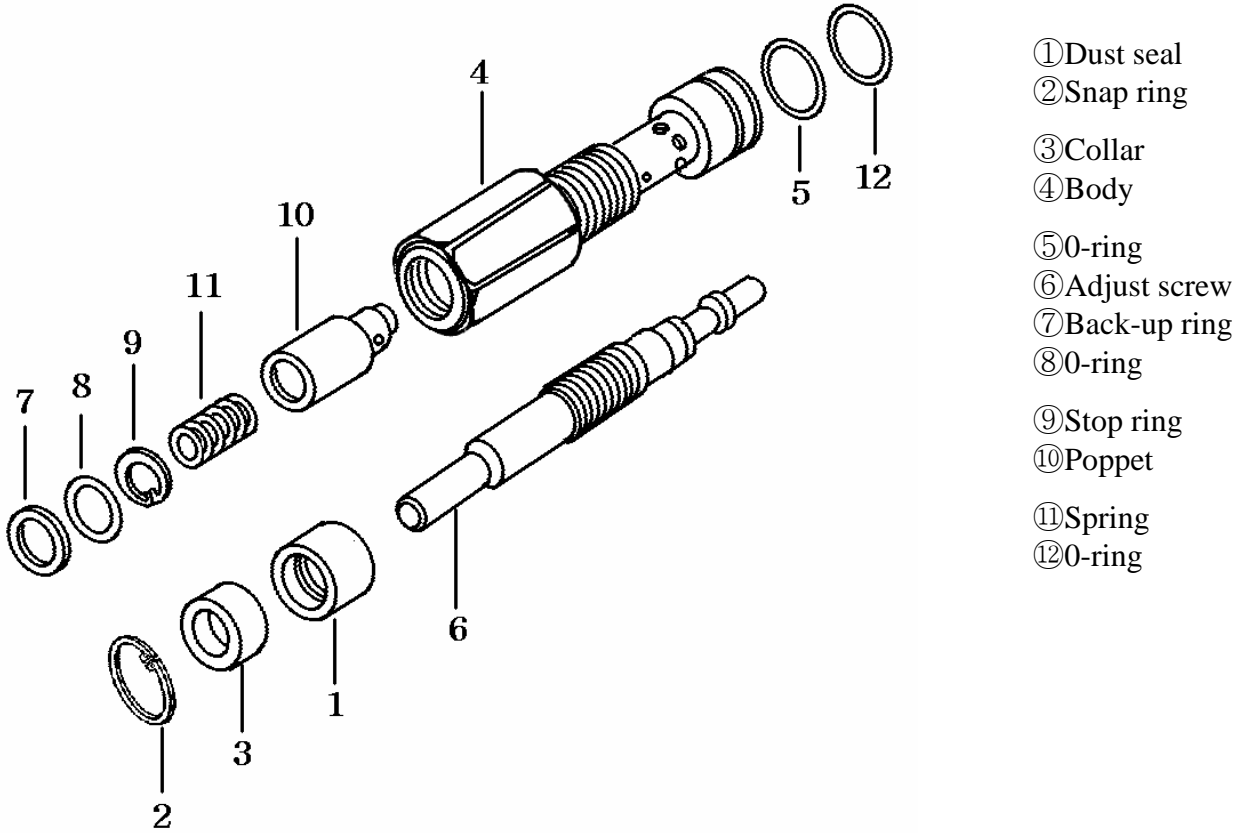

Fig. 9-48 Slow-return check valve Diagram

## 4.2 OPERATIONS

### 1) DOWN position

The fluid from port B pushes up stop ring (9) of poppet (10) until the ring comes into contact with adjust screw (6), as it reaches chamber (R). Consequently, the extent choke (C) is opened is determined by the positioning of adjust screw (6): that is, when adjust screw (6) is screwed in clockwise, the opening of choke (C) decreases and the lowering speed of the lift arm slows down; whereas the opening of choke (C) increases and the lowering speed of the lift is accelerated when the adjust screw is unscrewed counterclockwise. When the adjust screw is screwed in completely, the poppet comes into contact with body seat (S) and the choke is closed completely, so the lift arm stops.

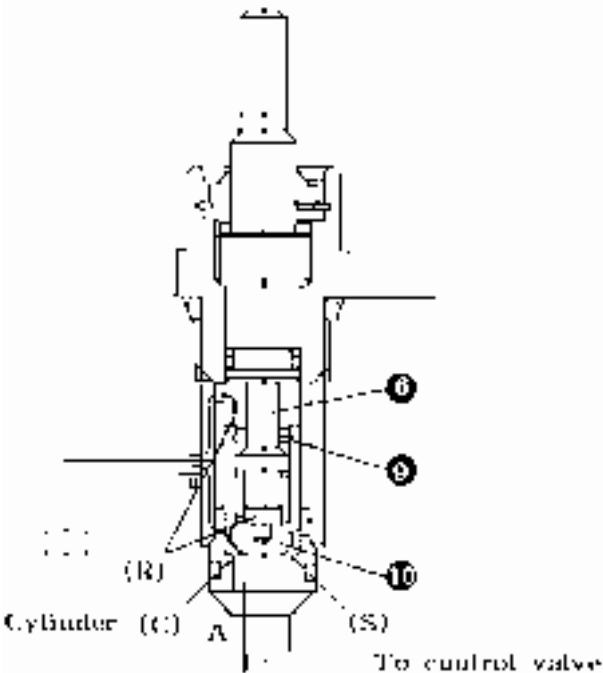

Fig. 9-50 Down position

### 2) Up position

The flow port A, overcoming the force of spring (11), pushes up poppet (10) and choke (C) is fully opened regardless of the position of adjust screw (6). Thus the fluid flows to port B and the cylinder, which results in raising the lift arm.

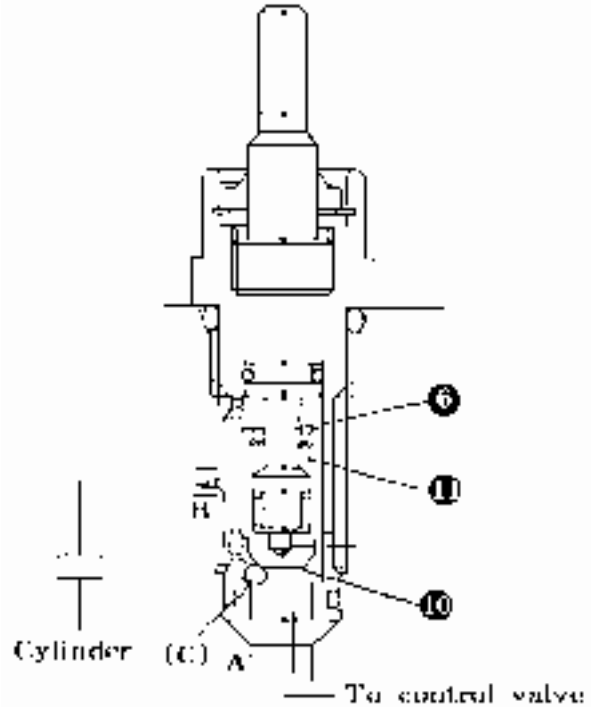

Fig. 9-51 Up position

## 5.SAFETY VALVE( Optional)

### 5.1 GENERAL DESCRIPTION

With the chock closed completely by turning the adjust screw tightly clockwise,the implement mounted on the lift is held at a specified height.While the tractor is traveling on roads in the condition,there is a possibility that the cylinder pressure will rise excessively when the implement bounces.In such a situation the cylinder pressure can rise so high as to break the cylinder.To prevent such an accident,the relief valve works to leak off the fluid in the cylinder to the tank via port P and port T to decrease the cylinder pressure

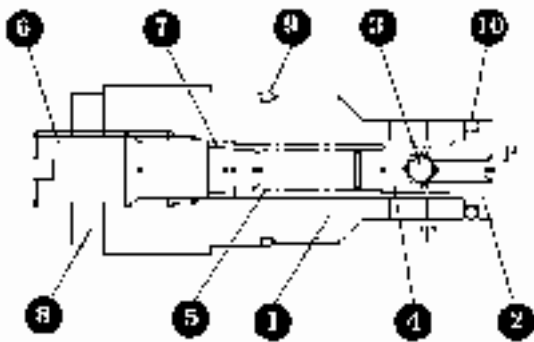

Fig.9-52

- 1.Body 2.seal 3.Ball 4.Spring seat  
5. Spring 6.Adjust screw 7.O-ring  
8.Lock nut 9.O-ring 10.O-ring

### Circuit diagram

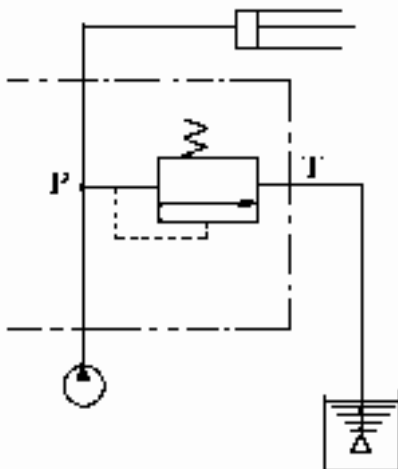

Fig.9-53

## 5.2 OPERATION

This valve is installed in the slow return check valve circuit and able to be installed in the cylinder case instead of Bolt. When the adjust screw of the slow return check valve is closed completely, the slow return check valve is completely closed. In this condition, when the cylinder pressure exceeds the regulated pressure of the relief valve: cracking pressure, the fluid pushed up ball (3), overcoming the force of spring (5). Then the surplus fluid is bled off to the tank via port P and Port T.

## 6. RELIEF VALVE

### 6.1 GENERAL DESCRIPTION

This valve regulates the maximum pressure in the whole hydraulic circuit. The regulated pressure can be set with the adjust screw.

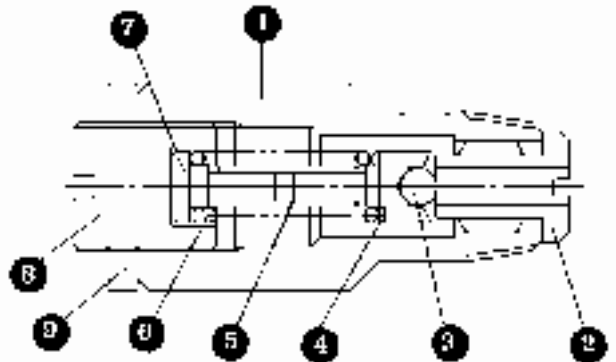

Fig.9-54

- 1.Body 2.seal 3.Ball 4.Spring seat  
5. Sleeve 6.Spring 7.Spring stopper  
8.Adjust screw 9.Lock nut

### 6.2 PRECAUTIONS FOR DISASSEMBLY AND REASSEMBLY

- (1) Tightening torque of lock nut (9) 5.0 ~ 6.0 kgf·cm<sup>2</sup> (36.2 ~ 43.4 ft.lbs)
- (2) Install seat (2) and then tap ball (3) (5/16) lightly so as to provide tight seating.
- (3) Wrap the valve threads with sealing tape and tighten the valve up to a specified torque of 5-6Kgf.m (36-43 ft.lbs)
- (4) Before disassembly, the current screwing-in depth of the adjust screw should be written down or memorized for later reference.

### 6.3 MEASUREMENT OF THE RELIEF PRESSURE

#### (1) 3 POINT TO TEST RELIEF PRESSURE

① Remove the plug in the delivery pipe on the right-hand side of the transmission case and install a compression gauge to measure the pressure.

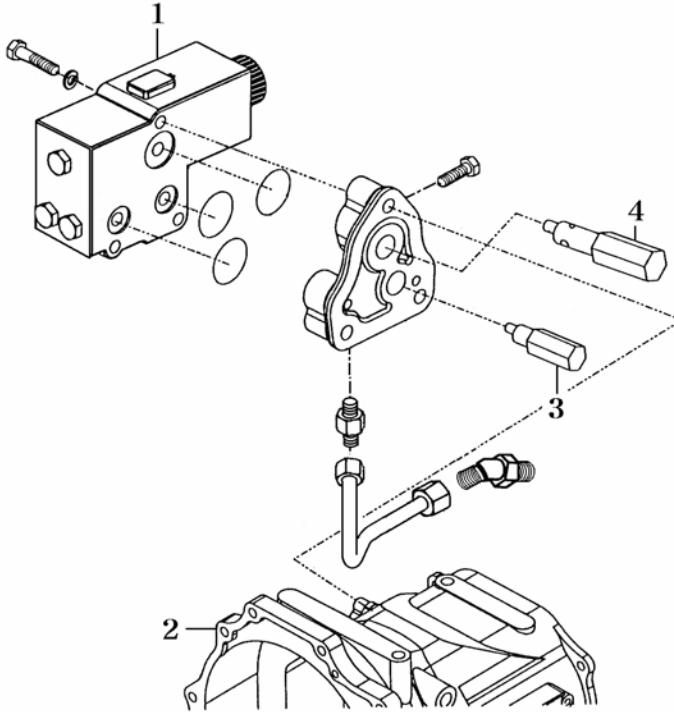

Fig.9-56

Keep the engine speed at 2600 rpm and shift the position control lever at the highest position.

② Control valve coupler.

③ Remove the plug in the hyd. pump flange and engage the pressure gauge and measure it.

Measurement the Pressure must be done 3 times and should be set within specified pressure.

Specified relief pressure	T390	160 ± 5 kgf·cm <sup>2</sup>
	T430	
	T431	

## 7.GEAR PUMP

### 7.1 GENERAL DESCRIPTION

Gear pump (Model: 4110.T390(T400).T430(T450).T431(T451))

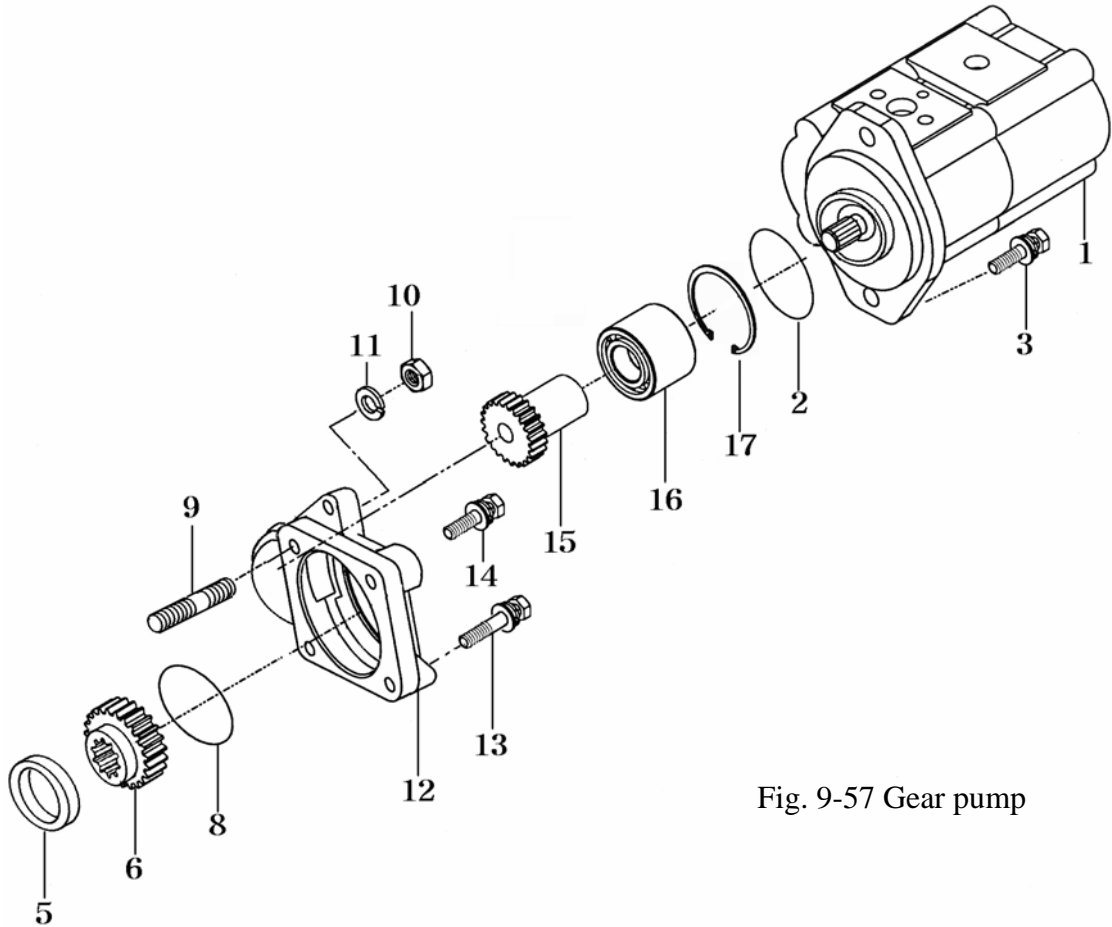

Fig. 9-57 Gear pump

1.Flange	2.Housing	3.Drive gear	4.Gear	5.Bushing	6.Bushing seal
7.Bushing	8.O-ring	9.Cover	10.Cap ring	11.O-ring	12.Housing
13.Drive gear	14.Gear	15.Oil seal	16.Socket bolt	17.Washer	18.Key
19.Snap ring	20.Ball				

### 7.2 OPERATIONS.

This pump induces fluid from one side and delivers it from the other side, by rotating two gears meshed with each other. The actual delivery is as mentioned below, Considering the consequences of fluid Temperature and volume efficiency in accordance with revolution speed.

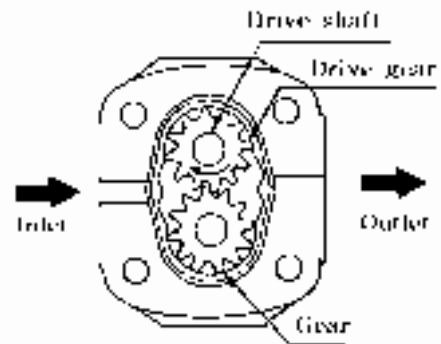

Fig. 9-58 Gear pump

### 7.3 DISASSEMBLY

#### NOTE:

① Before disassembling the pump, wash the outside clean. In the course of disassembling operation, all disassembled parts should be kept aside in a clean place such as on clean paper or cloth and be handled carefully so as to prevent them from becoming dirty or damaged.

Check all disassembled parts for damage and wash undamaged or usable parts in clean diesel fuel or kerosene. Inspect all parts referring to these point, and repair or replace defective parts.

#### (1) DISASSEMBLY

① Remove the key.

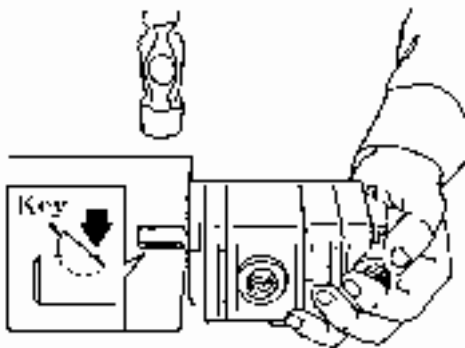

Fig. 9-59 Drive shaft key.

② Hold the pump in a vice with the mounting flange turned downward, and remove the bolts



Fig. 9-60 Cover bolt

③ Remove front and rear pump.  
Be sure not to be damaged the o-ring or steel ball

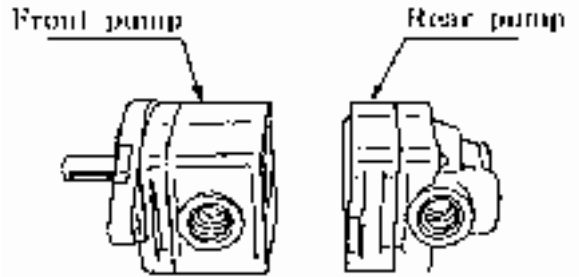

Fig. 9-61 Front and rear pump

④ Remove the rear pump

- ▶ Detach the cover
- ▶ Remove the o-ring
- ▶ Remove the bushing, drive gear, gear and bushing. Take care of removing the bushing which is marked and recorded.
- ▶ Remove the bushing seal from the bushing.

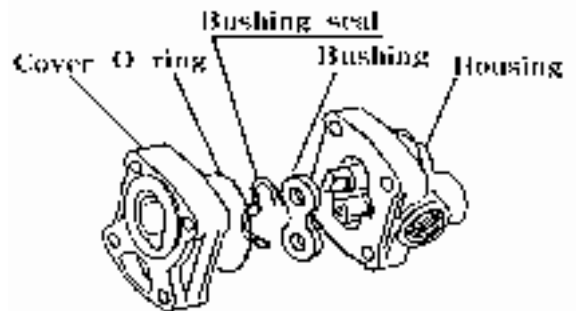

Fig. 9-62 Front and rear pump

⑤ Remove the front pump same as rear pump disassembly.

⑥ Remove the snap ring and extract oil seal from the flange.

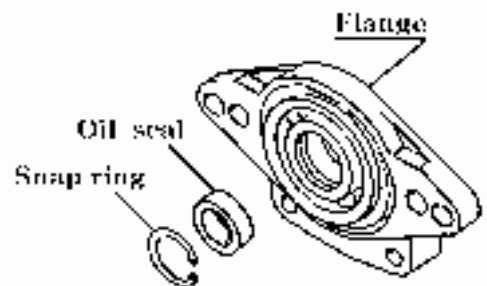

Fig. 9-63 Front and rear pump

### 3) REASSEMBLY

#### ① Install the rear pump.

- ▶ Install the bushing seal to bushing.
- ▶ Install the bushing, drive gear, gear, and bushing to the housing.
- ▶ Install the o-ring to the cover.
- ▶ Install the cover to the housing.

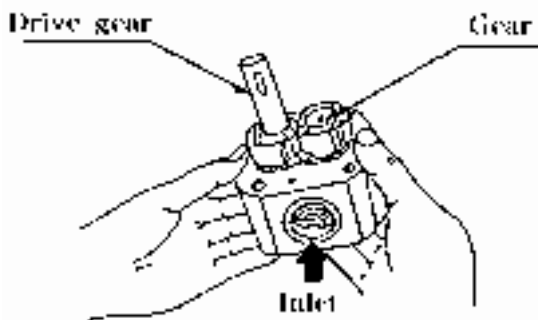
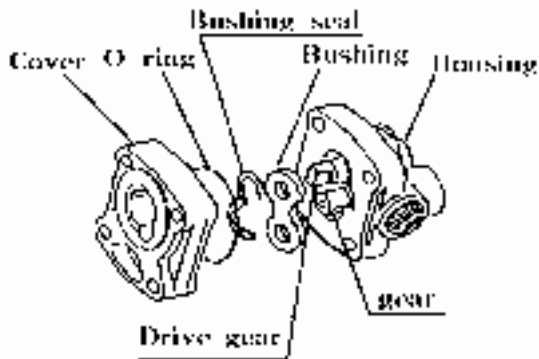

Fig. 9-64 Front and rear pump.

#### ② Install the front pump with rear pump.

#### ③ After installing the cap ring, and O-ring to the front pump, and install the rear pump.

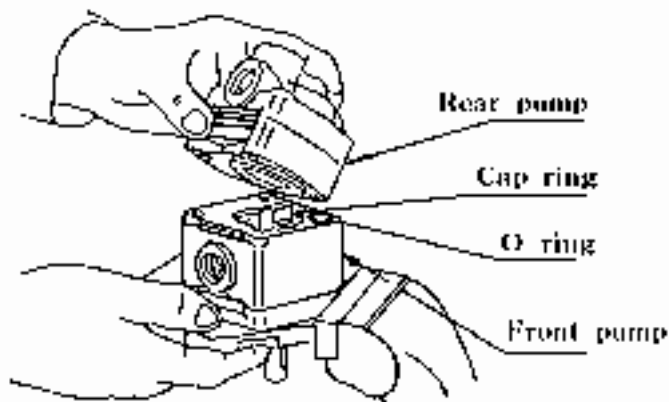

Fig. 9-65 Drive gear, gear, Gasket

#### ④ Tightening sequence and torque of the pump cover tightening bolts.

- ▶ Tightening torque: 2.5 ~ 2.8kgf·m



Fig. 9-66 Cover bolt

#### ⑤ Install the oil seal, snap ring, and key.

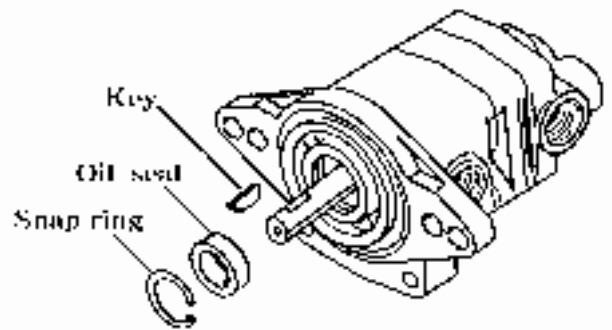

Fig. 9-67 Oil seal, snap ring, key.

#### ⑥ The gears should turn smoothly with a turning torque of less than 30 kgf.cm

(2.2ft.lbs)

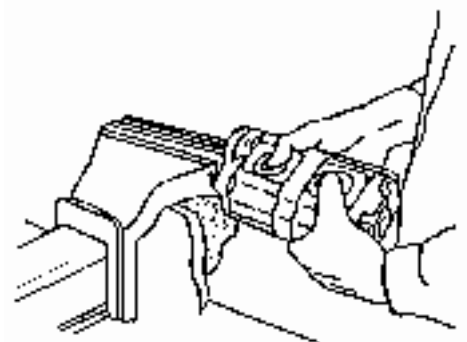

Fig. 9-68 Inspection after reassembly.



#### 4) INSPECTION AND REPAIR

(1) Check all disassembled parts for damage and wash undamaged or usable parts in clean diesel fuel or kerosene except rubber parts. Inspect all parts referring to these points, and repair or replace defective parts.

(2) Housing(casing)

- ① The gear pump is originally designed so that the gears come into light contact with the side of the pump body
- ② Therefore some evidence of contact can be found around the intake port of a pump once used.
- ③ The normal contact tracing is less than half the length of the gear housing bore and less than 0.05 mm(0.0020 in) in width. If width A is more than 0.1 mm(0.004 in), replace the gear pump set.

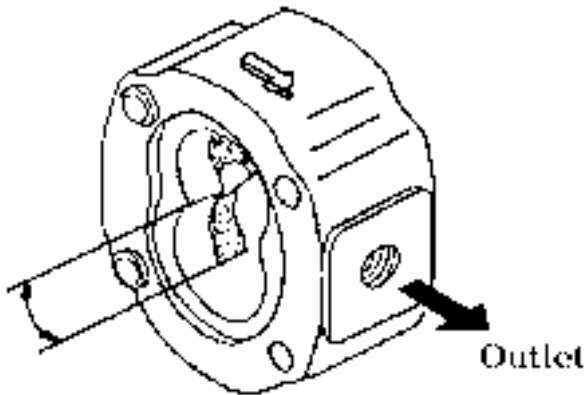

Fig. 9-69 Housing (casing)

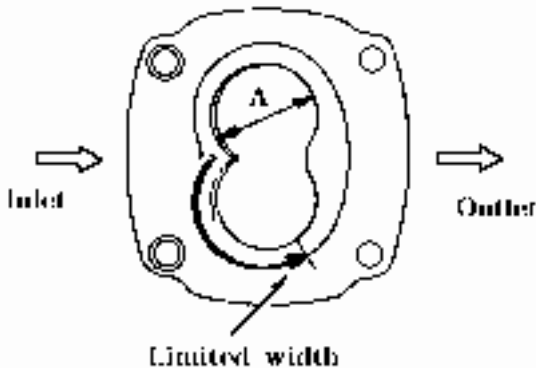

Fig. 9-70 Housing (casing)

(3) Bushing

- ① With clean working fluid, surfaces are rarely scratched and should be smooth.
- ② If there are many scratches on the bore walls, or on parts which are in contact with the gears, which can be readily felt or when the latter parts are darkened, the gear pump set should be replaced.

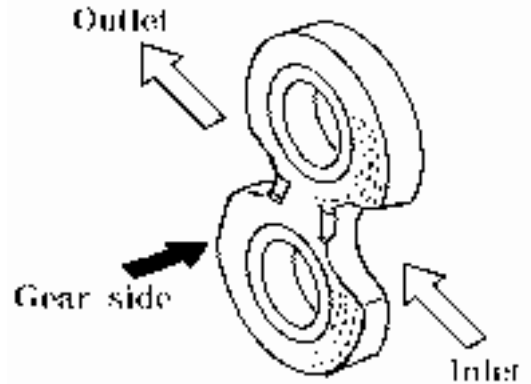

Fig. 9-71 Bushing

Problem and causes are as below

- a. contaminated fluid
- b. overload by relief valve damage
- c. cavitation or aeration
- d. overheat of fluid.
- e. Low density of fluid

④ Some evidence of contact can be found around the intake port of a bushing once used. The normal contact tracing is less than half the length of the bushing bore and less than 0.03mm(0.0012 in) in width. If width is more than 0.03 mm (0.0012 in). Replace the bushing.

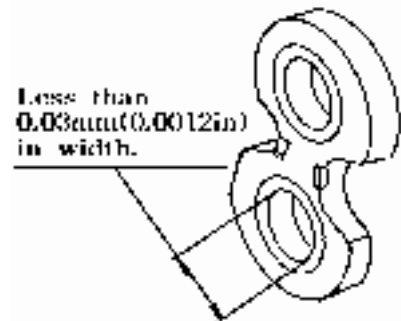
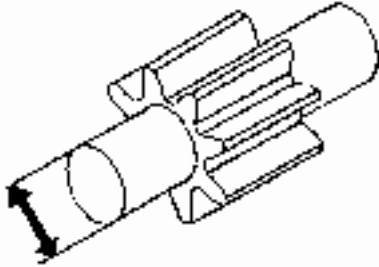

Fig. 9-72 Bushing

#### (4) GEAR

- ① With clean working fluid, surfaces are rarely scratched and should be smooth.
- ② If roughness can be felt by a finger nail, they are darkened, or the shaft diameter is less than 0.03 mm, replace the shaft.
- ③ Usable shaft diameter is as below



Shaft diameter less than 0.03

Fig.9-73 gear shaft

#### (5) Oil seal

The oil seal prevents oil leaks by its inner seal lip and dust from invading by its outer dust lip. Therefore if an oil seal has damaged or deformed lips, it should be replaced.

#### (6) MEASUREMENT OF THE PUMP

The best way to measure for the pump is to use a special tester.

But if it's not available, use installed tractor. Remove the plug in the delivery pipe on the right-hand side of the transmission case and install a compression gauge to measure the pressure.

Keep the engine speed at 2600 rpm and shift the position control lever at the highest position.

	T390	T430	T431
Delivery[liter/min]	29.8	27.7	27.7
Rpm with 91% of volume efficiency	2800rpm	2,600 rpm	

## 8. FILTER

- 1.Filter
- 2.O-ring
- 3.Bolt
- 4.Filter
- 5.Cartridge
- 6.Bracket
- 7.Bolt(S)
- 9.Washer
- 10.Bolt(S)
- 11.O-ring
- 12.Cylinder case
- 13.Rear transmission case

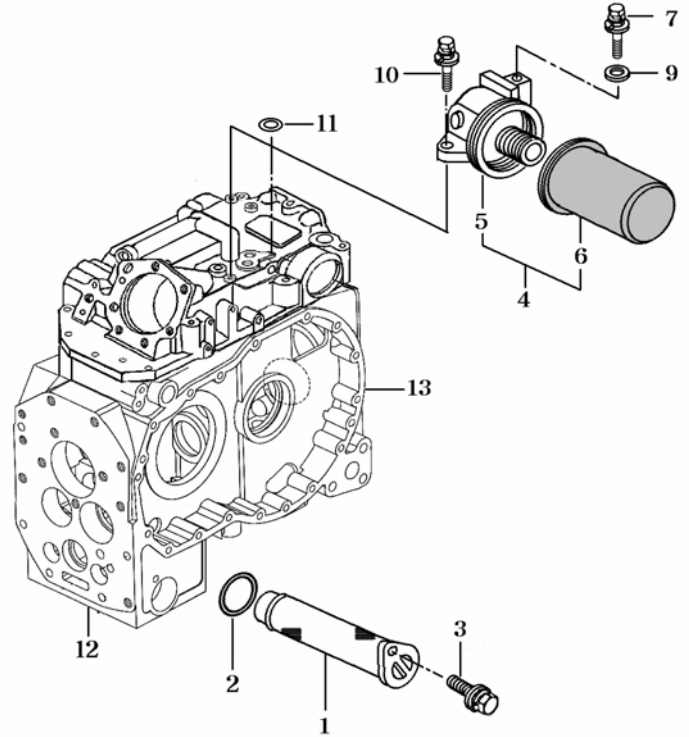

Fig. 9-67 Filter

### 8.1 GENERAL DESCRIPTION

The tractor is equipped with two oil filters: suction filter(1) and line filter(4),for better filtration.

### 8.2 SPECIFICATIONS

#### 1)Suction filter

Model	T390(T400)/T430(T450)/T431(T451)
Applicable oil	DONAX TD or RPM THF 500
Rated flow rate( $\ell/\text{min.}$ )	57
Filtration density	25 $\mu\text{m}$
Filtration area	11000 $\text{cm}^2$
Working oil temperature ( $^{\circ}\text{C}$ )	-30 ~ 130 $^{\circ}\text{C}$

#### 2) Line filter

Applicable oil	THF500
Rated flow( $\ell/\text{min.}$ )	32
Filtration density (mm)	10 micron
Filtration area( $\text{cm}^2$ )	3,276 mesh
Working oil temperature	-

### 8.3 REPLACEMENT

Check the O-rings for damage or deformation and replace defective ones. When installing the filters, be sure to install the O-rings properly with grease applied.

## SECTION 5. REMOTE HYDRAULIC CONTROL

### 1.GENERAL DESCRIPTION

- A hydraulic operated implement can be driven and controlled with this optional remote hydraulic control valve set.
- The valve is connected between the gear pump and the main control valve and is given a priority to draw hydraulic power.
- The valve is installed on the right-hand side of the hydraulic cylinder case and the connecting ports are provided under the right hand step .

### 2.FUNCTIONS

Lever position		Circuit diagram
 <p data-bbox="207 917 307 948">Raising</p>	<p data-bbox="572 644 672 675">Raising</p> <p data-bbox="578 917 666 948">A to B</p>	
	<p data-bbox="572 975 672 1006">Neutral</p> <p data-bbox="504 1203 741 1234">Closed at A and B</p>	
	<p data-bbox="558 1307 686 1338">Lowering</p> <p data-bbox="578 1580 666 1612">B to A</p>	

Fig. 9-68 Remote hydraulic pump

### 3. REMOTE HYDRAULIC CONTROL VALVE

#### 3.1 SPECIFICATIONS

Normal flow	ℓ/min	35
Maximum flow	ℓ/min	45
Maximum pressure (psi)	Kgf/cm <sup>2</sup>	400
System pressure (psi)	Kgf/cm <sup>2</sup>	160
A and B port leak Oil temperature:50°C (122°F) Under a load of 100Kgf/cm <sup>2</sup>		9 cc/min
Recommended fluid		THF 500
Operating temperature range		-20°C ~80°C

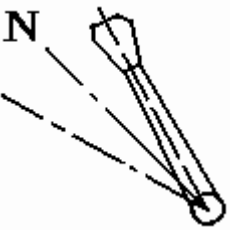
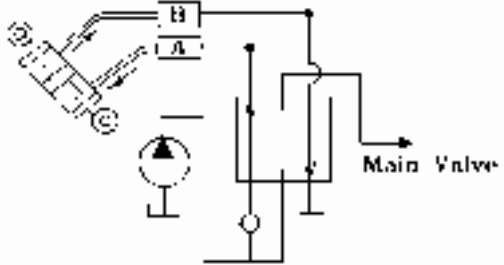
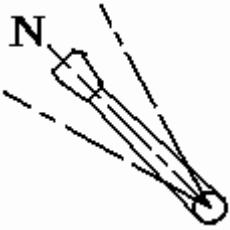
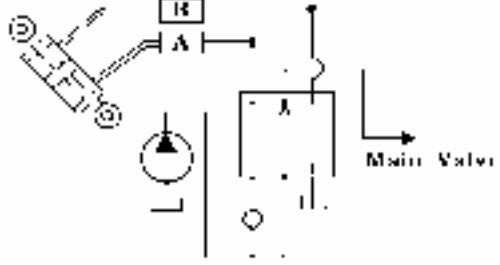
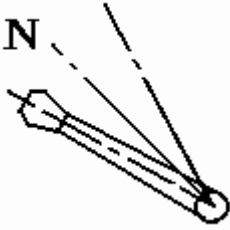
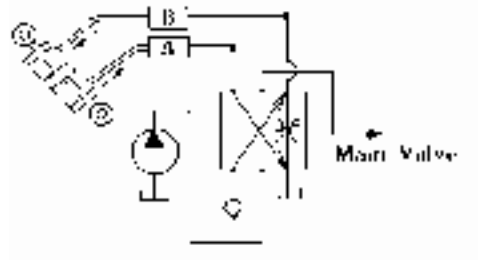
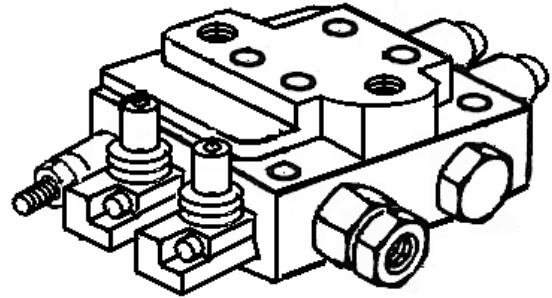
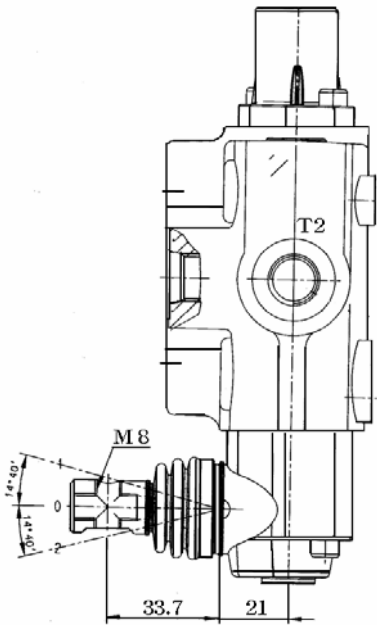

Fig. 9-69 Remote hydraulic pump

#### 3.1 HYDRAULIC CIRCUIT

P:From pump

T:To tank

A:High pressure port

B: Return port

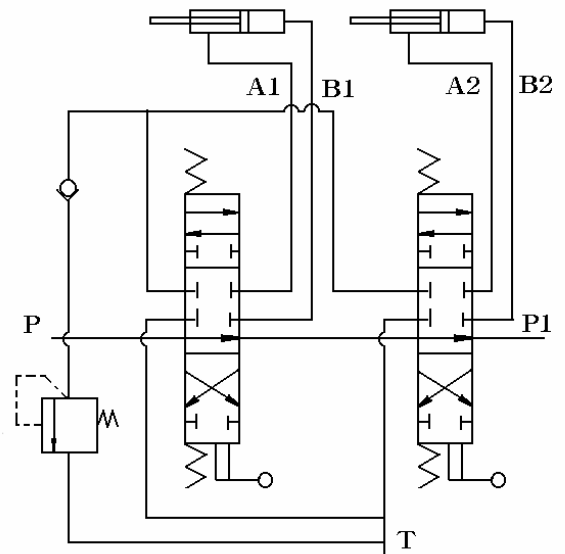

## SECTION 6. TROUBLESHOOTING

Problems	Causes	Countermeasures	
1.Lift does not rise	1) Insufficient engine speed	Raise engine speed slightly	
	2) Insufficient transmission oil	Maintain oil level by replenishing with the same kind of oil	
	3) Air taken in through suction	Tighten securely or replace broken parts.	
	4) Clogged suction filter	Clean.	
	5) Broken or poor hydraulic pump	Inspection pump and repair or replace if necessary.Pay particular attention to shaft seal because a broken seal sometimes intakes air.	
	6) Poor link mechanism	Inspect,adjust,repair,or replace if necessary.(Refer to section 3)	
	7) Excessive load on lift	Decrease load	
	8) Broken cylinder	Replace	
	9) Too low viscosity of transmission oil	As it will cause oil leaks or internal wear,replace with gear oil of SAE80	
	10)Maladjusted relief valve	Readjust. (Cracking:refer to the specifications)	
	11)Excessive internal leaks	Inspect cylinder and valves.Replace damaged seals,and repair. (Check each part systematically)	
	12)Broken flow divider (Stuck sequential valve spool)	Disassemble and wash spool clean. If it is damaged seriously,replace it as an assembly.If damage is minor,correct surface with oil stone and finish by lapping.	
	13)Broken control valve (Even when spool is shifted to up position,lift does not rise)		
	①Stuck compensator plunger (unloading valve 1)	Lap after repairing flaws with oil stone	
②Clogged orifices or slanted orifices in pilot passage.	Clean them with compressed air or a sharp point.		
③Stuck poppet(unloading valve 2)	Correct minor flaws with oil stone		
④Bitten or stuck check valve plunger	Lap after repairing flaws with oil stone		
14)Broken slow-return check valve			
①Stuck poppet	Lap after disassembling,cleaning, and repairing flaws with oil stone		

Problems	Causes	Countermeasures
2. Too low rising speed of lift	1) Above causes can also be possible	Repair according to above instructions.
	2) Too small a spool stroke in control valve	Inspect, readjust, or replace link mechanism if necessary.
	3) Broken compensator spring (unloading valve 1) in control valve	Replace spring.
	4) Stuck poppet (unloading valve 2)	Correct minor flaws with an oil stone
3. Lift lowers even when adjust knob is closed fully with adjust Handle (While engine is stopped)	1) Stuck poppet	Lap after disassembling, cleaning, repairing flaws with oil stone
	2) Poor valve seat	Replace valve
	3) Poor O-ring	Replace
4. Lift does not lower	1) Slow-return-check valve knob is turned to the lock position	Turn knob to fast position
	2) Stuck poppet of slow-Return-check valve	Lap after disassembling, cleaning, repairing flaws with oil stone
	3) Seized lift shaft	Apply grease and repair or replace bushings or shaft if necessary.
	4) Stuck main spool	Lap lightly after disassembling, cleaning, and repairing flaws with oil stone or replace as an assembly.
5. Too slow lift lowering speed	1) Above mentioned causes can also be possible.	Repair or adjust according to instructions mentioned above.
	2) Insufficiently lowered control lever	Lower lever sufficiently
	3) Excessively closed slow-return check valve	Open valve sufficiently
6. When hydraulic control lever is raised, relief, valve beeps.	1) Maladjusted lever stopper check valve	Readjust lever stopper guide position
	2) Poor link mechanism	Inspect, readjust, repair, or replace link mechanism if necessary.
7. Fluid overheating	1) Excessively high working pressure	Inspect and adjust
	2) Too high or low viscosity of working fluid.	Replace with fluid of adequate viscosity.
	3) Insufficient fluid	Maintain specified level by replenishing

Problems	Causes	Countermeasures
8.Pump noise	1) Partially clogged suction filter or suction piping.	Clean.
	2) Air inhaled through suction piping and intake pipe connections for pump	Inspect and retighten.
	3) Loosened pump cover tightening bolts.	Inspect and retighten
	4) Too rich oil viscosity	Replace with fluid of adequate viscosity.
	5) Broken or worn pump parts	Inspect and replace defective parts.
9.Excessive wear,deflection or damage of pump	1) Dirty fluid	Eliminate foreign matter and inspect filters.
	2) Circuit pressure exceeds pump capacity	Adjust relief valve or replace if necessary
	3) Oil-less operation due to Insufficient oil quantity	Inspect transmission oil level and maintain specified oil level by replenishing.In either case,clean, and repair pump parts and replace damaged ones if necessary.
10.Oil leaks outside pump	Broken or fatigues oil seal or O-ring	Replace
11.Oil leaks from piping or joints	Poorly connected piping	Inspect,clean,and eliminate dust. Repair flaws with oil stone if necessary. Retighten.
	Poor O-ring	Replace
	Broken piping	Replace with a new one after washing clean related parts.
12.Oil leaks around lift arm	Poor oil seals	Replace oil seal or bushing if necessary
13.Independent PTO clutch slips or is too slow in engaging	1) Clogged fixed orifice of Flow divider	Disassemble and wash clean.
	2) Port B regulated pressure is too slow	Inspect and reset pressure
	3) Clogged PTO pressure control valve or stuck	Disassemble and wash clean. Repair flaws with oil stone if necessary or replace with a new one.
	4) Poor flow divider solenoid valve	Disassemble and repair or replace with new one if necessary .



Problems	Causes	Countermeasures
14.Independent PTO clutch is too quick in engaging	1) Stuck pressure-reducing valve spool	Lap after correcting flaws with oil stone
	2) Fatigued or broken pressure-reducing valve spring	Replace.
	3) Worn or broken sealing of PTO clutch	Replace
	4) Worn friction plates or driven plates	Replace
	5) Overheated fluid	Refer to paragraph for "fluid overheating"
	6) Port B regulated pressure is too high of Flow-divider	Inspect and reset pressure
	7) Stuck pressure-reducing valve spool	Lap after correcting flaws with oil stone
	8) Clogged orifice in pressure-reducing valve spool	Clear clogged with compressed air or with a sharp point.

# Chapter 10 Electrical accessory and instruments

<b>SECTION 1. GENERAL DESCRIPTION</b>	<b>10-1</b>
<b>SECTION 2. SPECIFICATIONS</b>	<b>10-1</b>
<b>SECTION 3. BATTERY</b>	<b>10-2</b>
<b>1.1. Inspection</b>	<b>10-2</b>
<b>1.2. Inspection of electrolyte level</b>	<b>10-2</b>
<b>1.3. Inspection of electrolyte specific gravity</b>	<b>10-2</b>
<b>1.4. Battery testing chart</b>	<b>10-3</b>
<b>SECTION 4. Meters and switches</b>	<b>10-5</b>
<b>1. Meters</b>	<b>10-5</b>
<b>1.1 Removal</b>	<b>10-5</b>
<b>1.2 Tacho/Hour meter</b>	<b>10-5</b>
<b>1.3 Fuel gauge and fuel gauge sensor</b>	<b>10-5</b>
<b>1.4 Thermometer</b>	<b>10-6</b>
<b>2. Starter switch</b>	<b>10-6</b>
<b>3. Combination switch</b>	<b>10-6</b>
<b>4. Stop light switch</b>	<b>10-8</b>
<b>5. Relay unit</b>	<b>10-8</b>
<b>6. Fuse</b>	<b>10-8</b>
<b>7. Controller Unit</b>	<b>10-9</b>
<b>8. Trailer socket(7P)</b>	<b>10-11</b>
<b>SECTION 5. EARTHING POINT</b>	<b>10-12</b>
<b>SECTION 6. WIRING DIAGRAM</b>	<b>10-14</b>
<b>SECTION 7. TROUBLESHOOTING</b>	<b>10-15</b>

# Chapter 10 Electrical accessory and instruments

## SECTION 1. GENERAL DESCRIPTION

The basic electrical system of tractors consists of the engine cranking system ,battery charging system,lighting system,meters,switches,etc.

For further information concerning the engine cranking equipment and battery charging equipment, please refer to the engine manual.

The battery is a power source to activate the engine cranking system,lighting system,and other electrical equipment.The lighting system is used to activate the illumination lights,indicators,and signal lights.The meter is a device that enables the operator to be aware of the present operating conditions;oil pressure gauge,water temperature gauge(thermometer),fuel gauge,etc.are installed. All the controls,meters, and indicators are arranged around the operator’s seat for easy Maneuverability readability,and convenience.

## SECTION 2. SPECIFICATIONS

MODEL		T390/T400/T430/T450		
PART NAME		Specification(w)	Quantity	
1.lighting system	Head lights		35/35	2
	Front combination lights	Turn signal lights	21	2
		Small lights	5	2
	Rear combination lights	Turn signal lights	21	2
Stop lights		21	2	
Tail light		5	2	
2. Monitoring system	Meter assembly	Hour meter	-	1
		Fuel gauge	-	-
		Thermometer	-	-
		Pilot light	(3,4)	15
Horn		-	1	
3.Fuses	Fuses(A)	In main fuse box	15	4
		(with spare fuse)	10	6
	Fusible links	0.85	-	1
		1.25	-	1
4.Battery			12V110AH	1

**SECTION 3. BATTERY**

**1.INSPECTION**

**1.1 INSPECTION OF ELECTROLYTE LEVEL**

As the battery repeats charging and discharging during operation.The water content in the electrolyte gradually evaporates, and as a result,the level should be inspected at the specific level;replenish with distilled water.

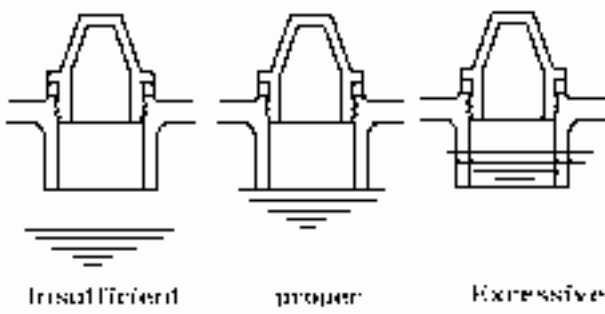

Fig.10-1 electrolyte level

**1.2 INSPECTION OF ELECTROLYTE SPECIFIC GRAVITY**

The specific gravity of the electrolyte lowers as the battery discharges,so the battery condition can be determined by measuring the specific gravity.The specific gravity can be measured generally with a suction type hydrometer which must be read properly as shown in Fig. 10-2

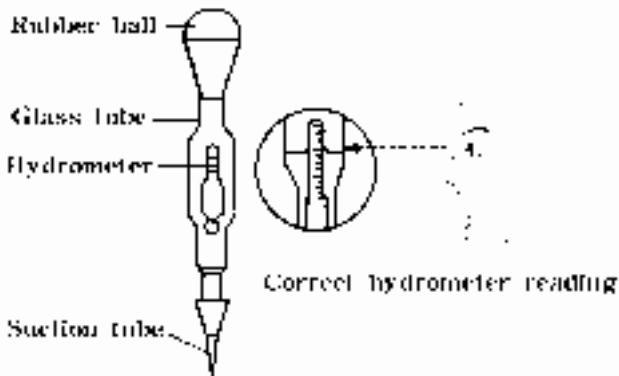

Fig.10-2 electrolyte gravity

Note:

When the distilled water is added,charge the battery to mix it well into the electrolyte before measuring the specific gravity.

a.Temperature correction of the hydrometer reading

The specific gravity of the battery electrolyte(diluted sulfuric acid) varies with the temperature of the electrolyte at a rate 0.0007 specific gravity point for each 1 °C change in temperature.Therefore, when the specific gravity of the electrolyte in the battery is measured with a suction type hydrometer,a temperature correction should be made,using the following formula to permit the direct comparison of the measured value with the standard specific gravity at 20 °C .

$$S_{20} : S_t + 0.0007(t - 20)$$

$S_{20}$  : Specific gravity at standard temperature of 20 °C .

$t$  : Temperature of the electrolyte at the time of measurement

$S_t$  : Specific gravity of the electrolyte measured at  $t$  °C .

**1.3 BATTERY CHARGING**

If the specified gravity of the battery electrolyte in lower than 1.220 (at 20 °C),the battery should be recharged,because leaving an undercharged battery without recharging it will lead to permanent battery damage.The battery is subject to self-discharge at a rate as shown in the table below.Therefore it should be recharged from time to time when storing the battery unused for a long period of time.

When recharging the battery,wash clean the outside of the battery case and the battery posts.Check the level of the electrolyte in each cell and replenish with distilled water as necessary.

Temperature	Self-discharge rate per day (%)	Decrease in specific gravity per day
30 °C	1	0.002
20 °C	0.15	0.001
5 °C	0.025	0.005

## 1.4 BATTERY TESTING CHARTS

Step 1.

### VISUAL INSPECTION

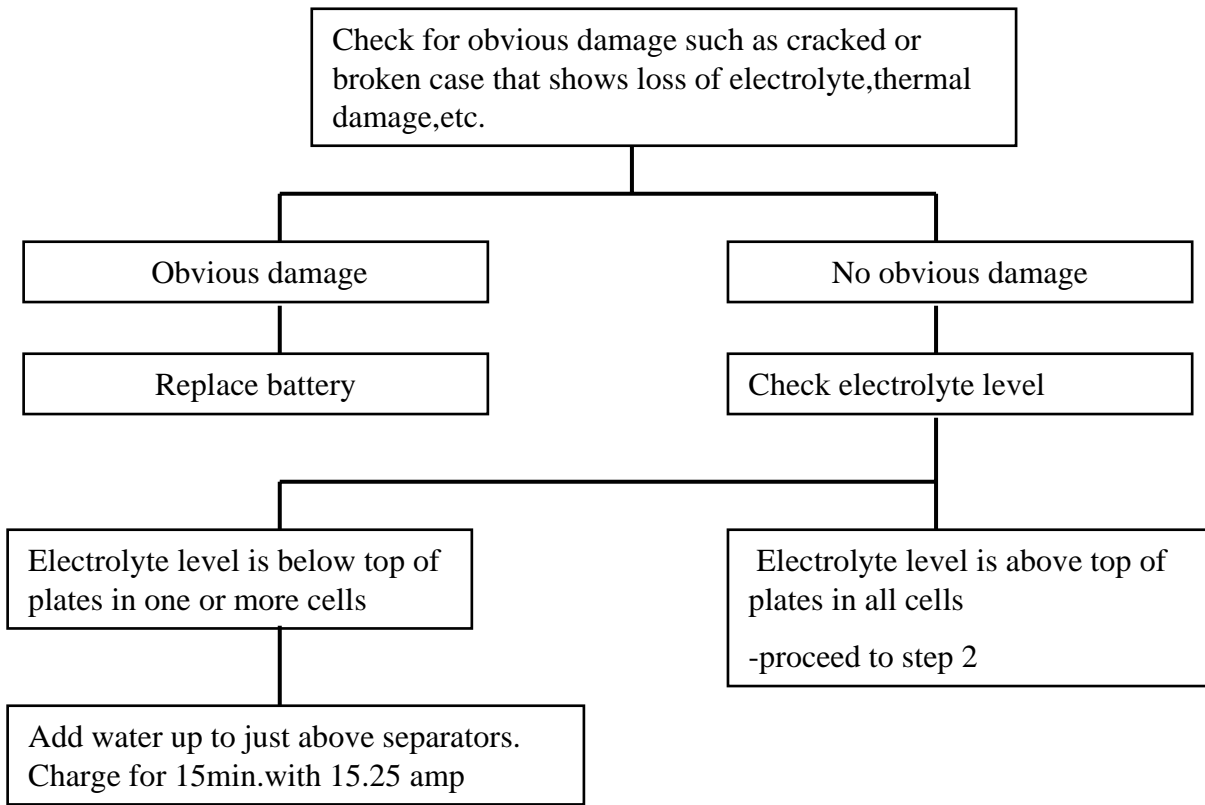

Step 2

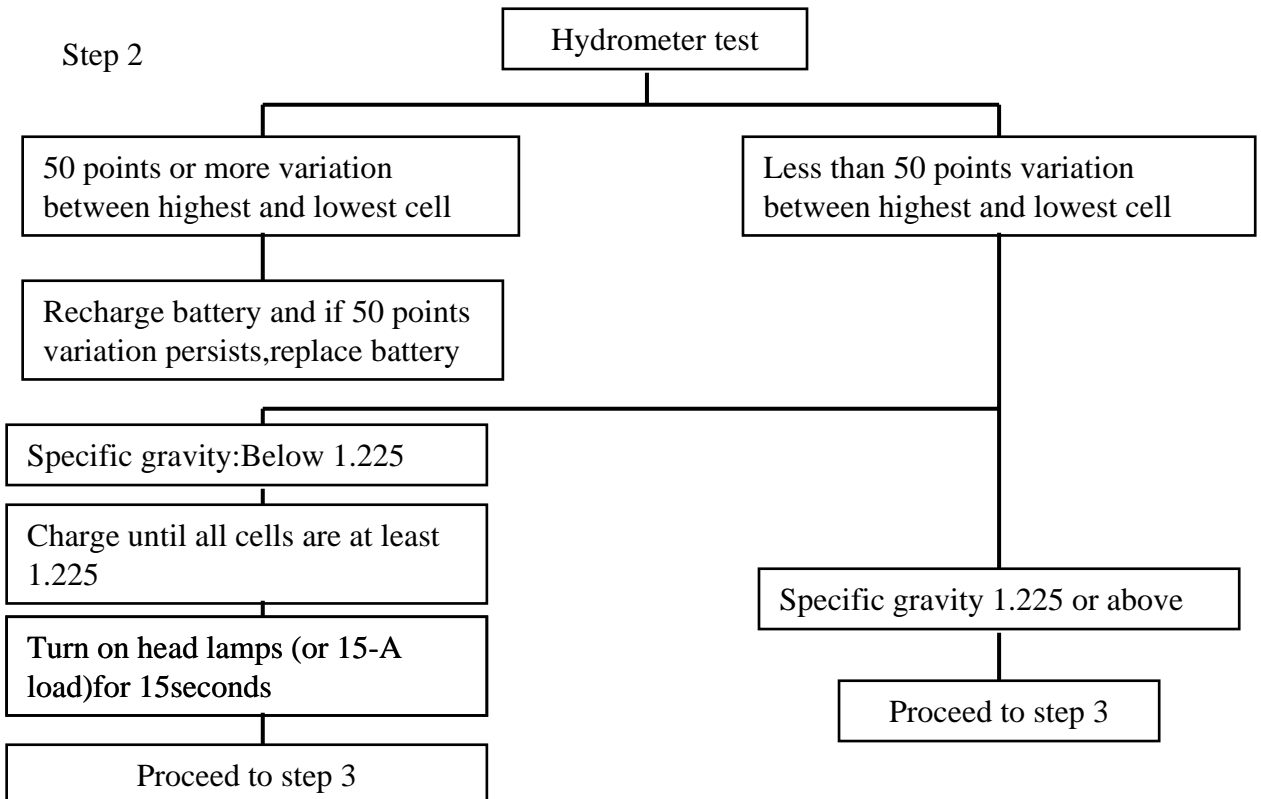

Step 3

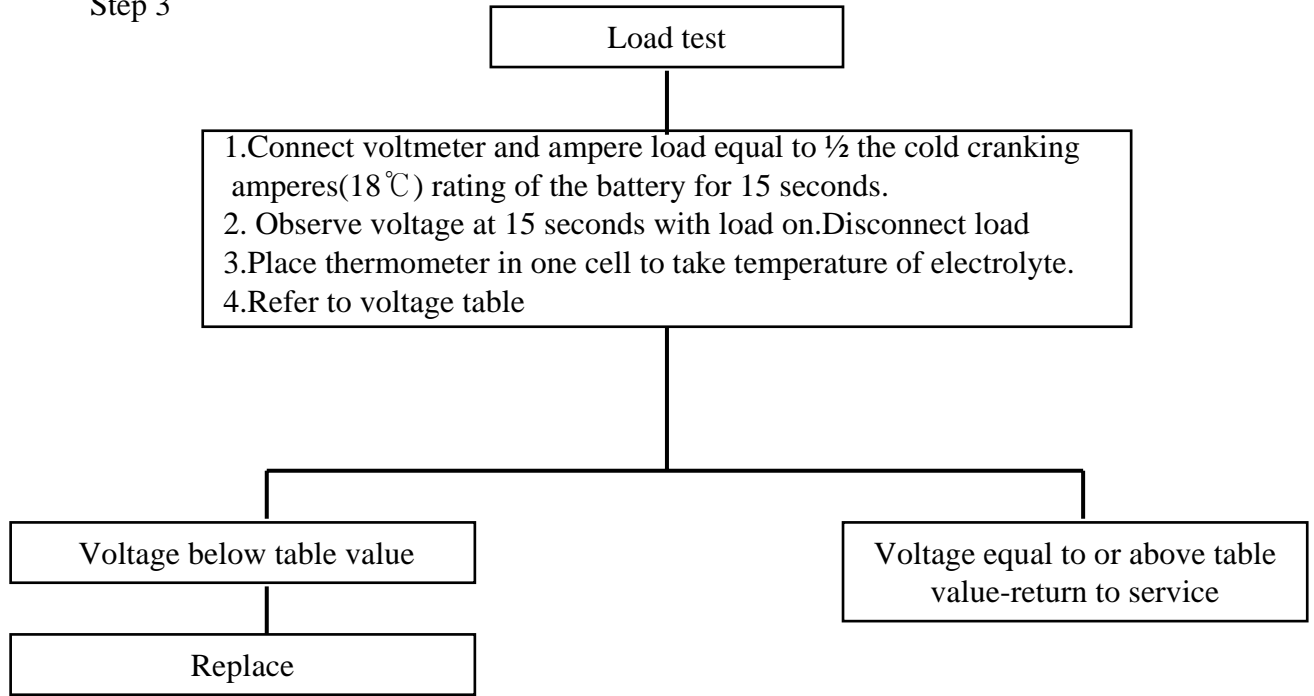

Voltage table	
Estimated electrolyte temperature	Minimum required voltage under 15 sec.load (Use 1/2 these values for 6-V batteries)
70 °F (21 °C) and above	9.6
60 °F (16 °C)	9.5
50 °F (10 °C)	9.4
40 °F (4 °C)	9.3
30 °F (-1 °C)	9.1
20 °F (-7 °C)	8.9
10 °F (-12 °C)	8.7
0 °F (-18 °C)	8.3

**SECTION 4. METERS AND SWITCHES**

**1.METERS**

**1.1 Removal**

- a. Disconnect the cable from the negative post.
- b. Remove the philips screw which hold the meter panel and lift up the panel assembly a little

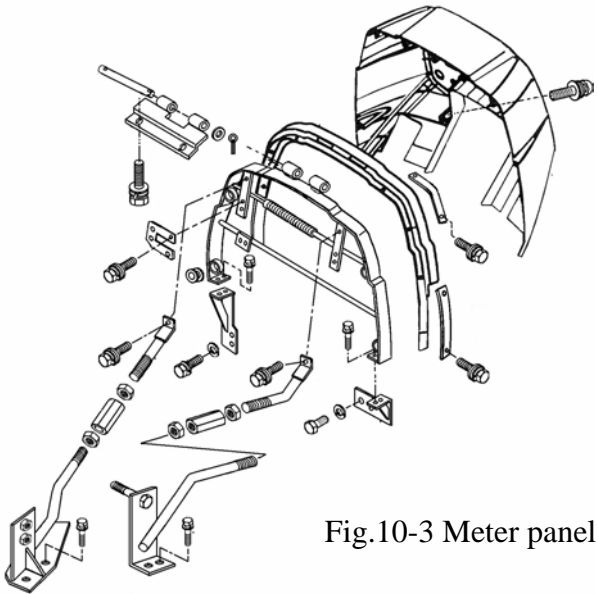

Fig.10-3 Meter panel

- c. Then the meter panel can be detached by removing the wire harness couplings.

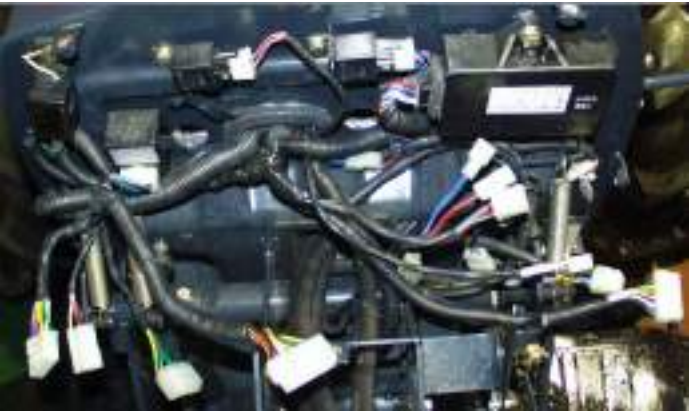

Fig.10-4 Wire harness

**1.2 Tacho/hour meter and sensor**

**a.Construction**

An electric tachometer is employed along with a Tachosensor.The tach/hour meter converts engine revolutions to electric signals,which is sent to the tachometer.The tachometer displays the engine revolutions visually.The tachosensor generates 14 pulses per one engine revolution.

The generated pulses are converted into voltage output through a converter.Then the voltage is divided into three different phase coils through a IC circuit.The tachometer pointer is swung by the compound magnetic field generated by the three point.

**b. Inspection**

-Tachometer

The allowable error of a tachometer reading is specified as shown on the table below.If the reading deviates from the specified value.replace the meter assembly.

Engine speed(rpm)	1000	2500
Allowable error(rpm)	±150	±150

**1.3 Fuel gauge and Fuel gauge sensor**

**a.Construction**

When the fuel tank is full,the float is at the top and has moved the variable resistor to a position of least resistance.This feeds maximum current into the meter circuit and the pointer swings fully to the F position.Consequently when the fuel level in the tank is low,everything acts in reverse.

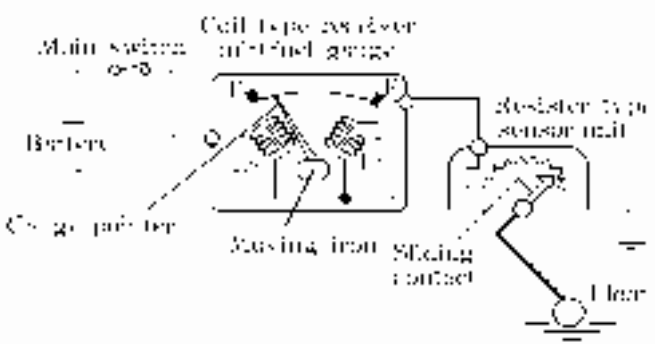

Fig.10-5 Fuel gauge sensor

## b. Inspection

### -Fuel meter

Connect the fuel gauge to form a circuit with the resistors as shown Fig.10-6 and check to see if the gauge pointer swings to each position: F, 1/2 and E by changing the resistance value. If it does not, change the gauge assembly.

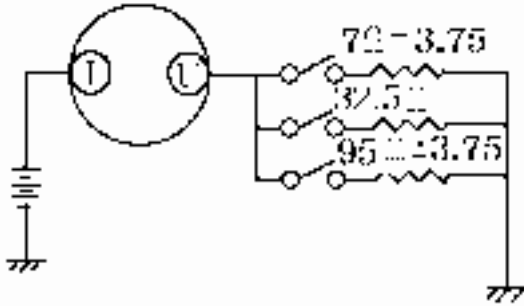

Fig.10-6

### -Fuel gauge sensor(variable resistor)

Check each resistance value with a tester at each float position as shown in Fig.10-7. If the measured values are deviated from respective specified values, replace the sensor assembly.

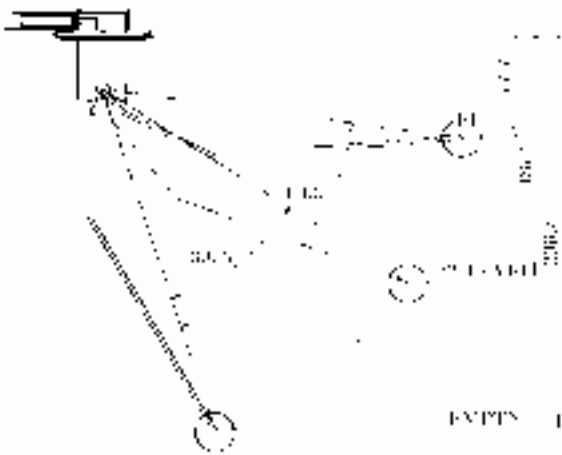

Fig.10-7

Standard pointer position	F	(1/2)	E
Regulated resistance(Ω)	7	32.5	95
Sensor Unit resistance(Ω)	7	(-)	95

Note:

- 1) Figures in parentheses are reference value
- 2) Inspect each position in order F to E
- 3) Read values in three minutes.

## 1.4. Thermometer

### a. Construction

This is the same moving magnet type meters as the fuel gauge. As the coolant temperature becomes higher, the resistance in the thermo unit(sensor) become lower, which results in more current to the meter circuit and swinging the meter pointer to the high temperature side on the scale. Of course, as the coolant temperature become lower, everything acts in reverse.

### b. Inspection

Normally the thermometer resisters higher values as the coolant temperature rises after the engine is running. If it does not, check the wiring first. If the wiring is normal. Replace assembly.

## 2. STARTER SWITCH

### (1) Removal

- a. Remove the dash cover(Upper)
- b. Remove the ring nut holding the starter switch using a conventional screw driver.
- c. Pull out the key switch as shown in Fig.10-8

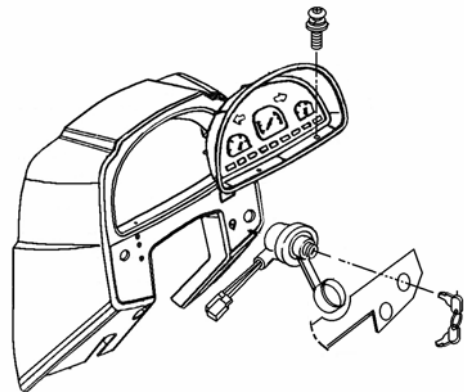

Fig.10-8



## (2) Inspection

a. The main switch circuit, switching positions, and terminals are as shown in the figures. Check the continuity across respective terminals referring to the switch circuit diagram. Replace a defective switch as an assembly

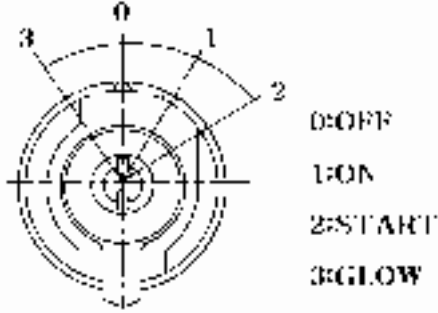

Fig.10-9

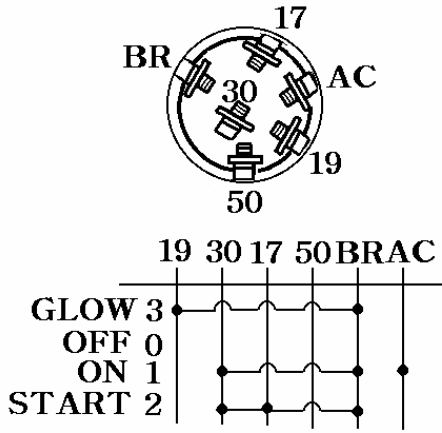

Fig.10-10

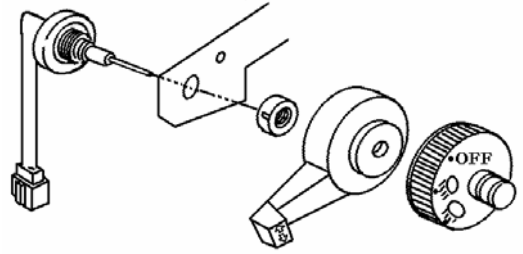

Fig.10-12

(3) Release the ring nut with a conventional screw drive(-) and remove the combination switch.

### 2) Inspection

Each switch circuit is as shown, so check each switch for a continuity across respective terminals with a tester. Replace a defective switch as an assembly.

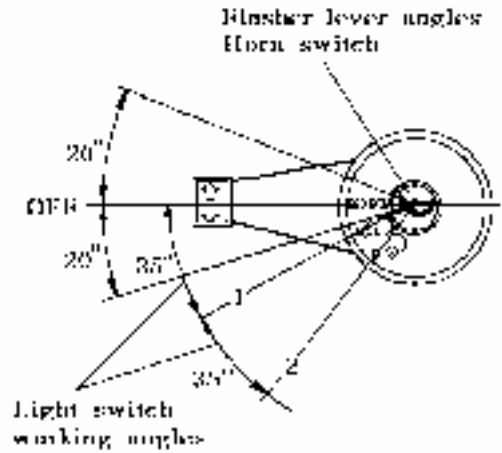

Fig.10-13 combination switch

## 3. COMBINATION SWITCH

### 1) Removal

- (1) Remove the meter panel
- (2) Remove the light switch knob and turn signal switch lever.

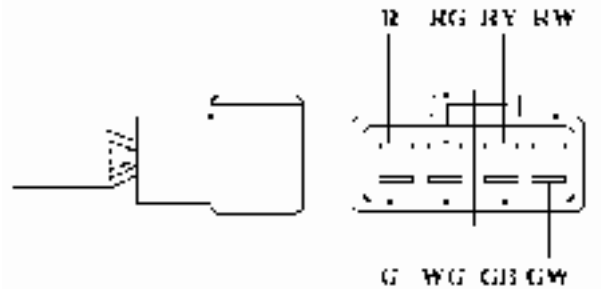

Fig.10-14 Harness socket

-Lighting

Color code	R (Red)	RG (Red/ Green)	RW (Red/ White)	RY (Red/ Yellow)
	B1* <sub>1</sub>	T	1	2
OFF ** <sub>2</sub>				
1	●	●	●	
2	●	●		●

\*<sub>1</sub>:Terminals

\*\*<sub>2</sub>: Switching positions

-Flasher

Color code	G (Green)	WG (White/ Green)	GB (Green/ Black)
	B2* <sub>1</sub>	R	L
1** <sub>2</sub>	●	●	
OFF			
2	●		●

\*<sub>1</sub>:Terminals

\*\*<sub>2</sub>: Switching positions

-Horn switch

Color code	R(Red)	GW(Green/White)
	B1* <sub>1</sub>	H
Free** <sub>2</sub>		
Push	●	●

\*<sub>1</sub>:Terminals

\*\*<sub>2</sub>: Switching positions

#### 4. STOP LIGHT SWITCH

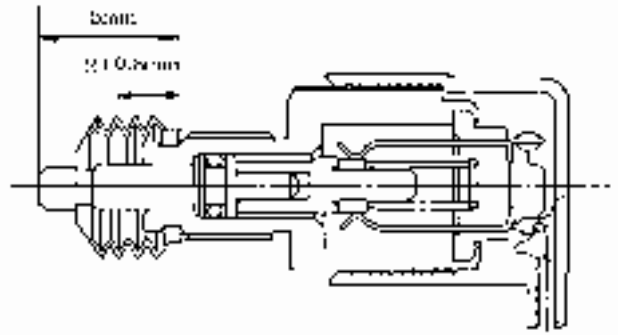

Fig.10-15 Stop light switch

Capacity	10~20A (DC12V)
Stroke to ON	3 ±0.5mm
Total stroke	8mm

#### 5.RELAY UNIT

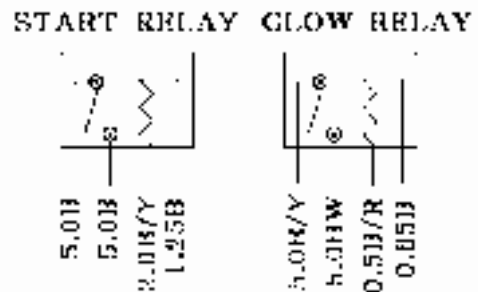

Fig.10-16 Relay unit

#### 6. FUSE

Fuses are installed in the main fuse box and one for the headlights. Three fusible links are installed to prevent the wiring from burning due to a short circuit.



Fig.10-17 Fuse box

Each fuse is connected as follows

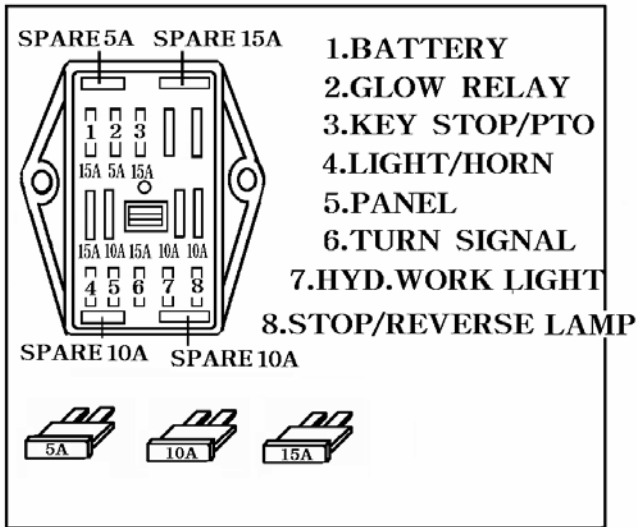

FUSE BOX

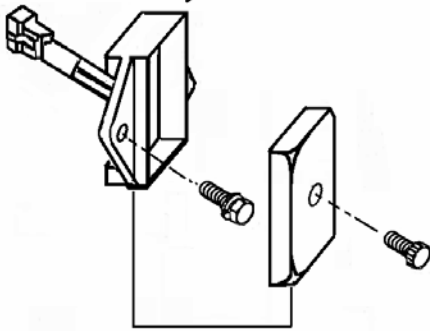

Fig.10-18

The circuit has 8 blade type fuses in its wiring circuit. When a fuse has blown replace it with one of the same value.

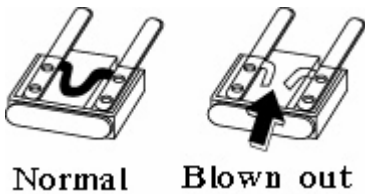

Fig.10-19

Note:

Using a large capacity fuse or wire burn out the wiring system.

**Use fuse tongs to replace fuses**

## 8.Trailer socket

A hella's 7-pin trailer socket is equipped as a standard equipment.Lamp on a trailer can be operated through the socket.

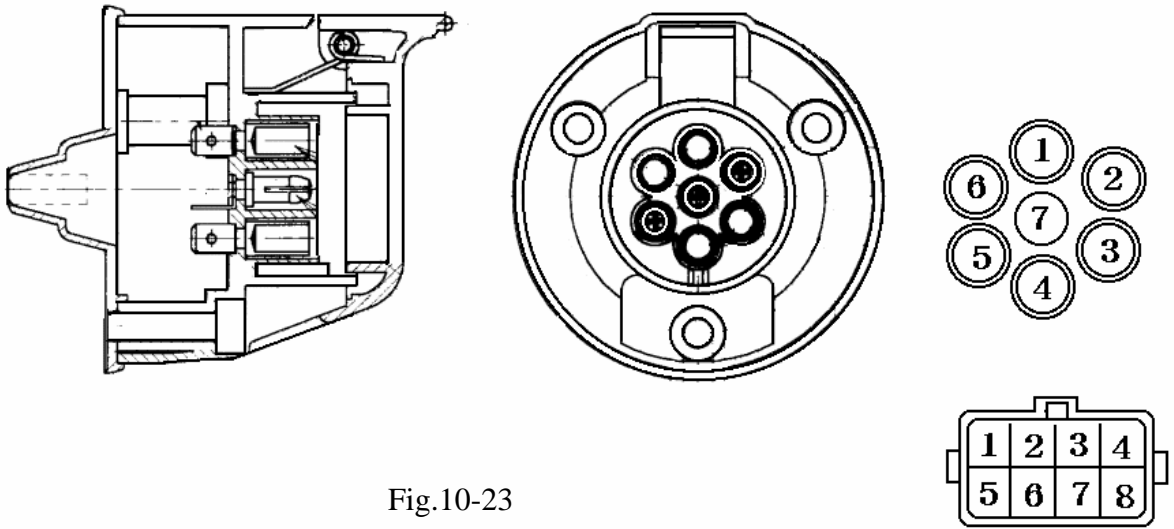

Fig.10-23

Socket No.	Description	Color	Specification	Wire Housing
1	Earth	B	AVSS 2.0	1
2	Small light(Tail light)	Y	AVSS 0.85	2
3	Turn signal (LH)	GB	AVSS 0.85	3
4	Stop Light	WL	AVSS 0.85	4
5	Turn signal (RH)	GY	AVSS 0.85	5
6	Rear Light (Number plate)	YW	AVSS 0.85	6
7	Reserve light	WG	AVSS 0.85	7

Note:

Lamp on the trailer should be of the same size or smaller than those on the trailer.

## SECTION 5. EARTHING POINT

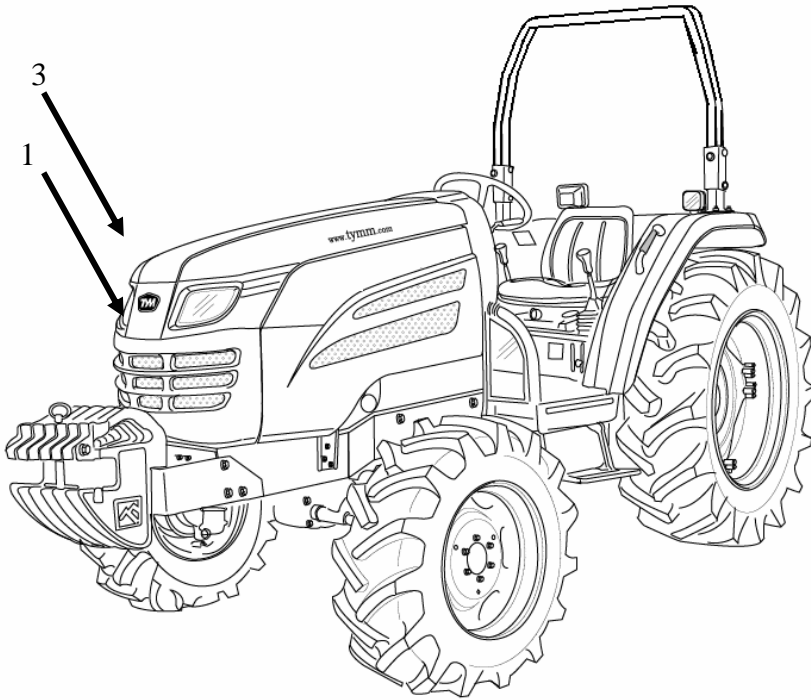

Fig.10-24

### 1) Front axle bracket (RH)

Earthed at upper upper tapped hole in the axle bracket A.

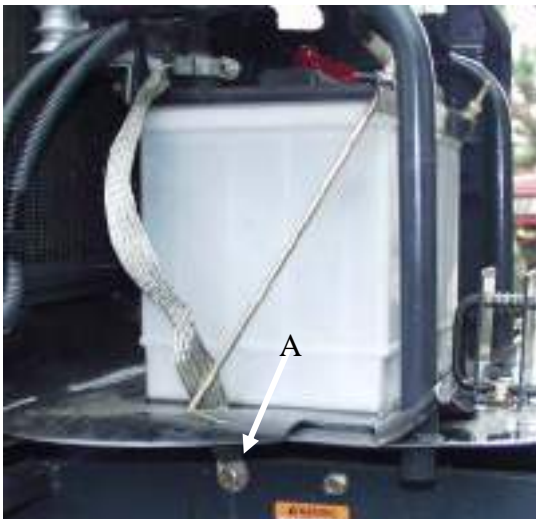

Fig.10-25

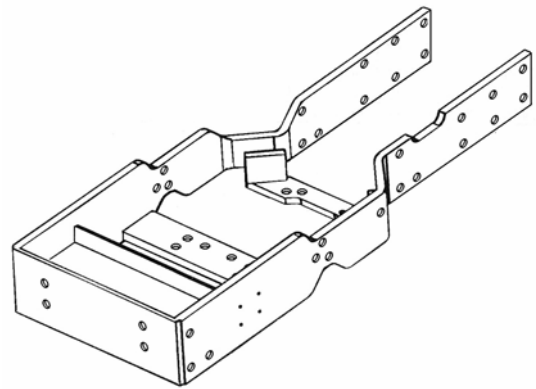

Fig.10-26

3) Right surface of the frame comp. Where the battery bracket is to be installed.

2) Contact surfaces of the axle bracket and engine where they tightened together

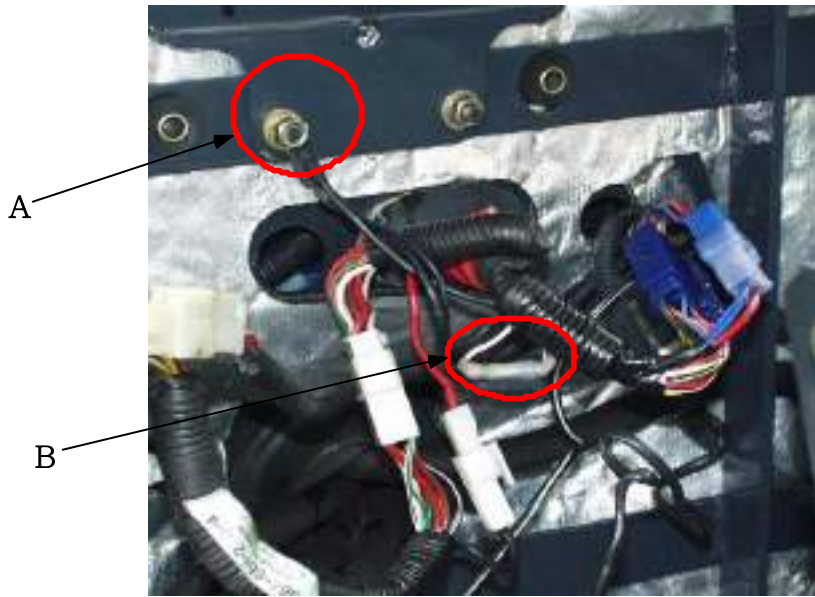
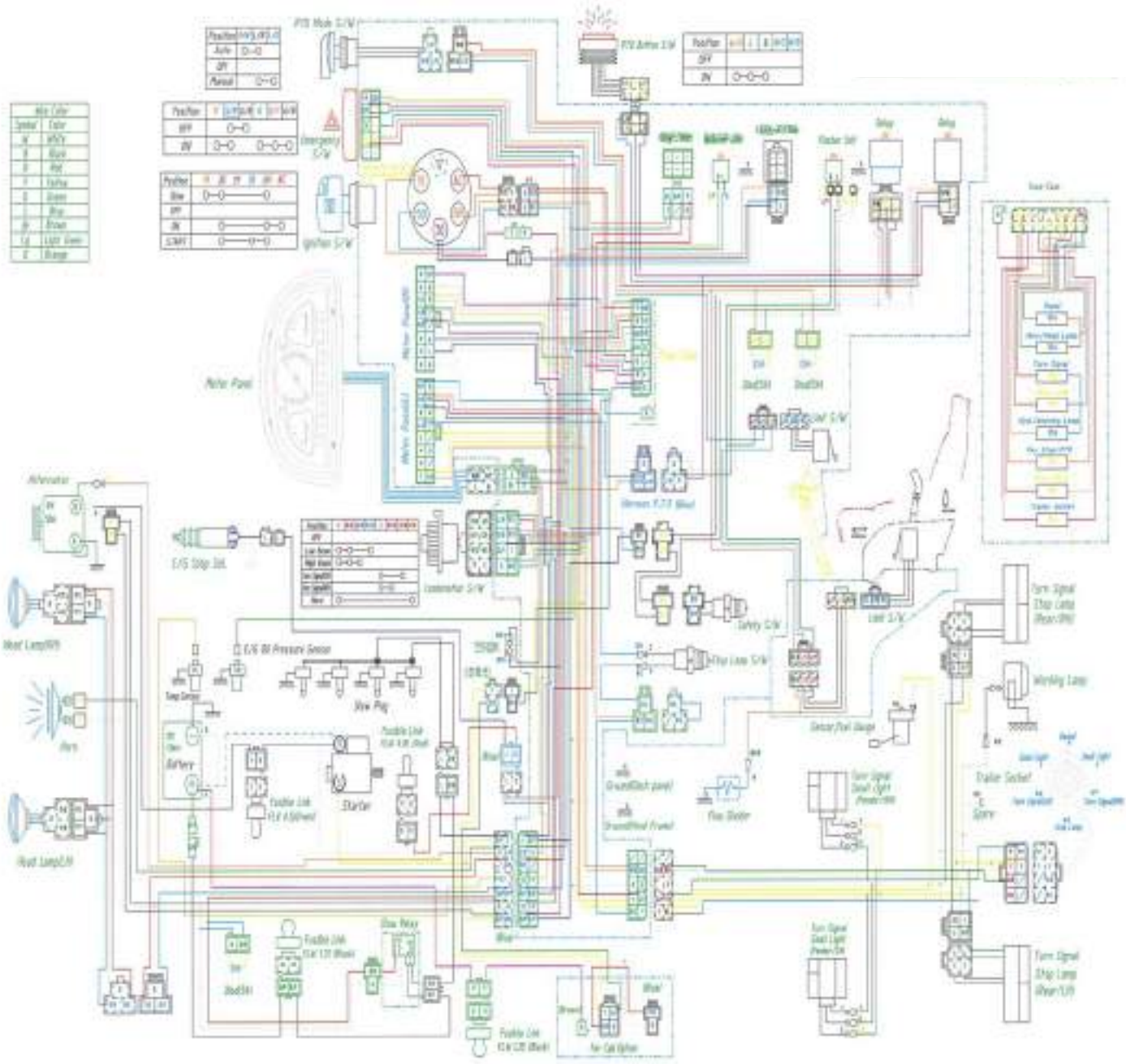

Fig.10-27 Hood frame

# SECTION 6. WIRING DIAGRAM(T390/T430)



## SECTION 7. TROUBLESHOOTING

Important: Whenever effecting a repair the reason for the cause of the problem must be investigated and corrected to avoid repeating failure.

The following table lists problems and their possible causes with the recommended remedial action

### 1. LIGHTING SYSTEM

Problems	Causes	Countermeasures
Several or all lights do not illuminate	Discharged battery	Check battery and charge or renew
	Loose or defective battery cable connection	Inspect, clean, and tighten connection
	Loose wire harness connectors	Check and ensure connectors securely engaged
	Burnt out fuse or fusible link	Inspect and renew. Check circuit before re-connecting power
	Faulty wiring	Check lighting Circuit wiring and repair or renew
	Defective light switch	Check and renew
	Several light bulbs burnt out due to defective voltage regulation	Check and renew voltage regulator (Alternator)
Individual lights do not illuminate	Burnt out bulb	Check and renew
	Defective or corroded bulb contact	Inspect, clean or renew
	Burnt out fuse	Inspect and renew. Check circuit before reconnecting power
	Loose or broken wires	Inspect ,secure,repair,or renew wiring
	Poor ground connection	Inspect, clean, and tighten ground connection
Lights burnt out repeatedly	Faulty voltage regulator	Check and renew voltage regulator (Alternator)
Turn signal lights do not illuminate	Blown fuse	Inspect and renew. Check circuit before re-connecting power
	Inoperative flasher unit	Check and renew
	Inoperative turn signal switch	Check and renew
	Defective wiring or connections	Inspect circuit, clean, and tighten connection. Repair or renew wiring if necessary



Problems	Causes	Countermeasures
Individual turn signal light does not illuminate	Burnt out bulb	Check and renew
	Corroded or loose bulb contacts	Inspect, clean, and renew
	Poor ground connection or damage wiring	Inspect, clean, and tighten connections or renew wiring
Turn signal pilot light is inoperative	Faulty bulb	Check and renew
	Defective flasher unit	Check and renew
	Faulty wiring or connections	Inspect, clean, and tighten connections or renew wiring
Stop lights does not illuminate	Inoperative stop light switch	Check and renew
	See "Individual lights do not illuminate"	See "Individual lights do not illuminate"
Inoperative work light	Work light switch is not turned on	Ensure work light illuminates
	See "Individual lights do not illuminate"	See "Individual lights do not illuminate"

## 2. INSTRUMENTATION

Problems	Causes	Countermeasures
Inoperative or erratic meters	Loose or broken wiring	Inspect Circuit, tighten connections or renew wiring
	Defective meters	Inspect and renew
	Defective sensors	Check and renew
	Defective Voltage regulator	Check and renew voltage regulator (Alternator)
Monitor light does not illuminate	Loose or broken wiring	Inspect circuit, tighten connections or renew wiring
	Faulty main switch	Check and renew
	Burnt out bulb	Check and renew
	Burnt out fuse	Check and renew
	Defective switch	Check and renew
	Loose or broken wiring	Check and renew
PTO does not operate	Burnt out fuse	Inspect and renew. Check circuit
	Loose or broken wires or connections	Inspect circuit, tighten connections, or renew wiring
	Defective PTO switch	Check and renew
	Defective PTO solenoid	Check and renew

Problems	Causes	Countermeasures
Inoperative horn	Burnt out fuse	Inspect and renew. Check circuit before re-connecting power
	Loose or broken wires of connections	Inspect circuit, tighten connections, or renew wiring
	Defective horn switch	Check and renew
	Defective horn	Check and renew

### 3.GLOW SYSTEM

Problems	Causes	Countermeasures
All glow plugs do not heat red	Discharged Battery	Check battery and charge or renew
	Loose or defective battery cable connections	Inspect, clean, and tighten connections
	Loose wire harness connections	Check and ensure connectors securely engaged
	Burnt out fusible link	Inspect and renew. Check circuit before re-connecting power
	Faulty wiring	Check glow plug circuit wiring and repair or renew
	Defective main switch	Check and renew
Individual glow plug does not glow	Defective glow plug	Check and renew
	Defective or corroded glow plug contacts	Inspect, Clean, or renew
	Loose or broken wires	Inspect, secure, repair, or renew wiring
Glow monitor light does not illuminate	Defective glow timer	Check and renew
	Defective glow monitor light or monitor and warning check unit	See "Light system troubleshooting"

#### 4. STARTING SYSTEM

Problems	Causes	Countermeasures
Starter motor does not spin	Discharged battery	Check battery and charge or renew
	Defective stop light switch	Check and renew
	Defective key switch	Check and renew
	Defective starter motor connections or loose battery connections	Check,clean and tighten connections
	Faulty starter motor	Inspect,repair,or renew
	Defective master brake pedal	Inspect and try to push brake pedal
	Faulty reverse or forward pedal	Inspect ,adjust neutral
	Defective push switch	Check and renew
	Defective controller	Check and renew
Engine cranks slowly	Discharged battery	Check battery and charge or renew
	Excessive resistance in starter circuit	Check circuit connections and repair or renew faulty wiring
	Defective starter motor	Refer to the engine manual
	Tight engine	Refer to the engine manual

#### 5. CHARGING SYSTEM

Problems	Causes	Countermeasures
Battery is low in charge or discharge	Loose or worn alternator drive belt	Check and adjust belt tension or renew
	Defective battery:It will not accept or hold charge.Electrolyte level is low	Check condition of battery and renew
	Excessive resistance due to loose charging system connections	Check,clean,and tighten circuit connections
	Defective alternator	Check and repair or renew
Alternator is charging at high rate (Battery is overheating)	Defective battery	Check condition of battery and renew
	Defective Alternator	Check and repair or renew
No output from alternator	Alternator drive belt is broken	Renew and tension correctly
	Loose connection or broken cable in charge system	Inspect system,tighten connections and repair or renew faulty wiring
	Defective voltage regulator	Check and renew
	Defective alternator	Check and repair or renew

Problems	Causes	Countermeasures
Intermittent or low alternator output	Alternator drive belt is slipping	Check and adjust belt tension or renew
	Loose connection or broken cable in charge system	Inspect system,tighten connections and repair or renew faulty wiring
	Defective alternator	Check and repair or renew
Warning light dims	Faulty external charging circuit connections	Inspect system,clean and tighten connections
	Faulty rotor slip rings or brushes	Inspect and repair or renew
	Defective monitor and warning unit	Check and renew
	Faulty rectifier or rectifying diodes	Check and renew
Warning light is normal but battery is discharged	Defective voltage regulator	Check and renew
	Faulty starter	Check and renew
	Faulty rectifier or rectifying diodes	Check and renew
Warning light is lit during operation	Loose or worn alternator drive belt	Check and adjust tension or renew
	Defective diodes	Check and renew
	Faulty rotor,slip rings,or brushes	Inspect,repair,or renew
	Defective starter	Check and renew
	Defective rectifier or rectifying diodes	Check and renew
Warning light flashes intermittently	Faulty external charging circuit	Inspect circuit,clean,and tighten connections.Repair or renew faulty wiring
	Alternator's internal connections	Inspect and test circuitry,Repair or renew

# CHAPTER 11. Service standards and other information

---

<b>SECTION 1. SERVICE STANDARDS</b> .....	<b>11-1</b>
<b>1.Engine accessories</b> .....	<b>11-1</b>
<b>2.Clutch damper</b> .....	<b>11-2</b>
<b>3.Transmission</b> .....	<b>11-2</b>
<b>4.Front axle</b> .....	<b>11-3</b>
<b>5.Rear Axle</b> .....	<b>11-4</b>
<b>6.Power steering system</b> .....	<b>11-4</b>
<b>7.Hydraulic system</b> .....	<b>11-4</b>
<b>8.Electrical equipment</b> .....	<b>11-7</b>
<b>SECTION 2. TIGHTENING AND STARTING TORQUE</b>	
<b>SPECIFIED FOR PARTS.</b> .....	<b>11-10</b>
<b>SECTION 3. CONVERSION TABLES</b> .....	<b>11-11</b>

# CHAPTER 11. Service standards and other information

## SECTION 1. SERVICE STANDARDS.

Part names and inspection items	Nominal dimensions	Standard value for reassembly	Usable limits	Service instructions and remarks
---------------------------------	--------------------	-------------------------------	---------------	----------------------------------

### 1.ENGINE ACCESSORIES(CHAPTER 3)

#### 1) RADIATOR

Coolant capacity	3.9 ℓ		Radiator alone
	9.0 ℓ		Whole cooling system
Radiator cap valve operating pressure	1.1 ±0.15kgf·cm <sup>2</sup>		

#### 2) AIR CLEANER

Element capacity	<p>Rated intake air : 2.6 m<sup>3</sup></p> <p>Air passing resistance : 120mmAq or less</p> <p>Filtering efficiency</p> <p>Total : 99.9% or more</p> <p>Cyclone : 45% or more</p> <p>Dust holding capacity : 700g or more</p>	
------------------	---	--

#### OUTER ELEMENT

1. Clean or wash the element after 100 hours of operation. Replace a damaged one or one which has been used more than 500 hours.

##### a. Cleaning (when dust is dry)

Apply compressed air of 7Kgf/cm<sup>2</sup> or lower to the inside of the element to blow dust outwards. Never strike element to dust.

##### b. Washing (when dust is wet or oily)

Dissolve element cleanser or neutral detergent of good quality in water. Keep the element immersed in the solution about 30 minutes and then wash it by shaking gently.

-Then, rinse it in fresh water; Water pressure should be less than 2.8 Kgf/cm<sup>2</sup>.

-Leave the washed element in a shaded, well-ventilated place to dry itself.

Never force-dry heat or compressed air.

2. An element which has been washed five times should be replaced with a new one.

3. When the tractor is used in dusty situation, inspect the element everyday and clean if necessary

Part names and inspection items		Nominal dimensions	Standard value for reassembly	Usable limits	Service instructions and remarks
2. MAIN CLUTCH (CHAPTER 4)					
CLUTCH DISC ASSEMBLY (Dry single plate) Facing wear			8.0 ±0.3mm (0.315 in)	6.5 mm (0.256 in)	Rivet head depression should maintained at more than 0.2 mm
Play between hub spline and input gear in rotational direction				0.3 mm (0.012 in)	Should be measured on the hub.
Clutch cover (Dual type) Pressure plate flatness			0.05 mm or less	0.5mm (0.020)	
Spline hub	No.of teeth	19			
	Large diameter		Ø35.0 mm (1.378 in)		
	Small diameter		Ø31.7 mm (1.248 in)		
Distance from release lever			0.7 mm (0.028 in)	1.0 mm (0.039 in)	
Distance from flywheel surface to release lever top		65.0 ±0.7 mm (2.55 in)			
Free play of CLUTCH PEDAL			20 ~ 30 mm (0.79-1.18 in)		Adjust with the clutch rod (turn buckle)
Total stroke			97 mm		
Clearance between safety switch and push arm			12 ±1 mm (0.47 ±0.04 in)		

Part names and inspection items	Nominal dimensions	Standard value for reassembly	Usable limits	Service instructions and remarks
---------------------------------	--------------------	-------------------------------	---------------	----------------------------------

### 3. TRANSMISSION (CHAPTER 5)

#### 1) FRONT AND SPACER TRANSMISSIONS

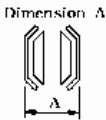
TRANSMISSION OIL CAPACITY				33 ℓ
SHIFTER DISENGAGING LOAD				
Main shift		18 - 22 kgf	17 kgf	Measured at the shifters (both for synchromesh and sliding-select gear)
Front wheel drive		18 - 22 kgf	17 kgf	Measure at the shifter
PTO shift		18 - 22kgf		Measure at the shifter
<b>SYNCHRONIZER ASSEMBLY</b>				
Assembled width		49.08-49.88 mm (1.932-1.964 in)		
Synchro-hub thrust load		13.0-18.8 kgf (28.7-41.5 lbs)	9.5 kgf (20.9lbs)	from neutral to engaging when applied on the spring
Individual gears back lash		0.1 ~0.2 mm	0.5 mm	
Independent Rear PTO clutch	Disk thickness	2.2 ±0.1 mm	1.9 mm	
	Disk flatness		0.2 mm	
	Driven plate flatness		0.2 mm	
	Brake disk thickness	3.0 ±0.1mm	2.5 mm	
	Brake disk flatness		0.2 mm	



Part names and inspection items	Nominal dimensions	Standard value for reassembly	Usable limits	Service instructions and remarks
---------------------------------	--------------------	-------------------------------	---------------	----------------------------------

## 2) REAR TRANSMISSION

### (1) DRIVE PINION & RING GEAR

Starting torque		0.11-0.13 kg·m		
Backlash		0.1 ~ 0.2 mm	0.5 mm	Backlash and tooth bearing should be adjusted properly when reassembled
Drive pinion and ring gear support shimming	Adjustment of relative positioning between drive pinion and ring gear		Available shims on drive pinion metal(support) Shim A : 0.1 mm (0.004 in) Shim B : 0.2 mm (0.008 in) Available shims on dif-case Shim A : 0.1 mm (0.004 in) Shim B : 0.2 mm (0.008 in)	

### (2) DIFFERENTIAL

Backlash between dif-pinion and dif-side gear		0.1 ~ 0.2 mm	0.5 mm	Worn pinion thrust collar or gear Right and Left dif-side gears are refined differently from each other,so take care not to interchange them when assembled
---	--	--------------	--------	--

Part names and inspection items	Nominal dimensions	Standard value for reassembly	Usable limits	Service instructions and remarks
---------------------------------	--------------------	-------------------------------	---------------	----------------------------------

#### 4. FRONT AXLE (CHAPTER 6)

##### 1) Front drive axle (4WD) (Updated version)

Tire inflation		Front : 2.2 kgf/cm <sup>2</sup> Rear : 1.8 kgf/cm <sup>2</sup>			
Wheel alignment		①Toe-in : 2 ~ 6 mm ②Camber : 3 °±1 ° ③Caster : 1 °±1 ° ④Rocking angle : 8 °±1 ° ⑤Steering angle : 52°±1°			
Front center pivot	shaft.dia.		Ø 50 mm	Ø 49.9 mm	wear limit : 0.1 mm
	bush	50 × 55 × 20	Ø 50 mm	Ø 55.35 mm	wear limit : 0.2 mm
Rear center pivot	shaft.dia.		Ø 75 mm	Ø 74.9 mm	wear limit : 0.1 mm
	bush	75 × 80 × 30	Ø 75 mm	Ø 75.2 mm	wear limit : 0.2 mm
Play in bush			0.3 mm		
Thrust play			0 ~ 0.2 mm	0.5 mm	Adjust with adjusting bolt
DIFFERENTIAL	Pinion gear		0.05 ~ 0.06kgf·m		
	Starting torque		6~7 kgf·cm		
Thrust play			0.1 ~ 0.3 mm		shim: 0.1, 0.2 mm
Drive pinion/ring gear backlash			0.1 ~ 0.2 mm		shim: 0.1, 0.2 mm

Part names and inspection items	Nominal dimensions	Standard value for reassembly	Usable limits	Service instructions and remarks
---------------------------------	--------------------	-------------------------------	---------------	----------------------------------

## 5. REAR AXLE (CHAPTER 7)

### 1) DISK BRAKE

FRICION PLATE THICKNESS (WEAR AND CARBONIZER )		$3.4 \pm 0.1$ mm	3.4 mm	
--	--	------------------	--------	--

### 2) SEPARATE PLATE

Thickness (wear and damage)		$2.5 \pm 0.09$ mm	2.5 mm	
-----------------------------	--	-------------------	--------	--

### 3) BRAKE ROD TURN BUCKLE

Pedal play at the top		30 ~ 40 mm		
-----------------------	--	------------	--	--

## 6. POWER STEERING SYSTEM( CHAPTER 8)

### 1) GEAR PUMP (Updated version)

Capacity	T390/T400/T430/T450 : 4.8cc	Theoretical value/revolution T390/T400 : 2,800 rpm T430/T450 : 2,600 rpm P=150 kgf/cm <sup>2</sup> Oil temperature : 50°C
Direction of revolution	CCW	

## 7. HYDRAULIC SYSTEM (CHAPTER 9)

### 1) PISTON AND CYLINDER

cylinder and bore		$\varnothing 75$ mm		O-ring : $\varnothing 65$ mm
-------------------	--	---------------------	--	------------------------------

Part names and inspection items	Nominal dimensions	Standard value for reassembly	Usable limits	Service instructions and remarks
2) Dynamic lift				
T390/T400/T430/T450		1300 kgf·cm <sup>2</sup>		
3) Cylinder case bush				
Left side	55 × 60 × 50	Ø 55 mm	Ø 55.2 mm	Wear limit: 0.2 mm
Right side	60 × 65 × 50	Ø 60 mm	Ø 60.2 mm	Wear limit: 0.2 mm
4) Flow divider				
Flow through PTO clutch port	5.0~6.0 cc(0.305 cu in)			Pressure:1 kgf/cm <sup>2</sup> (psi)
Setting pressure of PTO clutch port	15 kgf/cm <sup>2</sup> over			under a flow rate of 0.9 ℓ/min
5) Flow divider assembly				
Solenoid	Rated voltage	DC 12 V		
	Rated current	2.1 A		
	Switch-over frequency limit	2 times / sec		
Clearance between change over valve and casing			0.025 mm	
Free length of change over valve spring		15.5 mm	15.0 mm	
Clearance between sequential valve spool and casing			0.021 mm	
Free length of pressure reducing valve spring		30.0 mm	29.0 mm	
Sequence valve spring free length.		22.0 mm	21.5 mm	

Part names and inspection items	Nominal dimensions	Standard value for reassembly	Usable limits	Service instructions and remarks
---------------------------------	--------------------	-------------------------------	---------------	----------------------------------

### 6) SLOW RETURN CHECK VALVE(Flow control valve)

Maximum pressure	280 kgf/cm <sup>2</sup> (3982 psi)		Gear oil SAE #80 ~ #90 at a temperature of 50 ± 5°C (122 ±41 F)
Cylinder port leaks	1 cc/min.at a pressure of 90 kgf/cm <sup>2</sup>		

### 7) MAIN CONTROL VALVE (Updated version)

Cylinder port leaks	5 cc/min or less under a pressure of 100 kgf/cm <sup>2</sup>		Gear oil SAE #80 ~ #90 at a temperature of 50 ± 5°C
Clearance between main spool and casing		0.01 mm	

### 8) MAIN RELIEF VALVE (Updated version)

3510/4110/T390 /T400/T430/T450		135 ±5 kgf/cm <sup>2</sup>	
-----------------------------------	--	----------------------------	--

### 9) MAIN GEAR PUMP (Updated version)

3510/4110/T390 /T400/T430/T450		T390/T400: 26.026 ℓ T430/T450: 28.39 ℓ	Efficiency of 92 % at 2600 rpm
-----------------------------------	--	---	-----------------------------------

### 10) SUCTION FILTER (Updated version)

Rated flow		T390/T400:43 ℓ/min T430/T450:57 ℓ/min	
Filtration density		T390/T400:35 micron T430/T450:25 micron	
Filtration area		T390/T400: 6231 cm <sup>2</sup> T430/T450:11000 cm <sup>2</sup>	

### 11) LINE FILTER (Updated version)

Rated flow		35 ℓ/min	
Filtration density		150 mesh	
Filtration Area		790 cm <sup>2</sup>	

## 8.ELECTRICAL EQUIPMENT

### 1)BATTERY

#### (1)BATTERY TERMINAL POST

Terminal voltage	-	12 V	10.8 V	Charge or replace
Corrosion	-	-	-	Repair or replace

#### (2) BATTERY CELLS

Damage	-	-	-	Replace battery
--------	---	---	---	-----------------

#### (3) ELECTROLITE

Cloudy fluid	-	-	-	Replace battery
Specific gravity	-	1.24 - 1.26	-	Correct
Level	-	As specified on case	-	Replace with distilled water.

### 2) METER PANEL AND OTHER SWITCHES.

#### (1) STARTER SWITCH.

Continuity Across Each Terminal		Replace a defective switch assembly.
---------------------------------	--	--------------------------------------

#### 2) COMBINATION SWITCH

Continuity Across Each Terminal		Replace a defective switch assembly.
---------------------------------	--	--------------------------------------

**(3) Turn signal switch**

<p>● Turn signal switch</p>		<p>Replace a defective switch assembly.</p>
-----------------------------	--	---

**(4) Horn switch**

<p>● Horn switch</p>		<p>Replace a defective switch assembly.</p>
----------------------	--	---

**(5) PARKING AND LIGHT SWITCH**

<p>Continuity across each terminal</p>		<p>Replace a defective switch assembly.</p>
--	--	---

**(6) PTO SWITCH**

<p>Continuity across each terminal</p>	<p>Switched on when lever is moved by about 3 mm (0.12 in) across R and LR</p>	<p>Replace a defective switch assembly.</p>
--	--	---

**(7) STOP LIGHT SWITCH**

<p>Continuity across each terminal</p>	<p>Switched on when actuator is pushed in by about 3 mm(0.12 in)assembly</p>	<p>Replace a defective switch assembly.</p>
--	--	---

**(8) PARKING BRAKE SWITCH**

<p>Continuity across each terminal</p>	<p>Switched on when lever is pulled up by about 3 mm(0.12 in)</p>	<p>Replace a defective switch assembly.</p>
--	---	---

**(9) HAZARD WARNING SWITCH**

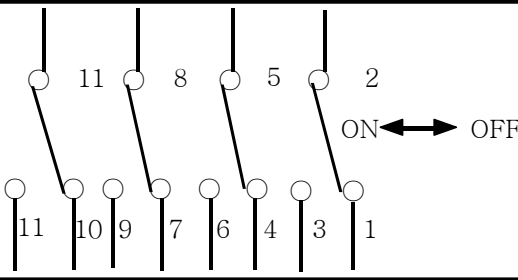
<p>Continuity across each terminal</p>		<p>Replace a defective switch assembly.</p>
--	---	---



## SECTION 2.TIGHTENING AND STARTING TORQUE SPECIFIED FOR MAJOR PARTS

### 1. 3510/4110/T390/T430

<b>TIGHTENING PARTS</b>	<b>Bolt and Nut (Hardness)</b>	<b>Tightening torque (kgf·m)</b>
1)Front axle housing (4WD type) ①Axle bracket ~ Engine tightening bolts ②Front pivot metal(support)tightening bolts ③Rear pivot metal(support) tightening bolts ④Front axle~ final case tightening bolts. ⑤Bearing cover tightening bolts. ⑥Wheel shaft cover tightening bolts. ⑦Front wheel tightening bolts. ⑧Bevel gear case tightening bolts ⑨Dif-metal(support) tightening bolts ⑩Ring gear ~ dif metal(support)tightening bolts Bevel pinion lock nut	M 16 (7T) M 12 (7T) M 14 (7T) M 12 (7T) M 18 (7T) M 110 (7T) M 16 (7T) M 8 M 8 M 8	16.0 ~ 18.0 9.0 ~ 11.0 13.0 ~ 15.0 9.0 ~ 11.0 2.0 ~ 2.4 5.5 ~ 7.0 16.0 ~ 18.0 1.3 ~ 1.8 1.3 ~ 1.8 1.3 ~ 1.8
2)Transmission ①Front transmission ~ Engine tightening bolts and nuts ②Front transmission Spacer transmission tightening bolts and nuts ③Space transmission ~ Rear transmission tightening bolts and nuts ④Input metal(support)tightening bolts and nuts. ⑤Drive pinion metal(support) tightening bolts. Drive pinion tightening nut ⑥Dif-case metal(support)tightening bolts. ⑦Dif case ~ ring gear tightening nuts.	M 12 (7T) M 12 (7T) M 12 (7T) M 12 (7T) M 10 (7T) M 12 M 12 (7T)	9.0 ~ 11.0 9.0 ~ 11.0 9.0 ~ 11.0 9.0 ~ 11.0 5.5 ~ 7.0 5.5 ~ 7.0 9.0 ~ 11.0

## SECTION 3. CONVERSION TABLES

### MILLIMETERS TO INCHES

mm	in.	mm	in.	mm	in.	mm	in.
1	0.0394	26	1.0236	51	2.079	76	2.9921
2	0.0787	27	1.0630	52	2.0472	77	3.0315
3	0.1181	28	1.1024	53	2.0866	78	3.0709
4	0.1575	29	1.1417	54	2.1260	79	3.1102
5	0.1968	30	1.1811	55	2.1653	80	3.1496
6	0.2362	31	1.2205	56	2.2047	81	3.1890
7	0.2756	32	1.2598	57	2.2441	82	3.2283
8	0.3150	33	1.2992	58	2.2835	83	3.2677
9	0.3543	34	1.3386	59	2.3228	84	3.3071
10	0.3937	35	1.3779	60	2.3622	85	3.3464
11	0.4331	36	1.4173	61	2.4016	86	3.3858
12	0.4724	37	1.4567	62	2.4409	87	3.4252
13	0.5118	38	1.4961	63	2.4803	88	3.4646
14	0.5512	39	1.5354	64	2.5197	89	3.5039
15	0.5905	40	1.5748	65	2.5590	90	3.5433
16	0.6299	41	1.6142	66	2.5984	91	3.5827
17	0.6693	42	1.6535	67	2.6378	92	3.6220
18	0.7087	43	1.6929	68	2.6772	93	3.6614
19	0.7480	44	1.7323	69	2.7165	94	3.7008
20	0.7874	45	1.7716	70	2.7559	95	3.7401
21	0.8268	46	1.8110	71	2.7953	96	3.7795
22	0.8661	47	1.8504	72	2.8346	97	3.8189
23	0.9055	48	1.8898	73	2.8740	98	3.8583
24	0.9449	49	1.9291	74	2.9134	99	3.8976
25	0.9842	50	1.9685	75	2.9527	100	3.9370

### INCHES TO MILLIMETERS

in.	mm	in.	mm
1/64	0.3969	33/64	13.0969
1/32	0.7937	17/32	13.4937
3/64	1.1906	35/64	13.8906
1/16	1.5875	9/16	14.2875
5/64	1.9844	37/64	14.6844
3/32	2.3812	19/32	15.0812
7/64	2.7781	39/64	15.4781
1/8	3.1750	5/8	15.8750
9/64	3.5719	41/64	16.2719
5/32	3.9687	21/32	16.6687
11/64	4.3656	43/64	17.0656
3/16	4.7625	11/16	17.4625
13/64	5.1594	45/64	17.8594
7/32	5.5562	23/32	18.2562
15/64	5.9531	47/64	18.6531
1/4	6.3500	3/4	19.0500
17/64	6.7469	49/64	19.4469
9/32	7.1437	25/32	19.8437
19/64	7.5406	51/64	20.2406
5/16	7.9375	13/16	20.6375
21/64	8.3344	53/64	21.0344
11/32	8.7312	27/32	21.4312
23/64	9.1281	55/64	21.8281
3/8	9.5250	7/8	22.2250
25/64	9.9219	57/64	22.6219
13/32	10.3187	29/32	23.0187
27/64	10.7156	59/64	23.4156
7/16	11.1125	15/16	23.8125
29/64	11.5094	61/64	24.2094
15/32	11.9062	31/32	24.6062
31/64	12.3062	63/64	25.0031

**LENGTH**

**FEET TO METERS**

ft	0	1	2	3	4	5	6	7	8	9	ft
	m	m	m	m	m	m	m	m	m	m	
—		0.305	0.610	0.914	1.219	1.524	1.829	2.134	2.438	2.743	—
10	3.048	3.353	3.658	3.962	4.267	4.572	4.877	5.182	5.486	5.791	10
20	6.096	6.401	6.706	7.010	7.315	7.620	7.925	8.230	8.534	8.839	20
30	9.144	9.449	9.754	10.058	10.363	10.668	10.973	11.278	11.582	11.887	30
40	12.192	12.497	12.802	13.106	13.411	13.716	14.021	14.326	14.630	14.935	40
50	15.240	15.545	15.850	16.154	16.459	16.764	17.069	17.374	17.678	17.983	50
60	18.288	18.593	18.898	19.202	19.507	19.812	20.117	20.422	20.726	21.031	60
70	21.336	21.641	21.946	22.250	22.555	22.860	23.165	23.470	23.774	24.079	70
80	24.384	24.689	24.994	25.298	25.603	25.908	26.213	26.518	26.822	27.127	80
90	27.432	27.737	28.042	28.346	28.651	28.956	29.261	29.566	29.870	30.175	90
100	30.480	30.785	31.090	31.394	31.699	32.004	32.309	32.614	32.918	33.223	100

**METERS TO FEET**

m	0	1	2	3	4	5	6	7	8	9	m
	ft	ft	ft	ft	ft	ft	ft	ft	ft	ft	
—		3.2808	6.5617	9.8425	13.1234	16.4042	19.6850	22.9659	26.2467	29.5276	—
10	32.8084	36.0892	39.3701	42.6509	45.9318	49.2126	52.4934	55.7743	59.0551	62.3360	10
20	65.6168	68.8976	72.1785	75.4593	78.7402	82.0210	85.3018	88.5827	91.8635	95.1444	20
30	98.4252	101.7060	104.9869	108.2677	111.5486	114.8294	118.1102	121.3911	124.6719	127.9528	30
40	131.2336	134.5144	137.7953	141.0761	144.3570	147.6378	150.9186	154.1995	157.4803	160.7612	40
50	164.0420	167.3228	170.6037	173.8845	177.1654	180.4462	183.7270	187.0079	190.2887	193.5696	50
60	196.8504	200.1312	203.4121	206.6929	209.9738	213.2546	216.5354	219.8163	223.0971	226.3780	60
70	229.6588	232.9396	236.2205	239.5013	242.7822	246.0630	249.3438	252.6247	255.9055	259.1864	70
80	262.4672	265.7480	269.0289	272.3097	275.5906	278.8714	282.1522	285.4331	288.7139	291.9948	80
90	295.2756	298.5564	301.8373	305.1181	308.3990	311.6798	314.9606	318.2415	321.5223	324.8032	90
100	328.0840	331.3648	334.6457	337.9265	341.2074	344.4882	347.7690	351.0499	354.3307	357.6116	100

**MILES TO KILOMETERS**

miles	0	1	2	3	4	5	6	7	8	9	miles
	km	km	km	km	km	km	km	km	km	km	
—		1.609	3.219	4.828	6.437	8.047	9.656	11.265	12.875	14.484	—
10	16.093	17.703	19.312	20.921	22.531	24.140	25.750	27.359	28.968	30.578	10
20	32.187	33.796	35.406	37.015	38.624	40.234	41.843	43.452	45.062	46.671	20
30	48.280	49.890	51.499	53.108	54.718	56.327	57.936	59.546	61.155	62.764	30
40	64.374	65.983	67.593	69.202	70.811	72.421	74.030	75.639	77.249	78.858	40
50	80.467	82.077	83.686	85.295	86.905	88.514	90.123	91.733	93.342	94.951	50
60	96.561	98.170	99.779	101.390	103.000	104.610	106.220	107.830	109.440	111.049	60
70	112.655	114.265	115.875	117.484	119.094	120.704	122.314	123.924	125.533	127.143	70
80	128.750	130.360	131.970	133.580	135.190	136.799	138.409	140.019	141.629	143.238	80
90	144.844	146.454	148.064	149.674	151.284	152.894	154.504	156.114	157.724	159.334	90
100	160.938	162.548	164.158	165.768	167.378	168.988	170.598	172.208	173.818	175.428	100

**KILOMETERS TO MILES**

km	0	1	2	3	4	5	6	7	8	9	km
	miles	miles	miles	miles	miles	miles	miles	miles	miles	miles	
—		0.621	1.243	1.864	2.486	3.107	3.728	4.350	4.971	5.592	—
10	6.214	6.835	7.457	8.078	8.699	9.321	9.942	10.562	11.185	11.805	10
20	12.427	13.049	13.670	14.292	14.913	15.534	16.156	16.776	17.399	18.019	20
30	18.641	19.263	19.884	20.506	21.127	21.748	22.370	22.990	23.613	24.233	30
40	24.855	25.477	26.098	26.720	27.341	27.962	28.584	29.204	29.827	30.447	40
50	31.069	31.690	32.311	32.933	33.554	34.175	34.797	35.417	36.040	36.660	50
60	37.282	37.904	38.525	39.147	39.768	40.389	41.011	41.631	42.254	42.874	60
70	43.497	44.118	44.739	45.361	45.982	46.603	47.225	47.845	48.468	49.088	70
80	49.711	50.332	50.953	51.575	52.196	52.817	53.439	54.059	54.682	55.302	80
90	55.924	56.545	57.166	57.788	58.409	59.030	59.652	60.272	60.895	61.515	90
100	62.138	62.759	63.380	64.002	64.623	65.244	65.866	66.486	67.109	67.729	100

AREA

SQUARE INCHES TO SQUARE CENTIMETERS

in <sup>2</sup>	0	1	2	3	4	5	6	7	8	9	in <sup>2</sup>
	cm <sup>2</sup>	cm <sup>2</sup>	cm <sup>2</sup>	cm <sup>2</sup>	cm <sup>2</sup>	cm <sup>2</sup>	cm <sup>2</sup>	cm <sup>2</sup>	cm <sup>2</sup>	cm <sup>2</sup>	
—		6.452	12.903	19.355	25.806	32.258	38.710	45.161	51.613	58.064	—
10	64.516	70.968	77.419	83.871	90.322	96.774	103.226	109.677	116.129	122.580	10
20	129.032	135.484	141.935	148.387	154.838	161.290	167.742	174.193	180.645	187.096	20
30	193.548	200.000	206.451	212.903	219.354	225.806	232.258	238.709	245.161	251.612	30
40	258.064	264.516	270.967	277.419	283.870	290.322	296.774	303.225	309.677	316.128	40
50	322.580	329.032	335.483	341.935	348.386	354.838	361.290	367.741	374.193	380.644	50
60	387.096	393.548	399.999	406.451	412.902	419.354	425.806	432.257	438.709	445.160	60
70	451.612	458.064	464.515	470.967	477.418	483.870	490.322	496.773	503.225	509.676	70
80	516.128	522.580	529.031	535.483	541.934	548.386	554.838	561.289	567.741	574.192	80
90	580.644	587.096	593.547	599.999	606.450	612.902	619.354	625.806	632.257	638.708	90
100	645.160	651.612	658.063	664.515	670.966	677.418	683.870	690.321	696.773	703.224	100

SQUARE CENTIMETERS TO SQUARE INCHES

cm <sup>2</sup>	0	1	2	3	4	5	6	7	8	9	cm <sup>2</sup>
	in <sup>2</sup>	in <sup>2</sup>	in <sup>2</sup>	in <sup>2</sup>	in <sup>2</sup>	in <sup>2</sup>	in <sup>2</sup>	in <sup>2</sup>	in <sup>2</sup>	in <sup>2</sup>	
—		0.155	0.310	0.465	0.620	0.775	0.930	1.085	1.240	1.395	—
10	1.550	1.705	1.860	2.015	2.170	2.325	2.480	2.635	2.790	2.945	10
20	3.100	3.255	3.410	3.565	3.720	3.875	4.030	4.185	4.340	4.495	20
30	4.650	4.805	4.960	5.115	5.270	5.425	5.580	5.735	5.890	6.045	30
40	6.200	6.355	6.510	6.665	6.820	6.975	7.130	7.285	7.440	7.595	40
50	7.750	7.905	8.060	8.215	8.370	8.525	8.680	8.835	8.990	9.145	50
60	9.300	9.455	9.610	9.765	9.920	10.075	10.230	10.385	10.540	10.695	60
70	10.850	11.005	11.160	11.315	11.470	11.625	11.780	11.935	12.090	12.245	70
80	12.400	12.555	12.710	12.865	13.020	13.175	13.330	13.485	13.640	13.795	80
90	13.950	14.105	14.260	14.415	14.570	14.725	14.880	15.035	15.190	15.345	90
100	15.500	15.655	15.810	15.965	16.120	16.275	16.430	16.585	16.740	16.895	100

VOLUME

CUBIC INCHES TO CUBIC CENTIMETERS

in <sup>3</sup>	0	1	2	3	4	5	6	7	8	9	in <sup>3</sup>
	cm <sup>3</sup> (cc)	cm <sup>3</sup> (cc)	cm <sup>3</sup> (cc)	cm <sup>3</sup> (cc)	cm <sup>3</sup> (cc)	cm <sup>3</sup> (cc)	cm <sup>3</sup> (cc)	cm <sup>3</sup> (cc)	cm <sup>3</sup> (cc)	cm <sup>3</sup> (cc)	
—		16.387	32.774	49.161	65.548	81.935	98.322	114.709	131.097	147.484	—
10	163.871	180.258	196.645	213.032	229.419	245.806	262.193	278.580	294.967	311.354	10
20	327.741	344.128	360.515	376.902	393.290	409.677	426.064	442.451	458.838	475.225	20
30	491.612	507.999	524.386	540.773	557.160	573.547	589.934	606.321	622.708	639.095	30
40	655.483	671.870	688.257	704.644	721.031	737.418	753.805	770.192	786.579	802.966	40
50	819.353	835.740	852.127	868.514	884.901	901.289	917.676	934.063	950.450	966.837	50
60	983.224	999.611	1015.998	1032.385	1048.772	1065.159	1081.546	1097.933	1114.320	1130.707	60
70	1147.094	1163.482	1179.869	1196.256	1212.643	1229.030	1245.417	1261.804	1278.191	1294.578	70
80	1310.965	1327.352	1343.739	1360.126	1376.513	1392.900	1409.288	1425.675	1442.062	1458.449	80
90	1474.836	1491.223	1507.610	1523.997	1540.384	1556.771	1573.158	1589.545	1605.932	1622.319	90
100	1638.706	1655.093	1671.481	1687.868	1704.255	1720.642	1737.029	1753.416	1769.803	1786.190	100

CUBIC CENTIMETERS TO CUBIC INCHES

cm <sup>3</sup> (cc)	0	1	2	3	4	5	6	7	8	9	cm <sup>3</sup> (cc)
	in <sup>3</sup>	in <sup>3</sup>	in <sup>3</sup>	in <sup>3</sup>	in <sup>3</sup>	in <sup>3</sup>	in <sup>3</sup>	in <sup>3</sup>	in <sup>3</sup>	in <sup>3</sup>	
—		0.0610	0.1220	0.1831	0.2441	0.3051	0.3661	0.4272	0.4882	0.5492	—
10	0.6102	0.6713	0.7323	0.7933	0.8543	0.9154	0.9764	1.0374	1.0984	1.1595	10
20	1.2205	1.2815	1.3425	1.4035	1.4646	1.5256	1.5866	1.6476	1.7087	1.7697	20
30	1.8307	1.8917	1.9528	2.0138	2.0748	2.1358	2.1969	2.2579	2.3189	2.3799	30
40	2.4409	2.5020	2.5630	2.6240	2.6850	2.7461	2.8071	2.8681	2.9291	2.9902	40
50	3.0512	3.1122	3.1732	3.2343	3.2953	3.3563	3.4173	3.4784	3.5394	3.6004	50
60	3.6614	3.7224	3.7835	3.8445	3.9055	3.9665	4.0276	4.0886	4.1496	4.2106	60
70	4.2717	4.3327	4.3937	4.4547	4.5158	4.5768	4.6378	4.6988	4.7599	4.8209	70
80	4.8819	4.9429	5.0039	5.0650	5.1260	5.1870	5.2480	5.3091	5.3701	5.4311	80
90	5.4921	5.5532	5.6142	5.6752	5.7362	5.7973	5.8583	5.9193	5.9803	6.0414	90
100	6.1024	6.1634	6.2244	6.2854	6.3465	6.4075	6.4685	6.5295	6.5905	6.6516	100

VOLUME

GALLONS (U. S.) TO LITERS

U.S. gal.	0	1	2	3	4	5	6	7	8	9	U.S. gal.
	liters	liters	liters	liters	liters	liters	liters	liters	liters	liters	
—		3.7854	7.5709	11.3563	15.1417	18.9271	22.7126	26.4980	30.2834	34.0638	—
10	37.8543	41.6397	45.4251	49.2105	52.9960	56.7814	60.5668	64.3523	68.1377	71.9231	10
20	75.7085	79.4940	83.2794	87.0648	90.8502	94.6357	98.4211	102.2065	105.9920	109.7774	20
30	113.5528	117.3482	121.1337	124.9191	128.7045	132.4899	136.2754	140.0608	143.8462	147.6316	30
40	151.4171	155.2025	158.9879	162.7734	166.5588	170.3442	174.1296	177.9151	181.7005	185.4859	40
50	189.2713	193.0568	196.8422	200.6276	204.4131	208.1985	211.9839	215.7693	219.5548	223.3402	50
60	227.1256	230.9110	234.6965	238.4819	242.2673	246.0527	249.8382	253.6236	257.4090	261.1945	60
70	264.9799	268.7653	272.5507	276.3362	280.1216	283.9070	287.6924	291.4779	295.2633	299.0487	70
80	302.8342	306.6196	310.4050	314.1904	317.9759	321.7613	325.5467	329.3321	333.1176	336.9030	80
90	340.6884	344.4738	348.2593	352.0447	355.8301	359.6156	363.4010	367.1864	370.9718	374.7573	90
100	378.5427	382.3281	386.1135	389.8990	393.6844	397.4698	401.2553	405.0407	408.8261	412.6115	100

LITERS TO GALLONS (U. S.)

liters	0	1	2	3	4	5	6	7	8	9	liters
	gal.	gal.	gal.	gal.	gal.	gal.	gal.	gal.	gal.	gal.	
—		0.2642	0.5283	0.7925	1.0567	1.3209	1.5850	1.8492	2.1134	2.3775	—
10	2.6417	2.9059	3.1701	3.4342	3.6984	3.9626	4.2267	4.4909	4.7551	5.0192	10
20	5.2834	5.5476	5.8118	6.0759	6.3401	6.6043	6.8684	7.1326	7.3968	7.6610	20
30	7.9251	8.1893	8.4535	8.7176	8.9818	9.2460	9.5102	9.7743	10.0385	10.3027	30
40	10.5668	10.8310	11.0952	11.3594	11.6235	11.8877	12.1519	12.4160	12.6802	12.9444	40
50	13.2086	13.4727	13.7369	14.0011	14.2652	14.5294	14.7936	15.0577	15.3219	15.5861	50
60	15.8503	16.1144	16.3786	16.6428	16.9069	17.1711	17.4353	17.6995	17.9636	18.2278	60
70	18.4920	18.7561	19.0203	19.2845	19.5487	19.8128	20.0770	20.3412	20.6053	20.8695	70
80	21.1337	21.3979	21.6620	21.9262	22.1904	22.4545	22.7187	22.9829	23.2470	23.5112	80
90	23.7754	24.0396	24.3037	24.5679	24.8321	25.0962	25.3604	25.6246	25.8888	26.1529	90
100	26.4171	26.6813	26.9454	27.2096	27.4738	27.7380	28.0021	28.2663	28.5305	28.7946	100

GALLONS (IMP.) TO LITERS

Imp gal.	0	1	2	3	4	5	6	7	8	9	Imp gal.
	liters	liters	liters	liters	liters	liters	liters	liters	liters	liters	
—		4.5460	9.0919	13.6379	18.1838	22.7298	27.2758	31.8217	36.3677	40.9136	—
10	45.4596	50.0056	54.5515	59.0975	63.6434	68.1894	72.7354	77.2813	81.8273	86.3732	10
20	90.9192	95.4652	100.0111	104.5571	109.1030	113.6490	118.1950	122.7409	127.2869	131.8328	20
30	136.3788	140.9248	145.4707	150.0167	154.5626	159.1086	163.6546	168.0005	172.7465	177.2924	30
40	181.8384	186.3844	190.9303	195.4763	200.0222	204.5682	209.1142	213.6601	218.2061	222.7520	40
50	227.2980	231.8440	236.3899	240.9359	245.4818	250.0278	254.5738	259.1197	263.6657	268.2116	50
60	272.7576	277.3036	281.8495	286.3955	290.9414	295.4874	300.0334	304.5793	309.1253	313.6712	60
70	318.2172	322.7632	327.3091	331.8551	336.4010	340.9470	345.4930	350.0389	354.5849	359.1308	70
80	363.6768	368.2228	372.7687	377.3147	381.8606	386.4066	390.9526	395.4985	400.0445	404.5904	80
90	409.1364	413.6824	418.2283	422.7743	427.3202	431.8662	436.4122	440.9581	445.5041	450.0500	90
100	454.5960	459.1420	463.6879	468.2339	472.7798	477.3258	481.8718	486.4177	490.9637	495.5096	100

LITERS TO GALLONS (IMP.)

liters	0	1	2	3	4	5	6	7	8	9	liter
	gal.	gal.	gal.	gal.	gal.	gal.	gal.	gal.	gal.	gal.	
—		0.2200	0.4400	0.6599	0.8799	1.0999	1.3199	1.5398	1.7598	1.9798	—
10	2.1996	2.4197	2.6397	2.8597	3.0797	3.2996	3.5196	3.7396	3.9596	4.1795	10
20	4.3995	4.6195	4.8395	5.0594	5.2794	5.4994	5.7194	5.9394	6.1593	6.3793	20
30	6.5993	6.8193	7.0392	7.2592	7.4792	7.6992	7.9191	8.1391	8.3591	8.5791	30
40	8.7990	9.0190	9.2390	9.4590	9.6789	9.8989	10.9189	10.3389	10.5588	10.7788	40
50	10.9988	11.2188	11.4388	11.6587	11.8787	12.0987	12.3187	12.5386	12.7586	12.9786	50
60	13.1986	13.4186	13.6385	13.8585	14.0785	14.2984	14.5184	14.7384	14.9584	15.1783	60
70	15.3983	15.6183	15.8383	16.0582	16.2782	16.4982	16.7182	16.9382	17.1581	17.3781	70
80	17.5981	17.8181	18.0380	18.2580	18.4780	18.6980	18.9179	19.1379	19.3579	19.5779	80
90	19.7978	20.0178	20.2378	20.4578	20.6777	20.8977	21.1177	21.3377	21.5576	21.7776	90
100	21.9976	22.2176	22.4376	22.6575	22.8775	23.0975	23.3175	23.5374	23.7574	23.9774	100



POUNDS TO KILOGRAMS

lbs.	0	1	2	3	4	5	6	7	8	9	lbs.
	kg	kg	kg	kg	kg	kg	kg	kg	kg	kg	
--		0.454	0.907	1.361	1.814	2.268	2.722	3.175	3.629	4.082	--
10	4.538	4.990	5.443	5.897	6.350	6.804	7.257	7.711	8.165	8.618	10
20	9.072	9.525	9.979	10.433	10.886	11.340	11.793	12.247	12.701	13.154	20
30	13.606	14.061	14.515	14.969	15.422	15.876	16.329	16.783	17.237	17.690	30
40	18.144	18.597	19.051	19.504	19.958	20.412	20.865	21.319	21.772	22.226	40
50	22.680	23.133	23.587	24.040	24.494	24.948	25.401	25.855	26.308	26.762	50
60	27.216	27.669	28.123	28.576	29.030	29.484	29.937	30.391	30.844	31.298	60
70	31.751	32.205	32.659	33.112	33.566	34.019	34.473	34.927	35.380	35.834	70
80	36.287	36.741	37.195	37.648	38.102	38.555	39.009	39.463	39.916	40.370	80
90	40.823	41.277	41.730	42.184	42.638	43.092	43.545	43.998	44.453	44.906	90
100	45.359	45.813	46.266	46.720	47.174	47.627	48.081	48.534	48.988	49.442	100

KILOGRAMS TO POUNDS

kg	0	1	2	3	4	5	6	7	8	9	kg
	lbs.	lbs.	lbs.	lbs.	lbs.	lbs.	lbs.	lbs.	lbs.	lbs.	
--		2.205	4.409	6.614	8.818	11.023	13.228	15.432	17.637	19.842	--
10	22.046	24.251	26.455	28.660	30.865	33.069	35.274	37.479	39.683	41.888	10
20	44.092	46.297	48.502	50.706	52.911	55.116	57.320	59.525	61.729	63.934	20
30	66.139	68.343	70.548	72.752	74.957	77.162	79.366	81.571	83.776	85.980	30
40	88.185	90.389	92.594	94.799	97.003	99.208	101.410	103.620	105.820	108.030	40
50	110.230	112.440	114.640	116.840	119.050	121.250	123.460	125.660	127.870	130.070	50
60	132.280	134.480	136.690	138.890	141.100	143.300	145.510	147.710	149.910	152.120	60
70	154.320	156.530	158.730	160.940	163.140	165.350	167.550	169.760	171.960	174.170	70
80	176.370	178.570	180.780	182.980	185.190	187.390	189.600	191.800	194.010	196.210	80
90	198.420	200.620	202.830	205.030	207.230	209.440	211.640	213.850	216.050	218.260	90
100	220.460	222.670	224.870	227.080	229.280	231.490	233.690	235.890	238.100	240.300	100

KILOGRAMS TO NEWTON

kg	0	1	2	3	4	5	6	7	8	9	kg
	N	N	N	N	N	N	N	N	N	N	
--	--	9.81	19.61	29.42	39.23	49.03	58.81	68.65	78.45	88.26	--
10	98.07	107.87	117.68	127.49	137.29	147.10	156.91	166.71	176.52	186.33	10
20	196.13	205.94	215.75	225.55	235.36	245.17	254.97	264.78	274.59	284.39	20
30	294.20	304.01	313.81	323.62	333.43	343.23	353.04	362.85	372.65	382.46	30
40	392.27	402.07	411.88	421.69	431.49	441.30	451.11	460.91	470.72	480.53	40
50	490.33	500.14	509.95	519.75	529.56	539.37	549.17	558.98	568.79	578.59	50
60	588.40	598.21	608.01	617.82	627.63	637.43	647.24	657.05	666.85	676.66	60
70	686.47	696.27	706.08	715.89	725.69	735.50	745.31	755.11	764.92	774.73	70
80	784.53	794.34	804.15	813.95	823.76	833.57	843.37	853.18	862.99	872.79	80
90	882.60	892.41	902.21	912.02	921.83	931.63	941.44	951.25	961.05	970.86	90
100	980.66	990.47	1000.30	1010.08	1019.89	1029.69	1039.47	1049.31	1059.11	1068.92	100

NEWTON TO KILOGRAMS

N	0	10	20	30	40	50	60	70	80	90	N
	kg	kg	kg	kg	kg	kg	kg	kg	kg	kg	
--	--	1.020	2.039	3.059	4.079	5.099	6.118	7.138	8.158	9.177	--
100	10.197	11.217	12.237	13.256	14.276	15.296	16.315	17.335	18.355	19.375	100
200	20.394	21.414	22.434	23.453	24.473	25.493	26.513	27.532	28.552	29.572	200
300	30.591	31.611	32.631	33.651	34.670	35.690	36.710	37.729	38.749	39.769	300
400	40.789	41.808	42.828	43.848	44.868	45.887	46.907	47.927	48.946	49.966	400
500	50.986	52.006	53.025	54.045	55.065	56.084	57.104	58.124	59.144	60.163	500
600	61.183	62.203	63.222	64.242	65.262	66.282	67.301	68.321	69.341	70.360	600
700	71.380	72.400	73.420	74.439	75.459	76.479	77.498	78.518	79.538	80.558	700
800	81.577	82.597	83.617	84.636	85.656	86.676	87.696	88.715	89.735	90.755	800
900	91.774	92.794	93.814	94.834	95.853	96.873	97.893	98.912	99.932	100.951	900
1000	101.972	102.990	104.011	105.031	106.051	107.071	108.090	109.110	110.130	111.149	1000

**PRESSURE POUNDS PER SQUARE INCHES TO KILOGRAMS PER SQUARE CENTIMETERS**

lb/in <sup>2</sup> (psi)	0	1	2	3	4	5	6	7	8	9	lb/in <sup>2</sup> (psi)
	kg/cm <sup>2</sup>	kg/cm <sup>2</sup>	kg/cm <sup>2</sup>	kg/cm <sup>2</sup>	kg/cm <sup>2</sup>	kg/cm <sup>2</sup>	kg/cm <sup>2</sup>	kg/cm <sup>2</sup>	kg/cm <sup>2</sup>	kg/cm <sup>2</sup>	
—		0.0703	0.1406	0.2100	0.2812	0.3515	0.4218	0.4921	0.5625	0.6328	—
10	0.7031	0.7734	0.8437	0.9140	0.9843	1.0546	1.1249	1.1952	1.2655	1.3358	10
20	1.4062	1.4765	1.5468	1.6171	1.6874	1.7577	1.8280	1.8983	1.9686	2.0389	20
30	2.1092	2.1795	2.2498	2.3202	2.3905	2.4608	2.5311	2.6014	2.6717	2.7420	30
40	2.8123	2.8826	2.9529	3.0232	3.0935	3.1639	3.2342	3.3045	3.3748	3.4451	40
50	3.5154	3.5857	3.6560	3.7263	3.7966	3.8669	3.9372	4.0072	4.0779	4.1482	50
60	4.2185	4.2888	4.3591	4.4294	4.4997	4.5700	4.6403	4.7106	4.7809	4.8512	60
70	4.9216	4.9919	5.0622	5.1325	5.2028	5.2731	5.3434	5.4137	5.4840	5.5543	70
80	5.6246	5.6949	5.7652	5.8356	5.9059	5.9762	6.0465	6.1168	6.1871	6.2574	80
90	6.3277	6.3980	6.4683	6.5386	6.6089	6.6793	6.7496	6.8199	6.8902	6.9605	90
100	7.0308	7.1011	7.1714	7.2417	7.3120	7.3823	7.4526	7.5229	7.5933	7.6636	100

**KILOGRAMS PER SQUARE CENTIMETERS TO POUNDS PER SQUARE INCHES**

kg/cm <sup>2</sup>	0	1	2	3	4	5	6	7	8	9	kg/cm <sup>2</sup>
	lb/in <sup>2</sup> (psi)	lb/in <sup>2</sup> (psi)	lb/in <sup>2</sup> (psi)	lb/in <sup>2</sup> (psi)	lb/in <sup>2</sup> (psi)	lb/in <sup>2</sup> (psi)	lb/in <sup>2</sup> (psi)	lb/in <sup>2</sup> (psi)	lb/in <sup>2</sup> (psi)	lb/in <sup>2</sup> (psi)	
—		14.22	28.45	42.67	56.89	71.12	85.34	99.56	113.78	128.01	—
10	142.23	156.45	170.68	184.90	199.12	213.35	227.57	241.79	256.02	270.24	10
20	284.46	298.69	312.91	327.13	341.35	355.58	369.80	384.03	398.25	412.47	20
30	426.70	440.92	455.14	469.36	483.59	497.81	512.03	526.26	540.48	554.70	30
40	568.93	583.15	597.37	611.60	625.82	640.04	654.27	668.49	682.71	696.94	40
50	711.16	725.38	739.61	753.83	768.05	782.28	796.50	810.72	824.94	839.17	50
60	853.39	867.61	881.84	896.06	910.28	924.51	938.73	952.95	967.18	981.40	60
70	995.62	1009.80	1024.10	1038.30	1052.50	1066.70	1081.00	1095.20	1109.40	1123.60	70
80	1137.80	1152.10	1166.30	1180.50	1194.70	1209.00	1223.20	1237.40	1251.60	1265.80	80
90	1280.10	1294.30	1308.50	1322.70	1337.00	1351.20	1365.40	1379.60	1393.90	1408.10	90
100	1422.30	1436.50	1450.80	1465.00	1479.20	1493.40	1507.70	1521.90	1536.10	1550.30	100

**KILOGRAMS PER SQUARE CENTIMETERS TO KILO PASCAL**

kg/cm <sup>2</sup>	0	1	2	3	4	5	6	7	8	9	kg/cm <sup>2</sup>
	KPa	KPa	KPa	KPa	KPa	KPa	KPa	KPa	KPa	KPa	
—	—	98.1	196.1	294.2	392.3	490.3	588.4	686.5	784.5	882.6	—
10	980.7	1078.7	1176.8	1274.9	1372.9	1471.0	1569.1	1667.1	1765.2	1863.3	10
20	1961.3	2059.4	2157.5	2255.5	2353.6	2451.7	2549.7	2647.8	2745.9	2843.9	20
30	2942.0	3040.1	3138.1	3236.2	3334.3	3432.3	3530.4	3628.5	3726.5	3824.6	30
40	3922.7	4020.7	4118.8	4216.9	4314.9	4413.0	4511.1	4609.1	4707.2	4805.3	40
50	4903.3	5001.4	5099.5	5197.5	5295.6	5393.7	5491.7	5589.8	5687.9	5785.9	50
60	5884.0	5982.1	6080.1	6178.2	6276.3	6374.3	6472.4	6570.5	6668.5	6766.6	60
70	6864.7	6962.7	7060.8	7158.9	7256.9	7355.0	7453.1	7551.1	7649.2	7747.3	70
80	7845.3	7943.4	8041.5	8139.6	8237.6	8335.7	8433.7	8531.8	8629.9	8727.9	80
90	8826.0	8924.1	9022.1	9120.2	9218.3	9316.3	9414.4	9512.5	9610.5	9708.6	90
100	9806.6	9904.7	10003.7	10101.8	10199.9	10298.9	10397.0	10495.1	10593.1	10691.2	100

**KILO PASCAL TO KILOGRAMS PER SQUARE CENTIMETERS**

KPa	0	100	200	300	400	500	600	700	800	900	KPa
	kg/cm <sup>2</sup>	kg/cm <sup>2</sup>	kg/cm <sup>2</sup>	kg/cm <sup>2</sup>	kg/cm <sup>2</sup>	kg/cm <sup>2</sup>	kg/cm <sup>2</sup>	kg/cm <sup>2</sup>	kg/cm <sup>2</sup>	kg/cm <sup>2</sup>	
—	—	1.020	2.039	3.059	4.079	5.099	6.118	7.138	8.158	9.177	—
1000	10.197	11.217	12.237	13.256	14.276	15.296	16.315	17.335	18.355	19.375	1000
2000	20.394	21.414	22.434	23.453	24.473	25.493	26.513	27.532	28.552	29.572	2000
3000	30.591	31.611	32.631	33.651	34.670	35.690	36.710	37.729	38.749	39.769	3000
4000	40.789	41.808	42.828	43.848	44.868	45.887	46.907	47.927	48.946	49.966	4000
5000	50.986	52.006	53.025	54.045	55.065	56.084	57.104	58.124	59.144	60.163	5000
6000	61.183	62.203	63.222	64.242	65.262	66.282	67.301	68.321	69.341	70.360	6000
7000	71.380	72.400	73.420	74.439	75.459	76.479	77.498	78.518	79.538	80.558	7000
8000	81.577	82.597	83.617	84.636	85.656	86.676	87.696	88.715	89.735	90.755	8000
9000	91.774	92.794	93.814	94.834	95.853	96.873	97.893	98.912	99.932	100.951	9000
10000	101.972	102.990	104.011	105.031	106.051	107.071	108.090	109.110	110.130	111.149	10000

**TORQUE**

**FOOT POUNDS TO KILOGRAMMETERS**

ft. lbs.	0	1	2	3	4	5	6	7	8	9	ft. lbs.
	kg-m	kg-m	kg-m	kg-m	kg-m	kg-m	kg-m	kg-m	kg-m	kg-m	
--		0.138	0.276	0.415	0.553	0.691	0.829	0.967	1.106	1.244	--
10	1.382	1.520	1.658	1.796	1.934	2.073	2.211	2.349	2.487	2.625	10
20	2.764	2.902	3.040	3.178	3.316	3.455	3.593	3.731	3.869	4.007	20
30	4.146	4.284	4.422	4.560	4.698	4.837	4.975	5.113	5.251	5.389	30
40	5.528	5.666	5.804	5.942	6.080	6.219	6.357	6.495	6.633	6.771	40
50	6.910	7.048	7.186	7.324	7.462	7.601	7.739	7.877	8.015	8.153	50
60	8.292	8.430	8.568	8.706	8.844	8.983	9.121	9.259	9.397	9.535	60
70	9.674	9.812	9.950	10.088	10.227	10.365	10.503	10.641	10.779	10.918	70
80	11.056	11.194	11.332	11.470	11.609	11.747	11.885	12.023	12.161	12.300	80
90	12.438	12.576	12.714	12.852	12.991	13.129	13.267	13.405	13.544	13.682	90
100	13.820	13.958	14.096	14.235	14.373	14.511	14.649	14.787	14.925	14.064	100

**KILOGRAMMETERS TO FOOT POUNDS**

kg-m	0	1	2	3	4	5	6	7	8	9	kg-m
	ft. lbs.	ft. lbs.	ft. lbs.	ft. lbs.	ft. lbs.	ft. lbs.	ft. lbs.	ft. lbs.	ft. lbs.	ft. lbs.	
--		7.23	14.47	21.70	28.93	36.17	43.40	50.63	57.87	65.10	--
10	72.33	79.57	86.80	94.03	101.27	108.50	115.74	122.97	130.20	137.43	10
20	144.67	151.90	159.13	166.37	173.60	180.84	188.08	195.30	202.54	209.77	20
30	217.00	224.23	231.46	238.70	245.93	253.17	260.41	267.63	274.87	282.10	30
40	289.34	296.57	303.79	311.04	318.27	325.50	332.75	339.98	347.21	354.44	40
50	361.66	368.89	376.12	383.36	390.59	397.82	405.07	412.30	419.53	426.76	50
60	434.00	441.23	448.45	455.70	462.93	470.17	477.41	484.64	491.87	499.10	60
70	506.34	513.57	520.80	528.04	535.27	542.50	549.75	556.98	564.21	571.44	70
80	578.68	585.91	593.14	600.38	607.61	614.85	622.09	629.31	636.55	643.78	80
90	651.00	658.23	665.46	672.70	679.93	687.17	694.41	701.63	708.87	716.10	90
100	723.34	730.57	737.80	745.04	752.27	759.51	766.75	774.07	781.21	788.44	100

**KILOGRAMMETERS TO NEWTONMETERS**

kg-m	0	1	2	3	4	5	6	7	8	9	kg-m
	N-m	N-m	N-m	N-m	N-m	N-m	N-m	N-m	N-m	N-m	
--		9.81	19.61	29.42	39.23	49.03	58.81	68.65	78.45	88.26	--
10	98.07	107.87	117.68	127.49	137.29	147.10	156.91	166.71	176.52	186.33	10
20	196.13	205.94	215.75	225.55	235.36	245.17	254.97	264.78	274.59	284.39	20
30	294.20	304.01	313.81	323.62	333.43	343.23	353.04	362.85	372.65	382.46	30
40	392.27	402.07	411.88	421.69	431.49	441.30	451.11	460.91	470.72	480.53	40
50	490.33	500.14	509.95	519.75	529.56	539.37	549.17	558.98	568.79	578.59	50
60	588.40	598.21	608.01	617.82	627.63	637.43	647.24	657.05	666.85	676.66	60
70	686.47	696.27	706.08	715.89	725.69	735.50	745.31	755.11	764.92	774.73	70
80	784.53	794.34	804.15	813.95	823.76	833.57	843.37	853.18	862.99	872.79	80
90	882.60	892.41	902.21	912.02	921.83	931.63	941.44	951.25	961.05	970.86	90
100	980.66	990.47	1000.30	1010.08	1019.89	1029.69	1039.47	1049.31	1059.11	1068.92	100

**NEWTONMETERS TO KILOGRAMMETERS**

N-m	0	10	20	30	40	50	60	70	80	90	N-m
	kg-m	kg-m	kg-m	kg-m	kg-m	kg-m	kg-m	kg-m	kg-m	kg-m	
--		1.020	2.039	3.059	4.079	5.099	6.118	7.138	8.158	9.177	--
100	10.197	11.217	12.237	13.256	14.276	15.296	16.315	17.335	18.355	19.375	100
200	20.394	21.414	22.434	23.453	24.473	25.493	26.513	27.532	28.552	29.572	200
300	30.591	31.611	32.631	33.651	34.670	35.690	36.710	37.729	38.749	39.769	300
400	40.789	41.808	42.828	43.848	44.868	45.887	46.907	47.927	48.946	49.966	400
500	50.986	52.006	53.025	54.045	55.065	56.084	57.104	58.124	59.144	60.163	500
600	61.183	62.203	63.222	64.242	65.262	66.282	67.301	68.321	69.341	70.360	600
700	71.380	72.400	73.420	74.439	75.459	76.479	77.498	78.518	79.538	80.558	700
800	81.577	82.597	83.617	84.636	85.656	86.676	87.696	88.715	89.735	90.755	800
900	91.774	92.794	93.814	94.834	95.853	96.873	97.893	98.912	99.932	100.951	900
1000	101.972	102.990	104.011	105.031	106.051	107.071	108.090	109.110	110.130	111.149	1000



# TEMPERATURE

## FAHRENHEIT TO CENTIGRADE

°F	°C	°F	°C
-20	-28.9	90	32.2
-15	-26.1	95	35.0
-10	-23.3	100	37.8
-5	-20.6	105	40.6
0	-17.8	110	43.3
1	-17.2	115	46.1
2	-16.7	120	48.9
3	-16.1	125	51.7
4	-15.6	130	54.4
5	-15.0	135	57.2
10	-12.2	140	60.0
15	-9.4	145	62.8
20	-6.7	150	65.6
25	-3.9	155	68.3
30	-1.1	160	71.1
35	1.7	165	73.9
40	4.4	170	76.7
45	7.2	175	79.4
50	10.0	180	82.2
55	12.8	185	85.0
60	15.6	190	87.8
65	18.3	195	90.6
70	21.1	200	93.3
75	23.9	205	96.1
80	26.7	210	98.9
85	29.4	212	100.0

## CENTIGRADE TO FAHRENHEIT

°C	°F	°C	°F
-30	-22.0	28	82.4
-28	-18.4	30	86.0
-26	-14.8	32	89.6
-24	-11.2	34	93.2
-22	-7.6	36	96.8
-20	-4.0	38	100.4
-18	-0.4	40	104.0
-16	3.2	42	107.6
-14	6.8	44	112.2
-12	10.4	46	114.8
-10	14.0	48	118.4
-8	17.6	50	122.0
-6	21.2	52	125.6
-4	24.8	54	129.2
-2	28.4	56	132.8
0	32.0	58	136.4
2	35.6	60	140.0
4	39.2	62	143.6
6	42.8	64	147.2
8	46.4	66	150.8
10	50.0	68	154.4
12	53.6	70	158.0
14	57.2	75	167.0
16	60.8	80	176.0
18	64.4	85	185.0
20	68.0	90	194.0
22	71.6	95	203.0
24	75.2	100	212.0
26	78.8		