

**TYM**

# **OPERATOR'S MANUAL**

---

**FRONT LOADERS:      TRAC-LIFT T50SS  
                                 TRAC-LIFT T50HLSS**

---

**Edition 6/2006**

**American Jawa Ltd., 7301 Allentown Blvd., Harrisburg PA 17112**

# SPECIFICATIONS

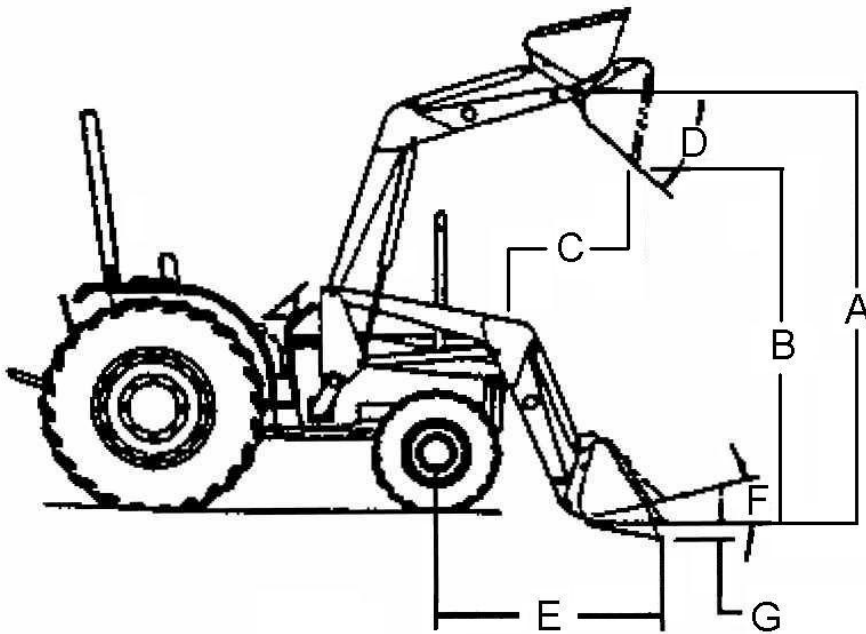

| LOADER MODEL                                | T50SS      | T50HLSS    |
|---|------------|------------|
| A Maximum Lift Height                       | 100 in.    | 106 in.    |
| B Clearance with Bucket Dumped              | 81.5 in.   | 87.5 in.   |
| C Reach at Maximum Height                   | 31.5 in.   | 25.5 in.   |
| D Maximum Dump Angle                        | 40 degrees | 40 degrees |
| E Reach on Ground                           | 59 in.     | 59 in.     |
| F Bucket Rollback Angle                     | 20 degrees | 20 degrees |
| G Digging Depth                             | 6 in.      | 6 in.      |
| Lift capacity to full height at pivot point | 2100 lb.   | 2540 lb.   |
| Breakout force at pivot point               | 2850 lb.   | 3450 lb.   |
| Loader lifting time                         | 4.3 sec.   | 5.3 sec.   |
| Bucket dump time                            | 3.5 sec    | 3.5 sec    |
| Bucket rollback time                        | 3.5 sec    | 3.5 sec    |
| Weight with 67 in. bucket                   | 1320 lb.   | 1320 lb.   |

## Safety



THIS SAFETY ALERT SYMBOL INDICATES IMPORTANT SAFETY MESSAGES IN THIS MANUAL. WHEN YOU SEE THIS SYMBOL, CAREFULLY READ THE MESSAGE THAT FOLLOWS AND BE ALERT TO THE POSSIBILITY OF PERSONAL INJURY OR DEATH



### WARNING

Only persons 18 year old or older should operate the loader.

1. Read the Operator's Manual. Learn to operate this loader safely.
2. Do not allow riders on the loader.
3. No one should ever stand under a raised loader.
4. Operate the loader only while in tractor seat.  
Always set loader bucket or attachment on the ground before leaving the tractor seat.
5. Add rear weights and/or calcium in rear tires for tractor stability.
6. Move the wheels to the widest settings for better stability.
7. Carry the loader arm at low position during transport.  
Move and turn the tractor at low speeds.
8. Avoid overhead electrical lines when raising the loader.
9. Operate carefully to avoid tipping when working on inclines, near loose rocks or holes.
10. Always make sure the attachment is locked on the tool carrier before beginning loader operation. This can be checked by observing the latching lever position.  
Failure to properly install attachment can cause the attachment to come off the tool carrier resulting in serious injury to operator or bystanders.
11. Always make sure that latches of both loader release levers are safely engaged.



### DANGER

To prevent rollback onto operator,  
Use only factory approved  
Bale lift for handling objects such  
As round bales



Never use 3-prong bale lift if one  
Of the prongs is missing



### NOTE

Maintain safety decals attached to loader in good condition

# Operator's Manual

## ATTACHING LOADER

Attaching and detaching of the loader should be performed on even and solid ground.

1. Drive tractor as centrally as possible into loader. Pins (1) will slide onto brackets (2) on tractor, all the way into their final location "X". Stop engine and engage hand brake.  
*If loader height does not match the height of the brackets on tractor, proceed as follows:*  
(A) Drive tractor as close to the loader as possible. Stop engine and connect four loader hoses to hydraulic couplers (follow color coding on couplers).  
(B) Start engine and tilt the bucket slowly as needed to adjust the height of the loader to match the height of loader brackets on tractor.

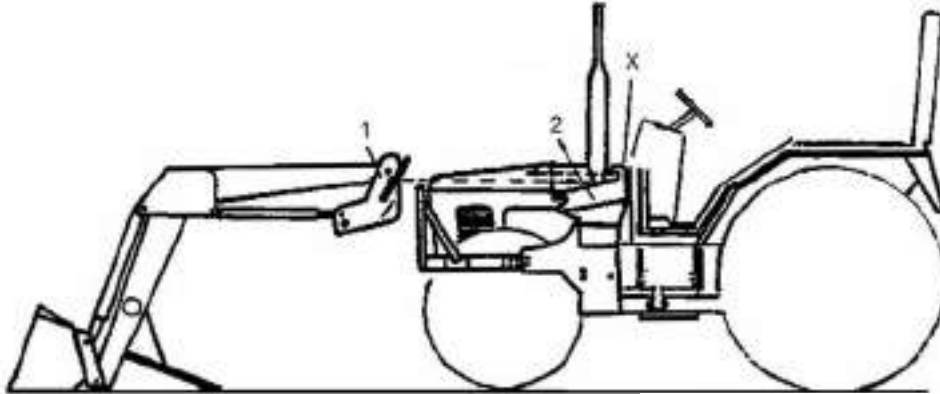

2. Move levers (3) (one on each side of the Loader) all the way down until latch (4) Engages.  
*Note: Do not force levers (3) down. If levers cannot be pushed down by hand, tractor needs to be moved closer to the loader.*

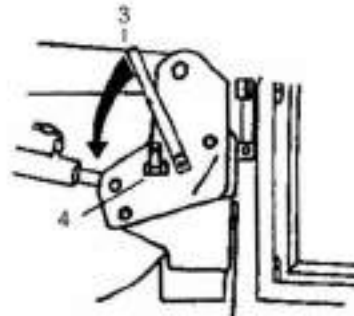

3. Connect four loader quick couplers if you have not done so earlier (follow color coding on the couplers)
4. Start engine and lift loader a few inches from the ground using the joystick control. Stop the engine. Fold loader stands up.

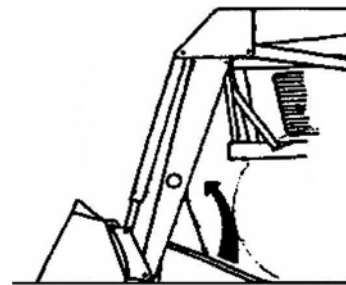

5. Start the engine and continue lifting the loader slowly all the way up. During lift, make sure the four hoses connecting the loader with the loader valve are shaped appropriately and will not be stretched or damaged by some loader part.

*Note: Gearbox oil level in tractor should be at the top mark. Check oil level with the engine stopped.*

# Operator's Manual

## DETACHING LOADER

Attaching and detaching of the loader should be performed on even and solid ground. Bucket does not have to be on the loader – loader is stable even without the bucket. If a bucket is attached, it must be level – in horizontal position (see picture).

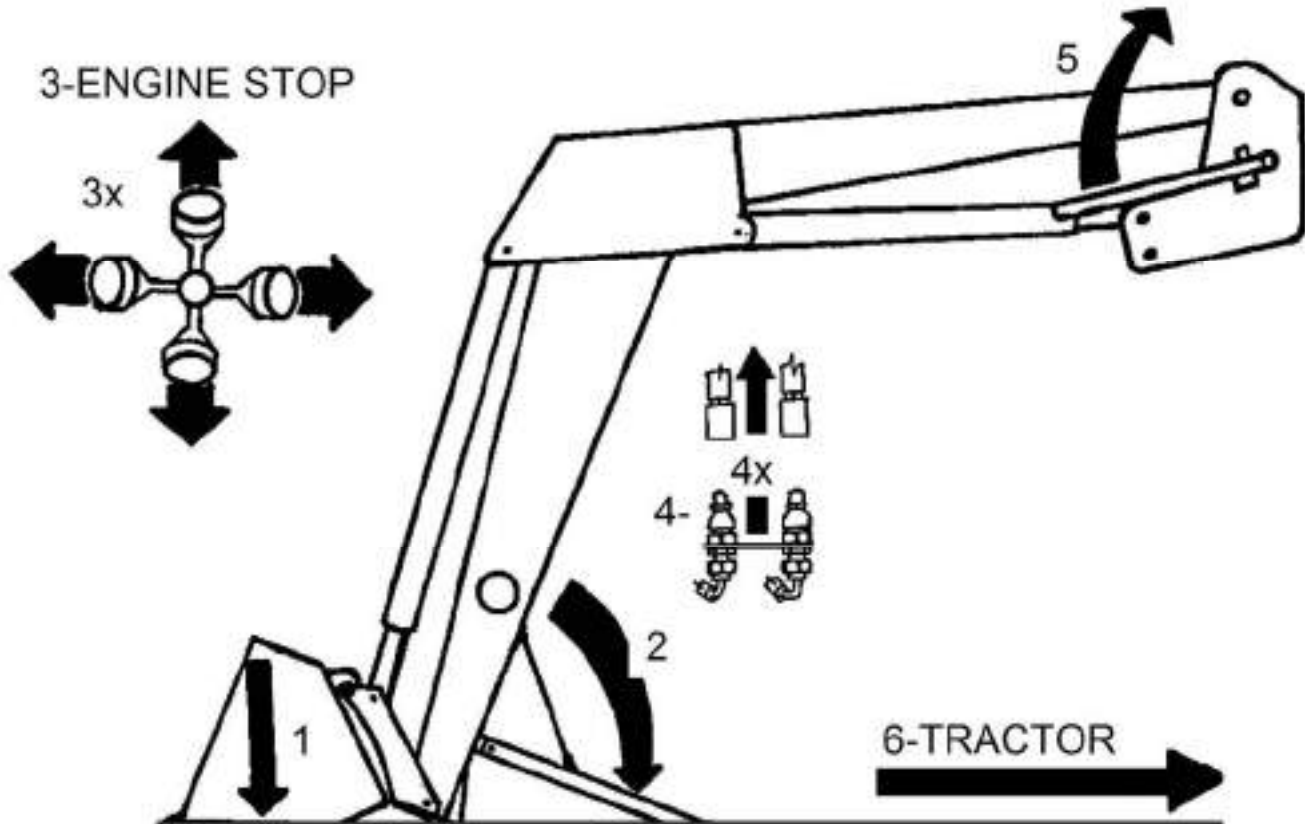

1. Stop engine and lower loader to ground (move joystick forward). To detach the loader easily, the bucket must be seated flat on the ground with its bottom side.
2. Engage the hand brake. Release and fold down stands (1).  
*Note: Adjust the height of the stands so they will be just touching the ground*
3. Move joystick control at least three times in all directions to remove any pressure from the system.
4. Disconnect four hoses with quick couplers from the loader valve. Plug disconnected couplers and hoses with rubber plugs, prevent hydraulic system contamination.
5. Move levers up after releasing latch on each lever.  
Push each lever all the way back to the stop. This will release the loader from its brackets.
6. Drive the tractor slowly away from the loader.

# Operator's Manual

## ATTACHING BUCKET OR OTHER ATTACHMENT LOADERS WITH SKID-STEER TOOL CARRIER



**WARNING:** Use only buckets and attachments compatible with SAE J2513 standard. Use of other attachments does not guarantee safe connection of the bucket with the loader. Serious injury or death may result. If unsure about the attachment origin, contact a TYM dealer and ask for assistance.

**CAUTION:** Except when detaching or attaching bucket or other attachment, keep the bucket latching handles in the LOCKED POSITION (handles in hor. position)

**CAUTION:** To maintain proper function of the quick attach system, inspect the latching handles, lockpins, attachment coupler and attachment flange for damage before attaching the bucket. If damage exists, replace component immediately.

**CAUTION:** Make sure all parts of the quick attach system are clean before attaching the bucket. Only clean components will function safely.

1. Move latching handles to the UNLOCKED position (UP).
2. Have the attachment coupler slightly tilted forward. Drive tractor centrally to the bucket. The top of the attachment coupler must be aligned with the attachment flange on the bucket. Lift loader a few inches and roll the bucket back.

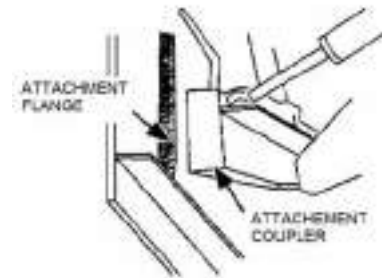
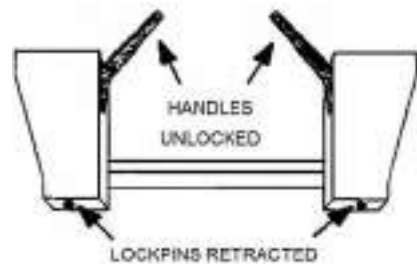

3. Move latching handles into LOCKED position (DOWN – handles must be horizontal). The lockpins must be extended and secured into the retaining slots on the bucket.  
**CAUTION: Before leaving the seat, stop engine and engage hand brake.**

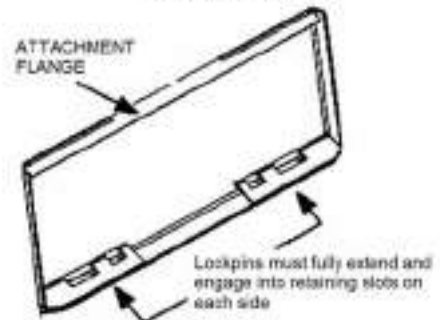
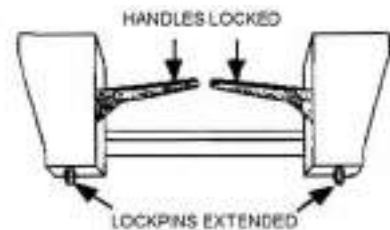

4. Check proper latching by lowering loader and pushing loader bucket against ground by moving joystick forward. (Improperly attached bucket would get loose while pushed against ground). Bucket must be level (in horizontal position) during this check.

# Operator's Manual

## DETACHING BUCKET OR OTHER ATTACHMENT LOADERS WITH SKID-STEER TOOL CARRIER

1. Lower loader so bucket is just a few inches above ground.  
Tilt bucket slightly forward.
2. Move latching handles into UNLOCKED POSITION (UP).  
CAUTION: Before leaving the seat, stop engine and engage hand brake.

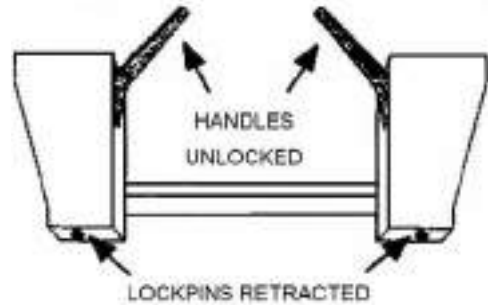

3. Start engine and lower the loader until the attachment coupler unhooks from the attachment flange on the bucket.

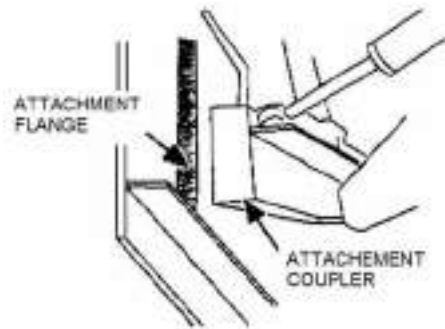

4. Drive away.

# Operator's Manual

## OPERATING THE LOADER



**CAUTION:** Operate loader controls only when seated in operator's seat. Before leaving the seat, set the bucket on the ground, stop engine and engage hand brake.

**WARNING:** When using loader, be alert of bucket position at all times. Loader in raised position with bucket rolled back can dump material onto tractor causing injury.

**WARNING:** Contact with overhead power lines can cause serious injury or death. Make sure there is enough clearance between raised equipment and overhead power lines.

**CAUTION:** Stop loader arms gradually when lowering or lifting, to reduce stress on the machine and to improve tractor stability.

**CAUTION:** A loaded bucket should be transported in a low position at slow ground speeds. Make turns slowly and use tractor brakes cautiously. A full bucket in the raised position alters the center of gravity location of the machine and makes the tractor less stable.

**DO NOT** use loader on slopes with more than 5 degrees incline. Spread rear wheels to the widest setting to improve tractor stability.

**CAUTION:** When handling heavy loads, use liquid in rear tires. Preferably, have rear tires loaded all the time. Cast iron weights are also available and may be combined with liquid.

Adequate weight on rear axle is required for safe loader operation. **DO NOT** use front weights while operating loader.

**WARNING:** When using bale lift: Never raise round bale to full height with bale lift rolled back, as serious injury or death can occur.

**WARNING:** When using pallet forks: Do not use pallet forks to handle round bales. Such loads can roll back onto the operator, causing serious injury. Pallet forks were specifically designed to load palletized materials only. Use only factory approved attachments to handle round bales.

### Before work:

Inspect loader hoses for damages or leaks

If loader was not used for a long time (three months or so), lubricate grease fittings (see picture).

Check bucket latch for proper engagement:

1. Check visually whether the bucket latch is properly engaged.
2. Start engine and check proper latching by lowering loader and pushing loader bucket against the ground by moving the joystick forward. (Improperly attached buckets will get loose while pushed against the ground). Bucket must be level (in horizontal position) during this test.

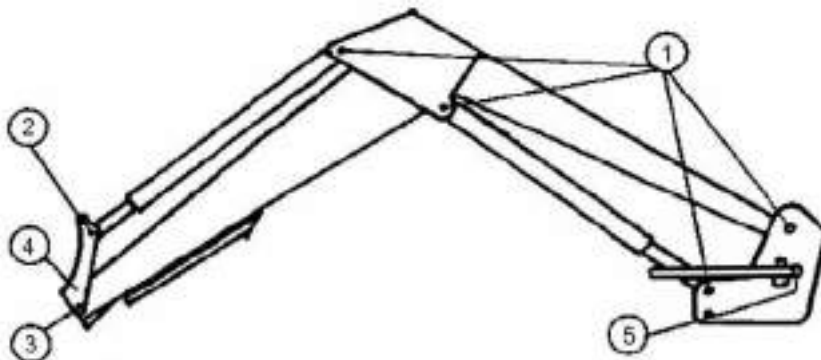



# Operator's Manual

## OPERATING THE LOADER

Operate loader with joystick:

1. Pull joystick back to raise the loader.
2. Push joystick forward to lower the loader.
3. Push joystick all the way forward to set loader in floating position (loader is free to move up and down to follow the terrain); joystick is detente in this position
4. Push joystick to the right to dump the bucket.  
Note: Most 50-series loaders are equipped with a quick dump feature. Moving joystick to the right against light spring produces dump at regular speed. Moving joystick further to the right against a heavier spring will produce fast dumping of the bucket. During fast dump, oil from the rod side of the cylinder re-circulates into the barrel side of the cylinder. Fast dump is not a floating position – the speed of dump is still controlled by the joystick.
5. Pull joystick to the left to roll the bucket back

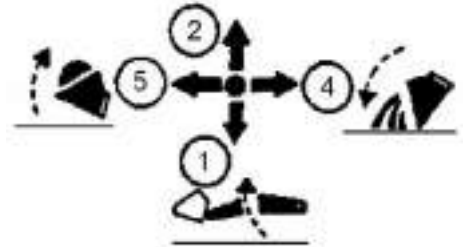

### Operating hints:

Place material in the center of the bucket. This reduces stress on the loader frame and improves tractor stability.

When loading bucket, drive straight into material, with bucket in level. Attempting to turn tractor while loading bucket can cause damage to both the loader and tractor.



When loading bucket, to best utilize its capacity, roll bucket back and at the same time lift the loader.

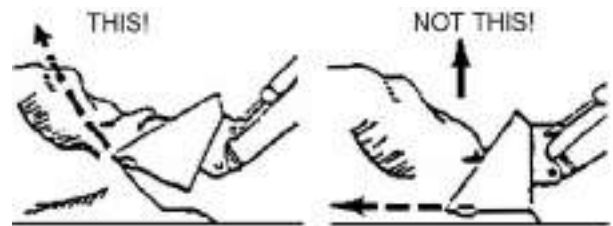

Do not use the bucket in dumped position for bull-dozing. This will cause severe shock loading on the bucket cylinders and make it more difficult to maintain a level grade.

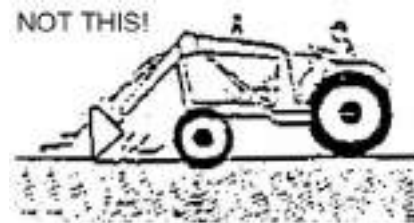

Backgrade work surface with a loaded bucket. Have the joystick in a floating position (all the way forward) so full weight of the bucket is scraping ground. Have the bucket in level (use heel of bucket for back grading).

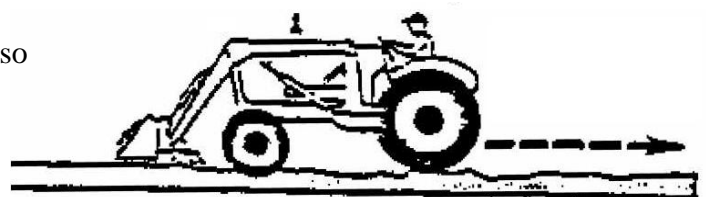

## Periodic Maintenance



**WARNING:** Do not perform maintenance of the loader or of the tractor while loader is raised. Do not use any kind of safety bar to support raised loader. If loader interferes with tractor maintenance, remove loader from tractor.

**CAUTION:** During any loader maintenance, stop engine, lower loader to ground and release hydraulic pressure by moving joystick repeatedly in all directions.

**NOTICE:** Maintain safety decals in good condition. Replacement decals are available under part number 945355

### Daily:

1. Make sure all parts of bucket quick attach system are clean. Only clean components will function safely.
2. Check tire inflation pressure. Refer to tractor Operator's Manual for recommended tire pressures.
3. Inspect loader hoses for damage. Replace any hose with even the slightest damage.

### Every 10 Hours of Operation:

Lubricate per diagram

1. Bushings
2. Bushings
3. Bushings
4. Bucket latching mechanism
5. Loader latching mechanism

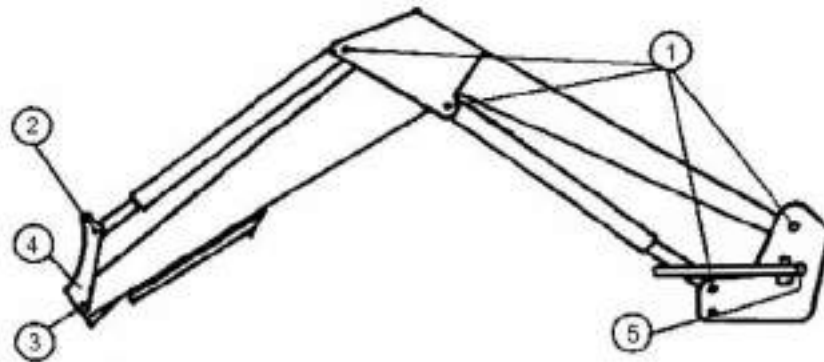

If using the bale lift, check the tightness of all three spear nuts.

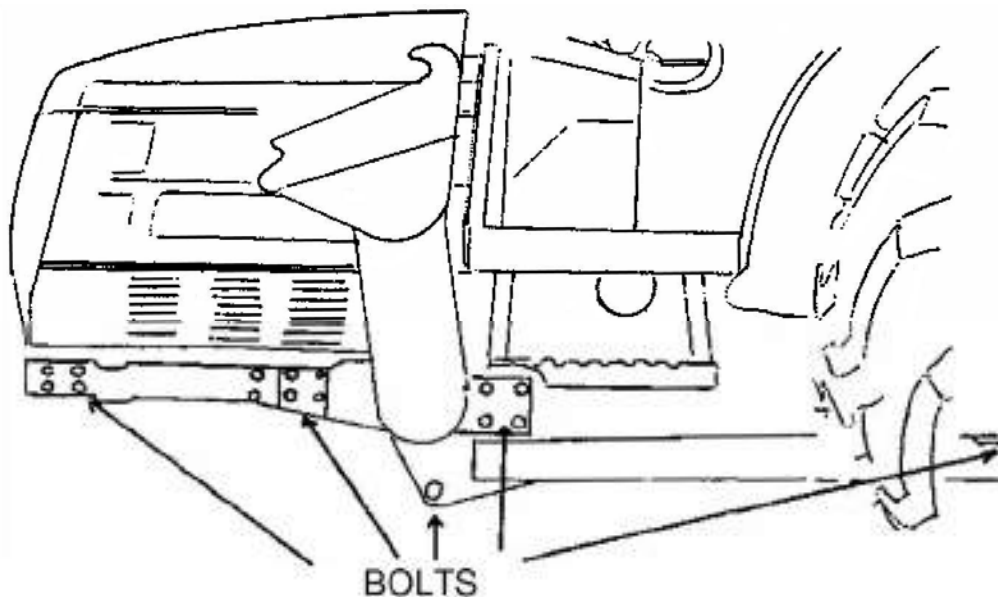

### Every 50 Hours of Operation:

Check tightness of bolts attaching Loader frame to tractor.

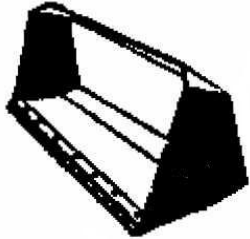

Note: If loader is not used for longer periods of time (a few days), lower the loader full the way down and roll the bucket back so cylinder piston rods are protected from damage.

## Attachments

| Image   | Description  | Part Number  |
|---|--|--------------|
|    | 67 in Bucket, 8.6 cu.ft struck level   | 532974921005 |
|    | 72 in Bucket, 12.5 cu. ft struck level   | 532974921010 |
|   | Pallet fork, 43.5” long, forged  | 532974921020 |
|  | Bale Lift (3 Spear); uses high strength, easy penetrating forged spear, 44 in. long  | 532974921030 |
|   | Third hydraulic function kit for attachments like grapple fork or similar with their own cylinder (kit includes distributor valve and joystick with electric switch) | 532982980695 |