

ILLUSTRATED PARTS LIST

MODEL NO. 96041002404

CUSTOMER CATALOG NO. LTH171

PRODUCT NO. 960 41 00-24

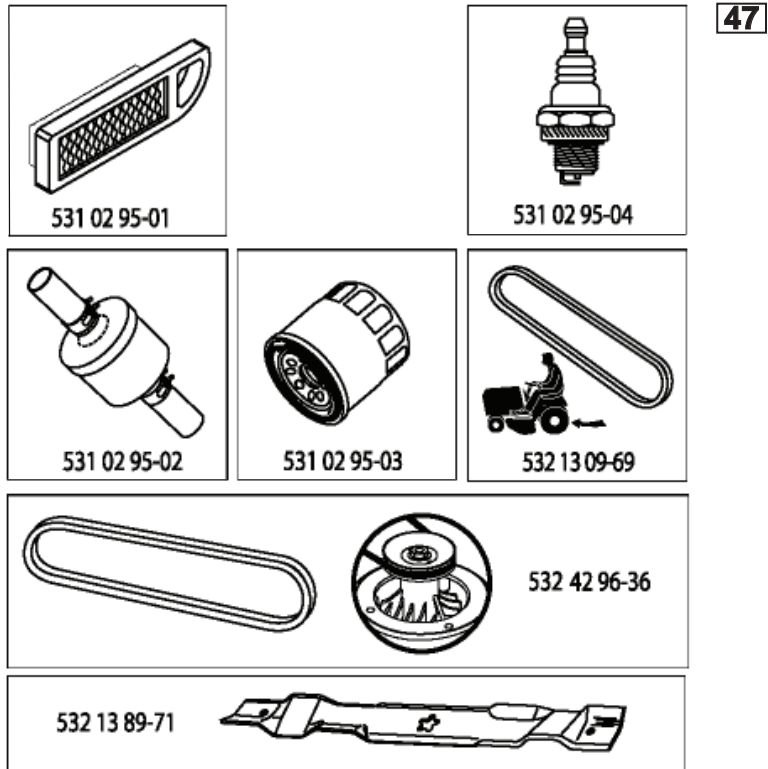

408773

**TRACTOR - - MODEL NO. LTH171 (96041002404), PRODUCT NO. 960 41 00-24
DECALS 27**

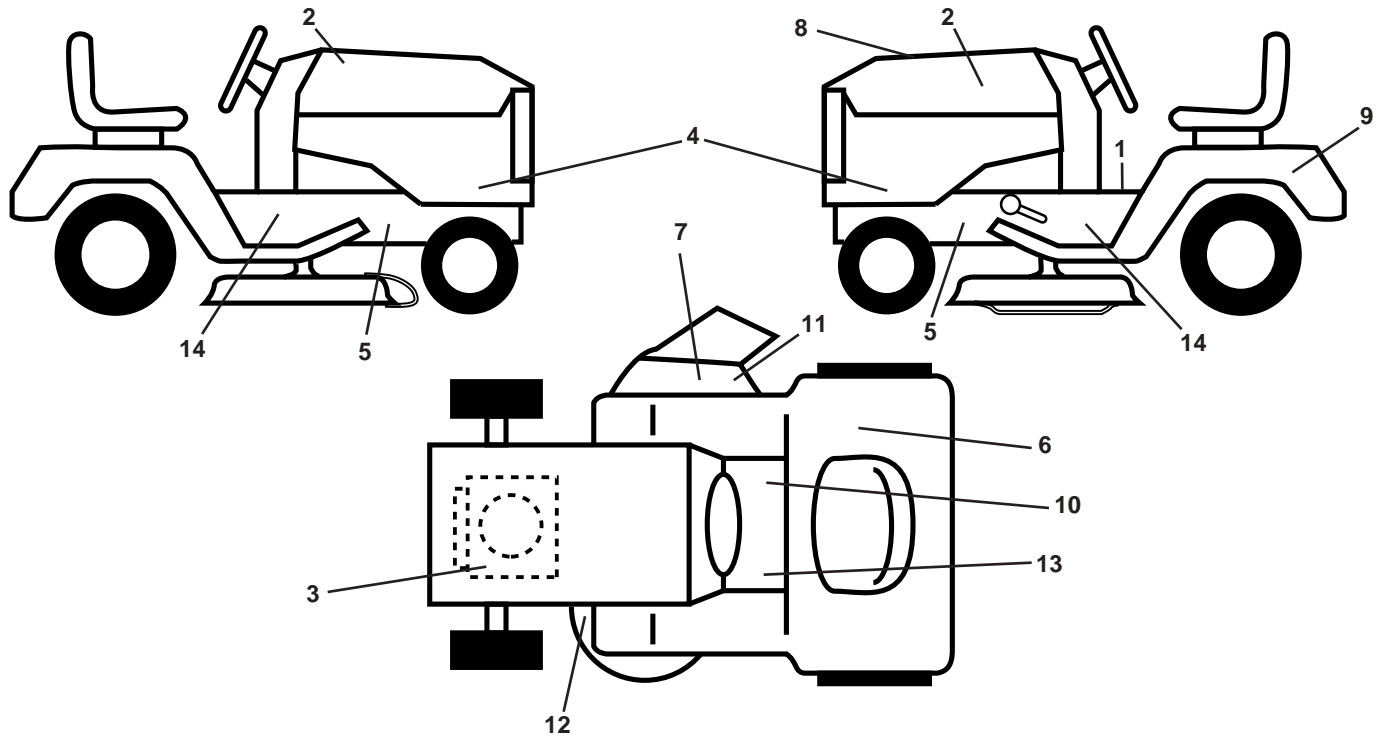

KEY PART NO.	NO.	DESCRIPTION
1	532 40 03-89	Decal, Operators
2	532 42 91-96	Decal, Hood
3	532 19 68-41	Decal, Warning Eng. Symbols
4	532 40 85-99	Decal, Hood Panel
5	532 15 97-36	Decal, Chassis Hot Muffler
6	532 18 04-32	Decal, Fender 100 DB/CE
7	532 18 21-66	Decal, Cutfinger CE
8	532 40 87-73	Decal, Rpl Kohl
9	532 14 50-05	Decal, Battery Dnge/Poi
10	532 14 08-37	Decal, Saddle Brake Parking

KEY PART NO.	NO.	DESCRIPTION
11	532 19 63-57	Decal, Warning
12	532 16 03-96	Decal, Mower V-Belt Schematic
13	532 15 97-37	Decal, Brake/Clutch Symbol
14	532 40 11-46	Decal, Warning Service/Fire
--	532 41 08-05	Pad, Footrest, LH
--	532 41 10-56	Pad, Footrest, RH
--	532 16 25-98	Decal, Drawbar Load Limit
--	532 16 69-60	Decal Bypass
--	532 43 17-06	Manual Oper. Euro

WHEELS AND TIRES

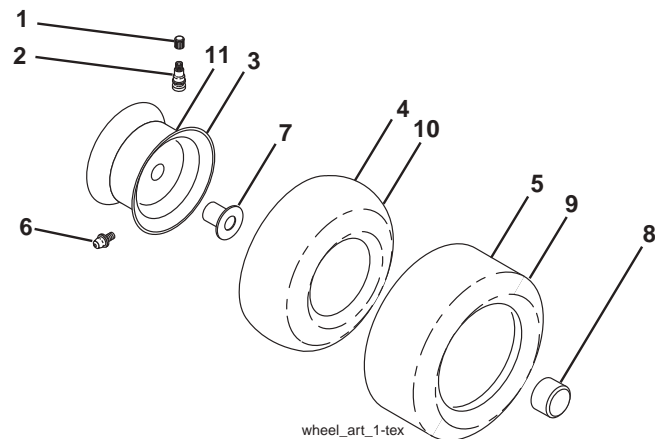

KEY NO.	PART NO.	DESCRIPTION
1	532 05 91-92	Cap Valve Tire
2	532 06 51-39	Stem Valve
3	532 13 83-36	Rim Asm 6" Front Service
4	532 05 99-04	Tube Front (Service Item Only)
5	532 10 62-22	Tire F T 15 x 6 0 - 6 Service
6	532 12 49-57	Fitting Grease (Front Wheel Only)
7	532 12 49-59	Bearing Flange (Front Wheel Only)
8	532 17 50-39	Cap Axle Blk 1 50 x 1 00
9	532 12 20-82	Tire R T 20 x 10-8C Service
10	532 12 49-26	Tube Rear (Service Item Only)
11	532 13 83-37	Rim Asm 8" Rear Service
--	532 14 43-34	Sealant, Tire (10 oz. Tube)

NOTE: All component dimensions given in U.S. inches
1 inch = 25.4 mm

TRACTOR - - MODEL NO. LTH171 (96041002404), PRODUCT NO. 960 41 00-24 SCHEMATIC 38

SCH10

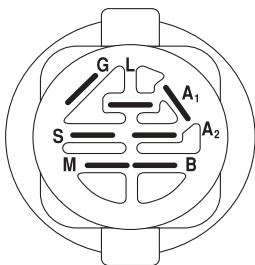
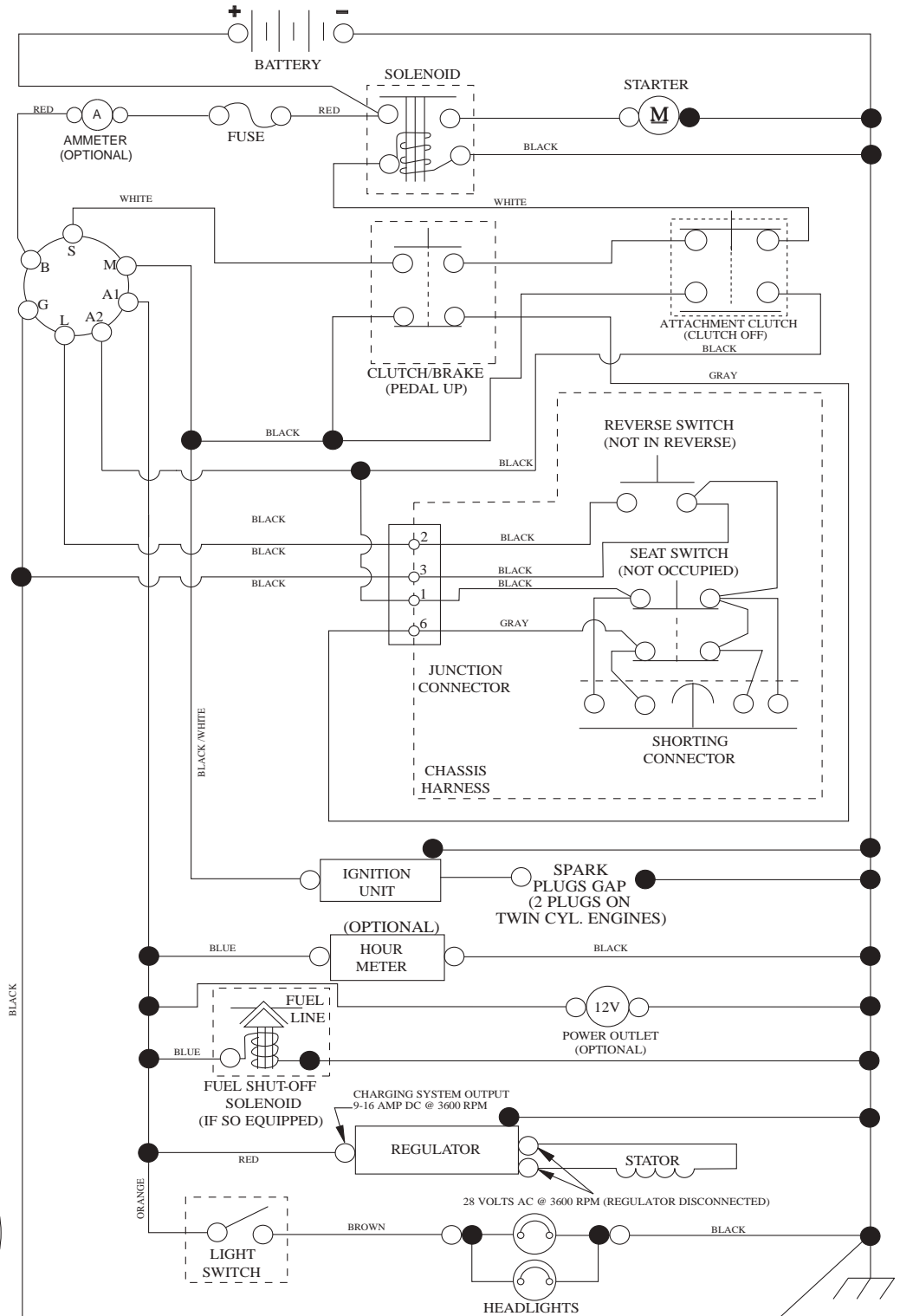

IGNITION SWITCH

POSITION	CIRCUIT	"MAKE"
OFF	M+G+A1	
RUN/OVERRIDE	B+A1	
RUN	B+A1	L+A2
START	B + S + A1	

03107

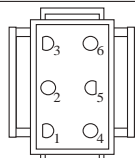

CHASSIS HARNESS CONNECTOR (MATING SIDE)

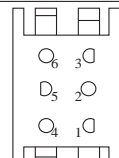

DASH HARNESS CONNECTOR (MATING SIDE)

WIRING INSULATED CLIPS
NOTE: IF WIRING INSULATED CLIPS WERE REMOVED FOR SERVICING OF UNIT, THEY SHOULD BE RE-INSTALLED TO PROPERLY SECURE YOUR WIRING.

● NON-REMOVABLE CONNECTIONS

○ REMOVABLE CONNECTIONS

TRACTOR - - MODEL NO. LTH171 (96041002404), PRODUCT NO. 960 41 00-24
ELECTRICAL **32**

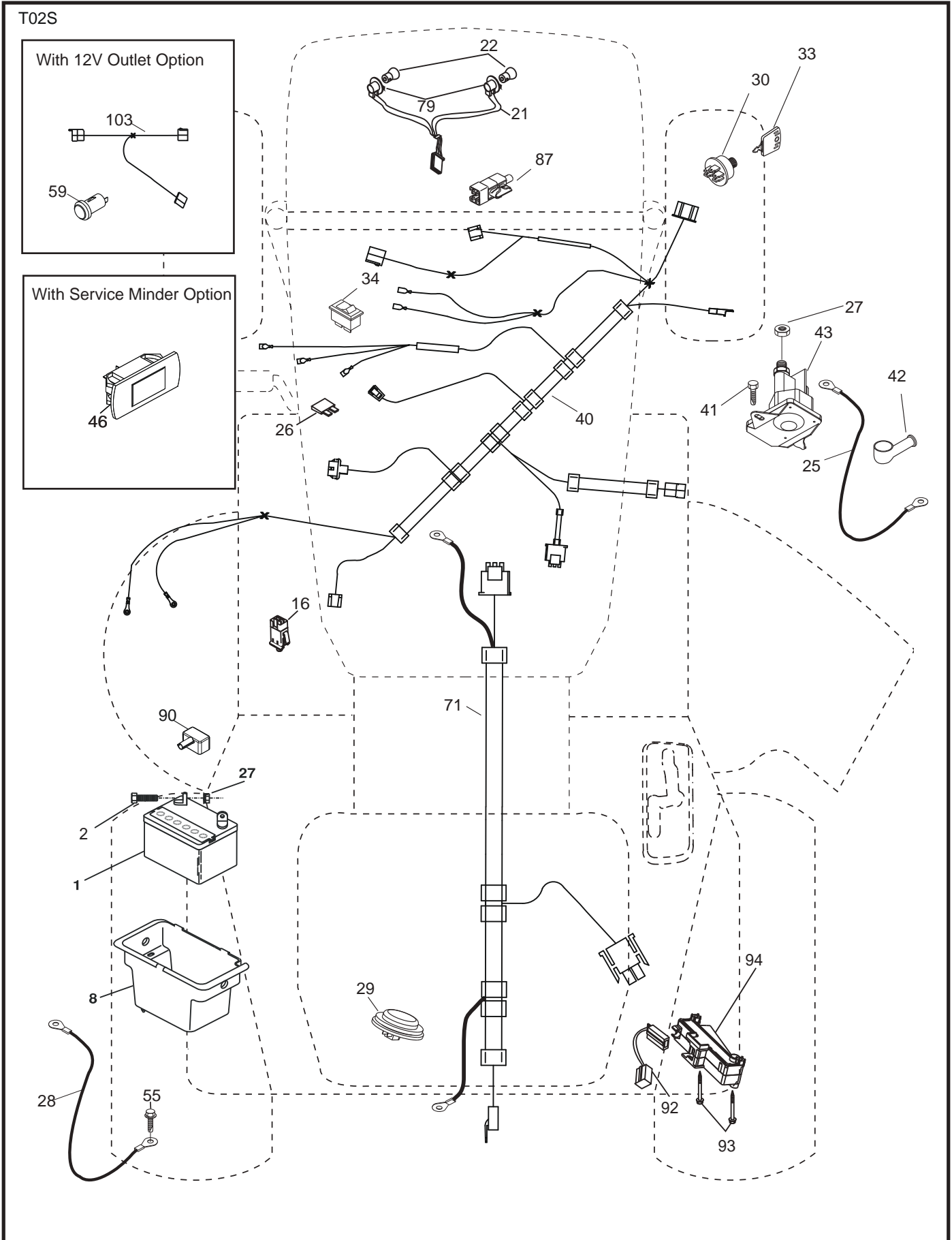

**TRACTOR - - MODEL NO. LTH171 (96041002404), PRODUCT NO. 960 41 00-24
ELECTRICAL 32**

KEY NO.	PART NO.	DESCRIPTION
1	532 16 34-65	Battery
2	874 76 04-12	Bolt Hex Head 1/4-20 x 3/4
8	532 19 32-28	Box Battery
16	532 17 61-38	Switch Interlock Push-In
21	532 40 02-52	Harness Socket Light w/4152J
22	532 00 41-52	Bulb Light
25	532 41 28-94	Cable Starter
26	532 17 51-58	Fuse
27	873 51 04-00	Nut Keps Hex 1/4-20 unc
28	532 19 88-85	Cable, Ground
29	532 40 15-45	Switch, Seat
30	532 19 33-50	Switch, Ign
33	532 41 19-35	Key/Chain
34	532 11 07-12	Switch Light/Reset
40	532 40 10-98	Harness Ign. Dash
41	817 72 04-08	Screw Thd Cut 1/4-20 x 1/2
42	532 13 15-63	Cover, Terminal
43	532 19 25-07	Solenoid
46	532 40 17-63	Gauge Hourmeter
55	817 06 05-12	Screw Thdrol 5/16-18 x 3/4 TYTT
71	532 40 04-49	Harness Ign.
79	532 17 52-42	Socket Asm
87	532 19 78-02	Switch Interlock Clutch Cbl
90	532 40 07-25	Cover Terminal
92	532 19 66-15	Harness Pigtail Reverse Switch
93	532 19 25-40	Screw Plastite 10-14 x 2.0
94	532 19 18-34	Module Reverse ROS

NOTE: All component dimensions given in U.S. inches
1 inch = 25.4 mm

TRACTOR - - MODEL NO. LTH171 (96041002404), PRODUCT NO. 960 41 00-24
CHASSIS **27**

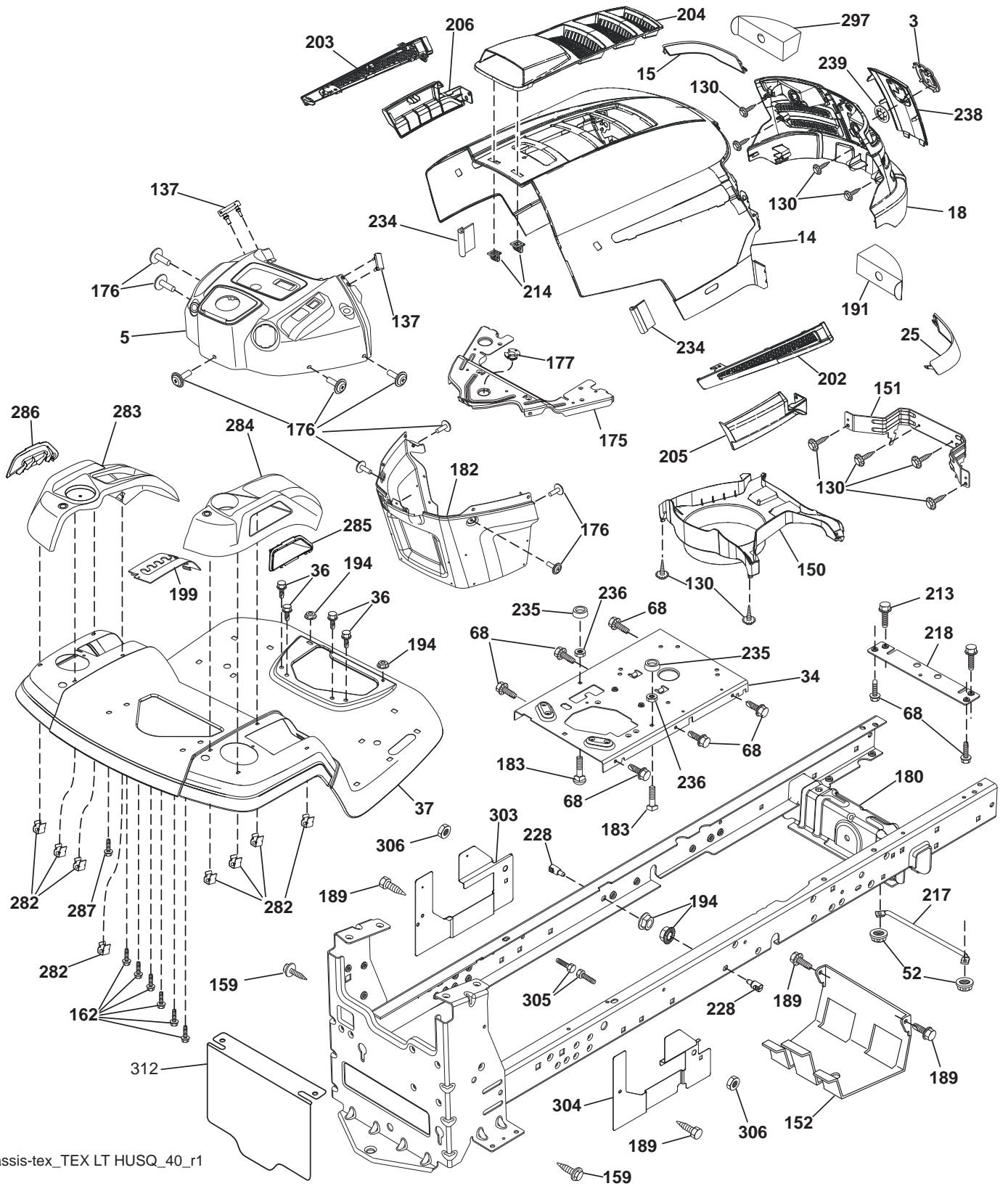

chassis-tex_TEX LT HUSQ_40_r1

**TRACTOR - - MODEL NO. LTH171 (96041002404), PRODUCT NO. 960 41 00-24
CHASSIS 27**

KEY NO.	PART NO.	DESCRIPTION	KEY NO.	PART NO.	DESCRIPTION
3	532 40 50-12	Logo	204	532 41 11-16	Vent Top Hood
5	532 40 75-92	Dash	205	532 41 10-76	Skirt Side RH
14	532 44 12-67	Hood	206	532 41 10-77	Skirt Side LH
15	532 41 10-79	Lens LH	213	874 76 05-12	Bolt 5/16-18 x 3/4
18	532 42 69-63	Grille	214	532 19 91-45	Clip Retainer
25	532 41 10-78	Lens RH	217	532 40 91-67	Rod Pivot Hood
34	532 19 61-25	Plate Engine	218	532 19 63-95	X-Piece Hood Stop
36	817 06 06-12	Screw 5/16-18 x 3/4	228	532 19 51-61	Stud Fastener
37	532 44 12-66	Fender	234	532 40 47-42	Bumper Hood
52	873 68 05-00	Nut Crown Lock 5/16	235	532 40 61-29	Spacer Fender
68	817 49 05-08	Screw THDROL 5/16-18 x 1/2	236	873 93 05-00	Nut Lock 5/16-18 unc
130	532 41 63-58	Screw #10 x 0.75 BOS Thread	238	532 41 11-19	Trim
137	532 40 75-90	Bumper Dash	239	532 40 48-83	Clip Tinnerman
150	532 40 75-37	Air Duct	282	532 41 41-10	Clip Retainer Console
151	532 40 78-07	Bracket Pivot	283	532 41 63-16	Console Deck Lift Husq N/FR GR
152	532 19 95-35	Shield Browning	284	532 41 63-45	Console SHFT HYD HUSQ LT
159	817 00 06-12	Screw Hexwsh Thrd 3/8-16 x 3/4	285	532 41 63-15	Console INSRT RH HUSQ
162	532 14 24-32	Screw	286	532 41 63-17	Console INSRT LH HUSQ
175	532 19 94-72	Crossmember	287	817 60 04-06	Screw Hex WASHEAD 1/4-20 x 3/8
176	532 40 07-76	Screw 10-24 x 5/8	297	532 40 66-65	Insert Reflective LH
177	532 19 52-28	Bushing Steering	303	532 42 09-59	Shield Chassis French LH
180	532 19 54-57	Chassis	304	532 42 15-09	Shield Chassis French RH
182	532 40 71-76	Dash Lower	305	872 11 06-06	Bolt.RDHD.SHT.SQNK 3/8-16 x3/4
183	874 52 05-20	Bolt 5/16-18 x 1-1/4 Full Thd.	306	873 90 06-00	Nut Lock Flg. 3/8-16 unc
189	817 00 05-12	Screw 5/16-18 x 3/4	312	532 42 09-60	Shield Drawbar French
191	532 41 65-00	Insert Reflective RH			
194	873 90 05-00	Nut Lock Hex Flange 5/16-18			
199	532 41 34-85	Plate Deck Lift Husqvarna LT			
202	532 41 10-75	Vent Side Hood RH			
203	532 41 10-74	Vent Side Hood LH			

NOTE: All component dimensions given in U.S. inches
1 inch = 25.4 mm

TRACTOR - - MODEL NO. LTH171 (96041002404), PRODUCT NO. 960 41 00-24
DRIVE **40**

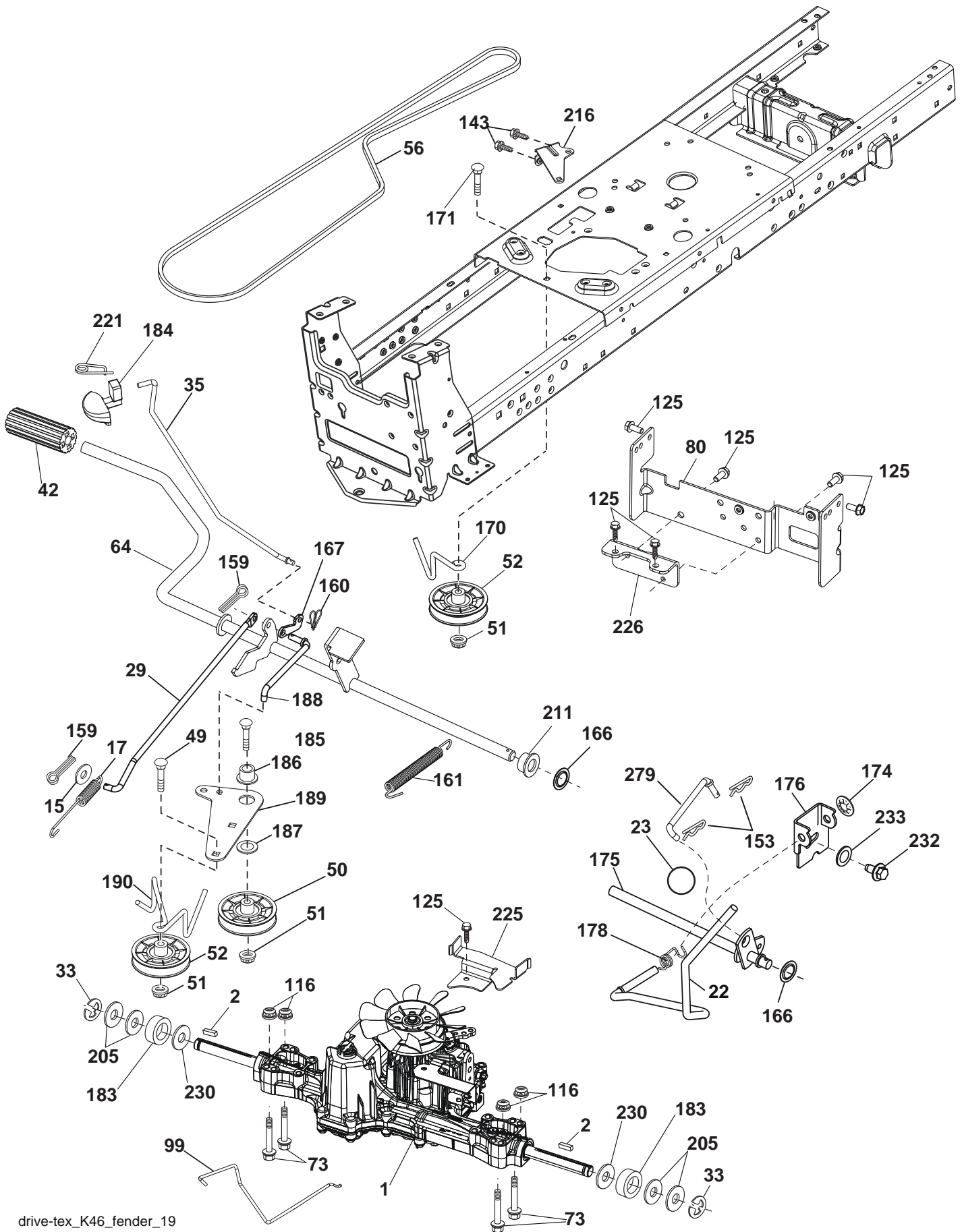

**TRACTOR - - MODEL NO. LTH171 (96041002404), PRODUCT NO. 960 41 00-24
DRIVE **40****

KEY NO.	PART NO.	DESCRIPTION	KEY NO.	PART NO.	DESCRIPTION
1	---	Transaxle, TUFFTORQ K46 BA	171	872 11 06-16	Bolt RDHD SQNK 3/8-16 unc x 2
2	532 12 35-83	Key	174	532 19 72-89	Nut Push
15	819 13 13-16	Washer 13/32 x 13/16 x 16 Ga.	175	532 40 62-08	Shaft Asm Shift
17	532 41 36-78	Spring Brake	176	532 19 62-14	Arm Clevis Rod Shift
22	532 19 76-60	Rod Shift	178	532 19 74-56	Spring Shift
23	532 12 12-74	Knob	183	532 13 70-57	Spacer Split
29	532 40 38-06	Rod, Brake	184	532 40 97-47	Handle Parking Brake
33	812 00 00-01	Ring E	185	872 11 06-22	Bolt Rdhd Sqnk 3/8-16 x 2-3/4 Gr. 5
35	532 40 10-31	Rod Brake Park	186	532 19 43-21	Spacer Retainer
42	532 12 48-72	Cover Foot Pedal	187	819 13 32-10	Washer
49	872 11 06-14	Bolt	188	532 19 43-23	Link Clutch Ground Drive
50	532 19 43-27	Pulley Idler Flat	189	532 19 43-17	Bellcrank Ground Drive
51	873 90 06-00	Lock Nut 3/8-16	190	532 19 43-18	Keeper Bellcrank Ground Drive
52	532 19 43-26	Idler V-Groove 910" Offset	205	532 12 17-48	Washer
56	532 13 09-69	V-Belt Drive	211	532 19 62-12	Bushing Brake Shaft
64	532 19 62-00	Shaft Asm. Pedal Brake Control	216	532 19 61-31	Bracket Pulley Idler
73	874 49 05-44	Bolt Hex Flghd 5/16-18 Gr. 5	221	532 40 31-87	Retainer Spring Clip Handle
80	532 41 00-24	Strap Torque	225	532 40 33-19	Keeper Belt Trans.
99	532 41 57-42	Rod Bypass Spring	226	532 40 15-64	Bracket Mount Torque
116	873 90 05-00	Nut Lock Hex Flange 5/16-18	230	532 18 89-67	Washer Hardened
125	817 00 05-12	Screw 5/16-18 x 3/4	232	874 78 07-16	Bolt 7/16-14 x 1 Gr. 5
143	817 49 05-08	Screw 5/16-18 x 1/2	233	532 40 52-96	Washer Serrated
153	532 12 47-88	Retainer Spring	279	532 40 62-07	Link Shift
159	876 02 04-12	Pin Cotter 1/8 x 3/4			
160	532 16 94-84	Retainer Clip			
161	532 10 57-09	Spring Return Clutch			
166	532 42 83-05	Nut Push			
167	532 40 52-57	Latch Brake Parking			
170	532 19 43-22	Keeper Belt Centerspan			

NOTE: All component dimensions given in U.S. inches
1 inch = 25.4 mm

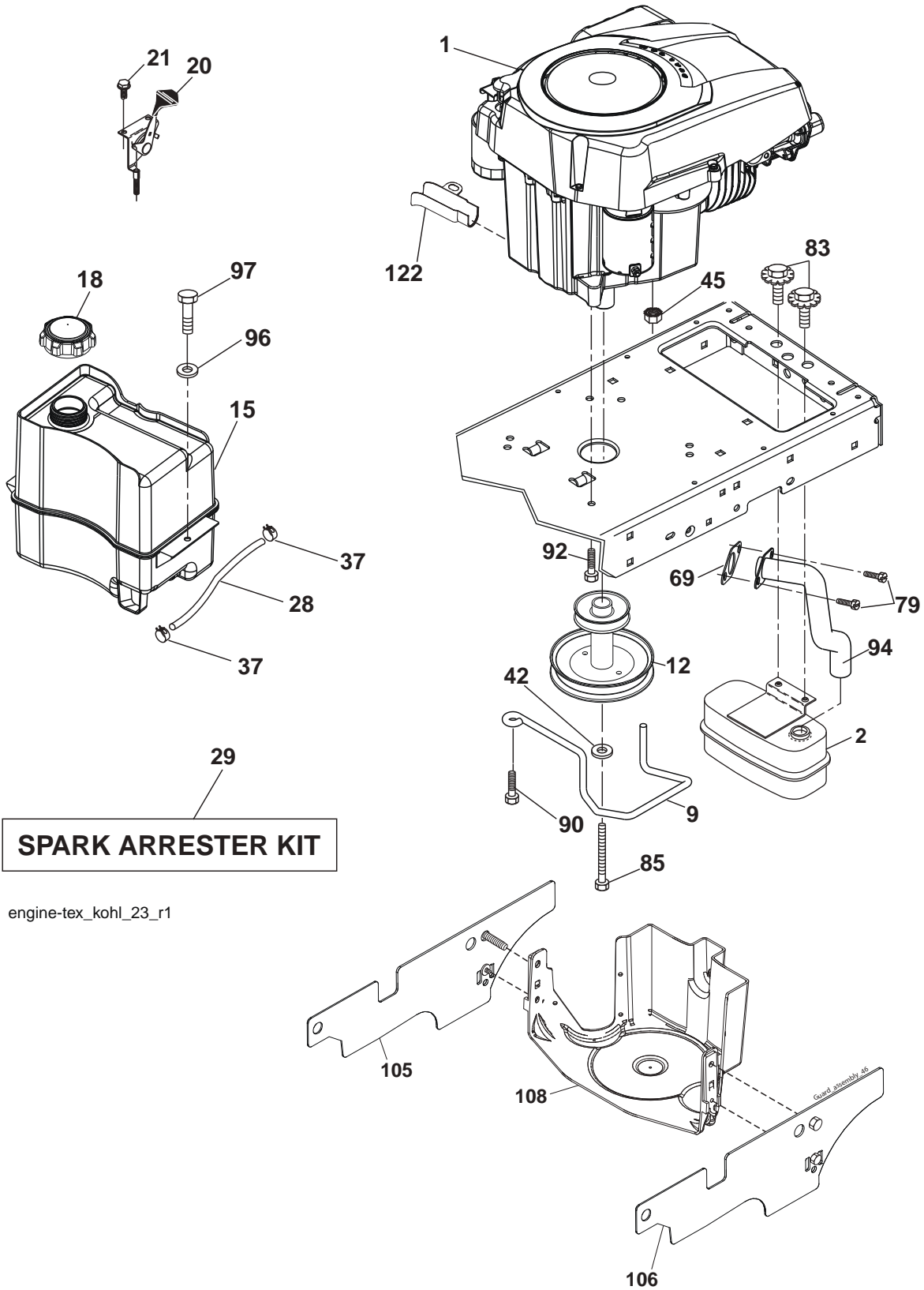

**TRACTOR - - MODEL NO. LTH171 (96041002404), PRODUCT NO. 960 41 00-24
ENGINE 24**

KEY NO.	PART NO.	DESCRIPTION
1	-----	Engine Kohler Model No. SV530-0212
2	532 18 86-55	Muffler
9	532 19 43-20	Keeper Belt Engine
12	532 40 54-71	Pulley Engine
15	532 40 75-45	Tank Fuel 1.5
18	532 42 51-62	Cap Fuel
20	532 18 38-97	Control Throttle
21	532 41 63-58	Screw #10 x 0.75 BOS Thread
28	532 13 70-40	Fuel Line
29	532 13 71-80	Spark Arrester Kit
37	532 12 34-87	Clamp Hose
42	810 04 07-00	Washer
45	873 51 04-00	Nut Keps Hex 1/4-20 unc
69	532 18 59-09	Gasket (Order From Eng. Mfgr.)
79	532 19 23-34	Screw Socket 5/16-18 x .75
83	532 17 18-77	Bolt 5/16-18 unc x 3/4 w/Sems
85	532 17 39-37	Bolt Hex 7/16-20 x 4 Gr. 5
90	817 00 06-16	Screw 3/8-16 x 1
92	817 12 06-16	Screw 3/8-16 x 1
94	532 18 86-54	Tube Exhaust
96	819 09 14-16	Washer 9/32 x 7/8 x 16 Ga.
97	817 67 04-12	Screw 1/4-20 x 3/4
105	532 44 06-81	Shield Side LH
106	532 44 06-80	Shield Side RH
108	532 42 17-94	Cover Asm Engine
122	532 42 19-22	Extension Oil Drain

NOTE: All component dimensions given in U.S. inches
1 inch = 25.4 mm

TRACTOR - - MODEL NO. LTH171 (96041002404), PRODUCT NO. 960 41 00-24
STEERING ASSEMBLY **41**

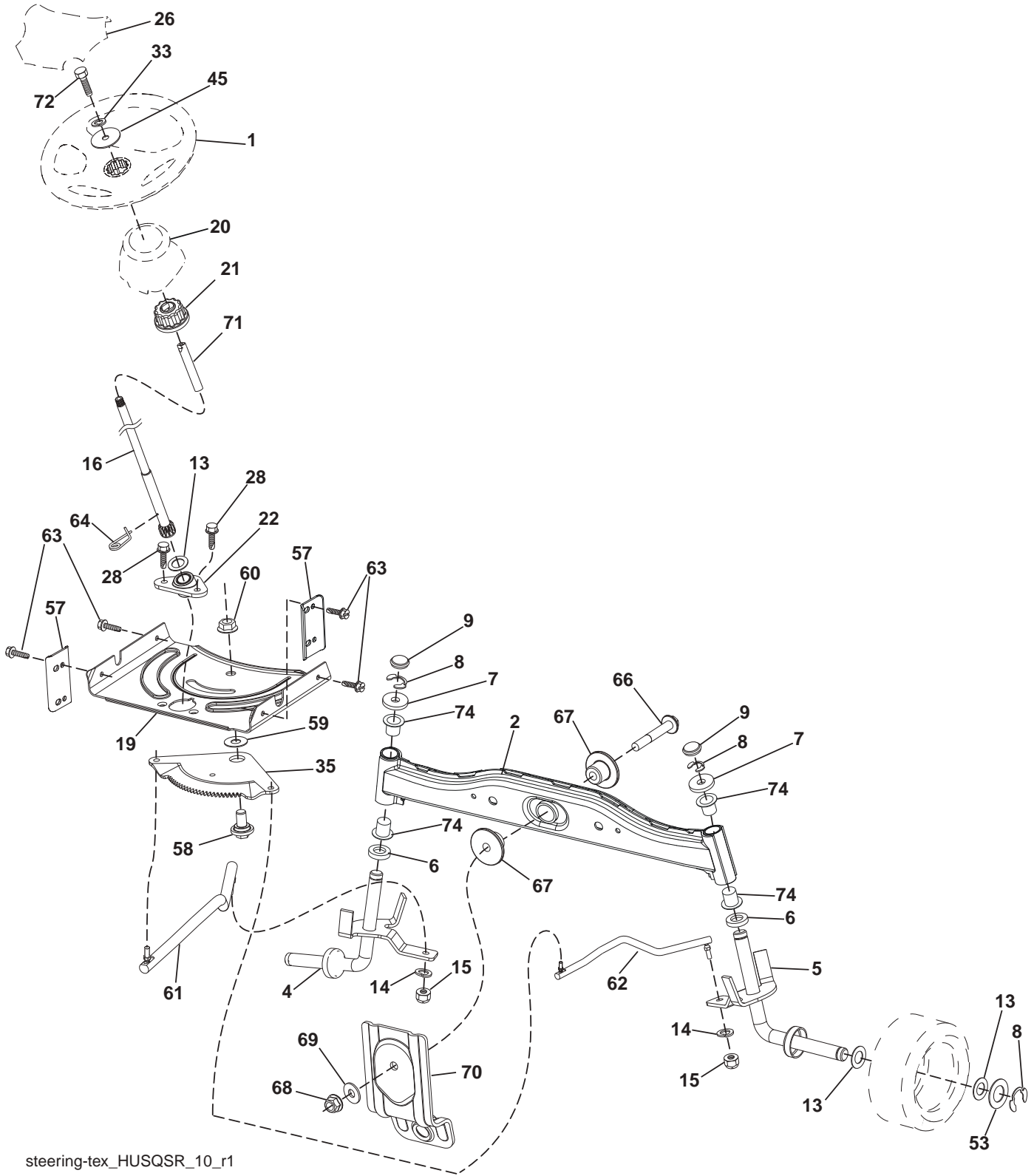

steering-tex_HUSQSR_10_r1

**TRACTOR - - MODEL NO. LTH171 (96041002404), PRODUCT NO. 960 41 00-24
STEERING ASSEMBLY 41**

KEY NO.	PART NO.	DESCRIPTION
1	532 41 64-80	Wheel, Steering Husq SR
2	532 41 81-68	Axle Asm., Front
4	532 40 30-87	Spindle Asm., LH
5	532 40 30-88	Spindle Asm., RH
6	532 12 49-31	Bearing, Race Thrust Harden
7	532 12 17-48	Washer 25/32 x 1-5/8 x 16 Ga.
8	812 00 00-29	Ring, Klip #T5304-75
9	532 12 12-32	Cap, Spindle
13	532 12 17-49	Washer 25/32 x 1-1/4 x 16 Ga.
14	810 04 06-00	Washer, Lock Hvy Hlcl Spr 3/8
15	873 54 06-00	Nut, Crown Lock 3/8-24 unf
16	532 42 93-73	Shaft Steering
19	532 19 47-29	Plate Steering
20	532 41 11-39	Boot, Steering
21	532 18 67-37	Adapter, Wheel Steering
22	532 42 05-37	Strg. Supt. Lower
26	532 41 59-87	Insert, Wheel, Steering Husq SR
28	817 00 06-12	Screw 3/8-16 x 3/4
33	810 04 05-00	Washer Lock 5/16
35	532 19 47-32	Gear, Sector Plate
45	819 11 38-12	Washer 11/32 x 3/8 x 12 Ga.
53	532 18 89-67	Washer Hardened .793 x 1.637 x .060
57	532 40 74-65	Bracket Upstop
58	532 19 47-47	Bolt Shoulder Sector Pivot CFM
59	532 19 47-48	Washer Thrust Sector Steering
60	873 97 10-00	Nut Flange Lock 5/8-11
61	532 19 47-40	Draglink, LH
62	532 19 47-41	Draglink, RH
63	817 00 05-12	Screw 5/16-18 x 3/4
64	532 19 98-49	Retainer Clip Spring Steering
66	871 02 07-48	Bolt Hex Fghd 7/16-14 x 3 Serr
67	532 19 47-37	Bushing PM Front Axle
68	873 90 07-00	Nut Lock Flange 7/16-14 Gr. 5
69	532 19 91-62	Washer 1.5 x .505 x .118
70	532 19 61-97	Bracket Deck Susp. Front
71	532 19 07-52	Shaft Extension Steering
72	532 42 89-82	Bolt Fin Hx 5/16-18 x 4 w/Patch
74	532 12 49-37	Bearing

NOTE: All component dimensions given in U.S. inches
1 inch = 25.4 mm

TRACTOR - - MODEL NO. LTH171 (96041002404), PRODUCT NO. 960 41 00-24
MOWER DECK 44

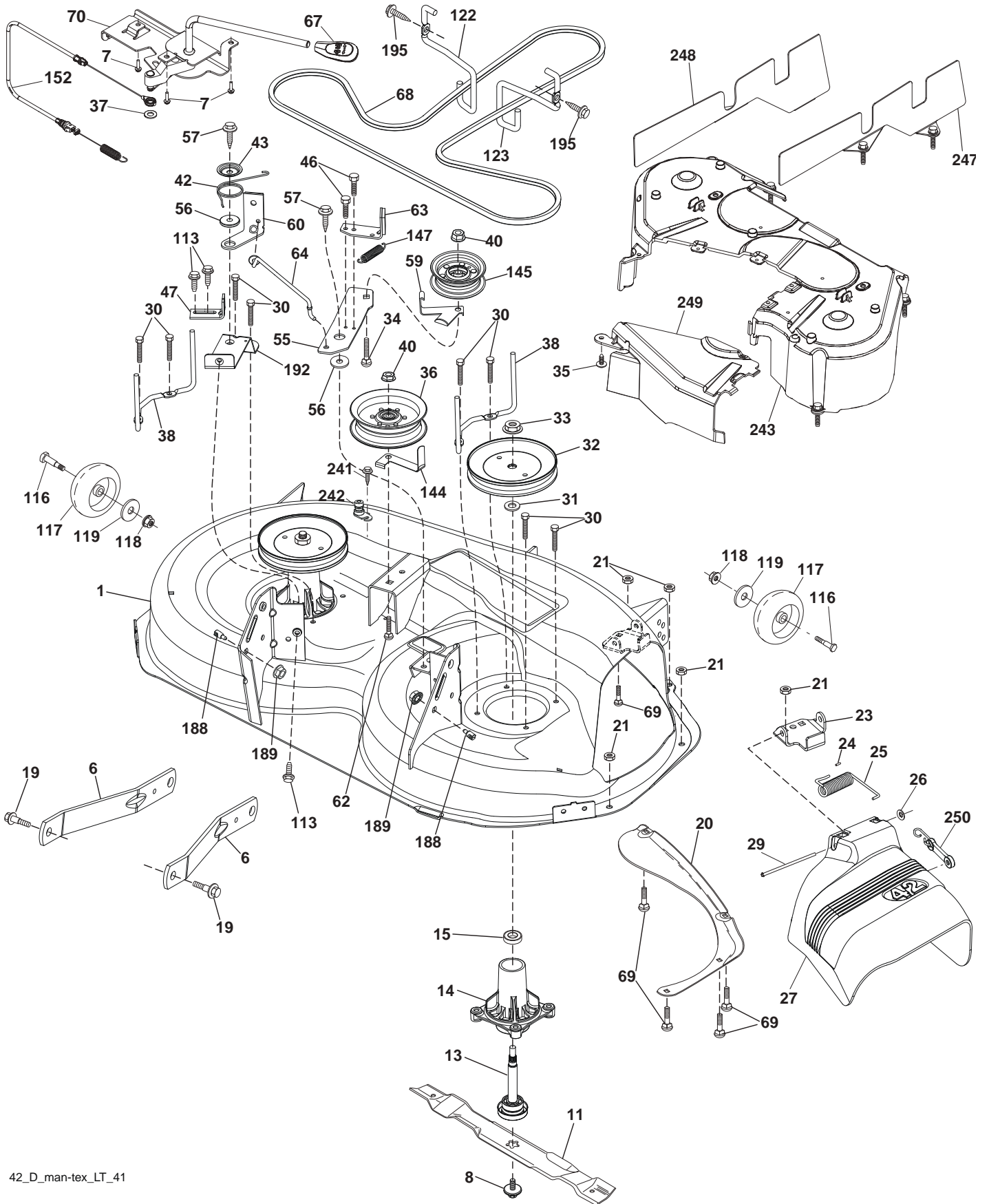

42_D_man-tex_LT_41

**TRACTOR - - MODEL NO. LTH171 (96041002404), PRODUCT NO. 960 41 00-24
MOWER DECK 44**

KEY NO.	PART NO.	DESCRIPTION	KEY NO.	PART NO.	DESCRIPTION
1	532 19 64-95	Mower Housing	64	532 19 97-90	Link Brake
6	532 19 51-86	Arm Suspension	67	532 40 30-12	Handle Clutch Cable
7	532 41 63-58	Screw #10 x 0.75 BOS Thread	68	532 42 96-36	Belt, Deck, Drive 42"
8	532 19 30-03	Bolt/Washer Asm 7/16-20 unf	69	872 14 05-05	Bolt
11	532 13 89-71	Blade, 42" Hi-Lift (For bagging or discharge)	70	532 40 12-46	Clutch Asm Manual
13	532 19 28-72	Shaft Assembly, Mandrel	113	817 00 05-10	Screw 5/16-18
14	532 18 72-81	Housing, Mandrel	116	532 12 48-42	Bolt Shoulder
15	532 11 04-85	Bearing, Ball, Mandrel	117	532 18 86-06	Wheel, Gauge
19	532 19 65-39	Bolt, Shoulder	118	873 93 06-00	Nut, Crownlock 3/8 x 1
20	532 15 97-70	Baffle, Vortex	119	819 12 14-14	Washer 13/32 x 7/8 x 14 Ga.
21	873 68 05-00	Nut, Crownlock 5/16-18 unc	122	532 19 72-58	Keeper Belt Engine LH
23	532 19 25-57	Bracket, Deflector	123	532 19 72-59	Keeper Belt Engine RH
24	532 10 53-04	Cap, Sleeve	144	532 19 92-04	Keeper Belt
25	532 19 70-26	Spring, Torsion, Deflector	145	532 19 31-97	Pulley Idler
26	532 11 04-52	Nut, Push	147	532 40 19-71	Spring Return
27	532 41 14-85	Shield, Deflector	152	532 40 87-14	Manual Clutch Cable
29	532 13 14-91	Rod, Hinge	188	532 19 51-61	Stud Fastener
30	532 17 39-84	Screw Thdrol Rolling Wsh Hd	189	873 90 05-00	Nut Lock Hex Flange
31	532 18 76-90	Washer, Spacer	192	532 19 72-60	Bracket Brake Stand LH
32	532 19 74-73	Pulley, Mandrel	195	817 00 06-12	Screw 3/8-16 x 3/4
33	532 40 02-34	Nut, Toplock, Flanged	241	532 15 29-27	Screw TT #10-32.5. 3/8 Flange
34	872 11 06-12	Bolt Carr Sh. 3/8-16 x 1-1/2 Gr. 5	242	532 41 55-98	Port Washout
35	532 13 38-35	Fastener, Christmas Tree	243	532 43 23-94	Cover Deck 42in.
36	532 19 73-79	Pulley, Idler, Flat	247	532 43 23-93	Shield Deck RH
37	819 13 13-16	Washer	248	532 43 23-92	Shield Deck LH
38	532 19 91-89	Keeper Belt LH Mandrel	249	532 40 65-14	Cover Cable Clutch
40	873 90 06-00	Nut, Lock Flg. 3/8-16 unc	250	532 43 60-87	Kit Bungee (Includes Phillips head screw, weld nut, screw, bungee latch, and bungee strap)
42	532 19 84-10	Spring Torsion Brake	--	532 19 28-70	Mandrel Assembly (Includes housing, shaft assembly, and bearing only - pulley/nut/washer and blade bolt/washers not included)
43	532 19 72-56	Spring Torsion Retainer	--	532 43 17-10	Replacement Mower, Complete
46	532 13 77-29	Screw Thd Roll 1/4-20 x 5/8			
47	532 19 72-50	Bracket Clutch Cable			
55	532 43 71-10	Arm, Idler			
56	532 19 90-92	Spacer, Retainer			
57	817 00 06-16	Screw 3/8-16 x 1			
59	532 14 10-43	Guard, Tuv Idler			
60	532 19 72-61	Arm Brake Mower			
62	872 11 06-16	Bolt Rd Hd Sq Nk 3/8-16 unc x 2			
63	532 19 94-77	Arm Brake Mower			

NOTE: All component dimensions given in U.S. inches
1 inch = 25.4 mm

**TRACTOR - - MODEL NO. LTH171 (96041002404), PRODUCT NO. 960 41 00-24
MOWER LIFT **45****

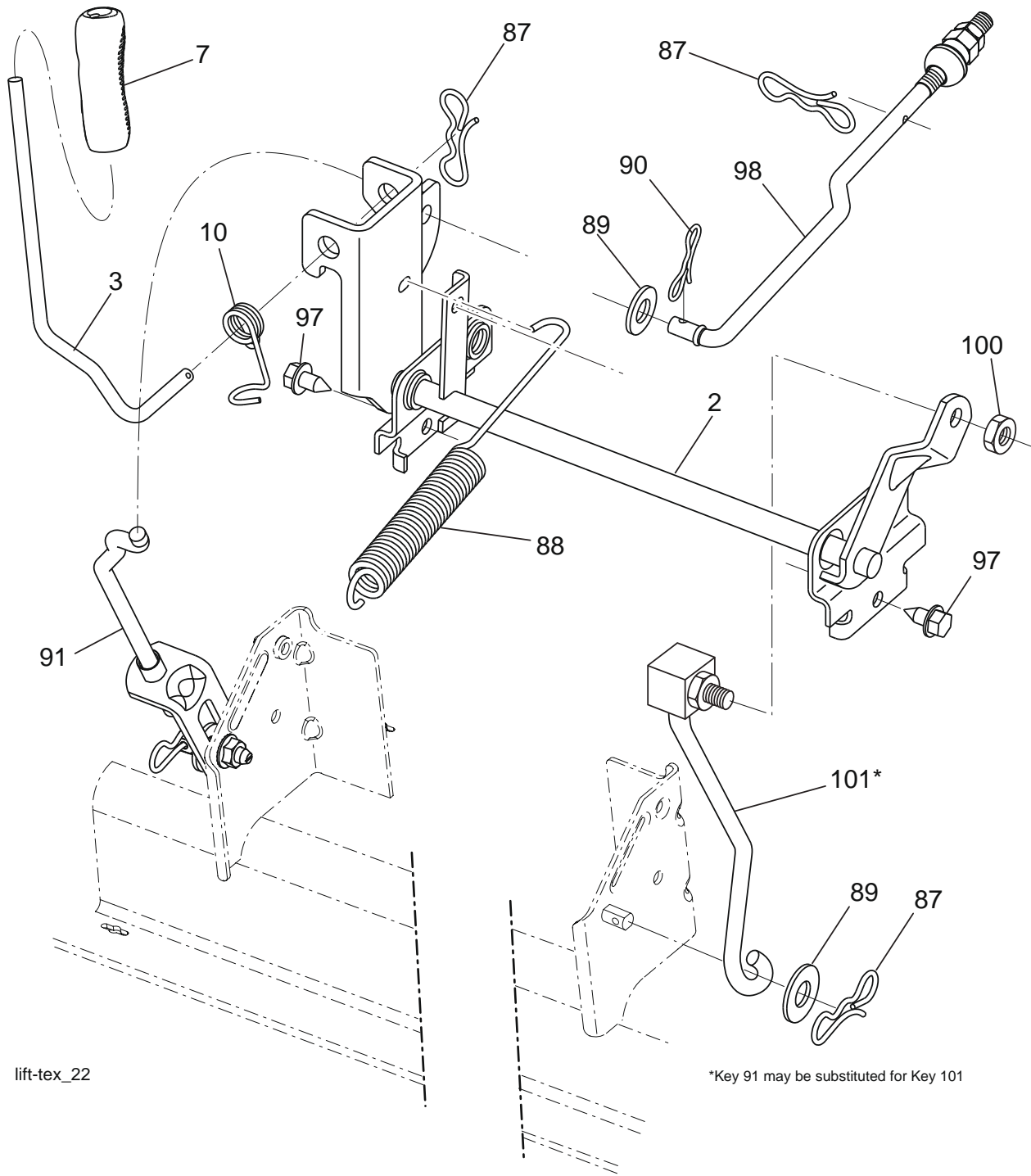

lift-tex_22

*Key 91 may be substituted for Key 101

KEY NO.	PART NO.	DESCRIPTION
2	532 42 20-27	Shaft Asm., Lift
3	532 19 52-31	Lever Asm., Lift RH
7	532 41 15-55	Grip, Lever
10	532 19 63-14	Spring Torsion
87	532 19 42-09	Pin Cotter 7/16 Bow Tie Lock
88	532 41 07-10	Spring Lift Assist
89	819 19 19-12	Washer Clear Zinc
90	532 19 42-08	Pin Cotter 5/16 Bow Tie Lock
91	532 19 51-81	Link Lift Susp Mower Rear

KEY NO.	PART NO.	DESCRIPTION
97	817 00 06-12	Screw 3/8-16 x .75
98	532 19 52-70	Link Lift Susp. Front Mower
100	873 93 06-00	Nut Centerlock 3/8-16
101	532 40 70-03	Link Asm Lift FXD

NOTE: All component dimensions given in U.S. inches
1 inch = 25.4 mm

**TRACTOR - - MODEL NO. LTH171 (96041002404), PRODUCT NO. 960 41 00-24
SEAT ASSEMBLY 42**

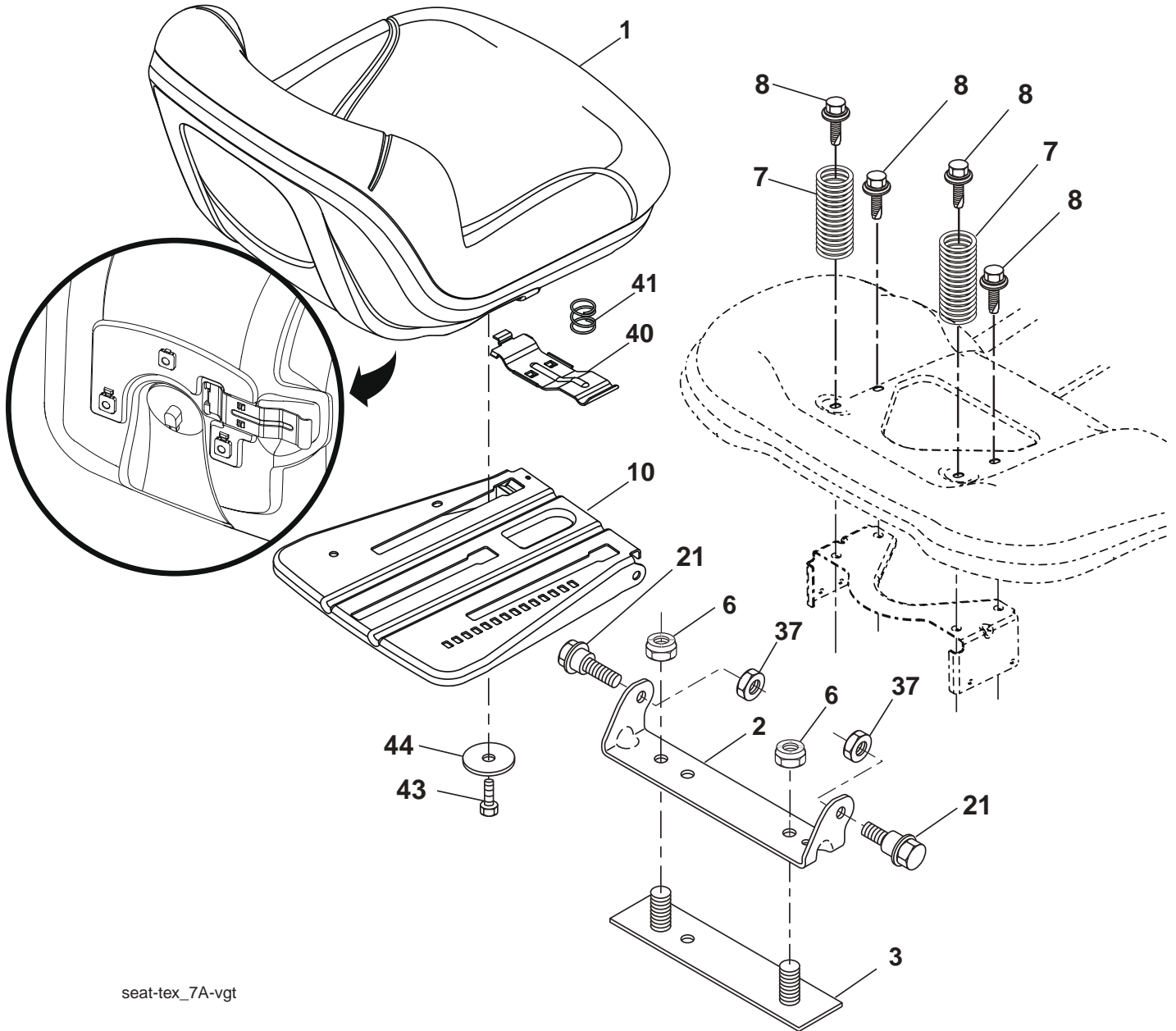

seat-tex_7A-vgt

KEY NO.	PART NO.	DESCRIPTION
1	532 42 40-67	Seat
2	532 18 01-66	Bracket Pivot Fender
3	532 14 06-75	Strap, Asm Fender
6	873 80 06-00	Nut, Lock w/Ins. 3/8-16 unc
7	532 12 41-81	Spring, Seat Cprsn
8	532 17 18-77	Bolt 5/16-18 unc x 3/4 w/Sems
10	532 19 69-77	Pan, Seat
21	532 17 18-52	Bolt, Shoulder 5/16-18

KEY NO.	PART NO.	DESCRIPTION
37	873 80 05-00	Nut, Lock 5/16-18 unc
40	532 19 76-61	Handle Slide
41	532 19 82-00	Spring Latch
43	874 76 06-12	Bolt Fin Hex 3/8-16 unc x 3/4
44	819 13 38-12	Washer 13/32 x 2-3/8 x 12 Ga.

NOTE: All component dimensions given in U.S. inches
1 inch = 25.4 mm

