

RT175

Serial Numbers 10720 and Before

RT210

Serial Numbers 21040 and Before

GEHL®

Form No.
918468
Revision E
Feb. 2013
ENGLISH

Original Instructions

Compact Track Loader



Operator's Manual

GEHL COMPANY

WARRANTY

GEHL COMPANY, hereinafter referred to as Gehl, warrants new Gehl equipment to the Original Retail Purchaser to be free from defects in material and workmanship for a period of twelve (12) months from the Warranty Start Date.

GEHL WARRANTY SERVICE INCLUDES:

Genuine Gehl parts and labor costs required to repair or replace equipment at the selling dealer's business location.

GEHL MAKES NO REPRESENTATIONS OR WARRANTIES OF ANY KIND, EXPRESS OR IMPLIED (INCLUDING THE IMPLIED WARRANTIES OF MERCHANTABILITY AND FITNESS FOR PARTICULAR PURPOSE), EXCEPT AS EXPRESSLY STATED IN THIS WARRANTY STATEMENT.

ANY OF THESE LIMITATIONS EXCLUDED BY LOCAL LAW SHALL BE DEEMED DELETED FROM THIS WARRANTY; ALL OTHER TERMS WILL CONTINUE TO APPLY.

SOME STATES DO NOT PERMIT THE EXCLUSION OR LIMITATION OF THESE WARRANTIES AND YOU MAY HAVE GREATER RIGHTS UNDER YOUR STATE LAW.

GEHL WARRANTY DOES NOT INCLUDE:

1. Transportation to selling dealer's business location or, at the option of the Original Retail Purchaser, the cost of a service call.
2. Used equipment.
3. Components covered by their own non-Gehl warranties, such as tires, batteries, trade accessories and engines.
4. Normal maintenance service and expendable, high-wear items.
5. Repairs or adjustments caused by: improper use; failure to follow recommended maintenance procedures; use of unauthorized attachments; accident or other casualty.
6. Liability for incidental or consequential damages of any type, including, but not limited to lost profits or expenses of acquiring replacement equipment.

No agent, employee or representative of Gehl has any authority to bind Gehl to any warranty except as specifically set forth herein.

Delivery Checklists

The following checklist is an important reminder of valuable information and inspections that **MUST** be made before the machine is delivered to the customer. Check off each item after the prescribed action is taken.

✓PRE-DELIVERY CHECK:

- Machine has not been damaged in shipment. Check for such things as dents and loose or missing parts. Correct or replace components as required.
- Battery is securely mounted and not cracked. Be sure cable connections are tight.
- Cylinders, hoses and fittings are not damaged, leaking or loosely connected.
- Cooler/radiator hoses and fittings are not damaged, leaking or loosely connected. Radiator is filled to proper level and has the proper anti-freeze protection.
- Filters are not damaged, leaking or loosely secured.
- Machine is properly lubricated and no grease fittings are missing or damaged.
- Hydraulic system reservoir, engine crankcase and drive gearcases are filled to their proper levels.
- Engine radiator is filled to proper level and has proper anti-freeze protection.
- All adjustments are made to comply with settings provided in the *Maintenance* chapter of this manual.
- All guards, shields and decals are in place and secured.
- Model and serial numbers for the machine are recorded in the spaces provided on this page.

IMPORTANT

Start the engine and test run the machine while checking that all controls operate properly.

- All drive and hydraulic controls operate properly and are not damaged or binding.
- Drive controls are properly adjusted for correct neutral position.
- The parking brake, along with the lock-out devices, are activated with the unit stationary (no pilot control pressure).
- All instrument panel gauges, indicator lights, etc. function properly.
- All installed lights, such as work lights, function properly.
- All hydraulic functions are **NOT** operational with the arm rests/safety bars in the raised, lock-out position.
- Hydraloc™ system functions properly as described in the Operator's Manual.

I acknowledge the pre-delivery procedures were performed on the machine as outlined on this page.

Dealership's Name

Dealer Representative's Name

Date Checklist Filled Out

Model & Serial Number

Engine Serial Number

✓AT-DELIVERY CHECK:

The following checklist is an important reminder of valuable information that **MUST** be passed on to the customer at the time of delivery. Check off each item as you explain it to the customer. Review with the customer the contents of this Operator's Manual, especially:

- The *Index* for quickly locating topics.
- The *Safety* and *Operation* chapters, for information regarding safe operation of the machine.
- The *Maintenance* and *Troubleshooting* chapters, for information regarding proper maintenance of the machine. Explain that regular lubrication and maintenance are required for continued safe operation and long machine life.
- A copy of the product warranty is included on the inside front cover of this Operator's Manual.
- Give this Operator's Manual and the AEM Safety Manual to the customer, and instruct the customer to read and completely understand the content of each manual before operating the machine.
- Explain that the customer **MUST** consult the engine manual (if provided) for related specifications, operating adjustments and maintenance instructions.
- Completely fill out the Owner's Registration, including customer's signature, and return it to the company.

Customer's Signature

Date Delivered

RETAIN FOR CUSTOMER'S RECORDS

This Page Intentionally Blank

The following checklist is an important reminder of valuable information and inspections that **MUST** be made before the machine is delivered to the customer. Check off each item after the prescribed action is taken.

✓PRE-DELIVERY CHECK:

- Machine has not been damaged in shipment. Check for such things as dents and loose or missing parts. Correct or replace components as required.
- Battery is securely mounted and not cracked. Be sure cable connections are tight.
- Cylinders, hoses and fittings are not damaged, leaking or loosely connected.
- Cooler/radiator hoses and fittings are not damaged, leaking or loosely connected. Radiator is filled to proper level and has the proper anti-freeze protection.
- Filters are not damaged, leaking or loosely secured.
- Machine is properly lubricated and no grease fittings are missing or damaged.
- Hydraulic system reservoir, engine crankcase and drive gearcases are filled to their proper levels.
- Engine radiator is filled to proper level and has proper anti-freeze protection.
- All adjustments are made to comply with settings provided in the *Maintenance* chapter of this manual.
- All guards, shields and decals are in place and secured.
- Model and serial numbers for the machine are recorded in the spaces provided on this page.

IMPORTANT

Start the engine and test run the machine while checking that all controls operate properly.

- All drive and hydraulic controls operate properly and are not damaged or binding.
- Drive controls are properly adjusted for correct neutral position.
- The parking brake, along with the lock-out devices, are activated with the unit stationary (no pilot control pressure).
- All instrument panel gauges, indicator lights, etc. function properly.
- All installed lights, such as work lights, function properly.
- All hydraulic functions are **NOT** operational with the arm rests/safety bars in the raised, lock-out position.
- Hydraloc™ system functions properly as described in the Operator's Manual.

I acknowledge the pre-delivery procedures were performed on the machine as outlined on this page.

Dealership's Name

Dealer Representative's Name

Date Checklist Filled Out

Model & Serial Number

Engine Serial Number

✓AT-DELIVERY CHECK:

The following checklist is an important reminder of valuable information that **MUST** be passed on to the customer at the time of delivery. Check off each item as you explain it to the customer. Review with the customer the contents of this Operator's Manual, especially:

- The *Index* for quickly locating topics.
- The *Safety* and *Operation* chapters, for information regarding safe operation of the machine.
- The *Maintenance* and *Troubleshooting* chapters, for information regarding proper maintenance of the machine. Explain that regular lubrication and maintenance are required for continued safe operation and long machine life.
- A copy of the product warranty is included on the inside front cover of this Operator's Manual.
- Give this Operator's Manual and the AEM Safety Manual to the customer, and instruct the customer to read and completely understand the content of each manual before operating the machine.
- Explain that the customer **MUST** consult the engine manual (if provided) for related specifications, operating adjustments and maintenance instructions.
- Completely fill out the Owner's Registration, including customer's signature, and return it to the company.

Customer's Signature

Date Delivered

RETAIN FOR DEALER'S RECORDS

This Page Intentionally Blank

Table of Contents

Delivery Checklists	i
Introduction	7
Safety Symbol	7
Contents and Use of this Manual	7
Safety Symbol and Signal Words.....	8
Safety Alert Symbol.....	8
Signal Words	8
Machine Orientation	8
Proper Machine Use.....	8
Service and Registration	9
Machine Model and Serial Numbers	9
Component Serial Numbers	9
Component Identification.....	10
Fields of Application	11
Using Attachments	11
Vibration Information	12
Vibration Measurement and Actions.....	12
Vibration Levels	13
Fire Extinguisher	13
Manufacturer Information	13
Indicator and Operation Symbols.....	14
Safety	15
Safety Symbol and Signal Words.....	15
Safety Alert Symbol.....	15
Signal Words	15
Mandatory Safety Shutdown Procedure.....	16
Before Starting	16
During Operation.....	17
Applications with Load-Handling Devices	20
Parking the Machine.....	20
Electrical Energy	20
Maintenance and Service Safety Practices.....	21
Battery Hazards.....	23
Fire Hazards.....	23
Additional Safety Equipment	24
Crystalline Silica Exposure.....	24
Transporting the Machine.....	24
Lifting the Machine with a Crane	24
Loading and Transporting the Machine.....	25
Safety Decals	25
New Decal Application.....	26
ANSI-Style Safety Decals.....	27
ISO-Style Safety Decals.....	29
Specifications	31
Fluids/Lubricants Types and Capacities.....	31
Dimensions.....	32
Payloads/Capacities.....	34
Weights	35
Track Drive	35
Coolant Compound Table	35

Engine.....	36
Hydraulic System.....	37
General	37
Drive Hydraulics.....	37
Pumps.....	38
Cylinders.....	39
Forces and Cycle Times	39
Electrical System	40
Sound Power/Pressure Levels	40
Vibration Levels	40
Features.....	41
Standard Features	41
Optional Features	41
Common Materials and Densities.....	42
Controls.....	43
Multi-Function Display	44
Switches/Indicators.....	45
Multi-Function Display Screens	46
Screen Access	46
Status, Maintenance and Error Code Screens	46
Configuration Screens	48
Audible Alerts.....	50
Control Joysticks.....	50
Joystick Tilt Function ISO/D-H Control Patterns.....	50
Activating D-H Control Pattern Option	50
Deactivating D-H Control Pattern Option	51
Left Joystick Functions.....	51
Right Joystick Functions	52
Joystick Buttons/Switch Functions.....	52
Joystick Control Sensitivity	53
Configuring Control Sensitivity.....	53
Parking Brake/Work Hydraulics Lock-out	54
Cab Heat and Air Conditioning (Option)	54
Operator's Seat.....	55
Seat Forward and Back Horizontal Adjustment	55
Seat Height Vertical Height/Weight Suspension Adjustment.....	55
Air Suspension	55
Mechanical Suspension.....	55
Seat Belt	55
Fastening/Unfastening the Seat Belt	56
Throttle Controls	56
Travel Controls	57
Travel Speed Range Selection	57
Travel Speed Limit (Option)	57
Activating Travel Speed Limit Option.....	57
Deactivating Travel Speed Limit Option	58
Travel Speed Limit Option Operation	58
Lift Arm Float Button	59
Hydraglide™ Button (Option).....	59
Work Lights.....	60
Work Lights	60
Battery Disconnect Switch (Option).....	60
Windshield Wipers/Washer.....	61
Wiper/Washer Control.....	61
Washer Fluid Reservoir	61

Operation	63
Operational Checks.....	63
Pre-Start Checks.....	63
Checks During Operation.....	64
Parking Checks.....	64
Before Operation.....	64
Cab Entry and Exit.....	64
Opening/Closing the Cab Door (Option).....	65
Seat Adjustment.....	65
Seat Belt.....	65
Parking Brake.....	66
Disengage Parking Brake.....	66
Starting the Engine.....	67
After Starting.....	68
Warm Up.....	68
Run-In Period.....	68
Stopping the Engine.....	68
After Operation.....	68
Jump-Starting.....	69
Travel Drive Operation.....	71
ISO Pattern Travel Drive Controls.....	72
D-H Pattern Travel Drive Controls (Option).....	72
Rubber Track Use Cautions and Tips.....	73
Travel Drive Error Condition Operation (Limp Mode).....	75
Alternate Transport Mode Activation.....	75
Alternate Transport Mode Cancel.....	76
Backup Alarm.....	76
Lift Arm Operation.....	76
Attachment Transport Position.....	76
Joystick Control Patterns.....	77
ISO Pattern Lift Arm Operation Controls.....	77
D-H Pattern Lift Arm Operation Controls (Option).....	77
Self-Leveling.....	78
Self-Leveling Cancel (Option).....	79
Lift Arm Float.....	79
Hydraglide™ Ride Control System (Option).....	79
Hydraulics Control Lock.....	80
Lift Arm Support.....	81
Engage Lift Arm Support.....	81
Disengage Lift Arm Support.....	82
Connecting/Disconnecting Attachments.....	83
Connecting Attachments.....	83
Disconnecting Attachments.....	84
Powering Attachments with Hydraulic Function.....	85
Connecting Hydraulic Attachments to the Auxiliary Hydraulic Circuits.....	85
Disconnecting Hydraulic Attachments from the Auxiliary Hydraulics Circuit.....	86
Auxiliary Hydraulics Operation.....	86
Standard-Flow Auxiliary Hydraulics Control.....	86
High-Flow Auxiliary Hydraulics Control (Option).....	87
Working with Buckets.....	87
Digging Tips.....	87
Safety Instructions When Working with Buckets.....	88
Working with Standard Buckets.....	89
Scooping.....	89
Loading.....	89
Tips When Loading Trucks.....	90
Grading.....	90

Grading	90
Grading without Float	90
Grading Using Float	91
Backfilling	92
Working with Pallet Forks	92
Safety Instructions When Working with Pallet Forks	92
Transporting Loads Using Pallet Forks	94
Loading Pallet Forks	94
Lifting Loads Using Pallet Forks	94
Transporting Load Using Pallet Forks	94
Setting Down Loads Using Pallet Forks	94
Lifting the Machine using a Crane	95
Crane Lifting Preparation	95
Loading and Transporting the Machine on a Transport Vehicle	96
Loading and Securing the Machine	96
Storage Box	97

Maintenance..... 99

Maintenance Schedule	100
Checks, Cleaning and Inspection	100
Leakage Check	101
Lubrication and Filter Changes	101
Functional Check	101
Maintenance Interval	102
Engine Maintenance	103
Engine Access	103
Closing Engine Covers	103
Engine Oil	104
Checking Engine Oil Level	104
Changing Engine Oil and Filter	104
Engine Air Filters	106
Changing Air Filter Elements	106
Engine Cooling System	107
Checking Coolant Level	107
Cleaning Radiator Fins	107
Draining/Refilling Cooling System	108
V-Belt Maintenance	109
Checking and Adjusting V-belt Tension	109
Air Conditioning V-Belt	109
Fuel System Maintenance	109
Adding Fuel	110
Water Separator Inspection/Maintenance	110
Changing Fuel Filter	111
Hydraulic System Maintenance	112
Checking Hydraulic Oil Level	112
Changing Hydraulic Oil and Filter	113
Hydraulic Hose Maintenance	114
Travel Motor Maintenance	115
Travel Motor Gearbox Oil	115
Track Maintenance	115
Track Replacement	116
General Lubrication	119
Tilting ROPS/FOPS	120
Raising ROPS/FOPS	120
Lower ROPS/FOPS	121
Electrical System	121
Battery	121

Using a Booster Battery (Jump-Starting)	122
Fuses and Relays	123
Engine Compartment Fuses/Relays	123
Fuses Under ROPS/FOPS	124
Control Modules	124
Multi-function Control Module	125
Drive, Lift Arm and Standard Auxiliary Flow Control Module	125
Engine Control Module (ECU)	125
Main/Drive Control Module	125
Long-Term Storage	125
Before Storage	125
After Storage	126
Air Conditioning Maintenance	126
Air Conditioning Filters	126
Cab Air Filter	126
Outside Air Intake Filter	127
Windshield Washer Reservoir	127
Final Shutdown / Decommissioning	128
Before Disposal	128
Machine Disposal	128
Maintenance Log	129

Troubleshooting 133

Engine Troubleshooting	133
Indicator Lamp Troubleshooting	134
Seal and Hose Troubleshooting	135
Hydraulic System Troubleshooting	136
Hydrostatic Travel Drive System Troubleshooting	137
Electrical Troubleshooting	139
Miscellaneous Troubleshooting	139
Error Codes	140
Controller Communication Error Codes	140
Engine Error Codes	140
Drive and Valve Error Codes	142

Schematics 143

Engine/Starting and Charging	143
Engine Sensors	144
Engine ECU	145
Power Distribution (Later Machines)	146
Power Distribution (Early Machines)	147
I/O Controller (Later Machines)	148
I/O Controller (Early Machines)	149
Solenoid Control – A (Later Machines)	150
Solenoid Control – A (Early Machines)	151
Solenoid Control – B	152
Operator/Drive Controls	153
High-Flow/Self-Level/Power-A-Tach® Quick Attach System (Later Machines)	154
High-Flow/Self-Level/Power-A-Tach® Quick Attach System (Early Machines)	155
HVAC	156
Track Tension/Lighting Control	157
Wipers/Washer Pumps	158
Work Lights	159
Auxiliary Power/Dome Light/Radio	160
Operator CAN Interface	161
Grounds	162
Hydraulic Schematic	163

Index 165

EC Declaration of Conformity 169

Torque Specifications 171

Introduction

Safety Symbol

Manitou Americas, in cooperation with the Society of Automotive Engineers, has adopted this:



Safety Alert Symbol

This symbol identifies potential safety hazards, which, if not properly avoided, could result in injury. When you see this symbol in this manual or on the machine, you are reminded to BE ALERT! Your personal safety is involved!

Contents and Use of this Manual

This Operator's Manual provides information about the safe and proper operation and maintenance for the machine. Major points of safe operation and maintenance are detailed in the *Safety* chapter of this manual.

This manual also includes general troubleshooting and specification information about the machine.

Follow the instructions in the Operator's Manual Safety, Operation and Maintenance chapters, concerning accident prevention regulations, safety and occupational regulations, and machine and traffic regulations. Manitou Americas is not liable for damage resulting from the failure to follow these regulations.



Improper operation, inspection and maintenance of the machine can cause injury or death. Read and understand the contents of this manual COMPLETELY and become familiar with the machine before operating it.

It is the owner's or employer's responsibility to fully instruct each operator in the proper and safe operation and maintenance of the machine.

A storage container is provided behind the operator's seat for storing the Operator's Manual. After using the manual, return it to the storage container.

This manual is considered a permanent part of the machine and should be with the machine at all times. If the machine is resold, include this operator's manual as part of the sale.

Replace this manual promptly if it becomes damaged, lost or stolen.

Some illustrations in this manual may show doors, guards and shields open or removed for illustrative purposes only. BE SURE all doors, guards and shields are in their proper operating positions BEFORE starting the engine to operate the machine.

Because of ongoing product improvements, information included in this manual may not exactly match the machine. Manitou Americas reserves the right to modify and improve products at any time without notice or obligation.

Introduction

Safety Symbol and Signal Words

This manual and decals on the machine warn of safety hazards and should be read and observed closely.

Manitou Americas, in cooperation with the Society of Automotive Engineers, has adopted this:



Safety Alert Symbol

This symbol is used throughout this operator's manual and on the decals on the machine. It identifies potential safety hazards, which, if not properly avoided, could result in injury. When you see this symbol in this manual or on the machine, you are reminded to **BE ALERT!** Personal safety is involved!

Signal Words



The word "DANGER" indicates an imminently hazardous situation, that, if not avoided, will result in serious injury or death.



The word "WARNING" indicates a potentially hazardous situation that, if not avoided, could result in serious injury or death.



The word "CAUTION" indicates a potentially hazardous situation that, if not avoided, may result in minor or moderate injury.

IMPORTANT: The word "IMPORTANT" indicates situations that can result in possible damage to the machine.

NOTE: The word "NOTE" indicates special or particularly useful information.

Machine Orientation

"Right" and "left", as described in this manual, are determined from a position sitting in the operator's seat and facing forward.

Proper Machine Use



Improper use of the machine can result in property damage, injury or death.

The machine is designed only for moving earth, coarse gravel or ballast and rubble. Use with approved attachments is also allowed (See "Fields of Application" on page 11). Use in any other way is considered as contrary to the intended use. Compliance with, and strict adherence to, the conditions of operation, service and repair as specified by the manufacturer, also constitute essential elements of the intended use.

The machine was designed and built according to the best available technology and approved safety regulations in the countries where it is sold. However, it is impossible to completely safeguard against abusive, improper use. The operator must always consider potential safety risks and hazards during operation. Accident prevention regulations, all other generally recognized regulations on safety and occupational medicine, and all road traffic regulations must be observed at all times.

The machine must be maintained in proper operating condition. Any damaged or malfunctioning parts must be repaired or replaced immediately.

Any arbitrary modifications carried out to the machine may relieve the manufacture of liability for any resulting damage or injury.

Introduction

Service and Registration

The wide Gehl dealership network stands ready to provide any assistance that may be required, including genuine service parts. All parts should be obtained from or ordered through your dealer.

When ordering service parts, provide complete information about the part and the quantity required. Also provide the model and serial numbers of the machine. For your safety and continued proper operation, use only genuine service parts. Record the model and serial numbers in the spaces below for quick reference.

NOTE: The machine model number is stamped on the right front axle attachment plate, and is also found on the type label located on the front right side of the machine.

Machine Model and Serial Numbers

Machine Model Number: _____

Machine Serial Number: _____



Model/Serial Number Placard

Compact Track Loader
West Bend WI 53095 USA

CE
Year of Const.

Product Identification Number: **GHLR175XXXXXXXXXX**

Model	Power	Rated Capacity	Operating Mass

Model Number

Serial Number

Component Serial Numbers

Engine Serial Number: _____



Hydraulic Pump Serial Number: _____

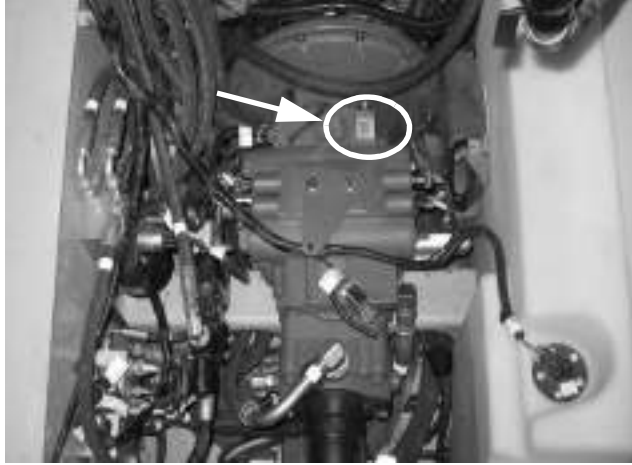

Hydraulic Motor Serial Number: _____



Introduction

Component Identification

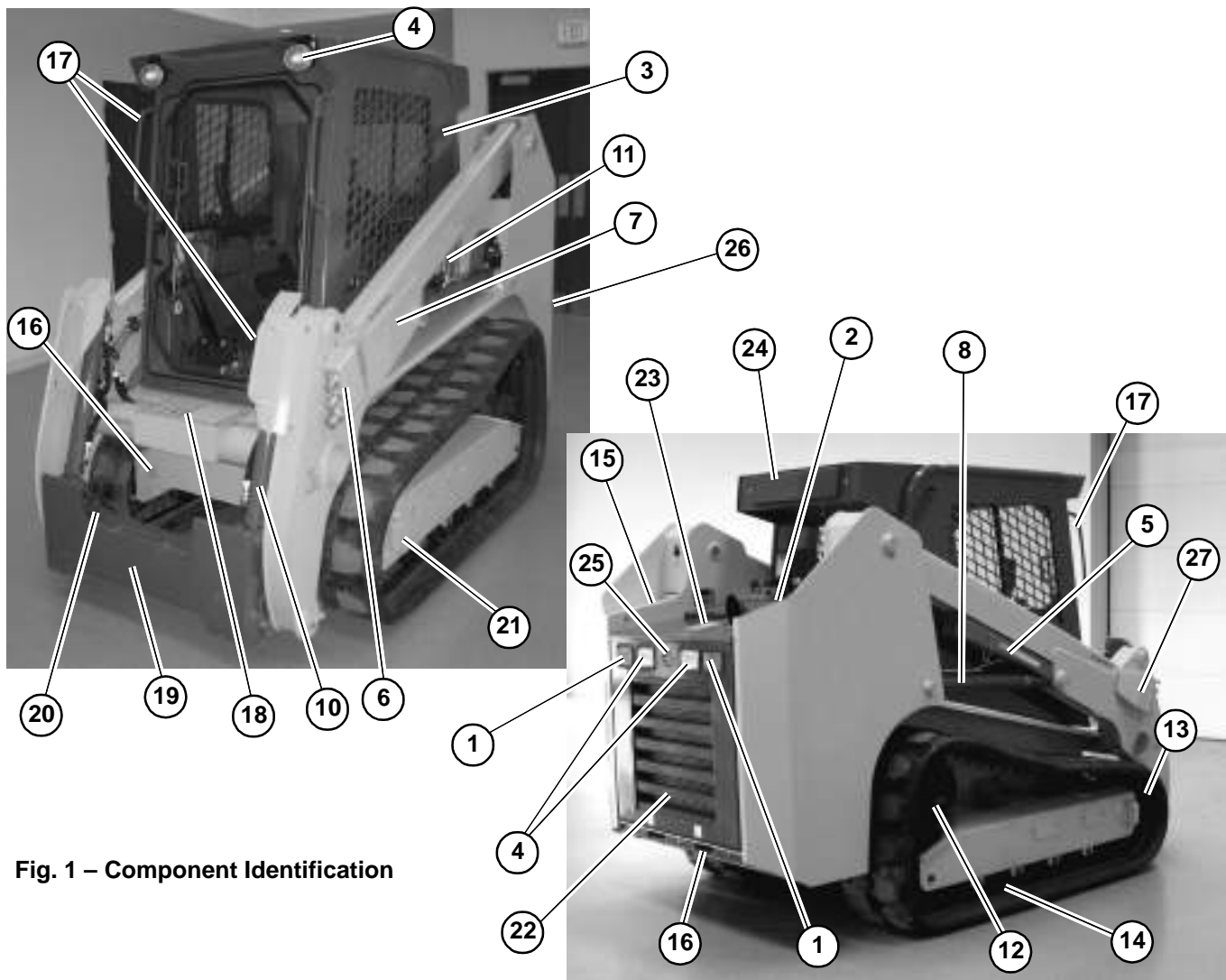

Fig. 1 – Component Identification

Item	Description
1	Tail light
2	Hydraulic tank filler cover
3	ROPS/FOPS
4	Work lights
5	Lift arm support
6	Standard auxiliary hydraulics lines
7	Lift arm
8	Lift arm cylinder
10	Tilt cylinder
11	Fuel filler cap
12	Travel motor
13	Rubber track
14	Track roller
15	Battery compartment cover

Item	Description
16	Lift points
17	Exit/entry hand-holds
18	Exit/entry step
19	Attachment hitch
20	Optional Power-A-Tach® quick attach system locking flag
21	Tie-down point
22	Back cover
23	Engine compartment cover
24	Optional Air conditioning intake cover
25	Backup alarm location
26	Storage compartment
27	Optional high-flow auxiliary hydraulics lines

Introduction

Fields of Application

Table 1: Fields of Application

Attachments	Model	Width	Height	Depth	Capacity
Dirt / Construction Bucket	RT175	1676 mm (66 in.)	508 mm (20 in.)	902 mm. (35.5 in)	0.43 m ³ (15.1 ft. ³)
		1676 mm (66 in.)	508 mm (20 in.)	937 mm (36.9 in.)	0.40 m ³ (14.3 ft. ³)
Light Material Bucket		1778 mm (70 in.)	600 mm (23.6 in.)	1021 mm (40.2 in.)	0.57 m ³ (20.3 ft. ³)
Dirt / Construction Bucket	RT210	1778 mm (70 in.)	531 mm (20.9 in.)	1044 mm (41.1 in.)	0.46 m ³ (16.1 ft. ³)
HD Dirt / Construction Bucket		1880 mm (74 in.)	577 mm (22.7 in.)	1113 mm (43.8 in.)	0.57 m ³ (20.3 ft. ³)
		1880 mm (74 in.)	595 mm (23.4 in.)	1113 mm (43.8 in.)	0.65 m ³ (22.8 ft. ³)
Light Material Bucket		1880 mm (74 in.)	671 mm (26.4 in.)	1074 mm (42.3 in.)	0.77 m ³ (27.2 ft. ³)
Pallet Forks	All	N/A	N/A	1067 mm (42 in.)	N/A
				1219 mm (48 in.)	

The attachments determine how the machine is used.



WARNING

Contact CEA Attachments at:
(<http://www.ceattachments.com/ContactUs.aspx>)
for information about available attachments approved for use with the machine.

Contact your CEA Attachments (<http://www.ceattachments.com/ContactUs.aspx>) before using attachments or equipment not approved by Manitou Americas. Use of non-approved attachments or unauthorized modifications is prohibited.

Using Attachments

Read all documentation provided with attachments to learn how to safely operate and maintain them.

Do not use the machine for any applications or purposes other than those described in this manual or manuals supplied with attachments. See “Fields of Application” on page 11 for information about approved attachments and their uses. Contact your dealer before using attachments or equipment not approved by Manitou Americas. Use of non-approved attachments or unauthorized modifications is prohibited.

Introduction

Vibration Information

Compact construction equipment is generally used in harsh environments. This type of usage can expose an operator to uncomfortable levels of vibration. It is useful to understand exposure to vibration levels when operating compact equipment and what can be done to reduce vibration exposure. As a result, equipment operation can be more efficient, productive and safe.

An operator's exposure to vibration occurs in two ways:

- Whole-Body Vibration (WBV)
- Hand-Arm Vibration (HAV)

WBV issues are primarily addressed in this manual, because evaluations have shown that operation of mobile compact construction equipment on work sites typically results in HAV levels less than the allowed exposure limit of 2.5 m/s². Member States of the European Union must comply with the Physical Agents (vibration) Directive, 2002/44/EC.

Effective control of vibration exposure for an operator involves more than just vibration levels on the machine. The work site, how the machine is used, and proper training all play important roles in reducing vibration exposure.

Vibration exposure results from:

- Work site conditions.
- How the machine is operated.
- The machine characteristics.

Common causes of high WBV levels:

- Using a machine that is improper for the task.
- Work site with potholes, ruts and debris.
- Improper operating techniques, such as driving too fast.
- Incorrect adjustment of the seat and controls.
- Other physical activities while using the machine.

Vibration Measurement and Actions

The vibration directive places the responsibility for compliance on employers. Actions that should be followed by employers include:

- Assess the levels of vibration exposure.
- Determine from this assessment if operators will be exposed to vibration levels above the limits stated in the directive.
- Take appropriate actions to reduce operator's exposure to vibration.
- Provide operators with information and training to reduce their exposure to vibration.
- Keep good records and update operations and training on a regular basis.

If the assessment concludes that vibration level exposure is too high, one or more of the following actions may be necessary:

1. Train operators:
 - Perform operations (accelerating, steering, braking, etc.) in a smooth manner.
 - Adjust the controls, mirrors and seat suspension for comfortable operation. Do not make adjustments when the machine is in use.
 - Travel across the smoothest parts of the work site and avoid ruts and potholes.
2. Choose proper equipment for the job:
 - Use machines with the proper power and capacity.
 - Select machines with good suspension seats.
 - Look for controls that are easy to use.
 - Ensure good visibility from the operator's position.
3. Maintain the work site:
 - Smooth ruts and fill potholes in traffic areas whenever possible.
 - Clean up debris frequently.

Introduction

- Vary traffic patterns to avoid exposure to rough terrain.
4. Maintain equipment. Check that seat suspension and all controls work smoothly and properly.

Vibration Levels

See “Vibration Levels” on page 40 for a table listing typical whole-body vibration levels for the machine.

Fire Extinguisher

An installation location for a fire extinguisher is on the shelf between the rear window and the operator's seat (Z, Fig. 2).

IMPORTANT: *Installation of a fire extinguisher according to DIN-EN 3 must be performed by an authorized dealer.*

NOTE: *A fire extinguisher is neither included as standard equipment nor available as an option from Manitou Americas, Inc.*

IMPORTANT: *Inspect the fire extinguisher at regular intervals as recommended by the fire extinguisher equipment manufacturer(s).*

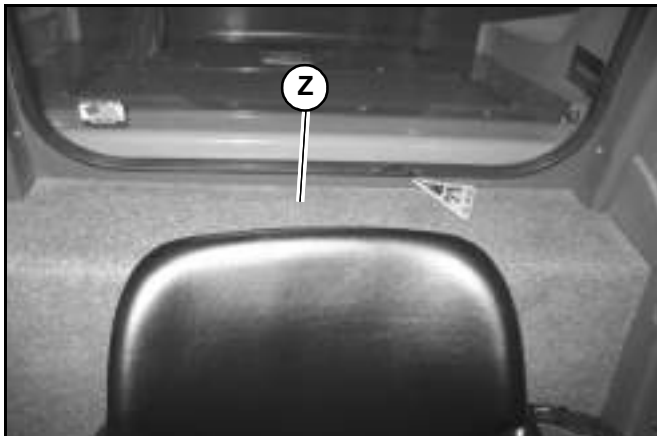



























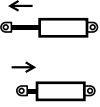







Fig. 2 – Location for Fire Extinguisher

Manufacturer Information

Products described in this manual are manufactured by Manitou Americas, Inc.

Introduction

Indicator and Operation Symbols

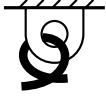
				
Safety Hazard	Lift Point	Hydraulic Oil Filter	Fast Speed	Slow Speed
				
Hydraulic Oil	Engine Start	Engine Stop	Engine Run	Wear Seatbelt
				
Back Door Latch	Service Hours	Engine Oil Pressure	Remove Key	Crush Hazard
				
Service Required	Crush Hazard	Hot Surface Hazard	Rotating Fan Keep Away	Safety Lock
				
Read Operator's Manual	Parking Brake	Windshield Wiper/Washer	Diesel Fuel	HVAC Fan
				
Auxiliary Hydraulics Flow	Work Lights	Lift Arm Float	Drive System Error	Pre-heat
				
Engine Coolant Temperature	Engine Air Filter	Horn	Hydraglide™	Tie-down Point

Safety

Safety Symbol and Signal Words

This manual and decals on the machine warn of safety hazards and should be read and observed closely.

Manitou Americas, in cooperation with the Society of Automotive Engineers, has adopted this:



Safety Alert Symbol

This symbol is used throughout this operator's manual and on the decals on the machine. It identifies potential safety hazards, which, if not properly avoided, could result in injury. When you see this symbol in this manual or on the machine, you are reminded to **BE ALERT!** Personal safety is involved!

Signal Words



The word "DANGER" indicates an imminently hazardous situation, that, if not avoided, will result in serious injury or death.



The word "WARNING" indicates a potentially hazardous situation that, if not avoided, could result in serious injury or death.



The word "CAUTION" indicates a potentially hazardous situation that, if not avoided, may result in minor or moderate injury.

- Before operating the machine, first read and study the safety information in this manual. Be sure that anyone who operates or works on the machine is familiar with the safety precautions. This includes providing translations of the warnings and instructions for operators who are not fluent in reading English.
- It is essential that operators be thoroughly trained in the safe operation of the machine and load handling. Operators must not be physically or mentally impaired. Do not allow minors or unqualified personnel to operate the machine, or to be near the machine unless they are properly supervised. It is recommended that the operator be capable of obtaining a valid motor vehicle operator's license.
- Do not use the machine for any application or purpose other than those described in this manual, or in manuals supplied with any attachments used with the machine.
- Use of this machine is subject to certain hazards that cannot be eliminated by mechanical means, but only by exercising intelligence, care and common sense. Such hazards include: hillside operation, overloading, load instability, poor maintenance, and using the machine for a purpose for which it was not intended or designed.
- Manitou Americas always takes operator's safety into consideration during the design process. Guards and shields are provided, which protect the operator and bystanders from moving parts and other hazards. Operators must be alert, however, because some areas cannot be guarded or shielded without preventing or interfering with proper operation.
- Different applications may require optional safety equipment. Users must evaluate the work-site hazards and equip the machine and the operator as necessary. The information in this manual does not replace any applicable safety rules and laws. Before operating the machine, learn the rules and laws for the local area. Make sure the machine is equipped as required according to these rules/laws.

Safety

- Remember that some risks to your health may not be immediately apparent. Exhaust gases and noise pollution may not be visible, but these hazards can cause permanent injuries.
- Some photographs in this manual may show doors, guards and shields open or removed for the purposes of illustration only. Be sure all doors, guards, shields and panels are in the proper operating positions before starting the engine to operate the machine.

Mandatory Safety Shutdown Procedure

BEFORE cleaning, adjusting, lubricating, fueling, or servicing the machine, or leaving it unattended:

1. Bring the machine to a complete stop on a level surface. If the machine must be parked on a slope, park across the slope and chock the tracks to prevent movement.
2. Empty the attachment and lower the lift arm and attachment to the ground. If the lift arm must be left in the raised position, DO NOT leave the operator's position unless the lift arm support is properly applied. See "Lift Arm Support" on page 77.
3. Move the throttle to the low-idle position and allow the engine to cool for approximately 2 minutes.
4. Shut off the engine.
5. Unfasten the seat belt, remove the ignition key and take it with you. Exit the machine using the hand-holds.

ONLY when these precautions have been taken can you be sure it is safe to proceed. Failure to follow this procedure could result in death or serious injury.

Before Starting

- Do not modify the Roll-Over Protective Structure/Falling Object Protective Structure (ROPS/FOPS) unless instructed to do so in Manitou Americas-approved installation instructions. Modifications, such as welding, drilling or cutting, can weaken the structure and reduce the protection it provides. A damaged ROPS/FOPS cannot be repaired – it must be replaced.
- Unauthorized modifications to the machine can cause injury or death. Never make unauthorized modifications to any part of the machine. Any machine modification made without authorization from Manitou Americas could create a safety hazard, for which the machine owner would be responsible.
- For safety reasons, use only genuine service parts. For example, using incorrect fasteners could lead to a condition in which the safety of critical assemblies is dangerously compromised.
- Manitou Americas equipment is designed and intended to be used only with Manitou attachments or Manitou-approved attachments. To avoid possible personal injury, equipment damage and performance problems, use only attachments that are approved for use on and within the rated operating capacity of the machine (see "Payloads/Capacities" on page 34). Contact your dealer or Manitou Americas for information about attachment approval and compatibility with specific machine models. Manitou Americas cannot be responsible if the machine is used with non-approved attachments.
- Optional kits are available through your dealer. Because Manitou cannot anticipate, identify and test all of the attachments owners may want to install on their machines, please contact Manitou Americas, Inc. for information on approval of attachments, and their compatibility with optional kits.
- Remove all trash and debris from the machine every day, especially in the engine compartment, to minimize the risk of fire.

- Never use ether starting aids. Engine pre-heating is used for cold weather starting. Engine pre-heating can cause ether or other starting fluid to detonate, causing injury or damage.
- Walk around the machine and inspect it before using it. Look for damage, loose or missing parts, leaks, etc. Repair as required before using the machine.
- Warn all nearby personnel before starting the machine.
- Contact the proper local authorities for utility line locations BEFORE starting to dig. In North America, contact the North American One-Call Referral System at 8-1-1 in the U.S., or 1-888-258-0808 in the U.S. and Canada.
- Below-ground hazards also include water mains, tunnels and buried foundations. Know what is underneath the work site before starting to dig.
- Before working near power lines (either above-ground or buried cable-type), always contact the power utility and establish a safety plan with them.
- If temperatures are changing, be cautious of dark and wet patches when working or traveling over frozen ground.
- Stay away from ditches, overhangs and other weak support surfaces. Be sure the surrounding ground has adequate strength to support the weight of the machine and the load.
- The operator's area, steps and hand holds must be kept free of oil, dirt, ice and unsecured objects.
- If a lighting system is installed, check its operation before working in darkness.
- Always keep windows, lights and mirrors clean. Poor visibility can cause accidents.
- Use warning tag/control lockout procedures during service. Alert others that service or maintenance is being performed by tagging the operator's controls — and other machine areas if required — with a warning notice.
- NEVER start the engine if there is any indication that maintenance or service work is in progress, or if a warning tag is attached to the controls.
- Replace damaged safety decals and a lost or damaged operator's manual. Always store this operator's manual in the storage compartment provided for it inside the cab.
- Work crew members should observe and monitor terrain and soil conditions at the work site, along with traffic, weather-related hazards and any above- or below-ground obstacles and hazards.
- Read the operator's manual provided with each attachment before using it.
- Adjust the seat to allow full actuation of the throttle pedal. Never adjust the seat during machine operation.
- Before working on or with the machine, remove jewelry, tie back long hair, and do not wear loose-fitting garments, such as, scarves, ties, unzipped jackets, etc., which could become caught in the moving parts of the machine and cause injury.

During Operation

- ALWAYS fasten the seat belt securely and properly. Never operate the machine without the seat belt fastened around the operator.
- Only start the engine and only operate the controls while seated in the operator's seat.
- Check indicators and displays for normal conditions after starting the engine. Check the operation of the controls. Listen for unusual sounds and remain alert for other potentially hazardous conditions.
- Always look to the rear, over both shoulders, before backing up.
- Control the machine cautiously and gradually until fully familiar with all the controls and handling.

Safety

- New operators must learn to operate the machine in an open area away from bystanders. Practice with the controls until the machine can be operated safely and efficiently.
- Do not overload the machine. See “Payloads/Capacities” on page 34 for the load limits.
- Do not raise or drop a loaded bucket or attachment suddenly. Abrupt movements under load can cause serious instability.
- Do not use the machine to lift or transport people.
- Stop the engine and place the controls in the lock-out position before mounting attachments. Check that attachments are securely fastened to the lift arm before working.
- Be aware that attachments affect the handling and balance of the machine. Adjust the operation of the machine as necessary when using attachments.
- Before coupling or uncoupling the hydraulic lines for the attachment, stop the engine and release the pressure in the hydraulic system by moving the control joystick in all directions a couple of times.
- Make sure the bucket is lowered to the ground before activating the lift arm float. Never activate the float function with the bucket or attachment raised, because this will cause the lift arm and bucket or attachment to drop suddenly.
- Be aware of overhead obstacles. Any object near the lift arm could represent a potential hazard, or cause the operator to react suddenly and cause an accident. Use a spotter or signal person when working near bridges, phone lines, work-site scaffolds, or other obstructions.
- Use extra care on loose ground. Working heavy loads over loose, soft ground or uneven terrain can cause dangerous side-load conditions and possible tip-over and injury. Traveling with a suspended load or an unbalanced load can also be hazardous.
- Stay away from the edges of loading docks, ramps, ditches, excavations, retaining walls and trenches.
- Do not place limbs near moving parts. Severing of body parts can result.
- Never carry riders. Do not allow others to ride on the machine or attachments, because they could fall or cause an accident.
- Always keep hands and feet inside the operator’s compartment while operating the machine.
- Wear safety goggles, ear and head protection, and any other protective clothing or equipment as needed while operating the machine.
- Exhaust fumes can kill. Do not operate the machine in an enclosed area without adequate ventilation. Internal combustion engines deplete the oxygen supply within enclosed spaces and may create a serious hazard.
- Operators should also be aware of any open windows, doors or duct work into which exhaust gases may be carried, exposing others to danger.
- Never allow anyone under a raised lift arm. Lowering the lift arm or a falling load can result in death or serious personal injury.
- Avoid slowing suddenly while carrying a load. Sudden slowing can cause the load to fall off the attachment, or cause the machine to tip over.
- Slow down the work cycle and use slower travel speeds in congested or populated areas. Use commonly understood signals so other members of the work crew can warn the operator to slow or halt work in a potentially hazardous situation.
- Use a signal person if you cannot see the entire work area clearly, in high traffic areas and whenever the operator’s view is not clear.
- Stay alert for people moving through the work area. When loading a truck, the operator should always know where the driver is.
- To cross railroad tracks, ditches, curbs or similar surfaces, cross perpendicularly and drive slowly.

- Exposed hydraulic hoses could react with explosive force if struck by falling or overhead items. NEVER allow hoses to be hit, bent or interfered with during operation. Extra guards may be required. Replace any damaged hoses.
 - Do not move the lift arm or attachment during transport. Lock out the lift arm controls during transport.
 - Machine stability is affected by:
 - Load being carried
 - Height of the load
 - Machine speed
 - Abrupt control movements
 - Driving over uneven terrain
- DISREGARDING ANY OF THESE FACTORS CAN CAUSE THE MACHINE TO TIP OR CAN THROW THE OPERATOR OUT OF THE SEAT OR MACHINE, WHICH COULD RESULT IN DEATH OR SERIOUS INJURY. Therefore, ALWAYS operate the machine only with the seat belt fastened. Do not exceed the machine's rated operating capacity (see "Payloads/Capacities" on page 34). Carry the load low. Move the controls smoothly and gradually, and operate at speeds appropriate for the conditions.
- If the machine becomes unstable and starts to tip, keep the seat belt fastened, hold on firmly and brace yourself. Lean away from the point of impact and stay with the machine. If tipping occurs, DO NOT jump from the machine. The machine is equipped with rollover protection, which can only protect the operator while in the operator's seat. Trying to escape from a tipping machine can result in death or serious personal injury.
 - Do not drive into materials at high speeds to avoid being thrown forward and injured.
 - To avoid tipping, travel with the bucket or attachment as low as possible: 200–300 mm (8–12 in.) from the ground.
 - Never travel over obstacles or slopes that will cause the machine to tilt severely. Travel around any slope or obstacle that would cause a tilt greater than 10°.
 - Avoid steep slopes. Do not make sharp turns on slopes. Drive up and down slopes, not across them. Drive slowly on slopes. Keep the heavy end of the machine pointed uphill.
 - Avoid sharp turns and high speeds while carrying loads, especially on slopes. The stability of the machine is reduced during sharp turns, and the load may shift, greatly increasing the possibility of an overturn.
 - Do not turn the machine when lifting loads. As loads are lifted, stability decreases, which can increase the possibility of a rollover.
 - Do not raise the safety bars/arm rests while traveling. Raising the safety bars/arm rests abruptly applies the parking brake, which can cause the machine to tip forward.
 - Do not turn off the ignition switch while traveling. Turning off the ignition will cause sudden braking, which may cause the machine to tip.
 - Be sure no one enters the work area of the machine. Anyone near the machine is at risk of being injured.
 - Unless necessary for servicing the machine, the engine hood must not be opened while the engine is running.
 - In cold weather, avoid sudden travel movements and stay away from even slight slopes. The machine can slide sideways on icy slopes.
 - Snow accumulation can hide potential hazards. Use care while operating and while using the machine to clear snow.
 - If the machine becomes damaged or malfunctions, stop the machine immediately and lock and tag it. Repair the damage or malfunction before using the machine again.
 - Never jump off the machine. Always leave the machine using the steps and hand-holds. Never get on or off a moving machine.

Safety

- If unable to exit out the front of the cab, remove the rear window by pulling the emergency rear window release triangle until the window seal is pulled out of the window frame, then push the window out of the frame.



Applications with Load-Handling Devices

- Specific procedures are required, when using load-handling devices (e.g., slings, chains) for transporting and placing loads. For example, assistance from other people is needed when lifting and lowering pipes, culverts or containers:
 - The machine may only be used with load-handling devices if the necessary safety devices are in place and functional.
 - The load must be secured to prevent it from falling or slipping.
 - Persons guiding the load must stay in visual contact with the operator.
 - The operator must guide the load to the ground as soon as possible and avoid any rotating or swinging movements.
 - The machine may be moved with a raised load only if the path of the machine is level.
 - Persons attaching or securing loads may only approach the machine from the side, after the operator has given permission. The operator may only give permission after the machine and the attachment are stationary.
 - Do NOT use any lifting attachments (slings, chains) that are damaged or of inadequate rated capacity.

Parking the Machine

- When shutting down the machine for the day, plan ahead so the machine will be on a firm, level surface away from traffic and away from high-walls, cliff edges and any area of potential water accumulation or runoff. Lower the attachment and lift arm to the ground. There should be no possibility of unintended or accidental machine movement.
- If the machine must be parked on a slope, park across the slope and chock the tracks to prevent movement.
- To avoid collisions when parking on streets, use barriers, caution signs, lights, etc., so that the machine can be easily seen at night.
- After the machine has been parked properly, shut down the machine according to the “Mandatory Safety Shutdown Procedure” on page 16.

Electrical Energy

- Stay away from high-voltage lines. Electrocutation can result from contact or proximity to high-voltage electric lines. The machine does not have to make physical contact with power lines for current to be transmitted. Use a spotter and hand signals to keep away from power lines not clearly visible to the operator.
- If the machine comes into contact with a live wire:
 - Do not leave the machine.
 - If possible, drive the machine out of the danger area.
 - Warn others not to approach or touch the machine.
 - Have the live wire de-energized.
 - Do not leave the machine until the wire has been safely de-energized.

- Depending upon the voltage in the power line and atmospheric conditions, strong electric shocks can occur if the bucket is closer than 3 m (10 ft.) from the power line. Higher voltages and rainy weather can further increase the safe operating distance.
- Work on the machine's electrical system must be performed only by trained technicians.
- Inspect and check the machine's electrical equipment at regular intervals. Problems found, such as loose connections or scorched cables, must be repaired before using the machine.
- Only use proper, original equipment fuses/circuit breakers with the specified current rating. Turn off the machine immediately if there is any indication of a problem with the electrical system.
- Allow no one under the raised lift arm and do not exit the machine if the lift arm is raised unless the lift arm support is properly applied. See "Lift Arm Support" on page 81. Disconnecting or loosening any hydraulic line, hose, fitting or component, parts failure, and venting hydraulic pressure all can cause the lift arm to drop.
- Keep fuel and other fluid reservoir caps tight. Do not start the engine until caps have been secured.
- Never attempt to bypass the keyswitch to start the engine. Use only the proper jump-starting procedure according to "Jump-Starting" on page 69.
- Never use hands to search for hydraulic fluid leaks. Instead, use a piece of paper or cardboard. Escaping fluid under pressure can be invisible and can penetrate the skin and cause serious injury. If any fluid is injected into your skin, see a doctor at once. Injected fluid must be surgically removed by a doctor or gangrene may result.

Maintenance and Service Safety Practices

- Only trained and authorized personnel, with a full awareness of safe procedures, should be allowed to operate or perform maintenance or service on the machine.
- Use solid support blocking. Never rely on jacks or other inadequate supports when maintenance work is being done. Never work under any equipment supported only by jacks.
- Always secure the ROPS/FOPS to the chassis with anchor bolts and washers before driving or using the machine.
- Always close the cab door before tilting the ROPS/FOPS.
- Stay clear from underneath the ROPS/FOPS as it is tilted.
- Always secure the ROPS/FOPS in the tilted position with the securing pin. Never allow anyone under the ROPS/FOPS if the securing pin is not in place.
- Check ROPS/FOPS tilt component condition at regular intervals. Replace damaged or worn parts immediately.
- Always wear safety glasses with side shields when striking metal against metal. In addition, it is recommended that a softer (chip-resistant) material be used to cushion the blow, otherwise, serious injury to the eyes or other parts of the body could result.
- Use care when seating retainer pins — retainer pins can fly out or splinter when struck and could cause injury.
- Do not smoke or have any spark- or flame-producing equipment or materials in the area while filling the fuel tank or working on the fuel or hydraulic systems.
- Do not attempt to loosen or disconnect any hydraulic lines, hoses, fittings, covers or caps without first relieving hydraulic circuit pressure. Relieve hydraulic pressure by performing the "Mandatory Safety Shutdown Procedure" on page 16 and slowly loosening the hydraulic reservoir filler cap. Be careful not to touch any hydraulic components that have been in recent operation. Failure to heed this warning could result in severe burns.

Safety

- Do not attempt to remove the radiator cap after the engine has reached operating temperature or if it is overheated. At operating temperatures, engine coolant is extremely hot and under pressure. Always wait for the engine to cool before attempting to relieve pressure and remove the radiator cap. Failure to heed this warning could result in severe burns.
 - Refer to the parts manual for information about assembly of components. Always use the correct parts and the proper torques — incorrect fastener connections can dangerously weaken assemblies.
 - Exhaust fumes can kill. Do not operate the machine in an enclosed area unless there is adequate ventilation.
 - Operators should also be aware of any open windows, doors or duct work into which exhaust gases may be carried, exposing others to danger.
 - Do not run the engine if repairs are being performed alone. There should always be at least 2 people present if the engine must be run during service. Both persons must maintain visual contact with each other. Keep a safe distance away from all rotating and moving parts.
 - Always use the proper tools while working on the machine. Inappropriate tools could break or slip, causing injury, or they may not adequately perform intended functions.
 - Unless necessary for servicing the machine, do not open the engine cover while the engine is running.
 - Do not use the machine when maintenance is scheduled to be performed. Postponing maintenance can result in a serious reduction of the service life of the machine, more serious and costly equipment failures, and contribute to unsafe operating conditions.
 - Do not work on hot engines, cooling systems or hydraulic systems. Wait for the engine to cool. When engine lube oil, gearbox lubricant or other fluids require changing, wait for fluid temperatures to decrease to a moderate level before removing drain plugs.
- NOTE:** *Temperatures below 49°C (120°F) will reduce the chances of scalding exposed skin while allowing the fluid to drain quickly and completely. Do not let the fluid fully cool, because drain time will be substantially increased.*
- Dispose of all oils and fluids properly. Used oils/fluids are environmental contaminants and may only be disposed of at approved collection facilities. Never drain any oils/fluids onto the ground, dispose of in municipal waste collection containers, or in metropolitan sewer systems or landfills. Check state and local regulations for other requirements.
 - All safety equipment must be maintained so it is always in good condition.
 - Safety-critical parts must be periodically replaced. Replace the following potentially fire-related components as soon as they begin to show signs of deterioration:
 - Fuel system flexible hoses, fuel tank overflow drain hose and the fuel filler cap.
 - Hydraulic system hoses, especially the pump outlet lines. Replace hydraulic hoses every 6 years from the date of manufacture, even if they do not appear damaged. The date of manufacture (month or quarter and year) is indicated on the hydraulic hoses.
 - Keep mounting brackets and hose and cable routing straps tight. Hose routing should have gradual bends.
 - After cleaning the machine, examine all fuel, lubricant and hydraulic oil lines for leaks, chafe marks and damage. Tighten any loose connections and repair or replace parts as necessary.
 - Hydraulic line and hoses must be routed and fitted properly. Make sure no connections are interchanged.
 - When handling oil, grease and other chemical substances, follow the product-related safety requirements Material Safety Data Sheet (MSDS) carefully to prevent burning or scalding.

- Do not use the machine in an environment where the hot muffler could present a fire hazard, such as hay or straw storage facilities.

Battery Hazards

- Disconnect the negative battery cable from the negative battery terminal, before performing electrical service or electrical welding on the machine.
- Do not use a battery when the fluid level is below the minimum level. Doing so will hasten the deterioration of the battery and shortens battery life, and can also cause rupturing or explosion.
- Turn off all electrical equipment before connecting leads to the battery, including electrical switches on the battery charger or jump-starting equipment.
- When disconnecting at the battery terminals, remove the cable connected to the negative terminal first. When installing a battery, connect the positive terminal cable first.
- Connect positive cable first when installing jumper cables. The final cable connection, at the metal frame of the machine being charged or jump-started, should be as far away from the battery as possible. Disconnect the negative cable first when removing jumper cables.
- Sparks and open flames can set off explosive battery gas from incidental contact or static discharge. Turn off all switches and the engine when working on batteries. Keep battery terminals tight. Contact between a loose terminal and post can create an explosive spark.
- When jump-starting from another machine, do not allow the machines to touch. Wear safety glasses or goggles while battery connections are made.
- Never jump-start the machine if it has a frozen battery. The battery could explode. Thaw a frozen battery before charging it or attaching jumper cables.
- Flush eyes with water for 10-15 minutes if battery acid is splashed in the face. Anyone swal-

lowing battery acid must have immediate medical aid. Call the Poison Control Center at 1-800-222-1222 in the United States.

Fire Hazards

- The machine must be cleaned on a regular basis to avoid the buildup of flammable debris, such as leaves, straw, etc. Accumulated debris, particularly in the engine compartment, creates a fire hazard.
- The machine has several components that operate at high temperature under normal operation conditions, primarily the engine and exhaust systems. Also, the electrical system, if not properly maintained or if damaged, can arc or produce sparks. These conditions make it extremely important to avoid circumstances where explosive dust or gases can be ignited by arcs, sparks or heat.
- It is recommended that a 2.27 kg (5 lb.) or larger, multi-purpose “A/B/C” fire extinguisher be mounted in the cab. Check the fire extinguisher periodically and be sure that work crew members are trained in its use.
- Add fuel, oil, antifreeze and hydraulic fluid to the machine only in a well ventilated area. The machine must be parked with controls, lights and switches turned off. The engine must be turned off before refueling or performing service checks.
- Do not smoke while filling the fuel tank, while working on the fuel or hydraulic systems, or while working around the battery.
- Take care to avoid spilling combustible fluids, such as oil or fuel, on a hot engine.
- Static electricity can produce dangerous sparks at the fuel-filling nozzle. In very cold, dry weather or other conditions that could produce static discharge, keep the tip of the fuel nozzle in constant contact with the filler neck of the fuel tank, to provide a ground. Make sure the static line is connected from the machine to the fuel truck before fueling begins.

Safety

- Oil from leaks can ignite on hot components. Repair any damaged or leaking components before using the machine.

Additional Safety Equipment

- Certain operations require use of additional safety equipment. Install additional safety equipment if conditions require. For example, when using a hydraulic breaker, a polycarbonate front window may be required.
- Never attempt to alter or modify the protective structure, by drilling holes, welding or re-locating fasteners. Any serious impact or damage to the system requires a complete integrity re-evaluation, and the replacement of the system may be necessary.
- Laminated glass or polycarbonate protection for the front, side or rear windows may also be required depending upon particular work conditions.
- Contact your dealer for available safety guards if there is any risk of objects striking the operator's cab.

Crystalline Silica Exposure

Exposure to crystalline silica (found in sand, soil and rocks) has been associated with silicosis, a debilitating and often fatal lung disease. A Hazard Review (Pub. No. 2002-129) by the U.S. National Institute for Occupational Safety and Health (NIOSH) indicates a significant risk of chronic silicosis for workers exposed to inhaled crystalline silica over a working lifetime. NIOSH recommends an exposure limit of 0.05 mg/m^3 as a time-weighted average for up to a 10-hr workday during a 40-hr work week. NIOSH also recommends substituting less hazardous materials when feasible, using respiratory protection and regular medical examinations for exposed workers.

Transporting the Machine

Obey federal, state and local over-the-road regulations. Check restrictions regarding weight, height, width and length of a load. The hauling vehicle, trailer and load must all be in compliance with applicable regulations. See “Loading and Transporting the Machine on a Transport Vehicle” on page 96.

Lifting the Machine with a Crane

Only lift the machine according to the following guidelines:

- The crane and rigging equipment must have sufficient capacity. See “Weights” on page 35.
- Secure the machine against unintentional movement. Use taglines as needed.
- Do not lift the machine with persons on or in the machine.
- Any person guiding the crane operator must be within sight or sound of the crane operator.
- Lift the machine only with the standard bucket installed, with the bucket empty and in the transport position.
- Persons must stay clear of, and not under, the machine when it is lifted.
- Fasten the rigging equipment so the machine is horizontal when it is lifted.
- Do not lift the machine by the cab. Attach the rigging equipment only at the lift points identified by this symbol:



- Lift the machine according to “Lifting the Machine using a Crane” on page 95.

Loading and Transporting the Machine

- Load and transport the machine according to “Loading and Transporting the Machine on a Transport Vehicle” on page 96.
- The transport vehicle must support the height, width, length and weight of the machine. See “Dimensions” on page 32 and “Weights” on page 35.
- Remove any dirt, snow or ice from the tracks on the machine, and from the loading ramps and transport platform, to prevent slipping.
- Secure the machine to the transport vehicle according to “Loading and Transporting the Machine on a Transport Vehicle” on page 96 to prevent unintentional movement.

Safety Decals

- The machine has decals that provide safety information and precautions. These decals must be kept legible. If missing or illegible, they must be replaced promptly. Replacements can be obtained from your dealer.
- Refer to the Parts Manual for decal part numbers and ordering information.

Safety

New Decal Application

- Surfaces must be free of dirt, dust, grease and foreign material before applying the decal. Remove the smaller portion of the decal backing paper and apply the exposed adhesive to the clean surface, maintaining proper position and alignment. Peel the rest of the backing paper and

apply hand pressure to smooth out the decal surface. Refer to the following pages for proper decal locations.

- If replacing a part that has a decal on it, ensure that the replacement part has the same decal.

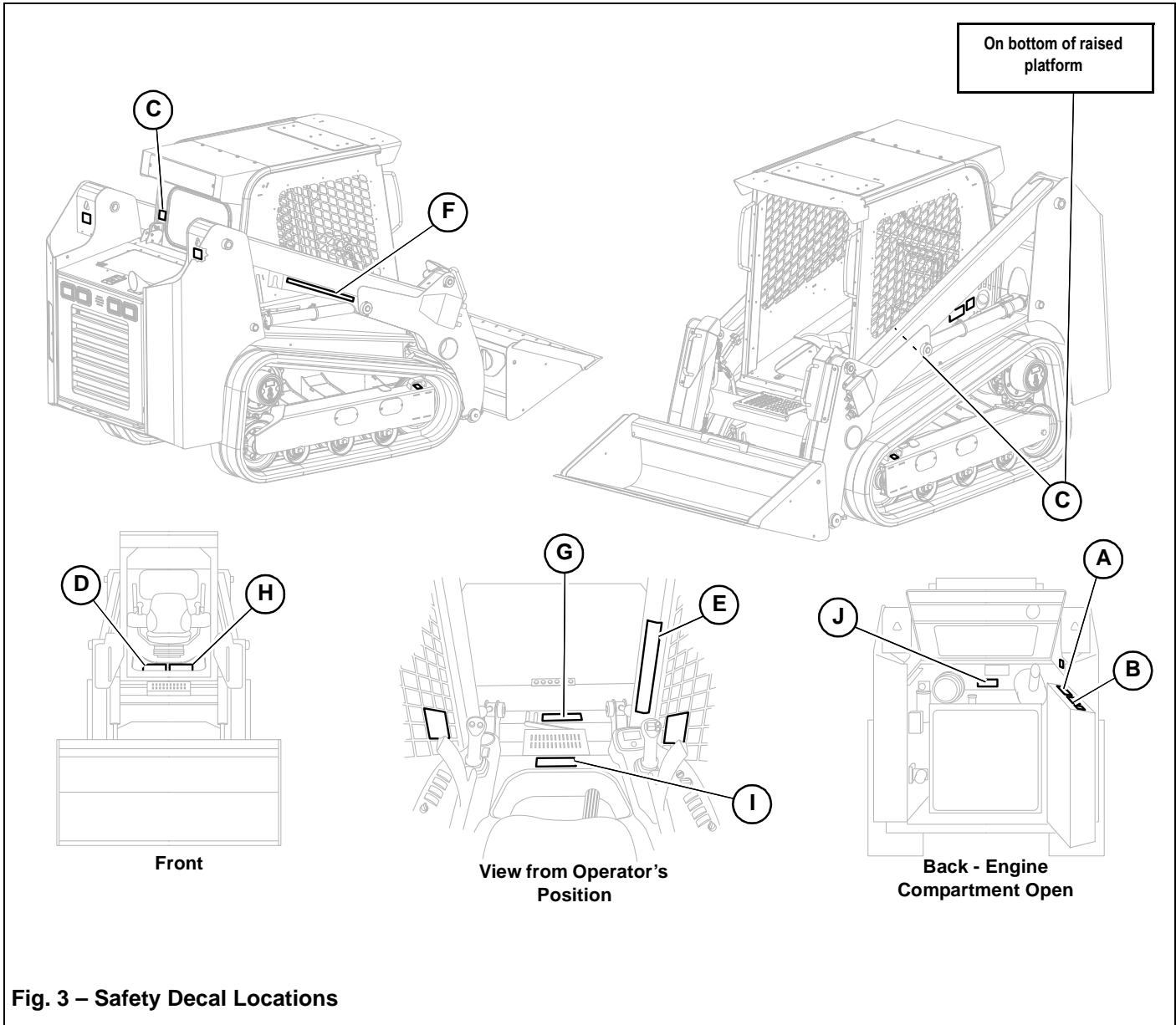

ANSI-Style Safety Decals

A



(Located inside the engine compartment)

Warning Decal

WARNING: ROTATING FAN / HOT SURFACES

- Keep hands out or stop engine.
- Do not touch hot engine or hydraulic system parts.

B



(Located inside the engine compartment)

Warning Decal

WARNING: AVOID INJURY OR DEATH

- Keep safety devices working.
- Jump start per Operator's Manual procedure.
- Keep guards, screens and windows in place.
- Do not smoke while fueling or servicing machine.
- Clean debris from engine compartment daily to avoid fire. Keep fire extinguisher nearby.
- Do not use hand to find hydraulic leaks. Escaping oil under pressure can be invisible and penetrate skin.
- Allow radiator to cool before removing cap. Loosen cap slowly to avoid burns.

C



(Located on the bottom of the ROPS / operator's platform and to the left of the rear cab window just above the ROPS tilt lock.)

Read Operator's Manual Decal

WARNING

- Be sure lock mechanism is securely engaged before working under ROPS.
- Read instructions for use in Operator's Manual.

D



(Located by the floor pan inside the cab, and on the manual box cover behind the operator's seat)

Read Operator's Manual Decal

WARNING: AVOID INJURY OR DEATH

- Read Operator's Manual and all safety signs before using machine.
- The owner is responsible to ensure all users are instructed on safe use and maintenance.
- Check machine before operating. Service per Operator's Manual.
- Contact dealer (or manufacturer) for information and service parts.

E



(Located on the inside of the right door pillar inside the cab)

Avoid Injury/Death/Overturn Decal

DANGER: AVOID INJURY OR DEATH

- ALWAYS wear seatbelt.
- Keep out from under lift arm unless lift arm is supported.
- Operate only from operator's seat.
- Look in direction of travel. Keep children and bystanders away.

WARNING: AVOID INJURY OR DEATH

Always follow "Mandatory Safety Shutdown Procedure".

1. Lower equipment to the ground.
2. Reduce throttle, stop engine.
3. Apply park brake; remove key.
4. Check safety interlocks.

WARNING: AVOID OVERTURN

- Carry load low.
- Do not exceed Rated Operating Capacity.
- Avoid steep slopes and high speed turns.
- Travel up and down slopes with heavy end uphill.

Safety

ANSI-Style Safety Decals (Cont.)

F

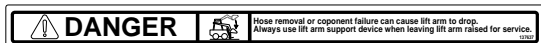

(Located on the lift arm lift support device)

Keep Out From Under Lift Arm Decal

DANGER

- Hose removal or component failure can cause lift arm to drop.
- Always use lift arm support device when leaving lift arm raised for service. See “Lift Arm Support” on page 81.

G

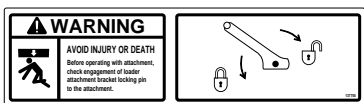

Manual Attachment Lock



Power-A-Tach® Quick Attach System Attachment Lock

(Located on the top of the attachment mounting plate)

Attachment Lock Warning Decal

WARNING: AVOID INJURY OR DEATH

Before operating with attachment, check engagement of loader attachment bracket locking pin to the attachment.

H

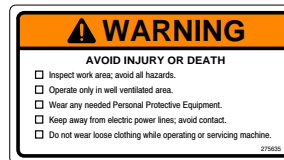

(Located by the floor pan inside the cab)

Avoid Injury or Death Decal

WARNING: AVOID INJURY OR DEATH

- Inspect work area; avoid all hazards.
- Operate only in well ventilated area.
- Wear any needed Personal Protective Equipment.
- Keep away from electric power lines; avoid contact.
- Do not wear loose clothing while operating or servicing machine.

I



(Located by the floor pan inside the cab)

No Riders Keep Out From Under Work Tool Decal

DANGER: AVOID INJURY OR DEATH

- Keep out from under work tool, unless lift arm is supported. See “Lift Arm Support” on page 81
- No riders! Never use work tools as work platform.

J

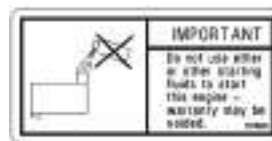

(Located inside the engine compartment)

IMPORTANT Decal

Do not use ether or other starting fluids to start this engine – warranty may be voided.

ISO-Style Safety Decals

A



(Located inside the engine compartment)

Warning Decal

WARNING: ROTATING FAN / HOT SURFACES

- Keep hands out or stop engine.
- Do not touch hot engine or hydraulic system parts.

B



(Located inside the engine compartment)

Warning Decal

WARNING: AVOID INJURY OR DEATH

- Read the Operator's Manual before performing any maintenance on the machine.
- Do not smoke while fueling or servicing machine. Keep sparks and open flames away from the engine compartment to avoid fire. Keep fire extinguisher nearby.
- Never attempt to bypass the keyswitch to start the engine. Use only the proper jump-starting procedure according to the Operator's Manual.
- Do not use hand to find hydraulic leaks. Escaping oil under pressure can be invisible and penetrate skin.
- Allow radiator to cool before removing cap. Loosen cap slowly to avoid burns.
- Exhaust fumes can kill. Do not operate the machine in an enclosed area without adequate ventilation.

C



(Located on the bottom of the ROPS / operator's platform and to the left of the rear cab window just above the ROPS tilt lock.)

Crush Hazard / Read Operator's Manual Decal

WARNING

- Be sure lock mechanism is securely engaged before working under ROPS.
- Read instructions for use in Operator's Manual.

D



(Located by the floor pan inside the cab, and on the manual box cover behind the operator's seat)

Read Operator's Manual Decal

WARNING: AVOID INJURY OR DEATH

- Read Operator's Manual and all safety signs before using, maintaining or servicing the machine.
- The owner is responsible to ensure all users are instructed on safe use and maintenance.
- Contact dealer (or manufacturer) for information and service parts.

E



(Located on the inside of the right door pillar inside the cab)

Avoid Injury/Death/Overturn Decal

DANGER: AVOID INJURY OR DEATH

- Keep out from under lift arm unless lift arm is supported. See "Lift Arm Support" on page 81
- ALWAYS wear seatbelt.
- Operate only from operator's seat.
- Look in direction of travel. Keep children and bystanders away.

WARNING: AVOID INJURY OR DEATH

- Read Operator's Manual and all safety signs before using, maintaining or servicing the machine.

1. Lower equipment to the ground.
2. Reduce throttle, stop engine.
3. Apply park brake; remove key.
4. Check safety interlocks.

WARNING: AVOID OVERTURN

- Read Operator's Manual and all safety signs before using, maintaining or servicing the machine.
- Carry load low.
- Do not exceed Rated Operating Capacity.
- Avoid steep slopes and high speed turns.
- Travel up and down slopes with heavy end uphill.

Safety

ISO-Style Safety Decals (Cont.)

F



(Located on the lift arm lift support device)

Keep Out From Under Lift Arm Decal

DANGER

- Keep out from under lift arm unless lift arm is supported.
- Always use lift arm support device when leaving lift arm raised for service. See "Lift Arm Support" on page 81.

I



(Located by the floor pan inside the cab)

No Riders Keep Out From Under Work Tool Decal

DANGER: AVOID INJURY OR DEATH

- Keep out from under work tool, unless lift arm is supported. See "Lift Arm Support" on page 81.
- No riders! Never use work tools as work platform.

G

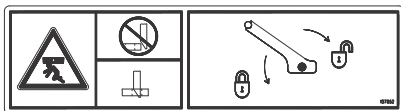

(Located on the top of the attachment mounting plate)

Attachment Lock Warning Decal

WARNING: AVOID INJURY OR DEATH

Before operating with attachment, check engagement of loader attachment bracket locking pin to the attachment.

J

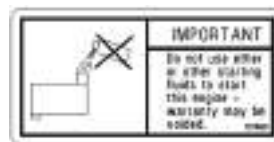

(Located inside the engine compartment)

IMPORTANT Decal

Do not use ether or other starting fluids to start this engine – warranty may be voided.

H



(Located by the floor pan inside the cab)

Avoid Injury or Death Decal

WARNING: AVOID INJURY OR DEATH

- Read Operator's Manual and all safety signs before using, maintaining or servicing the machine.
- Inspect work area; avoid all hazards.
- Operate only in well ventilated area.
- Keep away from electric power lines; avoid contact.
- Wear any needed Personal Protective Equipment.

Specifications

Fluids/Lubricants Types and Capacities

NOTE: Capacities shown are approximate.

Table 2: Fluids/Lubricants Types and Capacities

Component/Application	Type	Quantity	
		RT175	RT210
Engine Oil (with filter)	C1-4 10W - 30 below 32°F (0°C); 15W-40 above 32°F (0°C) (MIL-L-2104C; API CD/CE/CH4; CCMC-D4)	10.4 L (11 qts.)	
Hydraulic Oil Tank	HVLPD 46 (HYD0530)	41.6 L (11 gal.)	52.2 L (13.8 gal.)
Hydraulic System – Total	Biodegradable oil: AVILUB Syntofluid 46; PANOLIN HLP Synth 46	70.0 L (18.5 gal.)	81.4 L (21.5 gal.)
Grease Fittings, Lift Arm	Lithium-saponified, brand-name multi- purpose grease MPG-A	As required	
Battery Terminals	SP-B acid-proof Grease	As required	
Diesel Fuel Tank	ASTM D975-94 (no additives allowed!) DIN EN14214 Biodiesel (no additives allowed!) LSD or ULSD ¹ low sulfur or ultra-low sulfur, below 500 PPM. Up to 5% (B5) mixture of BioDiesel allowed.	92.4 L (24.4 gal.)	
Engine Coolant	Long life coolant ASTM D4985, D6210 (United States) SAE J814C, J1941, J1034 or J2036 (international) (See “Dimensions” table below	13.2 L (3.5 gal.)	14.4 L (3.8 gal.)
Radiator Cap Pressure		0.90 bar (13 psi)	
Air Conditioning (option)	R 134a refrigerant	1179 g. (2.6 lbs.) @ 24° C (76° F)	
Final Drives			
Motor Gearbox	SAE 75W90 Shell transaxle (synthetic fluid)	1 L (1.06 qts.) ± 10%	

1. Ultra-Low Sulfur Diesel (ULSD) fuel lubricity must have a maximum scar diameter of 0.45 mm, as measured by ASTM D6079 or ISO 12156-1, or a minimum of 3100 grams, as measured by ASTM D6078. Contact your fuel supplier for details. Specification 1-D or 2-D, ASTM D975-94.

Specifications

Dimensions

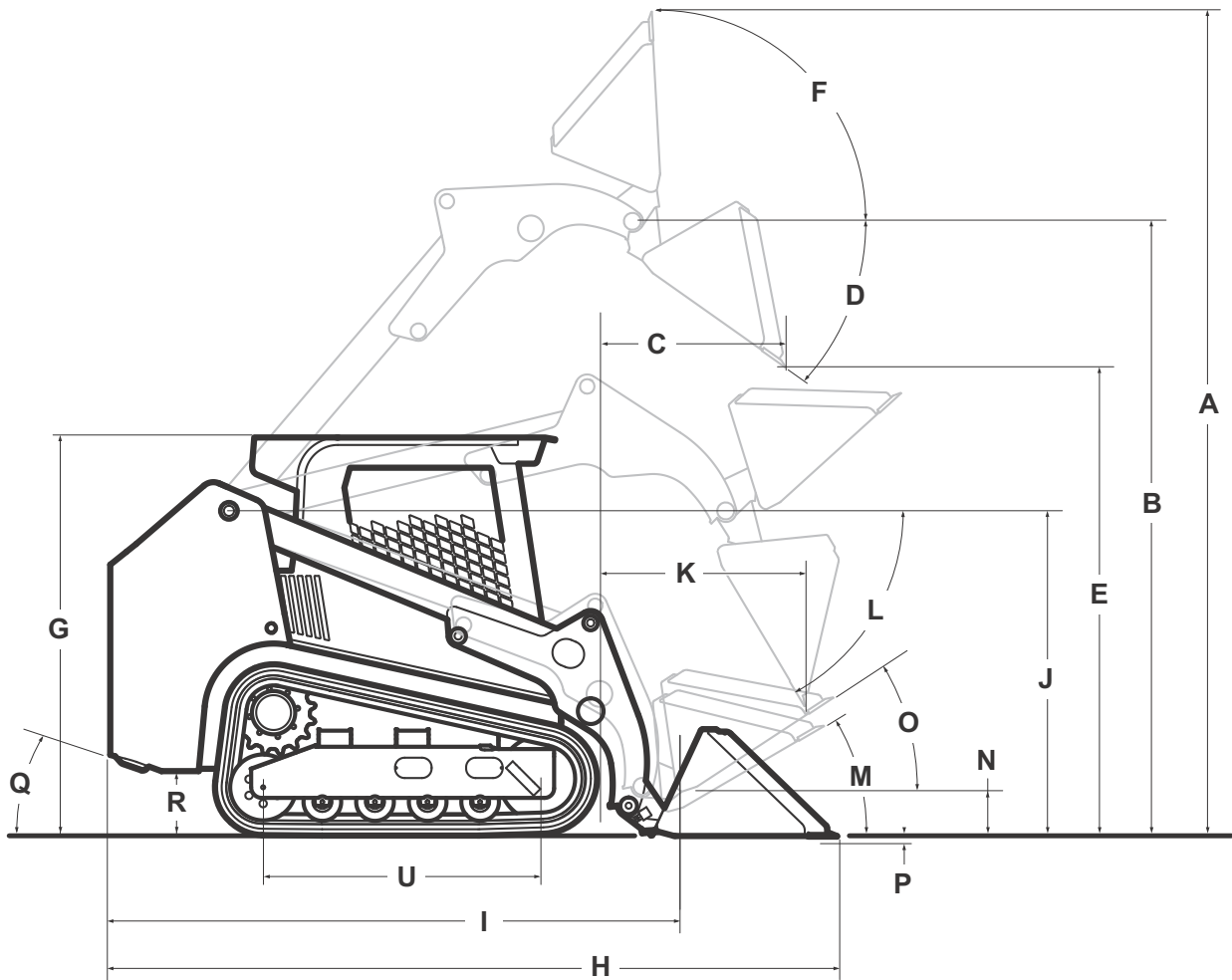
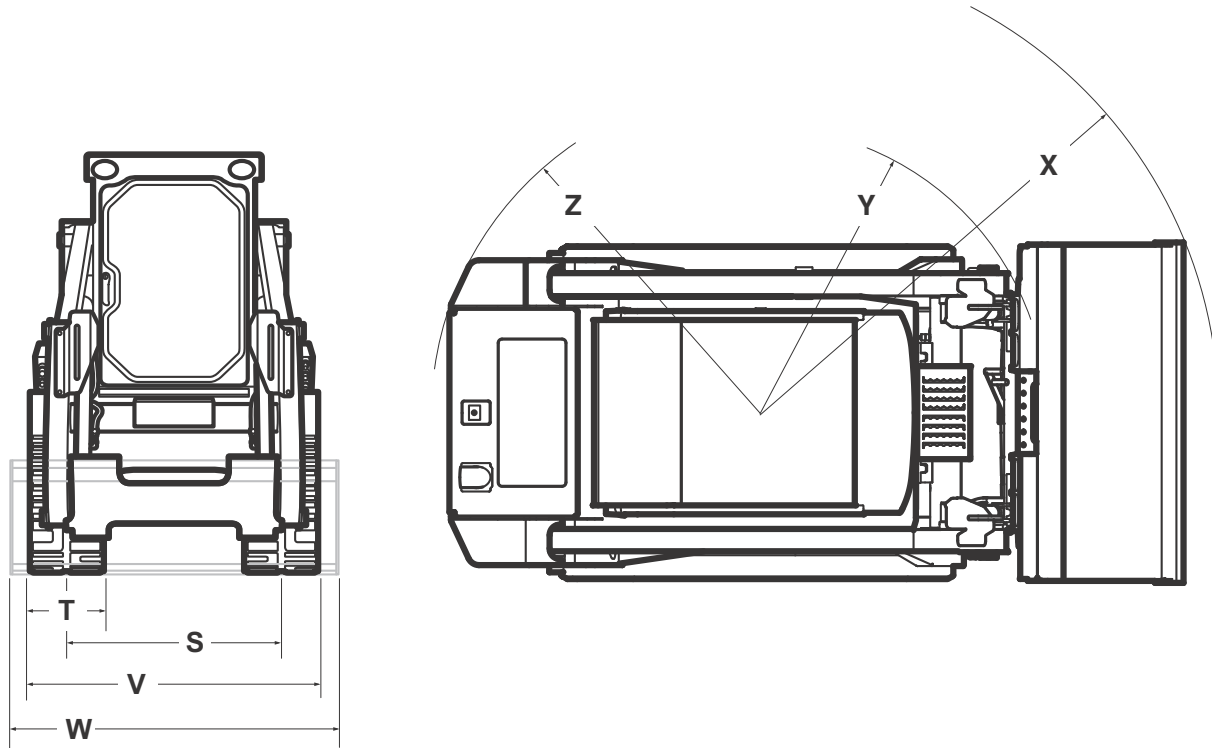

Table 3: Dimensions

		RT175	RT210
A	Overall Operating Height (fully raised)	4267 mm (168.0 in.)	4369 mm (172.0 in.)
B	Height to Hinge Pin (fully raised)	3239 mm (127.5 in.)	3251 mm (128.0 in.)
C	Reach (fully raised)	876 mm (34.5 in.)	940 mm (37.0 in.)
D	Dump Angle (fully raised)	40.2°	39.0°
E	Dump Height (fully raised)	2489 mm (98.0 in.)	2431 mm (95.7 in.)
F	Maximum Rollback Angle (fully raised)	102.5°	
G	Overall Height at ROPS	2103 mm (82.8 in.)	2111 mm (83.1 in.)
H	Overall Length (with bucket and standard counterweight)	3658 mm (144.0 in.)	3868 mm (152.3 in.)
I	Overall Length (w/out bucket)	2814 mm (110.8 in.)	2908 mm (114.5 in.)
J	Specified Height	1715 mm (67.5 in.)	1720 mm (67.7 in.)
K	Reach (at specified height)	790 mm (31.1 in.)	808 mm (31.8 in.)
L	Dump Angle (at specified height)	75.0°	
M	Maximum Rollback Angle (at ground)	30.0°	
N	Carry Position	178 mm (7.0 in.)	
O	Max. Rollback Angle (at carry position)	33.0°	
P	Digging Position	-7.6 mm (-0.3 in.)	-5.1 mm (-0.2 in.)
Q	Angle of Departure (standard counterweight)	30.4°	29.2°
R	Ground Clearance	343 mm (13.3 in.)	330 mm (13.0 in.)
S	Track Gage	1313 mm (51.7 in.)	
T	Track Shoe Width	320 mm (12.6 in.)	450 mm (17.7 in.)
U	Crawler Base	1392 mm (54.8 in.)	1483 mm (58.4 in.)
V	Overall Width (w/out bucket)	1636 mm (64.4 in.)	1765 mm (69.5 in.)
W	Bucket Width	1674 mm (65.9 in.)	1877 mm (73.9 in.)
X	Front Clearance Radius (with bucket)	2322 mm (91.4 in.)	2492 mm (98.1 in.)
Y	Front Clearance Radius (w/out bucket)	1448 mm (57.0 in.)	1491 mm (58.7 in.)
Z	Rear Clearance Radius (standard counterweight)	1577 mm (62.1 in.)	1641 mm (64.6 in.)
	Maximum Rollback at Specified Height	66.8°	
	Angle of Approach	90°	
	Grouser Height	25.4 mm (1.0 in.)	

Specifications

Payloads/Capacities

NOTE: *Pallet fork load center is the distance from the front face of the forks to the center of mass of the load.*

Table 4: Payloads/Capacities (Dirt/Construction Buckets)

	RT175	RT210
SAE Rated Operating Capacity @ 35% (standard counterweight)	794 kg (1750 lbs.)	953 kg (2100 lbs.)
SAE Rated Operating Capacity @ 50% (standard counterweight)	1134 kg (2500 lbs.)	1361 kg (3000 lbs.)
SAE Rated Operating Capacity @ 35% (optional counterweight)	841 kg (1855 lbs.)	1000 kg (2205 lbs.)
SAE Rated Operating Capacity @ 50% (optional counterweight)	1202 kg (2650 lbs.)	1429 kg (3150 lbs.)
SAE Tipping Load (standard counterweight)	2268 kg (5000 lbs.)	2722 kg (6000 lbs.)
SAE Tipping Load (optional counterweight)	2404 kg (5300 lbs.)	2858 kg (6300 lbs.)

Table 5: Payloads/Capacities (Pallet Forks - 48 in. [1229 mm])

15.7 in. (400 mm) Load Center per EN 474-3	RT175	RT210
SAE Rated Operating Capacity @ 35% (standard counterweight)	603 kg (1330 lbs.)	781 kg (1722 lbs.)
SAE Rated Operating Capacity @ 50% (standard counterweight)	862 kg (1900 lbs.)	1116 kg (2460 lbs.)
SAE Rated Operating Capacity @ 35% (optional counterweight)	651 kg (1435 lbs.)	829 kg (1827 lbs.)
SAE Rated Operating Capacity @ 50% (optional counterweight)	930 kg (2050 lbs.)	1184 kg (2610 lbs.)
SAE Tipping Load (standard counterweight)	1724 kg (3800 lbs.)	2231 kg (4919 lbs.)
SAE Tipping Load (optional counterweight)	1860 kg (4100 lbs.)	2367 kg (5219 lbs.)
19.7 in. (500 mm) Load Center per EN 474-3		
SAE Rated Operating Capacity @ 35% (standard counterweight)	582 kg (1282 lbs.)	738 kg (1627 lbs.)
SAE Rated Operating Capacity @ 50% (standard counterweight)	831 kg (1831 lbs.)	1054 kg (2324 lbs.)
SAE Rated Operating Capacity @ 35% (optional counterweight)	629 kg (1387 lbs.)	786 kg (1732 lbs.)
SAE Rated Operating Capacity @ 50% (optional counterweight)	899 kg (1981 lbs.)	1122 kg (2474 lbs.)
SAE Tipping Load (standard counterweight)	1661 kg (3662 lbs.)	2108 kg (4648 lbs.)
SAE Tipping Load (optional counterweight)	1797 kg (3962 lbs.)	2244 kg (4948 lbs.)
24 in. (610 mm) Load Center per SAE J1197		
SAE Rated Operating Capacity @ 35% (standard counterweight)	533 kg (1176 lbs.)	692 kg (1525 lbs.)
SAE Rated Operating Capacity @ 50% (standard counterweight)	762 kg (1680 lbs.)	988 kg (2179 lbs.)
SAE Rated Operating Capacity @ 35% (optional counterweight)	581 kg (1281 lbs.)	739 kg (1630 lbs.)
SAE Rated Operating Capacity @ 50% (optional counterweight)	830 kg (1830 lbs.)	1052 kg (2329 lbs.)
SAE Tipping Load (standard counterweight)	1524 kg (3360 lbs.)	1976 kg (4357 lbs.)
SAE Tipping Load (optional counterweight)	1660 kg (3660 lbs.)	2112 kg (4657 lbs.)

Weights

Table 6: Weights

	RT175	RT210
Operating Mass (standard counterweight) ¹	3903 kg (8605 lbs.)	4486 kg (9890 lbs.)
Operating Mass (optional counterweight) ¹	4044 kg (8915 lbs.)	4590 kg (10 120 lbs.)
Shipping Weight (standard counterweight)	3556 kg (7840 lbs.)	4028 kg (8880 lbs.)
Shipping Weight (optional counterweight)	3697 kg (8150 lbs.)	4132 kg (9110 lbs.)

1. Equipped with standard bucket, driver and full fluids.

Track Drive

Table 7: Track Drive

	RT175	RT210
Gradeability	30°	
Brakes	Mechanical / hydraulic; spring applied / hydraulically released	
Tractive effort	5371 kg (11 840 lbs.)	5606 kg (12 359 lbs.)
Track Type / Track Rollers / Roller Type	Rubber / 3 / steel	Rubber / 4 / steel
Track Dimensions	320 mm x 86 mm (12.5 in. x 3.4 in.) x 54 Pitches	450 mm x 86 mm (17.7 in. x 3.4 in.) x 56 Pitches
Track Ground Contact Length	1395 mm (55 in.)	1483 mm (58.4 in.)
Ground Pressure	0.44 kg/cm ² (6.2 psi)	0.33 kg/cm ² (4.7 psi)
Number of Track Rollers	3 (per side)	4 (per side)
Travel Speed	Low: 8.2 kph (5.1 mph) High: 12.1 kph (7.5 mph)	Low: 8.7 kph (5.4 mph) High: 12.7 kph (7.9 mph)

Coolant Compound Table

Table 8: Coolant Compound Table

Outside Temperature Up to °F (°C)	Water % by volume	Anti-corrosion agent		Antifreeze % by volume
		in ³ /gal (cm ³ /L)	% by Volume	
39 (4)	99	2.6 (10)	1	–
14 (- 10)	79			20
-4 (- 20)	65			34
-13 (- 25)	59			40
-22 (- 30)	55			45
-44 (-42)	50			50

Specifications

Engine

Table 9: Engine

	RT175	RT210
Engine Model	Yanmar 4TNV98-ZNMS	Yanmar 4TNV98T-ZXNMS
Design	In-line 4 cylinder, 4-stroke diesel, naturally aspirated	In-line 4 cylinder, 4-stroke diesel, turbocharged
Displacement	3.319 L (203 cu. in.)	
Bore and Stroke	98 x 110 mm (3.8 x 4.3 in.)	
Compression Ratio	18.5 : 1	18.1 : 1
Gross Power	52.1 kW (69.9 hp) @ 2500 rpm	53.7 kW (72.0 hp) @ 2500 rpm
Net Power	51.0 kW (68.4 hp) @ 2500 rpm	52.7 kW (70.7 hp) @ 2500 rpm
Peak Torque	242.7 Nm (179 lb.-ft.) @ 1600 rpm	279.3 Nm (206 lb.-ft.) @ 1800 rpm
Low/High Idle	1000 / 2530 rpm	
Rated - Full Load Speed	2500 rpm	
Fuel Injection System	Direct injection	
Fuel Delivery	In-line injection pump	
Fuel Shut-off	On injection pump	
Fuel Filtering	In-line filter cartridge w/water trap and replaceable element	
Estimated Fuel Consumption - Average Load	@ Rated - full load speed 14.4 L/hr (3.8 gph) / @ Rated - 55% load speed 7.8 L/hr (2.1 gph)	@ Rated - full load speed 15.1 L/hr (4.0 gph) / @ Rated - 55% load speed 8.3 L/hr (2.2 gph)
Firing Order	1-3-4-2	
Normal Starting Aid	500W manifold heater	
Cold Starting Aid (Optional)	400W block heater	
Lubrication	Pressure system w/replaceable filter	
Crankcase Ventilation	External	
Max. Inclined Angle (engine still supplied with oil)	30° in all directions	
Cooling System	Water / glycol	
Permissible Coolant Temperature	110° C (230°F)	
Thermostat Rating	82° C (180°F) cracking / 95° C (203°F) full open	
Permissible Coolant Temp	110°C (230°F)	
Fan Type / Ratio	Pusher / 1:0.9	
Exhaust Emission Compliance	Tier 3 / 4i	
Starter - Power	3 kW - 12 V	
Alternator Voltage / Amperage	12 V / 95 A	
Operating Range– Ambient Temperature ¹	-15°C (+5°F) – +45°C (+113°F)	

1. Operation above temperature range may result in overheating; operation below temperature range may result in hard-starting. Contact your dealer before operating the machine outside temperature range.

Hydraulic System

General

Table 10: Hydraulic System : General

	RT175	RT210
Hydraulic Self-Leveling	Hydraulic self-leveling in raise mode only. Full time-Standard; Switchable-Optional	
Main Relief Pressure	207 bar (3000 psi) @ 2500 rpm	
Pump-to-Engine Ratio	1 : 1	
System Pressure Setting	207 bar (3000 psi) @ 2500 rpm	
Optional High-Flow Auxiliary Hydraulics System Pressure Setting	200 bar (2900 psi) @ 2500 rpm	
Port Relief Pressures		
Boom Lift	241 bar (3500 psi)	
Boom Lower	121 bar (1750 psi)	
Tilt Rollback	241 bar (3500 psi)	
Tilt Dump	None	

Drive Hydraulics

Table 11: Hydraulic System : Drive Hydraulics

	RT175	RT210
Gear Box	2-stage Planetary Reduction 21.58:1 Ratio	
Drive Speed	Low speed range: 0-8.2 kph (0-5.1 mph) High speed range: 0-12.0 kph (0-7.5 mph)	Low speed range: 0-8.7 kph (0-5.4 mph) High speed range: 0-12.7 kph (0-7.9 mph)
Tractive Effort	5371 kg. (11 840 lbs.)	5606 kg. (12 359 lbs.)
Hydrostatic Drive Motors		
Type	Axial-piston with planetary gearbox reduction	
Rated Pressure	345 bar (5004 psi)	
Displacement	Low: 1049 cm ³ (64.0 in ³) High: 680 cm ³ (41.5 in ³)	Low: 1098 cm ³ (67.0 in ³) High: 714 cm ³ (43.6 in ³)
Maximum Output Torque (Low)	5768 Nm (4254 ft.-lbs.)	6020 Nm (4440 ft.-lbs.)
Rotating	Bi-directional	

Specifications

Pumps

Table 12: Hydraulic System : Pumps

	RT175	RT210
Auxiliary Hydraulics Pump (Standard)		
Type	Gear	
Main Relief Valve Pressure	Standard Flow 207 bar (3000 psi)	
Displacement	28.02 cm ³ (1.71 in ³)	32.94 cm ³ (2.01 in ³)
Theoretical Total Flow @ Rated Speed	70.0 L/m (18.5 gpm) @ 2500 rpm	82.5 L/m (21.8 gpm) @ 2500 rpm
Theoretical 100% Hydraulic Operating Power	24.2 kW (32.4 hp)	28.5 kW (38.2 hp)
Auxiliary Hydraulics Pump (Optional - High-Flow)		
Type	Tandem gear	
Main Relief Valve Pressure	High-Flow 248 bar (3600 psi)	
Displacement	Section 1: 29.00 cm ³ (1.77 in ³) Section 2: 22.45 cm ³ (1.37 in ³)	Section 1: 31.79 cm ³ (1.94 in ³) Section 2: 22.45 cm ³ (1.37 in ³)
Theoretical Total Flow @ Rated Speed	128.7 L/m (34 gpm)	136 L/m (35.9 gpm)
Theoretical 100% Hydraulic Operating Power	42.9 kW (57.5 hp)	45.3 kW (60.7 hp)
Travel Drive System Hydrostatic Pump		
Type	Axial piston	
Rated Pressure	345 bar (5004 psi)	
Displacement	41.0 cm ³ (2.5 in ³)	49.2 cm ³ (3.0 in ³)
Pump to Engine Ratio	1 : 1	
Charge Pressure	300-350 psi (21-24 bar)	

Cylinders

Table 13: Hydraulic System : Cylinders

	RT175	RT210
Tilt Cylinders		
Type	Double-acting piston	
Rod / Bore Diameter	35 mm / 64 mm (1.38 / 2.50 in.)	38 mm / 70 mm (1.50 / 2.75 in.)
Stroke Length	537 mm (21.14 in.)	
Closed Length	731 mm (28.76 in.)	
Pressure Rating	207 bar (3000 psi)	
Lift Cylinders		
Type	Double-acting piston	
Rod / Bore Diameter	38 mm / 64 mm (1.50 / 2.50 in.)	38 mm / 70 mm (1.50 / 2.75 in.)
Stroke Length	766 mm (30.14 in.)	
Closed Length	994 mm (39.14 in.)	
Pressure Rating	207 bar (3000 psi)	

Forces and Cycle Times

Table 14: Hydraulic System : Forces and Cycle Times

	RT175	RT210
Bucket Breakout		
SAE Breakout Force (tilt)	23.1 kN (5189 lbf.)	24.4 kN (5492 lbf.)
ISO Breakout Force (lift, standard counterweight, stability limited)	16.6 kN (3728 lbf.)	14.1 kN (3166 lbf.)
ISO Breakout Force (lift, standard counterweight, hydraulically limited)	21.5 kN (4840 lbf.)	24.0 kN (5398 lbf.)
ISO Breakout Force (lift, optional counterweight, stability limited)	18.7 kN (4194 lbf.)	15.4 kN (3452 lbf.)
ISO Breakout Force (lift, optional counterweight, hydraulically limited)	21.5 kN (4840 lbf.)	24.0 kN (5398 lbf.)
Hydraulic Function Time		
SAE Raising Time - Lift	4.5 seconds	4.6 seconds
SAE Lowering Time - Lift	3.0 seconds.	3.2 seconds
SAE Dump Time - Tilt	1.0 secs.	
Dump Time - Tilt (stop to stop)	3.2 seconds	3.3 seconds
SAE Rollback Time - Tilt	0.6 seconds	
Rollback Time - Tilt (stop to stop)	2.1 seconds	2.4 seconds
Bucket Capacity	0.4 m ³ (14.3 ft ³)	0.6 m ³ (20.0 ft ³)
Total Boom - Cycle Time	12.8 seconds	13.5 seconds

Specifications

Electrical System

Table 15: Electrical System

	RT175	RT210
Glow Plug (Engine Pre-heat)	Auto w/glow lamp	
Backup Alarm	112 + 4 dB(A) 2500 + 300 Hz	
Battery		
Type	Maintenance-free	
Volts	12 V	
Group Size	65	
Cold Cranking Amps @ Temperature	850 CCA @ -18°C (0°F)	
Minimum Reserve Capacity	140 minutes	

Sound Power/Pressure Levels

Table 16: Sound Power/Pressure Levels

	RT175	RT210
Noise Level / Environmental Level (EU Dir. 200/14/EC)	103 dB(A)	103 dB(A)
Operator Ear (EU Dir. 2006/42/EC)	82 (± 2.2) dB(A)	83 (± 2.8) dB(A)

Vibration Levels

Table 17: Vibration Levels

	RT175	RT210
Whole-Body Vibration (ISO 2631-1)	$\leq 0.74 \text{ m/s}^2 (\pm 0.37\text{k})$	$\leq 0.79 \text{ m/s}^2 (\pm 0.40\text{k})$
Hand-Arm Vibration (ISO 5349-1)	$\leq 3.5 \text{ m/s}^2 (\pm 1.75\text{k})$	$\leq 4.4 \text{ m/s}^2 (\pm 2.2\text{k})$

Features

Standard Features

Table 18: Features : Standard Features

All-Tach [®] attachment mounting system	Dual-element air cleaner with indicator
Engine alert system with error code display	Elevated planetary final drives with SAHR disc brakes
Back-up alarm	Maintenance-free track rollers
Self-leveling hydraulic lift action	EH-controlled hydrostatic drive
Auxiliary hydraulics - proportional electric control/continuous flow	Hand and foot throttles
HydraTrac [™] automatic track tensioning system	Combination radiator and hydraulic oil cooler
12-volt battery	5x5 drive control system - 5 drivability/responsiveness programs
Grid/manifold heater starter assist - automatic/manual	Interlock system for lift, tilt cylinders, auxiliary hydraulic functions and drives
Yanmar liquid-cooled diesel engine	Mechanical lift cylinder support
Horn	Rubber track undercarriage system
Independent hydraulic reservoir and cooler	Tilt-out radiator and hydraulic oil cooler
Joystick (electric-hydraulic) "hands-only" ISO controls	Tilt-out foot pod - easy clean out
Restraint bar and retractable seat belt	Vandalism lock provisions
ROPS/FOPS - Level 2-approved	Single flange front / dual flange rear idlers
Multi-function display screen - warning lights, gauges and configuration	Two front and two rear halogen lights
Two-speed hydrostatic drive system	Full-suspension seat - 6-way adjustable seat, controls and armrests
Engine automatic shutdown system - low oil pressure	Seat mounted controls and switches

Optional Features

Table 19: Features : Optional Features

Hydraglide [™]	High-flow auxiliary hydraulics
Cab enclosure	Air conditioning/HVAC with defrost
Swing-out door	High-capacity counterweight
Dual-hand (case controls)/ISO controls - selectable	Engine intake pre-heater
Power-A-Tach [®] attachment mounting system	AM/FM radio
Speed control, variable - selectable On/Off	Impact resistant swing-out door
Selectable (On/Off) self-leveling hydraulic lift action	Air suspension seat
Engine block heater	Strobe light

Specifications

Common Materials and Densities

Table 20: Common Materials and Densities

Material	Density	
	kg/m3	lbs./ft.3
Ashes	560-800	35-50
Brick-common	1792	112
Cement	1760	110
Charcoal	368	23
Clay, wet-dry	1280-1600	80-100
Coal	848-1008	53-63
Concrete	1840	115
Cinders	800	50
Coal-anthracite	1504	94
Coke	480	30
Earth-dry loam	1121-1442	70-90
Earth-wet loam	1281-1602	80-100
Granite	1488-1776	93-111
Gravel-dry	1602	100
Gravel-wet	1922	120
Gypsum-crushed	1840	115
Iron ore	2320	145
Lime	960	60
Lime stone	1440	90
Manure-liquid	1040	65
Manure-solid	720	45
Peat-solid	752	47
Phosphate-granular	1440	90
Potash	1088	68
Quartz-granular	1760	110
Salt-dry	1602	100
Salt-rock-solid	2160	135
Sand-dry	1728	108
Sand-wet	2000	125
Sand-foundry	1520	95
Shale-crushed	1440	90
Slag-crushed	1120	70
Snow	240-800	15-50
Taconite	1712	107

Controls

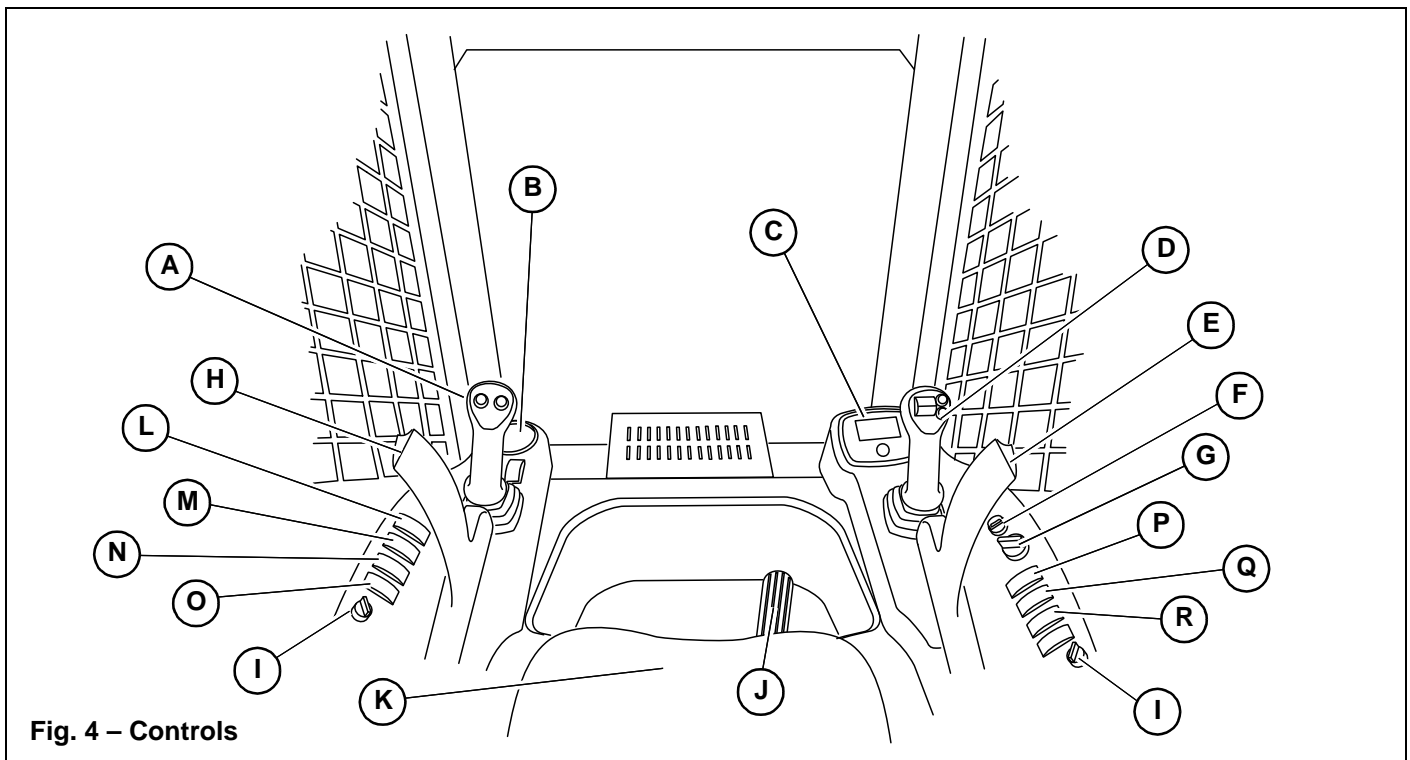

Fig. 4 – Controls

Table 21: Controls

Ref	Item	Description
A	Control Joystick - Left	Controls travel drive operation (and lift arm in option “D-H” control mode), horn and low/high speed travel mode. See “Control Joysticks” on page 50.
B	Cup Holder	Holds beverage containers up to 67mm (2-5/8”) in diameter.
C	Multi-Function Display	Displays operation status messages and configures performance options.
D	Control Joystick - Right	Controls attachment lift/tilt operation (travel drive and attachment tilt in “D-H” control mode), auxiliary hydraulic flow, lift arm float and optional Hydraglide™. See “Control Joysticks” on page 50.
E	Safety Bar/Arm Rest - Right	Applies parking brake, locks out work hydraulics and prevents engine start when in the raised position. See “Parking Brake/Work Hydraulics Lock-out” on page 54.
F	Ignition Switch	Controls ignition, engine start and run. See “Starting the Engine” on page 67.
G	Throttle Knob	Primary engine speed control. See “Throttle Controls” on page 56.
H	Safety Bar/Arm Rest - Left	Applies parking brake, locks out work hydraulics and prevents engine start when in the raised position. See “Parking Brake/Work Hydraulics Lock-out” on page 54.
I	Electrical Accessory Socket	12-volt accessory outlet.
J	Throttle Pedal	Supplemental engine speed control. See “Throttle Controls” on page 56.
K	Operator’s Seat	Seat plate according to ISO 7096 (located on seat).
L	Power-A-Tach® Switch	Controls Power-A-Tach®. See “Switches/Indicators” on page 45.
M	Self-Leveling Cancel Switch	Cancels optional self-leveling function. See “Switches/Indicators” on page 45.
N	Auxiliary Hydraulics Flow Switch	Controls high-flow auxiliary hydraulics. See “Switches/Indicators” on page 45 and “Auxiliary Hydraulics Operation” on page 86.
O	Parking Brake Switch	Controls the parking brake. See “Switches/Indicators” on page 45.
P	Rear Window Washer Switch	Controls rear window washer spray. See “Switches/Indicators” on page 45.
Q	Front Window Washer Switch	Controls front window washer spray. See “Switches/Indicators” on page 45.
R	Work Lights Switch	Controls work lights. See “Switches/Indicators” on page 45.

Controls

Multi-Function Display

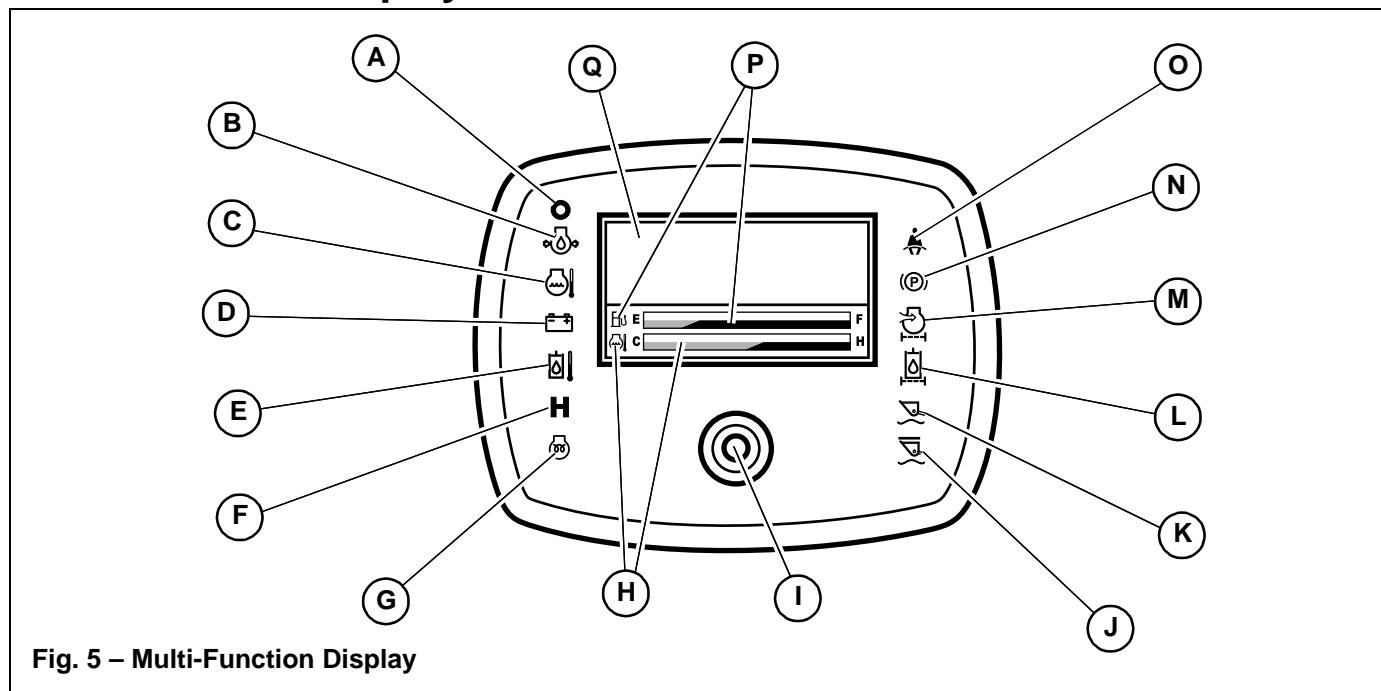

Fig. 5 – Multi-Function Display

Table 22: Multi-Function Display

No	Item	Description
A	Ambient Light Sensor	Senses ambient light for proper display screen contrast adjustment.
B	Engine Oil Pressure Warning Indicator	Is lit when engine oil pressure is too low. IMPORTANT! Immediately shut down the engine if this indicator is lit. Correct the problem before restarting the engine.
C	Coolant Temperature Warning Indicator	Is lit when coolant temperature is too high.
D	Battery Voltage Warning Indicator	Is lit when alternator is not charging the battery.
E	Hydraulic Oil Temperature Warning Indicator	Is lit when hydraulic temperature is too high.
F	High-Speed Travel Range Indicator	Is lit when high-speed travel range is activated.
G	Pre-Heat Indicator	Is lit when ignition switch is in the "I" (Run) position and engine pre-heat is required; goes out when engine pre-heat is complete.
H	Coolant Temperature Indicator	Displays coolant temperature.
I	Display Select Button	Used for screen selection and display/operation configuration. See "Screen Access" on page 46.
J	Hydraglide™ Indicator	Is lit when the Hydraglide™ lift arm cushion is activated.
K	Lift Arm Float Indicator	Is lit when the lift arm float is activated.
L	Hydraulic Oil Filter Warning Indicator	Is lit when hydraulic oil filter requires service. See "Changing Hydraulic Oil and Filter" on page 113.
M	Engine Air Filter Restriction Indicator	Is lit when engine air filter requires service. See "Engine Air Filters" on page 106.
N	Parking Brake Indicator	Is lit when parking brake is applied.
O	Seat Belt Reminder Indicator	Is lit when engine is started as a reminder to fasten the seat belt. See "Seat Belt" on page 65.
P	Fuel Gauge	Displays the level of fuel in the fuel tank. Status bar indicates Empty (E) to Full (F).
Q	Display Screen	Displays status / configuration information. See "Status, Maintenance and Error Code Screens" on page 46.

Switches/Indicators

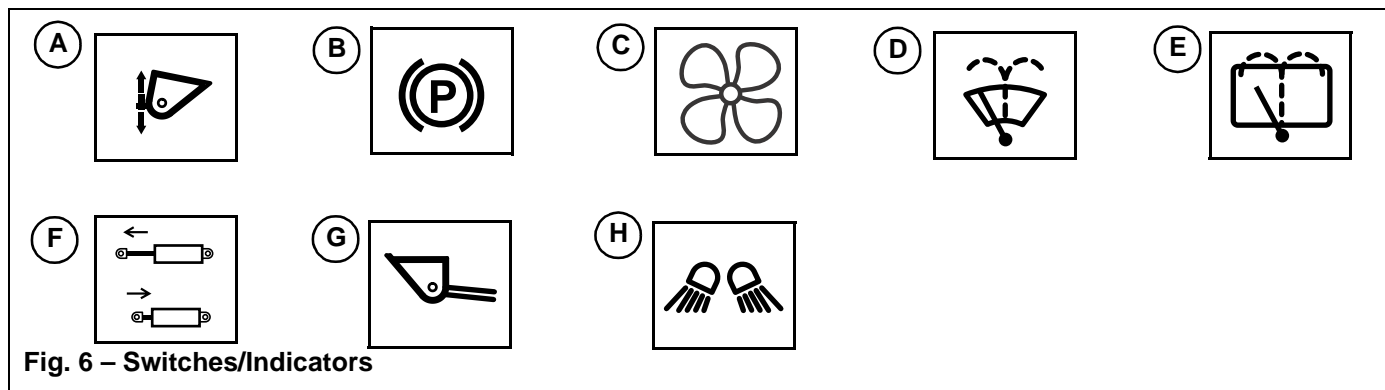

Fig. 6 – Switches/Indicators

Table 23: Switches/Indicators

No	Item	Description
A	Power-A-Tach®	Located on left panel. Press and hold bottom of switch to lock attachment onto the Power-A-Tach® quick attach system hitch; press and hold top of switch to unlock the attachment. See “Connecting/Disconnecting Attachments” on page 83.
B	Parking Brake	Press top of switch to apply parking brake. Press and hold top of switch to release parking brake. Indicator in switch is lit when parking brake is applied. IMPORTANT: <i>Parking brake is applied when either, or both, safety bar/arm rests are in the raised position, operator is not in seat and door (if equipped) is opened.</i>
C	Heat/Air Conditioning (HVAC)	Located on left panel. See “Cab Heat and Air Conditioning (Option)” on page 54.
D	Front Windshield Wiper/Washer (option)	Press bottom of switch to activate front windshield wiper; press and release top of switch to deactivate. Press and hold top of switch to operate front windshield washer spray. Indicator in switch is lit when front windshield wiper is activated.
E	Rear Windshield Wiper/Washer	Press bottom of switch to activate rear windshield wiper; press and release top of switch to deactivate. Press and hold top of switch to operate rear windshield washer spray. Indicator in switch is lit when rear windshield wiper is activated.
F	Auxiliary High-Flow Hydraulics	See “Auxiliary Hydraulics Operation” on page 86.
G	Self-Leveling Cancel (option)	Press top of switch to deactivate self-leveling; press bottom of switch to restore the self-leveling function. Indicator in switch is lit when self-leveling is deactivated.
H	Work Lights	Move switch to the middle position to activate the front work lights; press the top of switch to activate both the front and rear work lights; press bottom of switch to deactivate work lights. See “Work Lights” on page 60 Indicator in switch is lit when work lights are on.

Controls

Multi-Function Display Screens

The multi-function display screens provide the following functionality:

- Displays operational status such as engine RPM, coolant temperature, service hours and system voltage.
- Displays error fault codes.
- Configures displays settings.
- Configures control options.
- Audible alerts for selected error conditions.

Screen Access

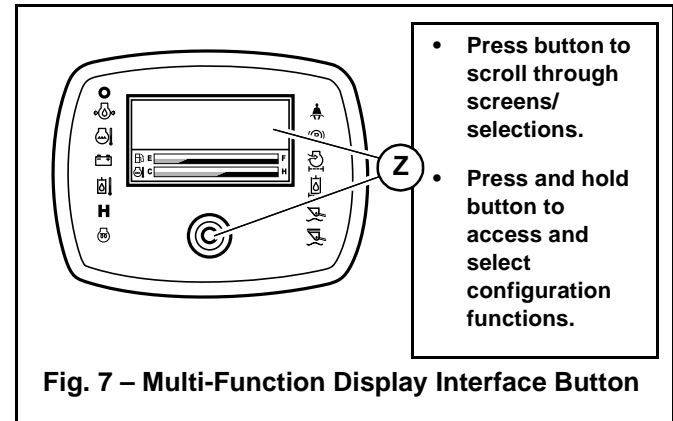

Press and release the multi-function display interface button (Z, Fig 7) to scroll through the status screens and any current error or maintenance required screens.





Press and hold the interface button for 5 seconds to display the configuration selection screens and to select a particular setting (page 48).

Status, Maintenance and Error Code Screens

Table 24: Status, Maintenance and Error Code Screens

Screen	Access/Description
Status Screens	
	<p>Coolant Temperature Screen</p> <p>Default screen when no error codes are active.</p> <p>Press and release interface button (Z, Fig. 7) as many times as required to access this screen. Displays coolant temperature in “°F” or “°C”, depending upon units selected in Temperature Units Configuration screen (M).</p>
	<p>Engine RPMs Screen</p> <p>Press and release interface button (Z, Fig. 7) as many times as required to access this screen. Displays engine crankshaft revolutions per minute.</p>
	<p>Battery Voltage Screen</p> <p>Press and release interface button (Z, Fig. 7) as many times as required to access this screen. Displays battery charge in volts.</p>
	<p>Accumulated Service Hours Screen</p> <p>Press and release interface button (Z, Fig. 7) as many times as required to access this screen. Displays accumulated operation time in hours. Time accumulates when engine is running.</p>

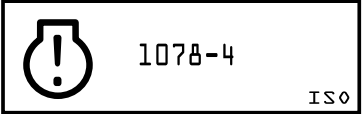
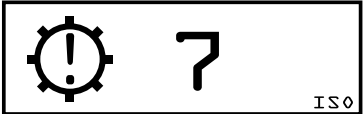
Table 24: Status, Maintenance and Error Code Screens

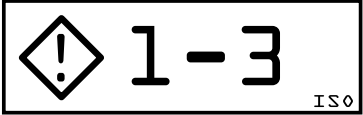
Screen	Access/Description
	<p>Low Fuel Screen Automatically displays when the fuel level is low.</p>
<p>Required Maintenance and Error Code Screens</p>	
	<p>Maintenance Required Screen Displays in the screen rotation along with status screens when scheduled maintenance is required. See page “Maintenance Schedule” on page 100. To dismiss this screen, press and hold the interface button (Z, Fig. 7). This screen will display in rotation when scrolling through the status screens. After 1 full rotation of all screens, the display will freeze on this screen, until the machine is shut-down and started back up.</p>
	<p>Engine Error Code Screen Displays in the screen rotation along with status screens when engine errors occur. See “Engine Error Codes” on page 140. Up to 3 errors can be displayed on a single screen; additional screens are displayed if more than 3 errors occur. The error code screen is dismissed when the underlying problem is solved -- error code screens take precedence over other screens.</p>
	<p>Drive / Valve Error Code Screen Displays in the screen rotation along with status screens when drive / valve system errors occurs. Up to nine drive / valve error codes can be displayed. See “Drive and Valve Error Codes” on page 142.</p>
	<p>Limp Mode Activated Screen Limp mode allows limited drive function when drive system errors (3-10) occur which disable the drive system for safety reasons. Two limp mode codes can be displayed – “38” and “39”. See “Travel Drive Error Condition Operation (Limp Mode)” on page 75.</p>
	<p>Module Communication Error Code Screen Displays in the screen rotation along with status screens when module communication errors occurs. Up to nine module communication error codes can be displayed.</p>

NOTE: *Error codes remain displayed after the error is corrected. Press the display several times to rotate through all display screens to refresh the display; corrected error codes will not reappear in the screen rotation.*

Controls

Configuration Screens

Table 25: Configuration Screens





Item	Access/Description
<p>Configuration Selection Screens</p> 	<p>Configuration Selection Screens</p> <p>To access these screens, press and hold interface button (Z, Fig. 7) for 5 seconds.</p> <p>Press and release interface button (Z, Fig. 7) to move selection caret (A) down through the configuration selections. Press and hold interface button for 5 seconds to go to the configuration screen selected by selection caret (A).</p> <p>To exit the configuration selection screens, move selection caret (A) to the “EXIT” option and press and hold interface button for 5 seconds.</p>
<p>Configuration Screens</p> 	<p>Control Sensitivity Configuration Screen</p> <p>To change joystick control sensitivity, press and release interface button (Z, Fig. 7) to scroll through selections and change control sensitivity. With the caret closer to the  symbol, joystick control becomes increasingly aggressive and immediate; with the caret closer to the  symbol, joystick control becomes less aggressive and more relaxed.</p> <p>Control sensitivity configuration changes are saved when exiting this screen. To exit this screen, press and hold interface button for 5 seconds.</p>
	<p>Travel Speed Limit Configuration Screen (Option)</p> <p>This screen displays only on machines equipped with the speed limit option. Press and release interface button (Z, Fig. 7) to choose between H-L (high/low) or speed limit travel drive modes. See “Travel Speed Range Selection” on page 57 for more information about the travel speed limit option.</p> <p>Vehicle speed limit configuration changes are saved when exiting this screen. To exit this screen, press and hold interface button for 5 seconds.</p>
	<p>Control Joystick ISO/D-H Pattern Selection Screen (Option)</p> <p>This screen displays only on machines equipped with the D-H control pattern option. Press and release interface button (Z, Fig. 7) to choose between ISO or D-H joystick control options. See “Control Joysticks” on page 50 for more information about the ISO and D-H control options.</p> <p>Control joystick pattern configuration changes are saved when exiting this screen. To exit this screen, press and hold interface button for 5 seconds.</p>
	<p>Coolant Temperature °F/°C Units Selection Screen</p> <p>Press and release interface button (Z, Fig. 7) to choose between coolant temperature display options (°F/°C).</p> <p>Coolant temperature units configuration changes are saved when exiting this screen. To exit this screen, press and hold interface button for 5 seconds.</p>

Table 25: Configuration Screens

Item	Access/Description
 <p>Higher Contrast Lower Contrast</p>	<p>Display Screen Contrast Configuration Screen</p> <p>Press and release interface button (Z, Fig. 7) to adjust the screen contrast.</p> <p>Screen contrast changes are saved when exiting this screen. To exit this screen, press and hold interface button for 5 seconds.</p>
	<p>Display Screen Font Size Configuration Screen</p> <p>Press and release interface button (Z, Fig. 7) to adjust the font size.</p> <p>Font size changes are saved when exiting this screen. To exit this screen, press and hold interface button for 5 seconds.</p>
 <p>Changes Display in Lower Ambient Light Changes Display in Higher Ambient Light</p> <p>(NIGHT-TIME MODE) (DAY-TIME MODE)</p> <p>Pointer Indicates Current Ambient Light Level</p>	<p>Night/Day Display Change Configuration Screen</p> <p>To maximize display visibility, the display changes between a black-on-white display and a white-on-black display, depending upon the intensity of ambient light. The set point where this change occurs can be adjusted using this screen.</p> <p>Press and release interface button (Z, Fig. 7) to adjust the night/day display change set point. When the caret is closer to the ☀ symbol, the display changes in brighter ambient light; when it is closer to the 🌙 symbol, the display changes in lower ambient light.</p> <p>Night/day display configuration changes are saved when exiting this screen. To exit this screen, press and hold interface button for 5 seconds.</p>

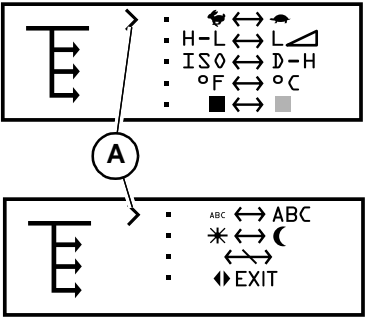
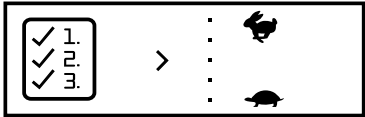
Controls

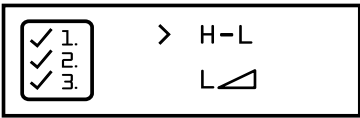
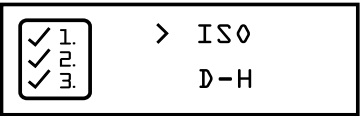
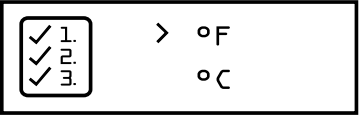
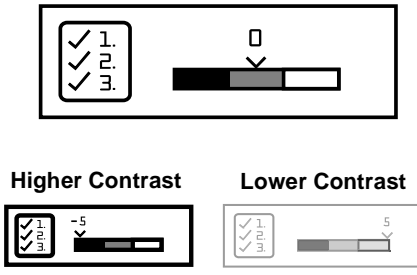
Audible Alerts

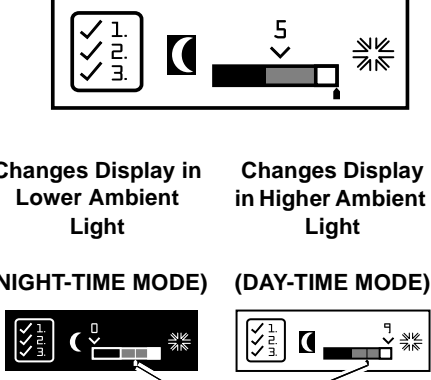
The multi-function display screens also emits audible alerts (buzzer) under the following conditions:

Table 26: Audible Alerts

Item	Description
4 Hz alarm – 5 seconds	When ignition is activated.
2 Hz alarm	Engine temperature too high.
	Engine oil pressure too low.
	Hydraulic oil temperature too high
	Low battery / charging fault.

Control Joysticks

The control joystick forward and back, and right to left tilting movements perform the following functions:

- Track drive control
- Lift arm raise/lower and attachment tilt

Buttons and switches on the control joysticks perform the following functions:

- High/low speed mode control
- Lift arm float activation/deactivation
- Hydraglide™ activation/deactivation (optional)
- Horn operation
- Auxiliary hydraulics flow control (momentary and continuous)

Joystick Tilt Function ISO/D-H Control Patterns

Control joystick functions are factory-configured to follow ISO-pattern controls. An optional additional D-H control pattern factory option is available.

Machines equipped with the optional D-H control pattern can switch between ISO and D-H control pattern functionality using the multi-function display control joystick ISO/D-H pattern selection screen.

Activating D-H Control Pattern Option

NOTE: Machines not equipped with the optional D-H control pattern will not display the control joystick ISO/D-H pattern selection screen.

1. Hold down the interface button (Z, Fig 8) on the multi-function display for 5 seconds.

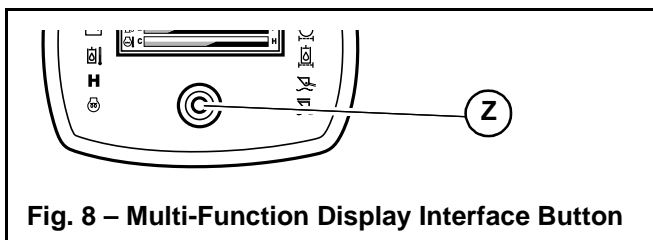

Fig. 8 – Multi-Function Display Interface Button

2. Press and release the interface button until the selection caret points to the “ISO/D-H” selection (Y, Fig 9). Press and hold the interface button for 5 seconds.

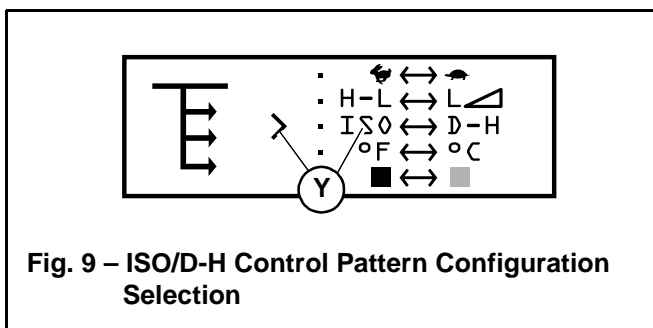

Fig. 9 – ISO/D-H Control Pattern Configuration Selection

- Press and release the interface button until the selection caret points to the “D-H” selection (X, Fig 10). Press and hold the interface button for 5 seconds.

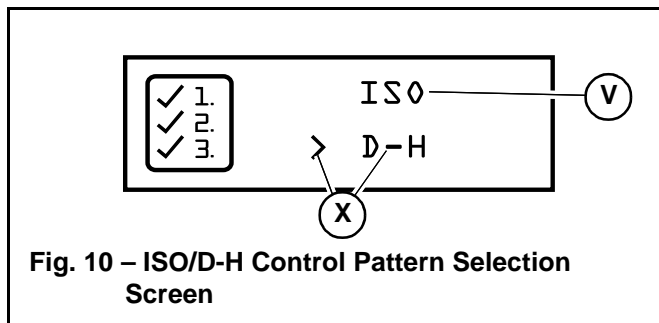

Fig. 10 – ISO/D-H Control Pattern Selection Screen

- Press and release the interface button until the selection caret points to the “EXIT” selection (W, Fig 11). Press and hold the interface button for 5 seconds. The D-H control pattern option is now activated.

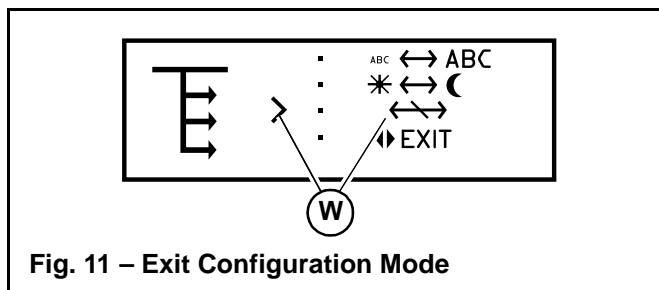

Fig. 11 – Exit Configuration Mode

Deactivating D-H Control Pattern Option

D-H control pattern option deactivation is identical to activation, with the exception of moving the selection caret to the “ISO” selection (V, Fig 10).

Left Joystick Functions

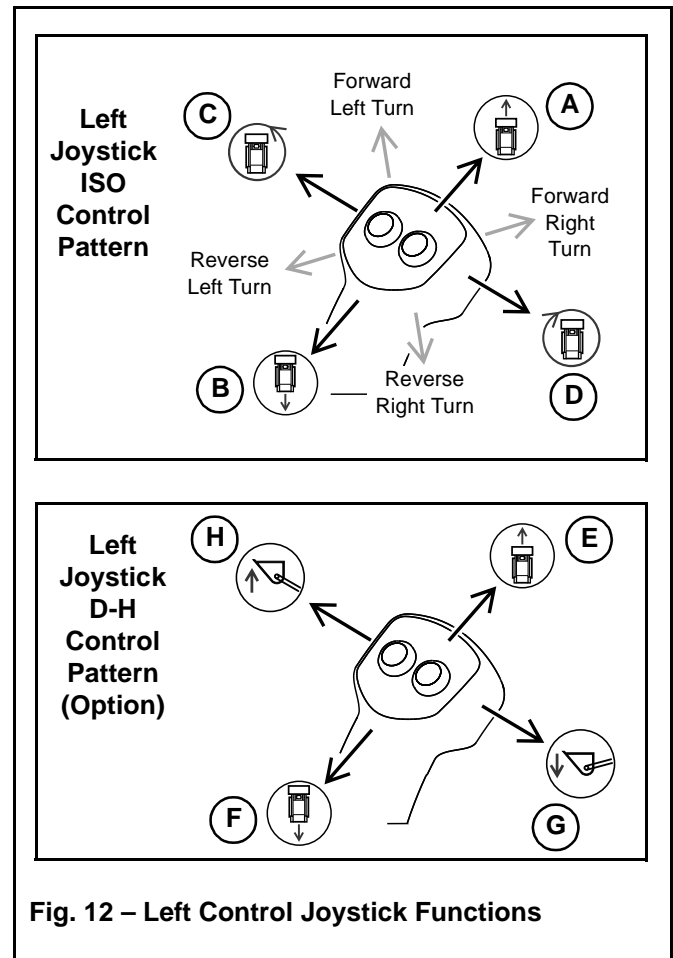

Fig. 12 – Left Control Joystick Functions

Table 27: Left Control Joystick Functions

	Joystick Direction	Function
ISO Control Pattern		
A	Forward	Track drive – forward
B	Backward	Track drive – reverse
C	Left	Track drive – left turn ¹
D	Right	Track drive – right turn ¹
D-H Control Pattern (Optional)		
E	Forward	Track drive – left track forward
F	Backward	Track drive – left track reverse
G	Left	Lift arm – up
H	Right	Lift arm – down

1. Tilting joystick directly left or right results in spin turns; tilting joystick diagonally results in more gradual turns.

Controls

Right Joystick Functions

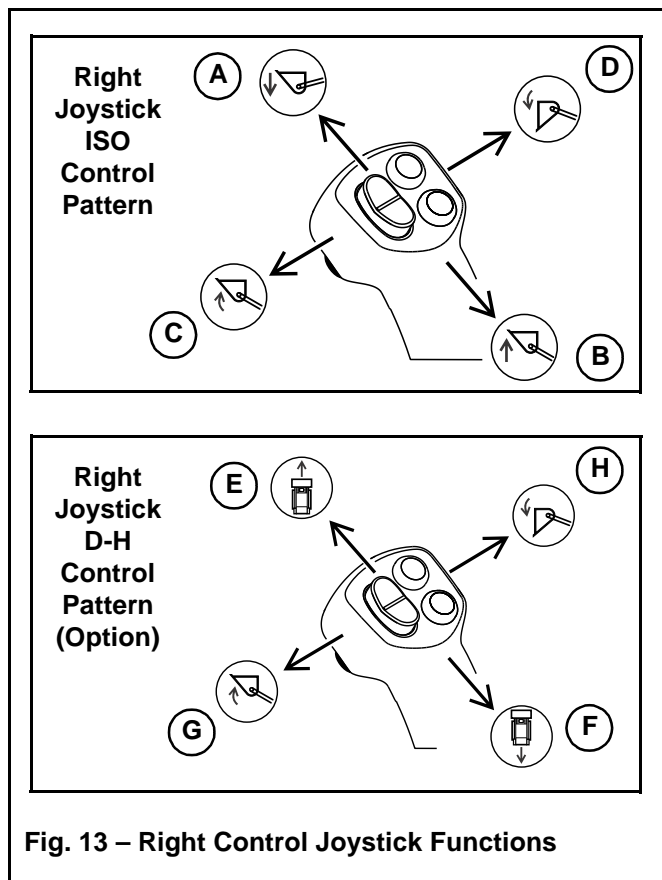

Fig. 13 – Right Control Joystick Functions

Joystick Buttons/Switch Functions

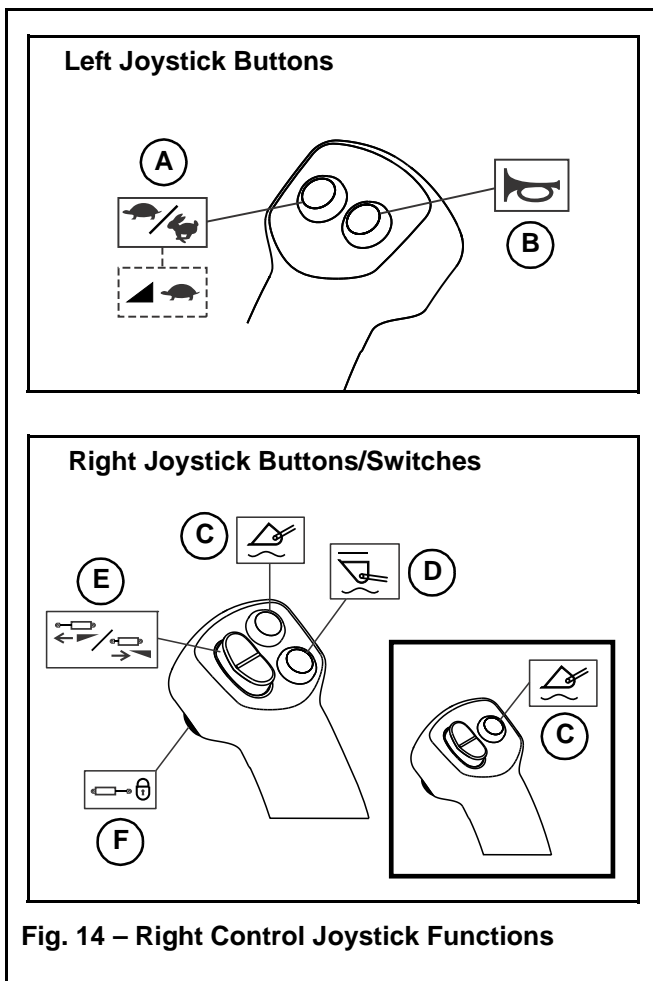

Fig. 14 – Right Control Joystick Functions

Table 28: Right Control Joystick Functions

	Joystick Direction	Function
ISO Control Pattern		
A	Forward	Lift arm – down
B	Backward	Lift arm – up
C	Left	Attachment tilt – tilt back
D	Right	Attachment tilt – tilt forward
D-H Control Pattern (Optional)		
E	Forward	Track drive – right track forward
F	Backward	Track drive – right track reverse
G	Left	Attachment tilt – tilt back
H	Right	Attachment tilt – tilt forward

Table 29: Joystick Button Functions

Button	Function
Left Joystick Buttons	
A	High/low drive speed selection (See “Travel Speed Range Selection” on page 57)
B	Horn
Right Joystick Buttons/Switch	
C	Lift arm float (See “Lift Arm Float” on page 79)
D	Hydraglide™ (See “Hydraglide™ Button (Option)” on page 59 and “Hydraglide™ Ride Control System (Option)” on page 79)
E	Auxiliary hydraulics flow (See “Powering Attachments with Hydraulic Function” on page 85)
F	Auxiliary hydraulics continuous flow lock (See “Auxiliary Hydraulics Operation” on page 86)
	Auxiliary hydraulics continuous flow will remain locked with the restraint bars in the raised position with the operator seat not occupied.

Joystick Control Sensitivity

The sensitivity of the ISO drive controls can be configured to be more or less aggressive/immediate. Five levels of control sensitivity are available.

Configuring Control Sensitivity

1. Hold down the interface button (Z, Fig 15) on the multi-function display for 5 seconds.

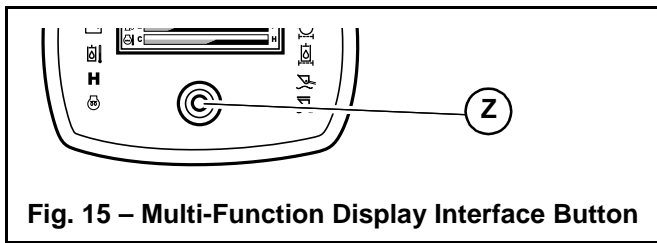

Fig. 15 – Multi-Function Display Interface Button

2. Press and release the interface button until the selection caret points to the / control sensitivity selection (Y, Fig 16). Press and hold the interface button for 5 seconds.

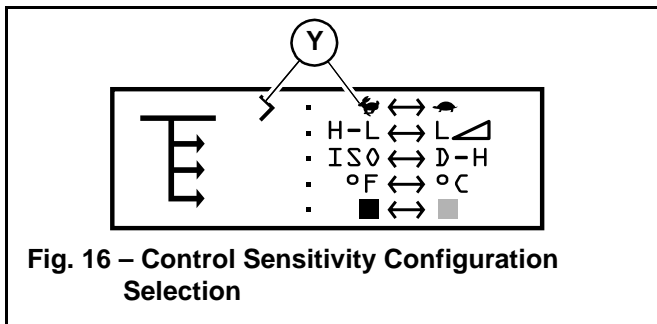

Fig. 16 – Control Sensitivity Configuration Selection

3. Press and release the interface button as required to select the desired level of control sensitivity (Fig 17). Five levels of control sensitivity are available.

Move the selection caret toward the top of the screen (V []) for more aggressive and immediate control sensitivity; move the selection caret toward the bottom of the screen (X []) for less aggressive and more relaxed control sensitivity.

Press and hold the interface button for 5 seconds to save control sensitivity configuration changes.

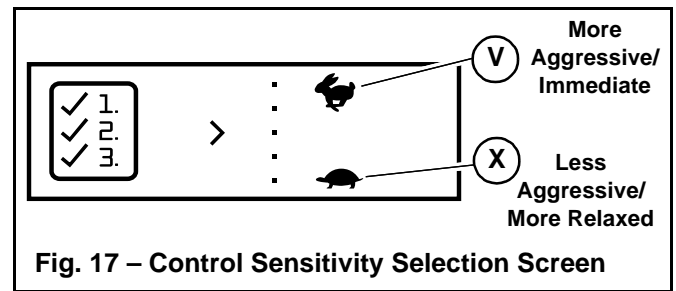

Fig. 17 – Control Sensitivity Selection Screen

4. Press and release the interface button until the selection caret points to the “EXIT” selection (W, Fig 28). Press and hold the interface button for 5 seconds. The currently selected control sensitivity is now activated.

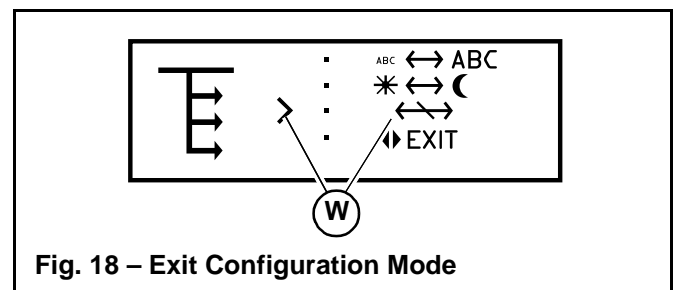

Fig. 18 – Exit Configuration Mode

Controls

Parking Brake/Work Hydraulics Lock-out

The parking brake is automatically applied whenever either of the safety bars/arm rests are in the raised position (B, Fig 19).

NOTE: *Raising the safety bars/arm rests also locks out work hydraulic functions.*

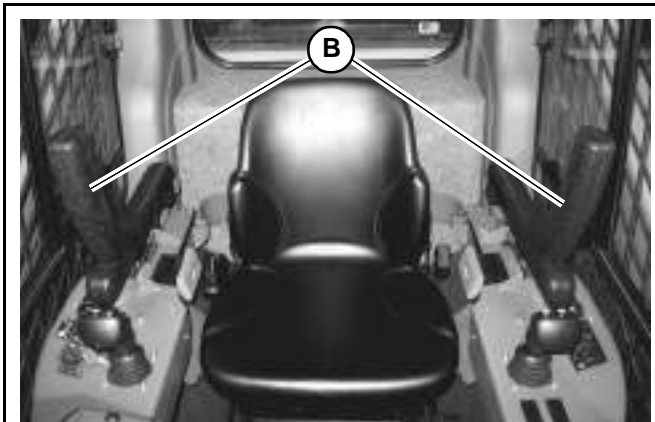

Fig. 19 – Safety Bars/Arm Rests in Raised Position

NOTE: *The parking brake is also applied whenever the operator leaves the seat, or if the cab door is opened.*

IMPORTANT: *The engine cannot be started with the safety bars/arm rests in the raised position, if the operator is not in the operator's seat, or if the cab door is not closed.*

Cab Heat and Air Conditioning (Option)

Controls for cab heat and air conditioning are located on the left control panel. The same controls are used to control both heating and air conditioning.

Control the heat/air conditioning fan using knob (A). Turning the switch clockwise increases fan speed; counter-clockwise decreases fan speed; all the way counter-clockwise turns heat/air conditioning off.

Control the heat/air conditioning output temperature using knob (B). Turn the switch clockwise for warmer temperature; counter-clockwise for cooler temperature.

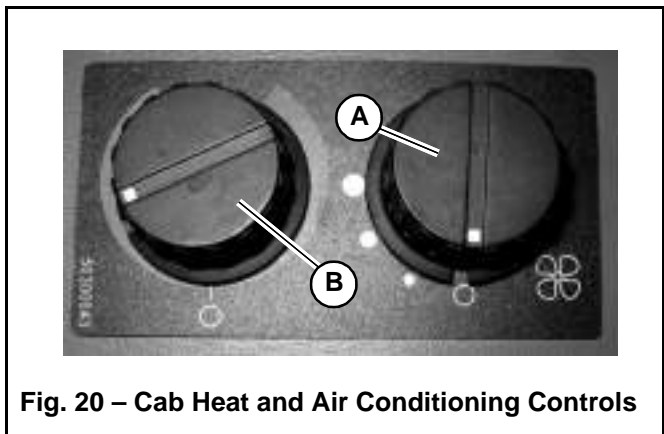

Fig. 20 – Cab Heat and Air Conditioning Controls

Operator's Seat

The operator's seat has adjustments for:

- Forward and back horizontal position (G, Fig. 21).
- Up and down vertical height/weight suspension (E).

WARNING

Never adjust the seat when the machine is in operation. Adjust the seat only when the machine is stopped and the arm rests/safety bars are in the raised position.

After adjustments, make sure the seat adjustment levers are fully engaged before using the machine.

Seat Forward and Back Horizontal Adjustment

While sitting in the operator's seat, pull up on handle (G, Fig. 21). Move the seat and control lever base forward or back as desired. Release bar (G) when the seat is in the desired position. Make sure the seat is locked in position after adjusting.

Seat Height Vertical Height/Weight Suspension Adjustment

Air Suspension

While sitting in the operator's seat, press the left/right side of toggle switch (H) as necessary to compensate for the drivers weight and preferred seat suspension stiffness. Toggle switch (H) to the left (J) to reduce support; toggle switch to the right (K) to increase support.

Mechanical Suspension

While sitting in the operator's seat, turn knob (E, Fig. 21) as necessary to center the black line on the yellow background in indicator (F).

Seat Belt

WARNING

ALWAYS fasten the seat belt securely and properly. Never operate the machine without the seat belt fastened around the operator.

Keep the seat belt clean; dirt can impair seat belt operation. Check seat belt condition regularly and have damaged or worn belts immediately repaired by an authorized workshop.

After an accident the seat belt strap is stretched and must be replaced with a new strap installed by an authorized workshop.

Make sure the seat belt is not twisted when it is fastened, and that it is fastened over the hips and not the stomach.

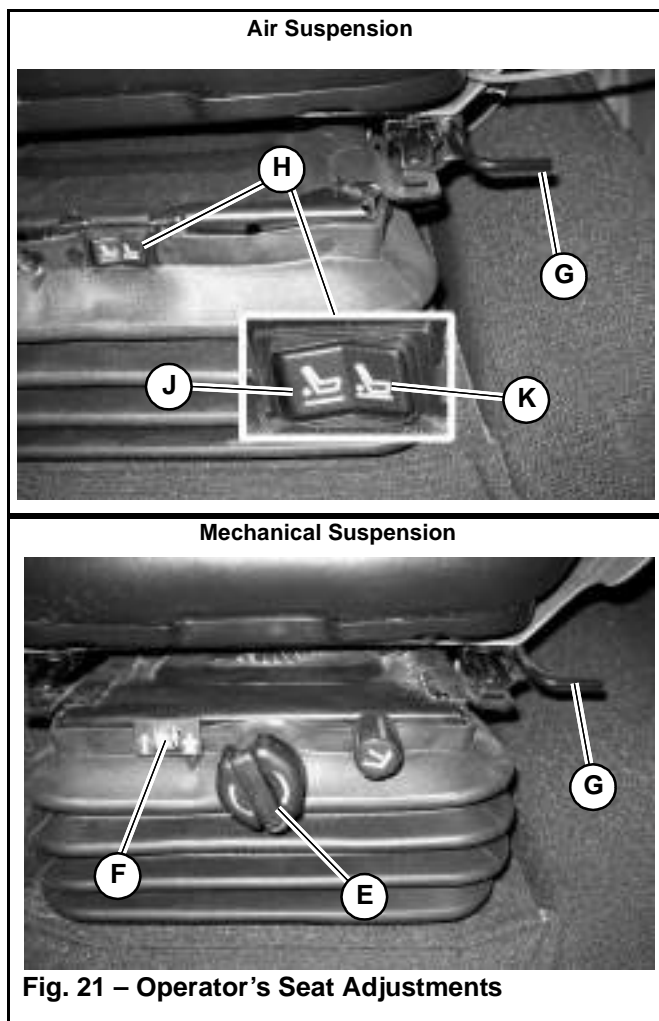

Fig. 21 – Operator's Seat Adjustments

Controls

Fasten the seat belt tightly and securely. Remove hard, edged or fragile objects from your pockets or clothes that might lie between the seat belt and your body.

Fastening/Unfastening the Seat Belt

Fasten the seat belt around your hips and waist and insert tongue (A, Fig 22) into buckle (B) until it clicks securely in place. Slack in the seat belt should automatically retract into seat belt spool (K).

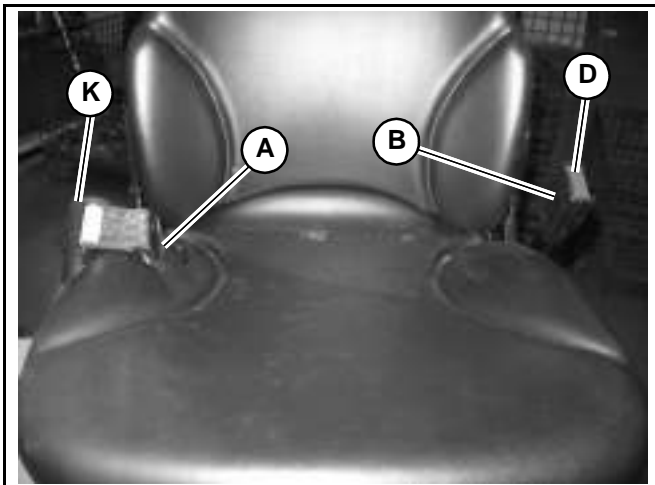

Fig. 22 – Seat Belt



If the seat belt spool does not retract slack in the seat belt, have it serviced immediately. Do not operate the machine until the seat belt is repaired.

Unfasten the seat belt by pressing button (D).

Throttle Controls

Engine throttle controls engine speed, which determines available power.

Engine throttle is controlled with both a knob (I, Fig 23) and a pedal (J).

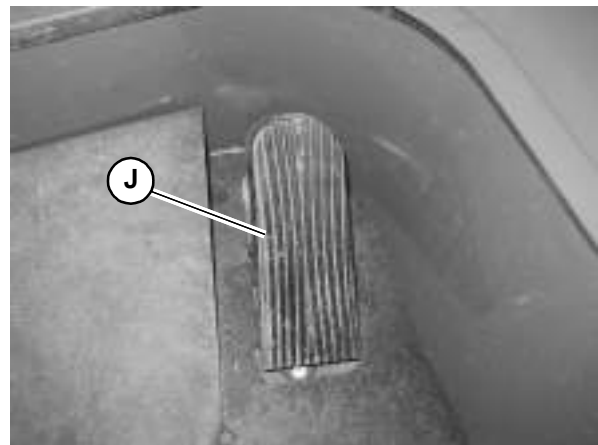

Fig. 23 – Throttle Knob and Pedal

The throttle knob (I) is the primary throttle control. Generally, the throttle is set with the knob to the desired idle/run position. The pedal can then be used to increase engine speed whenever additional power is required. When the pedal is released, the engine returns to the speed set by the throttle knob.

Travel Controls

Forward, reverse and turning functions are performed using the control joysticks. See “Control Joysticks” on page 50.

Travel Speed Range Selection

The machine has 2 travel speed ranges and one changeable speed limit option.

Pressing the speed range select button (K, Fig 24) on the left control joystick toggles between the two speed ranges. Indicator (H) is lit when the high-speed travel range is selected; indicator (H) goes out when low-speed range is selected.

NOTE: *Low-speed range is automatically selected when the machine is started.*

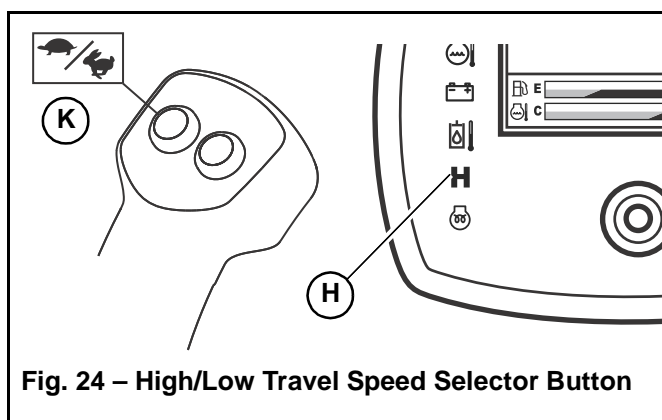

Fig. 24 – High/Low Travel Speed Selector Button

- Low-speed range:
 - Model RT175: 0-8.2 kph (0-5.1 mph).
 - Model RT210: 0-8.7 kph (0-5.4 mph).
- High-speed range:
 - Model RT175: 0-12.1 kph (0-7.5 mph).
 - Model RT210: 0-12.7 kph (0-7.9 mph).

NOTE: *Use the low-speed range for loading, unloading, and operations requiring precise speed control. Use the high-speed range for distance traveling.*

Travel Speed Limit (Option)

Travel speed limiting allows for fine control over slower travel speeds.

When the travel speed limit option is activated, ten levels of speed limiting can be selected using the high/low speed selector button (K, Fig 29).

Activating Travel Speed Limit Option

NOTE: *Machines not equipped with the travel speed limit option will not display the travel speed limit selection screen.*

1. Hold down the interface button (Z, Fig 25) on the multi-function display for 5 seconds.

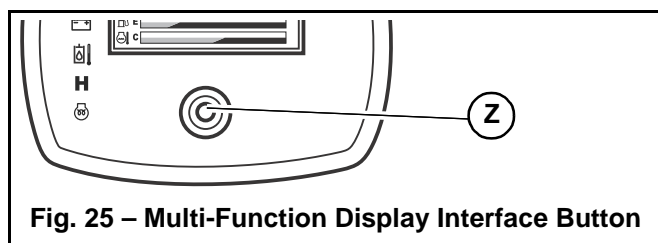

Fig. 25 – Multi-Function Display Interface Button

2. Press and release the interface button until the selection caret points to the travel speed limit configuration selection (Y, Fig 26). Press and hold the interface button for 5 seconds.

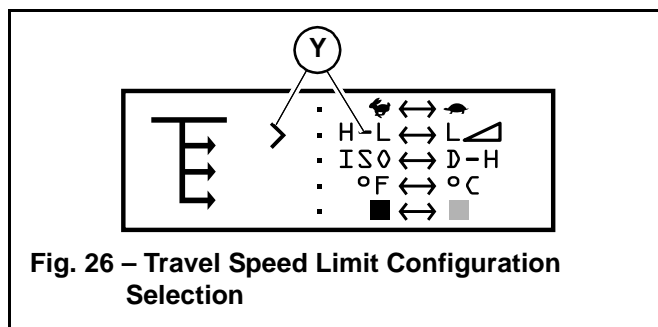

Fig. 26 – Travel Speed Limit Configuration Selection

3. Press and release the interface button until the selection caret points to the travel speed limit selection (X, Fig 27). Press and hold the interface button for 5 seconds.

Controls

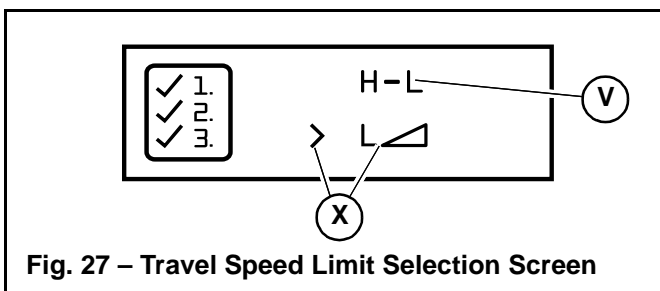

Fig. 27 – Travel Speed Limit Selection Screen

- Press and release the interface button until the selection caret points to the “EXIT” selection (W, Fig 28). Press and hold the interface button for 5 seconds. The travel speed limit option is now activated.

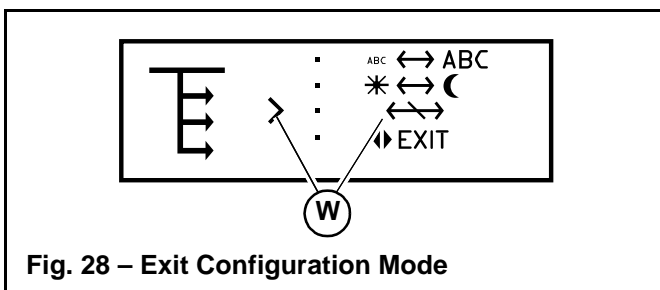

Fig. 28 – Exit Configuration Mode

Deactivating Travel Speed Limit Option

Travel speed limit option deactivation is identical to activation, with the exception of moving the selection caret to the “H-L” selection (V, Fig 27).

Travel Speed Limit Option Operation

When the travel speed limit option is activated, the currently enabled speed limit range is displayed in the top right corner of the multi-function display screen (L, Fig 29).

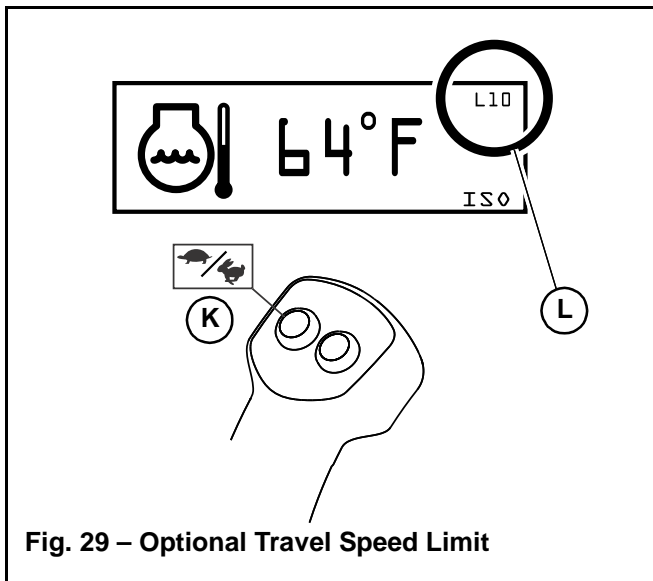

Fig. 29 – Optional Travel Speed Limit

Pressing the speed range selection button when the travel speed limit option is activated changes the speed limit range. Ten speed limit ranges are available and limit the travel speed to the following ranges when selected:

Table 30: Travel Speed Limit Option Settings

Speed Limit Range (L)	% of Available Speed Range:
L10	Not limited
L9	90%
L8	80%
L7	70%
L6	60%
L5	50%
L4	40%
L3	30%
L2	20%
L1	10%

Lift Arm Float Button



Make sure the bucket is lowered to the ground before activating the lift arm float. Activating float with an attachment raised will cause it to fall rapidly to the ground, which can cause severe injury or death.

Lift arm float is activated by lowering the attachment to the ground and using button (A, Fig. 30) on the right joystick. Press button (A) to activate float; press and hold button (A) for 5 seconds to engage continuous float activation. Press button (A) and quickly release to deactivate float.

NOTE: Indicator  on the multi-function display is lit whenever float is activated.

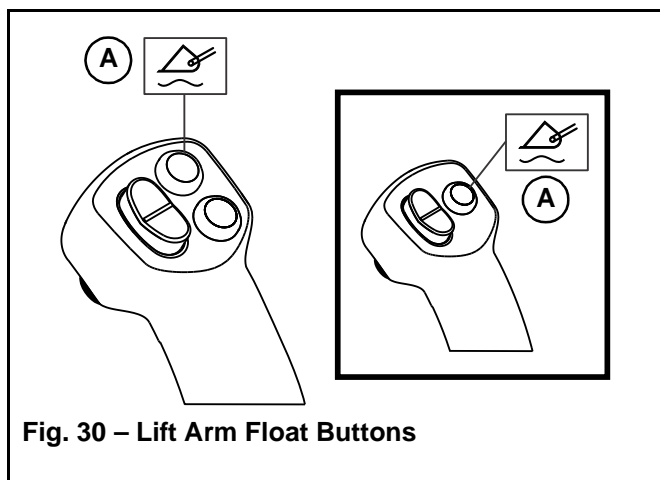

For lift arm float operation information see “Lift Arm Float” on page 79.

Hydraglide™ Button (Option)

Hydraglide™ cushions and dampens the movements of the lift arm. It eliminates unstable lift arm oscillation and increases drive comfort and safety.

On the right joystick, press switch (H, Fig 31) to toggle Hydraglide™ on/off.

NOTE: Indicator  on the multi-function display is lit whenever Hydraglide™ is activated.

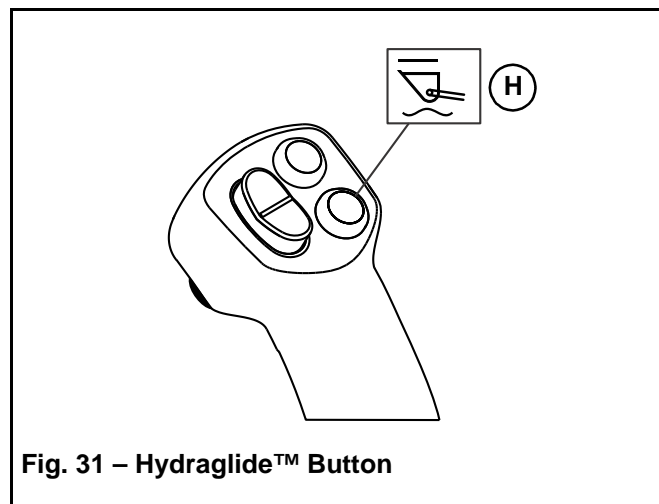

For Hydraglide™ operation information see “Hydraglide™ Ride Control System (Option)” on page 79.

Controls

Work Lights

The switches for the work lights are located on the right console.

Work Lights



Switch off the work lights when traveling on public roads. Work lights can dazzle motorists and cause accidents.

The front and back work lights operate using the same 3-position switch (Y, Fig 32).

Set switch (Y) to the middle position (V) to turn on the front work lights.

Set switch (Y) to the top (Z) position to turn both the front and back work lights on.

Set switch (Y) to the bottom (X) position to turn the work lights off.

NOTE: Indicator (W) is on when the work lights are activated.

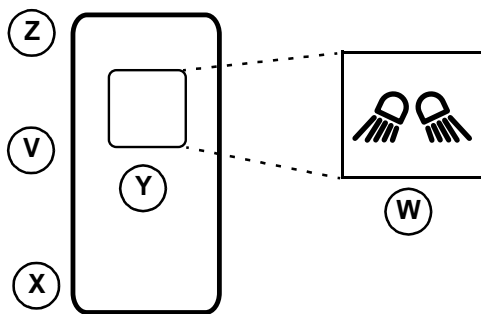

Fig. 32 – Work Light Switch

Battery Disconnect Switch (Option)

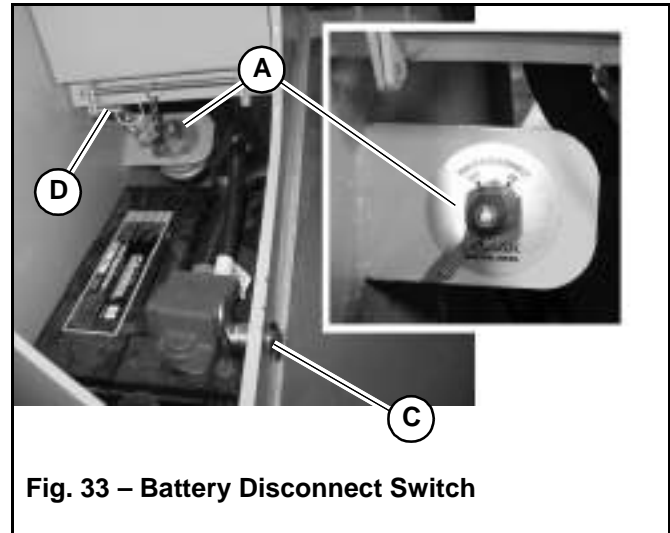

Fig. 33 – Battery Disconnect Switch

Before the engine can be started, the battery disconnect switch must be in the “on” position. The battery disconnect switch (A, Fig 33) is located inside the battery compartment in the back left corner of the machine.

Open the battery compartment using the key supplied with the ignition key in lock (C). Open the battery compartment cover and prop the cover open using pin (D).



Always prop the battery compartment cover open using pin (D). Severe injuries can result if the battery compartment cover falls on hands and/or fingers.

To disconnect the battery from the electrical system and disable all electrical functions: Turn the switch counter-clockwise to the “OFF” position.

To connect the battery to the electrical system and enable all electrical functions: Turn the switch clockwise to the “ON” position.

Windshield Wipers/Washer

Wiper/Washer Control

Press bottom (A, Fig 34) of wiper switch (C) to activate the wipers. Press and release top (B) of wiper switch (C) to turn the wipers off.

NOTE: Indicator (D) is on when the wipers are activated.

Push and hold top (B) of wiper switch (C) to activate the washer spray. Release the button to stop the spray.

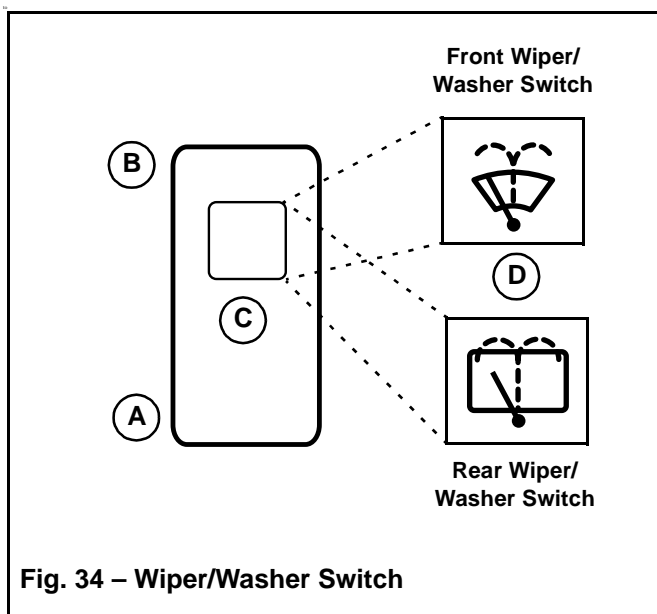

Washer Fluid Reservoir

See “Windshield Washer Reservoir” on page 127 for windshield washer reservoir location and filling information.

NOTES

Operation



WARNING

Read and understand this entire manual. Follow warnings and instructions for operation and maintenance. Failure to follow instructions can result in injury or death.

Read and understand all safety decals before operating the machine. DO NOT operate the machine unless all factory-installed guards and shields are in place.

Be sure you are familiar with all safety devices and controls before operating the machine.

Know how to stop the machine before starting.

Use only Manitou-approved accessories or referral attachments. Manitou Americas, Inc. cannot be responsible for safety if the machine is used with non-approved accessories or attachments.

Check for correct function after adjustments or maintenance.

Operational Checks

Pre-Start Checks

Complete these checks before starting the engine and using the machine. Repair any problems before using the machine.

Table 31: Pre-Start Checks

Check	Refer To:
Fuel tank filled?	"Adding Fuel" on page 110
Engine oil level correct?	"Checking Engine Oil Level" on page 104
Hydraulic system oil level correct?	"Checking Hydraulic Oil Level" on page 112
Engine coolant level correct?	"Checking Coolant Level" on page 107

Table 31: Pre-Start Checks

Check	Refer To:
Windshield washer reservoir filled?	"Windshield Washer Reservoir" on page 127
Grease fittings properly lubricated?	"General Lubrication" on page 119
V-belt condition good/tension adjustment correct?	"Checking and Adjusting V-belt Tension" on page 109
Track condition good	
Lights, signals, indicators, warning lights, indicators and horn operating properly?	"Work Lights" on page 60
Windows, lights and steps clean?	
Attachment securely fastened to hitch?	"Connecting Attachments" on page 83
Overall machine condition (including attachments) for bends, cracks, broken or missing parts, etc.	
Engine cover securely closed and latched?	"Engine Access" on page 103
Rags, tools, debris and other loose objects removed? (check especially after maintenance)	
Approved warning triangle, hazard warning light and first aid kit in the machine?	If required by local regulations
Seat position correctly adjusted?	"Seat Adjustment" on page 65
Seat belt fastened?	"Seat Belt" on page 65
Parking brake applied?	"Parking Brake" on page 66

Operation

Checks During Operation

Complete these checks after starting the engine and during operation.

Table 32: Checks During Operation

Check	Refer To:
After Starting the Engine/During Operation	
Engine oil pressure and charge indicator lights not on?	"Multi-Function Display Interface Button" on page 46
Park brake operating properly?	"Travel Drive Operation" on page 71
Coolant temperature within specification?	"Multi-Function Display Interface Button" on page 46
Track drive/steering operating properly?	"Travel Drive Operation" on page 71
Engine exhaust excessively smoky?	
Anyone hazardingly close to the machine?	
Visually check if automatic track tensioning is operating correctly.	
When Driving on Public Roads	
Attachments in transport position?	"Attachment Transport Position" on page 76
Machine work hydraulics locked-out?	"Parking Brake/Work Hydraulics Lock-out" on page 54

Parking Checks

Complete these checks when parking the machine.

Table 33: Parking Checks

Check	Refer To:
When Parking	
Attachments lowered to the ground?	
Parking brake applied?	"Parking Brake/Work Hydraulics Lock-out" on page 54
Machine cab locked (especially if the machine will not be supervised).	
When Parking on Public Sites	
Machine adequately secure/cab locked?	

Before Operation

Cab Entry and Exit

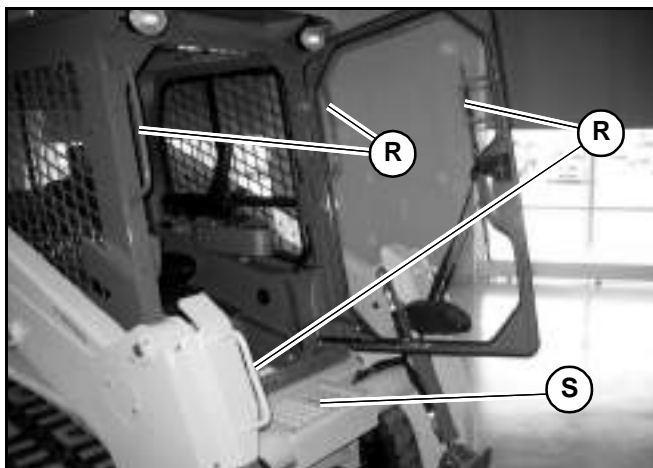

Fig. 35 – Cab Entry/Exit Handles/Steps

⚠ WARNING

Use only step (S, Fig 35) and handles (R) on the machine when entering/exiting the cab.

Keep the steps and the handles clean to ensure a secure hold at all times.

Never use the control joysticks as hand holds.

Always face the machine when entering/exiting.

When entering/exiting the cab, open the door fully to the locked position and check that it does not move (machines equipped with cab door).

Do not jump on or off the machine. Never climb onto or exit a moving machine.

Remove dirt (oil, grease, earth, snow and ice) from handles (R), steps (S) and your shoes before entering the cab.

Opening/Closing the Cab Door (Option)

Operate the door latch outside the cab using button (Z, Fig 36) on the exterior door handle.



Fig. 36 – Cab Exterior Door Handle

Lock/unlock the door using the ignition key in the key slot in button (Z).

Operate the door latch inside the cab by lifting lever (Y, Fig 37) located along the interior door frame.



Fig. 37 – Cab Interior Door Lever

Seat Adjustment

Adjust the operator's seat according to "Operator's Seat" on page 55.

WARNING

Never adjust the seat when the machine is in operation. Adjust the seat only when the machine is stopped and the parking brake is applied.

All controls must be within easy reach. The operator must be able to move the throttle pedal and the control joysticks through the complete range of motion.

After adjustments, make sure levers for seat adjustments are fully engaged before using the machine.

Seat Belt

Fasten the seat belt around your hips and waist and insert tongue (A, Fig 38) into buckle (B) until it clicks securely in place. Slack in the seat belt should automatically retract into seat belt spool (K).

WARNING

Never operate the machine without the seat belt fastened. Repair or replace any damaged seat belt and lock parts before operation.

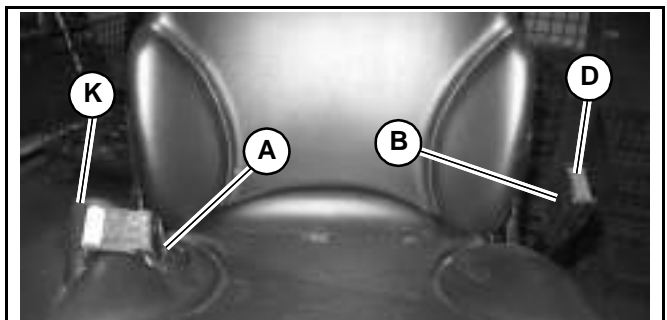

Fig. 38 – Seat Belt

Operation

WARNING

If the seat belt spool does not retract the slack in the seat belt, have it serviced immediately. Do not operate the machine if the seat belt is not fastened and working properly.

NOTE: Unfasten the seatbelt by pressing button (C).

Parking Brake

The parking is automatically applied whenever either of the safety bars/arm rests are in the raised position (B, Fig 39), the operator leaves the seat or the cab front door is opened.

Before starting the engine, sit in the operator's seat and lower the safety bars/arm rests. On machines equipped with a cab, close the door.

NOTE: Raising the safety bars/arm rests, leaving the operator's seat or opening the cab door also locks out work hydraulic functions, with the exception of standard auxiliary hydraulics continuous flow.

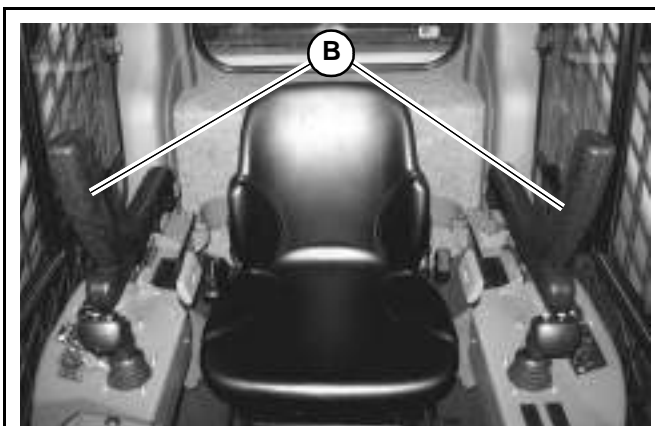

Fig. 39 – Safety Bars/Arm Rests in Raised Position

IMPORTANT: The engine cannot be started if the safety bars/arm rests are in the raised position, the cab door is open or the operator is not in the seat.

Disengage Parking Brake

1. Sit in the operator's seat and fasten the seat belt.
2. Close the cab door, if equipped.
3. Lower the safety bars/arm rests.
4. Start the engine.

NOTE: If the engine does not start due to failure to perform any of steps 1-3, the error code "0" is displayed on the multi-function display.

5. Press and hold the top of the parking brake switch (C, Fig 40) for several seconds until the indicator lights in the switch and on the multi-function display go out.

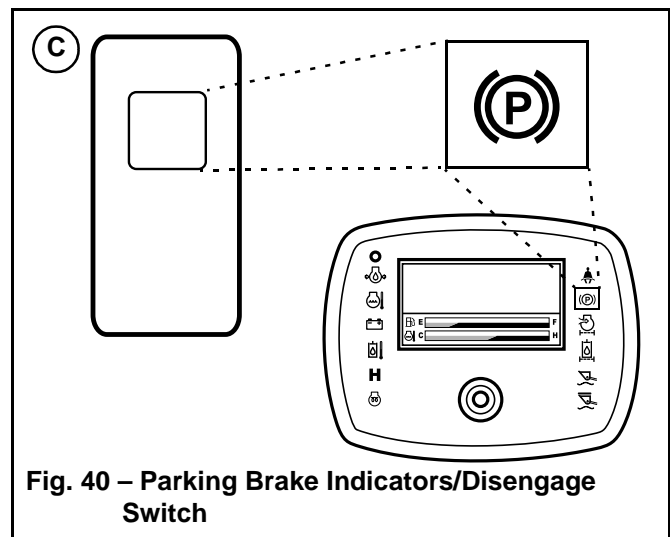

Fig. 40 – Parking Brake Indicators/Disengage Switch

Starting the Engine

NOTE: *The machine cannot be push- or tow-started. Attempting to push/tow start the machine may damage the drive systems of both the machine and the push/tow vehicle.*

1. Complete the “Pre-Start Checks” on page 63.
2. Sit in the operator’s seat and adjust the seat as required.

CAUTION

All controls must be within easy reach. The operator must be able to move the throttle pedal and the control joysticks through the complete range of motion.

3. Fasten the seat belt.

WARNING

Always fasten the seat belt before operating the machine. Repair or replace any damaged seat belt and lock parts before operation.

4. Close the cab door, if equipped.
5. Lower both arm rests/safety bars.

IMPORTANT: *The arm rests/safety bars must be lowered before the engine can be started. An engine error code (0) will display on the multi-function display if the ignition is switched to the start position when the arm rests/safety bars are in the raised position, the operator’s seat is not occupied or the cab door is not closed.*

6. Insert the ignition key into the ignition switch (T, Fig 41) and turn the key clockwise to the first detent. Indicators on the multi-function display should light up; a beeping tone will sound for a few moments as a reminder to fasten the seat belt. The battery voltage and pre-heat indicators might stay lit for 3-30 seconds.

NOTE: *The pre-heat indicator may stay on for longer periods in colder ambient temperatures.*

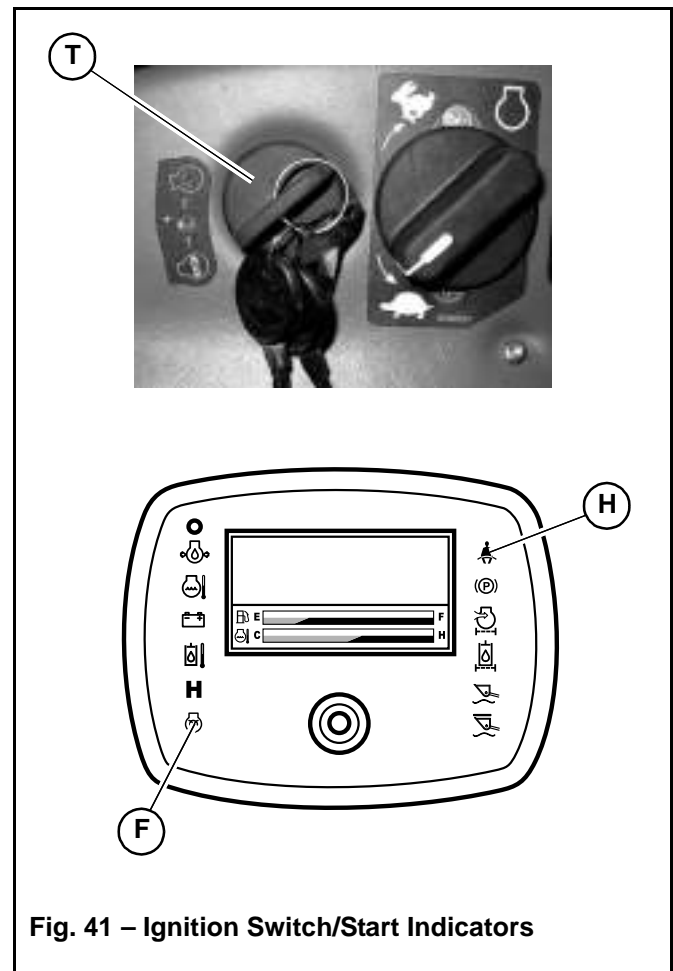

Fig. 41 – Ignition Switch/Start Indicators

NOTE: *When the key is turned clockwise to the first detent, seat belt indicator (H) activates and a tone sounds if the seat belt is not fastened.*

7. When the cold start indicator light (F) goes out, Turn the ignition key clockwise until the starter activates. Release the key when the engine starts.
8. If the engine does not start after 15 seconds, turn the ignition key all the way counter-clockwise, wait 1 minute and repeat steps 6-8. If the engine does not start after several attempts, see “Engine Troubleshooting” on page 133.
9. Disengage parking brake according to “Disengage Parking Brake” on page 66.

Operation

After Starting

1. Check that charge (F, Fig 41) indicator goes out after the engine starts.

IMPORTANT: *If the charge and/or the engine oil pressure indicators do not go out when the engine is running, shut down the engine immediately and correct the problem. Damage to the engine may result if engine is run and the problem is not corrected.*

IMPORTANT: *Do not run a cold engine at full throttle when starting. Stressing a cold engine can damage the engine. Perform the following warm up procedure before using the machine after starting.*

IMPORTANT: *When the machine is not under load, do not run the engine at high speed (above 20% of full throttle) for extended periods of time. Damage to the engine can result.*

Warm Up



Operating the work hydraulics before the hydraulics are warmed up is dangerous, because response will be slow and the machine might move in unexpected ways. Be sure to sufficiently warm up the machine before starting work.

IMPORTANT: *Do not operate the control joysticks suddenly until the hydraulic oil has reached operating temperature.*

1. After starting, allow the engine to run at low idle for a minimum of 5 minutes with no load (no drive, lift, tilt or auxiliary hydraulic functions).
2. Run the engine at 1800 rpm with no load for 5 minutes.
3. Raise the lift arm so the attachment is off the ground.
4. Extend and retract each of the cylinders several times with no load.
5. Travel slowly forward and backward several times.

6. Additionally, in cold weather, tilt the attachment all the way forward and keep it there for 20-25 seconds. Repeat this step until the attachment tilt speed is normal.

Run-In Period

The performance and service life of the machine is heavily dependent on using the machine carefully during its first 100 operating hours.

- Do not operate machine at the maximum rated operating capacity.
- Do not run the engine at a high speed for extended periods of time.
- Increase the load gradually while varying the engine speed.
- Follow the maintenance schedule. See “Maintenance Schedule” on page 100.

Stopping the Engine

Perform the “Mandatory Safety Shutdown Procedure” on page 16.

IMPORTANT: *Do not stop the engine at full throttle. Damage to the engine can result. Allow the engine to idle for approximately 2 minutes before shutting it off.*

After Operation



Park the machine on firm, level ground. Raise the arm rests/safety bars to apply the parking brake and lock out the hydraulic controls.

Never leave the engine running if leaving the machine unattended.

WARNING

Always apply the lift arm support if leaving the machine with the lift arm in the raised position. See “Lift Arm Support” on page 81.

If you must park on a slope or an incline, park across the slope and block the machine to prevent movement.

WARNING

If parking on a street, use barriers, caution signs, lights, etc. to increase the visibility of the machine and prevent collisions. This is especially important at night, during bad weather and in high-traffic areas.

After performing the “Mandatory Safety Shutdown Procedure” on page 16, perform the following tasks and checks:

- Check for coolant, fuel and/or oil leaks. Inspect all hoses, working components, covers and chassis for damage or advanced wear. Repair or replace damaged, leaking, worn or otherwise compromised components before starting the machine again.
- Fill the fuel tank. See “Fluids/Lubricants Types and Capacities” on page 31.
- Remove any dirt and/or debris from the engine compartment.
- Remove any mud from the chassis. Clean any dirt or water from the cylinder rod surfaces to prevent corrosion and protect the cylinder seals.
- If parking the machine for an extended period, lock the cab door, the storage compartment, the battery and hydraulic filler compartments and the engine compartment. Take the keys with you.

Jump-Starting

WARNING

Do not jump-start a frozen battery, or it may explode. A discharged battery can freeze at 14°F (10°C).

IMPORTANT: *The external power source must deliver 12 volts. Supply voltages higher than 12V can damage the electrical systems of both machines. Only use authorized jumper cables that are in good condition.*

The booster battery must have a nominal voltage of 12-volts. The capacity (Ah, or Amp-hour rating) of the current-supplying battery must be approximately equal to that of the discharged battery. Factory-installed batteries are approximately 70 Ah capacity.

CAUTION

To minimized the risk of a short circuit, keep metal parts on your clothing and metal watchbands away from the positive (+) pole of the battery.

1. Turn the ignition switches of both machines to OFF. Be sure the machines are not touching each other. If the machine with the booster battery has a drive transmission, place the transmission into neutral and apply the parking brake.
2. Using the accessory key (supplied with the ignition key), unlock (H, Fig 42) and open the battery compartment located at the rear left corner of the machine. Open the battery compartment cover and prop the cover open using pin (D).

Operation



Fig. 42 – Battery Compartment

CAUTION

Always prop the battery compartment cover open using pin (D). Severe injuries can result if the battery compartment cover falls on hands and/or fingers.

3. Check that battery jumper cables have a sufficient diameter. Route the jumper cables so that they cannot catch on any moving objects or components.
4. Connect the positive jumper cable to the positive (+) terminal (S, Fig 43) on the discharged battery.

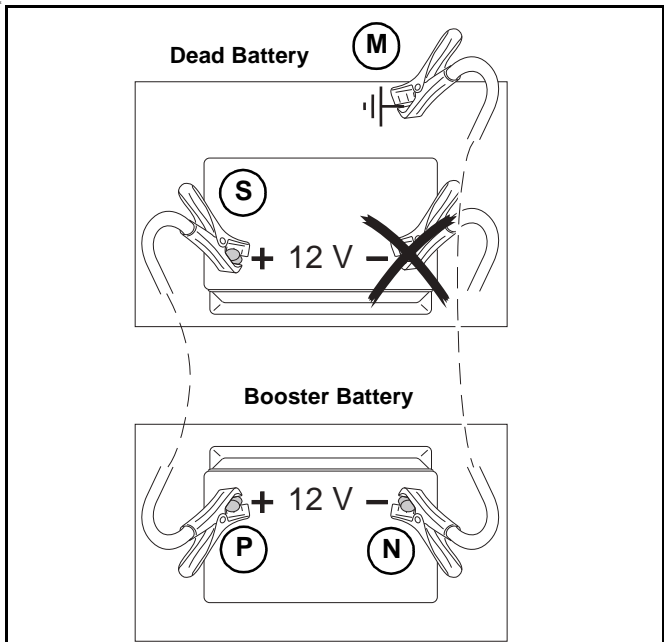

Fig. 43 – Booster Battery Connection

5. Connect the free end of the positive jumper cable to the positive (+) terminal (P) on the booster battery
6. Connect the negative jumper cable to the negative (-) terminal (N) on the booster battery.
7. Open the rear door of the engine compartment (“Engine Access” on page 103) and connect the free end of the negative jumper cable to the rear door catch (M, Fig 44) in the engine compartment.

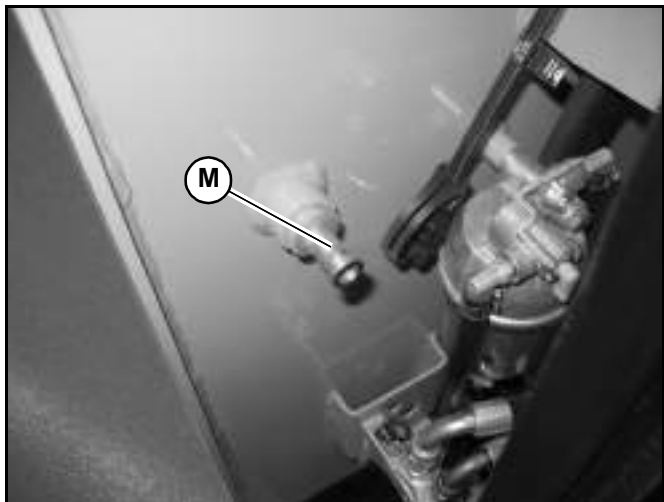

Fig. 44 – Chassis Ground/Rear Door Catch

 **WARNING**

Do not connect the other end of the jump lead to the negative terminal of the dead battery. Gas emerging from the battery may ignite if sparks are formed.

8. Start the machine with the discharged battery. See “Starting the Engine” on page 67. If the engine does not start immediately, stop cranking after 10 seconds and repeat starting procedure after approximately 30 seconds.

After the Engine Starts:

1. Disconnect the jumper cables in reverse order of steps 4 – 6 to avoid sparking near the battery.
2. Close the rear door and the engine cover according to “Closing Engine Covers” on page 103.
3. Allow the machine to run for at least 30 minutes to re-charge the battery.

Travel Drive Operation

 **WARNING**

Never allow anyone to enter inside the turning radius and the machine path.

Signal your intention to move by sounding the horn.

Traveling should be performed with the attachment in transport position. See “Attachment Transport Position” on page 76.

Avoid sudden stops, starts or turns.

Do not raise the arm rests/safety bars while traveling. Raising the arm rests/safety bars will apply the parking brake abruptly. Loss of control could result.

Do not switch off the ignition switch while traveling. Sudden braking will happen and loss of control could result.

Visual check behind you before traveling in reverse. Traveling in reverse without checking could result in collision with a person or obstacle.

Remove obstacles in the machine’s path before traveling with a load.

Operation

ISO Pattern Travel Drive Controls

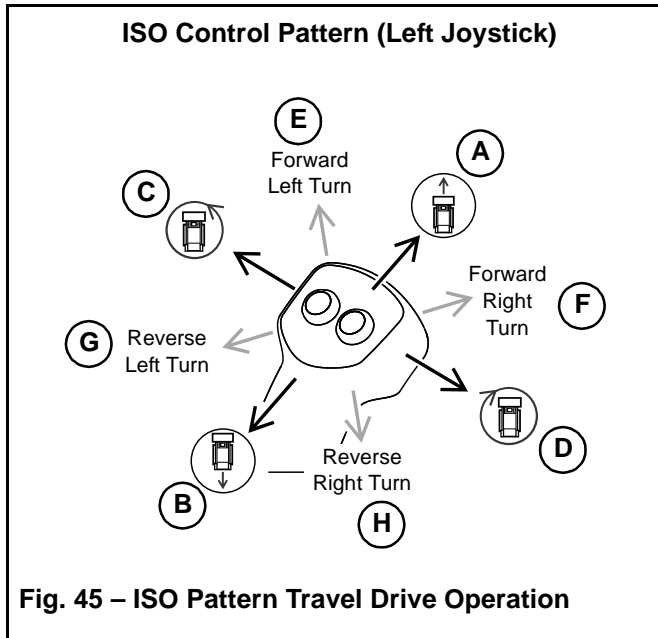

Fig. 45 – ISO Pattern Travel Drive Operation

ISO pattern travel drive is controlled exclusively using the left control joystick (Fig. 45):

- Push the left joystick forward to travel straight forward.
- Pull the left joystick rearward to travel straight in reverse.
- Tilt the left joystick to the left to spin-turn to the left.
- Tilt the left joystick to the right to spin-turn to the right.
- Tilt the left joystick diagonally forward and to the left to pivot turn forward and to the left.
- Tilt the left joystick diagonally forward and to the right to pivot turn forward and to the right.
- Tilt the left joystick diagonally rearward and to the left to pivot turn in reverse and to the left.
- Tilt the left joystick diagonally rearward and to the right to pivot turn in reverse and to the right.

D-H Pattern Travel Drive Controls (Option)

NOTE: See “Control Joysticks” on page 50 for information about switching to the optional D-H control pattern.

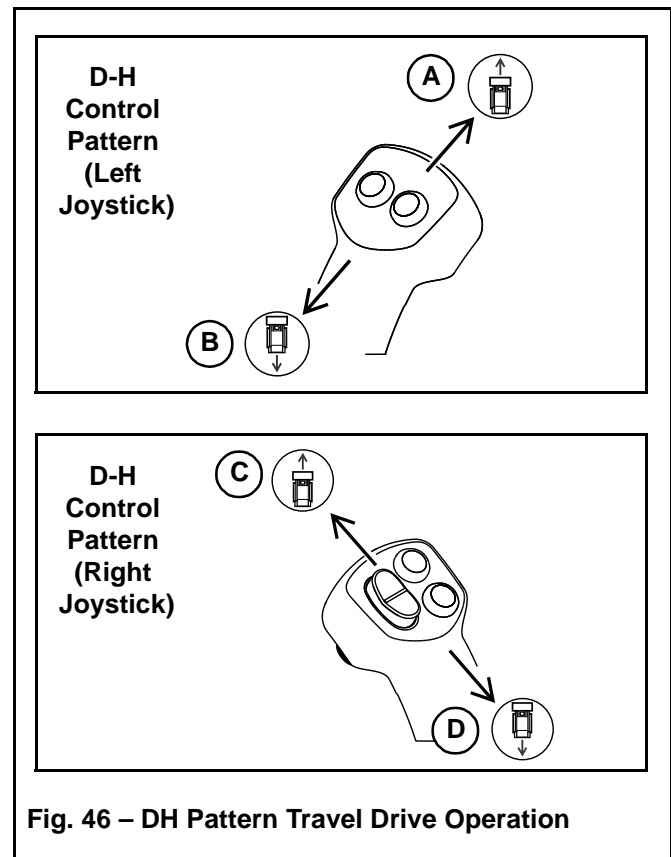

Fig. 46 – DH Pattern Travel Drive Operation

D-H pattern travel drive operation is shared between the right and left control joysticks (Fig. 46):

- Tilt the left joystick forward to drive the left track forward.
- Tilt the left joystick rearward to drive the left track in reverse.
- Tilt the right joystick forward to drive the right track forward.
- Tilt the right joystick rearward to drive the right track in reverse.

The left and right joysticks are used in combination for D-H pattern travel control.

- Both joysticks tilted forward: forward travel drive.
- Both joysticks tilted rearward: travel drive in reverse.

- One joystick forward/other joystick rearward: spin turns.
- One joystick forward more than other: pivot turns.

Rubber Track Use Cautions and Tips



CAUTION

If possible, avoid traveling over broken or jagged stone, metal objects, or other sharp objects that could damage or cut the tracks.

If possible, avoid traveling in areas with loose rocks that could get stuck in the tracks, or between the tracks and the track wheels.

Avoid using the machine in salt water areas. Salt can corrode the metal cores in the tracks.

Clean any fuel, oil, salt, fertilizer or chemical solvents that might get on the tracks. These substances could corrode the metal cores in the tracks.

Avoid traveling on roads immediately after asphaltting, or on other hot surfaces or over fires. Damage to the tracks could result.

If climbing steps or cobblestone, avoid climbing at an angle. Climb straight up the slope and do not change course at the top of the slope.

When climbing slopes. Do not suddenly change course at the point where the slopes starts.

Avoid traveling with one track on a slope or other raised surface and the other track on a flat surface.

Avoid sharp and spin turns on concrete surfaces.

Avoid drops that cause severe blows to the tracks.

Avoid rubbing the sides of the tracks against walls or other vertical surfaces.

NOTE: *Track damage caused by heavy and/or abusive use is not covered under warranty. Damaged tracks cannot be repaired and must be replaced.*

Operation

To extend track life, track tension is loosened when the engine is not running. When the engine is started, the tracks automatically adjust to the correct tension. Monitor the tracks at startup to ensure proper operation of automatic track tensioning. Tracks running loose can de-track. Over-tightened tracks can cause power loss, excessive roller and idler bearing wear, and track tearing.

Tracks and undercarriage should be cleaned on a regular basis. Mud or debris buildup in the track rollers or undercarriage structure can cause track wear, the tracks to be crowded off the rollers, and may even prevent roller rotation, leading to roller or track failure.

Change turning direction whenever possible. Always turning to the same side can accelerate wear of sprocket teeth, track tread, guide lugs and roller flanges.

Unnecessarily spinning the tracks can cause accelerated wear or track cutting. Use the engine power and lift/tilt hydraulics to dig into material, when filling a bucket, to minimize track slippage.

Avoid making spin turns or pivot turns, which can cause accelerated wear and de-tracking. Make wide turns whenever possible.

Don't allow the track sides to strike against concrete curbs or walls.

Working in heavily stone-laden soils or conditions may cause tracks to be de-tracked or damaged due to stones becoming lodged in the idler or drive sprockets.

Rubber tracks are not intended for use in any type of quarry application, recycling or demolition use.

Rubber track loaders are not intended for use with cold planers.

Avoid routinely driving and turning on asphalt and concrete to minimize wear.

Travel Drive Error Condition Operation (Limp Mode)

For safety reasons, drive system error conditions 3-10 (see “Drive and Valve Error Codes” on page 142) will disable the drive system.

In order to transport the machine to a service area to correct the error condition, two alternate transport modes are provided:

- Limp mode (X, Fig. 47) – results from drive error codes 7-10.
- Open loop mode (Y) – results from drive error codes 3-6.

WARNING

Use extreme care when using alternate transport modes to compensate for the resulting loss of drive control. Alternate transport modes will not correct the drive error condition. Because of this, the following drive conditions will exist when using alternate transport modes:

- **Limp Mode (X):** Loss of forward or reverse on one of the tracks.
- **Open Loop Mode (Y):** Jerky drive control operation, even at low engine speed.

Drive very slowly and at the lowest possible engine speed when using either alternate transport mode. Keep bystanders well away from the machine when using either alternate transport mode.

3. Make sure the error code 7-10 is displayed on the multi-function display and press and hold the interface button (Z) on the display for 3 seconds. When either the limp mode (X) or the open loop mode (Y) screen displays, an alternate transport mode is activated.

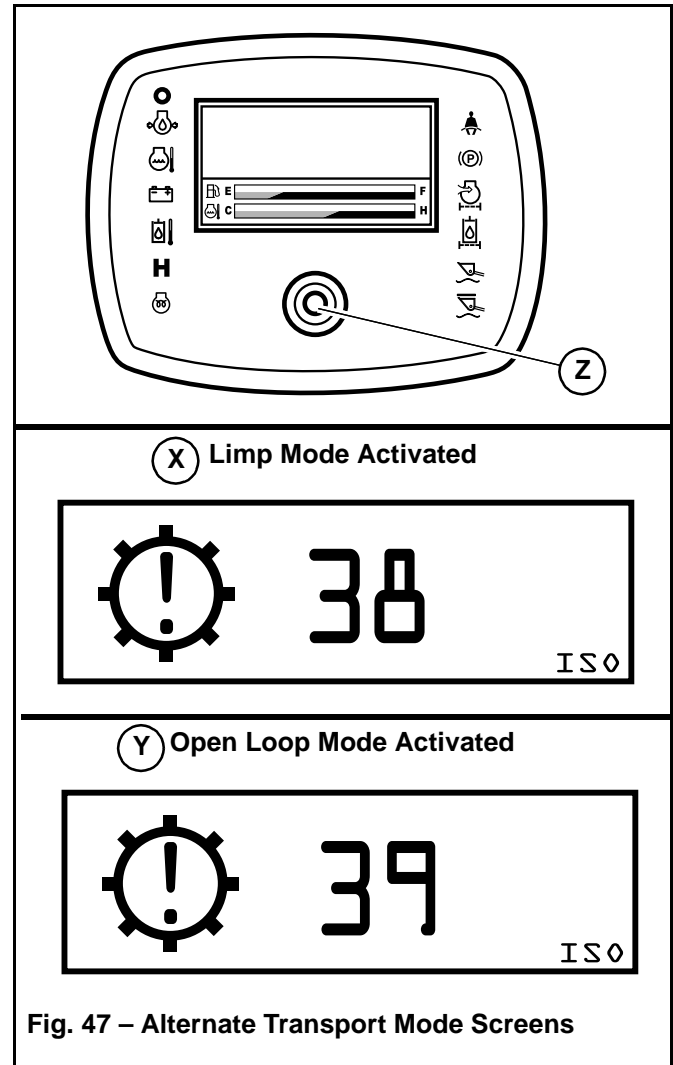

Fig. 47 – Alternate Transport Mode Screens

Alternate Transport Mode Activation

NOTE: Alternate transport modes can only be activated if only 1 drive error (codes 3-10) condition exists. Limp modes are NOT available if more than 1 drive error condition exists.

1. Turn the ignition clockwise to the first detent.
2. Disengage parking brake according to “Disengage Parking Brake” on page 66.

Operation

Alternate Transport Mode Cancel

Limp modes are canceled if any of the following occur:

- The parking brake is activated using the switch on the control panel.
- The operator leaves the seat.
- The arm rests/safety bars are raised.
- The cab door is opened.
- The engine is shut down.

When limp mode is canceled through any one of these actions, the drive system will remain disabled until the error condition is corrected or limp mode is re-activated.

Backup Alarm

The backup alarm (R, Fig. 48) is installed inside the rear door.

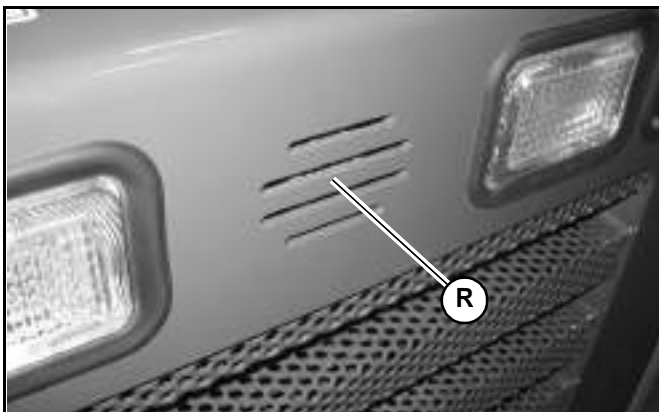

Fig. 48 – Optional Backup Alarm

The backup alarm emits a tone whenever the drive system is operated in reverse.

! DANGER

Do not rely exclusively on the backup alarm to alert others. Make sure that nobody is within the work area when traveling in reverse.

Lift Arm Operation

! WARNING

Do not lift loads exceeding rated operating capacity. See “Payloads/Capacities” on page 34.

Attachment Transport Position

! WARNING

Always transport loads in transport position to minimize the possibility of tipping or rollover accidents and unstable balance conditions that can cause loss of control.

Carry materials 200-300 mm (8-12”) above the ground, and adjust as necessary to clear obstacles. Generally, carry the load as low as safely possible. Tilt buckets back, as shown in Fig. “Transport Position” on page 76, to prevent spilling material.

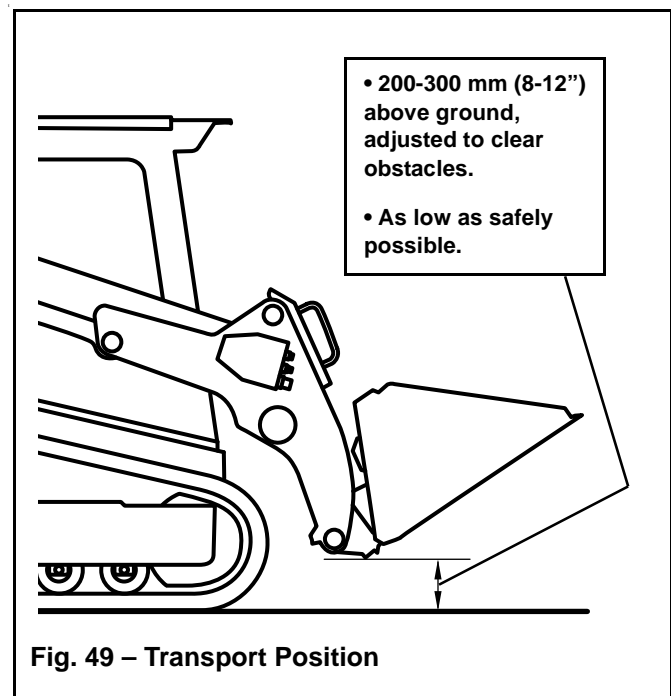

Fig. 49 – Transport Position

Joystick Control Patterns

WARNING

Always lock-out hydraulic functions by raising the arm rests/safety bars whenever parking the machine.

The control joysticks control lift arm raise and lower, attachment tilt, optional attachment quick-hitch lock, and auxiliary hydraulics flow control.

Two different control patterns are available for lift arm operation: ISO and D-H. See “Control Joysticks” on page 50 for information about switching between ISO and D-H control patterns.

NOTE: The D-H control pattern is an optional feature.

ISO Pattern Lift Arm Operation Controls

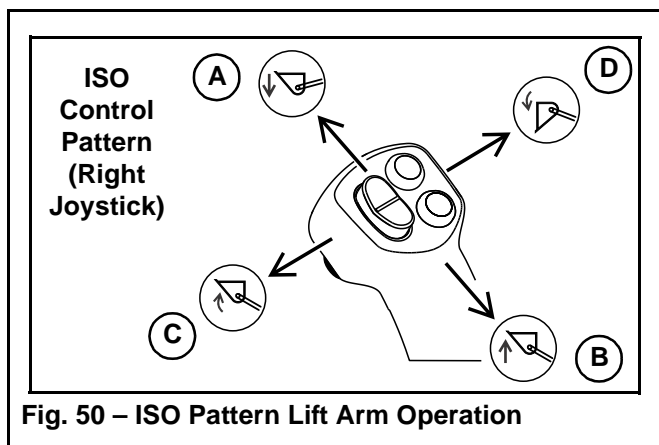

ISO pattern lift arm operation is controlled exclusively using the right control joystick (Fig. 50):

- A. Push the right joystick forward to lower the lift arm.

IMPORTANT: The lift arm can be lowered if the engine is off by turning the ignition key clockwise to the first detent and pressing the float button on the right joystick (See “Lift Arm Float” on page 79).

- B. Pull the right joystick backward to raise the lift arm.

- C. Tilt the right joystick to the left to tilt the attachment back.
- D. Tilt the right joystick to the right to tilt the attachment forward.

CAUTION

The lift arm may fall abruptly when it is lowered with the engine off. Make sure no one is near the machine when lowering the lift arm with the engine off.

D-H Pattern Lift Arm Operation Controls (Option)

NOTE: See “Control Joysticks” on page 50 for information about switching to the optional D-H control pattern.

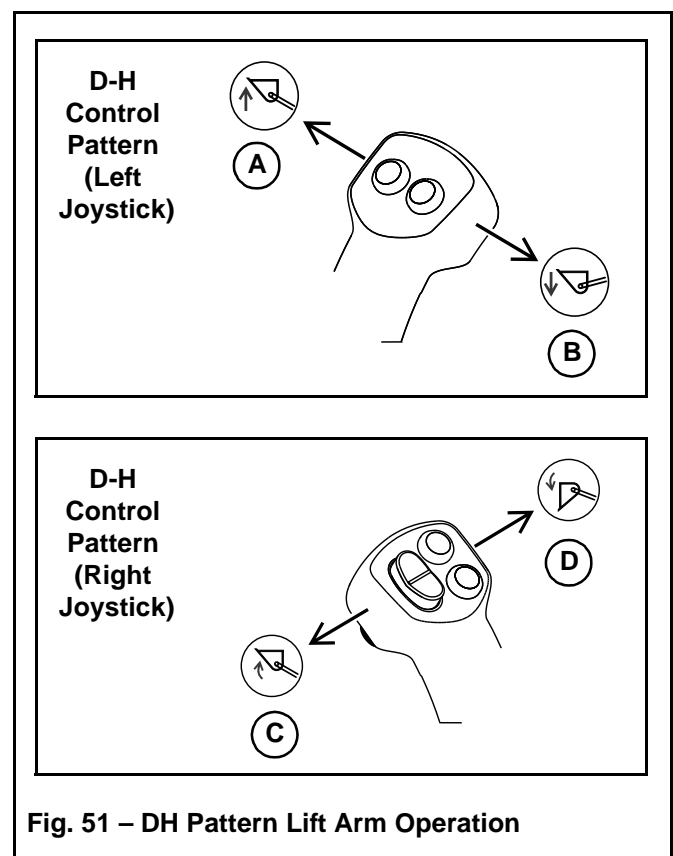

Operation

D-H pattern lift arm operation is shared between the right and left control joysticks (Fig. 51):

- A. Tilt the left joystick to the left to raise the lift arm.

IMPORTANT: *The lift arm can be lowered if the engine is off by turning the ignition key clockwise to the first detent and pressing the float button on the right joystick (See “Lift Arm Float” on page 79).*

- B. Tilt the left joystick to the right to lower the lift arm.
- C. Tilt the right joystick to the left to tilt the attachment back.
- D. Tilt the right joystick to the right to tilt the attachment forward.

CAUTION

The lift arm may fall abruptly when it is lowered with the engine off. Make sure no one is near the machine when lowering the lift arm with the engine off.

Self-Leveling

Self-leveling automatically keeps the tilt angle of the attachment constant (B, Fig. 52) when the lift arm is raised (A). This feature is especially useful when using pallet forks.

IMPORTANT: *Self-leveling operates only when the lift arm is raised: when the lift arm is lowered (C), self-leveling is not activated (D).*

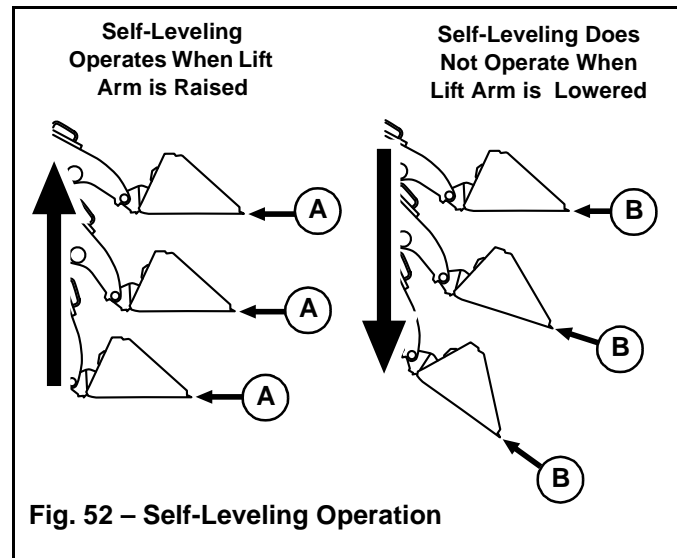

Fig. 52 – Self-Leveling Operation

Self-Leveling Cancel (Option)

The self-leveling cancel option allows deactivation of the self-leveling feature.

To deactivate self-leveling, press the top (G, Fig. 53) of the self-leveling cancel switch (K). To restore self-leveling, press the bottom (J) of the self-leveling cancel switch.

NOTE: The indicator in the switch is lit when the self-leveling cancel option is on and the self-leveling feature is deactivated.

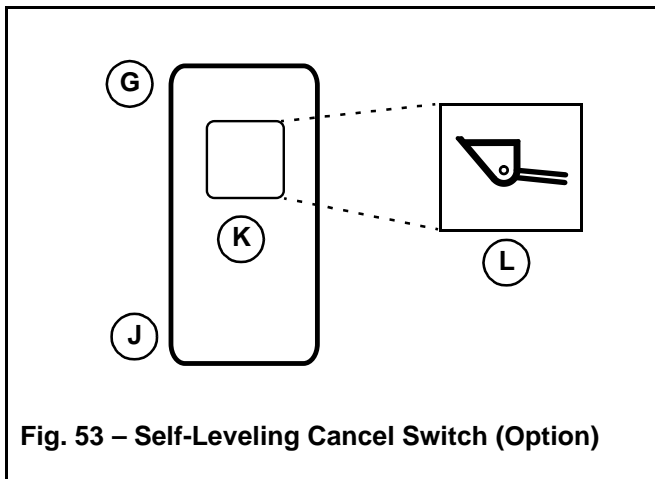

Fig. 53 – Self-Leveling Cancel Switch (Option)

Lift Arm Float

WARNING

Make sure the bucket is lowered to the ground before activating the lift arm float. Activating float with an attachment raised will cause the lift arm to fall rapidly to the ground, which can cause severe injury or death.

Do not drive the loader forward with the lift arm float activated. Damage to the machine and/or loss of control can result.

To activate lift arm float:

1. Lower the attachment to the ground.
2. Press button (A, Fig. 54) on the right joystick to activate float:

- a. Press button (A, Fig. 54) momentarily to apply float momentarily.
- b. Press and hold button (A, Fig. 54) on the right joystick for 5 seconds to activate continuous float.

NOTE: Indicator (B) in the multi-function display is lit when the lift arm float is activated. Indicator (B) blinks when momentary float is activated and is continuously lit when continuous float is activated.

Press button (A) again to deactivate continuous float.

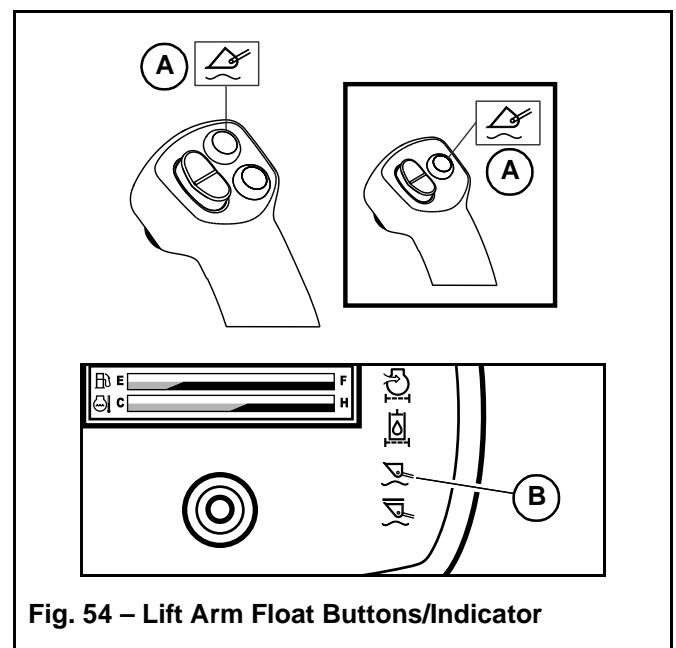

Fig. 54 – Lift Arm Float Buttons/Indicator

Hydraglide™ Ride Control System (Option)

Hydraglide™ cushions and dampens the movements of the lift arm. It eliminates unstable lift arm oscillation and increases drive comfort and safety.

IMPORTANT: Do not use Hydraglide™ when digging. Precise control of the digging operation is difficult with the Hydraglide™ option activated.

WARNING

Do not use Hydraglide™ when using pallet forks.

Operation

Activate Hydraglide™ when driving on public roads, for lighter loads, and for light off-road transport. Deactivate Hydraglide™ when working with heavy loads, such as when picking up excavated material.

WARNING

When Hydraglide™ is activated, the lift arm may drop slightly without a load, or several inches with a heavy load.

On the right joystick, press switch (H, Fig. 55) to toggle Hydraglide™ on/off.

The Hydraglide™ indicator on the multi-function display (L) lights up when Hydraglide™ is activated.

NOTE: Indicator (J) in the multi-function display is lit when the Hydraglide™ option is activated.

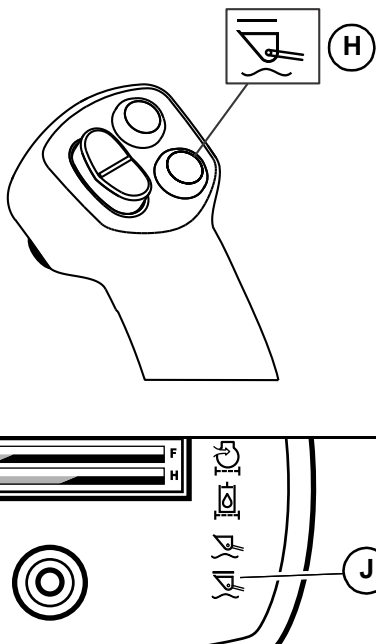

Fig. 55 – Hydraglide™ Button/Indicator

Hydraulics Control Lock

The hydraulics control are locked out whenever either of the safety bars/arm rests are in the raised position (B, Fig. 56), the operator's seat is unoccupied or the cab door is open.

NOTE: Raising the safety bars/arm rests also applies the parking brake.

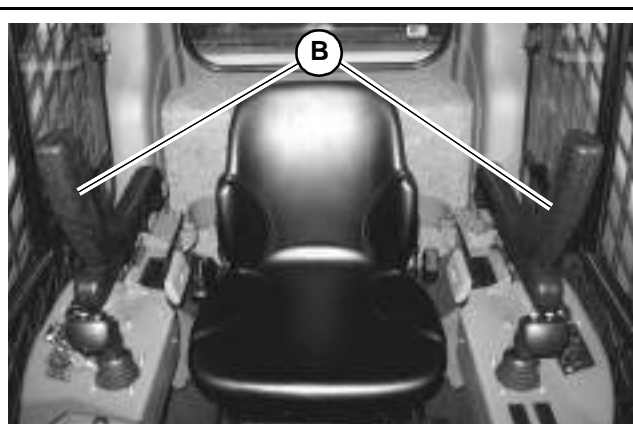

Fig. 56 – Safety Bars/Arm Rests in Raised Position

WARNING

Always raise the safety bars/arm rests to lock out hydraulics control and apply the parking brake whenever leaving the machine unattended.

Lift Arm Support



A falling lift arm could result in severe injury or death.

If the lift arm must be left in the raised position, **BE SURE** to properly apply the lift arm support device.

The operator must not leave the operator's position if the lift arm is in the raised position unless the lift arm support device is properly applied.



A second person on the outside of the machine is required to assist with applying the lift arm support.

Engage Lift Arm Support

1. Empty and remove the attachment.
2. Bring the machine to a complete stop on a level surface.
3. Raise the lift arm as high as it will go.
4. Move the drive controls to the neutral position.
5. Shut off the engine.
6. Move the lift/tilt controls to verify that the controls do not cause movement of the lift arm and hitch plate.
7. Raise the safety bars/arm rests to apply the parking brake and lock out the hydraulic controls.
8. Stay in the machine sitting in the operator's position. A second person, on the outside of the machine, must:
 - a. Remove retaining pin (Y, Fig. 57) securing lift arm support (Z) in the storage position.

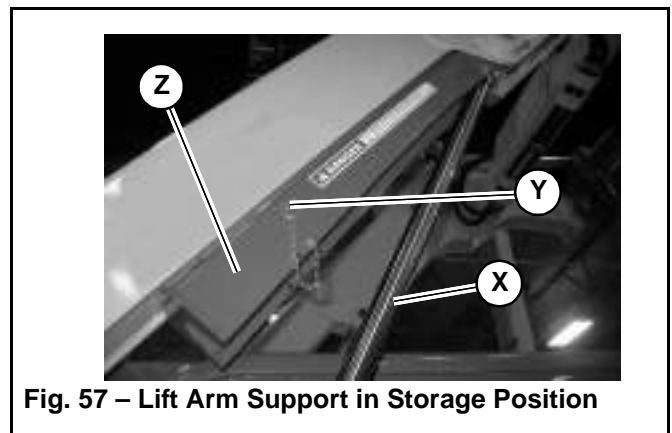

Fig. 57 – Lift Arm Support in Storage Position

- b. Position the lift arm support (Z, Fig. 58) over the lift arm cylinder rod (X, Fig. 57 and Fig. 58).

Operation

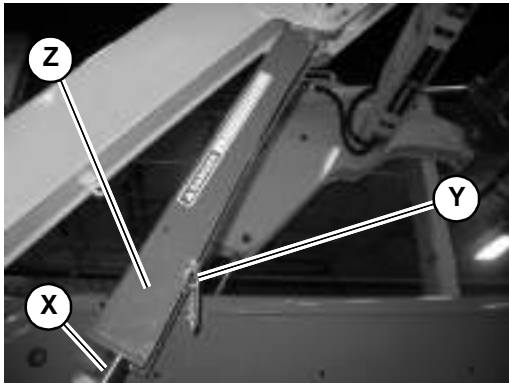

Fig. 58 – Lift Arm Support Applied

- c. Insert the retaining pin (Y, Fig. 59) through the lift arm support (Z) so it passes under the lift arm cylinder rod (X).

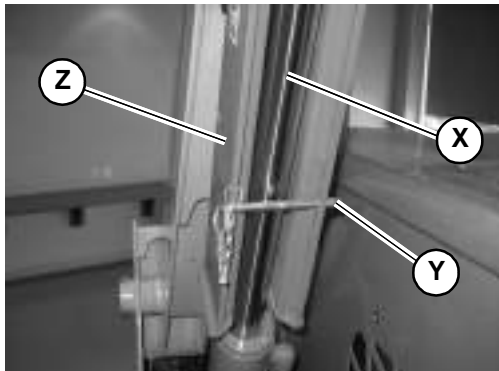

Fig. 59 – Lift Arm Support Retaining Pin

9. Start the machine and lower the lift arm against the lift arm support.
10. Shut off the engine.
11. Move the lift/tilt controls to verify that the controls do not cause movement of the lift arm and hitch plate.
12. Raise the safety bars/arm rests to apply the parking brake and lock out the hydraulic controls.
13. Unfasten the seat belt, remove the ignition key and take it with you. Exit the machine using the hand-holds.

Disengage Lift Arm Support



A second person on the outside of the machine is required to assist with disengaging the lift arm support.

1. Start the engine and raise the lift arm as high as it will go.
2. Move the drive controls to the neutral position.
3. Shut off the engine.
4. Move the lift/tilt controls to verify that the controls do not cause movement of the lift arm and hitch plate.
5. Raise the safety bars/arm rests to apply the parking brake and lock out the hydraulic controls.
6. Stay in the machine in the operator's position. A second person, on the outside of the machine, must:
 - a. Remove retaining pin (Y, Fig. 60) securing lift arm support (Z) in the support position.

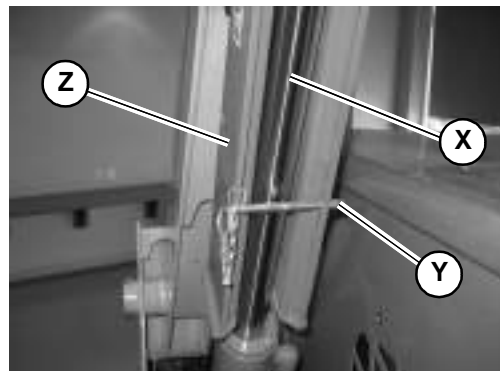
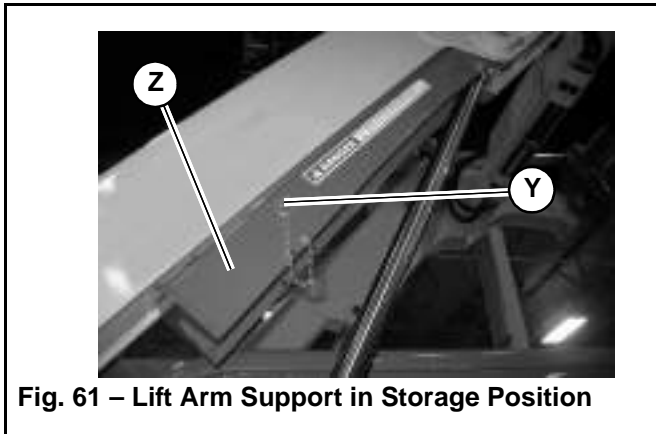

Fig. 60 – Lift Arm Support Retaining Pin

7. Have the second person stand away from the machine and lower the lift arm to the ground.

- Position the lift arm support (Z, Fig. 61) into the storage position and insert the retaining pin (Y) through the lift arm support (Z) and through the hole in the storage bracket to hold the lift arm support in the storage position.



Connecting/Disconnecting Attachments

Connecting Attachments

- Place the attachment lock into the unlocked position (Fig. 62):
 - Power-A-Tach® system hitch – Press the bottom of hitch lock switch (I) until safety flags (H) have moved all the way in.
 - Manual attachment hitch – move hitch lock lever (G) all the way to the right (G).

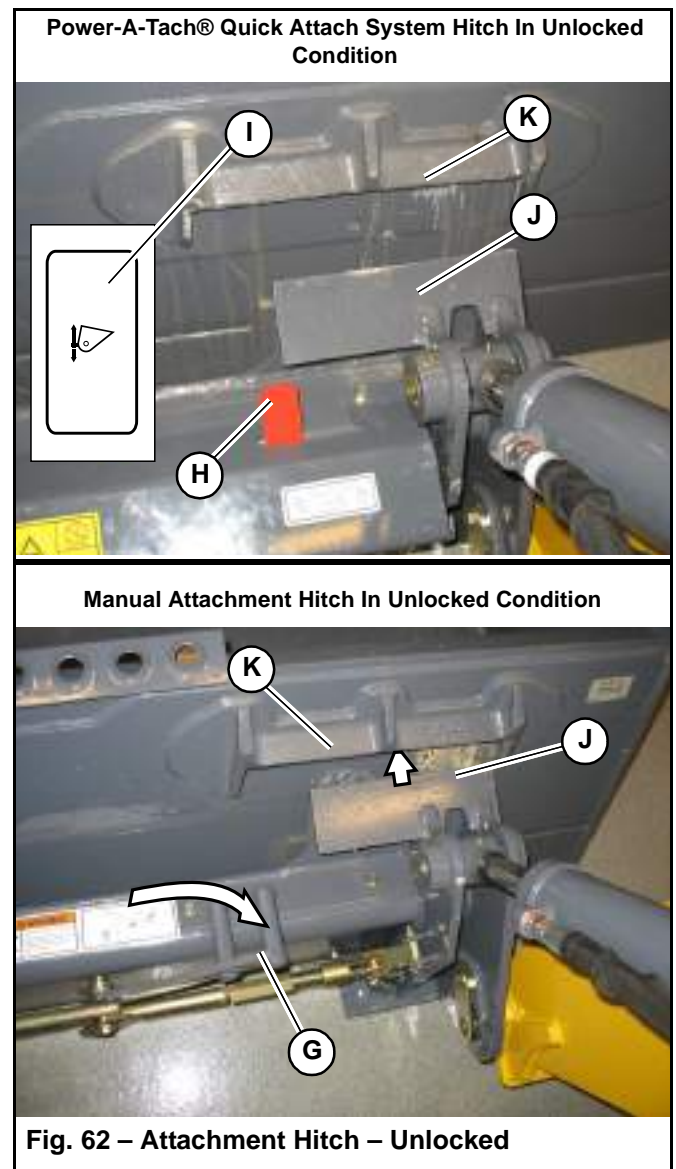

- Tilt the attachment plate forward and drive the machine straight forward toward the back of the attachment.

Operation

- Lower the lift arm so tabs (J) on the top of the attachment plate are aligned just under hooks (K) on the back of the attachment.
- Tilt the attachment plate back until tabs (J) on the top of the attachment plate are engaged against hooks (K) on the back of the attachment.
- Raise the lift arm slightly until the attachment is hanging from hooks (K) and tabs (J) are firmly inserted into the hooks. Tilt the attachment plate back, if necessary, so the back of the attachment is resting flat against the attachment plate.
- Place the attachment lock into the locked position (Fig. 63):
 - Power-A-Tach® system hitch – Press the top of hitch lock switch (I) until safety flags (H) have moved all the way out.
 - Manual attachment hitch – move hitch lock lever all the way to the left (G).

- Make sure the locking pins (F, Fig. 64) are fully engaged down through the holes in the attachment.

Manual Attachment Hitch Shown, Power-A-Tach® Quick Attach System Hitch Similar

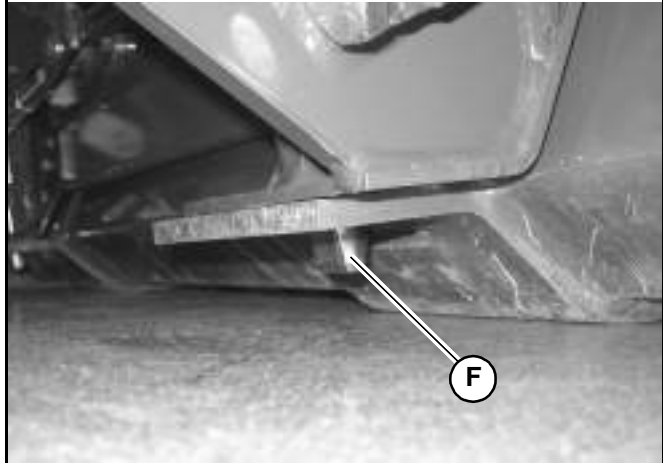
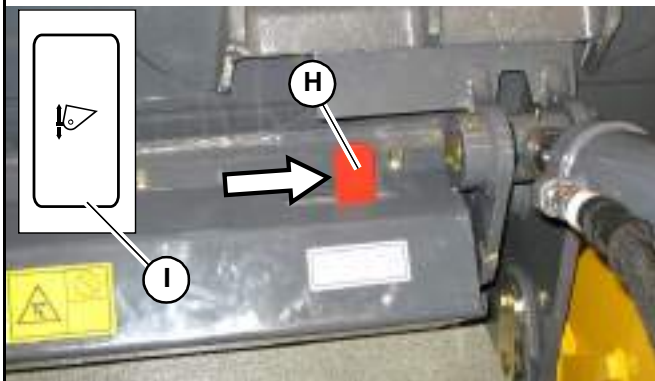

Fig. 64 – Attachment Locking Pins

Power-A-Tach® Quick Attach System Hitch In Locked Condition



Manual Attachment Hitch In Locked Condition

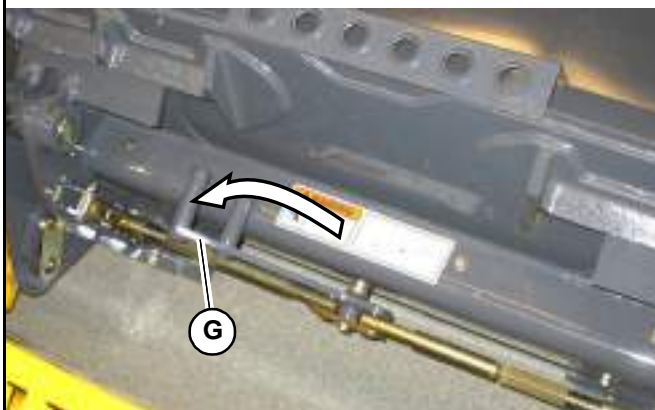

Fig. 63 – Attachment Hitch – Locked

WARNING

To prevent unexpected release of the attachment from the hitch, be sure to properly secure the hitch latch pins by hitch lock lever (G, Fig. 63) all the way to the left (manual All-Tach® hitch) or by ensuring that the safety flags (H, Fig. 63) are all the way to the outside (Power-A-Tach® hitch).

Locking pins (F) must be fully engaged through the holes in the attachment frame before using the attachment. The attachment could fall off if it is not locked on the hitch and cause serious injury or death.

Disconnecting Attachments

WARNING

Position the attachment so that after disconnecting the attachment will stand safely and not tip over. Serious injury can occur if an attachment tips over onto a person.

1. Empty the attachment and drive to a open, level area to disconnect the attachment.
2. Lower the attachment to the ground.
3. Place the attachment lock into the unlocked position (Fig. 65):
 - Power-A-Tach® system hitch – Press the bottom of hitch lock switch (I) until safety flags (H) have moved all the way in.
 - Manual attachment hitch – move hitch lock lever all the way to the right (G).

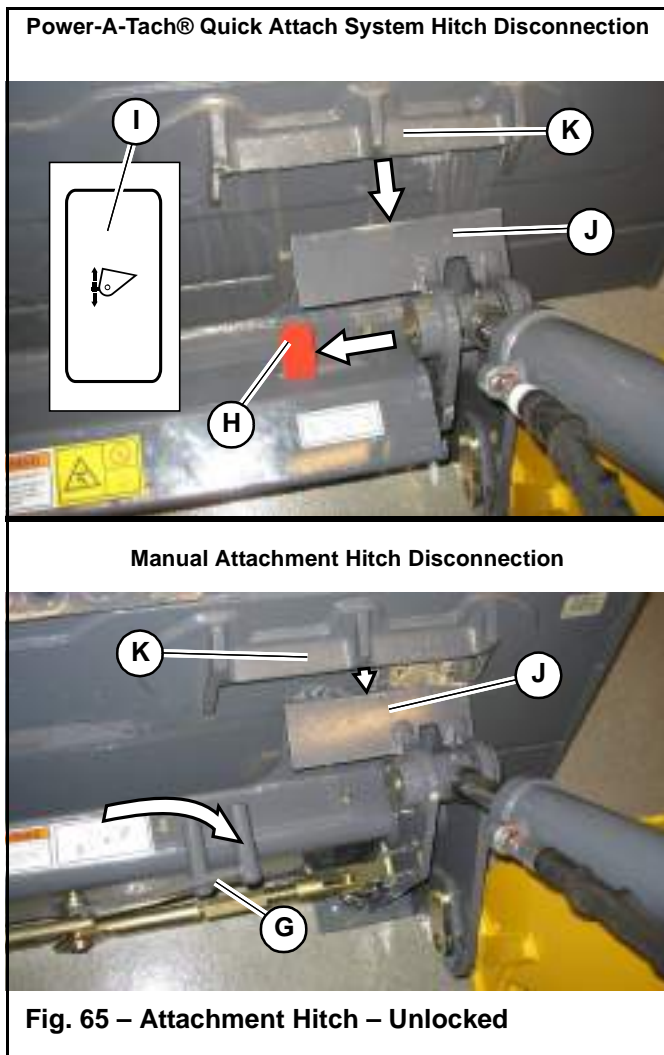

4. Lower the lift arm until tabs (J) on top of the attachment plate disengage out of hooks (K) on the back of the attachment.
5. Look behind you for bystanders and obstacles. Drive straight back in reverse away from the attachment.

Powering Attachments with Hydraulic Function

Hydraulically-powered attachments are powered using the auxiliary hydraulics circuits.

Connecting Hydraulic Attachments to the Auxiliary Hydraulic Circuits

IMPORTANT: Connect hydraulically-powered attachment hoses to the auxiliary circuits after the attachment is secured to the hitch.

Disconnect hydraulically-powered attachment hoses from the auxiliary circuits before removing the attachment from the hitch.

NOTE: The connection procedure is the same for both the normal and the optional high-flow auxiliary hydraulic circuits.

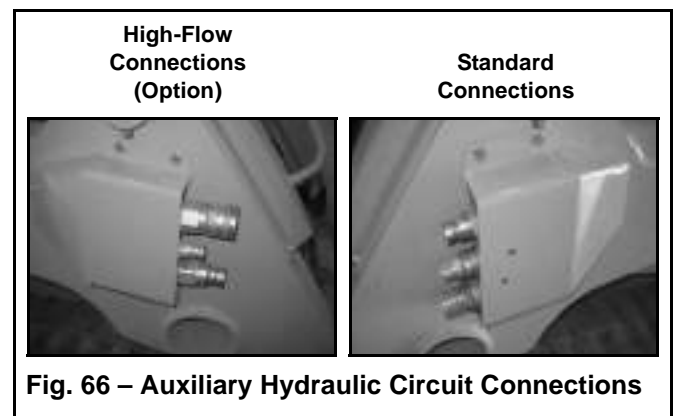

1. Empty the attachment and lower it to the ground.
2. Shut off the engine and turn off the ignition. Remove the ignition key and take it with you.
3. Raise the safety bars/arm rests to apply the parking brake.
4. Clean the hydraulic connections on the hoses and the connections.
5. Relieve the pressure in the standard auxiliary hydraulics circuit by pushing the attachment coupler firmly into the auxiliary coupler.

Operation

- Continue to push the hose connections firmly onto the auxiliary hydraulic connections until they snap into place.

CAUTION

Route the hydraulic hoses so they do not get pinched when the attachment is tilted forward and back. Damaged or burst hydraulic hoses could result.

IMPORTANT: Always check hydraulic function of the attachment before use, to make sure the hydraulic hoses have not been installed in reverse.

NOTE: Pressure build-up caused by heat in hydraulic attachments left in direct sunlight can make it difficult to connect the quick-couplers to the fittings on the attachment.

Disconnecting Hydraulic Attachments from the Auxiliary Hydraulics Circuit

- Empty the attachment and lower it to the ground.
- Shut off the engine and turn off the ignition. Remove the ignition key and take it with you.
- Raise the safety bars/arm rests to apply the parking brake.
- Push on the hose connection locking rings until the hose connections release.

Auxiliary Hydraulics Operation

Standard-Flow Auxiliary Hydraulics Control

The toggle and trigger switches (A and B, Fig. 67) on the right joystick controls standard-flow auxiliary hydraulics.

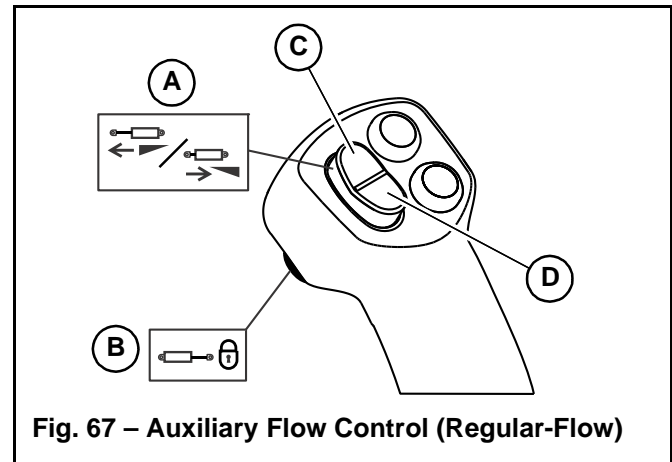

Press the top (C) of toggle switch (A) to activate auxiliary hydraulics flow in one direction. Flow control is proportional: the flow rate increases as the toggle switch is moved further. Release the switch to stop the flow.

Press the bottom (D) of toggle switch (A) to activate auxiliary hydraulics flow in the opposite direction. Flow control is proportional: the flow rate increases as the toggle switch is moved further. Release the switch to stop the flow.

For continuous flow:

- Move toggle switch (A) as far as it will go either forward or back – depending upon what direction flow is required.
- While holding the toggle switch (A) at the full forward or full reverse position, press trigger button (B). Release trigger button first (B), then release toggle switch (A).

NOTE: Standard flow auxiliary hydraulics continuous flow can only be activated if toggle switch (A) is held in either the FULL forward or FULL reverse position.

To stop continuous standard-flow, press and release trigger switch (B).

NOTE: Standard flow auxiliary hydraulics will remain in continuous flow with the safety bars/arm rests the raised position, the operator's seat unoccupied and the cab door open.

High-Flow Auxiliary Hydraulics Control (Option)

The optional high-flow hydraulics connections are located on the right side of the machine. See Fig. 66 on page 85.

Press and release the top (G, Fig. 68) of the high-flow toggle switch (K) to activate high-flow auxiliary hydraulics flow in one direction.

Press and release the bottom (J) of the high-flow toggle switch (K) to activate high-flow auxiliary hydraulics flow in the opposite direction.

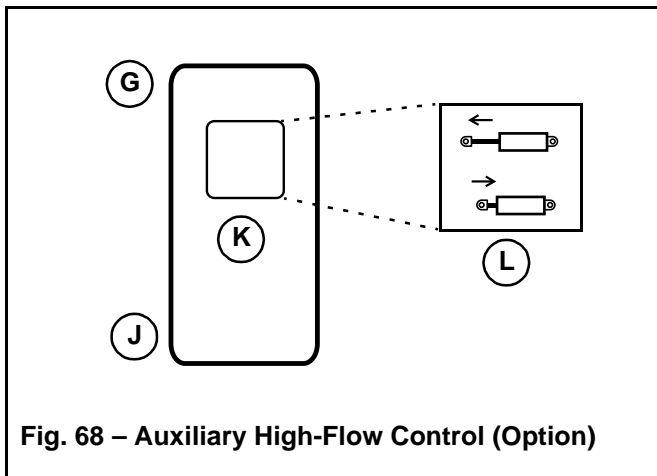

Fig. 68 – Auxiliary High-Flow Control (Option)

NOTE: Indicator (L) in the high-flow toggle switch (K) is lit when auxiliary hydraulics high-flow is activated.

To stop continuous high-flow, press and release switch (K)

NOTE: Continuous high-flow will stop if the safety bars/arm rests are raised, if the operator's seat is unoccupied, or if the cab door is opened.

Working with Buckets

Buckets are mainly used for digging, loosening, lifting, transporting and loading loose or solid materials.

WARNING

Read the “Safety” section in this manual, starting on page 15, before working with a bucket. Pay special attention to the “During Operation” information, starting on page 17.

Always follow the information included in the “Safety” section. Serious injury or death can occur if the safety information is not followed.

Make sure the bucket is securely attached to the hitch before starting work. See “Connecting Attachments” on page 83.

CAUTION

Follow the recommendations in “Fields of Application” on page 11.

Digging Tips

When completing a digging task:

- When digging in a pit, exit the pit outside the digging line, through an area as level as possible.
- If possible, dig by removing adjacent strips.
- Drive forward when transporting a full bucket out of the digging area.
- Drive in reverse when transporting a full bucket down a steep slope.

Operation

Safety Instructions When Working with Buckets



Avoid tilting a bucket back when the lift arm is fully raised. Material may fall over the rear of the bucket and onto the operator's position.

When on slopes, always set the lift arm to the transport position (“Attachment Transport Position” on page 76) and tilt the bucket fully back.

Secure heavy or awkward loads. If necessary, fit the rear of the bucket with a guard to prevent material from falling out of the back of the bucket.

Whenever possible, drive in reverse when transporting a bucket loaded with material down a steep slope.

Make sure you have a good view of the material you are digging, and of the area you will be working in.

Working with Standard Buckets

Scooping



Use extreme care when digging around foundations or walls. Never remove material that might compromise a wall or foundation.

1. Lower the bucket to the ground (Fig. 69).

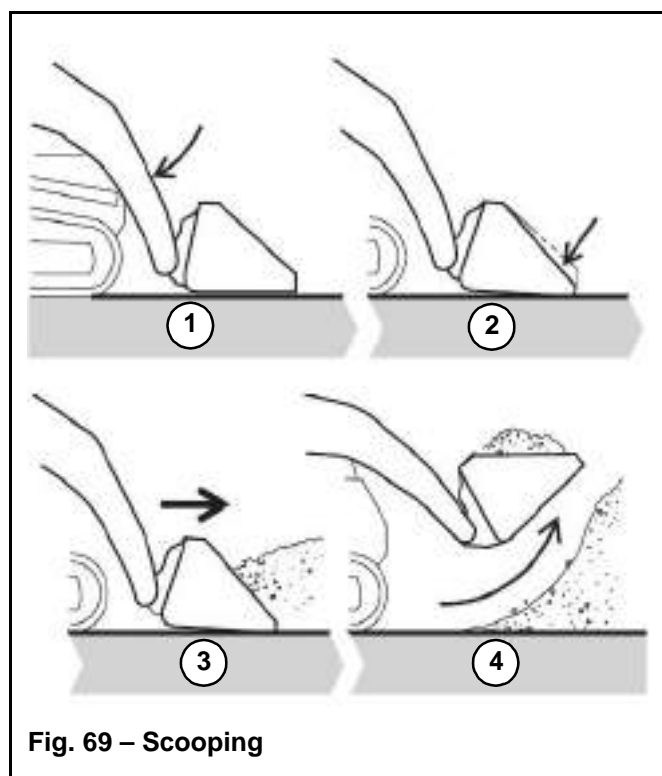

Fig. 69 – Scooping

2. Tilt the bucket slightly forward so the bucket blade is pointing slightly down into the ground.
3. Drive forward until the bucket is filled with material. Adjust the bucket tilt as needed to remove an even layer of ground and to reduce track slip.
4. Tilt the bucket back and raise it to scoop up material.
5. Reduce engine speed and back out of the material.
6. Set the bucket to transport position. See “Attachment Transport Position” on page 76.

Loading

IMPORTANT: When the self-leveling feature is on, the tilt angle of the attachment is kept constant when the lift arm is raised: when the lift arm is lowered, self-leveling is not activated. Refer to “Self-Leveling” on page 78 for more information about the self-leveling feature.

1. Approach the truck and stop, then raise the bucket until the lower edge of the bucket clears the truck bed (Fig. 70).

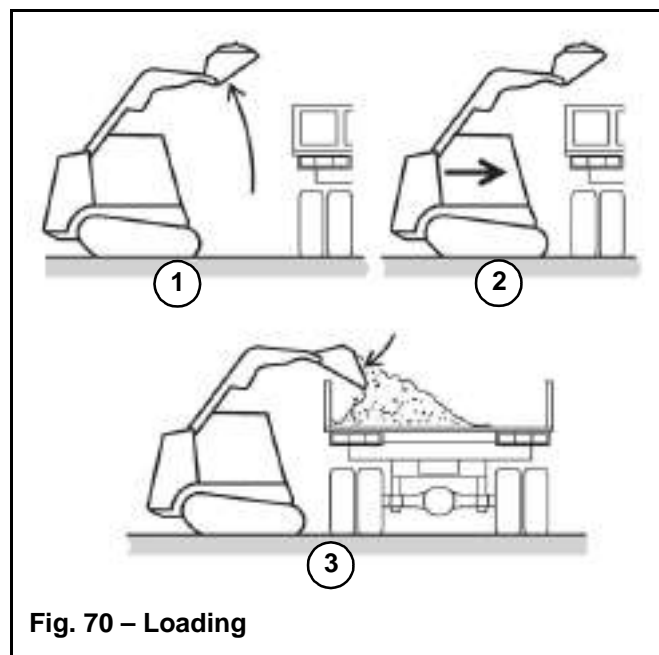

Fig. 70 – Loading

2. Drive slowly forward and stop at the position where the bucket will be dumped.
3. Tilt the bucket forward and dump the material into the truck bed.
4. When the truck is half-loaded, use the bucket to spread the load evenly.

Operation

Tips When Loading Trucks

When loading trucks:

- The truck and machine working direction should form an angle of 45°. (Fig 71).

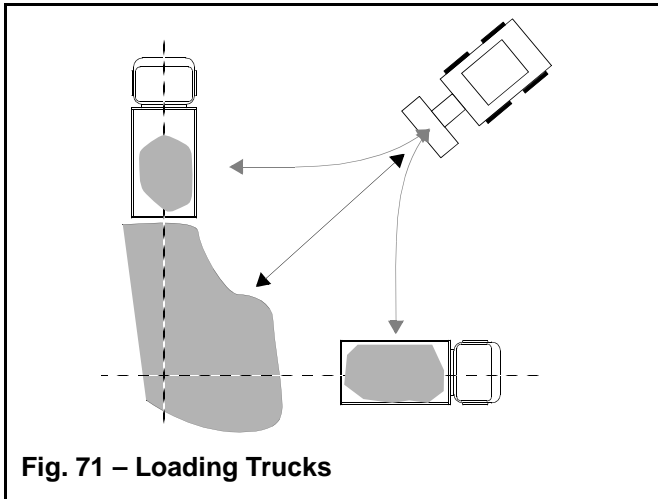

- Only raise a full bucket to the height needed for dumping when you are driving in a straight line toward the truck.
- Dump with the wind behind you to keep dust away from your eyes, air filters and fans.

Grading

1. Lower the bucket to the ground (Fig. 72).

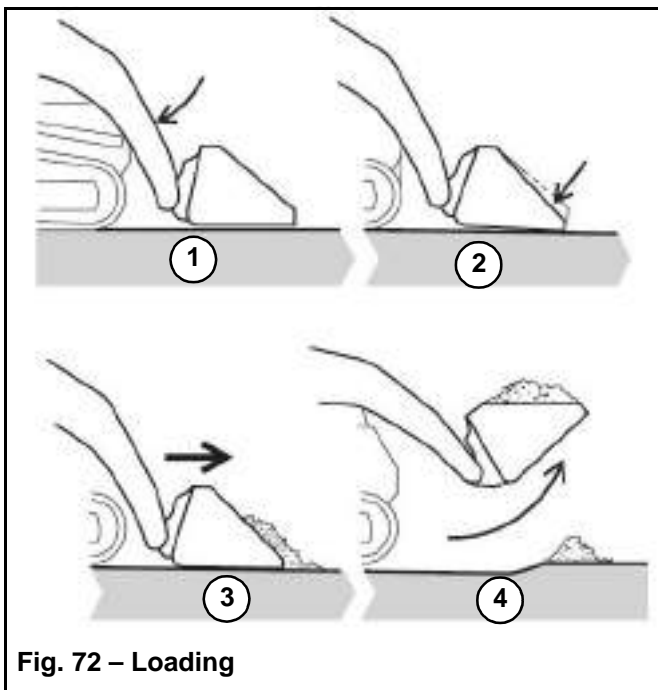

2. Tilt the edge of the bucket down at an angle appropriate for ground hardness.
3. Drive forward slowly, digging into the ground with the cutting edge of the bucket.
4. When the bucket is full, raise the bucket and tilt it back.

Grading

Grading without Float

1. Raise the bucket and tilt it forward (Fig. 73).

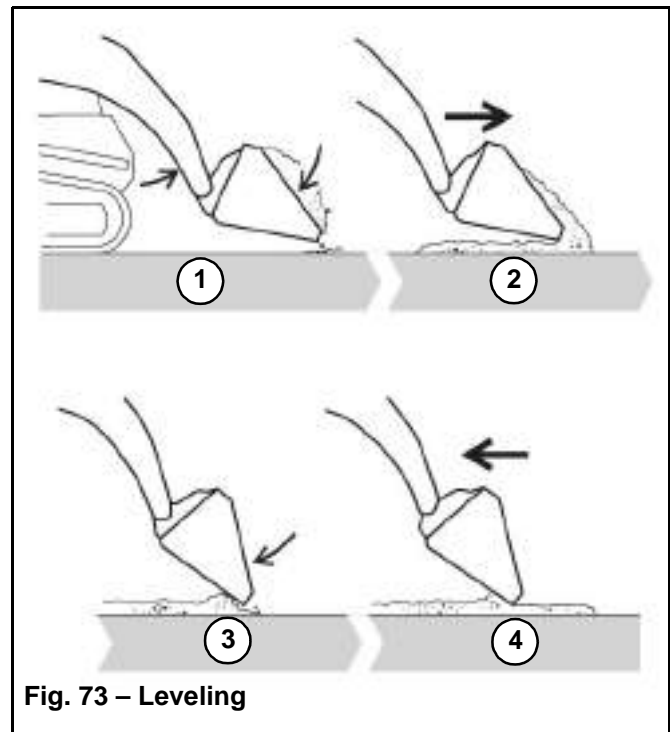

2. Release material from the bucket while driving forward.
3. Tilt the bucket forward and lower the front edge until it is slightly above the ground.
4. Drive in reverse, smoothing the material released in step 2 with the front edge of the bucket.

Grading Using Float

WARNING

Make sure the bucket is lowered to the ground before activating the lift arm float. Activating float with an attachment raised will cause it to fall rapidly to the ground, which can cause severe injury or death.

Do not drive the loader forward with the lift arm float activated. Damage to the machine and/or loss of control can result.

1. Lower the bucket to the ground (Fig. 74).

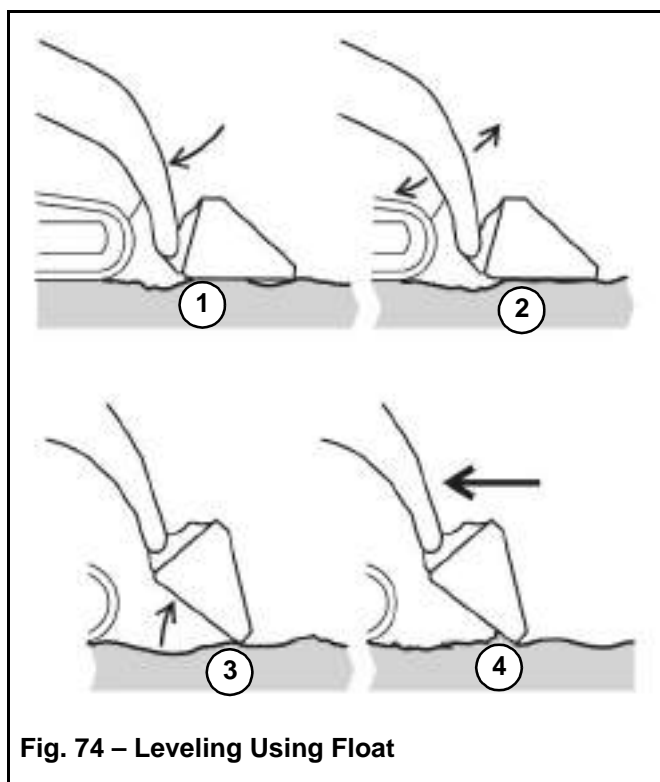

Fig. 74 – Leveling Using Float

2. Press button (A, Fig. 75) on the right control joystick to activate the lift arm float. See “Lift Arm Float” on page 79 for more information about the float feature.

NOTE: Indicator (B) in the multi-function display is lit when the lift arm float is activated. Indicator (B) blinks when momentary float is activated and is continuously lit when continuous float is activated.

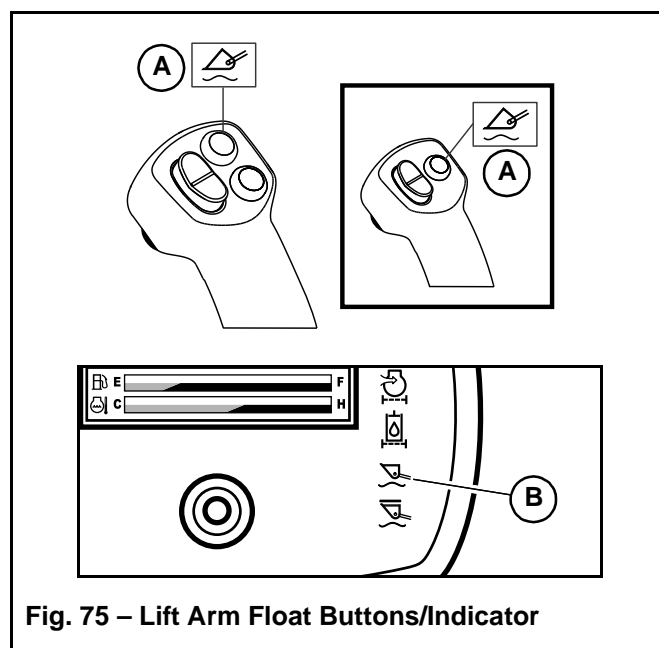

Fig. 75 – Lift Arm Float Buttons/Indicator

3. Tilt the bucket forward so it stands on the cutting edge (Fig. 74).
4. Drive in reverse, dragging the floating bucket.
5. When finished, press button (A, Fig. 75) again to deactivate the lift arm float.

Operation

Backfilling

1. Lower the bucket a few inches from the ground (Fig. 72). Slowly drive up to the hole until the front edge of the bucket is over the near edge of the hole.

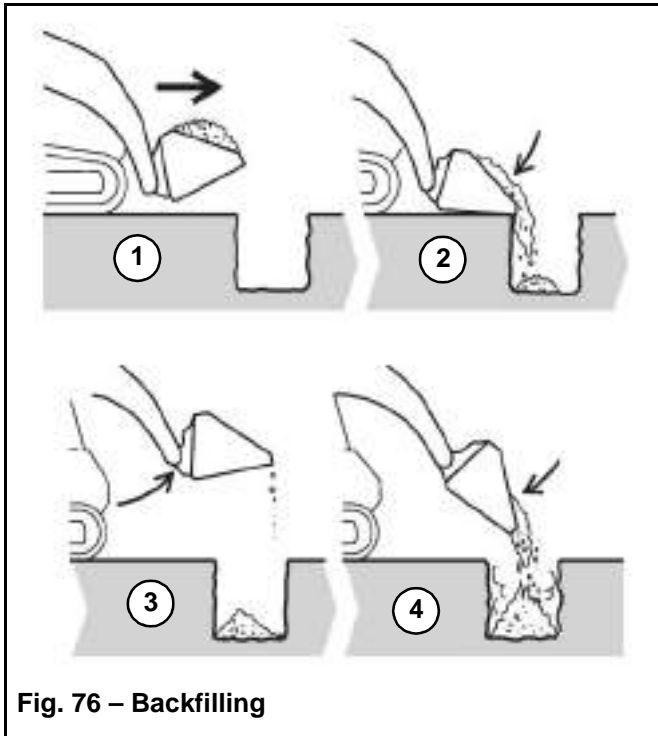

Fig. 76 – Backfilling

2. Tilt the bucket forward to dump material into the hole.
3. Tilt the bucket back and raise the bucket. Inspect the hole for proper filling.
4. Continue to dump material into the hole as necessary for proper fill.

Working with Pallet Forks

Safety Instructions When Working with Pallet Forks

WARNING

Read the “Safety” section in this manual, starting on page 15, before working with pallet forks. Pay special attention to the “During Operation” information, starting on page 17.

Follow all instructions in the Operator's Manual provided with the pallet forks.

Always follow the information included in the “Safety” sections. Serious injury or death can occur if the safety information is not followed.

Always approach the load from a straight-ahead position. Position the fork arms underneath the pallet, as far as they will go, so the load is distributed as closely as possible to the fork frame. Position the fork arms as far apart as possible. Load both fork arms evenly.

Lift and transport and unload loads only on firm and level ground with sufficient load-bearing capacity.

Always transport the load close to the ground as is safely possible. Observe minimum ground clearance.

Use pallet forks for material handling and/or material transport only.

Never lift a load using only one fork arm.

Make sure the fork arms are safely locked onto the fork frame before use.

Do not lift unstable material, or material that is not properly secured on the fork arms.

Never leave a machine with the forks raised or a load unattended. Make sure all persons stay clear of suspended loads.

WARNING

DO NOT exceed pallet fork load center and/or lifting capacity See the pallet fork payload / capacities table on page 34.

Do not use high travel speed range when using pallet forks.

DO NOT use standard fork arms as reverse (inverted) forks.

Maintain a minimum distance of 6 m (20 ft.) between the load and overhead electrical lines.

DO NOT push, pull or shove the fork arms, or move them in at a slanting angle (risk of damaging them due to lateral forces).

DO NOT pull off loads off the fork arms, or allow loads to fall onto the forks arms.

DO NOT tilt the pallet forks to raise loads.

DO NOT lift or transport molten material with pallet forks.

Repair work on fork arms must performed only by authorized personnel.

Always keep pallet fork arms clean.

Secure loads as directed in the pallet fork Operator's Manual to prevent the loads from falling.

Never modify pallet fork arms.

Do not lift or transport persons on the pallet forks.

Do not drive on public roads with pallet forks installed on the machine.

Do not stack loads which are not properly packaged or have damaged pallets/stacking containers. Do not stack loads on top of loads, which may have shifted.

Always tilt pallet forks back slightly during transport to help retain the load.

WARNING

Do not use bent, cracked, or otherwise damaged fork arms/pallet forks.

Always inspect pallet forks each time before using. Refer to the pallet fork manufacturer's documentation and/or contact the pallet fork manufacturer for information regarding safe pallet fork condition criteria:

- Check the fork arm locks for proper function and/or damage. Do not use pallet forks with damaged locks or locks that do not function properly.
 - Visually check the fork arm hooks and/or bends for cracks and/or deformations. Do not use fork arms that are cracked and/or have deformations that make the fork arms unsafe.
 - Do not use fork arms that have bends or blades that have more than 10% of the original material worn away.
 - Check the fork arms blades and tips for deformations or holes.
-

Operation

Transporting Loads Using Pallet Forks

IMPORTANT: *When the self-leveling feature is on, the tilt angle of the attachment is kept constant when the lift arm is raised. When the lift arm is lowered, self-leveling is not activated. Refer to “Self-Leveling” on page 78 for more information about the self-leveling feature.*

Loading Pallet Forks

1. Stop the machine immediately in front of the material
2. Position the fork arms parallel to the ground.
3. Make sure the fork arms are adjusted as far apart as possible, and are both the same distance away from the center-line of the load.
4. Adjust the height of the fork arms to fit the lifting area at the bottom of the pallet.
5. Drive slowly and carefully forward until the fork frame contacts the material.
6. Make sure the pallet is evenly and safely positioned on the pallet fork arms.

Lifting Loads Using Pallet Forks

7. Apply the parking brake.
8. Slowly raise the pallet forks. Do not raise the pallet forks any higher than required. Make sure to not exceed pallet fork load center and/or lifting capacity.
9. Lower the load immediately if you are unsure of the load, the equipment, or in case of any unsafe circumstances.
10. Tilt the pallet fork frame back slightly, to help retain the load.

Transporting Load Using Pallet Forks

11. Make sure the area around and behind the machine is clear of bystanders and obstacles.
12. Slowly and carefully drive in reverse and lower the pallet forks to transport position (“Attachment Transport Position” on page 76), when it is safe to do so.

13. Carry the load as low as safely possible during transport. Observe minimum ground clearance.

Setting Down Loads Using Pallet Forks

14. Drive slowly and carefully forward straight toward the place where the load will be set down.

NOTE: *If this will be on top of stacked material, make sure to align the in the center of the stack.*



WARNING

Do not stack loads which are not properly packaged or have damaged pallets/stacking containers. Do not stack loads, or on top of loads, which have shifted.

15. Raise the pallet forks slightly above where the load will be placed.
16. Tilt the pallet forks as needed to level the fork arms.
17. Carefully drive slowly forward until the load is positioned precisely above where it will be placed. Use care when aligning the load with a stack.
18. Slowly and carefully lower the lift arm until the load is placed.
19. Make sure the fork arms are no longer bearing weight and are free to be retracted.
20. Make sure the area around and behind the machine is clear of bystanders and obstacles.
21. Slowly and carefully drive in reverse away from the placed load until the lift arm can be lowered to transport position. See “Attachment Transport Position” on page 76.
22. Slightly tilt the pallet fork frame backwards.

Lifting the Machine using a Crane

WARNING

The crane and the lifting gear must be adjusted to the proper dimensions. Always lift the machine so it is horizontal when it is raised.

Make sure the crane and the lifting gear (cables, chains) have sufficient load-bearing capacity. The crane and the lifting gear must be adjusted to the proper dimensions.

Secure the machine against unintentional movement!

Keep clear of suspended loads.

Never lift with anyone in or on the machine.

Securely fasten the lifting gear to the machine at the designated lift points.

The crane lifting crew must include experienced crane operators only.

Lift the machine only with the standard bucket attached. The bucket must be empty and set to transport position. See “Attachment Transport Position” on page 76.

Crane Lifting Preparation

IMPORTANT: Crane handling requires lifting gear with a spreader bar with 4 ropes, chains, etc.

1. If a bucket is attached, make sure it is emptied.
2. Mount and safely lock and empty the standard bucket. Tilt the bucket back and lower it to transport position. See “Attachment Transport Position” on page 76.
3. Raise the arm rests/safety bars to apply the parking brake and lock out the hydraulic functions.
4. Turn off the engine and remove the ignition key.

5. If equipped, close and lock the cab door. Do not allow anyone to stay in the cab.
6. Close the doors and the engine cover.
7. Connect spreader bar and chains to front and rear lift points as shown. The spreader bar length should allow for the lift chains to be as vertical as possible during lifting. The lifting chain lengths should allow for lifting the machine as level as possible.

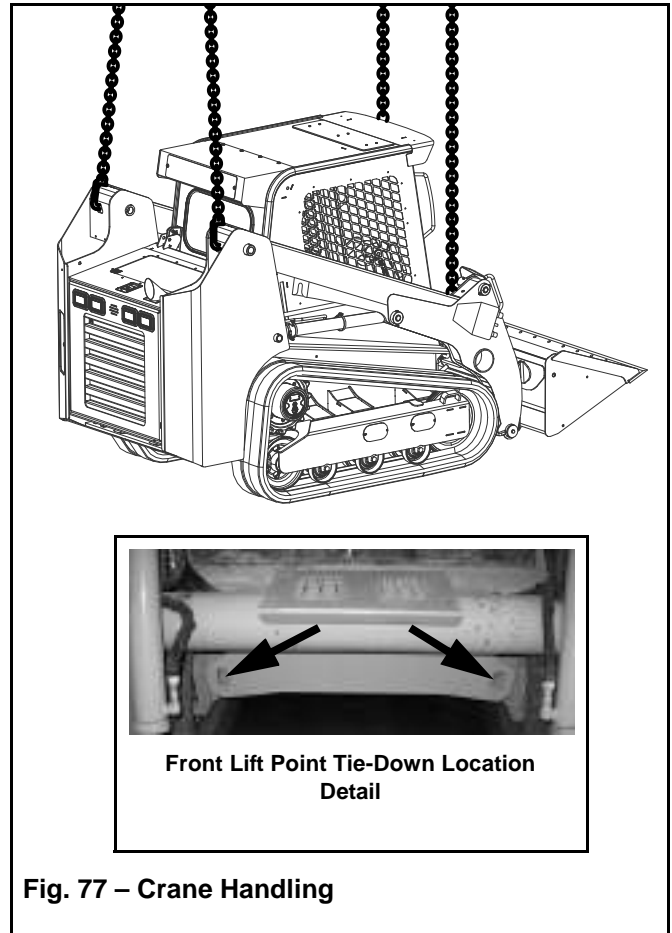

Fig. 77 – Crane Handling

CAUTION

Do not fasten the lifting gear to the cab to crane lift the machine.

8. Carefully raise the machine, keeping it as level as possible.

Operation

Loading and Transporting the Machine on a Transport Vehicle

WARNING

Do not exceed the transport vehicle's gross weight rating and the gross axle weight rating when loading and transporting the machine. The transport vehicle must have sufficient capacity for the size and weight of the machine. See "Specifications" on page 31.

Make sure the load does not fall short of the minimum axle load of the steering axle, otherwise the transport vehicle's steering could be seriously affected.

Remove any mud, snow or ice from the tracks on the machine to prevent slipping.

Position the machine at the lowest possible position on the transport platform, with the center of gravity of the load over center line of the transport vehicle. Distribute partial loads to ensure an even load on the axles on the transport vehicle.

Secure the machine properly so it cannot slip, slide, roll, tip over or fall, or cause the transport vehicle to tip over under transport conditions. Use anti-slip bases and linings, load-securing straps and chains, clamping beams, protective paddings, nets, edge protectors, etc. as needed to properly secure the load. Consider all possible transport conditions such as: heavy braking, evasive maneuvers, and uneven or rough roadways.

Adjust transport speed to the load, to the road/traffic conditions and to the handling of the transport vehicle.

Always use the proper tie-down points when using straps and chains. See "Component Identification" on page 10.

Loading and Securing the Machine

WARNING

Secure the loading ramps to the transport vehicle before loading. Position the loading ramps at the shallowest possible angle. Do not exceed an angle of 15°. Only use ramps with anti-skid surfaces.

Make sure the loading area is clear and access to it is not obstructed.

Make sure the driver of the transport vehicle knows the overall height, width and weight of the vehicle, including the loaded machine, before starting transport.

Know and follow the legal transport regulations for the area in which the transport will occur.

Make sure the loading ramps are free of mud, oil, grease, snow, ice, etc.

Know and follow the legal transport regulations for the area in which the transport will occur.

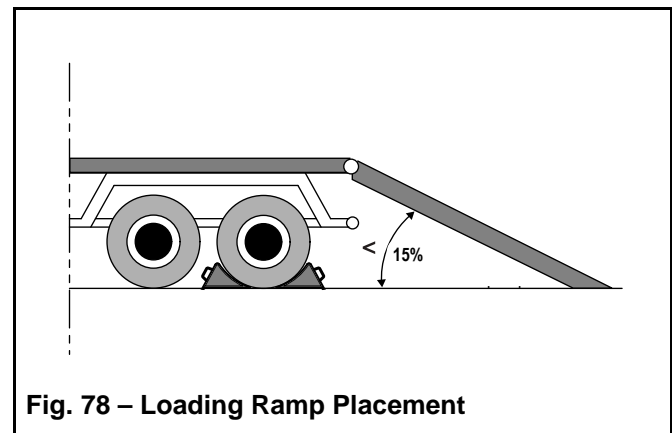

Fig. 78 – Loading Ramp Placement

1. Check the engine oil. The oil level must be at the “MAX” mark on the dipstick. Add oil if needed.

IMPORTANT: *When loading and driving on ramps, the engine can be damaged if the engine oil level is too low.*

2. Start the engine.
3. Raise the hitch plate/attachment enough so that it will not touch the loading ramps.
4. Slowly and carefully drive the machine in reverse onto the transport vehicle, with the bucket end facing down the ramp.
5. Do not adjust travel direction while traveling on the ramps. Instead, drive down off of the ramps, and re-align the machine with the ramps.
6. Position the machine at the lowest possible position on the transport platform, with the center of gravity of the load over center line of the transport vehicle.
7. Lower the bucket onto the loading area.
8. Stop the engine.
9. Raise the arm rests/safety bars to apply the parking brake and lock out the hydraulic functions.
10. Remove the ignition key.
11. Do not allow anyone to stay in the cab.
12. Close the doors and the engine cover.
13. Tie down the machine as follows:
 - a. Make sure the authorized maximum height is not exceeded.
 - b. Place blocks in front and behind tracks to prevent movement.
 - c. Securely strap the machine at the tie-down points (Fig. 79) to the platform. Use only belts or chains of sufficient capacity.

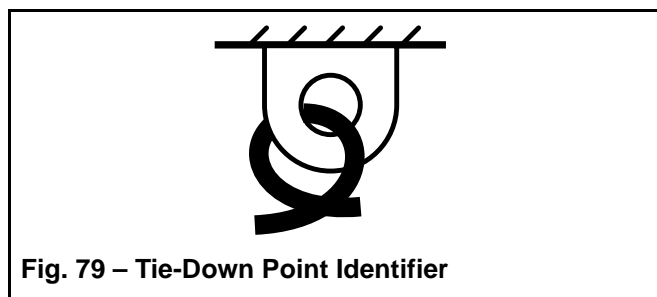

Fig. 79 – Tie-Down Point Identifier

IMPORTANT: *Before transporting the machine through heavy rain, close off the exhaust pipe with a cap or suitable adhesive tape.*

Storage Box

The machine is equipped with a locking storage box (Fig. 80) at the left rear corner of the machine.

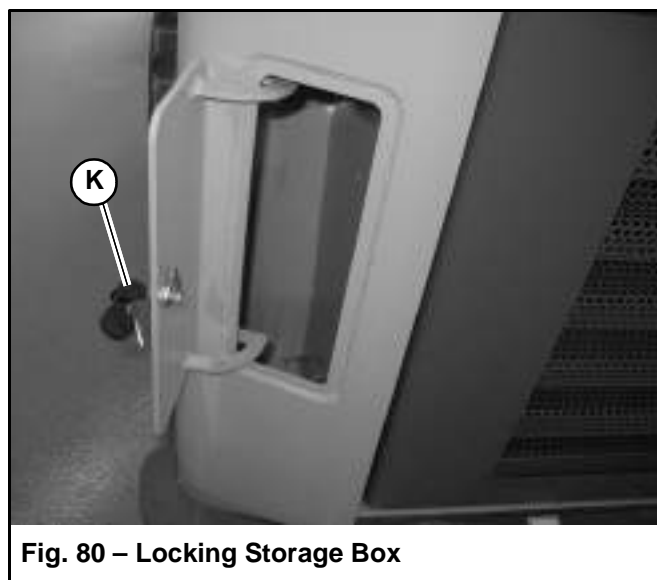

Fig. 80 – Locking Storage Box

Use the accessory key (supplied with the ignition key) to lock/unlock the storage box.

NOTES

Maintenance

Proper care and service improves machine operational readiness and service life.

Perform maintenance as indicated in the “Maintenance Schedule” on page 100, or earlier if required by conditions.

WARNING

Read and understand the “Safety” Chapter in this manual, starting on page 15, before servicing the machine. Follow all applicable warnings and instructions. Check for correct function after performing maintenance. Failure to follow instructions can result in injury or death.

BEFORE performing any maintenance, perform the **MANDATORY SAFETY SHUTDOWN PROCEDURE**. See “Mandatory Safety Shutdown Procedure” on page 16.

Fluid leaks from hydraulic hoses or pressurized components can be difficult to see, but pressurized oil can have enough force to pierce the skin and cause serious injury. Always use a piece of wood or cardboard to check for suspected hydraulic leaks. Never use your hands. Obtain immediate medical attention if pressurized oil pierces the skin. Failure to obtain prompt medical assistance could result in gangrene or other serious damage to tissue.

Do not smoke or allow any open flames in the area while checking or servicing the hydraulic, battery and fuel systems because all contain highly flammable liquids or explosive gases, which can cause an explosion or fire if ignited.

Wear a face shield when disassembling spring loaded components or working with battery acid. Always wear eye protection to protect eyes from electric arcs from shorts, fluids under pressure, and flying debris or loose material. Wear a helmet or goggles with special lenses when welding or cutting with a torch.

WARNING

When working beneath a raised machine, always use blocks, jack-stands or other rigid and stable supports. Wear appropriate protective clothing, gloves and shoes. Keep feet, clothing, hands and hair away from moving parts.

Always apply the lift arm support when maintenance work requires the lift arm in the raised position. See “Lift Arm Support” on page 81.

NEVER weld on the machine without the consulting the manufacturer. Special metals may be used, which require special welding techniques or parts be designed so that they should not be welded. **NEVER** cut or weld on fuel lines or tanks.

If repair welding is ever required, remove the positive (+) battery terminal connection before starting to weld. Be sure to attach the ground (-) cable from the welder as close as possible to the area to be repaired.

Allow only trained and authorized personnel, with full knowledge of safe procedures, to perform machine maintenance and service.

If any guards, shields and covers were removed during maintenance, **BE SURE** to replace them in their original positions **BEFORE** starting the machine.

CAUTION

Do not use the machine when maintenance is due. Postponed maintenance can result in a serious reduction of the service life of the machine, costly equipment failures, and contribute to unsafe operating conditions.

Do not perform maintenance or service not included in this manual. Maintenance and service not included in this manual should only be performed by a authorized repair shop.

Maintenance

Maintenance Schedule

IMPORTANT: Maintenance intervals apply to average operating conditions and loads. More frequent maintenance may be required depending upon the level and type of use.

Log all maintenance as it is performed in the “Maintenance Log” on page 129.

NOTE: Refer to the hour meter and the required maintenance display screen to determine maintenance interval timing. See “Maintenance Interval” on page 102.

Checks, Cleaning and Inspection

Table 34: Checks Cleaning and Inspection

Service Procedure	Maximum Interval		
	10 Hours (or daily)	250 Hours (or every 6 months)	500 Hours (or annually)
Clean machine	X		
Inspect machine for general wear/damage	X		
Check bucket cutting edge	X		
Check safety interlock system	X		
Inspect tracks for damage/wear	X		
Check automatic track tensioning	X		
Check engine oil level and condition	X		
Check coolant level and condition	X		
Check hydraulic fluid level and condition	X		
Check fuel level and fill if necessary	X		
Check windshield washer system and wiper blade, if applicable	X		
Check exhaust for excessive smoke emission	X		
Check hydraulic cylinder piston rods for damage/wear; clean if necessary	X		
Check ROPS structure (all fasteners must be installed and tightly secured)	X		
Check water separator and drain water, if present	X		
Check coolant system for leaks, dirt and debris	X		
Check hydraulic hoses and tubes for cracks, leaks and/or debris	X		
Check hydraulic tank, valves and cylinders for leaks and/or damage	X		
Check coolant anti-freeze mixture		X	
Check V-belt tension and condition		X	
Check engine cover lock		X	
Check engine idle		X	
Clean radiator/oil cooler fins		X	
Check hinge pins, joint bushings, pivot bolts and bearings			X
Check engine mounts			X
Check exhaust system for damage			X
Clean battery terminals			X
Check timing belt			X
Check fuel injectors			X
Check electrical system for damage, wire routing			X

Leakage Check

Table 35: Leakage Check

Service Procedure	Maximum Interval		
	10 Hours (or daily)	250 Hours (or every 6 months)	500 Hours (or annually)
Check engine for oil/coolant leaks	X		
Check cooling system for leaks	X		
Check hydraulic system for leaks	X		

Lubrication and Filter Changes

Table 36: Lubrication and Filter Changes

Service Procedure	Maximum Interval			
	10 Hours (or daily)	150 Hours (or every 4 months)	250 Hours (or every 6 months)	500 Hours (or annually)
Lubricate grease fittings according to lubrication diagram (See Fig. 110 on page 119)	X			
Travel motor gear oil		X ¹		
Change engine oil/filter			X ²	
Change cab air filter, if applicable			X ³	
Lubricate all levers, cables and hinges with oil			X	
Change outer air cleaner filter element; check and change inner air cleaner element if necessary			X ³	
Change hydraulic oil and return filter			X	
Change fuel filter; clean pre-filter			X	
Change coolant				X

1. After first 150 hours; every 1000 hours thereafter
2. After first 50 hours; every 250 hours thereafter.
3. Replace if needed.

Functional Check

Table 37: Functional Check

Service Procedure	Maximum Interval		
	10 Hours (or daily)	250 Hours (or every 6 months)	500 Hours (or annually)
Check seat belt	X		
Check service and parking brake function	X		
Check joystick operation	X		
Check windshield wipers, if applicable	X		
Check control switches/buttons, indicators and audible warning devices	X		
Check installed lighting systems	X		

Maintenance

Maintenance Interval



Do not postpone maintenance. Postponed maintenance can result in a serious reduction to the service life of the machine, more serious and costly equipment failures and can contribute to unsafe conditions.

NOTE: The display screen on the multi-function display includes an "Accumulated Service Hours Screen". See page 46. This screen displays accumulated operation time, which accumulates whenever the engine is running.

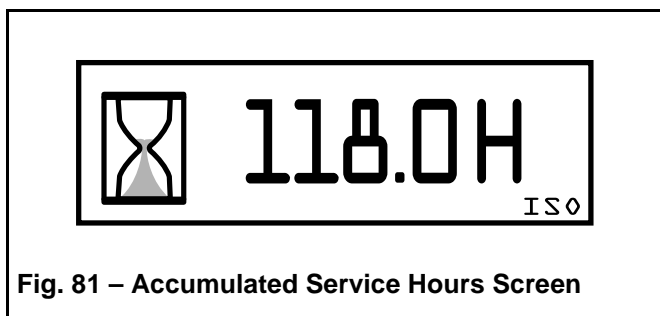

Fig. 81 – Accumulated Service Hours Screen

NOTE: Additional "Maintenance Required Screens" display at 50, 250, 500, 750, 100 and 250 (ongoing) service hour intervals. See page 46. These screens function as reminders that important maintenance is due.

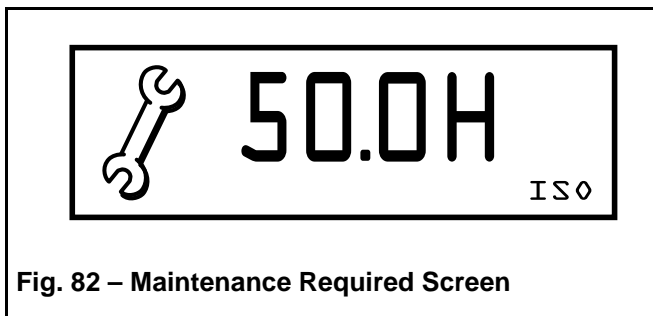

Fig. 82 – Maintenance Required Screen

IMPORTANT: "Maintenance required" screens display in rotation along with other status screens in the multi-function display. To dismiss "maintenance required" screens, press and hold the multi-function display interface button for 5 seconds.

IMPORTANT: If a "maintenance required" screen is not dismissed, it is still possible to page through the other screens for one rotation only. After this, the "maintenance required" screen will remain displayed until it is dismissed.

Engine Maintenance

Engine Access

1. Use the ignition key to unlock the latch (A, Fig. 83) on the top engine compartment cover. Pull up on the latch and lift the cover.

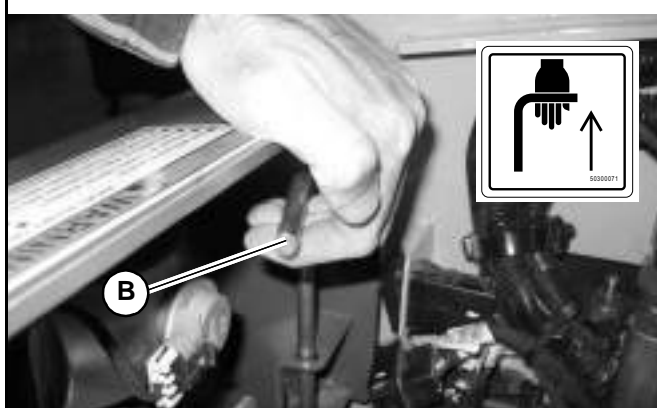
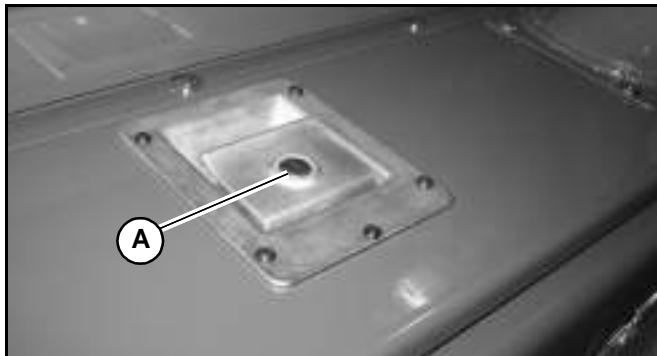

Fig. 83 – Engine Access

2. Pull up on handle (B) inside the top left lip of the rear door. Swing the door open to access engine components.

NOTE: Opening the rear door all the way engages stop (S, Fig. 84), which holds the door open.

Closing Engine Covers

1. Lift up on the rear door stop (S), and firmly close the rear door.

NOTE: It is important for the rear door to close and latch completely, so the top engine cover latch aligns properly with the pin on the rear door. Incomplete latching of the rear door/top cover may cause latches to stick.

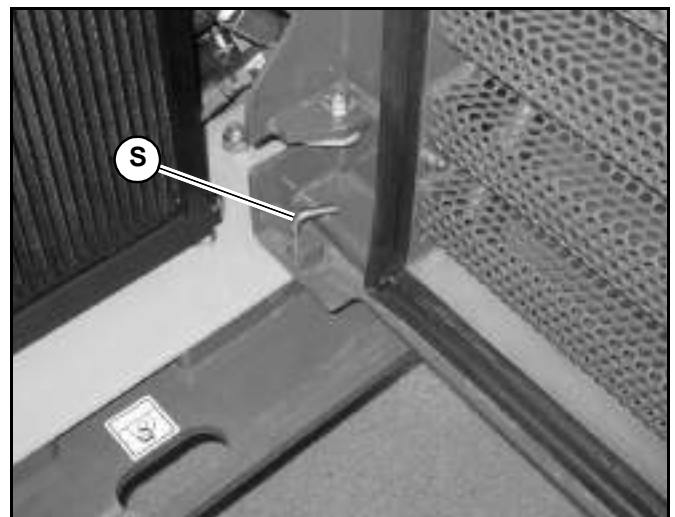

Fig. 84 – Engine Access

2. With the rear door completely closed and latched, firmly close the top engine cover until it is completely closed and latched.

Maintenance

Engine Oil

Checking Engine Oil Level

Check the engine oil level daily before starting the machine, or after every ten hours of use.

1. Park the machine on a level surface.
2. Perform the “Mandatory Safety Shutdown Procedure” on page 16.
3. Wait until the engine has cooled. See “Maintenance and Service Safety Practices” on page 21.
4. Open the engine cover “Engine Access” on page 103.
5. Twist engine oil dipstick (C, Fig. 85) counter-clockwise to unlatch it. Remove the dipstick from the engine.

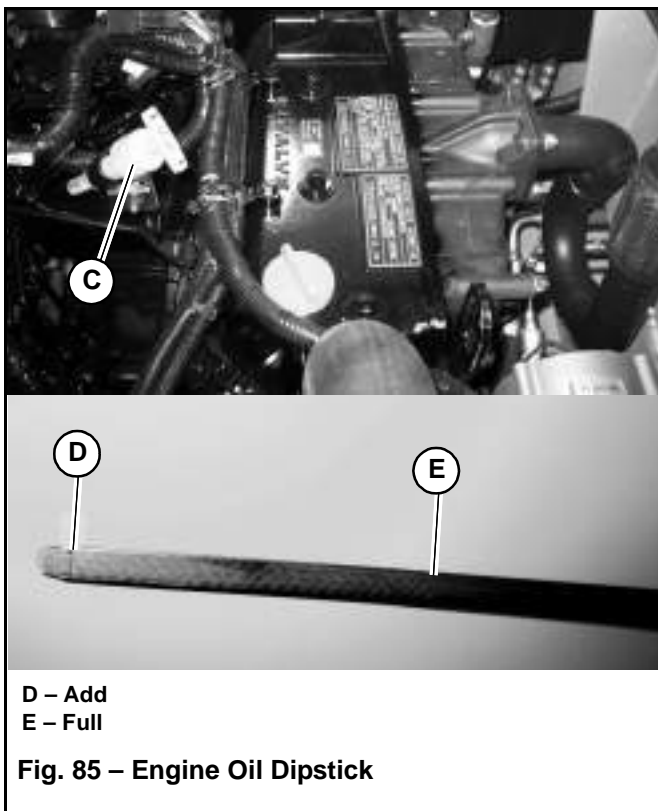

6. Wipe the dipstick with a clean cloth and replace it in the engine. Push it in until it is fully inserted.
7. Remove the dipstick again. The oil level should be within the “Add” and “Full” marking.

8. If the oil level is below the “Add” marking:
 - a. Clean the area around the oil fill cap (D) with a clean cloth
 - b. Remove fill cap (D).
 - c. Add oil through the fill cap opening until the level reaches the “Full” mark.
 - d. Replace and tighten fill cap (D).

IMPORTANT: Do not over-fill the engine with oil. Damage could result.

Changing Engine Oil and Filter

Change the engine oil and filter after the first 50 hours of use, and every 250 hours thereafter.

1. Park the machine on a level surface.
2. Perform the “Mandatory Safety Shutdown Procedure” on page 16.
3. Wait until the engine has cooled, but is not completely cold. Oil will drain faster and more completely if it is warm.
4. Open the engine cover “Engine Access” on page 103.
5. Remove hardware (M, Fig. 86) securing engine drain plug access panel (N). Remove panel to access engine oil drain plug (O).

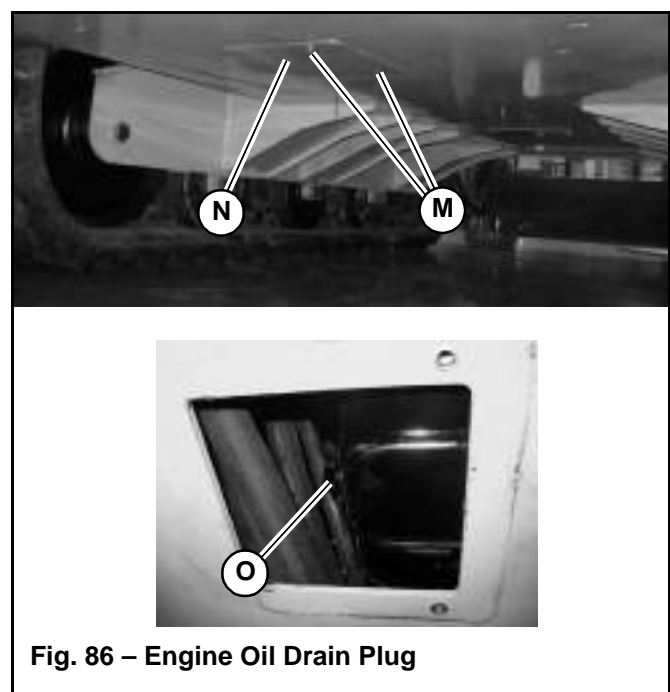

6. Position a waste oil collection container under the engine oil drain plug to catch draining oil.

IMPORTANT: *Dispose waste engine oil according to environmental laws, or take to a recycling center for proper disposal. DO NOT pour waste engine oil onto the ground or down a drain.*

7. Remove drain plug (O) from the engine oil pan and allow the oil to drain into the waste oil collection container.
8. Remove oil filter (D, Fig. 87), using a filter wrench if necessary. Carefully clean the filter head mounting surface with a clean cloth.

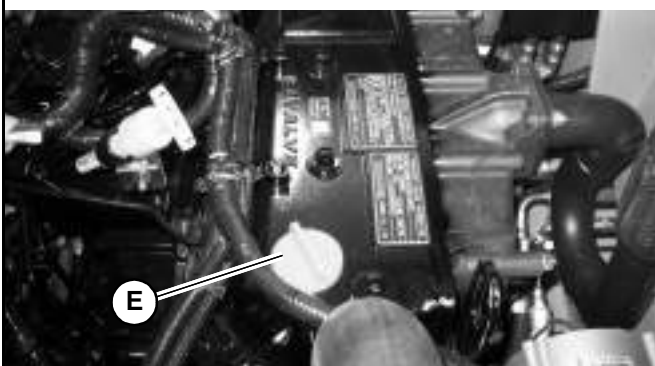
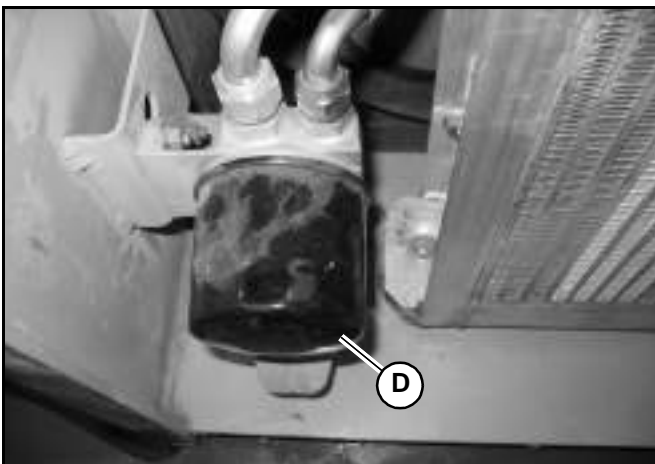

Fig. 87 – Engine Oil Filter and Oil Fill

9. Apply a coating of clean oil on the new oil filter gasket. Install the filter and tighten 3/4 rotation past the point where the gasket contacts the filter head.
10. Re-install and tighten the drain plug.

11. Clean the area around oil fill cap (E). Remove oil fill cap (E) and add the recommended type and amount of oil. See “Fluids/Lubricants Types and Capacities” on page 31. Replace and tighten oil fill cap (E) after the oil is added.

NOTE: *Oil capacity listed is approximate. Always verify proper oil level with the engine oil dipstick.*

IMPORTANT: *Do not over-fill the engine with oil. Damage could result.*

12. Start the engine and let it run for several minutes at low idle. Watch for leaks at the oil filter and drain plug. Stop the engine and wait for it to cool.
13. Check the oil level. Add oil if necessary until the oil level is at the “Full” mark on the dipstick (Fig. 85).

Maintenance

Engine Air Filters

IMPORTANT: Do not operate the engine without the air cleaner components installed or damage to the engine could occur.

Check, and if necessary replace, the engine air filters after every 250 hours of use, or every 6 months, or whenever the engine air filter restriction indicator is lit (F, Fig. 88).

NOTE: The engine air filter restriction indicator (F, Fig. 88) on the multi-function display is lit whenever the air cleaner becomes restricted. When this indicator is lit, the air filters require inspection and may need replacement.

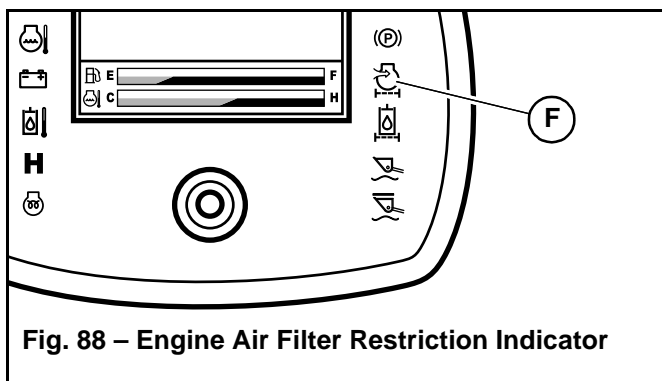

Fig. 88 – Engine Air Filter Restriction Indicator

The air cleaner consists of an outer (primary) filter element (G, Fig. 89), an inner (secondary) filter element (H) and an optional pre-cleaner.

Replace the inner filter element every third time the outer element is replaced, unless the outer element is damaged or the inner element is visibly dirty.

Be sure the air cleaner intake hose, clamps and mounting bracket hardware are properly tightened.

Changing Air Filter Elements

1. Perform the “Mandatory Safety Shutdown Procedure” on page 16.
2. Open the engine cover “Engine Access” on page 103.

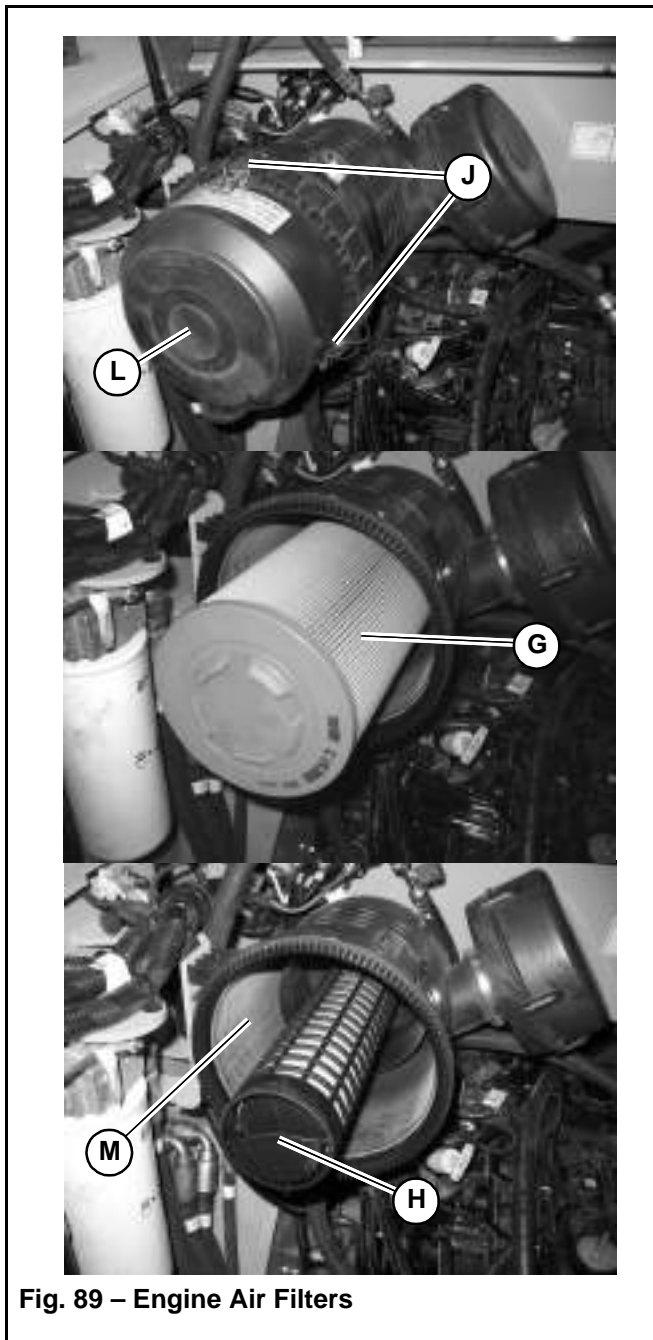

Fig. 89 – Engine Air Filters

3. Unlatch clamp (J, Fig. 89) on the air cleaner housing and remove the air filter cover (L).
4. Clean debris from inside the air cleaner housing and air filter cover.

- Carefully remove the outer filter element (G, Fig. 89). Do not remove inner filter element (H) unless it will be replaced. If inner filter element (H) will not be replaced, skip to step 10.

- Clean dirt from inside the air filter housing (M).

IMPORTANT: To prevent debris from entering the engine intake manifold, do not remove inner filter element (H) while cleaning the inside of the housing.

- Remove the inner filter element (H).
- Check the inside of the housing for damage.
- Install a new inner filter element (H).
- Install a new outer filter element (G).
- Replace air filter cover (L). Latch clamps (J). Make sure the cover is tightly secured and is seated properly in the housing.

Engine Cooling System

Checking Coolant Level

Check the coolant level daily before starting the machine, or after every ten hours of use.

- Park the machine on a level surface.
- Perform the “Mandatory Safety Shutdown Procedure” on page 16.
- Wait until the engine has cooled. See “Maintenance and Service Safety Practices” on page 21.
- Open the engine cover “Engine Access” on page 103.
- Check the coolant level in the expansion reservoir (R, Fig. 90). Coolant level must be between the “FULL” (T) and “ADD” (S) marks on the expansion reservoir. Add coolant to the expansion reservoir as required.

IMPORTANT: The coolant system is specifically designed for coolant level top-off only through the expansion reservoir. Do not add coolant directly to the radiator.

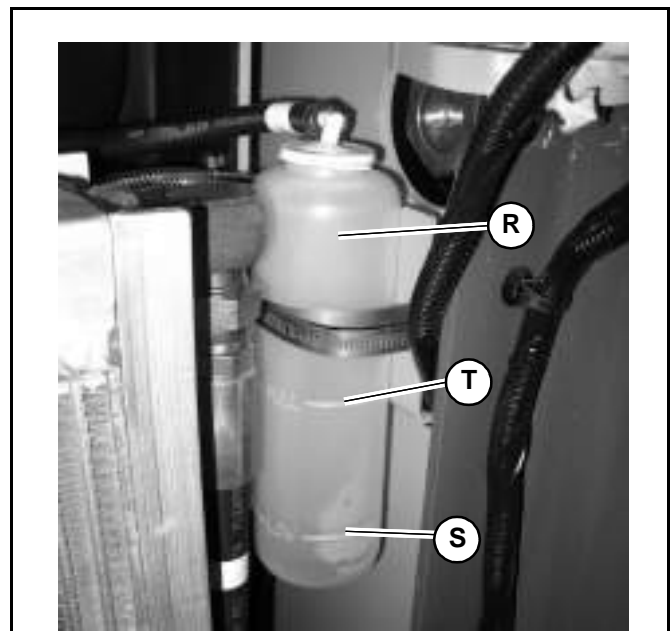

Fig. 90 – Coolant Expansion Reservoir

NOTE: Use a low-silicate ethylene glycol-based coolant, mixed with quality water and supplemental coolant additives (SCAs) suitable for heavy-duty diesel engines. See “Dimensions” on page 32 and the engine operation manual for additional information.

Cleaning Radiator Fins

The radiator fins can become blocked during use which will lead to reduced cooling function and engine overheating. Clean the radiator cooling fins after every 250 hours or 6 months of operation, whichever occurs first.

- Perform the “Mandatory Safety Shutdown Procedure” on page 16.
- Wait until the engine has cooled. See “Maintenance and Service Safety Practices” on page 21.
- Open the engine cover “Engine Access” on page 103.
- Clean the radiator fins by blowing air/water through the fins from the rear of the radiator, toward the engine.

IMPORTANT: Use caution! High pressure can damage radiator fins.

Maintenance

Draining/Refilling Cooling System

1. Park the machine on a level surface.
2. Perform the “Mandatory Safety Shutdown Procedure” on page 16.
3. Wait until the engine has cooled. See “Maintenance and Service Safety Practices” on page 21.
4. Open the engine cover. See “Engine Access” on page 103.

WARNING

Do not remove radiator cap when the coolant is hot. Serious burns may occur.

5. Slowly loosen radiator cap (P, Fig. 91) and allow pressure to escape. Remove cap.



Fig. 91 – Radiator Cap

6. Position a suitable collection container, with a minimum capacity of 15 L (4 gals.) underneath the radiator.

IMPORTANT: *Dispose waste coolant according to environmental laws. DO NOT pour coolant onto the ground or down a drain.*

7. Access radiator drain plug (X, Fig. 92) through access hole (Y) in the frame underneath the radiator. Using an allen wrench, remove radiator drain plug (X) and allow the coolant to drain into the container.

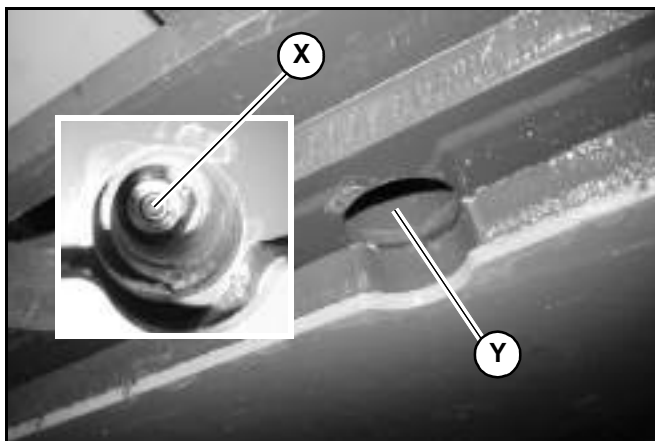

Fig. 92 – Radiator Drain Access

8. Replace the radiator drain plug and tighten securely.
9. Fill the radiator with coolant.

NOTE: *Use a low-silicate ethylene glycol-based coolant, mixed with quality water and supplemental coolant additives (SCAs) suitable for heavy-duty diesel engines. See “Dimensions” on page 32 and the engine operation manual for additional information.*

10. Reinstall radiator cap and tighten securely.
11. Start and run the engine until it reaches operating temperature.
12. Check the coolant level according to “Checking Coolant Level” on page 107.

V-Belt Maintenance

Check V-belt condition monthly, or after every 100 hours of use. Replace or adjust if necessary.

Checking and Adjusting V-belt Tension

1. Perform the “Mandatory Safety Shutdown Procedure” on page 16.
2. Wait until the engine has cooled. See “Maintenance and Service Safety Practices” on page 21.
3. Open the engine cover “Engine Access” on page 103.
4. Inspect V-belt (A, Fig. 93) for damage. If damaged, have belts replaced by an authorized repair shop.

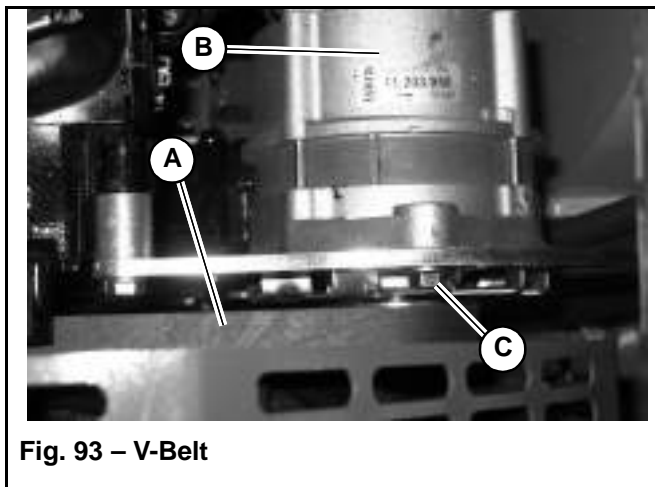

Fig. 93 – V-Belt

5. Press on V-belt (A) mid-way between pulleys to check deflection. The belt should not deflect more than 8 mm (5/16”).
6. If deflection is more than 8 mm (5/16”): Loosen adjustment bolt (C) and rotate alternator (B) outward until V-belt tension is correct. Tighten bolt (C) and re-check V-belt tension.

Air Conditioning V-Belt

Air conditioning V-belt (P, Fig. 94) tension is automatic and requires no adjustment.

Check air conditioning V-belt condition at regular intervals. Replace or adjust if necessary.

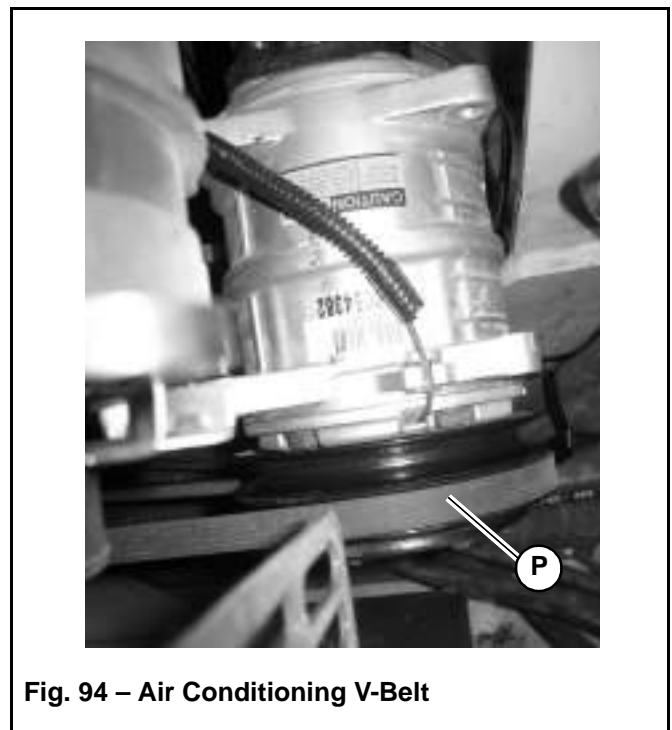

Fig. 94 – Air Conditioning V-Belt

Fuel System Maintenance

WARNING

Diesel fuel is flammable. Keep the machine away from open flames. Do not smoke when refueling or when working on the engine. Stop the engine before fueling.

Wear eye protection. The fuel system is under pressure and fuel could spray out when removing any fuel system component

Wipe up spills immediately. NEVER use a shop rag to catch draining/leaking fuel. Vapors from the rag are flammable and explosive.

Failure to follow these instructions can cause fire and result in injury or death.

Maintenance

CAUTION

Use only proper types and grades of diesel fuel (See “Fluids/Lubricants Types and Capacities” on page 31).

NOTICE: The fuel tank is filled at the factory with United States off-road grade diesel fuel, which is dyed red for identification. It may take several fillings of the fuel tank before the red dye is purged from the fuel system.

Adding Fuel

1. Perform the “Mandatory Safety Shutdown Procedure” on page 16.
2. Using the ignition key to unlock fuel cap (F, Fig. 95) and remove the fuel cap from the fuel filler neck.

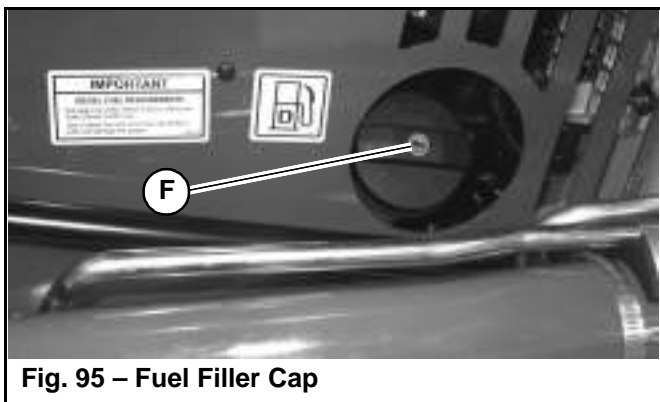

Fig. 95 – Fuel Filler Cap

3. Inspect the wire-mesh fuel strainer located in the filler neck opening and remove any accumulated residue. Replace the strainer if damaged.
4. Fill the fuel tank by adding fuel through the fuel filler neck opening.

IMPORTANT: Use only low sulfur or ultra-low sulfur diesel fuel to maintain proper engine performance. BioDiesel mixtures of up to a 5% (B5) are acceptable. Ultra-Low Sulfur Diesel (ULSD) fuel lubricity must have a maximum scar diameter of 0.45 mm, as measured by ASTM D6079 or ISO 12156-1, or a minimum of 3100 grams, as measured by ASTM D6078. Contact your fuel supplier for details. Also see “Fluids/Lubricants Types and Capacities” on page 31 and the engine operation manual.

5. When the fuel tank is full, replace and lock fuel cap (F) in the fuel filler neck opening.

IMPORTANT: To provide for proper fuel system venting, do not top off the fuel tank.

Water Separator Inspection/Maintenance

WARNING

NEVER service the fuel system while smoking, while near an open flame, or after the engine has been operated and is hot.

IMPORTANT: Water in the fuel system can cause severe engine damage. Drain water from the fuel filter/water separator anytime water is present.

Inspect the water separator weekly, or after every 50 hours of use.

The water separator contains an indicator ring (M, Fig. 96) that floats on top of accumulated water. Under normal conditions, the ring sits at the bottom of the separator cup. If the ring is somewhere between the top and bottom the cup, water must be drained.

1. Perform the “Mandatory Safety Shutdown Procedure” on page 16.
2. Wait until the engine has cooled. See “Maintenance and Service Safety Practices” on page 21.
3. Open the engine cover “Engine Access” on page 103.

4. On all machines except model RT250, inspect the water separator (Fig. 96) for the presence of water:

- If the indicator ring (M) is at the bottom of the cup, no action is required.
- If the indicator ring (M) is floating off the bottom of the cup, water is present and needs to be drained.

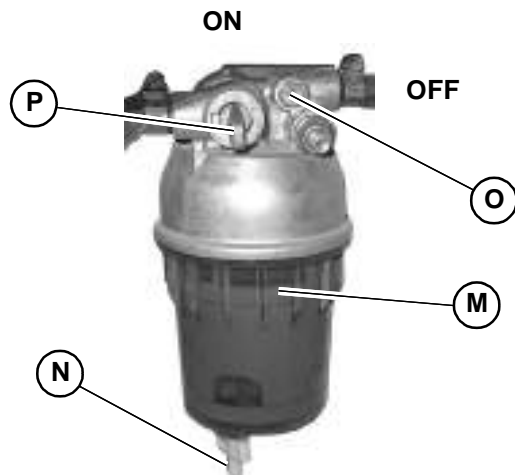

Fig. 96 – Water Separator

5. Drain water from the water separator:

- Position a suitable collection container underneath the water separator drain.
- Turn the fuel shut-off valve lever (P) on the water separator to the OFF position.
- Loosen drain plug (N) at the bottom of the water separator. Allow water to drain until indicator ring falls to the bottom of the cup.

NOTE: If the water does not drain well, loosen vent plug (O).

- Tighten drain plug (N) and discard fuel/water according to environmental laws.

IMPORTANT: Dispose waste fuel according to environmental laws. DO NOT pour fuel onto the ground or down a drain.

- Turn the fuel shut-off valve lever (P) on the water separator to the ON position. Tighten vent plug (O), if it was loosened.

Changing Fuel Filter



WARNING

NEVER service the fuel system while smoking, while near an open flame, or if the engine is hot.

Replace the fuel filter annually, or after every 500 hours of use.

IMPORTANT: The fuel filter change interval should be 250 hours when the available fuel has a sulfur content greater than 2000 ppm.

- Perform the “Mandatory Safety Shutdown Procedure” on page 16.
- Wait until the engine has cooled. See “Maintenance and Service Safety Practices” on page 21.
- Open the engine cover “Engine Access” on page 103.
- Turn fuel shut-off valve lever (P, Fig. 96) on the water separator to the OFF position.
- Remove the fuel filter (Z, Fig. 97), using a filter wrench if necessary. Carefully clean the filter head mounting surface with a clean cloth.

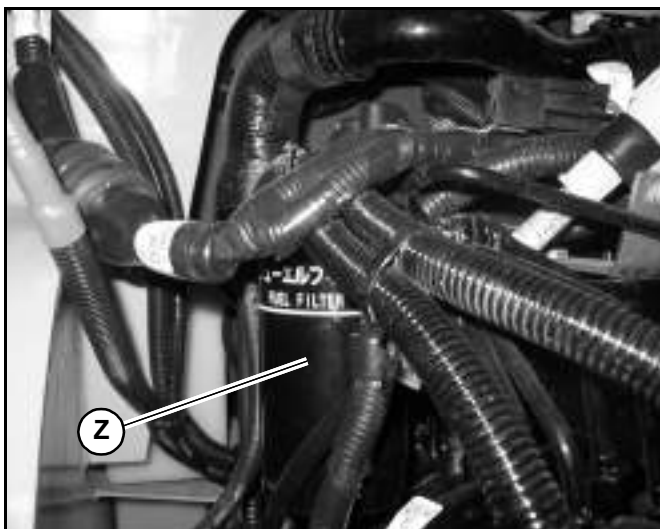

Fig. 97 – Engine Fuel Filter

6. Apply a coating of clean diesel fuel on the new fuel filter gasket. Install the filter and tighten 3/4 rotation past the point where the gasket contacts the filter head.
7. Turn shut-off valve on water separator to ON.
8. Open the fuel return line by turning the valve on the fuel tank clockwise.
9. The fuel system is self-priming. To remove air before starting, turn the ignition key to the ON position for 15 seconds.

Hydraulic System Maintenance

WARNING

Never use your hands to search for hydraulic fluid leaks; use a piece of paper or cardboard to find leaks. Escaping fluid under pressure can be invisible and can penetrate the skin, causing serious injury. If any fluid is injected into your skin, see a doctor at once. Injected fluid **MUST** be surgically removed, or gangrene may result.

Checking Hydraulic Oil Level

Check the hydraulic oil level daily before starting the machine, or after every ten hours of use.

1. Perform the “Mandatory Safety Shutdown Procedure” on page 16.
2. Wait until the engine has cooled. See “Maintenance and Service Safety Practices” on page 21.
3. Open the engine cover “Engine Access” on page 103.
4. Check the level of the hydraulic oil in the sight gauge (Y, Fig. 98) located in the right engine compartment wall. The oil level be in the middle of the sight gauge (A).

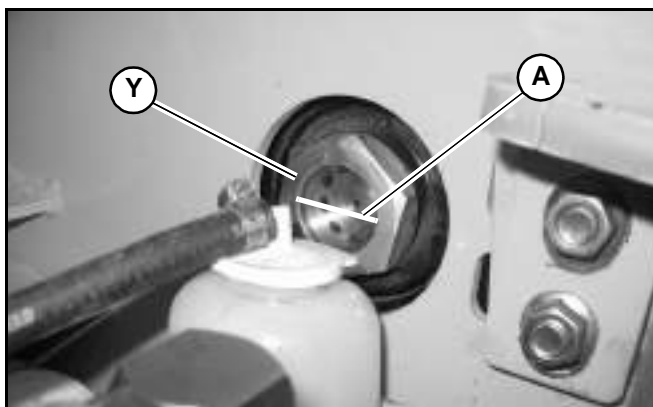

Fig. 98 – Hydraulic Oil Level Sight Gauge

- If the hydraulic oil level is low, use the accessory key (supplied with the ignition key) to unlock and open the hydraulic tank cover (H, Fig. 99), located on the top right of the machine next to the top engine cover.

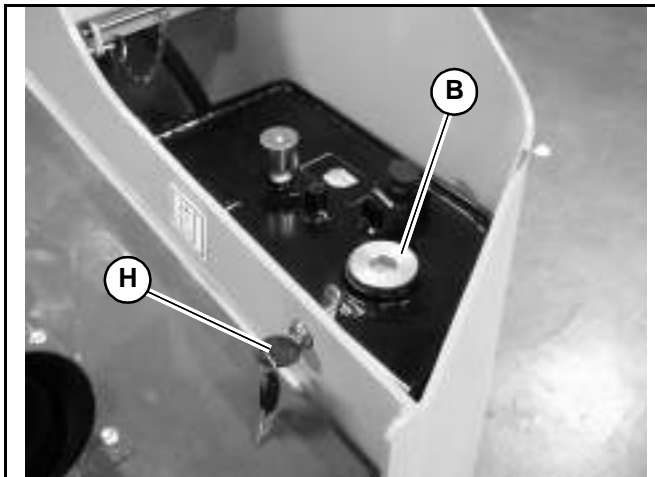

Fig. 99 – Hydraulic Oil Fill

- Slowly remove the hydraulic oil fill cap (B). Allow the pressure to escape before completely removing the cap.
- Add hydraulic fluid if required. See “Fluids/Lubricants Types and Capacities” on page 31 for proper hydraulic oil grade and type.

IMPORTANT: Do not mix different types/grades of hydraulic fluids.

Reinstall and tighten the oil fill cap. Close and lock the hydraulic tank cover.

Changing Hydraulic Oil and Filter

NOTE: The hydraulic oil filter can be changed without changing the hydraulic oil or draining the hydraulic reservoir.

Replace the hydraulic oil if it becomes contaminated, after major repairs, and after 500 hours or 1 year of use.

- Perform the “Mandatory Safety Shutdown Procedure” on page 16.
- Wait until the engine has cooled. See “Maintenance and Service Safety Practices” on page 21.

- Open the engine cover according to “Engine Access” on page 103.
- Position a waste oil collection container with a capacity of at least 53 L (14 gals.) underneath the hydraulic oil reservoir.

IMPORTANT: Always dispose of hydraulic fluids according to environmental laws or take to a recycling center for proper disposal. DO NOT pour onto the ground or down a drain.

- Remove the hydraulic reservoir drain plug and allow the oil to drain completely.

NOTE: The hydraulic reservoir drain plug is accessed from underneath the machine at the right rear corner.

- Remove the hydraulic oil return filter (D, Fig. 100), using a filter wrench if necessary. Carefully clean the filter head mounting surface with a clean cloth.

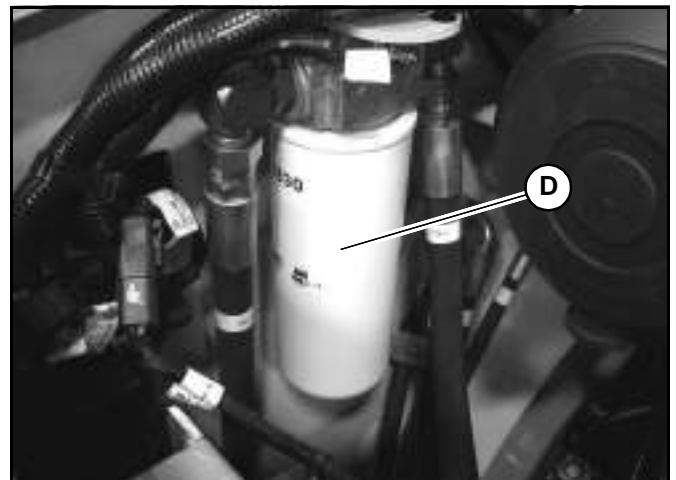

Fig. 100 – Hydraulic Oil Return Filter

- Apply a coating of clean oil on the new oil filter gasket. Install the filter and tighten 3/4 rotation past the point where the gasket contacts the filter head.
- Re-install and tighten the drain plug.
- Using the key, unlock and open the hydraulic tank cover (H, Fig. 99), located on the top right of the machine next to the top engine cover.

Maintenance

10. Remove hydraulic oil fill cap (B, Fig. 99) and add the recommended type and amount of oil. See “Fluids/Lubricants Types and Capacities” on page 31. Replace and tighten the hydraulic oil fill cap after the oil is added.

NOTE: *Hydraulic oil capacity listed is approximate. Always verify proper oil level with the engine oil dipstick.*

Hydraulic Hose Maintenance



Hydraulic hoses and connections must be inspected by a trained technician before the first use of the machine, and at least annually thereafter, for leaks and/or damage.

Leakages and damaged pressure hose/lines must be immediately repaired or replaced by an authorized service center.

Never use your hands to check for suspected hydraulic leaks. Always use a piece of wood or cardboard.

Leaks from hydraulic hoses or pressurized components can be difficult to see, but pressurized oil can have enough force to pierce the skin and cause serious injury.

Obtain immediate medical attention if pressurized oil pierces the skin. Failure to obtain prompt medical assistance could result in gangrene or other serious damage to tissue.

Always relieve hydraulic system pressure before performing any maintenance on the machine. Do not tighten leaking connections when the hydraulic system is under pressure.

Never weld or solder damaged or leaking pressure lines and/or screw connections. Always replace damaged hydraulic components.

Hydraulic hoses must be replaced every six years from the date of manufacture, even if they do not appear damaged. The date of manufacture (month or quarter and year) is indicated on hydraulic hoses. See Fig. 101.

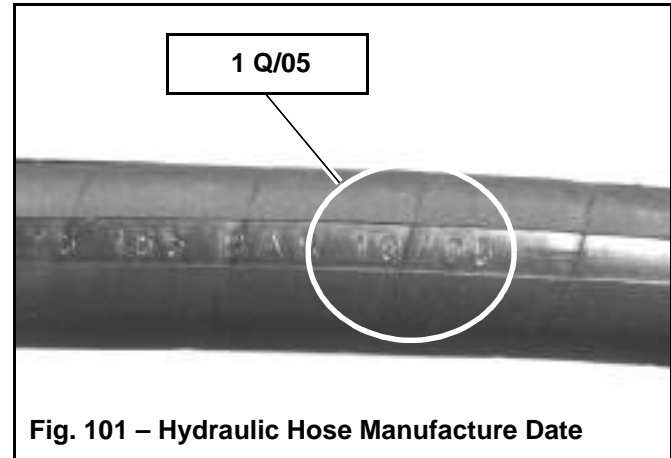

Travel Motor Maintenance

Travel Motor Gearbox Oil

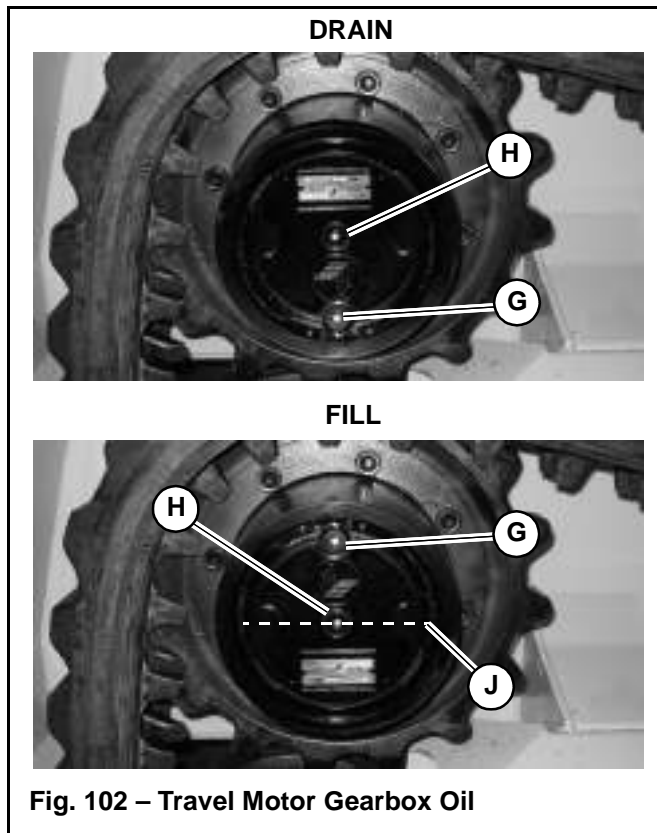

Replace the travel motor gearbox oil if it becomes contaminated, after major repairs, after the first 150 hours of use and every 1000 hours or annually thereafter.

1. Park the machine with travel motor gearbox drain/fill hole plug (G, Fig. 102) at the bottom.
2. Perform the “Mandatory Safety Shutdown Procedure” on page 16.
3. Position a waste oil collection container with a 1 quart/liter (± 0.10 quarts/liters) underneath the drain/fill hole plug (G).

IMPORTANT: Always dispose of hydraulic fluids according to environmental laws or take to a recycling center for proper disposal. DO NOT pour onto the ground or down a drain.

4. Remove breather hole plug (H).
5. Remove drain/fill hole plug (G) and allow the oil to drain completely.

6. Rotate the travel motor gearbox 180° so the drain/fill hole plug (G, Fig. 102) opening is at the top.
7. Fill the travel motor gearbox with the correct grade and type oil. Fill to level (J, Fig. 102).

NOTE: Oil level will be visible at breather hole (H) when correct oil level is reached.

8. Clean and replace drain/fill hole and breather plugs (G and H). Tighten securely.
9. Test the drive system and check for leaks

Track Maintenance

Inspect the tracks daily for damage and wear.

Observe the following conditions to extend track life:

- Avoid traveling or turning on broken stone, jagged rock, metal or other material that could damage or cut the tracks.
- Avoid traveling on riverbeds or areas with soft rocks that could become stuck in the tracks, which could cause damage to the tracks or cause the tracks to slip off.
- Avoid using the machine on the seashore. Sea salt can corrode the metal cores of the tracks.
- Immediately wipe any spilled fuel, oil, salt or chemical solvents off of the tracks, as these substances can corrode the coupling in the metal cores in the tracks, causing corrosion and peeling
- Avoid traveling on freshly paved roads or on hot surfaces (e.g. fires, metal sheets exposed to direct sunlight, etc.). Hot surfaces can damage the lugs or cause irregular wear.
- Avoid moving earth in area where the tracks may slip, which can cause excessive lug wear.

Maintenance

Track Replacement

WARNING

Keeps hands clear from between the track and the idler when installing tracks. Crushing of body parts and amputation can result.

1. With the machine running and the drive system not moving, remove tension cylinder stop (K, Fig. 103) on the side on the machine with the track to be replaced.

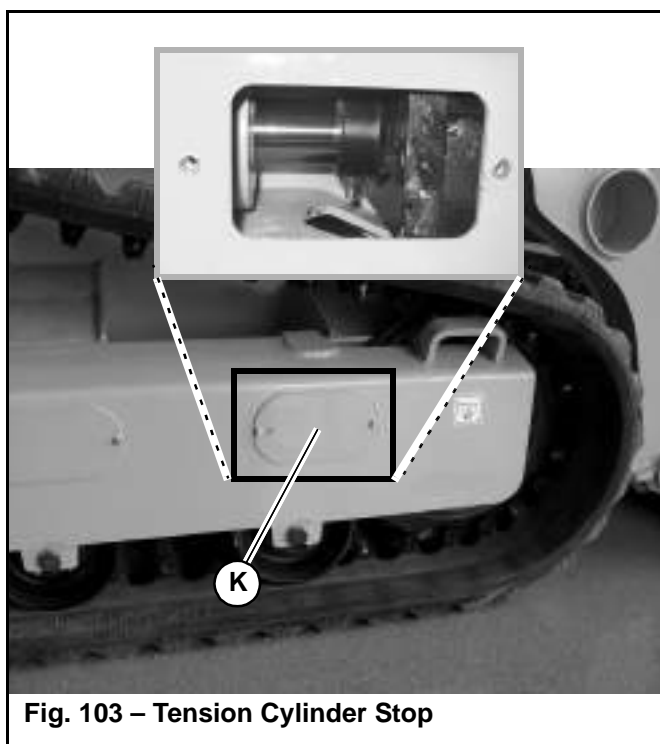

2. With the machine running and the drive system not moving, open the engine compartment. Press and hold the lock button (L, Fig. 104) on the track tension service switch, and press the top (M) of the switch to set the track tension cylinders into the service (retracted) position.

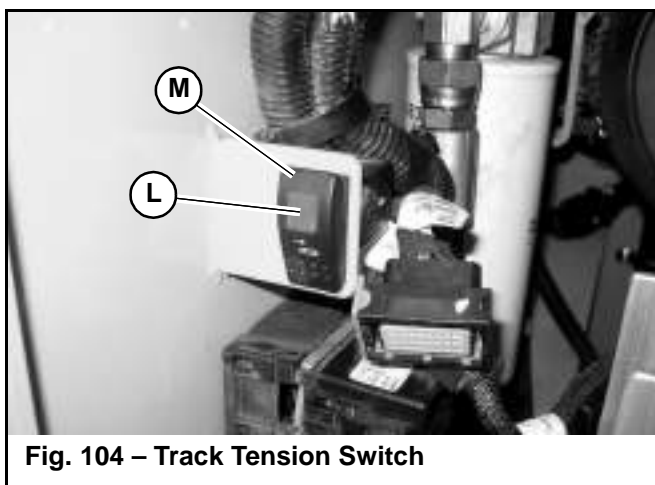

3. When the track tension cylinders are in the service (retracted) position, shut off the machine.
4. Raise the machine about 150 mm (6”), so the tracks are free to move.

WARNING

Use solid support blocking. Never rely on jacks or other inadequate supports when maintenance work is being done. Never work under any equipment supported only by jacks.

5. Use a pry bar to pry/guide the old track at (R, Fig. 105) off the front idler wheel.

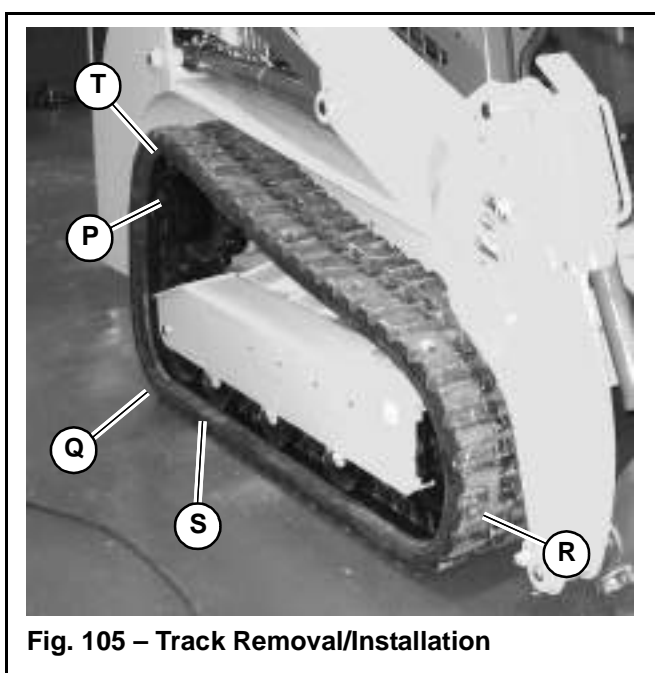

6. Using a hoist with a hook installed and a pry bar, lift/guide the old track at (T, Fig. 105) off the drive sprocket. Remove the old track.
7. Using a hoist with a hook, lift the new track at (T), and manoeuver the track under the rear idler wheel at (Q) using a pry bar and your foot.

IMPORTANT: Guides on the inside of the track must straddle the rear idler.

8. Place a block under the new track at (S), to hold the track against the bottom of the rear idler wheel.
9. Using a hoist with a hook and a pry bar, lift/guide the new track at (T) onto the drive sprocket.

IMPORTANT: Lugs on the inside of the track must be fully engaged by drive sprocket (P).

10. Using a pry bar (A, Fig. 106) and wedging blocks (U), pull/guide the new track at (R) over the front idler wheel, and under the bottom rollers. Carefully direct a helper to start the machine and direct the helper to operate the track drive slowly forward/back to work the track over the front idler wheel.

WARNING

Keeps hands and feet clear from between the track and the idler/roller wheels when installing tracks. Crushing of body parts and amputation can result.

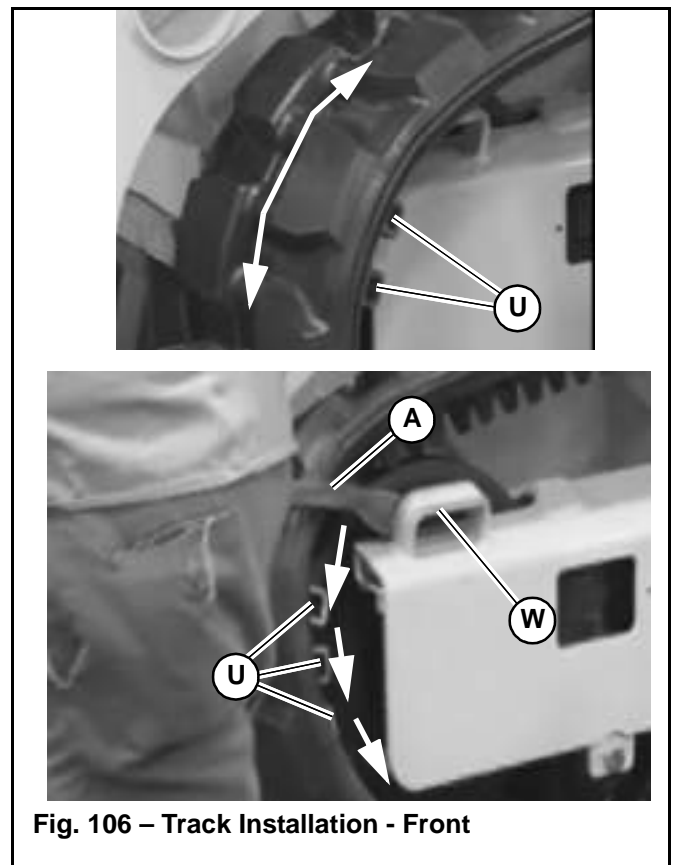

Fig. 106 – Track Installation - Front

NOTE: Tie-down bracket (W) can be used as a lever point for prying the track into place over the front idler wheel.

IMPORTANT: Guides on the inside of the track must straddle the front idler and bottom roller wheels.

11. Make sure the new track is fully engaged around the idler and roller wheels, and in the drive sprocket, all the way around.
12. Remove any wedging blocks (U) that were used to guide the track.
13. Remove the block placed under the track at (S, Fig. 105).
14. The installed track should look similar to Fig. 107.

Maintenance

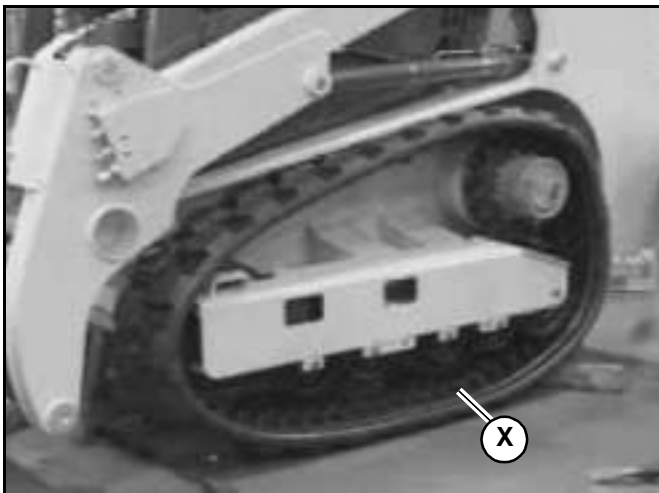

Fig. 107 – Track Installed Before Tensioning

15. Start the machine, open the engine compartment and press the bottom of the track tension service switch (N, Fig. 108), to set the track tension cylinders into the operating (extended) position.

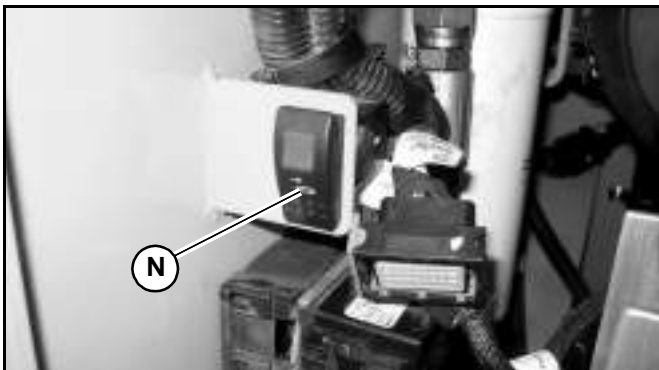

Fig. 108 – Track Tension Switch

16. Once the track tension cylinder has returned to the operating (extended) position, re-install cylinder stop (K, Fig. 109).

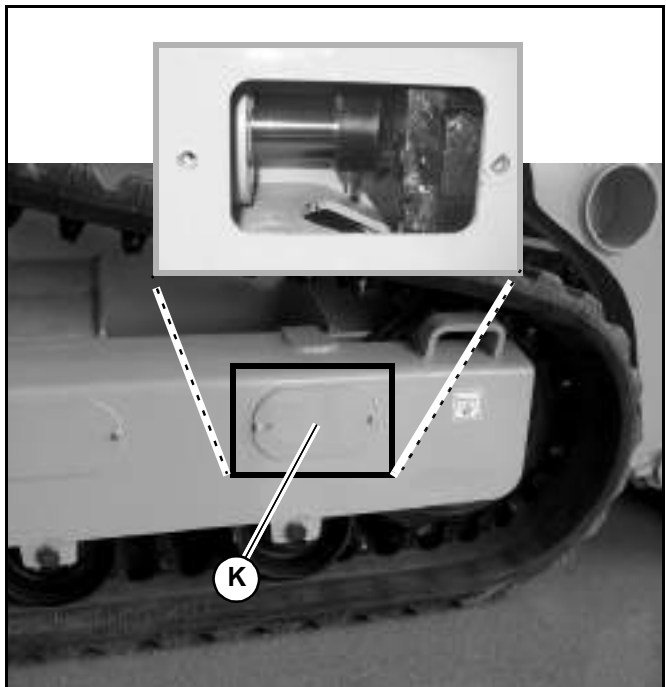

Fig. 109 – Tension Cylinder Stop

17. Operate the track drive forward/back to ensure the track is properly seated. Adjust track positioning if necessary.
18. Remove blocking and lower the machine to the ground.

General Lubrication

IMPORTANT: Use of lubricants not corresponding to manufacturer recommendations may invalidate warranty claims. Always dispose of waste lubrication oils and hydraulic fluids according to environmental laws or take to a recycling center for proper disposal. **DO NOT** pour fluids onto the ground or down a drain.

Refer to the following figures for grease fitting locations. See “Fluids/Lubricants Types and Capacities” on page 31 for proper grease specifications. Wipe dirt from the fittings before applying grease to prevent contamination. Replace any missing or damaged fittings. To minimize dirt build-up, avoid excessive greasing.

Lubricate Daily or After Every 10 Hours of Operation

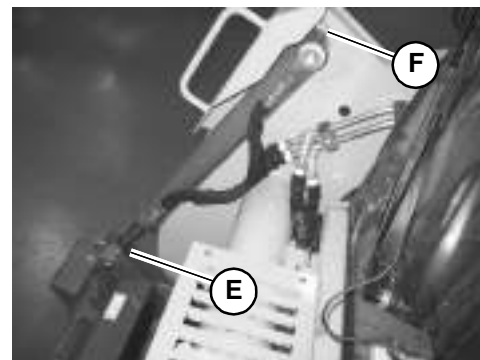
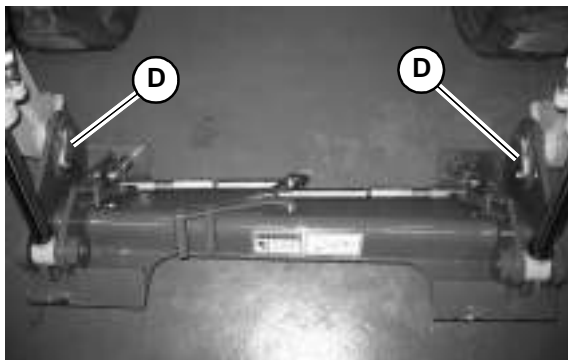
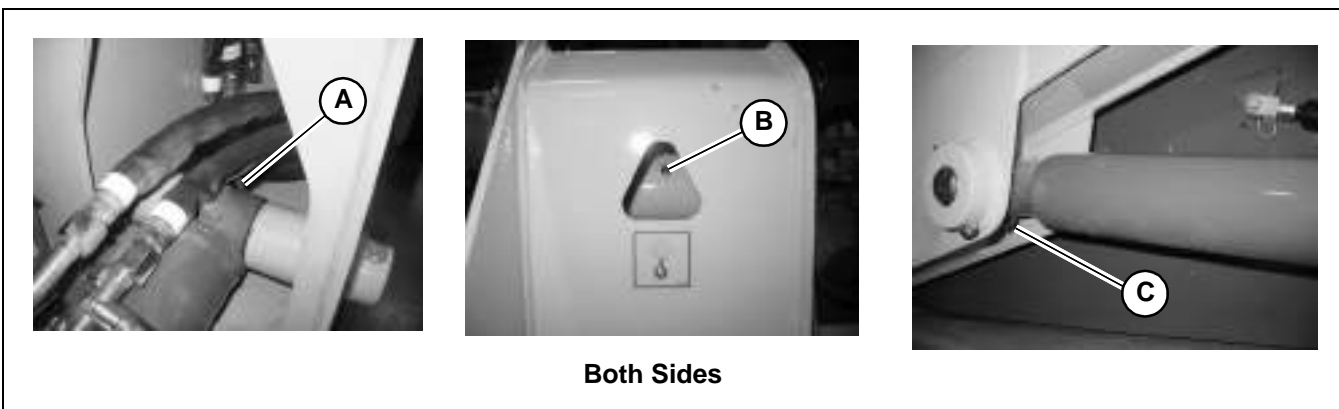

- A – Back Lift Cylinder Grease Fittings (2)
- B – Top Lift Arm Grease Fittings (2)
- C – Front Lift Cylinder Grease Fittings (2)
- D – Attachment Hitch Pivot Points (2)
- NOTE: Lubricate (D) from underneath.

- E – Bottom Tilt Cylinder Grease Fittings (2)
- F – Top Tilt Cylinder Grease Fittings (2)

Fig. 110 – Lubrication

Maintenance

Tilting ROPS/FOPS

Tilting up the ROPS/FOPS provides access to hydraulic and electrical components.

Raising ROPS/FOPS

WARNING

Always secure the ROPS/FOPS to the chassis with anchor bolts and washers (M, Fig. 111) before driving or using the machine.

Always close the cab door before tilting the ROPS/FOPS.

Stay clear from underneath the ROPS/FOPS as it is tilted.

Check ROPS/FOPS tilt component condition at regular intervals. Replace damaged or worn parts immediately.

1. Perform the “Mandatory Safety Shutdown Procedure” on page 16.
2. Remove anchor bolts and washers (M, Fig. 111) securing the front of the ROPS/FOPS to the chassis.

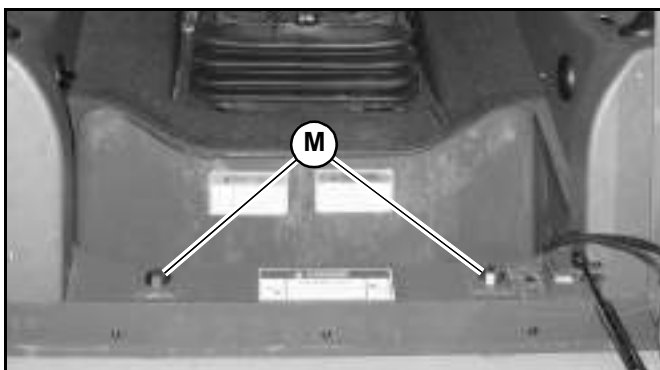

Fig. 111 – ROPS/FOPS Anchor Fasteners

3. On machines equipped with a cab, securely close and latch the cab door.
4. Raise the ROPS/FOPS up as far as it will go (Fig. 112).

NOTE: Hydraulic cylinders balance the ROPS/FOPS to aid raising and lowering.



Fig. 112 – ROPS/FOPS Tilting

5. Secure the ROPS/FOPS in the raised position with pins (T, Fig. 113) at brackets (N) on both sides behind the ROPS/FOPS. Secure pins (T) in place in the brackets using spring pins (S) on both sides.

WARNING

Secure the ROPS/FOPS in the raised position with pins (T) and spring pins (S). Never allow anyone under the ROPS/FOPS if the tilt securing pins are not in place.

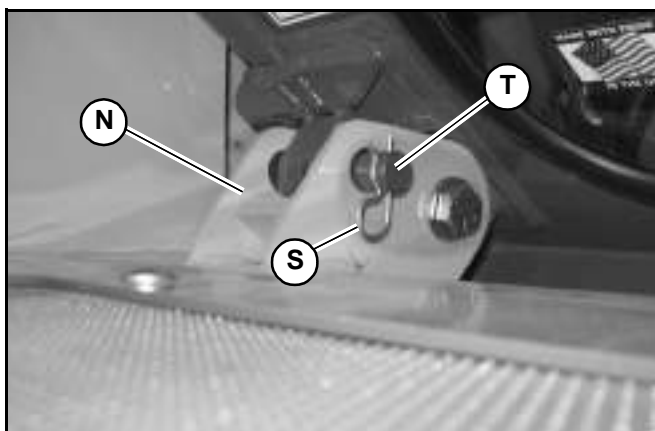

Fig. 113 – ROPS/FOPS Tilt Securing Pins

Lower ROPS/FOPS

1. Remove spring pins (S, Fig. 113) and pins (T) securing ROPS/FOPS in the tilted position from brackets.
2. Slowly and carefully tilt the ROPS/FOPS forward and down.

CAUTION

Stay clear from underneath the ROPS/FOPS as it is tilted down. Injury to limbs can result.

3. Secure the ROPS/FOPS to the chassis with anchor bolts and washers (M, Fig. 114). Torque anchor bolts to 75 lb.-ft. (102 Nm).

WARNING

Always secure the ROPS/FOPS to the chassis with anchor bolts and washers (M, Fig. 114) before driving or using the machine.

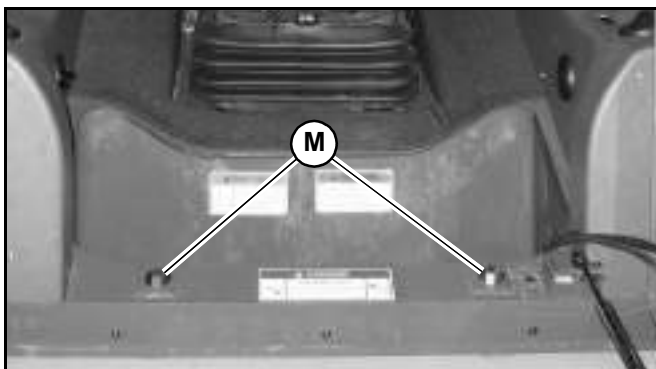

Fig. 114 – ROPS/FOPS Anchor Fasteners

Electrical System

WARNING

Inspect and check the machine's electrical equipment at regular intervals. Defects, such as loose connections or scorched cables must be repaired before using the machine.

Only use proper, original equipment fuses with the specified current rating. Turn off the machine immediately if there are any problems with the electrical system.

Work on the machine's electrical system must be done only by a trained technician.

Battery

WARNING

Before servicing the battery or electrical system, disconnect the negative cable from the negative battery terminal, or if the machine is equipped with a battery disconnect switch, turn the switch to the "OFF" position.

Explosive gas is produced while a battery is in use or being charged. Keep flames or sparks away from the battery area. ALWAYS charge the battery in a well-ventilated area.

Do not jump-start a frozen battery, or it may explode. A discharged battery can freeze at 10°C (14°F).

To prevent short circuits keep metal parts on your clothing and metal watchbands away from the positive (+) terminal of the battery.

Maintenance

WARNING

Never lay a metal object on top of a battery, because a short circuit can result. Battery acid is harmful to skin and fabrics. If acid spills, follow these first-aid tips:

- if battery acid spills on any clothing, remove it immediately.
- If acid contacts skin, rinse the affected area with running water for 10 to 15 minutes.
- If acid contacts eyes, flood eyes with running water for 10 to 15 minutes. See a doctor at once. Never use any medication or eye drops unless prescribed by the doctor.
- To neutralize acid spilled on the floor, use one of the following mixtures:
 - 0.5 kg (1 lbs.) of baking soda in 4 L (4 qts.) of water.
 - 0.5 L (0.5 qts.) of household ammonia in 4 L (4 qts.) of water.

To access the battery, use the accessory key (supplied with the ignition key) to unlock and open the battery cover (L, Fig. 115), located on the top left of the machine next to the top engine cover.

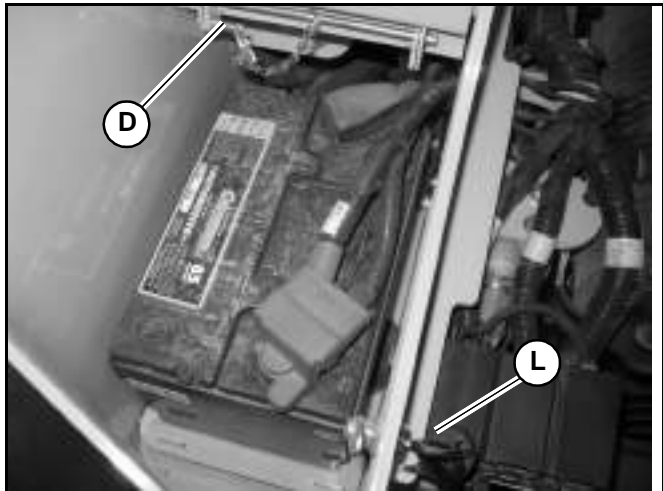

Fig. 115 – Battery Access

CAUTION

Always prop the battery compartment cover open using pin (D). Severe injuries can result if the battery compartment cover falls on hands and/or fingers.

Using a Booster Battery (Jump-Starting)

Jump-start the machine according to “Jump-Starting” on page 69.

Fuses and Relays

IMPORTANT: Blown fuses indicate electrical system malfunctions. Determine what caused the fuse to blow and repair the problem before replacing the fuse.

Engine Compartment Fuses/Relays

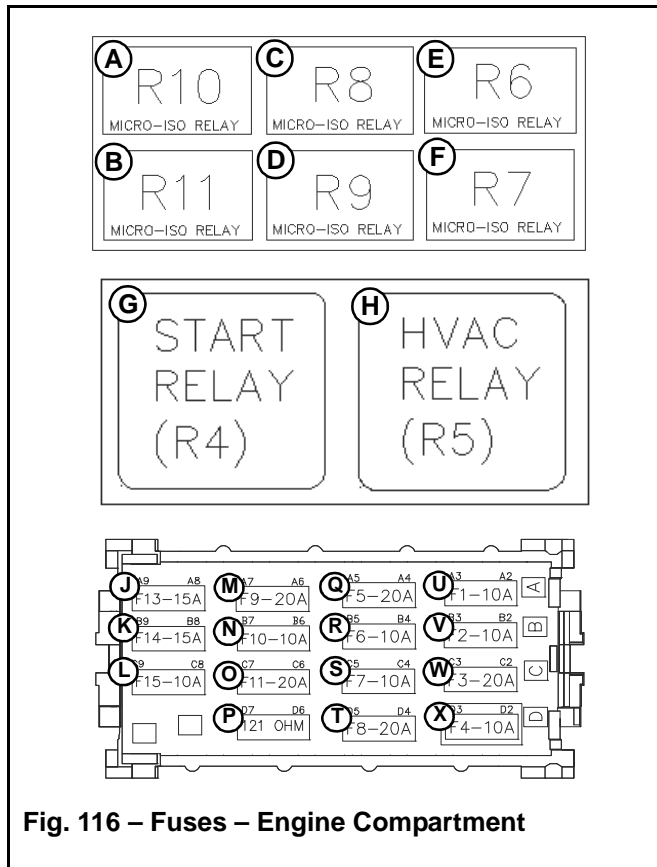

Fig. 116 – Fuses – Engine Compartment

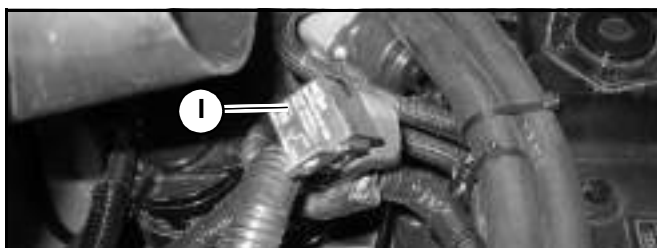

Fig. 117 – Engine Pre-heat Relay

Table 38: Engine Compartment Relays/Fuses

Fuse/ Resistor	Rated Current / Resista nce (A / Ω)	Protected Circuit
F		Air Conditioning Condenser Fan
G		Start
H		HVAC
I		Engine Pre-Hea
J	15A	Track Tension, Self Level
K	15A	Headlights
L	10A	Rear Door/Beacon Lights, Radio
M	20A	Work Lights
N	10A	Auxiliary Power Outlets
O	20A	Wipers
P	120Ω	Resistor, Oil Pressure Switch
Q	20A	Flasher Controller, Hazard Lights
R	10A	Display, Joysticks, Seat/Door Switches
S	10A	Fuel Pump, Power Splice
T	20A	HVAC Condenser
U	10A	Power/Relays, Main/Drive Logic Control Module
V	10A	Interlocks, 2-Speed, Hydraglide™, Lift, Tilt (Controller 3)
W	20A	Lift, Standard/High-Flow Aux. Hydraulic Controllers (Controller 1 & High-Flow Module)
X	10A	Brake Lights, Power-A-Tach® Quick Attach System Hitch Switch

Table 38: Engine Compartment Relays/Fuses

Relay	Circuit
A	Wiper Motors
B	Parking Brake Switch
C	Work Lights
D	Drive, Tilt (Controller 2)
E	Fuel Injection Pump

Maintenance

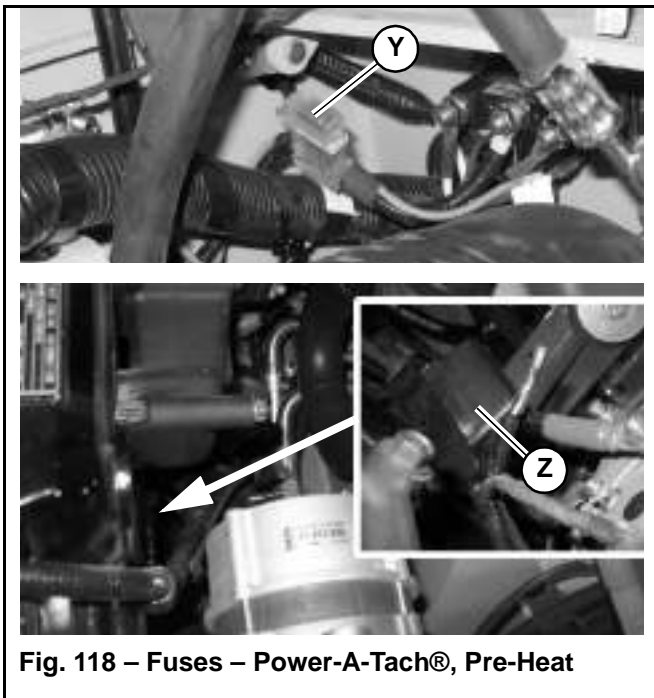

Fig. 118 – Fuses – Power-A-Tach®, Pre-Heat

Table 39: Engine Compartment Fuses

Fuse/ Resister	Rated Current / Resistance (A / Ω)	Protected Circuit
Y	30A	Power-A-Tach® System Hitch
Z	60A	Engine Pre-heat

Fuses Under ROPS/FOPS

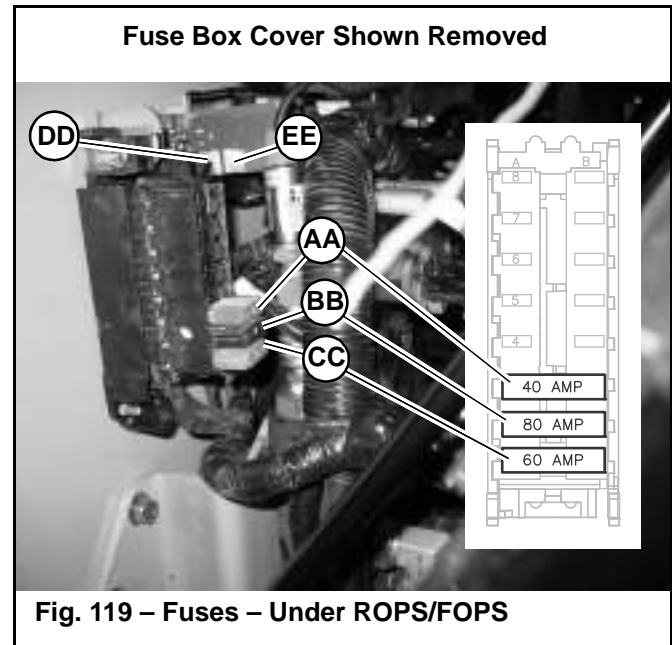

Fig. 119 – Fuses – Under ROPS/FOPS

Table 40: Fuses/Relays Under ROPS/FOPS

Fuse	Rated Current (Amp)	Protected Circuit
AA	40A	HVAC Relay Fuse (Maxi 3)
BB	80A	Power Relay, Ignition Switch, Dome Lights Fuse (Maxi 2)
CC	60A	Starter Solenoid Fuse (Maxi 1)
DD	N/A	Starter Solenoid Relay
EE	N/A	Main Power Relay

Control Modules

Electrical control modules are located on the chassis under the ROPS/FOPS.

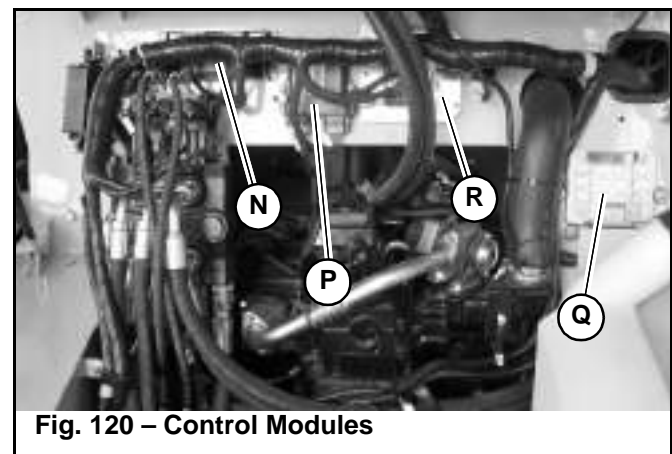

Fig. 120 – Control Modules

Multi-function Control Module

Multi-function control module (N, Fig. 120) provides the following control functions:

- Horn
- Fuel sender input
- Starter and parking brake interlock logic
- Hydraulic and air filters indicator inputs
- Two-speed travel logic
- Safety logic control
- Lift arm float and Hydraglide™ logic

Drive, Lift Arm and Standard Auxiliary Flow Control Module

Control module (P) includes outputs for lift arm and standard auxiliary hydraulics flow function.

Engine Control Module (ECU)

Control module (Q) controls engine control logic and error reporting.

Main/Drive Control Module

Main/drive control module (R) provides the following control functions

- Logic for travel drive and main control valve
- Bucket function
- Transmission, control valve and controller communication error codes broadcast output

Long-Term Storage

If storing the machine for a long period (longer than 2 months), perform the procedures in this section.

Before Storage

1. Wash the entire machine. Treat vinyl surfaces in the operator's compartment with a vinyl protectant.
2. Perform all steps for long-term engine storage according to the engine operation manual.
3. Lubricate all grease fittings. See "General Lubrication" on page 119.
4. Check all fluid levels and top-off as necessary.
5. Add a fuel stabilizer to the fuel system according to the fuel supplier's recommendations.
6. Remove and fully charge the battery. Store the battery in a cool, dry location.
7. If the machine will not be operated for a month or longer, apply grease to all exposed hydraulic cylinder rod areas or retract all cylinders so rod exposure is minimized. Apply grease to any remaining rod areas.
8. Protect against extreme weather conditions such as moisture, sunlight and temperature. Fill the engine coolant system with the proper mix of antifreeze and water as required for expected temperatures according to "Dimensions" on page 32.

IMPORTANT: *Contact your dealer for additional storage preparation information if the machine will be stored in an environment where temperatures could range below -42°C (-44°F), and/or above 49°C (120°F).*

Maintenance

After Storage

1. Replace and re-connect the battery.
2. Perform all steps for returning the engine to service according to long-term engine storage section in the engine operation manual.
3. Check V-belt tension.
4. Check all fluid levels and top-off as necessary.
5. Start the engine. Observe all indicators. If all indicators are functioning properly and reading normally, move the machine outside.
6. When outside, park the machine and let the engine idle for at least 5 minutes.
7. Shut off the engine and walk around machine. Make a visual inspection looking for evidence of leaks.

Air Conditioning Maintenance

Test air conditioning function weekly. Reduced air conditioning function could indicate a low refrigerant level. Low refrigerant or refrigerant leaks can cause air conditioning compressor overheating and failure.

IMPORTANT: *Air conditioning system should be filled only by technicians trained in the air conditioning fill processes.*

Air Conditioning Filters

Check the condition of the air conditioning filters every 250 hours of use and replace if necessary.

NOTE: *Extreme or dusty/dirty conditions may require more frequent maintenance.*

Cab Air Filter

1. Slide the operator's seat as far forward as it will go to provide access to the cab wall behind the seat.
2. Remove fasteners (A, Fig. 121) securing filter grilles (S) to the cab wall. Remove and discard the old filter elements.
3. Insert new filter elements and secure with grilles (S) and fasteners (A). Make sure the filter elements are completely seated in the openings and the grilles are firmly seated flush to the cab wall.

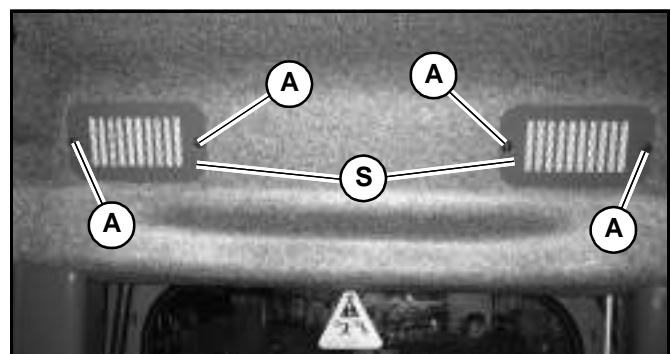

Fig. 121 – Cab Air Filters

Outside Air Intake Filter

1. Perform the “Mandatory Safety Shutdown Procedure” on page 16.
2. Remove hardware (F, Fig. 122) securing the outside air filter cover (G). Remove cover (G).
3. Remove old air filter (H)
4. Install new air filter (H), positioned so the side with the metal grate (Z) faces in.
5. If necessary, apply foam strips (I) to the outside edges of new air filter to provide a good seal.
6. Replace cover (H) and secure with hardware (F)

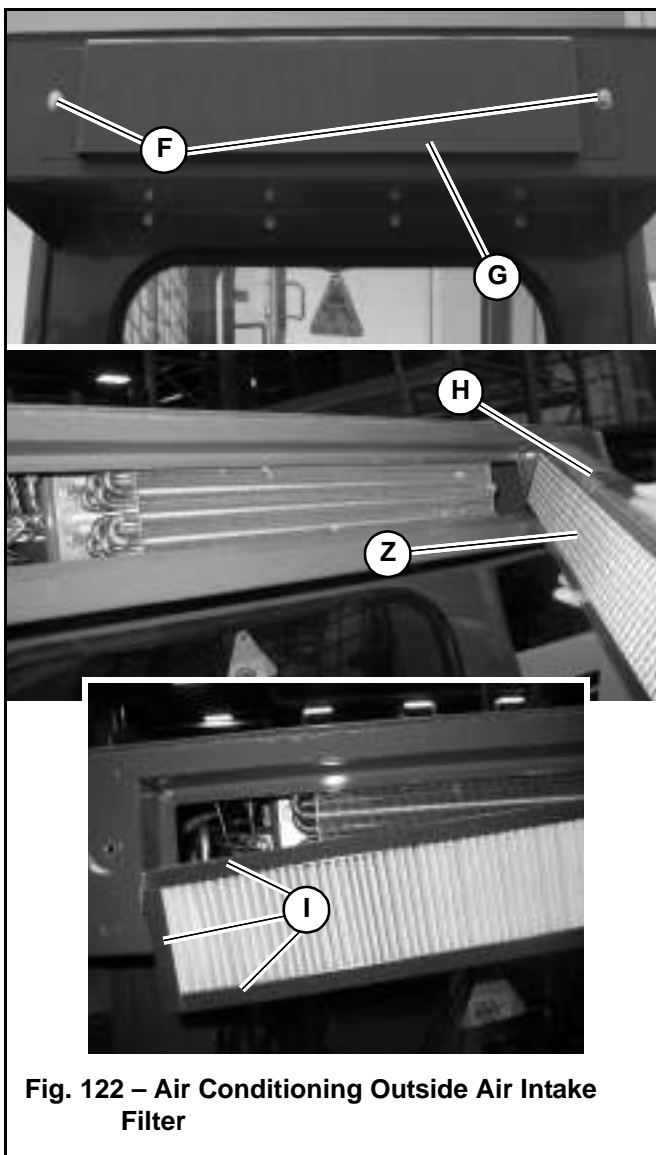

Fig. 122 – Air Conditioning Outside Air Intake Filter

Windshield Washer Reservoir

The windshield washer reservoir (R, Fig. 123) is located inside the engine compartment on the right. Check the windshield washer reservoir level daily before starting the machine and fill if necessary.

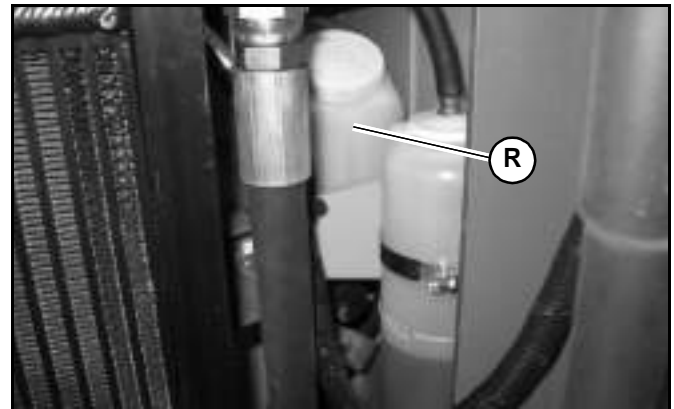

Fig. 123 – Windshield Washer Reservoir

IMPORTANT: Fill the windshield washer fluid reservoir with clean tap water only. Add a cleaning agent if required. Add antifreeze to the water in cold weather.

Maintenance

Final Shutdown / Decommissioning

IMPORTANT: *Dispose of all materials properly. Used oils/fluids are environmental contaminants and may only be disposed of at approved collection facilities. Never drain any oils/fluids onto the ground, dispose of in municipal waste collection containers, or in metropolitan sewer systems or landfills. Check state and local regulations for other material disposal requirements.*

If the machine will no longer be used as intended, shutdown, decommission and dispose of it according to the valid regulations.

Before Disposal

1. Shutdown the machine according to valid regulations regarding proper shutdown.
2. Park the machine on level, dry ground. Ensure the surface can support the weight of the machine. Ensure the location is protected against access by unauthorized persons.
3. Move the throttle to the low-idle position and allow the engine to cool for approximately 2 minutes.
4. Shut off the engine.
5. Move the lift/tilt control(s) to verify that the controls do not cause movement of the lift arm or hitch.
6. Raise the arm rests/safety bars to apply the parking brake and lock out the hydraulic controls.
7. Switch off all electrical switches.
8. Unfasten the seat belt, remove the ignition key and take it with you.
9. Ensure the machine cannot be operated after shutdown until further disposal.
10. Ensure no environmentally hazardous materials, fluids and/or fuel can escape the machine. Specifically check for leaks from the engine, the hydraulic system and the coolant system.
11. Ensure the machine poses no dangers in the place where it is standing.

12. Remove any dirt and/or debris from the engine compartment, the chassis and the cylinder rod surfaces.

13. Remove the battery

14. Lock the cab door, the storage compartment, the battery and hydraulic filler compartments and the engine compartment. Remove the key(s) and take it/them with you.

Machine Disposal

Make sure all materials are disposed of in an ecologically sound manner.

Recycling the machine in accordance with the current state of the art at the time of recycling. Observe all accident prevention regulations.

Dispose of all parts at the at the recycling sites specific to the material of the part. Take care to separate different materials for recycling.

Troubleshooting

Engine Troubleshooting

Table 42: Engine Troubleshooting

Problem	Possible Cause	Corrective Action
Engine does not start	Error code "0". Arm rest/safety bar in raised position; cab door not closed (if equipped); operator's seat not occupied	Lower arm rests/safety bars to operating position. Engine will not start with either arm rest/safety bar raised, or the cab door open (if equipped). Occupy operator's seat
	Engine error code "1078-4"	Check starting circuit wiring
	Blown fuse	Replace fuse
	Dead battery	Charge or replace battery. See "Jump-Starting" on page 69
	Operator not in operator's seat	Operator's seat must be occupied for the engine to start
	Malfunctioning seat switch or safety bar arm/rest switch	Replace seat switch or safety bar arm/rest switch
	Cab door open (if equipped)	Close cab door
Engine turns over but does not start	Engine cranking speed too slow	Check battery and charge/replace as necessary Tighten cables at battery terminals
	Fuel tank empty	Fill tank and vent fuel system as necessary
	Fuel filter plugged or restricted	Replace fuel filter
	Paraffin separation in winter	Use winter grade diesel fuel
	Fuel line leakage	Tighten all threaded connections and clamps
	Pre-heating module malfunction	Check connection and voltage and charge/replace as necessary
	Fuel shut-off solenoid not energizing	Check electrical connections/voltage to shut-off solenoid
	Fuel filter restricted	Replace filter
	Fuel pump malfunction	Contact dealer
	Fuel shutoff valve on water separator closed	Open valve
	Fuel hose restriction	Check for pinched fuel hose

Troubleshooting

Table 42: Engine Troubleshooting

Problem	Possible Cause	Corrective Action	
Engine overheating	Engine oil level incorrect	Adjust oil level. See "Checking Engine Oil Level" on page 104	
	Cooling air circulation restricted	Turn engine off and allow it to cool. Remove restriction	
	Fan shroud improperly positioned	Contact dealer	
	Improper oil grade or oil excessively dirty	Change engine oil and filter. See "Changing Engine Oil and Filter" on page 104	
	Exhaust restricted	Turn engine off and allow it to cool. Remove restriction	
	Air filter restricted	Replace filter(s)	
	Low coolant level		Add coolant. See "Checking Coolant Level" on page 107
			Check for leaks in coolant system and repair/replace if necessary
	Loose/worn V-belt	Tighten/replace V-belt. See "Checking and Adjusting V-belt Tension" on page 109	
Dirty/restricted radiator	Clean radiator. See "Cleaning Radiator Fins" on page 107		
Engine runs, but travel drive does not operate	Parking brake applied	Disengage parking brake. See "Disengage Parking Brake" on page 66	
	Parking brake switch malfunction	Replace parking brake switch(es)	
	Blown fuse	Check circuit and replace fuse. See "Fuses and Relays" on page 123	
	Operator not in operator's seat	Operator's seat must be occupied for travel drive to operate	
	Cab door open (if equipped)	Close cab door. Cab door must be closed for travel drive to operate	
	Drive system component malfunction	See "Drive and Valve Error Codes" on page 142	
	Error code present?	See "Error Codes" on page 140	

Indicator Lamp Troubleshooting

Table 43: Indicator Lamp Troubleshooting





Indicator Icon	Indicator Description	Possible Cause	Corrective Action
	Engine oil pressure	Engine oil pressure too low	Stop engine immediately. Check oil level and add oil of necessary
		Engine oil level incorrect	Adjust oil level. See "Checking Engine Oil Level" on page 104
		Oil pump malfunction	Contact dealer

Table 43: Indicator Lamp Troubleshooting

Indicator Icon	Indicator Description	Possible Cause	Corrective Action
	Hydraulic oil temperature	Hydraulic oil temperature too hot	Check cooling system. See “Engine Cooling System” on page 107 Check hydraulic oil level
		Drive system continuously overloaded	Improve operation procedure
		Lift/tilt or auxiliary system continuously overloaded	Improve operation procedure
		Drive motor(s) or hydrostatic pump(s) internal damage/leakage	Contact dealer
		Oil cooler fins restricted	Clean oil cooler fins. See “Cleaning Radiator Fins” on page 107
		Hydraulic oil filter restricted	Replace filter
	Hydraulic oil filter	Hydraulic oil filter maintenance required	Replace hydraulic oil and filter. See “Changing Hydraulic Oil and Filter” on page 113 NOTE: During cold start in cold temperatures, this indicator may be activated until hydraulic oil warms to operating temperature
	Coolant temperature	Coolant level too low	Add coolant
		Air filter plugged	Replace air filter
		Coolant leak	Repair cooling system and top-off coolant
	Battery voltage	Alternator not charging properly	Adjust V-belt tension Repair/replace alternator
		Engine air filter restriction	Air filter dirty/restricted Blockage in air filter housing

Seal and Hose Troubleshooting

Table 44: Seal and Hose Troubleshooting

Problem	Possible Cause	Corrective Action
Oil, coolant or fuel leakage	Loose hose connection(s)	Tighten hose connections
	Damaged seals or hoses	Change seals/hoses as necessary
Hydraulic fluid leakage	Loose fittings	Tighten hydraulic connections
	Seals, hoses or lines damaged	Change seals, hoses or lines as necessary

Troubleshooting

Hydraulic System Troubleshooting

Table 45: Hydraulic System Troubleshooting

Problem	Possible Cause	Corrective Action
Hydraulics do not work or have poor performance	Error code present?	See "Error Codes" on page 140
	Low hydraulic oil level	Top-off hydraulic oil. See "Checking Hydraulic Oil Level" on page 112
	Hydraulic oil is not at operating temperature	Allow longer warm-up
	Engine to pump coupling or hydraulic pump damaged	Contact dealer
	Pressure limiting valves set too low or damaged	Contact dealer
	Hydraulic cylinder(s) damaged	Contact dealer
	Control valve(s) damaged	Contact dealer
	Engine speed too low	Adjust engine speed. See "Throttle Controls" on page 56
	Dirty/restricted air filter(s)	Replace filter(s) and/or remove restriction
	Incorrect fuel type/grade	Replace fuel with proper type/grade. See "Fluids/Lubricants Types and Capacities" on page 31
Attachment tilts forward with control in neutral	Hydraulic oil leaking past cylinder seals (internal and/or external)	Contact dealer
	Leaking hydraulic system components, such as hoses, tubes, fittings, valves, etc. Leak past spool in control valve	Repair as necessary
	Joystick/electrical malfunction	See "Error Codes" on page 140
Lift arm does not raise/lower	Parking brake applied	Disengage parking brake. See "Disengage Parking Brake" on page 66
	Lift spool in control valve not actuated or leaking	Contact dealer
	Joystick/electrical malfunction code displayed	See "Error Codes" on page 140
Attachment tilt not working, but lift arm work properly	Tilt spool in control valve not actuated or leaking	Contact dealer
	Joystick/electrical malfunction code displayed	See "Error Codes" on page 140
Lift arm does not raise but attachment tilt works properly	Lift spool in control valve not actuated or leaking	Contact dealer
	Joystick/electrical malfunction code displayed	See "Error Codes" on page 140
Hydraulic system overheating	Dirty hydraulic oil cooler	Clean hydraulic oil cooler
	Low hydraulic oil level	Top-off hydraulic oil. See "Checking Hydraulic Oil Level" on page 112
	Load too high	Reduce load

Table 45: Hydraulic System Troubleshooting

Problem	Possible Cause	Corrective Action
Lift and/or tilt functions inconsistent/jerky	Air in hydraulic system	Cycle lift and tilt cylinders to maximum stroke and maintain for a few seconds to clear air from the hydraulic system
	Low hydraulic oil level	Top-off hydraulic oil. See "Checking Hydraulic Oil Level" on page 112
	Cylinder(s) malfunction	Contact dealer
	Joystick/electrical malfunction code displayed	See "Error Codes" on page 140
Lift arm does not maintain position with control joysticks in neutral	Hydraulic oil leaking past cylinder seals (external leak)	Contact dealer
	Hydraulic oil leaking past lift spool in control valve	Contact dealer
	Leaking hydraulic hoses, tubes or fittings between control valve and cylinders	Contact dealer
Auxiliary hydraulics not functioning	Spool in control valve not actuated or leaking	Contact dealer
	Hydraulic oil leaking past seals	Contact dealer
	Auxiliary hydraulics connected improperly	Correct hydraulic connections

Hydrostatic Travel Drive System Troubleshooting

Table 46: Hydrostatic Travel Drive System Troubleshooting

Problem	Possible Cause	Corrective Action
Hydrostatic drive and lift/tilt not responsive	Hydraulic oil viscosity too heavy	Allow longer warm-up
		Replace hydraulic oil with proper type/grade. See "Fluids/Lubricants Types and Capacities" on page 31
	Control system malfunction with error code displayed	See "Error Codes" on page 140
Drive does not operate in either direction	Parking brake applied	Disengage parking brake. See "Disengage Parking Brake" on page 66
	Low hydraulic oil level	Top-off hydraulic oil. See "Checking Hydraulic Oil Level" on page 112
	Low or no charge pressure	Contact dealer
	Hydrostatic pump(s) relief valves malfunction	Contact dealer
	Control system malfunction with error code displayed	See "Error Codes" on page 140

Troubleshooting

Table 46: Hydrostatic Travel Drive System Troubleshooting

Problem	Possible Cause	Corrective Action
Drive system noisy	Hydraulic oil viscosity too heavy	Allow longer warm-up
		Replace hydraulic oil with proper type/grade. See "Fluids/Lubricants Types and Capacities" on page 31
	Low hydraulic oil level	Top-off hydraulic oil. See "Checking Hydraulic Oil Level" on page 112
	Air in hydraulic system	Cycle lift and tilt cylinders to maximum stroke and maintain for a few seconds to clear air from the hydraulic system
	Drive motor(s) or hydrostatic pump(s) internal damage/leakage	Contact dealer
Sluggish acceleration	Low hydraulic oil level	Top-off hydraulic oil. See "Checking Hydraulic Oil Level" on page 112
	Low hydraulic system charge pressure	Contact dealer
	Drive motor(s) or hydrostatic pump(s) internal damage/leakage	Contact dealer
	Engine running rough	Poor fuel quality or incorrect fuel type/grade. Replace fuel with proper type/grade. See "Fluids/Lubricants Types and Capacities" on page 31
		Restricted fuel filter/fuel system. Replace fuel filter; remove restriction. See "Changing Fuel Filter" on page 111
		Contact dealer
Drive sensitivity set too low	See "Control Sensitivity Configuration Screen" on page 48	
Travel drive does not track straight when left joystick is in the forward or reverse position	Drive system needs to be adjusted for straight tracking	Contact dealer

Electrical Troubleshooting

Table 47: Electrical Troubleshooting

Problem	Possible Cause	Corrective Action
Loss of electrical power	Battery terminals or cables loose or corroded	Clean battery terminals/cable connections and tighten
	Battery malfunction	Test battery. Recharge/replace as necessary
	Blown main fuse	Replace main fuse
Instrument display does not activate when ignition is on	Blown main fuse	Replace main fuse
	Battery terminals or cables loose or corroded	Clean battery terminals/cable connections and tighten
	Ignition switch malfunction	Replace switch
	In very cold weather, display screen slow to display	Wait a few minutes for display to activate
Starter does not engage when key switch turned to start position	Loose/corroded starter electrical connections	Check/tighten/clean connections
	Battery terminals or cables loose or corroded	Clean battery terminals/cable connections and tighten
	Starter relay malfunction	Contact dealer
	Battery malfunction	Test battery. Recharge/replace as necessary
	Starter solenoid malfunction	Contact dealer
	Starter or pinion malfunctioning	Repair/replace as needed
	Error code "0". Arm rest/safety bar in raised position; cab door not closed (if equipped) operator's seat not occupied	Lower arm rests/safety bars to operating position. Engine will not start with either arm rest/safety bar raised, or the cab door open (if equipped). Occupy operator's seat
Work/road lights malfunction	Single light not working; light bulb burned out, faulty wiring	Check and replace light bulb as needed, check wiring connections
	No lights; blown fuse	Check circuit/replace fuse
	Light switch malfunction	Replace light switch
	Poor electrical ground	Check ground wire connections

Miscellaneous Troubleshooting

Table 48: Miscellaneous Troubleshooting

Problem	Possible Cause	Corrective Action
Non-functional cab heater	Thermostat oriented in housing with support bales/arms blocking feed hole to heater hose. (SOME heat delivered through heater)	Replace thermostat; align bales/arms properly (parallel to engine crankshaft) in housing.

Troubleshooting

Error Codes

The tables in this section describe error codes which may be reported on the multi-function display screen. More than one error can be reported at one time and each error code will display on a separate screen. Multiple errors will be reported on a summary screen. See “Multi-Function Display” on page 44.

Controller Communication Error Codes

NOTE: See “Control Modules” on page 124 for controller locations.

Table 49: Controller Communication Error Codes

Error Code	Error Description
1-2	No Communication between engine control module to display
1-3	No Communication between drive / lift arm / standard aux. flow control module to display
1-4	No Communication between display to main / drive control module
1-5	No Communication between multi-function control module to display
27	No CAN communication engine control module to main / drive control module
28	No CAN Communication main / drive control module to display
29	No CAN Communication drive / lift arm / standard aux. flow control module to main / drive control module

Engine Error Codes

Table 50: Engine Error Codes

Error Code	Engine Error Code Type	Error Description
29-0	Accelerator pedal position sensor “B”	Above normal operational range
29-1		Below normal operational range
29-2		Intermittent fault
29-3		Shorted to high source
29-4		Shorted to low source
29-8		Communication fault
29-15		Not available
91-0	Accelerator pedal position sensor “A”	Above normal operational range
91-1		Below normal operational range
91-2		Intermittent fault
91-3		Shorted to high source
91-4		Shorted to low source
91-15		Not available
100-1	Oil pressure	Too low
100-4		Shorted to low source
108-2	Barometric pressure sensor	Intermittent fault
108-3		Shorted to high source
108-4		Shorted to low source
110-0	Engine coolant temperature	Too high
110-2		Intermittent fault
110-3		Shorted to high source
110-4		Shorted to low source

Table 50: Engine Error Codes

Error Code	Engine Error Code Type	Error Description
158-0	System Voltage	Too high
158-1		Too low
167-1	Charge Warning	
167-4	Battery Charge Switch	Shorted to low source
190-0	Engine Speed	Over-speed condition
628-2	E-ECU Internal fault	FlashROM checksum error
628-12		FlashROM checksum error (main software)
630-2		EEPROM checksum error
630-12		EEPROM read/write fault
638-2	Engine	Malfunction
638-3	Engine fuel rack actuator	Shorted to high source
638-4		Shorted to low source
638-7		Mechanical malfunction
639-12	High-speed CAN communication	Communication fault
1078-4	Engine fuel injection pump speed sensor	Shorted to low source
1079-2	Sensor 5V	Intermittent fault
1079-3		Shorted to high source
1079-4		Shorted to low source
1136-0	E-ECU internal temperature	Too high
1136-2		Intermittent fault
1136-3		Shorted to high source
1136-4		Shorted to low source
1202-2	Immobilizer	System fault
1210-3	Engine Fuel Rack Position Sensor	Shorted to high source
1210-4		Shorted to low source
1485-4	E-ECU main relay	Shorted to low source
522241-2	Engine fuel rack actuator relay	Intermittent fault
522241-3		Circuit fault B
522241-4		Circuit fault A
522242-2	Cold start device	Intermittent fault
522242-3		Circuit fault B
522242-4		Circuit fault A
522243-2	Air heater relay	Intermittent fault
522243-3		Circuit fault B
522243-4		Circuit fault A
522251-3	EGR stepping motor "A"	Circuit fault B
522251-4		Circuit fault A
522252-3	EGR stepping motor "B"	Circuit fault B
522252-4		Circuit fault A
522253-3	EGR stepping motor "C"	Circuit fault B
522253-4		Circuit fault A
522254-3	EGR stepping motor "D"	Circuit fault B
522254-4		Circuit fault A
522314-0	Engine coolant temperature	Abnormal temperature

Troubleshooting

Table 50: Engine Error Codes

Error Code	Engine Error Code Type	Error Description
522323-0	Air cleaner	Mechanical malfunction
522329-0	Oily water separator	Mechanical malfunction
522402-4	Auxiliary speed sensor	Shorted to low source
522727-12	E-ECU internal fault	Sub-CPU error
522728-12		Engine map data version error
522730-8	Immobilizer	CAN pulse communication fault
522730-12		CAN Communication fault

Drive and Valve Error Codes

Table 51: Drive and Valve Error Codes

Error Code	Error Description
-1	No Faults (not shown on display)
0	Start interlock fault
1	Pump right sensor neutral drift fault
2	Pump left sensor neutral drift fault
3	Pump right sensor wiring fault
4	Pump left sensor wiring fault
5	Pump right sensor dynamic range fault
6	Pump left sensor dynamic range fault
7	Left forward solenoid wiring or coil fault
8	Left reverse solenoid wiring or coil fault
9	Right reverse solenoid wiring or coil fault
10	Right forward solenoid wiring or coil fault
11	Tilt forward valve solenoid B wiring or coil fault
12	Tilt back valve solenoid A wiring or coil fault
13	Control valve upper auxiliary solenoid wiring or coil fault
14	Control valve lower auxiliary solenoid wiring or coil fault
15	Lift arm up control valve lower solenoid wiring or coil fault
16	Lift arm down control valve upper solenoid wiring or coil fault
22	Left joystick output data fault
23	Right joystick output data fault
24	No left joystick CAN communication
25	No right joystick CAN Communication
35	Swash plate sensor supply voltage fault
36	Battery voltage fault
37	Pump and tilt solenoid supply voltage fault
38	Limp mode (See "Travel Drive Error Condition Operation (Limp Mode)" on page 75)
39	Open loop mode (See "Travel Drive Error Condition Operation (Limp Mode)" on page 75)

Schematics

Engine/Starting and Charging

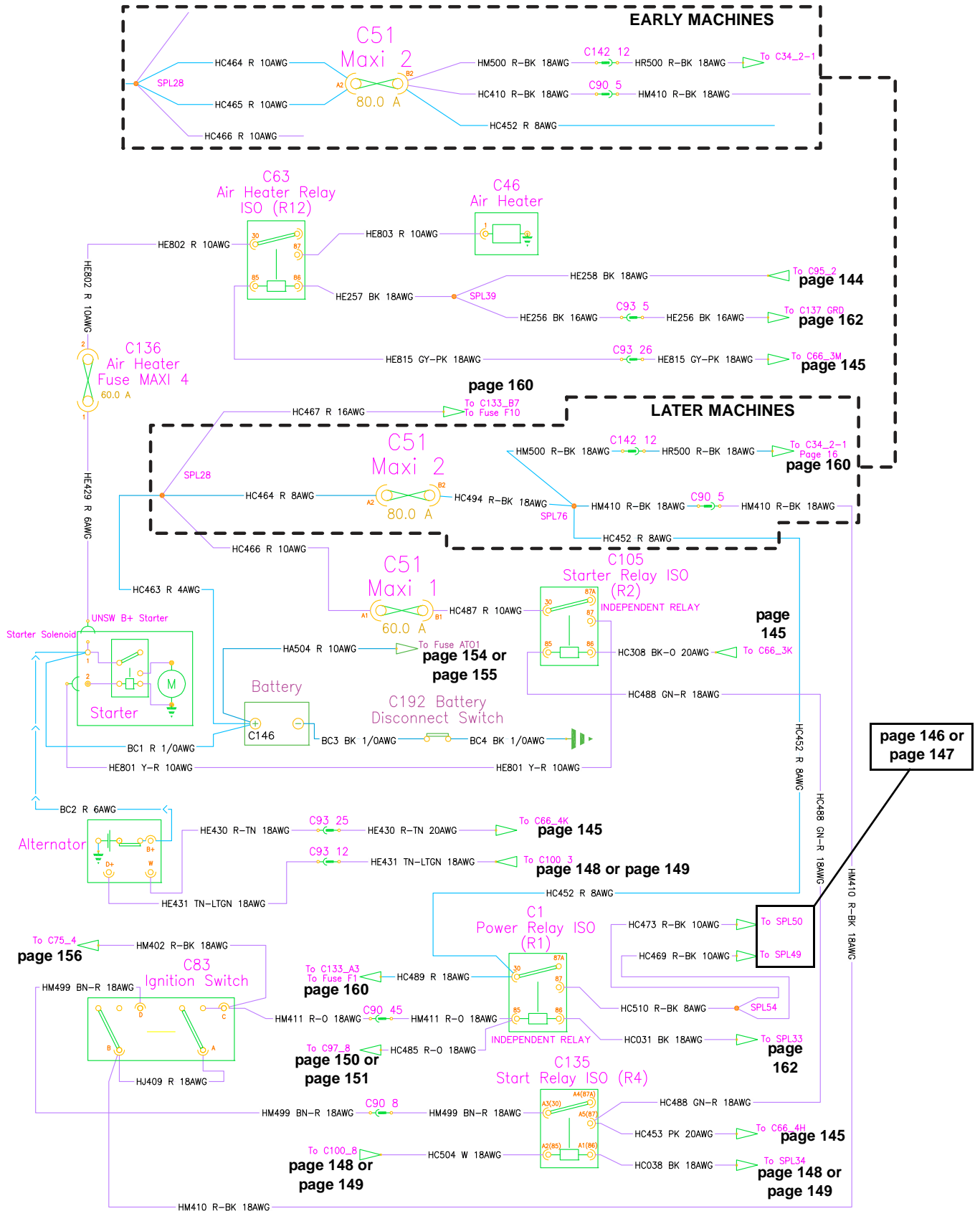

Schematics

Engine Sensors

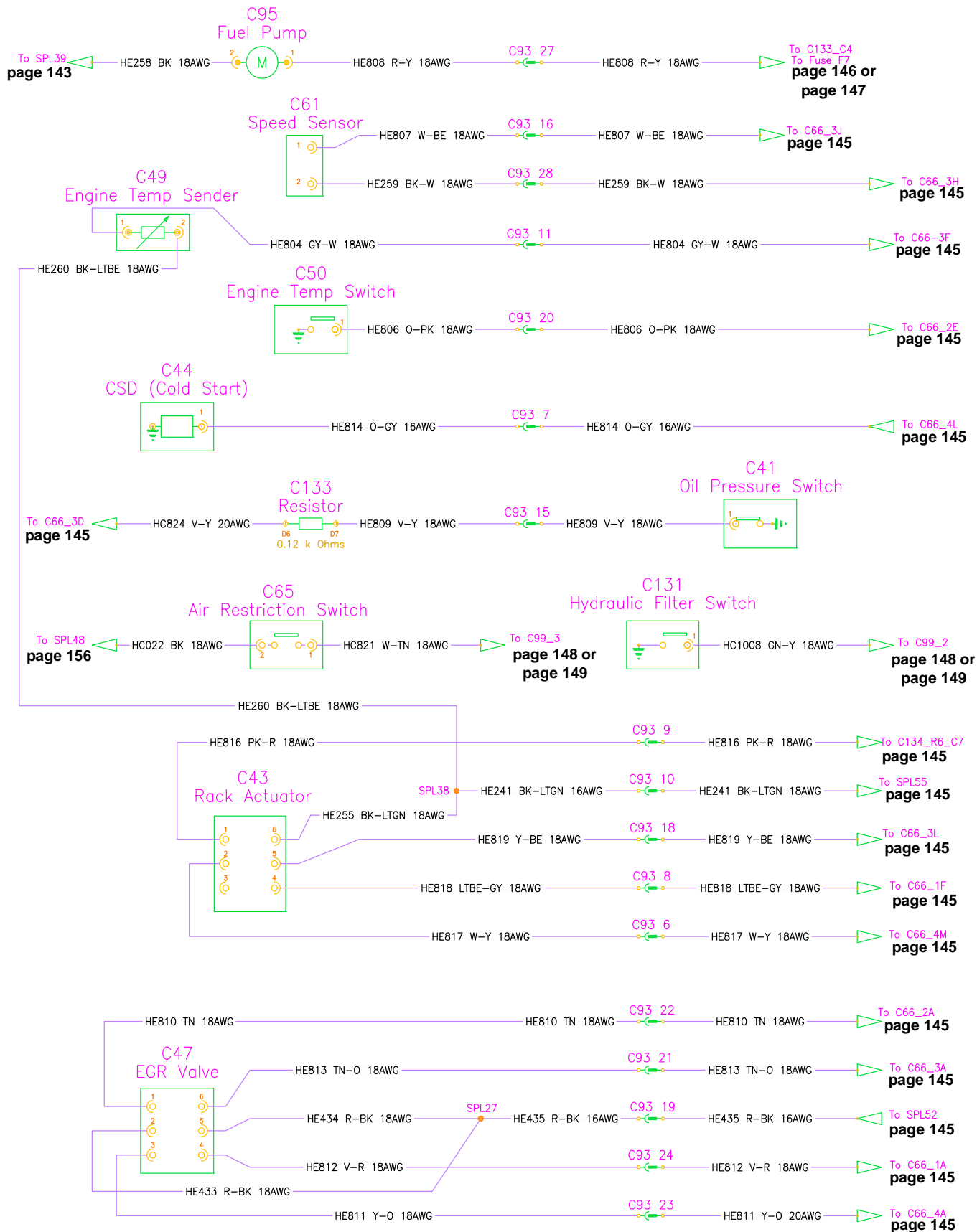

Engine ECU

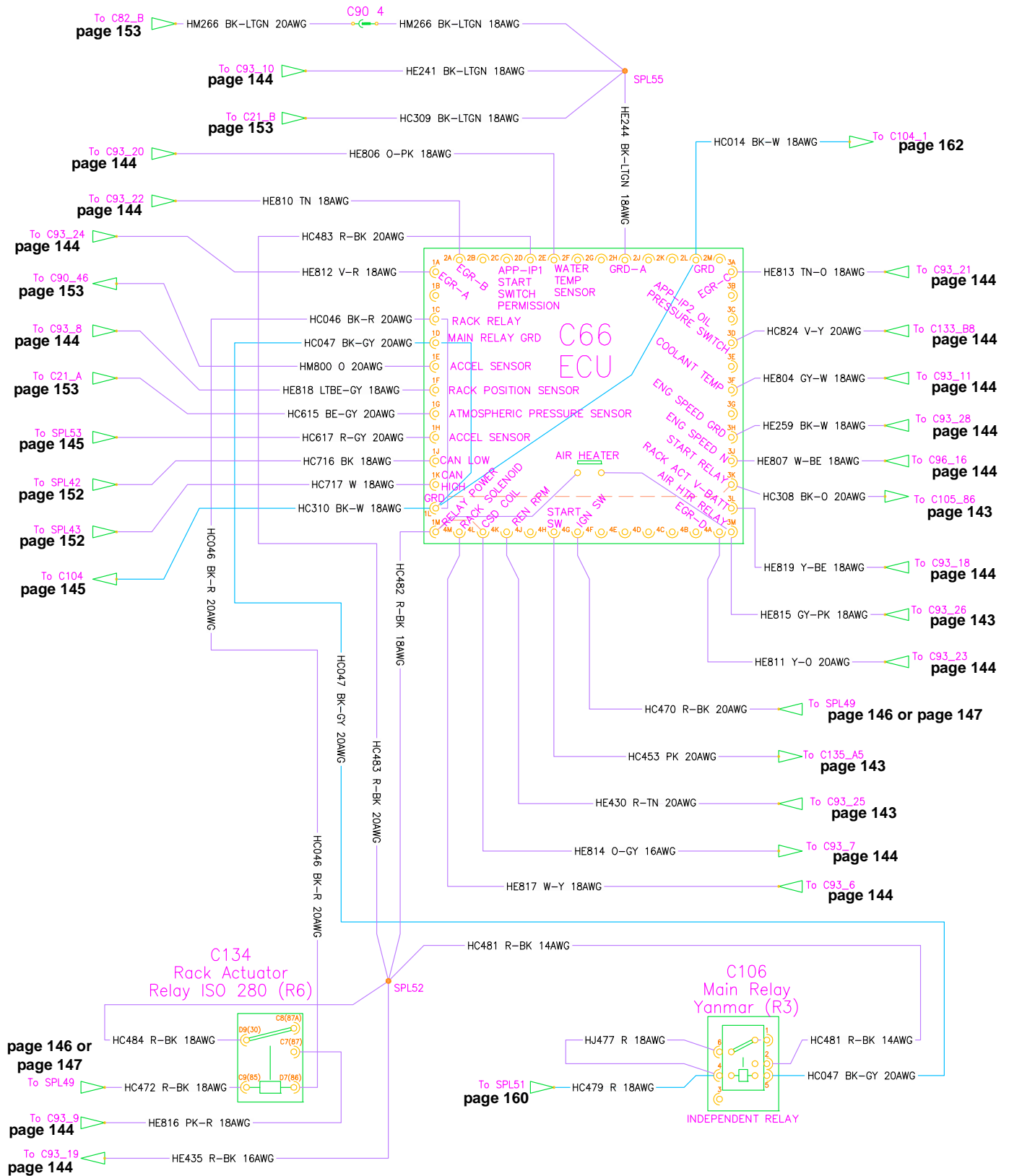

Schematics

Power Distribution (Later Machines)

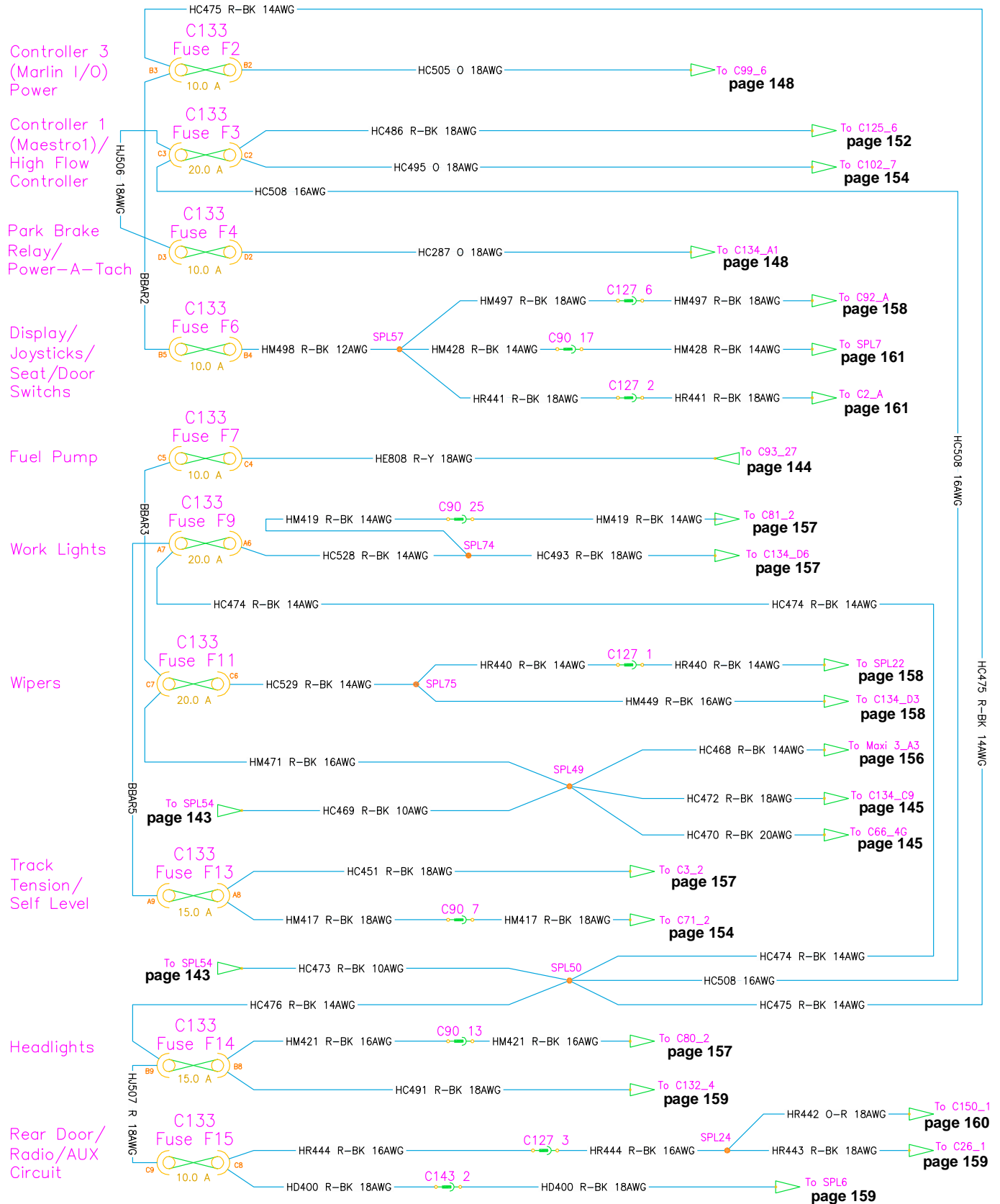

Power Distribution (Early Machines)

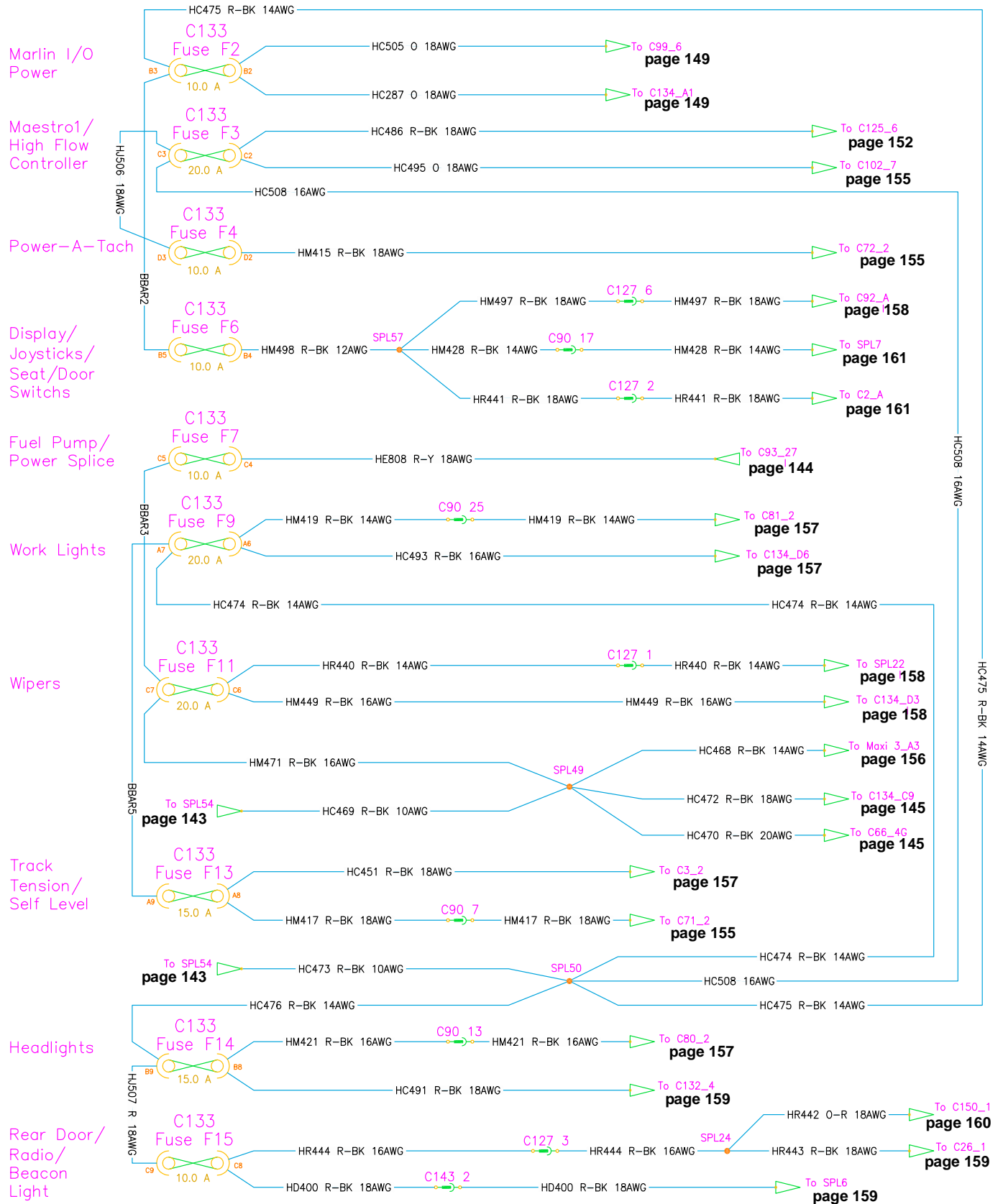

Schematics

I/O Controller (Later Machines)

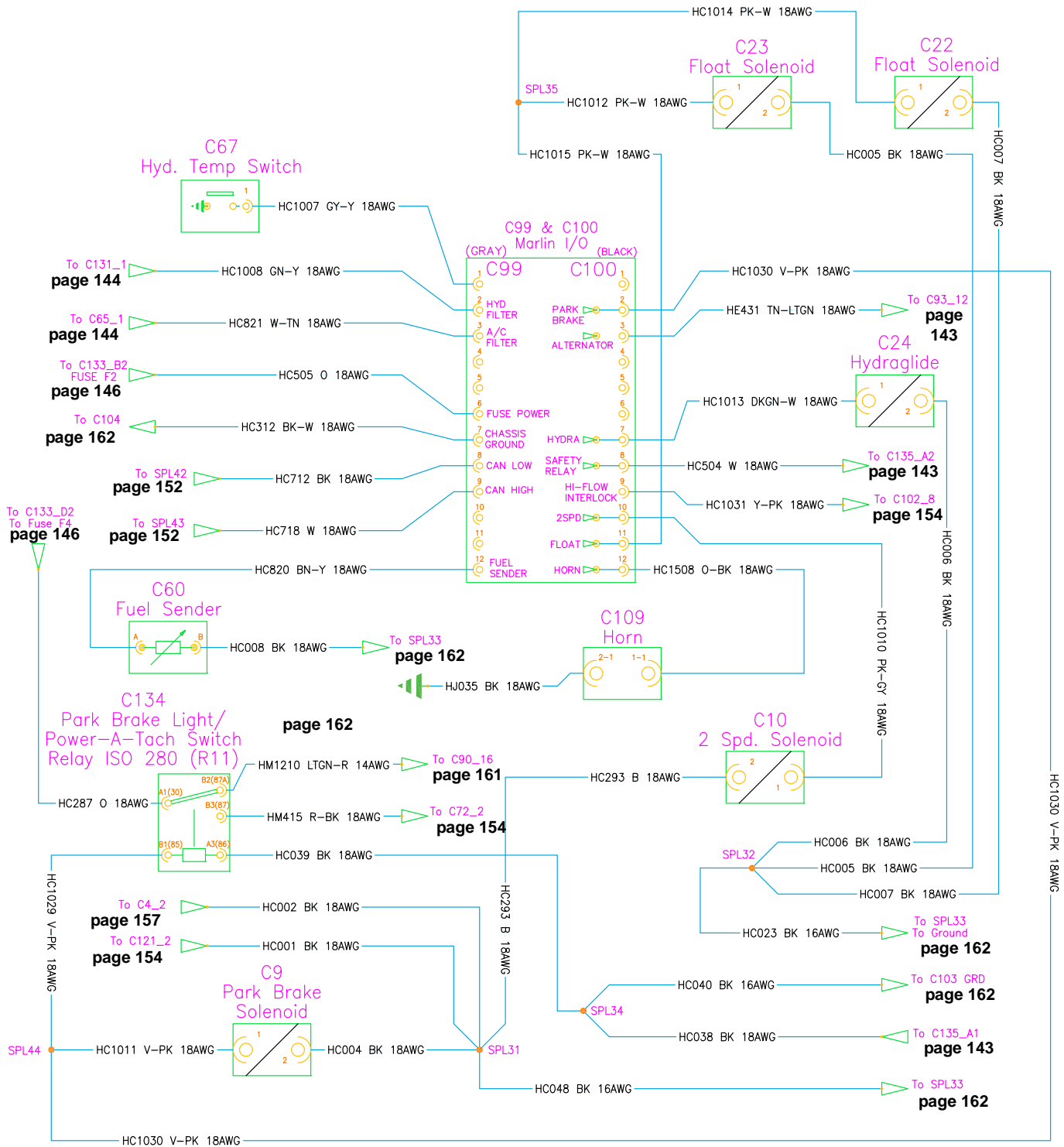

I/O Controller (Early Machines)

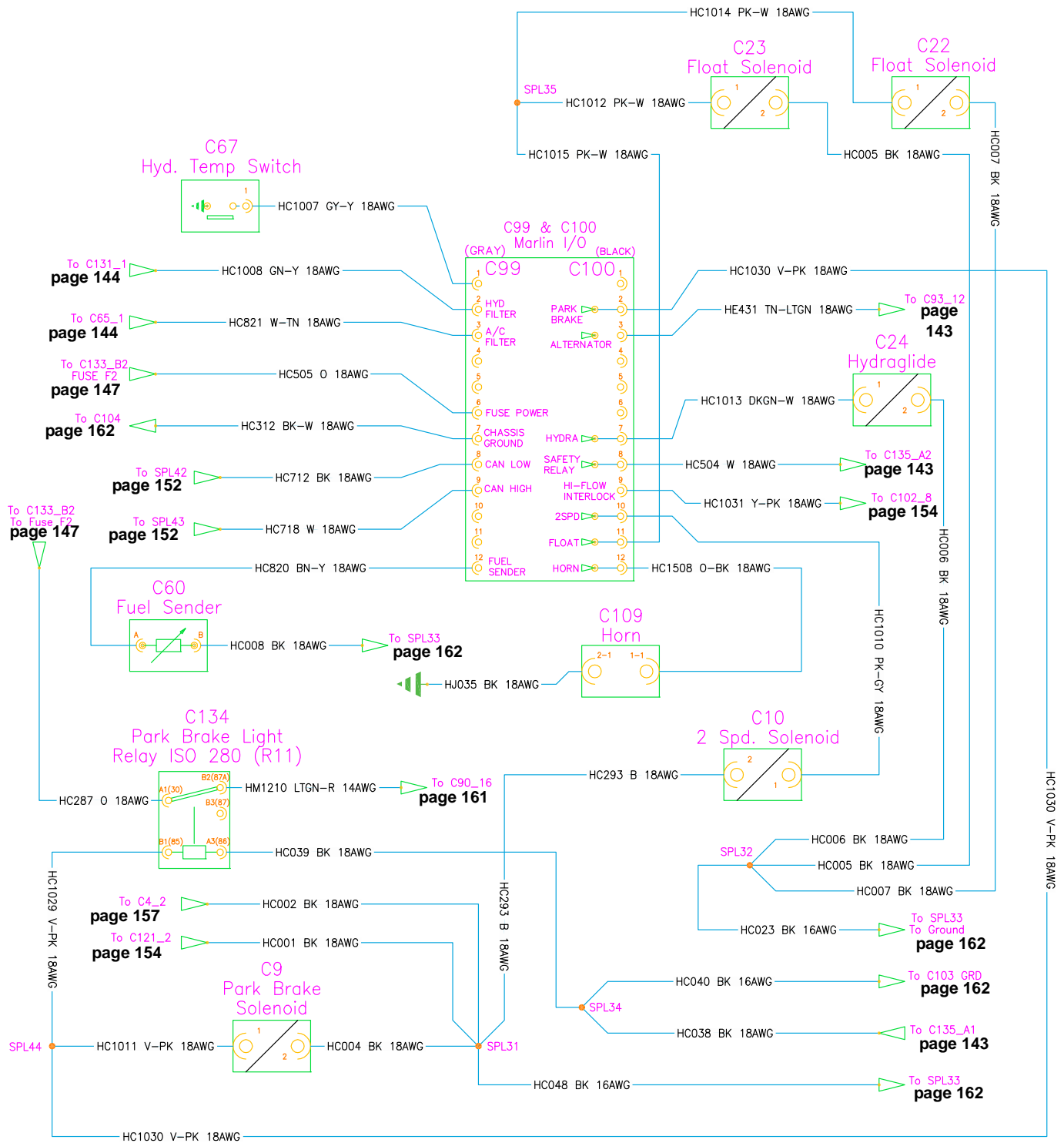

Schematics

Solenoid Control – A (Later Machines)

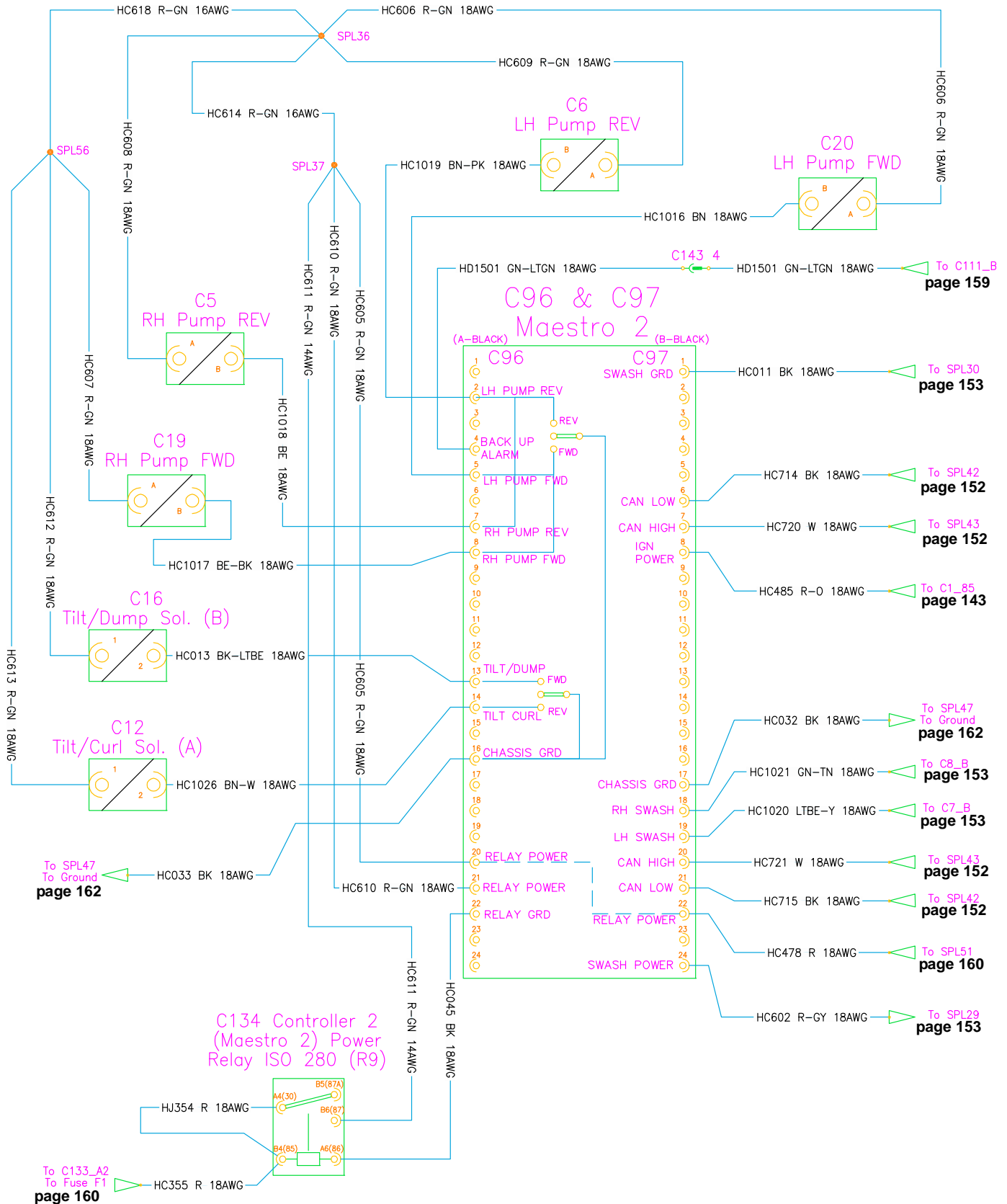

Solenoid Control – A (Early Machines)

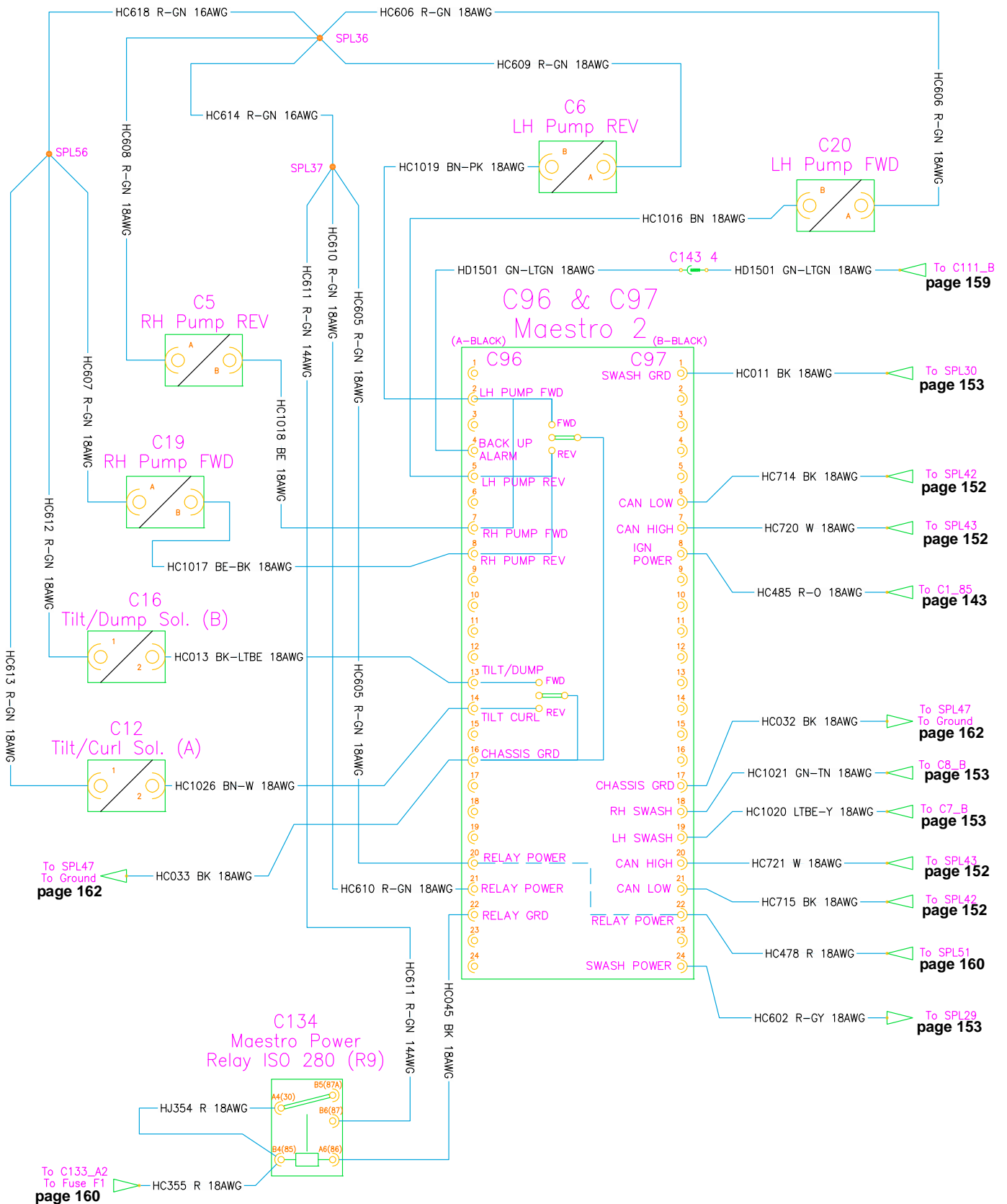

Schematics

Solenoid Control – B

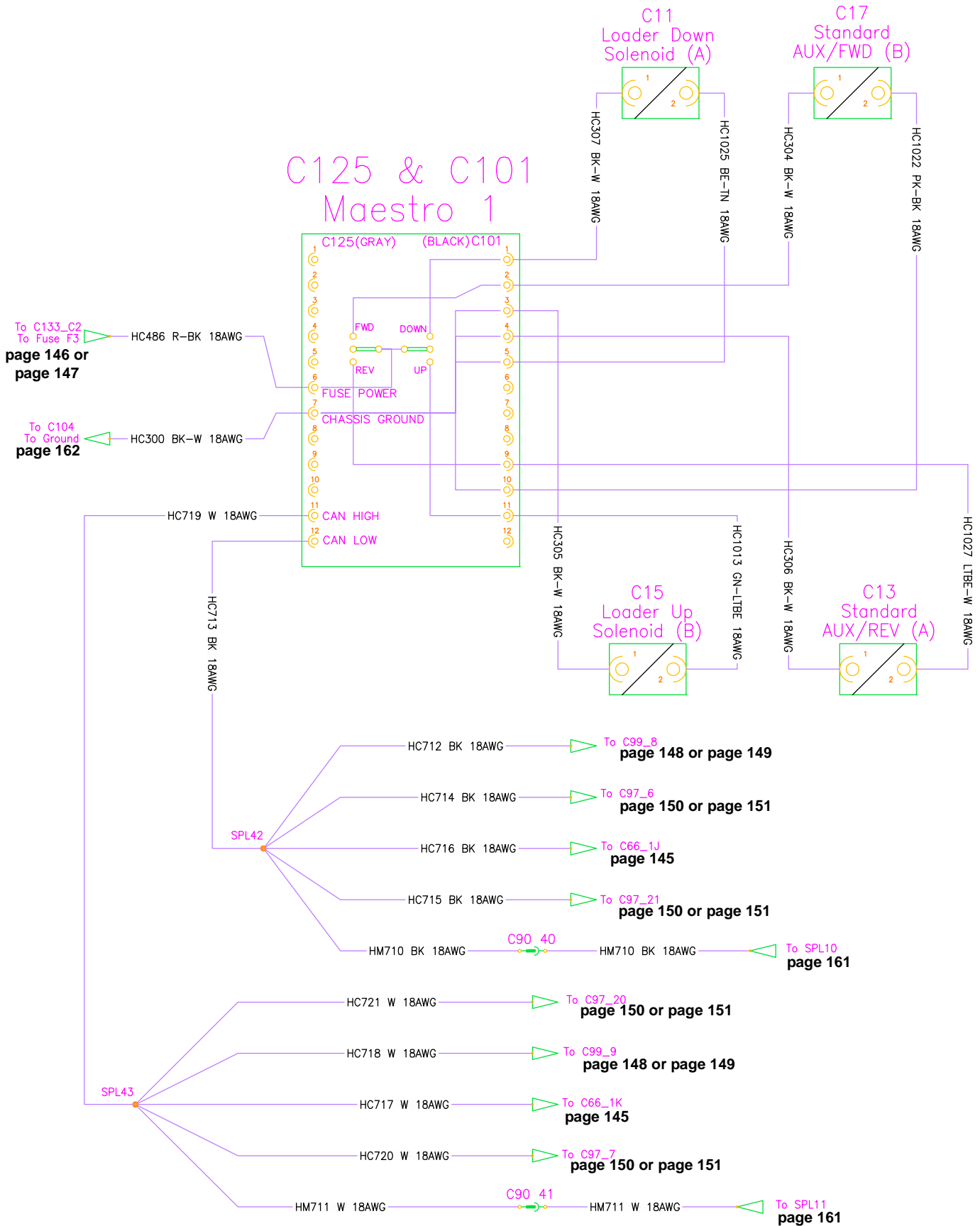

Operator/Drive Controls

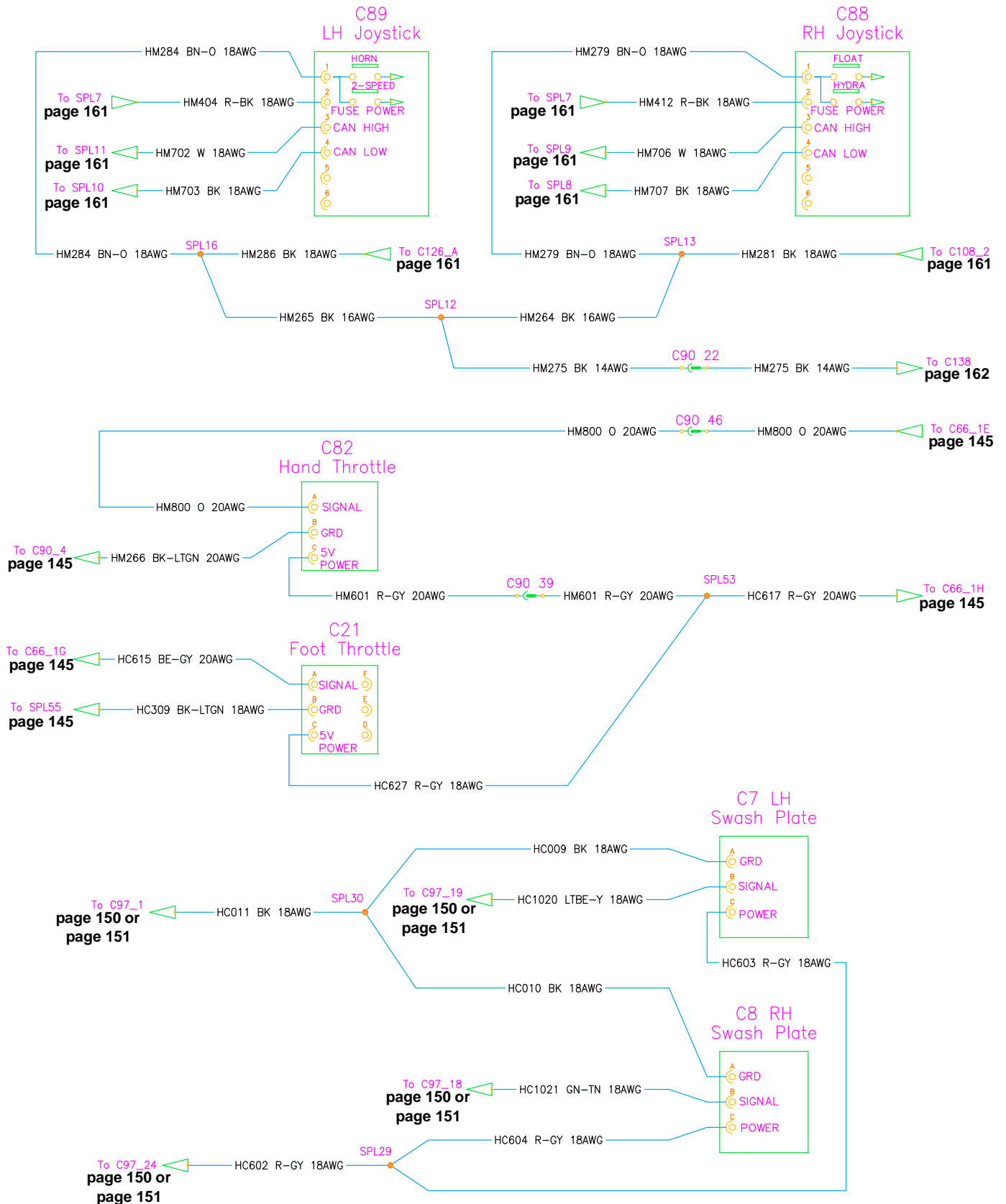

Schematics

High-Flow/Self-Level/Power-A-Tach® Quick Attach System (Later Machines)

page 148 or
page 149
To C100_9

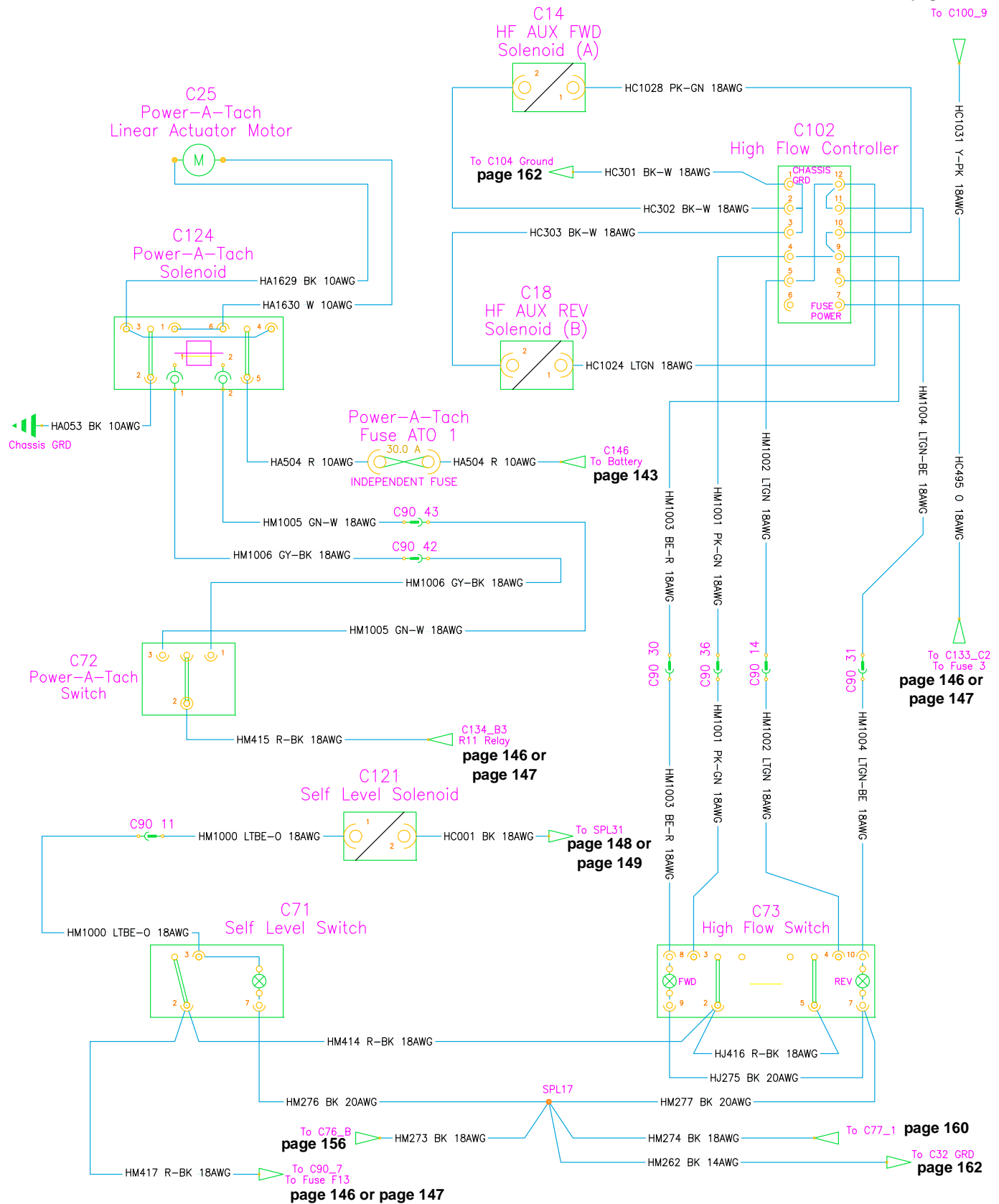

High-Flow/Self-Level/Power-A-Tach® Quick Attach System (Early Machines)

page 148 or
page 149
To C100_9

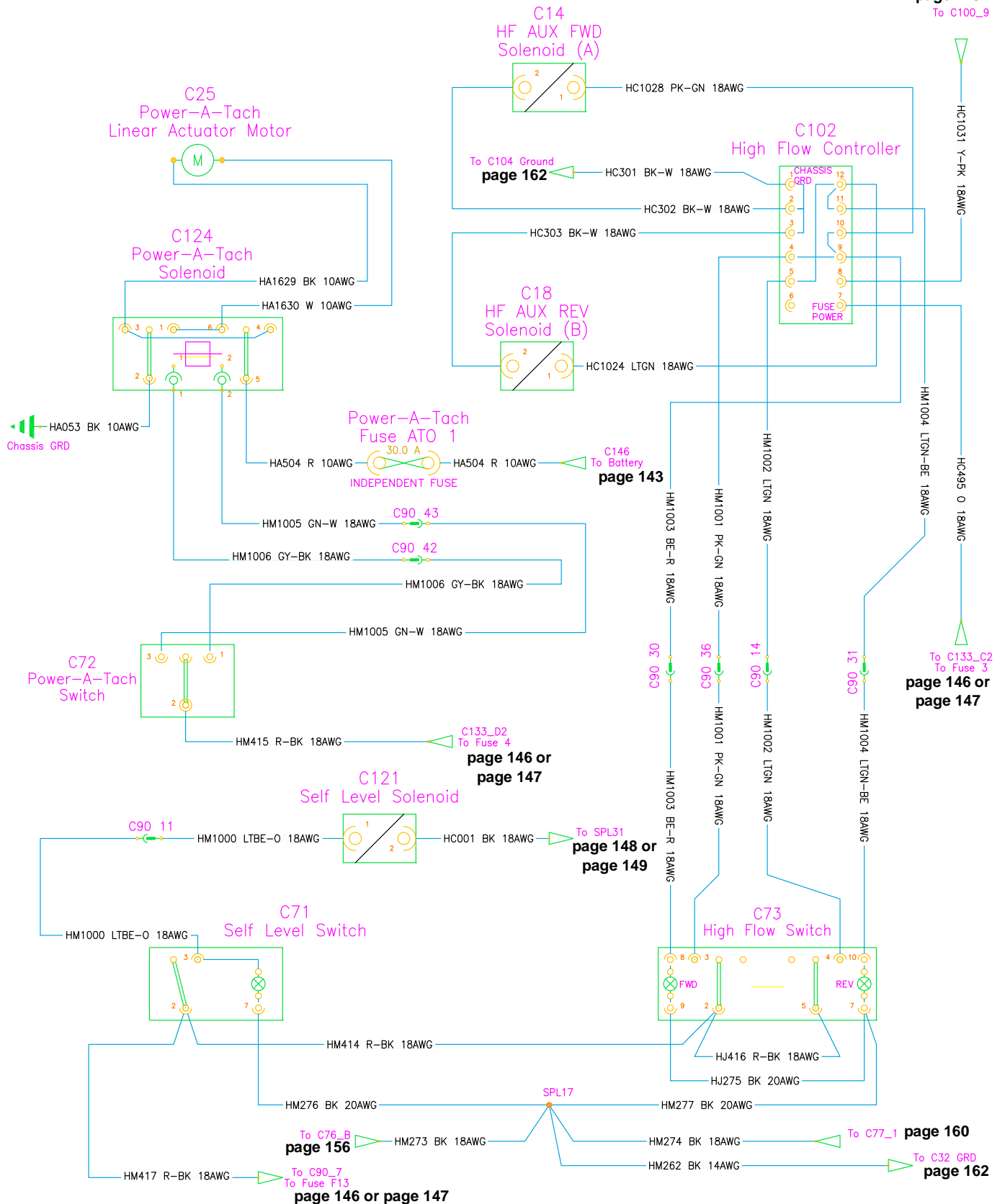

Track Tension/Lighting Control

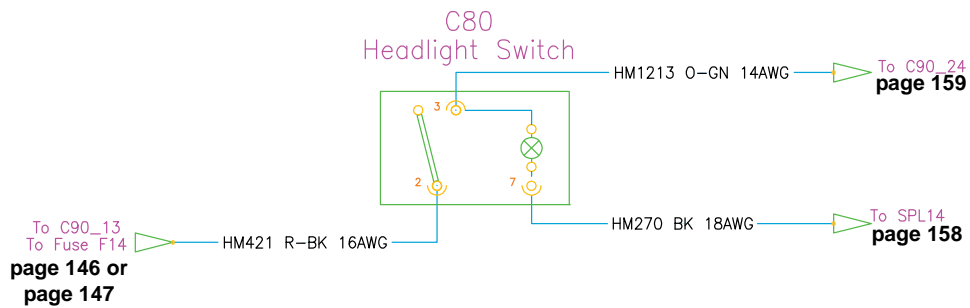
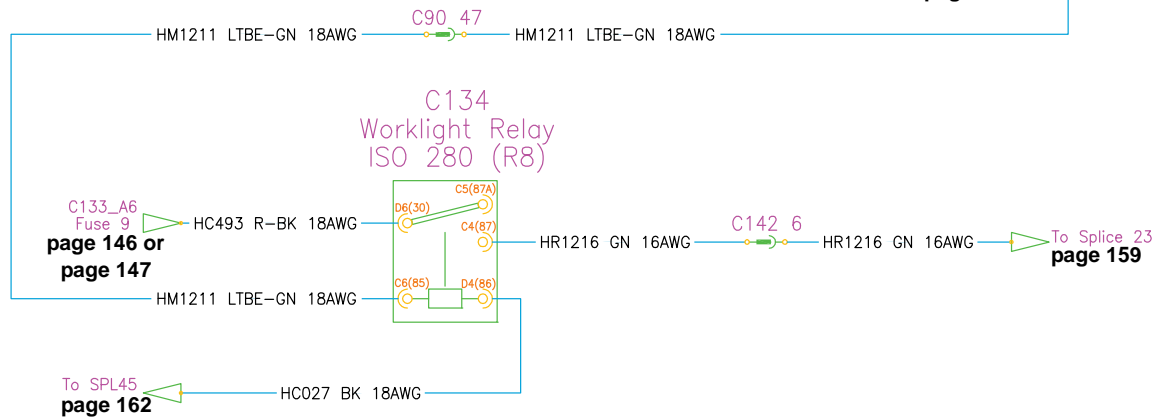
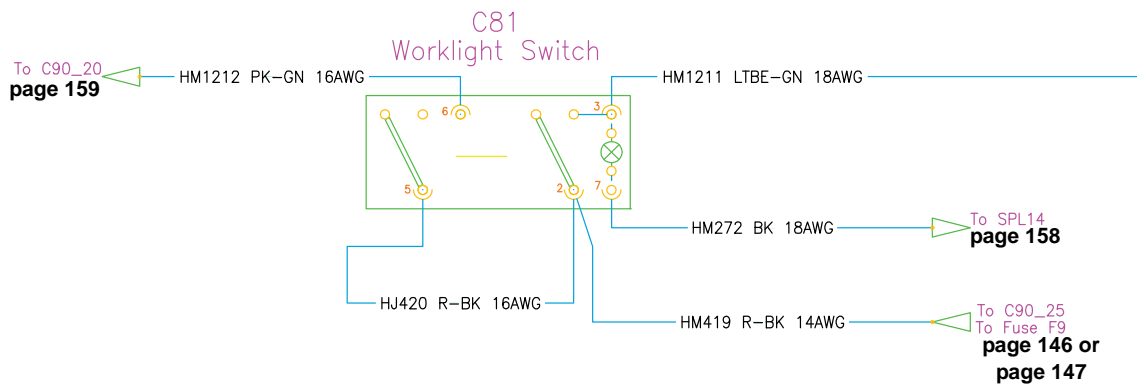
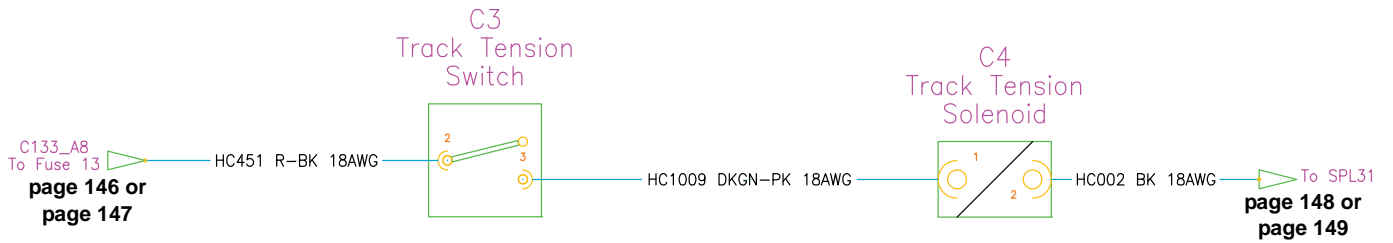

Schematics

Wipers/Washer Pumps

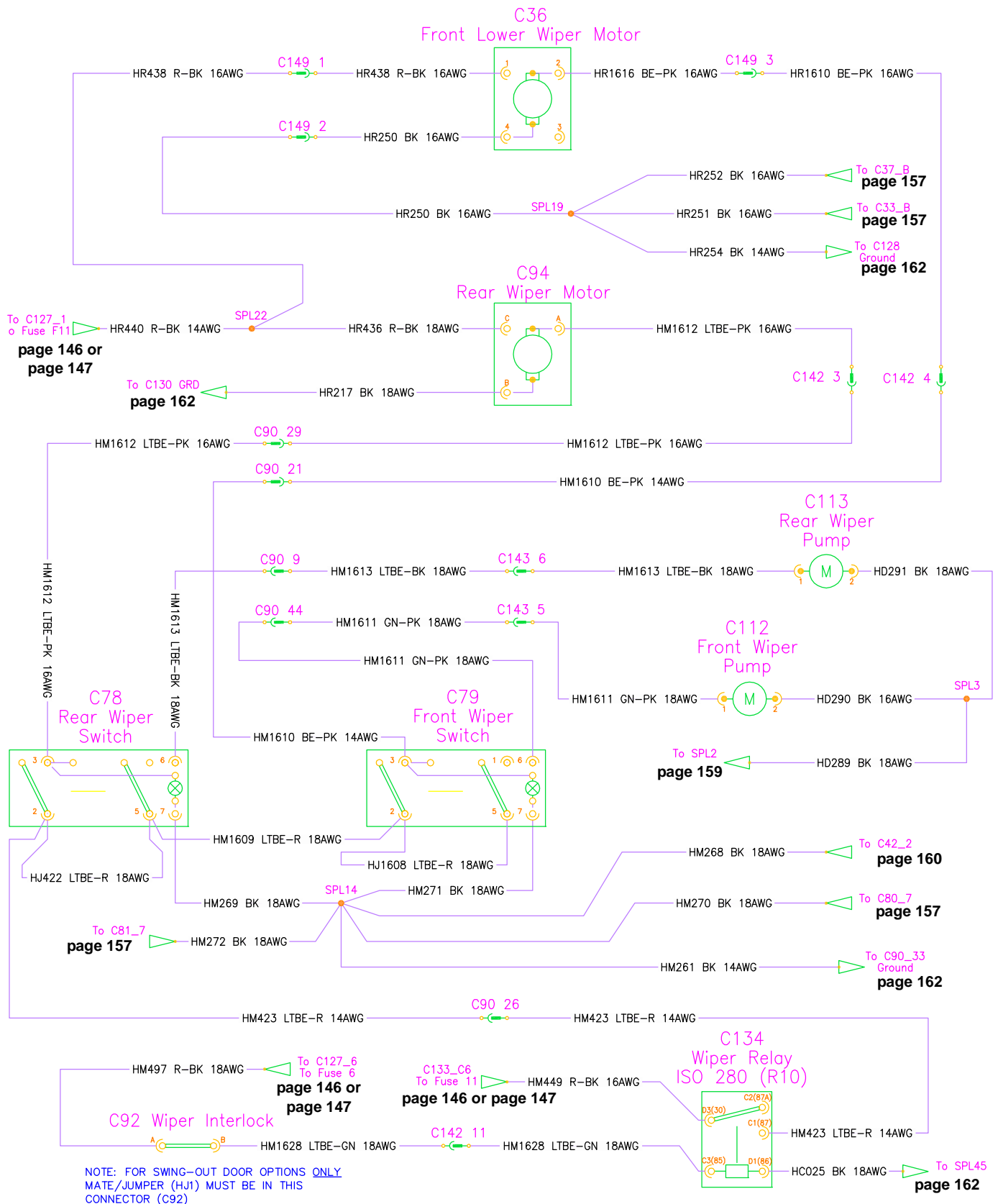

Work Lights

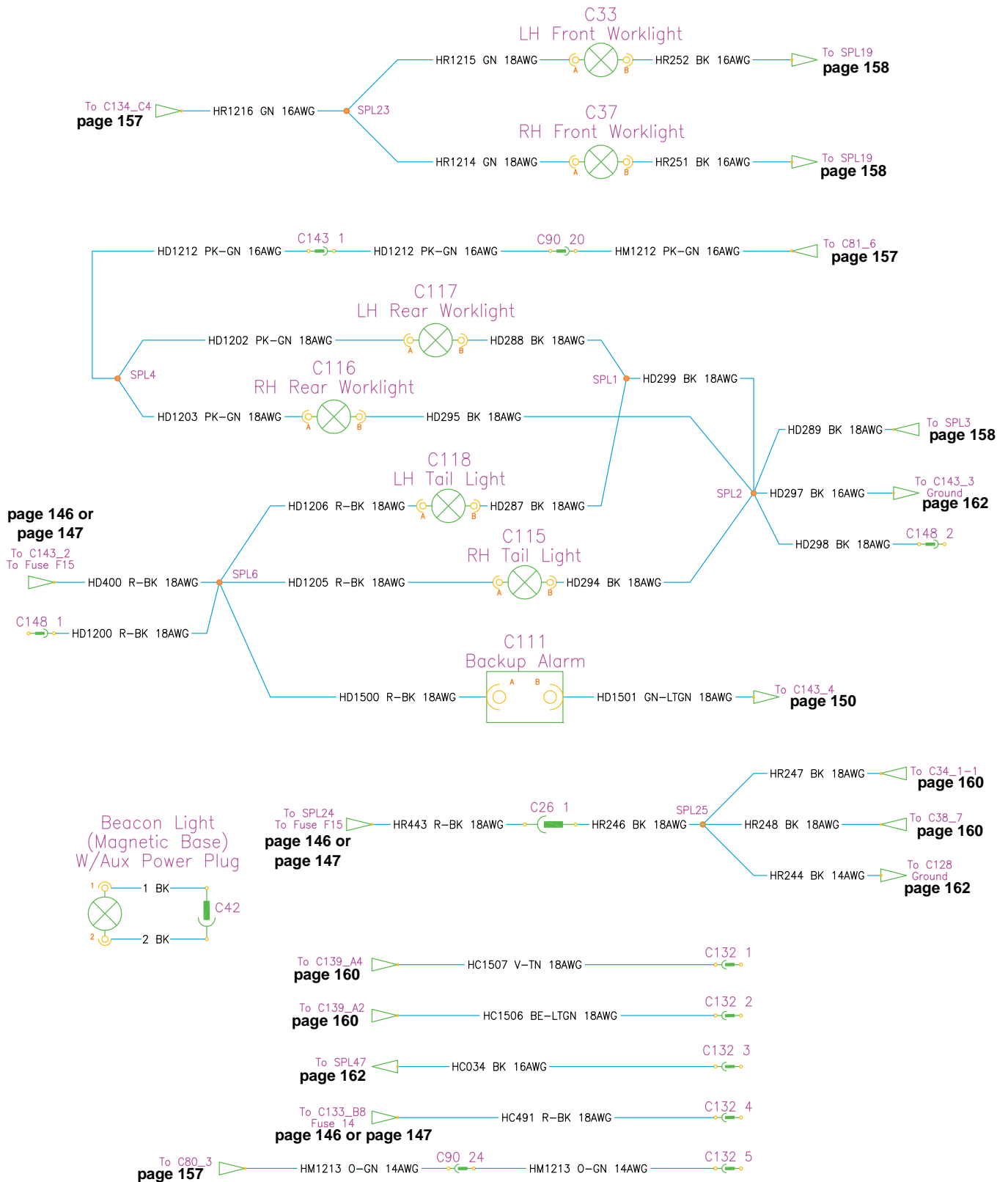

Schematics

Auxiliary Power/Dome Light/Radio

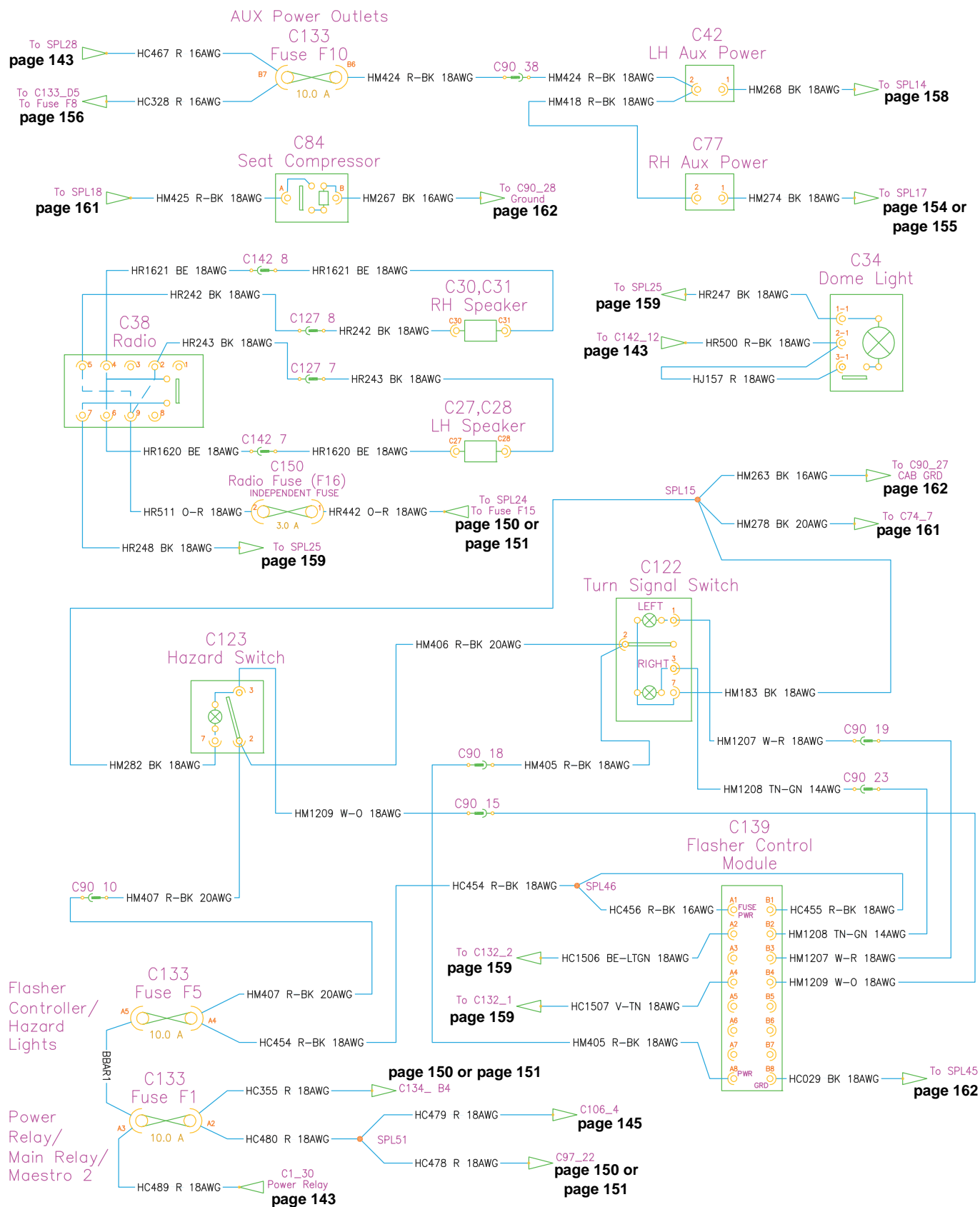

Operator CAN Interface

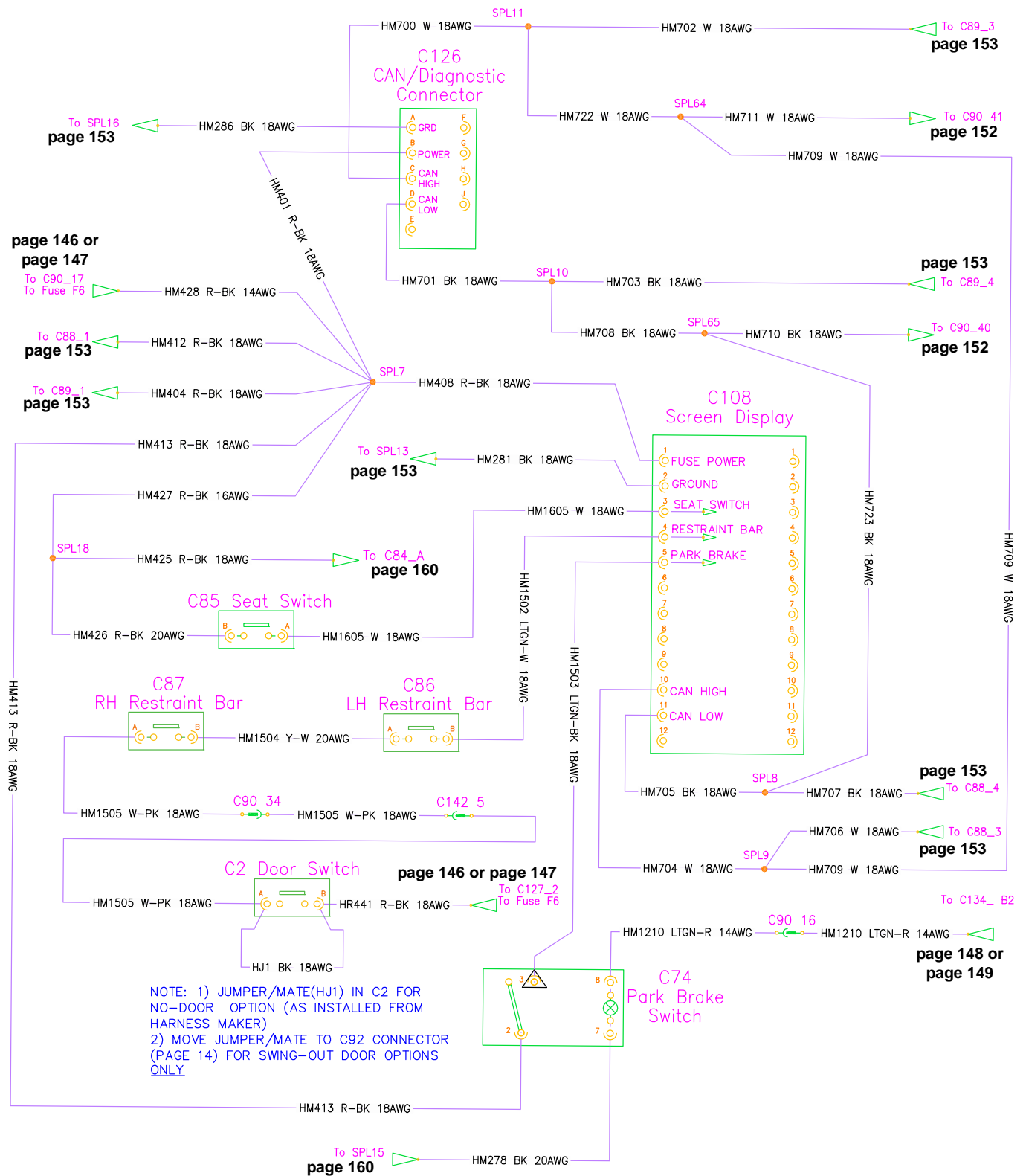

Schematics

Grounds

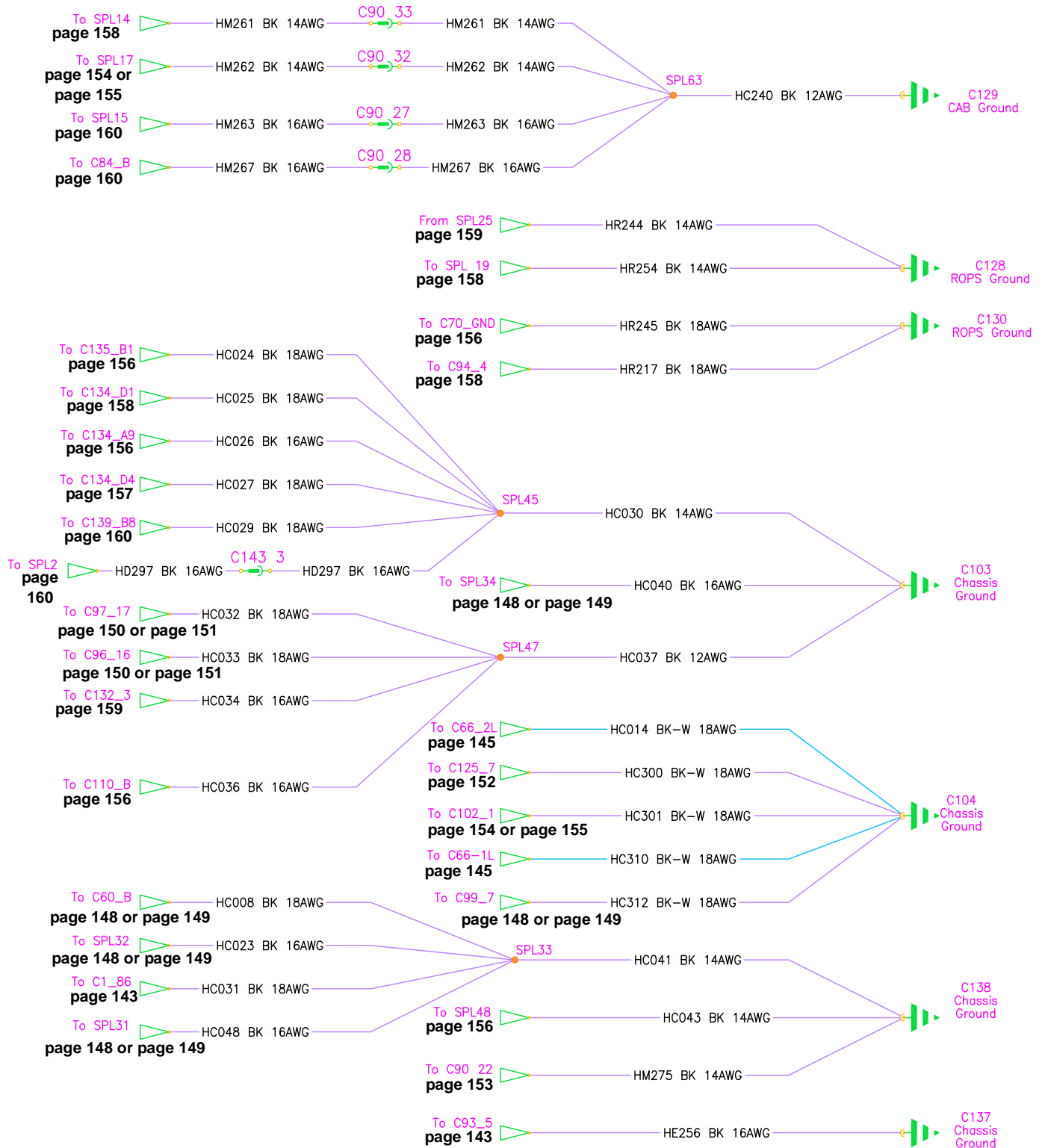

NOTES

Index

A

After Operation	68
Air Conditioning	
Maintenance	126
Attachments	
Connecting/Disconnecting	83
Hydraulic Powered	85
Auxiliary Hydraulics	
High-Flow Control	87
Operation	86

B

Backup Alarm	76
Battery	121
Jump-starting	122
Battery Disconnect Switch	60
Buckets	
Working with	87
Digging Tips	87
Safety Instructions	88
Standard Buckets	89, 90
Backfilling	92
Leveling	90
Scooping	89

C

Cab	64
Opening/Closing the Door	65
Securing the Door in the Open Position	54
Checks During Operation	64
Component Identification	10
Component Serial Numbers	9
Contents and Use of this Manual	7
Control Joysticks	50
Control Sensitivity	53
D-H Pattern	50
ISO Pattern	50
Control Modules	124
Controls	43
Crane Lifting	95

D

Declaration of Conformity	169
Decommissioning	128

Delivery Checklists	i
Drive System	
Travel Speed Range Selection	57

E

Electrical System	121
Engine	
Access	103
Air Filters	106
Cooling System	107
Checking Coolant Level	107
Cleaning Radiator Fins	107
Draining/Refilling Cooling System	108
Maintenance	103
Oil	104
Checking Level	104
Filter Changing	104
Oil Changing	104
Error Codes	140
Controller Communication Error Codes	140
Drive and Valve Error Codes	142
Engine Error Codes	140

F

Final Shutdown	128
Fire Extinguisher	13
Fuel System	
Maintenance	109
Adding Fuel	110
Changing Fuel Filter	111
Water Separator Inspection/Maintenance	110
Fuses	123

G

General Lubrication	119
Grading	90

H

Hydraglide™	59, 79
Button	59
Hydraulic Hose Maintenance	114
Hydraulic System	
Maintenance	112

Index

Changing Hydraulic Oil	113
Changing Hydraulic Oil Filter	113
Checking Hydraulic Oil Level	112
Specifications	37
Hydraulics Control Lock	80

I

Introduction	7
--------------------	---

J

Joystick Control Patterns	77
Jump-Starting	69

L

Lift Arm Operation	76
DH Pattern	77
ISO Pattern	77
Lift Arm Support	81
Lights	60
Work Lights	60
Loading/Transporting	96

M

Machine Model and Serial Numbers	9
Machine Orientation	8
Maintenance Schedule	133
Maintenance	99
Maintenance Interval	102
Maintenance Log	129
Maintenance Schedule	100
Manufacturer Information	13
Miscellaneous	
Electrical	139
Multi-Function Display	44
Screens	46
Access	46
Configuration	48
Error Codes	46
Maintenance	46
Status	46

O

Operation	63
Operational Checks	63
Operator's Seat	55

P

Pallet Forks	
Load Diagram	94
Working with	92
Parking Brake	64, 66
Parking Checks	64
Payloads	
Pallet Forks	34
Proper Machine Use	8

R

Relay	123
ROPS/FOPS	
Tilting	120
Rubber Track Use Cautions and Tips	73
Run-In Period	68

S

Safety	15
Additional Safety Equipment	24
Applications with Load-Securing Devices ...	20
Battery Hazards	23
Before Starting	16
Crystalline Silica Exposure	24
Decals	25
During Operation	17
Electrical Energy	20
Fire Hazards	23
Lifting the Machine with a Crane	24
Loading and Transporting the Machine	25
Maintenance and Service Safety Practices ...	21
Parking the Machine	20
Safety Alert Symbol	8, 15
Signal Words	8, 15
Transporting the Machine	24
Schematics	143
Auxiliary Power/Dome Light/Radio	160
Engine ECU	145
Engine Sensors	144
Engine/Starting and Charging	143
High-Flow/Self-Level/Power-A-Tach® ...	154, 155
HVAC	156
I/O Controller (Early Machines)	149
I/O Controller (Later Machines)	148
Operator CAN Interface	161
Power Distribution	147
Power Distribution (Later Machines)	146

Solenoid Control	152	DH Pattern	72
Solenoid Control (Early Machines)	151	ISO Pattern	72
Solenoid Control (Later Machines)	150	Troubleshooting	133
Track Tension/Lighting Control	157	Electrical	139
Wipers/Washer Pumps	158	Engine	133
Work Lights	159	Hydraulic System	136
Seat Adjustment	65	Hydrostatic Travel Drive System	137
Seat Belt	55, 65	Seals and Hoses	135
Serial Numbers	9	U	
Service and Registration	9	Using Attachments	11
Specific		V	
Operator/Drive Controls	153	V-Belt Maintenance	109
Specifications	31	Vibration Information	12
Coolant Compound Table	32	W	
Dimensions	32	Warm Up	68
Electrical System	40	Washer Fluid Reservoir	61
Engine	36	Windshield Washer Reservoir	127
Features	41	Windshield Wipers/Washer	61
Fluid Capacities	31	Work Hydraulics Lock-out	64
Grounds	162	Working with Buckets	
Hardware Torques	35	Tips When Loading Trucks	88
Hydraulic System	37		
Payloads/Capacities	34		
Sound Levels	40		
Track Drive	35		
Variable Displacement Motor	38, 39		
Vibration Levels	40		
Weights and Capacities	40		
Starting the Engine	67		
After Starting	68		
Stopping the Engine	68		
Storage	125		
Storage Box	97		
Straight Tracking Adjust	73		
Switches/Indicators	45, 46		
T			
Throttle Controls	56		
Track Maintenance	115		
Track Replacement	116		
Track Tension Cylinder Stops	116, 118		
Track Tension Switch	116		
Transport Position	76		
Transporting/Loading	96		
Travel Drive Operation	71		
Travel Motor			
Gearbox Oil	115		
Travel Motor Maintenance	115		
Travel Operation			

NOTES



EC Declaration of Conformity

1. Manufacturer: **Manitou Americas, Inc.**
2. Address: **One Gehl Way
West Bend, WI 53095-0179 U.S.A.**
3. Technical Construction File Location:
**Manitou Interface and Logistics Europe SA/NV
Chaussée de Wavre SN
1360 PERWEZ
Belgium**
4. Authorized Representative:
5. Address:
6. **We hereby declare that the machine listed below conforms to EC Directives: 2004/108/EC (EMC), 2006/42/EC (Machinery) and 2000/14/EC (Noise Emission), as amended by 2005/88/EC.**
7. In accordance with EN/ISO Standards:
8. Category: **EARTH-MOVING MACHINERY/LOADERS/
COMPACT/SEATED OPERATOR**
9. Models: **RT175, RT210**
10. Directive/Conformity Assessment Procedure/Notified Body:

2004/108/EC	Type-test	Self-certification
2006/42/EC	Self-certification	-----
2000/14/EC	Annex VIII – Full Quality Assurance	TÜV Industrie Service GmbH – TÜV SÜD Group Westendst. 199, D-80686 München, GERMANY

Torque Specifications

Note: Use these torque values when tightening hardware (excluding: locknuts and self-tapping, thread forming and sheet metal screws) unless specified otherwise.

Hydraulic fittings with various seals (light application). All torque values are in Nm (lb.-ft.) unless marked otherwise.					
Thread	Straight pipe fitting with thread and screwed plug (GE)			Non-return valve with elastic seal	Identification aid outside Ø
	Sealing washer	Elastic seal	O-ring		
M10X1.0	9 (7)	18 (13)	15 (11)	18 (13)	10 mm (0.4 in.)
M12X1.5	20 (15)	25 (18)	25 (18)	25 (18)	12 mm (0.5 in.)
M14X1.5	35 (26)	45 (33)	26 (35)	35 (26)	14 mm (0.6 in.)
M16X1.5	45 (33)	55 (41)	40 (30)	50 (37)	16 mm (0.6 in.)
M18X1.5	55 (41)	70 (52)	45 (33)	70 (52)	18 mm (0.7 in.)
M22X1.5	65 (48)	125 (92)	60 (44)	125 (92)	22 mm (0.9 in.)
M27X2.0	90 (66)	180 (133)	100 (74)	145 (107)	27 mm (1.0 in.)
M33X2.0	150 (111)	310 (229)	160 (118)	210 (155)	33 mm (1.3 in.)
M42X2.0	240 (177)	450 (332)	210 (155)	360 (266)	42 mm (1.7 in.)
M48X2.0	290 (214)	540 (398)	260 (192)	540 (398)	48 mm (1.9 in.)
G1/8A	9 (7)	13 (18)	15 (11)	18 (13)	9.73 mm (0.4 in.)
G1/4A	35 (26)	35 (26)	30 (22)	35 (26)	13.16 mm (0.5 in.)
G3/8A	45 (33)	70 (52)	45 (33)	50 (37)	16.66 mm (0.7 in.)
G1/2A	65 (48)	90 (66)	55 (41)	65 (48)	20.96 mm (0.8 in.)
G3/4A	90 (66)	180 (133)	100 (74)	140 (103)	26.44 mm (1.0 in.)
G1A	150 (111)	310 (229)	160 (118)	190 (140)	33.25 mm (1.3 in.)
G1 1/4A	240 (177)	450 (332)	210 (155)	360 (266)	41.91 mm (1.7 in.)
G1 1/2A	290 (214)	540 (398)	260 (192)	540 (398)	47.80 mm (1.9 in.)

Hydraulic fittings with various seals (heavy application). All torque values are in Nm (lb.-ft.) unless marked otherwise.

Thread	Straight pipe fitting with thread and screwed plug (GE)			Non-return valve with elastic seal	Identification aid outside Ø
	Sealing washer	Elastic seal	O-ring		
M12X1.5	20 (15)	35 (26)	35 (26)	35 (26)	12 mm (0.5 in.)
M14X1.5	35 (26)	55 (41)	45 (33)	45 (33)	14 mm (0.6 in.)
M16X1.5	45 (33)	70 (52)	55 (41)	55 (41)	16 mm (0.6 in.)
M18X1.5	55 (41)	90 (66)	70 (52)	70 (52)	18 mm (0.7 in.)
M20X1.5	55 (41)	125 (92)	80 (59)	100 (74)	20 mm (0.8 in.)
M22X1.5	65 (48)	135 (100)	100 (74)	125 (92)	22 mm (0.9 in.)
M27X2.0	90 (66)	180 (133)	170 (125)	135 (100)	27 mm (1.0 in.)
M33X2.0	150 (111)	310 (229)	310 (229)	210 (155)	33 mm (1.3 in.)
M42X2.0	240 (177)	450 (332)	330 (243)	360 (266)	42 mm (1.7 in.)
M48X2.0	290 (214)	540 (398)	420 (310)	540 (398)	48 mm (1.9 in.)
G1/8A	35 (26)	55 (41)	45 (33)	45 (33)	13.16 mm (0.5 in.)
G1/4A	45 (33)	80 (59)	60 (44)	60 (44)	16.66 mm (0.7 in.)
G3/8A	65 (48)	115 (85)	75 (55)	100 (74)	20.96 mm (0.8 in.)
G1/2A	90 (66)	180 (133)	170 (125)	145 (107)	26.44 mm (1.0 in.)
G3/4A	150 (111)	310 (229)	310 (229)	260 (192)	33.25 mm (1.3 in.)
G1A	240 (177)	450 (332)	330 (243)	360 (266)	41.91 mm (1.7 in.)
G1 1/4A	290 (214)	540 (398)	420 (310)	540 (398)	47.80 mm (1.9 in.)

With coarse-pitch thread. All torque values are in Nm (lb.-ft.) unless marked otherwise.

Thread	Threads according to DIN 912, DIN 931, DIN 933, etc.			Threads according to DIN 7984	
	8.8	10.9	12.9	8.8	10.9
M5	5.5 (4.1)	8 (6)	10 (7)	5 (4)	7 (5)
M6	10 (7)	14 (10)	17 (13)	8.5 (6.3)	12 (9)
M8	25 (18)	35 (26)	42 (31)	20 (15)	30 (22)
M10	45 (33)	65 (48)	80 (59)	40 (30)	59 (44)
M12	87 (64)	110 (81)	147 (108)	69 (51)	100 (74)
M14	135 (100)	180 (133)	230 (170)	110 (81)	160 (118)
M16	210 (155)	275 (203)	350 (258)	170 (125)	250 (184)
M18	280 (207)	410 (302)	480 (354)	245 (181)	345 (254)
M20	410 (302)	570 (420)	690 (509)	340 (251)	490 (361)
M22	550 (406)	780 (575)	930 (686)	460 (339)	660 (487)
M24	710 (524)	1000 (738)	1190 (878)	590 (435)	840 (620)
M27	1040 (767)	1480 (1092)	1770 (1305)	870 (642)	1250 (922)
M30	1420 (1047)	2010 (1482)	2400 (1770)	1200 (885)	1700 (1254)

With fine-pitch thread. All torque values are in Nm (lb.-ft.) unless marked otherwise.

Thread	Threads according to DIN 912, DIN 931, DIN 933, etc.			Threads according to DIN 7984	
	8.8	10.9	12.9	8.8	10.9
M8X1.0	25 (18)	37 (27)	32 (43)	22 (16)	32 (24)
M10X1.0	50 (37)	75 (55)	88 (65)	43 (32)	65 (48)
M10X1.25	49 (36)	71 (52)	83 (61)	42 (31)	62 (46)
M12X1.25	87 (64)	130 (96)	150 (111)	75 (55)	110 (81)
M12X1.5	83 (61)	125 (92)	145 (107)	72 (53)	105 (77)
M14X1.5	135 (100)	200 (148)	173 (235)	120 (89)	175 (129)
M16X1.5	210 (155)	310 (229)	360 (266)	180 (133)	265 (195)
M18X1.5	315 (232)	450 (332)	530 (391)	270 (199)	385 (284)
M20X1.5	440 (325)	630 (465)	730 (538)	375 (277)	530 (391)
M22X1.5	590 (435)	840 (620)	980 (723)	500 (369)	710 (524)
M24X2.0	740 (546)	1070 (789)	1250 (922)	630 (465)	900 (664)
M27X2.0	1100 (811)	1550 (1143)	1800 (1328)	920 (679)	1300 (959)
M30X2.0	1500 (1106)	2150 (1586)	2500 (1844)	1300 (959)	1850 (1364)



WARNING



**THIS OPERATOR'S MANUAL IS
PROVIDED FOR OPERATOR USE**

**DO NOT REMOVE
FROM THIS MACHINE**

Do not start, operate or work on the machine until you carefully read and thoroughly understand the contents of this Operator's Manual.

Failure to follow safety, operating and maintenance instructions can result in serious injury to the operator or bystanders, poor operation, and costly breakdowns.

If you have any questions on proper operation, adjustment or maintenance of the machine, contact your dealer or the Manitou Americas, Inc. Service Department before starting or continuing operation.

California Proposition 65 Warnings:

Diesel engine exhaust and some of its constituents are known to the State of California to cause cancer and birth defects and other reproductive harm. Battery post, terminals and related accessories contain lead and lead compounds, chemicals known to the State of California to cause cancer and birth defects and other reproductive harm. **Wash hands after handling battery.**

GEHL®

Manitou Americas, Inc.
P.O. Box 179
West Bend, WI 53095-0179 U.S.A
www.gehl.com