



# Operation and Maintenance Manual

---

## SEM636D Wheel Loader

---



# Table of Contents

TABLE OF CONTENTS.....	2
<b>SAFETY INFORMATION .....</b>	<b>6</b>
SAFETY MESSAGES AND ATTACHED LOCATIONS.....	7
GENERAL PRECAUTIONS.....	7
OPERATING PRECAUTIONS .....	11
MAINTENANCE PRECAUTIONS .....	18
<b>TECHNICAL SPECIFICATIONS.....</b>	<b>25</b>
KEY TECHNICAL SPECIFICATIONS.....	27
636D ARRANGEMENT DRAWING .....	29
<b>OPERATION .....</b>	<b>30</b>
SWITCHES AND GAUGES .....	31
ADDITIONAL ACCESSORIES .....	36
BREAKING-IN A NEW WHEEL LOADER .....	37
MACHINE OPERATION.....	38
PARKING AND STORAGE .....	40
SPECIFIC OPERATIONS .....	41
TRANSPORTING.....	45
<b>MAINTENANCE .....</b>	<b>47</b>
PERIODIC MAINTENANCE .....	48
MAINTENANCE SCHEDULE.....	49
ENGINE.....	52
TRANSMISSION.....	57
AXLE .....	58
HYDRAULIC SYSTEM.....	59
TIRES .....	61
BUCKET LIMITATION DEVICE .....	61
PARKING BRAKE.....	61
PIN AND DRIVESHAFT .....	63
WELDING OPERATION.....	66
BATTERY .....	66
FLUID SPECIFICATION.....	68
<b>FAILURE CAUSES AND REPAIR.....</b>	<b>70</b>
ENGINE SYSTEM.....	71
TRANSMISSION.....	71
BRAKE SYSTEM.....	72
WORK TOOL AND HYDRAULIC SYSTEM .....	73
STEERING SYSTEM.....	74
ELECTRIC SYSTEM .....	76
AIR CONDITIONING SYSTEM.....	76



## Foreword

This manual includes guidelines on how to use this Wheel Loader safely and effectively. This manual should be kept at hand and read periodically. If this manual is lost or becomes too dirty to be legible, you should buy a new one from your dealer. If you sell the machine, make sure this manual will be handed over to the new user.

This manual contains safety information, operation instructions, and lubrication and maintenance precautions. The information, specifications, and illustrations in this manual are based on information that was available at the time of publication. The specifications, torques, pressures, measurements & adjustments, illustrations, and other items may change at any time. These changes may affect the service that is given to the machine. Whenever a problem arises regarding the machine or the contents of this manual, please consult the manufacturer or dealers for the latest available information.

The safety section describes safety concerns that require your attention during operation, maintenance or repair. Most accidents that involve product operation, maintenance and repair are caused by failure to observe basic safety rules or protection measures. An accident can often be avoided by recognizing potentially hazardous situations before an accident occurs. All related personnel must be acquainted with potential risks of accidents. Those persons should also have the necessary training, skills and tools to perform repair the failures. Improper operation, lubrication, maintenance or repair of this product can be dangerous and could result in injury or death. Do not operate or perform any lubrication, maintenance or repair on this machine, until you have read and understood the operation, lubrication, and maintenance and repair information. Safety precautions and warnings are provided in this manual and on the product. If these hazard warnings are neglected, injury or death may occur.

The operation section describes basic operation technique, and guides the operator through correct procedures of checking, starting, operating and stopping the machine. Therefore the operator should keep this manual at hand for continuous reading and studying.

The maintenance section is a guide to machine daily maintenance, and classified on the basis of maintenance intervals. This manual lists the maintenance interval on the basis of service hour meter reading. Calendar intervals (days, weeks, months) can be used instead of service hour meter intervals if they provide more convenient servicing schedules and approximate the indicated service hour meter reading. Caterpillar (Qingzhou) Ltd. recommends that service should always be performed at the interval that occurs first. Under extremely severe, dusty or wet operating conditions, more frequent lubrication than is specified in the maintenance intervals schedule might be necessary. Perform service on items at multiples of the original requirement. For example, at every 500 service hours or 3 months, also service those items listed under every 250 service or monthly, 50 service hours, or weekly, and every 10 service hours or daily.

Caterpillar (Qingzhou) Ltd. cannot anticipate every possible circumstance that might involve a potential hazard. The warnings in this publication and on the product are therefore not all inclusive. If a tool, procedure, work method or operating technique not specifically recommended by Caterpillar (Qingzhou) Ltd. is used; you should ensure that it is safe for yourself and others. You should also ensure that the product will not be damaged or be made unsafe by the operation, lubrication, maintenance or repair procedures that you choose.

Each wheel loader has its own design operating capacity. Additional attachments or modifications exceeding machine design capacity may adversely affect operation performance of the loader, which include the operation stability as well as brakes and steering units. Please contact your dealer for the latest information.



# Components

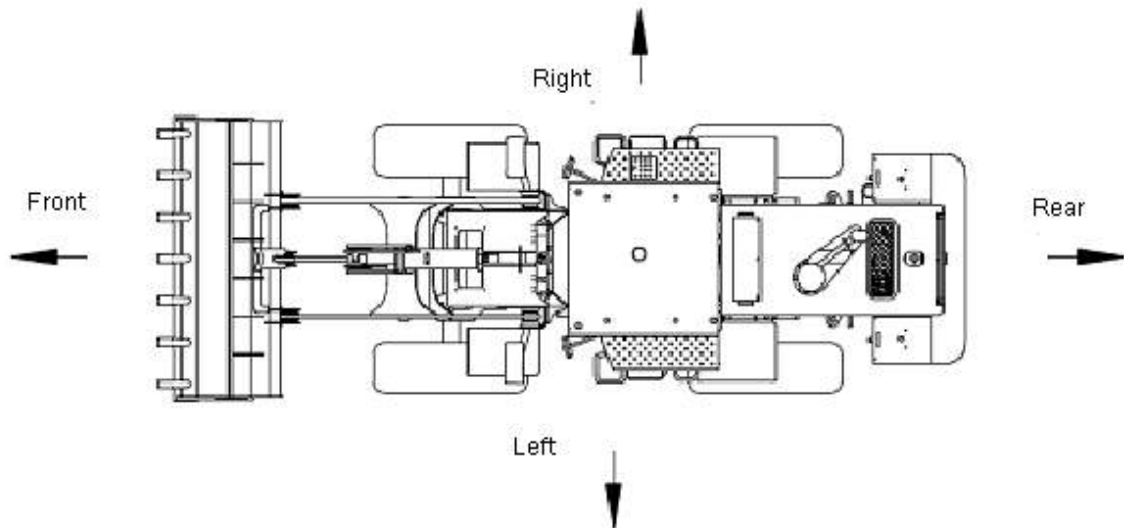
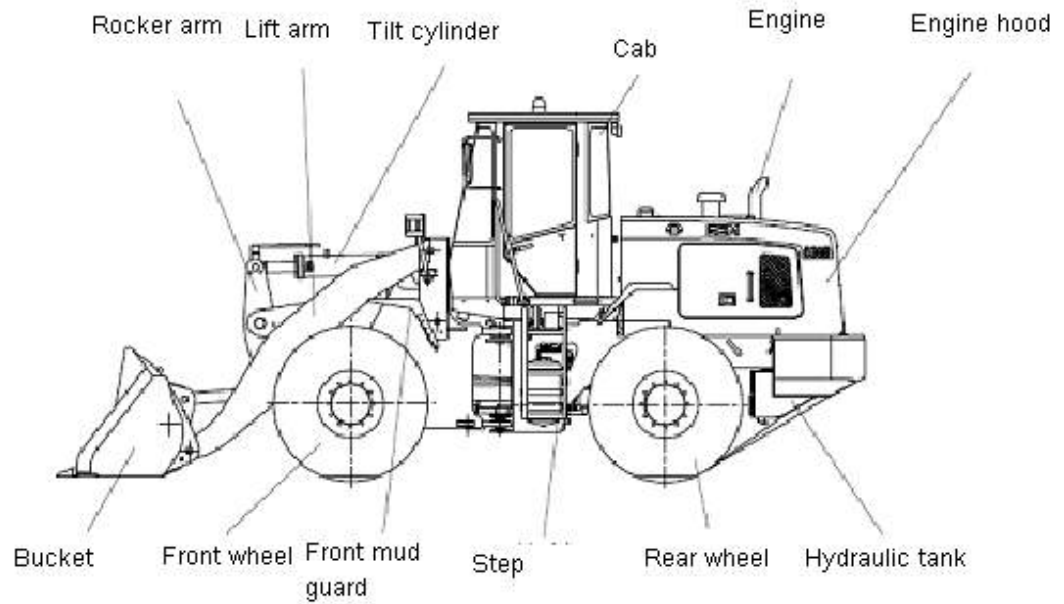



## Safety Information

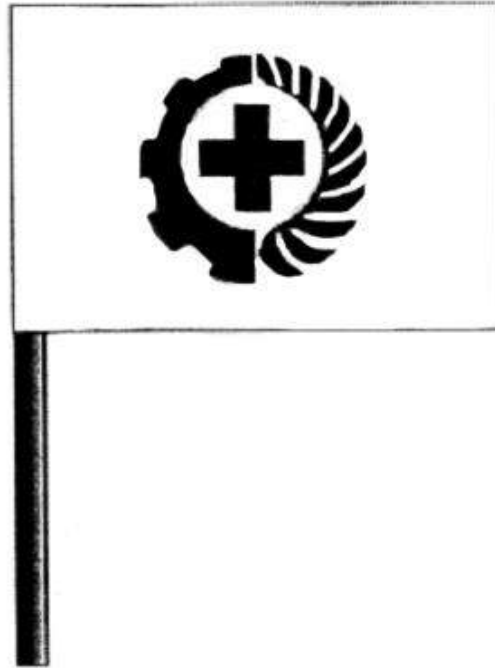

**Please read and become familiar with all of the safety information.  
Failure to do so may result in serious injury or death.  
This “Safety Information” section also contains precautions regarding  
options and attachments.**

## Safety Messages and Attached Locations

There are several specific safety messages on this machine. This section introduces the exact locations of those safety messages and description of related potential risks. Please become familiar with all safety messages. Make sure that all of the safety messages are legible, clean the safety messages or replace the safety messages if you cannot read the words or illustrations. When cleaning the safety messages, use a cloth and soapy water. Do not use solvent, gasoline to clean the safety messages. Replace any safety message that is damaged, missing or illegible after cleaning. If a safety message is attached to a part that has been replaced, install a new safety message on the replacement part.

### No Entry

(No 1: located in the articulation area of frame)



### Do not Walking Beneath Work Tools

(No 2: located on both sides of lift arms)



## Never Put Hands Close to Rotary Fan and Do not Get Too Close to the Machine

(No. 3 and 4: located at the rear end of engine hood)



## General Precautions

### Safety Rules

- Only a trained and qualified person is authorized to operate and maintain the machine.
- Follow all safety rules, precautions and instructions while operating or performing maintenance on the machine.
- Do not operate the machine if you are sick, sleepy, after taking medicine, or after drinking alcohol. Operating in such cases will adversely affect your judgment and may lead to an accident.
- When working with another operator or a flag person on the job site, ensure that all persons understand all hand signals that are to be used.
- Follow all rules and regulations concerning safety.

### Safety Devices

- Make sure that all protective guards and all covers are secured in place on the machine. Repair immediately if damaged.
- Use safety devices properly, such as control levers lockout device and seat belt.
- Never remove any safety devices. Always keep them in good operating condition.
- Improper use of safety devices could result in serious injury or death.



## Always Lock the Lockout Device When Leaving Operator's Seat

- Engage the parking brake by using the lever before leaving seat, otherwise the work tools may suddenly move by bumping control levers resulting in serious injury or damage.
- When leaving the loader, lower the work tools completely onto the ground, engage the parking brake lever into on position, stop the engine and use key to lock all devices, then carry the key with you.
- If the left window is closed, insure that it is rolled up tightly; if it is loose it could open.
- When locking up be sure that the seat is locked in place to prevent the glass from locking and the seat from moving when the operator enters the cab.

## Clothing and Personal Protective Items

- Do not wear loose clothing or jewelry and maintain short hair. These things can snag on controls or other parts of the equipment and cause serious injury or death.
- Do not wear oily clothing in order to avoid ignition.
- Wear a hard hat, safety glasses, safety shoes, mask or gloves when operating or maintaining the machine. Always wear safety goggles, a hard hat and heavy gloves particularly if your job involves scattering metal chips or minute materials. Also, when driving pins with a hammer and when cleaning the air cleaner element with compressed air make sure that no one is around the machine.
- Pressurized air can cause personal injury. When pressurized air is used for cleaning, wear face shield, protective clothing, and protective shoes. The maximum air pressure for cleaning purposes must be lower than 0.3Mpa.
- Check before using that all protective items will function properly.



Cat

## Unauthorized Modification

Any modification made without authorization from Caterpillar (Qingzhou) Ltd. may result in hazards. Consult authorized distributor appointed by Caterpillar (Qingzhou) Ltd. before making any modification. Caterpillar (Qingzhou) Ltd. is not responsible for any injury or damage caused by any unauthorized modification.

## Mounting and Dismounting

- Before getting on or off the machine, check the handles and steps. If there is any oil, lubricants, or mud on them, wipe it off immediately. In addition, repair any damaged parts and tighten any loose bolts.
- Never jump on or off the machine. Never get on or off a moving machine.
- When getting on or off the machine, always face the machine and maintain three-point contact (both feet and one hand, or both hands and one foot) with the handholds and steps to ensure that you support yourself.
- Never hold any control levers when getting on or off the machine.
- Do not get on the machine from the step at the rear of machine and never get off the machine from the tire beside cab.
- Do not get on or off the machine while carrying tools or other items. Use ropes to lift the required tools up to the operator station.

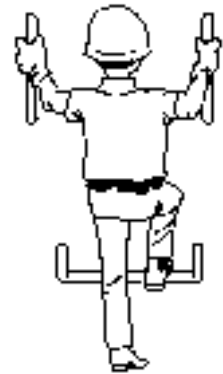

## Fire Prevention

Fuels, lubricants in the engine, hydraulic oil in the hydraulic system, converter oil and gear oil in the transmission, brake oil in the braking system, and antifreeze in radiator system are all flammable by direct flame. Fuel is particularly flammable and hazardous. Therefore, be sure to pay attention to the following precautions:

- Keep the above-mentioned flammable fluids away from direct flame.



- When refilling, park machine in a ventilated area, and stop the engine. Do not smoke when refilling.
- Tighten caps of storage containers for all the above flammable fluids.
- Store flammable fluids in properly marked containers, and in a specified place as per categories. Do not allow unauthorized person to use.
- Store oily rags and any flammable materials in protective containers, and in a secured place.
- Do not weld on or flame cut lines that contain flammable fluids. Clean any such lines thoroughly with a nonflammable solvent prior to welding or flame cutting.
- Remove all flammable materials such as fuel, oil, and debris from the machine.
- Do not operate the machine near any flame or burning brush.

This wheel loader is of general construction equipments. Therefore, do not operate under any flammable and explosive environment.



## Fire Extinguisher and First Aid Kit

Follow the precautions below in case of injuries or fire.

- Make sure that a fire extinguisher is available. Read the usage guide carefully and be familiar with the operation of the fire extinguisher.
- Make sure that a first aid kit is available at the job site. Check it regularly and add medical contents if necessary.
- Know what to do in the event of a fire or personal injury.
- Be sure you know the phone numbers of the people who should be contacted in case of an emergency, such as, doctors, first-aid centers, firehouses. Put up those numbers in a specified place, and make sure that all personnel know the numbers, location and the correct contact method.

## Asbestos Dust Hazard Prevention

Asbestos dust can be hazardous to your health if it is inhaled. Use the following guidelines when you handle any materials that contain asbestos:

- Never use compressed air for cleaning.
- Use water for cleaning so that the dust will be dissolved in the water.
- Areas that may have asbestos particles in the air are hazardous. Operate the machine in the same direction as the wind, whenever possible.
- Use an approved respirator if necessary.



## Precautions When Operating Under High Temperature

- Immediately after operations hydraulic oil, oil and water in the engine and radiator will be at high temperatures and under pressure. Attempting to remove the filler cap and radiator, to drain oil or water, or to replace the filters may lead to serious burns. Allow components to cool and follow the specified procedures.
- To prevent hot oil from spurting out, stop the engine first, and wait to allow oil to cool. Remove the filler cap slowly in order to relieve pressure. (When checking if the oil is cool enough, put your hand near the front face of the radiator of hydraulic oil and converter oil, and check the air temperature. Be careful not to touch the radiator.)
- When engine is hot, do not touch the relay

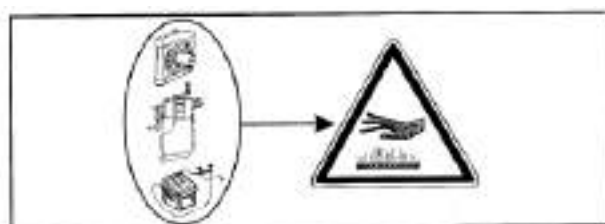



with your hand to avoid being burned.

- Do not remove the engine oil temperature sensor, water temperature sensor, converter oil sensor and air conditioner water tube when the machine is hot, to avoid being burned.

## Crushing Prevention and Cutting Prevention

- Keep your hands, arms and all body parts clear of all moving parts such as, the area between the work tools and cylinders or the area between the machine and work tools. The clearance in the linkage area will change with the movement of the work tools. This may lead to serious accident or personal injury. If entrance between the machine and moving parts is necessary, always stop the engine, and then lock the work tools.
- Support the machine properly before you perform any work beneath the machine. Do not depend on the hydraulic cylinders to hold up the equipment. Equipment can fall if a control is moved, or if a hydraulic line breaks.
- Unless otherwise stated, never make any adjustment when the machine is operating or the engine is running.
- Stay clear of all rotating and moving parts.
- Keep objects away from moving fan blades. The fan blade will throw or cut the tools or objects in between.



## Precautions When Using ROPS (Rollover Protective Structure)

If ROPS is installed, do not operate the machine with the ROPS removed. The ROPS is installed to protect the operator if the loader should roll over. It is designed not only to support the tipping load, but also to dampen the impact.

- The ROPS meets international specifications and standards. Its strength may be reduced after rolling over or being damaged

by falling objects, and its protection function may be weakened. In such a case, contact your dealer for repair.

- Even if ROPS is installed, when operating the machine, the operator should wear the seat belt, and use other the safety devices to provide proper protection.

## Precautions for Attachments

- When installing and using an optional attachment, read the instruction manual for the attachment and the information related to attachments in this manual.
- Do not use attachments that are not authorized by Caterpillar (Qingzhou) Ltd. or your Caterpillar (Qingzhou) Ltd. distributor. Use of unauthorized attachments could create a safety concern and adversely affect the proper operation and service life of the machine.
- Caterpillar (Qingzhou) Ltd. is not responsible for any injuries, accidents, machine damages resulting from the use of unauthorized attachments.

## Ventilation for Enclosed Areas

- In an enclosed or poorly ventilated area, if it is necessary to start the engine, handle fuel, flush parts, or paint, immediately open the doors and windows to ensure that adequate ventilation is provided to prevent gas poisoning.
- If opening the doors and windows does not provide adequate ventilation, fans should be installed.

## Lines, Tubes and Hoses

- Do not bend high-pressure lines or strike high-pressure lines. Do not install any tubes or hoses that are bent or damaged.
- Always repair any loose or damaged tubes and hoses in fuel or oil circuits and hydraulic system because any leaks can cause fire. Consult your Caterpillar (Qingzhou) Ltd. distributor immediately for repair or replacement parts.
- Carefully check lines, tubes and hoses. Tighten all connections to the recommended torque. Always wear safety glasses and thick

gloves, and use a piece of cardboard or a sheet of wood to check for oil leakage. Even a pinhole leak can penetrate your skin causing severe injury or death. If fluid is injected into your skin, you must immediately seek treatment from a doctor that is familiar with this type of injury.

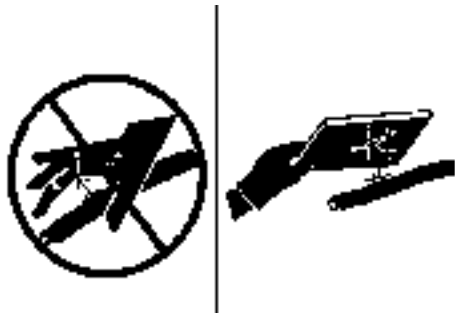

- Replace the parts if any of the following conditions are present:
  1. Fittings are damaged or leaking.
  2. Outer coverings are chafed or cut so that the steel wires are exposed.
  3. Part of the hose is ballooning.
  4. Hoses are obviously kinked or pressed.
  5. Outer covers have embedded armoring.
  6. End fittings are displaced.
- Make sure that all clamps, guards, and heat shields are installed correctly, to prevent vibration, rubbing against other parts, and excessive heat.
- When the connecting pipe of the air conditioning compressor is removed, direct flame is strictly prohibited, because poisonous gas could be produced, resulting in poisoning.

## Operating Precautions

### Turning on the Machine

#### Plan Your Operation Procedure

- Before starting operations, thoroughly check the area for unusual conditions that could be dangerous.
- Examine the shape of the ground, the quality of the soil, the jobsite, and determine the optimum method of operation.
- Make sure the ground is firm and level before starting engine. When working at dusty worksites, the ground should be watered.

- When working on public roads, position a flagman and warning signs, such as “NO ENTRY” to ensure the safety of passing traffic and pedestrians.
- In places where there are buried objects, such as water pipes, gas pipes, or pipes for high voltage cables, contact the company in charge to confirm the position of the buried object, and be careful not to damage the object during operations.
- When working in water or when crossing sand banks, first check the condition of ground, the water depth and flow speed. Be sure not to exceed the permitted water depth. When working in water or on swampy ground, do not let the water come above the bottom of the axle housing. After finishing the operation, wash and check all lubricating points.

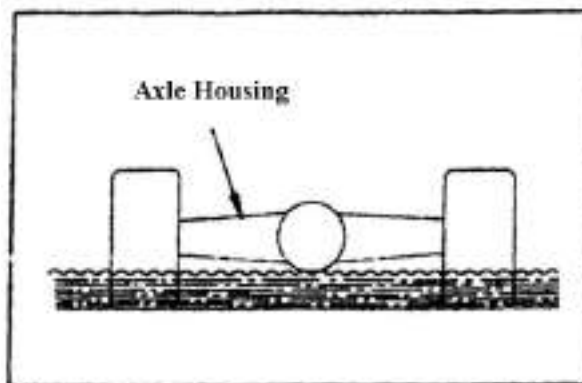

#### Before Starting Engine Checklist

Carry out the following checks before starting the engine at the beginning of the day's work. Failure to carry out these checks may lead to serious injury or damage.

- Completely remove all the flammable materials accumulated in the engine compartment and around the battery. Check fuel, lubrication, and hydraulic systems for leaks, and have any leaks repaired. Remove any dirt from the mirrors, handrails, and steps. Return all fuel containers to their proper place.
- Remove all parts and tools from the operator's compartment. The oscillation of walking and operating may get the tools fall off, then destroy the joy stick and switch, or make the joy stick starting again, it may lead to serious injury or damage.
- Clean your shoes before you get on the machine, and if there is dirt, clear immediately



in order to prevent dirt from accumulating on the accelerator pedal and break pedal, and to prevent pedal replacement

- Check the coolant level, fuel level, and oil level in the engine oil pan, clogging of the air cleaner, and damage to the electric wiring.
- Adjust the operator's seat to a position where it is easy to carry out operations, and check for wear or damage to the seat belt and mounting equipment. Change the seat belt after three years.
- Check that the gauges work properly, and check that the control levers are at the PARK position.
- Remove all dirt from the surface of the window glass and lights to ensure good visibility.
- Adjust the side mirror to a position, which gives the best view from the operator's seat, and clean the surface of the mirror. And clean the surface of the mirror. If the mirror glass is damaged, replace with a new part.
- Check that the front lamps and working lamps light up properly. If the results of the inspection show any abnormality, carry out the necessary repairs.
- Be sure a fire extinguisher is present and check the method of using it.
- Do not operate the machine near any fire or flame.

### **When Starting Engine**

- Walk around your machine and check for people and objects that might be in the way just before getting on.
- If a warning label, such as "DO NOT OPERATE", has been attached to control lever, DO NOT start the engine.
- When starting the engine, sound the horn as an alert.
- Start and operate the machine only while sitting in the operator seat.
- Only the operator is allowed in the cab. Do not allow anyone to ride on the machine body.
- Start the engine in the cab; never start the machine by creating a short circuit of the electromotor, this may damage the electro circuit, and it is very dangerous.
- If there is a backup alarm, please check that it works properly.

### **After Starting Engine Check-list**

Failure to carry out the checks properly after starting the engine will lead to delays in discovery of abnormalities. And, this may lead to serious injury or damage to the machine. When checking the area one must ensure that there are no obstacles and do not allow people to come near the operation area.

- Check the functionality of the gauges, work tools, and hydraulic system, brake system, travel system and lubricating system.
- Check for any abnormalities in the sound of the machine, vibration, heat, or smell; also check that there is no leakage of air, oil or fuel.
- If any abnormalities are found, carry out repairs immediately. If the machine is used when it is not in proper condition, it may lead to serious injury or damage to the machine.
- Before traveling or starting operations, check that safety bar is securely placed in the "unlocked" position.

## **Operation**

### **Precautions When Starting Off**

- Before starting off, check again that there is no one in the surrounding area and that there are no obstacles.
- When starting off, sound the horn as an alert.
- Operate the machine only when seated in the operator's seat.
- Always fasten the seat belt. (If equipped)
- Only the operator is allowed in the cab. Do not allow anyone ride on the machine body.
- If there is a backup alarm, please check that it works properly.

### **Precautions When Traveling**

- When traveling, never turn the key/start switch to the off position. It is dangerous if the engine stops when the machine is traveling because the steering becomes heavy. If the engine stops, apply the brake immediately to stop the machine.
- It is dangerous to look around when operating. Always concentrate on the work.
- It is dangerous to drive too fast, to start/stop suddenly, turn sharply, or zigzag.
- If you find an abnormality in the machine

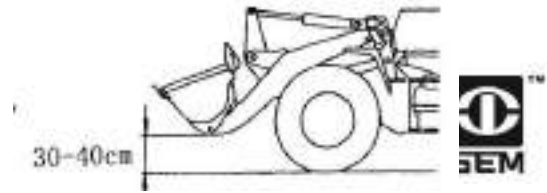

during operation (noise, vibration, smell, incorrect gauges, air leakage, oil leakage, etc.), move the machine immediately to safe place and look for the cause.

- Set the work tools to travel position. (Lift 30-40cm from level ground)

- When traveling, do not operate the work tool control levers. If the work tool control levers have to be operated, stop the machine first and then operate the levers.

- Do not operate the steering wheel suddenly. The work tools may hit the ground surface causing the machine to lose its balance, or may damage the machine or other structures in the area.

- When traveling on rough ground, travel at low speed and avoid sudden changes in direction.

- Avoid traveling over obstacles as often as possible. If the machine has to travel over an obstacle, keep the work tools as close to the ground as possible and travel at low speed.

- When traveling or carrying out operations, always keep your distance from other machines or structures to avoid coming into contact with them.

- Never drive in water that is in excess of the permissible water depth. Do not let the water come above the bottom of the axle housing.

- When passing over bridges or structures on private land, check first that the structure is strong enough to support the mass of the machine. When traveling on public roads, check first with the relevant authorities and follow their instructions.

- Always obey the traffic regulations when traveling on public roads. This machine travels at lower speed than normal automobiles, so keep to the side of the road and be careful to leave the center of the road free for other vehicles.

- If you drive the machine at high speed continuously for a long time, the tires will overheat and the internal pressure will become abnormally high. This may result in the tires bursting. If a tire bursts, it produces an extremely large destructive force, and this may cause a serious injury or accident.

- If you are going to travel continuously, please consult your Caterpillar (Qingzhou) Ltd. agent.

### Check When Changing Direction

To prevent serious injury or death, even that machine is equipped with a back up alarm and mirrors always do the following before moving the machine or the work tools:

- Sound the horn to warn people in the area.
- Check that there is no one near the machine. Be particularly careful to check behind the machine. This area cannot be seen clearly from the operator's seat.



- When operating in the areas that may be hazardous or have poor visibility, designate a person to direct worksite traffic.
- Ensure that no person can come within the direction of turning or direction of travel.
- When traveling at a high speed, never change direction.

### Restricted Operation

- To prevent the machine from turning over or the work tools from being damaged due to overload, always keep within the maximum load specified for the machine.

- Caterpillar (Qingzhou) Ltd. is not responsible for of any injuries, accidents or machine damage resulting from overload.

### Traveling On Slopes

- Be careful traveling on slopes can result in the machine tipping over or slipping to the side.

- When traveling on slopes, keep the bucket approximately 20-30cm (8-12in) above the ground. In case of emergency, quickly lower the bucket to the ground to help the machine to stop.

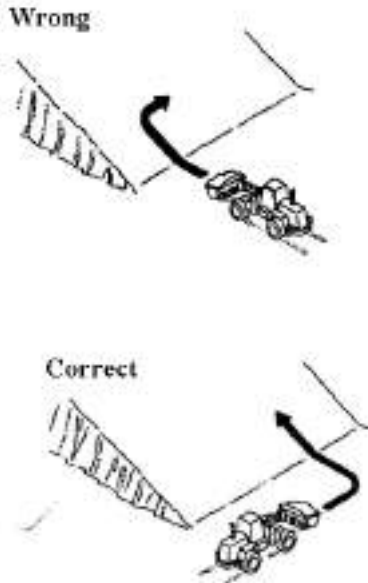

- Do not turn on slopes or travel across slopes; always go down to a flat place to perform these operations.
- When traveling downhill, never shift gears or shift to neutral. Always shift to a low gear before starting to travel downhill.
- When traveling downhill, use the engines braking force and travel slowly. If necessary, use the brake pedal to reduce the speed.
- At high speeds, do not travel on grass, fallen leaves, or wet steel plates. Even slight slopes may cause the machine to slip to the side, so travel at low speed and make sure that the machine is always traveling directly up or down the slope.
- If the engine shuts off when traveling downhill, using the brake pedal and fully the apply the brakes. Lower the bucket to the ground, and then apply the parking brake to hold the machine in position.
- When traveling up or down hills with a loaded bucket, always travel with the bucket facing uphill (travel forward when going uphill and in reverse when going downhill). When traveling on a slope with a loaded bucket, if the machine travels with the bucket facing downhill, there is danger that the machine may tip over.

### High-Voltage Cables

- Do not let the machine touch electric cables; even getting close to high-voltage cables can cause electric shock. Always maintain the safe distance given below

between the machine and the electric cable.

	Voltage V	Min. safety distance	
Lower voltage	100–200	2m	7ft
	6,600	2m	7ft
Higher voltage	22,000	3m	10ft
	66,000	4m	14ft
	154,000	5m	17ft
	187,000	6m	20ft
	275,000	7m	23ft
	500,000	11m	36ft

- To prevent accidents, always do as follows:

1. On the jobsite where there is danger that the machine may touch the electric cables, consult the electric company before starting operations to confirm that the appropriate precautions are taken and that the work abides to regulations.
2. Wear rubber shoes and gloves. Lay a rubber sheet on top of the operator's seat, and be careful not to touch the chassis with any exposed part of your body.
3. Use a signalman to give warning if the machine approaches the electric cables.
4. If the work tools should touch the electric cable, the operator should not leave the operator's compartment.
5. When carrying out operations near high voltage cable, do not let anyone come close to the machine.
6. Check with the electricity company about the voltage of the cables before starting operations.

### Driving Precaution

- Be careful not to get too close to the edge of cliffs. When marking embankments, landfills, or when dropping soil over a cliff, dump one pile and then use the next pile of soil to push the first pile.
- The load suddenly becomes lighter when the soil is pushed over a cliff or when the machine reaches the top of a slope. When this happens, there is danger that the travel speed will suddenly increase, so be sure to reduce the speed.
- When the bucket is fully loaded, never start, turn, or stop the machine suddenly.
- When handling unstable loads, such as

round or cylindrical objects or piled sheets, if the work tool is raised high, there is danger that the load may fall on top of the operator's compartment and cause serious injury or damage. When handling unstable loads, be careful not to raise the work tools too high or tip the bucket back too much.

- If the work tools is suddenly lowered or suddenly stopped, the reaction may cause the machine to tip over. Particularly when carrying a load, be sure to operate the work tools carefully.
- Do not use the bucket or lift arm for crane work.
- Do the following to ensure good visibility:
  1. When operating in dark places, turn on the working lamps and front lamps, and install lighting at the jobsite if necessary.
  2. Do not carry out operations in fog, snow, or heavy rain, or other conditions where the visibility is poor. Wait for the weather to clear so that visibility is sufficient to carry out work.
- Always do the following to prevent the work tools from hitting other objects
  1. When operating in tunnels, under bridges, under electric wires, or other places where the height is limited, be extremely careful not to let the bucket hit anything.
  2. When loading dump trucks, check that there is no one in the area around the machine and be careful not to let the bucket hit the operator's compartment of the dump truck.
  3. To prevent accidents caused by hitting other objects, always operate the machine at a speed, which is safe for operation, particularly in confined spaces, indoors, and in places where there are other

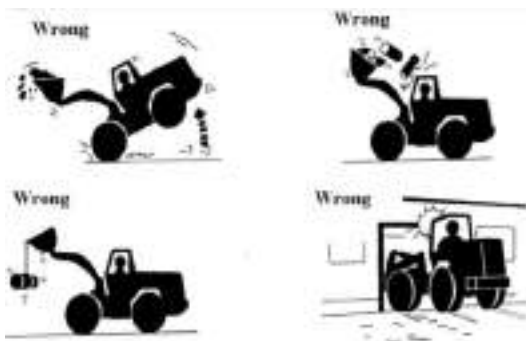

machines.

### Using Brakes

- Do not put your foot on the brake pedal unless necessary.
- Do not depress the brake pedal repeatedly unless necessary.
- When traveling downhill, use the engine as a brake, and never shift gear or place the transmission in neutral.

### Operating on Snow

- When working on snow or icy roads, even a slight slope may cause the machine to slip to the side, so always travel at low speed and avoid sudden starting, stopping, or turning. There is danger of slipping particularly on uphill or downhill slopes.
  - With frozen road surfaces, the ground becomes soft when the temperature rises, so the travel conditions become unstable. In such cases be extremely careful when traveling.
  - When there has been heavy snow, the road shoulder and objects placed beside the road will be buried in the snow and cannot be seen, so always carry out snow-removal operations carefully.
  - When traveling on snow-covered roads, always add tire chains.
  - When traveling on snow-covered slopes, never apply the brakes suddenly. Reduce the speed and use the engine as a brake while applying the foot brake intermittently. If necessary, lower the bucket to the ground to stop the machine.
  - The load varies greatly according to the characteristics of the snow, so adjust the load accordingly and be careful not to let the machine slip.

### Working on Loose Ground

- Do not operate the machine on soft ground because it will be difficult to get the machine out again.
- Avoid operating your machine too close to the edge of cliffs, overhangs, and deep ditches. If these areas collapse under the mass or vibration of your machine, the machine could fall or tip over and this could result in serious injury or death. Remember that after heavy



rain, blasting, or earthquakes, the soil will be weak in these areas.

- If the soil on the ground or near the ditches is loose. It can collapse under the mass or vibration of your machine and cause your machine to tip over.
- Install the head guard (FOPS) when working in areas where there is danger of falling stones or rocks.
- Install the ROPS and wear the seat belt when working in areas where there is danger of falling rocks or of the machine turning over.

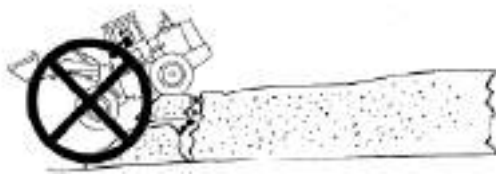

### **Parking the Machine**

- Park the machine on level ground and lower the work tools to the ground. Where there is no danger of falling rocks or landslides. Or of flooding if the land is low.
- If it is necessary to park the machine on a slope, set blocks under the wheels to prevent the machine from moving. Then, dig the work

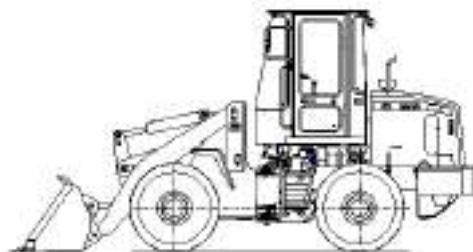

tools into the ground.

- When parking on public roads, provide fences, signs, flags, or lights, and put up any other necessary signs to ensure that passing traffic can see the machine clearly. And park the machine so that the machine, flags, and fences do not obstruct traffic.
- When leaving the machine, lower the bucket completely to the ground, parking brake lever to the on position, stop the engine, and lock all the equipment. Always remove the key and take it with you.

### **Operating in Cold Areas**

- After completing operations, remove all

water, snow, or mud stuck to the wiring harness, connector, switches, or sensors, and cover these parts. If the water freezes, it will cause malfunctions of machine when it is next used, and this may lead to unexpected accidents.

- Carry out the pre-heat/deicing operation thoroughly. If the machine is not thoroughly warmed up before the control levers are operated, the reaction of the machine will be slow, and this may lead to unexpected accidents.
- Operate the control levers to relieve the hydraulic pressure (raise to above the set pressure for the hydraulic circuit and release the oil to the hydraulic tank) to warm up the oil in the hydraulic circuit. This ensures good response from the machine and prevents malfunctions.
- If the battery electrolyte is frozen, do not charge the battery or start the engine with a different power source. There is danger that this will ignite the battery. When charging or starting the engine with a different power source, melt the battery electrolyte and check for leakage of battery electrolyte before starting.

### **Moving the Machine**

#### **Load and Unload the Machine**

- The potential danger factors always exist when loading and unloading the machine, so the workers should take care. The engine should be at low speed and the machine should run with a low speed.
- The machine should be loaded and unloaded in a hard flat ground. Keep safety distance from the roadside.
- Fix the shipping vehicle wheels all the time and put the seat pad under the access board.
- Use a ramp with enough intensity. Make sure the ramp is wide and long enough to provide a sloping ground for the loading and unloading. The angle between the sloping ground and the floor should not be larger than 15°. The distance of the ramp should be adaptable to the distance of the machine wheels.
- Make sure the ramp is fixed well and the





height of the two sides should be the same.

- Make sure the surface of the tilted-plate is clean, no lube, oil, ice or loose material. Clear up the contamination on the machine tires.
- Do not turn the direction off the ramp. If necessary, the machine should move away from the ramp, adjust the machine direction and then run up on the ramp.
- After the wheel loader is loaded on the trailer, wedge the tire and tie and tighten the machine with a cord.

### **Delivery**

- When using the tow truck to deliver the machine, the operator should obey by the regulation for the weight, width, length and the national and regional laws.
- When confirming the delivery route, the operator should consider of the machine's weight, height, width and length.
- When passing over bridges or structures on private land, check first that the structure is strong enough to support the mass of the machine. When the tow truck is running on the road, the delivery must meet the requirement of the related regulations and obey by them.
- When delivering the machine, the machine might be divided into several parts. So please contact the Caterpillar (Qingzhou) Ltd. dealer to conduct this work

### **Battery and Maintenance**

#### **Danger Precaution**

- The electrolyte of battery contains vitriol and the battery can produce the hydrogen. So the wrong battery treatment can cause the serious injury or fire. Therefore, do follow the following attentions. Never make the lightened cigarette or fire close to the battery.
- Wear the safe glasses or rubber gloves when you need to touch the battery during work.
- If the electrolyte of battery spatters onto the clothes or skin, please wash and clean with water immediately.
- The electrolyte of the battery spatters into one's eyes, it may result in loss of sight. If the electrolyte spatters into the eyes, please clean the eyes with a lot of water to wash and see a

doctor immediately. **Attention:** If electrolyte is swallowed inadvertently, drink large quantities of water, milk, beaten eggs or vegetable oil. Call a doctor immediately.

- Stop the engine before working with the engine.
- Avoid contacting with the metal that may cause a short circuit between positive terminal (+) and negative terminal (-).
- First connect the positive terminal (+) when assembling the battery. First disconnect the negative (-) terminal (on the side of ground cable) when disassembling the battery.
- First check which one is positive terminal (+) or negative terminal (-) when disassembling or assembling the battery. And tighten the nut.
- Wipe with the cloth when cleaning the top of the battery. Never use the gas, solvent, any other organic solvent or cleanser. Tighten the cover of battery.
- If the battery electrolyte is frozen, do not charge the battery or start the engine with a different power source. There is danger that this will ignite the battery. When charging or starting the engine with a different power source, melt the battery electrolyte and check for leakage of battery electrolyte before starting.
- Disassemble the battery from the machine before charging.

#### **Jump-Starting the Battery**

If the connection method of boosting cable is wrong, fire might be caused. Jump-start the machine according to the following method:

- Two operators are necessary when starting (one operator should sit down at the operator's seat.)
- Do not allow the 2 machines to touch when starting another machine.
- Turn off the two starting switches of normal machine and failed machine when connecting the boosting cable.
- First connect positive (+) cable when setting boosting cable. First disconnect the ground cable or negative cable (-).
- The last ground cable should be connected to the engine cylinder of the failed machine. However, this may cause fire. So



maintain a safe distance from the battery when connecting.

- Pay attention not to allow the boosting cable clips touch with each other or let the clip touch to the machine when removing the boosting cable.

### Battery Charging

If the battery is not correctly charged, it may have the possibility to explode. Therefore, charge the battery according to the correct procedure and following rules.

- Charge it under proper ventilation and remove the battery cover. This allows the hydrogen to diffuse and prevents explosion. The air from the battery might cause explosive.
- Do not have fire or spark near the battery and no smoking when charging.
- Set the voltage of charger to agree with one of charged battery. If there is something wrong with voltage, the charger will overheat and may catch fire, which might cause explosive.
- Connect the positive charging clip (+) to the battery the positive terminal (+) and tighten the two terminals.
- If the charging rate of battery is less than 1/10, charge it highly. Set the discrete value under the battery rated volume. If the charging current is too large, the electrolyte may leak or evaporate, which could cause fire or explosion.



## Towing

### Pulling the Machine

Improperly towing a machine that or by using an improper connection may result in damage or death, so please obey by the following regulations:

- Follow the towing instruction of the "O&MM".

- Wear leather gloves when using a steel wire line.
- When doing the work together with the other workers, make sure to use signals that everyone knows before starting the work.
- If the machine engine cannot start or there is a failure in the brake system, please contact the Caterpillar (Qingzhou) Ltd. dealer to repair the machine.
- It is very dangerous to pull a machine on an incline. The worker should select an area with a small gradient. If this does not exist, then select the area with the smallest possible gradient.
- If using the machine to tow another machine that has failed, the steel wire line must be strong enough to support the failed



machine's weight.

- There should not be any broken braided wire, knots or reduced diameter on the steel wire line.
- Do not stride two feet to stand on the tow wire or the steel wire line.
- When connecting the machine that needs towed, do not stand between the machine being towed and the towing machine.
- To make sure the hook is in the correct position, the hook of the towed machine should be in line with the towing part of the machine,.

## Maintenance Precautions

### Before Maintenance

**Attention:** If maintenance that is not instructed in this "Operation and Maintenance Manual" is done, unexpected failure may arise. Please contact the dealers appointed by Shandong Machinery CO., Ltd for service.

### Warning Label

- If somebody starts the engine or shifts gears during fueling or maintenance, serious injury or death may arise.
- Glue the warning label on the shift levers in the cab to remind people that you are

maintaining the machine. If necessary, put warning labels around the machine.

### Clean Before Overhaul and Maintenance

- Clean machines before overhaul and maintenance. This is to prevent dirt from falling into the machine and to make sure that the maintenance can be done safely.
- If the machine is dirty in the course of overhaul and maintenance, it is difficult to avoid dirt or mud going into eyes or slipping and getting injured.
- A few tips for cleaning wheel loaders:
  1. Wear anti-slip shoes to avoid slipping on wet surface.
  2. When cleaning wheel loaders with high-pressure water, wear safety clothing. This way, your eyes and skin can be protected from the impact of high-pressure.
  3. Do not spray water directly onto the electrical components (e.g. sensors, wire connectors). If water get into electrical system, operation failure may arise.

### Keep the Working Place Clean and Tidy

- Do not leave any service tools at the working place. Wipe up grease and lubricant etc. to protect people from slipping. Clean and tidy working place to ensure safe maintenance
- If the working place is not tidy, danger such as slipping and tripping may arise.

### Identify the Responsible Person for the Group

- Identify the person responsible during maintenance and while loading/unloading the wheel loader. Everybody should follow his instruction.
- When working together, misunderstanding may lead to a serious accident.

### Water Level in the Radiator

- When checking water level in the radiator, stop the engine. After engine and radiator cools down, check the water level of radiator. Do not randomly open the radiator cover.
- If it is necessary to open the radiator cover, follow the below instructions:
  1. Check the water level after water

temperature in the radiator cools down. (When checking if the water temperature has gone down, put your hand near the engine or the front face of the radiator and check the air temperature. Be careful not to touch the engine or the radiator.)

2. When the water fill cover can be opened with a bare hand, unfasten the fill cover to release the inner pressure.

- If the top cover of the radiator needs to be open, do not open it until the water temperature cools down and the inner pressure is released.

### Shut Down Engine Before Overhaul and Maintenance

- In the course of overhaul and maintenance, park wheel loader on the flat ground where there is no danger of falling rocks or land slides. If it is a low terrain, there should be no danger of flooding. Then shut down engine.
- After engine stops, move the work tool control lever to the “lifting”, “lowering” and “rack back” positions a few times as to release the remaining inner pressure in the hydraulic systems. Lower the work tools to the ground.
- Pull up the brake lever to implement the

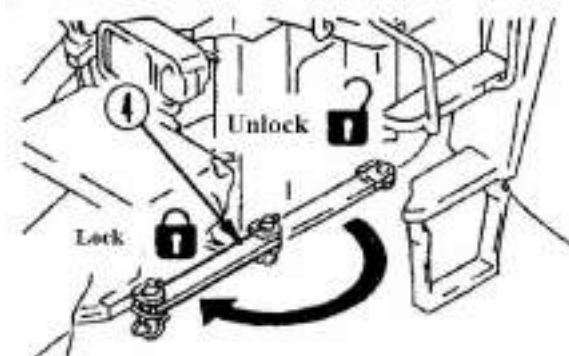

brake and then put the block under tires.

- Lock front and rear frame with lock bar.
- Be careful not to get hurt by moving components and parts.

### Support of Work Tools

- During check and maintenance when the bucket is lifted, support the lift arm so that it doesn't fall.

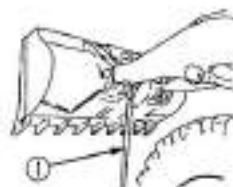



- Move the control lever to the “Center” position.

### Proper Tools

Only use the proper tools. Injury may result from using damaged, low quality, flawed or interim replacement tools.

### Periodic Replacement of Critical Parts and Components

Hoses in fuel system, hydraulic system and brake system and some other parts and components are the key to ensure safety, so they must be replaced periodically.

Specific skills are needed to replace these key parts and components. Please contact the appointed Caterpillar (Qingzhou) Ltd. dealer.

- These parts and component must be replaced with new ones no matter if they are failed or not. These parts can age gradually resulting in oil leakage or failure in the work tool system. And then serious accident may arise.
- Replace these parts and components right away if there is any issue, even of they are still within the usage period. Refer to the “Periodic Replacement of Critical Parts and Components” for the replacement of safety parts and components.

### Illumination

- Use the anti-explosive lighting equipment when checking the fuel, lubricant, and electrolyte of battery or window glass solvent. If such illumination equipment is not used, there is an explosive danger.
- If the application is dark without lightening equipment, injury may occur, so proper lightening equipment should be mounted.
- Though it is in the dark place, a lighter or flame should not be used for lightening, because there is possibility of fire. If the gas of the battery meets fire, explosion may occur.
- Follow the guide of Operation Maintenance Manual when using the machine to lighten.

### Fire Prevention

The gas diffused from fuel or battery might be flammable. Follow the following attentions

when repairing or maintaining.

- The storage of fuel, lubricant and other combustible material should be far away from the flame.
- Use non-combustible material such as a solvent to wash the parts. Do not use diesel or gas because it is flammable.
- No smoking when repairing or maintaining equipment. Smoke in the appointed places.
- Use non-flammable lightening equipment when checking the fuel, lubricant or electrolyte of battery. Never use a lighter or match.
- Move the combustible material to the safe place when grinding or welding the frame.
- Have an extinguisher at the repair and maintenance place.

### During Maintenance

#### Maintenance People

- Only a qualified person can do maintenance and repair. Unauthorized personnel are not allowed to enter the work area. If necessary, designate a person to guard.
- Pay special attention, while grinding, welding, or using a sledgehammer,.

#### Attachment

- Before we attach/detach an attachment or equipment, first designate an owner.
- A non-operator is not allowed to get close to machine or attachment.
- Detach the attachment to a safe place and make sure it will not fall down, Put a rail around the attachment, with the mark “do not enter”, to avoid people to get close.

#### Work Under the Machine

- At the beginning of maintenance or before repair under the machine, put the machine and all attachments on solid flat ground.
- Secure the tire with a wedge.
- If the tire is supported only by equipment, it will be dangerous for people to work under the machine, never work under poor quality support.



### Maintenance by Hanging the Frame

- When the equipment or if the frame is hanging, use the lock bar to lock the front and rear frame, put the handlebar in the middle and wedge the equipment and frame. Move the control lever to the “Center” position. Use the blocks to stop the work tools and frame from moving.
- Before hanging, wedge the wheel on one side; put blocks under the machine when finished.

### Work on Top of the Machine

- When working on the top of the machine,

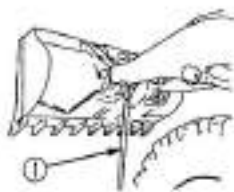

make sure the footing is clear and follow the rules to avoid falling.

1. Wipe up spilled lubricant oil or grease.
  2. Work without tools around.
  3. Watch your steps.
- Never jump from the machine. When climbing or down the machine, use the lift and handrail and keep three points of contact (two feet and one hand or two hands and one foot)
  - Using protective equipment if necessary.
  - At the top of the engine, the hood may be slippery and dangerous. Do not stand on it.
  - The top of the tire may be slippery and dangerous. Do not stand on it.
  - When cleaning the glass in the front of the cab, stand on the fender of front frame.

### Do Not Drop Foreign Material in Machine

- When repairing the window or oil tank, be careful not drop foreign objects (such bolts, nuts, twine or tools). These things may cause damage to the machine or cause other problems if dropped into the machine.
- If there are some foreign objects dropped inside, remove them immediately
- When repairing the machine, do not take



unnecessary tools or parts. Maintenance when the Engine is Running

To avoid getting hurt, do not do any maintenance when the engine is running. If it is necessary to do maintenance while the engine is running, abide by the following rules:

- One operator should sit in the operation chair and also prepare to shut off the engine when necessary. All the workers should keep contact with each other.
- When the working in a place close to the rotating parts, pay special attention to avoid being rolled up.
- Never allow any tools or any parts of body to touch the fan vane or fan belt. This is dangerous.
- When washing the inside of the radiator, prevent the equipment from turning. Also, pull the brake lever to implement braking.
- Do not touch any control levers. If you must touch them, first signal for other workers and warn them to go to a safety place.

### Using a Hammer

- When using a hammer, put on the safety glasses, safety helmet and other protection. Use copper stick as a mat between the hammer and the part, which is hit.
- When using the hammer to hit hard parts, such as pins or bearings, fragments may fly into ones eyes and result in harmful danger.

### Welding Repair

Welding repair should only be done in a designated place and by qualified personnel. The gas emitted by welding can cause fire and electricity danger. Never allow and unqualified operator to enter. When welding abide by the following the rules:

- Break the battery connector to avoid explosion. Remove the painting in the welding post and dangerous gas generated.
- When welding on the hydraulic system, pipes, or any place close to them, they may produce combustible fumes and sparks. There is danger of fire; so electric welding should be avoided in these areas.
- If electric welding spark falls directly onto a rubber hose, electric wire or pressure pipes, the electric wire may be damaged and the



pipes may break suddenly,. In such cases the anti-fire blanket should be used to cover up.

- Wear a protective coat while carrying things before and after welding.
- Keep the welding ventilated.
- Clean up all flammable materials, and a fire extinguisher should be available.

### **Storage Battery Maintenance**

While fixing electricity system or carrying on electric welding, discharge storage battery negative pole (-) or close the power supply totally, in order to prevent of electric current flow.

### **Finding the Problem**

- When finding a problem, it should be repaired immediately. Especially if it is in the braking system, steering system or other working equipment that will cause serious trouble.
- Please contact the Caterpillar (Qingzhou) Ltd. appointed dealer according to the failure type.

### **Rules for Adding Fuel or Lubricant Oil**

Fuel, lubricant, hydraulic oil, antifreeze, brake fluid and window cleaner can all be caught by open flame. Abide by the following rules:

- Turn off the engine when adding fuel or lubricant.
- No smoking.
- Any of the fuel, lubricant, hydraulic oil, antifreeze, brake fluid and window cleaner that has overflowed should be wiped immediately.
- Tightly screw the cover of all the fuel, lubricant, hydraulic oil, antifreeze, brake fluid and window cleaner containers.
- The place where fuel, lubricant, hydraulic oil, antifreeze, brake fluid and window cleaner is added should be kept well ventilated.

### **High-Pressure Hose**

- A high-pressure hose leakage may hinder operation, cause personnel injury, or damage equipment. Stop working and contact your appointed Caterpillar (Qingzhou) Ltd. dealer.
- When replacing the high-pressure hose, the operator should be aware of the height. The instillation torque, should be according the

type and size of hose, so do not repair by yourself, contact your appointed Caterpillar (Qingzhou) Ltd. dealer.

### **Notes for High-Pressure Oil**

When repairing or replacing, pipes in hydraulic systems, inspect system pressure (whether it has been released or not). If there is still pressure in pipes, it will cause serious injury or damage, so should follow the rules:

- Relevant detail about releasing pressure, see Hydraulic System Maintenance included in the Maintenance section of this manual. Do not continue work, check or replace before the pressure releases completely.
- Put on safety glasses and gloves.
- If the pipe leaks oil, the pipe and its surroundings will be wet, so check whether or not the steel pipe or hose has cracks or whether or not it has swelled up. If it is difficult to identify the location of leakage, please contact your appointed Caterpillar (Qingzhou) Ltd. dealer.
- Always wear safety glasses and thick gloves, and use a piece of cardboard or a sheet of wood to check for oil leakage.
- If shot by the high pressure oil spout, see a doctor immediately.

### **Check Under High Pressure**

- When the engine stops, the cooling water and oil for each part of the machine will be warm and highly pressurized. Opening the cover, removing the oil and water, or replace a filter, at this time all will cause burning or other harm. Wait for temperature to descend, and then operate according to operation maintenance manual.
- For other check items see Periodic Maintenance in the "Maintenance section of this manual for related contents.

### **Waste**

To prevent pollution, obey the following procedure especially with environment where people and animal living.

- Do not release oil to the sewer or river etc.
- Put the waste oil in a container, do not pour



onto the ground directly

- While handling harmful material, such as lubricant, fuel, and coolant, melting agent, filter, storage battery and other materials, obey relevant laws.

### Repair and Check after Maintenance

Unexpected problems may occur if the proper checks and maintenance procedures are not performed. It may even damage the machine or cause injuries, and so pay attention to the following issue.

- Checking when the engine is off
  1. Are all repair and maintenance parts checked?
  2. Are repair and maintenance items correct?
  3. Are there tools or parts dropped into the machine? It is dangerous if they are wedged into the linkage systems of the control levers?
  4. Is the leaking water or oil repaired? Are the bolts screws down?
- Checking when engine running

Pay attention to safety and the following items:

1. Do the repair and maintenance parts work normally?
2. Does the hydraulic system leak oil when the engine running, speeding up or adding load?

## Tires

### Handling of Tire

If a tire or a rim is handled in a wrong way, the tire may burst or may be damaged and the rim may be broken and scattered, which can cause serious injury or death. For the safety of maintenance workers, comply with the following proceedings.

- Since maintenance, disassembly, repair and assembly of the tires and rims require special equipment and skills, be sure to ask a tire repair shop to carry out the work.
- The specified tires must be used; inflate them to the specified pressure. The stated tires and pressure are in the "Tires" section in the Maintenance chapter.
- When inflating a tire, check that no one will enter the working area. And use an air chuck,

which has a clip and can be fixed to the air valve. While inflating the tire, check the inflation pressure occasionally so that it will not rise too high.

- If the rim is not fitted normally, it may be burst or deflate while the tire is being inflated. To ensure safety, place a guard around the tire and do not work in front of the rim but work on the tread side of the tire.

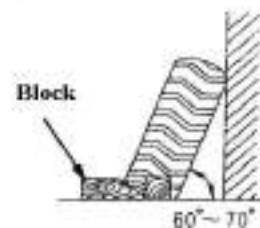
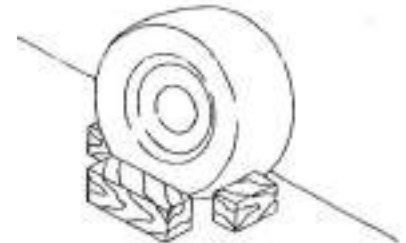

- Abnormal drop of inflation pressure and abnormal fitting of the rim indicate trouble in the tire or rim. In this case, be sure to ask a tire repair shop to carry out repairs.

- Do not regulate the inflation pressure after working at high speeds or high loads.
- Explosions of air-inflated tires have resulted from heat-induced gas combustion inside the tires. Explosions can be caused by heat that is generated by welding, heating rim components, external fire, or excessive use of brakes.



- The energy of tire explode are stronger than deflation. Explode can make tire rim and parts of transmission fly out more than 500 meter. It can arouse loss of property and personnel.

- It is recommended to fill tire with N<sub>2</sub>. If the tire has original air, it is suggested that nitrogen should be used to adjust the pressure. The nitrogen can be mixed with air. The tires inflated with nitrogen gas can prevent the tires from exploding because N<sub>2</sub> is inflammable. The N<sub>2</sub> can prevent from oxidation, aging of rubber and cauterization of rim parts.



- Avoid excessive charging; this requires the appropriate equipment and personnel for instruction.

### **Storage of Tires**

- Tires should be stored in a depot. People must not enter to the depot unless allowed. If tires are stored outside, it should be have barrier around tires, and hold up the sign of "NO ENTRY".
- Stand the tires on the ground and fixated them with a wedge so that they will not fall down when any unauthorized person touches them. If the tire is laid on the ground and one side is in contact with the surface, it will be staved and debased quality.
- Stand aside if the tires are fall down. Machines tires are very heavy and may cause injuries while attempting to control them.

### **Catalog and Change Cycle Parts Critical to Safety**

- To ensure safety at all times when operating or driving the machine, the user of the machine must always carry out periodic maintenance. In addition, to further improve safety, the user should also carry out periodic replacement of the parts given in the table. These parts are closely connected to safety and fire prevention.
- With these parts, the material may change as time passed, or may easily wear or deteriorate. It is difficult to judge the condition of the parts simply by periodic maintenance. So regardless of the condition they should always be replaced after a fixed time has passed. This is necessary to ensure that they always maintain their function completely.
- However, if these parts show any abnormality before the replacement interval has passed, they should be repaired or replaced immediately.
- If the hose clamps show any deterioration, such as deformation or cracking, replace the clamps at the same as the hoses.
- When replacing the hoses, always replace the O-ring, gaskets, and other such parts.
- Ask your Caterpillar (Qingzhou) Ltd. distributor to replace the parts critical to safety.



## Technical Specifications

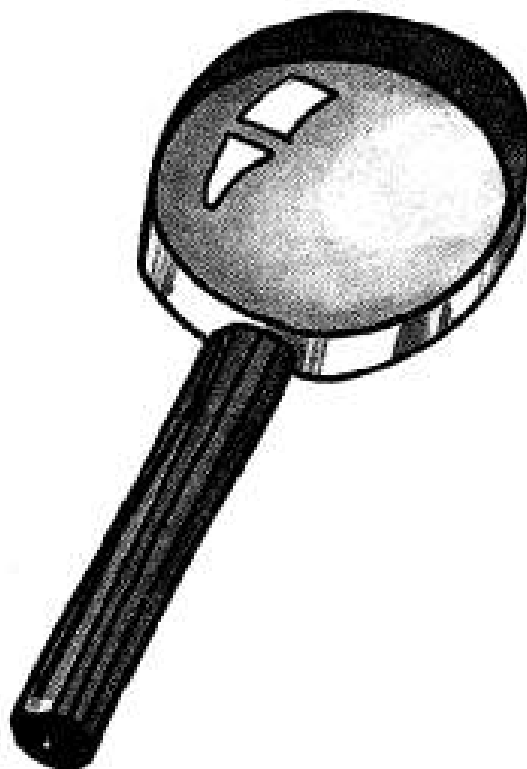

**The content of this chapter has significant impact toward correct use, maintenance and service of this machine.**



## Application

This wheel loader is a large type of construction equipment mainly used to load bulk material. Primary operations include: digging, flattening, pushing material, loading, and dragging.

## Working environment requirements

1. Height above sea level:  $\leq 2000\text{m}$
2. Environment temperature:  $-20^{\circ}\text{C} \sim 40^{\circ}\text{C}$
3. Depth in water:  $\leq 510\text{mm}$

This wheel loader is designed to work in ordinary construction applications, and is not fit to be used in flammable, explosive, or poison gas environments; or in environments with large amounts of airborne debris.

## Forbidden operation

1. Overloading
2. Use as a lifting crane.
3. Overhead digging

## Notes

The operation, maintenance and safe operation procedures written in the manual only apply when the machine is used as prescribed. If users don't follow these procedure as described, Caterpillar (Qingzhou) Ltd. assumes no responsibility for accidents safety responsibility caused by users' incorrect operation which will be taken on by users themselves.



## Key Technical Specifications

### Performance Parameters

Rated Load Capacity	3 tons
Rated Bucket Capacity	1.66 m <sup>3</sup>
Bucket Lift Time when Full Loaded	4.65sec
Three item time sum	8.34 sec
Maximum Travel Speed	
Forward Gear I	7.8 km/h
Forward Gear II	14 km/h
Forward Gear III	24.9 km/h
Forward Gear IV	39 km/h
Reverse Gear I	9.7km/h
Reverse Gear II	31 km/h
Maximum Traction Force	97 kN
Maximum Bucket Breakout Force	113kN
Maximum Grade ability	26°
Minimum Turning Radius	
Outside Bucket	5869 mm

### Dimension and Weight

Overall Length (bucket lying on the ground)	7422 mm
Overall Width (outside bucket)	2354 mm
Bucket Width	2440±50 mm
Overall Height (to cab roof)	3182mm
Wheel base	2740 mm
Operating Weight	10047 kg

### Engine

Commins Model (stage III)	QSB5. 9
Rated Power	97 kW
Rated Speed	2200 rpm

Commins Model (stage II)	6BT5. 9
Rated Power	92 kW
Rated Speed	2200 rpm

WDEC Model (stage II)	DHB06G0095
Rated Power	92 kW
Rated Speed	2200 rpm

### Transmission

#### Torque Converter

Type	single three-element part
Cooling Method	Oil-cooled, pressurized circulation



### Transmission

Type	power shift spur constant mesh
Gear Shift	four forward gears, two reverse gears
Transmission pump pressure	1.3-1.5Mpa

### Main drive and final drive reduction

Main drive type	spiral bevel gear single-stage reduction
Final drive reduction type	spur cylinder gear planetary reduction

### Drive axle and wheel

Type	four-wheel drive
Tire	17.5-25
Tire air pressure (front axle)	0.35Mpa
Tire air pressure (rear axle)	0.3Mpa

### Braking System

#### service brake

Type	single circuit air-over-oil four-wheel caliper disc brake
------	---

#### Parking brake and emergency brake

Type	manual mechanical type
System air pressure	0.784~0.824Mpa

### Steering hydraulic system

Type	Whole steering pump
System pressure	14Mpa
Steering angle	37° both left and right

### Work Tools Hydraulic System

Service pump type	gear pump
System pressure	18Mpa

### Electrical system

System voltage	24V
Bulb voltage	24V
Diesel start	24V Electrical start

# 636D Arrangement Drawing

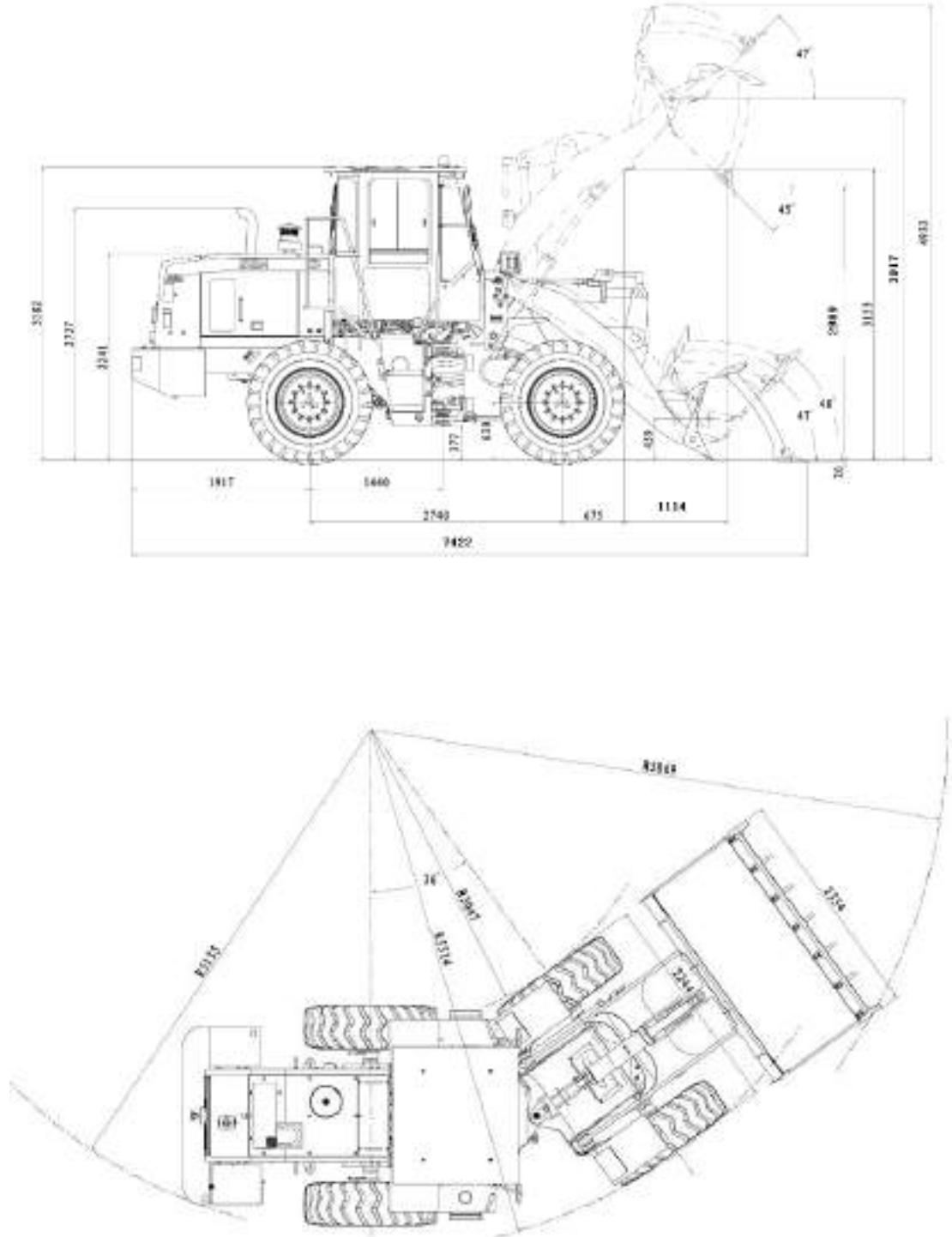











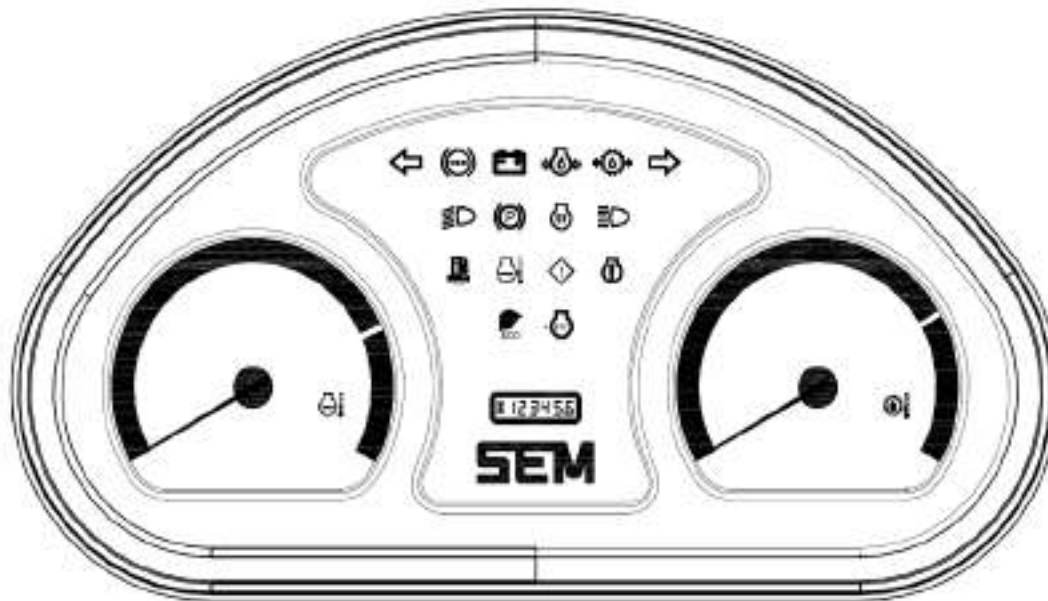

## Operation













**Please carefully read and understand the manual content before you use the machine in order to correctly operate the machine. Correct operation has great significance for users to remain safe, have high working efficiency, and extend service life.**

## SWITCHES AND GAUGES



Signal	Name	Function
	Water Temperature	Pointer showed in green area is normal, in red area is higher
	Temperature lamp of Gearbox oil	When the temperature is higher, the lamp is lighted
	Work hour Clock	Show the machine work hour
	Left Direction Lamp	Caution machine to turn left
	Right Direction Lamp	Caution machine to turn right
	Battery Charge Lamp	When the lamp is on, the battery is charged
	Engine oil Pressure Lamp	When the engine oil pressure is higher than 0.78Mpa or lower than 0.16Mpa, the lamp is lighted
	Gearbox Oil Pressure Lamp	Gearbox Oil Pressure Lamp is warning when the pressure is abnormal
	Brake Air pressure Lamp	When the brake air pressure is low and higher than normal, the lamp is warning



Signal	Name	Function
	Dipped Headlight Lamp	Dipped Headlight is on
	Park Brake Lamp	When the park brake is open ,the lamp is lighted
	Warmup Lamp	
	High Bream Lamp	High Bream is on
	Water in Oil Warning Lamp	Request to drain out the water
	Water Temperature Lamp	When the water is higher than 104 degree and before the temperature drop to 104 degree.
	Action Lamp	Show the brake pressure /gearbox pressure/battery chaging/ coolant temperature /oil pressure is abnormal
	Engine fault indicating lamp	Indicate the engine fault.
	Economic model	The Diversified power switch is at Economic model
	Heavy load	The Diversified power switch is at Heavy load





## Service Brake Pedal



The service brake pedal is placed on the left forward side of operator's seat. Step down on the service brake pedal and the wheel side brakes of both the front and rear axles will be engaged. At the same time, turn on the brake light switch so that the brake light shines. Loosen the service brake pedal and then free service brake. When braking system has failed immediately repair it to insure that the machine has sufficient brake ability.

## Air Condition System Switch



This machine's air condition gets three functions: Cooling/ Heating/Natural Wind  
Air Condition Control Panel

Air condition control panel is located on the left side of seat bottom bracket .Picture as below.

Air flow switch: 1.Clockwise—Wind increase /Counterclockwise-Wind reduce  
2. High/Middle/Low three grade wind 3. On OFF, wind close

Switch get natural wind (O) Cooling gear (AC)

Function and instruction as below:

Cooling:

1、After engine started, turn the wind switch to proper wind position.

2、 Turn the switch Clock wisely to cooling position. Cooling system begin to work, send cooling air from wind-gap

Heating:

1、 After engine started for a while, turn the wind switch to proper wind position  
2、 Turn the switch counterclockwise to Natural Wind position. Heating system begin to work, send warm air from wind-gap

Natural Wind:

This machine is equipped with an air system which can circulate inside and outside air wind. In Spring & Autumn cooling season .When you want use natural wind to adjust the cabs inside wind, turn the wind switch to proper wind position, and turn the switch to natural wind.

## Switch valve



Placed on the right plate of gauge panel. When normally working, the switch valve is turn to "OFF" position, brake won't shutdown transmission power to insure operation ability. When working on gradient place, switch valve is turned to "ON" position; brake won't shutdown transmission power to insure operation safety.

## Parking brake button



Parking brake closes to implement brake when draw up; Parking brake is free to release braking when press down. The parking brake is also used to be emergency brake. When machine is working, if urgent, pull up parking brake button and then implement emergency brake. When parking brake system errors and air pressure in service brake loop is lower than 0.4Mpa, parking brake implements brake automatically. Wheel loader implements emergency parking to insure safety.

### Pilot control lever

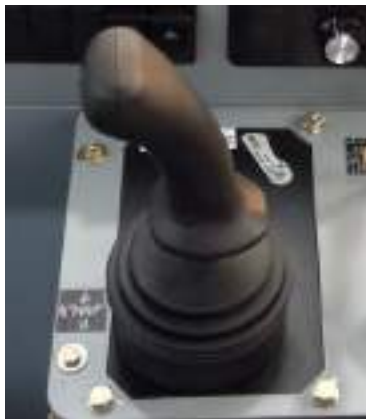

The device control levers are at the right side of the seat. They are used to control the working devices. The lever is used to control the bucket and lift arm. The levers are at the holding situation when they are at the neutral position, which is the middle position.

When the engine is working. The bucket tilt up when you push the 29 left, and the bucket tilt down when you push the 29 right  
ripper rises when pull 22 backward, ripper

falls when pull 22 forward.

The lift arm falls when you push 30 forward, the lift arm rises when you pull 30 backward.

The lift arm would be at the floating situation when you push the lift arm lever forward to the extreme position. When you pull the lift arm lever back to the middle position, the lift arm would be free from that situation.

When the lift arm falls, push the lift arm lever forward to the floating position, then the lift arm would fall due to gravity, meanwhile, the driver can do other operations by his right hand (like put the bucket flat), thus the operator can increase the work efficiency.

When you do the sticking and spading operation, push the lever to the floating position, and then the bucket can float with the ground, which can avoid the damage to the ground.

When you do the spading operation, make full use of the floating device of the lift arm and self-flatted device of the bucket, you can effectively reduce the work strength and make the operation more comfortable.

**Warning:** No matter what the situation that the machine is in, make sure that there are no obstacles and people around, under or above the machine before you operate the lift arm and bucket. Or else it may damage the devices or hurt the people.

### Accelerator Pedal



The accelerator pedal is located at the front-right side of the seat. The engine is at the idle speed when the pedal is in the



neutral position. The fuel supply and the power output of the diesel engine increase when the accelerator pedal is pressed down.

## Speed Control Handle



You can control the forward, reverse and neutral position by moving the handle forward or backward.

## Horn Switch



The horn switch is in the center of the steering wheel; the horn will sound when you press the horn switch.

## Direction-Speed Control Handle



The direction-speed control handle is under the steering wheel. You can control gear 1, gear 2, gear 3, gear 4, forward, reverse and the neutral position by moving the handle forward or backward.

## Steering Wheel



The machine has articulation coaxial fluid amplified steering. The steering wheel is inside cab and connected to coaxial fluid amplified steering control unit. During regular operation, turn steering wheel clockwise and the machine will turn right; counter-clockwise and the machine will turn left.

Features of coaxial fluid amplified steering:

1. The steering angle of steering wheel is not equal to that of machine, continuously turn the steering wheel until the steering angle of machine reaches the desired position.
2. The faster the steering wheel turns, the faster machine turns.
3. The steering wheel cannot return automatically, the steering angle of machine will not change. So when finishing steering, you should turn the steering wheel the opposite direction to keep machine running straight.

## Lift cylinder lock

Push the pole to the icon witch the lock is open, the Lift cylinder will work Normal, and when push the pole to the icon witch the lock is close, and the lift cylinder will hold the state, and Can't control by the Pilot control lever .

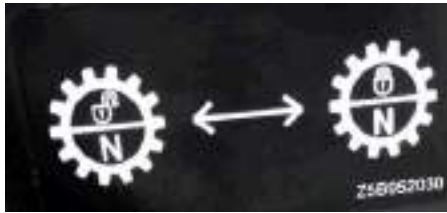

### Warning!

When the Arm is at the lift condition, if you need any operation (eg. maintenance or repair), must put this lock to the lock position. Otherwise will cause machine damage or personnel casualty!!

## Additional Accessories

### Lamps and Lanterns

The lamps and lanterns of the machine include: the front combined lamps (left and right), the rear combined lamps (left and right), the lamps in the cab, the anti-fog lamps (left and right), the rear lamps (left and right). The front combined lamps include: the front lamps, the front small lamps and the front steering lamps. The rear-combined lamps include the rear lamps, the rear small lamps and the rear steering lamps.

### Seat Adjustment

The seat of the machine can be adjusted in four ways: the rigidity (stiffness), forward or backward direction, the angle of the backrest, and the height of the headrest. Allowing the seat to adapt to different operators and different working conditions.

- **Forward or Backward:** There is a handle at the left underside and foreside of the seat, the seat can move forward or backward when you pull the handle to the outside of the seat, during the movement, you would meet several designated positions. When you move the seat to the designated position and loosen the handle, the seat would be secured at that position. The seat of the machine can be moved forward 75mm or backward 75mm, and the seat can only be secured at the designated positions.

- **Angle of the Backrest:** There is a handle at the right underside of the seat, first turn the handle clockwise, then move the headrest forward or backward to a comfortable position and loosen the handle so the seat is fastened at that position. The backrest can be adjusted forward 90°(folded), and backward 28°

- **Rigidity of the Seat:** There is a handle that is at the front-underside of the seat; it is used to adjust the rigidity of the seat, which can adapt to the operators with different weight. Turn the handle clockwise or anticlockwise in the vertical plane, when



it reaches one side, turn the handle to the other side in the horizontal plane, and then turn the handle in the vertical plane. There is a weight indicator beside the handle, while you turn the handle, the numerical value of the indicator will change with the movement, it shows the current rigidity of the seat. The rigidity would adapt to the operators with the weight as the numerical value. The rigidity of the seat can be adjusted infinitely between the range of 50kg - 130kg; when the machine leaves factory it is set to 70kg.

## Door Lock

The keys of the left and right door lock on the cab are the same. You cannot press the lock down when the door is locked. At this time, insert the key into the lock and turn 180°clockwise, then pull it out of the lock, hold the lock with you hand, press the lock with you thumb and draw the door outward at the same time, then you can open the door. When you want to lock the door, close the door firstly, and insert the key into the lock and turn 180° counterclockwise, then pull it out of the lock. **Warning:** When operating the machine, the operator must close the left and right doors for the safety requirement.

## Rearview Mirror Adjustment

There are two rearview mirrors at the top of the cab, one is at the right side and the other is at the left side. Before operating the machine, the operator must adjust the rearview mirrors to make sure that the operator can see behind the machine. Loosen the bolt that connects the bracket of the rearview mirror and the cab, and turn the bracket, then you can adjust the position of the rearview mirror to the cab. Loosen the bolt that connect the bracket and the rearview mirror, and turn the rearview mirror, then you can adjust the elevation of the rearview mirror. Please tighten the bolt after the adjustment is complete.

## Breaking-in a New Wheel Loader

Proper Break-in is very important to prolong the life of the machine, to eliminate potential malfunctions, and to avoid fatal accidents. After purchasing the machine, the users need to operate and maintain the machine according to the rules of proper break-in described in this manual, and then the machine can be operated normally.

### Break-in Rules:

1. The machine must be broken in before 100 hours of use.
2. Start the engine and let it run at speed for 5 min.
3. During break-in, forward gears I, II, III, IV, reverse gears I, II should be used conservatively.
4. Start the machine in idle speed, and speed it up gradually to the higher speed. Sudden start, speeding up, sharp steering and brake should be avoided except in emergency condition.
5. It will be better to load light things during break-in and to avoid abrupt operations. During break-in, the load should be less than the 70% of the rated load and the speed should be less than the 70% of the rated speed.
6. Pay attention to the lubricating state of loader, replace or add the lubricant or grease at set intervals.
7. Check frequently the temperatures of gearbox, torque converter, front and rear axles, hubs, brakes, and middle supporting axles and hydraulic oil, engine coolant, engine oil. Check out and fix the faults if there is overheating.
8. Check whether the bolts and nuts in each connecting part are loose.

### After the first 8 running hours

1. Check bolts and nuts, especially the bolts of diesel engine cylinder head, exhaust pipe and front, rear axles, nuts for rims, connecting bolts of driving shafts and



fixing nuts of diesel engine, gear box, bolts at front and rear axle articulation. If needed tighten them.

2. Check whether the tightness of fan belt, engine belt and AC compressor belt is proper.
3. Check oil levels of the transmission, drive axle, and the diesel engine.
4. Check the sealing condition of the hydraulic and brake systems.
5. Check the connecting condition of every control lever and throttle parts.
6. Check the temperatures and connecting condition of every electric system, states of electric supply from generator, lamps, lightening and steering signals.

**Attention:** When checking the oil level, comply with certain operation rules.

## After the Break-in

1. Check the tightening conditions of bolts and nuts, especially the bolts of diesel engine cylinder head, exhaust pipe and front, rear axles, nuts for rims, connecting bolts of driving shafts and fixing nuts of diesel engine, gear box, bolts at front and rear axle articulation.
2. Check whether or not the tightness of fan belt, engine belt and AC compressor belt is proper.
3. Check the sealing condition of the hydraulic and brake systems.
4. Replace the hydraulic oil in gearbox, lubrication in drive axle.
5. Replace the filter for gearbox, engine oil, and replace the filter elements for fuel tank.
6. Clean the return filter elements in hydraulic tank.

**Attention:** When replacing the transmission oil for, lubricant for drive axle and hydraulic oil for diesel engine, comply with the specified operation rules.

## Machine Operation

### Before Starting Engine

1. Check coolant level of engine.
2. Check oil level in engine oil pan.

3. Check the hydraulic oil level.
4. Check the sealing condition in the water pipe, oil pipe and other parts.
5. Check that there are no loose battery terminals, and tighten if necessary.
6. Check that the tire pressure is normal.

### Starting Engine

1. Check that there are no people or obstacles in the surrounding area, and there are no servicemen under the loader. Except for operator in the cab, do not allow any person to stand anywhere on the machine or sit in the cab.
  2. Turn on the battery switch.
  3. Follow the safety instructions when stepping on and off the machine.
  4. Adjust the side mirror to a position, which gives the best view from the operator's seat, and approaches to the loader as near as possible.
  5. Close the doors of cab.
  6. Inspect the safety belt and tightly secure it.
  7. Confirm the machine is in the neutral gear position; if not, please move the lever to the neutral gear position.
  8. Check whether the control lever is on the middle position. If not, please pull it to the middle position.
  9. Check whether the fan switch of air-conditioning system is in "natural fan" and the changeover switch on "OFF", if not, please turn it to the correct position.
  10. Insert the key and turn it once clockwise to power up the entire vehicle. Sound the horn, which means that the machine will start and other personnel cannot approach this machine.
  11. Check the fuel level in tank.
  12. Press accelerator pedal slightly, and continue to revolve the key clockwise to the next position to turn on the engine and start the motor. In the normal condition it can start in 10 seconds. When the machine is starting, you should release your hand and let the starting electric lock return.
- Attention:** Do not hold the key continuously for more than 15 seconds.



You should release the start switch immediately if the machine cannot start. Wait more than 30 seconds to start again. This is resulted from the characteristics of the starter and the battery, if the engine does not start after three consecutive times, check out the reason. After removing the trouble, wait at least three minutes to start the engine.

**13.** After starting the machine, it should remain in idle speed ( $750 \pm 20$ r/min) to warm the machine, after the engine cooling water temperature up to  $55^{\circ}\text{C}$ , the engine oil temperature up to  $45^{\circ}\text{C}$ , allow the machine work in capacity load.

**14.** Listen attentively whether or not the engine works normally in the low speed, and whether or not the gearbox brings the abnormal sound.

**15.** Inspect whether or not all gauges are normal and whether or not each lighting attachment, indicating lamp, horn, wiper, and brake light can work normally.

**Attention:** Especially pay attention to the indicated value of the engine oil pressure, it should not be lower than 0.1MPa (in idle speed condition). If it is lower than this value, you should stop and inspect whether or not there are troubles with the engine.

**16.** During winter, you should preheat the hydraulic oil. Pull the bucket control level back and maintain for 4 - 5 minutes, at the same time step on the accelerator pedal. This will cause the plate of bucket to stop against the lift arm and cause hydraulic oil overflow. This will make the oil temperature rise more quickly.

**17.** Inspect whether the service brake, and the parking brake systems work normally.

**18.** If there are no obstacles around the machine, you should slowly rotate the steering, observe whether there are movements in right or left orientation.

## Before Traveling

**1.** Operate the pilot valve control level, pull bucket control level back to rack-back position, and lift the lift arm to the carrying

position, namely the distance between the bottom of bucket and ground is about 30-40cm.

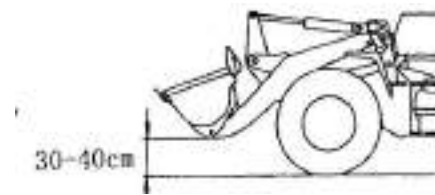

**2.** Press the service brake pedal, and push the parking brake lever down at the same time to release parking brake. Loosen the parking brake pedal slowly; observe whether or not the loader can move. **Warning:** If the machine can move, please press the service brake pedal immediately and press the parking brake pedal to apply the brake. Then, inspect whether the gearshift control system has troubles. If the machine is on the slope, first use wedge blocks under the wheels, this prevents the machine from moving, then inspect the machine.

**3.** Change the gearshift control lever to forward I gear or the reverse gear, and suitably press the throttle pedal to confirm that the loader moves forward or backward respectively.

**4.** Drive the loader to an open and flat site, if the steering inspection has not been carried out because of narrow site in the previous stage. Rotate the steering wheel now, inspect whether or not the machine can change direction freely.

**5.** Check the quality of the service pedal. In an open and flat place, drive the machine forward in gear 1 or gear 2, first release the accelerator pedal, then gently press down the service brake pedal, the machine should immediately decelerate and stop. **Attention:** If the machine does not immediately decelerate after pressing down the service brake pedal, please pull the parking brake lever immediately to implement emergency brake. At the same time, operate the pilot valve control level to drop the lift arm to the lowest position. Turn the bucket forward to make the bucket



teeth or bucket cutting edge insert or sit on the ground, forcing the machine to stop to ensure security.

6. Inspect the union situation of every gearshift. Drive the machine to an open and flat area; integrate every gear separately to inspect the situation of shift gears.

## Machine Steering Operation

When there appears to be curved road in front of the machine, you must properly steer the machine, please comply with the local traffic laws to carry on the operation. Before turning, push the turning signals to the relevant position. Move lever to bottom left to turn left and up and right to turn right, this notifies a person near the loader that the loader is going to operate steering. Then rotate the steering wheel for steering. This loader use articulated joint coaxial fluid amplified power steering. The rotation angle of the steering wheel and loader turning are not equal, rotate the steering wheel continually and enlarge the turning angle of the loader. The quicker you rotate the steering wheel, the quicker loader will turn. The steering wheel cannot return automatically, the steering angle of machine will not change. So, turn the steering wheel back after turning it in order to correct the relative angle of front and rear frame drive so the machine is in the linear direction. After steering, move the turning signal to the middle position, so the steering light and steering indicating light will go off. To operate steering at high speed, you should release the throttle pedal firstly and use service brake; when necessary to lower the service brake, operate steering to ensure the safety. **Warning:** Operating steering on slope is forbidden; you should drive the loader to the level ground for steering.

## Braking

First, release the throttle pedal when braking, and then press the brake pedal stably for braking. **Warning:** When the

machine is operated at high speed, sudden complete braking is not permitted except in urgent situations. This may result in an accident or damage to the machine.

## Parking and Storage

### Select Location

1. Park the machine in flat place, without falling stones, loose dirt or flooding.
  2. Stop the machine with the brake.
  3. Put the gearshift control lever to the neutral position.
  4. Put the hand brake lever to 'park' position.
  5. To operate pilot valve control lever, put the lift arm down to the ground and lower the bucket.
  6. To cool down every part evenly, keep the engine running for 5min after parked.
  7. Turn the power key to 'OFF' position, turnoff the engine, switch off the machine power, pull out the key.
  8. Put every switch to neutral or 'OFF' position.
  9. Lock the doors, and then step down using the ladders.
  10. If the machine will be stopped for a long time (overnight, for an example), open the right charged battery cover and put the power switch to 'OFF'.
  11. In winter, if there is no antifreeze in the machine, open each water valve in the engine, drain all the antifreeze in the cooling system and evaporate the air conditioning system to prevent frozen parts of the machine.
  12. Lock everything and take the keys with you.
- Attention:** Keep the machine on the plane ground. Use chock near the tire to stop the machine if the machine is located on a slope.

If the machine will be stopped for a long time, it should be located complying with the rules as follows:

### Before Long-Term Storage

- Clean all parts of the machine dry it





and put it in a dry garage. If it only can be put in open air, it should be put on concrete road and covered with a canvas.

- Fill the fuel tank and lubricate the moving pins, acting axels, and change the hydraulic oil.
- Put the gearshift control lever to the neutral position.
- Place the hand brake lever in the 'break' position.
- Put the bucket down to the ground, put the pilot valve control lever to the neutral position.
- Put every switch to neutral or 'OFF' position and lock every door.
- Apply a thin film of grease to hydraulic cylinder exposure part.
- Take out the battery from the machine.
- If the temperature is lower than 0°C, add antifreeze to the engine, make sure that the antifreeze can reach the engine parts and evaporate air conditioner. Or drain the water in the cooling system so the water in the air condition will also evaporate.
- Fix the front and rear with blocks or structure fixtures.

### During Storage

- Once a month start the machine, run every system, lubricate every moving pin, moving axle, and charge the batteries.
- Before starting the machine, clean up the grease on the rod of the hydraulic cylinders. Apply a thin film of grease again after the operation.
- Apply a thin film of rust preventive oil to every rusty part.

**Attention:** If applying the rust preventive oil indoors, open the door and window to vent the poisoned air.

### After Storage

When ending the long-term storage, do the following work:

- Change the lubrication in the engine, gearbox, driving axle and the hydraulic oil and antifreeze.
- Lubricate all the moving pins and

transmission shafts.

- Before starting the machine, clean up the grease on the rod of the hydraulic cylinders.

## Specific Operations

### Preparing before work

First, Clear and level the working site. Remove any rock or things that may cut the tires. If use this loader to dump for truck or carriage, base on the height of truck and carriage to adjust the limit height for bucket dumping safety, avoid to impact from material to trunk because the dump height is too high.

### General Shoveling

General dumping is used to shovel the loose material. Shift the gear to forward II speed, drive the loader to loose material and face the material with the middle of bucket. The operator handle the steering wheel by left hand and operate the lever of pilot valve arm operating to down the arm to 30cm from ground. Lower the arm when the distance is about 1000mm between the loader and material, create

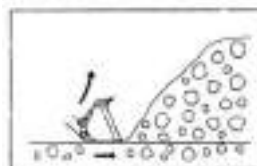
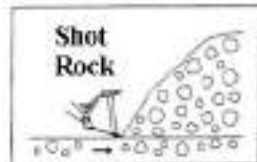
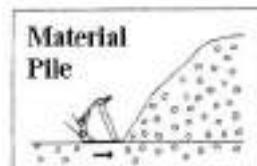
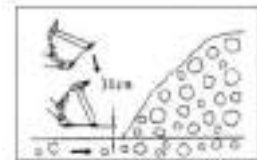

bucket contact with ground and change from forward II to forward I gear. **Attention:** When the bucket contacts the ground, make sure to avoid making large press on the surface, which will lead to unnecessary forward resistance. It should not have an angle between the front frame and the rear frame.

Press the throttle pedal, so that the bucket full inserts material pile; when the machine cannot move forward, move the control



lever of bucket pilot valve backward (to turn the bucket backward), then push the bucket lever to midpoint, the machine will continue forward to insert the material pile, repeat the operation of inserting and rotating the bucket until the bucket is filled with material.

## Combine Shoveling

Combine shoveling applies to shoveling the harder or more viscous material. The operation before the bucket is inserted in the material is the same as general shoveling. Move the buckets pilot valve lever backward after the bucket is inserted into the material, then push the lever to midpoint to make the bucket turn upward, therefore the bucket inserted a long way forward. After that, the operator moves the pilot valve lever backward, then move it to midpoint again to make the bucket backward rotation so that bucket could continue forward. Repeatedly insert, bring up the bucket, insert and rotate the bucket until the bucket is filled with material.

## Withdraw from Material Pile

Operator operates the pilot valve control lever of the bucket after the bucket is filled with material, rotate the bucket backward until the block on the bucket collision with arm, and then push the bucket control lever to the midpoint. At this point, the largest back tilt angle of bucket is obtained. Raise the bucket to a certain height; make sure the bucket avoids the material pile when the machine reverses. While the operator handles the steering wheel using the right hand, pull the gearshift control lever to the reverse position to allow the loader to reverse. After the machine backs away from the material pile, the operator lowers the control arm lever to lower the arm 30-40cm from the ground.

## Material Transporting

In the following cases, material can be transported

- The road is too soft and cannot be

done by using a truck.

- There is not a clear and level the working site and cannot be done by using a truck.
- Transporting by truck is not economic al when the distance is less than 500 meters.

Keep the bottom of bucket at the transporting location (30- 40cm from the ground), and the bucket turning back to the stop location (the stop plate touching the lift arm) in the transporting process, so that the material transporting process is smooth and safe, and the material is not easily scattered. Transporting speed is determined by the transporting distance and road condition, when machine pass a pothole or the protuberance, the worker should release the accelerator pedal, if necessary may use “point braking“ by reducing the speed, and passing the roadblock slowly, this reduces the impact to machine and scattering.

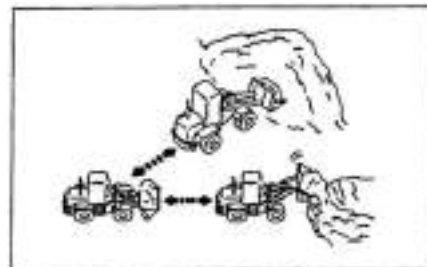

**Warning:** Lifting the bucket to a higher location to transporting material is forbidden. This may cause the machine to turn over.

## Unloading Material

### Unload to Truck and Hopper

Release the accelerator pedal while the wheel loader with full material is 15 meters away from the truck or the hopper, if necessary use the brake to decrease the speed, and approach the truck or the hopper slowly. At the same time the operator operates the control lever back to the last location, the lever will be magnetized by the electromagnet, and the



operator can release the control lever, which will not return to middle location. In this course, operator should drive the machine carefully, watching the circumstance of the bucket being close to the truck or the hopper, and turn back the operation handle at any moment. the bucket should not collide with the truck or hopper.

When the bucket is just on the top of the truck or the hopper, operator should step on the brake pedal to stop the machine and push ahead the bucket control lever to tip the bucket forward. Put the material in the truck or hopper, at this time operator should watch the bucket working process carefully, the bucket and the edge of the truck or hopper should not make the collide. If material is very viscous, the bucket control lever should be operated forward and backward several times in order to make the collision between bucket stop plate and lift arm time and time, and release the material with the bucket down and sticking into the material.

Unloading material should begin from the front of the pile if the length of the truck is twice or more for the width of the bucket.

**Notice:** When unloading, the collision force between bucket stop plate and lift arm should not too large, and collision times should be low to prevent to damage machine.

When machine finished unloading, the operator should turn the bucket rotating control lever back to last location until it

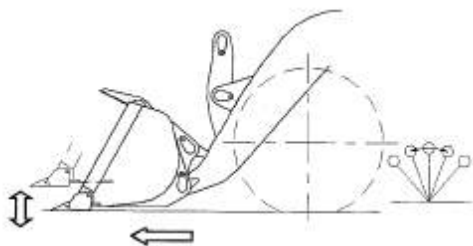

stops contact with lift arm, then move the lever to the middle location. After that, the operator moves the shifting lever to

reverse location, then release the brake pedal to make the machine leave from the truck or hopper. When machine leaves the truck or hopper, the operator should drive the machine carefully, watching the process bucket leaving the truck or hopper, not to collide between bucket and truck or hopper. After the bucket pulls away from the truck or hopper completely, the operator can let the lift arm down when driving, and prepare next work cycle.

### Unloading at Low Location

When transporting material among fields, sometimes unloading material is done at low locations or locations lower than ground level. At this time, after unloading, bucket back should first turn to the horizontal position, and then lift the arm. Otherwise you cannot lift the arm because of the interference of the work tools linkage structure.

### Carrying

When bucket is touching ground at even level, put the gearshift control lever in forward I gear, step on accelerator pedal to make the machine go forward, if finding some obstacle in process, can go on carrying with lifting the arm a little, the lift arm control lever should be in the position between downside and upside when operating the lift arm up and down, it should not be turned to either upside or downside position, to ensure the carrying work.

### Scraping Work

Lift the arm, and turn the bucket forward until the cutting edge is touching ground, the angle between cutting edge and ground should remain about 40 degrees, for a hard road, lift control lever, it should be put into the floating position, and it should be put the middle position for soft material road, gearshift lever should be turned backward shift, step on accelerator pedal, to make machine backward, scrape ground by cutting edge.



## Towing

Can transport 20 tons by towing. The method is as follows:

- Link to this machine's draught pin securely.
- Be sure to have good performance in the brake system.
- Lay the bucket in transporting position.
- Operating slowly when start and stop the machine be careful to brake before decelerating.

**Notice:** When braking, should brake for the tow truck firstly, and break this machine.

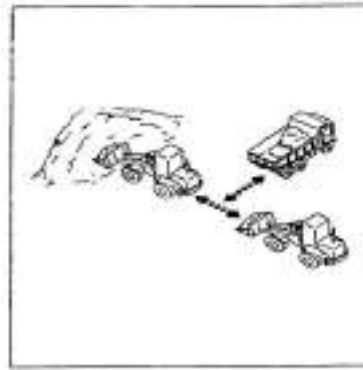

## Efficient Loading/Unloading

### V style Operation Method

As the following picture, wheel loader faces the material pile, the truck stops when the angle is 60 degrees from WL's driving direction and 12~15 meters away the pile. After WL loads full material, go directly back 12~15 meters away mass, turn around and drive to truck while lifting the bucket. After unloading, turn back to previous place, and do next operation.

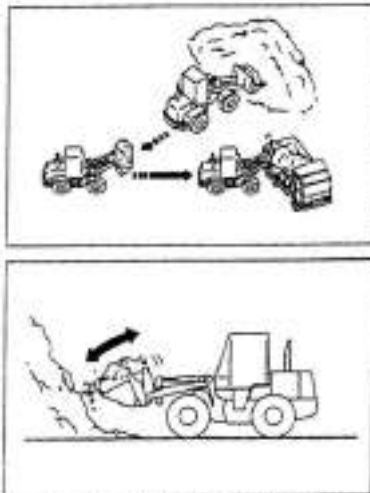

### Right Angle Loading

WL is faced to material mass, after shoveling material, drive along linear direction. And drive the dump truck between WL and material mass. This method needs little time and shortens the work cycle time effectively.

## Operation in cold weather

If temperature is too low, the engine will be difficult to start, and the radiator may be frozen, so you should do the following:

- All components should use low viscous fuel, hydraulic oil, lubricating oil; Antifreeze should be put into the cooling water. Specifications of the fuel should follow the "fluid specifications" of the Operation and Maintenance Manual.

- Notes of using antifreeze: do not mix the different type antifreeze together.

**Attention:** Keep antifreeze away from fire, no smoking when adding the antifreeze.

- Notes of using the battery. When outside temperature descends, the capacity of the storage battery will be reduced. If there is a low charge rate, the electrolyte may freeze, you should keep the charge rate near 100% as often as possible, and keep it warm as often as possible so engine could be easily start the next day. In extremely cold areas, you should use an anti-cold storage battery.

## After Daily Work

To ensure the machine easily starts avoid silt, water and freezing snow. If these are encountered you should do the following:

1. Thoroughly clean the silt, water and snow. To avoid damaging the seal performance because of silt, water and snow leaking into the seals and freezing.
2. Stop the machine on a dry and solid ground. If this is not possible, stop it on boards. Using boards can prevent the machine from being frozen to the ground.



3. In low temperature, as the parking time is longer the battery storage capacity will decrease, so the battery should be covered or move to a warmer place, and mounted on the second day.

## After Cold Season

As the season changes and turns warm, do the following:

- All components should use mid-viscosity fuel, hydraulic oil, lubricating oil. Specifications of the fuel should follow the “fluid specifications” of the Operation and Maintenance Manual.
- If you do not use permanent antifreeze, you must drain all of the fluid in radiator system, clean up the radiator, and change to new cooling fluid.

## Transporting

Before transport, the channel height, width and the allowable carrying capacity along the route should be checked. When the machine is placed on the transport truck, the total height, total width and total weight cannot exceed the related rules. If there are problems of being too tall or too wide, please consult the Caterpillar (Qingzhou) Ltd. or its dealer to find a solution. In order to prevent the accidents during transport, clean up any snow, ice or other material on dock or truck before transport. **Attention:** While transporting, please follow the national and local regulations regarding transport height, width, length and weight.

## Hauling on a Trailer

Follow this procedure:

1. Before shipping, lay blocks under the machine’s wheels.
2. When the truck is driving, do not make steering operations. If it is necessary, return the vehicle to flat ground and then follow through with the turning operation.
3. After parking the machine, use the frame bumper to fix the front and rear frame.
4. Lay the bucket with its flat side down in the transport truck, and put it in the neutral

position.

**Warning:** Incorrect shipping may cause vehicle damage and may lead personal injury or casualty.

## Urgent Towing

This vehicle cannot be towed except for in urgent conditions. Towing is only used so that the vehicle being towed can get to place to perform check and repair. Towing is not used to move long distances. This vehicle’s towing distance is limited to 10 kilometers and the towing speed is limited to 10 kilometers per hour. If these limitations are exceeded, the transmission will be damaged because of insufficient oil. If the vehicle must be moved in a long distance, a special trailer should be used.

**Warning:** Incorrect towing of the troubled vehicle may lead to personal injury or casualty. Towing a vehicle on bad road may cause further damage. If there is something wrong with the brakes, and the vehicle cannot brake during the towing process, the operator should be especially careful.

### Notices in the Towing Process

- This vehicle’s parking brake system is a spring brake and is pressure air released. Any malfunction caused by air system failure, brake air chamber leakage or air storage failure may cause the vehicle to become immobile. At this time the pin connecting the brake air chamber and brake detent rod should be taken off so that the brake is forced to release. **Attention:** Before releasing the parking brake, the wheels of the vehicle should be under laid with blocks to prevent vehicle from moving. If the blocks are not positioned well, the vehicle may move. The blocks should not be removed until beginning towing.
- People should not stand on the towed vehicle unless operator can control the direction and / or detent.
- Before towing you must confirm that the towrope or tow rod is in good condition and has enough strength to pull vehicle.



The strength of the towrope or tow rod must be at least 1.5 times the gross weight of the towed vehicle; this will allow it to pull the vehicle from the mud or a slope.

- Keep the towrope at an angle, the angle between dragrope and forefront location should not be more than 30 degrees.
- Vehicles moving too fast may make the towrope or tow rod to break or crack. Moving vehicle slowly and smoothly will result in effective work.
- When towing, all people should be far away from both sides of the towrope. This will prevent injury if the towrope were to break.

- Generally, the trailer should be the same size as the towed vehicle. Confirm the trailer has enough brake capability, weight and power to control and move two vehicles up a slope.
- In order to have enough control or brake capability when towing a vehicle down slope, there should be a bigger trailer or other machine behind it to prevent rolling when out of control.
- The operator must steer along with the towrope direction so that the towed vehicle direction can be controlled.

## Maintenance



**During uses this machine, please perform the maintenance according to the maintenance interval schedule and procedure specified in this manual. Good maintenance is helpful to extend the machine service life and the safeguard operational security**



## Periodic Maintenance

The service hour meter determines the maintenance intervals or calendar intervals (daily, weekly, monthly, etc.). Maintenance procedures are stated in this manual. Caterpillar (Qingzhou) Ltd. requested maintenance should be done either by the service hour meter or the time interval, whichever occurs first. Under extremely severe, dusty or wet operating conditions, more frequent lubrication than is specified in the maintenance intervals schedule might be necessary.

Other than daily maintenance schedules, four periodic maintenance points should be considered: PM250: every 250 service hours, PM500: every 500 service hours, PM1000: every 1000 service hours, and PM2000: every 2000 service hours

During maintenance, daily maintenance and initial maintenance of related components should be strictly performed. Then, perform respective periodic maintenance according to specific service hour.

### Notes:

**The engine info of this section is only applied to Weichai engine configuration, for Cummins engine' maintenance and troubleshooting&parts information, please refer to the supplied 《Cummins Operation And Maintenance Manual》**

## Fluid fill volume

Hydraulic oil	157L
Crankcase	18L (oil gauge graduation as actual refueling volume)
Transmission system	45L(oil gauge graduation as actual refueling volume)
Front axle (main drive and final drive reducer)	
.....	10L (oil gauge graduation as actual refueling volume)
Rear axle (main drive and final drive reducer)	
.....	10L (oil gauge graduation as actual refueling volume)





## Maintenance Schedule

Maintenance items	Daily	PM250	PM500	PM1000	PM2000
Check engine oil level	√	√	√	√	√
Check coolant level	√	√	√	√	√
Check hydraulic oil level	√	√	√	√	√
Check fuel level, Drain the water and the sediment from the fuel pre-filter	√	√	√	√	√
Check the operation of the lights and gauges	√	√	√	√	√
Check tire pressure and wear	√	√	√	√	√
Check transmission oil level	√	√	√	√	√
Check the lubrication at all lubrication points, apply grease to them according to the Machine Lubricating Figure attached on the machine	√	√	√	√	√
Check oil level of the brake booster	√	√	√	√	√
Check transmission control system, make adjustment if necessary	√	√	√	√	√
Check and tight the retaining nuts of the steering wheel	√	√	√	√	√
Walk around and visually inspect all the systems weather there are abnormal or leakage	√	√	√	√	√
Visually inspect engine fan and drive belt	√	√	√	√	√
Apply grease to every driveshaft according to the Machine Lubricating Figure attached on the machine	√	√	√	√	√
Tight all driveshaft connecting bolts	√				
Check the clearance between the parking brake shoe and brake drum at the first 50 service hours, make adjustment if necessary	Initial Check	√	√	√	√
Check the tightening torque of rims connecting bolts at the first 50 service hours	Initial Check	√	√	√	√
Initially replace the engine oil and oil filter (the first 50 service hours)	Initial Replacement				
Initially replace the powertrain filter and the oil for the transmission, torque converter and radiator		Initial Replacement			
Initially replace the hydraulic tank return element (upper element on the oil tank)		Initial Replacement			
Initially replace pilot hydraulic system oil filter element		Initial Replacement	Clean		



Maintenance items	Daily	PM250	PM500	PM1000	PM2000
Keep the battery post clean and apply Vaseline on it to prevent acid fog from corrosion		√	√		
Change engine oil and oil filter		√	√	√	√
Clean engine cylinder head		√	√	√	√
Clean radiator fins		√	√	√	√
Clean filling screen of the fuel tank		√	√	√	√
Clean filling screen of the engine oil tank		√	√	√	√
Check the tightening torque of the engine and transmission mounting bolts		√	√	√	√
Check work tool, front and rear frames, stress welding seams, and retaining bolts for cracks or loose		√	√	√	√
Check the oil level of front and rear axle		√	√	√	√
Check the engine air inlet system		√	√	√	√
Check the engine drive belt, air conditioning compressor belt for tension and damage		√	√	√	√
Check the operating capacity of service brake and parking brake		√	√	√	√
Change engine oil and oil filter		√	√	√	√
Change fuel pre-filter		√	√	√	√
Check the retaining bolts of frame hinge pin for loose			√	√	√
Check oil level of the brake booster			√	√	√
Tighten connecting bolts between frame and front, rear axle			√	√	√
Clean the screen of the air booster breather			√	√	√
Change fuel filter			√	√	√
Change oil tank breather element			√	√	√
Change air filter element			√		√
Adjust engine valve lash				√	√
Check the bearings of the engine tension pulley and the fan shaft bearing case				√	√
Fasten all the retaining bolts of the battery, clean the top of the battery				√	√
Clean fuel tank				√	√
Clean transmission, torque converter breather				√	√
Replace the oil for the transmission, torque converter and radiator				√	√
Replace transmission suction screen and return screen				√	√



Maintenance items	Daily	PM250	PM500	PM1000	PM2000
Replace the hydraulic tank return element (upper element on the oil tank)				√	√
Replace the lubricating oil of the axles				√	√
Initially replace pilot hydraulic system oil filter element				√	√
Check the engine shock absorber					√
Check the operation of service brake system lines and parking brake system. If necessary, remove and inspect the abrasion of disc, and replace brake lines					√
Check the flexibility of steering system, replace steering lines if necessary					√
Check the generator, starting motor, cleanup the turbocharger					√
Clean the seals and springs of brake booster, replace the brake oil, check the sensitivity of each brake					√
Check the sealing of distribution valve and power cylinder by measuring the cylinder natural subsidence					√
Change oil tank breather (filling screen)					√
Change fuel tank breather (filling screen)					√
Change coolant and coolant filter, Clean cooling system Replace the coolant every two years if the service hours do not occur first					√
Replace hydraulic oil, clean hydraulic tank and check the suction pipe					√

**Warning: Please use the spare parts approved by Caterpillar (Qingzhou) Ltd. or Caterpillar (Qingzhou) Ltd. dealer. The use unauthorized spare parts, may cause security problems and reduce the service life of machine.**



## Engine

### Engine Coolant

The proper maintenance of engine cooling system is very important. Overheating, overcooling, pitting, cavitations, cylinder head cracks, stuck piston and plugged radiator, are common problems of the cooling system, these problems will not only reduce the work efficiency of the engine, but also can cause the engine damage.

#### Antifreeze Fluid

The main function of antifreeze fluid is to decrease the condensation and increase the boiling point of the coolant. The antifreeze fluid is also needed when operating the machine under the normal temperature, because it can increase the boiling point of the coolant, the additive included in the antifreeze fluid can also reduce the framework corrosion and cracks.

The antifreeze fluid Caterpillar (Qingzhou) Ltd. recommends are listed as follows:

Lowest ambient Temperature (°C)	Changcheng Antifreeze Fluid Model
-50	YF-3
-45	YF-2A
-40	YF-2B
-35	YF-2
-25	YF-1

When replacing antifreeze fluid, use premium antifreeze liquid and fill according to its use guide. **Attention:** Antifreeze fluid is highly flammable, do not use near an open flame.

#### Checking the Coolant Level

The water radiator is located on the rear of the machine.

- Wait until the temperature of the engine coolant drops to below 50°C, then remove the water radiator filler cap slowly in order to relieve pressure. Any contact

with hot coolant or with steam can cause severe burns.

- Check the coolant level. The coolant should be located between the high-level mark and low-level mark of the radiator tank. Fill coolant to the high level mark if the coolant is below the low level mark.
- Check the sealing of the water radiator filler cap; change the filler cap if it is damaged.

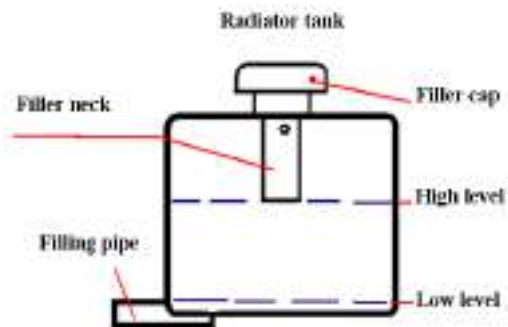

- Fasten the radiator filler cap.
- If filling coolant is needed every day, please check engine-cooling system for leaks. If there is a leakage, follow through with the necessary repair, then fill antifreeze fluid to corresponding level.

#### Fill the Coolant

Prior to filling the coolant of a new engine, or an engine with a clean cooling system, choose the anti-freeze fluid density of the coolant basing on the lowest local temperature (10°C below the lowest local temperature is even better), calculate the anti-freeze fluid quantity by volume of the total engine cooling system, the total cooling system volume of this machine is 30 liters.

**Attention:** Make sure not to use water as a coolant, this will caused corrosion damage. If water is used as coolant, the warranty to the cooling system is void.

**Attention:** Do not fill coolant then the engine is at a high temperature, this could cause engine body damage. Wait until the engine temperature is below 50°C, and then continue.

#### Fill the Coolant as Follows:

1. Turn on the power negative switch;



insert the key into the ignition and turn clockwise to 1 gear position, turn on the machine power; toggle the transfer switch of the air-conditioning system to the warm position.

2. Manually turn the engine water inlet pipe valve to the ON position (when in the ON position, valve handle and the pipe are in the same direction).

3. Open the radiator filler cap, fill the coolant slowly, until the coolant level is at the high level mark of the radiator tank, and maintain the level for ten minutes.

**Attention:** When filling the coolant, the air must be vented from the lines of the engine cooling system.

4. Keep the radiator filler cap open, start engine, run engine for 5 minutes at low idle speed, then another 5 minutes at high idle speed, and enable the coolant temperature to go above 85 °C.

5. Check the coolant level again. If necessary, continue to fill coolant to the high water level mark of the surge tank.

6. Check the sealing of the water radiator filler cap and change the filler cap if it is damaged.

**Attention:** If the coolant leakage is caused by the user, for any subsequent losses resulting from decreases in anti-freeze fluid density, Caterpillar (Qingzhou) Ltd. will not take any responsibility.

## Clean Cooling System

Every 2,000 service hours or two years (whichever occurs first), completely replace the coolant and clean cooling system. Before this, if the coolant becomes contaminated, the engine overheats or there are some bubbles in the radiator, clean the cooling system. Use the following steps to clean cooling system:

1. Turn the power to the negative switch; insert the key into start switch and turn clockwise to 1 gear position, turn on the machine power; toggle the transfer switch of the air-conditioning system to the warm position.

2. Turn the manual valve of the engine

water inlet pipe to the ON position (when in the ON position, valve handle and the pipe are in the same direction).

3. Start engine, run the engine for 5 minutes at idle speed, then stop engine. Turn the start switch to the first gear position again, turn on the machine power; toggle the transfer switch of the air-conditioning system to the warm position, make sure the electromagnetism water valve in open position.

4. Wait until the temperature of the engine coolant drops to below 50°C, then remove the radiator filler cap slowly in order to relieve pressure.

5. Open the drain valve under the radiator and the drain valve of engine lubricating oil cooler, drain the coolant to a container.

6. After draining the coolant, close the drain valve under the radiator and drain valve of engine lubricating oil cooler.

7. Check all water pipes and the clamps of the cooling system for damages, make replacement if necessary. Check the radiator for leaks, damage and dirt, clean and repair if necessary.

8. Fill the engine cooling system with cleaning fluid, which is mixed by the water and the sodium carbonate, the proportion of mixture is in every 23 liters of water add 0.5 liters sodium carbonate. The fluid level should be at the engine normal fluid level, and remain stable after ten minutes.

**Attention:** When filling the cleaning fluid, the air must be vented from the lines of the engine cooling system. During the entire cooling system cleaning process, the engine is running with the radiator filler cap open.

9. Keep the radiator filler cap open, start engine, when coolant temperature increases to more than 80°C, run the engine for another 5 minutes.

10. Stop the engine and drain cleaning fluid.

11. Fill the engine cooling system with clean water to the normal level, and keep for ten minutes. Keep the water radiator



filler cap open, start engine, when coolant temperature increases to more than 80°C, run the engine for another 5 minutes.

**12.** Stop the engine, drain out the water. If the water being drained is still dirty, the cooling system must be cleaned until the water is clean.

**Warning:** The engine coolant is poisonous, do not drink, please handle it according to the local relevant laws and regulations.

## Clean Radiator Fins

Perform following clean procedure if there is any mud or dirt stuck to the radiator.

1. Remove the bolts, take off the rear grill from the rear of the machine. At the same time, remove the connector of the rear work lamp.
2. Clean the dirt and leaves off o the radiator fins with compressed air. Steam or water may be used instead of compressed air.

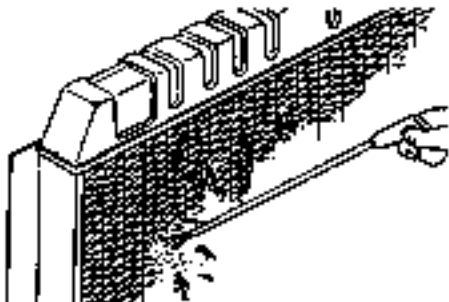

3. At the same time, check the rubber hoses. If the hoses are found to have cracks or to be hardened by ageing, they should be replaced with a new one. Also, tighten the loose hose clamps.

## Engine Air Filter

If the diesel engine generates black smoke or power decreases, the air filter may be plugged and need maintenance. Use the following procedure:

1. Stop the engine and open the engine hood. **Attention:** To avoid engine damage, never service the air filter when the engine is running.
2. Remove the outer cover of the air filter.
3. Remove the nut on the top of the primary filter element and take out the

primary filter element.

4. Clean the inside of the air filter body.
5. Clean the primary filter element with compressed air (less than 300 kPa), direct the airflow from the inside of the filter element and along its folds. **Attention:** When cleaning the primary filter element, do not hit it or beat it against anything, this may damage the engine.

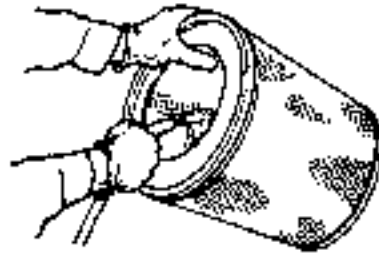

6. After cleaning up the primary filter element, perform a lamp inspection. If the eyelet or particle is found on it, or if the gasket or the seal are damaged, replace it with a new primary filter element.
7. Install a clean primary filter element into the air filter housing; keep the primary filter element end seals in uniform contact. Tighten the nut on the top of the primary filter element by hand, do not use tools in order to avoid damages the primary filter element.
8. Clean and install air filter cover, keep air filter gasket and air filter housing uniform contact.

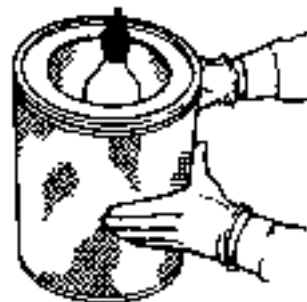

9. After cleaning primary filter element, start the engine, if the engine generates black smoke or power decreases again, replace the secondary filter element with a new one. The primary filter element must be changed after being cleaned 6 times. It



should be changed every year regardless of how many times it has been cleaned. Change the secondary filter element when changing the primary filter element.

### **Change Air Filter Secondary Element**

When changing the primary filter element also change the secondary filter element. Stop the engine and then open the engine hood.

1. Remove the outer cover of the air filter.
2. Remove the primary filter element.
3. Remove the nut on the top of the secondary filter element and take out the secondary filter element.
4. Clean the inside of the air filter body.
5. Install a new secondary filter element; the seal ring on the end must have uniform contact. Tighten the mounting nut of the secondary filter element by hand. Do not use tools.
6. Install a new primary filter element and the outer cover of the air filter. Tighten the nut on the top of the primary filter element by hand. Do not use tools.

**Attention:** Always replace the secondary filter element. Never attempt to reuse the secondary filter element by cleaning the element.

## **Diesel Fuel Use and Maintenance**

### **Diesel fuel tank**

The diesel fuel tank on this machine is located on the rear of the cab. Its volume is 150 liters. Open the engine hood; you can see the filler of the diesel fuel tank. Take off the filler cap, and then fill diesel fuel. When filling diesel fuel, please do not take out the filler screen. The filler screen and the diesel fuel tank should be cleaned regularly; the diesel fuel tank may be cleaned according to following method:

1. Remove the flange on the bottom of the diesel fuel tank,
2. Clean the internal surface of diesel fuel tank, loosen the drain plug under the diesel fuel tank, and drain the fuel
3. Repeatedly flush, until the drained fuel

is clean.

### **Drain the Sediment and Water in Diesel Fuel**

The fuel pump and injection pump nozzle are precision instruments, and if the diesel fuel contains water or dirt, it will not work properly and will wear quickly. You should drain the sediment and water in diesel fuel. The method is as follows:

1. When conditions permit, diesel fuel should be left drained for 24 hours before filling the diesel fuel tank.
2. Before filling fuel, open the drain plug on the bottom of the diesel fuel tank. Drain the sediment and water from the diesel fuel tank every week.
3. In order to vent the saturated air, fill the diesel fuel tank after completing the day's work.
4. In order to precipitate the sediment and water to the bottom of the diesel fuel tank, 5 to 10 minutes after filling fuel restart the engine.
5. Loosen the drain plug under the diesel fuel pre-filter and diesel fuel primary filter. Drain out the sediment and water after completing the day's work.

**Attention:** Never wait to fill fuel until the fuel of the tank has run out, this will make the engine stop, and the diesel fuel contains lots of water and sediment, can impact engine proper work.

### **The Sulfur Quantity in the Diesel Fuel**

The sulfur percentage in the diesel fuel affects the engine oil selection and replacement intervals. In the combustion process, the sulfur makes a chemical reaction and generates the sulfuric acid and the sulfurous acid; these acids can corrode the metal surface. So you must select diesel fuel contain less sulfur. Some chemical additives in the lubricating oil include alkali compound, the alkali compound can neutralize the acid. So the oil change intervals should be adjusted by the sulfur quantity in the diesel fuel:



1. If the content of sulfur in the diesel fuel is lower than 0.5%, replace the engine oil according to the intervals specified in Periodic Maintenance section of this manual.
2. If the content of sulfur in the diesel fuel is 0.5%~1%, replace the engine oil according to the half of the intervals specified in Periodic Maintenance section of this manual.
3. If the content of sulfur in the diesel fuel is more than 1.5%, replace the engine oil according to the 1/4 of the intervals specified in the Periodic Maintenance section of this manual.

## Replace the Diesel Fuel Filter and Pre-Filter

1. First, clean the peripheral region and the mounting base.
2. Remove the filter with the belt wrench from the mounting base.
3. Remove the gasket on the threaded adapter of the mounting base. Clean up the seal surface of the mounting base with the non- textile fiber cloth.



4. Attach a new gasket to the adapter of the pre-filter mounting base; coat engine oil on the filter seal surface; fill the clean fuel into the filter.
5. Fasten filter on the mounting base by hand, after it contacts the mounting base, turn by an additional 1/2 ~3/4. In order to avoid damaging the filter, do not use the mechanical method to fasten.

## Engine Oil Maintenance

### Check Engine Oil Level

1. Move the machine to flat ground, stop the engine, and pull up the parking brake lever.
2. After stopping the engine, wait for ten minutes; let the engine oil completely flow back to the engine oil pan.
3. Open the engine hood, the oil dipstick is located on the center of the right side of the engine, the oil filler is located on the front upper of the engine.
4. Draw out the oil dipstick, wipe it with clean cloth, reinsert the engine oil dipstick to the end, draw out again and check, the oil level should between the "L" scale and "H" scale.
5. If the oil level is under the "L" scale, add engine oil; if the oil level is above the "H" scale, loosen the drain plug, drain some oil. **Attention:** Too much or not enough oil may damage the engine.

### Change Engine Oil

When the specified oil change interval occurs, replace the engine oil. Park the machine on level ground, start the engine and wait until the water temperature is at 60°C, then stop the engine. Pull up the parking brake, remove the drain plug on the bottom of the engine oil pan, drain the oil into a container and replace oil filter. Fasten the plug; fill the clean engine oil until the oil level reaches the "H" scale on the dipstick. Run the engine at idle speed, check the oil filter and drain plug for leaks. Stop the engine, wait for about 10 minutes, and let the oil fully drain into the engine oil pan. Check the engine oil level once more, if the oil is insufficient, fill oil to the oil dipstick "H" scale. **Attention:** Within 15 seconds after engine starts, the engine oil pressure gauge should have the reading. If there is no reading, stop the engine immediately in order to avoid damaging engine, check engine oil level for correct position.



## Replace the Engine Oil Filter

1. Clean the peripheral region and the filter-mounting base.

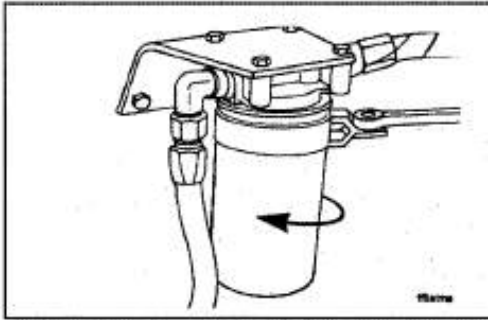

2. Remove the oil filter with the belt wrench.
3. Clean the contact surface of the mounting base gasket with the clean cloth.

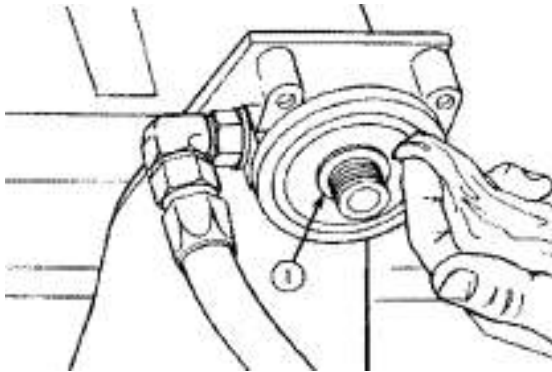

If the used O-ring sticks on the mounting base, remove it.

4. Install a new O-ring.
5. Install the oil filter on the mounting base, tighten the oil filter by hand till gasket surface just contact mounting base, fasten again the oil filter to the specified position with a belt wrench.

**Attention:** Tightening too much can damage the thread or the sealing of the oil filter.

## Transmission

### Transmission Oil

#### Check Oil Level

Transmission filling port is located inside the rear frame left side plate. Examine transmission oil level routinely according to the regulations in order to guarantee the oil quantity. Use the oil dipstick on filler cap of

transmission to check the oil level (oil level should be on the middle of oil dipstick scale of transmission when the machine is running.)

Use following steps to check transmission oil level:

1. Check the cold oil level before starting cold machines. The purpose for that is to have the enough oil when the machine starts. It is more important when the WL is parked for a long time.
2. The level should be on the upper position of the oil dipstick before starting the engine. If the level is on the lower position of the oil dipstick, add the enough oil in order to start the machine.
3. Park the machine on the flat field. The transmission control knob should be in the neutral position. Engage the parking brake. Mount the lock pin of frame to prevent the machine from moving and rotating. Run the engine at idle speed.
4. Start and run the engine for 5 minutes. The transmission oil level should be near the middle position of oil the dipstick. If the oil level is higher, drain some oil by loosening the drain plug on the bottom of transmission. If the oil level is lower, add transmission oil.

**Attention:** High or low transmission oil level may damage transmission. Keep the transmission oil level in the correct position.

**Attention:** Pay attention to the cleanliness when checking transmission oil level and replacing the transmission oil. Avoid dirt from entering into the transmission so it doesn't damage it.

#### Replacing Transmission Oil

On one side, the transmission oil is used as a service fluid for the hydraulic torque converter of the transmission hydraulic system. On the other side, it is used for cooling and lubricating the torque converter and transmission components. So the transmission oil type should match the requirement. Replace the transmission oil according to the specified oil change intervals. Otherwise, the service life of transmission will be shortened.



Use following steps to replace transmission oil:

1. Start the engine and leave it running for a few hours to allow the dirt, metal and sediment to float in the fluid.
2. Park the machine on a flat surface. When the transmission control knob is in the neutral position, engage the parking brake. Mount the lock pin on frame to prevent the machine moving and rotating.
3. Stop the engine, unscrew the drain plug located at the bottom of transmission, and drain the oil into a container.
4. Unscrew the drain plug under the torque converter; drain the oil into a container. **Warning:** The transmission oil temperature is still high. So wear protective equipment and operate carefully to avoid personal injury.
5. Use a magnet to clean the iron chips attached the drain plug and the iron chips in the transmission.
6. Install the drain plug of transmission, and drain plug and seals under the oil cooler of torque converter.
7. Install the drain plug and seals under the torque converter.
8. Unscrew the filler cap of transmission. Fill the clean transmission oil through filling hose. The transmission oil level should be at the highest level.
9. Start and run the engine for 5 minutes. Observe that the transmission oil level should be near the middle position of oil dipstick. If oil level is higher, drain some oil by loosening the drain plug on the bottom of transmission. If the oil level is lower, add transmission oil.
10. Turn the filler cap clockwise to fasten.

## Replace Transmission Suction Screen

1. Drain the oil according to the transmission oil replacement method.
2. Loosen the suction pan bolts and remove the suction pan. Take out the suction screen.
3. Install the new suction screen and tighten the suction pan bolts.

4. Fill the oil according to the transmission oil replacement method.

**Attention:** Pay attention to cover the parking brake before replacing the transmission oil. This will prevent the parking brake friction discs from getting saturated with oil, which will reduce the braking performance.

## Replace the Transmission Filter Element

1. Clean the peripheral region and the transmission filter-mounting base.
2. Remove the transmission filter housing with the belt wrench, and remove the element.

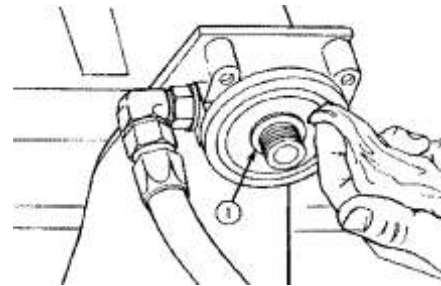

3. Clean the contact surface of the mounting base gasket with the clean cloth, and install a new element.
4. Install the transmission filter housing.

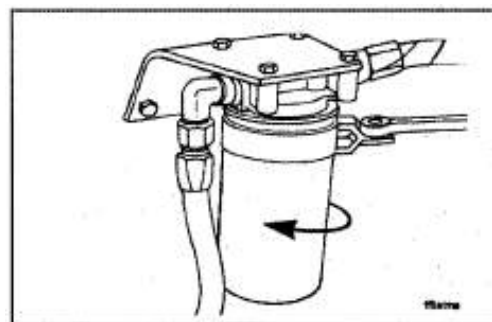

**Attention:** The transmission filter is directional. The arrow direction should be against the transmission pump when installing.

## Axle

### Axle Oil

Check the oil level and replace the axle oil



regularly according to the regulations of Periodic Maintenance.

### **Check the Axle Oil Level**

1. Drive the machine on a flat field. Move the machine slowly with slight throttle to make the drain plug, located on final drive end cover of front axle, at the leveling position. So check the oil level of front and rear axle twice.
2. Place the transmission control lever at the neutral position. Engage the parking brake to prevent the machine moving.
3. Clean the area near to the drain plug on both final drives of axle. Remove the drain plug to observe. The oil level in the axle should be at lower edge of the drain port. If the oil level is under the drain port, add clean axle oil. Observe for 5 minutes after filling the oil. If the oil level stays stable, it's ok.
4. Screw on the drain plug.
5. Check rear axle oil level according to above operation.

### **Replace the Axle Oil**

1. First run the machine for a while and let the impurities float. Then run the machine on the flat field and move the machine slowly with slight throttle so that the front axle's final drive drain plug is at the lowest position. The drain plugs on front and rear final drive cannot be at the lowest position at the same time, therefore the oil must be replaced for both the front and rear axle.
2. Stop the engine; place the transmission control lever in the neutral position. Engage the parking brake to prevent the machine moving.
3. Unscrew the drain plugs on both end covers of front axle and the drain plug in the middle of housing. Drain the oil into a container. **Warning:** The axle oil temperature is still high. So wear protective equipment and operate carefully to avoid personal injury.
4. Screw on the drain plug in the middle

of front axle.

5. Start the engine and push the parking brake lever to release the parking brake. Engage 1st gear of transmission and move the machine slowly with slight throttle to allow the drain plug on final drive of the front axle at the horizontal position. Then stop the engine, engage the neutral gear of transmission and pull the parking brake lever.
6. Fill the clean axle oil from the drain port on both final drive end covers of front axle until the oil level reaches lower edge the drain port on both end covers of front axle. Observe for 5 minutes after filling the oil. If the oil level remains stable, it's ok.
7. Screw on the two drain plugs of front axle.
8. Replace the rear axle oil according to the similar steps above mentioned.

## **Hydraulic System**

### **Hydraulic Oil**

Check the oil level and replace the Hydraulic oil regularly according to the regulations of Periodic Maintenance.

#### **Check Hydraulic Oil Level**

The hydraulic tank is located on the left side of cab. There is a level gauge to indicate the hydraulic oil level on the front part of hydraulic tank. When checking the hydraulic oil level, park the machine on a flat surface, place the bucket on the ground, and make sure the front frame and rear frame are straight without an angle. At this time, the hydraulic oil level should reach 2/3 of the level gauge.

#### **Replace the Hydraulic Oil**

Replace the hydraulic oil every 2000 service hours or every year. The method is as follows:

1. Clean the dirt in the bucket. Park the machine on a flat surface and put the transmission control lever in the neutral



position. Engage parking brake and mount the lock pin of frame. Start the engine and run it for 10 minutes at idle speed. Repeatedly raise the boom, lower the boom, dump and rack back bucket etc.

**2.** Finally, raise the boom to the highest position and pull the bucket to the furthest back position. Stop the engine.

**3.** Push the bucket control knob of working valve forward. Dump the bucket under the gravity effect and drain the fluid of tilt cylinder. When the bucket is tilted at the required position, push the boom control lever of working valve forward. Lower the boom under gravity effect and drain the oil of boom cylinder.

**4.** Clean the drain port under the hydraulic tank. Unscrew the drain plug; drain the hydraulic oil into a container. At the same time, unscrew the filler cap and quicken the drain process.

**5.** Remove the inlet pipe of hydraulic oil tank and drain the hydraulic oil left in the oil tank.

**6.** Remove the hydraulic return filter element from the hydraulic tank and replace it with a new filter element. Open the filler cap and take off the filling screen to wash it.

**7.** Remove the cleaning flange disc of the tank under the filling port. Use diesel to wash the bottom of hydraulic oil tank and its four sides and dry it with a clean cloth.

**8.** Mount the drain plug of hydraulic tank, return filter, cover, filling screen, tank cleaning flange port and the inlet pipe.

**9.** Fill the clean hydraulic oil from the filling port of hydraulic tank to allow the oil level reach the upper scale of hydraulic level gauge. Screw on the filler cap.

**10.** Remove the lock pin of frame and start the engine. Operate the working valve control lever. Raise and lower the boom, dump and rack back the bucket, and steer left and right at the largest possible angle twice or three times to make the hydraulic oil fill the cylinder and lines. Then, run the engine for 5 minutes at the idle speed to vent the air from the system.

**11.** Stop the engine and open the filler cover of hydraulic tank. Add the clean hydraulic oil to 2/3 scale of hydraulic tank level gauge.

### **Replace Heavily Polluted Hydraulic Oil**

If the operating condition is bad or the hydraulic oil is seriously polluted, such as being black, or foamy. Please immediately replace the hydraulic oil.

**1.** Clean the dirt from the bucket. Park the machine on a flat field and put the transmission control lever in the neutral position. Pull the parking brake lever and mount the lock pin of the frame. Start the engine and run it for 10 minutes at the idle speed. Repeatedly raise and lower the boom, dump and rack back the bucket etc.

**2.** Finally, raise the boom to the highest position and backward the bucket to the largest position. Stop the engine.

**3.** Push forward the bucket control knob. Dump the bucket under the gravity effect and drain the fluid of the tilt cylinder. When the bucket is tilted at the required position, push the boom control lever forward. Lower the boom under gravity effect and drain the oil of boom cylinder.

**4.** Clean the drain port under the hydraulic tank. Unscrew the drain plug; drain the hydraulic oil into a container. At the same time, unscrew the filler cap and quicken the drain process.

**5.** Remove one end of all pipes to drain the remained fluid of steering cylinder, hydraulic oil cooler and pipes.

**6.** After draining the oil, mount the drain port plug under the hydraulic tank and all pipes removed.

**7.** Open the filler cap of hydraulic tank and fill the clean hydraulic fluid to the lower mark of level gauge.

**8.** Replace the oil again according to the 'Replace the Hydraulic Oil' section mentioned above. And replace the return filter element. Clean filling screen and hydraulic tank.



## Replace the Return Filter Element of Hydraulic Tank

1. Raise the boom and at the same time put the bucket in the rack back position. Use the support against the boom to prevent the work tool falling. Position the work tool control lever in the neutral position. Apply parking brake and stop the engine.
2. Unscrew the mounting bolts of filter cover on the side of tank and remove the cover. The cover might come off because of the spring. When taking off the bolts, the cover should be pressed down.
3. Take off the spring, then remove filter element.
4. Mount the new filter element, spring and cover.
5. When installing the cover bolts, press the cover and tighten the bolts evenly.
6. Check the oil level and add the oil if necessary.
7. Check the filter cover for leaks.

## Tires

It is necessary for to use special equipment and special techniques to maintain, remove, repair and install the tires and rims. So ask the tire repair shop or people with special training to repair and follow all the related safety regulations. It is recommended to fill tire with N<sub>2</sub>. If the tire has original air, it is suggested that nitrogen is used to adjust the pressure. The nitrogen can be mixed with air. Inflating tires with nitrogen gas can prevent the tires from exploding because of N<sub>2</sub>'s inflammability. The nitrogen is helpful to preventing oxidation, rubber aging and rim parts corrosion. Check and adjust the tire inflation pressure after the tire cools down. The tire pressure is the same for both nitrogen and air filled tires. Caterpillar (Qingzhou) Ltd. suggests choosing the tire inflation pressure according to application:

Tire Spec.: 17.5-25

Tire Inflation Pressure (MPa)

Front Wheel: 0.343

Rear Wheel: 0.294

**Attention:** If the machine travels for a long distance and at high speed, park the machine for 30 minutes every 45 km in order for the tire to cool down.

## Bucket Limitation Device

The machine has a bucket automatic leveling function. Operate the bucket automatic leveling function reasonably to increase the production effectively.

## Adjust the Bucket's Automatic Leveling Device

1. Park the machine on a flat surface. Put the transmission control knob in the neutral position. Operate the control knob of working valve to make the bucket level to the ground. Pull the parking brake lever and stop the engine. Install the lock pin to the frame.
2. Loosen the arrow bolt. Move the arrow to the middle of the fitting body of tilt cylinder rod end. Tighten the arrow bolt.
3. Remove the fixed lock pin from the frame after finishing. Start the engine and check that adjustment is suitable.

## Parking Brake

The parking brake should be often checked to guarantee parking safety and the braking performance of emergency braking.

1. Adjust the tire pressure to the regulated value. The bucket is leveled at about 300mm away from ground. And confirm that the service brake works well.
2. Start the engine and allow the machine to face a slope of 18% (angle is 10°12'). The road should be flat and dry.
3. Step on the service brake pedal and stop the machine. Put the transmission control knob in the neutral position and then stop the engine.
4. Pull the parking lever button, loose the service brake pedal slowly and check if the machine moves or not.



## Service brake performance

Ensure the machine's parking brake system operate normally before checking the service brake performance in order to apply the parking brake to stop the machine in an emergency condition. The machine travels at 20km/h at the flat, straight and dry concrete road. Step on the service brake pedal to brake fully. After the machine stops, push the transmission control knob to the neutral position. Pull the lever of parking brake and then loosen the service brake pedal. Check the machine braking distance, which should not be more than 9 m when the machine travels at 32km/h. Break the machine quickly and ensure that the machine does not run off track.

### Replace Friction discs

3 longitudinal grooves on the friction disc of brake caliper signify the grinding capacity. Replace the new disc when the grooves are worn down. Easiest way to replace the new friction disc is the following steps.

#### External Friction Discs

**Step 1:** Loosen the retaining screw of brake caliper pin.



**Step 2:** Take out the fixed pin of friction disc.



**Step 3:** Lightly take off the friction disc.



**Step 4:** Replace it with a new friction disc.



**Step 5:** Punch the fixed pin lightly.



**Step 6:** Tighten the retaining screw of pin.



#### Internal Friction Discs

**Step 1:** Loosen the retaining screw of pin.



**Step 2:** Pull out the friction disc slowly after taking out the pin.



**Step 3:** Replace it with a new friction disc





**Step 4:** Punch the pin lightly and tighten the retaining screw of pin.



Finally, check the removed parts fully. Test the machine after confirming it's correct.

## Pin and Driveshaft

According to the machine lubricating maintenance figure, fill the grease on the joining point of front and rear frame, front, main, middle and rear driveshaft, oscillation frame, driveshaft support and other lubricating point until it overflows.

**Attention:** The grease site lies on the rear end of lifting cylinder. Press-fill the grease in the circular hole in the left and right outer side plate of front frame (refer to the picture).



## Machine Lubrication Service and Maintenance

In order to decrease the additional lubrication necessary, to decrease the failure rate, to improve the service and maintenance of the machine, to increase the machine life and reliability, and especially to correctly complete maintenance lubrication process, please complete maintenance strictly according to the following procedure:

### Reference points for lubrication addition:



The lubrication points located on the machine(21 joints total), please follow the process specified during maintenance for the lubrication of each joint, use the following table to ensure that each joint is lubricated:

Joint Location	Quantity
Bucket and Articulated Boom	2
Bucket and Hinged Bar	1
Bar and Rocker Arm	1
Rocker and Articulated Boom	1
Lift Cylinder and Articulated Boom	2
Dump Bucket and Rocker Arm	1
Boom and Front Frame Joint	2
Dump Bucket and Front Frame Joint	1
Lift Cylinder and Front Frame Joint	2
Steering Cylinder and Front Frame Joint	2
Steering Cylinder and Rear Frame Joint	2
Swing Stand and Rear Frame Joint	2
Front and Rear Frame Joint	2

## Prepare to add lubrication



First refer to the picture showing the Shangong lubrication gun model: ENDURA E9511. After adding the lubrication, test and confirm that it satisfies the lubrication requirement.

## Use of the Lubrication Gun

Before adding lubrication, be sure that the tip of the gun is clean, and insure that dirt



will not build-up or enter the nozzle.  
 Be sure that the equipment is in good condition before use, especially the soft (hard) pipe connections, lubricate the joints and ends, and make sure they are fasted firmly. Before adding oil, first remove the air from the lubrication gun to ensure that no pressure is lost.

Use as follows:



At the junction of the soft (hard) tubes and the lubrication nozzle, add lubrication using the handle until the oil begins to seep out.

**For daily lubrication maintenance, refer to the following pictures**

Swing Stand and Rear Frame Joint



Swing Stand and Rear Frame Joint



Bucket, Articulated Boom and Hinged Bar



After the Articulated Boom Assembly Pin



Pin assembly in front of the dump bucket



After the boom pin assembly, the main rocker pin assembly

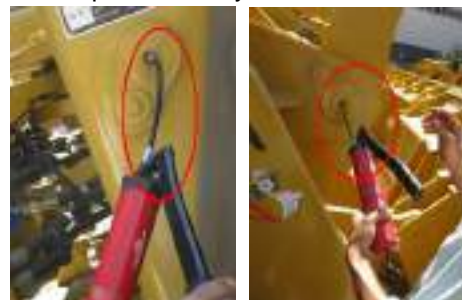





After the lifting cylinder pin assembly



### Oil Addition Schedule

Add lubrication once every two working days (this schedule should be strictly enforced so that the lubrication is added every two days)

### Notices for adding Lubrication



(55L, 65L, 80L etc.) Next turn the main hooped pin in order to add lubrication.



For the joint between the lifting cylinder and the front of the frame, must lift the lifting cylinder before adding oil



610B Wiggle the lubrication support and add the required lubrication under the vehicle, after misfire add more

### Wipe off excess oil:

After adding lubrication, the excess oil

should be removed. Be sure to avoid the oil-nozzle from absorbing impurities or build-up in the nozzle or next time lubrication is added the dirt will be released into the joint.

### Main Transmission Shaft Flow Process:

Currently the production of the 50 and 60 wheel loader transmission shaft is maintenance-free, but after 2400 maintenance-free working hours it is necessary to maintain and service the transmission. The following is the recommended maintenance procedures (in cases of extreme working conditions, perform the scheduled maintenance before the time specified):

1. The current shaft used is an Exxon Mobile Corporation UNIREX, which recommends the use of high-quality roller bearing grease.
2. Between 2400 and 4800 working hours maintain the machine at intervals less than 1200 working hours.
3. After 4800 working hours, complete maintenance at intervals less than 600 working hours.

**Important:** Due to the different lubrication mixtures that may occur leading to decreased performance, Caterpillar (Qingzhou) Ltd. does not recommend the use of any other types of lubrication, but if it is necessary to use a different type of lubrication the user must use common lithium-based grease, the purposed maintenance schedule is as follows:

1. Between 2400 and 4800 working hours maintain the machine at intervals less than 600 working hours.
2. After 4800 working hours, complete maintenance at intervals less than 300 working hours.

Maintenance-free universal joints are a result of the multi-shaft lip-type seal structure in order to ensure the sealing performance, it is required that the lubrication is added with a gun at a pressure of more than 40Mpa



(approximately 6000psi.

## Welding Operation

When welding on the machine, to avoid machine damage or safe accident, operate according to the following regulations.

1. Before welding, read and understand the relevant safe regulations of welding.
2. Before welding, shutdown the engine starting switch and disconnect the power negative switch.
3. Before welding, remove the connector of dashboard to prevent damaging the dashboard. Disconnect between the cab harness (underneath the cab right side and close to the frame joint) and machine harness.
4. Continuous use of voltage above 200Volts is not recommended.
5. The distance between welding area and ground cable should be 1m.
6. Avoid the seal ring and bearing exists between welding area and ground cable.
7. Do not weld or cut the pipes and container with fuel, engine oil and hydraulic oil.
8. Do not weld or cut the sealed or poor ventilated container.

## Battery

This machine uses maintenance-free battery. Follow these following operation regulations during usage.

### Causes for a Low Battery

1. The electrical element is left on for an extended amount of time when the machine is not running.
2. The machine is not run for a long term, large leakage in electric current, or excess electric instruments may lead to the battery power depletion.
3. Start the machine frequently.
4. Failure of the charging system, such as failed generator and failed electrical elements, if the charging pressure is too low due to the setting of generator voltage regulator, or the engine transmission belt is loose etc., does not allow the battery to

charge normally causing lower power. If the electrolyte of battery appears black, the engine may not start.

5. Unassembled battery if it is stored over 6 months.

If the battery has low power because of the reasons mentioned above, you can recharge the power and restore it to the normal condition.

### Before Charging the Battery

1. Do not charge the battery has a broken cover or accumulator. Replace the battery if this is the case.
2. The battery with the damaged post cannot be recharged. Replace this battery if this is the case.
3. Clean the post and remove the external oxidized cover before recharging.

### When Charging

1. Wear the safety glasses.
2. Keep vent when charging and charge at the normal temperature.
3. No smoking and avoid fire when charging.
4. After charging, first connect the positive wire when connecting the wire. After charging, first disconnect the negative wire.

### Battery Charging Operation

1. After cleaning, confirm the battery and charging circuits have a good connection.
2. The positive side of charger connects with the positive terminal of the battery. The negative side of charger connects with the negative terminal of the battery. Do not charge in-line battery (24 v).
3. It is suggested to use constant voltage 16.0 V (If it is higher than 16.2 V, the water will be electrolyzed, which will cause level decreases and battery condemned), limited current 25 A charger charge battery until charging indicator becomes green. The green charging indicator means that the charging is complete.
4. If the batteries voltage is lower than 11.0 V, the battery cannot be charged in



the initial charging period because the specific gravity of the sulfuric acid in the battery with very low power is near that of the pure water. This causes the internal resistance of the battery to be very high. At this time, reduce the charging current or change to a higher power charger. As the charging process is completed, the specific gravity of the sulfuric acid in the battery increases and the charging current returns to normal slowly.

**5.** During charging, if lots of acid is sprayed out of the vent hole, stop charging immediately and find out the reason.

**6.** If the battery temperature exceeds 45°C during charging, stop charging until the battery temperature reduces to the room temperature. Reduce the charging current to a half and continue to charge.



## Fluid Specification

Use the following regulated specification and varieties to ensure the machine normally operate when adding and replacing the different kinds of oil.

Component Used	Ambient Temp.	Specification	Remark
Engine	-40°C	API CH-4 , CG-4 , CF-4/SJ, SAE5W-40	Recommended oil: Please contact local agency or SEM dealer. Use SEM appointed oil.
	-15°C~50°C	API CH-4, CG-4, CF-4/SJ, SAE15W-40	
	-20°C~40°C	API CG-4 , CF-4 , CF/SJ, SAE10W-30	
	-15°C~50°C	API CF-4 , CF/SG , SAE15W-40	
Transmission	-5°C~40°C	ISOVG46, L-HM46	
	-26°C~40°C	ISOVG46, L-HV46	
	-40°C	SAE5W-40	
Axle	-40°C	SAE75W-90 , API GL-5	
	-20°C~40°C	SAE85W-90, API GL-5 or SAE80W-90, API GL-5	
Hydraulic System	-5°C~40°C	ISOVG46, L-HM46	
	-26°C~40°C	ISOVG46, L-HV46	
	-40°C	SAE5W-40	
Booster		SAEJ703 DOT4 or DOT3 Break Fluid	
Grease	Summer	NGLI2	
	Winter		
Antifreeze Fluid	Below 0°C	YF-2 OR YF-2A	
Fuel tank	Above -5°C	0# light diesel	
	Below -5°C	-10# or -35# light diesel	

**Notes:**

The engine info of this section is only applied to Weichai engine configuration, for Cummins engine' maintenance and troubleshooting&parts information, please refer to the supplied 《Cummins Operation And Maintenance Manual》

**ATTENTION**

1. Do not use a different brand of hydraulic oil. If you have to use different brand of hydraulic oil, you must clean the system first.

## Maintenance

2. If the machine works in a cold area for long time, HV46 low-temperature Anti-wear hydraulic oil must be used.
3. Change the oil on time. Even if the oil is clean, it may decrease in performance after a long time of storage.
4. Choose the fuel according to the lowest local temperature of environment.



## Failure Causes and Repair

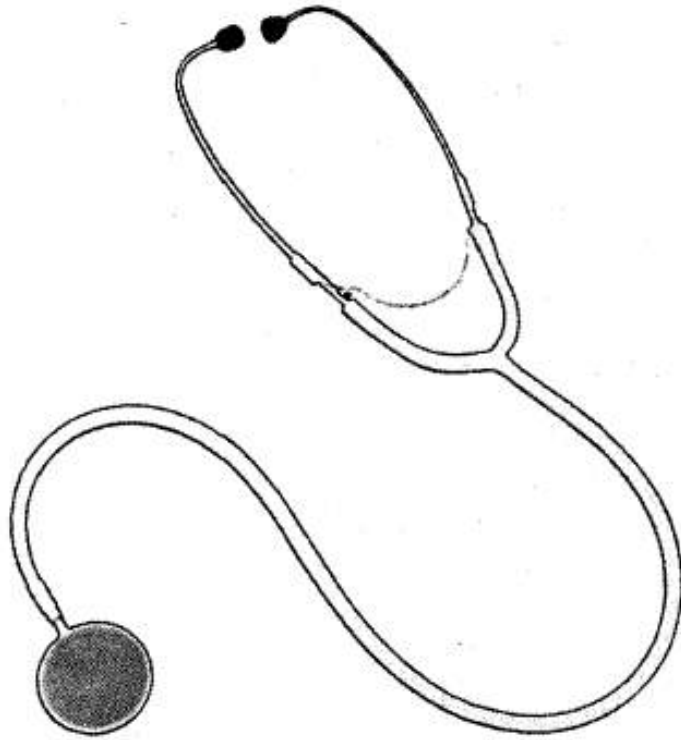

**Review common machine symptoms and related troubleshooting techniques for use by customers and servicemen.**



## Engine system

Refer to the engine manual for specific troubleshooting details.

### Transmission

#### Transmission oil pressure is too low in every gear

Problem	Solution
1. Transmission oil level is too low	1. Fill transmission oil level to the proper level
2. Oil leakage in main pipe lines	2. Check and repair
3. Transmission oil suction filter screen is blocked	3. Clean or replace the filter screen
4. Transmission oil pump is damaged	4. Repair or replace the pump
5. Improper pressure valve adjustment	5. Readjust the valve setting

#### Transmission oil pressure is too low in some gears

1. Damaged to piston seal ring	1. Replace the seal rings
2. Damaged seal rings in the transmission lines	2. Replace the seal rings
3. Oil leakage in the transmission lines	3. Check and repair

#### Torque converter oil temperature is too high

1. Transmission oil level is too low	1. Fill the oil to the proper level
2. Transmission oil level is too high	2. Drain the oil to the proper level
3. Oil coolant is blocked	3. Clean or replace coolant
4. Clutch is slipping	4. Check and adjust the transmission oil pressure
5. Excessive time running the machine at high loads	5. Idle or turn off the machine to cool it down

#### Loader cannot move after the engine has been started

1. A Gear not selected	1. Shift to desired gear or adjust the transmission control lever to the desired position
2. The transmission valve cannot reset after cut-off	2. Disassemble the valve for inspection to identify potential solutions
3. Low torque converter oil pressure	3. Adjust the torque converter overflow valve
4. Low transmission oil pressure	4. See (Transmission oil pressure is too low in every gear) and (Transmission oil pressure is too low in some gears)



## Insufficient machine power to drive the machine

<ol style="list-style-type: none"> <li>1. Low transmission oil pressure</li> <li>2. Torque converter oil temperature is too high</li> <li>3. Damaged torque converter impeller blades</li> <li>4. Insufficient output power from the engine</li> <li>5. Service or parking brake is engaged</li> </ol>	<ol style="list-style-type: none"> <li>1. See (Transmission oil pressure is too low in every gear) and (Transmission oil pressure is too low in some gears)</li> <li>2. See (Torque converter oil temperature is too high)</li> <li>3. Disassemble and check the torque converter, replace the damaged blades</li> <li>4. Check and repair the engine</li> <li>5. Check and repair the brake system, and/or disengage the service and/or parking brake</li> </ol>
--	---

## Brake System

### Insufficient service brake force

<ol style="list-style-type: none"> <li>1. Brake system oil leakage</li> <li>2. Air present in the brake system hydraulic brake lines</li> <li>3. Insufficient pressure in the air lines</li> <li>4. Worn booster cup</li> <li>5. Oil on friction disc</li> <li>6. High abrasion of the friction disc</li> </ol>	<ol style="list-style-type: none"> <li>1. Replace the sealing parts</li> <li>2. Bleed the air out of the brake system hydraulic brake lines</li> <li>3. Check the sealing performance in the air compressor, storage tank, and lines</li> <li>4. Change the cup</li> <li>5. Investigate root cause and determine corrective action</li> <li>6. Replace with a new friction disc</li> </ol>
---	--

### Transmission cannot be shifted after braking

<ol style="list-style-type: none"> <li>1. Brake valve cannot reset</li> <li>2. Transmission air valve is blocked</li> <li>3. Insufficient pressure in the rear chamber of transmission cut-off valve rod</li> </ol>	<ol style="list-style-type: none"> <li>1. Disassemble, clean and repair</li> <li>2. Disassemble, clean and repair</li> <li>3. Check the brake lines</li> </ol>
---	--

### Brakes do not release normally

<ol style="list-style-type: none"> <li>1. Push-rod of brake valve is not aligned to the correct position, or the piston rod is blocked and the reset spring is incorrectly set</li> <li>2. Inflexible reset of booster piston</li> <li>3. Brake pliers piston cannot reset</li> </ol>	<ol style="list-style-type: none"> <li>1. Check, adjust, or replace the damaged parts</li> <li>2. Check, clean, and identify potential solutions</li> <li>3. Clean or replace the rectangular seal ring</li> </ol>
---	--





## **Rapid air storage tank pressure loss after the machine is parked**

<ol style="list-style-type: none"><li>1. Brake inlet valve is blocked or damaged</li><li>2. Pipe connectors are loose or lines are damaged</li><li>3. Relief valve is not sealed</li></ol>	<ol style="list-style-type: none"><li>1. Brake continuously several times to remove dirt, or replace with a new valve</li><li>2. Tighten the connectors or replace the lines</li><li>3. Investigate and replace the valve if necessary</li></ol>
--	--

## **Slow pressure rise after the engine is started**

<ol style="list-style-type: none"><li>1. Abnormal working condition of the air compressor</li><li>2. Loose connectors</li><li>3. Unsealed brake or relief valve</li></ol>	<ol style="list-style-type: none"><li>1. Inspect the operating condition of the air compressor</li><li>2. Tighten the connectors</li><li>3. Repair or replace</li></ol>
---	---

## **Machine turns when brakes are applied**

<ol style="list-style-type: none"><li>1. The brake force for the right and left tires are different</li><li>2. Air pressure in the right and left tires are different</li></ol>	<ol style="list-style-type: none"><li>1. Check and repair the brake pliers and pipe lines</li><li>2. Ensure all tires are filled to the correct pressures</li></ol>
---	---

## **Insufficient parking brake force**

<ol style="list-style-type: none"><li>1. Excessive clearance between the brake hubs and brake discs</li><li>2. Oil on brake discs</li></ol>	<ol style="list-style-type: none"><li>1. Re-adjust to meet the recommended clearance</li><li>2. Clean the oil off</li></ol>
---	---

## **Work Tool and Hydraulic System**

### **Boom raise and bucket tilt functions are slow or dysfunctional**

<ol style="list-style-type: none"><li>1. Damaged cylinder oil seals</li><li>2. Oil leakage in hydraulic lines</li><li>3. Severe inner leakage of the pump</li><li>4. Improper adjustment of the safety valve, resulting in low system pressure</li><li>5. Air enters into the oil suction lines of the hydraulic pump, or the oil filter is blocked</li><li>6. Excessive hydraulic valve fitting clearance</li></ol>	<ol style="list-style-type: none"><li>1. Replace with new seals</li><li>2. Check and repair</li><li>3. Repair or replace the pump</li><li>4. Adjust the system pressure to the required specification</li><li>5. Clean the filter and/or replace the oil suction pipe</li><li>6. Repair or replace the valve</li></ol>
--	--



## Voiding of hydraulic oil in suction line or foaming of hydraulic oil

<ol style="list-style-type: none"> <li>1. Hydraulic oil level is too low</li> <li>2. Filter is blocked</li> <li>3. Damaged oil pump</li> <li>4. Air leakage in oil suction lines or damaged pump seals</li> <li>5. Contaminated and/or deteriorated hydraulic oil</li> </ol>	<ol style="list-style-type: none"> <li>1. Fill oil to the required level</li> <li>2. Clean the filter</li> <li>3. Repair or replace the pump</li> <li>4. Repair or replace the damaged parts</li> <li>5. Replace with recommended new hydraulic oil</li> </ol>
--	--

## Hydraulic oil temperature is too high

<ol style="list-style-type: none"> <li>1. Excessive time running the machine at high loads</li> <li>2. Hydraulic system pressure is too low</li> <li>3. Hydraulic oil level is too low</li> <li>4. Damaged oil pumps</li> <li>5. Blocked hydraulic lines and/or filter screen</li> <li>6. Insufficient engine fan cooling</li> </ol>	<ol style="list-style-type: none"> <li>1. Stop the machine to cool it down</li> <li>2. Adjust to the required pressure</li> <li>3. Fill oil to the required level</li> <li>4. Repair or replace the pump</li> <li>5. Repair, clean, or replace the hydraulic lines and/or filter screen</li> <li>6. Adjust the engine fan belt to meet the engineering requirement</li> </ol>
--	---

## Failure in resetting

<ol style="list-style-type: none"> <li>1. Deformation of the multi-way valve reset spring</li> <li>2. Dirt between multi-way valve rods</li> </ol>	<ol style="list-style-type: none"> <li>1. Replace</li> <li>2. Clean the parts</li> </ol>
--	--

## Steering System

### Heavy Steering

**Normal steering when the steering is slow, heavy steering when the steering is fast**

<ol style="list-style-type: none"> <li>1. Insufficient oil supply from the pump</li> <li>2. Inflexible operation of the priority valve spool</li> <li>3. Priority valve control pressure is too low</li> <li>4. Air present in the oil lines between the priority valve and steering gear</li> </ol>	<ol style="list-style-type: none"> <li>1. Repair and replace oil pump</li> <li>2. Identify potential solutions and/or replace the priority valve</li> <li>3. Adjust the control pressure</li> <li>4. Turn the steering wheel until the tires are at its maximum steering position, then continue to turn the steering wheel, forcing the safety valve open, thereby venting the air out of the steering system</li> </ol>
--	---



**Foam in the oil, abnormal sound coming from the oil, oil cylinders sometimes move and stop while the steering wheel is being turned**

1. Air in the system	1. Check oil level and add oil to the required level. Check whether there is air leakage in the suction oil and resolve venting the air out of the system
----------------------	---

**Easy steering without load, heavy steering with load**

1. Setting of the steering safety valve pressure lower than the operation pressure 2. Steering safety valve is blocked 3. High oil viscosity	1. Re-adjust the steering safety valve pressure setting 2. Clear the dirt off 3. Replace with the recommended oil
--	---

**Heavy steering when the throttle is low, normal steering when the throttle is high**

1. Low pump volume efficiency 2. Large clearance between the priority valve spool and body	1. Replace oil pump 2. Replace the priority valve
---	--

**No tactile operator feedback**

**Operation of the steering wheel is still light when the tires are at there limited steering position**

1. Pressure setting of the bidirectional cushion valve on the oil port of the steering gear is lower than that of the steering safety valve 2. Severe wear and excessive clearance between the valve body, sleeve, and spool, or between the stator and rotor pair of steering gear	1. Re-adjust the bidirectional cushion valve starting pressure, which should not less than 1.25 times of the steering safety valve set pressure 2. Replace the worn parts or the steering gear
--	---

**Steering failure**

**Steering wheel cannot return to the neutral position. The pressure drop increases in the neutral position**

1. Spring plates are broken	1. Replace the broken spring plates
-----------------------------	-------------------------------------

**Pressure run-out increases significantly, and even cannot rotate**

1. Pin puller or drive shaft opening is broken or deformed	1. Replace pin puller or drive shaft
--	--------------------------------------



## Electric System

### Generator does not generate electricity, or the voltage is low

<ol style="list-style-type: none"> <li>1. Drive belt is slipping</li> <li>2. Connector contains oily dirt or is worn</li> <li>3. Bad contact between electric brush and connector</li> <li>4. Excitation coil is open circuit</li> <li>5. Residual magnetism disappears</li> </ol>	<ol style="list-style-type: none"> <li>1. Adjust the belt</li> <li>2. Clean the oily dirt off using a clean cloth moistened with gasoline or grind it using fine abrasive paper</li> <li>3. Check and repair</li> <li>4. Inspect the outer magnetic field and check the excitation loop with a light bulb</li> <li>5. Magnetically charge or replace with a new generator</li> </ol>
--	--

### Battery does not charge or the charging current is weak

<ol style="list-style-type: none"> <li>1. Damaged voltage regulator</li> <li>2. Bad wire contacts or open circuit</li> </ol>	<ol style="list-style-type: none"> <li>1. Repair or replace</li> <li>2. Check connecting wires between the generator and battery</li> </ol>
--	---

### Large spark between the generator brush and connector

<ol style="list-style-type: none"> <li>1. Severe connector wear</li> </ol>	<ol style="list-style-type: none"> <li>1. Clean connector, clear the dirt out from the connector lugs</li> </ol>
--	--

### Generator is overheating

<ol style="list-style-type: none"> <li>1. High voltage regulator voltage</li> <li>2. Worn bearings or less lubrication</li> <li>3. Short circuit in connector or armature coil</li> </ol>	<ol style="list-style-type: none"> <li>1. Adjust regulator voltage</li> <li>2. Replace bearings or add lubrication oil</li> <li>3. Disassemble, repair or replace</li> </ol>
---	--

### Engine starts difficulty

<ol style="list-style-type: none"> <li>1. Low voltage or damaged battery</li> <li>2. Damaged start switch</li> <li>3. Bad wire contacts or open circuit</li> <li>4. Air present in engine fuel inlet lines</li> </ol>	<ol style="list-style-type: none"> <li>1. Charge or replace with a new battery</li> <li>2. Repair or replace</li> <li>3. Check and repair</li> <li>4. Venting the air out of the lines</li> </ol>
---	---

## Air Conditioning System

### Cooling air not emitted from the air conditioning vents

<ol style="list-style-type: none"> <li>1. Drive belt is too loose or is broken</li> <li>2. Fuse is blown, wire is disconnected, cooling air switch is damaged, or blower motor stops working</li> <li>3. Compressor does not rotate, belt is slipping on the pulley</li> </ol>	<ol style="list-style-type: none"> <li>1. Tighten belt or replace with a new belt</li> <li>2. Replace with new fuse, repair wire, switch, and/or blower motor</li> <li>3. Remove the compressor, repair or replace</li> </ol>
--	---



<p>4. Compressor does not work. When the engine speed varies, only slight changes are observed between low and high-pressure readings</p> <p>5. Cooling system lines are broken, or refrigerant is leaking, Low and high pressure readings are zero</p> <p>6. Dryer of the receiver or expansion valve is blocked</p>	<p>4. Repair or replace with the compressor valve plate</p> <p>5. Repair cooling system lines, inspect system for leakage, evacuate lines, and fill with Freon</p> <p>6. Disassemble, repair or replace</p>
---	---

### **Insufficient cooling air volume**

<p>1. Insufficient volume of air in the vent duct, air leakage in the vent duct</p> <p>2. Blower motor does not function properly</p> <p>3. Compressor electromagnetic clutch slips</p> <p>4. Compressor efficiency decreases</p> <p>5. Air exists in the cooling system, excessively high pressure shown in the high pressure gauge, misty/murky substances seen in the sight glass</p> <p>6. Insufficient refrigerant, bubbles can be seen in the sight glass, excessively high pressure shown in the high pressure gauge</p> <p>7. Insufficient air circulation around the radiator, excessively high pressure shown in the high pressure gauge</p>	<p>1. Clean or replace the air filter screen, clear off obstructions in the vent duct, reconnect the vent duct</p> <p>2. Repair or replace the blower motor</p> <p>3. Repair or replace the electromagnetic clutch</p> <p>4. Repair or replace the compressor</p> <p>5. Bleed air, evacuate the lines, and fill with Freon</p> <p>6. Add refrigerant until the bubbles disappear</p> <p>7. Clean the radiator and engine water tank, or install a condensation fan</p>
--	--

### **Cooling system working intermittently**

<p>1. Controllers for idle running and temperature are out of control</p> <p>2. Compressor electromagnetic clutch slips</p> <p>3. Electromagnetic clutch coil is loose or not grounded well</p> <p>4. Water in the cooling system causes an intermittent blocking of the expansion valve</p>	<p>1. Re-adjust or repair</p> <p>2. Disassemble the bracket or replace</p> <p>3. Disassemble, repair or replace</p> <p>4. Replace the dryer of the receiver</p>
--	---



## Increasing noise

<ol style="list-style-type: none"><li>1. Drive belt is loose or worn</li><li>2. Compressor is loose on its mounting bracket</li><li>3. Blower motor is loose or worn</li><li>4. Slip of the electromagnetic clutch is resulting in noise</li><li>5. Inner parts of the compressor are worn</li></ol>	<ol style="list-style-type: none"><li>1. Tighten belt or replace with a new belt</li><li>2. Tighten bracket mounting screws</li><li>3. Repair or replace the motor</li><li>4. Disassemble, repair or replace</li><li>5. Repair or replace the compressor</li></ol>
--	--