



Professional Shop Manual



I Series Riding Tractors

NOTE: These materials are for use by trained technicians who are experienced in the service and repair of outdoor power equipment of the kind described in this publication, and are not intended for use by untrained or inexperienced individuals. These materials are intended to provide supplemental information to assist the trained technician. Untrained or inexperienced individuals should seek the assistance of an experienced and trained professional. Read, understand, and follow all instructions and use common sense when working on power equipment. This includes the contents of the product's Operators Manual, supplied with the equipment. No liability can be accepted for any inaccuracies or omission in this publication, although care has been taken to make it as complete and accurate as possible at the time of publication. However, due to the variety of outdoor power equipment and continuing product changes that occur over time, updates will be made to these instructions from time to time. Therefore, it may be necessary to obtain the latest materials before servicing or repairing a product. The company reserves the right to make changes at any time to this publication without prior notice and without incurring an obligation to make such changes to previously published versions. Instructions, photographs and illustrations used in this publication are for reference use only and may not depict actual model and component parts.

© Copyright 2009 MTD Products Inc. All Rights Reserved

MTD Products Inc. - Product Training and Education Department

FORM NUMBER - 769-03231A

08/2009

Table of Contents

Chapter 1: Introduction	1
Professional Shop Manual intent	1
Description of the I-series	2
Model and Serial Numbers	2
Chapter 2: Engine related parts	3
Muffler	3
Exhaust pipes	5
Fuel tank removal/replacement	5
Chapter 3: Brakes	7
Brake system description	7
Brake adjustment - HydroGear transmissions	8
Brake adjustment - IVT transmissions	9
Brake puck/rotor replacement - HydroGear Transmissions	9
Brake shoes/drum - IVT transmissions	12
Brake cross shaft assembly	13
Chapter 4: Body/chassis	17
The hood	17
Bumper	18
Remove the fender	20
Chapter 5A: Drive system - HydroGear Transmissions	23
Drive belt	23
Belt adjustment	25
Transmissions	26
Drive pedal shaft	28
Chapter 5B: Drive system - IVT Transmission	29
Drive belt	32
Belt adjustment	35
Transmissions	36
Drop axle assemblies	38
Rebuilding the drop axles	39
Drive pedal shafts	42
Chapter 6A: Steering - Hydrogear Transmissions	49
Introduction	49
Cam Slot Angle Adjustment	49
Neutral and Transmission Links Adjustment	52
Wheel alignment	54
Steering gear box removal	55

Rebuilding the steering gear box	59
Wear block adjustment	71
Front wheels and axles	72
Drag links	74
Tie rod	74
Inboard steering gear	75
Pivot bar	76
Chapter 6B: Steering - IVT Transmission	81
Introduction	81
Cam Slot Angle Adjustment	81
Neutral and drive control links Adjustment	84
Wheel alignment	88
Steering gear box removal	89
Rebuilding the steering gear box	92
Front wheels and axles	102
Drag links	104
Tie rod	105
Inboard steering gear	106
Pivot bar	107
Chapter 7: electrical system	111
Introduction	111
Components	111
Electrical environment: AC Vs. DC	121
Types of circuits	124
Series	124
Parallel	124
Series/parallel	124
Shorts	124
Opens 1	124
Increased resistance	125
The Tools	125
Equipment that may be useful	125
Digital Multi-meter	125
Wiring diagram or schematic	126
Fused jumper wires	126
Test lights	126
Ammeters and specialized charging system testers	127
Batteries	130
Battery Testers	132
Testing the battery	132
Voltage Drop Test	136
Cutting decks	143

Chapter 8: Cutting Decks and lift shaft	143
Cleaning the deck	144
To clean the deck while it is removed.	144
Blades	144
PTO belt	146
Timing belt	147
Spindles	149
To replace a spindle	150
Leaving the deck	150
Side to Side Leveling	150
Front To Rear Leveling.	151
Deck Gauge Wheel Adjustment	152
Deck Rear Roller Adjustment	152
Deck lift shaft assembly bushings	153
Deck lift shaft assembly removal/replacement	154
Deck lift links and cables	155
Chapter 9: Maintenance intervals	157
Lubrication	157
Engine maintenance	157
The spark plugs	157
Air filter and foam pre cleaner	158
Oil change	159
Oil filter	160
Fuel system	161
Servicing the fuel system	161
Fuel filter	161
Clean the engine	162

CHAPTER 1: INTRODUCTION

Professional Shop Manual intent

This Manual is intended to provide service dealers with an introduction to the mechanical aspects of the I-series tractor.

This Professional Shop Manual covers the I-series tractor more specifically, and in greater depth than the original Shop Handbook.

- The content in this manual supersedes any content in the handbook.
- Detailed service information about the engine will be provided by the engine manufacturer, in most cases.

Disclaimer: The information contained in this manual is correct at the time of writing. Both the product and the information about the product are subject to change without notice.

About the text format:

NOTE: is used to point out information that is relevant to the procedure, but does not fit as a step in the procedure.

- Bullet points: indicate sub-steps or points.



Caution is used to point out potential danger to the technician, operator, bystanders, or surrounding

property.



Warning indicates a potentially hazardous situation that, if not avoided, could result in death or serious

injury.



Danger indicates an imminently hazardous situation that, if not avoided, will result in death or serious injury.

This signal word is to be limited to the most extreme situations

Disclaimer: This manual is intended for use by trained, professional technicians.

- Common sense in operation and safety is assumed.
- In no event shall MTD or Cub Cadet be liable for poor text interpretation or poor execution of the procedures described in the text.
- If the person using this manual is uncomfortable with any procedures they encounter, they should seek the help of a qualified technician or Cub Cadet Technical Support.

Fasteners

- Most of the fasteners used on the vehicle are sized in fractional inches. Some are metric. For this reason, wrench sizes are frequently identified in the text, and measurements are given in U.S. and metric scales.
- If a fastener has a locking feature that has worn, replace the fastener or apply a small amount of releasable threadlocking compound such as Loctite® 242 (blue).
- Some fasteners like cotter pins are single-use items that are not to be reused. Other fasteners such as lock washers, retaining rings, and internal cotter pins (hairpin clips) may be reused if they do not show signs of wear or damage. This manual leaves that decision to the judgement of the technician.

Assembly

Torque specifications may be noted in the part of the text that covers assembly, they may also be summarized in tables along with special instructions regarding locking or lubrication. Whichever method is more appropriate will be used. In many cases, both will be used so that the manual is handy as a quick-reference guide as well as a step-by-step procedure guide that does not require the user to hunt for information.

The level of assembly instructions provided will be determined by the complexity and of reassembly, and by the potential for unsafe conditions to arise from mistakes made in assembly.

Some instructions may refer to other parts of the manual for subsidiary procedures. This avoids repeating the same procedure two or three times in the manual.

INTRODUCTION

Description of the I-series

The I-series is a revolutionary new tractor platform introduced in the 2007 season. This platform combines a traditional lawn tractor with zero-turning capabilities. This is accomplished by controlling the drive of the rear wheels independently and the use of an innovative steering system. See Figure 1.1.



Figure 1.1

The Steering gear box operates the control linkages for the transmissions while turning the front wheels. This gives the I-series zero-turning capabilities while using a traditional steering wheel.

The I-series comes with 42", 46" and 50" deck options. The I-series tractors also have the Cub Cadet Rev-Tek system.

The I-series tractor can be equipped with two HydroGear Transmissions or an IVT transmission. The Infiltrak full-toroidal Infinitely Variable Transmission (IVT) was first introduced in Europe for the 2009 model year.

Model and Serial Numbers

The model and serial number tag can be found under the seat. See Figure 1.2.



Figure 1.2

The serial number is located to the right of the model number as shown above. See Figure 1.2.

The model number is 17AF9BKH710. The breakdown of what the number mean is as follows:

17.....residential zero turn mower
...A.....sales level
.....F.....engine code
.....9.....frame
.....B.....drive system
.....K.....hood style
.....H.....deck (H = 46" K = 50")
.....710....customer number

The serial number is 1J056G10005. The serial number reads as follows:

1.....engineering level
..J.....month of production (J = October)
....05.....day of the month
.....6.....last digit of the year
.....G.....plant it was built in
.....1.....assembly line number
.....0005.....number of unit built

CHAPTER 2: ENGINE RELATED PARTS

This chapter will cover the engine accessories that are manufactured by Cub Cadet.

IMPORTANT: The engine is manufactured by Kohler. Refer to the Kohler manual for engine specific service information.

Muffler

Remove the muffler by following these steps:

1. Remove the hood and bumper by following the steps described in Chapter 4: Body/Chassis.
2. Remove the two screws on each side that hold the muffler guard bracket. See Figure 2.1.



Figure 2.1

3. Remove the hood pivot brackets by removing the two screws that secure each one in place. See Figure 2.2.

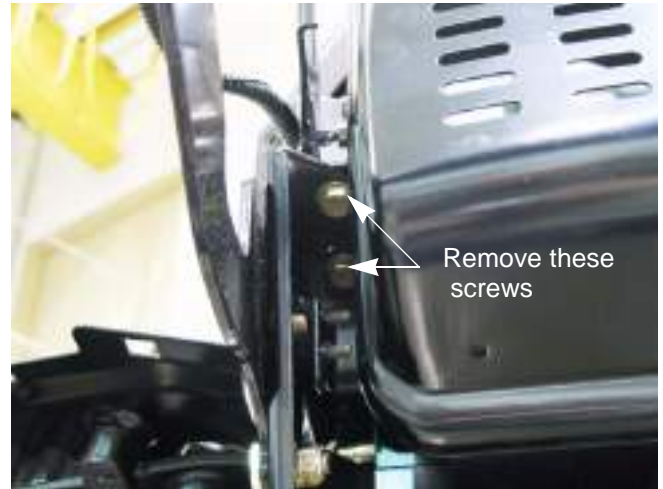

Figure 2.2

4. Pull the muffler cover and muffler out together. See Figure 2.3.



Figure 2.3

NOTE: The muffler slides onto the exhaust pipes. The heat of the exhaust makes the pipes expand and forms a seal with the muffler. Do not weld or place a sealer between the muffler and exhaust pipes.

ENGINE RELATED PARTS

5. With the muffler on a work bench, remove the four screws that fasten the muffler to the muffler bracket. See Figure 2.4.



Figure 2.4

6. Remove the two screws that fasten the muffler guard to the muffler bracket. See Figure 2.5.

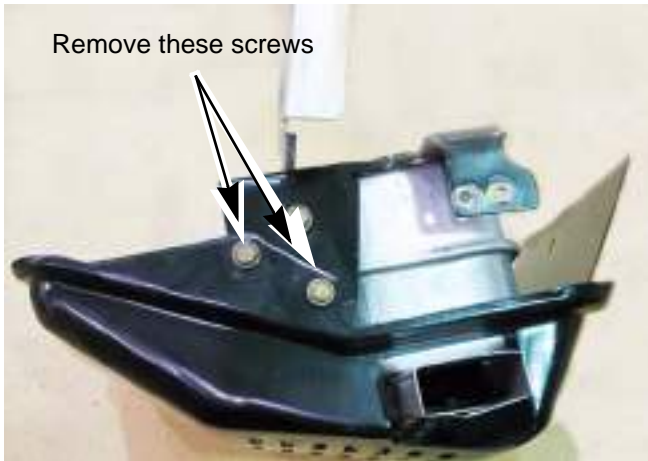

Figure 2.5

7. The muffler, muffler cover and the muffler bracket can now be separated. See Figure 2.6.

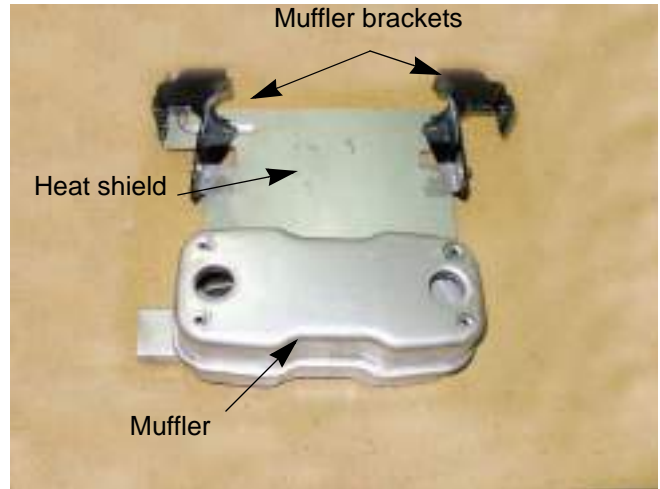

Figure 2.6

- NOTE:** The heat shield and muffler brackets can be left together and handled as one part.
8. Install the muffler by following the above steps in reverse order.

Exhaust pipes

The exhaust pipes are manufactured by Cub Cadet. To remove/replace the exhaust pipes:

1. Remove the muffler following the steps described in the previous section.
2. Remove the mounting bolts using a 1/2" wrench. See Figure 2.7.



Figure 2.7

3. Discard the old exhaust gaskets. Clean all gasket material from the cylinder head (and exhaust pipe if it is being reused).
4. Using new gaskets, install the exhaust pipes following the above steps in reverse order.

Fuel tank removal/replacement

Remove/replace the fuel tank by following these steps:



Gasoline and its vapors are extremely flammable. Use common sense when working around the fuel system

1. Remove the deck.
2. Remove the fender by following the steps described in Chapter 4: Body/Chassis.
3. Remove the hair pin clips retaining the deck lift cables and disconnect the cables. See Figure 2.8.

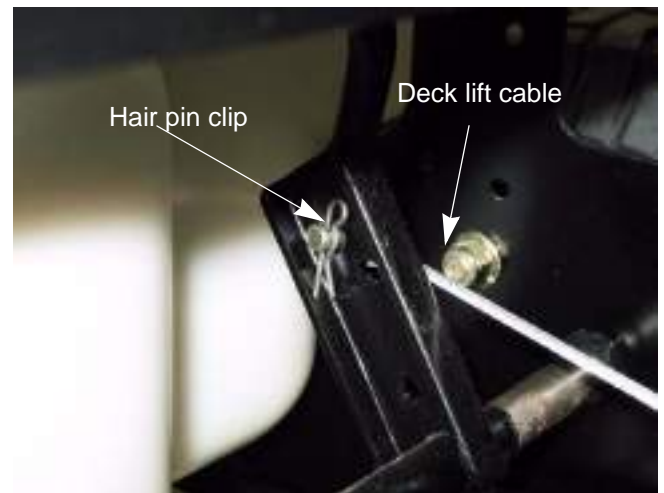

Figure 2.8

4. Unhook the deck lift assist spring. See Figure 2.9.



Figure 2.9

ENGINE RELATED PARTS

5. Remove the two screws and two nuts that fasten the seat box cover. See Figure 2.10.



Figure 2.10

6. Remove the seat box cover.
7. Clamp the fuel line. See Figure 2.11.

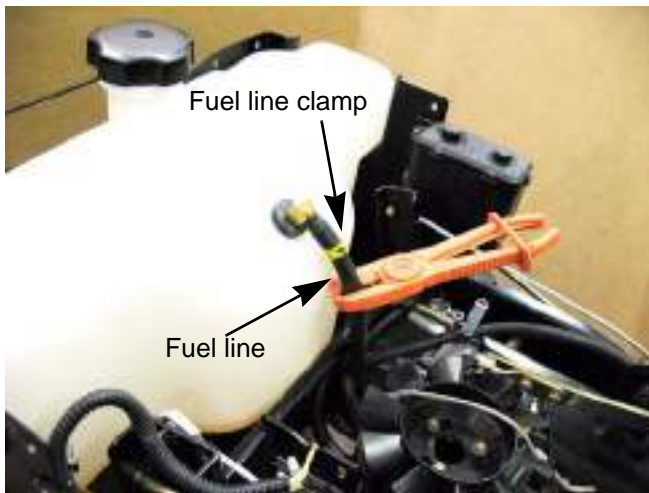

Figure 2.11

8. Remove the fuel line clamp and slide the fuel line off.
NOTE: The fuel tank has a barbed fitting. Anytime a fuel line is removed from a barbed fitting it should be replaced because of the damage caused to the fuel line liner.
9. Lift the fuel tank out of the seat box.
10. Install the fuel tank by following the above steps in reverse order.
11. Test run the tractor and check for leaks before returning to service.

CHAPTER 3: BRAKES

Brake system description

The I-series tractors have two braking systems available based on which transmission is used. HydroGear transmissions use a disc type brakes. The IVT transmission uses an external drum brake system.

For HydroGear transmissions:

- The brakes are located on each transmission.
- They are activated by pressing on the brake pedal.
- The brake pedal is attached to a brake cross shaft assembly. This will pull on the two brake rods.
- The brake rods are attached to the cam arms, in the brake calipers, by over travel springs.
- When the cam arms are pulled forward they push on the brake pins by a cam action applying pressure to the brake pads.
- The brake cross shaft assembly also has a link that is connected to the drive belt idler pulley bracket. When the brakes are applied, the idler pulley is pulled away from the drive belt. This de-tensions the belt, disengaging drive to the transmissions. See Figure 3.1.

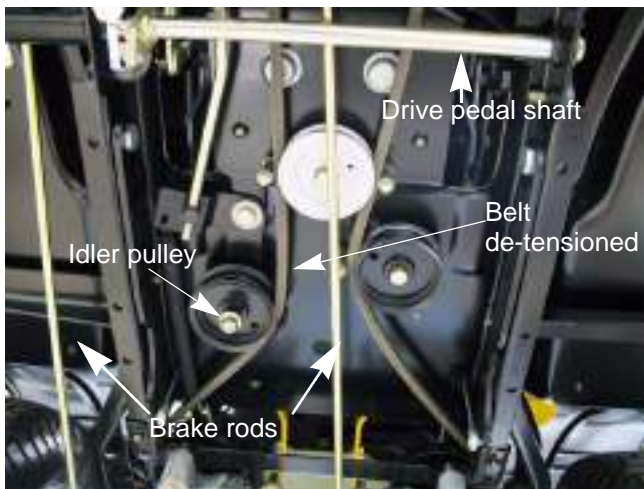

Figure 3.1

For the IVT transmission:

The IVT transmission has two drop axles. On each drop axle there is an external drum brake. See Figure 3.2.

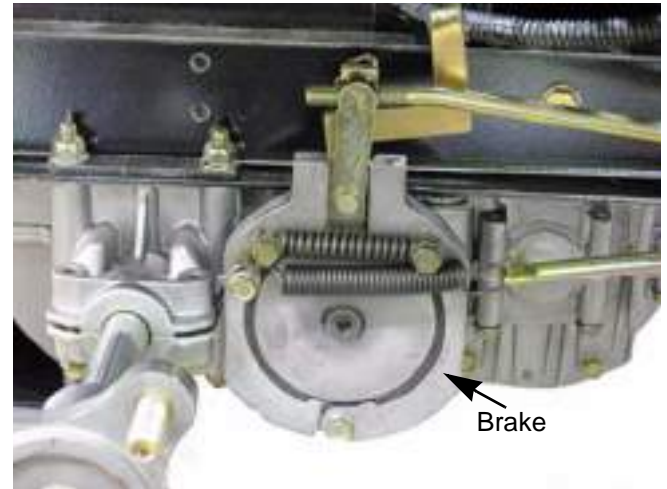

Figure 3.2

- The brakes are applied whenever the drive pedal is released.
- Depressing the brake pedal will disengage the drive belt and apply extra force to the rear shoes.
- The idler pulley bracket has a gas charged dampener attached to it. This dampener will smooth out the engagement of the drive belt when the brake pedal is released.

BRAKES

Brake adjustment - HydroGear transmissions

NOTE: Whenever performing a brake adjustment, inspect the brake components for signs of wear or damage.

1. Block the front wheels.
2. Lift and safely support the rear of the tractor. See Figure 3.3.



Figure 3.3

NOTE: Make sure the brake and parking brake are released.

3. Remove the rear wheels.
4. Remove the cotter pin locking the castle nut on the brake caliper. See Figure 3.4.

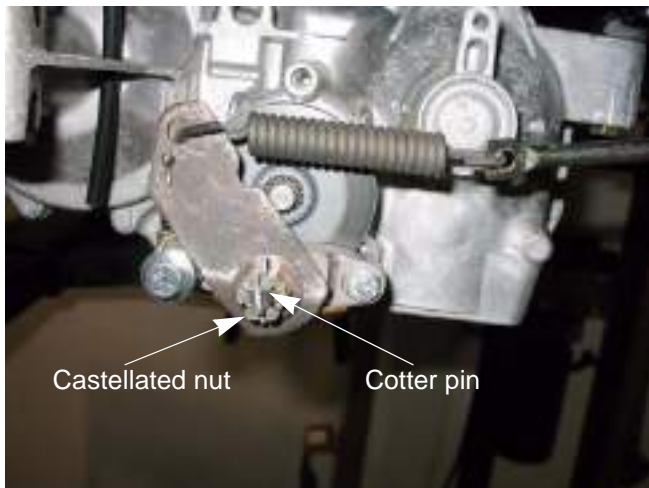

Figure 3.4

5. Back the castle nut off a few turns using a 9/16" wrench.

NOTE: Even if the brakes are set to the correct clearance, inserting a feeler gauge between the rotor and the brake puck can be very difficult. Loosen the castle nut first, then insert the feeler gauge and tighten the nut to set the proper clearances

6. Insert a .030" (0.8 mm) feeler gauge between the brake rotor and the outboard brake puck. See Figure 3.5.



Figure 3.5

NOTE: The tolerance for the brake clearance is .020" - .040" (0.5 - 1.0mm). The .030 feeler gauge will set the clearance at the midpoint.

7. Tighten the nut until there is a slight drag on the feeler gauge when sliding it out.

NOTE: For even braking, both sides should be set to the same clearance.

8. Install a new cotter pin.
9. Repeat same procedure on the other side.
10. Put the wheels back on. Tighten the lug nuts to a torque of 53 - 60 ft lbs. (72 - 81 Nm).
11. Take the tractor off of the jack stands.
12. Open the by-pass valves and check the parking brake before returning the tractor to service.

- With the brakes released, the tractor should have only hydraulic drag when it is pushed.
- With the brakes engaged, the wheels should slide before they rotate when the tractor is pushed.

Brake adjustment - IVT transmissions

To adjust the brakes on IVT transmission:

1. Lift the rear of the tractor and safely support it with a pair of jack stands.
2. Remove the rear wheels with a 3/4" wrench.
3. Release the parking brake.
4. Remove the cotter pin that retains the ferrule of the drive control rod. See Figure 3.6.

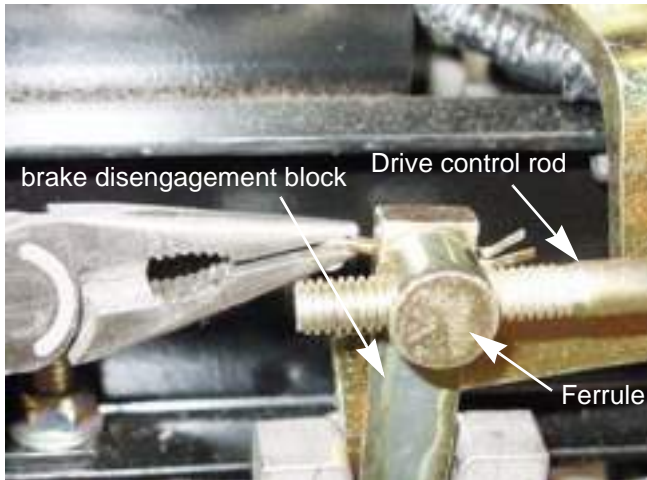

Figure 3.6

5. Slide the ferrule of the drive control rod out of the brake disengagement block.

NOTE: Once the control rod is disengaged, the springs will clamp the brake shoes against the drum. This will automatically center the disengagement block.
6. Adjust the ferrule until it slides into the hole in the disengagement block with out applying pressure to it.
7. Install a new cotter pin into the ferrule to secure it to the disengagement block.
8. Repeat the steps 4 - 6 on the other side of the tractor.
9. Install the rear wheels. Tighten the lug nuts to a torque of 53 - 60 ft lbs. (72 - 81 Nm).
10. Take the tractor off of the jack stands.
11. Test drive the tractor in a safe area before returning it to service.

Brake puck/rotor replacement - HydroGear Transmissions

On HydroGear transmissions, the brake pucks are a wearing part that will need to be serviced from time to time. If a tractor is operated with the parking brake dragging, the pucks will wear out rapidly and the brake rotor will develop hot spots. If the tractor is operated long enough, the rotor may have grinding marks on it with excessively worn pucks.



If the rotor shows hot spots or any other signs of damage, including warpage, it must be replaced. Failure to do so can result in the failure of the brakes

The brake pucks and the rotors are serviced at the same time. To service the brake pucks:

1. Jack up the tractor and remove the rear wheels as described in the previous section.
2. Make sure the brakes are released.
3. Disconnect the brake rod spring. See Figure 3.7.



Figure 3.7

BRAKES

4. Loosen the rear mounting bolt. See Figure 3.8.

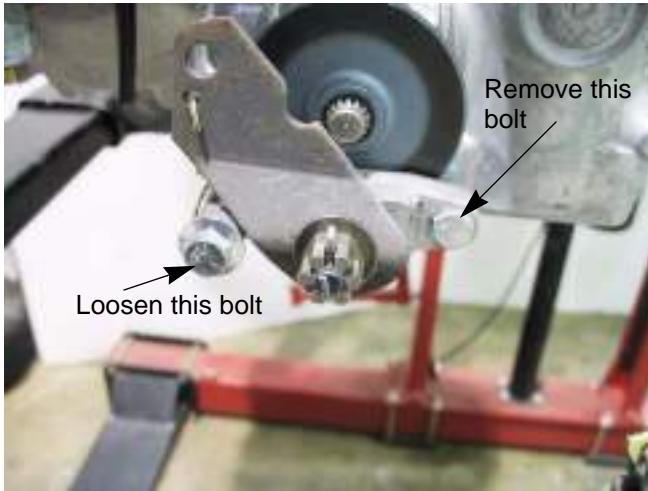

Figure 3.8

5. Remove the front mounting bolt, allowing the caliper to swing down. See Figure 3.9.



Figure 3.9

6. The outboard brake puck should fall out when the brake caliper swings down. If it did not, it can be removed now.

7. Slide the brake rotor off to reach the inboard brake puck. See Figure 3.10.



Figure 3.10

8. Remove the caliper for inspection when servicing the brake pucks. To do this, remove the rear bolt loosened in step 4.
9. With the caliper on a work bench, remove the brake puck, backing plate and the two brake pins. See Figure 3.11.

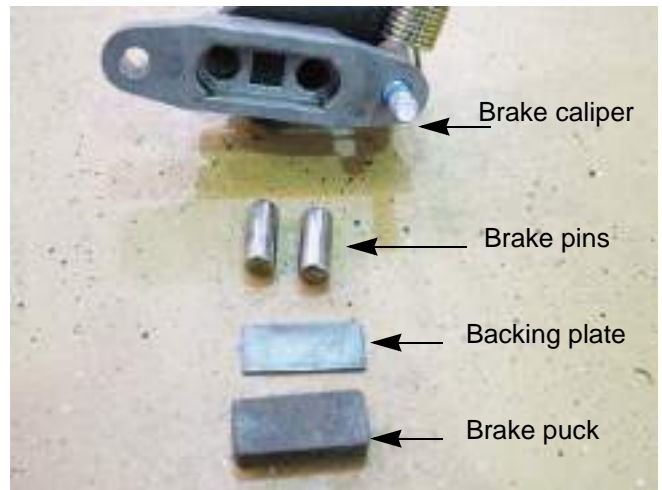

Figure 3.11

10. Check for free movement of the brake pins. A dry lubricant can be used on the brake pins sparingly.



Never put grease or anti-seize on brake pins. It can migrate to the brake pucks, preventing the braking action of the pucks.

11. Slide the brake pins into the caliper.
12. Place the backing plate in the caliper.
13. Place a new puck into the caliper.
See Figure 3.12.

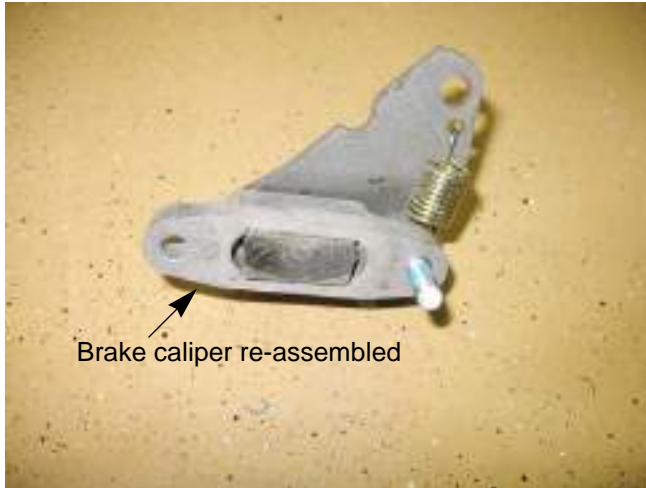

Figure 3.12

NOTE: A piece of scotch tape may be used to hold the new brake pucks in place for assembly. The tape will grind away when the brakes are applied.

14. Place a new brake puck into the recess in the transmission. Use a piece of scotch tape to hold it in place.
15. Slide the brake rotor in place, shoulder out.
16. Mount the brake caliper to the transmission. Apply a small amount of releasable thread locking compound such as Loctite® 242 (blue) to the mounting bolts and tighten to a torque of 80 - 120 in-lbs (9 - 13.5Nm).
17. Reconnect the brake rod spring.
18. Adjust the brakes as described in the previous section.
19. Put the wheel on.
20. Repeat steps 4-19 on the other side.
21. When both sides are completed and both wheels are back on, take the tractor off of the jack stands.
22. Open the by-pass valves and check the parking brake before returning the tractor to service.
 - With the brakes released, the tractor should have only hydraulic drag when it is pushed.
 - With the brakes engaged, the wheels should slide before they rotate when the tractor is pushed.

BRAKES

Brake shoes/drum - IVT transmissions

On IVT transmissions, the brake shoes and drums are the wearing parts that will need to be serviced from time to time. If a tractor is operated with the parking brake dragging, the shoes will wear out rapidly and the brake drum will develop hot spots. If the tractor is operated long enough, the drum may have grinding marks on it with excessively worn shoes.



If the drum shows hot spots or any other signs of damage, including warpage, it must be replaced. Failure to do so can result in the failure of the brakes

IMPORTANT: The brake shoes and the drums must be replaced at the same time.

To service the brakes:

1. Jack up the tractor and remove the rear wheels as described in the previous section.
2. Make sure the brakes are released.
3. Disconnect the brake rod spring. See Figure 3.13.

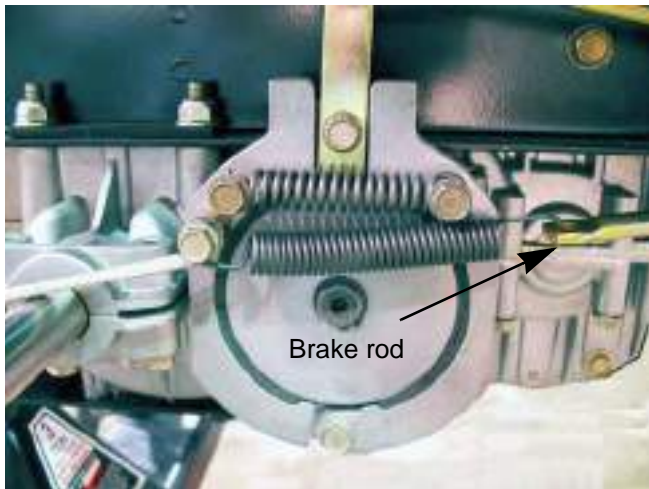

Figure 3.13

4. Disconnect the brake shoe spring. See Figure 3.14.

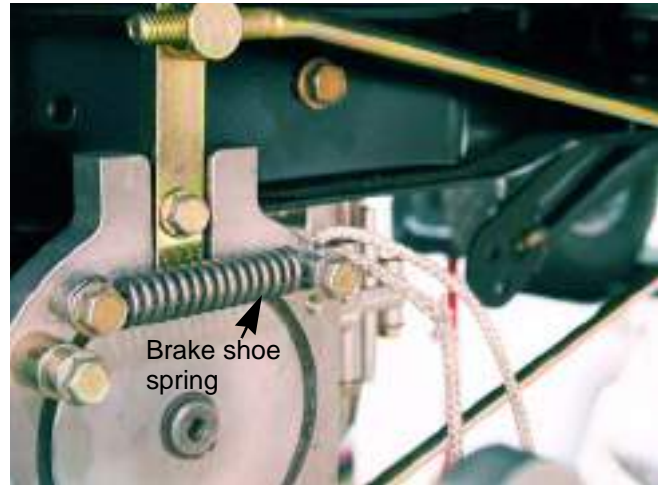

Figure 3.14

NOTE: There is a lot of tension in the brake shoe springs. A piece of starter rope can be used to remove the spring.



Do not remove the screws to disconnect the brake shoe springs. The springs are under high tension and can cause the screw to become a projectile as it is being removed.

5. Remove the pivot bolt at the bottom of the brake shoes.

NOTE: There is a spacer behind the shoes that will fall out as the pivot bolt is removed. See Figure 3.15.

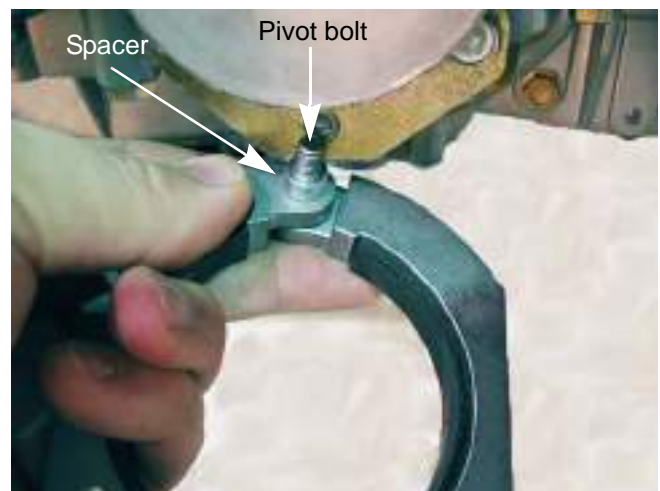

Figure 3.15

- Remove the snap ring that secures the drum with a pair of snap ring pliers. See Figure 3.16.



Figure 3.16

- Install the drum and shoes by following steps 1 - 7 in reverse order.
- Repeat steps 1-8 on the other side of the tractor.



Never put grease or anti-seize on the brake shoe pivot screw or the drum splines. It can migrate to the braking surfaces, preventing the braking action of the shoes.

- Test drive the tractor in a safe area before returning it to service.

Brake cross shaft assembly

The brake cross shaft assembly for the HydroGear transmissions and the IVT transmissions are not the same. The procedure to service them are the same.

The brake cross shaft assembly is supported by two bushings. Excessive movement in the brake cross shaft assembly may be an indication that the bushings are worn out.

To replace the brake cross shaft bushings:

- Remove the cotter pins that retain the three brake rods. Slide the brake rods out of the brake cross shaft assembly. See Figure 3.17.

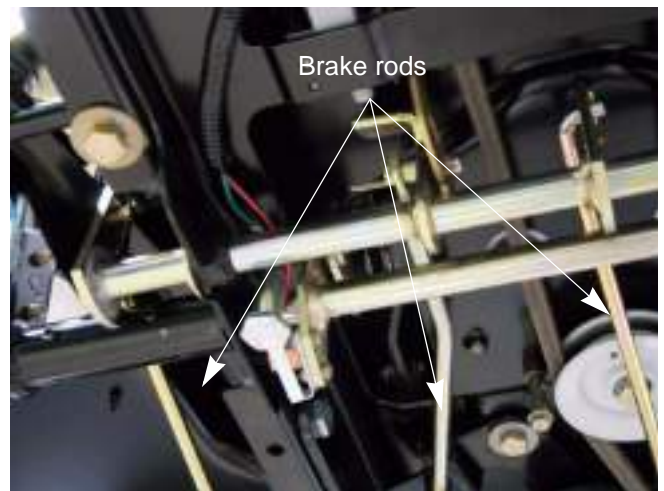

Figure 3.17

- Remove the cotter pins on each end of the brake cross shaft. See Figure 3.18.



Figure 3.18

BRAKES

3. Remove the right side bushing first. This will allow the shaft to slide far enough to the left to let the other bushing to come out.
4. Install new bushings by following the above steps in reverse order.

NOTE: Do not put grease on the bushings. Grease can trap dirt that will accelerate the wear of the bushing.

5. Check the operation of linkage and test drive the tractor in a safe area before returning to service.

To remove/replace the brake cross shaft assembly:

1. Remove the brake pedal by removing the two screws using a 1/2" wrench.
2. Remove the cotter pins that retain the three brake rods. Slide the brake rods out of the brake cross shaft assembly. See Figure 3.19.

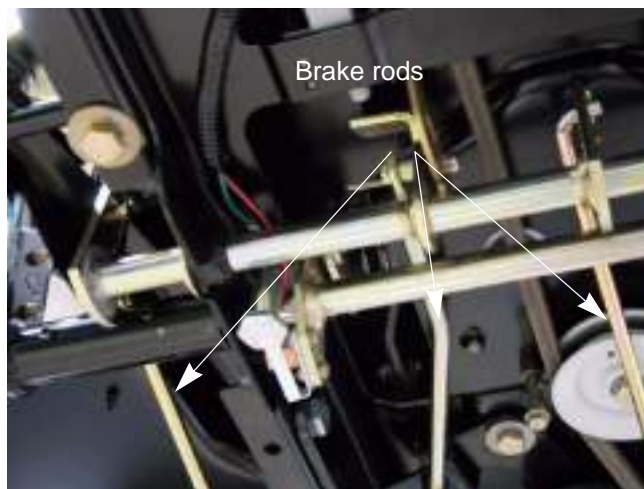

Figure 3.19

3. Remove the four screws (two on each side) that hold the sub-frame in place and slide it down. See Figure 3.20.



Figure 3.20

- Loosen the shoulder bolt that the parking brake plate pivots on. See Figure 3.21.

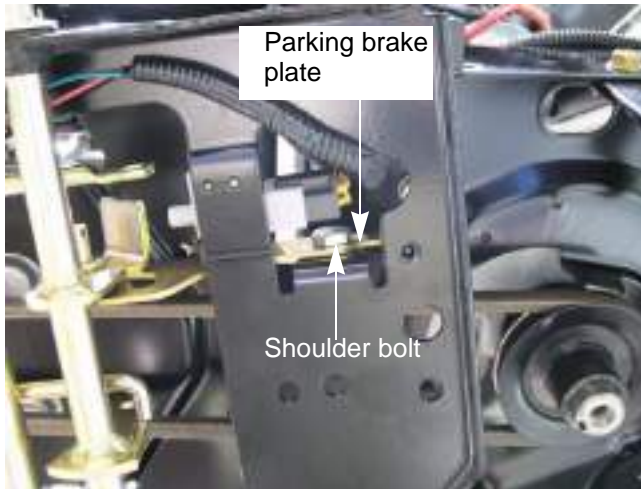

Figure 3.21

- Remove the cotter pin from each end of the brake cross shaft. See Figure 3.22.



Figure 3.22

- Slide the split bushings out of their pockets in the sub-frame, then pull them off of the brake cross shaft assembly. See Figure 3.23.

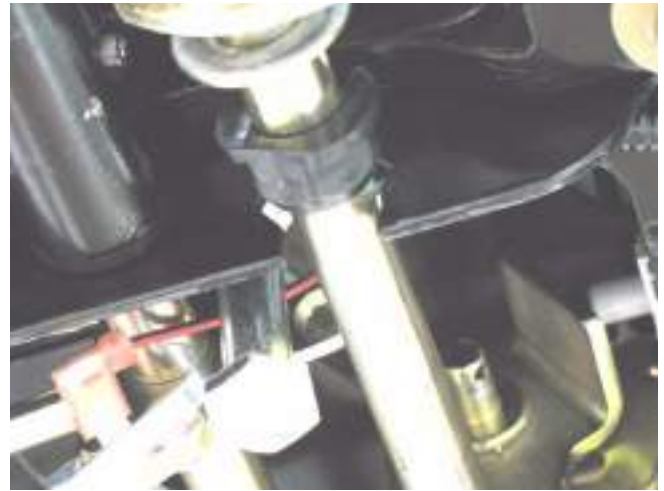

Figure 3.23

- Work the brake cross shaft out of the sub frame.

NOTE: Take care not to bend the parking brake plate while working the brake cross shaft out. Make sure the shoulder bolt is loose enough to give the shaft clearance. The plate can be removed if necessary. See Figure 3.24.

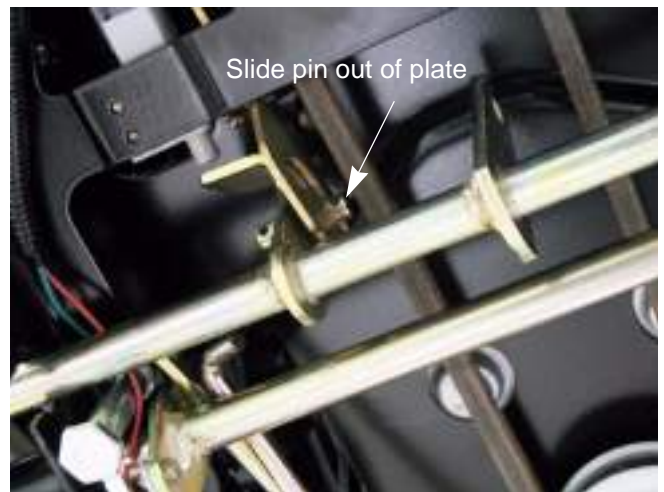

Figure 3.24

- Replace the brake cross shaft by following the above steps in reverse order.
- Test drive the tractor in a safe area before returning to service.

BRAKES

CHAPTER 4: BODY/CHASSIS

The hood

The I-series hood uses the same hood pivot system as the 1000 series for easy removal.

To remove the hood:

1. The hood is front-hinged. See Figure 4.1.



Figure 4.1

2. Open the hood by lifting the rear edge to tilt it forward.
3. Disconnect the headlight wires. See Figure 4.2.



Figure 4.2

NOTE: The ground terminals and power terminals on the headlights are two different sizes. The green wires (ground) fit the larger terminals. The red wires (power) fit the smaller terminals.

4. Cut the wire tie that secures the headlight harness to the hood. See Figure 4.3.

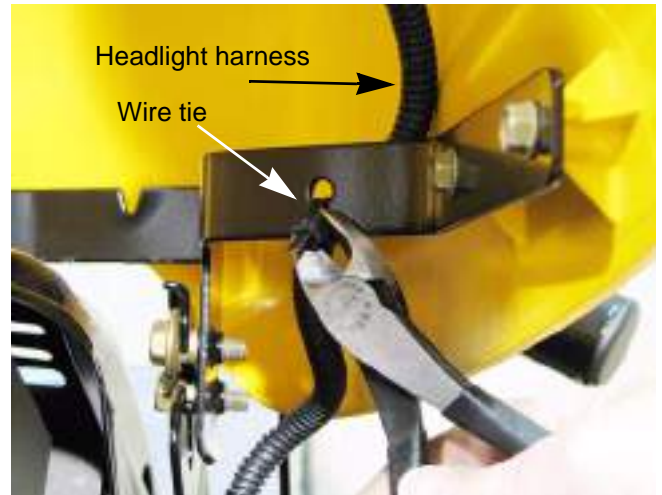

Figure 4.3

5. The hood hinges on a pair of shoulder bolts on each side that fit into slots in the hood bracket.
6. The hinge travel is limited by the top shoulder bolt that fits into a channel in the hood bracket.
7. Open the hood far enough to align the tabs with the slots, then lift the hood off of the tractor. See Figure 4.5.

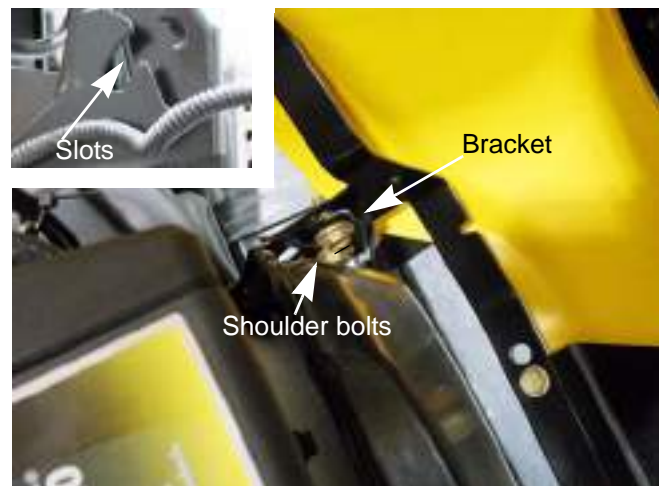

Figure 4.4

BODY/CHASSIS

Bumper

I-series tractors come equipped with a fast attach bumper. To remove the bumper:

1. Remove the two screws, one on each side, that secures the bumper bracket. See Figure 4.5.

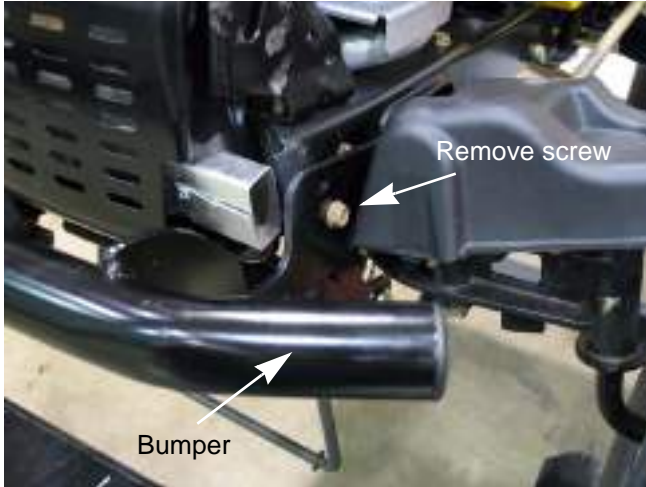

Figure 4.5

2. Pull the bumper straight forward, sliding the bumper off of the shoulder bolts. See Figure 4.6.



Figure 4.6

3. Install the bumper following the above steps in reverse order.

Dash Removal

The dash for the I-series is easy to remove. There are a few repair procedures, such as the cam angle adjustment or replacing the steering gearbox, that require the dash to be removed. The steps to remove it are as follows:

1. Remove the steering wheel:
 - 1a. Remove the center cover. See Figure 4.7.



Figure 4.7

- 1b. Remove the bolt with a 1/2" wrench. See Figure 4.8.



Figure 4.8

NOTE: There is no puller needed for the steering wheel. Once the bolt is removed it will lift off of the steering shaft.

NOTE: When replacing the steering wheel, lock the steering gear box in neutral as described in steering chapters (6A or 6B). This will make it easier to center the steering wheel.

2. Remove the dash:
 - 2a. Disconnect the key switch, module, PTO switch and the hour meter. See Figure 4.9.

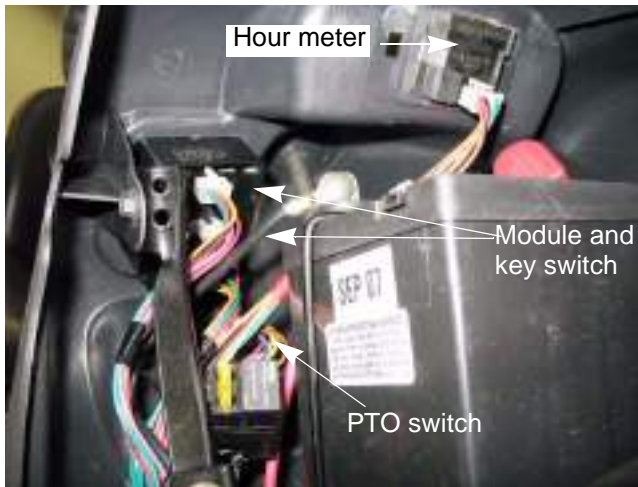

Figure 4.9

- 2b. Disconnect the parking brake by removing the hair pin clip and sliding the rod out of the lever. See Figure 4.10.



Figure 4.10

- 2c. Remove the two screws attaching the dash to the dash support. See Figure 4.11.



Figure 4.11

- 2d. Remove the two screws in the cargo net area, at the bottom of the dash. See Figure 4.12.



Figure 4.12

NOTE: The cargo net was removed for a clearer picture. Do not remove the net to remove the dash.

NOTE: If removing the dash, disconnect the throttle and choke cables at this point.

BODY/CHASSIS

- 2e. Remove the screws at the bottom of the dash, on each side. See Figure 4.13.



Figure 4.13

- 2f. The dash can now be lifted over the steering shaft and placed to the side or on top of the engine.

NOTE: If the throttle and choke cable are still attached to the dash, care should be taken to prevent damage to them when lifting the dash.

3. Install the dash by following the above steps in reverse order.

Remove the fender

1. Remove the dash by following the steps described in the previous section of this chapter.
2. Disconnect the wires to the seat switch.

NOTE: Tractors built prior to 2008 have two yellow wires that go to a switch on the side of the seat bracket. See Figure 4.14.

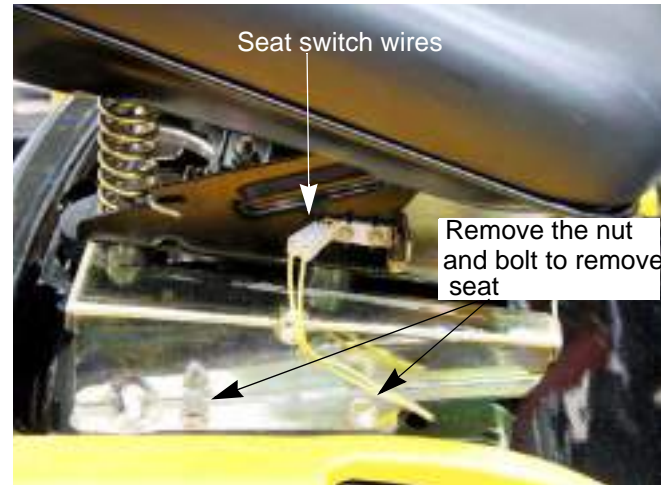

Figure 4.14

NOTE: Tractor built from 2008 to present have two yellow wires and a green wire that go to a switch inside the seat.

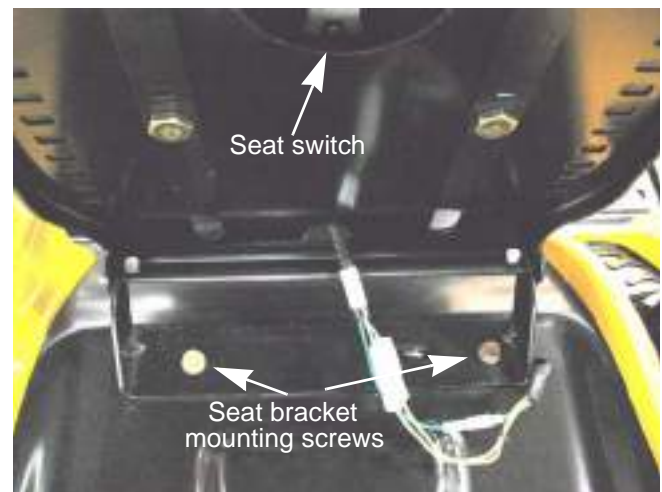

Figure 4.15

NOTE: When reconnecting the wires, the position of the two yellow wires does not affect the operation of the tractor.

3. Remove the seat bracket and seat as one piece.
4. Remove the grip from the deck lift handle.

5. Remove the nuts from the under side of the foot rests. See Figure 4.16.



Figure 4.16

6. Remove the brake and drive pedals.
7. Remove the screw from the center of the fender. See Figure 4.17.

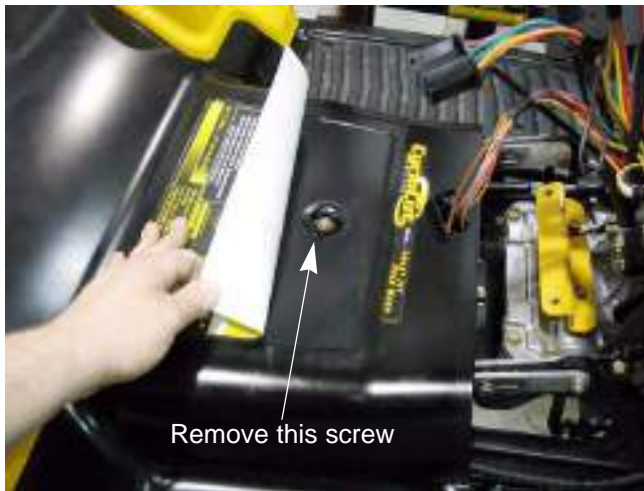

Figure 4.17

8. Remove the fuel cap.
9. Standing behind the tractor, lift the fender up till it clears the studs for the seat.

10. Place the steering wheel on the steering shaft. Turn the wheels to the left and right to allow the fenders to clear the steering arm assembly. See Figure 4.18.



Figure 4.18

NOTE: When lifting the fender off of the tractor, clear the left side first and rotate the fender to clear the deck lift lever.

11. Install the fender by following the previous steps in reverse.

BODY/CHASSIS

CHAPTER 5A: DRIVE SYSTEM - HYDROGEAR TRANSMISSIONS

There are two drive systems available for the I-series tractor. One system uses two HydroGear transmissions. The other system uses an Infitrak full-toroidal Infinitely Variable Transmission (IVT). This chapter will cover the HydroGear version of the tractor.

The HydroGear version of this tractor uses two EZT transmissions. The transmission control linkages work in unison with the steering linkage to create the zero-turn feature. The neutral adjustments for the transmissions and the transmission links are covered in chapter 6A: Steering - HydroGear.

The Hydro-gear shop manual for the EZT transmissions is form number BLN-52622.

Drive belt

The drive belt is the most common drive system component that will need attention. To remove/replace the drive belt:

1. Remove the deck as described in chapter 8: Cutting Decks and Lift Shaft.
2. Set the parking brake.
3. Unplug the electric PTO harness. See Figure 5A.1.

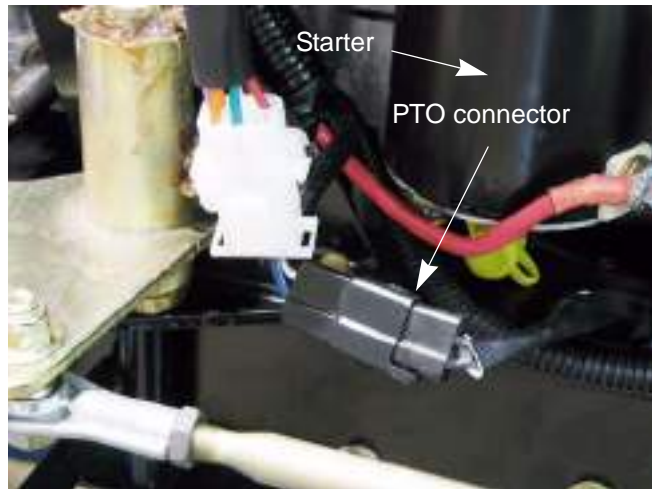

Figure 5A.1

4. Unbolt the electric PTO using an impact wrench and a 5/8" socket. See Figure 5A.2.

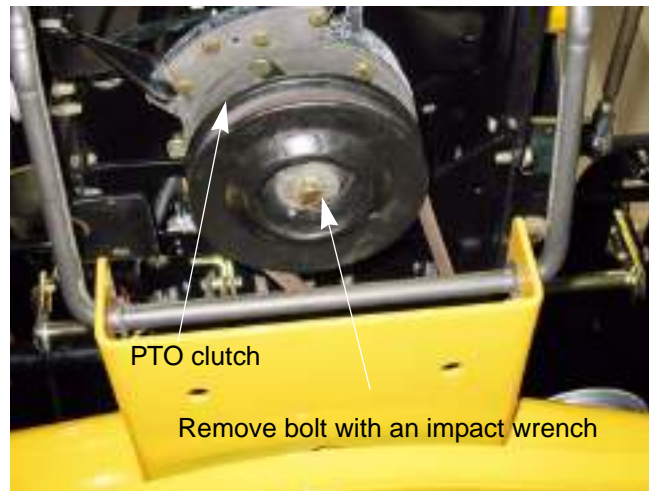

Figure 5A.2

NOTE: If the PTO clutch will not slide off of the crankshaft, thread the bolt half way into the crankshaft. Make sure the belt keeper is in place to prevent the clutch from rotating. Start the engine and turn the PTO on and off several times to shake it loose.

NOTE: If the PTO will not come off using the steps above, remove the engine mounting bolts and slide the engine back. This will give enough clearance to slide the belt off of the engine pulley.



Cub Cadet belts are designed to fit our equipment and are not standard lengths. Use of a non-OEM belt may prevent the de-clutching mechanism from working properly when the brakes are applied.

DRIVE SYSTEM-HYDROGEAR

- Slide the engine pulley down far enough to slip the belt off of the pulley. See Figure 5A.3.

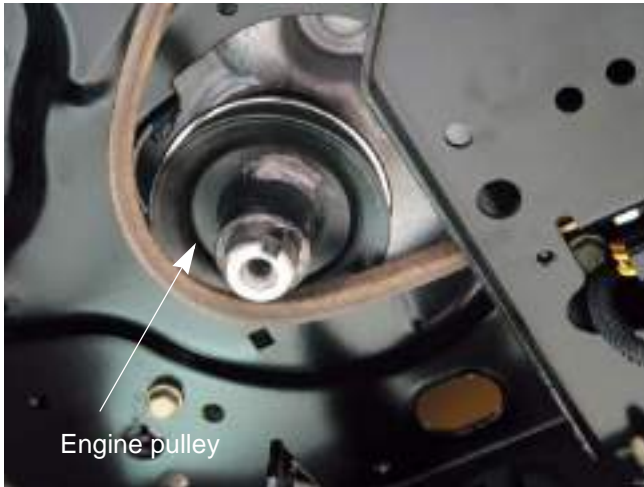

Figure 5A.3

NOTE: Note the direction of the key in the engine pulley. It should be facing down. If the pulley is installed upside down, the belt alignment will be off.

NOTE: When installing the engine pulley and electric PTO, coat the crank shaft with anti-seize. This will ease pulley and clutch removal in the future.

NOTE: If the engine pulley is seized to the crankshaft, the engine bolts can be removed to slide the engine to the rear. This will provide enough clearance to remove the belt.

- Remove the three belt guides near the idler pulleys. See Figure 5A.4.

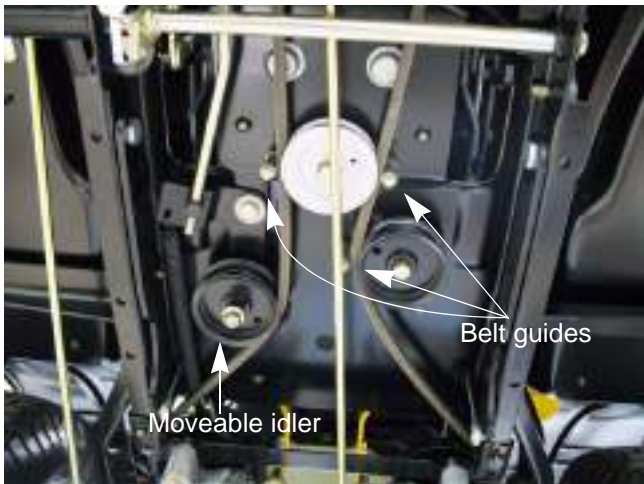

Figure 5A.4

- Work belt off of the idler pulleys.

NOTE: It may be necessary to loosen the moveable idler pulley to get the belt to clear the belt guide on the idler bracket. See Figure 5A.4.

- The transmission brace doubles as a belt keeper. Remove the two screws that hold the transmission brace to the transmission. Slide the brace to the rear of the tractor to make enough clearance to remove the belt. See Figure 5A.5.



Figure 5A.5

- Work belt around the transmission pulleys and fans.

NOTE: Use care to prevent damage to the fans when removing the belt.

10. Remove the two screws that hold the transmission links to the shifter plate. See Figure 5A.6.

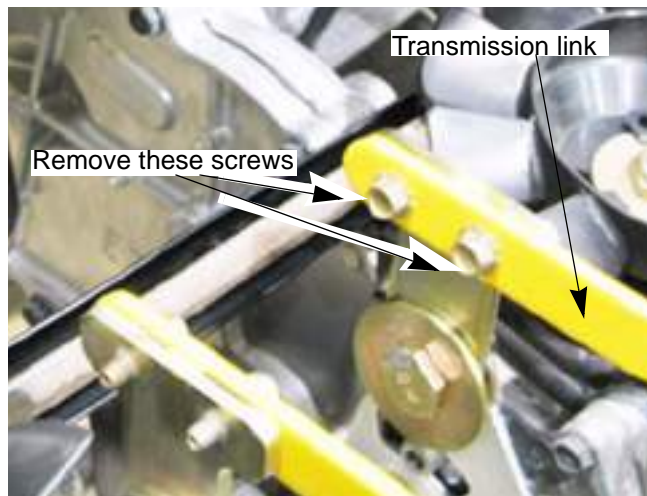

Figure 5A.6

11. The belt can now be snaked out of the tractor.
 12. Install the belt following the above steps in reverse order.
- NOTE:** Tighten the electric PTO clutch bolt to a torque of 450 - 600 in-lbs (51 - 68 Nm).
13. Test drive the tractor before returning to service.

Belt adjustment

The drive belt is tensioned by a spring loaded moveable idler pulley. When the brakes are applied, the drive belt is de-clutched. An adjustable linkage connects the tensioner pulley to the brake shaft. A brake link that is out of adjustment will prevent the moveable idler from correctly tensioning and de-tensioning the belt.

As the belt wears and stretches, the moveable idler needs to push the belt in further to keep proper belt tension. To do this, the ferrule at the end of the brake link needs to be at the middle of the slot in the idler pulley bracket. To adjust this brake link:

NOTE: The belt must be on when performing this adjustment.

1. Release the parking brake.
2. Remove the deck as described in chapter 8 Cutting Decks and Lift Shaft.
3. Remove the cotter pin and washer from the ferrule. See Figure 5A.7.

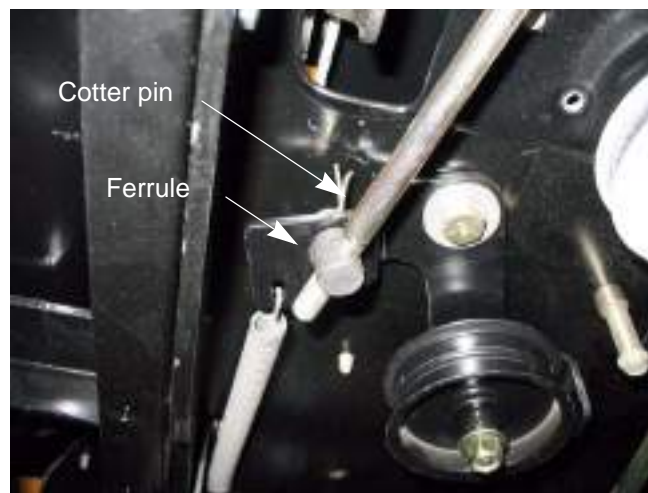

Figure 5A.7

DRIVE SYSTEM-HYDROGEAR

- Slide the ferrule out of the idler bracket.
See Figure 5A.8.



Figure 5A.8

- Adjust the ferrule so that it lines up with the rear of the slot and slides in without pulling on the spring. See Figure 5A.9.

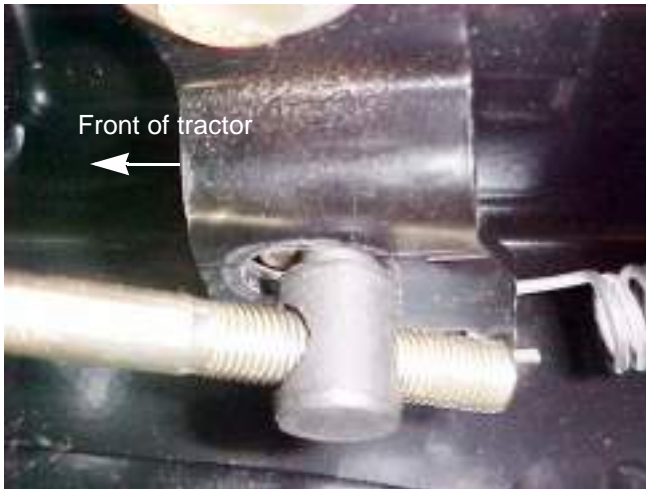

Figure 5A.9

- Install the washer and a new cotter pin.
- Test drive the tractor before returning to service.
- Re-attach the deck.

Transmissions

The I-series tractor uses two EZT transmissions from Hydro-gear. The transmissions can be removed separately. To remove a transmission:

NOTE: The transmission model and serial number tags are located on the frame channel next to the transmission that they refer to.

- Remove the deck as described in chapter 8 Cutting Decks and Lift Shaft.
- Remove the drive belt as described previously in this chapter.

NOTE: Leave the transmission links and the transmission brace disconnected.

- Lift and safely support the rear of the tractor.
- Remove the rear wheels.
- Unhook the by-pass rod. See Figure 5A.10.



Figure 5A.10

- Disconnect the brake rod by following the steps described in Chapter 3: Brakes.

7. Remove the two bolts that thread into the cross tubes. See Figure 5A.11.

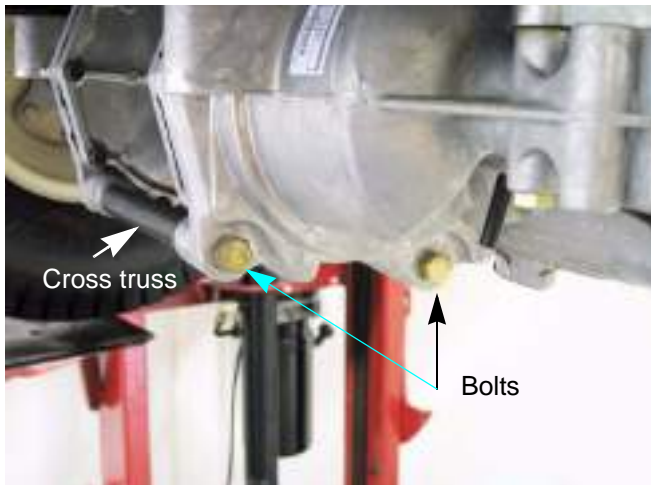

Figure 5A.11

8. Support the transmission to prevent it from falling while the mounting bolts are removed.
9. Remove the bolt holding the transmission to the torque bracket. See Figure 5A.12.

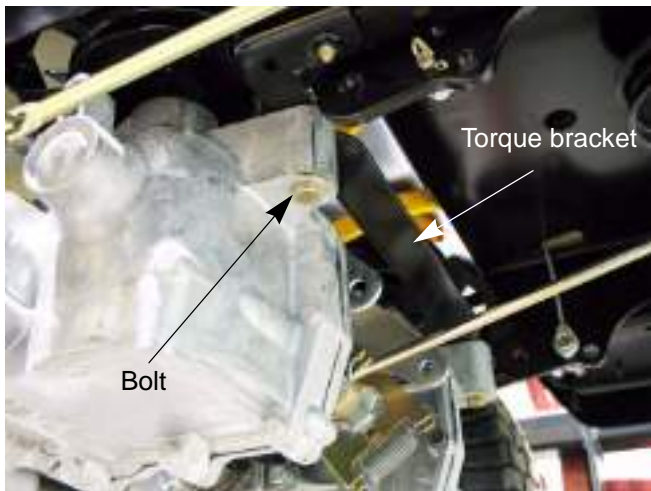

Figure 5A.12

NOTE: There is a nut on the top side of the torque bracket. Use a 7/16" wrench to hold it while removing the bolt.

10. Remove the two bolts that fasten the transmission to the frame. See Figure 5A.13.

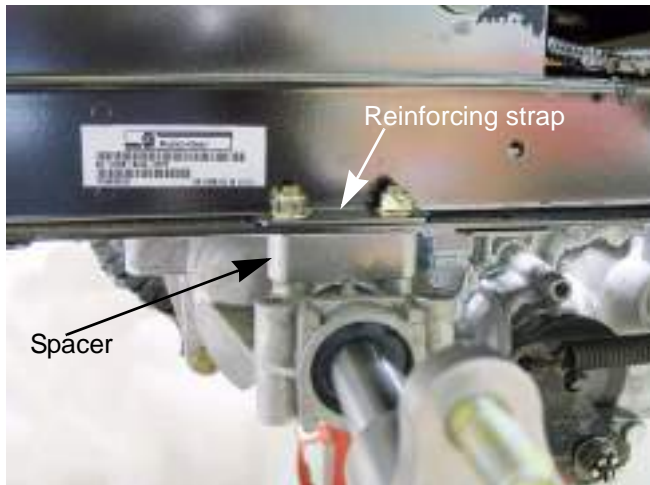

Figure 5A.13

NOTE: The two transmission bolts pass through a spacer and a reinforcing strap. When the bolts are removed, the spacer and strap can be removed. See Figure 5A.13.

11. The transmission can now be removed from the tractor.
12. If replacing the transmission, remove the transmission pulley and fan assembly.
13. Remove the wheel hub assembly.
14. Install the hub on the new transmission and tighten to a torque of 420 - 480 in-lbs (47.5 - 54Nm).
15. Install the transmission pulley and fan assembly on the new transmission and tighten to a torque of 300 - 460 in-lbs (34 - 52Nm).
16. Install the transmission by following steps 1 - 11 in reverse order.
17. Perform a neutral adjustment and wheel alignment by following the steps described in 6A: Steering - HydroGear.
18. Test drive the tractor in a safe area before returning to service.

DRIVE SYSTEM-HYDROGEAR

Drive pedal shaft

To remove the drive pedal shaft:

1. Remove the deck as described in chapter 8 Cutting Decks and Lift Shaft.
2. Disconnect the link between the steering gearbox and the bell crank on the drive pedal shaft. See Figure 5A.14.

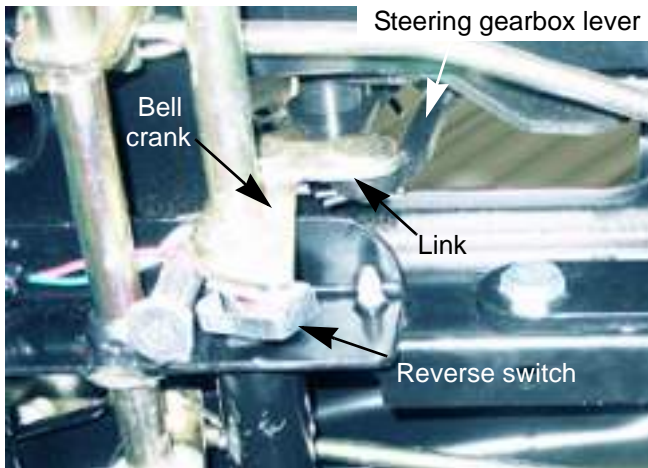

Figure 5A.14

NOTE: It does not matter which side of the link is disconnected.

3. Disconnect the reverse switch.
4. Remove and discard the cotter pin on the left side of the drive pedal shaft. See Figure 5A.15.

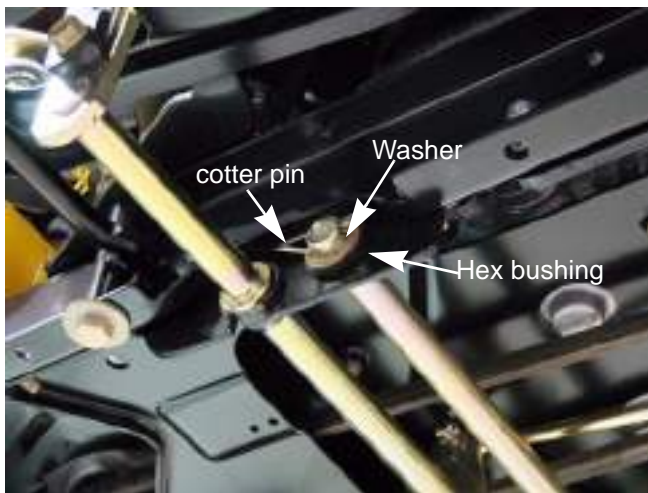

Figure 5A.15

5. Remove the washer and hex bushing. See Figure 5A.15.

6. Drive out the two roll pins that secure the drive pedal bracket to the drive pedal shaft. See Figure 5A.16.

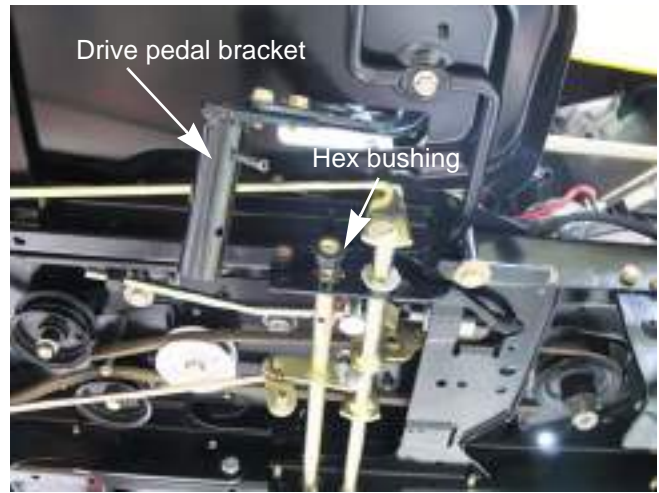

Figure 5A.16

7. Remove the hex bushing. See Figure 5A.16.
8. Slide the drive pedal shaft to the left to clear the hole for the right side hex bushing. See Figure 5A.17.



Figure 5A.17

9. Install the drive pedal shaft by following the previous steps in reverse order.
10. Test drive the tractor before returning it to service.

CHAPTER 5B: DRIVE SYSTEM - IVT TRANSMISSION

There are two drive systems available for the I-series tractor. One system uses two HydroGear transmissions. The other system uses an Infinitrak full-toroidal Infinitely Variable Transmission (IVT). This chapter will cover the IVT version of the tractor.

The Infinitrak full-toroidal Infinitely Variable Transmission (IVT) removes the constraints of conventional stepped ratio transmissions. Instead of using a system of gears to determine the ratio range, the IVT uses a variator that is made of a set of discs and rollers called a “full toroidal” variator. In the IVT, the torque is controlled allowing optimization of the power train by allowing the engine to run at its most efficient RPM range and stay there.

The IVT used on the I-series is a twin variator version. This means that there is one input and two outputs. See Figure 5B.1

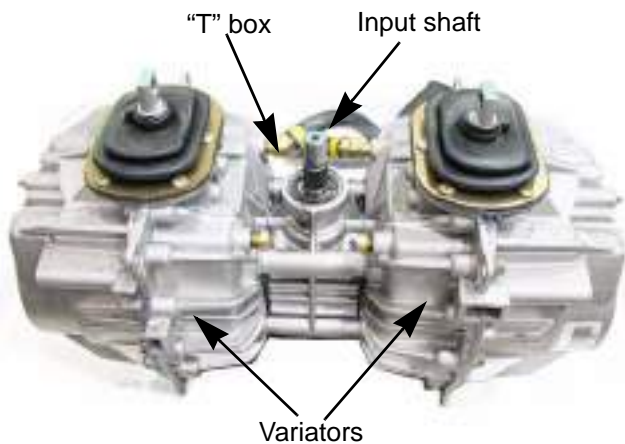

Figure 5B.1

The power from the engine is transferred to the transmission via a belt and pulleys. The power is applied to a “T” box assembly. The “T” box output drives the inner discs of the variator assemblies. See Figure 5B.2

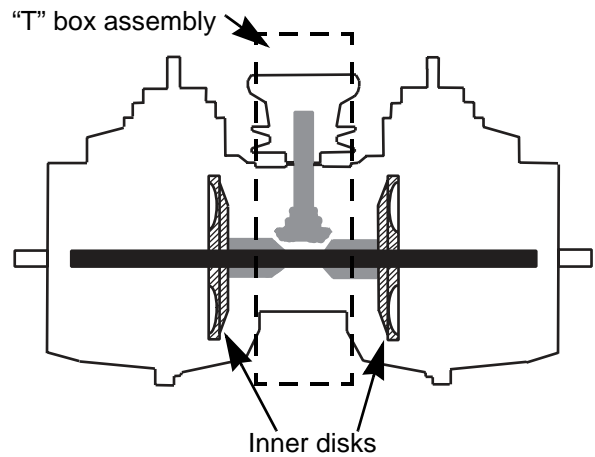

Figure 5B.2

Each inner disc drives a pair of rollers that drive the output discs. The angle of the rollers determines the speed of the output discs. When the rollers ride near the center of the input discs, they are pressing against the outer edge of the output discs. In this position, the output disc will be turning at a much slower rate than the input discs. See Figure 5B.3

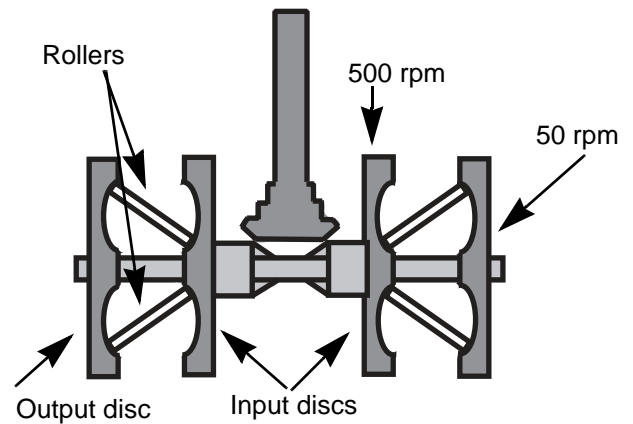

Figure 5B.3

DRIVE SYSTEM-IVT

NOTE: The RPM numbers used in figures 5B.2, 5B.3 and 5B.4 are not the actual measurements of the disc speeds. They are just an example to demonstrate the speed differences.

When the rollers ride near the outer edge of the input discs, they are pressing against the center of the output discs. In this position, the output disc will be turning at a much faster rate than the input discs. See Figure 5B.4

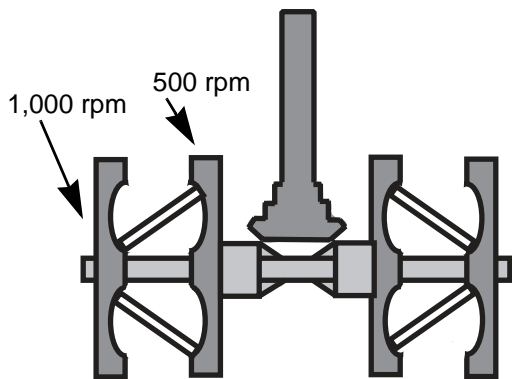

Figure 5B.4

When the rollers are in the neutral position or in the center of the disc valley, all of the discs are rotating at the same speed. See Figure 5B.5

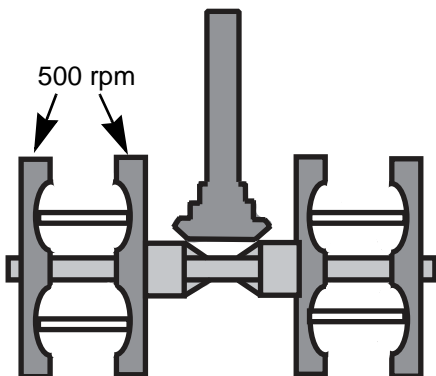

Figure 5B.5

The key to making this work is a special traction fluid that was developed for this transmission. A Traction fluid is a synthetic transmission fluid designed with properties specifically for transmitting torque between the discs and rollers.

Under normal load conditions this fluid acts like a conventional lubricating fluid. When the fluid is subjected to extreme pressure, such as in the contact area between the discs and rollers, the fluid changes to exhibit its ElastoHydrodynamic Lubricant (EHL) properties. The EHL property of the traction fluid causes the molecules in the fluid to become almost solid. This increases the shear force transmitting properties of the fluid.

The traction fluid in the contact area between the rollers and discs turns into a semi-solid. This allows the fluid to act like a gear tooth, transferring the torque from the disc to the roller or vice versa. It also prevents metal to metal contact extending the life of the moving parts.

NOTE: Putting motor oil or hydraulic fluid in an IVT transmission will destroy it.

Each of the variators are attached to a epicyclic, also know as planetary, gear set. See Figure 5B.6

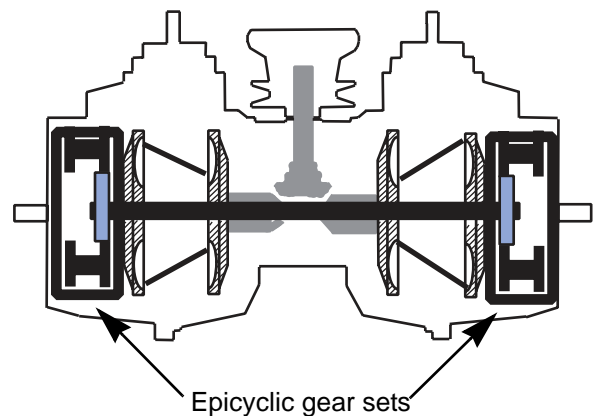

Figure 5B.6

The output shaft of the T-box drives a sun gear in the center of the planetary gears at the same speed as the input discs. The planetary gear carriers are attached to the output discs. See Figure 5B.7

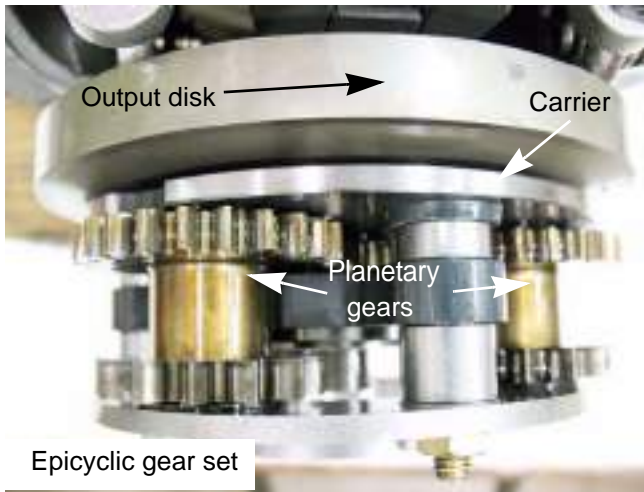

Figure 5B.7

The epicyclic gear set acts like an adding machine, it subtracts the input (sun gear) speed from the output (planetary gear carrier). See Figure 5B.8

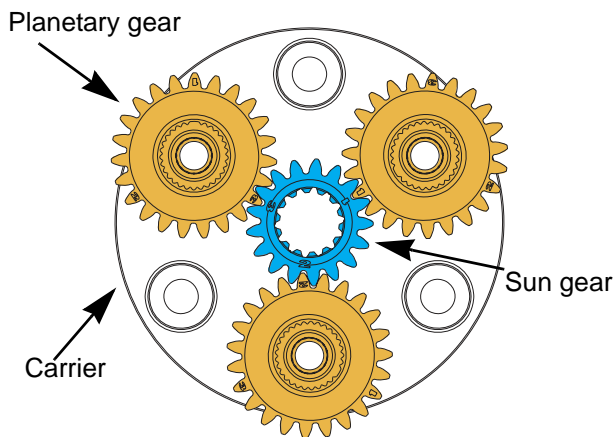

Figure 5B.8

If the answer is positive, transmission drives in a forward direction. If the answer is negative, the transmission drives in reverse. If the answer is zero, the transmission will have zero output and be in what is known as a geared neutral state. See Figure 5B.9

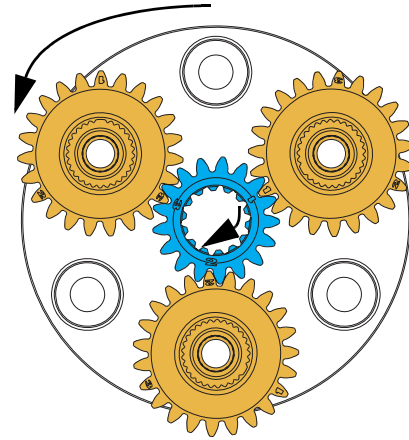

Figure 5B.9

The answers from the epicyclic gear sets are collected by the transmission output shafts that are driven by the planetary gears. See Figure 5B.10

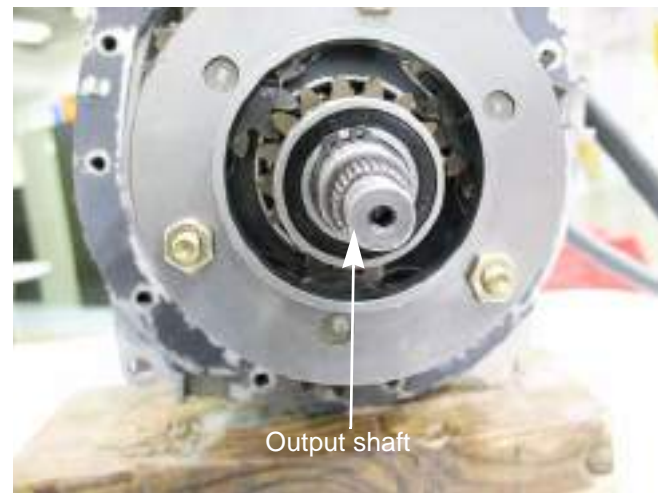

Figure 5B.10

DRIVE SYSTEM-IVT

The transmission output shafts drive a pair of drop axles assemblies.

The **IVT transmissions are NOT serviceable**. The drop axles and brakes are serviceable and will be covered in later sections of this chapter.

NOTE: Currently replacement traction fluid is not available for purchase.

Drive belt

The drive belt is the most common drive system component that will need attention. To remove/replace the drive belt:



Cub Cadet belts are design to fit our equipment and are not standard lengths. Use of a non-OEM belt may prevent the de-clutching mechanism from working properly when the brakes are applied.

1. Remove the deck as described in chapter 8: Cutting Decks and Lift Shaft.
2. Lift and safely support the rear of the tractor.
3. Remove the three belt guides near the idler pulleys. See Figure 5B.11



Figure 5B.11

- Slide the retainer clip half way out of the dampener end using small flat head screw driver. See Figure 5B.12

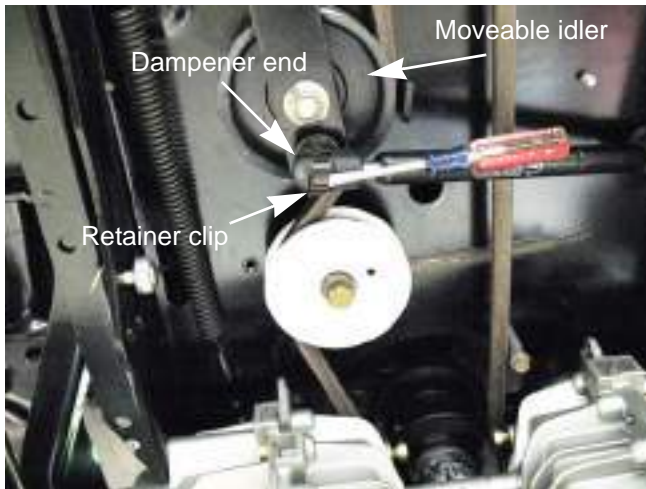

Figure 5B.12

- Disconnect the dampener from the moveable idler pulley bracket.
- Disconnect the brake link from the moveable idler pulley bracket.
- Loosen the moveable idler pulley enough for the belt to slip past the belt guide using a pair of 9/16" wrenches. See Figure 5B.13



Figure 5B.13

- Slip the belt off of the idler pulleys.

- Unplug the electric PTO harness. See Figure 5B.14

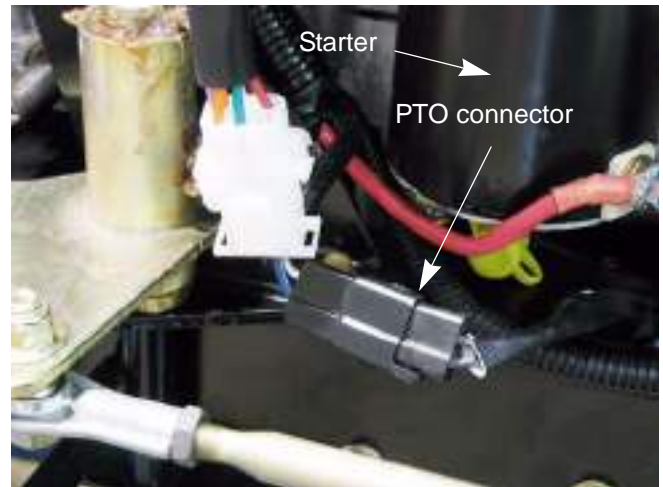

Figure 5B.14

- Unbolt the electric PTO using an impact wrench and a 5/8" socket. See Figure 5B.15

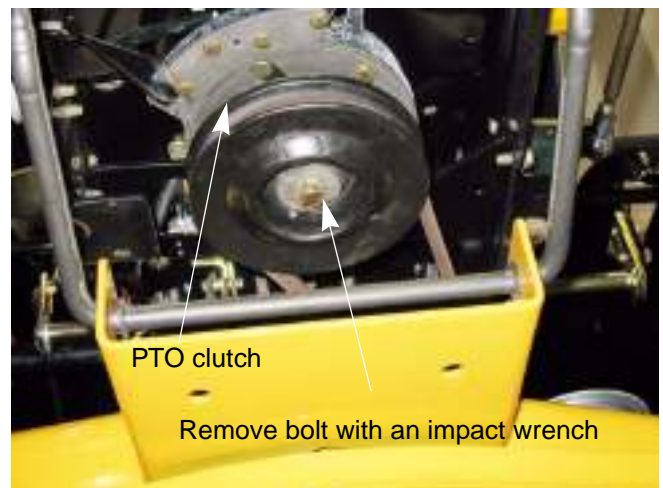

Figure 5B.15

NOTE: If the PTO clutch will not slide off of the crankshaft, thread the bolt half way into the crankshaft. Make sure the belt keeper is in place to prevent the clutch from rotating. Plug in the PTO clutch harness. Start the engine and turn the PTO on and off several times to shake it loose.

DRIVE SYSTEM-IVT

11. Slide the engine pulley down far enough to slip the belt off of the pulley. See Figure 5B.16

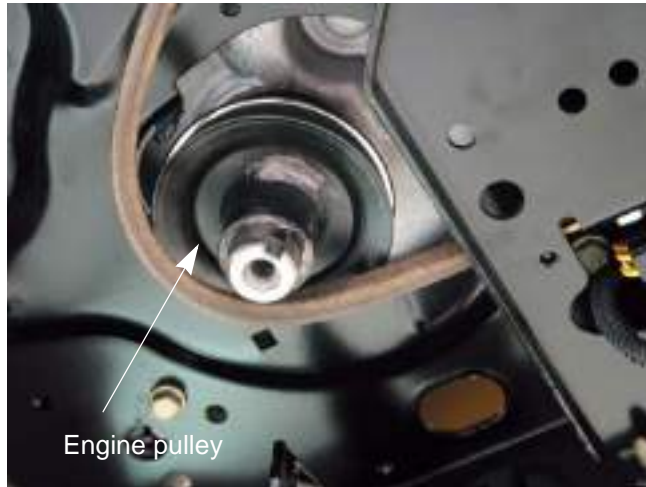

Figure 5B.16

NOTE: If the engine pulley will not slide down the crankshaft using the steps above, remove the engine mounting bolts and slide the engine back. This will give enough clearance to slide the belt off of the engine pulley.

NOTE: Note the direction of the key in the engine pulley. It should be facing down. If the pulley is installed upside down, the belt alignment will be off.

NOTE: When installing the engine pulley and electric PTO, coat the crankshaft with anti-seize. This will ease pulley and clutch removal in the future.

NOTE: There is a spacer above the engine pulley. It is symmetrical and can not be put on upside down. See Figure 5B.17

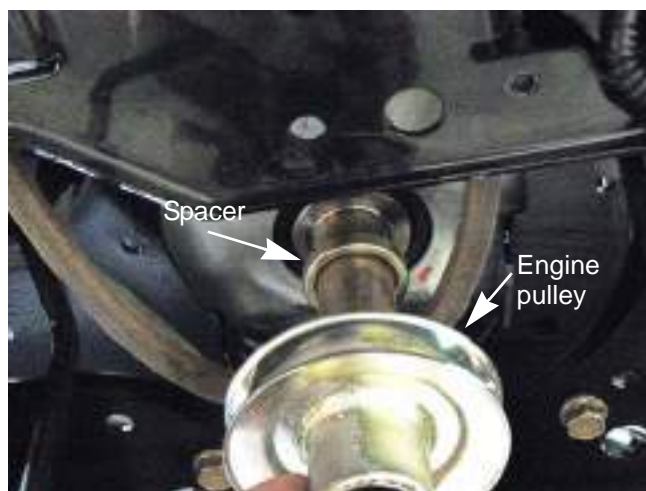

Figure 5B.17

12. Remove the rear wheels.
13. Remove the transmission fan.
 - 13a. Reach in through the wheel opening.
 - 13b. Remove the three transmission fan screws using a 5/16" wrench. See Figure 5B.18

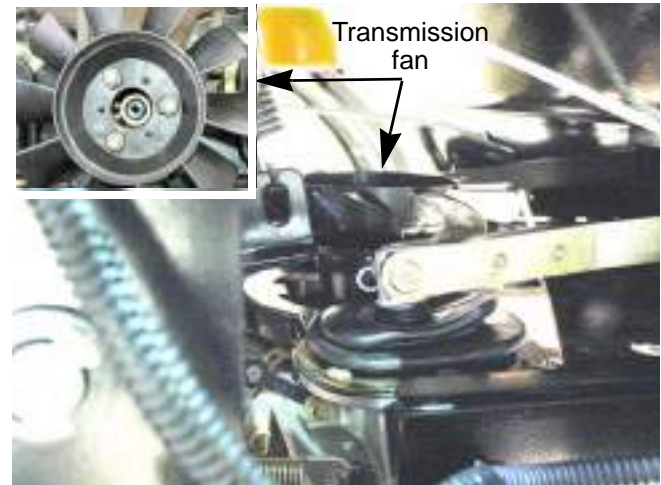

Figure 5B.18

- 13c. Remove the transmission fan.

NOTE: Never use an impact wrench to remove the transmission pulley. It will destroy the one way bearing on the input shaft.

14. Remove the transmission belt guard.
 - 14a. Remove the four screws using a 5/16" wrench. See Figure 5B.19



Figure 5B.19

- 14b. Remove the belt guard.

15. Slip the belt off of the transmission pulley.
16. Remove the belt from the tractor.
17. Install the belt following the previous steps in reverse order.

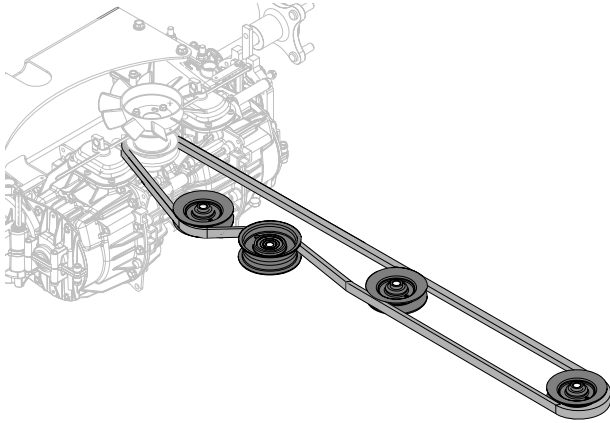

Drive belt routing

Figure 5B.20

NOTE: Tighten the electric PTO clutch bolt to a torque of 450 - 600 in-lbs (51 - 68 Nm).

18. Test drive the tractor before returning to service.

Belt adjustment

The drive belt is tensioned by a spring loaded moveable idler pulley. When the brakes are applied, the drive belt is de-clutched. An adjustable linkage connects the tensioner pulley to the brake shaft. A brake link that is out of adjustment will prevent the moveable idler from correctly tensioning and de-tensioning the belt.

As the belt wears and stretches, the moveable idler needs to push the belt in further to keep proper belt tension. To do this, the ferrule at the end of the brake link needs to be at the rear of the slot in the idler pulley bracket.

NOTE: The moveable idler pulley has a dampener on it. The dampener allows a slow, smooth engagement of the drive belt. See Figure 5B.21

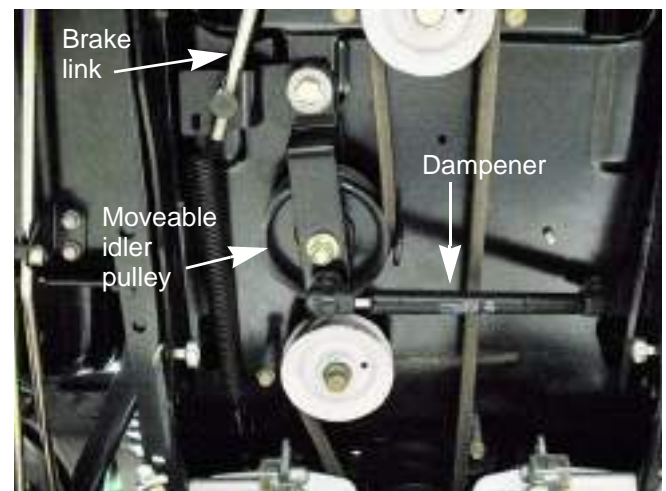
**Figure 5B.21**

The brake link is adjusted to the rear of the slot in the moveable idler bracket. This allows the brake pedal can return rapidly when the pedal is released, while the dampener slows the engagement of the drive belt.



Operating the tractor with the idler pulley dampener removed will result in the tractor lurching when the brake pedal is released.

To adjust this brake link:

NOTE: The belt must be on when performing this adjustment.

1. Release the parking brake.
2. Remove the deck as described in chapter 8 Cutting Decks and Lift Shaft.

DRIVE SYSTEM-IVT

3. Remove the cotter pin and washer from the ferrule. See Figure 5B.22

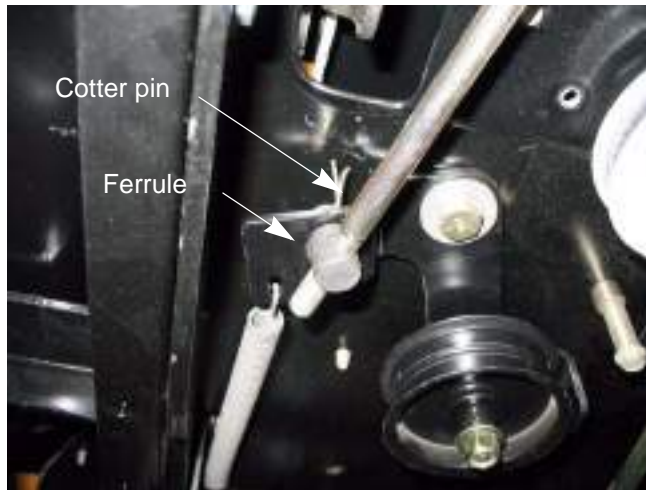

Figure 5B.22

4. Slide the ferrule out of the idler bracket. See Figure 5B.23

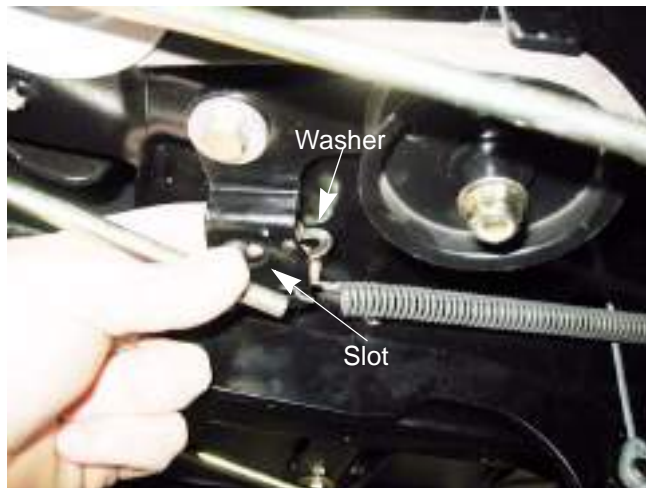

Figure 5B.23

5. Adjust the ferrule so that it lines up with the rear of the slot and slides in without pulling on the spring.
6. Install the washer and a new cotter pin.
7. Re-attach the deck.
8. Test drive the tractor before returning to service.

Transmissions

To remove the transmission:

1. Remove the deck as described in chapter 8 Cutting Decks and Lift Shaft.
2. Lift and safely support the rear of the tractor.
3. Remove the dash and fender by following the steps described in Chapter 4: Body/Chassis.
4. Remove the rear wheels.
5. Remove the drive belt from the engine pulley and the idler pulleys by following the procedures described in the drive belt section of this chapter.
NOTE: The belt can stay on the transmission pulley while the transmission is removed.
6. Unhook the by-pass rod spring on both sides of the transmission. See Figure 5B.24



Figure 5B.24

7. Disconnect the brake rods by following the steps described in Chapter 3: Brakes.
8. Disconnect the drive control links:

- 8a. Remove the hair and clevis pins.
See Figure 5B.25

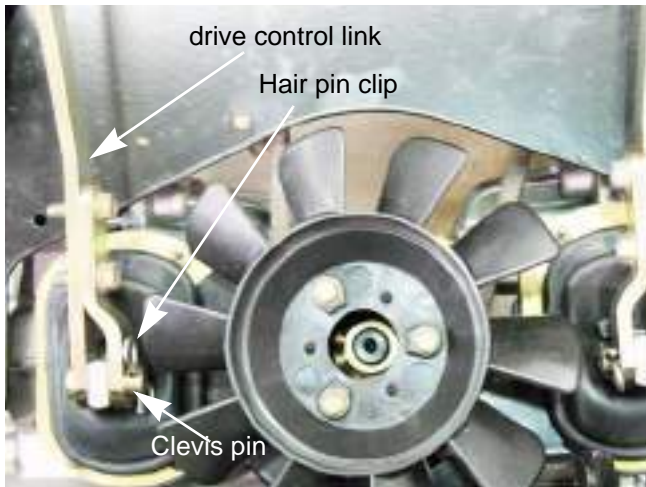

Figure 5B.25

- 8b. Slide the drive control links off of the input levers
9. Remove the two screws that fasten the expansion tank to the left side of the frame. See Figure 5B.26

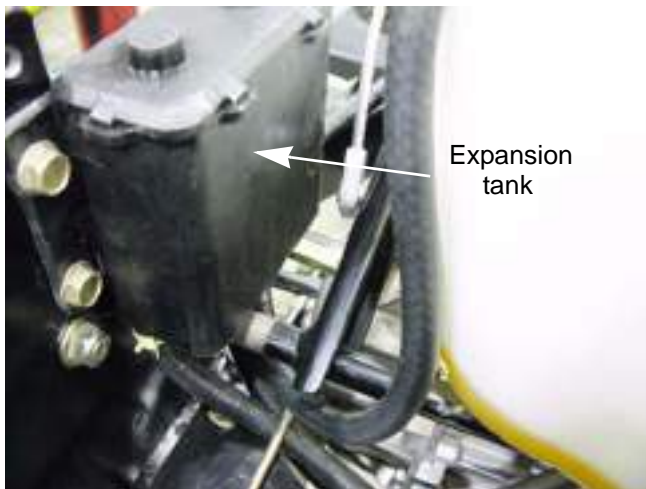

Figure 5B.26

NOTE: The seat frame plate was removed for a clearer picture.

NOTE: Clamp off both of the lines going to the expansion tank to help prevent loss of traction fluid. Currently replacement traction fluid is not available for purchase.

10. Remove front mounting screw on each side of the tractor using a 1/2" wrench.
See Figure 5B.27

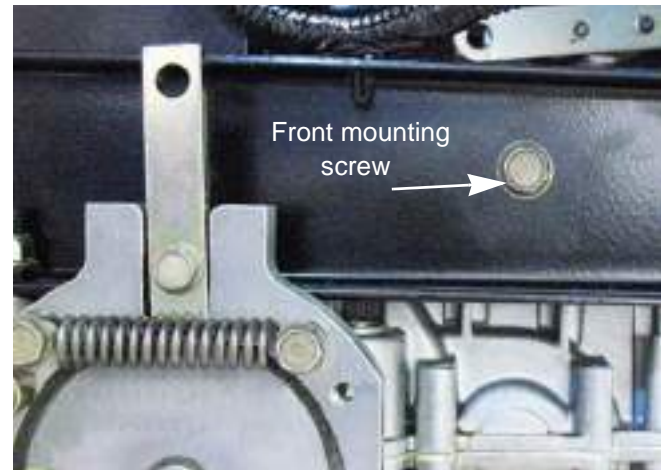

Figure 5B.27

NOTE: Support the transmission to prevent it from falling while the mounting bolts are removed.

11. Remove the two bolts that fasten the transmission to the frame and the support plate on each side of the tractor. See Figure 5B.28

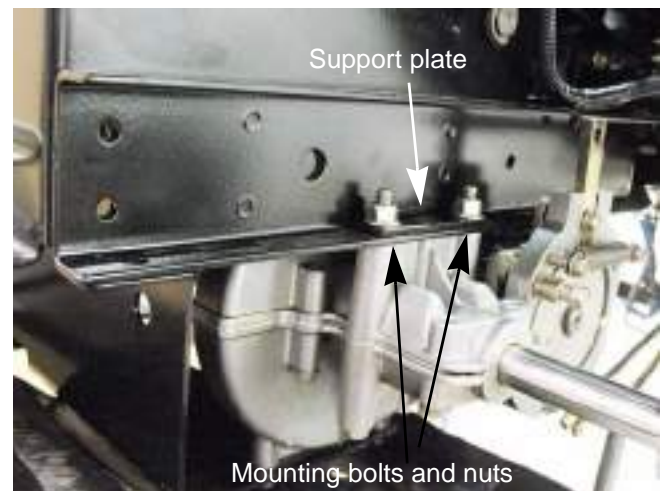

Figure 5B.28

12. Lower the transmission out of the tractor.

NOTE: Avoid spilling traction fluid while moving the transmission. Currently replacement traction fluid is not available for purchase.

DRIVE SYSTEM-IVT

13. If replacing the transmission assembly, remove the transmission fan.
14. If only replacing the IVT (center section of the transmission), remove the drop axles by following the procedures described in the drop axle section of this manual.
15. Install the transmission by following the previous steps in reverse order.
16. Perform a neutral adjustment and wheel alignment by following the steps described in 6B: Steering - IVT.
17. Test drive the tractor in a safe area before returning to service.

Drop axle assemblies

The drop axle assemblies on the IVT transmission perform three functions:

- The drop axle assemblies are a gearbox that will transmit the power of the IVT at a reduced speed to the drive wheels.
- The drop axle contains a dog clutch assembly to disconnect the transmission from the drive wheel. This allowing the tractor to be pushed by hand.

The drop axle assemblies are serviceable, separately from the IVT.

To remove the drop axles:

1. Remove transmission assembly from the tractor by following the procedures described in the previous section of this chapter.
2. Remove the eight screws that secure the transmission support bracket to the drop axles using a 1/2" wrench. See Figure 5B.29

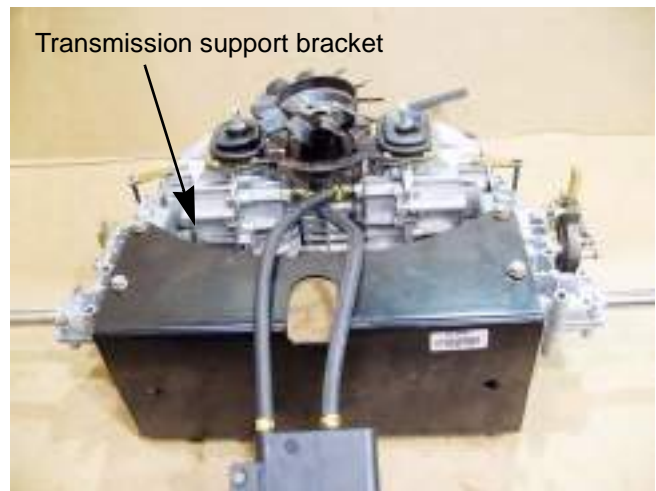

Figure 5B.29

3. Remove the four screws that secure the drop axle assembly to the IVT, using a 1/2" wrench. See Figure 5B.30

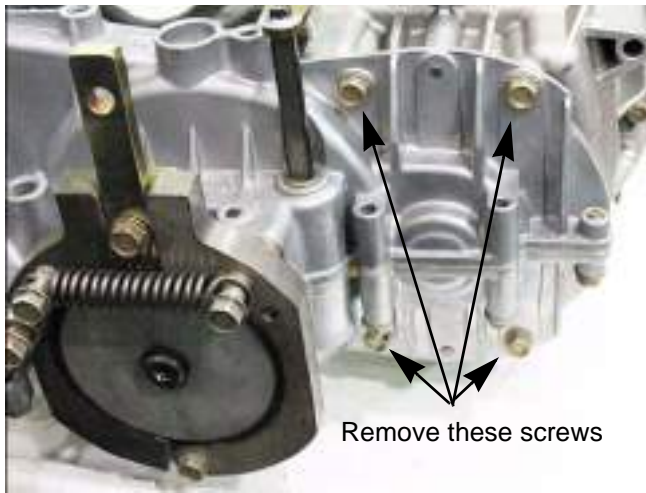

Figure 5B.30

4. Tap the drop axle off of the alignment dowels using a soft faced hammer. See Figure 5B.31



Figure 5B.31

5. Install the drop axle by following the previous steps in reverse order.
6. Test drive the tractor before returning it to service.

Rebuilding the drop axles

1. Remove the drop axle by following the procedures described in the previous section of this chapter.
2. Remove the brake:
 - 2a. Remove the snap ring that secures the brake drum to the brake shaft. See Figure 5B.32

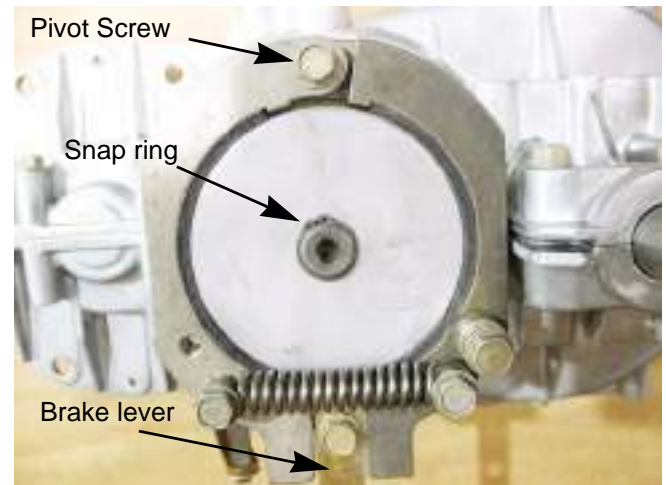

Figure 5B.32

- 2b. Remove the brake lever using a 3/8" wrench. See Figure 5B.32
- 2c. Unthread the pivot bolt from the brake mounting plate, but do not remove it.
- 2d. Slide the brake drum and shoes off of the brake shaft as one assembly.
3. Remove the push nut that secures the by-pass lever to the by-pass fork. See Figure 5B.33

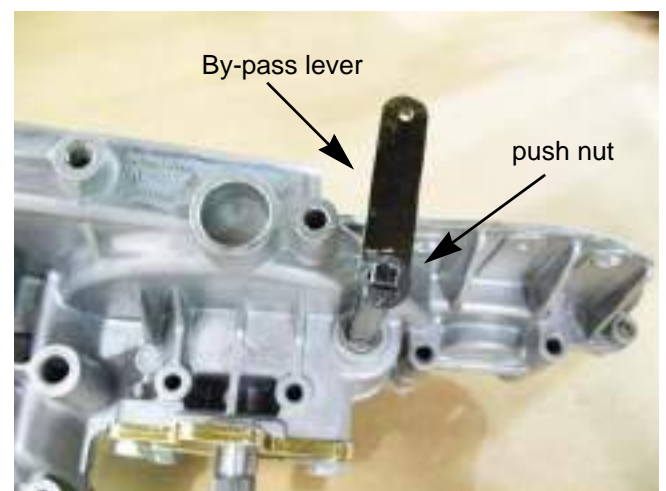

Figure 5B.33

NOTE: If the by-pass lever or fork are not being replaced, the push nut can be left in place.

DRIVE SYSTEM-IVT

4. Remove the by-pass lever.
NOTE: The by-pass lever has a very tight fit on the by-pass fork. It will need to be persuaded off.
5. Remove the eleven housing screws using a 3/8" wrench.
6. Lift the upper housing off of the gearbox.
7. Remove the drive axle assembly.
See Figure 5B.34

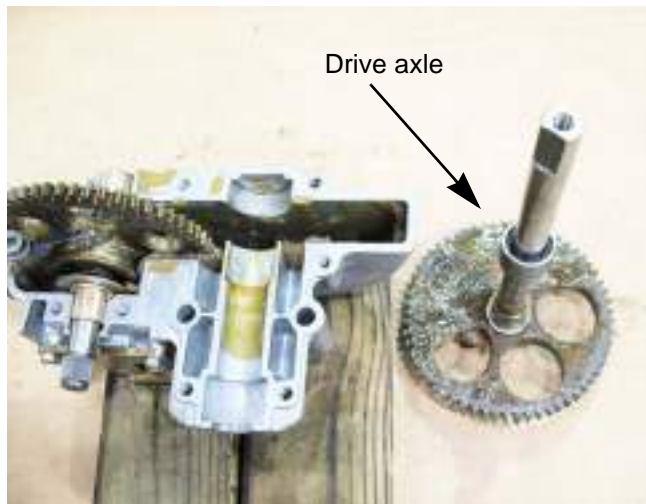

Figure 5B.34

8. Slide the bushing and the bearing off of the drive axle.
9. Remove the thrust bearing.
10. Remove the nut securing drive gear to the drive axle. See Figure 5B.35

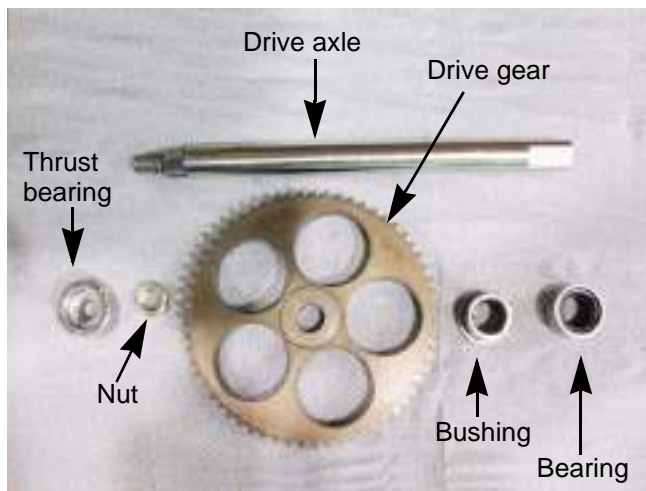

Figure 5B.35

NOTE: The nut is installed with Loctite #271 threadlocker.

11. Remove the brake shaft assembly.
See Figure 5B.36

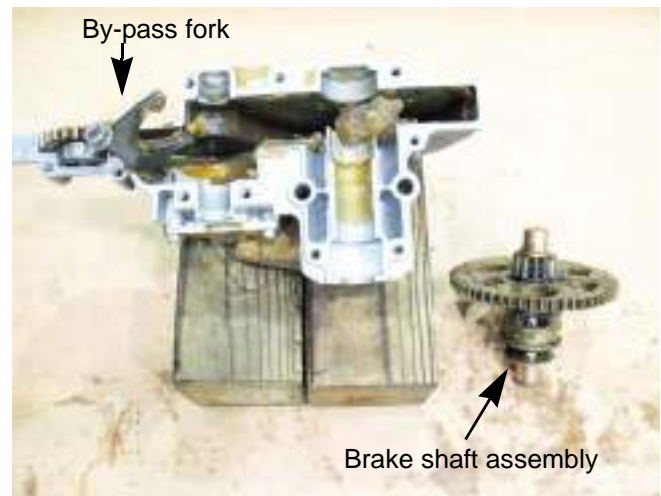

Figure 5B.36

12. Slide the bushings off of the brake shaft.
13. Slide the washer and the spring off of the brake shaft.
14. Slide the dog clutch off of the brake shaft.

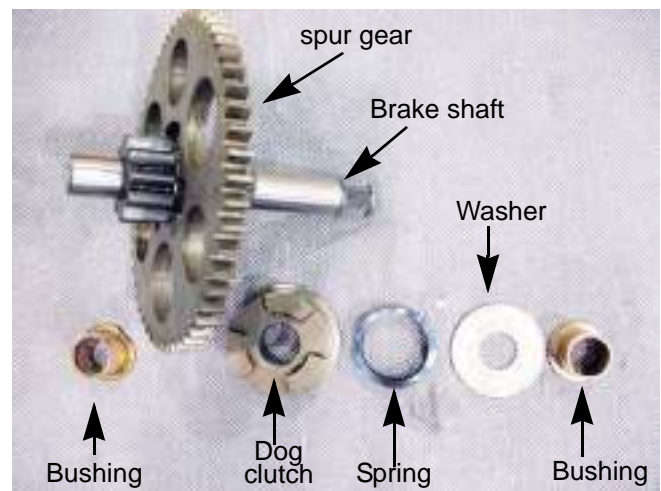

Figure 5B.37

NOTE: The dog clutch is spring loaded to engage the spur gear. When the by-pass lever is operated, the dog clutch slides out of the spur gear. This disconnects the Drive axle from the IVT.

- Separate the spur gear from the brake shaft by removing the retaining ring. See Figure 5B.38



Figure 5B.38

- Remove the bearing. See Figure 5B.39

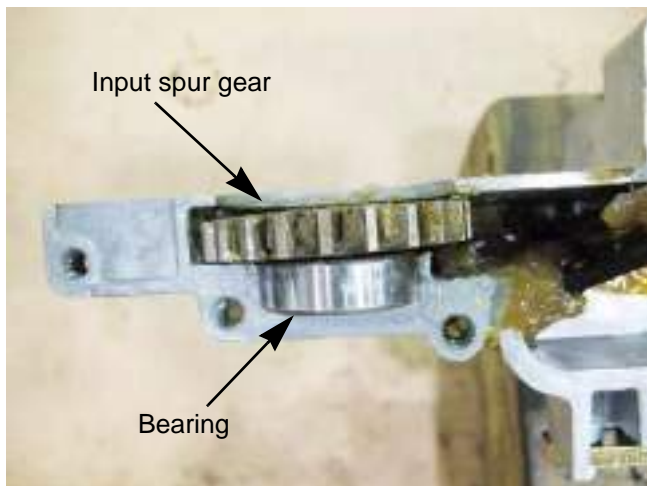

Figure 5B.39

- Remove the input spur gear. See Figure 5B.39
- Clean and inspect all for the parts for damage and signs of wear.
NOTE: Any parts that have damage or signs of wear must be replaced.
- Re-assemble the drop axle by following the previous steps in reverse order.

NOTE: When seating the bushings of the brake shaft in the drop axle housing, the tab on the bushings must seat in the notch in the housing.

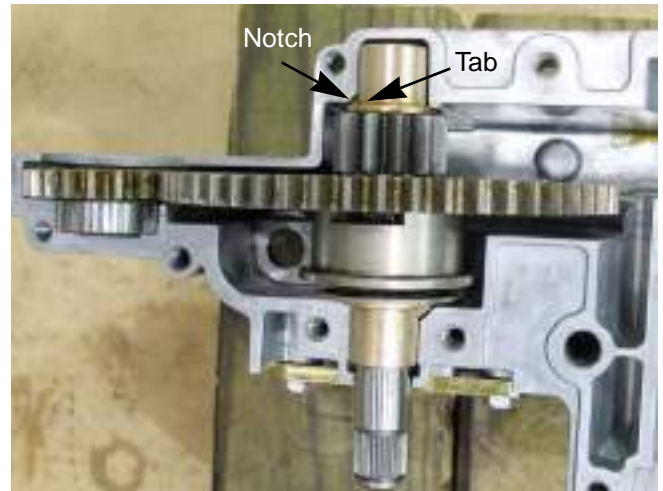

Figure 5B.40

NOTE: Apply Loctite #271 or an equivalent threadlocker to the threaded section of the drive axle. Tighten the nut that secures the drive gear to a torque of 42 - 50 ft lbs. (56 - 68 Nm).

NOTE: Fill the drop axle with 10.5 ounces of 737-0300A Durina™ grease.

NOTE: The drop axle has four different length screws securing the housings together. Figure 5B.51 shows where the different screws go.

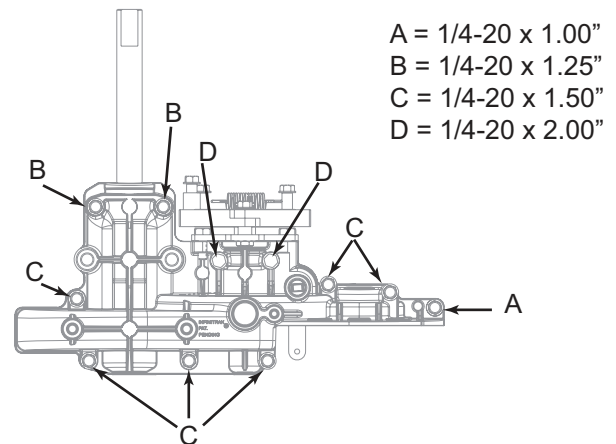

Figure 5B.41

NOTE: Tighten the screws to a torque of 90-120 in lbs. (10 - 14 Nm).

- Test drive the tractor in a safe area before returning it to service.

DRIVE SYSTEM-IVT

Drive pedal shafts

The I-series tractors equipped with the IVT transmission have two drive pedal assemblies. The main drive pedal shaft is attached to the forward drive pedal. It operates the brakes and pulls the drive control links in the forward direction. The reverse drive pedal shaft is geared to the main drive shaft. When the reverse pedal is depressed, the reverse drive pedal shaft will rotate the main drive pedal shaft in the reverse direction.

To remove the drive pedal shafts:

1. Remove the deck as described in chapter 8 Cutting Decks and Lift Shaft.
2. Remove the fender by following the steps described in Chapter 4: Body/Chassis.
3. Put a timing mark on the gears of the two shafts.
 - One mark on the fourth tooth from the bottom of the reverse gear.
 - One mark on the fourth valley from the valley of the main drive shaft gear. See Figure 5B.42

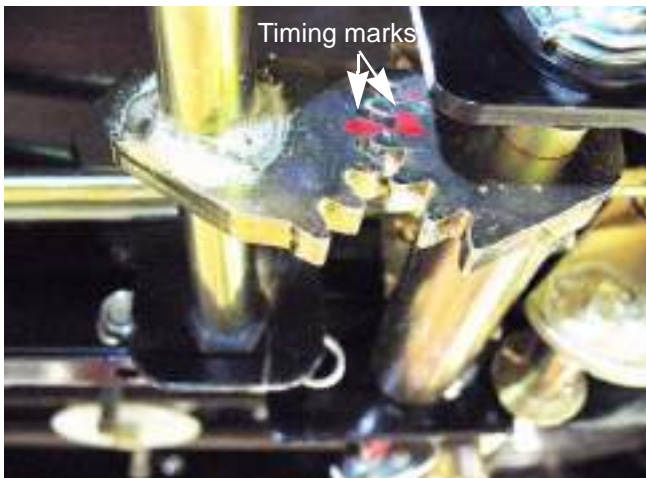

Figure 5B.42

NOTE: The timing marks will make re-assembly easier.

4. Remove the reverse drive pedal:

NOTE: If the main drive pedal shaft is the only part that needs to be serviced, the reverse pedal shaft can be left in place. However Cub Cadet recommends removing the reverse pedal shaft and replacing the bushings at the same time.

NOTE: Worn bushings on either drive pedal shaft will cause some loss of wheel speed.

- 4a. Remove the hair pin clip and washer.
See Figure 5B.43

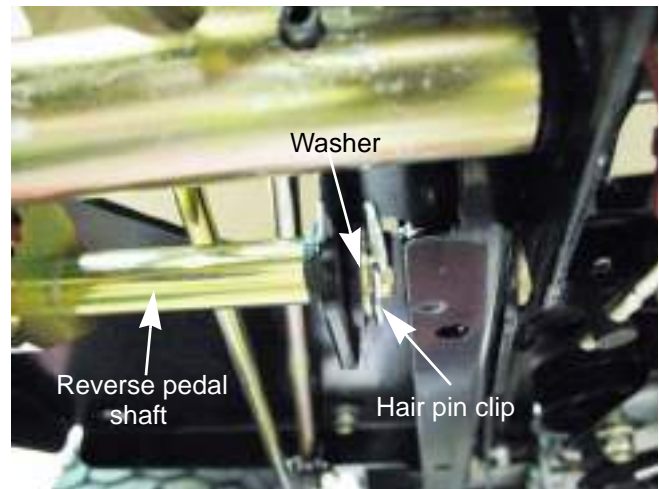

Figure 5B.43

- 4b. Remove the split hex bushing.
See Figure 5B.44

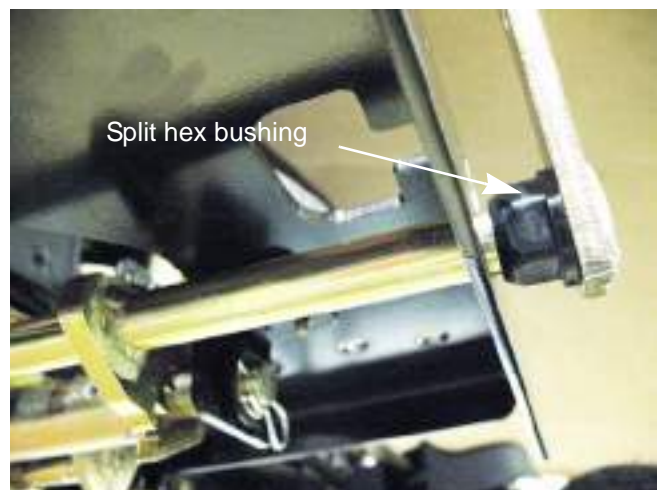

Figure 5B.44

- 4c. Rotate the reverse drive pedal shaft out of the reverse pedal support.
See Figure 5B.45

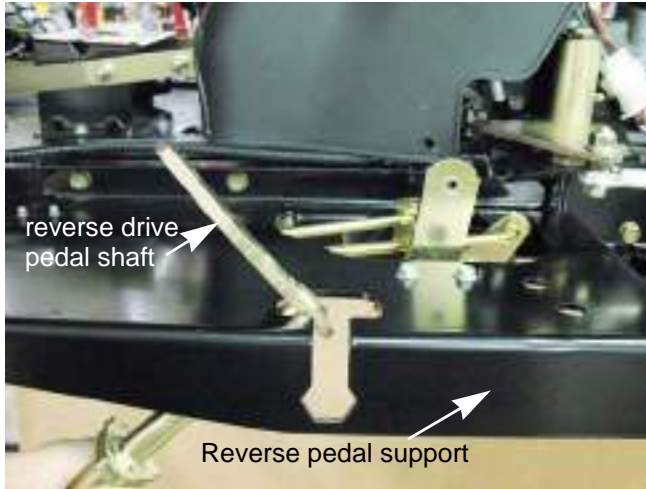

Figure 5B.45

6. Disconnect both brake release rods from the main drive pedal shaft by removing the cotter pins. See Figure 5B.47

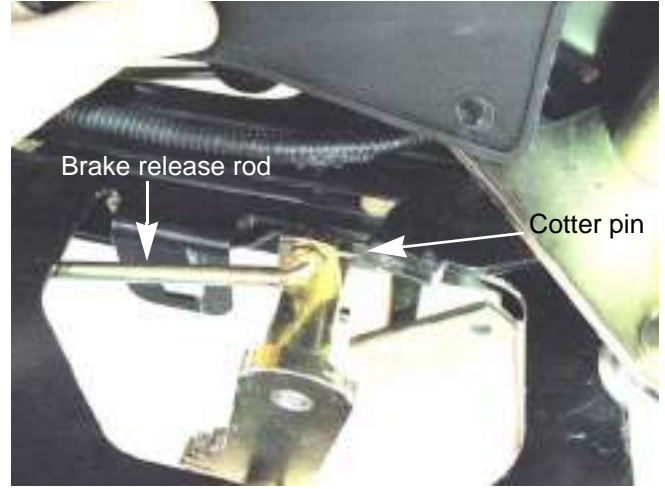

Figure 5B.47

5. Disconnect the right side brake link from the brake pedal shaft by removing the cotter pin. See Figure 5B.46

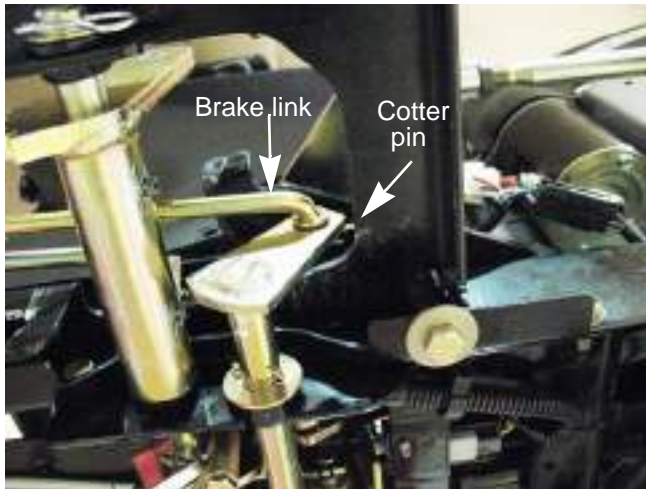

Figure 5B.46

7. Remove the cotter pin and the split hex bushing on the left side of the main drive pedal shaft. See Figure 5B.48

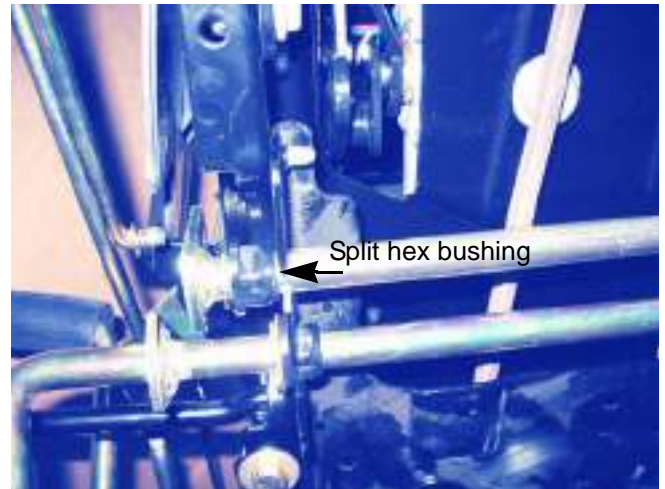

Figure 5B.48

DRIVE SYSTEM-IVT

8. Remove the hair pin clip, washer and hex bushing from the right side of the main drive pedal shaft. See Figure 5B.49

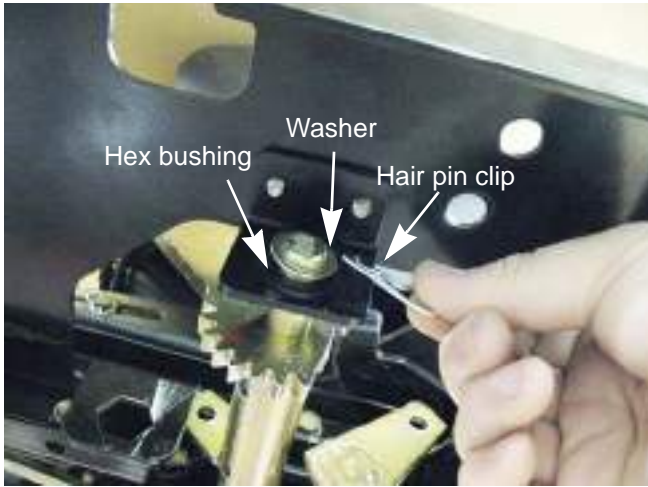

Figure 5B.49

9. Drive out both of the roll pins securing the drive pedal bracket to the main shaft using a 1/4" pin punch. See Figure 5B.50

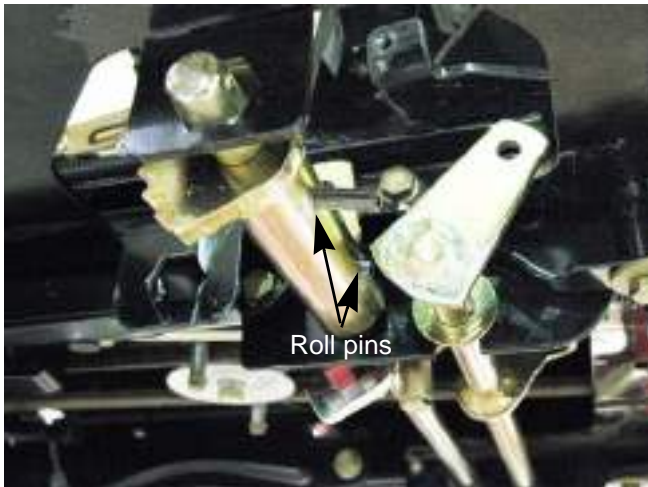

Figure 5B.50

10. Remove the three screws that secure the reverse pedal support using a 1/2" wrench. See Figure 5B.51



Figure 5B.51

11. Lift up on the outer edge of the reverse pedal support while rotating it to the front to remove the support.
12. Slide the drive pedal bracket off of the main shaft.
13. Remove the rear screw on both sides of the drive pedal shaft support bracket. See Figure 5B.52

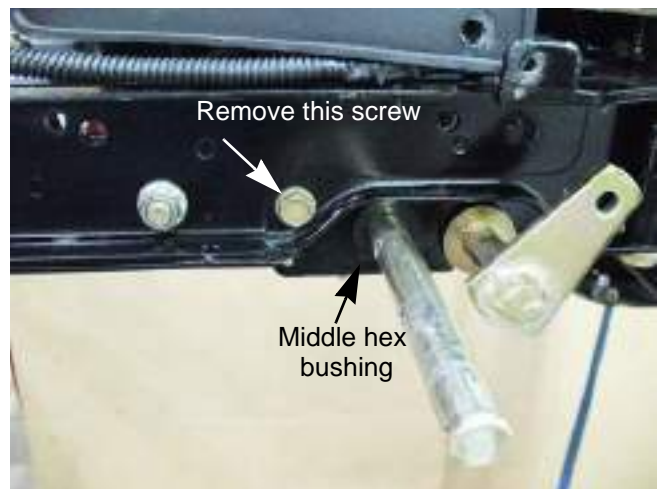

Figure 5B.52

14. Remove the middle hex bushing. See Figure 5B.52

15. Swing the rear of the drive pedal shaft support bracket down.
16. Disconnect the steering gear box from the main shaft by removing the hair pin clip. See Figure 5B.53

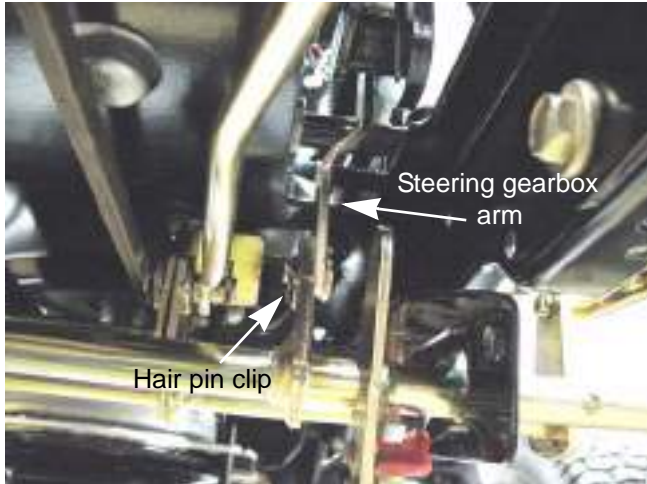

Figure 5B.53

17. Disconnect the reverse switch. See Figure 5B.54

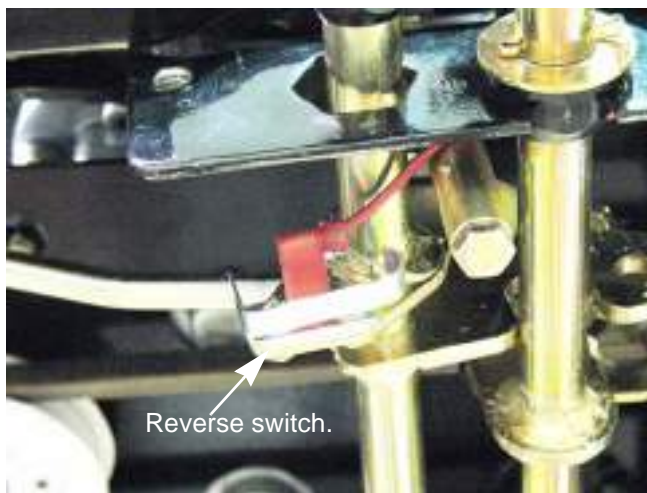

Figure 5B.54

18. Drop the left side of the main shaft out of slot.
19. Slide the main shaft out of the tractor.

To install the drive shaft assemblies:

1. Install the middle hex bushing. See Figure 5B.55

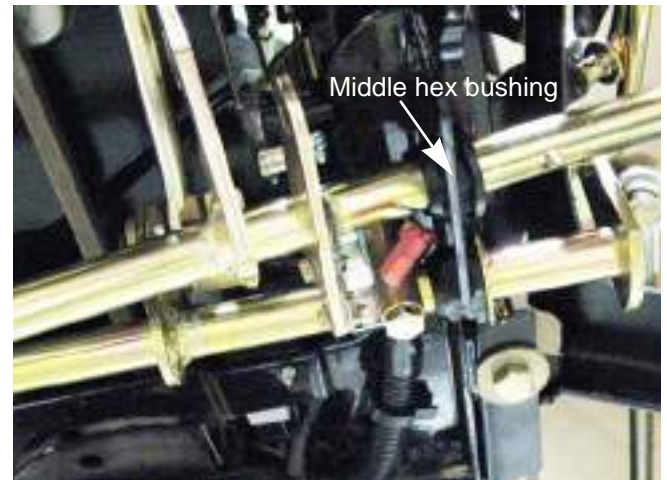

Figure 5B.55

2. Slide the right side of the main shaft through the middle hex bushing. See Figure 5B.55
3. Connect the reverse switch.
4. Connect the steering gearbox:
 - 4a. Slide the hole in the bell crank on the main shaft over the pin on the steering gearbox lever. See Figure 5B.56

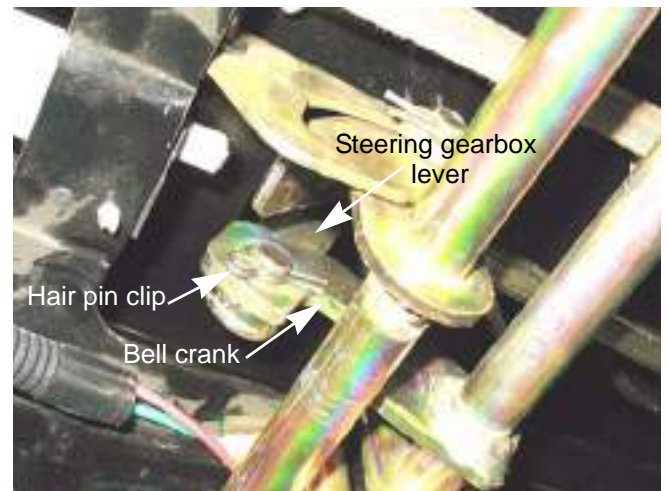

Figure 5B.56

- 4b. Install the hair pin clip. See Figure 5B.56

DRIVE SYSTEM-IVT

5. Insert the main shaft into the hole for the left hex bushing by sliding it through the slot.
See Figure 5B.57

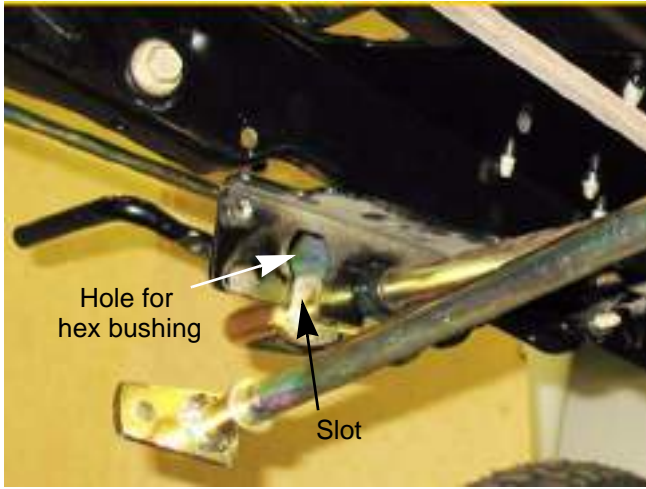

Figure 5B.57

NOTE: Do not install the hex bushing at this point. It will cause the main shaft to bind while working on the right side of the tractor.

6. Swing the rear of the drive pedal shaft support bracket into place.
7. Install the rear screw on each side of the drive pedal shaft support bracket. See Figure 5B.58

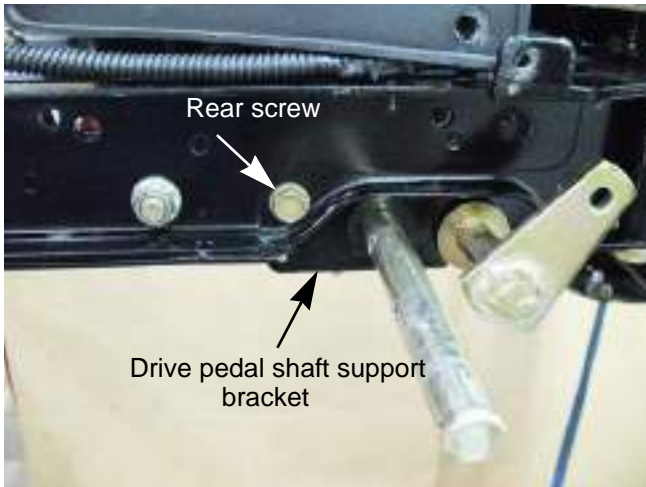

Figure 5B.58

8. Slide the drive pedal bracket onto the main shaft.
NOTE: Do not install the roll pins at this point.
9. Install the reverse pedal support.
10. Install the hair pin clip, washer and hex bushing on the right side of the main drive pedal shaft.
See Figure 5B.59

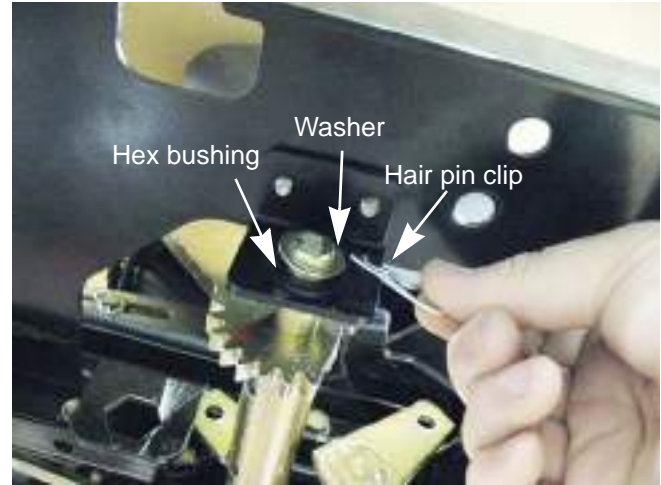

Figure 5B.59

11. Secure the drive pedal bracket to the main shaft by driving the two roll pins.
12. Install the split hex bushing on the left side of the main shaft. See Figure 5B.60

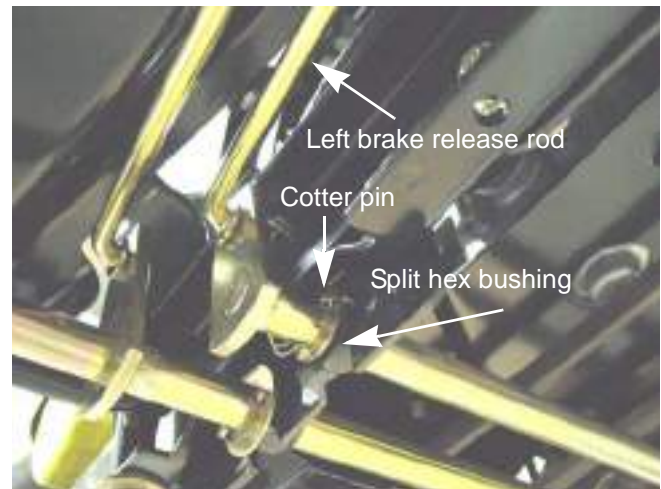

Figure 5B.60

13. Install a new cotter pin. See Figure 5B.60
14. Install both brake release rods from the main drive pedal shaft using new cotter pins.
See Figure 5B.60

15. Install the right side brake link onto the brake pedal shaft using a new cotter pin. See Figure 5B.61

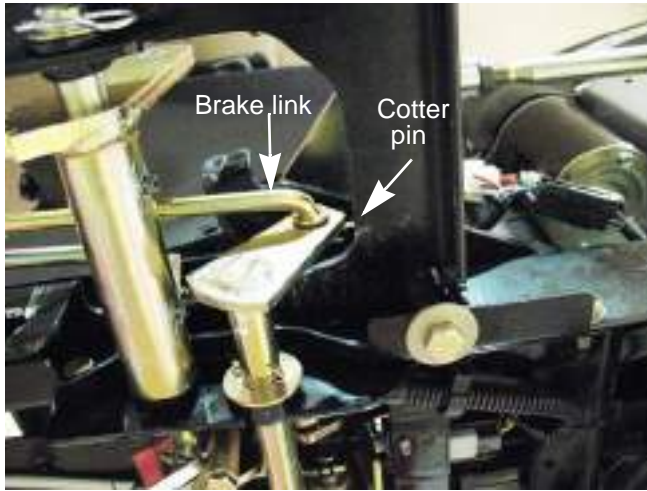

Figure 5B.61

16. Install the reverse drive pedal shaft.
 16a. Rotate the reverse drive pedal shaft into the reverse pedal support. See Figure 5B.45

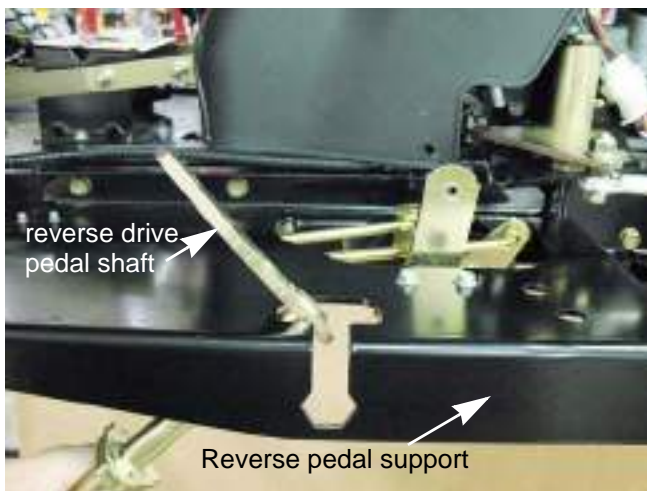

Figure 5B.62

- 16b. Install the split hex bushing.
NOTE: The split must face up while the bushing is installed.

- 16c. Modify the hex bushing by:
 • Cut or grind the bushing to an overall height of 1/2". See Figure 5B.63

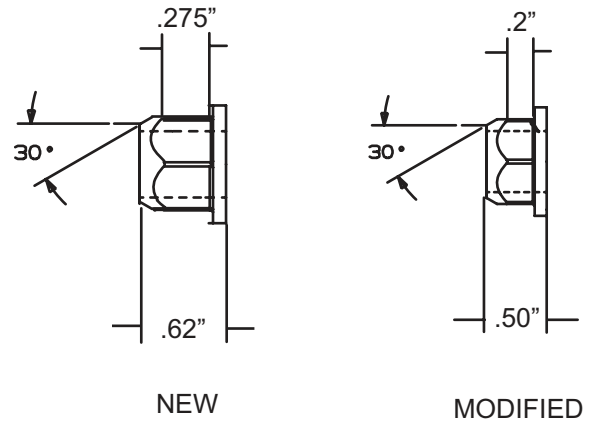

Figure 5B.63

- Grind a 30° taper on the hex end of the bushing.
NOTE: The hex part of the bushing must be at least 0.2" in height.

NOTE: Using a modified bushing will allow the bushings on the reverse drive pedal shaft to be serviced in the future without taking the fenders off of the tractor.

- 16d. Install the modified hex bushing. See Figure 5B.64

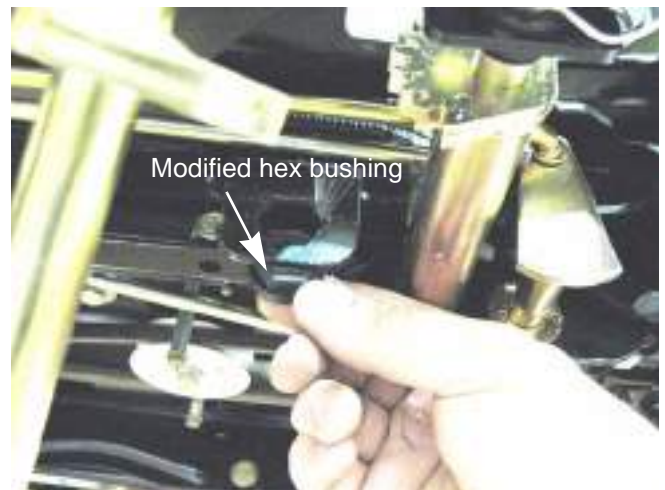

Figure 5B.64

DRIVE SYSTEM-IVT

16e. Slide the reverse drive pedal shaft into the modified hex bushing while aligning the timing marks on the gears of the two shafts. See Figure 5B.65.

- One mark on the fourth tooth from the bottom of the reverse gear.
- One mark on the fourth valley from the valley of the main drive shaft gear.

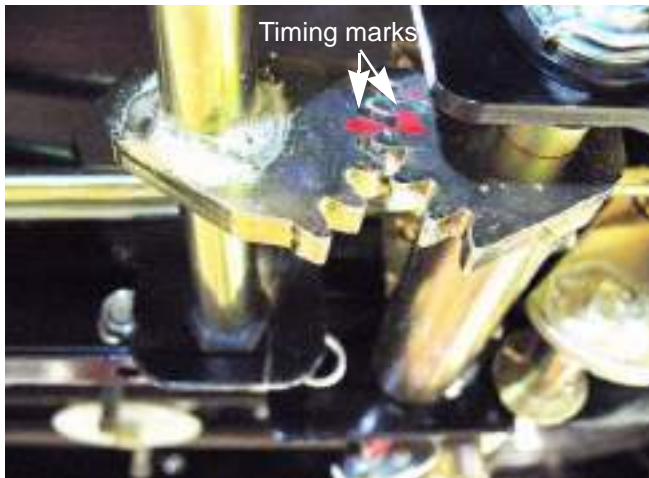

Figure 5B.65

16f. Install the washer and hair pin clip. See Figure 5B.66



Figure 5B.66

17. Install the fender by following the steps described in Chapter 4: Body/Chassis.

18. Test drive the tractor before returning it to service.

19. Install the deck as described in chapter 8 Cutting Decks and Lift Shaft.

CHAPTER 6A: STEERING - HYDROGEAR TRANSMISSIONS

Introduction

The steering on the I-series tractor works in two phases.

- First it will steer like any other tractor by turning the front wheels.
- Second and more importantly, the steering linkage will control the drive output of the rear wheels through the use of two HydroGear transmissions.

The steering gear box is connected to the front wheels by drag links. When the steering wheel is turned, the gear box will turn the wheels. The gear box will slow the drive speed of the inside rear wheel. At approximately 50° the steering gear box will start to slow down the outside drive wheel. When the inside front wheel reaches an angle of 90°, the rear wheel on that side will stop driving. Turning the wheel past that point will make the inside rear wheel go in reverse. The inside front wheel can reach a 108° angle and with the transmission on the inside of the turn driving in reverse. The tractor will then be in a zero turn.

Because the steering gear box is linked to the transmissions, the transmission adjustments and the wheel alignment must be addressed together. A transmission that is out of adjustment can make the steering look out of adjustment just as a steering linkage that is out of adjustment will affect the transmissions.

IMPORTANT: Check the tire air pressure before attempting to diagnose any problems with the steering or tracking of an I-series tractor. If the tire air pressures are not equal across the same axles, it will greatly affect the performance of the tractor.

Cam Slot Angle Adjustment

The cam slot adjustment is a critical adjustment on the I-series tractor, but it should only be necessary in two cases.

1. The cam slot angle adjustment must be set if the steering gear box is replaced.
2. In the extremely rare case that the angle is simply out of adjustment. The indications are as follows:

NOTE: Test tractor in a safe area in case the tractor moves during testing.

- A The tractor is running.
- B Parking brake released.
- C Feet off of the brake and drive pedals.
- D Turn the steering wheel fully in both directions.
- E If the tractor creeps, cam angle needs adjusted. If the tractor does not creep, cam slot angle adjustment is not needed. Proceed to the neutral and alignment adjustments.



The second would be a safety issue and must be addressed before returning the tractor to service

To adjust the cam slot angle:

NOTE: A special tool P/N 753-05437 is needed to make this adjustment. Do not attempt to make this tool, if needed it can be ordered from the Cub Cadet parts department.

1. Remove the dash and fender by following the steps described in Chapter 4: Body/Chassis.

STEERING-HYDROGEAR

2. Disconnect the transmission link from the right side of the gear box only.
 - 2a. Removing the nut and bolt that passes through the double roller. See Figure 6A.1.



Figure 6A.1

- 2b. Remove the cotter pin and clevis pin. See Figure 6A.2.

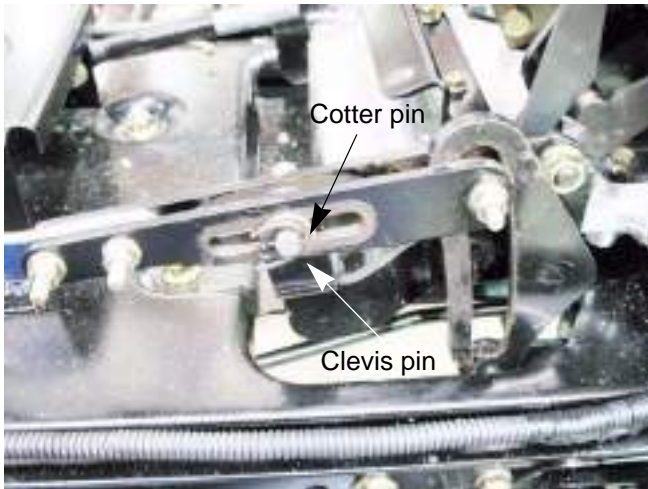

Figure 6A.2

- 2c. Raise the transmission link away from the cam slot.

NOTE: Catch the double roller when lifting the transmission link away from the steering gear box. See Figure 6A.3.

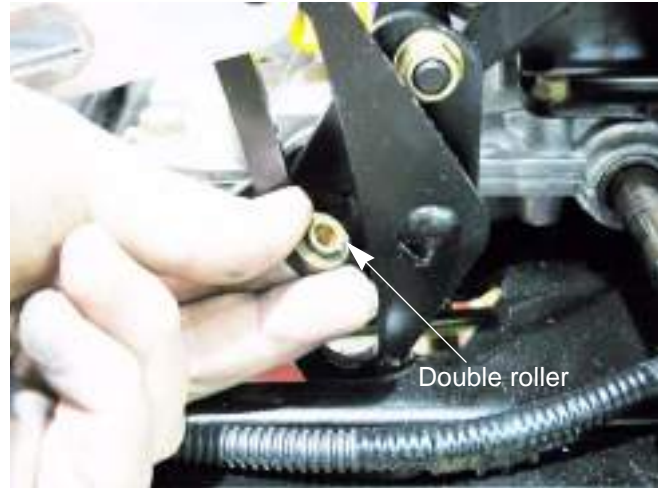

Figure 6A.3

3. Loosen the return to neutral bolt using a 9/16" wrench and a 1/4" hex key. See Figure 6A.4.



Figure 6A.4

4. Insert the pins of the gauge block tool P/N 753-05437 into the cam slot. See Figure 6A.5.

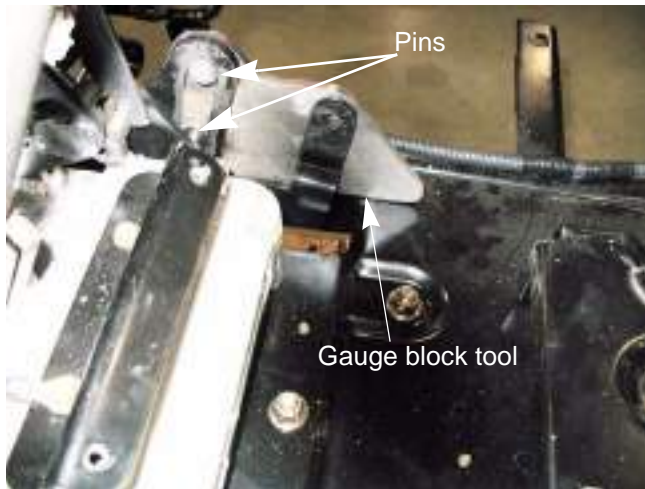

Figure 6A.5

5. Rest the tool flat against the frame. See Figure 6A.6.



Figure 6A.6

6. Tighten the return to neutral bolt. See Figure 6A.7.

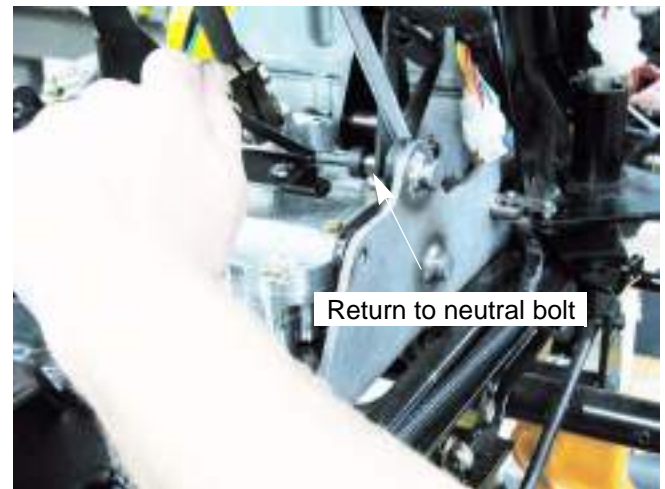

Figure 6A.7

7. Remove the gauge block.
8. Adjust the transmission for neutral and align the front wheels as described in the following sections of this chapter.
9. Reassemble the tractor.
10. Test drive the tractor in a safe area before returning it to service.

STEERING-HYDROGEAR

Neutral and Transmission Links Adjustment

The first step is to coordinate the neutral points of the steering gear box, both transmissions and the control linkages. The transmission links will self adjust when the neutral adjustment and wheel alignment are done. To establish neutral:

1. Lock Steering Gear Box in Neutral Position:

- 1a. Remove the 1/4"-20 plug screw from the steering gear box centering port using a 3/8" wrench. See Figure 6A.8.



Figure 6A.8

- 1b. Thread a 1/4"-20x2" bolt into the steering box centering port until you feel it touch the steering rack.
- 1c. While trying to gently thread the bolt further, slowly rotate the steering shaft back and forth until the bolt seats into the detent in the steering rack.

- 1d. Finger tighten the screw to set the screw fully into the detent. The steering gear box is now centered and locked. See Figure 6A.9.

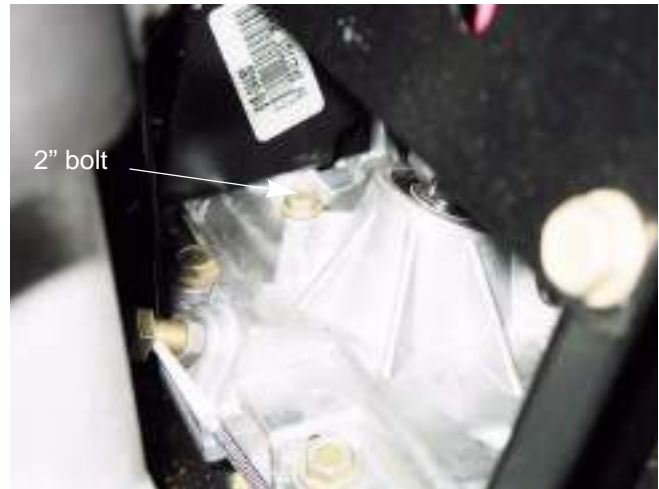

Figure 6A.9

2. Jack the tractor up so that both rear wheels are off of the ground. Place a pair of jack stands under the rear transmissions. See Figure 6A.10.

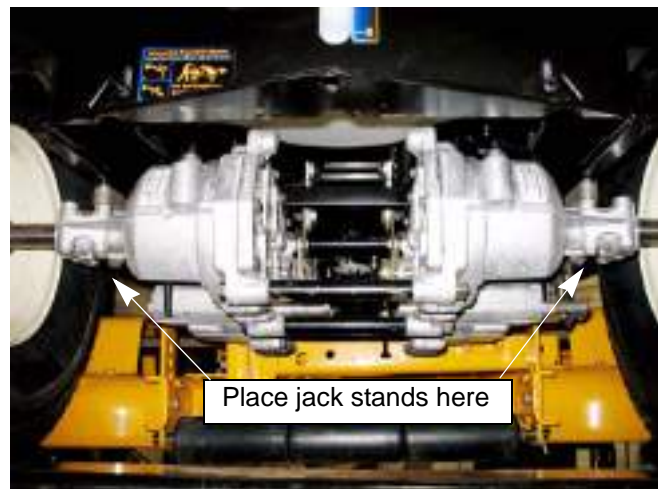

Figure 6A.10

3. Loosen the two screws that connect each drive control link to the shifter T-plate on each transmission. See Figure 6A.11.

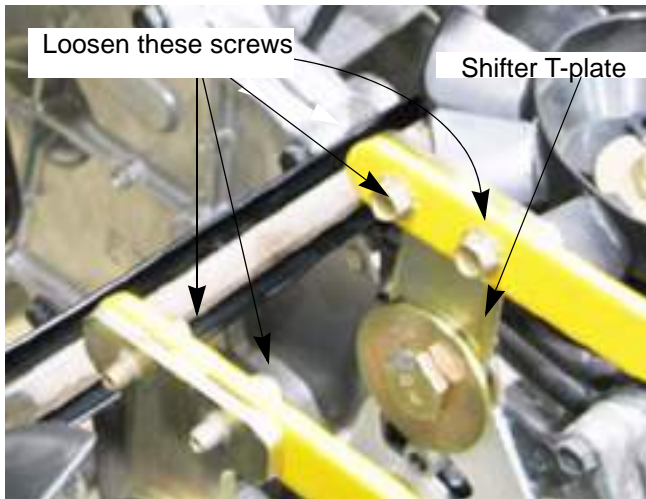

Figure 6A.11

NOTE: Feel the shifter T-plate, it should be free of any input from the transmission links. If tension is felt there, disconnect the links completely.

4. While sitting in the seat, start the tractor and run it at full throttle. Release the brake.



The tractor engine and drive system must be operated to complete this procedure.

Confirm that no hazards will be incurred by running the engine or operating the drive system

5. Check the rear wheels.

NOTE: The rear wheels should not turn. If either wheel turns, adjust the transmission for neutral by:

- 5a. Loosen the socket head cap screw in the slot of the shift selector plate. See Figure 6A.12.



Figure 6A.12

NOTE: It is not necessary to remove the fender for this step. The fender was removed in this photo for clarity.

NOTE: Only loosen the screws on the side that creeps.

- 5b. With the tractor still running, move the shift selector plate until the wheel stops moving.

NOTE: For the best zero-turn performance, Set the selector plate to the reverse side of the neutral band (region where the transmission is in neutral).

- 5c. Tighten the socket head cap screw.

NOTE: Leave the transmission links loose until the wheels are aligned.

6. Perform the wheel alignment by following the procedures described in the next section of this manual.

STEERING-HYDROGEAR

Wheel alignment

NOTE: The transmission neutral adjustment must be done prior to adjusting the steering linkage.

1. Remove the three screws holding each steering gear cover in place. See Figure 6A.13.

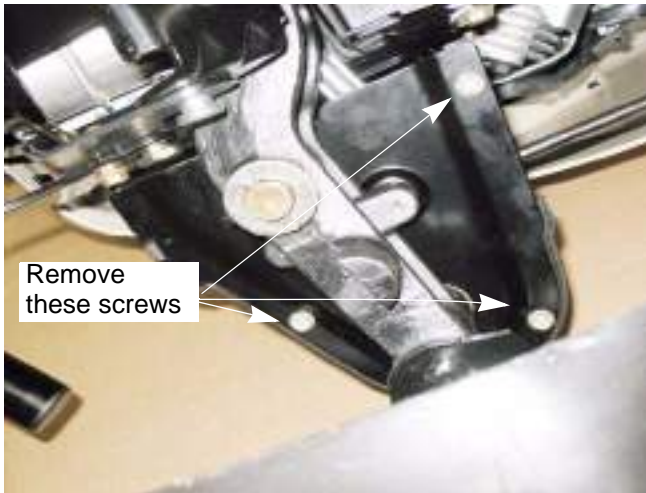

Figure 6A.13

2. Rotate the front tires until the marks on the axle gears and the steering gears align. See Figure 6A.14.

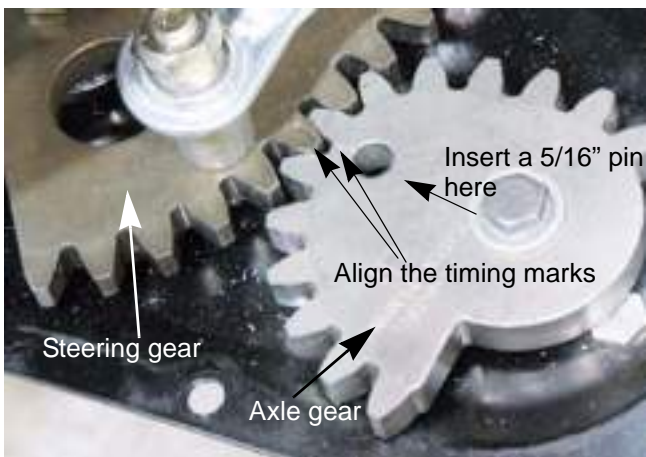

Figure 6A.14

3. Insert a 5/16" pin through the hole in the steering gear on each side. The pins should pass through the gears, through the lower cover plate and into the pivot bar. See Figure 6A.15.



Figure 6A.15

NOTE: If the alignment is off, the holes may not line up. If this is the case, adjust the front end by:

- 3a. Loosen the jam nuts on both ends of the drag link. See Figure 6A.16.



Figure 6A.16

- 3b. Adjust the drag link until the holes line up
See Figure 6A.17.



Figure 6A.17

NOTE: The punch should slide in and out without binding. As the drag links are being adjusted, rock the tires back and forth to remove the load created from the tires twisting on the floor.

- 3c. Tighten the jam nuts.
4. Tighten the drive control links to the T-plates.
 5. Remove the 1/4"-20x2" screw from the steering gear box.
 6. Reinstall the original plug screw in the steering gear box.
 7. Install the steering gear covers.



Never allow an I-series tractor to be operated with out the steering gear covers. Personal injury may result.

8. Test drive the tractor in a safe area before returning it to service.

Steering gear box removal

To replace the gear box:

1. Remove the dash and fender by following the steps described in Chapter 4: Body/Chassis.
2. Disconnect the transmission linkages:
 - 2a. Remove the cotter pins, washers and clevis pins in the linkages. See Figure 3.18.



Figure 3.18

- 2b. Remove the nuts and bolts connecting the transmission linkages to the levers on the steering gear box. See Figure 6A.19.



Figure 6A.19

- 2c. Lift the links away from the gear box.

NOTE: There are rollers in the slots. Take care not to lose them when removing the bolts.

STEERING-HYDROGEAR

3. At the bottom of the lever with the cam slot there is a connector link. Remove the hairpin clip and push it out of the lever. See Figure 6A.20.

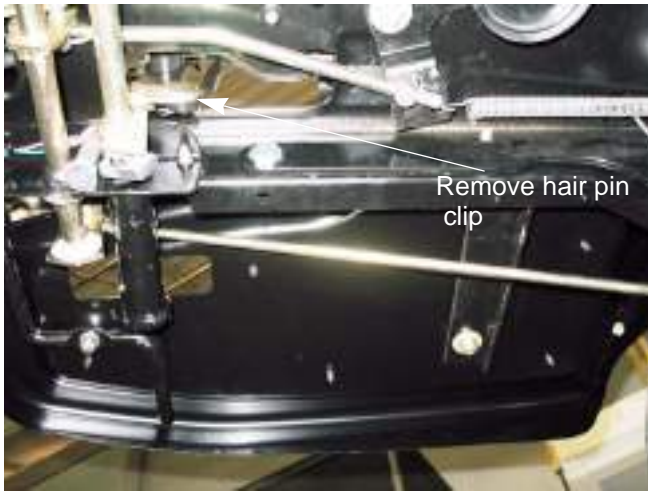

Figure 6A.20

4. Disconnect the steering links on both sides:
 - 4a. Gently pry the link retainer over the master link. See Figure 6A.21.

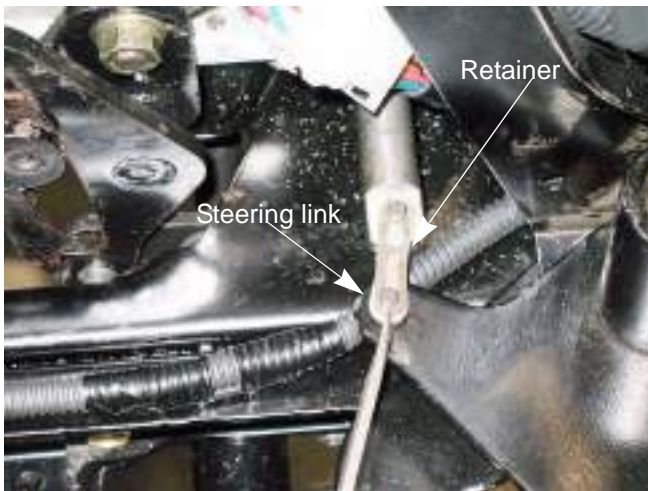

Figure 6A.21

5. Remove the transmission dampener cylinder using two 1/2" wrenches. See Figure 6A.22.

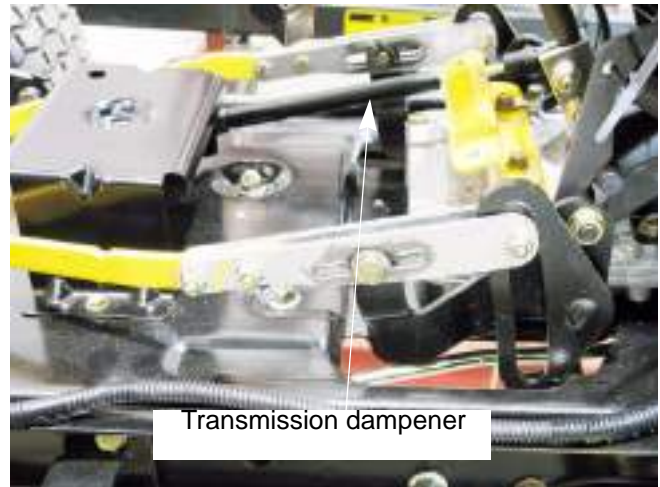

Figure 6A.22

6. Remove the steering shaft by removing the two clamp bolts in the steering shaft receiver and lifting the shaft out. See Figure 6A.23.

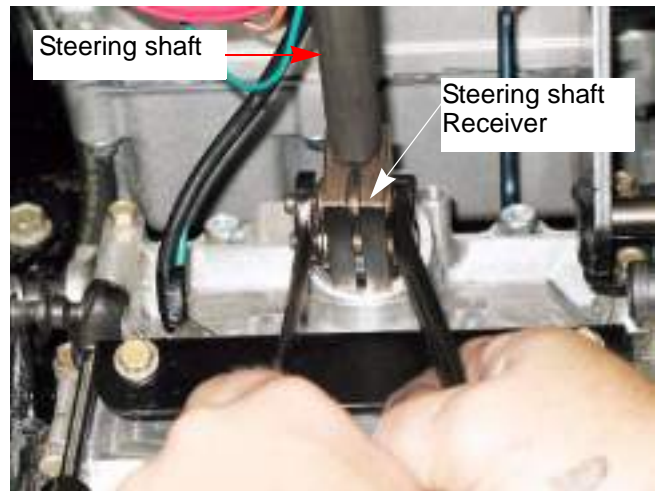

Figure 6A.23

NOTE: Rotating the steering shaft bushing 90 degrees will allow the bushing to pop out, relieving the pressure on the steering shaft. This will make it easier to remove or install the shaft. See Figure 6A.24.

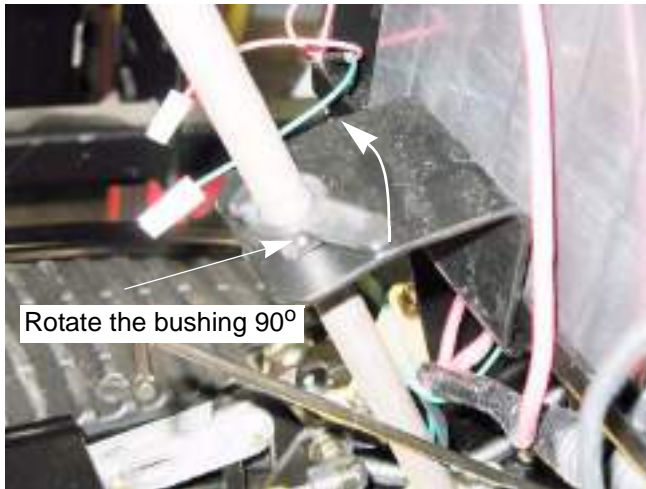

Figure 6A.24

7. Disconnect the ground wire. See Figure 6A.25.



Figure 6A.25

8. Remove the four screws holding the gear box to the frame with a 1/2" wrench. See Figure 6A.26.



Figure 6A.26

9. The new gear box should come with 1/4"-20 x 2" screw to lock it into the neutral/centered position.
10. Bolt the gear box to the frame with the four bolts removed in step 8.
11. Insert the steering shaft into the steering shaft receiver. Tighten the nuts to a torque of 130 - 160 in lbs (14.7 - 18.0 Nm).
12. Attach the steering links. Install the retainers.
13. Attach the transmission dampener to the gear box.
14. Place the link into the bottom of the lever with the cam slot. Insert the hairpin clip to hold it in place. See Figure 6A.27.

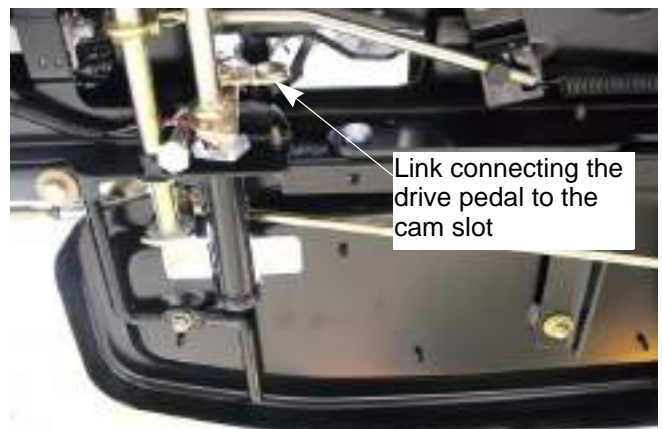

Figure 6A.27

STEERING-HYDROGEAR

15. Apply anti-seize compound to the rollers and the cam slots on the gear box levers.
See Figure 6A.28.



Figure 6A.28

16. Adjust the speed cam angle by following the steps described in the previous section.
17. Connect the transmission links.
 - 17a. Place the rollers into the cam slots and slide the transmission links over the levers.
 - 17b. Insert the bolt through the transmission link and roller.
 - 17c. Install the nut on the bolt and tighten to a torque of 8 ft lbs (11 Nm).
See Figure 6A.29.



Figure 6A.29

18. Insert the clevis pins, washers and cotter pins.
19. Align the wheels and adjust the transmission links by following the steps described at the beginning of this chapter.
20. Remove the 1/4"-20x2" bolt that came with the steering gearbox, and install the short one from the old gearbox.
21. Install the fender and dash by following the steps described in Chapter 4: Body/Chassis.
22. Test drive the tractor in a safe area before returning to service.

Rebuilding the steering gear box

There are two different gear boxes available for the I-series tractors that are equipped with HydroGear transmissions.

- The 618-04430 steering gear box was used until the end of the 2007 model year.
- The 618-04634 steering gear box was used in 2008 through current production.

The procedures to rebuild both gear boxes are similar. Where there are differences, they will be called out in the text.

To take the steering gear box apart:

1. Remove the steering gear box by following the procedures described in the previous section of this chapter.
2. Identify the gearbox assembly using the serial number tag located on the return to neutral bracket. See Figure 6A.30.



Figure 6A.30

3. Remove the return to neutral bracket using a 3/8" wrench. See Figure 6A.31.



Figure 6A.31

4. Remove the six remaining case screws using a 3/8" wrench. See Figure 6A.32.

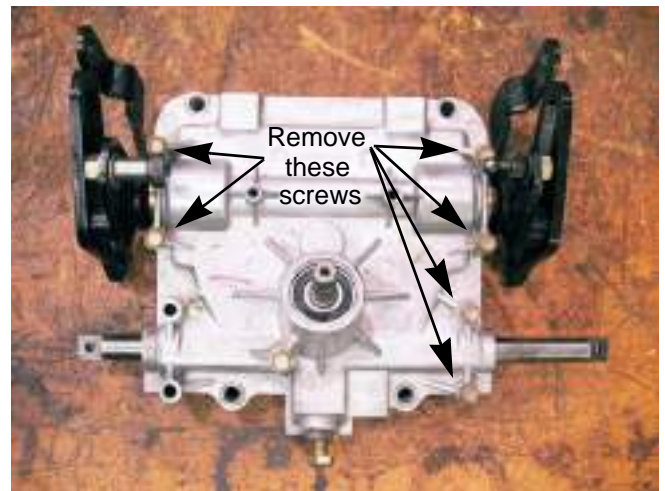

Figure 6A.32

STEERING-HYDROGEAR

5. Lift the upper housing off of the lower housing.

NOTE: There is no sealant between the two housings. They should easily slip apart. If they are stuck together, there are three pry points cast into the housings that can be used to separate the housings. See Figure 6A.33.

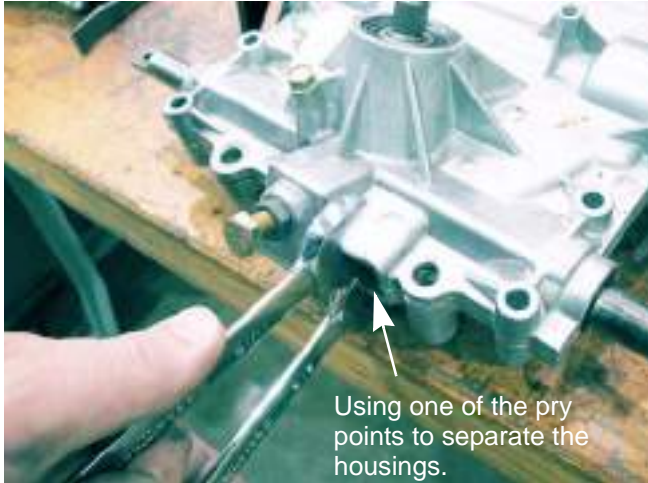

Figure 6A.33

6. Remove the steering rack. See Figure 6A.34.

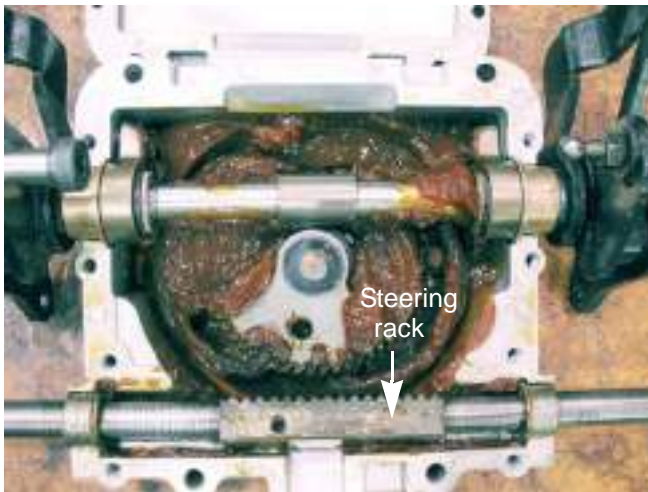

Figure 6A.34

7. Remove the speed cam assemblies. See Figure 6A.35.

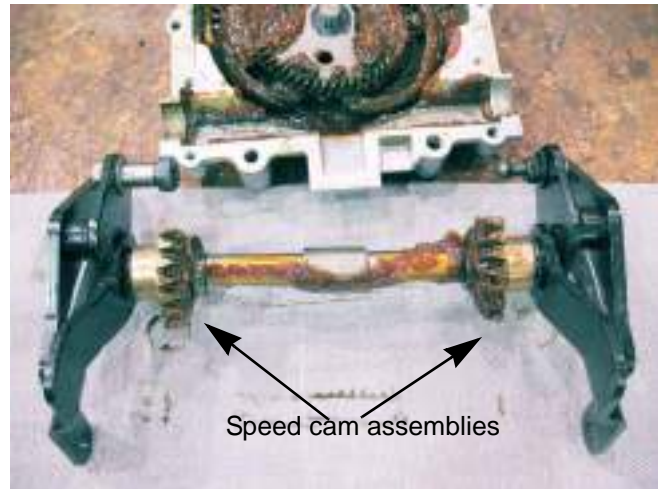

Figure 6A.35

8. Separate the speed cam assemblies. See Figure 6A.36.



Figure 6A.36

- 9. Separate the speed cam from the output bevel gear assembly by removing the small snap ring from the speed cam shaft. See Figure 6A.37.

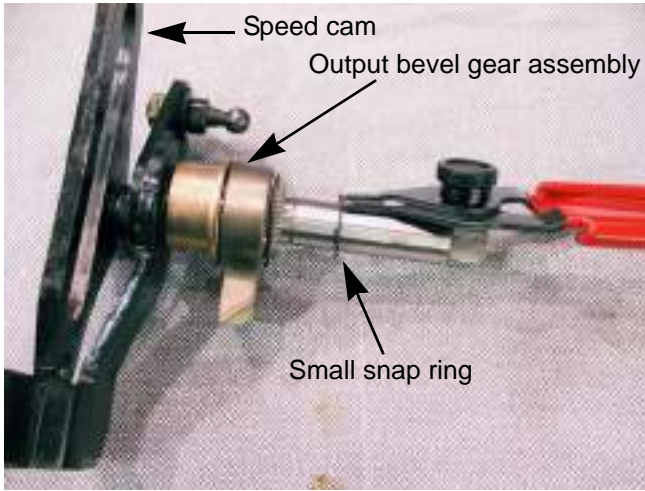

Figure 6A.37

- 10. Separate the output bevel gear assembly by removing the snap ring. See Figure 6A.38.



Figure 6A.38

- 11. Remove the washer from the input sector gear. See Figure 6A.39.

NOTE: The 618-04430 gear boxes only

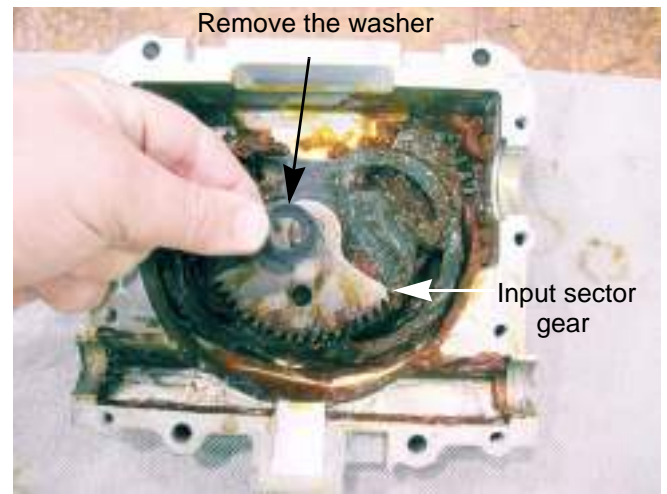

Figure 6A.39

- 12. Remove the input sector gear. See Figure 6A.40.



Figure 6A.40

STEERING-HYDROGEAR

13. Inspect the input sector gear bushings for damage and/or signs of wear. If they show signs of wear or damage, press both of the bushings out of the input sector gear using a press. See Figure 6A.41.

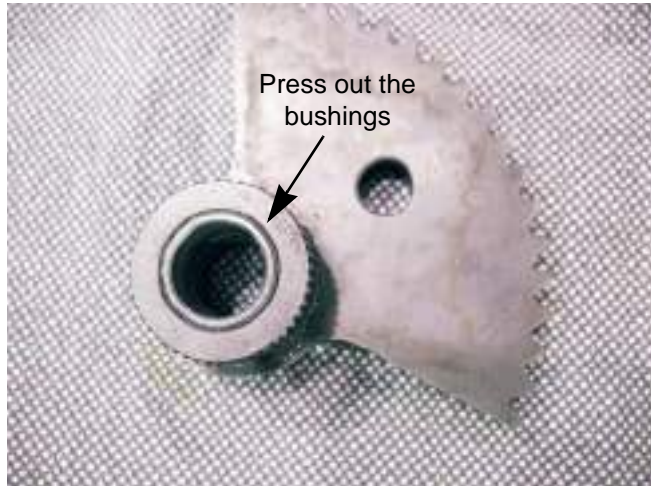

Figure 6A.41

14. Remove the internal cam, the washer under it and the steering shaft. See Figure 6A.42.

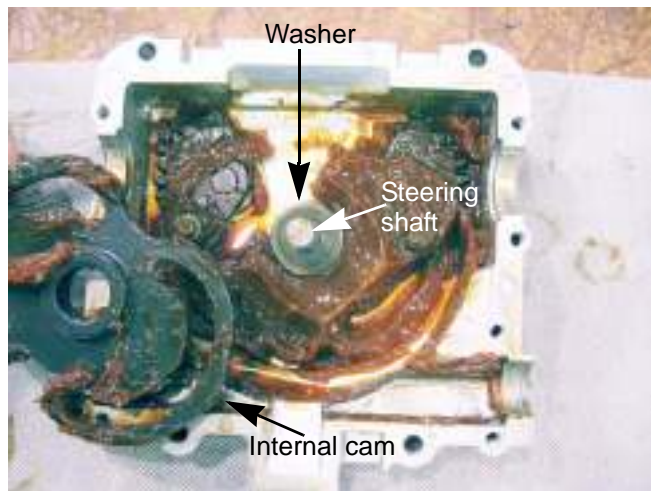

Figure 6A.42

15. Remove both of the bevel gears. See Figure 6A.43.

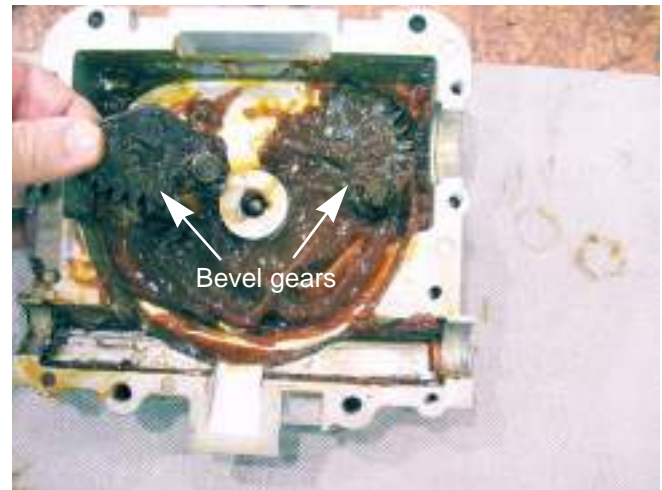

Figure 6A.43

16. Remove the spiral ring from the post on the bevel gear. Slide the roller off of the bevel gear. See Figure 6A.44.

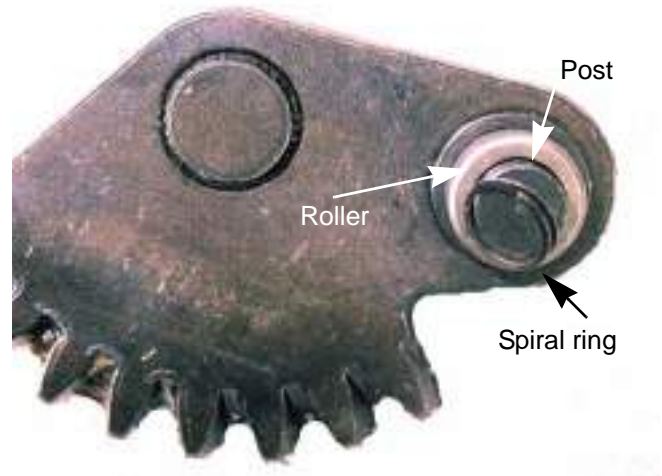

Figure 6A.44

17. Remove the snap ring from the input shaft.
See Figure 6A.45.



Figure 6A.45

18. Remove the input shaft from the inside of the housing. See Figure 6A.46.

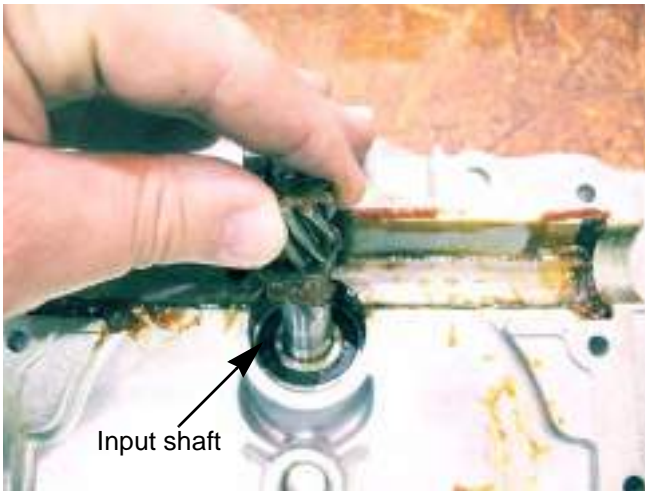

Figure 6A.46

19. Remove the wear block.

NOTE: On early production models of the 618-04430 and all versions of the 618-04634 steering gear boxes there is a spring that presses the wear block against the steering rack.
See Figure 6A.47.



Figure 6A.47

NOTE: On late production models of the 618-04430 steering gear boxes there is a bolt that applies pressure to the wear block. When removing the wear block; make sure to get the washer out of it. See Figure 6A.48.

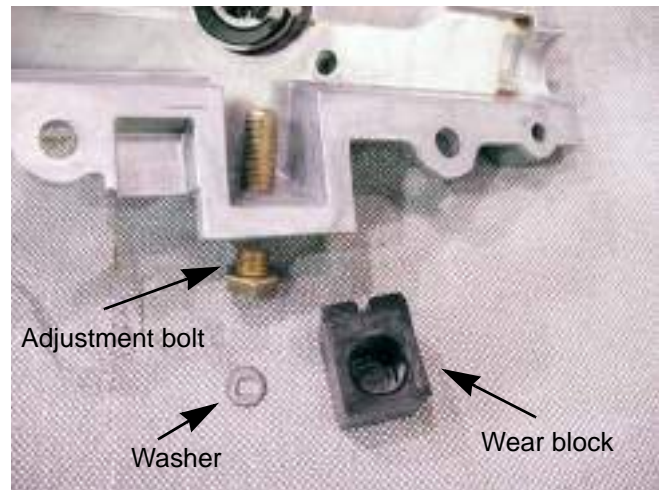

Figure 6A.48

NOTE: Unless the upper housing or wear block is being replaced, leave the adjustment bolt in place.

STEERING-HYDROGEAR

20. Inspect the bearings. If they are worn or rough, carefully drive the inner bearing out of the upper housing using a pin punch and hammer. See Figure 6A.49.

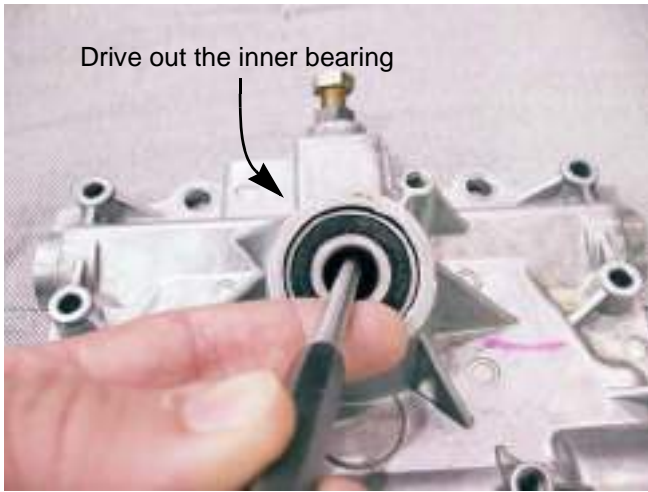

Figure 6A.49

21. Drive the outer bearing out of the upper housing using a pin or brass punch and hammer. See Figure 6A.50.



Figure 6A.50

22. Thoroughly clean and degrease all parts.
23. Inspect all parts for signs of wear or damage.
NOTE: If the part has signs of wear or damage; discard the part.
NOTE: If the two bushings in the bottom of lower gear box housing are worn, replace the lower housing and press in two new bushings.

To assemble the steering gear box:

1. Put a dab of 737-0300A Durina™ grease into each of the bushings in the lower housing. See Figure 6A.51.



Figure 6A.51

2. Install both of the bevel gears with the rollers line with the center of the housing. See Figure 6A.52.

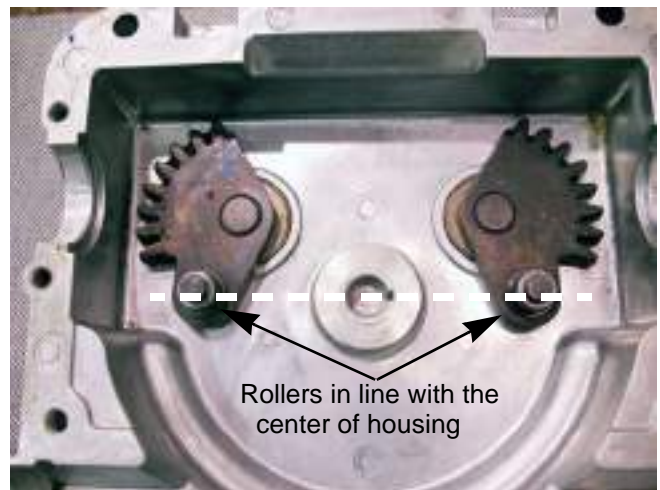

Figure 6A.52

3. Insert the steering shaft. See Figure 6A.53.

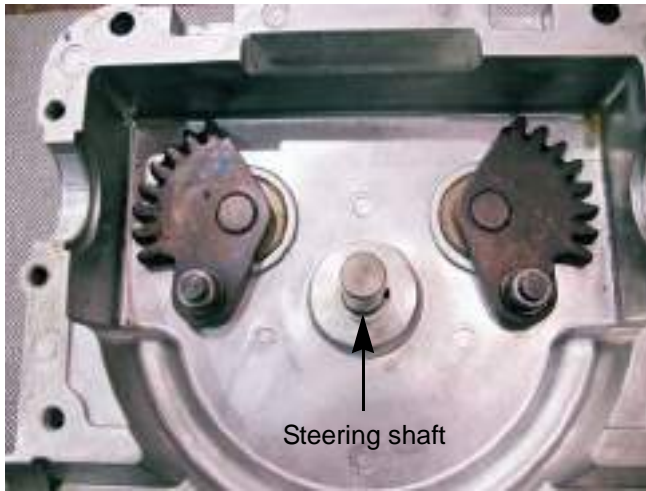

Figure 6A.53

4. Place the large washer over the steering shaft. See Figure 6A.54.



Figure 6A.54

5. Install the internal cam with the shoulder facing up. The bevel gear rollers in the slots. See Figure 6A.55.



Figure 6A.55

6. Apply a dab of 737-0300A Durina™ grease to the side of the steering shaft. See Figure 6A.56.



Figure 6A.56

STEERING-HYDROGEAR

7. Insert the input sector gear into the internal cam.

NOTE: The input sector gear and the internal cam have a master spline to time the two to each other. See Figure 6A.57.

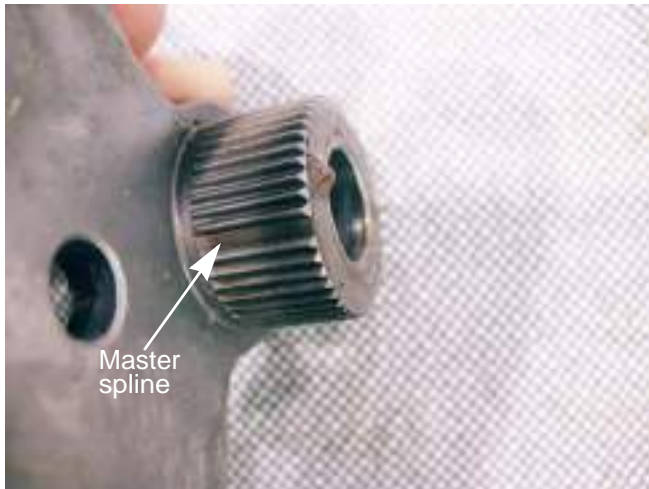

Figure 6A.57

8. On the 618-04430 gear boxes, place the smaller washer over the steering shaft. See Figure 6A.58.



Figure 6A.58

9. Assemble the output bevel gear assemblies.
- 9a. Insert the shaft of the left speed cam into the left hydro arm. See Figure 6A.59.
- 9b. Place a bushing over the hydro arm with the flange facing away from the arm. See Figure 6A.59.

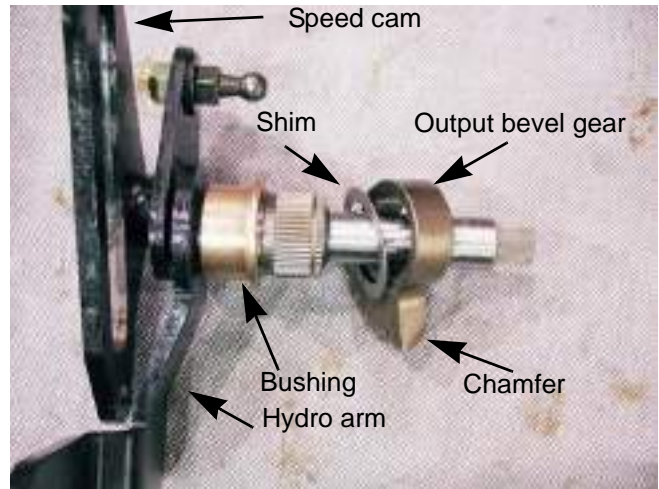

Figure 6A.59

- 9c. Place a .030" shim over the hydro arm. See Figure 6A.59.

NOTE: The bevel gear needs to be shimmed to a bind. That means that once the assembly is installed in the lower housing, there is zero play between the bushing and the bevel gear. It may take a few attempts to get the shims correct.

- 9d. Place the output bevel gear on the hydro arm with the chamfer facing away from the hydro arm. See Figure 6A.59.

NOTE: If the output bevel gears are put on backwards it will throw off the timing of the gearbox.

NOTE: The hydro arms and output bevel gears have master splines to time them to each other. See Figure 6A.60.

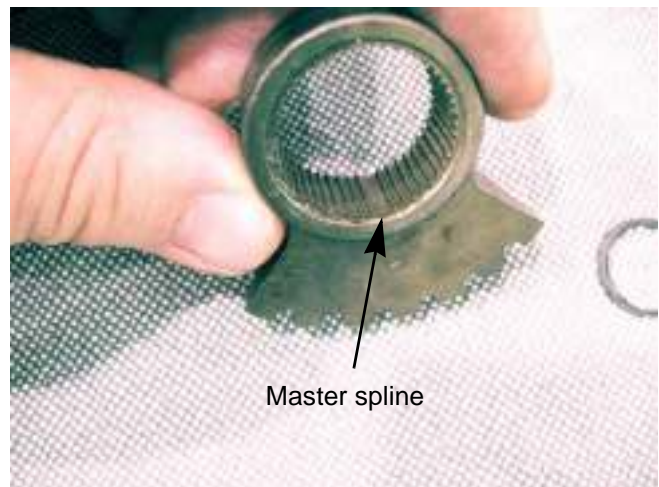

Figure 6A.60

- 9e. Install both of the snap rings.
- 9f. Repeat for the right output bevel gear assembly.
- 10. Place both output bevel gear assemblies on the bench, facing each other. With both assemblies resting on the same points of the speed cam, insert both shafts into the coupler. See Figure 6A.61.

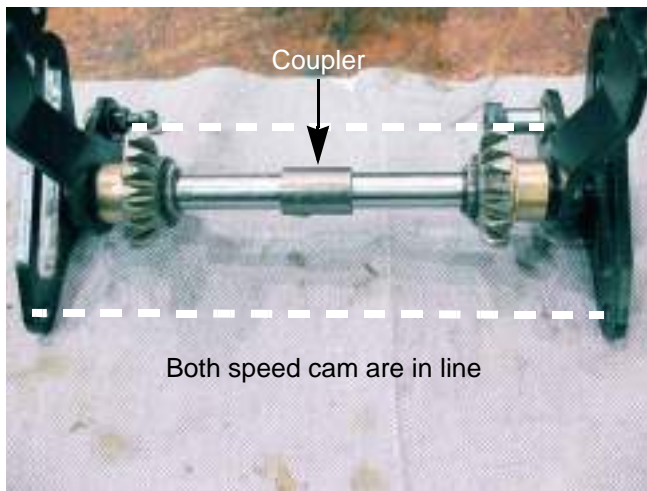

Figure 6A.61

NOTE: The coupler has a master spline, but the speed cam shafts do not. If both speed cams are not resting on the same points when coupled they are out of time.

- 11. Insert the speed cam assemblies in the lower housing.
 - Align the hole in the input sector gear with the the center of the square recess at the front of the lower housing. See Figure 6A.62.

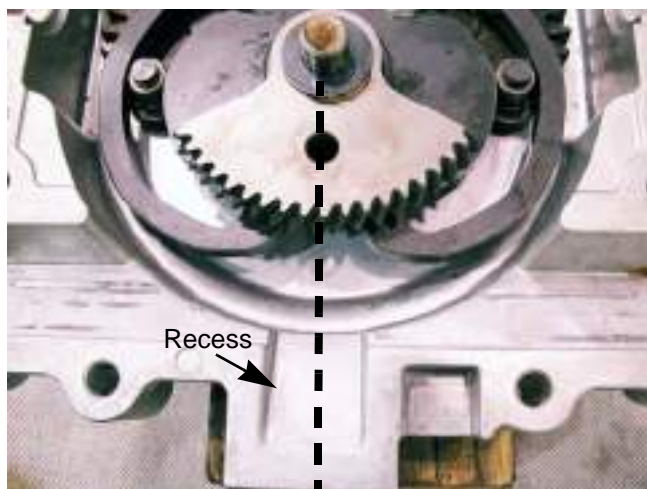

Figure 6A.62

- The bevel gears should face away from the input sector gear.
- The first tooth of each output bevel gear should rest in the first valley the bevel gears in the bottom of the lower housing.
- The output bevel gear should have no play once it is installed. If it does have play go back to step 9. See Figure 6A.63.

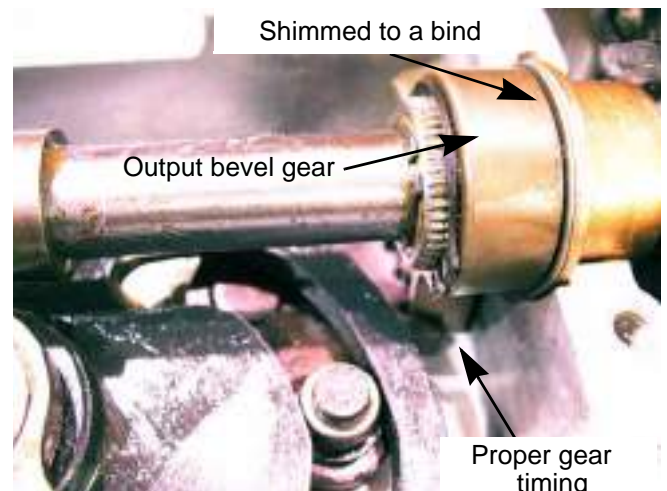

Figure 6A.63

NOTE: To test proper gear timing; measure from the farthest point of the output bevel gear to the top of the housing. It should measure a 1/4" for both sides. See Figure 6A.64.

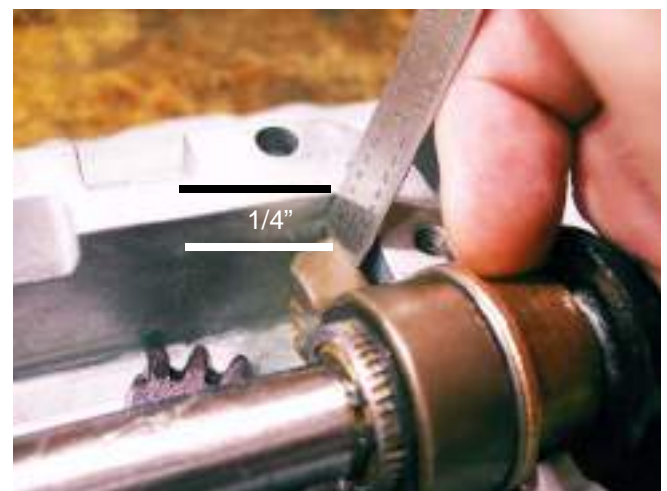

Figure 6A.64

NOTE: If one or both of the output bevel gears are out of time; the steering rack will lose travel on the affected side.

STEERING-HYDROGEAR

12. Fill the lower housing with 12 oz. of 737-0300A Durina™ grease. See Figure 6A.65.



Figure 6A.65

13. Press in the upper ball bearing into the upper housing. See Figure 6A.66.



Figure 6A.66

14. Press the lower ball bearing into the upper housing. See Figure 6A.67.

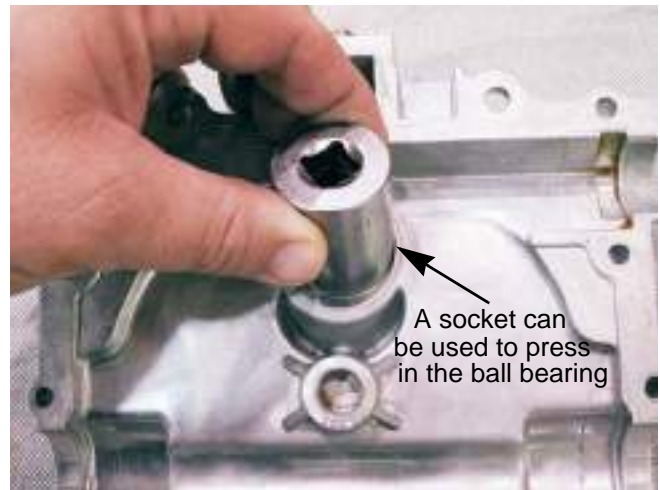

Figure 6A.67

15. Insert the input shaft through the ball bearings from the inside of the steering gear box. See Figure 6A.68.

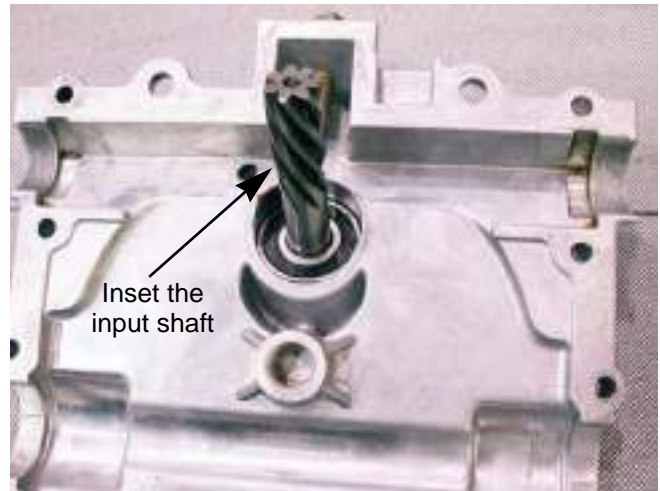

Figure 6A.68

16. Install the snap ring on the input shaft.
See Figure 6A.69.

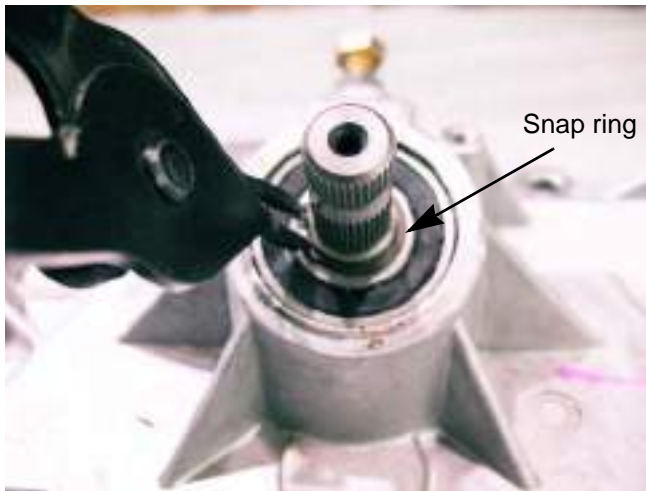

Figure 6A.69

17. Install the wear block:
 - For the 618-04430 steering gear boxes with the adjustment bolt:
 - 17a. Insert the washer into the hole in the wear block.
 - 17b. Slide the wear block and washer onto the adjustment bolt. See Figure 6A.70.



Figure 6A.70

- For all other steering gear boxes:
 - 17c. Insert the spring into the wear block.
 - 17d. Set the wear block and spring into the square recess in the upper housing.
See Figure 6A.71.

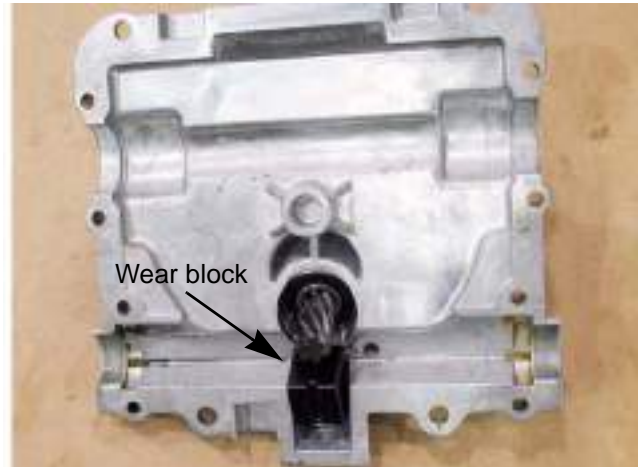

Figure 6A.71

18. Slide one new bushing onto each side of the steering rack, with the flanges facing the center of the rack.
19. Set the steering rack into the groove in the upper housing; trapping it between the input shaft and the wear block. See Figure 6A.72.

NOTE: The hole in the steering rack should line up with the hole in the housing.
See Figure 6A.72 Insert.



Figure 6A.72

STEERING-HYDROGEAR

20. With the wear block facing the front, adjust the steering rack until the right side measures 1.8" from the case to the shoulder at the end of the shaft. See Figure 6A.73.



Figure 6A.73

21. Holding the steering rack in place, carefully set the upper case onto the lower case.

NOTE: Removal of the return to neutral bolt and the dampener post from the speed cam assemblies will make it a lot easier to put the upper case half onto the lower case half.

NOTE: If removing the dampener post, mark its location on the speed cam assembly to ensure proper reassembly.

NOTE: The upper case should drop into place. Do not force it.

22. Check the timing of the gear box:
- 22a. Turn the input shaft until the steering rack has moved all the way to the left. The right shoulder should be flush with the housing. See Figure 6A.74.

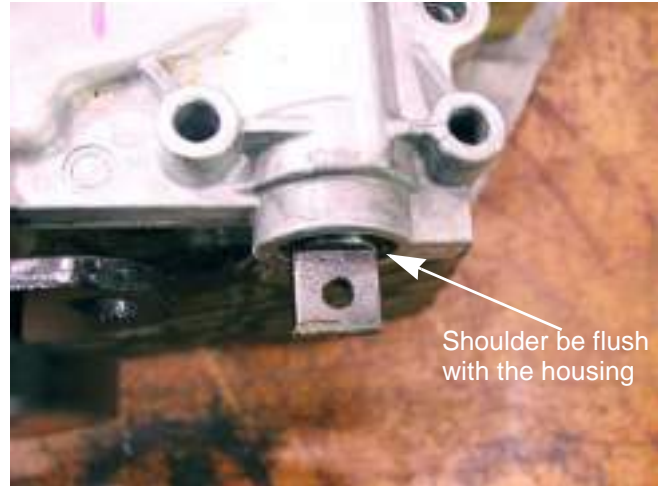

Figure 6A.74

- 22b. Turn the input shaft until the steering rack has moved all the way to the right. The left shoulder should be flush with the housing.
23. Install the return to neutral bracket.
24. Install the remaining housing screws.
25. If the dampener post was removed, re-install it.
26. If the return to neutral bolt was removed, re-install it.
- NOTE:** The return to neutral bolt does not need to be tightened at this time. It will be adjusted and tightened when it is installed in the tractor.
- NOTE:** On 618-04430 gear boxes with the adjustment bolt, perform the wear block adjustment by following the steps described in the wear bolt adjustment section of this chapter.
27. Thread a 1/4"-20x2" bolt into the hole in the gear box to lock the gear box in neutral.
28. Install the steering gear box in the tractor and perform the neutral adjustments, speed cam adjustments and the wheel alignment by following the procedures described in this chapter.
29. Test drive the tractor in a safe area before returning to service.

Wear block adjustment

All of the steering gear boxes have a wear block that presses the wear block against the steering rack to set the back lash between the steering rack and the input shaft. Most of the steering gear boxes have a spring that holds a constant pressure on the wear block.

On some of the 618-04430 steering gear boxes, there is an adjustment bolt for the wear block. To adjust the bolt:

NOTE: This procedure can be performed while the steering gear box is installed in the tractor.

1. If the steering gear box is installed in the tractor, isolate it by disconnecting both of the steering links. See Figure 6A.75.

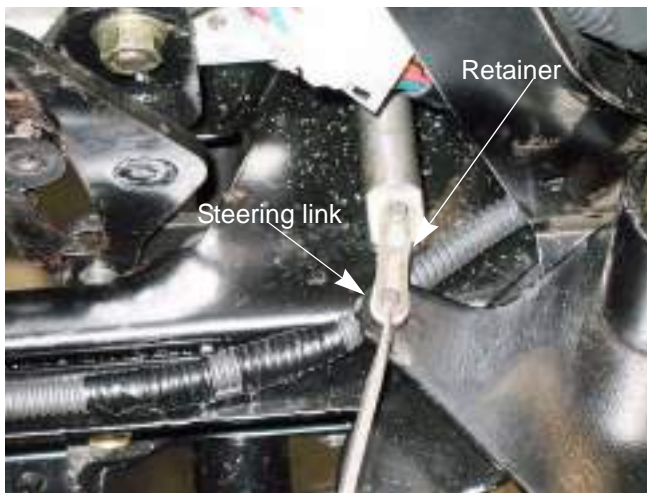

Figure 6A.75

2. Loosen the jam nut on the adjustment bolt using a 9/16" wrench. See Figure 6A.76.

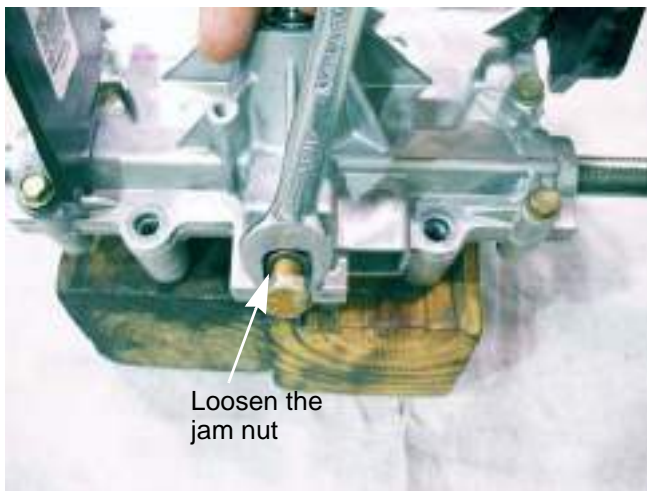

Figure 6A.76

3. While turning the input shaft, tighten the adjustment bolt until increased drag is felt. See Figure 6A.77.

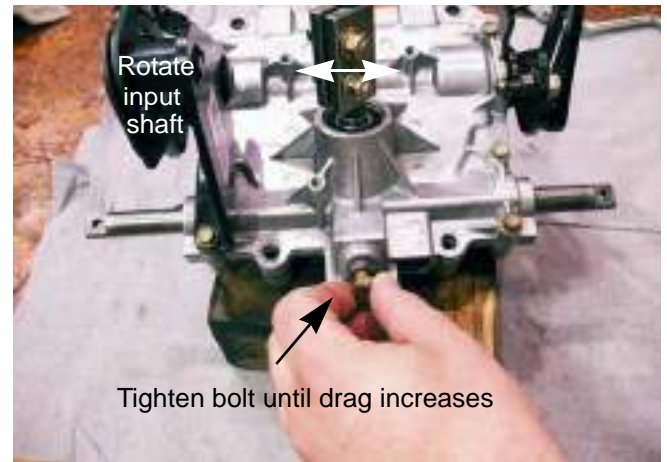

Figure 6A.77

4. Back the bolt off a quarter to a half turn.
5. While holding the adjustment bolt with one wrench, tighten the jam nut to lock it in place.
6. Check the steering gearbox by turning it through its full range of motion. Drag should be consistent through the complete range.
7. Install the gear box in the tractor or attach the steering links if it was already installed.
8. Test drive the tractor in a safe area before returning to service.

STEERING-HYDROGEAR

Front wheels and axles

Remove/ replace the front wheels:

1. Lift and safely support the front end of the tractor.
2. Gently pry off the hub cap. See Figure 6A.78.



Figure 6A.78

3. Remove and discard the cotter pin. See Figure 6A.79.

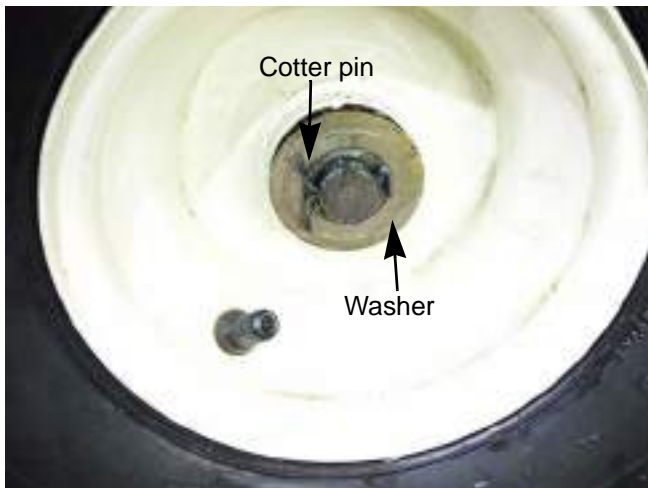

Figure 6A.79

4. Remove the washer. See Figure 6A.79.
5. Slide the wheel off of the axle.

To replace the front wheel ball bearings:

1. Lift and safely support the front end of the tractor.
2. Remove the front wheel by following the procedures describe in the previous section of this chapter.
3. Drive the bearings out of the wheel hub using a drift or pin punch. See Figure 6A.80.



Figure 6A.80

4. Drive in the new bearings using a brass punch. See Figure 6A.81.



Figure 6A.81

5. Install the front wheel.
6. Pump grease in the grease fitting on the front wheel until it starts to squirt out of the hub.
7. Test drive the tractor before returning it to service.

To remove/ replace the front axles:

1. Lift and safely support the front of the tractor.
2. Remove the front wheel by following the procedures the front wheel section of this chapter.
3. Remove the steering gear covers.
4. Insert a 5/16" pin punch into one of the alignment holes to lock the steering gears in place. See Figure 6A.82.

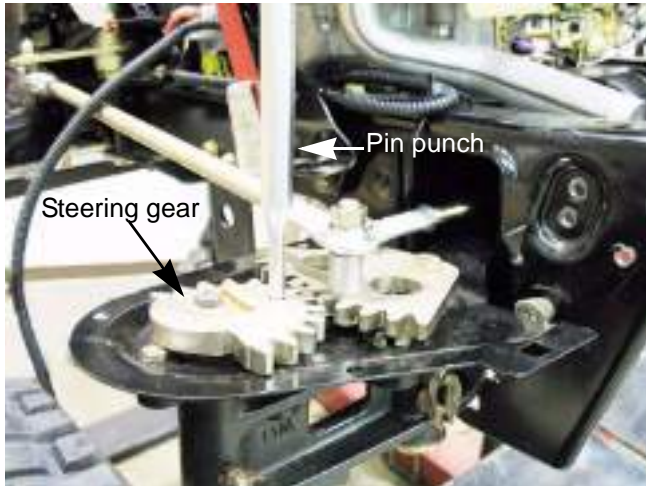

Figure 6A.82

5. Loosen the bolt that holds the outboard steering gear to the axle. Back the bolt half way out.
NOTE: The axle had a tapered double-D shaft. The steering gear will be very tight on the shaft.
6. Strike the bolt head, using a brass punch and a hammer. This will loosen the axle from the outboard steering gear. See Figure 6A.83.



Figure 6A.83

7. Take the bolt all the way out.
NOTE: The axle should fall out at this point.
8. Install the axle by following the previous steps in reverse order.
NOTE: Align the timing marks when installing the outboard steering gear. See Figure 6A.84.



Figure 6A.84

9. Test drive the tractor in a safe area before returning it to service.

STEERING-HYDROGEAR

Drag links

To remove/replace a drag link:

1. Remove the steering gear covers.
2. Remove and discard the nut holding the drag link to the inboard steering gear using two 9/16" wrenches (one of them should be a slim-line wrench). See Figure 6A.85.

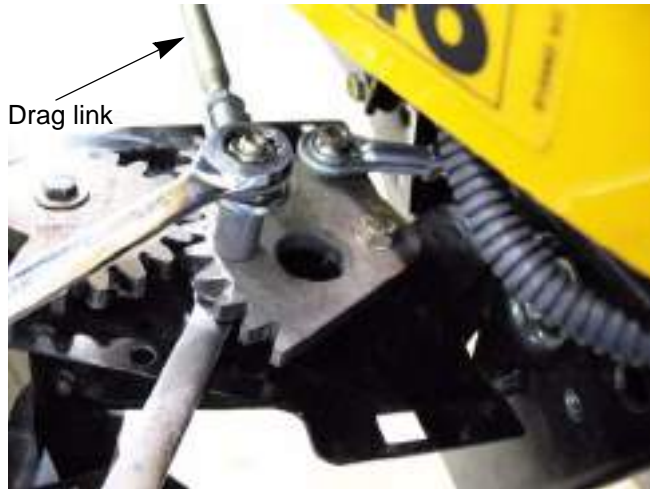

Figure 6A.85



The nuts used on the drag links and the tie rod are single use only. Do not try to reuse them by applying a thread locking compound. Use new nuts every time.

3. Remove the nut and bolt that secures the drag link to the steering arm. See Figure 6A.86.

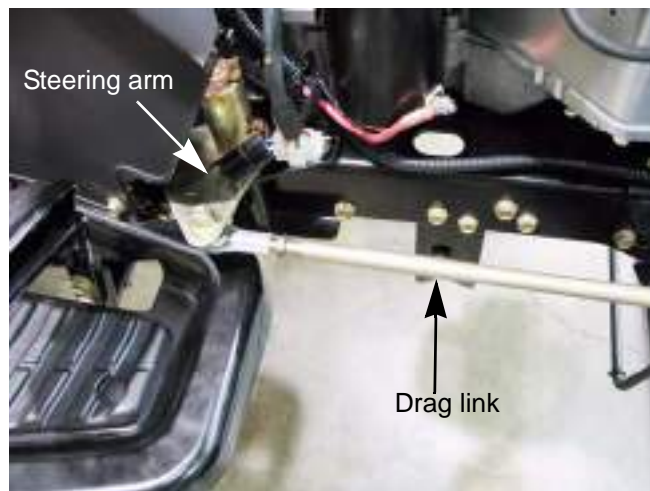

Figure 6A.86

4. Loosen the jam nuts.

5. Remove the spherical rod ends.

NOTE: Count the number of turns to remove the spherical rod ends.

6. Install new spherical rod ends.

NOTE: Install the spherical rod ends the same number of turn as it took to remove them from the old drag link.

NOTE: Leave the jam nuts loose.

7. Install the drag link on the tractor.

8. Perform a wheel alignment by following the procedures described in the wheel alignment section of this chapter.

9. Test drive the tractor in a safe area before returning it to service.

Tie rod

To remove/replace the tie rod:

1. Remove the steering gear covers.
2. Remove and discard the nut holding the tie rod spherical rod ends to the inboard steering gear using two 9/16" wrenches (one of them should be a slim-line wrench). See Figure 6A.87.



Figure 6A.87



The nuts used on the drag links and the tie rod are single use only. Do not try to reuse them by applying a thread locking compound. Use new nuts every time.

3. Repeat on the other side of the tractor.
4. Slide the tie rod out of the tractor.
5. Loosen the jam nuts.
6. Remove the spherical rod ends.
NOTE: Count the number of turns to remove the spherical rod ends.
7. Install new spherical rod ends.
NOTE: Install the spherical rod ends the same number of turns as it took to remove them from the old tie rod.
8. Install the tie rod on the tractor using new lock nuts.
9. Perform a wheel alignment by following the procedures described in the wheel alignment section of this chapter.
10. Test drive the tractor in a safe area before returning it to service.

Inboard steering gear

To remove/replace the inboard steering gear or king pin:

1. Remove the steering gear covers.
2. Remove and discard the nut holding the tie rod spherical rod ends to the inboard steering gear using two 9/16" wrenches (one of them should be a slim-line wrench). See Figure 6A.88.
3. Remove and discard the nut holding the drag link to the inboard steering gear using two 9/16" wrenches (one of them should be a slim-line wrench). See Figure 6A.88.

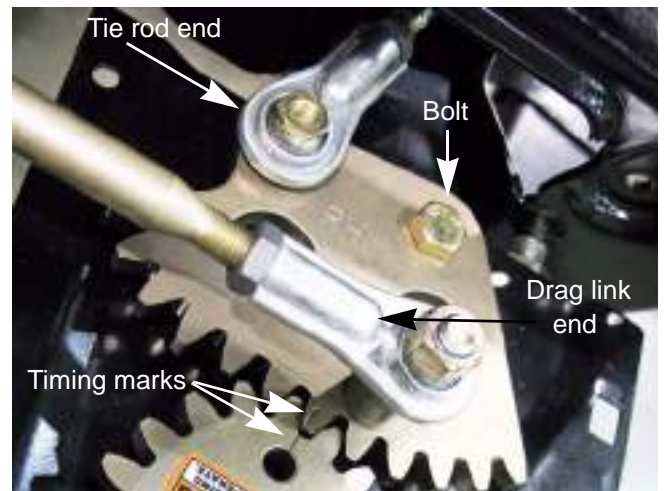

Figure 6A.88

4. Remove the inboard steering gear by removing the bolt using a 9/16" wrench.
5. Remove the cotter pin in the bottom of the king pins. See Figure 6A.89.
6. Push the king pins out of the pivot bar.

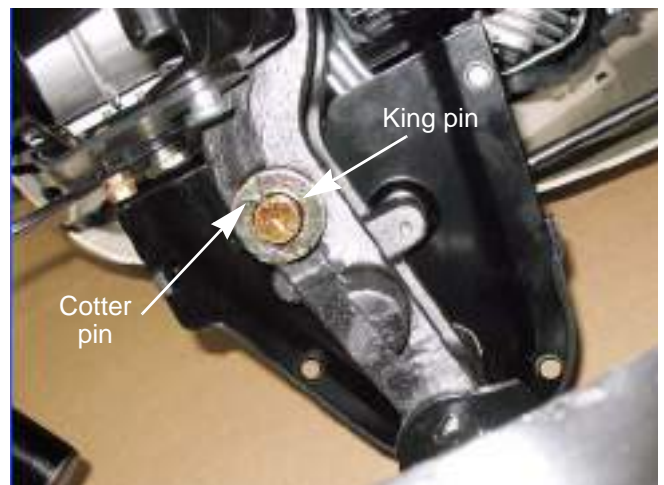

Figure 6A.89

STEERING-HYDROGEAR

7. Install the king pin.
8. Align the timing marks and install the inboard steering gear.

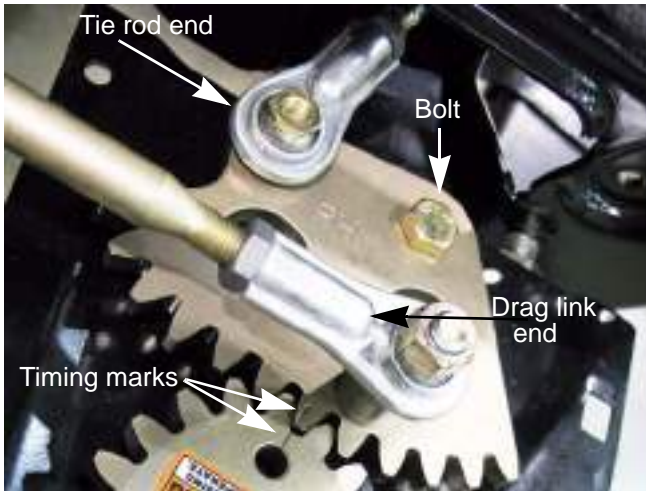

Figure 6A.90

9. Attach the tie and drag link ends using new lock nuts.
10. Perform a wheel alignment by following the procedures described in the wheel alignment section of this chapter.
11. Test drive the tractor in a safe area before returning it to service.

Pivot bar

To remove/replace the pivot bar:

1. Lift and safely support the front end of the tractor.
2. Remove the front axles by following the procedures described in the front wheels and axles section of this chapter.
3. Remove and discard the nut holding the drag link to the inboard steering gear using two 9/16" wrenches (one of them should be a slim-line wrench). See Figure 6A.91.



Figure 6A.91

4. Remove the muffler by following the steps described in Chapter 2: Engine Related Parts.
5. Remove the four screws fastening the bumper mount bracket to the frame. See Figure 6A.92.

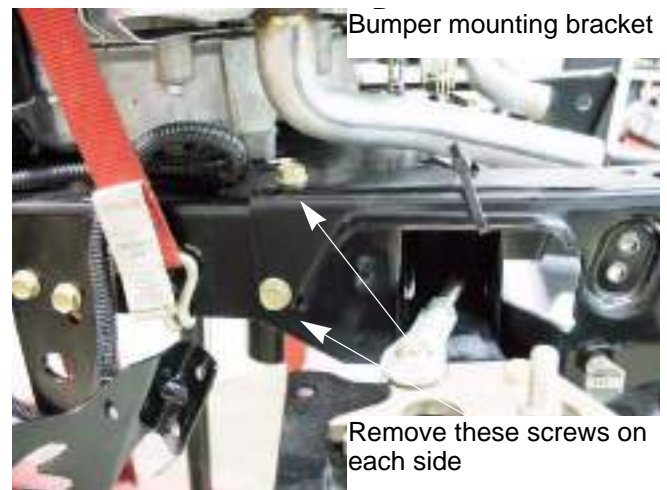

Figure 6A.92

6. Remove the pivot bar shoulder bolts. See Figure 6A.93.

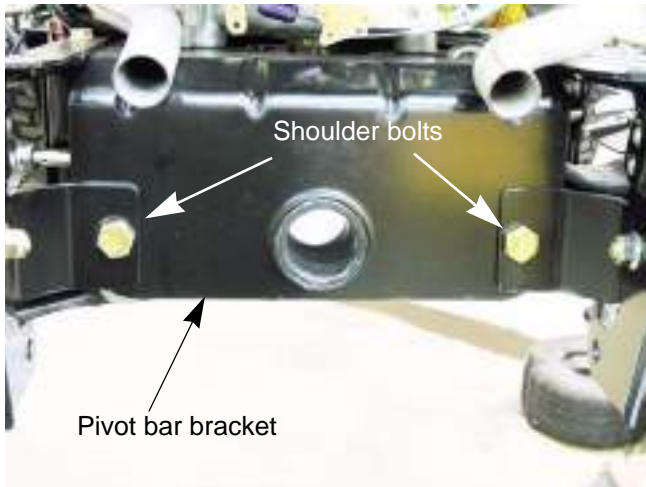

Figure 6A.93



At this point there is nothing holding the pivot bar in place. Take care to prevent the pivot bar from falling off of the tractor.

7. Slide the bumper mounting bracket and the pivot bar bracket off of the tractor.
8. Remove the pivot bar.
9. Inspect the contact areas where the pivot bar meets the frame. If there is any material that has erupted or any galling, sand it down. Repeat inspection on the inside of the pivot bar bracket. See Figure 6A.94.



Inspect contact area

Figure 6A.94

10. With the pivot bar on a bench, the inboard steering gear and the tie rod can be serviced.
11. Remove the tie rod by removing and discarding the nut holding the tie rod ends to the in board steering gear. See Figure 6A.95.

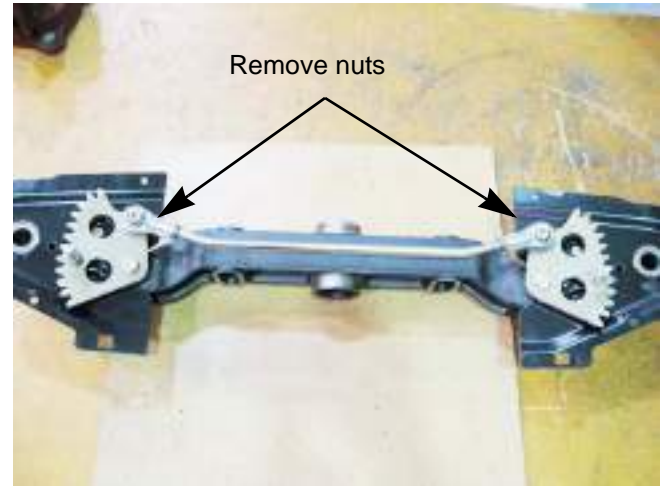

Figure 6A.95

12. Remove the inboard steering gear by removing the bolt using a 9/16" wrench.
13. Remove the steering king pins by:
 - 13a. Removing the cotter pins in the bottom of the king pins.
 - 13b. Push the king pins out of the pivot bar. See Figure 6A.96.

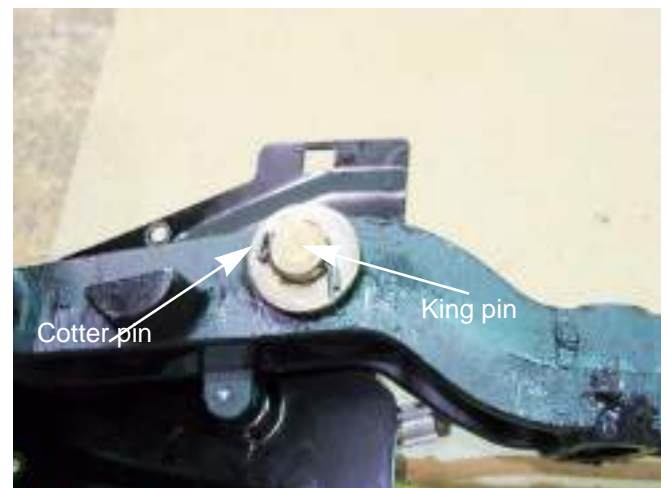

Figure 6A.96

STEERING-HYDROGEAR

14. Start re-assembling the pivot bar by inserting the steering king pins into the pivot bar. Secure them with new cotter pins. See Figure 6A.97.

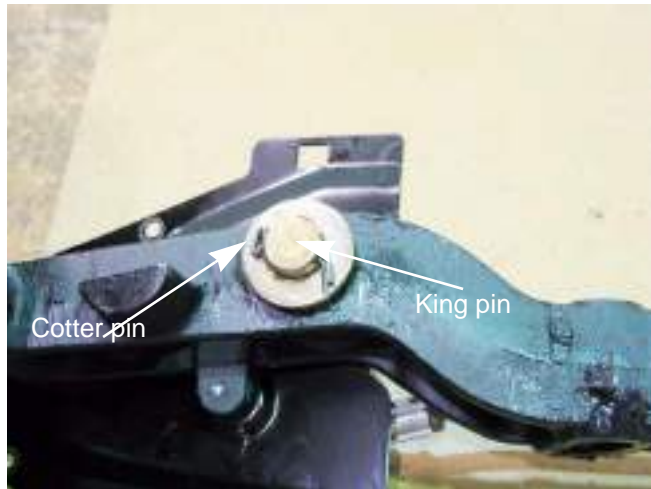

Figure 6A.97

15. Install the axle assemblies.
16. Place the outboard steering gears on the axles and tighten to a torque of 100 - 150 in-lbs (11 - 17 Nm).
NOTE: The steering gears are marked LH and RH. Make sure the LH is facing up on the left hand side and that the RH is facing up on the right.
17. Apply a small amount of releasable thread locking compound such as Loctite® 242 (blue) to the bolt for the in board steering gears. Align the timing marks on the inboard and outboard steering gears and tighten the bolt that fastens the inboard steering gears to a torque of 380 - 450 in- lbs (43 - 51 Nm).
NOTE: Make sure the bolts for the drag link and tie rod are in the in place before installing the steering gears.

18. Insert a 5/16" pin punch in the alignment holes of the out board steering gears.

NOTE: Make sure they go all the way through into the pivot bar to lock the gears in position. See Figure 6A.98.

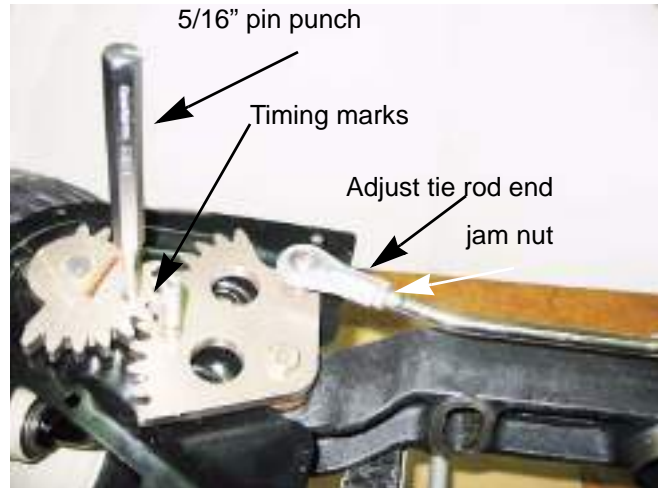

Figure 6A.98

19. Adjust the tie rod ends by loosening the jam nuts and rotating the tie rod ends until they slide on to the 1/4" bolts sticking up through the inboard steering gears. Tighten the jam nuts to lock the tie rod ends in place. See Figure 6A.98.
20. Install the tie rod end using a new lock nut.
21. Apply high quality grease to the frame and the inside of the pivot bar bracket, where the pivot bar rides. See Figure 6A.99.

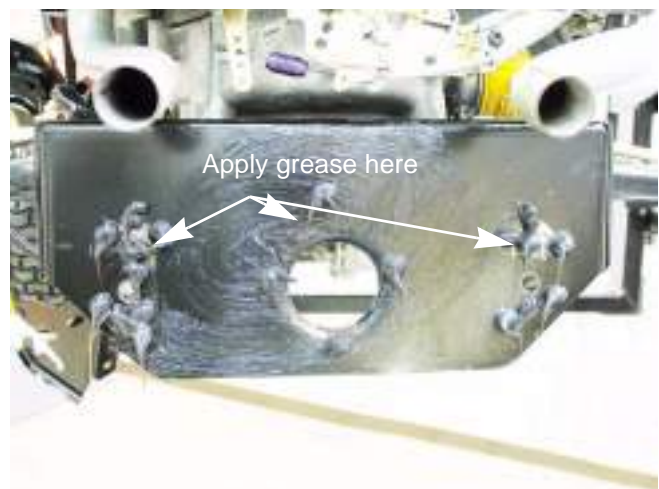

Figure 6A.99

22. Install the pivot bar by following steps 3 - 7 in reverse order.

NOTE: When installing the pivot bar, use a clamp to line up the screw holes in the frame, pivot bar and bumper mounting brackets. See Figure 6A.100.



Figure 6A.100

23. Slide the front wheels on and secure them with new cotter pins.
NOTE: Make sure the washer is installed between the wheel bearings and the cotter pin.
24. Push the hub caps on till they snap in place.
25. Take the tractor off of the jack stands.
26. Perform a neutral adjustment and wheel alignment as described in the beginning of this chapter.
27. Test drive the tractor in a safe area before returning to service.

CHAPTER 6B: STEERING - IVT TRANSMISSION

Introduction

Just like the I-series with HydroGear transmissions, the steering on the I-series tractor with the Infinitely Variable Transmission (IVT) works in two phases. First it will steer like any other tractor by turning the front wheels. Second and more importantly, the steering linkage will control the drive output of the rear wheels through the use of the IVT transmission.

The steering gear box is attached to the front wheels by drag links. When the steering wheel is turned, the gear box will turn the wheels. When the wheels reaches around a 55° angle from straight ahead, the gear box will start to slow the transmission on the inside of the turn and continue turning the front wheels. When the inside wheel reaches an angle of 90°, the rear wheel on that side will stop driving. Turning the wheel past that point will make the inside rear wheel go in reverse. The inside front wheel can reach a 108° angle. With the inside front wheel at a 108° angle and the transmission on the inside of the turn going in reverse, the tractor will be in a zero turn.

Because the steering gear box is linked to the transmission, the transmission adjustments and the wheel alignment must be addressed together. A transmission that is out of adjustment can make the steering look out of adjustment just as a front end that is out of adjustment will affect the adjustment of the transmission.

IMPORTANT: Check the tire air pressure before attempting to diagnose any problems with the steering or tracking of an I-series tractor. If the tire air pressures are not equal across the same axles, it will greatly affect the performance of the tractor.

Cam Slot Angle Adjustment

The cam slot adjustment is a critical adjustment on the I-series tractor. It should only be necessary when replacing the steering gear box.

1. The cam slot angle adjustment must be set if the steering gear box is replaced.
2. In the extremely rare case that the angle is simply out of adjustment. The indications are as follows:
 - A The tractor is running.
 - B Parking brake released.
 - C Feet off of the brake and drive pedals.
 - D Turn the steering wheel fully in both directions.
 - E If it creeps, cam angle needs adjusted.



The second would be a safety issue and must be addressed before returning the tractor to service

To adjust the cam slot angle:

1. Remove the dash and fender by following the steps described in Chapter 4: Body/Chassis.
2. Lock Steering Gear Box in Neutral Position:
 - 2a. Remove the 1/4"-20 plug screw from the steering gear box centering port using a 3/8" wrench. See Figure 6B.1.

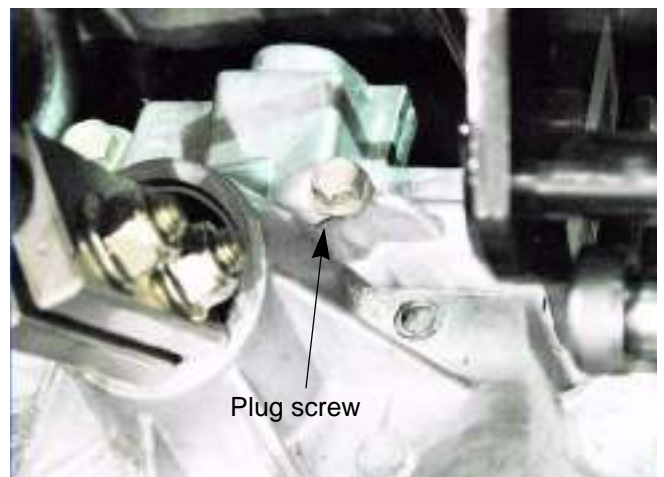

Figure 6B.1

STEERING-IVT

- 2b. Using a 1/4"-20x2" bolt, thread it into the steering box centering port until you feel it touch the steering rack. While trying to gently thread the bolt further, slowly rotate the steering shaft back and forth until the bolt seats into the detent in the steering rack. Finger tighten the screw to set the screw fully into the detent. The steering gear box is now centered and locked. See Figure 6B.2.

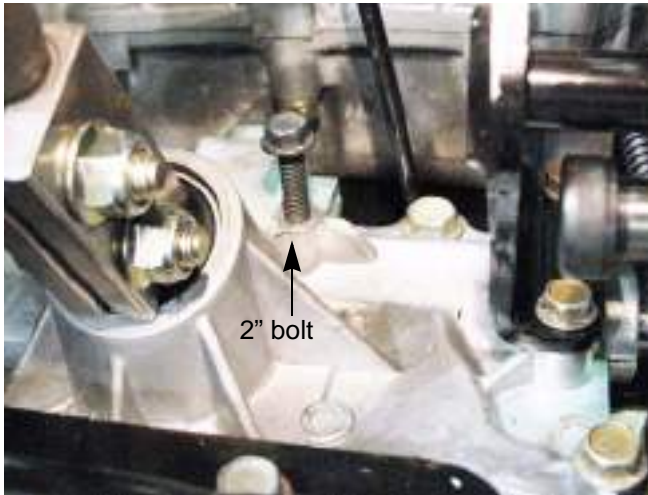

Figure 6B.2

3. Match mark the drive control link between the two nuts and bolts. See Figure 6B.3.

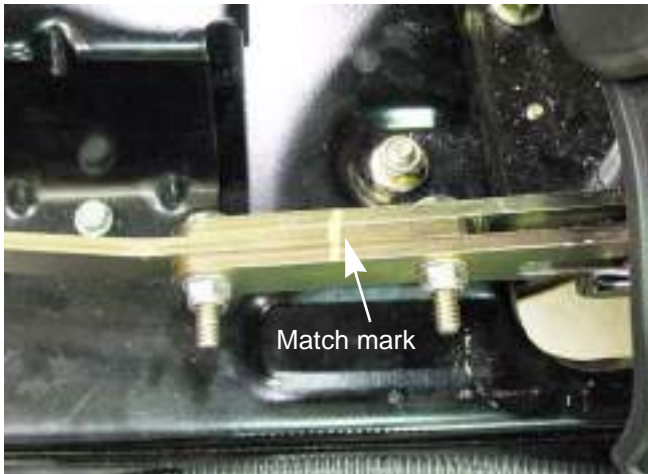

Figure 6B.3

NOTE: The match mark will make it easier to do the neutral adjustment later on.

4. Loosen the two nuts and bolts on the drive control link.
5. Remove the bow tie clip and clevis pin from the drive control link. See Figure 6B.4.

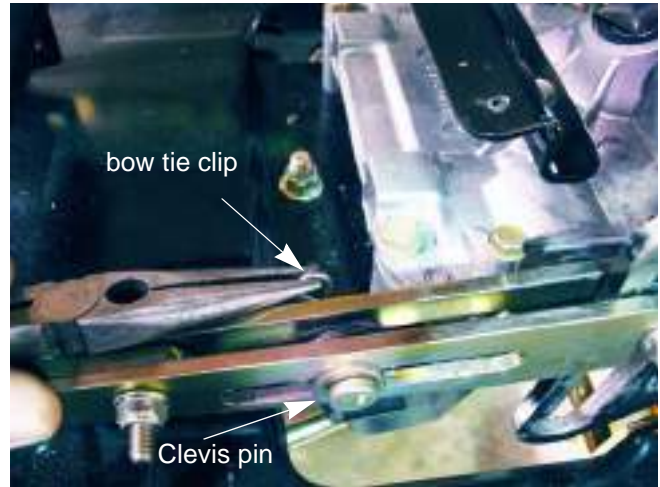

Figure 6B.4

6. Disconnect the drive control link from the right side of the gear box only:
 - 6a. Removing the nut and bolt. See Figure 6B.5.

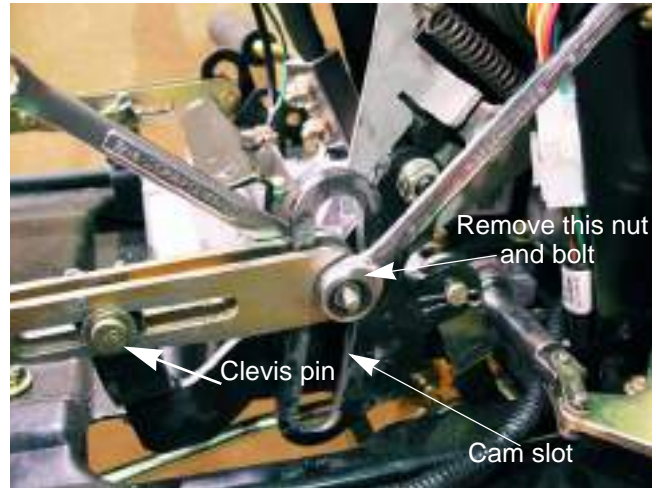

Figure 6B.5

- 6b. Remove the bow tie and clevis pins.
- 6c. Raise the drive control link away from the cam slot.

NOTE: Catch the double roller when lifting the drive control link away from the steering gear box. See Figure 6B.6.



Figure 6B.6

- 7. Loosen the return to neutral bolt using a 9/16" wrench and a 1/4" hex key. See Figure 6B.7.

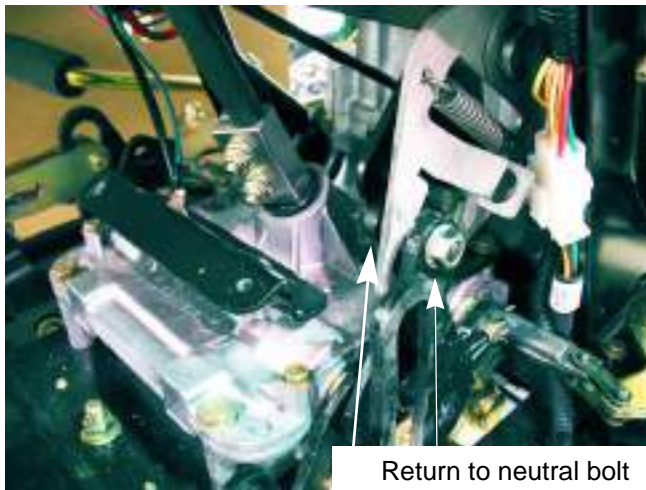

Figure 6B.7

- 8. Set the cam slot angle at 90° to the frame using a combination square. See Figure 6B.8.



Figure 6B.8

- 9. Tighten the return to neutral bolt.
- 10. Adjust the transmission for neutral and align the front wheels as described in the following sections of this chapter.

STEERING-IVT

Neutral and drive control links Adjustment

IMPORTANT: Check the tire air pressure before attempting to diagnose any problems with the steering or tracking of an I-series tractor. If the tire air pressures are not equal across the same axles, it will greatly affect the performance of the tractor.

Because the steering gear box is linked to the transmission, it is important to make sure the transmission is adjusted for neutral first. To establish neutral:

1. Remove the steering wheel by:
 - 1a. Remove the center cover. See Figure 6B.9.



Figure 6B.9

- 1b. Remove the bolt with a 1/2" wrench. See Figure 6B.10.



Figure 6B.10

NOTE: There is no puller needed for the steering wheel. Once the bolt is removed it will lift off of the steering shaft.

2. Disconnect the parking brake by removing the hair pin clip and sliding the rod out of the lever. See Figure 6B.11.

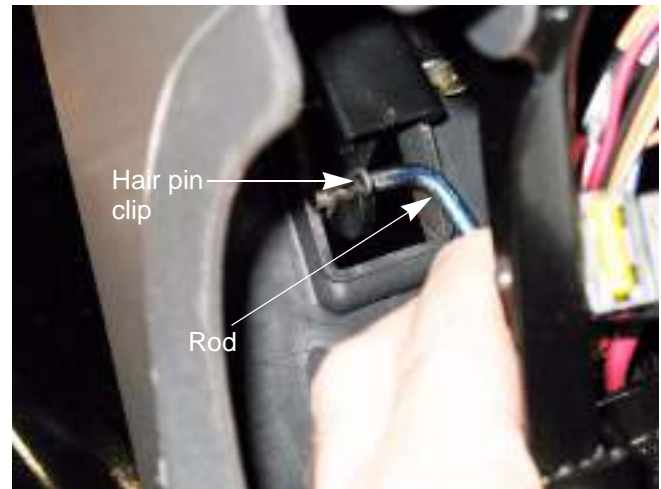

Figure 6B.11

3. Remove the two screws attaching the dash to the dash support. See Figure 6B.12.



Figure 6B.12

4. Remove the two screws in the cargo net area, at the bottom of the dash. See Figure 6B.13.



Figure 6B.13

NOTE: The cargo net was removed for a clearer picture. Do not remove the net to remove the screws.

5. Remove the screws at the bottom of the dash, on each side. See Figure 6B.14.



Figure 6B.14

NOTE: Do not disconnect the wiring. Leave the dash loose so that it can be lifted to remove the fender.

6. Remove fender by following the steps described in Chapter 4: Body/Chassis.

7. Lock Steering Gear Box in Neutral Position:
 - 7a. Remove the 1/4"-20 plug screw from the steering gear box centering port using a 3/8" wrench. See Figure 6B.15.

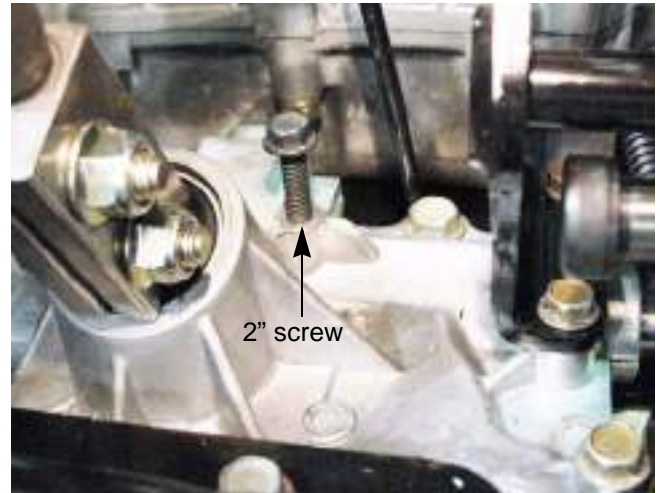

Figure 6B.15

- 7b. Using a 1/4"-20x2" bolt, thread it into the steering box centering port until you feel it touch the steering rack. While trying to gently thread the bolt further, slowly rotate the steering shaft back and forth until the bolt seats into the detent in the steering rack. Finger tighten the screw to set the screw fully into the detent. The steering gear box is now centered and locked. See Figure 6B.16.

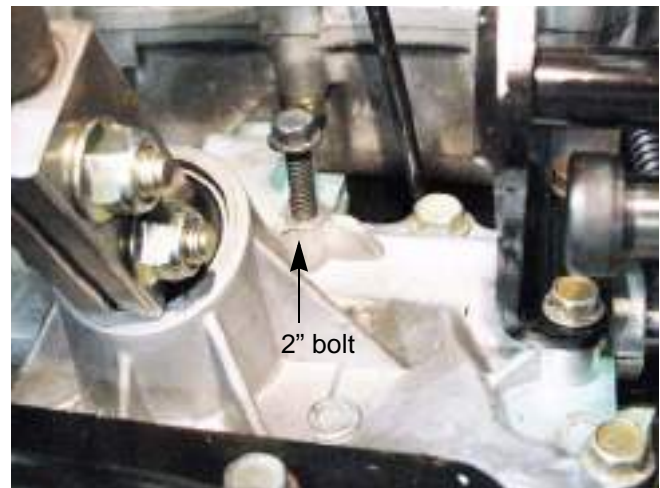

Figure 6B.16

STEERING-IVT

8. Jack the tractor up so that both rear wheels are off of the ground and place a pair of jack stands under the rear transmissions.
9. Remove the rear wheels.
10. Wedge the brakes open on both sides of the transmission. See Figure 6B.17.

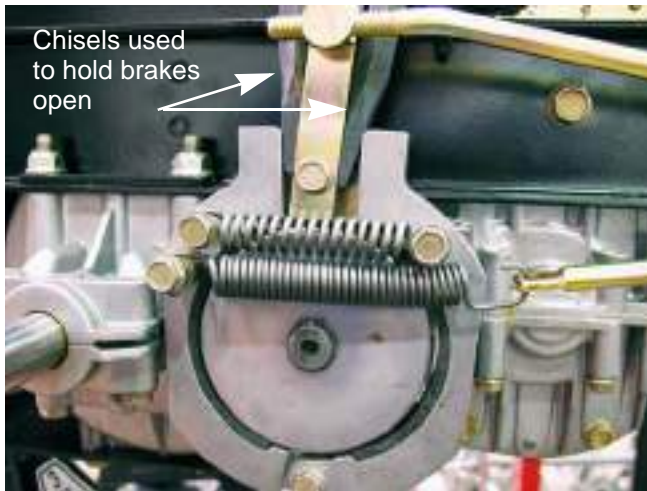

Figure 6B.17

11. Make sure all tools and wires are away from any moving parts.
12. Depress the brake pedal and start the tractor.
13. Release the brake pedal.
14. Measure the RPMs of the brake shaft on both sides of the transmission.



The tractor engine and drive system must be operated to complete this procedure.

Confirm that no hazards will be incurred by running the engine or operating the drive system

NOTE: If a tachometer is not available:

- 14a. Before starting the tractor, mark the brake drum and shoe with a reference mark. See Figure 6B.18.

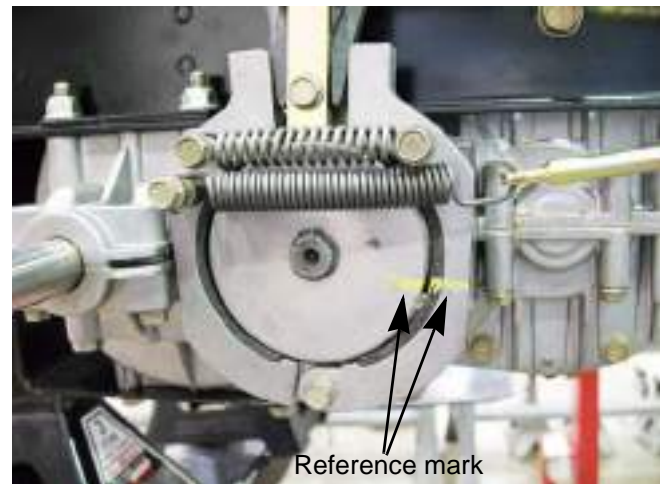

Figure 6B.18

- 14b. Time how long it takes for the brake drum to complete one revolution.

NOTE: The brake drum should be turning at 8RPMs or lower (more than 7.5 seconds per revolution).

NOTE: The closer to 0 RPMs the better the steering performance will be.

If the transmission needs adjusted:

15. Turn off the engine.
16. Loosen the two nuts and bolts in the center of the drive control linkage on the side that needs adjusted . See Figure 6B.19.

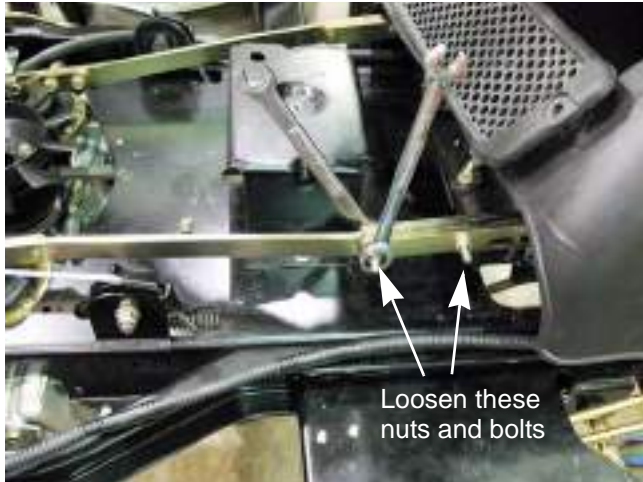

Figure 6B.19

17. Depress the brake pedal and start the tractor.
18. Release the brake pedal.
19. Adjust the length of the drive control linkages until the brake drum speed is less than 8 RPMs. See Figure 6B.20.



Keep hands away from the fan and belt while the engine is running.

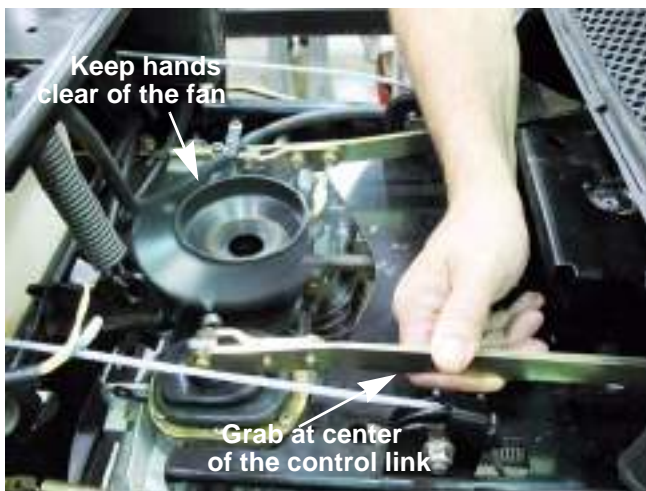

Figure 6B.20

NOTE: Holding the control link near the center will help keep the technicians hands clear of the fan and belt. See Figure 6B.20.

20. Tighten the two nuts and bolts in the center of the drive control linkage.
21. Reassemble the tractor.
NOTE: Leave the 1/4"-20x2" bolt threaded in the steering gearbox.
22. Perform the wheel alignment by following the procedures described in the next section of this manual.

STEERING-IVT

Wheel alignment

NOTE: The transmission neutral adjustment must be done prior to adjusting the steering linkage.

1. Remove the three screws holding each steering gear cover in place. See Figure 6B.21.

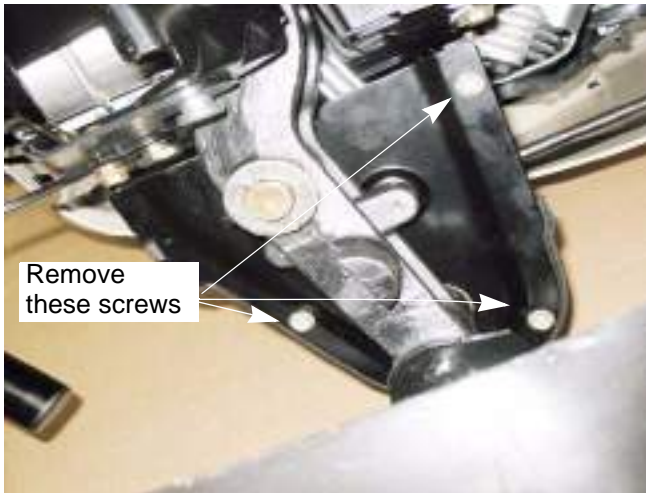

Figure 6B.21

2. Rotate the front tires until the marks on the axle gears and the steering gears align. See Figure 6B.22.

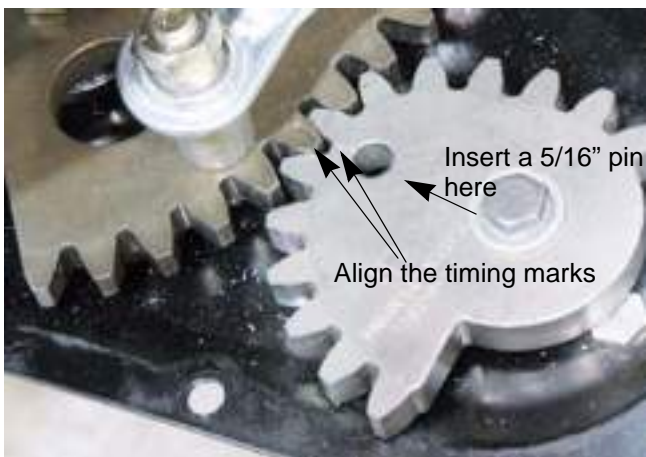

Figure 6B.22

3. Insert a 5/16" pin through the hole in the steering gear on each side. The pins should pass through the gears, through the lower cover plate and into the pivot bar. See Figure 6B.23.



Figure 6B.23

NOTE: If the alignment is off, the holes may not line up. If this is the case, adjust the front end by:

- 3a. Loosen the jam nuts on both ends of the drag link. See Figure 6B.24.



Figure 6B.24

- 3b. Adjust the drag link until the holes line up
See Figure 6B.25.



Figure 6B.25

NOTE: The punch should slide in and out without binding. As the drag links are being adjusted, rock the tires back and forth to remove the load created from the tires twisting on the floor.

- 3c. Tighten the jam nuts.

4. Remove the 1/4"-20x2" screw from the steering gear box.
5. Reinstall the original plug screw in the steering gear box.
6. Install the steering gear covers.
7. Install the dash and fender by following the procedures described in Chapter 4: Body/Chassis.



Never allow an I-series tractor to be operated without the steering gear covers. Personal injury may result.

8. Test drive the tractor in a safe area before returning it to service.



Make sure all safety features are working properly before returning to service.

Steering gear box removal

To replace the gear box:

1. Remove the dash and fender by following the steps described in Chapter 4: Body/Chassis.
2. Match mark the drive control link between the two nuts and bolts. See Figure 6B.26.

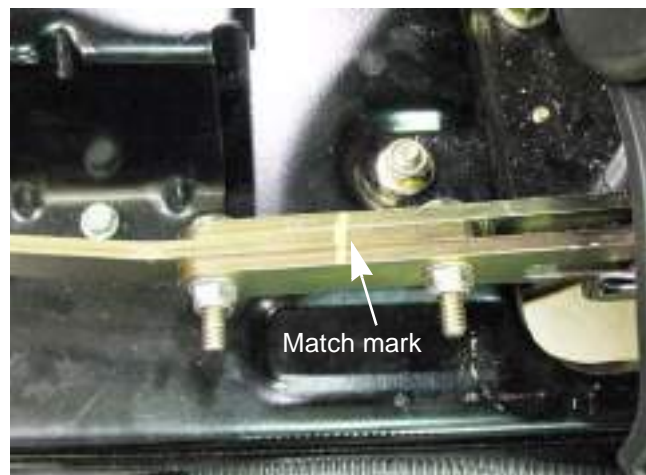

Figure 6B.26

NOTE: The match mark will make it easier to do the neutral adjustment later on.

3. Remove the bow tie clip and clevis pin from both drive control links. See Figure 6B.4.

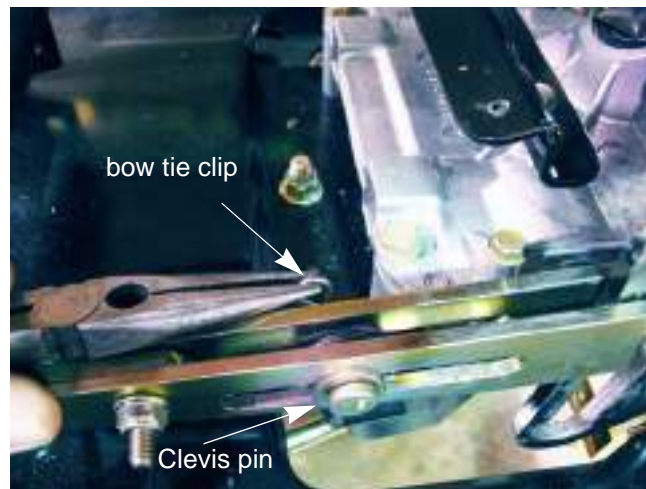

Figure 6B.27

STEERING-IVT

4. Disconnect the drive control link from both sides of the gear box by removing the nut and bolt. See Figure 6B.5.

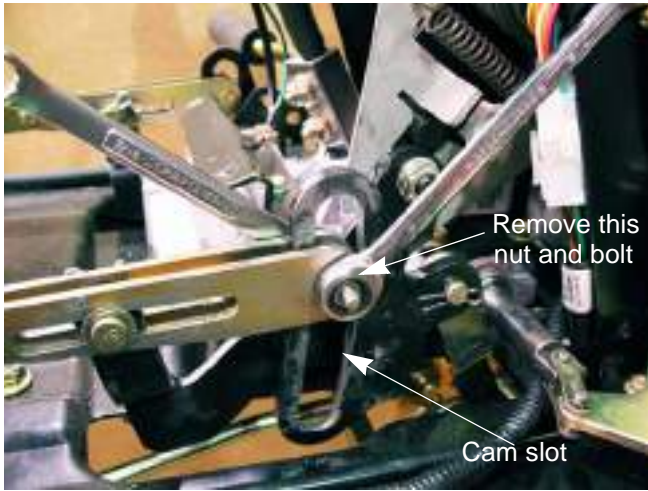

Figure 6B.28

5. Raise the drive control link away from the cam slot.

NOTE: Catch the double roller when lifting the drive control link away from the steering gear box. See Figure 6B.6.



Figure 6B.29

6. On the right side cam slot lever there is a connector link. Remove the hairpin clip. See Figure 6B.30.



Figure 6B.30

7. Disconnect the steering links on both sides:
 - 7a. Gently pry the link retainer over the master link. See Figure 6B.31.

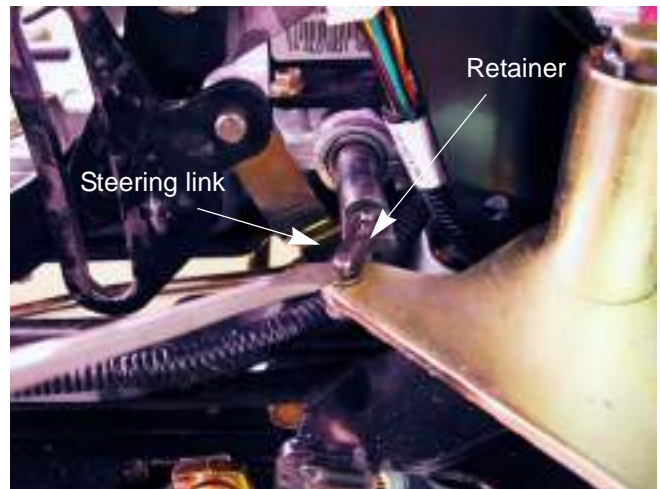

Figure 6B.31

- Remove the steering shaft by removing the two clamp bolts in the steering shaft receiver and lifting the shaft out. See Figure 6B.32.

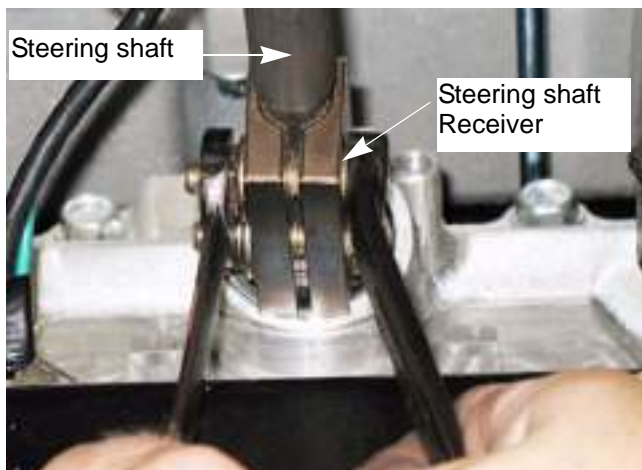

Figure 6B.32

NOTE: Rotating the steering shaft bushing 90 degrees will allow the bushing to pop out relieving the pressure on the steering shaft. This will make it easier to remove or install the shaft. See Figure 6B.33.

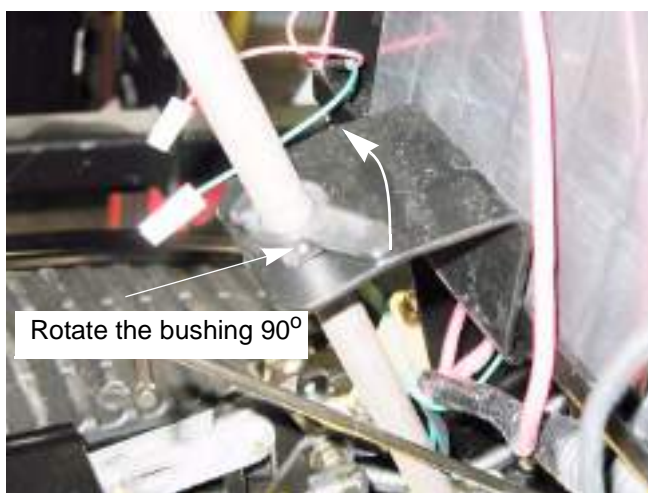

Figure 6B.33

- Disconnect the ground wire. See Figure 6B.34.

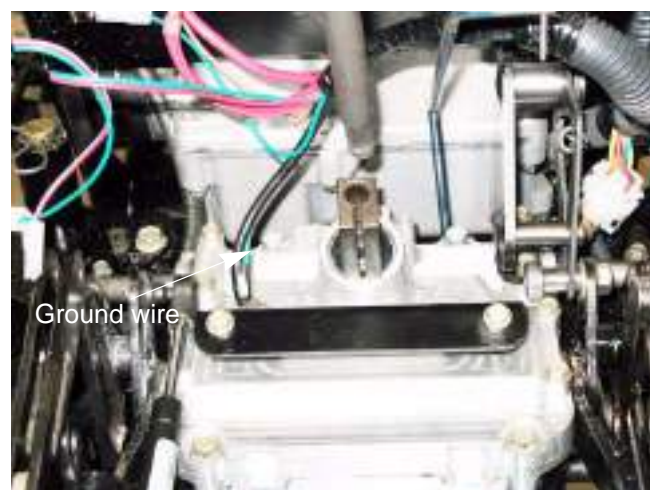

Figure 6B.34

- Remove the four screws holding the gear box to the frame with a 1/2" wrench. See Figure 6B.35.

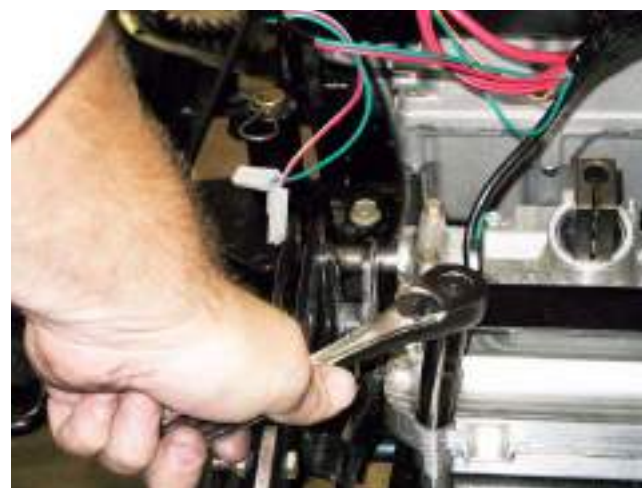

Figure 6B.35

- Slide the gear box to the right to disconnect the connector link, then lift out of the tractor.
- The new gear box should come with 1/4"-20 x 2" screw to lock it into the neutral/centered position.
- Work the gear box so that the connector link can be inserted into the hole in the cam slot lever.
- Install the hair pin clip removed in step 5.
- Bolt the gear box to the frame with the four bolts removed in step 8.
- Insert the steering shaft into the steering shaft receiver. Tighten the nuts to a torque of 130 - 160 in lbs (15 - 18 Nm).

STEERING-IVT

17. Attach the steering links. Install the retainers.
NOTE: If the retainers are bent or twisted, the whole link must be replaced. The retainers are not available separately.
18. Apply anti-seize compound to the rollers and the cam slots on the gear box levers.
19. Adjust the speed cam angle by following the step described in the cam slot angle section of the chapter.
20. Connect the drive control links.
 - 20a. Place the rollers into the cam slots and slide the drive control links over the levers.
 - 20b. Insert the bolt through the drive control link and roller.
 - 20c. Install the nut on the bolt and tighten to a torque of 8 ft lbs (11 Nm).
21. Insert the clevis pin, washers and bow tie clips.
22. Align the wheels and adjust the drive control links by following the steps described in the previous sections of this chapter.
23. Remove the 1/4"-20x2" bolt that came with the steering gearbox and install the short one from the old gearbox.
24. Install the fender and dash by following the steps described in Chapter 4: Body/Chassis.
25. Test drive the tractor in a safe area before returning to service.



Make sure all safety features are working properly before returning to service.

Rebuilding the steering gear box

To take the steering gear box apart:

1. Remove the steering gear box by following the procedures described in the previous section of this chapter.
2. Remove the return to neutral bolt using a 9/16" wrench and a 1/4" hex key. See Figure 6B.36.



Figure 6B.36

3. Remove the return to neutral bracket using a 3/8" wrench. See Figure 6B.37.



Figure 6B.37

- Remove the six remaining case screws using a 3/8" wrench. See Figure 6B.38.

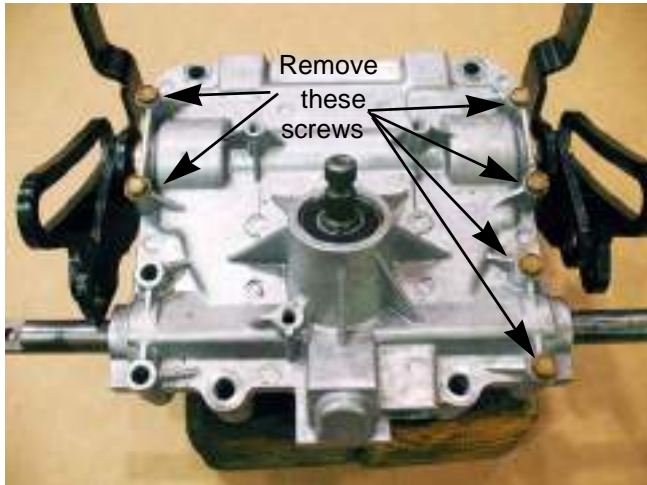

Figure 6B.38

- Lift the upper housing off of the lower housing.
NOTE: There is no sealant between the two housings. They should easily slip apart. If they are stuck together, there are three pry points cast into the housings that can be used to separate the housings.
- Remove the speed cam assemblies. See Figure 6B.39.

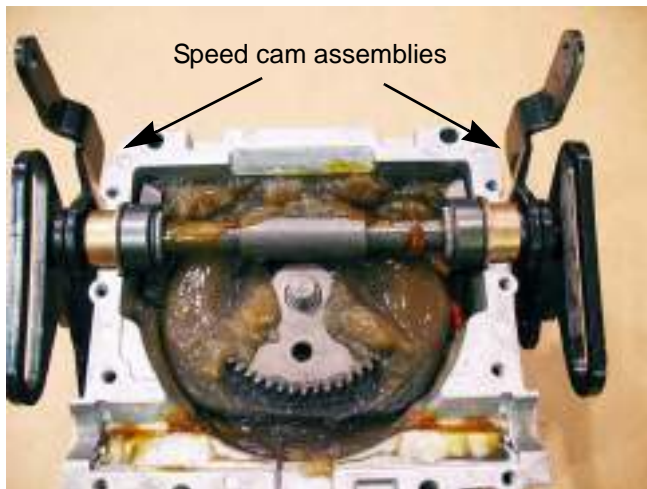

Figure 6B.39

- Separate the speed cam assemblies by driving out the two roll pins using a 5/32" pin punch and a hammer. See Figure 6B.40.

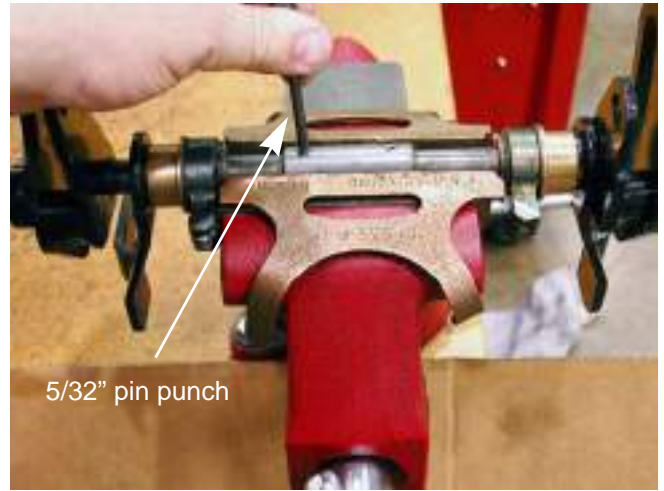

Figure 6B.40

- Separate the output bevel gear assembly by removing the snap ring. See Figure 6B.41.



Figure 6B.41

STEERING-IVT

9. Remove the input sector gear.
See Figure 6B.42.

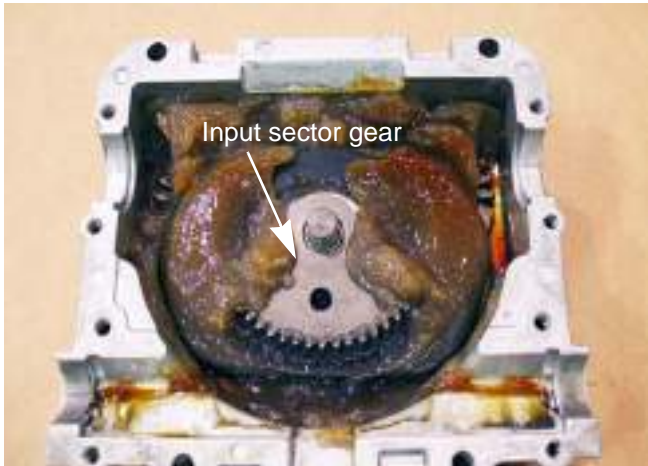

Figure 6B.42

10. Inspect the input sector gear bushings for damage and/or signs of wear. If they show signs of wear or damage, press both of the bushings out of the input sector gear using a press. See Figure 6B.43.

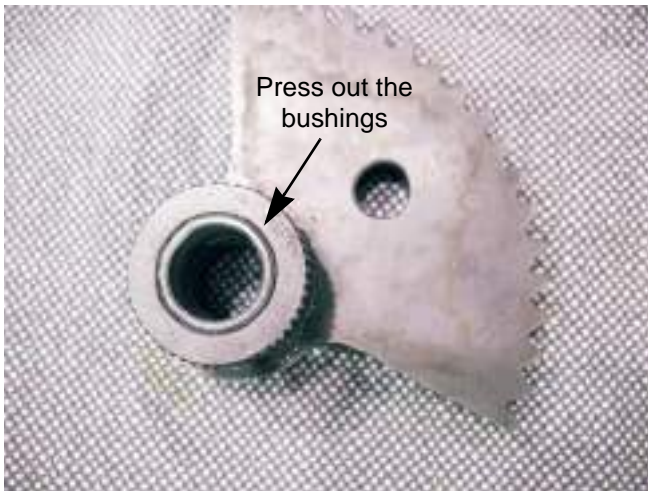

Figure 6B.43

11. Remove the internal cam and both of the washers on top of the cam. See Figure 6B.44.

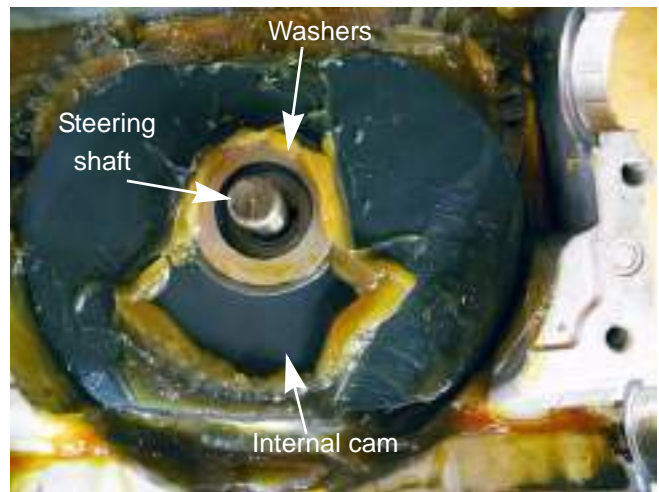

Figure 6B.44

NOTE: The steering shaft is pressed into the lower housing.

12. Remove both of the bevel gears.
See Figure 6B.45.

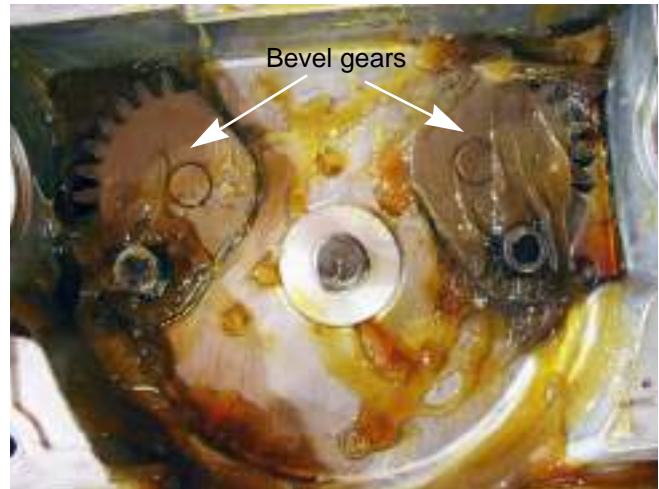

Figure 6B.45

NOTE: There may be a pocket of suction between the bevel gear and the lower housing because of the grease. It may be necessary to use a pry tool to lift the bevel gear out of the lower housing.

13. Slide the rollers off of the bevel gears. See Figure 6B.46.

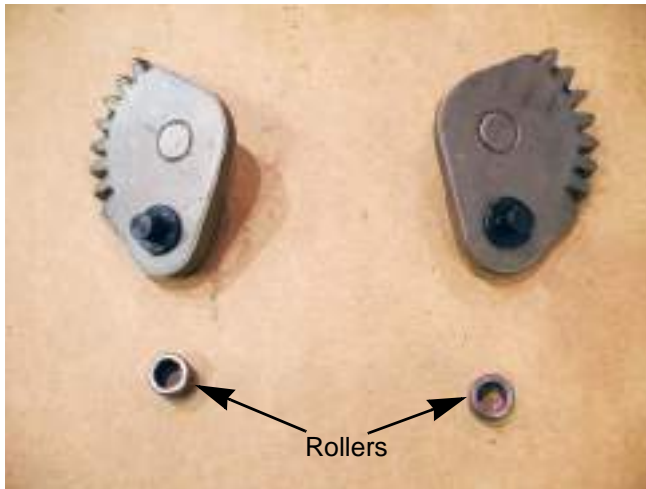

Figure 6B.46

NOTE: There are no retains for these rollers because they are trapped between the bevel gears and the cam.

14. Lift the steering rack out of the upper steering box cover.
15. Remove the wear block.

NOTE: There is a spring inside the wear block that presses the wear block against the steering rack. See Figure 6B.47.

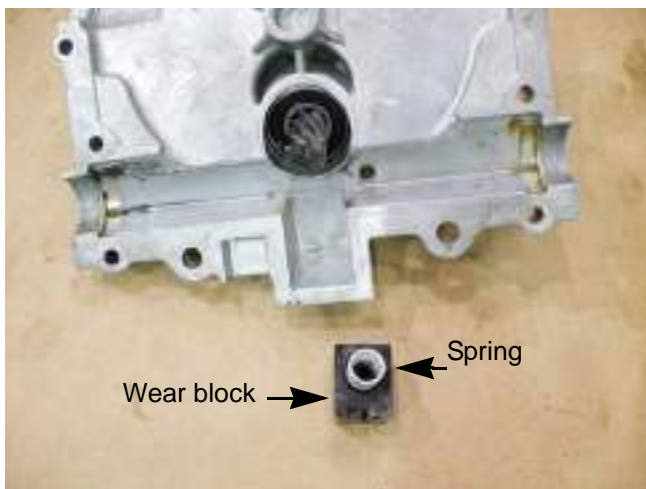

Figure 6B.47

16. Remove the snap ring from the input shaft. See Figure 6B.48.



Figure 6B.48

17. Remove the input shaft from the inside of the housing. See Figure 6B.49.

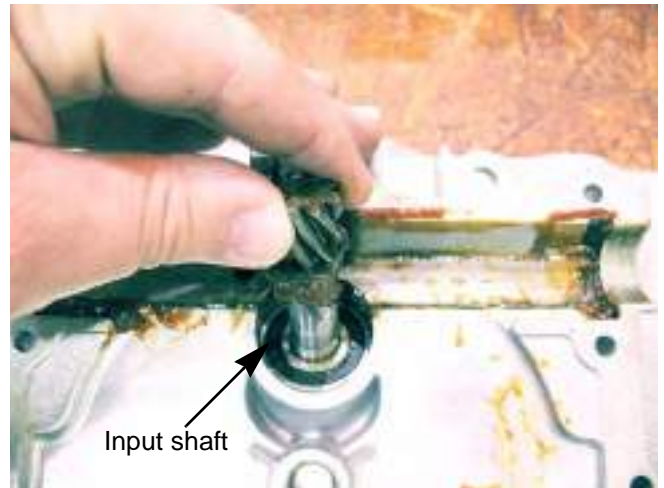

Figure 6B.49

STEERING-IVT

18. Inspect the bearings. If they are worn or rough, carefully drive the inner bearing out of the upper housing using a pin punch and hammer. See Figure 6B.50.

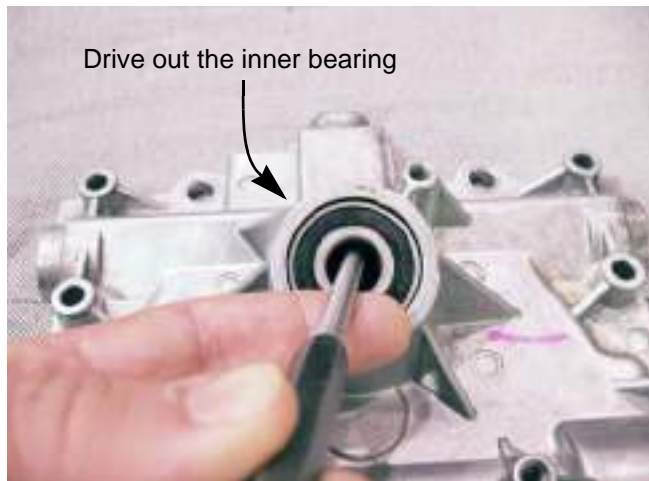

Figure 6B.50

19. Drive the outer bearing out of the upper housing using a pin or brass punch and hammer. See Figure 6B.51.



Figure 6B.51

20. Thoroughly clean and degrease all parts.
21. Inspect all parts for signs of wear or damage.
NOTE: If the part has signs of wear or damage, discard the part.
NOTE: If the two bushings in the bottom of lower gear box housing are worn, replace the lower housing and press in two new bushings.

To assemble the steering gear box:

1. Put a dab of 737-0300A Durina™ grease into each of the bushings in the lower housing. See Figure 6B.52.



Figure 6B.52

2. Install both of the bevel gears and rollers. The rollers should be in line with the front edge of the steering shaft. See Figure 6B.53.



Figure 6B.53

3. Install the internal cam so that the rollers on the bevel gears ride in the grooves of the cam. See Figure 6B.54.



Figure 6B.54

4. Set the thick washer on the internal cam, over the steering shaft. See Figure 6B.55.



Figure 6B.55

5. Set the thin washer on top of the thick washer. See Figure 6B.56.



Figure 6B.56

6. Apply a dab of 737-0300A Durina™ grease to the side of the steering shaft. See Figure 6B.57.



Figure 6B.57

STEERING-IVT

7. Insert the input sector gear into the internal cam.

NOTE: The input sector gear and the internal cam have a master spline to time the two to each other. See Figure 6B.58.



Figure 6B.58

8. Assemble the output bevel gear assemblies.

8a. Insert the shaft of the left speed cam into the left output arm. See Figure 6B.59.

8b. Place a bushing over the output arm with the flange facing away from the arm. See Figure 6B.59.

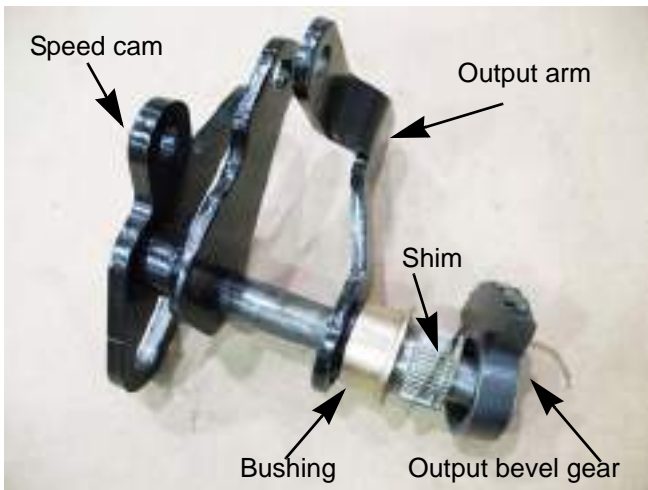

Figure 6B.59

- 8c. Place a .030" shim (or a wave washer if it came with one) over the output arm. See Figure 6B.59.

NOTE: The bevel gear needs to be shimmed to a bind. That means that once the assembly is installed in the lower housing, there is zero play between the bushing and the bevel gear. It may take a few attempts to get the shims correct.

NOTE: On later production models, the shims were replaced a wave washer between the bushing and the output bevel gear.

- 8d. Place the output bevel gear on the output arm with the chamfer facing away from the hydro arm. See Figure 6B.60.

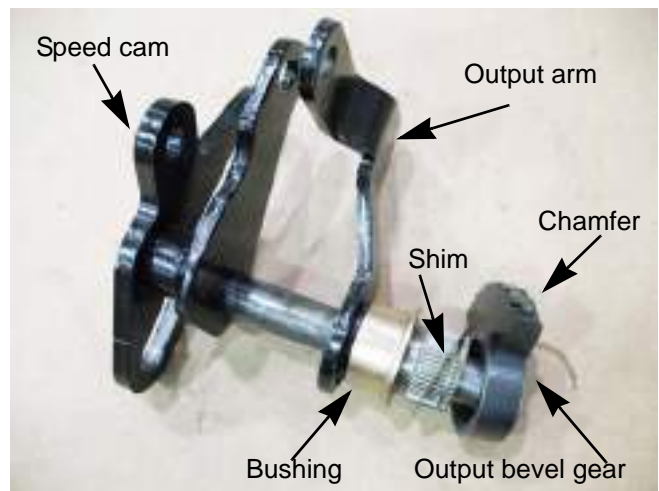

Figure 6B.60

NOTE: The output arms and output bevel gears have master splines to time them to each other. See Figure 6B.61.

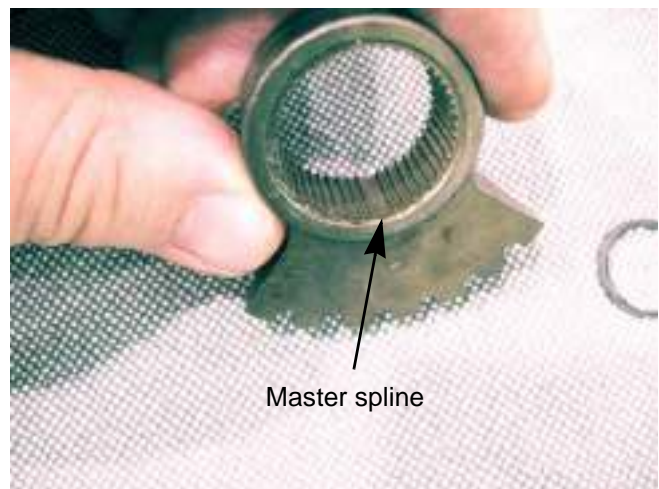

Figure 6B.61

- 8e. Install the snap ring.
- 8f. Repeat for the right output bevel gear assembly.
- 8g. Test fit each of the assemblies in the housing. The output bevel gear should have no play between the housing and the snap ring once it is installed. See Figure 6B.62.

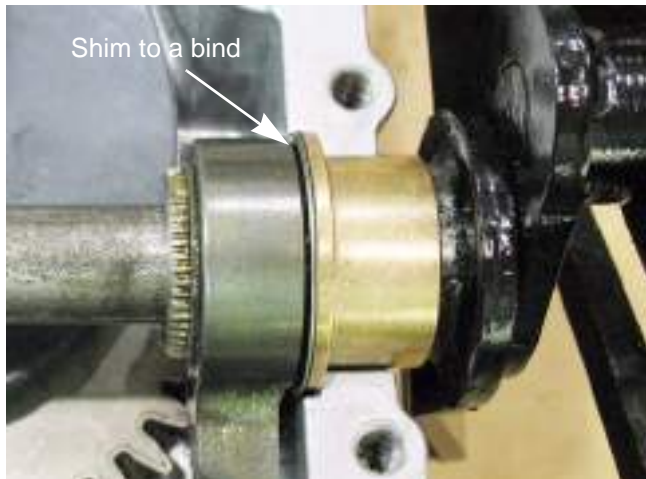

Figure 6B.62

- 9. Place both output bevel gear assemblies on the bench, facing each other. With both assemblies resting on the same points of the speed cam, insert both shafts into the coupler. See Figure 6B.63.

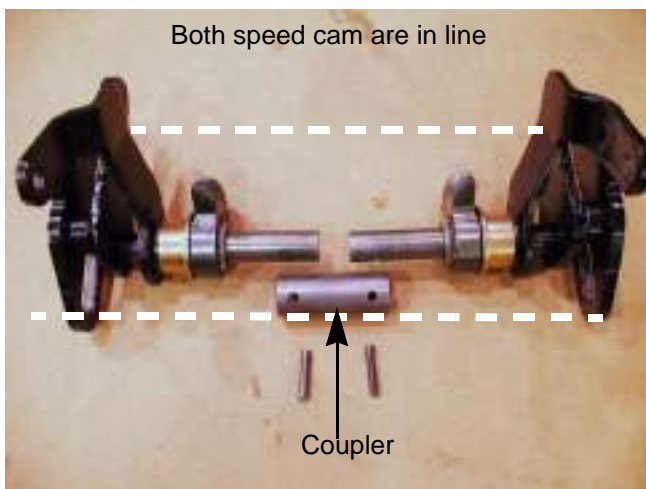

Figure 6B.63

- 10. Drive the roll pins through the coupler and the shafts to hold the assembly together.
- 11. Insert the speed cam assemblies in the lower housing.

- Line the hole in the input sector gear up with the the center of the square recess at the front of the lower housing.
- The bevel gears should face away from the input sector gear.
- The first tooth of each output bevel gear should rest in the first valley the bevel gears in the bottom of the lower housing.
- The output bevel gear should have no play once it is installed. If it does have play, go back to step 9. See Figure 6B.64.

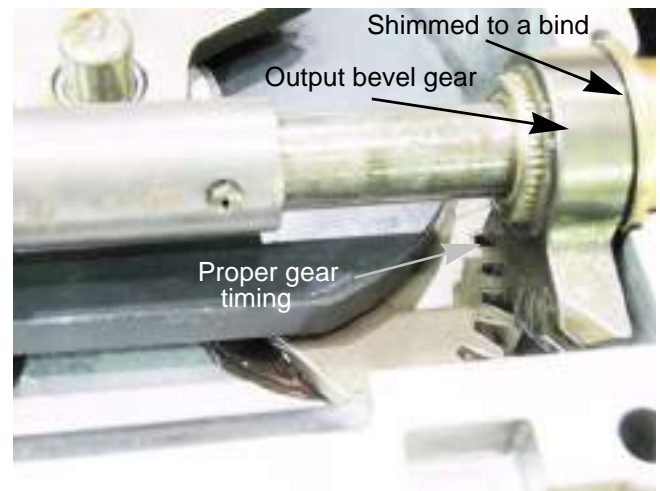

Figure 6B.64

NOTE: To test proper gear timing; measure from the farthest point of the output bevel gear to the top of the housing. It should measure a 1/4" for both sides. See Figure 6B.65.

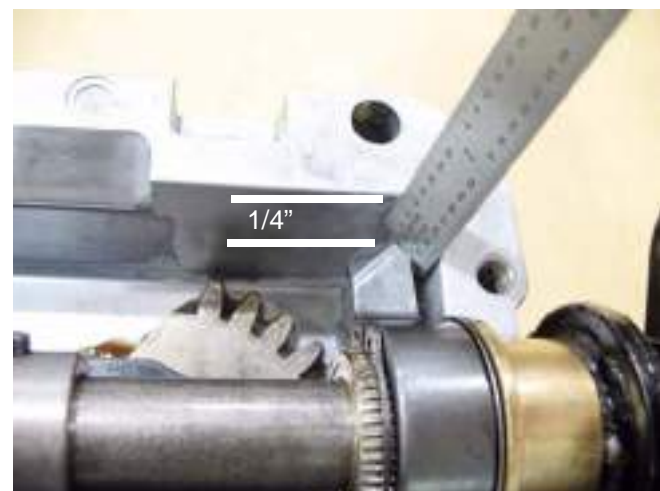

Figure 6B.65

STEERING-IVT

NOTE: If one or both of the output bevel gears are out of time, the steering rack will lose travel on the affected side.

12. Fill the lower housing with 12 oz. of 737-0300A Durina™ grease. See Figure 6B.66.



Figure 6B.66

13. Press in the upper ball bearing into the upper housing. See Figure 6B.67.



Figure 6B.67

14. Press the lower ball bearing into the upper housing. See Figure 6B.68.

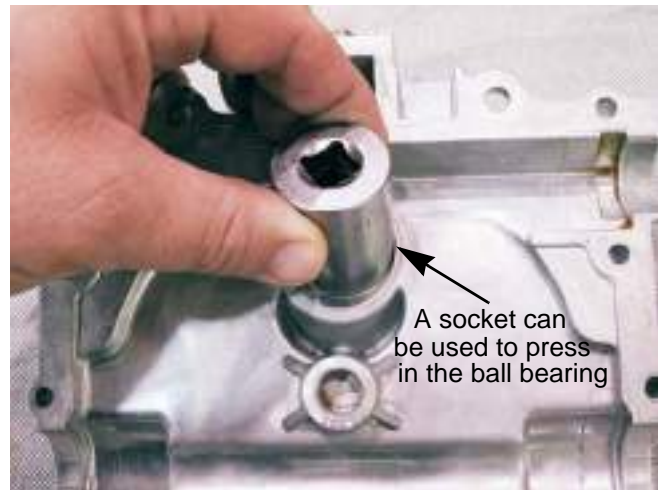

Figure 6B.68

15. Insert the input shaft through the ball bearings from the inside of the steering gear box. See Figure 6B.69.

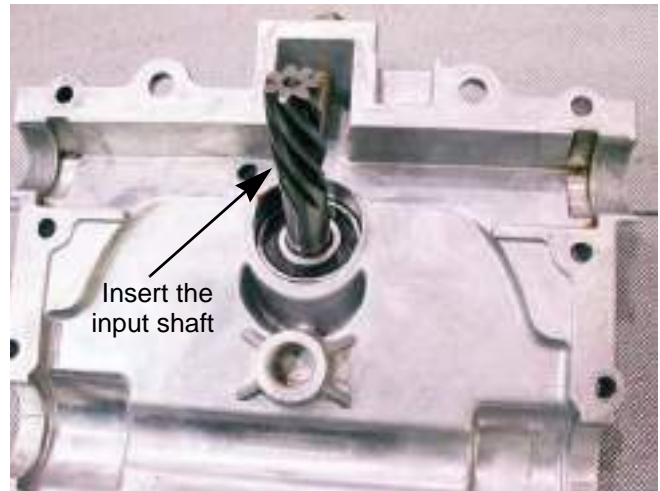

Figure 6B.69

16. Install the snap ring on the input shaft.
See Figure 6B.70.



Figure 6B.70

17. Install the wear block:
 - 17a. Insert the spring into the wear block.
 - 17b. Set the wear block and spring into the square recess in the upper housing.
See Figure 6B.71.

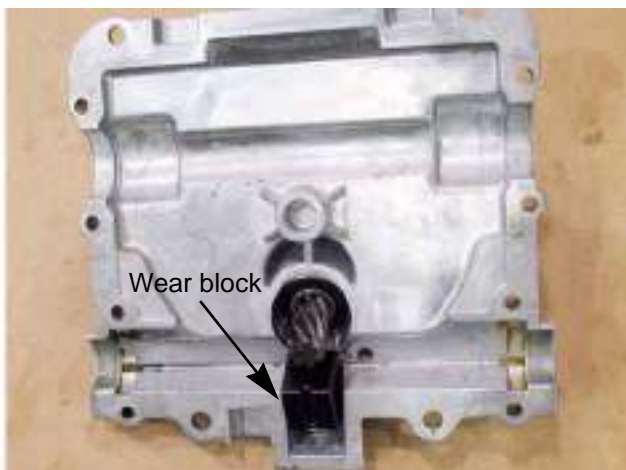

Figure 6B.71

18. Slide one new bushing onto each side of the steering rack with the flanges facing the center of the rack.

19. Set the steering rack into the groove in the upper housing. Trapping it between the input shaft and the wear block. See Figure 6B.72.

NOTE: The hole in the steering rack should line up with the hole in the housing.
See Figure 6B.72 Insert.



Figure 6B.72

20. Adjust the steering rack until the left side (as installed in the tractor) measures 1.8" from the case to the shoulder at the end of the shaft.
See Figure 6B.73.

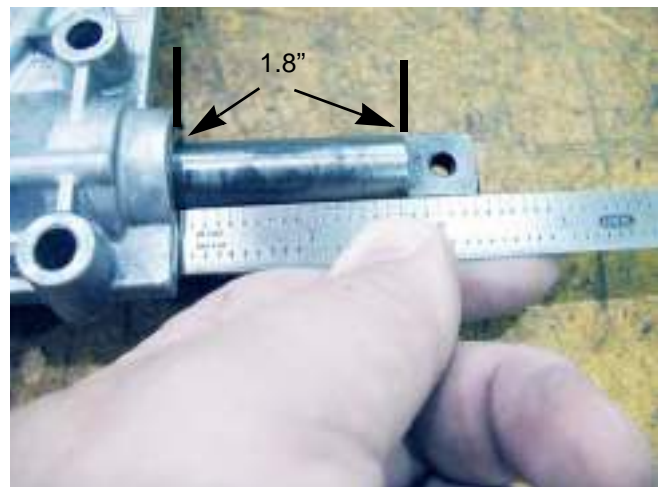

Figure 6B.73

21. Holding the steering rack in place, carefully set the upper case onto the lower case.

NOTE: The upper case should drop into place.
Do not force it.

STEERING-IVT

22. Check the timing of the gear box:
 - 22a. Turn the input shaft until the steering rack has moved all the way to the left. The right shoulder should be flush with the housing. See Figure 6B.74.

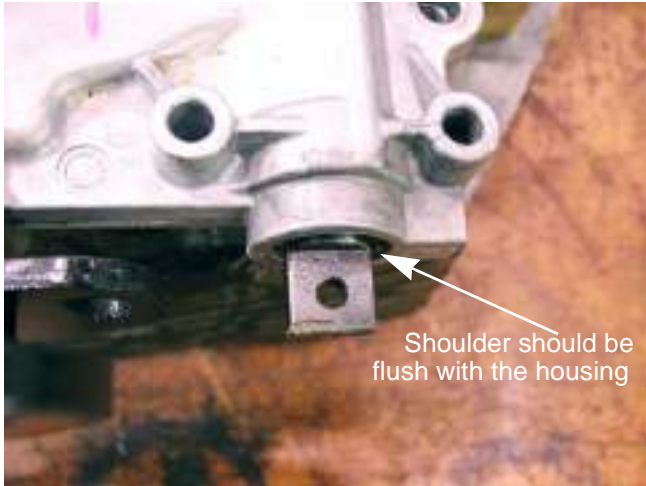

Figure 6B.74

- 22b. Turn the input shaft until the steering rack has moved all the way to the right. The left shoulder should be flush with the housing.
23. Install the return to neutral bracket.
24. Install the remaining housing screws.
25. Install the return to neutral bolt.

NOTE: The return to neutral bolt does not need to be tightened at this time. It will be adjusted and tightened when it is installed in the tractor.
26. Center the steering rack and thread a 1/4"-20x2" bolt into the hole in the gear box to lock the gear box in neutral.
27. Install the steering gear box in the tractor and perform the speed cam adjustment, neutral adjustments and the wheel alignment by following the procedures described in this chapter.
28. Test drive the tractor in a safe area before returning to service.

Front wheels and axles

Remove/ replace the front wheels:

1. Lift and safely support the front end of the tractor.
2. Gently pry off the hub cap. See Figure 6B.75.



Figure 6B.75

3. Remove and discard the cotter pin. See Figure 6B.76.

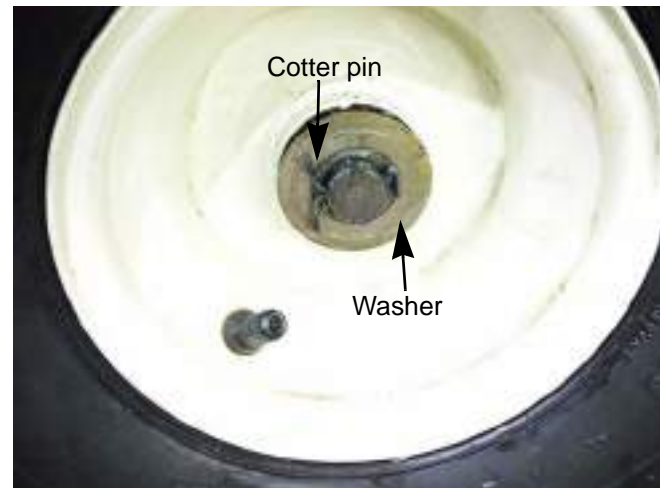

Figure 6B.76

4. Remove the washer. See Figure 6B.76.
5. Slide the wheel off of the axle.

To replace the front wheel ball bearings:

1. Lift and safely support the front end of the tractor.
2. Remove the front wheel by following the procedures describe in the previous section of this chapter.
3. Drive the bearings out of the wheel hub using a drift or pin punch. See Figure 6B.77.



Figure 6B.77

4. Drive in the new bearings using a brass punch. See Figure 6B.78.



Figure 6B.78

5. Install the front wheel.
6. Pump grease in the grease fitting on the front wheel until it starts to squirt out of the hub.
7. Test drive the tractor before returning it to service.

To remove/ replace the front axles:

1. Lift and safely support the front of the tractor.
2. Remove the front wheel by following the procedures in the front wheel section of this chapter.
3. Remove the steering gear covers.
4. Insert a 5/16" pin punch into one of the alignment holes to lock the steering gears in place. See Figure 6B.79.

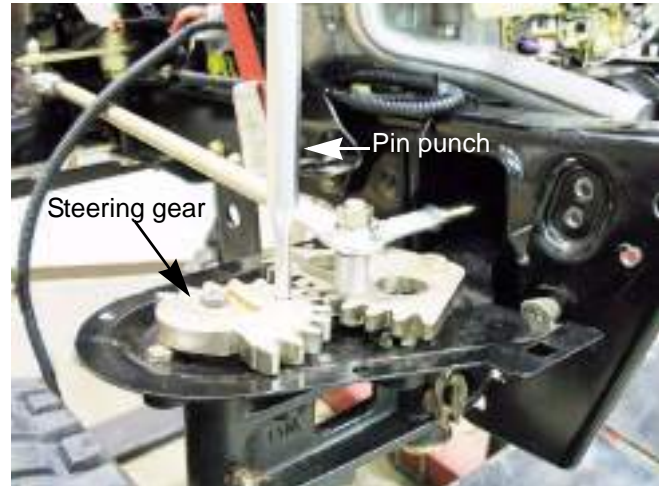

Figure 6B.79

5. Loosen the bolt that holds the outboard steering gear to the axle. Back the bolt half way out.

NOTE: The axle had a tapered double-D shaft. The steering gear will be very tight on the shaft.

6. Strike the bolt head, using a brass punch and a hammer. This will loosen the axle from the outboard steering gear. See Figure 6B.80.



Figure 6B.80

STEERING-IVT

7. Take the bolt all the way out.

NOTE: The axle should fall out at this point.

8. Install the axle by following the previous steps in reverse order.
9. Install the axle by following the previous steps in reverse order.

NOTE: Align the timing marks when installing the outboard steering gear. See Figure 6B.81.

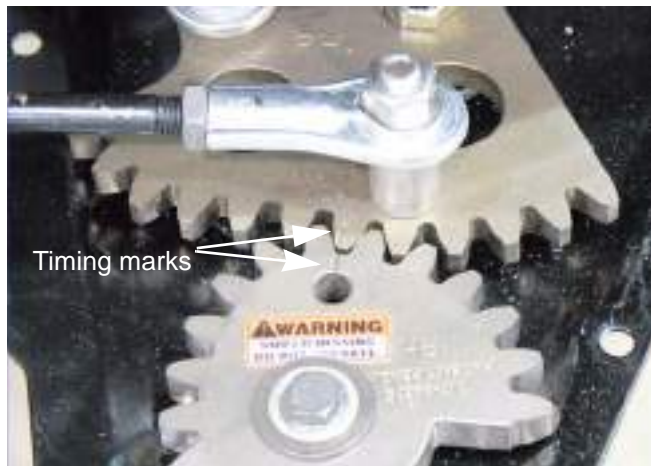

Figure 6B.81

10. Test drive the tractor in a safe area before returning it to service.

Drag links

To remove/replace a drag link:

1. Remove the steering gear covers.
2. Remove and discard the nut holding the drag link to the inboard steering gear using two 9/16" wrenches (one of them should be a slim-line wrench). See Figure 6B.82.



Figure 6B.82



The nuts used on the drag links and the tie rod are single use only. Do not try to reuse them by applying a thread locking compound. Use new nuts every time.

3. Remove the nut and bolt that secures the drag link to the steering arm. See Figure 6B.83.

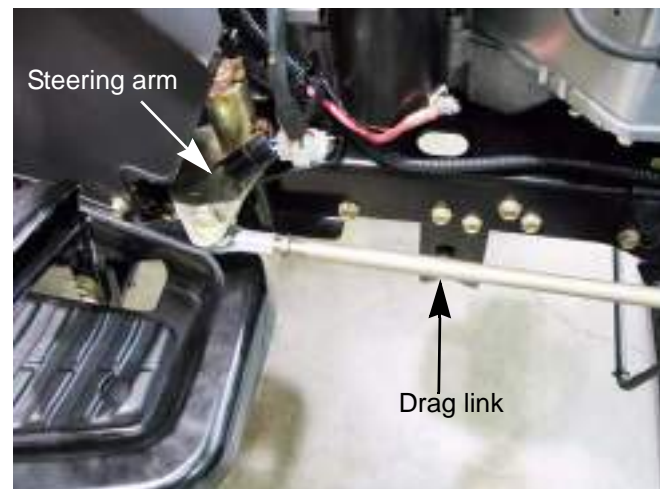

Figure 6B.83

4. Loosen the jam nuts.
5. Remove the spherical rod ends.
NOTE: Count the number of turns to remove the spherical rod ends.
6. Install new spherical rod ends.
NOTE: Install the spherical rod ends the same number of turn as it took to remove them from the old drag link.
NOTE: Leave the jam nuts loose.
7. Install the drag link on the tractor.
8. Perform a wheel alignment by following the procedures described in the wheel alignment section of this chapter.
9. Test drive the tractor in a safe area before returning it to service.

Tie rod

To remove/replace the tie rod:

1. Remove the steering gear covers.
2. Remove and discard the nut holding the tie rod spherical rod ends to the inboard steering gear using two 9/16" wrenches (one of them should be a slim-line wrench). See Figure 6B.84.



Figure 6B.84



The nuts used on the drag links and the tie rod are single use only. Do not try to reuse them by applying a thread locking compound. Use new nuts every time.

3. Repeat on the other side of the tractor.
4. Slide the tie rod out of the tractor.
5. Loosen the jam nuts.
6. Remove the spherical rod ends.
NOTE: Count the number of turns to remove the spherical rod ends.
7. Install new spherical rod ends.
NOTE: Install the spherical rod ends the same number of turn as it took to remove them from the old tie rod.
8. Install the tie rod on the tractor using new lock nuts.
9. Perform a wheel alignment by following the procedures described in the wheel alignment section of this chapter.
10. Test drive the tractor in a safe area before returning it to service.

STEERING-IVT

Inboard steering gear

To remove/replace the inboard steering gear or king pin:

1. Remove the steering gear covers.
2. Remove and discard the nut holding the tie rod spherical rod ends to the inboard steering gear using two 9/16" wrenches (one of them should be a slim-line wrench). See Figure 6B.85.
3. Remove and discard the nut holding the drag link to the inboard steering gear using two 9/16" wrenches (one of them should be a slim-line wrench). See Figure 6B.85.

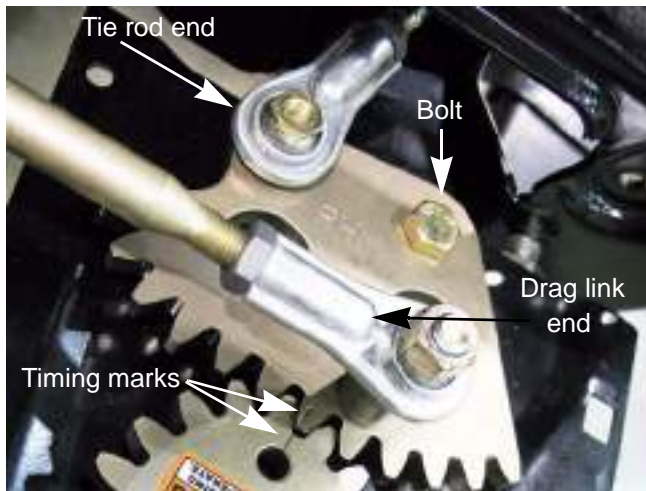

Figure 6B.85

4. Remove the inboard steering gear by removing the bolt using a 9/16" wrench.
5. Remove the cotter pin in the bottom of the king pins. See Figure 6B.86.
6. Push the king pins out of the pivot bar.

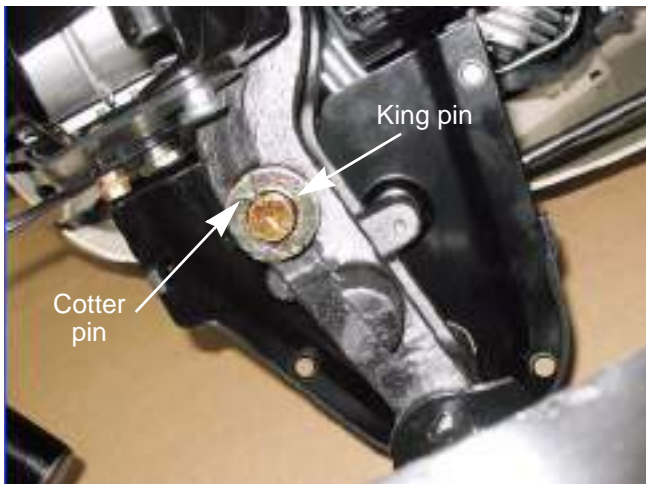

Figure 6B.86

7. Install the king pin.
8. Align the timing marks and install the inboard steering gear.

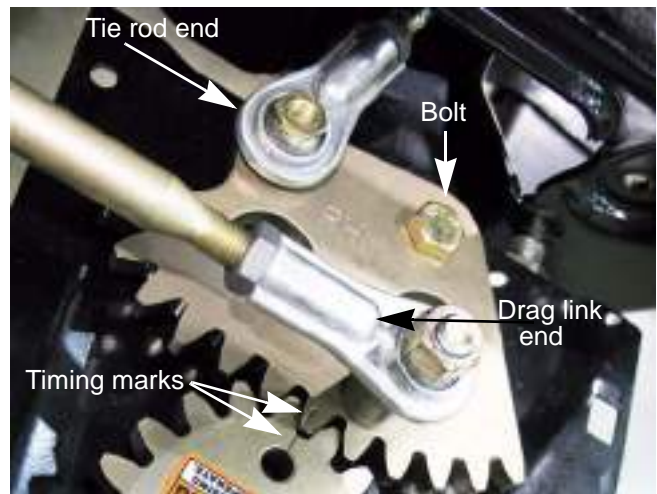

Figure 6B.87

9. Attach the tie and drag link ends using new lock nuts.
10. Perform a wheel alignment by following the procedures described in the wheel alignment section of this chapter.
11. Test drive the tractor in a safe area before returning it to service.

Pivot bar

To remove/replace the pivot bar:

1. Lift and safely support the front end of the tractor.
2. Remove the front axles by following the procedures described in the front wheels and axles section of this chapter.
3. Remove and discard the nut holding the drag link to the inboard steering gear using two 9/16" wrenches (one of them should be a slim-line wrench). See Figure 6B.88.



Figure 6B.88

4. Remove the muffler by following the steps described in Chapter 2: Engine Related Parts.
5. Remove the four screws fastening the bumper mount bracket to the frame. See Figure 6B.89.

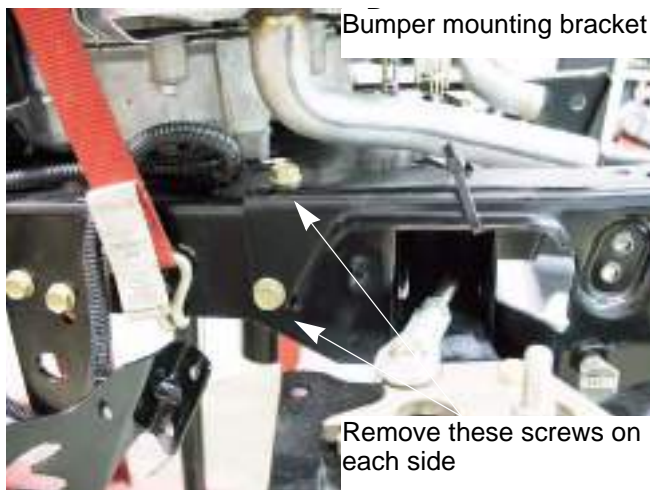

Figure 6B.89

6. Remove the pivot bar shoulder bolts. See Figure 6B.90.

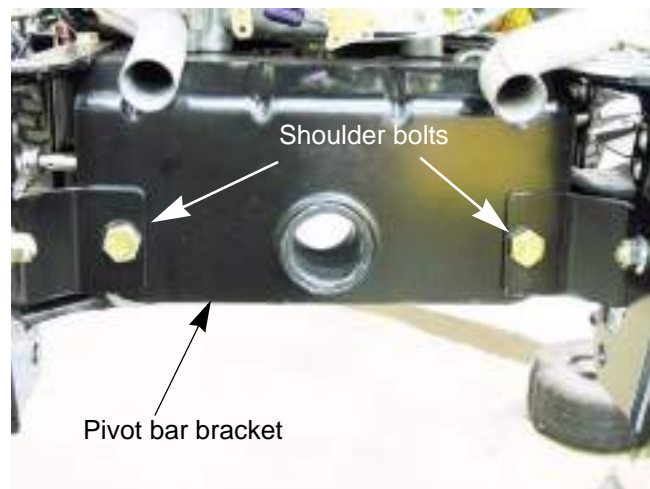

Figure 6B.90



WARNING At this point there is nothing holding the pivot bar in place. Take care to prevent the pivot bar from falling off of the tractor.

7. Slide the bumper mounting bracket and the pivot bar bracket off of the tractor.
8. Remove the pivot bar.
9. Inspect the contact areas where the pivot bar meets the frame. If there is any material that has erupted or any galling, sand it down. Repeat inspection on the inside of the pivot bar bracket. See Figure 6B.91.

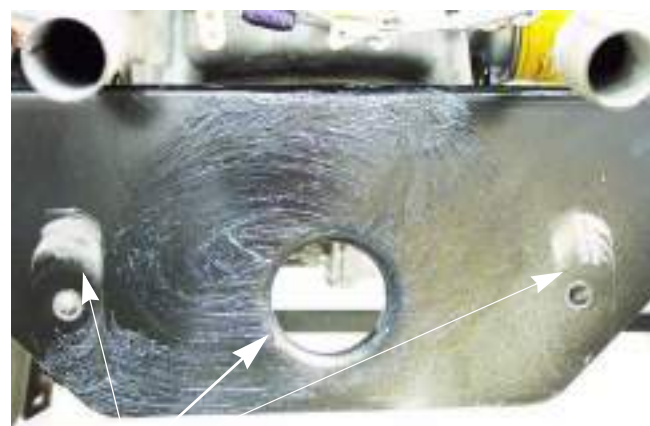

Figure 6B.91

STEERING-IVT

10. With the pivot bar on a bench, the inboard steering gear and the tie rod can be serviced.
11. Remove the tie rod by removing and discarding the nut holding the tie rod ends to the in board steering gear. See Figure 6B.92.

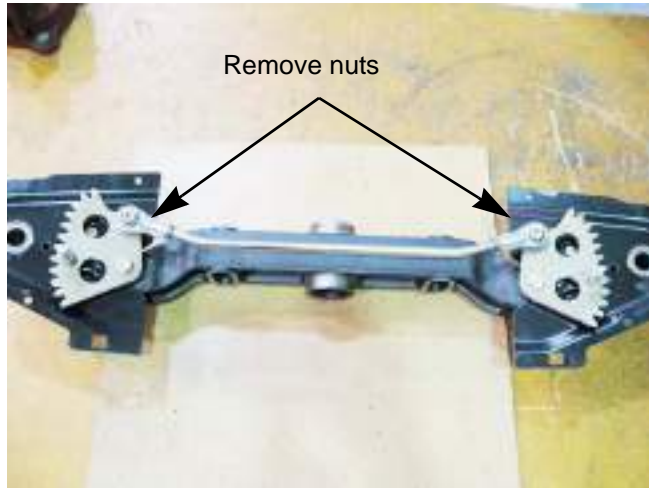

Figure 6B.92

12. Remove the inboard steering gear by removing the bolt using a 9/16" wrench.
13. Remove the steering king pins by:
 - 13a. Removing the cotter pins in the bottom of the king pins.
 - 13b. Push the king pins out of the pivot bar. See Figure 6B.93.

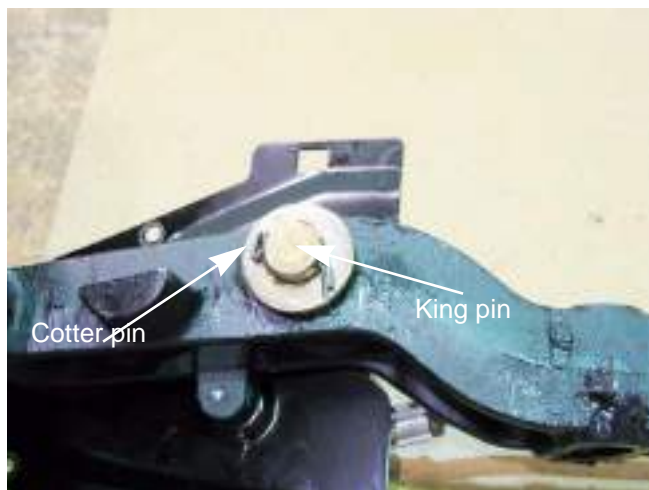

Figure 6B.93

14. Start re-assembling the pivot bar by inserting the steering king pins into the pivot bar. Secure them with new cotter pins. See Figure 6B.93.
15. Install the axle assemblies.
16. Place the outboard steering gears on the axles and tighten to a torque of 100 - 150 in-lbs (11 - 17 Nm).

NOTE: The steering gears are marked LH and RH. Make sure the LH is facing up on the left hand side and that the RH is facing up on the right.

17. Apply a small amount of releasable thread locking compound such as Loctite® 242 (blue) to the bolt for the in board steering gears. Align the timing marks on the inboard and outboard steering gears and tighten the bolt that fastens the inboard steering gears to a torque of 380 - 450 in- lbs (43 - 51 Nm).

NOTE: Make sure the bolts for the drag link and tie rod are in the in place before installing the steering gears.

18. Insert a 5/16" pin punch in the alignment holes of the out board steering gears.

NOTE: Make sure they go all the way through into the pivot bar to lock the gears in position. See Figure 6B.94.

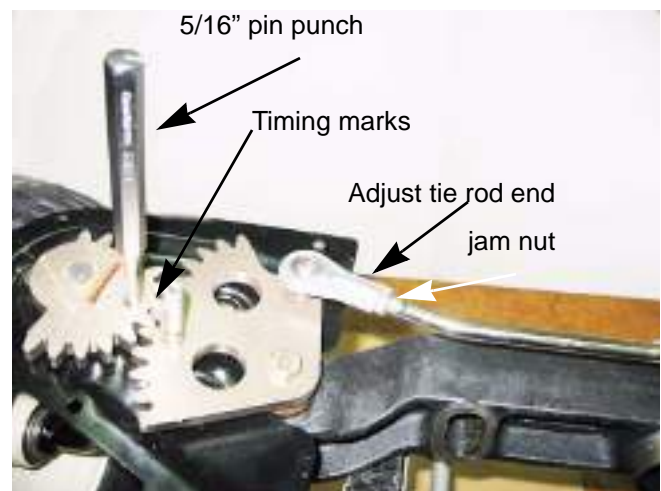

Figure 6B.94

19. Adjust the tie rod ends by loosening the jam nuts and rotating the tie rod ends until they slide on to the 1/4" bolts sticking up through the inboard steering gears. Tighten the jam nuts to lock the tie rod ends in place. See Figure 6B.94.

20. Install the tie rod end using a new lock nut.
21. Apply high quality grease to the frame and the inside of the pivot bar bracket, where the pivot bar rides. See Figure 6B.95.

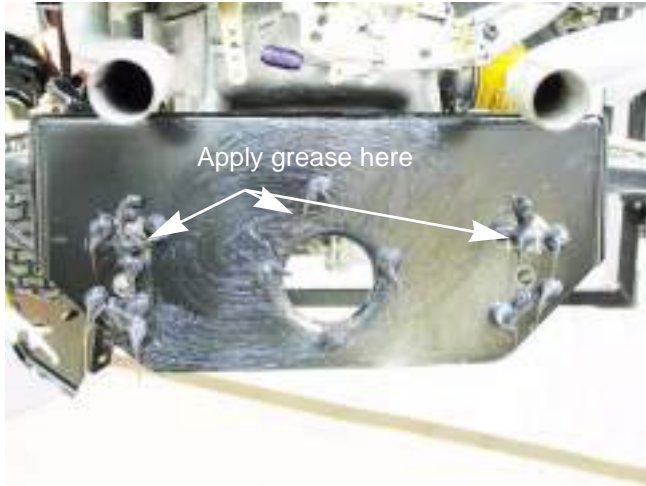

Figure 6B.95

22. Install the pivot bar by following steps 3 - 7 in reverse order.

NOTE: When installing the pivot bar, use a clamp to line up the screw holes in the frame, pivot bar and bumper mounting brackets. See Figure 6B.96.



Figure 6B.96

23. Slide the front wheels on and secure them with new cotter pins.

NOTE: Make sure the washer is installed between the wheel bearings and the cotter pin.
24. Push the hub caps on till they snap in place.
25. Take the tractor off of the jack stands.

26. Perform a neutral adjustment and wheel alignment as described in the beginning of this chapter.
27. Test drive the tractor in a safe area before returning to service.

CHAPTER 7: ELECTRICAL SYSTEM

Introduction

This chapter is divided into four sections:

- **Section 1:** About this chapter and precautions
- **Section 2:** Components
This section will describe the location and operation of the electrical components on the tractor. Where appropriate, some disassembly or component removal instructions will be included.
- **Section 3:** Diagnostic Techniques
This section will cover basic tools, techniques, and methodology for diagnosing electrical issues on the tractor. A lot of the information in this section can be applied to other equipment.
- **Section 4:** Schematics

Precautions



Before disconnecting any electrical component, take precautions to prevent the component or the wires attached to it from shorting out. The most effective means of doing this is to disconnect the battery ground cable from the negative battery terminal.



Unless performing tests that require the electrical system to be in operation, disconnect the negative cable from the battery before doing any work to the electrical system of the tractor.

Components

The I-series tractors have the Cub Cadet Rev-Tek system..

1. RMC Module

The **RMC module contains electronic logic circuits**. When diagnosing anything that is connected to the RMC module, a high impedance test light or a high impedance digital volt-ohm meter (DMMDMM) must be used. The amperage draw of a standard incandescent test light may over-burden some internal electronic circuits, burning-out the module.

NOTE: These tools are not outrageously expensive or exotic. High impedance test lights (Thexton model 125 is typical) can be purchased locally from stores like NAPA for under \$30.00. Appropriate multi meters can be purchased for under \$100.00, and are an invaluable tool for any competent technician.

- It is typical when industries **shift from electro-mechanical to electronic controls** that diagnosis shifts from tracing through a number of independent circuits to checking the in-puts to and out-puts from a central processor. This is similar to, but much less complex than the transition that the auto industry made with the conversion to fuel injection in the 1980s.
NOTE: The **starter safety circuit** has no connection to the RMC module.
- The **safety circuits that are capable of turning-off the engine** work through the RMC module.
- It is still important to be familiar with the workings of the individual components of the electrical system, but **some of them can now be checked from a central point on the tractor**. This makes life easier on the technician, frequently making it unnecessary to connect to difficult to reach switches in the preliminary stages of diagnosis.
- The function of individual safety switches can be seen as providing information "inputs" to the RMC module.
- The next part of this section gives a **detailed description of the electrical components** on this tractor, their function in the system, and their physical location on the tractor. Armed with this

ELECTRICAL SYSTEM

information and the proper tools, a technician should be able to efficiently diagnose most electrical problems.

2. Key switch

The **Key Switch** is similar to those used in a variety of MTD applications since 1999. The difference in this case is that it is incorporated in the same housing as the RMC module; the two items are not available separately. See Figure 7.1.



Figure 7.1

2a. In the **OFF** position, continuity can be found between the M, G, and A1 terminals. See Figure 7.2.

Key switch schematic

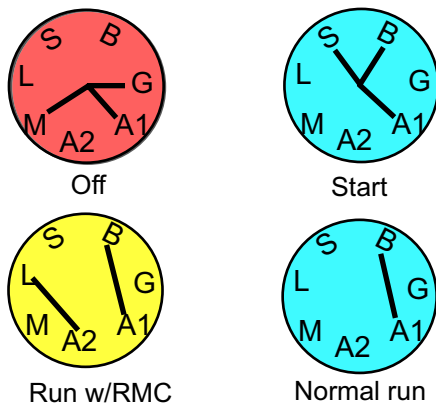

Figure 7.2

- M is connected to the magneto by a yellow wire, G is connected to ground by a green wire, and A1 is connected to the after fire solenoid.

NOTE: In the **OFF** position, the magneto primary windings are grounded, disabling the ignition system. The after-fire solenoid loses its power from the B terminal. This turns off the fuel supply.

- **Symptom-engine runs with key in OFF position:** The key switch is not completing the path to ground either because of an internal fault or a bad ground connection elsewhere in the harness. Check continuity between M, G, and A1 terminals with key switch in OFF position. Check green wire for continuity to ground.
- **Symptom-loud "BANG" when key is turned to the OFF position:** The after-fire solenoid is not closing, either because it is physically damaged or the power is not being turned off. Check for power at the solenoid. Check continuity between G and A1 terminals. Check for no continuity between A1 and the B terminals.

NOTE: If the engine is at an idle when the key is turned off, fuel is drawn into the engine through the idle ports of the carburetor by-passing the fuel shut off solenoid. The raw fuel will travel through the engine and ignite in the muffler causing an after fire.

- **Symptom-Engine runs 3-5 seconds after key is turned to OFF position:** The after-fire solenoid is turning off the fuel supply, but the ignition is continuing to operate. Check continuity between the M and G terminals in the OFF position. Check continuity from yellow wire connection all the way to the spade terminal on the magneto.

2b. In the **START** position, continuity can be found between B, S, and A1 terminals.

- Battery power from the B terminal is directed to the start circuit through the S terminal and to the after-fire solenoid through A1.

- **Symptom-No crank and no starter solenoid click**: Power is not getting to the trigger spade on the starter solenoid. Test for a good battery then check for power where the fused red wire with white trace connects to the B terminal. Check for continuity between B and S terminals in START position. If power is getting to the S terminal in the START position, the problem lies down-stream in the starter circuit, Check continuity from the orange wire on the S terminal to the orange wire with white trace on the trigger spade on the starter solenoid. If it is broken, trace through the brake and PTO switches.
 - **Symptom-No crank, solenoid click**: The problem lies in the heavy-gauge side of the starter circuit; battery cables, starter cable, solenoid, or ground issue.
 - **Symptom-Crank, spark, but not fuel**: First test for power at the solenoid, if no power then check for continuity from B to A1 in the START position. If power is reaching the red wire that connects to the A1 terminal in the start position, the problem lies down-stream of the key switch. A handy quick-check is to apply power to the red wires where they connect to the S terminal (whole circuit) or directly to the after fire solenoid to listen for the audible “click” that it makes when functioning.
 - **Symptom-Crank, but no spark**: This is a highly unlikely scenario. If it occurs after a key switch has been changed independently of the RMC module, this would arouse suspicion that the wrong key switch was installed. Otherwise, the problem lies elsewhere in the safety circuits or engine. Do not over-look the possibility of a bad magneto or chafed ground lead within the engine harness.
- 2c. In the **NORMAL RUN** position (green zone), the B and A1 terminals should have continuity. Once the engine is running, the alternator produces current that tracks-back to charge the battery, via the red wire connected to the B terminal.
- **Symptom-Battery does not charge**: Follow the engine manufacturer’s recommendations for testing alternator output. If alternator output is getting to and through the key switch, but not reaching the battery, the fuse may have blown after start-up. A blown fuse will disable the starter circuit. A simple quick-test for the presence of alternator output at the battery is to check across the battery posts for DC voltage.
- **Symptom-After fire solenoid does not work: engine starts and dies**: The after fire solenoid is powered directly by the red wire from the B terminal of the key switch, and should operate independently of anything else on the tractor once the engine is running. If the alternator fails *and* battery power is not reaching the after-fire solenoid through the key switch, it will not work. This is an unusual set of circumstances.
- 2d. In the **REVERSE CAUTION MODE** (yellow zone), the same characteristics are true as for the normal run position, but *in addition* the L terminal will have continuity with the A2 terminal. The A2 terminal is connected to the RMC module by a purple wire. The L terminal (formerly used for the lighting circuit) connects directly to the ground circuit of green wires. When the key is in the REVERSE CAUTION MODE position, the purple wire carries a ground signal to the RMC module. When the parking brake is not set, this ground signal arms (enables), *but does not turn on* the RMC module.
- **Symptom-RMC module will not turn on**: Check for continuity between A2 and L terminals on the key switch when it is in the REVERSE CAUTION MODE position. Confirm that the green wire has continuity to ground. If the switch is capable of establishing a ground signal to the RMC module, the problem is likely to lie elsewhere in the system.
 - **Symptom-RMC module will not turn on**: confirm that the ground path (continuity to ground) to the purple wire is broken when the key switch is in any position other than REVERSE CAUTION MODE. The RMC module is disarmed (disabled) when the parking brake is set. To re-arm the module, the key is moved to another position, breaking the ground signal, then returned to the REVERSE CAUTION MODE, re-establishing the ground signal. It works something like a latched relay. If it is not possible to break the ground-path, it is not possible to freshly establish it either, and the RMC module will not be armable. Causes for such a condition might include a shorted or incorrect key switch, or a chafed purple wire shorting to ground between the key switch and the RMC module.

ELECTRICAL SYSTEM

- 2e. The RMC Module is in the same housing as the key switch, and is not available separately. For the purpose of diagnosis it is treated separately. Diagnosis of the module with the key switch introduces too many over-lapping variables. See Figure 7.3.

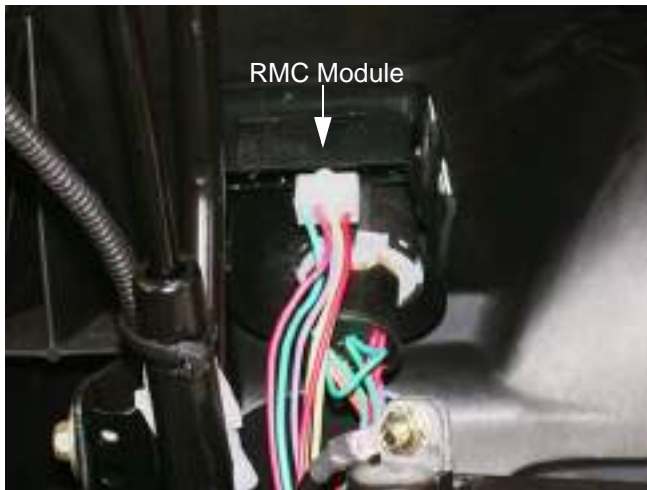

Figure 7.3

- **Principle:** To diagnose the module, the simplest approach is to check all of the inputs (safety circuits) that are connected to it. If the inputs work properly, but the RMC module does not work properly (outputs), then the module can be determined to be faulty. A specific procedure is covered, following the description of the correct operation of the RMC module.
- **Working properly:** The module cannot be diagnosed if its function is not understood. It is designed to work as follows: See Figure 7.4.



Figure 7.4

- When the **RMC module is disarmed**, the tractor will operate as MTD tractors have historically operated:

If reverse is engaged when the electric PTO is ON, the PTO clutch will turn off.

If the operator leaves the seat with the engine running, the engine will turn off.

If the operator leaves the seat with the PTO in the OFF position, the engine will turn off unless the brake is applied.

When the RMC module is armed, the tractor will operate identically to when the module is disarmed.

- When the **RMC module is armed and turned on**: The tractor will operate identically to when the module is disarmed, except that the operator will be able to put the transmission in reverse with the PTO engaged and the cutting deck will continue to run. The operator may put the tractor into and out of reverse as many times as they wish without having to re-arm or turn on the module again.
- **To arm the RMC module**: the operator must turn the key switch to the REVERSE CAUTION MODE (yellow zone), with the parking brake released.
- **To turn the RMC module ON**: The module must first be armed, then the orange triangular button is depressed, illuminating the red LED indicator to indicate that it is ON. It is important that the operator must take two actions to turn the RMC module ON so that they do not do so inadvertently.
- **The RMC module will turn OFF and disarm if**: The operator moves the key to any position other than REVERSE CAUTION MODE. The operator sets the parking brake. If the operator leaves the seat without setting the parking brake, the engine will turn off. The key movement necessary to re-start the engine will make it necessary to re-arm and turn on the RMC module if the operator wishes to continue with the ability put the tractor in reverse while the PTO is running.
- **To re-arm and turn the module ON**: If the key is in REVERSE CAUTION MODE position, it must be turned to another position (Normal Run), then returned to REVERSE CAUTION MODE. Once re-armed, the module can be turned-on by pressing orange triangular but-

ton. It will be confirmed that the module is ON by the illumination of the red LED on the module.

2f. **To identify a faulty RMC module:** If the RMC module does not function as described, the **RMC plug test** should be the first step in diagnosis.

- If the RMC plug test confirms that the safety circuits (inputs) work as designed, yet the RMC module does not work properly, the RMC module is faulty.
- The RMC plug test will give an indication of what the problem is if it is not a faulty RMC module. If the problem is identified in a particular circuit, check the safety switch that is associated with that circuit. If the switch is good, then the problem lies within the wiring harness.

NOTE: Like the electronic components found on most cars, the RMC module requires a fully charged battery to work properly. If the system voltage falls below 12 V, an accurate diagnosis of the RMC module is impossible because the module will be temporarily disabled by low voltage.

A Disconnect the molded 8-pin plug from the RMC module. See Figure 7.5.

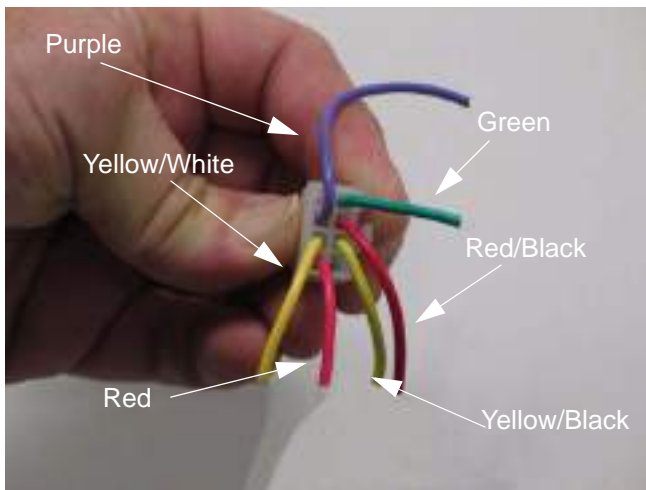

Figure 7.5

B Looking at the plug head-on, it will be configured as shown in the diagram: There will be 8 female pin terminals. When probed, they should yield the results described in the following sections. See Figure 7.6.

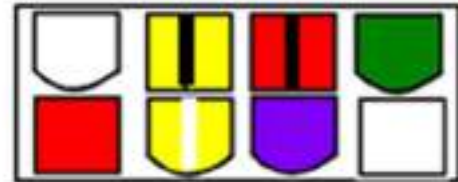

Figure 7.6

C Top left middle square-shape: Yellow wire with Black trace:

- **Behavior:** Should show DC power with the key on.

- **Circuitry:** The yellow wire with black leads directly to the PTO switch.

D Check the PTO and seat safety circuits with the 8-pin pigtail connector unplugged, then reconnect it and continue with the RMC plug test.

- **Behavior:** When the female pin terminal leading into the main harness is probed (yellow wire), there should be continuity to ground *only* when the seat is empty.

- **Circuitry:** The yellow wire with white trace leads to the forward terminal on the seat safety switch, where it finds a path to ground when the seat is empty.

- **Interpretation:** If behavior is correct, the seat safety circuit is good. If there is continuity to ground when the seat is occupied, the switch may be inoperative, or there may be a short to ground in the wire leading to it. If there is not continuity to ground when the seat is empty, the switch may be inoperative or there may be an open condition in the wire leading to it.

ELECTRICAL SYSTEM

- **Circuitry:** The yellow wire with black trace leads to the PTO switch, where it finds a path to ground when the PTO is ON.

- **Interpretation:** If behavior is correct, the N.C. side of the PTO switch /circuit is functioning properly

If there is continuity to ground when the PTO is OFF, the switch may be inoperative or there may be a short to ground in the wire leading to it. If there is not continuity to ground when the PTO switch is ON, the PTO switch may be inoperative, or there may be an open condition in the wire that leads to it.

- E There is a red wire with black trace between yellow wire with a black trace and the green wire. This wire provides the module with input from the **reverse switch**.

- **Behavior:** When the tractor is in reverse, this terminal should have continuity to ground.
- **Circuitry:** This wire runs directly to the reverse safety switch on the drive pedal shaft. This is a simple metal tang switch that grounds-out against a bolt.
- **Interpretation:** Continuity to ground when the tractor is not in reverse would indicate a short to ground. This could take the form of a chafed wire contacting ground, a bent reverse safety switch that is always in contact with another metal part, or a broken plastic insulator that separates the switch from the drive pedal shaft.

Lack of continuity to ground would indicate a broken or disconnected wire leading to the reverse safety switch, or a switch that is not closing because of physical damage or corrosion.

- F At the opposite end of the top row from the yellow wire with black trace is a green wire.

- **Behavior:** The green wire should always have continuity to **ground**.
- **Circuitry:** The green wire leads to ground.
- **Interpretation:** If this ground path is not good, there will probably be other ground-related issues with the tractor: slow starter motor, slow battery charge, dim lights. All ground connections should be mechanically secure and corrosion free.

- G The red wire on the OCR plug carries **battery voltage**.

- **Behavior:** D.C. battery voltage should show up on a volt meter when the red probe is touched to

this terminal and the black probe is grounded, regardless of the key switch position.

- **Circuitry:** This wire draws power directly from the B terminal on the key switch.
- **Interpretation:** If there is no battery voltage at this terminal, the tractor is probably not functioning at all. Look for a blown fuse, disconnected battery, disconnected ammeter or some other major fault.

- H The purple wire provides a **ground signal** to the RMC module when the key switch is placed in the **REVERSE CAUTION MODE**.

- **Behavior:** There should be continuity to ground at this terminal when the key switch is in the REVERSE CAUTION MODE position.
- **Circuitry:** When the key switch is in the REVERSE CAUTION MODE position, a ground path is established by connecting terminal A2 to terminal L within the key switch. The purple wire from the RMC module connects to A2, and a green ground wire connects to L.
- **Interpretation:** If the purple wire fails to reach a ground path when the key switch is in the REVERSE CAUTION MODE position, the RMC module will not arm or operate. Check the key switch for continuity between A2 and L in the REVERSE CAUTION MODE position, confirm that the green wire connecting to the L terminal does have good continuity to ground, and check for any loss of continuity in the purple wire that extends from the key switch to the RMC module, including the molded connector between the two components.

- I If the RMC plug test indicates fault with any of the safety switches, the next step is to test the suspect switch. The operation of those switches is described in the following sections.

3. Understanding the PTO switch

- 3a. A-COM is in the starter inhibit circuit. It is a normally closed (NC) set of contacts. When the PTO is OFF, and the contacts are closed, power coming from the brake switch (key switch in START, brakes ON) through the orange wire with black trace is passed on to the trigger terminal on the starter solenoid through the orange wire with white trace.

- 3b. B-COM is in the safety shut-down circuit. It is a normally opened (NO) set of contacts. A circuit is completed from the M terminal on the key switch through the yellow wire to the Magneto terminal on the RMC module through the yellow wire with black trace when the contacts are closed. This gives the RMC module the ability to turn off the engine when the PTO is ON.
- 3c. In C-Com, power is supplied to the PTO switch from the A1 terminal of the ignition switch through a red wire. When the PTO switch is turned on, this completes the circuit to allow power to go to the PTO clutch. It is a normally opened (NO) set of contacts.

4. The **Brake Switch** is mounted to the inside of the frame on the right side. See Figure 7.8.

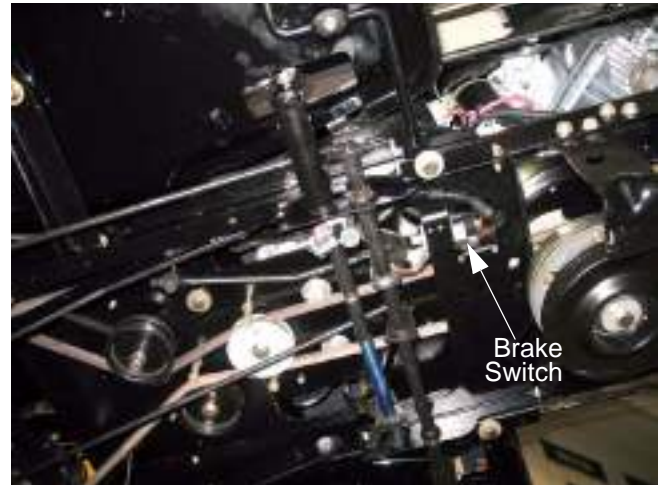

Figure 7.8

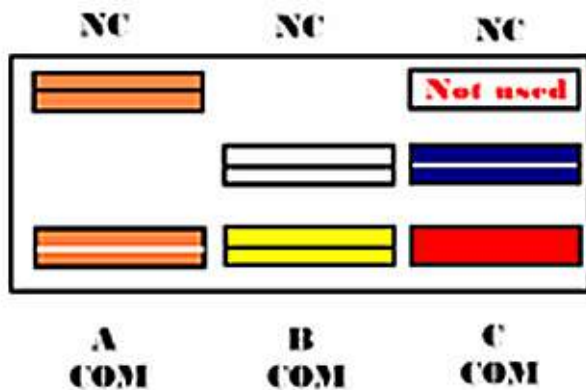

Figure 7.7

NOTE: The top terminals are showing normally closed at rest and the middle terminals are normally open at rest

NOTE: There are three contacts on the right side in the C-COM. For this application the normally opened (NO) contact is used.

- The plunger on the switch is depressed when the clutch / brake pedal is pressed-down, de-clutching the drive belt and applying the brakes. The switch contains two sets of contacts.
- A normally open (NO) set of contacts is in the starter inhibit circuit. When the clutch / brake pedal is depressed, the contacts are closed, power coming from the key switch (key switch in START) through the orange wire is passed on to the PTO switch through the orange wire with black trace.
- A normally closed (NC) set of contacts is in the safety shut-down circuit. A circuit is completed from the M terminal on the key switch, and directly from the magneto primary windings through the pair of yellow wires to the clutch / brake switch through to the yellow wire with black trace when the contacts are closed.
- The yellow wire with black trace leads to one element of the seat switch. If the seat is vacant *and* the pedal is up, the engine will turn off.

ELECTRICAL SYSTEM

5. The **Reverse Safety Switch** is a simple metal contact tang. When the drive pedal is pressed into reverse, the reverse switch is pushed into a bolt. This provides a path to ground. See Figure 7.9.

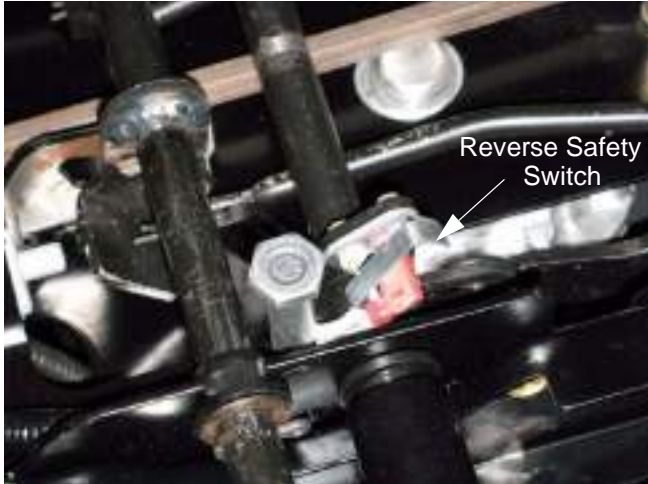

Figure 7.9

6. The **Seat Safety Switch** consists of a pair of simple metal contact tangs attached to the seat mounting bracket. See Figure 7.10.

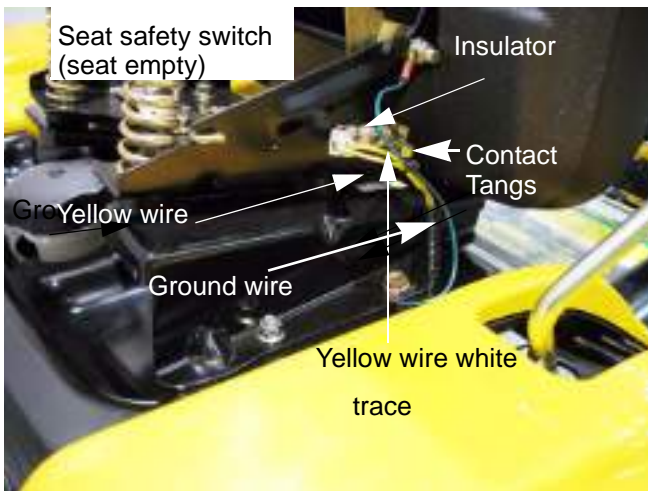

Figure 7.10

NOTE: The rubber mounts for the seat bracket insulates it from ground. There is a ground wire that provides a ground for the seat bracket. A failure in that wire will prevent the seat switch from working. See Figure 7.10.

- The yellow wire with white trace is connected to the front spade terminal on the seat safety switch. When the seat is vacant, the tab on the seat bracket closes a ground path in series with the PTO switch. If the PTO is ON and the seat is empty, the circuit is completed, shorting out the primary windings of the magneto, turning off the engine.
 - The yellow wire is connected to the rear spade terminal on the seat safety switch. When the seat is vacant, the tab on the seat bracket closes a ground path in series with the brake switch. If the brake is not applied, and the seat is empty, the circuit is completed, shorting out the primary windings of the magneto, turning off the engine.
 - The most common problems are likely to be caused by physical damage: a broken insulator between the switch and the seat bracket, an unplugged wire, or a bent tang.
7. The **starter solenoid** is mounted underneath the battery. The mounting bracket is visible from the left side of the engine. See Figure 7.11.



Figure 7.11

- When the proper safety conditions are met, (brake applied, PTO OFF) the orange wire with white trace energizes the windings that magnetize an iron core, pulling the contacts closed between the two heavy posts, connecting battery power to the starter motor.

8. The **lighting circuit** is hot whenever the engine is running. It does not draw from the battery, but runs directly off its own circuit on the alternator. See Figure 7.12.



Figure 7.12

- The blue wire carries alternator current, the green wire is a ground.
9. The 20A fuse is located near the RMC module / key switch assembly, under the dash panel. See Figure 7.13.

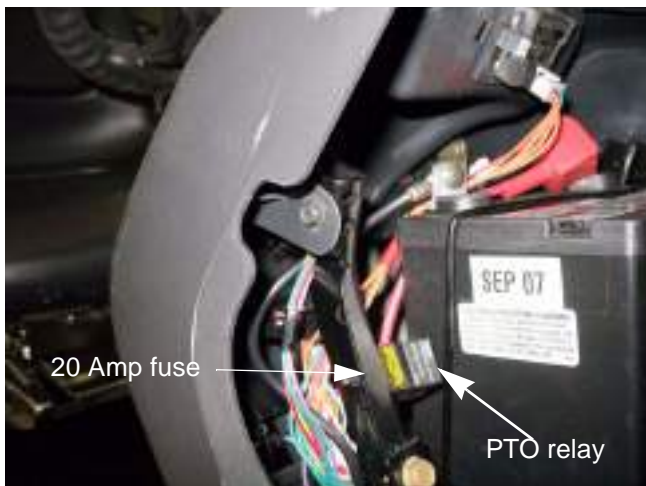

Figure 7.13

- The solid red wire feeds the fuse with power picked up from the battery cable connection to the “hot” post of the starter solenoid.
- The red wire with white trace carries fused power to the B terminal on the key switch.

- There is a second red wire with white trace for the auxiliary power point that will supply a 5 amp service to the power point.

CAUTION: DO NOT PUT A CIGARETTE LIGHTER IN THIS POWER POINT. this will cause the fuse to blow and can seriously damage the harness.

NOTE: The fuse for the auxiliary power point is located above the starter solenoid. See Figure 7.14.



Figure 7.14

- A failed fuse will disable most of the tractor’s electrical system.
- NOTE:** A fail fuse for the auxiliary power point will only affect the power point.
- Remember that a failed fuse has done its job of protecting the rest of the circuit from an overload. If a fuse blows, figure out why and correct the core problem before returning the tractor to service.
10. Refer to the engine manufacturer’s specifications to test the engine and charging systems.
 11. **Ground issues:** It is relatively easy to track where power is on the positive side of the system. The negative side is frequently neglected, though it may account for just as many electrical problems as the positive side.

ELECTRICAL SYSTEM

ELECTRICAL DIAGNOSIS

NOTE: Electrical diagnostic procedures and tools are the same for all Cub Cadet and MTD tractors. This section is written in a way to provide basic trouble shooting skills that can be used on any tractor.

With a basic understanding of the behavior of electricity and the tools used to measure that behavior, a technician can be about 80% effective at finding electrical problems.

80% effective is not bad, but the remaining 20% of the diagnoses are the really difficult ones that can devour the same amount of time as the easy 80%. Experience plays a big part in successfully diagnosing the really difficult electrical problems. Experience leads to greater understanding.

Two German Physicists, working independently during the late 18th and early 19th centuries summarized what they had figured out about electricity into some basic laws that can help a technician understand how a system works or why it does not work. Their names were Gustav Kirchhoff and Georg Ohm, and their laws are named for them.

There are basically three things that a technician is likely to test in trying to identify an electrical problem: Volts, Resistance, and Flow. To help technicians understand the behavior of electricity, this section begins with an explanation of:

- Basic electrical values.
- Ohm's law.
- Kirchhoff's current law.
- Kirchhoff's voltage law.
- How the system is wired together.

NOTE: A graphic explanation of Kirchhoff's laws can be found at the following web site:
<http://online.cctt.org/physicslab/content/phyapb/lessonnotes/DCcircuits/lessonKirchoff.asp>

The section then continues by explaining handy tools and techniques for diagnosing electrical problems on outdoor power equipment.

Electronics

The outdoor power equipment has historically had relatively simple electro-mechanical controls. Customer expectations and regulatory demands continue to drive change in the industry, while electronic controls have become relatively inexpensive.

In many cases, electronic controls can simplify a system that would otherwise be very complex. Instead of creating a huge mass of switches and relays that are tied together by spaghetti-like wiring harness, sensors (switches) in an electronic system send signals to a processor. These input signals are processed by a control module that produces outputs.

Outputs can include power to run an electric PTO clutch, a trigger signal to a starter solenoid, or the grounding of a magneto to turn off an engine if an unsafe condition exists.

Most electronic devices are quite dependable, but they are vulnerable to things that simple electrical devices are not bothered by. Examples include:

- **EMI:** Electro-Magnetic Interference is created by electronic "noise". This noise is created by ignition systems in general with non-resistor spark plugs being especially "noisy". Alternators, and even power passing through wires can also generate EMI. Countermeasures against EMI include metal shielding (take a look at the ignition system on a fiberglass-bodied Corvette), and filtering devices built into vulnerable components. Something as simple as putting non-resistor spark plugs in a machine with electronic controls can disable the controls.
- **Voltage Spikes:** A dramatic increase in voltage will damage many electronic devices. Such spikes may be caused when jumper cables are disconnected or a voltage regulator fails. Some early automotive systems could even be damaged by personal discharge of static electricity. Most are better protected now.
- **Low Voltage:** Many electronic devices simply stop working if system voltage falls below a given threshold. If a 12 volt system is run at 11 volts with a failing alternator, electronic controls may stop working.
- **Bad Grounds:** Bad grounds can reduce the effective system voltage, create resistance and heat, and send false signals. This is the single most common breeding ground of electronic gremlins.

- **Heat and Vibration:** Heat and vibration are hard on most mechanical devices. The same is true of electronics.
- **Moisture:** Moisture causes a nasty combination of corrosion and shorts. Corroded connections and wires create resistance that results in low voltage and ground issue. Many electronic components are “potted” or encased in a sealant that protects them from moisture. They are still vulnerable to bad inputs caused by corroded external connections and damaged switches.
- **Improper Tools:** Some test lights can overload electronic circuits.

Electrical environment: AC Vs. DC

Most modern outdoor power equipment that has an electrical system complex enough to require diagnosis will be equipped with an alternator that produces alternating current (AC). In most systems, this current is immediately rectified to direct current (DC), and regulated to a nominal 12 Volts. The presence of AC is very limited. The primary concern of this section is 12 Volt DC systems, though much of the theory and techniques apply equally well to other DC systems.

1. **Voltage:** Pressure

- Voltage is the “pressure” that electricity has. It is the amount of force pushing electrons through a circuit.
- The unit of measurement for this pressure is volts.
- The capital letter “V” is used to represent volts.
- Most (not all) outdoor power equipment operates on a nominal 12 volts. In practice, system voltage may run as high as 13.5V or 14V.

2. **Amperes:** Flow

- Current is the “flow” of electricity. It is the amount of electrons flowing in circuit.
- The flow of current is measured in Amperes or Amps for short.
- The capital letter “I” is used to represent Amps.

3. **Ohms:** Resistance

- Resistance is the opposition to current flow. It is a restriction that slows down the flow of current.
- Resistance is measured in Ohm’s.
- The greek letter omega “ Ω ”, or the letter “R” for Resistance is used to represent Ohm’s.
- Resistance creates heat. A circuit with too much electrical load, or too much resistance for the load placed on it will get hot.

ELECTRICAL SYSTEM

4. Ohm's Law

Ohm's Law relates voltage, amperage, and resistance. It states that voltage is the product of resistance times current.

- It is written as $V = I \times R$.
- In simplest terms, it goes like this:
It takes 1 volt to push 1 amp through a resistance of 1 ohm ($1 = 1 \times 1$).
- This equation can be rearranged using algebra to solve for any one variable.
- Those who were traumatized by algebra can represent Ohm's law as a triangle. When using the triangle, cover the value to be found, and the two values left exposed signify how to obtain that value. See Figure 7.15.

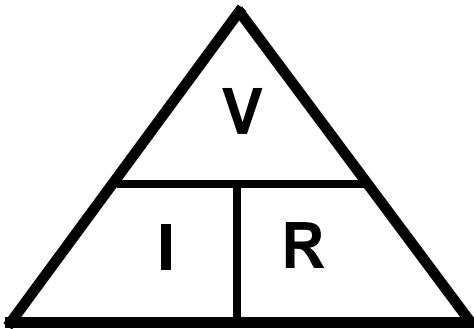

Figure 7.15

- As an example if the "R" is covered, the "V" is over the "I" which means "V" divided by "I" will solve for the covered letter "R" ($V/I = R$). If the "V" is covered, "I" and "R" are exposed on the same line, meaning that the product of "I" times "R" will solve for the unknown "V" ($I \times R = V$).

5. Kirchhoff's current law

Kirchhoff's current law deals with nodes. Nodes are the junction of two or more wires or the junction of a wire to a component.

Kirchhoff's current law states that what ever current goes into a node must come out.

As an example: Three wires are connected with a wire nut. One wire has 5 amps going into the connection:

- The sum of the currents coming out of the other two wires must equal 5 amps. That could be 3 amps in one wire and 2 amps in the other or it could be 2.5 amps in each wire, but the total coming out must be the same as the current going in. See Figure 7.16.

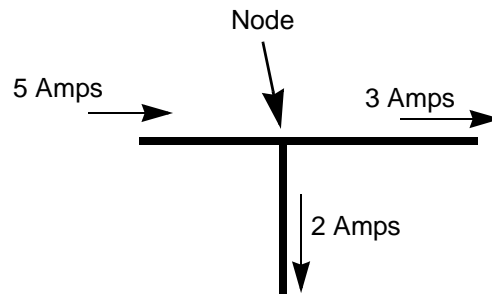

Figure 7.16

6. Kirchhoff's voltage law

Kirchhoff's voltage law deals with voltage drops. A voltage drop is the amount of voltage used up or "dropped" by resistance in a circuit. Ohm's law states that $V = I \times R$, every component in a circuit has resistance, even the wires. To push current through resistance, it takes voltage. Kirchhoff's voltage law states that the sum of all the voltage drops equals the source voltage.

As an example, imagine a circuit that has a 12V battery that produces 4 amps of current powering a light bulb that creates 3 Ω of resistance. The wires are assumed to have 0 Ω resistance*. The light bulb uses 12 volts (4 amps x 3 ohms = 12 volts). The battery produces 12 volts that equals the 12 volts used by the light bulb. See Figure 7.17.

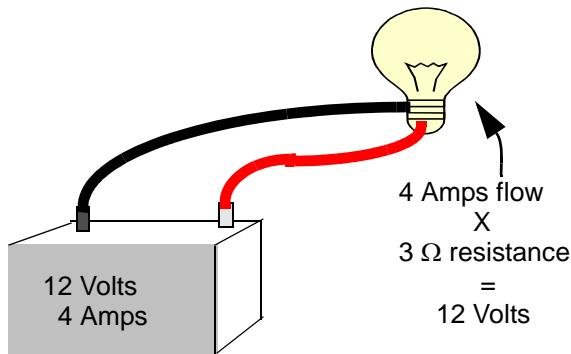

Figure 7.17

NOTE: * If the proper size wire is used and there is no corrosion in the wire, the resistance will be too small to worry about.

7. How the system is wired together

The Rules

All circuits have some basic rules that must be followed:

- 7a. All circuits must have at least one voltage source. It could be a battery, an alternator or both.
- 7b. All circuits must have a load. A circuit without a load is the same as shorting out the power source. Typical loads could be:
 - _ lights
 - _ a motor
 - _ a solenoid
- 7c. All circuits must have a complete path back to the voltage source. This is also known as having continuity.

NOTE: On outdoor power equipment, the frame of the machine is frequently used as the return path to the battery. This is referred to as grounding the machine. Any point on the frame should be the same as the negative post of the battery (Electrically) unless there is a bad connection between the battery and the frame or between the frame and the component or cable that is assumed to be grounded to it.

- 7d. Most circuits have additional components like switches and fuses.

ELECTRICAL SYSTEM

Types of circuits

There are three ways a circuit can be wired:

- Series
- Parallel
- Series/parallel

Series

Series circuits are wired so that the current has only one path to follow. If one component in the system fails, the circuit will be broken and whole system will not work. See Figure 7.18.

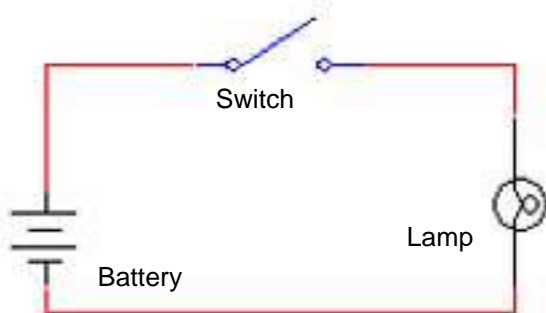

Figure 7.18

Parallel

Parallel circuits are wired so that current has multiple paths to follow. If a component in one of the parallel paths fails, the rest of the circuit will keep working. See Figure 7.19.

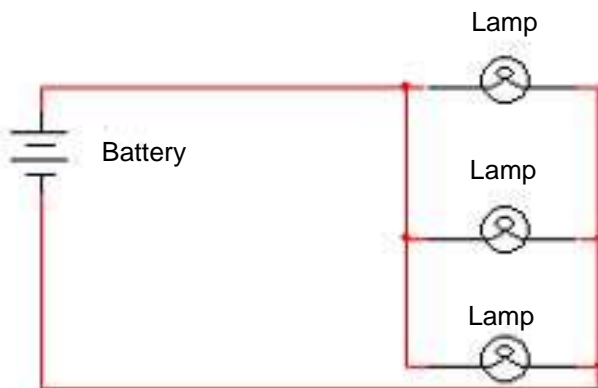

Figure 7.19

Series/parallel

Series/parallel circuits have some sections wired in series and some in parallel. See Figure 7.20.

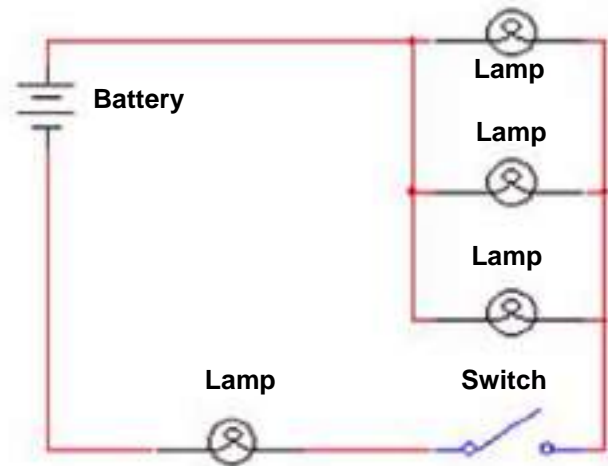

Figure 7.20

What can go wrong?

There are three types of failures that can occur in an electrical circuit:

1. Shorts
2. Opens
3. Increased resistance

Shorts

A short is when electricity takes a path that it was not designed to take by-passing a component in the circuit.

A common example of a short is a wire with insulation that chafed through, exposing the copper conductor. The bare copper will short the circuit when it touches a ground source.

Opens

An open is when current can not complete its path back to the power source. A common example of this is a burned-out lamp (light bulb) in a series circuit.

Increased resistance

Increased resistance is, as the name implies, an increase in resistance.

This can be caused by loose or corroded connections, or connections that are insulated by grease, paint, or coatings. Fasteners finished in oil/phosphate or black oxide are bad conductors. Use bright fasteners (zinc coated).

Resistance can be a problem on the ground side as well as the hot side of a system: remember that electricity must complete a loop (circuit) back to the battery post. Any resistance in that loop will interfere with the flow.

Arguably the most common electrical failure, and the hardest to find, increased resistance can have more subtle symptoms than outright open circuits. Many times affected circuits will still partially function. It is not an open because there is some current that can get through, but the increase in resistance is enough to affect the circuit.

The Tools

Equipment needed to diagnose an electrical system:

- DMMDMM (Digital Volt-Ohm Meter)
- Wiring schematic or diagram

Equipment that may be useful:

- Fused jumper wires.
- Test light
- Self-powered continuity light
- Ammeter
- Battery charger
- Battery tester
- Battery jumper cables
- Hand tools to gain access to components.
- Flash light.

Digital Multi-meter

A DMM is the most useful tool to trouble-shoot any electrical system. There is an amazing variety of DMMs on the market. Some are very basic, others are tailored to specific industries, and some high-end graphing meters function like oscilloscopes. Even the most basic ones are quite versatile. See Figure 7.21.



Figure 7.21

Uses

Voltage

Set meter to read “Volts DC (_ _ _)” if using an auto-ranging meter or to an appropriate scale (typically 20 Volts DC) if using a more basic model.

- Connect the **meter in parallel** to the circuit being measured, between the test point and a known-good ground. Turn on the circuit to be tested, and read the meter. For most tests the engine need not be running, but the key will be turned on.
- If the meter is connected with the **polarity** reversed, a “-” will appear in front of the voltage reading. It has no ill effects on the meter nor on accuracy.
- If the meter is set to Volts AC (~) it may not register any DC voltage, but no physical harm will be done to the meter nor the equipment being diagnosed. It may waste some time though.

ELECTRICAL SYSTEM

Amperage

Most DMMs have a very limited capacity to test amperage (2-3 Amperes). When measuring current flow, the meter must be connected in series with the component to be measured. That means opening the circuit and having the circuit go through the meter.

NOTE: Some meters have an inductive “Amp clamp” accessory that can be used without breaking the circuit.

IMPORTANT: Testing amperage beyond the capacity of the meter can burn out an internal fuse in some meters. The fuses can be expensive.

Resistance

Set the meter for the “ Ω ” scale.

- Isolate the part of the circuit to be tested (disconnect it from the source of power).
- Most auto-ranging meters will provide readings on several scales. For outdoor power equipment, the straight Ohm scale is most appropriate. If a letter appears next to the Ω on the screen of the DMM, it indicates different scales of sensitivity.
- “m” is micro-Ohms, a less sensitive scale that effectively moves the decimal point three places to the left of its location for plain Ω
- “K” is Kilo-Ohms, a more sensitive scale that effectively moves the decimal point six places to the right of its location for plain Ω
- “M” is Meg-Ohms, a more sensitive scale that effectively moves the decimal point three places to the right of its location for plain Ω
- A reading of “0” may be called “**Continuity**”. A reading of “OL” may be referred to as “**No Continuity**”.
- Mistaken Ohm readings most frequently come from bad technique. Poor connections between the probes and the point to be read can throw-off readings. False readings can be generated if the technician touches both probes with their fingers while taking the reading.
- The meter has its own power source to measure resistance. Connecting the meter to a component that has current going through it will damage the meter (usually beyond repair).

Wiring diagram or schematic

A wiring or a schematic diagram, and the ability to read it are very important in troubleshooting a circuit. The diagram shows how the circuit was designed and what paths the electricity is suppose to flow.

Fused jumper wires

Fused jumper wires are handy to help find bad grounds or to jump across switches for testing purposes.



Only use fused jumper wires. If there is a short in the circuit, using an unfused jump could damage components in the circuit.

Test lights

Test lights are used as a quick way to verify voltage at a point in a circuit. Like DMMs, they come in a wide variety from many manufacturers.

The most basic test lights simply use the current being checked to light an incandescent lamp. These should not be used on any equipment that has or may have solid-state circuitry. The power necessary to light the bulb is more than many solid-state circuits were designed to handle. Components will be destroyed in the process of testing them. See Figure 7.22.

IMPORTANT: Do not use a test light on an I-series tractor. It can damage the RMC module.

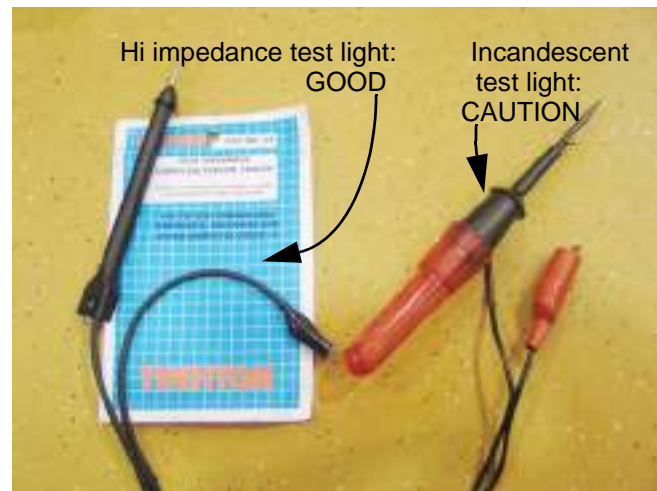

Figure 7.22

IMPORTANT: If a test light is used at all, it should have “**high-impedance**”, indicating that it only takes a sample of the electricity being tested, and illuminates an LED to indicate the presence of power.

NOTE: Some high impedance test lights are capable of indicating whether the current being sampled is AC or DC.

Self-powered continuity lights

Continuity lights can indicate whether a circuit is complete or not, but they give no indication of resistance. They are handy for finding point-break when static-timing some older engines, but have largely been replaced by DMMs.

There are some powered high-impedance test lights on the market that have a continuity feature, and some technicians like the fact that they can be less bulky than a DMM.

Battery Jumper Cables

The obvious use of jumper cables is to jump-start equipment to get it into the shop.

NOTE: This is not recommended for any fuel injected Kohler-powered equipment.

A clever use of jumper cables: If the technician suspects that there is resistance on the ground side of the system, a quick-and-dirty test can be made using jumper cables. See Figure 7.23.

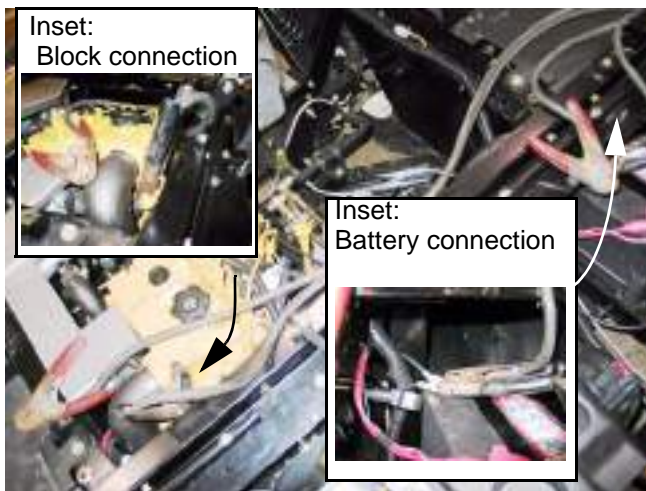

Figure 7.23

- Connect one cable clamp to the negative post of the battery, and connect the clamp at the other end of the same cable to the engine block.
- If there is an immediate difference in starter motor performance, use the voltage drop technique discussed later in this section to identify the source of the resistance.

Ammeters and specialized charging system testers

Inductive ammeters are available in many forms. Some are as simple as a gauge to be held against the circuit in question when it is energized. The operating principle is based on Ohm's Law, as described earlier in this section. See Figure 7.24.



Figure 7.24

There are two primary reasons to measure amperage. The first is to check the output of a charging system or battery. The second is to check the performance of a component that draws a substantial flow of power, typically a motor or clutch.

Briggs and Stratton sells a DC Shunt that converts amperage into a reading on the millivolt scale of a DMM. Briggs and Stratton part # 19359 covers low amperage systems, while part # 19468 tests higher amperage systems. The operating principle is based on Ohm's Law, as described earlier in this section. See Figure 7.25.

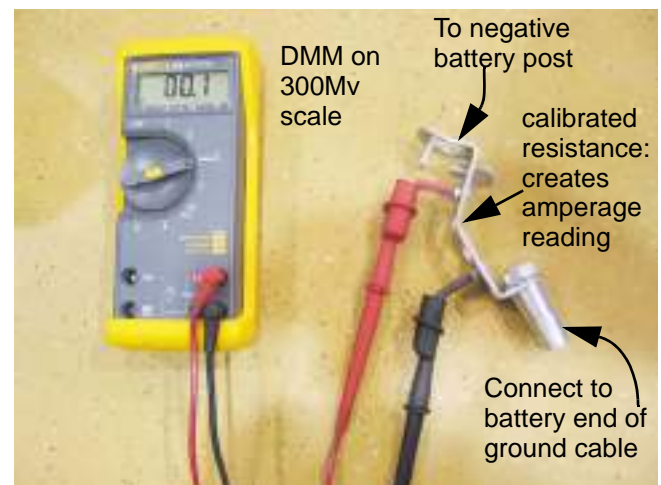

Figure 7.25

ELECTRICAL SYSTEM

NOTE: Usage of the DC Shunt tool is detailed in the 1995 and 1999 editions of their Update Seminar materials.

Kohler makes a proprietary Rectifier/Regulator tester (Kohler Part Number 25 761 20 and the up-dated version: 25 761 20-S). This tester works on Kohler regulator / rectifiers and the company claims it works on similar systems from other companies. See Figure 7.26.



Figure 7.26

- Instructions are included with the Kohler tool (TT480-A)

Testing the charging system:

Quick and dirty test:

1. Check voltage across the battery posts using a DMM/DMM set to read D.C. voltage with the engine turned-off. It will read battery voltage, typically around 12 V.
2. Start the engine and repeat the voltage measurement. The system voltage should rise, reflecting the output of the charging system, typically in the range of 12.5 - 14.5 V.

NOTE: If the voltage does not rise, or rises significantly above this threshold, there is a problem with the charging system that needs to be identified using more in-depth techniques.

NOTE: If system voltage is beyond roughly 15.7 volts, it is over charging and there is a problem with the voltage regulator / rectifier.

To identify a specific charging system problem, isolate the components of the system and check their performance individually.

1. First check the raw A.C. Voltage output from the stator. It will be necessary to compare it to the engine manufacturer's specified output. This varies from model to model. See Figure 7.27.

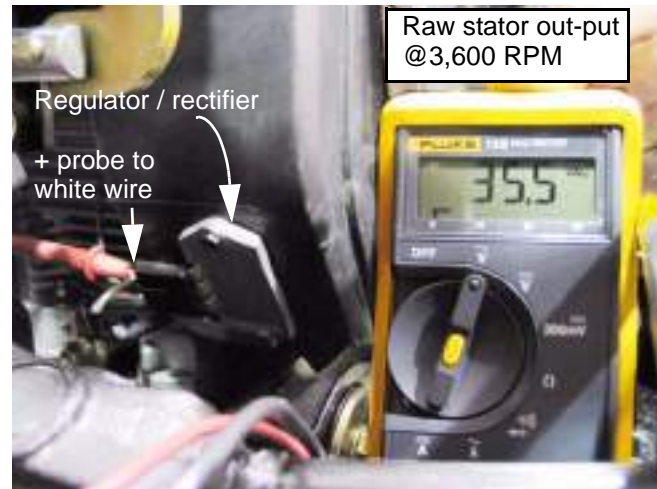

Figure 7.27

- 1a. With a DMM set to read A.C. Voltage, connect the probes between ground and one of the white wires from the stator.
- 1b. Leave the regulator-rectifier connected to the harness.
- 1c. Start the engine and run it at 3,600 RPM.
- 1d. Read the voltage on the meter.
- 1e. If the voltage is substantially low, try the other white wire.
2. If raw out-put of the running alternator is less than the manufacturer's specifications, check the stator.
 - 2a. With the engine stopped, unplug the stator lead from the voltage regulator / rectifier.

- 2b. Check the stator for resistance across the leads. It should be in the range of 0.1 -0.2Ω. See Figure 7.28.



Figure 7.28

- 2c. With the engine stopped and the stator lead unplugged from the voltage regulator / rectifier, check the resistance from each purple stator lead to ground (engine block).
- 2d. The meter should indicate O.L., indicating no continuity. See Figure 7.29.



Figure 7.29

- 2e. Interpretation: If the ohm meter indicates **no continuity** between the two the purple stator leads, there is a **fault** in the stator windings. If the ohm meter indicates continuity between either purple stator lead and **ground**, the stator windings are **shorted** to ground.

NOTE: If there is an intermittent charging system problem, perform these tests when the engine is cold, and again when the engine is hot.

NOTE: Low voltage readings may also result from poor test connections or low engine RPM.

3. If the stator is good, test the amperage output from the regulator / rectifier.
- 3a. Attach a DC shunt with DMM or an ammeter capable of reading up to 25 amperes of DC current. The most accurate point to take a reading will be at the battery ground cable.
- 3b. The alternator should produce the rated current at 3,600 RPM under an electrical load.
- 3c. Connect a load tester between the battery terminals.
- 3d. With the engine running at 3,600 RPM, energize the load tester to draw amperage from the system.
- 3e. Read the amperage on the meter. See Figure 7.30.



Figure 7.30

NOTE: Output varies with load. A fixed-load battery tester can be used to apply enough load to test the charging system out-put.

ELECTRICAL SYSTEM

- 3f. With the engine off, connect Kohler tool #25 7651-20 to the regulator/rectifier: The two black leads go to the terminals normally connected to purple stator leads. The red lead goes to the center terminal (B+). The ground clip goes to ground.
- 3g. Plug the tester into a 110V AC outlet, turn it ON and push the test button until it clicks. Repeat the test to confirm.
- 3h. Read the illuminated jewel for the verdict. See Figure 7.31.



Figure 7.31

NOTE: A flashing “LOW” jewel may result from a poor ground connection.

NOTE: If the regulator rectifier is being tested on the engine, check the ground quality using the voltage drop test described elsewhere in this section.

Batteries

1. Precautions: See Figure 7.32.



Batteries produce flammable and explosive gases, particularly during charging.



Figure 7.32

- Do not smoke or allow an open flame or heat source near the battery.
- Charge batteries in an open area
- Wear eye protection and acid resistant gloves when handling batteries.
- Do not allow direct metal contact across the posts. This will produce extreme heat that may cause direct burns or ignite flammable gas.



California Proposition 65 warning: Battery posts, terminals, and related accessories contain lead and lead compounds. These chemicals are known in the State of California to cause cancer and reproductive harm. Wash hands after handling.

NOTE: The batteries used in Current Cub Cadet equipment are sealed. It is not possible to check, test or add fluid.



Batteries contain electrolyte, which is highly corrosive. If a battery is ruptured, neutralize the electrolyte with baking soda, then carefully rinse the effected area with water.

2. Importance of battery charge level and condition: A fully charged battery that is in good condition is an important factor when trying to diagnose other parts of an electrical system:
 - Some charging systems do not work if the system voltage falls below 6V. It takes a certain amount of voltage to excite the fields in the alternator.
 - Some solid-state components will not work if the system voltage falls below a given threshold.
 - Some solid-state components can be damaged by the jump-starting that accompanies operation with a dead battery.
 - Many electric PTO clutches will fail to work dependably if battery needs to be replaced. Even though the charging system produces enough out-put to drive the clutch, it is over-taxed driving the clutch and forcing a charge into a damaged battery.
 - Continued operation with a weak battery over-taxes the charging system.
3. Charging the battery:

NOTE: It is best to remove batteries from equipment for charging to minimize corrosion from out-gassing during charging.

CAUTION: When disconnecting or removing the battery, disconnect the ground cable first. When reconnecting or installing a battery, connect the ground cable last. These steps will minimize the chance of shorting-out the battery posts with a tool.

3a. Batteries on most modern outdoor power equipment are 12 volts so set the charger to 12 volts.

3b. Set the charge rate to 2 amps.



Never charge an outdoor power equipment battery at a rate higher than 2 amps. Damage to the battery will result.



Never attempt to charge or jump a frozen battery.

3c. Charge the battery until it is fully charged. Most battery chargers have an amp gauge to show the charging rate. When the gauge is at zero, stop charging the battery.

4. Checking battery condition: There are three things to do when testing a battery:
 - Visual inspection
 - Electrolyte test
 - Operational test
- 4a. Visual inspection
 - Inspect the battery and battery connections for corrosion. Clean if necessary. Neutralize acid with baking soda, and protect the terminals once they are cleaned.
- NOTE:** Battery cable corrosion is the most common type of increased resistance circuit failures.
- Inspect the battery case for signs of damage and missing vent caps. Battery cases that bow out in the middle indicate that the battery froze or overheated and should be replaced.
5. Check the electrolyte level if the caps can be removed. Fill as needed with distilled water. After initial charging, do not add electrolyte to the battery.
6. Hydrometer test (non-sealed batteries only) See Figure 7.33.

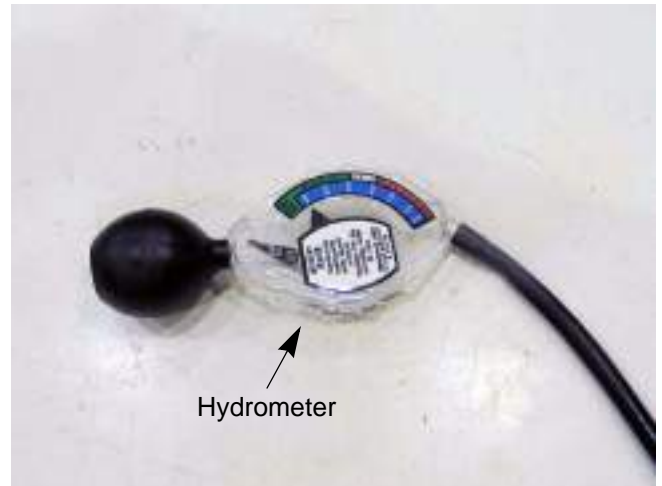

Figure 7.33



Always wear eye protection and acid resistant gloves when working with electrolyte. Use baking soda to neutralize any spilled acid.

- 6a. Give the battery at least ten minutes for the electrolyte to stabilize after charging the battery or adding water to the cells.
- 6b. Measure the temperature of the electrolyte in the middle cells of the battery.

ELECTRICAL SYSTEM

6c. Squeeze the bulb on the hydrometer, then insert the hose into the cell.

6d. Release the bulb, drawing electrolyte into the hydrometer to the fill line.

IMPORTANT: Hold the hydrometer straight up and down when drawing up the electrolyte. The float needs to float free, not rubbing against the sides of the hydrometer.

6e. Write down the specific gravity of each cell.

6f. The readings must be corrected for the temperature of the electrolyte. The hydrometer manufacture should list the temperature the float is calibrated to. Most are calibrated to 80°. To correct the reading, add .004 to the reading for every 10° Above the calibrated temperature or subtract .004 for every 10° below the calibrated temperature.

6g. Compare the reading to the chart.

Specific Gravity	Charge Condition
1.265	Fully Charged
1.225	75% Charged
1.190	50% Charged
1.155	25% Charged
1.12	Fully Discharged

IMPORTANT: To prevent damage to the charging system disconnect the battery to charge it.

NOTE: If battery needs to be charged, let battery sit for ten minutes to stabilize after charging. Apply a load to the battery for 15 seconds to remove the surface charge. Then re-check the battery.

Battery Testers:

There are four major ways to check a battery:

- Electrolyte test using a **Specific Gravity** tester to compare the density of the electrolyte in a fully charged battery to the density of water (water = 1.0 s.g.).
- Electrolyte test using a **Refractometer** to check the density of the electrolyte by measuring the degree to which light waves bend when passing through the electrolyte.
- **Load test** that checks the output of the battery after the fully charged battery has done a certain amount of work. Fixed load testers are commonly available. Variable load testers are not generally found in outdoor power equipment repair shops.
- **Capacitance** test that checks the condition of the battery plate core, regardless of the level of charge.

Testing the battery

1. Adjustable load testing

Adjustable load testing is used if an adjustable load tester is available. Follow the procedures specified by the manufacturer of the tester to connect to the battery.

1a. Disconnect the battery cables.

IMPORTANT: Disconnect the negative cable first to help prevent a shorting hazard.

1b. Measure the temperature of the electrolyte.

1c. Connect a voltmeter and the load tester to the appropriate terminals.

1d. Hook an amp probe onto the ground lead of the load tester.

NOTE: A shunt can be used in place of the amp probe, but a second voltmeter will be needed to get a measurement from the shunt.

1e. Apply a load equal to 50% of the battery's rated CCA for 15 seconds.

NOTE: CCA stands for cold cranking amps. The rating should be on the battery for aftermarket batteries. For OEM batteries, contact the manufacturer for the CCA rating. Most riding mower batteries are 200-275 CCA. See Figure 7.34.



Figure 7.34

- 1f. Record the voltage while the load was applied. Compare the voltage to the following chart:

Electrolyte Temperature	Minimum Required Voltage
≥70 deg. f. (21deg. c.)	9.6 V
60 deg. f. (16 deg. c.)	9.5 V
50 deg. f. (10 deg. c.)	9.4 V
40 deg. f. (4 deg. c.)	9.3 V
30 deg. f. (-1 deg. c.)	9.1 V
20 deg. f. (-7 deg. c.)	8.9 V
10 deg. f. (-12 deg. c.)	8.7 V
0 deg. f. (-18 deg. c.)	8.5 V

- 1g. If the battery voltage is above what is listed in the chart, the battery is good.
If the battery voltage is below what is listed in the chart, replace the battery.

2. Fixed load testing

Fixed load testers (sometimes called toasters) are inexpensive load testers found at any auto parts store. See Figure 7.35.



Figure 7.35



It is not recommended to use any fixed load tester on a battery under 200 CCA. To do so can boil the water out of the battery and damage the plates in the battery.

NOTE: Because they have a fixed load value, they do not give most batteries a reliable and safe load test. Most fixed load testers have a load that is more than 50% of the rated CCA of riding mower batteries. This makes them inappropriate to use on smaller pieces of outdoor power equipment.

- 2a. Disconnect the battery cables, ground first.
- 2b. Measure the temperature of the electrolyte in the middle cells.
- 2c. Connect a voltmeter and the load tester to the appropriate terminals.
- 2d. Apply the test load for 15 seconds. Monitor the meter on the load tester for the battery's performance.
- 2e. Refer to the manufacturer of the test on how to read the test meter.
- 2f. The results of this test are not accurate and should only be relied on if the battery fails badly.

ELECTRICAL SYSTEM

3. Capacitance testing

There are several brands of capacitance battery tester presently on the market. Capacitance battery testers use the battery being tested as their power source. These testers send a small AC signal through the battery to measure the capacity of the plate to hold a charge.

Capacitance testers are very easy to use and are far less damaging to the battery being tested. For these reasons, capacitance battery testing is the preferred method of battery testing.

NOTE: Contact the manufacturer of the tester being used for specific test procedures.

- 3a. Connect the tester to the battery.
- 3b. Set the tester to the CCA rating of the battery.
- 3c. Initiate the test.
- 3d. Read the display of the tester. The tester's display will indicate if the battery passed or not. See Figure 7.36.



Figure 7.36

4. Battery discharge test

Occasionally a battery will discharge while sitting unused. To test for a battery that is “leaking” voltage:

- 4a. Confirm that operator technique is not creating a situation that causes a draw. As an example, if a homeowner habitually turns their equipment off using a safety switch (perhaps vacating the seat with the key switch still ON), that may leave a relay or fuel shut-off solenoid energized.
- 4b. Disconnect and charge the battery fully.
- 4c. Use the ammeter function of a DMM to check for a power draw between the negative post on the battery and the end of the ground cable that normally connects to it. There should be no significant D.C. Amperage flow. See Figure 7.37.



Figure 7.37

NOTE: A spark jumping from the post to the cable end is an indication that there is a substantial current draw, but should not be used repeatedly as a diagnostic tool. This is an extremely unkind thing to do to any electronic components of the tractor.

- 4d. Once the presence of a draw is confirmed, disconnect components of the system one at a time while monitoring an ammeter to see which makes the draw stop.

- 4e. If the battery is being checked independently of the equipment it powers, measure and note the battery voltage while it is disconnected, over a three-day period.
 - 4f. There should be less than a .2 volt drop in the readings. If there is more than a .2 volt drop, the battery is bad.
5. Storage of batteries
 - 5a. Always store a battery with a full charge (unless the battery is a dry battery and the electrolyte has not been added yet). This may require periodic re-charging.
 - 5b. Take measures to prevent the battery from freezing in cold weather. The electrolyte in a fully charged battery has a lower freezing point than the electrolyte in a battery with a lower state of charge.
 - 5c. Store the battery in a cool, dry place.
 - 5d. If storing multiple batteries (primarily store stock), rotate the stock so that the oldest battery goes out first. This will increase the life of the batteries.
 6. Troubleshooting
 - 6a. The first step in troubleshooting is to always verify the complaint. Defining and verifying the problem reduces the possibility of misunderstanding and helps clarify the diagnostic approach.
 - 6b. The next step is to check the simple stuff first:
 - Check the **fuse** or fuses. Some models have ground side fuse. Failure of any fuse is an indication that there is a problem of some sort in the circuit that the fuse protects.
 - Look for obvious physical damage.
 - Use the hour meter and indicator lamps as a guide to direct the search. As an example, when diagnosing a “no-crank” condition on a lawn tractor with a PTO safety switch: if the PTO light is lit on the hour meter but the technician has visually verified that the PTO clutch is not engaged, the PTO circuit would be a reasonable place to check for problems.
 - Check the battery. A valid diagnosis of many systems cannot be made without full system voltage applied.

6c. Take a methodical approach to finding the problem. As a rule of thumb, start at one end of the circuit and work to the other.

6d. The next step is to decide what method to use to troubleshoot the circuit.

- If checking a safety circuit that grounds the magneto, use an Ohms meter to test for continuity.
- If checking a safety circuit that enables a starter motor or accessory, use a volt meter to confirm the presence of power at each junction in the system.
- If a circuit does not work at all, look for a short or an open.
- If the circuit works slowly or intermittently, look for resistance by doing a voltage drop test.

NOTE: In all diagnosis, it is very important to understand the circuit that is being checked. The use of a schematic is recommended, even if a technician is thoroughly familiar with the system.

7. Testing for opens/shorts

NOTE: When checking circuits for **continuity**, disconnect the circuit at the nearest plugs and use the metal terminals of the plug as a connection point for the test probes. **DO NOT STAB THE WIRES.**

NOTE: When checking circuits for **voltage**, back-probe the terminals nearest the point to be checked. **DO NOT STAB THE WIRES.** See Figure 7.38.



Figure 7.38

ELECTRICAL SYSTEM

- 7a. Starting with a fully charged battery and battery cable connections that are clean and tight, measure the battery voltage. See Figure 7.39.



Figure 7.39

- 7b. With the circuit energized, start at either end of the circuit and check for voltage.

- If starting at the battery-end of a powered circuit, trace it through until power vanishes.
- If starting at the far end of a powered circuit, trace it through to the point that power appears.
- If there is low voltage at the far end of the circuit, do a voltage drop test (as described later in this section) on the circuit to find the source of resistance.

NOTE: When working toward the battery, check each junction with the connector disconnected, then re-check with the junction reconnected. If there is voltage with the connector unplugged but not when it is connected there is a short between that point and the last connector tested.

NOTE: When working toward the battery, if one junction has lost power, but the next connector has voltage with its junction still connected, there is an open between the two junctions.

8. Continue checking each connector until the other end of the circuit is reached or the fault is found.

Voltage Drop Test

To review:

- Ohm's law states that it takes voltage to push current through a resistance.
- Kirchoff's voltage law states that the sum of all the voltage drops equals the source voltage.
- Combining those two laws, we see that any restriction in a circuit (e.g.: loose connector damaged wire, or corroded terminal) will use up some voltage as the current is pushed through.
- A voltage drop test is a way of looking for that voltage.
- Because electricity needs to complete a full circle (circuit), voltage drop tests are useful on both the positive or the negative side of the system.
- This text will address the negative side to begin with. Bad grounds are responsible for as many electrical failures as the positive side of the system, yet the ground side is frequently neglected by technicians. See Figure 7.40.



Figure 7.40

IMPORTANT: Ultimately, all current will find its way back to the negative post of the battery.

9. To check ground-side voltage drop: set-up a multimeter to measure 12V DC.
- 9a. Make a good electrical connection between the black (-) probe and the negative post on the battery.
- 9b. Make a good electrical connection between the red (+) probe and the suspect point of ground.
- 9c. Power-up the circuit in question.

9d. The voltage that shows-up on the meter is the voltage that is being used to pass current through a resistance in the circuit.

9e. Voltage drop on a good circuit should be less than 0.1 volts. A voltage drop reading on the meter of greater than 0.2 volts indicates a fairly substantial problem that demands attention.

- As an example, if the starter solenoid does not engage properly, check for voltage drop between the ground point for the starter solenoid and the negative post on the battery. See Figure 7.41.



Figure 7.41

- With the starter engaged, this machine exhibited a voltage-drop reading of 0.308 volts, indicating a poor ground connection.

9f. A similar ground-side test on a tractor with a slow-cranking starter motor can be conducted between the engine block and the negative battery post. See Figure 7.42.



Figure 7.42

- 9g. With the starter engaged, this machine exhibited a voltage-drop reading of 0.312 volts, indicating a poor ground connection.
- 9h. Individually, these readings should lead a technician to inspect the connection between the solenoid and the ground path on the first tractor (e.g. mounting hardware, green wire with eyelet beneath head of solenoid mounting bolt), or the engine and the frame on the second tractor (e.g. loose or rusty engine mounting bolts).
- 9i. If both of these readings were found on the same tractor, a common point in the system would be the primary suspect (e.g. poor connection between negative battery cable and frame).

ELECTRICAL SYSTEM

10. Applying this principle to the positive side of the system. See Figure 7.43.



Figure 7.43

IMPORTANT: Ultimately, all positive current will find its way from the positive post of the battery to the negative post.

- 10a. To check hot-side voltage drop: set-up a multi meter to measure 12V DC.
- 10b. Make a good electrical connection between the red (+) probe and the positive post on the battery.
- 10c. Make a good electrical connection between the black (-) probe and the suspect point of the circuit.
- 10d. Power-up the circuit in question.
- 10e. The voltage that shows-up on the meter is the power that is not following the intended path back to the negative battery post.
- 10f. Voltage drop on a good circuit should be less than 0.1 volts. A voltage drop reading on the meter of greater than 0.2 volts indicates a fairly substantial problem that demands attention.

- As an example, if the tractor had a slow-turning starter, the ground-side voltage drop measured below 0.1 volts, and there was not a parasitic load on the engine (e.g. PTO clutch that is not fully disengaged), it would be logical for the technician to check voltage drop to the starter. See Figure 7.44.



Figure 7.44

- With the starter motor engaged, the voltage drop reading here is nearly 0.6 volts, indicating a serious problem in the heavy-gauge circuit between the starter and the battery.
- 10g. Checking voltage-drop at various points along the circuit can help pin-point the problem.
- Check voltage-drop at the output lug on the starter solenoid:
- If there is a significant difference, the problem lies between the lug on the solenoid and the lug on the starter.
- If there is little change, the problem lies further up-stream.
- Check voltage drop at the input lug on the solenoid. If there is significant difference between the reading here and the reading at the output lug (greater than 0.10 volt), then the contacts inside the solenoid may be burned. If there is little change, the problem lies further up-stream, between the battery and the solenoid.
- Results may be cross-checked by testing voltage drop across the two posts of the starter solenoid while cranking the starter motor.

11. Testing switches:

- Refer to the “COMPONENTS” section of this chapter that describes the function of the individual switches to be tested.
- Switches can be tested “hot” by looking for voltage at the appropriate posts. This is not definitive, since the source of the voltage is not always confirmed. Checking for voltage does not work on switches that work by providing a ground path to the magneto primary windings or a solid state control device.
- The most valid way to test switches is a **continuity test**.
 - 11a. Understand the internal functions of the switch. Key switches and PTO switches can be fairly complex.
 - 11b. Isolate the switch from the rest of the circuit.
 - 11c. Test each pair of terminals for continuity in all modes of switch operation: at-rest, and actuated.
 - 11d. Many switches on Cub Cadet equipment are typed by their at-rest state: Normally Open, Normally Closed, Common.
- Normally Open (N.O.) contacts do not complete a circuit when the switch is at-rest (plunger extended). They close to complete a path through the switch when the plunger is depressed.
- Normally Closed (N.C.) contacts complete a circuit when the switch is at-rest (plunger extended). They open to break the path through the switch when the plunger is depressed.
- Some Cub cadet switches contain more than one pair of contacts. The same switch housing can contain normally open and normally closed switch elements.
- When testing a switch that contains more than one set of contacts (elements), the male spade terminals associated with Normally Closed contacts will be stamped “N.C.”

- The male spade terminals that are associated with each-other face each-other broad-surface to broad surface. See Figure 7.45.

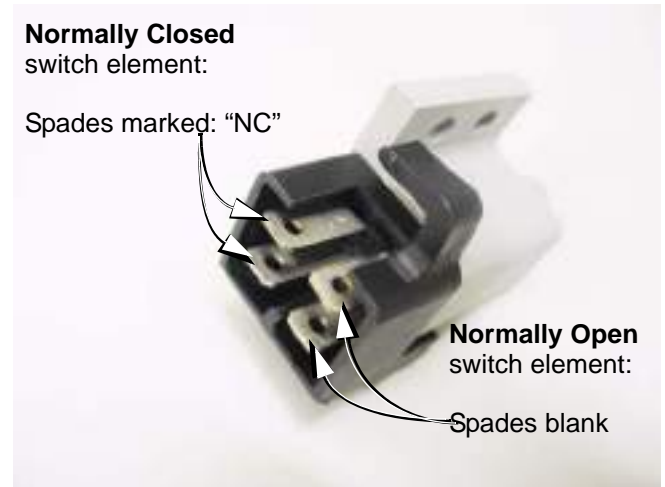

Figure 7.45

12. Diodes

What is a diode? A diode acts like a one way valve, allowing current to flow in only one direction. See Figure 7.46.

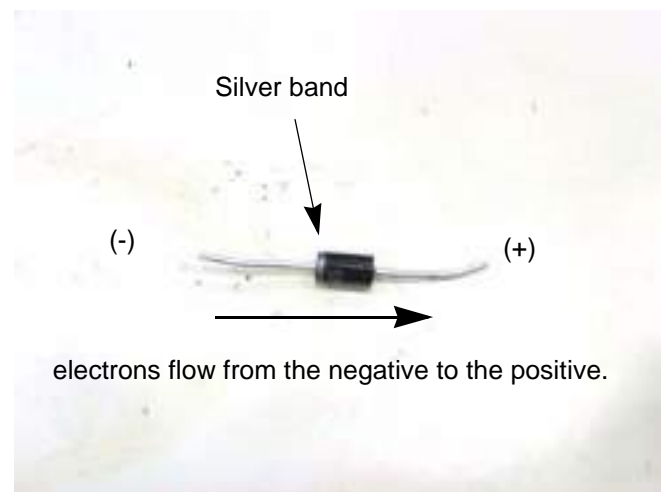

Figure 7.46

- Which way does this electrical check-valve work? There will be a band on one end of the diode. The band indicates the negative side of the diode
- Most DMMs have the ability to test a diode.

ELECTRICAL SYSTEM

Testing a diode:

- 12a. Isolate the diode in the circuit.
- 12b. Set the DMM to the diode or Ω scale. See Figure 7.47.

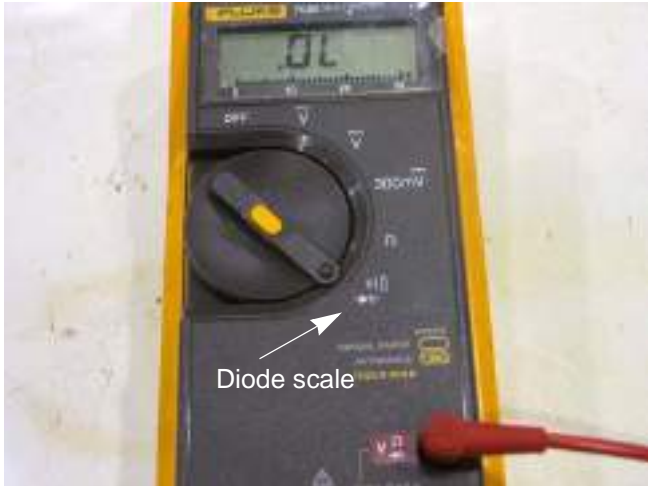

Figure 7.47

- 12c. Attach the negative lead of the DMM to the side of the diode with a band on it.
- 12d. Place the positive lead on the other side of the diode.
- 12e. There should be continuity. See Figure 7.48.



Figure 7.48

- 12f. Switch the leads.
- 12g. The meter should indicate no continuity. See Figure 7.49.



Figure 7.49

- 12h. If the results do not match the above, replace the diode.

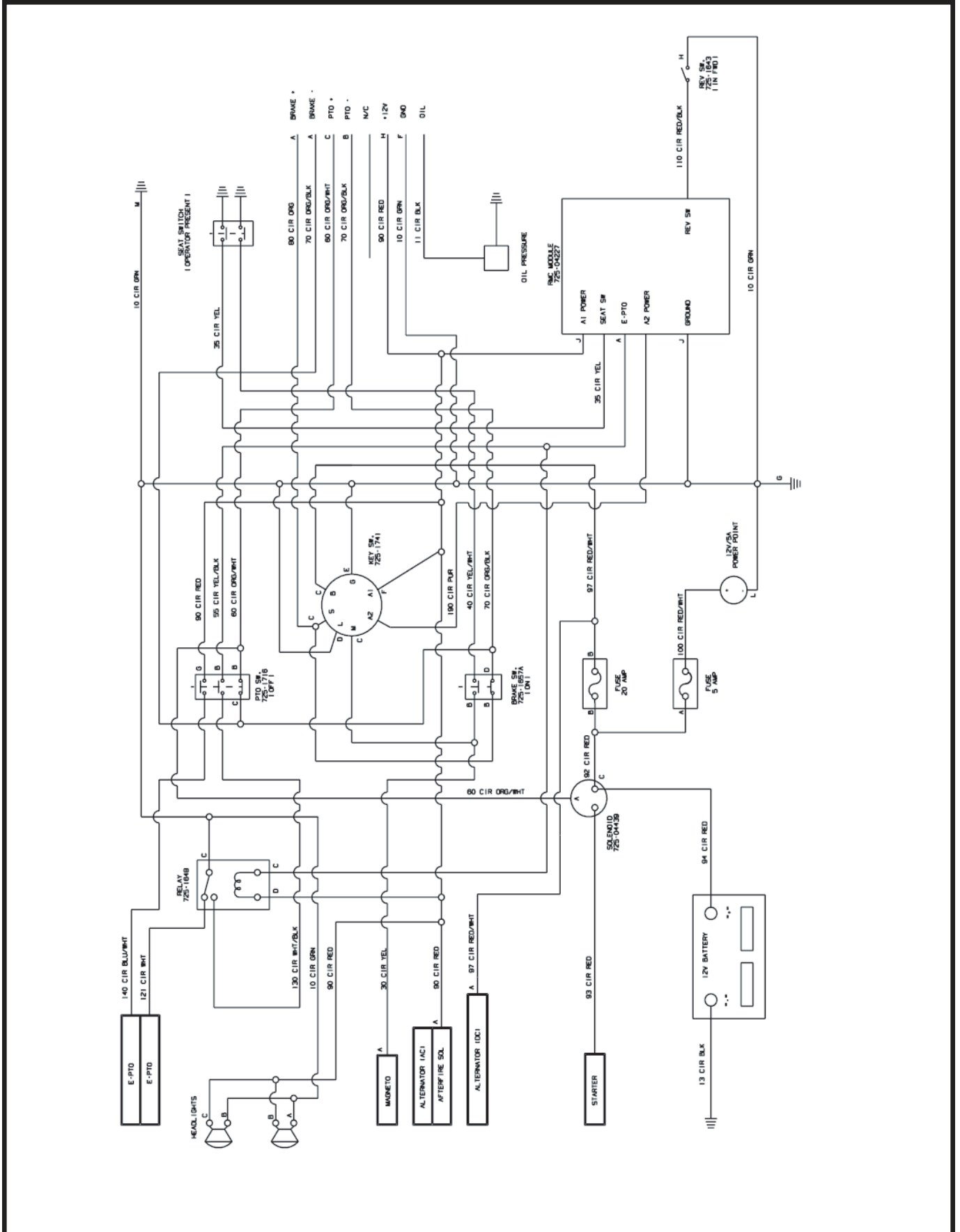

ELECTRICAL SYSTEM

CHAPTER 8: CUTTING DECKS AND LIFT SHAFT

Cutting decks

The I-series comes with the option of a 42", 46" or 50" deck. The procedure to remove the deck is the same for all of them.

To remove the deck:

1. Place the tractor on firm level ground and set the parking brake.
2. Lower the deck to the lowest cutting height.
3. Pull the deck pins on both sides and rotate them to keep them out. See Figure 8.1.



Figure 8.1

4. Raise the deck lift lever to the highest setting.

5. Slide the deck forward to unhook the front hanger. See Figure 8.2.

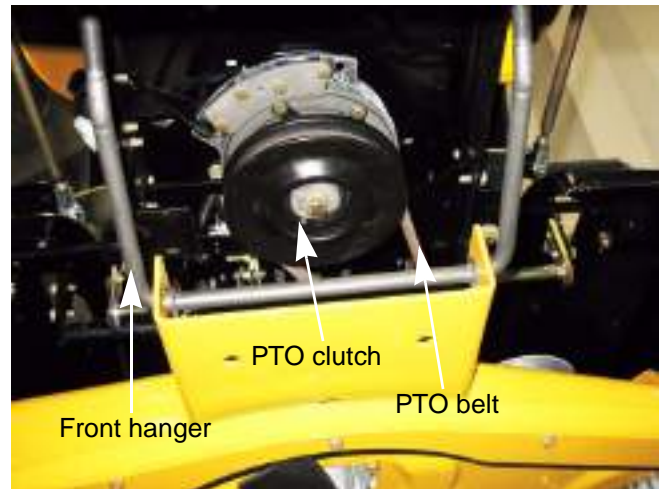

Figure 8.2

6. Slide the PTO belt off of the PTO clutch. See Figure 8.2.
7. Slide the deck out to the right, from underneath the tractor.
8. Install the deck by following the above steps in reverse order except the belt. The belt goes on the PTO clutch last.

NOTE: The deck is easier to install if the front edge is supported by a length of 2"x4" lumber. This brings the front hanger closer to the horizontal position. The closer the front hanger is to horizontal, the further back the deck can move to connect to the "J" pins in the rear of the deck to the lift links.

CUTTING DECKS AND LIFT SHAFT

Cleaning the deck

Cleaning debris off of the deck should be done every time the deck is removed. It is routine maintenance that will make the deck easier to work on and prolong the life of the deck and spindles.



Debris build up on the mower deck is an unsafe condition. The debris traps heat in the spindles causing damage to the spindle bearings. Debris around the belt can over-heat.

To clean the deck while it is removed:

1. Blow all the debris off of the top of the deck using compressed air.
2. Scrape off the debris build up from the under side of the deck using a plastic scraper.

NOTE: Applying a light coating of oil to the underside of the deck after scraping it clean will help prevent rusting of the deck and help keep the debris from building up on the underside of the deck.

Blades

The condition of the blades will greatly effect the quality of the cut.

The blades should be sharpened and balanced after every five acres, depending on local conditions. A dull blade tears the grass instead of cutting it. Torn grass blades leaves a rough look and makes the grass vulnerable to diseases.

Blades need to be examined for damage before sharpening. Blades must be balanced after sharpening to reduce the vibrations felt from the deck.

Bent blades are a sign of a blade impact. The blades must be replaced and the spindles inspected for bent shafts and cracked housings if a bent blade is found.

Blades come in a variety of styles; side discharge, mulching, bagging, combination, there are even de-thatching blades on the market. The I-series comes with what Cub Cadet calls a 3 in 1 blade. This means it can side discharge, bag and mulch.

The cutting deck on the I-series tractor is mounted with a slight rake, meaning that the front of the deck is a 1/4" - 3/8" lower than the rear of the deck. This is very important to get the proper air flow in the deck so that the blades can make the grass blades stand up to get cut.

The air flow in the cutting deck is generated by the spinning blades. If the blades are mounted upside down, the air flow will be reversed pushing the grass down instead of standing up.

NOTE: Blades that are mounted upside down, increase the risk of impacting an object.

To remove the blades:

1. Remove the deck as described in the previous section of this chapter or lift the tractor using a professional grade lift.
2. Block the blade with a piece of wood to prevent it from spinning.
3. Remove the blade nuts using an impact wrench and a 15/16" socket. See Figure 8.3.

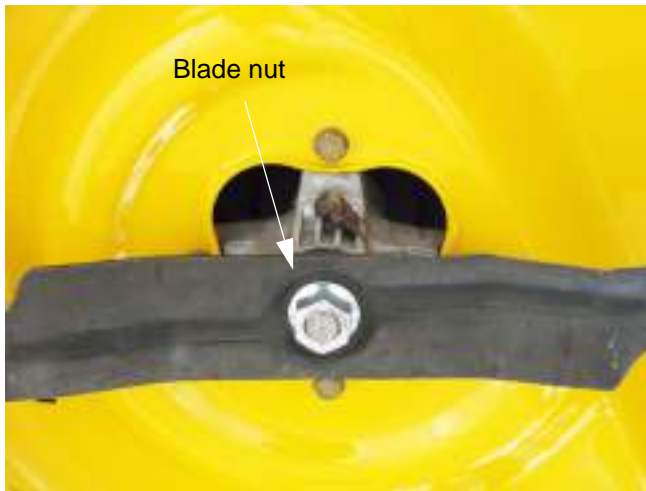

Figure 8.3



Use care around the blade while removing or tightening the nut. The blade can spin and cause an injury to the technician.

4. Remove the blade.
 5. When sharpening the blades:
 - To properly sharpen the cutting blades, remove equal amounts of metal from both ends of the blades along the cutting edges, parallel to the trailing edge, at a 25° to 30° angle.
 - Sharpen the top of the blade only, maintaining the factory cutting edge angle.
- IMPORTANT:** If the cutting edge of the blade has already been sharpened to within 1 5/8" from the edge, or if any metal separation is present, replace the blades with new ones.
- It is important that each cutting blade edge be ground equally to maintain proper blade balance.



A poorly balanced blade will cause excessive vibration and may cause damage to the tractor and result in personal injury.

- The blade can be tested by using a blade balancer. Grind metal from the heavy side until it balances evenly.
6. Install the blade by following the above steps in reverse order. Tighten the blade nut to a torque of 70 - 90 ft-lbs (95 - 122 Nm).

NOTE: The I-series blades have a star center. The star must seat on the raised star on the bottom of the spindle shaft with the fins of the blade pointing to the deck. If there is damage to the raised star of the spindle shaft, the spindle must be replaced. See Figure 8.4.

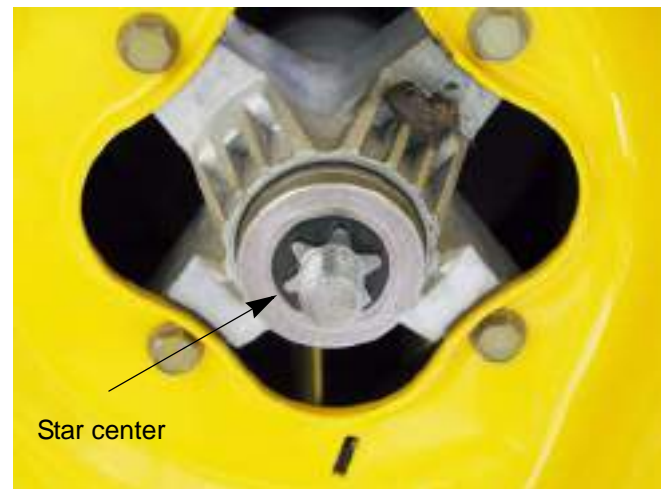

Figure 8.4

NOTE: The star on the timed deck spindle has the tips of two points shaped differently to time the blade to the spindle. See Figure 8.5.

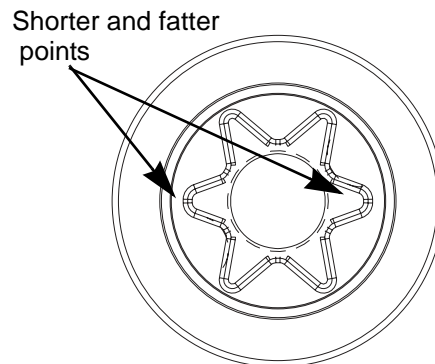

Figure 8.5

CUTTING DECKS AND LIFT SHAFT

PTO belt

Some cutting deck designs use a single belt to transfer power from the engine crankshaft directly to the blade spindles.

Other cutting deck designs use one belt to transfer power from the engine crankshaft to a second belt that drives the blade spindles.

The belt that goes around the crankshaft or PTO clutch is referred to in this text as the PTO belt. Where a second belt is used, it is called a deck belt or a timing belt (on timed decks).

The function of the PTO belt is to transfer the mechanical force from the engine to the blades. The belt faces a lot of different forces.

- The friction between the belt and the pulleys creates heat. The compression of the belt as it bends around the pulleys also creates heat. All of this heat softens the belt which weakens it.
- Every time the electric PTO is engaged, the PTO belt is subjected to an impact load. When the electric PTO is engaged, it goes from 0 to 3,600 RPM instantly. This can actually remove sections of the belt.

NOTE: Engaging the Electric PTO before the mowing deck is placed into the grass will reduce the impact load on the belt.

- When a blade hits an object like a rock or a tree root, the belt is subjected to an impact load similar to the impact load of engaging the electric PTO.
- The belt has rubber in it. As the rubber ages, it becomes brittle making it weaker.

NOTE: A damaged belt can cause the deck to vibrate when the deck is engaged. The vibration can be bad enough to simulate an engine issue.

NOTE: Not all belt damage is visible. Broken cords inside the belt are not visible to the naked eye, but can cause vibration issues and greatly reduce the life of the belt.



Cub Cadet belts are designed to fit our equipment and are not standard lengths. Use of a non-OEM belt may prevent the mowing deck from working properly.

To replace the PTO belt:

1. Remove the deck as described at the beginning of this chapter.

NOTE: Removal of the deck is not necessary, but makes it easier to route the belt around the spindles.

2. Slide the belt off of the pulleys.

NOTE: Generally it is not necessary to remove the spindle covers, however if there is debris build up under the spindle covers it is recommended to remove them and clean out the debris. To remove the spindle covers follow the steps described in the spindle section of this chapter.

3. Route the new belt around the pulleys.
- For a 50" deck, See Figure 8.6.

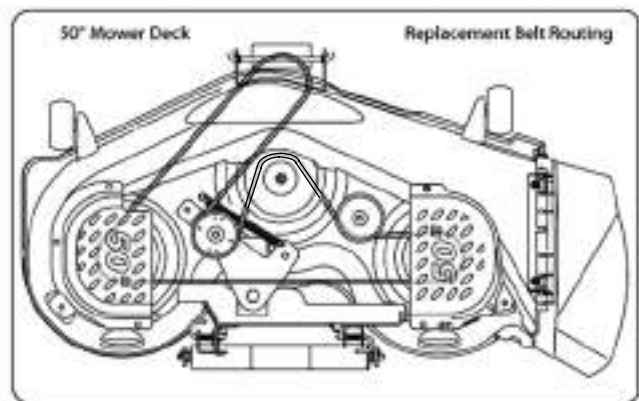

Figure 8.6

- For a 46" deck, See Figure 8.7.

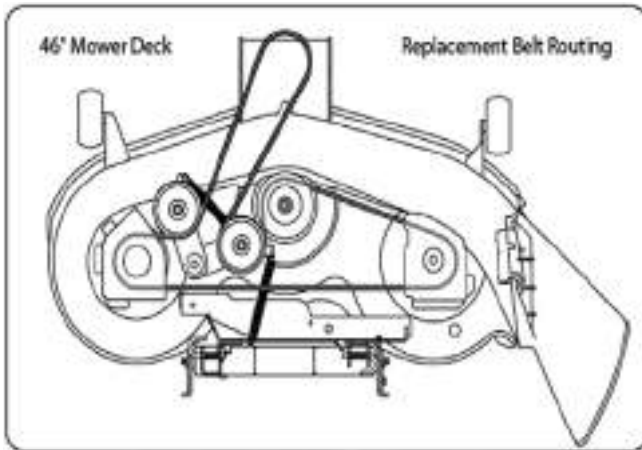

Figure 8.7

- For a 42" timed "R" deck, See Figure 8.8.

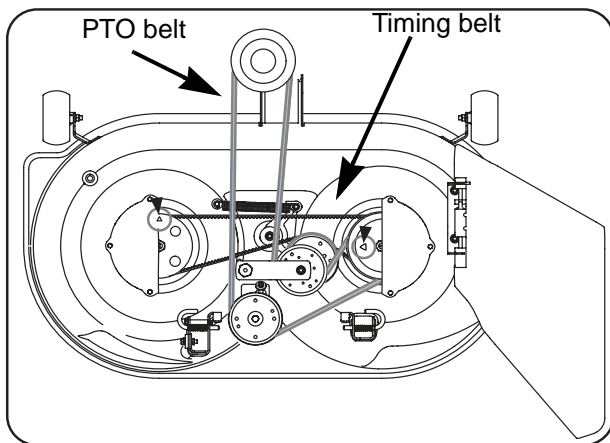

Figure 8.8

4. Install the deck as describe at the begining of this chapter.
5. Test drive the tractor before returning to service.

Timing belt

To service the timing belt:

1. Remove the deck as describe at the begining of this chapter.
2. Remove the PTO belt by following the steps described in the previous section of this manual.
3. Remove the PTO belt idler spring. See Figure 8.9.

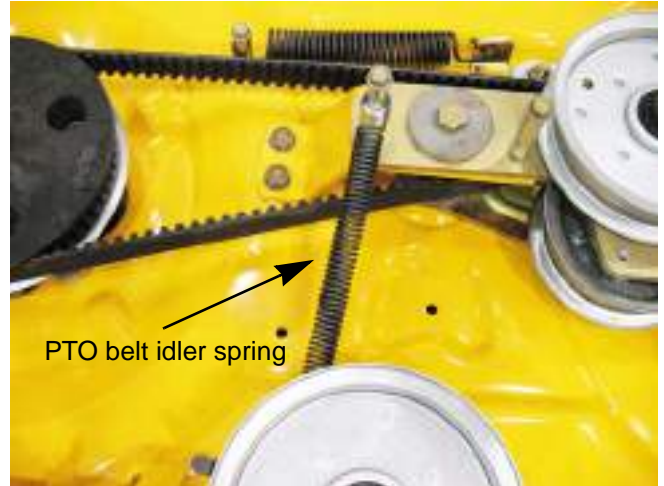

Figure 8.9

4. Remove the timing belt idler stop using a pair of 9/16" wrenches. See Figure 8.10.



Figure 8.10

NOTE: The idler spring pulley applies the tension to the timing belt. The timing belt idler stop will prevent the idler pulley from springing away from the timing belt during a blade impact. This helps prevent the blades from jumping time.

CUTTING DECKS AND LIFT SHAFT

NOTE: The idler pulley will back away from the idler stop bolt as the belt wears. The stop bolt should be adjusted after every 10 hours of use.

5. Remove the timing belt idler spring. See Figure 8.11.

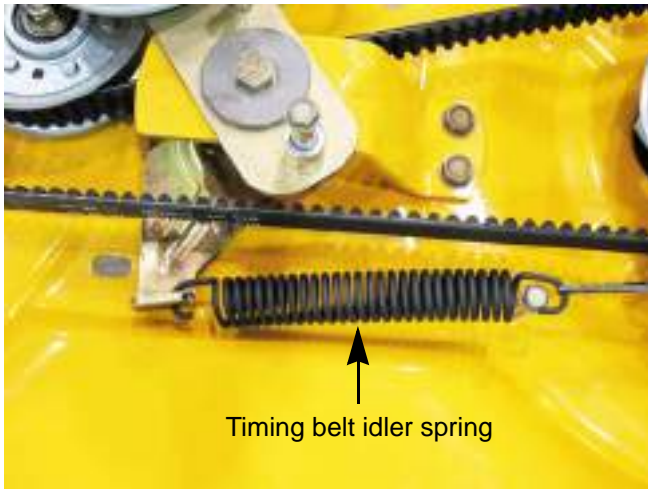

Figure 8.11

6. Work the belt off of the pulleys.

NOTE: The PTO idler pulley and the timing belt idler pulley can be moved apart, making clearance to remove the timing belt. See Figure 8.12.

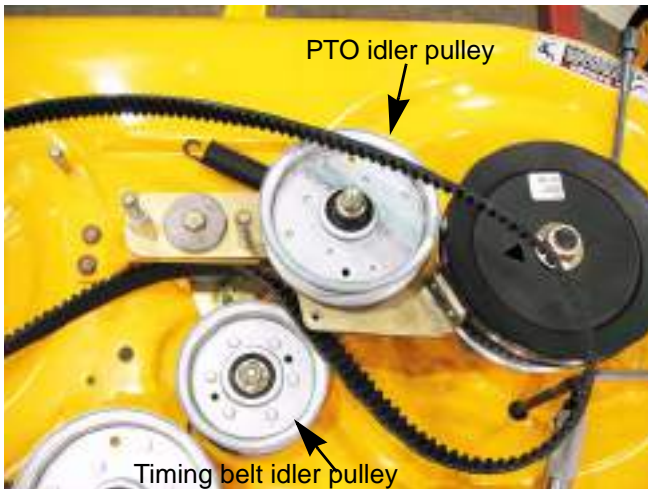

Figure 8.12

7. To install the timing belt turn the blades 90° apart. See Figure 8.13.

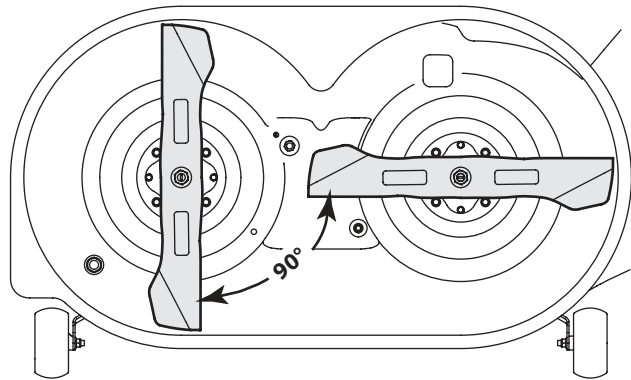

Figure 8.13

NOTE: Failure to time the blades will result in the blades hitting each other.

NOTE: The timing marks line up with the blades and need to be 90° apart. See Figure 8.14.

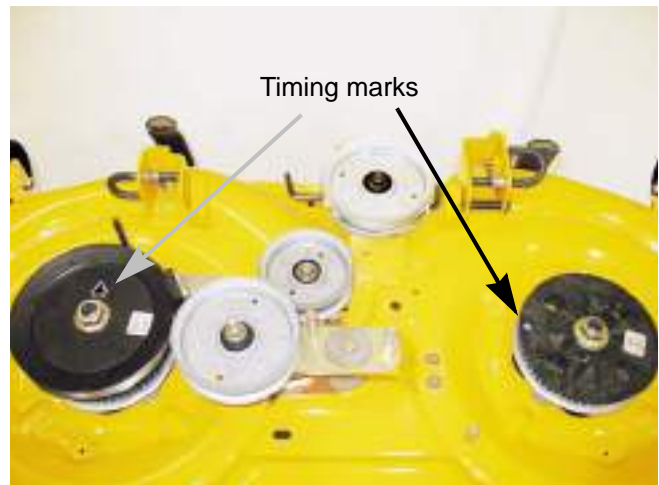

Figure 8.14

NOTE: The timing marks on the blade pulleys have been shown in white for clarity.

8. Install the timing belt by following steps 1 through 6 in reverse order.

Test run the tractor in a safe area before returning it to service.

Spindles

Each blade spindle is sold as a complete unit. The only replaceable parts are the pulley and nuts. The spindles are equipped with a grease fittings that should get one squirt of grease after every use of the deck wash system or every 10 hours of use.

To replace a pulley:

1. Remove the deck as described at the beginning of this chapter.
2. Slip the PTO belt off of the spindle pulley that is to be serviced.

NOTE: Timed decks will need to have the timing belt removed by following the procedures described in the timing belt section of this chapter.

NOTE: On 3-bladed decks, the center spindle pulley can be removed at this point using an impact wrench with a 15/16" socket to remove the pulley nut. See Figure 8.15.

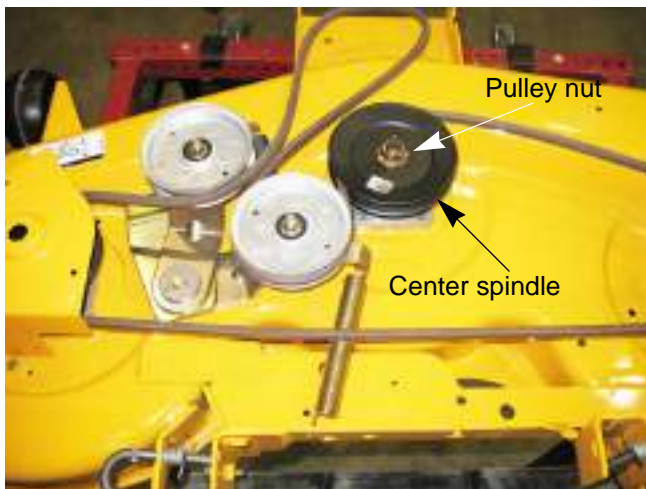

Figure 8.15

NOTE: The spindle bearings are sealed. The grease injected into the spindle housing will break down and seep through the seals to lubricate the bearings. It will also keep condensating moisture within the spindle from reaching the bearings.

3. To reach the outer spindles, remove the spindle covers. See Figure 8.16.



Figure 8.16

4. Remove the pulley nut using an impact wrench with a 15/16" socket.
5. Install the spindle pulleys by following the above steps in reverse order.
6. Tighten the pulley nut to a torque of 70 - 90 (95 - 122 Nm).
7. Test run the tractor before returning to service.

CUTTING DECKS AND LIFT SHAFT

To replace a spindle:

1. Remove the deck as described at the beginning of this chapter.
2. Remove the blade following the steps described in the previous section of this chapter.
3. Remove the spindle covers. See Figure 8.16.
4. Slip the PTO belt off of the spindle pulley that is to be serviced.

NOTE: Timed decks will need to have the timing belt removed also.

5. Remove the four bolts fastening the spindle to the deck. See Figure 8.17.

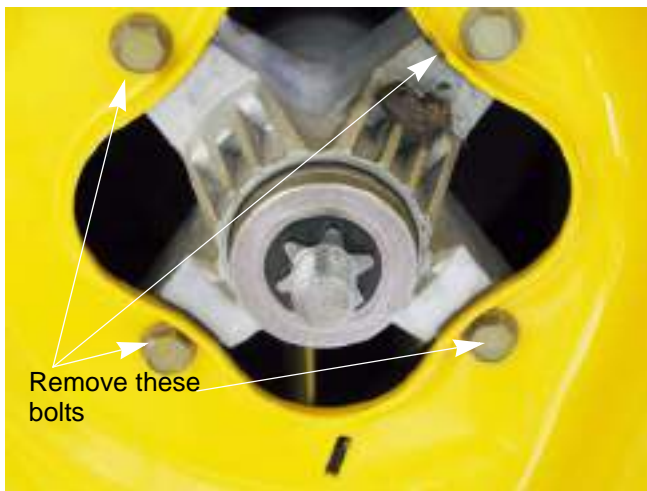

Figure 8.17

6. Lift the spindle out of the deck shell.
7. Install the spindle by following the above steps in reverse order.

NOTE: The four spindle bolts are self tapping bolts. The new spindle housing will not have threads in it.

NOTE: Tighten the spindle bolts to a torque of 200 - 300 in-lbs (23 - 34 Nm).

Leaving the deck

For the best quality cut, the deck must be level side to side and the front of the deck should be 1/4" - 3/8" lower than the rear of the deck.

To level the deck:

NOTE: Check the tractor's tire pressure before performing any deck leveling adjustments. The recommended operating tire pressure is:

- Approximately 10 psi for the rear tires
- Approximately 14 psi for the front tires

Side to Side Leveling

1. With the tractor parked on a firm, level surface, move the deck to the mid height position (third or fourth notch) using the deck lift lever. Rotate both blades so that they are perpendicular with the tractor frame.
2. Measure the distance from the outside of the left blade tip to the ground and the distance from the outside of the right blade tip to the ground. Both measurements taken should be equal. If they are not, note whether the left side of the deck is lower or higher and proceed to the next step.

NOTE: Use of Cub Cadet deck leveling gauge, part number 490-900-0041, will make measuring the blade tip height easier. See Figure 8.18.



Figure 8.18

3. Working from the left side of the tractor, loosen, but do not remove, the bolt on the left deck hanger bracket. See Figure 8.19.

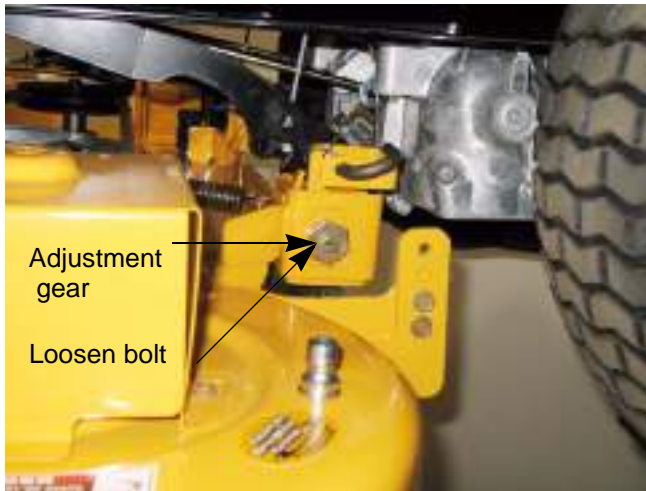

Figure 8.19

4. To level the deck turn the adjustment gear, located immediately behind the bolt. Turn the gear clockwise (rearward) to raise the left side of the deck. Turn the gear counter-clockwise (toward front) to lower the left side of the deck. See Figure 8.19.
5. The deck is properly leveled when both blade tip measurements, as described earlier, are equal.
6. Tighten the bolt on the left deck hanger bracket when proper adjustment is achieved.

Front To Rear Leveling

The front of the cutting deck is supported by an adjustable front deck hanger rod. This rod can be adjusted to set the front to rear pitch of the deck. The front of the deck should be between 1/4-inch and 3/8-inch lower than the rear of the deck. Adjust if necessary as follows:

1. With the tractor parked on a firm, level surface, move the deck to the mid height position (third or fourth notch) using the deck lift lever. Rotate the blade nearest the discharge chute so that it is parallel with the tractor frame.

2. Measure the distance from the front of the blade tip to the ground and the rear of the blade tip to the ground.

NOTE: The front measurement taken should be between 1/4" - 3/8" less than the rear measurement. Determine the approximate distance necessary for proper adjustment and proceed, if necessary, to the next step.

3. Working at the front of the tractor, loosen the two hex lock nuts at the front of the deck hanger rod. Thread the lock nuts away from the hex nuts behind them. See Figure 8.20.



Figure 8.20

NOTE: Both nuts are on the top (front) side of the bracket to float and rise if the deck impacts something. This helps to minimize the damage to the deck

4. Using a wrench, turn the inner hex nuts clockwise to raise the front of the deck, or counter-clockwise to lower the front of the deck. Adjust the hex nuts evenly so that the deck hanger rod is at the front of both slots in the hanger bracket on the front of the deck.
5. Tighten the two hex lock nuts when properly adjusted.

CUTTING DECKS AND LIFT SHAFT

Deck Gauge Wheel Adjustment

The cutting decks are of a “floating” design. This means that they are suspended above the ground. The gauge wheels occasionally touch the ground. They are designed to bump the deck up and over irregularities. This prevents scalping damage to the turf and to the deck.

Adjust the gauge wheels as follows:

1. Place the tractor on a smooth, flat surface and move the deck to the desired mowing height using the deck lift lever.
2. Check gauge wheels distance from the flat surface below. If the gauge wheels contact the ground, they must be raised. If the gauge wheels are higher than 1/2" above the ground, they should be lowered.
3. Remove the shoulder bolt securing one of the front ball wheels to the front index bracket.
4. Reposition the ball wheel to align with the one of four index holes that places the wheel 1/4" to 1/2" above the ground. See Figure 8.21.

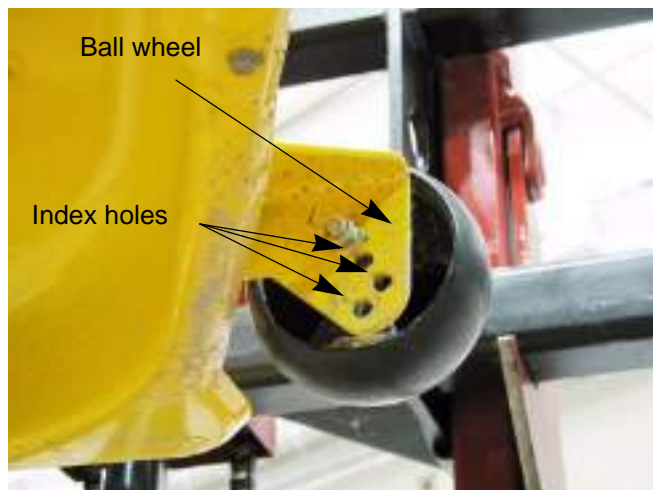

Figure 8.21

5. Secure the ball wheel to the index bracket with the shoulder bolt. Note the index hole used and secure the other ball wheel in the same position.

Deck Rear Roller Adjustment

The rear rollers on the mower deck are not designed to carry the weight of the deck. The rear rollers should be adjusted to approximately 1/4" to 1/2" above the ground when the deck is moved to the desired cutting height.

NOTE: The 42" deck does not have rear rollers.

To adjust the rear roller:

1. Place the tractor on a smooth, flat surface, move the deck to the desired cutting height.
2. Check the height of the rear rollers.

46" Deck ONLY

NOTE: The 46" deck roller assembly index bracket has three adjustment positions using either the bottom two holes, middle two holes, or top two holes.

- A Support the roller assembly and remove the two self tapping screws from both the left and right roller index brackets. See Figure 8.22.

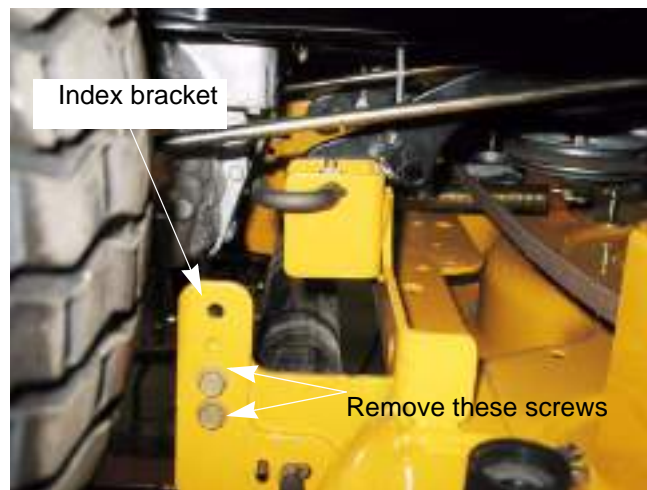

Figure 8.22

- B Position the roller assembly so that the rollers are approximately 1/4" to 1/2" above the flat surface below. Align the nearest two index bracket holes with holes in the deck mounting brackets.
- C Secure the roller assembly with the four self tapping screws.

NOTE: The self tapping screws should be in the corresponding holes of both the left and right roller index brackets.

50" Deck ONLY

NOTE: The 50" deck roller assembly index bracket has five adjustment holes.

- A While supporting the roller assembly, remove clevis pin and withdraw the clevis pins from both of the roller index brackets. See Figure 8.23.

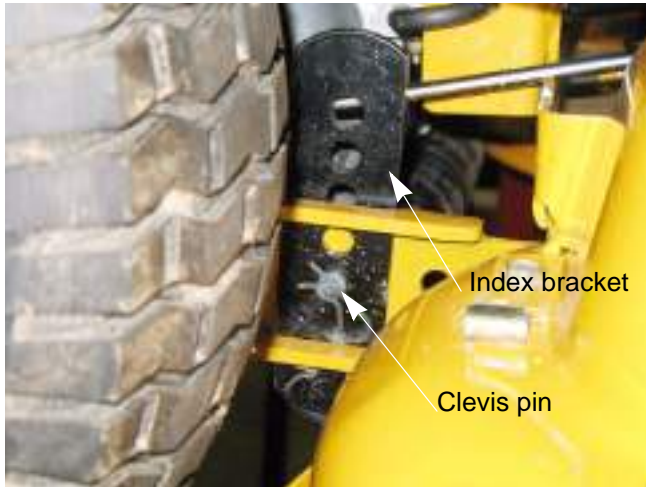

Figure 8.23

- B Position the roller assembly so that the rollers are approximately 1/4" to 1/2" above the flat surface below.
- C Align the nearest index bracket holes with the holes in the deck mounting brackets. Insert the clevis pins through the deck brackets and the index brackets and secure with the click pins.

NOTE: The clevis pins should be in the corresponding holes of both the left and right roller index brackets.

Deck lift shaft assembly bushings

The deck lift shaft assembly bushings for the I-series tractor can be replaced without removing the deck lift shaft assembly. To replace the bushings:

1. Remove the deck by following the steps described at the beginning of this chapter.
2. Remove the E-ring that retains the lift shaft bushing. See Figure 8.24.



Figure 8.24

3. Slide the old bushing out.
4. Slide the new bushing in.
5. Install the E-ring that retains the bushing.
6. Repeat steps 2 - 6 on the opposite side.
7. Install the deck.
8. Test drive the tractor in a safe area before returning to service.

CUTTING DECKS AND LIFT SHAFT

Deck lift shaft assembly removal/replacement

1. Remove the deck by following the steps described at the beginning of this chapter.
2. Remove the fender by following the steps described in Chapter 4: Body/Chassis.
3. Remove the hairpin clips that hold the top of the deck lift cables and slide the cables out of the deck lift shaft assembly. See Figure 8.25.



Figure 8.25

4. Unhook the lift assist spring. See Figure 8.26.



Figure 8.26

5. Remove the E-clips that retain the bushings. See Figure 8.27.



Figure 8.27

6. Slide the bushings out of the seat box assembly. See Figure 8.28.



Figure 8.28

7. Work shaft out of the seat box assembly.
8. Work the lift shaft handle and spring off of the deck lift shaft.
9. Install the deck lift shaft by following the above steps in reverse order.

NOTE: Do not put grease on the lift shaft or bushings. Grease will hold dirt and accelerate the wear of the bushings.

Deck lift links and cables

The deck lift links have two functions. The first function is to support the rear of the deck. The second function is to raise or lower the deck in response to movement of the deck lift lever.

To accomplish the second function, the deck lift cables run from the deck lift shaft assembly, over a pulley to the lift links.

As with most tractors made by Cab Cadet there are two holes in the lift link that the lift cable can go into. The top hole is for garden tractors and the bottom hole is for lawn tractor. See Figure 8.29.

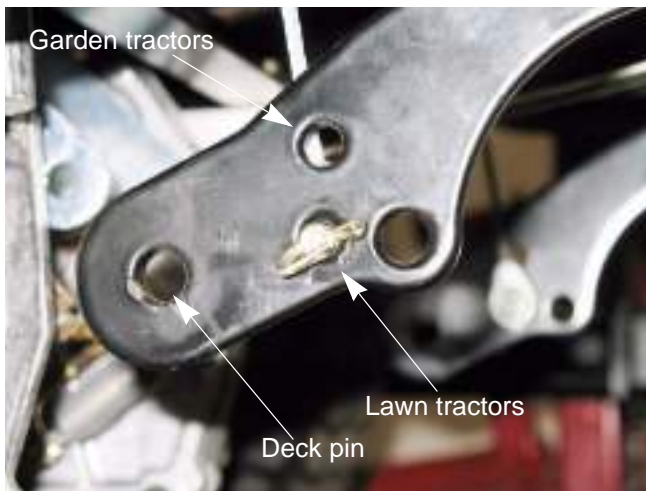

Figure 8.29

NOTE: If the cable is installed in the wrong hole, the belt angle between the electric PTO clutch and the deck will be off. This will result in the PTO belt being thrown off.

CUTTING DECKS AND LIFT SHAFT

CHAPTER 9: MAINTENANCE INTERVALS

Lubrication

To help keep the I-series in proper running order, Cub Cadet recommends the following lubrication intervals be used (adjustable to local conditions). Use a high quality petroleum grease to lubricate the tractor.

Table 1:

Lube Point	Number of fittings	Interval
Pivot bar	4	25 hours
Steering arms	2	25 hours
Wheel bearings	2	25 hours
Spindles*	3	10 hours

* On 42" timed decks, the idler stop bolt needs to be readjusted every 10 hours.

NOTE: Lubricate all of the pivot points with a light coating of oil once a season.

Engine maintenance

The recommended maintenance intervals listed in this manual are a guideline. They are adjustable for local conditions.

Table 2:

Maintenance items	Interval
Oil Change	100 hrs
Air filter pre cleaner	25 hrs
Air filter	50 hrs
Spark plugs	100 hrs
Fuel filter	100 hrs

The spark plugs

The spark plugs should be checked, cleaned and re-gapped on a monthly basis or every 100 hours of use. The plugs should be replaced every six months or 300 hours of use.

When checking the spark plugs, a dry, light colored residue on the plugs is a sign of running lean.

If there is a thick, wet, black residue on the plug the engine is running rich.

There should be a dry tan coating on the plugs. This would indicate the proper mixture.

To remove/replace the spark plugs:

1. Remove the spark plug wires on each side. See Figure 9.1.

NOTE: Do not use metal pliers on spark plug wires. Damage to the wire can result.



Figure 9.1

MAINTENANCE INTERVALS

2. Remove the spark plugs with a 5/8" spark plug socket. See Figure 9.2.



Figure 9.2

3. Clean the Spark plugs with carburetor cleaner or replace them with two Champion RC12YC spark plugs.

NOTE: Do not clean the spark plugs mechanically (sand blasting or scraping). This will damage the insulator.

4. Gap the electrodes to .030" (.76mm).
5. Thread the spark plugs into the spark plug holes.
6. Tighten the spark plugs to a torque of 18-22 ft - lbs (24.4 - 29.8Nm).

NOTE: Refer to Kohler manual TP-2574 for more detailed instructions.

7. Push the spark plug wires onto the spark plugs until they snap into place.

Air filter and foam pre cleaner

A dirty air filter and/or foam pre cleaner can reduce engine power, increase fuel consumption and make starting more difficult.

The foam pre cleaner should be checked before each use and cleaned every 25 hours.

The air filter should be cleaned before each use and replaced every two months or 50 hours of use.

To check the air filter and pre cleaner:

1. Swing open the air filter door located at the front of the engine. See Figure 9.3.

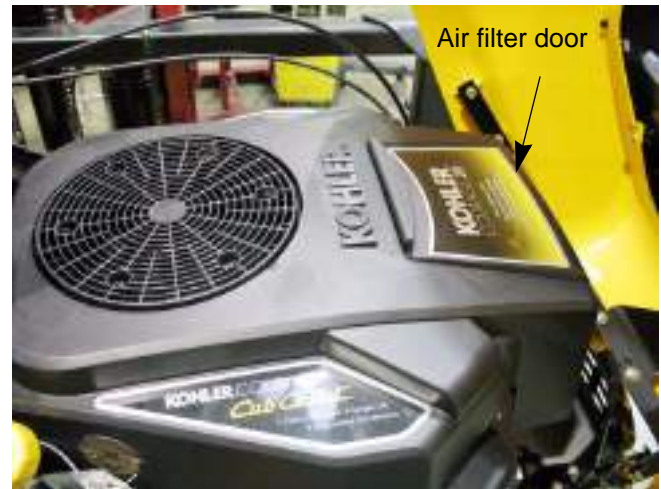

Figure 9.3

2. Lift up the wire retainer. See Figure 9.4.

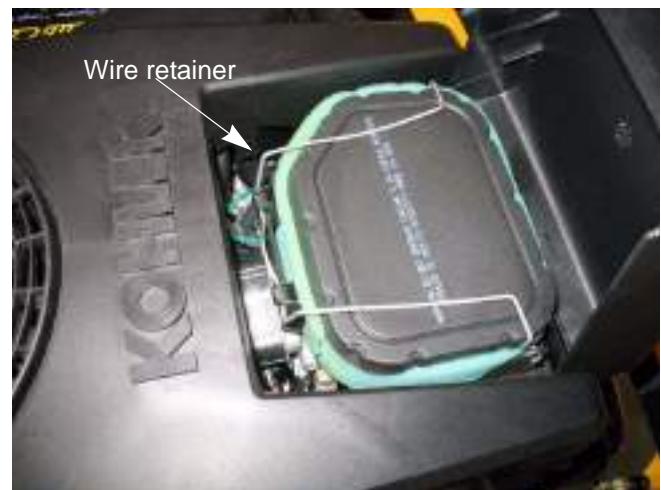

Figure 9.4

3. Remove the air filter and pre cleaner.
4. Slide the pre cleaner off of the air filter. See Figure 9.5.



Figure 9.5

5. Install by following the above steps in reverse order.

To clean a pre cleaner:

1. Remove the pre cleaner following the steps described above.
2. The foam pre clean should be cleaned by:
 - 2a. Wash the filter in warm soapy water.
 - 2b. Rinse it and let it air dry.

IMPORTANT: Always replace a damaged filter.

NOTE: Do not oil the pre cleaner before placing it on the air filter. The oil can wick into the air filter, reducing the air flow through the air filter.

Oil change

The oil change interval is every 100 hrs.

NOTE: The first oil change should be preformed at 5 hours.

To change the oil:

1. Remove the cap from the oil drain. See Figure 9.6.

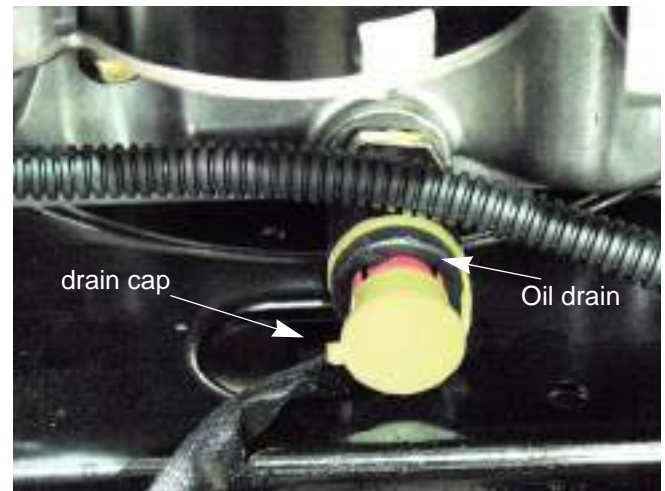

Figure 9.6

2. Remove the dipstick.
3. Slide a piece of 1/2" rubber hose onto the drain. See Figure 9.7.



Figure 9.7

4. Squeeze the two red tabs together and pull out on the drain. See Figure 9.7.

MAINTENANCE INTERVALS

5. After all of the oil has been drained, close the oil drain by pushing it in.
6. Remove the drain hose.
7. Place the cap back on the oil drain.
8. Fill engine with new oil. Use a good quality 10w30 motor oil that meets the specifications recommended by Kohler.
9. Check the dip stick to verify that the oil is at the proper level before returning to service.

Oil filter

To replace the oil filter:

1. Drain the oil by following the previously described steps.
2. Remove the oil filter by turning it counter-clockwise, as seen from the rear of the filter.



Figure 9.8

3. Place a light coating of oil on the O-ring of the new filter.
4. Pre-fill the new filter with fresh, clean oil.
5. Thread the new filter on to the engine. Hand tighten only.
6. Fill the engine with oil.
7. Test run the engine and check for leaks before returning to service.

Fuel system

What you should know about fuel.

Most of the fuel presently available in North America is oxygenated to some extent. This is commonly done through the addition of ethanol. Most engines offered for sale on outdoor power equipment in the North American markets are designed to tolerate no more than 10% ethanol by volume

Ethanol is hygroscopic, meaning it absorbs water. If left exposed to air, it will draw water out of the air.

Ethanol is an oxygenator, which means that it will oxidize (corrode) metal that it comes into contact with. Exposure to air causes fuel to go bad quickly, leaving gum and varnish deposits.

Fuel used in Cub Cadet outdoor power equipment should be no more than 30 days old. Because it may already have been stored at the refinery or gas station for a week or more, fuel should be purchased in small quantities and stored in safety approved gas cans with the caps closed.

For storage, all fuel should be run out of the tank and engine. Anti-oxidation additives will help keep the fuel fresher.

Servicing the fuel system

Inspect the fuel system every time the tractor is operated. If dirty or fuel that does not smell "right" is found in the fuel tank, drain the fuel tank and replace the fuel filter

Drain the fuel tank by removing the fuel line from the fuel filter and drain the fuel into an empty safety approved gas can. Dispose of the bad fuel in a safe, responsible and legal manner.



Gasoline and its vapors are extremely flammable. Use common sense when working around the fuel system.

Fuel filter

A dirty fuel filter can result in a lean run condition. The fuel filter should be replaced every 100 hours.

To replace the fuel filter:

1. Clamp off the fuel lines to prevent fuel from leaking when the lines are disconnected. See Figure 9.9.



Figure 9.9

IMPORTANT: Take care that the fuel lines are not damaged when clamping them off. Never insert a screw or anything else into the fuel line to prevent fuel from coming out. This will damage the inside of the fuel line.

NOTE: There are commercially available fuel line clamping tools that will not damage the fuel lines.

2. Squeeze the tabs on the fuel line clamps and slide them away from the filter.
3. Carefully slide the fuel lines off of the filter. If there are pieces of rubber on the barbs of the fuel filter, replace the affected fuel line.

IMPORTANT: The I-series tractor uses low permeation fuel line to meet EPA guidelines. When replacing the fuel lines, they must be replaced with the same type of low permeation fuel line.

4. Install the new filter by following the above steps in reverse order.
5. Test run the engine and check for leaks before returning to service.

MAINTENANCE INTERVALS

Clean the engine

Air cooled engines cool better if they are clean. Check for nesting or signs of nesting especially after dormant season storage. See Figure 9.10.

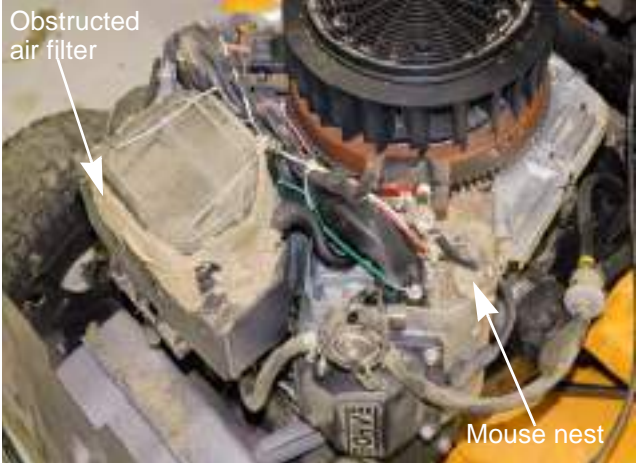

Figure 9.10