

PRODUCTS OF  MOTOR COMPANY

TRACTOR AND IMPLEMENT OPERATIONS (U.S.)

FORD TRACTOR DIVISION FORD MOTOR COMPANY
BIRMINGHAM, MICHIGAN

SE 8739 86236

PRINTED IN U.S.A.

FORD ALL-PURPOSE TRACTOR



Owner's Manual

Tractor Service Policy

AUTHORIZED	
	
AND IMPLEMENT DEALER'S SERVICE POLICY	
OWNER'S NAME _____	
MAILING ADDRESS _____	
CITY _____	STATE _____
TRACTOR MODEL _____	
SERIAL NUMBER _____	
DELIVERY DATE _____	
ISSUED BY: _____	
FORD TRACTOR AND IMPLEMENT DEALER _____	
CITY _____	STATE _____
<small>This Tractor Service Policy is valid only when issued with a new Ford or Fordson Tractor that is sold and delivered to the above-named owner by the undersigned Ford Tractor and Implement Dealer, and if signed by and correct to the time of issuance.</small>	
DEALER'S SIGNATURE _____	
OWNER'S SIGNATURE _____	

At the time of delivery of your new tractor, the Ford Tractor and Implement Dealer presented to you a copy of the Service Policy shown above. This policy certifies that your new Ford Tractor has been properly inspected and prepared for delivery by the dealer.

The policy should be presented to the dealer whenever you request any service which is authorized on it. We recommend, therefore, that you keep the policy in a safe place for ready reference at all times.

FORD TRACTOR

All Purpose Model

SERIES 2000 AND 4000

OWNER'S MANUAL

Copyright 1962

Ford Motor Company
Birmingham, Michigan

Prepared by
TRACTOR AND IMPLEMENT OPERATIONS (U.S.)
FORD TRACTOR DIVISION FORD MOTOR COMPANY
BIRMINGHAM, MICHIGAN

Litho in U.S.A.

SE 8739

SAFETY PRECAUTIONS

Your Ford Tractor embodies all the safety features consistent with good performance. Safety features alone, however, will not prevent accidents caused by carelessness. The following safety precautions are suggested to help prevent such accidents.



1. Do not permit anyone to ride on the tractor with the operator.
2. The operator should never leave the tractor seat when the tractor is in motion.
3. Use care when operating on steep grades to maintain proper stability.
4. Always drive tractor at speeds slow enough to insure safety, especially when operating over rough ground, near ditches, or turning.
5. Keep the tractor in gear when going downhill.
6. Always shut off the engine when leaving the tractor.
7. Make sure the brake pawls are set when parking the tractor. (4-speed and 5-speed transmission-equipped tractors.)
8. Always keep the tractor brakes in proper operating condition.
9. Do not refuel the tractor when the engine is overheated or running.
10. Never run the tractor engine in a closed garage. Carbon Monoxide fumes, expelled from the exhaust system, are very dangerous and cannot easily be detected because they are odorless.
11. Never install or remove the belt while the belt pulley is in motion.
12. Never wear loose clothing when operating the belt pulley or power take-off.
13. Always pull from the drawbar. Pulling from the top link or rear axle is dangerous.
14. If the front end tends to raise, check for proper weight distribution.



The Tractor and Implement Division of the Ford Motor Co. being a member of the National Safety Council is privileged to use the Green Cross to denote safety instructions in operator's manuals.

FOREWORD

We wish to congratulate you on your choice of the new Ford Tractor. We are happy to have you as a customer and are confident that you will receive unequalled performance from your Ford Tractor.

This manual has been prepared to acquaint you with the many features of your new Ford Tractor. Most of the information presented here is general and applies to both Series 2000 and 4000 All Purpose Tractors.

Many of the features covered in this manual are optional equipment on some models and standard on others. For further information on optional equipment and accessories, see your Ford Tractor and Implement Dealer.

Read this manual carefully at your first opportunity and keep it in a convenient location for later reference. You will be particularly interested in the "break-in" instructions starting on Page 17, and the maintenance instructions starting on Page 39.

If, at any time, you have a question or problem concerning your new tractor, remember that your Ford Tractor and Implement Dealer is best qualified and equipped to serve your needs. With the proper treatment and service, your Ford Tractor should provide you with a long life of profitable and dependable service.

TRACTOR MODEL AND SERIAL NUMBER

When ordering parts or requesting information from your Ford Tractor and Implement Dealer, always specify the Model and Serial Number of your Ford Tractor.

The Model and Serial Number is located on the left front side of the transmission housing and should be recorded immediately in the space provided below.

MODEL

SERIAL NO.

CONTROLS AND INSTRUMENTS

The controls on your new Ford Tractor are designed to help you do more work with the greatest possible convenience and comfort. All are within easy reach and are simple to operate.

The well-grouped instruments tell you, at a glance, whether the engine is operating efficiently and warn you of the possibility of trouble before it becomes serious.

Before attempting to start or operate your new tractor, familiarize yourself with the location and function of all controls and instruments.



*Know your controls and instruments
to assure Safe Operation.*

CONTROLS AND INSTRUMENTS

TRACTOR SEAT

Take your place in the tractor seat. If the seat is not in the most comfortable operating position, it may be moved forward or rearward as desired. The seat pan may be tilted back, permitting the operator to stand. Series 4000 All Purpose Tractors are equipped with a cushioned seat which may be adjusted to accommodate the weight of individual operators. The seat pan should always be tilted back when not in use to protect the cushion from dew and rain.

LIGHT SWITCH

The tractor lights are operated by means of a switch on the lower right side of the instrument panel, just below the side panel. Pull the switch out to turn the lights on.

KEY SWITCH

The Key Switch is located on the lower left side of the instrument panel, just below the side panel. Turn the key clockwise to turn the ignition "ON" for gas tractors, or to close the starting and charging circuit on diesel tractors. Turn the key counterclockwise for the "OFF" position.

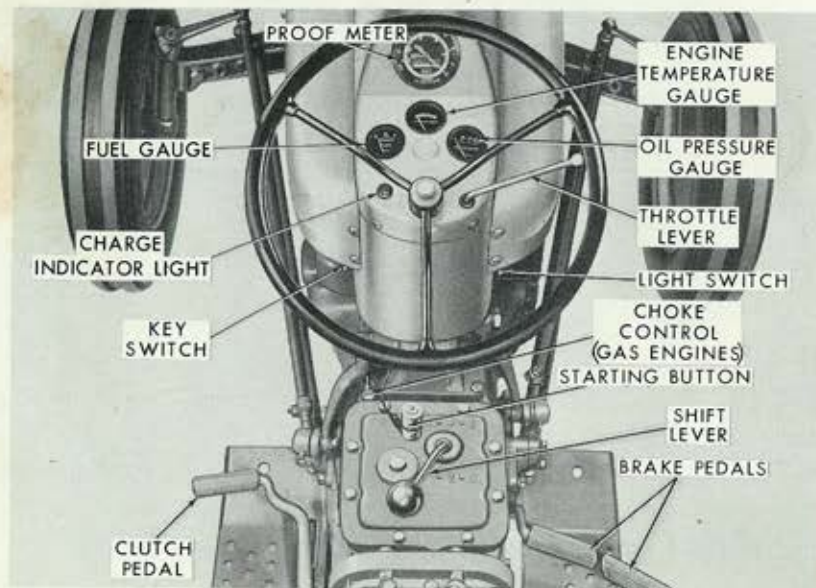

Figure 1
Controls and Instruments

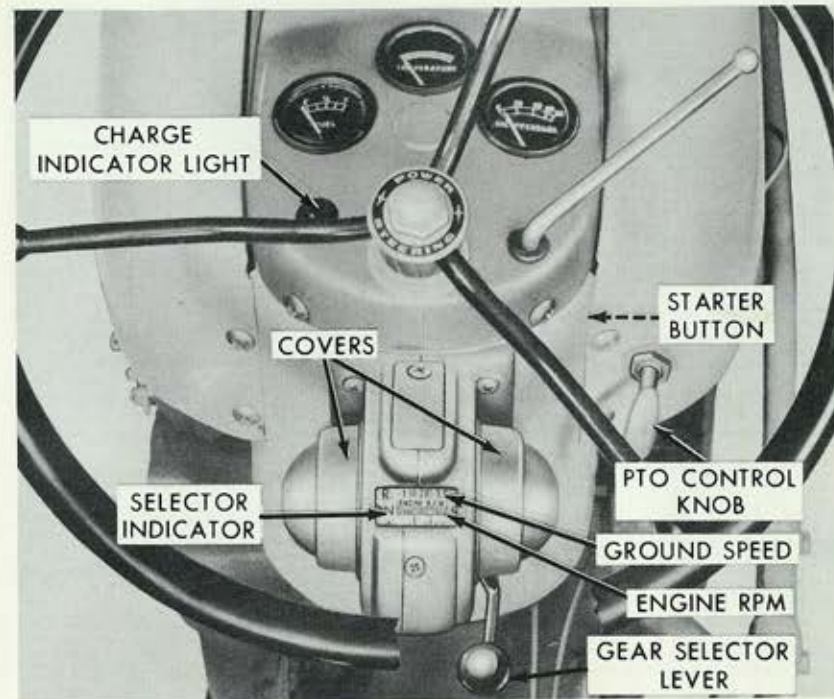

Figure 2
Instruments and Controls on the Select-O-Speed Transmission

CHOKE CONTROL (Gas Models)

Initial starting may require the use of the choke control located at the left front edge of the transmission case. After the engine has been sufficiently warmed up, the choke control should be returned to its normal position as soon as possible.

GEAR SHIFT LEVER

The 4-Speed and 5-Speed Transmission gear shift lever is located directly in front of the tractor seat.

For your convenience, a diagram of the shift positions is provided on the transmission cover as shown in Figure 3.

SELECT-O-SPEED SHIFT LEVER

The Select-O-Speed Transmission shift lever is located on the speed selector housing which is directly under the steering wheel.

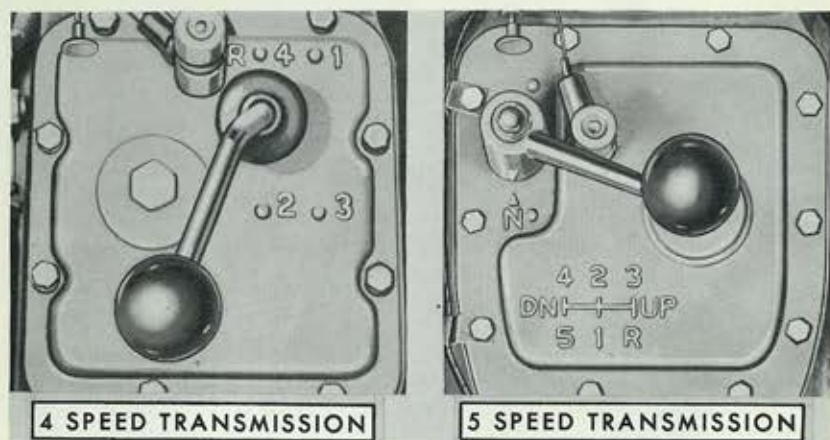

Figure 3
Gear Shift Positions

As the lever is shifted, a selector indicator, Figure 2, shows the gear selected.

STARTER BUTTON

On 4-Speed and 5-Speed Transmission equipped tractors, a safety type starter button is located on the top of the transmission housing within easy reach of the operator. As a safety feature, the starter button will not start the engine until the gear shift lever is placed in the neutral (N) position.

On Select-O-Speed Transmission equipped tractors, the safety type starter button, Figure 2, is located on the underside of the hood panel. As a safety feature, the starter button will not start the engine until the shift lever is placed in the park (P) position.

THROTTLE CONTROL

The hand-operated throttle control lever is located at the right side of the steering wheel column. Pull the lever to increase the engine speed. Push the throttle past the detent to shut off the diesel engine.

OIL PRESSURE GAUGE

The engine oil pressure gauge indicates the oil pressure through oil passages, but does not show the amount of oil in the crankcase. Oil in the crankcase can become dangerously low and still show pressure on the gauge. Check the engine oil dipstick, then check the pressure gauge



Figure 4
Brake Pawl Engaged



Figure 5
Power Take-Off Lever Engaged

periodically when operating your tractor to be sure that the lubrication system is operating satisfactorily.

TEMPERATURE GAUGE

The engine temperature gauge at the top center of the instrument cluster registers the temperature of coolant in the cooling system. Form the habit of checking this gauge frequently. The green block indicates normal temperature, red indicates overheating and orange shows that the engine is operating at below normal temperature.

FUEL GAUGE

The fuel gauge indicates the fuel level when the key switch is turned on. Check this gauge frequently to make sure the fuel supply is adequate.

CHARGE INDICATOR LIGHT

The generator charge indicator light will come on when the ignition switch is turned on and while starting the engine. After the engine starts and the engine speed is increased, the light will go out. The charge indicator light comes on if the generator is not supplying current to the battery.

CLUTCH PEDAL

On 4-Speed and 5-Speed transmission-equipped tractors the foot operated clutch pedal, located on the left side of the transmission housing, must be depressed to disengage the clutch. For information on the live

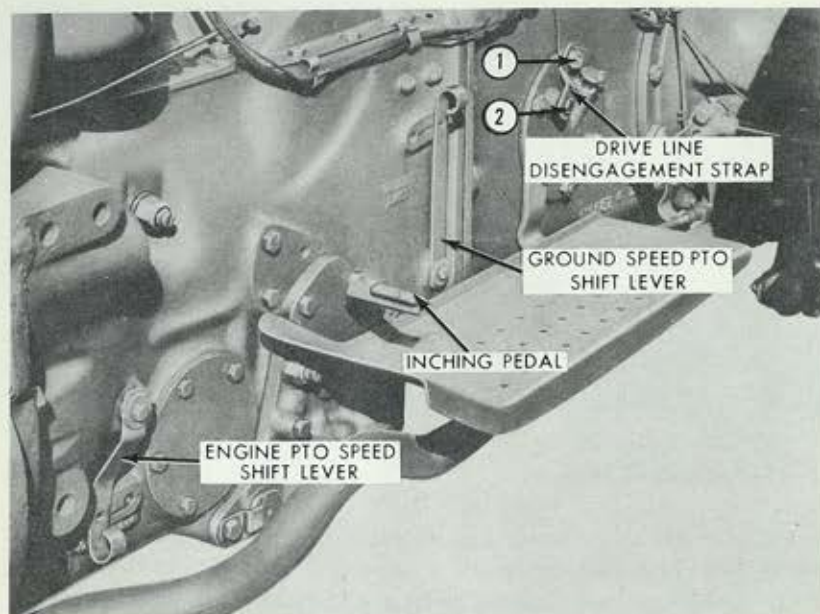

Figure 6
Controls on the Select-O-Speed Transmission

P.T.O. clutch (Tractor Models 21202 and 41202) see "Power Take-Off Operation" on page 27.

INCHING PEDAL

On Select-O-Speed Transmission-equipped tractors a foot-operated inching pedal, Figure 6, allows you to ease into implements when attaching them, and can be used for quick disengagement of power to the rear wheels.

BRAKE PEDALS

Foot-operated brake pedals are provided on the right side of the transmission housing. To stop the tractor, depress both pedals simultaneously. Apply the right brake when making short right turns, and the left brake when turning left.

CAUTION: When operating the tractor at high speeds, never attempt to make sharp turns by using the brakes.

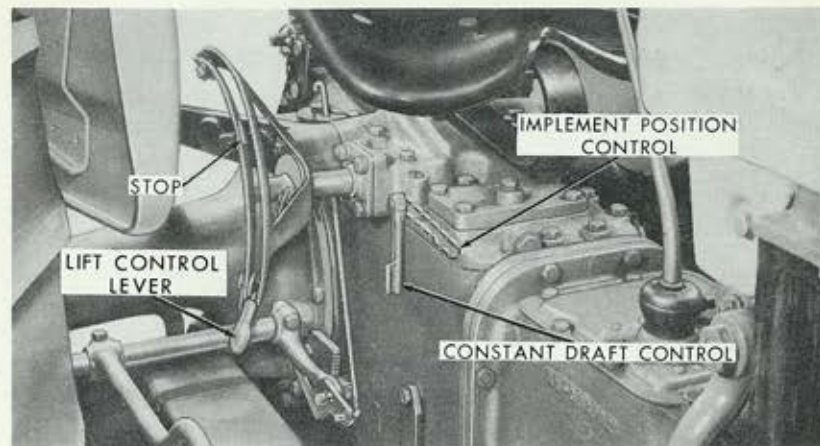

Figure 7
Hydraulic Control Levers

BRAKE PEDAL LOCKS

All 4-speed and 5-speed transmission-equipped tractors are equipped with brake locks, located on the right and left sides of the rear axle housing. The brake locks should always be set before leaving the tractor. To lock either brake, first depress the right or the left brake pedal and pull upward on the corresponding brake control rod to engage the brake pawl. Release the brake pedal slightly while holding the control rod upward. See Figures 4 and 5. To release either brake, depress the desired brake pedal sharply. This will permit the spring-loaded brake control rod to disengage the brake pawl from the brake lock.

P.T.O. LEVER

On 4-speed and 5-speed transmission-equipped tractors, the P.T.O. is engaged when the lever is in the rear position (see Figure 5), and is disengaged when the lever is forward. Always depress the clutch pedal when engaging or disengaging the P.T.O. while the tractor engine is running.

P.T.O. CONTROL KNOB

On tractors equipped with the Select-O-Speed Transmission, the P.T.O. control knob is conveniently located in front of the operator as shown in Figure 2. Slowly pulling the knob outward permits gradual engagement of the P.T.O. shaft to ease into loads. The P.T.O. is "independent," which means that it can be engaged or disengaged while the tractor is either moving or stopped. The ground speed P.T.O. shift lever must be in the disengaged or "OFF" position to pull out the P.T.O. control knob.

ENGINE P.T.O. SPEED SHIFT LEVER

Two engine P.T.O. speeds are available with the Model 41207 tractors. When the P.T.O. speed shift lever, Figure 6, is in the forward position, the P.T.O. shaft turns at the standard A.S.A.E. speed of 540 rpm. When the speed shift lever is in the rear position the shaft turns at 1000 rpm. Both P.T.O. speeds are obtainable at 1750 engine rpm.

GROUND SPEED P.T.O. SHIFT LEVER

The proportional ground speed P.T.O. is available with a Model 41207 tractor. Move the ground speed P.T.O. shift lever, Figure 6, to the forward position to place the shaft in operation. To disengage the shaft, move the lever back into the "OFF" position. The P.T.O. control knob on the dash must be pushed in before selecting ground speed P.T.O.

DRIVE LINE DISENGAGEMENT STRAP

To tow or push a Select-O-Speed Transmission-equipped tractor, when the engine is not running, the drive line must be disengaged from the rear axle. This is necessary as the Select-O-Speed Transmission automatically "locks up" in park (P) whenever the engine stops. Operation of the disengagement strap, Figure 6, is described on page 24 of this manual.

HYDRAULIC SELECTOR LEVER

The Hydraulic Selector Lever under the tractor seat changes the hydraulic system from Constant Draft to Implement Position Control. Place the

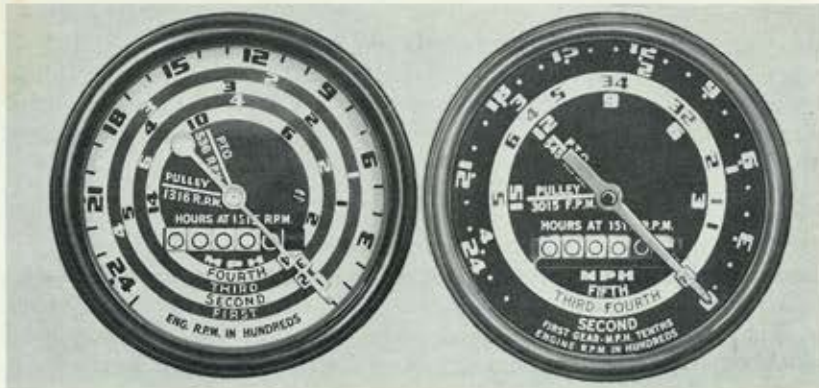

Figure 8
Proof-Meter 4-Speed

Figure 9
Proof-Meter 5-Speed

lever in the down position for Constant Draft Control, and in the up (horizontal) position for Implement Position Control. See Figure 7.

HYDRAULIC LIFT CONTROL LEVER

The lift control lever, which controls the hydraulic system, is the large lever to the right of the tractor seat, Figure 7. To raise the lift arms, raise the lever to the top position. To lower the lift arms, push the lever to the lower position.

FUEL SHUT-OFF VALVE

To shut off the flow of fuel to the carburetor, a fuel shut-off valve is provided and is located at the center underside of the fuel tank.

PROOF-METER

The Ford Tractor Proof-Meter, conveniently located at the top center of the instrument panel, is actually five instruments in one. The separate functions of the Proof-Meter are described in the following paragraphs.

Engine Speed: Engine revolutions per minute, from 0 to 2400 rpm, are shown on the outer band of the Proof-Meter. Knowing the correct engine speed is helpful in checking correct oil pressure and maintaining the proper engine idle speed.

Tractor Ground Speed: The ground speed (mph) on tractors with 4-speed transmissions, is read in the band directly under the gear number on the pointer, as shown in Figure 8. On tractors with 5-speed transmissions, the speed is read in the same manner except in third and fourth gear, where the respective speeds are indicated in different colors. See Figure 9. On Select-O-Speed Transmission-equipped tractors, the ground speed is given in 10th gear only and is read on the inner band of figures, as shown in Figure 10.

P.T.O. Speed: The American Society of Agricultural Engineers



Figure 10
Proof-Meter Select-O-Speed

(A.S.A.E.) standards for P.T.O. speed are 540 and 1000 rpm. The standard P.T.O. speed is shown on the 4-speed Proof-Meter at 1485 engine rpm and on the 5-speed and Select-O-Speed Proof-Meter at 1750 engine rpm. Most P.T.O. implements will operate at maximum efficiency when the Proof-Meter pointer is held at this speed. The 1000 rpm P.T.O. is available only on the Model 41207 tractor. For further information on the P.T.O., refer to page 27 of this manual.

Belt Pulley: For best performance, most stationary machinery must be operated at the correct belt speed. The A.S.A.E. has established a standard range for belt speeds of from 3000 to 3200 fpm. A belt speed within this range is reached with a standard nine inch belt pulley when the Proof-Meter indicates 1950 engine rpm for the 4-speed transmission-equipped tractor and 2200 engine rpm for the 5-speed and Select-O-Speed Transmission-equipped tractors. The belt speed is dependent on the size of the belt pulley and the pulley rpm. For further information on pulley sizes and belt speeds, consult the chart on page 32.

CAUTION: Do not operate the belt pulley with the engine P.T.O. speed shift lever in the 1000 rpm position on Select-O-Speed Transmission-equipped tractors.

Engine Hours: The hour meter portion of the Proof-Meter represents the hours your tractor engine has "worked", based on an average engine speed of 1515 rpm. Engine speeds below 1515 rpm accumulate hours more slowly than clock hours. Use this feature of the Proof-Meter to determine when service and maintenance are necessary. It will help you cut operating costs and prolong the life of your new tractor.

OPERATION

Your new Ford Tractor has been built with the knowledge gained through manufacturing over a million farm tractors. In it you will find many new and exclusive features, designed to make your work easier, faster and more profitable.

After familiarizing yourself with the tractor controls and instruments, read the following instructions on OPERATION. They will help you obtain maximum efficiency and dependable operation from your new Ford Tractor.



*A careful operator is the best insurance
against accidents.*

OPERATION

PRE-STARTING CHECK

Your Ford Tractor and Implement Dealer has checked your tractor thoroughly. We suggest, however, that you double check the tractor before placing it in operation. Make certain that the crankcase, transmission, hydraulic system, and rear axle lubricants are to the recommended level. Check the tires for proper air pressure and be sure that the radiator is filled with coolant.

FUEL

Gasoline Engines: Ford gasoline engines are designed to operate most efficiently with the anti-knock qualities in good regular grade gasoline. The use of poor quality fuel can cause knocking, overheating, vapor lock, and engine failure.

Diesel Engines: Above 20° F. normally use Diesel Fuel Oil No. 2 (No. 2D) with a minimum cetane rating of 45. In cold weather, below 20° F., use Diesel Fuel Oil No. 1 (No. 1D) with a minimum cetane rating of 50.



Figure 11
Using the Starter Button, Choke and Clutch Pedal

BREAK-IN PROCEDURE

Your new Ford Tractor should provide long and dependable service if given a good start by you, the operator. During the first 50 hours of operation, do not work the tractor at full capacity and avoid prolonged idling. Run the engine at medium speeds and use the lower gears whenever possible. Check the instruments frequently. Keep the radiator and oil reservoirs filled to the recommended level.

After 50 hours of operation, see your Ford Tractor and Implement Dealer. He will perform all necessary checks and adjustments in the "50 HOUR SERVICE AND INSPECTION," authorized by your Service Policy.

4-SPEED AND 5-SPEED TRANSMISSION TRACTORS— GASOLINE ENGINE

Starting the Engine: To start the engine under normal weather conditions, move the throttle lever to approximately $\frac{1}{4}$ open position, set the gear shift lever in neutral and turn the ignition key clockwise. Then, simply depress the clutch pedal and press the starter.

Initial starting of the engine may require the use of the choke. Under these conditions, pull out the choke control and depress the starter button at the same time. As soon as the engine starts, push the choke in to its normal operating position. Immediately check the engine oil pressure, then run the engine at about 1000 rpm until it warms up. A faster warm-up can be achieved if the tractor is placed under light load.

Driving the Tractor: Release both rear wheel brake locks and depress the clutch pedal. Next, move the gearshift lever to the desired gear. The shift positions are clearly indicated on the transmission cover and are shown in Figure 3.

You will save fuel and minimize engine wear by selecting the correct gear ratio for a particular operation. Operating the tractor in low gear with a light load and high engine speed will waste fuel. Too high a gear selection may cause harmful engine lugging. Lugging occurs when the load for a particular gear and throttle setting is excessive. It can be recognized when the engine will not respond to a throttle increase under load.

After shifting to the desired gear, increase the engine speed slightly and release the clutch pedal slowly and steadily. When the tractor is in motion, remove your foot from the clutch pedal and increase the ground speed as desired, with the throttle.

NOTE: DO NOT ATTEMPT TO SHIFT GEARS WHILE THE TRACTOR IS IN MOTION.

Stopping the Tractor: To stop the tractor, decrease the engine speed and depress the clutch pedal. Apply pressure evenly to both brake pedals

until the tractor is stopped. Then, place the gearshift lever in the neutral position, lock the brakes and turn the key switch off. If the engine is hot, let it idle for a few seconds before turning the key off.

Towing the Tractor: Do not tow the tractor faster than 20 mph.

Reversing Transmission: This auxiliary transmission is available as an accessory for use with the 4-speed transmission for fast forward and reverse shifting, such as shuttle operations. This transmission cuts cycle time and adds to the operator's productivity, since it is not necessary to shift the tractor transmission after the desired gear ratio is selected. The operator can change directions quickly and also have the same speed range in reverse that the tractor provides in forward gears.

The reversing transmission is operated in any selected forward gear by depressing the clutch pedal and placing the reversing transmission shift lever in the forward position for forward operation or to the rear for backing up. The tractor motion must be stopped and the clutch pedal depressed when the gears are shifted.

Over-Under Transmission: The over-under transmission is available as a factory installed option. This transmission is desirable where a wide variety of gear ratios are necessary. There are twelve forward speeds and three reverse speeds available with the over-under transmission. A ground speed of approximately 23 mph at full throttle can be reached in over drive 4th gear for highway driving, or a low speed gear ratio of 16.5 mph can be used for hard pulling.

To operate the over-under transmission, depress the clutch pedal, select the desired 4-speed gear ratio, and move the over-under lever:

- forward for under drive.
- in the middle for neutral.
- to the left from neutral and back for standard drive.
- straight back from neutral for over drive.

The 4-speed gear ratios and ground speeds are listed in the "SPECIFICATIONS" section of this manual. Conversion figures are also provided for the over-under ranges.

SELECT-O-SPEED TRANSMISSION TRACTOR—GASOLINE ENGINE

Starting the Engine: Place the transmission selector lever in park (P) position, depress the inching pedal, and turn the key switch to the "ON" position. Move the throttle lever to approximately $\frac{1}{4}$ open position and press the starter button. Use the choke control as required.

Operate the engine at approximately 1000 rpm to sufficiently warm both the engine and transmission oil before subjecting the tractor to a load.

Driving the Tractor: With the engine running and the inching pedal depressed, shift directly to the desired gear if the operation is anticipated to be in the low gear ratios (1 through 4). Shift to one gear below the anticipated operating gear for the higher gear ratios. Increase the throttle setting to handle the initial load, then let the inching pedal up slowly until the tractor moves off smoothly. Shift on-the-go to the gear ratio which will permit the best performance and move the throttle to the desired setting.

You will save fuel and minimize engine wear by selecting the correct gear ratio for a particular operation. Operating the tractor in low gear with a light load and high engine speed will waste fuel. Operating in too high a gear may cause harmful engine lugging. Lugging occurs when the load for a particular gear and throttle setting is excessive. It can be recognized when the engine will not respond to a throttle increase under load.

Stopping the Tractor: If operating in the high gear range, reduce the throttle setting and downshift the transmission using intermediate gears to slow the tractor's forward speed.



CAUTION: Avoid downshifting quickly through a series of gears as the sudden speed change may cause the tractor to slow down abruptly.

Then, downshift the transmission to the neutral (N) position or depress the inching pedal, if desired. Apply pressure evenly to both brake pedals until the tractor is stopped.

If operating in the low gear range, reduce the throttle setting and downshift the transmission to neutral (N). Apply both brakes equally until the tractor is stopped. Shift the selector lever to park (P) and turn the key switch off.

NOTE: The foot-operated inching pedal interrupts power flow and is operated similarly to a conventional clutch pedal where quick disengagement of rear wheels is desired.

4-SPEED AND 5-SPEED TRANSMISSION TRACTORS—DIESEL ENGINE

Starting the Engine: To start the engine under normal weather conditions, move the throttle down to the $\frac{1}{2}$ open position, set the gearshift lever in the neutral position and turn the key switch clockwise. Depress the clutch pedal and press the starter button until the engine starts. Avoid continuous cranking of the engine. The primary purpose of the electrical circuit in a diesel tractor is to start the engine. Once the engine

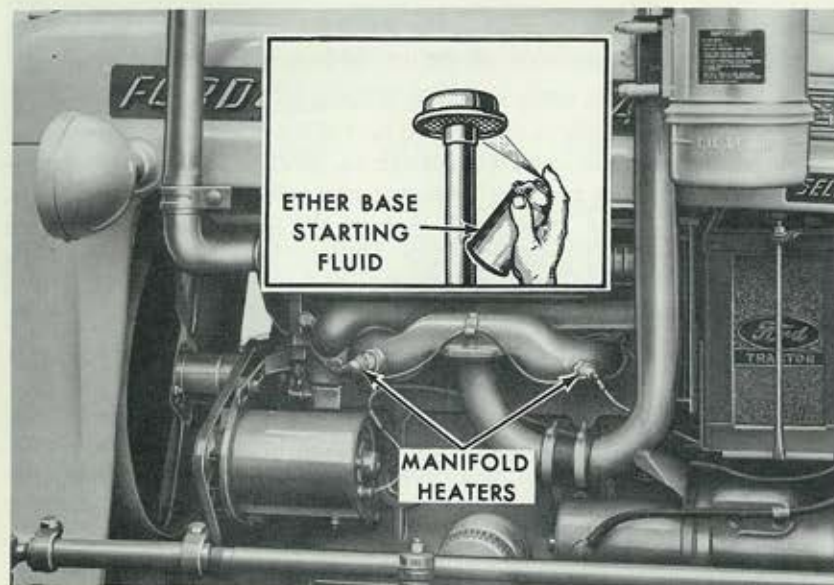

Figure 12
Diesel Starting Aids

is running it no longer requires the electrical circuit and it cannot be stopped by turning off the key switch. During operation of the tractor, the key switch is left on to operate the battery charging circuit.

Intake Manifold Heaters: These heaters are used as a starting aid for cold temperatures above 15° F. The manifold heater assembly, Figure 12, is installed in the air intake manifold to heat the air before it enters the combustion chamber. The panel button switch, controlling the electric current to the manifold heating elements, is mounted above the key. To operate the manifold heater, turn the key switch on and pull the throttle down to the 1/2 open position. Depress the heater circuit button for approximately 30 to 90 seconds, depending on the temperature. Release the heater button and proceed to start the engine.

Ether Starting Aid: For temperatures below 15° F. it is recommended that an ether base starting fluid be sprayed into the air inlet stack, Figure 12, while the engine is cranked. This starting fluid is available in spray-type containers at your Ford Tractor and Implement Dealer, or from diesel fuel suppliers. Complete instructions are given on the container.



CAUTION: Wait 15 minutes before using ether spray if you have attempted to use the manifold heater aid.

NOTE: The temperature given above at which the two aids perform satisfactorily will vary according to the length of time the tractor has been inactive and to the general condition of the engine.

Driving the Tractor: Release both rear wheel brake locks and depress the clutch pedal. Next, move the gearshift lever to the desired gear. Shift positions are clearly indicated on the transmission cover as shown in Figure 3.

You will save fuel and minimize engine wear by selecting the correct gear ratio for a particular operation. Operating the tractor in low gear with a light load and high engine speed will waste fuel. Operating in too high a gear may cause harmful engine lugging. Lugging occurs when the load for a particular gear and throttle setting is excessive. It can be recognized when the engine will not respond to a throttle increase under load. After shifting to the desired gear, increase the engine speed slightly and release the clutch pedal slowly and steadily. When the tractor is in motion, remove your foot from the clutch pedal and increase the ground speed as desired with the throttle.

IMPORTANT: Do not attempt to shift gears while the tractor is in motion.

Stopping the Tractor: To stop the tractor, decrease the engine speed, depress the clutch pedal and apply pressure evenly to both brake pedals until the tractor is stopped. Place the gearshift lever in the neutral position, lock the brakes and move the throttle lever past the idle stop to the closed position to shut off the engine. Turn off the key switch.

Towing the Tractor: Do not tow the tractor faster than 20 mph.

SELECT-O-SPEED TRANSMISSION TRACTOR—DIESEL ENGINE

Starting the Engine: Place the transmission selector lever in park (P) position. Depress the inching pedal and turn the key switch to the "ON" position. Move the throttle lever to approximately 1/2 open position and press the starter button until the engine starts. For cold weather starting, see "Intake Manifold Heater" on page 20.

Operate the engine at approximately 1000 rpm to sufficiently warm both the engine and transmission oil. A faster warm-up can be achieved by subjecting the tractor to a light load.

Driving the Tractor: With the engine running and the inching pedal depressed, shift directly to the desired gear if the operation is anticipated to be in the low gear ratios (1 through 4). Shift to one gear below the anticipated operating gear for the higher gear ratios. Increase the throttle setting to handle the initial load, then let the inching pedal slowly until the tractor moves off smoothly. Shift on-the-go to the speed

ratio which will permit the best performance and move the throttle to the desired setting.

You will save fuel and minimize engine wear by selecting the correct gear ratio for a particular operation. Operating the tractor in a low gear with a light load and high engine speed will waste fuel. Operating in too high a gear may cause harmful engine lugging. Lugging occurs when the load for a particular gear and throttle setting is excessive. It can be recognized when the engine will not respond to a throttle increase under load.

Stopping the Tractor: If operating in the high gear range, reduce the throttle setting and downshift the transmission using intermediate gears to slow the tractor's forward speed.



CAUTION: Avoid downshifting quickly through a series of gears as the sudden speed change may cause the tractor to slow down abruptly.

Then, downshift the transmission to the neutral (N) position or depress the inching pedal, if desired. Apply pressure evenly to both brake pedals until the tractor is stopped.

If operating in the low gear range, reduce the throttle setting and downshift the transmission to neutral (N). Apply both brakes equally until the tractor is stopped. Shift the selector lever to park (P) and turn the key switch off.

NOTE: The foot-operated inching pedal interrupts power flow and is operated similarly to a conventional clutch pedal where quick disengagement of rear wheels is desired.

OPERATING THE SELECT-O-SPEED TRANSMISSION

Shifting On-The-Go: It is important when shifting on-the-go that the selector lever be moved quickly and sharply. This can best be done by placing the lever in the heel of your palm and putting your thumb and forefinger on the bell of the selector cover. To obtain a smooth shift when shifting to a lower gear ratio under increased load conditions, shift before the engine has a chance to lug. When shifting to a higher gear ratio, a smoother shift can be obtained if the throttle setting is reduced slightly.



CAUTION: Avoid shifting quickly through a series of gears as the sudden speed change may cause the tractor to surge ahead or slow down abruptly.

Speed Selector Mechanism: The selector indicator, Figure 2, shows the gear selected and the ground speed when the tractor engine is at 1200, 1750, or 2200 rpm. Ten forward speeds (indicated by numerals 1 to 10), two reverse speeds (R_1 and R_2), a park (P), and a neutral (N), can be obtained by means of the gear selector lever. The selector indicator is lighted whenever the key switch is turned on.

The ten speed ranges overlap each other and provide speeds from .6 mph in 1st gear at 1200 rpm to 18 mph in 10th gear at 2200 rpm. The two reverse speeds will range from 1.9 mph in R_1 to 5.1 mph in R_2 . When moving the lever through the neutral (N) position, it will be necessary to hold it outward; otherwise it will drop into the neutral locating notch.

The park (P) position locks the rear wheels to prevent movement of the tractor. This feature is especially convenient as it prevents the tractor from rolling when attaching implements or doing belt work. Always select park (P) whenever you leave the tractor. Any time the engine is not operating, the transmission automatically "locks up" in park for safety purposes.

Repositioning the Selector Lever: For added convenience, the selector lever on your tractor can be mounted on either side of the shifter mechanism to permit right or left-hand shifting.

To move the selector lever to the opposite side of the shifter mechanism, take off both covers, Figure 2, by removing the Phillips head screw as shown at (1), Figure 13. Remove the selector lever from the shaft and position it on the shaft on the opposite side of the shifter mechanism. Switch the covers and reinstall with the Phillips head screws. Tighten securely.

Selector Lever Stops: Installation of the Lever Position Stops enables the operator to establish a pre-determined shift pattern between two gears. These stops are especially convenient for loader and other material handling operations. The speed stop screws can be positioned in any two of the gears 3, 5, 7, R_1 or R_2 by inserting them in the holes shown in Figure 13. These stops can be over-ridden to obtain any gear by pulling outward on the spring-loaded selector

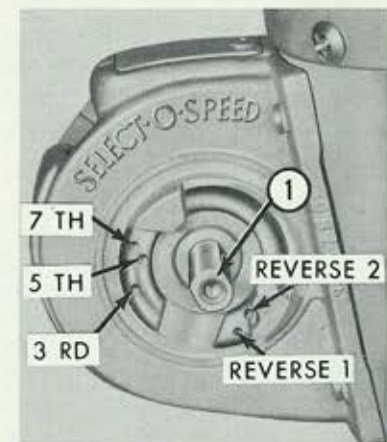

Figure 13
Selector Lever Stop Positions

lever and shifting to the desired gear. When selector stops are not desired, the stop screws should be placed in the holes on the side opposite the selector lever. Tractors will be shipped from the factory with the stop screws in this location.

Towing the Tractor: To tow or push a Select-O-Speed Transmission-equipped tractor when the engine is not running, the drive line must be disconnected from the rear axle. This is necessary as the Select-O-Speed Transmission automatically "locks up" in park whenever the engine stops.

To disengage the transmission, disconnect the traction coupling as follows: Remove the nut (1), Figure 18, and strap; turn the strap over and reinstall it on the shaft (2), then rotate the shaft approximately 60° to the rear. Rock the tractor to make sure the transmission is disengaged. Then, reposition the strap and install the nut to make sure that the traction coupling remains disengaged.

NOTE: Do not tow tractor faster than 20 mph.

THE HYDRAULIC SYSTEM

The Live Action Hydraulic System is available as a factory installed option. By simply moving the lift control lever, the system provides instant hydraulic power for raising a wide variety of implements. Regardless of whether the clutch pedal is up or down, or whether the P.T.O. is engaged or disengaged, the system will respond smoothly, enabling you to adjust implements in fractions of an inch. The system incorporates two types of hydraulic control. Depending upon the type of implement used, the soil conditions, and terrain encountered, the system may be operated in Implement Position Control or in Constant Draft Control. For lift capacity refer to the "Specifications" section of this manual.

Implement Position Control: To operate the hydraulic system in Implement Position Control, move the hydraulic selector lever, Figure 14, into the up position and set the implement at the desired depth by moving the lift control lever down. Where the ground is relatively level, the Implement Position Control will keep the implement at the desired depth, even though the soil texture may vary.

When in Position Control, the height of the implement is directly governed by the position of the lever in the quadrant. It is therefore possible to raise to any desired intermediate position for transport simply by

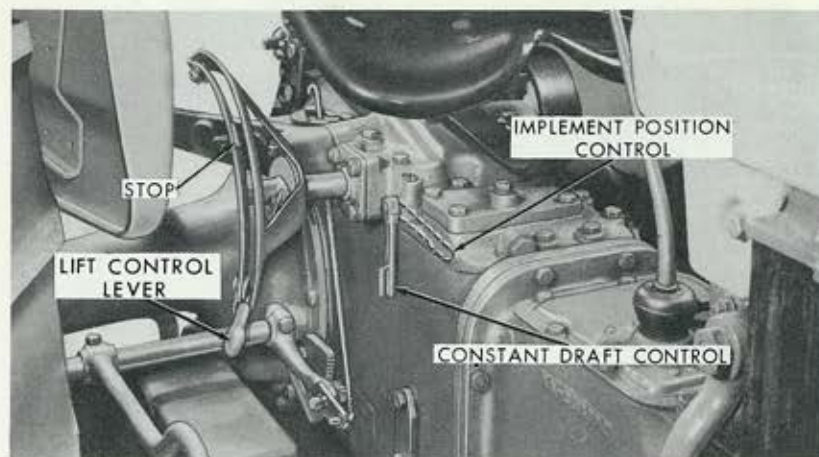

Figure 14
Hydraulic Control Levers

moving the control lever up the quadrant. The further the lever is moved up the quadrant, the higher the implement will be raised. To avoid imposing excessive shock loads on the hydraulic system with the implement in the raised position, do not travel at high speed. This is particularly true over rough ground.

By setting the adjustable stop on the quadrant, the implement can always be returned to the original depth by moving the lift control lever down to the stop.

Constant Draft Control: With the hydraulic selector lever in the down position, as shown in Figure 14, the hydraulic system is operating in Constant Draft Control. When an implement is lowered to work at a certain depth, the draft control will maintain the same draft, even though the ground contour or soil texture may change. If the draft increases, the hydraulic system will respond by raising the implement to decrease the draft. At the same time, some weight will shift to the tractor rear wheels, increasing traction until the implement has been automatically repositioned and the draft is decreased.

When it is desirable to operate an external cylinder off of the tractor hydraulic system, Constant Draft Control should be selected. Operate the tractor lift lever as follows. With the tractor engine running, raise the tractor lift lever until the cylinder starts to lift. Lower the lever slightly until the lifting action stops. This position of the lift lever is called neutral. Move the quadrant stop to the lower or front edge of

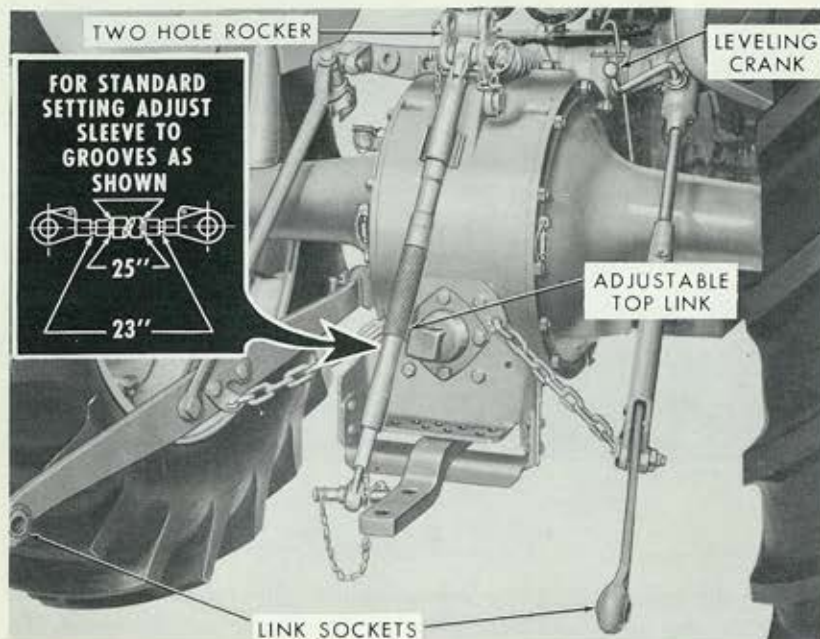

Figure 15
Leveling Crank and Adjustable Top Link

the neutral position. This will make it easy to always find neutral with the lift lever. To retract the cylinder, place the touch control below its neutral position. To extend the cylinder, place the touch control above its neutral position. When the cylinder is fully extended, always return the touch control to its neutral position to avoid "popping" of the tractor hydraulic system relief valve. Use a hydraulic Lift Arm Hold-Down Kit to prevent the lift arms from raising to the top of their travel and making the hydraulic system inactive.

Hydraulic Piston Pump: Your new Ford Tractor is equipped with a piston pump, containing six pistons. The pump is gear driven and provides a constant flow of oil to the Ford Tractor "live action" hydraulic system, in volumes which are proportional to engine speeds. For maximum efficiency of operation and long pump life, always use the recommended hydraulic fluid (Ford Spec. M-2C 41) when filling the tractor hydraulic reservoir. Always use clean containers for this operation. When service on the hydraulic system becomes necessary, see your local Ford Tractor and Implement Dealer. He is properly trained and equipped to meet your service needs.

ATTACHING IMPLEMENTS

Your tractor is equipped with Category I Linkage. Most implements can be easily and quickly attached to the tractor three-point linkage. With the selector lever in Implement Position Control, back the tractor so that the lift links are directly above the link pins on the implement. Lower the links with the lift control lever until the sockets are aligned with the link pins. Attach the tractor left lift link to the implement and secure with the linch pin provided. Then, adjust the right lift link with the leveling crank, Figure 15, and attach it in the same manner. Attach the adjustable top link to the implement and secure it with a linch pin.

Tractor Hydraulic Lift Rocker: The two hole hydraulic lift rocker on the Ford Tractor provides better control of sensitivity for light and heavy draft implements. Attach the top link in the upper hole for light draft loads (cultivating) and in the lower hole for heavy draft loads such as plowing.

Adjustable Top Link: The fully adjustable top link provides improved implement performance and operation. The link may be adjusted to suit implement operation requirements by releasing the lock and rotating the sleeve until the desired length is obtained. The standard length of 25 inches is obtained by adjusting the link to the inner grooves marked on the top link. See insert, Figure 15.

SWINGING DRAWBAR

The swinging drawbar on your Ford Tractor, permits quick, easy attachment of pull-type implements. The tractor can be operated with the swinging drawbar in either the 14" or 16" "extended" positions, and with the offset up or down, see Figure 16. The drawbar may also be set and used in positions to the left or right of center (seven in all).

When operating with P.T.O. driven equipment, the drawbar should be set at the 14" extended position for 540 rpm operation, and at the 16" extended position for 1000 rpm P.T.O. operation.

CAUTION: Remove the Swinging Drawbar when attaching close mounted implements.

POWER TAKE-OFF OPERATION

The P.T.O. transfers engine power directly to mounted or drawn implements, or to belt-driven equipment when a pulley is used.

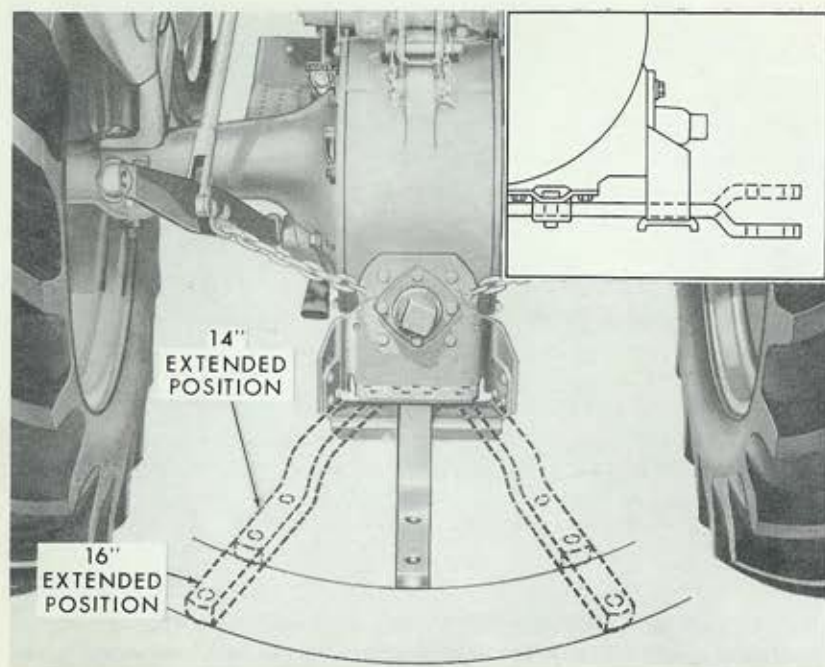

Figure 16
Swinging Drawbar

Engine P.T.O. Speeds: The American Society of Agricultural Engineers (A.S.A.E.) standards for P.T.O. speed are 540 ± 10 rpm and the new speed of 1000 ± 25 rpm. Most P.T.O. implements will operate at maximum efficiency when the P.T.O. functions within the speed range specified for that implement.

Power Take-Off Shaft: Your Ford Tractor is equipped with a standard P.T.O. shaft ($1\frac{3}{8}$ " diameter) in accordance with A.S.A.E. specifications for attaching P.T.O. driven equipment built to A.S.A.E. standards. A P.T.O. shield, see Insert, Figure 18, is available as extra equipment from your Ford Tractor and Implement Dealer. This shield should be used as a safety precaution and serves as the supporting member for pull-type implement drive line shields in all operations involving P.T.O. driven implements.

4-Speed and 5-Speed Transmission-Equipped Tractors: To operate the tractor P.T.O. shaft at the A.S.A.E. standard of 540 rpm, the engine should be operated at 1485 rpm with 4-speed transmissions and at 1750 rpm with 5-speed transmissions.

The P.T.O. shaft is engaged by depressing the clutch pedal and moving

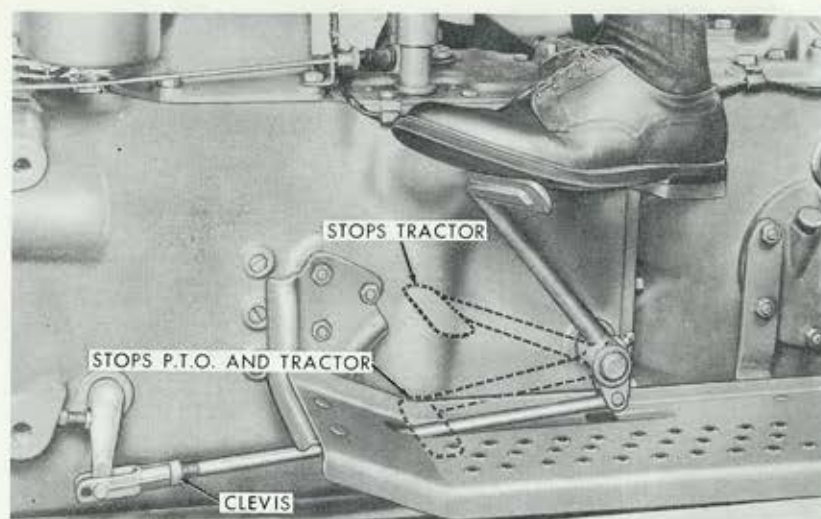

Figure 17
Operating the Live P.T.O. Clutch

the P.T.O. lever toward the rear of the tractor, see Figure 5. When engaged, operation of the shaft may be temporarily interrupted by depressing the tractor clutch pedal.

The 5-speed transmission tractors are equipped with a live P.T.O. clutch. To stop the forward motion of the tractor when operating with P.T.O. driven equipment, depress the clutch pedal about half-way, as shown in Figure 17. To stop both forward motion of the tractor and the operation of the implement, depress the clutch pedal all the way, as shown.

When desired, the live P.T.O. clutch may be disengaged and the pedal set for normal, single clutch operation by repositioning the pin in the front hole of the clevis shown in Figure 17. For further information on clutch adjustments, see page 67, under "Mechanical Maintenance."

Select-O-Speed Transmission-Equipped Tractors: Model 21205 and 41205 Tractors have an independent P.T.O. with an A.S.A.E. standard speed of 540 rpm at 1750 engine rpm. Model 41207 has two independent Power Take-Off A.S.A.E. standard speeds of 540 and 1000 rpm at 1750 engine rpm, plus a proportional ground speed P.T.O. Independent P.T.O. enables the P.T.O. shaft to be operated whether or not the tractor is in motion.

The engine speed P.T.O. shaft is engaged by the P.T.O. control knob, Figure 2. For gradual engagement of the P.T.O. shaft, pull the knob out slowly to a point where the load begins to feather in. Pick up the load

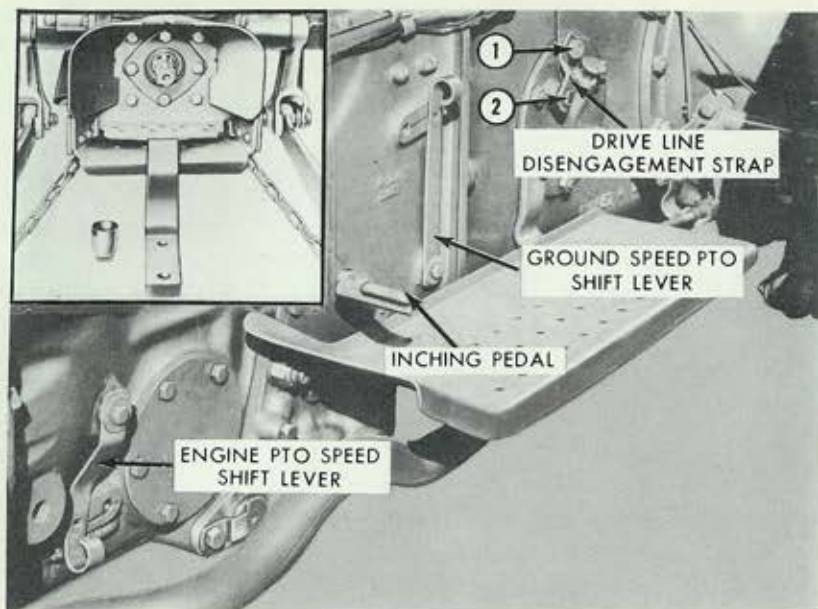

Figure 18
Controls on the Select-O-Speed Transmission

gradually by pausing briefly or pushing slightly inward as required, then slowly pull the knob to the full out position.

In Model 41207 tractors, the desired P.T.O. speed of 540 or 1000 rpm should first be selected using the P.T.O. shift lever, Figure 18. With the tractor engine stopped, shift to the forward position for the 540 rpm speed, or to the rearward position for the 1000 rpm speed.

NOTE: The correct P.T.O. adapter should be installed on the P.T.O. shaft to conform to the A.S.A.E. spline standards for 540 and 1000 rpm operated implements as described below.

All Model 41207 tractors are factory equipped with a 6-spline adapter for 540 rpm P.T.O. operation. To use the 1000 rpm P.T.O. speed, the 6-spline P.T.O. shaft adapter must be replaced with the 21-spline adapter provided in the tractor tool box. To change the adapter, loosen the socket head screw located inside the adapter shaft with the special Allen-wrench provided. Change to the other adapter and tighten the socket head screw securely.

IMPORTANT: Use the 1000 rpm speed only for implements designed for 1000 rpm use.

In Model 41207 tractors, ground speed P.T.O. permits the operating

speed of the implement to be in direct proportion to the forward speed or ground travel, of the tractor. For approximately every seven inches of forward travel of the tractor, the P.T.O. shaft will make one revolution, or for every 145 P.T.O. shaft rpm, the rate of forward travel will be 1 mph. The relationship between Ground Speed P.T.O. (rpm) and tractor forward travel remains constant regardless of transmission gear ratio and engine speed. Thus, in such applications as raking, planting, spreading manure, etc., the ground speed P.T.O. will permit a constant implement operating speed for any specific ground speed, regardless of transmission gear ratio.

The ground speed P.T.O. is engaged by moving the ground speed P.T.O. shift lever, Figure 18, to the "ON" position, making certain that the P.T.O. control knob is in the "IN" position. The P.T.O. shaft will only turn when the tractor is in motion. Consequently, to ease into P.T.O. loads, it will be necessary to use the inching pedal. **WHEN BACKING THE TRACTOR, THE GROUND SPEED LEVER MUST BE MOVED TO THE "OFF" POSITION.** Failure to do this may result in serious damage to the implement being operated.

There is a lock-out arrangement within the transmission which prevents the engagement of the ground speed and the engine speed P.T.O. at the same time.

NOTE: Do not shift the ground speed shift lever while the tractor is in motion.

If the implement is designed to operate at either 540 rpm or 1000 rpm, the Select-O-Speed Transmission provides several combinations of gear ratios and engine speeds to obtain these P.T.O. speeds. The following chart illustrates the combinations available to obtain the 540 and 1000 rpm P.T.O. speeds.

Engine Speed and Gear Selection Combinations for Ground Speed P.T.O.

P.T.O. SPEED	540 rpm (Ground Speed 3.7 mph)				1000 rpm (Ground Speed 6.9 mph)		
	Engine rpm	2067	1600	1395	1045	2010	1200
Gear Selection	5	6	7	8	8	9	10

P.T.O. Speeds with the Tractor Stationary: On tractors equipped with the Deluxe Select-O-Speed Transmission, the ground speed P.T.O. can be utilized to obtain P.T.O. speeds above 1000 rpm when the tractor is stationary. This is accomplished as follows:

1. With the engine stopped, block the tractor and move the drive line disengagement strap, Figure 6, to the front, disengaging power to the rear wheels.
2. Move the ground speed lever forward to the "ON" position.
3. Start the engine.
4. Depress the inching pedal and set the transmission selector at 7th,

8th, 9th, or 10th. Refer to the chart on page 38 for the P.T.O. speeds obtained at various engine rpms in the above gear selections. Note the example.

IMPORTANT: Do not use transmission selector in 1st, 2nd, 3rd, 4th, 5th, or 6th for driving the P.T.O. as described above, as it is possible to overload the P.T.O. in these gears.

BELT PULLEY

A nine-inch belt pulley is available as an accessory for use on your Ford Tractor. The pulley can be installed in any one of four positions; however, it should not be installed in the up position. To install, remove the P.T.O. safety cap, the drawbar, the drawbar hanger and the check chains. Then, position the pulley assembly on the P.T.O. shaft as desired and secure with the four stud bolts and lock washers provided.

NOTE: On Select-O-Speed Transmission-equipped tractors, the 6-spline P.T.O. shaft adapter must be installed to operate the belt pulley.

For best performance, most stationary machinery must be operated at the correct belt speed. The A.S.A.E. has established a standard range for belt speeds of from 3000 to 3200 fpm. A belt speed within this range is

PROPER SIZE OF THE DRIVEN PULLEY*

Engine R.P.M. 4-Speed Transmission	Engine R.P.M. 5-Speed Transmission	Engine R.P.M. Select-O-Speed Transmission	Nine Inch Pulley R.P.M. **	R.P.M. OF THE DRIVEN PULLEY											
				600	800	1000	1200	1400	1800	2200	2600	3000			
1000	1168	1154	679	10	7½	6	5	4½	3½	3					
1100	1285	1269	747	11	8½	6½	5½	5	3½	3					
1200	1402	1385	815	12	9	7½	6	5	4	3½	3				
1300	1517	1499	882	13	10	8	6½	5½	4½	3½	3				
1400	1634	1614	950	14	10½	8½	7	6	4½	4	3½	3			
1500	1751	1730	1018	15	11½	9	7½	6½	5	4	3½	3			
1600	1868	1845	1086	16½	12	10	8	7	5½	4½	4	3½			
1700	1985	1961	1154	17½	13	10½	8½	7½	6	4½	4	3½			
1800	2102	2076	1222	18½	13½	11	9	8	6	5	4	3½			
1900	2219	2192	1290	19½	14½	11½	9½	8½	6½	5½	4½	4			
2000	—	—	1358	20½	15½	12	10	8½	7	5½	4½	4			

*Figures are computed to the nearest ½ inch pulley size.

**Pulley speeds are based on 50 rpm P.T.O. speeds.

CAUTION: NEVER INSTALL OR REMOVE BELT WHILE PULLEY IS IN MOTION.

reached with a standard nine-inch belt pulley when the Proof-Meter indicates 1950 engine rpm for the 4-speed transmission-equipped tractor and 2200 engine rpm for the 5-speed and Select-O-Speed Transmission-equipped tractors.



CAUTION: Do not operate the belt pulley with the engine P.T.O. speed shift lever in the 1000 rpm position.

The belt speed is dependent on the size of the belt pulley and the pulley rpm. Belt-driven implements which do not meet A.S.A.E. standards should be operated at the speed recommended by the manufacturer. To obtain this speed, select a driven pulley of the proper size from the table on page 32.

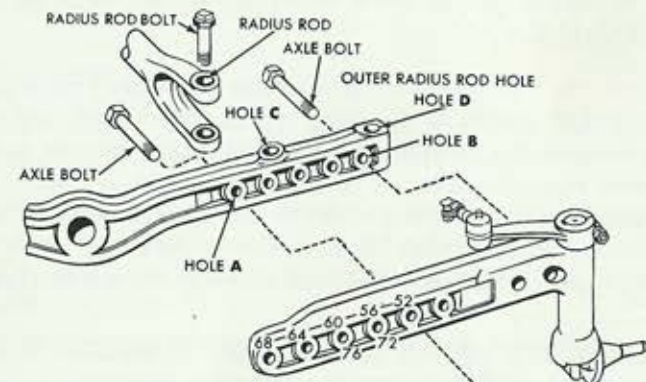

FOR TREAD WIDTH (INCHES)	LINE UP HOLE A AND HOLE NO.	LINE UP HOLE B AND HOLE NO.	SPACE BOLTS APART (INCHES)	SET RADIUS ROD TO HOLE	RADIUS RODS SPREAD (INCHES)
52	52		8½	C	29.08
56	56		8½	C	29.08
60	60		6¾	D	40.82
64	64		8½	D	40.82
68	68		8½	D	40.82
72		72	6¾	D	40.82
76		76	4¼	D	40.82

NOTE: ADJUST DRAG LINKS—SEE FRONT WHEEL TOE-IN

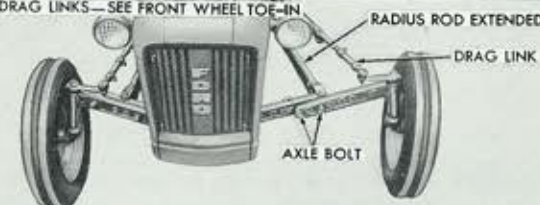

Figure 19
Front Wheel Tread Adjustments

WHEEL TREAD ADJUSTMENTS

The unique design of the Ford Tractor permits a wide range of front and rear wheel adjustments which can be made quickly and easily.

Front Wheel Tread Adjustment: The front wheels are adjustable from 52 to 76 inches in 4 inch spacings. To change the tread width, raise the front end of the tractor with a jack and remove the bolts which hold the outer axle sections to the center section. Move the front wheels apart until the desired tread width is obtained (see Figure 19), then replace the bolts and tighten securely. Always leave one or more open holes between the bolts.

NOTE: When front wheel adjustments are made, the drag links must be adjusted to obtain proper front wheel toe-in. See page 68, under "MAINTENANCE."

Rear Wheel Tread Adjustments: The tractor rear wheels are adjustable to the same tread widths as the front wheels. Tread width settings are made by changing the position of the steel discs and the rims to any of the positions from 52 inches to 76 inches, as shown in Figure 20. To change from the 52 inch tread width to the 72 inch width, it is only necessary to change the wheels from one side of the tractor to the other. Two other wheel changes are similar, as shown at the top of Figure 20.

INTER-CHANGING REAR WHEEL ASSEMBLIES GIVE THESE COMBINATIONS

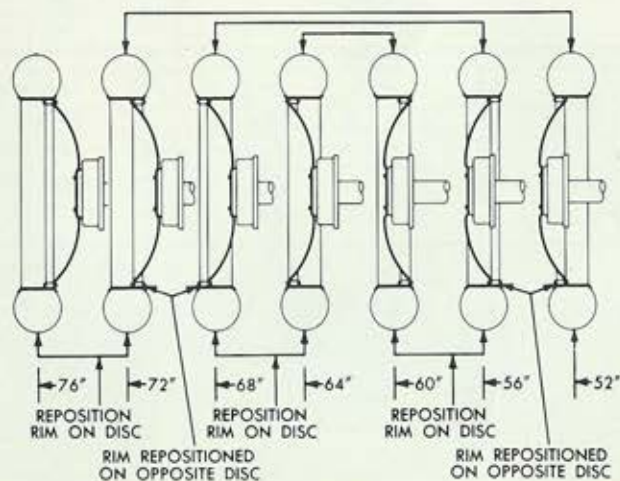

Figure 20
Rear Wheel Tread Adjustments

Rear Wheel Tire Options: Rear wheel tire options for 14.9-24 and 16.9-24 are available on 2000 and 4000 Series tractors. The tires are mounted on 12 x 24 rims and 24 inch cast steel wheel discs. The wheels may be spaced from 56 to 72 inches in four inch increments by repositioning the disc in respect to the rim in a similar manner as the standard rear wheels. The disc, however, is corded to the rim by means of six locking clamps, which must be tightened equally.

Ford regular duty vari-weights can be mounted at the 56 inch setting only, by extending the rear wheel weight disc with another set of rear wheel flange nuts.

Power Adjusted Rear Wheels: Power adjusted rear wheels are available as a factory installed option. For further information, see your Ford Tractor and Implement Dealer.

WHEEL WEIGHT

To obtain sufficient traction for maximum performance in heavy draft operations, weight should be added to the Ford Tractor.

Liquid Ballast: It is a common practice to add weight by filling the rear tractor tires with liquid. A calcium chloride-water solution is recommended because of its low freezing point, and greater weight per gallon than water.

The use of liquid ballast in the front tires will help counterbalance heavy rear mounted implements, and will further increase the traction and "pull-power" of your Ford Tractor in heavy draft operations. The recommended liquid capacities for tires are shown in the table, page 36. This table is based on a 90% fill of the tires, with 5 pounds of calcium chloride per gallon of water. The addition of this amount of calcium chloride will prevent freezing in most locations. For valve level filling of the tires listed, multiply the respective figures in the table by .8 to obtain the necessary information. See your Ford Tractor and Implement Dealer, who has the necessary special equipment required to obtain a 90% fill when weighting tires with liquid ballast.



CAUTION: Never pour water on calcium chloride. Slowly add the flakes to the water and stir until dissolved.

MAXIMUM CALCIUM CHLORIDE SOLUTION CAPACITIES

Size of Tire		Pounds of Calcium Chloride	Gallons of Water	Weight of Solution
12.4-28	4-ply	164	32	440 lbs.
13.6-28	4-ply	187	38	504 lbs.
6.00-16	4-ply	30	6	80 lbs.
5.50-16	4-ply	25	5	65 lbs.
7.50-16	4-ply	45	9	120 lbs.
6.50-16	6-ply	29.5	5.9	79 lbs.
7.50-16	6-ply	45	9	120 lbs.
14.9-24	4-ply	219	44	584 lbs.
14.9-28	4-ply	246	49	648 lbs.
16.9-24	6-ply	266	53	707 lbs.
14.9-24	6-ply	219	44	584 lbs.
14.9-28	6-ply	246	49	648 lbs.

Weight added to the tires, together with the weight of the mounted implement and tractor, should not exceed the recommended weight to be carried by the tires. The following table lists the maximum recommended weight that can be carried without overloading the tires.

Tire Size		Inflation Pressure (psi)	Maximum Lbs. Tire Load per Wheel
REAR:			
12.4-28	4-ply	12	1890
12.4-28	4-ply	14	2070
13.6-28	4-ply	14	2430
14.9-24	4-ply	14	2700
14.9-28	4-ply	12	2630
16.9-24	6-ply	16	3560
14.9-24	6-ply	14	2695
14.9-24	6-ply	16	2920
14.9-24	6-ply	18	3125
14.9-28	6-ply	14	2870
14.9-28	6-ply	16	3100
14.9-28	6-ply	18	3320
FRONT:			
5.50-16	4-ply	20	655
5.50-16	4-ply	24	725
5.50-16	4-ply	28	795
5.50-16	4-ply	32	860
6.00-16	4-ply	20	750
6.00-16	4-ply	24	835
6.00-16	4-ply	26	875
7.50-16	4-ply	20	1110
7.50-16	4-ply	24	1235
7.50-16	4-ply	28	1345
7.50-16	4-ply	32	1455
6.50-16	6-ply	40	1290
7.50-16	6-ply	36	1560

Cast Iron: In heavy work such as plowing and discing, added weight is necessary in most cases to provide sufficient traction to utilize the maximum power of the engine. Special cast iron weights are available, at extra cost, in different sizes for use on the Ford Tractor. These individual weight sections can be easily attached to or detached from the wheels as the job requires. On lighter jobs, removal of the weights will increase the operating economy of your tractor. The following chart describes the different types of weights and their recommended usage.

NOTE: For 14.9-24 and 16.9-24 rear tires, Regular Duty Vari-Weights can be mounted at the 56" setting only, by extending the mounting discs with another set of bolts.

FORD TRACTOR WHEEL WEIGHTS FOR ALL PURPOSE TRACTORS	SERIES 2000		SERIES 4000	
	Farm Use	Industrial Use	Farm Use	Industrial Use
FRONT (per tractor set) Wheel Weights—Inside mounted Two per wheel—50 lbs. each Total—200 lbs.	X	X	X	X
REAR (per tractor set) Regular Duty Weights Two Mounting Discs—68 lbs. Segments—(24) 30 lbs. each Bolts—12 lbs. Total—800 lbs. *Heavy Duty Weights Two Mounting Discs—68 lbs. Segments (24) 45 lbs. each Bolts—12 lbs. Total—1160 lbs.	X	X	X	X

***IMPORTANT:** Under no circumstances should Heavy Duty Weights be used on Series 2000 Tractors.

P.T.O. RPM VS ENGINE RPM IN GROUND SPEED DRIVE

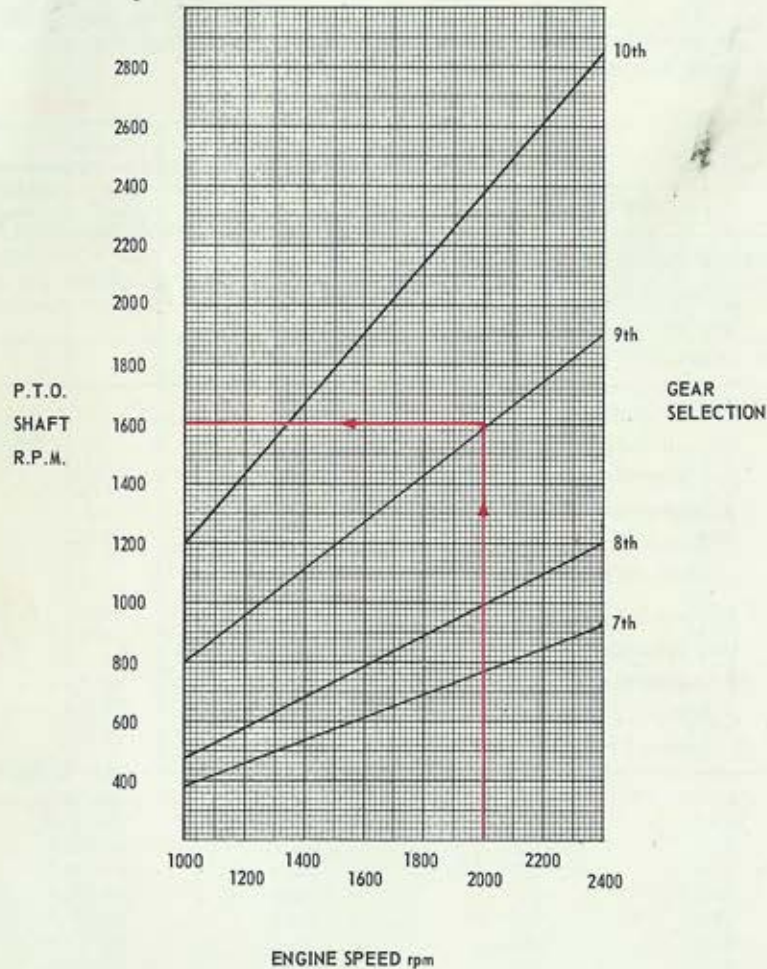

EXAMPLE 2000 ENGINE rpm IN 9th GEAR GIVES 1600 P.T.O. rpm

MAINTENANCE

How long and how well your Ford Tractor continues to give satisfactory performance depends largely upon proper maintenance. Keep the tractor in good working order by following the instructions in this section on lubrication, mechanical maintenance, minor adjustments and storage.

When major overhauls become necessary, see your Ford Tractor and Implement Dealer. He is interested in you and your tractor, and is properly equipped to meet your service needs.

*A properly maintained tractor
is a Safe tractor.*

INSPECTION

Before your tractor was delivered to you, the dealer performed a pre-delivery inspection which is the first step in the maintenance schedule of your tractor. Some of the more important items checked by your dealer are the cooling system, front end, engine, transmission, hydraulic system, rear end, and the general physical condition of your new tractor. A detailed listing of the inspections performed is shown on your Service Policy under the Pre-Delivery and 50-Hour Inspection report.

50-HOUR INSPECTION

After you have operated your tractor for a period of fifty hours, see your Ford Tractor and Implement Dealer. At this time, he will perform the factory recommended 50-Hour Inspection without charge, except for lubricants. Remember that the dealer is interested in your tractor's performance. See him periodically for continued good service.

LUBRICATION

Since your tractor will be subjected to a variety of operating conditions, it is extremely important that all moving parts be lubricated at the proper time. Use clean containers and recommended grades of lubricant to avoid causing serious damage to your tractor.

The following guide describes, in hourly intervals, the lubrication services required by your tractor. These time intervals are based on average working conditions. When operating under extremely hot or dusty conditions, lubricate the tractor more frequently.

The location of the lubrication points described in the lubrication guide are shown in Figures 28 and 29, on pages 48 and 49.

SERVICE DAILY OR EVERY TEN HOURS

Crankcase Ventilating System: Remove the element in the Rocker Arm Cover Breather and clean with a suitable solvent. Coat the element with light engine oil before replacing.

Oil Filler Breather Cap: (Gasoline Engines) Remove the element, clean the entire assembly with solvent and coat the element with light engine oil.



Figure 21
Crankcase Oil Level Dip Stick

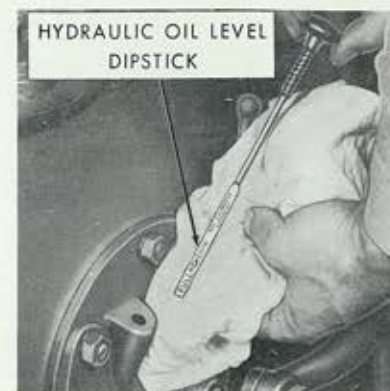

Figure 22
Hydraulic Oil Level Dip Stick

Pressure-Type Fittings: Clean the fittings on the Lift Link Leveling Box and Fork, Front Axle Spindles, Clutch Pedal, Steering Drag Links and the Clutch Release Bearing. Apply pressure gun grease and wipe the fittings clean. See Figure 28.

NOTE: It is recommended that the clutch release bearing be lubricated with high melting point lithium grease (M1C7B) after every eight to ten hours of operation. *The volume of grease to be inserted is one or two strokes from the average one-pound grease gun.*

Crankcase Dipstick: Remove the dipstick from the right side of the engine crankcase, see Figure 21. Always wipe the dipstick with a clean cloth, replace it and then remove it again to determine the oil level. Maintain the level at the full mark with a reputable brand of engine oil marked for Service MS for gasoline or DM for diesel. Refer to "SERVICE EVERY 100 HOURS."

NOTE: Install dipstick tightly, so that it seals the opening.

Hydraulic System Dipstick: Check the level of the hydraulic oil on the dipstick, shown in figure 22, and maintain at the full mark with the proper lubricant as recommended under "SERVICE EVERY 600 HOURS." *When checking the hydraulic oil level, always be sure all hydraulic cylinders are fully extended.*

NOTE: Tractors equipped with a P.T.O., but no hydraulic system, should have 6 quarts of Ford M-4864-A Oil in the front compartment of the center housing. This brings the oil level 3" above the bottom of the housing. This level requires no check during the life of the tractor under normal operating conditions.



Figure 23
Diesel Tractor Air Cleaner

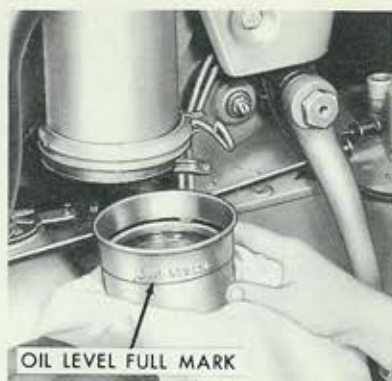

Figure 24
Checking the Air Cleaner Oil Level

Air Cleaner: Remove the oil cup and clean with a suitable solvent. Refill the cup to the oil level mark with engine crankcase oil. See Figure 23 for Diesel Tractors and Figure 24 for Gasoline Tractors.

Diesel Fuel Filter: The fuel filter should be drained daily to remove any water from the fuel system. This is done by opening the drain cock, Figure 25, at the rear of the filter base and allowing the fuel to drain for several seconds.

NOTE: It is necessary to bleed the fuel filter only when changing the filter element or when it is suspected that air is trapped in the system. See page 45 for bleeding the fuel filter.

SERVICE EVERY 100 HOURS

Gasoline Engine Crankcase: Change the engine oil in your new tractor at the 50-hour inspection and every 100 hours of operation thereafter. Drain the oil after the engine has reached normal operating temperature. Refill the crankcase with four quarts of a reputable brand of engine oil marked for Service MS and add one extra quart of oil if the filter is replaced.

*SAE 20 (20W-40)—Temperatures consistently above 90° F.

**SAE 10 (10W-30)—Temperatures between 90° F. and 32° F.

SAE 10W (10W-30)—Temperatures between 32° F. and -10° F.

SAE 5W (5W-20)—Temperatures below -10° F.

*SAE 30 recommended after the first year's operation.

**SAE 20 recommended after the first year's operation.

Diesel Engine Crankcase: Change the engine oil in your new tractor at the 50-hour inspection and every 100 hours of operation thereafter. Drain the oil after the engine has reached normal operating temperature. Refill the crankcase with four quarts of the recommended engine oil and add one extra quart of oil if the filter cartridge is replaced. It is recommended that a reputable brand of diesel engine oil be used.

SAE 30—Temperature above 55° F.

SAE 20-20W—Temperature 20° F. to 55° F.

SAE 10-10W—Temperature -10° F. to 20° F.

SAE 5-5W—Temperature below -10° F.

Oils marked with the API Service Classification DM or Supplement 1 (S1) are satisfactory for use under normal operating conditions. Oils marked with the API Service Classification DS or Series 3 are satisfactory for all engine operation and are strongly recommended when any one or a combination of the following conditions may be encountered:

- (a) High air temperatures.
- (b) Intermittent operation at low temperatures.
- (c) Fuel contains high sulfur content.

Distributor (Gasoline Engines):

Place a few drops of seasonal engine oil in the oil cup, Figure 21. Do not over lubricate.

Rear Axle: Remove the rear axle inspection plug (13), Figure 28, and check the level of the oil. If necessary, add oil. Refer to "SERVICE EVERY 600 HOURS."

4-Speed and 5-Speed Transmissions:

Remove the transmission oil level inspection plug (24), Figure 28, and add oil, if required. Refer to "SERVICE EVERY 600 HOURS."

Select-O-Speed Transmission:

The Select-O-Speed Transmission is hydraulically operated and pressure lubricated, so it is important that



Figure 25
Replacing Diesel Fuel Filter

the proper lubrication level be maintained at all times. When adding lubricant, use only M-2C41 Ford Universal Hydraulic Lubricant.

Check the oil level by removing the oil level check and filler plug, and add oil as required. Always use the utmost caution to be sure that no foreign material gains access to the transmission reservoir when either removing the filler plug or adding oil to the transmission. Refer to "SERVICE EVERY 600 HOURS".

Steering Housing: Check the lubricant level at the steering gearcase plug (20), Figure 28. Add grade "O" grease with a suction gun and fill to the level of the filler plug hole.

Power Steering Pump Reservoir: Check the oil level every 100 hours of operation. Remove the pump reservoir top, Figure 28. It is essential that the tractor wheels be straight ahead when checking the oil level and that the level be maintained to $\frac{5}{8}$ " from the top edge of the can. Clean the filter screen if sediment is noted in the fluid.

IMPORTANT: Use only automatic transmission fluid-type "A" or oil meeting Ford specification M-2C41, in the Power Steering System. Always use clean fluid. Dirty fluid may cause extensive damage to the system. Do not mix oils.

Air Cleaner: Remove the oil cup and chaff screen from the base of the filter, Figure 24. Remove the air cleaner body from the tractor. Clean the air cleaner assembly in solvent. Allow the filter mesh to drain dry and then install the body assembly on the tractor. Install the chaff screen, and fill the oil cup to the level mark with engine oil.

SERVICE EVERY 200 HOURS

Oil Filter: Replace the filter with every other engine oil change and add one additional quart of engine oil to fill the new filter.

Generator: Oil the generator rear bearing with light engine oil. Do not over lubricate.

Distributor (Gasoline Engines): Remove the cap and dust shield. Wipe the cam, the outside of the distributor, the wires and the coil with a clean cloth. Apply a portion of Ball Bearing Grease about the size of a match head on the distributor cam. Use Ball Bearing Grease only.

SERVICE EVERY 400 HOURS

(Diesel Engines)

Fuel Filter: The fuel filter element should be replaced after every 400 hours of operation. To replace the element, close the fuel shut-off valve located at the bottom center of the fuel tank. Open the drain cock at the bottom rear of the filter base, Figure 25, and drain the fuel into a drain pan. Remove the cover assembly and filter element by turning the cover counterclockwise.

NOTE: The filter element is spring-loaded and will raise from the filter base as the cover assembly is backed off. To prevent dirt from entering the outlet line to the fuel pump, the spring-loaded seal will cover the opening when the filter is removed. This should remain in place when changing the filters. There are two filter element gaskets; one located at the top and one at the bottom of the element. The gaskets and element should be discarded.

Wipe out the inside of the filter base with a clean lint-free cloth and flush with clean diesel fuel, allowing the fuel to drain through the drain cock. Clean the cover and bolt assembly in diesel fuel.

Position the new element over the rubber grommet on the center post of the filter base. Place the cover and bolt assembly through the center core of the element and depress the element slightly to start the bolt threads. Tighten the cover and bolt assembly finger tight, and then open the fuel shut-off valve.

After installing a new element, bleed the fuel filter. This is done by opening the drain cock at the bottom rear of the fuel filter base. The fuel will flow by gravity from the tank to the filter. When the fuel starts to flow through, close the drain cock. Open the air bleed screw, located at the top of the filter assembly, two turns to release the trapped air. When the air bubbles disappear, close the bleed screw.

NOTE: Never open the bleed screw when the engine is running, as air will be sucked into the system.



Figure 26
Diesel Fuel Filter

SERVICE EVERY 600 HOURS

Front Wheel Bearings: Clean the front wheel bearings thoroughly with solvent and repack with a high grade short fiber grease. Lubricate the spindle shaft before replacing the bearings.

4-Speed and 5-Speed Transmissions: Change the transmission oil at the 50-hour inspection and every 600 hours of operation thereafter. In winter, operate the tractor to thin the oil before draining. Fill the 4-speed transmission with 6½ quarts, and the 5-speed transmission with 8½ quarts of mild extreme pressure lubricant (SAE 80), both summer and winter.

Select-O-Speed Transmission: In order to obtain peak transmission operation and smooth shifting characteristics, it is important that you have your Ford Dealer adjust the transmission bands after every 600 hours of operation.

Hydraulic System: After the first 50 hours and every 600 hours of operation thereafter, change the oil in the hydraulic system. In winter, operate the system to thin the oil before draining. Clean the fill port area carefully before removing the plug to prevent dirt from entering the system. At temperatures below 10° F., use 6 quarts of M-4864-A and 2 quarts of M-4864-D hydraulic oil. Fill the system with 8 quarts of M-4864-A hydraulic oil at temperatures above 10° F. or 8 quarts of M-2C41 oil at any temperature. **NOTE:** Do not mix M-2C41 oil with other oils.

Differential: Replace the oil in the differential after the first 50 hours of operation and every 600 hours thereafter. In winter, operate the tractor to thin the oil before draining. On Series 2000 tractors, refill the differential with 8 quarts of oil. On Series 4000 tractors refill the differential with 11½ quarts of oil. See (25), Figure 28. Use mild extreme pressure lubricant SAE 80, both summer and winter.

NOTE: The tractor rear wheel bearings are sealed and require no further lubrication for the life of the tractor.

Diesel Fuel Injectors: Fuel injectors should be removed, cleaned, and tested after every 600 hours of operation. **THIS IS VERY IMPORTANT.** To prevent waste of useful tractor power, we suggest that you contact your Ford Tractor and Implement Dealer when the fuel injectors on your tractor have 600 hours of operating time. Your Ford Tractor and Implement Dealer has access to the special testing and adjusting equipment required for servicing diesel tractor injection systems. See Figure 35.

SERVICE EVERY 1200 HOURS

Select-O-Speed Transmission: After the first 50 hours and every 1200 hours of operation thereafter, have the transmission oil and filter changed by your Ford Tractor and Implement Dealer. Use Ford M-2C41 lubricant for replacement. See Figures 27 and 29.

MECHANICAL MAINTENANCE

In addition to lubrication services, regular mechanical maintenance is necessary to keep your tractor performing at maximum efficiency. The information in this section has been prepared to help you perform certain routine jobs on your tractor. Avoid breakdowns during the busy seasons by checking these items frequently and making the necessary repairs or adjustments. For major repair work or service parts, see your Ford Tractor and Implement Dealer.

COOLING SYSTEM

Radiator Pressure Cap: The cooling system shown in Figure 30, operates under pressure which is controlled by the radiator cap. Keep the cap installed tightly at all times.

CAUTION: When removing the radiator cap, slowly loosen the cap to prevent possible injury from escaping steam.

Always remove the cap when draining the radiator. If lost, a new cap may be purchased from your dealer.

Thermostat: The thermostat automatically regulates the temperature within the cooling system by controlling the flow of coolant through the radiator. If it does not function properly, it should be replaced. On gasoline engines, the thermostat should start to open at 157 to 162° F., and be fully open at 177 to 182° F. On diesel engines, the thermostat should start to open at 177 to 182° F., and be fully open at 197 to 202° F.

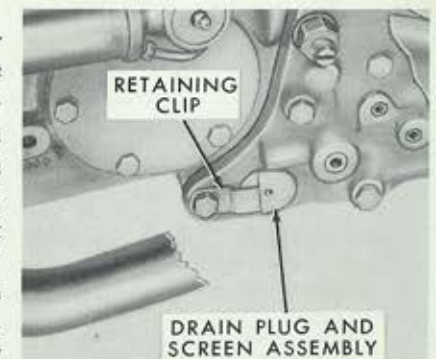

Figure 27
Select-O-Speed Drain Plug

LUBRICATION

EVERY 10 HOURS

19 ROCKER COVER BREATH-ER CAP (GAS EN-GINE)—Clean and Oil

15 OIL FILLER BREATHER CAP (GAS EN-GINE)—Clean and Oil

8 AIR CLEANER—Clean and Oil

18 CRANKCASE DIP STICK—Check Oil Level

12 HYDRAULIC SYSTEM DIP STICK—Check Oil Level

7 DIESEL FUEL FIL-TER—Drain Daily

LUBRICATE PRESSURE FITTINGS BELOW:

2 DRAG LINKS (FRONT)

6 POWER STEERING CYLINDER

4 SPINDLE PINS

23 DRAG LINKS (REAR)

10 CLUTCH PEDAL

26 LEVELING BOX

21 CLUTCH RELEASE Bearing (HD Option)

TOP VIEW OF TRACTOR

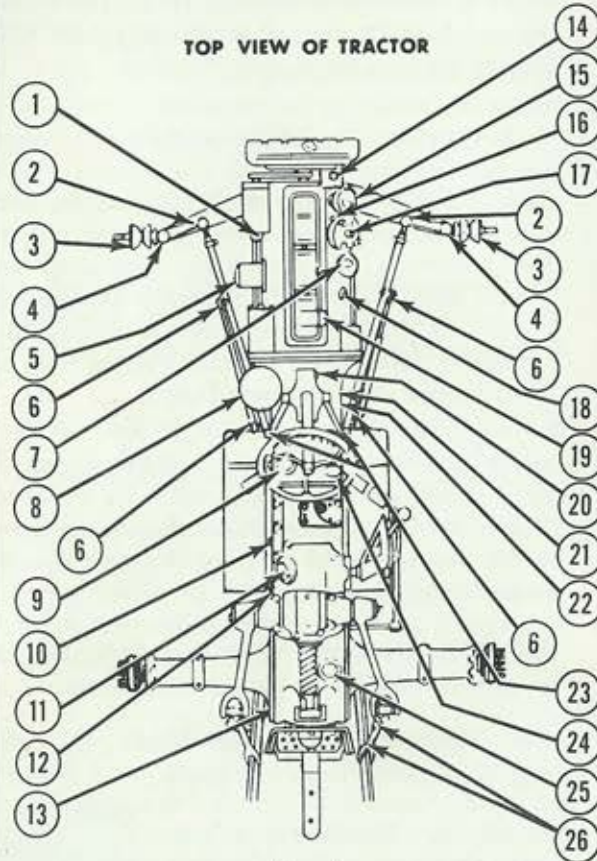

Figure 28

EVERY 100 HOURS

14 POWER STEERING PUMP RESERVOIR—Check Oil Level and Replenish with Automatic Transmission Fluid — Type "A" or oil meeting Ford specifications M-2C41.

27 ENGINE CRANKCASE—Drain and Refill; and See page 42 for correct Oil

13 DIFFERENTIAL—Check Oil at Level Plug on Side of Housing and Add Oil if necessary.

8 AIR CLEANER—Clean Chaff Screen

24 4-SPEED AND 5-SPEED TRANSMISSION—Check oil at level plug on side of housing and add oil if necessary.

22 SELECT-O-SPEED TRANSMISSION—Check oil at level and filler plug on side of housing and add oil, if necessary. (Use only M-2C41 Ford Universal Hydraulic Lubricant.)

20 STEERING HOUSING—Check Lube Level

16 DISTRIBUTOR (GAS ENGINE)—Few Drops of Engine Oil in Cup

CHART

UNDERSIDE VIEW OF TRACTOR

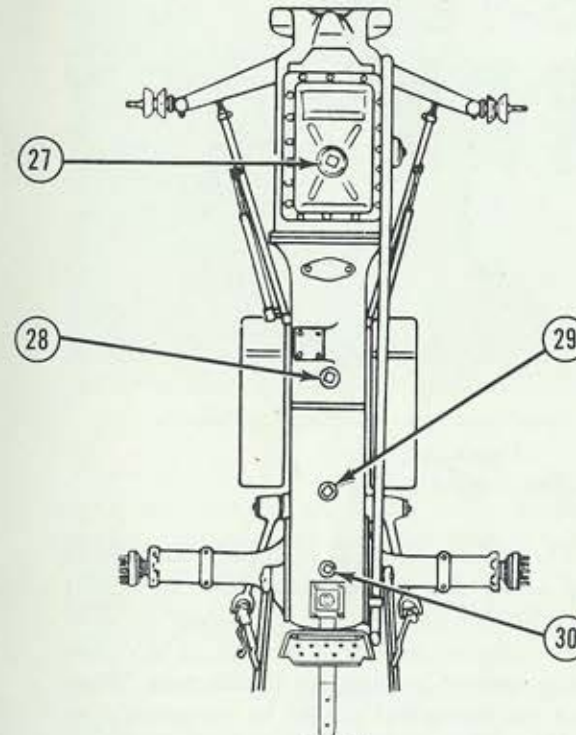

Figure 29

EVERY 600 HOURS

FUEL INJECTORS—Clean and Test

3 FRONT WHEEL BEAR-INGS—Repack with High Grade Short Fiber Grease (Ford Spec. M4664)

28 4-SPEED AND 5-SPEED TRANSMISSION—Drain and Refill (Use Mild Extreme Pressure Lubricant SAE 80, Both Summer and Winter)

29 HYDRAULIC SYSTEM—Drain and Refill (Below 10° F. — Mix 6 Qts. M-4864-A with 2 Qts. M-4864-D) (Above 10° F. — 8 Qts. M-4864-A) or 8 Qts. M-2C41 at any temperature

30 DIFFERENTIAL—Drain and Refill (Use Mild Extreme Pressure Lubricant SAE 80, Both Summer and Winter)

EVERY 1200 HOURS

22 SELECT-O-SPEED TRANSMISSION—After the first 50 hrs. and at 1200 hrs. thereafter, drain and refill using M-2C41 Lubricant both Summer and Winter

FUEL INJECTORS—Clean and Test

EVERY 200 HOURS

5 OIL FILTER—Replace every other engine oil change and add one quart of oil to fill new cartridge.

1 GENERATOR—Oil rear bearing with light oil. Do not over lubricate.

17 DISTRIBUTOR (GAS ENGINE)—Light Film of Distributor Lubricant on Cam.

EVERY 400 HOURS

7 DIESEL FUEL FILTER—Replace Element

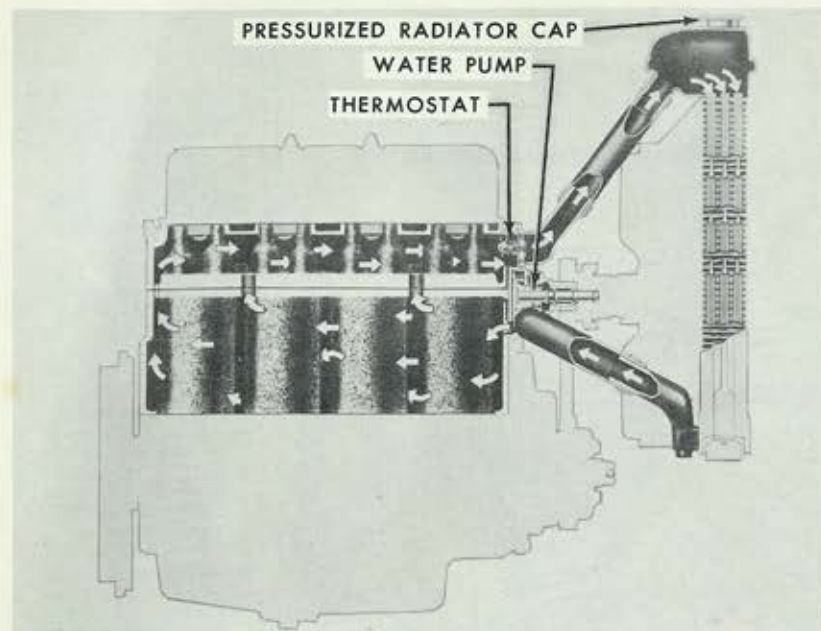

Figure 30
Engine Cooling System

Cleaning and Protection: The cooling system is equipped with a 50-50 mixture of Ethylene Glycol Anti-Freeze (Ford Specification M-97B18) of highest quality. The rust-inhibiting properties of the coolant are effective for two years. When the original coolant is drained, it is recommended that a similar quality coolant be used for replacement. When servicing the cooling system the thermostat should be temporarily removed and the radiator should be flushed.

Drain the system by opening the petcock at the bottom of the radiator, the drain cock at the left side of the cylinder block, and removing the radiator cap. When servicing the cooling system open the radiator grille and carefully clean the radiator fins by flushing with water.

Water Pump and Fan Belt: The water pump is driven by the fan belt. Check the belt periodically for proper tightness. Adjust the tension by loosening the two generator pivot bolts and the belt tension adjusting bolt. Move the generator away from the engine until a $\frac{1}{4}$ inch belt deflection is obtained with normal thumb pressure, as shown in Figure 31.



Figure 31
Adjusting Fan, Generator and Power Steering Pump Belts

Power Steering Pump Drive Belt: The power steering pump is driven by a belt from the crankshaft pulley. Check this belt periodically for proper tightness. Adjust the belt tension by tightening or loosening the turnbuckle, located between the top of the fuel tank bracket and the pump body, until a $\frac{1}{4}$ inch deflection is obtained with normal thumb pressure at belt center.

GASOLINE ENGINE FUEL SYSTEM

When properly cleaned and adjusted, the air and fuel system on the Ford Tractor will help provide maximum power and smooth engine performance with a minimum amount of fuel consumption.

Fuel Tank: Use only clean fuel which has been stored in a dry, cool place. At the end of each day of operation, refill the fuel tank to remove moisture laden air and reduce condensation. This is extremely important during cold weather.

Sediment Bulb: To clean the carburetor gas line sediment bulb, turn the fuel shut-off valve clockwise to the "OFF" position. Loosen the sediment bulb retaining nut and move the retaining clamp sideways until the bowl can be removed, Figure 33. Remove and clean the disc screen and wipe



Figure 32
Adjusting the Carburetor (Series 2000)

the bowl with a clean cloth. Then replace the assembly and tighten securely. Always clean the fuel filtering screen in the sediment bulb when the bulb is cleaned. If the sediment bulb quickly accumulates an excessive amount of dirt after cleaning, the fuel tank should be drained and cleaned thoroughly.

Carburetor: Before attempting to adjust the carburetor, the engine must be operated at normal temperature as shown on the gauge. Refer to Figure 32 for Series 2000 Tractors and Figure 33 for Series 4000 Tractors when performing the adjustments in the following three paragraphs:

***Idle Speed Adjustment Stop Screw:** With the hand throttle in the closed position, turn the stop screw on the engine side of the carburetor until the engine idle speed is 450 to 475 rpm on the Proof-Meter. On an engine that is not yet broken in, it may be necessary to set the idle speed higher to keep the engine from stalling at idle speeds.

**Maximum speed adjustment is explained under "Governor".*

Idle Air Adjustment Needle: For the initial setting, before the engine is started, turn the idle adjustment needle clockwise until it just seats. Then, back it off approximately one turn. Start the engine and turn the idle adjustment needle in (clockwise) until the engine begins to "roll" from too rich a mixture. Then, back the needle off until the engine runs smoothly.

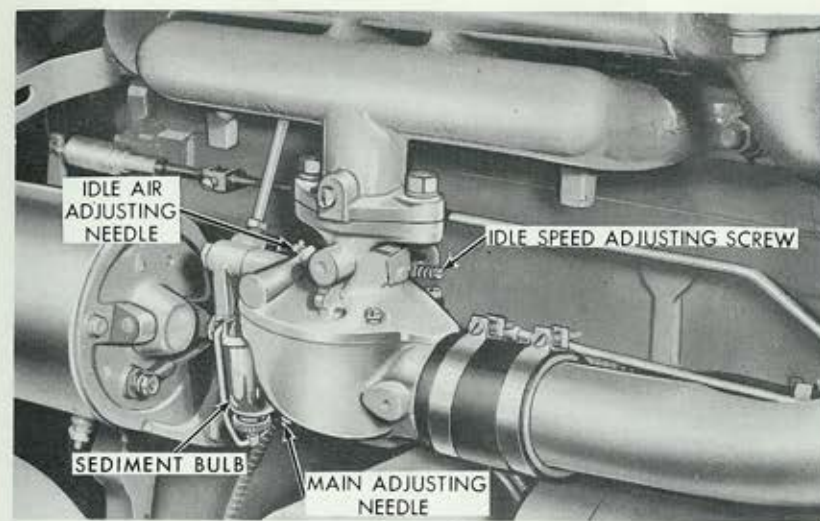

Figure 33
Adjusting the Carburetor (Series 4000)

Main Adjusting Needle: The initial setting for the main adjusting needle is $1\frac{1}{8}$ turns open (counterclockwise). The final adjustment should be made in the field or on a dynamometer. With the engine running at governed speed under full load, turn the adjustment needle in (clockwise) until the engine power just begins to drop off. Then, turn the screw out until the power picks up and the engine runs smoothly.

Governor: Constant engine speed for any given throttle setting is controlled by the action of the adjustable centrifugal governor, located on the forward end of the crankshaft. As the engine speed is increased, the action of the governor moves the governor arm, Figure 34, toward the closed carburetor throttle position until a balance between the spring tension and governor action is obtained. Maximum engine speed is controlled by the adjustable stop on the throttle rod, as shown.

Before attempting to set the engine governed speed, make certain the engine is shut off and that the governor lever and carburetor throttle arm are both in the full open position. This can be checked with the engine off by moving the hand throttle to the wide open position, removing the throttle rod at the carburetor, and holding the carburetor throttle arm in the wide open position. If the throttle rod connection will not slip over the ball on the carburetor throttle arm without moving the arm, the linkage must be adjusted. To do this, loosen the clevis lock nut and change the length of the rod as required.

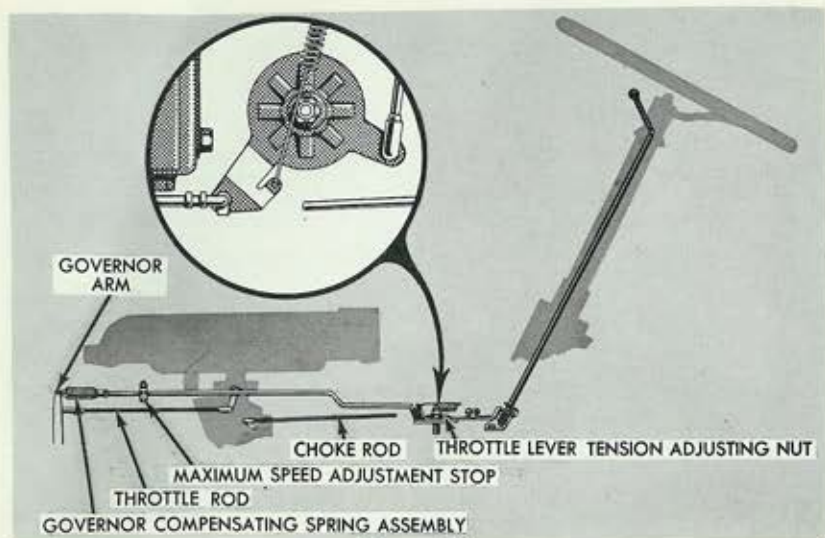

Figure 34

Governor and Control Linkage (Gasoline Engine)

Maximum governed speed must be set under no load conditions. After the tractor engine has been warmed up, set the idle speed at 450-475 revolutions per minute, then open the hand throttle to the wide open position. If the Proof-Meter registers 2200-2250 rpm on 4-speed transmission-equipped tractors, and 2400-2450 rpm on 5-speed or Select-O-Speed Transmission-equipped tractors, the governor is properly set. If adjustment is necessary, reposition the maximum speed adjustment stop as required.

Throttle Lever Position: After the tractor has been in service, some normal linkage wear occurs. The hand throttle lever may creep toward closed position when driving the tractor over rough ground. The fixed position of this lever is controlled by the tension applied by the spider spring washer on the bellcrank, see Insert, Figure 34. This tension can be increased by removing the cotter pin in the castellated nut and turning the nut clockwise until the desired tension is obtained. After adjustment, reinstall the cotter pin.

DIESEL ENGINE FUEL SYSTEM

When properly cleaned and adjusted, the air and fuel system on the Ford Tractor will help provide maximum power and smooth engine performance with a minimum amount of fuel consumption.

Fuel Tank: Use only clean fuel which has been stored in a dry, cool place. At the end of each day of operation, refill the fuel tank to remove moisture-laden air and reduce condensation. This is extremely important during cold weather.

Fuel Supply: The fuel supply to the combustion chamber is controlled by an injection pump. This pump meters and distributes the fuel under pressure to the individual injectors, which, spray (atomize) the fuel into each combustion chamber.

The volume of fuel supplied to the engine is controlled by a metering device within the pump, which is activated by the governor mechanism. The high pressure required to operate the injectors is created by internal mechanisms within the pump. The distribution of the fuel to each injector in the proper firing order is controlled by the relationship of the various passages within the pump. The injection pump is driven by the engine camshaft.

Diesel Fuel Storage: The tolerances of the closely fitted injector components and fuel injection pump parts are held within millionths of an inch. Therefore, it is vitally important that they be kept free from the damaging action of minute particles of dirt that may enter the fuel. This is particularly important during fuel handling or storage as explained in Figures 35 and 36.

Proper handling and storage of diesel fuels can help you to avoid costly repair bills on the fuel injection system of your tractor. Store diesel fuel in black iron tanks or containers. Galvanized tanks should never be used. Let the fuel settle at least 12 hours before use. This will permit any sediment or water in the fuel to settle to the bottom of the container. Use the largest container possible for the storage of fuel and keep the container as full as possible to avoid condensation.

If you are not using a filter on your storage tank, it is recommended that a funnel equipped with a 100 mesh screen be employed when filling your tractor fuel tank. A chamois skin will do the job if a mesh screen funnel is not available.

NOTE: The micron filter fitted in the fuel line of your tractor serves to remove occasional foreign material in the fuel, but it will not be sufficient to handle the volume of dirt caused by improper storage and handling. Change this filter every 400 hours or at least every 6 months.

DIESEL FUEL SYSTEM ADJUSTMENTS

The fuel injection pump is provided with an engine idle adjusting screw and a high speed adjusting screw as shown in Figure 37. In addition,

With clean injectors and normal fuel pressure (2700 pounds per square inch) only a small percentage of your tractor engine's power is required to operate the fuel injection pump.

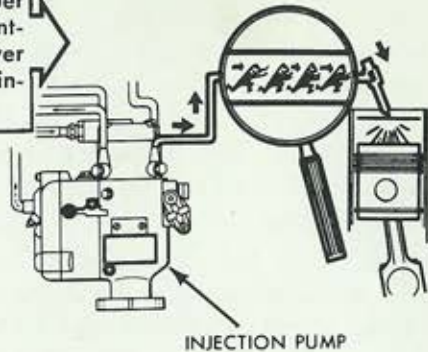

But...

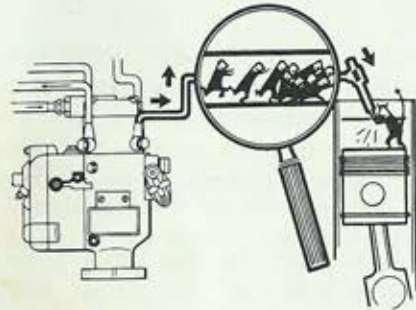

Dirty or improperly adjusted fuel injectors can contribute to a fuel pressure build-up as high as 7500 pounds per square inch in the injection lines . . . requiring an increased amount of the engine power to drive the injection pump.

This means loss of injector efficiency and loss of engine power! Power and efficiency that could be utilized for useful work. Greater fuel consumption and the possibility of worn or broken parts occur due to the additional load exerted on the pump.

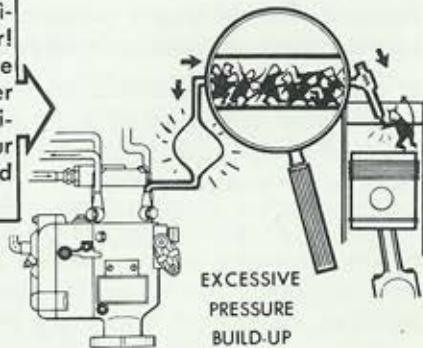
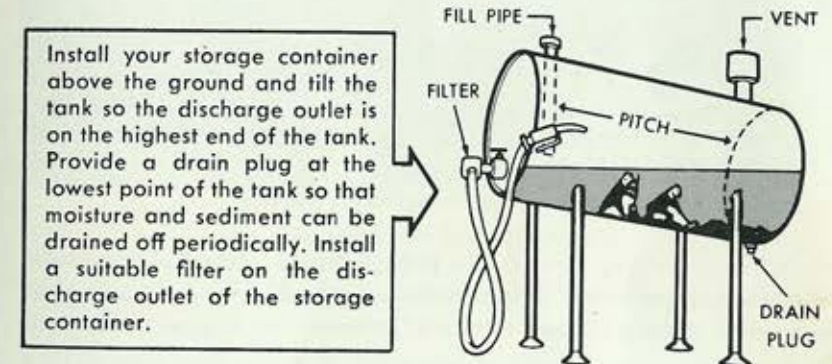

Figure 35
Fuel Injector Maintenance

the throttle linkage may be adjusted to provide for the correct amount of dead travel for the hand throttle lever. Each of these adjustments are important to the operating efficiency of the diesel tractor, and should be checked whenever the tractor is serviced.

Idle Speed Adjustment: With the hand throttle in the idle position and the engine at the normal operating temperature of 180° F., back off the jam nut 1/4 turn on the pump idle speed adjusting screw and adjust the screw for an idle speed of 675 rpm. Using an Allen wrench, turn the screw in to increase engine rpm and out to decrease engine rpm. After the correct idle speed has been obtained, lock the screw in position with the jam nut.



Install your storage container above the ground and tilt the tank so the discharge outlet is on the highest end of the tank. Provide a drain plug at the lowest point of the tank so that moisture and sediment can be drained off periodically. Install a suitable filter on the discharge outlet of the storage container.

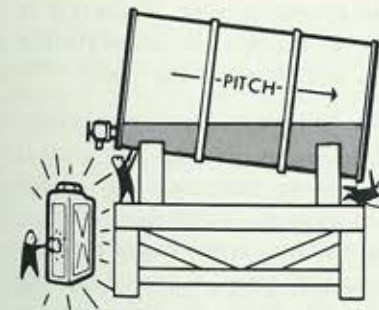

A 50 gallon drum makes a suitable container for diesel fuel, provided that it is tilted on the stand. The drum should be cleaned and flushed before each refilling.

Figure 36
Diesel Fuel Storage

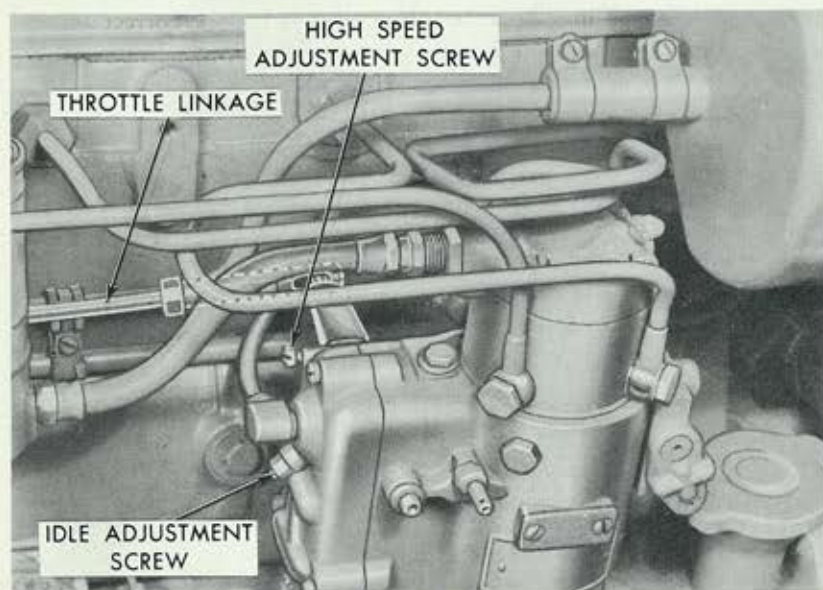

Figure 37
Diesel Fuel System Adjustments

Throttle Linkage Adjustment: The linkage should be checked for proper length in relation to the hand throttle lever dead travel at the idle position, when making normal service adjustments for engine speed.

With the engine running, set the hand throttle lever to the idle stop and disconnect the throttle linkage at the injection pump operating lever. Rotate the pump operating lever rearward to its idle position.

NOTE: There is no idle stop on the pump operating lever. When it is at idle position, a slight drag will be felt. When the lever is moved further to override this drag, it contacts the stop and shuts off the fuel.

With the pump operating lever in idle position, adjust the throttle linkage by loosening the lock nut and by turning the ball cage until it aligns with the ball on the pump operating lever. Reconnect the linkage and check for an idle speed of 675 rpm with the hand throttle lever against the idle stop. Adjust the idle speed setting at the pump if a correction is required. See "Idle Speed Adjustment". Move the hand throttle lever off of its stop (about $\frac{1}{4}$ to $\frac{1}{2}$ inch measured at the hand throttle lever). The engine should just start to pick up speed at this position, which provides a small amount of dead travel in the hand lever throttle before the engine accelerates.

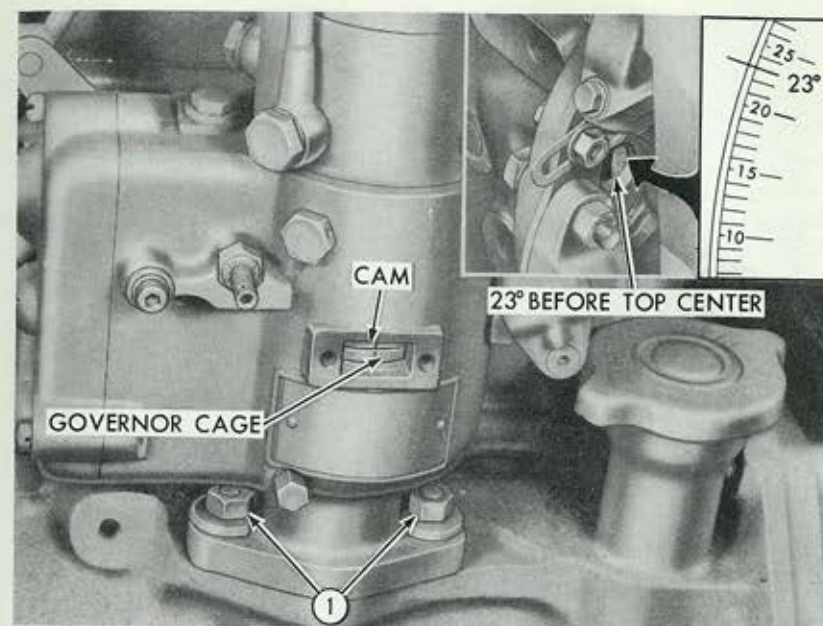

Figure 38
Diesel Pump to Engine Timing

Repeat the linkage adjustment until the hand throttle lever dead travel is established.

NOTE: The dead travel is entirely controlled by the length of the throttle linkage and must be obtained to prevent activating the pump governor in low idle range.

High Speed Adjustment: With the hand throttle in the full throttle position and the engine at the normal operating temperature of 180° F., back off the jam nut on the pump operating lever stop screw. Adjust the screw for a Proof-Meter reading of 2430 rpm with the 5-speed and Select-O-Speed Transmission tractors and for 2230 rpm with the 4-speed transmission tractor. Using a screwdriver, turn the screw out to increase engine rpm and in to decrease engine rpm. After the proper adjustments have been made, lock the screw in position with the jam nut.

Pump-to-Engine Timing: Remove the timing window cover and gasket on the fuel injection pump and rotate the engine until the timing marks align as shown in Figure 38. Remove the engine flywheel timing cover and check the flywheel degree marking, which should read 23° BTDC as shown in the Insert, Figure 38. If it does not, adjustment will have to be made.

AIR CLEANER

Regular service of the oil bath-type air cleaner is extremely important in prolonging the engine life of your tractor. See the "LUBRICATION" section under "SERVICE DAILY OR EVERY TEN HOURS", for proper servicing of the air cleaner. Figure 39 shows the passage of air through the intake screen, the oil bath, and the filtering mesh to the carburetor.

NOTE: Do not install accessory air cleaner equipment, except that handled by your Ford Tractor and Implement Dealer. The wrong type air cleaner accessory may result in increased fuel consumption and poor engine performance.

The diesel engine air cleaner, shown in Figure 23, may have to be re-located when installing certain implements on your tractor. See your local Ford Tractor and Implement Dealer for instructions.

DIESEL ELECTRICAL SYSTEM

The 12-volt electrical system of the Ford Diesel Tractor is grounded through the battery negative post.

Generator: The maximum charging rate of the generator is 25 amperes at 1500 engine rpm. The generator is driven by the fan belt. For belt adjustment, refer to "Water Pump and Fan Belt," under "COOLING SYSTEM."

If the generator will not charge, check the condition of the wires in the generating circuit. See Figure 40. Make sure all connections are clean and tight.

Battery: The level of electrolyte in the 12-volt battery should be checked at least twice each month, and if necessary, add distilled water. Battery terminals should be kept tight and free of corrosion. Two tablespoons of baking soda mixed with a pint of water will make a good solution for cleaning the battery case and corroded terminals. After cleaning, the battery should be washed with clean water. An application of petroleum jelly on the terminals will counteract corrosion.

An important point to remember is that when the battery is almost completely discharged, it will freeze at about the same temperature as pure water. Freezing will crack the battery case. For this reason, it is

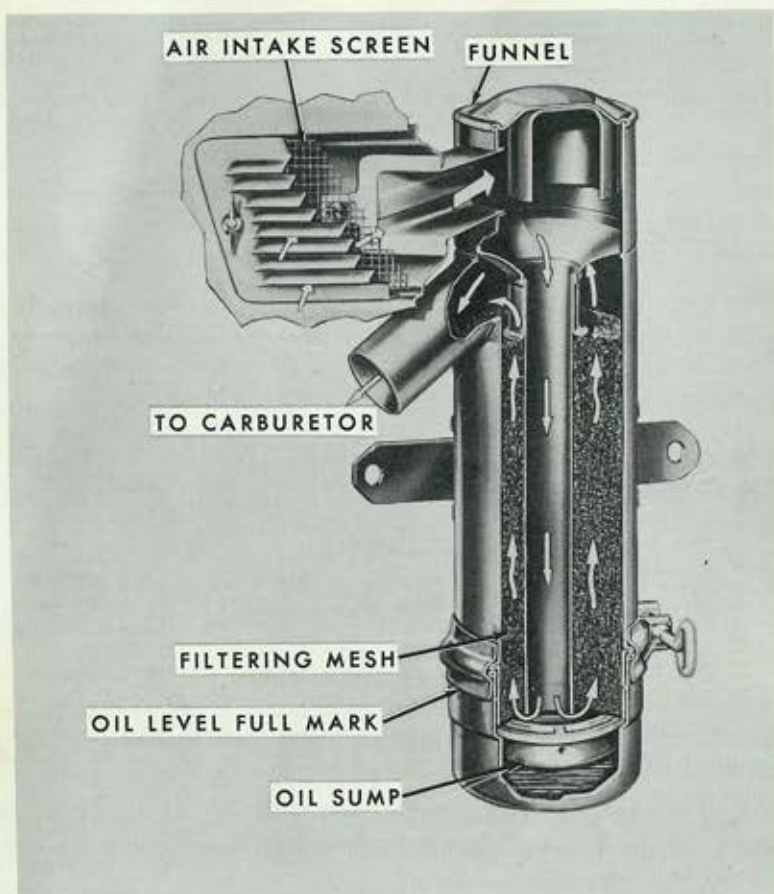

Figure 39
Air Cleaner Sectional View

To adjust, use a screwdriver on the flywheel ring gear to reverse the engine approximately 15° BTDC. Return the flywheel position back to the correct marking as outlined above. This procedure will remove the backlash from the pump drive. Loosen the pump housing at (1), Figure 38, and rotate the pump assembly until the timing marks align. Retighten the pump assembly nuts. Check the timing by rotating the engine until the alignment marks again align. If the proper timing has not been obtained, repeat the process.

Replace the engine timing cover and the pump timing window cover and gasket.

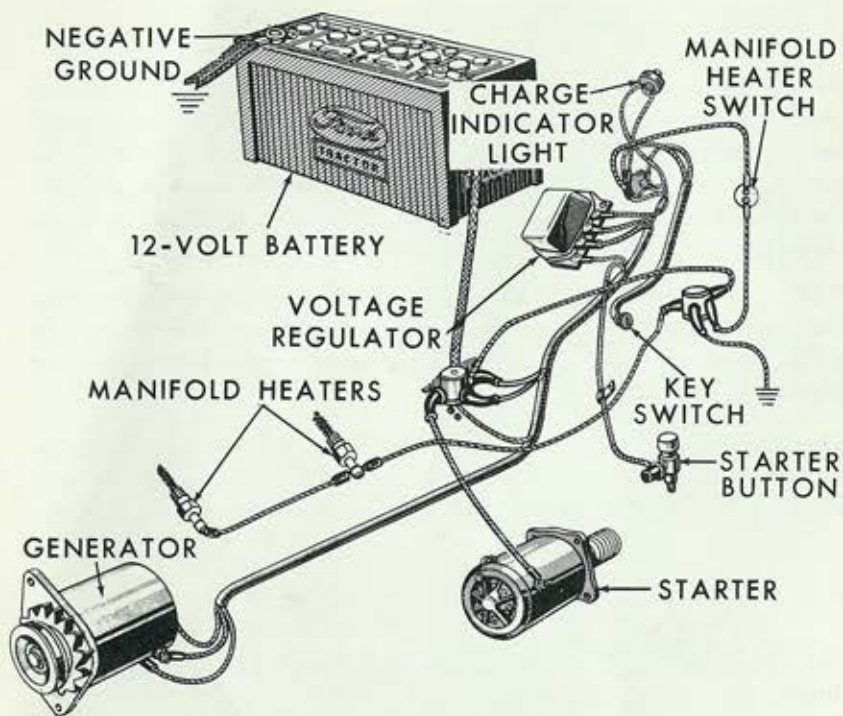

Figure 40
Diesel Tractor Electrical System

advisable to have the battery checked more frequently in cold weather to be sure it is fully charged.

The specific gravity of the electrolyte indicates the amount of battery charge. The amount of charge, with respect to specific gravity of the electrolyte, is shown in the following chart:

State of Charge	Specific Gravity Temperate Climates	Specific Gravity Tropical Climates
Fully Charged	1.275	1.225
75%	1.250	1.200
50%	1.225	1.175
25%	1.200	1.150
Discharged	1.175	1.125

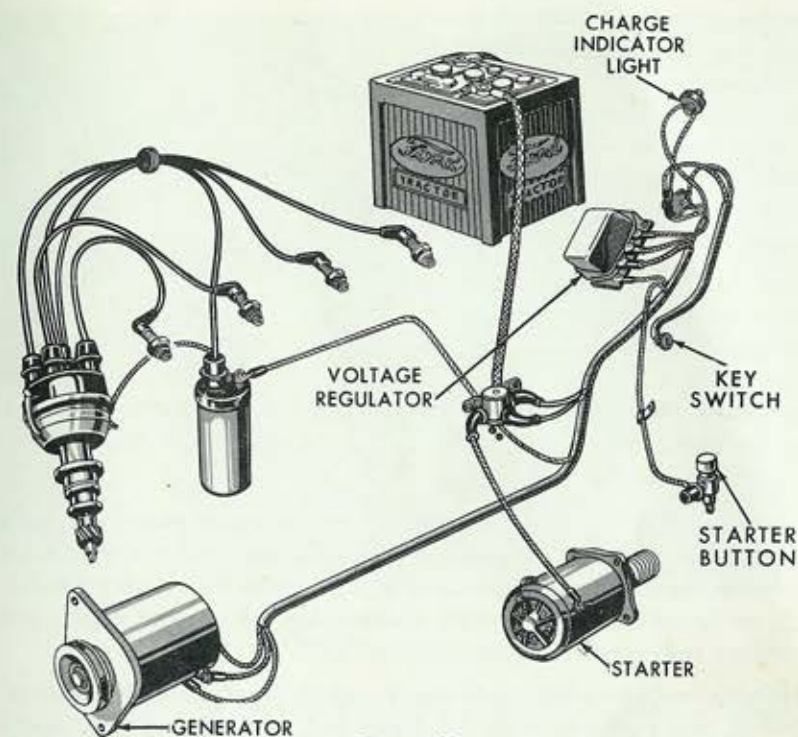

Figure 41
Gasoline Tractor Electrical System

GASOLINE ELECTRICAL SYSTEM

The 6-volt electrical system of the Ford Gasoline Tractor is grounded through the battery positive post.

Generator: The maximum charging rate of the generator is 20 amperes at 1650 engine rpm. The generator is driven by the fan belt. For adjustment, refer to "Water Pump and Fan Belt," under "COOLING SYSTEM."

If the generator will not charge, check the condition of the wires in the generating circuit, Figure 41. Make sure all connections are clean and tight.

Battery: The level of electrolyte in the battery should be checked at least twice monthly and, if necessary, add distilled water. Battery terminals should be kept tight and free of corrosion. Two tablespoons of baking

soda mixed with a pint of water make a good solution for cleaning the battery case and corroded terminals. After cleaning, the battery should be washed with clean water. An application of petroleum jelly on the terminals will counteract corrosion.

Keep the battery fully charged at all times. The specific gravity of the electrolyte indicates the amount of battery charge. The amount of charge, with respect to specific gravity of the electrolyte, is shown in the chart on page 62.



Figure 42
Checking Spark Plug Gap

Distributor Points and Spark Plugs: If the distributor points and spark plugs are not kept in proper adjustment and if the ignition system is not correctly timed, the operation of your tractor will be seriously affected. The results of improper ignition maintenance, are sluggish engine performance and excessive fuel consumption.

Under normal operating conditions, the spark plugs should be removed, cleaned, and inspected after 150 hours and replaced every 300 hours. Spark plug cleaning should be performed with a sand blast-type cleaner. Spark plugs which are cracked or have excessively burned electrodes should be replaced. The proper spark plug gap is 0.025 to 0.028 inch. To set the gap, use a standard round feeler gauge as shown in Figure 42.

Proper maintenance of distributor points is of the utmost importance. Cleaning of the points, replacing when excessively worn, and proper spacing are essential for peak efficiency.

To adjust the distributor points, remove the distributor cap and crank the engine until the breaker arm rubbing block (see Figure 43) is resting on a high point of the distributor cam. Loosen the point assembly lock screw. Insert an adjusting tool or screwdriver in the adjustment slot and move the point assembly until the proper gap is established. The point spacing is 0.024 to 0.026 inch. Tighten the point assembly lock screws after making the adjustment.

To replace the points, remove the distributor cap and remove the point assembly lock screws, Figure 43. Disconnect the condenser and primary lead, then lift the point assembly off the breaker plate. Position the new point assembly, install the lock screws, and reconnect the condenser.

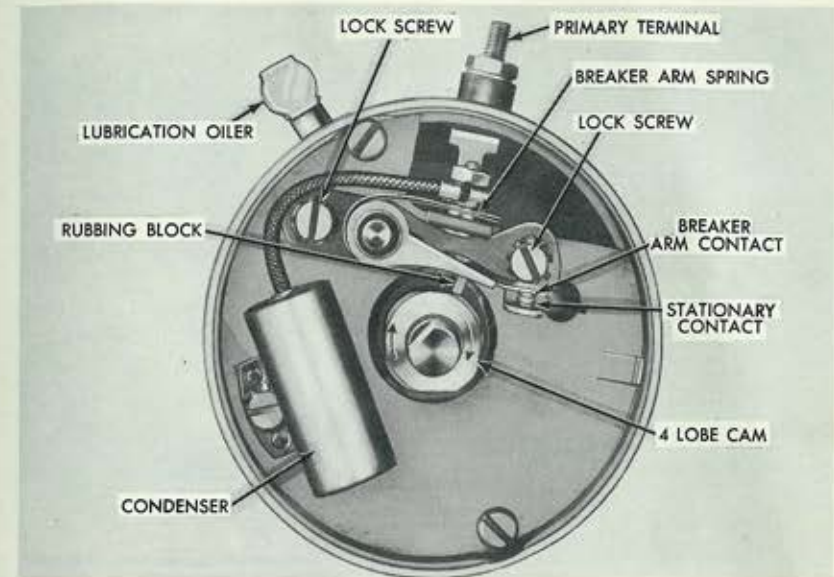

Figure 43
Distributor Assembly

Ignition Timing: When new distributor points are installed, the ignition system should be properly timed with a timing light. Connect the timing light to the engine with the high tension lead on the No. 1 spark plug and the other two leads on the proper battery terminals. Start the engine and run it at idle speed. Direct the timing light so that it flashes through the opening in the bell housing and note the timing marks, see Figure 44. Ignition timing should be 4° before top dead center at 450 engine rpm. Loosen the clamp screws, rotate the distributor slightly until this reading is obtained, and tighten the distributor body.

ENGINE

Valve Clearance: One of the most important factors governing good engine performance is that of correct valve tappet clearances. On a new tractor, correct clearances are set before the tractor leaves the factory and are checked again by your dealer at the pre-delivery inspection. It is recommended, however, that the valve clearance be checked every 250 hours of tractor operation.

To set valve clearance, run the engine until normal operating temperature is reached. Stop the engine, shut off the fuel supply, and remove

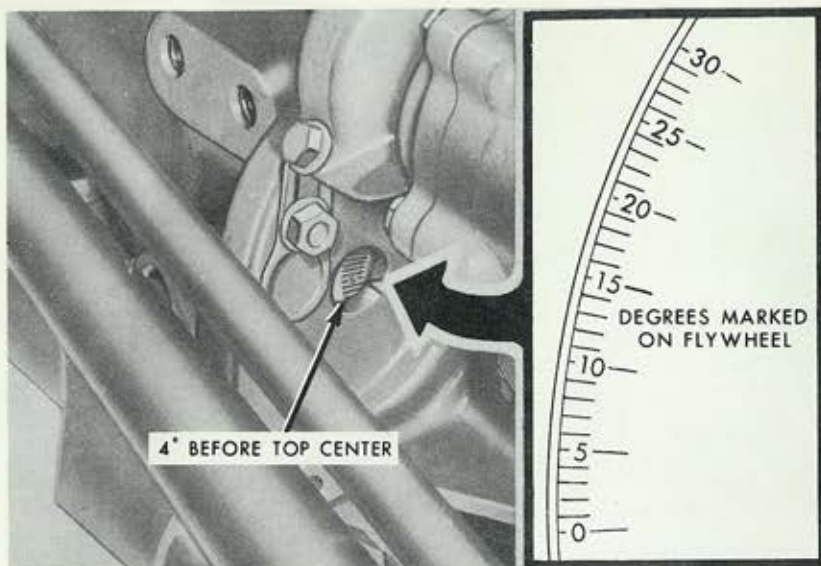

Figure 44
Basic Ignition Timing (Gasoline Engine)

the rocker shaft cover. Tappets can only be adjusted properly when the valve is fully closed. It may be necessary to crank the engine with the starter to allow valves to close when making adjustments. To adjust the tappets, turn the valve rocker arm adjusting screw in the desired direction. The correct valve clearance is .015 inch with the engine hot.

Valve Grinding: One of the factors involving good engine performance is absolute sealing of the combustion chamber by the valves and rings against compression losses. Valves and valve seats of modern engines are so hard that it is impossible to obtain a satisfactory valve reconditioning job by hand grinding. A good valve job is so important to engine performance that we recommend having your dealer perform this work whenever it becomes necessary.

Engine Tune-up: Engine tune-up procedure is intended to restore the engine to normal operating condition, providing excessive wear has not occurred. It is one of the most important maintenance services in that it determines whether or not the engine will perform with maximum economy and efficiency. Your dealer is best equipped to perform this service and advise as to the repairs or services necessary to restore the original performance of your tractor.

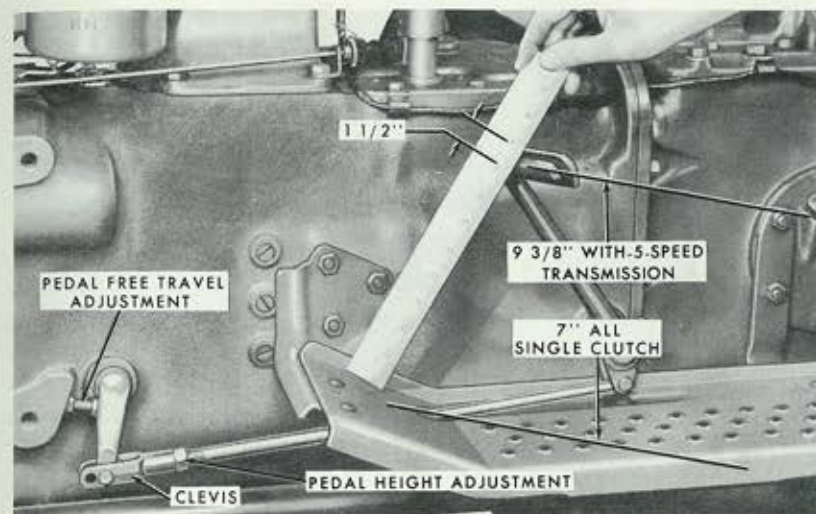

Figure 45
Clutch Pedal Adjustment

CLUTCH

To obtain proper operation and for a longer clutch life, it is necessary to maintain the recommended clutch pedal free travel. Free travel is the distance the clutch pedal can be pushed down before resistance is met.

To adjust pedal free travel, loosen the lock nut and turn the adjusting screw, Figure 45, in to increase free travel or out to decrease free travel. Set the pedal free travel at $1\frac{1}{2}$ ". Make sure the lock nut is securely tightened at all times.

For proper clutch disengagement, it is necessary that the pedal be positioned to the proper height above the running board. Adjustment is made by lengthening the clutch release rod to decrease height and shortening the rod to increase height. For all tractors except the 5-speed transmission model, adjust the height to 7". On the 5-speed transmission model, adjust to $9\frac{3}{8}$ ".

On the 5-speed transmission model, the clutch pedal can be repositioned to the 7" height for transmission clutch operation only, by relocating the clevis pin in the front clevis hole. See Figure 45.

WHEELS, BRAKES AND TIRES

Front Wheel Toe-In: When setting the wheels at the wide position, or when replacing spindles, it will be necessary to realign the wheels. This is done by measuring between the outside of the tire ribs at hub height, on both the front and rear of the wheels. Adjust the drag links until the correct toe-in of $\frac{1}{4}$ to $\frac{1}{2}$ inch is obtained.

Front Wheel Bearings: To adjust the front wheel bearings, raise the front of the tractor with a jack until the wheels rotate freely. Remove the hub cap and the cotter pin which holds the castellated nut, and turn the nut, Figure 46, until a slight drag is felt. Then back off the nut until the nearest slot in the nut is aligned with the hole in the spindle. Reinstall the cotter pin and hub cap. Pack the bearings with short fiber grease every 600 hours of operation, as directed in the "LUBRICATION" section.

Brake Adjustment: Jack the tractor up until both rear wheels are free. Remove the adjusting slot cover from the back plate and, with the brake pedals released, turn the adjusting screw clockwise until the brake drags. See Figures 47 and 48. Back off the adjusting screw until the brake drags very slightly when the wheel is turned. Adjust the left brake tie rod with the clevis until both brake pedals are in line when both brakes are engaged.

During the first hour of operation after the brakes have been adjusted, check the drums for overheating. If necessary, readjust as outlined above.

TRACTOR STORAGE

Tractors which are used seasonally should be protected while in storage.

The following operations are suggested:

1. Wash and clean the tractor thoroughly. Use Sprayon Touch-Up Enamel where necessary to avoid rust.
2. Depress the clutch pedal and secure it to the step plate with the hook provided in the tractor tool box.

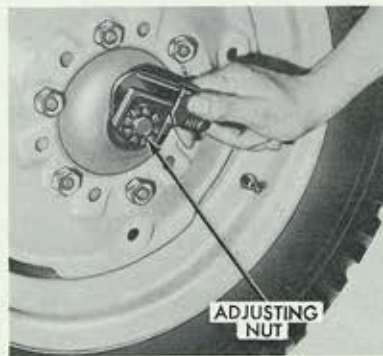

Figure 46
Adjusting Front Wheel Bearings



Figure 47
Brake Assembly—Drum Removed



Figure 48
Adjusting the Brakes

3. Lubricate the tractor, drain and refill the transmission, differential, hydraulic system, and engine, as directed under "LUBRICATION." Use engine preservative oil in the crankcase to prevent internal corrosion.
4. Remove the battery and be sure it is fully charged before placing it in storage, in a warm place. The battery should be charged periodically during storage.
5. Place blocking under the tractor axles to remove the weight from the tires.
6. Open drain cocks at bottom of radiator and on left side of engine block to drain the cooling system.
7. Check the tractor for worn or damaged parts. Replace with Ford Tractor parts.

Gasoline Engines: Drain the fuel tank and sediment bowl, and run the engine until the gasoline supply in the carburetor is exhausted.

Remove the spark plugs and pour three ounces of engine preservative oil into each cylinder. Turn the engine several revolutions with the starter, and replace the spark plugs. This will coat the combustion chamber with an oil film.

Diesel Engines: When the engine is to be stored or removed from operation for an extended period (two months or more), special precautions should be taken to protect the fuel injection pump and injector nozzles against corrosion and gumming during the shutdown period. Therefore, the fuel system should be flushed with a special oil, a quantity of which will remain in the system when the engine is shut down for storage.

Special diesel engine flushing oils are available from most oil companies. In the event that a special flushing oil is not readily obtainable, a mixture of 50% SAE No. 10W Lube Oil and 50% pure water white kerosene can be substituted. The kerosene must be sulphur free. Your local oil dealer can furnish further information on water white kerosene if necessary.

Fill the tank with two gallons of the special flushing oil and run the engine at normal speed until blue smoke appears in the exhaust to allow complete filling of the fuel injection system. There is no need to remove the injector nozzles for any special handling.

Tractors which have been placed in storage should be completely serviced in the following manner before putting back into use:

1. Inflate the tires to recommended pressure; fill cooling system (use corrosion inhibitor in warm weather, anti-freeze in winter); fill gasoline tank with fuel; check oil level in crankcase, rear end, transmission, and air cleaner, and install fully charged battery.
2. Start the engine and let it idle a few minutes. Be sure the engine is receiving lubrication and that each control is functioning correctly.
3. Drive the tractor without a load to be sure it is operating satisfactorily.

FORD TRACTOR ACCESSORIES AND SPECIAL ITEMS

TRACTOR ACCESSORIES

Bumper Assembly	P.T.O. Shield
Deluxe Seat with Backrest	Rest-O-Ride Tractor Seat
Dual Rear Wheel Kits	Reversing Transmission
Fixed Drawbar	Stabilizer Bars
Grease Gun and Bracket	Tire Pump and Gauge
Hydraulic Remote Control Valve Kit	Tractor Half Cab
Implement Lamp Kit	Vertical Exhaust Kit
Implement Warning Lamp Kit	Wheel Weights—Front
P.T.O. Belt Pulley Assembly	Wheel Weights—Rear

SPECIAL ITEMS

A complete line of chemicals, hydraulic oil and oil additives plus paints are available. For further details, see your Ford Tractor and Implement Dealer.

SPECIFICATIONS

The specifications on the following pages are provided for your information and reference. For further information see your local Ford Tractor and Implement Dealer.

The Ford Motor Company reserves the right to make changes in specifications or to add improvements at any time without notice or obligation.



*Be Safe—be careful
at all times.*

SPECIFICATIONS

SERIES 2000 AND 4000 ALL PURPOSE

GENERAL

Wheelbase @ 52" Tread Width	74.5 inches
Over-all Length @ 52" Tread Width	Series 2000 & 4000—120.83 inches
Over-all Width @ 52" Tread Width	65 inches
Front Tread Width	52 to 76 inches
Rear Tread Width	52 to 76 inches
Rear Tread Width	Power Adjusted Wheels—56 to 84 inches
Crop Clearance	21 inches (approx.)
Turning Space Diameter (with brakes)	18 feet 1 inch
Shipping Weight (Approx.)	
Series 2000 or 4000	3000 lbs.
Tire Size:	
Front-Standard	Series 2000—5.50-16-4 ply Series 4000—6.00-16-4 ply
Rear-Standard	Series 2000—12.4-28-4 ply Series 4000—13.6-28-4 ply
Rear-Optional	Series 2000—13.6-28-4 ply Series 4000—14.9-28-4 ply 14.9-28-6 ply 14.9-24-6 ply All models 14.9-24-4 ply 16.9-24-6 ply
Front Optional	Series 2000—5.50-16-4 ply 7.50-16-6 ply Series 4000—6.00-16-4 ply

CAPACITIES

Fuel Tank	Series 2000—13 U.S. gallons (10.83 Imperial gals.) Series 4000—17 U.S. gallons (14.16 Imperial gals.)
Cooling System	15 U.S. quarts (12.5 Imperial qts.)
Crankcase (including filter)	5 U.S. quarts (4.16 Imperial qts.)
Transmission	
4-speed	6 U.S. quarts (5.00 Imperial qts.)
5-speed	8½ U.S. quarts (7.08 Imperial qts.)
Select-O-Speed	12 U.S. quarts (10.00 Imperial qts.)
Hydraulic Reservoir	8 U.S. quarts (6.66 Imperial qts.)
Rear Axle	Series 2000—8 U.S. quarts (6.66 Imperial qts.) Series 4000—11½ U.S. quarts (9.58 Imperial qts.)
Steering Gear Housing	1½ pounds

CLUTCH

Type	4-speed—Single plate, 10 inch 5-speed—Double plate, 9 inch
Pedal free travel	1½ inch

4-SPEED TRANSMISSION

Gear Ratios:	
First Gear	11.00 to 1
Second Gear	9.06 to 1
Third Gear	6.22 to 1
Fourth Gear	2.98 to 1
Reverse Gear	10.50 to 1

OVER-UNDER TRANSMISSION

To obtain the under drive gear ratios, multiply the above direct drive ratios by 1.5. For the over drive ratios multiply by 0.66.

5-SPEED TRANSMISSION

Gear Ratios:	
First Gear	17.55 to 1
Second Gear	11.04 to 1
Third Gear	8.31 to 1
Fourth Gear	6.02 to 1
Fifth Gear	3.38 to 1
Reverse Gear	10.29 to 1

SELECT-O-SPEED TRANSMISSION

Gear Ratios:	
First Gear	37.93 to 1
Second Gear	26.66 to 1
Third Gear	25.63 to 1
Fourth Gear	18.01 to 1
Fifth Gear	11.27 to 1
Sixth Gear	8.77 to 1
Seventh Gear	7.62 to 1
Eighth Gear	5.92 to 1
Ninth Gear	3.66 to 1
Tenth Gear	2.47 to 1
Reverse—One Gear	12.80 to 1
Reverse—Two Gear	8.65 to 1

HYDRAULIC SYSTEM

Type	Live Action
Maximum Pressure	2000 psi
Pump:	
Type	Piston
Drive	Gear
Capacity	4 gpm at 2000 rpm (Engine)
Control (Selective)	Implement position or constant draft
Lift Capacity (at rated pressure*)	
at Ball Joints	2360 lbs.
36" behind Ball Joints	1590 lbs.

*2000 psi. Tractor must also be weighted properly on the front end.

POWER STEERING SYSTEM (OPTIONAL)

Type	External Linkage
Maximum Pressure (Relief Valve Setting)	750 psi
Pump:	
Type	Roller-Vane
Drive	Belt
Capacity	5 gmp @ 650 psi at 1600 Pump rpm
Cylinder	2 Twelve Inch Stroke Booster Cylinders
Steering Gear	Integral Steering Gear and Valve

REAR AXLE

Type	Semi-floating
Ratio	Series 2000—6.67 to 1 Series 4000—7.17 to 1

BRAKES

Type	Internal expanding
Control	Mechanical
Width	1½ inch
Drum Size	14-inch diameter
Pedal free travel	¾ inch

ENGINE (GASOLINE)

Type	4 cylinder, in-line, overhead valve
Bore	Series 2000—3.44 inches Series 4000—3.90 inches
Stroke	3.60 inches
Displacement	Series 2000—134 cu. inches Series 4000—172 cu. inches
Compression Ratio	Series 2000—7.5 to 1
Firing Order	1-2-4-3
Idle Speed	450-475 rpm
Maximum Speed (no load)	4-speed transmission—2200-2250 rpm 5-speed and Select-O-Speed Transmission—2400-2450 rpm
Pistons	Aluminum alloy
Tappet Clearance (intake and exhaust—hot)	.015 inch
Governor	Variable Speed, centrifugal type

COOLING SYSTEM

Type	Pressure
Fan	Three blade
Thermostat	Starts to open—157 to 162° F. Fully open—177 to 182° F.

FUEL SYSTEM

Type	Gravity flow
Carburetor	Single up-draft
Idle Fuel Adjustment	One turn-open
Main Fuel Jet Adjustment	Series 2000—One and one-eighth turns Series 4000—One and one-quarter turns

IGNITION SYSTEM

Type	Dist.-automatic centrifugal spark advance
Initial Timing	4 degrees B.T.D.C. at 475 rpm
Advance at 2000 rpm	20°
Distributor Point Spacing	.024 to .026
Spark Plug Size	14 MM
Spark Plug Gap	.025-.028

ELECTRICAL SYSTEM

Generator	Two brush shunt wound
Capacity	20 amps., 140 watts
Generator Regulator	Relay type
Battery	6volt-80 ampere hours
Terminal Grounded	Positive
Starter Motor	6-volt controlled with safety switch automatic follow through

ENGINE (DIESEL)

Type	4 cylinder, in-line, overhead valve
Bore	Series 2000—3.562 inches Series 4000—3.90 inches
Stroke	3.60 inches
Displacement	Series 2000—144 cu. inches Series 4000—172 cu. inches
Compression Ratio	16.8 to 1
Firing Order	1-2-4-3
Low Idle Speed	675 rpm
Maximum Speed (no load)	4-speed transmission—2230 rpm 5-speed and Select-O-Speed Transmission—2430 rpm
Pistons	Aluminum alloy
Tappet Clearance (intake and exhaust—hot)	.015 inch

COOLING SYSTEM

Type	Pressure
Fan	Two blade
Thermostat	Starts to open—177 to 182° F. Fully open—197 to 202° F.

FUEL SYSTEM

Type	Direct Injection
Governor	Centrifugal
Injection Pump	Single cylinder, opposed plunger opposed type
Pump to Engine Timing	23° B.T.D.C.

ELECTRICAL SYSTEM

Generator	Two brush shunt wound
Capacity	25 amps., 300 watts
Generator Regulator	Relay type
Battery	12 volt-135 ampere hours
Terminal Grounded	Neg.
Starter Motor	12 volt, controlled with safety switch, automatic follow through

AMERICAN PETROLEUM INSTITUTE OIL CLASSIFICATION GASOLINE ENGINES

TYPE OF OPERATION FOR WHICH OIL IS SUITABLE

API CLASS		REMARKS
MS (Motor Severe)	Recommended for all tractor operations, both light and heavy duty. This is the only type oil that should be used in tractors.	Anti-oxidation additive. Moderate detergency. In general, filling stations carry this oil in quart cans as their "best quality" oil. The terms "Premium," "HD," etc. on labels do not necessarily mean an oil of this class.
	NOTE: Oils classified ML (Motor Light) or MM (Motor Moderate), are not recommended for tractor use.	

AMERICAN PETROLEUM INSTITUTE OIL CLASSIFICATION DIESEL ENGINES

CLASSIFICATION	TYPE OF SERVICE
DG or MIL-L-2104A	Not recommended for tractor operation.
DM or Supplement 1 (S-1)	Satisfactory for general tractor operation.
DS or (Series 3)	Satisfactory for all types of operation and strongly recommended when any one or a combination of the following conditions may be encountered: <ol style="list-style-type: none"> 1. High air temperatures 2. Intermittent operation at low temperature 3. Fuel contains high sulfur content

CONTENTS

	Page
SAFETY PRECAUTIONS	2
FOREWORD	3
TRACTOR MODEL AND SERIAL NUMBER	4
CONTROLS AND INSTRUMENTS	5
OPERATION	15
4-Speed and 5-Speed Transmission Tractors—Gasoline Engine	17
Select-O-Speed Transmission Tractor—Gasoline Engine	18
4-Speed and 5-Speed Transmission Tractors—Diesel Engine	19
Select-O-Speed Transmission Tractor—Diesel Engine	21
Operating the Select-O-Speed Transmission	22
The Hydraulic System	24
Attaching Implements	27
Swinging Drawbar	27
Power Take-Off Operation	27
Belt Pulley	32
Wheel Tread Adjustments	34
Wheel Weight	35
MAINTENANCE	39
Inspection	40
Lubrication	40
Service Daily or Every Ten Hours	40
Service Every 100 Hours	42
Service Every 200 Hours	44
Service Every 400 Hours (Diesel Engines)	45
Service Every 600 Hours	46
Service Every 1200 Hours	47
Mechanical Maintenance	47
Cooling System	47
Gasoline Engine Fuel System	51
Diesel Engine Fuel System	54
Diesel Fuel System Adjustments	55
Air Cleaner	61
Diesel Electrical System	61
Gasoline Electrical System	63
Engine	65
Clutch	67
Wheels, Brakes and Tires	68
Tractor Storage	68
ACCESSORIES	70
SPECIFICATIONS	71