

FORD TRACTOR

701 AND 901

SERIES



OWNER'S

MANUAL

Prepared by
TRACTOR AND IMPLEMENT DIVISION
FORD MOTOR COMPANY

FORD *Row Crop* TRACTOR

SERIES 701 AND 901

OWNER'S MANUAL

Copyright 1958
Ford Motor Company
Dearborn, Michigan
All Rights Reserved

Prepared by
**TRACTOR AND IMPLEMENT DIVISION
FORD MOTOR COMPANY
BIRMINGHAM, MICHIGAN**

Litho in U.S.A.

SE 6172-D

STANDARD AND OPTIONAL EQUIPMENT CHART

MODEL		741	771	941	971	981
STANDARD EQUIPMENT	4-Speed Transmission	X		X		
	Select-O-Speed Transmission		X		X	X
	540 R.P.M. Transmission Driven P.T.O.	X		X		
	540 R.P.M. Independent P.T.O.		X		X	X
	1000 R.P.M. Independent P.T.O.					X
	Ground Speed P.T.O.					X
	Three Point Linkage	X	X	X	X	X
	Hydraulic System	X	X	X	X	X
	Swinging Drawbar	X	X	X	X	X
	Power Steering	X	X	X	X	X
	Proof Meter	X	X	X	X	X
	Power Adjusted Rear Wheels			X	X	X
	Tools and Tool Box	X	X	X	X	X
	Dual Front Wheels	X	X	X	X	X
	Rest-O-Ride Seat	X	X	X	X	X
11—28 4 Ply Tires	X	X				
12—28 4 Ply Tires			X	X	X	
OPTIONAL EQUIPMENT	Single Front Wheel	X	X	X	X	X
	Adjustable Front Axle	X	X	X	X	X
	Power Adjusted Rear Wheels	X	X			
	Auxiliary Transmission	X		X		
	13—28 4 Ply Tires			X	X	X
	13—28 6 Ply Tires			X	X	X

FOREWORD

We wish to congratulate you on your choice of the new Row Crop Ford Tractor. We are happy to have you as a customer and are confident that you will receive unequalled performance from the model you have selected.

This manual has been prepared to acquaint you with the many features of your new Ford Tractor. Due to the selection of front axle types, engines and transmissions available with the Row Crop Ford Tractors, most of the information presented here is general and applies to both Series 701 and 901 Tractors. Where differences exist, specific information is presented for each series or model. Read this manual carefully at your first opportunity and keep it in a convenient location for later reference. You will be particularly interested in the "break-in" instructions starting on Page 20, and the maintenance instructions starting on Page 38.

If, at any time, you have a question or problem concerning your new tractor, remember that your Ford Tractor and Implement Dealer is best qualified and equipped to serve your needs. With the proper treatment and service, your Row Crop Ford Tractor should provide you with a long life of profitable and dependable service.

TRACTOR AND IMPLEMENT DIVISION
FORD MOTOR COMPANY
SERVICE DEPARTMENT



TRACTOR MODEL AND SERIAL NUMBER

Row Crop Ford Tractors are identified by the model numbers 741, 771, 941, 971 and 981. These numbers identify the type of tractor, engine, transmission and clutch.

When ordering parts or requesting information from your Ford Tractor and Implement Dealer, always specify the Model and Serial Number of your Ford Tractor.

The Model and Serial Number is located on the left front side of the transmission housing and should be recorded immediately in the space provided below.

MODEL

SERIAL NO.

FRONT WHEEL TYPES

Your new Ford Tractor is equipped with one of three front wheel types, each of which contributes to the over-all desired working performance of your particular model.

The Dual Front Wheel, Single Front Wheel and Adjustable Front Axle Row Crop Ford Tractors were designed to cover a wide range of planting and cultivating operations, with and without front mounted equipment.

Each of these front wheel types is described in this section so that you may be afforded an opportunity to acquaint yourself with the versatility of your new Ford Tractor.



*Apply both brakes evenly when
making sudden stops.*

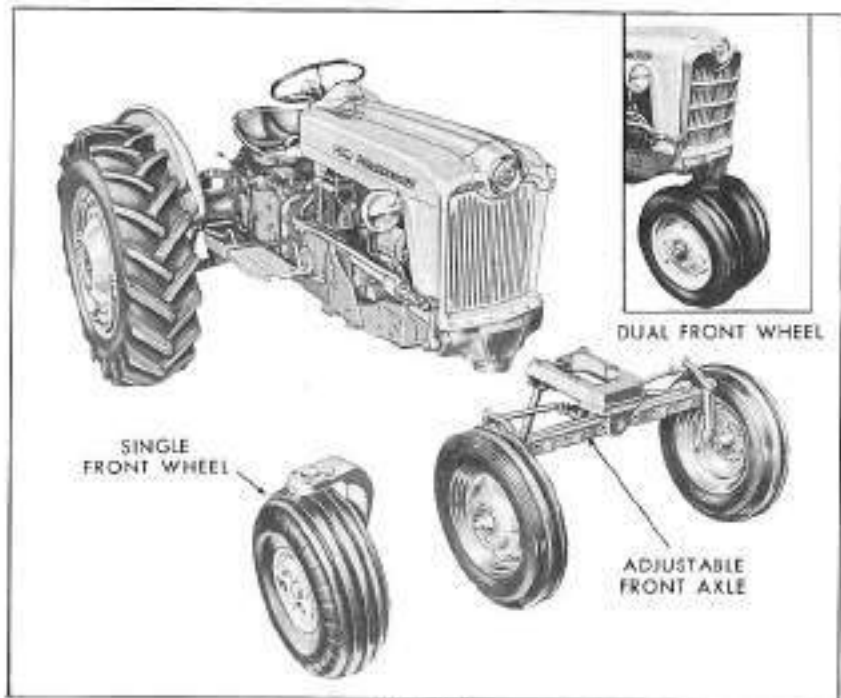

Figure 1
Row Crop Ford Tractors

DUAL FRONT WHEEL MODELS

The dual front wheel Ford Tractor is available in both the 701 and 901 Series. With its tricycle feature, it is desirable for use with front mounted equipment for planting and cultivating operations.

SINGLE FRONT WHEEL MODELS

The single front wheel Ford Tractor, also available in both the 701 and 901 Series, is especially desirable for use in irrigated fields. The single front wheel travels in the narrow furrow and steers easily with a minimum of disturbance to the furrow wall.

The single front axle shown in Figure 1 is bolted to the tractor "pedestal" a design feature which provides for the interchangeability of tractor types, from a tricycle model to a four wheel model by utilizing the adjustable front axle sold as optional equipment.

ADJUSTABLE FRONT AXLE MODELS

The adjustable front axle Ford Tractor is a four wheel model available in both the 701 and 901 Series. This model provides more belly clearance as a four wheel tractor when using specialized cultivating equipment. The adjustable front axle (See Figure 1) is bolted to the tractor pedestal. The pedestal design feature permits your Ford Tractor to serve as an all purpose or a row crop tractor by utilizing the single wheel or dual front wheel option available at extra cost. Agricultural type loaders and other equipment normally associated with four wheel tractors may also be utilized.

FRONT WHEEL OPTIONS

Owners of either the single wheel adjustable front axle or dual front wheel Ford Tractors, who desire to take advantage of the pedestal feature of these tractors, may obtain either front axle option at additional cost. See your local Ford Tractor and Implement Dealer.



Tractor Service Policy

AUTHORIZED

Ford

TRACTOR

AND
IMPLEMENT DEALER'S
SERVICE POLICY

NAME OF OWNER _____

ADDRESS _____

CITY _____

STATE _____

PHONE NUMBER _____

TRACTOR MAKE _____

TRACTOR MODEL _____

TRACTOR YEAR _____

TRACTOR TYPE _____

Serial Number and Capacity Marked _____

DATE _____

DEALER SIGNATURE _____

DEALER'S BUSINESS _____

The Ford Service Policy is valid only when used with a new Ford tractor or implement. It is not valid when used on a tractor or implement that is not new. It is not valid when used on a tractor or implement that is not new. It is not valid when used on a tractor or implement that is not new.

At the time of delivery of your new tractor, the Ford Tractor and Implement Dealer presented to you a copy of the Service Policy shown above. This policy certifies that your new Ford Tractor has been properly inspected and prepared for delivery by the dealer.

The policy should be presented to the dealer whenever you request any service which is authorized on it. We recommend, therefore, that you keep the policy in a safe place for ready reference at all times.

CONTROLS AND INSTRUMENTS

The controls on your new Ford Tractor are designed to help you do more work with the greatest possible convenience and comfort. All are within easy reach and are simple to operate.

The well-grouped instruments tell you, at a glance, whether the engine is operating efficiently and warn you of the possibility of trouble before it becomes serious.

Before attempting to start or operate your new tractor, familiarize yourself with the location and function of all controls and instruments.



*Know your controls and instruments
to assure Safe Operation.*

CONTROLS AND INSTRUMENTS

REST-O-RIDE TRACTOR SEAT

Take your place in the tractor seat. Special torsional rubber springs provide maximum comfort and safety, and permit adjustments to fit the weight of nearly any operator. If the seat is not in the most comfortable operating position, it may be moved forward, rearward or tilted up and down. The seat pan may be tilted back, permitting the operator to stand, or to protect it from dew and rain.

LIGHT SWITCH

The tractor lights are operated by means of a switch on the lower right side of the instrument panel, just below the side panel. Pull the switch out to turn the lights on.

IGNITION SWITCH

The ignition switch is located on the lower left side of the instrument panel, just below the side panel. Turn the key clockwise to turn the ignition on, and counter-clockwise to turn it off.

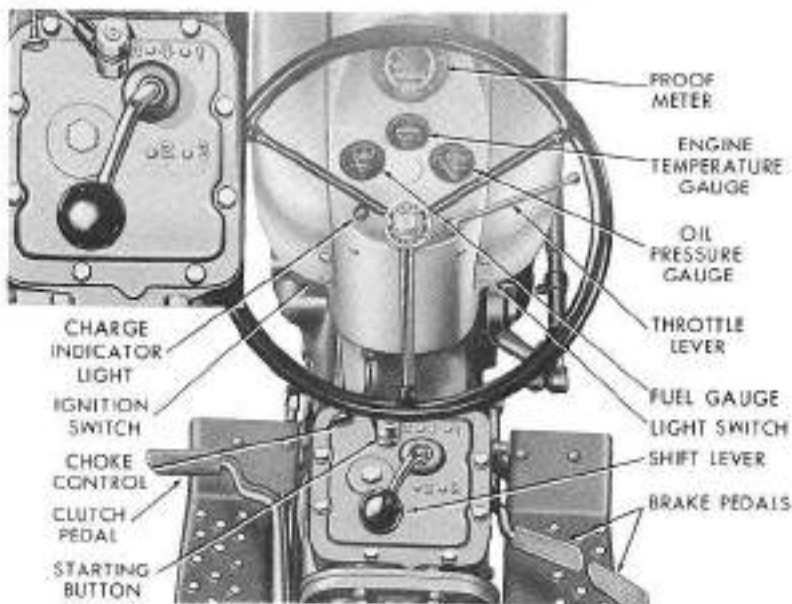

Figure 2
Controls and Instruments

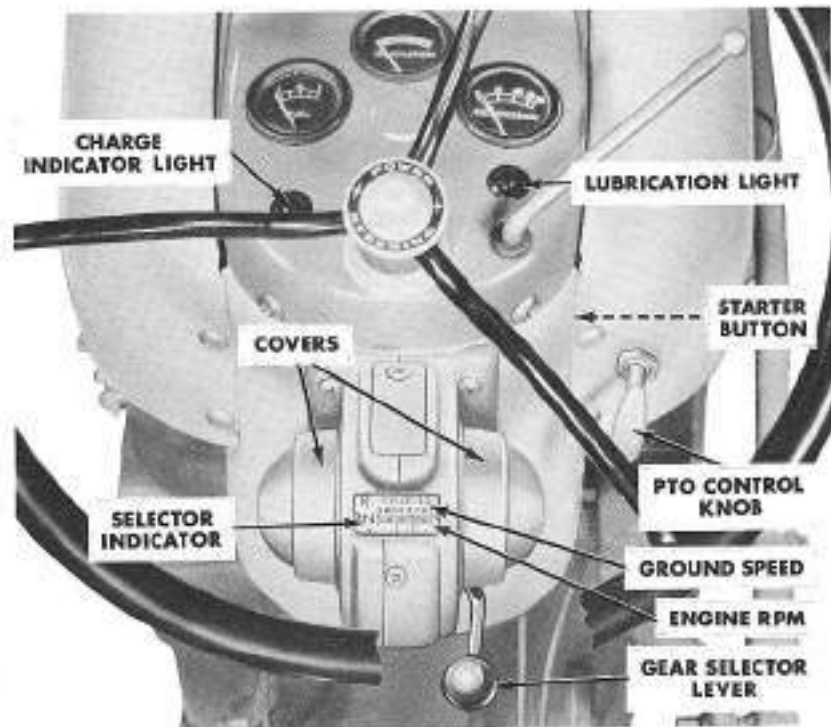

Figure 3

Controls and Instruments on the Select-O-Speed Transmission

CHOKE CONTROL

Initial starting may require the use of the choke control located to the left of the starter button. After the engine has been sufficiently warmed up, the choke control should be returned to its normal position as soon as possible.

GEAR SHIFT LEVER

The 4-Speed Transmission gear shift lever is located directly in front of the tractor seat.

For your convenience, a diagram of the shift positions is provided on the transmission cover as shown in the insert, Figure 2.

SELECT-O-SPEED SHIFT LEVER

The Select-O-Speed Transmission shift lever is located on the speed selector housing which is directly under the steering wheel. As the lever is shifted, a selector indicator, Figure 3, shows the gear selected.

STARTER BUTTON

On 4-Speed Transmission equipped tractors, a safety type starter button is located on the top of the transmission housing within easy reach of the operator. As a safety feature, the starter button will not start the engine until the gear shift lever is placed in the neutral (N) position.

On Select-O-Speed Transmission equipped tractors, the safety type starter button, Figure 3, is located on the underside of the hood panel. As a safety feature, the starter button will not start the engine until the shift lever is placed in the park (P) position.

THROTTLE CONTROL

The hand operated throttle control is located at the right side of the steering wheel column. Pull the lever down to increase the engine speed.

OIL PRESSURE GAUGE

The engine oil pressure gauge indicates the oil pressure through oil passages, but does not show the amount of oil in the crankcase. Oil in the crankcase can become dangerously low and still show pressure on the gauge. Check the pressure gauge periodically when operating your tractor to be sure that the lubrication system is operating satisfactorily.

TEMPERATURE GAUGE

The engine temperature gauge at the top center of the instrument cluster registers the temperature of coolant in the cooling system. Form the habit of checking this gauge frequently. The green block indicates normal temperature, red indicates overheating and orange shows that the engine is operating at too cold a temperature.

FUEL GAUGE

The fuel gauge indicates the fuel level when the ignition switch is turned on. Check this gauge frequently to make sure the fuel supply is adequate.

CHARGE INDICATOR LIGHT

The generator charge indicator light will flash on when the ignition switch is turned on and while starting the engine. After the engine starts and the engine speed is increased, the light will go out. The charge indicator light flashes on if the generator is not supplying current to the battery.

LUBRICATION LIGHT

The Select-O-Speed Transmission is pressure lubricated. A lubrication light, Figure 3, indicates low oil pressure when lit.

CLUTCH PEDAL

On 4-Speed Transmission equipped tractors the foot operated clutch pedal, located on the left side of the transmission housing, must be depressed to disengage the clutch.

INCHING PEDAL

On Select-O-Speed Transmission equipped tractors a foot operated inching pedal, Figure 6, allows you to ease into implements when attaching them, and can be used for quick disengagement of power to the rear wheels.

BRAKE PEDALS

Foot operated brake pedals are provided on the right side of the transmission housing. To stop the tractor, depress both pedals simultaneously. Apply the right brake when making short right turns, and the left brake when turning left. **CAUTION: DO NOT MAKE SHORT TURNS WHEN TRAVELING AT HIGH SPEEDS.**

BRAKE PEDAL LOCKS

Brake locks, located on the right and left sides of the rear axle housing should always be set before leaving the tractor. To lock either brake, first depress the right or the left brake pedal and pull upward on the corresponding brake control rod to engage the brake pawl. To insure lock engagement, release the brake pedal slightly while holding the control rod upward. See Figures 4 and 5. To release either brake, depress the desired brake pedal sharply. This will permit the spring loaded brake control rod to disengage the brake pawl from the brake lock.

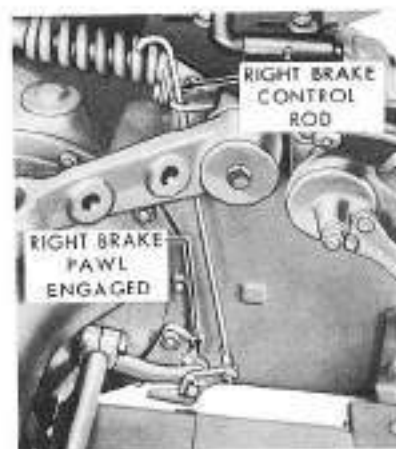

Figure 4
Brake Pawl Engaged



Figure 5
Power Take-Off Lever Engaged

POWER TAKE-OFF LEVER

On 4-Speed Transmission equipped tractors, the power take-off lever is located on the left side of the center housing. The power take-off is engaged when the lever is in the rear position (see Figure 5), and disengaged when the lever is forward. Always depress the clutch pedal when engaging or disengaging the power take-off while the tractor engine is running.

P.T.O. CONTROL KNOB

On tractors equipped with the Select-O-Speed Transmission the P.T.O. control knob is conveniently located in front of the operator as shown in Figure 3. Slowly pulling the knob outward permits gradual engagement of the P.T.O. shaft to ease into loads.

ENGINE P.T.O. SPEED SHIFT LEVER

Two engine P.T.O. speeds are available on the Model 981 tractor. When the P.T.O. speed shift lever, Figure 6, is in the forward position the P.T.O. shaft turns at the standard A.S.A.E. speed of 540 rpm. When the speed shift lever is in the rear position the shaft turns at 1000 rpm.

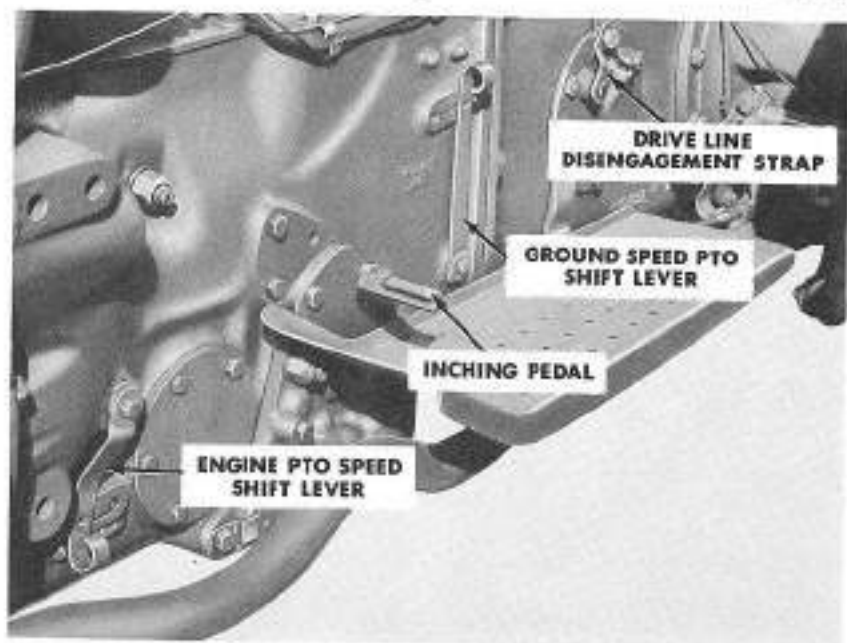

Figure 6
Controls on the Select-O-Speed Transmission

GROUND SPEED PTO SHIFT LEVER

The proportional ground speed P.T.O. is available on the Model 981 tractor. Move the ground speed P.T.O. shift lever, Figure 6, to the forward position to place the shaft in operation. To disengage the shaft, move the lever back into the "OFF" position.

DRIVE LINE DISENGAGEMENT STRAP

To tow or push a Select-O-Speed Transmission equipped tractor, when the engine is not running, the drive line must be disengaged from the rear axle. This is necessary as the Select-O-Speed Transmission shifts automatically to park (P) whenever the engine stops. Operation of the disengagement strap, Figure 6, is described on page 24 of this manual.

HYDRAULIC SELECTOR LEVER

The hydraulic selector lever under the tractor seat changes the hydraulic system from constant draft to implement position control. Place the lever in the down position for Constant Draft Control, and in the up or horizontal position for Implement Position Control. See Figure 7.

HYDRAULIC LIFT CONTROL LEVER

The lift control lever, which controls the hydraulic system, is the large lever to the right of the tractor seat. To raise the lift arms, raise the lever to the top position. To lower the lift arms, push the lever to the lower position.

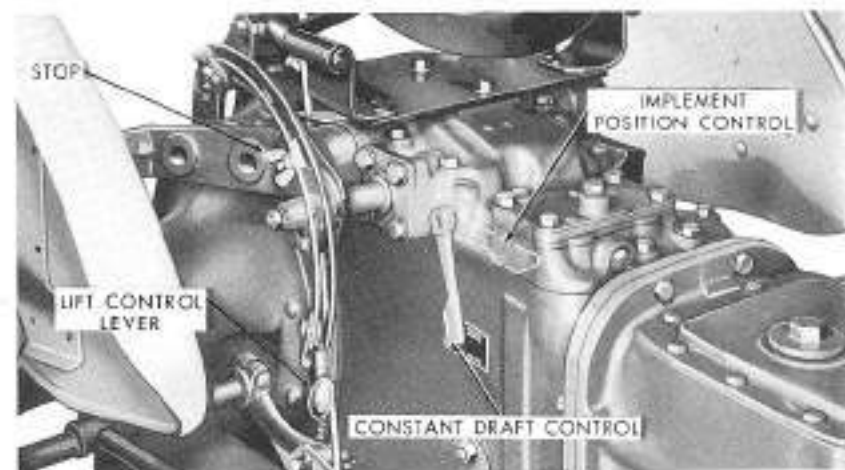

Figure 7
Hydraulic Control Levers

FUEL SHUT-OFF VALVE

The fuel shut-off valve is located at the center underside of the fuel tank (see Figure 31). Turn the valve to the right (clockwise) to shut off the fuel supply to the carburetor. Turn the valve (counterclockwise) to the stop to allow the fuel to flow.



Figure 8
Proof-Meter
4-Speed



Figure 9
Proof-Meter
Select-O-Speed

PROOF-METER

The Ford Tractor Proof-Meter, conveniently located at the top center of the instrument panel, is actually five instruments in one. The separate functions of the Proof-Meter are described in the following paragraphs and illustrations.

Engine Speed: Engine revolutions per minute, from 0 to 2400 rpm are shown on the outer band of the Proof-Meter. Knowing the correct engine speed is helpful in checking correct oil pressure and maintaining the proper engine idle speed.

Tractor Ground Speed: The ground speed (M.P.H.) on tractors with 4-Speed Transmissions is read in the band directly under the gear number on the pointer as shown in Figure 8. On Select-O-Speed Transmission equipped tractors, the ground speed is given in 10th gear only and is read on the inner band of figures as shown in Figure 9.

P.T.O. Speed: The American Society of Agricultural Engineers (A.S. A.E.) standard for power take-off speed is 540 = 10 revolutions per minute. This is shown on the 4-speed Proof-Meter at 1485 engine rpm and on the Select-O-Speed Proof-Meter at 1750 engine rpm. Most power take-off implements will operate at maximum efficiency

when the Proof-Meter pointer is held at this speed. On Model 981 tractors an additional P.T.O. speed of 1000 rpm is available. This P.T.O. speed is also indicated at 1750 engine rpm. For further information on the power take-off, refer to page 27 of this manual.

Belt Pulley: For best performance, most stationary machinery must be operated at the correct belt speed. The A.S.A.E. has established a standard range for belt speeds of from 3000 to 3200 feet per minute. A belt speed within this range is reached with a standard nine-inch belt pulley when the Proof-Meter indicates 1750 engine rpm for the 4-Speed Transmission equipped tractor and 2200 engine rpm for the Select-O-Speed Transmission equipped tractor. The belt speed is dependent on the size of the belt pulley and the pulley rpm. For further information on pulley sizes and belt speeds consult the chart on page 31.

CAUTION: Do not operate the belt pulley with the engine P.T.O. speed shift lever in the 1000 rpm position.

Engine Hours: The hour meter portion of the Proof-Meter represents the hours your tractor engine has "worked," based on an average engine speed of 1515 revolutions per minute. Engine speeds below 1515 revolutions accumulate hours more slowly than clock hours, and those above 1515 R.P.M. register faster than clock hours. Use this feature of the Proof-Meter to determine when service and maintenance are necessary. It will help you cut operating costs and prolong the life of your new tractor.

Watch Your Proof-Meter Decal

WATCH YOUR PROOF-METER

**EVERY
15 HOURS**

Lubricate All Fittings, Check Air Cleaner,
Check Engine Oil.

**EVERY
100 HOURS**

Change Engine Oil, Check Oil Level in Steering
Housing, Hydraulic System, Transmission and Rear
Axle, Pedestal and Both Right and Left Final Drives.

**EVERY
200 HOURS**

Change Oil Filter, Oil Rear Governor Bearing,
In-Airline Distributor Cam.

**EVERY
400 HOURS
OR MORE
OFTEN**

Inspect Front Wheel Bearings, High Grade Short
Fibre Grease, Renew and Clean Air Cleaner
Assembly, Change Oil in Transmission, Rear Axle
and Hydraulic System and Both Right and Left
Final Drives.

FOLLOW SEASONAL REQUIREMENTS BELOW

Engine Oil	WINTER (Below 32°F) S. A. E. 50—10W	SUMMER (Above 32°F) S. A. E. 30 or 30
Hydraulic System	(Below 10°F) Nix 3 Part M-4884-A With 1 Part M-4804-D	(Above 10°F) M-1854-A

Transmission, Rear
Axle, Pedestal and
Both Final Drives

Use Ford Hydraulic Oil H-4504-B
Winter and Summer

BATTERY CHECK AND FILL WITH CLEAN WATER WEEKLY

WARNING!

SERVICE AIR CLEANER DAILY
VERY DUSTY CONDITIONS TWICE DAILY
USE S. A. E. 30 OIL ABOVE 40°F
USE S. A. E. 10W OIL BELOW 40°F
AIR INLET SCREEN MUST BE KEPT
CLEAN AND FREE FROM OIL
CLEAN BOTTOM FILTER AND
CENTER TUBE MONTHLY
KEEP HOSE CONNECTIONS TIGHT
USE OF ADDITIONAL CLEANERS
NOT RECOMMENDED

THIS TRACTOR IS CONSTRUCTED
UNDER ONE OR MORE OF THE
FOLLOWING UNITED STATES
PATENTS

2,468,809	2,440,277
2,488,469	2,434,257
2,557,000	2,421,314
2,540,428	2,491,519

Other Patents Pending

MADE IN U.S.A.

Ford

REG. U. S. PAT. OFF.

CALL YOUR FORD TRACTOR DEALER
FOR SERVICE . . . USE ONLY
GENUINE FORD TRACTOR PARTS . . .



To emphasize the importance of establishing regularly scheduled lubrication periods, a copy of the above decal is fixed to the inside of every tractor hood. The information on the decal has been condensed from the lubrication information on pages 34 through 39. Watch your Proof-Meter and use the decal as a reminder of the lubrication services required by your tractor.

OPERATION

Your new Ford Tractor has been built with the knowledge gained through manufacturing over two million farm tractors. In it you will find many new and exclusive features, designed to make your work easier, faster and more profitable.

After familiarizing yourself with the tractor controls and instruments, read the following instructions on OPERATION. They will help you obtain maximum efficiency and dependable operation from your new Ford Tractor.



*A careful operator is the best insurance
against accidents.*

OPERATION

PRE-STARTING CHECK

Your Ford Tractor and Implement Dealer has checked your tractor thoroughly. We suggest, however, that you double check the tractor before placing it in operation. Make certain that the crankcase, transmission, hydraulic system, pedestal, rear axle and final drive housings are filled to the recommended level. Check the tires for proper air pressure and be sure that the radiator is filled with coolant.

FUEL

Ford high compression gasoline engines are designed to operate most efficiently with the anti-knock qualities in good regular grade gasoline. The use of poor quality fuel can cause knocking, overheating and engine failure.

BREAK-IN PROCEDURE

Your new Ford Tractor should provide long and dependable service if given a good start by you, the operator. During the first 50 hours of operation, do not work the tractor at full capacity. Run the engine at slow to medium speeds and use the lower gears wherever possible. Check the instruments frequently and keep the radiator and oil reservoirs filled to the recommended level.

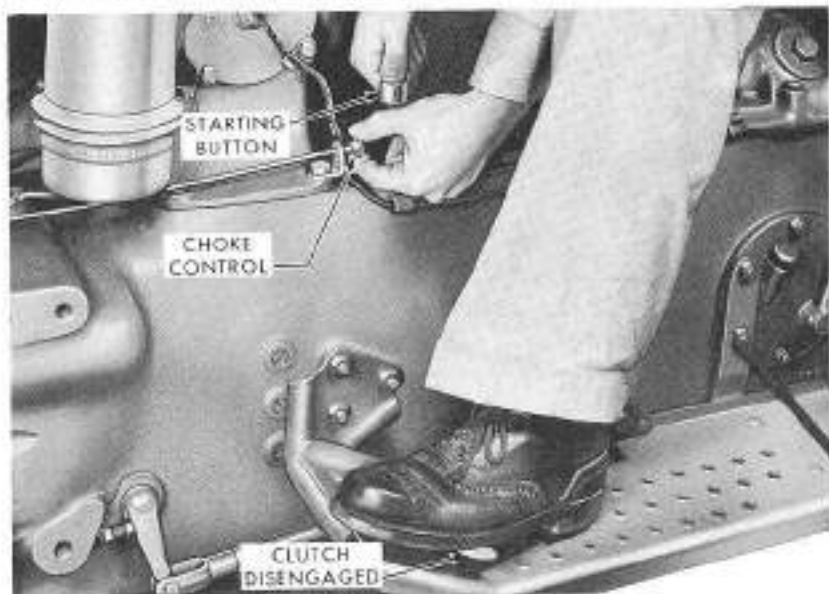

Figure 10

Using the Starter Button, Choke and Clutch Pedal

After 50 hours of operation, see your Ford Tractor and Implement Dealer. He will perform all necessary checks and adjustments in the **50 HOURS SERVICE AND INSPECTION**, authorized by your Service Policy.

4-SPEED TRANSMISSION

Starting the Engine: To start the engine under normal weather conditions, move the throttle lever to approximately $\frac{1}{4}$ open position, set the gear shift lever in neutral and turn the ignition key clockwise. Then, simply depress the clutch pedal and press the starter.

Initial starting of the engine, may require the use of the choke. Under these conditions, pull out the choke control and depress the starting button at the same time. As soon as the engine starts, push the choke in to its normal operating position. Run the engine at about 1000 rpm until it warms up before placing it under a load.

Driving the Tractor: Release both rear wheel brake locks and depress the clutch pedal. Next, move the gear shift lever to the desired gear. The shift positions are clearly indicated on the transmission cover and are shown in Figure 2.

You will save fuel and minimize engine wear by selecting the correct gear ratio for a particular operation. Operating the tractor in low gear with a light load and high engine speed is a waste of fuel. "Lugging" occurs when the load for a particular gear and throttle setting is excessive.

After shifting to the desired gear, increase the engine speed slightly and release the clutch pedal in the same manner as you would when driving an automobile. When the tractor is in motion, remove your foot from the clutch pedal and increase the ground speed as desired.

CAUTION: DO NOT ATTEMPT TO SHIFT GEARS WHILE THE TRACTOR IS IN MOTION. DO NOT TOW TRACTOR FASTER THAN 20 M.P.H.

Stopping the Tractor: To stop the tractor, depress the clutch pedal and decrease the engine speed. Apply pressure evenly to both brake pedals until the tractor is stopped, then place the gear shift lever in the neutral position, lock the brakes and turn the ignition key off. If the engine is hot, let it idle for a few seconds before turning the ignition key off.

SELECT-O-SPEED TRANSMISSION TRACTOR

Speed Selector Mechanism: The selector indicator, Figure 3, shows the gear selected and the ground speed when the tractor engine is at 1200, 1750 or 2200 rpm. Ten forward speeds (indicated by numerals 1 to 10), two reverse speeds (R₁ and R₂), a park (P), and a neutral (N), can be obtained by means of the gear selector lever. The selector indicator is lighted whenever the ignition is on.

The ten speed ranges overlap each other and provide speeds from .6 mph in 1st gear at 1200 rpm to 18 mph in 10th gear at 2200 rpm. The two reverse speeds will range from 1.9 mph in R₁ to 5.1 mph in R₂ at 2200 rpm. The selector lever will be retained in neutral for safety purposes. Therefore, when moving the lever through the neutral (N) position, it will be necessary to move it outward.

Since the transmission can be shifted "on the go", downshifting to 8th, 7th, 4th, 3rd, 2nd, and 1st gears will act as a very effective brake on down grades. The red diagonal marks on the dial for gears 5, 6 and 9 indicate that they are coasting or free wheeling gears. **CAUTION:** Do not shift to coasting gears when using the transmission as a brake or on down grades.

The park position locks the rear wheels to prevent movement of the tractor. This feature is especially convenient when attaching implements or doing belt work. Any time the engine is not operating, the transmission automatically shifts to park (P) for safety purposes.

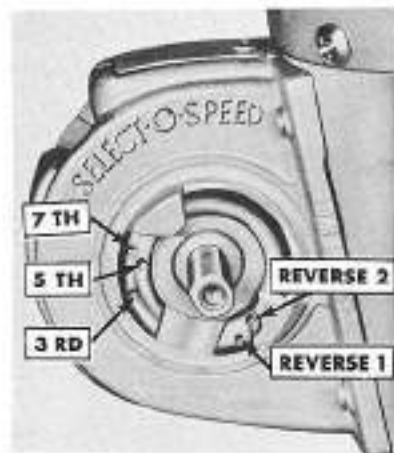

Figure 11

Selector Lever Stop Positions

Repositioning the Selector Lever:

For added convenience the selector lever on your tractor can be mounted on either side of the shifter mechanism to permit right or left hand shifting.

To move the selector lever to the opposite side of the shifter mechanism, take off both covers, Figure 3, by removing the Phillips head screw as shown at (1), Figure 11. Remove the selector lever from the shaft and position it on the shaft on the opposite side of the shifter mechanism. Switch the covers and reinstall with the Phillips head screws. Tighten securely.

Selector Lever Stops: Installation of the selector lever position stops enables the operator to establish a pre-determined shift pattern between two gears. These stops are especially convenient for loader and other material handling operations. The speed stop screws can be positioned in any two of the gears 3, 5, 7, R₁, or R₂, by inserting them in the holes provided as shown in Figure 11. These stops can be over-riden to obtain any gear by pulling outward on the spring loaded selector lever and shifting to the desired gear. When selector stops are not desired, the stop screws should be placed in the holes on the side opposite the selector lever. Tractors will be shipped from the factory with the stop screws in this location.

Starting the Engine: CAUTION: The operator should always be seated on the tractor when starting the engine.

Place the transmission selector lever in park (P) position and turn the ignition switch to the on position. Move the throttle lever to approximately ¼ open position and press the starter button. Use the choke control as required.

NOTE: The lubrication light will flash on when the ignition switch is turned on and while starting. After the engine starts, the light will go out. The light may also momentarily come on when either the foot inching pedal is partially depressed or during partial engagement of the P.T.O control knob.

CAUTION: If at any time the lubrication light remains on, low oil pressure is evident and the tractor should be immediately shut off as continued use may result in serious damage to the transmission.

Operate the engine at approximately 1000 rpm to sufficiently warm both the engine and transmission oil before subjecting the tractor to a load.

Driving the Tractor: Shift the selector lever to the desired gear and advance the throttle as required. The Select-O-Speed Transmission can be shifted while in motion.

CAUTION: Avoid shifting quickly through a series of gears while at high engine speeds as the sudden speed change may cause the tractor to surge ahead or slow down abruptly.

You will save fuel and minimize engine wear by selecting the correct gear ratio for a particular operation. Operating the tractor in low gear with a light load and high engine speed is a waste of fuel. "Lugging" occurs when the load for a particular gear and throttle setting is excessive.

Stopping the Tractor: Reduce the throttle setting, downshift the transmission to neutral (N) and apply pressure evenly to both brake pedals until the tractor is stopped. Shift the selector lever to park (P) and turn the starter switch off.

Additional braking by downshifting can be accomplished by the use of forward gears other than 5, 6 and 9, which are coasting gears and are indicated by diagonal red marks on the selector indicator.

CAUTION: Do not shift to coasting gears when using the transmission as a brake or on down grades.

NOTE: The foot operated inching pedal interrupts power flow and is operated similarly to a conventional clutch pedal where quick disengagement of rear wheels is desired.

Towing the Tractor: To tow or push a Select-O-Speed Transmission equipped tractor, when the engine is not running, the drive line must be disconnected from the rear axle. This is necessary as the Select-O-Speed Transmission automatically shifts into park (P) whenever the engine stops.

To disengage the transmission, disconnect the traction coupling as follows: Remove the nut (1), Figure 16, and strap; turn the strap over and reinstall on the shaft (2), then rotate the shaft approximately 60° to the rear. Rock the tractor to make sure the transmission is disengaged, and then replace the strap and reinstall the nut to assure that the traction coupling remains disengaged. **DO NOT TOW THE TRACTOR OVER 20 MPH.**

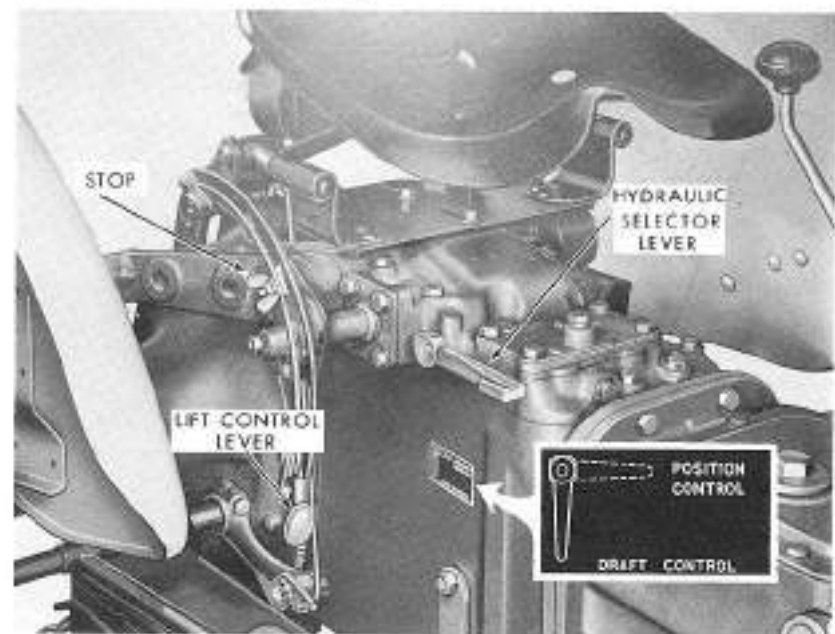

Figure 12
Hydraulic Control Levers

THE HYDRAULIC SYSTEM

One of the outstanding features of your new Ford Tractor is the Live Action Hydraulic System. By simply moving the lift control lever, the system provides instant hydraulic power for raising or lowering a wide variety of implements. Regardless of whether the clutch pedal is up or down, or whether the P.T.O. is engaged or disengaged, the system will respond smoothly, enabling you to adjust implement depth within fractions of an inch.

The system incorporates two types of hydraulic control. Depending upon the type of implement used and the soil conditions and terrain encountered, the system may be operated in Implement Position Control or in Constant Draft Control.

Implement Position Control: To operate the hydraulic system in Implement Position Control, move the hydraulic selector lever at the side of the tractor seat into the up position (see Figure 12), and set the implement at the desired depth by moving the lift control lever down. Where the ground is relatively level, the Implement Position Control will keep the implement at the desired depth, even though the soil texture may vary.

By setting the adjustable stop on the quadrant, the implement can always be returned to the original depth by moving the lift control lever down to the stop.

Constant Draft Control: With the hydraulic selector lever in the down position, as shown in Figure 12, the hydraulic system is operating in Constant Draft Control. When an implement is lowered to work at a certain depth, the draft control will maintain the same draft, even though the ground contour or soil texture may change. If the draft increases, the hydraulic system will respond by raising the implement to decrease the draft. At the same time, the weight will shift to the tractor rear wheels, increasing traction until the implement has been automatically repositioned and the draft is decreased.

When necessary, the operator may use the lift control lever to make small adjustments in the system.

Hydraulic Piston Pump: Your new Ford Tractor is equipped with a piston pump, containing six pistons. The pump, shown in Figure 13, is gear driven and provides a constant flow of oil to the Ford Tractor "live action" hydraulic system in volumes which are proportional to engine speeds. For maximum efficiency of operation and long pump life, always use the recommended hydraulic fluid (Ford Spec. M-4864-A or M-2C41) when filling the tractor hydraulic reservoir. Always use clean containers for this operation. When service on the hydraulic system becomes necessary, see your local Ford Tractor and Implement Dealer. He is properly trained and equipped to meet your service needs.

ATTACHING IMPLEMENTS

Most implements can be easily and quickly attached to the tractor three point linkage. With the selector lever in Implement Position

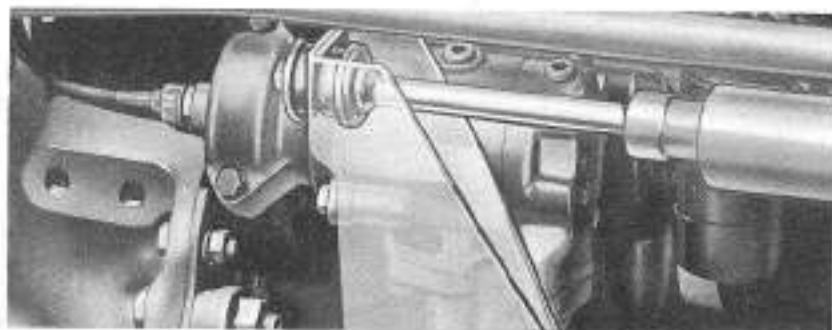

Figure 13
Hydraulic Piston Pump

Control, back the tractor so that the lift links are directly above the cross shaft of the implement. Lower the links with the lift control lever, until the sockets are aligned with the ends of the shaft. Attach the left link to the shaft and secure with the linch pin provided, then adjust the right link with the leveling crank (see Figure 14) and attach it in the same manner. Attach the adjustable top link to the implement and secure it with the linch pin.

Three Hole Hydraulic Lift Rocker: The three hole hydraulic lift rocker on the Row Crop Ford Tractor provides better control of sensitivity for light and heavy draft implements. Attach the top link in the upper hole for light draft loads (cultivating), in the middle hole for plowing (tractor wheel in furrow) and in the low hole for miscellaneous heavy draft loads when the tractor is level.

Adjustable Top Link: The fully adjustable top link provides improved implement performance and operation. The link may be adjusted to suit implement operation requirements by releasing the lock and rotating the sleeve until the desired length is obtained. The standard length of 23 inches is obtained by adjusting the link as shown on a decal located on the sleeve. (See insert, Figure 14.)

***Swinging Drawbar:** The swinging drawbar provided as standard equipment on your Ford Tractor, permits quick, easy attachment of pull type implements. The tractor can be operated with the swinging drawbar in either the "close-coupled" or "extended" positions (see Figure 15). The drawbar may also be set and used in different positions either to the left or right of center (seven in all). When operating with P.T.O. driven equipment, the drawbar should always be in the "extended" position with the offset down.

**Use bolts (not furnished) one on each side of drawbar in center position when P.T.O. is used.*

CAUTION: Remove the swinging drawbar when attaching close mounted implements.

POWER TAKE-OFF OPERATION

The power take-off transfers engine power directly to mounted or drawn implements, or to belt driven equipment when a pulley is used.

Engine P.T.O. Speeds: The American Society of Agricultural Engineers (A.S.A.E.) standard for power take-off speed is 540 ± 10 revolutions per minute and the new power take-off speed of 1000 ± 25 rpm. Most power take-off implements will operate at maximum efficiency when the P.T.O. functions within one of these two ranges.

Power Take-Off Shaft: Your Ford Tractor is equipped with a standard P.T.O. shaft ($1\frac{3}{8}$ " diameter) in accordance with A.S.A.E. specifications for attaching P.T.O. driven equipment built to A.S.A.E. standards. A P.T.O. shield, see insert, Figure 16, is available as extra equipment from your Ford Tractor and Implement Dealer. This shield should be used as a safety precaution and serves as the supporting member for pull type implement drive line shields in all operations involving P.T.O. driven implements.

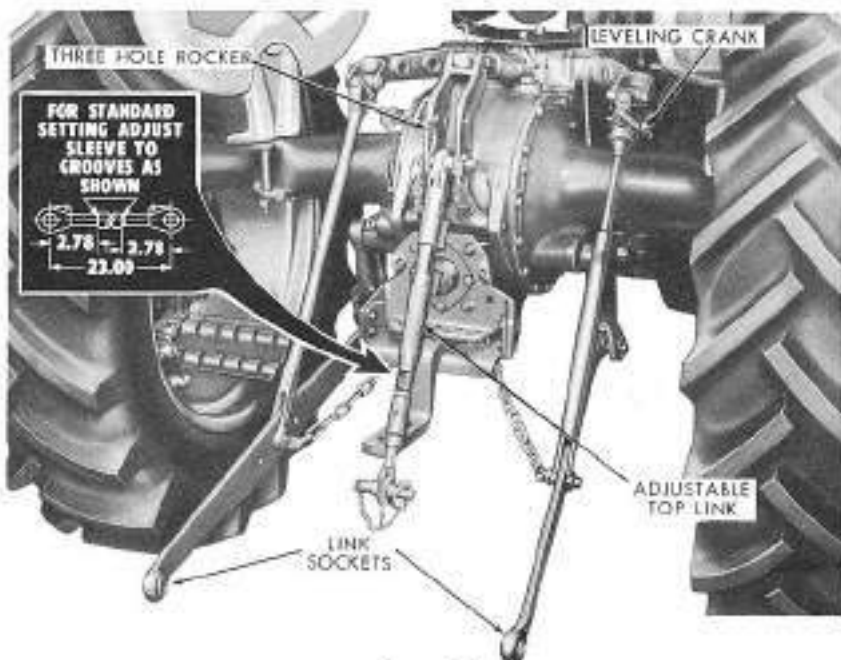

Figure 14
Leveling Crank and Adjustable Top Link

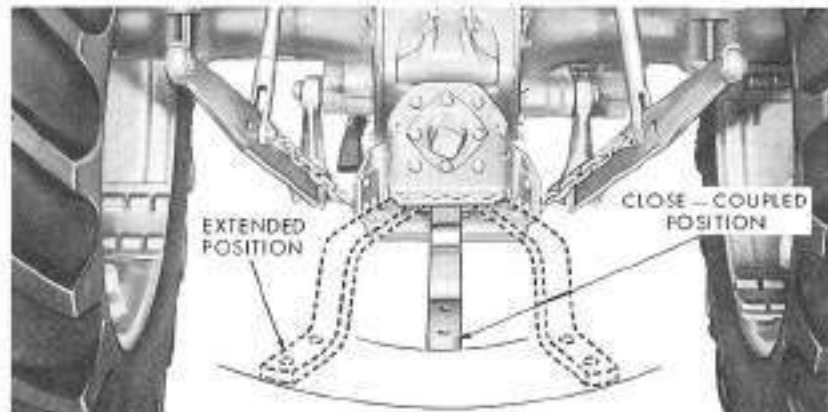

Figure 15
Swinging Drawbar

4 Speed Transmission Equipped Tractors: The power take-off shaft is engaged by depressing the clutch pedal and moving the P.T.O. lever toward the rear of the tractor (see Figure 5). When engaged, operation of the shaft may be temporarily interrupted by depressing the tractor clutch pedal.

To operate a 4-Speed Transmission equipped tractor P.T.O. shaft at the A.S.A.E. standard of 540 rpm, the engine should be operated at 1485 rpm.

Select-O-Speed Transmission Equipped Tractors with P.T.O.: The power take-off shaft is engaged by the P.T.O. control knob, Figure 3. For gradual engagement of the P.T.O. shaft to ease into loads, pull the knob out slowly until it reaches the full out position. The P.T.O. shaft is completely independent of the transmission and can be engaged or disengaged with the tractor stationary or moving.

Models 771 and 971 have a single speed engine driven P.T.O. The Proof-Meter will indicate 1750 engine rpm when the P.T.O. is operating at 540 rpm.

The Model 981 tractor is equipped with a proportional ground speed P.T.O. and two separate engine P.T.O. speeds of 540 rpm and 1000 rpm. Setting the engine P.T.O. speed shift lever, Figure 3, in the forward position will provide the 540 rpm speed and locating the lever to the rear will provide the 1000 rpm speed. These speeds are both obtained at 1750 engine rpm as shown on Proof-Meter.

All Model 981 tractors are factory equipped with a 6-spline adaptor for 540 rpm engine P.T.O. operation. To use the 1000 rpm engine P.T.O. speed, the 6-spline P.T.O. shaft adaptor must be replaced with the 21-spline adaptor provided in the tractor tool box. To change the

adaptor, loosen the socket head screw located inside the adaptor shaft with the special Allen wrench provided (in tool box). Change to the other adaptor and tighten the socket head screw securely. USE IMPLEMENTS DESIGNED FOR 1000 R.P.M. P.T.O. ONLY. The two adaptors are in accordance with A.S.A.E. Standards.

In ground speed P.T.O. the operating speed of the implement will always be proportional to the forward speed of the tractor. For every seven inches of forward travel of the tractor, the P.T.O. shaft will make one revolution, regardless of the transmission gear or engine speed.

Example of ground-drive P.T.O. speeds are as follows:

Ground Speed M.P.H.	P.T.O. Speed R.P.M.
1.5	226
2.5	377
3.5	528
4.5	679
5.5	830
6.5	981

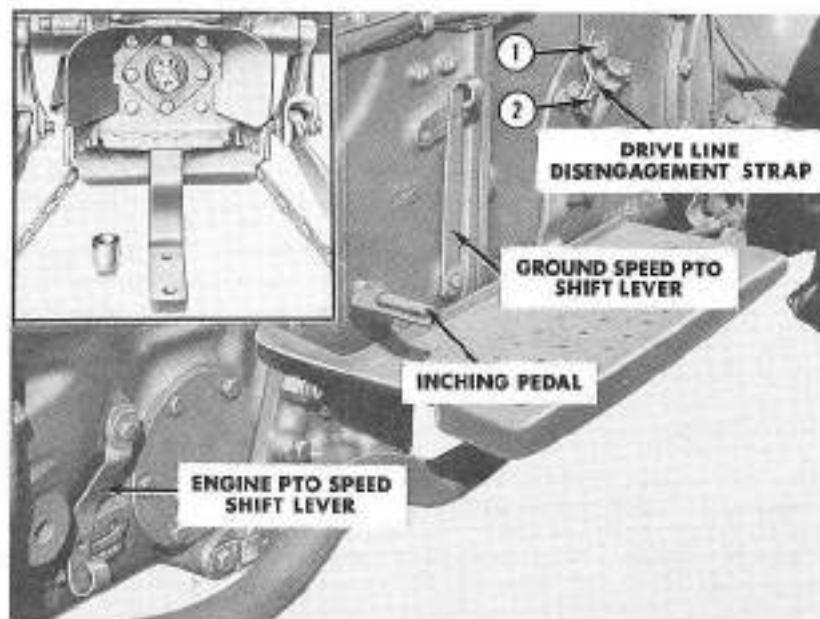

Figure 16
Controls on the Select-O-Speed Transmission

CAUTION: Never operate a P.T.O. driven implement at speeds exceeding manufacturers recommendations.

The ground speed P.T.O. is engaged by moving the ground speed P.T.O. shift lever, Figure 16, to the "ON" position, making certain that the P.T.O. control knob is in the "IN" position. The P.T.O. shaft will only turn when the tractor is in motion. Consequently, to ease into P.T.O. loads, it will be necessary to use the inching pedal. **WHEN BACKING THE TRACTOR, THE GROUND SPEED LEVER MUST BE MOVED TO THE "OFF" POSITION.** Failure to do this may result in serious damage to the implement being operated.

There is a lock-out arrangement within the transmission which prevents the engagement of the ground speed and the engine speed P.T.O. at the same time.

NOTE: Do not shift the ground speed shift lever while the tractor is in motion.

BELT PULLEY

A nine-inch belt pulley is available as an accessory for use on your Row Crop Ford Tractor. The pulley can be installed in any one of four positions; however, it should not be installed in the up position. To install, remove the PTO safety cap, the drawbar, the drawbar hanger and the check chains. Then position the pulley assembly on the P.T.O. shaft as desired and secure with the four stud bolts and lockwashers provided.

NOTE: On Select-O-Speed Transmission equipped tractors, the 6-tooth spline P.T.O. shaft adapter must be installed to operate the belt pulley.

For best performance, most stationary machinery must be operated at the correct belt speed. The A.S.A.E. has established a standard range for belt speeds of from 3000 to 3200 feet per minute. A belt speed within this range is reached with a standard nine-inch belt pulley when the Proof-Meter indicates 1750 engine rpm for the 4-Speed Transmission equipped tractor and 2200 engine rpm for the Select-O-Speed Transmission equipped tractor.

CAUTION: Do not operate the belt pulley with the engine P.T.O. speed shift lever in the 1000 rpm position.

The belt speed is dependent on the size of the belt pulley and the pulley rpm. Belt driven implements which do not meet A.S.A.E. standards should be operated at the speed recommended by the manufacturer. To obtain this speed, select a driven pulley of the proper size from the table on the opposite page.

PROPER SIZE OF THE DRIVEN PULLEY*

Engine R.P.M. 4-Speed Transmission	Engine R.P.M. Select-O- Speed Transmission	Nine Inch Pulley R.P.M. **	R.P.M. OF THE DRIVEN PULLEY								
			600	800	1000	1200	1400	1800	2200	2400	3000
1000	1154	679	10	7½	6	5	4½	3½	3		
1100	1269	747	11	8½	6½	5½	5	3½	3		
1200	1385	815	12	9	7½	6	5	4	3½	3	
1300	1499	882	13	10	8	6½	5½	4½	3½	3	
1400	1614	950	14	10½	8½	7	6	4½	4	3½	3
1500	1730	1018	15	11½	9	7½	6½	5	4	3½	3
1600	1845	1086	16½	12	10	8	7	5½	4½	4	3½
1700	1961	1154	17½	13	10½	8½	7½	6	4½	4	3½
1800	2076	1222	18½	13½	11	9	8	6	5	4	3½
1900	2192	1290	19½	14½	11½	9½	8½	6½	5½	4½	4
2000	—	1358	20½	15½	12	10	8½	7	5½	4½	4

*Figures are computed to the nearest ½ inch pulley size.

**Pulley speeds are based on 540 r.p.m. P.T.O. speeds.

CAUTION: NEVER INSTALL OR REMOVE BELT WHILE PULLEY IS IN MOTION.

WHEEL TREAD ADJUSTMENTS

The design of the Ford Tractors permits quick wheel tread adjustments with a minimum amount of work. Both the front wheel tread adjustments (where they apply) and the rear wheel tread adjustments for the Ford Tractors are discussed in the following.

Front Wheels, Dual Axle: The tread on the dual front wheels may be increased from 8.3 inches to 16.3 inches simply by reversing the wheels on the spindles.

When planting or cultivating listed crops, this wider front wheel setting will assist the operator in keeping the front wheels on the listed ridges. The extra clearance will also prevent the accumulation of mud when operating the tractor in wet or sticky soil.

NOTE: During normal operation, the tractor will handle much better when the dual front wheels are set in the narrow position.

Front Wheel, Single Axle: There are no front wheel adjustments for the single wheel Ford Tractors.

Front Wheels, Adjustable Front Axle: The front wheels are adjustable from 52 to 76 inches in approximately 4 inch spacings. To change the tread width, raise the front end of the tractor with a jack placed at the forward end of the transmission housing. Work on one axle section at a time and remove the hex head bolts, flat washers and nuts which hold the outer axle sections to the inner axle section. See insert, Figure 17. Next remove the hex head bolts, lockwashers and nuts

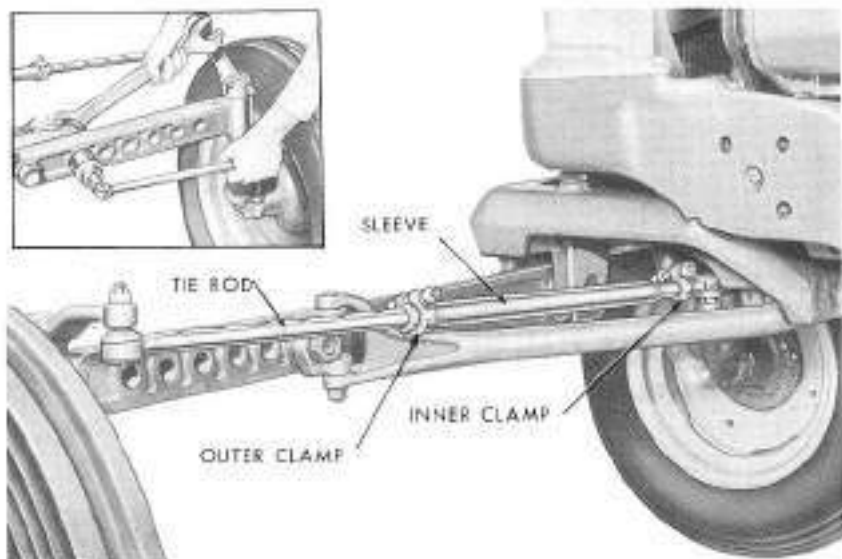

Figure 17
Adjustable Front Axle Adjustment

from the outer clamps shown in Figure 17 to release each tie rod from the locked position in its sleeve. Position the front wheels and tie rods in or out until the desired tread width is obtained. Figure 18 shows the correct minimum and maximum wheel tread adjustments. For intermediate tread adjustments, make certain that there is a minimum of *two bolt holes* between each axle bolt location.

Replace the bolts, flat washers and nuts. Tighten each nut evenly.

Position the front wheels straight ahead and align the hole in each outer clamp (see Figure 17) with the groove in each tie rod which is nearest the outer clamp hole. Align and insert the clamp bolts to lock the tie rods in the sleeves. Secure both outer clamps with the lockwashers and nuts previously removed.

NOTE: Normally, toe-in adjustment of the front wheels is not necessary when making front axle adjustments as the tie rod grooves are spaced to provide the proper toe-in at each increment of wheel tread spacing. If the toe-in wheel adjustment must be re-established for any reason, the procedure is given on page 57 under Maintenance. When necessary, a wider tread width of 80 inches can be obtained by setting the axles for the 72 inch tread width setting and then reversing the front wheels.

Manually Adjusted Rear Wheels: The manually adjusted rear wheels (Models 741 and 771 Tractors) are adjustable from 56 to 84 inches. Tread width settings are made by changing the position of the steel

discs and the rims to any of the positions shown in Figure 19. To change from the 56 inch tread width to the 84 inch width, it is only necessary to change the wheels from one side of the tractor to the other. Three other wheel changes are similar as shown at the top of Figure 19.

NOTE: *Figure 19 shows only one tractor wheel.*

Power Adjusted Rear Wheels: The Power Adjusted Rear Wheels are standard on Series 901 Tractor models and are available as optional equipment on the Series 701 Tractor models. If your Ford Tractor is equipped with the Power Adjusted Rear Wheels, you will be able to change rear wheel tread width quickly and easily by means of tractor power. The wheels may be spaced from 56 to 84 inches in 2 inch intervals. For tread widths of 56 to 76 inches, adjust the wheels, one at a time, as follows:

LOOSENING TIRE RIM FROM DISC: Loosen the nuts on the three locking clamps (see Figure 20), slide the clamps toward the center or retracted position, then retighten the nuts securely. Move the tractor until the wheel tread spacer clamp (Figure 20) is at the top of the wheel, then remove the spacer clamp from the disc and remove the large nut.

OPERATING WHEEL DISC IN THE RIM: When setting a wheel at the extreme inner or outer position, loosen the tire rim from the disc as described above, then simply move the wheel in or out to either end stop. For settings between 56 and 76 inches, first move the wheel to the extreme outer positions by engaging the clutch, with the tractor engine at idle speed. Use reverse gear for the left wheel and forward gear for the right wheel.

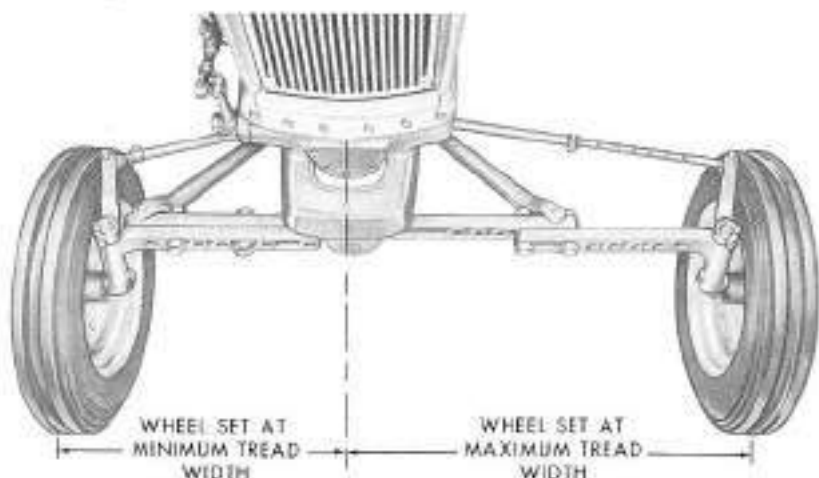

Figure 18

Front Wheel Tread Adjustments

INTER-CHANGING REAR WHEEL ASSEMBLIES
GIVE THESE COMBINATIONS

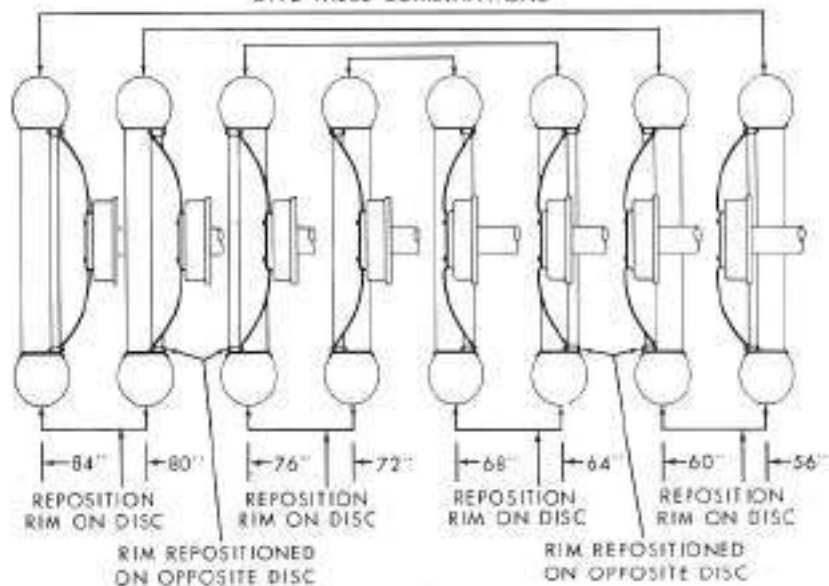

Figure 19
Rear Wheel Tread Adjustments

NOTE: Brake the opposite wheel slightly and allow the tractor to creep forward or rearward while the wheel is being adjusted. Next, place the spacer clamp in the channel thread bar which has stops at each end. Position the clamp for desired tread width and secure as shown in Figure 20. These settings will permit a full revolution, or adjustment of 2 inches for the wheel.

Rotate the disc back into the rim by engaging the clutch with the engine at idling speed. Use reverse gear for the right wheel and forward gear for the left wheel. Disengage the clutch as soon as the disc strikes the spacer clamp.

SECURING RIM IN POSITION: Move the tractor so that the spacer clamp can be replaced at the top of the wheel, then remove the clamp from the rim and reinstall it in the wheel. Tighten the large nut securely.

Loosen the nuts which hold the three locking clamps, move the clamps out to the lock position, then center the rim in the wheel by tightening the bottom locking clamp. Tighten the remaining two clamps securely. Tighten the nuts in sequence, make sure the clamps are positioned at approximately the same angle.

NOTE: Check the nuts for tightness after the tractor has been operated for a short time.

CHANGING WHEEL DISCS: To obtain a tread width setting of 80 inches, it is only necessary to power-adjust the wheels to a normal 60° setting (see Figure 20), then reverse the wheels on the tractor. The 84° setting is obtained in the same manner by setting the wheels at 56° and reversing them on the tractor. With the wheels in the reversed (dish in) position, it will be necessary to set the spacer clamp and locking clamps from the inside of each wheel when making adjustments. See Figure 21. Disengage the spacer and the locking clamps, move the wheel to its extreme "in" position and set the spacer clamp as desired. Then, use the tractor power to adjust the wheels to the desired width. After adjusting, replace the spacer clamp and locking clamps and tighten securely.

NOTE: THE ARROW ON THE SIDE WALL OF THE TIRE SHOULD ALWAYS POINT IN THE DIRECTION OF FORWARD ROTATION OF THE WHEEL.

WHEEL WEIGHT

To assure sufficient traction for maximum performance in heavy draft operations, weights should be added to the Ford Tractor.

Liquid Ballast: It is a common practice to add weight by filling the rear tractor tires with liquid. A solution of calcium chloride is recommended because of its lower freezing point, and greater weight per gallon than water.

The use of liquid ballast in the front tires will help counter-balance heavy rear mounted implements, and will further increase the traction and "pull-power" of your Ford Tractor in heavy draft operations. The recommended liquid capacities for tires are shown in the following table. This table is based on a 90% fill of the tires with 5 pounds of calcium chloride per gallon of water. The addition of this amount of calcium chloride will prevent freezing in most locations. A 90% fill of tires requires special equipment. See your Ford Tractor and Implement Dealer. For valve level filling of the tires listed, multiply the respective figures in the table by .8 to obtain the necessary information.

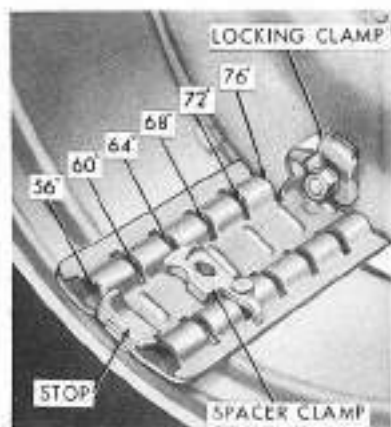

Figure 20
Adjusting Wheels (Normal Position)

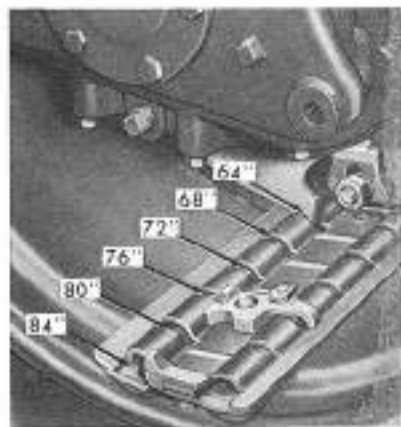

Figure 21
Adjusting Wheels (Reversed Position)

MAXIMUM CALCIUM CHLORIDE SOLUTION CAPACITIES

Size of Tire	Pounds of Calcium Chloride	Gallons of Water	Weight of Solution
11-28 4-ply	164	32	440 lbs.
12-28 4-ply	187	38	504 lbs.
6:00-16 4-ply	30	6	80 lbs.
5:50-16 4-ply	25	5	65 lbs.
9:00-10 8-ply	30	6	80 lbs.

Cast Iron: In heavy work such as plowing and discing, added weight is necessary in most cases to provide sufficient traction to utilize the maximum power of the engine. Special cast iron weights are available, at extra cost, in different sizes for use on the Ford Tractor. These individual weight sections can be easily attached to or detached from the wheels as the job requires. On lighter jobs, removal of the weights will increase the operating economy of your tractor. The following chart describes the different types of weights and their recommended usage.

The weights, as described below, may be used on both Series 701 and 901 Ford Tractors.

FRONT WEIGHT BOX	REAR WHEEL WEIGHTS
Segments—(6) 48 lbs. each Box—130 lbs. Total—418 lbs.	Regular Duty Weights (per tractor set) Two Mounting Discs—68 lbs. Segments—(24) 30 lbs. each. Bolts—12 lbs. Total—800 lbs.
*FRONT (per tractor set)	
Wheel Weights—inside mounted Two per wheel—50 lbs. each Total—200 lbs.	

Weight added to the tires, together with the weight of the mounted implement and tractor, should not exceed the recommended weight to be carried by the tires. The following table lists the maximum recommended weight that can be carried without overloading the tires.

Tire Size	Inflation Pressure	Maximum Lbs. Tire Load Per Wheel
Rear:		
11-28 4-ply	12	1890
	14	2070
12-28 4-ply	12	2220
	14	2430
Front:		
5.50—16 4-ply	20	655
5.50—16 4-ply	24	725
5.50—16 4-ply	28	795
5.50—16 4-ply	32	860
6.00—16 4-ply	20	750
6.00—16 4-ply	24	835
6.00—16 4-ply	26	875
9.00—10 8-ply	44	1715

MAINTENANCE

How long and how well your Ford Tractor continues to give satisfactory performance depends largely upon proper maintenance. Keep the tractor in good working order by following the instructions in this section on lubrication, mechanical maintenance, minor adjustments and storage.

When major overhauls become necessary, see your Ford Tractor and Implement Dealer. He is interested in you and your tractor, and is properly equipped to meet your service needs.



*A properly maintained tractor
is a Safe tractor.*

INSPECTION

PRE-DELIVERY INSPECTION

Before your tractor was delivered to you, the dealer performed a pre-delivery inspection which is the first step in the maintenance schedule of your tractor. Some of the more important items checked by your dealer are the cooling system, pedestal, engine, transmission, hydraulic system, power steering system, differential, final drive housings and the general physical condition of your new tractor. A detailed listing of the inspections performed is shown on your Service Policy under the Pre-Delivery and 50-Hour Inspection Reports.

50 HOUR INSPECTION

After you have operated your tractor for a period of fifty hours, see your Ford Tractor and Implement Dealer. At this time, he will perform the factory recommended 50-Hour Inspection, without charge, except for lubricants. Remember that the dealer is interested in your tractor's performance. See him periodically for continued good service.

LUBRICATION

Since your tractor will be subjected to a variety of operating conditions, it is extremely important that all moving parts be lubricated at the proper time. Use clean containers and recommended grades of lubricant to avoid causing serious damage to your tractor.

The following guide describes, in hourly intervals, all of the lubrication services required by your tractor. These time intervals are based on average working conditions. When operating under extremely hot or dusty conditions, lubricate the tractor more frequently.

The location of the lubrication points described in the lubrication guide are shown in Figures 28 and 29 on pages 42 and 43.

SERVICE DAILY OR EVERY TEN HOURS

Crankcase Ventilating System: Remove the element in the Rocker Arm Cover Breather and clean with a suitable solvent. Coat the element with light engine oil before replacing.

Oil Filler Breather Cap: Remove the element, clean the entire assembly with solvent and coat the element with light engine oil.

Air Cleaner: Remove the oil cup and clean with a suitable solvent. Refill the cup with 1.3 pints of engine oil for Series 901 tractors, 0.8 pints for Series 701 tractors. (Under extremely dusty conditions, service more often.)

Pressure Type Fittings: Clean the fittings on the Lift Link Leveling Box and Fork, Clutch Pedal and Steering Drag Link. Apply pressure gun grease and wipe the fittings clean. See Figures 28 and 29.

Distributor: Place a few drops of seasonal engine oil in the oil cup. Do not over lubricate. (See Figure 23.)

Crankcase Dip Stick: Remove the dip stick from the right side of the engine crankcase. Always wipe the dip stick with a clean cloth, replace it and then remove it again to determine the oil level. Maintain the level at the full mark with a reputable brand of engine oil marked For Service MM or MS. (See SERVICE EVERY 100 HOURS.)

Hydraulic System Dip Stick: Use the side of the dip stick that is marked "HYDRAULIC SYSTEM, ALL CYLINDERS EXTENDED." Check the level of the hydraulic oil and maintain at the full mark with the proper lubricant as recommended under SERVICE EVERY 600 HOURS. Make certain that all hydraulic cylinders are fully extended as noted on the dip stick, and that the hydraulic lift links are in the raised position.



Figure 22

Checking the Air Cleaner Oil Level

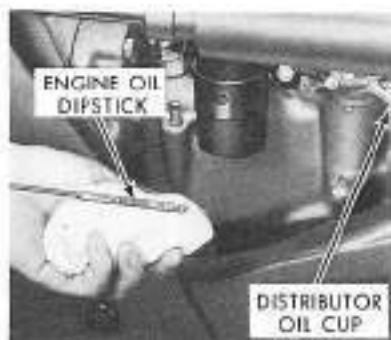

Figure 23

Crankcase Oil Level Dip Stick



Figure 24

Hydraulic Oil Level Dip Stick

SERVICE EVERY 100 HOURS

Engine Crankcase: Change the engine oil in your new tractor at the 50 hour inspection and every 100 hours of operation thereafter. Drain the oil after the engine has reached normal operating temperature. Refill the crankcase with four quarts of a reputable brand of engine oil marked for service MM or MS and add one extra quart of oil if the filter cartridge is replaced.

*SAE 20 — Temperatures consistently above 90° F.

**SAE 10 — Temperatures between 90° F. and 32° F.

SAE 10-10W — Temperatures between 32° F. and -10° F.

SAE 5W — Temperatures below -10° F.

Pedestal: To check the oil level, remove the tractor radiator grille and the pedestal filler opening plug. Wipe the plug dry and reinsert it into the opening, tightening to finger tightness. Remove the plug and check the oil level as indicated by the oil level mark, see Figure 25. Add oil if necessary. (SEE SERVICE EVERY 600 HOURS.)

Check the oil level every 100 HOURS OF OPERATION. Remove the pump reservoir top and check the oil level with the dipstick attached (Figure 26). For an accurate reading, the tractor wheels should be turned to the left against the stops.

CAUTION: Use only AUTOMATIC TRANSMISSION FLUID—TYPE "A" or oil meeting Ford Specification M-2C41 in the Power Steering System. Always use clean fluid for this purpose. Dirty fluid may cause extensive damage to the system.



Figure 25
Checking Pedestal Oil Level

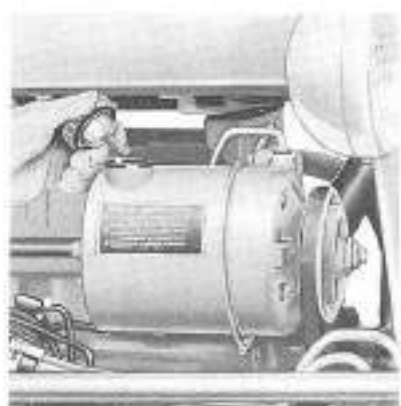

Figure 26
Power Steering Pump

*SAE 20 recommended after the first year's operation.

**SAE 20 recommended after the first year's operation.

Final Drive Housing: Check the oil level at the fill plug (9), Figure 28, and add oil if necessary. (See SERVICE EVERY 600 HOURS.)

Differential: Remove the rear axle inspection plug (10), Figure 28, and check the level of the oil. If necessary, add oil. (See SERVICE EVERY 600 HOURS.)

4-Speed Transmission: Remove the transmission oil level inspection plug (22), Figure 28, and add oil if required. (See SERVICE EVERY 600 HOURS.)

Select-O-Speed Transmission: The Select-O-Speed transmission is hydraulically operated and pressure lubricated, so it is very important that the proper lubrication level be maintained at all times. WHEN ADDING LUBRICANT, USE ONLY M-2C41 FORD UNIVERSAL HYDRAULIC LUBRICANT. Your Select-O-Speed Transmission has been built to operate continuously on the lubricant installed at the factory. Consequently, the oil need never be changed except during major service or overhaul.

Check the oil level by removing the oil level check and filler plug, and add oil as required. Always use the utmost caution to insure that no foreign material gains access to the transmission reservoir when either removing the filler plug or adding oil to the transmission.

Steering Housing: Check the oil level at the steering gear case plug (19), Figure 28, and add lubricant as required. Use extreme pressure gear lubricant SAE 90 in the summer and SAE 80 in the winter.

SERVICE EVERY 200 HOURS

Oil Filter: Replace the filter cartridge with every other engine oil change and add one quart of engine oil to fill the new cartridge.

Distributor: Remove the cap and dust shield. Wipe the cam, the outside of the distributor, the wires and the coil with a clean cloth. Apply a portion of Ball Bearing grease about the size of a match head on the distributor cam. Use Ball Bearing Grease only.



Figure 27
Replacing the Oil Filter
Cartridge

EVERY 10 HOURS

- 4 AIR CLEANER**—Clean and oil.
- 8 HYDRAULIC SYSTEM DIP STICK**—Check oil level.
- 14 OIL FILLER BREATHER CAP**—Clean and oil.
- 15 DISTRIBUTOR**—Few Drops of engine oil in cap.
- 17 CRANKCASE DIP STICK**—Check oil level.
- 18 CRANKCASE VENTILATING SYSTEM**—Clean and oil.

LUBRICATE PRESSURE FITTINGS BELOW

- 6 CLUTCH PEDAL**
- 11 DRAG LINK (FRONT)**
- 13 CONTROL VALVE AND CYLINDER ASSEMBLY**
- 20 DRAG LINK (REAR)**
- 24 LEVELING BOX**
- 25 TIE RODS**
- 26 SPINDLE PINS**
- 27 TIE RODS**

TOP VIEW OF TRACTOR

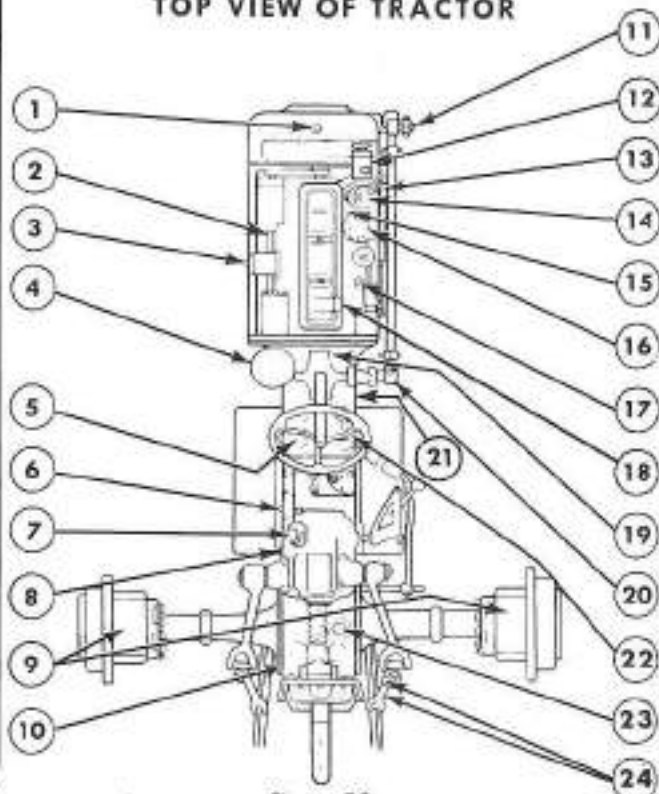
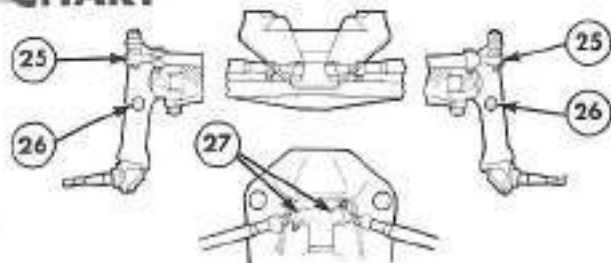

Figure 28

EVERY 100 HOURS

- 12 PUMP RESERVOIR**—Check oil level and replenish with Automatic Transmission Fluid—Type A or oil meeting Ford Specifications M-2C41.
- 28 ENGINE CRANKCASE**—Drain and refill: and
14 Summer (Below 32° F.) SAE 10W or 20W;
 Winter (Above 32° F.) SAE 20; (above 50° F.) SAE 30
- 10 DIFFERENTIAL**—Check oil at level plug and
23 on side of housing and add oil if necessary.
- 9 FINAL DRIVE**—Check oil level.
- 22 4-SPEED TRANSMISSION**—Check oil at level plug on side of housing and add oil if necessary.
- 21 SELECT-O-SPEED TRANSMISSION**—Check oil at level and filler plug on side of housing and add oil, if necessary. (Use only M-2C41 Ford Universal Hydraulic Lubricant.)
- 19 STEERING HOUSING**—Check oil level.
- 1 PEDESTAL**—Check oil level.



UNDERSIDE VIEW OF TRACTOR

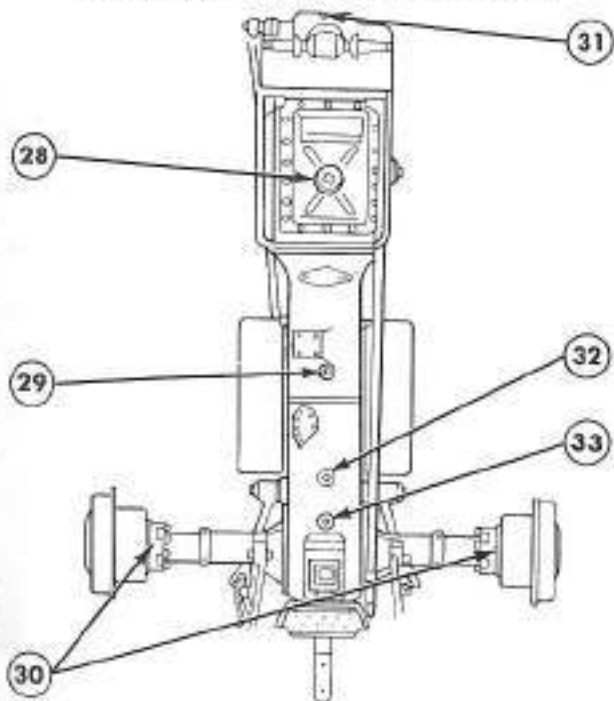

Figure 29

EVERY 600 HOURS

FRONT WHEEL BEARINGS—(Not shown) Re-pack with (M-4664) short fibre grease.

30 FINAL DRIVE—Drain and refill. (Use mild E. P. 9 Lubricant SAE 80, both summer and winter.)

29 4-SPEED TRANSMISSION—Drain and refill. (Use Mild Extreme Pressure Lubricant SAE 80, Both Summer and Winter)

31 PEDESTAL—Drain and refill. (Use E. P. Lubricant 1 SAE 80, both summer and winter.)

32 HYDRAULIC SYSTEM and —Drain and refill. (Below 7 10° F.—Mix 6 Qts. M-4664-A with 2 Qts. M-4664-B) (Above 10° F.—8 Qts. M-4664-A or 3 Qts. of M-2CBL at any temperature.

33 DIFFERENTIAL—Drain and refill. (Use mild E. P. 23 Lubricant SAE 80, both summer and winter.)

EVERY 200 HOURS

3 OIL FILTER—Replace cartridge every other engine oil change and add one extra quart of oil to fill crankcase.

2 GENERATOR—Oil rear bearing with light oil. Do not over lubricate.

16 DISTRIBUTOR—Light film of distributor lubricant on cam.

Generator: Oil the generator rear bearing with light oil. Do not over lubricate.

SERVICE EVERY 600 HOURS

Front Wheel Bearings: Clean the front wheel bearings thoroughly with a solvent and repack with (M-4664) short fibre grease. Lubricate the spindle shaft before replacing the bearings.

4-Speed Transmission: Change the transmission oil at the 50 hour inspection and every 600 hours of operation thereafter. In winter operate the tractor to thin the oil before draining. Fill the 4 speed transmission with 6 quarts of mild extreme pressure lubricant. Use mild E. P. lubricant SAE 80, both summer and winter.

Select-O-Speed Transmission: In order to assure peak transmission operation and smooth shifting characteristics, it is important that you have your Ford Dealer adjust the transmission bands at this time.

Hydraulic System: After the first 50 hours and after every 600 hours operation, change the oil in the hydraulic system. In winter, operate the system to thin the oil before draining. Clean the fill port carefully before removing to prevent dirt from entering the system. At temperatures below 10° F., use 6 quarts of M-4864-A or M-2C41 and 2 quarts of M-4864-D hydraulic oil. Fill the system with 8 quarts of M-4864-A hydraulic oil at temperatures above 10° F. or 8 quarts of M-2C41 oil at any temperature.

Differential: Replace the oil in the axle rear after the first 50 hours of operation and every 600 hours thereafter. In winter, operate the tractor to thin the oil before draining. Refill with 8 quarts of oil. Use mild extreme pressure lubricant SAE 80, both summer and winter.

Final Drive Housings: Change the oil after the first 50 hours and after every 600 hours of operation. Fill each housing with 1½ quarts of mild E. P. lubricant SAE 80, both summer and winter.

Pedestal: Change oil every 600 hours. Fill to the mark on the *dipstick (2 quarts) with mild E. P. lubricant SAE 80, both summer and winter.

MECHANICAL MAINTENANCE

In addition to lubrication services, regular mechanical maintenance is necessary to keep your tractor performing at maximum efficiency. The information in this section has been prepared to help you perform certain routine jobs on your tractor. Avoid breakdowns during the busy seasons by checking these items frequently and making the necessary repairs or adjustments. For major repair work or service parts, see your Ford Tractor and Implement Dealer.

COOLING SYSTEM

Radiator Pressure Cap: The cooling system on your Ford Tractor operates under pressure which is controlled by the radiator cap.

*See "Pedestal" under, *Service Every 100 Hours*, page 40.

Cleaning and Protection: The cooling system should be drained, flushed and refilled with clean, soft water every spring. Remove the thermostat prior to the flushing operation. Drain the system by removing the plug at the bottom of the radiator, the drain cock on the left side of the cylinder block and the radiator cap. Add a good grade of rust inhibitor when refilling the system with water. Open the radiator grille and clean the radiator fins with a wire brush. In the fall, the cooling system should be drained, flushed and refilled with a good grade of permanent type anti-freeze. Alcohol is not recommended as protection against freezing because it starts to boil at 170° and during heavy duty operation, the tractor may operate at temperatures above this figure. Anti-freeze may be purchased from your local dealer.

NOTE: The United States Department of Commerce, National Bureau of Standards and the American Society for Testing Materials recommend that antifreeze be drained and discarded after one season's use as the corrosion inhibiting properties of permanent anti-freeze will normally be depleted.

FUEL SYSTEM

When properly cleaned and adjusted, the air and fuel system on the Ford Tractor will help provide maximum power and smooth engine performance with a minimum amount of fuel consumption.

Fuel Tank: Use only clean fuel which has been stored in a dry, cool place. At the end of each day of operation, refill the fuel tank to remove moisture laden air and reduce condensation. This is extremely important during cold weather.

Sediment Bulb: To clean the carburetor gas line sediment bulb, turn the fuel shut-off valve clockwise to the off position. Loosen the sediment bulb retaining nut, and move the retaining clamp sideways until the bowl can be removed. Remove and clean the disc screen and wipe the bowl with a clean cloth. Then replace the assembly and tighten securely. Always clean the fuel filtering screen in the sediment bulb when the bulb is cleaned. If the sediment bulb quickly accumulates an excessive amount of dirt after cleaning, the fuel tank should be drained and cleaned thoroughly.



Figure 31
Fuel Shut-Off Valve Assembly

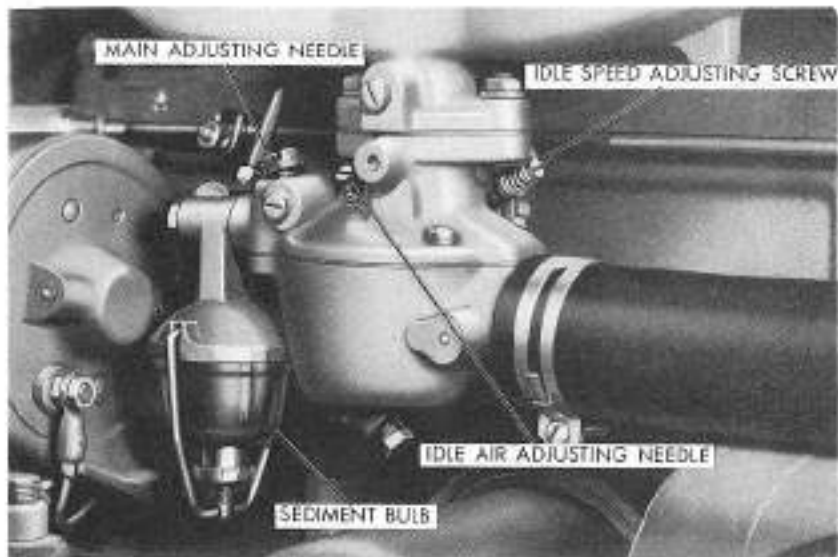

Figure 32
Adjusting the 701 Carburetor

Carburetor: Three adjustments are provided on the carburetor. When adjusting the carburetor, operate the engine at normal temperature as shown on the gauge.

***Idle Speed Adjustment Stop Screw:** With the hand throttle in the closed position, turn the stop screw on the engine side of the carburetor until the engine idle speed is 450 to 475 R.P.M. as indicated on the Proof-Meter. On an engine that is not yet broken in, it may be necessary to set the idle speed higher to keep the engine from stalling at idle speeds.

Idle Air Adjustment Needle: For the initial setting, before the engine is started, turn the idle adjustment needle clockwise until it just seats, then back it off approximately one turn. Start the engine and turn the idle adjustment needle "IN" (clockwise) until the engine begins to "roll" from too rich a mixture, then back the needle off until the engine runs smoothly. It may be necessary to readjust the idle speed.

Main Adjusting Needle: The initial setting for the main adjusting needle is $1\frac{1}{8}$ turns open (counterclockwise) on Series 701 tractors and $1\frac{1}{4}$ turns on Series 901 tractors. The final adjustment should be made in the field. With the engine running at governed speed under full load, turn the adjustment needle in (clockwise) until the engine power begins to drop off, then turn the screw out until the power picks up and the engine runs smoothly.

*Maximum speed adjustment is fully outlined on page 54.

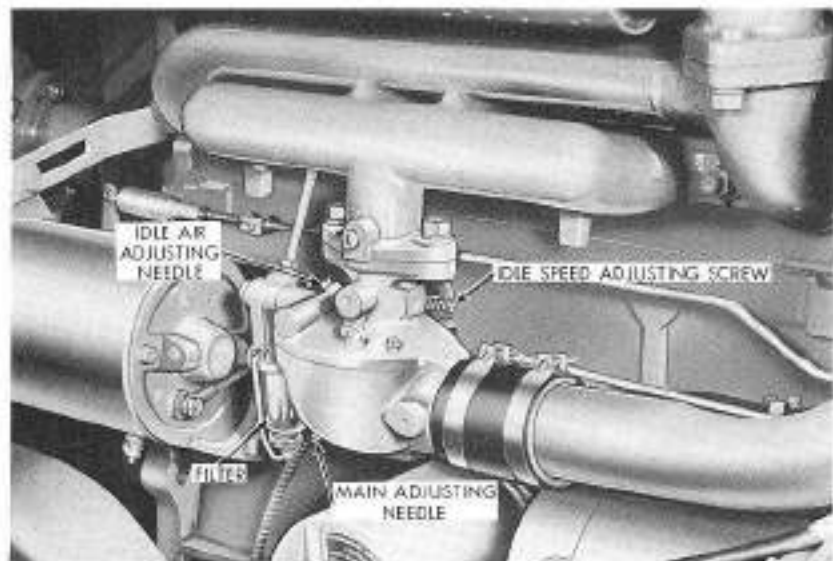

Figure 33
Adjusting the 901 Carburetor

NOTE: For extreme cold weather operation, the initial setting of the main adjusting needle should be $1\frac{1}{2}$ turns open (counterclockwise) on Series 701 tractors. The initial setting remains at $1\frac{1}{4}$ turns on the Series 901 tractors.

Carburetor Air Cleaner: Regular service of the oil bath type air cleaner is extremely important in prolonging the engine life of your tractor. See the section on LUBRICATION, under Service Daily or Every Ten Hours, for proper servicing of the air cleaner. Figure 34 shows the passage of air through the intake screen, oil bath, filtering mesh and to the carburetor.

The installation of any accessory designed to further the filtering process serves no useful purpose and may result in increased fuel consumption and poor engine performance.

ELECTRICAL SYSTEM

Generator: The maximum charging rate of the generator is 20 amperes at 1650 engine R.P.M. and above. The generator is driven by the fan belt. For adjustment, refer to "Water Pump and Fan Belt," under COOLING SYSTEM, page 45.

If the generator will not charge, check the condition of the wires in the generating circuit (Figure 35). Make sure all connections are clean and tight.

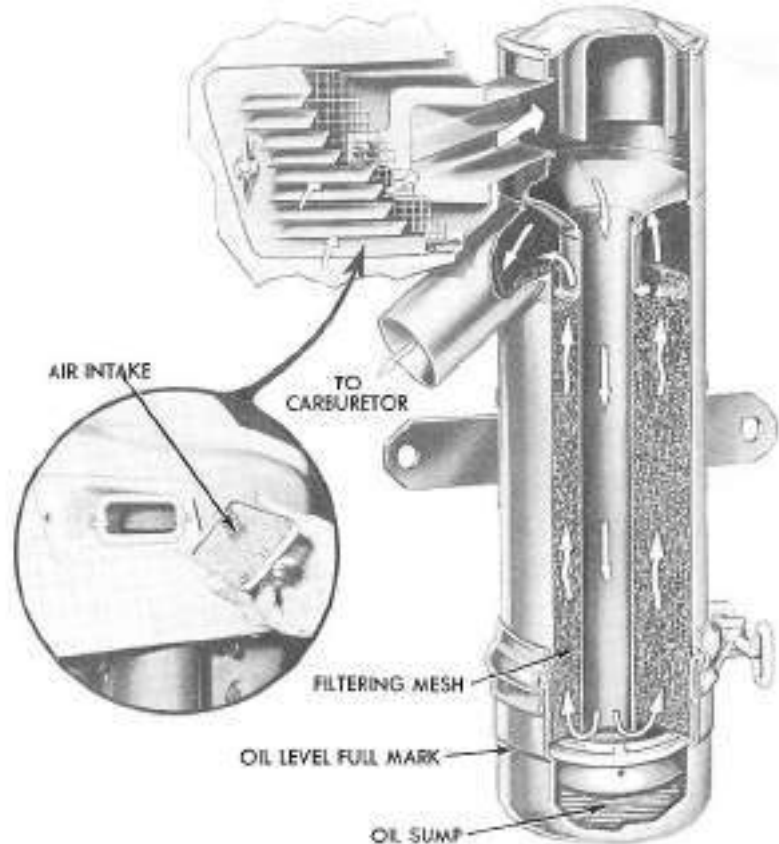

Figure 34
Sectional View of Carburetor Air Cleaner

Battery: The level of electrolyte in the battery should be checked at least twice monthly and distilled water added if necessary. Battery terminals should be kept tight and free of corrosion. Two tablespoons of baking soda mixed with a pint of water make a good solution for cleaning corroded terminals and the battery case. After cleaning, the battery should be washed with clean water. An application of petroleum jelly on the terminals will counteract corrosion.

Keep the battery fully charged at all times. The specific gravity of the electrolyte indicates the amount of battery charge. The amount of charge, with respect to specific gravity of the electrolyte, is shown in the following chart.

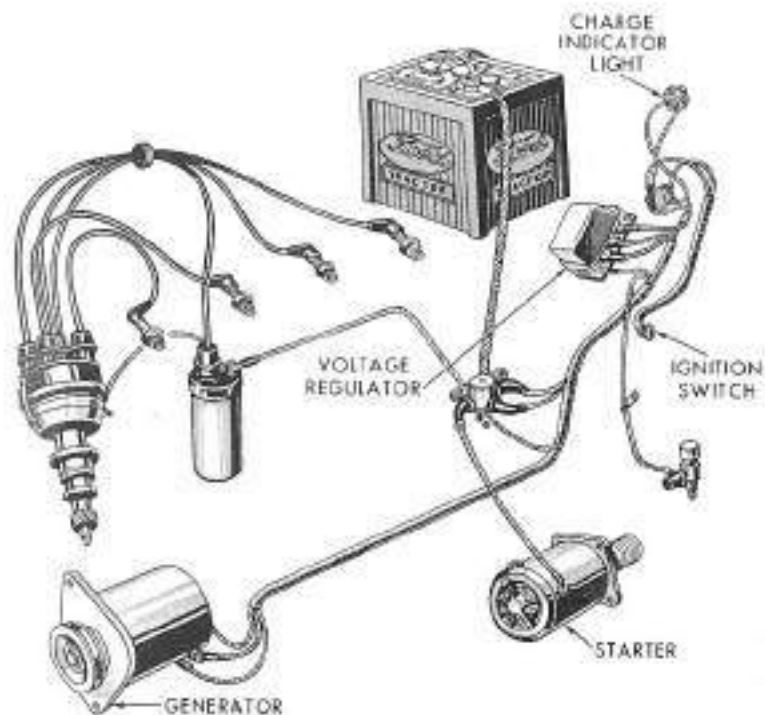

Figure 35
Generating System

State of Charge	Specific Gravity Temperate Climates	Specific Gravity Tropical Climates
Fully Charged	1.280	1.225
75%	1.230	1.180
50%	1.180	1.135
25%	1.130	1.090
Discharged	1.080	1.040

Distributor Points and Spark Plugs: If the distributor points and spark plugs are not kept in proper adjustment and if the ignition system is not correctly timed, the operation of your tractor will be seriously affected. The results of improper ignition maintenance are sluggish engine performance and excessive fuel consumption.

Under normal operating conditions, the spark plugs should be removed, cleaned and inspected after 150 hours and replaced every 300 hours. Spark plug cleaning should be performed with a sand blast type cleaner. Spark plugs which are cracked or have excessively burned electrodes should be replaced. The proper spark plug gap is 0.025 to 0.028 inch. To set the gap, use a standard round feeler gauge as shown in Figure 36.

Proper maintenance of distributor points is of the utmost importance. Cleaning of the points, replacing when excessively worn, and the proper spacing are essential for peak efficiency.

To adjust the distributor points, remove the distributor cap. Crank the engine until the breaker arm rubbing block (see Figure 37) is resting on a high point of the distributor cam. Loosen the point assembly lock screws. Insert an adjusting tool or screwdriver in the adjustment slot and move the point assembly until the proper gap is established. The point spacing is 0.024 to 0.026 inch. Tighten the point assembly lock screws after making the adjustment and recheck the adjustment on at least one additional lobe.



Figure 36
Checking Spark Plug Gap

To replace the points, remove the distributor cap. Remove the point assembly lock screws (Figure 37). Disconnect the condenser and primary lead, then lift the point assembly off the breaker plate. Position the new point assembly, install the lock screws, then reconnect the condenser.

Ignition Timing: When new distributor points are installed, the ignition system should be properly timed with a timing light. Connect the timing light to the engine with the high tension lead on the No. 1 spark plug and the other two leads on the proper battery terminals. Start the engine and run it at idle speed. Direct the timing light so that it flashes through the opening in the bell housing (see Figure 38), and note the timing marks. Ignition timing should be 4° before top dead center on both Series 701 and 901 tractors at 450 engine R.P.M. Loosen the clamp screws, rotate the distributor slightly until this reading is obtained, then tighten the distributor body.

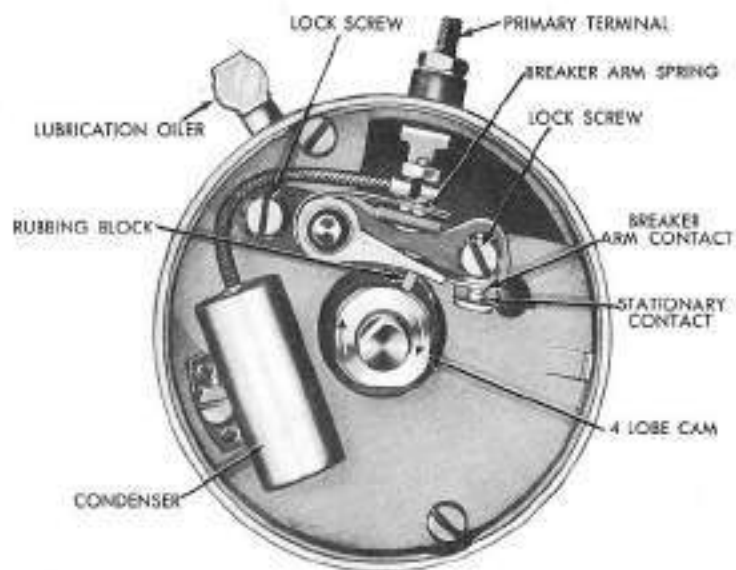

Figure 37
Distributor Assembly

ENGINE

Valve Clearance: One of the most important factors governing good engine performance is that of correct valve tappet clearances. On a new tractor, correct clearances are set before the tractor leaves the factory and are checked again by your dealer at the pre-delivery inspection. It is recommended, however, that the valve clearance be checked every 250 hours of tractor operation.

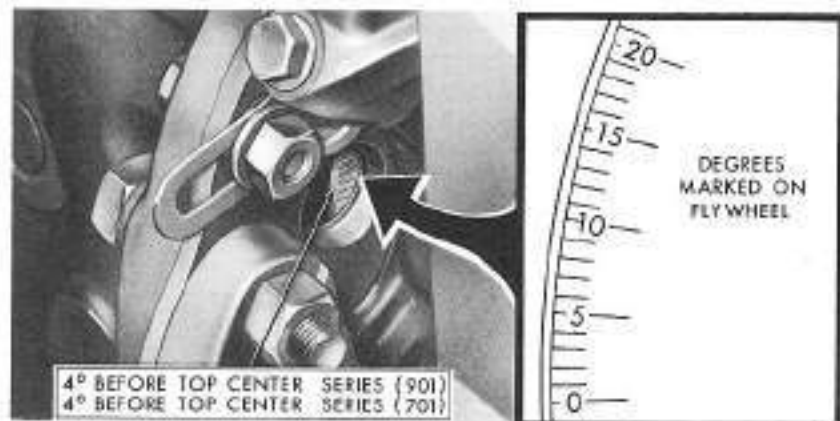

Figure 38
Basic Ignition Timing

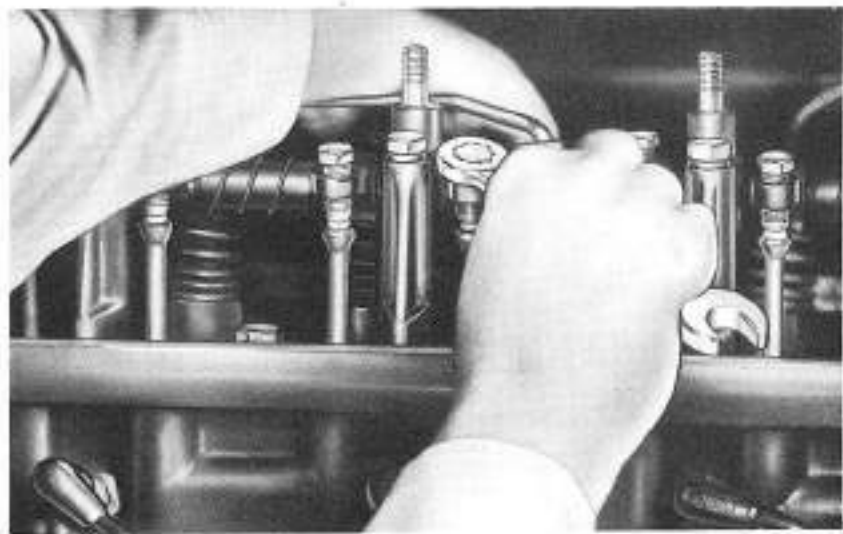

Figure 39
Valve Tappet Adjustment

To set valve clearance, run the engine until normal operating temperature is reached. Stop the engine and remove the rocker shaft cover. Tappets can only be adjusted properly when the valve is fully closed. It will be necessary to crank the engine with the starter to allow valves to close when making adjustments.

To adjust the tappets, turn the valve rocker arm adjusting screw in the desired direction as shown in Figure 39. The correct valve tappet clearance is .014 to .016 inch with the engine hot.

Valve Grinding: One of the factors involving good engine performance is absolute sealing of the combustion chamber by the valves and rings against compression losses. Valves and valve seats of modern engines are so hard that it is impossible to obtain a satisfactory valve reconditioning job by hand grinding. A good valve job is so important to engine performance that we recommend having your dealer perform this work whenever it becomes necessary.

Engine Tune-up: Engine tune-up procedure is intended to restore the engine to normal operating condition, providing excessive wear has not occurred. It is one of the most important maintenance services in that it determines whether or not the engine will perform with maximum economy and efficiency. Your dealer is best equipped to perform this service and advise as to the repairs or services necessary to restore the original performance of your tractor.

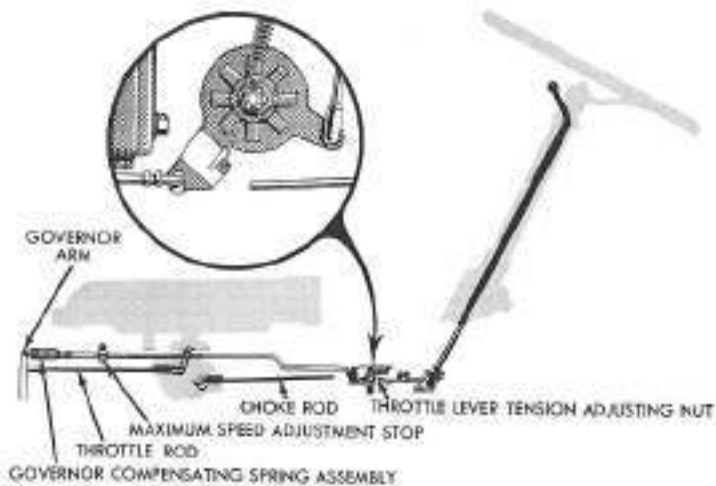

Figure 40
Governor and Control Linkage

Governor: Constant engine speed for any given throttle setting is controlled by the action of the adjustable centrifugal governor, located on the forward end of the crankshaft. As the engine speed is increased, the action of the governor moves the governor arm (see Figure 40) toward the closed carburetor throttle position until a balance between the spring tension and governor action is obtained. Maximum engine speed is controlled by the adjustable stop on the throttle rod, as shown.

Before attempting to set the engine governed speed, make certain the governor lever and carburetor throttle arm are both in the full open position. This can be checked by moving the hand throttle to the wide open position, removing the throttle rod at the carburetor, and holding the carburetor throttle arm in the wide open position. If the throttle rod connection will not slip over the ball on the carburetor throttle arm without moving the arm, the linkage must be adjusted. To do this, loosen the clevis lock nut and change the length of the rod as required.

Maximum governed engine speed must be set under no load conditions. After the tractor engine has been warmed up, set the idle speed at 450 to 475 revolutions per minute, then open the hand throttle to the wide open position. If the Proof-Meter registers 2300 to 2325 R.P.M. on 4-Speed Transmission equipped tractors, and 2500 to 2525 R.P.M. on Select-O-Speed Transmission equipped tractors, the governor is properly set. If adjustment is necessary, reposition the maximum speed adjustment stop as required.

Throttle Lever Position: After the tractor has been in service, some normal linkage wear occurs. The hand throttle lever may creep toward closed position when driving the tractor over rough ground. The fixed position of this lever is controlled by the tension applied by the spider spring washer on the bell crank, see insert Figure 40. This tension can be increased by removing the cotter pin in the castellated nut and turning the nut clockwise until the desired tension is obtained. After adjustment, reinstall the cotter pin.

Clutch: To obtain proper operation and to insure a longer clutch life, on 4-Speed Transmission equipped tractors, it is necessary to maintain the recommended clutch pedal free travel. Free travel is the distance the clutch pedal can be pushed down before resistance is met.

To adjust pedal free travel, loosen the lock nut and turn the pedal free travel adjusting screw in to increase free travel or out to decrease free travel. Set the pedal free travel at $\frac{3}{4}$ ". Make sure the lock nut is securely tightened at all times.

To insure proper clutch disengagement, it is necessary that the pedal be positioned to 7" above the running board. Adjustment is made by lengthening the clutch release rod to decrease height and shortening the rod to increase height.

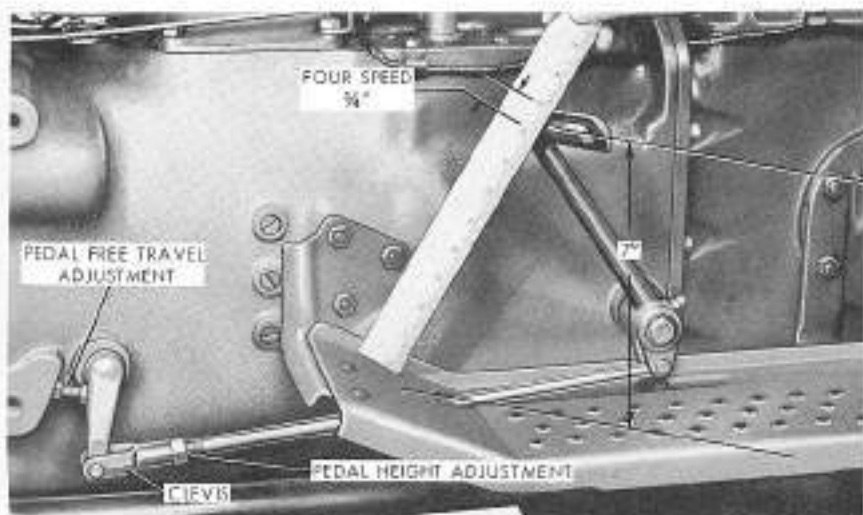

Figure 41
Clutch Pedal Free Travel Adjustment

STEERING, WHEELS, BRAKES AND TIRES

Power Steering System: The power steering system on your Ford Tractor (see Figure 42) requires very little mechanical maintenance. Check the three cylinder support bolts and the piston rod lock nut periodically and tighten if necessary. Check both the pump return and pressure hose connections for oil leakage. Maintain tight hose connections. When it is necessary to remove or disconnect the pump return and pressure hoses for tractor engine maintenance purposes or hose replacement, make certain that the hoses are reinstalled correctly. The **pump return hose** connects to the pump reservoir at one end and to the **REAR PORT** of the cylinder and valve assembly. The **pressure hose** connects to the pressure port in the pump at the top and to the **FRONT PORT** of the cylinder and control valve assembly. The pump, cylinder and valve assembly and drag link require no mechanical maintenance. Power steering adjustments and replacements on your Ford Tractor should be made only by your local Ford Tractor and Implement Dealer.

Pedestal: Check the mounting bolts in the tractor side rails and pedestal from time to time. Tighten the nuts on the bolts, if necessary.

Any adjustment of the spindle shaft and sector gear located in the tractor pedestal should be made only by your local Ford Tractor and Implement Dealer.

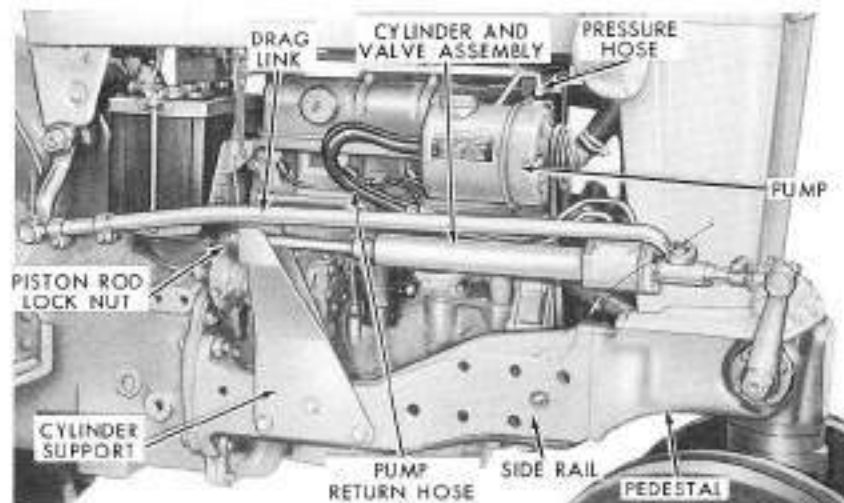

Figure 42
Power Steering System

Front Wheel Toe-In Adjustable Front Axle Models: Front wheel toe-in adjustments on your Ford Tractor were made at the factory. If the toe-in adjustment must be re-established for any reason, remove the **Outer Clamp** bolts which lock the tie rods in the sleeves and loosen the **Inner Clamp** bolts (see Figure 17, Page 32). Mark or otherwise note the slot in each tie rod that aligns with the outer clamp hole. Measure between the outside of the tire ribs at hub height, on both the front and rear of the wheels. Adjust the drag links by turning the sleeves until the correct toe-in of $\frac{1}{8}$ to $\frac{1}{4}$ inch is obtained. Tighten the inner clamps and replace the bolts in the outer clamps making certain that the outer clamp holes align with the marked grooves in the tie rods. Secure the outer clamps.

Front Wheel Bearings: To adjust the front wheel bearings, raise the front of the tractor until the wheels rotate freely. Remove the hub cap and the cotter pin which holds the castellated nut and turn the nut until a slight drag is felt. Then back off the nut until the nearest slot in the nut is aligned with the hole in the spindle. Reinstall the cotter pin and hub cap. Pack the bearings with short fibre grease every 600 hours of operation as directed under LUBRICATION, page 44.

Brake Adjustment: Jack the tractor up until both rear wheels are free. Remove the adjusting slot cover from the back plate and, with the brake pedals released, turn the adjusting screw clockwise (see Figure 44) until the brake drags. (Figure 43 illustrates the adjusting mechanism.)



BRAKE ADJUSTING SCREW

Figure 43

Brake Assembly with Drum Removed



Figure 44

Adjusting the Brakes

Back off the adjusting screw until the brake drags very slightly when the wheel is turned. Adjust both brakes in this manner, then adjust the left brake tie rod with the clevis until both brake pedals are in line when both brakes are engaged.

During the first hour of operation after the brakes have been adjusted, check the drums for overheating. If necessary, readjust as previously outlined.

Tire Removal: Remove the wheel from the hub and deflate the inner tube completely. Press the valve through the valve hole and loosen both tire beads from the wheel rim, using a tire iron and heavy mallet. With the wheel lying flat, stand on the tire with your feet about 15 inches apart opposite the valve, then force the bead seat into the drop center of the rim.

Insert two tire irons, about 8 inches apart, between the tire bead and the wheel rim near the valve, then pry the bead over the wheel rim. Leaving one tire iron in position, follow around the wheel rim with the other tire iron to remove the remainder of the bead. Remove the inner tube.

Turn the wheel over and block up the disc until the rim is off the floor, as shown in Figure 46. Pry the tire off the rim, starting with a small section and following around the wheel.

Tire Installation: Place the wheel and rim in a flat position. Inflate the inner tube until it is barely rounded out, then install the tube in the tire.

Coat the inside and outside of the tire beads with a soft soap and water solution to protect the bead, then pry the bead over the edge of the rim. See recommended tire inflation pressure chart, page 36.



Figure 45
Loosening Tire Bead from Edge of Rim

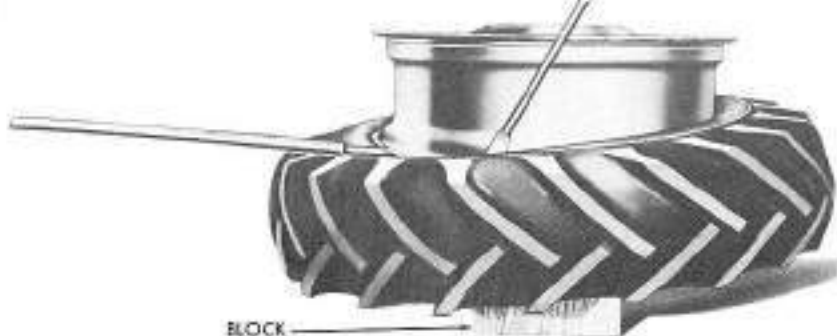

Figure 46
Prying Rim Out of Tire

Tire Removal—Single Front Wheel: Jack the tractor up sufficiently to free the front wheel. Remove the dust cap, cotter pin, castellated nut and flat washer from the wheel spindle. Remove the wheel and deflate the inner tube completely by removing the valve core. **CAUTION: FAILURE TO REMOVE ALL THE AIR MAY RESULT IN THE RIM HALVES FLYING APART DUE TO AIR PRESSURE.** Remove the five flange bolts and insert two of these bolts in the opposed thread holes of the flange as shown in "A" Figure 47. Turn the bolts in to break the flange from the hub. Use tire irons to remove the flange from the tire (See "B" Figure 47). Lift the tire off of the hub and remove the tube liner and tube (See "C" Figure 47). Remove the two flange bolts from the flange.

Tire Installation: Inflate the tube partially and install the tube and tube liner in the tire. Place the hub in the tire and guide the tube valve stem through the valve stem hole provided. Install the flange in the tire and rotate the flange until the bolt holes align in both hub and flange. Insert the five flange bolts and tighten each bolt evenly. Recommended tire inflation pressure is 44 pounds.



Figure 47
Single Front Wheel Tire Removal

Install the wheel on the spindle and replace the flat washer and castellated nut. Adjust the nut in accordance with procedures outlined under "Front Wheel Bearings" Page 57.

TRACTOR STORAGE

Tractors which are used seasonally should be protected while in storage. The following operations are suggested:

1. Wash and clean the tractor thoroughly. Use Sprayon Touch-Up Enamel where necessary to avoid rust.
2. Block or tie down the clutch pedal so that the clutch faces are disengaged.
3. Lubricate the tractor, drain and refill transmission, pedestal, final drive housings, differential, hydraulic system, and engine, as directed under LUBRICATION. Use engine preservative oil in the crankcase to prevent internal corrosion.
4. Drain the fuel tank and sediment bowl, then run the engine until the gasoline supply in the carburetor is exhausted.
5. Remove the spark plugs and pour three ounces of engine preservative oil into each cylinder. Turn the engine several revolutions with the starter, then replace the spark plugs. This will coat the combustion chamber with an oil film.
6. Remove the battery and be sure it is fully charged before placing it in storage in a warm place. The battery should be charged periodically during storage.
7. Place blocking under the tractor axles to remove the weight from the tires.
8. Open drain cocks at bottom of radiator and on left side of engine block to drain the cooling system.
9. Check the tractor for worn or damaged parts. Replace with genuine Ford Tractor parts.

Tractors which have been placed in storage should be completely serviced in the following manner before putting into use.

1. Inflate the tires to recommend pressure; fill cooling system (use corrosion inhibitor in warm weather, anti-freeze in winter), fill gasoline tank with fuel; check oil level in crankcase, rear end, transmission, and air cleaner, and install fully charged battery.
2. Start the engine and let it idle a few minutes. Be sure the engine is receiving lubrication and that each control is functioning correctly.
3. Drive the tractor without a load to be sure it is operating satisfactorily.

ACCESSORIES

A wide variety of accessories, attachments and special items are available for use on your new Row Crop Ford Tractor.

These are designed to make your farm work easier by providing you with maximum convenience and operating comfort. In many cases, they will improve the performance of your Ford Tractor and Equipment. All of the accessories, attachments and special items listed in this section are available at extra cost from your Ford Tractor and Implement Dealer. For a more detailed description of these items, see your "Ford Tractor Accessories" Booklet included in your owner's envelope.



Be safe, be seen, use lights at night.

ROW CROP FORD TRACTOR ACCESSORIES AND SPECIAL ITEMS

SERIES 701 AND 901

TRACTOR ACCESSORIES

Dry Charge Battery

Grease Gun and Bracket

Implement Lamp Kit

Implement Warning Lamp Kit

Power Adjusted Rear Wheels (Standard on Series 901 Tractors)

PTO Belt Pulley Assembly

PTO Shield

Remote Control Attachments

Stabilizer Bars

Tire Pump and Gauge

Tractor Half Cabs

Vertical Exhaust Kits

Weight Box—Pedestal Mounted (Not used Adjustable Front
Axle Models)

Wheel Weights—Rear—Regular Duty

Wheel Weights—Front (Adjustable Front Axle Models Only)

SPECIAL ITEMS

A complete line of chemicals, hydraulic oil and oil additives plus paints are available. For further details, see your Ford Tractor and Implement Dealer.

SPECIFICATIONS

The specifications on the following pages are provided for your information and reference. For further information see your local Ford Tractor and Implement Dealer.

The Ford Motor Company reserves the right to make changes in specifications or to add improvements at any time without notice or obligation.



Be Safe—be careful at all times.

SPECIFICATIONS

SERIES 701 AND 901

GENERAL

Wheelbase:

Single and Dual Front Wheel Models.....85.3 inches

Adjustable Front Axle Models.....94.0 inches

Over-all Length:

Single and Dual Front Wheel Models.....132 inches

Adjustable Front Axle Models.....140 inches

Over-all Width @ 52 inch Tread Setting.....71.7 inches

Front Tread Width:

Dual Front Wheel Models.....8.3 to 16.3 inches

Adjustable Front Axle Models.....51.5 to 81 inches

Rear Tread Width.....56 to 84 inches

Crop Clearance:

Single and Dual Front Wheel Models...Series 701—27.49 inches

Series 901—28.44 inches

Adjustable Front Axle Models.....21.0 inches

Turning Circle Diameter with brakes set:

Single Front Wheel Models.....15 feet, 2 inches

Dual Front Wheel Models.....15 feet, 10 inches

Adjustable Front Axle Models.....23 feet, 6 inches

Shipping Weight:

Single Front Wheel Models.....Series 701—3194 lbs.

Dual Front Wheel Models.....Series 701—3100 lbs. (approx.)

Adjustable Front Axle Models.....Series 701—3345 lbs.

Single Front Wheel Models.....Series 901—3400 lbs. (approx.)

Dual Front Wheel Models.....Series 901—3344 lbs. (approx.)

Adjustable Front Axle Models...Series 901—3550 lbs. (approx.)

Tire Size—Front (Standard):

Single Front Wheel

Models.....Series 701 and 901—9:00 x 10—8 ply

Dual Wheel and Adjustable

Front Axle Models.....Series 701—5:50—16—4 ply

Dual Wheels.....Series 901—5:50—16—4 ply

Adjustable Front Axle.....Series 901—5:50—16—4 ply

Tire Size—Rear (Standard).....Series 701—11:00—28—4 ply

Series 901—12:00—28—4 ply

CAPACITIES

Fuel Tank:

Series 901.....17 U.S. gallons (14.16 Imperial gals.)

Series 701.....13 U.S. gallons (10.82 Imperial gals.)

Cooling System.....15 U.S. quarts (12.5 Imperial qts.)

Crankcase (including filter).....5 U.S. quarts (4.16 Imperial qts.)

Transmission.....4 Speed—6 U.S. quarts (5.00 Imperial qts.)

Select-O-Speed—12 U.S. quarts (10.00 Imperial qts.)

Hydraulic Reservoir.....8 U.S. quarts (6.66 Imperial qts.)

Differential.....8 U.S. quarts (6.66 Imperial qts.)

Final Drive (each housing).....1½ U.S. quarts (1.2 Imperial qts.)

Steering Gear Housing.....	1½ pounds
Pedestal.....	2 U.S. quarts (1.67 Imperial qts.)
Power Steering System.....	1.5 U.S. quarts (1.25 Imperial qts.)

ENGINE

Type.....	4 cylinder, in-line, overhead valve
Bore.....	Series 701—3.44 inches Series 901—3.90 inches
Stroke.....	3.60 inches
Displacement.....	Series 701—134 cu. inches Series 901—172 cu. inches
Compression ratio.....	Series 701—7.5 to 1 Series 901—7.5 to 1
Firing Order.....	1-2-4-3
Idle Speed.....	450-475 R.P.M.
Maximum Speed (no load).....	4 Speed Transmission—2300-2325 R.P.M. Select-O-Speed Transmission—2500-2525 R.P.M.
Sleeves.....	Cast iron, dry type
Pistons.....	Aluminum alloy
Tappet Clearance (intake and exhaust—hot).....	.014 to .016 inch
Governor.....	Variable speed, centrifugal type

COOLING SYSTEM

Type.....	Pressure
Fan.....	Three blade
Thermostat.....	Starts to open—157 to 162° F. Fully open—177 to 182° F.

FUEL SYSTEM

Type.....	Gravity flow
Carburetor.....	Single up-draft
Idle Fuel Adjustment.....	One turn—open
Main Fuel Jet Adjustment.....	Series 701—One and one-eighth turns Series 901—One and one-quarter turns

IGNITION SYSTEM

Type.....	Dist.—automatic centrifugal spark advance
Initial Timing.....	Series 701 and 901— 4 degrees B.T.D.C. at 450 R.P.M.
Advance at 2000 R.P.M.....	Series 701 and 901—22 degrees
Distributor Point Spacing.....	.024 to .026
Spark Plug Size.....	14 MM
Spark Plug Gap.....	.025—.028

ELECTRICAL SYSTEM

Generator.....	Two brush shunt wound
Capacity.....	20 amps.
Generator Regulator.....	Relay type
Battery.....	6 volt—80 ampere hours
Terminal Grounded.....	Positive
Starter Motor.....	Automatic, with safety switch 6 volt—follow through

CLUTCH

Type.....Single plate, 10 inch
 Pedal Free Travel..... $\frac{3}{4}$ inch

4-SPEED TRANSMISSION

Gear Ratios:

First Gear.....11.00 to 1
 Second Gear.....9.06 to 1
 Third Gear.....6.22 to 1
 Fourth Gear.....2.98 to 1
 Reverse Gear.....10.05 to 1

SELECT-O-SPEED TRANSMISSION

Gear Ratios:

First Gear.....38.00 to 1
 Second Gear.....26.70 to 1
 Third Gear.....25.60 to 1
 Fourth Gear.....18.00 to 1
 Fifth Gear.....11.30 to 1
 Sixth Gear.....8.77 to 1
 Seventh Gear.....7.62 to 1
 Eighth Gear.....5.93 to 1
 Ninth Gear.....3.66 to 1
 Tenth Gear.....2.47 to 1
 Reverse—One Gear.....12.80 to 1
 Reverse—Two Gear.....8.65 to 1

HYDRAULIC SYSTEM

Type.....Live action
 Maximum Pressure.....2000 p.s.i.

Pump:

Type.....Piston
 Drive.....Gear
 Capacity.....4 G.P.M. at 2000 R.P.M. (Engine)
 Control.....Implement position or constant draft

POWER STEERING SYSTEM

Type.....External Linkage
 Maximum Pressure.....700-800 p.s.i.

Pump:

Type.....Piston
 Drive.....Belt
 Capacity.....5.00 G.P.M. at 1250 R.P.M.

Cylinder:

Type.....Integral Cylinder and Valve

REAR AXLE

Type.....Semi-floating
 Ratio.....7.18 to 1

BRAKES

Type.....Internal expanding
 Control.....Mechanical
 Width..... $1\frac{1}{2}$ inch
 Drum Size.....14 inch diameter
 Pedal Free Travel..... $\frac{3}{4}$ inch

AMERICAN PETROLEUM INSTITUTE OIL CLASSIFICATION

TYPE OF OPERATION FOR WHICH OIL IS SUITABLE

API CLASS		REMARKS
ML (Motor Light)	Not suitable for tractors. Used primarily for passenger cars when operation consists of daily driving 20 to 100 miles per trip on highways at 30 to 35 MPH.	Straight mineral oil. No additives. Generally sold in bulk or two-gallon cans.
MM (Motor Moderate)	Suitable for light duty tractor operation such as; raking, mowing, windrowing, light cultivating, hoeing, and pulling engine driven equipment or light wagon loads.	Has anti-oxidation additives. This is the premium oil which filling stations carry in quart cans.
MS (Motor Severe)	Basic Tractor Oil suitable for general to heavy duty operations such as: plowing, subsoiling, discing, front and rear loading, and dozing.	Anti-oxidation additive. Moderate detergency. In general, filling stations carry this oil in quart cans as their "best quality" oil. The terms "Premium," "HD," etc. on labels do not necessarily mean an oil of this class.

CONTENTS

	PAGE
STANDARD AND OPTIONAL EQUIPMENT CHART.....	2
FOREWORD.....	3
TRACTOR MODEL AND SERIAL NUMBER.....	4
FRONT WHEEL TYPES.....	5
CONTROLS AND INSTRUMENTS.....	9
Tractor Seat.....	10
Light Switch.....	10
Ignition Switch.....	10
Choke Control.....	11
Gear Shift Lever.....	11
Select-O-Speed Shift Lever.....	11
Starter Button.....	12
Throttle Control.....	12
Oil Pressure Gauge.....	12
Temperature Gauge.....	12
Fuel Gauge.....	12
Charge Indicator Light.....	12
Lubrication Light.....	12
Clutch Pedal.....	13
Inching Pedal.....	13

	PAGE
Brake Pedals.....	13
Brake Pedal Locks.....	13
Power Take-Off Lever.....	14
P.T.O. Control Knob.....	14
Engine P.T.O Speed Shift Lever.....	14
Ground Speed P.T.O. Shift Lever.....	15
Drive Line Disengagement Strap.....	15
Hydraulic Selector Lever.....	15
Hydraulic Lift Control Lever.....	15
Fuel Shut-Off Valve.....	16
PROOF METER.....	16
Engine Speed.....	16
Tractor Ground Speed.....	16
P.T.O. Speed.....	16
Belt Pulley.....	17
Engine Hours.....	17
OPERATION.....	19
Pre-Starting Check.....	20
Fuel.....	20
Break-In Procedure.....	20
4-SPEED TRANSMISSION TRACTOR.....	21
Starting the Engine.....	21
Driving the Tractor.....	21
Stopping the Tractor.....	21
SELECT-O-SPEED TRANSMISSION TRACTOR.....	22
Speed Selector Mechanism.....	22
Repositioning the Selector Lever.....	22
Selector Lever Stops.....	23
Starting the Engine.....	23
Driving the Tractor.....	23
Stopping the Tractor.....	23
Towing the Tractor.....	24
THE HYDRAULIC SYSTEM.....	25
Implement Position Control.....	25
Constant Draft Control.....	25
Hydraulic Piston Pump.....	25
ATTACHING IMPLEMENTS.....	25
Three Hole Hydraulic Lift Rocker.....	26
Adjustable Top Link.....	26
Swinging Drawbar.....	26

	PAGE
POWER TAKE-OFF OPERATION.....	27
Engine P.T.O. Speeds.....	27
Power Take-Off Shaft.....	27
Belt Pulley.....	30
Wheel Tread Adjustments.....	31, 32, 33, 34, 35
Wheel Weight.....	35
MAINTENANCE.....	37
Pre-Delivery Inspection.....	38
50 Hour Inspection.....	38
LUBRICATION.....	38
Service Daily or Every Ten Hours.....	38, 39
Service Every 100 Hours.....	40
Service Every 200 Hours.....	41
Lubrication Chart.....	42, 43
Service Every 600 Hours.....	44
MECHANICAL MAINTENANCE.....	44
Cooling System.....	44
Fuel System.....	46
Electrical System.....	48
Engine.....	52
Clutch Adjustment.....	55
Steering, Wheels, Brakes and Tires.....	56
Tractor Storage.....	60
ACCESSORIES.....	61, 62
SPECIFICATIONS.....	63
General.....	64
Capacities.....	64
Engine.....	65
Cooling System.....	65
Fuel System.....	65
Ignition System.....	65
Electrical System.....	65
Clutch.....	66
4-Speed Transmission.....	66
Select-O-Speed Transmission.....	66
Hydraulic System.....	66
Power Steering System.....	66
Rear Axle.....	66
Brakes.....	66
Oil Classification.....	67

