



1690 Tractor Operators Manual

Rac 9-7522

Written in Clear
And
Simple
English

J I Case
A Tenneco Company





THIS SAFETY ALERT SYMBOL INDICATES IMPORTANT SAFETY MESSAGES IN THIS MANUAL. WHEN YOU SEE THIS SYMBOL, CAREFULLY READ THE MESSAGE THAT FOLLOWS AND BE ALERT TO THE POSSIBILITY OF PERSONAL INJURY OR DEATH.

IMPORTANT

If This Machine Is Used By an Employee Or is Loaned Or Rented, Make Certain That The Operator (s), Prior To Operating:

- 1. Is Instructed In Safe And Proper Use.**
- 2. Reviews And Understands The Manual (s) Pertaining To The Machine.**



SAFE OPERATING INSTRUCTIONS

- | | |
|--|--|
| <ol style="list-style-type: none"> 1. SECURELY FASTEN YOUR SEAT BELT IF THE TRACTOR HAS A ROPS. 2. WHERE POSSIBLE, AVOID OPERATING THE TRACTOR NEAR DITCHES, ENBANKMENTS AND HOLES. 3. REDUCE SPEED WHEN TURNING, CROSSING SLOPES, AND ON ROUGH, SLICK, OR MUDDY SURFACES. 4. STAY OFF SLOPES TOO STEEP FOR SAFE OPERATION. 5. WATCH WHERE YOU ARE GOING. | <ol style="list-style-type: none"> 6. ESPECIALLY AT ROW ENDS, ON ROADS, AND AROUND TREES. 6. DO NOT PERMIT OTHERS TO RIDE. 7. OPERATE THE TRACTOR SMOOTHLY, NO JERKY TURNS, STARTS OR STOPS. 8. HITCH ONLY TO THE DRAWBAR AND HITCH POINTS RECOMMENDED BY TRACTOR MANUFACTURER. 9. WHEN TRACTOR IS STOPPED, SET BRAKES SECURELY AND USE PARK LOCK IF AVAILABLE. |
|--|--|

PER OSHA 1928.51.

EMPLOYER SHALL NOTIFY EMPLOYEES WHO OPERATE AGRICULTURAL TRACTORS OF THESE INSTRUCTIONS AT INITIAL ASSIGNMENT AND ANNUALLY THEREAFTER.

	Page		Page
TO THE OWNER	3	Control Levers	
SAFETY		(Low Profile)	67
Safety Rules	4	Operators Seat Adjustments ..	78
HAND SIGNALS	20	Cab Air Flow Control	79
DECALS	22	Cab Air Flow Arrangements ..	80
TRACTOR IDENTIFICATION ..	26	Air Conditioner Operation ...	83
SPECIFICATIONS		Cab Door Lock	83
Diesel Engine	28	Tool Compartment	83
General Specifications	30	Rear View Mirrors	84
APPROXIMATE TRACTOR		Cab Window Lever	84
SPEEDS		Seat Belts	85
Synchromesh Transmission ..	35	Amber Warning Lamps,	
Power Shift Transmission ...	36	Direction Turn Signals and	
APPROXIMATE		SMV Symbol	86
MEASUREMENTS		Implement Warning Lamps ..	88
High Platform with Cab: MFD	37	DIESEL ENGINE	
High Platform with Cab	38	Before Starting the Engine ...	89
Low Profile: 2 Post ROPS	39	Starting the Engine	90
TIRE PRESSURES	40	Before stopping the Engine ..	91
TIRE ARRANGEMENTS:		Stopping the Engine	91
MFD	41	TRANSMISSION	
TREAD POSITIONS		Power Shift Tractor	92
Front Axle: 2 Wheel Drive	42	Synchromesh Tractor	95
Front Axle: MFD	43	BALLAST	97
Rear Wheels: Manual Adjust ..	44	MEASURING WHEEL SLIP ...	98
Rear Wheels: Power Adjust ..	45	POWER TAKE OFF	
FUEL SPECIFICATIONS	46	Single Speed	99
FUEL CONDITIONER	47	Reversible Shaft	100
LUBRICANTS	48	TREAD ADJUSTMENT	
Recommendations and		Front Axle	101
Capacities	49	Rear Wheels: Power	
OPERATING		Adjusted	102
Operating Instruments	50	HITCH	
Operating Controls	54	Position of Parts	103
Cab Controls	58	Stabilizers	104
Ventilation Control Settings ..	59	Mechanical Flotation	105
Control Levers		DRAWBAR	
(High Platform)	60	Changing Positions	106
		DRAFT CONTROL	
		Position of Levers	108

CONTENTS

	Page		Page
Operating with Draft Control	110	Fan and Alternator Belts	136
POSITION CONTROL		Fuel Filters	136
Position of Levers	111	Removing Air from Fuel System	137
Operating with Position Control	112	Air Cleaner Elements	139
DIAGRAM OF HYDRAULIC SYSTEM	113	Hydrostatic Steering	140
DOUBLE ACTING REMOTE VALVES	114	Torque Figures	141
SINGLE ACTING EQUIPMENT	115	Operators Seat Belt	141
HOSES AND COUPLING MAINTENANCE	115	Operators Seat	142
Introduction	116	Roll Over Protective Structure	144
LUBRICATION CHARTS	117	1000 HOUR SERVICE	
DAILY INSPECTION	122	Hydraulic System	146
50 HOUR SERVICE	123	Brake and Clutch Fluid	146
Power Steering	123	Final Drives	146
Brakes	123	Cooling System	147
Coolant	124	Differential and Reductions:	
Transmission Clutch	124	MFD	148
PTO Clutch	125	Front Hub Bearings	148
Battery	125	Power Shift Oil Pressure	148
Tires	125	COMPRESSOR BELT REPLACEMENT	149
Fuel Water Trap	125	AIR CONDITIONER CHECKS	152
Wheel Nuts	126	DOME LIGHT: OPERATORS CAB	156
Transmission	126	FUSE PANEL: OPERATORS CAB	156
100/125 HOUR SERVICE		ALTERNATOR	157
Engine Oil Change	127	BATTERY	158
Final Drives	127	AUXILIARY BATTERY	
Front Axle: MFD	128	Connecting Instructions	159
Fuel Injection Pump	128	HOOD AND SIDE PANELS	160
Cab Air Filter	129		
200/250 HOUR SERVICE			
Engine Oil Filter	132		
Compressor Belt	133		
500 HOUR SERVICE			
Transmission Oil Filter	134		
Injectors	135		
Valve Clearances	135		

TO THE OWNER OF A CASE TRACTOR

Use this manual as your guide. If you follow the instructions given in this manual, your Case Tractor will work well for many years.

Your Authorized Case Dealer can give you assistance with J I Case Company made parts and persons with special training that know the best methods of repair and maintenance for your tractor.

Call your Authorized Case Dealer if you need any assistance or information.

Your Authorized Case Dealer



NOTE: When you are in the tractor seat looking forward, the right hand and left hand of the tractor are the same as your right hand and left hand.

SAFETY RULES

Understand that your safety and the safety of other persons is measured by how you service, and operate this machine. Know the positions and operations of all controls before you try to operate. **MAKE SURE YOU CHECK ALL CONTROLS IN A SAFE AREA BEFORE STARTING YOUR WORK.**

READ THIS MANUAL COMPLETELY and make sure you understand the controls. All equipment has a limit. Make sure you understand the speed, brakes, steering, stability, and load characteristics of this machine before you start to operate.

The safety information given in this manual does not replace safety codes, insurance needs, federal, state and local laws. Make sure your machine has the correct equipment needed by the local laws and regulations.

J I Case is continuing to work for your safety: by making tractors with better protection and by giving these rules for safe operation

BEFORE STARTING

CAUTION: Provide a first aid kit for use in case of accident.

CAUTION: It is good practice to carry a fire extinguisher on the tractor. Be sure that the extinguisher is properly maintained and be familiar with its proper use.



WARNING: Before starting engine study Operator's Manual safety messages.

Read all safety signs on machine.

Clear the area of other persons.



Learn and practice safe use of controls before operating.

It is your responsibility to understand and follow manufacturer's instructions on machine operation, service, and to observe pertinent laws and regulations.

Operator and Service Manuals may be obtained from your equipment dealer.

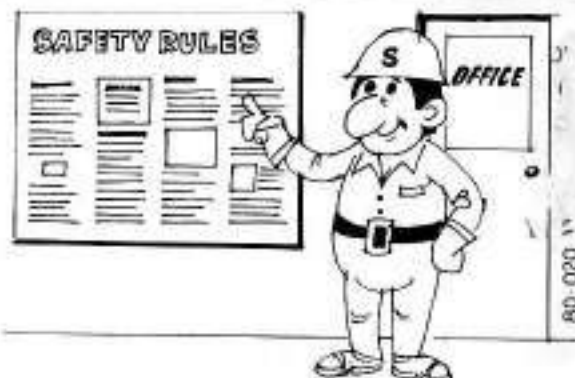

WARNING: Before starting engine be sure all operating controls are in neutral.

Operate controls only when seated in Operator's seat.

On roads, use flasher/lights according to local laws.

Keep SMV emblem visible.



Shields help protect from injury, keep in place.

Stop engine before working on PTO driven machine or PTO shaft, or doing any maintenance.

Before leaving tractor unattended, lower hydraulically raised equipment to ground.

WARNING: Before starting the engine be sure all operating controls are in neutral. This will ease starting loads on the starter and batteries and will prevent the accidental start up of PTO Driven equipment.

! **WARNING:** Before leaving the tractor, stop the engine, place all controls in neutral, and apply the parking brake.



80-021

! **WARNING:** Operate controls only when seated in the Operator's seat.



80-022

! **DANGER:** Before towing a trailer or operating the machine on a road, fasten the brake pedals together with the lock bar. If this is not done the machine will turn suddenly when only one brake is applied and this could result in an accident.



80-025

! **WARNING:** On roads, use flasherlights according to local laws. Keep SMV emblem visible.

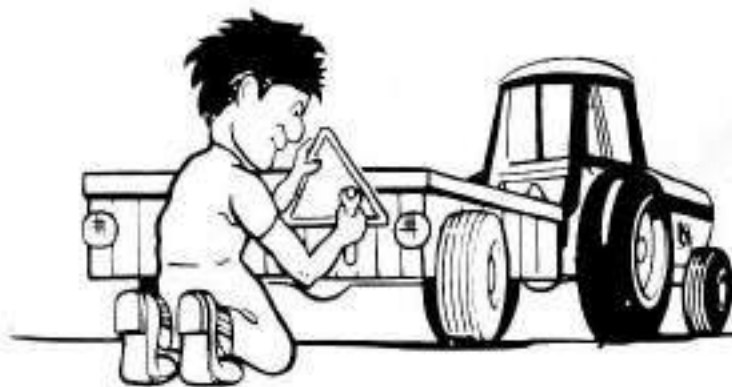

80-025

CAUTION: Stop, look and listen before entering a highway, stay on your side of the road and pull over to let faster traffic pass. Slow down and signal as you turn off.



80-025

WARNING: Do not permit others to ride. Only one person — the operator — must be on a tractor when it is in operation.



80-026



80-027

WARNING: Engage a low gear when going down difficult grades. DO NOT go down any grade with the transmission in the neutral position. If you do, there is no control and the result could be an accident. Keep away from grades that are too steep for safe operation.



80-028

WARNING: Extra weight increases your braking distance. Remember that liquid in the tires, weights on the tractor or wheels, tanks filled with fertilizer, herbicides or insecticides — all these add weight and increase the distance you need in which to stop.



WARNING: When the differential lock is engaged, the tractor will not steer normally. Use the differential lock as an aid to traction only. Before you operate on any road, make sure the differential lock is disengaged. Failure to do this can cause an accident.



WARNING: Rear upset can result if pulling from wrong location on tractor. Hitch only to the drawbar. Use 3 point hitch only with the implements designed for its use — not as a drawbar.



DANGER: Excess tractor speed is the big killer. Only experienced drivers should be permitted on highways.



WARNING: Extreme care must be exercised when adjusting and checking hitch and control levers when the engine is running and when hitch is under hydraulic or mechanical load. Study the hitch travel — keep the hands, arms, legs and feet out of the travel arc of the hitch.



80-033

CAUTION: Do not try to make any repairs that you do not understand.

WARNING: Engine can start with transmission in gear when neutral safety switch is by-passed:

1. Do not connect across terminals on starter.
2. Attach booster batteries according to safe method in Operator's Manual. Then use recommended starting procedure from Operator's seat.

Machine run-away can cause injury or death to operator and bystanders.

WARNING: Rotating machinery can cause serious injury. Always remove any loose clothing when you work near moving parts of the tractor or implements.



70-034

WARNING: PTO driven machinery can cause serious injury if it is not used correctly. Make sure that you do the following.

Use the correct speed of PTO shaft for the implement.
Keep the guards fastened correctly at all times.
Before working on or near the PTO shaft or driven machine, put the PTO clutch lever in the disengaged position, the PTO selector lever in the neutral position, and STOP the tractor engine.

WARNING: Hot coolant can spray out if cap is removed suddenly. Remove cap by turning to first notch. Wait until pressure is released, then continue removal. Scalding can result from fast cap removal.

! **DANGER:** Exhaust gases can cause death. Do not run an engine in a closed building.



! **WARNING:** Do not put fuel in the machine when you are smoking, near a fire or when the engine is running.

! **CAUTION:** Never smoke while refueling the machine, servicing the fuel system, checking the batteries or using cold weather starting aids.

! **CAUTION:** Never use gasoline, naphtha or any other volatile material for any cleaning purposes. These materials may be toxic and/or flammable.



! **CAUTION:** When you dismount from the machine, do not jump to the ground. Prevent possible injury by facing the cab and using the steps.

! **CAUTION:** Check the machine for leaks and broken or missing parts. Make sure that all caps, dipsticks, battery covers, etc., are correctly fastened. A failure during operation can cause injury.

! **CAUTION:** Make sure that the implement does not make contact with the cab in the operating or fully raised position.

! **CAUTION:** A machine that is not operating correctly can cause an accident. Before each operating period, check the brakes, steering and controls. If necessary, make any adjustments or repairs before operating.



WARNING: Lower hydraulically or mechanically raised implements to the ground before servicing or when leaving the equipment.

CAUTION: The implement must be lowered to the ground before uncoupling of the remote hydraulic hoses.

CAUTION: Liquid refrigerants can cause severe and painful frostbite. Do not try to service the air conditioning system unless you understand the system and know the safety rules for handling liquid refrigerant. See your Authorized Case Dealer who is experienced in servicing air conditioning systems and handling liquid refrigerants.

WARNING: Operate the machine at a speed that is correct for the conditions and the work area. Be careful when you are operating in dust or smoke. When you cannot see clearly, go slower. If you do not, the result can be an accident.

DANGER: Batteries produce explosive gases. Keep sparks, flame and cigarettes away. Ventilate when charging or using in enclosed space. Always shield eyes when working near batteries.

POISON/DANGER: Batteries contain sulfuric acid which can cause severe burns. Avoid contact with skin, eyes or clothing. Antidote; **EXTERNAL** flush with water; **INTERNAL**, drink large quantities of water or milk. Follow with milk of magnesia, beaten egg or vegetable oil. Call physician immediately; **EYES**, flush with water for 15 minutes and get prompt medical attention. Keep out of reach of children.



WARNING: When working around storage batteries, remember that all of the exposed metal parts are "live". Never put a metal object across the terminals because a spark or short circuit will result.

WARNING: Battery explosion and/or damage to electrical components can result from improper connection of booster batteries or charger. Connect positive to positive and negative to negative. Externally, battery acid can cause burns and blindness, and taken internally is poison.

CAUTION: Do not try to make electrical system connections with the engine running.



CAUTION: When you remove a battery always disconnect the negative (—) terminal first. When installing a battery always connect the negative (—) terminal last.



WARNING: Stopping distance increases with speed and the weight of the load. Make sure that the total weight of a trailed vehicle not equipped with brakes is not greater than the weight of the machine that is towing it.



WARNING: The seat belt is for your protection. Use it at all times when operating the machine. Fasten the belt correctly and make sure it is not loose or twisted. If the machine starts to turn over, hold the steering wheel and stay seated. DO NOT try to get out of the cab.



CAUTION: Do not drill or weld the safety cab. Any parts that are damaged must be replaced with new parts. Replacement bolts must be of the correct tensile strength. Do not lift the tractor with the cab lifting hooks. If the cab is damaged in this way, your future safety will be reduced.



WARNING: If the engine stops or there is a failure of the power steering system, stop the machine as quickly as possible. A failure of this type will make the tractor difficult to steer and could result in an accident.



DANGER: Engage low gear BEFORE you go down a slope. DO NOT travel at any time with the transmission in the neutral position.



WARNING: Hydraulic systems operate with high pressures. Oil leaking from a hydraulic system can penetrate the skin and damage body tissues. Use a piece of wood or cardboard, not your hands when looking for a hydraulic oil leak.

HAND SIGNALS

For communication under noise conditions and special operations the American Society of Agricultural Engineers has made standard agricultural hand signals. You will find that the hand signals can decrease time loss and prevent accidents.

Start the Engine



Start the engine. Move arm in a circle at waist level.

Stop the Engine



Stop the engine. Move your right arm across your neck from left to right.

Move Toward Me — Follow Me

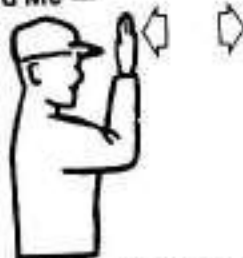

Move toward me or follow me. Look toward person or vehicle you need to move. Hold one hand in front of you with the back of the hand toward the machine and move your arm from the elbow to the fingers backward and forward.

This Far To Go



This far to go. Put your hands in front of your face with the back of your hands outward. Move your hands in or out as an indication how far to go.

Move Out



Move out. Face in the needed direction of movement. Put your arm straight out behind you. Then, swing your arm over your head and forward until your arm is straight out in front of you with the back of your hand up.

HAND SIGNALS

Come to Me



Come to me (Can also be come to me because I need assistance) Lift your arm vertically over your head with the back of your hand to the rear and turn your arm in large horizontal circles.

Decrease Speed

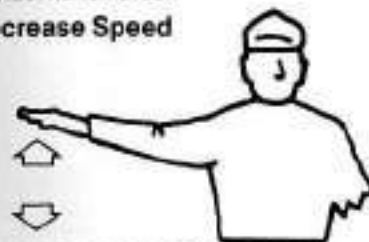

Decrease speed. Put your arm out horizontally with the back of your hand up and then move your arm down about 45 degrees minimum many times. Keep your arm straight and do not move your arm above your shoulder.

Increase Speed

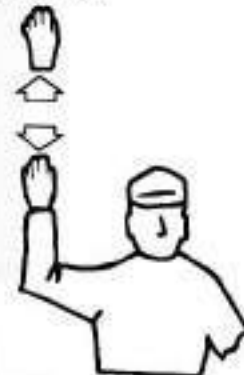

Increase speed. Lift your hand to shoulder level with your fingers

closed. Move your closed hand fully up and then return to shoulder level. Do this fast, many times.

21 is understood.

Raise Equipment



Raise equipment. Point up with one finger and at the same time, move your hand in a circle at head level.

Lower Equipment



Lower equipment. Point to the ground with one finger and at the same time, move your hand in a circle.

Stop



Stop. Raise your arm fully up with the back of your hand to the rear. Keep this position until the signal

DECALS

IMPORTANT: Install new decals if the old decals are destroyed, lost, painted over or can not be read. When parts are replaced that have decals, make sure you install a new decal with each new part.

NOTE: New decals are available from your Authorized Case Dealer or write to:

J I Case Company
Agricultural Equipment Division
25th and Mead Street
Racine, Wisconsin 53403



80-043



80-044



80-045



80-046

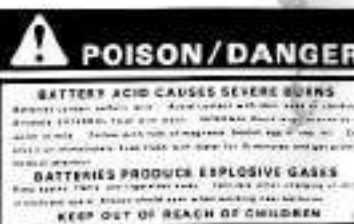



! WARNING

TO PREVENT POSSIBLE PERSONAL INJURY DUE TO P.T.O. DRIVEN MACHINE SHAFT BOTTOMING OR SEPARATING, DRAWBAR FRONT PIN MUST BE PROPERLY POSITIONED IN PIVOT BRACKET.

P.T.O. SHAFT	P.T.O. SHAFT END TO HITCH PIN HOLE
540 RPM 6 SPLINE	14.93 IN. (379mm)
1000 RPM 21 SPLINE	16.93 IN. (429mm)

! WARNING

THIS TRACTOR IS EQUIPPED WITH A DUAL SPEED P.T.O.—

6 SPLINE 21 SPLINE



540 R.P.M.



1000 R.P.M.

BE SURE IMPLEMENTS ARE MATCHED FOR THE PROPER DRIVESPEEDS CENTER AND LOCK DRAWBAR WHEN USING P.T.O.

! WARNING

REAR UPSET CAN RESULT IF PULLING FROM WRONG LOCATION ON TRACTOR. HITCH ONLY TO THE DRAWBAR. USE 3 POINT HITCH ONLY WITH IMPLEMENTS DESIGNED FOR ITS USE. NOT AS A DRAWBAR.



! WARNING

ROTATING MACHINE PARTS
STAY CLEAR, KEEP SHIELDS INSTALLED TO HELP PROTECT FROM CLOTHING ENTANGLEMENT AND INJURY.



! WARNING

TO PREVENT PERSONAL INJURY FROM ENTANGLEMENT IN MACHINERY, BEFORE DOING ANY WORK ON OR NEAR THE PTO SHAFT OR DRIVEN MACHINE: PLACE PTO CLUTCH LEVER IN LATCHED POSITION, PTO SHIFT LEVER IN NEUTRAL, AND **STOP** TRACTOR ENGINE.

PRODUCT IDENTIFICATION NUMBERS (PIN)

The product identification number is on the right-hand top face of the main frame.

The engine serial number is on the right-hand side of the cylinder block below the steering pump and reservoir.

The cab serial number is on a plate fastened inside the cab.

The front axle (MFD) serial number is on the left-hand top face of the axle casting.

The PIN plate is fastened to the left-hand side of the clutch casing.

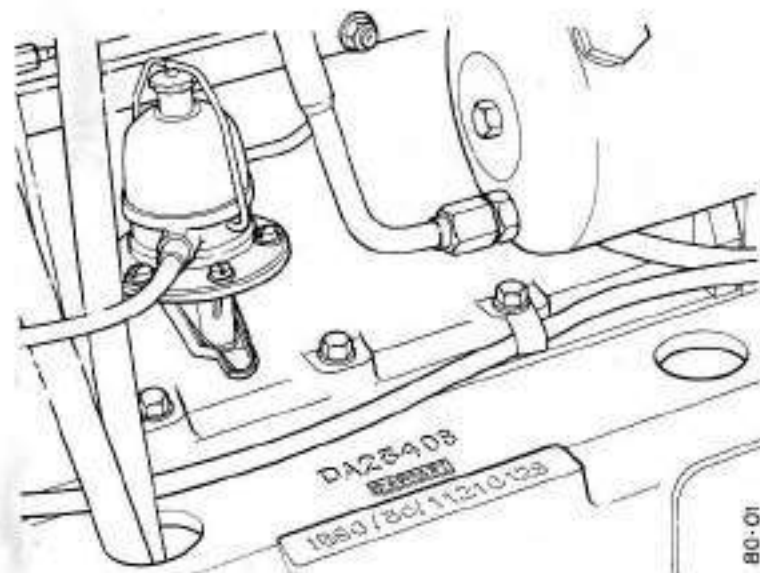

PRODUCT IDENTIFICATION NUMBER _____

ENGINE SERIAL NUMBER _____

CAB SERIAL NUMBER _____

CAB DOOR KEY NUMBER _____

FRONT AXLE (MFD) SERIAL NUMBER _____



FIGURE 1. PIN Plate on clutch casing

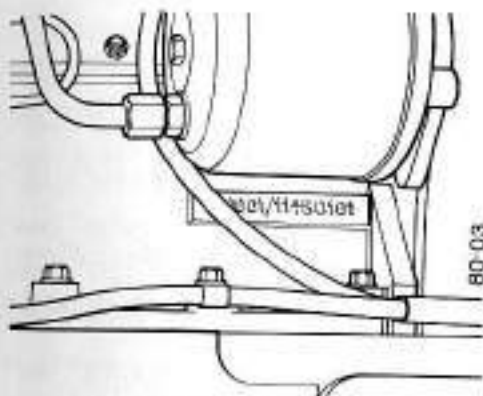

FIGURE 2. Engine Number

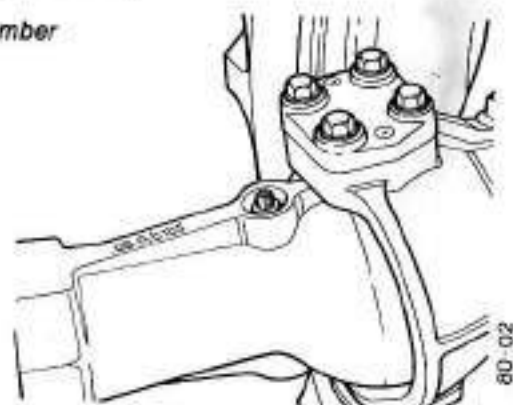

FIGURE 3. MFD Axle Number

Case	J I Case	Manufactured in England
Kewanee, Waukegan, 53004 U.S.A.		MADE IN U.S.A.
Model No. _____		
Product Identification Number _____		

80,049

DIESEL ENGINE SPECIFICATIONS

General

Type	6 Cylinder, Four Stroke Cycle, Natural Aspirated, Valve in Cylinder Head, Cross Flow Porting
Firing Order	153624
Bore	3.94in (100mm)
Stroke	4.5in (114.3mm)
Piston Displacement	329in ³ (5.4 litre)
Compression Ratio	16 to 1
Maximum Speed (Full Load)	2300 r/min
Idle Speed	750 r/min
Maximum Brake Horsepower at 2300 r/min*	110 (82 kW)

*Power Rating to SAE J270

Rocker Arm to Valve Clearance

0.010in (0.25mm)

IMPORTANT: Rocker arm to valve clearance adjustments must be made when the engine is cold.

Piston and Connecting Rod

Compression Rings per Piston	3
Scraper Rings per Piston	1
Type of Piston Pin	Full Float
Type of Bearings	Steel Back with Aluminum Tin Liners

Main Bearings

Quantity of Bearings	7
Type of Bearings	Steel Back with Aluminum Tin Liners

Engine Lubrication System

Oil Pressure	40 to 55 lb/in ² at Operating Temperature
Type of System	Pressure and Spray
Oil Pump	Gear Type
Oil Filter	Full Flow, Cartridge Type with By-Pass Valve
Oil Capacity	13.2 U.S. Qt (12.5 litres)

Fuel System

Fuel Injection Pump	In Line CAV P5463
Pump Timing	25 Degrees Before Top Dead Center
Fuel Injectors	CAV BDLL 140S 6592
Fuel Transport Pump ..	Diaphragm Type, Engine Camshaft Operated
Water Trap	Part of Fuel Transport Pump
Fuel Filters	Two Stage Micronic Paper Elements
Fuel Tank Location	One at Each Side of Tractor, connected by a balance pipe

Fuel Tanks Total Capacity

Standard Tractor	26 U.S. gallon (100 litres)
High Platform Tractor	36 U.S. gallon (136 litres)

GENERAL SPECIFICATIONS

Starting Aid

Thermostart Component activated by the starter switch which injects heated fuel into the intake manifold

Air Intake System

Type Two Stage with Service Indicator and Dust Release Valves

Filter Elements Dry Type with Main and Safety Element

Cooler System

Type Pressure system, Thermostat Control with Expansion Tank

Pump Impeller Type

Radiator Heavy Duty Fin and Tube

Fan 6 Blades, 17 in (432mm) diameter

Thermostat..... Starts to Open at 174 to 181° F (79 to 83° C)
Fully Open at 199 to 205° F (93 to 96° C)

Pressure Cap Set to 7lb/in² (48 kPa)

Capacity 16 U.S. quarts (15.3 litres)

Differential Lock

Type..... Mechanical

Operation Engaged by Pedal, Disengaged by Spring Pressure

Electrical System

Type of System 12 Volt, Negative Ground

Battery One 12 Volt, 128 Amp/h

Alternator Standard Tractor 28 Amp., High Platform 55 Amp

Voltage Regulator Inside Component of the Alternator

Started Motor Engaged by solenoid

Head Lights 12v 40/60W Sealed Beam

Side Lights 12V 5W

Side Direction Turn Signals 12V 21W

Rear and Stop Light..... 12V 5/21W

Rear Direction Turn Signals 12V 21W

Instrument Warning Lights No. 16

Instrument Illumination Lights No. 19

Fuses (4)..... two 35A, one 25A, one 15A

Power Steering

Type Hydrostatic, Metering Actuated by Steering Wheel

Pump Rotor, Engine Driven

Steering Cylinder Equal Displacement

Oil Capacity..... 1½ U.S. Quarts (1.4 litres)

Synchromesh Transmission

Type Four Speed Range Gear with a Three Forward,
One Reverse Gear Section

Gear Selection Twelve Speeds Forward, Four Speeds Reverse

Shift Control Manual with synchromesh between
Second and Third Gear

Power Shift Transmission

Type Four Speed Planetary Gearbox with a
Three Forward, One Reverse Gear Section

Gear Selection Twelve Speeds Forward, Four Speeds Reverse

Shift Control Hydraulic Controlled by Lever on the Panel

Clutch

Type Double Dry Disc, 12in (300mm) Diameter

Operation Transmission Clutch Hydraulic by Pedal,
PTO Clutch by Lever and Cable

Brakes

Type Wet Multiple Disc

Number and Diameter of Discs six 8.75in (222mm)

Operation Pedal Actuated Hydraulic System with
Pressure Equalizing Valve

Park Brake Actuated by Lever and Cables

Hydraulic System

Pump Type Gear, Front Mounted, Engine Driven

Control Valve Open center with return to neutral position

Combining Valve Provides for hitch and remote valve
operation or supplies total capacity to
remote valves

Number of Remote Outlets (Standard) One or Two
(High Platform) Three maximum

Maximum Oil Flow to Remote Outlets

Combine Position 20 gal/min (76 litre/min)

Separate Position 9 gal/min (34 litre/min)

Maximum Pressure 2500 lb/in² (17235 kPa)

Front Axle: MFD Models Center Pivot with Planetary
Reduction Hubs

Approximate Weights

Low Profile with 2 Post ROPS 7590lb (3442kg)

High Platform with 4 Post ROPS 8660lb (3928kg)

High Platform with Cab 8900lb (4037kg)

Maximum Operating Weight 14000lb (6350kg)

SPECIFICATIONS

Power Take Off

Type Reversible Shaft 540 r/min 6 Spline
 1000 r/min 21 Spline

Optional Single Speed, 1000 r/min

Shaft Diameter 1 1/2 in (35mm)

Rotation Clockwise when seen from the Rear

Hitch System

Type of Sensing Top Link

Control Hand Lever

Draft Arms Swinging with Fixed or Float Position on Lift Arms, Adjustable Left Link and Levelling Adjustment

Type of Hitch Three Point, Category II

Lifting Capacity 5500lb (2495kg) at 24in (610mm) Load Centers

Drawbar

Type Swinging, extendable, height adjustable

Swinging Range 12in (300mm)

Lateral Positions 2

Height Adjustments 14 to 20in (355 to 508mm)

Pin Hole Diameter 1in (25.4mm)

SPECIFICATIONS

APPROXIMATE TRACTOR SPEEDS IN MILES AND KILOMETERS PER HOUR AT 2300 r/min ENGINE SPEED

SYNCHROMESH TRANSMISSION: Final Drive Ratio 9:59 (MFD Models)

RANGE LEVER	GEAR LEVER								TIRE SIZE
	1		2		3		R		
	miles	km	miles	km	miles	km	miles	km	
1	1.1	1.8	1.9	3.0	3.2	5.2	1.9	3.0	16.9-38 18.4-38
2	2.3	3.8	3.7	6.0	6.4	10.3	3.8	6.1	
3	2.9	4.6	4.7	7.6	8.1	13.1	4.8	7.7	
4	5.7	9.2	9.4	15.1	16.2	26.1	9.5	15.3	
1	1.0	1.7	1.7	2.8	3.0	4.8	1.8	2.8	13.6-38 16.9-34 18.4-34 15.5-38
2	2.7	4.3	4.4	7.0	7.6	12.1	4.5	7.2	
3	2.1	3.4	3.5	5.6	6.0	9.6	3.5	5.7	
4	5.3	8.6	8.7	14.1	15.1	24.3	8.9	14.3	

SYNCHROMESH TRANSMISSION: Final Drive Ratio 11:58 (Standard)

1	1.4	2.3	2.3	3.7	4.0	6.4	2.4	3.8	16.9-38 18.4-38
2	2.8	4.5	4.6	7.4	8.0	12.8	4.7	7.6	
3	3.6	5.7	5.8	9.4	10.1	16.2	5.9	9.6	
4	7.1	11.4	11.7	18.8	20.1	32.4	11.8	19.1	
1	1.3	2.1	2.2	3.5	3.7	6.0	2.2	3.5	13.6-38 16.9-34 18.4-34 15.5-38
2	3.3	5.4	5.5	8.8	9.4	15.1	5.5	8.9	
3	2.6	4.2	4.3	6.9	7.4	12.0	4.4	7.0	
4	6.6	10.7	10.9	17.5	18.8	30.2	11.0	17.8	

APPROXIMATE TRACTOR SPEEDS IN MILES AND KILOMETERS PER HOUR AT 2300 r/min ENGINE SPEED

POWER SHIFT TRANSMISSION

RANGE LEVER	POWER SHIFT LEVER								TIRE SIZE
	1		2		3		4		
1	1.6	2.5	2.2	3.4	2.8	4.5	3.8	6.1	16.9-38 18.4-38
2	3.4	5.4	4.6	7.4	6.0	9.7	8.2	13.2	
3	7.1	11.3	9.6	15.5	12.5	20.2	17.1	27.6	
R	3.6	5.8	4.9	7.9	6.4	10.3	8.8	14.1	
1	1.5	2.4	2.0	3.2	2.6	4.2	3.6	5.7	13.6-38 16.9-34 18.4-34 15.5-38
2	3.2	5.0	4.3	7.0	5.6	9.0	7.7	12.3	
3	6.6	10.6	9.0	14.5	11.7	18.8	16.0	25.7	
R	3.4	5.4	4.6	7.4	6.0	9.6	8.2	13.2	

APPROXIMATE OVER ALL MEASUREMENTS

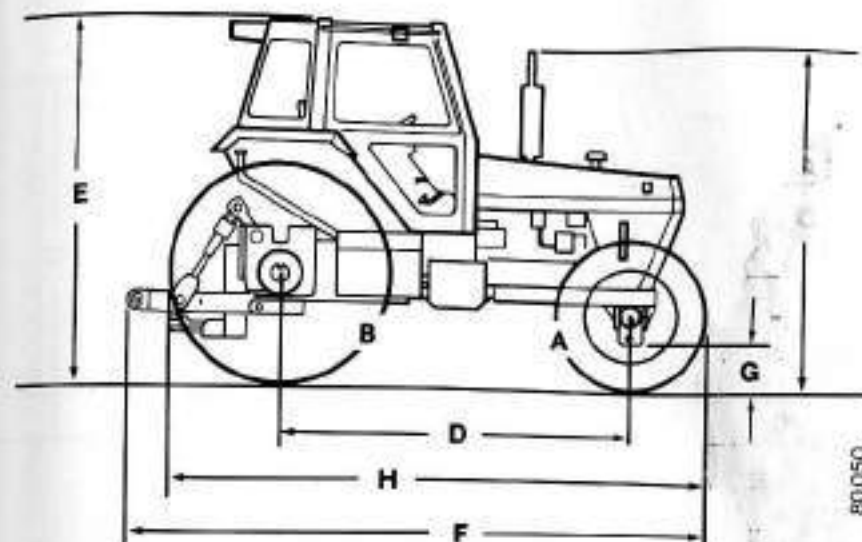

FIGURE 4. HIGH PLATFORM WITH CAB AND MFD

A	13.6-24	TIRE	B	18.4-38	TIRE	
C	105.5" (2680 mm)		D	100.50" (2553 mm)	E	107.50" (2731 mm)
F	163" (4140 mm)		G	16" (406 mm)	H	158.50 (4026 mm)

IMPORTANT: The total tractor weight with ballast and weights must never be more than 14,000 lb (6350 kg).

OPERATOR'S CAB

This operator's cab has roll over protection as given in SAE Standard J1194 and OSHA Regulation 1926.1001.

APPROXIMATE OVER ALL MEASUREMENTS

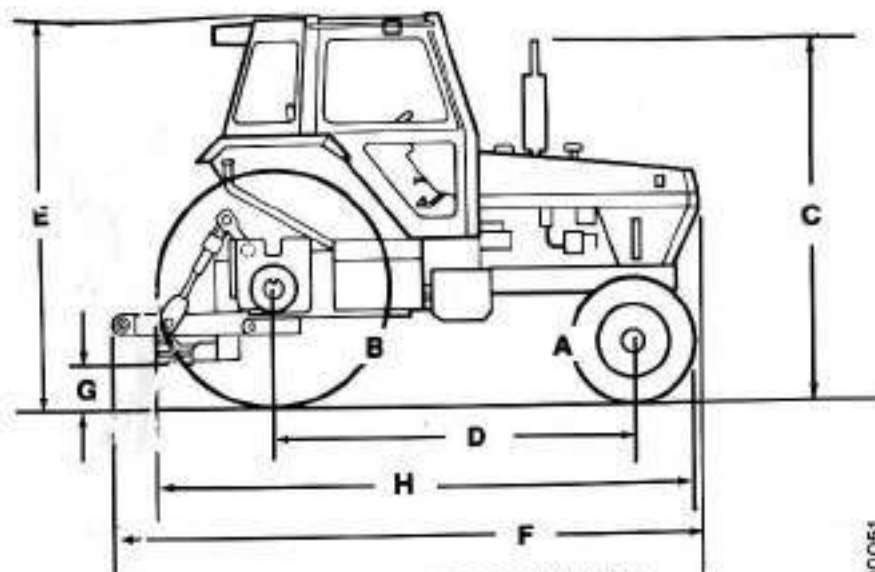

FIGURE 5. HIGH PLATFORM WITH CAB

80051

A	11L-15	TIRE	B	18.4-34	TIRE
C	106"	(2692 mm)	D	101"	(2565 mm)
			E	108"	(2743 mm)
F	163"	(4140 mm)	G	13.25"	(337 mm)
			H	149"	(3785 mm)

IMPORTANT: The total tractor weight with ballast and weights must never be more than 14,000 lb (6350 kg).

OPERATOR'S CAB

This operator's cab has roll over protection as given in SAE Standard J1194 and OSHA Regulation 1926.1001.

APPROXIMATE OVER ALL MEASUREMENTS

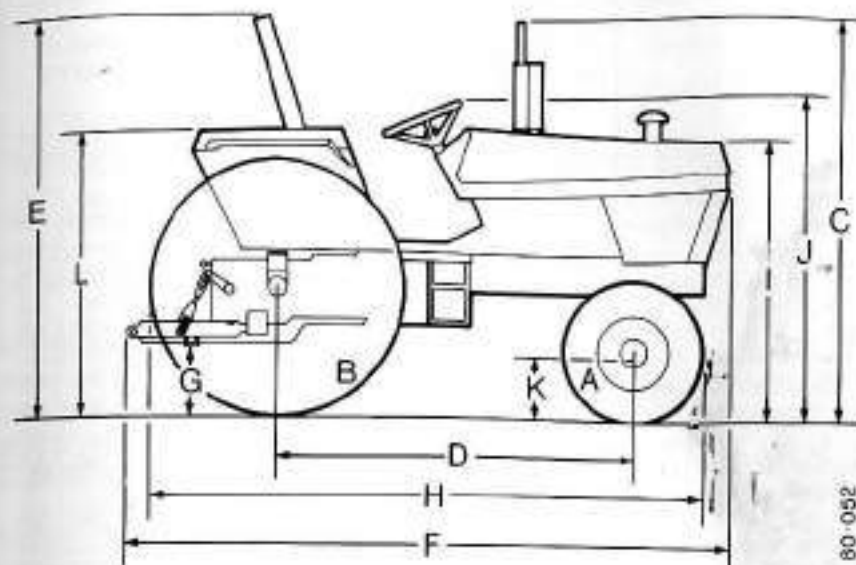

FIGURE 6. LOW PROFILE 2 POST ROPS

80-052

A	10.00-16	TIRE	B	18.4-34	TIRE
C	106"	(2692 mm)	D	100"	(2540 mm)
			E	97.8"	(2484 mm)
F	156"	(3962 mm)	G	15"	(381 mm)
			H	148"	(3759 mm)
I	63"	(1566 mm)	J	75.5"	(1892 mm)
			K	21"	(533 mm)
			L	69.5"	(1756 mm)

IMPORTANT: The total tractor weight with ballast and weights must never be more than 14,000 lb (6350 kg).

Tire Pressures

Type of Work	Tire size	Ply Rating	Maximum load on each tire at the recommended pressure		Recommended pressure			Maximum pressure		
			lb	kg	lb/in ²	kPa	bar	lb/in ²	kPa	bar
Front, General Work	7.50 x 16	6	1565	710	38	248	2.5	40	275	2.7
	7.50 x 18	8	1565	710	32	220	2.2	50	344	3.5
	11L x 15	6	1565	710	20	138	1.4	28	193	1.9
Front Loader Work	7.50 x 16	6	1640	745	40	275	2.7	40	275	2.7
	7.50 x 18	8	2030	920	50	344	3.5	50	344	3.5
	11L x 15	6	1910	865	28	193	1.9	28	193	1.9
Front MFD Field Work	12.4/11-24	6	1760	800	12	83	0.8	24	165	1.7
	13.6/12-24	6	2270	1030	14	96	1.0	22	152	1.5
Front MFD Road and Loader Work	12.4/11-24	6	2640	1200	24	165	1.7	24	165	1.7
	13.6/12-24	6	2960	1340	22	152	1.5	22	152	1.5
Rear All Models Field Work	13.6/12-38	6	2810	1275	14	96	1.0	20	138	1.4
	15.5-38	8	3160	1430	14	96	1.0	26	179	1.8
	16.9/14-34	6	4170	1890	16	110	1.1	18	124	1.2
	16.9/14-38	8	4360	1985	16	110	1.1	18	124	1.2
	18.4/15-34	6	4950	2245	16	110	1.1	16	110	1.1
18.4/15-38	8	5250	2380	16	110	1.1	20	138	1.4	
Rear All Models Road Work	13.6/12-38	6	3470	1575	20	138	1.4	20	138	1.4
	15.5-38	8	3890	1765	26	179	1.8	26	179	1.8
	16.9/14-34	6	4460	2025	18	124	1.2	18	124	1.2
	16.9/14-38	8	5560	2520	18	124	1.2	18	124	1.2
	18.4/15-34	6	4950	2245	20	138	1.4	20	138	1.4
18.4/15-38	8	5990	2720	20	138	1.4	20	138	1.4	

NOTE: The pressures shown are for both cross-ply and radial tires.

Tire Arrangements: MFD Tractors

Front	Rear
12.4/11-24.....	16.9/14-34
	13.6/12-38
13.6/12-34.....	18.4/15-34
14.9/13-24.....	16.9/14-38

IMPORTANT: The use of any other tire arrangement will cause damage to the transmission.

Do not install dual wheels and tires.

NOTE: Keep tires filled to given pressures. Check tire air pressure every 50 hours of operation or one time per week. Do not decrease rear tire pressure to increase traction. When using the tractor to pull a plow, increase the furrow wheel tire pressure 4 PSI (28 kPa) (0.28 bar).

NOTE: The given tire pressures are for normal tractor operation. If different tire pressures are needed because of special traction conditions, see your Authorized Case Dealer before you change pressures.

IMPORTANT: Do not remove, install or make repairs to a tractor tire on a rim. Take the tire and rim to a tire shop where persons with special training and special safety tools are available. If the tire is not in correct position on the rim, or if too full of air, the tire bead can loosen on one side and cause air to leak at high speed and with large force. Because the air leak can thrust the tire in any direction, and with much force, you will be in danger of injury.

TREAD POSITIONS**FRONT WHEEL TREAD POSITIONS: 2 WHEEL DRIVE MODELS**

FIGURE 7. TREAD POSITIONS STANDARD FRONT AXLE

NOTE: Tread widths are measured between the centers of each tire at a point as near the ground as possible.

FRONT WHEEL TREAD POSITIONS: MFD

FIGURE 8. FRONT WHEEL TREAD POSITIONS: MFD

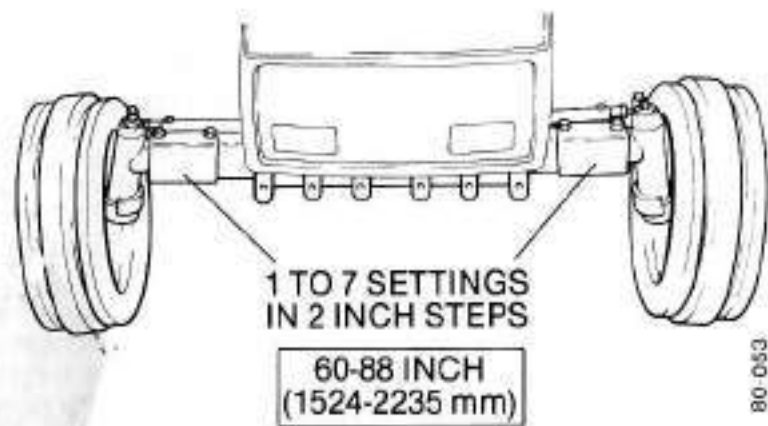
REAR WHEEL TREAD POSITIONS (18.4-34 and 18.4-38 Tires)

FIGURE 9. REAR WHEEL TREAD POSITIONS

78-061

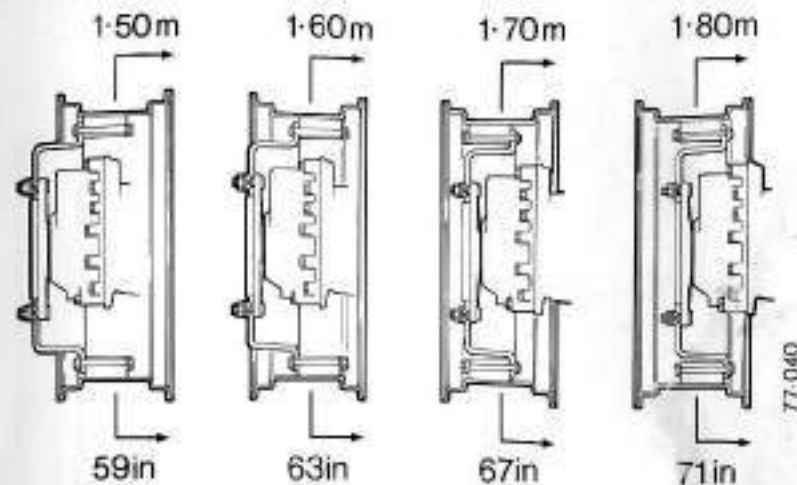
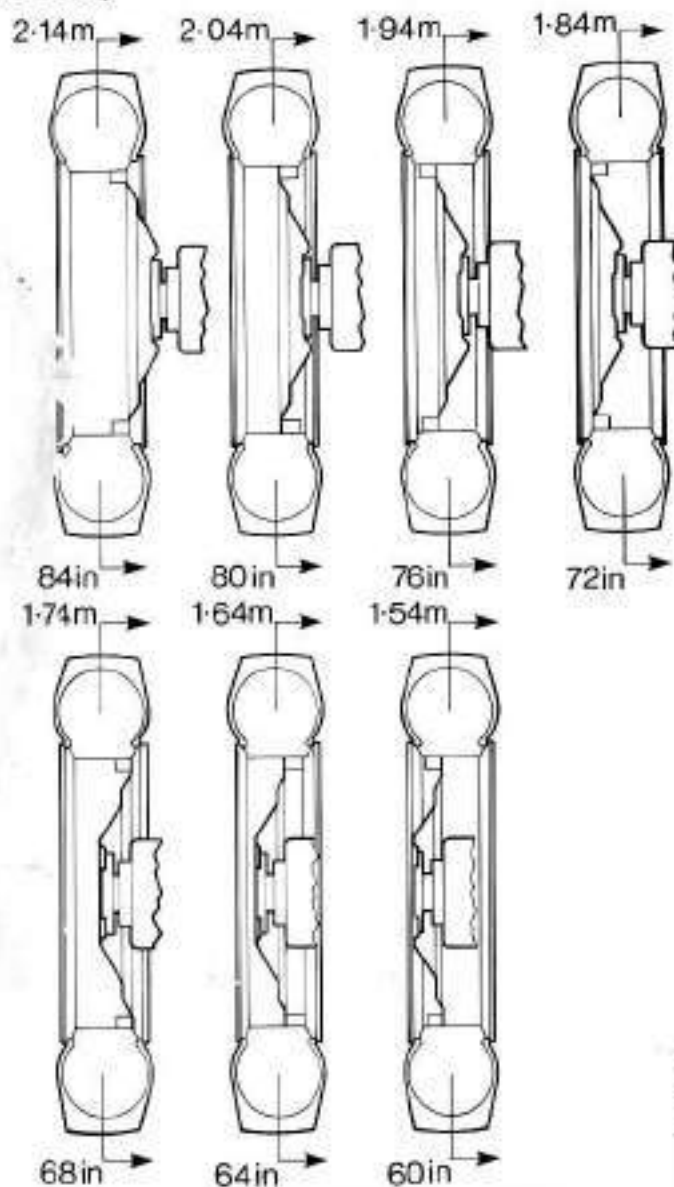
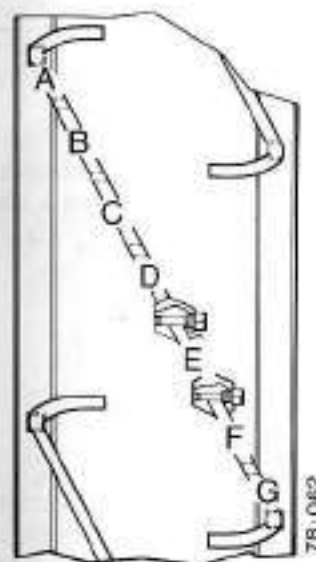
REAR WHEEL TREAD POSITIONS: POWER ADJUSTED (18.4-34 and 18.4-38 Tires)

FIGURE 10. POWER ADJUSTED WHEELS

- A. 65in (1.65m)
- B. 69in (1.75)
- C. 73in (1.85)
- D. 77in (1.95m)
- E. 81in (2.05m)
- F. 85 in (2.15m)
- G. 89in (2.26)

78-062

FUEL SPECIFICATIONS

DIESEL

Use a good grade of Number Two Diesel Fuel in your Case Diesel Engine. Do not use other types or grades of fuel. The use of other fuels will result in loss of engine power and high fuel consumption.

NOTE: *When the temperature is very cold, the use of a mixture of Number One and Number Two Diesel Fuel is permitted for a short period of time.*

SPECIFICATIONS

For Acceptable Number Two Diesel Fuel

A.P.I. Gravity (Min)	30
Pour Point (Max)	10° F (5° C) below ambient operating temperature
Distillation (90% Point)	540 to 625° F (282 to 329° C)
Flash Point (min)	125° F (52° C) or legal
	Kinematic Viscosity Centistokes
at 100° F (38° C)	2.0 to 4.3 Seconds*
Cetane Number (Min)	40 (45 to 55 For Cold Temperature or High Altitude use)
Water and Sediment Volume (Max)	0.05%
Ash Weight (Max)	0.01%
Sulphur Weight (Max)	0.5%
Carbon Residue or 10% Residuum (Max)	0.02%
Corrosion, Copper Strip, 3 hours at 212° F (100° C)	Number 3

(*32 to 40 Saybolt Universal Seconds)

Fuel Conditioner

Case Diesel Fuel Conditioner is available from you Authorized Case Dealer. Instructions for the use of the fuel conditioner is on the container.

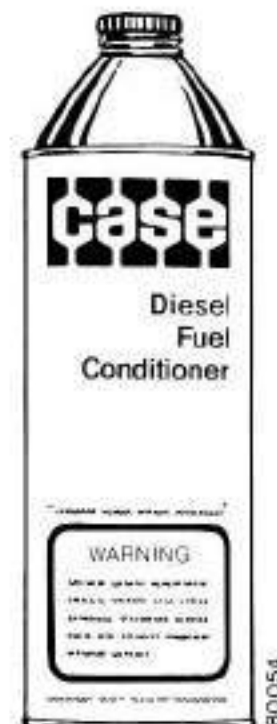

The use of Case Diesel Fuel Conditioner will:

1. Prevent deposits that can form in the fuel system.
2. Make an improvement in lubrication of the engine.
3. Prevent stopping of the fuel injector nozzles, valves and manifold.
4. Keep water in the fuel in suspension so that the water can be burned with the fuel.
5. Give better engine performance from the fuel the engine burns.

LUBRICANTS

Case HDM Engine Oil is the J I Case Company recommendation for use in your Case Tractor Engine. The Case HDM oil formula will give lubrication to your engine correctly under all operating conditions.

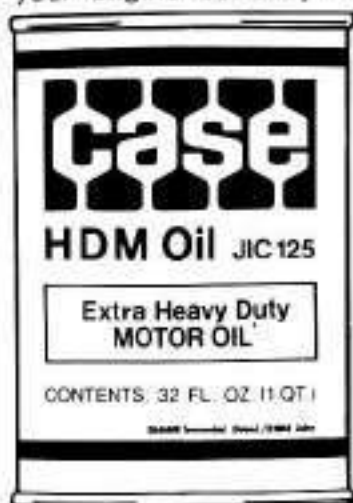

NOTE: Do not put "Performance Additives" or other oil additive products in the engine crankcase. The oil change intervals given in this manual are according to tests with Case lubricants.

When Case HDM Engine Oil is not available use only oil that is the same as API engine oil service category SE/CD and Mil-L-2104C.

Engine Lubrication Oil Viscosity

AMBIENT AIR TEMPERATURE RANGES

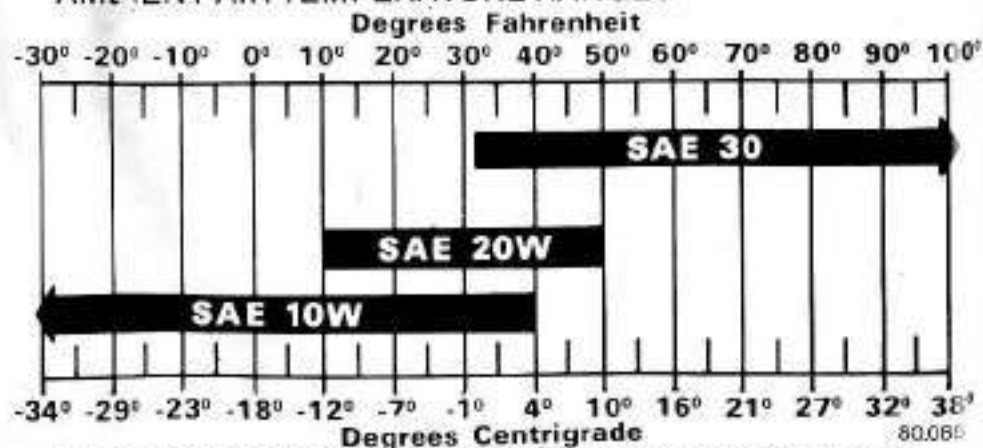

Use the correct viscosity oil for the ambient temperature range in which you are operating your tractor. Do not use a multi-viscosity oil.

RECOMMENDED LUBRICANTS AND CAPACITIES

COMPONENT	SPECIFICATION	CAPACITY	
		U.S.	Metric
Engine Crankcase	30° to 100° F (-1° to 38° C) HDM SAE 30	13 qt	12.5 litres
	10° to 50° F (-12° to 10° C) HDM SAE 20W		
	-30° to 40° F (-34° to 4° C) HDM SAE 10W		
Transmission (Power Shift and Synchronesh)	Case TFD Fluid U.S. B17445 (5 gal) B17446 (55 gal)	44 qt	42 litres
Final Drive Units (each)	Case ETHB Fluid	8 qt	7.4 litres
Power Steering	Case TFD Fluid	1½ qt	1.4 litres
Front Differential Case (MFD)	Case FDL SAE 90	4 qt	4.0 litres
Front Hubs (MFD)	Case FDL SAE 90	1½ qt	1.4 litres
Clutch and Brake Hydraulic System	Dextron ATF	As required	
Pressure Fittings (Oil)	Case FDL SAE 140		
Pressure Fittings (Grease)	32° F (0° C) and above	No 2 Lithium Base	
	Below 32° F (0° C)	No 1 Lithium Base	

OPERATING INSTRUMENTS (High Platform Tractor)

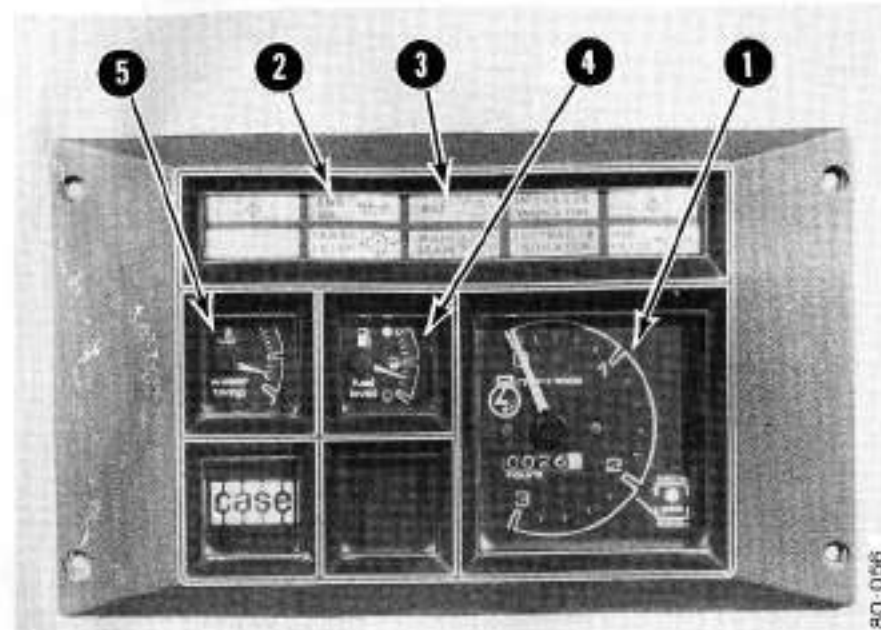

FIGURE 11.

1. Tachometer and Hourmeter

The tachometer shows the engine speed in revolutions per minute (RPM). The normal operating range of the engine must be in the green area for maximum engine life. The engine must not operate in the red area. The correct operating speed for the power takeoff is indicated by a symbol at 2050 RPM.

NOTE: *It is normal for the engine to operate for a moment in the amber area when you move the transmission controls to a slower gear while pulling a light load.*

The hourmeter shows the hours and tenths of hours that the engine has run. The hourmeter does not show clock hours. The hourmeter shows the hours that the engine runs at an average RPM.

2. Engine Oil Pressure Lamp

The engine oil pressure warning lamp will illuminate when the key switch is turned to the IGNITION and START positions and must stop illuminating when the engine starts to run. If the warning lamp keeps illuminating or illuminates at any time during operation, STOP THE ENGINE AND CHECK FOR THE CAUSE.

3. Alternator Warning Lamp

The alternator warning lamp will illuminate when the key switch is turned to the ACCESSORY and IGNITION positions and must stop illuminating when the engine starts running. If the warning lamp is illuminated when the engine starts and runs, the batteries will discharge because the alternator is not working. If the engine is started at low idle speed, the warning lamp can be illuminated until the engine RPM is increased. When the engine speed is increased, the warning lamp must stop illuminating. If the warning lamp continues to illuminate when the engine speed is increased or the lamp illuminates at any time during operation, STOP THE ENGINE AND CHECK FOR THE CAUSE.

4. Fuel Gauge

The pointer can be in any position when the key switch is turned to OFF. To get a fuel level indication, the key switch must be turned to ACCESSORY OR IGNITION position. The gauge shows how much fuel is in the tank. If the pointer is in the red area, the fuel tank is empty. Fuel level is shown by three balls.

1/8 black ball - fuel is needed.

1/2 black ball - fuel tank is 1/2 filled with fuel.

All black ball - fuel tank is filled with fuel.

5. Engine Water Temperature Gauge

The pointer can rest in any position when the key switch is turned to OFF position. The gauge has a green area, amber area and red area.

Pointer in green area - Engine operating at normal temperature.

Pointer in amber area - Engine operating below normal temperature.

Pointer in red area - STOP THE ENGINE AND CHECK FOR THE CAUSE.

OPERATING INSTRUMENTS (High Platform Tractor)

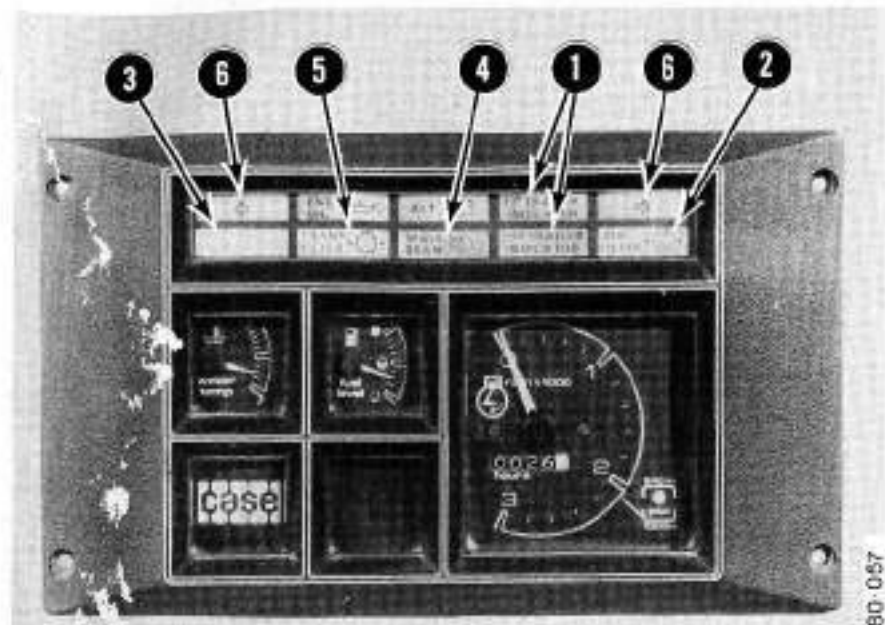

FIGURE 12.

1. **Trailer Indicator Warning Lamp**
When a trailer is connected to the tractor, the warning lamps show that the direction indicators on the trailer (or trailers) are working correctly.
2. **Air Filter Warning Lamp**
The warning lamp will illuminate if there is a restriction in the air filter. If the lamp illuminates when the engine is running, STOP THE ENGINE AND CHECK THE CAUSE.
3. **Differential Lock Warning Lamp**
The warning lamp will illuminate when the differential lock is engaged. It will be illuminated until the differential lock is disengaged.
4. **Headlamp Main Beam Warning Lamp**
The warning lamp is illuminated when the main beam of the headlamp is being used.

5. **Transmission Filter Pressure Lamp (If Equipped)**

The transmission filter pressure warning lamp will illuminate when the key switch is turned to the START position and the engine is being started and will stop illuminating when the engine starts to run. The lamp can be illuminated a little longer period of time in cold ambient temperatures. If the lamp is illuminated after the engine is running or illuminates during tractor operation, the filters are dirty and must be changed. If the lamp is illuminated after a filter change, STOP THE ENGINE AND CHECK FOR THE CAUSE.

6. **Turn Signal Indicator Lamps**

When the direction turn signal switch is pushed to the left, the indicator lamp for the left hand turn signal will illuminate on and off. When the direction turn signal switch is pushed to the right, the indicator lamp for the right hand turn signal will illuminate on and off. See Operating Controls for complete instructions.

NOTE: To clean the gauge and warning lamp windows, use a soft cloth or air under low pressure. Do not use rough material of any type which will scratch or damage the windows.

OPERATING CONTROLS (High Platform Tractor)

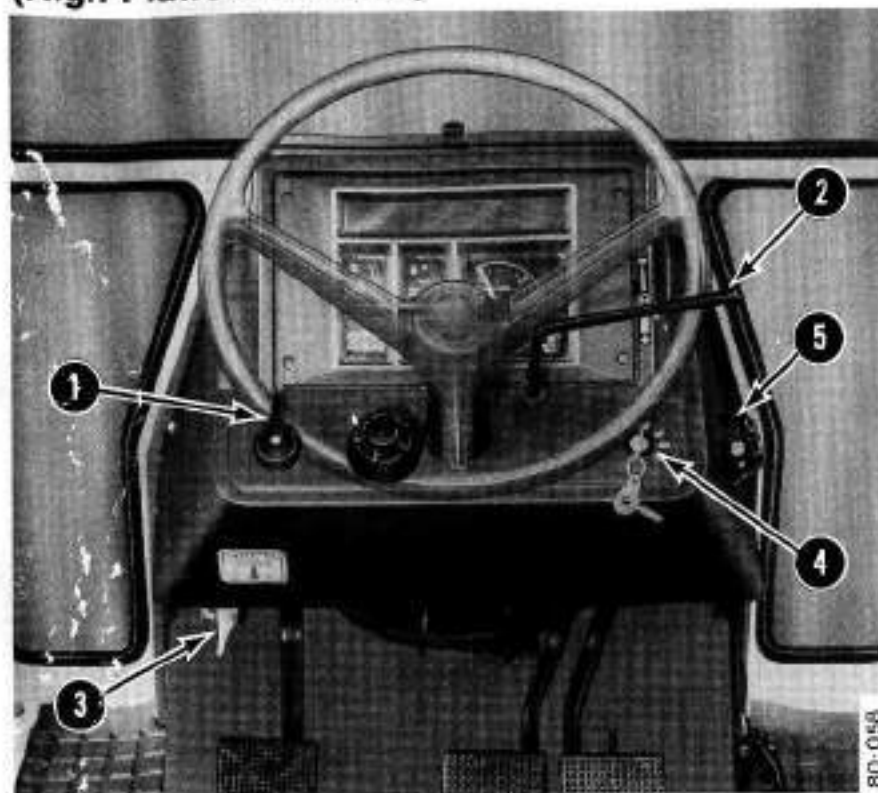

FIGURE 13.

1. Direction Turn Signal Switch

To indicate that you will turn the tractor to the right, move the turn signal switch to the right. To indicate that you will turn the tractor to the left, move the turn signal switch to the left.

2. Hand throttle Control Lever

Move the lever to the rear for maximum speed. Move the lever forward for idle speed.

3. Engine Stop Control

To start the engine, pull the stop control handle out of the safety position. Move the handle to the left and push the handle forward.

To stop the engine, pull the stop control handle to the rear. Move the handle to the right and push the handle forward into the safety position.

4. Ignition Key Switch

Four position switch as follows:

Number 1 - OFF Position. The key is in the vertical position. The tractor can not be started without the key. You can only remove the key in this position.

Number 2 - Accessory Position. First position clockwise from OFF. This position energizes the accessories such as the radio.

Number 3 - Heat Position. Second position clockwise from OFF. This position energizes the thermostart.

Number 4 - Start Position. Third Position clockwise from OFF. This position energizes the starter motor.

NOTE: To prevent operation by persons not authorized to operate, and discharge of batteries when you leave the tractor, remove the key.

IMPORTANT: While the engine is operating, keep the key switch in ACCESSORY position so that the instruments and warning lamps will function.

IMPORTANT: Do not keep the key switch in ACCESSORY position for long periods of time with the engine not operating. Warning lamps will be illuminated which will cause too much heat in the instrument cluster.

5. Main Lamp Switch

Four position switch as follows:

Number 1 - OFF Position - (Full counterclockwise) - All lamps are OFF.

Number 2 - First position clockwise from OFF. Illuminates head lamps (low beam), front fender lamps, tail lamps, and instrument panel lamps.

Number 3 - Second position clockwise from OFF. Illuminates head lamps (low and high beam), front fender lamps, tail lamps and instrument panel lamps.

Number 4 - Third position clockwise from OFF. Illuminates head lamps (low beam), front fender lamps, tail lamps, instrument panel lamps and flasher.

OPERATING CONTROLS (High Platform Tractor)

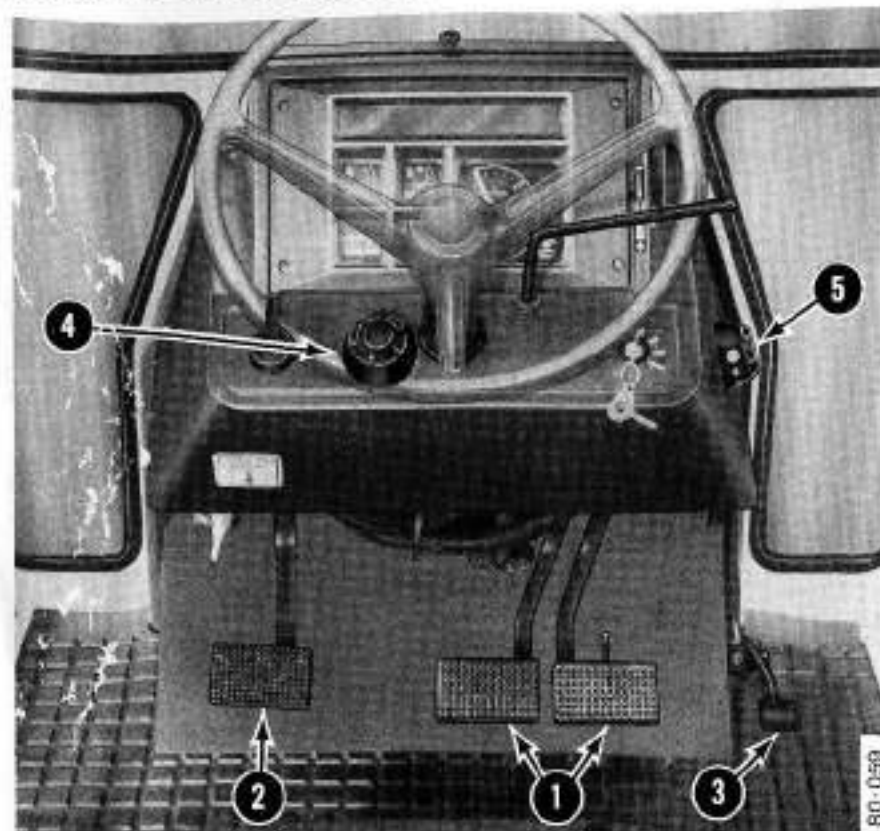

FIGURE 14.

1. Brake Pedals

The LH pedal stops the LH tractor wheel and the RH pedal stops the RH tractor wheel. For LH or RH turning assistance

use the pedals separately. For safe operation on roads lock the pedals together with the interlock lever so that both brakes are applied together.

2. Transmission Clutch Pedal

Push the pedal down to disengage the clutch. Engage the clutch smoothly using the available gears and the throttle to control the tractor speed. "Slipping" the clutch to reduce forward speed is detrimental to clutch life.

Remove your foot from the pedal until it is necessary to stop the tractor or select a different gear.

IMPORTANT: *The clutch must have the correct amount of clearance at all times. Check the clutch clearance at least every 50 hours and adjust if necessary.*

DO NOT use an operating procedure which will decrease the life of the clutch. For example: DO NOT operate the tractor with no clearance.

DO NOT keep your foot on the pedal after the clutch is engaged.

DO NOT try to move the tractor with a heavy load in a high gear.

DO NOT select a high gear and then use the clutch to control the speed of the tractor.

DO NOT operate the tractor at any time with the clutch not fully engaged.

DO NOT disengage the clutch when operating down a slope.

3. Foot Throttle Pedal

This pedal is in addition to the hand throttle and makes it easier to operate the tractor on road work.

4. Flood Lamp Switch

Four position switch as follows:

Number 1 - OFF position (fully counterclockwise) - All lamps are OFF.

Number 2 - First position clockwise from OFF. Illuminates rear fender mounted flood lamps.

Number 3 - Second position clockwise from OFF. Illuminates rear fender mounted flood lamps and all cab mounted flood lamps.

Number 4 - Third position clockwise from OFF. Illuminates all cab mounted flood lamps.

5. Horn Switch

The horn switch is in the center of the main lamp switch. Push lamp switch in to energize the horn.

CAB CONTROLS (High Platform Tractor)

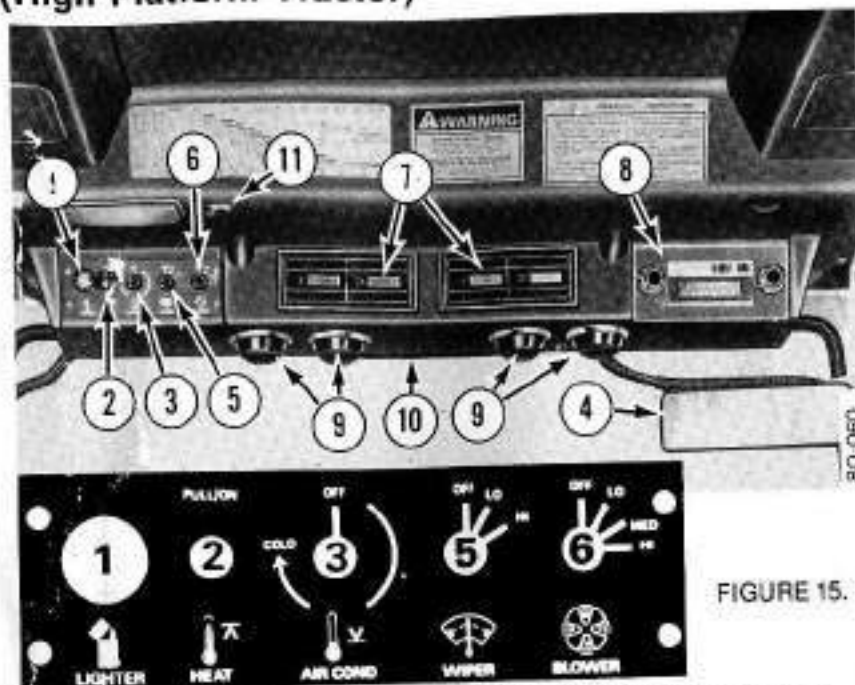

FIGURE 15.

1. Cigarette Lighter

To start the lighter, push the cigarette lighter in. The cigarette lighter will extend and be ready to use.

2. Heat Temperature Control

Pull the heat temperature control out to the needed heat temperature. To stop the heated air flow, push the control in.

3. Air Conditioner Temperature Control

Turn the air conditioner temperature control clockwise to the needed air temperature.

4. Rear View Mirror

You can adjust the mirror for view as needed.

5. Windshield Wiper Control

To select the speed of the wiper, turn the switch knob clockwise. For OFF position, turn the switch knob counter-clockwise.

6. Blower Switch

To get the needed blower speed, turn the knob clockwise to Low, Medium or High.

7. Air Louvers

To control the air flow direction, adjust the air louvers up or down and left or right.

8. Radio

Radios for your Case cab are available from your Authorized Case Dealer.

9. Air Deflectors

To adjust the air flow for cooling and for heat, the air deflectors can swivel and turn. The deflectors can either be open or closed.

10. Defroster Control

The defroster control air louvers can be moved up and down and to the left and right to control the direction of air flow. Turn the adjusting wheel to close the air louvers and stop the air flow to the windshield.

11. Cab Light Switch

Three position switch to control the cab dome light.

Push on LH side of switch - Dome light illuminates when the cab door is open and will stop illuminating when cab door is closed.

Center Position - OFF - Dome light will not illuminate.

Push on RH side of switch - Dome light will illuminate with door open or closed and keep illuminating until switch is turned OFF.

VENTILATION CONTROL SETTINGS

Type Condition Needed	CONTROL SETTINGS						Flow Control
	(6) Blower	(7) Louvers	(9) Deflectors	(10) Defroster	(3) Air Con.**	(2) Heater	
Max Pressure	HI	Open	Open	Open	ON or OFF	ON or OFF	Closed
Max Air Flow	HI	Open	Open	Open	ON or OFF	ON or OFF	Open
Max Cool	HI	Open	Open	Open	ON Max Cold	OFF	Open
Cool	MED	Open	Open	Open	ON Center Range	OFF	Open
Max Heat	HI	Open	Open	Open	OFF	ON Max	Open
Heat	MED to LO	Open	Open	Open	OFF	Adjust to Need	Open
Inside Window Moisture Removal*	HI	Open	Open	Open	ON Center Range	ON Max.	Open

*With Low Ambient Temperature.

**Air Conditioner

CONTROL LEVERS (High Platform Tractor)

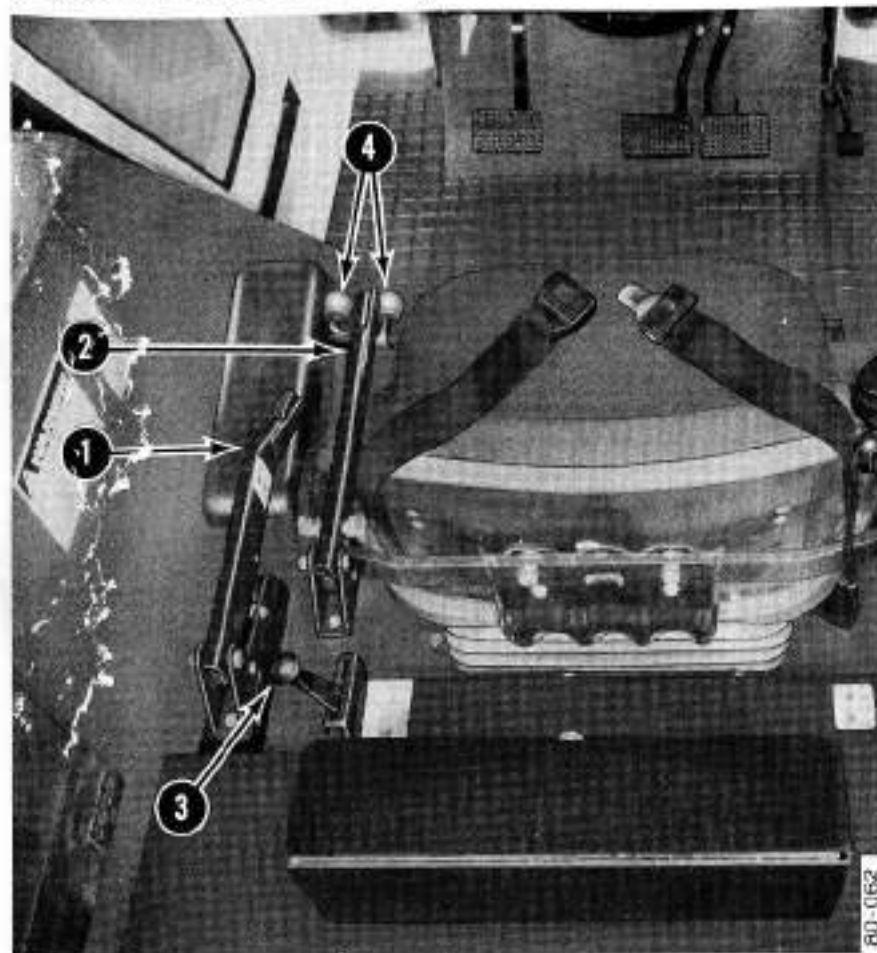

FIGURE 16.

1. **Power Take-Off Clutch Lever**
The PTO clutch is operated by a lever at the left-hand side of the operator's seat. When the lever is in the down position, the PTO clutch is engaged.

To disengage the PTO clutch, pull the lever up until the ratchet is engaged.

To engage the PTO clutch, pull the lever up, press the ratchet lever inwards and lower the hand lever slowly.

2. **Parking Brake Lever**
Pull the brake lever up to apply the parking brake. To release the parking brake, pull the brake lever up and press the ratchet inwards. Then push the brake lever down.

3. **Four-Wheel Drive Selector** (if equipped)
To engage the four-wheel drive, move the control lever to the rear. To disengage, move the control lever forward.

NOTE: To engage the four-wheel drive, the tractor must be operating under conditions of little or no load.

4. **Range Levers** - (Synchromesh Transmission)
Use these levers to select one of four ranges needed for the operating conditions. Disengage the transmission clutch before moving the range levers to any of the range positions.

NOTE: See transmission operating instructions for further details.

CONTROL LEVERS (High Platform Tractor)

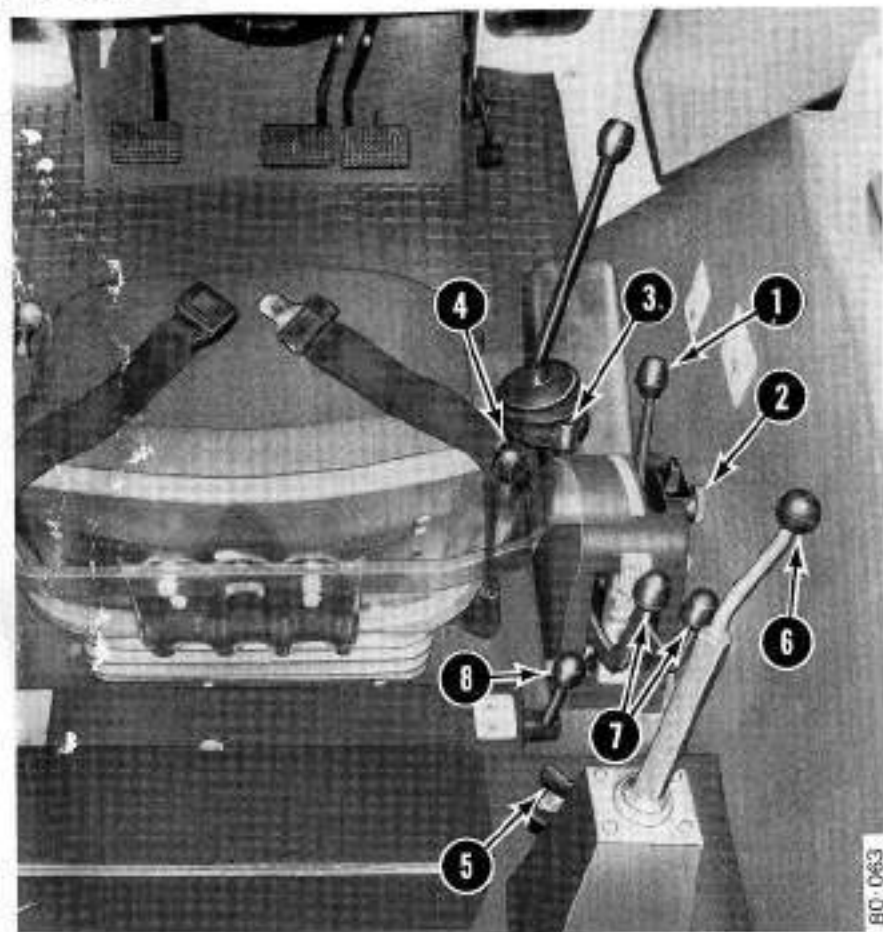

FIGURE 17.

1. Three Point Hitch Control

This lever controls the position of the three point hitch. Push the lever down to lower the hitch. Pull the lever up to raise the hitch.

2. Finger Guide

The finger guide can be moved to any position on the lever quadrant and is held by a thumb screw.

3. Dump Valve Control

Use this control for fast lowering of the three point hitch. Pull the control up to lower the hitch.

4. Lowering Speed Control Valve

The speed of lowering the three point hitch can be adjusted with this control. Turn the knob counterclockwise to slow the lowering speed. Turn the knob clockwise to increase the lowering speed.

5. Draft/Position Control Selector

This lever is used to select either draft control or position control. Draft control is used for implements, without gauge wheels, that are used in the ground. Position control is used for implements that are used above ground. Turn the control to the left for draft control and to the right for position control.

6. Level Screw Control

This lever is used to adjust the height of the RH draft arm to level the hitch and mounted implements as required. Turn the lever counterclockwise to raise the draft arm and clockwise to lower the draft arm.

7. Remote Valve Levers

These levers operate the double acting remote valves. If remote valves are not standard equipment on your tractor, one or two remote valves can be installed by your authorized Case Dealer.

8. PTO Selector Lever

This lever is used to engage or disengage the PTO. To engage the PTO, move the lever forward. To disengage the PTO move the lever rearward.

IMPORTANT: Before engaging the drive to the PTO, disengage the PTO clutch.



WARNING: Do not use the dump valve when an implement is installed on the linkage. Do not use this valve when any person is near the linkage.

CONTROL LEVERS (High Platform Tractor)

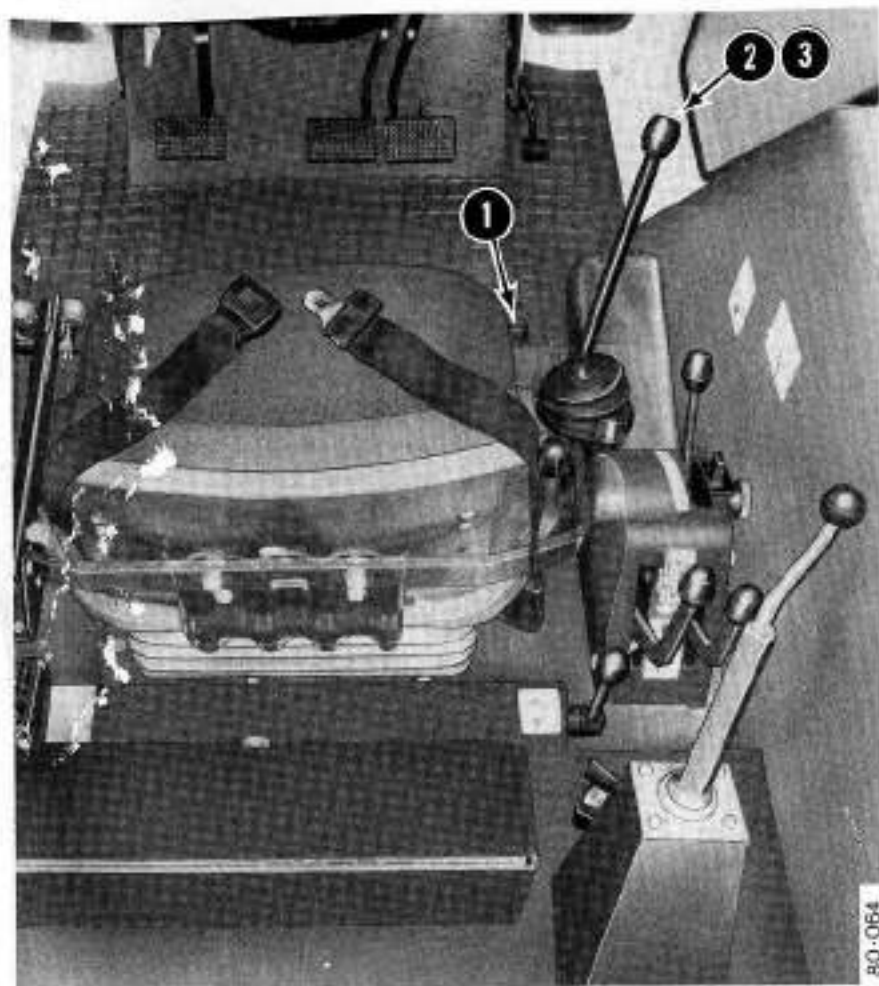

FIGURE 18.



WARNING: When the differential lock is engaged, the tractor will not steer correctly. Do not operate the tractor at high speeds or attempt to turn the tractor with the differential lock engaged.

1. Differential Lock

Push the pedal down to engage the differential lock. The lock will be engaged until the pressure on the pedal is released. The differential lock is under spring pressure to push it out of engagement when the pedal is released. If the differential lock does not disengage easily, push down on either of the brake pedals. If the tractor is stopped and the differential lock is engaged, reverse the tractor for a short distance.

IMPORTANT: Do not try to engage the differential lock unless:

- A. Both rear wheels are turning at the same speed, or
- B. You have disengaged the transmission clutch.

2. Range Lever - (Power shift transmission)

The range lever has a neutral position and can be used to select three forward and one reverse speed. This lever also operates a switch which prevents the starter being actuated unless the lever is in the neutral position.

NOTE: The transmission clutch must be disengaged before selecting any range gear.

3. Gear Shift Lever (Synchromesh transmission)

The shift lever has a neutral position and is used to select three forward speeds or reverse. There is a synchromesh hub between second and third gear which permits gear changes to be made while the tractor is moving. The transmission clutch must be disengaged when changing gear. The tractor must be stopped before selecting reverse gear. This lever also operates a safety switch which prevents the starter being activated unless the lever is in the neutral position.

CONTROL LEVERS (High Platform Tractor)

1. **Power Shift Lever (If Equipped)**
There are four power shift positions in each of three forward and one reverse range. Each position can be selected while the tractor is moving without disengaging the transmission clutch.

NOTE: When shifting down, make sure that the engine speed does not increase to above the safe maximum. Move the power shift lever one position at a time and wait for the speed of the tractor to decrease before moving the shift lever to the next position.



FIGURE 19.

CONTROL LEVERS (Low Profile Tractor)

1. **Power Shift Lever (If equipped)** There are four power shift positions in each of three forward and one reverse range. Each position can be selected while the tractor is moving without disengaging the transmission clutch.

NOTE: When shifting down, make sure that the engine speed does not increase to above the safe maximum. Move the power shift lever one position at a time and wait for the speed of the tractor to decrease before moving the shift lever to the next position.

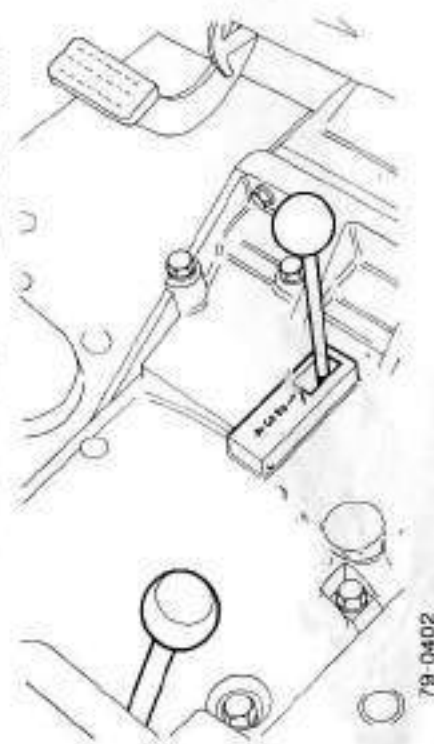

FIGURE 20.

CONTROL LEVERS (Low Profile Tractor)

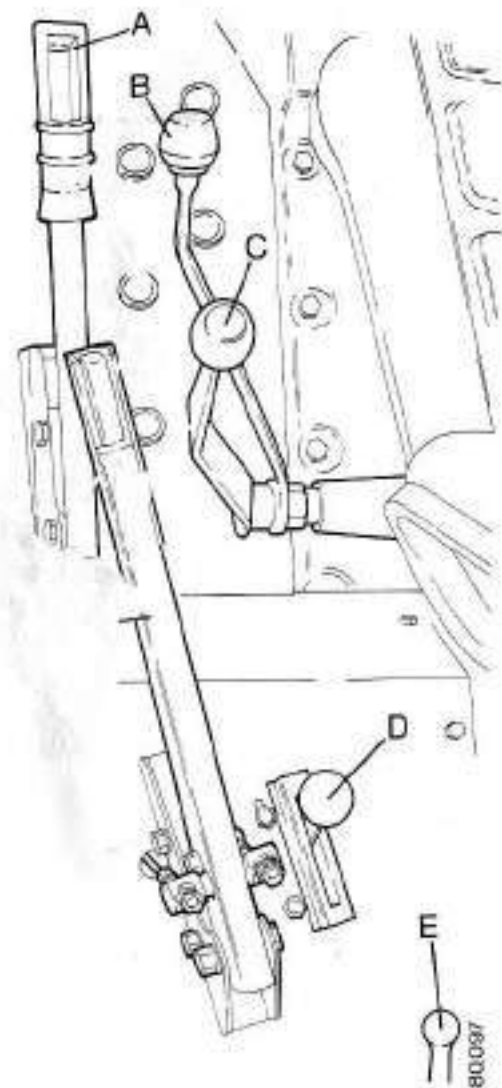

FIGURE 21. CONTROL LEVERS:
SYNCHROMESH TRACTOR
(LOW PROFILE)

- A. PTO Clutch Lever
- B. Range Levers
- C. } Range Levers
- D. MFD Selector Lever
- E. PTO Selector Lever
- F. Parking Brake Lever

Power Take-Off (PTO) Clutch

The PTO Clutch is operated by a lever at the left-hand side of the operator's seat. When the lever is in the down position, the PTO clutch is engaged. To disengage the PTO clutch, pull the lever up until the ratchet is engaged. To engage the PTO clutch, pull the lever up, press the ratchet lever inwards and release the hand lever slowly.

Before engaging the drive to the PTO, disengage the PTO clutch.

Parking Brake Lever

Pull the hand lever up to apply the parking brake. To release the parking brake, pull the hand lever up and press the ratchet inwards. Then push the hand lever down.

**Range Lever
(Synchromesh Tractors)**

Use these levers to select one of four ranges needed for the operating conditions. Disengage the transmission clutch before moving the range levers to any of the range positions.

**Four Wheel Drive Selector
(MFD Tractors only)**

Use lever E to engage or disengage four-wheel drive. Only engage four-wheel drive when the tractor is operating in conditions of little or no load.

PTO Selector Lever

(Single Speed and Reversible Shaft)

This lever has two positions, engaged or disengaged.

Differential Lock

Push the pedal down to engage the differential lock. The lock will be engaged until the pressure on the pedal is released.



WARNING: When the differential lock is engaged, the tractor will not steer correctly. Use the differential lock as an aid to traction only. Before you operate on any road, make sure the differential lock is disengaged. Failure to do this can cause an accident.

IMPORTANT: Do not try to engage the differential lock unless:

1. Both the rear wheels are turning at the same speed, or
2. You have disengaged the transmission clutch.

NOTE: The differential lock has a spring to push it out of engagement when the pedal is released. If the differential lock does not disengage easily, push down on either of the brake pedals. If the tractor is stopped and the differential lock is engaged, reverse the tractor for a short distance.

Gear Lever

Use this lever to select three forward speeds or reverse. There is a synchromesh hub between second and third gear which permits gear changes to be made while the tractor is moving. It is necessary to disengage the transmission clutch when changing gear, and to stop the tractor before selecting reverse gear. This lever operates a safety switch which prevents the starter being energised unless the lever is in the neutral position.

CONTROL LEVERS (Low Profile Tractor)

FIGURE 22. CONTROL LEVERS: SYNCHROMESH TRACTOR (LOW PROFILE)

J. Differential Lock

K. Gear Lever

Remote Valve Levers

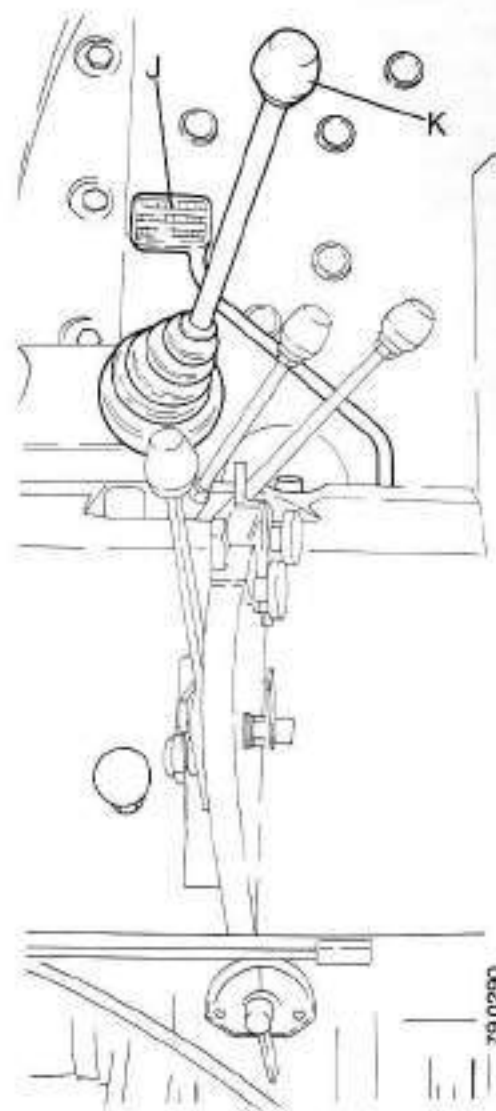
These levers operate the double acting remote valves. If these are not standard equipment on your tractor, one or two remote valves can be installed as extra equipment by your Authorized Case Dealer.

Lowering Control Valve

The speed of lowering the three-point linkage is controlled by the knob. Turn the knob counter-clockwise to increase the speed of lowering.

Finger Guide

The finger guide, can be moved to any position on the lever quadrant and is held by a thumb screw.

Selector Dial Lever

Use this lever to select the service needed for the implement that is to be used.

Dump Valve

Use this valve when you need fast lowering of the linkage or pick-up hitch.

Pull the knob up to lower the linkage.



WARNING: Do not use this valve when an implement is installed on the linkage. Do not use this valve when any person is near the linkage.

Hand Lever

This lever controls the position of the three-point linkage.

CONTROL LEVERS (Low Profile Tractor)

FIGURE 23.
CONTROL LEVERS:
SYNCHROMESH TRACTOR
(LOW PROFILE)

- L. } Remote Valve Levers
- M. }
- N. Lowering Control Valve
- P. Finger Guide
- R. Selector Pointer
- S. Dump Valve
- T. Hand Lever

CONTROL LEVERS (Low Profile Tractor)

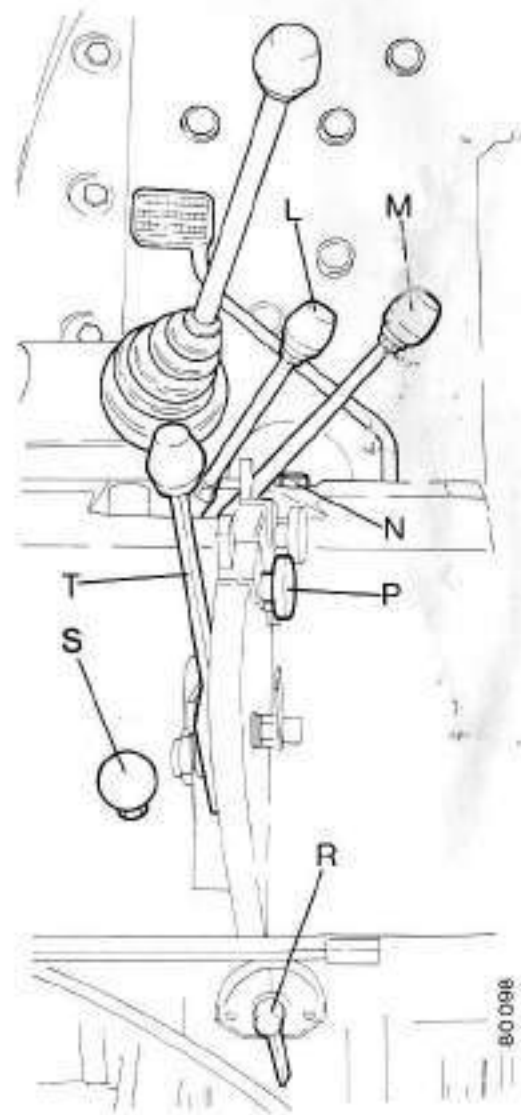
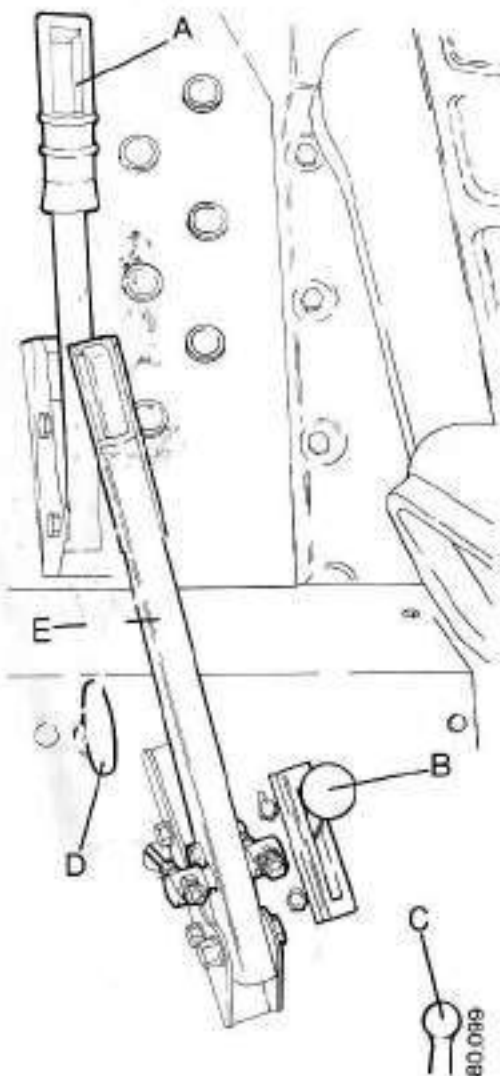

FIGURE 24. CONTROL LEVERS: POWER SHIFT TRACTOR (LOW PROFILE)

- A. PTO Clutch Lever
- B. MFD Selector Lever
- C. PTO Selector Lever
- D. Dump Valve
- E. Parking Brake Lever

Power Take-Off (PTO) Clutch

The PTO Clutch is operated by a lever at the left-hand side of the operator's seat. When the lever is in the down position, the PTO clutch is engaged. To disengage the PTO Clutch, pull the lever up until the ratchet is engaged. To engage the PTO clutch, pull the lever up, press the ratchet lever inwards and release the hand lever slowly.

Mechanical Front Drive Selector (MFD Tractors only)

Use lever B to engage or disengage four-wheel drive. Only engage four-wheel drive when the tractor is operating in conditions of little or no load.

PTO Selector Lever

(Single Speed and Reversible Shaft)

This lever has two positions, engaged or disengaged.

Before engaging the drive to the PTO, disengage the PTO clutch.

Dump Valve

Use this valve when you need fast lowering of the linkage or pick-up hitch. Pull the knob up to lower the linkage.

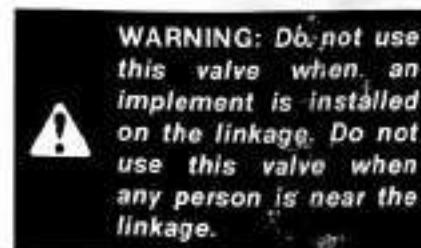
**Parking Brake Lever**

Pull the hand lever up to apply the parking brake. To release the parking brake, pull the hand lever up and press the ratchet inwards. Then push the hand lever down.

Differential Lock Pedal

Push the pedal down to engage the differential lock. The lock will be engaged until the pressure on the pedal is released.

IMPORTANT: Do not try to engage the differential lock unless:

1. Both the rear wheels are turning at the same speed, or
2. You have disengaged the transmission clutch.

NOTE: The differential lock has a spring to push it out of engagement when the pedal is released. If the differential lock does not disengage easily, push down on either of the brake pedals. If the tractor is stopped and the differential lock is engaged, reverse the tractor for a short distance.

**Range Lever
(Power Shift Tractors)**

This lever has a neutral position and can be moved to select three forward and one reverse speed. It also operates a switch which prevents the starter being energized unless the lever is in the neutral position.

The transmission clutch must be disengaged before selecting any range gear.

Remote Valve Levers

These levers operate the double acting remote valves. If these are not standard equipment on your tractor, one or two remote valves can be installed by your Authorized Case Dealer.

Finger Guide

The finger guide, can be moved to any position on the lever quadrant and is held by a thumb screw.

Selector Dial Lever

Use this lever to select the service needed for the implement that is to be used.

Hand Lever

This lever controls the position of the three-point linkage.

CONTROL LEVERS (Low Profile Tractor)

FIGURE 25. CONTROL LEVERS: POWER SHIFT TRACTOR (LOW PROFILE)

- G. Differential Lock Pedal
- H. Range Lever
- J. Remote Valve Levers
- K. Finger Guides
- L. Selector Dial Lever
- M. Hand Lever

OPERATOR'S SEAT (High Platform Tractor)

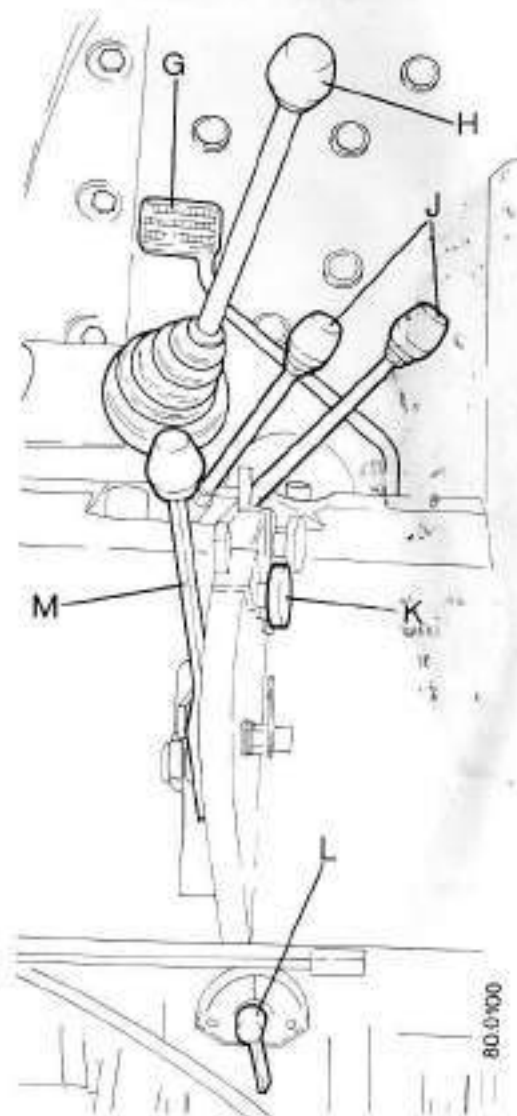
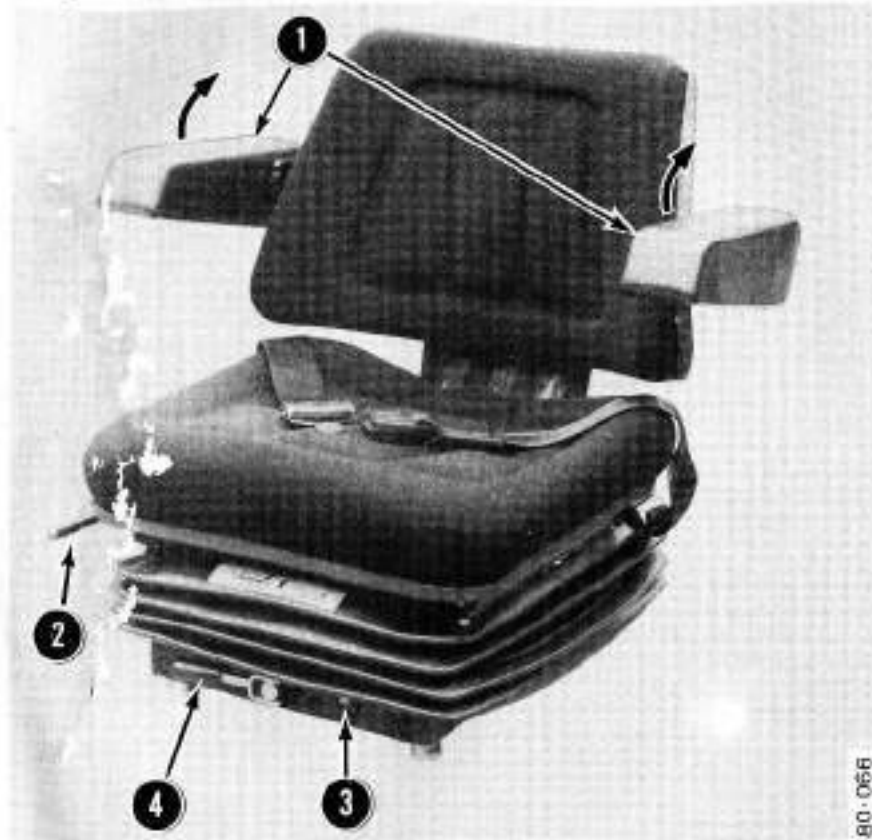

FIGURE 26.

1. Arm Rest

The two arm rests can be tilted until even with the back rest.

2. Front to Rear Adjustment

To release the seat, move the lever to the right. Slide the seat to the needed position and release the lever to keep the seat in the selected position.

3. Weight Indicator

The seat is adjustable for different weights. The scale range

is 50 kg (110lbs.) to 130 kg (287 lbs.).

4. Weight Adjustment

To adjust the seat for your weight, turn the adjusting handle until the correct weight shows on the weight indicator. Turn the handle clockwise to increase the weight setting and counterclockwise to decrease the weight setting.

CAB AIR FLOW CONTROL (High Platform Tractor)

The cab air flow control is in the headliner, above the rear window. For maximum movement of air in the cab, turn the flow control knob counterclockwise until

loose, then slide to open. To stop or decrease the movement of air flow, turn the control knob counterclockwise until loose, then slide to close.

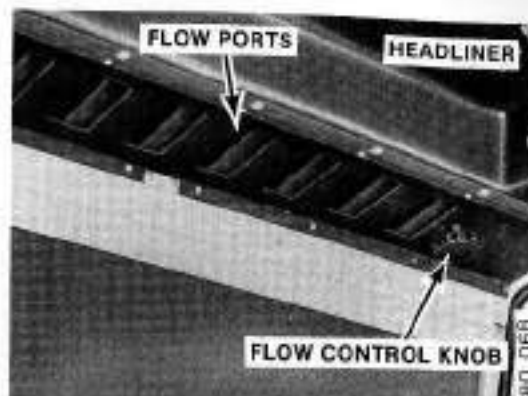

FIGURE 27.

Cab Defroster Control

The cab defroster control is in front of the headliner on the defroster air louvers. To open or close the air louvers and to con-

trol air flow direction, turn the adjusting wheel. The air louvers can also move up or down for added air flow control.

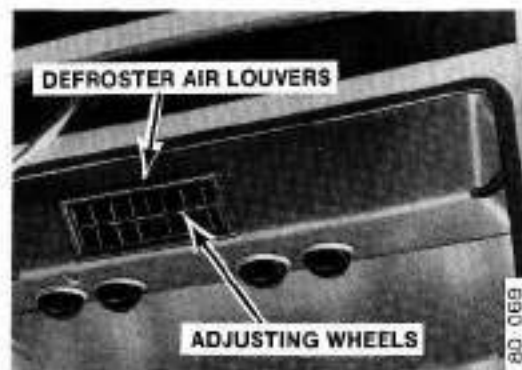

FIGURE 28.

CAB AIR FLOW ARRANGEMENTS

Shown here and on the next pages are arrangements that can be used to heat or cool the cab for different ambient temperatures.

Controlled Pressure and Air Flow Without The Use Of The Air Conditioner or Heater

Pressure is controlled by the use of the three blower speeds and /or the position of the air flow control door. For the most inside cab pressure close the air flow control door and run the blower at HI position. This setting is used during field operations in wind or dust.

For minimum cab pressure and air flow, open the air flow control door and run the blower at LO position.

NOTE: At any position of the air flow control, new air will be pulled into the cab.

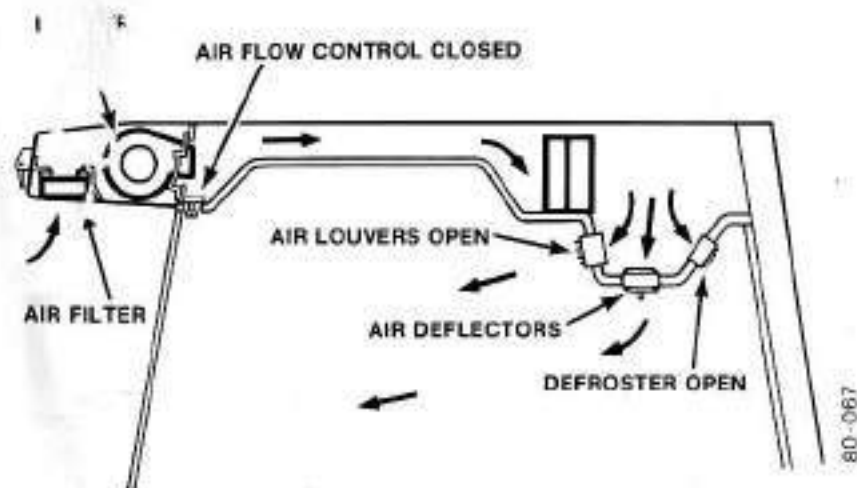

FIGURE 29.

Controlled Pressure and Air Flow With Heater

1. Permit the tractor engine to reach operating temperature. Open the air flow control door, put the heat temperature control to maximum heat, the blower on HI, the louvers closed, defroster and deflectors open.

3. With the blower on LO, air flow is decreased and so is air speed, so the heated air temperature will be a little higher than with the blower at HI or MED.

2. To keep the outside air entering the cab to a minimum which will decrease the time needed to heat the cab, keep the air flow control door open.

NOTE: With the air flow control door open or closed, outside air will be pulled in to keep moisture off the glass.

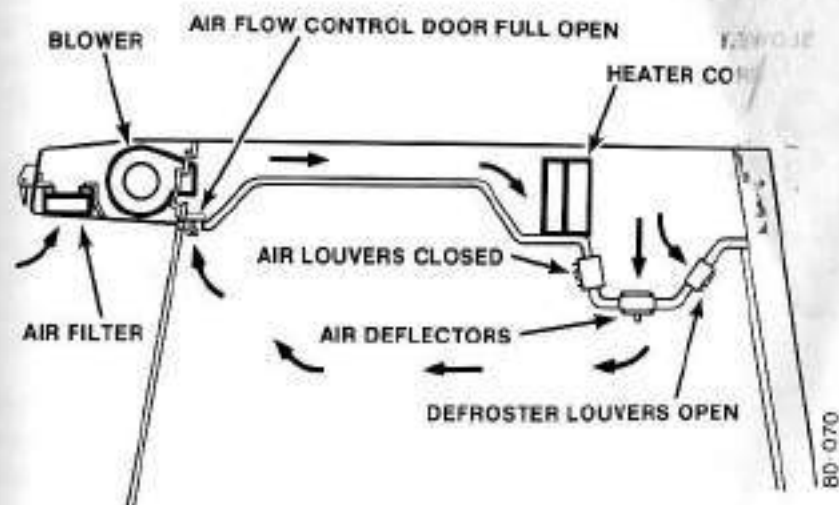

FIGURE 30.

Controlled Pressure and Air Flow With Air Conditioner

For maximum flow of air in the cab (fast cool down):

1. Open flow control door, blower on HI, temperature control on maximum cold and air louvers, defroster and deflectors all open.
2. After the cab temperature is correct, adjust the temperature control, blower speed and air flow control as needed.
3. To increase the temperature level below the belt line (feet and legs), close the defroster. When the defroster is closed, the air flow through the louvers is automatically increased.

4. For maximum air flow at the head level, close the defroster.

NOTE: Under some conditions of humidity and temperatures, it is possible to have ice on the core. This can be caused by operating at LO blower speed and maximum cold setting of the temperature control. It is best to operate at MED or HI blower speeds and center range temperature control settings. If ice occurs, close the air flow control, turn the temperature control to off or set to minimum cool, and run the blower at HI. If ice continues, check the cab air filter and clean or replace the filter.

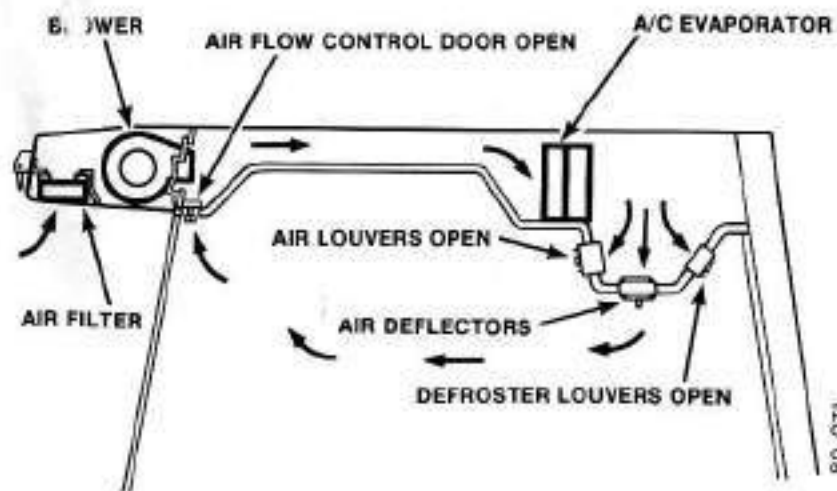

FIGURE 31.

AIR CONDITIONER OPERATION

To operate the air conditioner, the blower must be on. The blower speed and temperature control must be adjusted together to get the best cooling for the ambient temperature. Under normal operating conditions, with the cab sealed correctly, and the windows and door closed, temperatures in the cab of 10° F to 25° F (6° C to 15° C) less than the ambient temperature will occur. When operating the air conditioner system, the humidity is decreased.

NOTE: The air conditioner system has two safety components for protection of the system from low refrigerant level and high restrictions. If, during tractor operation, the air conditioner stops working, See Refrigerant Check Section.

IMPORTANT: The cab air filter does not remove chemicals or fumes. When you use agricultural chemicals, follow the instructions given with the implement and with the chemical.

CAB DOOR LOCK

The cab door can be held in open position by pushing the door outward until the upper latch takes hold. To lock the cab from the outside use the lock in the handle of the cab door.

IMPORTANT: Do not operate the tractor at any time with the cab door open.

TOOL COMPARTMENT

For storage of tools and accessories, a tool compartment is behind the seat.

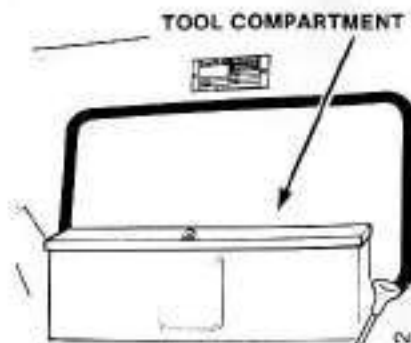

FIGURE 32.

REAR VIEW MIRRORS

Side mount rear view mirrors are available for your Case tractor from your Authorized Case Dealer. The parabolic mirror gives the operator a clear, two way rear view for distance and an immediate rear view to check implements when working.

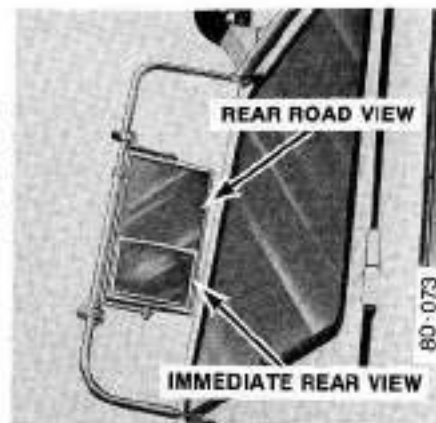

FIGURE 33.

A 4 by 6 inch (101.6 by 152.4 mm) convex side mirror is also available.



FIGURE 34.

CAB WINDOW LEVER

The rear window and the RH side window can be opened. To open the windows, turn the lock knobs to loosen, pull the slotted arms out from the window and push the window out to the needed position. Tighten the lock knob to keep the window in the selected position.

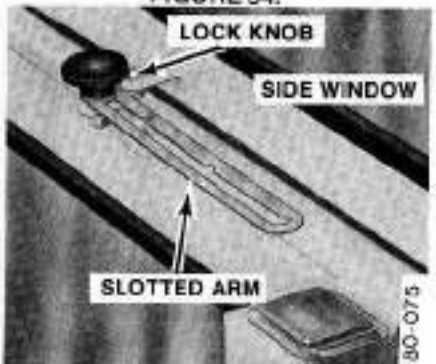

FIGURE 35.

SEAT BELTS (High Platform Tractor)

Tractors equipped with a cab or rollover protective structure (ROPS) will also have seat belts.

IMPORTANT: For maximum safety, use the seat belts. During a tractor accident, the ROPS equipment works best when the operator is held in position inside the ROPS.



WARNING: Securely fasten your seat belt as this tractor is equipped with a ROPS cab. The seat belts can help insure your safety if they are used and maintained.

Operate your seat belts using this procedure:

1. Adjust the seat to your need.
2. Keep your back straight in the seat. Hold the buckle of the seat belt in one hand and the eye end in the other hand.
3. Put the belt across your hips as **LOW ON YOUR BODY AS POSSIBLE**.
4. Push the metal eye into the open end of the buckle until you hear the buckle fasten.
5. To prevent sliding under the belt, pull the end of the belt that extends from the buckle until the belt is tight.

be held by the strong hip area. Any other belt position will result in injury.

To adjust the seat belt for more length, put the buckle at a right angle to the belt. Slide the belt through the buckle. To release the seat belt, push the button on top of the buckle.

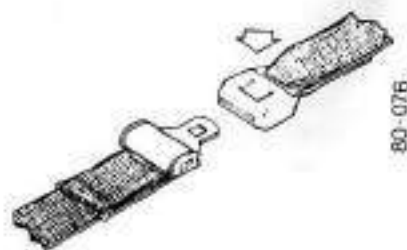

FIGURE 36.

NOTE: The low, tight position of the belt is necessary so that the pressure put on the body by the seat belt during an accident will



CAUTION: Never wear a seat belt loosely or with slack in the belt system. Never wear the belt in a twisted condition or pinched between the seat structural members.

AMBER WARNING LAMPS - DIRECTION TURN SIGNALS AND SMV SYMBOL (High Platform Tractor)



FIGURE 37.



CAUTION: Stop, look and listen before entering a highway, stay on your side of the road and pull over to let faster traffic pass. Slow down and signal as you turn off.

For the safety and protection of the tractor operator and of the vehicle operator's when using the tractor on a road, Case tractors have flashing warning lamps, direction turn signals, tail lamps and Slow Moving Vehicle (SMV) symbol. The flashing amber

warning lamps must be operating when the tractor is operated on a road during the day or night. A vehicle operator that comes near the tractor must see the SMV symbol and tail lamps from the rear and the flashing amber warning lamps from the front and rear.

AMBER WARNING LAMPS - DIRECTION TURN SIGNALS AND SMV SYMBOL (High Platform Tractor)



FIGURE 38.

When the light switch on the steering console is turned to the fourth (flasher) position, the amber warning lamps will illuminate on and off, the tail lamps will illuminate and the head lamps will illuminate. When the direction turn signal switch is moved to the right, the RH warning lamp will operate on and off and the LH warning lamp will be illuminated at all times. When the direction turn signal switch is moved to the left, the LH warning lamp will op-



FIGURE 39.

erate on and off and the RH warning lamp will be illuminated at all times. When the direction turn signal switch is put in left or right position, the tail lamps will illuminate if the light switch is off. **IMPORTANT:** When towing an implement or wagon with the tractor, the complete rear area warning system (amber warning lamps, red tail lamps and SMV symbol) must be easily seen by any vehicle operator coming near the tractor.



WARNING: On roads, use flasher/lights according to local laws. Keep SMV emblem visible.



DANGER: Excess tractor speed is the big killer. Only experienced drivers should be permitted on highways.

IMPLEMENT WARNING LAMPS - SMV SYMBOL

When pulling an implement or wagon on roads during the day or at night, use implement warning lamps for the safety of the tractor and other vehicle operators.

The implement warning lamps must be used:

1. If the flashing warning lamps and red taillights on the tractor can not be seen because of the implement.
2. If the implement is four feet (1.2 m) or longer behind the hitch point of the tractor.
3. If the towed implement is four feet (1.2 m) or more to the left of the center of the tractor.

Install the warning lamps to show the very far left side of the implement.

The Slow Moving Vehicle (SMV) symbol must be installed on the center, rear part of the implement or wagon. Install the SMV symbol on the implement or wagon using a special bracket which you can get from your Authorized Case Dealer.

IMPORTANT: USE THE IMPLEMENT WARNING LAMP AND THE SMV SYMBOL FOR PROTECTION OF VEHICLE OPERATORS.

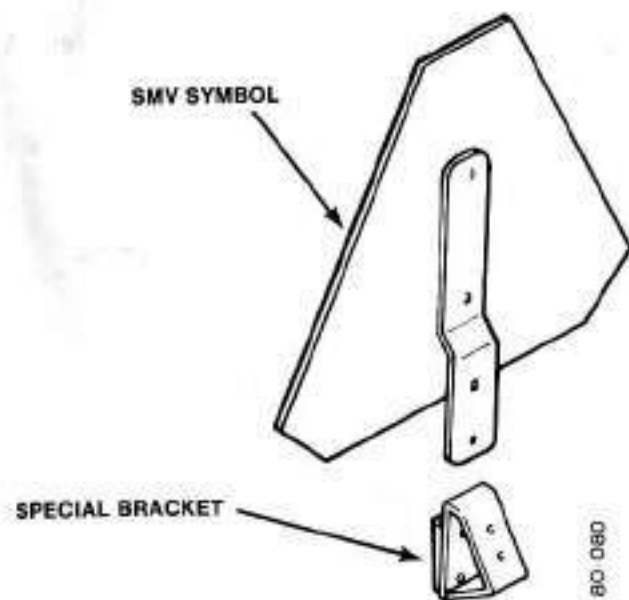

FIGURE 40.

DIESEL ENGINE

BEFORE STARTING THE ENGINE

WARNING: Before starting engine study Operator's Manual safety messages.

Read all safety signs on the tractor.

Clear the area of other persons.



Learn and practice safe use of controls before operating.

It is your responsibility to understand and follow manufacturer's instructions on machine operation and service and to observe the laws and regulations in your area.

Before starting the engine for the first time and before each operating period, check the following:

1. Make sure there is enough fuel of the correct grade in the tank.
2. Check all oil and fluid levels and add oil or fluid as necessary.
3. Check for oil, fuel and coolant leaks.
4. Check the tension of fan and alternator belts.

5. Remove any water or dirt from the fuel pump water trap.

6. Check the tire pressures.

7. If the tractor has a PTO make sure that the safety guard is correctly installed.

STARTING THE ENGINE

1. Make sure that the gear lever, (Synchronesh Tractors) or the range lever, (Power Shift Tractors) is in the neutral position and the Power Shift lever (Power Shift Tractors) is in position 1.
2. Put the engine stop control into the RUN position.
3. Move the hand throttle lever toward the operator approximately one quarter of the maximum distance.

NOTE: *When the engine is cold, move the throttle lever to the maximum speed position.*

4. Turn the starter key clockwise to the first position. Check that all the warning lamps are illuminated. If any lamp is not illuminated, repair the defect or change the bulb.
5. Continue to turn the starter key against the pressure of a spring inside the switch, to the next position. In this

position the Thermostart is in the HEAT position.

Hold the starter key in this position for between 20 and 25 seconds.

6. Then turn the key in the same direction to the START position. This will energise the starter motor. Release the starter key when the engine starts. If the engine does not start when it has turned for 30 seconds, release the starter key. Wait for 30 seconds, then repeat the starting procedure.

DO NOT push the clutch pedal down when operating the starter.

7. Before starting the engine make sure you know the stopping procedure.

NOTE: *There is a safety switch on the range lever of the Power Shift tractors and the gear lever of Synchronesh tractors which prevents the starter operating unless the lever is in the neutral position.*

WARNING: *Engine can start with transmission in gear when neutral safety switch is by-passed:*

1. Do not connect across terminals on starter.

2. Attach booster batteries according to safe method in Operator's Manual. Then use recommended starting procedure from Operator's seat.

Machine run-away can cause injury or death to operator and bystanders.

BEFORE STOPPING THE ENGINE

Before the engine is stopped, it must be given time to cool. If this is not done, the sudden increase in temperature can cause damage to the exhaust valves and a possible loss of coolant.

Do the following procedure:

1. Run the engine at 1600 r/min for two minutes.

NOTE: *if the engine stalls at any time, it must be restarted immediately.*

STOPPING THE ENGINE

1. Decrease the engine speed to idle.
2. Put the stop control into the STOP position.

Make sure that the control is in the safety slot.

3. Turn the starter key to the OFF position.
4. Remove the key.

WARNING: *Before leaving the tractor, put the PTO clutch in the engaged position, the PTO Selector lever in the neutral position and stop the engine. Then apply the parking brake and remove the switch key.*

TRANSMISSION POWER SHIFT TRACTOR

The transmission in the Power Shift tractor has a four-speed power shift section and a three forward, one reverse mechanical gear section. This arrangement gives 12 forward and four reverse speeds.

Use the chart shown below as a guide before you operate the tractor.

Typ of Work	RANGE LEVER POSITION	POWER SHIFT LEVER Any of these positions can be used for different conditions of load, speed and terrain
Transplanting Cultivation Potat Harvesting Planting	RANGE 1	1 2 3 4
Plowing Fertilizer spreading General tillage work	RANGE 2	1 2 3 4
General Hauling Spraying Light cultivation	RANGE 3	1 2 3 4
Loader work	REVERSE RANGE	1 2 3 4

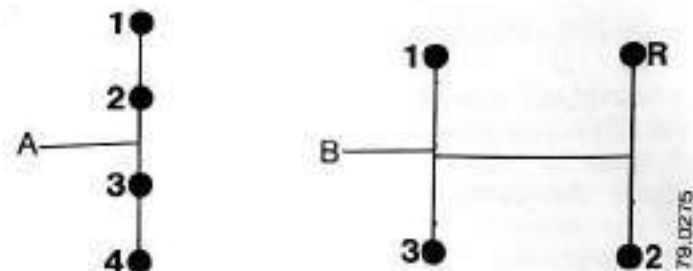

FIGURE 41. LEVER POSITIONS: POWER SHIFT LOW PROFILE TRACTOR

A. Power Shift Lever B. Range Lever

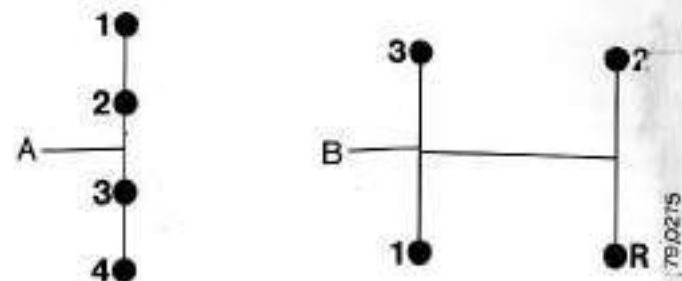

FIGURE 42. LEVER POSITIONS: POWER SHIFT TRACTOR WITH CAB OR HIGH PLATFORM

A. Power Shift Lever B. Range Lever

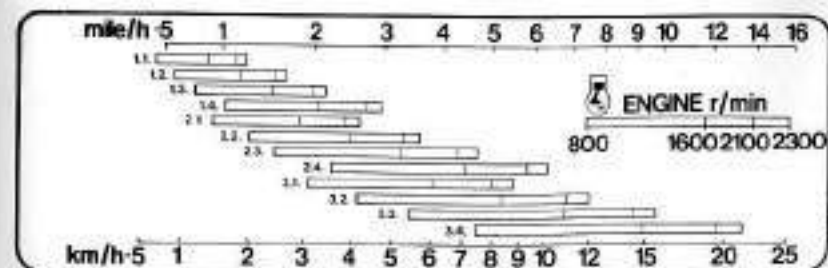

FIGURE 43. TYPICAL TRAVEL SPEED CHART

METHOD OF OPERATION:

1. Make sure that the Power Shift lever is in position 1.
2. Disengage the transmission clutch and move the range lever to the position that you need.
3. Engage the transmission clutch slowly.
4. When the tractor is moving, the travel speed can be increased by moving the Power Shift lever to position 2 and then to position 3 and 4.

To decrease the travel speed, move the Power Shift lever one position at a time to position 3, 2 or 1.

To do this, it is not necessary to disengage the clutch or to change the engine speed. The maximum amount of braking by the engine is available in every gear.

NOTE: *When shifting down, be careful not to run the engine at more than its maximum speed.*

Shift one gear at a time and give time for the speed of the tractor to decrease before shifting to the next gear.

USING THE TRAVEL SPEED CHART

A travel speed chart is fastened to either the windshield or the instrument panel of your tractor.

The horizontal bars indicate the gears. The three engine speed ranges are shown by yellow, green and blue bands.

The travel speed is shown in mile/h and km/h at the top and bottom lines of the chart.

EXAMPLE 1:

Engine speed 2100 r/min Gear 3-1.

Travel speed 2.5 mile/h (4 km/h)

EXAMPLE 2:

Engine speed 1200 r/min Gear 3-3.

Travel speed 4 mile/h (6.3 km/h)

SYNCHROMESH TRACTOR

The synchromesh transmission has a three forward and one reverse gear section and a four-speed range section. This arrangement gives 12 forward and four reverse speeds.

The lowest gear ratios, 1-1, 1-2 and 2-1 have been designed to give slow speeds for light cultivation and PTO work.

Use gear ratios 1-3, 2-2 and 2-3 only for light traction and PTO work.

For continued heavy traction work, use gear ratios 3-1, 3-2, 4-1, 3-3, 4-2 and 4-3.

Method of Operation:

1. Disengage the transmission clutch and move the gear lever to first or reverse gear.
2. Engage the transmission clutch slowly.
3. When the tractor is moving, you can change gear from first to second, second to third and third to second.
4. To do this, disengage the transmission clutch and move the gear lever to the position needed.

NOTE: *When shifting from third to second, be careful not to run the engine at more than its maximum speed.*

IMPORTANT: *When changing direction from reverse to forward, or forward to reverse, the tractor must be stationary before the gear is selected.*

Using the Travel Speed Chart

A travel speed chart is fastened to either the windshield or the instrument panel of your tractor.

The horizontal bars indicate the gears. The three engine speed ranges are shown by yellow, green and blue bands.

The travel speed is shown in mile/h and km/h at the top and bottom lines of the chart.

EXAMPLE 1:

Engine speed 2100 r/min Gear 3-1.

Travel speed 2.5 mile/h (4 km/h)

EXAMPLE 2:

Engine speed 1200 r/min Gear 3-3.

Travel speed 4 mile/h (6.3 km/h)

SYNCHROMESH TRACTOR

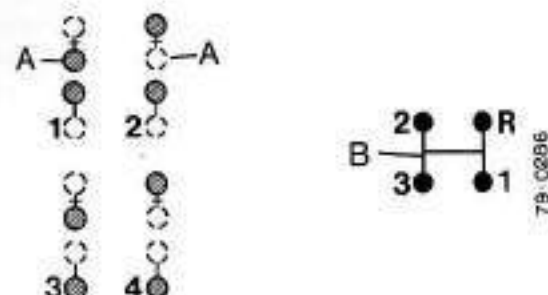

FIGURE 44. LEVER POSITIONS: SYNCHROMESH LOW PROFILE TRACTOR

A. Range Levers B. Gear Lever

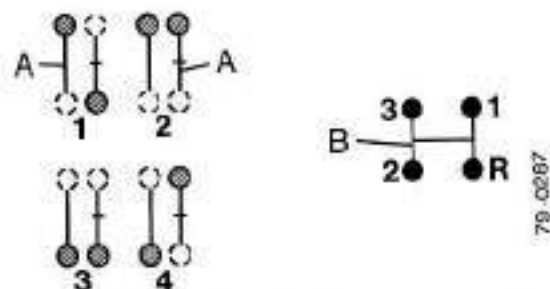

FIGURE 45. LEVER POSITIONS: SYNCHROMESH TRACTOR WITH CAB OR HIGH PLATFORM

A. Range Levers B. Gear Lever

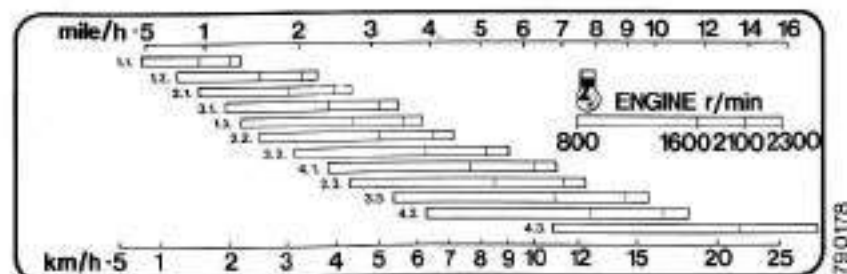

FIGURE 46. TYPICAL TRAVEL SPEED CHART

BALLAST

Introduction

Adding ballast to a tractor is an easy and efficient method of increasing traction in most conditions. When ballast is used, it is very important that the total weight of the tractor is not more than the maximum operating weight.

Frame weights improve the steering characteristics when heavy hitch loads cause a movement of tractor weight from the front to the rear wheels.

Rear wheel weights and adding water to the rear tires increase traction by putting weight on to the driving wheels.

The ballasting method of adding weight to a tractor where it is needed is the same for tractors with front-wheel drive.

How and when to use ballast

Ballast for your tractor is rear wheel weights, frame weights and water ballast in the tires. Some implements cause a large amount of weight to move from the front of the tractor to the rear. In these conditions always add weights to the front of the tractor.

Always remove the ballast when it is not needed. Do not add too much weight to try to pull very heavy loads.

Remember that the power used to move a tractor that has too much weight will decrease the power available to pull the implement.

The frame weight is made of a number of weights mounted in a frame and secured with a locking bar. The assembly weighs approximately 1000 lb (454 kg).

The rear wheel weights can be fastened to the outside of the rear wheels. They weigh 96 lb (42 kg) each.

If you need to add weight by putting water in the rear tires, see your Authorized Case Dealer for the procedure and special cautions that must be followed.

IMPORTANT: The total weight of your tractor must not be more than 14000 lb (6350 kg).

MEASURING WHEEL SLIP

To get maximum efficiency from your tractor, wheel slip of approximately 10% on full load is necessary.

To measure the amount of wheel slip use the following method:

1. Put a reference mark on the side of one of the rear tyres.
2. Operate the tractor with the implement in the ground.
3. Get an assistant to put a mark on the ground at the place where the reference mark on the tyre comes to the ground. (Tractor moving)
4. Count 10 wheel revolutions. Put a second mark on the ground where the reference mark on the tyre comes to the ground for the tenth time.
5. Raise the implement out of the ground. Move the tractor to the start of the test.
6. Put the tractor in position with the rear tyre next to the first mark. Put a new mark on the tyre next to ground. Wipe off the old mark.

7. Move the tractor slowly, with the implement raised, from the first mark on the ground to the second mark. Count the number of revolutions of the wheel between the two marks.

8. Use the number of revolutions of the wheel (from paragraph 7) in the following table to find the wheel slip (%).

Revolutions of the Wheel from paragraph 7	Wheel Slip (%)
9½	5
9	10
8½	15
8	20
7½	25
7	30

9. Add or remove ballast from the tractor to decrease or increase slip to approximately 10%.

POWER TAKE-OFF (PTO)

WARNING: PTO driven machinery can cause serious injury if it is not used correctly. Make sure that you do the following:



Use the correct speed of PTO shaft for the implement.

Keep the guards fastened correctly at all times.

Before working on or near the PTO shaft or driven machine, put the PTO clutch lever in the disengaged position, the PTO lever in the neutral position, and STOP the tractor engine.

SINGLE SPEED TYPE

A single speed PTO can be installed either as standard or optional equipment.

It has a 21-splined shaft and operates at 1000 r/min with an engine speed of 2050 r/min.

The drive to the PTO can be engaged or disengaged by a hand lever at the side of the PTO casing.

REVERSIBLE SHAFT TYPE

One end of the drive shaft has six splines to use with 540 r/min implements. The other end has 21 splines to use with 1000 r/min implements. To get these speeds, run the engine at between 2050 and 2075 r/min.

The drive to the PTO can be engaged or disengaged by a hand lever at the side of the PTO casing.

To change the speed of the drive shaft, do the following:

1. Remove the four special bolts which fasten the flange of the drive shaft to the driving flange of the PTO.

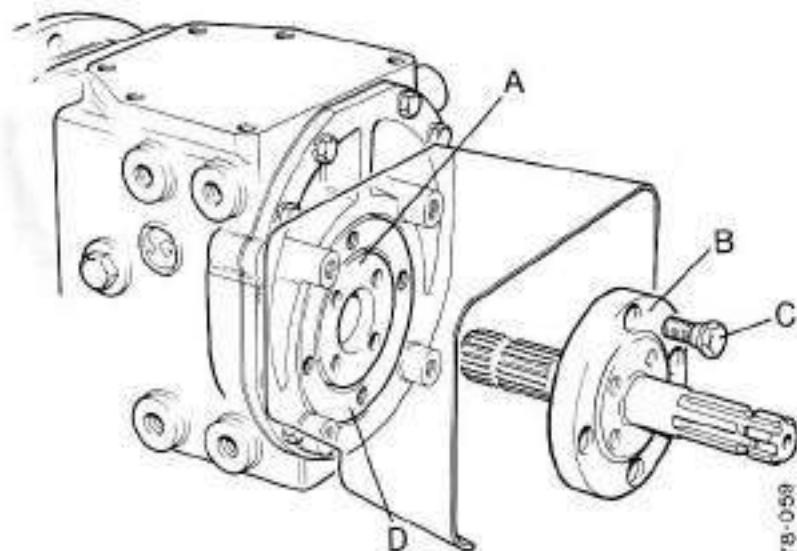

FIGURE 47. REVERSIBLE SHAFT PTO

- | | |
|--------------------|-------------------|
| A. 1000 r/min face | C. Special bolts |
| B. Drive shaft | D. 540 r/min face |

TREAD ADJUSTMENT

FRONT AXLE: STANDARD

NOTE: *Tread widths are measured between the centers of each tire at a point as near to the ground as possible.*

To change the tread width, do the following:

1. Use a jack to raise the front wheels off the ground.
2. Remove the bolts A and C from either beam extension.
3. Move the axle extension to the position you need.
4. Install the bolts A and tighten to 130 lb ft (176 Nm).

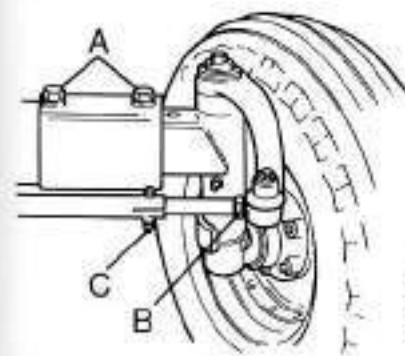

FIGURE 48. FRONT AXLE ADJUSTMENT

- | |
|-----------------|
| A. Axle Bolts |
| B. Locknut |
| C. Tie Rod Bolt |

78-060

REAR TREAD: POWER ADJUSTED

To change the tread width do the following:

1. Clean the rails and guides.
2. Move one stop bracket on each rear wheel to the new setting.
3. Loosen the rim clamps on both rear wheels.

4. Start the engine and select gears as follows:

- 1.1 to move the rims OUTWARD.
- 1.R to move the rims INWARD.

5. Move the tractor slowly until the rims are against the stops.

6. Move the other stops against the rim clamps.

7. Tighten the rim clamps.

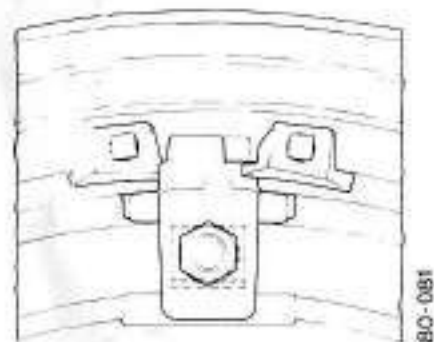

FIGURE 49. RIM CLAMP AND STOPS

HITCH

The hitch has been made to use with Category II implements. The position of links, lift rods, check chains and stabilizer bars are as shown.

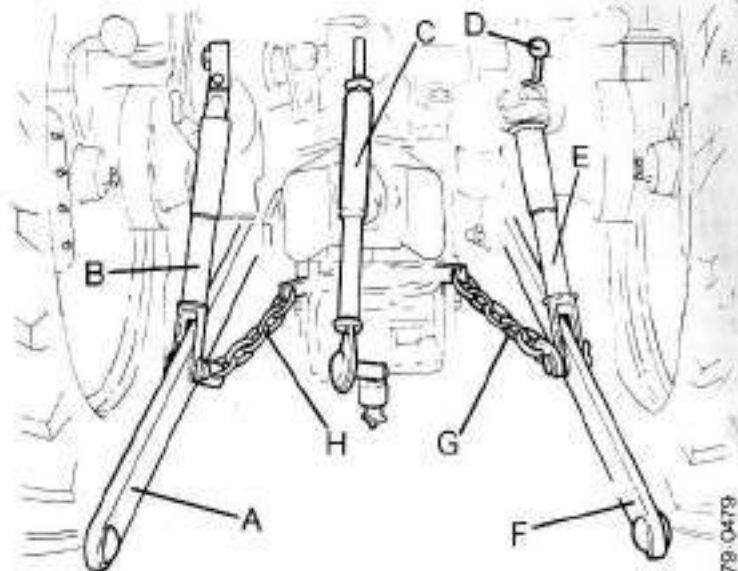

FIGURE 50. HITCH

- | | |
|-------------------|-------------------|
| A. Lower Link | E. Lift Rod |
| B. Lift Rod | F. Lower Link |
| C. Top Link | G. } Check Chains |
| D. Leveling Lever | H. } |

Stabilizers

Stabilizer bars can be installed as shown in Figure 51. The length of the stabilizer bars can be adjusted from 24 $\frac{1}{2}$ to 27 $\frac{1}{2}$ in (630 to 705 mm).

Method of Adjustment

1. Install the implement on the hitch.
2. Remove the lock pins A, and the pins B.
3. Turn the turnbuckle D to adjust the length of each stabilizer bar until the implement bar is in the correct position on the hitch.
4. When the implement is in position, increase the length of each stabilizer bar until there is no free side movement of the hitch.
5. Turn each turnbuckle the minimum amount to align the holes for the pins.
6. Install the pins and lock pins.

NOTE: Use a small bar through the hole C if the turnbuckle is difficult to move.

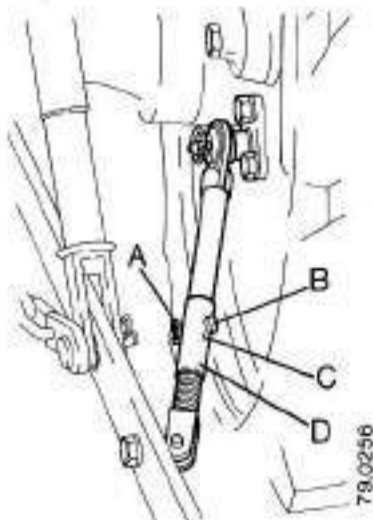

FIGURE 51. STABILIZERS

- A. Lock pin
- B. Pin
- C. Hole for bar
- D. Turnbuckle

Mechanical Flotation

The pins which fasten the check chains to the draft arms also go through the lift rods. There are two positions for these pins. Holes A give a fixed position and slots B permit the implement to move 3 in (75 mm) up or down on either or both sides. Use slots B when operating on ground which is not level.

When operating with a plow that has a wheel at the back, it is our recommendation that the right-hand pin is installed in slot B.

NOTE: Check the Operator's Manual for the implement to see if mechanical flotation is also the recommendation of the maker of the implement.

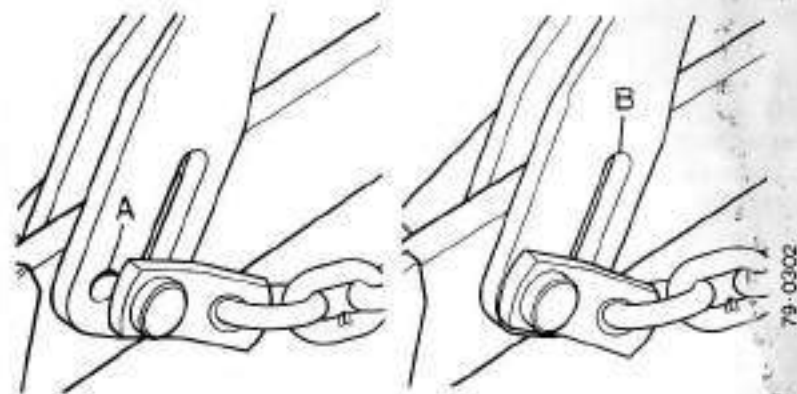

FIGURE 52. MECHANICAL FLOTATION

A. Holes

B. Slots



CAUTION: Make sure that the implement does not make contact with the cab in the operating or fully raised position.



WARNING: Rear upset can result if pulling from wrong location on tractor. Hitch only to the drawbar. Use 3 point hitch only with the implements designed for its use — not as a drawbar.

DRAWBAR

The drawbar has movement from side to side, three forward and four height positions.

There are three holes in the drawbar to give three different positions.

Use the forward position for weights up to a maximum of 3000 lb (1360 kg).

The other positions are for PTO driven implements. The center position gives PTO shaft to drawpin distance of 14 in (360 mm) and the rear position a distance of 16 in (405 mm).

NOT!: *The maximum drawbar load in the PTO positions must not be more than 2500 lb (1130 kg).*

Removing or Changing the Position of the Drawbar: Move the drawbar until it is aligned with the slot B in the drawbar frame. Remove the lock pin from the pivot pin A, and lower the front of the drawbar until it is away from the pivot pin.

Remove the drawbar toward the rear.

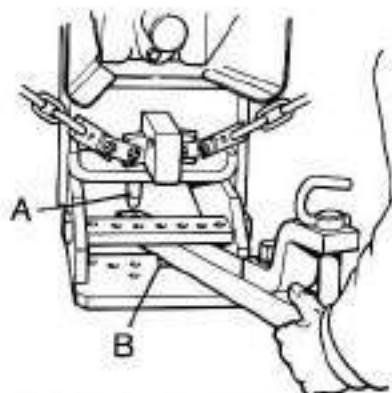

FIGURE 53. DRAWBAR ADJUSTMENT

- A. Drawbar Pivot Pin
- B. Slot in Drawbar Frame

78-065

Lateral Adjustment

Remove the bolts C, move the drawbar to the position you need and install the bolts.

Height Positions

The drawbar frame can be fastened at either A or B. The drawbar can also be turned upside down. This gives a total of four height positions.

IMPORTANT: *Check the bolts at regular intervals to make sure they are tight.*

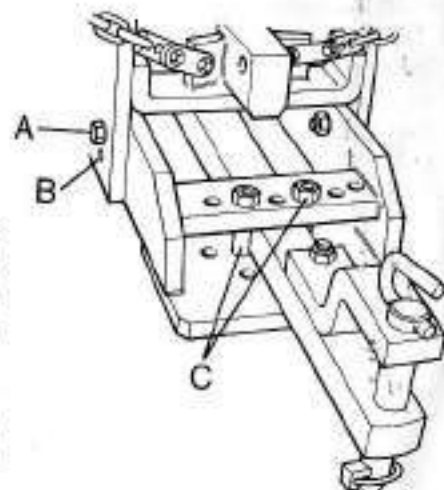

FIGURE 54. DRAWBAR HEIGHT POSITIONS

- A. Securing bolt in top position
- B. Alternate lower position
- C. Bolts for lateral adjustment

78-064

DRAFT CONTROL

POSITION OF LEVERS FOR DRAFT CONTROL

Before using an implement without a gauge wheel, do the following procedure:

1. **Sensing Unit:** Move the control lever to one of the three positions.

Before you change the position of the control lever, make sure that there is no load on the top link.

POSITION A — For light draft implements similar to plows, hoes and cultivators.

POSITION B — For medium draft implements similar to plows and cultivators.

POSITION C — For heavy draft implements similar to chisel plows, sub-soilers, multi-furrow moldboard and disc plows.

NOTE: *These positions may not be correct for all implements, and can be changed according to the characteristics of an implement.*

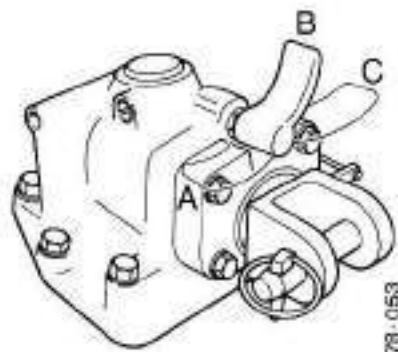

FIGURE 55. SENSING UNIT

- A. Light Draft Position
- B. Medium Draft Position
- C. Heavy Draft Position

2. **Selector Dial:** Move the hand lever to the SELECT position, hold the hand lever in this position and move the pointer of the selector dial to DRAFT CONTROL.

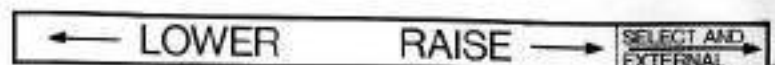
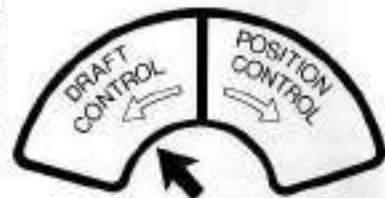

FIGURE 56. SELECTOR DIAL AND HAND LEVER

3. **Lowering Control:** Turn the knob fully in, then out four turns. When operating the tractor move the knob to get the speed of lowering that you need.
4. **Finger Guide:** Move the finger guide to the center of the quadrant.
5. **Combining Valve (Tandem Pump):** Push the control knob IN to the separate flow position.

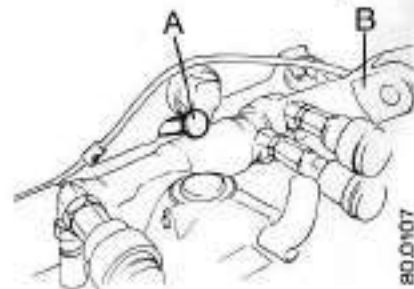

FIGURE 56A. COMBINING VALVE
A. Valve Control Knob
B. Hitch Lift Arm

OPERATING WITH DRAFT CONTROL

Move the tractor forward and at the same time move the hand lever forward to the maximum LOWER position.

When the implement is in the ground, move the hand lever to RAISE or LOWER until the implement is at the depth you need. Move the finger guide until it is aligned with the hand lever and tighten the knob to keep the guide in position. At the end of the furrow, move the hand lever to RAISE to raise the implement.

At the start of the next furrow, move the hand lever so that it is again aligned with the finger guide. The implement will go into the ground and keep to the same depth as in the first furrow.

POSITION CONTROL

POSITION OF LEVERS FOR POSITION CONTROL

Before using an implement that works above the ground, do the following procedure:

1. **Selector Dial:** Move the hand lever to the SELECT position, hold the hand lever in this position and move the pointer of the selector dial to POSITION CONTROL.

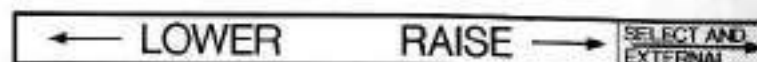

FIGURE 57. SELECTOR DIAL

2. **Lowering Control:** Turn the knob fully in, then out four turns. When operating the tractor move the knob to get the speed of lowering that you need.
3. **Finger Guides:** Move the finger guide to the center of the quadrant.
4. **Combining Valve (Tandem Pump):** Push the control knob IN to the separate flow position.

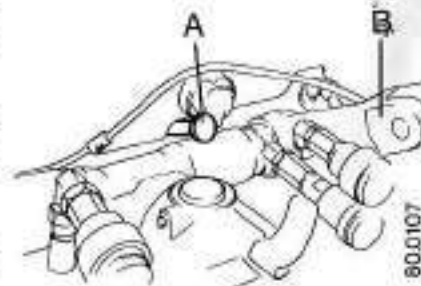
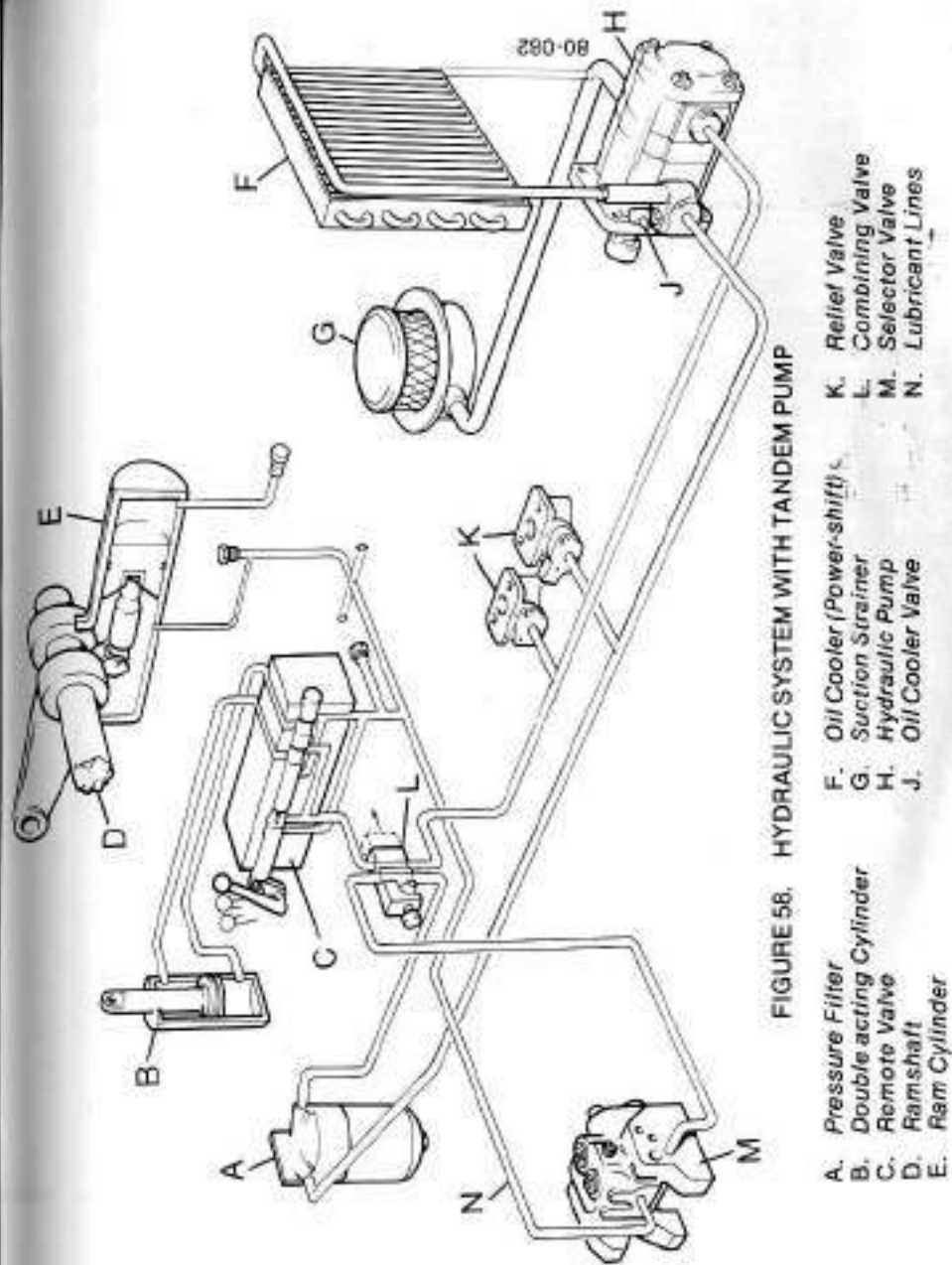

FIGURE 57A. COMBINING VALVE

- A. Valve Control Knob
B. Hitch Lift Arm

OPERATING WITH POSITION CONTROL

Move the hand lever to the RAISE position to raise the implement. Move the hand lever forward until the implement is at the height you need. Move the finger guide until it is aligned with the hand lever and tighten the knob to keep the guide in position. When the hand lever and the guide are aligned the implement will keep to the same height position.



DOUBLE ACTING REMOTE VALVES

Either one or two double acting valves can be installed to operate one or two remote double acting cylinders.

When the control lever is moved to the maximum distance in either direction, a detent ball holds the lever in that position until the cylinder is at the end of its stroke. An automatic release will then return the lever to the center position and any equipment connected to the valve or valves is held stationary.

Moving the lever A forward causes oil under pressure to flow from port C. At the same time port B is opened so that oil from the external equipment can return to the gearbox.

Moving the lever backward changes the direction of oil flow. Port B is now under pressure and oil returns through port C.

IMPORTANT: Always connect the hose couplings so that when the lever is pushed forward the implement is lowered.

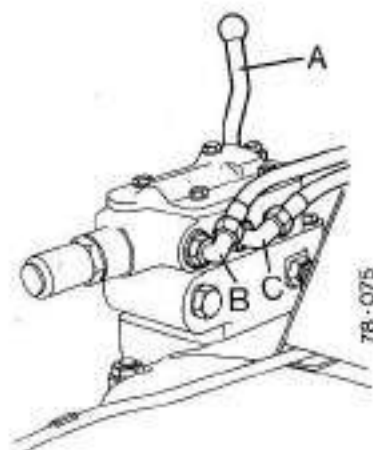

FIGURE 59. DOUBLE ACTING REMOTE VALVE

SINGLE ACTING EQUIPMENT

If your implements use a single acting cylinder, see your Authorized Case Dealer for a valve and fittings so that you can operate a single acting cylinder and the three-point hitch at the same time.

NOTE: To operate the remote cylinders at the same time as the three-point hitch, the combining valve knob must be put in the SEPARATE position.

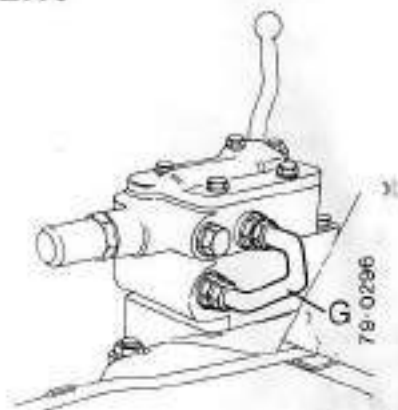

FIGURE 60. MODIFICATION FOR SINGLE ACTING CYLINDER
G. Oil Return Hose

HOSE AND COUPLERS

Hose and couplers are available from your Authorized Case Dealer. The two-way valve kit includes ASAE Standard Female Couplers that will fit any ASAE Standard Male Coupler.

If your implement hoses do not have ASAE Standard $\frac{3}{4}$ in 14 UNF threads, adaptors are available from your Authorized Case Dealer.

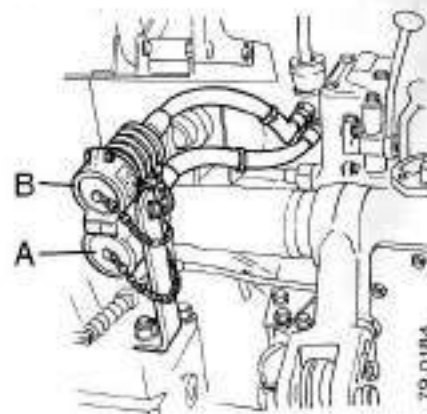

FIGURE 61. QUICK RELEASE COUPLINGS

- A. Supply with Control Lever Forward
- B. Supply with Control Lever Backward

MAINTENANCE

Introduction

Preventive maintenance is important to you.

As the owner of a Case Tractor, you have a machine that is made to the highest possible standards. Preventive maintenance is an easy and low cost method to make sure that your tractor gives you many hours of efficient operation.

Before it is important, the procedure has been made very easy. It is a recommendation that maintenance is done at the end of the operating period. The oil will then be warm and if necessary can be removed easily. If possible, do maintenance jobs under cover and make sure you do the following:

Before using a grease gun, clean the grease fittings.

Before removing drain or fill plugs, clean the plugs and the area around the plug.

Before putting new oil or diesel fuel into a container, make sure that the container is clean.

Call your Authorized Case Dealer if you need assistance or information.

LUBRICATION CHART

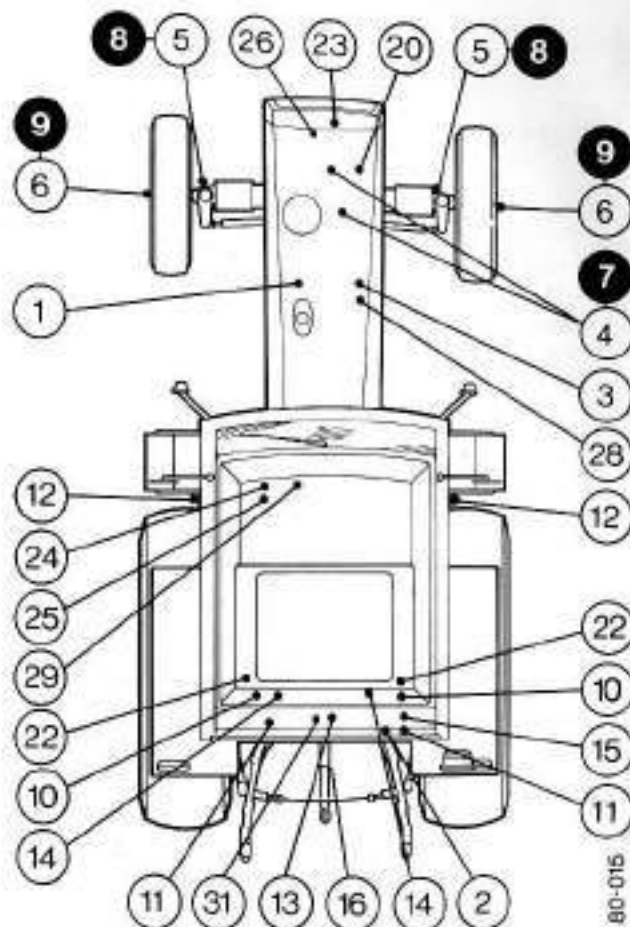

FIGURE 62.

Ref Number	Service Points	No of Points	Apply Grease	Apply Oil	Remove Fluid	Check	Clean	Change	Frequency
1	Engine Oil Level	1				X			○ 10 hours or Daily
2	Fuel Tank Level	1				X			
3	Air Cleaner: Severe Dust Conditions	1				X	X		
4	Axle Pivot	2	X						
5	Kings Pins	2	X						
6	Front Wheel Hubs	2	X						
Severe Wet Conditions									
7	Axle Pivot	2	X					● 50 hours	
8	King Pins	2	X						
9	Front Wheel Hubs	2	X						
10	Brake Cables	2	X						
11	Drive Output Shaft	2	X						
12	Cross Shaft	2	X						
13	Sensor Unit Cable	1	X						
14	Lift Pads	3	X						
15	Levelling Lever Gearbox	1	X						
16	Top Link	1	X						
17	Axle Pivot: MFD	2	X						
18	King Pins: MFD	2	X						
19	Drive Shaft: MFD	1	X						
20	Power Steering Reservoir	1				X			
21	Control Levers Pivot Points	1	X						
22	Brakes	2				X			
23	Coolant Level	1				X			
24	Transmission Clutch	1				X			
25	PTO Clutch	1				X			
26	Battery	1				X			
27	Tires	4				X			
28	Fuel Water Trap	1				X			
29	Brake and Clutch Reservoir: Cab Only	2				X			
30	Wheel Nuts	1				X			
31	Transmission Oil Level	1				X			

LUBRICATION CHART

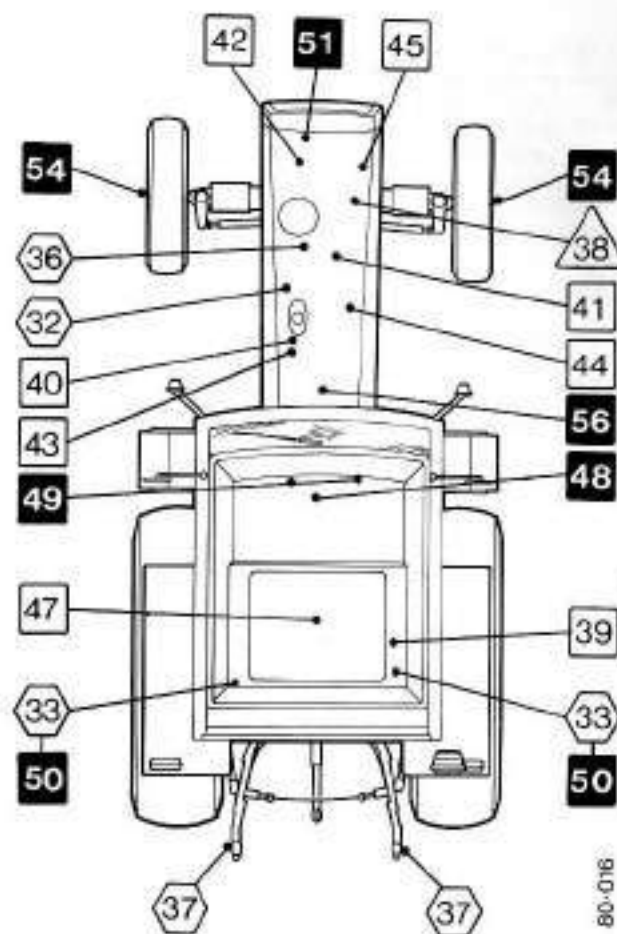

FIGURE 63.

Ref Number	Service Points	No of Points	Apply Grease	Apply Oil	Remove Fluid	Check	Clean	Change	Frequency
32	Engine Oil	1						X	
33	Final Drive Oil Level	2				X			⬡
34	Differential Oil Level: MFD	1				X			
35	Front Hub Oil Level: MFD	2				X			100/125 hours
36	Fuel Injection Pump Oil	1						X	
37	Three-Point Hitch Ends	2	X				X		
	Oil Filter	1						X	△ 200/250 hours
39	Transmission Oil Filter	1						X	
40	Injectors	6				X			
41	Valve Clearances	12				X			
42	Fan and Alternator Belts	2				X			
43	Fuel Filters	2						X	
44	Air Cleaner Elements	2				X	X		□ 500 hours
45	Power Steering Oil Reservoir	1						X	
46	External Nuts and Bolts	1				X			
47	Operator's Seat and Seat Belt	1				X			
48	Transmission Oil	1						X	
49	Brake and Clutch Fluid	2						X	
50	Final Drive Oil	2						X	
51	Coolant	1				X			
52	Differential Oil: MFD	1						X	■ 1000 hours
53	Front Hub Oil: MFD	2						X	
54	Front Wheel Bearings	2				X			
55	Powershift Oil Pressure	1				X			
56	Cab Air Filter	1						X	

LUBRICATION CHART

Front Axle: MFD

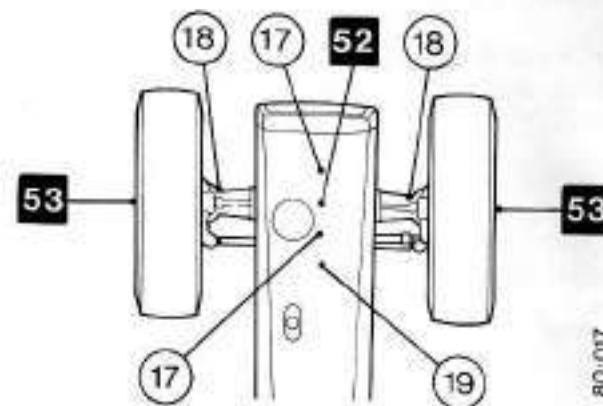

FIGURE 64.

Ref Number	No of Points	Apply Grease	Apply Oil	Remove Fluid	Check	Clean	Change	Frequency
17. Axle Pivot: MFD	2	X						● 50 hours
18. King Pins: MFD	2	X						
19. Drive Shaft: MFD	1	X						
52. Differential Oil: MFD	1						X	■ 1000 hours
53. Front Hub Oil: MFD	2					X		

DAILY INSPECTION

- 1. Inspection:** Check for oil, water and fuel leaks.
- 2. Engine:** Check the oil level in the sump and add oil if necessary.
- 3. Fuel:** Fill the tank to $\frac{3}{4}$ in (40 mm) from the top. Check the condition of the water trap and clean if necessary.
- 4. Air Cleaner:** If the tractor is operating where there is a large amount of dust, check the warning lamp and clean the air filters if the lamp is illuminated.

IMPORTANT: If the element of the air cleaner has any damage, install new element.

- 5. Grease Fittings:** In dirty or wet conditions, add lubricant to the following points:
Axle Trunnions, King Pins.
Use SAE 140 Gear oil.
Front Wheel Hubs.
Use Lithium Base Grease.
- 6. Wheels:** Tighten the wheel nuts every day for the first 50 hours when the tractor is new or if the wheel nuts have been removed and installed.

Transmission Clutch

Check the free pedal movement.

50 HOUR SERVICE

Do the daily inspection and then the following jobs:

- 1. Lubrication Fittings:** (See the Lubrication Chart).
- 2. Power Steering**
Check the oil level and add oil if necessary.

MFD Tractors: Turn the front wheels to the maximum right position before you check the level of oil in the reservoir.

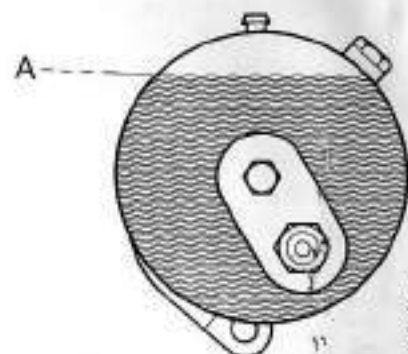

FIGURE 65. OIL LEVEL
A. Correct Oil Level

- 3. Controls:** Lubricate control levers and pivot points with engine oil. DO NOT lubricate in dusty conditions.
- 4. Brakes:** Adjust the brakes as follows:
Use a jack to raise one rear wheel from the ground. Turn the nut B clockwise until the wheel is difficult to turn by hand.

Turn the nut B counter-clockwise $2\frac{1}{2}$ turns.

Do the same operation to the other wheel.

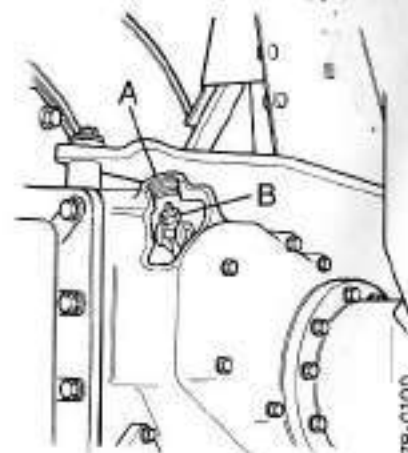

FIGURE 66. BRAKE ADJUSTMENT

- A. Hole with Plug Removed
B. Adjusting Nut (Self-Locking)

5. **Coolant:** Check the level and add coolant if necessary up to the level mark on the expansion container.

WARNING: There is pressure in the cooling system which can cause injury if the radiator cap is suddenly removed. Turn the radiator cap to the first position and wait until the pressure is released before removing the cap.

6. **Transmission Clutch:** Check the free movement and adjust if necessary to $\frac{1}{2}$ in (12.7 mm).

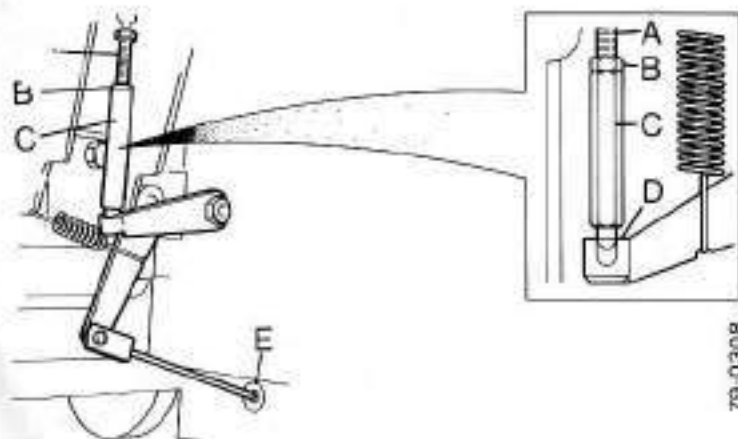

FIGURE 67. TRANSMISSION CLUTCH ADJUSTMENT

- | | |
|---------------------|-------------------------|
| A. Push Rod | D. Check Clearance here |
| B. Locknut | E. PTO Adjuster Locknut |
| C. Adjusting Sleeve | |

7. **PTO Clutch:** Check the free movement and adjust if necessary to a minimum of $\frac{1}{2}$ to $\frac{3}{4}$ in (12.7 to 19.0 mm).

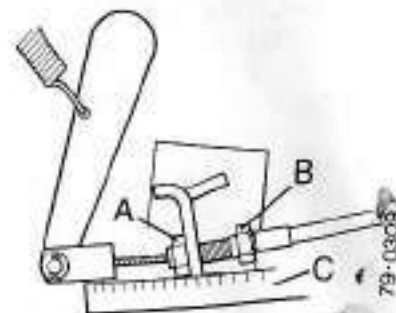

FIGURE 68. PTO CLUTCH ADJUSTMENT

- | |
|--------------------|
| A. Locknut |
| B. Adjusting Screw |
| C. Rule |

8. **Battery:** Check the electrolyte level and add clean water if necessary. Clean the top of the battery.

9. **Tires:** Check that the tire pressures are correct for the operating conditions. Add or remove air if necessary.

10. **Fuel Water Trap:** Clean the sediment bowl.

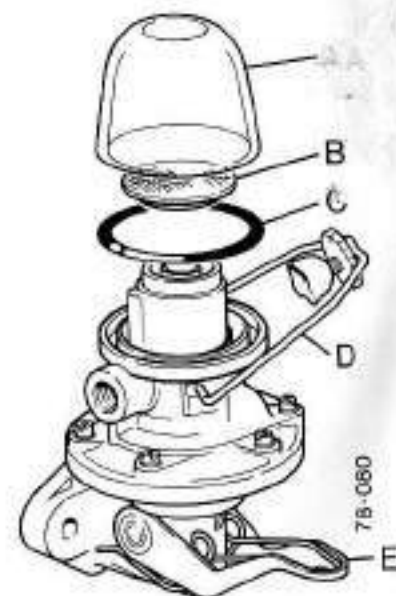

FIGURE 69. SEDIMENT BOWL

- | | |
|------------------|---------------|
| A. Sediment Bowl | D. Screw |
| B. Filter | E. Hand lever |
| C. Seal | |

11. **Wheel Nuts:** Check that all the wheel nuts are tight.

12. **Transmission:** Check the oil level with the dipstick and add oil if necessary.

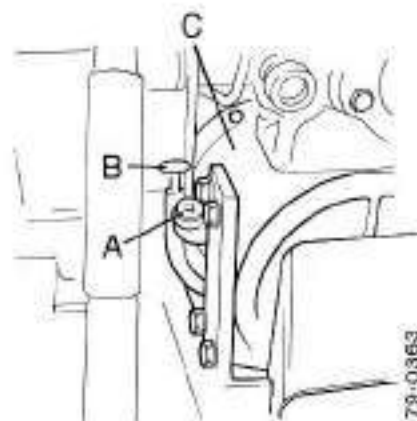

FIGURE 70. TRANSMISSION DIPSTICK AND FILLER PLUG

- A. Filler Plug
- B. Dipstick
- C. PTO Case

78-0363

100/125 HOUR SERVICE

Do the daily inspection, the 50 hour service and then the following jobs:

1. **Engine Oil Change:** Remove the oil when the engine is hot. Fill with new oil to the safe level mark on the dipstick.

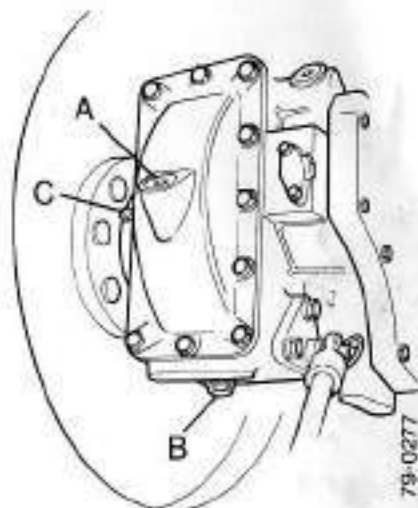

FIGURE 71. FINAL DRIVE REDUCTIONS

- A. Filler/level Plug
- B. Drain Plug
- C. Hub Grease Fitting

79-0277

2. **Final Drives:** Check the oil levels and add new oil if necessary.

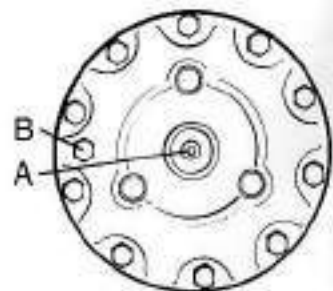

FIGURE 72.

- A. Level Plug
- B. Fill and Drain Plug

78-0304

3. **Front Axle: MFD Tractors:** Check the oil levels in the differential and reduction hubs. Add new oil if necessary.

4. **Fuel Injection Pump:** Remove the oil from the fuel pump. Add oil through the fill plug until it flows from level plug.

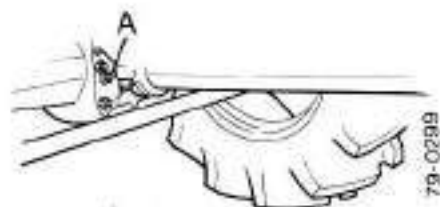

FIGURE 73.
A. Fill and Level Plug

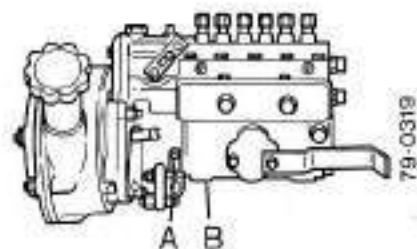

FIGURE 74. FUEL INJECTION PUMP
A. Level Plug
B. Drain Plug

AIR FILTER REMOVAL (Operator's Cab)

5. **Cab Air Filter**
Filter Service Interval After every 100 hours of operation.

The cab filter is in the extended housing at the rear of the cab. To remove the filter element, open the two latches.

Let the filter housing door swing down. Remove the filter element. Clean the housing door louvers.

When you install the filter, make sure the arrows on the edge of the filter point up. Put the filter in the housing door, swing the door up and keep the door in position with the two latches.

NOTE: When operating the tractor in conditions with too much dust, the air flow in the cab can decrease because of dust on the filter. To increase the air flow, open and close the cab door several times - the force caused by the door will push the dust out of the filter.

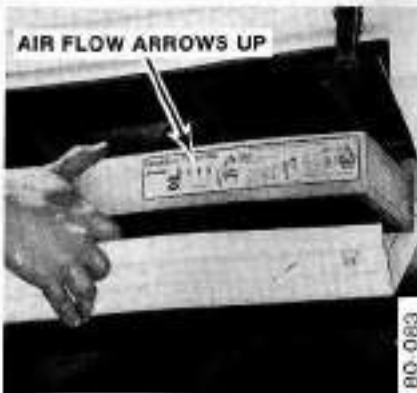
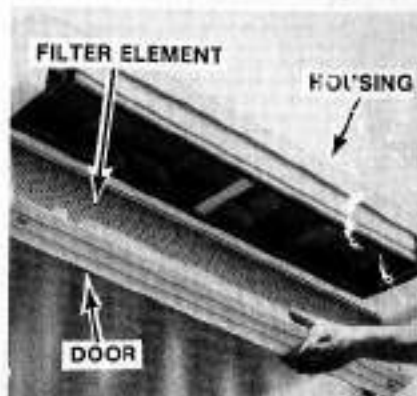
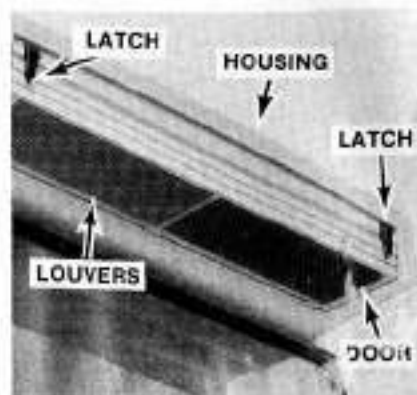

AIR FILTER SERVICE (Operator's Cab)

Check and clean the air filter every 100 hours. Replace the filter if there is damage or when the filter can not be cleaned for efficient operation.

The filter can be cleaned by three methods:

- A. Hit the outside of filter - Do not use force.
- B. Clean with compressed air.
- C. Wash with water.

METHOD A - When most of the dirt is silt, this method can be used to clean the filter. Hit the dirty side of the filter against a flat surface. Do not use force that can cause damage to the filter.

METHOD B - The compressed air method is used if most of the dirt is dust. Move the flow of air up and down the clean side of the filter opposite to the air flow arrows shown on the element.

IMPORTANT: *The maximum air pressure at the nozzle must not be more than 100 PSI (690 kPa)(6.9 bar). Too much air pressure will cause damage to the filter.*



TAPPING



COMPRESSED AIR



METHOD C - If the filter has heavy dirt and soot, use the water washing method to clean.

1. Wash the element in water using Case Filter Element Cleaner, Part Number A40910. Mix two ounces (56.7 grams) of cleaner to one gallon (3.8 litres) of water at 70°F to 100°F (21° to 38°C).
2. Wash the filter for 15 minutes. Clean the element completely with a water hose. Do not use

3. Permit the filter to become completely dry in the air before use in the tractor. The filter needs 24 to 72 hours to dry.

IMPORTANT: *Do not use compressed air to dry the filter. Get a second filter to use while you permit the washed filter to dry.*



WASHING



CASE PART
NUMBER A40910

200/250 HOUR SERVICE

Do the daily inspection, the 50 and 100 hour service, and then the following job:

1. **Engine Oil Filter:** when the oil is removed from the engine, install a new oil filter.

Use the following procedure:

Remove the old filter with an oil filter wrench.

Clear the seating in the cylinder block and the area around it.

Put a small amount of engine oil on the new filter sealing ring.

Install the filter on the cylinder block and turn the case until the sealing ring is against the face. Then tighten the sealing ring by turning the case half to three quarters of a turn more.

Put the engine stop control in the STOP position.

Turn the engine with the starter for ten seconds.

Check the engine oil level and add oil if necessary.

Start the engine and check for leaks.

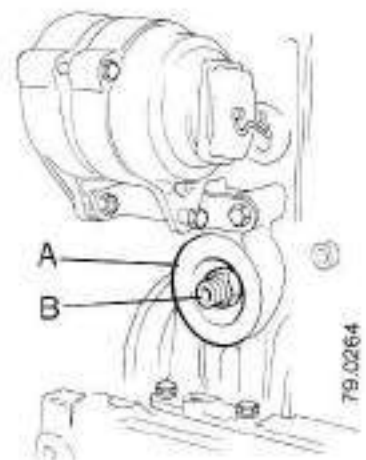
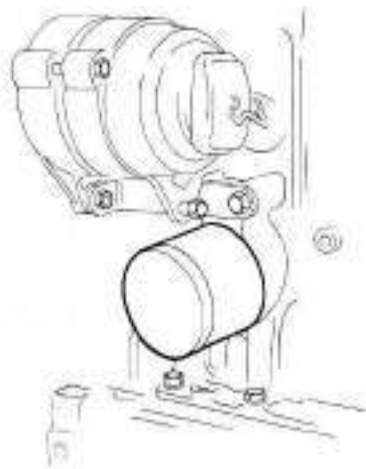

FIGURE 75. ENGINE OIL FILTER

- A. Face
B. Thread

COMPRESSOR BELT ADJUSTMENT

2. **Compressor Belt: Air Conditioning**



Measure the compressor belt for correct tension using a belt tension gauge. Belt tension must be 70 to 90 lbs. (90 to 122 N). Adjust the belt after 50 hours of operation and every 250 hours of operation after that.



Turn the adjusting bracket until the correct tension for the belt is reached. Then tighten the bolt.



To adjust the belt tension, loosen the bolt in the belt adjusting bracket.



WARNING: Rotating fan and belts. Contact can injure. Keep clear.

500 HOUR SERVICE

Do the daily inspection, the 50, 100 and 200/250 hour service, and then the following jobs:

NOTE: Many owners have this service done by their Dealer. See your Authorized Case Dealer for information on this service

1. **Change Transmission Oil Filter:** This filter is installed between the hydraulic pump and the distribution block. It is fastened to the right-hand ramshaft bracket. To replace the element, do the following:
Clean the filter bowl and the area around it.

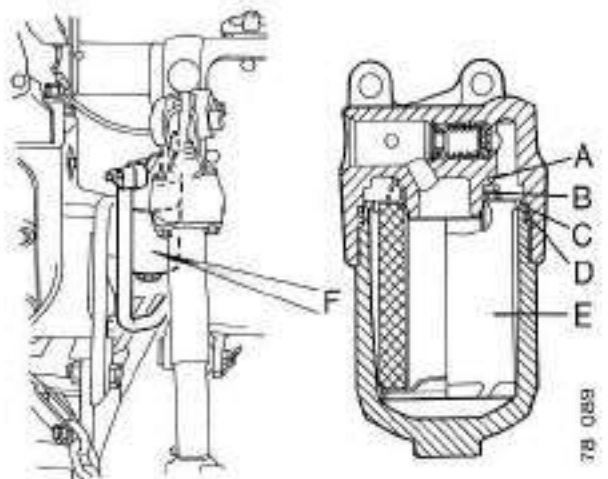

FIGURE 76. TRANSMISSION OIL FILTER

- | | |
|----------------|-----------------------|
| A. Spring | D. Back up Ring |
| B. Filter Seal | E. Filter Element |
| C. O' Ring | F. Hexagon for Wrench |

Use a wrench on the hexagon to remove the bowl.

Remove and discard the element.

Clean inside the filter bowl.

Remove the back up ring and the "O" ring.

Install a NEW "O" ring and a back up ring.

Install a new element, closed end downward, in the bowl.

Install the bowl on the filter body.

Tighten the bowl to 25 lb ft (34 Nm).

2. **Injectors:** If the equipment is available, remove and test the injectors for correct operation. If necessary send the injectors to your Authorized Case Dealer for reconditioning.

If test equipment is not available, check the engine for loss of power, using too much fuel, or too much exhaust smoke. If there are any of these defects remove the injectors for reconditioning.

Use new copper washers when installing injectors.

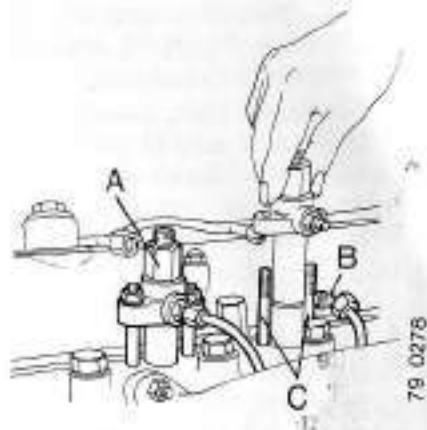

FIGURE 77. REMOVING INJECTORS

- | |
|-----------------------|
| A. Leak off Pipe |
| B. High Pressure Pipe |
| C. Studs |

3. **Valve Clearances:** Check all the valve clearances and adjust if necessary to 0.010 in (0.25mm).

The adjustment must only be made when the engine is cold.

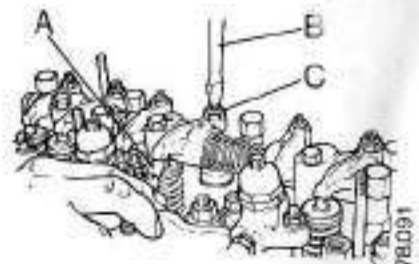

FIGURE 78. VALVE CLEARANCE

- | |
|--------------------|
| A. Feeler Gage |
| B. Adjusting Screw |
| C. Locknut |

4. **Fan Belt:** Check the belts for the correct tension as shown in Figure 74. Adjust if necessary as follows:

Alternator Belt: Loosen the bolts at A and B. Move the alternator away from the engine to increase the tension.

Water pump belt: Loosen the nuts C and D.

Move the mounting plate E down to increase the tension. Tighten the nuts and bolts.

NOTE: Use only the pressure of one finger to check the belt tension.

5. **Fuel Filters:** Install new fuel filter elements.

When you have done this a 'air must be removed from the fuel system before the engine can be started. See instructions: Removing Air from the Fuel System.

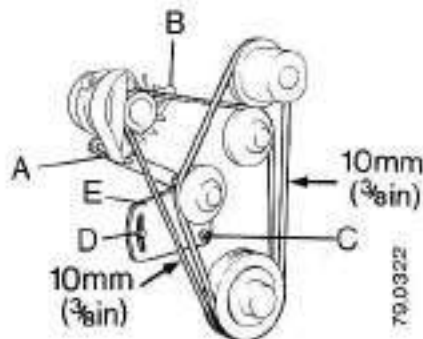

FIGURE 79. BELTS

- A. Locking Bolt
B. Mounting Bolt
C. Pivot Nut
D. Locking Nut
E. Mounting Plate

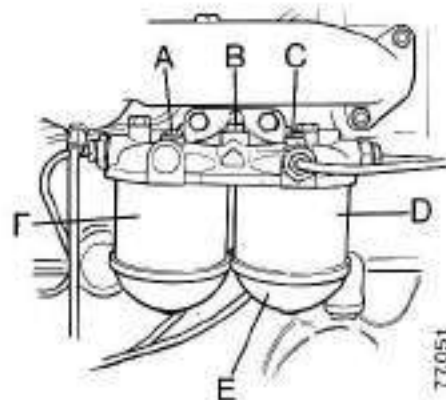

FIGURE 80. FUEL FILTERS

- A. Fastening Bolt
B. Vent Plug
C. Fastening Bolt
D. First Filter
E. Filter Base
F. Second Filter

6. **Air Cleaner Elements:** The two air cleaners each have a main and a safety element. The safety element is installed inside the main element to give protection to the engine if the main element is damaged. It is not necessary to clean or replace the main element until the filter warning lamp is illuminated. When you install filter elements, make sure that the seals are in good condition and the elements are in their correct position in the filter body.

Clean the element by hitting it against a surface similar to a tire. Then check for damage using a 12v bulb as shown in Figure 83. If there is any damage, install a new element. DO NOT remove the safety element during this operation.

If, after cleaning the main element, the warning lamp illuminates in a shorter than normal running period, install a new main and safety element.

DO NOT try to clean a safety element.

IMPORTANT: Do not use a lamp bulb with a rating of more than 12 volts.

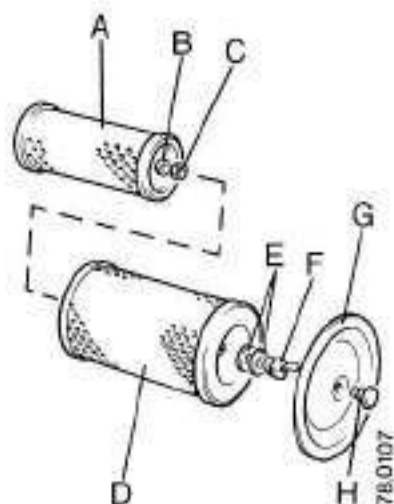
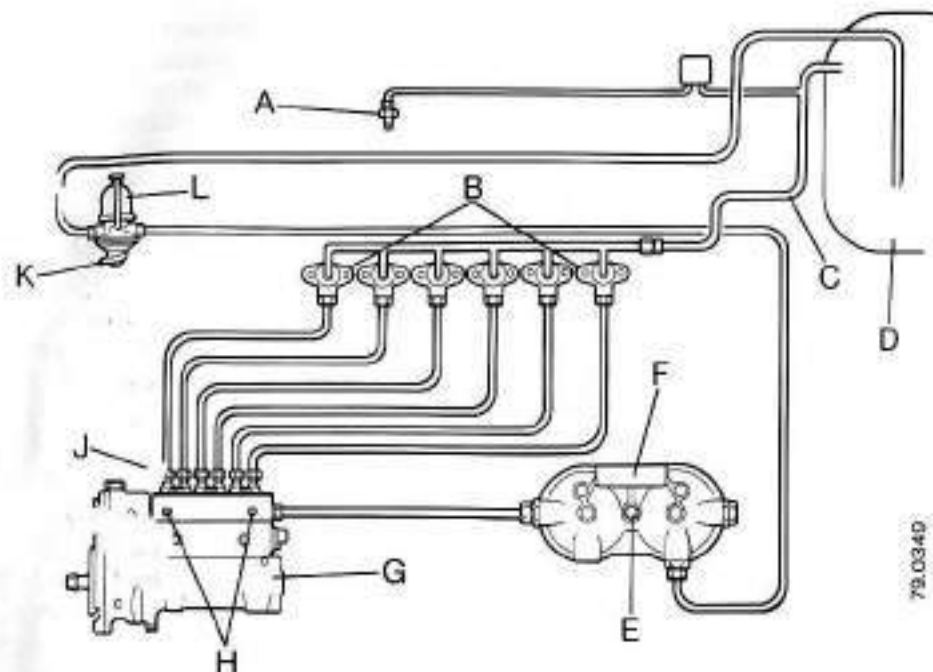

FIGURE 82. AIR CLEANER ELEMENTS

- A. Safety Element
B. Nylon Washer
C. Nut
D. Main Element
E. Washers
F. Wing Nut
G. Cover Plate
H. Nut



FIGURE 83. CHECKING ELEMENT



79.0349

FIGURE 81. DIAGRAM OF FUEL SYSTEM

- | | |
|--------------------------|-----------------------------|
| A. Thermostart | G. Fuel Pump |
| B. Injectors | H. Fuel Pump Vent Plugs |
| C. Leak-off Pipe | J. High Pressure Fuel Pipes |
| D. Fuel Tank | K. Hand Priming Lever |
| E. Fuel Filter Vent Plug | L. Fuel Pump Bowl |
| F. Fuel Filters | |

7. **Removing Air from the Fuel System:** After you have replaced the fuel filters it is necessary to remove air from the fuel system. Follow this procedure:

Make sure there is a minimum of 2 gal (8 litres) of fuel in the fuel tank.

Clean the area around the vent plugs E and H.

Loosen the vent plug E on the filter housing.

Operate the hand priming lever K until fuel is flowing freely, then tighten the vent plug.

Loosen the two vent plugs H on the fuel injection pump. Operate the hand priming lever until fuel is flowing freely, then tighten the vent plugs.

Loosen the injector pipes at the connections B.

Put the engine stop control in the RUN position and the hand throttle lever to the maximum speed position.

Operate the starter until you can see fuel at the loose connections.

Tighten the connections. Start the engine and check for leaks.

8. **Hydrostatic Steering:** Install a new filter element and add new oil to the correct level. It is a recommendation that you get your Authorized Case Dealer to do this job.

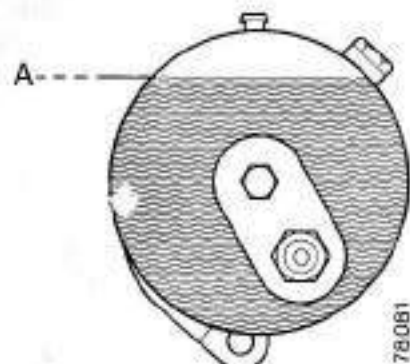

FIGURE 79. OIL LEVEL

A. Correct oil level

78.081

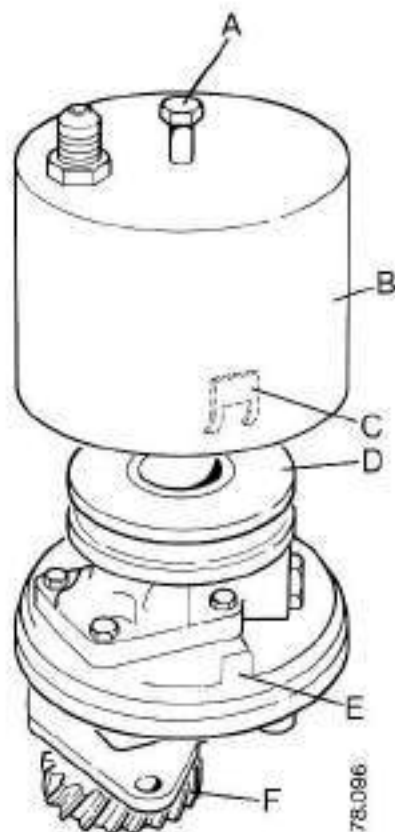

FIGURE 85. HYDROSTATIC PUMP AND FILTER

- A. Center Bolt
- B. Cover
- C. Location Part
- D. Filter Element
- E. Lug
- F. Drive Gear

78.096

9. **External Nuts and Bolts:** Check the tightness of all nuts and bolts using the table below:

Thread Diameter	Torque
1/4 in	7 lb ft (9.5 Nm)
5/16 in	15 lb ft (20 Nm)
3/8 in	25 lb ft (34 Nm)
1/2 in	45 lb ft (61 Nm)
5/8 in	65 lb ft (88 Nm)
3/4 in	110 lb ft (150 Nm)
7/8 in	140 lb ft (190 Nm)

10. **Operator's Seat Belt**

WARNING: Securely fasten your seat belt as this tractor is equipped with a ROPS cab. The seat belts can help insure your safety if they are used and maintained.

1. Keep sharp edges and items that can cause damage, away from the belts.
2. From time to time, check belts, buckles and mounting bolts for damage.
3. Replace all parts that have damage or wear.
4. Replace belts that have cuts that can make the belt weak.
5. Check that bolts are tight on the seat bracket.
6. Keep seat belts clean and dry.
7. Clean belts only with a soap solution and warm water.
8. Do not use bleach or dye on the belts because this can make the belts weak.

11. Operator's Seat

Your Case cab has a seat made of foam material for maximum operator comfort. The seat is made of soft material and panels of soft foam material.



Remove dust and dirt from the seat with a vacuum cleaner or soft brush. Clean stains with the correct use of a material cleaner.

Before removing stains, try to find what type and how old the stains are. Some stains can be removed with water or soap solution.

Stains must be removed immediately. Oil stains and some types of grease are very difficult to remove and some times can not be removed completely. When removing this type of stain, make sure you do not make the area of the stain larger. Some times it is better to have a small stain than a large stain area.



CAUTION: Never use gasoline, naphtha or any other volatile material for any cleaning purposes. The materials may be toxic and/or flammable.

CLEANER FLUID - This type of cleaner can be used for grease or oil stains. Carefully remove the item that caused the stain with a scraper or a knife that is not sharp. Use very little cleaner, no pressure, and clean cloths. Move the cloth from the outside of the stain toward the center of the stain and constantly change to a clean section of cloth.

When the stain is removed from the material, immediately use a cloth to dry the area and to prevent a cleaner circle pattern. If a circle pattern occurs, clean the complete area.

NOTE: A difficult stain can need a second application of cleaner fluid followed immediately by the use of a soft brush to completely remove the stain.

FOAM CLEANER - This type of cleaner is good for all stains on material and for removal of circle patterns.

Use a vacuum cleaner to remove loose dirt. Clean a minimum of a full panel or section. For protection of the material, put a cover over the area next to the section to be cleaned. Mix detergent foam cleaners according to the instructions on the label of the container. Use foam only on a clean sponge or soft brush.

NOTE: Do not make the material wet or clean with a hard brush. Clean with a cloth not fully wet. Immediately after the material is clean, dry the material with a cloth.

12. Roll Over Protective Structure (ROPS)

Every 500 hours do the following:

1. Check all ROPS mounting bolts and tighten as specified in illustration;
2. Check all cab to platform bolts and tighten as follows:
 1/2" dia. grade 5, 80 to 96 ft. lbs. (111 to 133 Nm)(11.1 to 13.3 kgm)
 3/8" dia. grade 5, 35 to 42 ft. lbs. (48 to 58 Nm)(4.8 to 5.8 kgm)
 5/16" dia. self tapping, 10 to 12 ft. lbs. (13.6 to 16.3 Nm)(1.36 to 1.63 kgm)
3. Check the operator's seat and seat mounting. Tighten the seat mounting stud nuts and mounting bolts to a torque of 17 to 20 ft. lbs. (23 to 27 Nm)(2.3 to 2.7 kgm). Tighten the seat belt mounting bolts to a torque of 35 to 42 ft. lbs. (48 to 58 Nm)(4.8 to 5.8 kgm).
4. Check and replace all parts that have damage or wear.

DO NOT TRY TO MAKE REPAIRS OR WELD ROPS.



CAUTION: To provide more secure hand and foot mobility, preventing slipping and possible injury, always face the tractor when mounting and dismounting.

Safety Rules

1. Do not make modifications to the ROPS. Example, welding an accessory to the ROPS, or drill a hole in the ROPS.
2. Do not install attachments that will cause the total weight of the tractor to be more than 14,000 lbs. (6 350 kg) shown as the "For maximum gross vehicle weight" on the ROPS label.
3. Special fasteners are used to install the operator protective parts. Replacement parts must be the same as given in the Case Parts Catalog.

ROPS is a special safety unit. After an accident the ROPS must be replaced so that you will get the same protection as a new ROPS. ROPS, the operator's seat, the seat belts and all the mounting, accessories and wiring inside the operator's protective system must be carefully checked after a tractor accident and all parts with damage replaced immediately.

ROLL OVER PROTECTIVE STRUCTURE (ROPS) (High Platform Tractor)

Your Case tractor has a Four Post ROPS Frame (with seat belts) or a ROPS Cab with seat belts. Follow these instructions to get all the safety advantages of ROPS. Seat belts are a part of your pro-

ective system and must be worn at all times. If the protective frame or cab is to work, the operator must be held to the seat inside the frame.

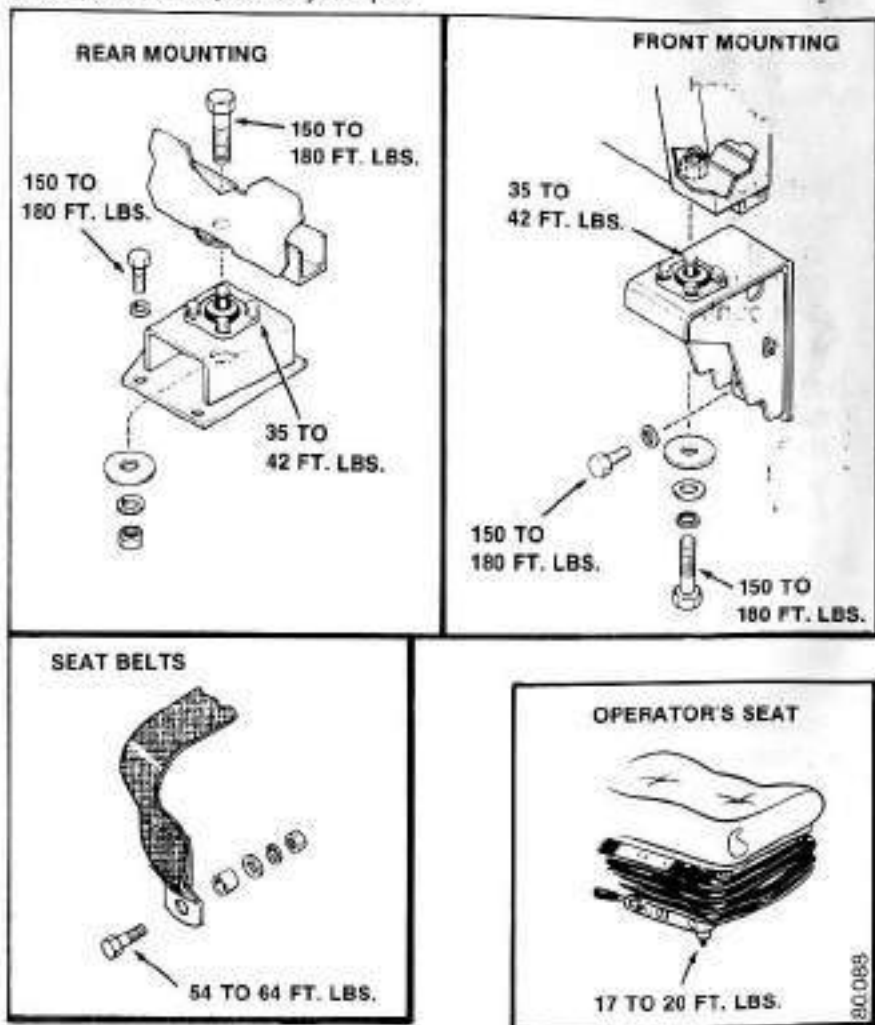

FIGURE 86. ROPS TIGHTENING TORQUE FIGURES

1000 HOUR SERVICE

Do the daily inspection, the 50, 100, 200/250 and the 500 hours service. Then do the following jobs:

NOTE: Many owners have this service done by their Dealer. See your Authorized Case Dealer for information on this service.

1. **Hydraulic System:** Remove plugs A and B and discard the oil. Clean the Power-Shift filter mesh with clean fuel oil or kerosene. Install the plugs and add new oil to the correct level.

2. **Brake and Clutch Fluid:** Remove all the fluid from the brake and clutch hydraulic systems.

Fill with new fluid of the correct grade.

Check the condition of the pipes.

3. **Final Drives:** Remove the oil from both reduction units and discard the oil. Add new oil to the correct level.

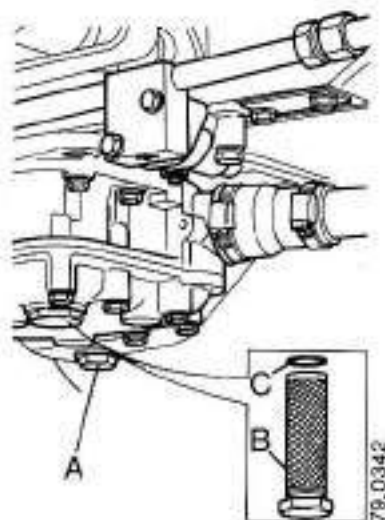

FIGURE 87. DRAIN PLUGS

- A. Axle Case Drain Plug
B. Transmission Case Drain Plug with Power-Shift Filter Mesh
C. 'O' Ring

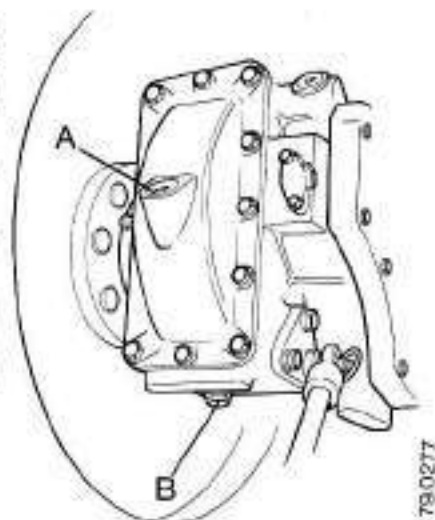

FIGURE 88. FINAL DRIVE UNITS

- A. Filler/Level Plug
B. Drain Plug

4. **Cooling System:** When the engine is cold, open the radiator and the cylinder block drain cocks. Close the drain cocks when the system is empty.

Install a good type of radiator cleaner and follow the instructions given with the cleaner.

Flush the cooling system with clean water.

Use a high boiling type of ethylene glycol anti-freeze and mix the amount you need according to the manufacturer's instructions.

Remove the fill plug from the top of the radiator.

Fill the radiator with the anti-freeze mixture.

Add anti-freeze mixture to the expansion container up to the level shown on the container.

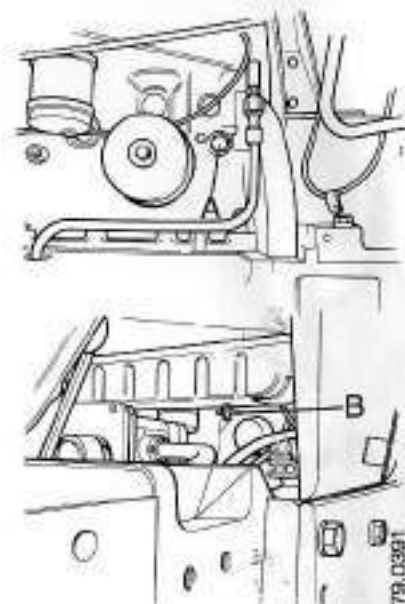

FIGURE 89. COOLING SYSTEM DRAIN PLUGS

- A. Cylinder Block Drain Plug
B. Radiator Drain Cock

IMPORTANT: Always have a minimum of 50 percent Ethylene Glycol coolant in the cooling system at all times and all ambient temperature ranges. Do not install more than 50 percent Ethylene Glycol in the cooling system unless the ambient air temperature will be less than -34°F (-36°C). More than 50 percent Ethylene Glycol decreases heat transfer and will cause the engine surface temperature to be more than normal.

5. **Differential and Reduction Hubs: MFD Tractors:** Remove the oil from the differential and both reduction hubs.
Add new oil to the correct level.

6. **Front Hub Bearings: 2WD Tractors:** Raise the front wheels from the ground and check the hub bearings for free movement.

If there is too much movement adjust the bearings as follow.

Remov. the hub caps.

Remove the split pin from the special nut.

Tighten the special nut until all free movement has been removed.

Install a NEW split pin.

NOTE: The stub axle has two holes for split pins at 90 degree intervals.

Check that the wheel turns freely.

Install the hub cap.

7. **Power-Shift Oil Pressure:** Get your Authorized Case Dealer to check the oil pressure.

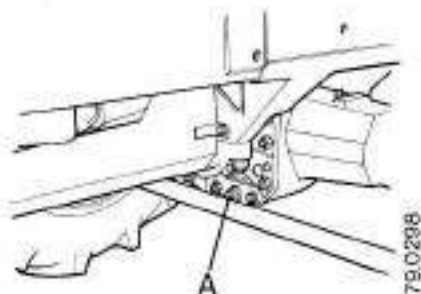

FIGURE 90.

A. Drain Plug

79.0238

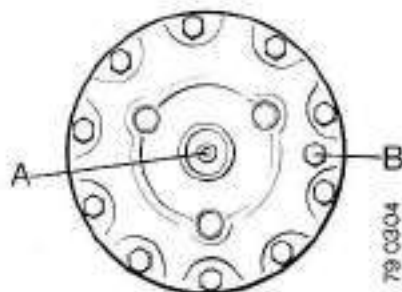

FIGURE 91.

A. Level Plug
B. Fill and Drain Plug

79.0304

COMPRESSOR BELT REPLACEMENT



Loosen the bolt in the belt adjusting bracket and turn the bracket to loosen the belts.

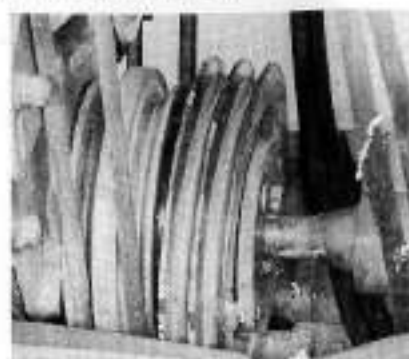

Remove the bolts and remove the belts from the air conditioner pulley.

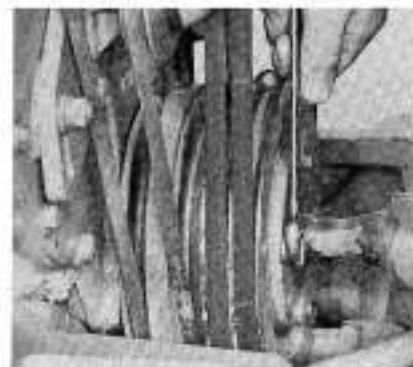

Loosen the bolts holding the air conditioner drive pulley to the crankshaft pulley.



Move the air conditioner pulley away from the crankshaft pulley. Remove the rubber disc from between the hydraulic pump drive shaft and the crankshaft drive pulley.

50.008

COMPRESSOR BELT REPLACEMENT

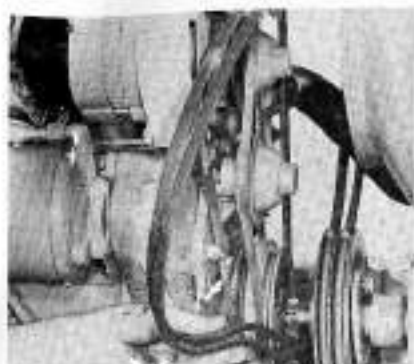

Remove the old belts and install the new belts.

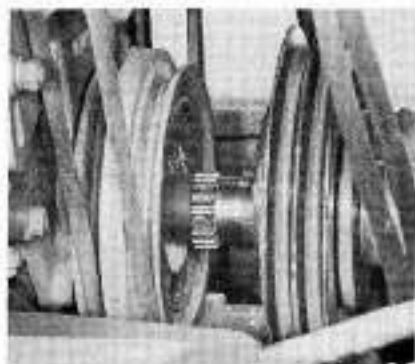

Rubber disc installed.

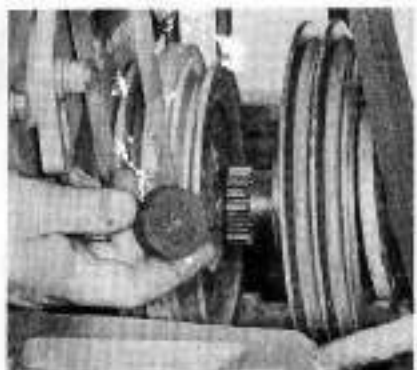

Install the rubber disc between the hydraulic pump drive shaft and the crankshaft pulley.



Move the air conditioner pulley into position. Install the mounting bolts. Install the belts on the air conditioner pulley.

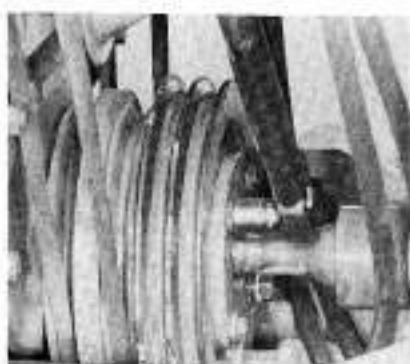

Torque the pulley mounting bolts to 35 to 42 ft. lbs. (48 to 58 Nm)(4.8 to 5.8 kgm).



Turn the adjusting bracket until the correct belt tension is reached. Then tighten the bolt.



Install a belt tension gauge on the belts.

AIR CONDITIONING

RECEIVER-DRIER



With the engine operating at fast idle speed, and the air conditioner operating at full capacity, check the sight glass. If you see bubbles or foam, the system is low on refrigerant. See Refrigerant Check Section.

NOTE: *It is normal to see bubbles for a moment in the sight glass when the compressor clutch is first engaged.*

HEADLINER



The foam headliner in your cab decreases noise. To keep the headliner in good operating condition, remove dust with a vacuum cleaner.

IMPORTANT: *Do not wash the headliner with water because water can cause damage to the headliner and lower the noise control capacity of the headliner.*



Clean dust from the motor and blowers. A clean motor will run cooler. Dust on the blowers will change the balance and cause damage to the motor.

IMPORTANT: *Do not add lubrication to the motor bearings. The motor needs no lubrication at any time.*

IMPORTANT: *If your tractor has a heater and an air conditioner, the tractor cooling system must have a permanent type Ethylene Glycol solution during ambient temperatures of 15° F (-9° C) or higher to prevent the heater core from freezing.*

Door Hinges

Use graphite for lubricant on the door hinges. Do not use oil.

Hoses and Wiring

Check all hoses and wiring for damage or loss of refrigerant. If damage occurs, see your Authorized Case Dealer for replacement of parts or refrigerant.

AIR CONDITIONING

Refrigerant Check

Check the sight glass at ambient temperatures above 70° F (21° C) when the system is operating, to see if there is enough refrigerant. After approximately 5 to 10 minutes of compressor operation, if you see slow moving bubbles (vapor) in the sight glass, the system needs some refrigerant. Foam or a heavy flow of bubbles shows that the system needs much refrigerant. Oil marks on the sight glass shows that the system has no refrigerant.

No bubbles in the sight glass will show that either the system is full, too full or a complete loss of refrigerant. With the engine operating at approximately 1500 RPM, turn the temperature control switch for the air conditioner to the on and then to the off position while you look at the sight glass. During the time that the switch is in the off position, bubbles will show if refrigerant is in the system. Bubbles will not occur when the switch is in the on position. If no bubbles show during the changing of the switch from the on to off position, there is no refrigerant in the system.

If the sight glass is clear and the cooling performance of the system is good, some periods of bubbles is not an indication the system is low on refrigerant.

NOTE: *Under conditions of very high ambient temperature, some foam or bubbles may show in the sight glass from time to time.*

NOTE: *If, during operation, the air conditioner stops working, the first item to check is the refrigerant level. If the refrigerant level is good, but the system is not working, check the evaporator for dirt in the core which can cause freezing of the evaporator. It will be necessary then, to remove the ice from the evaporator by turning the air conditioner to the off position. Flush the core with cold water using a hose without a pressure nozzle. Make sure the water goes into the pan under the core. If the air conditioner still does not work, see your Authorized Case Dealer.*

REFRIGERANT CHECK

Before the start of the warm ambient temperatures and if there is a loss of cooling, check the refrigerant level in the sight glass in the top of the receiver-drier.

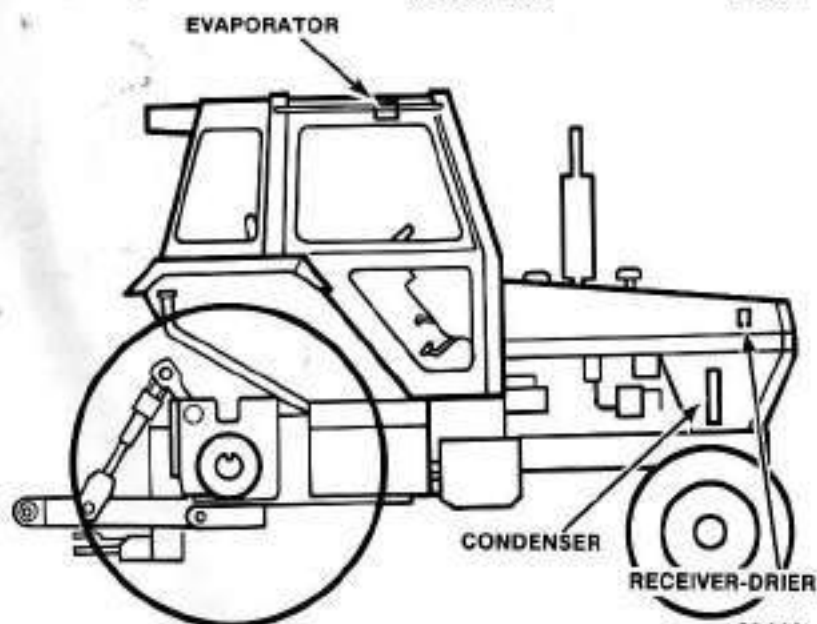
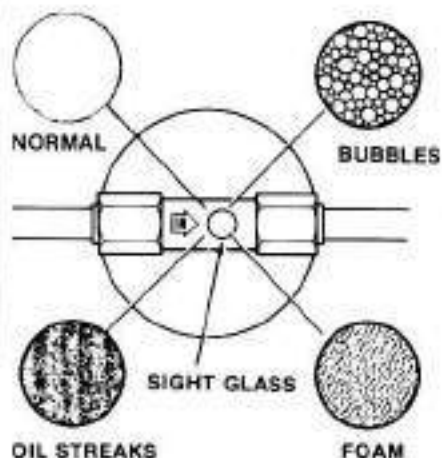

FIGURE 92. REFRIGERANT CHECK

AIR CONDITIONING

COMPRESSOR BELT



Check for correct tension after the first 50 hours of operation and every 250 hours after that. See Compressor Belt Adjustment Section.

COMPRESSOR

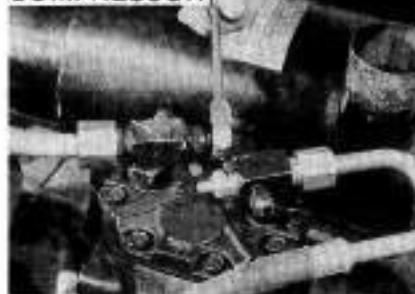

Make sure valve stop stems on top of compressor are turned all the way counterclockwise before starting the air conditioner.

IMPORTANT: So that the seals in the compressor do not become dry, operate the air conditioner for a minimum of 15 minutes each month. In ambient temperatures below 32° F (0° C) put a cover on the condenser to make sure the refrigerant and lubricants in the system reach a good operating temperature.

CONDENSER



Keep core free of dust. To clean the condenser, use compressed air or a rigid brush.

IMPORTANT: Because the condenser fins bend easily, be careful when you clean the condenser.

EVAPORATOR



Keep dust from core. When evaporator is dry, clean with compressed air or a vacuum cleaner. If core is not dry, flush core with water, using a hose without pressure. Make sure the water goes into the pan under the core.

NOTE: Top panel of cab must be removed to clean the evaporator.

AIR FILTER

Check the filter for dirt every 100 hours. See Air Filter Removal Section.

DOMELIGHT (Operator's Cab)

To replace the bulb in the dome light:

1. Remove the screws from both ends of the light shield and remove the shield.
2. Push in and turn the bulb, then pull the bulb out of the socket.
3. Push a new bulb into the socket and turn the bulb to lock the bulb in the socket.
4. Install the light shield and hold in position with two screws.

NOTE: Do not tighten the screws too much because the light shield can break.

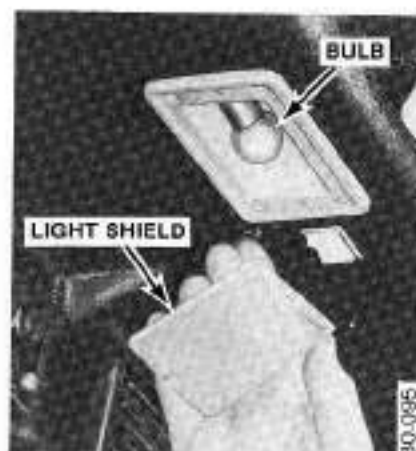

FUSE PANEL (Operator's Cab)

A fuse panel, to give protection to the cab electrical circuits, is inside the front headliner of the cab. To replace a fuse remove the defroster air louvers and then remove the front left air louver to gain access to the fuse panel.

The circuits are described as follows:

1. 20 ampere - Blower (and compressor clutch for air conditioner)
2. 15 ampere - Front wiper
3. 7.5 ampere - Cigarette lighter
4. Blank Optional Rear Wiper

5. 10 ampere - Optional front RH flood lamp
6. 10 ampere - Optional front LH flood lamp
7. 10 ampere - Optional Rear RH and LH flood lamp
8. 3 ampere - Dome light

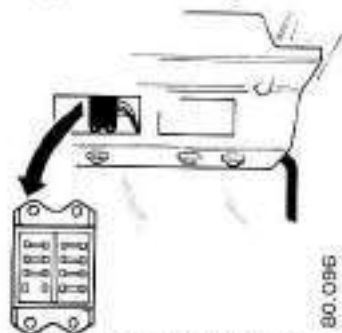

FIGURE 93. FUSES

ALTERNATOR

The bearings are sealed and lubrication is not necessary. To prevent damage to the alternator, make sure that you understand the following instructions.

1. Before doing any work on the electrical system, disconnect the battery cables from the battery terminals.
2. Do not make a reverse battery connection.
3. If you use an auxiliary battery for starting, connect negative to negative and positive to positive.
4. When charging the tractor batteries, disconnect the battery cables from the battery terminals.
5. Do not use a battery charging machine for starting.
6. Do not run the engine when the battery cables have been disconnected.
7. When you do maintenance on the tractor, prevent foreign material from getting in the alternator.

8. If you do any electric welding on the tractor, put the ground cable as near as possible to the weld area. Do not put the ground cable in a position where current can flow through bearings.

BATTERY



DANGER: Batteries make gases. Make sure that you keep sparks, flame and cigarettes away from batteries. Make sure there is a good movement of air in any place where batteries are stored or charged. Wear safety glasses when you work near batteries.

1. Check the battery electrolyte level every 50 hours, or daily if operating in hot conditions. Add pure drinking water as necessary so that the separators are under water.
2. Keep the battery with a full charge as shown with a hydrometer.
3. Keep the battery clean and dry.
4. Make sure the battery is correctly fastened in position.
5. If the battery has to be replaced, make sure that the new battery is the correct type.
6. When a battery is not being used, charge it at regular intervals to keep the Specific Gravity at or above 1.250. Batteries that are not in use will become discharged.

AUXILIARY BATTERY



WARNING: Engine can start with transmission in gear when neutral safety switch is by-passed:

1. Do not connect across terminal on starter.
2. Attach booster batteries according to safe method in Operator's Manual. Then use recommended starting procedure from Operator's seat. Machine run-away can cause injury or death to operator and bystanders.

When you connect an auxiliary battery or use a battery charger, make sure that you connect positive to positive and negative to negative.

DO NOT connect auxiliary battery cables to the terminals on the starter. Start the engine only when in the operator's seat.

IMPORTANT: The only safe method of starting the engine using an auxiliary battery is as follows:

1. Connect the positive cable clamp (+) of the auxiliary battery to the positive (red) terminal of the tractor battery.
2. Connect the negative cable clamp (-) to ground. (Tractor main frame for example).

NOTE: Always disconnect the ground cable first and connect the ground cable last so that you do not cause a spark at the battery. A spark can cause a battery explosion and serious injury.



WARNING: Battery explosion and/or damage to electrical components can result from improper connection of booster batteries or charger. Connect positive to positive and negative to negative. Externally, battery acid can cause burns and blindness, and taken internally is poison.

HOOD

Raising:

1. Remove the exhaust silencer and the air precleaner.
2. Use the tool to turn the lock on each side of the hood frame.
3. Raise the hood top by lifting at the front.

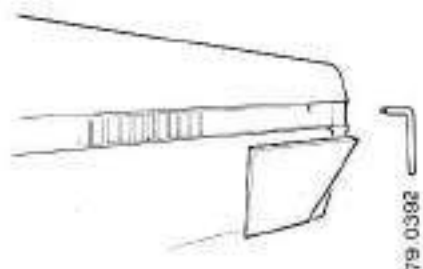

Lowering:

1. Raise the front of the hood top a small amount to disengage the catch. Then lower the hood.
2. Use the tool to turn the locks.

FIGURE 94. HOOD AND SIDE PANELS

- A. Hood Catch (1 each side)
 B. Spring

HOOD SIDE PANELS

To get access to the battery, oil pump and oil cooler, remove one or both hood side panels.

1. Raise the hood top.
2. Release the spring inside the top of the panel.
3. Pull the top outwards and lift it from the retainers.

