

**BRAKE ASSEMBLY**  
(REF. NO. 159)

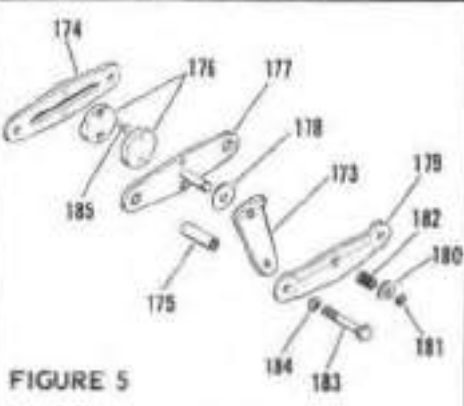

**FIGURE 1**

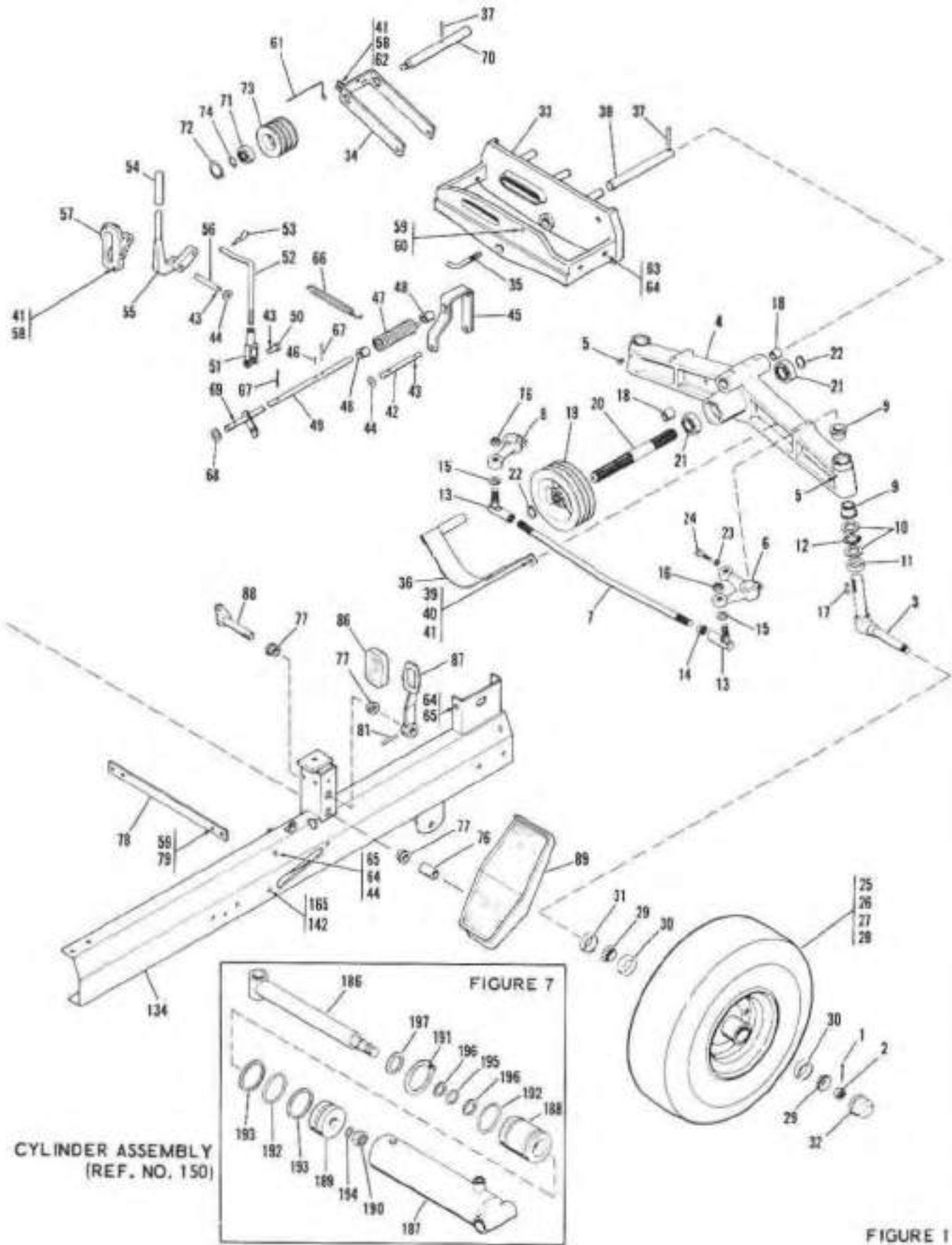

CYLINDER ASSEMBLY  
(REF. NO. 150)

FIGURE 1

Ref. No.	Part No.	Description	No. Req'd
1	1100 351	Cotter Pin 1/8 x 1-1/4	7
2	1100 948	Castle Nut 5/8 x 11	2
3	1718 504	Wheel Spindle	2
4	1718 602	Front Axle	1
5	1104 954	Grease Fitting	4
6	1718 502	Steering Arm - R. H.	1
7	1718 575	Tie Rod	1
8	1718 513	Steering Arm - L. H.	1
9	1185 728	Flange Bearing	4
10	1185 730	Race Thrust	4
11	1706 611	Dust Seal	2
12	1185 729	Thrust Bearing	2
13	1719 003	Ball Joint	4
14	1109 533	Hex Nut 5/8 - 18	1
15	1100 247	Lockwasher 5/8	5
16	1185 082	Lock-Nut 5/8 - 18	4
17	1104 336	Square Key 1/4 x 1	2
18	1185 612	Sleeve Bearing	2
19	1718 515	PTO Sheave	1
20	1718 568	PTO Shaft	1
21	1185 100	Ball Bearing	2
22	1185 689	Retaining Ring	2
23	1100 243	Lockwasher 3/8	2
24	1107 209	Capscrew 3/8 - 24 x 1-1/2	2
25	1719 157	Wheel & Tire Ass'y	2
26	1719 153	Tubeless Tire 5.70/5.00 x 8	2
27	1719 154	Wheel Only	2
28	1715 895	Valve Stem Only	2
29	1185 275	Roller Bearing Cone	4
30	1185 276	Roller Bearing Cup	4
31	1719 155	Felt Seal	2
32	1719 156	Cap	2
33	1718 572	Axle Support	1
34	1718 616	Idler Shaft Bail	1
35	1719 147	Belt Guide	1
36	1718 497	Belt Guide	1
37	1185 376	Roll Pin 3/16 x 1-1/2	2
38	1718 548	Axle Pivot Pin	1
39	1106 878	Capscrew 5/16 - 18 x 1	2
40	1182 563	Hex Nut 5/16 x 18	2
41	1100 242	Lockwasher 5/16	6
42	1718 533	Arm Pin	1
43	1100 346	Cotter Pin 3/32 x 3/4	10
44	1107 383	Flat Washer 3/8	11
45	1718 528	Control Arm	1
46	1120 209	Roll Pin 3/16 x 3/4	1
47	1718 532	Torsion Spring	1
48	1718 550	Spacer	2
49	1718 488	Control Rod	1
50	1112 587	Clevis Pin	1
51	222 007	Clutch Yoke	1
52	1718 526	PTO Control Rod	1
53	1703 011	Spring Cotter	1
54	1718 535	Handle Grip	2
55	1718 518	Lever	1
56	1718 558	Pivot Pin	1
57	1718 508	Bracket	1
58	1106 872	Capscrew 5/16 - 18 x 5/8	4

Ref. No.	Part No.	Description	No. Req'd
59	1100 241	Lockwasher 1/4	10
60	1121 507	Hex Nut 1/4 - 20	2
61	1718 606	Belt Guide	1
62	1107 382	Flat Washer 5/16	3
63	1106 915	Capscrew 3/8 - 16 x 3/4	4
64	1100 243	Lockwasher 3/8	24
65	1106 913	Capscrew 3/8 - 16 x 5/8	6
66	1714 279	Extension Spring	1
67	1185 552	Drive Pin 3/16 x 3/4	2
68	1107 385	Flat Washer 1/2	2
69	1100 356	Cotter Pin 3/32 x 1	2
70	1718 567	Idler Shaft	1
71	1185 064	Ball Bearing	1
72	1187 439	Int. Retaining Ring	1
73	1719 202	Idler Sheave	1
74	1118 809	Ext. Retaining Ring	1
75	1718 494	Speed Control Pedal Shaft	1
76	1718 559	Spacer	2
77	1185 034	Flange Bushing	4
78	1718 545	Tie Strap	1
79	1106 830	Capscrew 1/4 - 20 x 1/2	4
80	1121 509	Hex Nut 3/8 - 16	11
81	1713 432	Drive Pin 3/16 - 1-1/4	5
82	1718 541	Control Rod	1
83	1719 556	Brake Rod Assembly	1
84	1187 385	Cotter Pin 1/16 - 1/2	2
85	1107 381	Flat Washer 1/4	1
86	1719 539	Pedal Pad	1
87	1719 547	Pedal Assembly	1
88	1719 520	Brake Arm Assembly	1
89	1718 585	Speed Control Pedal	1
90	1718 544	Control Arm	1
91	1718 531	Universal Joint Ass'y	1
92	1106 888	Capscrew 5/16 - 18 x 2	1
93	1110 107	Lock Nut 5/16 - 18	1
94	1185 342	Set-Screw 5/16 - 18 x 3/8	2
95	1108 844	Square Key 1/4 x 1-1/4	1
96	1718 588	Steering Shaft	1
97	1185 319	Bronze Bearing	1
98	1719 149	Steering Bridge	1
99	1707 546	Thrust Washer	2
100	1185 711	Bronze Bearing	1
101	1107 064	Capscrew 5/8 - 11 x 2	1
102	1107 386	Flat Washer 5/8	1
103	1718 555	Spacer	1
104	1718 506	Gear 23T	1
105	1719 540	Bracket	1
106	1719 552	Arm Assembly	1
107	1719 041	Pivot Block	1
108	1719 453	Bowed Washer	2
109	1121 511	Hex Nut 1/2 - 13	2
110	1107 037	Capscrew 1/2 - 13 x 2-1/4	1
111	1108 889	Hex Nut 1/2 x 13	1
112	1104 436	Woodruff Key 3/16 x 3/4	1
113	1714 063	Pillow Block	1
114	1711 486	Belt Guide	1
115	1106 917	Capscrew 3/8 - 16 x 7/8	5
116	1718 462	Oil Relief Spool Link	1

\* Includes Ref. #26 thru 32

Ref. No.	Part No.	Description	No. Req'd
117	1713 416	Ball	1
118	1713 417	Compression Spring	1
119	1200 034	Key 1/4 - 7/8	1
120	1718 464	Fendor Support	1
121	1106 852	Capscrew 1/4 - 20 x 2	2
122	1718 565	Oil Relief Spool	1
123	1718 521	Oil Relief Spool Guide	1
124	1106 985	Capscrew 1/2 - 13 x 1	4
125	1100 245	Lockwasher 1/2	6
126	1715 428	Wheel Bolt 1/2 - 20	12
127	1714 101	Hitch	1
128	1106 983	Capscrew 1/2 - 13 x 7/8	2
129	1108 847	Square Key 5/16 x 1-1/8	2
130	1107 387	Flat Washer 3/4	4
131	1120 390	Lock Nut 3/4 - 10	2
132	1718 581	Wheel Hub	2
133	1718 599	Frame - L. H.	1
134	1718 596	Frame - R. H.	1
135	1700 401	Extension Spring	1
136	1715 927	End Yoke	1
137	1718 463	Parking Pawl Link	1
138	1104 954	Grease Fitting	2
139	1718 593	Block Bearing	2
140	1708 126	Clevis Pin 3/8 - 3/16	1
141	1104 201	Cotter Pin 3/32 - 5/8	1
142	1106 923	Capscrew 3/8 - 16 x 1-1/4	6
143	1718 485	Pivot Shaft Ass'y	1
144	1106 832	Capscrew 1/4 - 20 x 1	1
145	1185 745	Roll Pin 3/16 x 2	1
146	1719 151	Pin	1
147	1718 682	Support Arm	1
148	1719 178	Cylinder Hose Ass'y	1
149	1185 739	Elbow 90°	2
150	1719 145	Cylinder	1
151	1892 435	Idler Tension Spring	1
152	1719 179	Cylinder Hose Ass'y	1
153	1719 152	Pivot Pin	1
154	1718 573	Pivot Shaft	1
155	1106 840	Capscrew 1/4 - 20 x 1	1
156	1718 583	Speed Control Pedal	1
157	1718 574	Drag Link	1
158	1109 533	Hex Nut 5/8 - 18	1
159	1719 555	Brake Assembly (Fig. 5)	1
160	1710 348	Pin	1
161	1719 538	Disk Assembly	1
162	1719 006	Fan	1
163	1185 737	Elbow 90°	2
164	1106 919	Capscrew 3/8 - 16 x 1	5
165	1108 887	Jam Nut 3/8 - 16	2
166	1717 850	Trans. Assembly (See Figure #3)	1
167	1107 037	Capscrew 1/2 - 13 x 2-1/4	1
168	1108 889	Jam Nut 1/2 - 13	1
169	MODEL 19621 - STD. LAWN TIRE KIT		
	1719 416	Wheel and Tire Assy	2

Ref. No.	Part No.	Description	No. Req'd
	1717 204	Tire 27 x 8.50 - 15	2
	1718 162	Wheel	2
	1718 242	Valve	2
170	MODEL 19615 - STD. AGRIL TIRE KIT		
	1719 417	Wheel and Tire Assy R.H.	1
	1719 418	Wheel and Tire Assy L.H.	1
	1718 243	Tire 27 x 8.50 - 15	2
	1718 162	Wheel	2
	1718 242	Valve	2
171	MODEL 19620 - TERRA LAWN TIRE KIT		
	1719 549	Wheel and Tire Assy	2
	1719 548	Tire - 26 x 12 - 12	2
	1718 277	Wheel	2
	1718 242	Valve	2
172	MODEL 19616 - TERRA AGRIL TIRE KIT		
	1719 419	Wheel and Tire Assy R.H.	1
	1719 420	Wheel and Tire Assy L.H.	1
	1718 298	Tire 26 x 12 - 12	2
	1718 277	Wheel	2
	1718 242	Valve	2
	FIGURE 5 - BRAKE ASSEMBLY		
173	1719 557	Actuating Cam	1
174	1719 558	Carrier - Solid Side	1
175	1719 559	Spacer	2
176	1719 560	Puck	2
177	1719 561	Carrier - Cam Side	1
178	1719 562	Washer	1
179	1719 563	Actuator	1
180	1719 564	Washer	1
181	1719 565	Snap Ring	1
182	1719 567	Spring	1
183	1719 568	Bolt 1/4-2	2
184	1100 241	Lockwasher 1/4	2
185	1719 569	Rivet	4
	FIGURE 7 - CYLINDER ASSEMBLY		
186	1719 818	Piston Rod Assembly	1
187	1719 819	Butt and Tube Assembly	1
188	1710 820	Gland	1
189	1719 821	Piston	1
190	1719 822	Hex Nut	1
191	1719 823	Snap Ring	1
192	1719 824	O-Ring	2
193	1719 825	Backup Washer	2
194	1719 826	O-Ring	1
195	1719 827	O-Ring	1
196	1719 828	Backup Washer	2
197	1719 829	Wiper	1

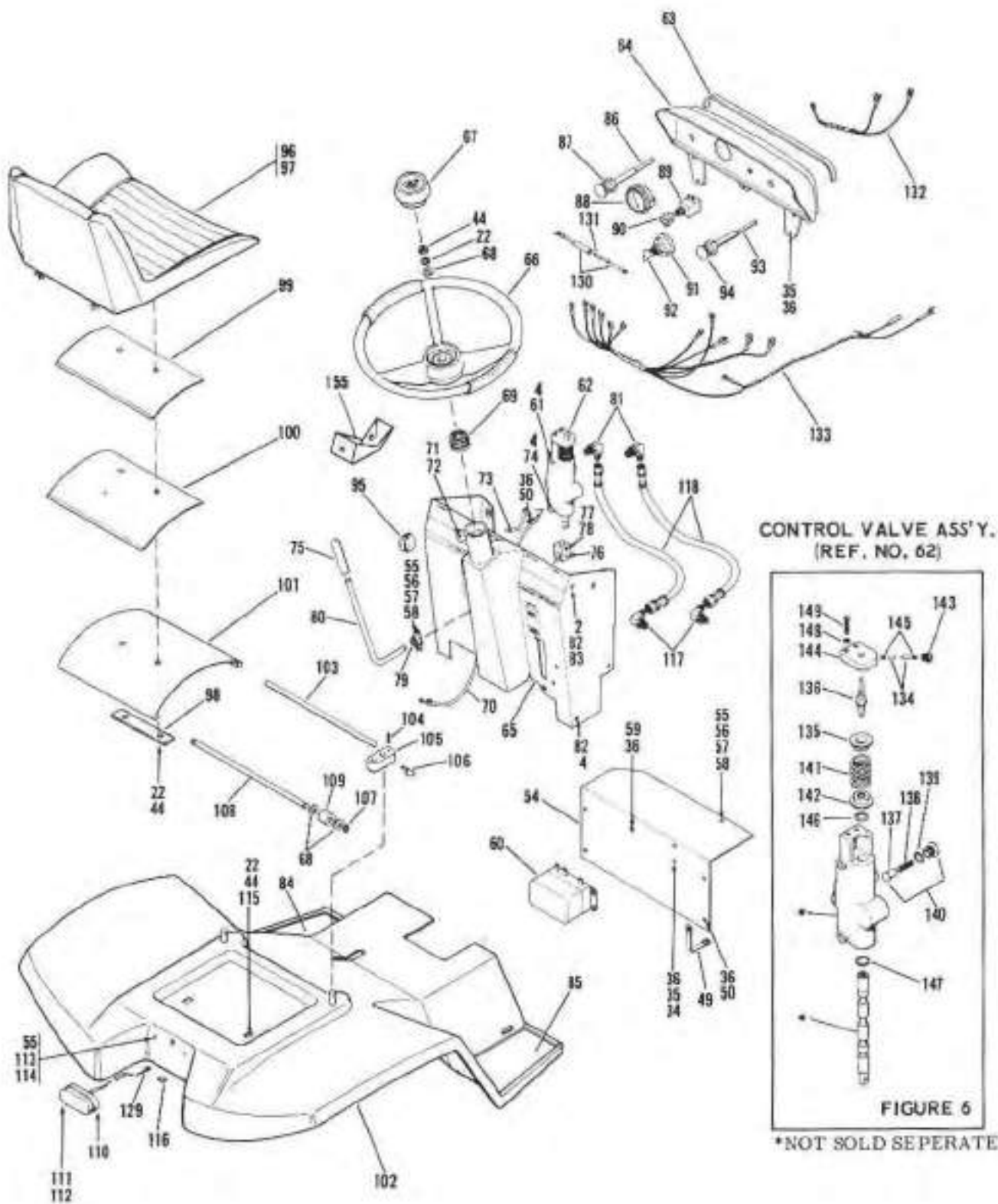

FIGURE 2

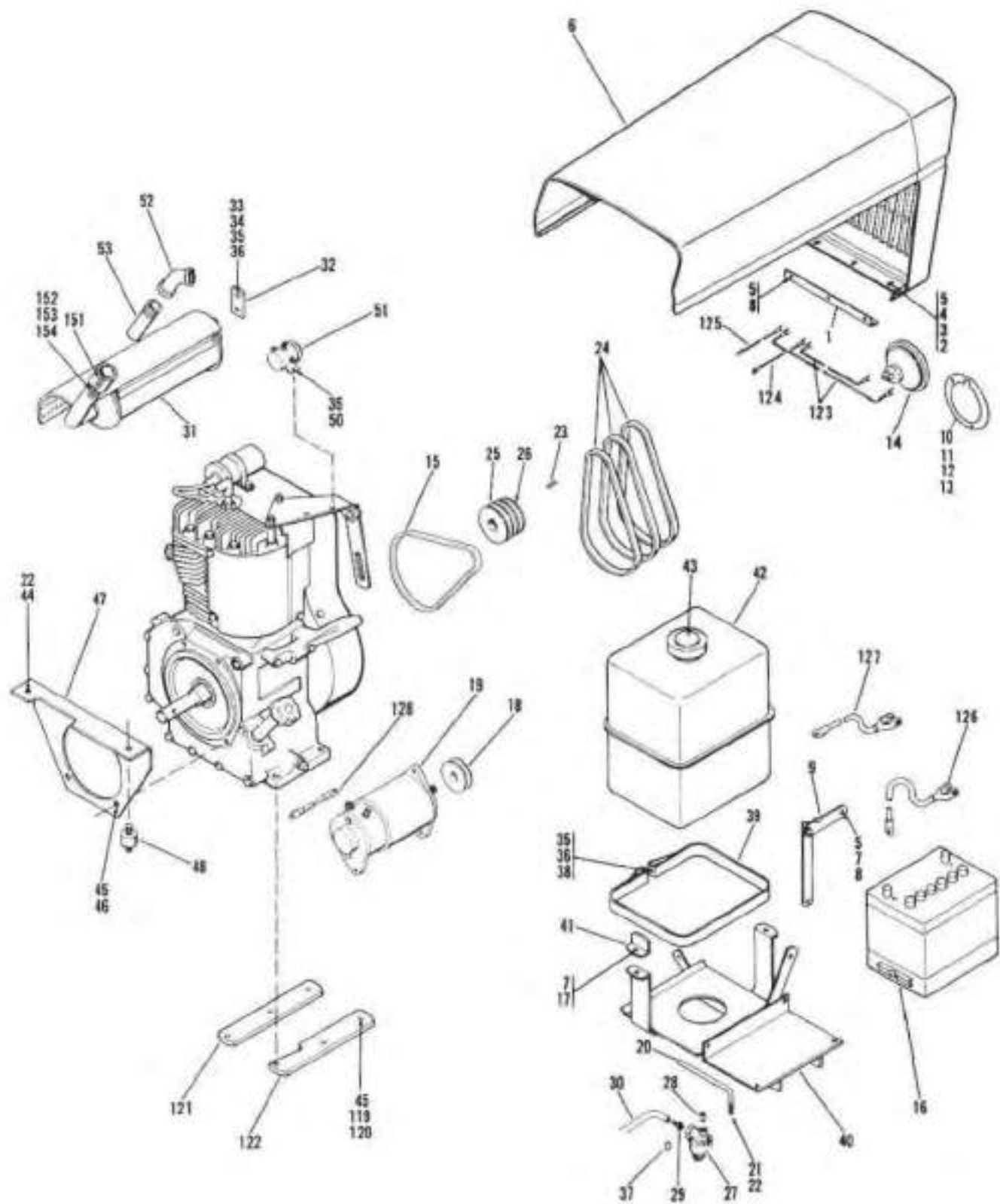

FIGURE 2



Ref. No.	Part No.	Description	No. Req'd
1	1717 246	Hinge	1
2	1107 382	Flat Washer 5/16	10
3	1182 563	Hex Nut 5/16 - 18	4
4	1100 242	Lockwasher 5/16	12
5	1106 872	Capscrew 5/16 - 18 x 5/8	8
6	1718 570	Grille & Hood Assy	1
7	1110 107	Lock-Nut 5/16 - 18	4
8	1705 905	Bowed Washer	2
9	1718 500	Hood Stop Assembly	1
10	1103 994	Wave Washer	6
11	1165 749	Rivet	6
12	1185 746	Spring Clip	6
13	1719 708	Retaining Ring	2
14	*	Headlight Bulb (Mfg. No. 4406)	2
15	1711 844	Gen. Belt 35 5/8" cog.	1
16	1718 027	Battery	1
17	1106 878	Capscrew 5/16 - 18 x 1	5
18	1719 146	Pulley	1
19	1716 169	Starter Generator	1
20	1718 576	Battery Rod	2
21	1110 024	Wing Nut 3/8 - 16	2
22	1100 243	Lockwasher 3/8	13
23	1108 844	Square Key 1/4 - 1-1/4	1
24	1719 203	Drive Belt 32" (Matched Set of 3)	1
25	1719 198	Drive Sheave	1
26	1103 470	Set Screw 5/16 - 18 x 1/2	2
27	1700 141	Fuel Strainer	1
28	1701 875	Nipple	1
29	1707 369	Fuel Line Fitting	1
30	1719 204	Fuel Line	1
31	1719 446	Exhaust Muffler	1
32	1719 451	Muffler Hanger	1
33	1107 381	Flat Washer 1/4	2
34	1106 840	Capscrew 1/4 - 20 x 1	4
35	1121 507	Hex Nut 1/4 - 20	11
36	1100 241	Lockwasher 1/4	20
37	1718 185	Hose Clamp	2
38	1114 474	Mach Screw 1/4 - 20 x 1-1/2	1
39	1718 519	Gasoline Tank Strap	1
40	1718 476	Battery & Gas Tank Support	1
41	1718 543	Gas Tank Clip	2
42	1718 600	Gas Tank (Incl 43)	1
43	1718 756	Gas Tank Cap Only	1
44	1121 509	Hex Nut 3/8 - 16	11
45	1160 244	Lockwasher 7/16	8
46	1106 964	Capscrew 7/16 - 14 x 3/4	4
47	1718 603	Engine Face Plate	1
48	1718 542	Engine Mount Rubber	4
49	1719 191	Engine Ground Wire	1
50	1106 830	Capscrew 1/4 - 20 x 1/2	7
51	1717 048	Solenoid	1
52	1165 070	Elbow - 90°	1
53	1719 452	Special Nipple	1
54	1718 491	Heat Shield	1
55	1160 240	Lockwasher #10	6
56	1118 172	Mach Screw 10 - 24 x 5/8	4

Ref. No.	Part No.	Description	No. Req'd
57	1103 959	Flat Washer #10	4
58	1109 766	Hex Nut 10-24	4
59	1106 832	Capscrew 1/4 - 20 x 5/8	1
60	1719 181	Voltage Regulator	1
61	1106 893	Capscrew 5/16 - 18 x 2-1/2	1
62	1719 005	Control Valve Assy (Fig. 6)	1
63	1717 599	Rubber Pad	1
64	1717 249	Instrument Panel	1
65	1718 612	Steering Column Assy	1
66	1719 164	Steering Wheel	1
67	1719 165	Steering Wheel Cap	1
68	1107 393	Flat Washer 3/8	5
69	1716 172	Self Aligning Bearing	1
70	1719 125	Gauge Control	1
71	1185 726	External Gripping	2
72	1185 727	Tolerance Ring	1
73	1718 608	Gauge Arm	1
74	1106 888	Capscrew 5/16 - 18 x 2	1
75	1718 534	Handle Grip	1
76	1718 537	Valve Adapter	1
77	1120 210	Roll Pin 3/16 x 1	1
78	1104 222	Cotter Pin 3/16 x 1-1/2	1
79	1715 933	Pillow Block	1
80	1718 538	Control Lever	1
81	1185 737	Elbow - 90°	2
82	1106 870	Capscrew 5/16 - 18 x 1/2	4
83	1185 725	Centerlock Nut 5/16 - 18	2
84	1719 182	Foot Pad - L. H.	1
85	1719 183	Foot Pad - R. H.	1
86	1718 607	Choke Control (Incl 87)	1
87	1718 232	Choke Knob-Wire Only	1
88	1714 146	Ammeter	1
89	1717 256	Light Switch (Incl 90)	1
90	1718 231	Light Switch Knob Only	1
91	1719 143	Ignition Switch (Incl 92)	1
92	1718 266	Key Only	1
93	1717 590	Throttle Control (Incl 94)	1
94	1718 233	Throttle Knob & Wire Only	1
95	1719 004	Knob	1
96	1717 352	Seat Pan	1
97	1717 355	Seat Pad	1
98	1718 552	Mounting Strap	1
99	1718 530	Leaf Spring	1
100	1718 511	Leaf Spring	1
101	1718 510	Leaf Spring	1
102	1718 617	Rear Fender	1
103	1718 580	Pivot Pin	1
104	1177 625	Roll - Pin 1/8 x 3/4	2
105	1719 206	Adjusting Block	2
106	1703 011	Spring Cotter	2
107	1118 799	Retaining Ring	2
108	1718 566	Roller Shaft	1
109	1718 562	Roller	2
110	1717 597	Taillight Assembly (Incl No. 111 & 112)	1
111	*	Bulb (Mfg. No. 1889)	1
112	1718 234	Lens Only	1
113	1114 755	Mach Screw 10 - 32 x 5/8	2

\* Not Stocked. Purchase from your local automotive or electrical supplier.

Ref. No.	Part No.	Description	No. Req'd	Ref. No.	Part No.	Description	No. Req'd
114	1109 845	Hex Nut 10-32	2	136	1719 474	Detent Float Screw	1
115	1106 917	Capscrew 3/8 - 16 x 7/8	2	137	1719 475	Lift Check Plunger	1
116	1717 581	S - Clip	3	138	1719 476	Lift Check Spring	1
117	1185 738	Elbow - 90°	2	139	1719 481	O' Ring 3/32 x 1/2 I.D.	1
118	1719 177	Trans. Hose Assembly	2	140	1719 477	Lift Check Plug Ass'y	1
119	1107 013	Capscrew 7/16 - 14 x 1-3/4	4	141	1719 478	Spool Center Spring	1
120	1110 109	Lock-Nut 7/16 - 14	4	142	1719 480	Deep Washer	1
121	1718 523	Engine Support	1	143	1719 482	Detent Pawl Plug	1
122	1718 579	Engine Support	1	144	1719 483	Detent Block	1
123	1717 370	Lead Assembly	2	145	1719 484	Detent Pawl Spring	2
124	1717 394	Lead Assembly	1	146	1719 485	O' Ring 3/32 x 5/8 I.D.	1
125	1717 369	Lead Assembly	1	147	1719 486	O' Ring 1/8 x 5/8 I.D.	1
126	1719 189	Ground Wire	1	148	1100 241	Lockwasher 1/4	2
127	1719 190	Positive Wire	1	149	1100 122	Mach Screw 1/4 x 20 x 1	2
128	1719 192	Starter Wire	1	150	1719 487	Seal Repair Kit (Incl 139, 146 & 147)	1
129	1719 188	Switch - Taillight Wire	1	151	1719 815	Clamp	1
130	1719 193	Fuse Holder	1	152	1111 267	Carr Bolt 5/16-18 x 1-1/4	1
131	1719 194	Fuse	1	153	1100 242	Lockwasher 1/4	1
132	1719 186	Wiring Assembly	1	154	1110 107	Hex-Nut 5/16-18	1
133	1719 187	Wiring Harness	1	155	1719 744	Heat Shield	1
134	1719 472	Detent Pawl	2				
135	1719 473	Shallow Washer	1				

**TRANSAXLE ASSEMBLY MODEL 197**  
(Parts List For Figure 3 on Page 10)

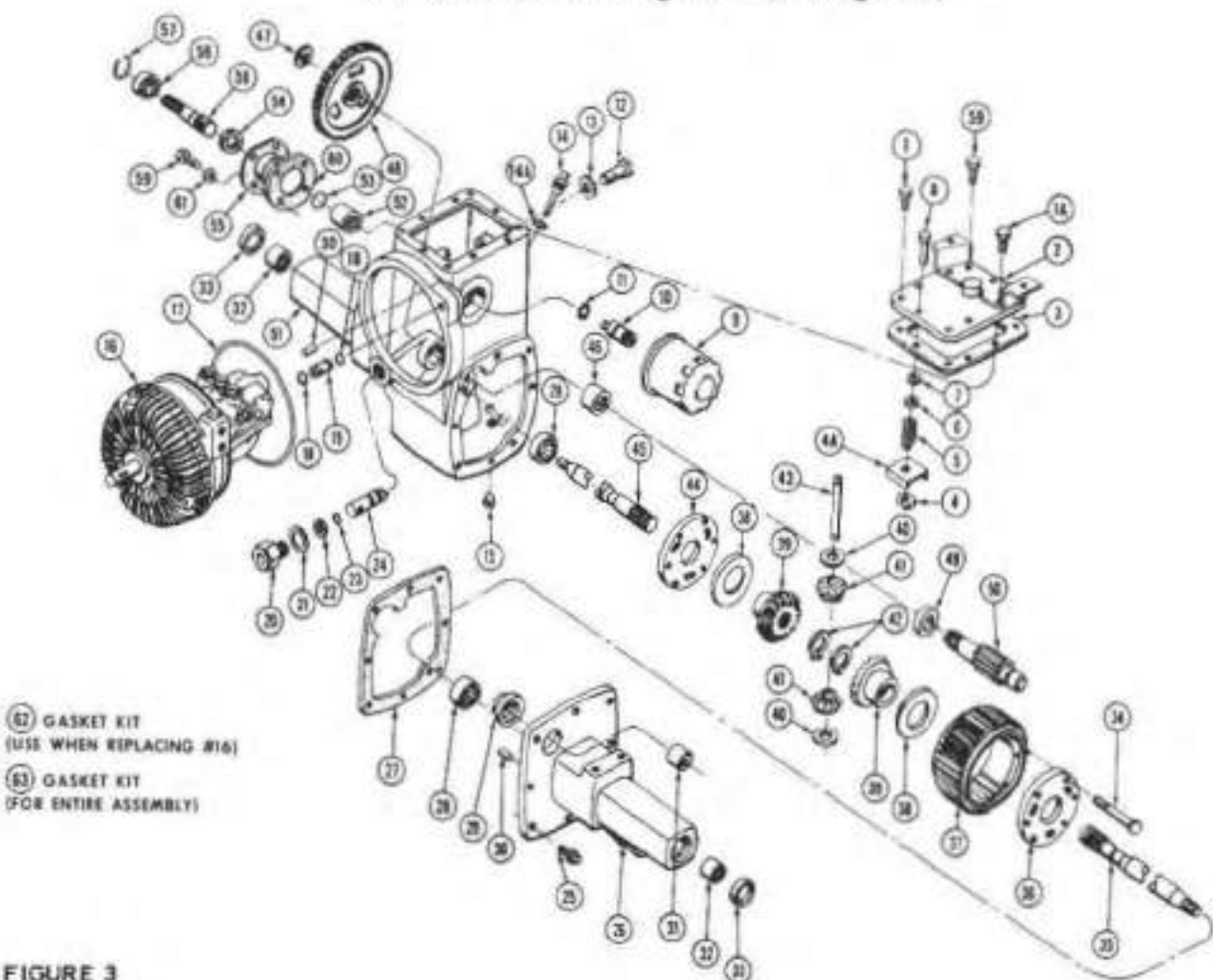

FIGURE 3



Ref. No.	Part No.	Description	No. Req'd
1	1720 306	Capscrew 1/4-20 UNC x 5/8	3
2A	1720 287	Capscrew 1/4-20 UNC x 3/4	2
2	1719 851	Cover Service Kit (includes 1A + 3 and 4)	1
3	1719 852	Gasket (Transmission Cover)	1
4	1719 853	Speed Nut	1
4A	1719 854	Deflector	1
5	1719 855	Spring	1
6	1719 856	Washer	1
7	1719 857	Gasket (Button Ass'y)	1
8	1719 858	Button Sub-Assembly	1
9	1719 859	Oil Filter	1
10	1719 860	Filter Stud	1
11	1720 309	"O" Ring (Filter Stud)	1
12	1719 861	Capscrew 1/2-13 UNC x 2-1/2	1
13	1719 862	Seal Washer (Mounting Bolt)	1
14	1719 863	Dipstick	1
14A	1720 310	"O" Ring (Dipstick)	1
15	1720 311	Drain Plug 1/4-18 NPTF	1
*16	1719 864	Hydrostatic Package	1
17	1719 865	"O" Ring (Transmission Housing)	1
18	1719 866	"O" Ring (Connecting Tube)	2
19	1719 867	Tube-Connecting	1
20	1719 868	Bushing (Parking Pawl)	1
21	1719 869	Sealing Washer (Parking Pawl)	1
22	1719 870	Quad-Ring (Parking Pawl)	1
23	1720 312	"O" Ring (Parking Pawl)	1
24	1719 871	Parking Pawl	1
25	1719 872	Capscrew 3/8-16 UNC x 1-1/4 Special	8
26	1719 873	Axle Housing	1
27	1719 874	Gasket (Housing)	1
28	1720 313	Needle Bearing	2
29	1719 875	Spacer	1
30	1719 876	Dowel 5/16 x 3/4	2
31	1720 314	Needle Bearing (Closed End)	1

Ref. No.	Part No.	Description	No. Req'd
32	1720 315	Needle Bearing	2
33	1719 877	Oil Seal (Axles)	2
34	1720 316	Capscrew 3/16-16 UNC x 3-1/2	6
35	1719 878	Axle (Left Hand)	1
36	1719 879	Cover (Left Hand)	1
37	1719 880	Ring Gear	1
38	1719 881	Shim .500	AR
38	1720 307	Shim .010	AR
39	1719 882	Side Gear (Differential)	2
40	1719 883	Thrust Washer	2
41	1719 884	Pinion Gear (Differential)	2
42	1720 317	Retaining Ring	2
43	1719 885	Shaft	1
44	1719 886	Cover (Right Hand)	1
45	1719 887	Axle (Right Hand)	1
46	1720 318	Needle Bearing	1
47	1720 319	Bowed "E" Ring	1
48	1719 888	Bull Gear	1
49	1719 889	Spacer	1
50	1719 890	Intermediate Gear	1
51	1719 891	Transmission Housing Sub-Assembly	1
52	1719 892	Coupling	1
53	1719 893	Snap Ring (Brake Shaft)	1
54	1719 894	Oil Seal (Brake)	1
55	1719 895	Flange Bearing Adapter	1
56	1720 320	Ball Bearing	1
57	1719 896	Snap Ring (Bearing)	1
58	1719 897	Brake Shaft	1
59	1720 321	Capscrew 5/16-18 UNC x 3/4	7
60	1719 898	Gasket (Brake Flange)	1
61	1719 899	Sealing Washer (Brake Bolts)	4
62	1720 288	Gasket Kit (Use when replacing #16) (Includes #3, 11, 13, 17, 18, 60, 61)	1
63	1720 289	Gasket Kit (For entire assembly) (Includes #14A, 21, 22, 23, 27, 62)	1
	1719 650	Hydrostatic Fluid, 1 gal	

\* Available only as a complete package

# DUAL LIGHT GROUP WIRING DIAGRAM

**NOTE:**

WIRES DESIGNATED BY COLOR  
ONLY ARE CONTAINED IN  
WIRING HARNESS PART  
NO. 1719B7

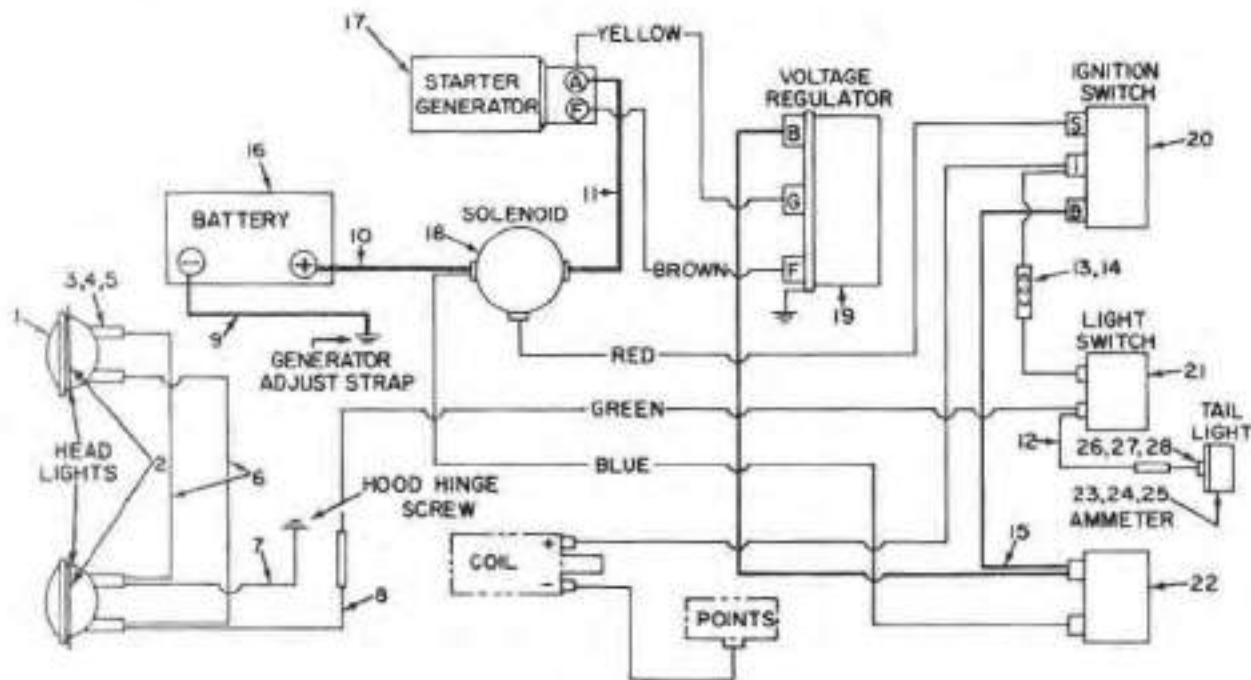

FIGURE 4

Ref. No.	Part No.	Description	No. Req'd
1	*	Headlight Bulb (Mfg No. 4406)	2
2	1719 708	Retainer Ring	2
3	1185 680	Phillips Screw 10-32 x 3/4	8
4	1100 240	Lockwasher #10	6
5	1109 845	Hex Nut #10-32	6
6	1717 370	Lead Assembly	2
7	1717 394	Lead Assembly	1
8	1717 369	Lead Assembly	1
9	1719 189	Ground Wire	1
10	1719 190	Positive Wire	1
11	1719 192	Starter Wire	1
12	1719 188	Switch-Taillight Wire	1
13	1719 193	Fuse Holder	1
14	1719 194	Fuse	1
15	1719 186	Wiring Assembly	1

Ref. No.	Part No.	Description	No. Req'd
16	1718 027	Battery	1
17	1716 169	Starter Generator	1
18	1717 048	Solenoid	1
19	1719 181	Voltage Regulator	1
20	1719 143	Ignition Switch	1
21	1717 256	Light Switch	1
22	1714 146	Ammeter	1
23	1717 597	Taillight Assembly (Incl. Ref. No. 24 & 25)	1
24	*	Bulb (Mfg No. 1889)	1
25	1718 234	Lens Only	1
26	1114 755	Mach. Screw 10-32 x 5/8	2
27	1100 240	Lockwasher #10	2
28	1109 845	Hex Nut #10-32	2