

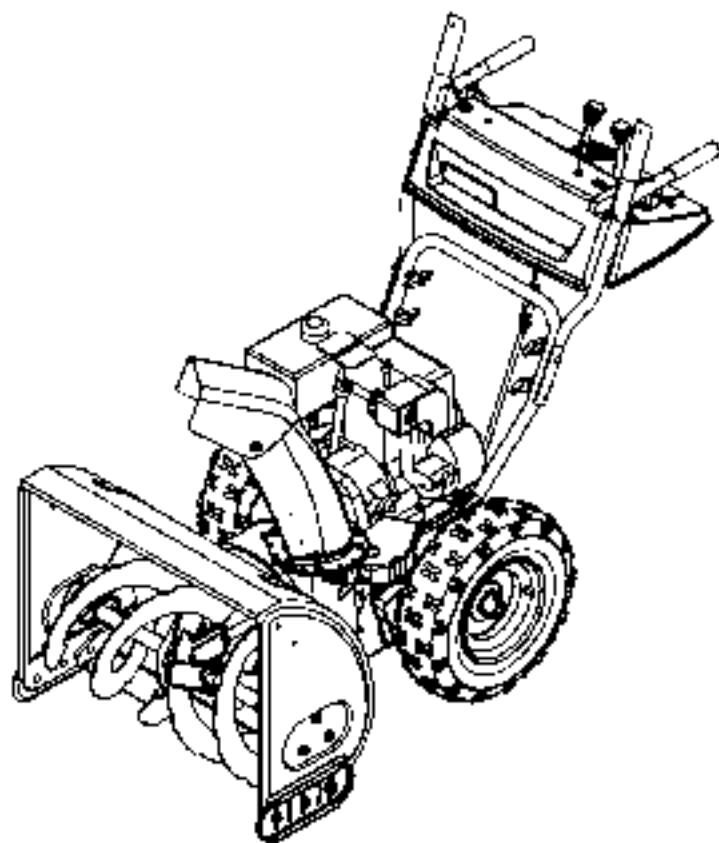

OPERATOR'S MANUAL



Snow Thrower

Models

31AH5C3F401

31AH5Q3G401

MTD

IMPORTANT: READ SAFETY RULES AND INSTRUCTIONS CAREFULLY

Warning: This unit is equipped with an internal combustion engine and should not be used on or near any unimproved forest-covered, brush-covered or grass-covered land unless the engine's exhaust system is equipped with a spark arrester meeting applicable local or state laws (if any). If a spark arrester is used, it should be maintained in effective working order by the operator. In the State of California the above is required by law (Section 4442 of the California Public Resources Code). Other states may have similar laws. Federal laws apply on federal lands. A spark arrester for the muffler is available through your nearest engine authorized service center or contact the service department, P.O. Box 368022 Cleveland, Ohio 44136-9722.

MTD PRODUCTS INC. P.O. BOX 368022 CLEVELAND, OHIO 44136-9722

TABLE OF CONTENTS

Content	Page
Important Safe Operation Practices.....	3
Assembling Your Snow Thrower.....	5
Know Your Snow Thrower.....	7
Operating Your Snow Thrower.....	8
Making Adjustments.....	10
Maintaining Your Snow Thrower.....	11
Servicing Your Snow Thrower.....	12
Troubleshooting.....	16
Parts List.....	17

FINDING MODEL NUMBER

This Operator's Manual is an important part of your new Snow Thrower. It will help you assemble, prepare and maintain the unit for best performance. Please read and understand what it says.



Before you start assembling your new equipment, please locate the model plate on the equipment and copy the information from it in the space provided below. The information on the model plate is very important if you need help from your local authorized dealer.

You can locate the model number by looking at the lower frame cover on the rear of your snow thrower. A sample model plate is explained below. For future reference, please copy the model number and the serial number of the equipment in the space below.

<u>(Model Number)</u>	<u>(Serial Number)</u>
 MTD PRODUCTS INC CLEVELAND, OHIO 44136	

Copy the model number here: _____

Copy the serial number here: _____

CALLING CUSTOMER SUPPORT

If you have difficulty assembling this product or have any questions regarding the controls, operation or maintenance of this unit, please call the Customer Support Department.



Call 1- (330) 220-4MTD (4683) or 1- (800)-800-7310 to reach a Customer Support representative. Please have your unit's model number and serial number ready when you call. See previous section to locate this information. You will be asked to enter the serial number in order to process your call.

For more details about your unit, visit our website at www.yardman.com

SECTION 1: IMPORTANT SAFE OPERATION PRACTICES



WARNING: This symbol points out important safety instructions which, if not followed, could endanger the personal safety and/or property of yourself and others. Read and follow all instructions in this manual before attempting to operate this machine. Failure to comply with these instructions may result in personal injury. When you see this symbol - **heed its warning.**

WARNING: Engine Exhaust, some of its constituents, and certain vehicle components contain or emit chemicals known to State of California to cause cancer and birth defects or other reproductive harm.

DANGER: This machine was built to be operated according to the rules for safe operation in this manual. As with any type of power equipment, carelessness or error on the part of the operator can result in serious injury. This machine is capable of amputating hands and feet and throwing objects. Failure to observe the following safety instructions could result in serious injury or death.

Training

1. Read, understand, and follow all instructions on the machine and in the manual(s) before attempting to assemble and operate. Keep this manual in a safe place for future and regular reference and for ordering replacement parts.
2. Be familiar with all controls and their proper operation. Know how to stop the machine and disengage them quickly.
3. Never allow children under 14 years old to operate this machine. Children 14 years old and over should read and understand the operation instructions and safety rules in this manual and should be trained and supervised by a parent.
4. Never allow adults to operate this machine without proper instruction.
5. Thrown objects can cause serious personal injury. Plan your snow throwing pattern to avoid discharge of material toward roads, bystanders and the like.
6. Keep bystanders, helpers, pets and children at least 75 feet from the machine while it is in operation. Stop machine if anyone enters the area.
7. Exercise caution to avoid slipping or falling, especially when operating in reverse.
8. Adjust collector housing height to clear gravel or crushed rock surfaces.
9. Disengage all clutch levers before starting the engine.
10. Never attempt to make any adjustments while engine is running, except where specifically recommended in the operator's manual.
11. Let engine and machine adjust to outdoor temperature before starting to clear snow.
12. To avoid personal injury or property damage use extreme care in handling gasoline. Gasoline is extremely flammable and the vapors are explosive. Serious personal injury can occur when gasoline is spilled on yourself or your clothes which can ignite. Wash your skin and change clothes immediately.
 - a. Use only an approved gasoline container.
 - b. Extinguish all cigarettes, cigars, pipes and other sources of ignition.
 - c. Never fuel machine indoors.
 - d. Never remove gas cap or add fuel while the engine is not or running.
 - e. Allow engine to cool at least two minutes before refueling.
 - f. Never over fill fuel tank. Fill tank to no more than 1/2 inch below bottom of filler neck to provide space for fuel expansion.
 - g. Replace gasoline cap and tighten securely.
 - h. If gasoline is spilled, wipe it off the engine and equipment. Move machine to another area. Wait 5 minutes before starting the engine.
 - i. Never store the machine or fuel container inside where there is an open flame, spark or pilot light (e.g. furnace, water heater, space heater, clothes dryer, etc.).
 - j. Allow machine to cool 5 minutes before storing.

Preparation

1. Thoroughly inspect the area where the equipment is to be used. Remove all door mats, newspapers, steel boards, wires and other foreign objects which could be inhaled or thrown by the auger/impeller.
2. Always wear safety glasses or eye shields during operation and while performing an adjustment or repair to protect your eyes. Thrown objects which ricochet can cause serious injury to the eyes.
3. Do not operate without wearing adequate winter outer garments. Do not wear jewelry, long scarves or other loose clothing which could become entangled in moving parts. Wear footwear which will improve footing on slippery surfaces.
4. Use a grounded three wire extension cord and receptacle for all units with electric start engines.

Operation

1. Do not put hands or feet near rotating parts in the auger/impeller housing or discharge chute. Contact with the rotating parts can amputate hands and feet.
2. The auger/impeller clutch lever is a safety device. Never bypass its operation. Doing so makes the machine unsafe and may cause personal injury.

3. The clutch levers must operate easily in both directions and automatically return to the disengaged position when released.
4. Never operate with a missing or damaged discharge chute. Keep all safety devices in place and working.
5. Never run an engine indoors or in a poorly ventilated area. Engine exhaust contains carbon monoxide, an odorless and deadly gas.
6. Do not operate machine while under the influence of alcohol or drugs.
7. Muffler and engine become hot and can cause a burn. Do not touch.
8. Exercise extreme caution when operating on or crossing gravel surfaces. Stay alert for hidden hazards or traffic.
9. Exercise caution when changing direction and while operating on slopes.
10. Plan your snow throwing pattern to avoid discharge towards windows, walls, cars, etc. To avoid property damage or personal injury caused by a couchel.
11. Never direct discharge at children, bystanders and pets or allow anyone in front of the machine.
12. Do not overload machine capacity by attempting to clear snow at too fast of a rate.
13. Never operate this machine without good visibility or light. Always be sure of your footing and keep a firm hold on the handles. Walk, never run.
14. Disengage power to the auger/impeller when transporting or not in use.
15. Never operate machine at high transport speeds on slippery surfaces. Look down and behind and use care when in reverse.
16. If the machine should start to vibrate abnormally, stop the engine, disconnect the spark plug and ground it against the engine. Inspect thoroughly for damage. Repair any damage before starting and operating.
17. Disengage all clutch levers and stop engine before you leave the operating position (behind the handles). Wait until the auger/impeller comes to a complete stop before unclogging the discharge chute, making any adjustments, or inspections.
18. Never put your hand in the discharge or collector openings. Always use a clearing tool to unclog the discharge opening.
19. Use only attachments and accessories approved by the manufacturer (e.g. wheel weights, tire chains, cabs, etc.).
20. If situations occur which are not covered in this manual,

use care and good judgment. Contact your dealer or telephone 1-800-800-7310 for assistance and the name of your nearest servicing dealer.

Maintenance And Storage

1. Never tamper with safety devices. Check their proper operation regularly.
2. Disengage all clutch levers and stop engine. Wait until the auger/impeller comes to a complete stop. Disconnect the spark plug wire and ground against the engine to prevent unintended starting before cleaning, repairing, or inspecting.
3. Check lights, and screws for proper tightness at frequent intervals to keep the machine in safe working condition. Also, visually inspect machine for any damage.
4. Do not change the engine governor setting or over-speed the engine. The governor controls the maximum safe operating speed of the engine.
5. Snow thrower shave plates and skid shoes are subject to wear and damage. For your safety protection, frequently check all components and replace with original equipment manufacturer's (O.E.M.) parts only. Use of parts which do not meet the original equipment specifications may lead to improper performance and compromise safety.
6. Check clutch controls periodically to verify they engage and disengage properly and adjust, if necessary. Refer to the adjustment section in this operator's manual for instructions.
7. Maintain or replace safety and instruction labels, as necessary.
8. Observe proper disposal laws and regulations for gas, oil, etc. to protect the environment.
9. Prior to storing, run machine a few minutes to clear snow from machine and prevent freeze up of auger/impeller.
10. Never store the machine or fuel container inside where there is an open flame, spark or pilot light such as a water heater, furnace, clothes dryer, etc.
11. Always refer to the operator's manual for proper instructions on off-season storage.



WARNING: Restrict the use of this power machine to persons who read, understand and follow the warnings and instructions in this manual and on the machine.



SECTION 2: ASSEMBLING YOUR SNOW THROWER

NOTE: Any reference in this manual to the left or right side of the snow thrower is observed from the operator's position.

Unpacking

- Remove screws from the top sides and ends of the shipping crate.
- Set panel aside to avoid fire punctures or personal injury.
- Remove and discard plastic bag that covers unit.
- Remove any loose parts included with unit (i.e., Operator's Manual, etc).
- Roll unit out of crate.

Loose Parts

The augers are secured to the auger shaft with two shear bolts and hex lock nuts. If you hit a foreign object or ice jam, the snow thrower is designed so that the bolts may shear. Two replacement shear bolts and nuts are provided for your convenience. Store in a safe place until needed. See Figure 1.

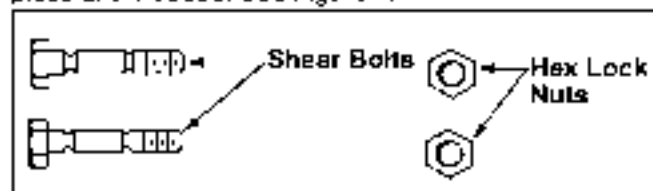

Figure 1

Assembly



WARNING: Disconnect the spark plug wire and ground it against the engine to prevent unintended starting.

- Remove the lower two plastic wing nuts, cupped washers and carriage bolts from each side of the lower handle. See Figure 2.

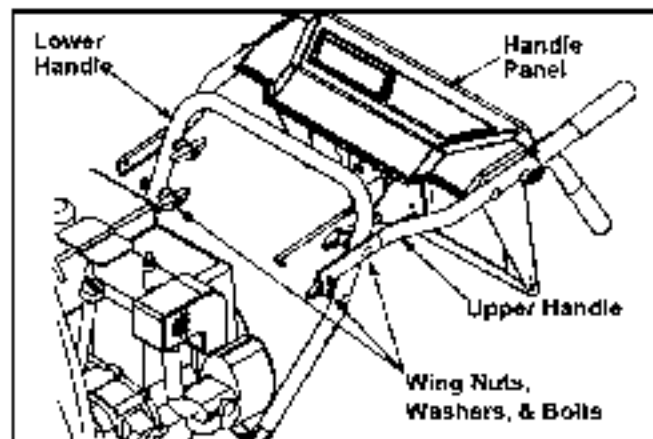

Figure 2

- Raise the upper handle assembly until it locks over the lower handle.
- Look at the lower rear of the snow thrower frame to be sure all the cables are aligned with the cable roller guides.
- Secure the upper handle and lower handle with the two plastic wing nuts, cupped washers and carriage bolts previously removed and tighten the upper two plastic wing nuts. See Figure 3.

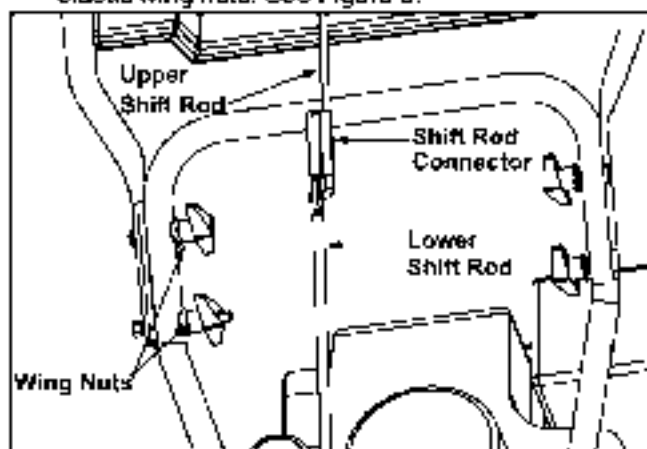

Figure 3

- Slide the shift rod connector down over the end of the lower shift rod. Tap the connector until it locks over the lower shift rod. See Figure 3.

NOTE: If the connector is not properly assembled, the shift rod will pivot and you will not be able to change speeds or change directions.

- If not already attached, slip the cables that run from the handle panel to the chute into the cable guide located on top of the engine. See Figure 4.

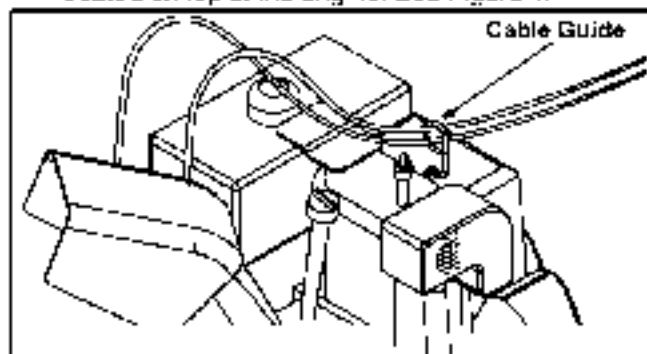

Figure 4

- Unwrap the headlight wire, which is attached to the headlight beneath the handle panel.
- Wind the headlight wire around the right handle until excess slack is removed.
- Plug the wire from the headlight into the wire lead coming from the right side of the engine, beneath the fuel tank.

Final Adjustments

Auger Control Adjustment

Check the adjustment of the auger control as follows:

- Push forward on the auger control until the small rubber bumper contacts the upper handle. There should be slack in the cable. See Figure 5.
- Release the auger control. The cable should be straight. Make certain you can depress the auger control against the left handle completely without using excess force.

If adjustment is necessary, proceed as follows:

- Loosen the jam nut and thread the cable in (for less slack) or out (for more slack) as necessary. See Figure 5.
- Recheck the adjustment before retightening the jam nut against the cable.

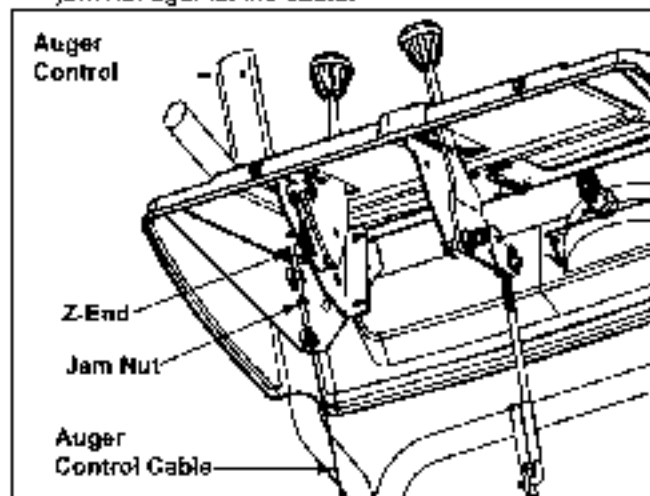

Figure 5

Skid Shoe Adjustment

The space between the shave plate and the ground can be adjusted by repositioning the skid shoes found on either side of the snow thrower's auger housing. For close snow removal, place skid shoes in the low position. Use middle or high position when area to be cleared is uneven. See Figure 6.

IMPORTANT: It is NOT recommended that this snow thrower be operated on a gravel surface, as loose stones can be easily picked up and thrown by the machine. If you must operate on a gravel surface, ALWAYS adjust the skid shoes into the HIGH position to allow the shave plate maximum clearance.

Adjust skid shoes as follows:

- Loosen, but do NOT remove, the three hex nuts which fasten the skid shoe to the auger housing.
- Raise or lower the skid shoe to desired position.

NOTE: Make certain the entire base of both skid shoes are against the ground to avoid uneven wear on the skid shoes. When one side does wear out, the skid shoes are reversible.

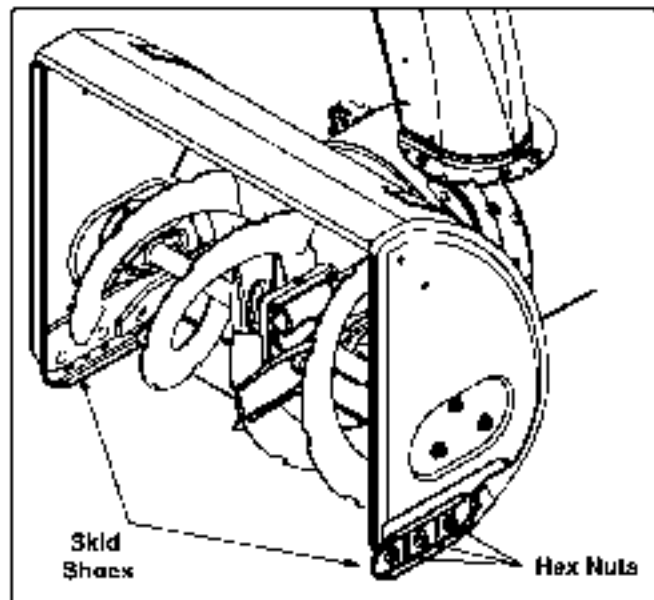

Figure 6

- Retighten the hex nuts loosened earlier.
- Repeat this adjustment on the skid shoe found on the opposite side of the snow thrower.

Traction Control and Shift Lever Adjustment

To check the adjustment of the traction control and shift lever, proceed as follows:

- Move the shift lever into sixth (6) position.
 - a. With the traction control (refer to Figure 7) released, squeeze in triggers and gently push the snow thrower forward, then pull it back. Disregarding the overall weight of the snow thrower, the machine should otherwise move freely.
 - b. Engage the traction control and attempt to move the machine both forward and rearward. You should experience resistance as the wheels should not be turning.
- Move the shift lever into the fast reverse (R2) position and repeat the previous steps (a & b).

If you experienced resistance either when repositioning the shift lever from 6 to R2 or when attempting to move the machine forward or rearward with the traction control released, your snow thrower's traction control is in need of adjustment and you should NOT operate the machine before completing the adjustment as follows:

- Loosen the jam nut on the traction control cable and UNTHREAD the cable one full turn.
- Recheck the adjustment.
- Retighten the jam nut to secure the cable when correct adjustment is reached.

If the machine can be moved freely both forward and rearward when the traction control fully depressed, proceed as follows:

- Loosen the jam nut on the traction drive cable and THREAD the cable in one full turn.

- Recheck the adjustment and repeat adjustment as necessary.
- Retighten the jam nut to secure the cable when correct adjustment is reached.

NOTE: If you are uncertain that you have reached the correct adjustment, refer to *Traction Control Adjustment in Adjustment Section*.

SECTION 3: KNOW YOUR SNOW THROWER

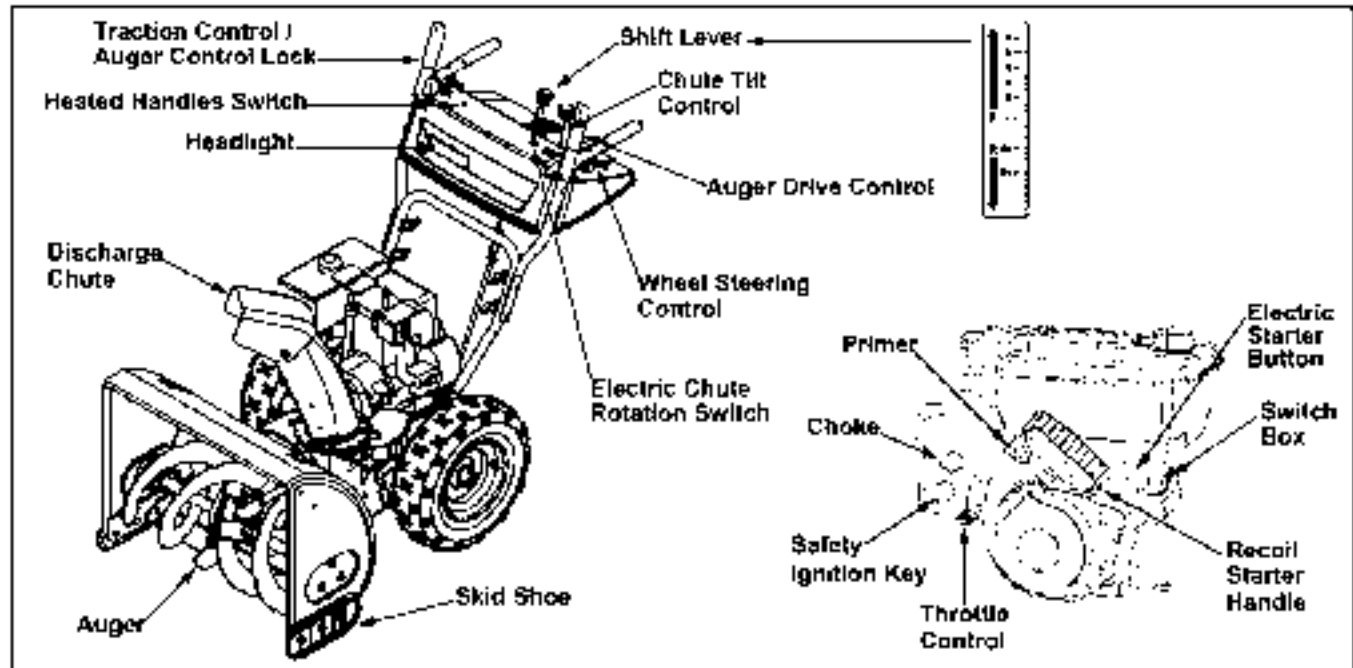

Figure 7



WARNING: Read, understand, and follow all instructions and warnings on the machine and in this manual before operating.

Traction Control / Auger Control Lock

The traction control is located on the right handle. Squeeze the traction control to engage the wheel drive. Release to stop. See Figure 7.

This same lever also locks the auger control so you can turn the chute directional control without interrupting the snow throwing process. If the auger control is engaged along with the traction control, the operator can release the auger control (on the left handle) and the augers will remain engaged. Release the traction control to stop both the augers and track drive (auger control must also be released).

IMPORTANT: Always release tractional control before changing speeds.

Auger Drive Control

The auger drive control is located on the left handle. Squeeze the control grip to engage the augers. Release to stop the snow throwing action. (Traction control must also be released.) See Figure 7.

Chute Tilt Control

The distance snow is thrown can be changed by adjusting the angle of the chute assembly. Move the chute tilt control forward to decrease the distance, toward the rear to increase. See Figure 7.

Skid Shoe

The position of the skid shoe is determined by the condition of the ground from where snow has to be removed. See Figure 7.

Shift Lever

The shift lever is located in the center of the handle panel and is used to determine both ground speed and direction of travel. It can be moved into any of eight positions. See Figure 7.

Forward

Your snow thrower has six forward (F) speeds. Position number one (1) is the slowest. Position number six (6) is the fastest.

Reverse

Your snow thrower has two reverse (R) speeds. R1 is the slowest, while R2 is the faster of the two.

IMPORTANT: Always release tractional control before changing speeds.

Electric Chute-Rotation Switch

The electric chute-rotation switch is located on the left side of the snow thrower dash panel. See Figure 7. To change the direction in which discharged snow is thrown, proceed as follows:

- Push the toggle switch to the left to rotate the chute counterclockwise.
- Push the toggle switch to the right to rotate the chute clockwise.

IMPORTANT: Release the switch once the chute has completed its rotation cycle in either direction. Failure to do so can result in damage to the electric chute motor and/or its drive gear.

Heated Handles Switch

The heated handles switch is located on the right side of the snow thrower handle panel. To activate the heated handles, toggle the switch to the right to generate heat within the handles. Toggle the heated handles switch to the left into the OFF position after using the snow thrower.

NOTE: The heated handles are a complement to, not a substitute for, proper cold weather outerwear for hands. It is recommended that the user wear adequate winter protection for hands (like gloves/mittens) when operating this snow thrower.

Wheel Steering Controls

The left and right wheel steering controls are located on the underside of the handles and are used to assist in steering the snow thrower. Squeeze the right wheel steering control when turning right, squeeze the left control when turning left. Operate your snow thrower in open areas until you become familiar with these controls. See Figure 7.

NOTE: It is easier to maneuver a non-running snow thrower with both wheel steering controls held in simultaneously.

Headlight

The headlight is on whenever the engine is running.

Throttle Control

The throttle control is located on the engine. It regulates the speed of the engine and will shut off the engine when pushed down completely. See Figure 7.

Safety Ignition Key

The safety ignition key must be fully inserted in the switch before the unit will start. Remove the ignition key when the snow thrower is not in use. See Figure 7.

IMPORTANT: Do NOT attempt to turn the key.

SECTION 4: OPERATING YOUR SNOW THROWER

Before Starting



WARNING: Read, understand, and follow all instructions and warnings on the machine and in this manual before operating.

Gas And Oil Fill-up

Service the engine with gasoline and oil as instructed in the separate engine manual packed with your snow thrower. Read instructions carefully.



WARNING: Use extreme care when handling gasoline. Gasoline is extremely flammable and the vapors are explosive. Never fuel machine indoors or while the engine is hot or running. Extinguish cigarettes, cigars, pipes and other sources of ignition.

- A plastic cup is provided inside the fuel fill opening on the fuel tank. Remove and discard this cup before filling up the tank. Use the separate fuel tank cap to close after fill up.

To Start Engine

NOTE: If unit shows any sign of motion (drive or augers) with the clutch grips disengaged, shut engine off immediately. Readjust as instructed in the Final Adjustments in the Assembly Section.

- Attach spark plug wire to spark plug. Make certain the metal loop on end of the spark plug wire (inside the boot) is fastened securely over the metal tip on the spark plug.
- Make certain the auger and drive clutch levers are in the disengaged (released) position.
- Move throttle control up to FAST position. Insert ignition key into slot. See Figure 7. Be certain it snaps into place. Do not turn key.

NOTE: Engine will not start unless ignition key is inserted into ignition slot in carburetor cover.

Electric Starter

- Determine that your house wiring is a three-wire grounded system. Ask a licensed electrician if you are not certain.



WARNING- The electric starter is equipped with a grounded three-wire power cord and plug and is designed to operate on 120 volt AC household current. It must be used with a properly grounded three-prong receptacle at all times to avoid the possibility of electric shock. Follow all instructions carefully prior to operating the electric starter.

- If your house wiring system is not a three-wire grounded system do not use this electric starter under any conditions.
- If your home electrical system is grounded, but a three-hole receptacle is not available, one should be installed by a licensed electrician before using the electric starter.
- If you have a grounded three-prong receptacle, proceed as follows:
 - Rotate choke knob to OFF position and do not prime engine.
 - Connect power cord to switch box on engine. Plug the other end of power cord into a three-hole, grounded 120 volt AC receptacle.
 - Push starter button on top of the engine to crank engine. As you crank the engine, move choke knob to FULL choke position.
 - When engine starts, release starter button and move choke gradually to OFF. If engine falters, move choke immediately to FULL and then gradually to OFF.
 - When disconnecting the power cord, always unplug from the three-prong receptacle first and then from the snow thrower.

Recoil Starter

- Rotate choke knob to FULL choke position (cold engine start). If engine is warm, place choke in OFF position instead of FULL.
- Push primer button two or three times. If engine is warm, push primer button once only.

NOTE: Always cover vent hole in primer button when pushing. Additional priming may be necessary for first start if temperature is below 15°F.

- Grasp starter handle and pull rope out slowly, until it pulls slightly harder. Let rope rewind slowly.
- Pull starter handle rapidly. Do not allow handle to snap back. Allow it to rewind slowly while keeping a firm hold on the starter handle.
- Repeat the previous steps until engine starts.

To Stop Engine

- Run engine for a few minutes before stopping to help dry off any moisture on the engine.
- To help prevent possible freeze up of starter, proceed as follows.

Electric Starter:

- Connect power cord to switch box on engine, then to 120 volt AC receptacle. With the engine running, push starter button and spin the starter for several seconds. The unusual sound made by spinning the starter will not harm engine or starter. Disconnect the power cord from receptacle first, and then from switch box.

Recoil Starter

- With engine running, pull starter rope with a rapid, continuous full arm stroke three or four times. Pulling the starter rope will produce a loud clattering sound, which is not harmful to the engine or starter.
- Move throttle control to "stop" or "off" position.
- Remove ignition key. Do not turn key. Disconnect the spark plug wire from the spark plug to prevent accidental starting while equipment is unattended.

NOTE: Keep it in a safe place. Engine will not start without ignition key.

Wipe all snow and moisture from the carburetor cover in the area of the control levers. Also, move control levers back and forth several times.

To Engage Wheel Drive

- With the engine running near top speed, move the shift lever into one of the six FORWARD positions or two REVERSE positions. Select a speed appropriate for the snow conditions that exist.

NOTE: Use slower speeds in higher snow, and until you are familiar with the operation of the snow thrower.

- Squeeze the traction control against the right handle and the snow thrower will move. Release it and the drive motion will stop.

IMPORTANT: NEVER move the shift lever without first releasing the traction control. Doing so will cause premature wear to the drive system's friction wheel.

To Engage Augers

To engage the augers and start the snow throwing action, proceed as follows.

- Squeeze the auger control against the left handle. To disengage power to the augers

- Release both the auger control and the traction control, if engaged.

The auger control can be locked so you can turn the electric chute directional control without interrupting the snow throwing process.

Operating Tips

NOTE: Allow the engine to warm up for a few minutes. The engine will not develop full power until it reaches operating temperature.



WARNING: The temperature of the muffler and the surrounding areas may exceed 150° F. Avoid these areas.

- For the most efficient snow removal, remove snow immediately after it falls.

- Discharge the snow downwind whenever possible.
- Slightly overlap each previous path.
- Set the skid shoes 1/4" below the shave plate for normal usage. The skid shoes may be adjusted upward (to lower the shave plate) for hard-packed snow. Adjust downward (to raise the shave plate) when using on gravel or crushed rock.

SECTION 5: MAKING ADJUSTMENTS



WARNING: NEVER attempt to make any adjustments while the engine is running, except where specified in the operator's manual.

Chute Assembly Adjustment

The distance snow is thrown can be adjusted by adjusting the angle of the chute assembly. Refer to the Chute Tilt Control in the Know Your Snow Thrower Section.

Traction Control Adjustment

Refer to the information found under Final Adjustment in the Assembly Section to adjust the traction control. If you are uncertain that you have reached the correct adjustment, proceed as follows:



WARNING: Drain the gasoline out of the snow thrower's tank, or place a piece of plastic film under the gas cap to avoid spillage BEFORE making the adjustment.

- Tip the snow thrower forward, allowing it to rest on the auger housing.
- Remove the frame cover underneath the snow thrower by removing the six self-tapping screws.
- With the traction control released, there must be clearance between the friction wheel and the drive plate in all positions of the shift lever.
- With the traction control engaged, the friction wheel must contact the drive plate. See Figure 8.

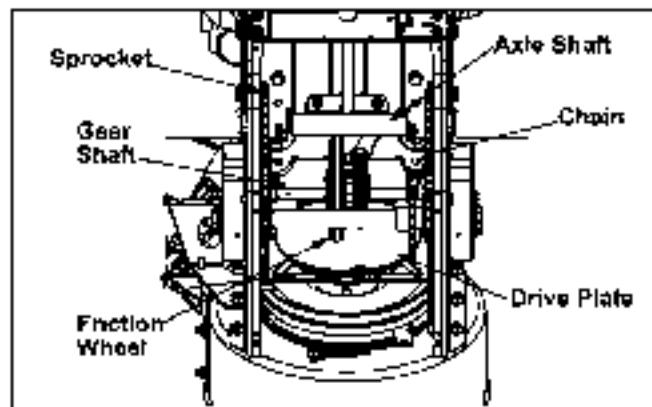

Figure 8

If adjustment is necessary:

- Loosen the jam nut on the traction drive cable and adjust the cable as necessary. Refer to Figure 5.
- Retighten the jam nut to secure the cable when correct adjustment is reached.
- Reassemble the frame cover.

NOTE: If you placed plastic film under the gas cap, be certain to remove it before operating the snow thrower.

Shift Rod Adjustment

To adjust the shift rod, proceed as follows:

- Remove the hairpin clip and slide the shift rod connector up, to separate the upper shift rod from the lower shift rod. See Figure 9.

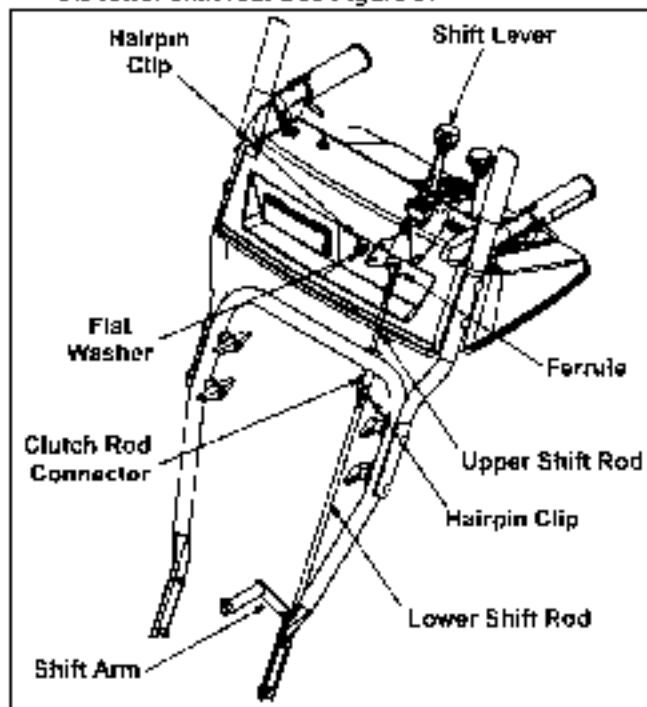

Figure 9

- Place the shift lever into the 5-th (B) position.
- Rotate the shift arm clockwise (from the operator's position) as far as it will go.
- Thread the upper shift rod downward until the elbow on its lower end aligns with the hole found in the lower shift rod.

- Reconnect the upper shift rod to the lower shift rod by reinserting the hairpin clip removed earlier and sliding the shift rod connector back down into place.

IMPORTANT: Make certain to check for correct adjustment of the shift rod as instructed under Final Adjustments in the Assembly Section, before operating the snow thrower.

Drive Wheels

The wheels may be adjusted for two different methods of operation. The adjustment is made by placing the click pins in one of two different holes on the right side of the unit. See Figure 10.

One Wheel Driving: Insert the click pin only through the outside hole of the axle (NOT the rim) on the right side of the snow thrower. This position gives power drive to the left wheel only, making the unit easier to maneuver.

Both Wheels Driving: Insert the click pin through the hole in the hub of the rim and the **INSIDE** hole on the snow thrower's right axle. This position is good for heavy snow as there is power drive in both wheels.

IMPORTANT: NEVER operate the snow thrower with the click pin inserted through both the RIM and the **OUTSIDE HOLE** in the axle. Doing so can result in serious damage to the drive system.

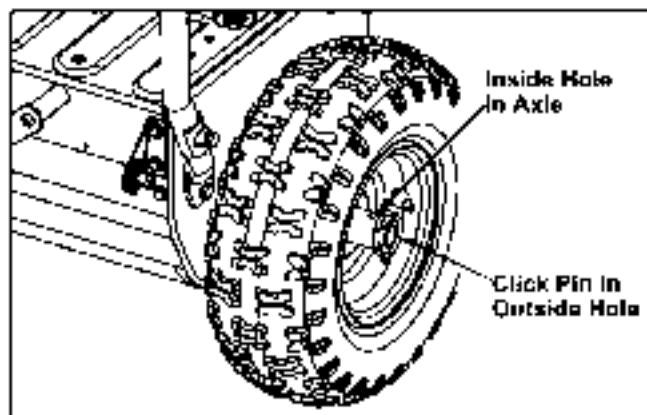

Figure 10

Skid Shoe Adjustment

The space between the skid plate and the ground can be adjusted by raising or lowering the skid shoes. Refer to Skid Shoe Adjustment in the Assembly Section.

Auger Control Adjustment

Refer to the information found under Final Adjustments in the Assembly Section to adjust the auger control.

SECTION 6: MAINTAINING YOUR SNOW THROWER



WARNING: Before lubricating, repairing, or inspecting, disengage all clutch levers and stop engine. Wait until all moving parts have come to a complete stop. Disconnect spark plug wire and ground it against the engine to prevent unintended starting.

Lubrication

Engine

Refer to the separate engine manual packed with your unit for all engine lubrication instructions.

IMPORTANT: When following instructions in separate engine manual for draining oil, be sure to protect frame to avoid oil dripping onto transmission parts.

Gear Shaft

Lubricate the gear shaft with 6-in-1 grease at least once a season or after every 25 hours of operation (available at automotive stores, or order part number 737-0170). Refer to Figure 6.

IMPORTANT: Keep all grease and oil off of the rubber friction wheel and aluminum drive plate.

Drive and Shifting Mechanism

Lubricate at least once a season or after every 25 hours of operation. Remove the rear cover, lubricate any chains, sprockets, gears, bearings, shafts, and shifting mechanism at least once a season. Use engine oil or a spray lubricant. **Avoid getting oil on the friction wheel rubber and aluminum drive plate.** Refer to Figure 8.

There is a grease fitting on the top of the axle shaft which drives the rear track drive wheels on both sides of the unit. Grease these fittings every 25 hours or once a season.

Traction Control / Auger Control Lock

The cams on the ends of the control rods which interlock the traction drive and auger drive controls must be lubricated at least once a season or every 25 hours of operation. The cams can be accessed beneath the handle panel. Use a multi purpose automotive grease.

Electric Chute-Rotation Motor

The gear on the electric chute rotation motor and the base of the discharge chute itself should be lubed with multi-purpose automotive grease once a season. See Figure 11.

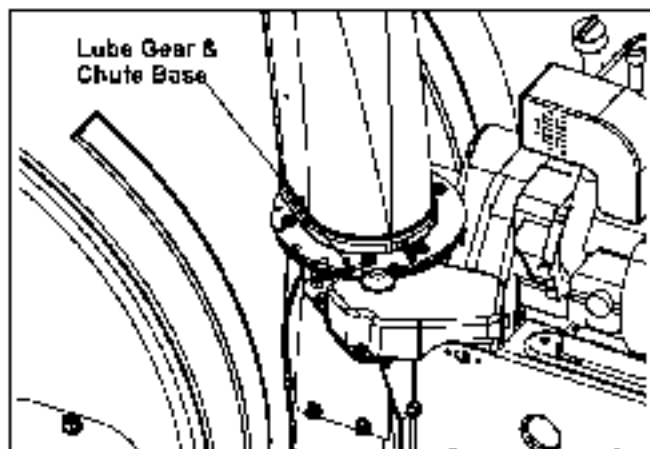

Figure 11

Gear Case

The gear case is lubricated with grease at the factory and it does not require checking. If disassembled for any reason, lubricate with 2 ounces of Shell Alvania grease FPR00, part number 737-01168. Before reassembling, remove old sealant and apply new sealant. See SECTION 7.

IMPORTANT: Do not overfill the gear case since damage to the seals could result. Be sure the vent plug is free of grease in order to relieve pressure.

Auger Shaft

At least once a season, remove the shear bolts on the auger shaft. Spray lubricant inside the shaft. Also lubricate the plastic auger bearings at least once a season and grease the fittings on the end of the auger shaft with a standard grease gun. See Figure 12.

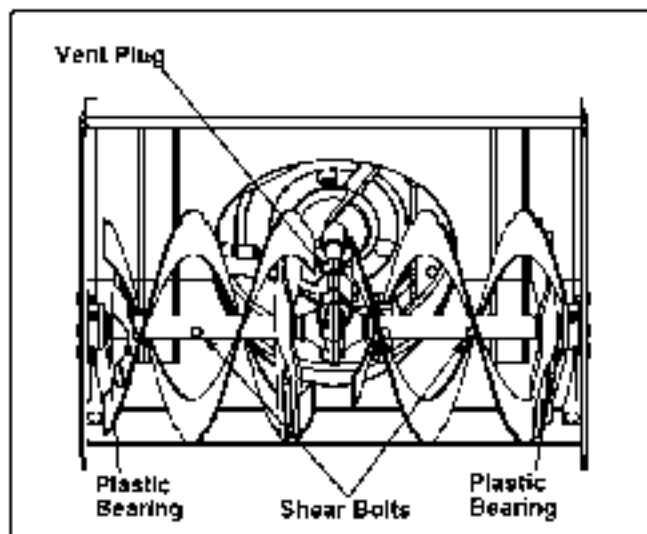

Figure 12

SECTION 7: SERVICING YOUR SNOW THROWER



WARNING: Before servicing, repairing, or inspecting, disengage all clutch levers and stop engine. Wait until all moving parts have come to a complete stop. Disconnect spark plug wire and ground it against the engine to prevent unintended starting.

Engine

Refer to the separate engine manual packed with your unit for all engine maintenance procedures.

Augers

- The augers are secured to the spiral shaft with two shear bolts and hex lock nuts. If you hit a hard foreign object or ice jam, the snow thrower is designed so that the bolts may shear. Refer to Figure 12.
- If the augers will not turn, check to see if the bolts have sheared. Replacement shear bolts and hex lock nuts have been provided with the snow thrower. When replacing bolts, spray an oil lubricant into shaft before inserting new bolts.

IMPORTANT: NEVER replace the auger shear bolts with standard hex bolts. Any damage to the auger gearbox or other components as a result of doing so will NOT be covered by your snow thrower's warranty.

Shave Plate and Skid Shoes

The shave plate and skid shoes on the bottom of the snow thrower are subject to wear. They should be checked periodically and replaced when necessary. To remove the skid shoes, proceed as follows:

- Remove the six carriage bolts, bell washers, and hex nuts which attach them to the snow thrower.
- Reassemble new skid shoes with the six carriage bolts, bell washers (cupped side goes against skid shoes) and hex nuts. Make certain the skid shoes are adjusted to be level.

To remove shave plate, remove the carriage bolts, bell washers, and hex nuts which attach it to the snow thrower housing. Reassemble new shave plate, making sure heads of the carriage bolts are to the inside of the housing. Tighten securely.

Belt Removal And Replacement

Auger Belts

- Remove the plastic belt cover at the front of the engine by removing the two self-tapping screws. See Figure 13.
- Drain the gasoline from the snow thrower, or place a piece of plastic film under the gas cap.
- Tip the snow thrower up and forward so that it rests on its auger housing.

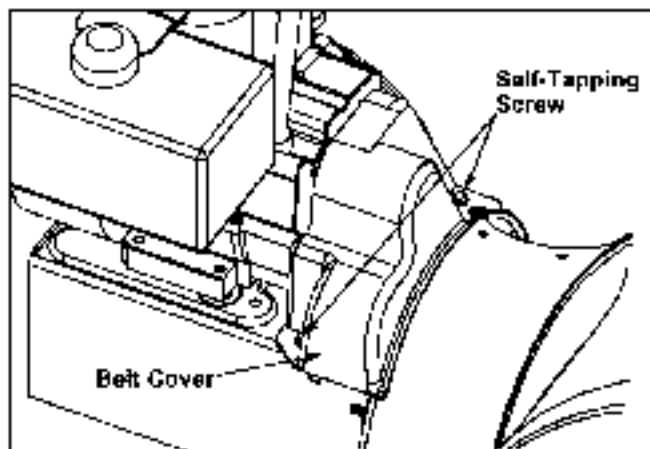

Figure 13

- Remove the six self-tapping screws from the frame cover underneath the snow thrower.
- Roll the front and rear auger belts off the auger drive pulley. See Figure 14.

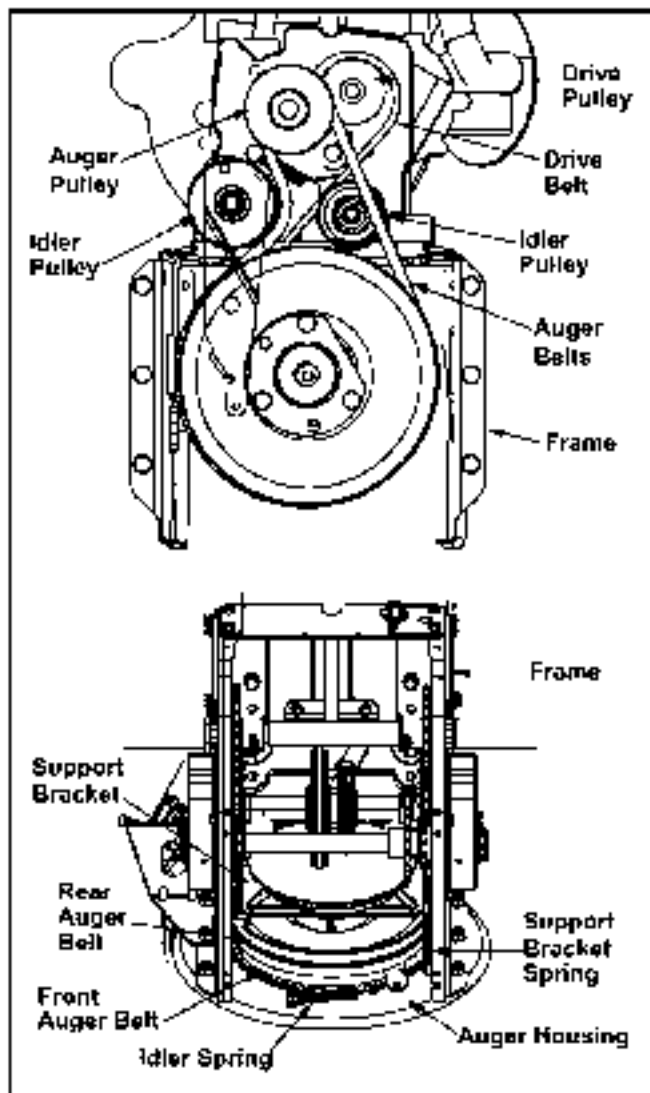

Figure 14

- Unhook the idler spring from the hex bolt on the auger housing. See Figure 14.
- Back out the stop bolt until the support bracket rests on the auger pulley.

NOTE: Loosening the six nuts that connect the frame to the auger housing may aid in belt removal.

- Lift the rear auger belt from the auger pulley, and slip the belt between the support bracket and the auger pulley. Repeat this step for the front auger belt.
- Replace both auger drive belts by following instructions in reverse order.

NOTE: If you placed plastic film under the gas cap, be certain to remove it before operating the snow thrower.

Drive Belt

- Follow the first four steps of the instructions for servicing the auger belts.
- Pull the idler pulley up and lift the belt off the wheel drive pulley and friction wheel disc. See Figure 14.
- Back out the stop bolt until the support bracket rests on the auger pulley. See Figure 15.
- Slip the belt between the friction wheel and drive disc. Remove and replace the belt. Reassemble following the instructions in reverse order.

NOTE: The support bracket must rest on the stop bolt after the new belt has been assembled.

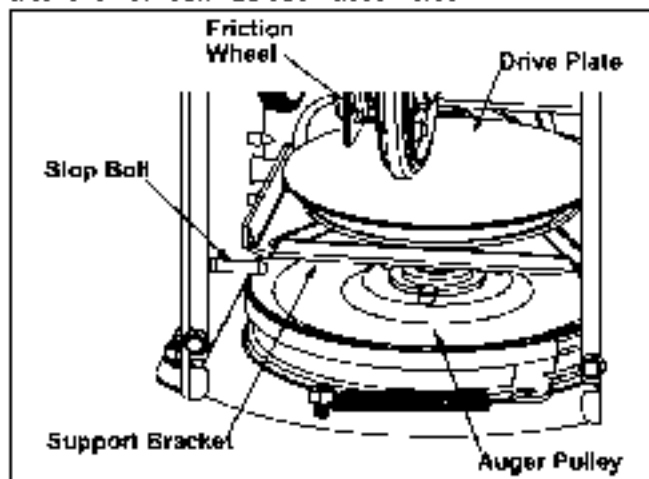

Figure 15

Replacing Friction Wheel Rubber

The rubber on the friction wheel is subject to wear and should be checked after 25 hours of operation, and periodically thereafter. Replace the friction wheel rubber if any signs of wear or cracking are found.

- Drain the gasoline from the snow thrower, or place a piece of plastic under the gas cap.
- Tip the snow thrower up and forward, so that it rests on the housing.
- Remove the six self-tapping screws from the frame cover underneath the snow thrower.

- Remove the click pin that secures the left wheel to the axle and slide the wheel from the axle.
- Remove the four screws securing the left drive cover to the frame. Remove the drive cover. See Figure 16.

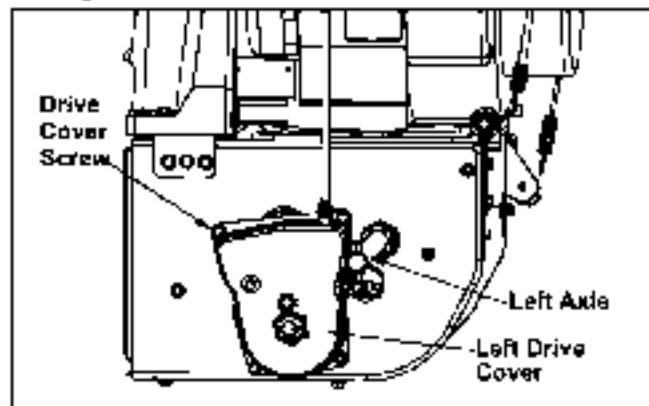

Figure 16

- Holding the friction wheel assembly, slide the hex shaft out of the left side of the frame. The spacer on the right side of the hex shaft will fall and the sprocket should remain hanging loose in the chain. See Figure 17.

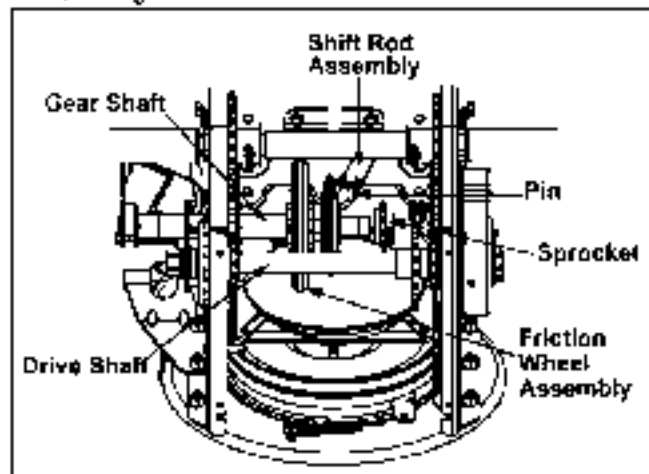

Figure 17

- Lift the friction wheel assembly out between the axle shaft and the drive shaft assemblies.
- Remove the six screws from the friction wheel assembly (three from each side). Remove the friction wheel rubber from between the friction wheel plates. See Figure 18.
- Reassemble the new friction wheel rubber to the friction wheel plates and hub, tightening the six screws in rotation and with equal force.
- Position the friction wheel assembly up onto the pin of the shift rod assembly, and slide the hex shaft through the friction wheel assembly. Reassemble in reverse order.

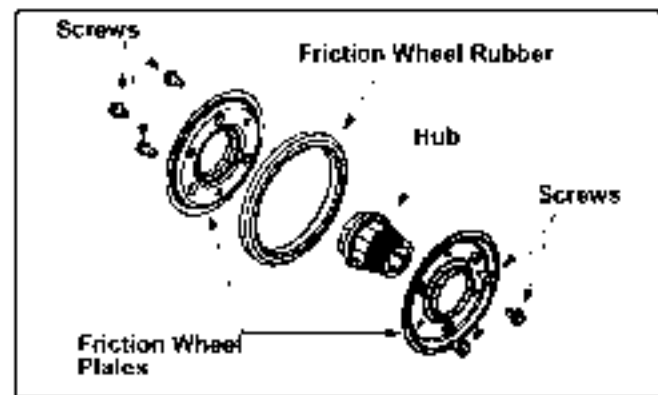

Figure 18

Off-season Storage



WARNING: Never store the machine or fuel container indoors where there is an open flame, spark, or pilot light such as on water heater, furnace, clothes dryer, or other gas appliance.



WARNING: Drain fuel into an approved container outdoors, away from an open flame. Allow engine to cool. Extinguish cigarettes, cigars, pipes, and other sources of ignition prior to draining fuel. Fuel left in engine for extended periods deteriorates and will cause starting problems.

If unit is to be stored over 30 days, prepare for storage as follows:

- Remove gasoline from carburetor and fuel tank to prevent gum deposits from forming on these parts and causing possible malfunction of engine.
- Run engine until fuel tank is empty and engine stops due to lack of fuel.
- Drain carburetor by pressing upward on bowl drain, located below the carburetor cover.

NOTE: Fuel stabilizer is an acceptable alternative in minimizing the formation of fuel gum deposits during storage. Do not drain carburetor if using fuel stabilizer.

- Wipe equipment with an oiled rag to prevent rust.
- Remove spark plug and pour one ounce of engine oil through spark plug hole into cylinder. Cover spark plug hole with rag. Crank engine several times to distribute oil. Replace spark plug.
- Follow the lubrication recommendations found in the Maintenance Section.
- Always store the snow thrower in a clean, dry area.

NOTE: When storing any type of power equipment in an unventilated or metal storage shed, care should be taken to rust proof the equipment. Using a light oil or silicone, coat the equipment, especially any chains, springs, bearings and cables.

SECTION 8: TROUBLE SHOOTING

Problem	Cause	Remedy
Engine fails to start	<ol style="list-style-type: none"> 1. Fuel tank empty or stale fuel. 2. Blocked fuel line. 3. Choke not in ON position 4. Faulty spark plug. 5. Safety key not in ignition switch on engine 6. Spark plug wire disconnected 7. Primer bulb not being used properly 8. Fuel shut off valve closed. 	<ol style="list-style-type: none"> 1. Fill tank with fresh gasoline 2. Clean the fuel line. 3. Move switch to ON position 4. Clean, adjust gap or replace. 5. Insert the key fully into the switch 6. Connect spark plug wire 7. Refer to the engine manual 8. Open fuel shut-off valve.
Engine runs erratic	<ol style="list-style-type: none"> 1. Unit running on CHOKE. 2. Blocked fuel line or stale fuel 3. Water or dirt in fuel system. 4. Carburetor out of adjustment 	<ol style="list-style-type: none"> 1. Move choke lever to OFF position 2. Clean fuel line. Fill tank with clean, fresh gasoline 3. Drain fuel tank and carburetor. Refill with fresh fuel. 4. Refer to the engine manual.
Loss of power	<ol style="list-style-type: none"> 1. Spark plug wire loose. 2. Gas cap vent hole plugged 3. Exhaust port plugged. 	<ol style="list-style-type: none"> 1. Connect and tighten spark plug wire 2. Remove ice and snow from gas cap. Be certain vent hole is clear 3. Refer to the engine manual.
Engine overheats	<ol style="list-style-type: none"> 1. Carburetor not adjusted properly 	<ol style="list-style-type: none"> 1. Refer to the engine manual or have the carburetor adjusted by an authorized engine service dealer.
Excessive vibration	<ol style="list-style-type: none"> 1. Loose parts or damaged auger 	<ol style="list-style-type: none"> 1. Stop engine immediately and disconnect spark plug wire. Tighten all bolts and nuts. If vibration continues, have unit serviced by an authorized service dealer.
Unit fails to propel itself	<ol style="list-style-type: none"> 1. Traction control cable in need of adjustment. 2. Drive belt loose or damaged. 	<ol style="list-style-type: none"> 1. Adjust traction control cable. Refer to Adjustment Section. 2. Replace drive belt. Refer to Servicing Section.
Unit fails to discharge snow	<ol style="list-style-type: none"> 1. Discharge chute clogged 2. Foreign object lodged in auger. 3. Auger control cable in need of adjustment. 4. Auger belt loose or damaged 5. Shear bolt(s) sheared. 	<ol style="list-style-type: none"> 1. Stop engine immediately and disconnect spark plug wire. Clean discharge chute and inside of auger housing. 2. Stop engine immediately and disconnect spark plug wire. Remove object from auger. 3. Refer to Final Adjustments in Assembly Section. 4. Refer to the Servicing Section 5. Replace shear bolt(s).
Electric chute fails to turn	<ol style="list-style-type: none"> 1. Loose electrical connections. 2. Blown Fuse. 	<ol style="list-style-type: none"> 1. Make sure all connections are tight and fully installed. 2. Replace with #5A fuse. The fuse is under handle panel near switch connector.
Electric chute turns in opposite direction of the switch	<ol style="list-style-type: none"> 1. The switch connector is installed backwards 	<ol style="list-style-type: none"> 1. Unplug the switch connector under the handle panel. Turn connector 180° and reconnect
Heated grips are not creating heat	<ol style="list-style-type: none"> 1. Loose electrical connections 2. Blown fuse 3. Faulty grip. If one heated grip fails, both grips will not function 	<ol style="list-style-type: none"> 1. Under the handle panel, check connections from the handles to the wiring harness. 2. Replace with #5A fuse. The fuse is under handle panel near switch connector. 3. Have the grips checked at an authorized service dealer

Notes

Models H5C3F & H5Q3G

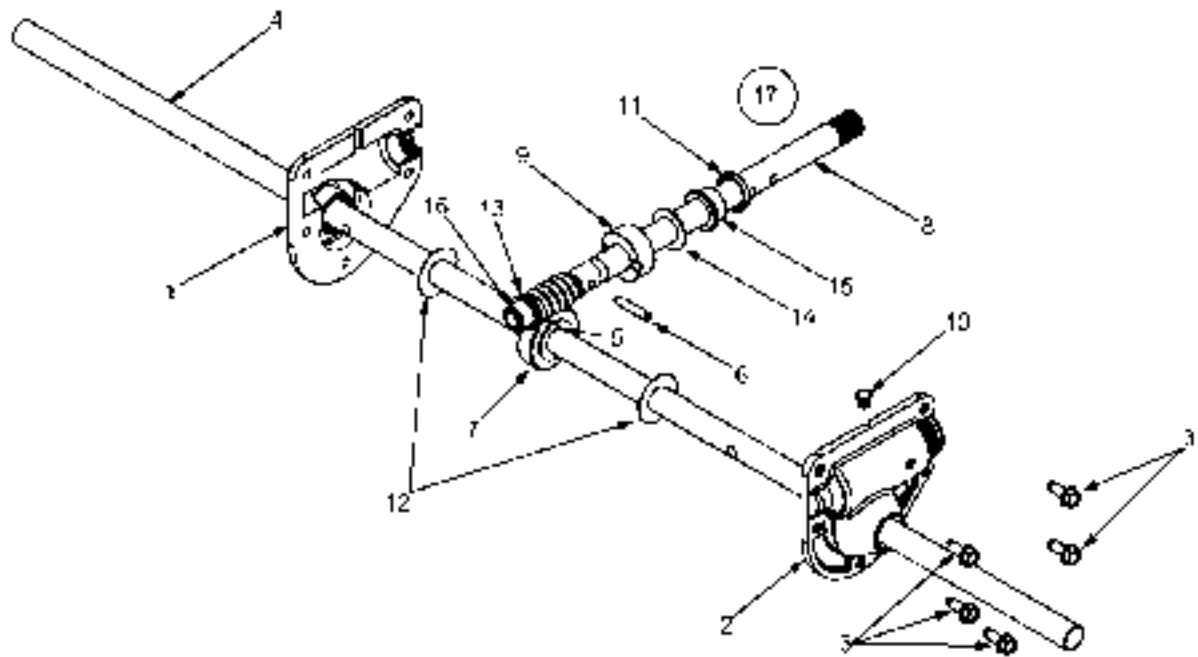

Ref. No.	Part No.	Part Description
1.	618-C123	RH Housing
2.	618-C124	LH Housing
3.	710-C647	Self Tapping Screw 1/4-20 x .75
4.	711-C909A	Sorral Axle 26' (H5C3F)
	711-C910A	Sorral Axle 26' (H5Q3G)
5.	714-C161	Hi-Pin Key 3/16 x 5/8
6.	715-C143	Spring Spiral Pin .25 x 1.25
7.	717-C528	Worm Gear 20-tooth
8.	717-C526	Worm Shaft
9.	718-C186	Thrust Collar
10.	721-C325	Grease Plug
11.	721-C327	Grease Seal
12.	736-C351	Flat Washer .76 x 1.5 x .030
13.	736-C369	Flat Washer .508 x 1.0 x .020
14.	736-C245	Flat Washer .76 x 1.5 x .060
15.	741-C667	Flange Bearing 75 x 1.0 x .59
16.	741-C663	Flange Bearing 50347 x .75 OD
17.	618-C121A	Gear Ass'y Complete 26' (H5C3F)
	618-C122A	Gear Ass'y Complete 26' (H5Q3G)

Models H5C3F & H5Q3G

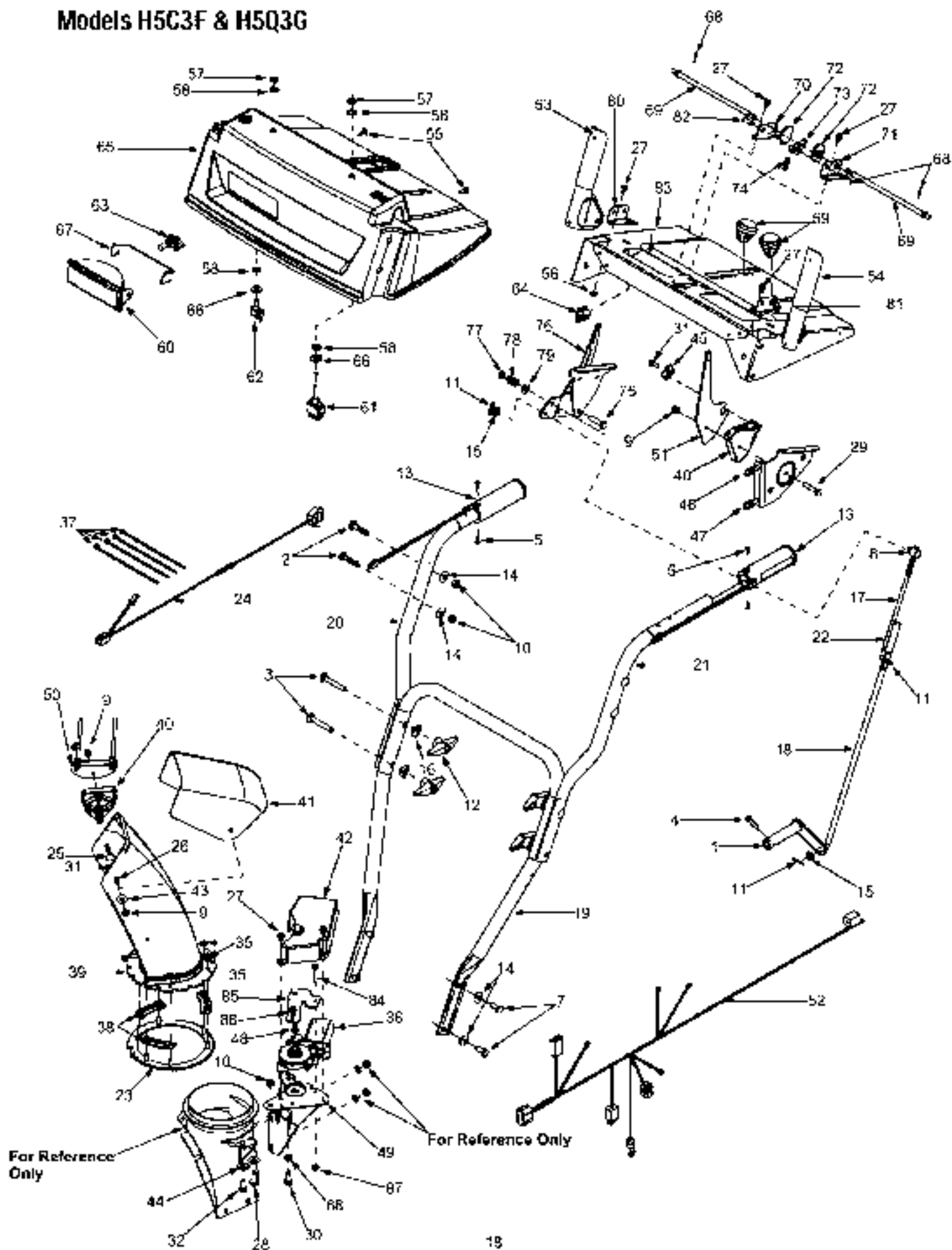

Models H5C3F & H5Q3G

Ref No.	Part No.	Part Description	Ref. No.	Part No.	Part Description
1.	684-008A	Shift Arm Assembly	47.	748-0901	Control Cable
2.	710-0458	Carnage Bolt 5/16-18 x 1.75"	48.	741-1140	Bushing
3.	710-0449	Carnage Bolt 5/16-18 x 2.25"	49.	784-5745	Minor Bracket
4.	710-0788	11 Screw 1/4-20 x 1"	50.	784-5594	Cable Bracket
5.	710-0837	U-Sunk Screw #10-16x 0.625"	51.	784-5004	Handle: Chute Tilt
7.	710-1880	Hex Screw 5/16-18 x .75"	52.	029-0936A	Harness Assembly: Upper
6.	711-0677	Ferrule	53.	084-0036A	Handle Assm bly RH
9.	712-0429	Hex Lock Nut 5/16-18	54.	084-0037B	Handle Assm bly LH
10.	712-3068	Hex Nut 5/16-18	55.	710-1003	Special Hex Screw
11.	714-0104	Cotter Pin	56.	712-0271	Hex Semi Nut 1/4-20
12.	720-0284	Handle Knob	57.	712-0893	Hex Nut
13.	725-1757	Heated Grip	58.	718-0398	Lock Ring, Toggle Switch
14.	736-0242	Belleville Washer	59.	720-0232	Self Knob
15.	736-0275	Hex Washer	60.	725-1872	Lamp Housing
16.	736-0451	Saddle Washer	61.	725-1755	Toggle Switch Double Throw
17.	747-0620A	Shift Rod: Upper	62.	725-1756	Toggle Switch Single Switch
18.	747-0621	Shift Rod: Lower	63.	725-1759	Halogen Lamp: 50W, 12V
19.	749-0051	Lower Handle	64.	728-0152	Mounting Clamp
20.	749-0052A	Upper Handle: L Style RH	65.	731-2275	Handle Panel
21.	749-0053A	Upper Handle: L Style LH	66.	738-0226	Flat Washer
22.	750-0663	Connector, Shift Rod	67.	747-1136	Headlight Relays
23.	618-0419	Gear Assembly, Ring	68.	714-0507	Cotter Pin, 3/32 x .75
24.	629-0837	Electric Harness, Lower	69.	747-0877	Gear Rod
25.	710-0262	Carnage Bolt, 5/16-18 x 1.5"	70.	784-5880	RH Handle Support Bracket
26.	710-0451	Carnage Bolt 5/16-18 x .750"	71.	784-5879	LH Handle Support Bracket
27.	710-0599	TT Screw 1/4-20 x 0.5"	72.	748-0382	Gear Handle Link
28.	710-0602	TT Screw 5/16-18 x 1"	73.	748-0363	Handle Lock Pawl
29.	710-0805	Hex Screw 5/16-18 x 1.5"	74.	732-0145	Compression Spring, .36 x 1.0
30.	710-0650	Hex Washer Screw 5/16-18 x .875	75.	710-0459A	Hex Cap Screw, 3/8-24 x 1.5
31.	710-0696	Hex Screw AB 1/4-14 x 0.625"	76.	784-5819A	Shift Handle
32.	710-3008	Hex Screw, 5/16-18 x .75"	77.	712-0116	Jam Nut, 3/8-24
35.	712-3027	Hex Flange Lock Nut	78.	732-0193	Control Spring, .38 x .6 x .88
36.	724-02499	Electric Motor: Chute Crank	79.	738-0105	Self Washer
37.	725-0157	Cable Tie	80.	784-5882	RH Handle Support Bracket
38.	731-0051A	Chute Flange Keeper	81.	784-5881	LH Handle Support Bracket
39.	731-1300A	Lower Chute	82.	711-0653	Clevis Pin
40.	731-1313C	Cable Guide: Chute Tilt	83.	684-0102	Handle Panel
41.	731-1320	Upper Chute	84.	710-0606	Hex Cap Screw 1/4-20 x 1.5
42.	731-2811	Motor Cover: Chute Rotation	85.	784-0411	Top Support Motor Bracket
43.	736-0159	5/16 Washer	86.	710-1652	Hex Washer Screw 1/4-20 x 1.5
44.	736-0242	Belleville Washer	87.	712-3027	Hex Flange Nut 1/4-20
45.	736-0506	Special Washer	88.	738-0119	Lock Washer 5/16
46.	746-0096	Control Cable			

Models H5C3F & H5Q3G

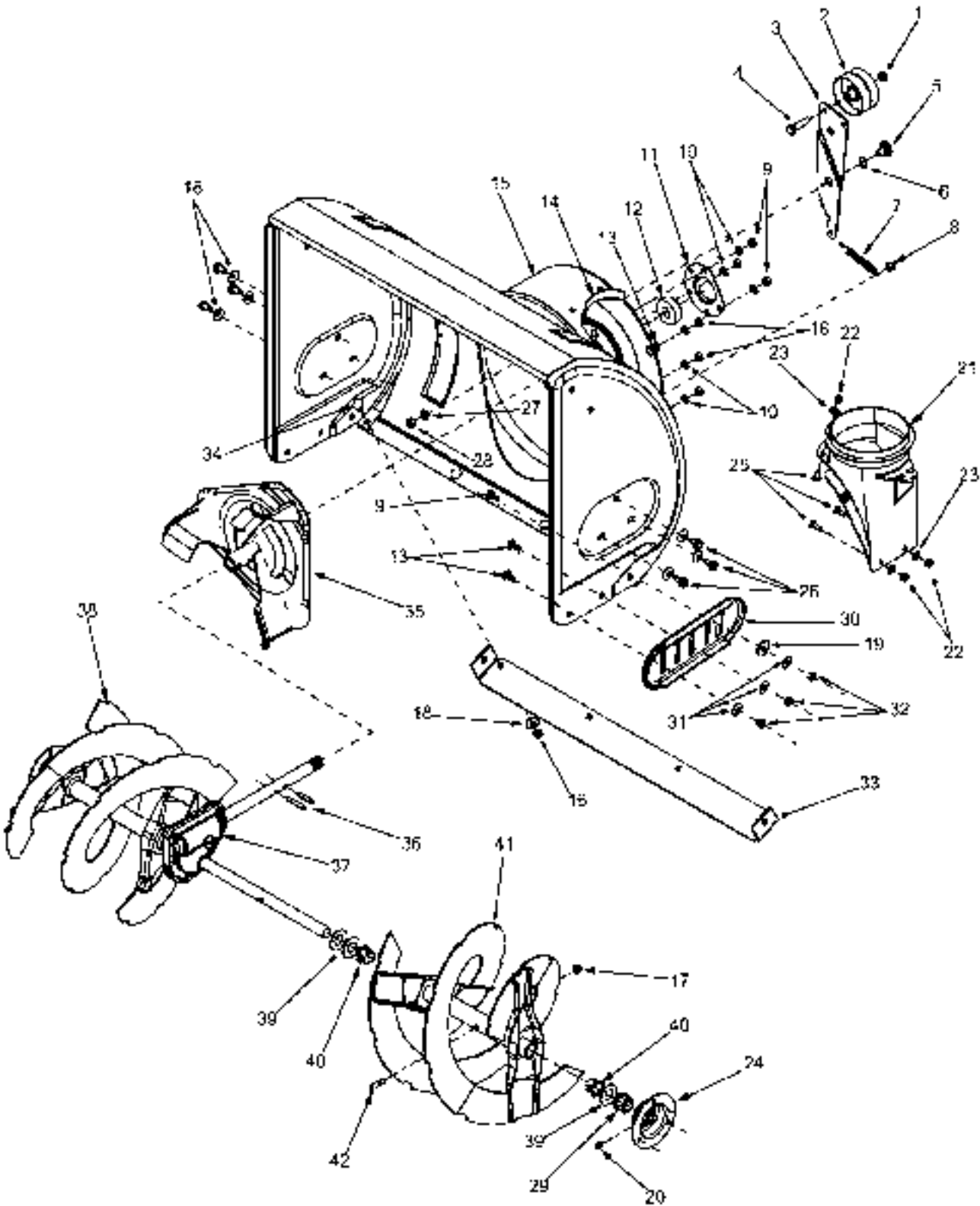

Models H5C3F & H5Q3G

Ref. No.	Part No.	Part Description	Ref. No.	Part No.	Part Description
1	712-0116	Lock Jam Nut 3/8-24	26	710-0604A	Hex Screw 5/16-18
2	756-0178	Flat Idler	27	736-0189	Lock Washer 3/8
3	784-5632A	Auger Idler Arm	28	712-0798	Hex Nut 3/8-16
4	710-0459A	Hex Cap Screw 3/8-24 x 1.50	29	741-0245	Hex Flange Bearing
5	738-0281	Shoulder Screw	30	784-5038B	Skid Shoe
6	736-0167	Wave Washer	31	736-0242	Bolt Washer
7	732-0611	Extension Spring	32	712-3010	Hex Nut 5/16-18
8	712-3068	Hex Nut 5/16-18	33	784-5578A	Shave Plate (H5C3F)
9	710-0276	Carriage Bolt, 5/16-18 x 1.00		784-5572A	Shave Plate (H5Q3G)
10	736-0119	Lock Washer 5/16	34	710-0260	Carriage Bolt 5/16-18 x .62
11	06931A	Housing	35	684-0065	Impeller Assembly
12	741-0369	Ball Bearing	36	715-0114	Pin
13	710-0451	Carriage Bull, 5/16-18 x .75	37	618-0121A	26" Gear Assy (H5C3F)
14	705-5226	Chute Reinforcement		618-0122A	28" Gear Assy (H5Q3G)
15	684-0040C	26" Housing Assy (H5C3F)	38	605-5192A	26" Spiral RH (H5C3F)
	684-0041C	28" Housing Assy (H5Q3G)		605-5196A	28" Spiral RH (H5Q3G)
16	712-3010	Hex Nut 5/16-18	39	736-0188	Flat Washer
17	712-0429	Lock Nut 5/16-18	40	741-0483A	Flange Bushing
18	736-0242	Bellville Washer	41	605-5183A	26" Spiral LH (H5C3F)
19	736-0231	Flat Wshr. 3/4ID x 1.125 OD		605-5187A	28" Spiral LH (H5Q3G)
20	737-3000	Grease Fitting, 3/10" Drive	42	710-0890A	Shear Bolt 5/16-18 x 1.5
21	731-1379C	Chute Adapter		777120711	Label Handle Panel (L)
22	712-0324	Hex Lock Nut 1/4-20		777120722	Label Handle Panel (R)
23	736-0463	Flat Washer		777S30514	Label Fixating Danger
24	754-5618	Bearing Housing		777S30611	Label Chute Danger
25	710-0703	Carriage Screw 1/4-20 x .75			

NOTE: For painted parts, please refer to the list of color codes below. Please add the applicable color code, wherever needed, to the part number to order a replacement part. For instance, if a part numbered 700-sextets is painted Yard-Man Green, the part number to order would be 700-sextets-0665.

Yard-Man Green 0665

Yard-Man Yellow 0674

Powder Black 0637

Models H5C3F & H5Q3G

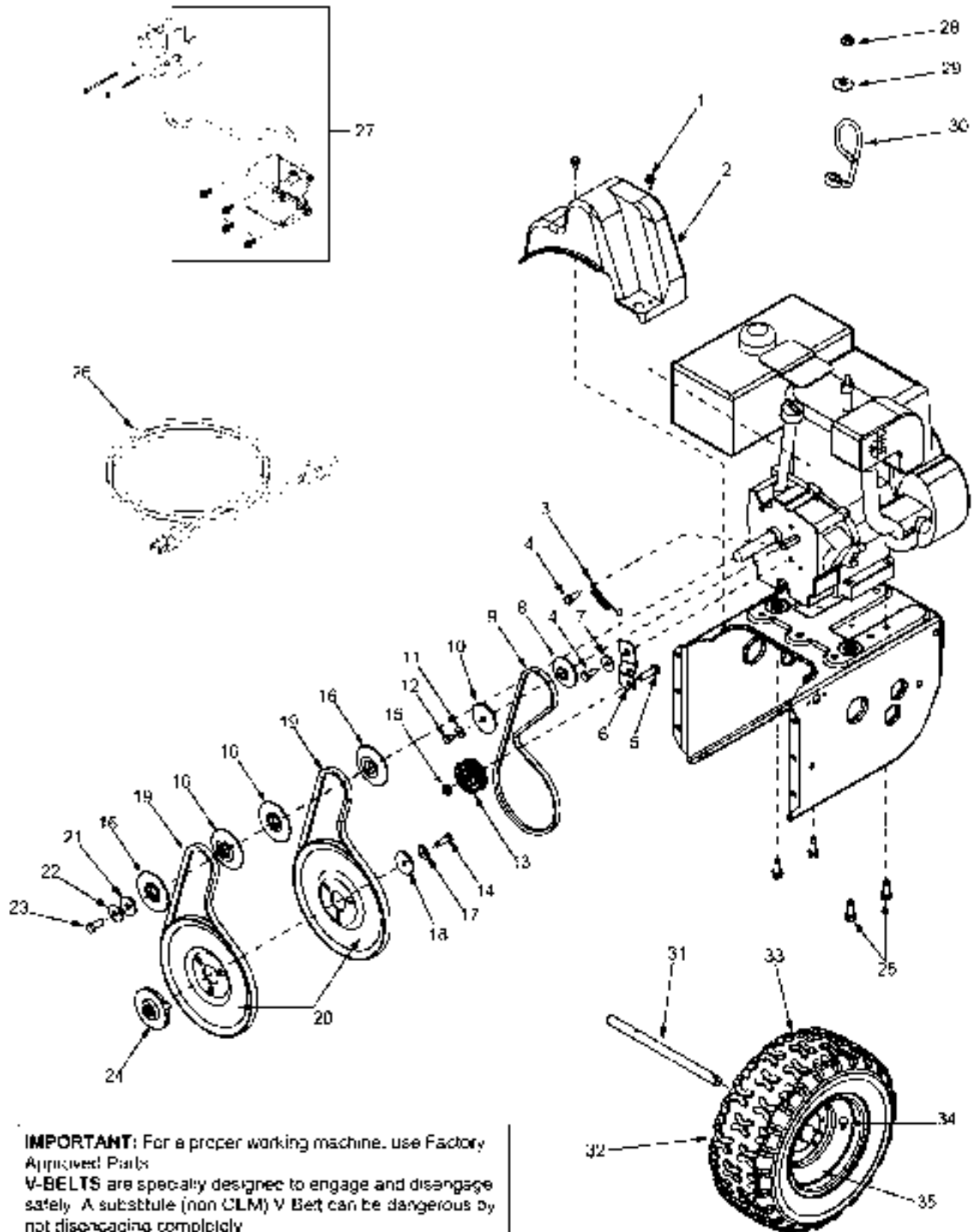

IMPORTANT: For a proper working machine, use Factory Approved Parts
V-BELTS are specially designed to engage and disengage safely. A substitute (non CLM) V Belt can be dangerous by not disengaging completely

Models H5C3F & H5Q3G

Ref. No.	Part No.	Part Description
1.	710-1652	Hex Washer Screw 1/4-20 x .625
2.	731-1321	Beil Cover
3.	732-0710	Extension Spring
4.	710-0627	Hex Screw 5/16-24 x .75
5.	710-3005	Hex Cap Screw 3/8-16 x 1.25
6.	05995A	Drive Clutch Idler Bracket
7.	748-0234	Shoulder Spacer
8.	750-0987	Pulley Half
9.	754-0348	V-Bolt
10.	750-0988	Pulley Half
11.	730-0270	Beil Washer
12.	710-0230	Hex Cap Screw 1/4-28 x .50
13.	753-0313	Flat Idler
14.	710-1245A	Lock Hex Cap Screw 5/16-24
15.	712-0181	Lock Jam Nut 3/8-16
16.	756-0569	Pulley Half
17.	736-0242	Beil Washer
18.	730-0505	Flat Washer
19.	754-0430A	Bolt
20.	753-0907	Auger Pulley
21.	730-0247	Flat Washer 3/8 x 1.25 OD
22.	730-0331	Beil Washer
23.	710-0098	Hex Cap Screw 3/8-24
24.	748-0360	Adapter Pulley
25.	710-0654A	Hex Screw 3/8-16 x 1.0
26.	629-0071	Extension Cord
27.	DFM-390-987	Electric Start Kit
28.	712-0324	Lock Nut, 1/4-20
29.	736-0173	Flat Washer, 28 x .74 x .063
30.	732-0705	Cable Guide
31.	738-0994A	Axle .75 dia x 12.2" Lg
32.	734-1709	Wheel Ass'y Comp 16.5" x 4.8"
33.	734-1530	Tire 16.5" x 4.8" x 4"
34.	734-0255	Tubeless Air Valve
35.	734-1708	Rim Assembly

Models H5C3F & H5Q3G

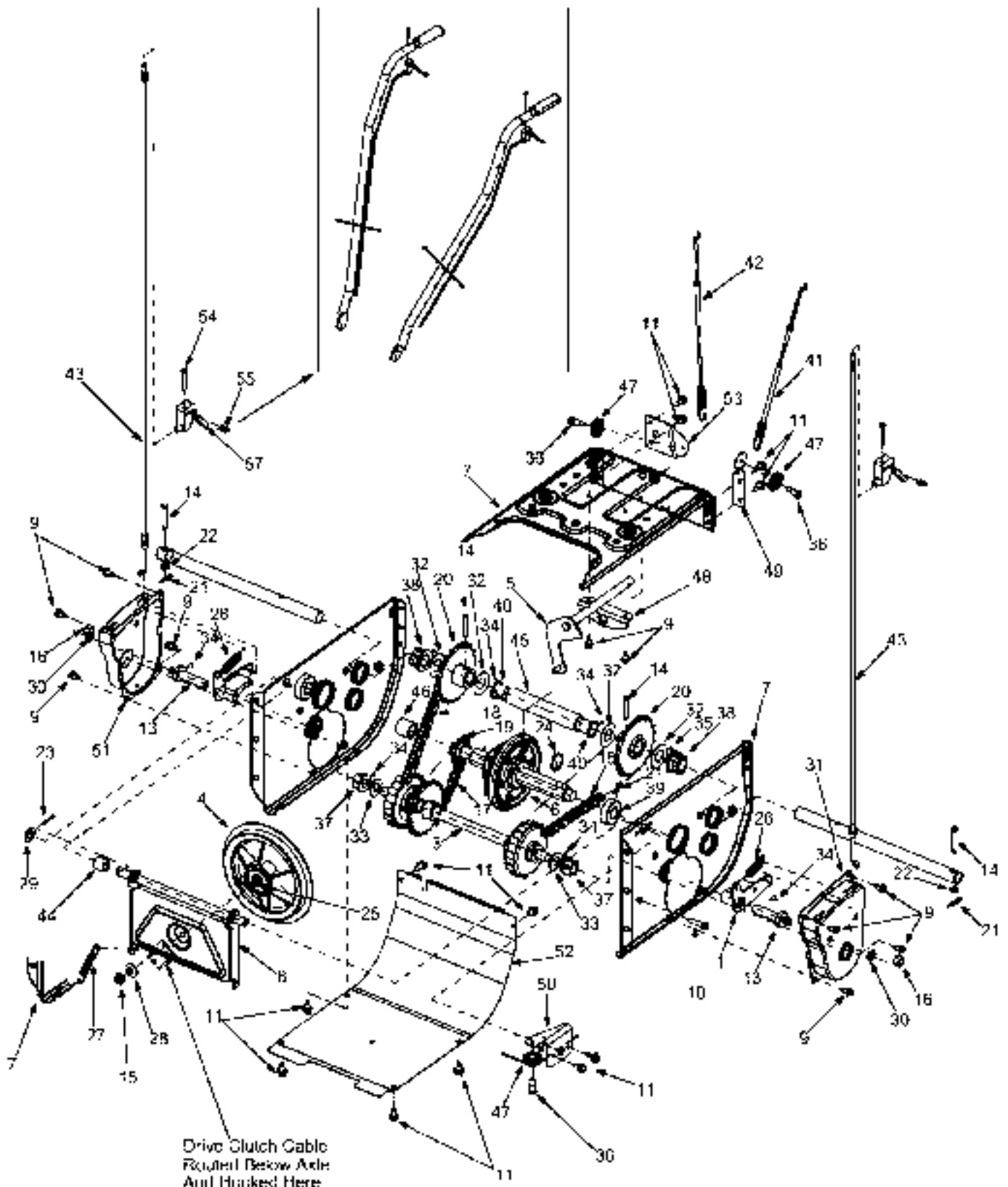

Models H5C3F & H5Q3G

Ref. No.	Part No.	Part Description	Ref. No.	Part No.	Part Description
1.	618-0043	Dogg Assembly: RH	30	736-0169	Lock Washer
2.	618-0044	Dogg Assembly: LH	31	784-5740	Drive Cover: LH
3.	618-0575	Shift Assembly Steerable Drive	32	736-0351	Flat Washer
4.	656-0012A	Friction Wheel Disc Assy	33	736-0676	Flat Washer
5.	684-0014B	Shift Rod Assembly	34	737-0170	Lubricant: 6 in 1
6.	684-0042C	Bearing	35	737-0316	Grease
7.	784-5731A	Transmission Frame Assembly	36	738-0974	Shoulder Screw
8	684-0131A	Support Bracket Assembly	37	741-1111	Hex Flange Bearing
9.	710-0509	Hex Washer Screw 1/4-20 x .5	38	741-0596	Hex Flange Bearing
10	710-0809	Hex Washer Screw 1/4-20 x 1	39	741-0900	Ball Bearing
11	710-1652	Hex Screw 1/4-20 x .025"	40	741-0701	Flange Bushing
12	711-1267	Drive Shaft	41	746-0897	Auger Clutch Cable
13.	711-1268	Actuator Shaft	42	746-0896	Drive Clutch Cable
14	711-1364	Pin	43	746-0956	Steering Cable
15	712-0711	Jam Nut 3/8-24 Gr.8	44	748-0190	Spacer
16	712-3017	Hex Nut 3/8-16	45	750-1161A	Axle Support Tube
17	713-0233	Chain	46	750-1162	Spacer
18	713-0374	Chain	47	756-0625	Roller Cable
19	713-0413	Sprocket: 10T	48	784-5560	Shift Bracket
20	713-0472	Sprocket	49	784-5687A	Auger Cable Guide Bracket
21	714-0104	Cotter Pin	50	784-5689A	Front Support Guide Bracket
22	736-0142	Flat Washer	51	784-5730A	Drive Cover: LH
23	714-0474	Cotter Pin	52	784-5732	Frame Cover
24	716-0102	Snap Ring	53	784-5733	Roller Bracket: Drive Cable
25	721-0263	Adhesive: Loctite	54	710-1233	Oval C-Sunk Machine Screw
26	732-0209	Extension Spring	55	712-0127	Weld Nut
27	732-0264	Extension Spring	56	725-0157	Cable Tie
28	736-0105	Bell Washer	57	746-0950	Trim Trigger
29	736-0160	Flat Washer			

NOTE: For painted parts, please refer to the list of color codes below. Please add the applicable color code, wherever needed, to the part number to order a replacement part. For instance, if a part numbered 700-sextets is painted Yard-Man Green, the part number to order would be 700-sextets-0665.

Yard-Man Green 0665

Yard-Man Yellow 0674

Powder Black 0637

MANUFACTURER'S LIMITED WARRANTY FOR:



The limited warranty set forth below is given by MTD PRODUCTS INC. ("MTD") with respect to new merchandise purchased and used in the United States, its possessions and territories.

MTD warrants this product against defects in material and workmanship for a period of two (2) years commencing on the date of original purchase and will, at its option, repair or replace, free of charge, any part found to be defective in material or workmanship. This limited warranty shall only apply if this product has been operated and maintained in accordance with the Operator's Manual furnished with the product and has not been subject to misuse, abuse, commercial use, neglect, accident, improper maintenance, alteration, vandalism, theft, fire, water or damage because of other peril or natural disaster. Damage resulting from the installation or use of any accessory or attachment not approved by MTD Products Inc. for use with the product(s) covered by this manual will void your warranty as to any resulting damages.

Normal wear parts or components thereof are subject to separate terms as follows: All normal wear part or component failures will be covered on the product for a period of 90 days regardless of cause. After 90 days, but within the two year period, normal wear part failures will be covered ONLY if caused by defects in material or workmanship of OTHER component parts. Normal wear parts and components include, but are not limited to, belts, blades, blade adapters, grass bags, rider cock woods, seats, snow thrower skid shoes, shave plates and tines. Batteries are covered by a 90-day limited replacement warranty.

HOW TO OBTAIN SERVICE. Warranty service is available, WITH PROOF OF PURCHASE THROUGH YOUR LOCAL AUTHORIZED SERVICE DEALER. To locate the dealer in your area, please check for a listing in the Yellow Pages or contact the Customer Service Department of MTD PRODUCTS INC. by calling 1-800-800-7310 or writing to P.O. Box 368022, Cleveland, Ohio 44136-9722.

This limited warranty does not provide coverage in the following cases:

- The engine or component parts thereof. These items carry a separate manufacturer's warranty. Please refer to the applicable manufacturer's warranty on these items.
- Log splitter pumps, valves and cylinders have a separate one year warranty.

- Routine maintenance items such as lubricants, filters, blade sharpening and tune-ups, or adjustments such as brake adjustments, clutch adjustments or deck adjustments; and normal deterioration of the exterior finish due to use or exposure.
- MTD does not extend any warranty for products sold or exported outside of the United States of America, its possessions and territories, except those sold through MTD's authorized channels of export distribution.

No implied warranty, including any implied warranty of merchantability or fitness for a particular purpose, applies after the applicable period of express written warranty above as to the parts as identified. No other express warranty or guaranty, whether written or oral, except as mentioned above, given by any person or entity, including a dealer or retailer, with respect to any product shall bind MTD. During the period of the Warranty, the exclusive remedy is repair or replacement of the product as set forth above. (Some states do not allow limitations on how long an implied warranty lasts, so the above limitation may not apply to you.)

The provisions as set forth in this Warranty provide the sole and exclusive remedy arising from the sales. MTD shall not be liable for incidental or consequential loss or damages including, without limitation, expenses incurred for substitute or replacement lawn care services, for transportation or for related expenses, or for rental expenses to temporarily replace a warranted product. (Some states do not allow the exclusion or limitation of incidental or consequential damages, so the above exclusion or limitation may not apply to you.)

In no event shall recovery of any kind be greater than the amount of the purchase price of the product sold. Alteration of the safety features of the product shall void this Warranty. You assume the risk and liability for loss, damage, or injury to you and your property and/or to others and their property arising out of the use or misuse or inability to use the product.

This limited warranty shall not extend to anyone other than the original purchaser, original lessee or the person for whom it was purchased as a gift.

How State Law Relates to this Warranty: This limited warranty gives you specific legal rights, and you may also have other rights which vary from state to state.