

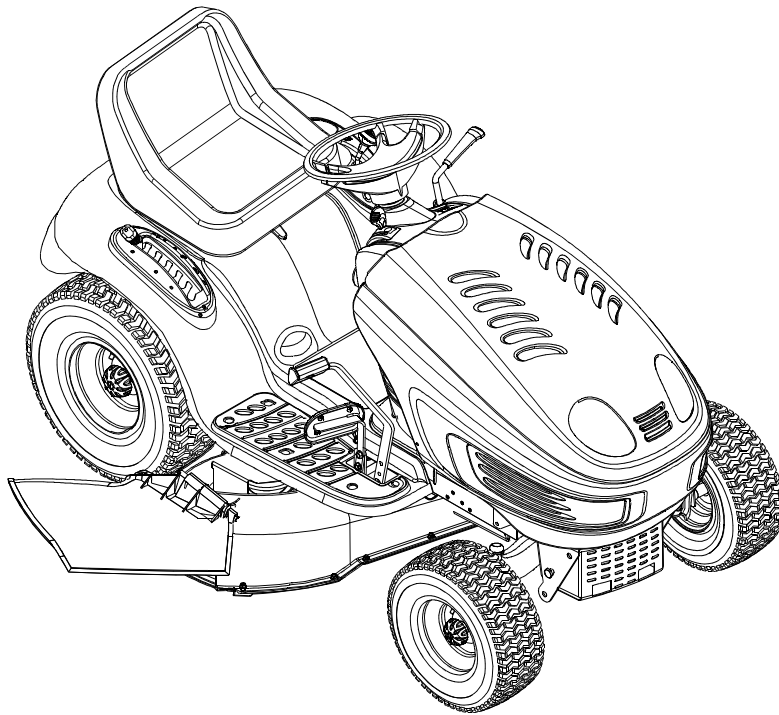

Operator's Manual



Hydrostatic Lawn Tractor

Model X614G

IMPORTANT: Read safety rules and instructions carefully before operating equipment.

Warning: This unit is equipped with an internal combustion engine and should not be used on or near any unimproved forest-covered, brush-covered or grass-covered land unless the engine's exhaust system is equipped with a spark arrester meeting applicable local or state laws (if any). If a spark arrester is used, it should be maintained in effective working order by the operator. In the State of California the above is required by law (Section 4442 of the California Public Resources Code). Other states may have similar laws. Federal laws apply on federal lands. A spark arrester for the muffler is available through your nearest engine authorized service dealer or contact the service department, P.O. Box 361131 Cleveland, Ohio 44136-0019.

MTD LLC, P.O. BOX 361131 CLEVELAND, OHIO 44136-0019

PRINTED IN U.S.A.

FORM NO. 769-00581
(11/2002)

TABLE OF CONTENTS

Content	Page
Important Safe Operation Practices.....	3
Slope Gauge.....	7
Tractor Set-up.....	8
Know Your Lawn Tractor	9
Operating Your Lawn Tractor	12
Making Adjustments	16
Maintaining Your Lawn Tractor.....	18
Service	19
Off-Season Storage.....	23
Attachments & Accessories	23
Troubleshooting.....	24
Parts List.....	25

FINDING MODEL NUMBER

This Operator's Manual is an important part of your new lawn tractor. It will help you assemble, prepare and maintain the unit for best performance. Please read and understand what it says.



Before you start assembling your new equipment, please locate the model plate on the equipment and copy the information from it in the space provided below. The information on the model plate is very important if you need help from our Customer Support Department or an authorized dealer.

- You can locate the model number by looking beneath the seat. A sample model plate is explained below. For future reference, please copy model number and serial number of the equipment in the space below.

_____	_____
(Model Number)	(Serial Number)
	
www.yardman.com	
MTD, LLC P. O. BOX 361131 CLEVELAND, OH 44136 330-220-4683 800-800-7310	

Copy the model number here: _____

Copy the serial number here: _____

ENGINE INFORMATION

The engine manufacturer is responsible for all engine-related issues with regards to performance, power-rating, specifications, warranty and service. Please refer to the engine manufacturer's Owner's/Operator's Manual packed separately with your unit for more information.

CALLING CUSTOMER SUPPORT

If you have difficulty assembling this product or have any questions regarding the controls, operation or maintenance of this unit, please call the Customer Support Department.



Call 1- (330) 220-4MTD (4683) or 1- (800)-800-7310 to reach a Customer Support representative. Please have your unit's model number and serial number ready when you call. See previous section to locate this information. You will be asked to enter the serial number in order to process your call.

For more details about your unit, visit our website at www.yardman.com

SECTION 1: IMPORTANT SAFE OPERATION PRACTICES



WARNING: This symbol points out important safety instructions which, if not followed, could endanger the personal safety and/or property of yourself and others. Read and follow all instructions in this manual before attempting to operate this machine. Failure to comply with these instructions may result in personal injury. When you see this symbol—heed its warning.



WARNING: The Battery and Engine Exhaust contains chemicals known to the State of California to cause cancer, birth defects or other reproductive harm. The battery and posts contain lead; wash hands after handling.



WARNING: This machine was built to be operated according to the rules for safe operation in this manual. As with any type of power equipment, carelessness or error on the part of the operator can result in serious injury. This machine is capable of amputating hands and feet and throwing objects. Failure to observe the following safety instructions could result in serious injury or death.

General Operation

1. Read, understand, and follow all instructions on the machine and in the manual(s) before attempting to assemble and operate. Keep this manual in a safe place for future and regular reference and for ordering replacement parts.
2. Be familiar with all controls and their proper operation. Know how to stop the machine and disengage them quickly.
3. Never allow children under 14 years old to operate this machine. Children 14 years old and over should read and understand the operation instructions and safety rules in this manual and should be trained and supervised by a parent.
4. Never allow adults to operate this machine without proper instruction.
5. To help avoid blade contact or a thrown object injury, keep bystanders, helpers, children and pets at least 75 feet from the machine while it is in operation. Stop machine if anyone enters the area.
6. Thoroughly inspect the area where the equipment is to be used. Remove all stones, sticks, wire, bones, toys, and other foreign objects which could be picked up and thrown by the blade(s). Thrown objects can cause serious personal injury.
7. Plan your mowing pattern to avoid discharge of material toward roads, sidewalks, bystanders and the like. Also, avoid discharging material against a wall or obstruction which may cause discharged material to ricochet back toward the operator.
8. Always wear safety glasses or safety goggles during operation and while performing an adjustment or repair to protect your eyes. Thrown objects which ricochet can cause serious injury to the eyes.
9. Wear sturdy, rough-soled work shoes and close-fitting slacks and shirts. Loose fitting clothes and jewelry can be caught in movable parts. Never operate this machine in bare feet or sandals.
10. Be aware of the mower and attachment discharge direction and do not point it at anyone. Do not operate the mower without the discharge cover or entire grass catcher in its proper place.
11. Do not put hands or feet near rotating parts or under the cutting deck. Contact with the blade(s) can amputate hands and feet.
12. A missing or damaged discharge cover can cause blade contact or thrown object injuries.
13. Stop the blade(s) when crossing gravel drives, walks, or roads and while not cutting grass.
14. Watch for traffic when operating near or crossing roadways. This machine is not intended for use on any public roadway.
15. Do not operate the machine while under the influence of alcohol or drugs.
16. Mow only in daylight or good artificial light.
17. Never carry passengers.
18. Disengage blade(s) before shifting into reverse. Back up slowly. Always look down and behind before and while backing to avoid a back-over accident.
19. Slow down before turning. Operate the machine smoothly. Avoid erratic operation and excessive speed.
20. Disengage blade(s), set parking brake, stop engine and wait until the blade(s) come to a complete stop before removing grass catcher, emptying grass, unclogging chute, removing any grass or debris, or making any adjustments.
21. Never leave a running machine unattended. Always turn off blade(s), place transmission in neutral, set parking brake, stop engine and remove key before dismounting.
22. Use extra care when loading or unloading the machine into a trailer or truck. This unit should not be driven up or down ramp(s), because the unit could tip over, causing serious personal injury. The unit must be pushed manually on ramp(s) to load or unload properly.

23. Muffler and engine become hot and can cause a burn. Do not touch.
24. Check overhead clearances carefully before driving under low tree branches, wires, door openings etc., where the operator may be struck or pulled from the unit, which could result in serious injury.
25. Disengage all attachment clutches, depress the brake pedal completely and shift into neutral before attempting to start engine.
26. Your machine is designed to cut normal residential grass of a height no more than 10". Do not attempt to mow through unusually tall, dry grass (e.g., pasture) or piles of dry leaves. Dry grass or leaves may contact the engine exhaust and/or build up on the mower deck presenting a potential fire hazard.
27. Use only accessories and attachments approved for this machine by the machine manufacturer. Read, understand and follow all instructions provided with the accessory or attachment.
28. Data indicates that operators, age 60 years and above, are involved in a large percentage of tractor-related injuries. These operators should evaluate their ability to operate the tractor safely enough to protect themselves and others from serious injury.
29. If situations occur which are not covered in this manual, use care and good judgment. Contact your Yard-Man dealer for assistance.

Slope Operation

Slopes are a major factor related to loss of control and tip-over accidents which can result in severe injury or death. All slopes require extra caution. If you cannot back up the slope or if you feel uneasy, do not mow it.

For your safety, use the slope gauge included as part of this manual to measure slopes before operating this unit on a sloped or hilly area. If the slope is greater than 15 degrees as shown on the slope gauge, do not operate this unit on that area.

Do:

1. Mow up and down slopes, not across. Exercise extreme caution when changing direction on slopes.
2. Watch for holes, ruts, bumps, rocks, or other hidden objects. Uneven terrain could overturn the machine. Tall grass can hide obstacles.
3. Use slow speed. Choose a low enough speed setting so that you will not have to stop or shift while on the slope. Tires may lose traction on slopes even though the brakes are functioning properly. Always keep machine in gear when going down slopes to take advantage of engine braking action.
4. Follow the manufacturer's recommendations for wheel weights or counterweights to improve stability of the machine. Use extra care with grass catchers or other attachments. These can change stability of the machine.

5. Keep all movement on the slopes slow and gradual. Do not make sudden changes in speed or direction. Rapid engagement or braking could cause the front of the machine to lift and rapidly flip over backwards which could cause serious injury.
6. Avoid starting or stopping on a slope. If tires lose traction, disengage the blade(s) and proceed slowly straight down the slope.

Do Not:

1. Do not turn on slopes unless necessary; then, turn slowly and gradually downhill, if possible.
2. Do not mow near drop-offs, ditches or embankments. The mower could suddenly turn over if a wheel is over the edge of a cliff, ditch, or if an edge caves in.
3. Do not try to stabilize the machine by putting your foot on the ground.
4. Do not use a grass catcher on steep slopes.
5. Do not mow on wet grass. Reduced traction could cause sliding.
6. Do not shift to neutral and coast downhill. Over-speeding may cause the operator to lose control of the machine resulting in serious injury or death.
7. Do not tow heavy pull behind attachments (e.g. loaded dump cart, lawn roller, etc.) on slopes greater than 5 degrees. When going down hill, the extra weight tends to push the tractor and may cause you to lose control. (e.g. tractor may speed up, braking and steering ability are reduced, attachment may jack-knife and cause tractor to overturn).

Children

1. Tragic accidents can occur if the operator is not alert to the presence of children. Children are often attracted to the machine and the mowing activity. They do not understand the dangers. Never assume that children will remain where you last saw them.
 - a. Keep children out of the mowing area and in watchful care of a responsible adult other than the operator.
 - b. Be alert and turn machine off if a child enters the area.
 - c. Before and while backing, look behind and down for small children.
 - d. Never carry children, even with the blade(s) shut off. They may fall off and be seriously injured or interfere with safe machine operation.
 - e. Use extreme care when approaching blind corners, doorways, shrubs, trees or other objects that may block your vision of a child who may run into the machine.
 - f. Disengage the cutting blade(s) before shifting in reverse. The "No-Cut-In Reverse"

feature emphasises not to cut in reverse and to avoid back-over accidents; do not defeat it.

- g. Keep children away from hot or running engines. They can suffer burns from a hot muffler.
 - h. Remove key when machine is unattended to prevent unauthorized operation.
9. Never allow children under 14 years old to operate the machine. Children 14 years old and over should read and understand the operation instructions and safety rules in this manual and should be trained and supervised by a parent.

Towing

1. Tow only with a machine that has a hitch designed for towing. Do not attach towed equipment except at the hitch point.
2. Follow the manufacturers recommendation for weight limits for towed equipment and towing on slopes.
3. Never allow children or others in or on towed equipment.
4. On slopes, the weight of the towed equipment may cause loss of traction and loss of control.
5. Travel slowly and allow extra distance to stop.
6. Do not shift to neutral and coast downhill.

Service

Safe Handling Of Gasoline

1. To avoid personal injury or property damage use extreme care in handling gasoline. Gasoline is extremely flammable and the vapors are explosive. Serious personal injury can occur when gasoline is spilled on yourself or your clothes which can ignite. Wash your skin and change clothes immediately.
 - a. Use only an approved gasoline container.
 - b. Never fill containers inside a vehicle or on a truck or trailer bed with a plastic liner. Always place containers on the ground away from your vehicle before filling.
 - c. When practical, remove gas-powered equipment from the truck or trailer and refuel it on the ground. If this is not possible, then refuel such equipment on a trailer with a portable container, rather than from a gasoline dispenser nozzle.
 - d. Keep the nozzle in contact with the rim of the fuel tank or container opening at all times until fueling is complete. Do not use a nozzle lock-open device.
 - e. Extinguish all cigarettes, cigars, pipes and other sources of ignition.
 - f. Never fuel machine indoors.
 - g. Never remove gas cap or add fuel while the engine is hot or running. Allow engine to cool at least two minutes before refueling.

- h. Never over fill fuel tank. Fill tank to no more than ½ inch below bottom of filler neck to allow space for fuel expansion.
- i. Replace gasoline cap and tighten securely.
- j. If gasoline is spilled, wipe it off the engine and equipment. Move unit to another area. Wait 5 minutes before starting the engine.
- k. To reduce fire hazards, keep machine free of grass, leaves, or other debris build-up. Clean up oil or fuel spillage and remove any fuel soaked debris.
- l. Never store the machine or fuel container inside where there is an open flame, spark or pilot light as on a water heater, space heater, furnace, clothes dryer or other gas appliances.
- m. Allow a machine to cool at least 5 minutes before storing.

General Service

1. Never run an engine indoors or in a poorly ventilated area. Engine exhaust contains carbon monoxide, an odorless, and deadly gas.
2. Before cleaning, repairing, or inspecting, make certain the blade(s) and all moving parts have stopped. Disconnect the spark plug wire and ground against the engine to prevent unintended starting.
3. Periodically check to make sure the blades come to complete stop within approximately (5) five seconds after operating the blade disengagement control. If the blades do not stop within the this time frame, your unit should be serviced professionally by an authorized dealer.
4. Check brake operation frequently as it is subjected to wear during normal operation. Adjust and service as required.
5. Check the blade(s) and engine mounting bolts at frequent intervals for proper tightness. Also, visually inspect blade(s) for damage (e.g., excessive wear, bent, cracked). Replace the blade(s) with the original equipment manufacturer's (O.E.M.) blade(s) only, listed in this manual. "Use of parts which do not meet the original equipment specifications may lead to improper performance and compromise safety!"
6. Mower blades are sharp. Wrap the blade or wear gloves, and use extra caution when servicing them.
7. Keep all nuts, bolts, and screws tight to be sure the equipment is in safe working condition.
8. Never tamper with the safety interlock system or other safety devices. Check their proper operation regularly.
9. After striking a foreign object, stop the engine, disconnect the spark plug wire(s) and ground against the engine. Thoroughly inspect the machine for any damage. Repair the damage before starting and operating.

10. Never attempt to make adjustments or repairs to the machine while the engine is running.
11. Grass catcher components and the discharge cover are subject to wear and damage which could expose moving parts or allow objects to be thrown. For safety protection, frequently check components and replace immediately with original equipment manufacturer's (O.E.M.) parts only, listed in this manual. "Use of parts which do not meet the original equipment specifications may lead to improper performance and compromise safety!"
12. Do not change the engine governor settings or over-speed the engine. The governor controls the

- maximum safe operating speed of the engine.
13. Maintain or replace safety and instruction labels, as necessary.
14. Observe proper disposal laws and regulations for gas, oil, etc. to protect the environment.

Your Responsibility

Restrict the use of this power machine to persons who read, understand and follow the warnings and instructions in this manual and on the machine.



Label shape may vary by tractor model. Label contents do not vary.

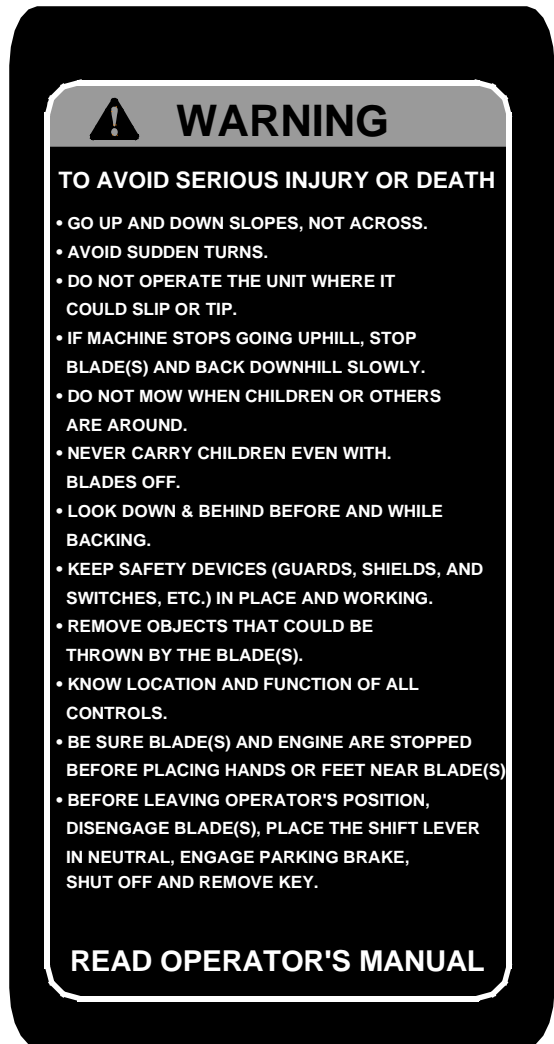

SECTION 2: SLOPE GAUGE

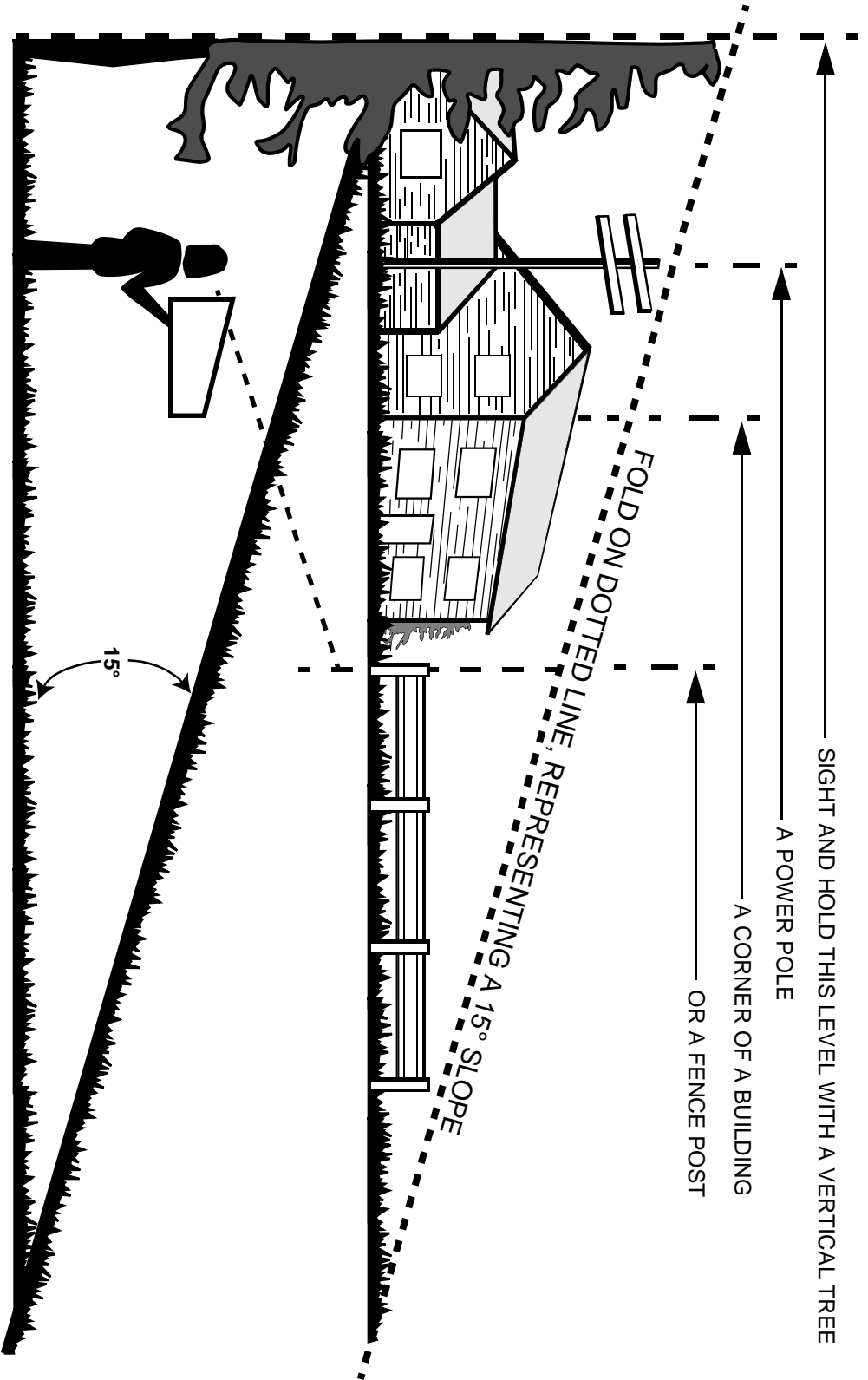

Do not mow on inclines with a slope in excess of 15 degrees (a rise of approximately 2-1/2 feet every 10 feet). A riding mower could overturn and cause serious injury. If operating a walk-behind mower on such a slope, it is extremely difficult to maintain your footing and you could slip, resulting in serious injury. Operate RIDING mowers up and down slopes, never across the face of slopes.

SECTION 3: SETTING UP YOUR TRACTOR

NOTE: Reference to *RIGHT* or *LEFT* side of the tractor in this manual is observed from operator's position.

Attaching the Battery Cables

NOTE: The positive battery terminal is marked Pos. (+). The negative battery terminal is marked Neg. (-).

- The positive cable (heavy red wire) is secured to the positive battery terminal (+) with a carriage screw and hex nut at the factory. Make certain that the rubber boot covers the terminal to help protect it from corrosion.
- Remove the shoulder bolt and wing nut from the negative cable.
- Remove the black plastic cover, if present, from the negative battery terminal and attach the negative cable (heavy black wire) to the negative battery terminal (-) with the bolt and the wing nut.
- Make certain the hold-down strap is in position over the battery, securing it in place. See Figure 1.

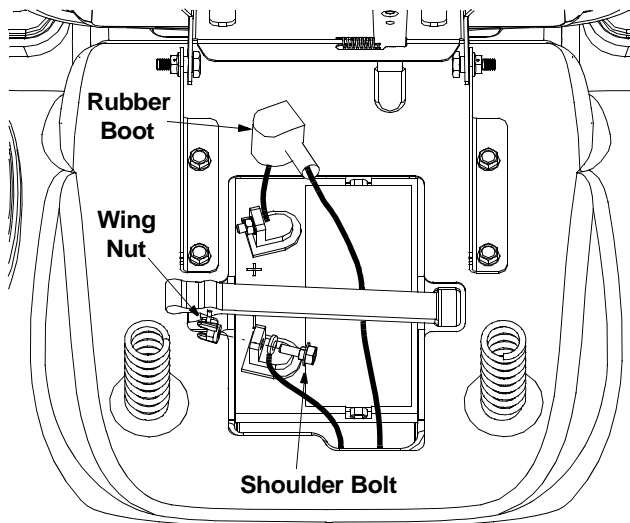

Figure 1

NOTE: If the battery is put into service after the date shown on top of battery, charge the battery as instructed on page 22 of this manual prior to operating the tractor.

Gas and Oil Fill-Up

- The gasoline tank is located under the hood and has a capacity of either two or three gallons according to the respective model. Do not overfill.
- Service the engine with gasoline and oil as instructed in the separate engine operator/owner manual packed with your tractor. Read instructions carefully.



WARNING: Use extreme care when handling gasoline. Gasoline is extremely flammable and the vapors are explosive. Never fuel machine indoors or while the engine is hot or running. Extinguish cigarettes, cigars, pipes, and other sources of ignition.

- Your tractor is shipped with motor oil in the engine. However, you **must** check the oil level before operating. Be careful not to overfill.

Removing Shipping Brace



WARNING: Make sure the tractor's engine is off, ignition key removed, and parking brake set before removing the shipping brace.

IMPORTANT: The shipping brace, used for packaging purposes only, must be removed and discarded before operating your lawn tractor.

- Locate the shipping brace and accompanying warning tag on the right side of the tractor, between the discharge chute and the cutting deck. See Figure 2.

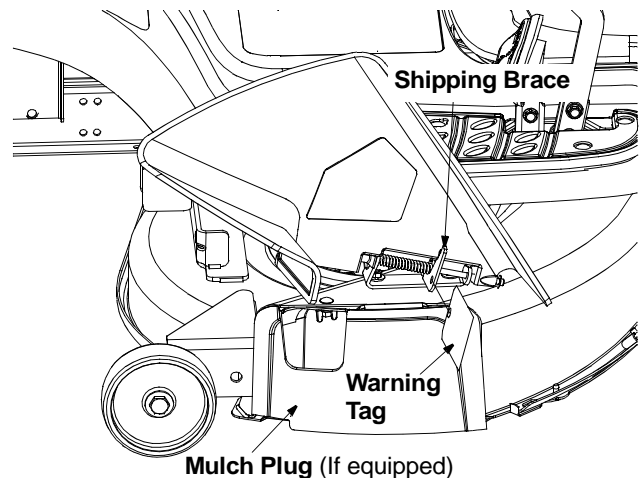

Figure 2

- While holding the discharge chute with your left hand, remove the shipping brace with your right hand by grasping it between your thumb and index finger and rotating it clockwise. Do not discard the mulch plug, if already installed on the unit.



WARNING: The mowing deck is capable of throwing objects. Failure to operate the tractor without the discharge cover in the proper operating position could result in serious personal injury and/or property damage.

SECTION 4: KNOW YOUR LAWN TRACTOR

Compare the illustration in Figure 3 with the controls on your tractor; get familiar with these features before you start to operate the tractor. This manual covers two models. So follow the descriptions and instructions pertaining to your tractor model only.

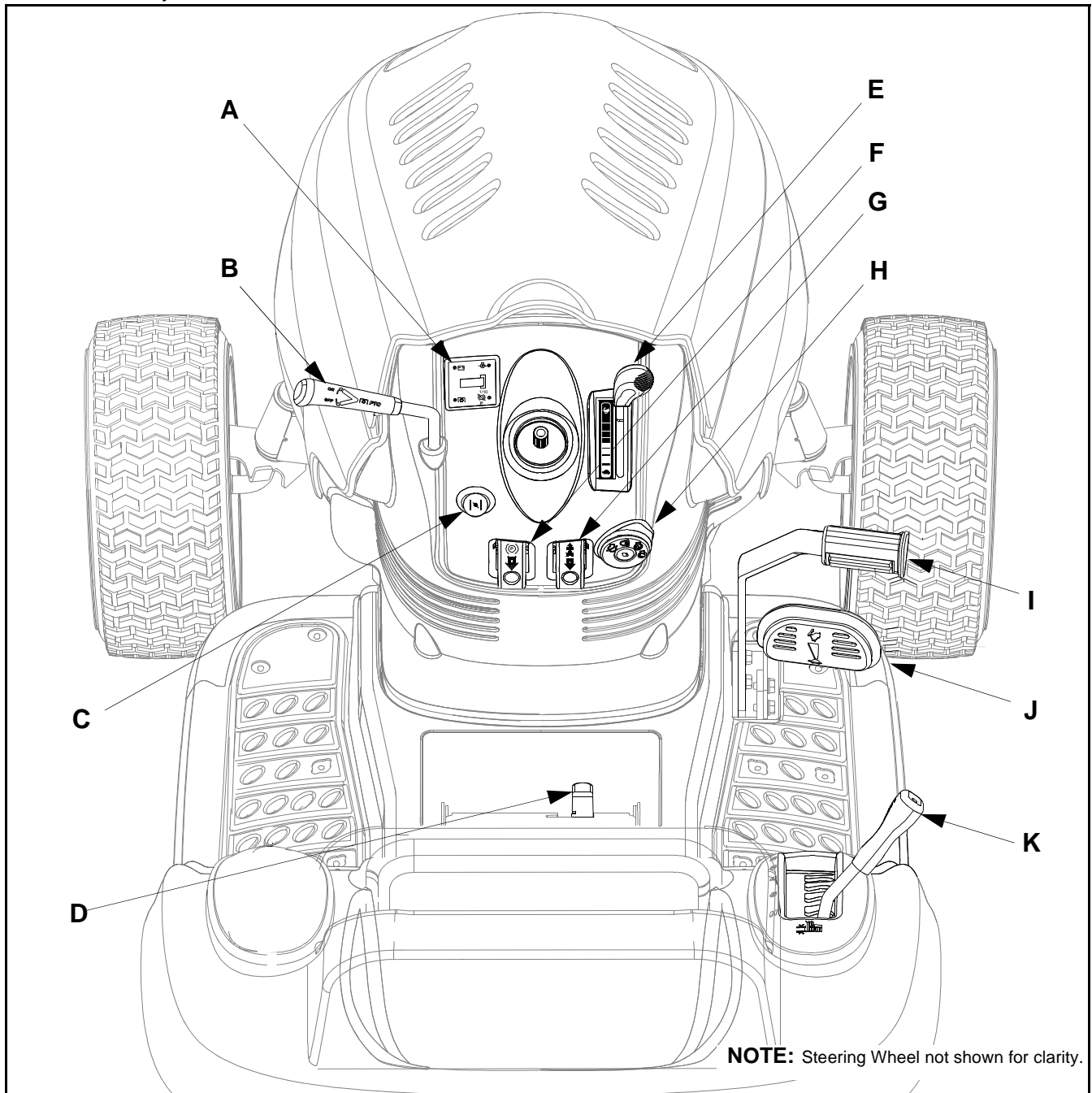

Figure 3

- | | |
|---|--------------------------------|
| A Systems Indicator Monitor/Hour Meter | G Cruise Control Button |
| B PTO (Power Take-off) Lever | H Ignition Switch |
| C Choke Control (If equipped) | I Brake Pedal |
| D Seat Adjustment Lever | J Drive Pedal |
| E Throttle Control Lever | K Deck Lift Lever |
| F Parking Brake Button | |

Throttle Control Lever

The throttle control lever is located on the right side of the tractor's dash panel. This lever controls the speed of the engine. When set in a given position, the throttle will maintain a uniform engine speed.

IMPORTANT: When operating the tractor with the cutting deck engaged, make sure that the throttle lever is always in the **fast** (rabbit) position.

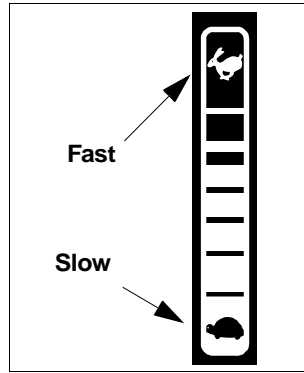

Choke Control

The choke control can be found on the left side of the dash panel and is activated by pulling the knob outward. Activating the choke control closes the choke plate on the carburetor and aids in starting the engine. Refer to Starting The Engine on page 12 of this manual for detailed instructions.

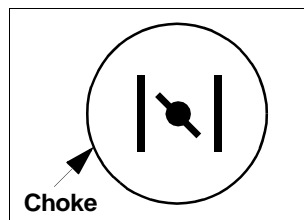

Brake Pedal

The brake pedal is located on the right front side of the tractor above the drive pedal and along the running board. This pedal can be used for sudden stops or setting the parking brake.

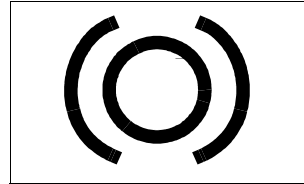

NOTE: Brake pedal must be fully depressed to activate the safety interlock switch when starting the tractor.

Ignition Switch

To start the engine, insert the key into the ignition switch and turn clockwise to the **start** position. Once the engine starts, turn the key to **on** position.

Refer to Starting The Engine on page 12 of this manual for more details.

The ignition switch is also used to operate the tractor's headlights. Refer to Operating The Headlights on page 15 for details.

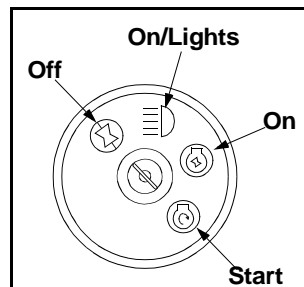

Drive Pedal

The drive pedal is located below the brake pedal on the right side and along the running board. Depress the upper portion of the drive pedal forward to cause the tractor to travel forward. Depress the lower portion of the drive pedal with the ball of your right foot (**not** your heel) to cause the tractor to travel in reverse. Ground speed is also controlled with the drive pedal. The further forward or rearward that the pedal is pivoted, the faster the tractor will travel. The pedal will return to its original position when it is not depressed.

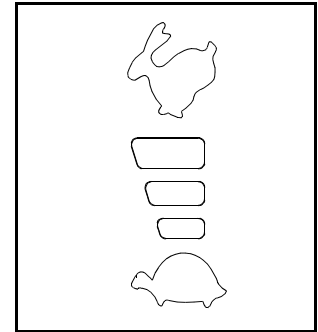

WARNING: Never leave a running machine unattended. Always disengage PTO, move shift lever into neutral position, set parking brake, stop engine and remove key to prevent unintended starting.

Systems Indicator Monitor / Hour Meter

Your tractor is equipped with four indicator lights and an hour meter located on the left side of the dash panel. These indicators are shown here.

The hour meter runs whenever the engine is running and records the actual hours of operation.

It is normal for the oil light and the battery light to be illuminated while the engine is **cranking**, but if either lights up while the **engine is running**, follow the steps given below.

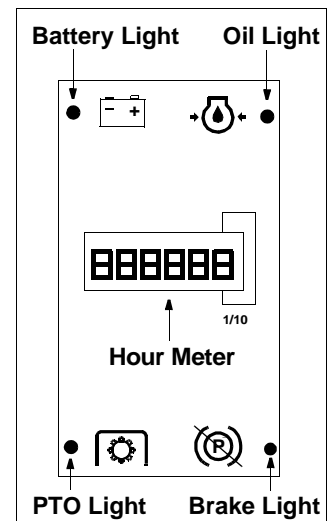

Brake Light Engage the parking brake.

PTO Light Move the PTO lever into the **off** (disengaged) position.

Oil Light Stop the tractor immediately and check the crankcase oil level as instructed in the engine manual. Add oil as required.

Battery Light Indicates that the battery needs to be charged or that the engine's charging system is not generating sufficient amperage. Refer to Battery charging procedure on page 22 or have the engine's charging system checked by an authorized dealer.

PTO (Power Take-off) Lever

The PTO lever is located on the left side of the dashboard next to the steering wheel. Move the PTO lever forward to engage power to the cutting deck or other (separately available) attachments; move the PTO lever backward (toward the rear of the tractor) to disengage power to the attachments.

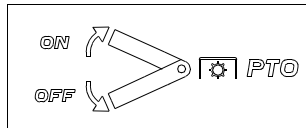

NOTE: The PTO lever must be in the **off** position when (i) starting the engine, (ii) travelling in reverse or (iii) if the operator leaves the seat.

Parking Brake Button

To set the parking brake, fully depress the brake pedal and push the parking brake button in. Hold the button in while taking your foot off the brake pedal. Both the parking button and the brake pedal will then stay depressed. To release the parking brake, depress the brake pedal slightly. The parking brake button will then return to its original position.

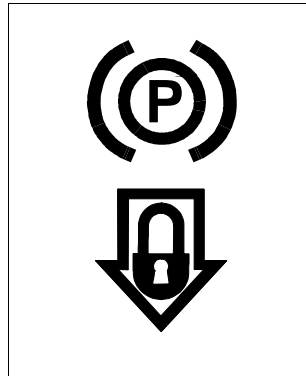

NOTE: The parking brake must be set if the operator leaves the seat with the engine running or the engine will automatically shut off.

IMPORTANT: Always set the parking brake when leaving the tractor unattended.

Deck Lift Lever

Located on your tractor's right fender, the deck lift lever is used to change the height of the cutting deck. To use, move the lever to the left, then place in the notch best suited for your application.

Cruise Control Button

The cruise control button is located on the dash panel of the tractor to the left of the ignition switch. Push the cruise control button while the tractor is traveling forward at a desired speed. Holding the button in, release pressure from the drive pedal. This will engage cruise control and allow the tractor to maintain that speed without applying pressure to the drive pedal. Depress the brake pedal or the drive pedal to **deactivate** cruise control. Refer to OPERATING YOUR LAWN TRACTOR section on page 12 for detailed instructions.

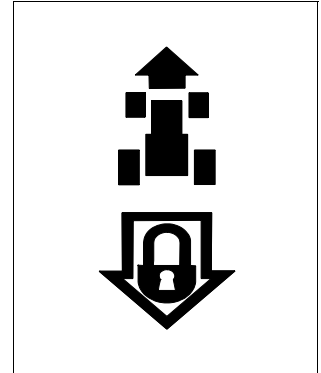

NOTE: Cruise control cannot be engaged at the tractor's fastest ground speed. If the operator should attempt to do so, the tractor will automatically decelerate to the fastest optimal mowing ground speed.

Seat Adjustment Lever

To adjust the seat forward or backward, slide the seat adjustment lever to the left and reposition the seat to the desired position. Once a comfortable position is found, release the seat adjustment lever to lock the seat in place. Refer to Seat Adjustment on page 17 for more detailed instructions.

SECTION 5: OPERATING YOUR LAWN TRACTOR



WARNING: Read, understand, and follow all instructions and warnings on the machine and in this manual before operating.

Safety Interlock Switches

This tractor is equipped with a safety interlock system for the protection of the operator. The safety interlock system prevents the engine from cranking or starting unless the parking brake is engaged and the PTO lever is in the disengaged (**off**) position.

The safety interlock system will automatically shut off the engine if:

1. the operator leaves the seat before engaging the parking brake;
2. the operator leaves the tractor's seat with the PTO lever in the engaged (**on**) position, regardless of whether the parking brake is engaged;
3. the PTO lever is moved to the engaged (**on**) position with drive pedal placed for reverse travel.

IMPORTANT: Tampering with or attempting to bypass the tractor's safety interlock switches in any way **will void** your tractor's warranty.



WARNING: This safety interlock system was designed for your safety and protection. If this system should ever malfunction, do not operate the tractor; contact an authorized service dealer.

Setting the Cutting Height

- Select the height position of the cutting deck by placing the deck lift lever in any of the six different cutting height notches on the right fender.
- Adjust the deck wheels so that they are between ¼-inch and ½-inch above the ground when the tractor is on a smooth, flat surface such as a driveway.



WARNING: Keep hands and feet away from the discharge opening of the cutting deck.

NOTE: *The deck wheels are an anti-scalp feature of the deck and are not designed to support the weight of the cutting deck.*

Refer to Leveling the Deck on page 16 for more details regarding various deck adjustments.

Starting the Engine

NOTE: *Refer to page 8 of this manual for Gasoline and Oil Fill-Up instructions.*

- Insert the tractor key into the ignition switch.
- Place PTO lever in the disengaged (**off**) position.
- Engage the tractor's parking brake.
- Pull the choke control outward or move the throttle control lever into the choke position as the case may be.
- Turn the ignition key clockwise to the start position. After the engine starts, release the key. It will return to the **on** position.

IMPORTANT: Do **not** hold the key in the START position for longer than ten seconds at a time. Doing so may cause damage to your engine's electric starter.

- After the engine starts, de-activate choke control and place throttle control in the FAST position.

NOTE: *Do **not** leave the choke control on while operating the tractor. Doing so will result in a "rich" fuel mixture and cause the engine to run poorly.*



WARNING

AVOID SERIOUS INJURY OR DEATH

- GO UP AND DOWN SLOPES, NOT ACROSS.
- AVOID SUDDEN TURNS.
- DO NOT OPERATE THE UNIT WHERE IT COULD SLIP OR TIP.
- IF MACHINE STOPS GOING UPHILL, STOP BLADE(S) AND BACK DOWNHILL SLOWLY.
- DO NOT MOW WHEN CHILDREN OR OTHERS ARE AROUND.
- NEVER CARRY CHILDREN, EVEN WITH BLADES OFF.
- LOOK DOWN AND BEHIND BEFORE AND WHILE BACKING.
- KEEP SAFETY DEVICES (GUARDS, SHIELDS, AND SWITCHES) IN PLACE AND WORKING.
- REMOVE OBJECTS THAT COULD BE THROWN BY THE BLADE(S).
- KNOW LOCATION AND FUNCTION OF ALL CONTROLS.
- BE SURE BLADE(S) AND ENGINE ARE STOPPED BEFORE PLACING HANDS OR FEET NEAR BLADE(S).
- BEFORE LEAVING OPERATOR'S POSITION, DISENGAGE BLADE(S), PLACE THE SHIFT LEVER IN NEUTRAL, ENGAGE BRAKE LOCK, SHUT ENGINE OFF AND REMOVE KEY.

READ OPERATOR'S MANUAL

Stopping the Engine

- If the blades are engaged, place the PTO lever in the disengaged (**off**) position.
- Turn the ignition key counterclockwise to the **off** position.
- Remove the key from the ignition switch to prevent unintended starting.



WARNING: If you strike a foreign object, stop the engine, disconnect the spark plug wire(s) and ground against the engine. Thoroughly inspect the machine for any damage. Repair the damage before restarting and operating

Driving the Tractor

IMPORTANT: Avoid sudden starts, high speed and sudden stops.



WARNING: Do not leave the seat of the tractor without first placing the PTO lever in the disengaged (**off**) position, depressing the brake pedal and engaging the parking brake. If leaving the tractor unattended, also turn the ignition key off and remove the key.

- Briefly depress the brake pedal to release the parking brake and let the pedal up. Move the throttle lever into the **fast** (rabbit) position.
- To travel forward, slowly depress the upper portion of the drive pedal forward until the desired speed is achieved. See Figure 4.

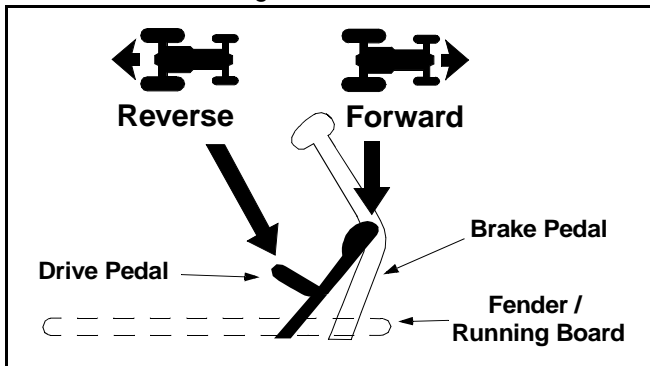

Figure 4

- To travel in reverse, check that the area behind is clear then slowly depress the lower portion of the drive pedal with the ball of your foot (**not** your heel) until the desired speed is achieved. See Figure 4.

IMPORTANT: Do **not** attempt to change the direction of travel when the tractor is in motion. Always bring the tractor to a **complete** stop before pivoting the drive pedal from forward to reverse or vice versa.

Engaging the Parking Brake

To engage parking brake:

- Fully depress brake pedal and hold it there while gently pushing the parking brake button inward.
- Hold parking brake button in while removing your foot from the brake pedal.
- Once engaged, the parking brake button and the brake pedal will lock in the “down” position.

To disengage parking brake:

- Slightly depress the brake pedal.

NOTE: The parking brake must be engaged if the operator leaves the seat with the engine running or the engine will automatically shut off.

Driving on Slopes

Refer to the SLOPE GAUGE on page 7 to help determine slopes where you may operate tractor safely.



WARNING: Do not mow on inclines with a slope in excess of 15 degrees (a rise of approximately 2-1/2 feet every 10 feet). The tractor could overturn and cause serious injury.

- Mow up and down slopes, **never** across.
- Exercise extreme caution when changing direction on slopes.
- Watch for holes, ruts, bumps, rocks, or other hidden objects. Uneven terrain could overturn the machine. Tall grass can hide obstacles.
- Avoid turns when driving on a slope. If a turn must be made, turn down the slope. Turning up a slope greatly increases the chance of a roll-over.
- Avoid stopping when driving up a slope. If it is necessary to stop while driving up a slope, start up smoothly and carefully to reduce the possibility of flipping the tractor over backward.

Setting the Cruise Control

NOTE: The cruise control feature should only be utilized while traveling in the forward direction.

To engage cruise control:

- Slowly depress the drive pedal until the desired speed is achieved.
- Lightly depress the cruise control button.
- Holding the cruise control button in, lift your foot from the drive pedal (you should feel the cruise latch engage).
- Once engaged, the cruise control button and the drive pedal will lock in the “down” position, and the tractor will maintain the same forward speed.

NOTE: Cruise control cannot be engaged at the tractor's fastest ground speed. If the operator should attempt to do so, the tractor will automatically decelerate to the fastest optimal mowing ground speed.

To disengage cruise control: (Follow one of two methods described below.)

1. Depress the brake pedal to disengage the cruise control and stop the tractor.
2. Lightly depress the drive pedal.

To change direction to reverse when operating with cruise control:

- Depress the brake pedal to disengage the cruise control and bring the tractor to a complete stop.
- Depress the lower portion of the drive pedal with the ball of your foot to travel in reverse.

Moving The Tractor Manually

Your tractor's transmission is equipped with a hydrostatic relief valve for occasions when it is necessary to move the tractor manually. Activating this valve allows the rear tires to "freewheel." To engage the hydrostatic relief valve, proceed as follows:

- Locate the hydrostatic bypass rod in the rear of the tractor. See Figure 5.

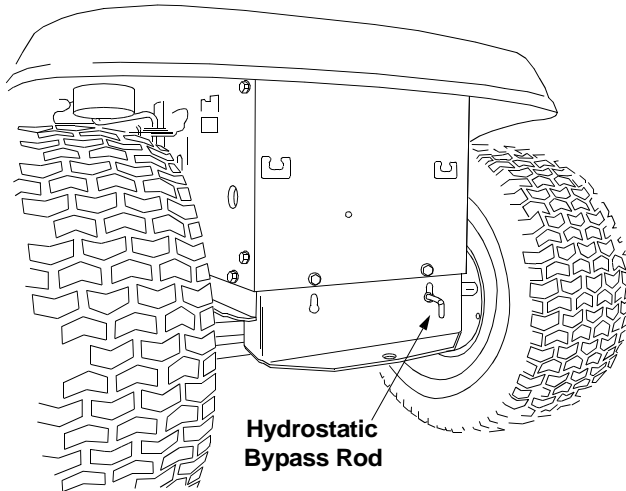

Figure 5

- Pull the hydrostatic bypass rod outward, then down, to lock it in place.

NOTE: The transmission will **not** engage when the hydrostatic bypass rod is pulled out. Return the rod to its normal position prior to operating the tractor.

IMPORTANT: Never attempt to move the tractor manually without first engaging the hydrostatic relief valve. Doing so will result in serious damage to the tractor's transmission.

Using the Deck Lift Lever

- To raise the cutting deck, move the deck lift lever to the left, then place it in the notch best suited for your application. Refer to Setting The Cutting Height earlier in this section.

Engaging the PTO

Engaging the PTO transfers power to the cutting deck or other (separately available) attachments. To engage the PTO, proceed as follows:

- Move the throttle control lever to the **fast** (rabbit) position.
- Grasp the PTO lever and pivot it all the way forward to the engaged (**on**) position.

IMPORTANT: The engine will automatically shut off if the PTO lever is moved into the engaged (ON) position with the drive pedal in position for reverse travel. Refer to Safety Interlock Switches on page 12.

- Keep the throttle lever in the **fast** (rabbit) position for the most efficient use of the cutting deck or other (separately available) attachments.

NOTE: The operator must remain on the tractor seat at all times of operation. If the operator leaves the seat without moving the PTO lever into the disengaged (OFF) position, the tractor's engine will automatically shut off, regardless of whether the parking brake is engaged or not.

Operating the Headlights

To turn on the headlights:

- Start the engine. Turn the key one notch counter-clockwise into the On/Lights position of the ignition switch. Refer to figure on page 10.

To turn off the headlights:

- Turn the key either into the **on** position (to leave the engine running) or the **off** position (to shut the engine off). Refer to figure on page 10.

NOTE: Never move the key into the Start position while the engine is running. Doing so may cause damage to the tractor's electric starter.

Mowing



WARNING: To help avoid blade contact or a thrown object injury, keep by-standers, helpers, children and pets at least 75 feet from the tractor while it is in operation. Stop the tractor if anyone enters the area.

This tractor is equipped with one of Yard-Man's high quality cutting decks. The following information will be helpful when using the cutting deck with your tractor.



WARNING: Plan your mowing pattern to avoid discharge of materials toward roads, sidewalks, by-standers and the like. Also, avoid discharging material against a wall or obstruction which may cause discharged material to ricochet back toward the operator.

- Do not mow at high ground speed, especially if a mulch kit or grass collector is installed.
- For best results it is recommended that the first two laps be cut with the discharge thrown towards the center. Then reverse the direction to throw rest of the discharge to the outside. This will give a better appearance to the lawn.
- Do not cut the grass too short. Short grass invites weed growth and yellows quickly in dry weather.
- Mowing should always be done with the engine at full throttle.
- Under heavier conditions it may be necessary to go back over the cut area to get a clean cut.

- Do not attempt to mow heavy brush and weeds and extremely tall grass. Your tractor is designed to mow lawns, not clear brush.
- Keep the blades sharp and replace the blades when worn. Refer to Cutting Blades on page 19 for blade sharpening instructions.

Mulching

The mulch kit, already standard on your tractor, includes special blades to recirculate grass clippings beneath the cutting deck. The ultra-fine clippings are then forced back into the lawn where they act as a natural fertilizer. Observe the following points for best results in mulching:

- Never attempt to mulch if the lawn is damp. Wet grass tends to stick to the underside of the cutting deck preventing proper mulching of the clippings.
- Do not attempt to mulch more than 1/3 the total height of the grass or approximately 1-1/2 inches. Doing so will cause the clippings to clump up beneath the deck and not be mulched effectively.
- Maintain a slow ground speed to allow the grass clippings more time to effectively be mulched.
- Always position the throttle control lever in the **fast** (rabbit) position and allow it to remain there while mowing. Failing to keep the engine at full throttle places strain on the tractor's engine and does not allow the blades to properly mulch grass.

NOTE: *It is not necessary to remove the discharge chute to operate the mower with the mulch kit installed.*

- To operate the cutting deck without mulching, simply remove the mulch plug by unthreading the plastic wing nut which fastens it to the cutting deck. This will allow the clippings to discharge through the side-discharge opening. See Figure 6 .

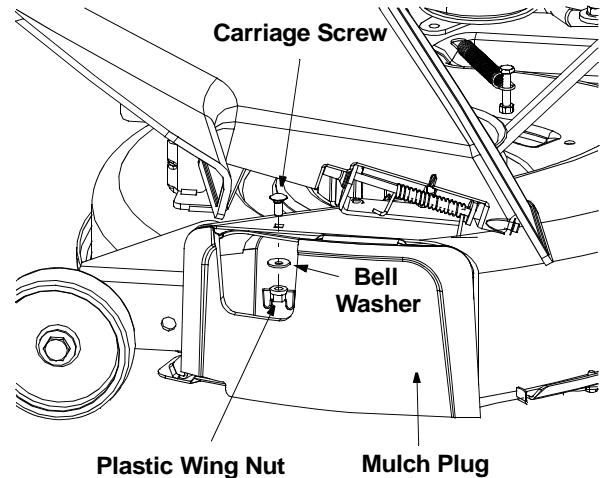

Figure 6

SECTION 6: MAKING ADJUSTMENTS



WARNING: Disconnect the spark plug wire(s) and ground against the engine before performing any adjustments, repairs or maintenance.



WARNING: Do not make any adjustments while the engine is running, except where specified in this or the engine manual.

Leveling the Deck

NOTE: Check the tractor's tire pressure before performing any deck leveling adjustments. Refer to Tires on page 22 for information on tire pressure.

Front To Rear

The front of the cutting deck is supported by a stabilizer bar that can be adjusted to level the deck from front to rear. The front of the deck should be between 1/4-inch and 3/8-inch lower than the rear of the deck. Adjust if necessary as follows:

- With the tractor parked on a firm, level surface, place the deck lift lever in the top notch (highest position) and rotate the blade nearest the discharge chute so that it is parallel with the tractor.
- Measure the distance from front of the blade tip to the ground and rear of the blade tip to the ground.
- The first measurement taken should be between 1/4" and 3/8" less than the second measurement. Determine the approximate distance necessary for proper adjustment and proceed, if necessary, to the next step.

- Loosen the two jam nuts on the rear side of the deck stabilizer bracket. See Figure 7A.
- Locate the two lock nuts on the opposite side of the stabilizer bracket. See Figure 7A. Tighten the lock nuts to raise the front of the deck; loosen the lock nuts to lower the front of the deck.
- Retighten the two jam nuts loosened earlier when proper adjustment is achieved.

Side to Side

If the cutting deck appears to be mowing unevenly, a side to side adjustment can be performed. Adjust if necessary as follows:

- With the tractor parked on a firm, level surface, place the deck lift lever in the top notch (highest position) and rotate both blades so that they are perpendicular with the tractor.
- Measure the distance from the outside of the left blade tip to the ground and the distance from the outside of the right blade tip to the ground. Both measurements taken should be equal. If they're not, proceed to the next step.
- Loosen, but do **not** remove, the hex cap screw on the left deck hanger bracket. See Figure 7B.
- Balance the deck by using a wrench to turn the adjustment gear (found immediately behind the hex cap screw just loosened) clockwise/up or counterclockwise/down.
- The deck is properly balanced when both blade tip measurements taken earlier are equal.
- Retighten the hex cap screw on the left deck hanger bracket when proper adjustment is achieved.

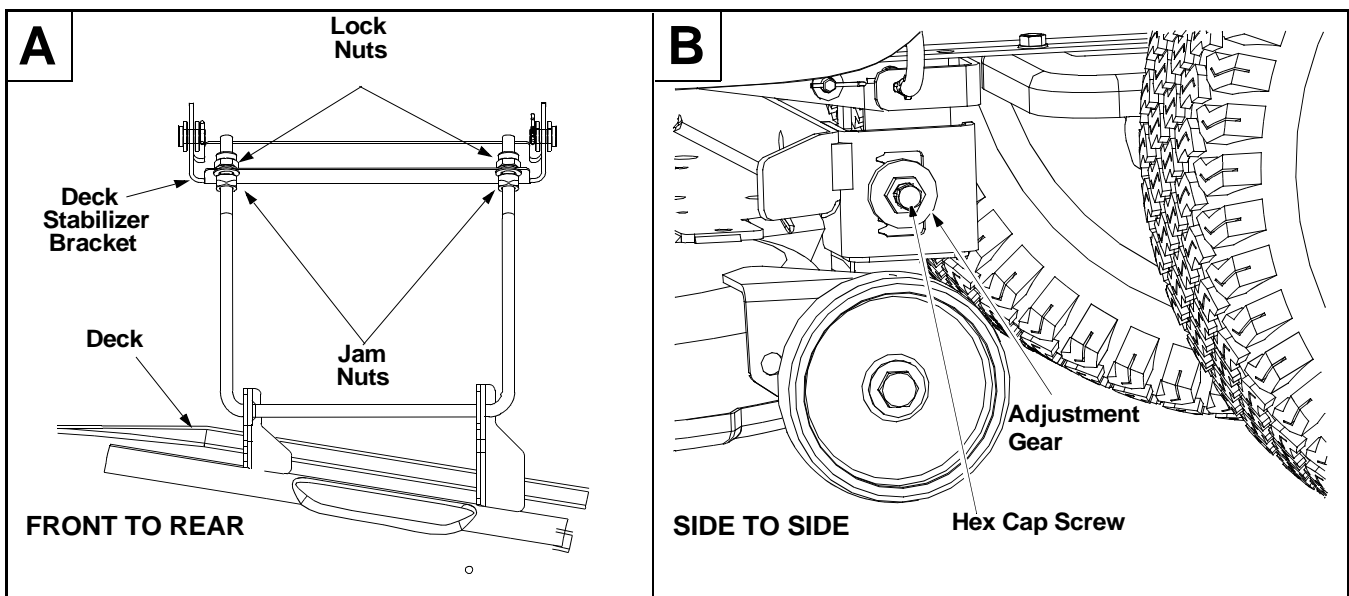

Figure 7

Seat Adjustment



WARNING: Before operating this machine, make sure the seat is engaged in the seat stop, stand behind the machine and pull back on seat until fully engaged into stop.

- Move the seat adjustment lever to the left and slide the seat forward or rearward. Make sure seat is locked into position **before** operating the tractor.

Parking Brake Adjustment



WARNING: Never attempt to adjust the brakes while the engine is running. Always disengage PTO, move shift lever into neutral position, stop engine and remove key to prevent unintended starting.

Adjust the brake if (i) the tractor does not come to a complete stop when the brake pedal is completely depressed, or (ii) the tractor's rear wheels roll even with the parking brake applied. Locate the brake disc on the right side of the transmission in the rear of the tractor. Adjust as follows:

- From the right side of the tractor, locate the brake rod and brake disc. See Figure 8 inset.

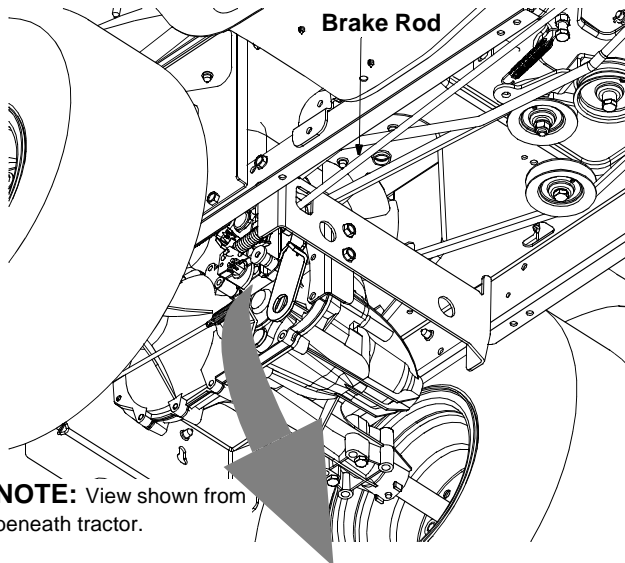

NOTE: View shown from beneath tractor.

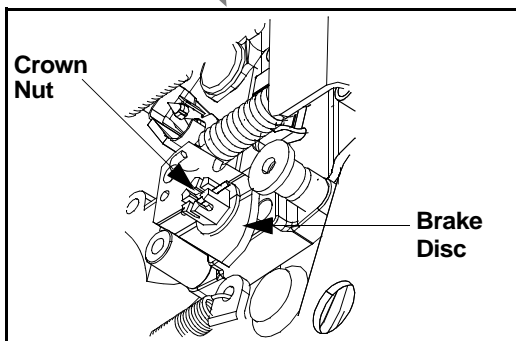

Figure 8

- Carefully remove the cotter pin from the crown nut on the right side of the brake assembly.
- Using a feeler gauge, check the gap between the brake disc and the brake puck. Proper gap is .011".
- Tighten crown nut until the proper gap is achieved.
- Insert a replacement cotter pin (part number 714-0111) into the crown nut.

Steering Adjustment

If the tractor turns tighter in one direction than the other, or if the ball joints are being replaced due to damage or wear, the steering drag links may need to be adjusted.

Adjust the drag links so that equal lengths are threaded into the ball joints on the left and the right:

- Loosen the jam nut found on the drag link at the rear of the ball joint. See Figure 9 .
- Remove the hex nut and lock washer on the top of ball joint. See Figure 9 .
- Thread the ball joint toward the jam nut to shorten the drag link. Thread the ball joint away from the jam nut to lengthen the drag link.
- Replace hex nut and lock washer and retighten the jam nut after proper adjustment is achieved.

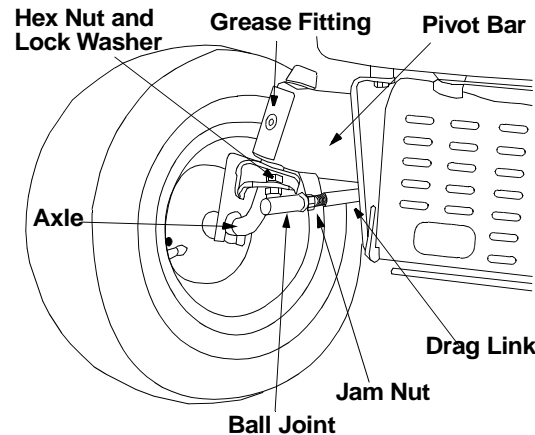

Figure 9

NOTE: Threading the ball joints too far onto the drag links will cause the front tires to "toe-in" too far. Proper toe-in is between 1/16" and 5/16".

Front tire toe-in can be measured as follows:

- Place the steering wheel in position for straight ahead travel.
- In front of the axle, measure the distance horizontally from the inside of the left rim to the inside of the right rim. Note the distance.
- Behind the axle, measure the distance horizontally from the inside of the left rim to the inside of the right rim. Note the distance.
- The measurement taken in front of the axle should be between 1/16" and 5/16" less than the measurement taken behind the axle.
- Adjust if necessary.

SECTION 7: MAINTAINING YOUR LAWN TRACTOR



WARNING: Before performing any maintenance or repairs, disengage PTO, move shift lever into neutral position, set parking brake, stop engine and remove key to prevent unintended starting.

Cleaning Engine and Deck

- Promptly wipe off any fuel or oil spilled on the machine. Do **not** allow debris to accumulate around the cooling fins of the engine or on any other part of the machine, especially on the belts, pulleys and other moving parts.
- Clean the underside of the deck with a wire broom, scraper or forced air after each mowing.

NOTE: The use of a pressure washer or garden hose to clean your tractor is not recommended. It may cause damage to electrical components, spindles, pulleys, bearings or the engine. The use of water will shorten life of the tractor and reduce its serviceability.

Maintaining the Engine

Refer to the engine manual for maintenance instructions. also follow these steps to maintain the engine in good working order.

- Check **engine oil level** before each use as instructed in the engine manual. Read and follow instructions carefully.

Changing Engine Oil

- Unscrew oil fill cap and remove dipstick from the oil fill tube. See Figure 10 .
- Pop open the protective cap on the end of the oil drain valve to expose the drain port. See Figure 10 .
- Push the oil drain hose (packed with this manual) onto the oil drain port. Route the opposite end of the hose into an appropriate oil collection container with a capacity great enough to collect the used oil.
- Push the oil drain valve in slightly, then rotate counter-clockwise and pull outward to begin draining oil. See Figure 10 .
- Service the oil filter (if so equipped) as instructed in the engine manual.
- Perform the above steps in the opposite order after oil has finished draining.
- Refill the engine with new motor oil.

IMPORTANT: Refer to the engine manual for the proper weight of motor oil to be used.

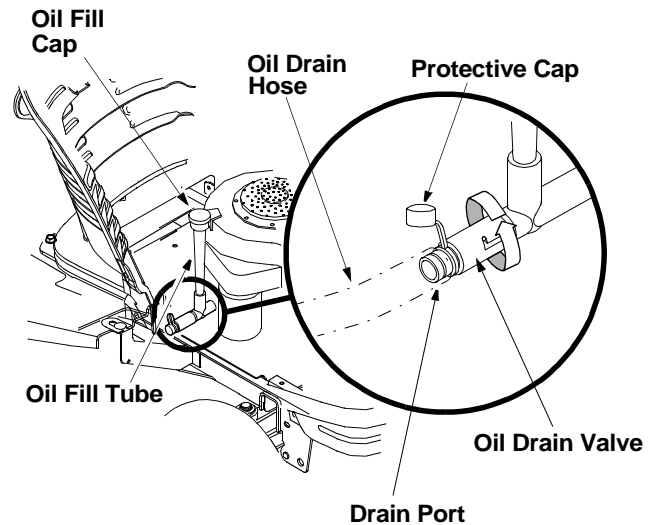

Figure 10

Air Cleaner

- Service the pre-cleaner, if so equipped, and cartridge/air cleaner element as instructed in the engine manual.

Spark Plug

- The spark plug should be cleaned and the gap reset once a season. Spark plug replacement is recommended at the start of each mowing season. Refer to the engine manual for correct plug type and gap specifications.

Lubrication

Engine

Lubricate the engine with motor oil as instructed in the engine manual.

Pivot Points & Linkage

Lubricate all the pivot points on the drive system, parking brake and lift linkage at least once a season with light oil.

Rear Wheels

The rear wheels should be removed from the axles once a season. Lubricate the axles and the rims well with an all-purpose grease before re-installing them.

Front Wheels

Each of the front wheel axles is equipped with a grease fitting (Figure 9). Lubricate with a grease gun after every 25 hours of tractor operation.

SECTION 8: SERVICE



WARNING: Before performing any maintenance or repairs, disengage PTO, move shift lever into neutral position, set parking brake, stop engine and remove key to prevent unintended starting.

Cutting Blades

- Periodically inspect the blade adapter and/or spindle for cracks or damage, especially if you strike a foreign object. Replace immediately if damaged.



WARNING: Protect your hands by using heavy gloves or a rag to grasp the blade.

To remove blade:

- Remove the deck from beneath the tractor, (refer to Cutting Deck Removal on page 19). Then gently flip the deck over to expose its underside.
- Place a block of wood between the center deck housing baffle and the cutting blade to act as a stabilizer. See Figure 11 .

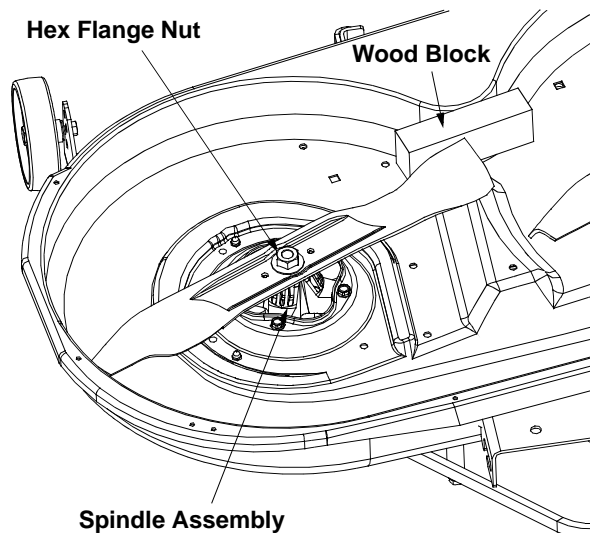

Figure 11

- Use a 15/16" wrench to remove the hex flange nut that secures blade to the spindle assembly. See Figure 11 .

To sharpen blades:

- Remove equal amounts of metal from both ends of the blades along the cutting edges, parallel to the trailing edge, at a 25° to 30° angle. See Figure 12 .
- If the cutting edge of the blade has already been sharpened to within 5/8" of the wind wing radius, or if any metal separation is present, replace the blades with new ones. See Figure 12 .

- Grind each blade edge equally to maintain proper blade balance.
- Test the blade by balancing it on a round shaft screwdriver. Grind metal from the heavy side until it balances evenly.

IMPORTANT: A poorly balanced blade will cause excessive vibration and may cause damage to the tractor and/or personal injury.

To replace blade:

- When replacing the blade, be sure to install the blade with the side marked "Bottom" (or with a part number stamped in it) facing the ground when the mower is in the operating position.
- Use a torque wrench to tighten the blade spindle hex flange nut to between **70 foot-pounds and 90 foot-pounds**.

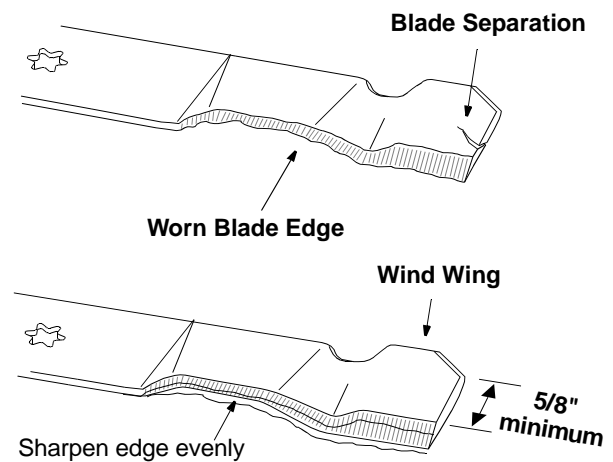

Figure 12

Removing Cutting Deck

- Place the PTO lever in the disengaged (OFF) position and engage the parking brake.
- Lower the deck by moving the deck lift lever into the bottom notch on the right fender.
- Remove the PTO belt from around the cutting deck's center pulley.
- Looking at the cutting deck from the left side of the tractor, locate the deck support pin on the rear left side of the deck.
- Pull the deck support pin outward to release the deck from the deck lift arm. See Figure 13.
- Rotate the pin slightly toward the rear of the tractor and release the pin into the hole provided. Repeat on the right side.

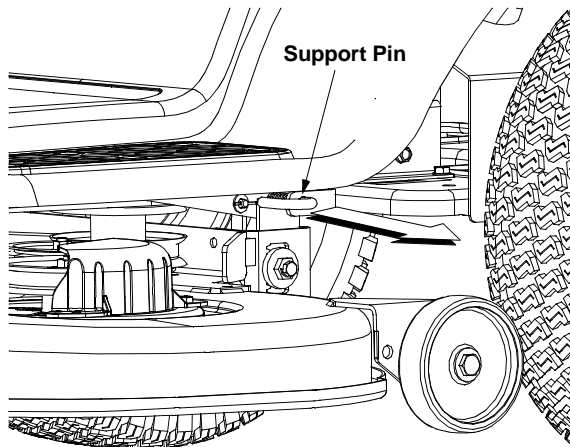

Figure 13

- Move the deck lift lever into the top notch on the right fender to raise the deck lift arms up and out of the way.
- Gently slide the cutting deck toward the front of the tractor allowing the hooks on the deck to release themselves from the deck stabilizer rod.
- Gently slide the cutting deck (from the right side) out from underneath the tractor.

Changing Deck Belts



WARNING: Be sure to shut engine off, remove ignition key, disconnect spark plug wire(s) and ground against engine before starting this job.

IMPORTANT: The V-belts, found on your tractor, are specially designed to engage and disengage safely. A substitute (non-OEM) V-belt can be dangerous by not

disengaging completely. For a proper working machine, use factory approved belts only.

All belts on your tractor are subject to wear and should be replaced if any signs of cracking, shredding or rotting are observed.

To change deck belts, see the relevant section of and proceed as follows:

- Lower the deck by moving the deck lift lever into the bottom notch on the right fender.
- Remove the belt guards by removing the self-tapping screws that fasten them to the deck.
- Grasp the PTO idler bracket and pivot it toward the discharge chute to relieve tension on the PTO belt.
- Remove the PTO belt from the engine pulley and from around the PTO idler pulleys.
- Grasp deck idler pulley and pivot it toward the left side of the deck to relieve tension on the deck belt.
- Remove the belt from around all pulleys, including the deck idler pulley.
- Route the new belts as shown in .
- Remount the belt guards removed earlier.

Changing Transmission Drive Belt



WARNING: Be sure to shut the engine off, remove ignition key, disconnect the spark plug wire(s) and ground against the engine to prevent unintended starting before removing the belt(s)

All belts on your tractor are subject to wear and should be replaced if any signs of cracking, shredding or rotting are present.

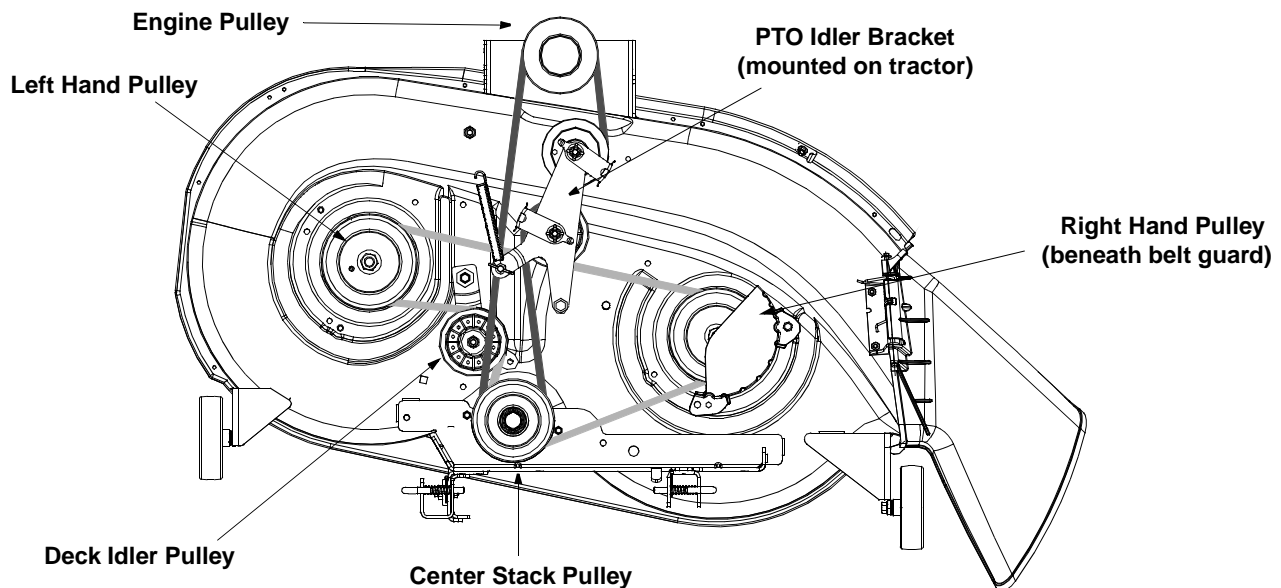

Figure 14

IMPORTANT: The V-belts found on your tractor are specially designed to engage and disengage safely. A substitute (non-OEM) V-belt can be dangerous by not disengaging completely. For a proper working machine, use factory approved belts.

To change or replace the drive belt on your tractor, proceed as follows:

NOTE: It is recommended that both drive belts be replaced at the same time.

- Remove the cutting deck as instructed earlier.
- After disconnecting the battery cables, remove the battery and battery tray from beneath the seat.

IMPORTANT: When removing the battery, disconnect the **negative** (black) wire from its terminal first, followed by the **positive** (red) wire. Re-install in reverse order.

NOTE: Proper removal of the drive belt requires the removal of several tractor components. Read through the following procedure prior to attempting it to determine if you could successfully complete it. Otherwise see an authorized service dealer.

IMPORTANT: Note the routing of the lower drive belt around all the pulleys and the belt keepers (if present) **before** performing the following steps.

- Locate the fixed V-idler pulley found on the left underside of the frame. See Figure 15.
- Grasp the belt on both sides of the pulley and gently move it toward the left frame rail allowing it to unseat itself from the fixed v-idler. See Figure 15.

- Pivot the double-idler bracket forward slightly before removing the idler extension spring from the stud and the double-idler bracket itself. Do not discard the spring.
- Roll the drive belt out from around both the V-idler pulley and the flat idler pulley found on the double-idler bracket.
- Remove the hex bolt from the center of the engine pulley and gently lower it off the engine crankshaft.

IMPORTANT: Be careful not to lose any washers or spacers which may be on top of the electric PTO clutch or the engine pulley, as the case may be.

- Lower the engine pulley far enough to be able to remove the upper drive belt from around it.

IMPORTANT: When remounting the engine pulley, torque the center hex bolt to between 38 foot-pounds and 50 foot-pounds.

- Remove the drive belt by feeding it from front to rear, toward the hydrostatic transmission. See Figure 15.
- Continue removing the drive belt by gently lifting it off the transmission pulley and over the cooling fan.

IMPORTANT: The fins on the cooling fan are only slightly flexible. Be careful not to damage the fan when removing the belt from around the transmission pulley.

- Reroute the new belt around the pulleys and belt keepers, if present, exactly as the old one was routed. Refer to Figure 15.

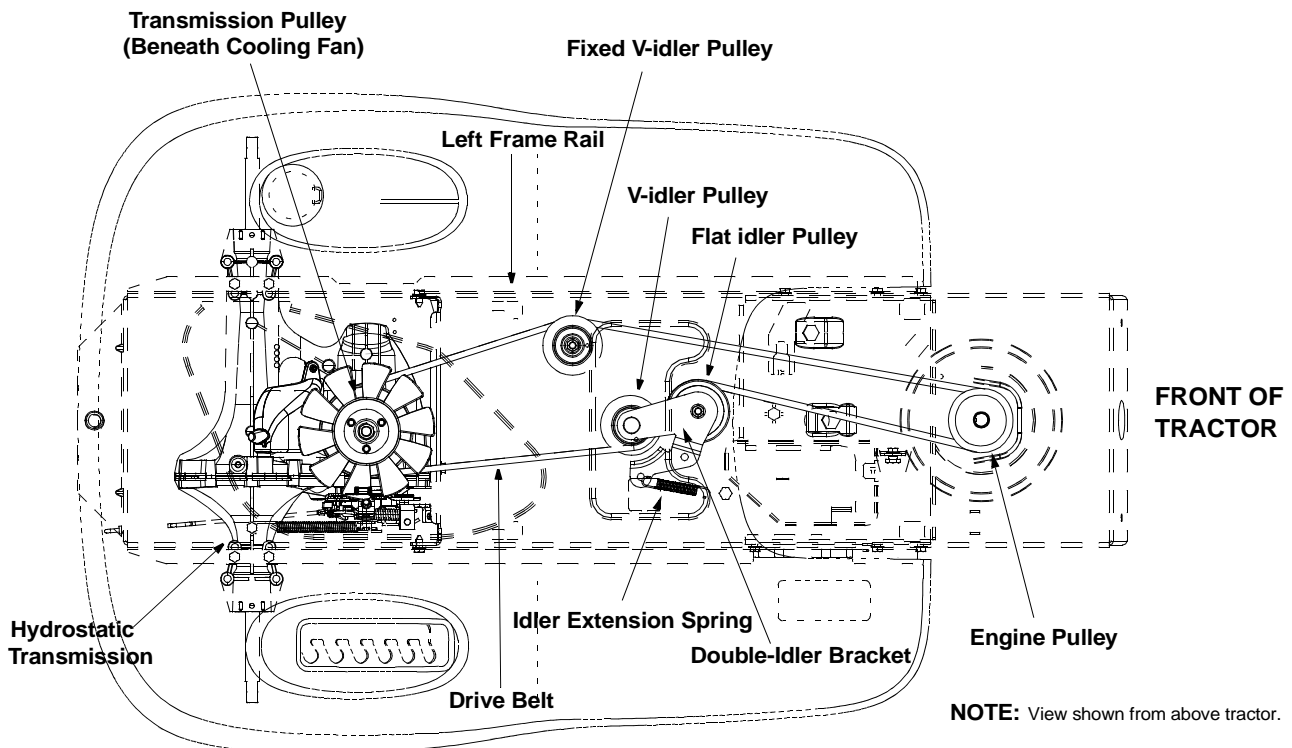

Figure 15

Tires



WARNING: Never exceed maximum inflation pressure shown on sidewall of the tire.

- The recommended operating tire pressure is 10 psi for the rear tires and 14 psi for the front tires approximately. Refer to the tire sidewall for exact tire manufacturer's recommendation. Do not overinflate. Uneven tire pressure could cause the cutting deck to mow unevenly.

Battery

The battery is sealed and is maintenance-free. Acid levels cannot be checked. Listed below are some general recommendations for proper use of battery.

- Always keep battery cables and terminals clean and free of corrosive build-up.
- After cleaning, apply a light coat of petroleum jelly or grease to both terminals.
- Always keep the rubber boot positioned over the positive terminal to prevent shorting.
- If removing the battery for any reason, disconnect the **negative** (black) wire from its terminal first, followed by the **positive** (red) wire. When re-installing the battery, always connect the **positive** (red) wire to its terminal first, followed by the **negative** (black) wire.

IMPORTANT: Be certain that wires are connected to the correct terminals; reversing them could change polarity and cause damage to the engine's alternating system.

Charging

If tractor has not been operated for an extended period of time, charge the battery with an automotive-type 12-volt charger for a minimum of one hour at six amps.



WARNING: Batteries give off an explosive gas while charging. Charge battery in a well ventilated area and keep away from an open flame or pilot light as on a water heater, space heater, furnace, clothes dryer or other gas appliances.

Fuses

Two fuses are installed in your tractor's wiring harness to protect the tractor's electrical system from any potential damage caused by excessive amperage.

- If the electrical system does not function, or your tractor's engine will not crank, first check to be certain that the fuse has not blown. One fuse can be located under the hood mounted behind the top of the dash panel on the support bar. The other can be located under the seat mounted to the inside of the tractor frame, next to the battery tray.
- Pull the fuse out and inspect it to determine if it is good or blown.
- Replace with a new fuse if necessary.

IMPORTANT: Always use a fuse with the same amperage capacity for replacement.

SECTION 9: OFF-SEASON STORAGE

Clean and lubricate the tractor as instructed on page 18 before storing for an extended period.



WARNING: Drain fuel only into an approved container outdoors, away from an open flame. Allow engine to cool. Extinguish cigarettes, cigars, pipes, and other sources of ignition prior to draining fuel.



WARNING: Never store the machine or fuel container indoors where there is an open flame, spark or pilot light such as on water heater, furnace, clothes dryer or other gas appliance.

Follow the instructions in the **Service, Storage & Specifications** section of the engine manual for proper engine care prior to storing your tractor.

SECTION 10: ATTACHMENTS & ACCESSORIES

The following attachments and accessories are compatible for **Lawn Tractor Models**. See the retailer from which you purchased your tractor, an authorized service dealer or call (800) 800-7310 for more information.

NOTE: *These lawn tractor models are **not** designed for use with any type of ground-engaging attachments (e.g. tiller or plow). Use of this type of equipment **will** void the tractor's warranty.*

MODEL	DESCRIPTION
OEM-190-180	FastAttach™ Twin Bagger Grass Collector (for 42-inch Decks)
OEM-190-603	FastAttach™ Grille Guard (mounts on front of tractor)
OEM-190-604	FastAttach™ Yard-Mate™ Storage Container/Toolbox (mounts on rear of tractor)
OEM-190-607	FastAttach™ Deluxe Tractor Sunshade
OEM-190-823	FastAttach™ 42-inch Two-stage Snow Thrower

SECTION 11: TROUBLESHOOTING

Trouble	Possible Cause(s)	Corrective Action
Engine fails to start	PTO lever engaged. Parking brake not engaged. Spark plug wire(s) disconnected. Throttle control not in correct position. Choke not activated Fuel tank empty, or stale fuel. Blocked fuel line. Faulty spark plug. Engine flooded.	Place PTO lever in disengaged (OFF) position. Engage parking brake. Connect wire(s) to spark plug. Place throttle lever to fast or choke (if so equipped). Activate choke. Fill tank with clean, fresh (less than 30 days old) gas. Clean fuel line or replace fuel filter, if so equipped. Clean, adjust gap or replace plug. Crank engine with throttle in FAST position.
Engine runs erratic	Unit running with CHOKE applied. Spark plug wire loose. Blocked fuel line or stale fuel. Vent in gas cap plugged. Water or dirt in fuel system. Dirty air cleaner.	Place throttle lever in FAST position or push CHOKE control (if so equipped) in. Connect and tighten spark plug wire. Clean fuel line; fill tank with clean, fresh (less than 30 days old) gasoline. Replace fuel filter, if so equipped. Clear vent or replace cap if damaged. Drain fuel tank. Refill with clean, fresh (less than 30 days old) gasoline. Replace air cleaner cartridge/element or clean pre-cleaner, if so equipped.
Engine overheats	Engine oil level low. Air flow restricted.	Fill crankcase with proper capacity and weight of oil. Clean grass clippings and debris from around the engine's cooling fins and blower housing.
Engine hesitates at high RPM	Spark plug gap too close.	Remove spark plug and reset the gap to .030".
Idles poorly	Spark plug fouled, faulty or gap too wide. Dirty air cleaner.	Replace spark plug. Set plug gap to .030". Replace air cleaner cartridge/element or clean pre-cleaner, if so equipped.
Excessive vibration	Cutting blade loose or unbalanced. Damaged or bent cutting blade.	Tighten blade and spindle. Balance blade. Replace blade.
Mower will not mulch grass	Wet grass. Excessively high grass. Dull blade.	Do not mow when grass is wet; wait until later to cut. Mow once at a higher cutting height, then mow again. Sharpen or replace blade.
Uneven cut	Deck not balanced properly. Dull blade. Uneven tire pressure.	Perform side-to-side deck adjustment. Sharpen or replace blade. Check tire pressure in all four tires.

SECTION 12: PARTS LIST FOR MODEL X614G

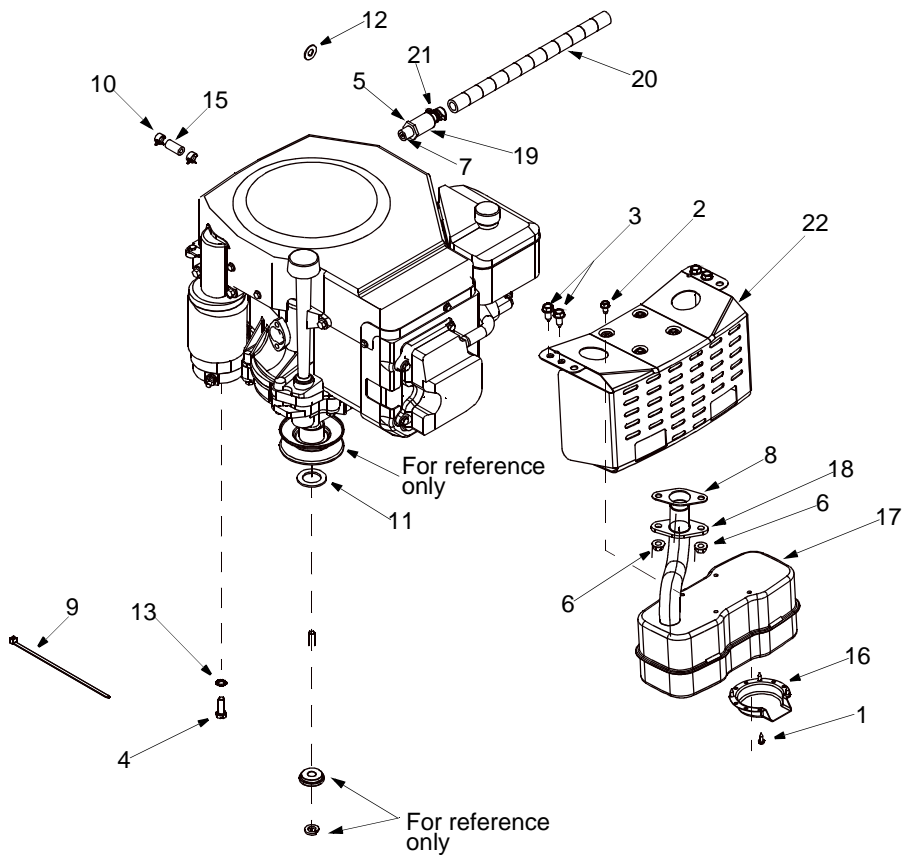

Ref. No.	Part No.	Description
1.	710-0227	AB Screw #8-18 x 0.5
2.	710-0599	TT Screw 1/4-20 x 0.5
3.	710-0726	AB Screw 5/16-12 x 0.75
4.	710-3206A	Hex Screw M8
5.	712-3017	Hex Nut 3/8-16
6.	712-3086	Flange Nut M8
7.	721-0331	Sealant: Loctite™
8.	721-0375	Gasket: Exhaust
9.	725-0157	Cable Tie
10.	726-0205	Hose Clamp
11.	736-0277	Flat Washer
12.	736-0300	Flat Washer
13.	736-0607	Lock Washer 5/16
15.	751-0535	Hose: Fuel Line
16.	751-0564	Deflector: Muffler
17.	751-0617	Muffler: Single Inlet
18.	751-0810A	Exhaust Pipe
19.	751-3140	Oil Drain
20.	751-3141	Oil Drain Extension
21.	751-3142	Oil Drain Cap
22.	783-0615B	Heat Shield

Model X614G

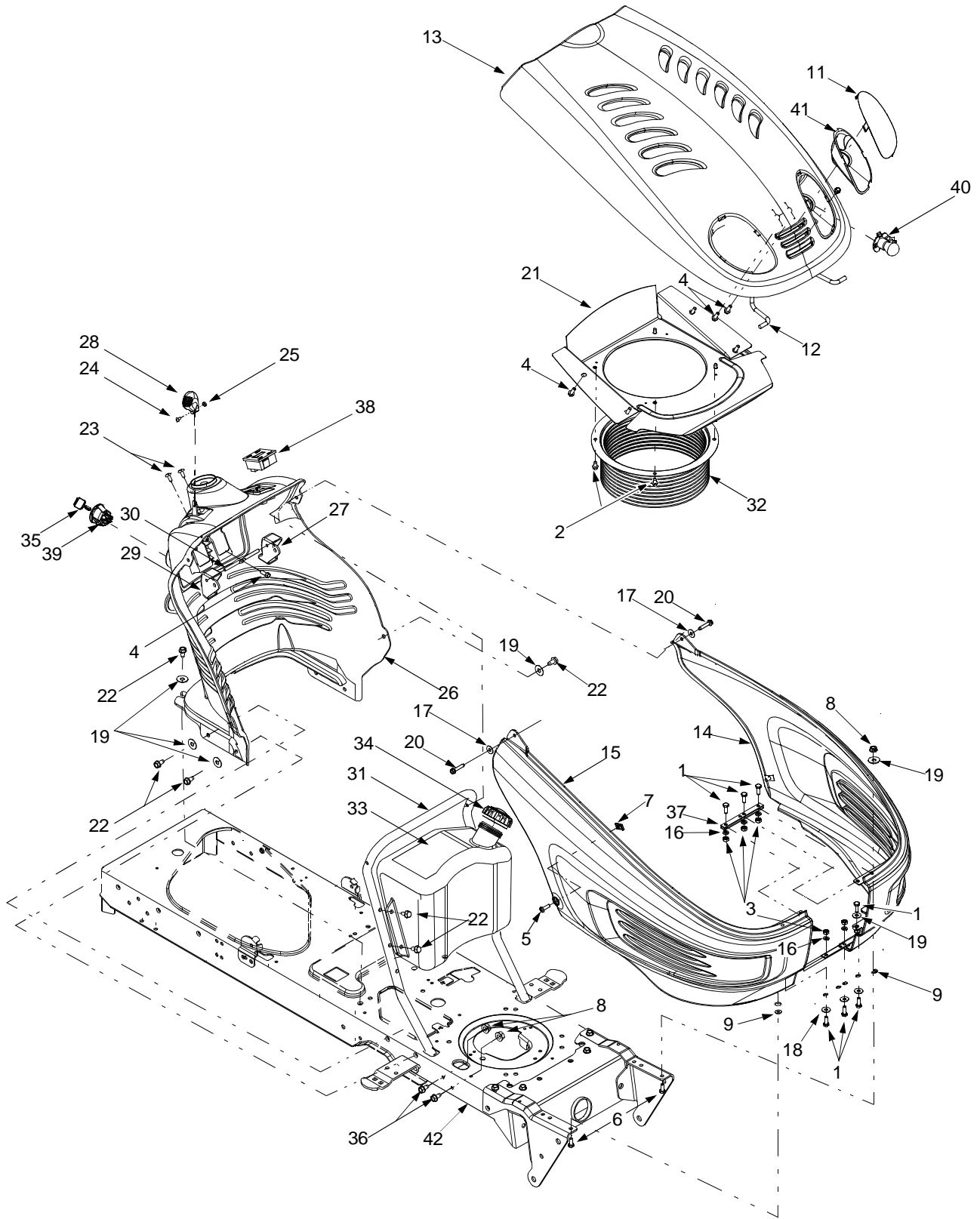

Model X614G

REF. NO.	PART NO.	DESCRIPTION	REF. NO.	PART NO.	DESCRIPTION
1.	710-3015	Hex Cap Screw, 1/4-20 x .75	24.	710-3217	Torx Screw, #8-32 x .375
2.	710-0599	Self-tapping Screw, 1/4-20 x .5	25.	712-0142	Hex Nut, 8-32
3.	712-3006	Hex Nut, 1/4-20	26.	731-0071C	Dash Panel, 4-style
4.	710-0895	Self-tapping Screw, 1/4-15 x .75	27.	731-0072	Parking Brake Button
5.	710-0924	Pan Phillips Screw, 1/4-20 x .75	28.	731-1857	Throttle Control Lever
6.	710-0376	Hex Screw, 5/16-18 x 1.0	29.	731-2106	Cruise Control Button
7.	712-0292	U-type Speed Nut, 1/4-20	30.	747-1155	Brake/Cruise Pivot Rod
8.	712-3004A	Flange Lock Nut, 5/16-18	31.	749-1087B	Dash Support Tube
9.	726-0201	Speed Nut	32.	731-2232	Intake Bellow
10.	747-2127	Hood Latch Rod	33.	751-0658D	Fuel Tank, 3-gallon
11.	731-1978	RH Head Light Lens	34.	751-0603	Fuel Cap
	731-1979	LH Head Light Lens	35.	725-1745	Ignition Key w/ plastic cover
12.	747-1132A	Hood Support Rod		725-1744	Ignition Key w/o plastic cover
13.	731-1980A	Hood	36.	710-0650	TT Screw 5/16-18 x 0.875
14.	731-1981C	LH Side Panel	37.	783-1000A	Grille Support Bracket
15.	731-1982C	RH Side Panel	38.	725-1976	Systems Indicator Monitor
16.	736-0329	Lock Washer, 1/4	39.	725-1741	Ignition Switch
17.	736-0342	Flat Washer, .283 x .75 x .030	40.	625-0051	Headlight Assembly
18.	736-0173	Flat Washer, .28 x .74 x .063	41.	731-1995	RH Headlight Reflector
19.	736-3078	Flat Washer, .349 x 1.0 x .063		731-1996	LH Headlight Reflector
20.	710-0642	Self-tapping Screw, 1/4-20 x 0.75	—	629-0469B	Headlight Wire Harness
21.	783-0808A	Hood Heat Shield w/o Intake Bellow	—	629-1072	Tractor Wire Harness
22.	710-0726	AB Screw, 5/16-12 x .75	42.	683-0304C	Lower Frame
23.	710-0599	Self-tapping Screw, 1/4-20 x .50			

NOTE: For **painted parts**, please refer to the list of color codes below. Please add the applicable color code, wherever needed, to the part number to order a replacement part. For instance, if a part numbered 700-xxxx is painted Yard-Man Green, the part number to order would be 700-xxxx-0665.

Yard-Man Green: 0665
 Yard-Man Yellow: 0674
 Powder Black: 0637

Model X614G

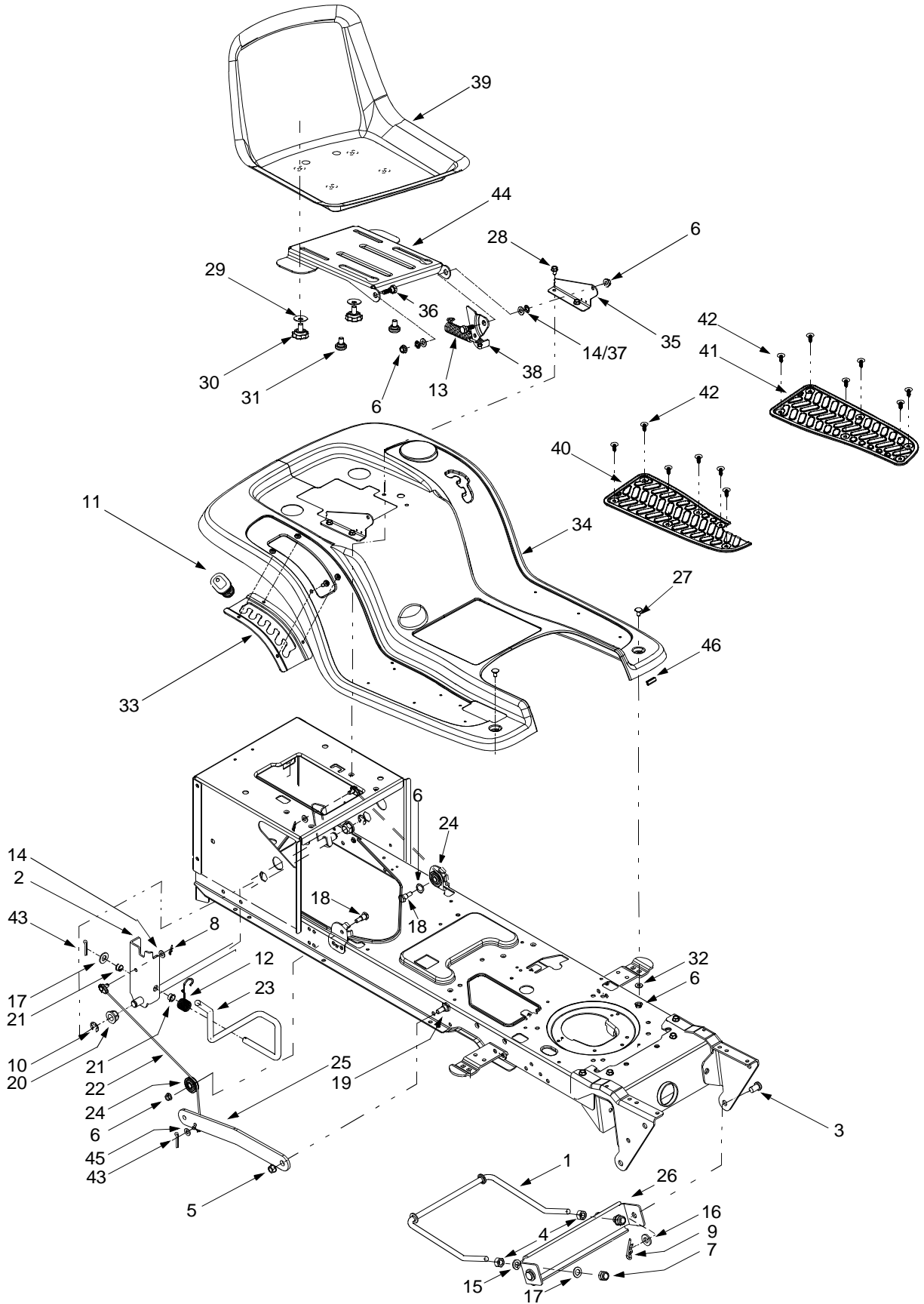

Model X614G

REF. NO.	PART NO.	DESCRIPTION	REF. NO.	PART NO.	DESCRIPTION
1	747-1130B	Deck Stabilizer Rod	23	747-1111A	Lift Handle
2	683-0197B	Lift Shaft Assembly	24	756-1154	Roller Pulley
3	711-0332	Clevis Pin, .5 x .78	25	783-0678A	Arm Lift
4	712-0206	Hex Nut, 1/2-13	26	783-0720A	Deck Stabilizer Bracket
5	712-0431	Flange Lock Nut, 3/8-16	27	710-0260A	Carriage Bolt, 5/16 x 0.62
6	712-3004A	Flange Lock Nut, 5/16-18	28	710-0726	AB Screw, 5/16-12 x 0.75
7	712-3083	Hex Nut, 1/2-13	29	736-0331	Bell Washer, .390 x 1.13 x .062
8	714-0104	Internal Cotter Pin	30	720-04009	Knob, 3/8-16
9	714-0145	Internal Cotter Pin	31	738-04012	Shoulder Screw
10	716-0106	E-ring	32	736-3078	Flat Washer, .349 x 1.0 x .063
11	720-0311	Handle Grip	33	783-1010	Lift Adjustment Bracket
12	732-0874	Torsion Spring	34	783-0840A	Fender
13	732-1184	Extension Spring, .84 x 4.6	35	783-1489	Seat Mounting Bracket
14	736-0275	Flat Washer, 5/16	36	738-0296	Shoulder Screw
15	736-0921	Lock Washer, 1/2	37	726-0201	Speed Clip
16	736-3019	Flat Washer, .531 x 1.062 x .134	38	783-0209A	Seat Lift Bracket
17	736-3084	Flat Washer, .51 x 1.12 x .06	39	757-04011	Medium Back Seat, Yellow
18	738-0138A	Hex Cap Screw, 5/16-18 x .62	40	735-0672	RH Foot Pad, Rubber
19	738-0143	Shoulder Screw, 3/8-16	41	735-0673	LH Foot Pad, Rubber
20	741-0225	Hex Flange Bearing	42	726-3046	Foot Pad Clips
21	741-0715	Snap Flange Bearing	43	714-0111	Cotter Pin
22	746-0968	Lift Cable, 16.16 (T604G)	44	783-04081	Seat Pivot Bracket
	746-1144	Lift Cable, 15.62 (T604H)	45	736-0204	Flat Washer, .344 x .62

NOTE: For **painted parts**, please refer to the list of color codes below. Please add the applicable color code, wherever needed, to the part number to order a replacement part. For instance, if a part numbered 700-xxxx is painted Yard-Man Green, the part number to order would be 700-xxxx-0665.

Yard-Man Green: 0665
 Yard-Man Yellow: 0674
 Powder Black: 0637

Model X614G

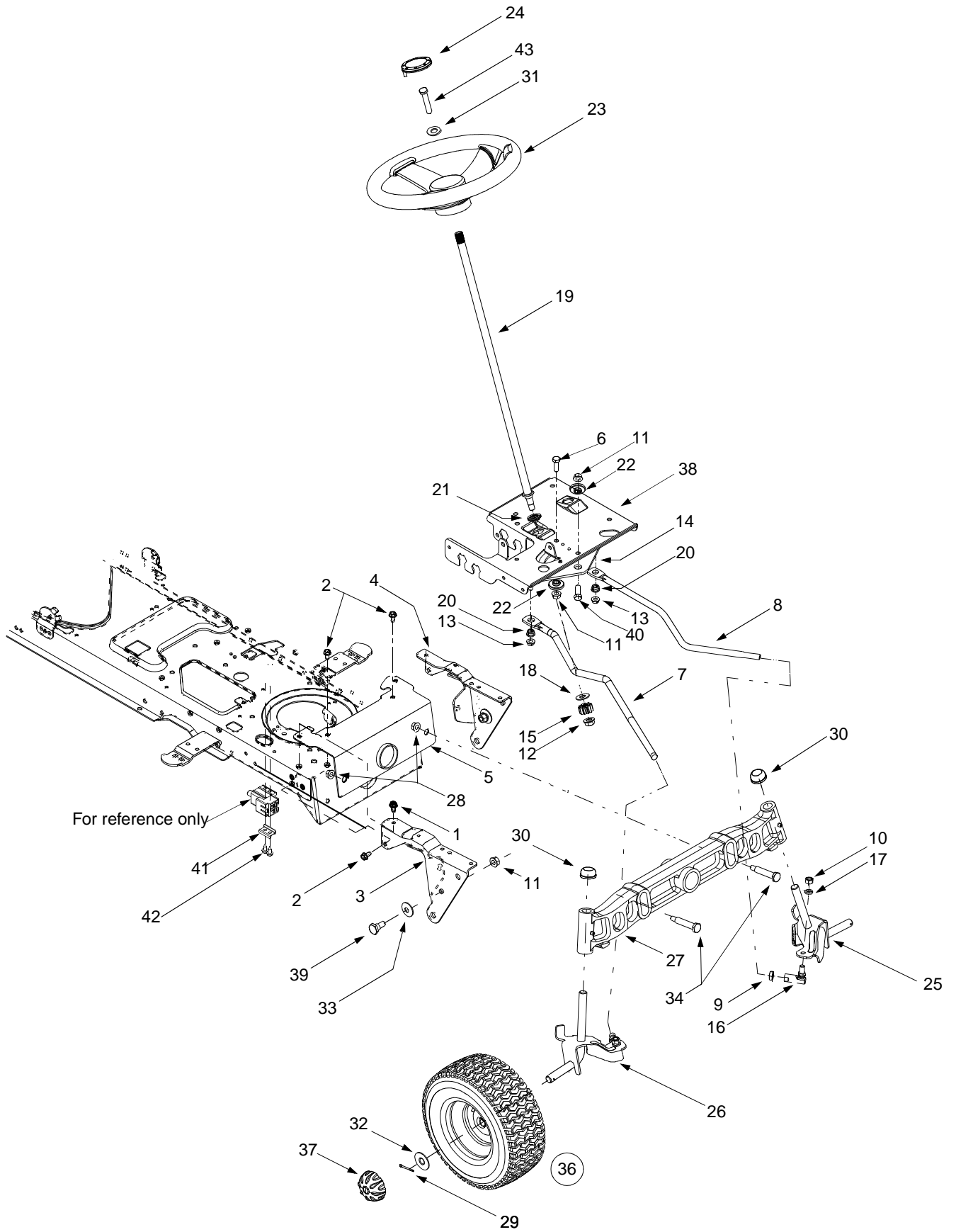

Model X614G

REF. NO.	PART NO.	DESCRIPTION	REF. NO.	PART NO.	DESCRIPTION
1	710-1260A	Self-tapping Screw, 5/16-18 x .75	24	731-04040	Steering Wheel Cap
2	710-0604A	Self-tapping Screw, 16-18 x .625	25	638-0021A	LH Axle Assembly, .75 Diameter
3	783-0726B	RH Pivot Support Bracket	26	638-0022A	RH Axle Assembly, .75 Diameter
4	783-0727A	LH Pivot Support Bracket	27	719-0399B	Cast Iron Pivot Bar w/ Fittings, .75
5	783-0728	Pivot Bar Bracket	28	712-0431	Flange Lock Nut, 3/8-16
6	710-0514	Hex Cap Screw, 3/8-16 x 1 (Grade 5)	29	714-0162	Cotter Pin
7	711-1408	RH Drag Link	30	726-0341	Push Cap, .750
8	711-1409A	LH Drag Link	31	736-0242	Bell Washer, .34 x .872
9	712-0240	Jam Nut, 7/16-20 (Grade 2)	32	736-0285	Flat Washer, .635 x 1.589 x .06
10	712-0241	Hex Nut, 3/8-24 (Grade 2)	33	736-0331	Bell Washer, .39 x 1.13 x .062
11	712-0431	Flange Lock Nut, 3/8-16	34	738-1011	Shoulder Screw, .5 x 2.2, 3/8-16
12	712-0459	Flange Lock Nut, 7/16-20	35	710-0643	Hex Bolt, 5/16-18 X 1
13	712-3004A	Flange Lock Nut, 5/16-18	36	634-0105A	Wheel Assembly Complete, 15 x 6 x 6
14	717-1550D	Steering Gear, 11/90 Ratio		634-0172	Rim Only w/ Plastic Bearing
15	717-1554	Steering Pinion Gear		734-0255	Air Valve (Not Shown)
16	723-0448A	Ball Joint, 7/16-20		734-1731	Tire Only, Square Shoulder
17	736-0169	Lock Washer, 3/8	37	734-2290	Hub Cap
18	736-3084	Flat Washer, .51 x 1.12 x .06	38	783-0653E	Steering Support Bracket
19	738-1001A	Steering Shaft, .625 OD x 24.4	39	738-0143	Shoulder Screw, 3/8-16
20	741-0475	Plastic Bushing, .38 ID	40	710-04095	Hex Screw 3/8-16 x 1.0
21	741-0656	Hex Flange Bearing, 5/8	41	17962	Switch Plate
22	738-0372B	Shoulder Spacer, .38 ID	42	710-0224	AB Screw #10-16 x 0.5
23	631-04008	Steering Wheel: 3 Spoke			

NOTE: For **painted parts**, please refer to the list of color codes below. Please add the applicable color code, wherever needed, to the part number to order a replacement part. For instance, if a part numbered 700-xxxx is painted Yard-Man Green, the part number to order would be 700-xxxx-0665.

Yard-Man Green: 0665
 Yard-Man Yellow: 0674
 Powder Black: 0637

Model X614G

REF. NO.	PART NO.	DESCRIPTION	REF. NO.	PART NO.	DESCRIPTION
1	17840	Transaxle Mounting Bracket	42	747-1151	Hydrostatic Control Rod
2	618-0319	Hydrostatic Transmission	43	750-0535	Spacer, .376 x .625 x .22
3	629-0949A	Reverse Wire Harness Adapter & Ground	44	754-0349	Drive Belt
4	736-0242	Bell Washer, .34 x .872	45	756-0116	V-idler Pulley, 3.06
5	683-0251	Double Idler Bracket Assembly	46	756-0981A	Flat Idler Pulley, 2.75
6	710-0176	Hex Cap Screw, 5/16-18 x 2.75	47	756-1166	Input Pulley, 5.0
7	710-0227	Screw, #8-18 x .5	48	783-0810	Transmission Torque Bracket
8	710-0344	Hex Cap Screw, 3/8-16 x 1.5	49	783-1019	Switch Actuator Bracket
9	710-0726	AB Screw, 5/16-12 x .75	50	647-0031B	Brake Control Assembly
10	710-0599	Self-tapping Screw, 1/4-20 x .375	51	647-0049	Drive Control Assembly
11	710-3007	Screw, #12-24 x .375	52	683-0267C	Hydro Pedal Assembly
12	710-3011	Hex Cap Screw, 3/8-16 x 2.25	53	710-0650	Self-tapping Screw, 5/16-18 x .875
13	710-3103	Hex Cap Screw, 5/16-18 x 2.0	54	710-1260A	Self-tapping Screw, 5/16-18 x .75
14	711-0677	Ferrule, 5/16-18	55	711-0736	Ferrule, 1/4-20
15	711-0832	Ferrule, 3/8-24	56	711-1363	Pin, 3/8-16 x 2.43
16	712-0333	Hex Nut, 1/2-20	57	732-0335	Compression Spring, .405 OD x 1.17
17	712-0431	Flange Lock Nut, 3/8-16	58	756-0978A	Engine Pulley
18	712-3006	Flange Lock Nut, 1/4-20	59	732-0963	Extension Spring, .50 OD x 6.37
19	712-3010	Hex Nut, 5/16-18	60	735-0662	Drive Pedal Pad
20	712-3017	Hex Nut, 3/8-16	61	735-3049	Brake Pedal Pad
21	714-0104	Internal Cotter Pin	62	736-0133	Flat Washer, .411 x 1.25 x 1.0
22	714-0111	Cotter Pin	63	736-0187	Flat Washer, .64 x 1.24 x .06
23	725-0157	Cable Tie	64	736-0222	Ext. Lock Washer
24	725-1644	Short Spring Switch	65	710-1611B	TT Screw 5/16-18 x 0.75
25	726-0320	Insulator Nut Plate	66	738-0155	Shoulder Screw, .437 x 1.62
26	731-1449A	10-inch Fan	67	710-0627	Hex Cap Screw, 5/16-24 x .75
27	732-0209	Extension Spring, .48 x 2.03	68	741-0225	Hex Flange Bearing
28	732-0716	Extension Spring, .59 x 4.0	69	741-3065B	Split Hex Flange Bearing
29	732-0729	Wire Ring	70	747-04096	Cruise Control Rod
30	732-0429A	Extension Spring, .5 x 3.97	71	747-04093	Brake Lock Control Rod
31	732-0994	Extension Spring, .5 x 7.0	72	748-0413	Cruise Latch
32	732-3118	Extension Spring, 3/8 x 1.44	73	736-3008	Flat Washer, .344 x .750 x .120
33	736-0140	Flat Washer, .385 x .62 x .063	74	783-0653E	Steering Support Bracket
34	736-0329	Lock Washer	75	783-0663C	Drive Lockout Bracket
35	736-0169	Lock Washer, 3/8	76	783-0773	Brake Pedal
36	736-0275	Flat Washer, .344 x .688 x .065	77	634-0104	Wheel Assembly Complete 20 x 8 x 8
37	736-0921	Lock Washer, 1/2		634-0070	Square Shoulder
38	736-3010	Flat Washer, .407 x .812 x .135			Rim Assembly Only
39	738-0372B	Shoulder Spacer, .38		734-0255	Air Valve (Not Shown)
40	747-1149	Hydrostatic Bypass Rod		734-1730	Tire Only, 20 x 8 x 8, Square Shoulder
41	747-1150	Hydrostatic Brake Rod	78	734-2290A	Deluxe Hub Cap (Ref. 79 Required)
			79	736-0430	Flat Washer, .350 x 1.59 x .062

NOTE: For painted parts, please refer to the list of color codes below. Please add the applicable color code, wherever needed, to the part number to order a replacement part. For instance, if a part numbered 700-xxxx is painted Yard-Man Green, the part number to order would be 700-xxxx-0665.

Yard-Man Green: 0665

Yard-Man Yellow: 0674

Powder Black: 0637

Model X614G

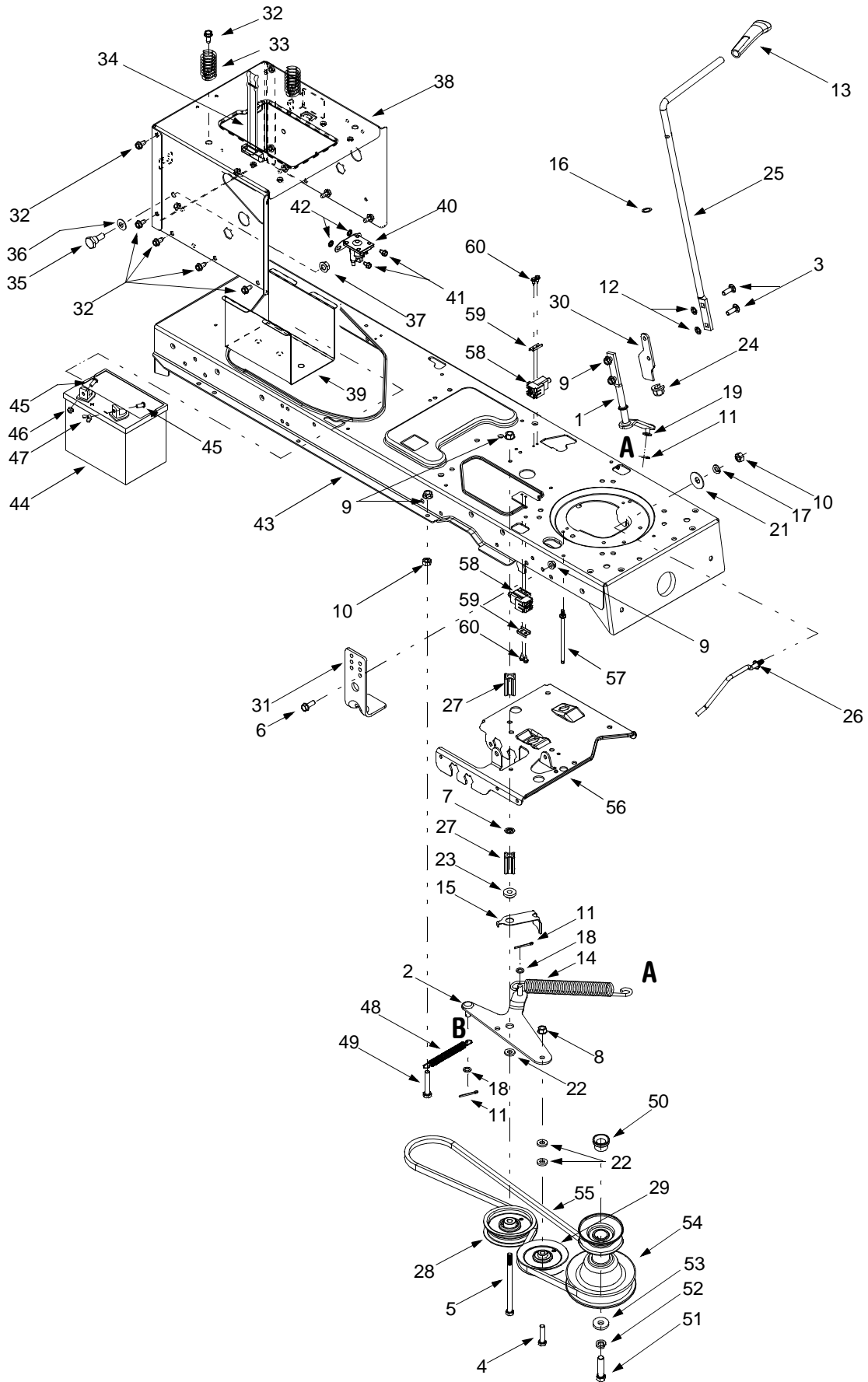

Model X614G

REF. NO.	PART NO.	DESCRIPTION	REF. NO.	PART NO.	DESCRIPTION
1	647-0064	PTO Engage Lever Assembly	31	783-0891B	Deck Stop
2	683-0450	PTO Engage Plate Assembly	32	710-0604A	Self-Tapping Screw, 5/16-18 x .625
3	710-0276	Carriage Screw, 5/16-18 x 1.00	33	732-04035	Compression Spring, 1.28 x 3.125
4	710-0520	Hex Cap Screw, 3/8-16 x 1.5	34	723-0444	Battery Strap
5	710-0831	Hex Cap Screw, 3/8-16 x 5.5	35	738-1020	Shoulder Screw, .625 x .5, 7/16-20
6	710-1238	Hex Head Washer Screw, 5/16-18 x .875	36	736-0407	Bell Washer, .45 x 1.0 x .062
7	712-0229	Push Nut, 3/8	37	712-0459	Flange Lock Nut, 7/16-20
8	712-0431	Flange Lock Nut, 3/8-16	38	783-1031A	Hitch Plate
9	712-3004A	Flange Lock Nut, 5/16-18	39	783-0349	Battery Tray
10	712-3010	Hex Nut, 5/16-18	40	725-1426	Solenoid, 12-Volt, 100 Amp
11	714-0470	Cotter Pin, 1/8 x 1.25	41	710-0599	Self Tapping Screw, 1/4-20 x .5
12	726-0201	Speed Nut, .3125	42	736-0222	Lock Washer, 1/4
13	731-2111A	PTO Knob	43	683-0304C	Lower Frame Assembly
14	732-0944	Extension Spring, .75 x 6.75	44	725-1706	12-volt Battery, 270 CCA
15	732-0991A	Belt Guard	45	710-0751	Hex Cap Screw, 1/4-20 x .62
16	736-0108	Flat Washer, .510 x .750 x .033	46	712-0271	Hex Sems Nut, 1/4-20
17	736-0119	Lock Washer, 5/16	47	712-3044	Wing Nut, 1/4-20
18	736-0140	Flat Washer, .385 x .62 x .063	48	732-1165	Extension Spring, .50 x 5.0
19	736-0275	Flat Washer, 5/16	49	710-3180	Hex Cap Screw, 5/16-18 x 1.75
20	736-3000	Flat Washer, .406 x .875 x .059	50	750-0596	Spacer Cup
21	736-0331	Bell Washer, .39 x 1.13 x .062	51	710-3029	Hex Head Cap Screw, 7/16-20 x 1.25
22	736-3010	Flat Washer, .407 x .812 x .135	52	736-0171	Lock Washer, 7/16
23	738-0372	Shoulder Spacer, .380	53	736-0322	Flat Washer, .450 x 1.25
24	741-0708	Hex Split Flange Bearing, .5	54	756-0982B	Engine Pulley, 3.56 OD x 5.56
25	747-1112D	PTO Engage Handle	55	754-0497	PTO Belt
26	747-1286A	Belt Keeper Rod	56	783-0653F	Steering Support Bracket
27	748-0415A	Spacer, 3/8 x 1.54	57	711-1044	Keeper Pin, 5/16 x 4.75
28	756-0627B	Idler Pulley, 3.5	58	725-1657A	Switch
29	756-1208	Idler Pulley, 4.0	59	17962	Switch Plate
30	783-0744A	Engagement Stop	60	710-0224	Screw, #10-16 x .5

NOTE: For **painted parts**, please refer to the list of color codes below. Please add the applicable color code, wherever needed, to the part number to order a replacement part. For instance, if a part numbered 700-xxxx is painted Yard-Man Green, the part number to order would be 700-xxxx-0665.

Yard-Man Green: 0665
 Yard-Man Yellow: 0674
 Powder Black: 0637

42-inch Cutting Deck: Style G

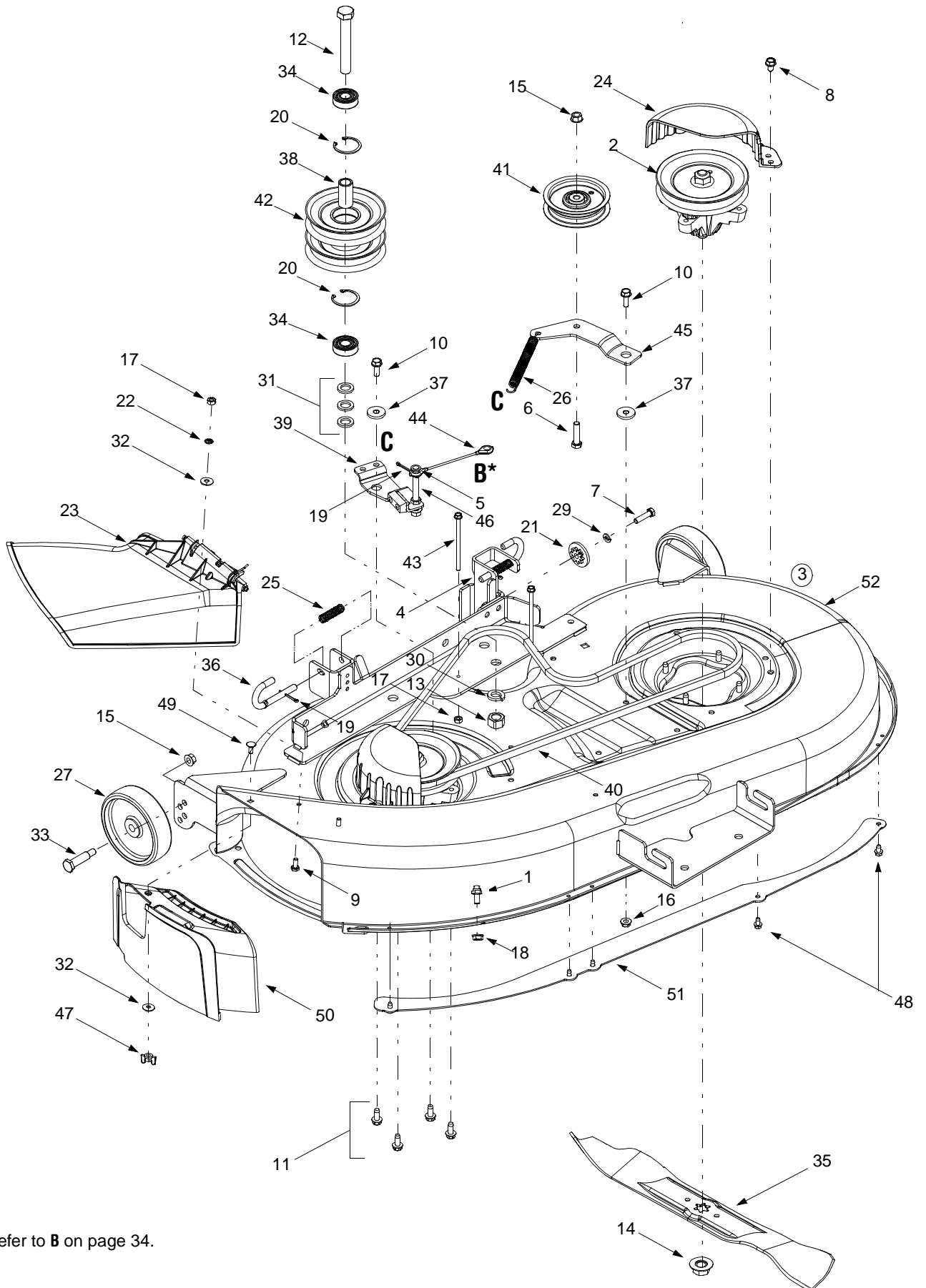

* Refer to B on page 34.

42-inch Cutting Deck: Style G

REF. NO.	PART NO.	DESCRIPTION	REF. NO.	PART NO.	DESCRIPTION
1	711-04069	Pin: Grasscatcher	26	732-0470A	Extension Spring, .50 x 4.74
2	618-0565	Spindle Assembly, 5.75 Dia.	27	734-0973	Deck Wheel, 5 x 1.38
	756-0980	Pulley Only	29	736-0119	Lock Washer, 5/16
3	683-0198F	42-inch Deck Assembly Complete	30	736-0158	Lock Washer, 5/8
4	683-0254	Deck Adj. Bracket w/ Weld Nut	31	736-0162	Flat Washer, .64 x 1.0 x .12
5	736-0140	Flat Washer, .385 x .62 x .063	32	736-0270	Bell Washer, .265 x .75 x .062
6	710-0520	Hex Cap Screw, 1/4-20 x 1.5	33	738-0373	Shoulder Screw, .498 x 1.53
7	710-0528	Hex Cap Screw, 5/16-18 x 1.25	34	741-0524	Bearing, .625 x 1.574 x .470
8	710-0726	Self-tapping Screw, 5/16-18 x .625	35	742-0616A	3-in-1 Blade, Star Center, 21.23"
9	710-0751	Hex Cap Screw, 1/4-20 x .62	36	747-1116	Deck Release Pin
10	710-1238	Hex Hd. Wash. Scr. 5/16-18 x .875	37	748-0331	Shoulder Spacer, .625 x .324
11	710-1260A	Self-Tapping Screw, 5/16-18 x .75	38	750-0932A	Spacer, .635 x .88 x 1.72
12	710-3151	Hex Cap Screw, 5/8-18 x .875	39	683-0440	Deck Brake Assembly
13	712-0337	Hex Nut, 5/8-18	40	754-0498	Deck Belt
14	712-0417A	Hex Flange Nut, 5/8-18	41	756-0627B	Idler Pulley, 3.5
15	712-0431	Flange Lock Nut, 3/8-16	42	756-1202	Double Pulley, 5.0
16	712-3004A	Flange Lock Nut, 5/16-18	43	710-1830	Self-tapping Screw, 1/4-20 x 4.0
17	712-3006	Hex Nut, 1/4-20	44	746-0970	Brake Cable, 5.05
18	712-3027	Hex Flange Lock Nut, 1/4-20	45	783-1291	Idler Bracket
19	714-0470	Cotter Pin, 1/8 x 1.25	46	711-1534	Pin, 3/8-16, 3/8 x 3.27
20	716-3020	Internal Snap Ring	47	712-3087	Wing Nut, 1/4-20
21	717-1553B	Deck Adjustment Gear	48	710-0599	Self-Tapping Screw, 1/4-20 x .5
22	726-0233	Push Nut. .25 x .5	49	710-0134	Carriage Screw, , 1/4-20 x .62
23	731-1032B	Side Discharge Chute Assembly	50	731-2363	Mulch Plug
24	731-2486A	Belt Cover	51	783-1146A	Deck Skirt
25	732-0306	Comp. Spring, .406 x .531 x 1.75	52	783-0621C	Deck Assembly: Side-Discharge

NOTE: For **painted parts**, please refer to the list of color codes below. Please add the applicable color code, wherever needed, to the part number to order a replacement part. For instance, if a part numbered 700-xxxx is painted Yard-Man Green, the part number to order would be 700-xxxx-0665.

Yard-Man Green: 0665
 Yard-Man Yellow: 0674
 Powder Black: 0637

Model X614G

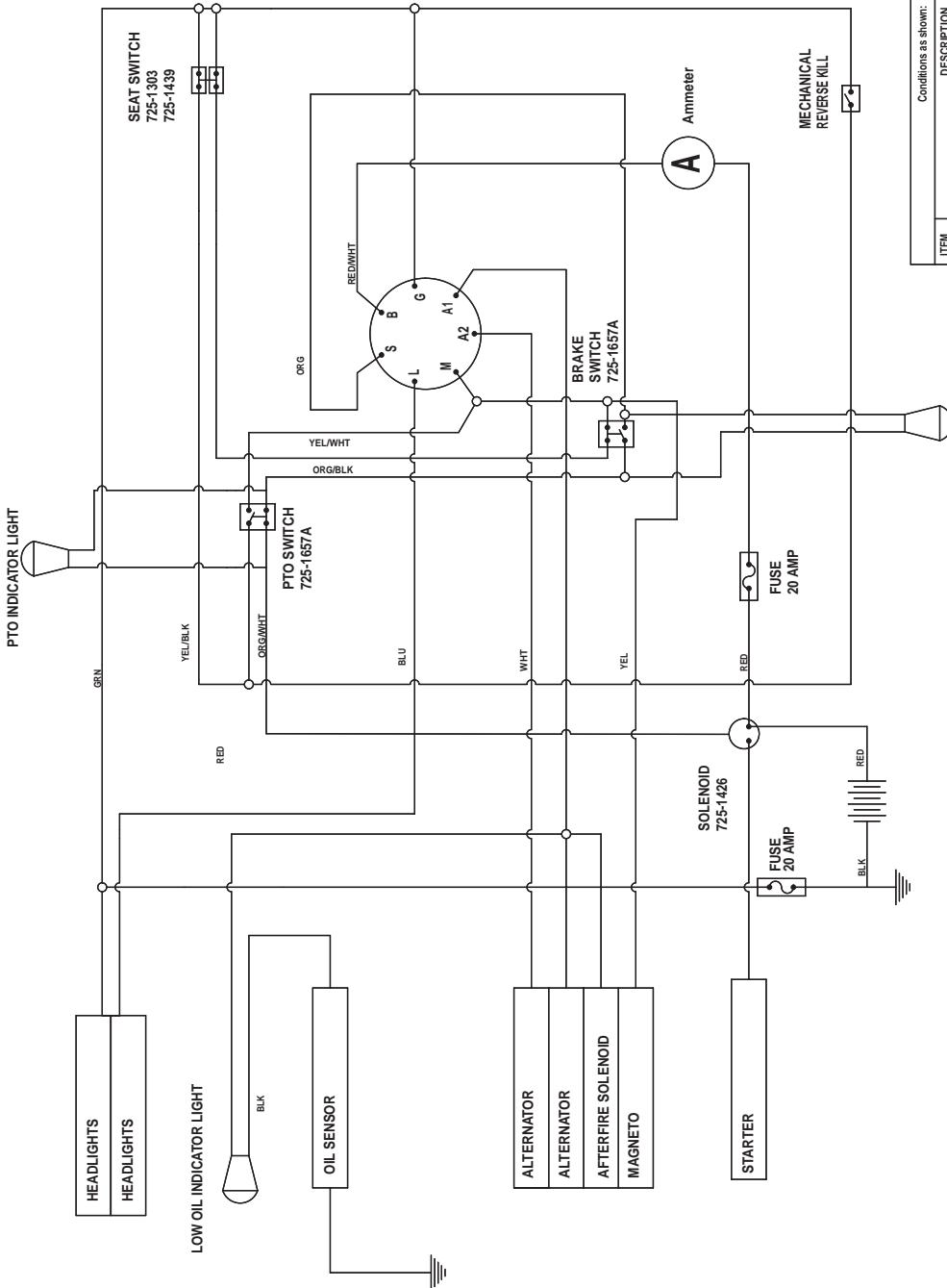
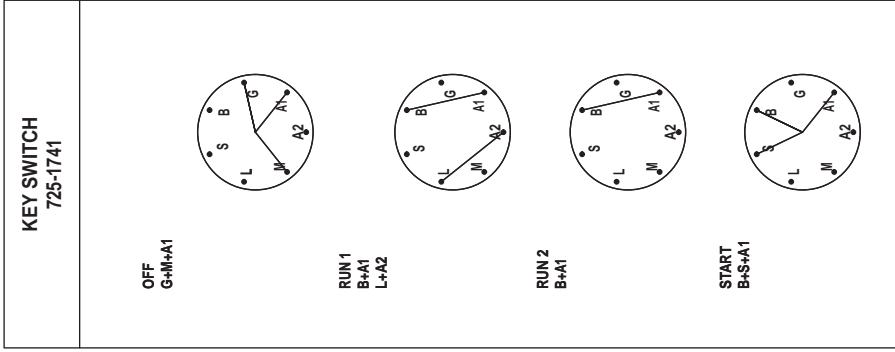

Conditions as shown:

ITEM	DESCRIPTION
1	KEY SWITCH OFF
2	PTO OFF
3	TRACTOR UNOCCUPIED
4	BRAKE SWITCH OFF

MANUFACTURER'S LIMITED WARRANTY FOR:



The limited warranty set forth below is given by MTD LLC with respect to new merchandise purchased and used in the United States, its possessions and territories.

MTD LLC warrants this product against defects for a period of two (2) years commencing on the date of original purchase and will, at its option, repair or replace, free of charge, any part found to be defective in materials or workmanship. This limited warranty shall only apply if this product has been operated and maintained in accordance with the Operator's Manual furnished with the product, and has not been subject to misuse, abuse, commercial use, neglect, accident, improper maintenance, alteration, vandalism, theft, fire, water, or damage because of other peril or natural disaster. Damage resulting from the installation or use of any accessory or attachment not approved by MTD LLC for use with the product(s) covered by this manual will void your warranty as to any resulting damage.

Normal wear parts or components thereof are subject to separate terms as follows: All normal wear parts or component failures will be covered on the product for a period of 90 days regardless of cause. After 90 days, but within the two year period, normal wear part failures will be covered ONLY IF caused by defects in materials or workmanship of OTHER component parts. Normal wear parts and components include, but are not limited to: batteries, belts, blades, blade adapters, grass bags, rider deck wheels, seats, snow thrower skid shoes, shave plates, auger spiral rubber, and tires.

HOW TO OBTAIN SERVICE: Warranty service is available, WITH PROOF OF PURCHASE, through your local authorized service dealer. To locate the dealer in your area, check your Yellow Pages, or contact MTD LLC at P.O. Box 361131, Cleveland, Ohio 44136-0019, or call 1-800-800-7310 or log on to our Web site at www.mtdproducts.com.

This limited warranty does not provide coverage in the following cases:

- a. The engine or component parts thereof. These items carry a separate manufacturer's warranty. Refer to applicable manufacturer's warranty for terms and conditions.
- b. Log splitter pumps, valves, and cylinders have a separate one year warranty.
- c. Routine maintenance items such as lubricants, filters, blade sharpening, tune-ups, brake adjustments, clutch adjustments, deck adjustments, and normal deterioration of the exterior finish due to use or exposure.
- d. MTD LLC does not extend any warranty for products sold or exported outside of the United States, its possessions and territories, except those sold through MTD LLC's authorized channels of export distribution.
- e. Parts that are not genuine MTD parts are not covered by this warranty.
- f. Service completed by someone other than an authorized service dealer is not covered by this warranty.
- g. Transportation charges and service calls are not covered.

No implied warranty, including any implied warranty of merchantability of fitness for a particular purpose, applies after the applicable period of express written warranty above as to the parts as identified. No other express warranty, whether written or oral, except as mentioned above, given by any person or entity, including a dealer or retailer, with respect to any product, shall bind MTD LLC. During the period of the warranty, the exclusive remedy is repair or replacement of the product as set forth above.

The provisions as set forth in this warranty provide the sole and exclusive remedy arising from the sale. MTD LLC shall not be liable for incidental or consequential loss or damage including, without limitation, expenses incurred for substitute or replacement lawn care services or for rental expenses to temporarily replace a warranted product.

Some states do not allow the exclusion or limitation of incidental or consequential damages, or limitations on how long an implied warranty lasts, so the above exclusions or limitations may not apply to you.

In no event shall recovery of any kind be greater than the amount of the purchase price of the product sold. **Alteration of safety features of the product shall void this warranty.** You assume the risk and liability for loss, damage, or injury to you and your property and/or to others and their property arising out of the misuse or inability to use the product.

This limited warranty shall not extend to anyone other than the original purchaser or to the person for whom it was purchased as a gift.

HOW STATE LAW RELATES TO THIS WARRANTY: This limited warranty gives you specific legal rights, and you may also have other rights which vary from state to state.

MTD LLC, P.O. BOX 361131 CLEVELAND, OHIO 44136-0019; Phone: 1-800-800-7310