

47

D 7006

7915/1

7916/1





D 7006

Gültig ab Traktor-Nr. 7915/1
Effective from tractor No. 7915/1
Valable à partir du tracteur No. 7916/1
Válida a partir tractor No.

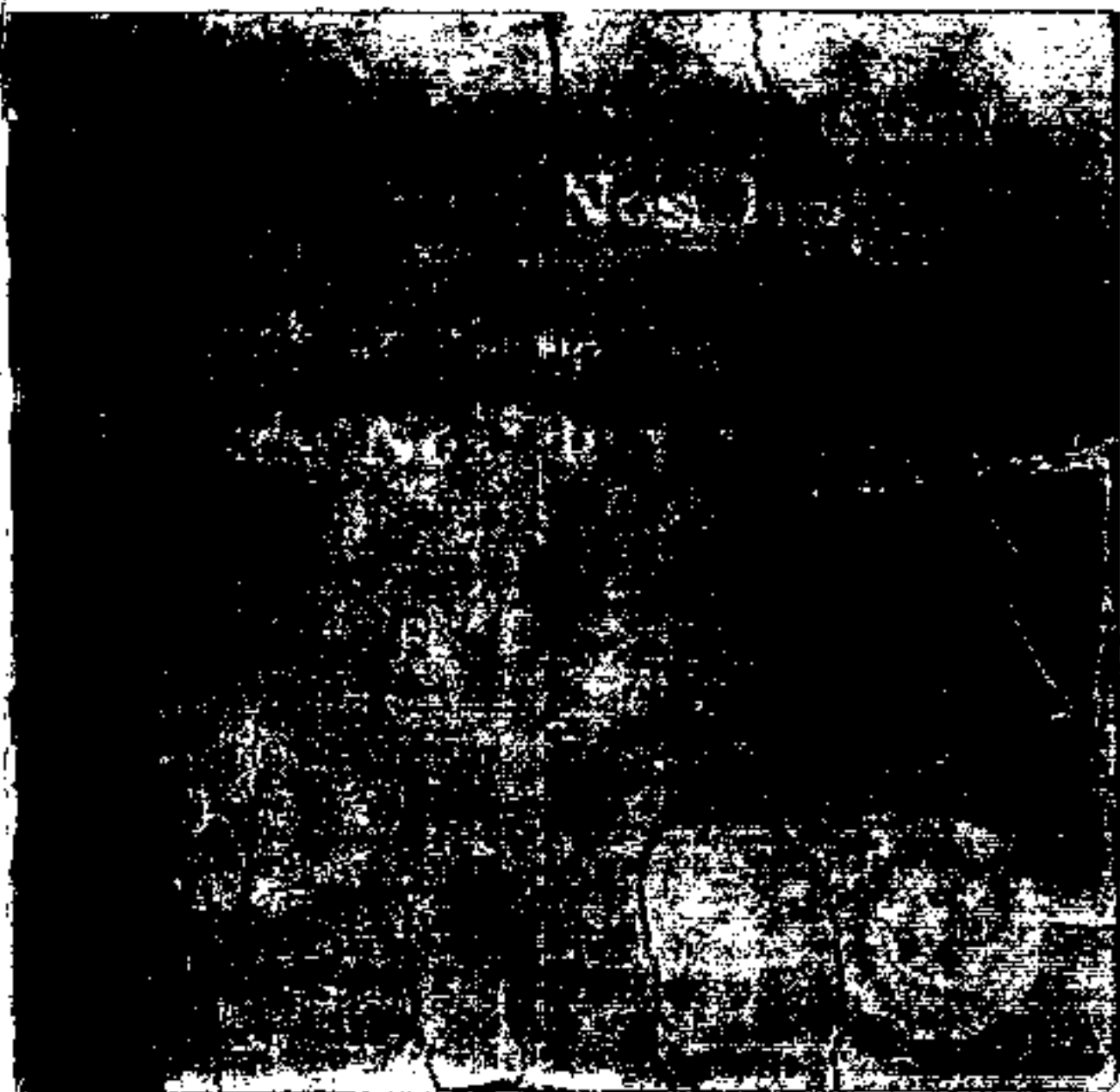

1002	Unabhängige Doppelkupplung mit Befestigungsteilen	9-13
1003	Betätigung zur Doppelkupplung unabhängig	15-19
1008	Kupplungsgehäuse mit Befestigungsteilen	21-25
1011	Wechselgetriebe für Synchron und für Allrad	27-45
1012	Schaltung zum Wechselgetriebe	47-51
1014	Schaltung für Duo-Zapfwelle	53-55
1016	Vorgelegebremse	57-59
1019	Riemenscheibenantrieb	61-65
1021	Getienkwelle	67-69
1023	Zwischenwelle, Kegeltrieb	71-73
1024	Ausgleichgetriebe	75-77
1025	Ausgleichgetriebesperre	79-81
1026	Vorderradantrieb mit Schallung	83-89
1027	Hinterachse	91-93
1028	Triebachse mit Pendellager und Lenkungsämpfer	95-107
1029	Getriebebremsbetätigung	109-113
1030	Betätigung für Fahrbremse, Doppelbremse	115-119
1032	Achslagerbock, Dallastgerichte und Rangierkupplung	121-123
1033	Vorderachse	125-129
1037	tech. Lenkung	131-145
1041	Kotorhaube und Trennwand	147-151
1042	Kraftstoffbehälter mit Tankanzeige	153-157
1043	Deutz-Siccopur-Filter und Deutz-Siccopur-Filter-Ansaugung nach oben	159-165

1044	Auspuffanlage	167-169
1046	Drehzahlverstellung	171-173
1047	Abstellvorrichtung	175-177
1049	Elektr. Ausrüstung, Schaltkasten, Armaturen, Scheinwerfer, Positionsleuchten, Schlußleuchten	179-199
1051	Hintere Kotflügel 360 breit, hintere Kotflügel 452 breit	201-209
1052	Kotflügel vorne normal und für Allrad	211-215
1054	Fahrersitz	217-221
1055	Verkleidungskasten	223-225
1058	Räder, Ballastgewichte	227-229
1061	Schutzrahmen	231-233
1063	Anhängerkupplung	235-237
1076	Beifahrersitz, Werkzeugkasten, Rückstrahler, Rückblickspiegel	239-241
1077	Duo-Zapfwelle	243-247
1085	Heizungsanlage	249-251
1901	Hydr. Pumpe und Leitungen	253-257
1904	Remote - Control	259-267
1907	Remote-Anschlüsse	269-275
1908	Regelhydraulik, Kraftheber K 45.1	277-291
1911	Dreipunktkupplung	293-299
1914	Zugpendel	301-305
1920	Hubkupplung	307-311
1955	Druckluftanlage, Druckluftanlage (Zweileitungsanlage)	313-329
1956	Hydr. Bremse für Anhänger	331-335

1002	Independent Dual Clutch with Fastening Parts Embrayage à double effet et pièces d'adaptation en présence d'une prise de force autonome Embrague doble independiente con elementos de fijación	9- 13
1009	DP10 Dual Clutch Control Assembly Commande de l'embrayage double effet en présence d'une prise de force autonome Accionamiento para embrague doble u. toma de fuerza "independiente"	15- 19
1008	Transmission Case with Fastening Parts Carter de transmission, pièces d'adaptation Caja del tren de engranajes con elementos de fijación	21- 25
1011	Synchronized Transmission, Transmission (Standard) for all-wheel drive Boite de vitesses synchronisée, Boite de vitesses exécution "boîtes roues motrices" Caja de cambio con sincronización, Cambio de velocidades para modelo de tracción en las 4 ruedas	27- 45
1012	Gear-shift Assembly Commande de la boîte de vitesses Mando para el cambio de velocidades	47- 51
1014	Two-speed PFD Control Assembly Commande mécanisme prise de force permettant d'obtenir 2 régimes, connexion pour toma de fuerza tipo "Loo"	53- 55
1016	Final Drive Brake Frein sur réducteur Freno actuado sobre la transmisión	57- 59
1019	Beil Pulley Drive Mécanisme de la poulie de bailare Accionamiento para polea	51- 65
1021	Joint Shaft Arbre à cardan Arbol cónico	67- 69
1023	Intermediate Shaft with Bevel Gear Arbre intermédiaire, couple conique Eje intermedio, grupo cónico	71- 73
1024	Differential Unit Différentiel Diferencial	75- 77
1025	Differential Lock Blocage du différentiel Bloqueo del diferencial	79- 81
1026	Front Wheel Drive with Control Assembly Pont-moteur AV et sa commande Tracción delantera con mando	83- 85
1027	Standard Rear Axle Train AR Puente trasero	91- 93
1028	Driven Front Axle with Dual Bearing and Vibration Dampers, Driven Front Axle AL 1550 Pont motodirecteur à poutre oscillant et amortisseur de direction, Pont motodirecteur AL 1550 Eje delantero motriz con soporte pendular y amortiguador de dirección, Eje delantero motriz tipo AL 1550	95-107
1029	Transmission Brake Control Assembly Commande de frein agissant sur la Transmission Accionamiento para freno sobre transmisión	109-113
1030	Operating Brake and Parking Brake Commande du frein au pied Accionamiento de freno de rodadura; freno de estacionamiento	115-119
1032	Coil Spring Ballast Weights resos de laire Bercan de lair AV resos d'élancement Cballate de soporte de eje delantero	121-123

1033	Front Axle Essieu AV Eje delantero	125-129
1037	Mechanical Steering Assembly, Steering Linkage, Hydrosteering Assembly Mécanisme de direction mécanique (linéaire), Tringlerie de direction, Mécanisme de direction hydro-assistée (Timonerie) Dirección mecánica, Varillaje de dirección, Servodirección hidráulica	131-145
1041	Engine Hood and Bulkhead Capot-moteur, écran vertical Capot y tabique de separación	147-151
1042	Fuel Tank with level Gauge Réservoir avec indicateur de niveau de fuel Tanque de combustible e indicador de nivel de combustible	153-157
1043	Deutz-Siccopur Air Cleaner, Deutz-Siccopur Air Cleaner; Intake from Above Épurateur type sec, Deutz-Siccopur, Épurateur type sec, Deutz-Siccopur pipe d'aspiration vers le haut Filtro en seco Deutz-Siccopur, Filtro de aire en seco, Deutz-Siccopur, aspiración desde arriba	159-165
1044	Exhaust System Échappement Sistema de escape	167-169
1046	Speed Control Device Dispositif de variation de régime Sistema de aceleración	171-173
1047	Shut-down Device Dispositif d'arrêt Sistema de parada	175-177
1049	Electrical Equipment, Instrument Panel, Headlights, Side and Tail Lights Équipement électrique, Tableau de bord et instruments, Phares, feux d'encombrement, feux AR Equipo eléctrico, Caja de instrumentos con instrumentos, Faros, lámparas de posición, luces de cola	179-199
1051	Rear Mudguards, Rear Mudguards, 560 front Guard-boue AR, Guard-boue AR 452 front Guardabarras traseros, Guardabarras traseros	201-209
1052	Front Mudguards (Standard), Front Mudguards (All-wheel Drive) Aileron AV, version standard, aileron AV, version toutes roues motrices Guardabarras delanteros, normales, Guardabarras delanteros para versión de tracción de las 4 ruedas	211-215
1054	Driver's Seat Siège du conducteur Asiento de conductor	217-221
1055	Tank Paneling Revêtement des tôles Caja de revestimiento	223-225
1058	Wheels, Ballast Weights Roues, masses d'alourdissement Ruedas, pesos de lastre	227-229
1061	Protective frame protecteur Chassis protector Marco para	231-233
2063	Trailer Hitch Chape d'attelage Acoplamiento para remorque	235-237
2076	Passenger Seat, Seat Cushion Toulbus, Reflector, Driving Mirror Siège de conducteur coffre à outils, culaphotes, rétroviseur Asiento para el acompañante, caja de herramientas, reflectores, espejo retrovisor	239-241
1077	Two-speed PTO Shaft Prise de force permettant d'obtenir 2 régimes de rotation Árbol toma de fuerza tipo Duo	243-247

1905	Heating System Climatisation Sistema de calefacción	249-251
1906	Pump with Piping Pompe hydraulique, conduits Bomba hidráulica con tuberías	253-257
1906	Remote Control Télécommande hydraulique Control remoto	259-267
1907	Remote Connections Equipements de télécommande Equipos de control remoto	269-275
1908	Automatic Hydraulic System, Lift Unit K 45.1 Relevage hydraulique à double contrôle, Vérin hydraulique K 45.1 Elevador hidráulico de efecto regulado, Elevador hidráulico K 45.1	277-291
1911	Three-Point Hitch Attelage trois points Sistema de acoplamiento en 3 puntos	293-299
1914	Oscillator Barre oscillante Pendulo de tracción	301-306
1920	Pick-up Clutch Attelage Gancho de acople de elevación hidr.	307-311
1955	Compressed-air System, Compressed-air System Générateur d'air comprimé, Générateur d'air comprimé Sistema de aire comprimido, Sistema de aire comprimido	313-329
1956	Hydraulic Brake for Trailer Hydraulique du frein pour de remorque de freno, hidráulico para remolques	331-335

Unabhängige Doppelkupplung mit Befestigungsteilen
Independent Dual Clutch with Fastening Parts
Embrayage à double effet et pièces d'adaptation en présence d'une
prise de force autonome
Embrague doble independiente con elementos de fijación

1002

Die Schlepper 7915/1144 bis 1174 sind mit F+S Kupplung
ausgerüstet. Diese Kupplung ist gegen die in der
Serie eingebaute Walterscheid-Kupplung voll
austauschbar. Falls F+S Kupplung defekt, Walterscheid
Kupplung einbauen, da Einzelteile für F+S nicht
geliefert werden. Siehe 531/71 vom 22.7.71

Unabhängige Doppelkupplung
1002 mit Befestigungstellen

Independent Dual Clutch with Fastening Parts
Embrayage à double effet et pièces d'adaptation en présence d'une prise de force autonome
Embrague doble independiente con elementos de fijación.

Bld-Nr.	Schleppenummer		Fußnote	Teilnummer	Anzahl	
	ab	bis				
4				M 8x35 DIN 912-8.8phos. (112 3700)	9	
5				8 DIN 7980 (111 9610)	9	
6	X	<i>ohne lose Scheibe</i>		231 6029 438 6358	1	1006-02
6/1				231 9445	1	1006-02
6/2				231 0630	1	1006-02
6/3				231 0631	1	1006-02
6/4				232 3245	1	1006-02
6/5				232 3247	1	1006-02
6/6				231 0636	1	1006-02
6/7				231 0637	1	1006-02
6/8				230 3408	8	1171-02
6/9				231 0638	3	1006-02
6/10				231 0639	3	1006-02
6/11				232 3235	1	1006-02
6/12				232 3237	1	1006-02
6/13				232 3243	1	1006-02
6/14				231 0643	3	1006-02
6/15				232 3241	1	1006-02
6/16				230 3419	3	1171-02
6/17				232 3418	1	1171-02
6/18				230 3423	3	1171-02
6/19				10,5 DIN 125 (110 7109)	3	
6/21				231 0655 438 6364	1	1006-02
6/22				8,4 DIN 93-St (110 6048)	3	
6/23				M 6x12 DIN 533-8.8 A4C (112 2290)	3	
6/24				b. 6x25 DIN 93-8.8 (111 2331)	3	
X AT = 294 0403						

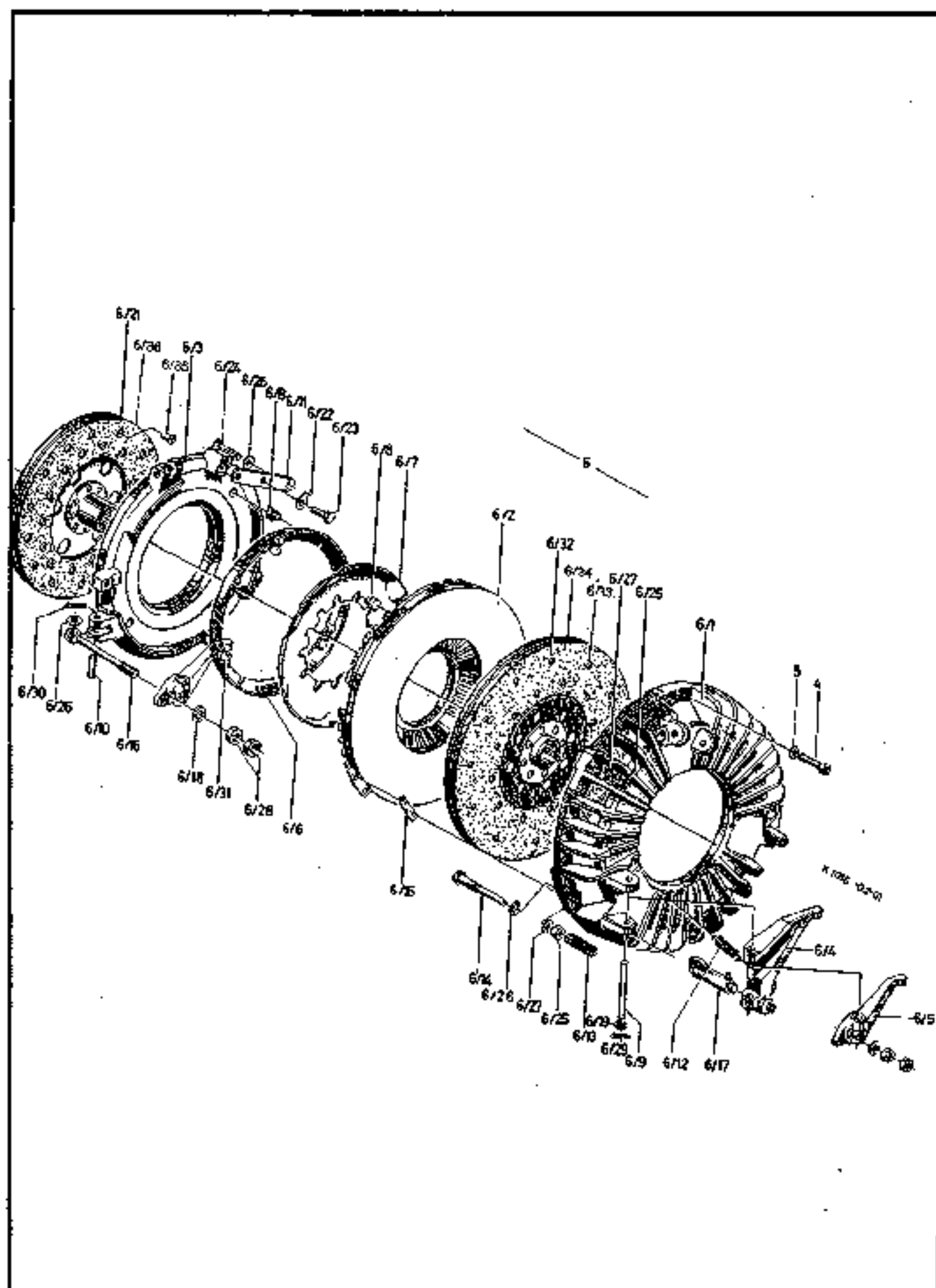

Unabhängige Doppelkupplung
1002 mit Befestigungstellen

Independent Dual Clutch with Fastening Parts
Embrayage à double effet et pièces d'adaptation en présence d'une prise de force autonome
Embrague doble independiente con elementos de fijación

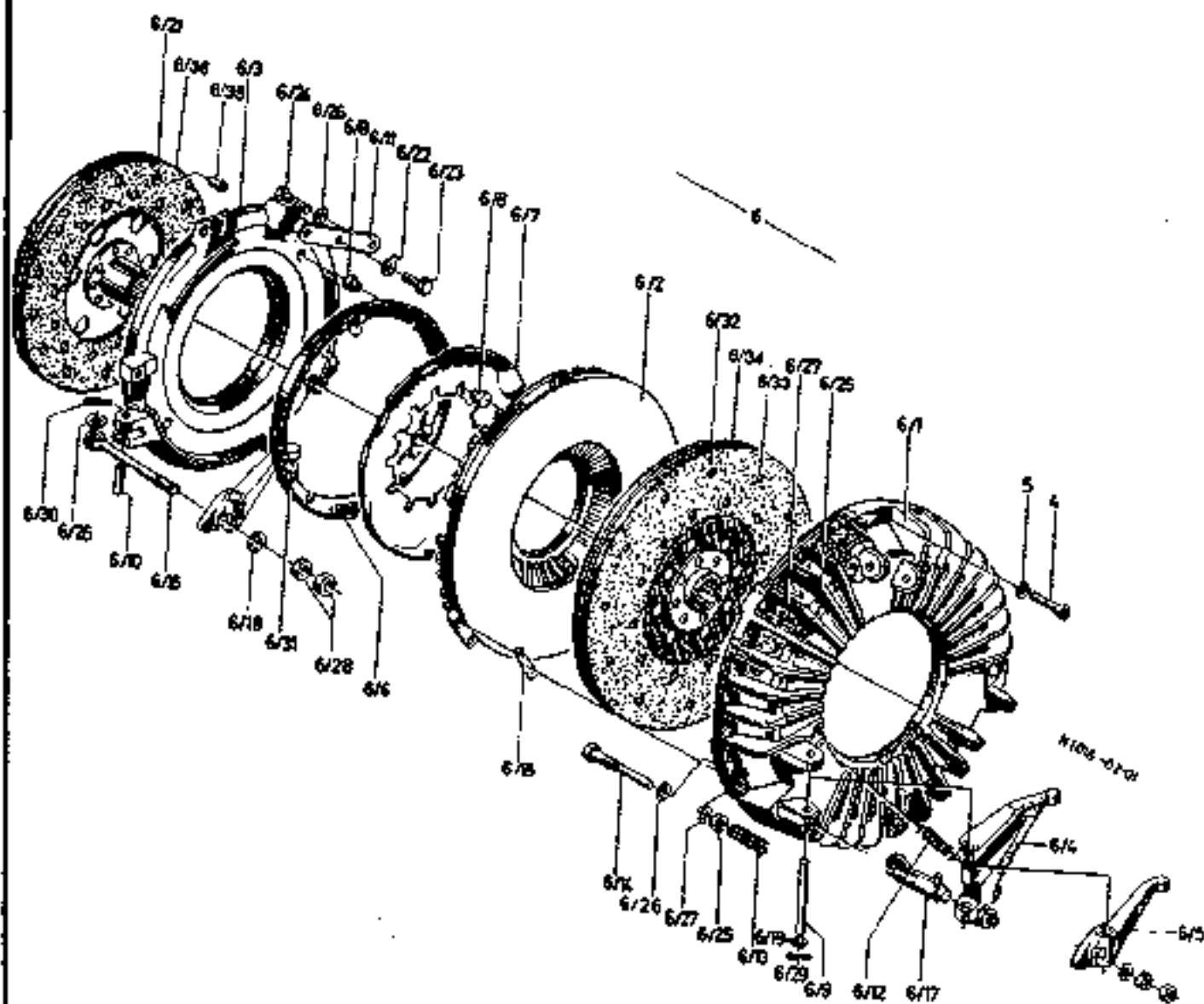

Unabhängige Doppelkupplung
mit Befestigungsteilen

Independent Dual Clutch with Fastening Parts
Embrayage à double effet et pièces d'adaptation en présence d'une prise de force autonome
Enbrague doble independiente con elementos de fijación

1002

Bild-Nr.	Schleppernummer		Fußnote	Teilnummer	Anzahl	
	ab	bis				
6/25				M 8 DIN 934-8 A4C (111 2824)	5	
6/26				8,4 DIN 125 A4C (110 7107)	9	
6/27				A 8 DIN 128 A4C (110 2799)	8	
6/28				M 10x1 DIN 938-6.8 A4C (110 0690)	6	
6/29				3x15 DIN 94 (110 6427)	3	
6/30				3x12 DIN 94 A4C (113 0639)	3	
6/31				14 mm III DIN 5401 (111 6965)	6	
6/32				231 6012 438 1285	1	1006-02
6/33				231 6037	40	1006-02
6/34				231 6031	2	1006-02
6/35				C 3x6 DIN 7336 CU (111 8499)	24	
6/36				231 0657	2	1006-02

Betätigung zur Doppelkupplung "Unabhängig"

IPTO Dual Clutch Control Assembly

Commande de l'embrayage double effet en présence d'une prise de force autonome

Accionamiento para embrague doble p. toma de fuerza "independiente"

1003

Bild-Nr.	Schleppenummer		Fußnote	Teilnummer	Anzahl	
	ab	bis				
1				233 0772	1	1006-03
2				232 0860	1	1006-03
3				232 0839	1	1006-03
4				232 0838	1	1006-03
5				232 1810	1	1006-03
6				230 9284	1	1006-03
7				230 9286	1	1006-03
8				230 5299	1	1005-02
9				1145-02-01.06 (338 9261)	2	
10				1138-03-01.08 (338 8905)	1	
11				232 0968	1	1006-03
12				230 9282	1	1006-03
13				232 0863	1	1006-03
14				230 9280	1	1006-03
15				230 9295	1	1006-03
16				232 0846	1	1006-03
17				230 8369	1	1006-03
18				230 9298	1	1006-03
19				1055-33-08.21 (338 6958)	2	
20				126 0070	1	8738-44
21				6014-2 BS (110 1461)	1	
22				2 260 B 13 (121 0873)	1	
23				6x16 DIN 1481 (111 5433)	2	
24				M 12 DIN 1479 (111 5362)	1	
25				* 12 DIN 934-8 A4C (111 2858)	4	
26				4x22 DIN 94 A4C (110 8449)	4	

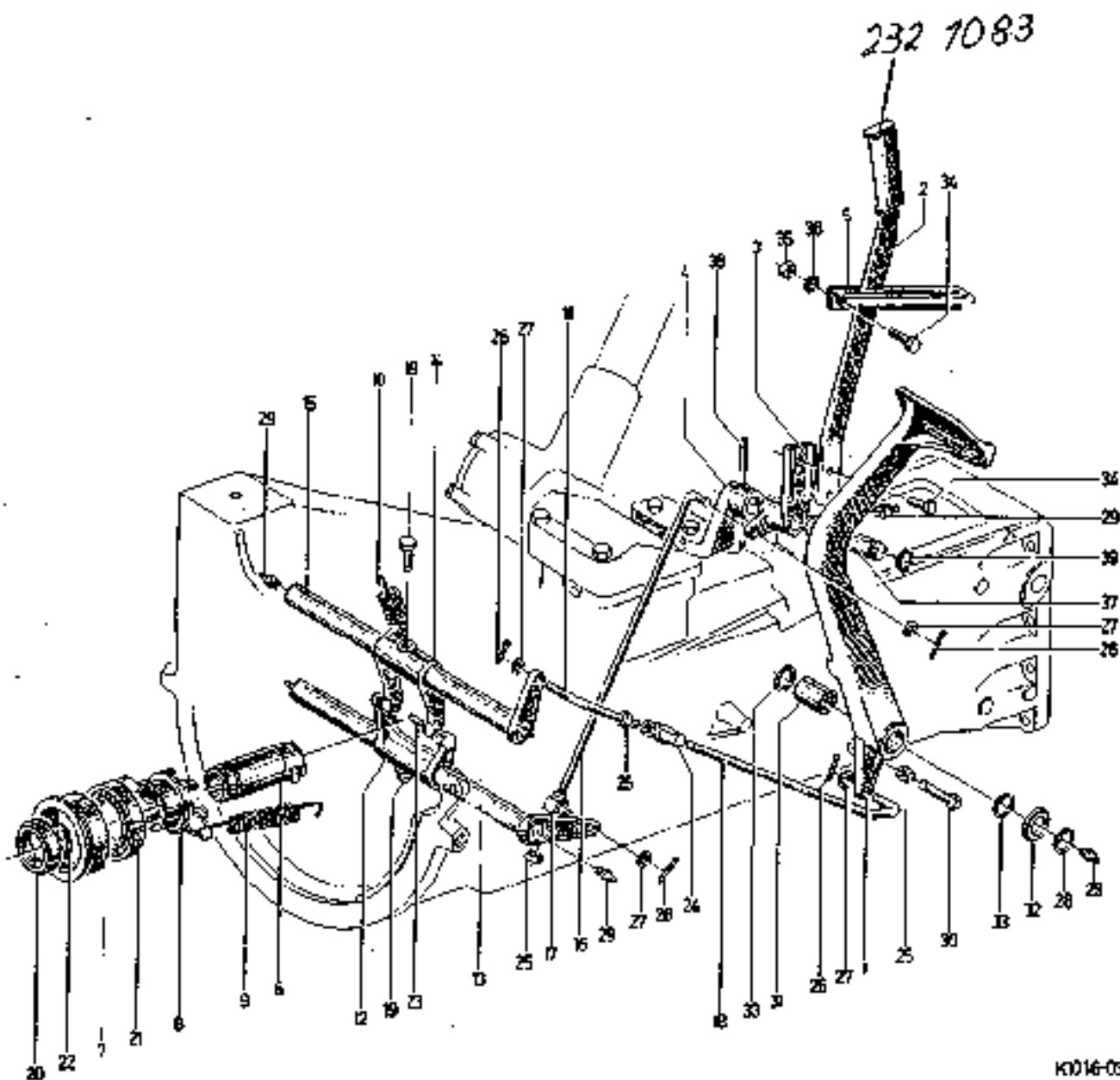

K016-03-01

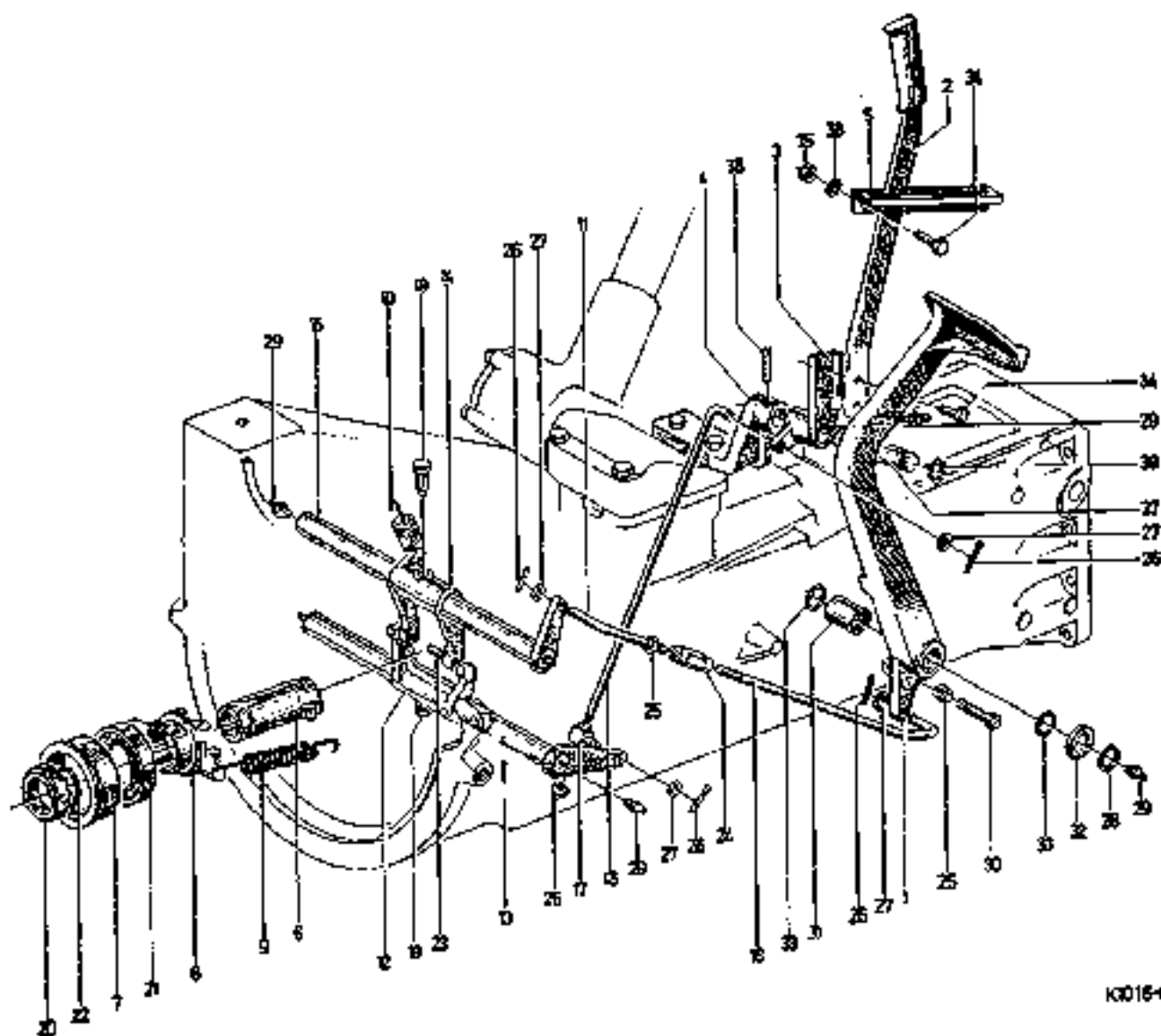

K016-03-01

Bild-Nr.	Schleppenummer		Fußnote	Teilnummer	Anzahl	
	ab	bis				
27				13 DIN 125 A4C (110 7110)	4	
28				30x1,5 DIN 471 (110 7742)	1	
29				SA 8H 3360 (116 8225)	4	
30				M 12x90 DIN 933-8.8 A4C (110 1701)	1	
31				2 HK 30x37x38 H 4455 (116 1639)	1	
32				30 DIN 1440 vzkc (111 5027)	1	
33				231 1207	2	1000-02
34				M 8x15 DIN 933-8.8 A4C (111 2305)	4	
35				M 8 DIN 555 vzkc (110 8064)	2	
36				S H 2203 vzkc (116 9689)	2	
37				230 1688	1	1171-03
38				6x50 DIN 1481 (111 8461)	1	
39				28x1,5 DIN 471 (110 7740)	1	

Getriebegehäuse mit Befestigungsteilen
Transmission Case with Fastening Parts
Carter de transmission, pièces d'adaptation
Caja del tren de engranajes con elementos de fijación

1008

Bild-Nr.	Schleppernummer		Fußnote	Teilnummer	Anzahl	
	ab	bis				
5				M 10x30 DIN 933-8,8 A4C (111 2429)	5	
6				10 H 2203 vzkc (116 9694)	5	
7				M 14x30 SE DIN 933-8,8 (111 2610)	3	
8				14H 2203 vzkc (116 9696)	3	
9				M 14x40 DIN 933-8,8 A4C (111 2624)	10	
11				M 12x25 DIN 933-8,8 (111 2512)	8	
12				12 H 2203 (116 9695)	8	
14				M 14x20 DIN 933-8,8ph06 (111 2595)	4	
16				1455-08-01.18 (339 3018)	1	
17				M 10x90 DIN 933-3,8 A4C (111 2476)	3	
18				M 10 DIN 934-8 A4C (110 2659)	1	
19				M 10x120 DIN 912-8,8 A4C (111 0724)	4	
21				M 10x160 DIN 912-8,8 A4C (111 0744)	3	
22				M 10x70 DIN 912-8,8 A4C (112 2363)	6	
24				1455-08-01.28 (339 3020)	1	
26				95x6 H 721 (116 6065)	2	
27				13 M 6x24 DIN 7 (110 5211)	1	
28				AM 22x1,5 DIN 7604 vzkc (111 8980)	1	
29				A 22x27 DIN 7603 Cu (111 8737)	1	
32				8 H 2203 (116 9689)	6	
33				M 8x20 DIN 933-8,8 A4C (111 2322)	6	
41				M 8x10 DIN 933-8,8 A4C (111 2252)	4	
47				231 3806	1	1455-08
52				B 25 M 711 (116 5830)	1	
53				1455-08-02.53 (339 3030)	1	
58				1455-08-02.58 (339 3034)	1	

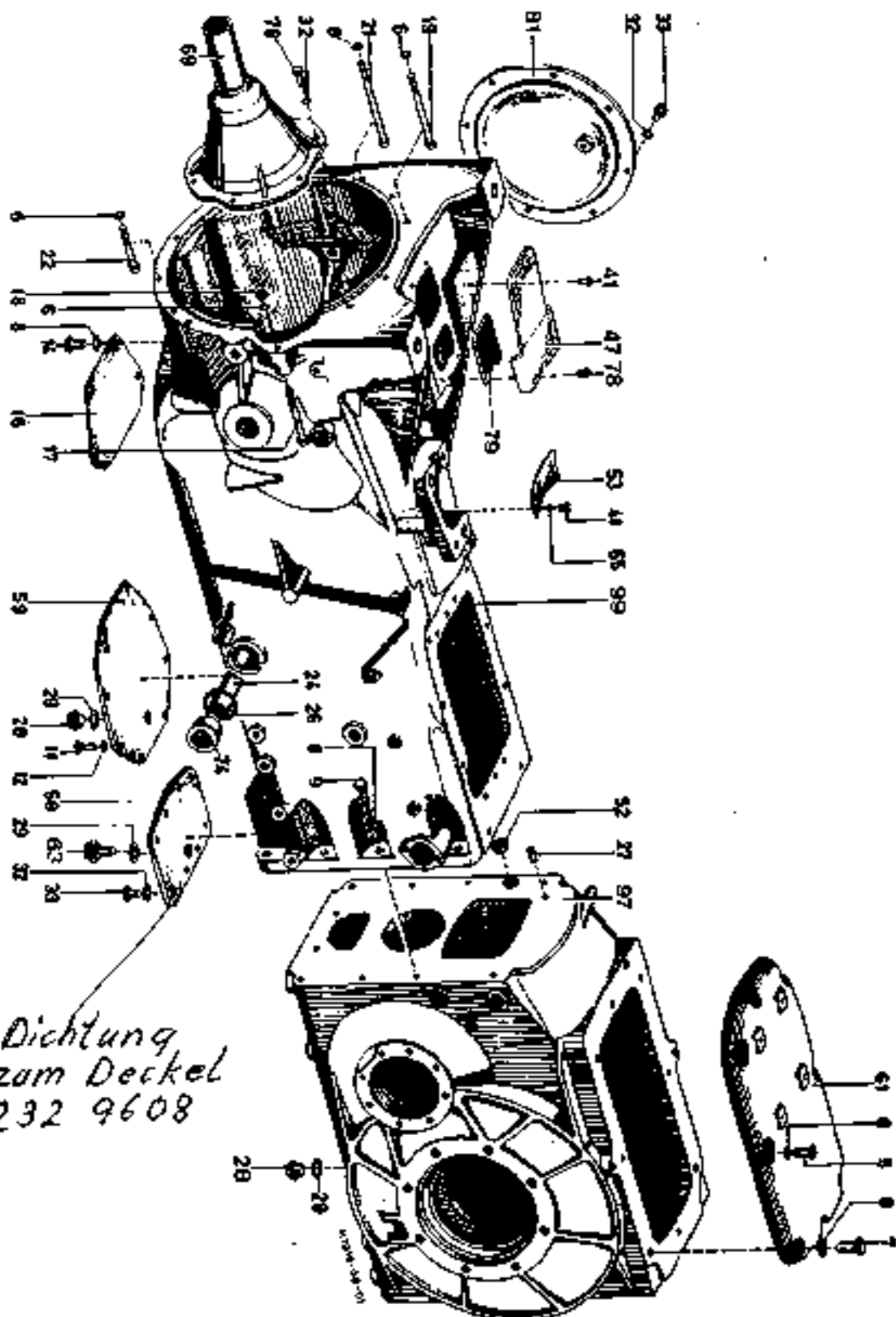



Bild-Nr.	Schleppernummer		Fußnote	Teilnummer	Anzahl	
	ab	bis				
59				1455-08-02.59 (339 3035)	1	
61				1455-08-02.61 (339 3036)	1	
63				2 B14 N 2 (121 8437)	1	
65				6 H 2203 vzkc (116 7194)	2	
69				230 9278	1	1455-08
74				231 1122	2	1455-08
76				M 3x25 DIN 933-8.8 A4C (111 2333)	6	
78				230 8245	2	1145-08
79				231 3806	1	1455-08
81				231 3632	1	1455-08
97				232 1725	1	TW 55.2 1401-08
99				232 5171	1	1401-08

Wechselgetriebe synchron
Synchronized Transmission
Boite de vitesses synchronisée
Caja de cambio con sincronización

1011

Wechselgetriebe für Allrad
Transmission (Standard) for all-wheel drive
Boite de vitesses execution "toutes roues motrices"
Cambio de velocidades para modelo de tracción en las 4 ruedas

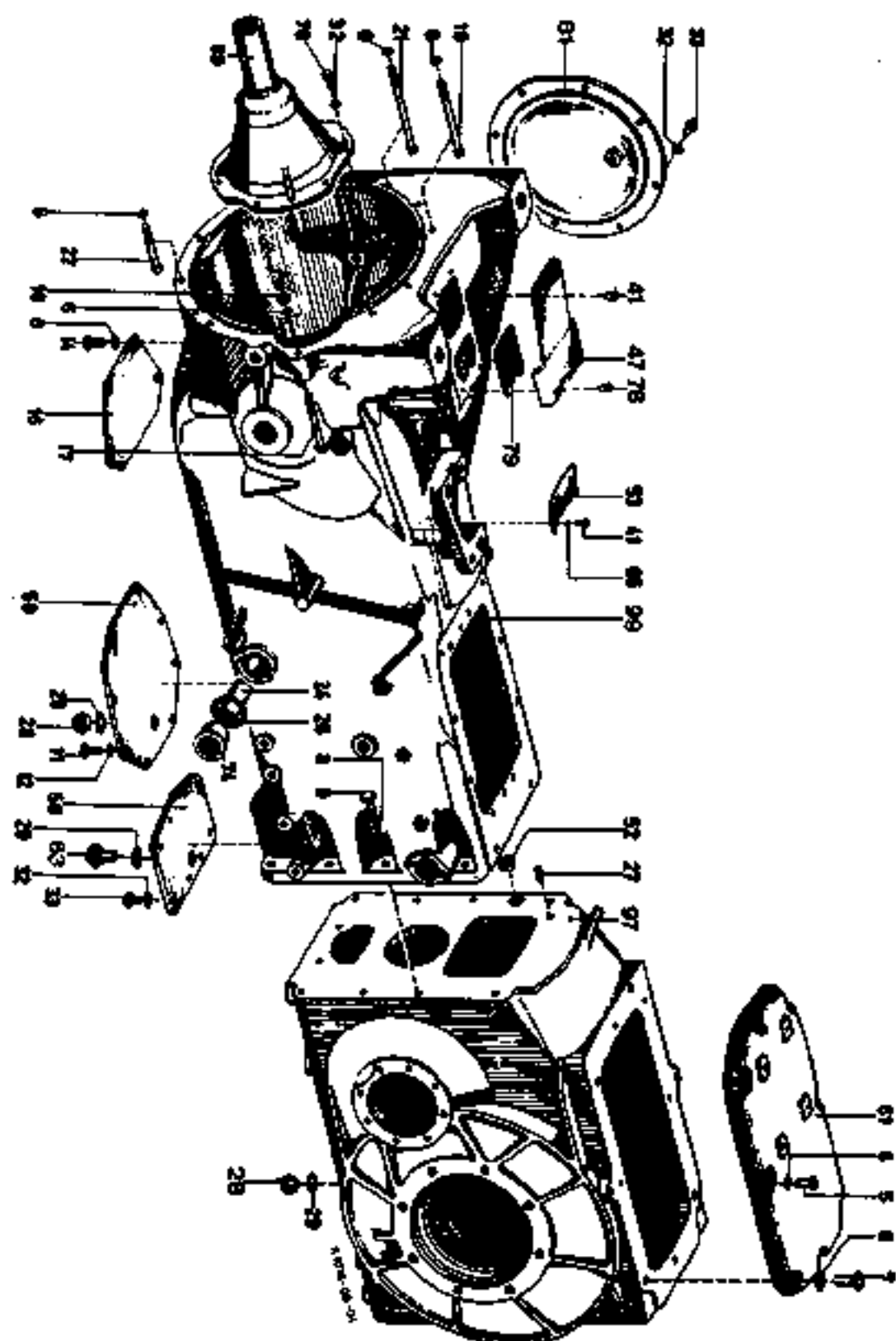
1011/1

Bild-Nr.	Schleppenummer ab bis		Fußnote	Teilnummer	Anzahl	
3				8209 Z (110 9071)	1	
5				G 26x34x4 H 2939 (117 0601)	1	
6				AE 26x34x16 H 4455 (117 0683)	1	
7				232 1595 34x1,5 H 2259 (116 7226)	2	1401-11
8				A 48x3 H 2273 (116 3125)	1	
12					1	
13				231 6293 E 58x83x17 H 4455 (116 2483)	1	1455-11
14					2	
15				231 6292 K 25x29x17 H 4455 (117 0686)	1	Z=40 1455-11
16					1	
17				232 1708	1	1401-11
17/1				232 1709	1	1401-11
17/2				231 6019	1	1401-11
17/3				232 1710	1	1401-11
17/4				75x2,5 DIN 472 (110 7852)	1	
18				29x1,2 H 2259 (117 0576)	1	
20				92x2,5 H 2259 (116 3073)	1	
21		113 7321		40x2,5 DIN 471 (110 2753)	1	
22				25x1,2 DIN 471 (110 7737)	1	
23			+	291 1786 1455-11-03,01 (339 3088)	1	0,5 mm
				1455-11-03,02 (339 3089)	nB	0,6 mm
				1455-11-03,03 (339 3090)	nB	0,7 mm
				1455-11-03,04 (339 3091)	nB	0,8 mm
				1455-11-03,05 (339 3092)	nB	0,9 mm
				1455-11-03,06 (339 3093)	nB	1 mm
				1455-11-03,17 (339 3105)	nB	2,0 mm
				1455-11-03,26 (339 3111)	nB	2,8 mm

+ Beilagensatz

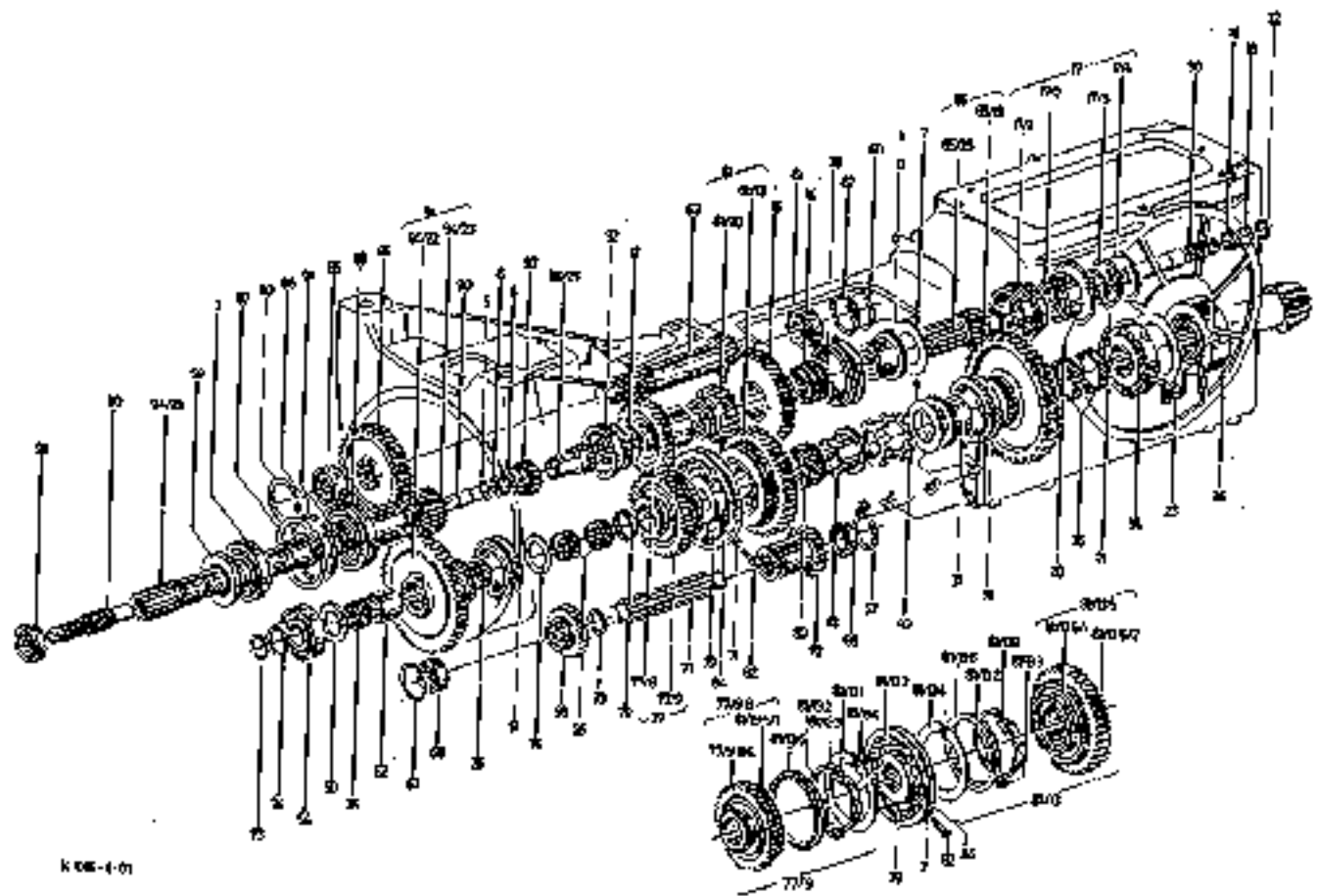

KOE-1-01

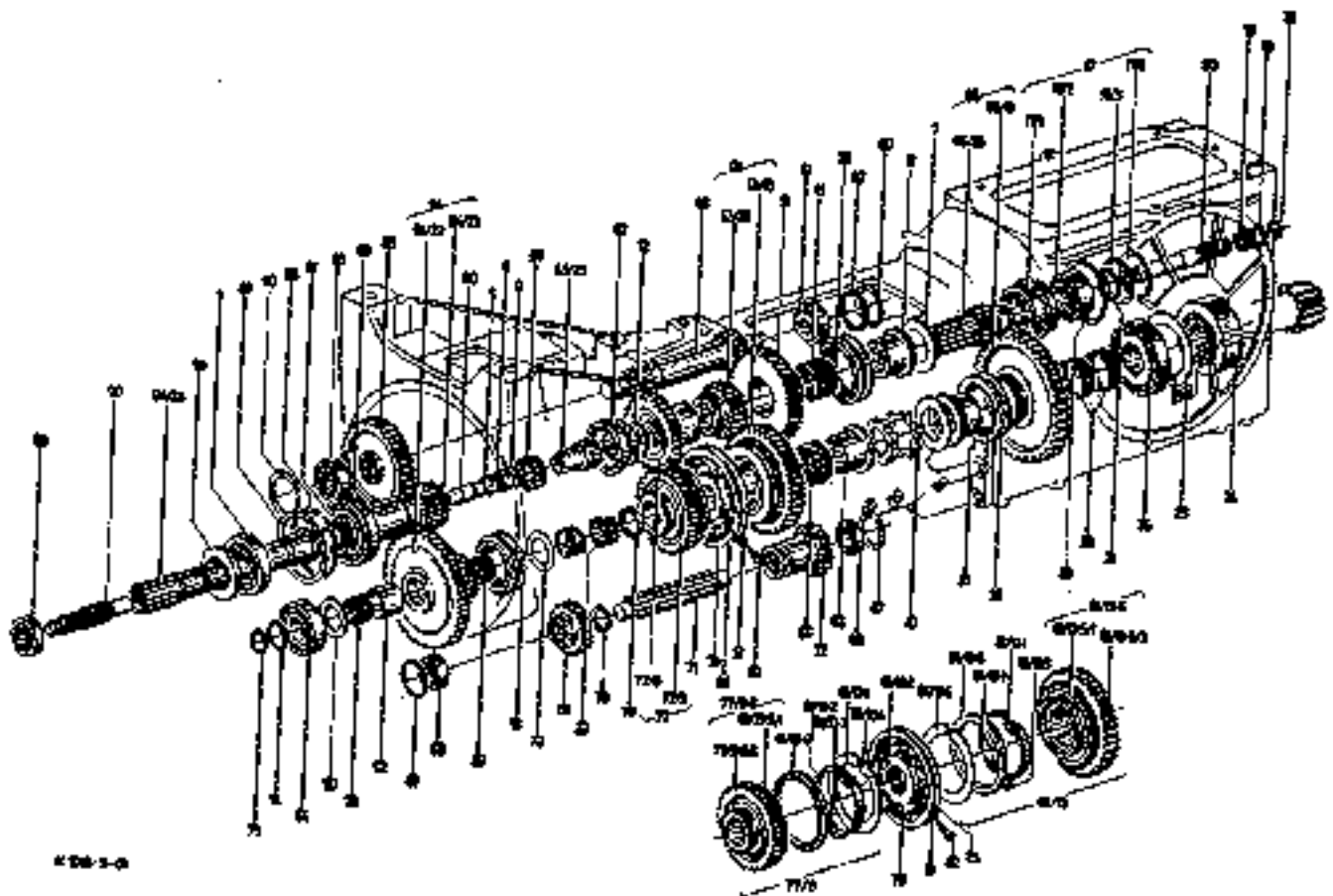

4 28-3-0

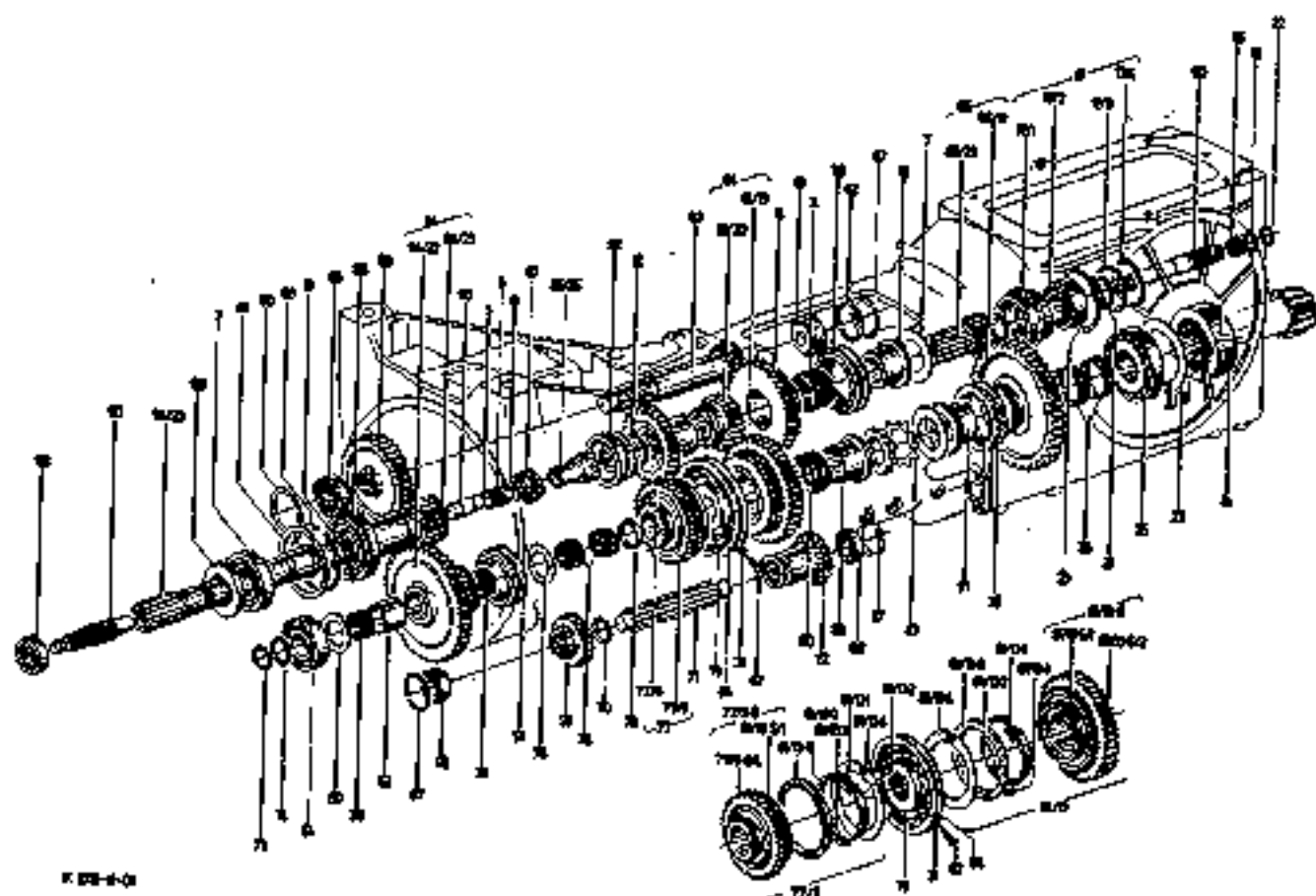



Bild-Nr.	Schleppenummer		Fußnote	Teilnummer	Anzahl	
	ab	bis				
				1455-11-03.28 (339 3113)	nB	3 mm
24				1455-11-01.02 (339 3040)	1	
26				HS 40x45x17 H 4455 (116 8741)	4	
31				8 H 2203 v&K (116 9686)	1	
35				231 6271	1	1455-11
36				K 58x64x18 H 4455 (116 3075)	1	
37				231 2412	1	1. Gang 1455-11
38				231 6728	2	1446-11
40				1455-11-07.116 (347 1131)	1	
50			†	291 1724	1	
				1455-11-02.01 (339 3047)	nB	2 mm
				1455-11-02.02 (339 3048)	nB	2,1 mm
				1455-11-02.03 (339 3049)	nB	2,2 mm
				1455-11-02.05 (339 3051)	nB	2,4 mm
				1455-11-02.06 (339 3052)	nB	2,5 mm
				1455-11-02.08 (339 3054)	nB	2,7 mm
				1455-11-02.12 (339 3057)	nB	3 mm
				1455-11-02.14 (339 3059)	nB	3,2 mm
				1455-11-02.16 (339 3061)	nB	3,4 mm
				1455-11-02.18 (339 3063)	nB	3,6 mm
++ BEILAGESATZ						

Bild-Nr.	Schleppernummer		Fußnote	Teilnummer	Anzahl	
	ab	bis				
				1455-11-02,21 (339 3065)	nB	3,2 mm
				1455-11-02,23 (339 3067)	nB	4 mm
				1455-11-02,34 (339 3077)	nB	5 mm
				1455-11-02,37 (339 3080)	nB	5,3 mm
				1455-11-02,38 (339 3081)	nB	5,4 mm
				1455-11-02,39 (339 3082)	nB	5,5 mm
				1455-11-02,45 (339 3087)	nB	6 mm
51				230 8689	1	1465-11
52				1455-11-04,21 (339 3114)	1	



K 171-0-01

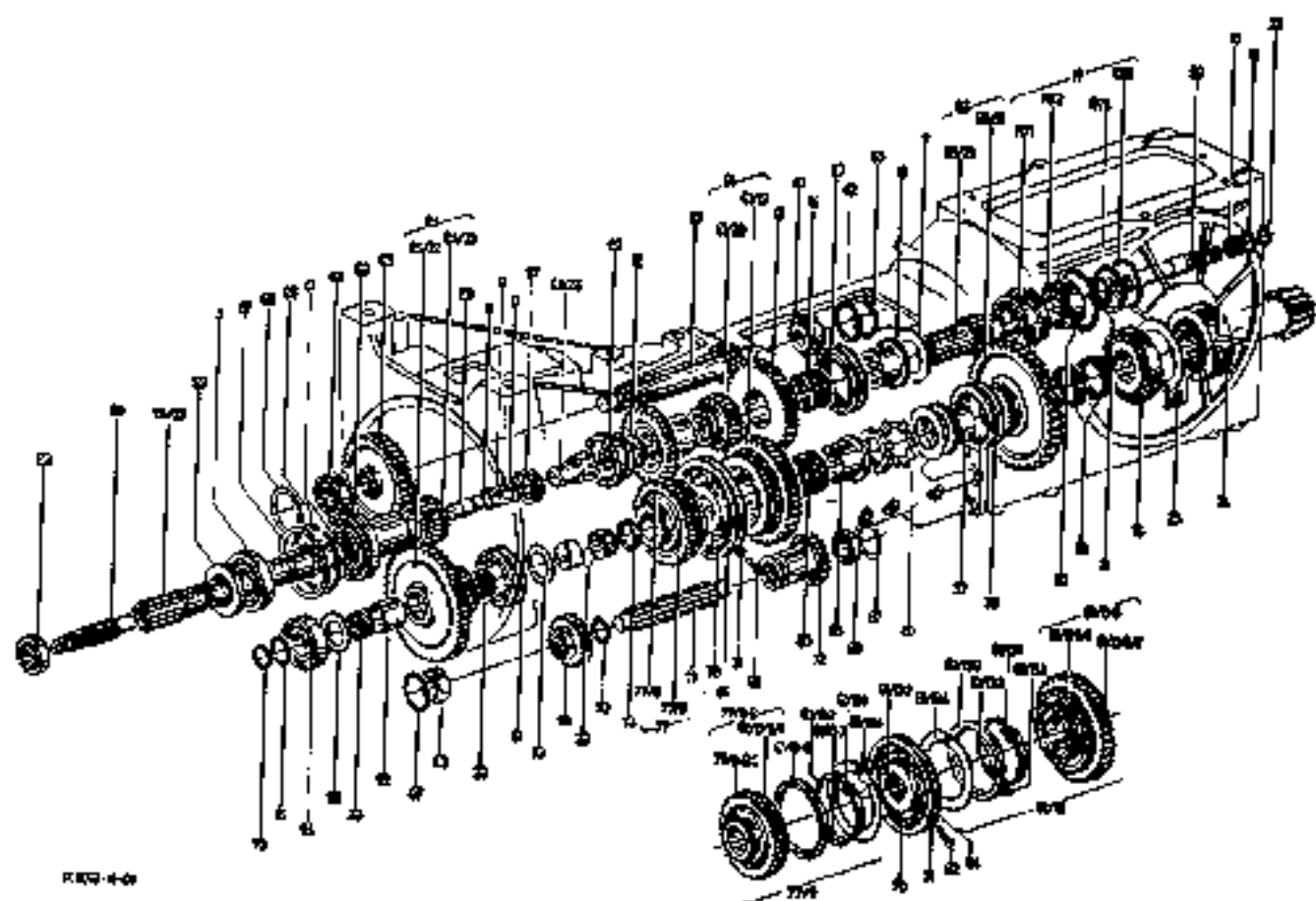
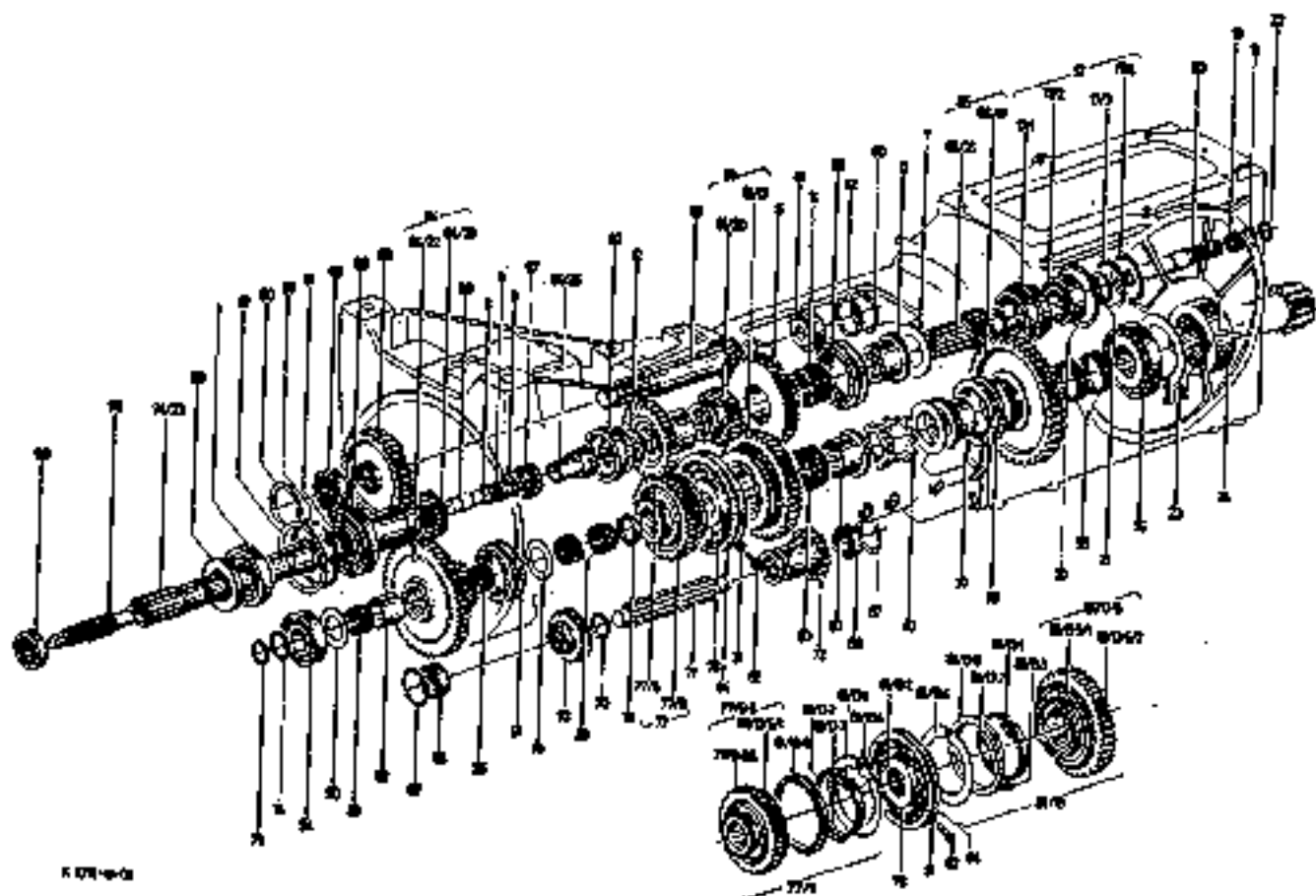
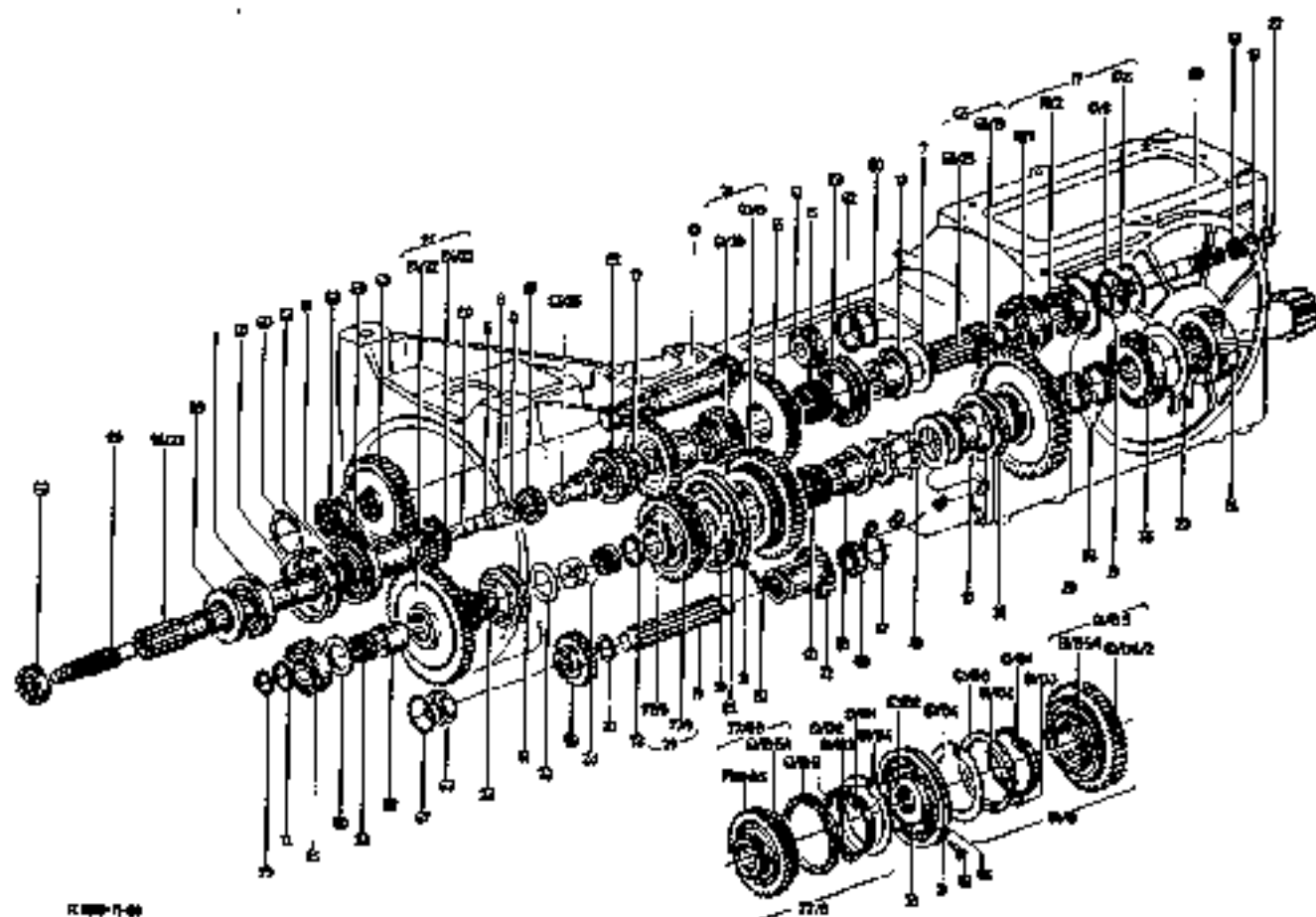

K 1011-1-01

Bild-Nr.	Schleppenummer		Fußnote	Teilnummer	Anzahl	
	ab	bis				
54				8307 (110 9129)	1	
59				A 15x80x8 K 2940-N1 (116 1578)	1	
60				62x2 DIN 472 (110 7774)	2	
61				32308 A (110 0950)	1	
62				232 1737	nB	1401-1
						3,3 mm
				232 1738	nB	1401-1
						3,4 mm
				232 1739	nB	1401-1
						3,5 mm
				232 1740	nB	1401-1
						3,6 mm
				232 1741	nB	1401-1
						3,7 mm
				232 1742	nB	1401-1
						3,8 mm
				232 1743	nB	1401-1
						3,9 mm
				232 1744	nB	1401-1
						4,0 mm
				232 1745	nB	1401-1
						4,1 mm
				232 1746	nB	1401-1
63				231 6290	1	1455-11
66				6208 C 3 (110 9001)	1	
67				52x2 DIN 472 (110 7838)	2	
68				6205 (110 9014)	2	
70				32x1,5 DIN 471 (110 7716)	1	
71				1455-11-07,66 (339 3133)	1	
72				231 2488	1	1455-11
73				35x2,5 DIN 471 (110 7749)	1	
74				2 308 A 42 (121 8427)	1	
76				1455-11-02,06 (339 3052)	1	
77				Siehe Bild-Nr. 77/6 u. 77 9	1	
77/8				231 2487	1	1455-11
77/9				231 3434	1	1455-11

Bild-Nr.	Schleppenummer		Fußnote	Teilnummer	Anzahl	
	ab	bis				
77/9.6				231 3423	1	3. Gang 1455-11
77/9.8/4			+	231 2486	1	3. Gang 1455-11
78				1455-11-07,104 (347 5085)	1	
79				1455-11-07,111 (347 5087)	1	
80				K 55x60x30 H 4455 (116 9840)	1	
81				Siehe Bild-Nr. 81/13u./20	1	
81/13				(231 5058) 1455-11-21,10	1	
81/13,1				Siehe Bild-Nr. 81/13	2	
81/13,2				Siehe Bild-Nr. 81/13	4	
81/13,3				Siehe Bild-Nr. 81/13	2	
81/13,4				Siehe Bild-Nr. 81/13	2	
81/13,5				Siehe Bild-Nr. 81/13	1	2. Gang
81/13,5/1				Siehe Bild-Nr. 81/13	1	
81/13,5/2				Siehe Bild-Nr. 81/13	1	Z=44
81/13,6				1455-11-21,06 (347 5093)	1	
81/20				231 1617	1	Z=22 1455-11
82				230 6694	1	1455-11
83				1455-11-07,115 (347 5088)	1	
84				1455-11-07,109 (347 5086)	1	
85				Siehe Bild-Nr. 85/19u./25	1	
85/19				232 1608	1	Z=52 1401-11
85, 35				232 5156	1	1401-11
86				SP 100 DIN 5417 (111 7459)	1	
87				107x4 H 2274 (116 3191)	1	
88				MUP 211 N (110 3594)	1	
89				232 5148	1	Z=37 1401-11
90				232 5157	1	1401-11

+ Z : 35/36

Bild-Nr.	Schleppernummer ob bis		Fußnote	Teilnummer	Anzahl	
91				55x2 DIN 471 (110 7770)	1	
92				232 5154	1	1401-11
93				232 5150	1	1401-11
94				Siehe Bild-Nr. 94/22 u. 94/23	1	
94/22				232 5152	1	1401-11
94/23				232 5146	1	1401-11
97				232 5081	1	1401-11
98				8304-2 RS (110 9118)	1	

Bild-Nr.	Schleppernummer		Fußnote	Teilnummer	Anzahl	
	ab	bis				
3				6209 Z (110 9071)	1	
4				G 26x34x4 H 2999 (117 0601)	1	
5				AK 26x34x18 H 3455 (117 0682)	1	
7				232 1595 34x1,5 H 2259 (116 7220)	2	1401-11
8				A 48x3 H 2273 (116 3125)	1	
12					1	
13				231 6293	1	1455-11
14				K 58x63x17 H 4455 (116 2483)	2	
15				231 6292	1	Z=40 1455-11
16				K 25x29x17 H 4455 (117 0688)	1	
17				232 1708	1	1401-11
17/1				232 1709	1	1401-11
17/2				231 6913	1	1401-11
17/3				232 1710	1	1401-11
17/4				75x2,5 DIN 472 (110 7852)	1	
18				29x1,2 H 2759 (117 0576)	1	
20				92x2,5 H 2259 (116 3073)	1	
21		113 7321		40x2,5 DIN 471 (116 2993)	1	
22				25x1,2 DIN 471 (110 7737)	1	
23				Siehe Bildt. 1011 Bild 23	nB	
24				1455-11-01.02 (339 3040)	1	
26				RS 40x43x17 H 4455 (116 8741)	3	
30				1455-11-07.12 (339 3123)	1	
31				8 H 2203 vzkc (116 9389)	1	
35				231 6271	1	1455-11
36				K 58x64x19 H 4455 (116 3073)	2	
37				231 2412	1	1. Gang 1455-11

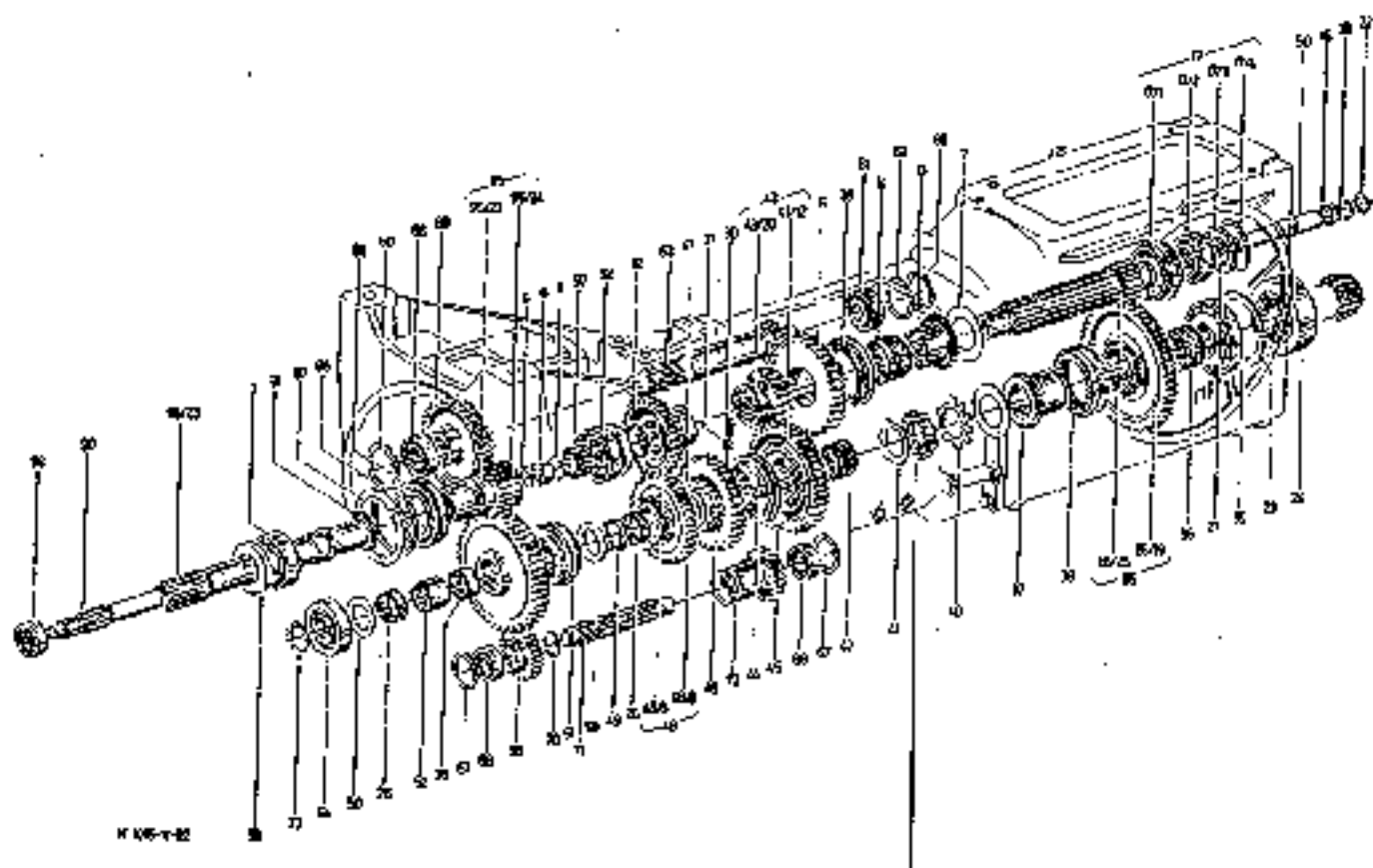

K 146-1-82

Nutmatter 337 1147



Bild-Nr.	Schleppenummer		Fußnote	Teilnummer	Anzahl	
	ab	bis				
38				231 6728	2	1446-11
40				1455-11-07.116 (347 1131)	1	
41				1455-11-07.145 (347 1138)	1	
42				2 K 45x50x30 H 4455 (117 0692)	1	
43				232 1724	1	1401-11
43/12				1453-11-07.142 (347 1136)	1	Z=44
43/20				231 1617	1	1455-11 Z=22
44				231 5432	19	1455-11
45				231 6673	1	1455-11
46				1455-11-07.138 (347 1133)	1	Z: 32
47				1455-11-02.16 (339 3031)	1	
48				Siehe Bild-Nr. 48/6u. 48/8	1	
48/6				231 2487	1	1455-11 Z=31
48/8				231 2485	1	Z = 36 1455-11
49				HS 40x49x13 H 4455 (117 0326)	1	
50				Siehe Bildt. 1011 Bild-Nr. ⁵⁰	nB	
51				230 6689	1	1455-11
52				1455-11-04.21 (339 3114)	1	
54				6307 (110 9129)	1	
59				A 45x80x8 H 2940 N1 (116 1576)	1	
60				62x2 DIN 472 (110 7774)	2	
61				32305 A (110 0950)	1	
62				S. Bildt. 1011 Bild-Nr. 62	nB	
63				231 6290	1	1455-11
66				6206 C 3 (110 9061)	1	
67				5212 DIN 472 (110 7838)	2	
68				5205 (110 9044)	2	

Bild-Nr.	Schleppenummer		Fußnote	Teilnummer	Anzahl	
	ab	bis				
70				32x1,5 DIN 471 (110 7746)	1	
71				1455-11-07.66 (339 3133)	1	
72				231 2488	1	Z:19 1455-11
73				35x2,5 DIN 471 (110 7749)	1	
85				Siehe Bild-Nr.85/19u.85/25	1	1. Gang
85/19				232 1608	1	Z=52 1401-11
85/25				232 5156	1	1401-11
86				SP 100 DIN 5417 (111 7459)	1	
87				107 x 4 H 2274 (116 3191)	1	
88				NUP 211 N (110 3594)	1	
89				232 5148	1	Z= 37 1401-11
90				232 5063	1	1401-11
91				55x2 DIN 471 (110 7770)	1	
92				232 5154	1	1401-11
93				232 5150	1	Z =21 1401-11
95				Siehe Bild-Nr.95/23u.95/24	1	
95/23				232 5146	1	1401-11
95/24				232 5158	1	Z=48
97				232 5081	1	1401-11
98				8304-2 RS (110 9118)	1	

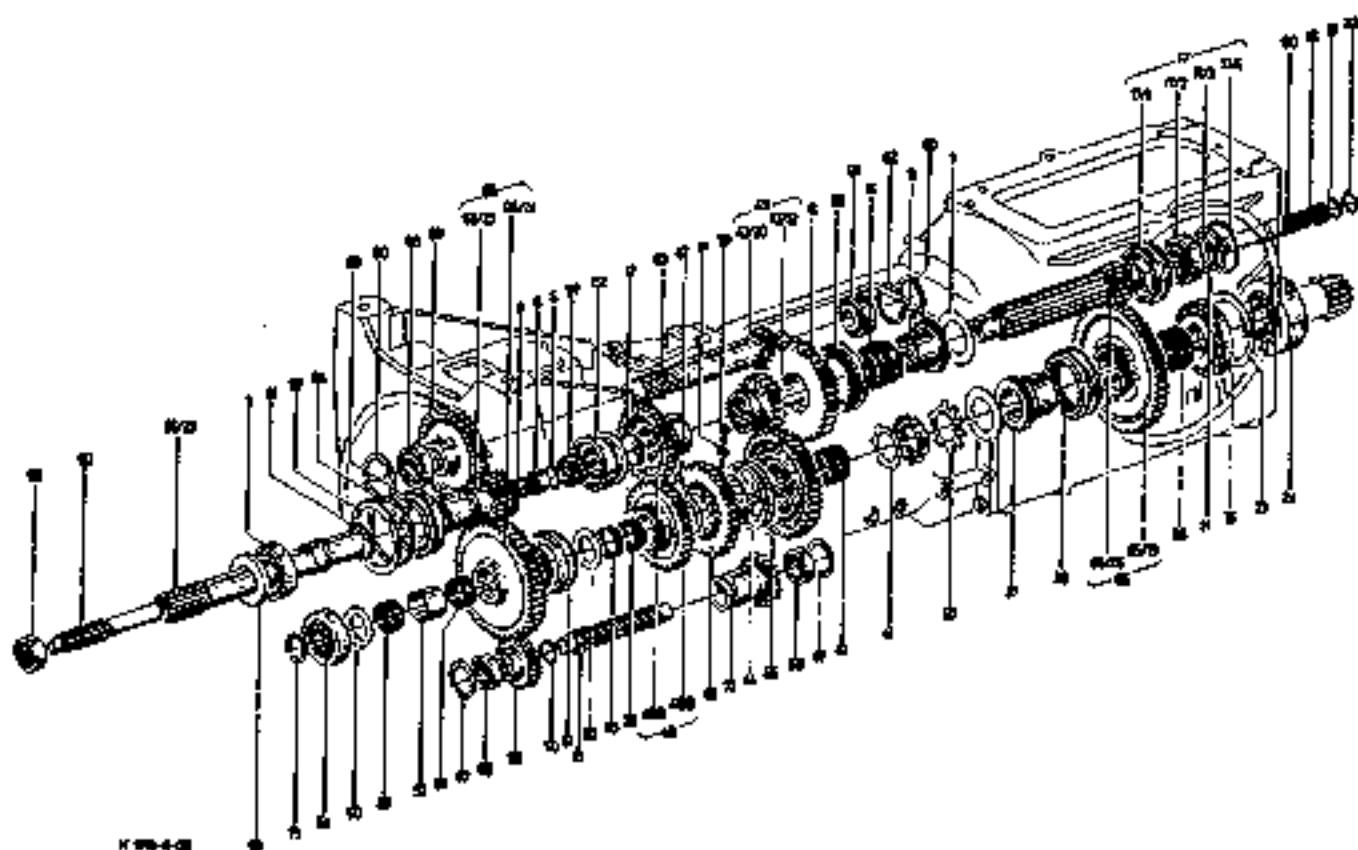
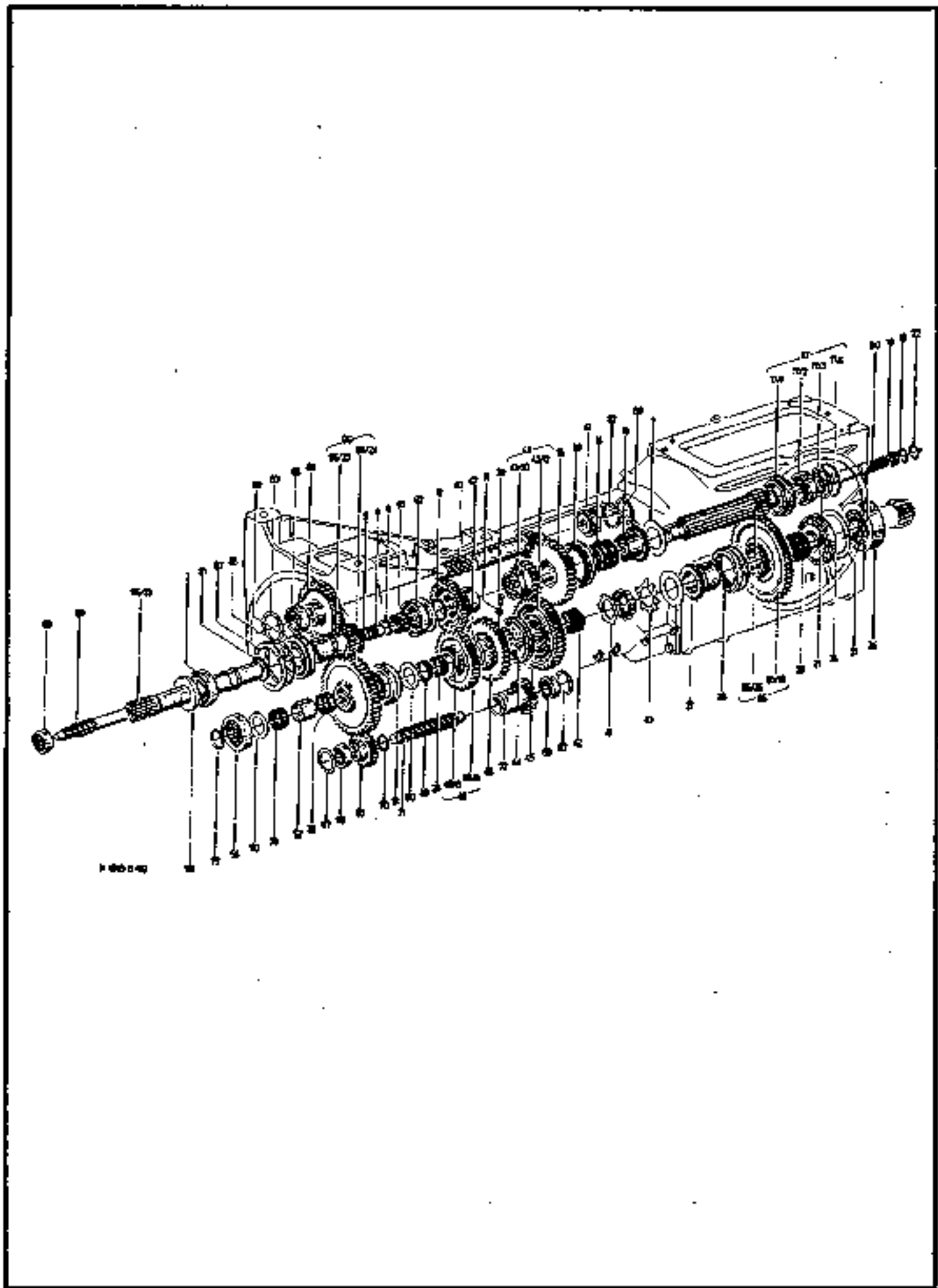

Bittstellung an STP Herrn Schulte

Betr.: Einführungs-nr. D 6006 - D 7006

Ab unten aufgeführten Traktoren-Nr. ist eine verstärkte Schaltgabel (1. Gang) eingeführt.

D 6006

7913/427

7914/153

7989/711

D 7006

7915/2090

7915/427

Verteiler:

CKV,

SKA 2

Traktorenabnahme
BKPA

(Wirtz)

Mitteilung S 14/71
1. Nachtrag

Umlauf

2/1

Köln-Kalk, den 25.8.1971
STTR Ma/Scha.

An die Deutz-Fahr Verkaufsstellen

Dortmund, Frankfurt, Hamburg, Hannover,
Köln, München, Nürnberg, Stuttgart

Betreff: Getriebebeschaltung D 6006 und D 7006

Inzwischen hat sich herausgestellt, daß die von uns angegebene Kulisse 233 4003 nicht eingeführt werden konnte. Dies ist auch nicht erforderlich, da durch den anderen Federteller und den geänderten Schalthebel das Problem beherrscht wird. Die bisherige Kulisse 231 3552 bleibt. Wir machen aber darauf aufmerksam, daß der Schalthebel 230 6783 geändert wurde in die Teilnummer 232 9543. Bei Verwendung des letztgenannten Schalthebels ist zusätzlich die Handkugel B 40x14 H 3517 (beinhaltet auch die erforderliche Spannhülse) erforderlich. Der Schalthebel wurde dann anschließend in der Kröpfung geändert und später das in unserer Mitteilung vom 12.7.1971 angegebene Maß von 17,5 auf 14 mm geändert. In Ersatzteillager sind nur noch Schalthebel 232 9543 mit Maß 14 mm vorhanden.

42

Werk Pa 11:

STTR

Hertens

Verteiler

H. Rosenann
H. Dammernann
H. Ackermann
H. Tack
H. Moscicki
H. Peter
H. Keil
H. Ritzgen
H. Beerlage
H. Schana
H. Benckendorff
Fa. EDF, Paris
Fa. Cie Espanola, Madrid
Fa. Sieberg, Ede
Fa. Caspart, Zallik
Fa. Mosope, Issadon
Fa. Euromacchine, Mailand
Fa. Würgler, Affoltern
Fa. Mehele, Hohenema
St. SE, WZA 2, WSW, WED 4,
TR, Rep.Werk West, STPD, STTR

Schaltung zum Wechselgetriebe
Gear-shift Assembly
Comande de la boite de vitesses
Mando para el cambio de velocidades

1012

Bild-Nr.	Schleppernummer		Fußnote	Teilnummer	Anzahl	
	ab	bis				
1				232 1495	1	1455-12
2		+	1424-12-01.34 (339 1933)	3	
	7915/977 7916/157	siehe S14/77	+1	231 3631	2	1446-12
3				14 DIN 9045 (111 8824)	2	
4				1424-12-05.33 (339 1944)	2	
5				1424-12-05.12 (339 1948)	2	
6				A H 735 (116 6343)	2	
7				B H 735 (116 6345)	2	
8				8 MM III DIN 5401 (111 6956)	5	
9				1055-12-01.33 (338 6770)	5	
10				A 8 DIN 128 A4C (110 2799)	14	
11				M 8x20 DIN 933-8.8 A4C (111 2322)	5	
12				M 8x50 DIN 931-8.8 A4C (111 1158)	2	
13				1424-12-01.16 (339 1929)	2	
14				6m 6x12 DIN 7 (110 5127)	2	
15				C H 735 (116 6346)	2	
16				D H 735 (116 6347)	2	
17				M 8x15 DIN 933-8.8 A4C (111 2305)	3	
18				M 8x65 DIN 931-8.8 A4C (111 1174)	4	
19				M 10x50 DIN 933-8.8 A4C (111 2456)	2	
20				A 10 DIN 128 A4C (110 2800)	3	
21				M 10x25 DIN 933-8.8 A4C (111 2418)	1	
22		+ ...	+	B 40x10 H 3517 (116 8284)	2	
		+1	B 40x14 H 3517 (116 3642)	2	
23		+	230 6783	1	1455-12
		+1	232 9542	1	1455-12

+ Von 7915/845 außer 7915/901-905, Allrad von 7916/136
+1 Ab 7915/846 außer 7915/901-905, Allrad ab 7916/137

S14/77

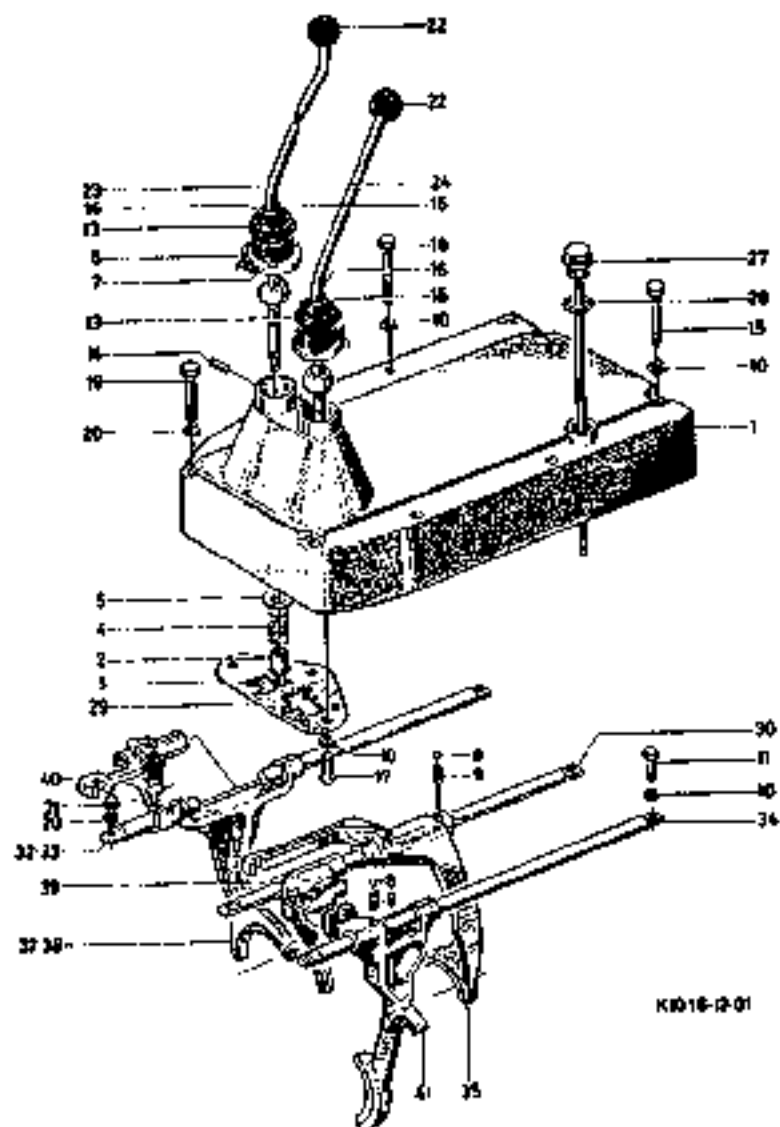

Deutz/Fahr 2. H. H. Meier !!

Diese Schaltkurbelisse für D7006 A

12 Gang wird
benötigt

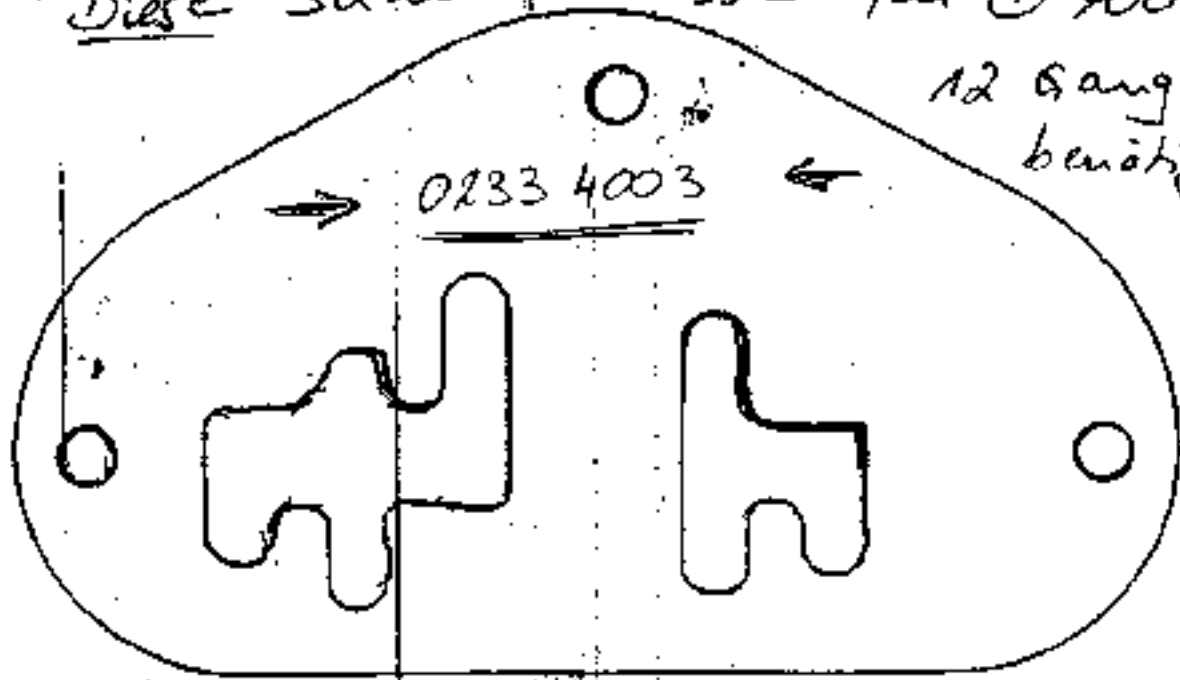

Diese Schaltkurbelisse für 12 Gang

TN 0232 9709

wurde
geliefert

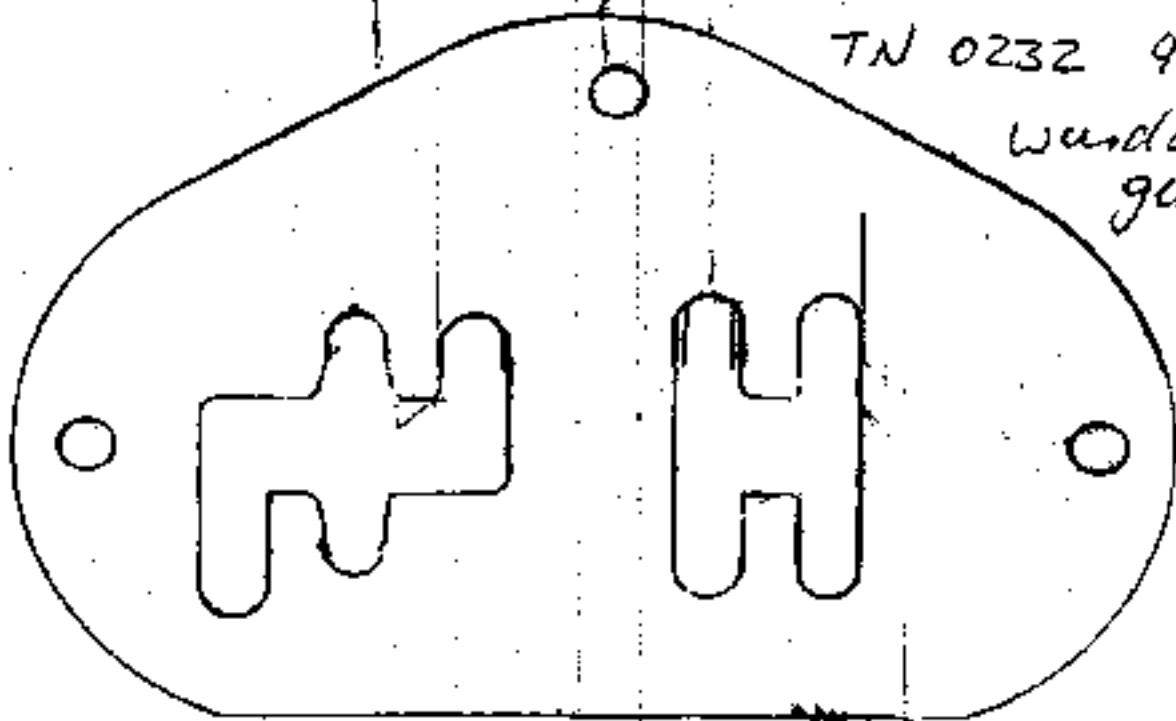

mf. F. Meier

Schaltung für Duo-Sapfwelle
Two-speed PTO Control Assembly
Commande mécanisme prise de force permettant d'obtenir 2 régimes
Connexión para toma de fuerza tipo "Duo"

1014

Bild-Nr.	Schleppernummer		Fußnote	Teilnummer	Anzahl	
	ab	bis				
1				232 1084	1	1401-14
2				251 1299	1	1401-14
5				230 7702	1	1401-14
6				230 9536	1	1401-14
7				990 970 4 (121 9657)	1	
8				230 9554	1	1401-14
9				M 8x20 DIN 933-B.8 A4C (111 2322)	5	
10				A 8 DIN 128 A4C (110 2799)	5	
11				8,4 DIN 233 A4C (110 7548)	1	
12				2x15 DIN 94 A4C (110 6407)	1	
13				6x32 DIN 1481 (111 5455)	1	
14				16x3 3 721 (116 6006)	1	
15				229 002 B (331 4976)	2	
16				3x18 DIN 94 A4C (110 6430)	2	
18				232 1767	1	1401-14
19			+	232 5676	1	1401-14 TW 55.1 A
+ Bei Allrad-Ausführung						

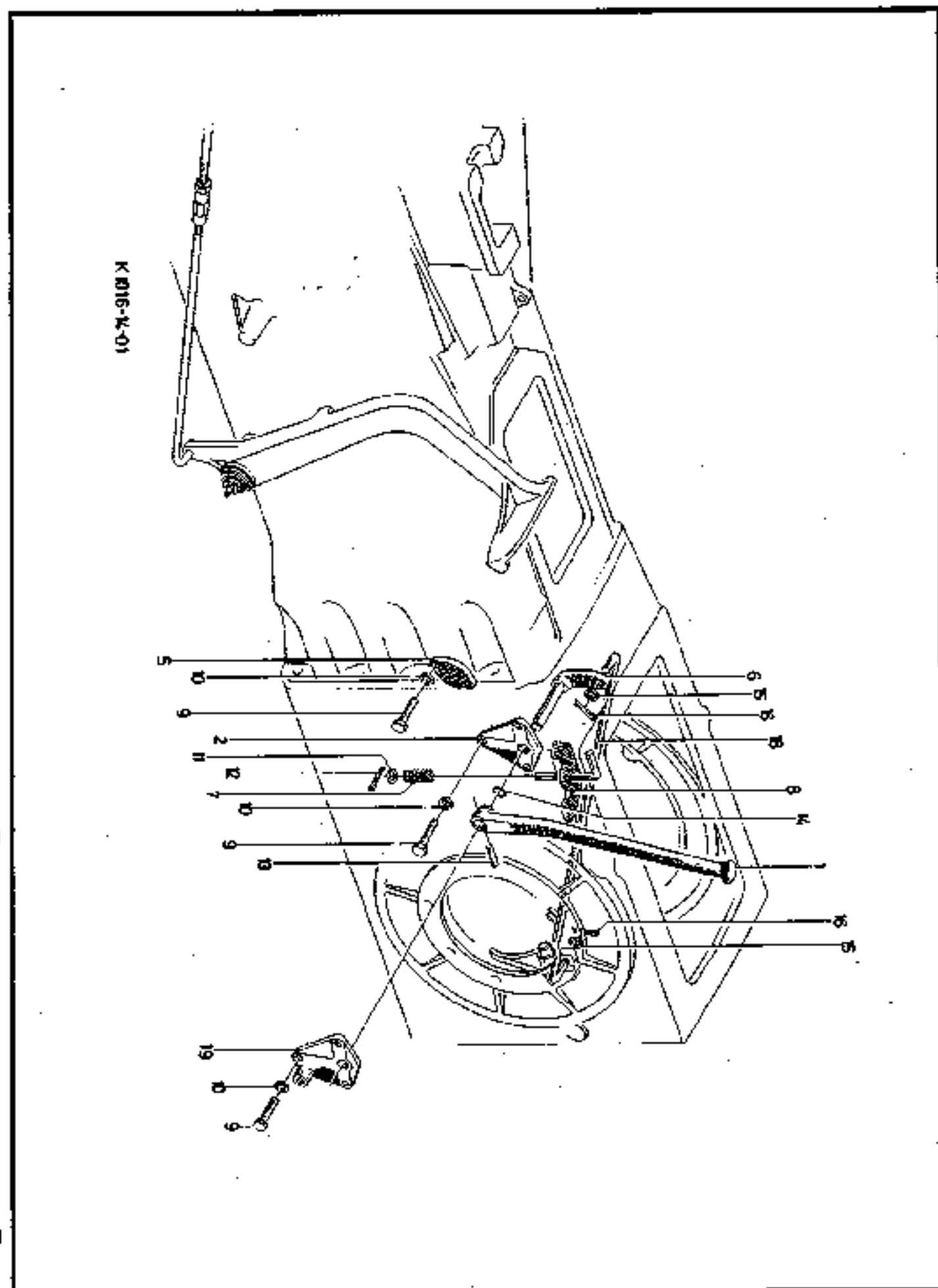

Vorgelegebremse
Final Drive Brake
Frein sur réducteur
Freno actuando sobre la transmisión

1016

Bild-Nr.	Schleppernummer		Fußnote	Teilnummer	Anzahl	
	ab	bis				
1				1455-16-02.01 (339 3177)	1	
2				1455-16-02.02 (339 3179)	1	
4				1455-16-02.04 (339 3180)	1	
5				10x28 DIN 1481 (111 5407)	1	
6				A 32x38 DIN 7603 Cu (111 8797)	1	
7				1455-16-02.07 (339 3182)	1	
8				M 8x20 DIN 933-8.8 (111 2320)	3	
9				8 H 2203 vzke (116 9689)	3	
12				230 5452	1	1455-16
14				232 1005	1	1455-16
A 11			+	1455-16-01.11 (347 4377)	1	

+ Bei Fortfall der Vorgelegebremse

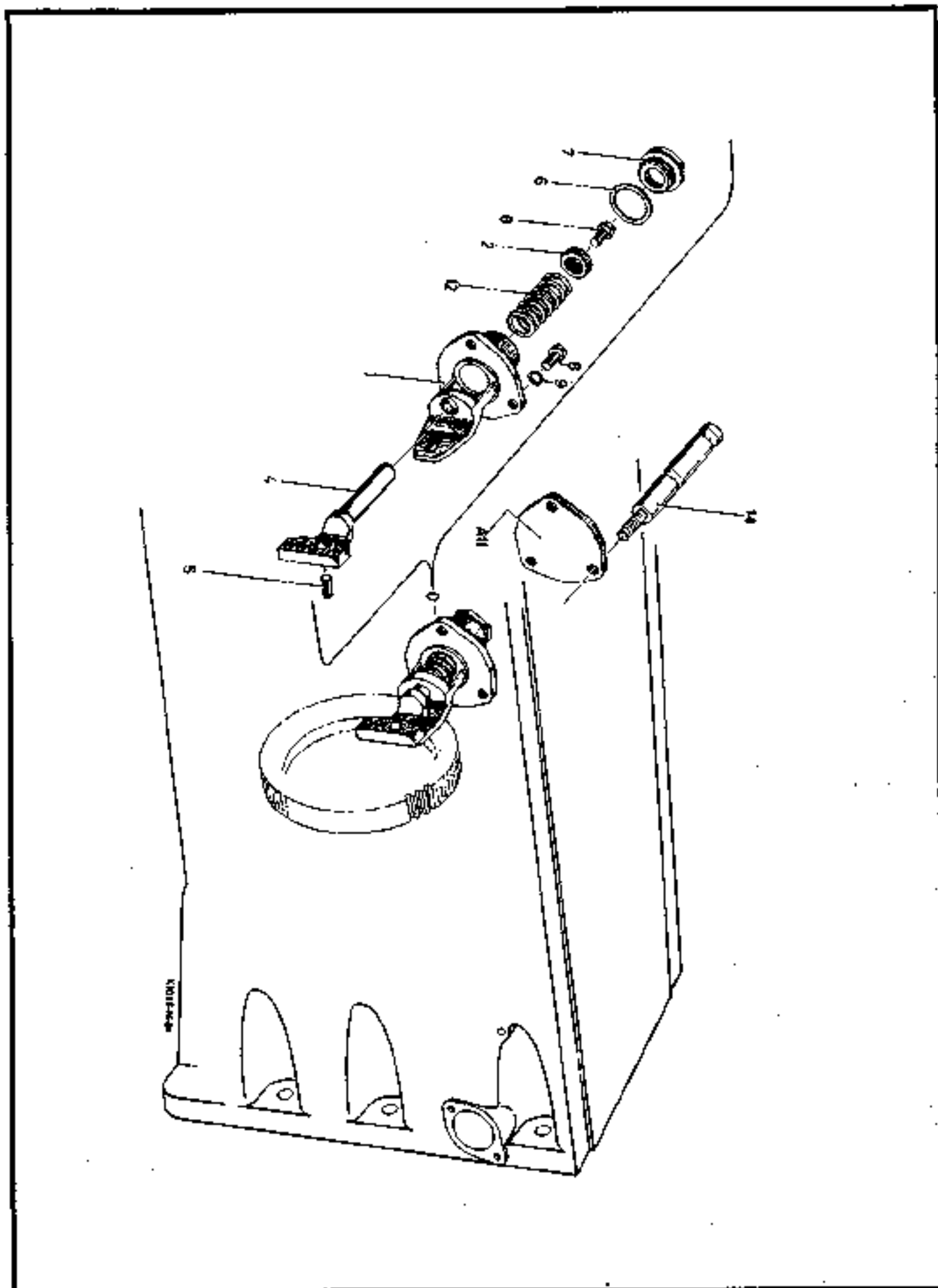

Riemenscheibenantrieb
Belt Pulley Drive
Mecanisme de la poulie de battage
Accionamiento para polea

1019

Bild-Nr.	Schleppernummer		Fußnote	Teilnummer	Anzahl	
	ob	bit				
1				1455-19-01.01 (347 1141)	1	
2				M 6x15 DIN 912-B.8 A4C (111 0509)	4	
3				6 H 2203 vsko (116 7194)	10	
4				1455-19-01.04 (335 3185)	1	
5				A 42x55x7 H 645 (116 9479)	1	
A 5			+	1455-19-02.05 (347 5098)	1	
6				16 H 2203 vsko (116 9697)	2	
A 6			+	1171-19-01.04 (339 0765)	2	
A 7			+	1171-19-12.10 (339 0769)	2	
8				M 45x1,5 H 2174 (116 7164)	2	
9				1434-19-01.09 (339 2275)	2	
11				1434-19-01.11 (339 2277)	2	
A 11			+	16 DIN 7980 vsko (111 9619)	2	
12				45,5x77,8x19.0H4450 (116 8683)	1	
A 12			+	1455-19-02.12 (347 5099)	2	
13				1434-19-02.03 (339 2292)	nB	6,6
				1434-19-02.04 (339 2293)	nB	6,7
				1434-19-02.05 (339 2294)	nB	6,8
				1434-19-02-06 (339 2295)	nB	6,9
				1434-19-02.07 (339 2296)	nB	7,0
A 13			+	1455-19-02.13 (231 6988)	2	
14				51,5x96,8x21 H 4450 (116 8684)	1	
A 14			+	230 5147	1	1455-19
15				1434-19-01.20 (339 2282)	1	
16				B40 H 711 (116 5836)	1	
A 16			+	M 16x70 DIN 931-B.8 A4C (111 1888)	2	

+ A 5 - A 16

Bei Ausführung mit Zugpendel

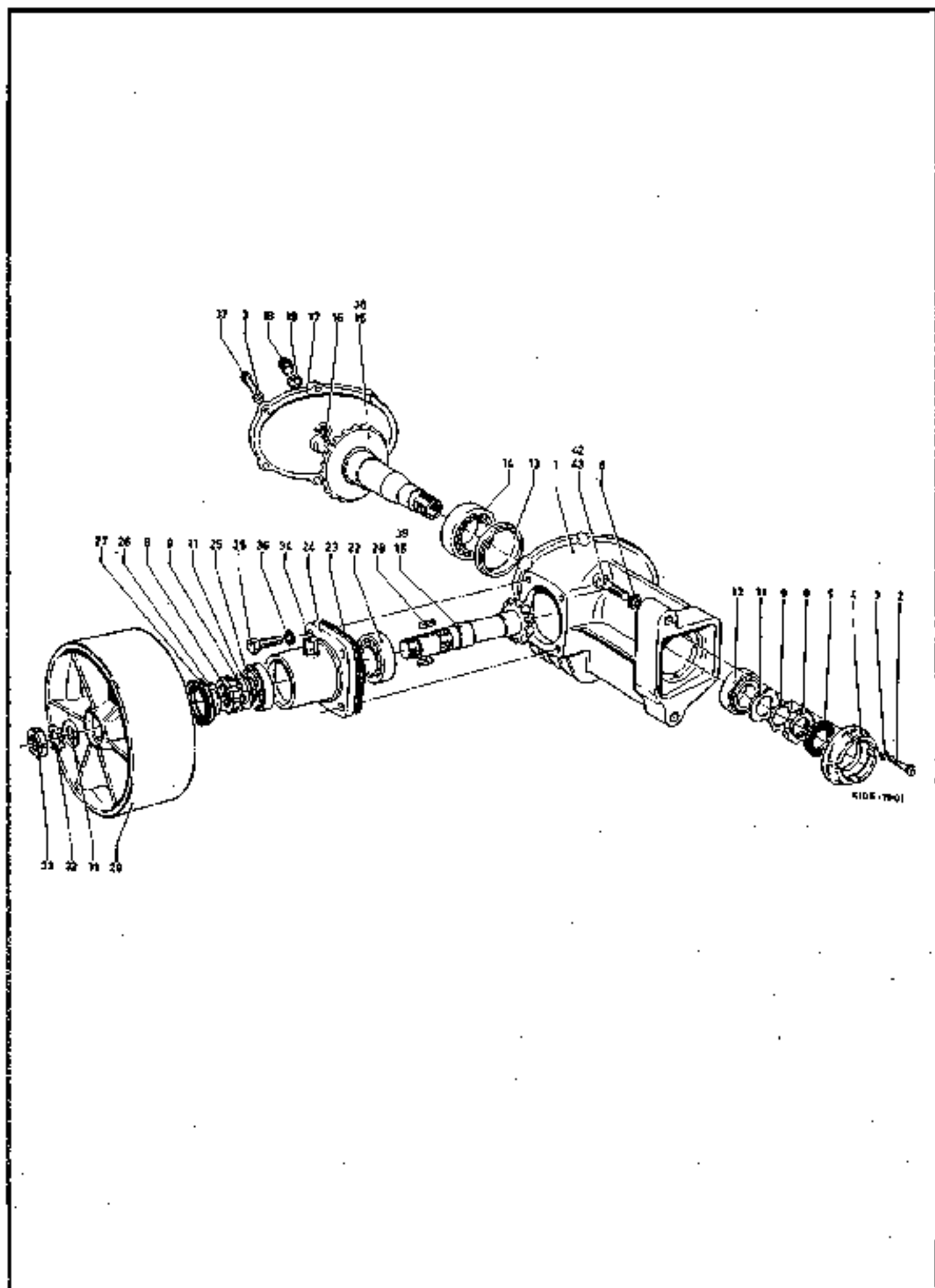



Bild-Nr.	Schleppenummer		Fußnote	Teilnummer	Anzahl	
	ab	bis				
17				1434-19-01.17 (339 2290)	1	
A 17			+	A 16 DIN 128 A4C (110 2803)	2	
18				AM 10x1,5 DIN 7604 A4C (111 8971)	1	
A 18			+	1771-19-11.10 (339 0767)	2	
19				A 18x22 DIN 7603 Cu (111 8713)	1	
A19			+	35x2,5 DIN 471 (110 7749)	1	
A 20			+	231 0053	2	1435-19
A 21			+	M 16x70 DIN 912-B.8 A4C (112 2379)	2	
22				44,5x88,9x30,2 H 4450 (116 8682)	1	
23				1434-19-03.10 (339 2304)	nB	D, 2-2, 0mm
24				1434-19-01.24 (339 2283)	1	
25				44,5x82,9x23,9 H 4450 (116 8681)	1	
26				1434-19-01.26 (339 2267)	1	
27				A 65x85x10 E 645 (116 5286)	1	
28				A 12x8x36 DIN 6385 (111 8098)	2	
29				1434-19-01.29 (339 2280)	1	
31				35x54x2 H 2308 (116 7261)	1	
32				2 250 C 1 (121 6055)	1	
33				M 35x1,5 H 2174 (116 7161)	1	
34				1155-19-03.10 (339 0420)	1	
35				R 12x35 DIN 933-B.8 A4C (111 2530)	4	
36				12 H 2205 vzko (116 9695)	4	
37				A 6x15 DIN 933-B.6 A4C (111 2251)	6	
38				Entfällt	1	
42				M 16x65 DIN 931-B.8 A4C (110 1785)	1	
43				M 16x105 DIN 931-B.8A4C (110 1786)	1	
+ A17-A21 Bei Ausführung mit Zugpendel						

Gelenkwelle
Joint Shaft
Arbre à cardan
Arbol cardan

1021

Bild-Nr.	Schleppernummer		Fußnote	Teilnummer	Anzahl	
	ab	bis				
2			*	232 6053	8	1006-21
3				M 10x1 DIN 985-8 A4 C (110 1008)	8	
4				2x22 DIN 94 A4C (110 6412)	8	
5				231 5600	1	1006-21
6				231 5624	1	1006-21
7				M 14x20 DIN 933-8.8A4C (111 2596)	2	
8				A 14 DIN 126 phos. (110 7203)	2	
10				232 2853	1	1016-21
10/1				1171-21-21.01 (231 4088)	1	
10/3				1171-21-21.03 (231 4088)	2	
10/4				1171-21-21.04 (231 4089)	1	
10/5				SA 10 H 3360 (116 8226)	1	
10/6				SC 8 H 3360 (116 8229)	2	
10/7				1171-21-21.07 (231 4090)	1	
10/13				Wir liefern n. Bild-Nr. 10		

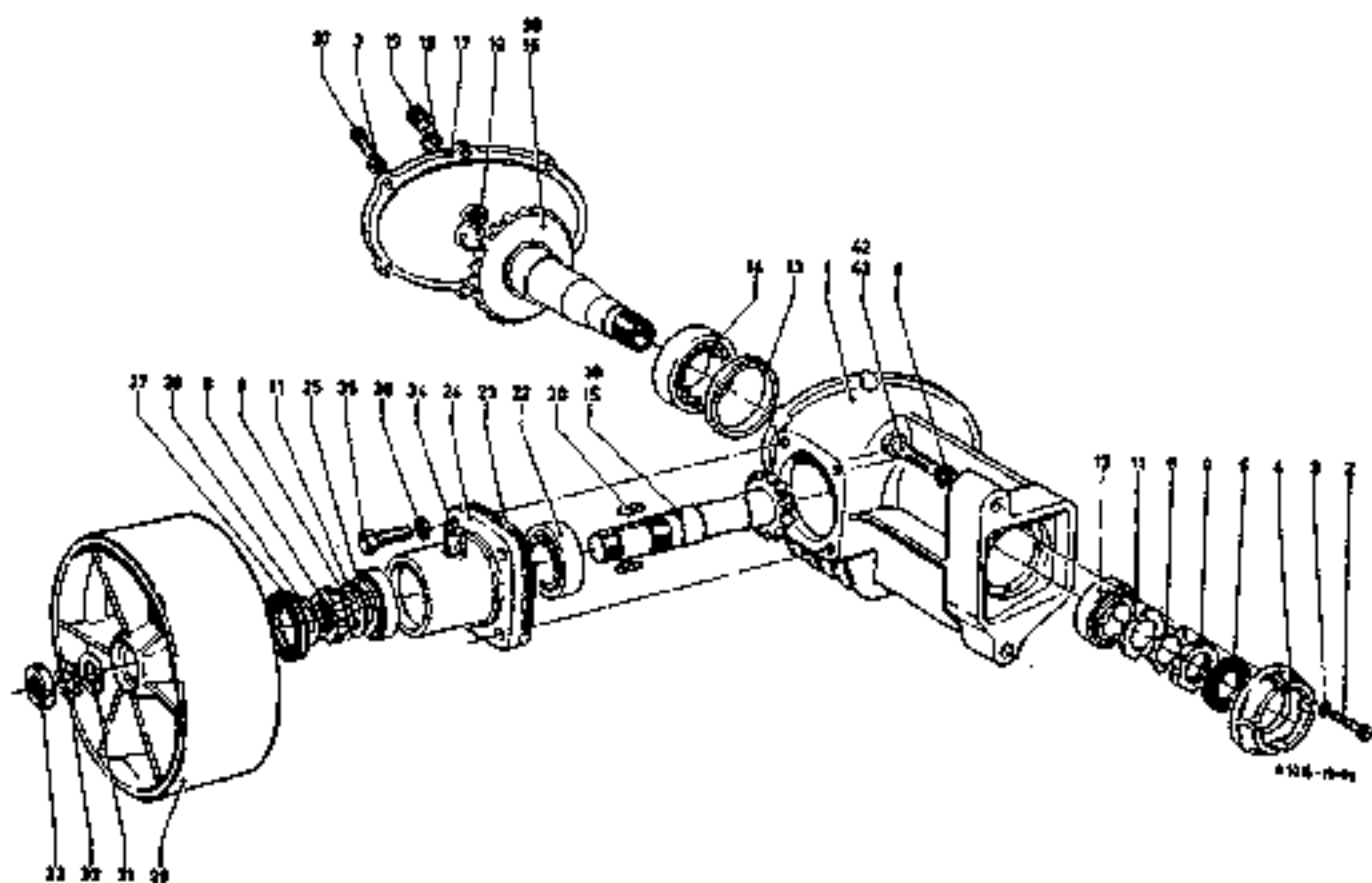
Zapfwellenkreuz eingebaut: 2 Stück = 238 2547

Lagerbüchse " 8 " = 238 2573

* Bei erstmaligem Ersatz position 8 mitliefern

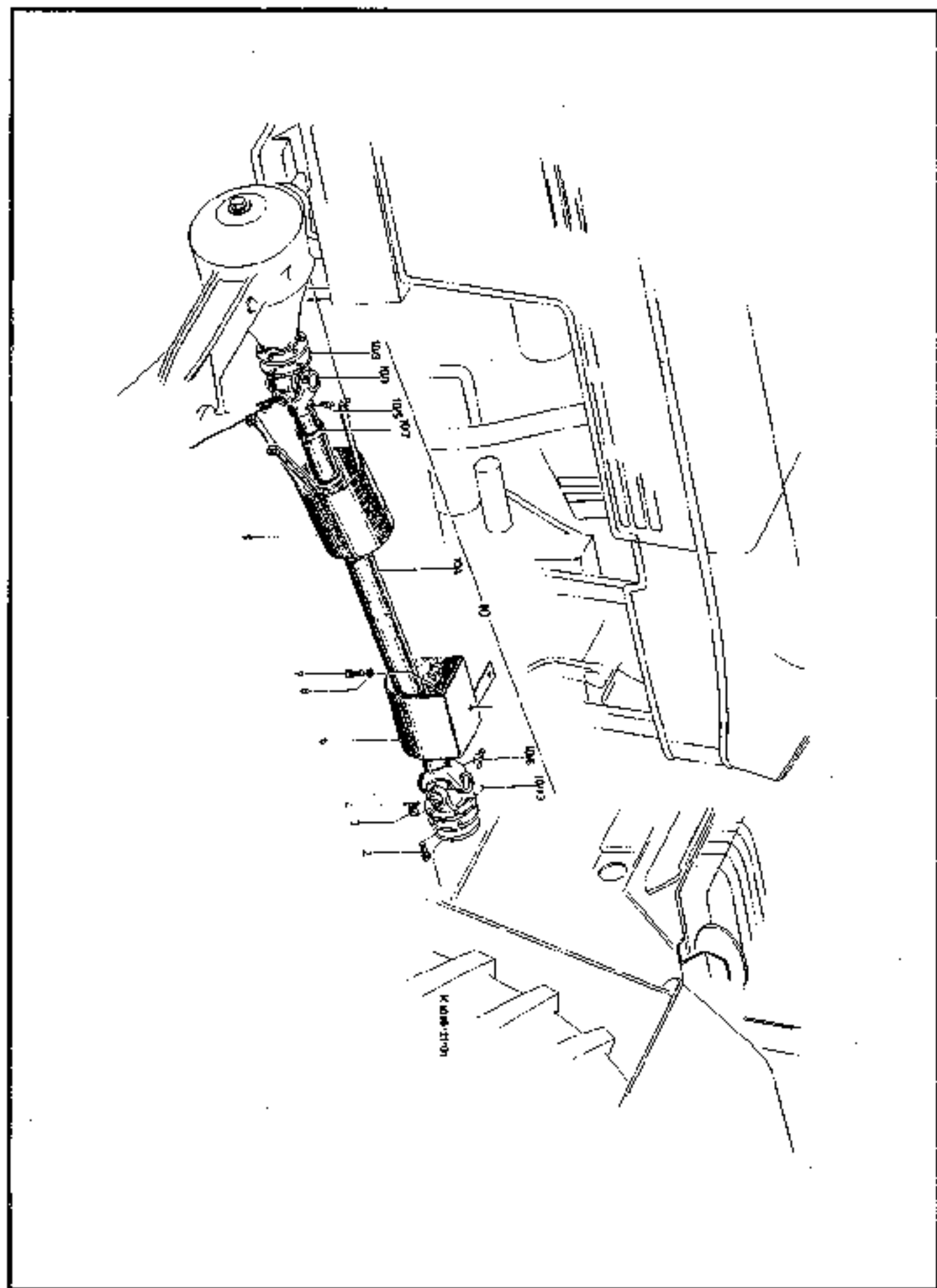

Zwischenwelle. Kegeltrieb
Intermediate Shaft with Bevel Drive
Arbre intermédiaire, couple conique
Eje intermedio, grupo conico

1023

Bild-Nr.	Schleppernummer		Fußnote	Teilnummer	Anzahl	
	ab	bis				
3				230 9736	2	1453-23
4				1453-23-01.06 (339 3109)	2	
6				50 215 (110 9966)	2	
7				K 55x60x20 H 4455 (116 8767)	1	
8				230 5100	1	Za14 1401-23
9				HK 35x42x20 H 4455 (117 0832)	1	
10				10 DIN 7980 (111 9612)	16	
11				M 10x30 DIN 933-8.8 (111 2429)	16	
12				A 60x75x8 H 2940 N1 (116 0798)	2	
13				230 9564	2	1401-23
14				230 5099	1	1401-23
A 64			+	231 6382	1	Z=38:9 1453-23
A 64/1			+	2 173 A d (121 6030)	1	
A 66			+1	231 6384	1	Z=38:9 1453-23
A 66/1			+1	1453-11-07.144 (347 1137)	1	

+ TW 55.1 Var. SL +1 TW 55.1 A Var. S

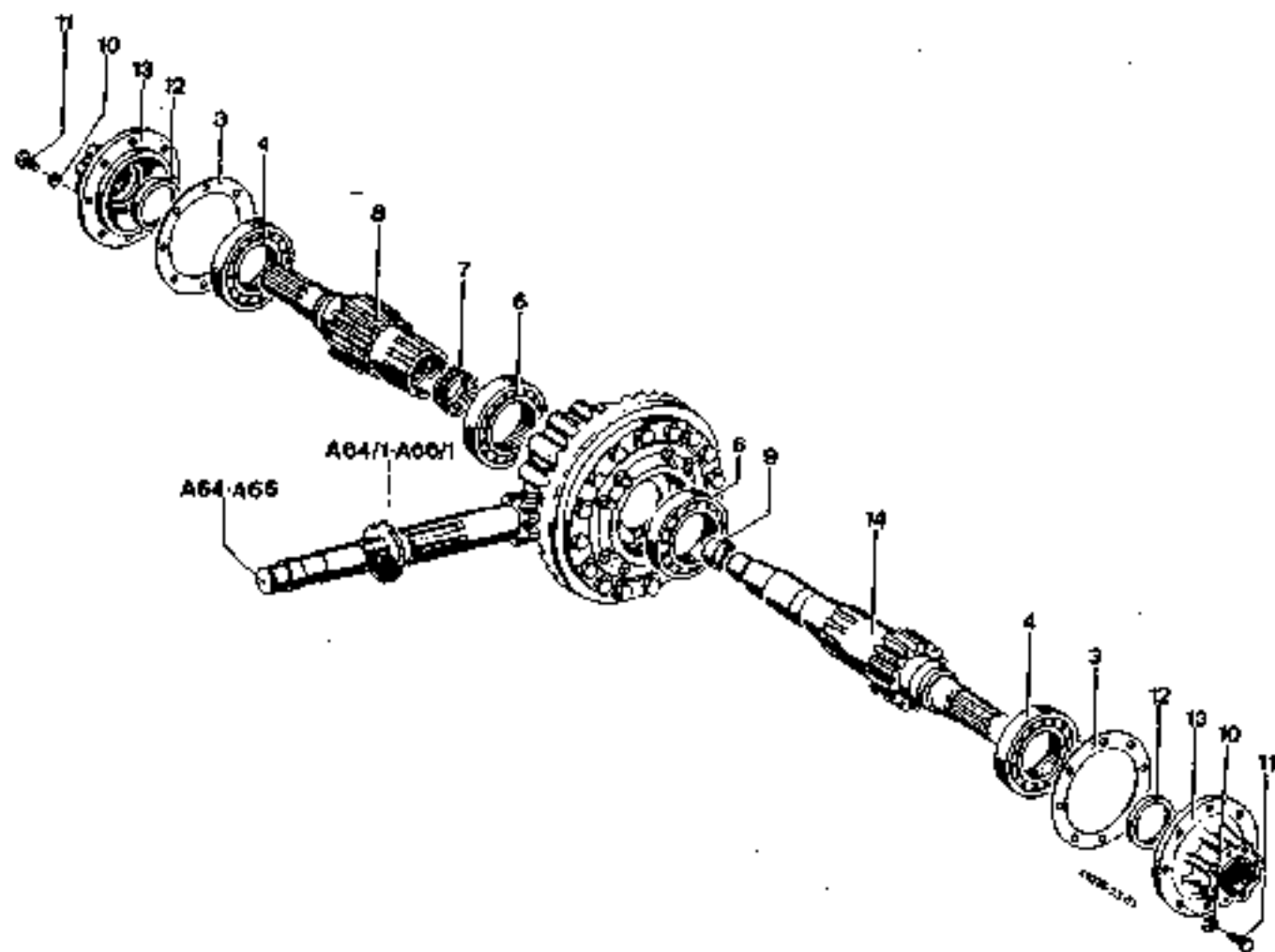

Mitteilung an STT Herrn Schulte

Betr.: Einführungs-Nr. Differentialzapfen 20 59.1 - 20 55.2

Ab unten aufgeführten Traktoren-Nr. ist der Differentialzapfen (Kreuzzapfen) **teniferiert** (und **nikotriert**).

D 6006

Ab 7888/9296	bis	9474	= teniferiert
7913/72	"	396	= "
7913/397			= nikotriert
7896/7054	"	7166	= teniferiert
7890/8923	"	9057	= "
7898/9858			= nikotriert
7889/281	"	330	= teniferiert
7889/536	"	685	= "
7889/686			= nikotriert

D 7006

Ab 7915/1321	bis	2000	= teniferiert
7915/2001			= nikotriert
7916/262	"	416	= teniferiert
7916/417			= nikotriert

Verteiler:
TZV
MZA 2

Traktorenabnahme
BRPA

(Wirtz)

Ausgleichgetriebe
Differential Unit
Différentiel
Diferncial

1024

N.0016-02-01

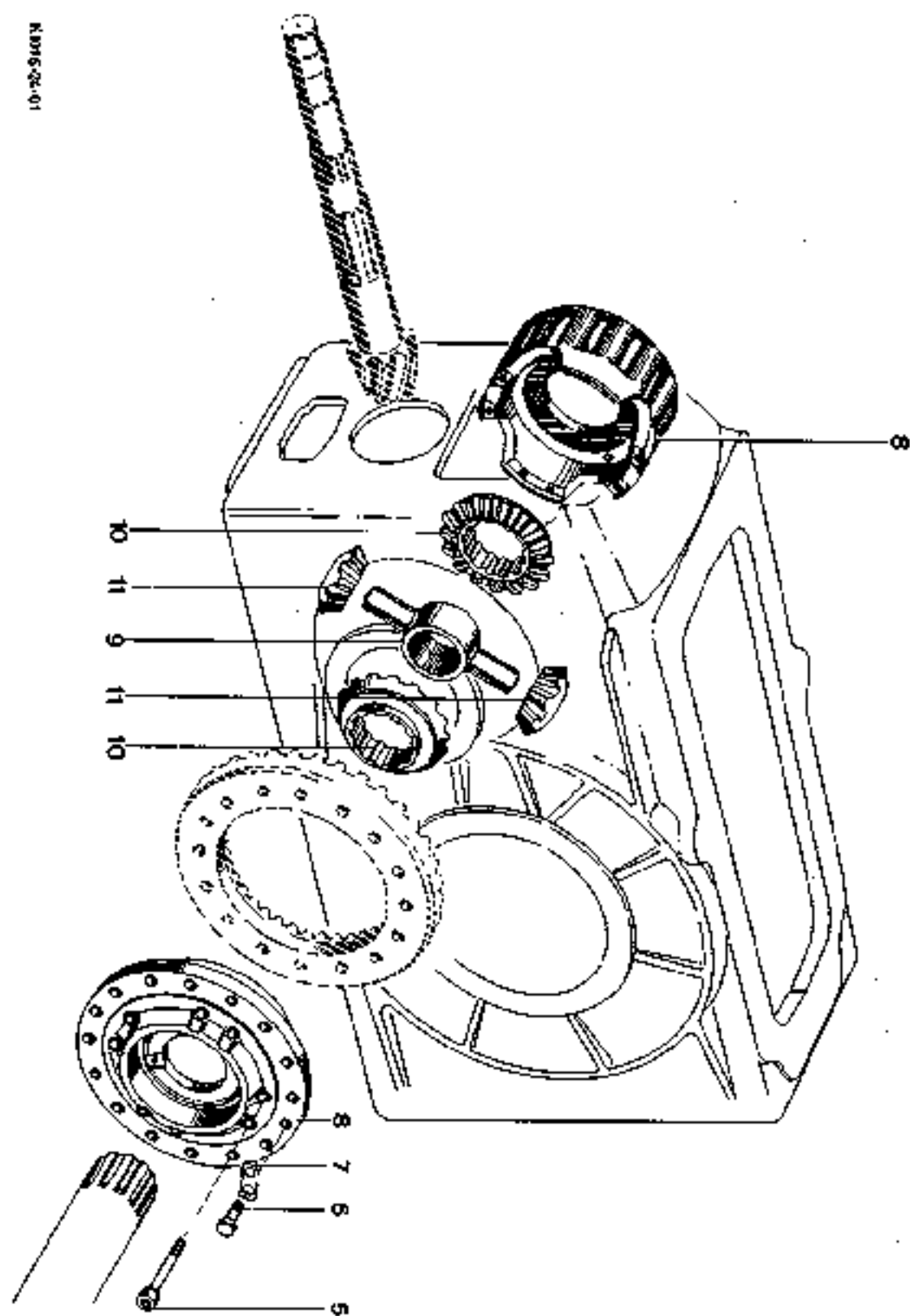

Ausgleichgetriebesperre
Differential Lock
Blocage du différentiel
Bloqueo del diferencial

1025

Bild-Nr.	Schleppernummer		Fußnote	Teilnummer	Anzahl	
	ab	bis				
1				230 9690	1	1401-25
2				230 9692	1	1401-25
3				230 9693	1	1401-25
4				231 3626	1	1401-25
5				1424-12-07.01 (231 5043)	2	
6				1455-25-05.14 (339 3259)	4	
7				1455-10-09.11 (231 5042)	1	
10				1455-25-06.13 (339 3260)	1	
11				230 9695	12	1401-25
12				230 9703	1	1401-25
13				20x3 H 721 (116 6022)	1	
14				231 6873	1	1455-25
15				232 1493	1	1455-25

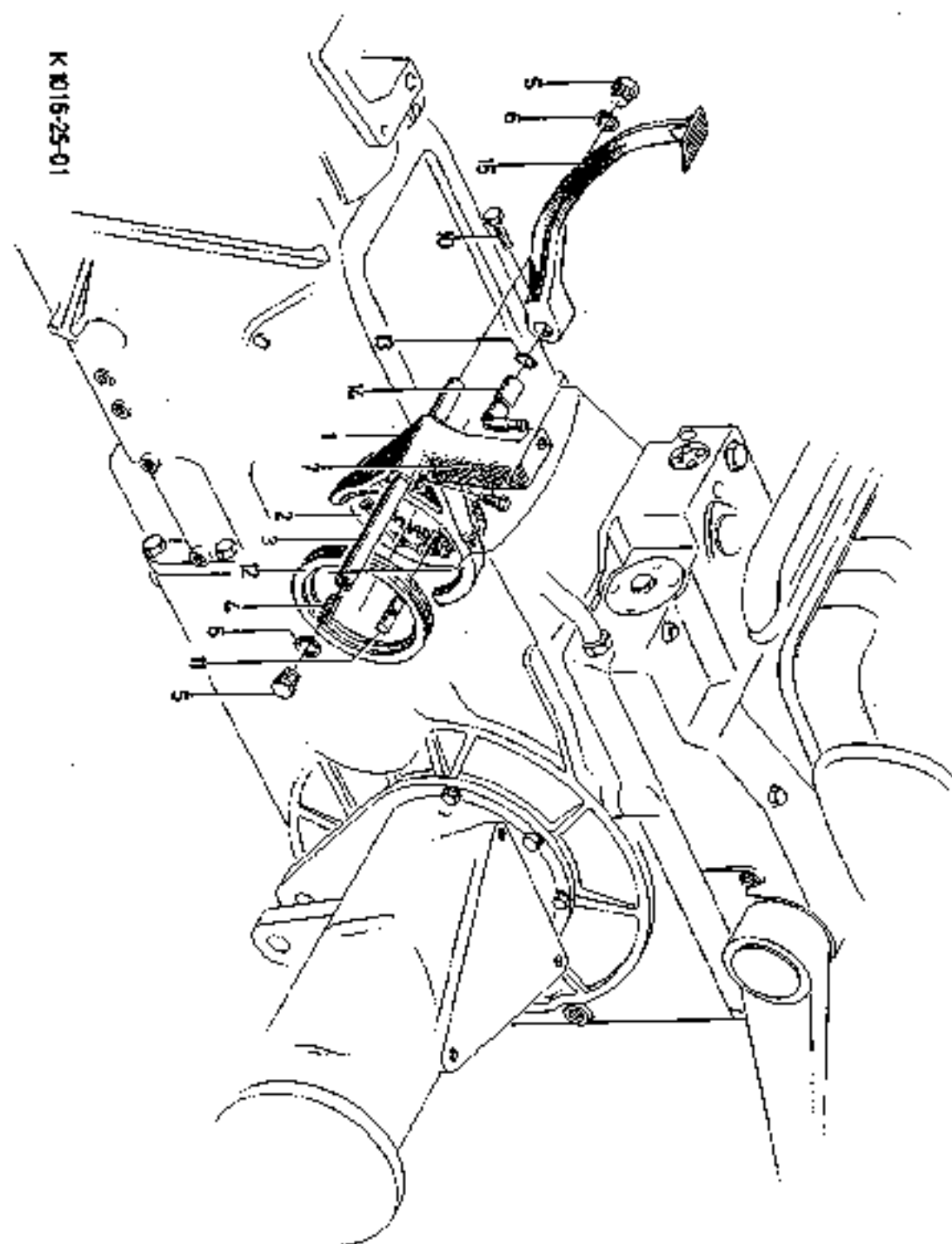

Vorderradantrieb mit Schaltung
Front Wheel Drive with Control Assembly
Pont-moteur AV et sa commande
Tracción delantero con mando

1026

Bild-Nr.	Schleppernummer		Fußnote	Teilnummer	Anzahl	
	ab	bis				
1				230 1548	1	1455-26
2				230 1550	1	1455-26
3				230 1551	1	1455-26
6				230 1554	1	Z=32 1455-26
7				230 1555	1	Z=20 1455-26
8				230 1556	1	1455-26
9				230 1557	1	1455-26
11				230 1561	2	1455-26
12				232 1072	1	1455-26
13				230 1563	1	1455-26
14				230 1564	1	1455-26
15				10 M ¹⁰ ITI DIN 5401 (111 6960)	1	
16				B 22 H 711 (116 5829)	1	
17				M 30x25 DIN 933-8.8 A4C (111 2418)	1	
18				10 H 729 (116 6296)	1	
19				5x16 DIN 1481 (111 5433)	1	
20				230 1566	1	1455-26
21				230 1567	1	1455-26
22				230 1568	1	1455-26
23				M 10x30 DIN 912-6.9vskc (111 0664)	3	
24				230 1570	3	1455-26
25				230 1572	1	1455-26
26				M 8x20 DIN 933-8.8 A4C (111 2322)	15	
27				48x1,75 DIN 477 (110 7766)	1	
28				N J 207 (111 7066)	1	
29				N J 2208 E (110 1013)	1	
30				N J 2306 E (110 1012)	1	

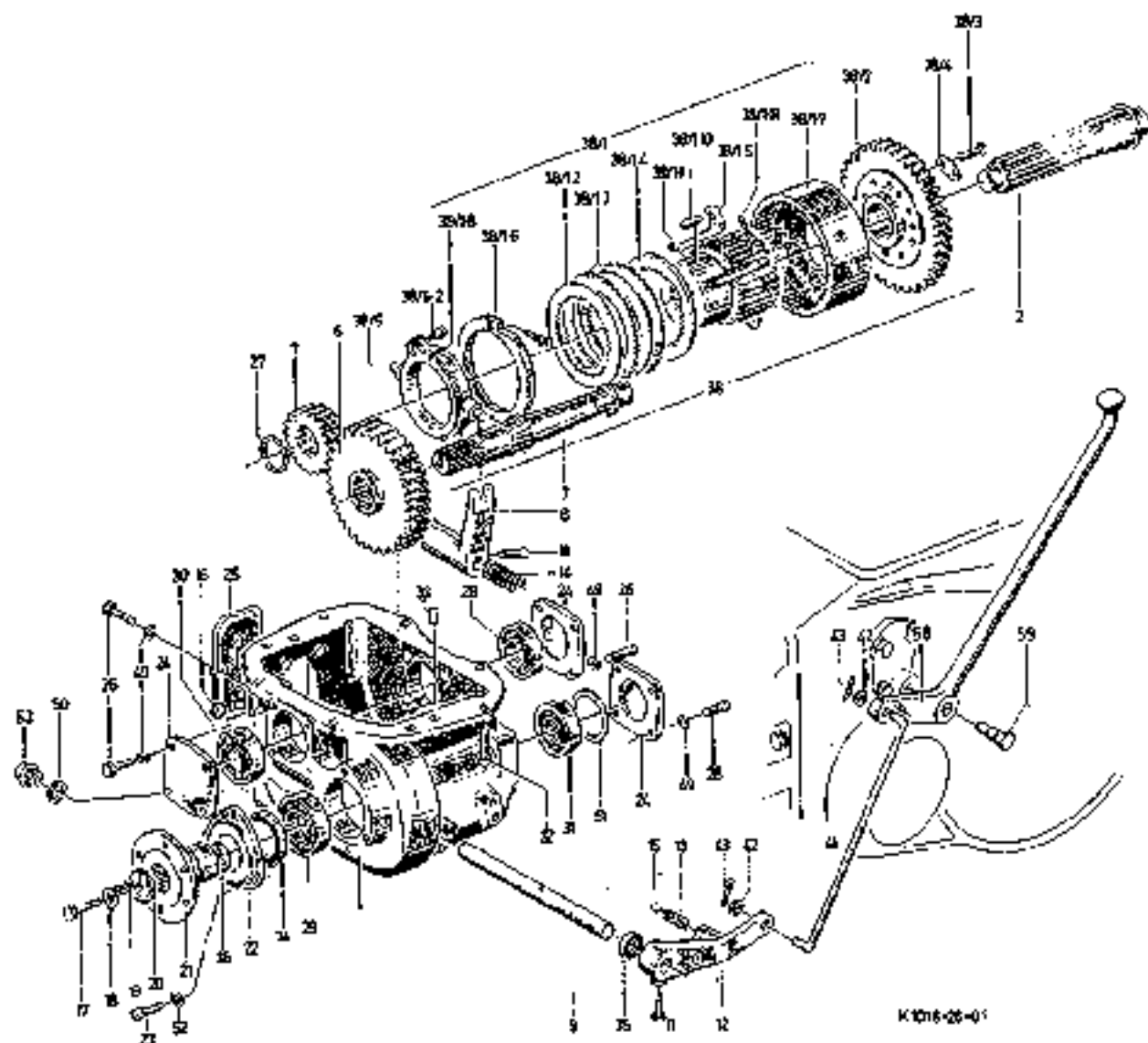

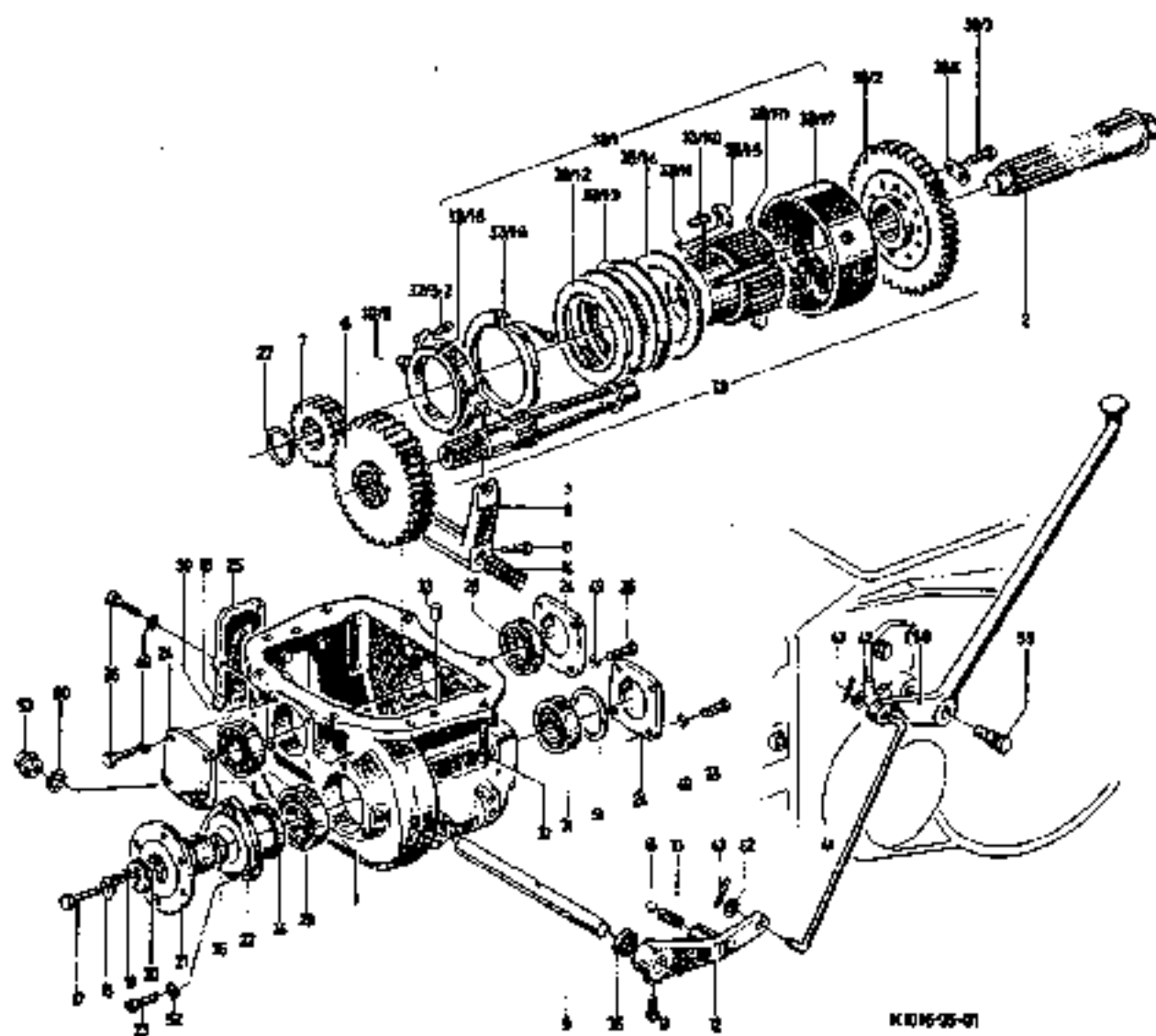

K0016-25-01

Bild-Nr.	Schleppernummer		Fußnote	Teilnummer	Anzahl	
	ab	bis				
31				6306 (110 9125)	1	
32				M 12x30 DIN 912 - 8.8 A4C (111 0757)	8	
33				13 M 6x20 DIN 7 (110 5209)	2	
34				S 52x72x12 H 2940 Ni (116 0056)	1	
35				S 22x35x7 II 2940 Ni (116 0055)	1	
36				40x3 H 2827 (116 7379)	1	
38			*	230 1574	1	1455-26
38/1				230 1576	1	1455-26
38/1.1				231 9680	1	1455-26
38/1.2				231 9681	7	1455-26
38/1.3				231 9682	6	1455-26
38/1.4				231 9683	1	1455-26
38/1.5				232 0628	1	1455-26
38/1.6				231 9685	1	1455-26
38/1.7				231 9686	1	1455-26
38/1.8				231 9687	1	1455-26
38/1.10				A 10x8x36 DIN 6885 (110 1341)	1	
38/1.11				6 M6x36 DIN 6325 (112 7414)	3	
38/2				230 1578	1	49 Zähne 1455-26
38/3				M 8x25 DIN 931 - 8.8 A4C (111 1124)	12	
38/4				230 3445	12	1455-26
38/5				230 1559	1	1455-26
38/5.2				M 6x15 DIN 912 - 8.8 A4C (111 0509)	2	
41				232 1092	1	1455-26
42				13, 5 DIN 433 A4C (110 7554)	2	
43				4x25 DIN 94 A4C (110 6451)	2	
49				A 8 DIN 128 A4C (110 2799)	15	

* Lamellenkupplung mit Zahnrad vollst.

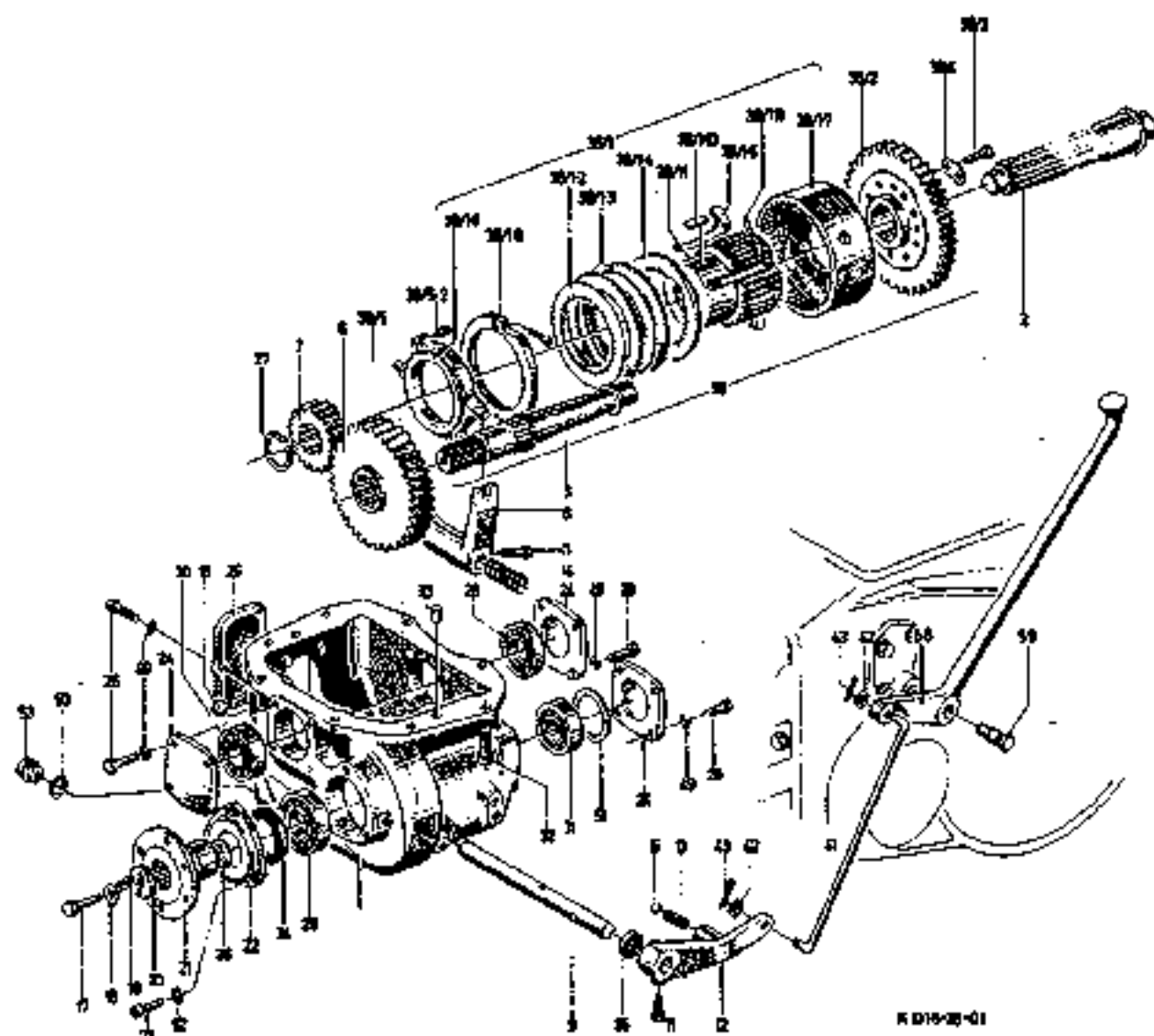

Hinterachse
Standard Rear Axle
Train AR
Puente trasero

1027

Bild-Nr.	Schleppernummer		Fußnote	Teilnummer	Anzahl	
	ab	bis				
1				232 1729	2	2 et. 6 1401-27
1/1				Siehe Position 1		
1/2				Siehe Position 1		
2				6218 NC 3 (112 6105)	2	
3				90x3 DIN 471 (110 7788)	2	
4				KJ 170 H 712 (116 0580)	2	
5				SP 160 DIN 5417 (110 3356)	2	
6				14 H 2203 vzkc (116 9696)	16	
7				232 1694	2	1401-27
8				1455-27-01.07 (339 3262)	2	
9				SR 8 H 3360 (116 8227)	2	
10				230 9493	2	1455-27
11				6215 (110 8091)	2	
12				A 18 DIN 74861-6.8vzkc (112 3546)	16	
13				1455-27-02.18 (339 3268)	16	
14				S 85x100x12H2940 Ni (116 0856)	2	
15				12 H 2203 vzkc (116 9695)	16	
16				M 12x35 DIN 933-8.8 (111 2536)	16	
17				231 1847	1	1401-27
18				231 1845	1	1401-27
19				M 14x50 DIN 931-8.8A4C (111 1672)	4	
20				M 14x55 DIN 931-8.8A4C (111 1682)	10	

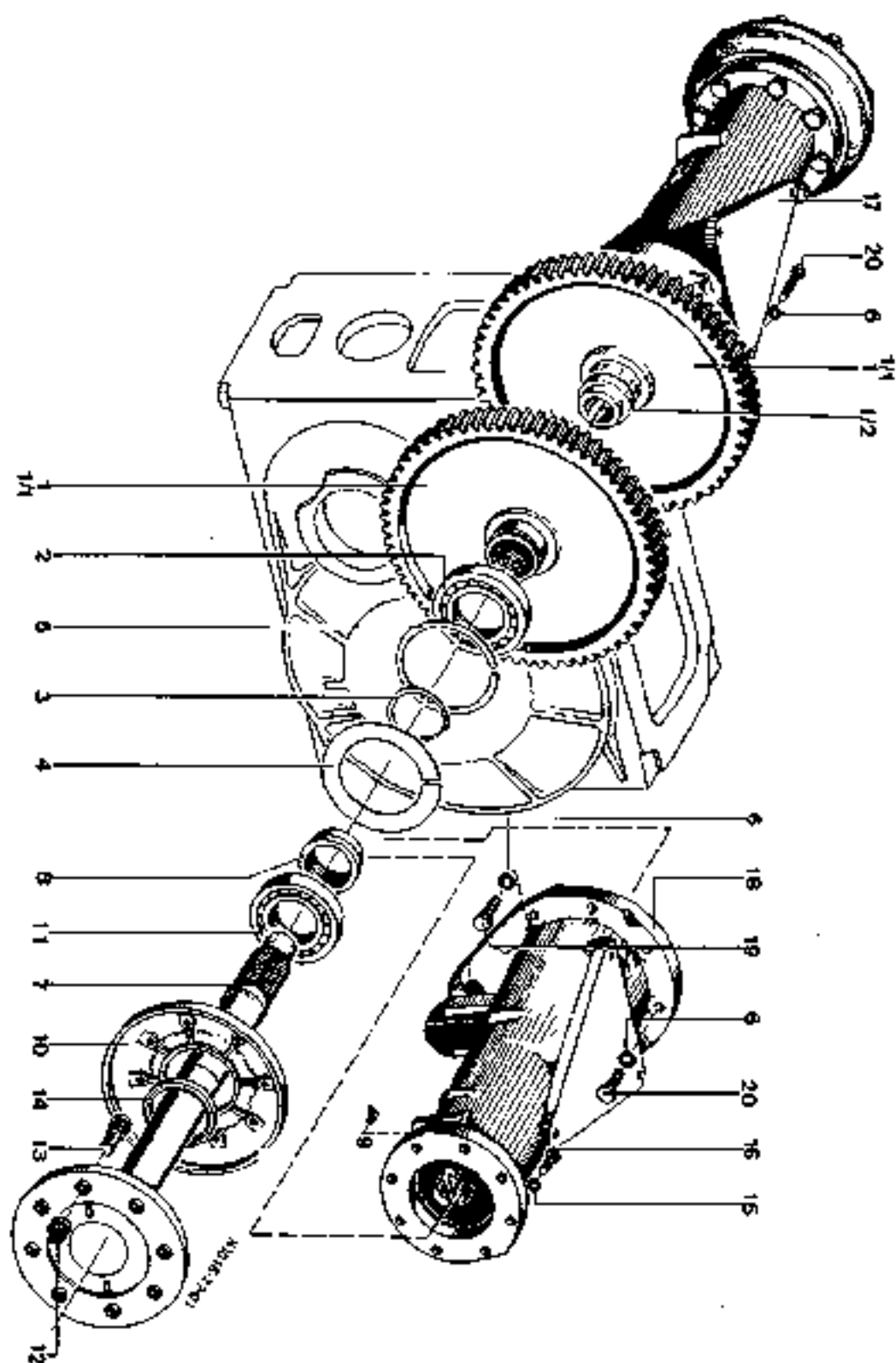

Triebachse mit Pendellager und Lenkungs-dämpfer
Driven Front Axle with Pivot Bearing and Vibration Damper
Pont motodirecteur á pivot oscillant et amortisseur de direction
Eje delantero motriz con soporte pendular y amortiguador de dirección

1028

Triebachse AL 1550
Driven Front Axle AL 1550
Pont motodirecteur AL 1550
Eje delantero motriz tipo AL 1550

1028/1

Bild-Nr.	Schleppernummer		Fußnote	Teilnummer	Anzahl	
	ab	bis				
1				232 2873	1	
1/4				A 18 DIN 74361-8 A4C (110 1323)	16	
1/10				232 1050	10	4,9-6,3um 1006-33
2				4448 302 022 (130 0949)	1	
3				M 20x80 DIN 931-8, 8 (111 2064)	6	
4				4459 302 015 (237 1805)	2	
5				4459 302 016 (237 1803)	1	
6				M 20x2x95 DIN 609-8, 8 (112 2250) /vzkc	2	
7				M 20x2 DIN 934-8 (111 2922)	2	
8				0501 200 094 (129 5543)	1	
9				0501 302 826 (129 5615)	1	
10				0501 303 028 (129 5620)	2	
11				4459 303 034 (129 7209)	1	
A1			+	233 4805	1	
		+ ...	+1	231 5660	1	1006-37
A2				231 5703	1	1006-37
A3				231 5704	1	1006-37
A4				12K6x62x57 DIN1434vzk (110 2658)	2	
A5				M 12x30 DIN 933-10, 9 (111 2525)	3	
A6				13 DIN 125 A4C (110 7110)	2	
A7				4x25 DIN 94 vzkc (110 6450)	2	

* bei Ausführung mit Triebachse SIGE
 +1 bei Ausführung mit Triebachse AL 1550

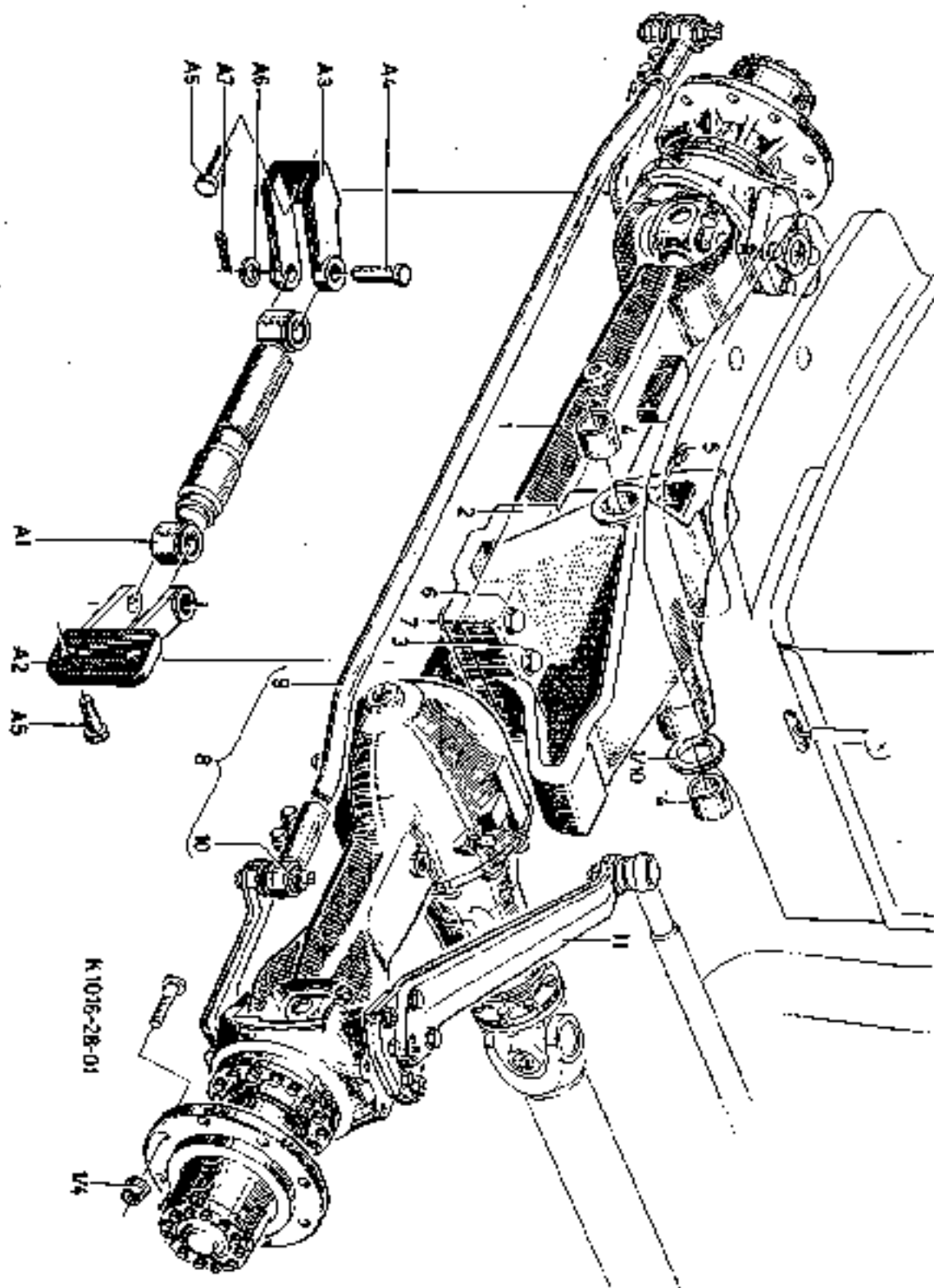

K 1036-2B-01

- einfach Gelenkhose gibt es nicht mehr
 sondern nur Doppelgelenkhose

Bild-Nr.	Schleppernummer		Fußnote	Teilnummer	Anzahl	
	ab	bis				
1				4458 2o1 o13 (129 7199)	1	Z=7/38
1/1				Wir lief. nur Pos. 1	1	Z=38
1/2				Wir lief. nur Pos. 1	1	Z=7
2				44o7 3o1 o89 (129 7182)	1	
3				44o7 3o1 o19 (129 7179)	1	
4				232 6o53	8	
5				M 1ox1 DIN 985-8 A4C (111 4363)	8	
6				2x22 DIN 94 St (11o 6411)	8	
11				4448 3o3 o29 (129 7191)	16	
12	Ab Achse Nr. 4027			o5o1 2o2 241 (13o o933)	1	
13	Ab Achse Nr. 4027			o5o1 2o2 242 (13o o934)	1	
14				44o7 2o1 o51 (13o o667)	1	
14/1				Wir lief. nur Pos. 14		
15				Wir lief. nur Pos. 14		
16				44o1 3o1 o39 (129 7176)	4	
17				M14x9oSK DIN931-1o.9 (112 616o) / A4C	4	
18				o73o 1oo 593 (129 5898)	4	
19				4458 2o1 oo3 (129 7195)	1	
19/1				Wir lief. nur Pos. 19		
19/2				Wir lief. nur Pos. 19		
22				M 12x85SK DIN 931-8.8 (112 6157)	8	
23				M14xi, 5x3oSKDIN961- (112 6231) / 1o.9	12	
24				o73o ooo 983 (129 583o)	4	
25				o731 3o5 oo2 (129 6o4o)	4	
26				o73o 1o1 766 (129 5952)	oB	Wahlweise S=2,0
95o				o73o 1o1 767 (129 5953)	oB	Wahlweise S=1,9
951				o73o 1o1 768 (129 5954)	oB	Wahlweise S=1,8

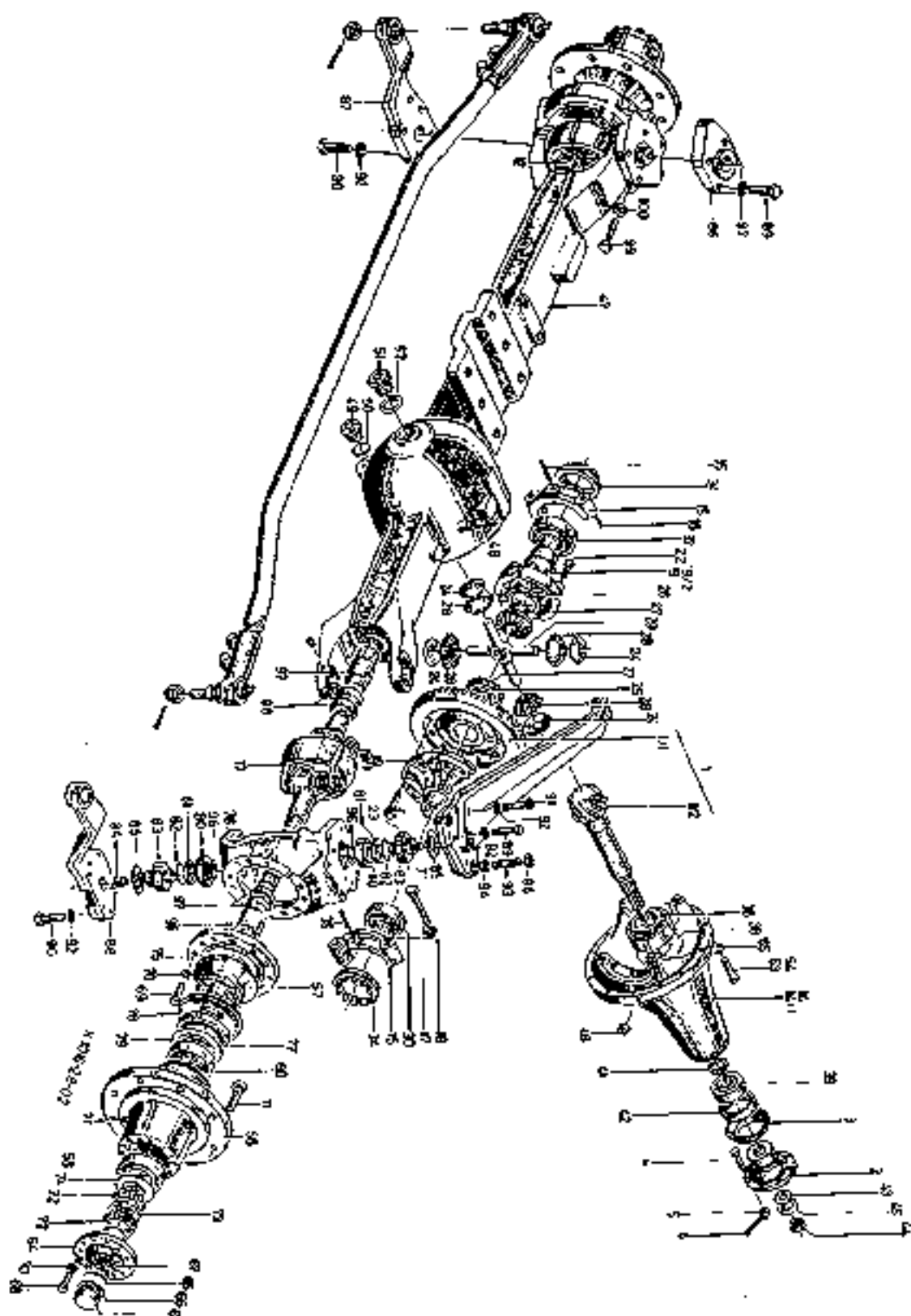



Bild-Nr.	Schleppernummer		Fußnote	Teilnummer	Anzahl	
	ob	bis				
27				4458 301 004 (129 7198)	2	
28				4458 201 002 (129 7195)	4	
29				4458 301 003 (129 7197)	1	
30			+	0635 501 320 (130 0936)	1	
			+	0635 501 319 (129 5782)	1	
32			+	0635 501 346 (129 5786)	1	
			+	0635 501 345 (129 5785)	1	
34				4407 301 036 (129 7181)	2	
35				6x45 DIN 94 St (110 6585)	2	
36			+	0635 501 340 (129 5784)	1	
			+	0635 501 339 (129 5783)	1	
38			+1	4407 301 015 (130 0948)	1	
39			+	0635 501 344 (129 9421)	1	
			+	0635 501 131 (130 0306)	1	
41			+1	0730 101 932 (129 5957)	1	Wahlweise S=6,5
				0730 100 954 (129 5928)		Wahlweise S=6,4
				0730 101 933 (129 9456)		Wahlweise S=6,3
				0730 100 953 (129 5927)		Wahlweise S=6,2
				0730 101 934 (129 5958)		Wahlweise S=6,1
				0730 100 881 (129 5913)		Wahlweise S=6,0
				0730 100 949 (129 5923)		Wahlweise S=5,9
				0730 100 950 (129 5924)		Wahlweise S=5,8
				0730 100 951 (129 5925)		Wahlweise S=5,7
				0730 100 952 (129 5926)		Wahlweise S=5,6
42				0634 309 257 60x80 * 76 (129 5745)	1	
+ Nur zusammen lieferbar			+1 Wahlweise			

Bild-Nr.	Schleppernummer		Fußnote	Teilnummer	Anzahl	
	ab	bis				
43				o73o 1oo 747 (129 59o1)	1	
44				o737 oo8 o2o (129 7976)	1	
45				44o7 3o1 o2o (129 718o)	1	
46				oo15 3oo 154 (129 7888)	1	
47				4459 3o2 o29 (129 9666)	1	
48				o732 612 ool (127 2515)	1	
49				o636 3o8 oo2 (129 7971)	1	
50				A 24x29 DIN 76o3 Cu (111 8748)	1	
51				M 42x1, 5DIN9o8-5.8 (111 o429)	1	
52				A 42x49 DIN 76o3 Cu (111 883o)	1	
53				M 1ox28 DIN 933-1o.9 (112 7o54)	8	
54				M 1ox35 DIN 933-1o.9 (111 2435)	4	
55				A 1o DIN 128 St A4C (11o 28oo)	12	
56				4459 3o3 o2o (129 43o4)	2	
57				4459 3o3 o37 (129 721o)	2	
58			+	o635 5o1 186 (129 5773)	2	Lagerau- ßenring
			+	o635 5o1 228 (129 8419)	2	Lagerinnen- ring
60			+	o635 5o1 37o (13o o937)	2	Lagerau- ßenring
			+	o635 5o1 371 (13o o938)	2	Lagerin- nenring
63				56 DIN 443 phr 6St. 13 (112 3626)	2	
64				4459 3o3 oo8 (129 72o4)	2	
65				o73o 362 o46 (129 6o.9)	2	
66				56x2 DIN 472 -FSt (11o 7841)	2	
67				42x1, 75DIN 471 FSt (11o 7758)	2	
68				M 12x3oDIN933-8. 8A4C (111 2529)	26	
69				M 12x35 DEN933-8. 8A4C (111 2538)	22	

+ nur zusammen lieferbar



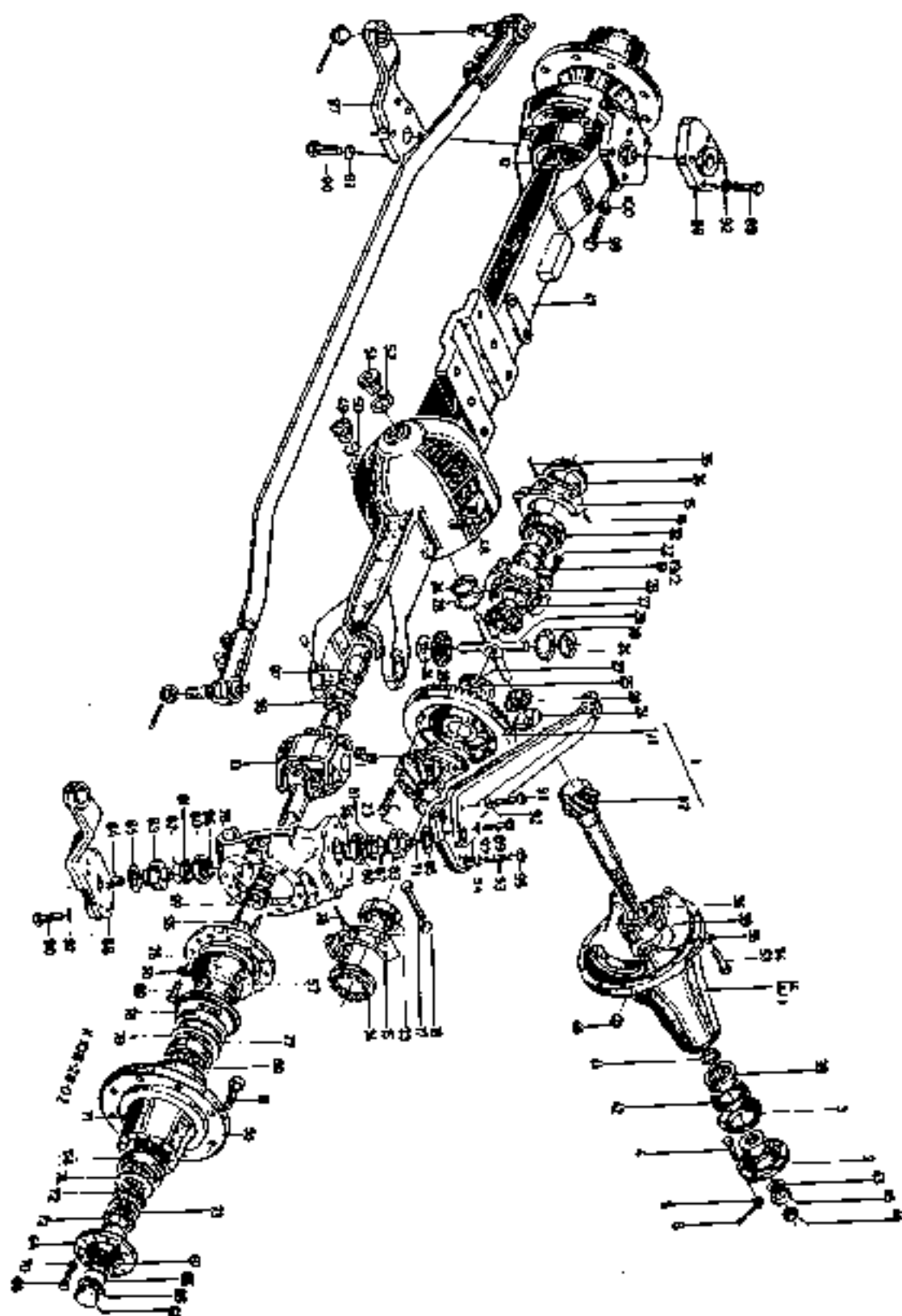
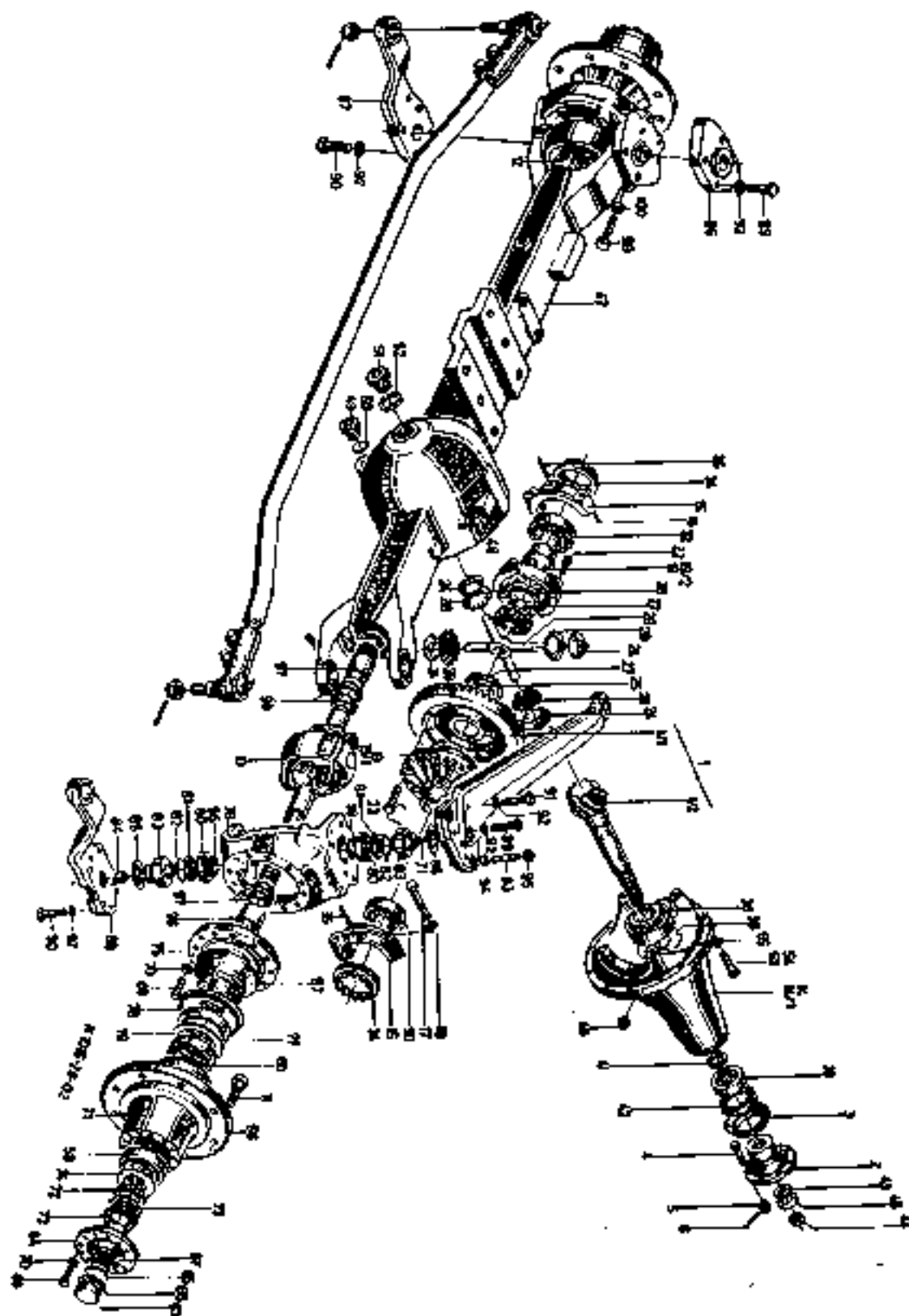

Bild-Nr.	Schleppenummer		Fußnote	Teilnummer	Anzahl	
	ab	bis				
70				B 12 DIN 137-FSt A4C (110 7289)	48	
71				S A 8 H 3360 (118 8225)	4	
72				M 55x1,5 DIN70852-8,8 (112 0616)	4	
73				4430 303 002 (129 7184)	2	
74				4430 303 007 (129 7185)	2	
75				4459 303 021 (129 7200)	2	
76				4459 303 036 (120 8681)	2	
77				0634 300 764 (129 5681)	2	
78				0734 307 080 (129 8458)	2	
79				0730 001 350 (129 5842)	2	
80			++	0635 501 113 (129 5769)	4	Lagerau- ßenring
			++	0635 501 114 (129 5770)	4	Lagerin- nenring
81				4469 350 006 (129 7212)	4	
82				0634 303 966 (235 1922)	4	
83			+	4468 353 016 (130 1048)	4	
84				S B 8 H 3360 (110 8227)	2	
85				0730 101 888 (129 5955)	4	Wahlweise S = 3,0
				0730 102 664 (130 1045)		
				0730 102 085 (129 5964)		Wahlweise S=2,9
				0730 102 086 (129 5965)		Wahlweise S=2,8
				0730 102 087 (129 5966)		Wahlweise S=2,7
				0730 102 088 (129 5967)		Wahlweise S=2,6
				0730 102 089 (129 5968)		Wahlweise S=2,5
				0730 102 090 (129 5969)		Wahlweise S=2,4
				4459 303 023 (129 7207)	1	
87				4448 303 101 (130 1393)	1	rechts
88				4448 303 100 (130 1392)	1	links

* Bei Ersatzlieferung ist Einstellscheibe Pos. 85, 0730 102 664, mit zu lieferb.
++ nur zusammen lieferbar (130 1045)

Bild-Nr.	Schleppenummer		Fußnote	Teilnummer	Anzahl
	ab	bis			
89				M 14x36 DIN 933-8. 8vzke (111 2617)	6
90				M 14x46 DIN 931-129 (111 1656)	8
91				M 14x55 DIN 931-8. 8vzke (111 1680)	2
92				B 14 DIN 137-FSt A4C (112 6727)	6
93				o736 610 011 (129 6074)	6
94				4411 303 009 (129 7183)	6
95				M 14 DIN 934-8 (111 2678)	6
96				52 DIN 470 St phr. 6 (110 0481)	4
97				o640 100 036 (129 5793)	4
98				o734 300 035 (129 9487)	8
99				o736 617 006 (129 6075)	2
100				M 12x1,5 DIN 934-8 A4C (112 4854)	2

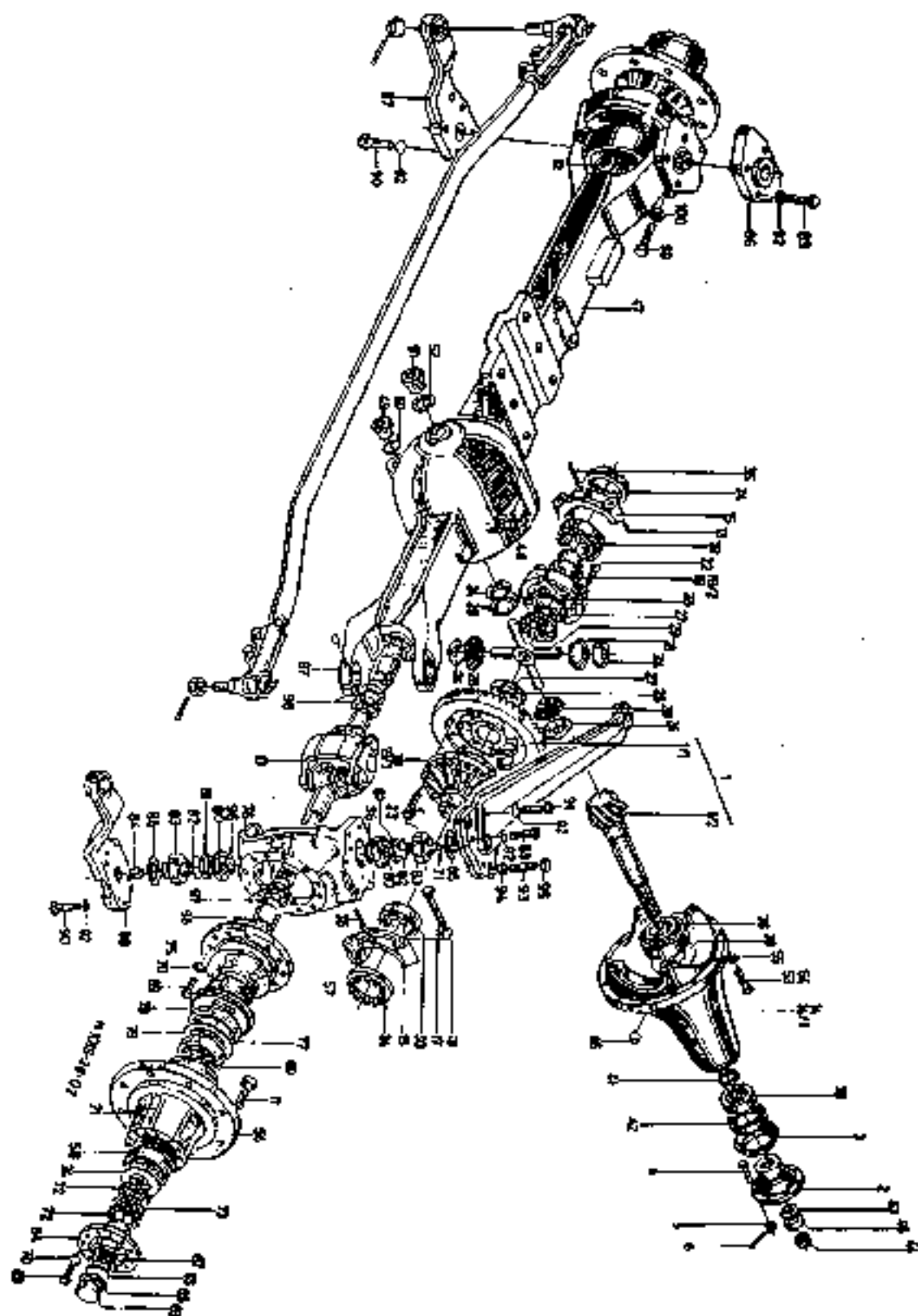
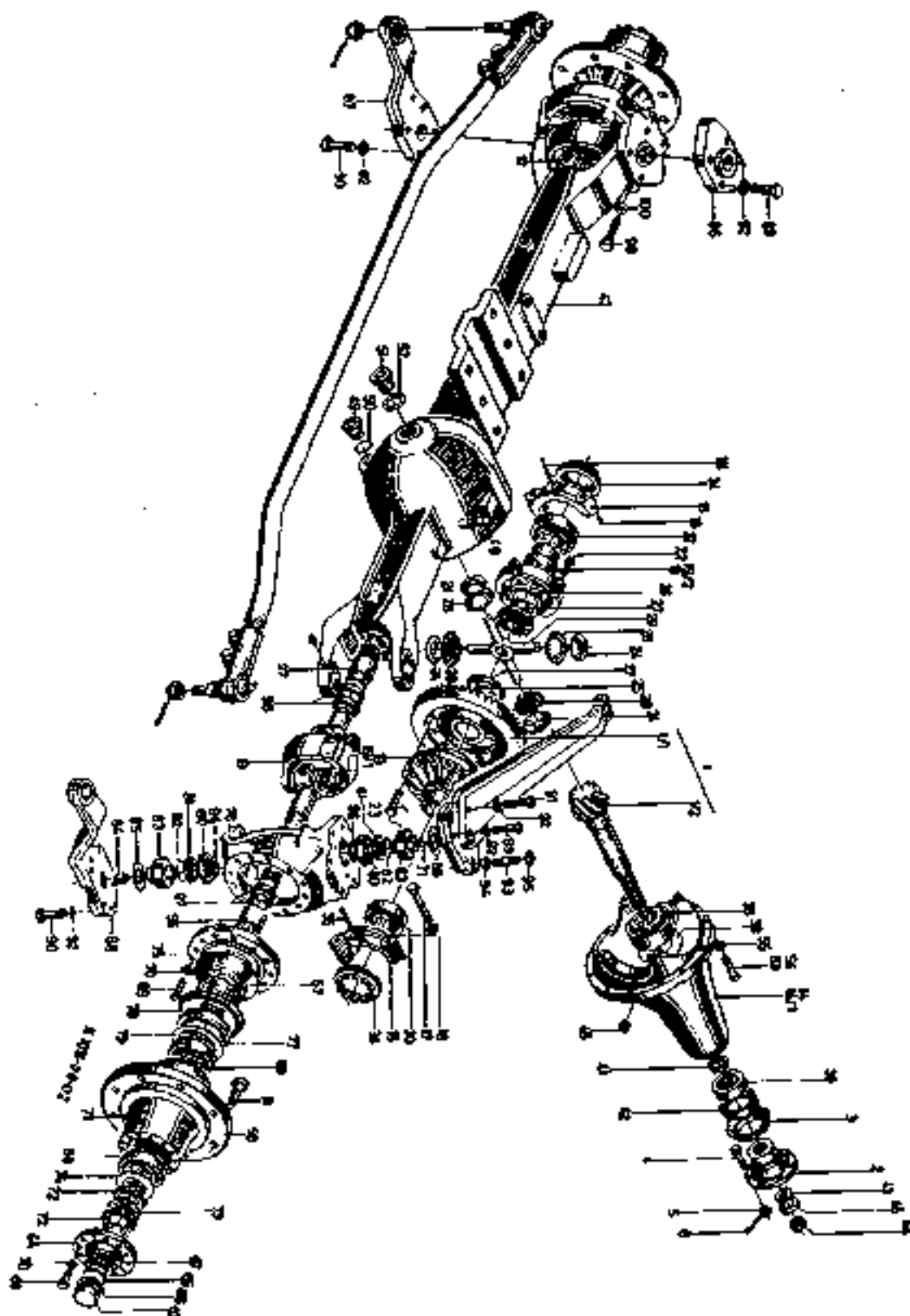

Getriebebremsbetätigung
Transmission Brake Control Assembly
Timonerie de frein agissant sur la Transmission
Accionamiento para freno sobre la transmisión

1029

Bild-Nr.	Schleppernummer		Fußnote	Teilnummer	Anzahl	
	ab	bis				
1				232 0976	1	1455-29
2				M 10x18 DIN 933-8, 8A4C (111 2397)	1	
3				10 H 2203 vzkc (116 9694)	1	
4				M 10 DIN 934-8 vzkc (110 2659)	1	
5				232 0978	1	1455-29
6				232 0977	1	1455-29
7				6 DIN 6789 (111 7928)	2	
8				232 0971	1	1455-29
8/1				232 0973	1	1455-29
8/2	<i>wir liefern nur Bild Nr. 8</i>			232 0974	1	1455-29
9				232 0980	1	1455-29
10				232 0979	1	1455-29
11				232 0981	1	1455-29
12				232 0982	1	1455-29
13				5x18 DIN 1481 (112 2674)	2	
14				4x14 DIN 1481 (111 5416)	2	
15				232 0935	1	1455-29
16				9 DIN 6789 (111 7930)	1	
17				232 0939	1	1455-29
18				5x30 DIN 1481 (111 5439)	1	
19				232 0933	1	1455-29
20				M 8x30 DIN 933-8, 8 (111 2339)	2	
21				8 H 2203 vzkc (116 9689)	2	
22				SA 8 H 3360 (116 8225)	1	
23				232 0937	1	Aussen 1455-29
24				5x40 DIN 1481 (111 5443)	1	
25				232 0940	1	1455-29

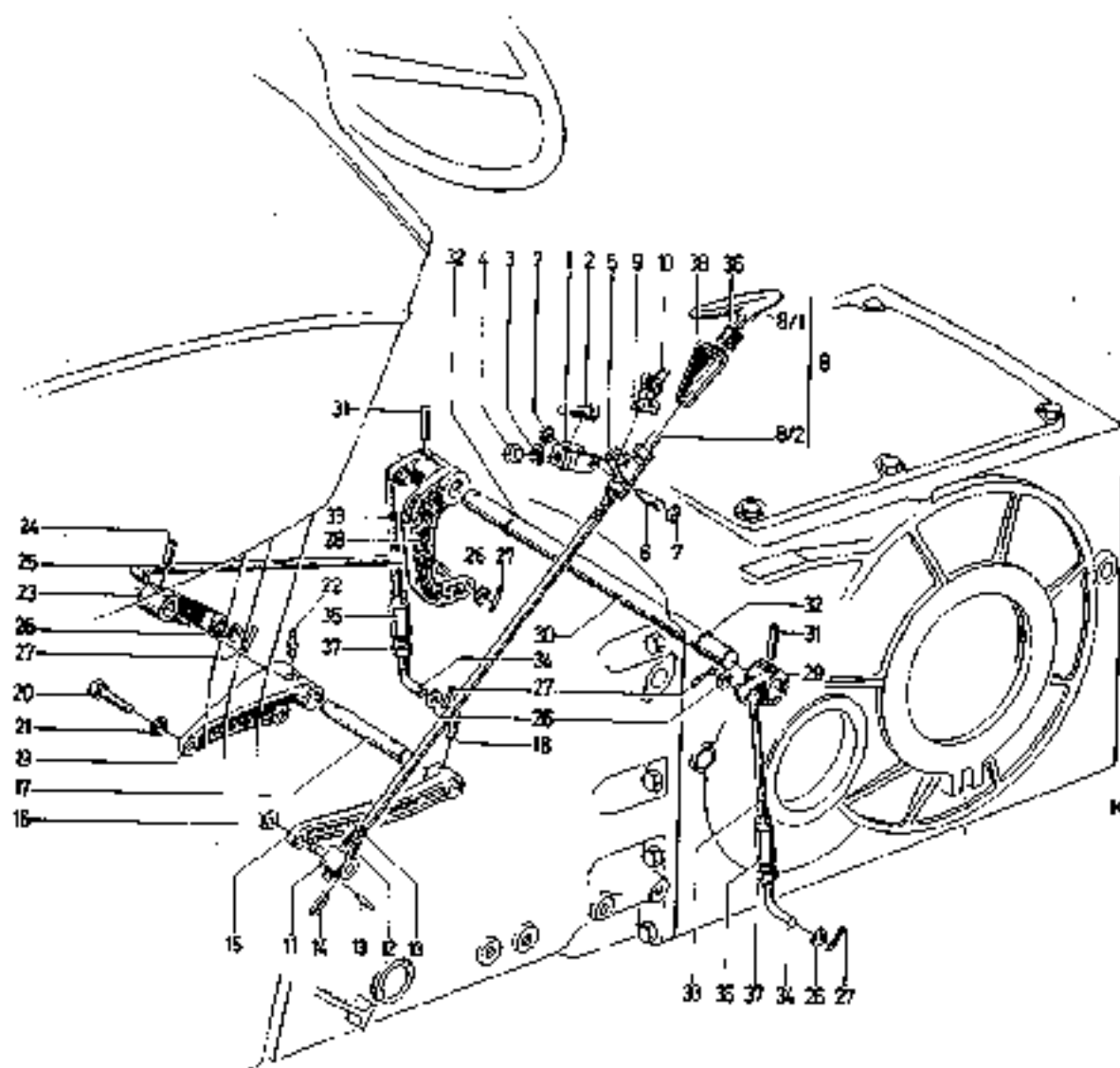



Bild-Nr.	Schleppernummer ab bis		Fußnote	Teilnummer	Anzahl	
26				13,5 DIN 433 (110 7553)	6	
27				4x22 DIN 94 (110 6448)	6	
28				232 0842	1	rechts 1455-29
29				232 0844	1	links 1455-29
30				232 0841	1	1455-29
31				8x45 DIN 1481 (111 5475)	2	
32				20x2 H 721 (116 9584)	2	
33				1455-29-01. 07 (339 3278)	2	
34				1455-29-01. 08 (339 3279)	2	
35				M 12 DIN 1479 (111 5362)	2	
36				12x30 DIN 79411 (110 3184)	1	
37				M 12 DIN 934-8 A4C (111 2858)	2	
38				232 4636	1	1455-29

Betätigung für Fahrbremse
Operating Brake and Parking Brake
Timonerie du frein au pied
Accionamiento de freno de rodadura; freno de estacionamiento

1030

Doppelbremse
Duplex Brake
Frein á double mâchoire
Freno doble

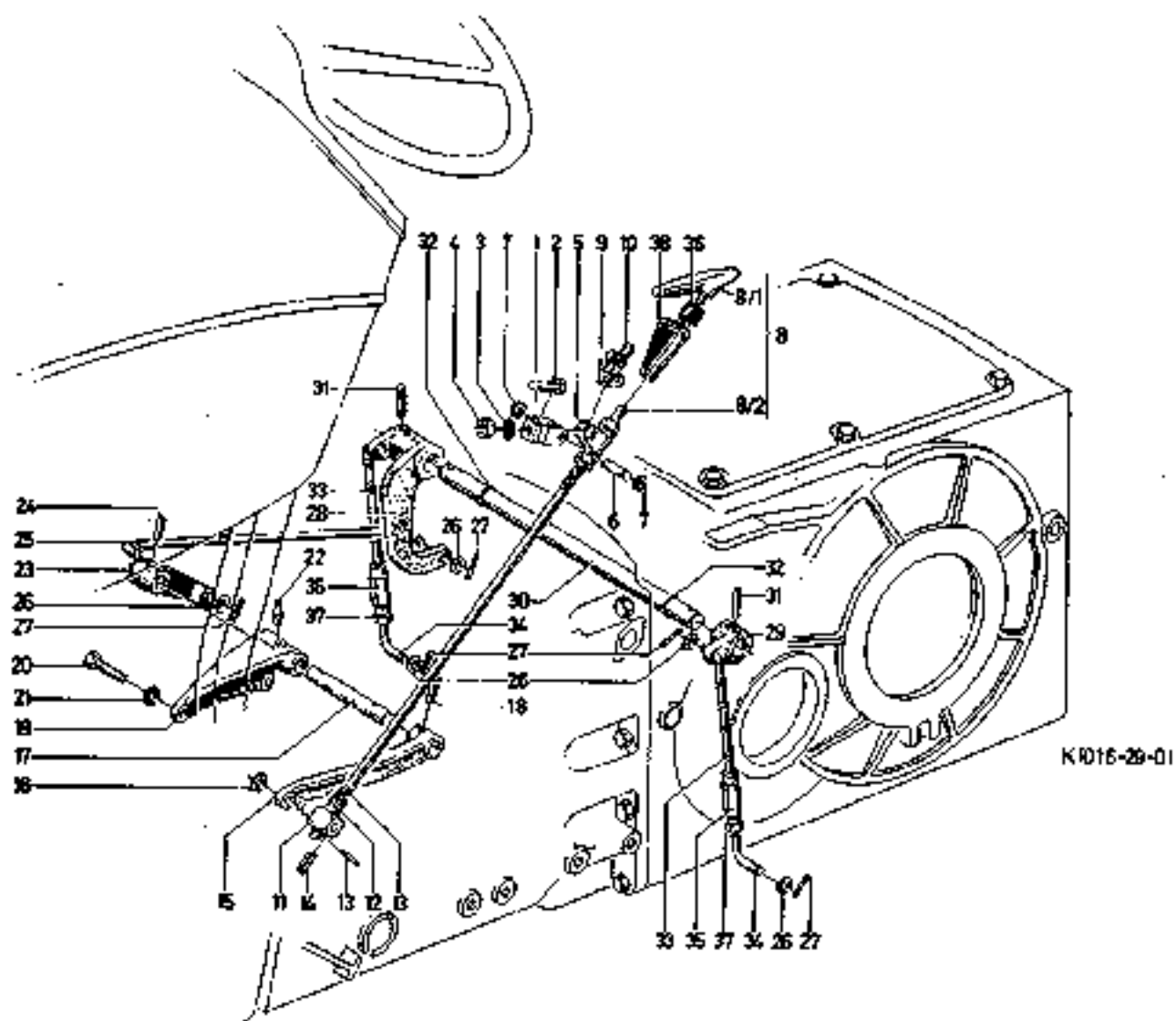
1030/1

Bild-Nr.	Schleppernummer		Fußnote	Teilnummer	Anzahl	
	ab	bis				
1				232 0952	1	Links 1006-30
2	2015/11e1 2016/2e7	2015/11d0 2016/2e6		232 0983 233 2646	1 1	1006-30 rechts
3				232 0954	1	1006-30
4				231 5695	2	1006-30
5				1152-30-01.05 (338 8796)	2	
6				1136-30-01.14 (338 8945)	2	
7				M 12 DIN934-8 A4C (111 2858)	2	
8				M 12 DIN 1479 vzkc (111 5363)	2	
9				13,5 DIN 433 vzkc (110 7554)	4	
10				1125-30-01.16 (338 7776)	4	
11				3ox1,5 DIN 471 (110 7742)	1	
12				1055-33-08.24 (338 6958)	2	
13				SA 8 H 8960 (116 8225)	2	
14				230 8090	2	1152-30
15				232 1015	2	1006-30



Bild-Nr.	Schleppernummer		Fußnote	Teilnummer	Anzahl	
	ab	bis				
1				1455-30-01.01 (339 3285)	2	
2				1455-30-02.10 (339 3286)	1	rechts
2/1				230 5235	1	rechts 1455-30
2/2				230 5236	1	linke 1455-30
2/3				230 5237	4	1455-30
2/3.2				230 5250	2	1455-30
2/3.3				B 4x10 DIN 7338 Cu (110 1455)	16	
2/4				230 5239	4	1455-30
2/5				230 5240	2	1455-30
2/6				26x2 H 2927 (116 0969)	2	
2/7				230 5241	2	1455-30
2/8				230 5242	2	1455-30
2/9				5x28 DIN 1481 (111 5437)	1	
2/10				230 5243	4	1455-30
2/10.2				230 5263	2	1455-30
2/10.3				B 3x8 DIN 7338 Cu (110 1454)	7	
2/11				230 5245	4	1455-30
2/12				230 5246	2	1455-30
2/13				22x2 H 2927 (116 0764)	2	
2/14				230 5247	2	1455-30
2/15				230 5248	2	1455-30
2/16				5x28 DIN 1481 (111 5437)	1	
3				1455-30-02.20 (339 3287)	1	links
4				47x1,75 DIN 471 (110 7763)	2	
5				2010A8	16	
6				A12 DIN 128	16	



MZA 2 H. Wichter

Köln-Kalk, den 11.11.1971
wi/pa (BKPA)

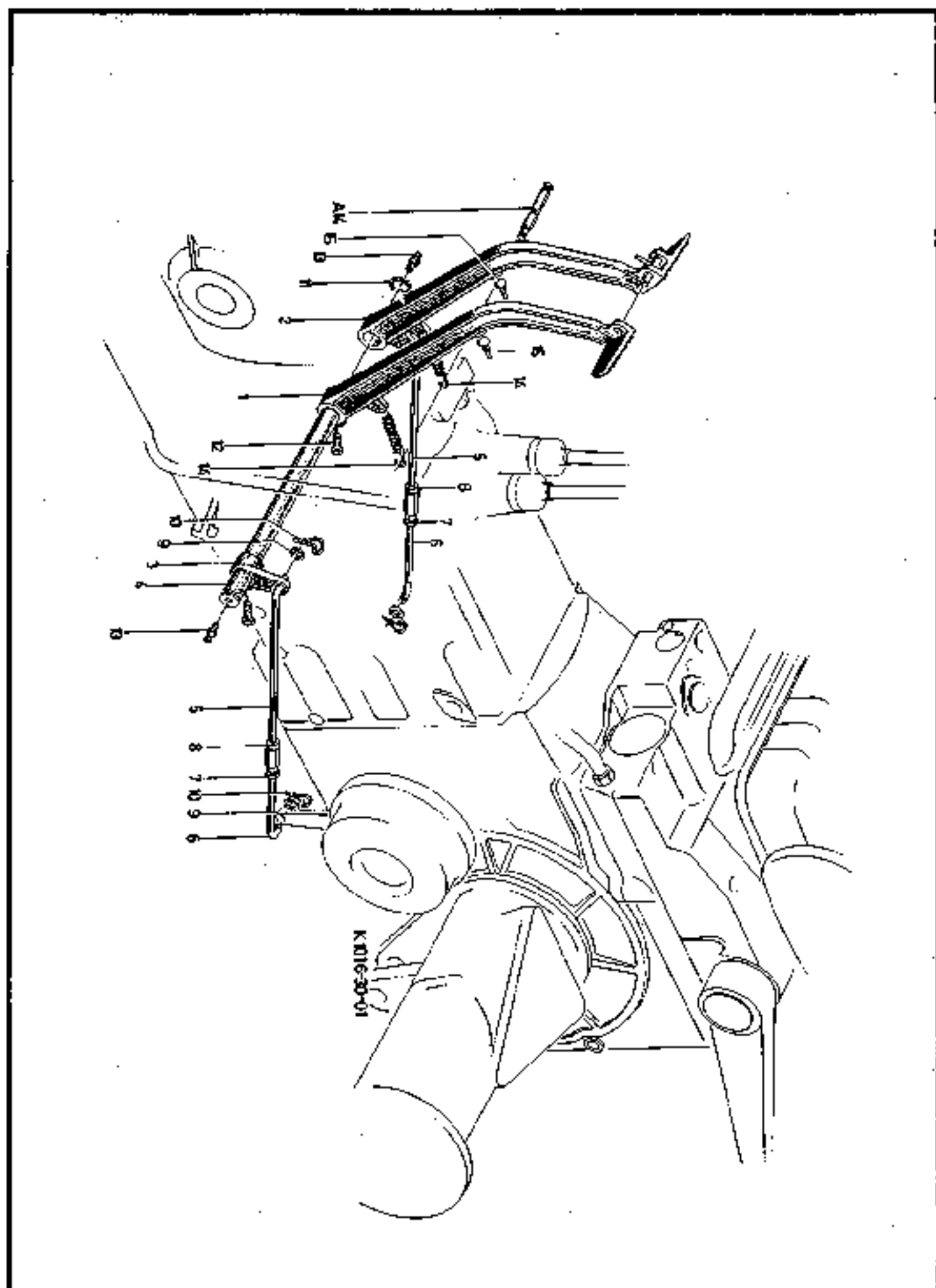
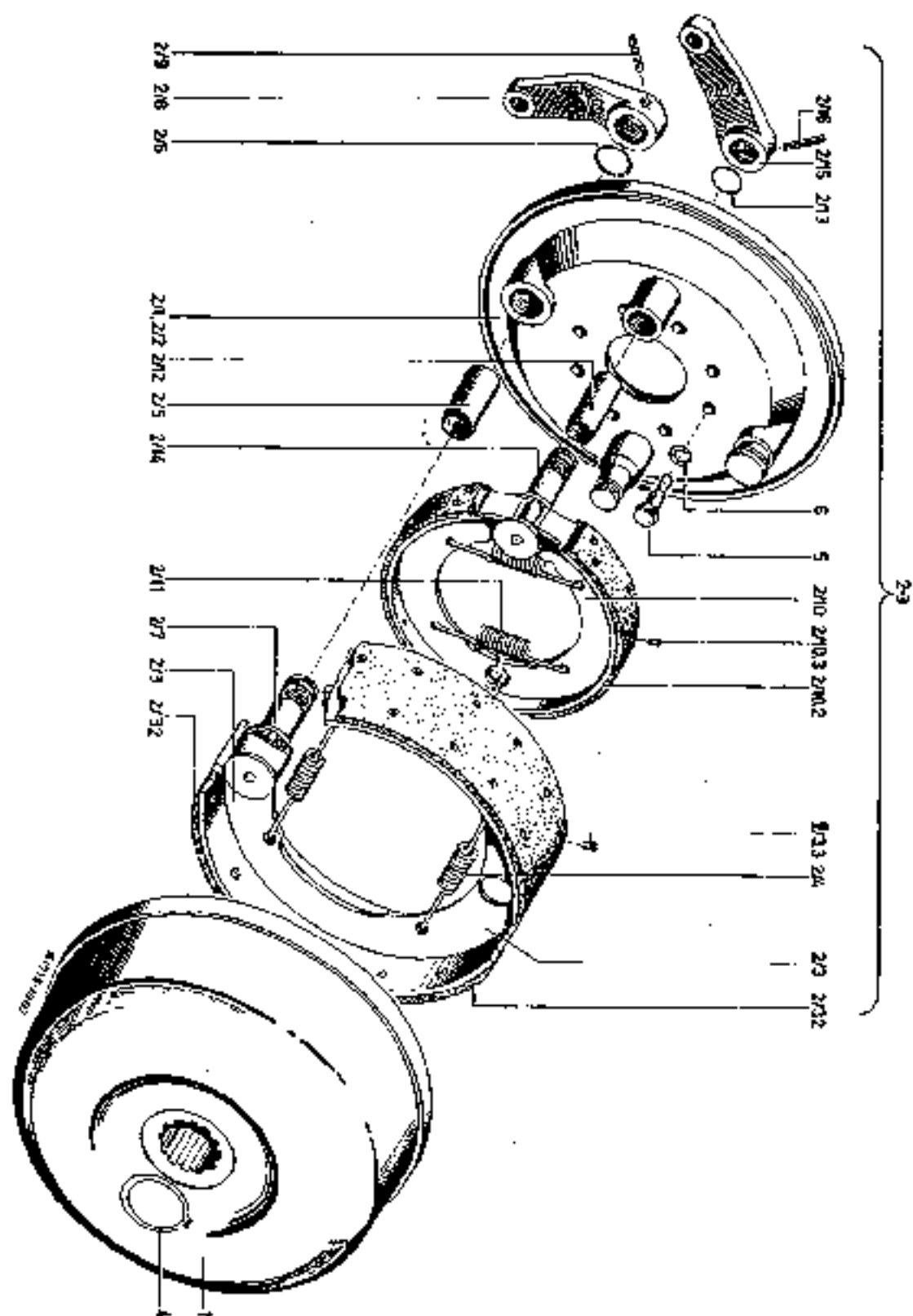
Mitteilung an Sff Herrn Schultz

Betreff: ZLG-Ausführung D 7006

Mit unten aufgeführten Traktoren-Nr. hat der geteilte Vorder-
schlaggerock eingeführt. Gleichzeitig entfällt die Verschleiß-
scheibe am Pendelrohr.

Änderungsmittellungs-Nr. 1001-32-13

Ab 7915/1701
7916/304

Verteiler:
BE,
2-3000,
TSV,
MZA 2.

Traktorenabnahme
BKPA
[Signature]
(Wirts)

Achslagerbock, Ballastgewichte, Rangierkupplung
Axle Bracket Ballast Weights pesos de lastre
Berceau du train AV masses d'alourdissement
Caballette de soporte de eje delantero

1032

Bild-Nr.	Schleppernummer		Fußnote	Teilnummer	Anzahl	
	ab	bis				
950			230 4040	1	
1		+	230 6288	1	1008-32
2				M 16x50 DIN 931-8. 8A4C (111 1853)	2	
3				230 2218	1	1171-32
4				1171-32-01.03 (339 0796)	1	
6				M 18x2 DIN 934-vzkc (111 2908)	2	
8				M 18x2x85DIN609-8.8 (110 1007) / vzkc	2	
A 1				232 0822	1	1008-32
A2				8,3 DIN 11024 vzkc (110 2874)	1	
A3				232 0871	1	1001-32
B4				232 2765	1	1971-62
B 5				231 3814	1	1971-62
C1				230 6319	1	1971-62
C 4				M 16x110 DIN 931-8. 8A4C (110 1543)	2	
C 5				17 DIN 125 A4C (110 7117)	4	
C 6				M 16 DIN 934-5 A4C (111 2886)	2	
C 7i				M 16x80 DIN 931-8. 8 A4C (111 1870)	2	
C 8				M 16x100 DIN 931-8. 8A4C (111 1930)	1	
C10				231 5730	1	1971-62
C11				M 16x95 DIN 931-8. 8 A4C (111 1924)	2	
C12				232 2851	2	44 kg 1971-62

+ Bei erster Ersatzlieferung bis Schl.-Nr. Ballastträger 233 2431 -1001-32 mitliefern.

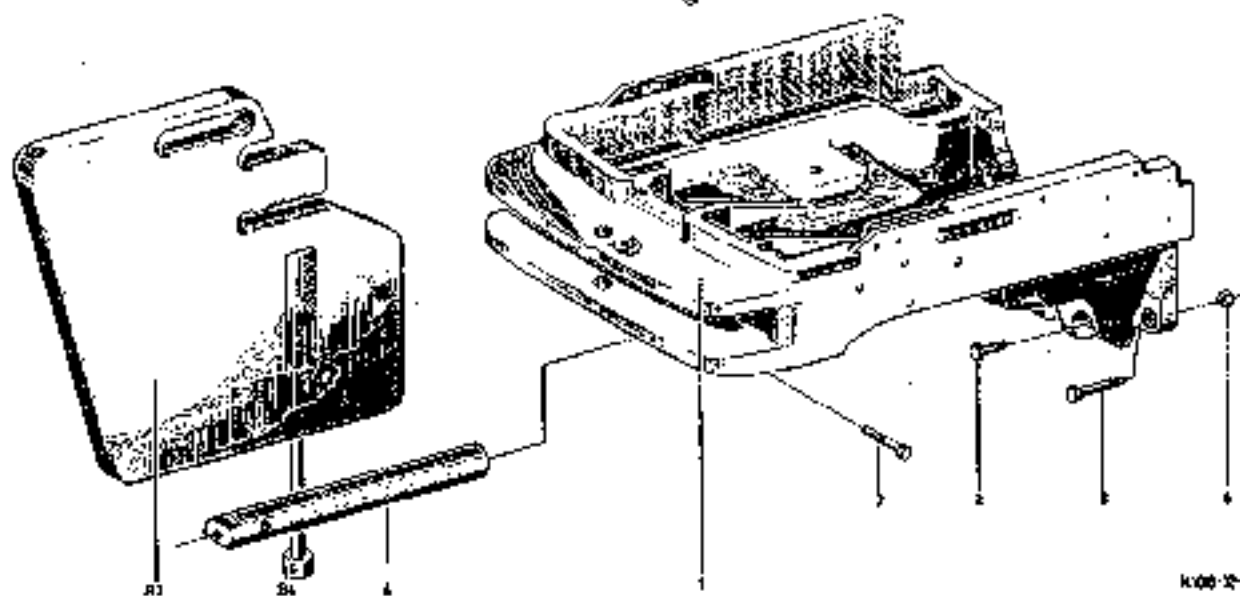
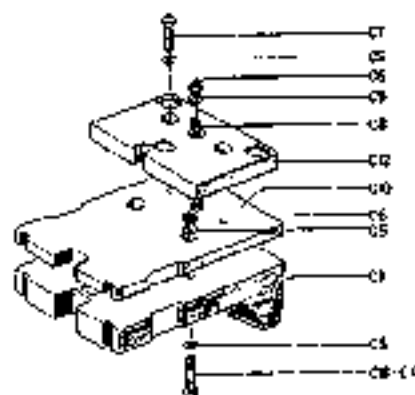
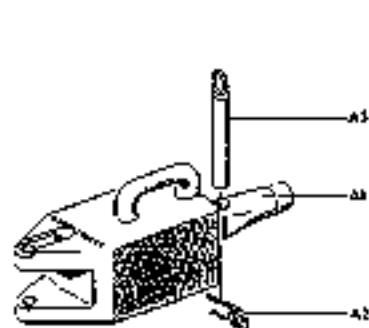

K00-2-0

Vorderachse
Front Axle
Essieu AV
Eje delantero

1033

Bild-Nr.	Schleppernummer		Fußnote	Teilnummer	Anzahl	
	ab	bis				
4		7915/651		1110-33-01.13 (338 7372)	10	
5	7915/1141	7915/1140		232 1060 233 0365	nB	1006-33
10		7915/651		Wird nicht vollst. geliefert	1	
10/2				231 3912	1	1007-33
10/2.2				1135-33-11.07 (338 8465)	2	
10/3				231 3914	1	1007-33
10/4				M 20x1,5x110 DIN 960-109 (111 4044)	4	
10/5				M 20x1,5 DIN 934-8 (111 2918)	2	
10/6 X				231 3915	1	1007-33
10/7 XX				231 3918	1	1007-33
10/8				1135-33-15.16 (338 8481)	2	
10/9				1135-33-15.14 (338 8480)	2	
10/10				1135-33-01.13 (338 8444)	2	
10/12-				A 10x8x38 DIN 6885 (110 1341)	2	
10/13				1135-33-01.23 (338 8449)	2	
10/14				M 27x1,5 DIN 934-08 (111 2953)	2	
10/15		7915/651	+	232 5818	2	
10/16				SB 8 H 3860 (116 8227)	5	
10/17				30208 (110 9968)	2	
10/18				1135-33-01.02 (338 8440)	2	
10/19				1135-33-01.03 (338 8441)	2	
10/20				1135-33-01.01 (338 8439)	2	
10/21				32206 (111 0000)	2	
10/22				1353-33-17.31 (339 1336)	2	
+ mitzuliefern bis Schlepper Nr. 7915/651 5 Radbolzen 338 8964 + 5 Kugelbundmuttern 112 1785						

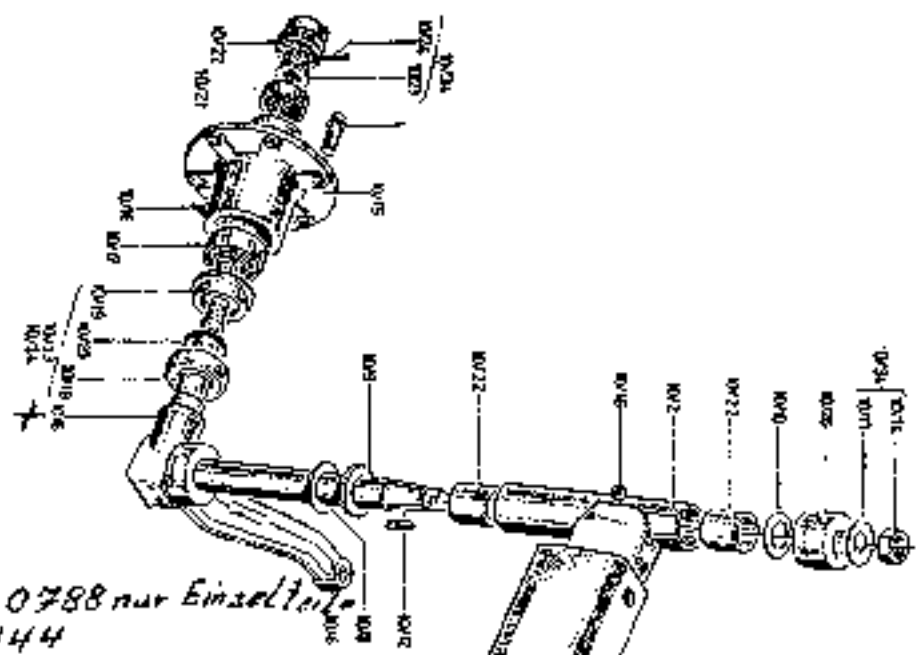

X Ersatz: 430 0788 nur Einzelteile
 1x 430 0444
 1x 430 0442
 1x 113 3798
 1x 113 6604

XX Ersatz: 430 0786 nur Einzelteile
 1x 430 0443
 1x 430 0473
 1x 113 6604

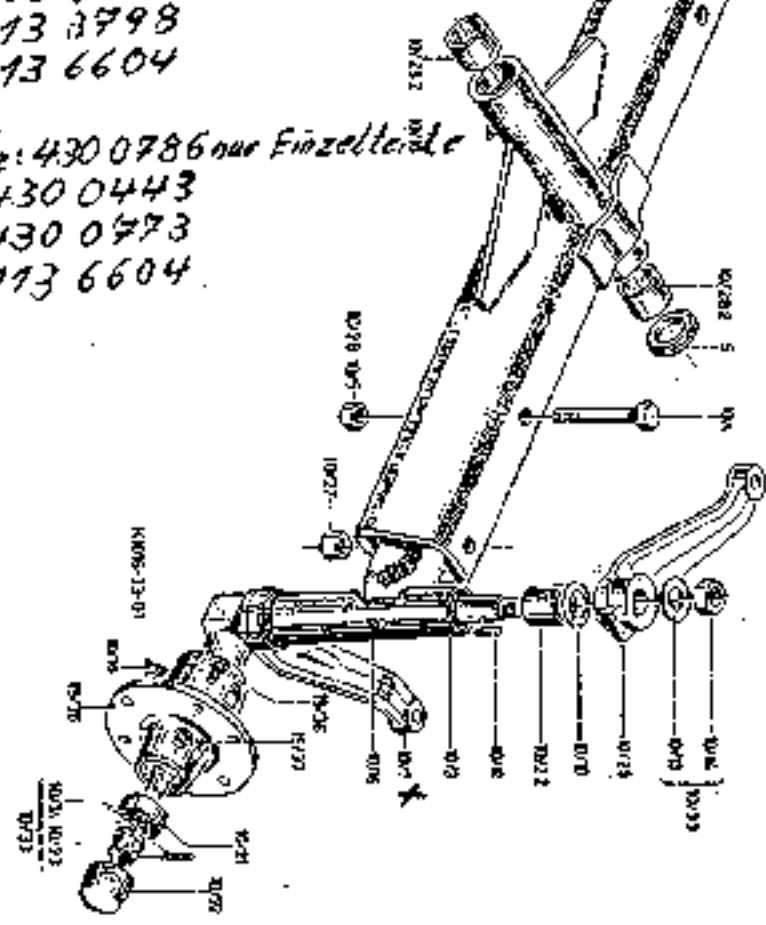



Bild-Nr.	Schleppernummer		Fußnote	Teilnummer	Anzahl	
	ab	bis				
10/23				1135-33-03.28 (338 8451)	2	
10/24				5x30 DIN 94 (110 6467)	2	
10/26				231 3921	1	1007-33
10/27				1171-33-01.05 (339 0800)	2	
10/28				231 3905	1	1007-33
10/28.2				1353-33-01.27 (339 1285)	2	
10/29				232 2847	1	1016 1007-33
10/33				231 3918	1	1007-33
10/34				231 3916	1	1007-33
15	7915/652			Wird nicht vollst. geliefert.	1	
15/35	7915/652		+1	232 5816	2	1006-33
15/36	7915/652			1055 33-08.34 (338 6964)	10	
15/37	7915/652			A 14 DIN 74361-8 A4C (110 4760)	10	

+1 Bei erstmaligem Ersatz bis Schl.-Nr. 7915/651, Bild-Nr. 15/36 u. 15/37 mit-liefern.

Mechanische Lenkung
Mechanical Steering Assembly
Mécanisme de direction mécanique (Timonerie)
Dirección mecánica

1037

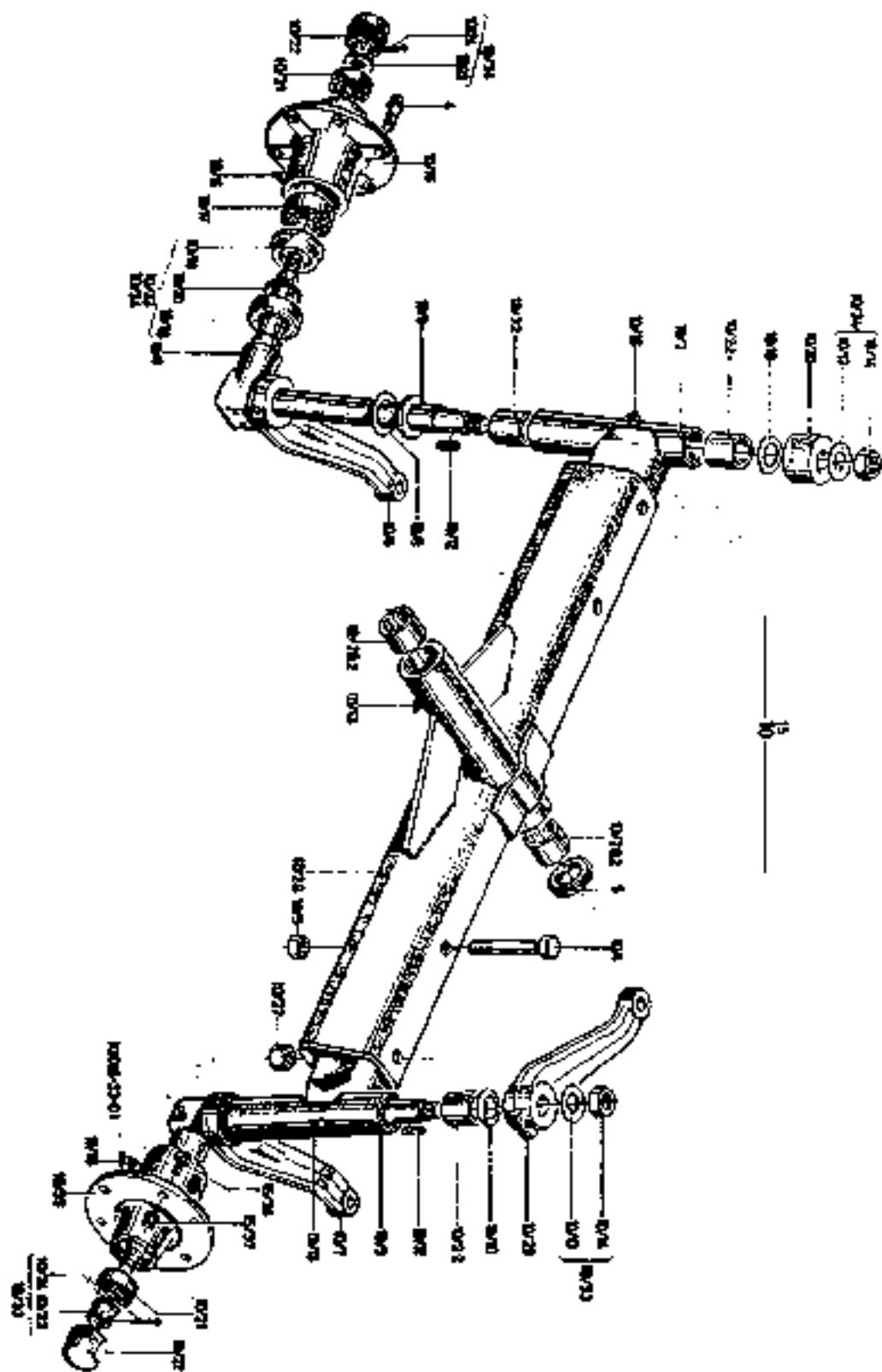
Lenkgestänge
Steering Linkage
Tringlerie de direction
Varillaje de dirección

1037/1

Hydrolenkung
Hydrosteering Assembly
Mécanisme de direction hydro-assistée (Timonerie)
Servodirección hidráulica

1037/2

Bild-Nr.	Schleppernummer		Fußnote	Teilnummer	Anzahl	
	ab	bis				
2				232 0830	1	1006-37
2/1				232 4913	1	1006-37
2/3				232 4658	1	1007-37
2/4				232 4797	1	1007-37
2/7				232 4914	1	1006-37
2/9				M 8x25 DIN 933 8.8 A4C (111 2333)	4	
2/10				⌀ 14x1,5 DIN 936-8 A4C (111 3164)	1	
2/11				232 4901	1	1006-37
2/12				M 18x1,5 DIN 936-8 phos. (111 3185)	1	
2/13				1358-37-08.15 (339 1356)	2	
2/14				232 4654	2	1007-37
2/15				232 4902	1	1006-37
2/16				D36-37-02.19 (338 8973)	1	
2/17				232 4857	1	1007-37
2/18				231 1226	nB	2,1 1145-37
				231 1227	nB	2,15 1145-37
				231 1228	nB	2,2 1145-37
				231 1229	nB	2,25 1145-37
				231 1230	nB	2,3 1145-37
				231 1231	nB	2,35 1145-37
				231 1232	nB	2,4 1145-37
				231 1233	nB	2,45 1145-37
				231 1234	nB	2,5 1145-37
2/27				M 30x1,5 DIN 936-8 (111 3213)	1	
2/28				232 4660	1	1007-37
2/29				232 4903	1	1006-37
2/30				232 4662	1	1007-37

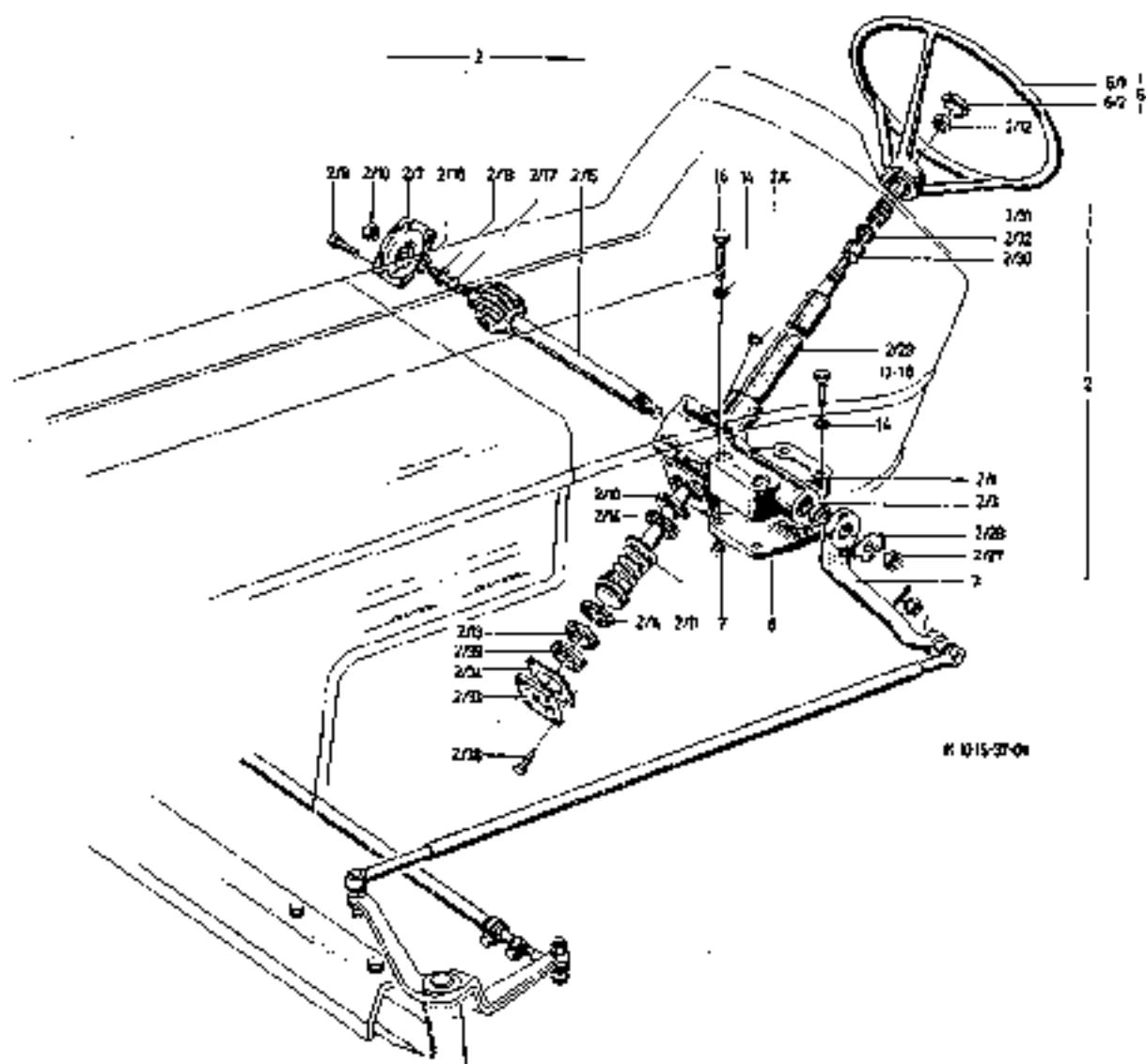



Bild-Nr.	Schleppenummer		Fußnote	Teilnummer	Anzahl	
	ab	bis				
2/31				1125-37-02.31 (338 7849)	1	
2/32				1110-37-02.14 (338 7406)	1	
2/33				232 4912	1	1007-37
2/34			+	1355-37-04.43 (339 1788)	1	0,1 mm
			+	1355-37-04.44 (339 1789)	-	0,12 mm
			+	1355-37-04.45 (339 1790)	-	0,15 mm
			+	1355-37-04.46 (339 1791)	-	0,3 mm
2/38				M 8x25 DIN 933-8.8 A4C (111 2333)	4	
2/39				232 4691	1	1007-37
3				232 0743	1	1006-37
6				232 1955	1	1003-37
6/1				232 1992	1	1003-37
6/2				338 7869	1	1125-37
7				232 0840	2	1006-37
8				232 0837	1	1006-37
14				14 H 220S vzkc (116 9696)	4	
16				M 14x85 DIN 931-8.8 A4C (112 4823)	2	
17				M 14x65 DIN 931-8.8 A4C (111 1709)	2	
18				M 14x80 DIN 931-8.8 A4C (110 1016)	2	

+ wahlweise

Bild-Nr.	Schlappennummer		Fußnote	Teilnummer	Anzahl	
	ab	bis				
1				230 7469	1	1006-37
4				1152-37-05.21 (338 9809)	1	
5			+	231 5979	1	1006-37
6				232 1855	1	1003-37
6/1				232 1992	1	1003-37
6/2				1125-37-05.05 (338 7869)	1	
9				230 1516	2	1171-37
10				1171-37-01.12 (338 0826)	1	
11		<i>hier Hydro-Denkig.</i>		232 1115	1	1016-37
12			+1	232 2881	1	1016-37
13				231 5578	1	1008-37
13/1				231 1220	1	1171-37
13/2				231 5645	1	1008-37
13/3				231 5646	1	1008-37
13/4				231 1215	1	1171-37
13/5				M 10x90 DIN 931-8.8 (111 1306)	2	
13/6				M 10 DIN 934-8 (111 2841)	3	
13/7				A 10 DIN 128 A4C (110 2800)	3	
13/8				231 5643	1	1008-37
13/9				231 1225	1	1171-37
13/10				M 10x45 DIN 931-8.8 (111 1294)	1	
13/11				231 1219	2	1171-37
13/12				M 18x1,5 DIN 937-8.8 (111 3265)	2	
13/13				4x35 DIN 94 (110 6455)	2	
14				14 H 2203 vzkc (116 9696)	4	
15				M 14x80 DIN 931-8.8 A4C (110 1016)	2	
17				M 14x65 DIN 931-8.8 A4C (111 1709)	2	
+ Lenkstockhebel Allrad			+1 Lenkstange Allrad			



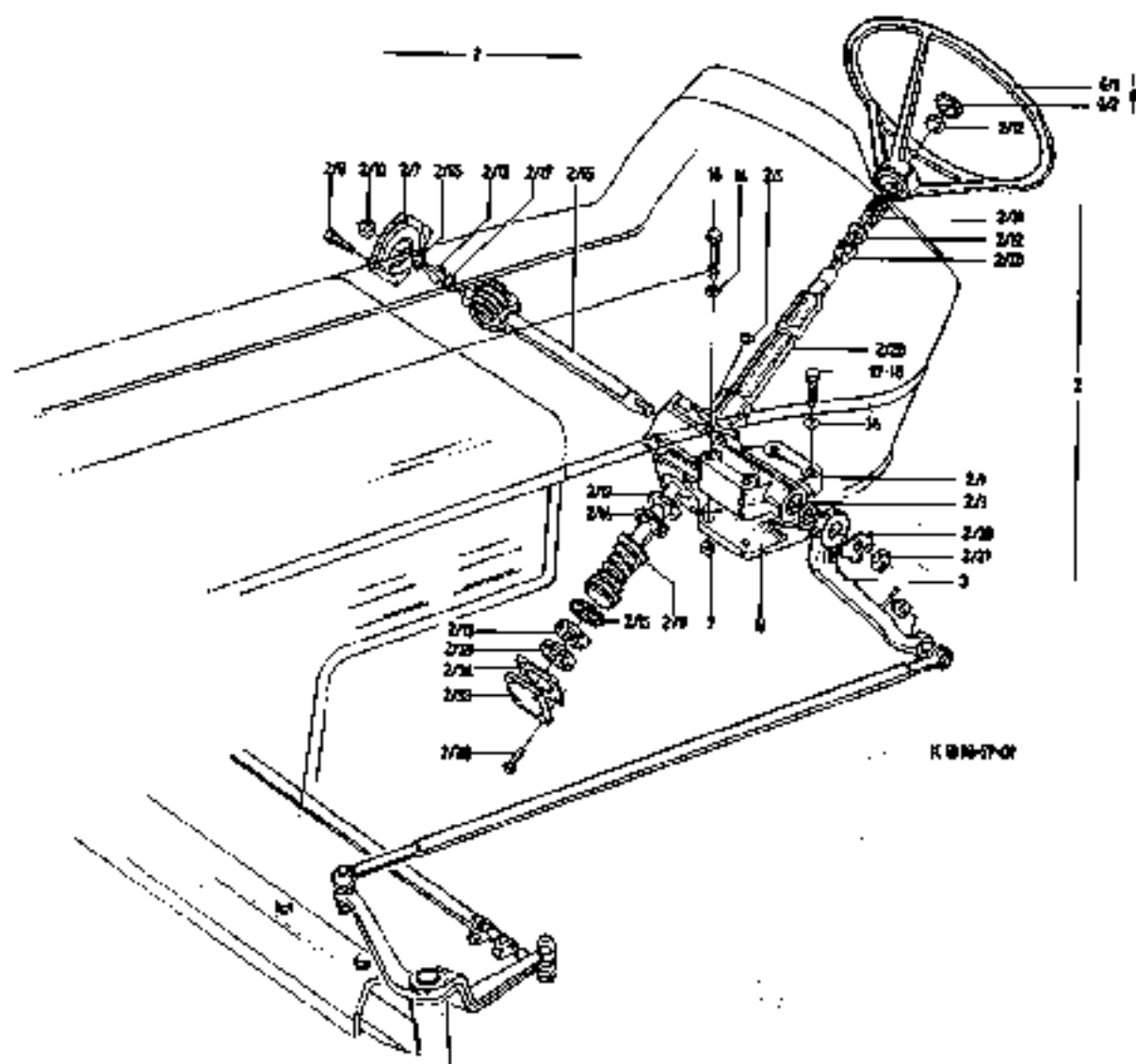
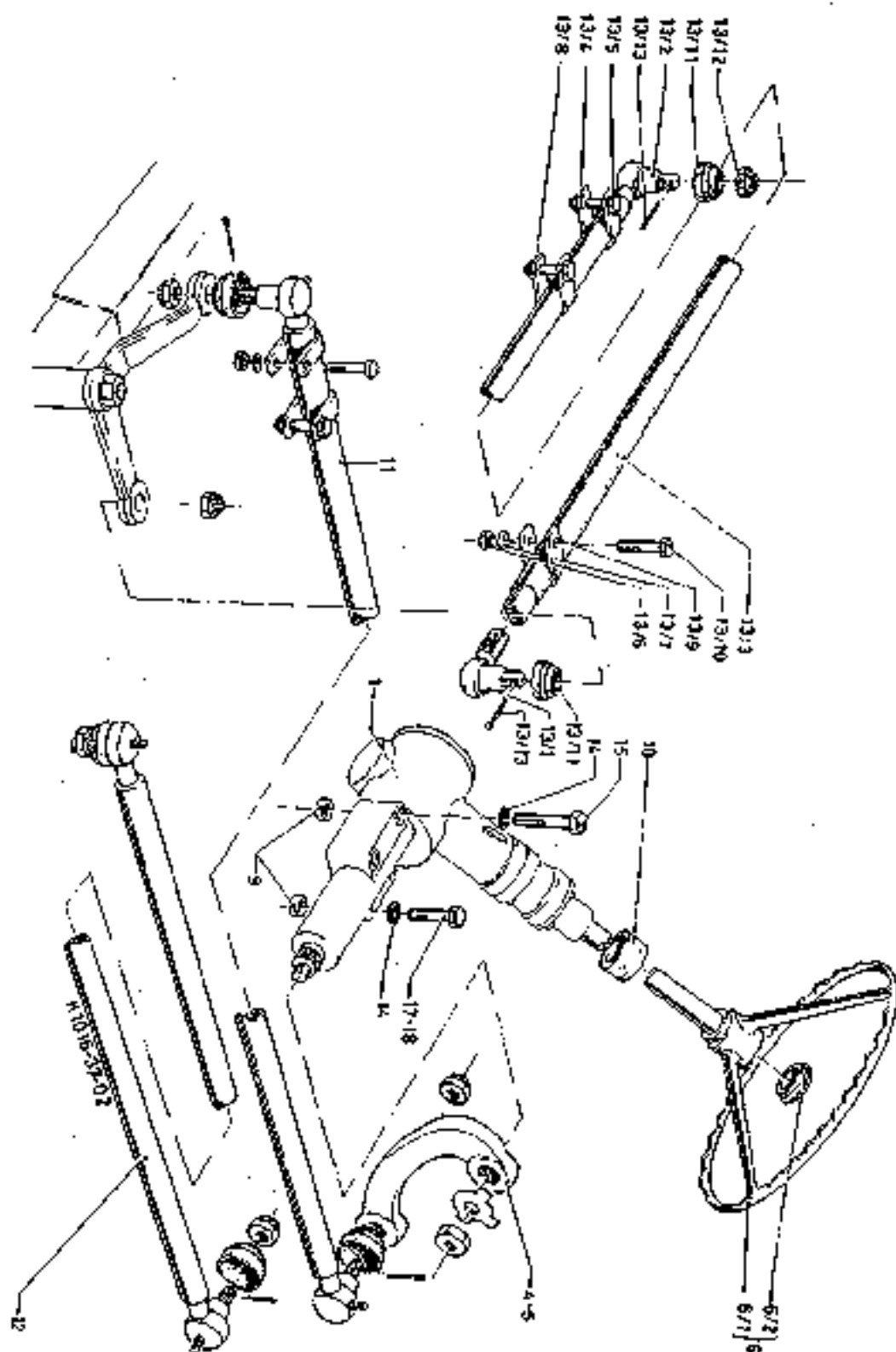

Bild-Nr.	Schleppernummer		Fußnote	Teilnummer	Anzahl	
	ab	bis				
2				230 9743	1	1145-37
2/6				1171-37-21,05 (339 0829)	1	
2/7				56x2 DIN 472 (110 7841)	1	
8				1145-37-40.08 (231 5139)	1	
9				1145-37-40.09 (231 5140)	1	
12				1145-37-40.17 (231 5142)	13	
13				M 12x1,5 DIN 910-5,8 (110 2309)	1	
14				A 12x15,5 DIN 7603 Cu (111 8673)	1	
15				1145-37-40.22 (231 5143)	1	
16				230 9776	1	1171-37
17				1145-37-40.76 (231 5144)	2	
18				1145-37-40.11 (231 5145)	2	
19				1145-37-40.12 (231 5146)	2	
20				1145-37-40.13 (231 5147)	2	
21				1145-37-40.15 (231 5148)	1	
22				M 35x1,5 DIN 938-8phosph. (111 3219)	1	
23				1145-37-40.27 (231 5149)	1	
24				230 9777	1	1171-37
25				M 8x40 DIN 912-8,8 A4C (112 3701)	6	
26				1145-37-40.29 (231 5150)	1	
27				1145-37-40.28 (231 5151)	2	
28				1145-37-40.26 (231 5152)	1	
29				1145-37-40.24 (231 5153)	1	
30				1145-37-40.25 (231 5154)	1	
31				1145-37-40.23 (231 5155)	4	
33				231 1251	1	1008-37
33/3				231 1253	1	1008-37



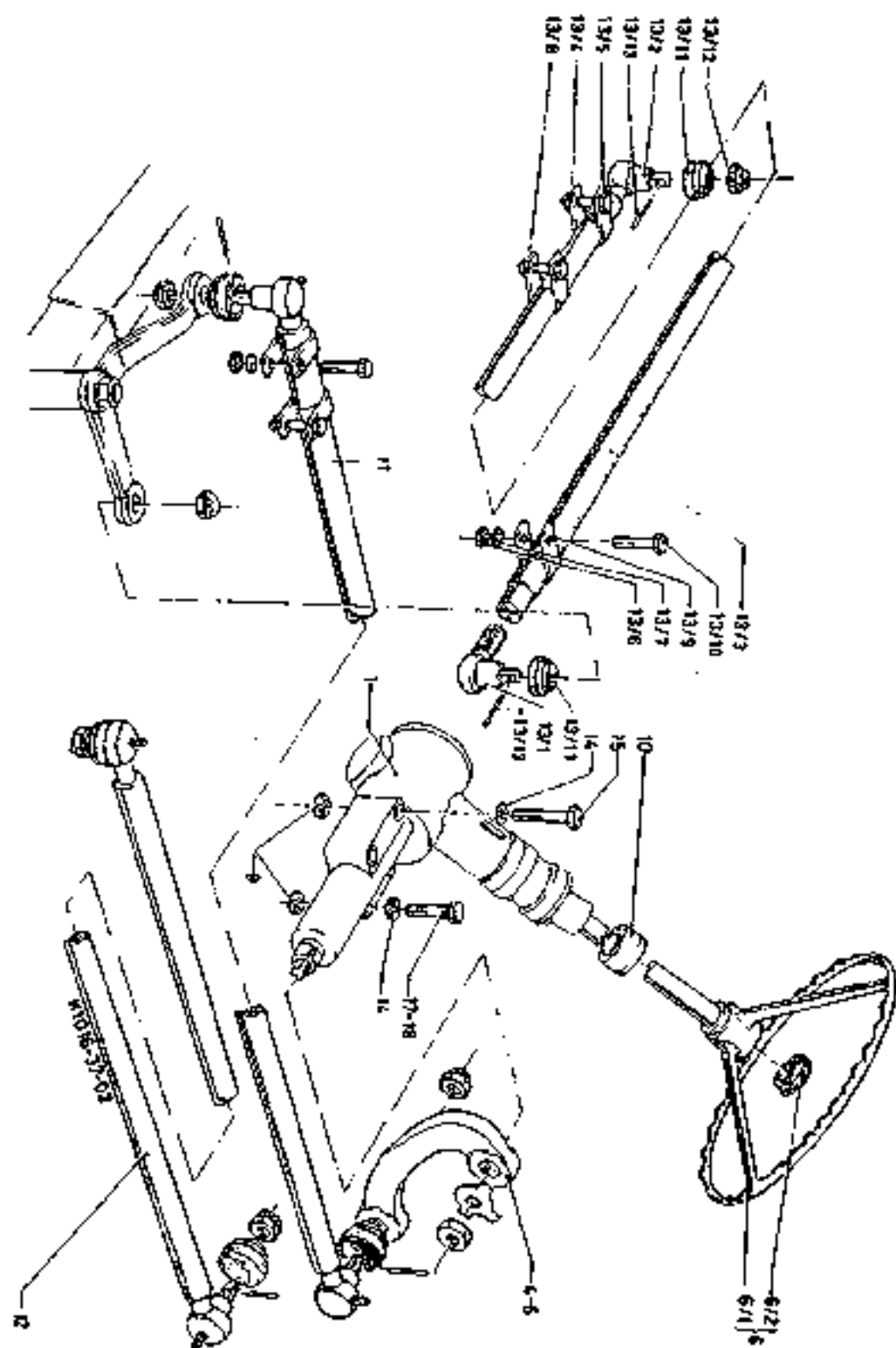
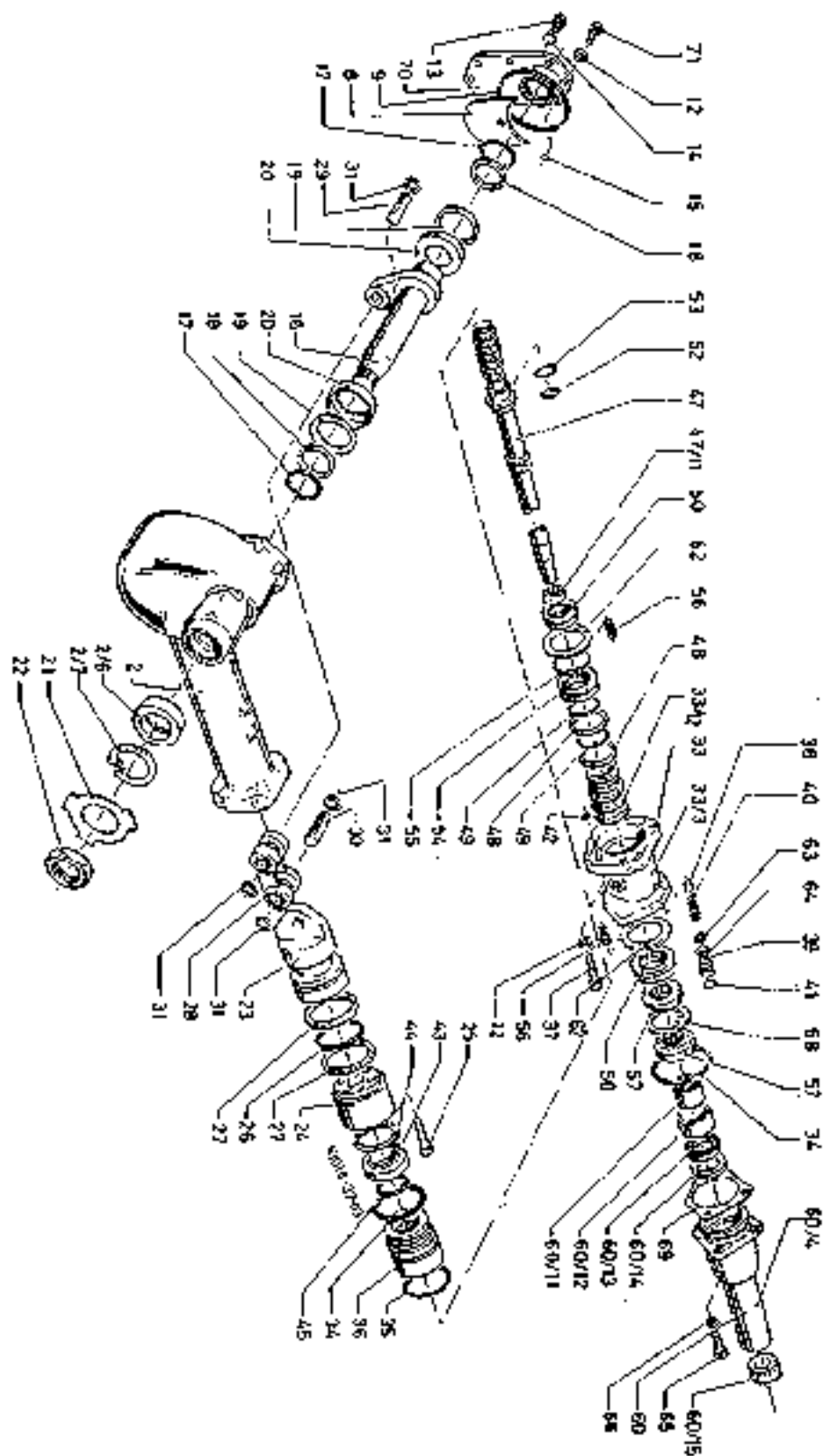

Bild-Nr.	Schlappernummer		Fußnote	Teilnummer	Anzahl	
	ab	bis				
33/12				1145-37-40.46 (231 5156)	1	
34				1145-37-40.66 (231 5157)	2	
35				230 9779	1	1171-37
36				1145-37-40.65 (231 5168)	1	
37				M 10x55 DIN 912-10,9 (112 2362)	4	
38				1145-37-40.82 (231 5159)	1	
39				1145-37-40.64 (231 5160)	1	
40				1145-37-40.63 (231 5161)	1	
41				1145-37-40.57 (231 5162)	1	
42				1145-37-40.65 (231 5163)	4	
43				230 9780	1	1171-37
44				40x1,75 DIN 472 (110 7827)	1	
45				230 9781)	1	1171-37
47				231 1252	1	1008-37
47/11				M 18x1,5 DIN936-8phosph. (111 3185)	1	
48				1145-37-40.42 (231 5164)	2	
49				1145-37-40.41 (231 5165)	2	
50				51106 (110 9688)	2	
52				230 9783	1	1171-37
53				230 9784	1	1171-37
54				230 9785	1	1171-37
55				230 9786	1	1171-37
56				231 4603	20	1171-37
57				1145-37-40.48 (231 5168)	2	
58				25 DIN 462 (112 4659)	1	
60				231 1272	1	1008-37

Bild-Nr.	Schleppenummer		Fußnote	Teilnummer	Anzahl	
	ab	bis				
60/4				Wir liefern n. Bild-Nr. 60	1	
60/11				1145-37-40.67 (231 5169)	1	
60/12				1145-37-40.68 (231 5170)	1	
60/13				1145-37-40.69 (233 4614)	1	
60/14				1145-37-40.71 (231 5172)	1	
60/15				1145-37-40.75 (231 5173)	1	
62				231 1282	2	1008-37
63				231 1284	1	1008-37
64				1145-37-43.10 (231 5175)	Satz	
65			M	6x25 DIN 912-8.8 (111 0576)	4	
66				1145-37-40.73 (231 5174)	4	
69				1145-37-42.10 (231 5176)	Satz	
70				230 9746	1	1171-37
71			M	10x30 DIN 931-10.9 (111 1265)	9	

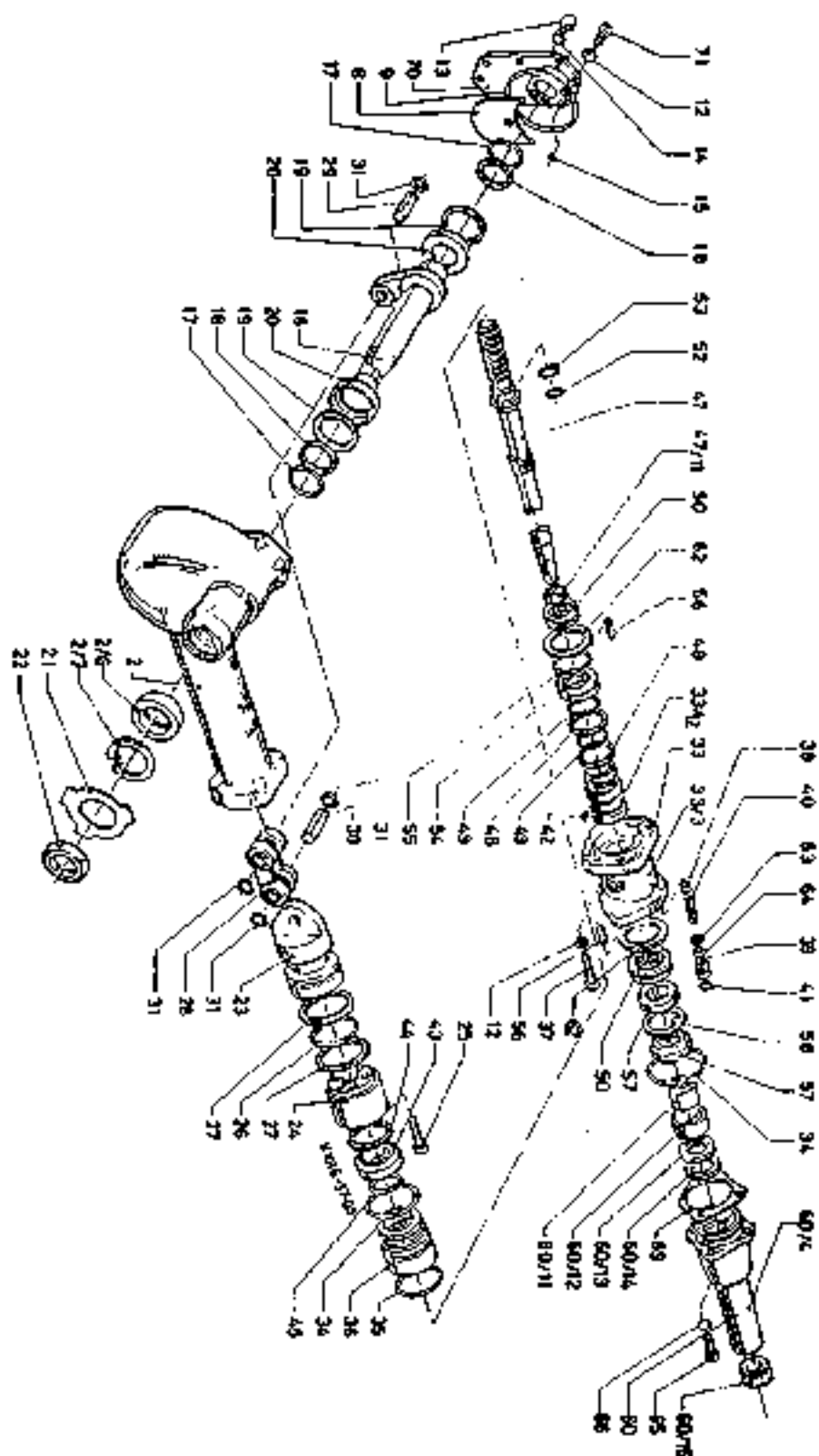
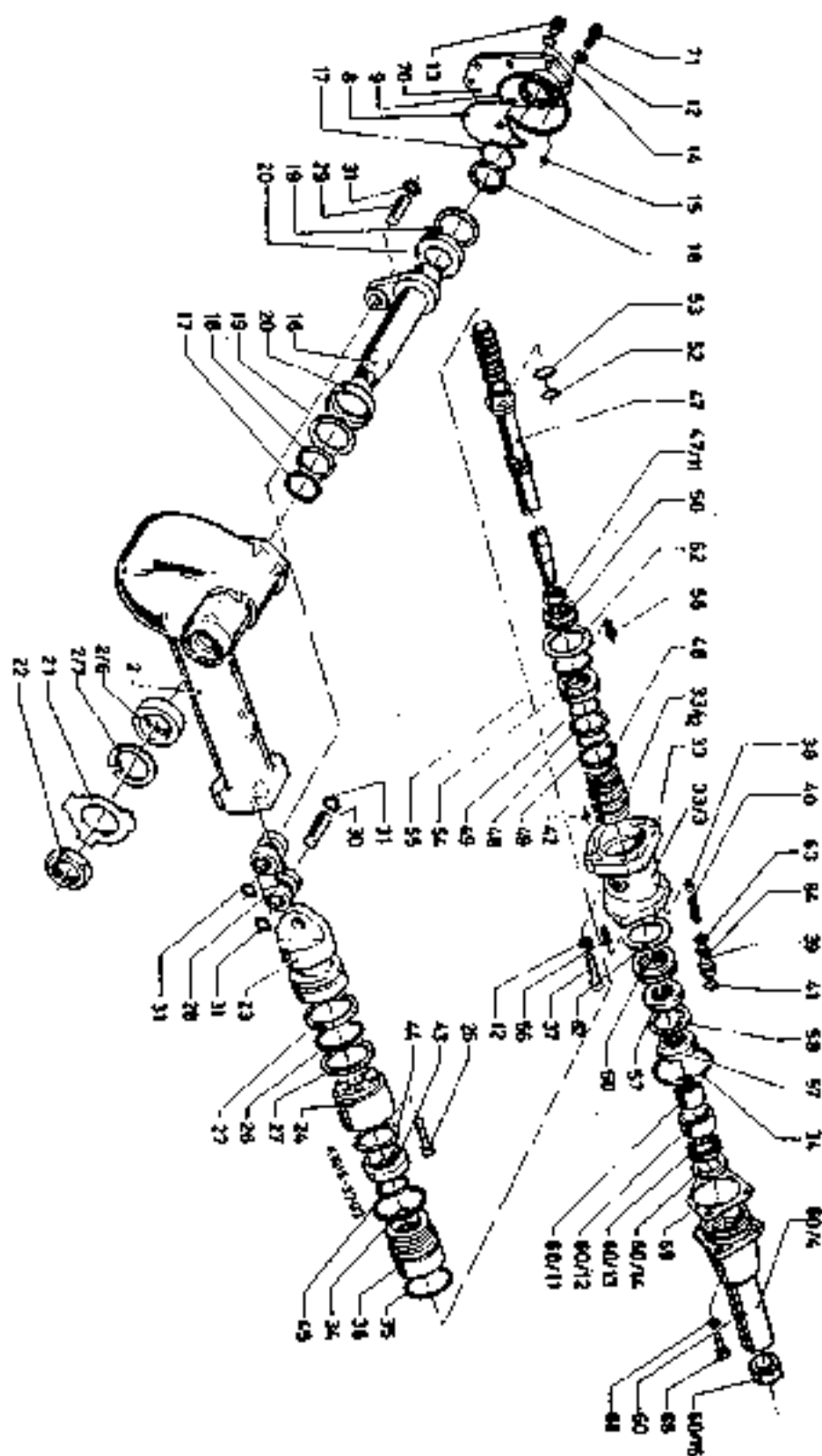

Motorhaube und Trennwand
Engine Hood and Bulkhead
Capot-moteur, écran vertical
Capot y tabique de separación

1041

Bild-Nr.	Schleppernummer ab bis	Fußnote	Teilnummer	Anzahl	
1		+	232 2820	1	1016-41
2		+1	232 2821	1	1016-41
3		+2	232 2822	1	1016-41
4		+3	232 2823	1	1016-41
5		+4	233 4549	1	rechts 1001-41
6		+4	233 4548	1	links 1001-41
7		+5	233 4546	1	vorne 1001-41
8			231 1552	2	1001-41
9			231 5723	2	1001-41
10			6,4 DIN 933 A4C (112 4654)	4	
11			232 2849	1	1016-41
11/1			230 4654	1	1006-41
11/2			230 4661	1	links 1006-41
11/3			230 4662	1	rechts 1006-41
11/4			230 4658	4	1006-41
11/5			230 4651	2	1006-41
11/6			230 4707	1	links 1006-41
11/7			M 8x20 DIN 933-8.8 A4C (111 2317)	2	
11/8			M 8 DIN 934-8 A4C (111 2624)	3	
11/9			6 H 2203 A4C (116 9689)	7	
11/10			M 6x12 DIN 933-8.8 A4C (111 2243)	2	
11/11			M 6 DIN 934-8 A4C (111 2813)	2	
11/12			6 H 2203 vzkc (116 7194)	2	
11/13			8 F 8x40x36,5 DIN 1434vzkc (110 2846)	1	

- + Motorhaube f. Scheinwerfer und Auspuffaul. normal
 +1 Motorhaube f. Scheinwerfer und Auspuffaul.oben
 +2 Motorhaube o. Scheinwerfer und Auspuffaul. normal
 +3 Motorhaube o. Scheinwerfer und Auspuffaul. n. oben
 +4 Bei erstm.Ersatz Schutzgitter links TN 233 4549 oder Schutzgitter re. TN 233 4548
 u.Schutzgitter vorn TN 233 4546 mitliefern.
 +5 Bei erstm.Ersatz Schutzgitter re. TN 233 4548 u.Schutzgitter li. TN 233 4549
 mitliefern.

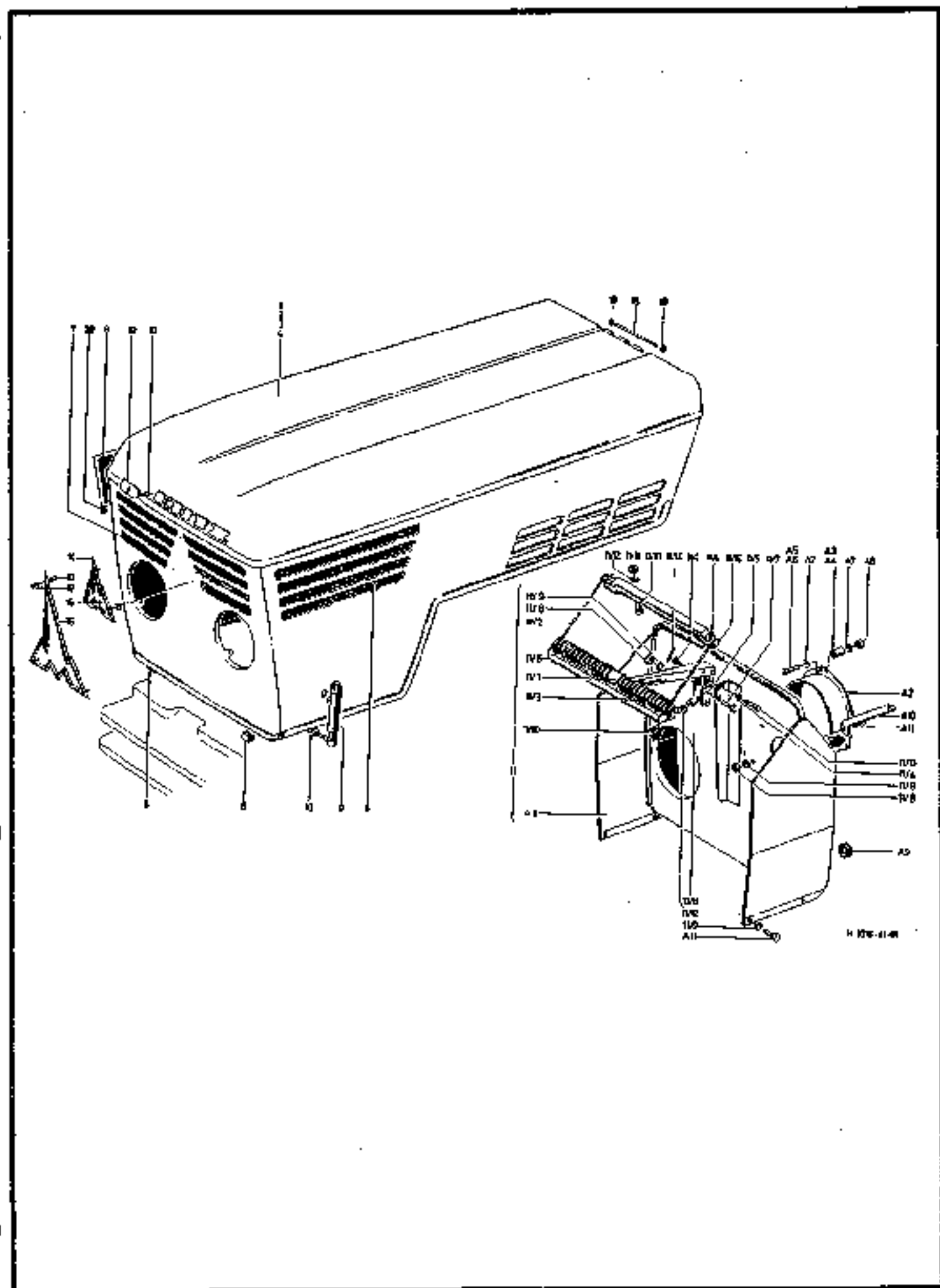



Bild-Nr.	Schleppernummer		Fußnote	Teilnummer	Anzahl	
	ob	bis				
11/14				2x14 DIN 94 vzkc (112 3618)	1	
11/15				230 4698	1	1006-41
12				4303 A 182 (121 0675)	1	
13				7553 A 1 (121 0674)	10	
14				4 315 A (121 8017)	1	
15				A 2,5 H 2219 (116 7204)	3	
16			+	4 315 A 4 (121 1099)	1	
17			+	2 401 A 1 (121 1100)	4	
18				230 4203	1	1001-41
19				2 217 B 6 (121 0790)	2	
20				230 4393	10	1001-41
A 1				232 5684	1	1016-38
A 2				230 4564	1	1006-38
A 3				231 6048	2	1006-38
A 4				231 9551	1	1006-38
A 5				AM 5x25 DIN 84-4,8 A4C (110 5593)	2	
A 6				AM 5x30 DIN 84-4,8 A4C (112 3582)	1	
A 7				5,3 DIN 125 vzkc (110 7089)	6	
A 8				M 5 DIN 934-8 A4C (111 2803)	3	
A 9				D 17x24x2 H 2928 (116 7427)	1	
A10				230 4514	1	1002-38
A11				M 8x15 DIN 933-8,8 A4C (111 2305)	5	

+ Bei Motorhaube ohne Scheinwerfer

Kraftstoffbehälter und Tankanzeige bis Schl.Nr.7915/760
Fuel Tank with Level Gauge Allrad 7916/115
Réservoir avec indicateur de niveau de niveau de fuel
Tanque de combustible e indicador de nivel de combustible

1042

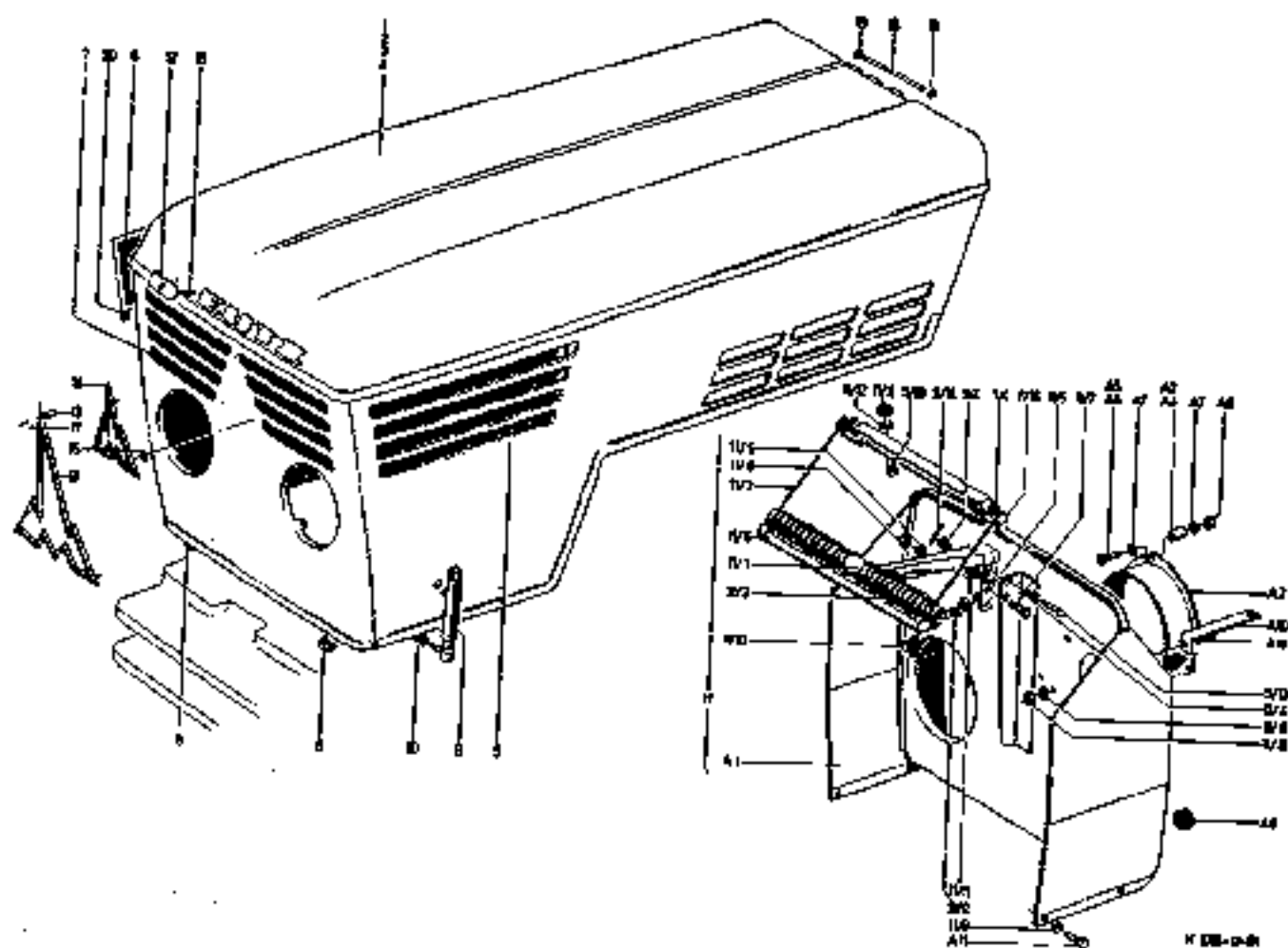
Kraftstoffbehälter
Fuel Tank
Réservoir a combustible
Tanque de combustible

ab Schl.Nr.7915/761
Allrad 7916/116

1042h

Bild-Nr.	Schleppernummer		Fußnote	Teilnummer	Anzahl	
	ab	bis				
1				231 9711	1	1006-42
2				1135-42-08.10 (338 8395)	1	
3				A 8 DIN 7623 vzko (111 9246)	2	
4				A 14x18 DIN 7603 Cu (111 8936)	4	
5				231 1826	1	1006-42
6				1,5x2x9x17 h 7590 SG 6 (116 2740)	2	
7				231 1411	1	1001-42
8				230 6374	1	1006-42
9				M 10 DIN 934-8 A4C (110 2659)	1	
10				1116-42-08.10 (338 7433)	1	
12				231 3744	1	1003-42
13				1452-42-03.20 (123 0003)	1	
13/2				1452-42-03.02 (123 0004)	1	
14				A 12x15,5 DIN 7603 Cu (111 8573)	2	
A 1				230 8166	1	1006-69
A 2				Wir liefern u. Bild-Nr. A1		
A 3				1152-69-01.02 (347 1085)	1	
A 4				B 60x12 VFH 4234 (116 0348)	1	
A 5				M 12 V 2 W DIN 72601 (112 1418)	1	
A 6				1152-69-21.10 (347 1086)	1	
A 7				1152-69-22.10 (347 1087)	1	
A 8				1 RC 6 H 7602 (116 9070)	1	
A 9				wird vollst. nicht gelief.		
A 10				1152-69-01.08 (347 5079)	1	

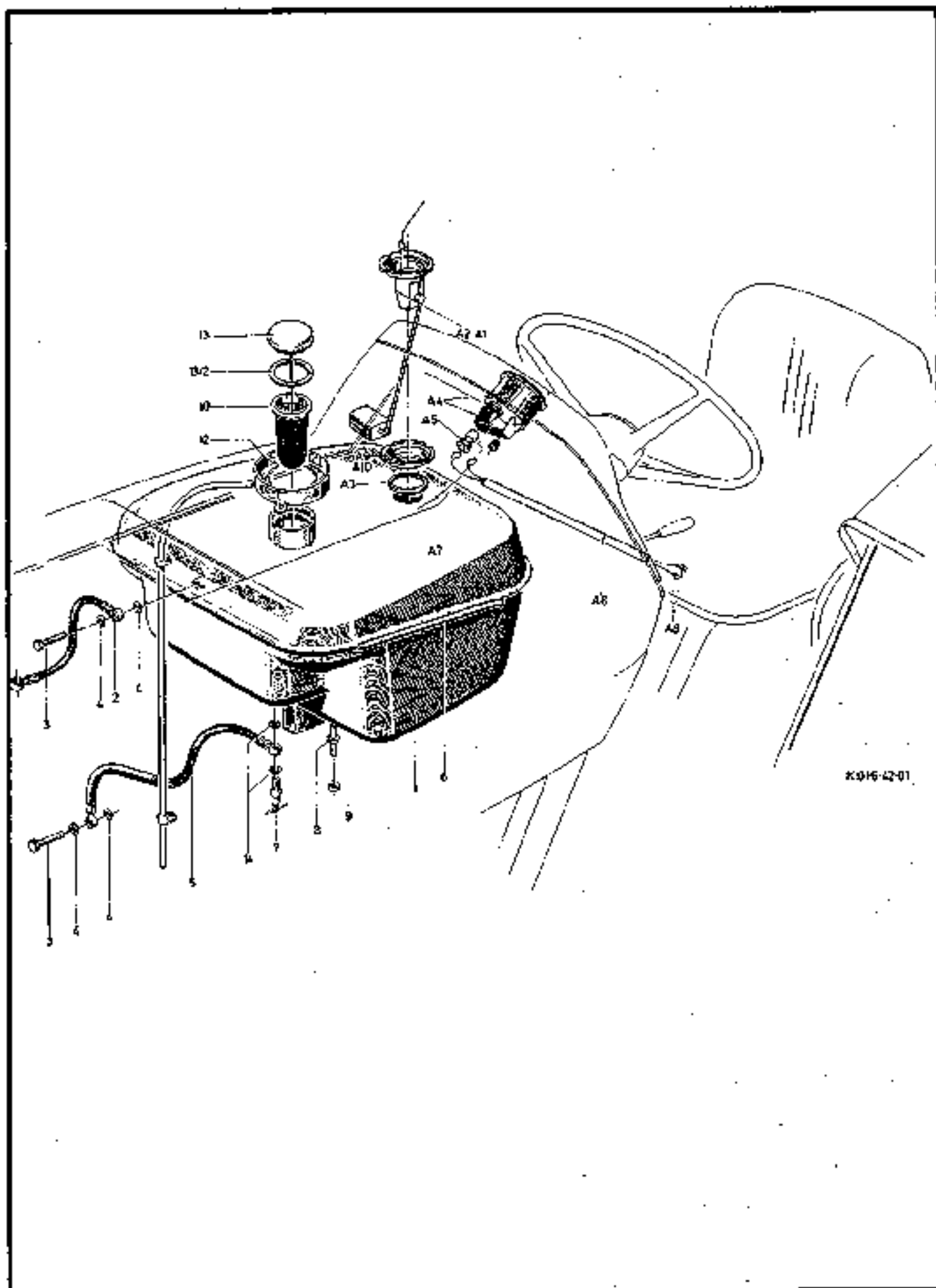

K916-42-01

Bild-Nr.	Schlappernummer		Fußnote	Teilnummer	Anzahl	
	ab	bis				
1				233 2570	1	1006-42
2				1135-42-08.10 (338 8595)	1	
3				A 8 DIN 7823 A4C (111 9246)	2	
4				A 14x18 DIN 7603 Cu (111 8936)	4	
5				231 1696	1	1006-42
6				V 1,5x8x9x470 H7560-SGE (116 2740)	2	
7				231 1411	1	1001-42
8				M. 10x60 DIN 931-8.8-A4C (111 1319)	1	
9				233 2576	1	1006-42
11				233 2555	1	1006-42
12				231 5744	1	1003-42
13				1452-42-03.20 (123 0003)	1	
14				A 12x15,5 DIN 7603-cu (111 8673)	2	
15				231 0888	1	1001-42
16				233 2575	1	1006-42
17				230 8167	1	1006-69
18				1152-69-01.02 (347 1065)	1	
19				1152-69-01.08 (347 5079)	1	
20				1152-69-01.02 (347 1065)	1	
22				230 8168	1	1006-69

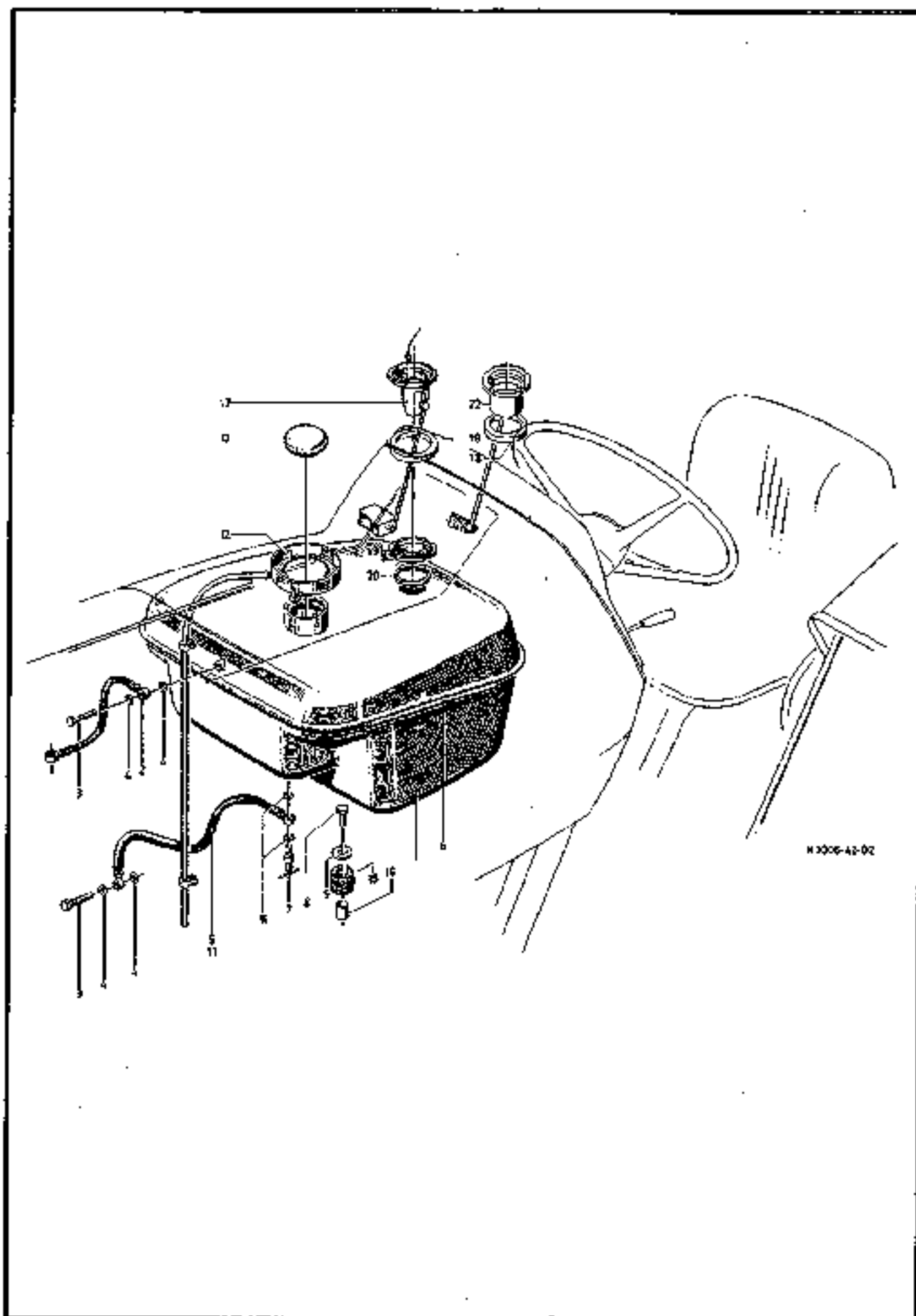

Deutz-Siccopur-Filter

Deutz Siccopur Air Cleaner

Epurateur type sec Deutz-Siccopur

Filtro en seco Deutz-Siccopur

bis Schl.Nr.7915/970 u. 7916/156 **1043**
Allrad

Deutz-Siccopur-Filter ,Ansaugung von oben

Deutz Siccopur Air Cleaner; Intake from above

Epurateur type sec, Deutz-Siccopur pipe d'adspiration vers le haut

Filtro de aire en seco, Deutz-Siccopur, aspiración desde arriba

1043/1

Deutz-Siccopur-Filter

Deutz-Siccopur Air Cleaner

Epurateur type sec Deutz-Siccopur

Filtro en seco Deutz-Siccopur

ab Schl.Nr.7915/971 u.7916/157 **1043/2**
Allrad

Bild-Nr.	Schleppnummer ab bis	Fußnote	Teilnummer	Anzahl	
1		+	231 5824	1	1006-43
2			231 1665	1	1145-43
3			231 5897	1	1001-43
4			231 3728	1	1001-43
4/1			231 5965	1	1001-43
4/2			231 5967	1	1001-43
4/3			231 5968	1	1001-43
5			231 5911	1	1001-43
6			M 8x25 DIN 912-6,9 A4C (111 0575)	1	
7			M 8 DIN 557 (110 8079)	1	
8			8 H 2203 verk (116 9689)	4	
10			M 8 DIN 934-8 A4C (111 2824)	4	
11			S 78x15 H 735 (116 8415)	1	
12			S 80x15 H 735 (116 8417)	1	
13			70x55 DIN 73411 (112 1627)	1	
21			231 5914	1	1001-43
22			231 5912	1	1001-43
25			M 5x12 DIN 933-6,8 A4C (111 2201)	1	
26			231 9511	1	1003-43
+ Filter vollst.					

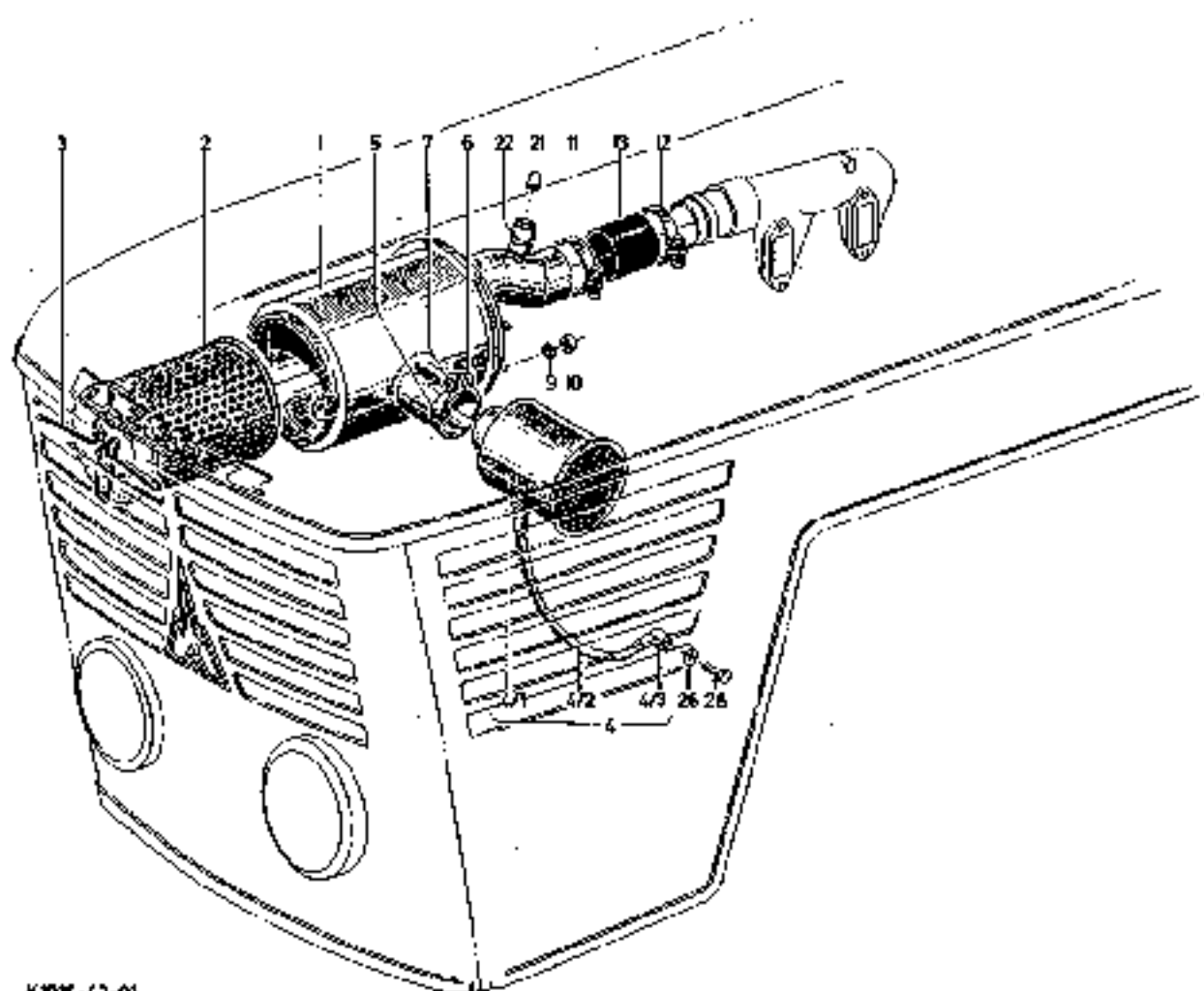

K3016-43-01

Bild-Nr.	Schleppenummer		Fußnote	Teilnummer	Anzahl	
	ab	bis				
1				231 5988	1	1006-43
2				231 1565	1	1145-43
3				231 5897	1	1001-43
5				8 H 2203 vzkc (116 9689)	4	
6				M 8 DIN 934-8 A4C (111 2824)	4	
7				S 78x15 H 735 (116 6416)	1	
8				S 80x15 H 735 (116 6417)	1	
9				70x55 DIN 73411 (112 1627)	1	
12				231 5914	1	1001-43
13				231 5912	1	1001-43
16				231 9532	1	1003-43
16/4				231 9528	1	1003-43
16/5				M 8x15 DIN 916-G 40 (110 7377)	1	
17				231 5451	1	1008-43



Bild-Nr.	Schleppenummer		Fußnote	Teilnummer	Anzahl	
	ab	bis				
			+	232 5740	1	1006-43
1				232 5637	1	1006-43
3				231 1585	1	1145-43
4				231 5897	1	1001-43
5				232 2921	3	1008-43
6				M 8x15 DIN 933-8,8 A4C (111 2303)	3	
8				8 H 2209 A4C (116 9889)	3	
9				M 8 DIN 934-8 A4C (111 2824)	3	
10				70x55 DIN 73411 (113 1627)	1	
11				S 80x16 H 735 (116 6417)	2	
12				231 5914	1	1001-43
13				232 5736	1	1001-43
14				231 5967	1	1001-43
15				231 5968	1	1001-43
18				5x12 DIN 933-8,8 A4C (111 2201)	1	
17				231 9611	1	1003-43
				4508 A 838 (121 1590)	1	Bedie- nungsch.
+ Filter vollst.						



Auspuffanlage
Exhaust System
Echappement
Sistema de escape

1044

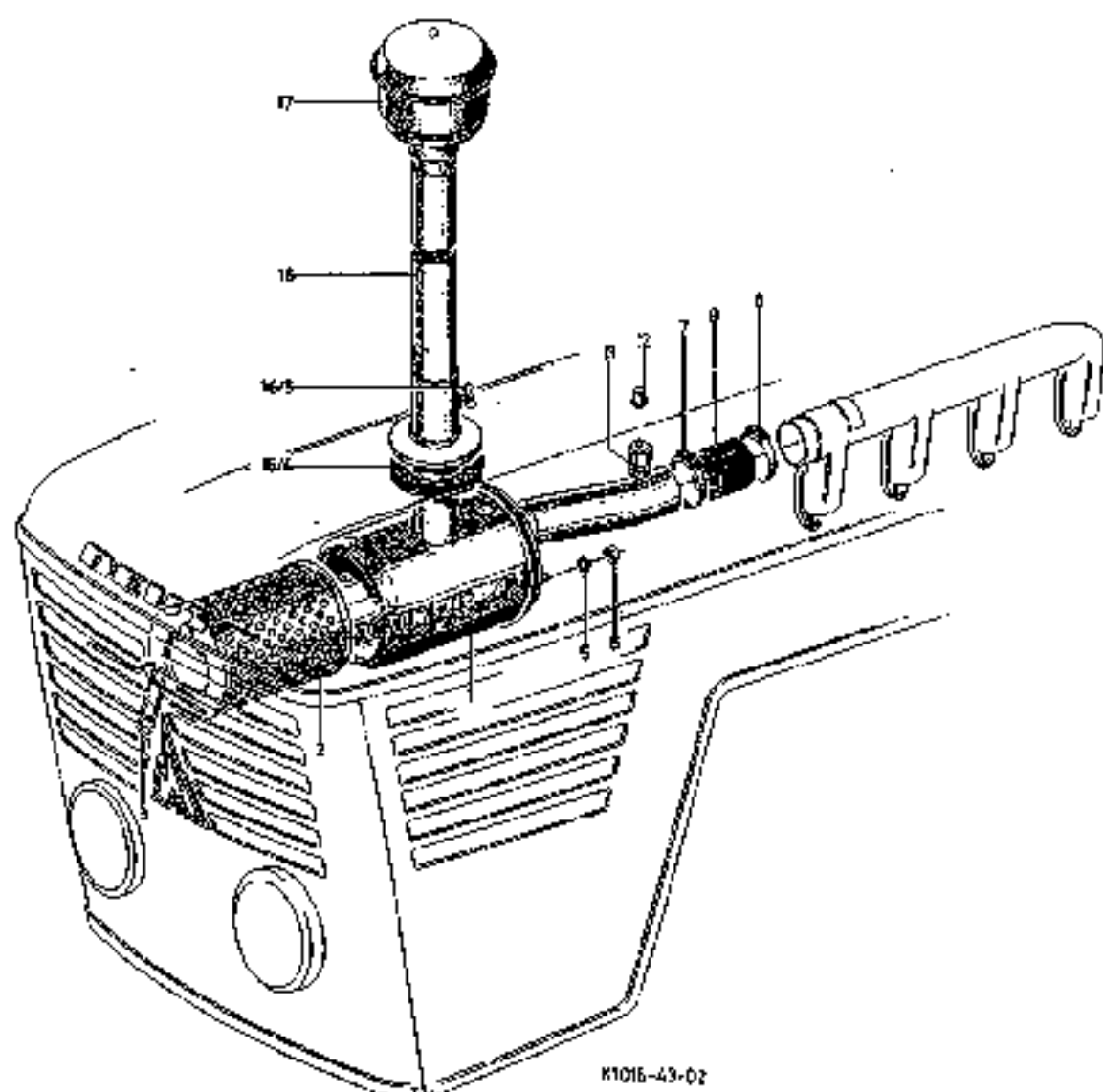
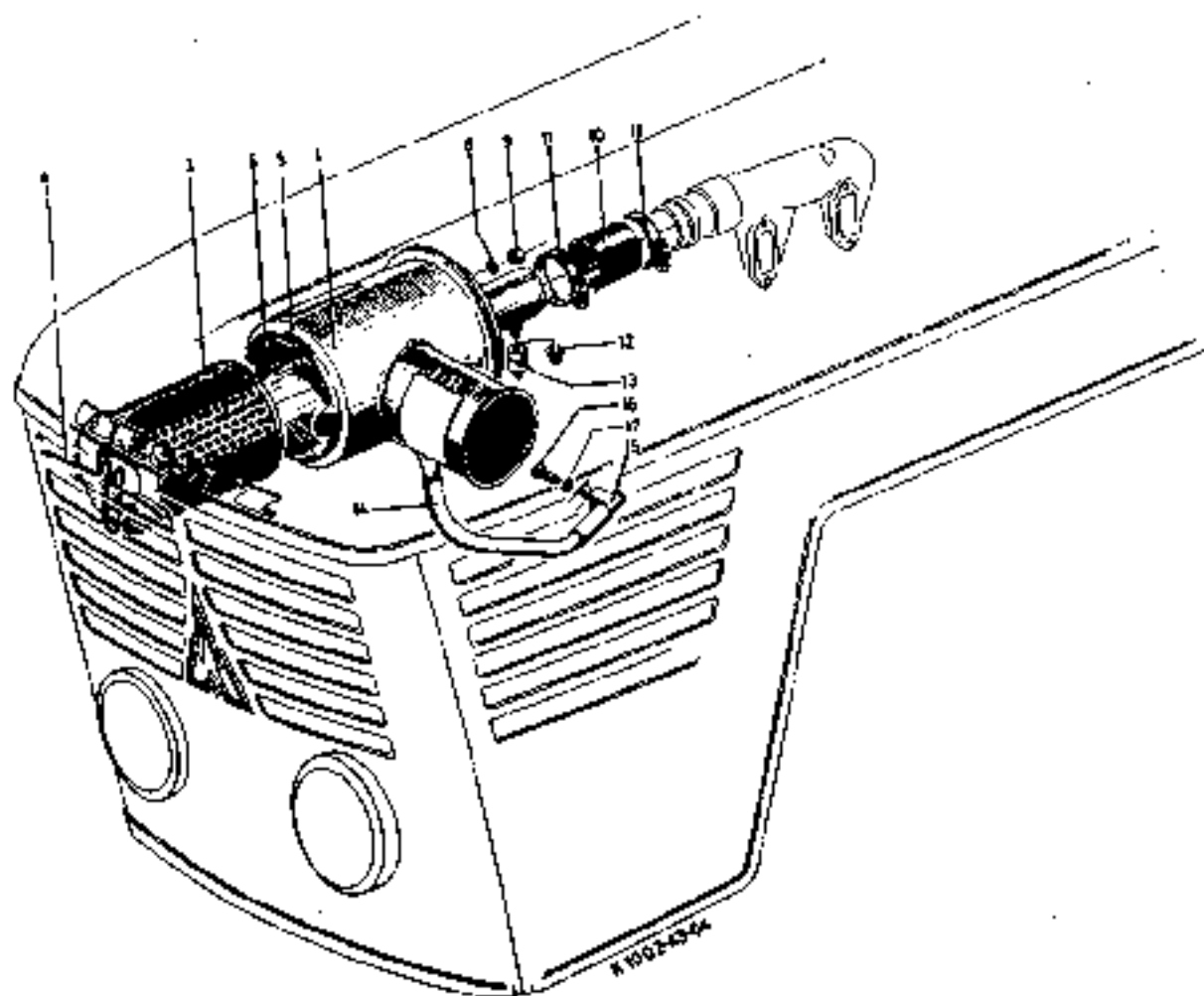
Bild-Nr.	Schleppernummer ab bis	Fußnote	Teilnummer	Anzahl	
1			232 0755	1	1006-44
2			232 0762	1	1001-44
3			232 0754	1	Hinten 1006-44
4			1136-44-05,04 (338 9040)	1	
5			1136-44-05,05 (338 9041)	1	
6			M 8x25 DIN 933-8,8 A4C (111 2333)	3	
7			M 8 DIN 934-8 A4C (111 2824)	3	
8			8 H 2203 vzkc (116 9689)	4	
9			M 6x15 DIN 933-8,8 A4C (111 2306)	1	
10			1136-44-05,13 (338 9042)	1	
11			M 6x20 DIN 933-8,8 A4C (111 2864)	2	
12			M 6 DIN 934-8 A4C (111 2813)	2	
13			8 H 2203 vzkc (116 7194)	2	
A 2			231 1052	1	1006-44
A 3			231 3911	1	1001-44
A 4			231 2681	1	1003-44
A 5			0150-41-408,09 (336 3929)	1	
A 6			236245 D (331 6466)	4	81
A 7			A 8 DIN 128 A4C (110 2799)	4	
A 8			M 8x30 SN4 DIN 833-8QA4C (112 6128)	4	
A 9			216 3249	1	0199-41

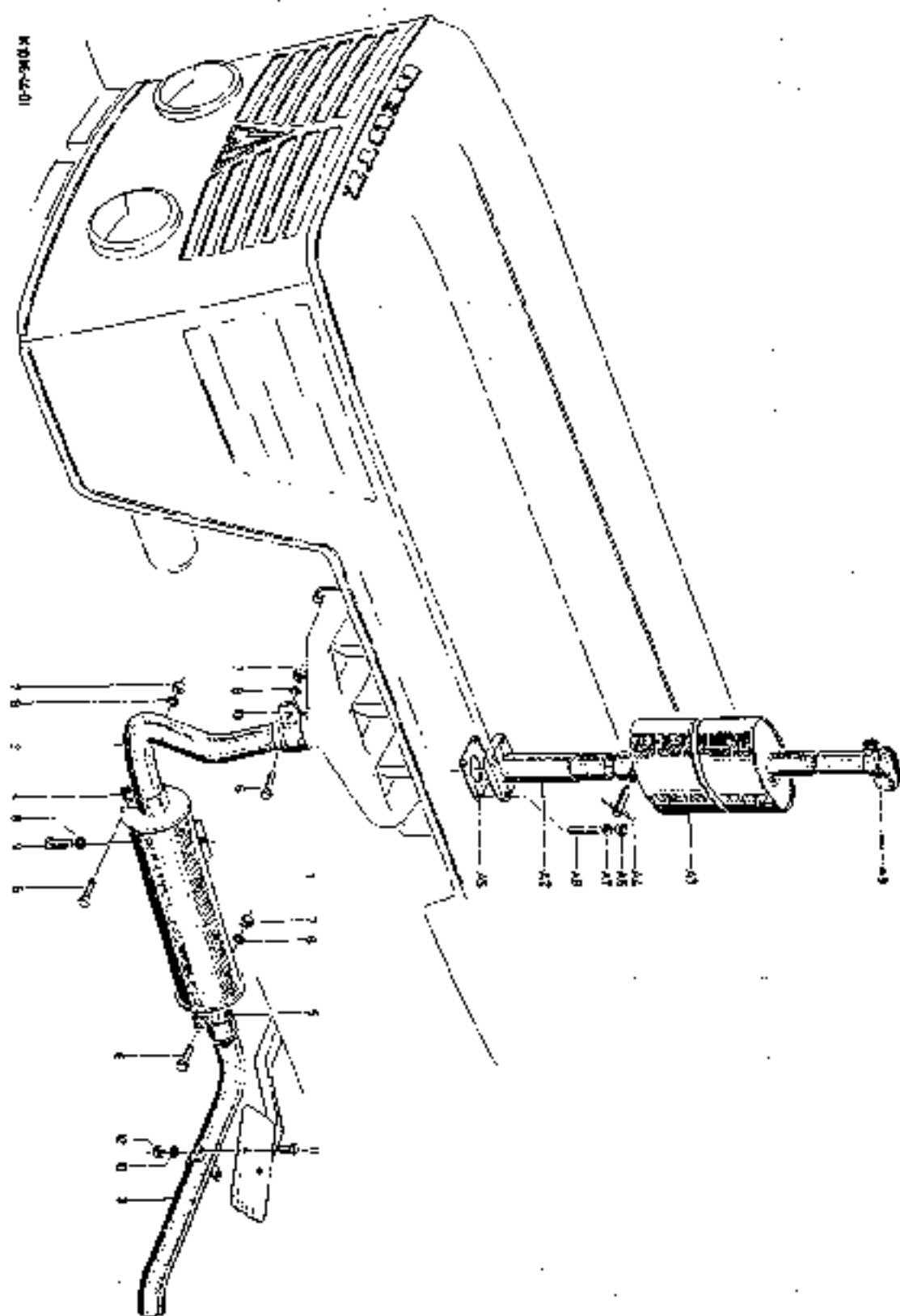

Drehzahlverstellung
Speed Control Device
Dispositif de variation de regime
Sistema de aceleracion

1046

Bild-Nr.	Schleppnummer		Fußnote	Teilnummer	Anzahl	
	ab	bis				
1				231 9538	1	1001-46
2				230 7089	1	1008-46
3				232 0885	1	1008-46
4				232 0889	1	1006-46
5				1136-46-01,18 (338 9059)	2	
6			+	231 5723	1	1008-46
7				231 5716	1	1006-46
8			+1	230 7473	1	1006-46
9				231 5720	1	1006-46
10				10x1 DIN 471 A4C (110 7717)	1	
11				1136-46-01,16 (233 2504)	1	
12				M 6 DIN 934-8 A4C (111 2813)	4	
13				BM 8x30 DIN 7985-4.8 A4C (110 2020)	2	
14				2x12 DIN 94 v2Kc (110 6404)	6	
15				6,4 DIN 125 A4C (110 7095)	6	
16				10,5 DIN 125 A4C (110 7105)	2	
17				232 0891	1	1008-46
18				232 0880	1	1006-46
19				4 DIN 6799 (110 3870)	1	
20				232 0861	1	1006-46
21				232 0866	1	1006-46
22				8,4 DIN 125 A4C (110 7101)	2	
23				1125-49-11,21 (338 7988)	2	
24				2x15 DIN 94 A4C (110 6407)	2	
+	Mittlere Zugstange			+1	Vordere Zugstange	

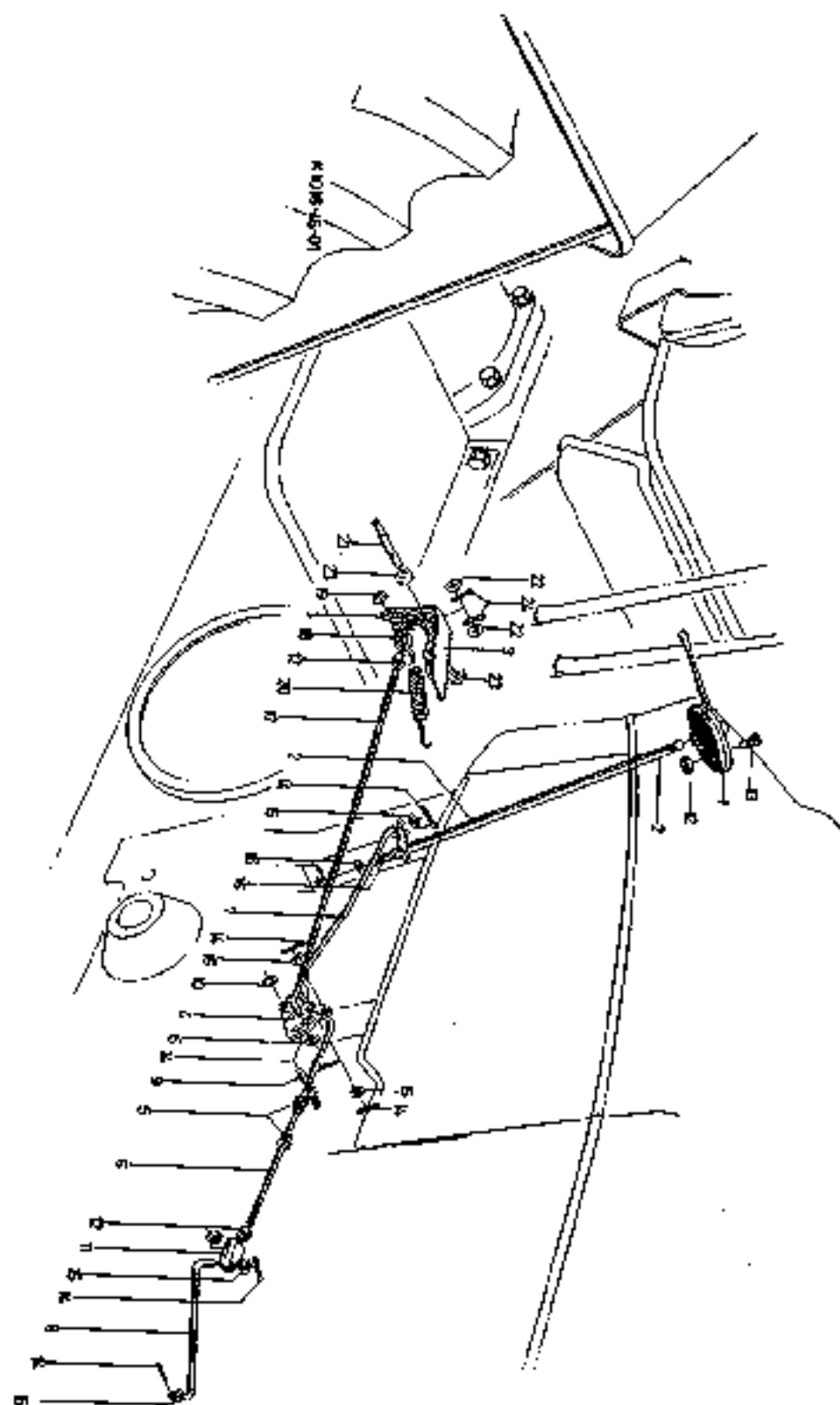

Abstellvorrichtung
Shut-down Device
Dispositif d'arret
Sistema de parada

1047

Bild-Nr.	Schleppernummer		Fußnote	Teilnummer	Anzahl	
	ab	bis				
2				230 7427	1	1006-47
3				M 10x15 DIN 933-8, 8vzkc (111 2391)	1	
4				6x0,7 DIN 471 (110 7711)	1	
5				M 5x8 DIN 933-8, 8 A4C (111 2193)	1	
6				5 H 2203 vzkc (116 7193)	2	
7				1x15 DIN 72571 vzkc (112 1261)	2	
8				2 928 A 1 (121 6315)	2	
9				7 565 G 9 (121 0637)	1	
10				M 5x12 DIN 933-8, 8 A4C (111 2202)	1	
11				M 5 DIN 934-8 A4C (111 2803)	1	
13				231 5415	1	1006-47
14				Siehe Pos. A3		
A 1				232 5811	1	1006-47
A 2				232 5768	1	1001-47
A 3				231 5854	1	1001-47
A 4				5, 3 DIN 125 A4C (110 7089)	1	
A 5				2x12 DIN 94 vzkc (110 6404)	1	

2-14 bis Schlepper-Nr. 7915/405 Allrad 7916/90

A 1 - A 5 ab Schlepper-Nr. 7915/406 Allrad 7916/91

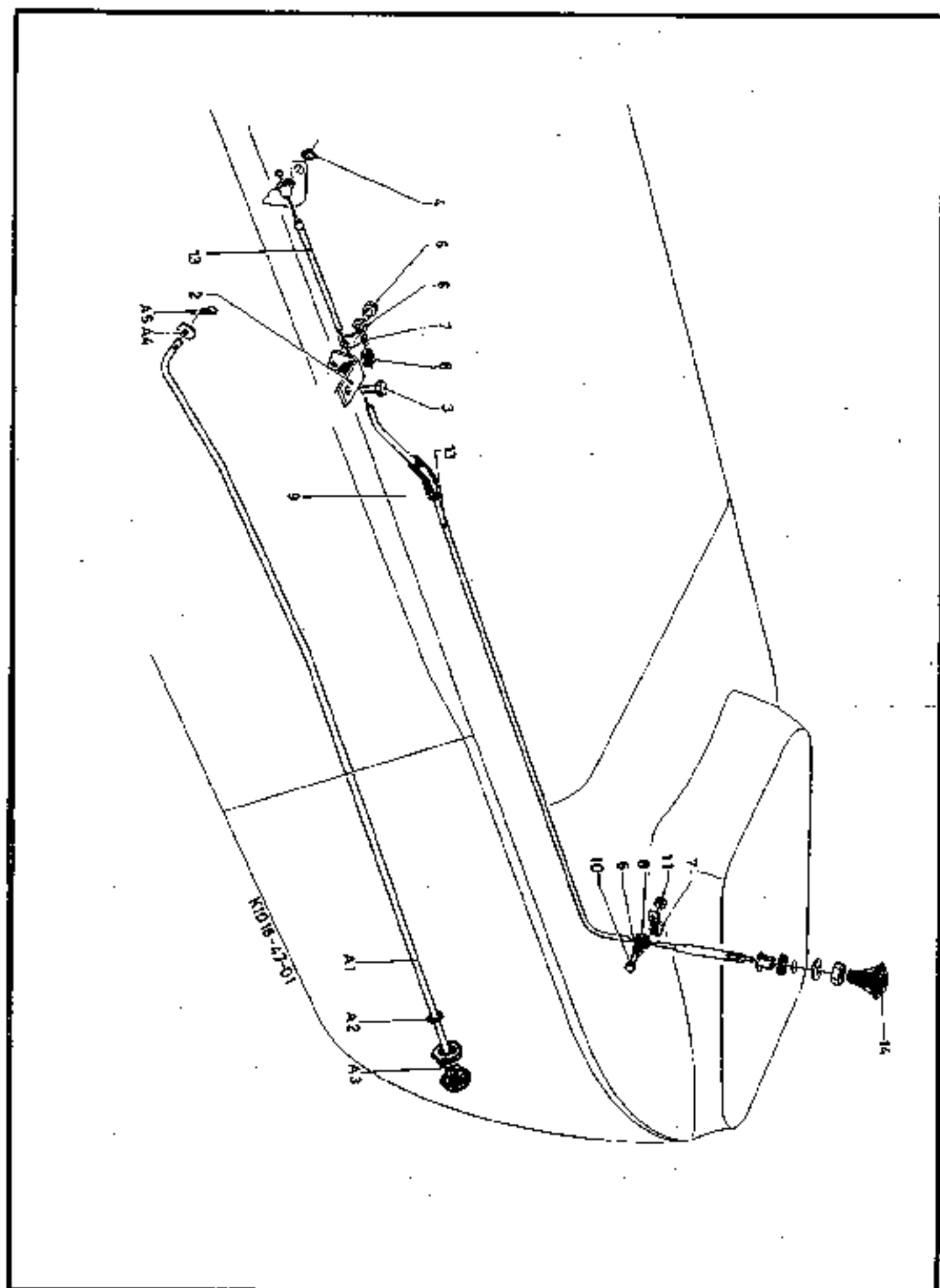

M Z H 2

ESln-Kalk, den 8.12.71
BKPA, wi/pa

Mitteilung an STZ Herren Schalte

Betreff: BLO-Ausführung 2 7006

Ab unten aufgeführten Traktor-Nr.:

7915/1851

7916/307

Änderung

Gesamte elek. Anlage geändert - neues Schaltbrett - Dauer-
abblendlicht.

Verteiler:

BE
2-3800
T2V
KLA 2

Traktorenabnahme
BKPA



(Hirtz)

A 4.

Elektrische Ausrüstung
Electrical Equipment
Equipement électrique
Equipo eléctrico

1049

Schaltkasten mit Armaturen
Instrument Panel
Tableau de bord et instruments
Caja de instrumentos con instrumentos

1049/1

Scheinwerfer, Positionsleuchten, Schlußleuchten
Headlights, Side an Tail Lights
Phares ,feux d'encombrement, feux AR
Faros, lámparas de posición, luces de cola

1049/2

Bild-Nr.	Schleppernummer		Fußnote	Teilnummer	Anzahl	
	ab	bis				
2				12V 143 AH 630 A DIN (112 1083) / 72311	1	
3		7915/970 7916/156-11c		231 9679	1	1006-49
	7915/971 7916/157-11c			231 9678	1	1006-49
6				230 6330	1	1001-49
7				1145-49-01.95 (338 9438)	1	
8				M 8 DIN 315-G GTW 35 (110 7359) /vzkc	1	
9				1171-49-01.123 (339 0956)	1	
12				100x12 H 7650 (116 9304)	1	
13				1125-49-11.21 (338 7988)	1	
15				230 6628	1	1001-49
16				BM 6x20 DIK 7989-4.8 A4C (110 1604)	2	
17				CM 10 H 4207 (116 8501)	1	
18				C 1 H 7659 (116 2924)	1	
19				232 1985	1	rechts 1006-49
20				232 2717	1	1125-49
21				232 2716	1	1125-49
22				232 1991	1	hio. re. 1006-49
23				232 1989	1	hio. li. 1006-49
24				A 7 H 7642 (116 2367)	1	
25				231 6013	1	1008-49
26				1138-49-16.49 (338 9107)	1	
27				K 18 H 7565 (116 9030)	1	
28				A H 7672 P. M. (116 9359)	1	
29				A H 7672 P. M. (116 9359)	1	
30				A H 7672 (116 9359)	1	
31				A 1 H 7672 (116 9360)	3	
32				B 10x15x1,6 H 2928 (116 7412)	4	

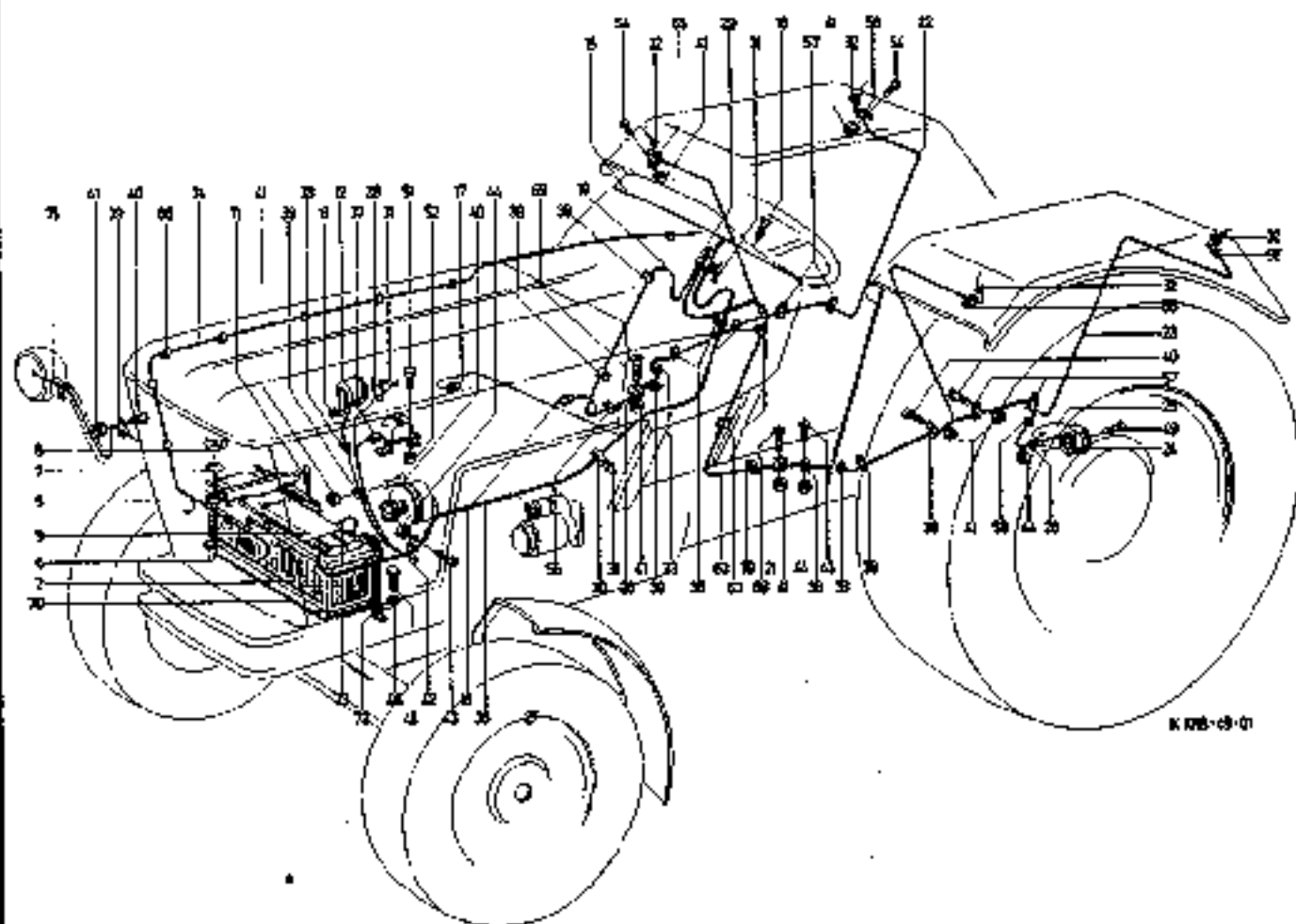



Bild-Nr.	Schleppenummer		Fußnote	Teilnummer	Anzahl	
	ab	bis				
33				D 13, 5x17x1, 5 H 2928 (116 7425)	2	
35			+	232 2702	1	1005-49
37				G 1 H 7842 (116 1165)	1	
38				1x12 DIN 72571 vzkc (112 1257)	4	
39				1x8 DIN 72571 vzkc (112 1253)	14	
40				AM 4x10 DIN 7985-4, 8 (111 9628)	21	
41				M 4 DIN 934-8 A4C (111 2796)	27	
42				1145-49-01.72 (338 9432)	1	
43				AM 5x10 DIN 7985-4, 8 (111 9632)	4	
44				M 5 DIN 934-8 A4C (111 2803)	7	
45				M 8x15 DIN 933-8, 8 A4C (111 2305)	1	
46				8, 4 DIN 125 vzkc (110 7101)	1	
49				AM 5x35 DIN 84-4, 8 A4C (112 3583)	3	
51				M 6x18 DIN 933-8, 8 A4C (111 2258)	2	
52				M 6 DIN 934-8 A4C (111 2813)	2	
53				1152-49-01.78 (338 9845)	2	
54				AM 4x50 DIN 7985-4, 8 (110 2012)	4	
56				1x6 DIN 72571 vzkc (112 1249)	7	
57				1x10 DIN 72571 vzkc (112 1255)	2	
58				D 17x24x2 H 2928 (116 7427)	1	
63			+1	232 1987	1	1006-49
66				230 4186	9	1001-49
68				AM 4x40 DIN 84-4, 8 A4C (112 3579)	1	

* Für Drehstrom-Lima

+1 Mitto links

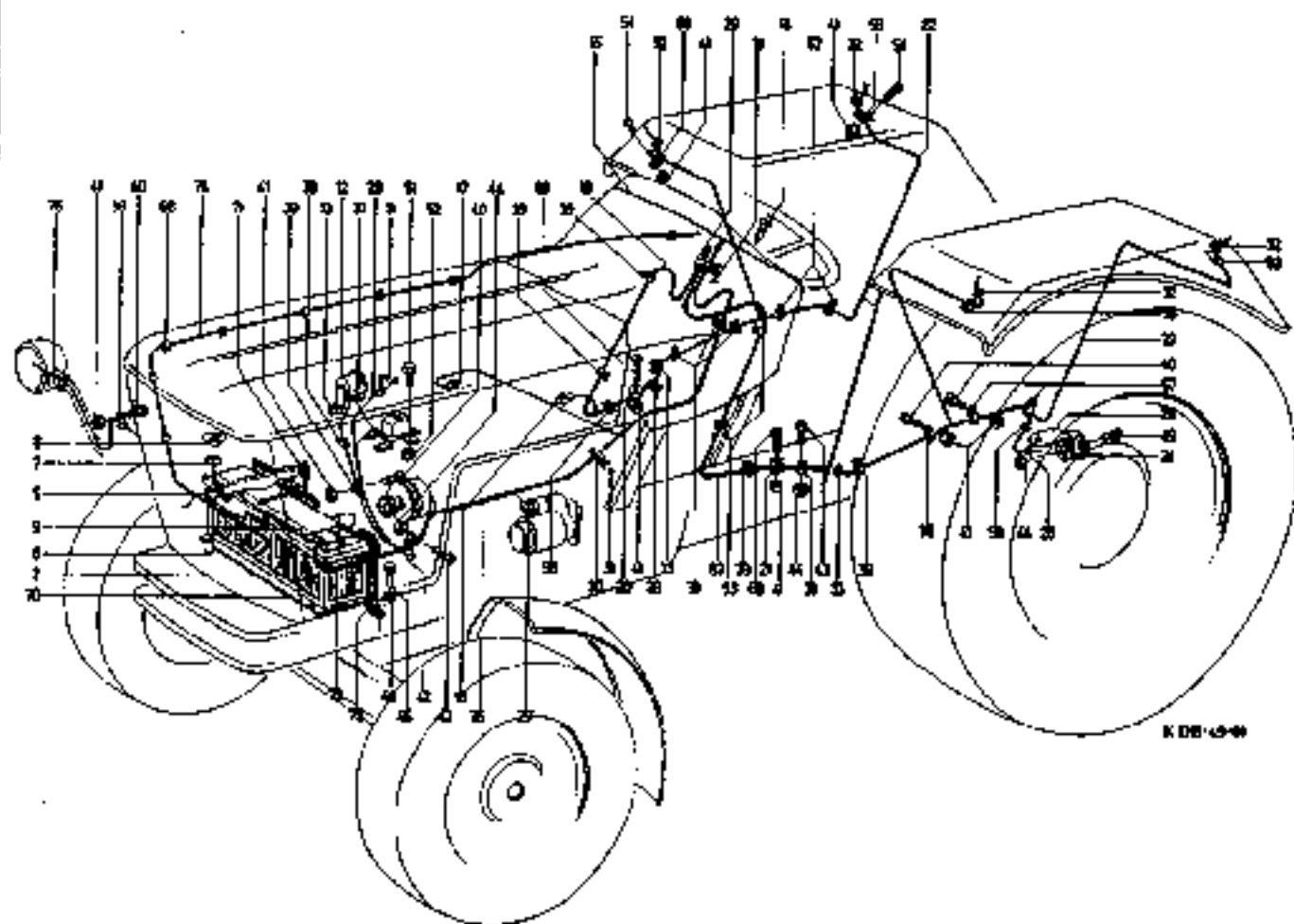

Bild-Nr.	Schleppenummer ab bis	Fußnote	Teilnummer	Anzahl	
1		231 5727	1	1001-49
		233 4039	1	1001-49
3			1136-49-o2.o3 (338 9o72)	1	
4			1136-49-o2.o4 (338 9o73)	1	
5			23o 6723	1	1001-49
7	<i>Knopf 3343 231 070</i>	x	C H 7662 (116 9343)	1	
		C F H 7662 (116 392o)	1	
8		A 8 H 7644 (116 924o)	1	
		A 8 S 2 H 7644 (116 3816)	1	
9			C S H 7661 (117 23o1)	1	
10			C H 7642 (116 9332)	1	
11			1135-49-23.29 (338 8o29)	1	
12			8 DIN 72581 (112 133o)	5	
13			16 DIN 72581 (11o 3177)	2	
14		231 3726	1	1001-49
		233 2876	1	1001-49
15			D H 768o (116 944o)	4	
16			J 12 V 2 W DIN 726o1 (112 1432)	4	
17			M 4 DIN 934-8 vzkc (111 2796)	2	
18			AM 4x1o DIN 7988-4Svzkc (111 9628)	2	
19			3 H 14x18x8 H 7565 (116 9o82)	5	
20			AM 5x15 DIN 84-4Svzkc (11o 5526)	2	
21			M 5 DIN 934-8 A4C (111 28o3)	2	
22			5 H 22o3 vzkc (116 7193)	2	
23			7665 A 1 (121 8o59)	1	
24			23o 6726	1	1001-49
<i>x Knopf 3343 231 070</i>					





Bild-Nr.	Schleppernummer		Fußnote	Teilnummer	Anzahl	
	ab	bis				
25				1AM 5x10 DIN 7988-4.8 v _z (111 9649)	2	
26				F 1 H 7677 (116 9438)	1	
27				1136-49-13.10 (338 9103)	1	
28				B 1 H 7677 (116 9432)	1	
29				5 DIN 72581 (112 1329)	1	
30				230 5282	1	1130-49
31				7 602 B 1 (121 0566)	2	
35				B 2, 5x22x60 H 7633 (116 1112)	1	
36				231 3727	1	
37			C 1 H 7660 (116 2780)	1	
			C 4 H 7660 (116 3921)	1	
38				291 4431	1	
39				232 5968	1	1013-49
40				3H 6x8x11 H 7565 (116 9035)	2	
41				230 7272	1	1001-58
44			+	232 0819	1	1001-49
45			+1	232 0820	1	1001-49
A 16			46 T 115x2500x45H 4260 (116 0148)	1	MPVar.S
A 16			17 T 100x2500x45H 4260 (116 4036)	1	MP/HS
A 18			49 T 115x2500x45H 4260 (116 0149)	1	KMVar.S
A 18			16 T 100x2500x45H 4260 (116 4035)	1	KM/HS
A 38				H 12V 2W DIN 72601 (112 1418)	5	
A 41				1171-56-01.21 (339 1044)	1	
A 42				A H 7672 P. M. (116 9359)	1	
A 43			+1	Z 2 E H 4217 (116 8559)	1	
A 45			+1	4 217 B 6 (121 6889)	1	
+ Kabelsatz mit Blinklicht u. Flammglühkerze +1 Bei Ausführung ohne Blinklicht						

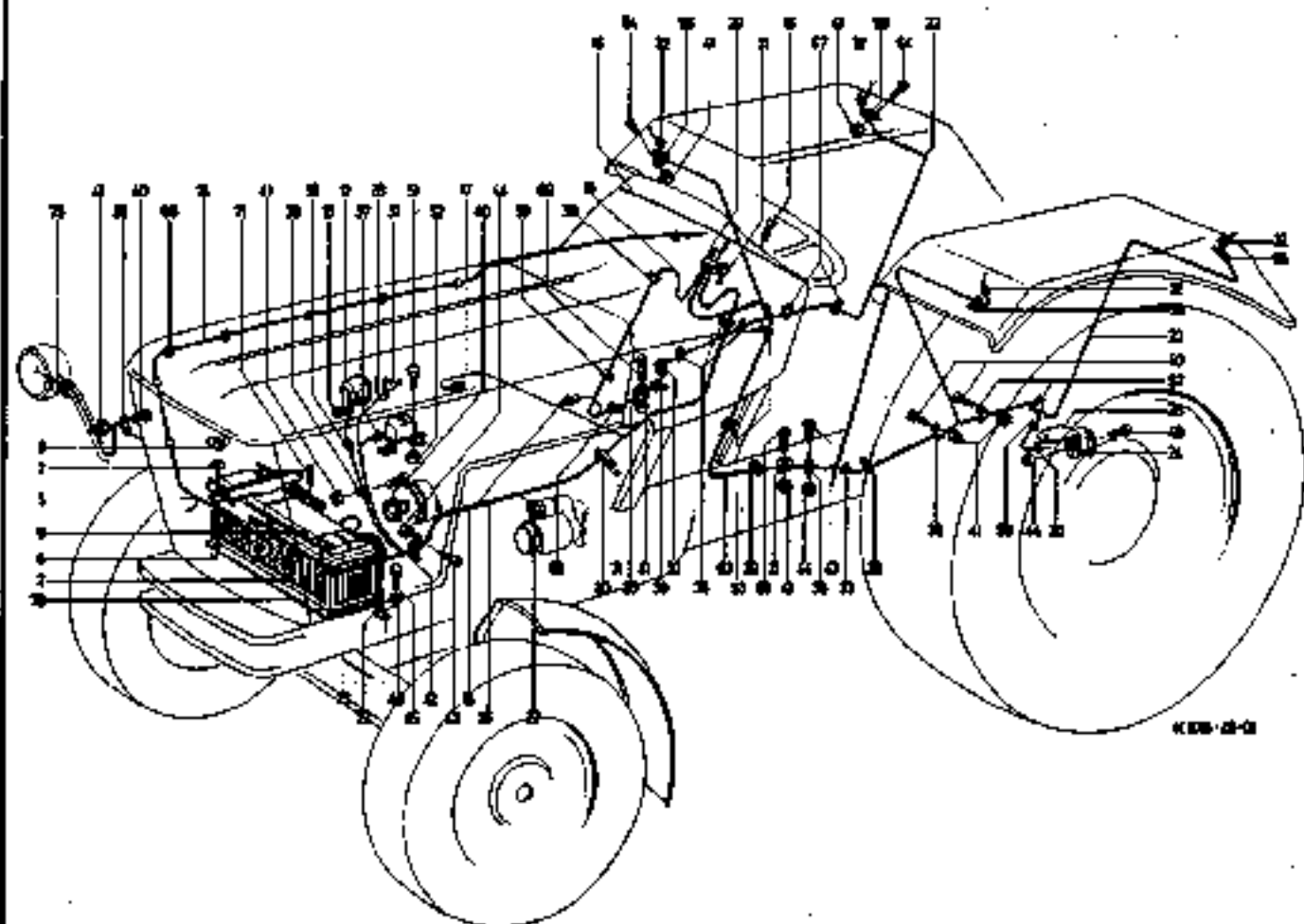
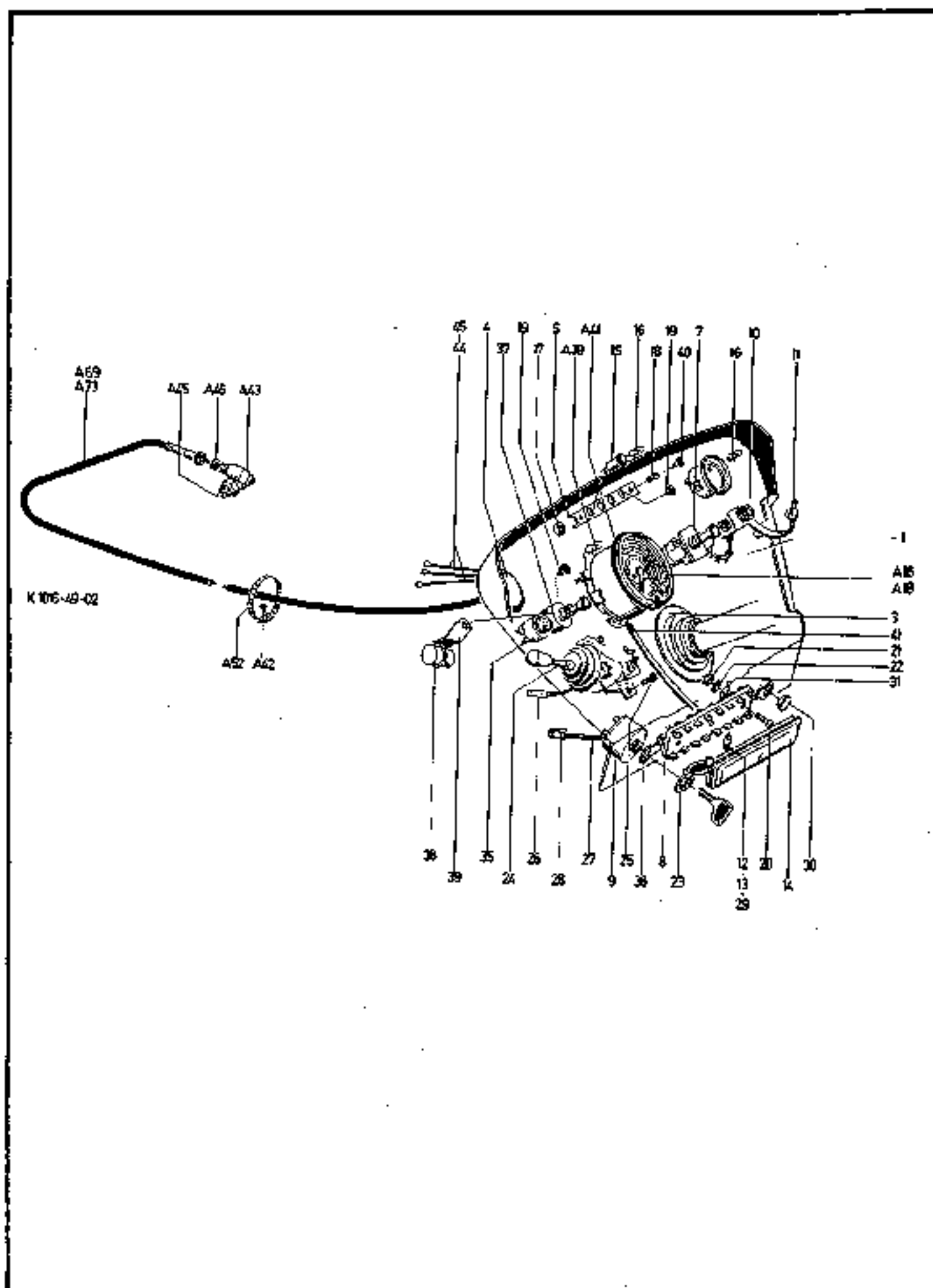

Bild-Nr.	Schleppernummer		Fußnote	Teilnummer	Anzahl	
	ab	bis				
1	<i>Kella 105</i>	<i>273 (2)</i>		230 6919	2	1001-49
1/1				233 2186	1	1001-49
1/2				233 2187	1	1001-49
1/3				233 2188	1	1001-49
1/4				233 2189	1	1001-49
1/5				AM 4x50 DIN 91-4, 8verchr. (110 4919)	2	
1/6				233 2190	2	1001-49
1/7				M 4 DIN 934-8 A4C (151 2798)	2	
1/8				233 2191	1	1001-49
1/9				233 2192	1	1001-49
1/10				233 2193	1	1001-49
2				B 12V 35W/35 DIN 72601 (112 1372)	2	
3				230 6326	3	1001-49
4				230 6327	3	1001-49
5				230 6328	2	1001-49
6				B 12V 35W/35 DIN 72601 (112 1373)	1	gelb
8				B 12V 35/35W DIN 72601 (110 2658)	1	unverst.
A 1				230 6333	1	links 1001-49
A 1/1				233 2199	1	1001-49
A 1/2				B 4, 2x13 DIN 7971 vzkc (112 7573)	2	
A 1/3				233 2195	2	1001-49
A 1/4				233 2196	1	1001-49
A 2				230 6308	1	rechts 1001-49
A 2/1				233 2200	1	1001-49
A 3				230 6338	1	ll. + re, 1001-49
A 3/1				233 2204	1	1001-49
A 5				K 12V 18W DIN 72601 (112 1438)	1	



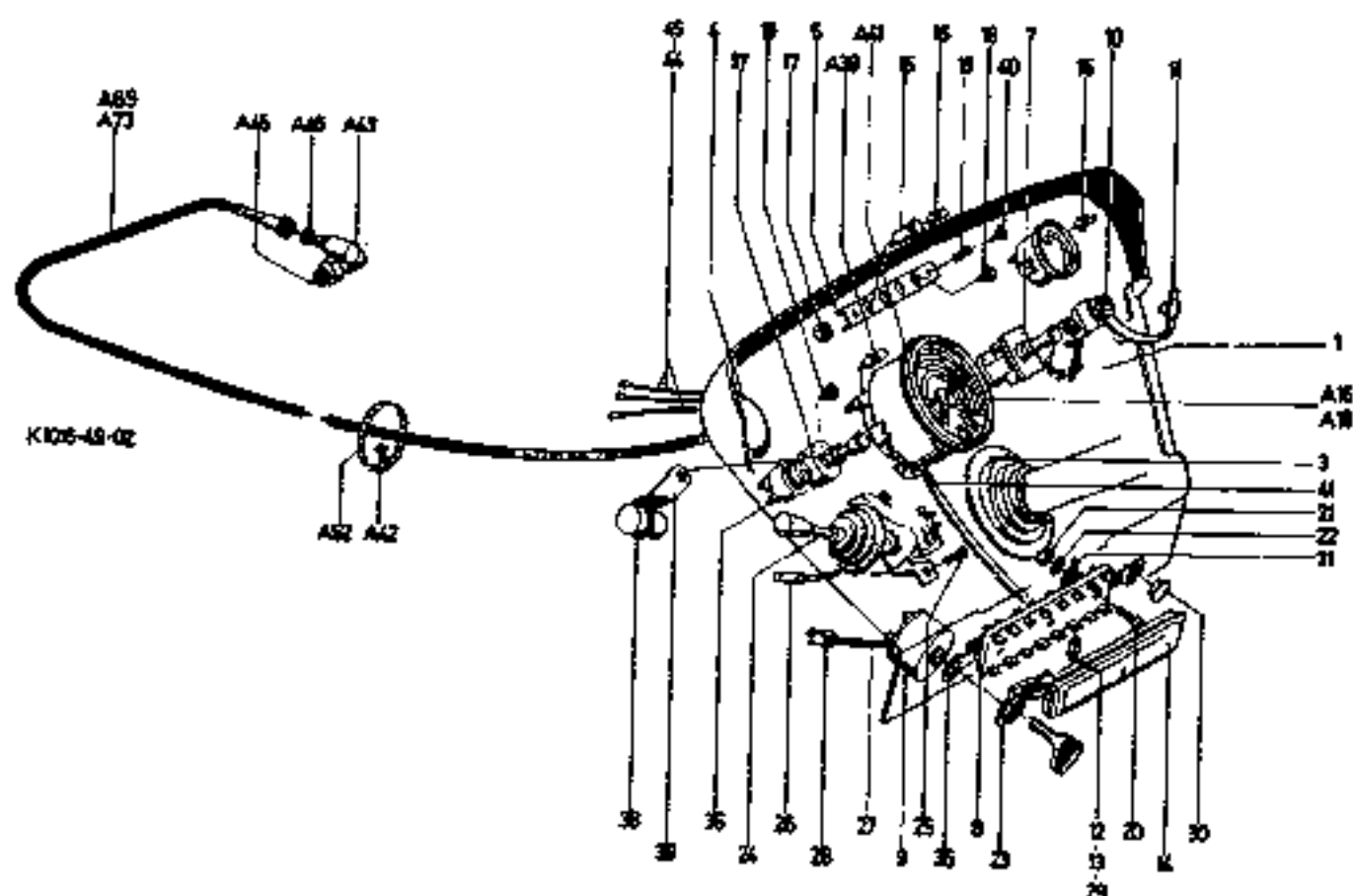

Bild-Nr.	Schleppernummer		Fußnote	Teilnummer	Anzahl	
	ab	bis				
A 6				L 12V 5W DIN 72601 (112 1444)	1	
A 7				230 6343	1	1001-49
A 8				1 BC 6 H 7602 (116 9070)	1	
A 9				M 6x100 DIN 931-8.8 A4C (110 1940)	1	
B 1			+	230 6632	1	1001-49
B 1/1				233 2197	1	1001-49
B 2			+1	230 6631	1	1001-49
B 2/1				233 2194	1	1001-49
B 3			+2	230 6336	1	1001-49
B 3/1				233 2266	1	1001-49
B 4			+3	230 6337	1	1001-49
B 4/1				233 2265	1	1001-49
B 5				230 6341	1	1001-49
B 6				B 4, 8x32 DIN 7981 vzkc (110 1505)	1	
B 8				L 12V 5W DIN 72601 (112 1444)	1	
B 9				K 12V 18W DIN 72601 (112 1438)	2	
B 10				230 6342	1	hinten 1001-49
B 11				1 BC 6 H 7602 (116 8070)	1	
B 12				M 6x85 DIN 931-8.8 vzkc (110 1947)	1	
C 1				231 1733	1	rechts 1006-49
C 2				231 1732	1	links 1006-49
C 3				M 16x35 DIN 933-8.8 A4C (111 2679)	4	
C 4				1125-49-57.10 (338 8085)	1	rechts
C 4/1				232 1180	1	1125-49
C 4/2				232 1225	1	1125-49
C 4/3				232 1226	1	1125-49
C 4/4				232 1227	6	1125-49

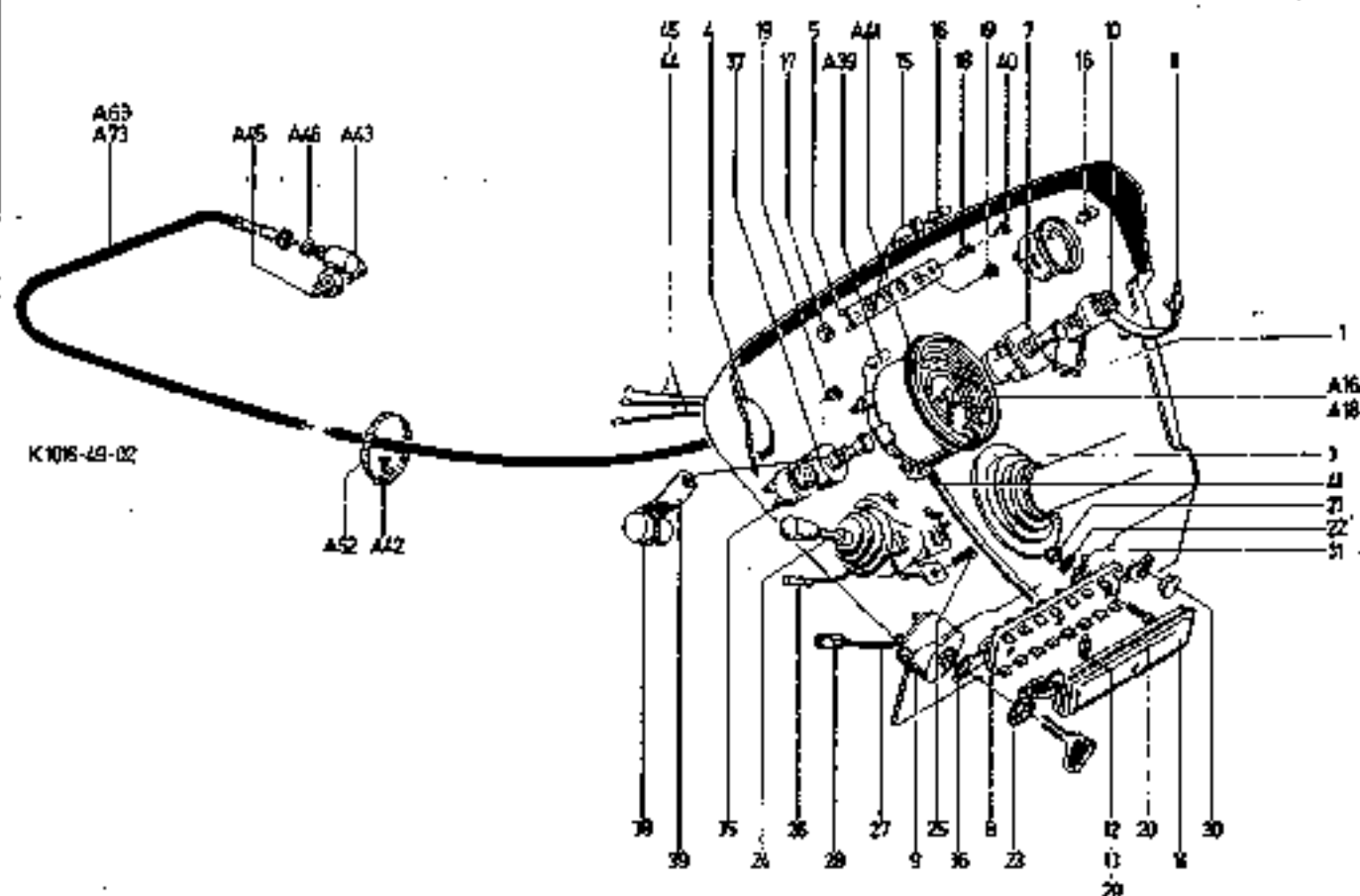
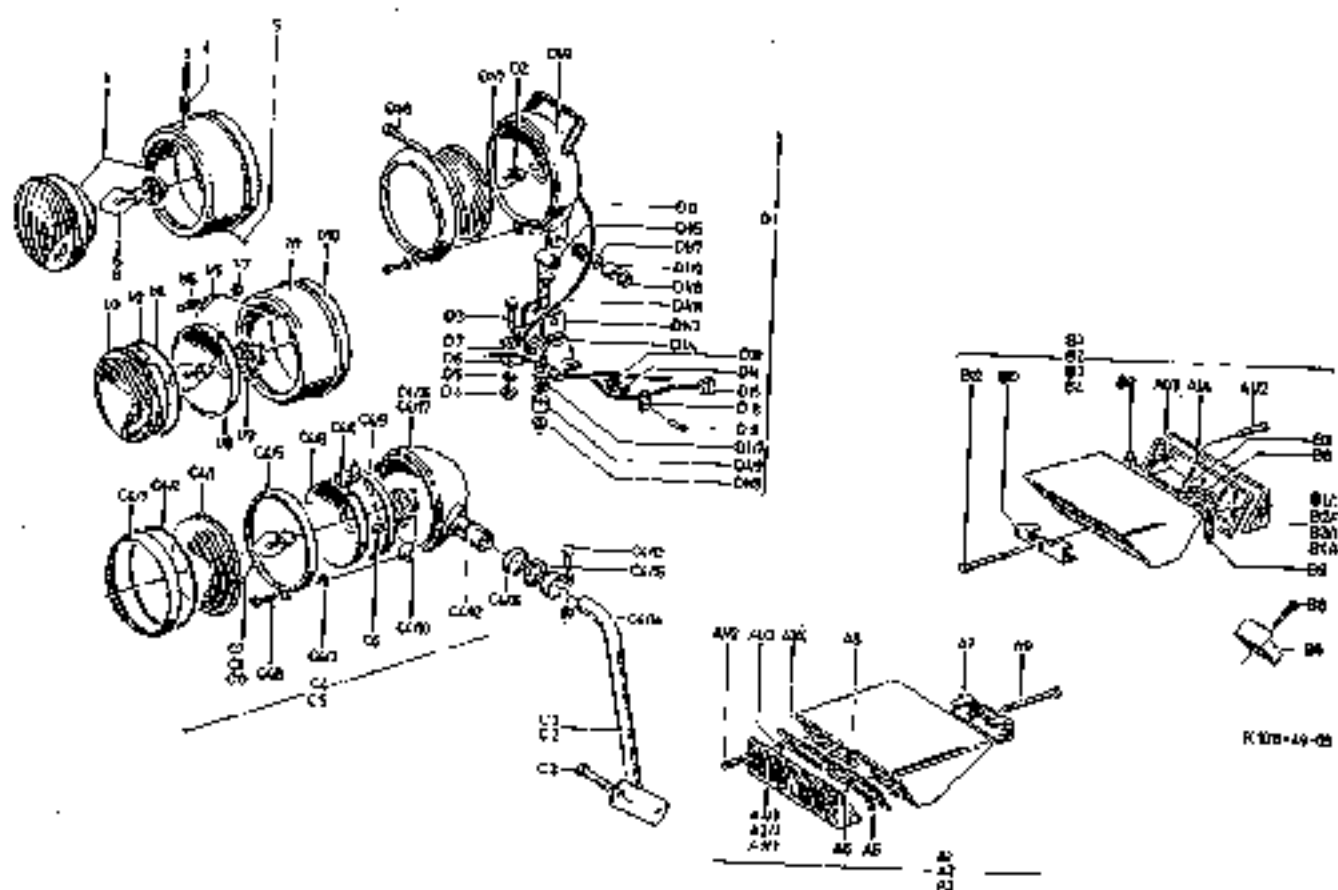
+ Schluss-Brems-Blink-u. Kennzeichenleuchte
+2 Schluss-Brems-u. Kennzeichenleuchte

+1 Schluss-Brems-u. Blinkleuchte
+3 Schluss-Brems. Leuchte

Bild-Nr.	Schleppernummer		Fußnote	Teilnummer	Anzahl	
	ab	bis				
C 4/5				232 1228	1	1125-49
C 4/6				AM 5x15 DIN 84-4, 8 (110 5526)	1	
C 4/7				232 1229	1	1125-49
C 4/8				232 1230	1	1125-49
C 4/9				232 1231	1	1125-49
C 4/10				232 1232	1	1125-49
C 4/11				232 4821	1	1125-49
C 4/12				232 4822	1	1125-49
C 4/13				M 10x40 DIN 931-8, 8 A4C (112 5798)	1	
C 4/14				M 10 DIN 934-8 (111 2841)	1	
C 4/15				M 30x1, 5 DIN 934-8 (111 2961)	1	
C 4/16				232 4823	1	1125-49
C 4/17				232 4824	1	1125-49
C 5				1125-49-57. 20 (338 8086)	1	links
C 6				HL 12V 4W DIN 72601 (112 1426)	2	
C 7				B 12V 35W 35DIN 72601 (112 1372)	2	
C 8				B 12V 35W/35DIN 72601 (112 1373) /gelb	2	
C 10				B 12V 35/35W DIN 72601 (110 2656) /unverst.	2	
D 1				1053-49-19. 10 (338 6499)	1	
D 1/B				M 10 DIN 553 (110 8065)	2	

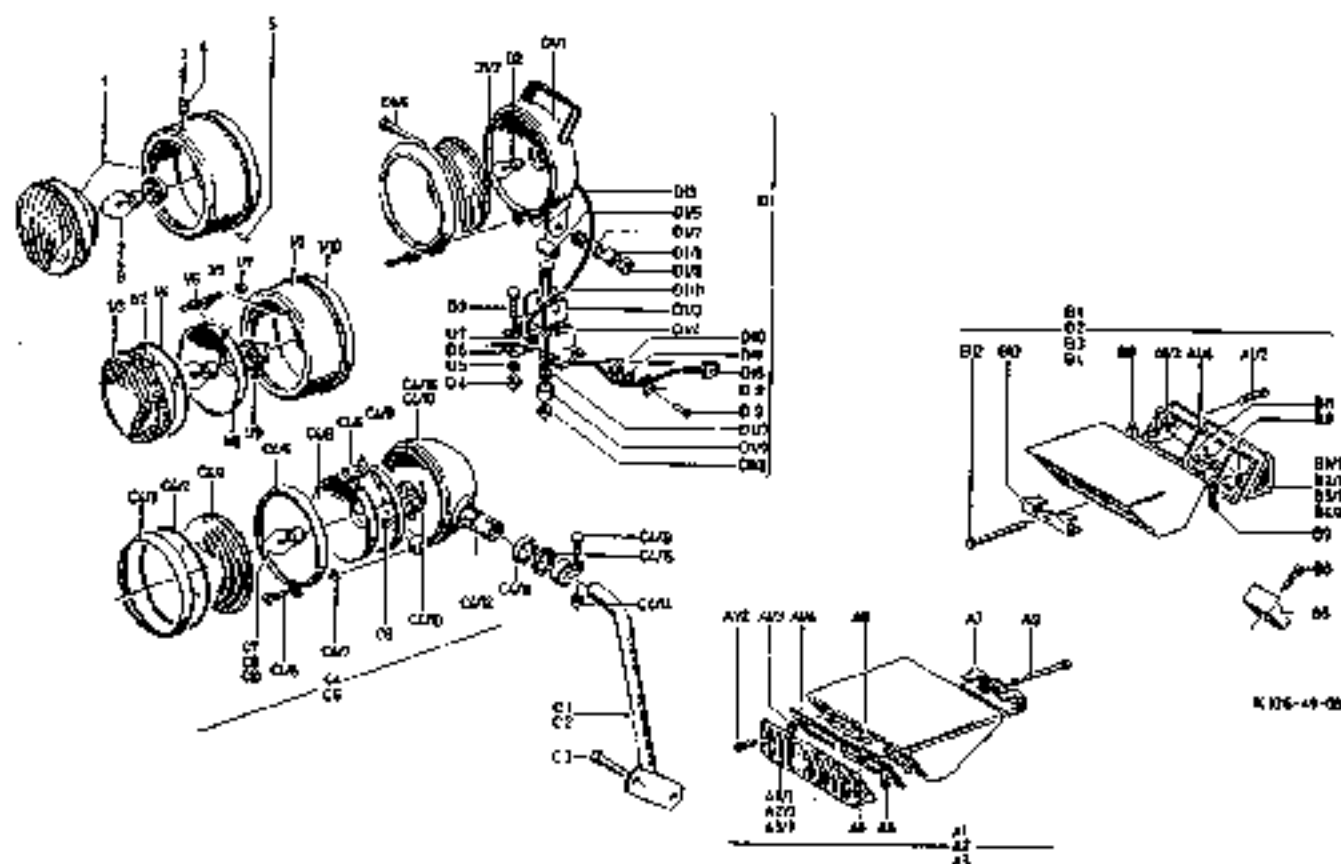
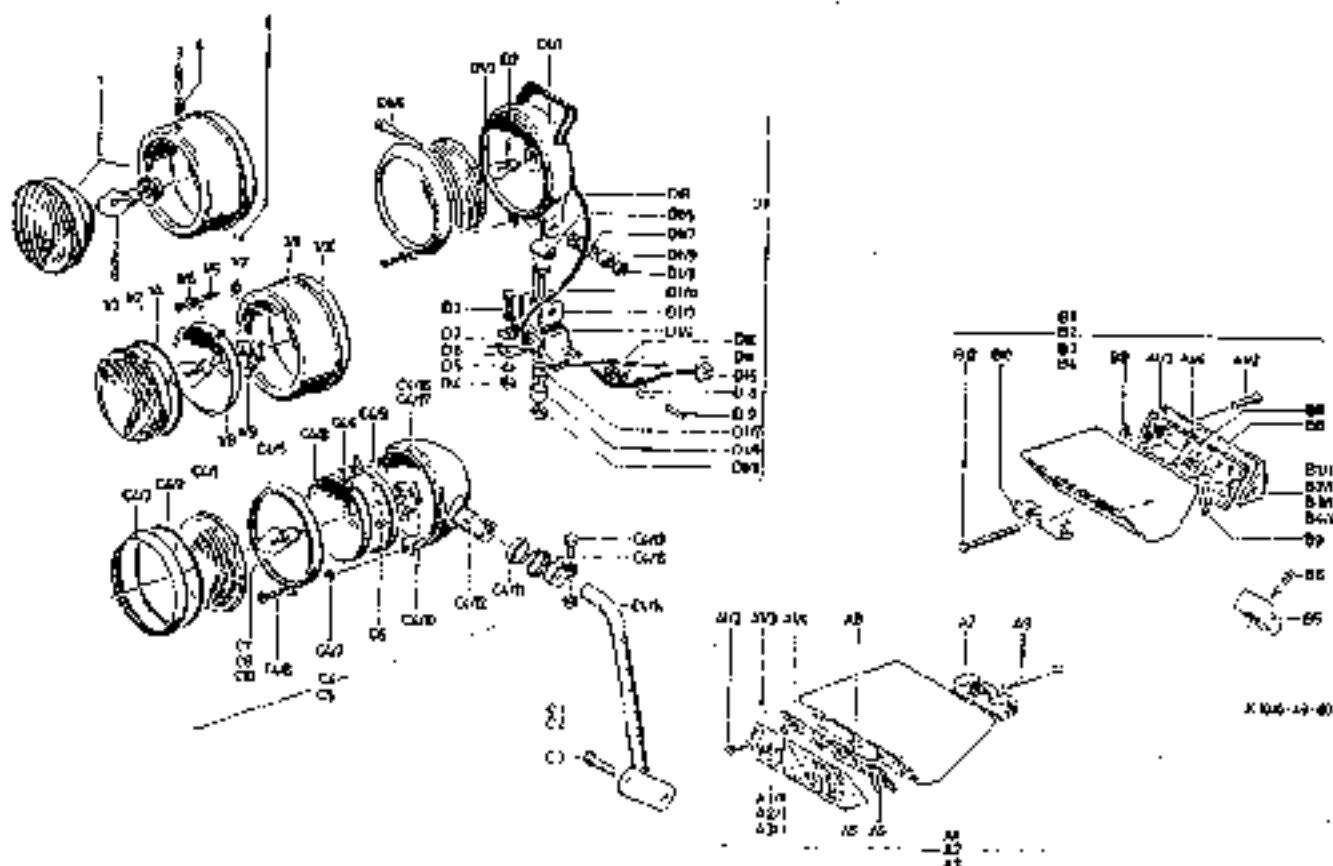

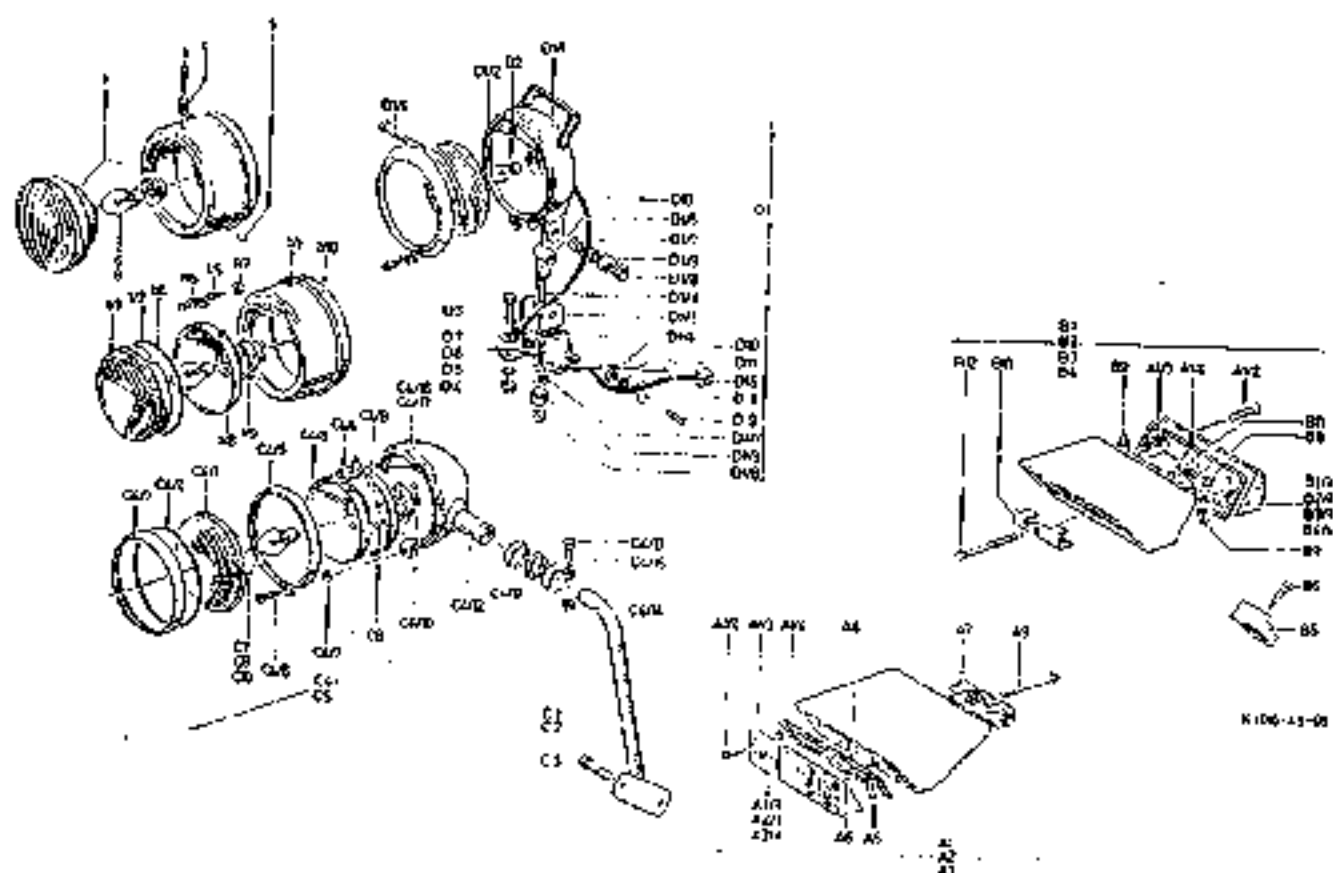

Hintere Kotflügel, 560 breit
Rear Mudguards
Garde-boue AR
Guardabarros traseros

1051

Hintere Kotflügel, 452 breit
Rear Mudguards
Garde-boue Alt
Guardabarros traseros

1051/1

Bild-Nr.	Schleppernummer ab bis		Fußnote	Teilnummer	Anzahl	
3				230 4893	1	links 1006-51
4				230 4908	1	rechts 1006-51
5				230 4890	2	1006-51
6				231 1347	1	1006-51
6/1				231 1323	1	1006-51
6/3				231 1348	2	1006-51
7				230 4917	1	1006-51
8				232 3029	1	links 1006-61
8/1				Wir liefern n. Position 8	1	
8/3				Wir liefern n. Position 8	1	
9				232 3030	1	rechts 1006-61
9/2				Wir liefern n. Position 9		
10				230 4918	2	
12				M 8x15 DIN 933-8.8 A4C (111 2305)	8	
13				A 8,2 DIN 6797 vzkc (110 1492)	12	
14				M 14x25 DIN 912-8.8 A4C (111 0802)	2	
15				14 H 2203 vzkc (118 9696)	2	
16				AM 16x60 DIN 939-8.8 A4C (111 3664)	6	
17				M 16 DIN 934-8 A4C (111 2886)	6	
18				A 16 DIN 128 vzkc (110 2803)	6	
19				230 1538	11	1171-51
20				230 4771	6	1006-51
23				232 7072	1	Wahlweise 1006-51
24			+	232 3109	1	1006-51
25			+1	232 3110	1	1006-51
26				M 10x45 DIN 933-8.8 A4C (111 2451)	16	
27				M 10 DIN 934-8 A4C (110 2659)	16	
+ Kotflügel links, f. Schutzrahmen			+1 Kotflügel rechts, f. Schutzrahmen			



Bild-Nr.	Schleppernummer		Fußnote	Teilnummer	Anzahl	
	ab	bis				
1				230 4896	1	links 1006-51
2				230 4897	1	rechts 1006-51
3				233 0745	21	11. Norm 1006-51
4				230 4908	1	rechts 1006-51
5				230 4890	2	1006-51
6				231 1347	1	1006-51
6/3				231 1348	2	1006-51
7				230 4917	1	1006-51
8				230 4609	2	1006-51
9			+1	232 7339	2	27 Hoch 1006-51 1002-51
			+2	230 4120		
10		390 kg		232 7058	4	1008-51
11				M 20x2 DIN 934-B A4C (111 2923)	16	
13				M 8x15 DIN 933-B, 8 A4C (111 2305)	8	
14				A 8,2 DIN 5797 vzkc (110 1492)	12	
15				M 14x25 DIN 912-10, 9A4C (111 0802)	2	
16				14 II 2203 vzkc (116 9696)	2	
17				AM 18x60 DIN 939-8, 8A4C (111 3664)	6	
18				M 16 DIN 934-B A4C (111 2886)	6	
19				A 16 DIN 128 vzkc (110 2803)	6	
20				AM 12x45 DIN 939-6, 8A4C (111 3587)	6	
21				AM 12x70 DIN 939-8, 8 A4C (110 1932)	6	
23				M 12 DIN 934-B A4C (111 2858)	6	
25				232 7220	6	1006-51
26				1145-51-01.37 (338 9469)	6	
27				1151-51-04.42 (338 9709)	12	
28				1145-51-01.36 (338 9468)	12	
30			+	232 7088	1	1006-51

+ Kotflügel links, für Schutzrahmen +1 Ausführung Inland +2 Ausführung Export



10-15-90 X

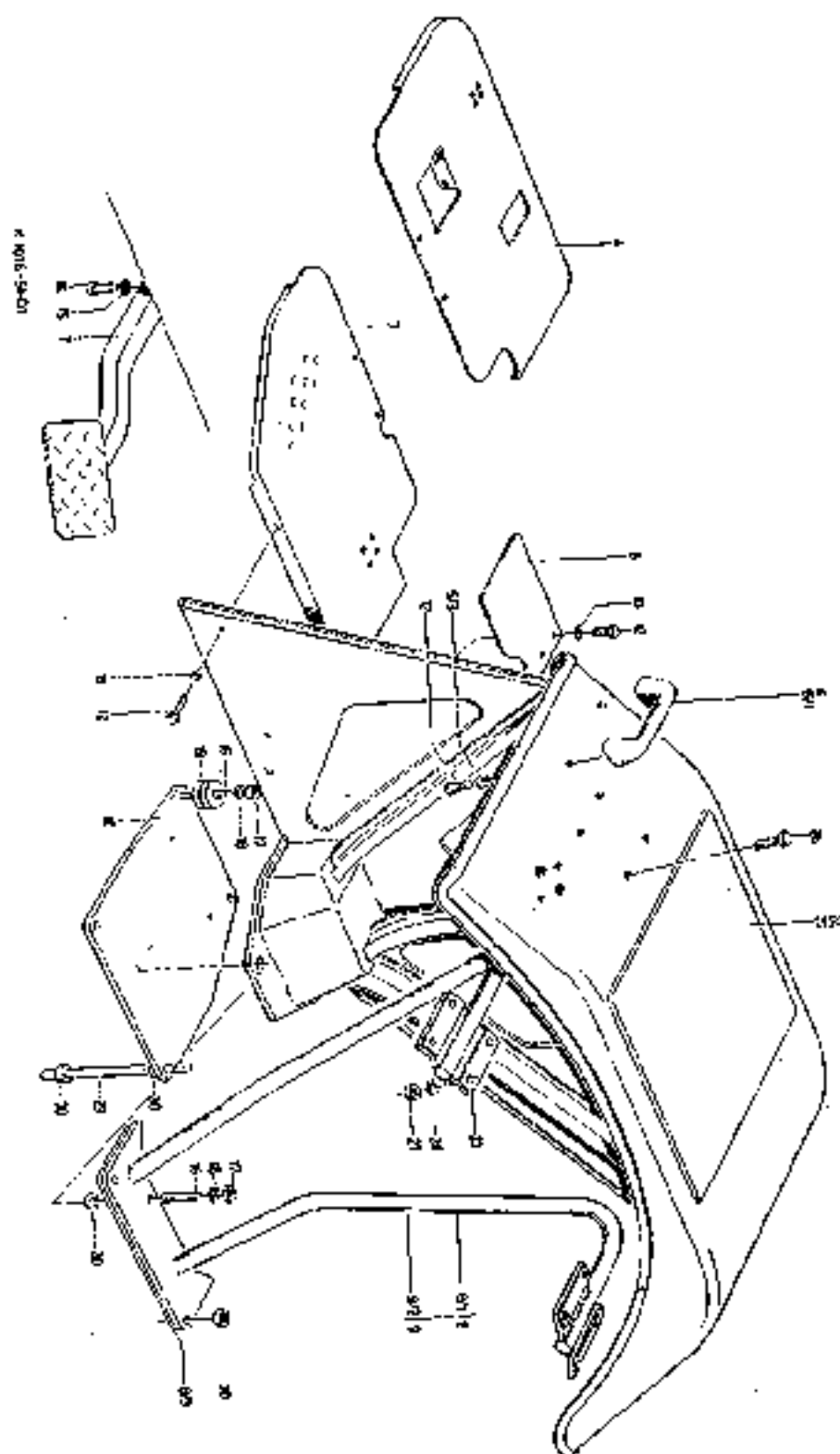
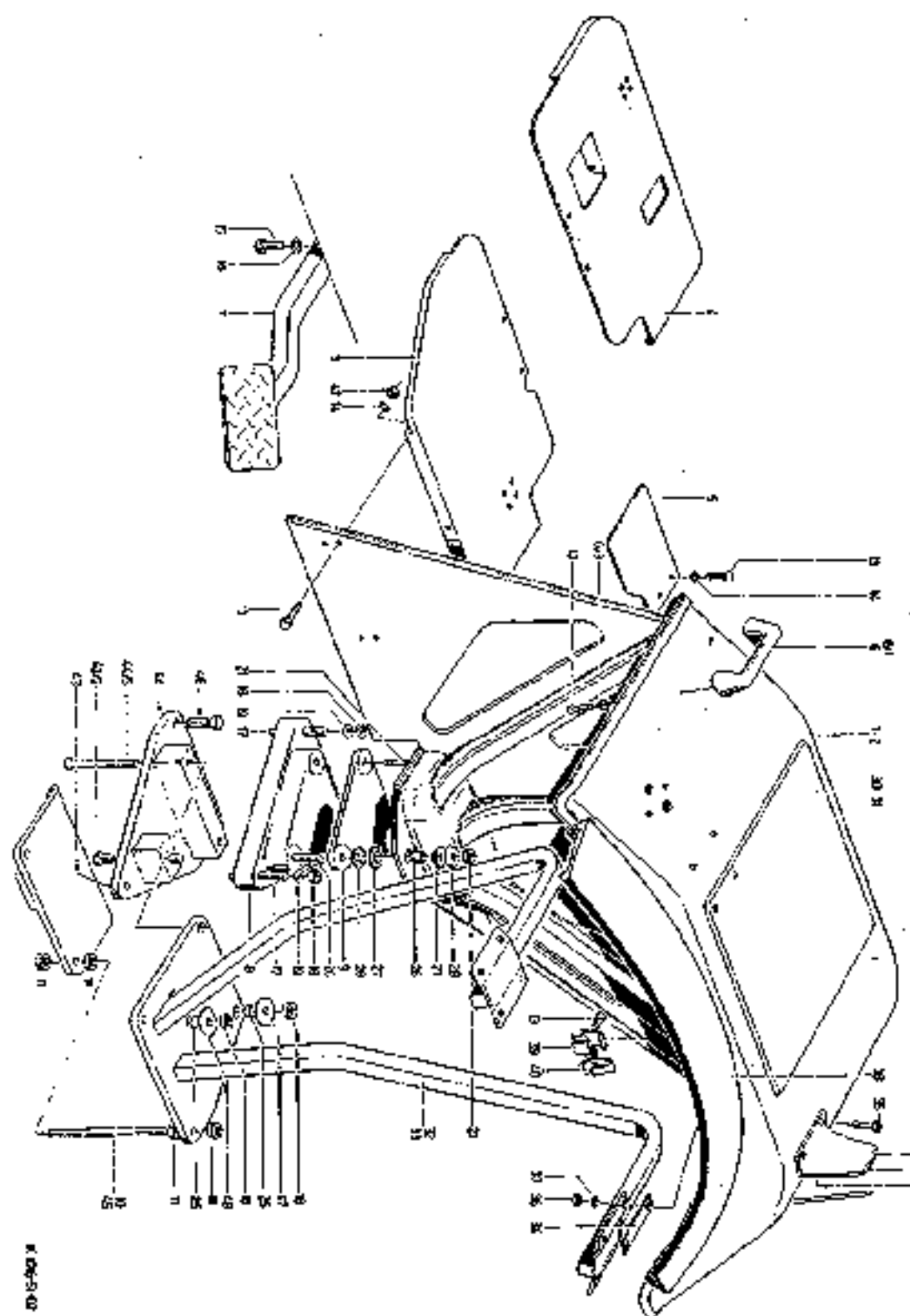

Bild-Nr.	Schleppenummer ab bis	Fußnote	Teilnummer	Anzahl	
31	Siehe RM 1006 51-32	+	232 7099	1	1006-51
32		+1	232 7092	1	1006-51
33		+2	232 7093	1	1006-51
34			232 7072	1	1006-51
35			M 10x45 DIN 933-8, 8A4C (111 2451)	16	
36			M 10 DIN 934-8 A4C (110 2659)	16	
37			10, 5 DIN 125 A4C (110 7105)	16	
38			232 7091	2	1006-51
39			232 7089	12	1006-51
40			232 7090	12	1006-51
42			M 8 DIN 934-8 A4C (111 2824)	1	
43	ohne Schutzrahmen		232 7223	2	1006-51
43/2			M 16x140 DIN 931-8, 8A4C (111 1949)	1	
44	mit Schutzrahmen		232 7224	2	1006-51
44/3			M 16x170 DIN 931-8, 8A4C (110 0581)	1	
45	340lg.		232 7057	4	1007-51
46			M 16x40 DIN 933-8, 8A4C (111 2687)	6	
47			230 1538	4	1171-51
48			232 7219	2	1006-51

+ Kotflügel rechts f. Schutzrahmen, +1 Schutzrahmen, Unterteil links
+2 Schutzrahmen, Unterteil rechts

Kotflügel vorn, Normal
Front Mudguards (Standard)
Aileron AV, version standard
Guardabarros delanteros, normales

1052

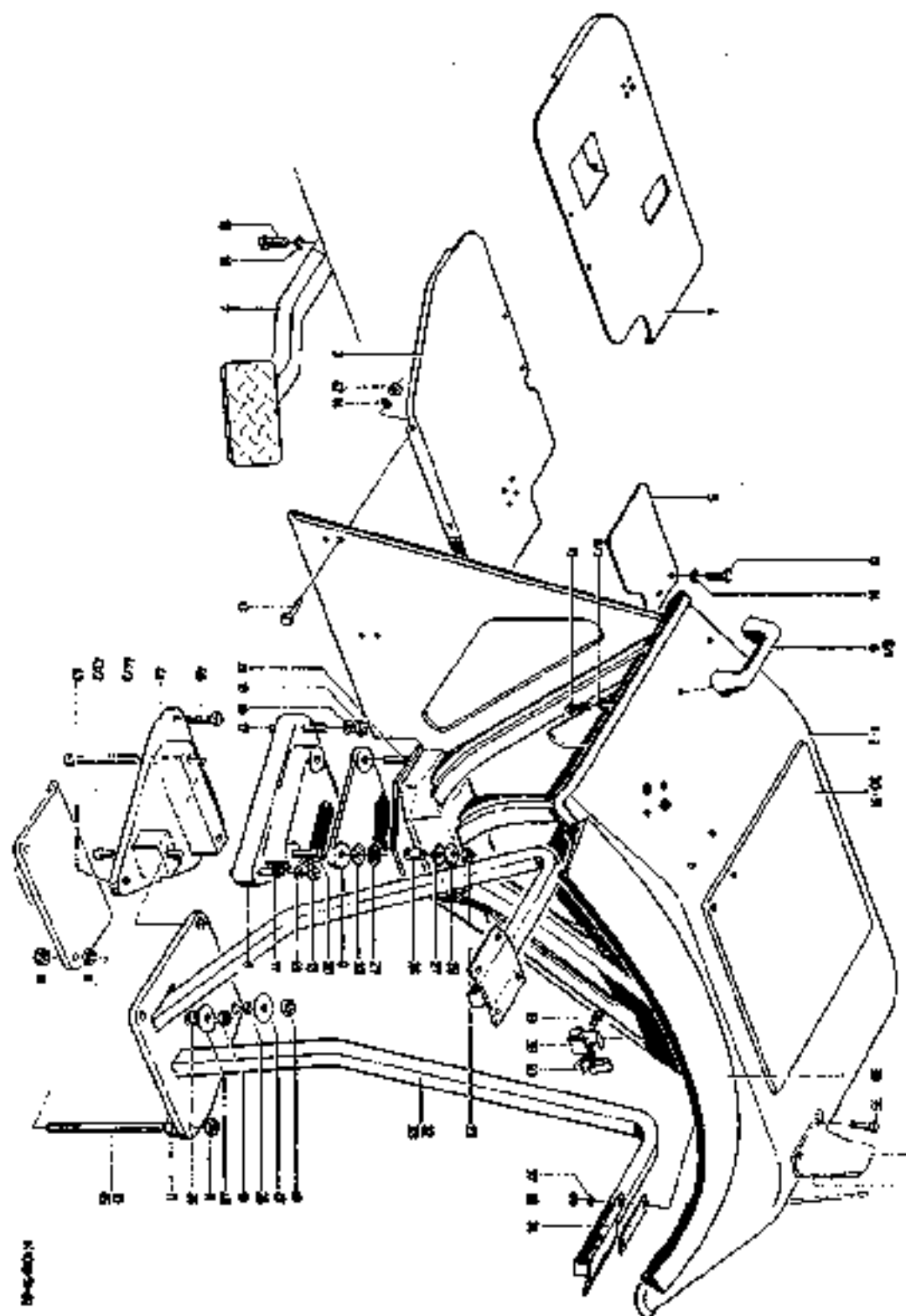
Kotflügel vorn, Allrad
Front Mudguards (All-Wheel Drive)
Aileron AV, version toutes roues motrices
Guardabarros delanteros para version de traccion en las 4 ruedas

1052/1

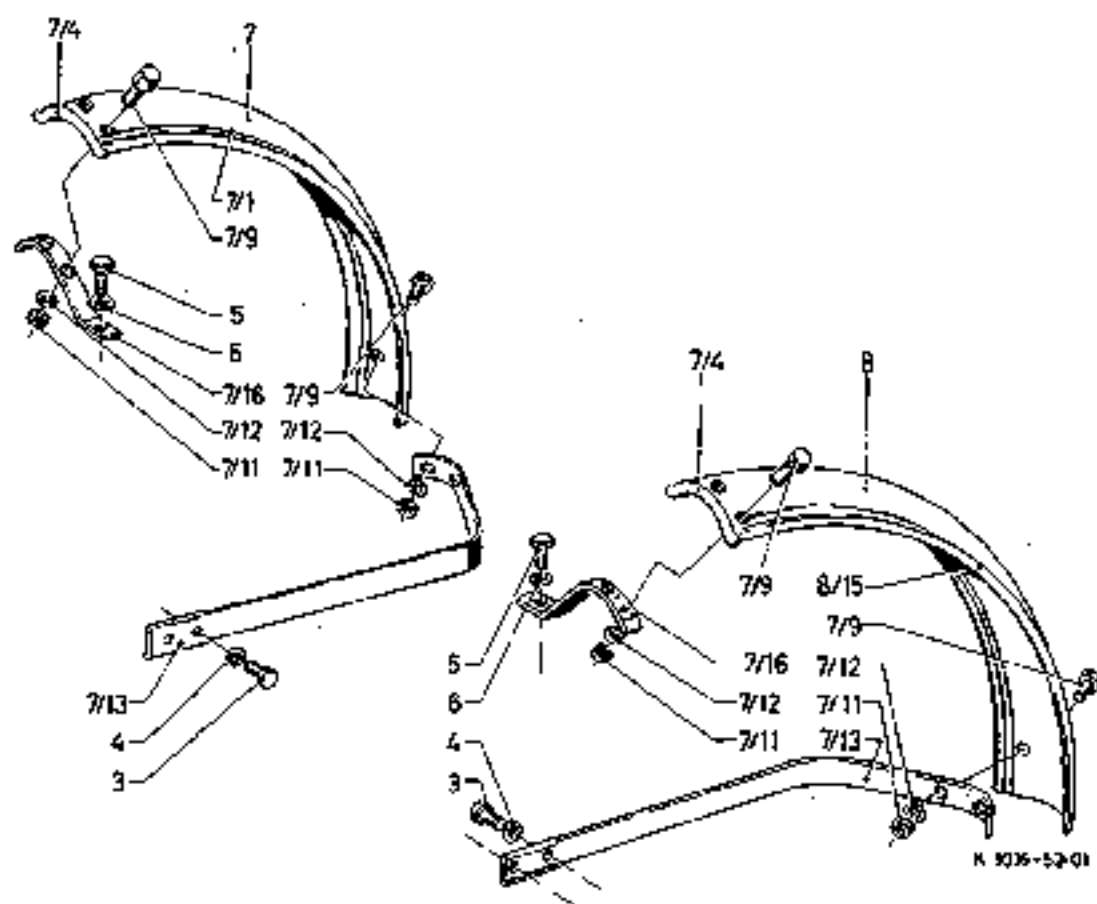

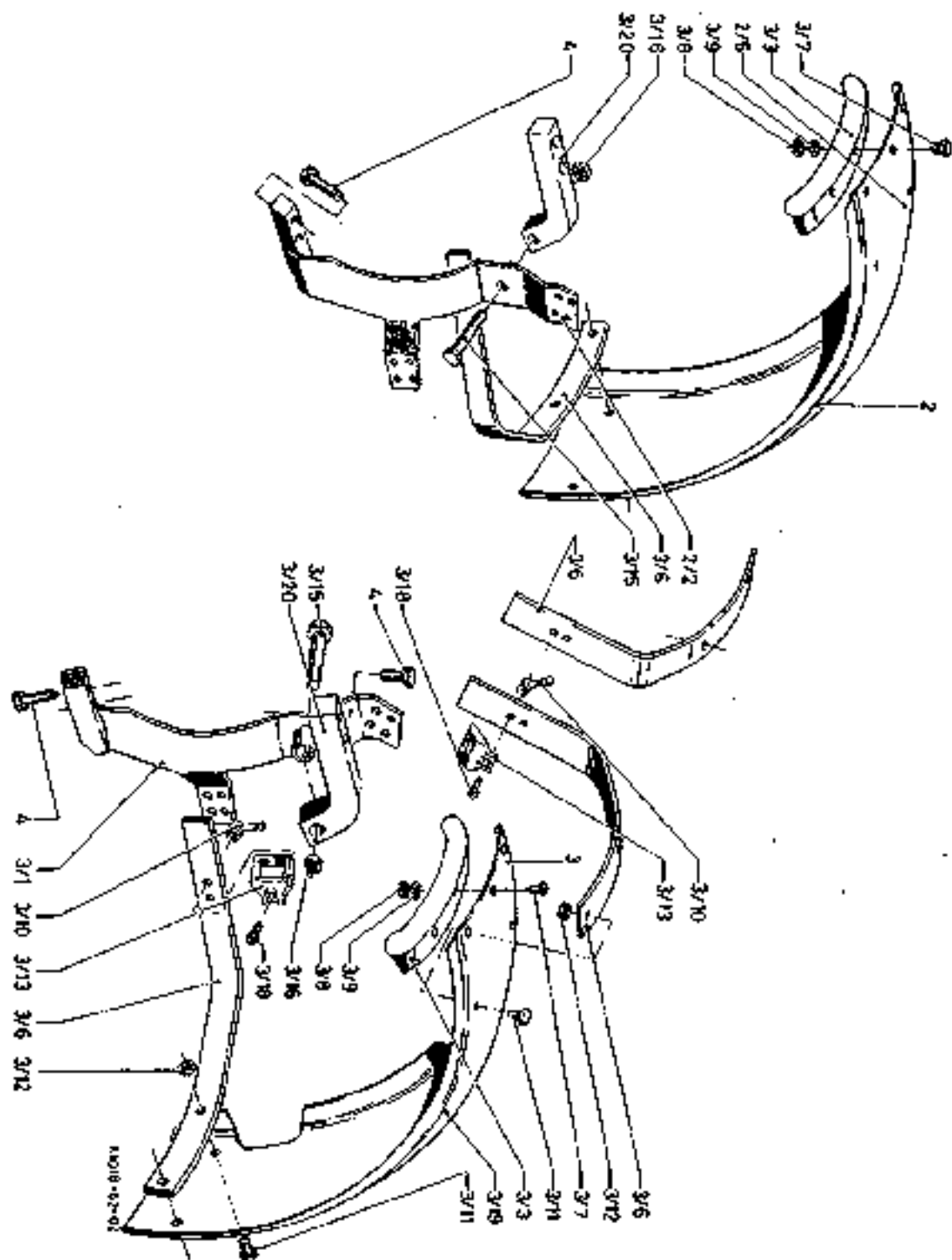

Führersitz
Driver's Seat
Siège du conducteur
Asiento de conductor

1054

Bild-Nr.	Schleppernummer		Fußnote	Teilnummer	Anzahl	
	ab	bis				
1				233 8047 *	1	1001-54
1/1				233 8049	1	1001-54
1/2				231 0778	1	1001-54
1/3				231 0918	2	1001-54
1/4				232 1828	2	1145-54
1/5				4x24 DIN 1481 (111 5423)	2	
1/6				232 1185	1	1001-54
1/8				M12 DIN 985-8 A4C (111 4365)	2	
1/9				M12x35 DIN 933-3.8 A4C (111 2538)	2	
1/10				13 DIN 125 A4C (110 7110)	2	
1/11				232 1187	1	1001-54
1/12				231 4547	1	1171-54
1/13				232 1186	2	1001-54
1/14				3x20 DIN 94 (110 6491)	1	
1/15				231 0931	1	1001-54
1/16				231 0908	1	1001-54
1/17				9 DIN 6799 (111 7930)	2	
1/18				232 1117	1	1001-54
1/19				232 1188	2	1001-54
1/20				232 1118	1	1001-54
1/24				232 1830	1	1145-54
1/25				8,4 DIN 125 A4C (110 7101)	2	
1/26				M 8 DIN 315-G GTW35vzls (110 7359)	3	
1/27				231 0910	1	1001-54
1/28				231 0080	1	1171-54
1/29				231 0912	1	1001-54
1/30				M 8x15 DIN 933-8,8 A4C (111 2305)	1	



Bild-Nr.	Schleppenummer		Fußnote	Teilnummer	Anzahl	
	ab	bis				
1/32				231 0775	1	1001-56
1/33				AM 8x10 DIN 86-8 A4C (110 5772)	2	
1/34				6,4 DIN 125 A4C (110 7095)	2	
2				232 1958	1	1001-54
3				232 1004	1	1001-54
3/1				232 0882	1	1001-54
3/2				232 0881	1	1001-54
3/3				5x16 DIN 1481 vzkc (111 5433)	1	
3/4				232 1011	1	1001-54
3/5				232 1012	1	1001-54
3/6				232 5588	1	1001-54
4				M 8x12 DIN 933-8.8 A4C (111 2299)	2	
5				M 6x25 DIN 933-8.8 vzkc (112 3749)	4	
6				M 8 DIN 934-8 A4C (111 2824)	6	
7				231 5435	4	1001-54
8				230 2205	1	1145-54
9				M 8x13 DIN 933-8.8 A4C (111 2311)	4	
10				M 8x15 DIN 933-8.8 A4C (111 2305)	2	
16				M 6 DIN 934-8 A4C (111 2318)	4	
17				232 1074	1	links 1006-54
18				232 1075	1	rechts 1006-54

Verkleidungskasten
Tank Panelling
Revetement en tôle
Caja de revestimiento

1055

Bild-Nr.	Schleppernummer		Fußnote	Teilnummer	Anzahl	
	ab	bis				
1				230 4869	1	1006-55
4				230 4142	1	1006-55
7				M 6/6 H 2139 vzkc (116 7130)	2	
8				7 585 D 2 (121 0432)	2	
9				M 8x12 DIN 933-8,8 A4C (111 2209)	9	
10				M 8 DIN 555 vzkc (110 8064)	2	
11				8 H 2203 vzkc (116 9689)	11	
12				M 8x15 DIN 933-8,8 vzkc (111 2305)	2	
13				AM 4x10 DIN 94-4,8 A4C (110 5510)	2	
14				M 4 DIN 934-8 A4C (111 2796)	2	
15				4 H 2203 vzkc (116 7192)	2	
18				230 4862	1	1001-55
19				230 4481	1	1001-53
20				B 5,5x19 DIN 7981 vzkc (110 1957)	1	
21				232 1024	1	Seitl. 11. 1006-55
22				232 1027	1	Var. NS 1006-53
24			232 1032	1	Normal. 1006-55
			233 2949	1	
25			232 2033	1	b. Hzg. 1006-55
			233 2948	1	

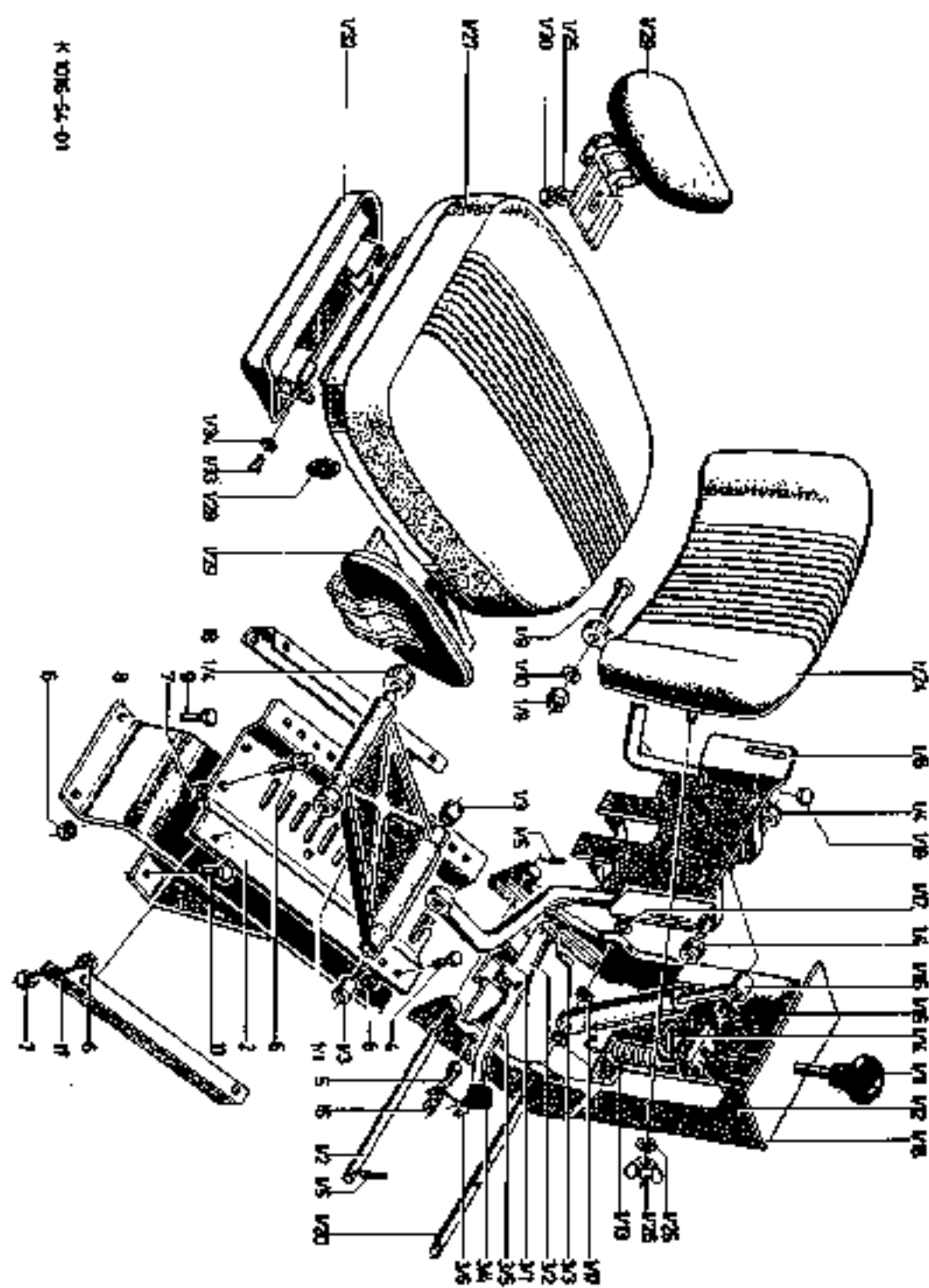
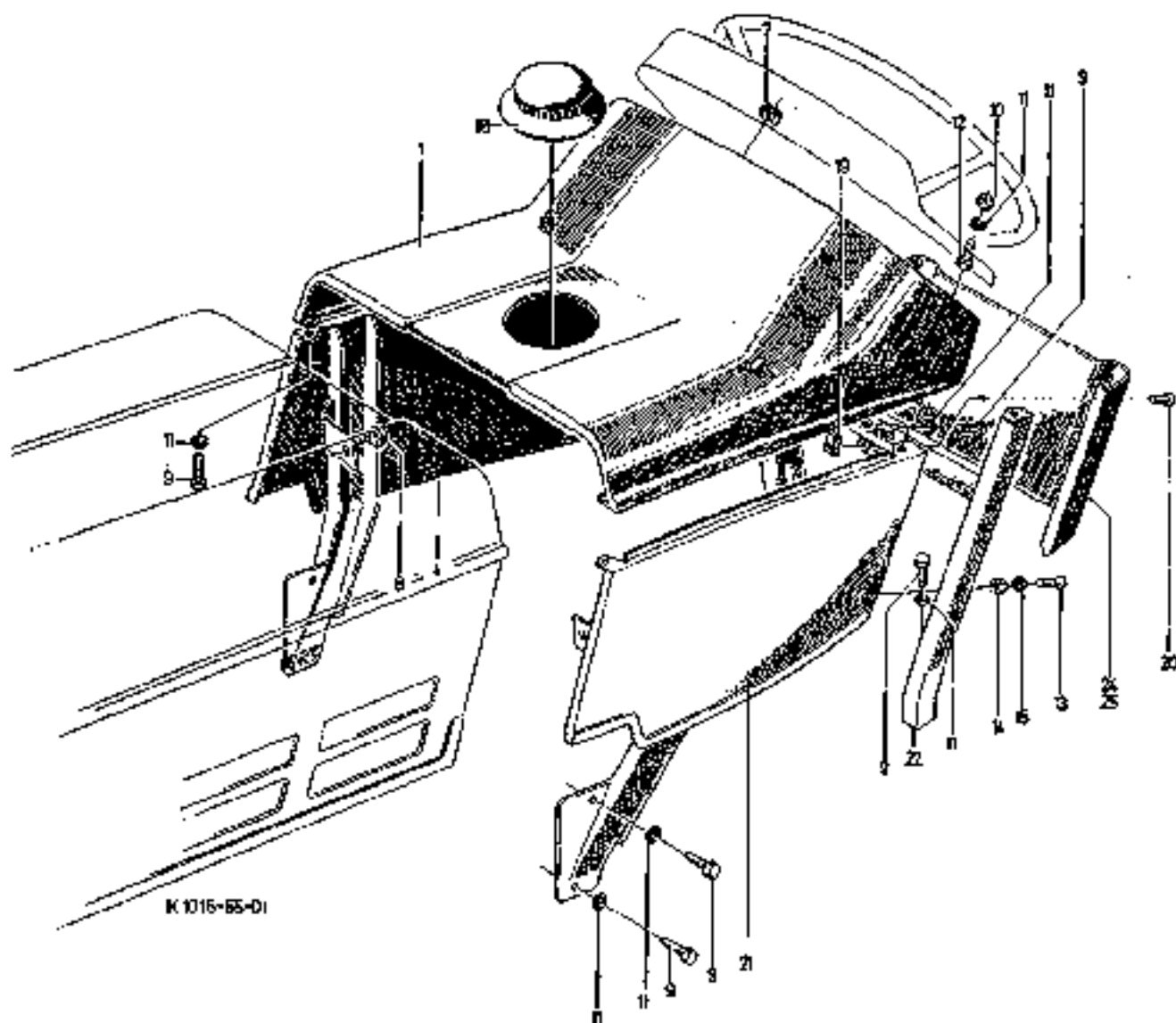

Rader, Ballastgewichte
Wheels, Ballast weights
Roues masses d'alourdissement
Ruecas, pesos de lastre

1058

Bild-Nr.	Schleppenummer		Fußnote	Teilnummer	Anzahl
	ab	bis			
1			+	11x20-275x18x58 H 7331 (117 0337)	1
2			+1	5,00F20-160x14x28 H 7331 (117 0336)	1
3			+2	A4,00E18-160x14x36H7331 (116 8644)	1
4			+3	9x20-275x18x58 H 7331 (116 1843)	1
5			+4	5,50F18-160x14x36H7331 (118 2154)	1
6			+5	W11x36x205x18x70 H 7331 (118 0014)	1
7			+6	W14Lx30x205x18x70 H 7331 (118 0013)	1
8				wird vollständig nicht geliefert	
9				wird vollständig nicht geliefert	
10				wird vollständig nicht geliefert	
11				wird vollständig nicht geliefert	
12				wird vollständig nicht geliefert	
13				wird vollständig nicht geliefert	
15				M14x1,5 DIN 934-10 A4C (110 0169)	8
16				2308 A 41 (121 8426)	18
17				2014 B 7 (121 8410)	16
18			+7	205x18xox100x760H 7339 (116 0008)	1
21			+8	W14Lx34x100x760x8H7340 (116 0009)	1
A1				1982-61-01,01 (340 1478)	4
A2				M16x60 DIN 931-8.8 A4C (111 1870)	12
A3				M16x100 DIN 931-8.8 A4C (111 1930)	12
A4				M16x140 DIN 931-8,8vzkc (111 1948)	12
A5				18 H 2203 vzkc (116 9897)	12
A6				W16 DIN 934-8 vzkc (111 2886)	12
+	Für Bereifung 12,5 - 20		+1	Für Bereifung 6,50 - 20	
+2	Für Bereifung 6,00-19		+3	Für Bereifung 10,5 - 20	
+4	Für Bereifung 7,50-18		+5	Für Bereifung 12,4/11-36 u. 13,6/12-36	
+6	Für Bereifung 16,9/14-30,18,4/15-30		+7	Zu Verstellrad 9-13	
+8	Zu Verstellrad 13				

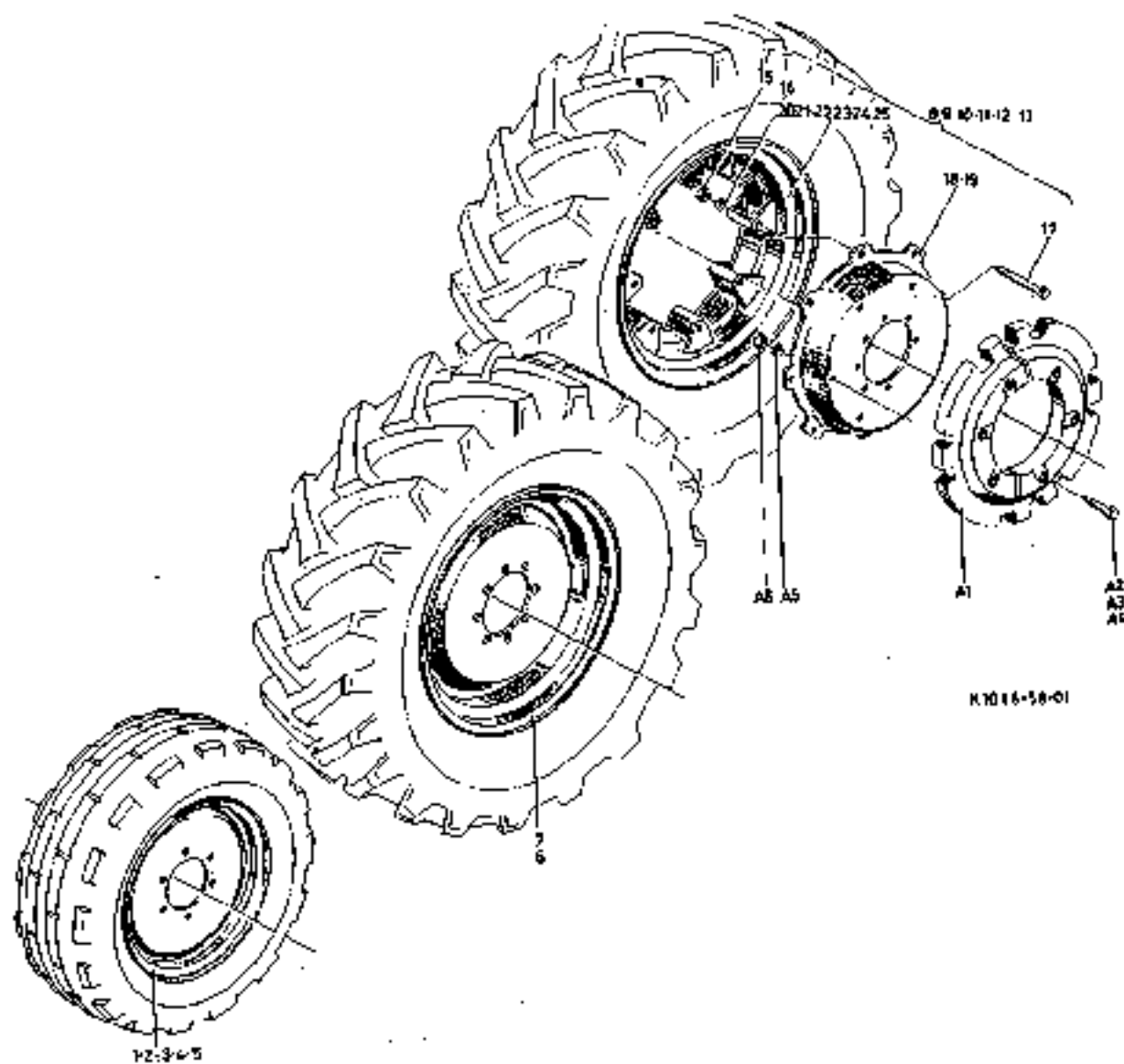

Schutzrahmen
Protective frame
protecteur Chassis
protector Marco para

1061

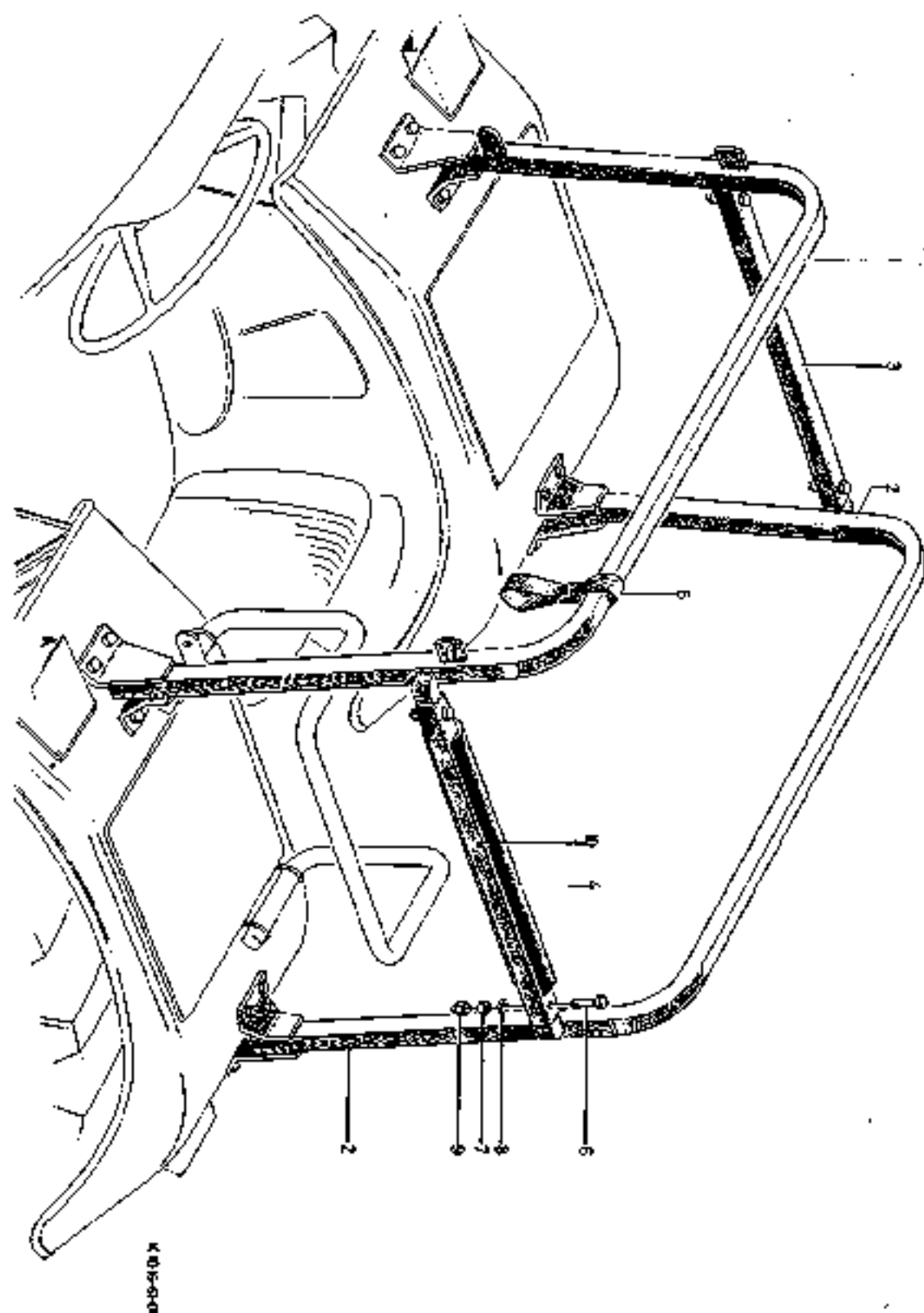

010-910 X

Anhängekupplung
Trailer Hitch
Chape d'attelage
Acoplamiento para remolque

1063

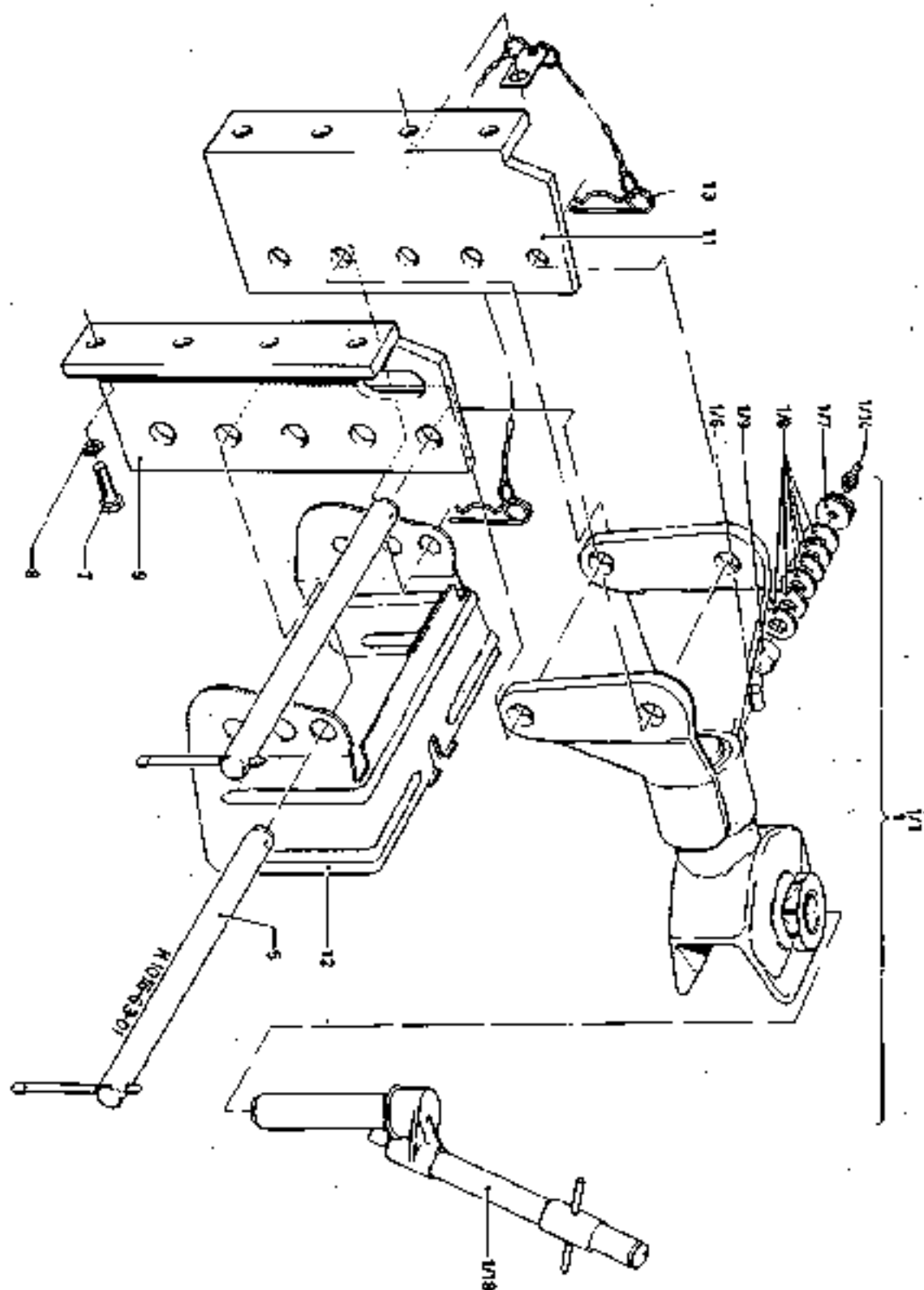

Beifahrersitz, Werkzeugkasten, Rückstrahler, Rückblickspiegel
Passenger Seat, Seat Cushion Toolbox, Reflector Driving Mirror
Siège de convoyeur coffre à outils, cataphotes, retroviseur
Asiento para el acompañante caja de herramientas, reflectores, espejo retrovisor

1076

Bild-Nr.	Schleppernummer		Fußnote	Teilnummer	Anzahl	
	ab	bis				
1				230 6322	1	1001-76
2				1055-51-01.06 (338 7158)	4	
3				1055-51-01.05 (338 7157)	4	
4				6 H 2203 vzkc (116 7194)	8	
5				M 6 DIN 934-8 vzkc (111 2813)	8	
6				230 6798	2	1001-76
10				230 6817	1	1001-76
A1				230 6803	1	1001-60
A2				230 6797	2	1001-60
A3				230 8040	2	1152-60
A4				M 10 DIN 934-8 A4C (110 2658)	2	
A6				M 10x28 DIN 933-8.8 A4C (111 2429)	2	
B1				230 6923	2	1006-68
B2				375 80 245 (335 1866)	2	
B3				M 6x15 DIN 933-8.8 A4C (111 2251)	4	
B4				M 6 DIN 934-8 vzkc (111 2813)	4	
B5				6 H 2203 vzkc (116 7194)	4	
C1				232 7346	1	1001-67
C2				1110-67-04.10 (338 7583)	1	
C3				1110-67-03.03 (338 7582)	1	
C4				7 565 C 5 (121 8034)	2	
C7				M 10 DIN 985-8 A4C (110 2756)	1	

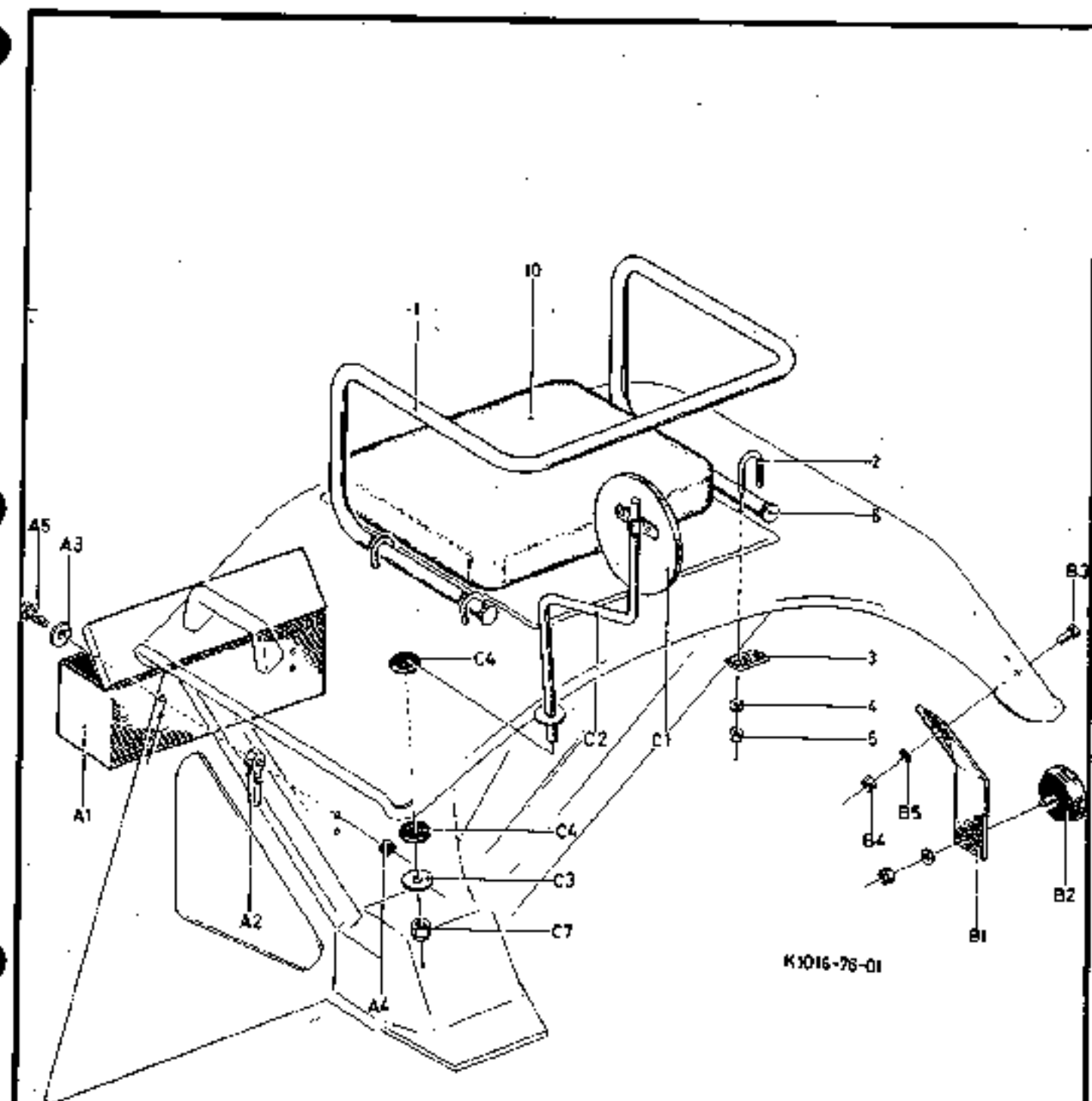

K1016-76-01

Duo-Zapfvelle

Two-speed PTO Shaft

Prise de force permettant d'obtenir 2 régimes de rotation

Arbol toma de fuerza tipo Duo

1077

Bild-Nr.	Schlappnummer		Fußnote	Teilnummer	Anzahl	
	ab	bis				
1				22x1 DIN 472 (110 7812)	1	
2				230 9444	1	1401-77
3				230 9445	1	1401-77
4				1424-11-04.68 (339 1900)	1	
5				31x1, 5 H 2259 (116 7224)	1	
6				230 9446	1	Z=12 1401-77
7				NUP 2208 E (110 2340)	1	
8				40x1, 75 DIN 471 (110 7755)	1	
9				230 9447	1	Z=18 1401-77
10				NJ 1009 ZS (112 2859)	1	
11				230 9449	1	1401-77
12				M 10x55 DIN 912-8, 8 A4C (112 6138)	2	
13				32x2 DIN 471 (110 1816)	1	
14				230 9452	1	1401-77
15				HS 92x97x17 H 4455 (116 1122)	2	
17				35 H 2271 (116 1510)	1	
22				230 9457	1	1401-77
23				230 9458	1	Z=39 1401-77
24				K 43x48x27 H 4455 (116 1512)	1	
25				6209 N (110 1784)	1	
26				10 DIN 7980 (111 9612)	7	
27				M 10x40 DIN 912-10, 9 A4C (112 4774)	5	
28				SP 85 DIN 5417 (111 7457)	1	
29				45x2, 5 DIN 471 (112 4663)	1	
30				8 H 2203 vzkc (116 9689)	4	
31				M 8x20 DIN 912-10, 9 A4C (111 0561)	4	

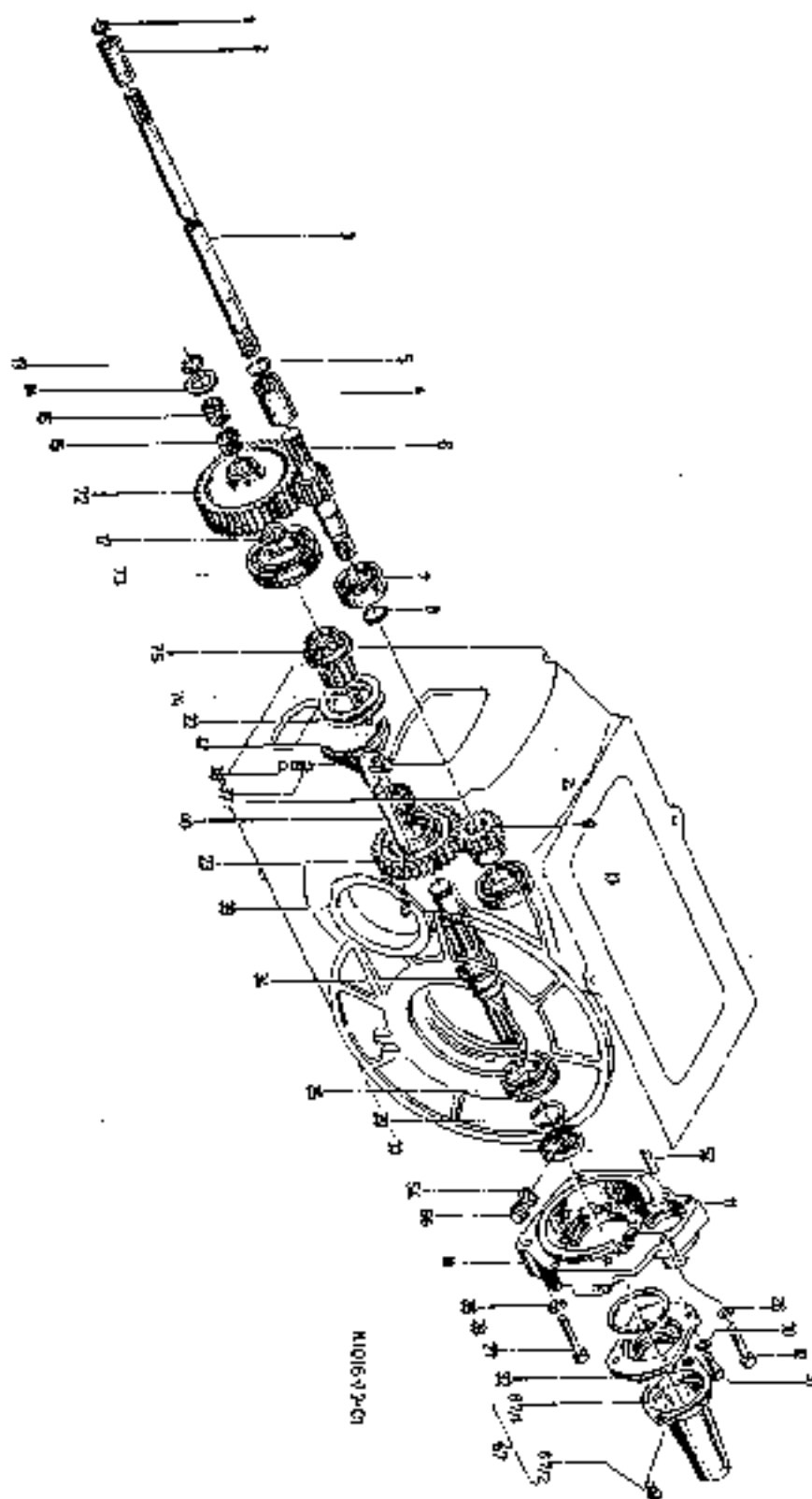

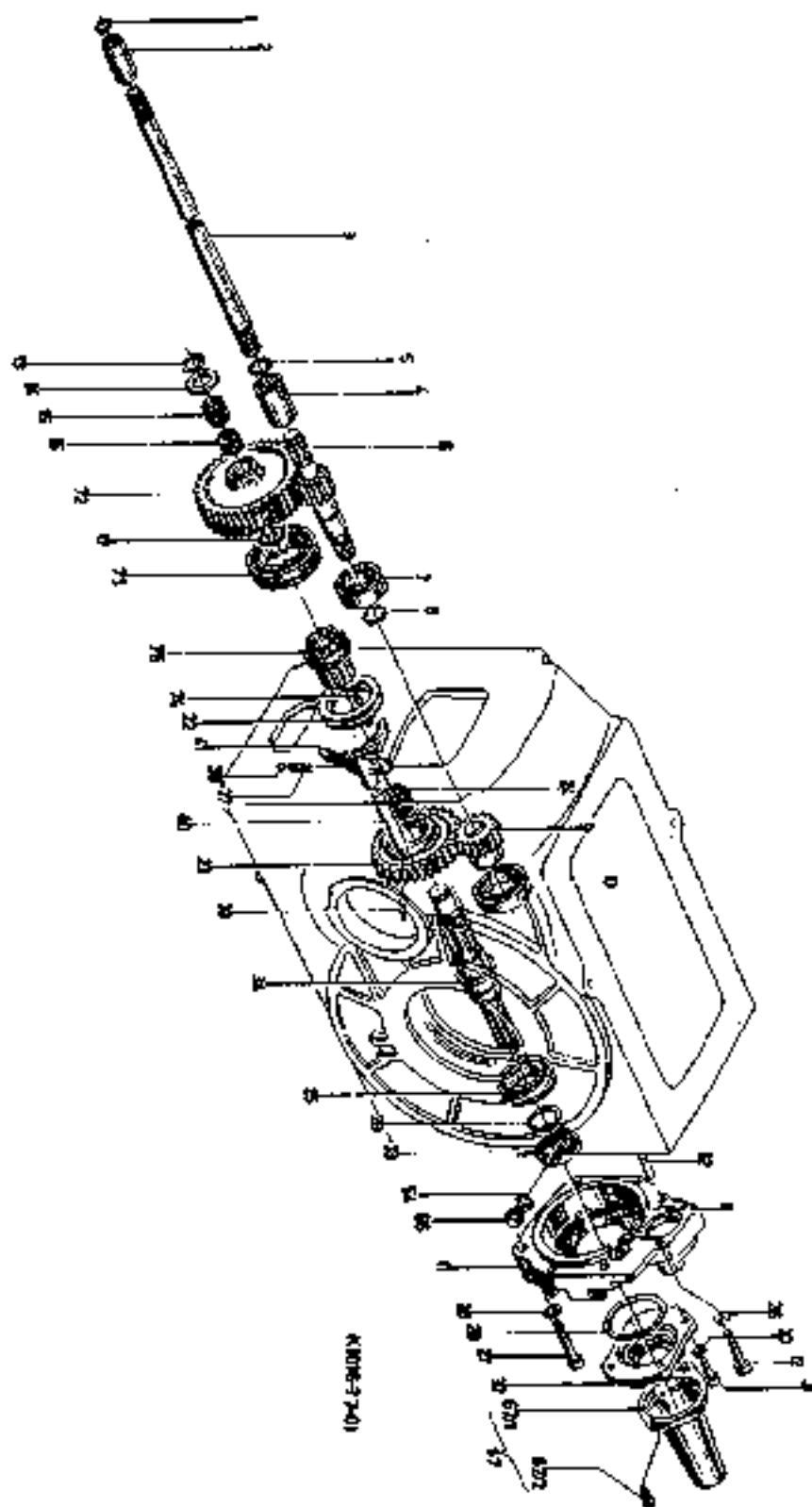

Heizungsanlage
Heating System
Climatisation
Sistema de calefaccion

1085

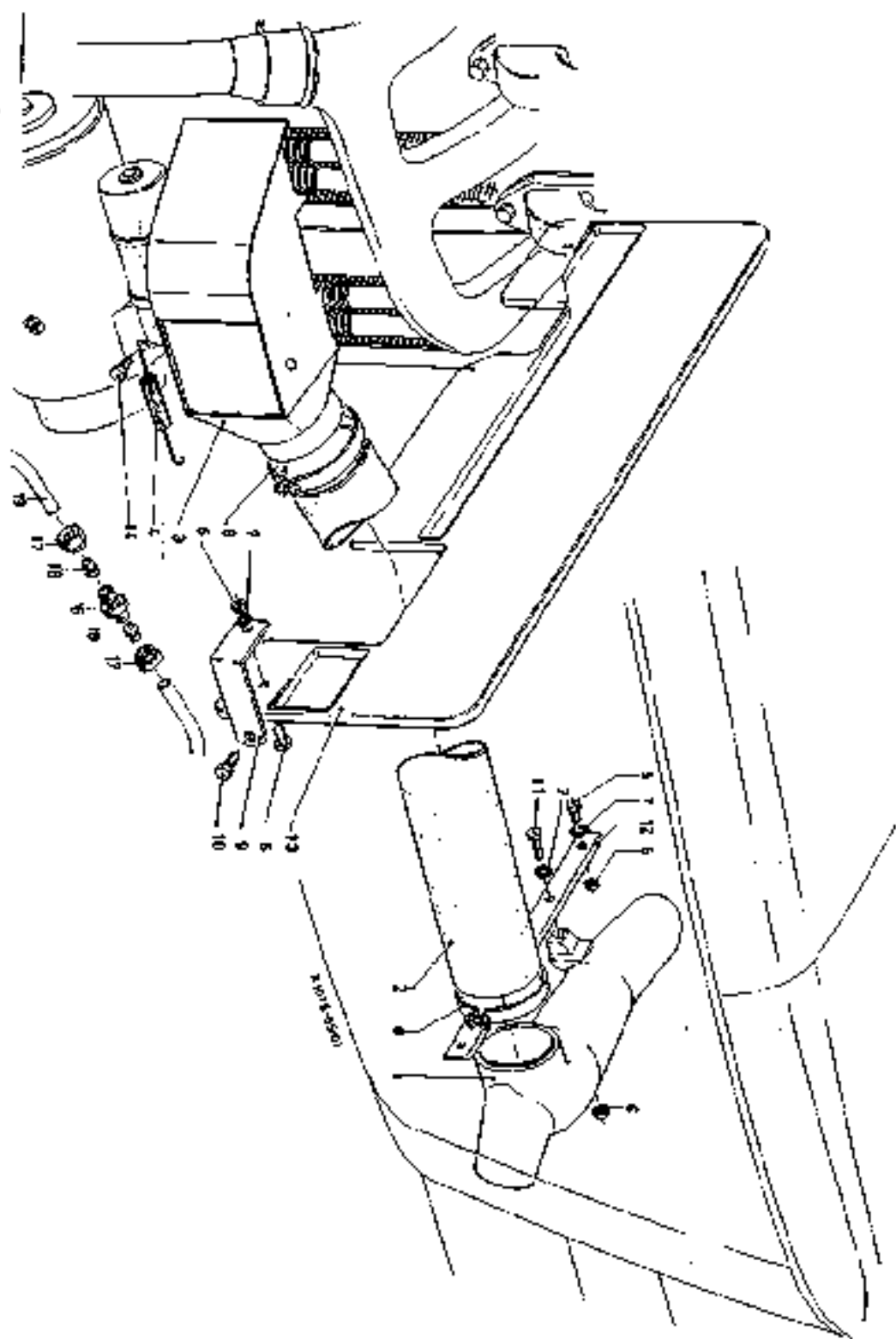

Hydr. Pumpe mit Leitungen
Pump with Piping
Pompe hydraulique, conduits
Bomba hidráulica con tuberías

1901

Bild-Nr.	Schleppernummer ab bis	Fußnote	Teilnummer	Anzahl	
1		+	230 8661	1	Wahlweise 1940-01
2			1940-01-24.02 (340 0561)	1	
3			M 12x1,5 DIN 985-8 A4C (112 2569)	1	
4		+1	230 8341	1	Wahlweise 1971-01
5			L 15 DIN 3902 vzke (111 6711)	1	
6			M 10x45 DIN 912-8.8 A4C (110 0517)	2	
7			10 DIN 7980 A4C (111 9613)	2	
8			0150-83-09.07 (336 4291)	1	
9			1941-01-01.29 (340 0736)	1	
10			230 3354	1	1952-01
11			25x2,5 H 721 (116 6033)	1	
12			1940-01-24.05 (340 0563)	1	
13			18x2,5 H 721 (116 6015)	1	
14			M 6x22 DIN 912-10.9 A4C (111 0517)	8	
15			6 DIN 7980 vzke (111 9609)	8	
16			AL 22 DIN 3870 vzke (111 6656)	1	
17			L 22 DIN 3861-St (111 6620)	1	
18			AL 15 DIN 3870 vzke (111 6653)	5	
19			L 15 DIN 3861 St (111 6626)	5	
20			231 2614	1	1952-01
21			L 15 M DIN 3901 A4C (111 6687)	1	
22			A 18x22 DIN 7803-Cu (111 8713)	1	
23		+2	124 2307 121 0596	1 1	8931-07 8931-10
24			A 26x31 DIN 7803-Cu (111 8760)	1	
25			AL 12 DIN 3870 A4C (112 2817)	1	
26			L 12 DIN 3861-St (111 6624)	1	
27			L 12 M DIN 3901 A4C (112 2822)	1	
+ Hydro Pumpe, 11 CCM Pro Umdr. 175 Atü					
+1 Hydro-Pumpe, 14 CCM Pro Umdr. 175 Atü +2 Schneidring zu Bild 23					

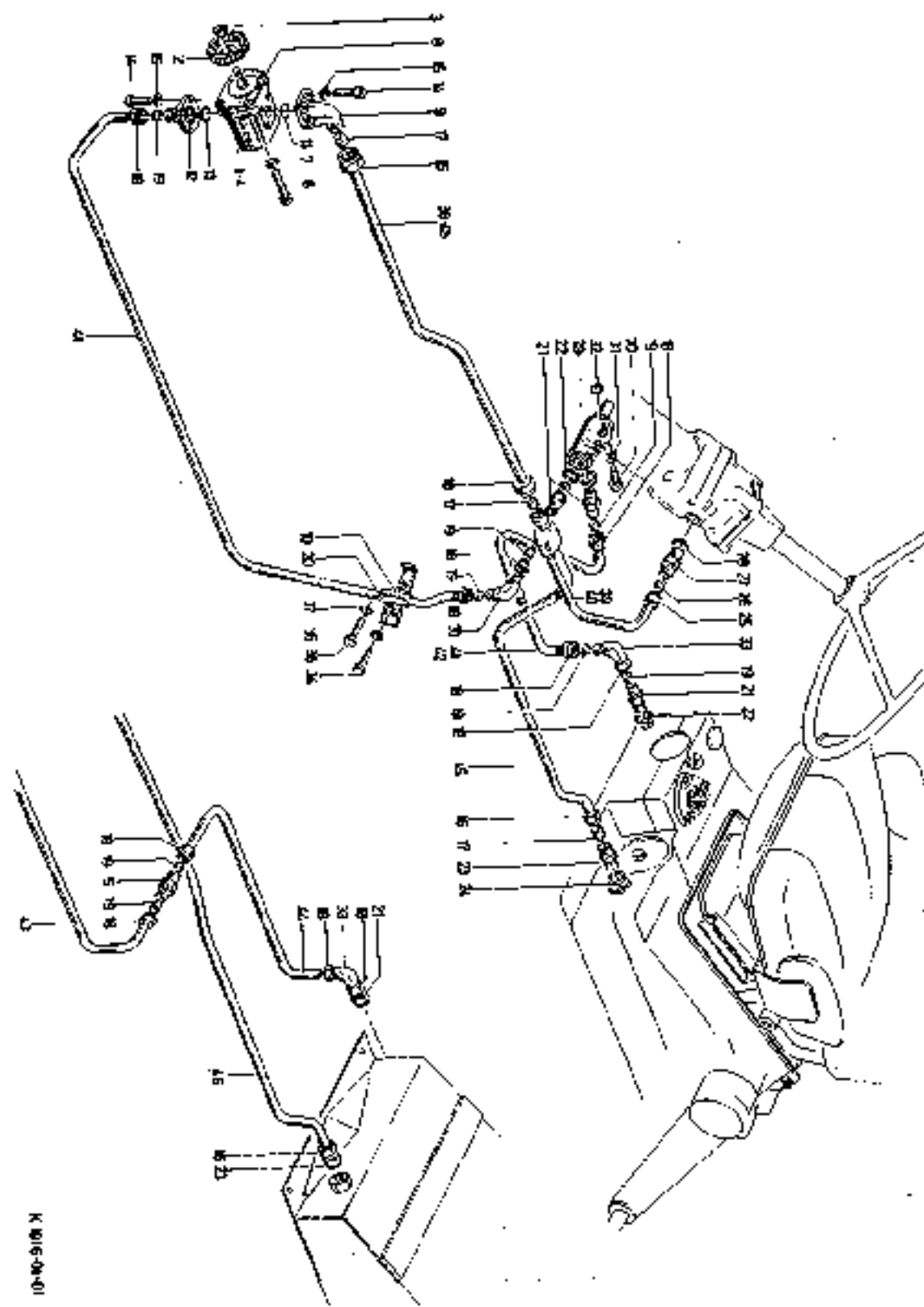

K 916-04-01

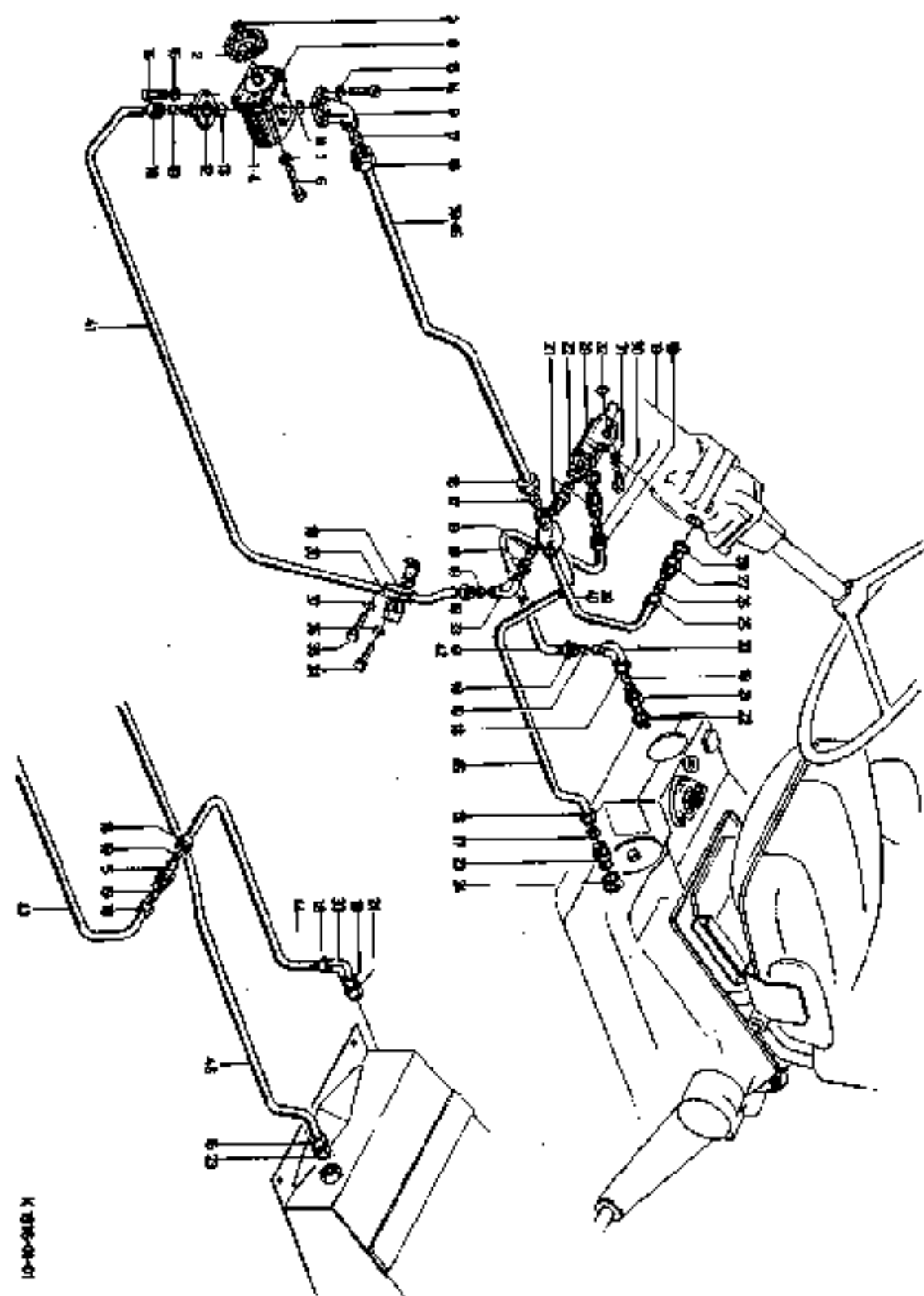

K 318-04-01

Remote - Control
Remote - Control
Télécommande hydraulique
Control remote

1904

Bild-Nr.	Schleppnummer		Fußnote	Teilnummer	Anzahl	
	ab	bis				
1				233 3728		Endgerät 1-Rastig
1/1				10x2 H 2927 GI 9 (116 9761)	1	
2			+	233 3726		
3				Wir lief. nur Bild-Nr. 3A		
3/1				1952-o8-22. 95 (340 1283)	1	
3/2				22x2 H 2927 -Gi (116 9764)	1	
3/3				18x2 H 2927 -Gi (116 9763)	2	
4			+1	Wir lief. nur Bild-Nr. 4/1		
4/1			+2	1941-o7-21. 10 (340 0767)	1	
4/2				M 18x1, 5x12 H 3132 (116 0286)	2	
4/3				A 18x24 DIN 7603 Cu (111 8718)	2	
4/4				14x3 H 721 (116 6000)	3	
5			+3	Wir lief. nur Bild-Nr. 5/1		
5/1			+4	231 0890	1	1941-07
5/1.1				M 8x90 DIN 931-8. 8 A4C (111 1200)	5	
5/1.2				B M 8 DIN 439-8 A4C (112 6748)	5	
5/1.2				231 4392	2	1941-07
5/1.4				231 4398	1	1941-07
5/1.5				231 4394	1	1941-07
5/1.6				231 5089	1	1941-07
5/4				M 8x170 DIN 931-8. 8A4C (112 6980)	1	
6			+5	1952-o7-12. 10 (231 4044)		
6/1				1952-o7-12. 01 (347 1280)	1	
6/3				M 12x1, 5 DIN 908 phosph. (112 2350)	2	
6/4				A 12x15, 5 DIN 7603 Cu (111 8673)	2	
6/6				25x2, 5 H 721 (116 6033)	1	

* Zwischenger. vollst. m. Sicherheitsvent. 2-Rastig

+1 Anflanschger. vollst., 2 Anschl.-Doppelwirk. m. Rundschnurringen

+2 Hydr. Steuervent. 2 Anschl.-Doppelwirk.

+3 Zwischenger. vollst., 2 Anschl. Doppelwirk. mit Rundschnurringen

+4 Zwischengerät, 2 Anschl., Doppelwirk. m. Schrauben u. O-Ringe

+5 Zwischenplatte vollst.

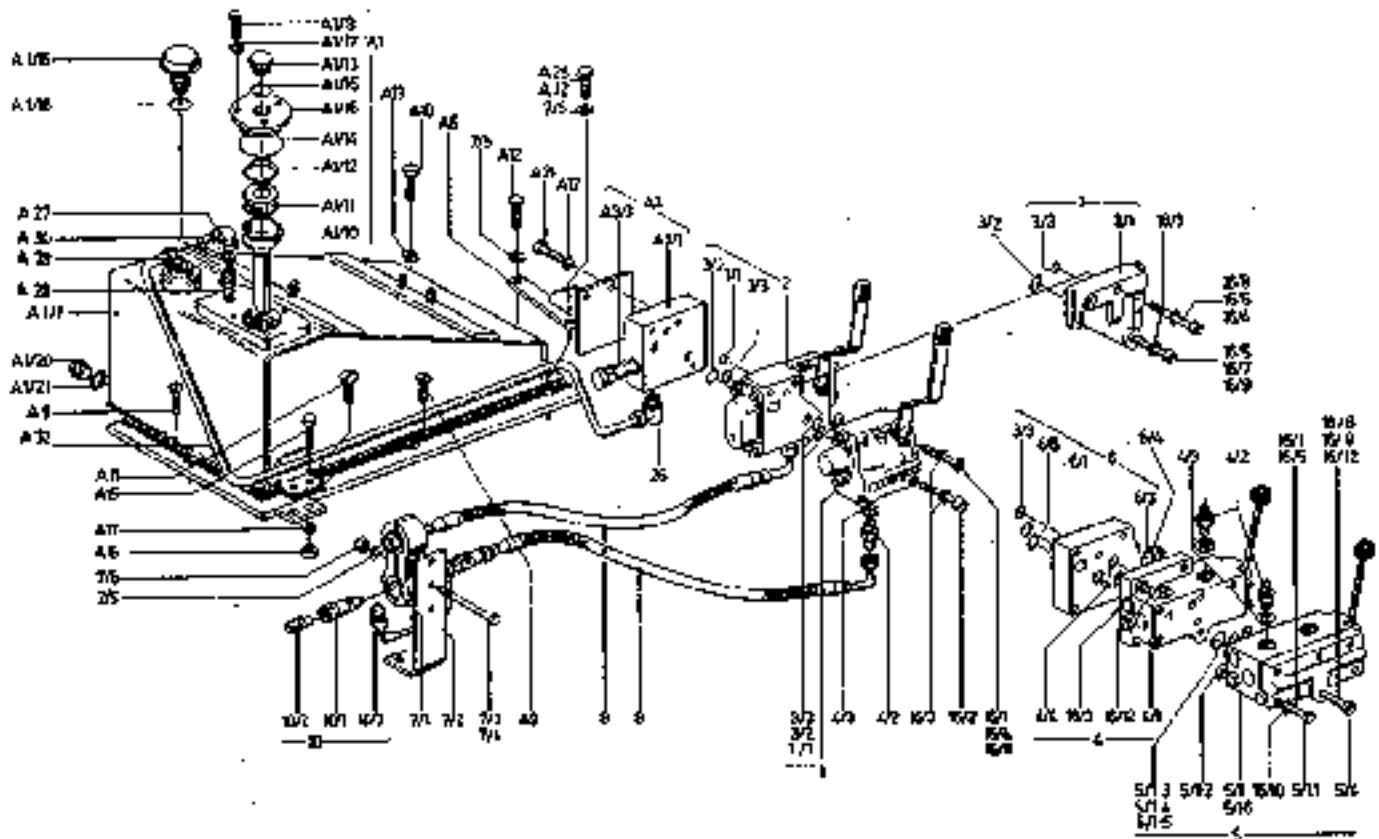

908-04-01

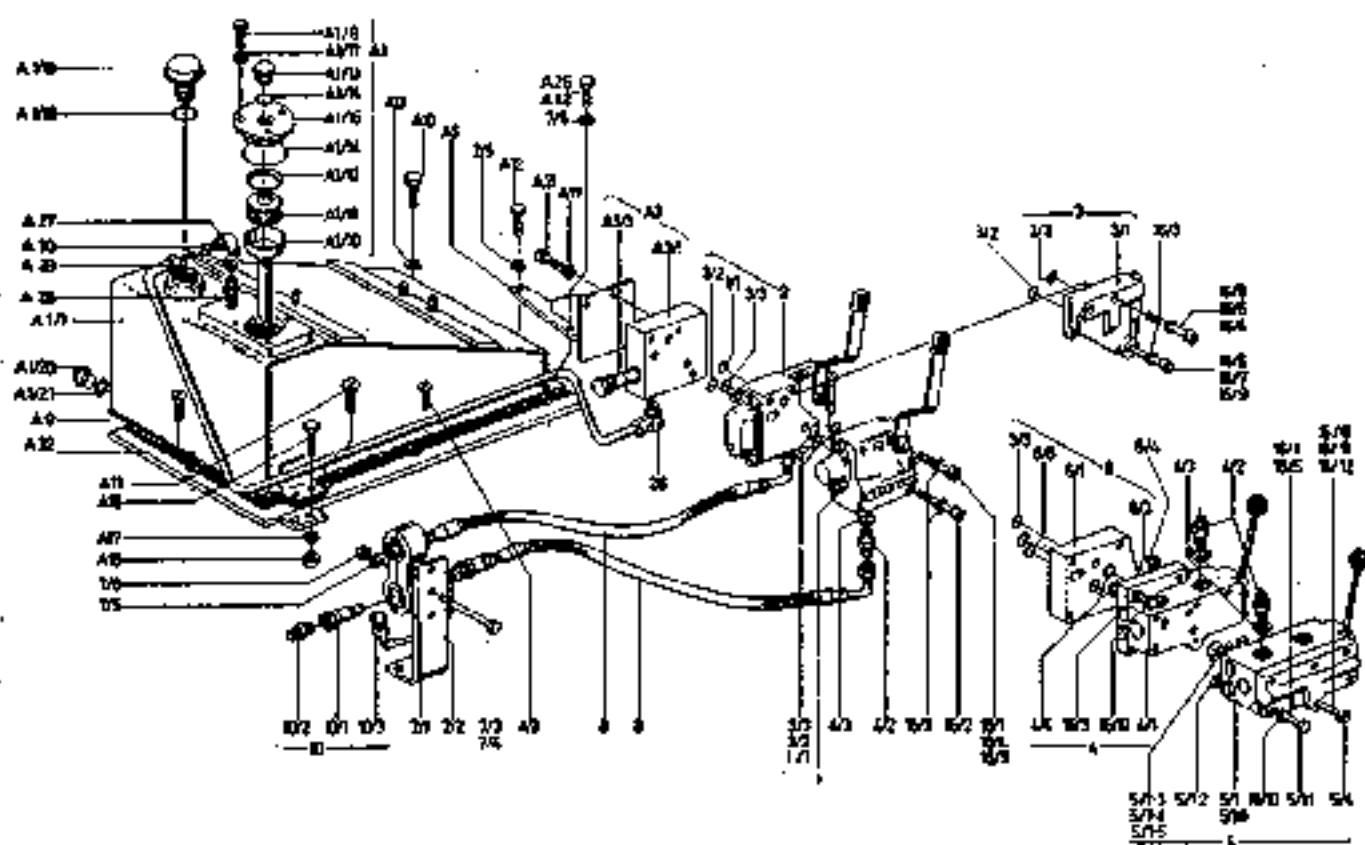

1916-06-01

Bild-Nr.	Schleppernummer		Fußnote	Teilnummer	Anzahl	
	ab	bis				
7/1				231 3039	1	1971-07
7/2				231 3129	1	1926-04
7/3				M 10x75 DIN 931-8.8vzkc (111 1336)	1	
7/4				M 10x130 DIN 931-8.8vzkc (112 4803)	1	
7/5				A 10 DIN 128 A4C (110 2800)	1	
7/6				M 10 DIN 934-8 A4C (110 2659)	1	
8				1971-04-27.20 (340 1654)	2	
10				1941-07-24.10 (347 1265)	1	
10/1				1941-07-24.01 (231 9364)	1	
10/2				1941-07-24.02 (231 9365)	1	
10/3				1941-07-24.03 (231 9366)	1	
16/1				M 8x40 DIN 912-8.8 A4C (112 3701)	2	
16/2				M 8x50 DIN 912-8.8 A4C (110 1405)	1	
16/3				8 H 2203 vzkc (116 9689)	3	
16/4				M 8x80 DIN 912-8.8 A4C (111 0622)	2	
16/5				M 8x90 DIN 912-8.8 A4C (110 1406)	1	
16/6				M 8x120 DIN 912-8.8 A4C (112 3702)	2	
16/7				M 8x130 DIN 912-8.8 A4C (110 1407)	1	
16/8				M 8x160 DIN 912-8.8 A4C (110 2048)	2	
16/9				M 8x170 DIN 912-10.8 A4C (112 3703)	1	
16/10				A 8 DIN 128 A4C (110 2799)	4	
16/11				M 8x75 DIN 912-8.8 A4C (110 2141)	3	
16/12				M 8x35 DIN 912-8.8 A4C (112 3700)	3	
A2			+	Wir lief. nur Bild-Nr. A1		
A1/1				230 1139	1	
A1/3				M 6x15 DIN 933-8.8 A4C (111 2251)	3	
A1/10				1941-08-01.41 (340 0808)	1	

+ Ölbehälter 15 Liter

Bild-Nr.	Schleppernummer		Fußnote	Teilnummer	Anzahl	
	ab	bis				
A1/11				1941-08-01.33 (340 0802)	1	
A1/12				1941-08-01.128 (340 0816)	1	
A1/13				1952-04-01.45 (340 1272)	1	
A1/14				63x2 H 721 (116 9587)	1	
A1/15				1941-08-01.49 (340 0808)	1	
A1/16				1941-08-01.134 (340 0803)	1	
A1/17				6, 4 DIN 125 vzkc (110 7095)	3	
A1/18				A 30x36 DIN 7603 Cu (111 8784)	1	
A1/19				8741-30-08.01 (126 6675)	1	
A1/20				AM 16x1,5 DIN 7604 vzkc (111 8965)	1	
A1/21				A 16x22 DIN 7603 Cu (111 8707)	1	
A2			*	230 2139	1	1952-04
A2/1				230 2141	1	1952-04
A3			+1	231 3119	1	1926-04
A3/1				231 3118	1	1926-04
A3/3				1952-08-85.136 (340 1392)	1	
A5				231 3113	1	1952-04
A9				AM 10x30 DIN 87-4.8 A4C (112 6574)	3	
A 10				M14x35 DIN 933-8.8 vzkc (111 2617)	1	
A 11				AM14x30 DIN 87-4.8 A4C (112 6576)	2	
A 12				M 10x40 DIN 933-8.8 A4C (111 2447)	2	
A 13				A 14 DIN 128 vzkc (110 2802)	1	
A 15				M 8x30 DIN 933-6.8 vzkc (111 2341)	2	
A 16				M 8 DIN 934-8 A4C (111 2824)	2	
A 17				A 8 DIN 128 A4C (110 2799)	2	
A 21				M 8x25 DIN 933-8.8 A4C (111 2333)	3	
* Ölbehälter 37 Liter		+1 Sockel vollst. m. Sicherheitsventil für Steuergerät mit KHD-Flansch				

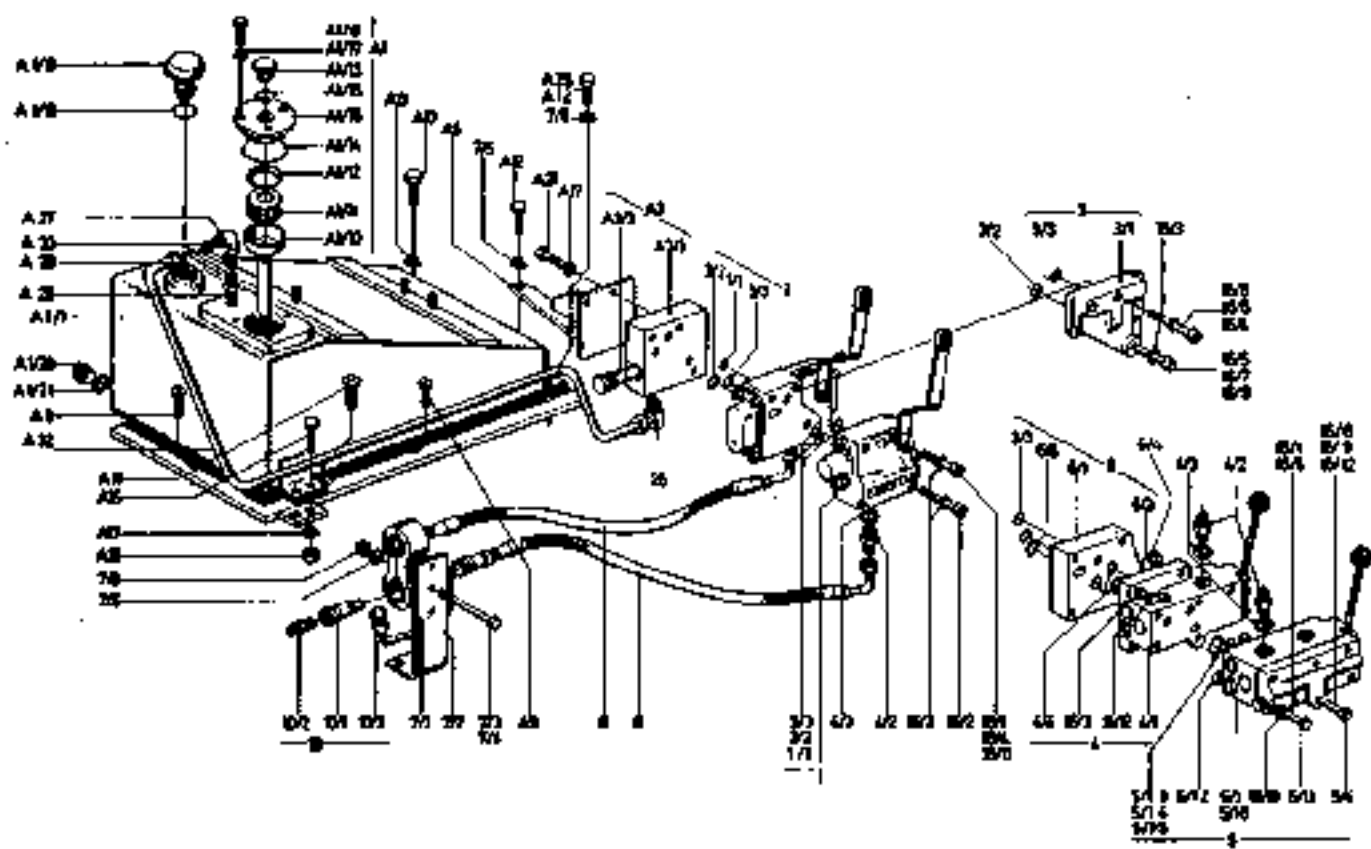

756-04-01

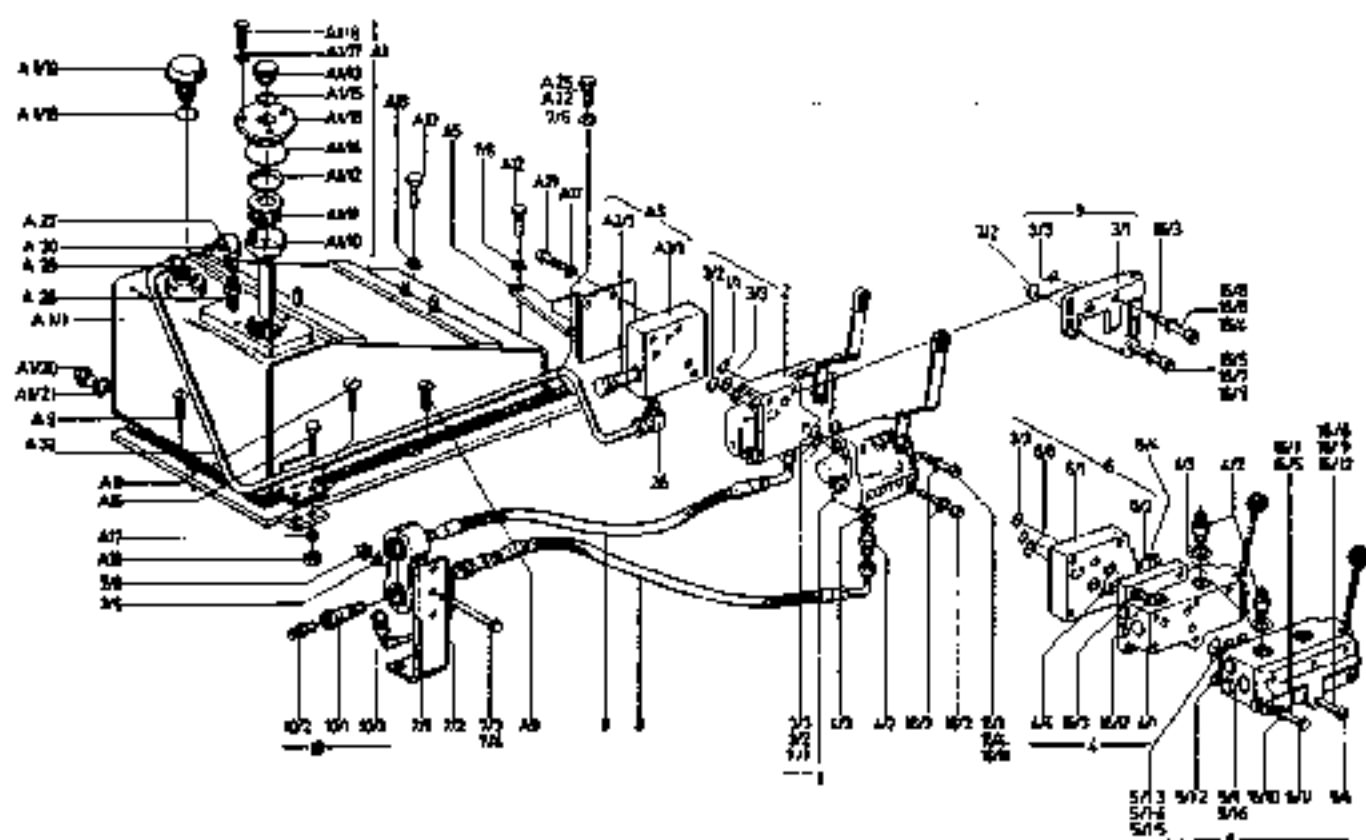

B6-04-01

Remote-Anschlüsse
Remote Connections
Equipements de télécommande
Españoles de control remoto

1907

Bild-Nr.	Schleppernummer		Fußnote	Teilknummer	Anzahl	
	ab	bis				
1				233 3728		Endgerät (1-Rastig)
2			+	233 3726		
3				Wir lief. nur Bild-Nr. 3/1		
3/1				1952-08-22.35 (340 1283)	1	
3/2				22x2 II 2927-Gi (116 9764)	1	
3/3				18x2 H 2927-Gi (116 9763)	2	
4				Wir lief. nur Bild-Nr. 4/1		
4/1				1941-07-21.10 (340 0767)	1	
4/2				M 18x1,5x12 II 9132 (116 0236)	2	
4/3				A 18x24 DIN 7603 Cu (111 8718)	2	
4/4				14x3 H 721 (116 6000)	3	
5				Wir lief. nur Bild-Nr. 5/1		
5/1				231 0890	1	1941-07
5/1.1				M 8x80 DIN 931-8.8 A4C (111 1200)	3	
5/1.2				B M 8 DIN 439-5.8 A4C (112 6748)	5	
5/1.3				231 4392	2	1941-07
5/1.4				231 4393	1	1941-07
5/1.5				231 4394	1	1941-07
5/1.6				231 5089	1	1941-07
6				1952-07-12.10 (231 4044)		
6/1				1952-07-12.01 (347 1280)	1	
6/3				M 12x1,5 DIN 908 phosph. (112 2350)	2	
6/4				A 12x15,5 DIN 7603 Cu (111 8678)	2	
6/6				25x2,5 H 721 (116 6033)	1	
7/1				231 3039	1	1971-07
7/3				M 10x75 DIN 931-8.8vzkt (111 1336)	1	
7/5				A 10 DIN 128 A4C (110 2800)	1	

* Zwischengerät vollst. mit Sicherheitsventil 2-Rastig

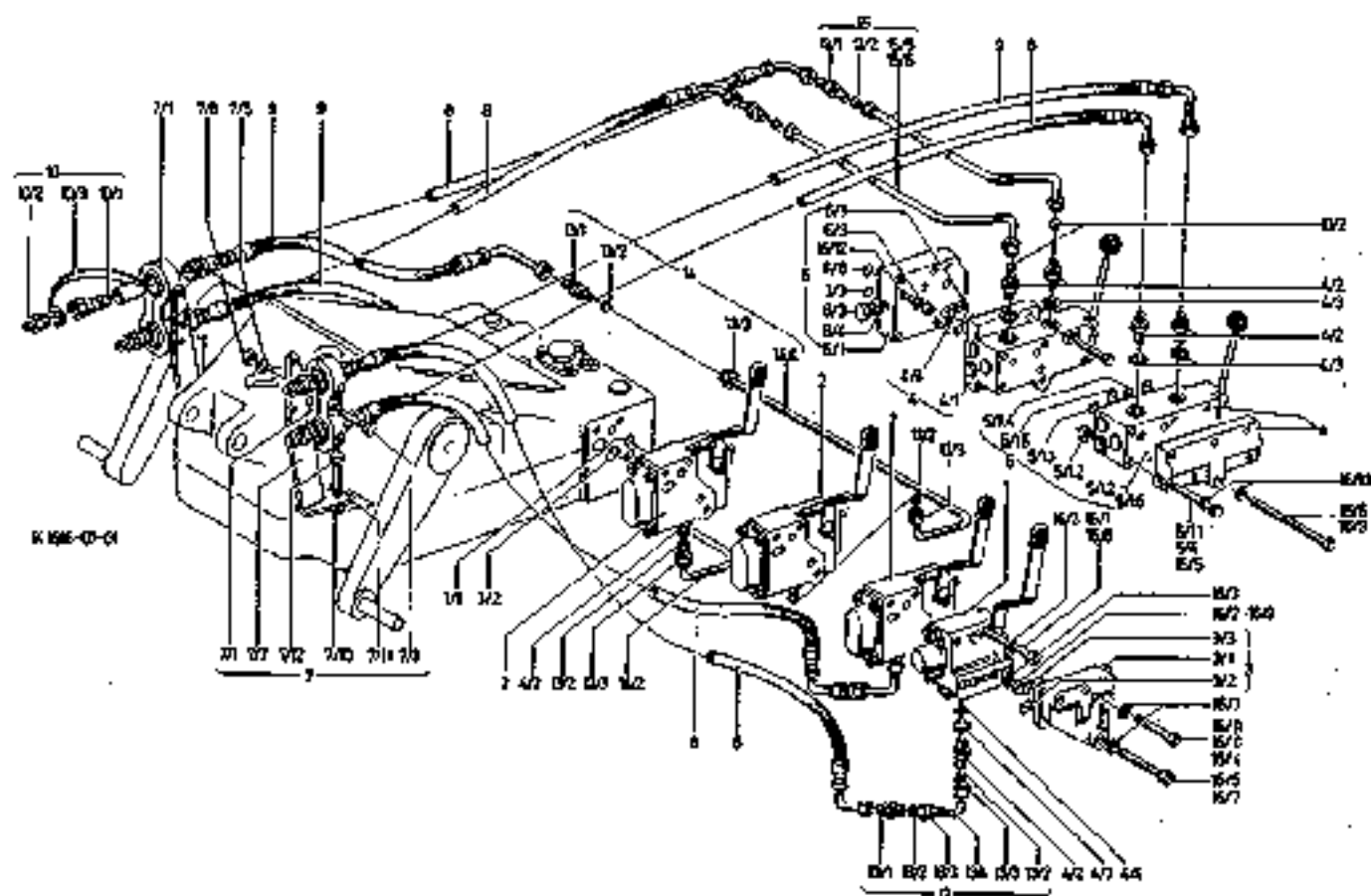



Bild-Nr.	Schleppernummer		Fußnote	Teilnummer	Anzahl	
	ab	bis				
7/6				M 10 DIN 934-8 A4C (110 2659)	1	
7/7				231 3151	1	1941-07
7/10				15 DIN 125 A4C (110 7114)	2	
7/11				A 14 DIN 128 (110 2835)	1	
7/12				M 14x130 DIN 931-8.8A4C (112 4812)	1	
8			+	1971-04-27. 20 (340 1654)		
9			+1	1971-04-27. 10 (340 1653)		
10				1941-07-24. 10 (347 1265)	1	
10/1				1941-07-24. 01 (231 9364)	1	
10/2				1941-07-24. 02 (231 9365)	1	
10/3				1941-07-24. 03 (231 9366)		
13				231 3155		
13/1				L 12 DIN 3902 vzkc (111 6709)	1	
13/2				L 12 DIN 3861-St vzkc (111 6624)	2	
13/3				AL 12 DIN 3870 A4C (112 2817)	2	
13/4				231 3157	1	1941-07
14			+2	231 6458		1941-07
15			+3	231 6459		1941-07
15/5				12x1 DIN 2391-GZF-P. M (112 5083)	1	
15/6				12x1 DIN 2391-GZF-P. M (112 5083)	1	
16/1				M 8x40 DIN 912-8.8 A4C (112 3701)	2	
16/2				M 8x50 DIN 912-8.8 A4C (110 1405)	1	
16/3				8 H 2203 vzkc (116 9689)	3	
16/4				M 8x80 DIN 912-8.8 A4C (111 0622)	2	
16/5				M 8x90 DIN 912-8.8 A4C (110 1406)	1	
16/6				M 8x120 DIN 912-8.8 A4C (112 3702)	2	
+		Schlauchleitung, kurzer Winkel		+1 Schlauchleitung, langer Winkel		
+2		Rohrleitung für KHD-Steuergerät		+3 Rohrleitung für Westinghousegerät		



an 24600 - Mr. Harroz

HZT
17.2.72

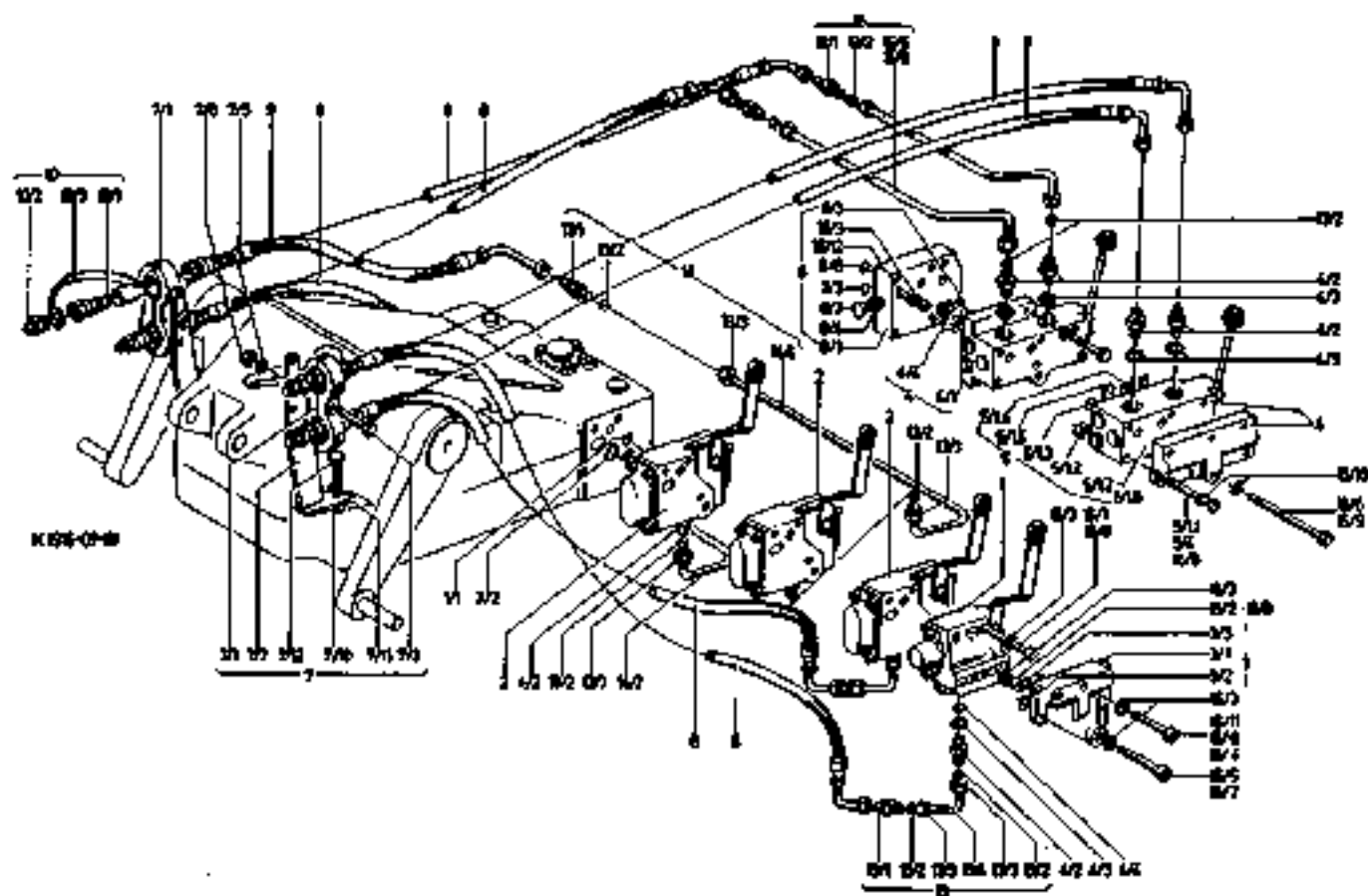
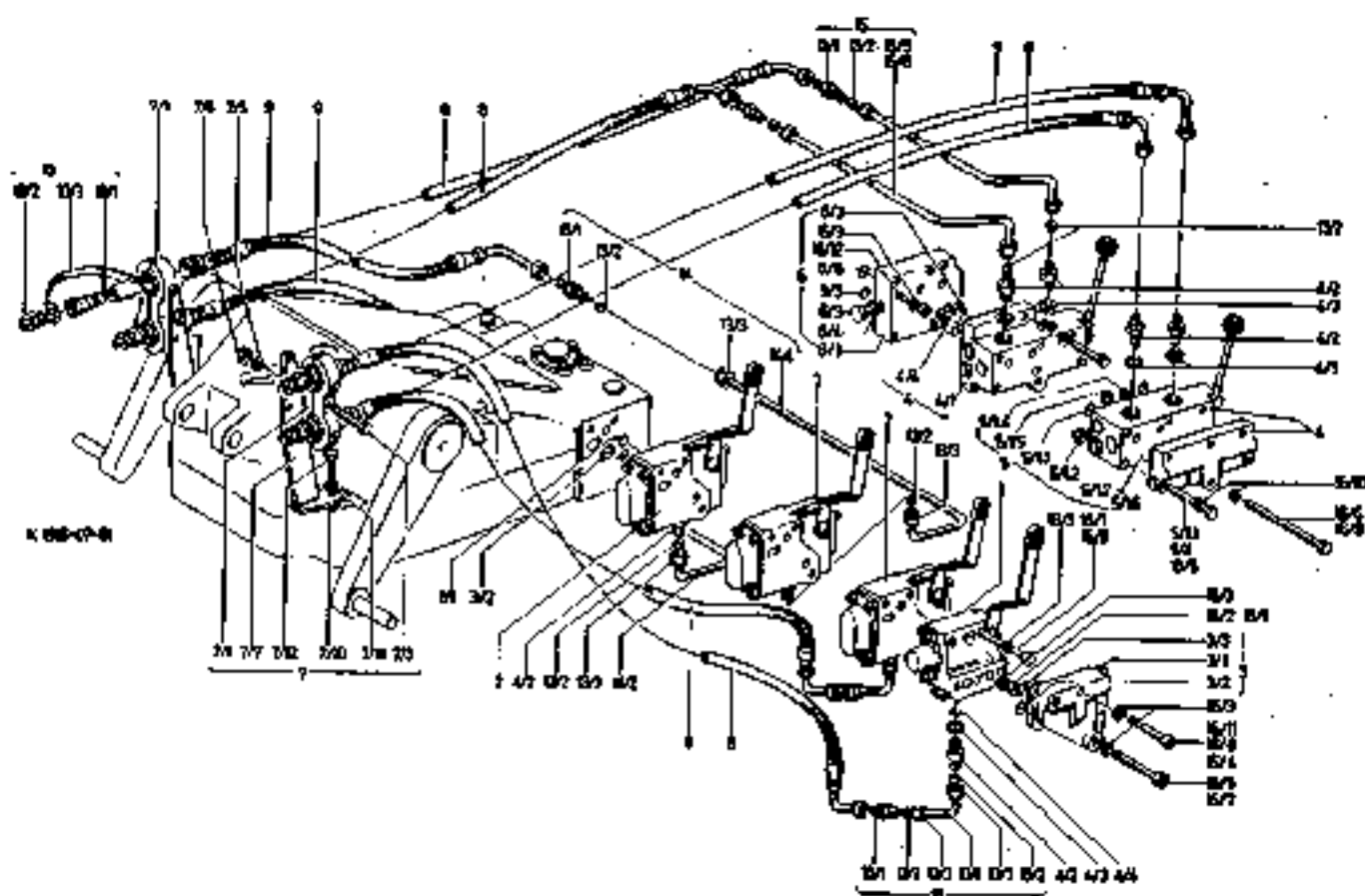

Die Zeichen	Die Mitteilung von	Unser Zeichen	Blattzahl	Datum
		HET Ad-Ja	415	17.2.1972

Betreff: K 45.1 200 bar - Druckbegrenzungsventil -
Unterlage 230 2834 UA 1952-08, Pos. 219

Das Druckbegrenzungsventil heißt entgegen der Stücklisten-
angabe HY/VA1/200 A (17/1) und hat die Bosch-Bestell-Nr.
0 532 001 052. Zum Unterschied zu der 175 bar Ausführung
ist die Feder schwarz. Auf der Verpackung ist auf die
schwarze Feder und die 200 bar Ausführung hingewiesen.

HET
Adams
Adams

2x

Verteilt:
GWH 220
SPT
HSTK

Regelhydraulik
Automatic Hydraulic System
Relevage hydraulique à double controle
Elevador hidráulico de efecto regulado

1908

Kraftheber K 45.1
Lift Unit K 45.1
Vérin hydraulique K 45.1
Elevador hidráulico K 45.1

1908/1

Bild-Nr.	Schleppernummer		Fußnote	Teilnummer	Anzahl	
	ob	bis				
3				M 14x11o DIN 933-8. 8A4C (111 178o)	2	
6				M 14x13o DIN 912-1o. 9 (112 4782) /A4C	2	
9			1925-o8-11. 79 (34o o137)	1	
			293 156 4	1	1952-o8
10			M 12 DIN 934-8 A4C (111 2858)	1	
			M 12 DIN 936-8 A4C (111 3153)	1	
11			1925-o8-17. 1o (34o o162)	1	wahlw-
			13 DIN 125 A4C (11o 711o)	1	
12				M 12x4o DIN 912-1o. 9A4C (111 o764)	2	
13				12 DIN 798o A4C (111 9615)	2	
14				1925-o8-11. 114 (34o o143)	1	
15				1925-o8-11. 73 (34o o134)	1	
16				1o. 5 DIN 125 A4C (11o 71o5)	1	
17				3x25 DIN 94 A4C (11o 6435)	1	
18				1952-o8-41. 1o2 (34o 13o8)	1	
19				M 12x4o DIN 912-1o. 9 A4C (111 o764)	2	
20				1925-o8-11. 72 (34o o133)	1	
21				1925-o8-11. 74 (34o o135)	1	
22				232 6795	1	1952-o8
23				M 12x35 DIN 933-8. 8 A4C (111 2538)	2	
24				1952-o8-24. 22 (34o 1285)	1	
25				1952-o8-24. 23 (34o 1286)	1	
26				M 8x3o DIN 912-8. 8 A4C (112 3699)	2	
27				M 1o x 17o DIN 931-8. 8A4C (112 48o4)	2	
28				8. 4 DIN 125 A4C (11o 71o1)	1	
29				2x2o DIN 94 A4C (112 2o7o)	1	

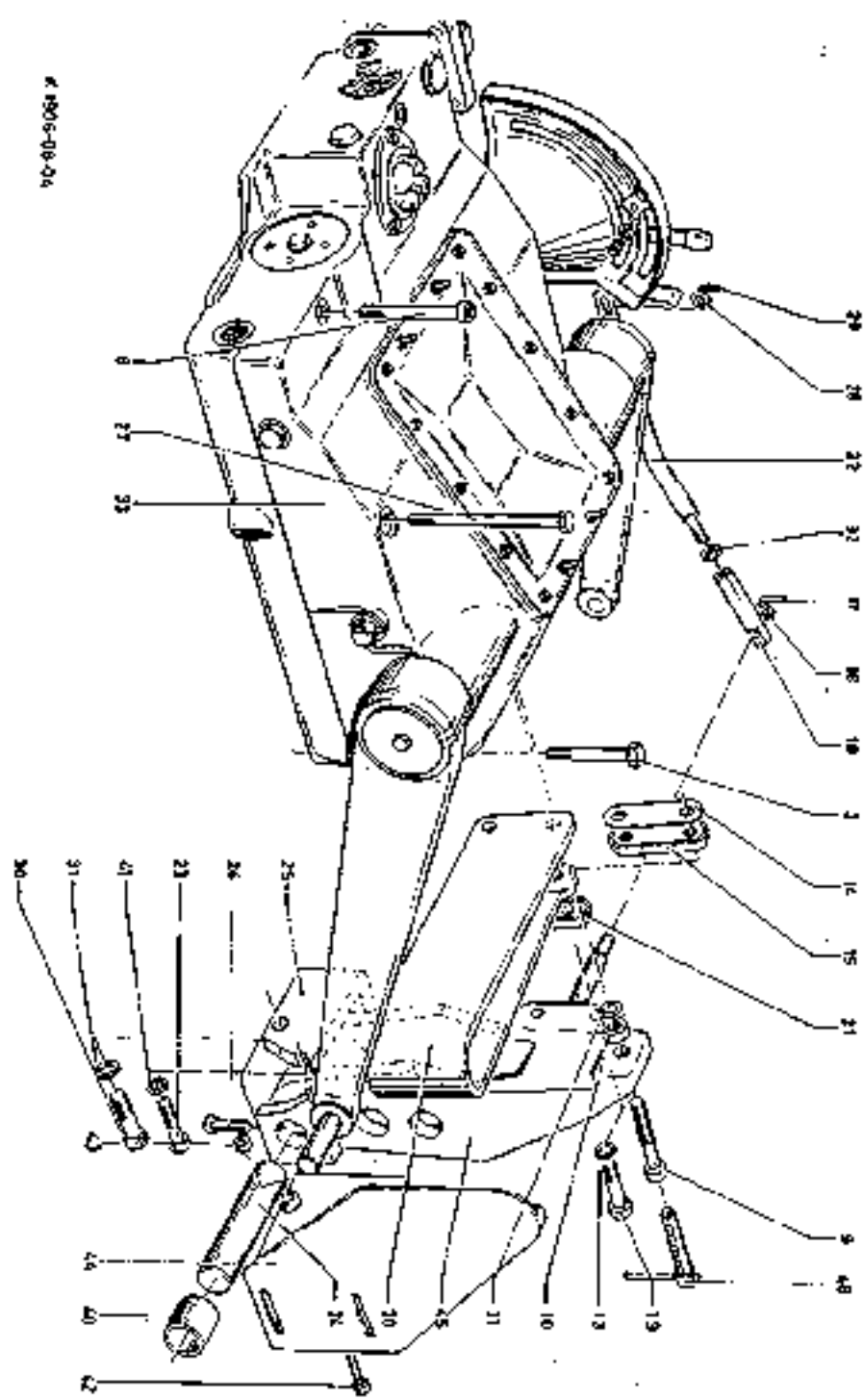



Bild-Nr.	Schleppernummer ab bis	Fußnote	Teilnummer	Anzahl	
1	27 900 27 899		233 1691 1952-08-76.30/281 9761	1	1952-08 K 45.1
1/2			1952-08-55.29 (340 1321)	1	
1/3			B 60 II 711 (116 5842)	1	
1/7	27 900 27 899		233 1641 1952-08-76.07/340 1371	1 1	K 45.1 1952-08
1/11		+	230 6597	1	1952-08
1/11.1		+1	230 6581	1	1952-08
1/11.2			1925-01-02.05 (340 0021)	1	
1/11.3			1,5x30 DIN 94 (110 6398)	1	
1/14			B 18 H 711 (116 5827)	1	
1/15			A 17 H 2855 (116 2041)	1	
1/16			A 16x2 H 984 (116 7017)	1	
1/17			232 0098	1	1952-08
1/17.1			232 0094	1	1952-08
1/17.2			232 0095	1	1952-08
1/17.3			232 0096	1	1952-08
9			M 6x18 DIN 933-8.8 A4C (111 2258)	3	
4			8 H 2203 vzkc (116 7194)	3	
5			1952-08-41.06 (340 1287)	1	
6			1952-08-41.07 (340 1288)	1	
7			M 8x12 DIN 933-8.8 A4C (111 2299)	10	
8			8 H 2203 vzkc (116 9689)	15	
9			8.4 DIN 433 A4C (110 7548)	14	
13			230 6604	1	1952-08
14			1941-08-01.49 (340 0808)	1	
17			M 8 DIN 934-8 A4C (111 2824)	4	
18			Wird nicht vollst. gelief. 1952-08-79.01 (340 1384)	1	
+ Entlüftungsröhr n. Schnüffelventil		+1 K 35, K 45, K 45.1			



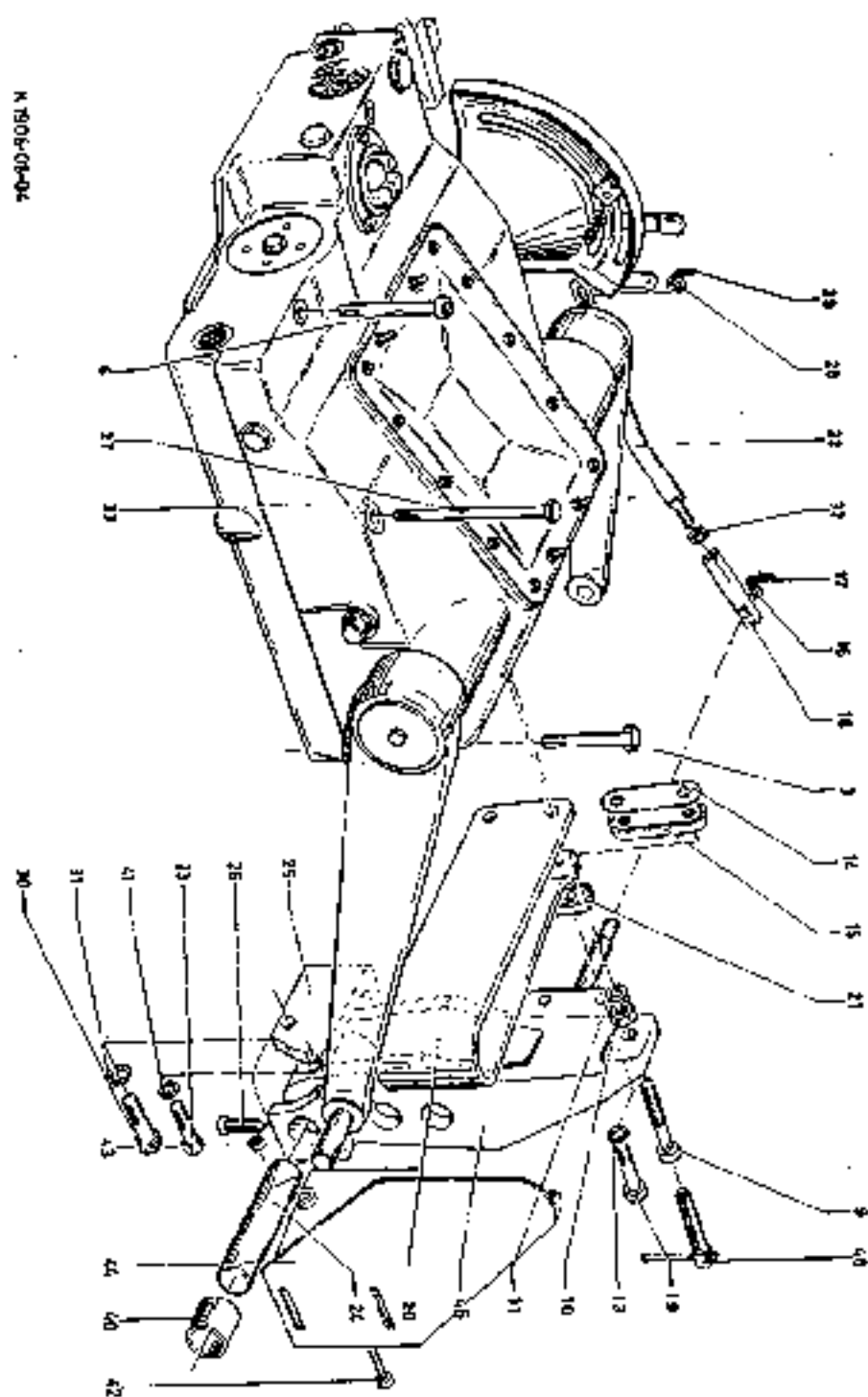
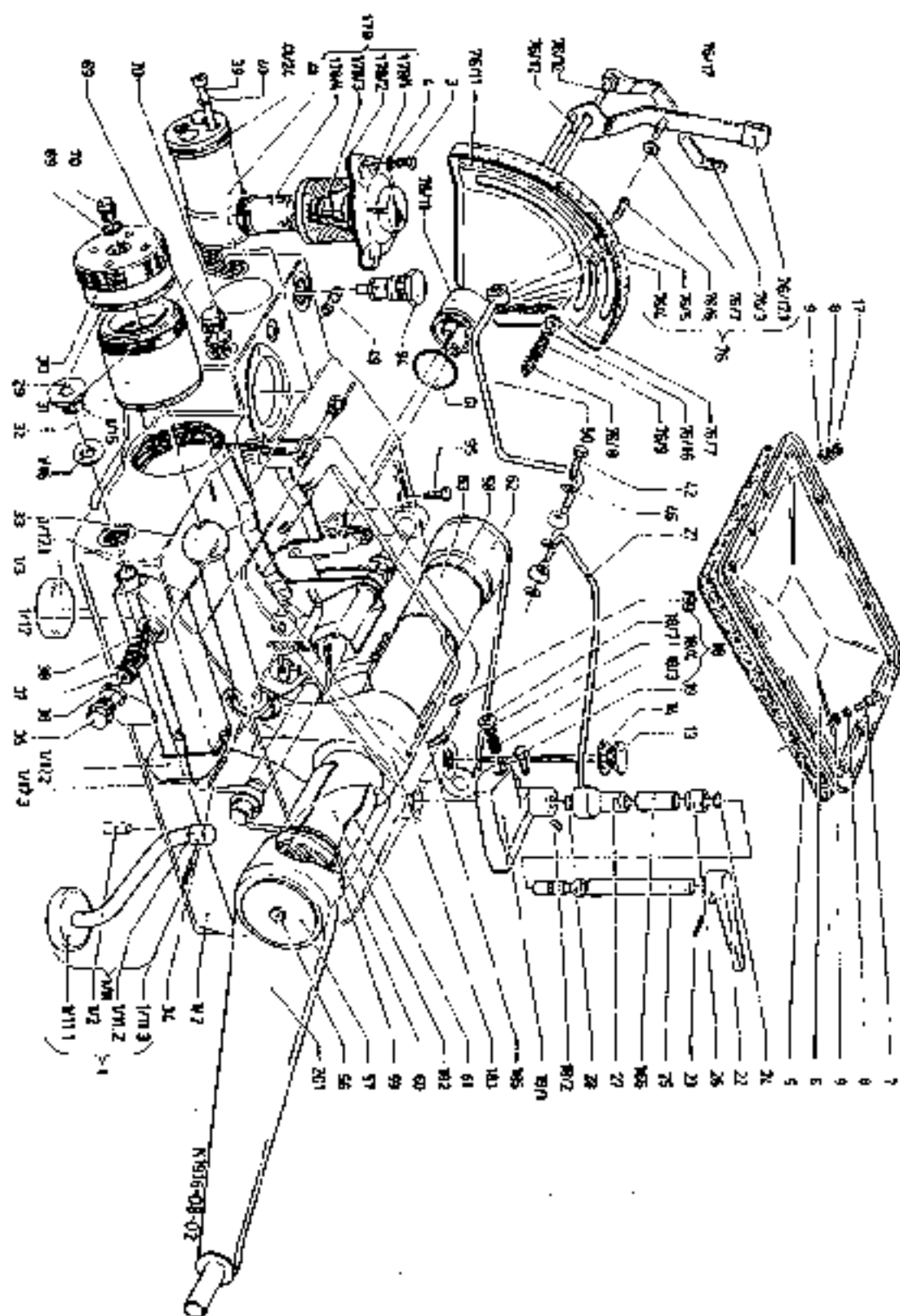
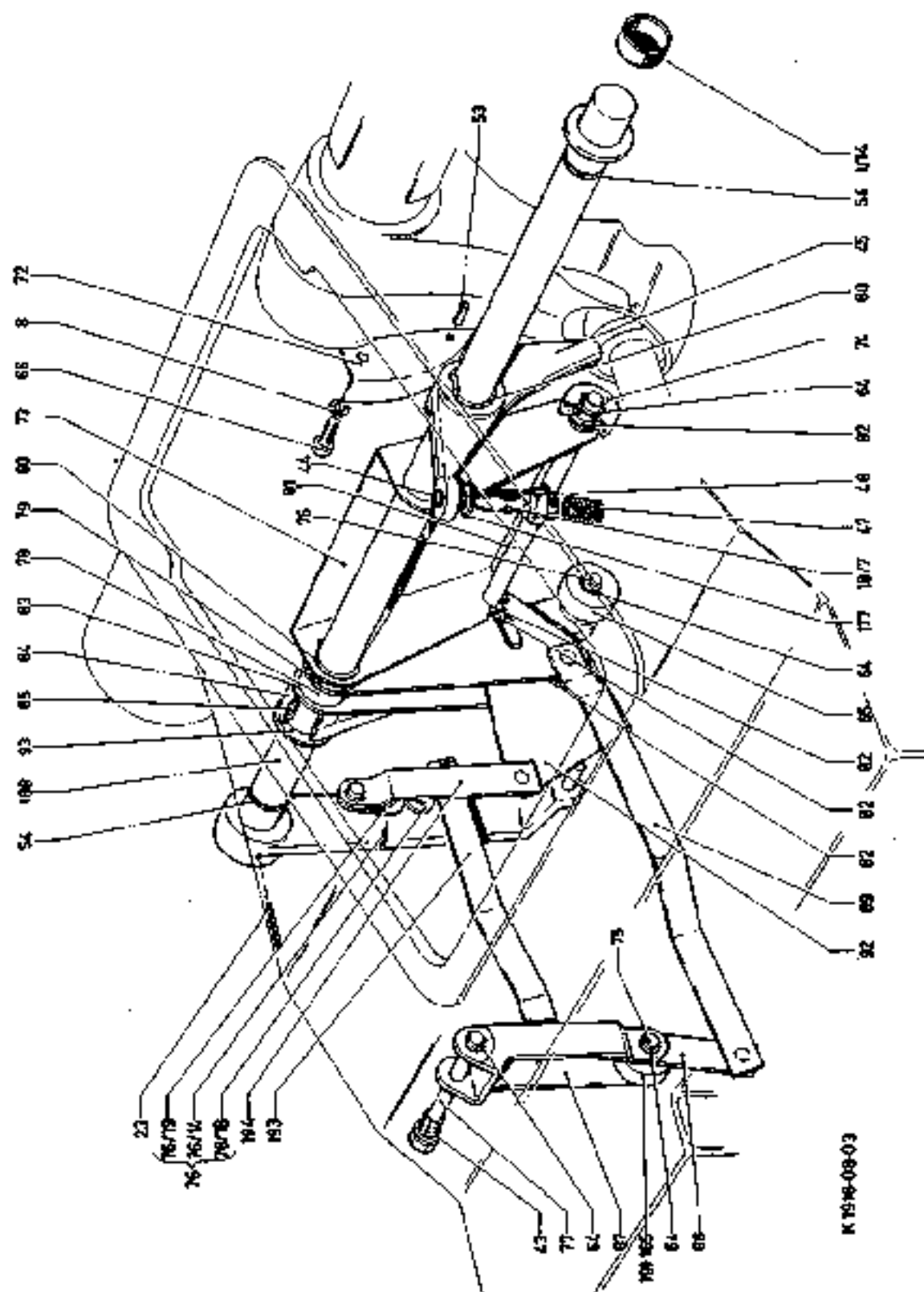

K 1908-08-03

Bild-Nr.	Schleppernummer		Fußnote	Teilnummer	Anzahl	
	ab	bis				
18/2				1952-08-44, 03 (340 1316)	1	
18/3				1952-08-11, 46 (340 1282)	1	
18/4				230 1251	1	1952-08
18/7				230 1250	1	1952-08
19				AM 8x20 DIN 581-5 S (110 8137)	1	
22				1952-08-55, 19 (340 1318)	1	
23				5x32 DIN 1481 (111 5440)	1	
24				16x2 H 2927 -Gi (116 0039)	2	
25				230 6498	1	1952-08
26				1952-08-55, 24 (340 1320)	1	
27				230 6525	1	1952-08
28				10x2 H 2927-Gi (116 0044)	1	
29				84x3 H 2927-Gi (116 1643)	1	
30				1952-08-89, 34 (340 1389)	1	
31				1952-08-55, 33 (340 1322)	1	
32				1952-08-55, 34 (340 1323)	1	
33				1952-08-41, 37 (340 1295)	1	
34				5x70 DIN 1481 (112 3860)	1	
35				M 26x1, 5 DIN 908 (112 4760)	1	
36				A 26x31 DIN 7603-Cu (111 8760)	1	
37				1941-08-26, 10 (340 0830)	1	
38				A 14x18 DIN 7603 Cu (111 3688)	1	
39				M 8x120 DIN 912-8, 8 (112 3702)	1	
40				1952-08-55, 38 (340 1325)	1	
41				230 0908	1	1952-06
41/24				50x24 H 721 (116 6080)	1	
42				230 293 R (331 5353)	1	

Bild-Nr.	Schlappnummer		Fußnote	Teilnummer	Anzahl	
	ab	bis				
43				A 12x15,5 DIN 7603 Cu (111 8673)	1	
44				1952-08-55.43 (340 1327)	1	
45				230 2633	1	1952-08
46				A 10x13,5 DIN 7603 Cu (111 8659)	3	
47				1952-08-11.46 (340 1282)	1	
48				230 1251	1	1952-08
49				1952-08-41.56 (340 1297)	1	
50				233 5240	1	
51				40x3 H 721 (116 6059)	1	
53				5x16 DIN 1481 (111 5433)	1	
54				10x3 H 2927-Gi (116 0038)	1	
56				M 8x15 DIN 933-8,8 A4C (110 2193)	2	
57				1952-08-41.86 (340 1298)	2	
58				231 2187	1	1952-08
59				1952-08-41.79 (340 1299)	1	
60				231 2188	1	1952-08
61				1952-08-41.75 (340 1300)	1	
62				1952-08-41.76 (340 1301)	1	
63				1952-08-41.77 (340 1302)	1	
64				1952-08-55.66 (340 1328)	9	
65				1952-08-78.09 (340 1378)	2	
66				M 8x15 DIN 912-8 (111 0553)	1	
69				A 18x22 DIN 7603 Cu (111 8713)	2	
70				AM 18x1,5 DIN 7804 vzko (111 8971)	2	
72				1952-08-95.82 (340 1400)	1	
73				1952-08-95.83 (340 1401)	1	



Bild-Nr.	Schleppernummer		Fußnote	Teilnummer	Anzahl	
	ab	bis				
74				1952-08-78,20 (231 9764)	1	
75				1952-08-95,64 (340 1402)	2	
76				wird vollst. nicht gelief.	1	
76/3				1952-08-107,10 (340 1412)	1	
76/4				D 40 DIN 6335-09 (111 7557)	1	
76/5				8,4 DIN 125 A4C (110 7101)	1	
76/6				1952-08-03,09 (340 1281)	1	
76/7				1952-08-70,06 (340 1367)	2	
76/8				M 6 DIN 985-8 (111 4386)	1	
76/9				1952-08-70,08 (340 1368)	1	
76/11				1952-08-106,11 (340 1411)	1	
76/12				1952-08-59,13 (340 1396)	2	
76/14				3x16 DIN 1481 (111 5407)	2	
76/16				6,4 DIN 125 A4C (110 7095)	1	
76/17				231 7206	1	1952-08
76/17.2				wir liefern n. Pos. 76/17		
76/18				231 4868	1	1952-08
76/19				231 4870	1	1952-08
77				1952-08-95,67 (340 1403)	1	
78				1952-08-95,69 (340 1404)	1	
79				17 DIN 433 (110 7557)	1	
80				1952-08-95,71 (340 1405)	3	
81				1952-08-95,72 (340 1406)	1	
82				8,4 DIN 125 (110 7098)	5	
83				1952-08-95,73 (340 1407)	2	
84				1952-08-95,74 (340 1408)	1	

Bild-Nr.	Schleppnummer		Fußnote	Teilnummer	Anzahl	
	ab	bis				
85				3x5 DIN 6888 (111 8323)	1	
87				1952-08-85.126 (340 1390)	1	
88				1952-08-85.129 (340 1391)	1	
89				1952-08.113.10 (340 1421)	1	
92				1952-08.97.02 (340 1409)	1	
93				1952-08.114.10 (232 0492)	1	
94				1952-08-85.136 (340 1392)	1	
				1 520 210 000 (128 9584)	1	Gummiring z. Pos. 94
				1 520 105 006 (128 9582)	1	Dichtungsl zubild. 94
95				8x SX35 DIN 581-5,8 A40 (112 6091)	1	
165				1952-08-78.06 (340 1379)	1	
166				230 6603	1	1952-08
177				250 1250	1	1952-08
178				231 1984	1	1952-08
178/1				231 1985	1	1952-08
178/2				231 1986	1	1952-08
178/3				¹⁹⁷⁵ 231 1985	1	1952-08
178/4				231 1987	1	1952-08
182				231 2042	1	1952-08
183				231 2044	1	1952-08
185				8x55 DIN 1481 (111 5479)	1	
188				231 4742	1	1952-08
191				1952-08-78.05 (347 1292)	1	
193				231 4874	1	1952-08
194				231 4872	1	1952-08
199				AM 8x25 DIN 939-6,8 vzkc (111 3389)	4	
201				232 3726	2	1952-08

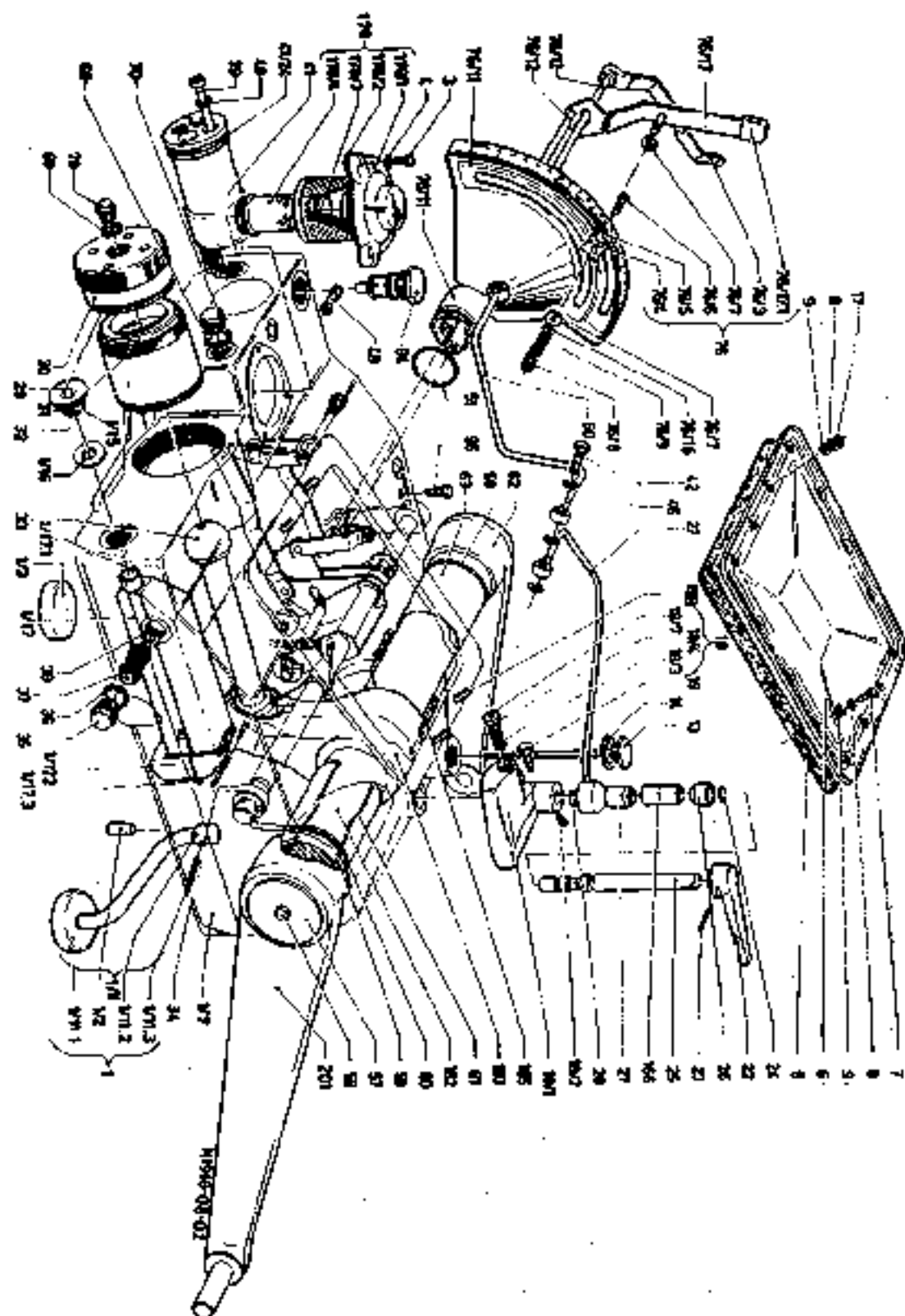
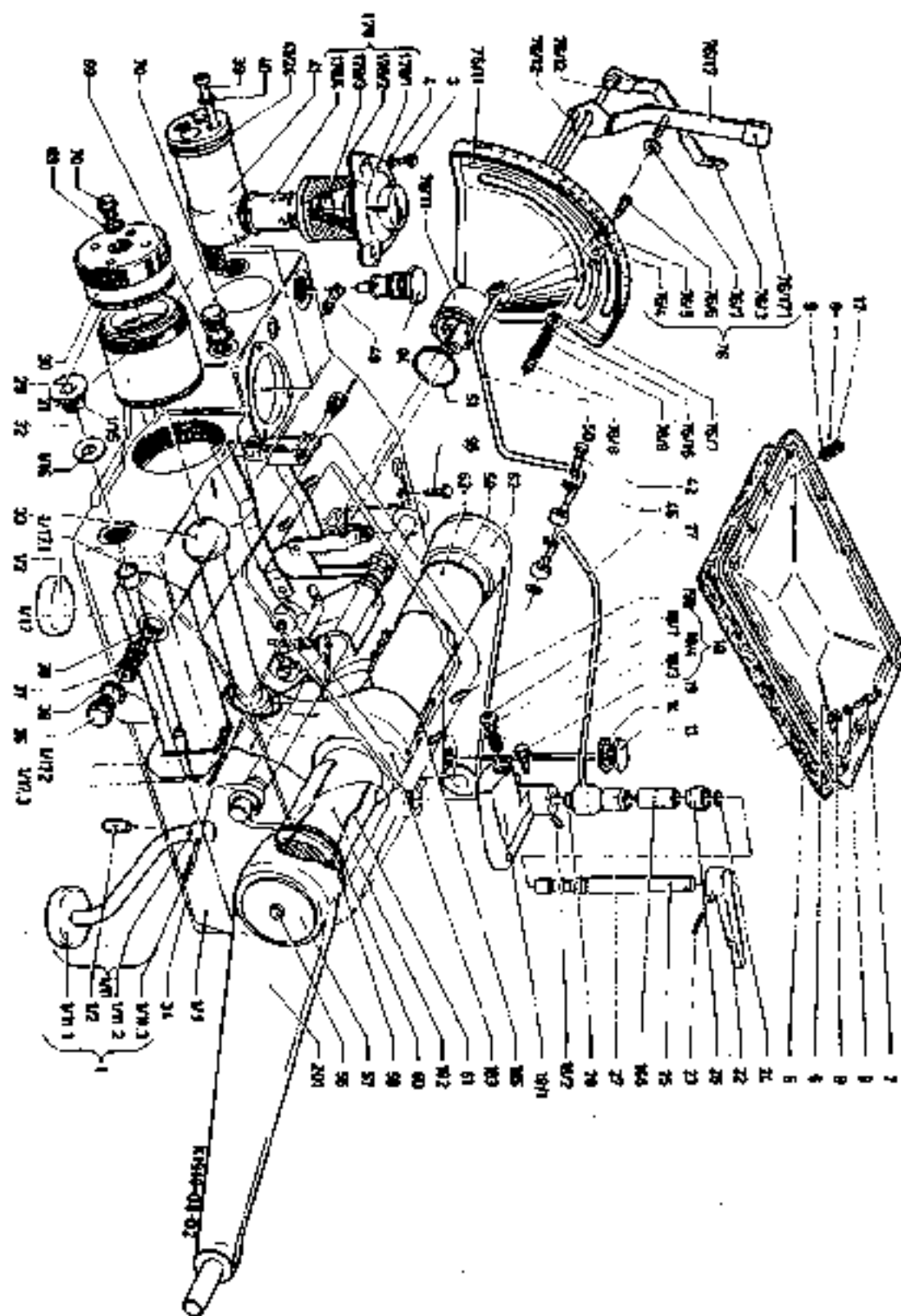

Dreipunkt-Kuppung
Three-Point Hitch
Attelage trois points
Sistema de acoplamiento en 3 puntos

1911

Bild-Nr.	Schleppenummer		Fußnote	Teilnummer	Anzahl
	ab	bis			
2				1925-11-36,34 (340 0220)	2
5				8x45 DIN 94 A4C (110 6499)	1
6				28 DIN 1440 vzkc (111 5024)	2
8				1952-11-03,10 (347 1320)	1
8/1				1952-11-03,01 (340 1440)	1
8/2				1952-11-03,02 (340 1442)	1
8/3				5x30 DIN 94 A4C (110 6463)	1
8/4				19 DIN 125 A4C (110 7121)	1
8/5				5 DIN 11023-St50-2vzkc (112 5312)	1
8/6				1952-11-03,06 (340 1443)	1
8/7				SA 8 H 3360 (116 9224)	1
8/8				1952-11-02,14 (340 1439)	1
11				1940-11-15,10 (340 0636)	1
17				M 16x40 DIN 933-8,8A4C (111 2687)	8
18				1952-11-07,18 (340 1449)	2
19				8x80 DIN 1481 vzkc (112 3869)	2
21				1940-11-22,10 (340 0647)	2
22				8 H 2203 vzkc (116 9689)	2
23				M 8x30 DIN 933-8,8 A4C (111 2341)	2
24				M 8 DIN 934-8 A4C (111 2824)	2
25				5x30 DIN 94 A4C (110 6468)	2
27				21 DIN 125 A4C (110 7124)	2
28				1952-11-01,20 (340 1432)	2
29				1952-11-09,10 (340 1450)	1
40				M 22x2 DIN 935-8 A4C (110 3491)	2
41				23 DIN 1440 vzkc (111 5021)	2

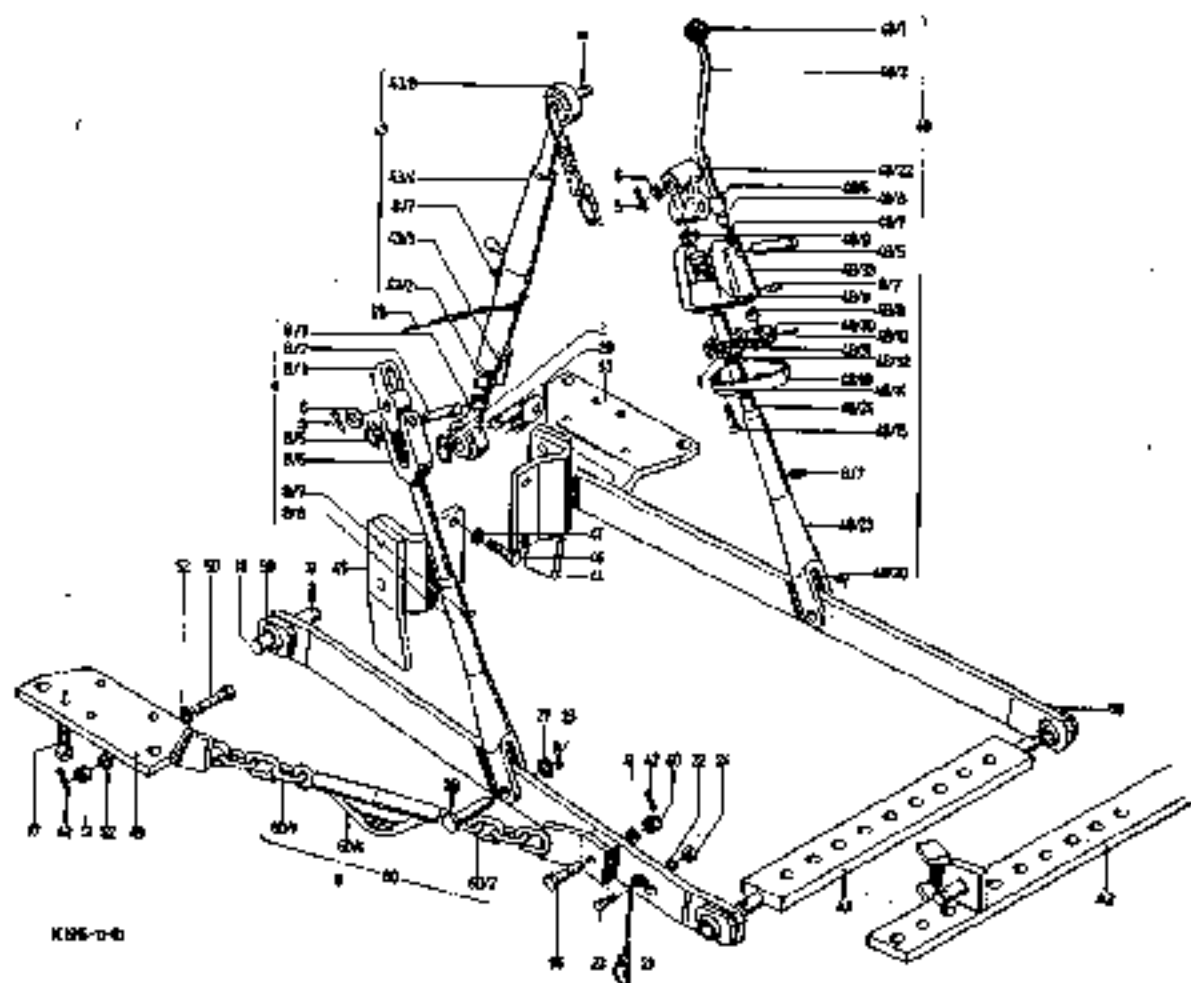



Bild-Nr.	Schleppernummer		Fußnote	Teilnummer	Anzahl	
	ab	bis				
42				3x50 DIN 94 A4C (110 6474)	4	
43				231 2244	1	1952-11
43/2				231 4748	1	1952-11
43/3				231 2246	1	1952-11
43/4				231 2254	1	1952-11
43/5				SA 6 H 3380 (116 8224)	1	
43/8				231 4750	1	1952-11
44				231 1921	1	rechts 1952-11
45				231 1919	1	links 1952-11
46				M 16x50 DIN 931-8.8 A4C (111 1853)	4	
47				A 16 DIN 128 A4C (110 2803)	4	
48			+	231 4819	1	1962-11
48/1				B 32x12 H 3517 (116 2420)	1	
48/2				230 1363	1	1926-11
48/3				231 2296	1	1926-11
48/6				231 2112	1	1926-11
48/7				5x16 DIN 1481 (111 5433)	1	
48/8				230 1362	2	1926-11
48/9				M 40x1,5 H 710 vzko (116 5799)	1	
48/10				SA 6 H 3360 (116 8224)	1	
48/11				230 1365	1	1926-11
48/13				4x18 DIN 1481 (111 5418)	1	
48/14				4x5 DIN 6988 (111 8325)	1	
48/15				M 6x40 DIN 931-8.8 A4C (111 1071)	2	
48/18				230 1364	1	1926-11
48/20				20 DIN 9045 (111 9827)	1	

*Hubstange mit Kurbel vollst.

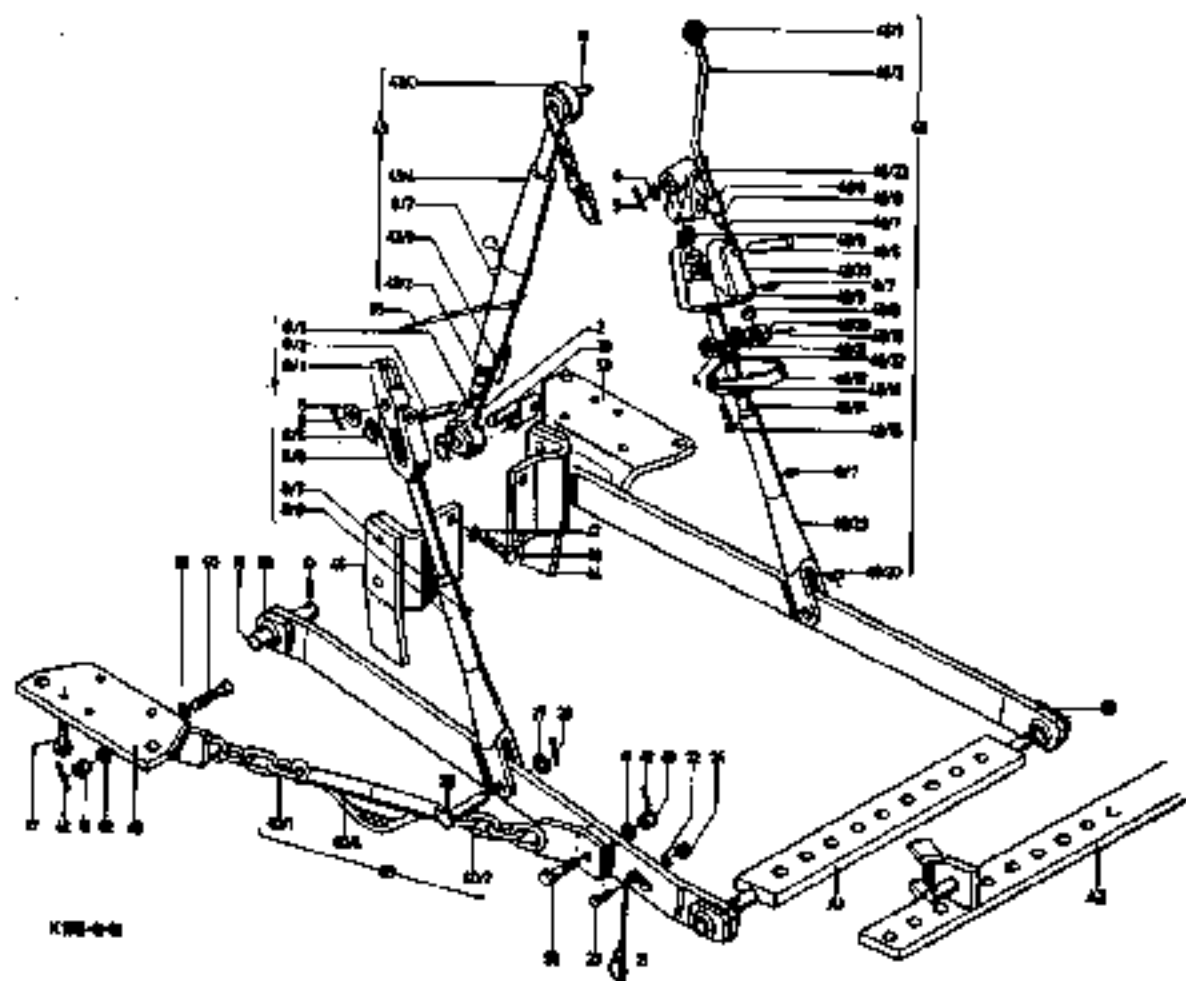
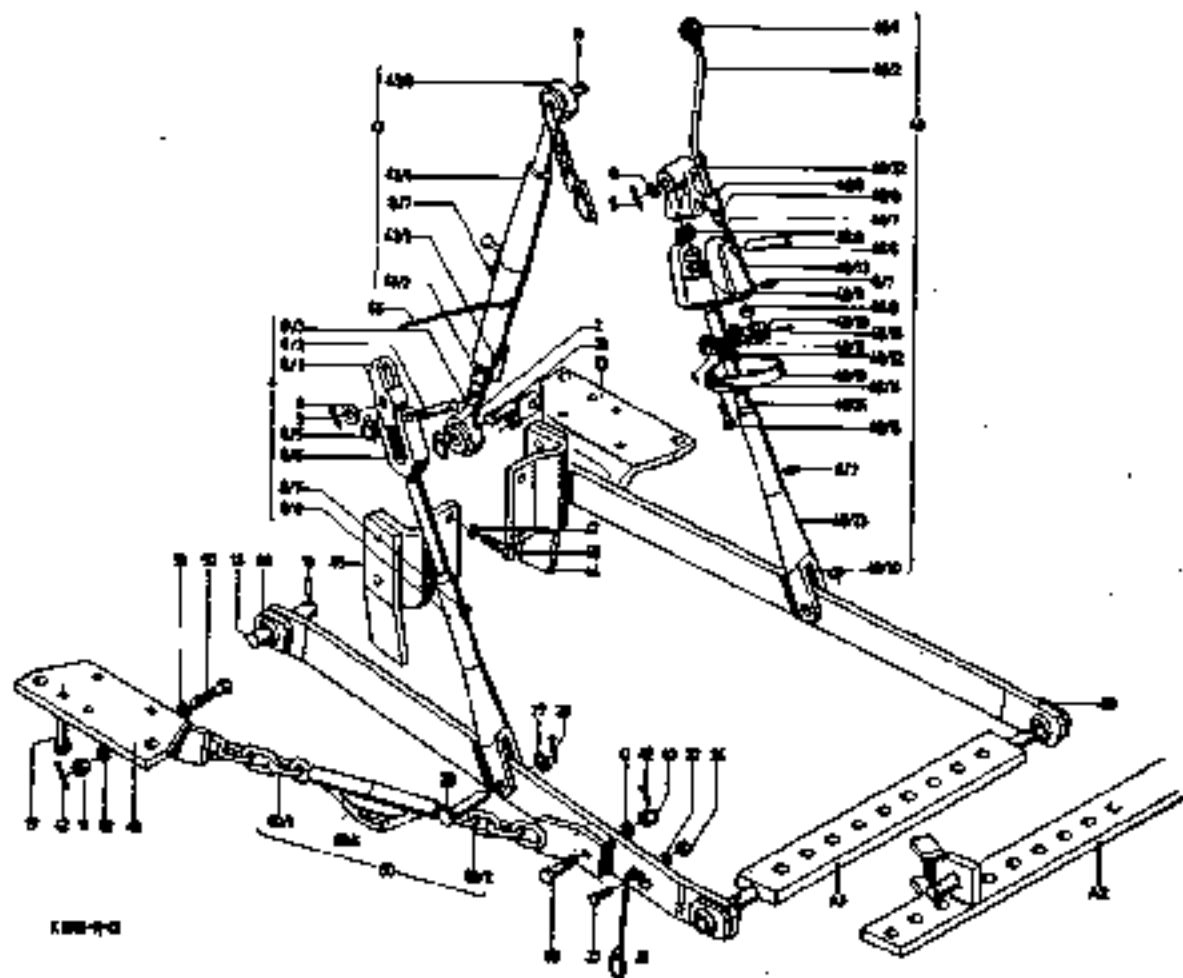

Zugpendel
Drawbar
Barre oscilante
Péndulo de tracción

1914

Bild-Nr.	Schleppernummer		Fußnote	Teilnummer	Anzahl
	ab	bis			
1				1952-14-21.10 (340 1455)	1
2				1952-14-01.02 (340 1452)	1
3				1952-14-22.10 (340 1456)	1
4				EG 30/40x20 DIN 1498 (112 3866)	1
5				M 16x95 DIN 931-8.8 A4C (111 1924)	4
6				A 16 DIN 128 A4C (110 2803)	10
7				B 20x20 H 2341) (117 0189)	2
8				M 16x45 DIN 933-8.8 A4C (111 2683)	6
11				1952-14-23.10 (340 1457)	1
12				23411x105x95 DIN 1436 MST 60-20vzk (112 3835)	2
13				1124-62-01.11 (338 7615)	2
14				1952-14-24.10 (340 1458)	1
15				1952-14-01.15 (340 1453)	1
16				wird vollst. nicht geliefert.	
16/15				1945-14-08.02 (340 1070)	1
16/16				M 18x2x70 DIN 960-6.8A4C (112 4469)	2
16/17				M 18x2 DIN 934-8 vzkc (111 2908)	2
16/18				A 18 DIN 128 vzkc (110 2804)	2
16/33				1971-14-32.10 (340 1804)	1
21				1952-14-01.21 (340 1454)	1
22				1952-14-25.10 (340 1459)	1
23				6x40 DIN 94 A4C (110 6484)	1
A5			+	1971-14-01.13 (340 1787)	2
A7			+	M 16x90 DIN 931-8.8 A4C (111 1919)	4
A11			+	1971-14-24.10 (340 1792)	1
A12			+	1952-14-26.10 (347 1332)	1
+ A 5- A12 Bei Zugpendel großer Schwenkbereich					

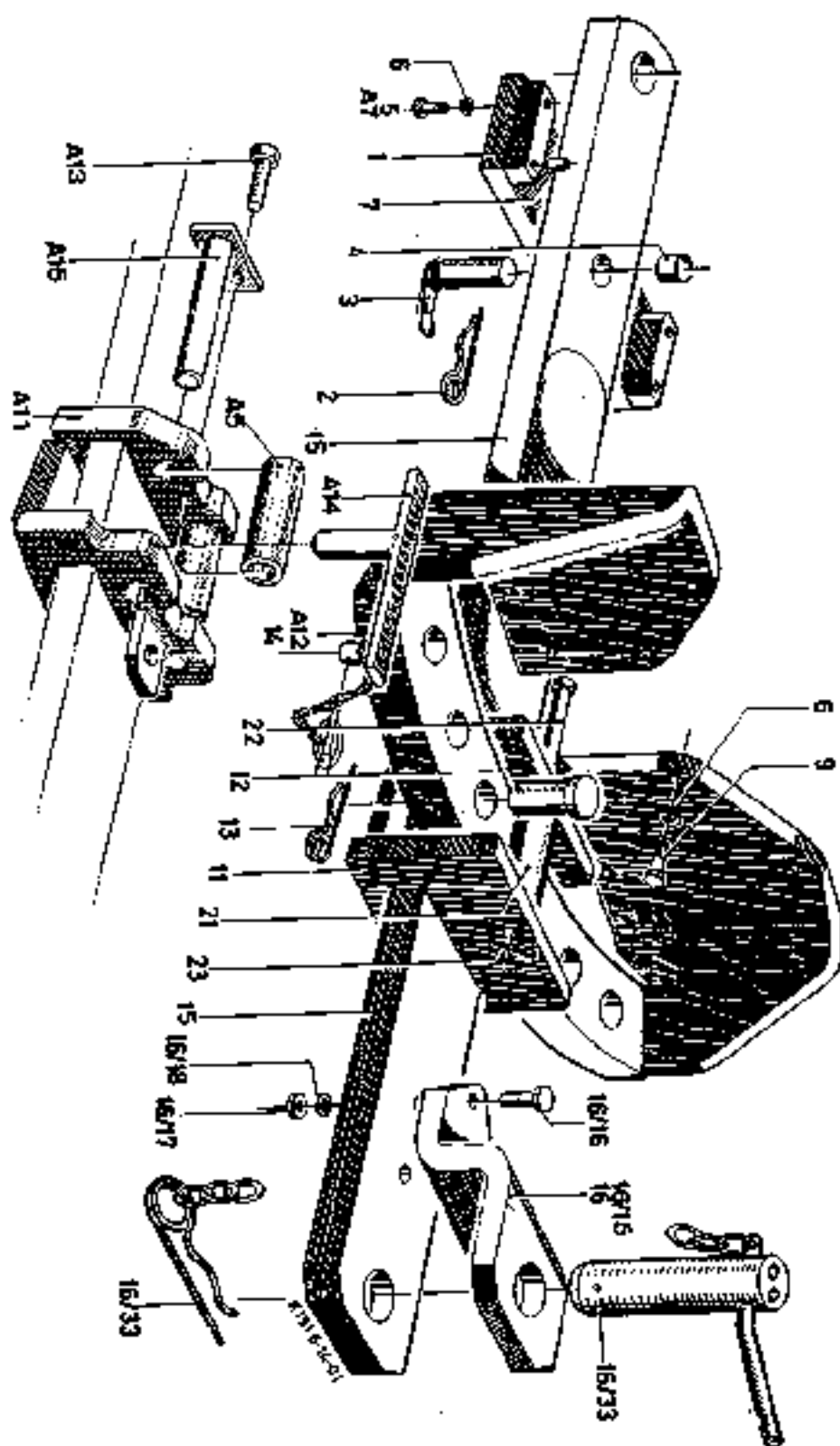

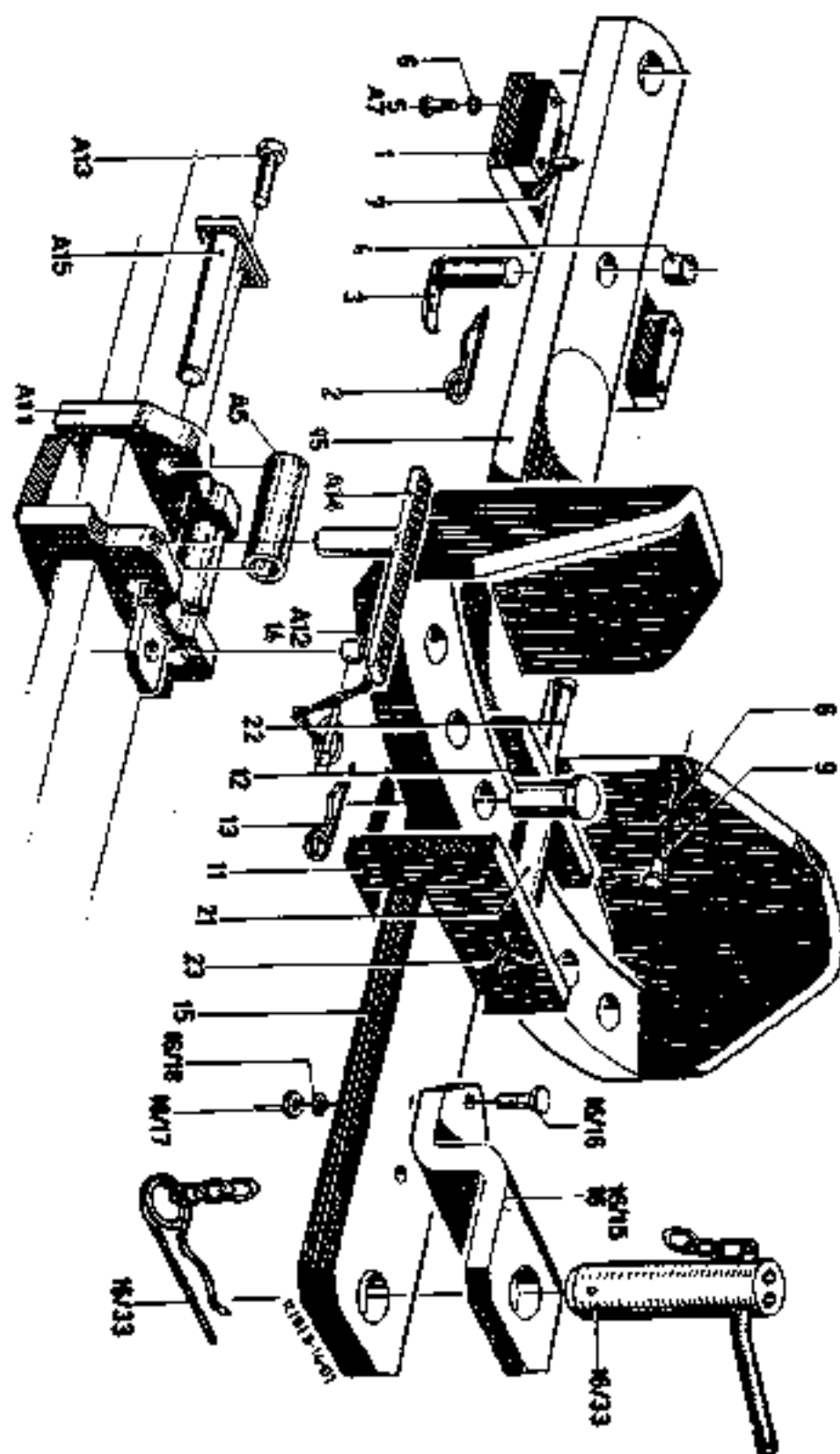

Hubkupplung
Pick-up Clutch
Attelage
Gancho de acople, de elevación hidr.

1920

Bild-Nr.	Schleppernummer		Fußnote	Teilnummer	Anzahl	
	ab	bis				
2				231 2781	1	1926-20
2/10				231 2792	1	1926-20
2/11				1110-63-03.11 (338 7577)	1	
2/12				1110-63-03.07 (338 7574)	1	
2/13			A	25 DIN 2093 (111 6029)	12	
3				231 2799	1	1926-20
6				231 2779	1	1926-20
7				8x55 DIN 94 (110 6501)	1	
8				232 4393	1	1926-20
9			M	14x120DIN 931-8.8 A4C (112 4811)	1	
10				16 DIN 128 A4C (110 7114)	2	
11				8 DIN 11023-St50-2vzke (110 1084)	2	
12				12,5 DIN 128 (110 7107)	1	
13				1145-02-01.06 (338 9261)	2	
14				4x20 DIN 94 A4C (110 6447)	1	
16				231 2766	1	1926-20
17				1941-14-05.13 (340 0865)	1	
19				1124-63-01.11 (338 7615)	2	
22			M	16x50 DIN 933-8.8 A4C (111 2697)	1	
23				231 2828	2	1926-20
27				231 2894	1	1926-20
28				231 2892	1	links 1926-20
29				231 2893	1	rechts 1926-20
30			M	16x40 DIN 933-8.8 A4C (111 2687)	4	
31			A	16 DIN 128 A4C (110 2803)	6	
32				1152-63-22.10 (338 8889)	1	
33			M	16x75 DIN 931-8.8 A4C (111 1896)	2	

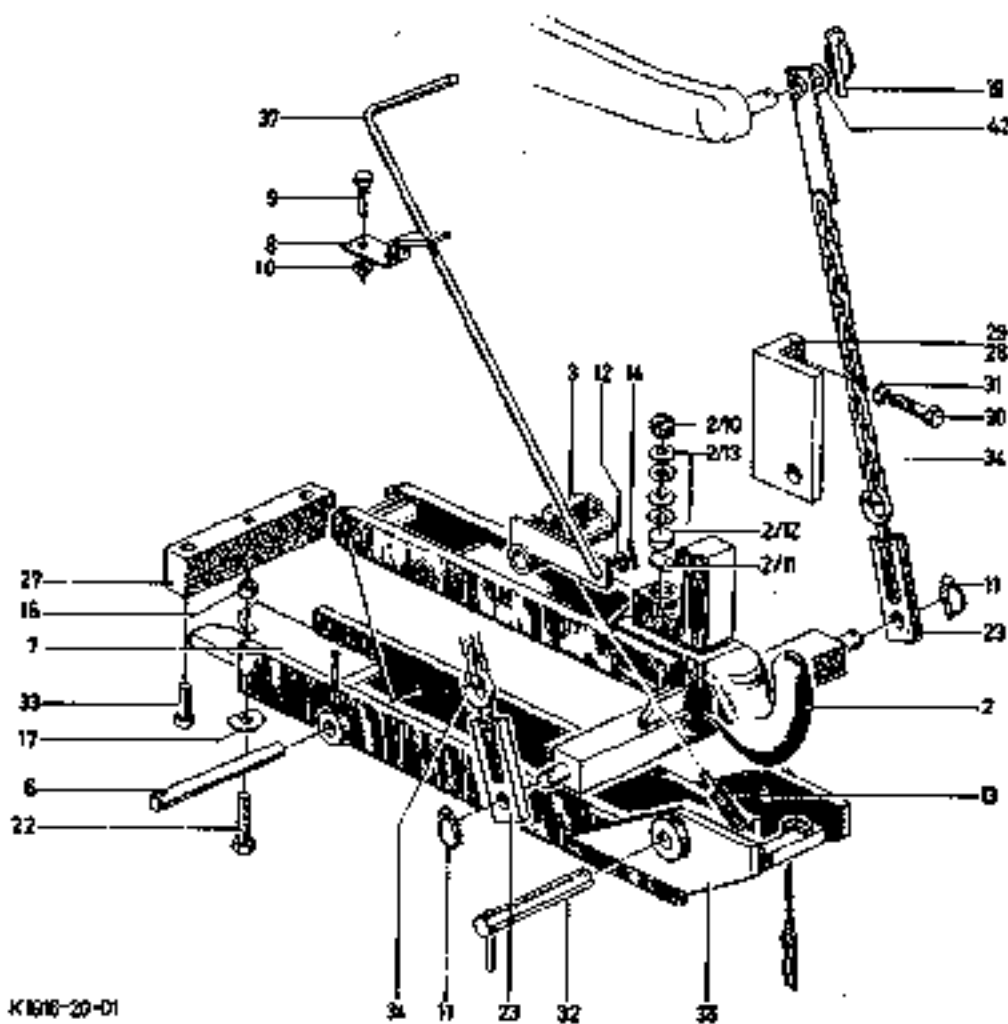

K1816-29-01

Druckluftanlage
Compressed-air System
Générateur d'air comprimé
Sistema de aire comprimido

1955

Druckluftanlage (Zweileitungsanlage)
Compressed-air system
Générateur d'air comprimé
Sistema de aire comprimido

1955/1

Bild-Nr.	Schleppernummer		Fußnote	Teilnummer	Anzahl	
	ab	bis				
2				B 15 DIN 74297 A4C (112 3533)	11	
3				C 15 DIN 74297 A4C (112 3534)	11	
4				D 12 DIN 74297 (112 1715)	9	
5				AM 22x1,5 DIN 74297 A4C (112 1705)	11	
6				CM 22x1,5 DIN 74298 vzkc (112 1735)	4	
7				25 DIN 74306 A4C (112 3545)	4	
8				M 22x1,5 DIN 74306 A4C (112 3543)	5	
9				13 M22x1,5 DIN 7606 A4C (112 2969)	2	
10				A DIN 74304 A4C (112 1766)	2	
11				BM 22x1,5 DIN 74301 vzkc (112 3537)	3	
12				1941-63-22.10 (340 0937)	1	
13				15x600 DIN 74310 (112 1776)	1	
14				N 6x10 DIN 933-8.8 A4C (111 2232)	3	
15				6 H 2203 vzkc (116 7194)	5	
16				M 6 DIN 934-8 A4C (111 2813)	7	
17				C R 3145 (123 5136)	1	
25				N 8x90 DIN 933-8.8 A4C (111 2379)	1	
26				A 8 DIN 128 A4C (110 2799)	30	
27				18x4 H 721 (118 6017)	1	
28				AM 8x83 DIN 939-8.8 A4C (111 3427)	1	
29				M 8x25 DIN 933-8.8 A4C (111 2933)	10	
30				9,5x1450 H 3701 (116 1580)	1	
31				12,5x1025 H 3701 (116 2717)	1	
32				230 0750	1	1971-55
34				0150-33-405.40 (336 3646)	1	
36				S 80x15 H 735 (116 6417)	3	
37				AB 735 (116 6343)	3	

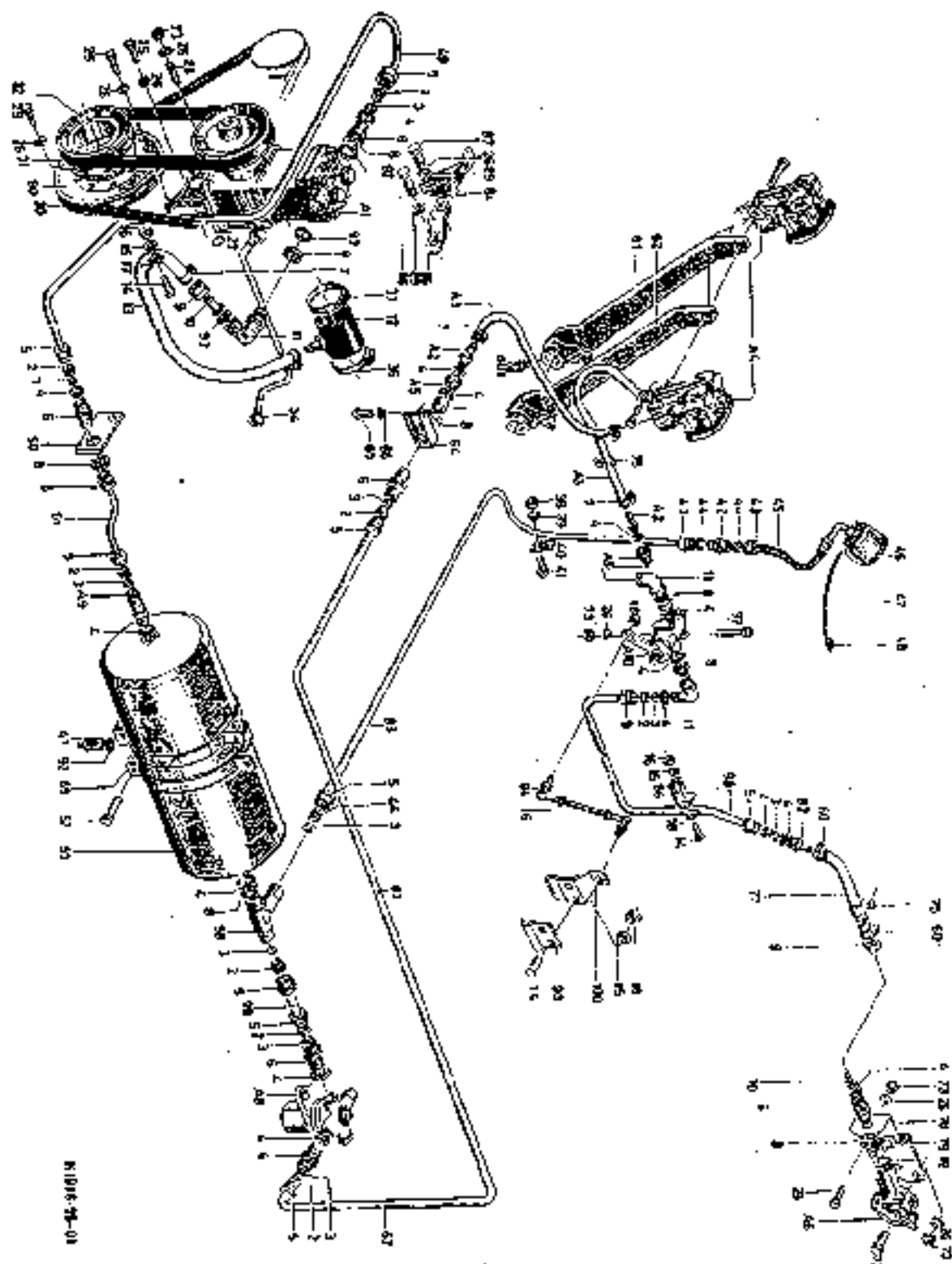

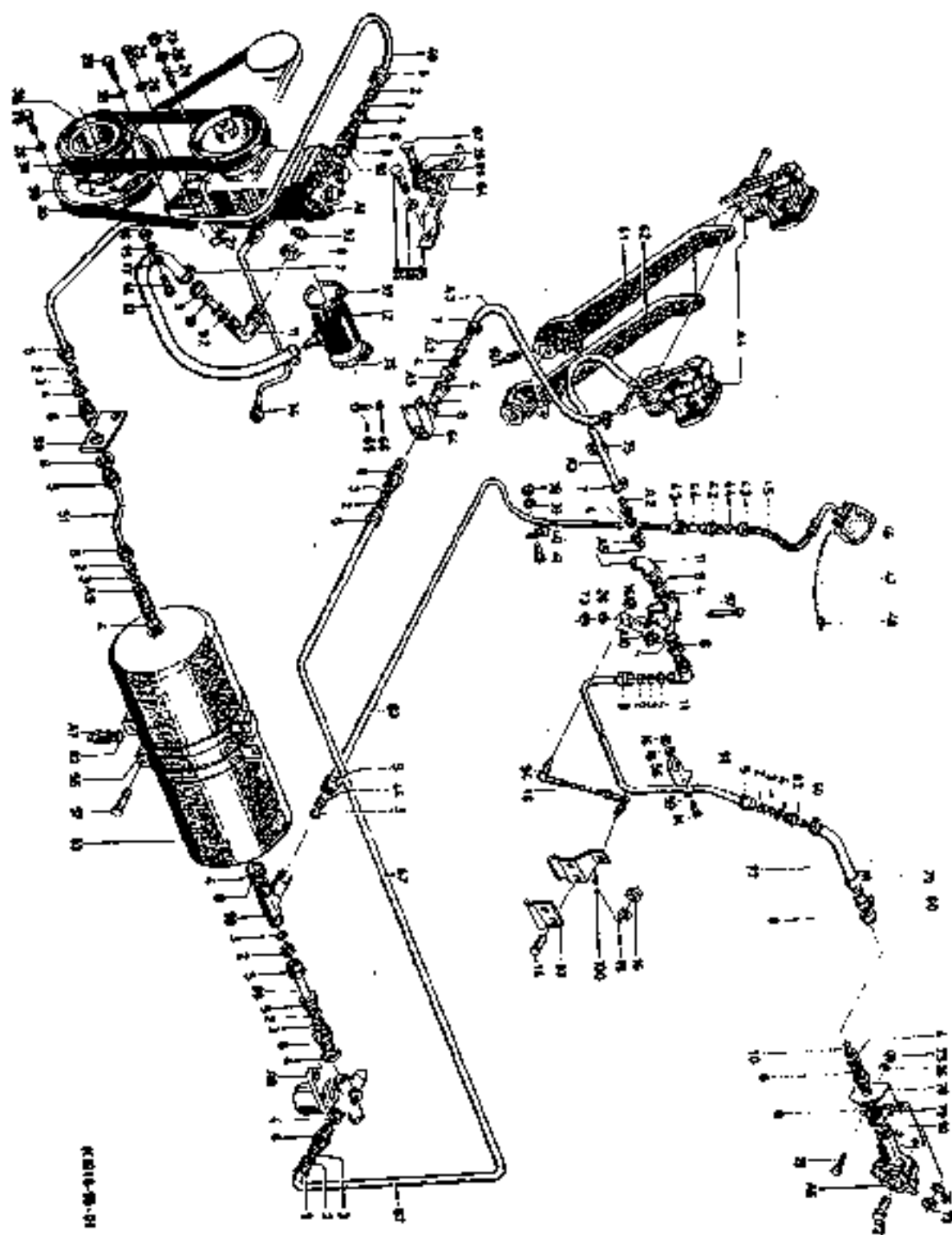

K 1018-50-01

Bild-Nr.	Schleppenummer		Fußnote	Teilnummer	Anzahl	
	ab	bis				
38				M 4 DIN 934-8 A4C (111 2796)	1	
39				4 H 2203 vzkc (116 7192)	1	
40				6 DIN 72572 vzkc (112 3496)	1	
41				AM 4x12 DIN 84-4.8 A4C (110 5512)	1	
42				M 12x1,5 DIN 74298 vzkc (112 3535)	1	
43				AM 12x1,5 DIN 74297 A4C (112 3530)	2	
44				B 6 DIN 74297 A4C (112 3532)	2	
45				1940-55/03, 93 (340 0705)	1	
46				231 3396	1	1941-55
47				1941-55-29,10 (340 0945)	1	
48				1 BC 6 H 7802 (116 9070)	1	
49				15RDx1,5 DIN2391-ST35GZF P.X (112 3897)	2	1640 mm
50				232 9204	1	1952-55
51				15RDx1,5DIN2391-ST35GZF P.K (112 3897)	1	760 mm
53				231 9922	1	1952-55
55				232 9186	2	1952-55
56				1952-55-01,05 (340 1461)	1	
57				M 8x35 DIN 931-8.8 A4C (111 1136)	2	
58				CM 22x1,5 DIN 74302 A4C (112 3538)	1	
59				B 15 H 8201 (116 8145)	1	
60				S 14x9 H 735 (116 6352)	4	
61			231 3101	1	rechts 1952-55
			232 9174	1	rechts 1952-55
61/1				SA 8 H 3360 (116 8225)	1	
62			231 3100	1	links 1952-55
			232 9170	1	links 1952-55

Bild-Nr.	Schleppernummer		Fußnote	Teilnummer	Anzahl	
	ab	bis				
64				1971-55-01,79 (340 1821)	1	
65				M 14x20 DIN 933-8,8 A4C (111 2396)	1	
66				A 14 DIN 128 vzkc (110 2802)	1	
67				15RDx1,5DIN2391-St35GZF P.M. (112 3897)	2	1190 mm
72				M 8x20 DIN 933-8,8 A4C (111 2322)	5	
73				M 8 DIN 934-8 A4C (111 2824)	9	
75				3 204 C 4 vzk (121 6759)	3	
77				13x800 DIN 74310 (110 1706)	1	
78				231 9844	1	1941-55
79				C DIN 74294 vzkc (112 3529)	1	
82				BM 22x1,5 DIN 74304 A4C (112 3542)	1	
83				6RDx1 DIN 2391-St35GZF P.M. (112 5075)	2	1450 mm
84				231 9980	1	1971-55
85				232 9211	1	1941-55
86				M 8x35 DIN 933-8,8 A4C (111 2350)	1	
87				M 8x15 DIN 933-8,8 A4C (111 2305)	1	
89				8,4 DIN 125 A4C (110 7101)	1	
90				213 4336	1	0150-05
92				A 22x27 DIN 7603 Cu (111 8737)	7	
93				232 9196	1	
94				A 10 DIN 71802 vzkc (112 0936)	2	
97				M 8x60 DIN 931-8,8 A4C (111 1168)	2	
98				15RDx1,5DIN2391-St35 P.M. (112 3897)	2	1400 mm
				GZF		
99				15RDx1,5DIN2391-St35 P.M. (112 3897)	1	83 mm
				GZF		

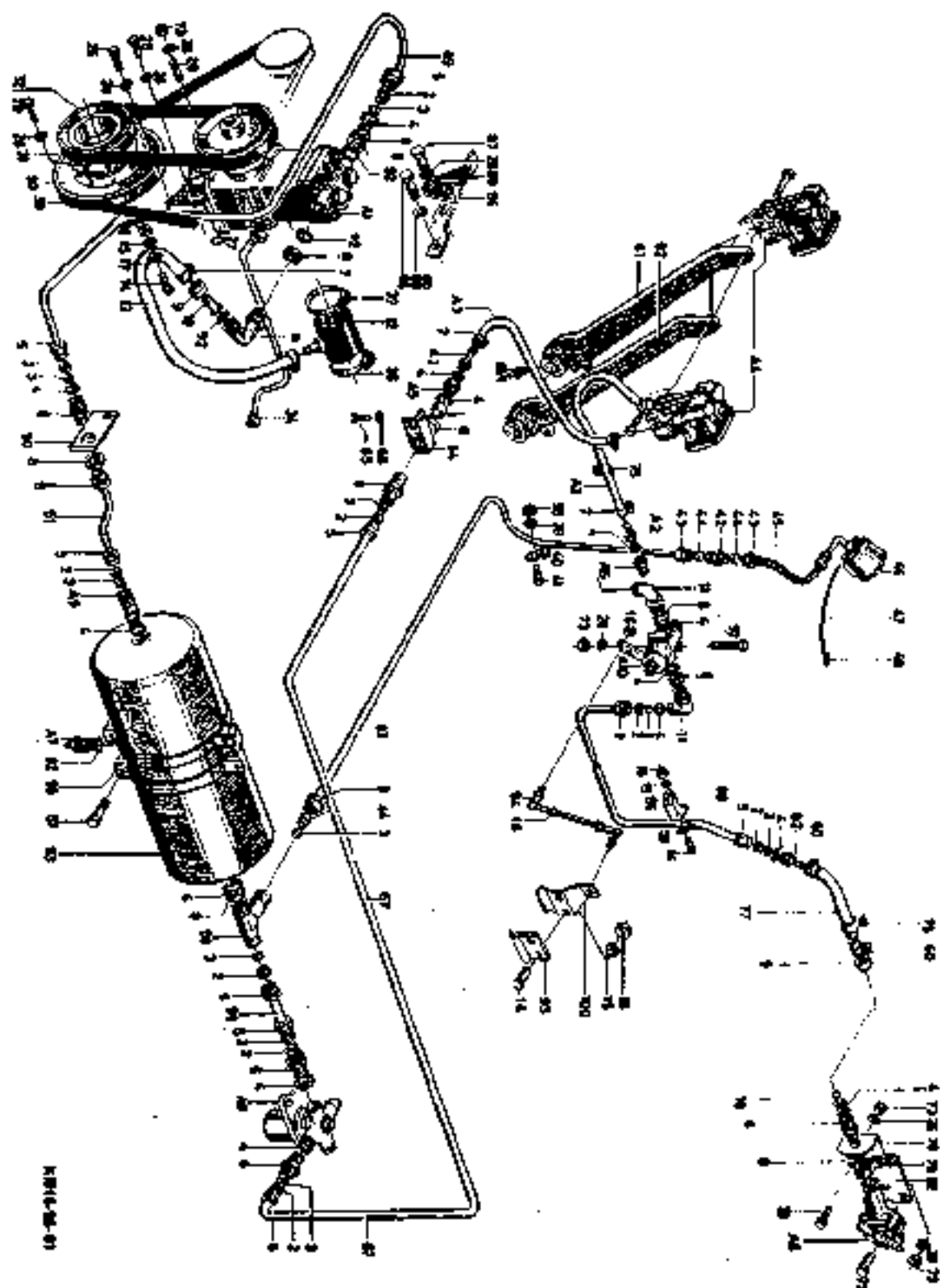



Bild-Nr.	Schleppernummer		Fußnote	Teilnummer	Anzahl	
	ab	bis				
1				B 15 DIN 74297 A4C (112 3533)	14	
2				C 15 DIN 74297 A4C (112 3534)	14	
3				D 13 DIN 74297 (112 1715)	16	
4				AM 22x1,5 DIN 74297 A4C (112 1705)	15	
5				CM 22x1,5 DIN 74299 vzkc (112 1735)	8	
6				25 DIN 74306 A4C (112 3545)	4	
7				M 22x1,5 DIN 74306 A4C (112 3543)	8	
8				A 22x27 DIN 7803 Cu (111 8737)	8	
9				13 M 22x1,5 DIN 7606 A4C (112 2969)	1	c
10				A DIN 74304 A4C (112 3539)	4	
11				BM 22x1,5 DIN 74301 A4C (112 3537)	3	
12				1941-55-22.10 (340 0837)	1	
13				13x600 DIN 74310 (112 1778)	1	
14				M 6x10 DIN 933-8.8 A4C (111 2232)	1	
15				8 H 2203 vzkc (116 7194)	1	
16				M 6 DIN 934-8 A4C (111 2813)	1	
17				C N 3145 (123 5136)	1	
19				M 8 DIN 934-8 A4C (111 2824)	2	
25				M 8x90 DIN 931-8.8 A4C (111 1200)	1	
26				A 8 DIN 128 A4C (110 2799)	10	
27				18x4 H 721 (116 6017)	1	
28				4M 8x85 DIN 939-6.8 A4C (111 3427)	1	
29				M 8x25 DIN 933-8.8 vzkc (111 2333)	10	
30				9,5x1450 H 3701 (116 6080)	1	
31				12,5x1025 H 3701 (116 2717)	1	
32				230 0750	1	1971-55
34				0150-39-405.40 (336 3646)	1	



K1816-55-02

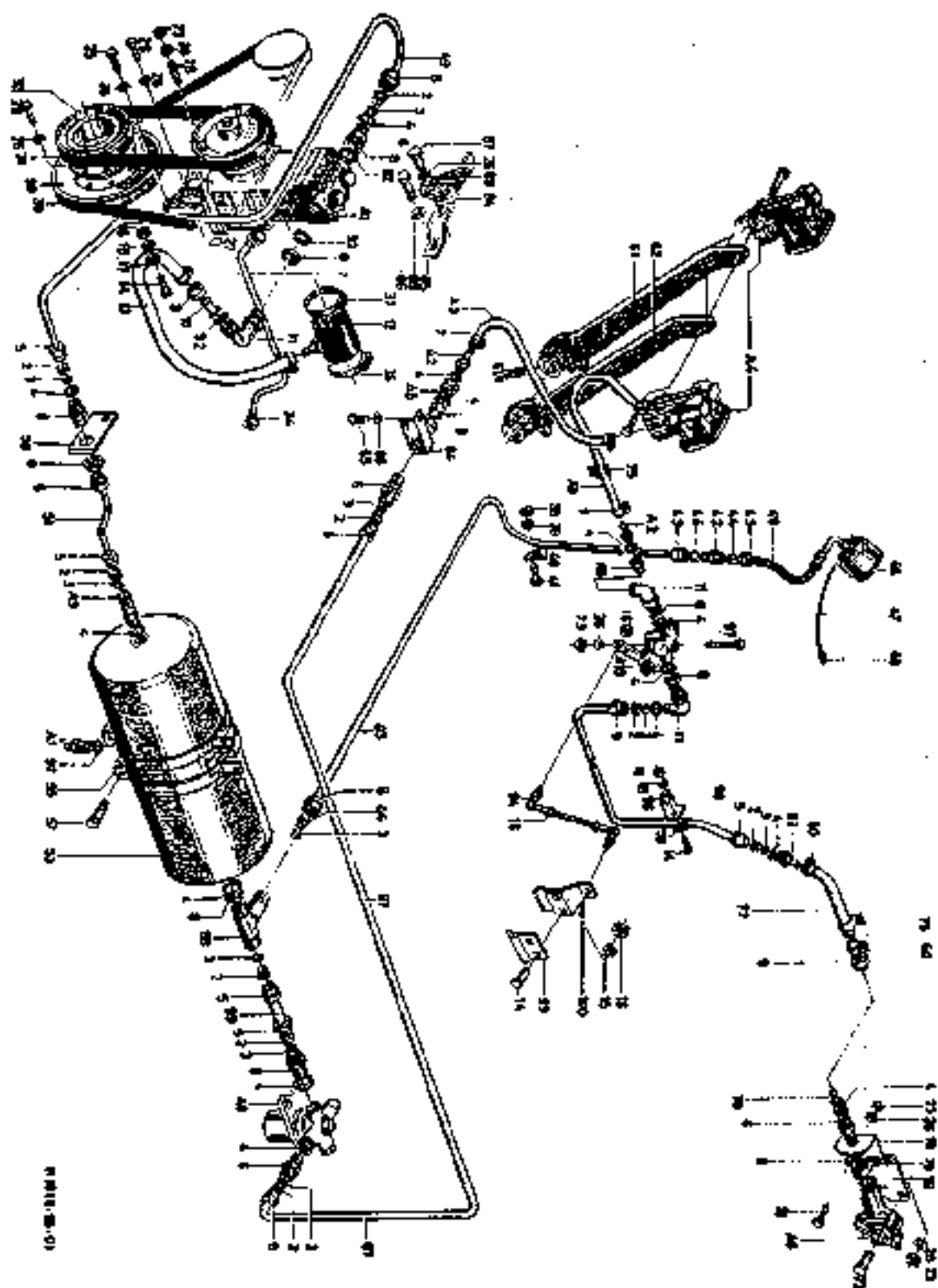
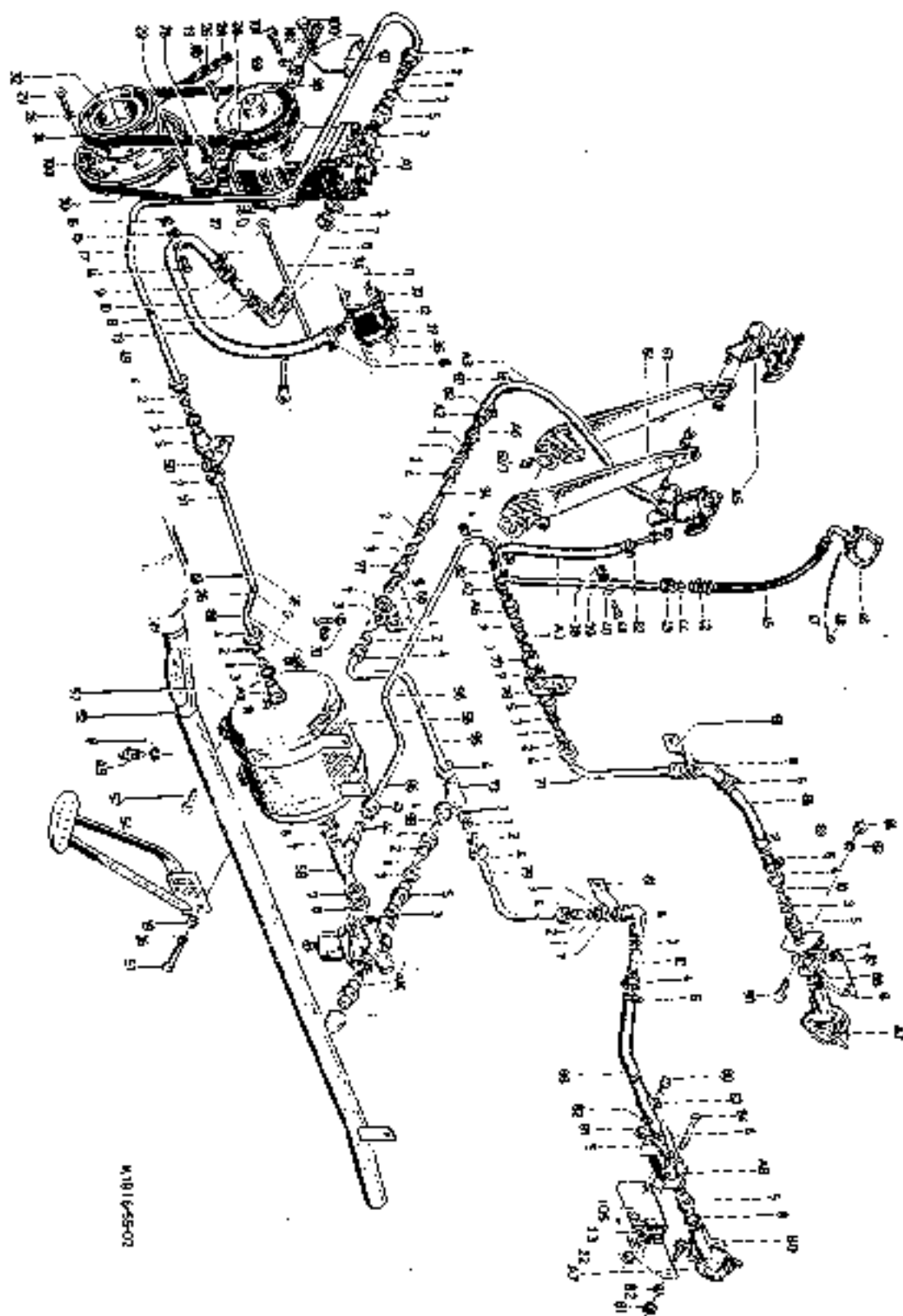

Bild-Nr.	Schleppenummer		Fußnote	Teilnummer	Anzahl	
	ab	bis				
36				B 80x15 H 735 (116 6417)	2	
37				A H 735 (116 6343)	2	
38				M 4 DIN 934-8 A4C (111 2796)	1	
39				4 H 2203 vzkc (116 7192)	1	
40				6 DIN 72572 vzkc (112 3496)	1	
41				AM 4x12 DIN 84-4,8 A4C (110 5512)	1	
42				M 12x1,5 DIN 74298-9S20K (112 3535)	1	
				vzkc		
43				AM 12x1,5 DIN 74297 A4C (112 3530)	2	
44				B 8 DIN 74297 A4C (112 3532)	2	
45				1940-35-03.93 (340 0705)	1	
46				231 3396	1	1941-55
47				1941-55-29,10 (340 0945)	1	
48				1 BC 6 H 7602 (116 9070)	1	
49				15RDx1,5 DIN 2391st35G2F P.M (112 3897)	2	1640 mm
50				232 9204	1	1952-55
51				15RDx1,5 DIN 2391-ST35G2F P.M (112 3897)	1	760 mm
52				Entfällt		
53				Entfällt		
54			+	231 3106	1	1952-55
55				232 9186	2	
57				M 6x35 DIN 931-8,8 Vzkc (111 1196)	2	
58				CM 22x1,5 DIN 74302 A4C (112 3538)	1	
61				231 3394	2	1952-55
62				B 14x9 H 735 (116 6352)	4	
63				231 3101	1	rechts 1952-55
				232 9174	1	rechts 1952-55

+ Nur bei Auspuff nach vorn

Bild-Nr.	Schleppenummer		Fußnote	Teilnummer	Anzahl	
	ab	bis				
63/7				S A 8 H 3360 (116 8225)	1	
64			231 3100	1	LINKS 1952-55
			232 9170	1	LINKS 1952-55
67				B 15 H 3201 (116 8145)	2	
68				1971-55-01.79 (340 1821)	1	
69				M 14x20 DIN 933-B.8 A4C (111 2596)	1	
70				A 14 DIN 128 vzkc (110 2802)	1	
71				15RDX1,5DIN2391St35GZFP.M. (112 3897)	1	760 mm
73				CM 22x1,5 DIN 74302 (112 1756)	1	
77				230 1124	1	1971-55
78				231 3393	1	1952-55
79				15RDX1,5DIN2391St35GZF (112 3897)	1	620 mm
80				M 8x20 DIN 933-B.8 A4C (111 2322)	6	
81				M 8 DIN 934-8 A4C (111 2824)	4	
82				8 H 2203 vzkc (116 9689)	4	
83				3 204 C 4 vzkc (121 6759)	2	
84				M 10x70 DIN 931-B.8 A4C (112 3727)	2	
86				13x800 DIN 74310 (110 1706)	2	
87				231 9844	1	1941-55
88				C DIN 74294 vzkc (112 3529)	1	
92				BM 22x1,5 DIN 74304 A4C (112 3542)	2	
93				15 RDX1,5 DIN 2391St 35 (112 3897)	1	80 mm
				GZF P.M.		
94				15 RDX1,5 DIN 2391-St 35 (112 3897)	1	100 mm
				GZF P.M.		
95				15 RDX1,5 DIN 2391-St 35 (112 3897)	1	560 mm
				GZF P.M.		

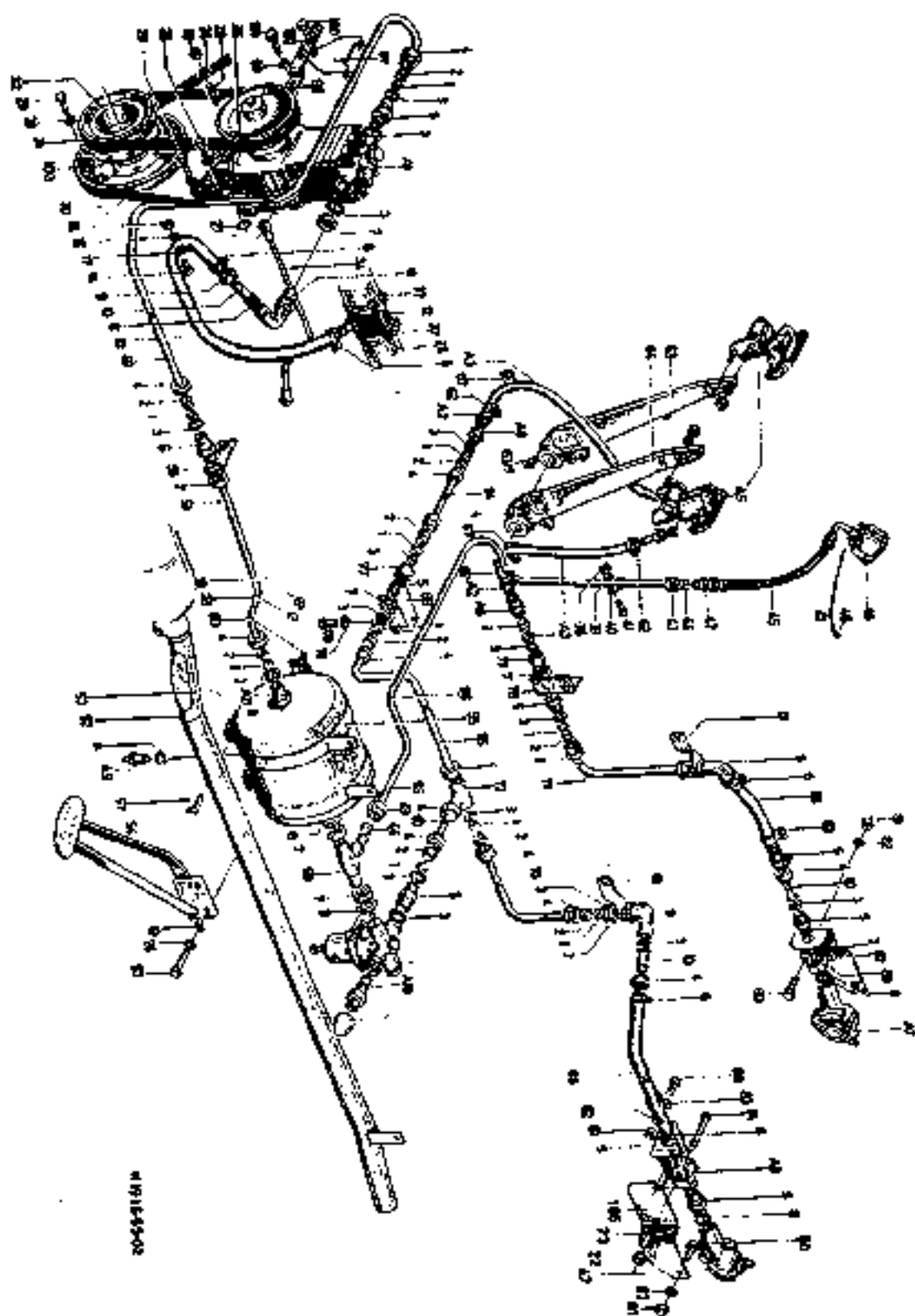
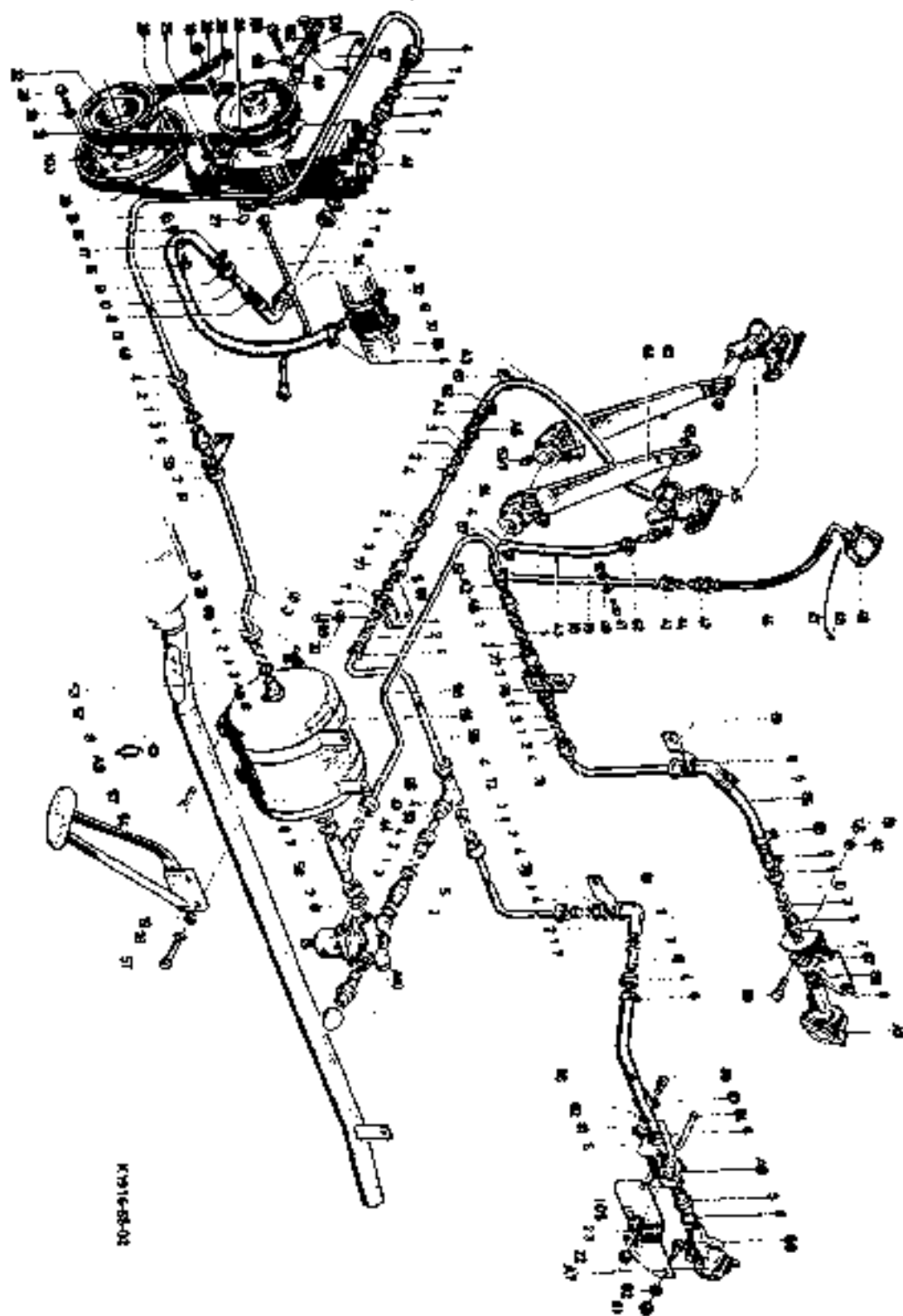

20-25-9141X

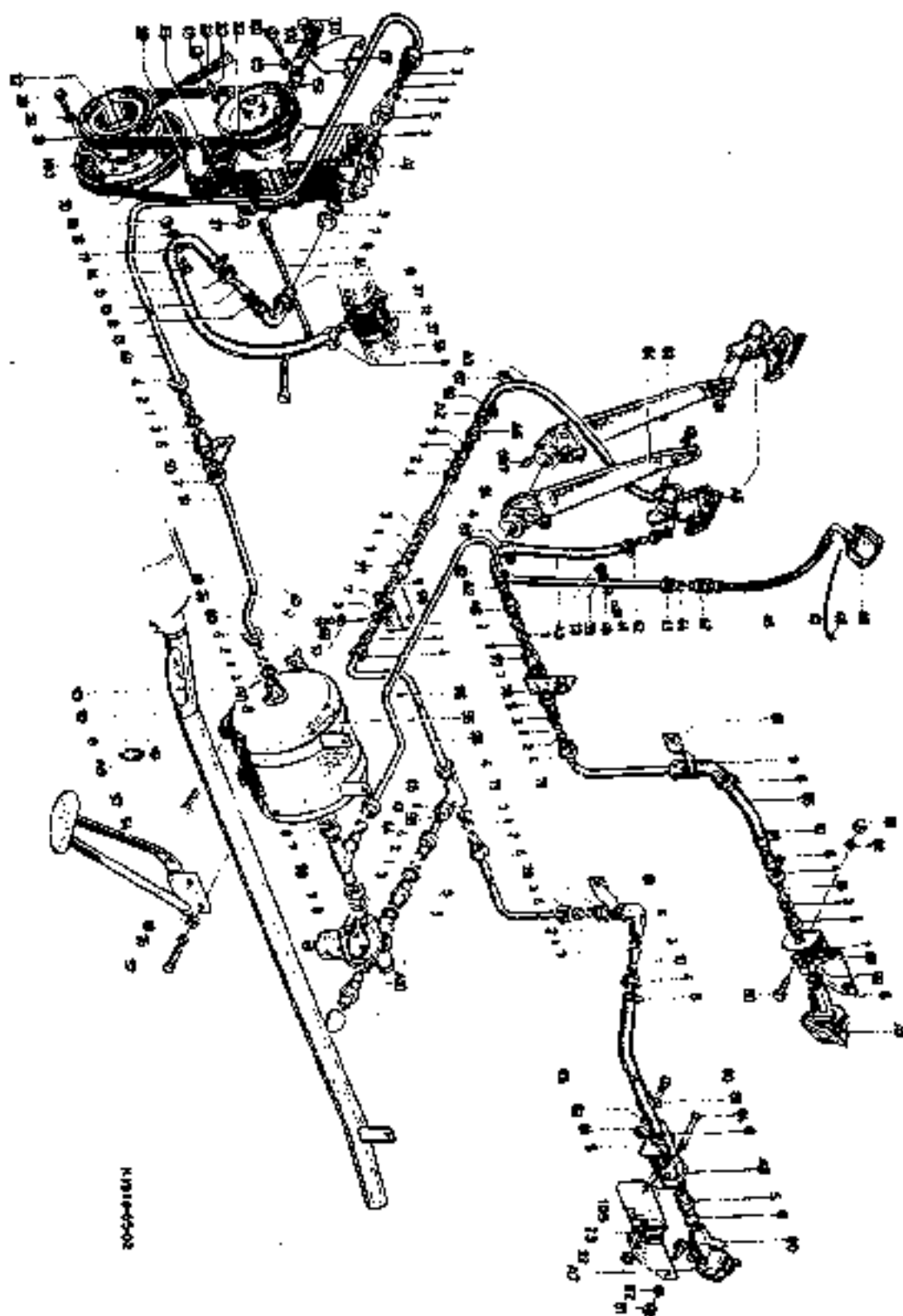

Hydraulische Bremse für Anhänger
Hydraulic Brake for Trailer
hydraulique du frein pour de remorque
de freno, hidráulico para remolques

1956

Bild-Nr.	Schleppernummer		Fußnote	Teilnummer	Anzahl	
	ab	bis				
1				232 4481	1	1952-56
1/3				B 40x10 H 3517 (116 8284)	1	
2				232 4479	1	1952-56
3				232 9110	1	1952-56
4				8731-29-01,20 (126 6006)	3	8731-29
5				L 15 DIN 3361 St (111 6626)	4	
6				AL 25 DIN 3870 vzke (111 6653)	4	
7				126 6007	1	8731-29
8				L 12 DIN 3361 St (111 6624)	2	
9				A1 12 DIN 3870 (111 6651)	2	
10				10F8x30x25 DIN 1434-5.8 (111 4663)	1	
				phosph		
11				10,5 DIN 125 vzke (110 7105)	1	
12				9x20 DIN 94 vzke (110 6432)	1	
13				8F8x23x17,5 DIN 1434-5.8 (111 4584)	1	
				phosph.		
14				8,4 DIN 125 vzke (110 7101)	1	
15				2x12 DIN 94 vzke (110 6404)	1	
16				232 9117	1	1952-56
17				5x16 DIN 1481 (111 5433)	1	
18				M 8x20 DIN 933-8.8 A4C (111 2322)	6	
19				A 8 DIN 128 A4C (110 2789)	6	
20				Entfällt		
21				M 8x16 DIN 933-8.8 A4C (111 2311)	2	
22				Entfällt		
23				M 10x75 DIN 931-8.8 A4C (111 1356)	1	
24				A 10 DIN 128 A4C (110 2800)	1	

