

YANMAR

OPERATOR'S MANUAL

DIESEL TRACTOR

EF393T

 Original instructions

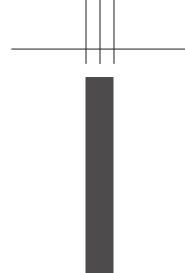
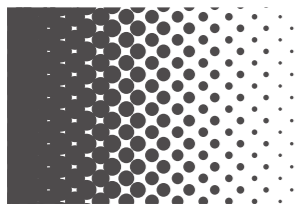

YANMAR

OPERATOR'S MANUAL

DIESEL TRACTOR

DIESEL TRACTOR

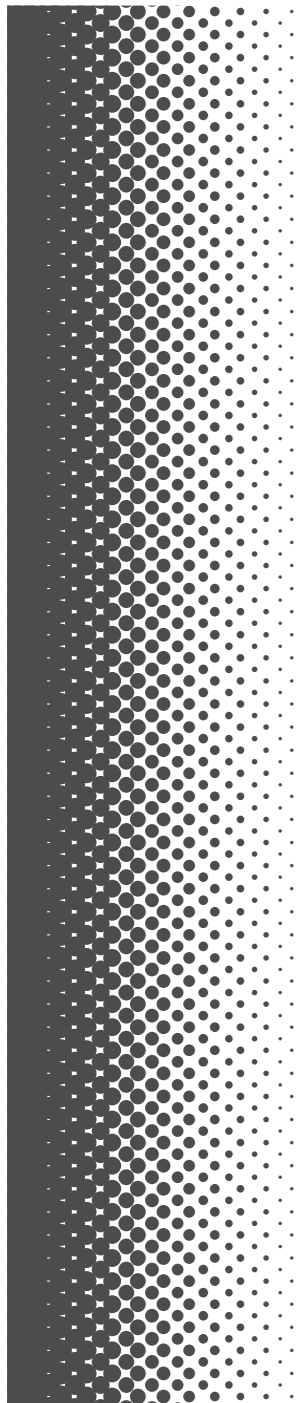

YANMAR



YANMAR CO., LTD.

<http://yanmar.com>

0A041-ENXXXX
Oct. 2014

EF393T

 Original instructions

SAFETY



WARNING

Never attempt to operate or service this machine until you have first read and understood all of the applicable Safety Instructions that are set forth in this Manual.

The failure to comply with all relevant Safety Instructions could result in bodily injury.

TO THE OWNER

This instruction manual describes how to maintain your tractor in good condition and how to operate it safely and correctly. Please read this manual carefully before using the tractor. Keep this manual close to your tractor, after you have read through it. If you lose or damage this manual, ask your YANMAR dealer for a new manual right away.

IMPROVEMENT

Sometimes parts are changed to improve or upgrade the features of the tractor, or for other reasons. Therefore, the parts shown in this manual may not apply to your tractor.

Note:

- All data are subject to change without prior warning. Some illustrations and photographs may show optional accessories.
- A Roll-over Protective Structure (ROPS) is optional.

SYMBOLS USED

1. Safety-alert Symbol

This is the safety-alert symbol. When you see this symbol on your tractor or in this manual, be alert to the possibility of personal injury and carefully read the messages that follow.



2. Signal Words

The signal words "DANGER" "WARNING" "CAUTION" are used with the safety-alert symbol.

- (1) "DANGER" indicates an imminently hazardous situation which, if not avoided, will result in death or serious injury.
- (2) "WARNING" indicates a potentially hazardous situation which, if not avoided, could result in death or serious injury.
- (3) "CAUTION" indicates a potentially hazardous situation which, if not avoided, could result in minor or moderate injury.



3. Service instructions

- (1) This stop symbol indicates important proper operation or service messages in this manual. When you see this symbol, carefully read the messages that follow.
- (2) "NOTE" describe precautions to take while working.



IMPORTANT

NOTE

4. Measurements

This tractor is of metric design. All hardware are therefore metric (ISO). Make sure to use the specified metric hardware when service becomes necessary.



5. Direction

Right-hand and Left-hand sides of the tractor are determined by facing in the direction of the tractor forward travel.

TABLE OF CONTENTS

SAFETY INSTRUCTIONS	1
AFTER SALES SERVICES	15
TRACTOR OUTLINE	17
PARTS NAMES	18
LABEL LOCATIONS	19
CONTROLS	21
OPERATIONS	29
1. Pre-operation checks	29
2. Break-in (initial 50 hours)	33
3. Before starting	33
4. Start and stop	34
4-1. Start and stop engine	34
4-2. Start, gear shifting and stop tractor	35
5. Driving on a road	37
6. Driving on a slope	38
7. Driving in and out of fields	38
8. Setting adequate speed	38
9. Turning in a field	39
10. Differential gear lock	39
11. Loading and unloading	40
12. Wheel tread	41
13. Hydraulic power take off	42
14. Using 3-point hitch	42
15. Drawbar hitch	44
16. General precautions on attaching and detaching an implement	44
17. Power steering	45
18. Safety frame (ROPS)	45
19. Tightening torque of bolts and nuts	45
OPENING BONNET	46
AFTER OPERATION	47

PERIODICAL SERVICE	49
1. Check intervals	49
2. Oil and grease	50
3. Capacity of oil and water	50
4. Equivalent oil to transmission fluid TF500	50
5. Fuel system	51
5-1. Fuel and refill	51
5-2. Drain and cleaning of water separator	51
5-3. Replacing fuel filter (cartridge type)	52
6. Oil and filter	53
6-1. Engine oil and filter	53
6-2. Transmission-hydraulic oil and filter	54
6-3. Front axle oil	55
7. Engine coolant	56
8. Radiator screen	57
9. Cleaning air cleaner element (dual element)	57
10. Checking battery	58
10-1. Check battery	59
10-2. Removing and installing battery	59
10-3. Charging battery	60
11. Checking pipes and hoses	60
12. Checking electric wires	60
13. Greasing	61
14. Adjusting brake pedal	62
15. Adjusting clutch pedal	62
16. Checking steering wheel	63
17. Adjusting fan belt	63
18. Checking and adjusting toe-in	64
19. Replacing fuse	64
19-1. Fuse box	64
19-2. Slow blow fuse	65
20. Checking tire and wheel	65
21. Color of exhaust gas	65
TROUBLESHOOTING	66
SPECIFICATIONS	69
IMPLEMENT CAPACITIES	70



SAFETY INSTRUCTIONS



DANGER

Read these instructions carefully.

Important instructions are given for the safe operation and servicing of the tractor.

Failure to follow these instructions is likely to result in an accident involving death or serious injury.

STUDY THE TRACTOR AND IMPLEMENTS

Do not permit anyone unfamiliar with the tractor or the operations of its implements to use the machine.

The operator's manual should be considered a permanent part of the tractor and should remain with the tractor.

Know the positions and functions of all controls and the meaning of any identification symbols on your controls, gauges, and indicators before attempting to operate the tractor.

Know how to stop the engine in an emergency.

Make sure you understand the capabilities, operating characteristics and limitations of the tractor and implement, such as maximum ballast weight, hydraulic lifting capacity, speed, turning radius, operating clearances etc.

Do not add extra ballast weight to compensate for a load that is too heavy.

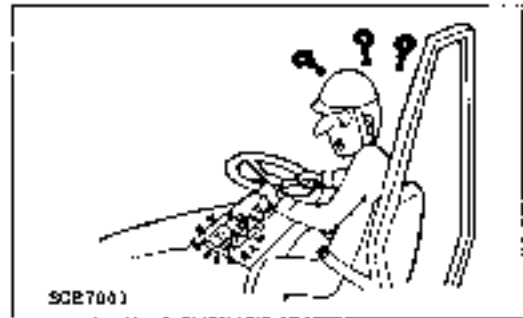
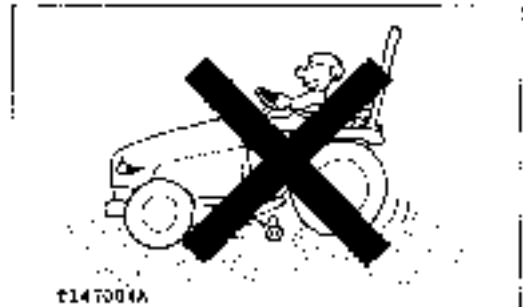

PROTECT OPERATOR SAFELY

Install an approved Roll-over Protective Structure (ROPS) for safe operation. If a tractor rolls over without a ROPS, death or serious injury is likely.

Always fasten the seat belt while operating the tractor with Roll-over Protective Structure (ROPS) up.

Do not use the seat belt if the foldable Roll-over Protective Structure (ROPS) is in the folded position or the tractor does not have the Roll-over Protective Structure (ROPS).

Extreme caution is required when operating a tractor around trees or other overhead obstructions, such as guy wires or power lines. Interference between the ROPS and these obstructions may cause the tractor to tip backwards.

Do not modify any structural portions of the ROPS by welding, bending, grinding or cutting them. If any component of the ROPS is damaged or involved in a rollover incident, replace it with a complete new cage. Do not attempt to repair the original one. Damaged or modified structural parts impair the strength of the ROPS and may lead to injury.

Avoid loose fitting or baggy clothing, torn clothing, bulging pockets, frayed edges or heavy cuffs. Loose frayed and bulky clothing can easily become entangled in rotating parts. Wear work clothes and work shoes or boots. Also you may need a: **SAFETY HELMET, SAFETY SHOES, EYE PROTECTION, HEAVY DUTY GLOVES, HEARING PROTECTION, REFLECTIVE CLOTHING, OR A RESPIRATOR/FILTER MASK.**

Wear whatever safety gear and clothing is necessary for the job.

Prolonged exposure to loud noise can cause impairment or permanent loss of hearing. Wear a suitable hearing protective device such as ear protectors or earplugs to protect against objectionable or uncomfortable noise.

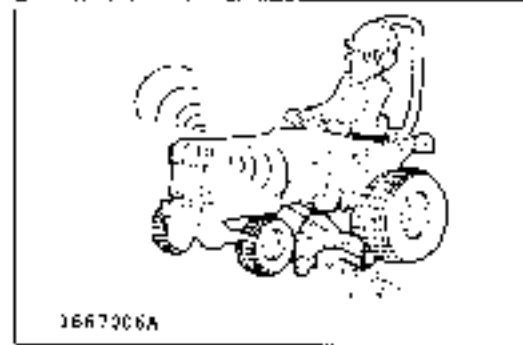
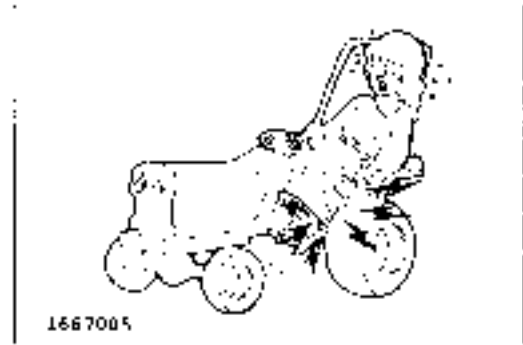
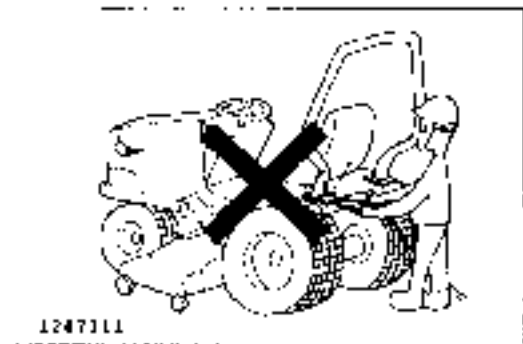
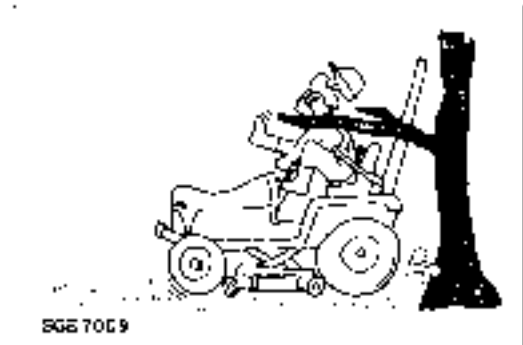
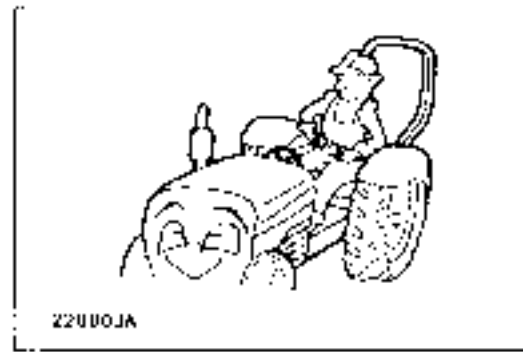

BEFORE OPERATING

Do not operate the tractor when tired, sick, sleepy, drunk, feeling overworked, taking medicine, pregnant, suffering from mental disease or if other improper conditions are present. These conditions impair a person's skill and judgment. When you begin feeling tired while operating the tractor, take a 10-minute break to stretch, walk about, lie down or snack. Do not continue if you still feel tired after taking a break.

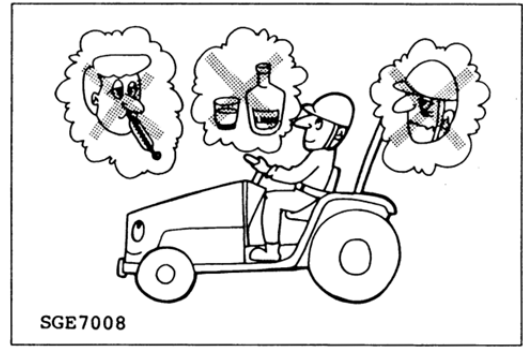

Remove oil, grease or mud from the hand rails, steps, pedals, controls, and floor to avoid slips or loss of control.

In winter, scrape off any ice or snow on the hand rails, steps, pedals, controls, and floor.

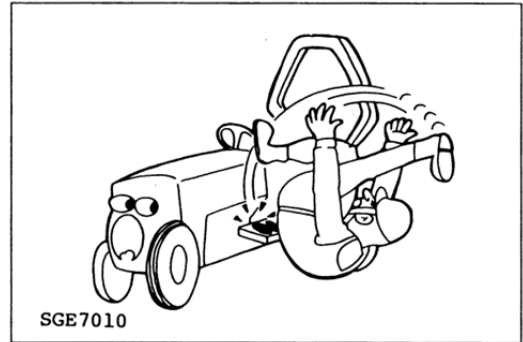

To attach or remove an implement, refer to the implement and tractor manufacturer's manuals for the proper procedures.

To unhitch an implement, move to a level area, lower the implement to the ground and then block the equipment in position before unhitching. If an implement has wheels, block them to prevent it from rolling.

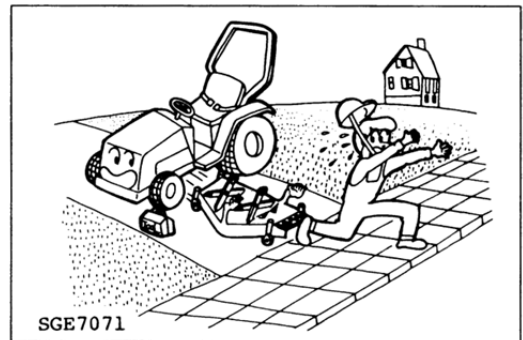

Make sure

- (1) The tractor and implements are in good condition and properly adjusted.
- (2) To check for loosened bolts, adequate lubricants, damaged or under-inflated tires, safety shields and devices, steering and braking linkages, hydraulic leaks, etc. Refer to this manual for more detailed information.
- (3) That implements are properly attached and hooked up. Check that the PTO U-joint yoke and locking devices are securely latched on their shafts.
- (4) That the tractor's PTO speed matches the implement's specifications.

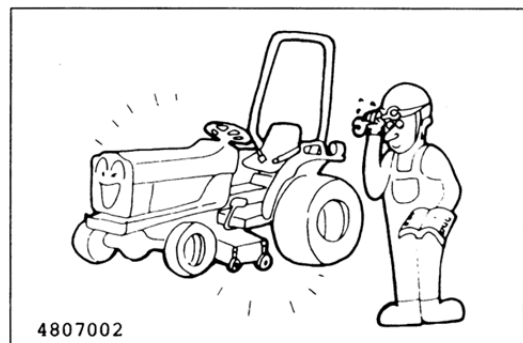

STARTING

START THE ENGINE SAFELY

If you operate the engine inside a closed building, be sure there is plenty of ventilation before starting the engine. Exhaust fumes are poisonous. Carbon monoxide is especially dangerous because it is odorless and colorless. You can easily be overcome without realizing it.

Always stay near the tractor and keep the parking brake set securely while warming it up.

Only start the engine from the operator's seat. Never start the engine while standing on the ground.

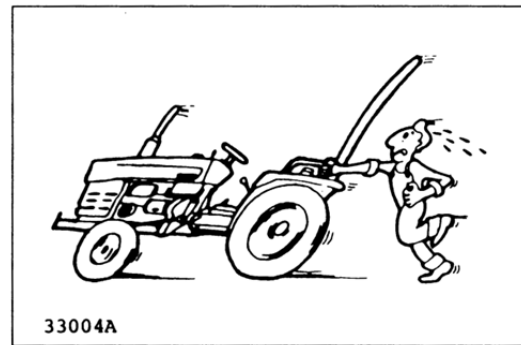
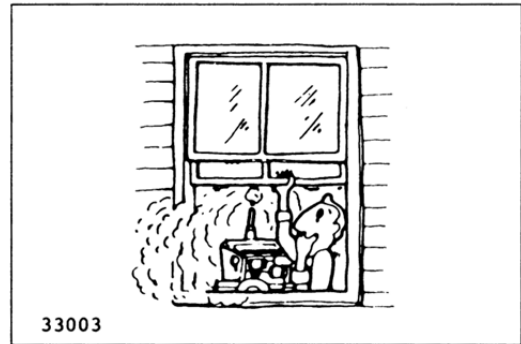

Before you start the engine:

- (1) Sit in the operator's seat and adjust the seat position if necessary.
- (2) Make sure the ROPS is in working condition and seat belt securely fastened.
- (3) Lower any implement to the ground.
- (4) Place speed shift lever and the PTO switch in neutral.
- (5) Set the parking brake.
- (6) Disengage the PTO for the neutral position.
- (7) Check all the instruments, gauges and indicator lights.
- (8) Be sure everyone is clear of the tractor and implement.

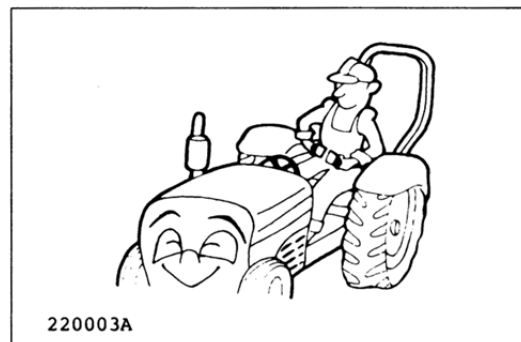

DURING OPERATION

OPERATE THE TRACTOR SAFELY

Keep people and pets a safe distance away when starting and operating the tractor and implement.

Do not permit any person other than the operator to ride or board the tractor or implements, including any wagons.

Do not play games with the tractor.
Never allow children to ride on your lap.

Do not touch the muffler, radiator, engine or other high temperature parts before they have cooled down completely.

Do not try to get on or off a moving tractor or implements. Always use the hand rails and steps and face the tractor when getting on and off. Never use control levers as a hand hold and never step on foot controls when getting on and off. Do not get on the tractor with wet or greasy hands, or muddy shoes. Do not jump off the tractor. Be aware of slippery conditions on the ground.

Make sure you check the connecting points on your equipment.

Keep hands, feet and clothing away from power-driven parts. Keep others away from articulated joints, hitches, drawbar, lift arms, PTO drives, cylinders, and anything else that moves.

Never stand, or allow anyone else to stand, between the tractor and an implement, unless the engine is turned off and the parking brake is engaged securely.

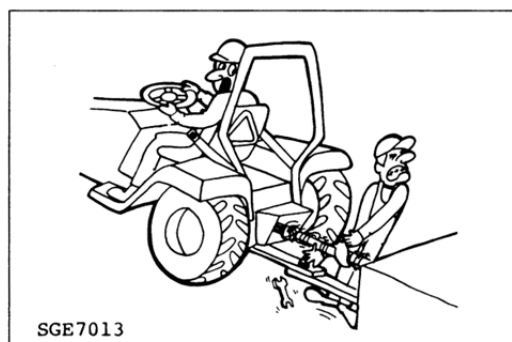
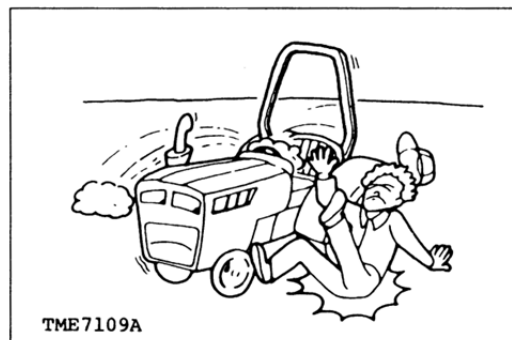
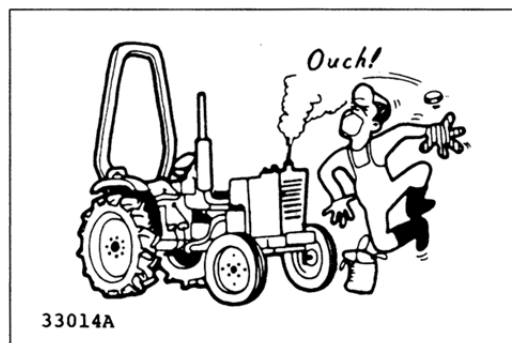
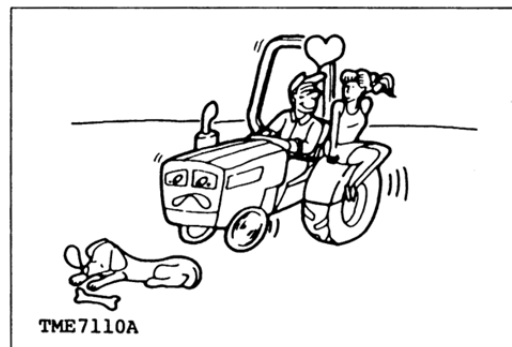

OPERATE THE TRACTOR SAFELY (continued)

Oversized implements are dangerous for tractor operation and are not safe for you. Refer to the implement's operator manual for the minimum and maximum horsepower requirements and weights that are allowed.

When using a heavy implement in front, always install ballast or an implement on the rear for safe, stable steering control.

When using a heavy implement on a rear 3-point hitch, always install ballast or an implement on the front for safe, stable steering control.

Slow the tractor down when crossing rough ground, tall grass or weeds. Rocks, holes and stumps may be hidden in the brush.

Do not let your tractor bounce. You may lose steering control.

Never use the tractor to round up farm animals.

Do not allow the tractor to coast downhill **with the clutch in**, or with the gear shift in neutral.

When operating the tractor on a slope, set the wheel tread as wide as possible for maximum stability, reduce the engine speed and avoid quick application of the brakes or sharp turns.

Stay off hills and slopes which are too steep.

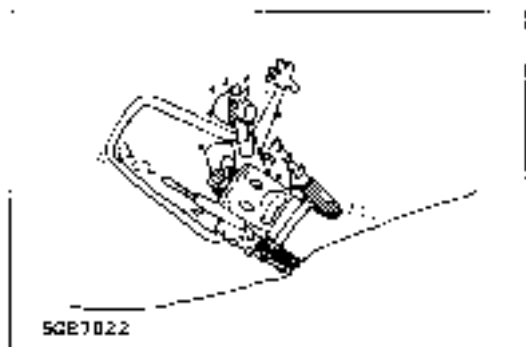
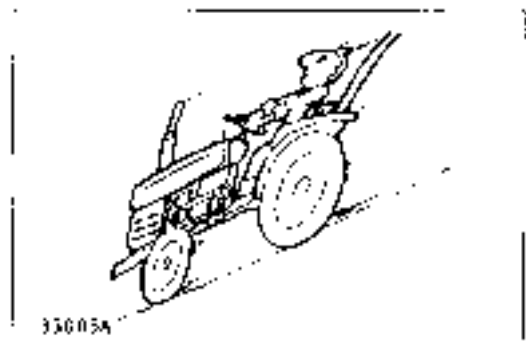
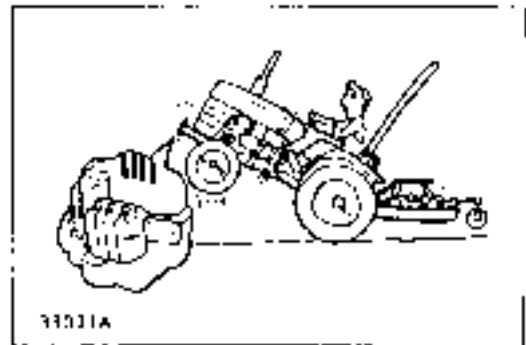
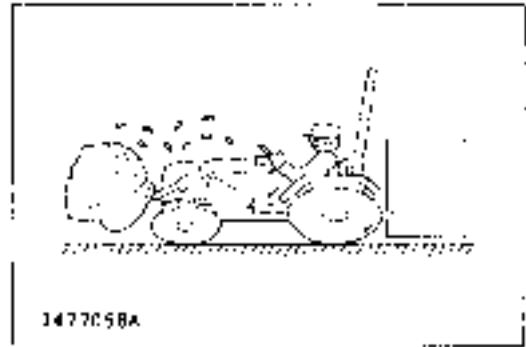

AVOID TIPPING OVER

When starting the tractor on an uphill slope, shift to as low a gear as possible and reduce the engine speed to avoid tipping over backward.

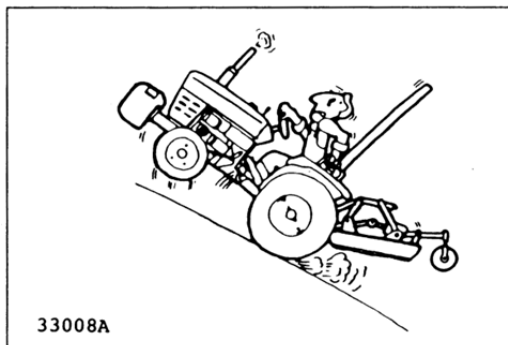

Do not drive near the edge of a gully or a steep embankment. Avoid holes, ditches, etc. which may cause the tractor to tip over, especially on hillsides or steep slopes.

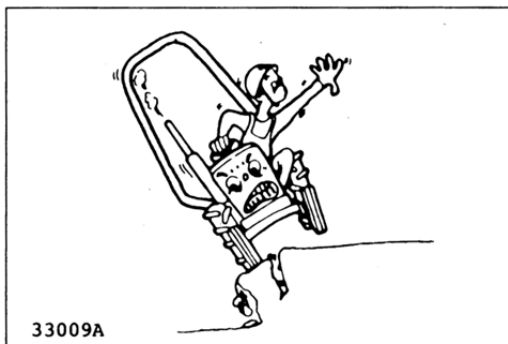

When operating on slopes or rough uneven ground, it is important to have as much distance as possible between the wheels. Operate the tractor carefully at the lowest speed.

Do not pull carts etc. from the top link or the top link hinge, rear axle, or any point above the drawbar. Doing so could cause the tractor to tip over backward. Only attach items to be pulled to the drawbar.

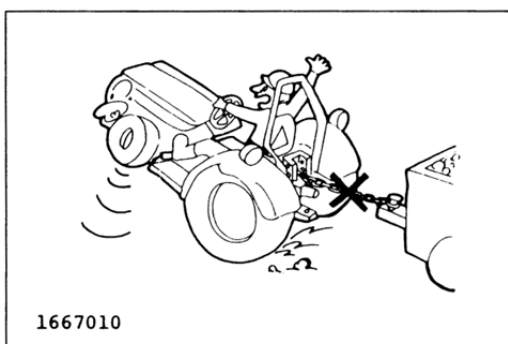

Use care when pulling loads or installing a heavy implement.

- (1) Only use approved hitch points.
- (2) Limit loads to those which you can control safely.
- (3) Limit travel speeds so that you can control the tractor safely.
- (4) Do not turn too quickly.
- (5) Use care when backing up.
- (6) Install the amount of ballast recommended in the operator's manual.

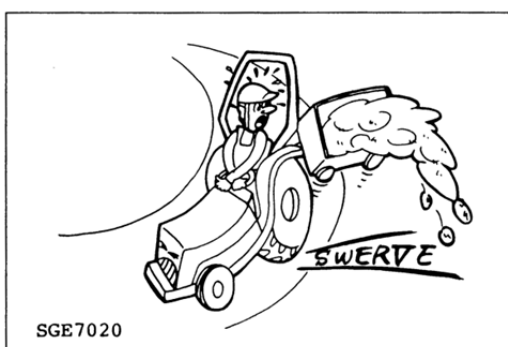

Driving forward out of ditch or in muddy conditions, or up a steep slope, could cause the tractor to tip over backward. If the mud is deep enough it will keep the wheels from turning. Then, the tractor will rotate up and back around the axle very quickly. When stuck in muddy conditions, do not remove the implement or ballast weight. Always back out.



STAY CLEAR OF THE PTO

The PTO shaft safety guard (A) should be installed when the PTO system is not in use.

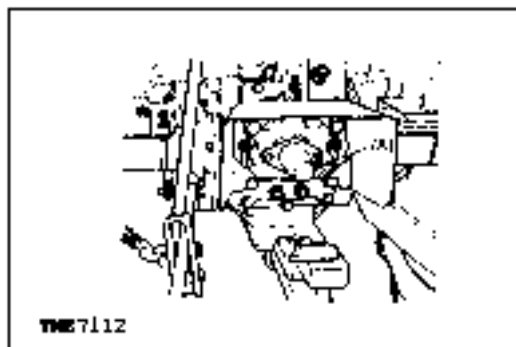

Make sure that the tractor PTO speed matches the implement's required PTO speed.

Do not drive or operate the implement beyond the tractor's PTO speed.

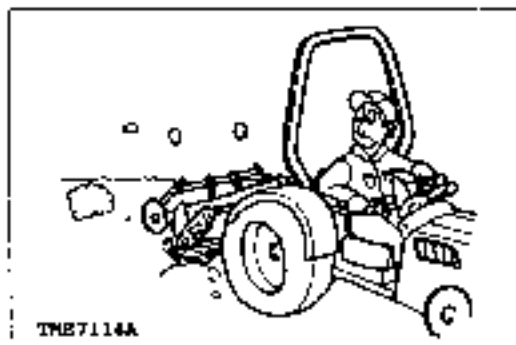

Stop the engine and be sure the PTO has stopped moving before:

- (1) Connecting or disconnecting the PTO shaft.
- (2) Making any adjustment to the PTO drive or 3-point hitch.
- (3) Adjusting, cleaning or servicing PTO driven implements.

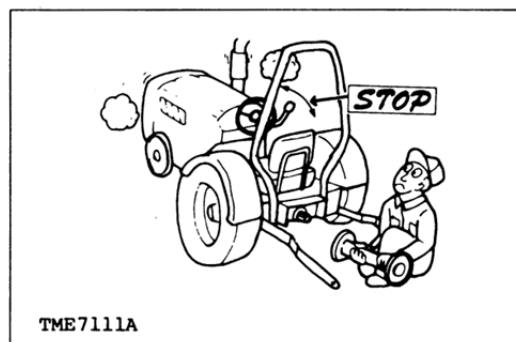

TRANSPORTING

Raise all implements and place them in the locked-for-transport position.

Do not drive the tractor on the road with implements in motion.

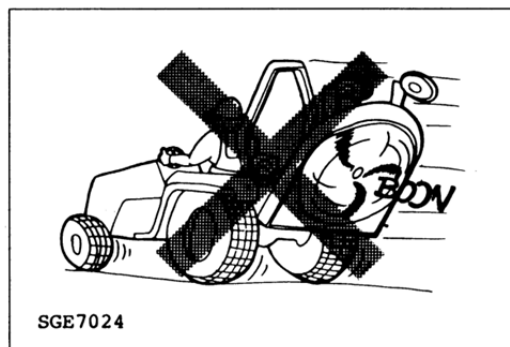

Couple the brake pedals together for travel at road speeds. (This only applies to models with two brake pedals.)

Do not make sharp turns at road speeds.

Always dim your headlights when another vehicle is coming toward you. Keep the lights adjusted so that they will not blind the driver of another vehicle.

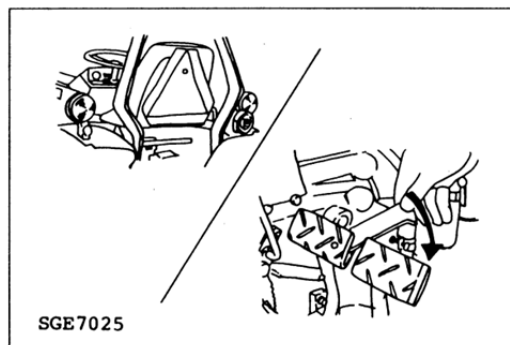

Before going down a steep hill, shift to the lowest speed in order to control tractor with the least braking possible. Do not coast downhill.

Do not stop or start suddenly when going uphill or downhill.

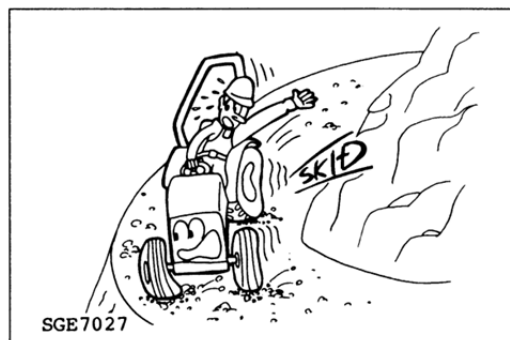

When loading (or unloading) the tractor onto a vehicle, use care as follows:

- (1) Use a strong loading ramp or loading dock.
- (2) Use the lowest reverse speed and drive up the loading ramp backward.
- (3) Set the parking brake and place wheel blocks firmly under the vehicle's wheels.
- (4) Do not try to drive onto a trailer from the bank of a ditch.

Secure the tractor and any other load with chains. Be sure they are tight.

If chains are not available, use rope, wire, blocks, or a winch cable. Check the load after traveling a few kilometers, and every 100 km thereafter, to make sure that the ties are not coming loose. Also, check after rough bumps in the road.

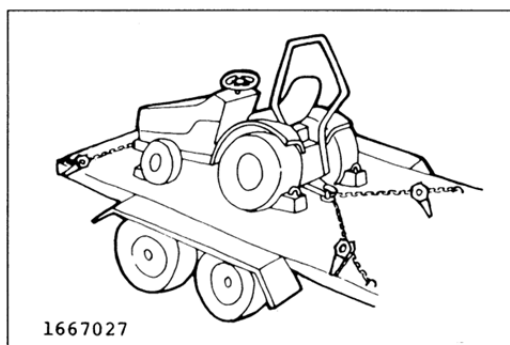
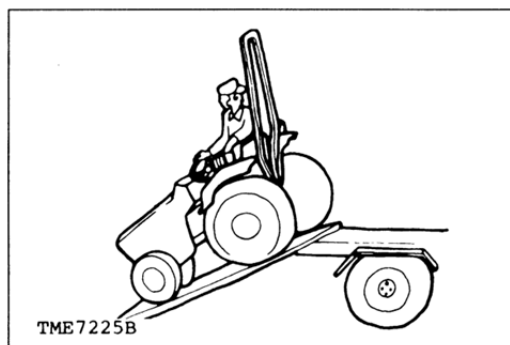

TOWING

When towing a load that weighs more than the tractor, the trailer should have its own brakes. When towing, drive slowly, avoid hills and apply the brakes gently.

A safety chain will help control an implement being pulled if it accidentally separates from the drawbar while traveling. Using appropriate adapter parts, attach the chain to the tractor drawbar support or to some other specified anchor location. Leave only enough slack in the chain to permit turning.

Do not tow the tractor faster than the tractor's maximum travel speed in the highest gear, and never more than 25 km/h (16 mph).

Check local regulations concerning towing. Towing is illegal in some countries.

AFTER THE DAY'S OPERATION

PARK THE TRACTOR SAFELY

Park tractor on a firm level surface.

When parking the tractor, couple the brake pedals together and set the parking brake securely. When you must park on a slope, position the tractor at a right angle to the slope and set the parking brake securely. Then, block both the front and rear wheels.

Take all possible precautions as follows when leaving tractor unattended:

- (1) Disengage the PTO and lower any implement to the ground.
- (2) Move all shift levers to neutral.
- (3) Couple the brake pedals together and set the parking brake lever.
- (4) Run the engine for 2 to 3 minutes at one-third throttle speed and no load in order to cool it.
- (5) Stop the engine and remove the key.
- (6) Cycle the hydraulic controls to eliminate any residual pressure.

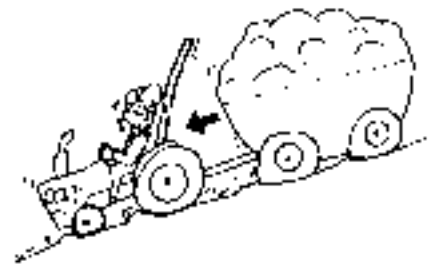

2MR115A



1667026

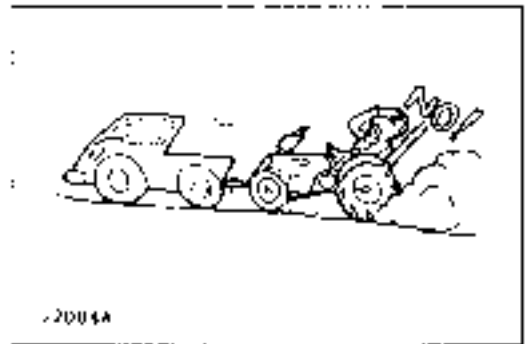

22004A

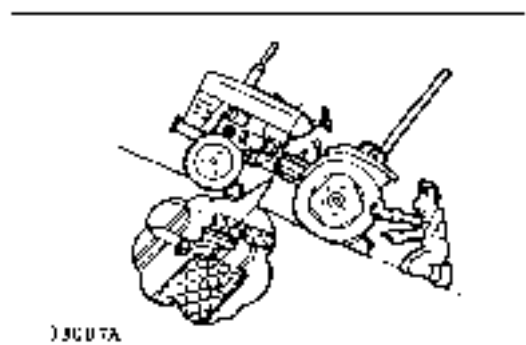

3JG07A

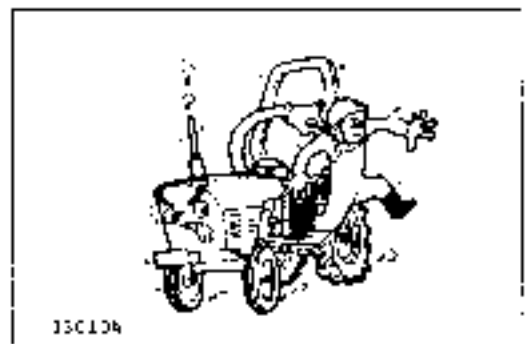

13C104

MAINTENANCE AND SERVICE

AVOID EXPLOSIONS OR FIRES

Refuel the tractor when the engine is cool and in a well-ventilated area, preferably outside.

Never fill the fuel tank with the engine running.

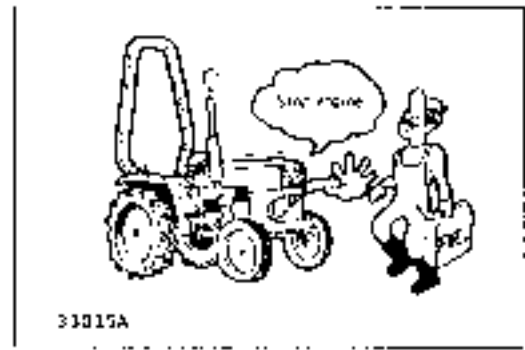

Be sure to use the correct type and grade of fuel.

Keep all sparks, flames and smoking materials well away while handling fuel.

Ground the fuel funnel or nozzle against the filler neck on the tractor to prevent sparks.

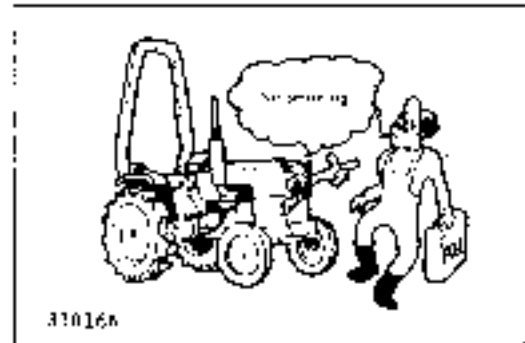

Do not overfill the tank or spill the fuel. If fuel is spilled, wipe it up immediately. Install the fuel tank cap securely after refueling.

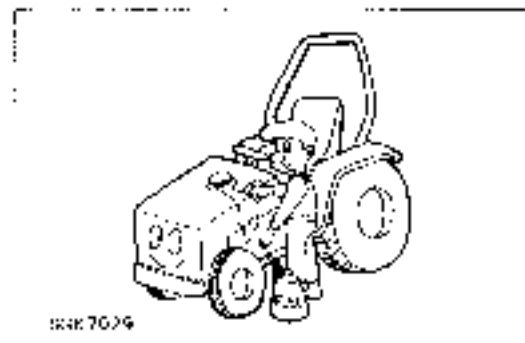

Be sure there is plenty of ventilation before charging the battery. Gas produced while charging the battery is explosive.

Keep all sparks, flames, and smoking materials well away from battery. Hydrogen gas at a concentration as low as 7 per cent can explode in the presence of a spark or open flame and spatter acid. Use a flashlight to check the battery electrolyte level. Never use an open flame or match to check.



Keep the engine clean and free of grass, leaves, or excessive grease.

Let the engine cool down before storing the tractor in an enclosure or covering it with a sheet.

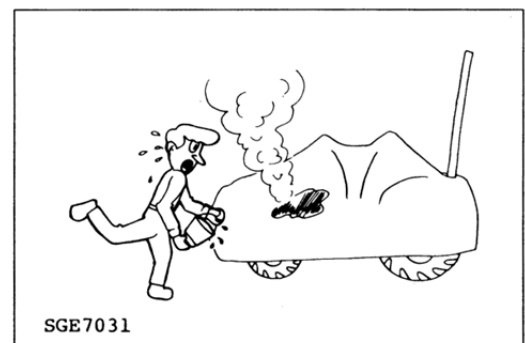

MAINTENANCE AND SERVICE (continued)

Do not service the tractor while it is in motion or while the engine is running.

Before servicing the tractor, always set the parking brake, block the wheels, lower the implement, release all hydraulic pressure and place all the controls in neutral.

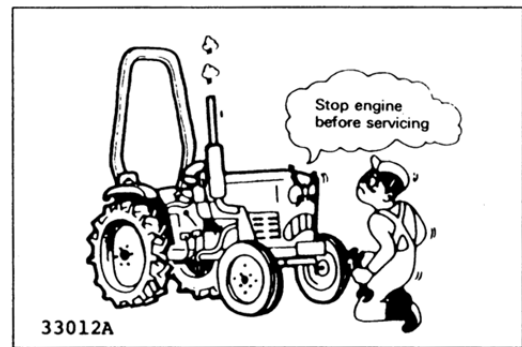

Use only the correct tools and equipment.

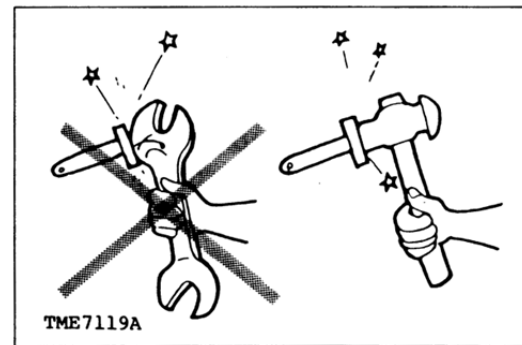

Unauthorized modification to the tractor may impair its function, create an unsafe situation and reduce the tractor's useful working life.

Do not use substitute parts that may not meet the strength and design requirements or may not fit the tractor.

Do not use repair parts not approved by YANMAR.

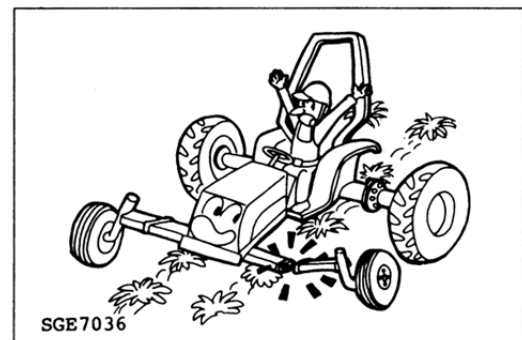

Remove the radiator cap only when the coolant temperature is low. Wait at least one hour after operation, to allow the coolant to cool down.

Cover the radiator cap with a cloth before opening it and release the pressure gradually before completely removing the cap.

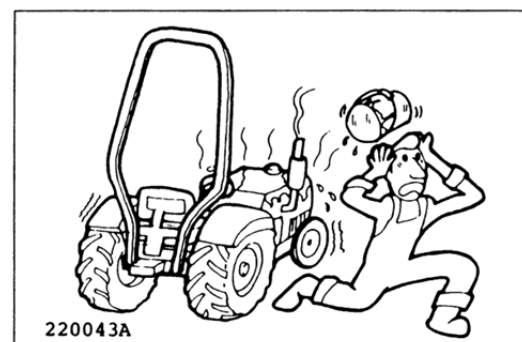

Do not service the hydraulic system when the hydraulic oil is hot.

Do not set the relief valve pressure higher than stated in the tractor or implement specifications.

Do not close off the overflow or bypass lines.

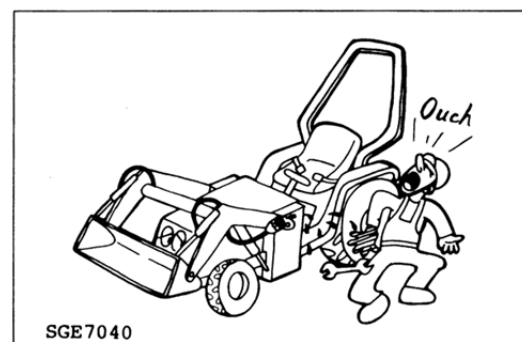

MAINTENANCE AND SERVICE (continued)

Hydraulic oil or diesel fuel escaping under pressure can penetrate the skin and cause serious injury. Before disconnecting any lines, be sure to relieve all pressure. Before applying pressure, be sure all connections are tight and all components are in good condition.

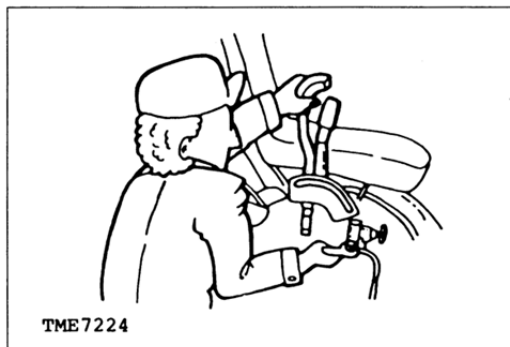

Fluid escaping under pressure from a very small hole can be almost invisible. Wear safety goggles for eye protection and use a piece of cardboard to check for suspected leaks. Do not use your hands. If injured by escaping fluid, see a doctor at once. Serious infections and other problems can develop if proper medical treatment is not administered immediately.

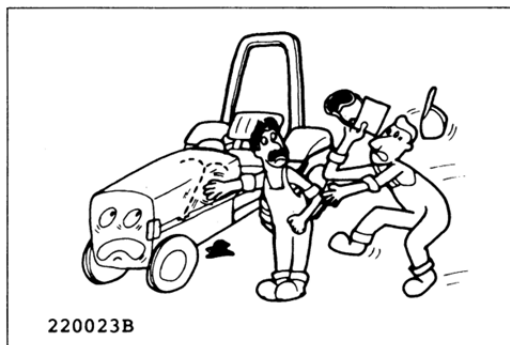

Disconnect the battery ground cable before working on the electrical system or working in any area where you might come into contact with electrical components. Disconnect the ground cable first and reconnect it last.

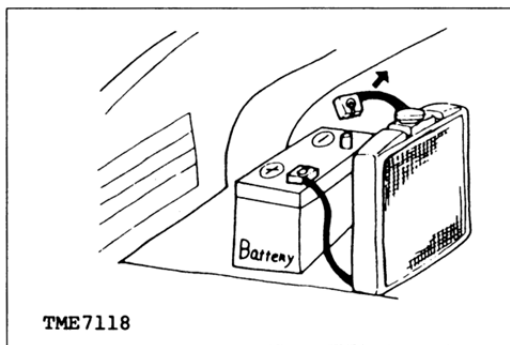

The sulfuric acid in a battery is poisonous. It can destroy clothing and burn the skin. Wear eye protection and rubber gloves when filling the battery. If you spill acid on yourself, flush your skin with water and apply baking soda or lime to neutralize the acid. Then seek medical attention right away. If acid is swallowed, get medical attention immediately!

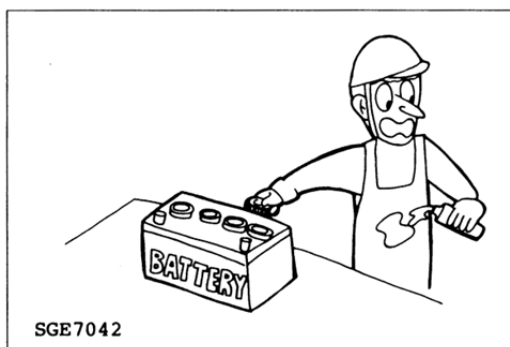

Storage

Whenever the tractor will not be used for a few months, do the following:

- (1) Drain the fuel tank.
- (2) Lower any implement still attached.
- (3) Set the parking brake and block the wheels.
- (4) Remove the battery and store it in a cool, dry place, out of the reach of children.

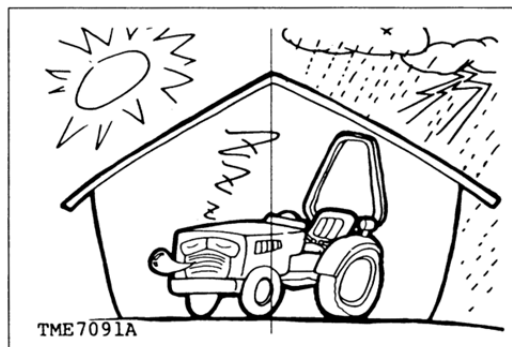

CAUTION

ALWAYS BE ENVIRONMENTALLY RESPONSIBLE

- Follow the guidelines of the governmental agency for the proper disposal of hazardous materials such as engine oil, diesel fuel, engine coolant and, machine fluid, grease.
- NEVER dispose of hazardous materials irresponsibly by dumping them into a sewer, on the ground, or into groundwater or waterways.
- Failure to follow these procedures may seriously harm the environment.
- Comply with legal regulations and guidelines for disposal of: empty containers for fuel, cooling water (coolant), oil, grease; fuel/oil filters; batteries; machine itself; machine accessories; and packaging materials.

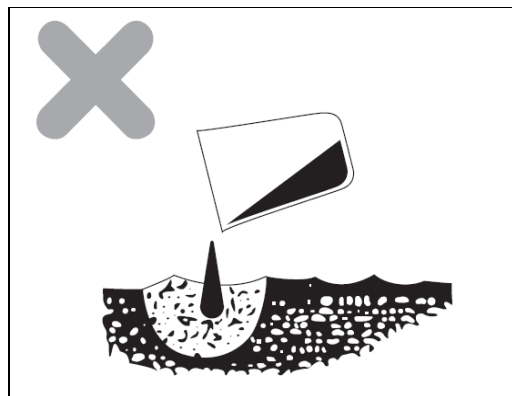

AFTER SALES SERVICES

After sales services

When your tractor is not working normally, check it referring to the troubleshooting section. You can of course consult with your service representative.

Whenever you ask service to your service representative, following information are very helpful to identify your tractor.

- 1) The label of tractor model name and serial number (A) is on the left rear fender and the stamp of the serial number (B) is on right side of front frame.
- 2) Engine model name and serial number (C).
- 3) Hour-meter (D) shows estimated hours of operation. Turn on key switch to read hours.



- 4) Operating conditions.
Kind of work and implement used when a problem is happened.
- 5) Any other information when a trouble is occurred.
Noise, vibration, function etc.

Availability of spare parts

Maintenance parts or spare parts are available for 10 years after the production of this tractor series has been discontinued. However, special parts will be subject to consultation. Yanmar may be able to supply a particular part after the normal supplying period.



(A) Tractor model name & serial number

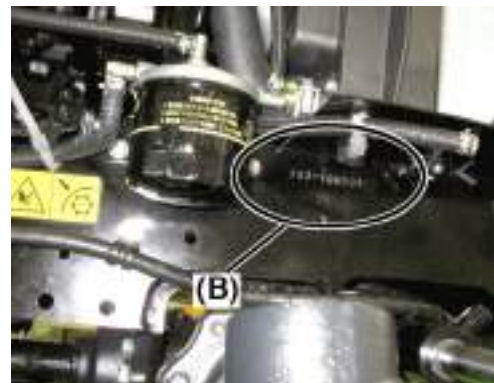

(B) Tractor serial number

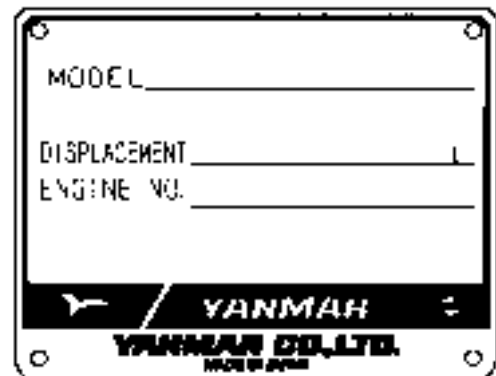

(C) Engine model name & serial number



WARNING

- Do not move the tractor if the wheel mounting bolts or nuts are loose. If the tractor is driven with loose nuts or bolts, there is a possibility that an accident will occur.
- Make daily and periodic wheel inspections to check for loose nuts and bolts on the wheels. If they are loose, retighten them to the specified torque.



IMPORTANT

The first 50 hours of handling and maintenance greatly affect the service life and performance of a new tractor. In particular, pay special attention to the following points during this period of time.

- (1) Refrain from sudden acceleration and sudden braking.
- (2) Do not increase the speed too much or carry any more load than is necessary.
- (3) Operate the tractor only after the engine has warmed up sufficiently.
- (4) Slow down on a rough road or on a slope.
- (5) Check the tightness of the wheel mounting bolts after the first 10 hours and again after the first 50 hours. If they are loose, retighten them. (For specific tightening torques, refer to the table in the instruction manual.)



IMPORTANT

When the tractor gets stuck in a muddy portion in field, do not tie a piece of lumber, log or pipe to the front or rear wheels to drive out of the muddy portion. It may break transmission and/or rear axle inner parts or cases.

Put a ladder bridge under the wheels and then drive out. Or use strong rope or chain to pull it out of the muddy portion slowly by the other tractor or so.



Note:

These photos show rear tire with cage wheel.

TRACTOR OUTLINE

- | | | | |
|-----|------------------|------|---------------------|
| (1) | Head light | (8) | Lower link |
| (2) | Turn signal lamp | (9) | Top link |
| (3) | Tail lamp | (10) | Fender, R |
| (4) | Fuel refill port | (11) | Fender, L |
| (5) | Operator's seat | (12) | Front tire |
| (6) | Sub-step | (13) | Rear tire |
| (7) | Bonnet | (14) | ROPS (Safety frame) |

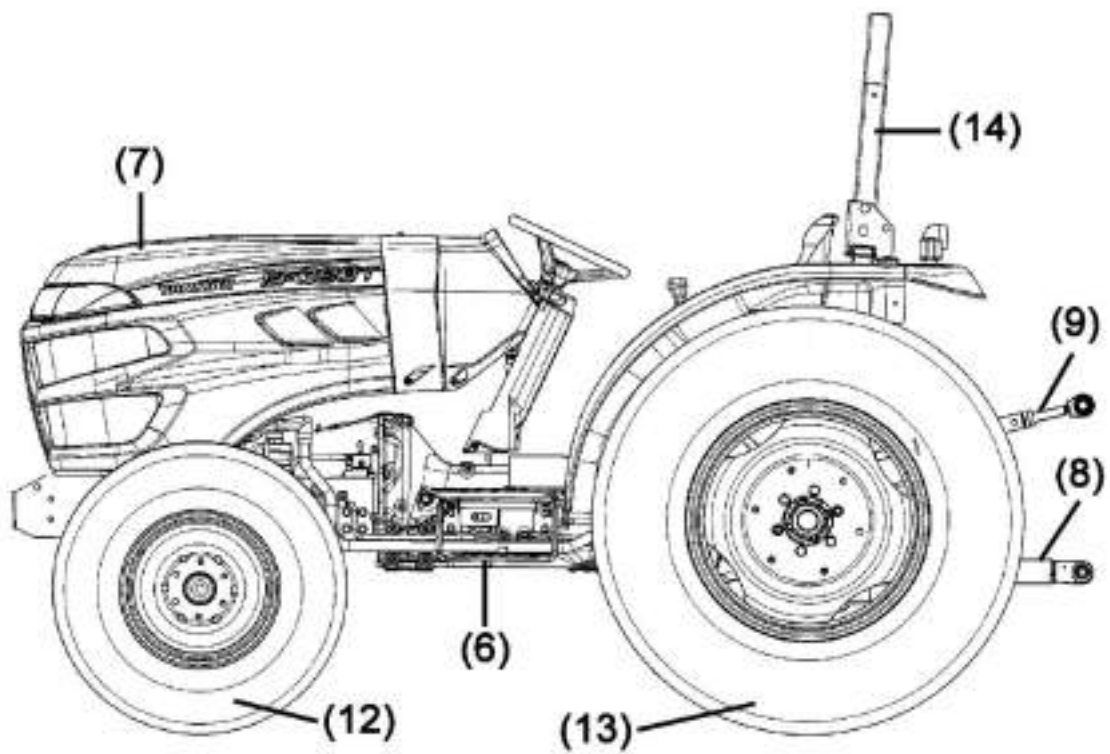
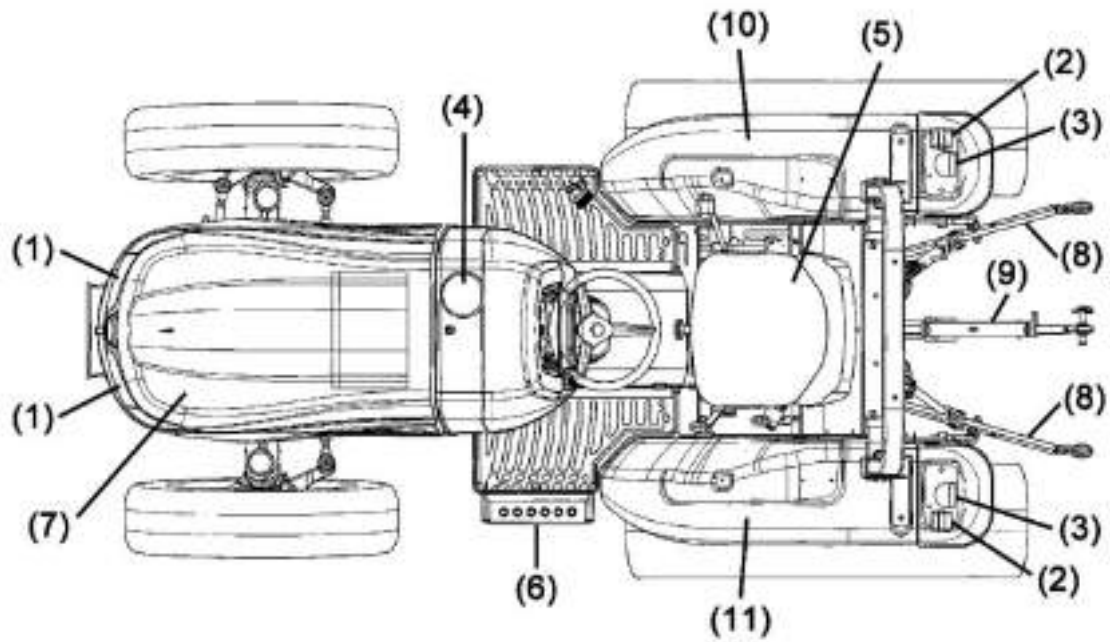

PARTS NAMES

- | | | |
|---|-----------------------------|-----------------------------------|
| (1) Main switch | (7) Range gear shift lever | (13) Position control lever |
| (2) Accelerator lever | (8) PTO gear shift lever | (14) Differential gear lock pedal |
| (3) Parking brake lever | (9) Brake pedal connector | (15) Seat adjust lever |
| (4) Combination switch
Head light, turn signal, horn | (10) Brake pedal | (16) Stop & slow return valve |
| (5) Reverser lever | (11) Foot accelerator pedal | (17) Front wheel drive lever |
| (6) Clutch pedal | (12) Main gear shift lever | (18) Seat belt |

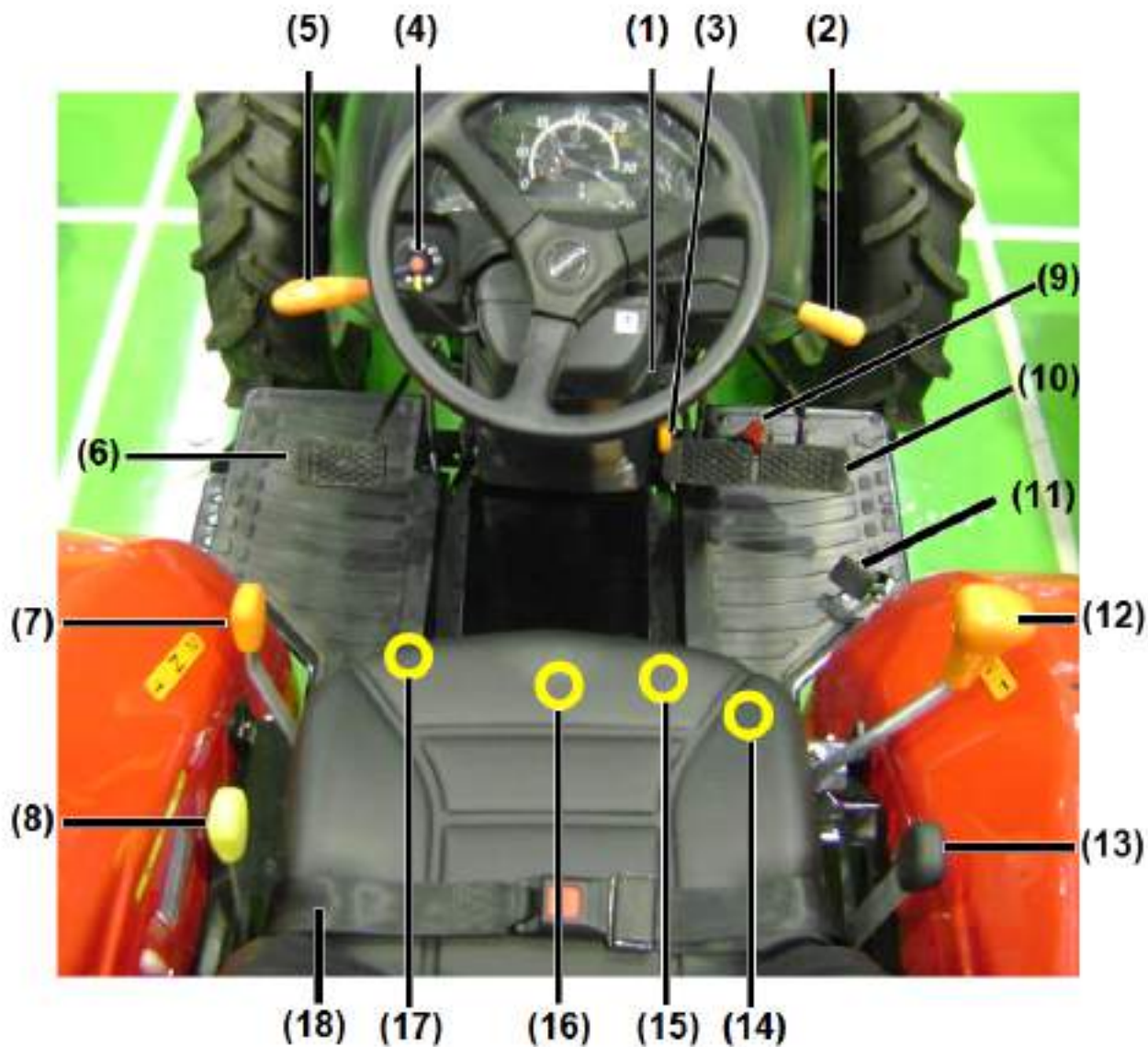

Meter panel indicators

- (1) Fuel gauge
- (2) Engine coolant alarm lamp
- (3) Engine speed meter, RPM
- (4) Hour meter
- (5) Battery charge pilot lamp
- (6) Engine oil pressure pilot lamp



LABEL LOCATIONS

Keep the safety instructions labels clean and clearly visible for your safety. If any of them are damaged or missing, replace them with new ones.

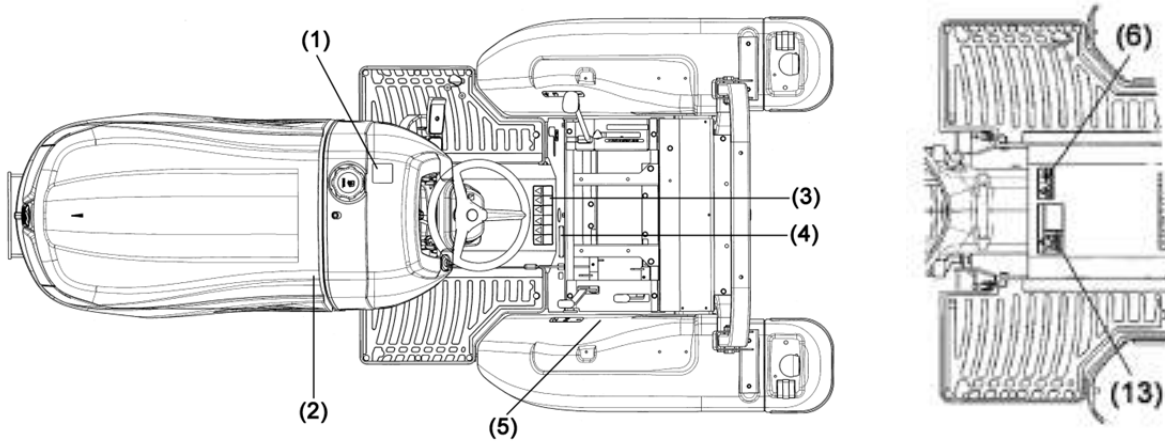

(1) 1A8310-65340
Label, fire caution



(2) 198163-65930
Label, caution muffler

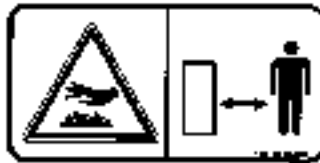

(3) 1A8310-65310
Label, caution



(4) 198283-65651
Label, Thailand only

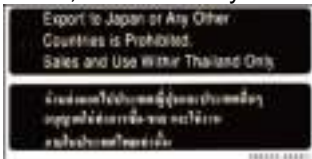

(5)



(6) 1A7874-65360
Label, brake coupling



(13) 1A8310-65300
Label, warning escape



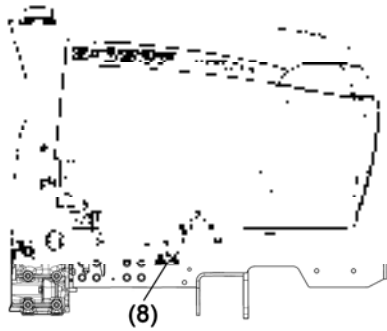
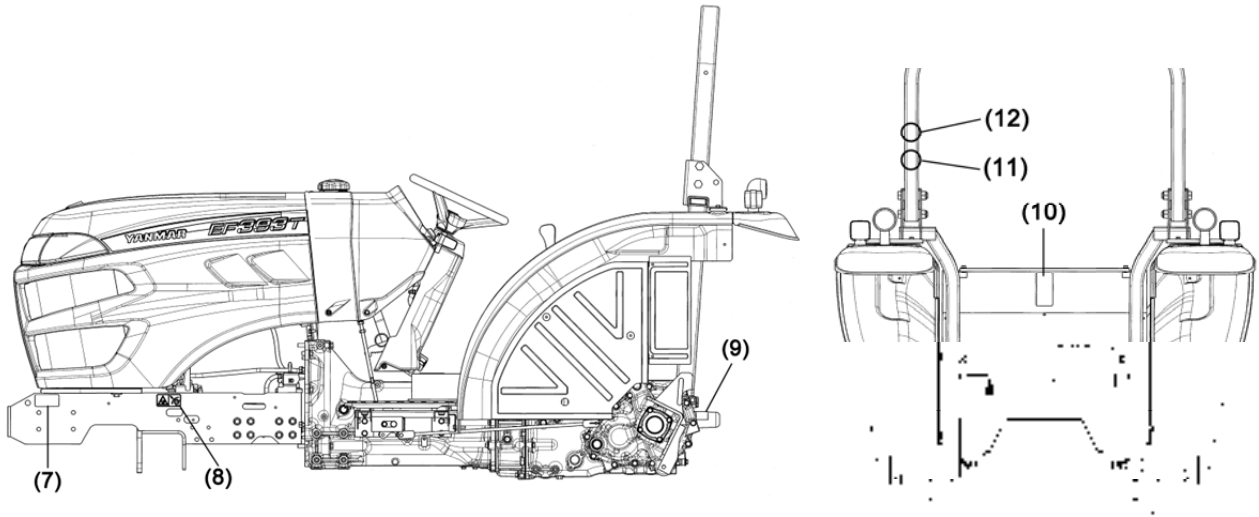

(7) 198163-65930
Label, caution muffler



(8) 198163-65940
Label, safety cover



(9) 1A6150-93151
Label, PTO shaft cover



(10) 198163-65350
Label, danger shaft rotate



(11) 198163-65950
Label, seat belt



(12)



CONTROLS

ENGINE

Main switch

The switch is used to turn on and off the engine

OFF



The electric current is shut off.
The engine stops. (The key can be removed.)

ON



The electric current is on. If the engine is stopped, the engine oil pressure lamp (6) and battery charge lamp (5) turn on.

START



Starter motor runs to start the engine, when range shift lever is at neutral.
Release the key when the engine starts and the key returns to the "ON" position automatically.

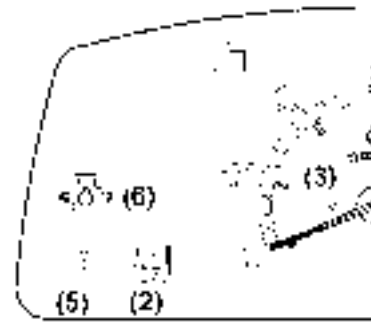
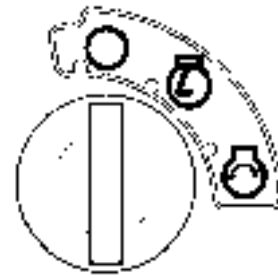

- (5) Battery charge lamp
- (6) Engine oil pressure lamp

Accelerator lever

The accelerator lever (A) is used to increase or decrease the engine speed or keep the engine at a constant speed.

- (A) Accelerator lever
- (S) Slower engine speed
- (F) Faster engine speed

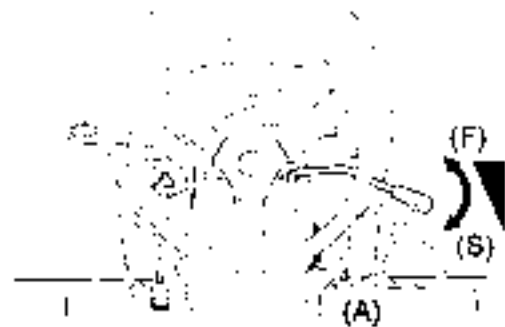

Accelerator pedal

The accelerator pedal (A) is used to increase or decrease the engine speed, mainly during travel on a road. To increase the engine speed, depress the pedal.

- (A) Accelerator pedal



TRAVELLING, PTO RE RELATED FUNCTIONS

Main shift lever

The transmission has 4 main gear shifts.
Depress the clutch pedal fully, and move the lever to desired position.

(A) Main shift lever

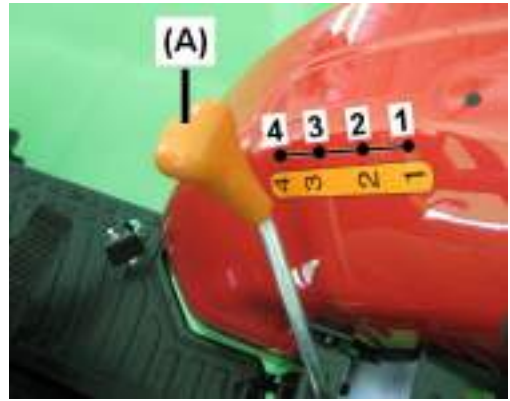

IMPORTANT

Be sure the tractor stops whenever shifting. If not, it may cause damage to transmission gears.

Range shift lever

The transmission has 2 range gear shift aside from 4 main gear shifts.

(B) Range shift lever
2: High Speed range
1: Low speed range
N: Neutral

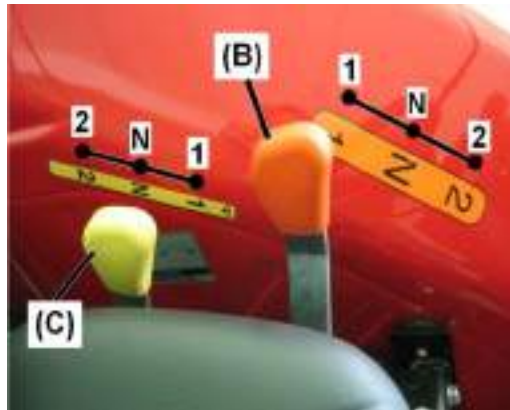

IMPORTANT

Be sure tractor stops when shifting. Do not change Range shift lever while moving.

Reverser lever

Reverser lever changes the direction of travel of the tractor, forward or reverse. Depress the clutch pedal and stop tractor whenever shift the lever.

Lift up the lever to put it in a required position.

(A) Reverser lever
F: Forward
N: Neutral
R: Reverse



WARNING

Be sure to stop the tractor when shifting. Never change Reverser lever while moving. Sudden change of running direction back and forward may cause serious injury.

PTO shift lever

The transmission has 2 PTO speeds. To change the speed, depress the clutch pedal fully.

(C) PTO shift lever

PTO speed at engine 2,800 rpm

- 1 584 rpm
- 2 836 rpm



CAUTION

Strictly maintain the PTO speed as specified by the implement. Otherwise, the implement or transmission can be damaged and may cause an injury.

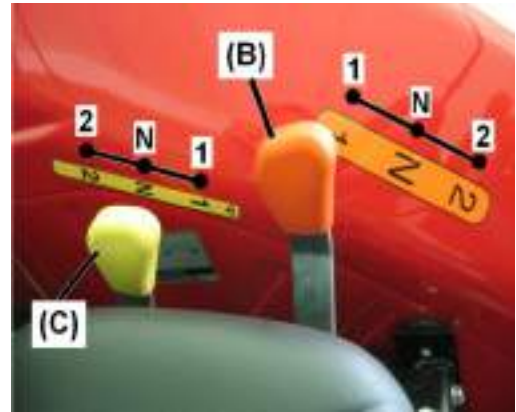

Brake pedal

Tractor has brake pedals for right and left turn independently and they can be applied separately. For a sharp turn in the field, depress the brake in which direction you want to turn. For driving on a road, be sure to connect both pedals with the connector.

To avoid unnecessary wear of brake discs, do not rest foot on the brake pedal during operation.

- (A) Brake pedals
- (B) Brake pedal connector

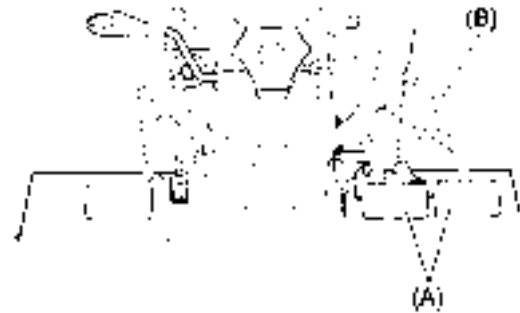

WARNING

Be sure to connect the both brake pedals with the connector when driving on a road. Tractor may turn over by one-sided braking in high speed.

Parking brake lever

To apply parking brake;
Connect brake pedals, depress brake pedals and raise parking brake lever.

To release parking brake;
Depress brake pedals slightly and down parking brake lever.

- (A) Parking brake lever
- (B) Brake pedals
- (C) Brake connector
- (L) Apply parking brake
- (R) Release parking brake

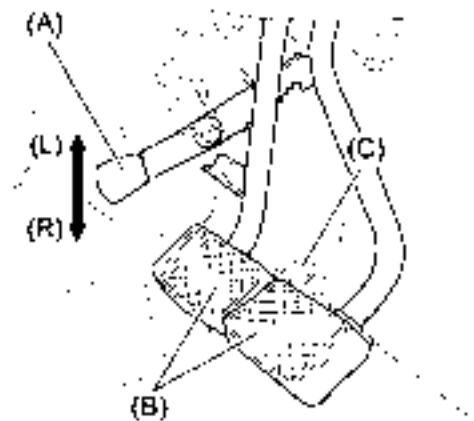

CAUTION

Be sure to connect the both brake pedals with the connector when applying parking brake. If not, only left tire is locked and it may not brake tractor sufficiently.

Clutch pedal

The clutch is a device for connecting and disconnecting engine power to the transmission.

To disconnect engine power to the transmission, depress the clutch pedal fully.

To connect the engine power, release the clutch pedal gradually and the engine power transmits to transmission.



(A) Clutch pedal



IMPORTANT

Do not rest your foot on the clutch pedal while operating. The clutch disc may wear prematurely.

Differential gear lock pedal

A differential gear system is equipped on front and rear axles of this tractor for smooth turning.

Depressing this pedal locks rear axle differential gear box and rear wheels rotate as if right and left axles are connected. When one side rear wheel spins and the other does not rotate, depress the pedal to lock the differential gear for escaping.

To unlock differential, release the depressed pedal.



(A) Differential gear lock pedal
(R) Release lock (release pedal)
(L) Lock differential gear
(keep depressing pedal)



IMPORTANT

When differential gear is locked, drive tractor slow speed and keep going straight. Never steer tractor while depressing the pedal.



WARNING

Never fail to unlock the differential gear after escaping from the place. Otherwise, you cannot make an intended turn and an accident may result.

Front wheel drive lever

The lever engages or disengages front wheel drive. Depress clutch pedal and move the lever when tractor stops.

- (A) Front wheel drive lever
- (2w) OFF: Two-wheel drive
- (4w) ON: Four-wheel drive



IMPORTANT

Be sure to stop the tractor whenever move the lever. Disengage front wheel drive when drive with high gear on a road, hard surface place or towing trailer. The front tire may wear prematurely or front axle gears may break in case of heavy braking.

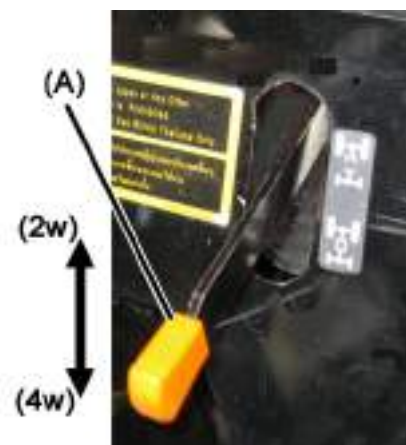

HYDRAULIC SYSTEM

Position control lever

Position control lever holds desired height of a rear hitched implement.

Lever stopper (B) limits lowering an implement to limit the working range of the lever, or when traveling on road.

- (A) Position control lever
- (B) Lever stopper
- (C) Raise
- (D) Lower

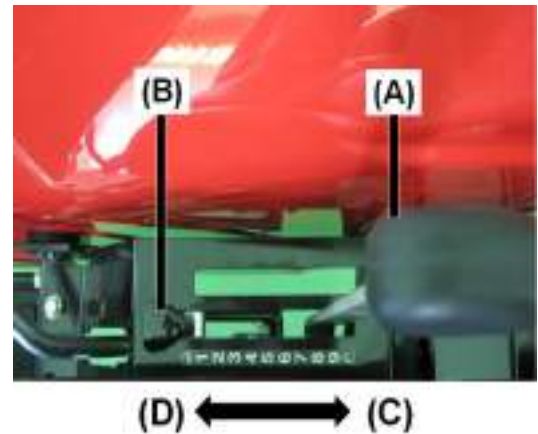

Hydraulic stop and slow return valve

The stop and slow return valve controls lowering speed of implement.

- (A) Hydraulic stop and slow return valve
- (C) The lowering speed of implement becomes slower and it stops hydraulic flow when turned fully.
- (O) It opens the valve and the lowering speed of implement becomes fast (normal speed).

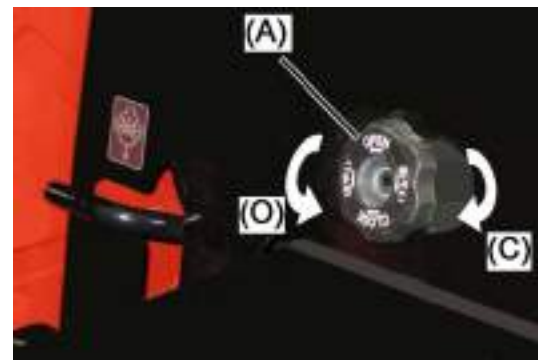

IMPORTANT

When driving on a road with rear hitched implement, open the hydraulic stop and slow return valve and fix the hydraulic control lever in raise position with stopper.

Do not operate the hydraulic control lever when the valve is fully closed. Otherwise, it may damage hydraulic parts.

ELECTRIC SYSTEM

Turn signal switch

Turn signal functions when key switch turns on.
Turn the turn signal switch anticlockwise to blink right side turn signal lamp and turn clockwise to blink left side lamp.

- (A) Turn signal switch
- (R) Right lamp blinks.
- (L) Left lamp blinks.

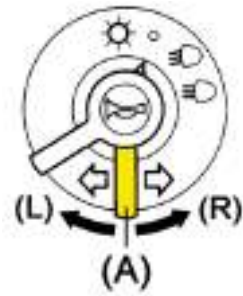

Head light switch

Headlights turn on when key switch turns on.
Turn head light switch clockwise to turn on head lights.

- (B) Light switch
- (OFF) Headlights turn off.
- (L) Headlights turn on with low beam.
- (H) Headlights turn on with high beam.

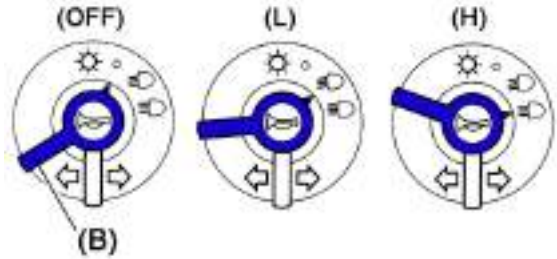

CAUTION

When there is an oncoming vehicle in night time, be sure to switch to low beam position. If keep on high beam, it may cause traffic accident.

Horn button

Horn functions in any positions of the key switch.
Push horn button to blow horn.

- (C) Horn button

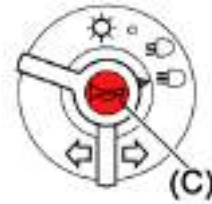

INSTRUMENT PANEL

- (1) Fuel gauge
- (2) Engine coolant alarm lamp
- (3) Tachometer
- (4) Hour meter
- (5) Battery charge pilot lamp
- (6) Engine oil pressure pilot lamp



(1) Fuel gauge

It indicates fuel level remained in fuel tank when key switch turns on.



- (a) Full
- (b) 1/2
- (c) Empty soon
- (d) Empty warning

The fuel tank will be empty in a short time.

The indicated amount is approximate.

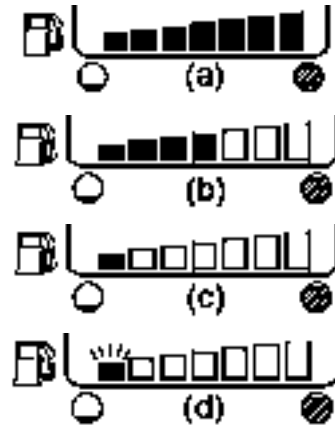

(2) Engine coolant alarm lamp

It indicates engine coolant temperature.

If the lamp turns on, reduce engine speed to idling and wait for cooling down. Find out the cause and call your dealer if necessary.

When the lamp is;

- (1) turning on: 100 degree centigrade
- (2) blinking: 110 degree centigrade or short circuit



(3) Tachometer

Indicates engine speed in revolution per minute (RPM).

It also indicates PTO shaft speed 540rpm when the needle stands at the yellow mark in the position 1 of PTO shift lever.

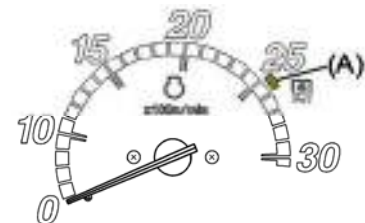

(A) Yellow mark

(4) Hour meter

It shows actual operating time of the engine in hourly unit. It counts whenever the engine is running. For example, 10.5 means 10 hours and 30 minutes of the engine running time.

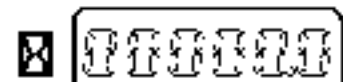

(5) Battery charge pilot lamp

This lamp lights when the key switch is in "ON" position.

The charge lamp turns off when engine starts. If the lamp does not turn off at 1500rpm engine speed or higher, see your dealer.

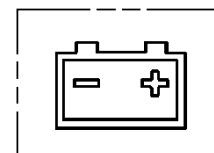

(6) Engine oil pressure pilot lamp

This lamp lights when the key switch is in "ON" position and goes off when the engine starts. If the lamp does not turn off after engine starts, stop the engine immediately and check oil level. If oil level is sufficient, see your dealer.



OTHERS

Seat adjust lever

It adjusts the operator's seat position in 5 steps backward or forward.

Raise the lever and slide forward or backward to desired position. Lower the lever to latch the seat.

(A) Seat adjust lever

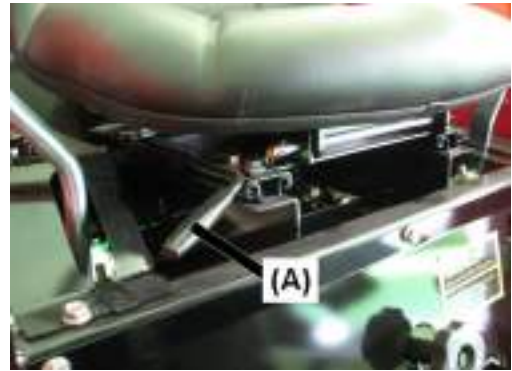

Seat belt



WARNING

- Always fasten seat belt while operating the tractor with the Roll-over Protective Structure (ROPS).
- Do not use the seat belt if the tractor does not have the ROPS.

(A) Seat belt

(B) PRESS button

Fasten the seat belt properly without twisting. Adjust the belt length to operator figure.

Press "PRESS" button on the buckle to unfasten seat belt.

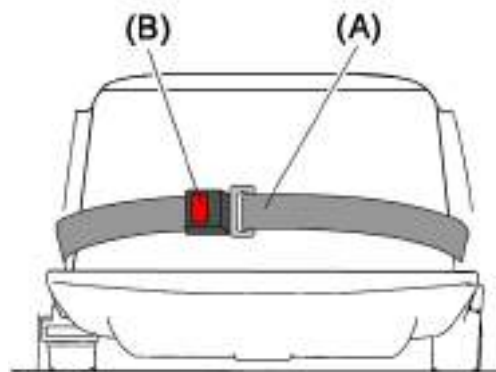

Opening bonnet

- (1) Raise the lever to open bonnet. The bonnet goes up and is hold with gas damper.

(A) Bonnet open lever

(B) Gas damper



OPERATIONS

1. Pre-operation checks



DANGER

- 1) Never smoke or use bare lamps/lights during oil replenishing.
- 2) Never fill fuel oil while the engine is running or hot.
- 3) After filling fuel, be sure to cover the fuel tank with screw-top and wipe off spilled fuel. If not, a fire may be caused.
- 4) Check the fuel lines daily. Fuel leaks on a damaged fuel line.



WARNING

- 1) Whenever servicing the tractor, place it on a flat and leveled area. Be sure no traffic neither people around the tractor. Otherwise, the tractor can cause an unexpected accident.
- 2) Whenever servicing under rear hitched implement, close hydraulic stop and slow return valve (A) and place lock device or support to the implement. Otherwise the implement may fall down incidentally and it can cause injuries.

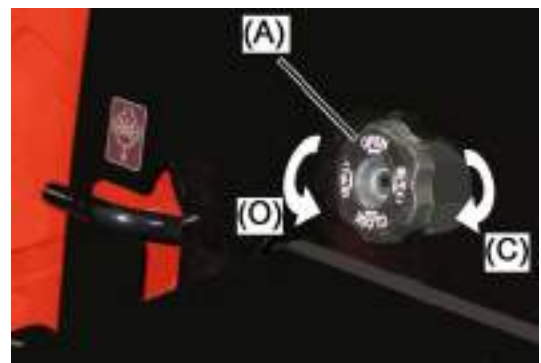

(C) Close



CAUTION

- 1) Never fail to stop the engine before checks or maintenance. If not, you may be trapped in a rotating part and heavily injured.
- 2) To check or service the tractor, wait until the engine and muffler are cooled down. If not, you may get burned and be injured.
- 3) Never fail to reinstall covers and parts detached for service. Otherwise, you may be trapped in the tractor and heavily injured.

For safety reasons, always check the tractor before day's work. Remove any abnormalities.

At least check the followings in order:

(1) Abnormalities in previous day

(2) Walk around the tractor to look into:

- Deformed, damaged, wearing or lost exposed parts
- Air inflation pressure and wear of tires
- Loosened or lost bolts and nuts of the tire rims and disks



(3) Check inside the bonnet

- Engine oil level and leaks.



- Fuel oil amount, leak and damages on fuel lines.



- Engine coolant level, leaks and damage on lines.



- Battery electrolyte (liquid).
Depending on battery type;
Check electrolyte level, to be between upper and lower limit.
Check the color of the hydrometer, to be green.

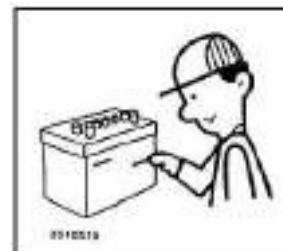

- Clogging or dirt in air filter.



- Tension or damage of cooling fan belt.



- Radiator screen, grille and engine room for dust.



- Hydraulic joint and lines for damages and loose connection.

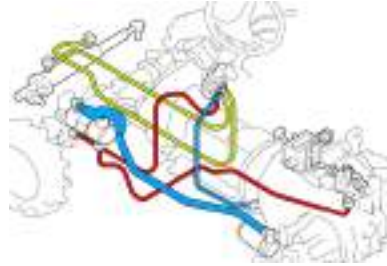

- Check electrical wirings for wear or damages of lead sheaths and loose connections.

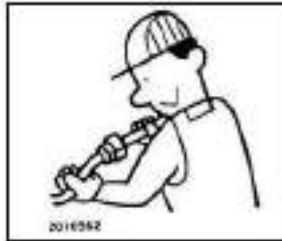

(4) Check operating system

- Play of brake pedals.
Brake pedals must have reasonable play (A) and plays of both right and left brake pedals must be equal. (25-35mm)

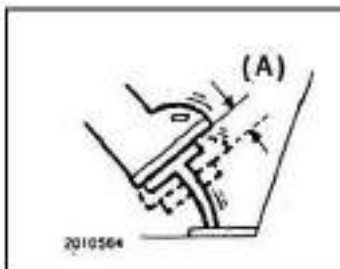

- Play of clutch pedal.
Clutch pedal must have reasonable play (A). (15-25mm)

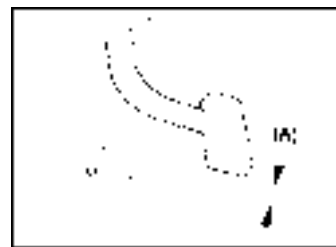

- Play of steering wheel.
Steering wheel must have reasonable play (A). (20-50mm)

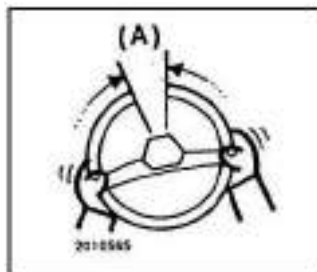

(5) Check hitched implement

- PTO Drive shaft lock pin must be in groove of PTO output and input shafts.
- Pins must be inserted in proper positions.
- Loosened bolts and nuts.
- Damaged or worn parts.
- Connection of 3-point linkage.



(6) Start the engine and check:

- Abnormal sound or noise.



- Color and smell of exhaust gas.

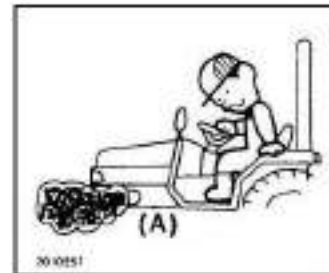

- Function of each lamp, gauge and meter



2. Break-in (initial 50 hours)

The new tractor should be carefully operated for the first 50 hours. It will surely have an effect on the lifetime and performance of the tractor throughout the life. Pay attention to the following points in particular:

- (1) Avoid quick start or abrupt brake if it is not in emergency case.
- (2) Do not operate in higher speed or heavier load more than necessary. Do not operate with full load. Avoid from operation such engine speed comes down by a load or smoke while working.
- (3) Start operation after the engine is sufficiently warmed up.
- (4) Slow down on the rough road or slope.
- (5) Check tire fixing bolts at the first 10 hours and 50 hours operation. If loosened, tighten it. See "12. Wheel tread" for bolt tightening torque.
- (6) Check the tractor at the time of first 50 hours operation.

3. Before starting



WARNING

- 1) Before starting the engine, sit on the operator's seat and make sure shift levers (reverser, PTO shift, range shift, main shift) are at neutral position, and position control lever is at down position. Negligence may cause tractor sudden start and serious injury.
- 2) Do not run engine in a closed room. Run the engine in well-ventilated area. If you are forced to start the engine in a confined room, make sure the ventilation is proper. Exhaust gas is poisonous and it can lead to death.



CAUTION

- 1) Before and after operation, never fail to check and service the tractor. Particular check will be required at brake pedals, controls, steering devices and tire rim fitting bolts. Negligence can cause a heavy injury or accident to the tractor and the human.
- 2) Set the parking brake during the warm-up operation. Otherwise the tractor may abruptly start to run.

4. Start and stop

4-1. Start and stop engine

Start engine



IMPORTANT

- 1) Do not run the engine starter motor for more than 10 seconds. It may cause a breakage of the starter motor. If the engine does not start, keep it cool for 2-5 minutes before retry. Then, execute steps (3) - (4).
- 2) Never turn the main switch to start position while engine is running.

(1) Open the fuel cock of water separator (A).

(2) Put the reverser lever and PTO shift lever to "N" position.

(3) Set position control lever in the LOW position. Make sure that the implement is lowered.

(4) Push accelerator lever forward to higher speed position.

(5) Insert the key and turn it to "ON" position.



- Check pilot lamps on meter panel;
- (A) Battery charge pilot lamp is on.
 - (B) Engine oil pressure pilot lamp is on.

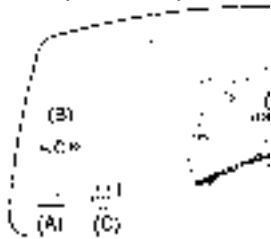

(6) Turn the key switch to "START" position.

(7) As engine starts, immediately release key switch and it goes back to "ON" position automatically.

When engine starts, battery charge and engine pressure pilot lamps turn off.

(8) Warm up the engine by running without load at 1500 rpm for about 5 minutes. Especially if the temperature is below 0°C, at least 10 minutes warm-up is required.

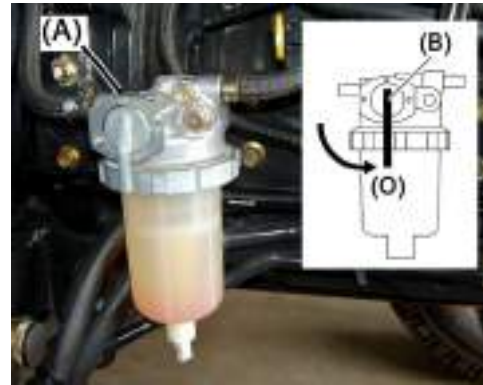

(A) Water separator
(B) Fuel cock (O) Open



(A) Reverser lever

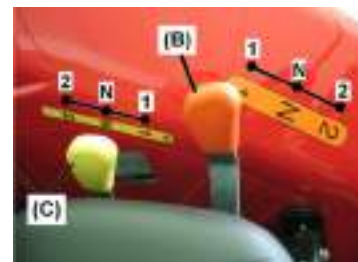

(C) PTO shift lever



(D) ← (C)
(A) Position control lever

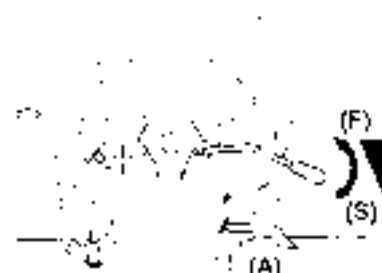

(A) Accelerator lever

Stop engine

- (1) Pull accelerator lever (A) rearward (S) to decrease engine speeds.
- (2) Turn key switch to "OFF" position.
- (3) See main shift lever, range shift lever, reverser lever and PTO shift lever are in neutral positions.

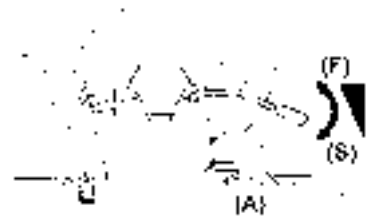

(A) Accelerator lever (S) Slow speed



IMPORTANT

Sudden stop of heated engine may cause engine overheating. Prior to stop engine, keep engine running at 1200 - 1500 rpm for about 2 minutes to cool down.

4-2. Start, gear shifting and stop tractor

Start tractor

- (1) Be sure right and left brake pedals are connected by connector.
- (2) Set engine speed about 1500 rpm.
- (3) Move position control lever backward and raise rear hitched implement.

- (A) Position control lever
- (C) Raise rear hitch implement

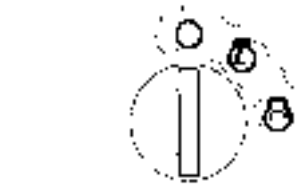

(A) Brake pedals (B) Connector

- (4) Depress clutch pedal fully and shift main shift lever and range shift lever to desired speed.

- (A) Main shift lever
- (B) Range shift lever

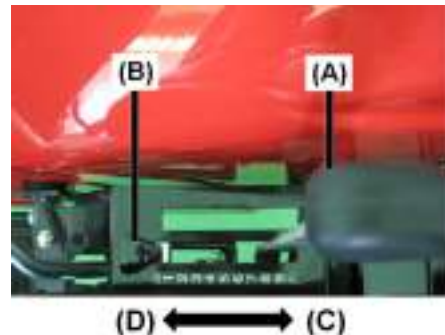

- (5) Shift reverser lever to forward or reverse.
- (6) Release clutch pedal gradually and tractor starts.



IMPORTANT

- 1) Never rest your foot on clutch pedal while operating. It will cause premature wearing of clutch disc.
- 2) Be sure to apply the parking brake when you leave the tractor.
- 3) Look around the tractor before starting.



(A) Reverser lever (N) Neutral
(F) Forward (R) Reverse

Gear shifting

- (1) Main shift lever
Depress clutch pedal fully and shift lever to desired speed after tractor stops.
- (2) Range shift lever
Depress clutch pedal fully and shift reverser lever to desired speed after tractor stops.
- (3) Reverser lever
Depress clutch pedal fully and shift reverser lever to (F) or (R) after tractor stops.



IMPORTANT

Never shift the main shift, range shift and reverser lever while tractor is moving. If not, it may cause breakage of transmission inner gear.

Stop tractor

- (1) Pull accelerator lever backward to reduce speed.
- (2) Depress clutch pedal and brake pedals at the same time.
- (3) Shift range shift, reverser and PTO shift levers to "N" position.
- (4) Make sure brake pedals are connected with connector and apply parking brake (lock brake pedal with parking brake lever).
- (5) Lower rear hitch implement if it is attached.
- (6) Turn key switch to "OFF" position and remove the key.

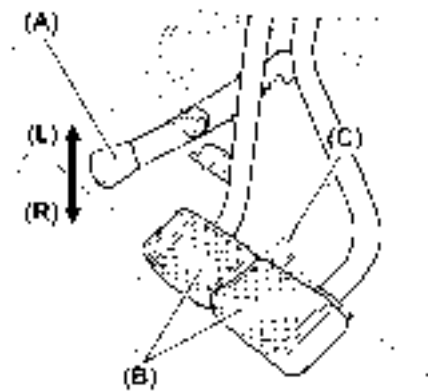

(A) Parking brake lever (B) Brake pedals
(C) Connector
(L) Lock (R) Release

5. Driving on a road



WARNING

- 1) Make sure that left and right brake pedals are connected whenever traveling on a road or cross a farm ridge. One-sided braking effect will roll over the tractor or result in a sharp turn.
- 2) Follow the traffic regulations and rules in your place when running on a road. Strictly one operator only on tractor.



CAUTION

Remove an implement when traveling on a road. If not, an accident may result in. Put the PTO shift lever in "N".

- (1) Connect right and left brake.
- (2) Shift PTO shift lever to "N" position.
- (3) Open hydraulic stop and slow return valve fully.

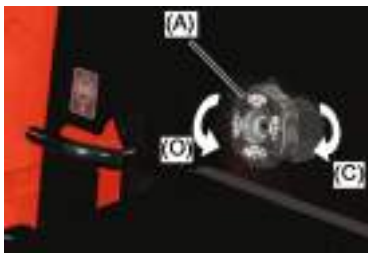

(A) Hydraulic stop and slow return valve
(O) Open valve

- (4) Move position control lever up and lock it with stopper.



CAUTION

Make sure that position control lever is held when traveling on a road. If not, hand may touch position control lever incidentally and implement would go down. It may cause an accident and injury.



IMPORTANT

- 1) Adjust the traveling speed with the foot accelerator pedal.
- 2) When you turn tractor or change traveling course, notify others by turning signal lamp.
- 3) When there is on-coming vehicle in night time, make headlight be low beam.
- 4) Disengage front wheel drive except in special case.

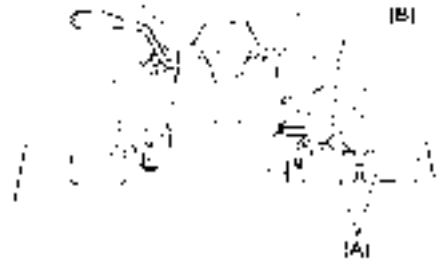

(A) Brake pedals (B) Connector

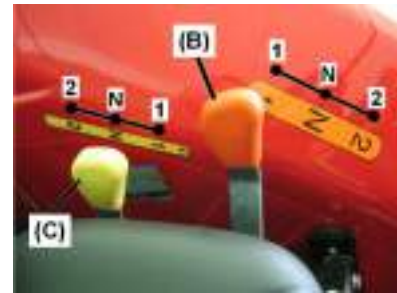

(C) PTO shift lever

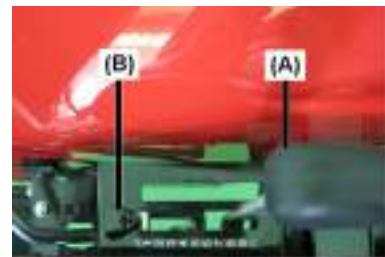

(A) Position control lever (B) Stopper
(C) Raise rear hitched implement

6. Driving on a slope



WARNING

- 1) Select a correct speed before approaching a slope. Never change shift levers on a slope. Tractor may coast down unintentionally.
- 2) Never travel on the slope with reverser lever, main shift lever or range shift lever set in "N" position.
- 3) Never depress the clutch pedal on a slope. Tractor may coast down unintentionally and it may cause an accident.
- 4) To start on an up-slope, shift gears to low speed and engage clutch slowly and carefully. Abrupt start will jump up the front wheel.
- 5) Do not park tractor on a slope as much as possible. If it is required, apply parking brake and put wheel block to avoid from coasting down.

(1) Select slow speed before going into a slope.

(2) Travel slowly on a slope.

(3) Apply engine brake on a down-slope.

7. Driving in and out of a field



WARNING

- 1) Be sure to connect left and right brake pedals with connector. One-sided brake results in causing a roll over.
- 2) In case field ridge is high, use a gangplank with sufficient strength. Lower an implement and go through ridge in slow speed.
- 3) If a way to field is steep slope, go up with a reverse gear.

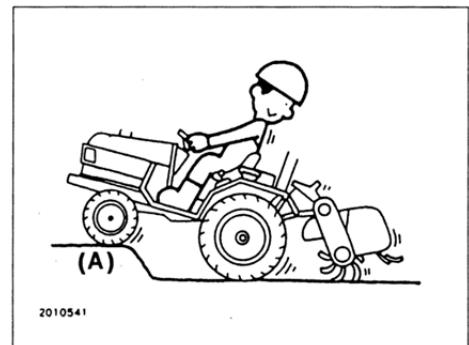

(A) Ridge

8. Setting adequate speed

8 forward speeds and 8 reverse speeds are available by the combination of main, range and reverser shift levers. Select adequate speed for works.

Suggested operation by working speed.

Shift	Main shift	Range shift	Speed (km/hr)	Operation
F1	1	1	1.90	Rotary
F2	2		2.74	
F3	3		3.92	
F4	4		5.91	Spreader
F5	1	2	6.79	Plow
F6	2		9.79	
F7	3		14.0	Traveling with the trailer
F8	4		21.1	

(At engine speed: 2800rpm)

9. Turning in a field



WARNING

Release foot from differential lock pedal to release differential gear before turning. Otherwise, tractor cannot turn when it is, required and an accident may result.

Unlatch brake pedal connector in a field.

- (1) Reduce the engine speed.
- (2) Move position control lever rearward to raise the implement
- (3) Turn steering wheel to desired direction and depress brake pedal in the same direction of steering wheel turn at the same time.

Ex:

When you turn steering wheel clockwise to turn right, depress right side brake at the same time.

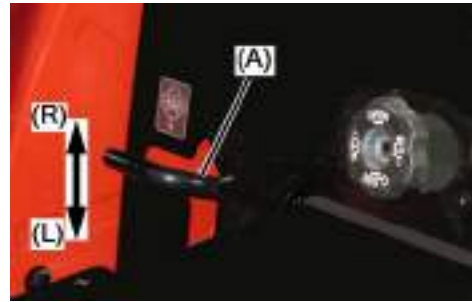

(A) Differential lock pedal (R) Release

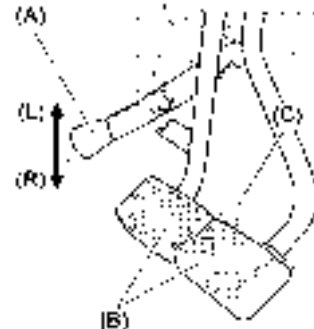

(B) Brake pedal
(C) Brake pedal connector

10. Differential gear lock



WARNING

- 1) Release differential gear lock before making a turn. Otherwise, tractor cannot turn and an accident will result.
- 2) Never depress differential lock pedal while traveling on a road. If you depress the pedal, you could not steer and may cause an accident and injury.

Differential gear lock system is effective when one side rear wheel is locked and the other tire slips. When differential gear is locked, right and left rear axle rotate as if both axles are connected. It is easier to go out from muddy and slippery place.

Operation

- (1) Lower engine speed.
- (2) Depress differential lock pedal.
- (3) Release the pedal to unlock differential gear lock.
If it is difficult to unlock the differential system, depress clutch pedal or step on right and left brake pedal alternately.



(A) Differential lock pedal
(R) Release lock (Release pedal)
(L) Apply differential lock (Depress pedal)



IMPORTANT

- Never turn steering wheel while differential lock pedal is depressed.

11. Loading and unloading



DANGER

- 1) Never steer tractor on loading bridge while loading into or unloading from cargo truck. Drive tractor in slowest speed. If not, loss of control can result in injure or damage the tractor.
- 2) Never depress clutch pedal on loading bridge. Tractor may coast down and cause injury.
- 3) Connect left and right brake pedals with the connector. If not, tractor may steer unintentionally when depress one side brake pedal only. Tractor may fall down from loading bridge and may cause injury.
- 4) Never stand against loading bridge. Be away from loading work.



WARNING

- 1) Loading bridge must be of sufficient size, strength and with anti-slip surface. Length of the loading bridge must be longer than 4-time of floor deck height. Fix loading bridge with floor deck of truck.
- 2) Reverse tractor for loading into truck, go forward for unloading. Shift gear to slow speed.
- 3) Tie tractor firmly to truck with a rope of sufficient strength.

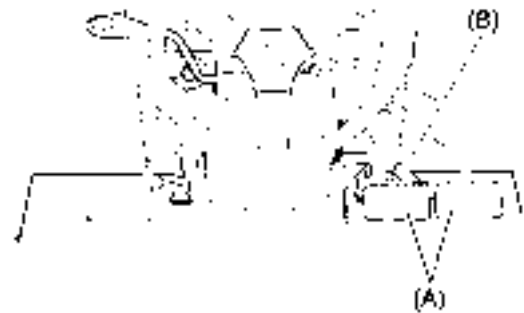
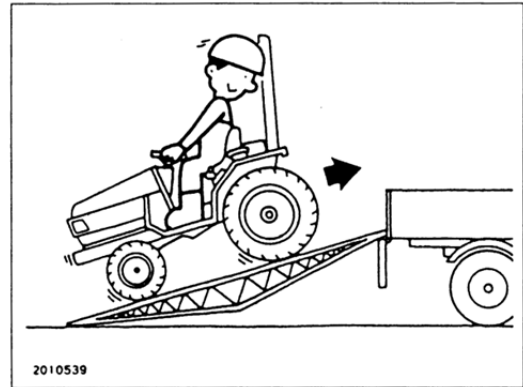

(A) Brake pedal

(B) Connector

(1) Loading truck preparation

Park the truck on a flat and leveled place where is wide enough and no traffic expected.
Stop truck engine and apply the parking brake.
Block wheels of the truck.

(2) Loading

Connect right and left brake pedals with the connector.
Shift gear levers to slow speed.
Slow down engine speed and reverse tractor to load.
Make sure tractor is aligned with loading bridge.

[If engine stops on loading bridge]

Depress brake pedal immediately and gradually release brake pedal to go down slowly.
Start engine and load again.

(3) On the floor deck

Apply parking brake of tractor.
Stop tractor engine.
Lower rear hitched implement if any.
Tie tractor with truck

(4) Unloading

Untie tractor.
Start engine and shift gears to low speed.
Raise rear hitched implement if any.
Start tractor forward in slow speed. Do not steer.

12. Wheel tread



IMPORTANT

The tread of front and rear wheel is not adjustable.

Wheel tread

Tire	Size (ply rate)	Wheel tread (mm)
Front	8-16 (4)	1,065
Rear	12.4-24 (6)	1,120

Tightening torque of wheel disc mounting bolt and nut

Tire	N-m	Kgf-m
Front	118-147	12.5-15.0
Rear	177-196	18.0-20.0

Front wheel disc mounting bolt: M14x24 fine tread



DANGER

- Do not move the tractor if the wheel mounting bolts or nuts are loose. If the tractor is driven with loose nuts or bolts, there is a possibility that an accident will occur.
- Make daily and periodic wheel inspections to check for loose nuts and bolts on the wheels. If they are loose, retighten them to the specified torque.

Rear wheel

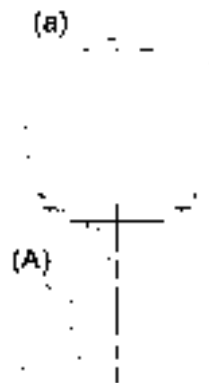

(A) Wheel disc
(a) Wheel tread

Rear wheel disc mounting bolt and nut

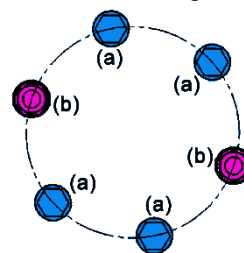

(a) Bolt M14x24 fine tread
(b) Stud bolt M14x31 fine tread, nut M14 fine tread and lock washer M14

13. Hydraulic power take off

Single action cylinder

In case of single action cylinder, remove the hydraulic outlet plug (A) on right side of control valve, and connect hydraulic hose from cylinder of implement.

<Operation>

- (1) Set the position control lever in the lower position.
- (2) Fasten the hydraulic stop/slow return valve (B) at fully clockwise position.
- (3) Operate the position control lever to move the implement.

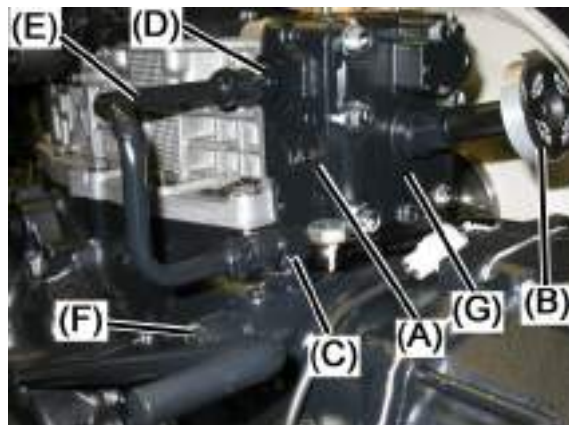

- (A) Hydraulic outlet (single action) (G3/8)
- (B) Hydraulic stop/slow return valve
- (C) Hydraulic outlet (double action, out) (G3/8)
- (D) Hydraulic outlet (double action, in) (G3/8)
- (E) High pressure pipe
- (F) Relief valve
- (G) Hydraulic control valve

Double action cylinder

<Connection>

- (1) Remove operator's seat.
- (2) Remove the dust cover under the seat.
- (3) Remove the high pressure pipe (E).
- (4) Connect hydraulic hose to port (C) that the oil goes to SCV and connect hose to port (D) that oil comes back from SCV.
- (5) Install the dust cover and the seat.

Keep the high pressure pipe for the time when removing SCV.

14. Using 3-point hitch

3-point rear hitch type is Category 1.

Top link

Adjust length of top link (A) to implement. Loosen lock nut turn turnbuckle on top link and adjust the length. Follow instructions of implements.

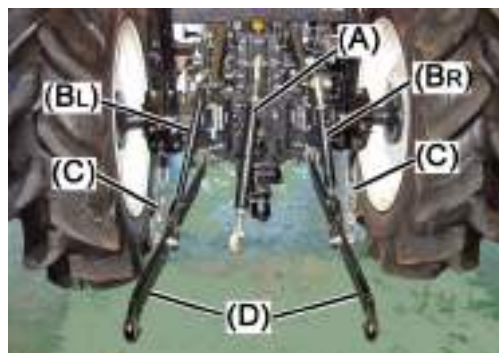

- (A) Top link
- (BL) Lift link, Left
- (BR) Lift link, Right
- (C) Check chain
- (D) Lower link

Lift link and lower link

Set lower link hole and lift link hole according to implement and work.

Lower link hitch point height

Lower link		Lift link hole (a)	Lift link hole (b)	Lift link hole (c)
hole	Hitch point height			
(1)	X	270	212	162
	Y	857	817	785
(2)	X	453	403	338
	Y	848	818	785

(mm)

X: Minimum height of lower link hitch point
Y: Maximum height of lower link hitch point

Heights would vary according to tire air pressure, lift arm free play and/or field condition etc.

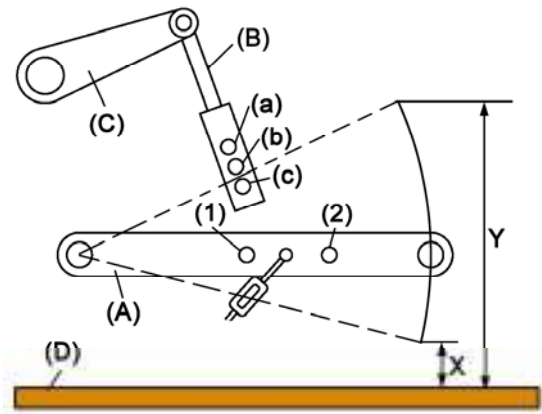

(A) Lower link (B) Lift link
(C) Lift arm (D) Ground

Check chain

Check chain adjustment.

- (1) For implements such as a plough, harrow and subsoil plow, adjust check chains so as an implement could be swung about 5 cm. Make sure that lower link does not hit tire.
- (2) For implements such as a rotary tiller and mower, adjust check chains so that an implement can move 1cm to right and left.

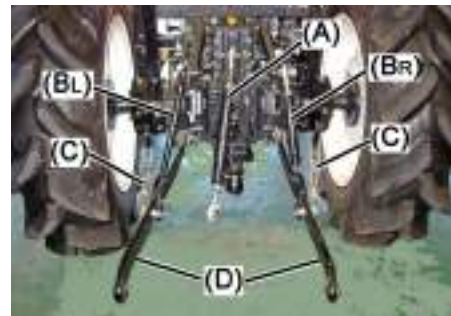

(C) Check chain



IMPORTANT

When an implement is not attached to tractor, tie lower links to avoid from hitting rear tire while driving.

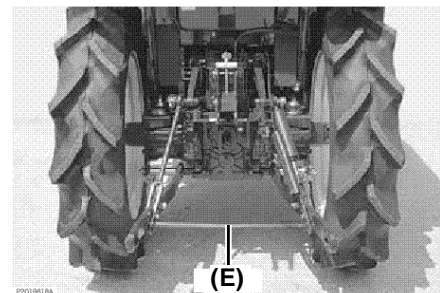

15. Drawbar hitch

Use Drawbar when towing a trailer.



IMPORTANT

Remove the drawbar if the drawbar interferes with an implement. When attaching a PTO driven implement, PTO drive shaft may interfere with the drawbar and it may cause breakage of related parts.

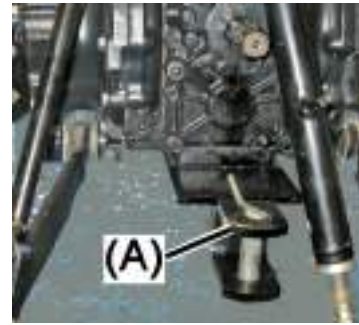

(A) Drawbar

16. General precautions on attaching and detaching an implement



WARNING

- 1) When moving the tractor to attach an implement, never allow a person between the tractor and the implement. Always keep the moving speed in the lowest.
- 2) Attach or detach an implement on a flat and leveled ground in a safe way. Use lights during nighttime work.
- 3) When leaving the tractor for attaching or detaching an implement, never fail to set the parking brake and stop the engine.
- 4) Be sure to use the tractor's original drawbar hitch for towing work.
- 5) Attaching an implement results in a considerable longer overall length. Pay attention to bystanders or constructions nearby when driving tractor.
- 6) Never place objects on the tractor or try to use your own body as counterbalance the tractor. Use only authorized genuine balance weight or implement.
- 7) Maximum counter weight on front bracket and rear wheel is;
Front bracket: 150 kgs
Rear wheel weight: 100kgs for each wheel
- 8) Add the front weight so that the weight of the front axle may always become 20% or more of the total weight.
- 9) Install a cover on PTO shaft when it is not used. Otherwise, it may cause injury.
- 10) For safe and correct operations, read the instruction manual for an implement.

Negligence of safety precautions causes a serious injury or death.

17. Power steering

This tractor is equipped with hydrostatic powered steering system.

The hydraulic power assists steering works only when the engine is running. The steering wheel may become a little heavier at low engine speeds



WARNING

Whenever the engine is running, steering wheel turns with light force. Avoid from abrupt steering or it may cause uncontrollable steering and may cause accident or injury.



IMPORTANT

- 1) When the steering wheel is turned to its end, the relief valve works and chirp sound comes out. If relief valve works in a short time, it is not a problem but long time work of valve may cause trouble in the hydraulic system.
- 2) When tractor dose not run, do not turn steering wheel as much as possible. It may cause damage on tires or rims.

18. Safety frame (ROPS)

The safety frame is designed to protect the driver from an accident. Never fail to use the safety frame when the tractor is in use.



WARNING

- Always fasten the seat belt while operating the tractor with Roll-over Protective Structure up.
- Do not use the seat belt if the foldable Roll-over Protective Structure (ROPS) is in the folded position or the tractor does not have the ROPS.
- Do not modify the safety frame. Safety factor can be lost.
- Damaged frame should be replaced as a complete set. Partial repair may lead loss of safety level.



19. Tightening torque of bolts and nuts

Bolts and nuts being used on this tractor are of grade "7T" unless otherwise grade is not specified in this manual. Tighten torques show on right table.

Bolt size (mm)	Grade 7T	
	(N-m)	(kgf-m)
M6	8 - 12	0.8 - 1.2
M8	23 - 30	2.3 - 3.0
M10	44 - 59	4.5 - 6.0
M12	78 - 98	8.0 - 10.0
M14	118 - 147	12.0 - 15.0
M16	167 - 206	17.0 - 21.0
M18	235 - 284	24.0 - 29.0
M20	323 - 402	33.0 - 41.0

OPENING BONNET

Bonnet

Opening

- (1) Pull up the bonnet lever (A) to release the bonnet lock.
- (2) Lift the bonnet. The damper (B) keeps the bonnet open.

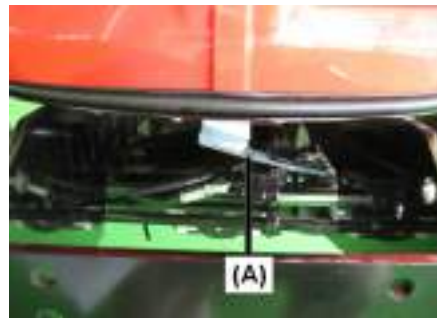

(A) Bonnet lever

Closing

- (1) Push down the bonnet.
- (2) Make sure the bonnet is locked securely after closing the bonnet.



(B) Bonnet damper

AFTER OPERATION

1. After operation

Clean thoroughly the tractor after daily operation to keep it in good condition for a long time. In particular, clean lower and front areas before storing it.

Wash the tractor with water and wipe off. Lubricate moving parts and sliding parts. Apply grease to all grease nipples especially after working in wet field.

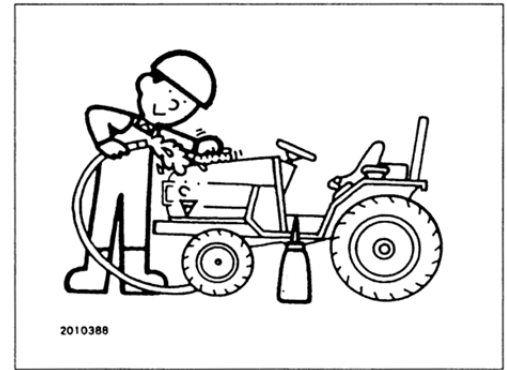

IMPORTANT

Do not splash or spray water on electrical parts. Water can cause a trouble in the electrical system.

2. Care for long period of storage



WARNING

When tractor is stored for a long time, remove the battery and main key. Deterioration of electric wire or rat biting may cause electric leakage and may start a fire.

When storing for a long time, take following procedures.

- (1) Turn off all switches and remove the main switch key.
- (2) Place the tractor in a well ventilated place and remove counterbalance weights or other implements.
- (3) Coat exposed metallic parts with anti-rusting oils, engine oils or greases.
- (4) Fill up the fuel tank with fuel. Otherwise, moisture will develop in the tank and cause rust. Close cock of water separator and fuel filter.
- (5) Charge the battery fully. Remove the battery from the tractor and keep it in a dark and cool place. If the battery is kept on the tractor, be sure to disconnect the ground line (negative lead).
- (6) Drain coolant from the engine.
Move the hose clip and pull out the drain plug.

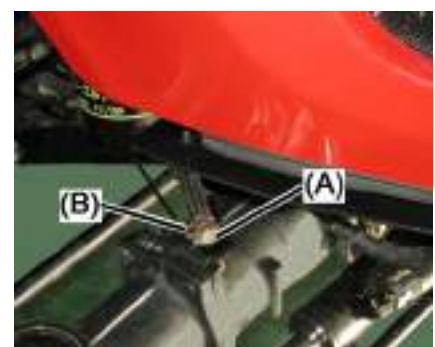
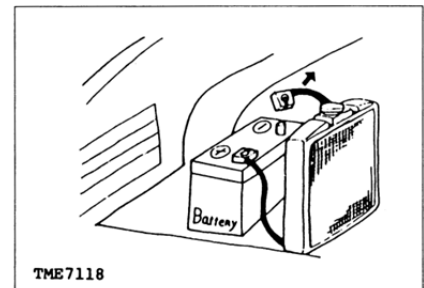
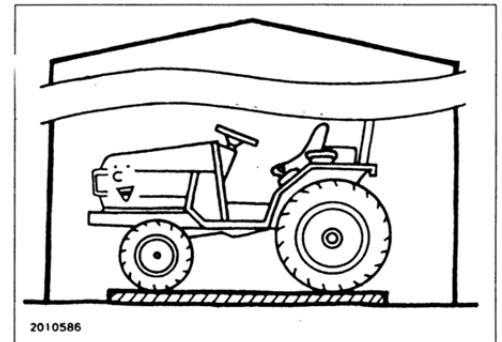

(A) Coolant drain plug
(B) Hose clip



IMPORTANT

The battery is subject to self-discharge. Charge it fully at least once a month.

(7) Put blocks or stands under tractor to take weight off tires. Protect tires from heat and sunlight.

(8) Inflate the front and rear tires with air to the normal pressure.

	Size, (ply number)	kg/cm ² (kPa)
Front tire	8-16, (4)	1.6 (157)
Rear tire	12.4-24, (6)	1.6 (157)



PERIODICAL SERVICE



WARNING

- 1) Stop the engine before servicing.
- 2) Service tractor on a flat and leveled place, free from normal traffic and bystanders.
- 3) Fix the tractor wheels not to move.



CAUTION

Check periodically fuel lines and power steering hoses for damages, wearing and loose connections. If there is damage, wearing or loose, be sure to see your dealer. Otherwise an accident or injury can result.

Periodic inspection and maintenance in off-season will ensure the preferable conditions of your tractor. To keep your tractor working in good conditions, ask your service dealer for a regular inspection.

It is recommended to replace fuel pipes, rubber hoses, and electrical wires every two years at least.

1. Check intervals

CHECK ITEMS	O: Replace x: Checks required											
	50 h	100h	150h	200h	250h	300h	350h	400h	450h	500h	550h	600h
Engine lubrication oil	O	O		O		O		O		O		O
Transmission oil	O	x	x	x	x	O	x	x	x	x	x	O
Front axle oil	O	x	x	x	x	O	x	x	x	x	x	O
Engine oil element	O					O						O
Radiator interior	Clean the interior of radiator when replacing cooling water											
Water separator element	Clean	Clean	Clean	Clean	Clean	Clean	Clean	Clean	Clean	Clean	Clean	Clean
Fuel filter						O						O
Cooling water (Replace)	Check before every work (Replacing every year)											
Transmission oil filter	O					O						O
Air cleaner element	x	x	x	x	x	O	x	x	x	x	x	O
Clean dust net	x	x	x	x	x	x	x	x	x	x	x	x
Clean cooling fan, radiator	x	x	x	x	x	x	x	x	x	x	x	x
Battery liquid level	Check before every work											
Battery liquid gravity		x		x		x		x		x		x
Fuel piping, connections	x	x	x	x	x	x	x	x	x	x	x	x
Rubber hoses (Power steering)	x	x	x	x	x	x	x	x	x	x	x	x
Radiator hoses	Replace hoses every two years											
Hydraulic rubber hoses	Replace hoses every two years											
Fuel pipe, electric wires	Replace pipes and wires every two years											
Electric wiring, connections	x	x	x	x	x	x	x	x	x	x	x	x
Grease-up	x	x	x	x	x	x	x	x	x	x	x	x
Fastening of steering wheel fix nut		x		x		x		x		x		x
Important nuts and bolts	x	x		x		x		x		x		x
Cooling fan belt	x	x		x		x		x		x		x
Engine breather pipe	x	x	x	x	x	x	x	x	x	x	x	x
Engine crank case												x
Clearance of exhaust valve												x
Fuel injection valve												x
Alternator, start motor	x	x				x				x		
Hydraulic system	x	x				x				x		
Fixing bolts of tires	x	x		x		x		x		x		x

Check at the first 50 operating hours or after first one-year operation.

2. Oil and grease

Oil, Grease	Type
Fuel oil	Diesel fuel only
Engine oil	API grade CD or better grade, 15W40
Transmission and Hydraulic system oil	Yanmar TF-500 Transmission fluid or equivalent
Front axle	Gear oil SAE #90
Grease	Multipurpose grade

3. Capacity of oil and water

(Unit: liters)

Fuel oil		38
Cooling water	Radiator	4.3
	Sub-tank	0.45
Engine oil		3.8
Transmission and hydraulic system oil		28
Front axle oil		5.5
Power steering oil		Common uses of transmission oil

All capacities are approximate.

4. Equivalent oil to transmission fluid TF500

Supplier	Brand name
Mobil	Mobil Fluid 425
Castrol	Agricastrol MP
John Deere	J14A, J20B
ESSO	Torque Fluid 56
Shell	Shell Tellus Oil 32 or 37

*Oil must not be mixed with other brand.

5. Fuel system

5-1. Fuel and refill

Use diesel fuel only.



DANGER

- 1) Never smoke or use a bare lamp/light during filling fuel.
- 2) After filling fuel, be sure to put the fuel tank cap back firmly. Clean off spilled fuel.
- 3) Fill fuel after the engine stops and becomes cool. A fire may result from heating.



IMPORTANT

- 1) Fill fuel tank at end of each day's operation. This reduces deposit of water in fuel tank.
- 2) Proper fuel storage is important. Keep all dirt, water, and other contaminants out of fuel. Avoid from storing fuel for long time.

Turn the key switch to ON position to check fuel amount in the tank. Fuel gauge shows amount that fuel remained in the tank. Refill fuel as required.

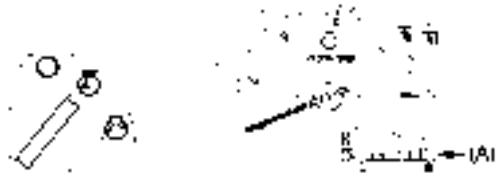

(A) Fuel gauge

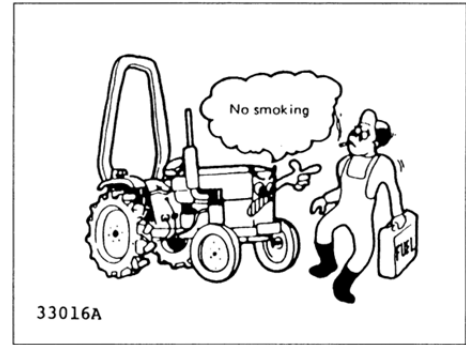

(A) Fuel tank cap

5-2. Drain and cleaning of water separator

Water separator removes water in fuel. When water is deposited in the bowl of the separator, drain it.

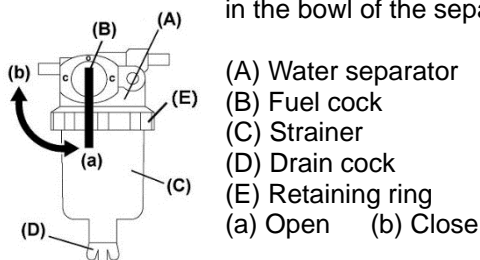

- (A) Water separator
- (B) Fuel cock
- (C) Strainer
- (D) Drain cock
- (E) Retaining ring
- (a) Open (b) Close



(A) Water separator

- (1) Turn the fuel cock to close position.
- (2) Loosen the drain cock on the bottom of the water separator and drain water. Do not remove drain cock.
- (3) If water is dirty, loosen retaining ring and remove the bowl. Clean inside of bowl and strainer.
- (4) Tighten drain cock or reinstall the removed bowl, strainer to the original position.
- (5) Open fuel cock and see water separator is filled up with fuel. Crank engine for about 5 – 10 seconds to bleed the air from the fuel and start engine.



IMPORTANT

The water separator strainer is not required to replace regularly unless it is damaged.

5-3. Replacing fuel filter (cartridge type)

Be sure to replace the fuel filter (cartridge type) regularly.

Replace
Every 300 hours

- (1) Apply lubricating oil to the rubber ring of fuel filter.
- (2) Install it surely.



IMPORTANT

Be sure to use a genuine filter.

The allowance of plunger and the barrel in fuel injection pump is very severe. If the filtering efficiency is low, it may cause a trouble in fuel injection pump, such hard starting.

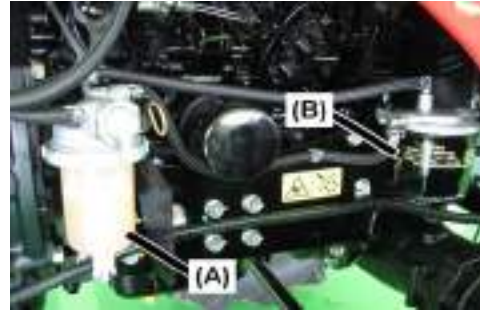

(B) Fuel filter

5-4. Bleeding fuel lines of air

If the engine stops due to lack of fuel or if the fuel strainer element or fuel piping has ever been detached for maintenance purpose, bleed air by the following procedure:

- (1) Fill up fuel tank if engine stop by short of fuel.
- (2) Turn the fuel cock to the "O" position (Open), and wait for approximately ten seconds.
- (3) See the bowl of water separator is filled with fuel and fuel cock is open.
- (4) Pull accelerator lever **forward** to the maximum speed position.
- (5) Turn the main switch in the start position and run the starter motor for 5 - 10 seconds.
- (6) If the engine did not start, run the starter motor again.
When the engine starts, air bleeding is finished.



IMPORTANT

Never run the starter motor more than 10 seconds. It may cause breakage of starter motor. If you cannot start engine within 10 seconds, restart engine after 2-5 minutes.

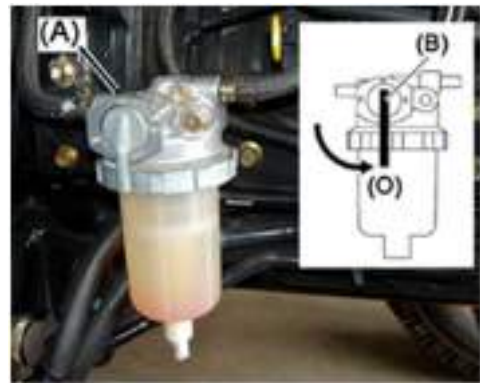

(A) Water separator (B) Fuel cock

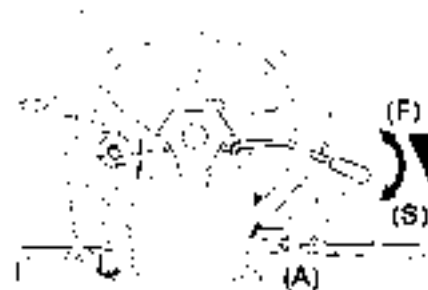

(A) Accelerator lever
(F) Increase speed (higher speed)

6. Oil and filter

6-1. Engine oil and filter



DANGER

Never refill or add oil while the engine is hot or running. A fire may occur or you may be burnt.

Check oil level

Pull out the oil gauge (A) and wipe off oil with a clean cloth. Reinsert and remove it again to see if the oil level is within the upper and lower marks.

If insufficient, add oil to reach to specified level zone (c). Never add oil more than upper limit. It may cause more oil consumption and carbon deposit in combustion system.



IMPORTANT

- 1) Park the tractor on a level place, apply parking brake and stop engine to check oil level. If the tractor is on an inclined place, oil level is not correct.
- 2) Check the oil level before engine starts or engine is cool. Never check oil level immediately after engine stops. Wait for at least 20 minutes.
- 3) Never dispose of oil in rivers, field or place that contaminates nature. Have the oil handled by professionals.

Replacing oil

Remove drain plug on the bottom of engine crankcase. Refill new oil through the oil supply port. Select a proper type of engine oil and replace it periodically.

Capacity	Type
3.8 lit.	CD or better grade, 15W40

Replace
First 50hrs and every 100 hrs.

Engine oil filter

Replace
First 50hrs and every 300 hrs or every 2-3 times of replacing engine oil, which comes earlier.

Replacing engine oil filter

- (1) Drain engine oil.
- (2) Turn engine oil filter anticlockwise with a filter wrench.
- (3) Apply a little engine oil on the rubber ring on the bottom of the new filter and install it.
- (4) Refill engine oil and run the engine until engine oil pressure indicator lamp turns off.
- (5) Stop engine and wait for about 20 minutes or more to check the oil level. Add oil if necessary.

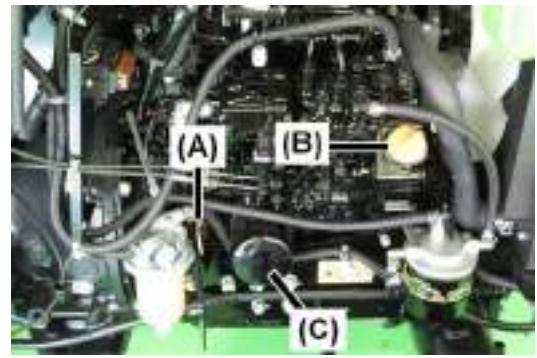

(A) Dipstick (B) Oil supply port

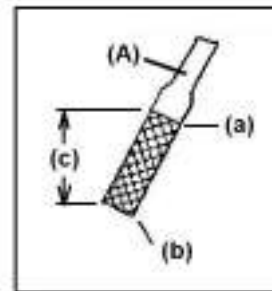

(A) Dipstick
(a) Upper limit (b) Lower limit
(c) Specified level zone



(D) Drain plug

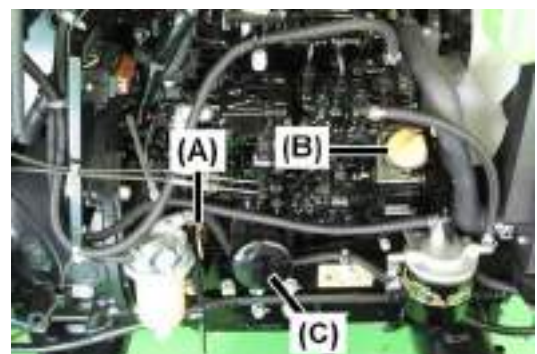

(C) Engine oil filter

6-2. Transmission-hydraulic oil and filter

The transmission oil functions as lubricant of transmission gears, brake discs and hydraulic system oil as well. The transmission oil quality and filter is very important to keep good condition of transmission and hydraulic system.

Check oil level

- (1) Check oil level at oil level window on backside of transmission. Adequate oil level is between a half of window and the lowest (L).
- (2) If the oil is no seen in oil level window, replenish oil.

Replacing oil

Remove drain plug and drain oil. When transmission is warm, draining oil is easier.

Oil Capacity

Capacity	Replace
28 lit.	First 50hrs and every 300 hrs.

Use Yanmar hydraulic-transmission fluid TF-500 or equivalent. Do not mix oil with other brand.

Equivalent oil

Supplier	Brand name
Mobil	Mobil Fluid 425
Castrol	Agricastrol MP
John Deere	J14A, J20B
ESSO	Torque Fluid 56
Shell	Shell Tellus Oil 32 or 37

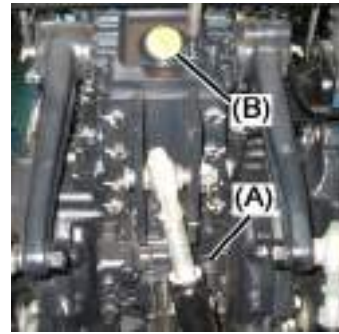

(A) Oil level window (B) Oil supply port
(L) Adequate oil level

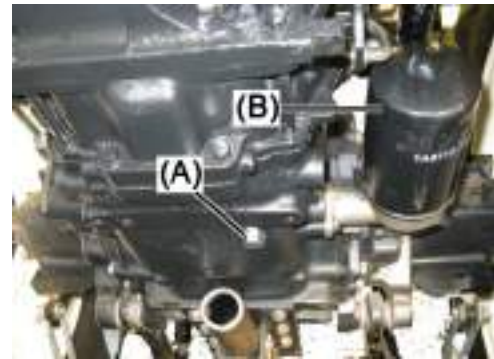

(A) Transmission oil drain plug



IMPORTANT

When you install drain plug, pay attention not to break screw tread of transmission case. Transmission case is made of aluminum. Case itself has enough strength for normal works, but if you put a bolt improperly, screw tread is sometime broken easily. To install drain plug, screw the drain plug by hand first and when most of tread get in, tighten it by a wrench finally.

Transmission oil filter (Line filter)

Replace
First 50 hours and every 300 hours.

Replacement

- (1) Remove drain plug to drain oil.
- (2) Turn transmission oil filter anticlockwise with a filter wrench.
- (3) Apply a little transmission oil on the rubber ring on the bottom of the new filter and install it.
- (4) Refill transmission oil and run the engine for a few minutes
- (5) Stop engine and wait for about 20 minutes or more to check the oil level. Add oil if necessary.

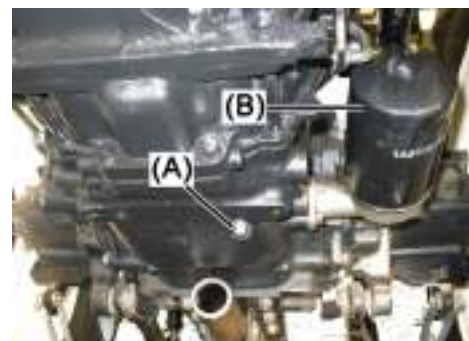

(B) Transmission oil filter

6-3. Front axle oil

Check

Park the tractor on a level place.
 Hold yellow part of dipstick and turn it anti-clockwise to loosen screw. Pull out dipstick and wipe off oil. Insert dipstick without screwing, pull it out and check oil level. Oil level must be between upper and lower limit.



(A) Dipstick



IMPORTANT

Park the tractor on a level place, apply parking brake and stop engine to check oil level. If the tractor is on an inclined place, oil level is not correct.

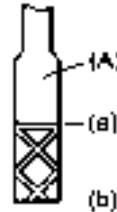

(A) Dipstick
 (a) Upper limit
 (b) Lower limit

Replacing oil

Drain plugs of front axle case are located on lower part of front axle gear case, both right and left individually. Remove both drain plugs to drain oil.

Capacity	Oil type	Replace
5.5 lit.	Gear oil SAE #90	First 50hrs and every 300 hrs.

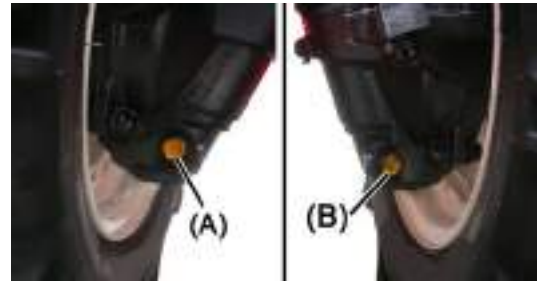

(A) Drain plug, left side
 (B) Drain plug, right side



IMPORTANT

As gear oil #90 is high viscous oil, it takes time to settle in the front axle case. Wait 1 hour after filling new oil and check oil level. Check the oil level again after operation of several hours.

7. Engine coolant



DANGER

Never open the radiator cap when the engine is hot. Hot steam and boiled water may blow out and you may suffer severe burns.

Check

Open the bonnet and check water level in the sub-tank whether water is between "FULL" and "LOW" marks. If water is insufficient, remove sub-tank cap and add clean water.

Be sure to close the sub-tank cap firmly.

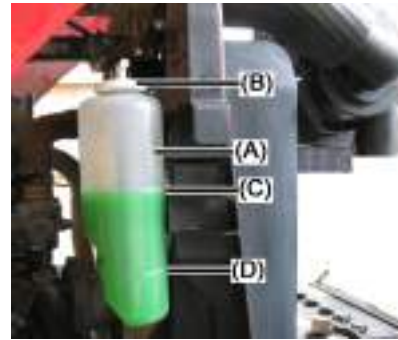

(A) Sub-tank
(B) Sub-tank cap
(C) Upper limit (FULL)
(D) Lower limit (LOW)



(E) Radiator cap

Replacing coolant

- (1) Remove the coolant drain plug and drain cooling water. It is easier for draining to open radiator cap.
- (2) Clean the inside of radiator with tap water until dust or rust does not come out. It is suggested to use radiator detergent. Fill radiator with water and detergent and run the engine in idle speed for more than 15 minutes. Drain the water.
- (3) Fill radiator with clean water. It is recommended to mix anticorrosive. Run the engine for about 5 minutes in idle speed to mix water and anticorrosive.



(A) Coolant drain plug
(B) Hose clip



IMPORTANT

The mixing ratio of anticorrosive varies depend on manufacturer. Follow the instruction of its manufacturer.

8. Radiator screen

Radiator screen catches dust getting into radiator fins. If the screen is covered by dust, it causes engine over heat. Check the screen before every work.

Open the bonnet and check radiator screen.

Pull up radiator screen along the screen hook angle and clean it.

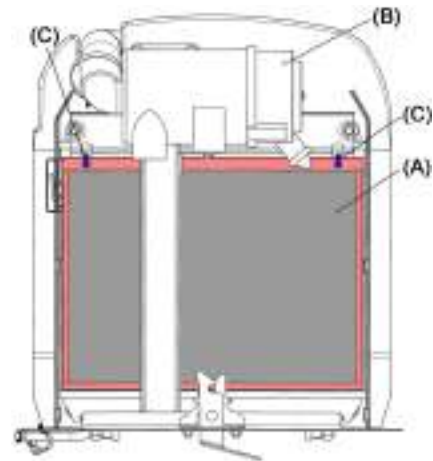
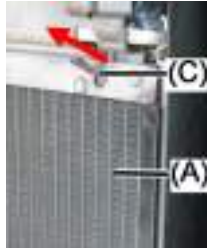

(A) Radiator screen (B) Air cleaner
(C) Screen hook

9. Cleaning air cleaner element (dual element)

The air cleaner serves to keep the engine in favorable conditions by removing dust in air and preventing the cylinder liner and piston ring from premature wearing.

For operation in a dusty environment, clean the air cleaner element every 50 hours or earlier and replace it every 400 hours or earlier.

For operation in a normal condition, clean it every 100 hours and replace it every 1000 hours or every year.

- (1) Open the cap and take out the outer element. Tap dust out of the outer element. If much dust on the element, blow air from inside of the element. Be careful not to damage the fins.
- (2) Return the outer element, close the cap as "TOP" mark upward and clip firmly.

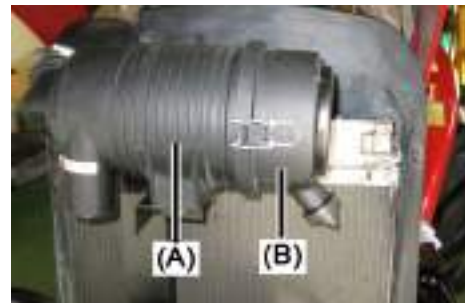

(A) Air cleaner (B) Cap

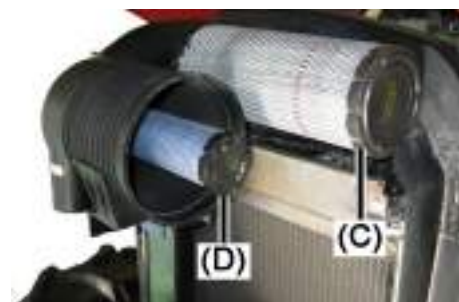

(C) Outer element
(D) Inner element



IMPORTANT

- 1) Do not take out the inner element. It avoid from getting dust into the engine air intake part. It is not necessary to replace the inner element unless it is damaged or very dirty.
- 2) Never operate engine with inner element only. Inner element cannot catch fine dust like as the outer element.

10. Checking battery



CAUTION

- 1) Battery electrolyte evaporates and hydrogen gas comes out. Hydrogen gas is flammable. Never smoke while handling battery. Keep all sparks and open flames away from battery. If hydrogen gas catches fire, battery will explode and cause serious injury.
- 2) Use flashlight to check battery electrolyte level. Never use open flame.
- 3) Make sure to disconnect battery ground cable before servicing any part of electrical system.
- 4) To remove battery, disconnect the ground (negative) cable first and disconnect positive cable. To install battery, connect the positive cable first and connect ground (negative) cable.



WARNING

Sulfuric acid in battery electrolyte is injurious and poisonous. It is strong enough to burn skin, eat holes in clothing, and cause blindness if it is splashed into eyes.

To avoid the hazards:

- (1) Filling battery in a well-ventilated area.
- (2) Wearing eye protection and rubber gloves.
- (3) Avoiding breathing fumes when electrolyte is added.
- (4) Avoiding spilling or dripping electrolyte.

If you spill acid on yourself:

- (1) Flush your skin with water.
- (2) Apply baking soda or lime to help neutralize the acid.
- (3) Flush your eyes with clean water for 10 - 15 minutes and get medical attention immediately.
- (4) If acid is swallowed, get medical attention immediately.

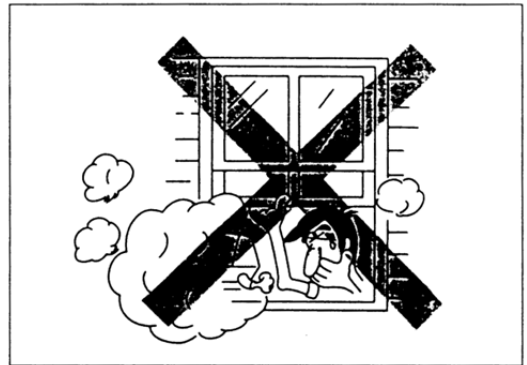
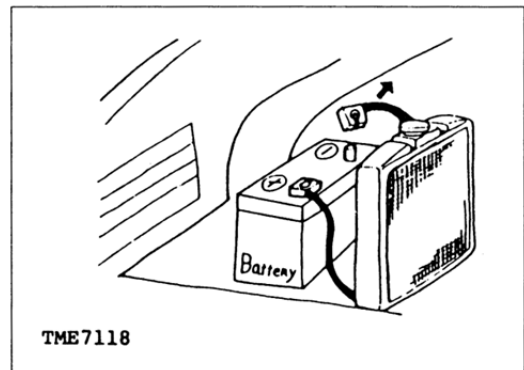
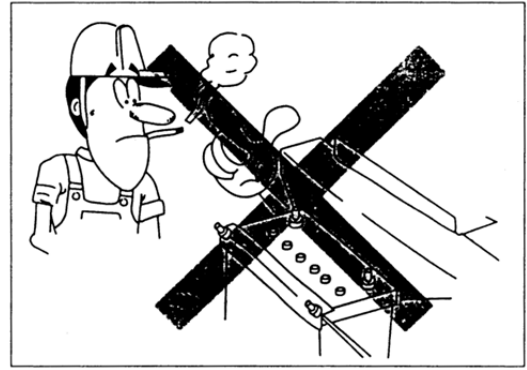

10-1. Check battery

Check whether the electrolyte level is between upper and lower limit lines.

If the electrolyte level is close to the lower limit line, add purified (or distilled) water.

Adding water

- (1) Remove vent plugs.
- (2) Add purified water to the upper limit line.
- (3) Tighten vent plugs.



IMPORTANT

Make sure the tractor is level when checking electrolyte level.

Never add purified water over the upper limit line.
Be sure to use purified water specified for battery.



WARNING

It is recommended to replace battery promptly if under mentioned situation occurs.

- If the electrolyte level is kept below the lower limit line while operating, it may accelerate deterioration of internal metals and decreasing of electrolyte. It may result explosion of battery.
- If the inner metal plates are exposed because of decreasing electrolyte, addition of water cannot compensate and there is a risk of explosion.

10-2. Removing and installing battery

Remove

- (1) Open the bonnet.
- (2) Disconnect the negative (ground) cable first from the battery.
- (3) Disconnect the positive cable.
- (4) Loosen fixing nuts and remove the battery.

Installation

- (1) Connect positive cable first.
- (2) Connect negative cable.
- (2) Tighten fixing nut.



IMPORTANT

- 1) When connecting the battery cables, wipe oil away from the terminal contacts. After connecting cables, apply grease to the terminals.
- 2) Be sure to attach the rubber boots for the positive terminal of the battery.
- 3) When replacing the battery, be sure to use the genuine battery or equivalent specified in the right table
- 4) For environmental protection and recycle of resources, return the old battery following the regulation of your place.

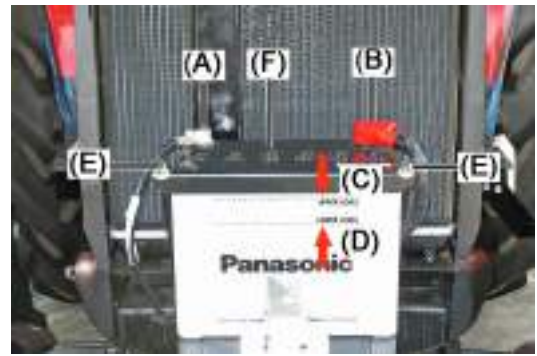

- (A) Negative (ground) terminal
- (B) Positive terminal
- (C) Upper limit line
- (D) Lower limit line
- (E) Fixing nut, 2 pieces
- (F) Vent plug, 6 pieces

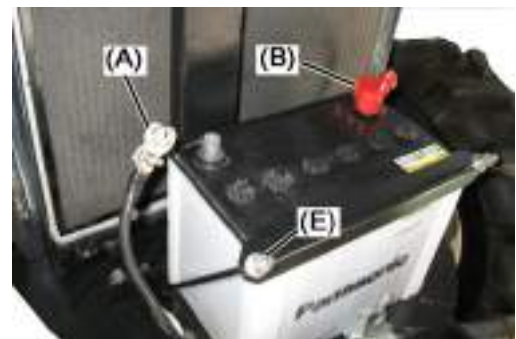

- (A) Negative (ground) cable
- (B) Positive cable
- (E) Fixing nuts

Battery type

Specified battery	Parts code No.
75D26R	1A7781-51500

Voltage	12 Volts
Capacity 5HR	52 AH
Charging rate	6.5 Amperes

10-3. Charging battery



DANGER

Never charge the battery with quick charger or fast charger. Internal pressure of the battery increases and the battery may explode. It may cause serious injury.

Charge the battery as following procedures.

- (1) Remove the battery.
- (2) Connect the battery positive cable to the positive side of the charger, the battery negative cable to the negative side of the charger.
- (3) Charge the battery at approximately 3 amperes for 8 to 10 hours. When the hydrometer color becomes green, charge is completed.
- (4) Install the battery to the tractor.

11. Checking pipes and hoses

Check fuel pipes, hydraulic power steering pipes and radiator hoses for leak and loose connections. It is recommended to replace such parts every two years.



DANGER

Aged or damaged pipes leak fuel or hydraulic oil and it may cause a fire. If a leak is found, replace the pipe with new one.



(A) Fuel pipe
(B) Radiator hose



(C) Radiator hose

12. Checking electrical wires

Open the bonnet. Check damage, loose connection. Check them every 50 hours or have them periodically checked every year.



WARNING

- 1) A damaged electric wire causes short circuit and it may cause a fire. Check before starting day's work.
- 2) Clear dust, weeds or rice straws away wires and connections before starting works. Those objects cause a short circuit and it may cause a fire.

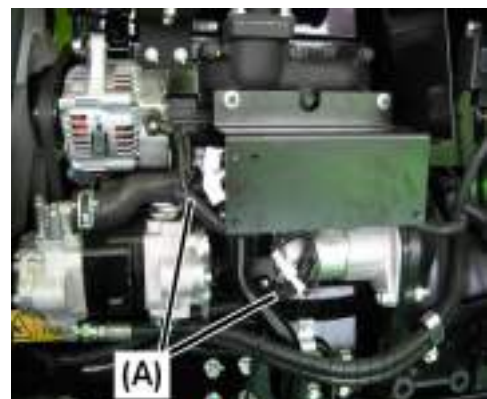

(A) Electric wires

13. Greasing

Before starting day's work, check the greasing condition at each point.
Apply grease normally every 50 hours.

Apply grease after every day's work when you work in wet paddy field.

(1) Tie rod end

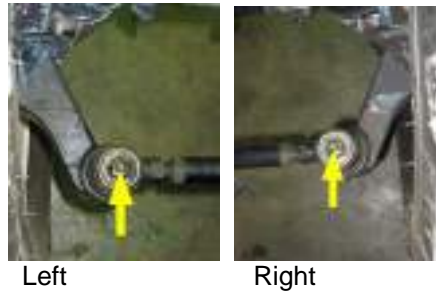

Left

Right

(2) Power steering rod



Right

(3) Center pin support



Front

Rear

(4) Brake pedal shaft



Left

Right

(5) Lift arm

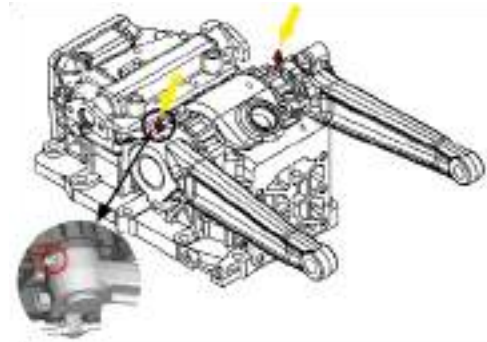

Left & Right

(6) Levers fulcrum rotating part

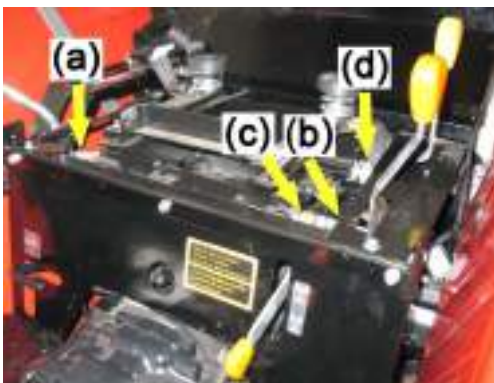

- (a) Main gear shift lever
- (b) Range gear shift lever
- (c) Front wheel drive lever
- (d) PTO gear shift lever

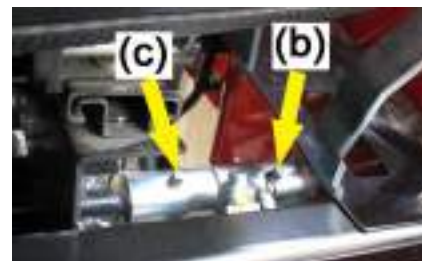
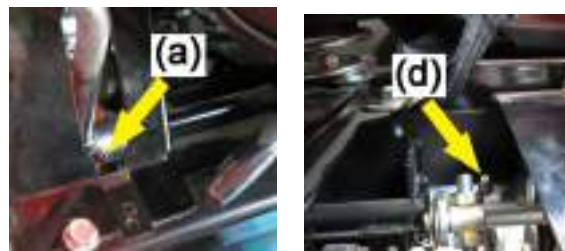

14. Adjusting brake pedal



WARNING

- 1) Check free play of brake pedal before every work.
If brake is not work properly, accident may occur.
- 2) Unequal free play of left and right brake can cause abrupt turn and it may cause injury. Keep the same amount of play. Otherwise, an accident can result.

Disconnect brake pedals if latched.

Push down right and left brake pedals one by one and check free play of each pedal to be 25-35mm. Both pedals must have the same free play.

Adjustment

- (1) Loosen lock nut of brake rod. Turn brake rod to adjust pedal free play to 25-35 mm. The free play of one pedal must equal to the other.
- (2) Make sure to tighten lock nut.



IMPORTANT

Make sure parking brake can be applied firmly.

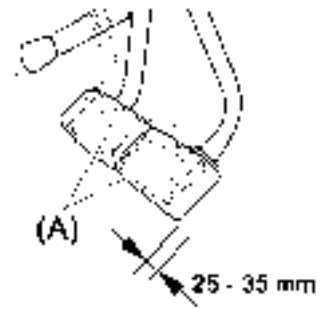

(A) Brake pedal

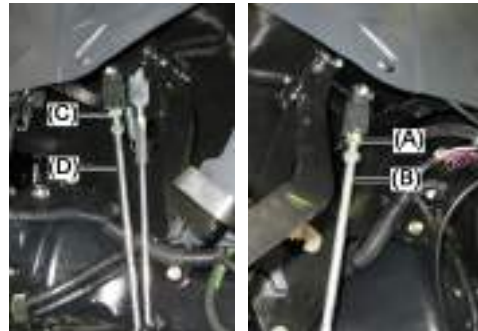

(A) Lock nut, Right (B) Brake rod, Right
(C) Lock nut, Left (D) Brake rod, Left

15. Adjusting clutch pedal

Push down the clutch pedal and check the free play. The specified free play of clutch pedal is 15-25 mm.



IMPORTANT

Do not rest foot on clutch pedal while operating. It may cause premature wearing of clutch disc.

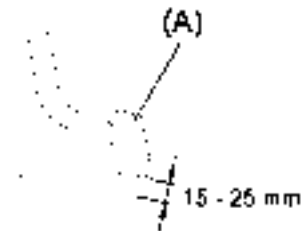

(A) Clutch pedal

Adjustment

- (1) Loosen lock nut. Turn the turnbuckle to adjust free play to 15-25 mm.
- (2) Tighten lock nut firmly.



IMPORTANT

- 1) When free play is less than 15 mm;
Engagement of engine flywheel and clutch disc is not enough and it will cause premature wearing of clutch disc.
- 2) When free play is more than 25 mm;
Disengagement of engine flywheel and clutch disc is not enough and it will cause noise when shifting gears. It also may cause damage on gears.



(A) Lock nut (B) Turnbuckle
(C) Clutch rod

16. Checking steering wheel



WARNING

Check free play of steering wheel. The normal free play is 20-50 mm.

This tractor is equipped with hydrostatic power steering and it causes less wearing of steering system. When free play is more than normal, check wearing of tie rod ends. The wearing of tie rod end causes more free play on steering wheel.

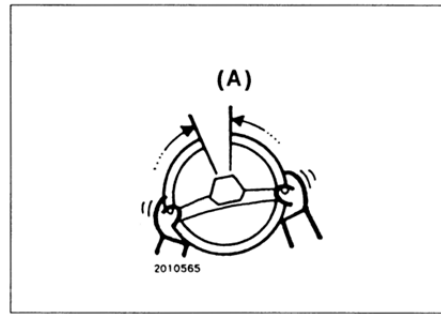

(A) Steering wheel free play.
Measure the free play on wheel circle.



(A) Tie rod (B),(C) Tie rod end

17. Adjusting fan belt



CAUTION

Stop the engine and wait until the engine is sufficiently cooled down. Otherwise, you may be burned.

Check

Press the fan belt with a finger at the midpoint and see the belt deflections.

The specified deflection is 10 -15 mm.

Adjustment

- (1) Open the bonnet.
- (2) Loosen alternator bolt, belt adjuster bolt, and alternator nut.
- (3) Move alternator to stretch the belt tight. Tighten alternator bolt and see deflection. If the deflection is 10 - 15 mm, tighten alternator bolt, alternator nut and belt adjuster bolt.



IMPORTANT

When tractor is new, fan belt stretched in a short time. Check belt deflection frequently.

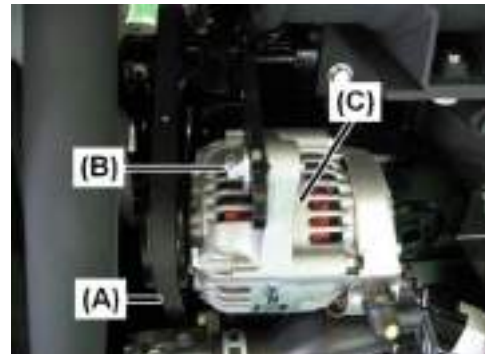

(A) Fan belt (B) Alternator bolt.
(C) Alternator



(B) Alternator bolt (C) Alternator
(D) Belt adjuster (E) Belt adjuster bolt
(F) Alternator nut

18. Checking and adjusting toe-in

When a tractor runs, front wheels intend to go outward due to camber angle. The toe-in gives a counter force against outward force to run straight. If the toe-in is not adjusted appropriately, steering may not be stable.

Check

- (1) Put front wheel to be straight.
- (2) Measure the distance between the center of right tire and left tire in front side (b).
- (3) Measure the distance between the center of right tire and left tire in rear side (a).
- (4) See the difference.

The amount of (a) must be bigger than (b).

Specified toe-in: $a - b = 1 - 8 \text{ mm}$

Adjustment

- (1) Lift up front wheel slightly. It is not necessary that front tires are floating.
- (2) Loosen the lock nuts, left and right.
- (3) Turn tie rod to adjust the front wheel tread and measure front side and rear side of wheel tread.
- (4) When the toe-in is specified amount, tighten the lock nuts.

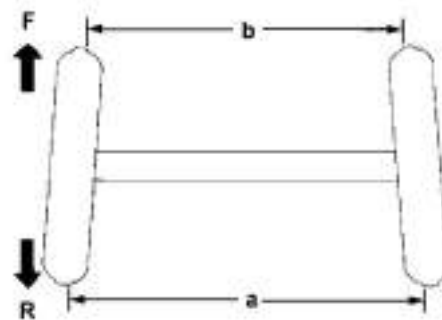

F: Forward

R: Rearward

a: distance between the center of tires, rear
b: distance between the center of tires, front



(A) Tie rod (D) Lock nut, right and left

19. Replacing fuse

19-1. Fuse box

The fuse box is located at right side of dashboard nearby clutch rod.

Check fuses and replace the blown fuse with new one if any.



CAUTION

Be sure to use a fuse of specified capacity. If a bigger capacity fuse is replaced, it may burn electric wire and cause a fire. Never use electric wire or iron wire etc. as a fuse.



(A) Fuse box

No.	Written on label	Fuse	Related parts
(1)	STOP SOLENIID	5 A	Fuel cut solenoid
(2)	REVERSER	5 A	Reverser neutral switch
(3)	HEAD LAMP	15 A	Head lamp
(4)	METER	5 A	Meter lamps, gauges
(5)	WORK LAMP	10 A	Work lamp
(6)	FLASHER	5 A	Turn signal lamp
(7)	HORN	5 A	Horn
(8)	START	5 A	PTO neutral switch

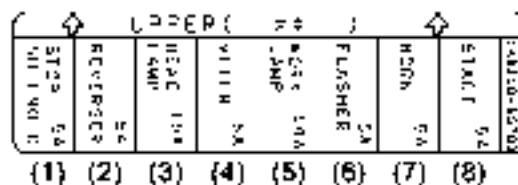

19-2. Slow blow fuse

Slow blow fuses are located on left side of the engine. The slow blow fuse protects main electric circuit that requires heavy current.

CAUTION

Be sure to use a genuine slow blow fuse. Never use electric wire or iron wire etc. as a fuse. It may cause a fire.

There are 2 slow blow fuses.

- 1) Alternator circuit 65A
- 2) Main circuit 65A

NOTE:

The main slow blow fuse may sometimes be placed above the alternator slow blow fuse.

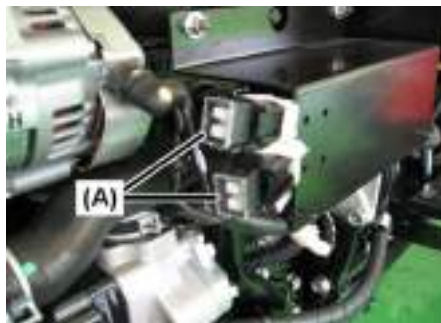

(A) Slow blow fuse

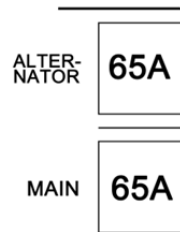

20. Checking tire and wheel

Check dairy damages, wear and air inflation of tires. Check dairy looseness of tire hub bolts and nuts. Check dairy crack and bent of wheel and rim.

WARNING

Never operate the tractor when a tire hub bolt or nut is loosened. It may cause injury if a tire is taken off while operating.

Checking tires

Adjust the inflation pressures of the front and rear tires to the standard pressure. Also check for any crack or faults on the tires.

Hub bolt and nut tightening torque

Tighten hub bolts and nuts with specified tightening torque. A rear wheel is fixed with 4 bolts and 2 nuts.

IMPORTANT

Do not tighten more than specified torque. It may break screw tread and fixing would be insufficient. When a hub bolt or nut loosen frequently, check screw tread and replace if necessary.

21. Color of exhaust gas

The color of exhaust gas is black just after engine starts and it is gray or no color during operation.

Black: Incomplete combustion due to dense fuel.
 White: Engine oil is burning.
 Normal exhaust may look white at extremely low temperature.

If exhaust gas is black or white without a load on the tractor, consult with your service dealer.

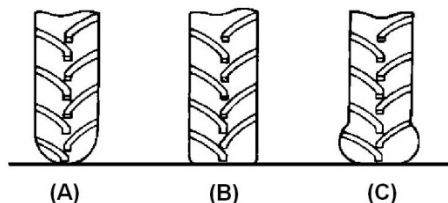

- (A): Excessive
 (B): Standard
 (C): Insufficient

Standard inflation pressure of tire

	Tire size (ply)	Pressure kg/cm ² (kPa)
Front	8-16 (4)	1.6 (157)
Rear	12.4-24 (6)	1.6 (157)

Tightening torque	Front wheel	118 to 147Nm (12 to 15kgf-m)
	Rear wheel	177 to 196Nm (18 to 20kgf-m)

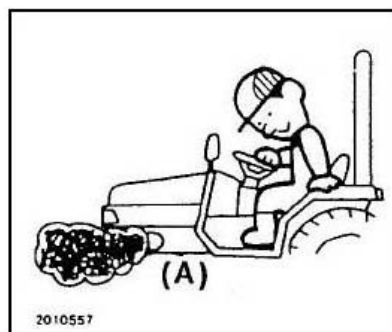

2010557

TROUBLESHOOTING

If abnormal operations are found, stop the engine and found a problem by referring to the following table.

1. Engine

PROBLEM		CAUSE	REMEDY
Engine hard to start or not start	Starter motor runs.	No fuel or improper fuel	Fill fuel. Drain wrong fuel and fill proper fuel.
		Water, dirt, or air in fuel system	Drain, flush & bleed fuel system.
		Clogged fuel filter	Clean or replace fuel filter.
		Fuel shut-off valve closed	Open fuel shut-off valve.
		Accelerator lever not pulled	Pull throttle lever.
		Engine oil too heavy	Use oil of proper viscosity.
	Starter motor doesn't run.	Reverser lever is not set to "N".	Set the lever to neutral.
		PTO shift lever is not set to "N".	Set the lever to neutral.
		Low voltage	Charge battery.
		Slow blow fuse blown	Replace slow blow fuse.
Engine runs irregularly or stalls frequently	Vent in fuel tank cap clogged	Clean cap in solvent and blow dry.	
	Fuel filter clogged	Clean or replace fuel filter.	
	Water, dirt, or air in fuel system	Drain, flush & bleed fuel system.	
	Dirty or faulty injection nozzles	See your YANMAR dealer.	
	Improper type of fuel	Use proper fuel.	
	Engine solenoid linkage out of adjustment	See your YANMAR dealer.	
	Insufficient oil	Add oil	
Engine knocks	Engine overheating	See "Engine overheats".	
	Idle speed too slow	Check idle speed.	
	Improper type of fuel	Use proper fuel.	
Lack of engine power	Engine overloaded	Reduce load or shift to lower gear.	
	Air cleaner element clogged	Clean air cleaner element.	
	Clogged fuel filter	Clean or replace fuel filter.	
	Improper type of fuel	Use proper fuel.	
	Engine overheating	See "Engine overheats".	
	Improper ballast	Adjust ballast to load.	
	Hydraulic stop valve closed	Open stop valve.	
	Improper implement mounted	Check required horsepower for implement.	

1. Engine (continued)

PROBLEM	CAUSE	REMEDY
Engine overheats	Engine overloaded	Reduce load or shift to lower gear.
	Low coolant level	Fill coolant and check cooling system for loose connections or leak.
	Loose or defective fan belt	Adjust fan belt and replace if needed
	Radiator screen or fins clogged	Clean radiator screen or fins.
	Cooling system needs flushing	Flush cooling system.
	Defective thermostat	Remove and check thermostat.
	Defective temperature gauge or sender	See your YANMAR dealer.
High oil consumption	Oil viscosity is too light	Use proper viscosity oil.
	Oil leaks	Check for leaks in lines, seals, drain plug and around gaskets.
Engine emits white smoke	Improper type of fuel	Use proper fuel.
	Low engine temperature	Warm up engine to normal operating temperature.
Engine emits black or gray smoke	Improper type of fuel	Use proper fuel.
	Engine overloaded	Reduce load or shift to lower gear.
	Air cleaner clogged	Clean or replace air cleaner element.
High fuel consumption	Improper type of fuel	Use proper fuel.
	Engine overloaded	Reduce load or shift to lower gear.
	Air cleaner clogged	Clean or replace air cleaner and element.
	Crankcase breather clogged	Clean breather pipe.
	Radiator screen or fins clogged	Clean radiator screen or fins.
	Improper implement mounted	Check required horsepower for implement.
	Tire pressure too low.	Inflate tires to proper pressure.
	Clutch slipping.	Adjust clutch free travel or replace disk.
Unusual noise	Defective component parts	See your YANMAR dealer.

2. Electrical system

PROBLEM	CAUSE	REMEDY
Battery not charged	Loose or corroded connections	Clean and tighten connections.
	Battery service life is ending	Check electrolyte level and specific gravity and replace if necessary.
	Loose or defective fan belt	Adjust belt tension or replace belt.
	Excessive engine idling	Allow engine to idle when necessary.
Charging indicator lamp lights during operation	Low engine speed	Increase speed.
	Defective battery	Check electrolyte level and specific gravity and replace if necessary.
	Loose or defective fan belt	Adjust belt tension or replace belt.
Engine oil pressure indicator lamp lights	Low oil	Add oil.

3. Hydraulic system

PROBLEM	CAUSE	REMEDY
Implement not raises	Low oil level	Fill system with proper oil.
	Hydraulic stop valve closed	Open stop valve.
	Excessive load on hitch	Reduce load.
	Hydraulic oil too cold	Allow oil to warm up.
	Hydraulic oil filter clogged	Replace filter.
	Defective hydraulic pump or control valve	See your YANMAR dealer.
	Oil leaks	Check oil leaks.
Hitch drops slowly or does not drop	Hydraulic stop valve closed	Open stop valve.
	Slow return valve set slow	Open valve and adjust drop speed.
System drops too fast	Slow return valve set fast	Close valve and adjust drop speed.
	Improper oil	Use oil with proper viscosity.
System overheating	Incorrect oil viscosity	Drain and fill oil with proper viscosity.
	Low oil level	Fill to proper oil level.
	Dirty oil	Drain and fill clean oil.
	Keeping steering wheel at the end	Release steering wheel.
	Control lever not returned to neutral position when using implement	Return lever to neutral position.

4. Power train

PROBLEM	CAUSE	REMEDY
Abnormal noise	Transmission oil level low	Add proper type of oil.
	Worn or broken gears/bearings	See your YANMAR dealer.
Tractor is pulled to one side	Brakes adjusted unevenly	Adjust brake pedal free travel.
	Right and left tires inflated unevenly	Inflate tires to proper pressure.
	Implement improperly adjusted	See implement operator's manual

SPECIFICATIONS

Model		EF393T	
Engine	Make		Yanmar
	Model		3TNV88
	Type		Direct injection, Water cooled, diesel
	Output	SAE Gross (ps)	39.0
	Rated RPM		(rpm) 2800
	No. of cylinders		3
	Displacement		(cc) 1,642 cc
	Fuel tank		(lit.) 38
Dimension	Overall length		(mm) 2940
	Overall width		(mm) 1430
	Overall height (steering wheel)		(mm) 1950 (1400)
	Tread	Front	(mm) 1065
		Rear	(mm) 1120
	Wheelbase		(mm) 1650
	Ground clearance		(mm) 320
Weight		(kg) 1090	
Tire size	Front		8 - 16
	Rear		12.4 - 24
Steering		Hydrostatic power steering	
Brake		Wet multi-disc type	
Clutch		Dry single	
Transmission	No. of shifting gears		8 forward and 8 reverse (constant mesh)
	Reverser		Syncho-mesh
	Travel speed	Forward	(km/hr) 1.90 – 21.1
		Reverse	(km/hr) 1.84 – 21.9
Turning radius	(with brake) (m)	2.4	
PTO	Gear 1		584 rpm (at engine speed: 2800rpm)
	Gear 2		836 rpm (at engine speed: 2800rpm)
Hydraulic system	Type		Position control
	Hitch		3-point hitch
	Category		Category 1
	Max. lifting capacity (at lower link end)		(kg) 925
	Hydraulic pump capacity		(lit./min) 20.2

Note:

All technical data, measurement and weight are approximate, and the manufacturer has the right to make alteration without prior notice.

IMPLEMENT CAPACITIES

The Yanmar tractor has been carefully tested in the configuration equipped with implements sold or approved by Yanmar and has proved to perform properly. Do not use any implement that has not been sold or recommended by Yanmar, or that fails to satisfy the specified values given below. Using with implements that are not approved by Yanmar could result in malfunction, failure, and damage to the tractor and/or implement, and increase the possibility of injury to the operator or other people. The Yanmar warranty does not cover any malfunction or failure that results from use of an unapproved implement.

	Lower link end maximum lifting capacity	Implement weight and size	Maximum drawbar load	Trailer loading weight maximum capacity
	W0	W1	W2	W3
kg	925	As specified in the implement capacity list	330	1,500

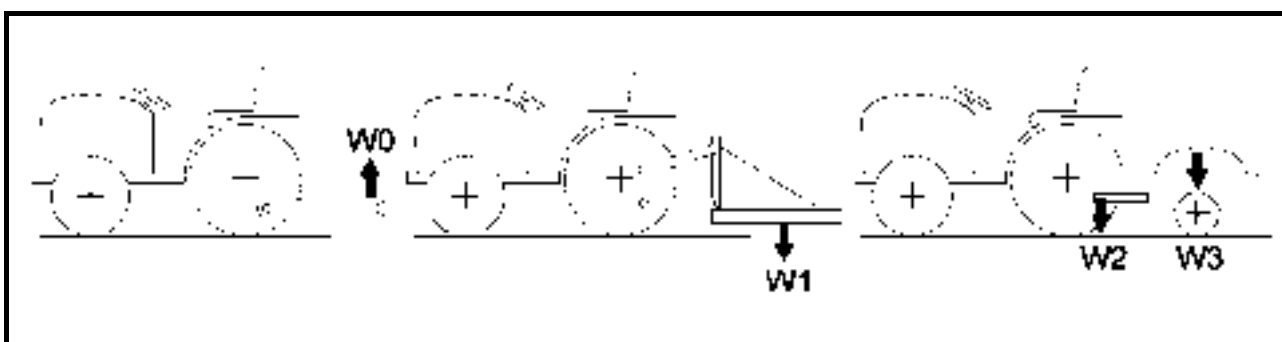

Implement capacity list

Implement	Description	Unit	Maximum Amount
Rotary	Tilling Width	m	1.7
	Weight	kg	310
Disc plough	Disc Size(inch) & Total disc	Inch x disc	22X4
	Weight	kg	300
Poly disc plough	Disc Size(inch) & Total disc	Inch x disc	22X6
	Weight	kg	350
Front blade	Width	m	1.7
	Weight	kg	290
Trailer	Load Capacity	kg	1,500
	Drawbar Load	kg	330
Front weight	Weight	kg	90