

**YANMAR**

OPERATOR'S MANUAL

# COMBINE HARVESTER

AW70V, VNQ  
AW82V, VNQ

en Original instructions

# INTRODUCTION

**Thank you very much for purchasing the YANMAR product!**

- **Components and parts of this product are applicable to relevant JIS (Japan) and ISO (international) standards.**
- **This manual describes the methods for operation and precaution for using of YANMAR combine harvester AW70V. Please read this manual carefully and understand it before using the machine. If the operator has not participated in any training on operation of the machine or fails to use it in strict accordance with this manual, the user shall be independently liable for any consequences caused thereby. This machine can only be operated, maintained and repaired by technicians who are familiar with its features and have the knowledge on safety in operation. It should be understood that any fault or failure caused by improper operation and maintenance is not covered by the scope of warranty provided by the dealer or the company.**
- **Please feel free to consult your YANMAR dealer about any questions or concerns you may have.**
- **Please keep this manual near the machine after reading, and attach it with the machine when lending or transferring it to others.**
- **To improve or upgrade this machine in quality or performance or for safety consideration, parts are sometimes changed, so some parts of the description or illustration in this manual may not apply to your machine. Please understand such circumstances beforehand.**
- **Use this machine for the harvest only. Never modify or use it for any other purpose for which it was not designed. This machine will not be covered by the scope of warranty if it is modified or used for any other purpose. In addition, neither the dealer nor the company will be liable for any accidents, personal injuries caused by modification to this machine or property loss.**

- The horse power of this machine is properly set at the time of delivery. The dealer will not supply any warranty services if the user changes or adjusts the parameter at will.
- After delivering of this machine, the dealer will provide operating instructions for practical use at the first time.
- This machine should comply with relevant regulations on accident prevention and other safety countermeasures at any time, and relevant traffic laws and regulations should be followed when it is driven on road.
- It is not allowed to duplicate or publish this manual without permission of the company. Our company reserves all rights to publish, change or modify this manual according to laws. The right to interpret this manual shall be owned by the company.
- The positions of relevant products in this manual are in the same direction of driving by the operator.
- This manual includes chapter “Safety Instructions” for your safety in operation. Be sure to read it before using and abide by it during operation.
- Pay full attention to the following warning signs that are very important for safety.
- Export to Any Other Countries is prohibited. Sales and Use Within Philippines Only.

## **DANGER**

“DANGER” indicates a hazardous situation which, if not avoided, will result in death or serious injury.

## **WARNING**

“WARNING” indicates a hazardous situation which, if not avoided, could result in death or serious injury.

## **CAUTION**

“CAUTION” indicates a hazardous situation which, if not avoided, could result in minor or moderate injury. It is also used to alert against unsafe practices.

# CONTENTS

	<b>Safety Instructions</b>	<b>5</b>
	<b>Service and Warranty</b>	<b>22</b>
<b>1</b>	<b>Name of Parts</b>	<b>24</b>
	<b>Attachment Position of Safety Labels</b>	<b>27</b>
	<b>Function of Parts</b>	<b>31</b>
<b>2</b>	<b>Driving</b>	<b>38</b>
	1. Pre-operation checks .....	38
	2. Starting and stopping the engine .....	40
	3. Starting, turning and parking .....	42
	4. Traveling .....	43
	5. Loading/unloading on truck .....	44
	<b>Operation</b>	<b>45</b>
	1. Conditions of crops and field .....	45
	2. Field preparation and harvesting .....	47
	3. Preparation for harvesting with combine .....	49
4. Harvesting .....	50	
5. Alarm .....	62	
<b>3</b>	<b>Maintenance after Operation</b>	<b>63</b>
	1. Post-operation maintenance .....	63
	2. Detaching and opening of each part .....	63
	3. Oiling of each part .....	66
	4. Cleaning of each part .....	68
	5. Long-time storage .....	70

# CONTENTS

<b>4</b>	<b>Periodic Inspection</b>	<b>71</b>
	1. Schedule for refueling, oiling and water supply.....	72
	2. Checking and replacing oil of each part.....	73
	3. Replacing HST filter and hydraulic oil.....	76
	4. Checking and replacing cooling water.....	76
	5. Replacing fuel filter.....	77
	6. Cleaning the water separator.....	78
	7. Draining the fuel tank.....	78
	8. Bleeding fuel system.....	79
	9. Cleaning and replacing the air filter.....	79
	10. Cleaning the engine dust protector.....	79
	11. Maintaining the battery.....	80
	12. Checking the piping system.....	81
	13. Checking the muffler.....	82
	14. Checking the electrical wiring.....	82
	15. Maintaining and adjusting the cutter blades.....	82
	16. Adjusting the gap between feeding auger and base plate.....	83
	17. Adjusting the gap between platform auger finger and base plate.....	83
	18. Adjusting the position of reel.....	84
	19. Checking and replacing fuse.....	84
	20. Adjusting the chains.....	85
	21. Adjusting the belts.....	86
22. Checking and adjusting the crawler.....	91	
<b>5</b>	<b>Trouble Shooting</b>	<b>94</b>
	1. Engine section.....	94
	2. Harvesting and conveying section.....	95
	3. Threshing section.....	96
	<b>Technical Specification</b>	<b>97</b>
	<b>Main Wearing Parts</b>	<b>98</b>
	<b>Accessories</b>	<b>99</b>
	<b>Others</b>	<b>100</b>

# Safety Instructions

- Be sure to abide by the following instructions which are very important for safety.
- Personal injury, death, other accidents and damages to the machine may be caused if the precautions are not followed.

## 1. Precautions on operator's physical condition and clothes

### **⚠ WARNING**

**Do not operate if you are:**

- Overtired, sick, under the influence of medication or otherwise incapacitated
- Drunk
- Pregnant
- Under eighteen years of age

**[If not]**

**It may result in an accident.**

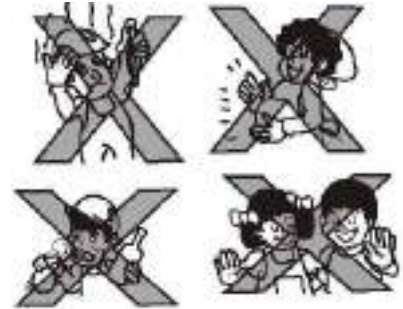

### **⚠ WARNING**

**Wear the clothes appropriate for operation**

Do not put the towel around your head, neck and waist. You may need the safety helmet, safety shoes, coveralls, other protections and clothes suitable for operation. Your hearing may be harmed or lost if working for long time in noisy environments. So be sure to wear the earmuffs or earplugs.

**[If not]**

**You may fall, be rolled in the machine and injured.**



## 2. Precautions before use

### **IMPORTANT**

**Be sure to check the machine before working.**

Check and correct any abnormalities before using the combine. Additionally, check and repair if there is any abnormality after working.

**[If not]**

**Accident or mechanical failure may be caused as a result of poor maintenance.**



# Safety Instructions

## **⚠ DANGER**

**This manual must be accompanied when the machine is transferred to others.**

Explain the operating methods in details, and request the operator to read the Operator's Manual carefully before operation.

[If not]

**It may cause death, irreparable injury or damages to the machine.**

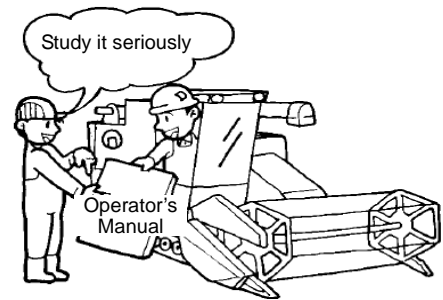

## **⚠ WARNING**

**Put the fire extinguishers in the designated places.**

Check the fire extinguishers are under normal condition and placed in the designated places before using the combine.

[If not]

**It will be unavailable to extinguish the fire quickly if any.**

## **⚠ WARNING**

**Make ready the first-aid kit.**

Keep ready the first-aid kit and write down the phone numbers of doctor, medical aid station, hospital and fire brigade nearby in advance.

[If not]

**First aid may be delayed and personal injury be caused in case of safety accident.**

## **IMPORTANT**

**Be sure to perform the periodic inspection and maintenance.**

Perform the periodic inspection, repair and maintenance of all parts on a quarterly basis. In particular, the fuel channel should be replaced every two years, and electrical wiring be checked yearly.

[If not]

**Accident, personal injury or mechanical failure may sometimes be caused due to improper maintenance.**

# Safety Instructions

## 3. Precautions for checking before test run and operation

### **⚠ DANGER**

**Refuel and lubricate the machine after the engine is cooled down.**

Do not refuel or lubricate the machine while the engine is running or at a high temperature.

Be sure to refuel outdoors.

[If not]

**Fuel or engine oil may be ignited and cause personal injury or fire.**

### **⚠ DANGER**

**Never use fires while refueling.**

Do not smoke or use open fire for lighting while refueling.

[If not]

**Fuel may be ignited and cause personal injury or fire.**



### **⚠ DANGER**

**Checking on a stable and level ground.**

Perform the pre-operation inspection on an even and stable ground to prevent the machine from turning over or sliding.

[If not]

**Accident may be caused.**



### **⚠ WARNING**

**Fasten the fuel tank cap securely and wipe off the spilled fuel after refueling.**

Fuel may spill sometimes if the fuel tank cap is loose. Fasten the fuel cap securely. In addition, be sure to wipe off the spilled fuel if any.

[If not]

**Fire hazard or personal injury may be caused sometimes.**



# Safety Instructions

## **⚠ WARNING**

### **Be sure to check the fuel leakage.**

Be sure to check whether the fuel line is damaged and there is fuel leakage.

[If not]

**Fire hazard or personal injury may be caused.**



## **⚠ WARNING**

### **Be sure to check the wiring of electrical parts.**

Check whether the electrical wiring is in touch with the sharp tips of other parts, falls off or is loosely connected, and its insulation has peeled off.

[If not]

**Short-circuit may be caused, resulting in fire or burning.**

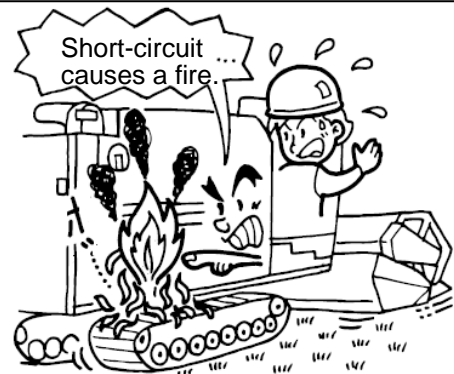

## **⚠ WARNING**

### **Pay full attention to exhaust emission.**

Do not start up the engine in a closed room, but run it outdoors with good ventilation. Ensure adequate ventilation if you have to run it indoors.

[If not]

**Poisoning or fatal accident may be caused due to exhaust emission.**

# Safety Instructions

## **⚠ WARNING**

### **Check the brake and control levers.**

It will be very dangerous if the brake does not work or there is deviation in the control levers. Be sure to check and adjust the same.

[If not]

**Personal injury or damages to the machine may be caused.**

## **⚠ WARNING**

### **Be sure to properly fix the panel covers dismantled.**

Make sure to replace the panel covers dismantled during checking prior to starting up and operation. Ensure the covers are not deformed or damaged. Keep your hands, feet and clothes away from the running parts.

[If not]

**Person injury may be caused.**



## **⚠ WARNING**

### **Clean up straw near the engine, muffler and belt pulley.**

Check whether there is straw, dust or fuel attached on the engine, muffler and belt pulley before daily operation.

[If not]

**Dust may be ignited and cause fire or personal injury.**



## **⚠ CAUTION**

### **Put all control levers in the neutral position when starting up the engine.**

Be sure to sit in the driver's seat and put all control levers in the neutral position before starting up the engine.

[If not]

**The engine may not be started up.**

# Safety Instructions

## 4. Precautions for operation and moving

### **⚠ WARNING**

#### **Never park on slope.**

Wood blocks must be used for preventing sliding, and at the same time, the brake pedal must be locked if you have to park the machine on a slope.

[If not]

**The machine may slide and cause accident.**

### **⚠ WARNING**

#### **Do not drive close to road edge.**

Do not come close to the road edge or slippery road surface while driving.

[If not]

**The road edge may collapse and cause turn-over of the machine or personal injury.**



### **⚠ WARNING**

#### **Use the gangplank when crossing a ridge or ditch.**

Be sure to use the gangplank of the width, length and strength suitable for the machine when entering the field, crossing a ditch or high ridge, or passing through a soft field.

[If not]

**The machine may loss balance, fall over and cause injuries.**

### **⚠ WARNING**

#### **Be sure to comply with relevant laws and regulations, and wear the safety helmet.**

You are required to abide by relevant laws and regulations, and for safety consideration, wear the safety helmet during working and driving on road.

[If not]

**Unexpected injuries may be caused.**

# Safety Instructions

---

## WARNING

**Sound the horn for signaling before starting slowly.**

Check the surroundings and give a signal to remind the workers around of safety before starting the machine slowly.

[If not]

**Person injury may be caused.**

## WARNING

**Do not carry anyone else.**

Do not carry anyone else in the machine or let others come close during driving.

[If not]

**Unexpected injuries may be caused.**

## WARNING

**Do not operate the range shift lever while ascending or descending a slope.**

Do not stop the machine or operate the auxiliary shift lever while ascending a slope.

[If not]

**The machine may run backward and cause accident.**

## CAUTION

**Pay attention to the gravity center of the machine on an inclined ground.**

Get off the machine and operate on the ground if the angle of inclination at any points in the front/rear or left/right side of the combine exceeds 10 degrees.

[If not]

**The machine may loss balance, fall over and cause injuries.**

# Safety Instructions

## **⚠ CAUTION**

**Adjust the speed according to road and working condition.**

Do not turn the machine abruptly while ascending or descending a slope.

Pay attention to the machine width and turning space for the rear part for the driving performance may be affected by its working status and road conditions. Turn slowly while driving on a slope or uneven ground.

Avoid the cavity, groove, ditch or other obstacles that may cause the machine to fall over if any.

[If not]

**Accident may be caused.**

## 5. Precautions for loading/unloading

### **⚠ DANGER**

**Use gangplanks of sufficient length, width and strength for loading/unloading**

The gangplanks should be firm, secure and provided with anti-skid measures, be inclined less than 15 degrees when put on the truck frame, and have a length over 4 times of the frame height.

[If not]

**Accident may be caused.**

### **⚠ DANGER**

**Make sure the ramp boards are parallel and stable while loading/ unloading**

Be sure to hook the ramp boards stably and reliably in parallel.

[If not]

**The machine may loss balance, fall over and cause injuries.**

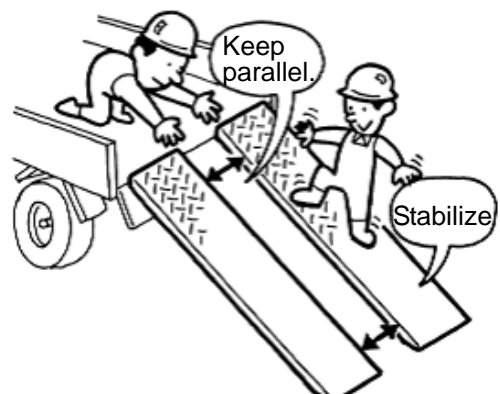

# Safety Instructions

## **⚠ DANGER**

### **Put non-slipping blocks against wheels of the truck for loading/unloading**

Turn off the engine, put the main shift lever to "1" or "R" position, and lock the parking brake, and add non-slipping blocks against the wheels.

[If not]

**The truck may slide, fall over and cause accident.**

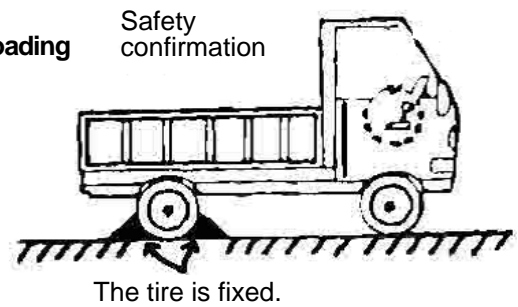

## **⚠ DANGER**

### **Arrange an assistant for loading/unloading**

An assistant should be arranged and the surroundings be checked before loading/unloading. Never allow the assistant to stand in front of or behind the machine. Be sure to perform loading/unloading on an open and even ground.

[If not]

**The machine may fall over.**

## **⚠ DANGER**

### **Never change the direction of traveling on lamp boards.**

[If not]

**The machine may fall over.**

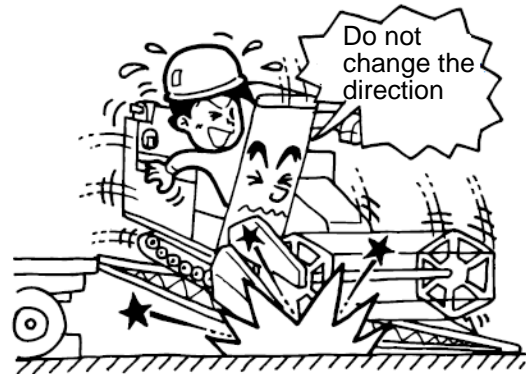

## **⚠ WARNING**

### **Turn off the engine and lock the parking brake during transportation.**

Be sure to turn off the engine and lock the parking brake of the combine during transportation by truck.

[If not]

**The machine may fall off the truck and cause accident during transportation.**

# Safety Instructions

## **⚠ WARNING**

### **Fix the machine on the truck with rope**

Put a rope with sufficient strength on the rope hook of the combine to fix it securely with the truck.

[If not]

**The machine may fall off the truck and cause accident during transportation.**



## 6. Precautions for operation

### **IMPORTANT**

#### **Pay attention to the power lines during operation or driving.**

The driver/operator may get an electric shock once the machine is in contact with the power line. 3m space should be kept in front of and right above the machine to avoid electric shock.

[If not]

**Heavy casualties may be caused.**

### **⚠ DANGER**

#### **It is prohibited to perform manual threshing in the same position for a long time.**

Remove straw accumulated in the rear part timely or move the machine during manual threshing.

[If not]

**Straw may generate heat and cause fire as a result of heat of the exhaust pipe.**



### **⚠ DANGER**

#### **Never allow anybody to come close to the machine in operation.**

Pay full attention to the surroundings, and especially do not allow children to come close to the machine during operation. Be sure to sound the horn, pay attention to the surroundings, and do not perform the sack loading/unloading while turning or reversing.

[If not]

**Fatal or major injury accident may be caused.**

# Safety Instructions

## **⚠ WARNING**

Do not try to clean the threshing section or other moving parts during operation.

[If not]

The sickle may be struck away and cause personal injury.

## **⚠ WARNING**

Be sure to keep slightly away from the harvesting section and feed a little crop while manual threshing.

Do not stand in front of the harvesting section. The assistant should sit in the driver's seat and be prepared for turning off the engine. Put the harvesting section and reel to the highest position and lock them. Roll up your cuff, and do not wear gloves or put the towel around your head, neck or waist.



[If not]

You may be rolled in the machine and injured.

## **⚠ WARNING**

Turn off the engine before removing blockage from the machine.

Be sure to turn off the engine and lock the brake pedal removing any blockage in the harvesting and threshing sections.

[If not]

Unexpected injuries may be caused.



# Safety Instructions

## **⚠ WARNING**

### **Do not get under the machine.**

Never get under or put your hands or feet under the machine. Put on the harvesting lock lever while checking.

[If not]

**The harvesting section may fall down unexpectedly and cause injury.**

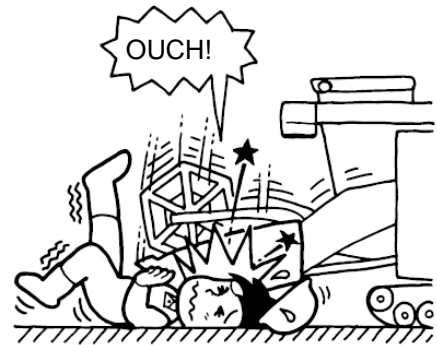

## **⚠ WARNING**

### **Remove straw on the engine, exhaust muffler pulley timely.**

Remove straw, dust and fuel on the engine, exhaust muffler and pulley regularly.

Especially, do the cleaning around the exhaust muffler after it works of deep field.

[If not]

**Straw or dust may be ignited and cause fire and burning.**



## **⚠ WARNING**

### **Drive at the lowest speed in a right angle while crossing a ridge.**

Do not cross the ridge in an inclined angle, but in a right angle to the ridge.

[If not]

**The machine may fall over and cause injury due to loss of balance.**

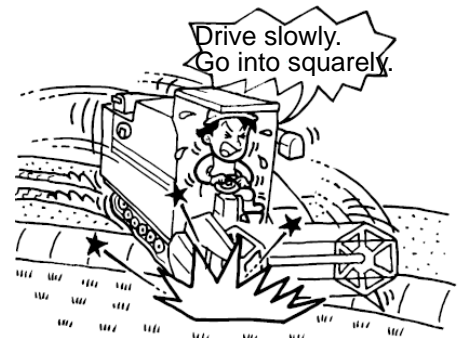

## **IMPORTANT**

### **Beginners should start from slow-speed operation.**

Beginners or less killed operators are recommended to put the main shift lever to "4" or lower gears to prevent collision. Set the main shift lever in the "High Speed" position and pay full attention to crop and field conditions after becoming skilled.

[If not]

**The harvesting performance may be affected, and the machine may be damaged.**

# Safety Instructions

## IMPORTANT

**Turn off the engine before removing dust on the engine dust screen.**

Turn off the engine, check the dust screen and radiator, and use soft brush to remove dust on the screen if any. At the same time, the air filter and the filter in the front part should be cleaned.

[If not]

**Overheating may be caused.**

## IMPORTANT

**Add lubricant, diesel oil and other oils as specified to ensure normal operation of the machine.**

[If not]

**Failures may be caused.**

## CAUTION

**Use working lamp for night work**

Use the working lamp during night work.

[If not]

**Accident may be caused due to difficulty in grasping the operating condition.**



## IMPORTANT

**Do not work in rainy or foggy days or when the crop water content is relatively high.**

[If not]

**Blockage, mechanical loss and failures may be caused by operation with high water content.**

# Safety Instructions

## 7. Precautions for maintenance and storage after operation

### IMPORTANT

**Perform inspection and maintenance after operation.**

After completion of operation, clean the machine, perform inspection and maintenance, and then check the tools. Do not leave the tools on the machine to avoid damages.

[If not]

**Accident may be caused due to poor maintenance.**



### IMPORTANT

**Store the machine on a level ground.**

Store the machine on a level ground, lower down the harvesting section, and lock the brake pedal.

[If not]

**The combine may move and cause accident.**

### **⚠ DANGER**

**Do not put on the machine cover before it had been cooled down.**

Let the engine cool down before storing the machine in an enclosure or covering it with a sheet.

[If not]

**Fire hazard may be caused.**



## 8. Precautions for checking and maintenance

### **⚠ DANGER**

**Do not open the radiator cap before it had been cooled down.**

Do not touch the muffler, radiator, engine or other high temperature parts before they had been cooled down completely.

[If not]

**Hot water may spurt and burn you.**

Note the burn.



# Safety Instructions

---

## IMPORTANT

**Load and unload the battery in the correct order.**

Connect the anode firstly, and then connect the cathode when installing the battery.  
Disconnect the cathode firstly, and then disconnect the anode when unloading the battery.

[If not]

**Burning and fire may be caused due to short-circuit.**

## IMPORTANT

**Use the designated battery only.**

Be sure to use the battery of the capacity specified in the Operator's Manual for replacement when necessary.

[If not]

**Burning and fire may be caused due to short-circuit.**

## WARNING

**Be sure to turn off the engine and lock the brake pedal during checking and maintenance.**

Turn off the engine, lock the brake pedal, and put non-skid device under the pulley before checking and maintaining the machine on an even ground.

[If not]

**The combine may move suddenly and cause accident.**

## WARNING

**Be sure to check and maintain the brake.**

It will be very dangerous if the brake does not work.

Be sure to perform inspection and maintenance of the brake on a regular basis.

[If not]

**Fatal or injury accident may be caused, and the machine may be damaged.**

# Safety Instructions

## **⚠ WARNING**

**Be sure to check the control levers.**

Check whether there is obvious loosening or deviation in the main shift lever and other control levers.

[If not]

**The machine may not be driven normally and cause fatal and injury accidents or damages.**

## **⚠ WARNING**

**Adjust the brake properly.**

Adjust the brake to the best condition, or order the maintenance for your purchase place if it cannot be adjusted.

[If not]

**Fatal or major injury accident may be caused.**

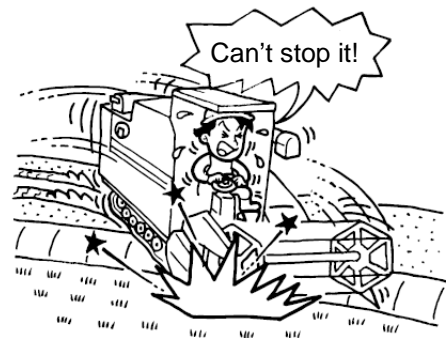

## **⚠ WARNING**

**Do not touch the rotating shaft and parts**

Do not touch the rotating shaft or parts while the engine is operating.  
Confirm all parts have stopped rotating before maintenance.

[If not]

**Major injury may be caused.**

## **⚠ WARNING**

**Do not touch the high-pressure leaking oil.**

[If not]

**Oil may penetrate into your skin and cause serious burning and other personal injuries.**

# Safety Instructions

## **⚠ WARNING**

### **Keep the removed parts properly.**

Keep the removed parts properly, and do not allow children or any authorized persons to come close to the storage place.

[If not]

**The parts may bruise their hands or feet or cause other accidents.**

## **⚠ WARNING**

### **Dispose the wastes generated by the combine to avoid environmental pollution.**

The wastes (oil, cooling water, filter and battery) generated by the combine during harvesting are hazardous and may pollute the environment. Therefore, they should be handed over to relevant departments of environmental protection for proper treatment, but not be discarded directly. In addition, no tableware should be used for storage of waste to avoid being eaten by mistake.

[If not]

**Environmental pollution or personal injury may be caused.**

## **⚠ CAUTION**

### **Wear heavy gloves while replacing the cutting blades.**

[If not]

**Your hands may be scratched.**



## **⚠ WARNING**

### **Keep the removed parts properly.**

Keep the removed parts properly, and do not allow children or any authorized persons to come close to the storage place.

[If not]

**The parts may bruise their hands or feet or cause other accidents.**



# Service and Warranty

## Warranty card

The warranty card is required for receiving after-sale services. Therefore, keep it properly.

## When the machine runs abnormally

Specify the following information and contact your YANMAR dealer if the abnormality still exists after you perform inspection and treatment as instructed in the chapter "Trouble Shooting" on Page 94.

### <Content of contact>

- Model number and manufacture number of the machine
- Engine number
- How do you use the machine?  
(At what a speed you run the machine?)
- How long have you used the machine?  
(How much area or how long?)
- Explain the problems as detail as possible

Machine identification plate

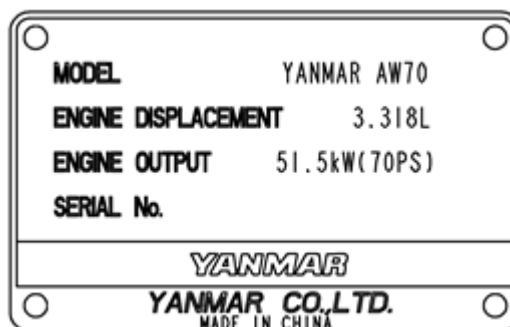
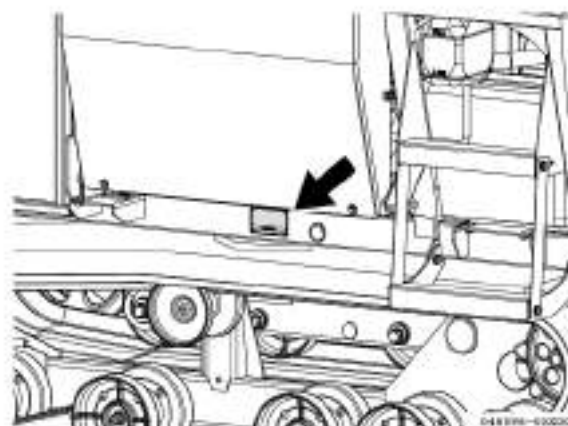

Engine identification plate

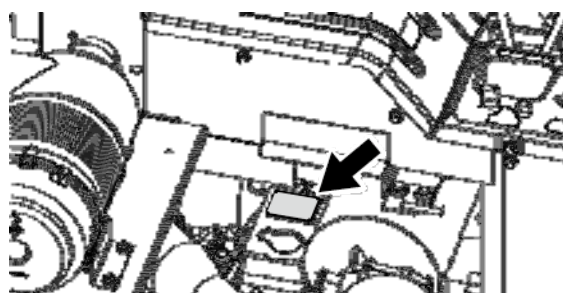

# ***Service and Warranty***

---

## **Spare Parts Availability**

Usually, spare parts for maintenance of this machine will generally be available for five years after production is discontinued. However, the delivery term of some special parts should be determined through consultation within the supply period. In principle, supply of spare parts is to be suspended after expiry of the above-mentioned period. If supply of spare parts is requested after the specified period, the term and price of delivery should be determined through consultation.

## **Genuine Parts and Oil**

Genuine parts certified by us have been rigorously tested and must pass a strict quality inspection. They can be used with confidence. When replacing parts, be sure to use the designated genuine parts.





# Name of parts

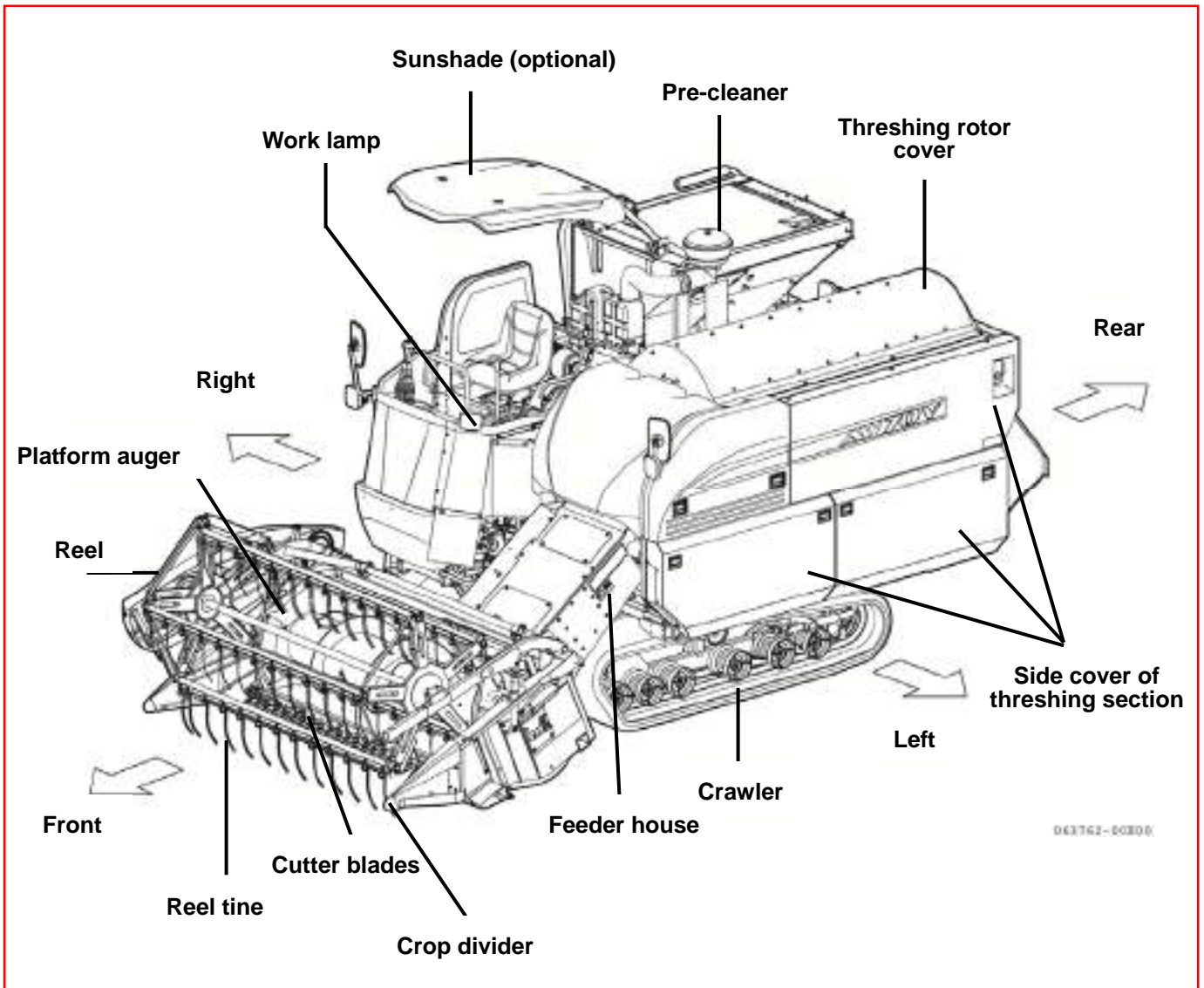

# Name of parts

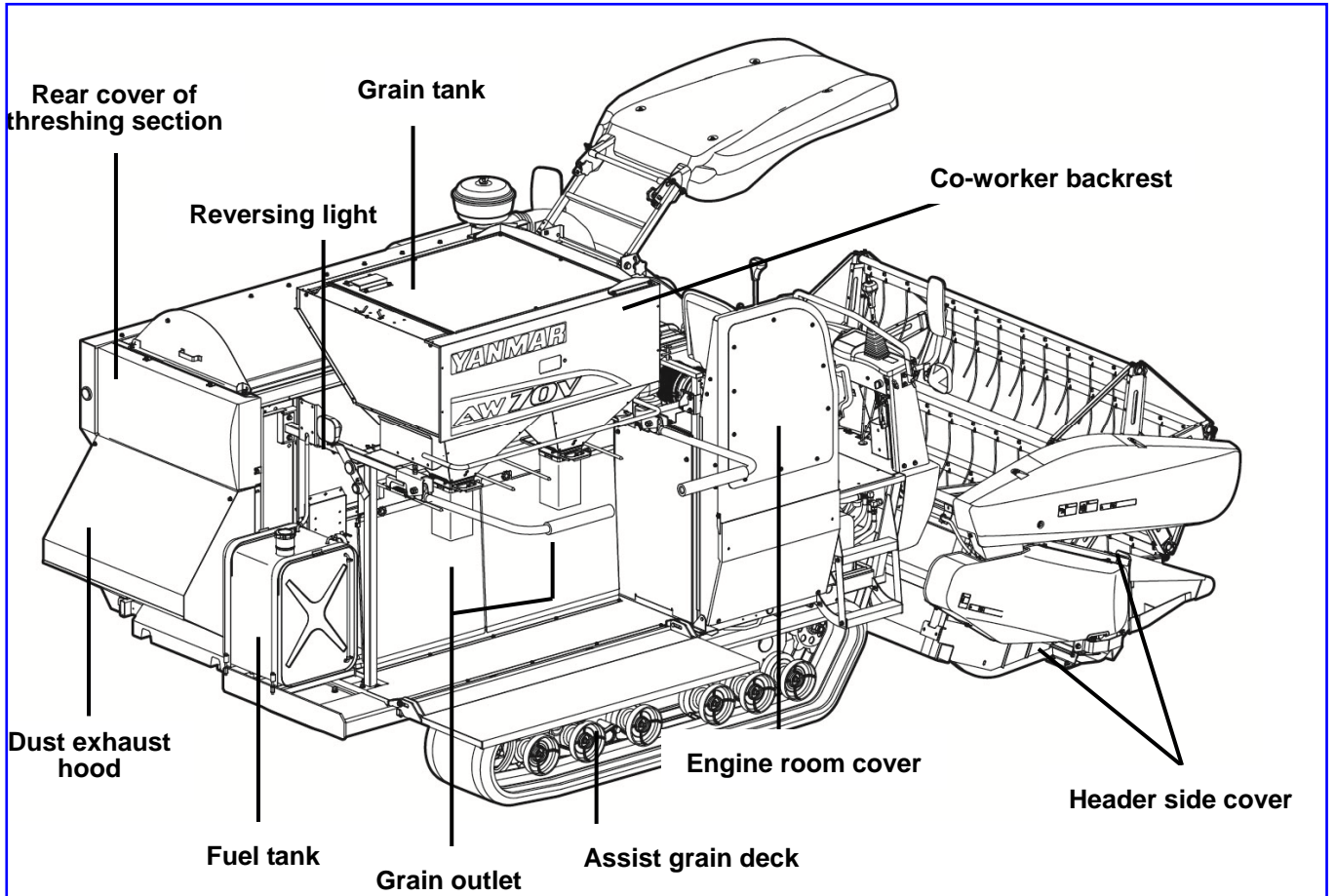

# Name of parts

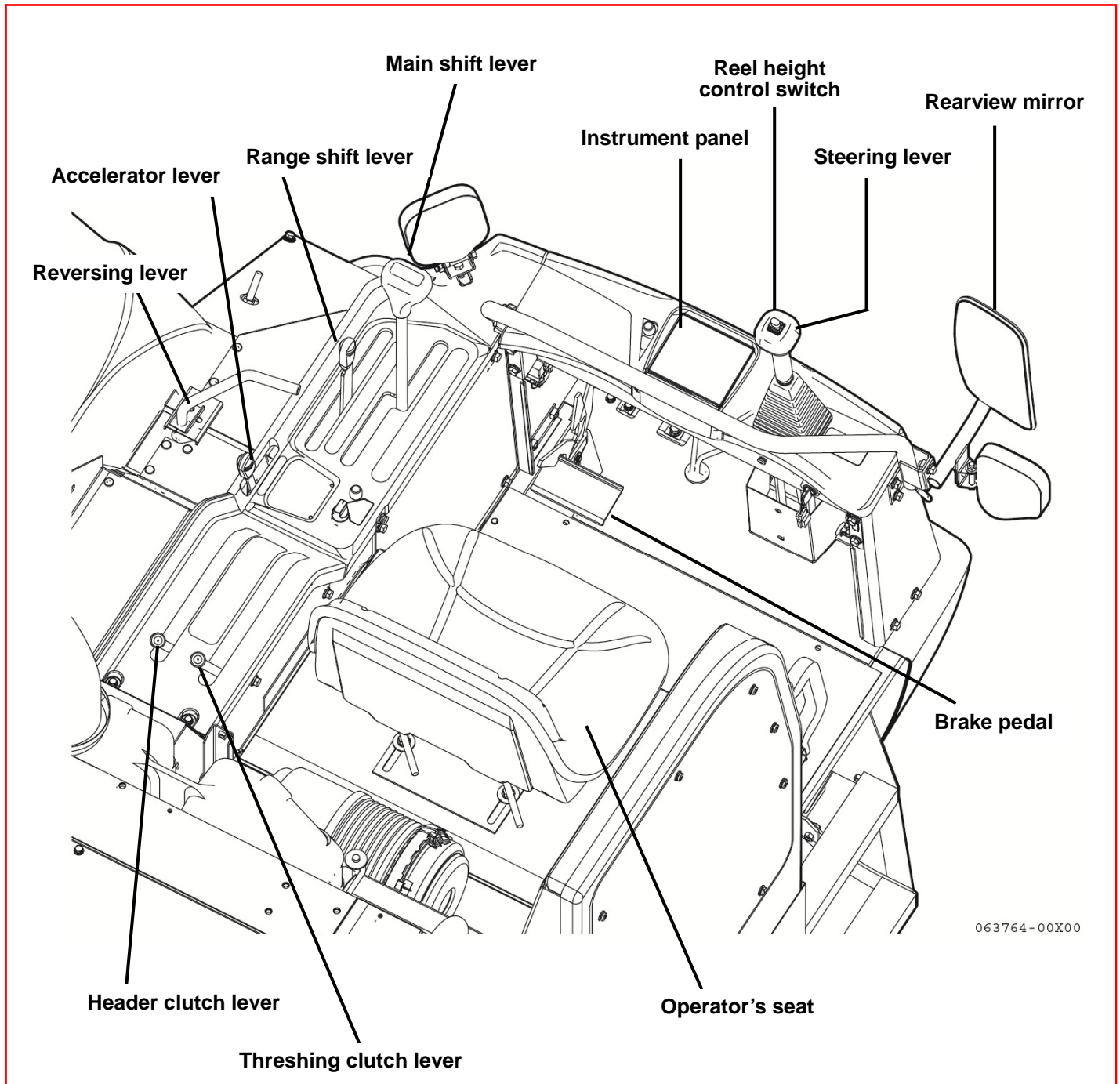

# Attachment position of safety labels

The attachment positions of safety labels for your safe operation are shown below.

The safety labels should be kept clean and complete, and be replaced with new ones in case of damage or loss.

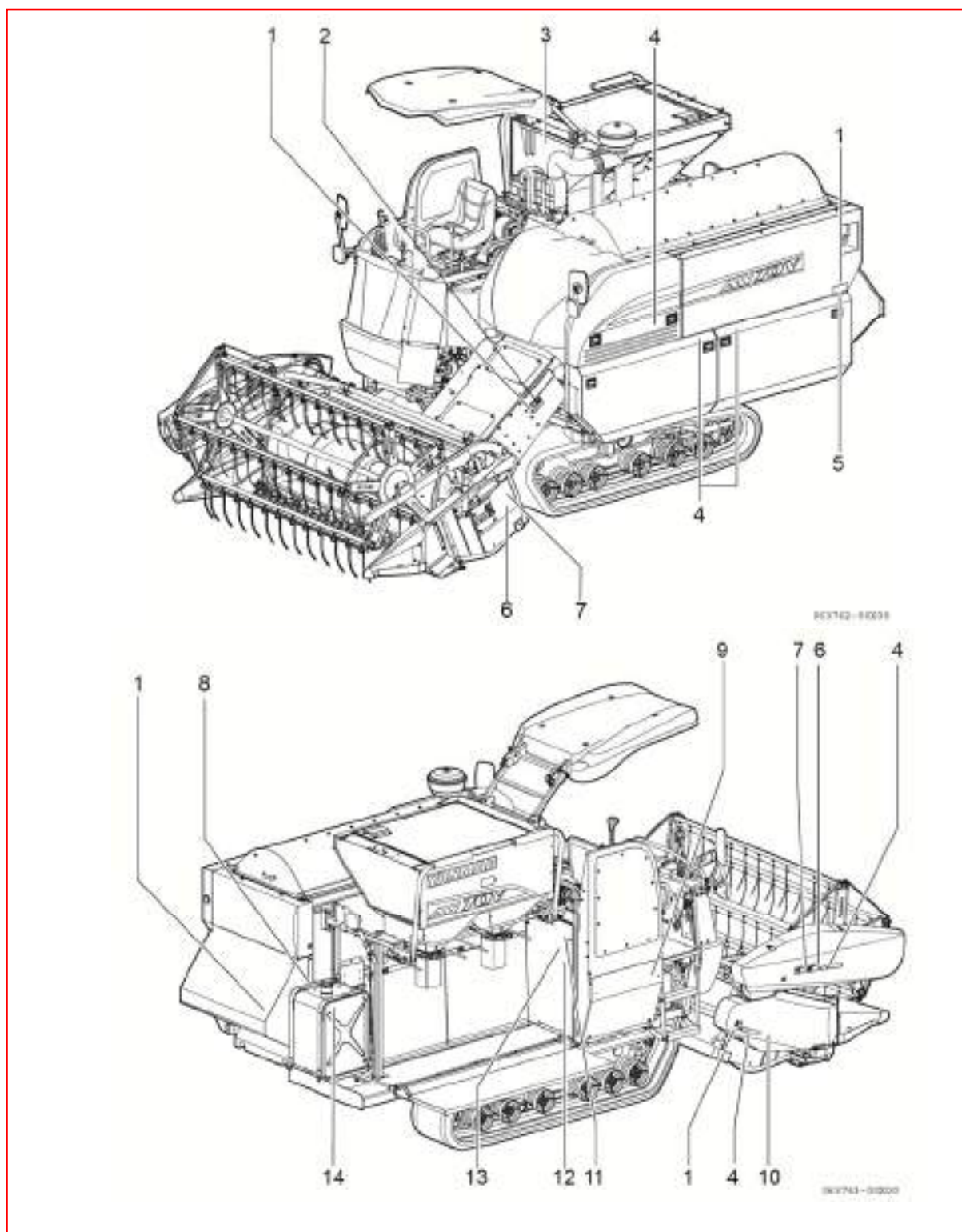



# Attachment position of safety labels

1



2



3

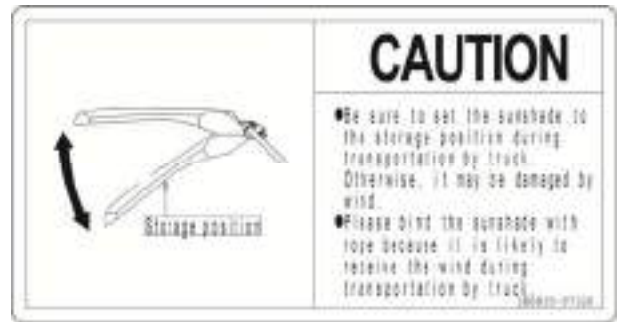

4

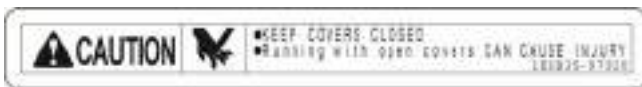

6



5

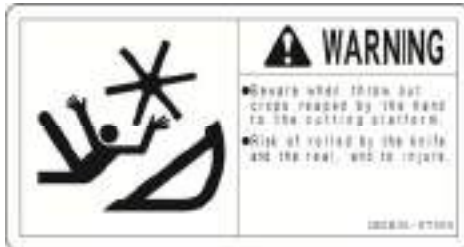

7



8



9



11

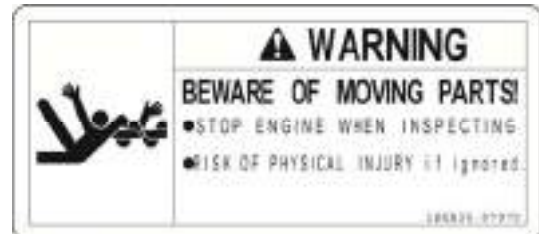

10

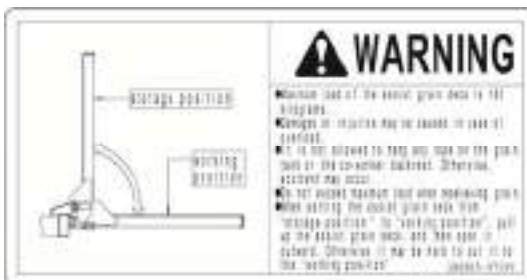

13



12

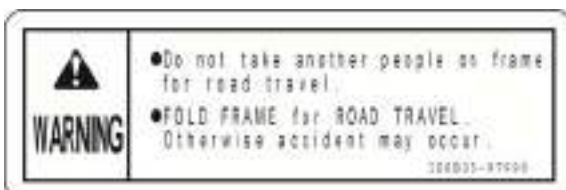

14



## ***Attachment position of safety labels***

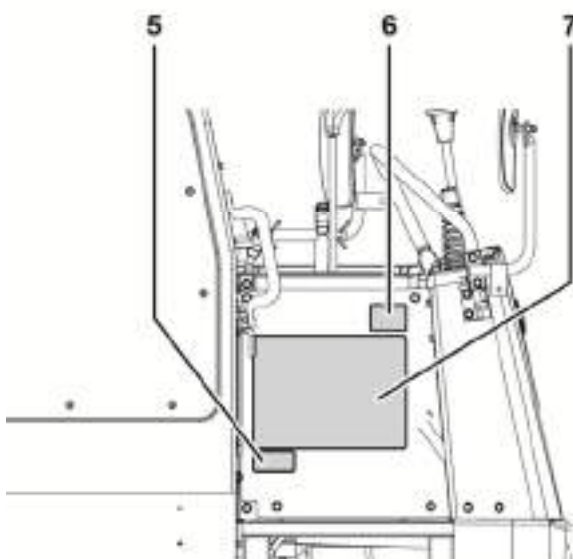
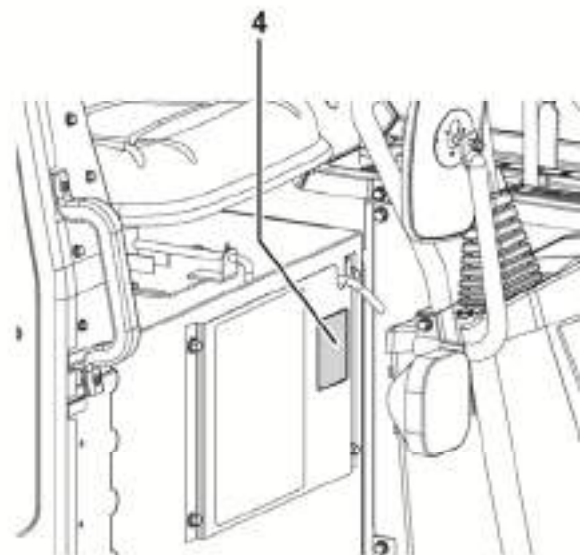
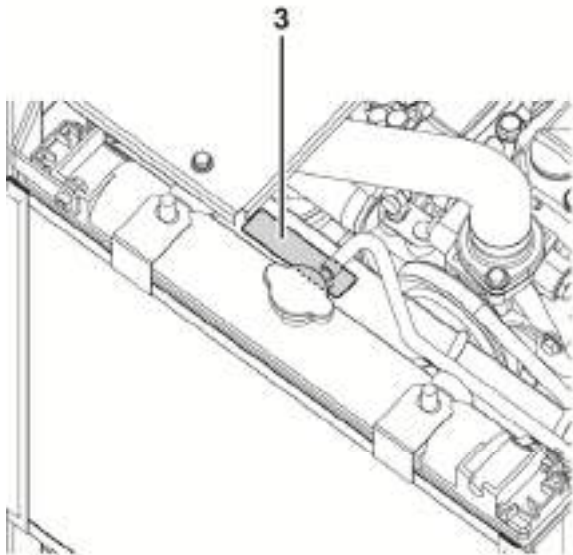
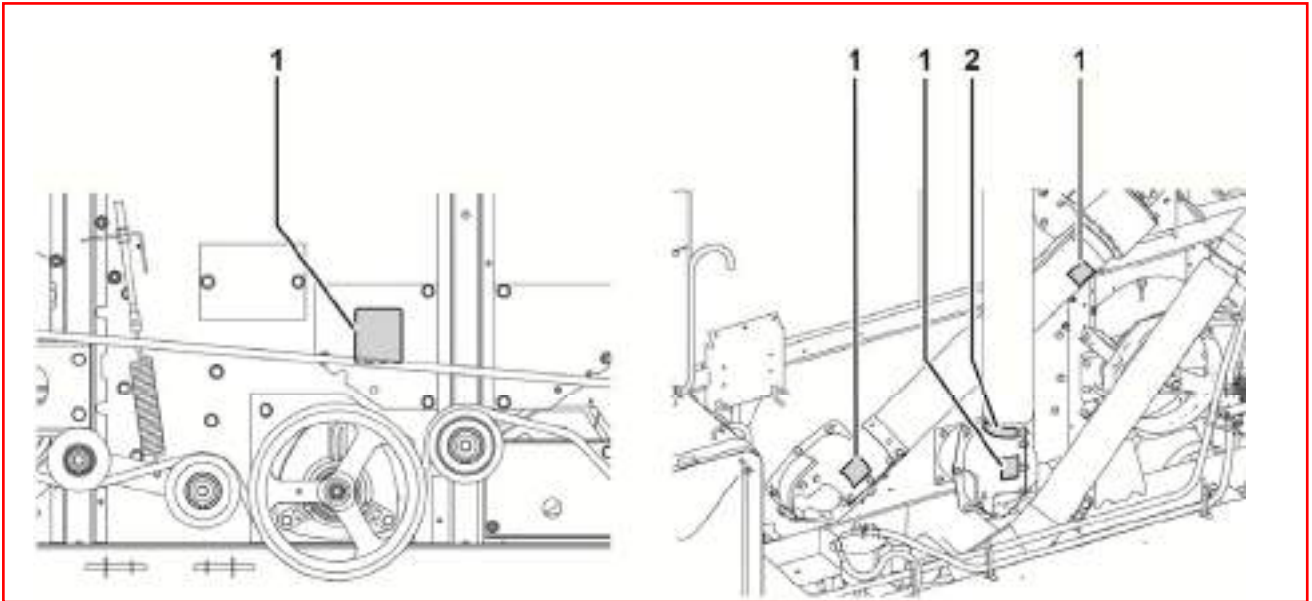

# Attachment position of safety labels

1



2



3



4



5

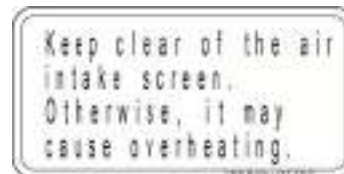

6



7

**CAUTION**

**Starting and starting the machine**

- To avoid the injury, before starting up the engine, move the main shift lever to "N" position, the brake clutch lever to "off" position, the throttle clutch lever to "off" position, the key switch to "off" position, and then, secure the horn and confirm the safety, and then, depress the brake pedal and start the engine.

**Traveling on the road**

- Follow the warning as instructed on the operators manual.
- Give the driver, front seat and the operator's seatbelt before traveling.

**Working on the field**

- Follow the warning as instructed on the operators manual.
- When traveling, move the head clutch lever to "on" position of the throttle clutch lever to "off" position, confirm the safety and avoid the injury.

**Loading, unloading and crossing the ridge**

- Follow the warning as instructed on the operators manual.
- Do not change the direction on the gangplank.
- When loading or unloading by using the gangplank, get off the machine and operate.
- When crossing the ridge or wide canal, use the gangplank.

**Checking and maintenance**

- Be sure to stop the engine during working.
- Geting away from the machine.
- Be sure to lock the brake pedal.

**PRECAUTION**

- When starting up the engine, move the main shift lever to "N" position and depress the brake pedal. (The engine can not start when the brake pedal is not depressed.)
- When stopping the engine, the key switch is "off" position and lock the brake pedal.
- When working, adjust the engine rpm in the green zone of the instrument panel, and adjust traveling speed by the main shift lever.
- When changing the range shift, lower down the main shift lever to "N" position and change the shift. You must to depress the brake pedal except for changing the shift on the slope.
- Slow down the speed when turning on the road.
- Do not use the range shift lever "R" position during working. It may cause the trouble.

**HOW TO WORKING IN COLD REGION(PREHEATING OF MACHINE)**

1) Depress the brake pedal and then fix it with brake lock.	2) To traveling and repress clutch levers on "off" position.	3) Move the throttle lever to "low" position, and start engine and then slowly warm-up.	4) Move the accelerator lever to "high" position, and then slowly up the throttle lever to "low" position.	5) Take off the brake pedal, and moving the main shift lever 2-3 times then moving the accelerator lever to "high" position, and begin to work.

Specified transmission oil  
**YANMAR TF500(or TF300)**  
Failure may be caused if using any other products.

Specified hydraulic oil  
Water-resistant hydraulic oil VGHSINO56  
Failure may be caused if using any other products.

Checking the slow blow fuse  
The slow blow fuse protects electric system by cutting off. When not powered on, check the operators manual.

How to use the brake pedal  
Start-up the engine: Depress the brake pedal.  
Parking: Put the brake lock.

126B35-97960

# Function of parts

## Engine control section

### 1 Key switch

The key switch is used to start up the engine.

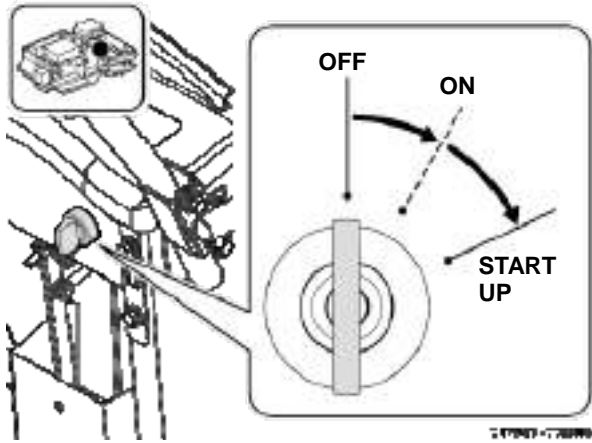

“OFF”:  
Used to stop the engine.  
All this position, no current flows  
and the key can be pulled out.

“ON”:  
Current flows through the switches  
of electrical parts. The oil pressure  
and charging indicators are lit when  
the engine stops.

“START UP”:  
The starter motor rotates to start up  
the engine. Release the key  
immediately after start-up of the  
engine. The key will automatically  
return to the “ON” position for  
continuous operation.

### 2 Accelerator lever

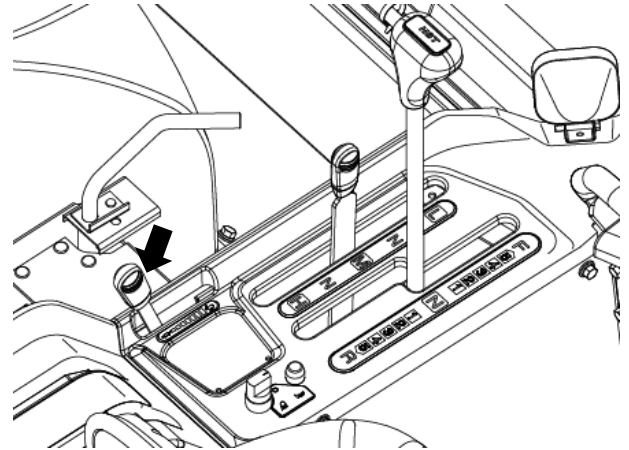

The accelerator lever is used to regulate the engine speed. Pull the lever backward and push it forward, the engine speed will decrease and increase respectively.

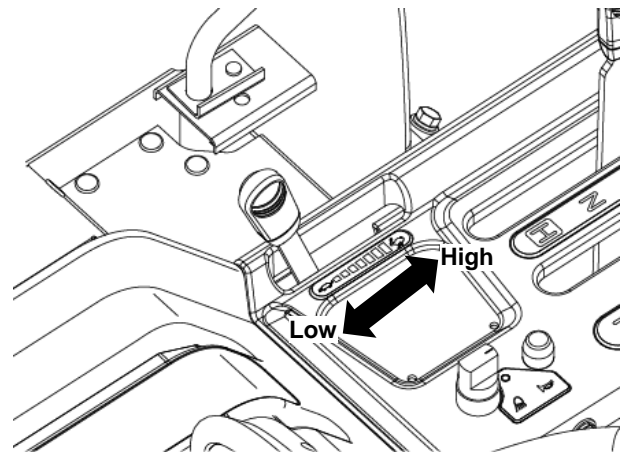



# Function of parts

## Operation-related section-1

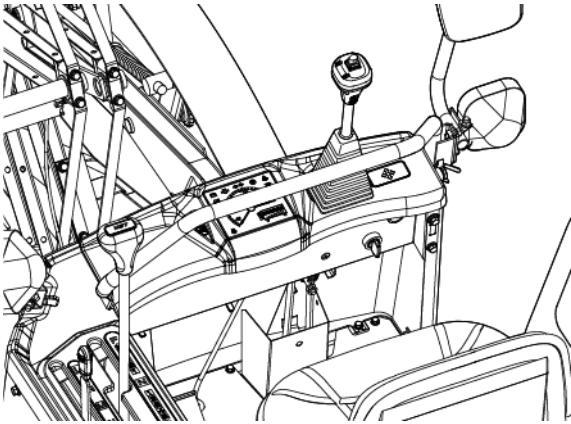

### 1 Steering lever

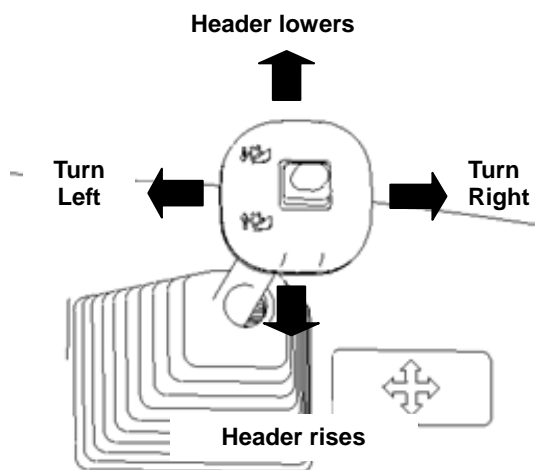

After start-up of the engine, push the steering lever forward, and the header will be lowered; pull the lever backward, and the header will be raised. During traveling, the machine will turn left and right by moving the lever left and right.

### [Precaution]

Be careful to prevent the machine from leaning forward when moving the steering lever left or right while traveling. Otherwise, the header may descend and the crop divider may touch the ground to cause damages.

### 2 Direction switch of reel

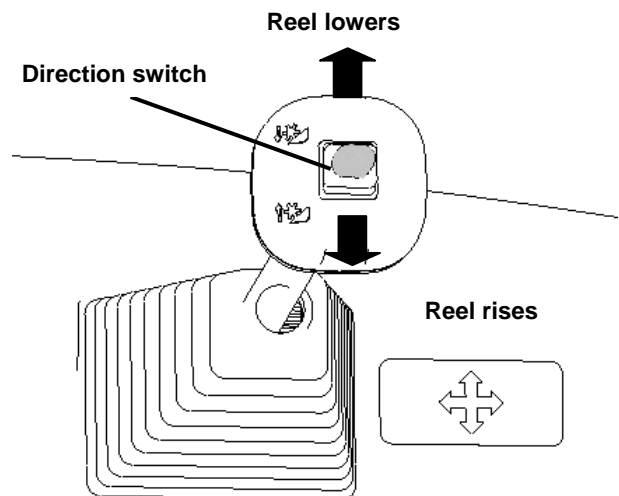

Move the direction switch forward, and the reel will descend; move the switch backward, and the reel will ascend.

# Function of parts

## Operation-related section-2

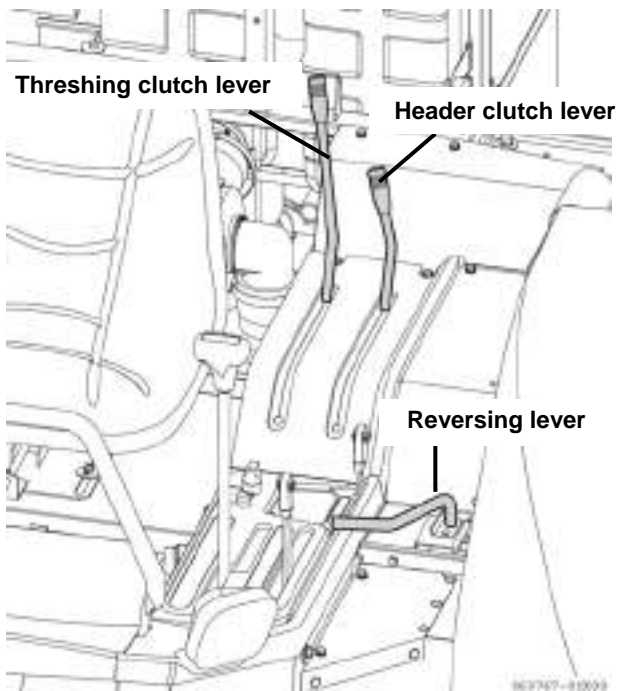

### 3 Header clutch lever

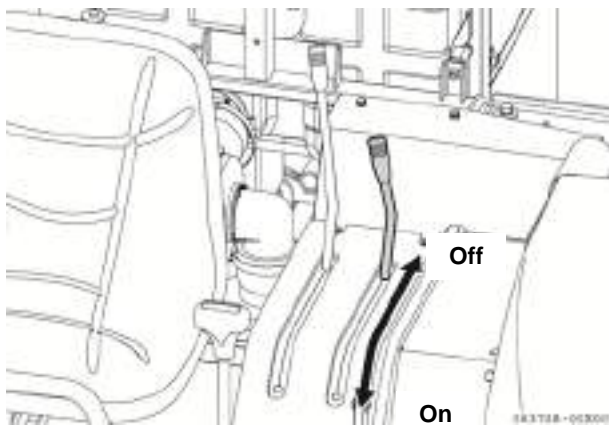

The reaping section (header) will start working if the header clutch lever is pulled to "ON". The section will stop working if the threshing clutch lever is set to "OFF".

**[Precaution]**

Adjust the engine speed to "Low" before operation of the harvesting clutch lever; and regulate the speed to normal after the lever is put to "ON". The threshing clutch must be engaged before engagement of the header clutch, and be disengaged in the reverse order.

### 4 Threshing clutch lever

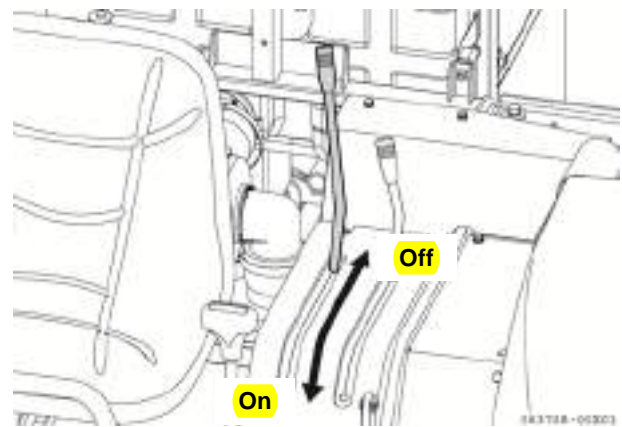

Pull the lever to "ON", and the threshing section will start working; pull it to "OFF", and the section will stop working.

**[Precaution]**

Adjust the engine speed to "Low" before operation of the threshing clutch lever; and regulate the speed to normal after the lever is put to "ON"

### 5 Reversing lever

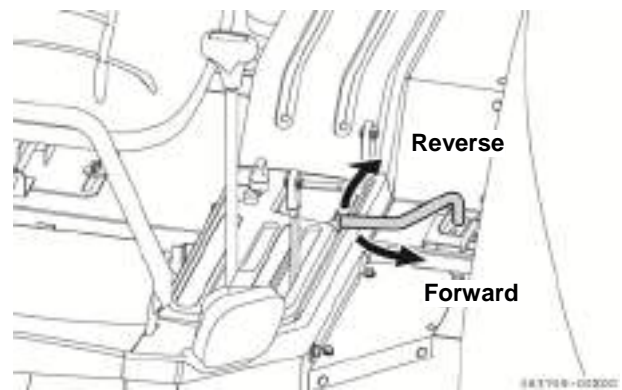

The reaping section (header) and the feeding chamber will give loud noise or the harvesting section will stop working or otherwise fails if the section and chamber are blocked by straw during harvesting. In this case, use the lever to reverse the harvesting section to remove obstacles

**[Note]**

- Switch the reversing lever after turning off the header clutch.
- Use reversal function by the engine idling speed.

# Function of parts

## Traveling section

### 1 Main shift lever (HST)

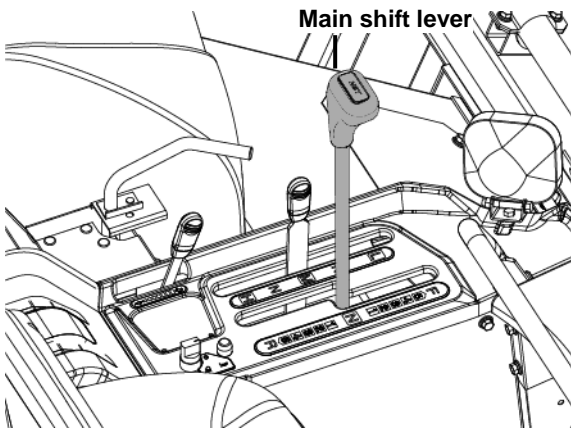

The main shift lever is used to move the machine forward or backward during traveling. You can push the lever to enable step-less speed change.

### 2 Range shift lever

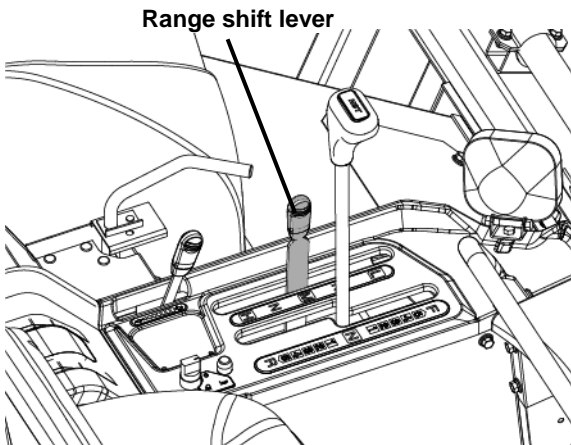

This lever provides three gears, namely "L" (Low), "M" (Middle) and "H" (High) according to the purpose and conditions of operation.

#### [Precaution]

- Be sure to put the main shift lever to "N" in advance.

Do not change the speed on a slope.

LとN間のストッパーに関する記述削除

### 3 Brake pedal

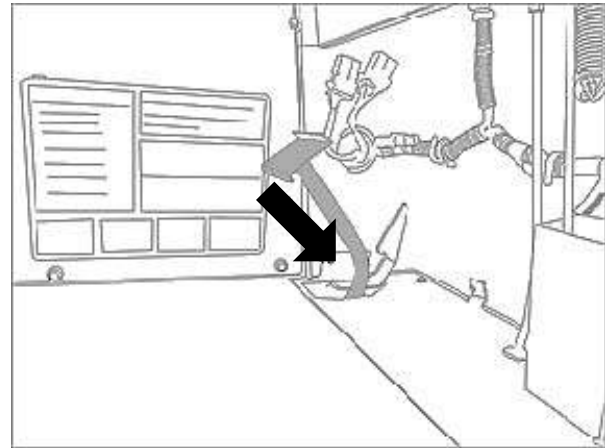

Step the brake pedal for emergency stop of the machine in traveling.

### 4 Brake pedal lock

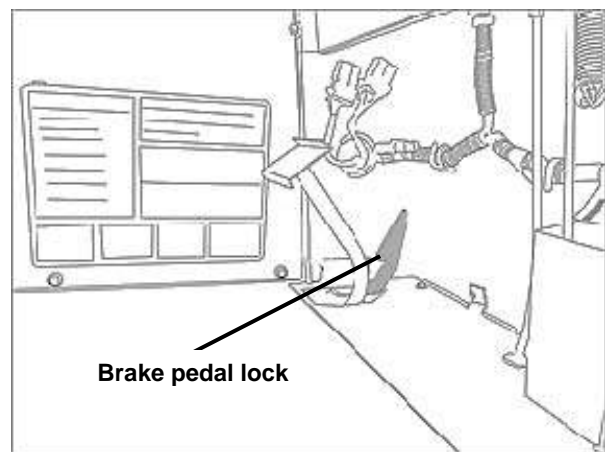

Step the brake pedal and engage the pedal lock to completely stop the machine. This lock can be released by stepping the pedal to the floor.

# Function of parts

## Electrical section

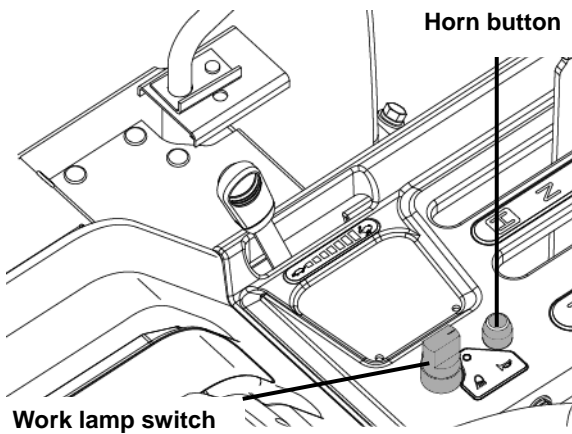

### 1 Work lamp switch

Pull the key switch to "ON", and turn the working light switch clockwise, the head light and work lamp for the feeder house, reaping section and the rear part will be lit simultaneously.

### 2 Horn button

Pull the key switch to "ON" and press the horn button, the horn will give sound.

### 3 Buzzer stop button

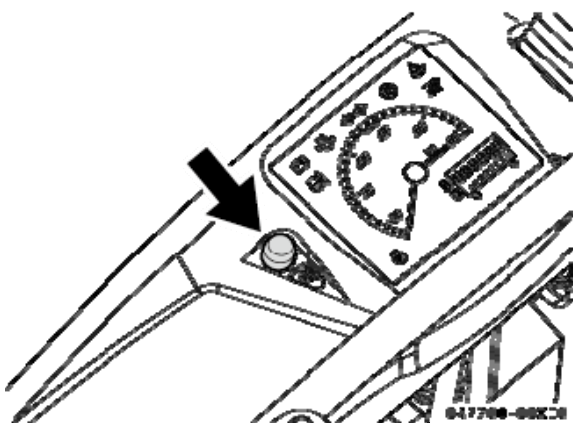

This button is used to stop the alarm buzzer.

## Alarm indicators



The indicators are the alarm devices for abnormalities in various parts during operation, through which, or together with the buzzer, the abnormal parts can be indicated.

### 1 Charge indicator

This indicator will be lit if the battery is not charged during operation of the engine.

### 2 Oil pressure alarm

This indicator will be lit when the pressure of engine lubricant decreases.

### 3 Water temperature alarm

This indicator will be lit and the buzzer will give sound when the temperature of engine cooling water rises abnormally.

### 4 Full grain tank alarm

This indicator will be lit and the buzzer will give sound when the tank is filled with grain.

### 5 2nd conveyer blocking alarm

This indicator will be lit and the buzzer will give sound when the revolving speed of secondary auger is lower than the rated level.

# Function of parts

## 6 Warm-up



Pull the key switch to and remain it in "ON", this indicator will be lit. The engine can be started up after the indicator is off.

## Fuel level indicator

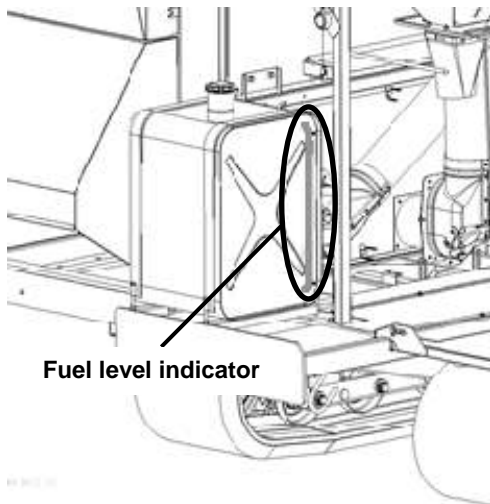

This indicator is used to display the fuel level in the fuel tank.

## Tachometer

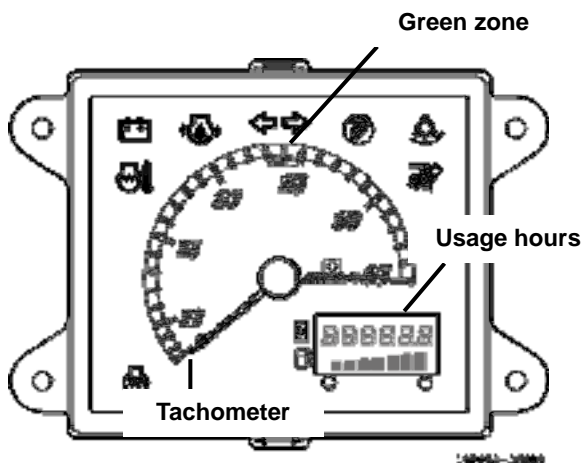

This meter is used to indicate the speed and Usage hours of the engine. Do not change the engine speed, and remain the hand in the green zone during operation.

## Others

### 1 Operator's seat

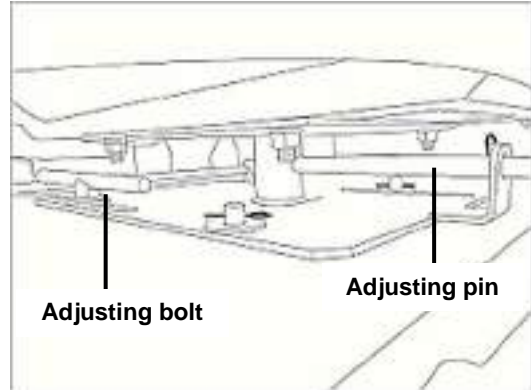

Move the adjusting pin, and loosen the bolt to adjust the seat up and down to the position easy for operation.

### 2 Engine room cover lock lever

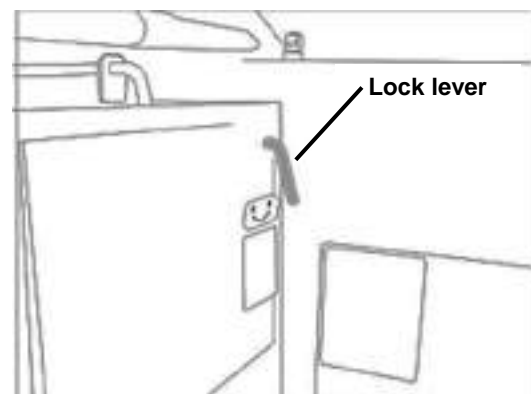

Open the engine room cover with force.

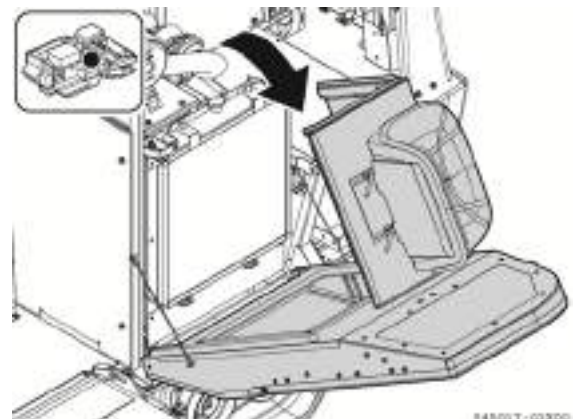



### 3 Safety lock of header

#### **⚠ WARNING**

When checking, maintaining and adjusting the lifted header, be sure to use the safety lock to prevent unexpected fall of the header. Otherwise, personal injury may be caused.

[Precaution]

- Raise the header to the highest position.
- Pull of the pin on one end of the safety lock, and secure the end on one end of the oil cylinder shell.
- Replace the lock after inspection, maintenance and adjustment.

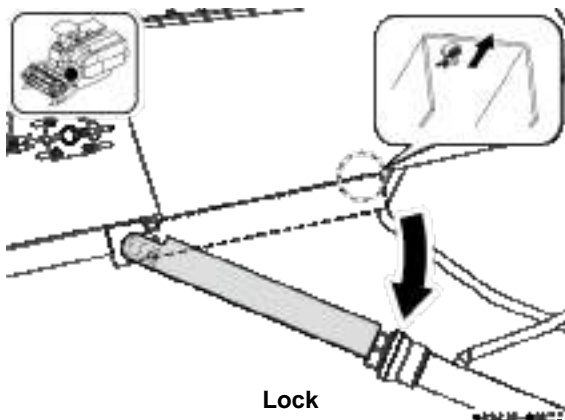

### 4 Co-worker backrest

Press the fixing lever and pull down the backrest to the setting position.

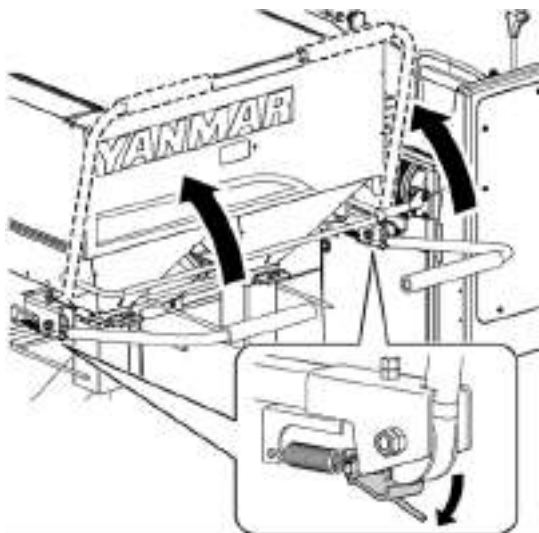

# Driving

## 1. Pre-operation checks

### **⚠ DANGER**

- Never refuel or lubricate with the engine at high temperature.
- Keep all smoking and naked bulbs away while handling fuel.
- Shut the fuel cap and wipe off spilled fuel immediately, when refilled. Otherwise, fuel or oil may catch and cause a fire.

### **⚠ WARNING**

- Be sure to turn off the engine, and lock the brake pedal before check and maintenance.
- When checking and maintaining and adjusting, put the machine on a firm level surface. Otherwise, it may result in injury.
- When checking and maintaining and adjusting, stop the engine and apply parking-brake. Otherwise, it may result in injury by rolled in.

### **⚠ CAUTION**

- Install covers that were once removed for checking. Otherwise, it may result in injury by rolled in.

Check the machine before daily operation to ensure safe and comfortable work.

Check in the following order:

#### **1 Abnormal parts in previous day**

In case of any abnormal parts in the previous day, check whether they will affect operation.

Perform check, maintenance or repair of the abnormal parts before operation.

#### **2 Around the machine**

- Check any damaged or contaminated parts and loose bolts.
- Clean and check tension of the track section, and add lubricant.

#### **3 Operation the engine room**

- Quantity, cleanness and leakage of engine oil.



- Fuel quantity and leakage or water leakage if any.

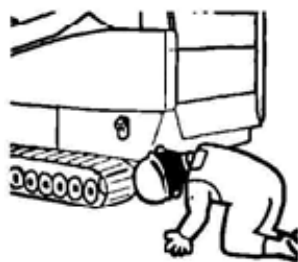

- Cooling water quantity and leakage, and any damage to the hose.



- Dirt in the air filter and pre-cleaner of engine.



# Driving

- Tension and damage of cooling fan belt.

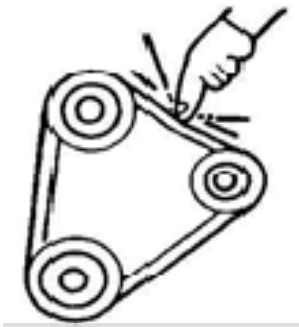

- Dust and dust on the dust screen of radiator, oil cooler and in the engine body.



- Damage of wire harness and loose connection



## 4 Operator's seat

- Functioning of indicators, instruments and switches



## 5 Starting the engine

- Abnormal sound after start-up of engine



- Color of exhaust gas



- Functioning of clutches and switches

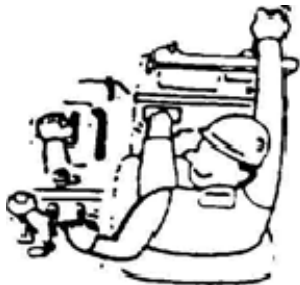

- Functioning of brake pedal



- Functioning of steering lever





## 2. Starting and stopping the engine

### **⚠ WARNING**

- Low-speed drive, and start rapidly or neither rapid turn nor never stop rapidly.
- Do not high-speed drive in the road where a lot of slopes, ruggedness, and curves exist.

### **⚠ CAUTION**

- When starting, it signals to surroundings, and it starts while confirming safety slowly.
- When being working and moving, the helmet is worn for safety.

### Starting the engine

1- Put the main shift lever and range shift lever to "N".

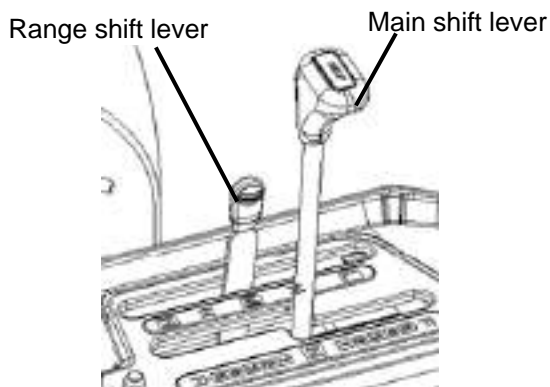

2- Pull the threshing clutch lever and header clutch lever to "OFF".

- The engine cannot be started up if the two levers are set in the "ON" position.

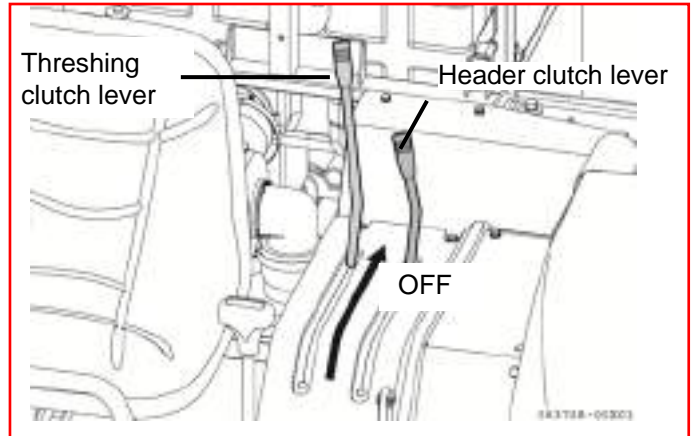

3- Set the accelerator lever to "Low".

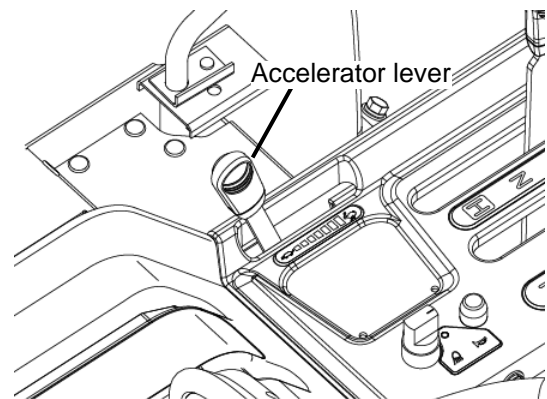

4- Step the brake pedal to the floor, and pull the key switch to "Start".

- The safety switch will not work and the engine can not be started up if the brake pedal is not stepped to the floor.

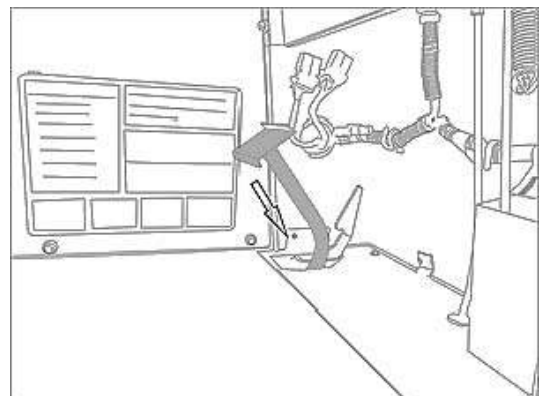

# Driving

- 5- Release your hands quickly from the key switch after start-up of the engine. Both the oil pressure indicator and the charging indicator will be lit before start-up, and will go out immediately after start-up.
- 6- Put the accelerator lever to "Low", and add no load within 5 minutes after start-up of the engine. (Be sure to warm up the engine)

## [Precaution]

- Do not use continuously for over 10 seconds as large current is required for starting up the engine. (If the engine is not started up within 10 seconds, shut down the switch, wait for one minute, and then repeat the operations in step 4)
- Do not pull the key switch to "Start" during operation of the engine. Otherwise, the machine may be damaged.

## Starting the engine under cold condition

- 1- Operate as instructed in steps 1to3 "Starting the engine".
- 2- Turn the key switch to "ON".
- 3- After the warm-up indicator on the instrument panel is off, Step the brake pedal to the floor quickly, and turn the key switch to "Start".

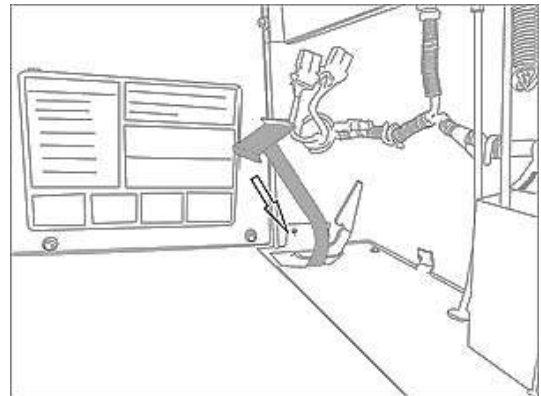
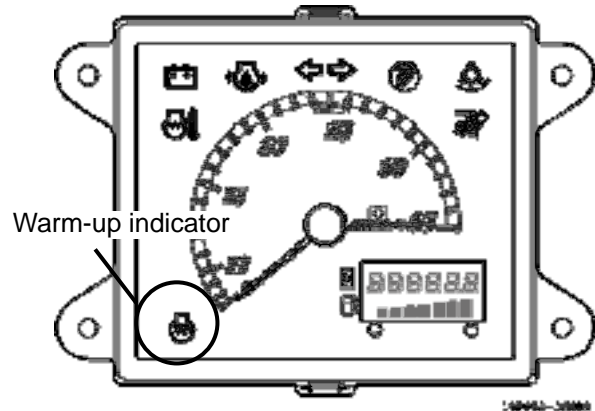

## Stopping the engine

- 1- Put the accelerator lever to "Low".

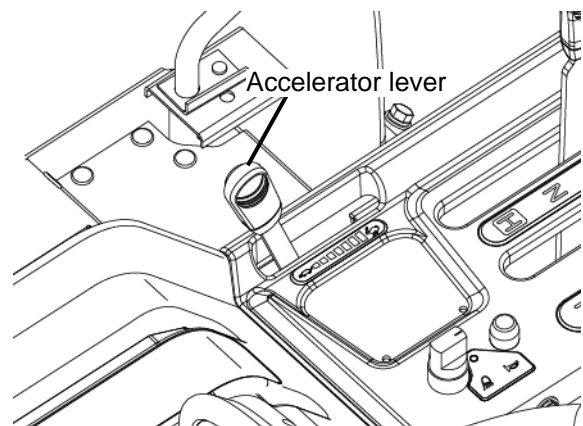

- 2- The engine will be stopped after the key switch is turned to "OFF".

## 3. Starting, turning and parking

### **⚠ WARNING**

- Check the around the machine before starting the machine.
- Wear the safety helmet during operation and moving for your safety.
- Be sure to warm up the engine after start-up of the engine for operation under low temperature.

### Starting

- 1- Start the engine.
  - 2- Increase the engine speed by the accelerator lever.
  - 3- Raise the header.
  - 4- Put the range shift lever to the appropriate position.
- Operate the main shift lever and range shift lever only after the engine speed is over 1600 rpm.
- 5- Push forward the main shift lever from "N" slowly to move the machine.

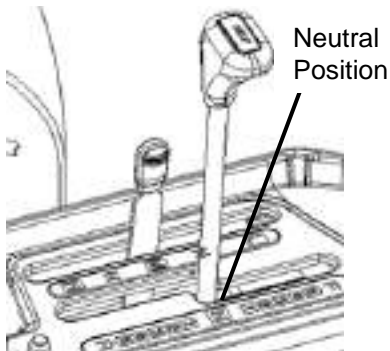

### [Precaution]

Move the main shift lever from "Forward" to "Reverse" or from "Reverse" to "Forward" after the machine is completely stopped. The machine may be damaged if the lever is operated before the machine is completely stopped.

### Turning

Move the steering lever to the side of turning, and the machine will turn to the corresponding direction.

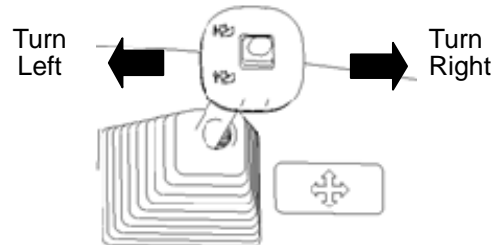

### Stopping and parking

- 1- Put the main shift lever to "N".
- 2- Put the range shift lever to "N".

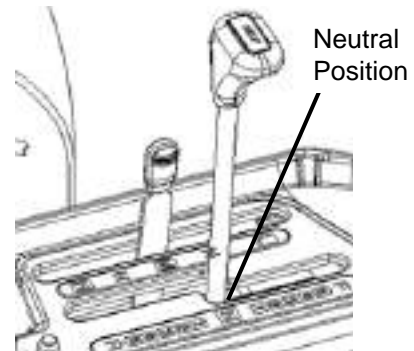

- 3- Lower down the header.
- 4- Pull the accelerator lever to "Low".
- 5- The engine will be stopped after the key switch is turned to "OFF".

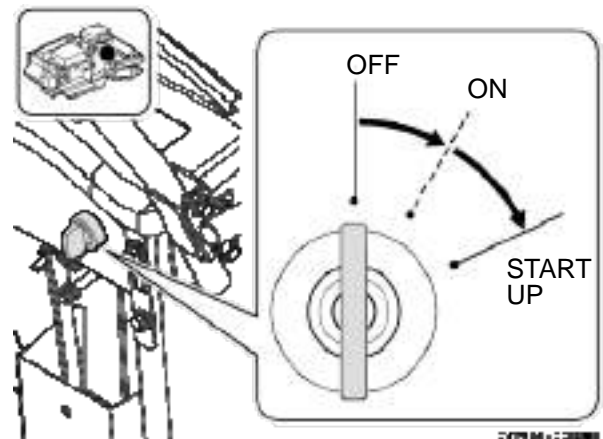

- 6- Turn off the key for your safety.
- 7- Be sure to engage the brake pedal lock before leaving the combine.

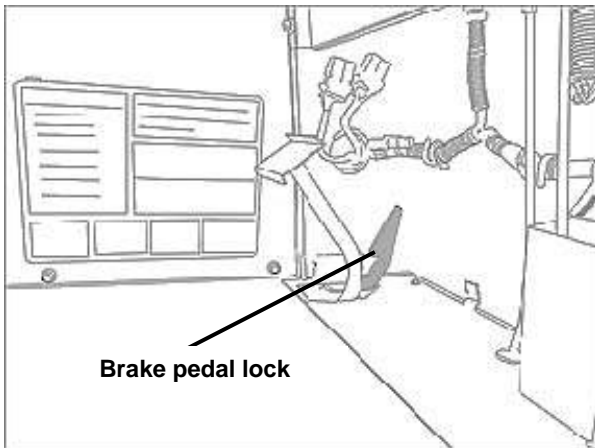

## Emergency stopping

- 1- If emergency stopping is required while the main shift lever is in "Forward" or "Reverse", step the brake pedal to the floor, and the machine will be stopped.
- The linked main shift lever and brake pedal will return to "N" automatically.

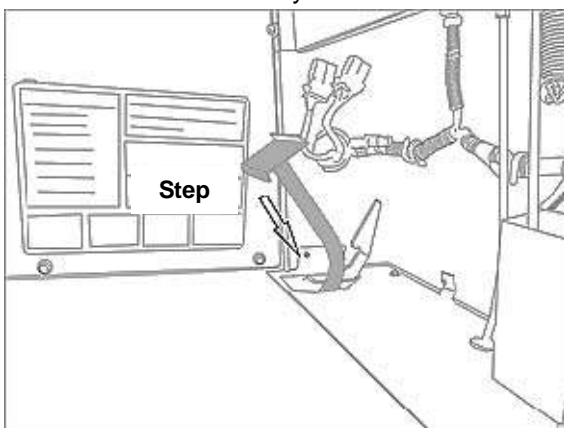

### [Precaution]

- Main shift lever can not return to "N", and the machine can not be stopped if the brake pedal is not stepped to the floor.
- Emergency stopping has only the function of a traveling. Neither a threshing part nor a header part stops.

## 4. Traveling

### ⚠ DANGER

The center of gravity of this machine rises when there is a paddy in the grain tank, there is fear of the fall, and it is very dangerous. Empty the tank.

### ⚠ WARNING

- No person other than the driver is allowed to get on the machine.
- Do not drive the machine on a ground with an inclination over 10 degrees in the four directions. Otherwise, the machine may fall over.
- Check the surroundings before starting.
- Wear the safety helmet for your safety.
- Pay full attention to the road side and drive slowly on a slope, narrow road or those road segments with thick growth of grass.
- When changing the direction of traveling, be sure to give hand signals, and notify the moving direction of others or the machine.
- Avoid long-distance traveling that may cause damage to the crawler.

- 1- Fold the co-worker backrest upward and retract it.
- 2- Withdraw the assist grain deck.
- 3- Put the threshing clutch lever and header clutch lever to "OFF".
- 4- Raise the engine speed by the accelerator lever.

### [Precaution]

Be sure to adjust the engine speed to the point that tachometer hand falls in the "Green Zone". Otherwise, the machine may be damaged.

- 5- Raise the header from the ground to 30cm or more..
- 6- Put the main shift lever to "N" and the auxiliary lever to the appropriate position.
- 7- Check the surroundings when starting, push forward the main shift lever slowly to raise the speed gradually.

## 5. Loading/unloading on truck

### **⚠ WARNING**

- Do not change the moving direction on gangplank. Otherwise, the track may break away from the gangplank to cause fall-over.
- An even and safe place without hazardous materials around should be selected for loading/unloading.
- Secure the ramp boards hook to avoid height difference with the truck body.
- Do not stand in front of or behind the combine to prevent dangers caused by sudden sliding.
- Be careful of the sudden change in gravity center when the combine crosses the joint between gangplank and truck. The machine may fall over especially when the moving speed is high. So put the auxiliary shift lever to “Low” and move slowly.  
(Preparation of truck)
- The parking brake of truck should be locked, and anti-skid devices be placed against the wheels.

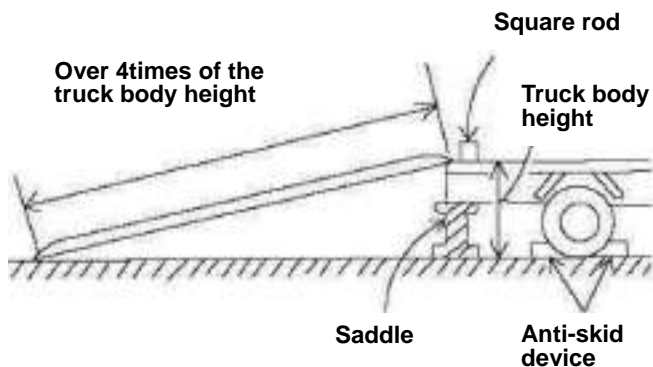

- Use proper saddle to support the rear part of truck body to ensure the body strength.

- Gangplank specification
  - Length: Over 4 times of truck body height
  - Width: Over 45cm
  - Strength: Able to bear loads over 3000kg
  - Surface should be roughened and can not be too smooth. There should be no sharp angles to prevent damaging the track.

#### [Note]

- Operate as specified for traveling above.
- Put the range shift lever to “Low”.
- Be sure to adjust the engine speed of the tachometer in the “Green Zone”.
- Perform loading/unloading slowly in the direction of lamp boards. Return to original position and adjust the direction of the track deviates from the lamp boards.
- Step the brake pedal to the floor in case of sudden stalling of engine or emergency stop.
- Step the brake pedal and apply the pedal lock after loading on truck. Fold the sunshade after engine stalling.
- Perform loading/unloading in the moving directions listed below.

		Moving direction
Traveling direction	Loading	Forward
	Unloading	Reverse

### **⚠ WARNING**

- Secure a strong rope on the “rope hook” of the combine.
- Be sure to keep the traveling direction of combine in line with the direction of lamp boards to make the track pass through the center of lamp boards during unloading of the combine. Additionally, unload the combine slowly.

# Operation

## 1. Conditions of crops and field

The way to reap crops depends on the conditions of crops and breadth of field.

Check them in advance to work efficiently.

### Length of crops

The length of crops suitable for this combine harvester is 30 to 150 cm.

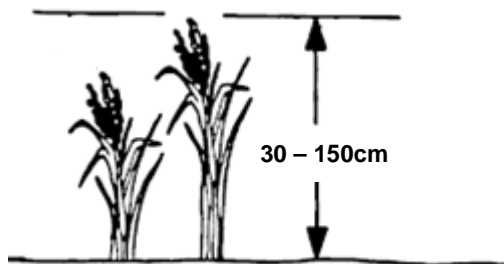

- Raise the header as high as possible to reap crops over 150cm long.
- Descend the header as low as possible to reap crops below 30cm long.

### Moisture of crops

Screening of grain will be affected if crops are not dry. Harvest after crops are sufficiently dry.

### Diseases and insect pests of crops

It is difficult to thresh and clean the crops with diseases and insect pests. In this case, put the range shift lever to "Low" before operation.

### Harvesting time of crops

It's the time to harvest when most of grains and over a half of the spike-stalk become yellow.

There will be more green rice-grain branches and less harvest, and the total loss rate may exceed the national standard if crops are reaped too early. On the other hand, there will be more lodging, sprouting, broken spike, cracked grains and loss if crops are harvested too late.

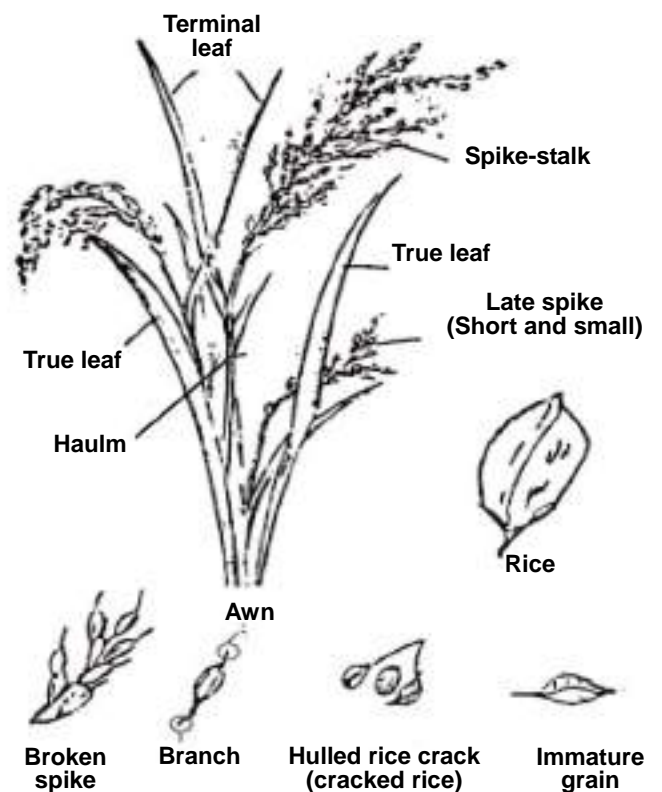

- There will be un-threshed grain (more branches), and the awn of some special varieties can not be removed if the tension of grain and branch is higher than 100g.

# Operation

Determine the direction of harvesting according to the lodging condition of crops.

- Reverse harvesting Lodging angle  $<70^\circ$
- Forward harvesting Lodging angle  $<85^\circ$

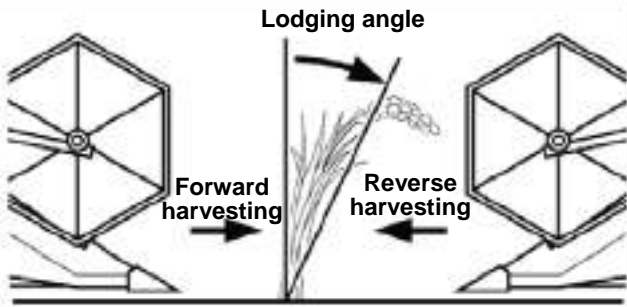

(Range shift lever in "Low")

	Lodged	Leaning	Stand
① Forward harvesting	△	○	◎
② Reverse harvesting	×	△	○
③ Lodging to left	△	△	○
④ Lodging to right	×	△	○

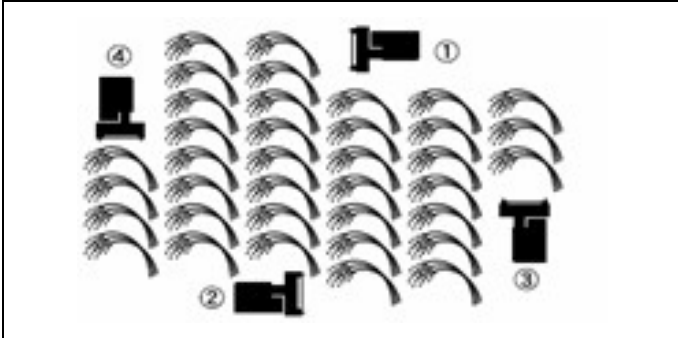

- ◎ ..... Suitable for harvesting
- ..... Take care during harvesting
- △ ..... Take care and harvest slowly
- × ..... Difficult to harvest

- Select the appropriate speed according to crop condition.

## Condition of field

Operation can be started when the plow pan depth is less than 20cm.

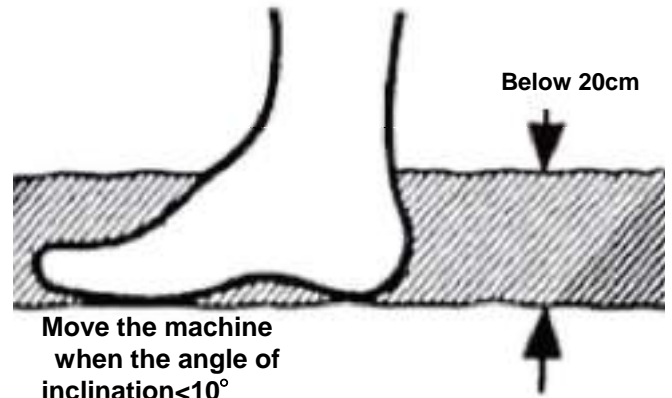

Harvest when the angle of inclination  $<5^\circ$



# Operation

## 2. Field preparation and harvesting

### **⚠ DANGER**

When harvesting, pay full attention to the surroundings. Avoid the access of children. Otherwise, they may be rolled in the moving parts, or collision accident may occur when turning.

### **⚠ WARNING**

- When moving backward, watch out behind the combine harvester and drive slowly.
- In case of abnormalities, turn off the engine immediately, engage the brake pedal lock, and put all work-related control levers to “OFF” before checking.
- Make sure to turn off the engine, engage the brake pedal lock, and put all work-related control levers to “OFF” before removing chaff and straw blockage.
- When working with co-worker (s), use the horn for mutual signaling. Otherwise, accidental injury may occur.
- Never park the combine harvester in the places piled up with chaff. Otherwise, fire hazard may be caused.
- Do not harvest the crops with dew or much moisture. Otherwise, the concave screen may be damaged and can not clean the grain.

### Preparation of field

Check around the field and remove any miscellaneous objects such as stone, steel plate, reed and wood pile before operation. To ensure work efficiency, harvest the four corners by hand as shown below.

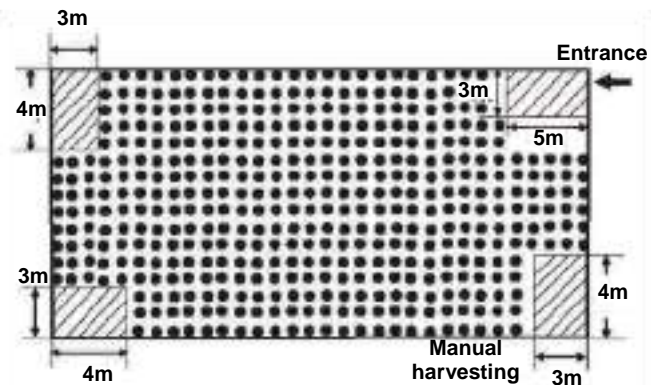

### Efficient working

Skilled operator can reap the four corners by driving obliquely for 3 to 4 times to realize efficient working.

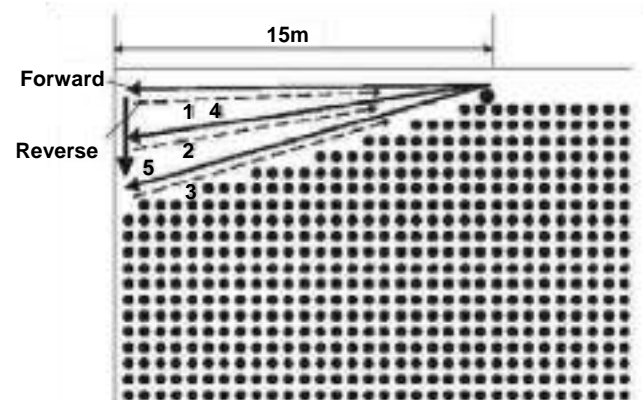

#### [Precaution]

- Perform slant harvesting linearly. The length of straws may be uneven and the threshing performance be affected if the moving direction is changed during harvesting.
- Remove the cobs lodged on the ridge or change the lodging direction to make the ridge visible.



# Operation

## Field harvesting

As a rule, crops should be harvested along the rows in two directions according to the following steps.

1. Turn left by ridge for harvesting.

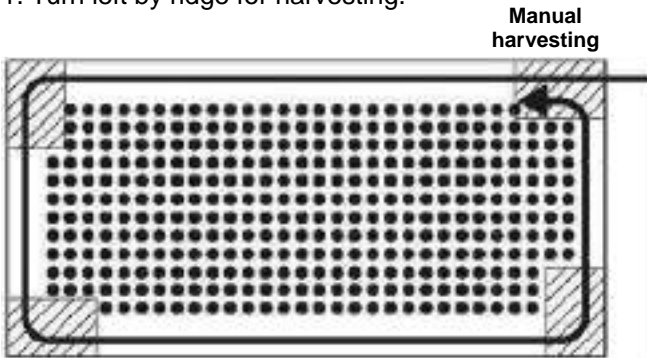

- Harvest completely the areas manually handled.
- If it is hard to harvest as the ridge is too high, reserve 2-3 rows around, and then turn right for harvesting.

2. Turn left for harvesting after reversing.

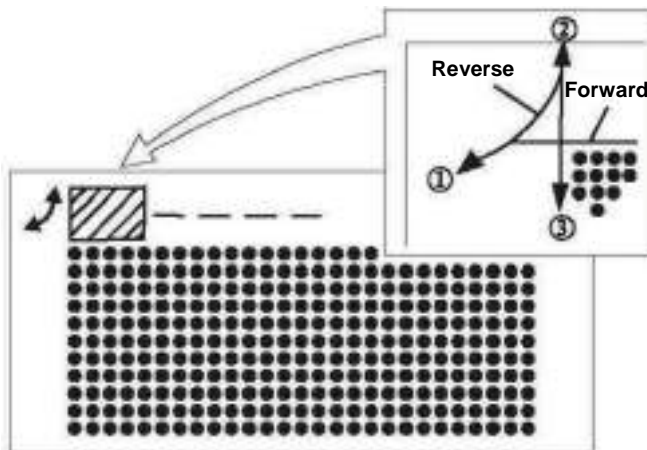

## Bidirectional harvesting (for long field)

3. Harvest in two directions if there is enough space on both ends of the field.

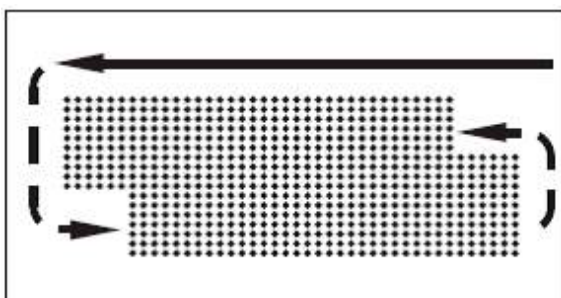

## Harvesting for small field

4. When working in small fields where distance "L" is short, operate the combine by the procedure of the illustration below.

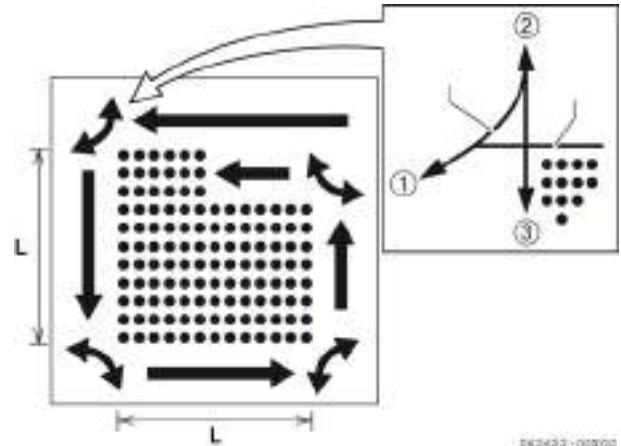

5. Move slowly and turn right to harvest the 2-3 rows reserved by the ridge.

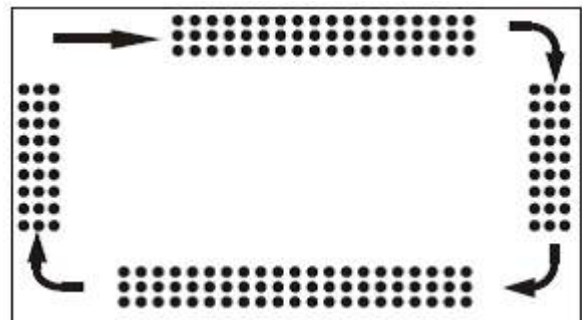

### [Precaution]

- Do not reduce the engine speed when turning. Otherwise, "poor screening" or "blocking" may be caused.
- Take care to prevent the reel from breaking in or running into the ridge during harvesting by ridge.

# Operation

## Harvesting in a broad field

For a broad field, the method of middle harvesting is suggested to improve the harvesting efficiency.

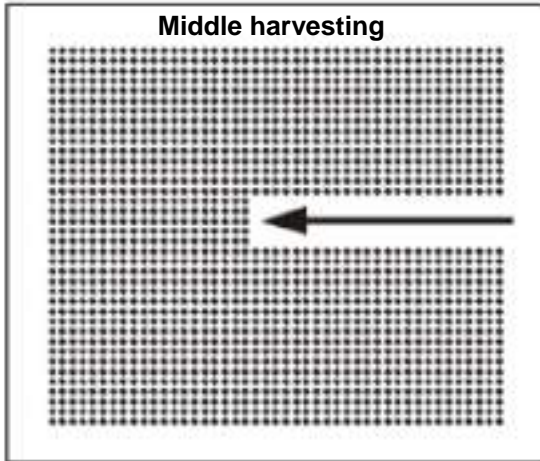

## 3. Preparation before harvesting

### ⚠ WARNING

The Reaping section, conveying chain, cutters, threshing section, drive belt and other moving parts may cause accident or personal injury during cleaning and checking. Therefore, make sure to turn off the engine and engage the brake pedal lock before cleaning and checking.

## Cutter and chain oiling

### ⚠ CAUTION

Be sure to turn off the engine before oiling the moving parts, or personal injury may be caused. Add oil to cutters and chains before operation and every 2 hours during operation.

## Auxiliary assist grain deck and grain bag

### ⚠ WARNING

The auxiliary assist grain deck can bear the maximum load of 180kg. If overloaded, the deck may break and cause personal injuries. Do not pile any filled grain bags on it.

- 1- Raise the auxiliary receiving platform to the operating position.

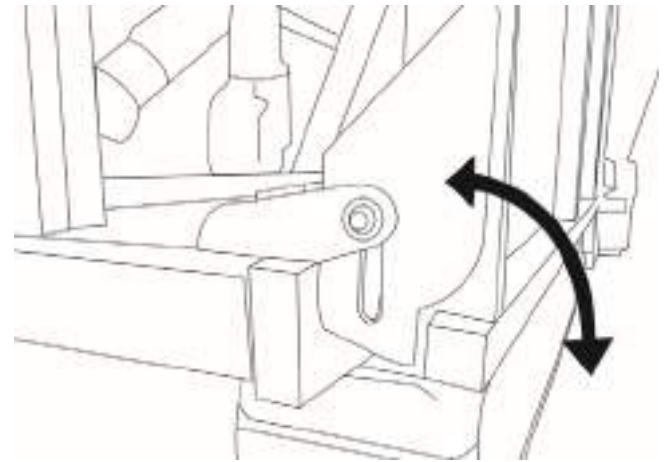

- 2- Hang 20-30 bags on the fixed hooks.
- 3- Mount 1 sack on each outlet.
- 4- Open the grain discharging shutter.

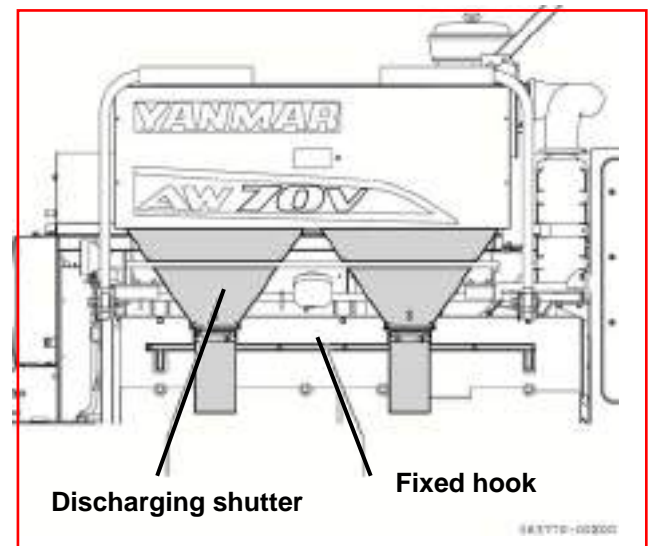

# Operation

## 4. Harvesting

### Moving in and out of the field

#### ⚠ WARNING

- Use the “Forward” gear for ascending and “Reverse” for descending a steep slope, and drive slowly. Otherwise, the machine may fall over.  
Set the range shift lever to “Low” and main shift lever to “1” to cross straightly the ridge.
- Use the ramp boards if the ridge is over 10cm high.

### Harvesting by the ridge

Harvest manually within the areas 30cm from the ridge.

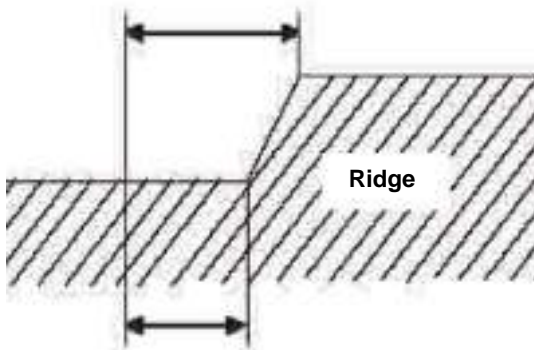

Pay attention to the crops not harvested near the ditch and outside the track.

### Order of operation

#### (1) Adjusting the swing separator pieces

The swing separator is used to separate grains from chaff after threshing. Adjust the angle of chaff sieves of the screen according to the crop variety and threshing condition.

- 1- Remove the left rear cover of the threshing section.
- 2- Unfasten two bolts to take down the cover plate of swing separator.

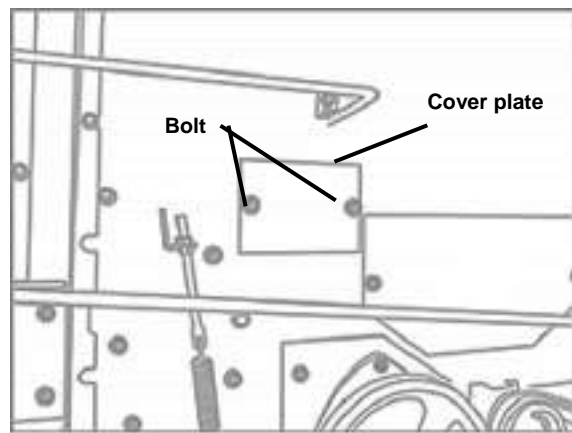

- 3- Turn the chaff sieve clearance adjust lever to change the angle of chaff sieves.

- “Open” In case of heavy loss
- “Standard” Standard rice
- “Close” When the 2nd conveyer outlet is blocked. Grain selection is poor.

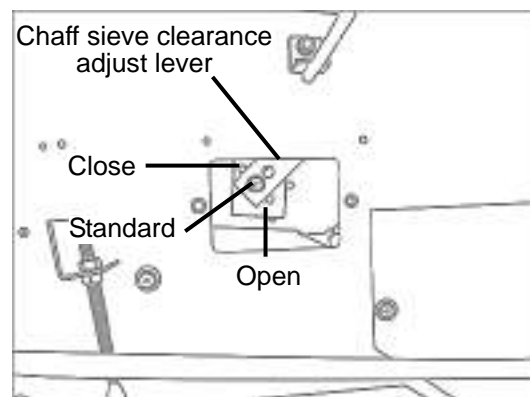

#### [Reference]

Adjust the lever to “Standard” when delivery.

- 4- Replace the cover plate after adjustment.

# Operation

## (2) Adjusting the screening air volume

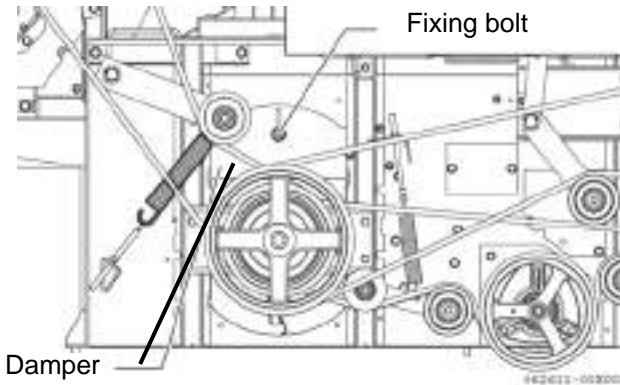

Loosen the fixing bolt and move the damper up and down to adjust the air volume. Remove the damper in case of poor screening.

Close the damper in case of much back loss.

If light grain is still a loss from the back side of the machine even when the damper is completely closed, attach the winnower shutter (accessory) and decrease the screening air volume.

## (3) Adjusting the end plate of swing separator up and down

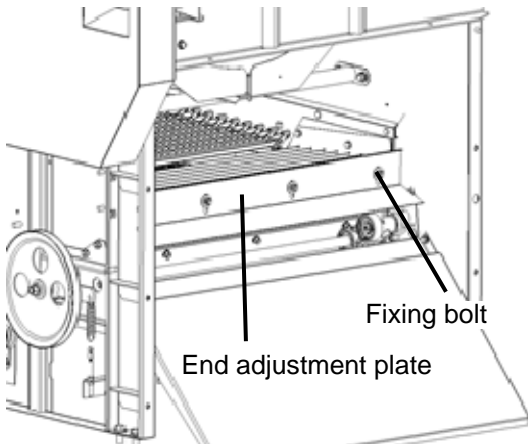

Loosen the 4 fixing bolts at the end of swing separator to move the adjustment plate up and down. Move the plate upward in case of much scattering at the rear of the machine, or downward in case of poor screening.

## (4) Put the range shift lever to “Standard”, “Low” or “High” according to the condition of crop.

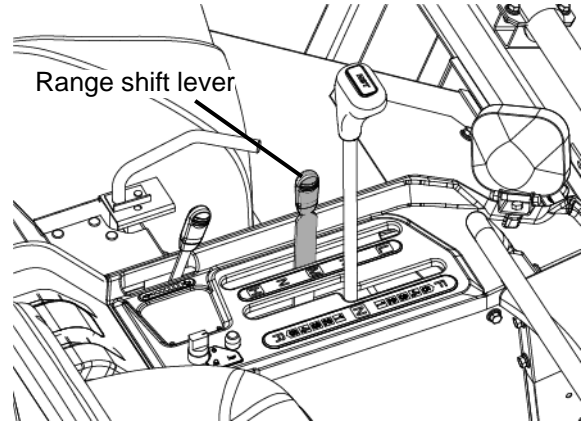

## (5) Use the accelerator lever to adjust the engine speed to the point that tachometer hand falls in the “Green Zone” of tachometer.

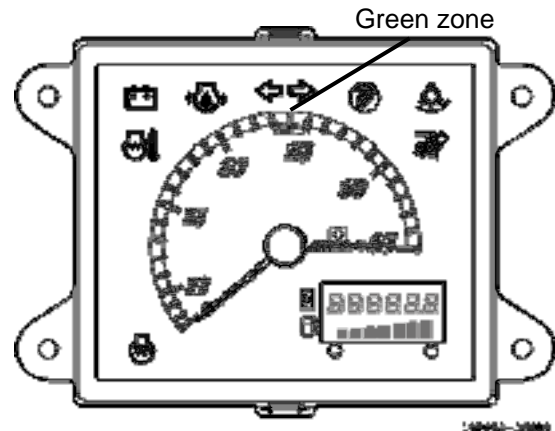

### [Precaution]

Threshing may be incomplete and low in efficiency, and the threshing section may be blocked if the engine speed is below the rated level. The percentage of broken grain may rise if the engine speed is too high.

## (6) Put the threshing clutch lever and header clutch lever to “ON”.



# Operation

(7) Operate the main shift lever to lower down the header to prevent missing any rice spike during harvesting.

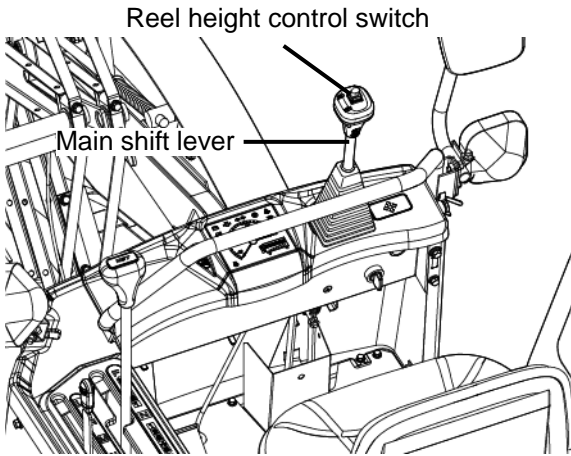

(8) Adjust the reel by height control switch the lift button to ensure that the reel tines touch the stalk below spike when cutting, and the reel is in the position available for gripping crops.

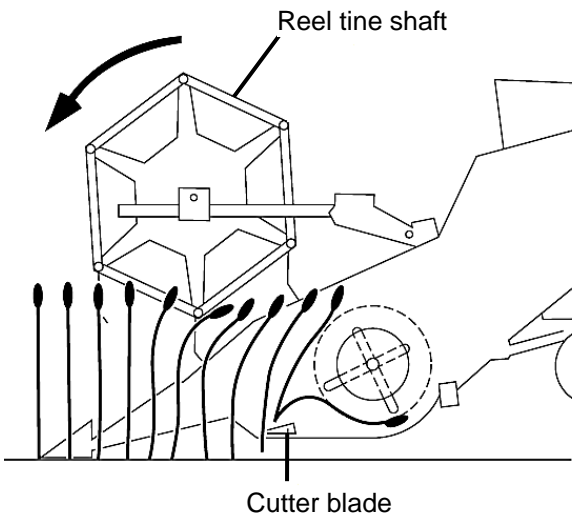

(9) The reel can be flexibly adjusted forward and backward by changing the position of pin hole.

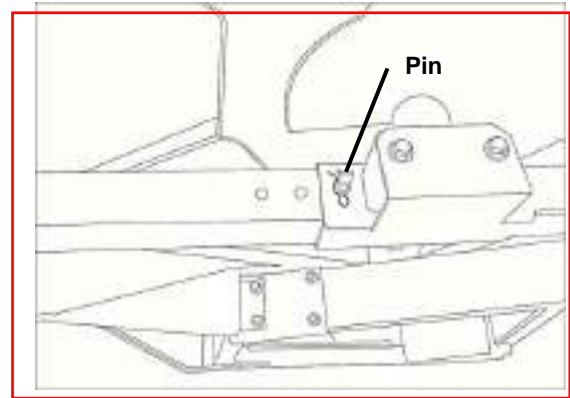

[Note]

Number of pin holes : 3  
Standard position : Rear hole

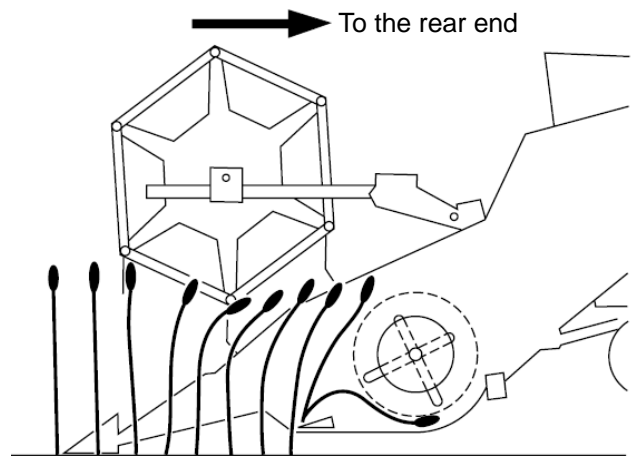

# Operation

## (10) Adjusting the header height when harvesting

Under normal condition (crops grow normally), the harvesting height should be 60-70cm from the spike tip.

### [IMPORTANT]

- If the harvesting height exceeds 70cm, the power consumption will be increased and energy efficiency be decreased; the threshing chamber may be accumulated with dust, swing separator be blocked, and threshing loss be increased, leading to poor screening.
- If the harvesting height is below 60cm, friction effect in the threshing chamber will be impaired and grain loss be increased. Put the chaff discharge adjust lever to “Close” to reduce loss.

## (11) Push the main shift lever forward to start harvesting slowly

Put the main shift lever to “Standard” or lower speed gears in case of grain loss during “High Speed” harvesting of ledged, moist, immaturely or high-yield crops.

### [Note]

If the range shift lever is to be operated during traveling, stop the machine before switching.

- ## (12) Upon completion of harvesting, put the header clutch lever to “OFF”, and after no grain is discharged from the outlet, move the threshing clutch lever to “OFF”, and then turn off the engine.

## Harvesting the ridged crops

- Harvesting height: To prevent missing during harvesting,

Harvesting height

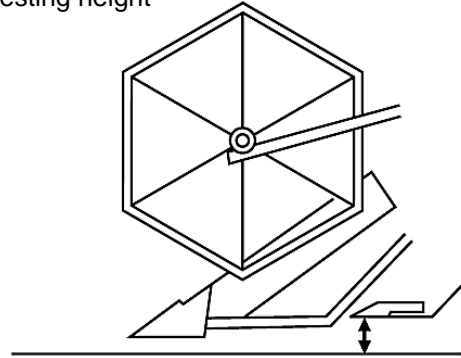

- Reel height: To be lowered down as possible.

Reel height

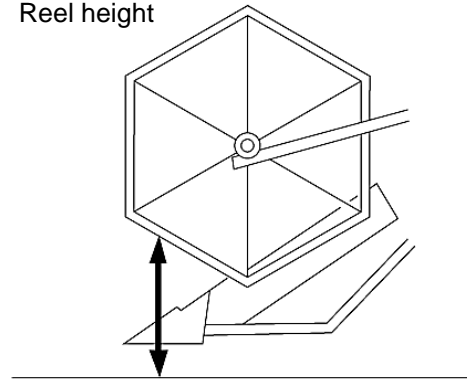

- Front/rear position of reel: The reel should be extended to an appropriate height to prevent missing in gripping and reeling up mud.

Front / rear position of reel

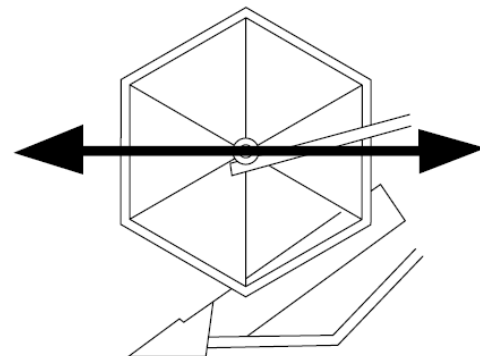

- Change to a low-speed sprocket (accessory) and slow down the reel speed.

# Operation

- Position of crop dividers: To be determined based on that of the right divider to prevent missing in harvesting.

Position of crop dividers

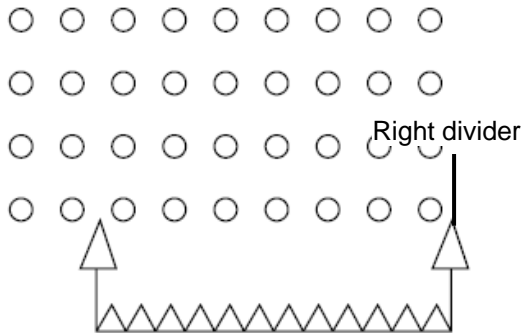

## Turning during operation

### **⚠ WARNING**

Be sure to warn the co-worker (s) before turning, moving forward or backward during operation.

If turning is required after harvesting, raise the header to prevent hitting any stubble or crops discharged.

[Precaution]

- Do not put the threshing clutch lever to “OFF” or reduce the engine speed during turning, when the threshing section is still working.
- The total loss rate may be increased if you turn at a high speed during harvesting of crops high in yield. Turn slowly.

# Operation













## Operating speed

Select the gears of range shift lever and main shift lever according to the condition of operation and crops to ensure optimum efficiency of operation.

### [Precaution]

Put the main shift lever to “4” or lower before operation if you are a beginner or unfamiliar with the machine or the field condition is operation. Move the main shift lever to the highest speed according to the condition of crops and field after you become skilled.

Use the main shift lever and auxiliary shift lever to adjust the harvesting speed in reference to the table below.

Crop moisture	Operating speed	Position of range shift lever	Position of main shift lever	Lodged crops		
				Lodging angle		Harvesting direction and speed
Much  Little	Low  High	Low	Stop  Forward	Large  Small	Upright Crops 	Forward harvesting  
		Standard	Stop  Forward			Left / right lodging  
		Traveling	Stop  Forward			Reverse harvesting 



# Operation

## Replacing the grain bag

### **⚠ WARNING**

When removing obstacles or observing the operating status of grain tank while the machine is running, do not put your hand or body deep in the machine. Otherwise, you may be injured.

1- The alarm buzzer will sound and the full grain tank alarm on the instrument panel will be lit when the tank is full of grain.

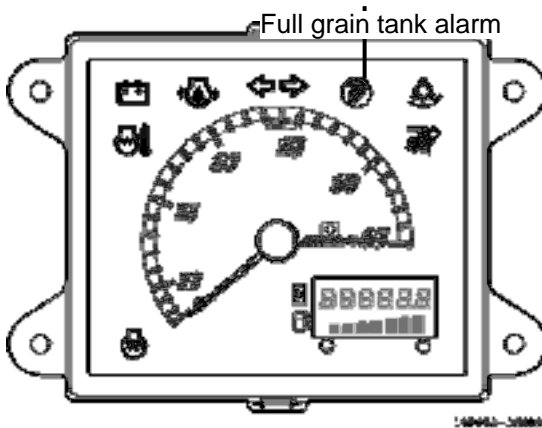

2- After the bag is filled with grain, close the discharging gate and replace the bag.

### [Precaution]

Check the volume of grain tank frequently during operation. If the grain tank is excessively filled, grain will block the outlet of lift conveyor to cause blocking, burning of belt and other failures.

## Manual threshing

### **⚠ WARNING**

- Park the combine on a horizontal ground and engage the parking brake.
- Two persons should be assigned for coordination during threshing by the means of feeding, one of which should seat in the operator seat to stop the engine immediately in case of abnormality.

- You may be rolled in the reel and injured in the process of threshing by feeding. So, be sure to follow the instructions below.
- A co-worker must sit in the operator seat during operation so as to timely stop the engine in case of abnormality.
- Roll up your cuff, and do not wear a towel around your head, neck or waist during operation.
- The operator should stand diagonally away from the reaping section and feed crops gradually in small amount.
- Chaff may pile up below the dust exhaustor hood during threshing by feeding. Do not let the piled chaff come into contact with the engine exhaust pipe. Otherwise, fire hazard may be caused.
- Discharged straw and chaff may pile up below the discharging section in case of large-amount threshing while the combine harvester is stopped. Fire hazard may be caused by chaff in contact with the outlet of engine exhaust pipe. In this case, move the machine or remove the piled chaff.

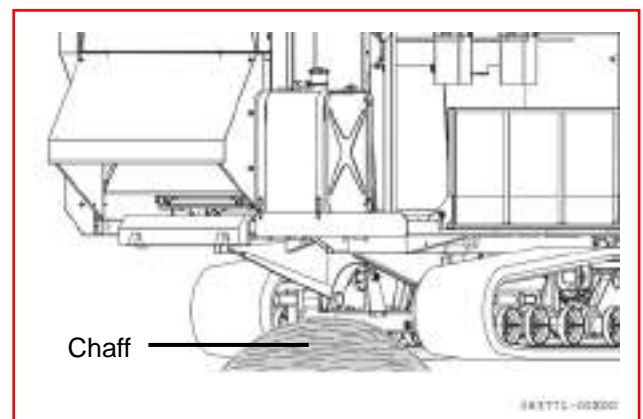

# Operation

---

- 1- Step the brake pedal to the floor and engage the parking brake lock after the combine is stopped.
- 2- Lift up the header slightly, and raise the reel to the highest position.
- 3- Put the threshing clutch lever and header clutch lever to "ON".
- 4- Pull the accelerator lever to make the tachometer into the "Green Zone".
- 5- Put the crops manually harvested into the platform auger gradually in small amount.

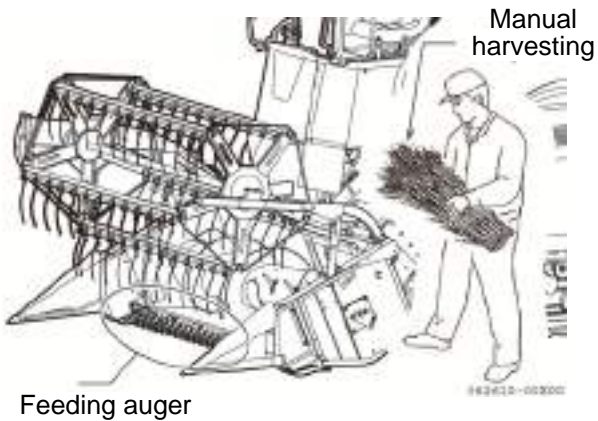

# Operation

## Check/remedy of grain loss during harvesting-1

Limited by the condition of crops and field, this machine may sometimes be subject to grain loss during harvesting. The causes and adjustment methods are listed below.

S.N	Phenomenon	Main Factors	Remedy
1	Spike tip loss	1) Crop variety easy to be threshed (grains always fall off when you grip the spike tip)	1) Reel speed is relatively high, leading to more threshing and high operating speed. 2) Adjust the reel height. (reel tine should not be in direct contact with spike tip, but with spike root)
		2) Remaining lodged rice after harvesting	1) Move the reel forward, and pick up the lodged rice.
2	Rice scattering (3rd loss)	1) Early harvesting, high moisture content of rice (over 26%)	1) Wait for the appropriate time for harvesting. 2) Reduce the harvesting speed.
		2) High grain yield per unit area (over 900kg per 100m <sup>2</sup> )	1) Reduce the harvesting speed or width as possible. 2) Put the chaff sieve clearance adjust lever to "Open".(as indicated in Page 50)
		3) Rubber support behind the swing separator is improperly placed	1) Move it upward. However, the end plate of the swing separator plate may be affected and loss at the 3rd outlet be increased <b>if it is raised too much.</b>
		4) Wind power of the fan is too high	1) Reduce the wind power of fan. (turn the damper properly to "Lower side")
		5) Openings in the chaff sieves of the swing separator are blocked (under the circumstance of wet rice)	1) Remove the obstacles.
		6) Engine speed is too high	1) Operate at the specified engine speed.
3	Un-threshed grain (4th loss)	1) Operating speed is too high comparing to yield	1) Reduce the harvesting speed.
		2) Openings in the concave screen are blocked (under the circumstance of wet rice)	1) Remove the obstacles.
4	Threshing loss	1) Crop variety hard to be threshed (grains do not fall off when you grip the spike) (branch tension over 150g)	1) Reduce the harvesting speed.
		2) Operating speed is too fast comparing to yield	1) Reduce the harvesting speed.
		3) Check whether the gap between concave screen and threshing rotor teeth is widened due to wear or deformation	1) Correct the deformation and wear, or replace with new ones.
		4) Low engine speed	1) Operate at the specified engine speed.

# Operation

## Check/remedy of grain loss during harvesting-2

S.N	Phenomenon	Main Factors	Remedy
4	Threshing loss	5) Drive belt of main roller loosened (low revolving speed of the threshing rotor)	1) Adjust the belt tension or replace it.
		6) Crops intermittently conveyed from the harvesting section to the feeder house	1) Properly adjust the height, front/rear distance of the reel.
5	Lots of straw, green leaves and dust (poor screening)	1) Chaff sieve clearance adjust lever opened too much	1) Adjust it toward the "Close" side. (as indicated in page 50 )
		2) Wind power of the fan is too low	1) Increase its wind power. (adjust the damper toward "Upper" position)
		3) Operating speed is too low comparing to yield	1) Raise the harvesting speed.
		4) Low engine speed	1) Operate at the specified engine speed.
		5) Drive belt of the swing separator loosened (low revolving speed of the screen)	1) Adjust the belt tension or replace it.
6	Hulled rice	1) High engine speed	1) Operate at the specified engine speed.
		2) Vibrating screen closed too much	1) Turn the screen toward "Open" side.
		3) Conveyer wear	1) Check and replace the conveyer.
		4) High moisture content of rice (wet)	1) Harvest after rice becomes dry. 2) Reduce the harvesting speed.
7	Lots of branch	1) Chaff sieve clearance adjust lever opened too wide	1) Turn the screen toward "Close" side. (as indicated in page 50 )
		2) Check whether the gap between concave screen and cylinder teeth is widened due to wear or deformation	1) Correct the deformation and wear, or replace with new ones.

# Operation

## Working in wet field

### [IMPORTANT]

- When the machine cannot move in a wet field, it may be unable to escape from the field, causing failure of the machine or damage to the crawler. In this case, do not perform the following operations or procedures.
- Do not operate the main shift lever toward “Forward” or “Reverse” for over 10 seconds, or move it repeatedly. (If the main shift lever is operated when the machine is sunk in a wet field, HST of the gear may be damaged, and the machine could not move.)

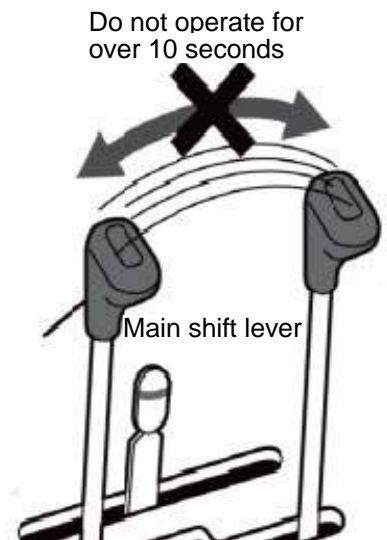
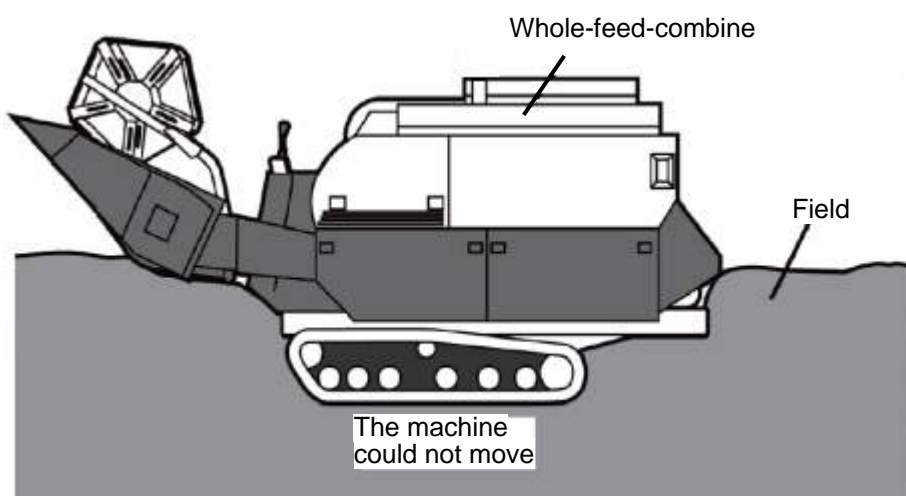

- Do not place any rods, bars or square stock under the crawler. (Otherwise, the crawler may be damaged)
- When the machine could not move in a wet field, be sure to call for the rescue truck for escape. Secure a steel wire rope on the rope hook or towing hook at the back of the machine, and use a heavy-duty truck or other rescue vehicles for towing slowly when escaping from the wet field. Tow the machine straightly in the moving direction. The rope hook or towing hook tied with wire rope on one side of the machine may be damaged, and the machine may be unavailable to escape if the moving direction is changed.

### [Example: Towing backward]

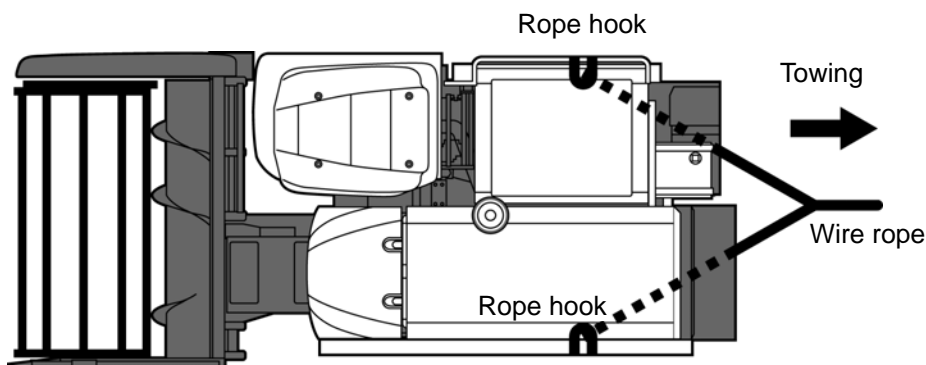

# Operation

If it is unavailable to use a rescue truck for towing, loading/unloading plate, gangplanks and other materials can be used to make the machine available for towing. In this case, fully remove clay attached on the track. Otherwise, the machine cannot be towed due to crawler sliding.

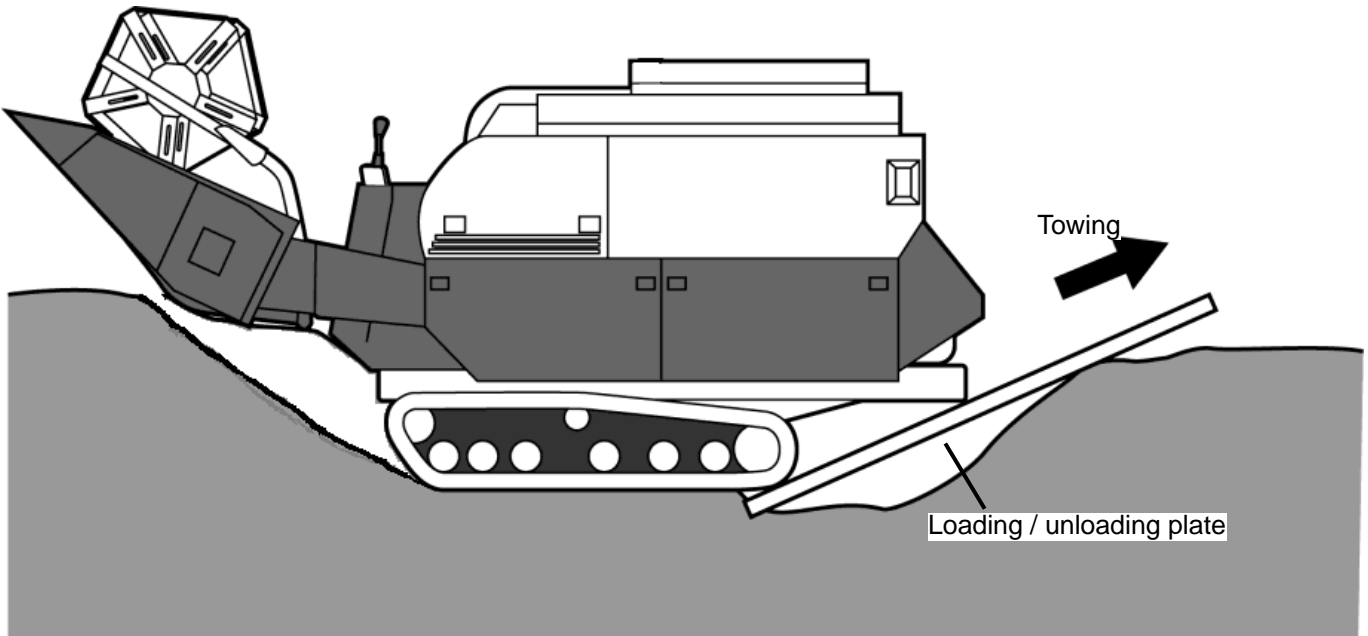
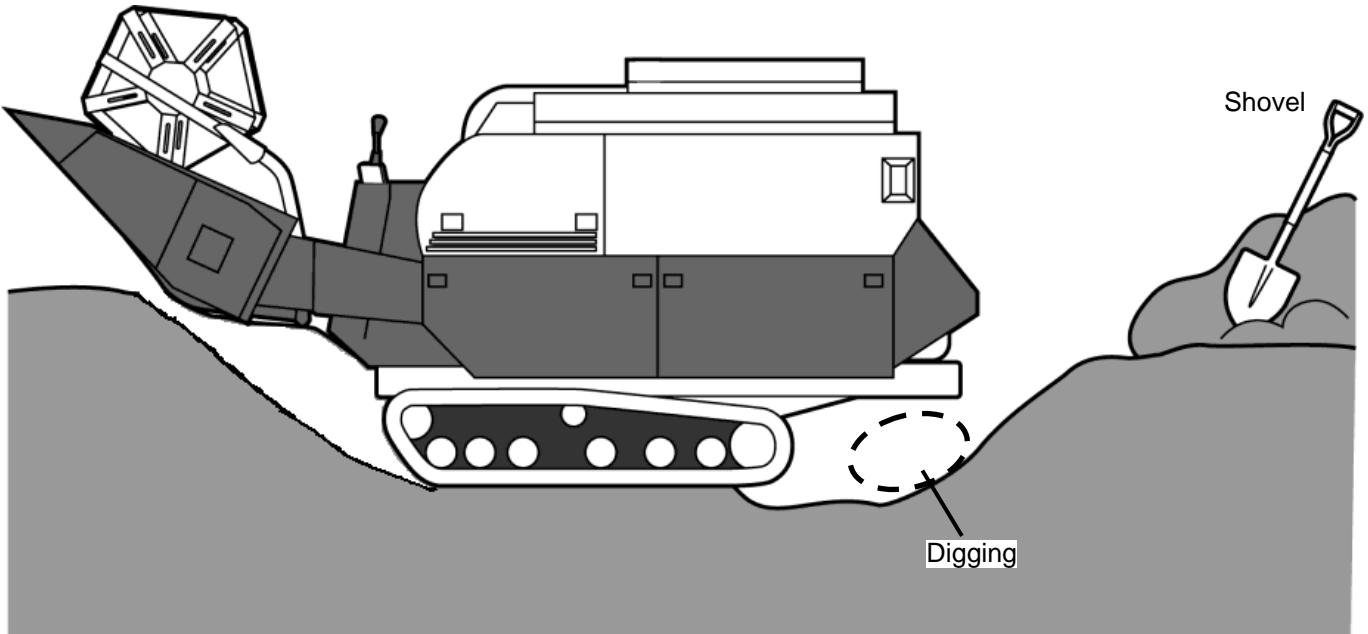

**[Note]**

Never use your combine harvester to tow any other machines, or mechanical failure may be caused.

# Operation

## 5. Alarm

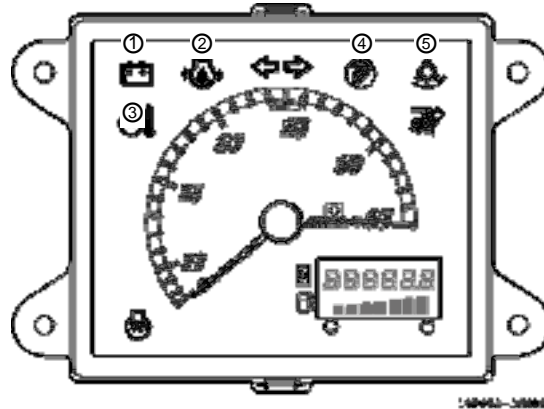

### ⚠ WARNING

- Stop the engine without fail and engage the brake pedal lock, when you remove jam.
- Do not put the hand in the conveyor and the chain. It causes to injure.

When the indicator lamps or the buzzer sounds, make sure of abnormal point and take the following steps.

No	Mark	Name	Alarm	Remedy	Check/maintenance
1		Charging	○	It is normal that the indicator is on after turning the key switch to "ON" and off after the engine starts up. Check the charging circuit if the indicator remains lit during operation.	<ul style="list-style-type: none"> <li>● Tension of engine fan belt</li> </ul>
2		Oil pressure	○	It is normal that the indicator is on after turning the key switch to "ON" and off after the engine starts up. Check oil quantity if the indicator remains lit during operation.	<ul style="list-style-type: none"> <li>● Insufficient engine oil.</li> <li>● Low oil viscosity</li> </ul>
3		Water temperature	◎	Perform no-load operation at a low speed till the indicator goes out, and then turn off the engine. If the cooling liquid is insufficient, add after the engine cools down.	<ul style="list-style-type: none"> <li>● Tension of fan belt</li> <li>● Water leakage</li> <li>● Cleaning dust on the screen of radiator</li> </ul>
4		Grain tank	◎	When the tank is full of grain, stop the harvesting, and discharge grain.	
5		2nd	◎	If the secondary conveyor is blocked, stop the machine and clean completely.	<ul style="list-style-type: none"> <li>● Belt tension</li> </ul>

○ means the indicator is lit; ◎ means the indicator is lit while the buzzer sounds;



# Maintenance after operation

## 1. Post-operation maintenance

### **⚠ WARNING**

- Be sure to stop the engine and lock the brake pedal before lock cleaning and unclogging.
- Your hand may be nipped by moving parts or cutter and injuries be caused in case of maintenance while the engine is running.
- Never smoke or use open fire for lighting during refueling.
- Tighten the fuel tank cover and wipe off any spilled fuel after refueling.

After cleaning with water, wipe off water fully, and then add lubricant in various moving and sliding parts. In particular, the cutters should be coated with lubricating grease in advance, chains, wires and other greasing parts must be added with lubricant.

### [Precaution]

- It is not allowed to clean with water any parts other than the chassis, so as to avoid failures.
- After inspection and maintenance of parts, be sure to perform test run to check their working condition.

## 2. Detaching and opening of each part

### **⚠ WARNING**

Be sure to stop the engine and lock the brake pedal before detaching or opening any parts. Otherwise, you may be injured.

### **⚠ CAUTION**

Make sure to replace the detached panels after operation, or you may get injured.

### Opening the threshing section

Open the threshing section as instructed below for section of the concave screen and inside.

- 1- Lower down the header to the lowest position, and then open the upper cover and side cover of the threshing section.

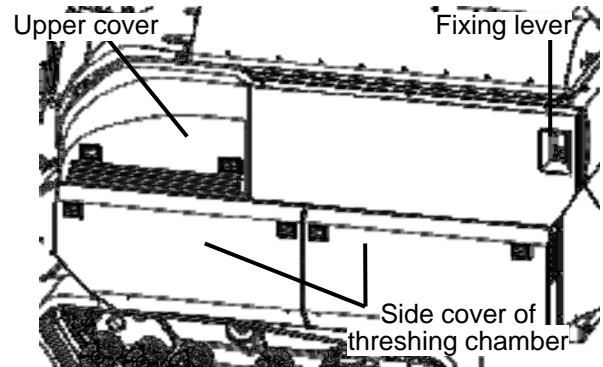

- 2- Pull out the pin of rotating fulcrum of the side threshing section.

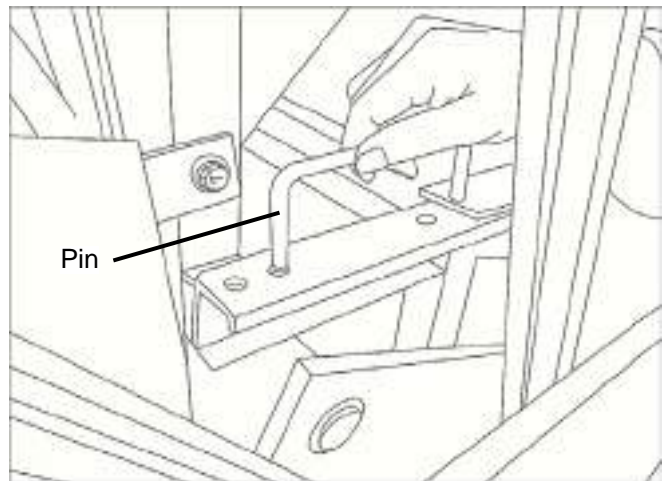

- 3- Pull the fixing lever of threshing section outward to open the side threshing section.

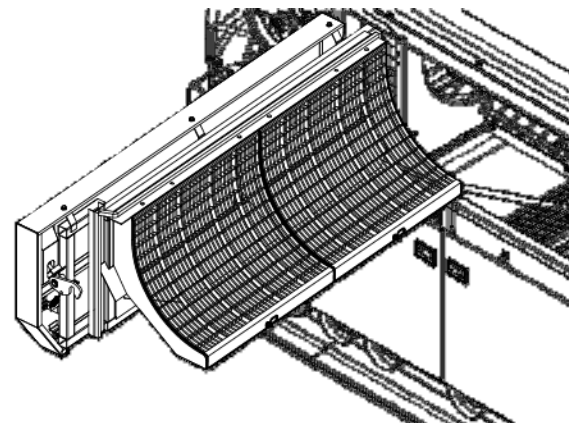



# Maintenance after operation

4- Change the position of pin hole to fix the side threshing chamber after it is opened.

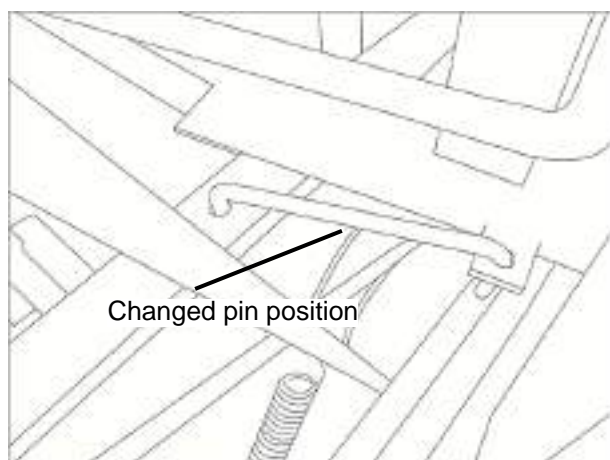

## Detaching the concave screens

Open the side threshing chamber, and loosen the fixing bolts to detach the 4 concave screens inside and outside.

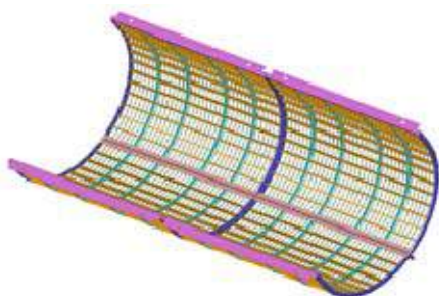
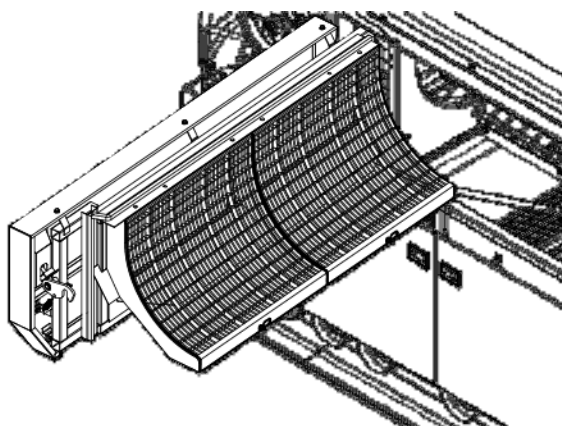

## Detaching the swing separator

- 1- Open the side threshing section.
- 2- The swing separator can be seen after the two protective covers at the rear end are removed.

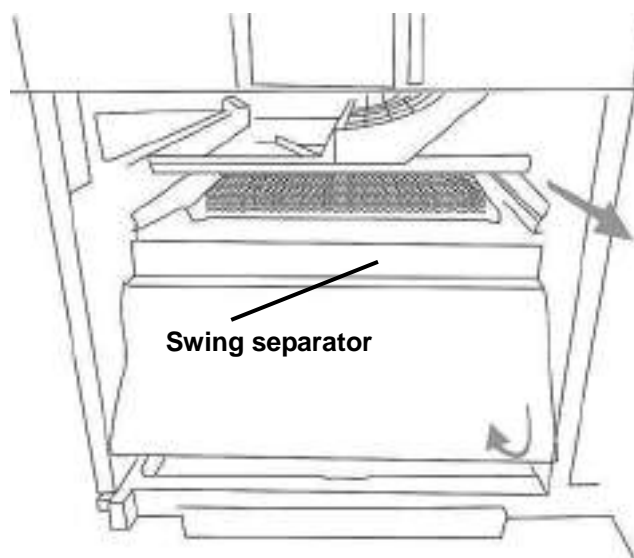
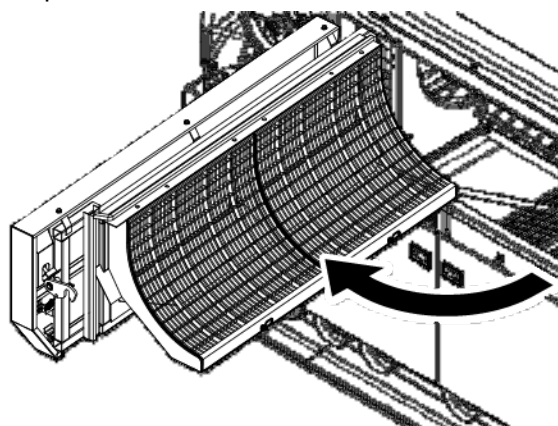

脱こく上カバー着脱項目削除に伴い、ページレイアウトを変更しています。

# Maintenance after operation

3- Remove the two bolts on the left and right sides of the rear end of vibrating screen.

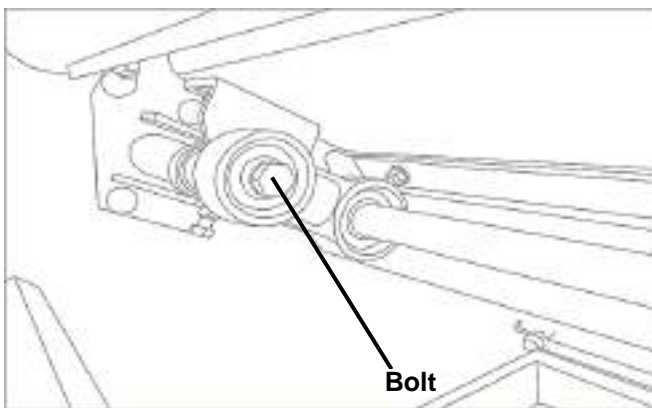
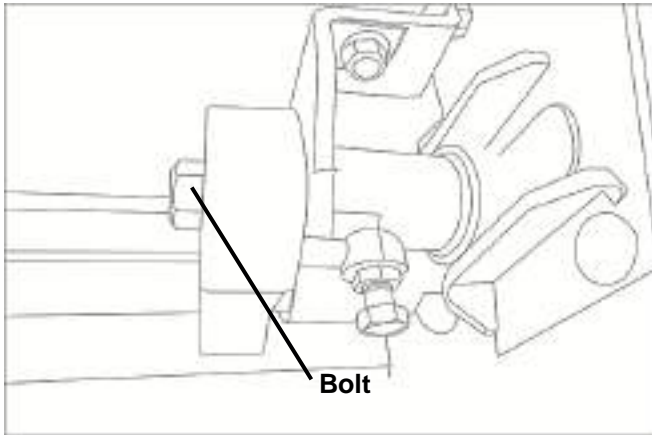

4- Draw out the swing separator rearwards.

**[Note]**

Seals (rubber gaskets) should be mounted as shown below when assembly of the swing separator.

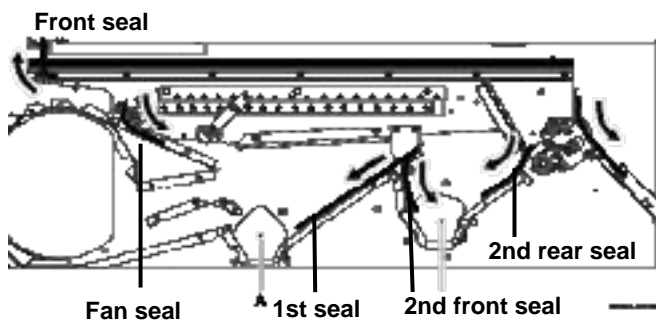

1- Mount the front seal on the front of swing separator.

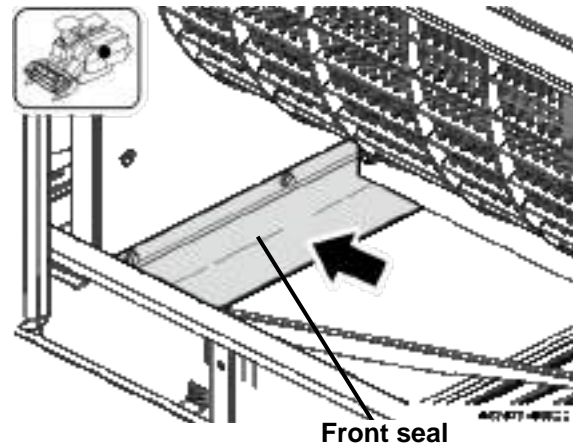

2- Mount the 1st seal and 2nd front seal after the cleanout is opened.

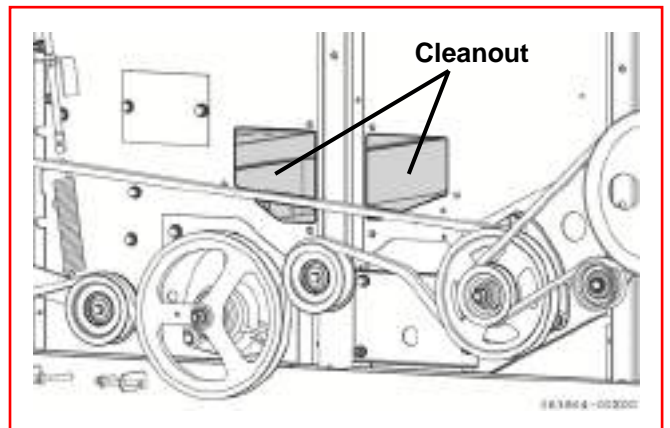

3- Mount the 2nd rear seal on the rear end of swing separator.

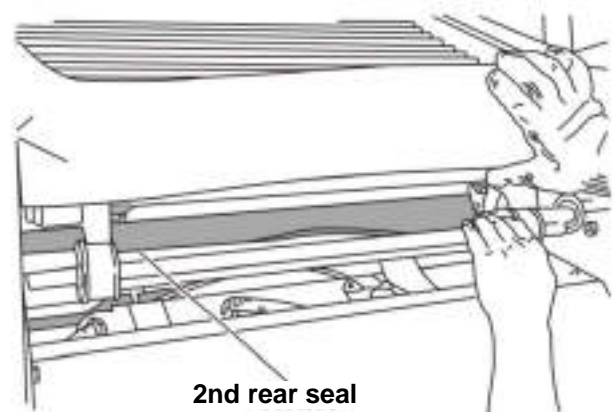

**[Precaution]**

Loss may be caused if the seals are not mounted as shown above.

# Maintenance after operation

## Opening the engine room cover

### **⚠ WARNING**

The engine room cover must be fixed with lever during operation, or accident may occur.

### [Precaution]

When opening the engine room cover, be sure to hold the support arm till it is completely open. The engine may deform if you let it go in the course of opening.

Pull the lock lever of engine compartment toward the direction of release, and hold the support arm to open the compartment.

When closing, the engine room cover will be locked automatically. Check whether it is locked.

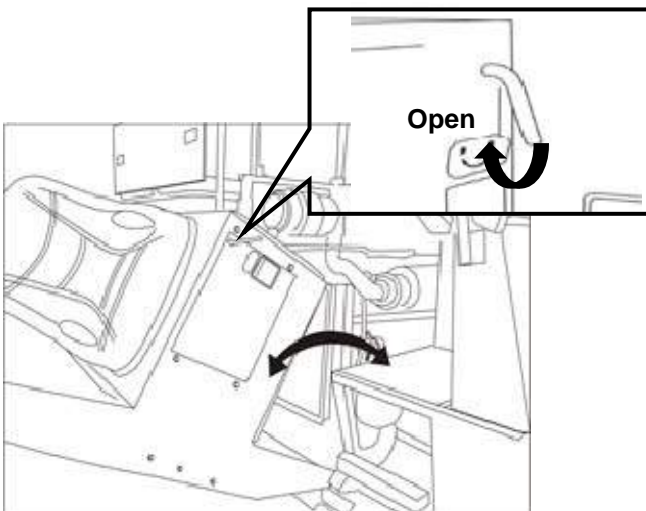

## 3. Oiling of each part

Add oil to the drive chains of cutters and reaping section.

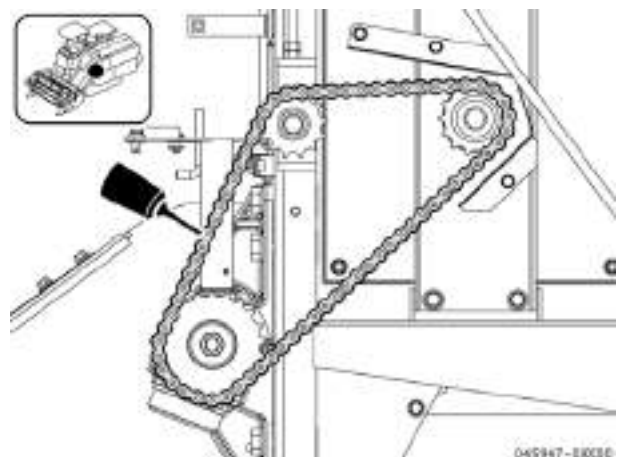
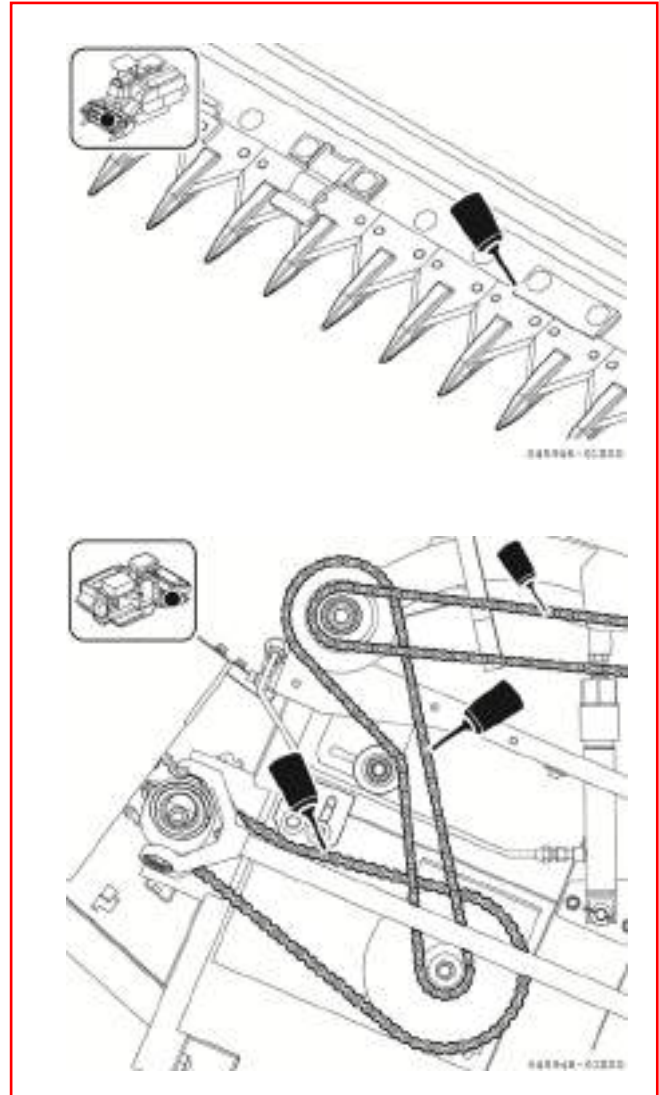



# Maintenance after operation

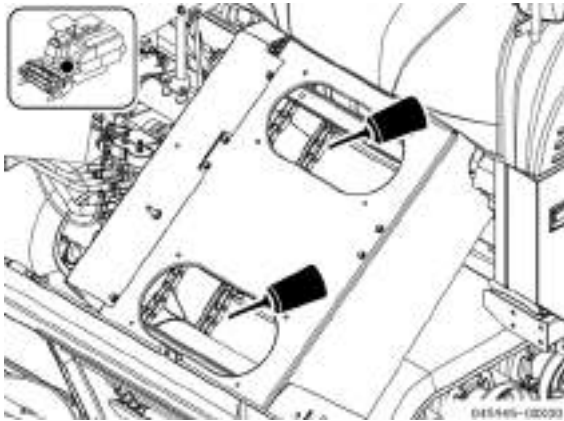

## Greasing

Add grease to the following positions after cleaning.  
(Every 30-50 hours)

### 1. Traveling section

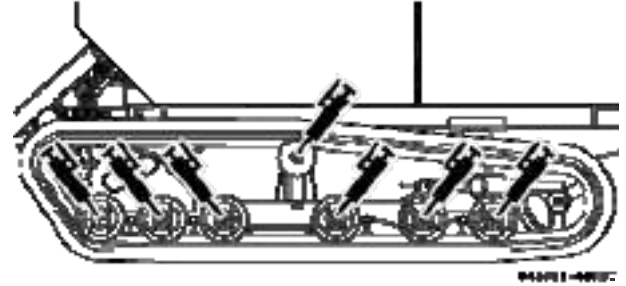

### 2. Rear bearing rotor

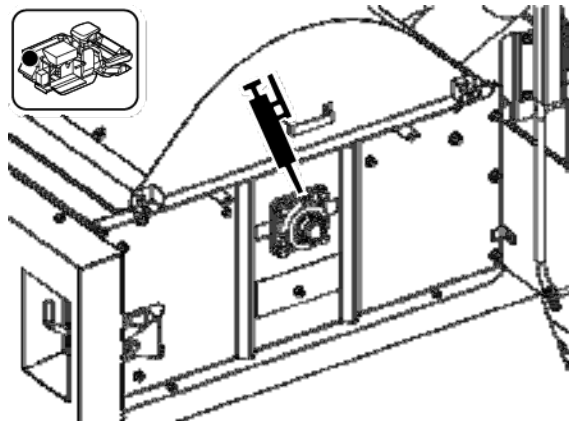

### 3. Oil cylinder pin of header

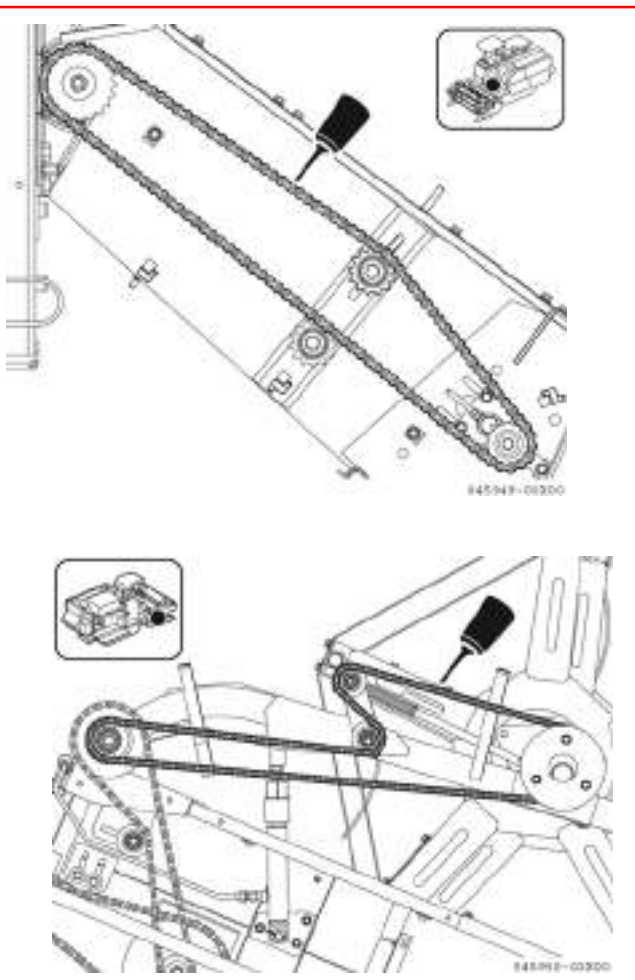
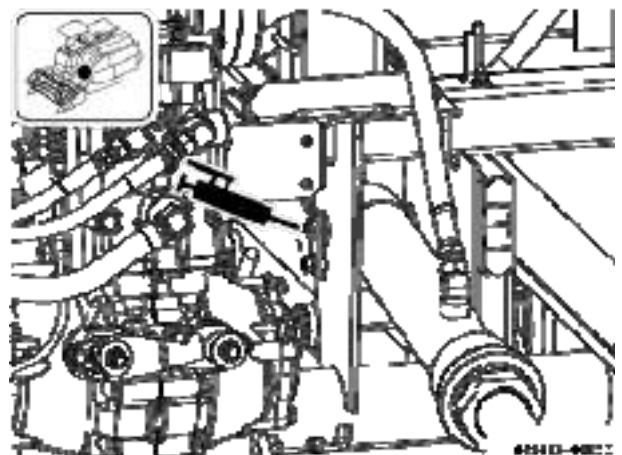

## ⚠ WARNING

Be sure to turn off the engine and lock the brake pedal before oiling of rotating parts. Otherwise, you may be injured.

# Maintenance after operation

## 4. Cleaning of each part

### ⚠ WARNING

- Be sure to turn off the engine and lock the brake pedal before cleaning and removing obstacles.
- Your hand may be nipped by moving parts or cutters and other injuries may be caused if you perform maintenance while the engine is running.

Open all cleanouts and clean inside to prevent different varieties.

脱こく上カバー着脱項目削除に伴い、ページレイアウトを変更しています。

### 1. Cleanout of 1st conveyer

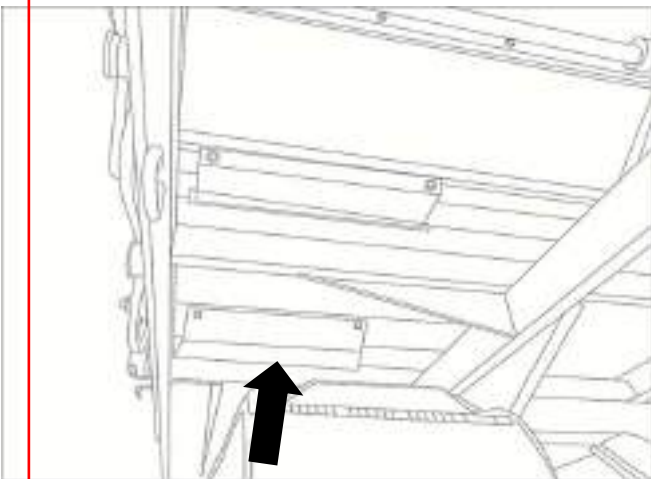

### 2. Cleanout of 2nd conveyer

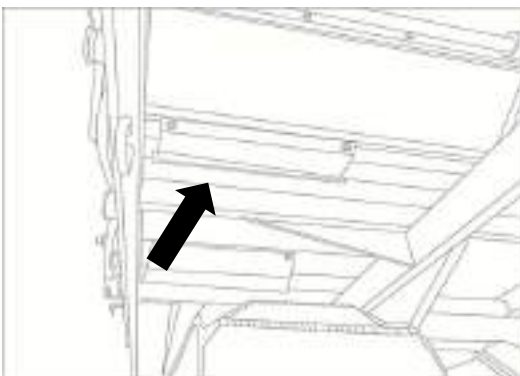

### 3. Feeder house

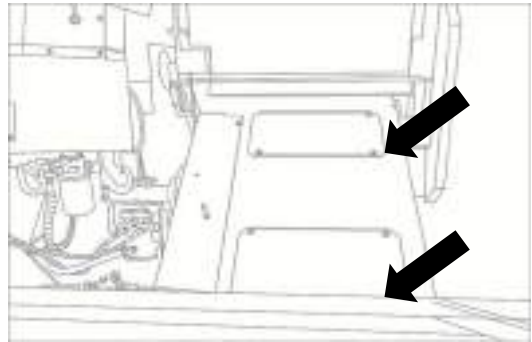

### 4. Connection between 1st and 2nd conveyers

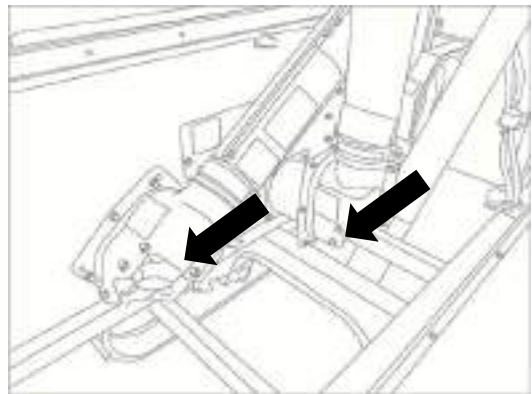

### 5. Swing separator (open the threshing section)

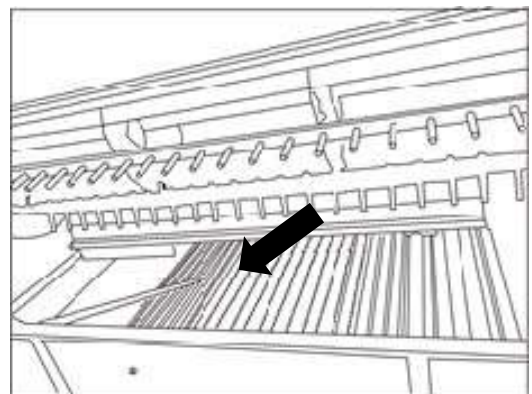

# Maintenance after operation

## 6. Exhaust muffler

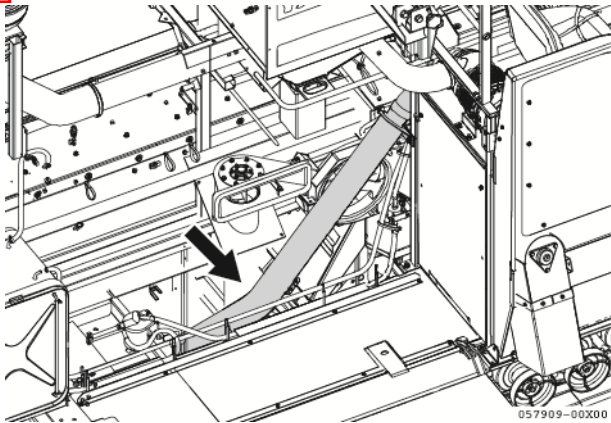

## Cleaning the front air filter

Dust may accumulate in the pre-cleaner during operation. Clean it on a daily basis.

<Cleaning>

Remove the wing nut on top of the pre-cleaner to remove dust inside.

- The pre-cleaner front can not collect all dust. Clean the air filter while cleaning the pre-cleaner.

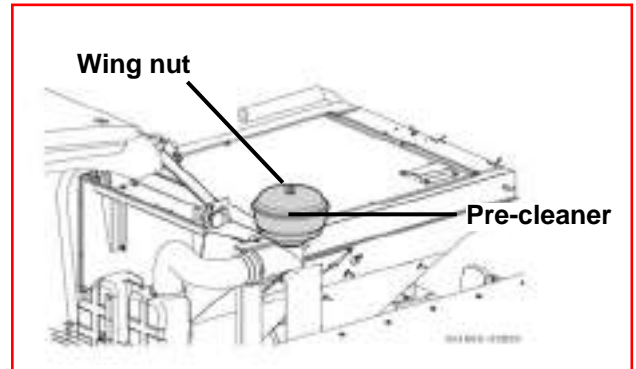

### [Precaution]

- Stop operation and use waterproof cloth to cover the machine in case of rain during operation. Pay special attention to the pre-cleaner to prevent rain. Pay full attention to prevent air filter from being caught in the rain in the event that it rains during transportation.
- In case of damage to air filter or inlet pipe, replace it with a new one. Otherwise, water may enter and cause engine failure.

# Maintenance after operation

## 5. Long-time storage

Store the machine as instructed below if it is not to be used for a long time.

- 1- Store the machine in a dry and well-ventilated place protected against rain, and add wood planks under the crawler.
- 2- Put all control levers to "OFF".
- 3- Close the assist grain deck.
- 4- Lower the header to the floor.
- 5- Fill the fuel tank. There will be water drops and the tank may be rusted if it is left empty.
- 6- Coat anti-rust oil, engine oil or grease on external surfaces subject to rust.
- 7- Fully charge the battery. Try to remove it from the machine and store in a cool and well-ventilated place. The cathode should be detached before the battery is mounted on the machine.

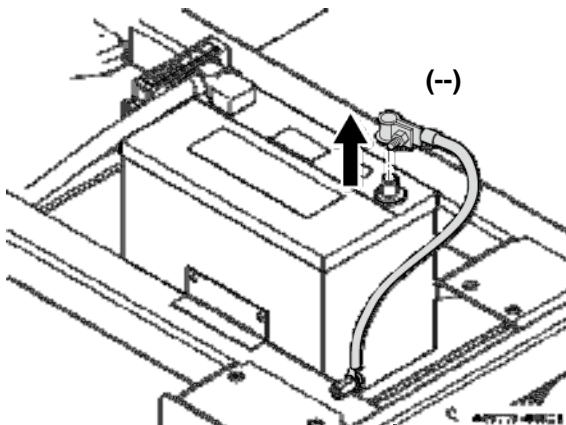

Remove wire harness from the cathode (-) terminal

### [Precaution]

The battery is subject to natural discharging even if it is not used. Charge it on a monthly basis.

If the machine is not to be used for a long time, it should be arranged with periodic inspection and maintenance according to the guidelines for inspection and maintenance, so as to ensure it is under the optimal operating condition when used at the next time.

### [Precaution]

- In case of residual grains and straws in the parts, rats may nest there and bite the electrical wires, and thus future operation be affected. Clean them thoroughly.
- Take out the key and keep it properly.

# Periodic Inspection

## Maintenance of YANMAR Combine harvester

Due to rotating and vibration of the machine, wear of parts and changes in load and operating environment during operation or transportation, its technical conditions may be worsened, efficiency be reduced, parts be damaged, or serious accidents be caused. To prevent the accidents, the machine should be correctly operated to extend its service life, all parts be checked and cleaned, bolts be tightened and adjusted, or parts be replaced when necessary. This is the so-called maintenance.

<Content of daily maintenance>

- 1- Check and clean the air filter elements, the screen of oil cooler & radiator and engine dust protector.
- 2- Check the amount of engine oil, radiator & sub water tanks for leakage.
- 3- Clean the parts required to be cleaned (cleanouts of 1st and 2nd conveyers).
- 4- Remove straw stuck in and between the drive shaft and driven shaft of chains, as well as chaff attached on drive belts.
- 5- Lubricate all chains, remove mud and chaff on cutters, check any damage in the chains and cutters, and add lubricant in the gap between upper and lower cutter blades. (Lubricate the chains and cutters every 2 hours during operation)
- 6- Check whether the tension spring of chains is loosened.
- 7- Remove chaff on the concave screen and swing separator of the threshing section. In particular, check the degree of wear on the concave screen (high moisture content of crops), and replace it when necessary.
- 8- Check the threshing tooth, mount reversely or replace them if necessary.
- 9- Check the crawler tension, and tighten it if necessary. Be sure to remove the mud, grass or straw on/between the sprocket, rollers, crawler guide, frame and transmission. Otherwise, the crawler may

hardly move, its power is reduced, and the sprocket and crawler be subject to early wear.

10- Fill the fuel tank.

11- Check whether the engine and other parts are under normal conditions.

12- Check whether the bolts and nuts are loosened.

### [Precaution]

- **Protect electrical parts, the swing separator and belts from water, or failures may be caused.**
- **Fuel without dirt is supplied.**

### **WARNING**

- **Check whether the engine is shut down, control levers are in the “OFF” position, and wait till are moving parts are completely stopped before inspection, maintenance and adjustment. Otherwise, you may be injured.**
- **Be sure to fix the safety lock of header section before raising it for inspection, maintenance and adjustment. Otherwise, the header may fall down quickly and cause injuries. Refer P37.**
- **Full ventilation should be provided during inspection indoors. Otherwise, you may be poisoned by exhaust gas from the engine.**
- **When multiple maintenance operations, take out the key from the switch to ensure safety.**

It is recommended that periodic inspection and maintenance be performed in the slack season to ensure full mechanical performance, safe and comfortable operation in the busy season. Therefore, safety of all parts should be ensured during inspection and maintenance. In particular, the radiator of fuel channel and other rubber tubing should be replaced every 2 years, and the electrical wiring be checked on a yearly basis, so as to maintain the machine under the optimal working condition.



# Periodic Inspection

---

## 1. Schedule for refueling, oiling and water supply

Item		Capacity	Type	Interval
Fuel		80L	Diesel fuel	Before and after operation
Cooling water	Main water tank	7.2L	Pure water, anti-freezing liquid Or long life coolant	Every year
	Aux. water tank	1.1L		
Engine oil		10.2L	Engine oil 15W-40 CD	First time: 50 hours 2nd time : 200 hours After : every 200 hours
Transmission oil		8.5L	TF300 transmission oil (*TF500 recommended)	First time: 50 hours 2nd time : 400 hours After : every 400 hours
Rotor drive case		1.4L	90# gear oil	First time: 50 hours 2nd time : 400 hours After : every 400 hours
Hydraulic oil tank (about 3L in the pipe)		17L	Wear-resistant hydraulic oil VG46 or VG56	Every 400 hours

### [IMPORTANT]

When changing or adding oil, after filling a predetermined amount of oil and running the engine for a few minutes, check that the oil is within the range of oil gauge again.

If it is exceeding the oil gauge, either add or release oil

### [Precaution]

- Replace oil while periodic inspection. (Use the designated oil)
- Never drain the waste oil directly into a river or sewer, but employ a professional agent for treatment.

### CAUTION

#### ALWAYS BE ENVIRONMENTALLY RESPONSIBLE

- Follow the guidelines of the governmental agency for the proper disposal of hazardous materials such as engine oil, diesel fuel, engine coolant and, machine fluid, grease.
- NEVER dispose of hazardous materials irresponsibly by dumping them into a sewer, on the ground, or into groundwater or waterways.
- Failure to follow these procedures may seriously harm the environment.
- Comply with legal regulations and guidelines for disposal of: empty containers for fuel, cooling water (coolant), oil, grease; fuel/oil filters; batteries; machine itself; machine accessories; and packaging materials.

# Periodic Inspection

## 2. Checking and replacing oil of each part

**[Precaution]**

Keep the machine on a horizontal level while oiling. Oiling may be insufficient if the machine is inclined.

### Engine oil

**<Checking>**

1- Open the engine room cover

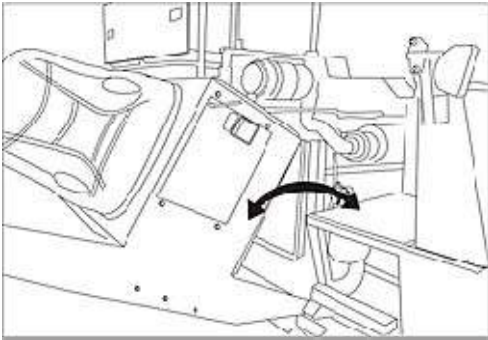

2- Pull out the dipstick and clean its front end. Push the dipstick all the way in, and then take it out to check whether the oil level falls between the upper limit and lower limit of the dipstick. Fill or drain when necessary.

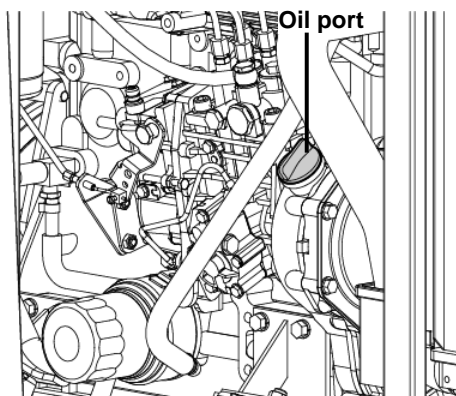
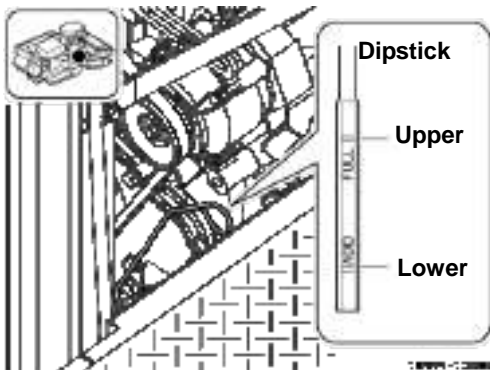

Replacing interval

First time: 50 hours  
2nd time : 200 hours  
After : every 200 hours

**<Replacing>**

1- Drain oil by taking off the drain bolt under the engine, and add oil through the port.

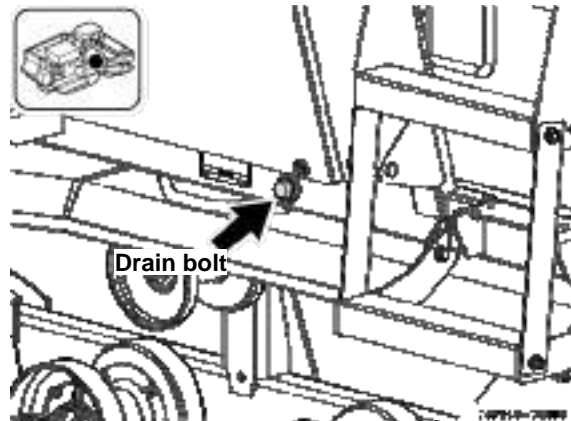

2- After replacing oil, start up the engine and run at a low speed till the oil pressure indicator is off.

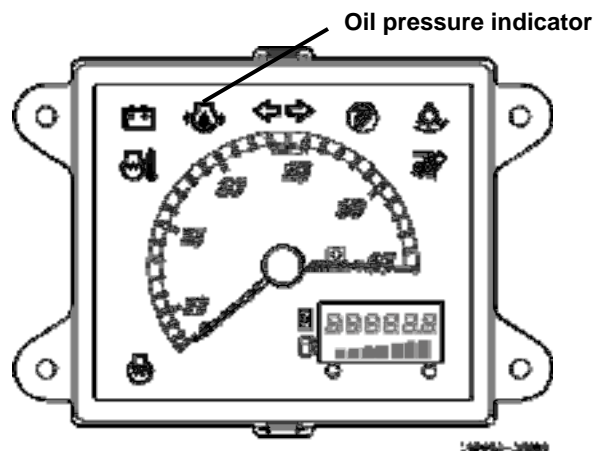

3- If engine oil is insufficient, add through the oil port to the specified level, and check any leakage.

4- After the oil pressure indicator is off, turn off the engine, and use the dipstick to check oil level 5 minutes later. Replenish if it is insufficient.

- Check and replace oil before the engine is started up or after it is cooled down.
- It will be easier to drain oil if you screw off the port cover.

# Periodic Inspection

## <Replacing the engine oil filter>

The engine oil filter is used to filter small particles and foreign matters in engine oil.

\* The filter should be replaced on a regular basis as it is a one-piece filter cartridge.

1- After engine oil is drained, rotate the filter in the direction of arrow to remove it.

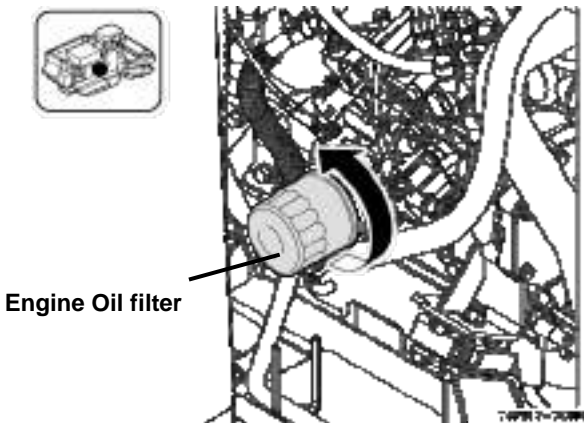

Engine Oil filter

2- Apply new engine oil on the rubber ring of the new filter.

3- Screw the filter by 1 around or more turns after the rubber ring touches the installation surface of the filter.

4- Add engine oil to the specified level.

5- Check the oil level at steps 2 to 4 of "Checking".

### [Precaution]

- Be sure to check whether there is any oil leakage on the installation surface of the filter.
- Use the genuine YANMAR engine oil filter. Failures may be caused if you use any other products.

Replacing interval	First time: 50 hours 2nd time : 200 hours After : every 200 hours
--------------------	---

## Transmission oil

### <Checking>

Check the transmission oil level through the sight glass on the left side of gear box, and add to the standard level if it is insufficient, and check any oil leakage at the same time.

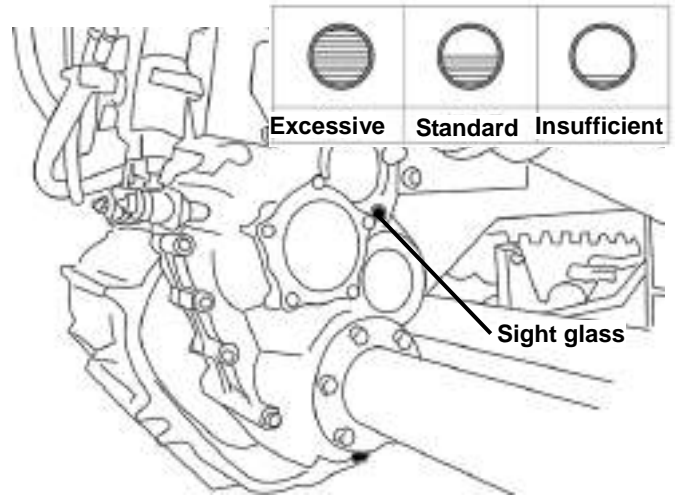

Recommended oil	Replacing interval	Standard level
TF300 or TF500 Transmission oil	First time: 50 hours 2nd time : 400 hours After: every 400 hours	8.5L

### <Replacing>

Remove the drain bolt at the bottom of the gear box to drain the old transmission oil. When adding oil, mount the drain bolt and take down the oil port cover to add, through the port, new oil to the standard level shown by the sight glass.

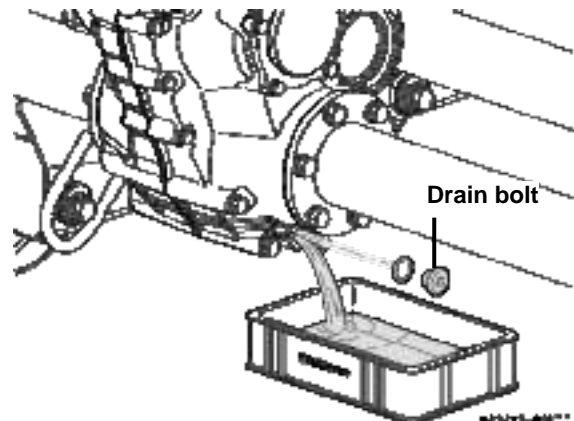

# Periodic Inspection

\* Be sure to wait till the engine becomes cool before checking the oil level.

\* It will be easier to drain oil if you remove the oil port cover.

## [Precaution]

- Keep the machine on a horizontal level ground.
- Raise the header to the highest position and fix the safety lock.
- Gears and bearing in the transmission and the case may be damaged if transmission oil is not replaced as scheduled.
- The transmission should be disassembled and checked every 1000 service hours of the machine.

## Other parts

Add oil to the specified level through the oil port.

	Recommended oil	Replacing interval	Standard level
Rotor drive case	Gear oil 90#	First time: 50 hours 2nd time : 400 hours After: every 400 hours	1.4L
Hydraulic oil tank (about 3L in the pipe)	Hydraulic oil VG46 or VG56	Every 400 hours	17L

## Rotor drive case

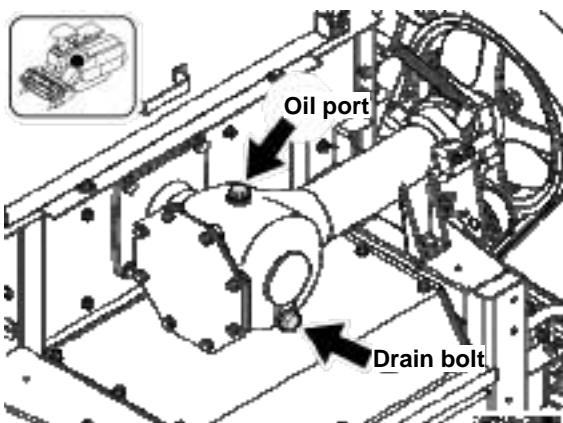

## Hydraulic oil tank

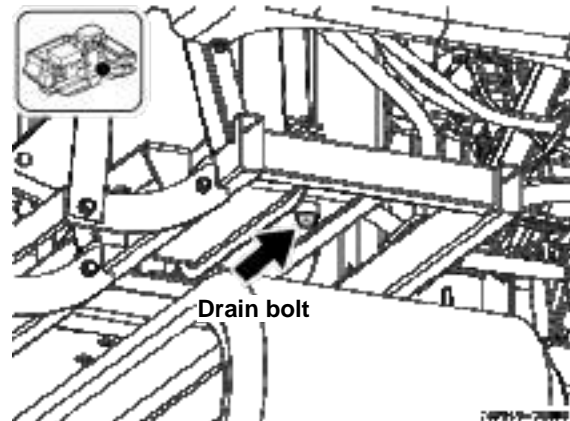
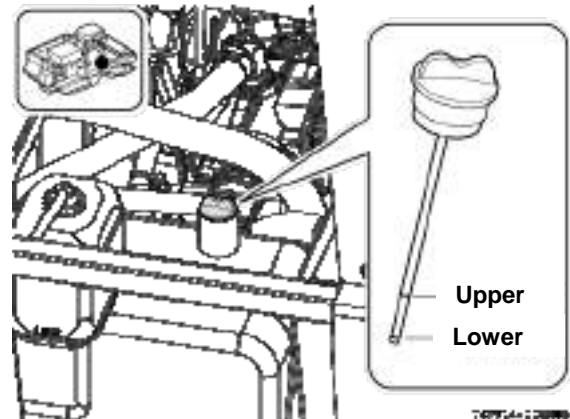

# Periodic Inspection

## 3. Replacing HST filter and hydraulic oil

HST filter and HST hydraulic oil should be replaced at the same time.

Replacing HST filter and hydraulic oil

1- Remove the drain plug at the bottom of hydraulic oil tank to drain the old oil.

(Refer to the diagram for hydraulic oil tank above)

2- Turn the HST filter element to the left to remove it.

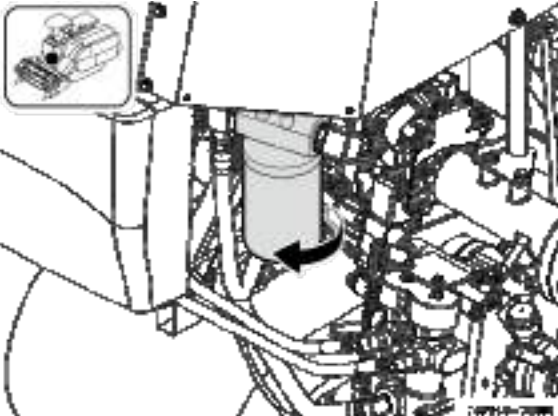

3- Apply new oil to the rubber sealing ring of the new HST filter, and then mount it in the original position.

4- Remove the cover of hydraulic oil tank to add oil to the specified level.

(Refer to the diagram for hydraulic oil tank above)

5- After replacement, perform idle running of the engine for a few minutes, stop it and check the oil level with a dipstick.

Replacing interval	Every 400 hours
--------------------	-----------------

### [Precaution]

- Be sure to check oil leakage on the installation surface of the filter.
- Use the genuine YANMAR HST filter only.
- Wipe off oil on the machine body.

## 4. Checking and replacing cooling water

### ⚠ DANGER

**Do not open the radiator cap during operation of the engine or immediately after the engine stops. Otherwise, hot water may spill out and cause burning.**

### <Checking>

Check cooling water level in the sub tank, which should fall between "FULL" and "LOW". Add pure water in the sub tank through the inlet port, and check water leakage at the same time.

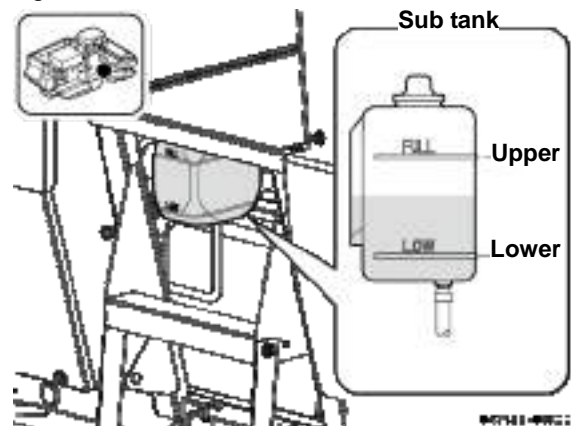

### <Replacing>

1- Remove the cover of engine room cover and the drain pin to completely drain water in the radiator.

2- Remove the cover of main radiator, and wash out dust and rust inside with clean water.

- Before adding the detergent mixed with radiator cleaning fluid, drain water inside after 15 minutes idle running of the engine to make it easier to clean the radiator.

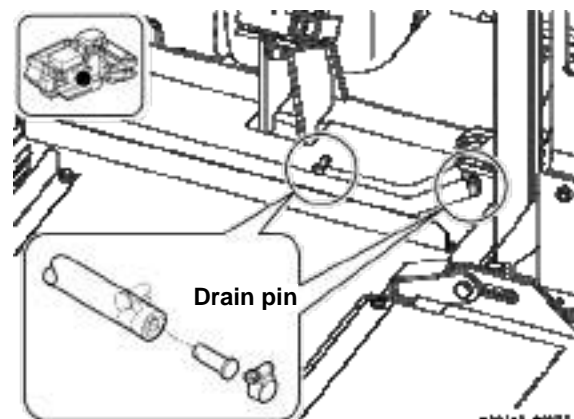

# Periodic Inspection

- 3- Mount the drain pin, add necessary anti-freezing liquid or long life coolant, and fill with pure water.
- 4- Mount the cover of main radiator cap and start up the engine to fully mix the anti-freezing liquid or long life coolant with cooling water.

Replacing interval	Cooling water level
1 year	Appr. 7.2L

### <Use of anti-freezing liquid>

Anti-freezing liquid can reduce the freezing point of water. Before delivery, the mixing ratio of the liquid is determined based on a cold resistance of -15°C, namely 70% water and 30% anti-freezing liquid. This mixing ratio should be adjusted if the ambient temperature is below -15°C.

Ambient temperature(°C)		-5	-10	-15	-20	-25	-30
Ratio	Water (%)	85	75	70	65	60	55
	Anti-freezing liquid (%)	15	25	30	35	40	45

### <Long life coolant>

It is suggested to use a long life coolant for diesel engine instead of clean water. The long life coolant avoids from rusting inside of the radiator.

### [Precaution]

- When replacing with new cooling water, be sure to add the anti-freezing liquid or long life coolant and perform idle running of the engine for 5 minutes to mix the liquid as quickly as possible.
- The mixing ratio, which varies with manufacturers, should be determined according to the instruction manual provided by the manufacturer.
- You can fill with pure water to make up natural consumption of cooling water.
- The effective period of anti-freezing liquid is 1 year. Therefore, replace with new anti-freezing liquid every year.

## 5. Replacing fuel filter

### ⚠ DANGER

Open flame is prohibited during operation.

### ⚠ WARNING

Be sure to wipe off fuel attached on all parts. Otherwise, fire hazard may be caused.

After opening the rear cover of engine, you can see the fuel filter above the rear part of engine, a black container connected with the fuel inlet pipe and the inlet pipe of injection pump. (This is a one-piece filter that can not be cleaned and should be replaced with a new one.)

Replacing interval	Every 200 hours
--------------------	-----------------

### <Replacing>

- 1- When mounting the new filter with air inside, turn the key switch to "ON" to exhaust air.

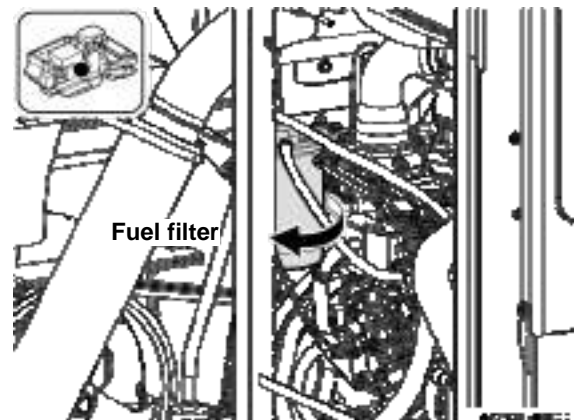



# Periodic Inspection

## 6. Cleaning the water separator

**⚠ DANGER**

Open flame is prohibited during operation.

**⚠ WARNING**

Be sure to wipe off fuel attached on all parts. Otherwise, fire hazard may be caused.

The water separator in the rear part of the machine can remove dirt and water in fuel.

### <Draining>

Dismount the drain bolt shown below to remove water and dirt.

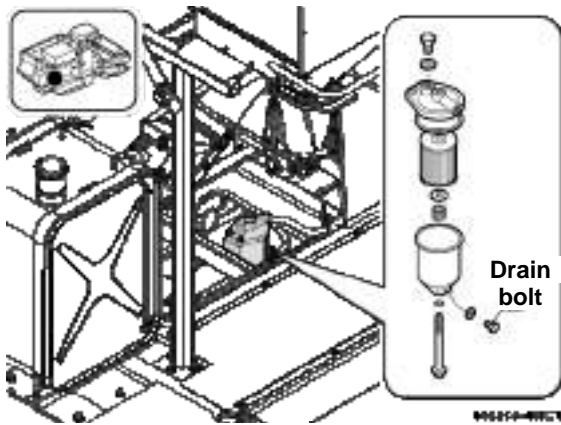

### <Cleaning>

Dismount the water separator to clean the filter element inside.

Item	Interval
Draining	Every 50 hours
Cleaning the filter element	Every 100 hours
Replacing the filter element	Every 200 hours

### [IMPORTANT]

The time of cleaning and replacing should be adjusted as per fuel quality.

## 7. Draining the fuel tank

**⚠ DANGER**

Open flame is prohibited during operation.

**⚠ WARNING**

Be sure to wipe off fuel attached on all parts. Otherwise, fire hazard may be caused.

The fuel tank is subject to water and dirt sediment inside. The sediments may enter the fuel pipeline to cause problems, thus should be removed regularly.

### <Draining>

Take off the drain plug at the bottom of the fuel tank to remove sediments inside.

Interval	Every 100 hours
----------	-----------------

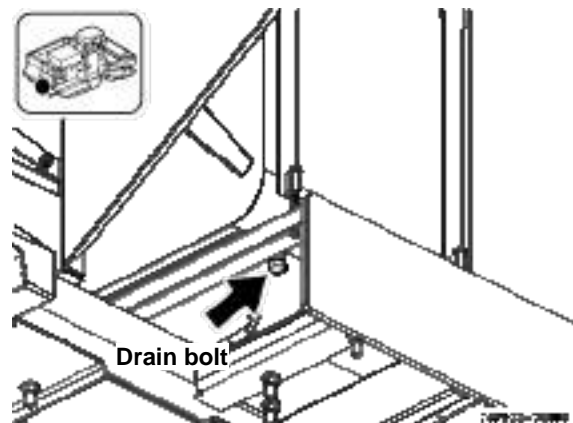
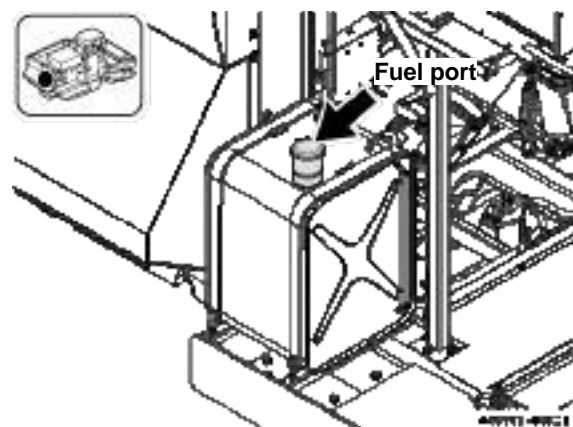

## 8 Bleeding fuel system

### ⚠ WARNING

Be careful to avoid fuel spilling on the engine fan belt, rubber vibration insulator, hose and other parts, and clean them with water if any to avoid fire hazard.

Air may enter the fuel system and result in stalling of the engine after fuel is used up.

1. Tighten the fuel tank cap after refueling.
2. Put the key switch to "ON", wait 20-30 seconds till air in the fuel pipeline is exhausted, and then move the switch to "Start" to start up the engine.

## 9. Cleaning and replacing the air filter

The air filter can remove dust in the air to prevent wear of parts inside the engine. As lots of dust may be generated during harvesting, the filter should be cleaned frequently (every day) and replaced every 400 hours.

Cleaning interval	Replacing interval
Every day	Every 400 hours

### <Cleaning and replacing>

1. Open the air cleaner cover.
2. Take out the filter element.
3. Use the compressed air (7 kg/cm<sup>2</sup>) to purge inside the element.

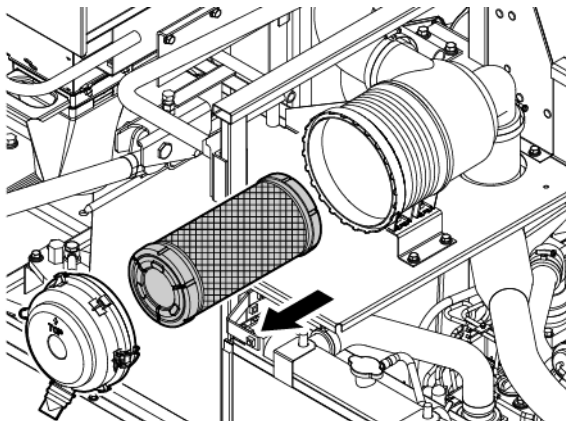

### [Precaution]

- Keep the filter element dry.
- Do not clean the filter element with water or oil.

### ⚠ CAUTION

- Engine oil may be consumed and failures be caused if the filter element is blocked.
- Be careful to prevent deformation of the element during cleaning. Otherwise, dust may enter and cause abnormal wear of the engine piston and cylinder.

## 10. Cleaning the engine dust protector

The air entry is designed for suction of cooling air. It may be accumulated with dust, thus should be cleaned with a soft brush after the engine is stopped. Open the engine room cover, and remove dust on it.

The screen of hydraulic oil cooler and radiator exposed to dust should also be cleaned.

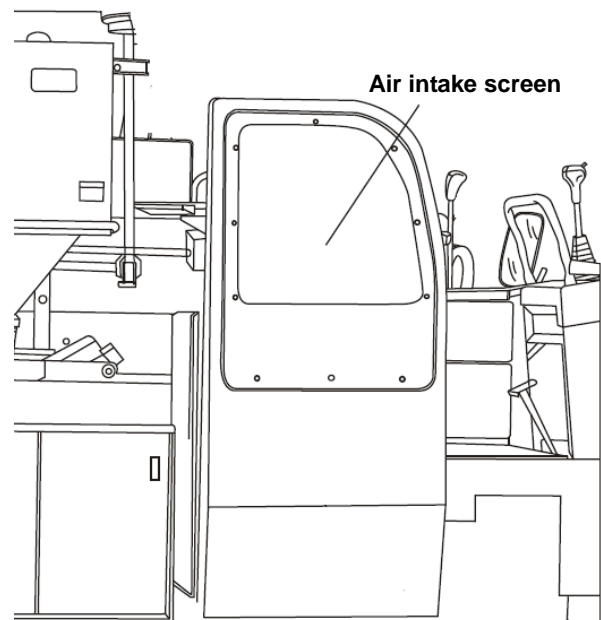



# Periodic Inspection

**[Precaution]**

Open the engine room cover to clean the hydraulic oil cooler inside it.

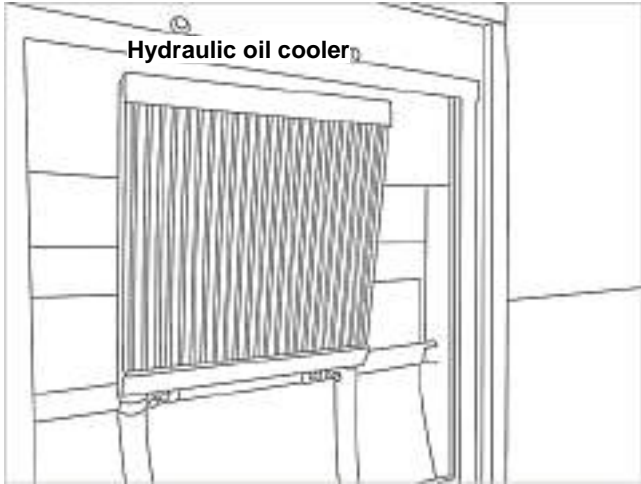

**<Cleaning the radiator screen>**

Open the engine compartment and dismount the radiator screen to remove chaff and dust on the side of hydraulic oil cooler.

- The screen must be cleaned before and after operation.

Chaff and dust on it should be removed in a certain interval.

**[Precaution]**

Use a brush to clean deep inside.

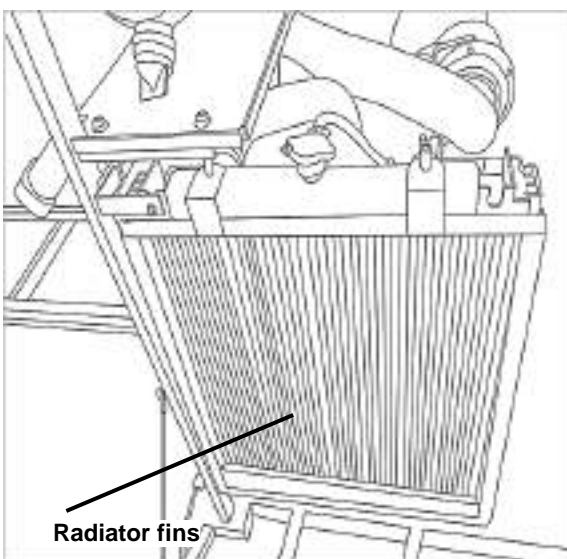

**[Precaution]**

- Check the screens frequently, and remove dust if any.
- Clean the fins of the radiator & the hydraulic oil cooler with a soft brush on a daily basis, and use the compressed air or low-pressure water to purge it after the busy season.
- The engine load may be increased if the air intake screen, the radiator screen and the fins of the radiator and the hydraulic oil cooler radiator are blocked by dust.

## 11. Maintaining the battery

The battery used for this machine is free of maintenance. It is sealed and does not need any water prior to expiry of the service life. Use a hydrometer to check the battery status. If the meter is "transparent", it means there is little electrolyte in the battery, service life of the battery is to expire, and the battery can be replaced.

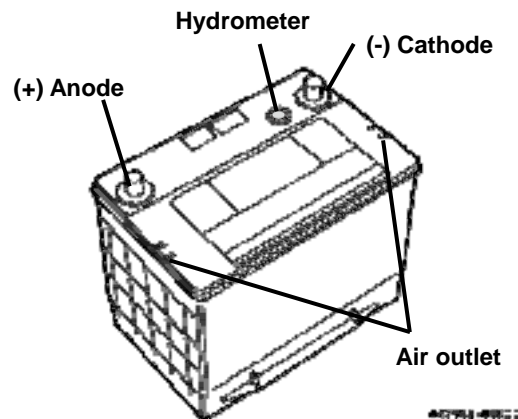

Designated battery	95D31L
--------------------	--------

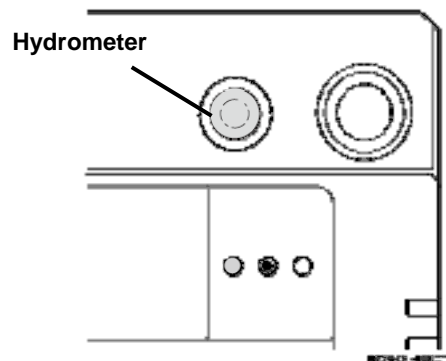

# Periodic Inspection

Hydrometer color	State of charge	Disposal
Green	Normal	Usable
Black	Discharged	To be recharged
Transparent (No color)	Little electrolyte	Service life expired; unable to start up the engine; battery to be replaced

## DANGER

- **Do not start up the engine after recharging of the battery if the hydrometer is “transparent”. Spark may be generated in the battery, igniting gas inside and causing damages to the battery when the engine is started.**
- **Wear safety goggles and rubber gloves when checking the battery.**
- **No children or any other persons who do not understand the operating method and dangers are allowed to check the battery.**
- **Do not block air vents of the battery. Otherwise, gas inside the battery may increase the internal pressure and cause damages.**

### [Precaution]

- Disconnect the cathode ((-) terminal) when removing electrical wires from the battery.
- Be sure to use the specified battery for replacement.
- Tighten the electrodes holding bolt of battery.

## Recharging

The battery should be recharged when the ambient temperature is low in cold areas, it is hard to start up the engine or the indicator lights out.

The battery should be recharged if the engine is not started up for over 2 weeks.

### <Method of recharging>

Remove the battery from the machine for recharging.

### <Method of direct recharging>

Connect the anode ((+) terminal) of the battery with anode ((+) terminal) of the charger, and the cathode ((-) terminal) of the battery with cathode ((-) terminal) of the charger for recharging at 7 Ampere for 8-10 hours.

### [Precaution]

For consideration of environmental protection, the battery replaced should not be discarded at random, but be handed over to a professional agent for treatment.

## 12. Checking the piping system

### WARNING

- **Fire hazard may be caused by fuel leakage due to aging and damages of fuel pipes. Check the piping system before and after operation, and replace in case of leakage.**
- **Do not forget to check the drain pipe of the engine oil. Otherwise, fire hazard may be caused in case of damage.**
- **Check the metal fasteners during oil and water leakage inspection.**

# Periodic Inspection

## 13. Checking the muffler

### ⚠ WARNING

The muffler is designed with small holes that may give out sparks and cause fire. Check the muffler every 200 hours.

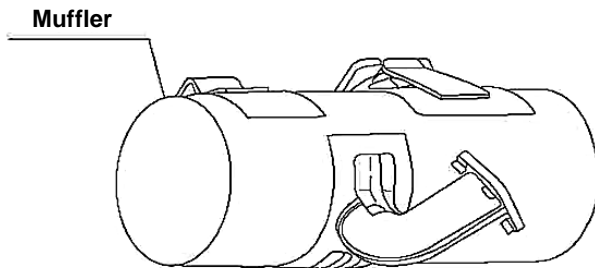

## 14. Checking the electrical wiring

### ⚠ WARNING

- Remove the chaff and dust on the battery and wiring before and after operation to prevent fire.
- Check whether the electrical wire is in contact with other parts, the coating has peeled off or the connections are loose, and repair in case of damage

## 15. Maintaining and adjusting the cutter blades

### ⚠ WARNING

Be sure to fix the safety lock of the header. Otherwise, it may fall down rapidly and cause injuries.

### ⚠ CAUTION

Do not touch the cutter blades during maintenance or replacement to avoid injury.

Adjust the gap between cutter blades if the crops could not be cut off.

### <Adjusting>

- 1- Raise the header to the highest position and fix it.
- 2- Adjust the upper and lower gaps between backing edge and cutter blades by slightly hammering the front end of shims or adding gasket to the loosened nuts.
- 3- Adjust the front and rear gaps between blades by loosening the fixing nuts and moving the friction plate forward or backward.

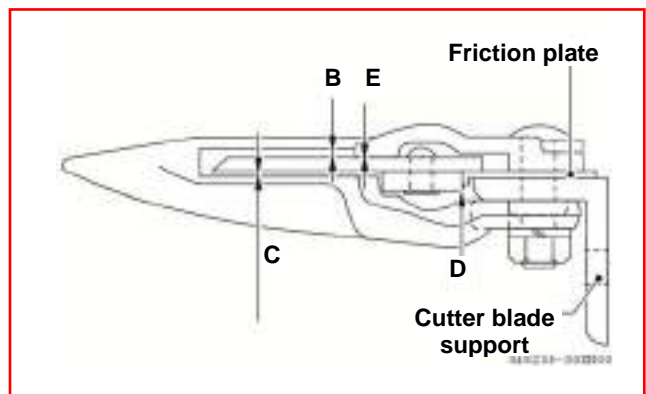
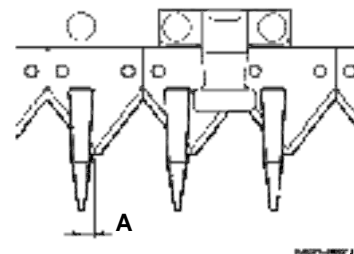

# Periodic Inspection

Deviation between cutter blade and backing edge at the end of stroke A (0-3mm)

Max. gap between the upper side of cutter blade and backing edge B (1.7mm)

Max. gap between the lower side of cutter blade and backing edge C (0.5mm)

Max. gap between the front and rear ends of cutter blade D (0.79mm)

If the gap is too large, adjust with a shim (accessory).

## [Precaution]

- Do not screw the adjusting bolt M8 too tight.
- Remove chaff, mud and oil on cutter blades after daily operation.
- Raise the reel to the highest position when adjusting cutter blades.
- In the fixed part of the backing edge, there might be spacers for the gap adjustment.

## <Checking>

The cutting blade is installed perpendicularly to the cutting blade drive (the knife head and the drive are positioned in parallel.)

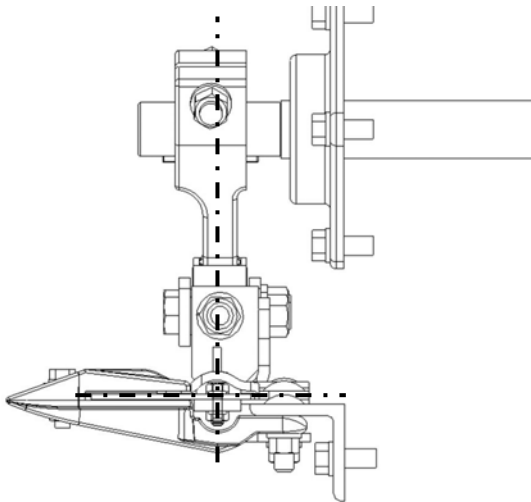

## 16. Adjusting the gap between platform auger and base plate

### ⚠ WARNING

Be careful that both the cutter blades and reel will move when you rotate the platform auger with hand.

### <Adjusting>

- 1- Raise the reel to the highest position.
- 2- Loosen the 8 fixing bolts on both ends of the auger.
- 3- Use the adjusting bolt to set the auger to a proper height.

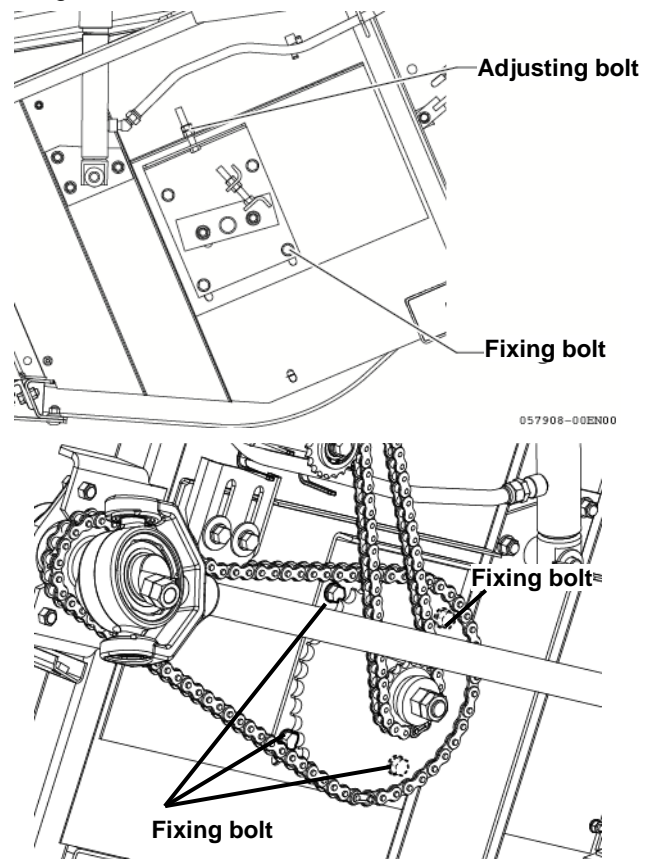

- 4- Adjust the gap between the auger and base plate to

$9 \pm 1$ mm.

- 5- Tighten the fixing bolts on both ends of the auger.

# Periodic Inspection

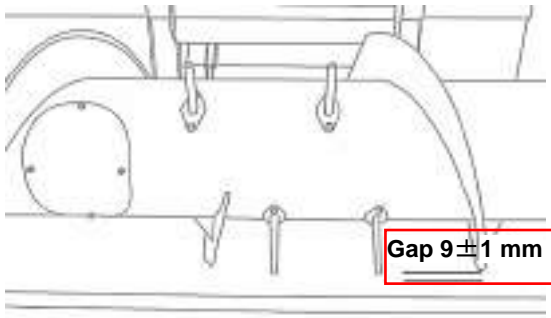

## 17. Adjusting the gap between platform auger finger and base plate

### ⚠ WARNING

Be careful that both the cutter blades and reel will move when you rotate the platform auger with hand.

#### <Adjusting>

- 1- Rotate the header manually to make the central finger of auger as close to the base plate of header as possible.

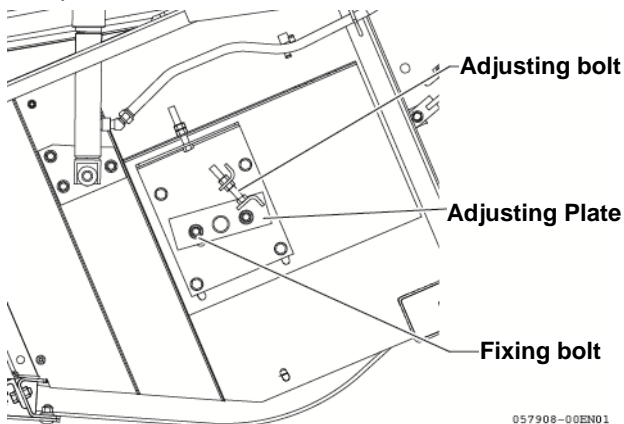

- 2- Loosen the 2 fixing bolts of the adjusting plate.
- 3- Rotate the adjusting plate by turning the adjusting bolt to get a gap of  $5 \pm 1 \text{ mm}$  between the front end of auger finger and the base plate.

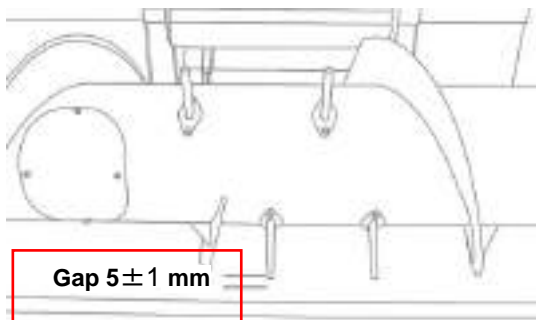

## 18. Adjusting the position of reel

### ⚠ WARNING

Be careful that both the cutter blades and reel will move when you rotate the platform auger with hand.

#### <Adjusting>

- 1- Set the reel on the lifting arm in the back-end position.

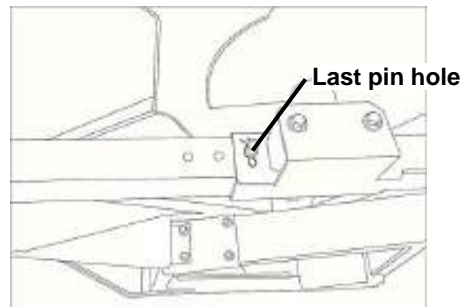

- 2- Loosen the fixing nuts at the end of the lift cylinder.

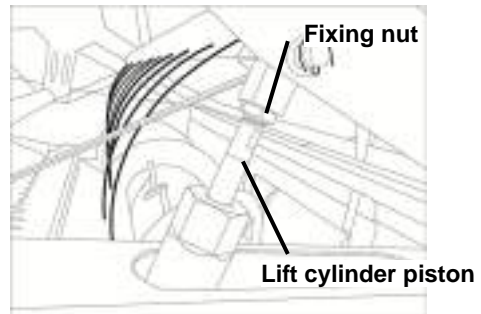

- 3- Rotate the lift cylinder piston.
- 4- Set the gap between reel tine and cutter blade A at  $30 \pm 5 \text{ mm}$ , and that between the platform auger B at  $32.5 \pm 7.5 \text{ mm}$ .

#### [Note]

Rotate the reel in the direction of normal rotation during adjusting.

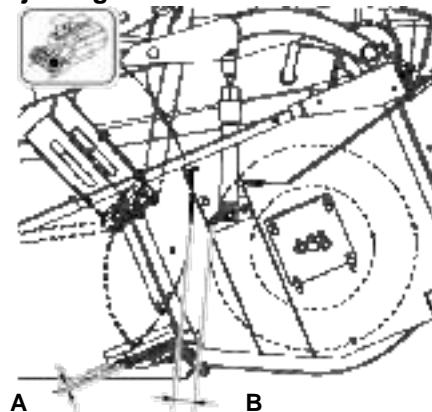



# Periodic Inspection

## 19. Checking and replacing fuse

### ⚠ WARNING

**Do not use any fuses not specified. Otherwise, fire hazard may be caused.**

Use the specified fuse for replacement if the fuse in the fuse box breaks.

In case the fuse is once again broken after replacement, take it to the dealer for checking.

The fuse box is located in the left board under the driver's seat.

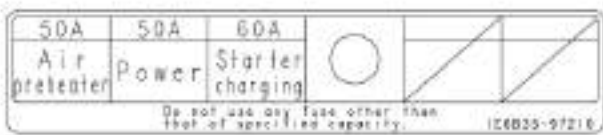
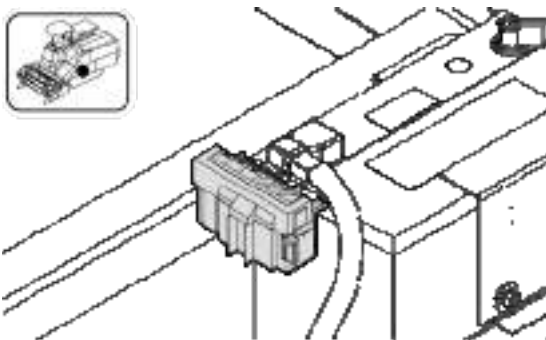
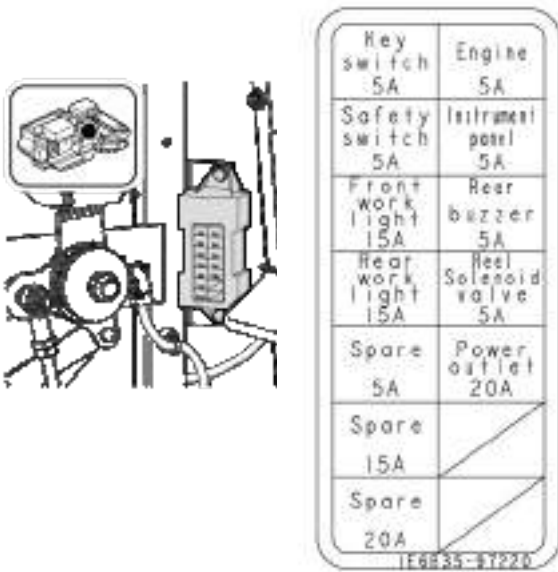

**Do not use any fuse other than that of the specified capacity.**

## 20. Adjusting the chains

### Header drive chain

Bending A ( $15 \pm 3\text{mm}$ ) of the chain when you press the central part (part B) slightly by hand.

#### <Adjusting>

- 1- Remove the upper and lower covers of threshing section.
- 2- Remove the fixing bolts of tension wheel.
- 3- Use the adjusting bolt to tension the chain.
- 4- Fasten the fixing bolt and mount the side covers.

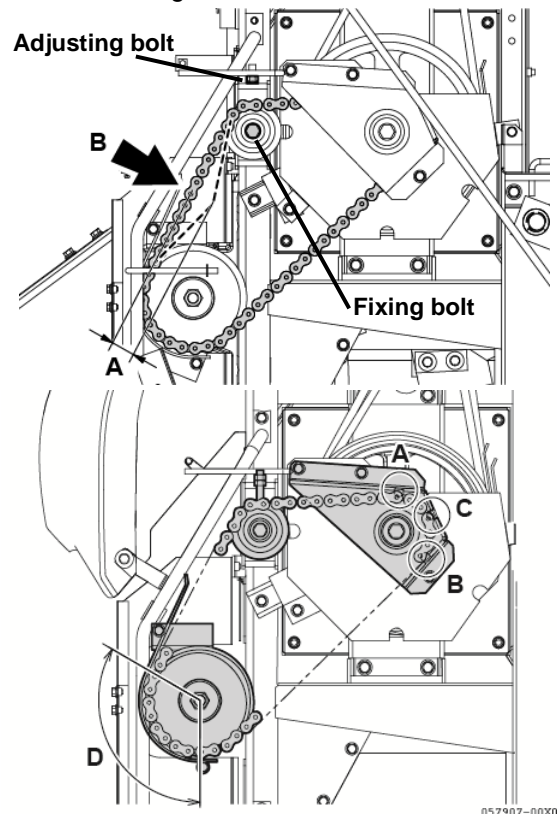

#### [Note]

**Check whether there is a space between the covers with the chain at A, B, C, and zone D.**

### Drive chains of the platform auger and reel

Bending A of the reel drive chain ( $16 \pm 3\text{mm}$ ) and B of the platform auger drive chain ( $19 \pm 3\text{mm}$ ) when you press the central parts (A and B) slightly by hand.

#### <Adjusting the reel drive chain>

- 1- Remove the right side cover of the header.
- 2- Loosen the fixing bolt to move the tensioning wheel.
- 3- Screw down the fixing bolt and mount the upper side cover.

# Periodic Inspection

## <Adjusting the header auger drive chain>

- 1- Remove the right side cover of the header.
- 2- Loosen the fixing bolt to adjust the tensioning nut.

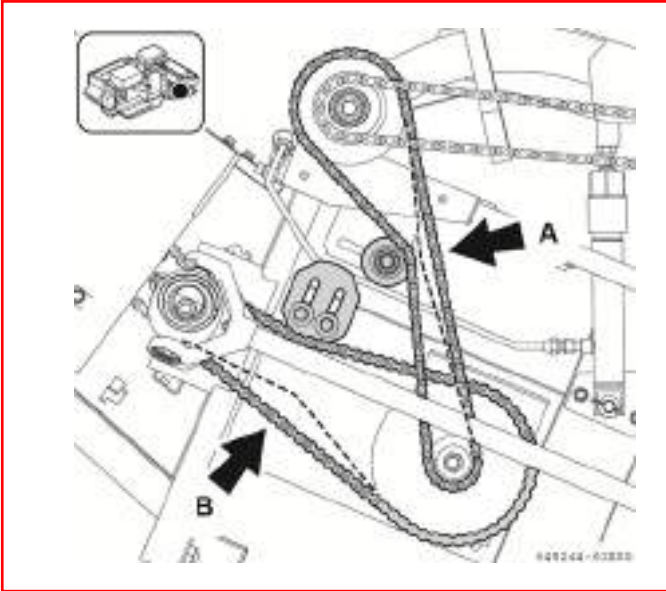

## <Adjusting the feeder house drive chain>

- 1- Remove the chain cover.
- 2- Rotate the feeder house drive chain by hand.
- 3- Adjust the left and right sides concurrently.

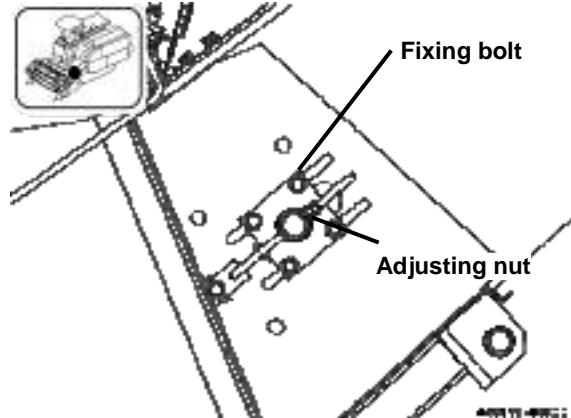

- 4- Loosen the fixing bolt and turn the adjusting nut.
- 5- Tighten the fixing bolt and mount the cover.

## Reaping section drive chain

The bending is about  $20 \pm 3\text{mm}$  when you press the central part (part A) slightly by hand.

## Feeder house drive chain

The gap between the chain slat and the bottom of feeder house is over  $6 \pm 1\text{mm}$  (part A).

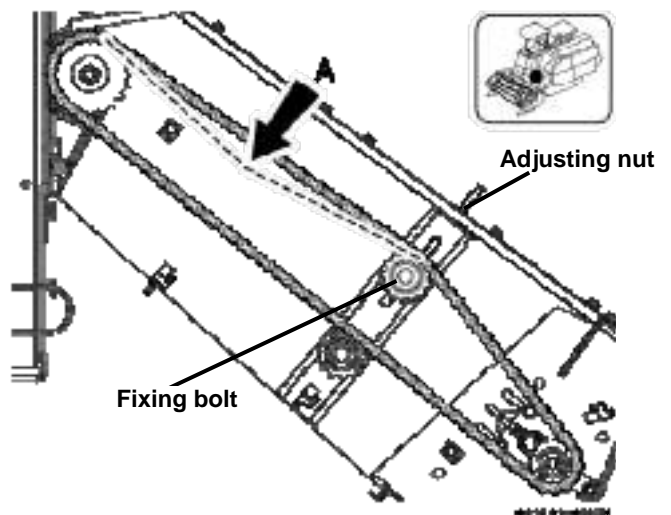
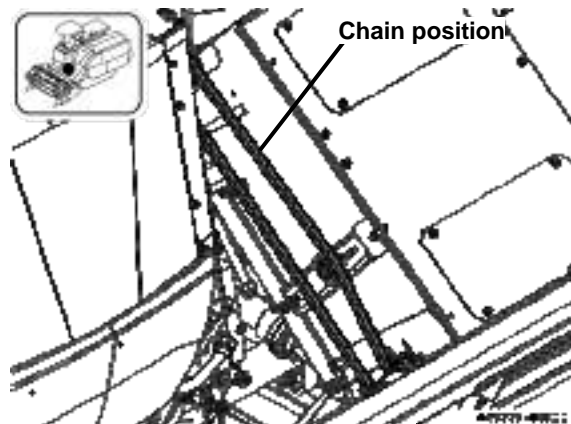
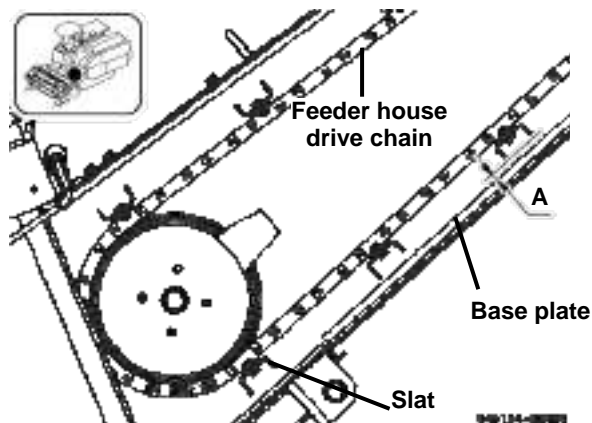
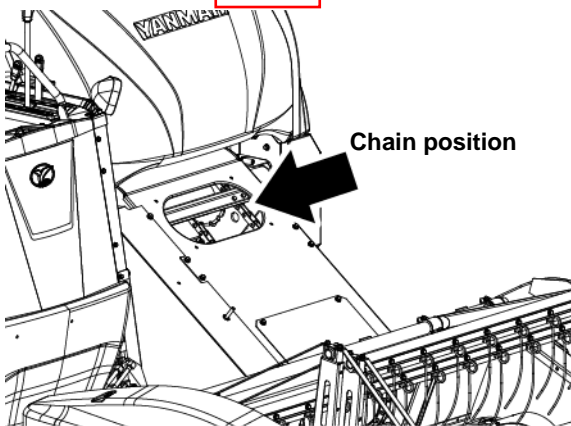

# Periodic Inspection

- 1- Loosen the fixing bolt and use the adjusting nut to change the chain tension.
- 2- After checking the bending of part A, tighten the bolt and mount the side cover.

## 21. Adjusting the belts

### Checking the belt tensioning wheel

#### **⚠ WARNING**

Spark may be generated during operation and cause fire if the belt tensioning wheel is in contact with other parts (except the belt).

#### [Precaution]

Check whether the belt tensioning wheel is in contact with other parts before daily operation. Adjust immediately in case of contact, and check the internal bearing of belt wheel.

### Cooling fan belt (engine)

Press the belt center with your finger to adjust the deflection to  $12.5 \pm 2.5 \text{mm}$ .

#### <Adjusting>

- 1- Open the engine room cover.
- 2- Loosen the fastening bolt of generator.
- 3- Draw the generator to the direction of arrow to tension the belt.
- 4- Tighten the fastening bolt.

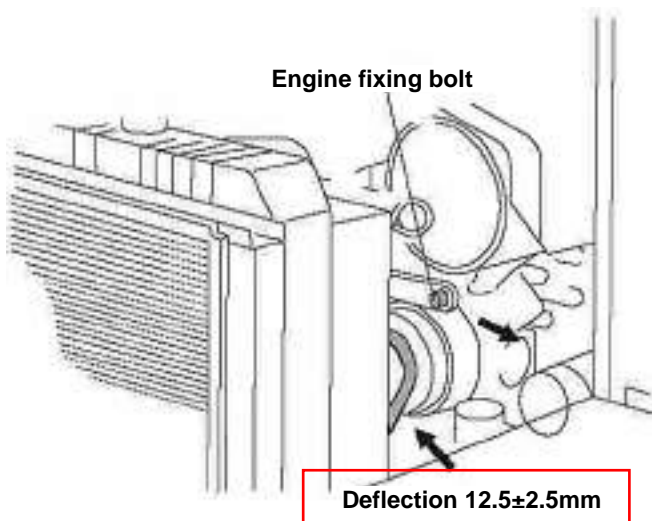

### Adjusting the tension of threshing clutch belt

Put the threshing clutch lever to "ON" and check whether the size of tension spring falls between  $190 \pm 2 \text{mm}$ .

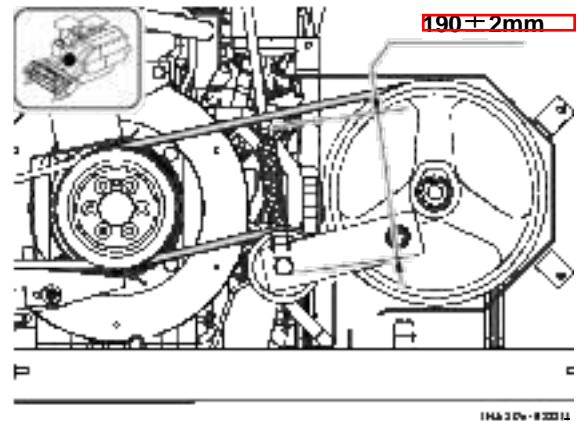

#### <Adjusting>

- 1- Remove the two covers of engine rear side.
- 2- Put the threshing clutch lever to "ON".
- 3- Loosen the lock nuts (2 pieces) of threshing clutch lever, and use the tensioning screw to adjust the spring length to  $190 \pm 2 \text{mm}$ , as shown below.



### Adjusting the tension of header clutch belt

Put the header clutch lever slightly to "ON" and check whether the tension spring size falls in  $233 \pm 2 \text{mm}$ .

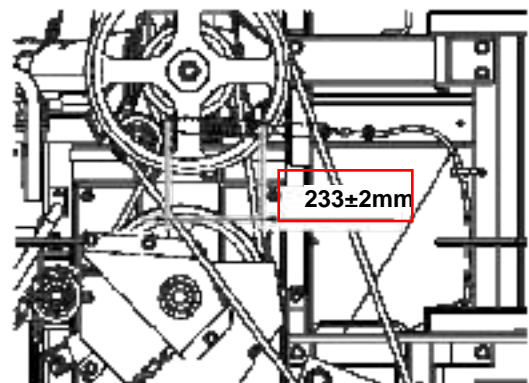



# Periodic Inspection

## <Adjusting>

- 1- Open the upper cover of the threshing section.
- 2- Put the header clutch lever to "ON".
- 3- Use the header clutch wire (part B) to adjust the spring length to  $233\pm 2\text{mm}$ , as shown below.

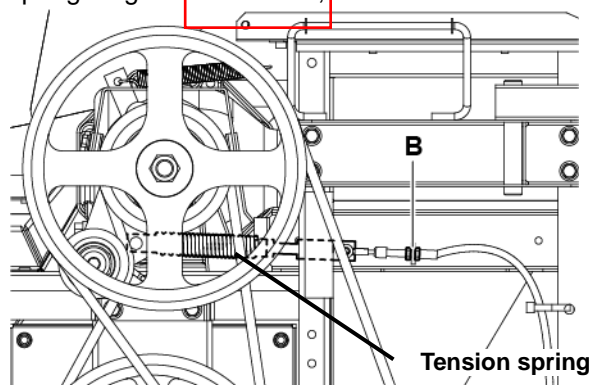

## Threshing rotor drive belt

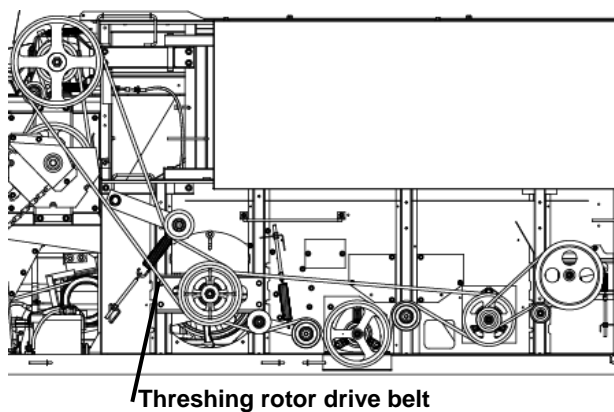

Adjust the tension spring length to  $270\pm 2\text{mm}$ .

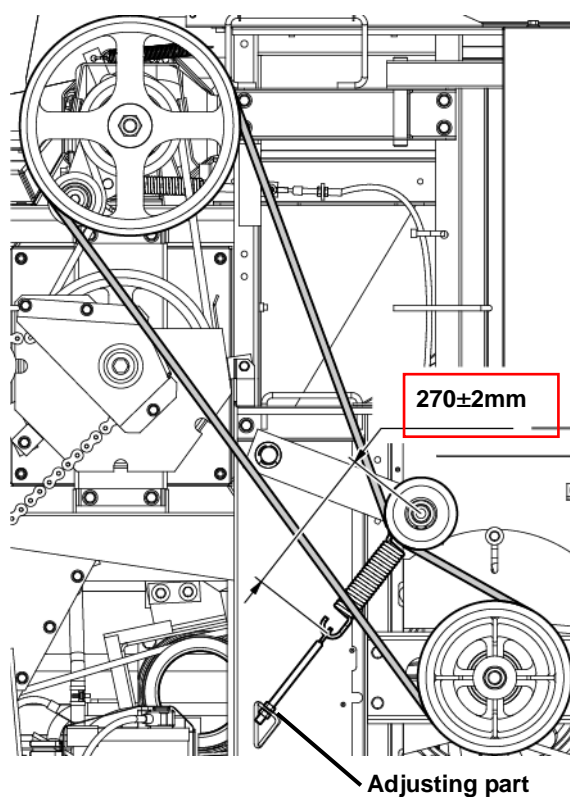

## <Adjusting>

1. Remove the side cover of the threshing section.
2. Loosen the lock nut and turn the adjusting nut to change the spring length.
3. Fix it with the lock nut.

# Periodic Inspection

## Screening belt

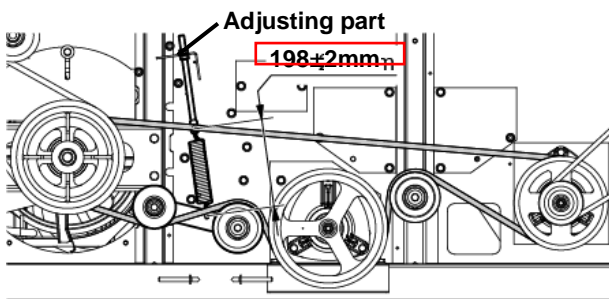
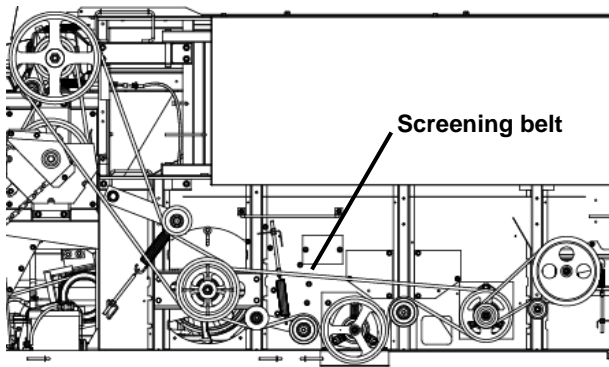

### <Adjusting>

1. Remove the lower cover of the threshing section.
2. Loosen the lock nut and turn the adjusting nut to change the spring length.
3. Fix it with the lock nut.

## Swing separator drive belt

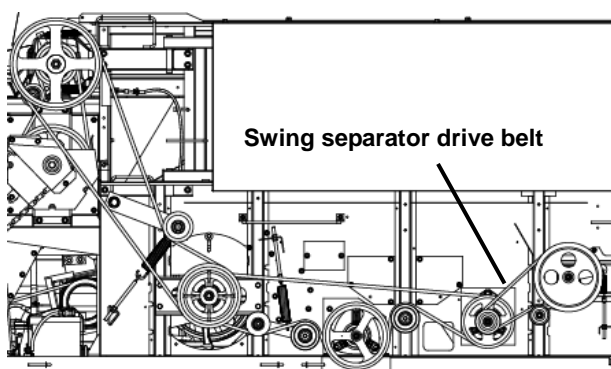

Adjust the tension spring length to  $106\pm 2\text{mm}$ .

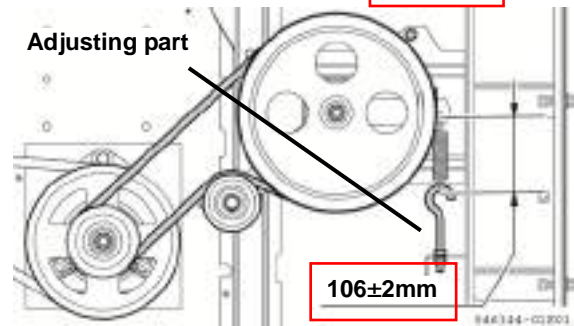

### <Adjusting>

1. Remove the lower cover of the threshing section.
2. Loosen the lock nut and turn the adjusting nut to change the spring length.
3. Fix it with the lock nut.

## Transmission drive belt

### ⚠ WARNING

**Be sure to fix the safety lock of the header. Otherwise, it may fall down rapidly and cause injuries.**

### <Adjusting>

1. Loosen the lock nut, and use the nut to adjust the hook length of traveling tension spring to  $150\pm 2\text{mm}$ .
2. Fix it with the lock nut.

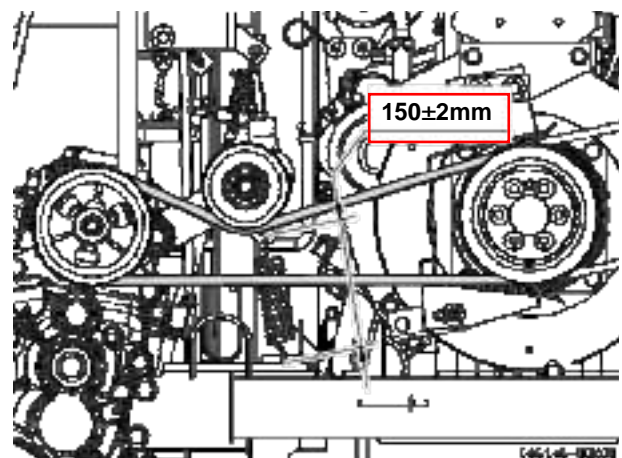

# Periodic Inspection

## Adjusting the resetting mechanism of main shift lever

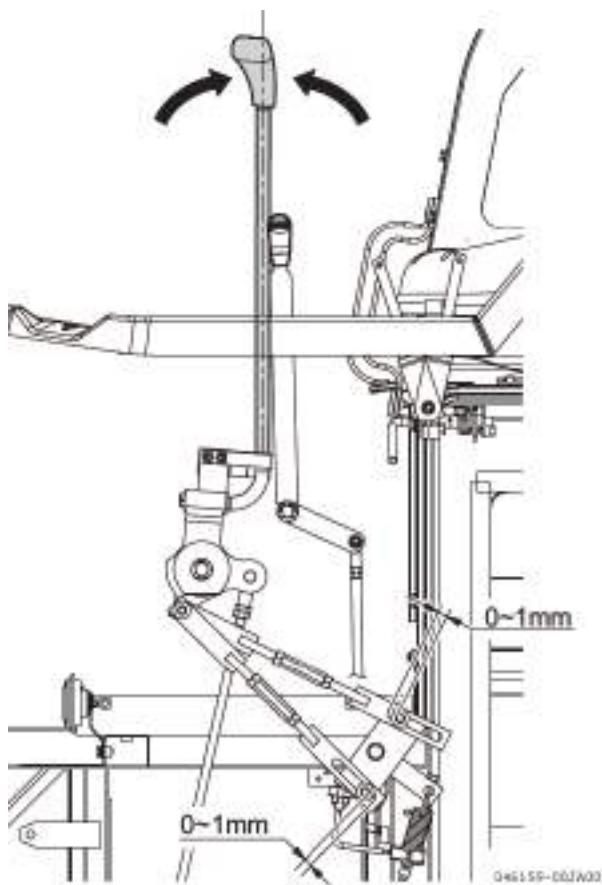
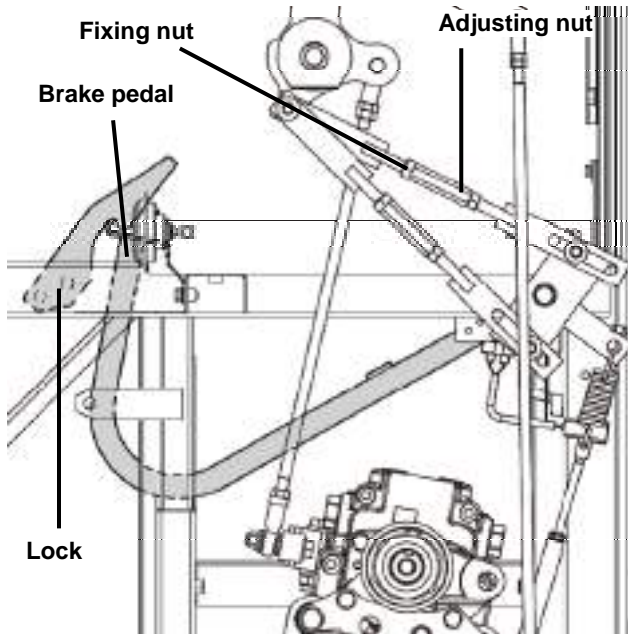

### <Adjusting>

1. Engage the brake pedal lock.
2. Put the main shift lever to "Neutral", loosen the fixing nuts on both ends of the adjusting section, and turn the adjusting nut to control the gap between the inner surface of pin hole and pin outer surface of the pin within 0-1mm.
3. Fix it with lock nuts.

## Adjusting the brake pedal

### <Adjusting>

1. Engage the brake pedal lock.
2. Use the nut to adjust the hook length of tension spring to  $110.2 \pm 0.5 \text{mm}$ .
3. Fix it with lock nuts.

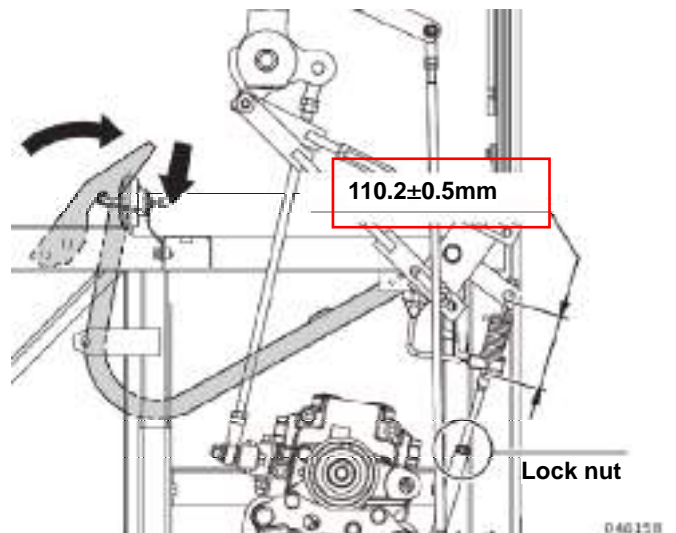

# Periodic Inspection

## Adjusting the steering system

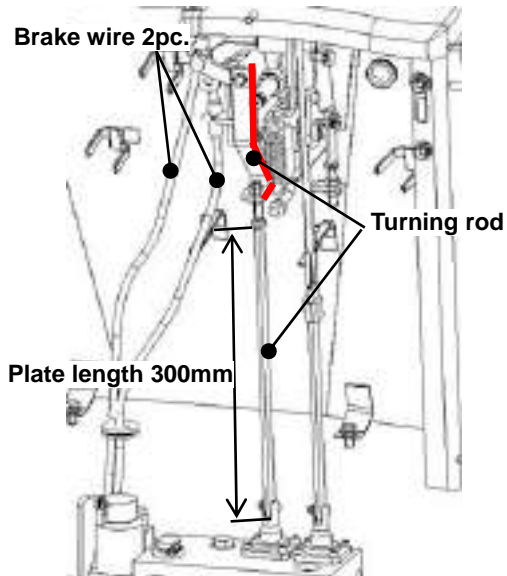

### [Note]

Be sure to install the turning rod to the correct position (direction).

### 1. Adjustment of the turning lever neutral position

Adjust the tightening position of the nut (C) so that the clevis pin (B) loosely moves (with no pressure or tension applied to the turning rod) when there is no clearance between the turning link and the stopper pin (A) (pinching the turning link from the top).

### [Note]

- Make sure that there is no torsion in the rod when tightening the nut.
- Be sure to lock with the nut.

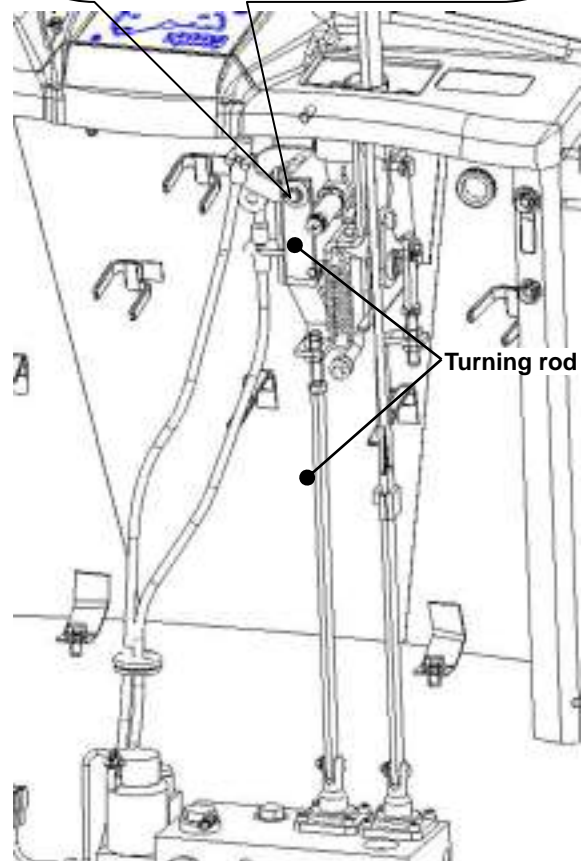
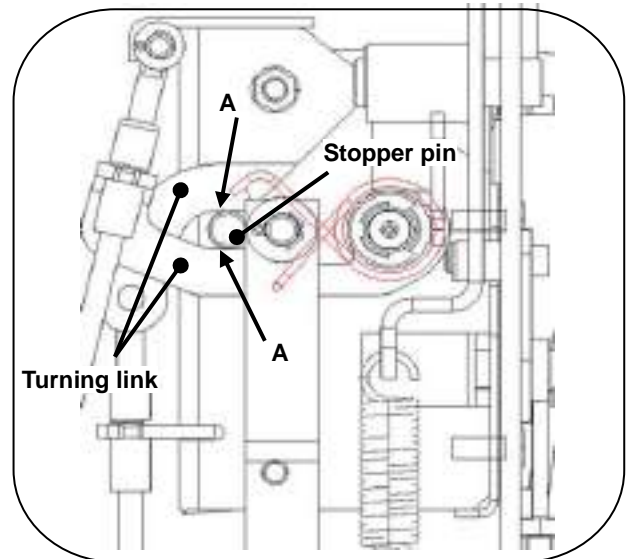

If the neutral position of the turning lever is not adjusted correctly, the following problem may occur.

- The response that the operator feels when turning right and left varies
- Adjustment procedure 3 (Page 93) is not satisfied.

# Periodic Inspection

## 2. Adjustment of the spool machine bolt located on the upper side of the actuator

Machine bolt margin E:  $17.5 \pm 1$  mm (both right and left)

### [Note]

Be sure to lock with the nut.

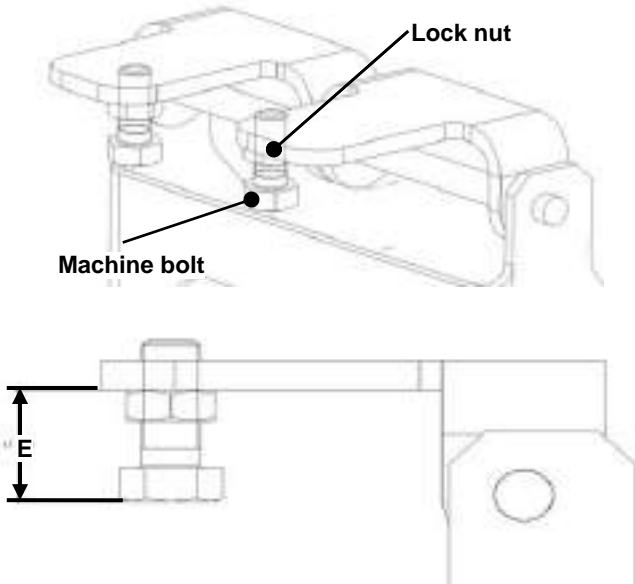

If dimension E is not adjusted correctly, the following problem may occur.

- The response that the operator feels when turning right and left varies
- Adjustment procedure 3 (Page 93) is not satisfied.

## 3. Adjustment of brake wire

The clearance between the spool on the upper side of the actuator and the machine bolt while lifting the machine bolt fixing seat when the turning lever is in the neutral position.

H:  $10 \pm 1$  mm (both right and left)

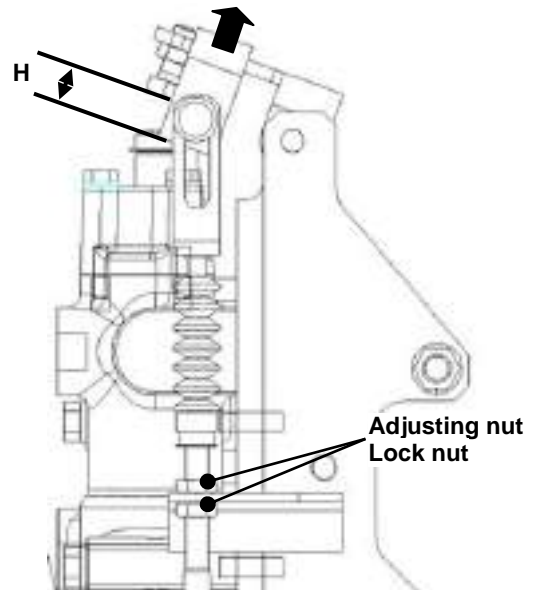

If dimension H is insufficient, the following problem may occur.

- Sudden turning when operating the turning lever
- Excess lever operating force
- Premature wear to the side clutch blade



# Periodic Inspection

The spool retaining ring clearance on the upper side of the actuator when the turning lever is fully turned down  
G: 0-1 mm (both right and left side)

<The turning lever is in the neutral position>

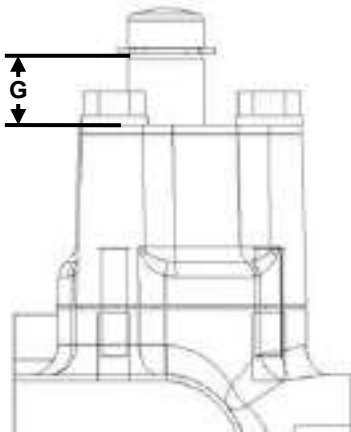

<The turning lever is fully turned down>

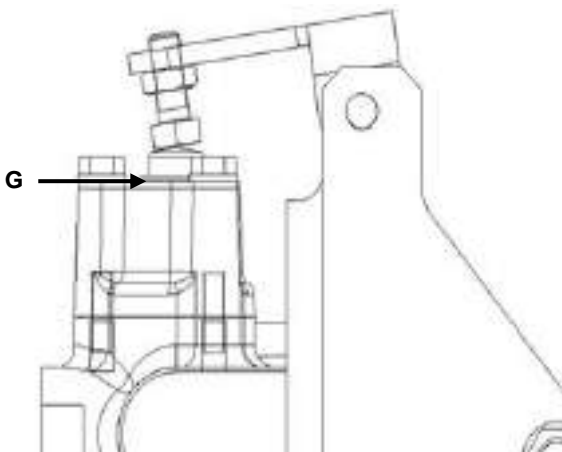

If dimension G is more than the specified dimension, the following problem may occur.

- Turning with one of the side clutch brakes engaged cannot be performed at an early stage.

### [Note]

Be sure to lock with the nut.

## 4. Clearance adjustment between the SC lever and the machine bolt attached at the bottom of the actuator.

The clearance between the machine bolt and the SC lever while taking the play in the SC lever at the bottom.  
J: 0-0.5 mm (both right and left)

### [Note]

- Make sure that dimension J is not a minus value. (SC lever is being pushed.)
- Be sure to lock with the nut.

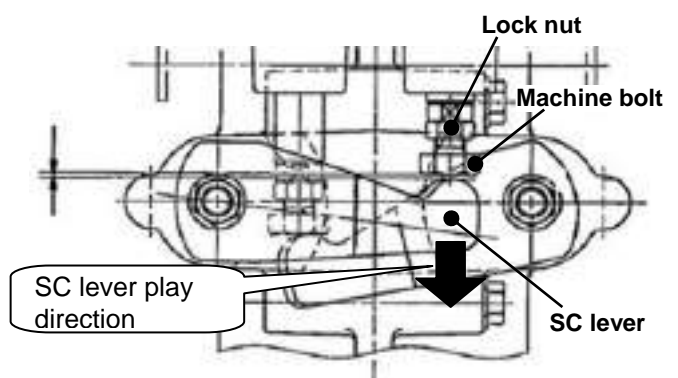

If dimension J is more than the specified dimension, the following problem may occur.- Turning with one of the side clutch brakes engaged cannot be performed at an early stage.

If dimension J is a minus value, the following problem may occur.

- Parts inside the transmission become worn
- Transmission oil temperature increases

## 5. Checks after adjustment

- Machine turns with one of the side clutch brakes engaged (inner crawler stops) when the turning lever is fully pushed down. (Both right and left)
- Turning with one of the side clutches disengaged, gradual turning, or turning with one of the side clutch brakes engaged, can be performed depending on the pushing angle of the turning lever. (Both right and left)
- The response that the operator receives from the right and left sides is the same.
- Nut is not loose and adjustment is not displaced after the test operation.

# Periodic Inspection

## 22. Checking and adjusting the crawler

Jack up the chassis and the lower part of transmission to adjust the gap between the 4th track roller and the crawler to  $12.5 \pm 2.5$ mm.

### <Adjusting>

Jack up the machine on a level ground. The jack capacity must be over 3 tons. Support the chassis (pipe), left and right sides of chassis.

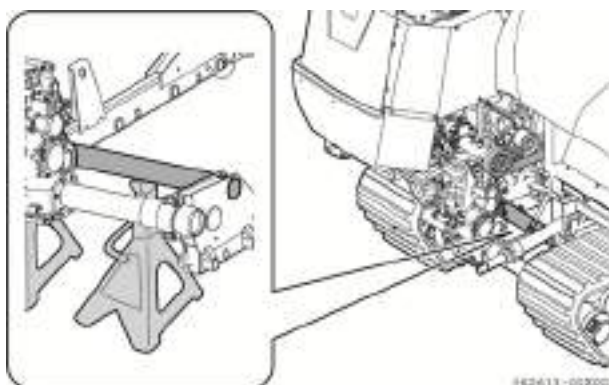

Add a buffer (wood plank) between the jack and transmission

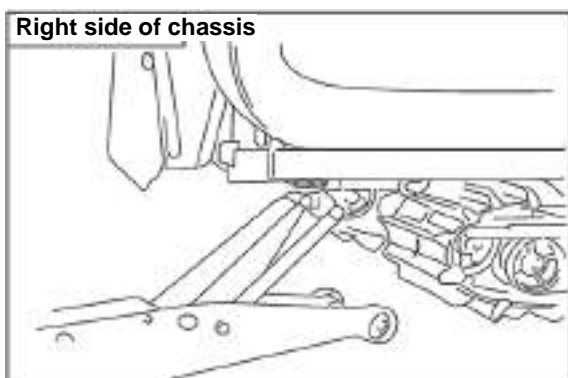
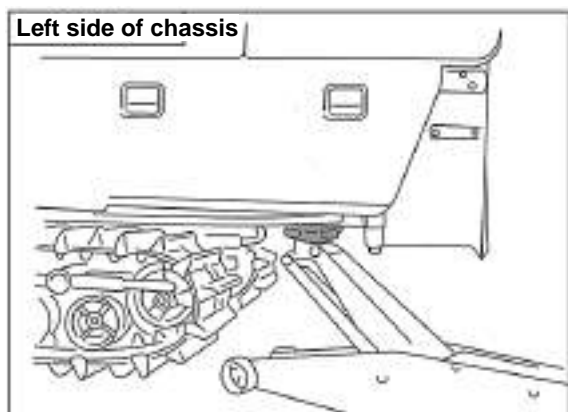

### <Adjusting>

- 1- Remove the adjust nut stopper.
- 2- Loosen the lock nuts.
- 3- Turn the adjusting nut to set the gap.

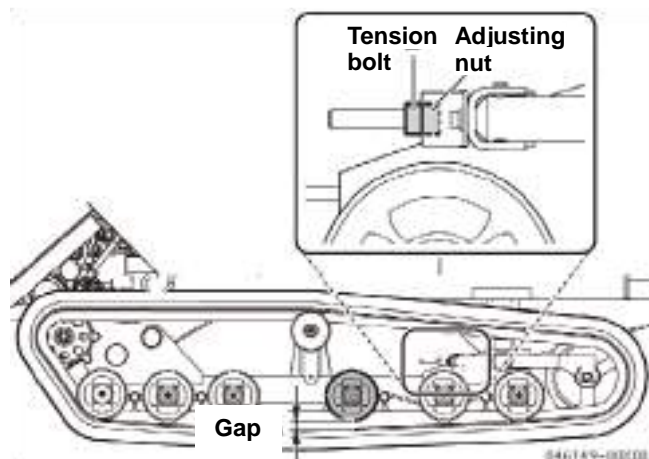

### [Precaution]

Do not tension the crawler too tight (gap below  $12.5 \pm 2.5$ mm)

The crawler will be lengthened within a short time if it is excessively tensioned. As a result, the gap between the driving sprocket and the crawler will be widened, and the crawler iron core may be in contact with the driving sprocket, causing abnormal wear and damage.

# Periodic Inspection

## <Crawler structure>

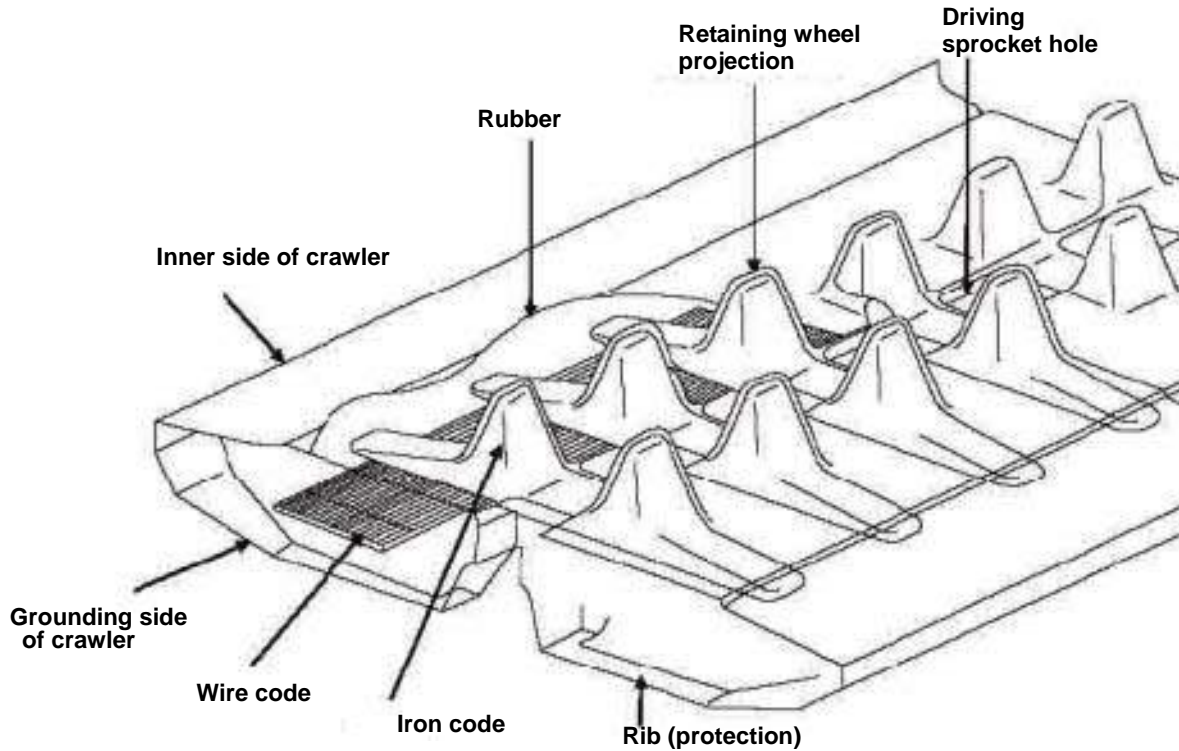

## <Common damages and failures of the crawler and the causes>

●-Most related

▲-Related

Cause \ Damage/failure	Tension of crawler	Driving method	Road condition	Poor cleaning/maintenance	Poor storage
Iron core wear, breakage and fall-off	▲	●	▲	▲	
Rib/projecting part damage		●	●		●
Damage of crawler inner side	▲	●	▲	▲	
Fatigue/damage of each parts		●	●	●	
Wire cord breakage	▲	●	●		
Driving sprocket wear	●	●	▲		
Track roller / idler roller wear		▲	▲	▲	
Insufficient traction	▲				
Crawler falling off wheel	●	●	▲		



# Periodic Inspection

## <Main causes of crawler damage>

- Traveling/moving along steps or ridges



- Traveling over bridge.

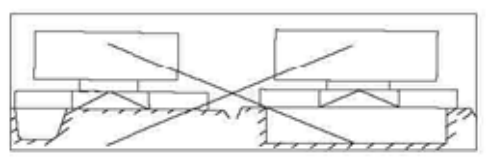

- Traveling on roads with sharp bumps (steel bar, stone etc.).

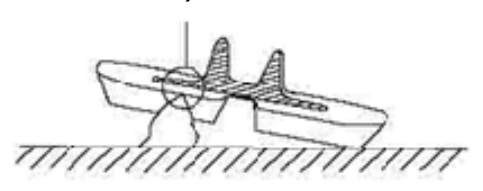

## [Other precautions]

- Operating temperature -20°C~55°C.
- Chemicals, oil and salt in sea water may damage the track.
- It is prohibited to climb up steps or cross deep ditches directly. Any steps or deep ditches should be leveled with soil or wood.
- It is prohibited to drive obliquely on a slope to prevent accidents caused by the crawler running off the rails.
- It is prohibited to turn abruptly during traveling at a high speed. Otherwise, the crawler may fall off the rails and cause accident.
- It is prohibited to travel on roads in a long distance. Use a truck or other vehicles for long-distance traveling.
- It is prohibited to use any ramp boards without anti-skid measures.
- Check the crawler tension on a regular basis for timely adjustment. Otherwise, wear of the driving sprocket and iron core of the track may be early.
- Check the wear condition of driving sprocket, idler wheel and track roller, and replace when necessary to prevent damage and crack of the crawler.
- Try to avoid crossing the ridge or ditch during field operation, so as to prevent damage and crack of the crawler.
- Timely remove the mud, straw and other foreign matters stuck in the crawler if any. Otherwise, the traveling resistance may be increased.
- Reducing the power may lead to crawler crack, inner side scratch and early wear of the driving sprocket.
- The track must be correctly tensioned. It may run off the rails if it is tensioned too loosely, or break if tensioned too tight. In case of abnormal wear of the driving sprocket, the crawler core may be drawn out and lead to crawler damage, as shown below.



Wear condition of driving sprocket



## [Note]

The driving sprocket should be replaced if the dimension measured by the calipers shown above is <20mm.

# Trouble shooting

**In the event that mechanical condition becomes worse, turn off the engine and engage the brake pedal lock firstly, and then perform trouble shooting as instructed below to prevent accidents. Contact the dealer if you could not handle a failure.**

## 1. Engine section

Condition	Check	Remedy
Starter motor does not work when the key switch is turned to "Start"	Brake pedal stepped?	Put the key switch to "Start" after stepping the brake pedal to the floor
	Threshing clutch lever in "ON" position?	Put the lever to "OFF"
	Dead battery?	Recharge the battery
	Battery terminals loosened or corroded?	Clean the terminals and apply antirust oil on them after tightening
	Fuse blown?	Replace the fuse
Starter motor rotates, but the engine can not be started	Does the fuel pump work? (Blown fuse or faulty fuel pump)	Replace the fuel pump
	Any fuel in the fuel tank?	Refuel
	Fuel pipe damaged?	Replace the fuel pipe
	Air mixed in fuel?	Exhaust air
	Range shift lever in the "N" (neutral) position?	Put the lever to "N"
	Water leaking into the fuel tank?	Drain water accumulated in the fuel filter or water separator
	Is the pipe blocked after the fuel tank is contaminated?	Clean the fuel tank and pipe
Engine stops unexpectedly during operation	Any fuel?	Refuel

## ***Trouble shooting***

---

### **2. Harvesting and conveying section**

Condition	Check	Remedy
Crops not conveyed	Cutter blades and conveying chain stuck by grass, straw, mud, stone or other foreign matters?	Check the blades and chain, and remove the foreign matters if any.
	Header drive belt loosened?	Adjust the belt
Rice root pulled out	Crop divider cuts in the root of crop?	Adjust the front end of reel
	Too rapid harvesting?	Harvest at a speed suitable to the condition of crops and field
	Cutter blades?	Adjust the gap between cutter blades
Heavy loss in the reaping section	Crops accumulated in the front of cutter blades?	Lower the reel so that crops can flow smoothly from the cutter blades to the platform auger
	Header too high, or the harvested crops too short?	Lower the header as crops should be appropriately long to be evenly conveyed to the platform auger
	Reel presses the crops when reverse harvesting?	Adjust the reel to a proper height
Reel stuck	Angle of reel tines too small?	Adjust the angle of reel tines properly
	Reel too low?	Adjust the reel to a proper height
Entry of clay and stone	Header too low?	Raise the header to a proper height

## ***Trouble shooting***

### **3. Threshing and screening section**

Condition	Check	Remedy
Crops not threshed completely	Revolving speed of the threshing rotor too low?	Check the engine tachometer, and adjust the accelerator lever to raise the engine speed to the "Green zone"
	Chaff discharge adjust lever in the "Open" position?	Put the lever to "Close" side
	Insufficient feed of crops?	Raise the harvesting speed slightly
	Crops conveyed unevenly?	Speed up harvesting, and lower the reel backward if it is too near the front
Grain splashing	Chaff discharge adjust lever in the "Open" position?	Put the lever to "Close" side
	Engine speed too high?	Check the engine tachometer, and adjust the accelerator lever to raise the engine speed to the "Green zone"
	Angle of the chaff sieve of swing separator adjusted improperly?	Adjust to an appropriate angle according to the crop condition
	Air volume of fan selected properly?	Adjust correctly
Abnormal sound in the threshing section, or efficiency decreased	Crops wet out by dew?	Harvest after crops become dry
	Revolving speed of the threshing rotor too low?	Check the engine tachometer, and adjust the accelerator lever to raise the engine speed to the "Green zone"
	Operating speed too high?	Reduce the existing speed of operation
	Chaff discharge adjust lever in the "Close" position?	Put the lever to "Open" if the moisture content of rice is high
	Crops conveyed unevenly?	Find out the cause of uneven conveying and remove it.
Poor screening	Angle of the chaff sieve of swing separator adjusted improperly?	Adjust to an appropriate angle according to the crop condition
	Engine speed too low?	Check the engine tachometer, and adjust the accelerator lever to raise the engine speed to the "Green zone"
	Air volume of fan, or chaff accumulated at the air inlet?	Remove the chaff and other obstacles
	Air volume of fan selected properly?	Adjust correctly
Lots of damaged grains	Grain fed properly?	Reduce the harvesting speed in case of abnormal sound in the threshing section when harvesting speeds up.
	Crops conveyed unevenly?	Find out the cause of uneven conveying and remove it.
	Angle of the chaff sieve of swing separator adjusted improperly?	Adjust correctly
	Lift conveyer pipe attached with mud?	Clean out the mud.
	Threshing rotor speed too high?	Check the engine tachometer, and adjust the accelerator lever to raise the engine speed to the "Green zone"

# Technical specification

## Technical specification

			YANMAR
			AW70V
Model			Top sacker
Overall dimension	Total length	mm	5040
	Total width	mm	2285
	Total height	mm	2865
Total weight		kg	3005
Engine	Model number		4TNV98
	Type		4-cylinder, water-cooling, single-row, vertical, 4-stroke
	Total displacement	cc	3318
	Power/rev.	Kw(ps)	51.5 (70.0)/2500rpm
	Fuel		Diesel fuel
	Fuel tank capacity	L	80
	Starting mode		Electric starting
Traveling section	Track	Width × grounding length	mm 425 × 1660
		Center distance	mm 1170 (between SP, 1185)
		Average grounding pressure	kPa 20.9
	Mode of speed regulation		HST hydraulic reversing clutch
	Shift gear		- 3 gears
	Traveling speed (under the rated engine speed)		Low: 0~0.93 Standard: 0~1.50 High: 0~1.85
	Min. ground clearance		mm 245
	Header	Gap at the front end of crop divider	
Type of harvesting device		Reel × feeder house	
Cutter blade width		mm 1975	
Stubble range		mm -50~1000	
Reel		Diameter × width	mm 900 × 1920
		Revolving speed	rpm 43 (37)
Threshing section	Type		Axial-flow type longitudinally mounted front roller
	Roller	Diameter × length	mm 640 × 1850
		Revolving speed	rpm 570(19m/s)
	Mode of screening		Vibration, air blast
	Screening width		mm 850
	Screening plate width × length		850 × 1410
	Mode of secondary reduction		Grain conveying pipe and vibrating screen
	Concave screen area		m <sup>2</sup> 1.75
	Mode of threshing		2nd outlet of grain bin
Capacity of main grain tank or bin		L 490	
Other devices	Alarm and automation equipment		Water temperature, hydraulic pressure, recharging, secondary alarm and full grain tank
Operating efficiency (calculated value)		ha/hr	0.2 – 0.6

- Specifications in this catalogue are subject to change without further notice.

# Main wearing parts

---

## List of wearing parts

NO.	Name
1	Resin parts
2	Rubber parts
3	Pin and key
4	Bearing
5	Switch
6	Relay
7	Bulb
8	Belt
9	Friction plate
10	Chain
11	Spring
12	Auger and conveyer
13	Wire (steel wire, flexible shaft)
14	Oil seal, cylinder gasket, sealing ring and other seals
15	Fuel injection nozzle components
16	Clutch
17	Drive (chain) wheel
18	Roller
19	Battery
20	Threshing screen (concave screen)
21	Threshing bar
22	Oil cylinder body
23	Shaft sleeve and bush
24	Grass scraper
25	Brush
26	Bolt, nut, rivet, snap ring and other fasteners
27	Reel tine
28	Cutter
29	Crawler, drive sprocket, idler
30	Guide rail
31	Fuel injection pump component

# Accessories

---

## List of accessories

NO.	Name	Quantity	Remarks
1	Filter element	1	Air filter
2	Starting key	1	
3	Reel tine	5	
4	Shim	6	0.4mm x 3, 0.8mm x 3
5	Cutter blade	6	2 kinds
6	Backing edge	1	
7	Oil filter element	1	HST
8	Oil filter element	1	Engine
9	Tension bolt	2	Traveling unit
10	Slow blow fuse 50A	2	
11	Slow blow fuse 60A	1	
12	Rivet	8	Cutter blade
13	Filter element	1	Water separator
14	Winner shutter	2	
15	Bolt M8x16	4	

**[Note]**

Our Company may modify or adjust the list of accessories according to the condition of use. Refer to the list supplied at the time of delivery.



# Others

## Schedule for Inspections and Replacement of Major Replaceable Components

The following table is a schedule that displays the number of service hours between periodic inspections and replacement of major replaceable components. Be aware that the crops harvested and working conditions may affect the service hours between replacements.

Contact your dealer if you could not handle a maintenance.

- : Check first time
- : Check or adjustment
- ▲: Replacement
- : Rotation

Inspection portion	Inspection, replacement period																			
	20	50	100	150	200	250	300	350	400	450	500	550	600	650	700	750	800	1000	1y	2y
Fan belt		●	○		○		○		○		▲	●	○		○		○	▲		
Air cleaner element		○	○	○	○	○	○	○	▲	○	○	○	○	○	○	○	▲	○		
Air cleaner hose																				▲
Fuel filter			▲		▲		○		▲		○		▲		○		▲	▲		
Oil filter		●	○		▲		○		▲		○		▲		○		▲	▲		
Water separator		○	○		▲		○		▲		○		▲		○		▲	▲		
Fuel hose																			○	▲
Fuel tank			○		○		○		○		○		○		○		○	○		
Engine oil drain hose																				▲
Water hose																				▲
Accelerator wire		○	○	○	○	○	○	○	▲	○	○	○	○	○	○	○	▲	○		
Transmission drive belt	●	○	○	○	○	○	○	○	▲	●	○	○	○	○	○	○	▲	○		
Hydraulic tank filter									○								▲			
Crawler		○	○	○	○	○	■	○	○	○	○	○	○	○	○	○	○	○		
Driving sprocket					■				■				▲				■	■		
Idler									○								▲			
Track roller									○								▲			
Carrier roller									○								▲			
Crawler guide									○								▲			
Oil seal, Bearing, Sleeve (Track roller)					○				▲				○				▲	○		
Oil seal, Bearing (Carrier roller)					○				▲				○				▲	○		
Oil seal, Bearing, (idler)					○				▲				○				▲	○		
Side clutch wire		○	○	○	○	○	○	○	▲	○	○	○	○	○	○	○	▲	○		
Bearings, oil seals, O-rings (transmission)									○								▲			
Parking brake (transmission)									○								▲			

# Others

- : Check first time
- : Check or adjustment
- ▲: Replacement
- : Rotation

	Inspection portion	Inspection, replacement period																				
		20	50	100	150	200	250	300	350	400	450	500	550	600	650	700	750	800	1000	1y	2y	
Traveling section	Axle seal (transmission)									○								▲				
	HST filter									▲								▲				
	Hydraulic fluid pipe																				▲	
	Muffler																					▲
	Silencer																					▲
	Header clutch wire		○	○	○	○	○	○	○	○	▲	○	○	○	○	○	○	○	▲	○		
Header section	Header clutch belt	●	○	○	○	○	○	○	○	▲	●	○	○	○	○	○	○	▲	○			
	Reel chain	●	○	○	○	○	○	○	○	○	○	▲	●	○	○	○	○	○	▲			
	Platform auger drive chain	●	○	○	○	○	○	○	○	○	○	▲	●	○	○	○	○	○	▲			
	Drive chains of platform auger and reel	●	○	○	○	○	○	○	○	○	○	▲	●	○	○	○	○	○	▲			
	Header drive chain	●	○	○	○	○	○	○	○	○	○	▲	●	○	○	○	○	○	▲			
	Reaping section drive chain	●	○	○	○	○	○	○	○	○	○	▲	●	○	○	○	○	○	▲			
	Feeder house drive chain	●	○	○	○	○	○	○	○	○	○	▲	●	○	○	○	○	○	▲			
	Cutter blades CMP		●	○		○		○		▲	●	○	○	○	○	○	○	○	▲	○		
	Finger			○		○		○		▲		○		○		○		▲	○			
	Finger guide (resin)			○		○		○		▲		○		○		○		▲	○			
	Reel bracket (resin)									▲									▲			
	Reel tine												▲							▲		
	Feeder house slat			○		○		○		▲		○		○		○		▲	○			
	Bearing									▲									▲			
	Sleeve, (Header section)		●	○		▲	●	○		▲	●	○		▲	●	○		▲	▲			
	Seal, (Header section)		●	○		▲	●	○		▲	●	○		▲	●	○		▲	▲			
	Platform auger			○		○		○		○		○		○		○		○	○			
	Cutter blades			○		○		○		○		○		○		○		○	○			
	Each tension spring and roller					○				▲				○				▲	○			
	Threshing clutch belt	●	○	○	○	○	○	○	○	○	▲	●	○	○	○	○	○	○	▲	○		
Threshing rotor drive belt	●	○	○	○	○	○	○	○	○	▲	●	○	○	○	○	○	○	▲	○			

# Others

- : Check first time
- : Check or adjustment
- ▲: Replacement
- : Rotation

	Inspection portion	Inspection, replacement period																				
		20	50	100	150	200	250	300	350	400	450	500	550	600	650	700	750	800	1000	1y	2y	
Threshing section	Screening belt	●	○	○	○	○	○	○	○	▲	●	○	○	○	○	○	○	▲	○			
	Swing separator drive belt	●	○	○	○	○	○	○	○	▲	●	○	○	○	○	○	○	▲	○			
	Threshing bar			○		○		■		○		○		▲		○		○	○			
	Concave					■		■		■		▲			■			▲				
	Elevating grain conveyor									▲								▲				
	1st conveyor									▲								▲				
	2nd conveyor									▲								▲				
	2nd vertical conveyor									▲								▲				
	Conveyor blades									▲								▲				
	Chain	●	○	○	○	○	○	○	○	○	○	▲	●	○	○	○	○	○	○	▲		
	Bearings (rotor shaft, rotor case)					○				▲				○				▲	○			
	Bearings (other)					○				▲				○				▲	○			
	Threshing feed plates								○								▲					
	Gutter, pipe								○								▲					
	Blade (front)								○								▲					
	Impeller reinforcement parts								○								▲					
	Chaff discharge parts								○								▲					
	reinforcement (rotor cover parts)								○								▲					
	1st, 2nd conveyor transfer case								○								▲					
	Each tension spring and roller					○				▲				○				▲	○			
Electrical section	Battery			○		○		○		○		○		○		○		▲	○			
	Generator					○			○				○					○	○			
	Wire harness																			○		
	Battery cable																			○		
	Fuse			○		○		○		○		○		○		○		○	○			
	Work lamp	Every day																				
Switch	Every day																					
Hydraulic section	Electrical valve					○			○				○				○	○				
	Hydraulic cylinder (header)					○			○				○				○	○				
	Hydraulic cylinder (reel)					○			○				○				○	○				
	Oil cooler					○			○				○				○	○				
	Oil seal, header cylinder								○									▲				
	Oil seal, reel cylinder								○									▲				