



Operating Manual



Wheel Loader TL160

Keep in a safe place for later use!

Place of safe keeping: Behind the driver's seat.

Ausgabe • Edition

2006-10

GÜLTIG AB FZ-ID.NR. • VALID FROM SERIAL NO. • A PARTIR DU NO. DE SERIE

TL01600101 > TL01600198

TEREX GMBH • D-74595 LANGENBURG

Hauptverwaltung/Verkauf Direction générale/Vente Central Administration/Sales	Kundendienst Service après-vente Service Department	Ersatzteile Pièces de rechange Spare parts
Terex GmbH Postfach 61 • D-74595 Langenburg Schaeffstr. 8 • D-74595 Langenburg Phone + 49 (0) 7905/58-0 Fax +49 (0) 7905/58-114	Terex GmbH Postfach 12 64 • D-91534 Rothenburg Erlbacher Str. 115 • D-91541 Rothenburg Phone + 49 (-451) 9861/972-0 Fax + 49 (0) 9861/972-460	Terex Ersatzteile GmbH Postfach 12 64 • D-91534 Rothenburg Erlbacher Str. 115 • D-91541 Rothenburg Phone + 49 (0) 9861/972-0 Fax + 49 (0) 9861/972-410

Order number:

5 780 200 363

englisch

1	Introduction	7
1.1	Warranty and maintenance	8
1.2	Copyright	8
1.3	Notes on using the Operating Instructions	8
1.4	Regulations concerning environmental protection	9
1.5	Pictograms	10
2	Safety and Accident Prevention	13
2.1	Declaration of Conformity	13
2.2	Preliminary remarks	13
2.3	Proper use	13
2.4	General safety notes	14
2.5	Operation	14
2.6	Danger zone	15
2.7	Transport of persons	15
2.8	Stability	15
2.9	Driving	16
2.10	Working Operation	16
2.11	Guides	16
2.12	Danger of falling objects	17
2.13	Working in the vicinity of underground power lines	17
2.14	Working in the vicinity of overhead power lines	17
2.15	Operation in closed spaces	18
2.16	Work stoppages	18
2.17	Change of work attachments, maintenance, repair	19
2.18	Recovery, Loading and Transporting	20
2.19	Monitoring and inspections	20
2.20	Fire protection	20
2.21	Emergency exit	21
2.22	Notes concerning residual dangers	21
3	Technical Specifications	23
3.1	Views	23
3.1.1	Dimensioned drawing with bucket, directly mounted	23
3.1.2	Dimensioned drawing with bucket and quick-attach system	24
3.1.3	Dimensioned drawing with multi-purpose bucket	25
3.1.4	Dimensioned drawing with fork lift attachment	26
3.2	Engine	27
3.3	Electrical system	27
3.4	Travel drive	27
3.5	Brakes	28
3.6	Hydraulic system	28
3.7	Axles	28
3.8	Tires	29
3.9	Fuels, lubricants, and coolants	29
3.9.1	Fluid capacities	29
3.9.2	Fuel, lubricant, and coolant specifications	30
3.10	Permissible loads in compliance with German Road Traffic Regulations (StVZO)	31
3.11	Sound level values, vibration	31
3.12	Dimensions and weights	32
3.13	Optional accessories (options)	34

Index

4	Operation	35
4.1	Initial familiarization	35
4.2	Display elements and operator controls	36
4.3	Engine	40
4.3.1	Starting	40
4.3.2	Monitoring the machine during operation	41
4.3.3	Switching off the engine	41
4.4	Driver's seat / Steering wheel tilt adjustment	42
4.5	Heating / Ventilation / Air-conditioning	43
4.6	Lighting in compliance with German Road Traffic Regulations (StVZO)	46
4.7	Hydroinflation of tires	47
4.8	Driving, steering and braking	48
4.8.1	Driving	48
4.8.2	Steering	50
4.8.3	Brakes	50
4.8.4	Driving on roads	51
4.8.5	Switching off the machine (parking)	52
5	Working Operation	53
5.1	Operation - Loader	53
5.2	Changing work attachments	55
5.2.1	General	55
5.2.2	Assembly of work attachments	56
5.3	Notes on how to work with the machine	58
5.3.1	Loading	58
5.3.2	Scraping and grading	58
5.3.3	Excavating	58
6	Recovery, Loading and Transporting	59
6.1	Recovery	59
6.2	Loading the machine by use of a crane	61
6.3	Transport of the machine	61
7	Care and Maintenance	63
7.1	Intervals	63
7.2	Regular oil analyses	64
7.3	Warranty	64
7.4	Inspection parts and aids	65
7.5	Care and cleaning	66
7.6	Notes for winter operation	66
7.7	Checking, maintenance and inspection plans	68
7.7.1	Initial inspection (Handing-over inspection)	68
7.7.2	Daily and weekly tasks	70
7.7.3	Overview of lubricating points	72
7.7.4	Inspection plan	74
7.8	Inspection and maintenance work	76
7.8.1	Checks using the display	76
7.8.2	Engine oil	76
7.8.3	Changing the engine oil filter	78
7.8.4	Cooling system - combined hydraulic oil-water cooler	78
7.8.5	Fuel system	81
7.8.6	Air filter, air intake	83
7.8.7	V-belt	87

7.8.8	Checking the valve lash	89
7.8.9	Brakes	90
7.8.10	Hydraulic oil tank	92
7.8.11	Hydraulic oil suction filter	93
7.8.12	Hydraulic oil return filter	94
7.8.13	Replacing the breather	95
7.8.14	Axles	96
7.8.15	Wheels	99
7.8.16	Injection valves	100
7.8.17	Electrical equipment	100
7.8.18	Cabin ventilation dust filter	102
7.8.19	Removing the dust filter for cabin ventilation	102
7.8.20	Windshield washer system	102
7.9	Immobilization	103
7.9.1	Preservation (temporary immobilization)	103
7.9.2	During immobilization	103
7.9.3	After immobilization	103
8	Trouble-shooting	105
8.1	Engine	105
8.2	Table of faults	105
9	Appendix	109
10	Index	111

1 Introduction

You decided to buy a Terex **TL160** Wheel Loader.

The confidence placed in this model will be rewarded by the efficient and economical performance of the machine.

These Operating Instructions contain all information necessary for the correct use of the machine.

They are intended for use by personnel responsible for operation, maintenance, repair, and supervision of the machine.

Please read them carefully before putting the machine into operation and make sure that they are kept at hand at all times.

Should you need further explanations or should anything be unclear, please contact your dealer immediately.

Special equipment and attachments are not included in these Operating Instructions.

We reserve the right to make improvements on the machine within the scope of impending technical developments, without incurring any obligation to change these Operating Instructions.

Attention

Any modifications of Terex products and their equipment using extras and work attachments which are not included in our product range require our written approval. If our approval is not sought, our warranty expires, as does our product liability for any resulting consequential damage.

Please state the vehicle type and vehicle identification number when making inquiries or orders, and in all written correspondence.

Attention

The vehicle identification number of the machine is stamped onto the type label (1/1) .

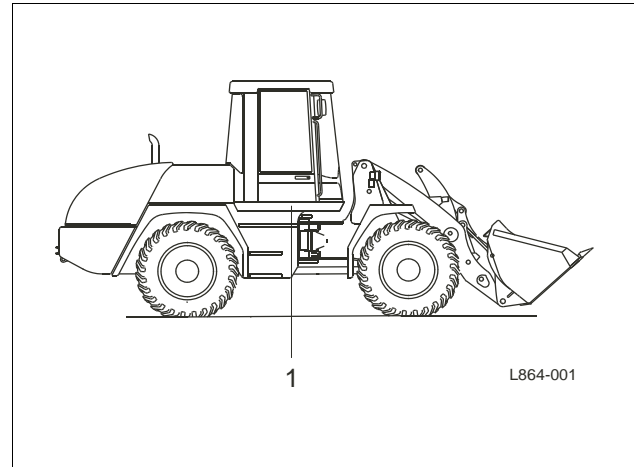

Fig. 1 Type label

1 Introduction

1.1 Warranty and maintenance

The warranty period covers 12 (twelve) months, beginning with the day the machine is handed over or put into operation.

Safe working conditions and good working order of the machine are prerequisites for efficient work. Your Terex Radlader fulfils these requirements when correctly handled and when serviced and maintained as specified.

Careful observation of the machine whilst in function and the use of the specified fuels, lubricants, and coolants will prevent malfunction.

Trained specialist personnel are responsible for any servicing of the machine which requires expert knowledge. Inspections and repairs must therefore be carried out by your dealer's customer service.

In respect of possible claims for damages during the warranty period, all work specified in the maintenance and inspection plan must be carried out at the specified intervals.

After the warranty period, too, regular maintenance must be performed in order to ensure that the machine is constantly in good working order and enjoys a reasonable service life.

Insist that only original Terex spare parts are used in the event of any repair work. In this way, you will have a product of lasting high quality, thereby ensuring that your machine maintains its original condition.

1.2 Copyright

This Operating Manual is copyrighted. It must not be copied, disseminated or used for competitive purposes, either fully or in part, without prior written permission.

1.3 Notes on using the Operating Instructions

Presentation of Figures and Positions

(1/1) = Figure 1, Item number 1

Presentation of cross references to Chapters and activities

→ 1.4, 7 = Chapter/Section 1.4, Page 7

Pictogram "Danger to life"



Danger to life

This indicates a potential danger represented by the machine which, if appropriate precautions are not taken, may result in death.

Pictogram "Danger of injury/machine damage"



Danger of injury/machine damage

This indicates a potentially hazardous situation which, if not avoided, may result in minor or moderate injury, or property/equipment damage.

Pictogram "Attention"



Attention

This symbol is employed for information containing important notes about the correct use and/or how to proceed. Non-compliance may lead to malfunction.

1.4 Regulations concerning environmental protection

Applicable environmental requirements must be observed for all tasks performed on and with the machine.

During installation, repair and maintenance tasks, particular care must be taken that substances that would damage the environment such as:

- lubricating greases and oils
- hydraulic oils
- fuels
- coolant
- cleaning fluids containing solvents

do not seep into the ground or the sewerage system.













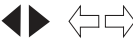









These substances must be kept, transported, collected and disposed of in suitable containers.

If the substances listed above do reach the soil, the leak or outlet must be stopped immediately and the fluid must be cleaned up with a suitable absorbent material. If necessary, the soil involved must be removed. Absorbent materials and removed soil must be disposed of properly. Applicable environmental requirements must be observed.







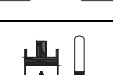
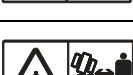
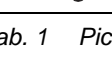
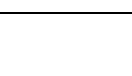







1 Introduction

1.5 Pictograms

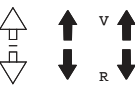
The following Table explains the meaning of the pictograms which may be attached to your machine.

Symbol	Description	Symbol	Description
	Danger to life		Horn
	On machine: Caution, safety distance In Operating Instructions: Danger of injury/machine damage		Direction indicator LT/RT
	Attention		Working floodlight(s)
	Battery charge indicator		High-beam indicator
	Preheating		Rotating beacon
	Engine oil pressure		Hazard warning system
	Engine oil temperature		Hydraulic rock breaker
	Engine oil level		Working hydraulics shut-off
	Coolant temperature		Unlocked
	Coolant level		Locked
	Air filter		Float position
	Fuel, fuel level		On machine: Safety distance
	Hydraulic oil Hydraulic oil level		Danger of injury
	Hydraulic oil temperature		Danger of crushing

Tab. 1 Pictograms on the machine

Symbol	Description	Symbol	Description
	Hydraulic oil filter clogging indicator		Observe notes in Operating Instructions
	Fan for heating/ventilation		Grease gun
	Windshield washer and wiper system		Operating mode indicator Operating hours
	Parking brake		Lashing points
	Travel direction FWD/REV		Suspension points for loading by crane
	Travel speed, FAST		First-aid kit
	Travel speed, SLOW		Fire extinguisher

Tab. 1 Pictograms on the machine

1 Introduction

2 Safety and Accident Prevention

2.1 Declaration of Conformity



Declaration of Conformity

The machine complies with the fundamental requirements stipulated in the applicable European guidelines.

Conformity has been proven. The respective documents and the original of the Certificate of Conformity are kept by the manufacturer.

A copy of the Certificate of Conformity is attached to the sales documents.

2.2 Preliminary remarks

Before putting the earth-moving machine into operation, read these Operating Instructions carefully and strictly observe the indicated references for safe operation.

National safety regulations - e.g. the Accident Prevention Regulations, "Earth-Moving Machinery" (BGR 500, 2.12) and "Vehicles" (BGV D29) in the Federal Republic of Germany - must also be complied with when operating the earth-moving machine.

In addition to the Operating Instructions, legal regulations governing road traffic and road safety measures must also be observed. Such requirements could also apply in respect of handling hazardous goods or the wearing of personal safety gear, for example.

Furthermore, safety laws governing work in particular locations (tunnels, adits, quarries, pontoons, contaminated areas, etc.) must likewise be observed.

2.3 Proper use

The earth-moving machine with standard bucket equipment is intended solely for work which is suitable for the function of the machine and its work implements.

Such work involves loosening, taking up, transporting and dumping soil, rock or other materials as well as loading these materials on trucks, conveyor belts or other means of transport, when the transport of the material is normally done by positioning the earth-moving machine.

The mounting of special work implements such as multi-purpose buckets, side-dump buckets, sweepers, fork lift attachments, etc. allows the machine to perform above mentioned work.

Any usage above and beyond that specified here, e. g. the transport of persons or the usage of the lift equipment as work platform is regarded as improper use. The supplier cannot be held responsible for any damage resulting from improper use. This risk is borne solely by the user.

Compliance with the Operating and Maintenance Instructions, the performance of maintenance work as specified and adherence to replacement intervals all form part of the concept of proper use.

2 Safety and Accident Prevention

2.4 General safety notes

- It is important to refrain from any working methods which impair safety.
- The earth-moving machine may only be operated with cabin or canopy.
- The earth-moving machine is only to be used if it is in a safe, operational condition.
- The manufacturer's instructions must be complied with for operation, maintenance, repair, assembly, and transportation.
- The plant operator must provide additional special safety instructions, wherever necessary, for specific local conditions.
- The Operating Instructions and any information pertaining to safety must be carefully kept in the driver's cabin.
- The Operating Instructions and safety notes must be complete and fully readable.
- Safety equipment on earth-moving machines must not be deactivated or removed.
- Protective clothing must be worn during operation. Rings, scarves and unbuttoned jackets are to be avoided. Protective goggles, protective boots, helmets, gloves, reflecting jackets, ear-muffs, etc. may be required.
- Before commencing work, information must be obtained on first aid and possible means of rescue (emergency ambulance, fire brigade, helicopters).
- A check must be carried out to ensure that the first aid box is at hand and that its contents comply with regulations.
- Personnel must be aware of the location and method of operation of the fire extinguishers on the earth-moving machine as well as on-site fire-warning and fire-fighting equipment.
- Loose parts such as tools or other accessories must be secured to the earth-moving machine.
- Open doors, windows, covers, flaps, etc. must be closed or secured against slamming shut if in an open condition.

2.5 Operation

Earth-moving machines are only to be independently operated and serviced by persons who:

- are physically and mentally suitable
- have been instructed in the operation or maintenance of earth-moving machines and have demonstrated this ability to the plant operator
- can be expected to perform their allocated duties reliably.

All such persons must be of the legal minimum age.

They must be designated by the plant operator to operate or service the earth-moving machine.

Operating equipment and controls are only to be operated from the driver's seat.

The earth-moving machine is only to be ascended and entered using the entrances and surfaces intended for this purpose.

It is the driver's responsibility to ensure that the operator's stand, entrances and other surfaces of the earth-moving machine which have to be stepped on are kept free of dirt, grease, oil, ice, and snow.

2.6 Danger zone

- Nobody must be allowed to remain in the danger zone of an earth-moving machine.
- The danger zone encompasses the area around the earth-moving machine in which persons may be injured by movements of the earth-moving machine during operation, its work implements and attachments, or by swinging out or falling loads.
- The machine operator is only to work the earth-moving machine if nobody is in the danger zone.
- The machine operator must give a warning signal to persons who may be in danger.
- The machine operator must stop work with the earth-moving machine if someone remains in the danger zone despite the warning.
- To ensure no danger of crushing, a sufficient safety distance (min. 0.5 m) must be kept from solid objects, e.g. buildings, excavation slopes, scaffolding, other machines, etc.
- If the above safety distance cannot be maintained, the area between solid objects and the working zone of the earth-moving machine must be blocked off.
- If conditions are such that the machine operator's view of the driving and working zone is restricted, he must be guided or the driving and working zone must be marked by a solid barricade.

2.7 Transport of persons

The transport of persons on the machine is forbidden.

2.8 Stability

- The earth-moving machine must be used, driven and operated in such a manner that its stability against overturning is ensured at all times.
- The machine operator must drive at speeds which are suitable for local conditions.
- The permitted payload of the earth-moving machine must not be exceeded.
- The earth-moving machine must remain at a sufficient distance from the edges of quarries, pits, mounds and slopes to ensure there is no risk of falling. Earth-moving machines must be secured so that they cannot roll or slip when in the vicinity of excavations, shafts, ditches, pits and slopes.

2 Safety and Accident Prevention

2.9 Driving

Before putting the earth-moving machine into operation, the driver's seat, mirrors and operator controls must be adjusted so as to ensure safe working.

A safety belt (seat belt), if installed, must always be fastened.

The windows must be clean and free of ice.

Driving tracks must be designed so as to ensure smooth, safe operation, i.e. they must be sufficiently wide, on ground which has as few slopes as possible and sufficient carrying capacity.

Downhill tracks must be set out in such a way that earth-moving machines can be safely braked.

Before driving downhill, the appropriate gear for the terrain must be selected and the gear lever not be moved during downhill travel (road or off-road gear).

On steep drops and uphill gradients, the load must be carried on the uphill side, if possible, in order to increase stability.

The carrying capacity of bridges, cellar roofs, vaults, etc. must be verified before the earth-moving machine can drive over them.

The internal dimensions of constructions must be noted before entering underground passages, tunnels, etc.

It is the plant operator's responsibility to ensure that equipment such as first-aid box, warning triangle, hazard lights are kept with the earth-moving machine according to the traffic regulations valid in the user's country and that the driver has the appropriate license as required by the national traffic laws of the country in question.

Outside areas covered by general traffic regulations, e. g. on factory premises, traffic regulations should be applied in the proper manner. This should also apply with regard to drivers' licenses.

2.10 Working Operation

Daily before commencing work and after every change of work attachments, the machine operator must check the correct fastening of the work attachment as well as the correct lock of the quick-attach system (QAS). Work attachments are to be carefully moved at low height. During this check nobody must be allowed to remain in the danger zone of the earth-moving machine.

The machine operator may only swing the work equipment over occupied drivers' seats, operator consoles and workplaces of other machines if these are protected by canopies (FOPS).

If a cabin does not have the required protection, the driver of this vehicle must leave the operator's stand while the work equipment is being swung overhead.

The vehicles must be loaded in such a manner as to ensure that there is no overloading and no material can be lost as long as the machine is moving. The vehicle must be loaded from the lowest possible height.

At dumping points, earth-moving machines may only be operated if suitable measures have been taken to prevent rolling or falling.

2.11 Guides

Guides must be easily recognizable, e.g. by means of reflective clothing. They must remain within the machine operator's field of vision.

While guiding the machine, guides shall not be given other jobs which may distract them from their task.

2.12 Danger of falling objects

Earth-moving machines are only to be used where there is a danger of falling objects if the operator's stand has a canopy (FOPS). A front guard must be employed if there is a risk of materials breaking through into the cabin.

In front of walls e. g. of stacked materials, earth-moving machines must be positioned and operated in such a way that the driver's seat and entry to the driver's seat are not situated on the side facing the wall.

Demolition work is only to be performed by earth-moving machines where there is no danger to persons and if the machine is equipped with canopy, cabin-mounted front guard and the appropriate work implement.

Observe the instructions and regulations valid in the user's country.

2.13 Working in the vicinity of underground power lines

Before commencing excavating work using earth-moving machines, it must be determined whether any underground power lines are present in the intended working zone which may present a danger to persons.

If underground power lines are present, their exact position and course must be determined in consultation with the proprietor or operator of the lines, and the necessary safety precautions decided and implemented.

The course of power lines in the work area must be clearly marked, under supervision, before commencing any excavation work. If the position of lines cannot be determined, search ditches must be dug - manually, if need be.

If underground power lines are encountered unexpectedly or they or their protective covers are damaged, the machine operator must discontinue work immediately and notify the supervisor.

2.14 Working in the vicinity of overhead power lines

If the earth-moving machine is being used in the vicinity of overhead power lines and trolley wires, a safety distance which varies depending on the nominal voltage of the overhead line must be maintained between the lines and the earth-moving machine and its work equipment, to prevent current overspill. This also applies to the distance between these lines and attached implements or loads.

The safety distances specified below must be complied with.

Nominal voltage in kV	Safety distance meters
– 1	1.0
>1 to 110	3.0
>110 to 220	4.0
>220 to 380	5.0
nominal voltage unknown	5.0

Tab. 2 Prescribed safety distances

In the observation of safety distances, all working movements of earth-moving machines, e. g. positions of the work equipment and the dimensions of attached loads must be taken into consideration. Uneven ground which would cause the earth-moving machine to be inclined and thus nearer to overhead lines must also be taken into account.

During work in windy conditions, both overhead lines and work equipment may swing out, thus reducing the safety distance.

If it is impossible to maintain sufficient distance from overhead power lines and trolley wires, the plant operator must consult with the proprietor or operator of the overhead lines to find other safety precautions to prevent current overspill. Such measures could be, e. g.

- Switching off the current,
- Re-routing the overhead line,
- Cabling, or
- Limiting the operating zone of earth-moving machines

2 Safety and Accident Prevention

2.15 Operation in closed spaces

If earth-moving machines are to be used in closed spaces, these areas must be sufficiently ventilated and special regulations observed.

2.16 Work stoppages

Before rest periods and at the end of the working day, the driver of the earth-moving machine must park the machine on ground which has sufficient carrying capacity and is as level as possible, and must secure it against unintended movement.

Before rest periods and at the end of the working day, the driver must lower the work equipment onto the ground or secure it so that it cannot move.

The driver is not to leave the earth-moving machine if the work equipment has not been lowered to the ground or secured.

Earth-moving machines are only to be parked in places where they do not present an obstacle to others, e.g. on the construction site or to plant traffic. Warning devices, e. g. triangles, warning cordons, flashing or hazard lights are to be used if necessary.

Before leaving the operator stand, the driver must bring all operating equipment and controls into home position, switch off the working hydraulics and apply the brakes.

If the driver is leaving the earth-moving machine unattended, he must first turn off the engine and ensure that it cannot be started up by unauthorized persons (e. g. removing ignition keys).

2.17 Change of work attachments, maintenance, repair

Earth-moving machines are only to be converted, maintained or serviced under the guidance of a suitable person designated by the plant operator and following the manufacturer's Operating Instructions.

After every change of work attachments, the driver must convince himself that the quick-attach system is correctly fastened and locked.

Work on e. g.

- braking,
- steering,
- hydraulic and
- electric systems

of the machine is only to be carried out by expert personnel specially trained in these areas.

Stability must be ensured during all type of work on the machine at all times.

The machine must be suitably secured by chocks so that it cannot roll away whenever work is performed, particularly under the machine.

The work equipment must be secured against movement by lowering it to the ground or equivalent measures, e.g. cylinder supports, trestles. As long as the engine is running, the unprotected working and articulation range must not be entered.

When jacking up earth-moving machines, jacking devices must be positioned so that they cannot slip. Jacks must be positioned and applied absolutely straight, without tilting.

Raised earth-moving machines must be supported by suitable structures such as crosswise stacks of planks, square timbers or steel trusses.

Earth-moving machines which are raised with work equipment must be stabilized by a supporting structure immediately after lifting. Work under raised machines which are only supported by their hydraulics is forbidden.

The engine/motor(s) must be turned off prior to all maintenance and repair work. These requirements may only be ignored in the case of maintenance or repair work which cannot be performed without the engine/motor(s) running.

When performing maintenance and repair work on the hydraulic system, the hydraulic system must be relieved of pressure. With the engine turned off, lower the work equipment to the ground and actuate all hydraulic control levers until there is no more pressure in the hydraulic system.

- Before working on the electrics or when performing arc-welding on the machine, the connection to the battery must be disconnected.
- When disconnecting the battery, first the negative pole then the positive pole must be disconnected. The battery must be re-connected in reverse order.
- During repair work around the battery, it must be covered with insulating material. Tools should never be placed on or near the battery.

Protective devices of moving machine parts are only to be opened or removed after the drive has been switched off and cannot be switched on again by unauthorized persons. Protective devices are e. g. engine/motor covers, doors, protective grating, trim.

Upon completion of assembly, maintenance or repair work, all protective devices must once more be attached in the proper manner.

Load-bearing parts of earth-moving machines are only to be welded following consultation with the manufacturer and in accordance with recognized welding principles.

Protective structures (ROPS, FOPS) are not to be welded or drilled in any way.

Before commencing work on the hydraulic system, the operating pressure, pilot pressure, back pressure and pressure inside the tank must be let off.

Swallowing lubricants as well as long and repeated skin contact can be hazardous to health and should therefore be avoided. When used properly, there is no particular danger to health. The safety specification sheets from the mineral companies must be observed.

Only the hoses specified by the manufacturer may be used.

Hydraulic hoses must be routed and assembled by expert personnel.

In the vicinity of fuel or batteries, smoking and naked flames are prohibited.

2 Safety and Accident Prevention

2.18 Recovery, Loading and Transporting

Earth-moving machines are only to be loaded onto recovery vehicles if adequate towing vehicles are used.

The tow fixing points specified by the manufacturer must be employed.

For loading and transportation, earth-moving machines and all necessary auxiliary equipment must be secured against unwanted movement.

The traveling gear and crawler unit of earth-moving machines must be sufficiently cleaned of mud, snow and ice to ensure that ramps can be driven up without risk of slipping.

When transporting the earth-moving machine on trucks, flatbed trailers, or by rail, it must be sufficiently secured with chocks and by attachment to the lashing points.

Before setting off, the route to be taken must be examined to determine whether the roads are wide enough, entrances and passages under bridges are large enough and that roads and bridges have sufficient carrying capacity.

2.19 Monitoring and inspections

The machine must be submitted to a general inspection according to the regulations in force in the user's country (e.g. Accident Prevention Regulations in Germany); this inspection must be carried out by an expert (e.g. machine engineer or machine foreman):

- before the machine is put into operation for the first time and before the machine is again put into operation after essential modifications have been made
- at least once a year
- in the meantime, according to operating conditions and local environments

The results of this inspection have to be recorded in writing and this record kept until the next inspection takes place.

Prior to every work shift, the machine operator must check the earth-moving machine according to the inspection and maintenance plan.

Hydraulic hoses must be replaced as soon as the following damage is recognized:

- Damage to the outer layer which reaches the intermediate layer,
- Embrittled patches on the outer layer,
- Deformations when under pressure or without pressure which differ from the original shape of the installed hose,
- Leaks,
- Damage to hose fittings or to the connection between the fitting and the hose.

The coolant level may only be checked after the engine has cooled down; the cap must be turned carefully in order to let off excess pressure.

Prior to operations, the machine operator must check the function of the safety devices.

The machine operator must advise the supervisor immediately - and his replacement, if there is a change of operator - with regard to any shortcomings.

In the event of shortcomings which jeopardize the operating safety of the earth-moving machine, it is not to be used until these have been eliminated.

2.20 Fire protection

- Switch off the engine when filling the fuel tank and take special care as long as the engine is hot.
- Never smoke or handle open flames whilst refueling the tank of the machine.



The fire extinguisher must be kept in the cabin.

The fire extinguisher symbol must be attached.

2.21 Emergency exit

The right-hand cabin door acts as an emergency exit.

2.22 Notes concerning residual dangers

Failure of hydraulic system

If the hydraulic system fails because the diesel engine is not running, the hydraulic pump is damaged or hydraulic oil has been lost, only the following emergency functions can still be performed:

- manual steering (without servo assistance) and
- lower work equipment (only if ignition is switched on).

2 Safety and Accident Prevention

3 Technical Specifications

3.1 Views

3.1.1 Dimensioned drawing with bucket, directly mounted

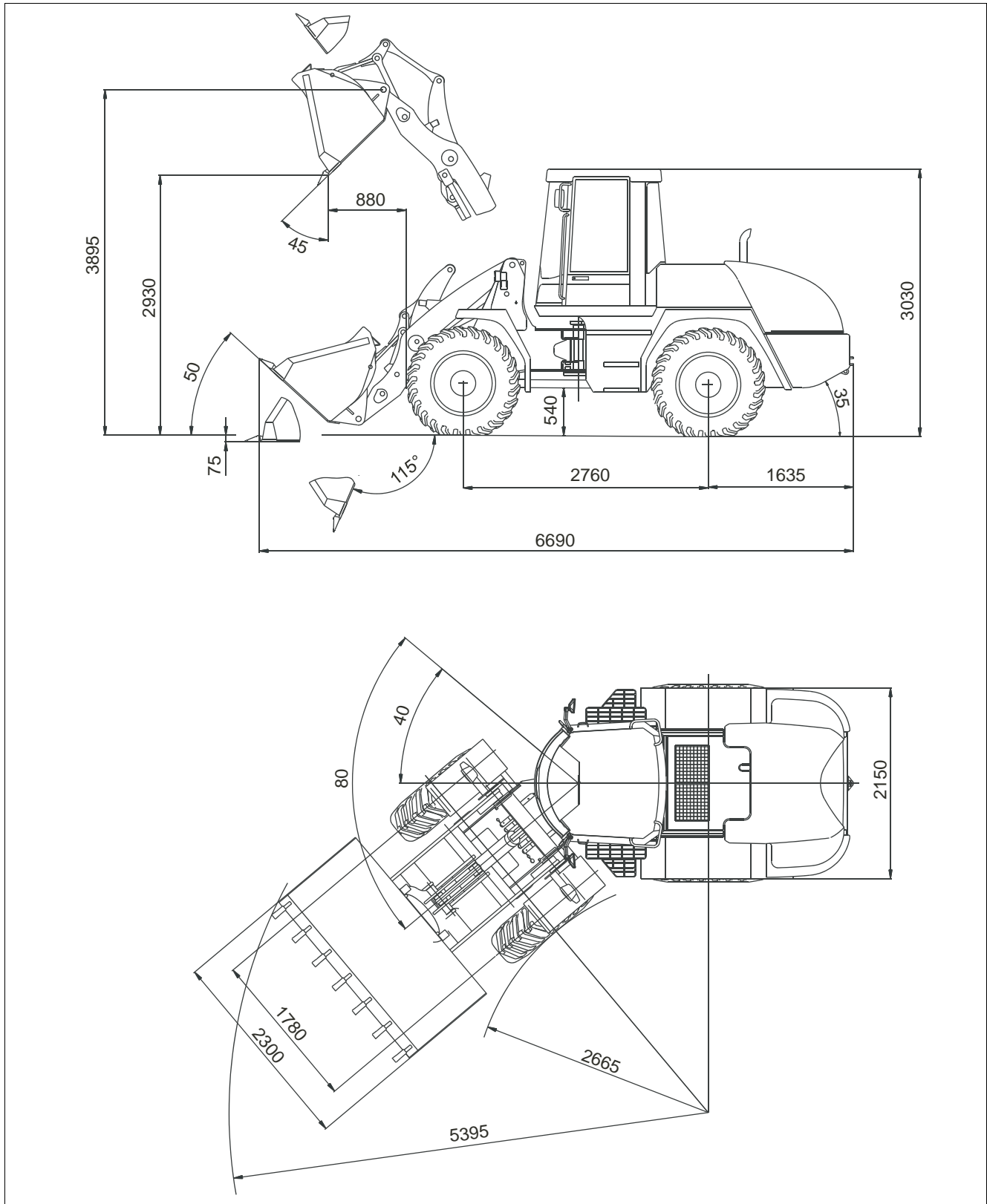

Fig. 2 Dimensioned drawing with bucket and tires 15.5 R 25

3 Technical Specifications

3.1.2 Dimensioned drawing with bucket and quick-attach system

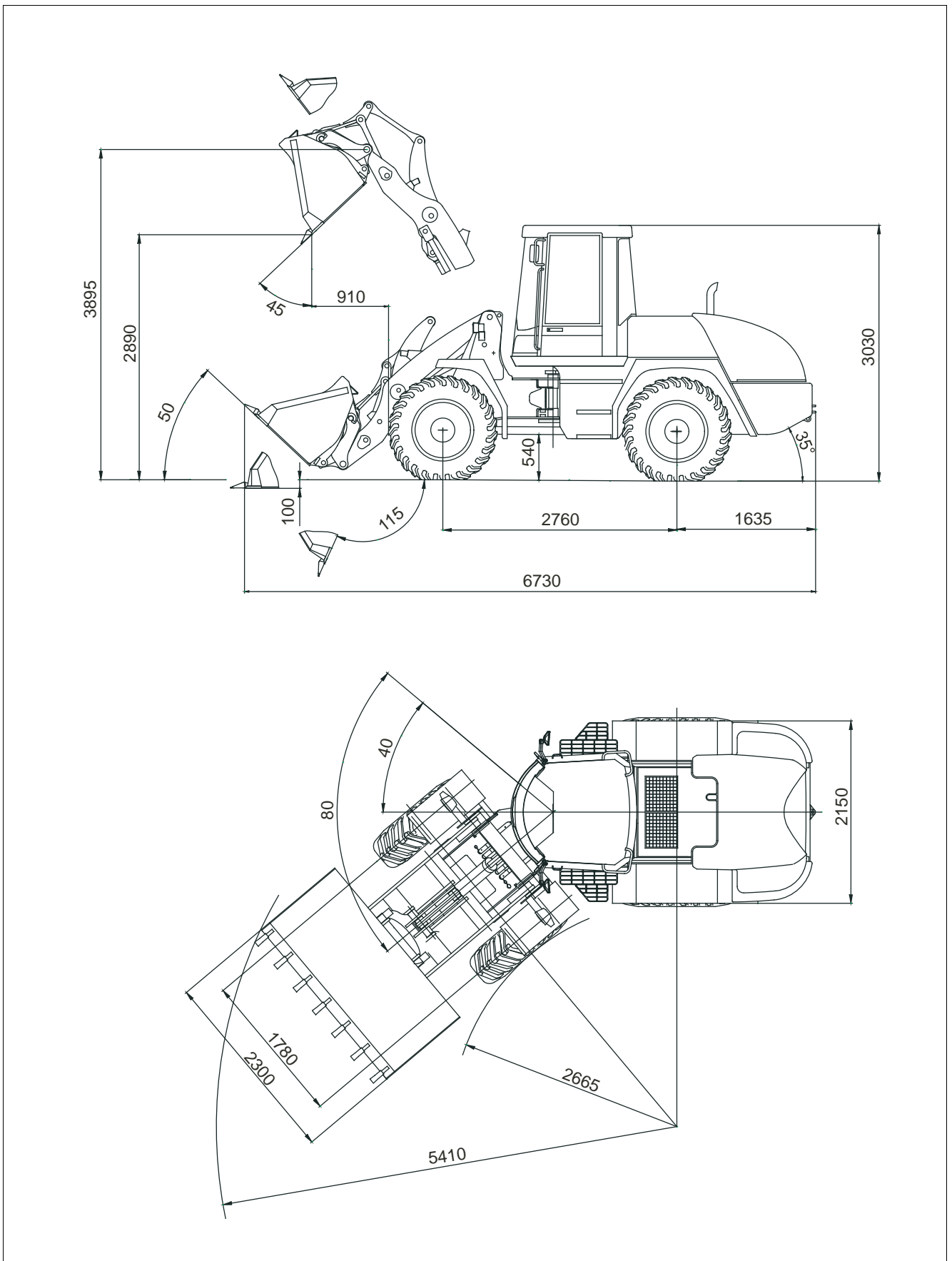

Fig. 3 Dimensioned drawing with bucket and tires 15.5 R 25

3 Technical Specifications

3.1.4 Dimensioned drawing with fork lift attachment

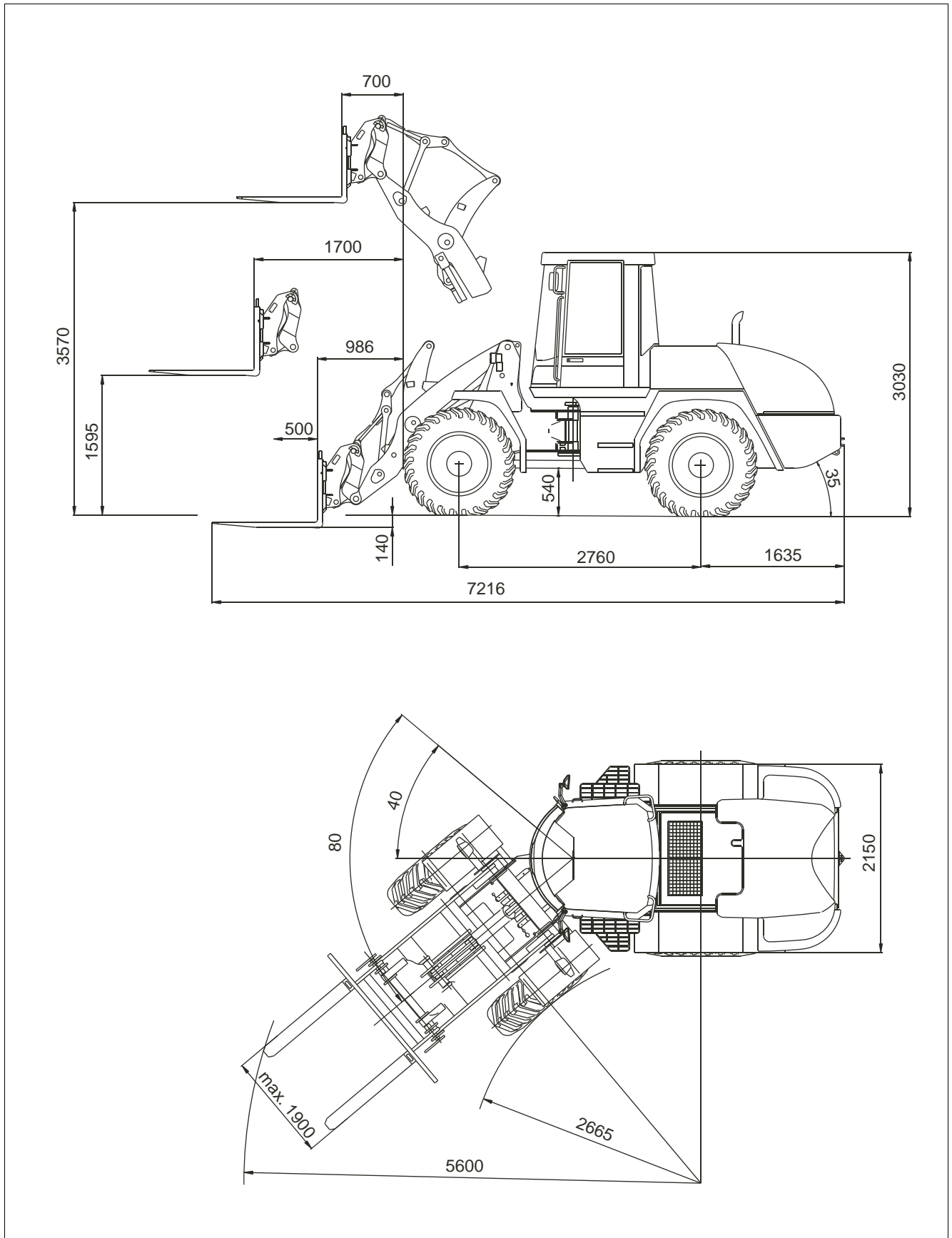

Fig. 5 Dimensioned drawing with fork lift attachment and tires 15.5 R 25

3.2 Engine

Engine	
Manufacturer	Perkins
Type	1104C-44T four-stroke turbocharged diesel engine
Design	4 cylinders in line 4-stroke turbocharged diesel engine with direct injection exhaust-gas optimized (COM II / EPA II)
Displacement	4400 cm ³
Power output according to DIN 70020	74.5 kW at 2200 rpm
Max. torque	412 Nm / 1400 rpm
Specific fuel consumption at nominal engine speed	215 g/kWh
Cooling	Water-antifreeze mixture for all-year operation
Heating	Cabin hot water heating with three-speed heater fan
Max. inclined position	30° in all directions
Engine lubricating-oil supply	Observe the overturning limit angle of the machine!

Tab. 3 Technical specifications - Engine

3.3 Electrical system

Electrical system	
Operating voltage	24 V
Battery	2 x 12 V – 74Ah / 660A (EN) / 400 A (DIN)
Generator	24 V – 75 A
Starter	24 V / 4.5 kW
Cold-starting aid	1 glow element per cylinder
Lighting system	in compliance with German Road Traffic Regulations (StVZO) with Halogen H 4 headlamps 2 front and 2 rear working floodlights

Tab. 4 Technical specifications - Electrical system

3.4 Travel drive

Travel drive				
Travel drive	Variable displacement pump, flange-mounted directly onto diesel engine, two-stage variable displacement motor with power shift on rear axle reduction gear. High-speed version featuring rear axle manual transmission shiftable in standstill position. Suction and return filter in the form of a tank insert filter.			
Travel speeds	Forward - Reverse			
		TL160	TL160S	
			Travel range I	Travel range II
	Travel range "Work"	0 – 6.0 km/hour	0 – 6.0 km/hour	0 - 20 km/hour
	Travel range "Road"	0 – 20 km/hour	0 - 12 km/hour	0 - 40 km/hour
Power transmission	Hydrostatic travel drive with advanced driving automatics. Automatic adjustment of propulsive force and speed. Continuous speed regulation forward and in reverse. Four-wheel drive via propeller shaft connection.			
Max. operating pressure - driving	420 bar			

Tab. 5 Technical specifications - travel drive

3 Technical Specifications

3.5 Brakes

Brakes	
Service brake (standard)	Hydraulic two-circuit power brake. Wet discs in both axles acting on all 4 wheels via four-wheel drive.
Service brake (high-speed version)	Hydraulic two-circuit power brake. Wet discs in both axles acting on all 4 wheels via four-wheel drive.
Parking brake	Spring-loaded brake acting on the discs of both axles.
Additional brake	Hydrostatic through closed-circuit travel drive.

Tab. 6 Technical specifications - brakes

3.6 Hydraulic system

Hydraulic system	
Hydraulic pump	Variable displacement piston pump with pressure-flow rate governor Max. pump capacity: 99 l/min. Working pressure, steering: 175 bar Working pressure, loading: 310 bar
Priority valve	Priority supply of hydraulic oil to steering through load-sensing system, ensuring that all the available oil can be provided if necessary. Rapid steering movements even at low engine revs.
Steering	Fully hydraulic, proportionally acting articulated steering. Two double-acting steering cylinders.
Total steering angle	80°
Loader installation	Double-acting work cylinders, two lift cylinders and one tilt cylinder. Control block with load-sensing flow distribution. Control circuits "Lift / Lower" and "Dump / Tilt-back" pilot-operated. Electro-hydraulically operated float position. Single, four-way control lever (joystick) with integrated direction-of-travel switch, float position switch and switch for additional control circuit.
Additional control circuit	Max. oil flow 99 l/min Max. operating pressure 230 bar
Hydraulic oil cooler	Thermostatically controlled, hydrostatic fan drive

Tab. 7 Technical specifications - Hydraulic system

3.7 Axles

Axles	
Front axle	Planetary drive axle with self-locking differential, rigidly mounted.
Rear axle (standard)	Oscillating planetary drive axle with self-locking differential and integrated reduction gear. All-wheel drive through propeller shaft to front axle.
Rear axle (high-speed version)	Planetary drive axle with self-locking differential and integrated 2-stage reduction gear, oscillating. All-wheel drive through propeller shaft to front axle.
Rear axle oscillating angle	± 12°

Tab. 8 Technical specifications - axles

3.8 Tires

Tire size	Type	Profile	Tire pressure in bar front	Tire pressure in bar rear
15.5	R 25	GP2B L-2	3.5	2.5
17.5	25TL	12 PR SGL	2.5	2.0
16/70-24	EM 10 PR	E 91-2	4.0	2.5
19.5	LR 24	XM 27 TL	2.7	2.0
15.5	R 25	XHA	3.5	2.5
17.5	R 25	XHA	2.5	2.0
17.5	R 25	XTLA	2.5	2.0
455/70	R 24	SPT9 TL	3.7	2.5
15.5	25TL	12 PR EM60	3.5	2.5

Tab. 9 Technical specifications - tires



Special tires available on request!

If solid-rubber or foamed tires are used, special measures must be taken and restrictions apply.



Attention

The tire pressure refers to standard equipment. During fork lift operations, the tire pressure of the front wheels must be increased by at least 0.5 bar.

3.9 Fuels, lubricants, and coolants

3.9.1 Fluid capacities

All values stated are approximate. The level marking is always the decisive factor.





Fluid capacities	in liters	Fuels and lubricants
Fuel tank	140.0	Diesel fuel
Engine with oil filter	9.5	Engine oil (change quantity)
Hydraulic oil, tank, system, brakes	99.0*	Hydraulic oil
Hydraulic oil tank	72.0	Hydraulic oil (change quantity)
Front axle center housing	13.5	Transmission oil
Rear axle center housing and transmission (standard)	15.7 + 1.1	Transmission oil
Rear axle center housing and transmission (high-speed version)	15.7 + 1.1	Transmission oil
Wheel hubs, front / rear axle	1.7 each	Transmission oil
Coolant	28.0	Mixture of water, additives and glycol (50 / 50)

Tab. 10 Fluid capacities

* The hydraulic oil quantity depends on the equipment level of the machine.

3 Technical Specifications

3.9.2 Fuel, lubricant, and coolant specifications

Application	Code designation according to Bi ¹	Prescribed fuels, lubricants, and coolants for Central Europe		Remarks
		Designation	Specification, standards, Quality	
Engine	–	Diesel fuel	EN 590 ASTM D975 1-D / 2-D	 Attention Before using RME fuels (rape oil methyl ester), it is essential to consult your responsible Terex dealer for further details.
Engine	EO 1540 A	Engine oil	SAE 15W-40 API CF4 ACEA E3 or E2	See also engine manufacturer's Operating Manual.
Hydraulic system	HYD 1040	Hydraulic oil or multi-grade engine oil	HVLP 46 or SAE 10W-40	The following viscosity limit values must be observed (according to ASTM 445): at 100 °C min. 8 mm ² /s (cSt) at –10 °C approx. 1500 mm ² /s (cSt)
	BIO-E-HYD-HEES	Biodegradable hydraulic oil on synthetic ester base	Filling according to customer specifications. Brand label on machine.  Machine damage caused by non-mixable bio oils. <ul style="list-style-type: none">Do not mix bio oils from different manufacturers.	 Attention When changing from mineral to biodegradable hydraulic oils, the tank and hydraulic system must be completely drained, cleaned and flushed. For further details before changing oils, please consult your responsible Terex dealer.
Axles, Wheel hubs	GO 90 LS	Transmission oil	SAE 85W-90LS API-GL 5	Alternative recommendations SAE 90LS SAE 80W-90LS
Lubricating points	MPG-A	Multi-purpose, lithium-soap based grease	K2K-30 DIN 51825	
Cooler		Mixture of water, additives and glycol	 Machine damage due to incorrect coolant and mix proportions. Observe the information on the cooling system given in the engine manufacturer's Operating and Maintenance Manual.	The antifreeze is factory-set to approx. –25 °C.

Tab. 11 Fuel, lubricant, and coolant specifications

¹ In conformity with the regulation lubricants of the Main Association of the German Building Industry e. V.

Alternative recommendation for other temperature ranges

Engine oil

In compliance with API CG 4 or CH 4 and in compliance with ACEA E3 or E5

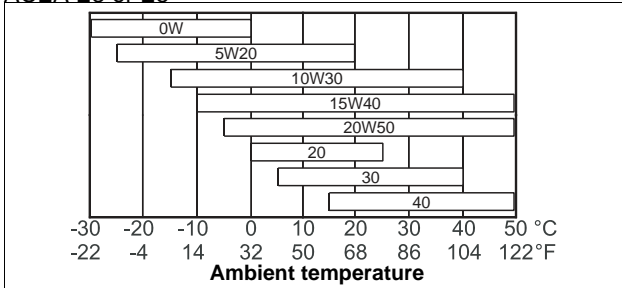

Fig. 6 Recommended viscosity classes applying to engine oil

Hydraulic oil

In compliance with DIN 51524.T3 HVLP

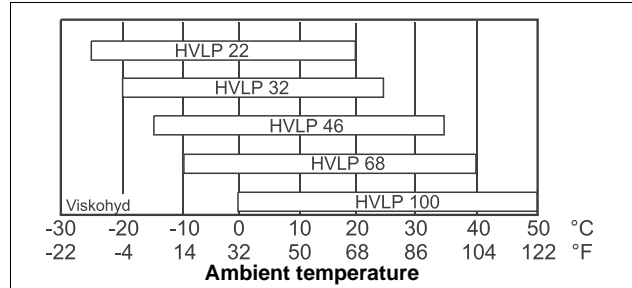

Fig. 7 Recommended viscosity classes for hydraulic oil

3.10 Permissible loads in compliance with German Road Traffic Regulations (StVZO)

Permissible loads in compliance with German Road Traffic Regulations (StVZO)	
Permissible total weight	see type label, and / or General Certification
Permissible axle load, front	
Permissible axle load, rear	

Tab. 12 Permissible loads in compliance with German Road Traffic Regulations (StVZO)

3.11 Sound level values, vibration

Sound level values		
Guaranteed sound power level	$L_{WA} = 102 \text{ dB (A)}$	
Sound pressure level (at driver's ear)	$L_{PA} = 75 \text{ dB (A)}$	

Tab. 13 Sound level values in compliance with directive 2000/14/EC and EN 474

Vibration values		
Effective values of acceleration below	0.5 m/s^2	for entire body
and	2.5 m/s^2	for upper limbs.

Tab. 14 Vibration values in compliance with directive 98/37/EEC and EN 474

3 Technical Specifications

3.12 Dimensions and weights

Dimensions and weights	
Operating weight, standard equipment ¹	approx. 9200 kg
Total length, standard bucket on ground (quick-attach system / directly mounted)	6730 / 6690 mm
Total width	2300 mm
Total height (cabin roof)	3030 mm
Wheel base	2760 mm
Tire tread with, FR / RR	1780 mm
Rear overhang angle	35°
Ground clearance below propeller shaft	540 mm
Turning radius at outside edge of bucket in transport position (quick-attach system/ directly mounted)	5410 / 5395 mm
Turning radius at inside edge of tires	2665 mm

Tab. 15 Dimensions and weights - Specifications refer to general-purpose bucket and 15.5 R 25 tires

¹ according to ISO 6016

Front loader installation	Quick-attach system	Direct mounting
Width of bucket	2300 mm	2300 mm
Capacity to DIN/ISO 7546 (max. density = 1.8 t/m ³)	approx. 1.5 m ³	approx. 1.6 m ³
Payload in bucket	2700 kg	2880 kg
Dump height at 45° dump angle	2890 mm	2930 mm
Dump reach at max. dump height	910 mm	880 mm
Max. bucket hinge pin height	3895 mm	3895 mm
Tilt-back angle	50°	50°
Dump angle at max. dump height	45°	45°
Digging depth, horizontal bucket	100 mm	75 mm
Lift capacity at ground level ¹	85.5 kN	85.5 kN
Ripping force at cutting edge of bucket ¹	83.2 kN	86 kN
Tipping load, straight ¹	6575 kg	6575 kg
Tipping load, articulated ¹	5780 kg	5780 kg
Work cycle time, "Lift"	5.7 s	5.7 s
Work cycle time "Dumping in uppermost position – IN"	3.7 s	3.7 s
Work cycle time "Dumping in uppermost position – OUT"	2.0 s	2.0 s
Work cycle time "Dumping in upper position"	1.4 s	1.4 s

Tab. 16 Dimensions and weights - Specifications refer to general-purpose bucket and 15.5 R 25 tires - Stability conforms to DIN 24094

¹ according to ISO 8313

Buckets	Width mm	Capacity, heaped ¹ m ³	Max. density (γ) t/m ³
Bucket	2300	1.5 / 1.6	1.8
Bucket with bolt-on cutting edge	2300	1.5 / 1.6	1.8
Earth bucket	2300	1.7 / 1.8	1.6
Earth bucket with bolt-on cutting edge	2300	1.7 / 1.8	1.6
Multi-purpose bucket	2300	1.25 / -	1.6
Multi-purpose bucket with bolt-on cutting edge	2300	1.25 / -	1.6
Light-material bucket with bolt-on cutting edge	2300	2.2 / -	1.2
Light-material bucket with bolt-on cutting edge	2500	2.6 / -	0.8
High-tip bucket	2300	1.5	1.2

Tab. 17 Bucket dimensions

¹ Quick-attach system / directly mounted

Fork lift attachment	mm
Width of fork carrier	1900
Length of forks	1120
Fork cross section	140 x 50
Max. stacking height	3570

Tab. 18 Dimensions of fork-arm connection in compliance with ISO/FEM Class 3 Form B, DIN 15 173 / ISO 2328 respectively

The payloads are determined in compliance with DIN 24094 / ISO 8313 respectively with a stability factor of 1.25 or 80 % of the tipping load and the machine moving over level ground.

The payloads are valid for the machine fitted with 15.5R25 tires and the equipment condition as described in compliance with ISO 6016.

Total lift range				
			S=2.0	S=1.25
		kg	2000	3200
		lbs	4710	7040
		kg	2180	3500
		lbs	4820	7700

Tab. 19 Total lift range of fork attachment

Transport position				
			S=1.67	S=1.25
		kg	2620	3500
		lbs	5770	7700
		kg	2620	3500
		lbs	5770	7700

Tab. 20 Transport position of fork lift attachment



If screw-on rear axle weights or rear tires with hydroinflation are used.



Attention

During fork lift operations, the tire pressure of the front wheels must be increased by at least 0.5 bar.

3 Technical Specifications

3.13 Optional accessories (options)

- Orthopedic air-cushioned driver's seat
- Fire extinguisher
- Height and tilt-adjustable steering wheel
- Pressurized cabin
- Air-conditioning
- Engine-independent diesel heater with timer
- Diverse electrical accessories such as working floodlights, rotating beacon, radio, etc.
- FOPS-roof guard
- Sliding window, right-hand door
- Diesel exhaust cleaner
- Catalytic converter
- High-speed version including equipment for the roading approval procedure (as stipulated by StVZO in Germany)
- Ride control system (LSD)
- Anti-theft device
- Back-up alarm system
- Electric refueling pump
- Quick-attach system, hydraulically operated
- Snow blade
- Sweeper
- Load hook for attaching to forks
- Rear axle weights
- Outlet for hydraulic hand hammer
- Filling with biodegradable hydraulic oil (ester-based "BIO-E-HYD-HEES")

Further optional equipment available on request!



Machine damage

due to unauthorized alterations to the design, additional equipment and work attachments of Terex products.

- *Please note that any modification requires the written approval from the manufacturer. If our approval is not sought, our warranty expires, as does our product liability for any resulting consequential damage.*

4 Operation

4.1 Initial familiarization

***Danger to life***

due to unintentional operation of controls.

- *The machine must be entered from the left-hand side as seen in the direction of travel.*

The right-hand cabin door acts as an emergency exit.

If the cabin is entered by the right-hand door, the joystick may be operated unintentionally.

- If you are not familiar with the operator controls and display elements of this machine, read this Chapter carefully before operating the machine.

This Chapter deals with all functions.

- Before driving and working with the machine it is necessary to thoroughly familiarize yourself with the display elements and operator controls.
- Each time before putting the machine into operation it must be subjected to a thorough visual inspection. Ensure that there is no damage, loose or missing screws, oil accumulations, oil or fuel leakage. Shortcomings must be remedied immediately. In the event of shortcomings which jeopardize the operating safety, the machine must not be put into operation until these have been eliminated.
- Before putting the machine into operation, the inspections according to → 7.8, 76 must be carried out.

4 Operation

4.2 Display elements and operator controls



Attention

The following list includes non-standard equipment!

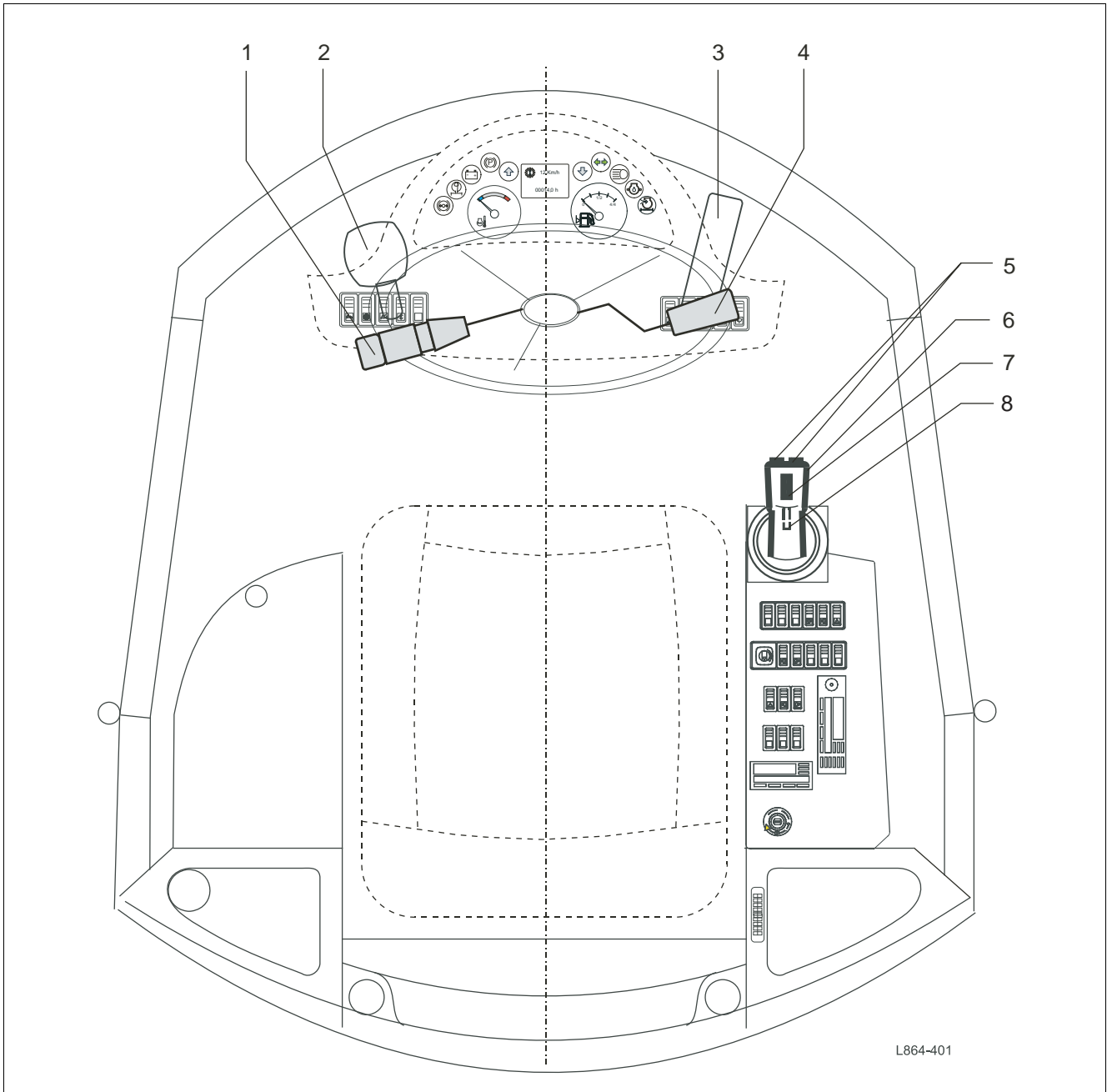

Fig. 8 Operator controls

Legend Fig. 8

- 1 *Direction indicator, horn, low-high beam (steering-column switch)*
- 2 *Brake-inching pedal*
- 3 *Accelerator pedal*
- 4 *Tilt adjustment of steering wheel (option: height adjustment)*
- 5 *Operation – additional control circuit (left OFF, right ON)*
- 6 *Control lever - loader installation*
- 7 *Travel direction preselection (without function if working hydraulics are disabled)*
- 8 *Impulse mode - float position*

4 Operation

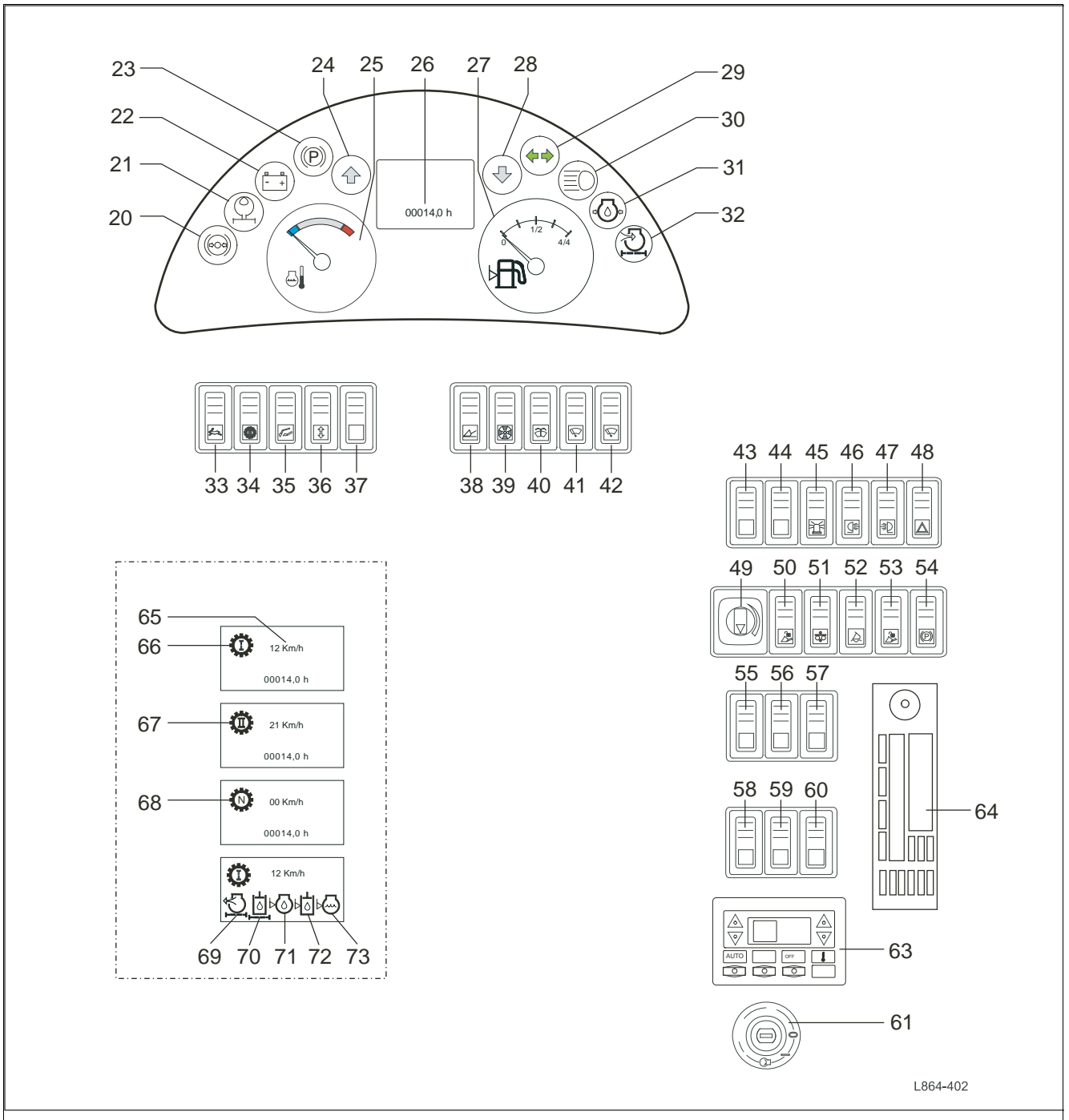





Fig. 9 Instrument panel

Legend Fig. 9

- | | |
|---|--|
| <p>20 Brake accumulator pressure</p> <p>21 ORANGE - pre-heating monitor</p> <p>22 RED - battery charge indicator</p> <p>23 RED - parking brake</p> <p>24 GREEN - travel direction, forward</p> <p>25 Coolant temperature</p> <p>26 Operating hour meter</p> <p>27 Fuel-level indicator</p> <p>28 GREEN - travel direction, reverse</p> <p>29 GREEN - direction indicator</p> <p>30 BLUE - high beam</p> <p>31 RED - engine oil pressure</p> <p>32 RED - air filter indicator</p> <p>33 Travel speed - FAST - SLOW</p> <p>34 High-gear changeover switch</p> <p> Attention
Transmission only shifts at a speed of below 0.5 km/h!</p> <p>35 Multi-function switch with lock for work equipment cut-off and change-over of the direction-of-travel preselection switches from Pos. 7 to Pos. 36</p> <p> Machine damage
due to incorrect operation.
Only press if machine is at standstill!</p> <p>36 Preselection of travel direction - Function only active if working hydraulics are disabled</p> <p>37 Not assigned*</p> <p>38 Option – bucket return positioner</p> <p>39 Engine cooler reversing fan changeover switch</p> <p>40 Windshield washer function front/rear</p> <p>41 Windshield wiper, front</p> <p>42 Windshield wiper, rear</p> <p>43 Option – rear fog lamp</p> <p>44 Option – back-up warning lamp</p> <p>45 Option – rotating beacon</p> <p>46 Working floodlight, rear</p> <p>47 Working floodlight, front</p> <p>48 Hazard warning switch</p> <p>49 Flow rate adjustment for 3rd control circuit</p> <p>50 Option – preselection switch for 4th control circuit OFF/Impulse/Continuous operation</p> <p>51 Option – ride control system</p> <p>52 Preselection switch - float position - OFF/Impulse/Continuous operation</p> | <p>53 Preselection switch for 3rd control circuit OFF/Impulse/Continuous operation</p> <p>54 Parking brake preselection switch ON/OFF, ON = locked</p> <p>55 Not assigned*</p> <p>56 Not assigned*</p> <p>57 Not assigned*</p> <p>58 Option – mirror heating</p> <p>59 Option – pressurized cabin</p> <p>60 Option – central lubrication</p> <p>61 Glow plug and starter switch</p> <p>62 Not assigned*</p> <p>63 Control unit heating / Klimatronic</p> <p>64 Option - radio</p> <p>65 Speed indicator</p> <p>66 Monitor - indicator "manual transmission range I"</p> <p>67 Monitor - indicator "manual transmission, range II" (optional for high-speed version)</p> <p>68 Monitor - indicator "manual transmission not ready for operation"</p> <p> Attention
If this symbol comes up, the manual transmission is in an intermediate position. The machine is not ready for driving! This can be remedied by performing brief steering movements until the manual transmission engages.</p> <p>69 Option – soot filter clogging indicator</p> <p>70 Hydraulic oil filter clogging indicator</p> <p>71 Engine oil level</p> <p>72 Hydraulic oil level</p> <p>73 Coolant Level</p> |
|---|--|

* for non-standard equipment

4 Operation

4.3 Engine

4.3.1 Starting



Attention

Each time before putting the machine into operation, the inspections according to (→ 7.8, 76) must be carried out.



Danger to life

due to presence in the danger zone.

- Before switching on the engine always ensure that no-one is in the danger zone of the machine.

- All gearshift levers to neutral.
- Parking brake selector switch (10/54) in position ON, travel direction preselector (10/7; 10/36) in position "0".
- Insert ignition key in glow plug and starter switch (10/61).

Hot start

- Switch on ignition and wait for approx. 5 sec.



Attention

The display establishes the internal readiness for operation. All indicator lamps are briefly activated for a functional check.

- The indicator lamps (10/22, 10/31) light up.
- Press the accelerator pedal (10/3) completely down for normal start and to the quarter-open position for hot start.
- After the indicator lamp (10/21) has gone out, turn the glow plug and starter switch to "START". As soon as the engine is running, turn the ignition key to "1" and decrease the revs to low idle speed. The indicator lamps should go out.
- If the engine has not started after max. 20 seconds, turn the ignition key to "1" or "0", and pause for at least 1 minute before trying again. Repeat the start-up procedure.



Engine damage

Avoid damaging the engine by:

- not driving the engine at full throttle straight away.
- driving with restraint until the engine has reached its operating temperature.

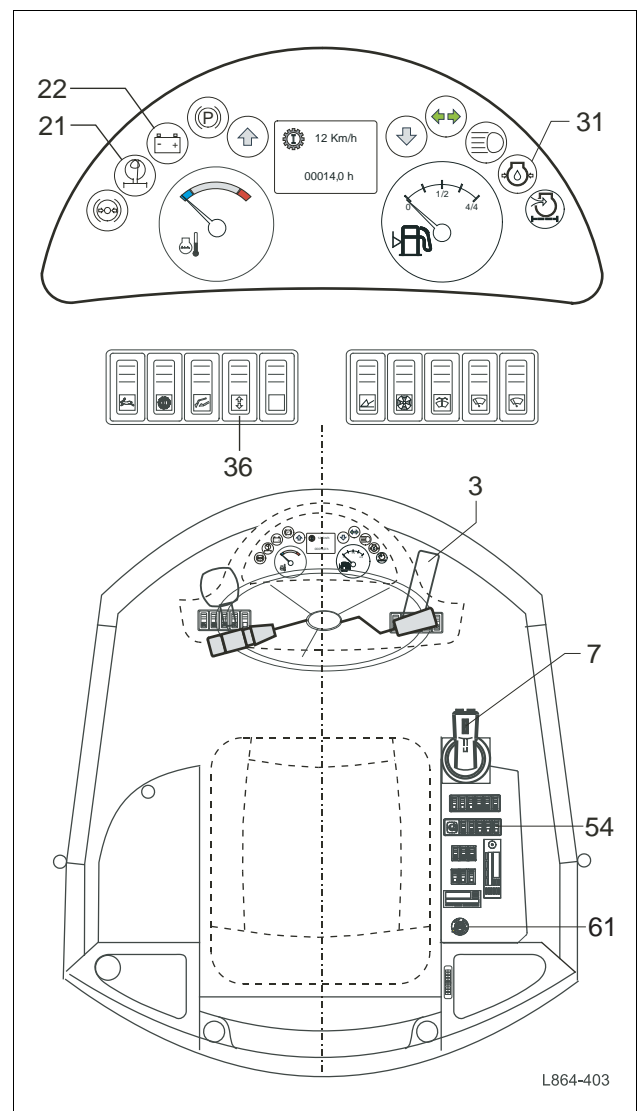

Fig. 10 Starting the engine

4.3.2 Monitoring the machine during operation



Engine damage

due to fault which has not been remedied.

- The fault must be remedied before restarting the engine and operating the machine again.
- If the battery charge indicator (11/22) or the engine oil pressure indicator lamp (11/31) lights up, switch off the engine immediately and determine the cause. If necessary, call for service personnel.
- If the permitted coolant temperature (11/25) is exceeded, stop work, open the engine hood and keep the engine running at idle speed to allow it to cool down.
- Once the engine has cooled down, turn it off and determine the cause of overheating. If necessary, call for service personnel.
- If the air filter service indicator lamp (11/32) lights up, perform the necessary air filter maintenance.

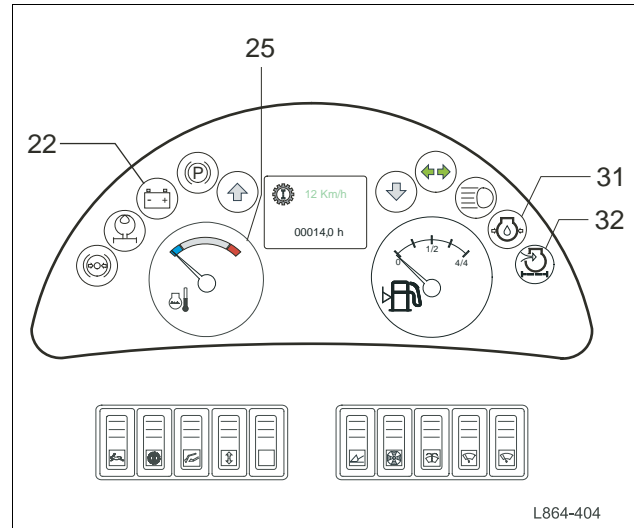

Fig. 11 Monitoring and switching off the engine

4.3.3 Switching off the engine



Attention

Do not switch off the engine when running at full throttle, but allow it to run for a short time without load at low idle-running speed.

- Turn the ignition key to "0".
- The engine stops automatically.

4 Operation

4.4 Driver's seat / Steering wheel tilt adjustment

The comfort seat is spring-mounted with oil-pressure operated shock absorbers and lap belt.

The seat meets international quality and safety standards in compliance with ISO 7096 and ISO 6683 (Fig.12).

1. Horizontal adjustment
 2. Weight adjustment
 3. Seat back adjustment
 4. Armrest (option)
 5. Vertical adjustment
- Raising seat: Raise seat until it clicks audibly into place.
 - Lowering seat: Raise seat as far as the stop; the seat then sinks to its lowest position.

Tilt adjustment of steering wheel

- Push down lever (13/4).
- Adjust steering-wheel tilt.
- Release lever.

Height adjustment of steering wheel (option)

- Push up lever (13/4).
- Adjust steering-wheel height.
- Release lever.

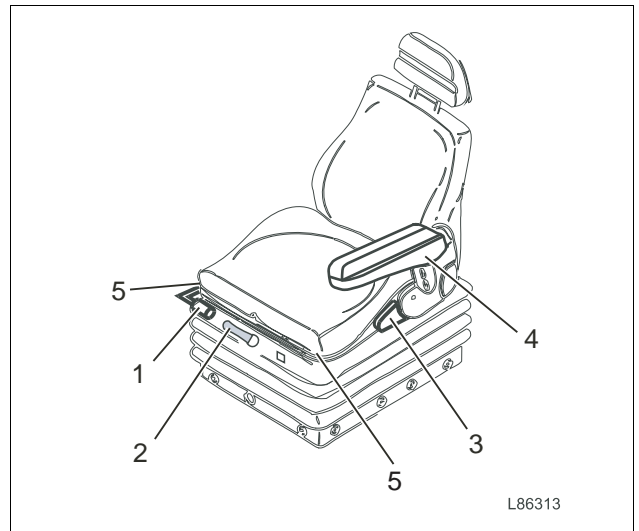

Fig. 12 Driver's seat

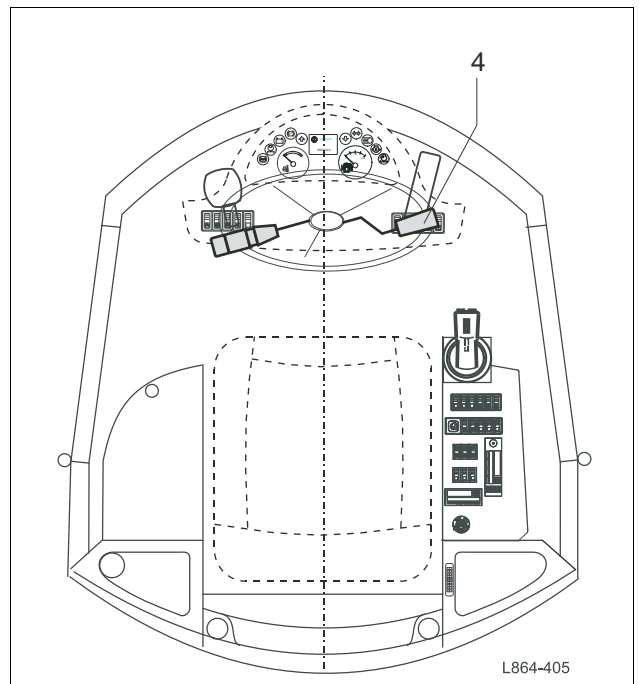

Fig. 13 Tilt and height adjustment of steering wheel

4.5 Heating / Ventilation / Air-conditioning

Button assignment of operator control panel

- The heating is connected to the coolant circuit.

 **ON/OFF/Circulating air** button (14/63c)

The control unit is switched on and off by pressing the button. If the control unit is switched off, all functions such as heating and ventilation are deactivated. If the LED under the button lights up, recirculation mode is activated. If the LED does not light up, fresh air mode is activated.

 **Display** (14/63g)

The display shows the relevant temperatures or trouble codes in case of malfunction.

Heating

 **Inside-outside temperature** button (14/63d)

The inside temperature is shown on the display for approx. 6 sec by pressing the button (14/63g). The cabin temperature is measured by the interior temperature sensor (14/63l). If the air-conditioning unit is in cooling-air mode, the outside temperature is shown on the display for approx. 6 sec by pressing the button (14/63g).

 **Temperature preselection** buttons (14/63e 63f)

Each time the button is pressed (14/63e), the temperature increases by 1°C. Each time the button is pressed (14/63f), the temperature decreases by 1°C down to the outside temperature at most.

Ventilation

 **Fan indicator** (14/63h)

The LEDs in the fan symbol indicate the momentary fan speed.

 **Fan speed** buttons (14/63i 63k)

Each time the button is pressed (14/63i), the fan speed increases by one step. Each time the button is pressed (14/63k), the fan speed decreases by one step.

- The air is distributed by adjusting the air vents.

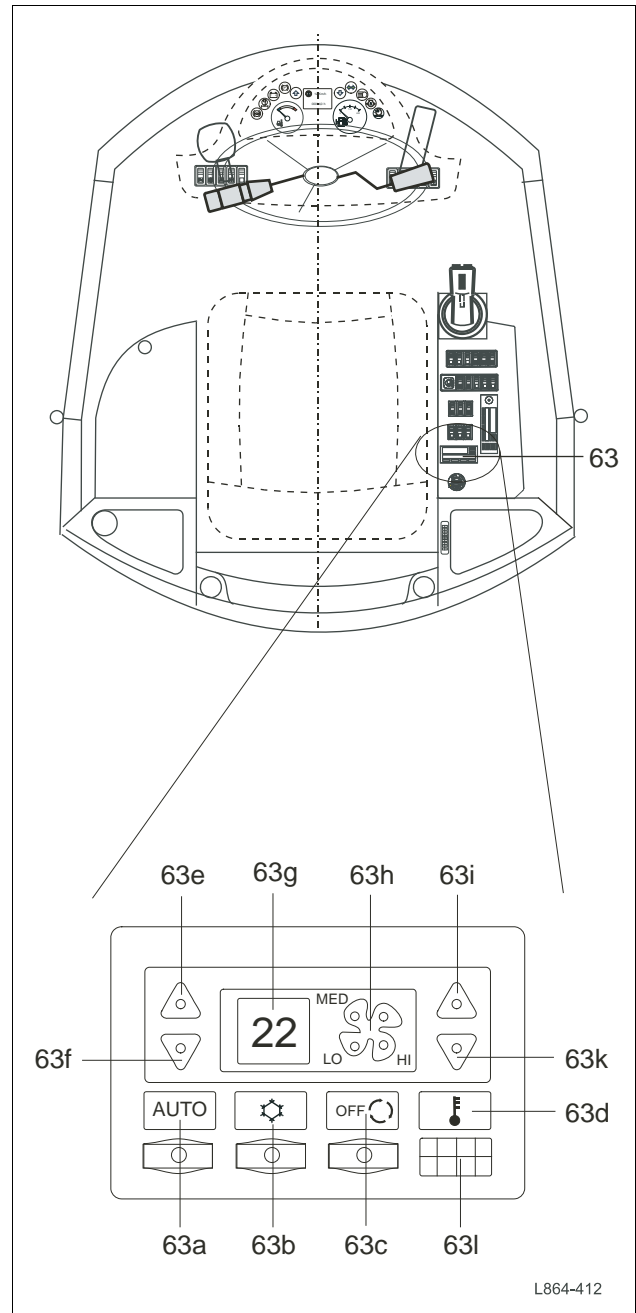

Fig. 14 Heating and ventilation

4 Operation

Air-conditioning (option)

- Operate the air-conditioning system using the control unit (15/63). A description of the buttons is given on the following page.



Attention

The air-conditioning unit should be switched on for approx. 5 minutes at least once a month to lubricate the compressor seals.



How to achieve good cooling performance:

- After switching on the air-conditioning system, open the windows 2-3 minutes to allow the hot air (stored heat) to escape.
- Keep windows and doors closed.
- It is recommended to cool down the vehicle interior temperature by no more than 6 °C to 8 °C below outside temperature.

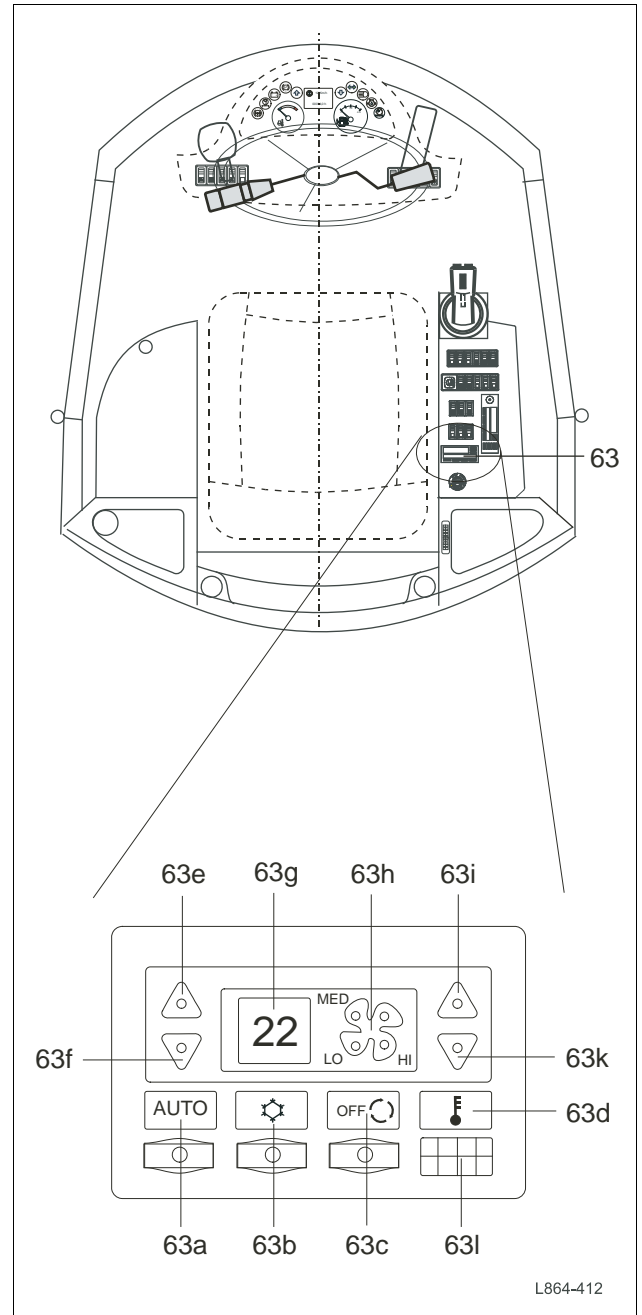

Fig. 15 Air-conditioning

Button assignment of operator control panel

AUTO Automatic diagnosis button (16/63a)

The engine cover should be closed and the engine itself be at operating temperature. The outside temperature should be between 15°C and 30°C. The air-conditioning system is ON.

Keep button pressed: The air-conditioning unit performs an automatic diagnosis. As soon as the type and the version of the air-conditioning unit can be seen on the display, release the button.

Cooling button (16/63b)

If the LED below the button lights up, cooling is ON. If the LED does not light up, cooling is OFF.

OFF ON/OFF/Circulating air button (16/63c)

The control unit is switched on and off by pressing the button. If the control unit is switched off, all functions such as heating and ventilation are deactivated. If the LED under the button lights up, recirculation mode is activated. If the LED does not light up, fresh air mode is activated.

Inside-outside temperature button (16/63d)

The inside temperature is shown on the display for approx. 6 sec by pressing the button (16/63g). The cabin temperature is measured by the interior temperature sensor (16/63i). If the air-conditioning unit is in cooling-air mode, the outside temperature is shown on the display for approx. 6 sec by pressing the button (16/63g).

Temperature preselection buttons (16/63e 63f)

Each time the button is pressed (16/63e), the temperature increases by 1°C. Each time the button is pressed (16/63f), temperature decreases by 1°C.

22 Display (16/63g)

The display shows the relevant temperatures or trouble codes in case of malfunction.

Fan indicator (16/63h)

The LEDs in the fan symbol indicate the momentary fan speed.

Fan speed buttons (16/63i 63k)

Each time the button is pressed (16/63i), the fan speed increases by one step. Each time the button is pressed (16/63k), the fan speed decreases by one step.

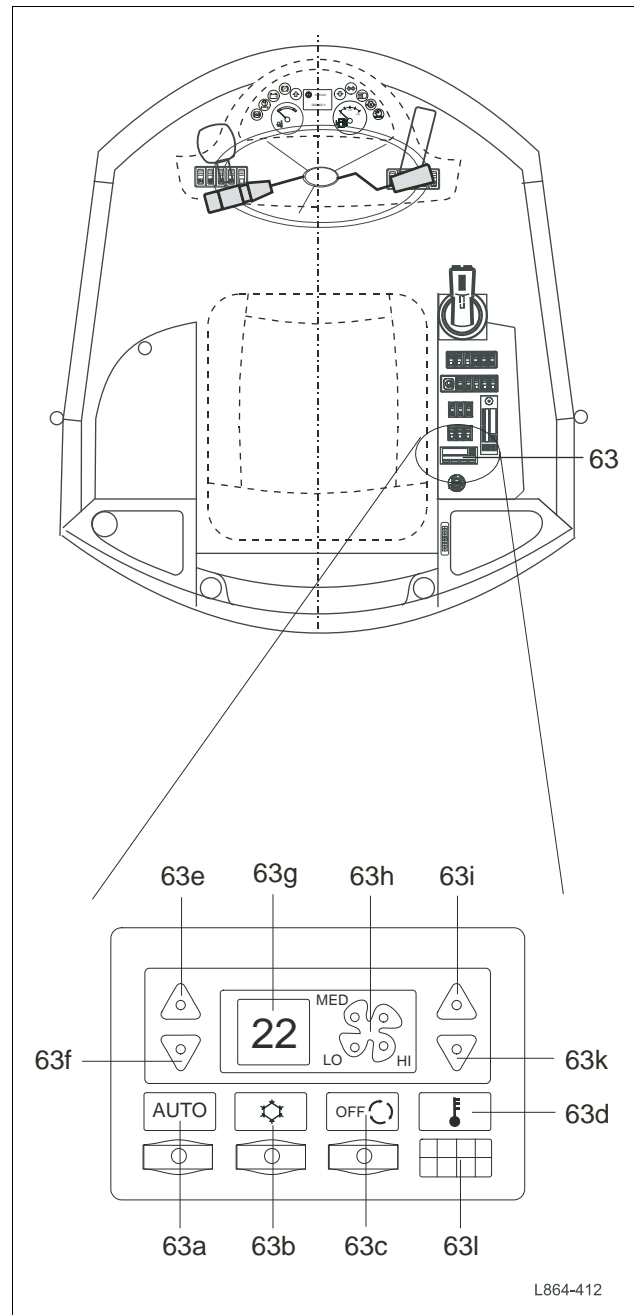

Fig. 16 Air-conditioning

4 Operation

4.6 Lighting in compliance with German Road Traffic Regulations (StVZO)

- The lighting of the loader is switched on and off by turning the steering-column switch (17/1).

Setting 0	Light OFF
Setting 1	Parking light
Setting 2	Driving light (low beam / high beam). Switch from one to another by lifting the steering-column switch (17/1). Blue indicator lamp (17/30) lights up.

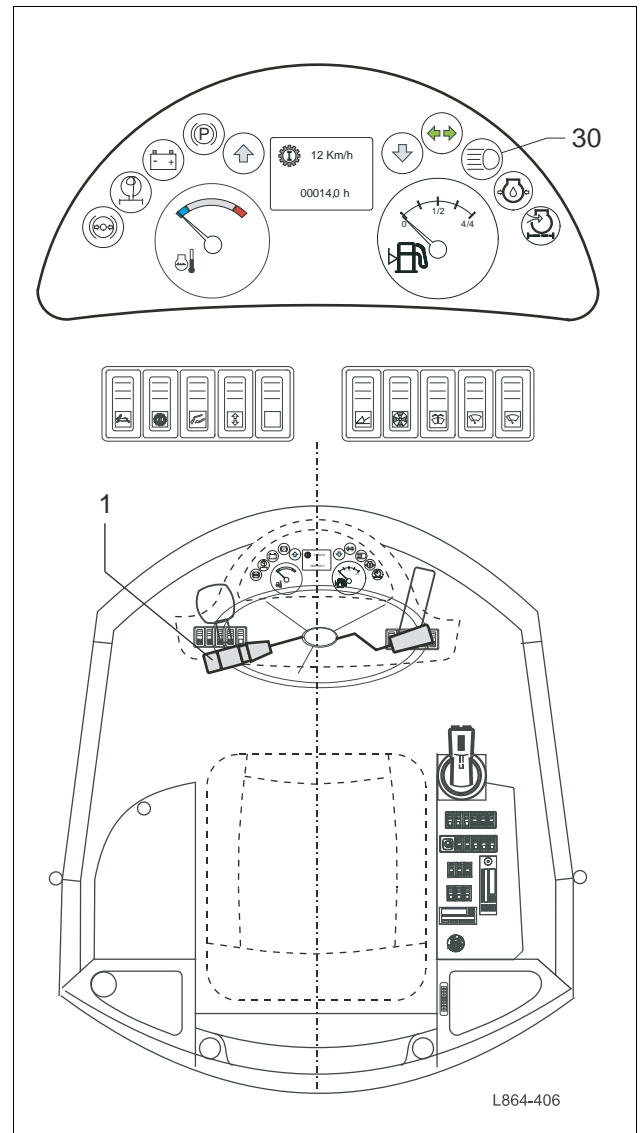

Fig. 17 Lighting

4.7 Hydroinflation of tires

When the loader is used with a fork lift attachment, the rear wheels may be filled with a water-antifreeze mixture to increase the lifting capacity.

Prepare the mixture in an appropriately sized container. Allow it to cool and stir until there are no more lumps.



Danger to health

due to incorrect handling of magnesium chloride.

Observe the following items when handling magnesium chloride:

- Always pour magnesium chloride into the water, not the other way round!
- Do not allow the solution to come into contact with eyes, skin or clothing - caustic substance!

Type of tire	Values per wheel		
	MgCl ₂ approx. kg	H ₂ O l	Total kg
15.5 R 25	68	132	200
17.5 25TL	86	165	251
16/70-24 EM 10 PR	63	108	171
19.5 LR 24	104	173	277
15.5 R25	68	132	200
17.5 R 25	86	165	251
455/70 R 24	93	120	213

Tab. 21 Water-antifreeze mixture – Recommendation when filled to 75 % with antifreeze protection to -30 °C

MgCl₂ = Magnesium chloride

H₂O = Water

4 Operation

4.8 Driving, steering and braking

4.8.1 Driving



Attention

When driving on public roads, the wheel loader, as a self-propelled work machine, is subject to the legal regulations valid in the user's country. (For example, in the Federal Republic of Germany, StVZO and StVO).

The machine has two preselection switches for travel direction which are alternately active.

Change-over by operating the multi-function switch (18/35).

One preselection switch for travel direction (18/36) is located on the instrument panel and another such switch on the joystick (18/7) controlling the working hydraulics.



Danger to life

due to incorrect operation.

- The multi-function switch (18/35) is only to be pressed if the machine is at a standstill and both travel direction preselection switches are in neutral position. If the two direction-of-travel preselection switches are pressed in a contradictory manner, the machine will not move.
- When driving on roads, the joystick (18/7) for the work equipment must be deactivated by operating the multi-function switch (18/35). By doing so, the travel direction preselection switch on the joystick (18/7) is without function, too.

The direction of travel is preselected using the switch (18/36) on the instrument panel.

In working mode, the joystick (18/7) for the work equipment must be activated by operating the multi-function switch (18/35). By doing so, the switch (18/36) on the instrument panel is without function.

The direction of travel is preselected using the travel direction preselection switch on the joystick (18/7).

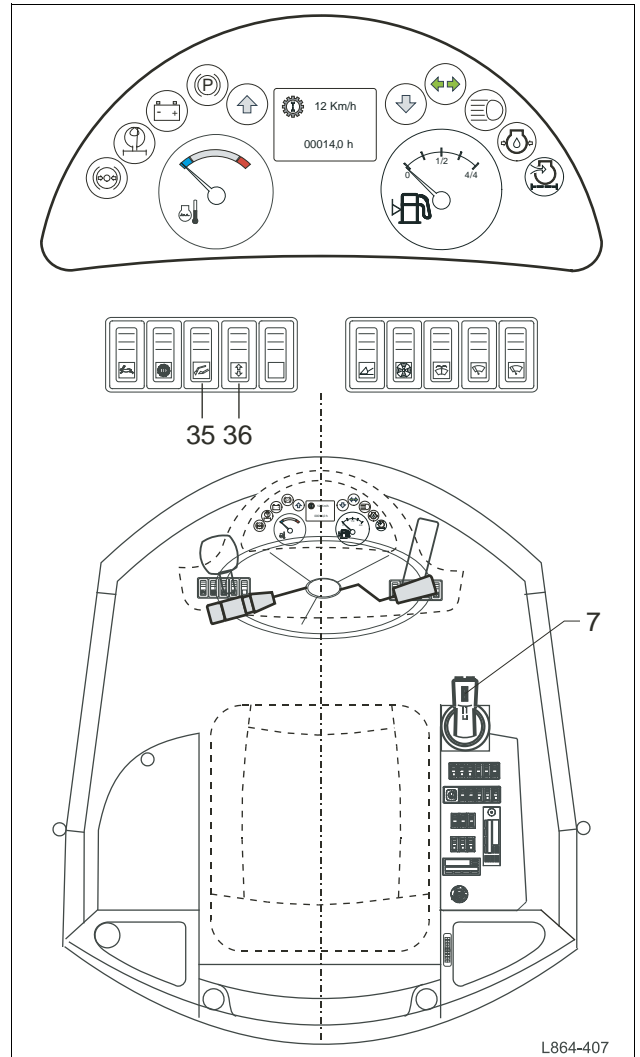

Fig. 18 Driving and steering

Driving off

- Set the travel direction preselection rocker switch on the joystick (19/7) and on the instrument panel (19/36) to "0" (neutral position).
- The indicator lamps (19/24 and 19/28) must not light up.
- Start engine.
- Raise lift frame as far as the "Travel" height mark (20/1).
- Select speed range "FAST" or "SLOW" (19/33) as required.
- High-speed version (option) - select speed range I or II (19/34).
- Observe the indicator lamp (19/66-68).
- Release the parking brake (19/54).
- Adjust the desired travel direction using the preselection switches (19/7 / 19/36 respectively).
- The indicator lamp (19/24 or 19/28) lights up.
- Press accelerator pedal (19/3). The machine only drives off once a certain engine speed is reached.
- Travel speed is increased and decreased using the accelerator pedal. Travel speed directly depends on engine speed.
- The direction of travel may be changed quickly by operating the preselectors (19/7 / 19/36 respectively).

Coming to a halt

- Travel speed is reduced by releasing the accelerator pedal. The hydrostatic travel drive acts as a non-wearing auxiliary brake.

- Operate the brake-inching pedal (19/2) as required.
- Also refer to → 4.8.3, 50

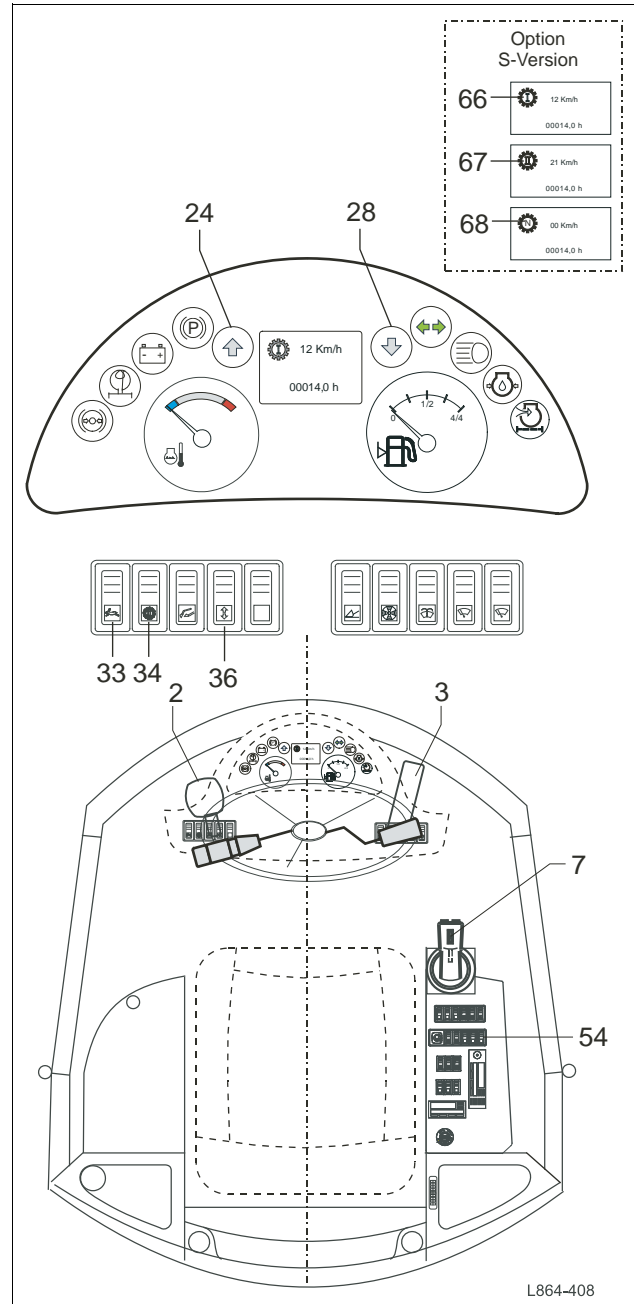

Fig. 19 Driving off and coming to a halt

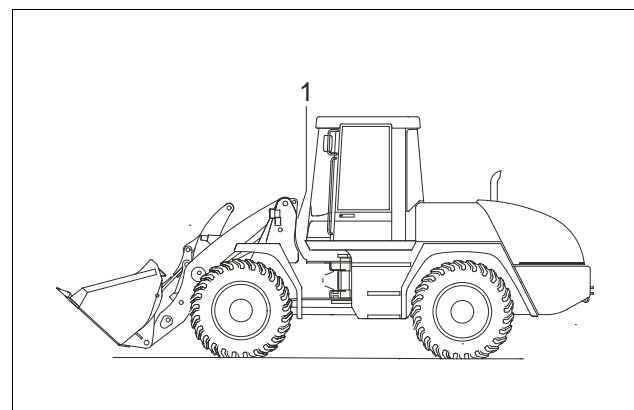

Fig. 20 Height color mark

4 Operation

4.8.2 Steering

- The wheel loader features a fully hydraulic, proportionally acting articulated steering.
- Priority supply of hydraulic oil to steering through load-sensing system.



Machine damage

due to fault which has not been remedied.

- In the event of steering malfunctions, determine the cause immediately (see *Trouble-Shooting Table*) and call for service personnel if necessary.

4.8.3 Brakes

Service and auxiliary brake

- To bring the machine to a halt, release the accelerator pedal (21/3). The hydrostatic travel drive then acts as an auxiliary brake.
- Operate the brake-inching pedal (21/2) as required.

Parking brake

- Only apply the parking brake (21/54) if the machine is stationary.



Attention

Once the parking brake is applied (21/54), the travel drive is deactivated.

Brake-inching mechanism

- The machine features a brake-inching mechanism altering the relationship between travel speed and engine speed.
- When the brake inching pedal (21/2) is operated, travel speed is reduced - irrespective of engine speed - until the machine comes to a stop. This mechanism permits sensitive driving at maximum engine speed, e. g. when loading a truck, where fast working cycles are required.

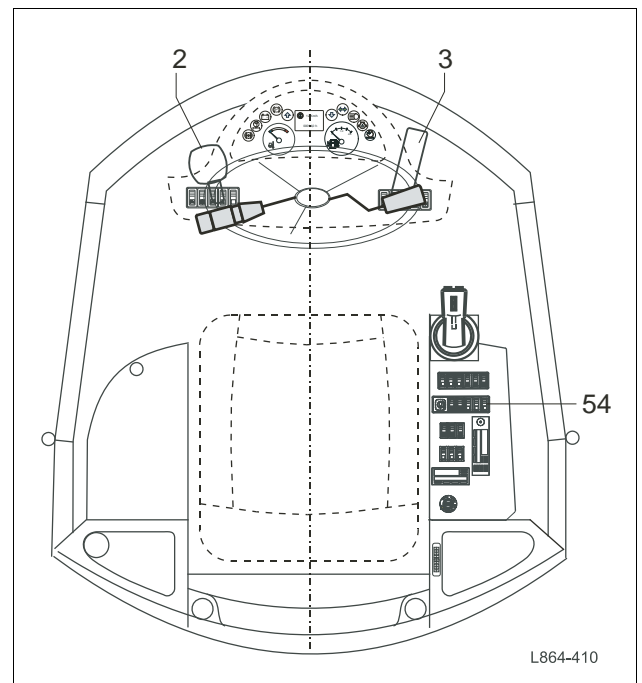

Fig. 21 Brakes

4.8.4 Driving on roads

- Before driving on open roads, the following points have to be observed:



Endangerment of road-traffic

due to missing equipment.

Ensure that the wheel loader is equipped as stipulated by the regulations authorizing the use of vehicles for road traffic in the user's country.

- Empty the bucket and tilt back completely.
- Attach the protective device onto the front bucket edge.
- Secure the side-dump bucket with socket pins.
- Completely retract the high-tip bucket.
- Fold up the forks of the fork lift attachment, lock in place and secure against lateral shifting.



Danger to life

due to rigid forks.

- *Rigid forks must be dismantled before driving on public roads!*

- Raise the lift frame as far as the height color mark (22/1) until sufficient ground clearance is secured.
- Set the travel direction preselection rocker switches on the joystick (23/7) and on the instrument panel (23/36) to "0" (neutral position).
- Switch off the working hydraulics (23/35).



Attention

Only press when machine is stationary!

- Check the function of the direction indicators, hazard warning lights, horn, low/high beam.
- Close the cabin door.

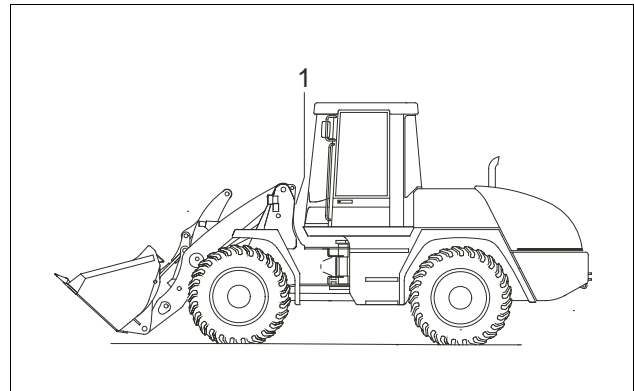

Fig. 22 Height color mark

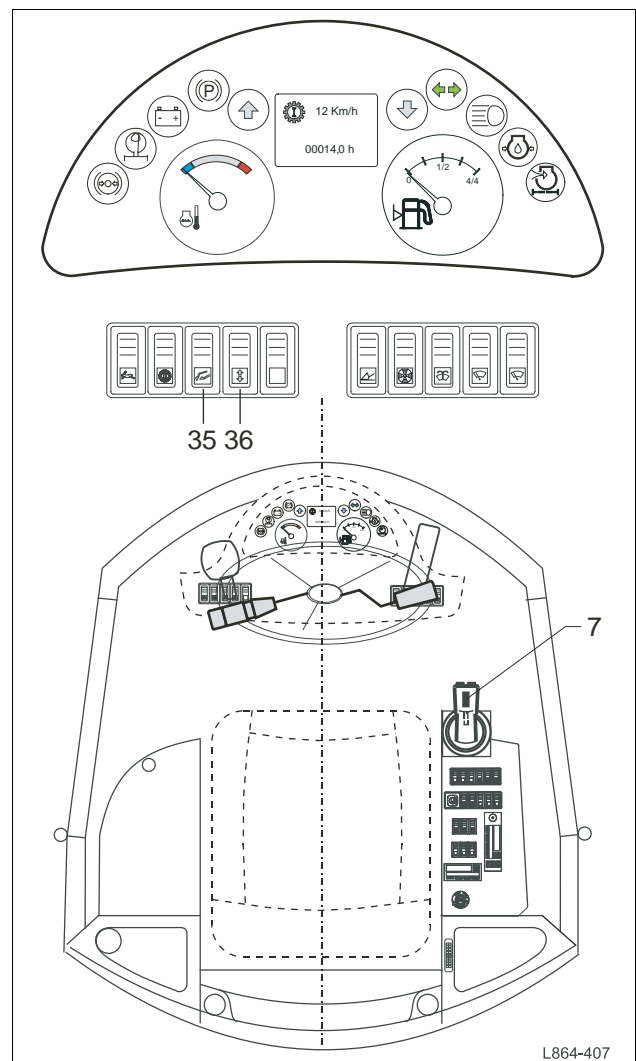

Fig. 23 Driving on roads

4 Operation

4.8.5 Switching off the machine (parking)

- Set the direction-of-travel preselection rocker switches (24/7 and 24/36) to "0".
- Lower the work attachment onto the ground.
- Switch off the working hydraulics (24/35).
- Apply the parking brake (24/54).
- Stop the engine and remove the ignition key.
- Lock the cabin after finishing work to keep unauthorized persons from getting in.



Danger to life

due to the machine rolling away.

If there is a danger of the machine rolling away, secure it with chocks.

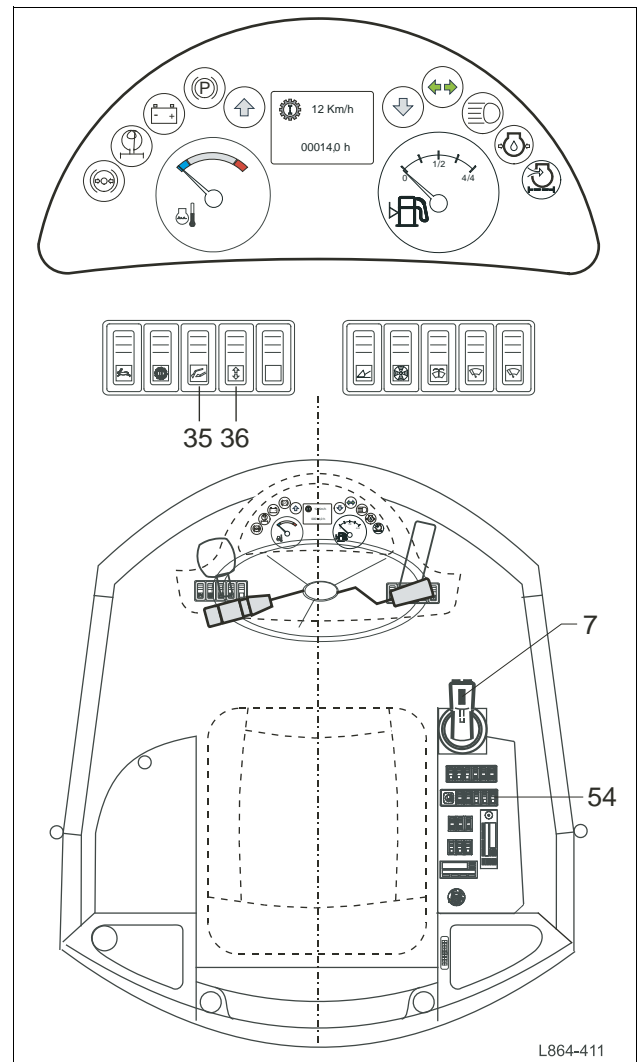

Fig. 24 Switching off the machine (parking)

5 Working Operation



Danger to life

due to incorrectly fastened work attachments.

- Daily before commencing work and after every change of work attachments, a check must be carried out to ensure that the work attachment is correctly fastened, and the quick-mount hitch is properly locked.
- The bucket must be moved carefully at a low height.
- Before commencing loading work, memorize the lever controls well.
- During loading operations, driving and work movements should flow in smooth succession.
- Drive slowly when familiarizing yourself with the controls.

5.1 Operation - Loader

- Switch on the work equipment (25/35).

Operation - Bucket

- Operate joystick (25/6).

Operation - additional control circuit (adjustable)

- Additional control circuit (25/53) in Position 1.
- Press right-hand / left-hand push-button switch (25/5) (e. g. open/ close multi-purpose bucket).



Attention

The additional control circuit must always be switched off unless additional equipment is operated. The hydraulic power of a number of attachments must be adjusted, e. g. rotational speed of sweepers, etc.

- Move the attachment to operating position.
- Operate the turning knob (25/49) to adjust hydraulic power (e. g. rotational speed).

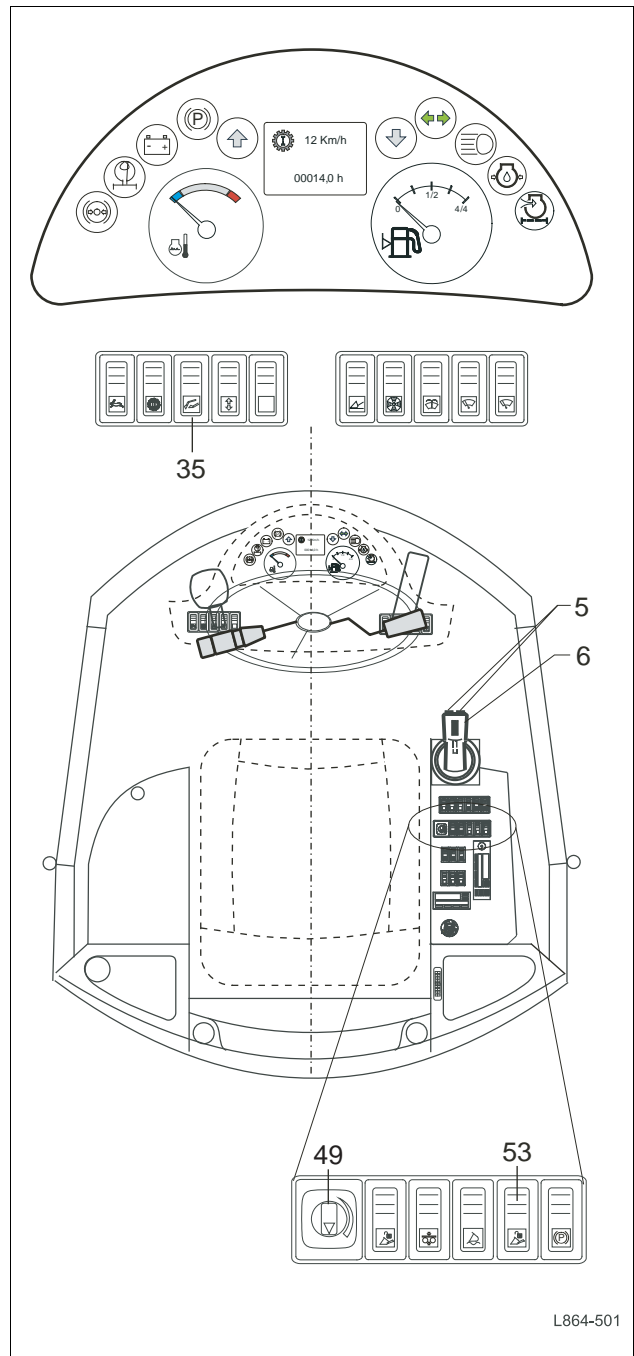

Fig. 25 Operating the loader

5 Working Operation

Continuous operation - Additional control circuit

- Additional control circuit (26/53) in Position 2 - red indicator lamp lights up.



Danger to life

due to incorrect operation.

- *Observe the function of the attachment (e. g. rotating direction of attachment).*



Attention

The additional control circuit must always be switched off unless additional equipment is operated.

Operation - Float position of lift frame



Attention

The float position must always be switched off unless operated. Switch (26/52) in Position "0".

Impulse Mode

- Float position switch (26/52) in Position "1".
- Lower the bucket onto the ground.
- Press switch (26/8). Float position is activated.

Continuous operation

- Lower the bucket onto the ground.
- Switch (26/52) in Position "2" - green indicator lamp lights up.

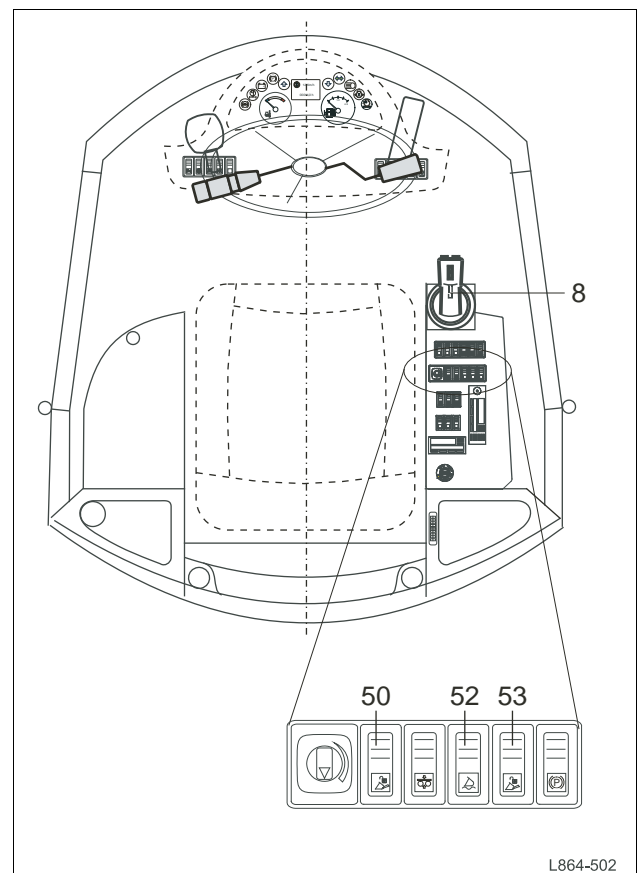

Fig. 26 Operating the loader

5.2 Changing work attachments

5.2.1 General

To achieve maximum utilization of the machine for a variety of applications, a great number of work attachments and accessories are available.

The machine is equipped with a quick-attach system, to shorten the time it takes to change attachments.

When mounting a multi-purpose bucket, front sweeper, etc., an additional control circuit is required.



Attention

Under certain circumstances, it is possible to use the work attachments of predecessor models on our machines. When mounting work attachments of predecessor models, however, these may have to be adjusted and/or are subject to utilization restrictions. The installation of work attachments which are not included in our product range requires our written approval. It is essential to consult your dealer before mounting such a work attachment.



Danger of injury

due to unsecured work attachments.

- *When attachments have been removed, they must be secured against overturning to avoid possible injury to persons.*

5 Working Operation

5.2.2 Assembly of work attachments



Attention

- *Ensure that the bearings of the lift frame, work attachment and quick-mount hitch are free from dirt.*
- *Before disconnecting hydraulic connections, the system must be released from pressure.*

Procedure for changing directly mounted work attachments



Attention

- *In the event of a hydraulically operated attachment, first of all the hydraulic connection must be disconnected (system must be without pressure).*
- Lower the work attachment onto the ground and position so that it cannot tilt.
- Remove the pin of the linkage and the pin of the lift frame.
- Move the lift frame out of the work attachment and install a new tool.

Procedure for changing work attachments with hydraulic quick-attach system (option)

- Lower the work attachment onto the ground and position so that it cannot tilt.
- Switch off the diesel engine.
- Switch on the ignition.
- Operate the push-button switches (27/5) for pressure relief.
- In case of hydraulically controlled additional tools: Release the hydraulic connections on both distributor blocks.
- Ball valve in position "Unlock quick-attach system" (Fig. 28).
- Start the diesel engine.
- Unlock the quick-attach system (27/5) and move out of the work attachment.
- Take up new work attachment and lock by pressing the push-button switch (27/5).



Danger to life

due to incorrectly fastened work attachments.

- Perform a visual check to ensure that the quick-attach system is correctly locked.

- Switch off the diesel engine.
- Switch on the ignition.
- Operate the push-button switches (27/5) for pressure relief.
- Ball valve in position "Quick-mount hitch locked" (Fig. 28).
- Connect the hydraulically operated work attachment to the connection of the additional control circuit.



Machine damage

due to additional control circuit which has not been switched off.

- The additional control circuit (27/53) must be switched off unless a hydraulically operated additional attachment is connected.

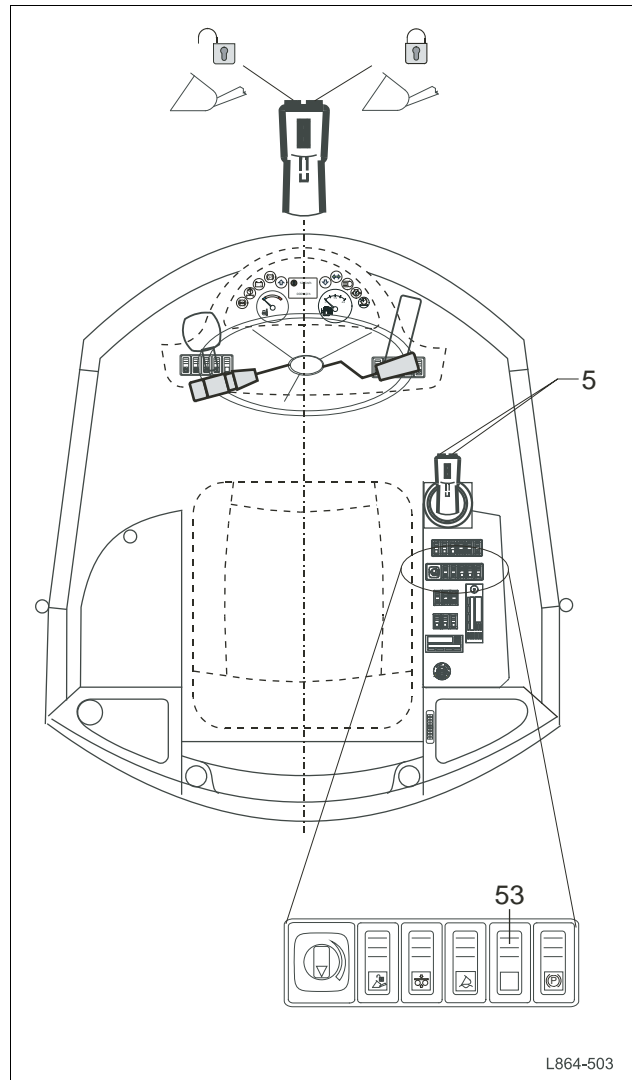

Fig. 27 Operating the quick-attach system

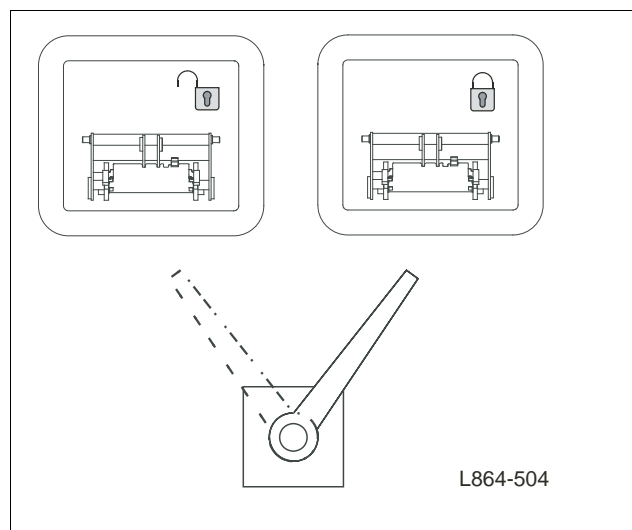

Fig. 28 Releasing and locking the hydraulic quick-attach system

5 Working Operation

5.3 Notes on how to work with the machine

5.3.1 Loading

During transport, the bucket - either filled or empty - must be kept as close to the ground as possible.

If possible, avoid long transport distances!



Attention

- *For loading, lower the bucket and position the cutting edge parallel to the ground. Reduce driving speed by inching as required.*
- *Move the bucket into the material to be loaded.*
- *As soon as the bucket is filling, slightly raise the lift frame and tilt back the bucket.*
- *For dumping, raise the bucket until it is above the point of dumping and dump the material.*

5.3.2 Scraping and grading

- Lower the lift frame and move the cutting edge into the ground keeping a flat angle of inclination. Do not penetrate too deeply to ensure smooth removal of earth.
- During this operation, the depth is only to be leveled by moving the bucket in and out.

5.3.3 Excavating

- To dig out an excavation, strip layers which are as regular as possible.
- Plan the excavating work in such a way as to enable the wheel loader to drive forward with full bucket out of the excavation.
- Keep the outward run of the excavation as flat as possible.

6 Recovery, Loading and Transporting

6.1 Recovery

Towing of the wheel loader must be restricted to clearing a junction or a road, to prevent damage to the hydrostatic travel drive.

If possible, let the diesel engine run at low idle during towing.



Machine damage

due to excessively fast towing.

- Tow the machine at walking speed.

Towing lugs

- Front: right and left on the axle plates.
- Rear: bottom right and left on the side plates of the rear end.



Attention

Max. load suspension of towing lugs approx. 9200 kg.

- Whenever the wheel loader has to be towed, for whatever reason, the “Travel” oil circuit must be opened so that the hydrostatic transmission no longer acts as an auxiliary brake.
- At the two high-pressure relief valves (29/1) with bypass, loosen the screw (30/1) by no more than 3 turns.
- After towing, screw back in screw (30/1) until the stop.



Machine damage

due to hydraulic system contamination.

- Absolute cleanliness is essential when working on the hydraulic system.



Danger to life

due to machine rolling away.

- Always secure the machine with chocks and relieve the hydraulic system of pressure before carrying out maintenance and repair work.



Fig. 29 Hydraulic pump

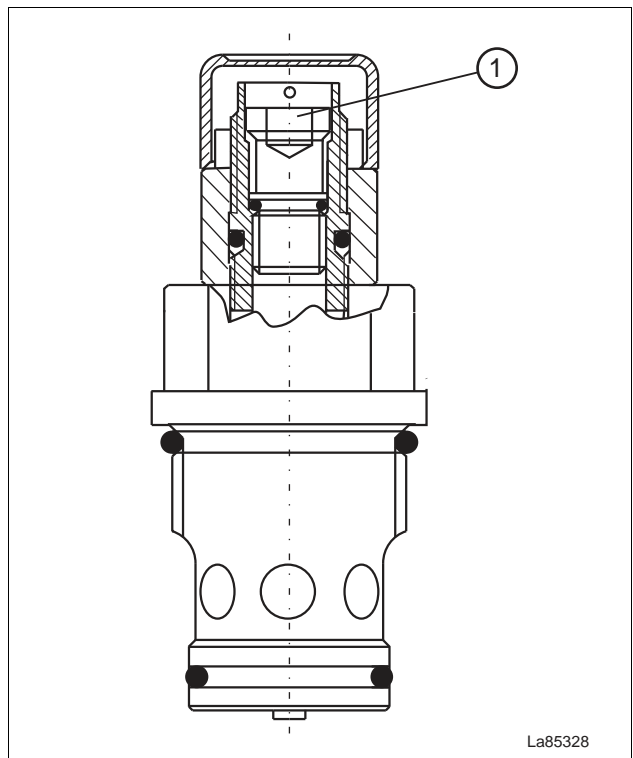

Fig. 30 High-pressure relief valve

6 Recovery, Loading and Transporting

Releasing the spring-loaded brake

- Switch on the ignition (31/61)
- Release the spring-loaded brake by operating the switch (31/54).
- If the spring-loaded brake cannot be released, release it in both axles by screwing in the adjusting screws (32/1).



Attention

After towing, re-adjust the spring-loaded brake as specified in Chapter → 7.8.9.3, 91.

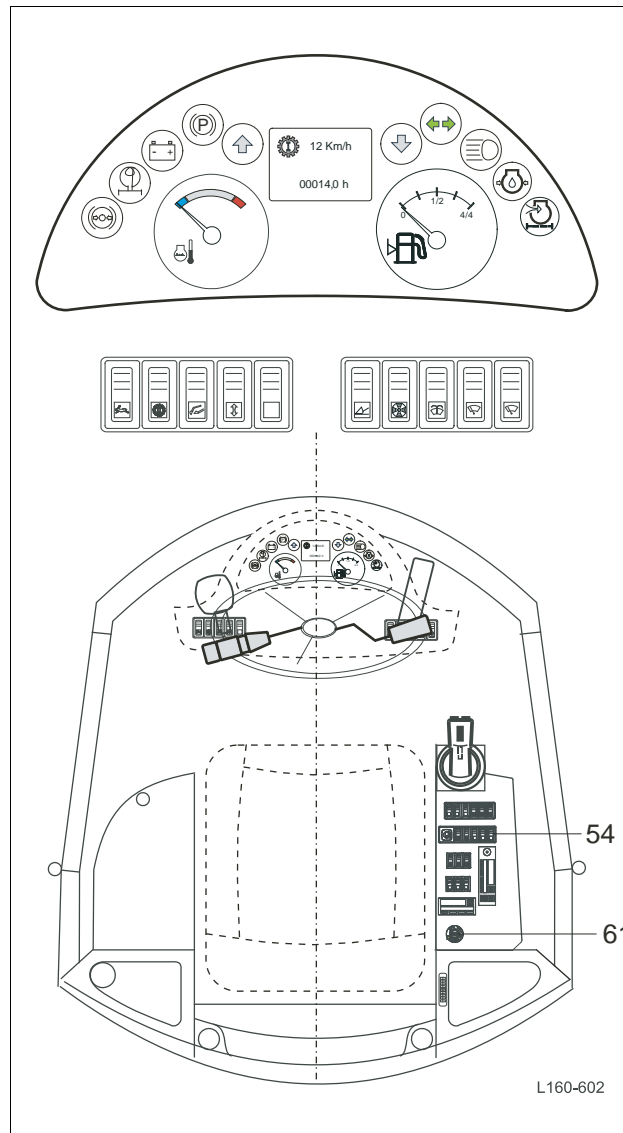

Fig. 31 Releasing the parking brake

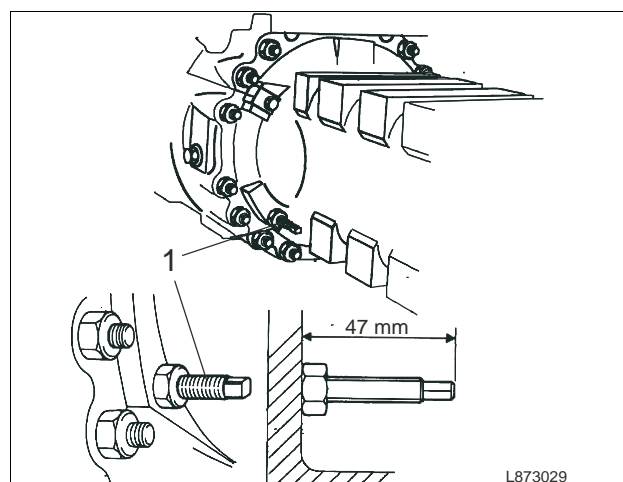

Fig. 32 Releasing the spring-loaded brake

6.2 Loading the machine by use of a crane



Danger to life

due to exceeding the maximum weight-lifting capacity.

- Ensure that the maximum lifting capacity of the crane and the crane harness is not exceeded.

To load the machine by use of a crane, the following preparations are required:

- Empty the bucket and tip back.
- Move the lift frame to travel position.
- Apply the pin of the articulation lock (33/1 on the articulation).
- Lower the work tool onto the ground.
- Switch off the engine.
- Dismount from the machine and close the doors.
- Attach the loader to the hoisting appliance at the specified, marked points (Fig. 33) in the correct manner.

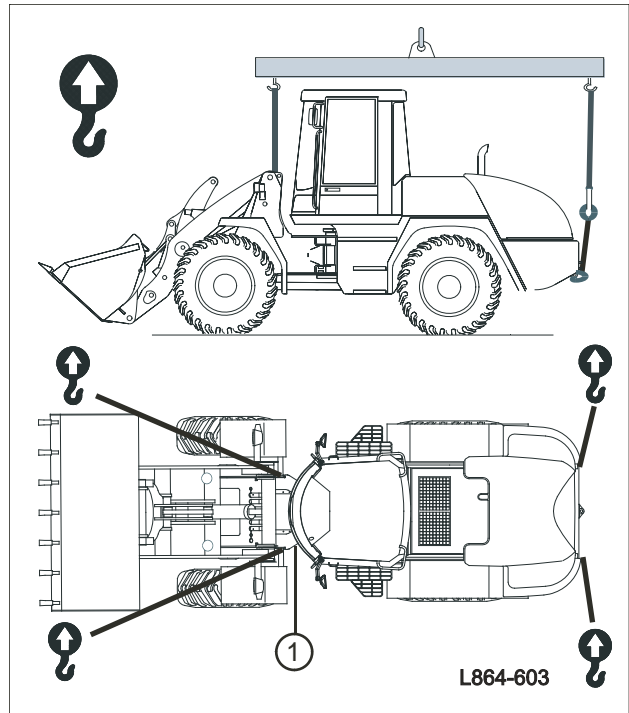

Fig. 33 Crane suspension

6.3 Transport of the machine

To transport the machine onto a flat bed trailer, railway goods wagon, etc. the following measures must be taken:

- Empty the bucket and tilt back.
- Drive the machine onto the flat bed trailer, goods wagon, etc., or lift by crane if required.
- Apply the pin of the articulation lock (34/1 on the articulation).
- Lower the work tool onto the ground.
- Switch off the engine.
- Dismount from the machine and close the doors.
- Attach the machine at the points illustrated (Fig. 34) in the correct manner.



Danger to life

due to disregarding the total transport height.

- It is essential to observe the clearance heights of tunnels, bridges, etc.

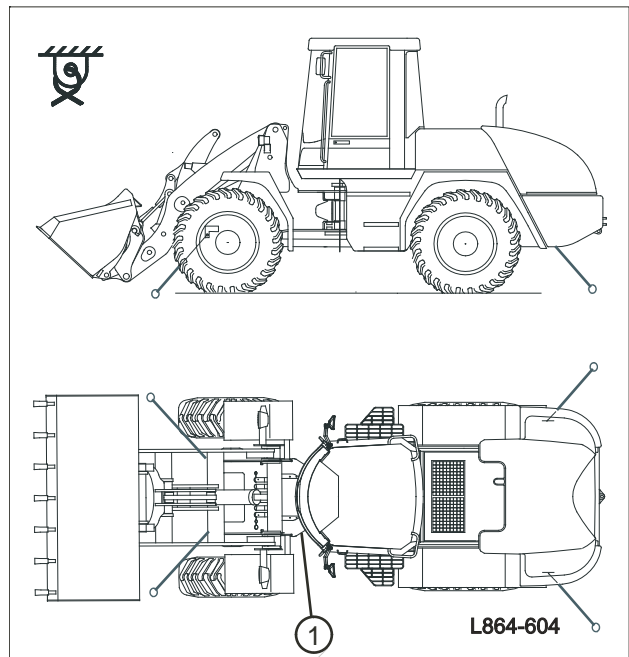

Fig. 34 Lashing for transport

6 Recovery, Loading and Transporting

7 Care and Maintenance

The good operating condition and life expectancy of machines are largely influenced by care and maintenance.

For this reason, it is in every machine owner's interest to perform the specified maintenance work and comply with the service intervals. This Chapter deals in detail with periodic maintenance, inspection and lubricating tasks.

The type-specific maintenance and inspection plan lists all work to be performed on the machine at regular intervals. Maintenance and inspection plans for this purpose are contained in every Instruction Book.

It is essential that the recommendations in the Chapter "Safety and Prevention of Accidents" are observed (→ 2, 13).

7.1 Intervals

Initial inspection	once before first putting into operation	→ 7.7.1, 68
Daily tasks	Every 10 operating hours or every work shift ¹	→ 7.7.2, 70
Weekly tasks	Weekly or after 50 operating hours ¹	→ 7.7.2, 70
100 operating hours	once after first putting into operation ²	→ 7.7.4, 74
Every 500 operating hours	After every 500 operating hours or 6 months	→ 7.7.4, 74
Every 1000 operating hours	After every 1000 operating hours or 12 months	→ 7.7.4, 74
Every 2000 operating hours	After every 2000 operating hours or after 2 years	→ 7.7.4, 74

Tab. 22 Intervals

¹ whichever comes first

² also applicable if new or overhauled diesel engines are put into operation.

7 Care and Maintenance

7.2 Regular oil analyses

Oil analyses are not intended as a substitute for the oil change intervals but – apart from a possible reduction of maintenance costs and as a form of preventive maintenance – they take into account the increasing environmental awareness.

Advantages of an oil analysis

- Extension of the oil change intervals under standard or light-duty operating conditions.
- Minimum wear of high-quality components with optimum use of the lubricants.
- Periodic laboratory analyses enable an early detection of imminent damage.
- Repairs performed before they actually become absolutely necessary help prevent serious and unexpected damage.
- Sequential damage can be avoided.

How often should the oil be analyzed?

Periodic oil analyses reveal trends in the condition of the oil and the machine. The oils should be analyzed at the following intervals:

- Hydraulic oil: 1000 operating hours
- Transmission oil: 500 operating hours
- Engine oil: 100 operating hours

Based on the first results, the laboratory recommends the interval for the next sampling. Ask your Terex dealer for an information booklet detailing the scope and procedures of the oil analysis.

7.3 Warranty

During the warranty period thorough inspections are stipulated which are obligatory and must be carried out by trained specialist dealer personnel.



Attention

The inspections are obligatory and must be paid for.

The performance of inspections as specified must be confirmed on the inspection cards in the warranty/handing-over certificate.

If omitted, this may affect the warranty covered by us.

7.4 Inspection parts and aids

Maintenance parts	Spare part number
Hydraulic oil filter insert – return filter	5 380 658 088
Hydraulic oil filter insert – suction filter	5 003 659 261
Breather with screen element	5 003 650 362
Engine oil filter	5 568 656 650
Fuel filter with seal	5 568 664 196
Air filter - main cartridge	5 501 660 932
Air filter - safety cartridge	5 501 660 934
V-belt 13 x 1375 (air-conditioning system) >XXX/0122	5 568 656 588
V-belt l=1237mm (air-conditioning system) XXX/0123>	5 568 663 264
V-belt l=1212mm XXX/0123>	5 568 664 340
Dust filter for cabin	5 388 665 293
Cylinder head cover gasket	5 568 664 195
Service package after 100 operating hours	MPS160004C
Service package every 500 operating hours	MPS160005C
Service package every 1000 operating hours	MPS160006C
Extras	
Terex hydraulic oil, mineral	4 312 005 050
Terex hydraulic oil, biodegradable	Please contact your Terex dealer for further information.
Transmission oil (SAE 85 W 90 LS)	4 314 005 775
Engine oil (SAE 15 W 40)	4 312 905 759

Tab. 23 Inspection parts and aids



Attention

Maintenance and wearing parts for inspections should be ordered well in advance.

Fuels, lubricants, and coolants

- The machine's life expectancy and operating condition largely depend on the use of the specified lubricants and compliance with the service intervals.
- If lubricants which do not conform to our recommendations are used, consequential damage may occur for which we will not assume liability, even inside the warranty period.
- Observe the specifications for fuels, lubricants, and coolants (→ 3.9.2, 30).

7 Care and Maintenance

7.5 Care and cleaning



Attention

The machine must be cleaned on a suitable surface with an oil separator.

- Neither a steam-jet appliance nor a high-pressure cleaning apparatus may be used for cleaning during the first two months after the machine has been used for the first time, or when newly painted, to ensure that the paint can harden sufficiently.
- Do not use aggressive detergents for cleaning the machine. We recommend using commercially available cleaning agents for passenger cars.
- When cleaning with a steam-jet appliance, the hot water jet should not exceed 80 °C and a spray pressure of 70 bar.
- Linings (insulating materials, etc.) should not be exposed directly to water, steam or high-pressure jets.
- When cleaning with water or steam jets, take care not to spray exhaust-gas and air filter openings.
- When cleaning the engine with water or steam jets, do not expose sensitive engine parts, such as generators, cabling, oil pressure switches, etc. directly to the jet.
- After each wet clean, the machine must be lubricated in accordance with the lubricating plan and a test of all work cycles, support and driving functions carried out.

7.6 Notes for winter operation

The following points - and the relevant notes in the Engine Instruction Book - should be observed during winter operation:

Hydraulic oil

- If the machine is not used for longer periods at temperatures around and below freezing, warm it up by running the engine at medium speed (approx. 3 – 5 min).

Engine oil

- The oil viscosity (SAE class) should be selected according to the ambient temperature at the machine's place of operation.

Coolant

- Before the beginning of the cold season, check the level of antifreeze and adjust in line with the ambient temperature if necessary. At the factory, the antifreeze protection is set to approx. -25 °C.

Condition of the battery

- A good cold start performance requires a well-charged battery. By warming the battery to approx. +20 °C (remove the battery after the engine has been turned off and store it in a warm room), the minimum starting temperatures can be lowered by 4 – 5 °C.
- When installing the battery, ensure good contact of terminal connections.
- Only tighten terminal screws so that they are "hand-tight", to prevent deformation of the terminal cones.

Fuel specification

The use of high-quality fuel is a prerequisite for achieving the engine output specified.

Recommended fuel specification

- N590-diesel engines - Auto/C0/C1/C2/C3/C4
- BS2869 Class A2
- ASTM D975-91 Class 2-2DA, US DF1, US DF2, US DFA
- JIS K2204 (1992) Class 1, 2, 3 and special class 3.



Attention

If sulfur-free fuel is used, additions to lubricants must be used.

Sufficient fuel specification



Attention

The fuel specification listed below is sufficient but may reduce the life expectancy of the fuel injection system.

- ASTM D975-91 Class 1-1DA
- JP7, MIL T38219 XF63
- NATO F63

Fuel with low sulfur content

- Only use commercially available brand-named diesel fuel with a sulfur content of less than 0.5%.

Sulfur content in fuel in %	Oil change interval
< 0.5	normal
0.5 to 1.0	0.75 of normal
> 1.0	0.50 of normal

Tab. 24 Oil change interval if sulfur content in fuel is higher

Winter fuel

Use only winter diesel fuel in winter to prevent line connections becoming blocked through paraffin deposits. At very low temperatures, troublesome deposits may also occur when winter diesel is used.

7 Care and Maintenance

7.7 Checking, maintenance and inspection plans

7.7.1 Initial inspection (Handing-over inspection)

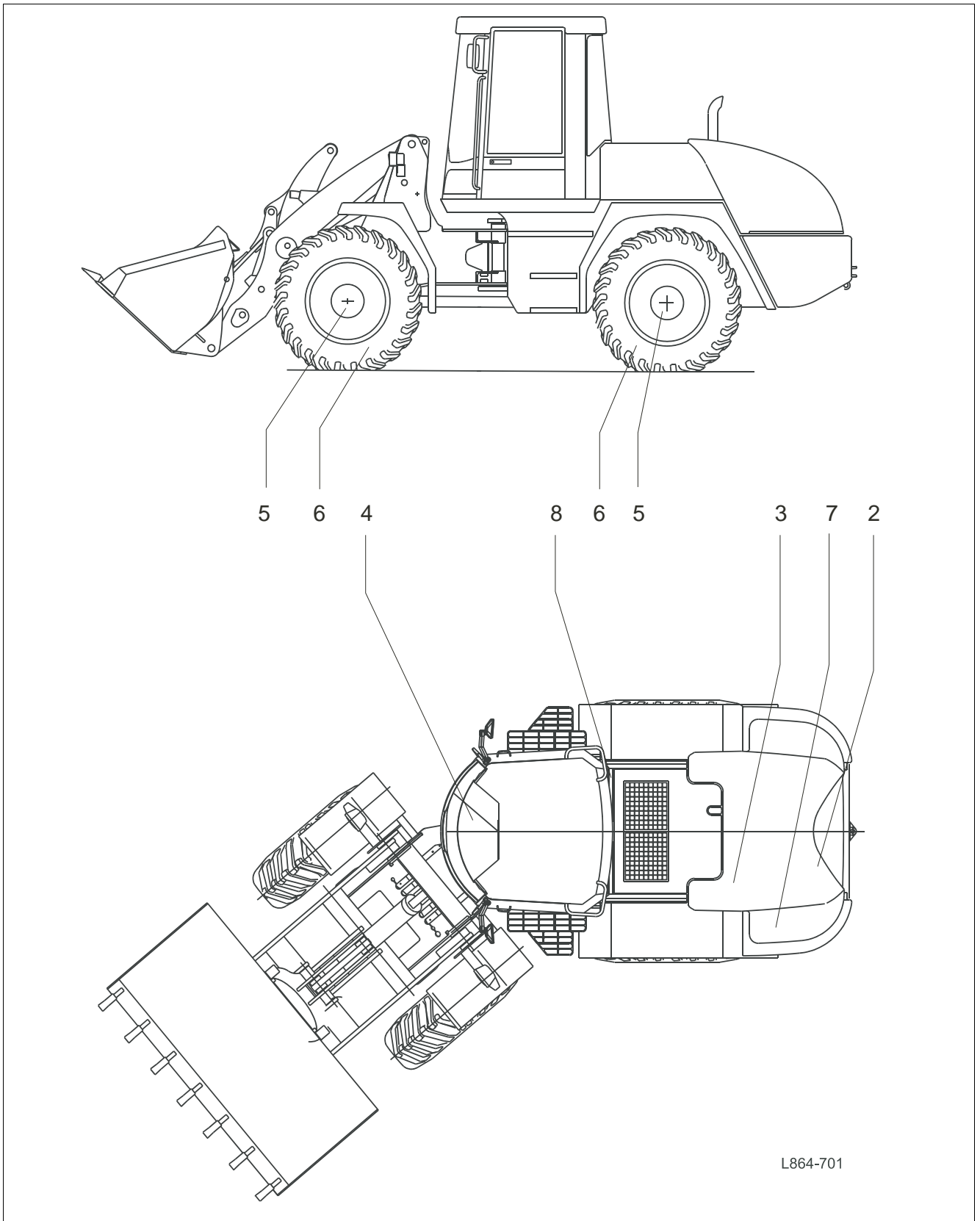

L864-701

Fig. 35 Initial inspection

Work to be carried out by trained dealer service personnel.

Activities		Chapter
1	Check whether machine-specific Operating Manual is in the machine.	
2	Check engine oil level.	→ 7.8.2, 76
3	Check hydraulic oil level.	→ 7.8.10, 92
4	Check fuel level.	→ 7.8.5.1, 81
5	Check oil level of differential and axle hubs.	→ 7.8.14.2, 97
6	Check tire pressure and tightness of wheel nuts.	→ 7.8.15, 99
7	Check the battery fluid level and charge condition.	→ 7.8.17, 100
8	Top up windshield washer system.	→ 7.8.20, 102
9	Grease machine (all lubricating points).	→ 7.7.3, 72
10	Test run, hydraulic function check and test work.	
11	Visual inspection for tightness of all hoses, pipes, cylinders, etc.	
12	Check function of electrical indicating and warning elements, and the lighting system.	
13	Initial delivery/handing-over certificate and return to manufacturer.	

Tab. 25 Work involved in initial start-up

7 Care and Maintenance

7.7.2 Daily and weekly tasks

Inspection and maintenance jobs to be performed by operating personnel.

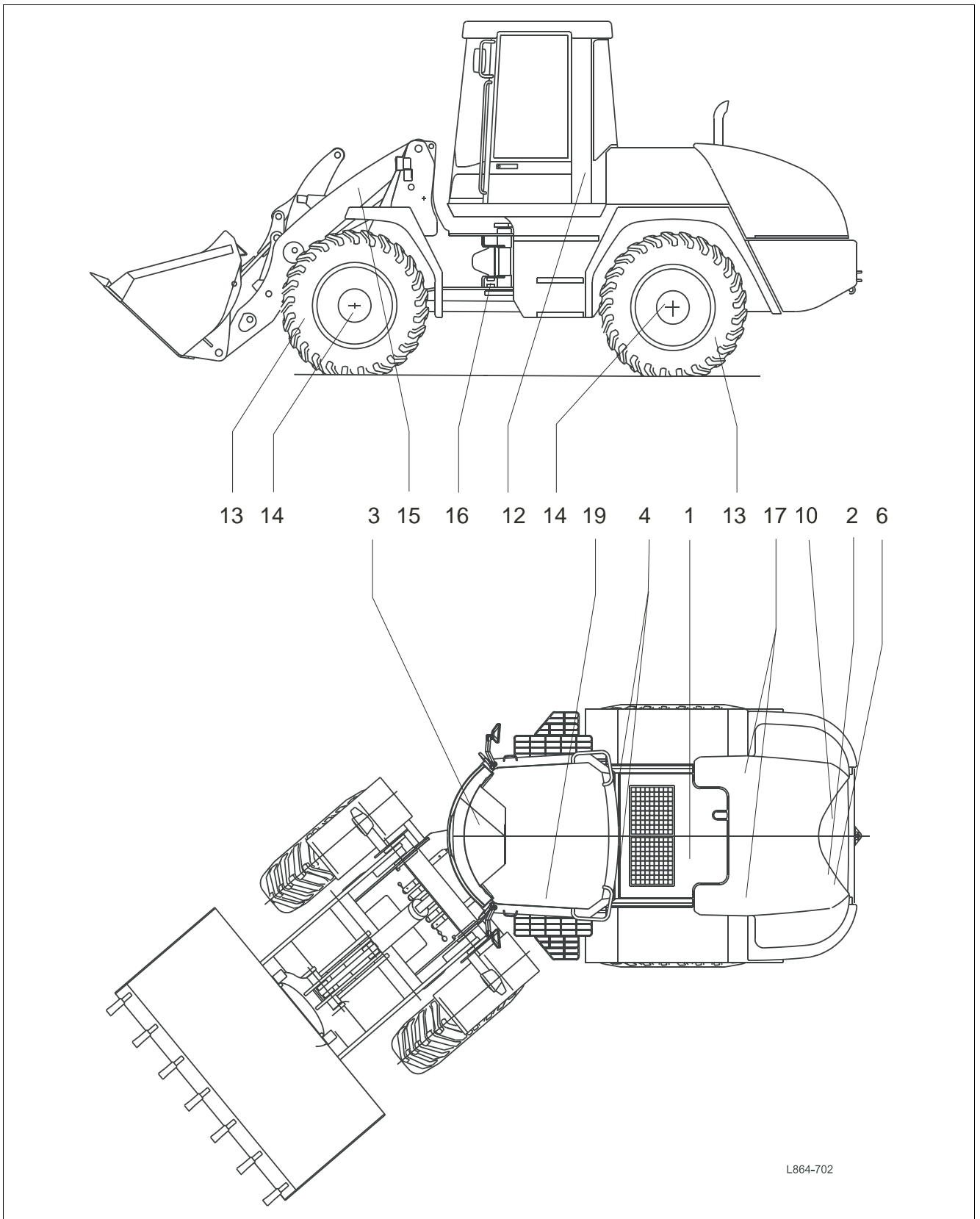





Fig. 36 Inspection and maintenance plan

Daily		Chapter
1	Check hydraulic oil level.	→ 7.8.10, 92
2	Check engine oil level.	→ 7.8.2, 76
3	Check fuel level (fuel gauge on instrument panel).	→ 7.8.5.1, 81
4	Check windshield washer-fluid level.	→ 7.8.20, 102
5	General visual inspection for material cracks, external damage, completeness, etc.	
6	Draining the water separator.	→ 7.8.5.2, 81
7	Check for leaks in pipes, hoses, control unit, hydraulic pumps, cylinders, etc.  Attention <i>The screw-in couplings must be locked when tightening hose or line connections to prevent rotation.</i>	
8	Check function of electrical indicating and warning elements, and the lighting system.	
9	Check smooth running of operator controls.	

Tab. 26 Daily tasks

Weekly		Chapter
10	Drain fuel filter.	→ 7.8.5.3, 82
11	Check the cooling fins of the combined cooler.  Machine damage <i>due to strong accumulation of dust.</i> <ul style="list-style-type: none"> • Clean the combined cooler by hand. 	→ 7.8.4.4, 80
12	Check that door catches function perfectly.	
13	Check tire pressure and tightness of wheel nuts.	→ 7.8.15, 99
14	Check fastening of axles and propeller shaft.	
15	Check bearing bushings and pins/bolts of work equipment.	
16	Check pins/bolts, bushings, and the linkage assembly of the articulated steering.	
17	Check that pneumatic springs of engine hood function perfectly.	
18	Check function of brakes.	
19	Check if the dust filter for cabin ventilation is dirty and clean if required.  Machine damage <i>due to strong accumulation of dust.</i> <ul style="list-style-type: none"> • Shorten the inspection and cleaning intervals. 	→ 7.8.19, 102
20	Check function, condition and completeness of safety devices.	
21	Grease machine according to overview of lubricating points.	→ 7.7.3, 72

Tab. 27 Tasks to be performed weekly

7 Care and Maintenance

7.7.3 Overview of lubricating points



Machine damage

due to damaged lubricating nipples.

- Replace damaged grease nipples immediately and check if grease passes through.

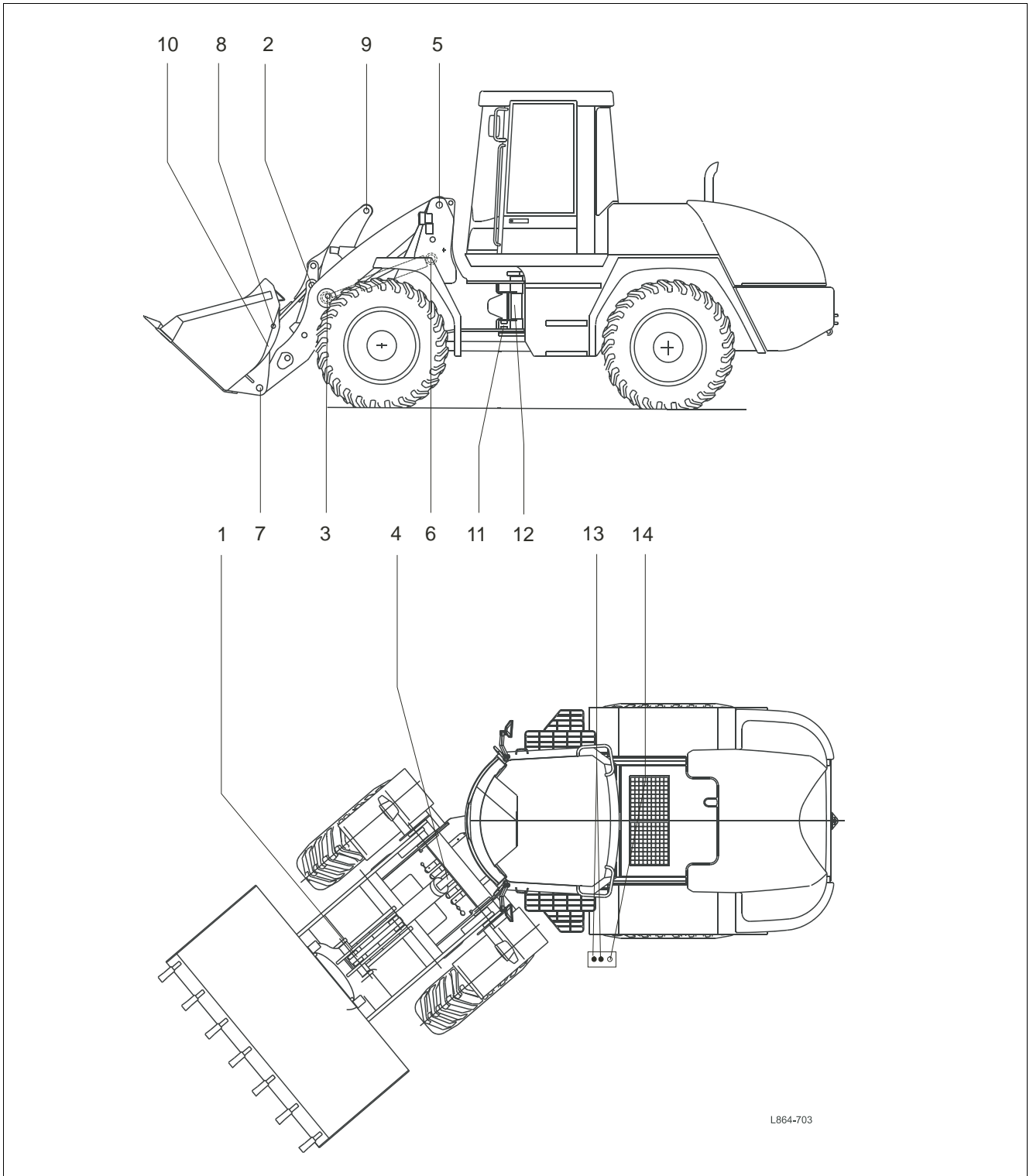

Fig. 37 Overview of lubricating points

- Grease all lubricating points with multi-purpose grease.



Attention

The intervals stated are valid for single-shift operation.

- Shorten the lubrication intervals for special operations, e.g. on sandy ground in order to achieve self-cleaning of the bearing points.

Item	Lubricating point	Number	Daily	Weekly	Chapter
1	Tilt cylinder – Tilt control lever	1		X	--
2	Lift frame – Tilt control lever	1		X	--
3	Lift cylinder – Lift frame	2		X	--
4	Tilt cylinder – Front-end	1		X	--
5	Lift frame – Front-end	2		X	--
6	Lift cylinder – Front-end	2		X	--
7	Lift frame – Quick-attach system	2		X	--
8	Linkage – Quick-attach system	2		X	--
9	Tilt control lever – Linkage	1		X	--
10	Hydr. quick-mount hitch	2		X	--
11	Steering cylinder – Front-end	2		X	--
12	Articulation	3		X	--
13	Steering cylinder – Rear-end	2		X	--
14	Rear axle bearing	2		X	--

Tab. 28 Lubricating points

7 Care and Maintenance

7.7.4 Inspection plan

Work to be carried out by trained dealer service personnel.

O = Checking, maintenance X = Replace Perform work with machine at operating temperature		operating hours				min. 2 x an- nual- ly	min. 1 x an- nual- ly	Chapter
		after 100	ev- ery 500	ev- ery 1000	ev- ery 2000			
1	Check whether machine-specific Operating Manual is in the machine.	O	O					
2	Change engine oil.		X				X	→ 7.8.2.2, 77
3	Change engine oil filter.		X				X	→ 7.8.3, 78
4	Drain water from fuel tank.	O	O			O		→ 7.8.5.5, 83
5	Change fuel filter.		X				X	→ 7.8.5.4, 82
6	Check air intake.	O	O					→ 7.8.6, 83
7	Replace air filter main cartridge.	according to service indicator					X	→ 7.8.6.5, 85
8	Replace air filter safety cartridge.	as required ¹						→ 7.8.6.4, 84
9	Check level of antifreeze in coolant.						O	→ 7.8.4.2, 78
10	Change coolant.	as required ¹						→ 7.8.4.3, 79
11	Check V-belt tension.	O	O					→ 7.8.7.2, 87
12	Check engine mounting and pump attachments.	O	O					
13	Check engine speed adjustment, upper and lower idling speeds.	O	O					
14	Check valve lash on engine and adjust if necessary.			O			O	→ 7.8.8, 89
15	Check injection valves.			O				→ 7.8.8, 89
16	Check crankcase breather in valve cover.				O			
17	Check acid level and battery connections.	O	O					→ 7.8.17.1, 100
18	Check condition of tires, tire pressure and tightness of wheel nuts.	O	O					→ 7.8.15, 99
19	Check fastening of axles and propeller shaft.	O	O					
20	Check bearing bushings and bolts of work equipment and replace if necessary.	O	O					
21	Check bushings and bolts of the articulation and the articulated steering and replace if necessary.	O	O					
22	Check that door catches function perfectly, and replace if necessary.	O	O					
23	Clean or replace the dust filter for cabin ventilation.	O		X			X	→ 7.8.19, 102
24	Check electrical indicating and warning elements and lighting equipment.	O	O					
25	Check smooth running of operator controls and adjust if necessary.	O	O					
26	Check for leaks in all pipes, hoses, control valves, hydraulic pumps, cylinders, etc.  Attention The screw-in couplings must be locked when tightening hose and line connections to prevent rotation.	O	O					
27	Check or change hydraulic oil.	O	O	X ²			X	→ 7.8.10, 92
28	Replace insert of hydraulic oil return suction filter.	X	X			X		→ 7.8.10, 92
29	Replace breather.			X			X	→ 7.8.13, 95
30	Check function of brakes and brake disc play.	O	O		X		X	→ 7.8.9.2, 90
31	Bleed brake	O	O					→ 7.8.9.2, 90

Tab. 29 Inspection plan

¹ At least every two years.

² Extension of oil change intervals according to oil sample analysis and laboratory report → 7.2, 64.

³ Within warranty.

O = Checking, maintenance X = Replace Perform work with machine at operating temperature		operating hours				min. 2 x	min. 1 x	Chapter
		after 100	ev- ery 500	ev- ery 1000	ev- ery 2000	an- nual- ly	an- nual- ly	
32	Differential – rear axle including transmission: oil check and/or oil change	X	O	X			X	→ 7.8.14.2, 97
33	Differential – front axle: oil check and/or oil change.	X	O	X			X	→ 7.8.14.1, 96
34	Wheel hubs of front and rear axles: oil check or oil change	X	O	X			X	→ 7.8.14.3, 99
35	Grease machine according to overview of lubricating points.	O	O					→ 7.7.3, 72
36	Check function, condition and completeness of safety devices.	O	O					
37	Hydraulic function check with pressure function test.	O	O					
38	Test run and test work.	O	O					
39	Initial inspection card and return to manufacturer.	O	O ³					→ 7.3, 64

Tab. 29 Inspection plan

¹ At least every two years.

² Extension of oil change intervals according to oil sample analysis and laboratory report → 7.2, 64.

³ Within warranty.

7 Care and Maintenance

7.8 Inspection and maintenance work

7.8.1 Checks using the display



Attention

All checks must be carried out with the machine standing on level ground and cooled down.

The levels of engine oil, hydraulic oil and coolant can be read on the check display.



Attention

With the diesel engine running, the level indicator is without function!

Checking

- Switch on the ignition.
- The symbols “engine oil level” (38/71), “hydraulic oil level” (38/72) and “coolant level” (38/73) light up for approx. 3 sec on the display.
- If the level is insufficient, the relevant level indicator lamp continues to light up.
- If required, top up the missing fluid.

7.8.2 Engine oil

7.8.2.1 Checking the engine oil level

- The oil level must be checked daily before start-up with the machine standing on level ground.
- Observe the level indicator on the display of the instrument panel.
- Insert the oil dipstick (39/1) until the stop. The notches on the dipstick indicate the minimum and maximum oil levels.
- Top up engine oil if necessary. Open the filler neck (39/2) and add oil using a clean container. Close the filler neck again.



Machine damage

due to excess oil.

Observe the permissible filling level of the engine oil pan and avoid overfilling. Excess oil may enter the crankcase breather and lead to engine-speed control faults.

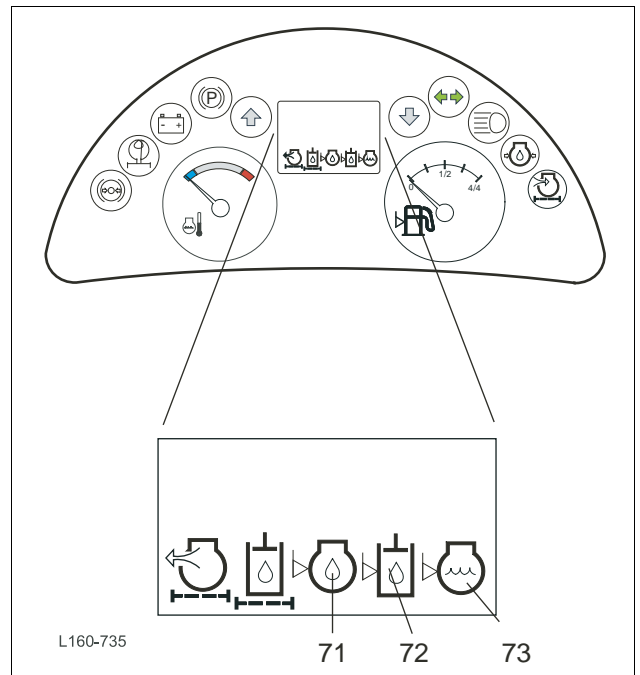

Fig. 38 Checks using the display



Fig. 39 Checking the engine oil level

7.8.2.2 Changing the engine oil



Attention

- Collect the waste oil in a suitable container and dispose of in compliance with regulations.

- Run the engine until it reaches operating temperature, engine oil temperature approx. 80 °C.
- Park the machine on a level surface.
- Stop the engine.
- Remove the cover from the bottom rear-end.
- Place suitable drip pans under the opening.



Danger of scalding

due to hot oil getting into contact with skin or eyes.

- Wear appropriate protective clothing/safety goggles.
- Screw the oil drain hose onto the oil-change valve (40/1).
- Drain oil.
- Remove the oil drain hose and screw the protective cap onto the valve (40/1).
- Close the service opening with the cover.
- Replace the engine oil filter (40/2) (→ 7.8.3, 78).
- Top up engine oil to the "MAX" mark on the oil dipstick (40/3) using the filling hole (40/4).



Machine damage

due to excess oil.

Observe the permissible filling level of the engine oil pan and avoid overfilling. Excess oil may enter the crankcase breather and lead to engine-speed control faults.

- Start the engine and run at low idle speed for approx. 2 min.
- Stop the engine.
- Check the oil level and top up oil if required.



Fig. 40 Changing the engine oil

7 Care and Maintenance

7.8.3 Changing the engine oil filter

The engine oil filter must be replaced every time the engine oil is changed.

- Place oil drip pan below the engine oil filter.
- Clean the outside of the engine oil filter.
- Unscrew the filter cartridge (41/1) using a commercially available tool and check that the fastening stud is firmly secured in the filter head.
- Dispose of the filter cartridge according to regulations.
- Check the filter head condition and clean.
- Fill the new filter with oil, wet the sealing ring with oil and tighten firmly by hand.
- After a test run, check the tightness of the engine oil filter cartridge.



Fig. 41 Changing the engine oil filter

7.8.4 Cooling system - combined hydraulic oil-water cooler

7.8.4.1 Checking coolant level / topping up coolant

The coolant level is monitored automatically. If the coolant level is insufficient, the coolant level indicator appears on the display as soon as the ignition is switched on. (42/73).

- Top up coolant if the coolant level is insufficient with the machine standing on level ground.



Danger of scalding

due to hot coolant getting into contact with skin or eyes.

- Only open the cooler cap after the engine has cooled down.
- Remove the cover (43/1) and top up coolant if required. With the engine cooled down, the compensation tank should be half full.



Attention

Refill with a mixture of 50 % water and 50 % antifreeze.

7.8.4.2 Checking the level of antifreeze

Before the beginning of the cold season, check the level of antifreeze.

- At the factory, the antifreeze protection is set to approx. - 25 °C. If temperatures are lower, the level of antifreeze must be adjusted accordingly.

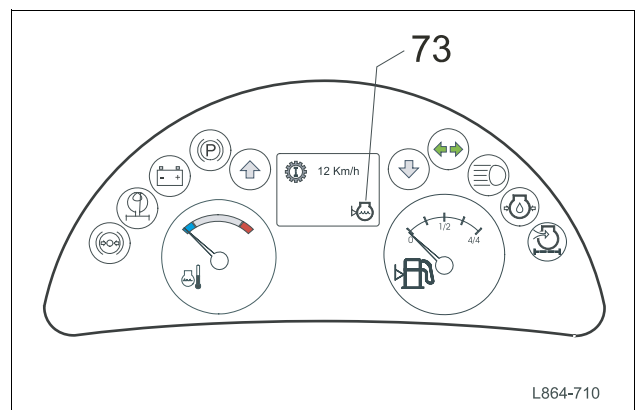

Fig. 42 (42/Coolant level indicator



Fig. 43 Combined cooler

7.8.4.3 Changing coolant



Danger of scalding

due to hot coolant getting into contact with skin or eyes.

- Only open the cooler cap after the engine has cooled down.

- Park the machine on level ground.
- Switch off the engine and **allow the cooling system to cool down.**
- Remove the cooler cap (44/1).
- Remove the rear maintenance cover.
- Unscrew the water-drain plug (45/1) on the drain hose (45/2) and drain coolant.
- Collect the coolant and dispose of according to regulations.
- If necessary, flush the cooling system with clean water.
- Close the drain hose using the drain plug.
- Re-install the rear maintenance cover.
- Fill the cooling system with coolant (→ 3.9, 29) and close the cap.
- Start the engine and bring to operating temperature; turn off the engine and allow to cool.



Danger of scalding

due to hot coolant getting into contact with skin or eyes.

- Only open the cooler cap after the engine has cooled down.

- Remove the cap (44/1) and top up coolant if required. With the engine cooled down, the compensation tank should be half full.

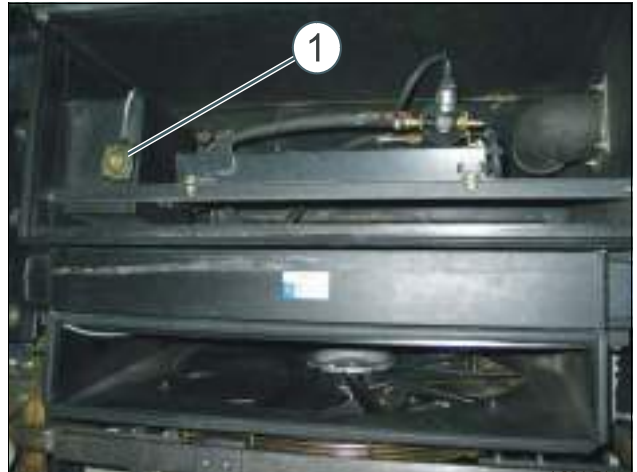

Fig. 44 Combined cooler

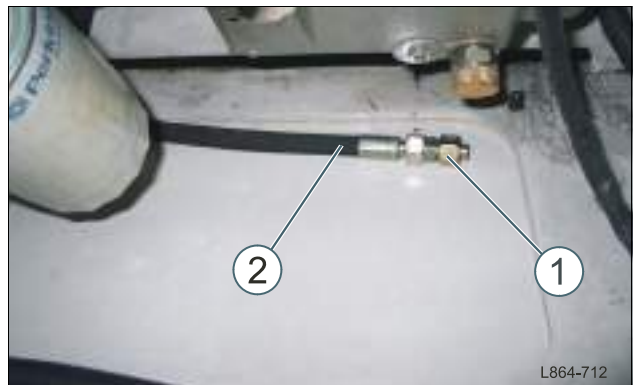

Fig. 45 Changing coolant

7 Care and Maintenance

7.8.4.4 Cleaning cooling fins in case of extreme exposure to dust

The combined cooler features a fan (46/1) with hydrostatic drive (46/2).

Due to the automatic reverse of the running direction of the fan, the cooler fins are automatically cleaned at regular intervals.

If there is increased exposure to dust, the cooler fins are subject to premature contamination.



Machine damage

due to strong accumulation of dust.

- Clean the cooler fins in due time to prevent overheating of the engine and/or the hydraulic oil.
- Press the engine cooler fan changeover switch (47/39).

The fan briefly runs in the opposite direction. The cooling fins are cleaned.

7.8.4.5 Cleaning cooling fins in case of strong exposure to dust



Machine damage

due to strongly contaminated cooler.

- Clean the cooler fins in due time to prevent overheating of the engine and/or the hydraulic oil.
- If necessary, e.g. in case of an oiled combined cooler, clean with cleaning agents or a steam jet device.
- After cleaning, run the engine until it reaches operating temperature to allow the combined cooler to dry.



Attention

- Collect the detergent and waste water in a suitable container and dispose of according to regulations!
- Ensure that no substances hazardous to water reach the sewerage or water systems.

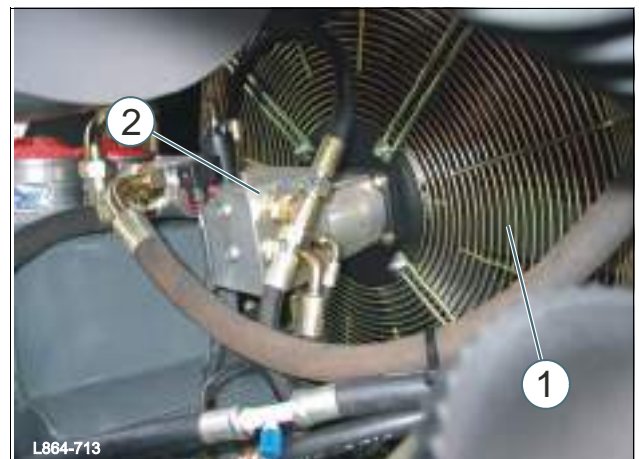

Fig. 46 Engine cooler fan

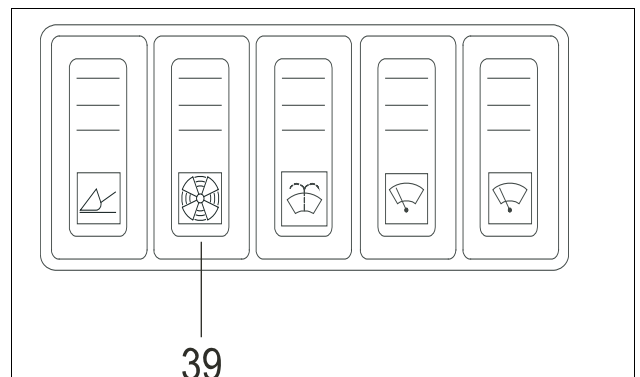

Fig. 47 Engine cooler fan changeover switch

7.8.5 Fuel system

7.8.5.1 Checking the fuel level

- Check the fuel level using the fuel gauge (48/27).



Danger of injury

due to excessive pressure while refueling.

- When topping up fuel using the electric refueling pump, open the fuel tank cap to avoid excessive pressure in the fuel tank!
- Top up fuel every day after use to prevent condensation from forming before the machine is next put into operation.

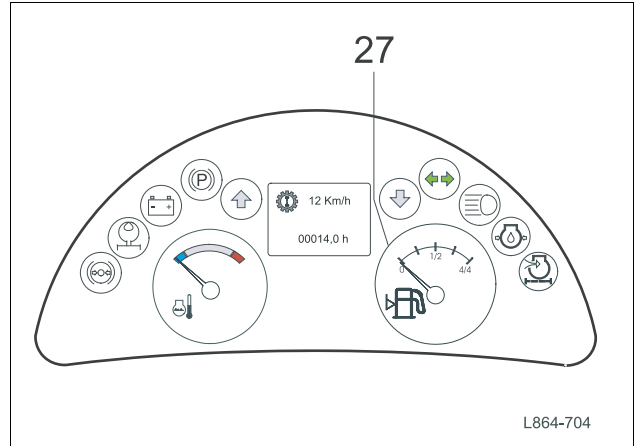

Fig. 48 Checking the fuel level

7.8.5.2 Draining the water separator



Machine damage

due to full water separator.

Never allow the engine to run if the water separator is filled by more than 50%. Failure to do so will result in damage to the engine.

- Check daily using the sight glass (49/1) and drain if required.
- Open the drain (49/2) and collect any escaping water in a suitable container.
- Dispose of the water according to regulations.
- Close again the drain (49/2).



Fig. 49 Draining the water separator

7 Care and Maintenance

7.8.5.3 Draining the fuel filter

- Open the fuel filter on the water drain (50/2) until pure fuel escapes.
- Close again the water drain.

7.8.5.4 Replacing the fuel filter

- Clean the outside of the fuel filter (50/1).



Attention

- *Collect the fuel in a suitable container and dispose of according to regulations.*
- Open the water drain (50/2) on the filter bottom to drain fuel from the filter.
- Unscrew the filter housing (51/4) using commercially available tools and remove the filter housing along with the filter element from the filter flange.
- Push down the filter element against the springs on the filter element (51/1) and turn to the left to remove it from the filter housing (51/4).
- Dispose of the filter element according to regulations!
- Push down the new filter element (51/1) against the springs and turn to the right to snap it into place in the filter housing (51/4).
- Install the new seal (51/3) on the filter housing. Slightly wet the surface of the seal with clean fuel.
- Examine the thread (51/2) on the inside of the filter element for possible damage.
- Place the filter onto the filter flange and tighten by hand until the filter touches the flange. Tighten the filter manually by another quarter turn. Do not use any tools for this purpose.
- Close the drain cock (52/2) on the fuel filter (52/1) and remove the container.



Machine damage

due to air in the filter.

- *Before starting the engine, operate the fuel pump one minute to remove air from the filter.*
- Start the engine and check for leaks.

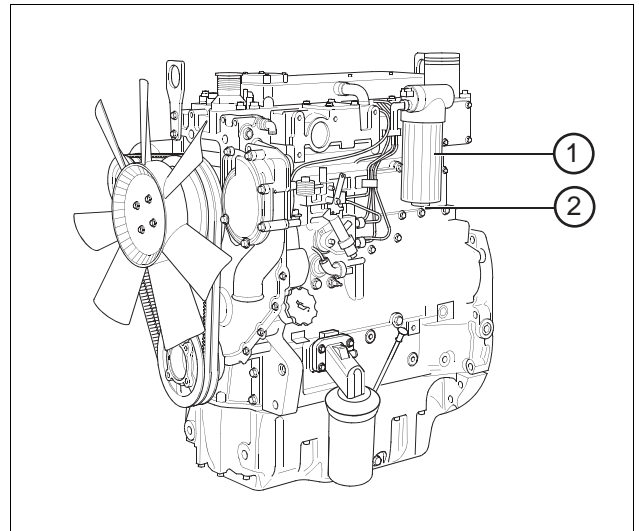

Fig. 50 Draining and replacing the fuel filter

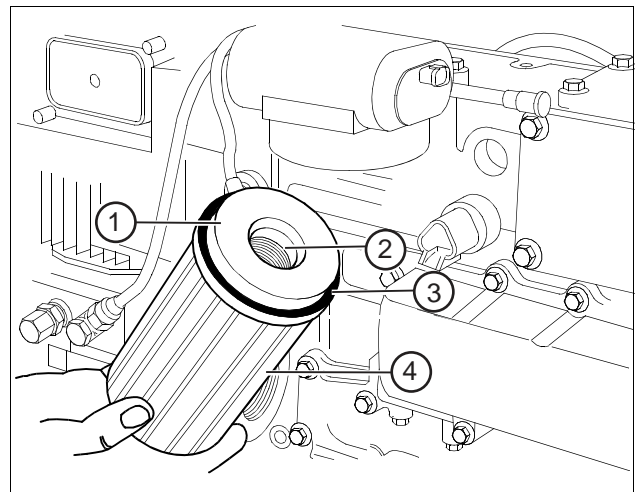

Fig. 51 Replacing the fuel filter

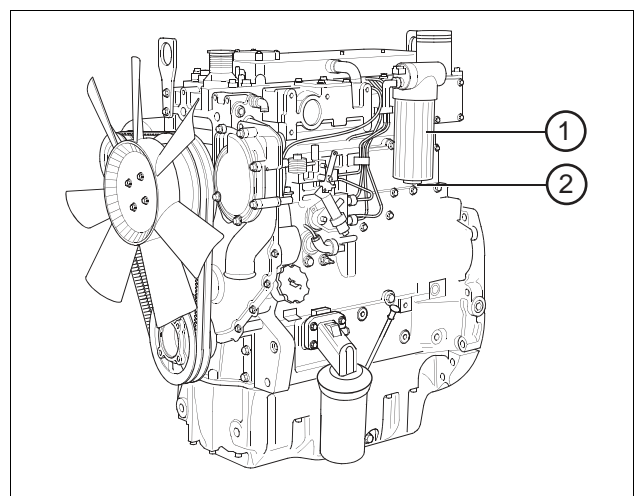

Fig. 52 Replacing the fuel filter

7.8.5.5 Draining the fuel tank and cleaning the screen

- Drain water from the fuel tank through the water-drain plug (53/1).
- Clean the filling screen (53/2) and check for damage; replace if required.

7.8.6 Air filter, air intake



Machine damage

due to dust being drawn into the engine.

- All work on the air intake system must be carried out with the engine off.
- Do not start the engine while the filter cartridge is removed.

7.8.6.1 Cleaning the dust ejection valve

The dust ejection valve (54/1) is largely maintenance-free.

- Any baked-on dust can be removed by squeezing the valve together.

7.8.6.2 Cleaning or replacing the air intake

- Check the air filter attachment and retaining straps for damage.
- Check the tightness of the air intake between the air filter and the engine.
- Examine rubber parts for damage and replace if necessary.



Attention

- Replace damaged parts immediately!

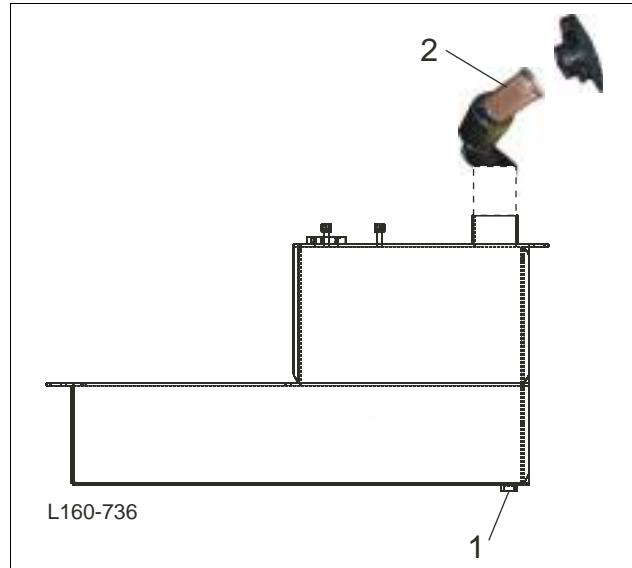

Fig. 53 Draining the fuel tank and cleaning the screen

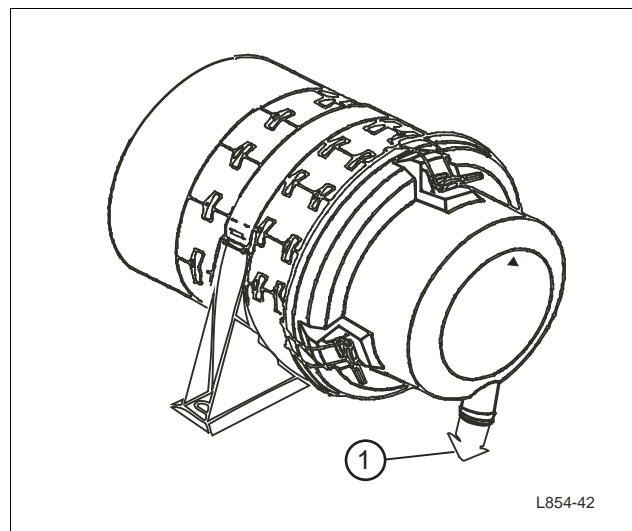

Fig. 54 Cleaning the dust ejection valve

7 Care and Maintenance

7.8.6.3 Cartridge maintenance intervals

The air filter main cartridge must be replaced as soon as the filter maintenance indicator lamp (55/32) on the instrument panel lights up during operation.



Attention

A brief delay in maintenance does not result in lower filter efficiency.

7.8.6.4 Replace the air filter safety cartridge:

- after the third maintenance of the main cartridge
- after 2 years of operation at the latest
- if the service indicator switches on after the main cartridge has just been serviced
- if the main cartridge is damaged
- if the safety cartridge is damaged.

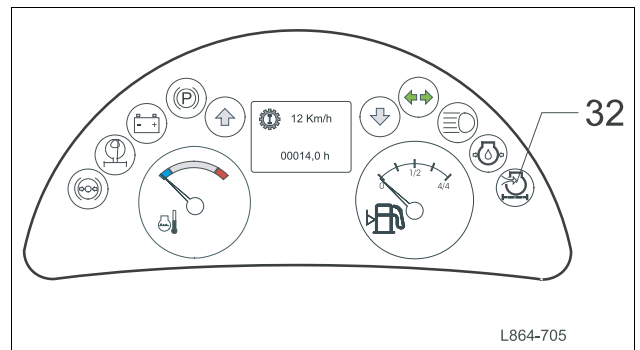

Fig. 55 Filter maintenance indicator lamps

7.8.6.5 Changing the main cartridge

- Release the wire fasteners (56/1) and remove the bottom of the housing (56/4).
- Withdraw the main cartridge (56/2) by twisting slightly to and fro.
- Check whether the safety cartridge (56/3) must be replaced.



Attention

Remove the safety cartridge only in the case of necessary maintenance work. Only open the seal (56/5) of the safety cartridge for the purpose of replacement.

- Note down the date of maintenance in the appropriate sections of the safety cartridge (56/3).
- Insert the new or cleaned main cartridge carefully into the filter housing starting with the open side and check that it is correctly positioned.
- Fit the lower part of the housing. (Pay attention to the position of the dust ejection valve).
- Place the wire fasteners in the groove of the flange on the filter housing and tighten.

7.8.6.6 Changing the safety cartridge

- Remove the main cartridge.



Machine damage

due to damaged safety cartridge.

Observe that the safety cartridge must not be cleaned and used again once it has been removed.

- Using a suitable tool (e. g. screwdriver), pierce the seal (56/5) of the safety cartridge (56/3) from the inside, then lift up the two clips (56/6).
- Grasp the safety cartridge (56/3) by the two clips (56/6), withdraw by twisting slightly to and fro, and dispose of it.
- Insert a new safety cartridge and check that it is correctly positioned.
- Re-install the main cartridge.

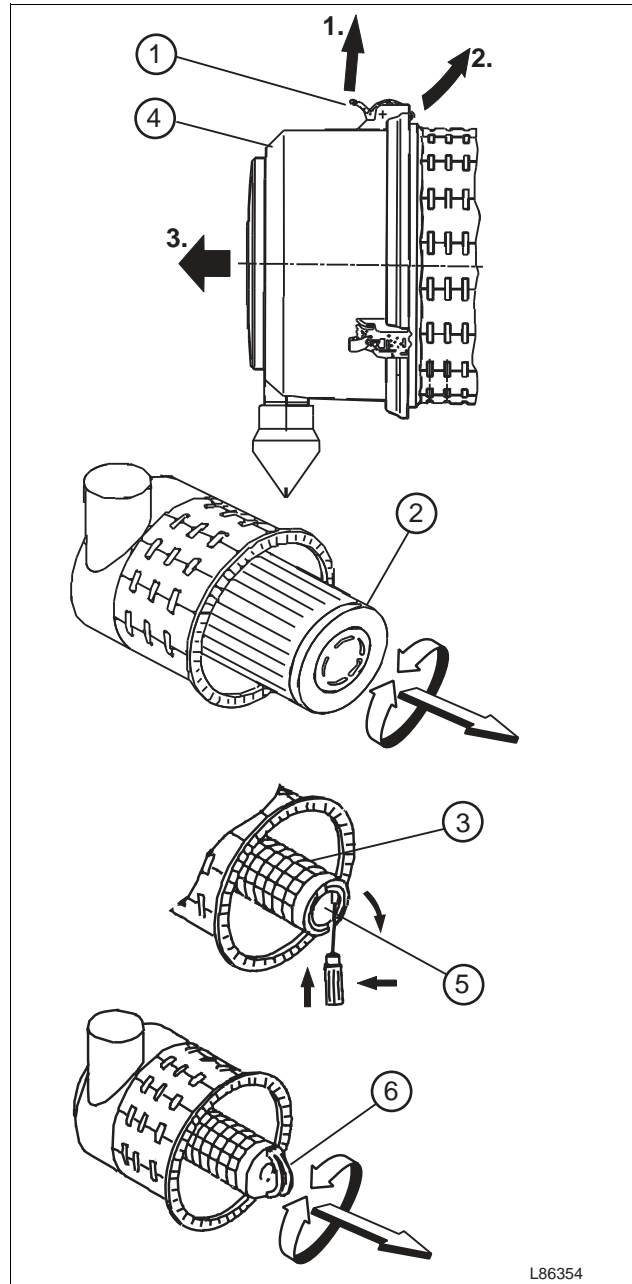

Fig. 56 Changing air filter cartridges

L86354

7 Care and Maintenance

7.8.6.7 Cleaning the main cartridge



Machine damage

due to damaged main cartridge.

Never wash or brush out the main cartridge.

When blowing out, ensure that no dust enters the inside of the main cartridge.

- The main cartridge can be cleaned up to five times if necessary. It must be replaced once it reaches its maximum service life of two years, at the latest. The number of times it is cleaned must be marked.
- For cleaning (57/1), a pipe the end of which is bent at 90° should be attached to a compressed-air pistol. It must be sufficiently long to reach the floor of the cartridge. Blow out the main cartridge from the inside to the outside with dry compressed air (max. 5 bar) by moving the pipe up and down in the cartridge and continue until no more dust escapes.
- Check the clean main cartridge for damage to the paper bellows and rubber seals (57/2). Tears and perforations in the paper bellows can be determined using a torch.



Machine damage

due to damaged main cartridge.

Never continue to use damaged main cartridges. If in doubt, use a new one.

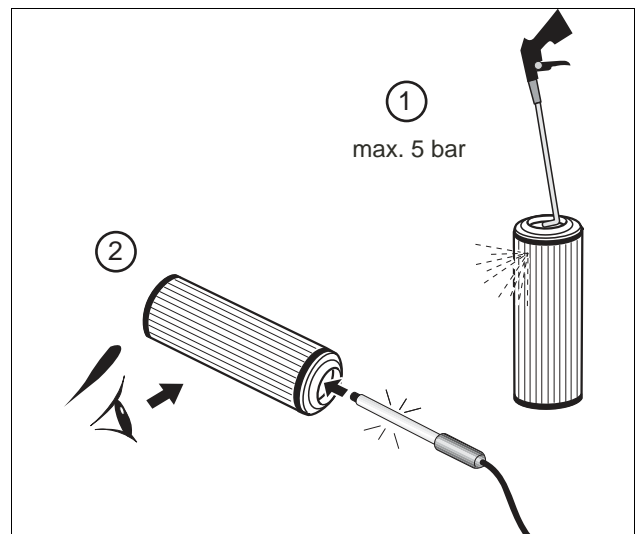

Fig. 57 Cleaning the main cartridge

7.8.7 V-belt



Attention

If the machine features air-conditioning, only one V-belt is used.

- *If the V-belt must be replaced, observe the size of the V-belt when ordering the spare part.*

7.8.7.1 Checking the condition of the V-belt



Danger of injury

due to rotating V-belts.

- *Only check and tension V-belts with the engine off.*
- *Secure the engine against unauthorized starting.*



Attention

In case of double V-belts (machine not featuring air-conditioning), observe the following:

- *If one damaged or worn V-belt must be replaced, always change both V-belts together.*
- Check the entire V-belt for damage (visual inspection).
- Replace damaged or worn V-belts immediately.

7.8.7.2 Checking the V-belt tension



Attention

We recommend checking the V-belt tension using a belt tensioner gauge.

- *Check the tension in accordance with the manufacturer's Operating Instructions.*

7.8.7.3 Checking without a belt tensioner gauge

- To check the tension, press the V-belt with your thumb in the middle of the greatest free length, and measure the sag.



Attention

Using medium thumb pressure of approx. 45 N (approx. 4.5 kg), the V-belt sag should equal 10 mm .

7 Care and Maintenance

7.8.7.4 Tensioning the V-belt

- Slacken the fastening screws 58/1, 58/3 and 59/1.
- Rotate the generator (58/2) until the tension is correct.
- Re-tighten the fastening screws 58/1, 58/3 and 59/1.
- Check the tension again.

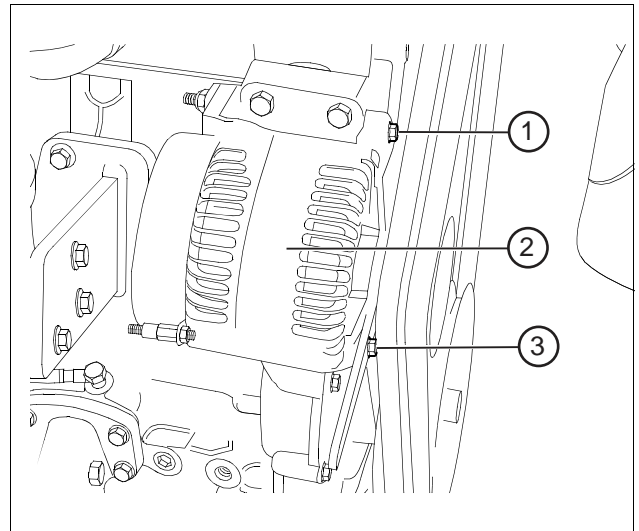

Fig. 58 Tensioning and replacing V-belts

7.8.7.5 Changing V-belts

- Slacken the fastening screws 58/1, 58/3 and 59/1.
- Rotate the generator against the direction of tensioning.
- Remove the V-belt and fit on an appropriately sized new one.
- Rotate the generator (58/2) in the direction of tensioning until the V-belt tension is correct.
- Re-tighten the fastening screws 58/1, 58/3 and 59/1.
- Check the tension again.



Attention

- *If V-belts have been replaced, their tension must be checked again after approx. 20 operating hours.*

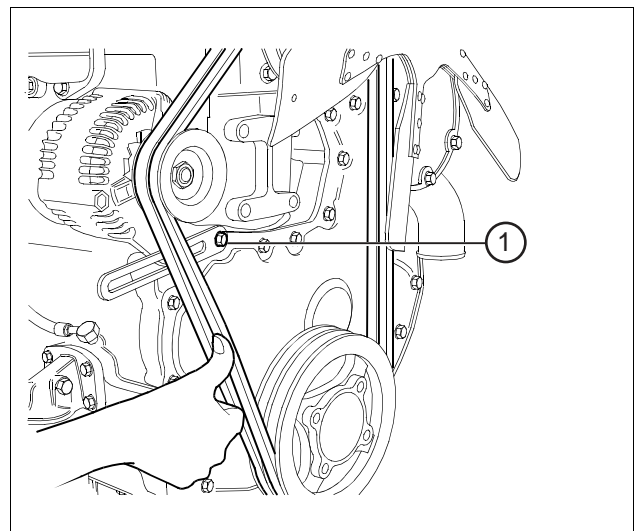

Fig. 59 Tensioning and checking V-belts

7.8.8 Checking the valve lash

- Test the valve lash (60/1) on a cold engine by placing a feeler gauge between the upper part of the tappet (60/3) and the rocker arm (60/2).

The correct valve lash is as follows:

Inlet valve = 0.20 mm
 Outlet valve = 0.45 mm

If necessary, adjust the valve lash as follows:

- Slacken counternut (60/4).
- Using a screwdriver, adjust the setting screw (60/5) in such a way that the correct valve lash (60/1) is obtained after the lock nut is tightened.
- Re-tighten counternut.



Attention

The 1st cylinder is located at the front on the fan side of the engine.

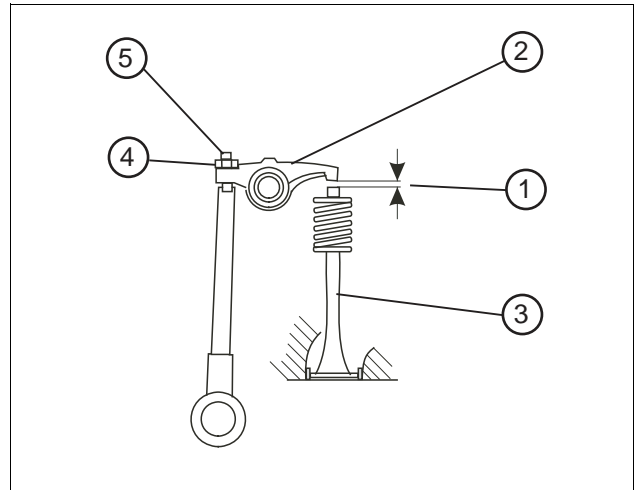

Fig. 60 Adjusting the valve lash

Valve adjustment

- Remove the cylinder head cover.
- Turn the crankshaft in normal direction of rotation until the inlet valve 61/7 of cylinder no.4 begins to open; the outlet valve 61/8 of the same cylinder is not yet closed completely.
- Check the valve lash of valves 61/1 and 61/2 of cylinder no. 1 and adjust if required.
- Adjust the valves 61/3 and 61/4 of cylinder no. 2, as described above for the valves of cylinder no. 4, for overlap.
- Then check the valve lash of valves 61/5 and 61/6 of cylinder no. 3 and adjust if required.
- Adjust the valves 61/1 and 61/2 of cylinder no. 1 for overlap.
- Check the valve lash of valves 61/7 and 61/8 of cylinder no. 4 and adjust if required.
- Adjust the valves 61/5 and 61/6 of cylinder no. 3 for overlap.
- Check the valve lash of valves 61/3 and 61/4 of cylinder no. 2 and adjust if required.
- Re-mount the cylinder head cover along with a new gasket.

Cylinder no.	1		2		3		4	
Valve no.	1	2	3	4	5	6	7	8
Valve	I	O	I	O	I	O	I	O
	I = inlet		O = outlet					

Tab. 30 Cylinder and valve numbers

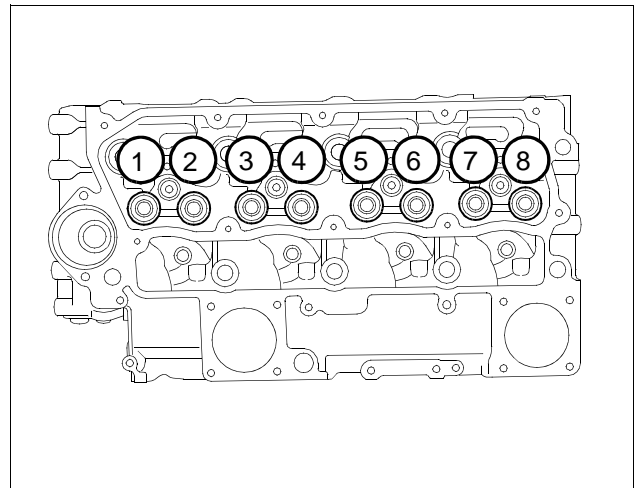

Fig. 61 Valve adjustment

7 Care and Maintenance

7.8.9 Brakes

7.8.9.1 Checking the brake disc thickness

This check must be performed twice on each of the two axles.

- Operate the parking brake preselection switch (62/54), thereby applying the parking brake.
- Open the first inspection hole (63/1) on the front axle.
- Check the wear of the brake discs using a measuring gauge.



Attention

Minimum thickness of brake discs:
 $S = 4.5 \text{ mm}$

- Close the inspection hole.
- Check the remaining brakes of the other axle side and the rear axle.

7.8.9.2 Bleeding the brake



Attention

- Collect the escaping oil in a suitable container and dispose of in compliance with regulations.



Attention

- Two persons are required to bleed the brakes.

- Remove the cover on the front-end above the axle.
- Let the engine run at medium speed.
- Fully depress the brake pedal
- Connect the bleeder hose to the first bleeder screw (64/1) of the front axle and route it into the collection bottle.
- Open the bleeder screw (64/1) until the brake fluid (hydraulic oil) escapes without bubbles.
- Remove the bleeder hose and re-tighten the bleeder screw.
- Connect the bleeder hose to the second bleeder screw (64/1) of the front axle and route it into the collection bottle.
- Open the bleeder screw (64/1) until the brake fluid (hydraulic oil) escapes without bubbles.
- Remove the bleeder hose and re-tighten the bleeder screw.

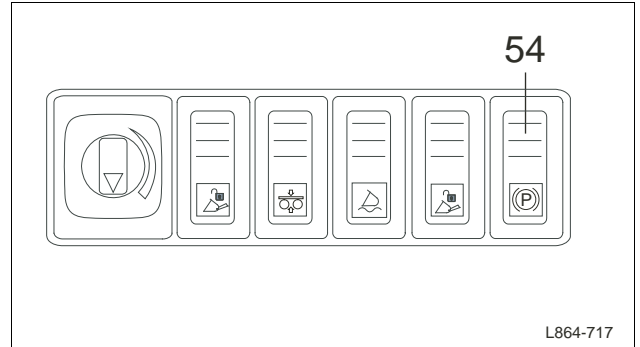

Fig. 62 Operation of parking brake

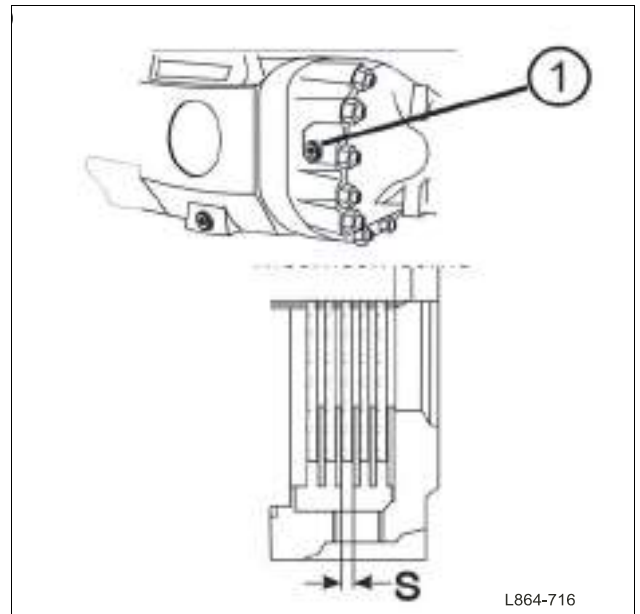

Fig. 63 Checking brake discs

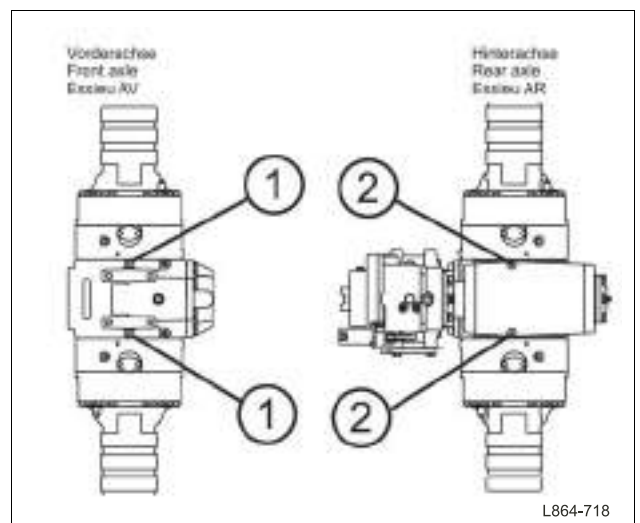

Fig. 64 Bleeding the brake

- Connect the bleeder hose to the first bleeder screw (64/2) of the rear axle and route it into the collection bottle.
- Open the bleeder screw (64/2) until the brake fluid (hydraulic oil) escapes without bubbles.
- Remove the bleeder hose and re-tighten the bleeder screw.
- Connect the bleeder hose to the second bleeder screw (64/2) of the rear axle and route it into the collection bottle.
- Open the bleeder screw (64/2) until the brake fluid (hydraulic oil) escapes without bubbles.
- Remove the bleeder hose and re-tighten the bleeder screw.
- Connect the bleeder hose to the bleeder screw on the inch valve of the hydraulic "Travel" pump and route it into the collection bottle.
- Open the bleeder screw until the brake fluid (hydraulic oil) escapes without bubbles.
- Remove the bleeder hose and re-tighten the bleeder screw.
- Re-mount the cover on the front-end.

7.8.9.3 Adjusting the brake disc play

- Place the machine on a level surface and secure it with chocks to prevent it from rolling away.
- Release the hand brake

 **Do not switch off the engine!**

- Remove the screw (65/1) along with the retaining fixture (65/2) on the left-hand brake of the front axle.
- Move the adjusting device (65/3) to the left (anti-clockwise) until the stop.
- Move the adjusting device 3 full turns to the right (clockwise).
- Re-install the retaining fixture. The play between the brake discs is now adjusted.
- Adjust the remaining brakes of the other axle side and the rear axle.

7.8.9.4 Adjusting the spring-loaded cylinder

- Slacken counter nut (65/5).
- Adjust the mechanical unlocking mechanism (65/4) to 47 mm.
- Re-tighten counter nut.
- Adjust the spring-type actuators of the other brakes accordingly.

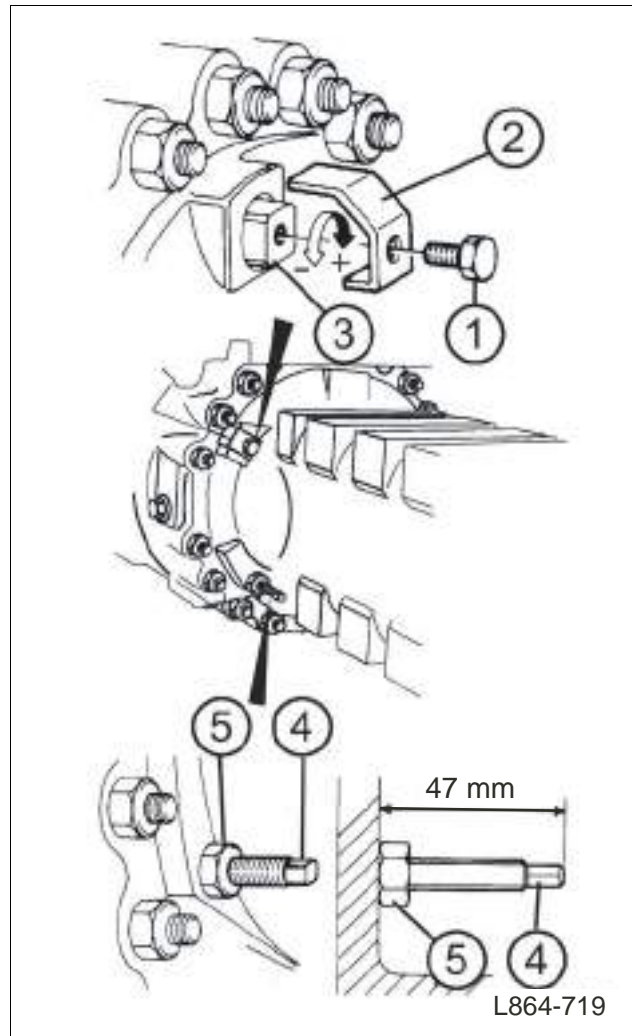

Fig. 65 Adjusting the brake

7 Care and Maintenance

7.8.10 Hydraulic oil tank

7.8.10.1 Checking the hydraulic oil level

- Check the hydraulic oil level every day with the machine standing on level ground.
- Observe the level indicator on the display of the instrument panel.
- Read off the hydraulic oil level on the sight glass (66/1) and, if required, top up hydraulic oil using the breather (66/2).

7.8.10.2 Changing hydraulic oil



Danger of scalding

due to hot oil getting into contact with skin or eyes.

- *Wear appropriate protective clothing/safety goggles.*

- Retract all hydraulic cylinders.
- Stop the engine.
- Remove the drain plug on the hydraulic oil tank and drain oil into a clean receptacle.



Attention

- *Collect the waste oil in a suitable container and dispose of in compliance with regulations.*
- Flush and clean the hydraulic oil tank if required; to do so, remove the breather (66/2), return filter (66/3) and suction filter (66/4).
- Screw back on the drain plug carefully.
- Fill up with clean hydraulic oil using the return filter; to do so, open the filter cover.
- Install the return filter cover.



Fig. 66 Checking the hydraulic oil level, changing hydraulic oil

7.8.11 Hydraulic oil suction filter



Machine damage

due to dirt reaching the uncovered hydraulic oil tank.

- Before starting, clean all parts above the tank.



Attention

- After a larger repair job, renew the filter cartridge following the test run.

Changing the filter insert

- Switch off the engine.
- Open the breather (67/2).
- Loosen the filter cover (68/1) of the suction filter (67/1) with the aid of a tool.
- Remove the assembly (68/10) by turning and completely removing the filter cover, paying attention to the O-ring (68/3).



Attention

- Remove the suction filter above a receptacle for the collection of waste oil.

- Grasp the assembly by the filter cover (68/1) and unscrew the valve (68/2).
- Remove the filter insert and dispose of according to regulations.
- Clean the filter cover with centre rod (68/8) and the valve with diesel oil or benzine. While doing so, pay attention to the retaining plate (68/6) along with the seals (68/5), (68/7) and the compression spring (68/4).
- Check the O-ring (68/3) and seals (68/5), (68/7), (68/11) and replace any damaged part.
- Place surface "A" of the filter cover on a solid base, push a new filter insert onto the centre rod and fit onto the seal (68/5).
- Push the filter insert downward against the springs and tighten the valve (68/2) by hand.
- Push the assembly (68/10) into the housing (68/12), tighten the filter cover by hand and ensure that the O-ring (68/3) is in exactly the right position.
- Screw back on the filter cover (68/1) and tighten by hand.
- Check the tightness of the filter by means of a test run.

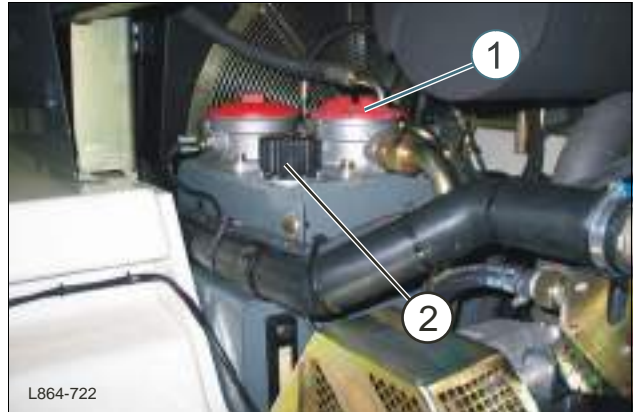

Fig. 67 Hydraulic oil tank

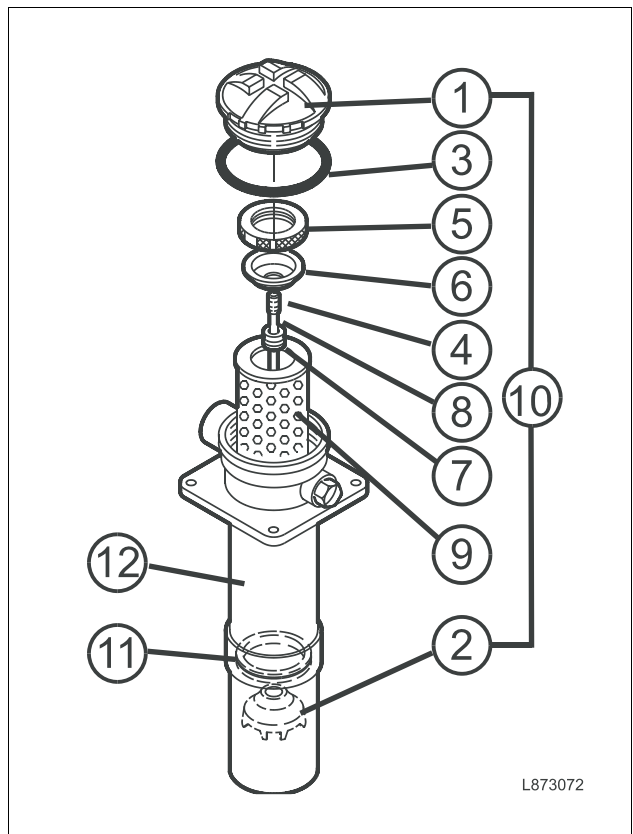

Fig. 68 Changing the filter insert of the suction filter

7 Care and Maintenance

7.8.12 Hydraulic oil return filter



Machine damage

due to dirt reaching the uncovered hydraulic oil tank.

- Before starting, clean all parts above the tank.



Attention

- After a larger repair job, renew the filter cartridge following the test run.

Changing the filter insert

- Switch off the engine.
- Open the breather (69/2).
- Remove the return filter cover (69/3).
- Pull out the filter bowl (70/2) along with the filter insert (70/3).
- Remove the filter insert from the filter bowl by turning and pulling at the same time.
- Clean the filter bowl using appropriate detergents.
- Ensure that the O-rings (70/4-6) are in perfect condition and replace any damaged part.
- Insert a new filter element in the filter bowl.
- Re-insert the filter bowl along with the cartridge into the hydraulic oil tank.
- Apply a light coat of grease to the cover seal.
- Install the return filter cover and tighten by hand.
- Check the tightness of the filter by means of a test run.

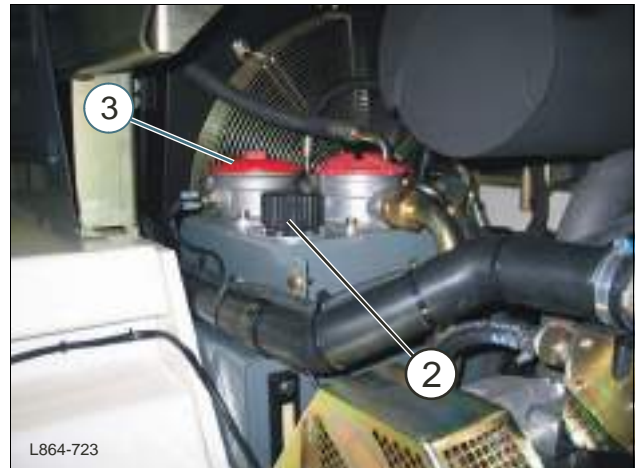

Fig. 69 Hydraulic oil tank

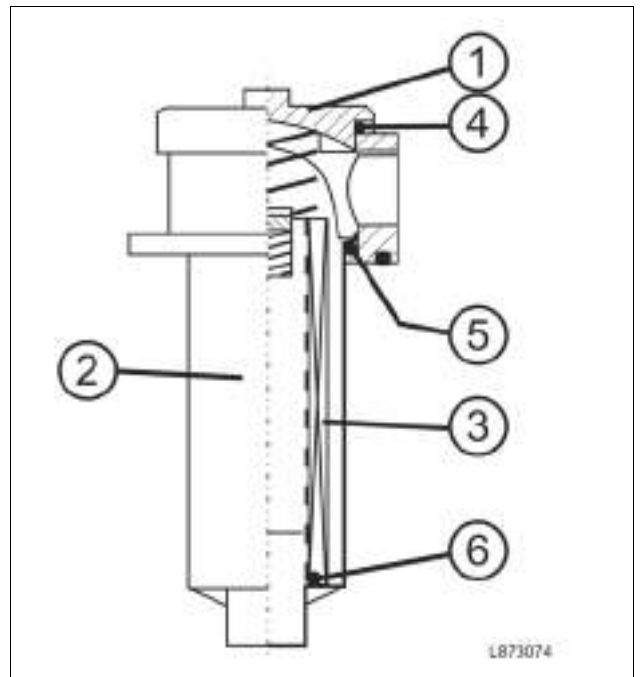

Fig. 70 Changing the filter insert of the return filter

7.8.13 Replacing the breather



Machine damage

due to dirt reaching the uncovered hydraulic oil tank.

- Before starting, clean all parts above the tank.



Attention

- The breather must be replaced if it is dirty, for example due to hydraulic oil vapor.

- Remove the breather (71/2) and dispose of according to regulations.
- Clean the screen (72/3) and check for damage; replace if required.
- Screw in new breather (72/1) with O-ring (72/2) and tighten by hand.



Fig. 71 Hydraulic oil tank



Fig. 72 Replacing the breather

7 Care and Maintenance

7.8.14 Axles

General

The axle oil must be changed at operating temperature.



Attention

- Collect the waste oil in a suitable container and dispose of in compliance with regulations.



Machine damage

due to insufficient oil in axles.

- After filling the axles with oil, move the machine for approx. 5 minutes to ensure that the oil is evenly distributed.
- After 5 minutes, check the oil level again, and top up if necessary.

7.8.14.1 Front axle differential

Checking the axle oil level

- Park the machine on level ground.
- Remove the inspection-filling plugs (73/1).
- Check if the oil is up to the edge of the inspection-filling hole.
- Top up oil if required.
- Carefully close the inspection-filling plugs.

Changing axle oil

- Park the machine on level ground.
- Clean the area around the inspection-filling plugs (73/1) and drain plugs (73/2).



Attention

- Collect the waste oil in a suitable container and dispose of in compliance with regulations.

- Open the inspection-filling plugs (73/1).
- Open the drain plugs (73/2) on the differential and brake housings and drain oil.
- Flush out the axle if necessary.
- Carefully close the drain plugs.
- Pour in oil using the inspection-filling hole until oil escapes from the other inspection-filling hole.
- Carefully close the inspection-filling plugs.

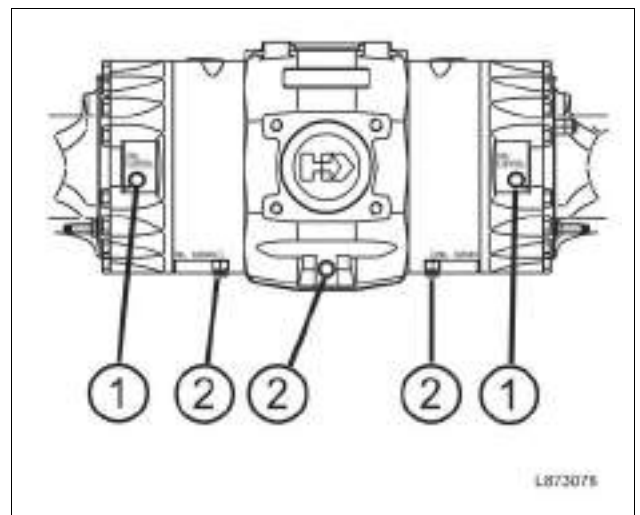

Fig. 73 Checking / replacing the front axle oil

7.8.14.2 Differential of rear axle with transmission

Checking the axle oil level

- Park the machine on level ground.
- Remove the inspection-filling plugs (74/1).
- Check if the oil is up to the edge of the inspection-filling hole.
- Top up oil if required.
- Carefully close the inspection-filling plugs.

Changing axle oil

- Park the machine on level ground.
- Clean the area around the inspection-filling plugs (74/1) and drain plugs (74/2).



Attention

- Collect the waste oil in a suitable container and dispose of in compliance with regulations.

- Open the inspection-filling plugs (74/1).
- Open the drain plugs (74/2) on the differential and brake housings and drain oil.
- Flush out the axle if necessary.
- Carefully close the drain plugs.
- Pour in oil using the inspection-filling hole until oil escapes from the other inspection-filling hole.
- Carefully close the inspection-filling plugs.

Checking the transmission oil level

- Park the machine on level ground.
- Remove the inspection plug (75/1).
- Check if the oil is up to the edge of the inspection hole.
- Top up oil if required.
- Carefully close the inspection plug.

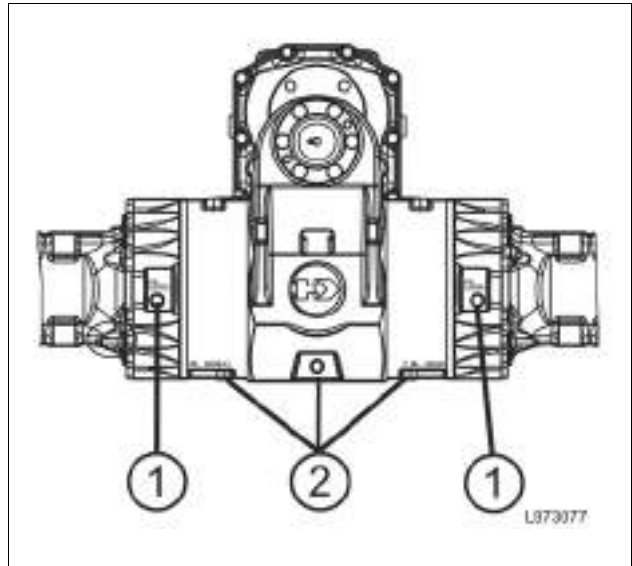

Fig. 74 Checking / replacing the rear axle oil.

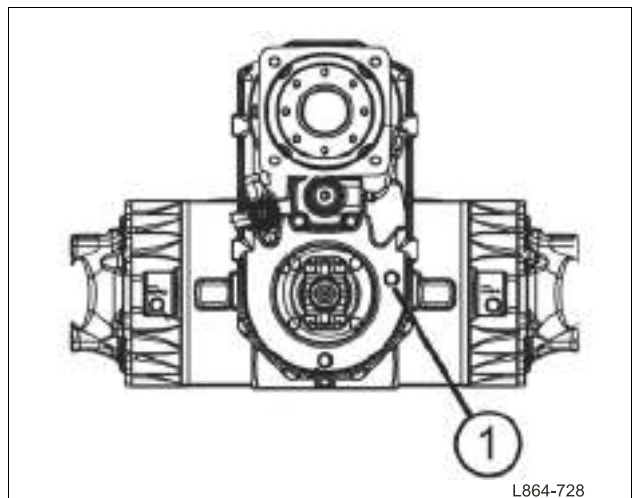

Fig. 75 Checking the transmission oil

7 Care and Maintenance

Replacing the transmission oil

- Park the machine on level ground.
- Clean the area around the inspection, filling (76/1) and drain plugs (76/2).



Attention

- *Collect the waste oil in a suitable container and dispose of in compliance with regulations.*
- Open the inspection-filling plug (76/1).
- Open the drain plugs (76/2) on the differential and brake housings and drain oil.
- Flush out the axle if necessary.
- Carefully close the drain plugs.
- Pour in oil using the filling hole until oil escapes from the other inspection hole.
- Carefully close the inspection-filling plug (76/1).

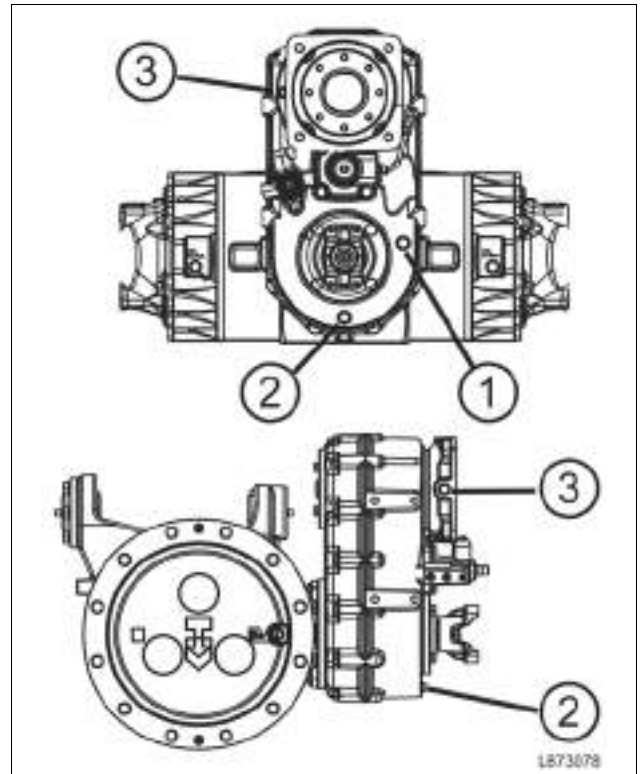

Fig. 76 Replacing the transmission oil

7.8.14.3 Wheel hub

Checking the axle oil level

- Remove the inspection plug (77/1).
- Check if the oil is up to the edge of the inspection hole.
- Top up oil if required.
- Carefully close the inspection plug.

Changing axle oil



Attention

The wheel hub has a combined inspection, filling and drain plug!

- Turn the wheel until the screw plug (77/1) on the hub is at the bottom (drain position).
- Open the screw plug and catch the escaping oil.
- Flush out if necessary.
- Turn the wheel to the filling and inspection position; the inspection mark must be horizontal (77/1).
- Fill in oil up to the lower edge of the inspection hole.
- Carefully close the screw plug.

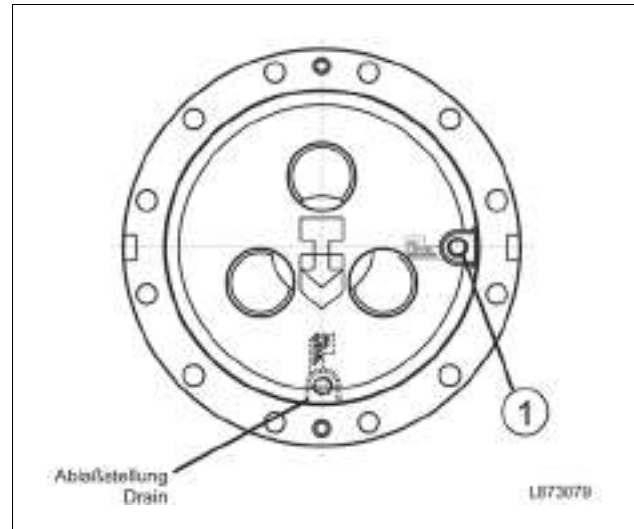

Fig. 77 Checking and replacing the axle oil

7.8.15 Wheels

7.8.15.1 Checking the tire pressure

- Check the air pressure in accordance with the pressure chart given in → 3.8, 29.

7.8.15.2 Checking the tightness of wheel nuts

- During the first 50 operating hours, check the tightness of the wheel nuts (M 22 x 1.5) daily and subsequently every week, and tighten to the correct torque if necessary.



Attention

Note that the tightening torque of 610 Nm applies to the wheel nuts M 22 x 1.5.

- When fitting a wheel, tighten the nuts to the correct torque crosswise in several stages.

7 Care and Maintenance

7.8.16 Injection valves

Injection valves must be checked by your service specialist.

7.8.17 Electrical equipment

7.8.17.1 Batteries

The two batteries are located in the rear-end below the engine hood, behind the left-hand wheelhouse.



Attention

The instructions of the battery manufacturer must be observed when using the battery for the first time.

- Only check the batteries with the engine switched off.
- The acid level should be approx. 10 mm above the plates.
- If necessary, top up with pure distilled water.



Attention

In the case of maintenance-free batteries, this check is not necessary.

7.8.17.2 Removing the battery

- Turn off the battery main switch (78/1).
- First disconnect the ground cable (79/1) on battery 1 (79/6), then the positive cable (79/2) on battery 2 (79/6).
- Remove the jumper cable (79/3).
- Release the clamping brackets (79/4; 2 on each battery side).
- Lift out the batteries.

7.8.17.3 Installing the battery

- Place both batteries into the machine.
- Attach the batteries using 2 clamping brackets for each battery (79/4).
- Re-attach the jumper cable (79/3): Connect the positive terminal (+) of battery 1 (79/5) with the negative terminal (-) of battery 2 (79/6).
- Connect the positive cable (79/2) to the positive terminal (+) of battery 2 (79/6).
- Connect the ground cable (79/1) to the negative terminal (-) of battery 1 (79/5).



Machine damage

due to incorrect connection of terminals.

- Ensure that the negative terminal is connected to the negative pole (-) and the positive terminal to the positive pole (+).



Attention

In winter, in particular, the battery charge should be closely monitored.

7.8.17.4 Checking the lighting and warning equipment

- Check the function of the lighting equipment.
- Check the function of the indicator lamps.
- Check the function of the warning equipment.

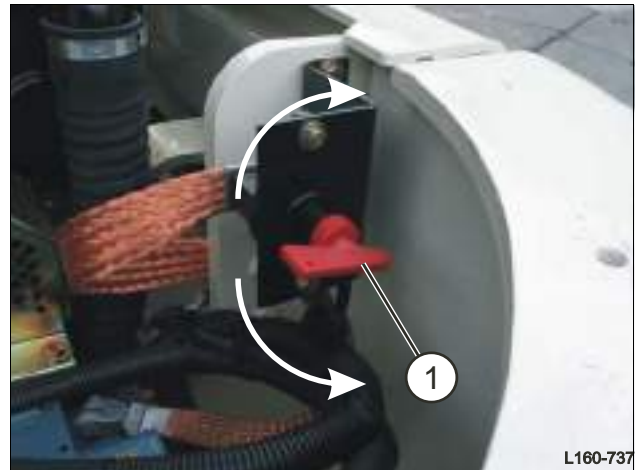

Fig. 78 Battery main switch

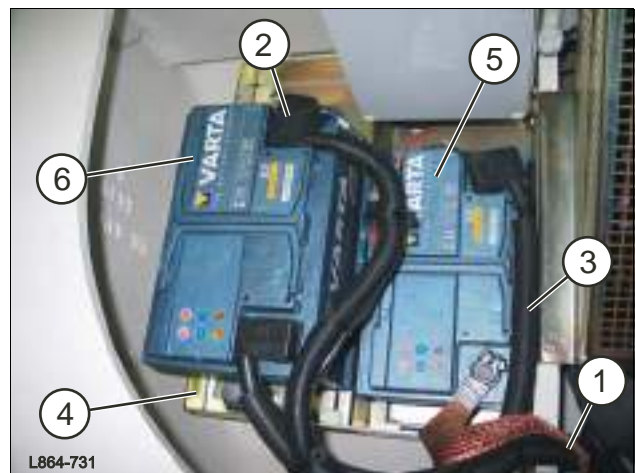

Fig. 79 Removing and installing the battery

7 Care and Maintenance

7.8.18 Cabin ventilation dust filter

The air intake for the heater and fresh air supply of the cabin features a dust filter, optionally a charcoal/pollen filter.

7.8.19 Removing the dust filter for cabin ventilation

- Remove the ventilation louver (80/1).
- Remove the angle bracket (80/2).
- Remove the dust filter (80/3).
- Clean the filter or replace it.

7.8.19.1 Cleaning the dust filter



Attention

Never wash or brush out the filter.

- Knock the filter with the intake side (side covered by expanded metal) several times on a flat and hard surface.
- Using dry compressed air (max. 5 bar), blow against the direction of flow.
- Check the filter for damage to the paper bellows and seal.



Attention

Never continue to use damaged dust filters!

7.8.19.2 Installation

- Insert new or cleaned dust filter until the stop.



Attention

Observe the mounting position of the dust filter; the air flow arrows must point towards the cabin.

- Re-attach the dust filter with the angle bracket.
- Re-install the ventilation louver.

7.8.20 Windshield washer system

- Top up the windshield washer tanks (81/1) as required.
- Add antifreeze when temperatures are around or below freezing.

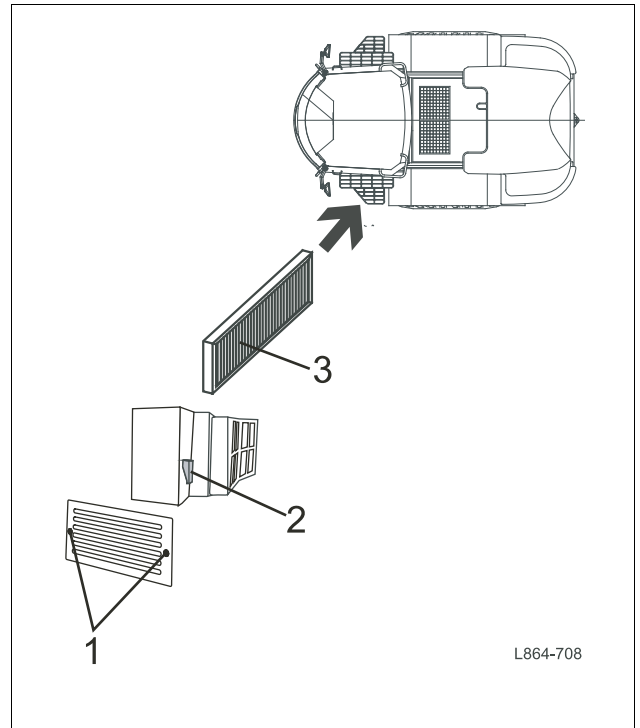

Fig. 80 Removing the dust filter for cabin ventilation

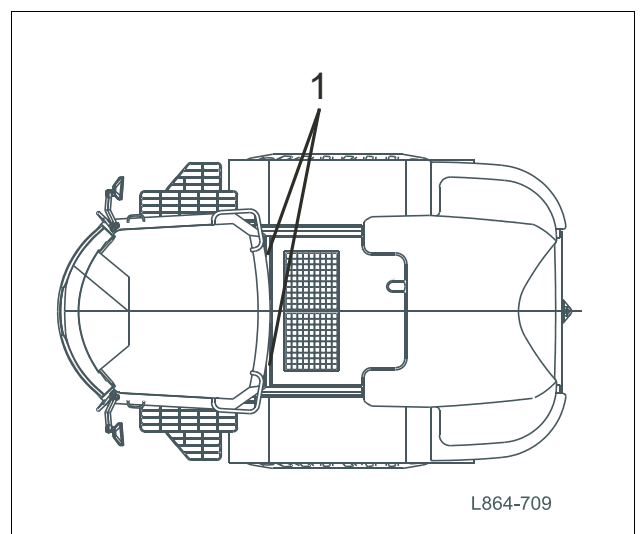

Fig. 81 Topping up the windshield washer tank

7.9 Immobilization

7.9.1 Preservation (temporary immobilization)



Machine damage

due to damage from storage (e.g. corrosion damage) during shutdown periods over three months.

- Perform the preservation measures.

Preservation measures:

- We recommend keeping the machine in a dry, dust-free room during the storage period.
- Thoroughly clean the inside and outside of the machine, including the engine.
- Lubricate the machine according to the lubrication plan.
- Check the oil levels of all assemblies such as axles, transmission(s), etc. and top up if necessary.
- Check the hydraulic oil level and top up if necessary.
- Repair any paint damage.
- Fill the diesel tank completely, to prevent corrosion of the tank walls.
- Check the antifreeze level in the coolant and adjust if necessary.
- Perform all preservation measures specified in the Diesel Engine Operating Instructions.
- Check the tire pressure according to the prescribed value and protect the tires from direct sunlight.
- Treat bare piston rods with a commercially available anti-corrosion agent.
- Remove and clean the battery and keep it according to regulations in a dry - in winter, frost-proof - room. Coat connections with a little pole grease.
- Seal off the air intake opening of the air filter system and the exhaust pipe opening.

7.9.2 During immobilization

When the machine is out of use for 6 months, after this time all assemblies must be brought to operating temperature and maneuvered for approx. 15 minutes.

- Beforehand, the anti-corrosion coat must be removed from the piston rods, and the openings of the air filter system and the exhaust pipe freed.
- After the maneuvering cycle, preserve the machine once more as previously described.

7.9.3 After immobilization

Before putting the machine into operation once more, the following measures must be carried out:

- Anti-corrosion coat must be cleaned from the piston rods.
- Seal off the air intake opening of the air filter and the exhaust pipe opening.
- Remove the air filter insert, check its condition and replace if necessary.
- Clean the machine with a neutral detergent.
- Check and, where required, re-charge and re-install the battery.
- Carry out all measures for putting the diesel engine back into operation listed in the Engine Operating Manual.
- If the machine has been out of use for more than 6 months, the oil in the assemblies such as axles, transmission(s), etc. must be changed.
- If hydraulic oil filters such as suction and return filters as well as breathers have been out of use for more than 6 months, they must be replaced.
- Lubricate the machine according to the lubrication plan.

7 Care and Maintenance

8 Trouble-shooting

Operating problems may occur due to irregular maintenance, the use of unsuitable materials, or incorrect handling of the machine.

The following Table presents a summary of a range of problems and their possible causes.

During the warranty period, malfunctions must be dealt with by your responsible Service Agent or a specialist workshop.

If a problem can only be eliminated through repair, then your responsible Service Agent must be called in.

8.1 Engine

All faults in the diesel engine must be examined as described in their specific Perkins Engine Operating Instructions 1104C-44T.

8.2 Table of faults

Possible cause	Remedy
No steering movement	
Oil supply to pump interrupted	Check and repair suction line
Hydraulic pump damaged	Repair or replace
Priority valve damaged	Remedy fault (call Service Agent)
Hand metering unit damaged	Remedy fault (call Service Agent)
Steering cylinder damaged	Repair
Mechanical fault	Repair
Insufficient performance of service brake	
Wear in brake discs	Adjust or repair (call Service Agent)
Brake control system damaged	Repair or replace (call Service Agent)
Mechanical fault	Repair (call Service Agent)
Insufficient performance of parking brake	
Wear in brake discs	Re-adjust or repair
Hydraulic fault in brake actuation	Replace and/or re-adjust
Hydrostatic travel drive without neutral position	
Switch for travel direction damaged	Replace / repair
Solenoids of valve damaged	Replace / repair
Neutral position incorrectly adjusted	Check / re-calibrate (call Service Agent)
Internal damage to travel pump	Replace travel pump
Excessive engine idling	Re-adjust engine idling

Tab. 31 Table of faults

8 Trouble-shooting

Possible cause	Remedy
Hydraulic oil exceeds max. admissible temperature	
Thermo switch damaged	Replace
Oil level too low	Top up oil to mark on dipstick
Oil cooler dirty or damaged	Clean, check and replace if required
Suction filter clogged	Replace
High-pressure valves do not respond all the time or too early	Check high-pressure valves, re-adjust or replace if necessary
Flushing circulation not functioning	Check pressure of flushing and charge pump, possible back pressure in cooling circuit, check housing pressure
Travel pump or travel motor damaged (wear)	Replace
Loader pump worn	Replace
Main pressure relief valve damaged	Replace
Sluggish acceleration and deceleration, too little propulsive power	
Insufficient engine power	Check diesel engine
Brake has got stuck	Check, remedy damage
No tank pressurization	Check ventilation filters and breathers, replace
Suction filter clogged	Replace filter
FAST-SLOW-gear not functioning due to electric or mechanical fault	Check power supply and solenoid valve, repair and replace if necessary Check travel motor
Fault in operation of brake-inching pedal	Check, adjust, replace
Charge pump sucking up air	Check, eliminate leaks
Travel pump incorrectly adjusted	Re-adjust travel pump
Insufficient charge or supply pressure	Check pressure, adjust
Pressure relief valve of charge circuit dirty or damaged	Check, re-adjust or replace
Insufficient high-pressure	Check high-pressure; re-adjust or replace pressure cut-off and high-pressure valves if required.
Travel pump does not open fully, pilot pressure too low	Nozzles clogged, check, repair
Internal damage to travel pump or travel motor	Replace units
Travel motor incorrectly adjusted	Re-adjust travel motor

Tab. 31 Table of faults

Possible cause	Remedy
Transmission works in one direction only	
Switch for travel direction damaged	Repair or replace if necessary
Solenoid valve gets stuck or is damaged	Repair or replace if necessary
Power supply towards switch for travel direction or solenoid valve interrupted	Check and repair (incl. ground connection)
Pilot pressure too low on one side	Nozzles clogged, check, repair
High-pressure relief valve is faulty or incorrectly adjusted	Swap valves around. If machine now travels in the other direction, examine valve, clean and replace if necessary.
Transmission works in neither direction	
Too little hydraulic oil in tank	Top up oil to mark on dipstick
Mechanical connection to diesel engine faulty	Check, repair
Charge pump damaged, no charge pressure	Remove pump and examine, install new pump if necessary
Switch for travel direction damaged	Repair or replace if necessary
Solenoid valve for travel direction damaged	Repair or replace if necessary
Suction filter clogged	Replace filter
Suction line between tank and pump kinked	Check and eliminate kink
Power supply towards switch for travel direction and solenoid valve interrupted	Remedy cause of interruption
Internal damage to travel pump or travel motor	Replace units completely
Mechanical connection between travel motor and axle interrupted	Check, repair
Loader installation is not working	
Oil supply to pump interrupted	Check suction line and repair if required
Main pressure relief valve damaged	Check and replace if necessary
Hydraulic pump damaged	Check, repair or replace
Hydraulic pump drive mechanically interrupted	Check and repair

Tab. 31 Table of faults

8 Trouble-shooting

Possible cause	Remedy
Decrease in machine's performance (loader installation)	
Insufficient engine power	Check diesel engine and adjust if necessary
Hydraulic oil level too low	Top up hydraulic oil to mark on dipstick
Pump is sucking up air	Re-tighten hose connections. Replace O-ring or seals
Insufficient operating pressure	Re-adjust main pressure relief valve, replace if necessary
Pump worn	Replace pump
Incorrect hydraulic oil	Quality of hydraulic oil must conform to our recommendation
Working cylinders are not working satisfactorily	
Seals in cylinders worn	Re-seal cylinders
Secondary valves damaged	Check secondary valves and replace completely if necessary
Faults in the electrical system	
Outside and/or internal lighting damaged	Check cables, connections, bulbs and fuses
Windshield wiper not working	Check cables, connections, and fuses Examine windshield wiper for mechanical damage, replace if necessary
Horn not responding	Check cables, connections, and fuses Replace complete horn if required
Control organs are imprecise	Determine the fault or source of the problem, call Service Agent if necessary
Starting system does not work satisfactorily	Check charge capacity of battery Test starter function Check connection and condition of power and battery ground cables Check function of ignition lock, replace if necessary

Tab. 31 Table of faults

9 Appendix

Ride control system (LSD)

Depending on the machine's operating weight, road conditions, and speed, there may be pitching oscillations when driving wheel loaders.

The ride control system reduces pitching oscillation, which results in the following advantages:

- higher transport speed
- improved material-handling performance
- more stable steering performance
- shorter braking distance
- increased ride comfort



Attention

Load-retaining valves (option) are without function as long as the ride control system is activated!

Operation

- Switch on the ride control system (82/51): green indicator lamp ON.

The ride control system is automatically activated as soon as the travel speed is more than 6 km/h.



Attention

The bucket tilt cylinder must not be at a cylinder stop (bucket not completely tilted back) as otherwise free oscillation is not possible.

Repair



Danger to life

due to pressure in the hydraulic system.

Before working on the loader hydraulic system, the accumulator pressure of the ride control system must be let off.

To do so, proceed as follows:

- Stop the machine in the proper manner.
- Switch off the ride control system (82/51).
- Remove the front-end cover.
- Carefully release the setscrew (83/1).
Pressure is reduced.

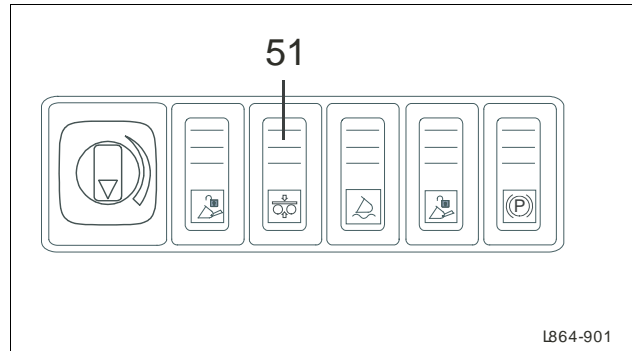

Fig. 82 Operation



Fig. 83 "LSD" (ride control system) pressure reduction

9 Appendix

10 Index

- A**
- Air filter83
 - Air intake83
 - Air-conditioning44
 - Antifreeze78
- B**
- Battery100
 - Biodegradable oils30
 - Breather95
- C**
- Canopy17
 - Care63, 66
 - Cartridge maintenance intervals84
 - Change of work attachments19
 - Checking78
 - Checking the V-belt tension87
 - Cleaning66
 - Closed spaces18
 - Condition of the battery66
 - Coolant66
 - Coolant Level78
 - Copyright8
- D**
- Daily tasks70, 71
 - Danger zone15
 - Declaration of Conformity13
 - Dimensions32
 - Draining83
 - Driver's seat42
 - Driving16
 - Dust ejection valve83
- E**
- Electrical equipment100
 - Electrical system27
 - Emergency exit21
 - Engine27, 105
 - Engine oil31, 77
 - Engine oil filter78
 - Engine oil level76
 - Environmental protection9
- F**
- Filter insert93, 94
 - Fire extinguisher20
 - Fire protection20
 - Fuel filter83
 - Fuel tank83
 - Fuels, lubricants, and coolants30
- G**
- Guides16
- H**
- Handing-over inspection68
 - Heating43, 45
 - Hydraulic oil31, 66, 92
 - Hydraulic oil level92
 - Hydraulic oil return filter93, 94
 - Hydraulic oil tank92
 - Hydraulics21, 28
- I**
- Immobilization103
 - Initial inspection68
 - Inspection plan74, 114
 - Inspection plans68
 - Intervals63
- L**
- Lighting equipment101
 - Loading20, 61
- M**
- Main cartridge85
 - Maintenance19, 63
 - Maintenance and Inspection Plan113
 - Monitoring20
- O**
- Oil analyses64
 - Operation14, 35
 - Operator controls36
 - Overhead power lines17
 - Overview of lubricating points72
- P**
- Preservation103
- R**
- Recovery20, 59
 - Repair19
 - Ride control system109
- S**
- Safety distance from overhead power lines17
 - Sound level values31
 - Stability15
 - Starting the engine40
 - Steering48
 - Steering wheel height adjustment42
 - Switching off the engine41
- T**
- Table of faults105
 - Technical Specifications23
 - Tilt adjustment of steering wheel42
 - Transport20, 59
 - Travel drive27
 - Travel-drive gear unit97
 - Trouble-shooting105

10 Index

U

Underground power lines 17

V

Valve lash 89, 90

V-belt 88

Vehicle identification number 7

Ventilation 43, 46

Views of the machine 23

W

Warning equipment 101

Warranty 8, 64

Weekly tasks 70

Winter operation 66

Work stoppages 18

Working Operation 16, 53

Handing over the Machine and Instructing the Operator

The following checklist should be followed when handing over the machine to the operator:

1. Operating Manual

Go through the Operating Instructions (page by page) and explain them in detail through practical training on the machine. Items which are particularly important include:

- Accident Prevention Regulations published by the employer's liability insurance associations in the user's country
- Technical Specifications
- Operator controls, indicating and warning elements
- Checks before putting the machine into operation
- Diesel engine running-in instructions
- Starting and stopping the diesel engine
- Explanation of hydrostatic travel drive
- Driving, speed ranges, notes for driving on roads
- Recovery and transport of the machine
- Operation of all functions
- Operation of quick-attach system
- Explanation of maintenance intervals and points according to Maintenance and Inspection Plan by demonstrating and explaining maintenance points on machine
- Lubrication intervals and points of lubrication according to lubrication chart and demonstration of these points on the machine
- Handing-over of Diesel Engine Operating Instructions

2. Spare Parts List

- Structure of Spare Parts List, Figures and the associated texts
- Instructions for ordering spare parts - always state the type of machine, the vehicle identification number ("Fz-Id.Nr."), parts designation, complete spare part number, number of pieces, delivery address, etc.

3. Warranty

- Explanation of warranty offered by manufacturer.
- Explanation of inspection cards and note on maintenance and inspection plan.
- The warranty/handing-over card must be filled out correctly and sent back to the manufacturer.

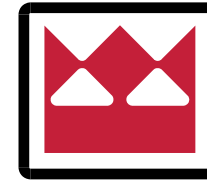

Wheel Loader

TL160

Maintenance and Inspection Plan

(for trained dealer service personnel)

The careful performance of all prescribed inspections is the best prerequisite for the machine's continuous readiness for operation.

The inspections are obligatory. If omitted, this may affect the warranty covered by us.

The following applies to maintenance and inspection work:

- The machine must be thoroughly cleaned before inspection takes place.
- All maintenance work specified should be performed in the prescribed sequence with the machine at operating temperature.

