



Operating Manual

 **TEREX | SCHAEFF**

Loader - Excavator
SKB 800

Keep behind driver's seat for later use!

AUSGABE • EDITION

1.80

GÜLTIG AB FZ-ID.NR. • VALID FROM SERIAL NO. • À PARTIR DU NO. DE SÉRIE

021/0453>021/0608

SCHAEFF-TEREX GMBH & CO. KG • D-74595 LANGENBURG

I.	Introduction	1
II.	Technical Data	2
III.	General Description	7
	1. Front loader	
	2. Backhoe	
	3. Hydraulic Cylinder	
	4. VARIO-LOAD-SYSTEM	
IV.	Operation and Employment	11
	1. Levers and Controls	
	2. Road Travel	
	3. Loader operation	
	4. Backhoe operation	
	Important Notes	
V.	Maintenance and Service	15
	1. General	
	2. Maintenance with grease schedule	
	3. Times of replacement	
VI.	Source of troubles and removal	25
	Towing of the machine	
	Fault table	
VII.	Safety Regulations	29
	Maintenance and Inspection Plan	
	Hydraulic oil recommendation table	
	Spare Parts Appendix	

1. INTRODUCTION

You decided for the

SCHAEFF
 ARTICULATION LOADER-
 EXCAVATOR
 SKIS 80J
 with VARIO LOAD SYSTEM

This well based decision and the given trust in this make will be justified by the economical advantage of the machine which complies with the up to date standard.

With this Operating Instructions covering all main joints providing the operating safety and long service life of the machine, we want to help you to get familiar with the unit and at the same time we want to give you the correct instructions.

For faults and damages which are caused by wrong operation and maintenance or not knowing, no compensation for warranty can be claimed.

Therefore it is in your own interest to read these operating instructions very carefully, what the machine is capable of later under the most varying of conditions will largely depend on just how familiar you are with the machine and understanding of how it works.

To get the best from the machine, it should be always ready for operation. This can be provided only, in case it is regularly maintained by an expert.

Only call in the authorized customer service of your dealer or the SCHAEFF-Service for both repairs and inspections. Likewise only use original SCHAEFF spare parts to ensure that your machine is maintained in mint condition and it operates perfectly, you maintain your full right to claim for compensation in warranty cases during the guarantee period.



The details given below are not binding. We reserve the right to make alterations and modifications to any element, component and accessory in the interests of progress, which will lead to improvement in performance or any other purpose we may consider expedient, while retaining the main feature of the machine described here.

Furthermore we shall not be obliged to have these operating instructions amended accordingly.

11. TECHNICAL DATA

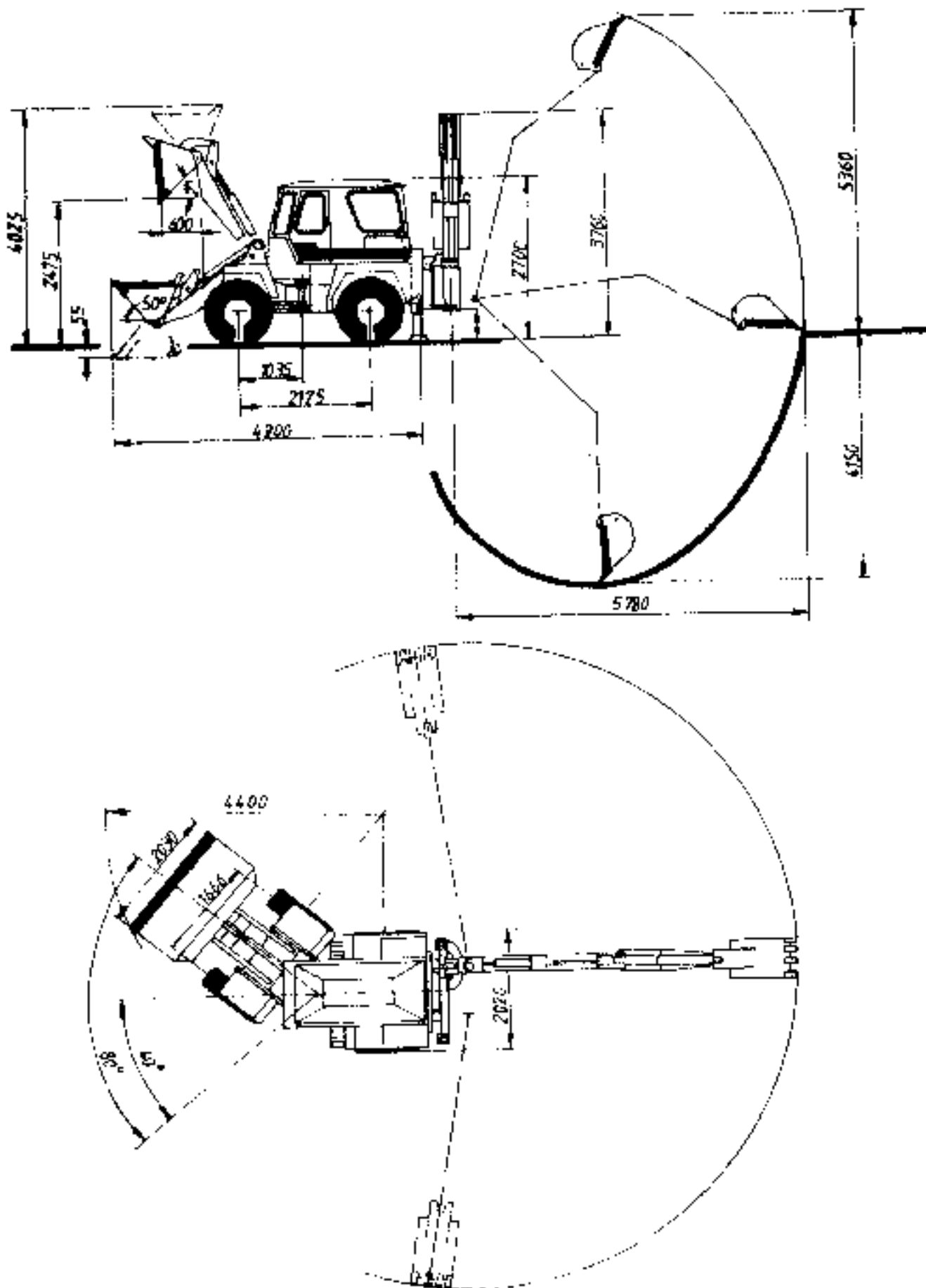

Type of engine:	Air-cooled 4-cylinder Fourstroke Diesel engine
Make of engine:	Deutz, Type F 4 L 512
Capacity according to DIN 70024: for further details please see 54 kW at 2500 r.p.m. instruction booklet engine	
Drive (Power transmission)	Hydrostatic travel gear four-wheel drive Forward and reverse stepless control of the speed
Speed: (forward and reverse)	Road gear: 0 - 20 km/h Cross-country gear: 0 - 10 km/h
Brakes:	1. Hydraulic foot brake as service- brake acting on front wheels 2. Parking brake as drum brake 3. Hydrostatic gear as additional service brake The brakes act on all wheel through four-wheel drive
Hydrostatic drive:	1. Stepless adjustable and reversible pump unit with travel automatic 2. Hydraulic adjusting motor with gear and axle designed as one unit 3. Closed hydraulic circuit with micro-filter
Max. Operating pressure of travel hydraulics:	390 bar
Steering:	Hydraulic articulated steering con- sisting of a high pressure gear-type pump with steering control unit. Approx. 4.5 circulation of the steering wheel from the maximum de- flection to another. Total wheel deflection 80°
Steering hydraulics, max. operating pressure:	175 bar
Tires:	Front and rear: 14,5 MFT 10 PR Track: EM
Tire pressure:	Front and rear: 2,5 bar
Track width:	Front and rear: 1665 mm

Electric Equipment:

Battery 12 V 100 Ah
 Three-phase generator 14 V 33 A
 Starter 12 V = 3 kW
 2 head-lights
 Blinker with warning switch
 Rear lights
 Flag
 Equipment complies with most traffic acts

Dimensions and Weights:

Operation weight, without backhoe, approx.	5500 kg
Operation weight, with backhoe, approx.	7400 kg
Total length in transport position	
without backhoe:	4000 mm
Total length in transport position	
with backhoe:	5600 mm
Total width without backhoe	2030 mm
Total width with backhoe	2200 mm
Total height up to cabin	2700 mm
wheel base	2175 mm
ground clearance under shaft:	490 mm
turning radius, edge of tires	3950 mm
turning radius, edge of backhoe	4400 mm

Permitted weights according to German Road Traffic Act:

Permitted total weight	7500 kg
Permitted load front axle	3300 kg
Permitted load rear axle	5200 kg

Filling quantities:

Fuel tank, approx.	100 ltr Diesel
Engine oil; approx.	11 ltr H-011 ⁺
Hydraulic tank, approx.	65 ltr ⁺⁺
Hydraulic system in circulation, approx. (incl. backhoe)	100 ltr
Front axle; approx.	4,75 ltr SAE 90 Hypoid
Rear axle, approx.	4,75 ltr SAE 90 Hypoid
Reduction gear, approx.	0,5 ltr SAE 90 Hypoid

+ see Diesel engine manual
 ++ see Hydraulic oil, page 20

Front-Loader equipment

Standard shovel	width 2050 vice
Capacity according to SAE heaped:	0,9 m ³
Dumping height, approx	2475 mm
Dumping reach, upper end position:	6081 mm
Max. dumping reach	1720 mm
Loading height	2875 mm
Back tipping angle	50°
(discharge angle)	45°
Digging depth of levelled bucket lip	55 mm
Max. digging depth	825 mm
Payload	10500 N
Lift power on ground	40000 N
Lift power up to end position	18500 N
Hydraulic system/Loader equipment	High pressure gear type pump with 3-fold valve bank, operation of loader with one lever
Max. operating pressure of operating hydraulic	190 bar

Backhoe

	<u>Standard</u>	<u>Elongatec</u>
Bucket arm	1800 mm	2200 mm
Digging depth	4150 mm	4550 mm
Discharge height	3430 mm	3700 mm
reach	5780 mm	6050 mm
Pulling force of stick	36000 N	25000 N
breakout force	130000 N	
Max. payload at full reach	1120 kg	
Tipping angle of bucket	195°	
slewing range of boom	195°	
Laterol adjustment of boom	1300 mm	
Hydraulic system backhoe:	Pressure from loader pump through connection block	6-fold valve bank
Max. Operating pressure	175 bar	

<u>Tools for the Backhoe</u>	<u>width</u>	<u>capacity struck</u>
Bucket with scraper	2000 mm	0,105 m ³
Bucket with scraper	3000 mm	0,140 m ³
Bucket with scraper	4500 mm	0,145 m ³
Bucket/Dipper	6000 mm	0,200 m ³
Bucket/Dipper	8000 mm	0,270 m ³
Shaped ditch digging bucket	700/4000 mm	0,150 m ³
Ditch cleaning bucket	1500/1900 mm	
Ripper, working depth approx.		500 mm

Optional Extrasfor
Frontloader

Quick exchange device, mechanical or hydraulic operation, for all standard loading shovels etc.

Light material shovel	width 2000 mm capacity 1,1 m ³ acc. to SAE heaped
UNI-shovel	width 2000 mm capacity 0,75 m ³ acc. to SAE heaped
Custom made shovels	
Fork lift attachment, with lift frame, forks to be lateral adjustable	payload approx. 1,6 - 1,9 t
Sweeping machine	
Optional tires, front and rear	16/71-211 M-1 10 PR EM-Tread

for
Backhoe

Clim shell grab, mechanical or hydraulic) slidable

Clim shell grab 3500 - 6000 mm wide,	0,100 - 1,250 m ³ capacity
Digging depth (without elongation)	4550 mm
Max. reach	5225 mm
Reach with raised boom	2435 mm
Discharge height	3050 mm

Bucket with hydraulic adjustable angle (for slopes)

Telescopic bucketarm

Further optional extras upon request

alteration rights reserved!

III GENERAL DESCRIPTION

The SCHAEFF 5K8 802 has been designed and built as a manoeuvrable articulated Loader-Excavator for all fields of civil engineering, industry and municipal use.

Due to its compactness and enormous manoeuvrability it can be employed where space is very tight.

Its versatility is achieved through a range of accessories designed and built especially for this machine.

1. Loader

1.1 Articulated steering

Steering is carried out hydraulically via 2 cylinders allowing the steering wheel to be turned through 80° (40° to either side). The articulation is located precisely in the center, so that the wheels always run exactly in their tracks.

Any stress that might occur are taken up reliably by the sturdy articulated frame. The articulated steering system makes for precise steering to within a fraction of an inch.

1.2 Loader Assembly

The reach and lifting height are great enough to allow even large building site trucks to be loaded.

Well balanced loading kinematics are of special advantage in the different phases of movement transmitting large forces. The special system incorporating just one lift and one dumping cylinder limits the number of bearings.

This also results in a shovel control system with constant parallel guidance and without selflocking brackets. An effect which has been proven very favourable with the Parklift attachment and when employing the LWI-shovel.

1.3 Hydrostatic Drive and Travel Automatic Gear

The technically perfect drive system makes for smooth, careful working. The hydrostatic gear unit with variable pump is connected up to the diesel engine. The hydraulic motor behind the pump transmits the power directly to the axles via the reduction gear.

The automatic travel gear enables the machine to be driven like a normal car.

The travel automatic connected with the adjusting cylinder of the adjusting pump has the following operation features:

1.3.1 Electric travel direction selector

Gears:

FORWARD	(green light)
0	(Stop)
Reverse	(yellow light)

In the selected positions "Forward" or "Reverse" the vehicle will only start to move when the accelerator has been actuated and a certain engine speed has been attained.

It is possible to change from "Full forward" to "Full reverse" while travelling without the hydrostatic transmission being damaged in any way.

1.3.2 Automatic determination of the vehicle travel speed dependent on the combustion engine speed

The automatic travel gear adjusts the hydrostatic pump automatically according to the engine speed. The axial piston pump is driven directly by the combustion engine, so that its speed is identical to that of the engine.

At a determined engine speed the hydrostatic pump starts to cut out only to run at maximum capacity at a certain engine speed. In this way it is ensured that the vehicle begins to travel at a certain engine speed, attaining its maximum running speed at maximum engine speed. The automatic travel gear system is adjusted on the test stand at the factory.

1.3.3 Starting-up with the same combustion engine speed despite varying starting loads

Unlike a hydrodynamic gear system, a hydrostatic transmission system can ensure maximum pulling forces of a vehicle even at a low travel speed. To utilize these advantages to full effect, the automatic travel gear is constructed in such a way that starting-up always occurs at the one and the same given combustion engine speed (with but a few minor deviations) and no matter what the starting load may be.

1.3.4 Automatic adaption to load

The travel gear regulates the delivery rate of the hydrostatic pump (analogous to the running speed) dependent on the performance of the combustion engine - no matter whether this output is reduced by the pressure of the hydrostatic transmission (travel resistance) or by the hydraulic loading or steering system.

1.5 Inching-Equipment (Control Clutch)

As far as actual operating conditions are concerned, it is not always desirable that the running speed is dependent on the speed of the combustion engine as described under 1.3.2. The hydraulic pump has an inching valve, which when actuated enables the speed to be taken back infinitely variably from the positions otherwise corresponding to 1.3.2 to the neutral position. In other words by actuating this inching facility it is possible to travel at lowest speed and stop even with the combustion engine running with fully open throttle.

1.4.5 Braking and Stopping

Braking and stopping are possible firstly through the hydrostatic transmission by reducing the acceleration and also stopping on the foot brake. Moreover, the vehicle can also be brought to a standstill by stepping on the inching pedal.

2. Backhoe

The backhoe is connected to the carrier machine without clearance. The hydraulic supply is provided by a hydraulic connection block direct through the central hydraulic system of the SKD 800.

2.1 Mounting plate

The mounting plate manufactured in case carrier type is designed to carry the backhoe on the one hand, and on the other to attach the complete unit to the machine. Due to the guiding rails mounted on the upper and lower edge, the bearing slide with slide sheet metals can be adjusted 1300 mm laterally on the mounting plate.

2.2 Outriggers

The guiding pipes of the outriggers are incorporated in the mounting plate. The outriggers are operated by 2 independent working hydraulic cylinders. They are equipped with swing mounted base plates and provide a safe position of the machine.

2.3 Bearing slide

The boom of the backhoe is connected with slewing column to the bearing slide. The hydraulic jamming holds the slide in the desired position after the boom has been side moved.

2.4 Slewing column

The slewing of the boom is done by hydraulic cylinder with damping devices in the end position. The slewing range is approx. 195°.

2.5 Boom, Bucket arm

Boom and Bucket arm are built in welded box-type design.

The bearing points of the equipment, suspension of the cylinders and hinges of the bucket to bucket arm are equipped with exchangeable bushes.

2.6 Valve Combination

Control of the backhoe is provided by 6 longitudinal gate valves. Each gate valve controls two functions. All control circuit, except outriggers are equipped with secondary relief valves.

2.7 Slewing drive

Slewing of the boom is provided by 2 cylinder controlled by the cross-type steering. This means that by actuating the control lever either one side of the piston and the rod side of the other cylinder is put under pressure. An after sucking valve takes care that the oil stream flows continuously.

To avoid damages when slewing the boom, both cylinders are equipped with damping devices in the end position.

2.8 Hydraulic jamming

Fixing of the boom on the slide is provided by two plunger cylinders actuated by the jam valve.

3. Hydraulic Cylinders

All hydraulic cylinders, except the Plunger cylinders, are double action cylinders. Ball- and-socket joints are built into the piston rod head and piston eyes to compensate any misalignment of the bearings when being fitted and to avoid torques on the piston rods and cylinders.

The cylinder tubes are made of seamless tube with cold formed and honed inner surface. This ensures a long service life of the sealing elements. The piston rods are made of steel, the surfaces being hardened and chromium-plated.

4. VARIO-LOAD-System

The Vario-Load-System provides the shifting of the center of gravity on the loader-Excavator without mounting extra weights. According to the requirement, when loading or excavating, the weights will be shifted in the position favourable for the job. Thereby the stability is improved.

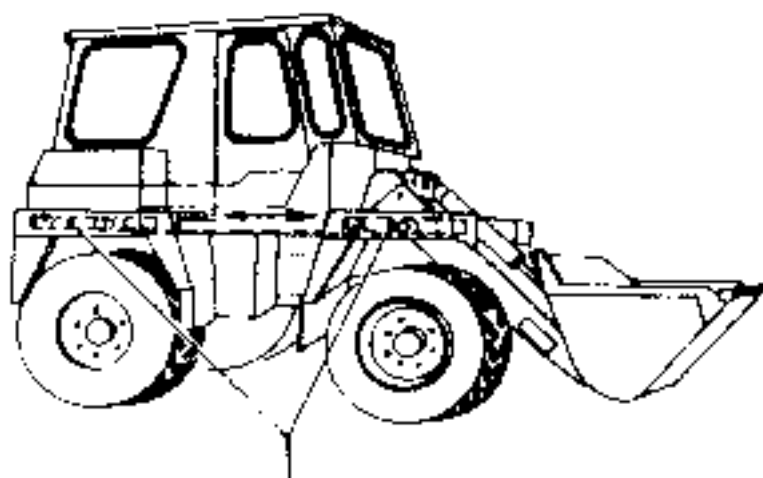

VARIO-LOAD System

IV OPERATION AND EMPLOYMENT

Before putting the machine into commission you must get to know how it operates and what control does what.

Adjust the hydraulic vibration absorbers of the seat to your bodyweight and set the seat in the most favourable position for you, so that

- a) all control levers can be reached easily
- b) you have an all-round view of your work area

Directly in front of you, you will have the dashboard with the control instruments and operating switches.

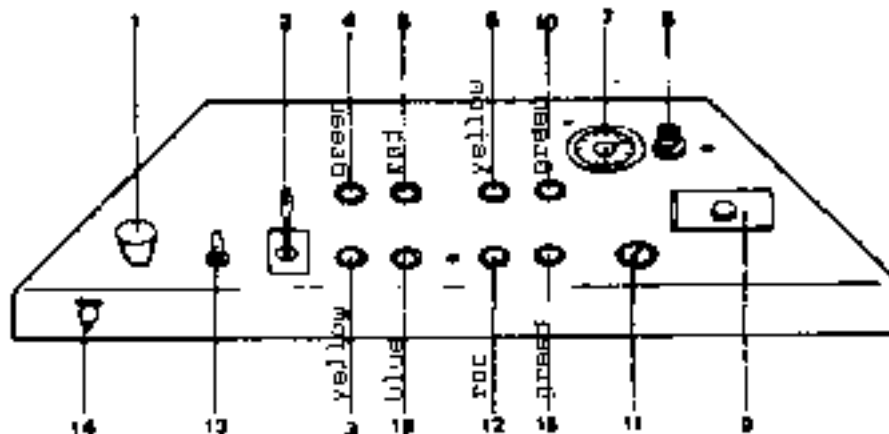

- | | |
|------------------------------------|---|
| 1. Warning light switch | 9. Fuse box |
| 2. Travel direction selector | 10. Blinker control lamp (green) |
| 3. Reverse travel (yellow) | 11. Light-Ignition switch |
| 4. Forward travel (red) | 12. Fuel lack indicator (red) |
| 5. Charger control (red) | 13. Speed selector |
| 6. Oil pressure indicator (yellow) | 14. Plug |
| 7. Operating hour counter | 15. Blinker control lamp (green)
for backhoes only |
| | 16. Head lights (blue) |

IMPORTANT:

As soon as the

Charger control lamp (red, item 5)

Oil pressure indicator (yellow, item 6)

is on, switch off engine immediately and establish cause (see also engine manual)

When the

Fuel lack indicator (red)

lights up, you have fuel left for about 45 minutes.

ATTENTION: BEFORE LEAVING THE CAB, THE TRAVEL DIRECTION SELECTOR MUST BE SWITCHED TO "0" (STOP) AND THE HANDBRAKE MUST BE APPLIED

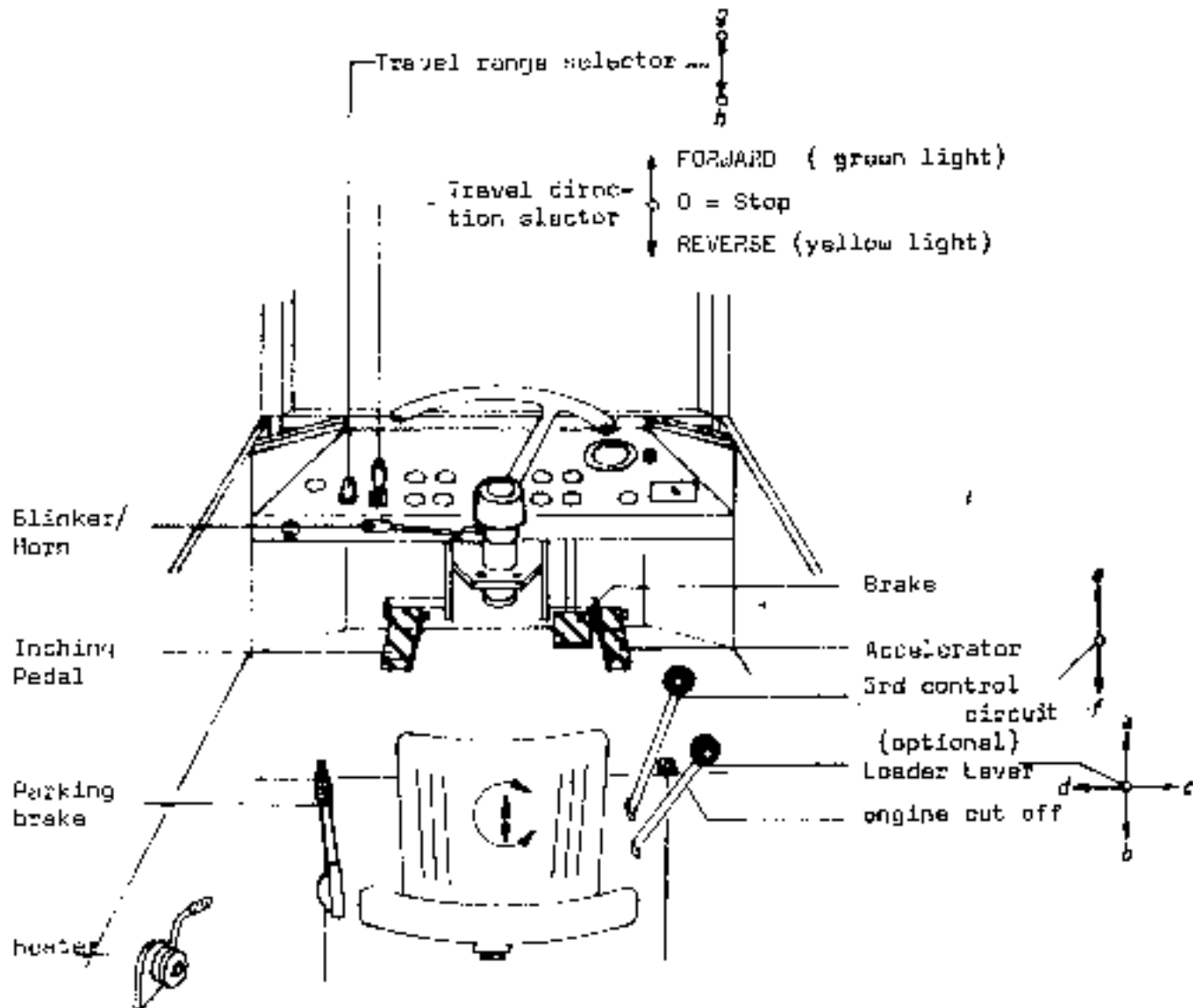

a) Frame lowers

b) Frame raises

c) Discharge of shovel

d) Tipping in of shovel

e) UNI shovel opens

f) UNI shovel closes

g) Road range - transport step

h) Cross country range - operating step

OPERATION OF BACKHOE

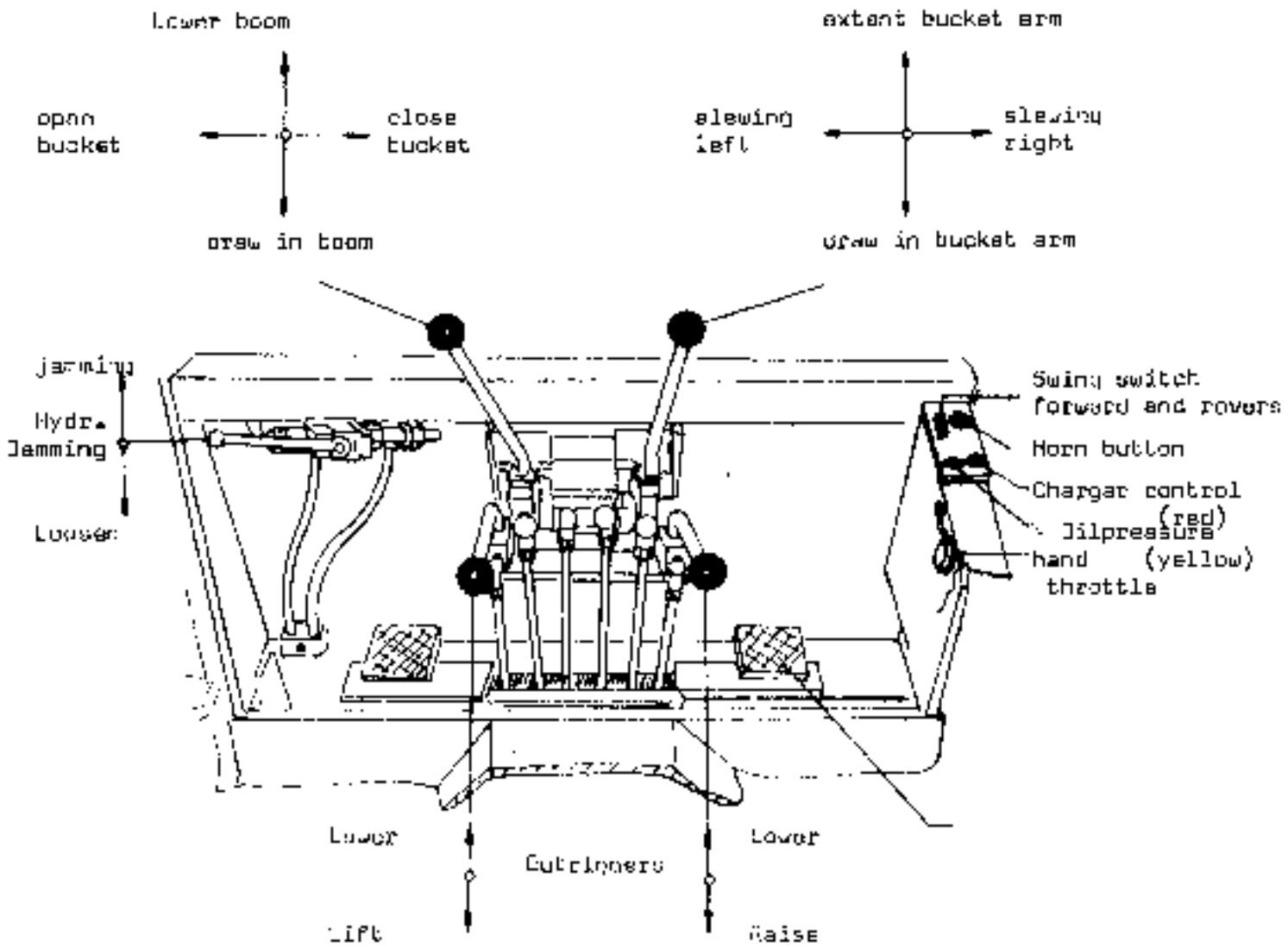

VARIO - LOAD System

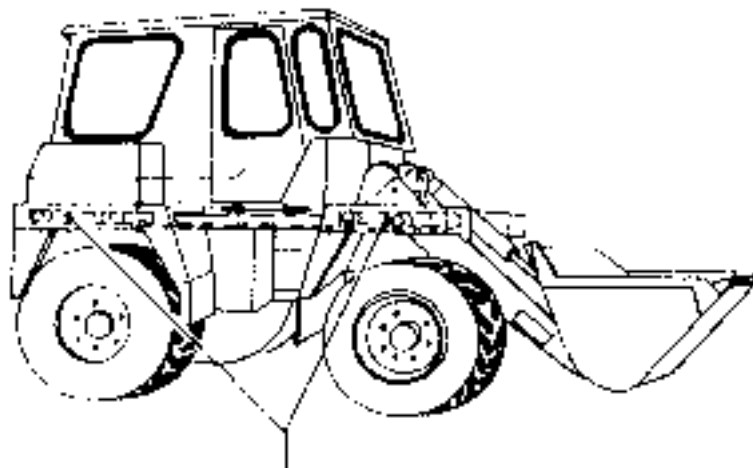

VARIO-LOAD System

2. Driving the machine

Put the travel direction selector lever in the "0" (Stop) position.

Start the engine and raise the frame sufficiently, so that the height mark on the frame coincides with the mark on the front of the actual vehicle. Select road travel or cross-country travel as the case may be and release the hand brake.



Set the direction required with the travel direction selector, press down the accelerator (right) according to the driving speed required.

As soon as you take your foot off the accelerator, it will automatically return to its initial position, causing the vehicle to brake.

Even if you shift from full speed "Reverse" to full "Forward" the servo-control of the hydrostatic drive will brake the reverse movement gently and accelerate in the opposite direction.

To stop: Take your foot from the accelerator. The foot brake need only be used in emergencies.

Please note: When leaving the cab, set the direction selector to "0" (Stop) and apply handbrake. Brake regulations for wheel loaders are to be observed (See sticker in cab)

Road travel

When driving along public thoroughfares, the

SKB 81.0

as a self-propelled machine must conform with the local traffic regulations. In the Federal Republic of Germany the machine conforms with the STUZD and ScVO.

Before commencing to travel, lower the bucket to the height mark, empty it, fold it right back and fit the tooth guard.

The operating lever for the loader hydraulic system must be locked by the transport safety facility.

The backhoe is to be moved to one side, slewed in and locked.

Finally check the controls e.g. directional indicator, signal horn, headlights etc.

To start engine! The travel direction selector must be in "0" (stop) position.

Put off engine

Pull out off till engine is at idle. Press out off in old position again.

NOTE: Do not switch off the engine while it is running at full capacity, but allow it to idle for a short period for temperature compensation purposes.

3. Lugger operation

Please note: Select "cross-country" gear when using the lugger. When working with the loader, it is important to know that the hydrostatic system can transmit the full thrust force even when the wheels are at a standstill.

NE: No thrust force at all is transmitted when wheels spin. By pressing the locking pedal the dependence of the travel speed on the engine speed is altered. (See page 8, paragraph 1.5).

Working Instructions Loading

General:

The travel and loading movements should flow into one another when using the loader. To master this, begin at a low engine speed.

As a matter of principle you should keep the shovel - no matter whether filled or empty - as close to the ground as possible. Articulated loaders are safest (particularly when running at an angle to the gradient) with the shovel lowered.

Operate the latching pedal to lift the shovel, e.g. when approaching a lorry.

Scrape loading

Lower frame and drive the edge of the shovel into the ground at a flat angle. Do not penetrate too deeply to ensure smooth operation. Just move the shovel up and down to level the depth during this scraping operation.

Loading from a slope

Divide up the slope to be cleared into different stripping levels. Operate the shovel with feeling, avoid wheel spin and any uprooting of the ground.



Last but not least

After being familiar with all functions practical work should be commenced. In what sequence it is best to work depends primarily on the work to be done.

The given examples are not binding guide lines. After all it is a question of the driver's experience, his command over the machine and the ground conditions as to whether the best possible performance can be attained.

Working with the Sweeping machine

Provision is the existence of an additional control circuit.

Connection of the sweeper drive is done through hydraulic quick couplings and controlled by the additional control lever.

Important: When working with the machine do not put in floating position!

4. Connection of the Backhoe

The SKS 300 drives close to the backhoe, to enable the connection of the hydraulic lines.

Pressure- and return lines are connected by couplings.

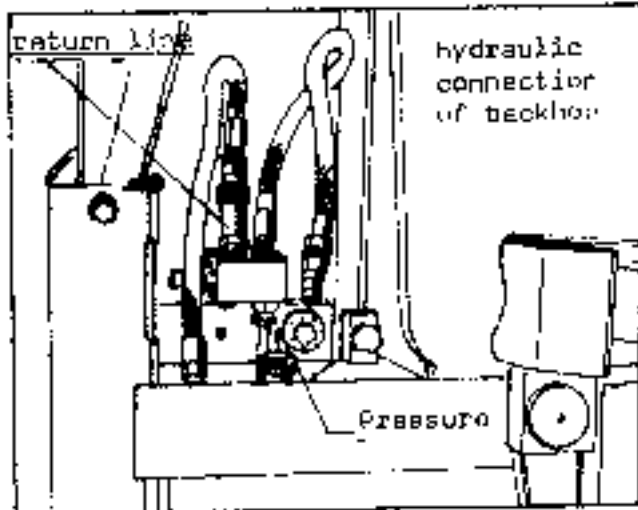

The connections are designed in such a way that the correct connection is given in any case.

By means of the outriggers and the bucket arm, the unit is to be aligned by lifting, lowering or slewing, till the mounting points fit and locking of backhoe with carrier machine is possible. After drawing in of the supports and the boom, the excavator is ready for operation.

Important:

After disconnection of the backhoe, the pressure hose of carrier machine is to be inserted into the socket or the connection block. This provides a free oil flow for the carrier unit.

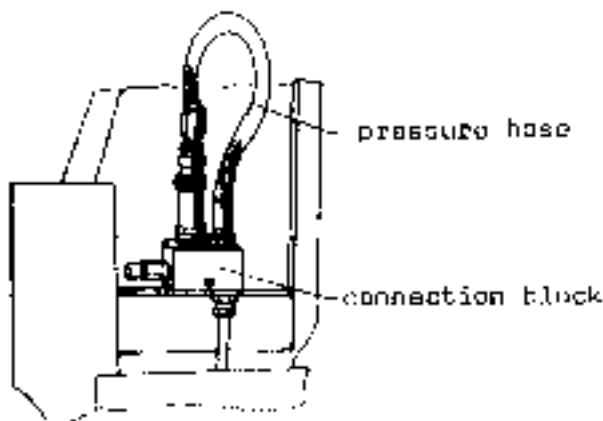

Sideshift of the boom

The boom can be shifted to the outer edge of the mounting plate. Therefore it is possible to work at side limits like house walls precisely, furthermore the reach of the boom is extended cross to travel direction.

Loosen and shifting of the bearing slide

Open up the jam valve by actuating the lever and slew boom in or in opposite direction of the required shifting direction.

After dropping the bucket to the ground and actuating the bucket-arm, the slide with the boom is pushed or pulled in the desired position.

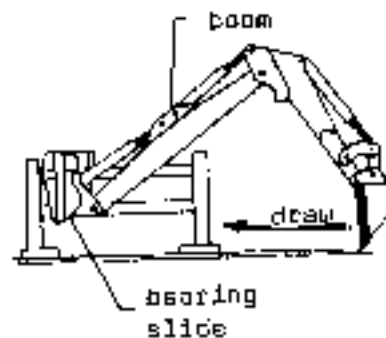

Jamming of the bearing slide

After shifting, the jam valve is to be closed and the boom is to be raised as high as possible to build up the necessary pressure. In this way, the bearing slide is jammed and the backhoe is ready for operation.

It is important to proceed exactly to the given rules and the jamming of the bearing slide is to be done carefully.

Operation of Jacking

Gentle, quick control movements increase the output of the bucket compared with hard, jerky movements.

The material should be loaded by early crawling in of the bucket. Under all circumstances working against the excess pressure valve is to be avoided to ensure that there is no unnecessary heating up of the oil.

As soon as the cylinder piston is in its end position and a whistling noise can be heard from the valve block, this is a sign that the excess pressure valve has responded.

Changing buckets or clamshell grabs

Since a number of buckets are also necessary to ensure best possible utilisation of this machine for different operations for which the HT 21 can be employed, the suspension fitting has been designed and constructed so that such buckets can be changed in a minimum of time.

To change buckets, the splints and pins, with which the bucket is connected with the bucket stick and arm, are to be released.

The bucket or the grab is to be stored safely after it has been removed, otherwise there is a danger of accidents.

When changing a mechanical turning clamshell grab (optional extra) two hose couplings have to be released apart from the splints and bolts on the bucket arm.

Four hose couplings have to be undone on the hydraulically turning clamshell grab.

Special points to watch

1. The accident prevention regulations of national and local authorities are to be observed.
2. Do not run the Diesel engine at too low a speed. "Cross-country gear and full engine speed is better than road travel and half engine speed". Then the engine lubrication, cooling and efficiency are better.
3. Move the control levers smoothly. The block sliding controls have fine guiding edges, so that delicately sensitive movements can be carried out.
4. Avoid frequent working against the pressure relief valves, since excessively heated oil not only reduces performance, but leads to premature ageing of the oil and greater wear of sleeves and J-rings.
5. When parking the vehicle on steep slopes, put the brake shoe under the wheel as well as apply the hand brake.
6. When taking up material, raise the frame occasionally for a short time, so that the full load remains on the front axle.
7. For towing see page 25.
8. The trailer coupling is not to be used for towing trailers on public roads.
9. Important:

In case the machine is equipped with hydraulic quick exchange device, the device is to be operated only when the tools are on the ground.

V MAINTENANCE AND CARE

Continual readiness for immediate operation and long service life of your machine are influenced by maintenance and care.

Therefore the strict accordance of the instructed maintenance is in the interest of each machine owner. The operator's manual emphasizes the daily and weekly maintenance, checks and grease service.

In addition to the regular maintenance, three thoroughly done inspections are foreseen within the warranty period and which are to be done by trained experts.

Maintenance and inspection schedules for each machine are included in the operator's manual and in the warranty certificate.

Inspection intervals

1. Inspection - after approx. 100 operating hours
2. Inspection - after approx. 300 operating hours
3. Inspection - after approx. 600 operating hours

Important: The 1st + 3rd inspection are compulsory. In case of neglect the warranty could be affected.

We cover a share of the costs of the first and third inspection with a lump sum, after the inspection check lists have been submitted.

We highly recommend the 2nd inspection, however it is the customer's decision. This check is to be charged, we will not carry a share.

Important: The maintenance on the Diesel engine before the 100 hours inspection is to be done according to the engine manual.

Notes:

1. Cleanliness is absolutely essential when carrying out repairs, particularly as far as the hydraulic system is concerned.
2. Repairs on the hydraulics are to be done by trained experts only!
3. Do not attempt to do any repairs or servicing work on the machine unless it is completely secured and powerless.

Powerless means to say: Lower the extended boom and the lift frame to the ground while the Diesel engine is at idle and actuate all controls until the hydraulic system is powerless, furthermore apply the parking brake and insert the brake shoe to prevent the machine from rolling away.

IMPORTANT 1

When the lifting frame is raised, the assembly support is to be mounted on the lift cylinder.

DAILY MAINTENANCE WORK

Check

and if necessary
eliminate
replace or
fill up

1. Oil level in Diesel engine
2. Air filter
3. Fuel level
4. Hydraulic oil level
5. Cylinders, pressure hoses, pressure pipe lines, valve bank, etc. for leaks

When tightening up the hose couplings, the unions must be counterlocked to prevent them from coming loose on own accord.

6. Electrical system
7. Controls for function
8. General condition of machine

*Greasing

1. Every grease point according to schedule

Replace defective grease nipples immediately

WEEKLY MAINTENANCE WORK

Check

and if necessary
eliminate
replace or
fill up

1. Electric system (acid level in battery)
2. Tire pressure (see tech. data)
3. Wheel nuts - check daily during the first 50 hours torque: 40 mkg
4. Axle suspension
5. Brake fluid

*Greasing

1. Every grease point according to schedule

+ use a lithium saponified multi-purpose grease

GR FASE SCHEDULE

P Check

△ Greasing

Maintenance see
manual for
Diesel engine

W E F K L Y

D A I L Y

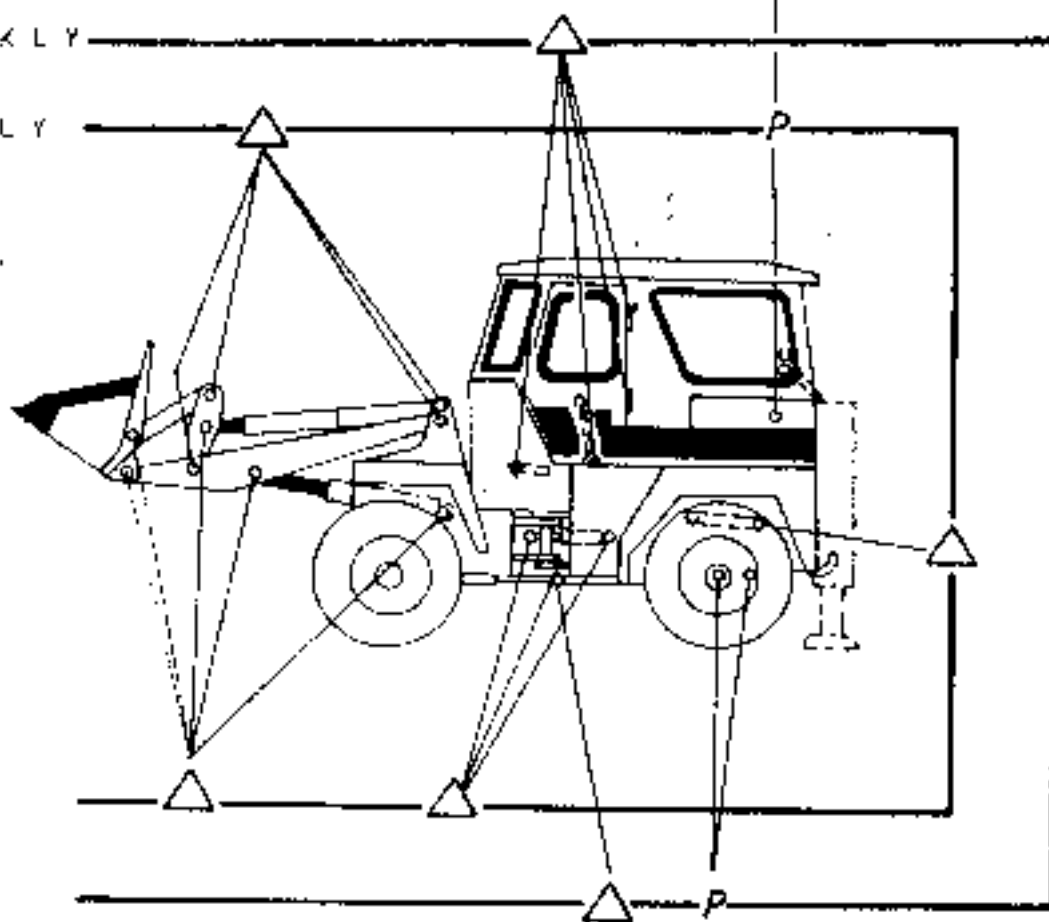

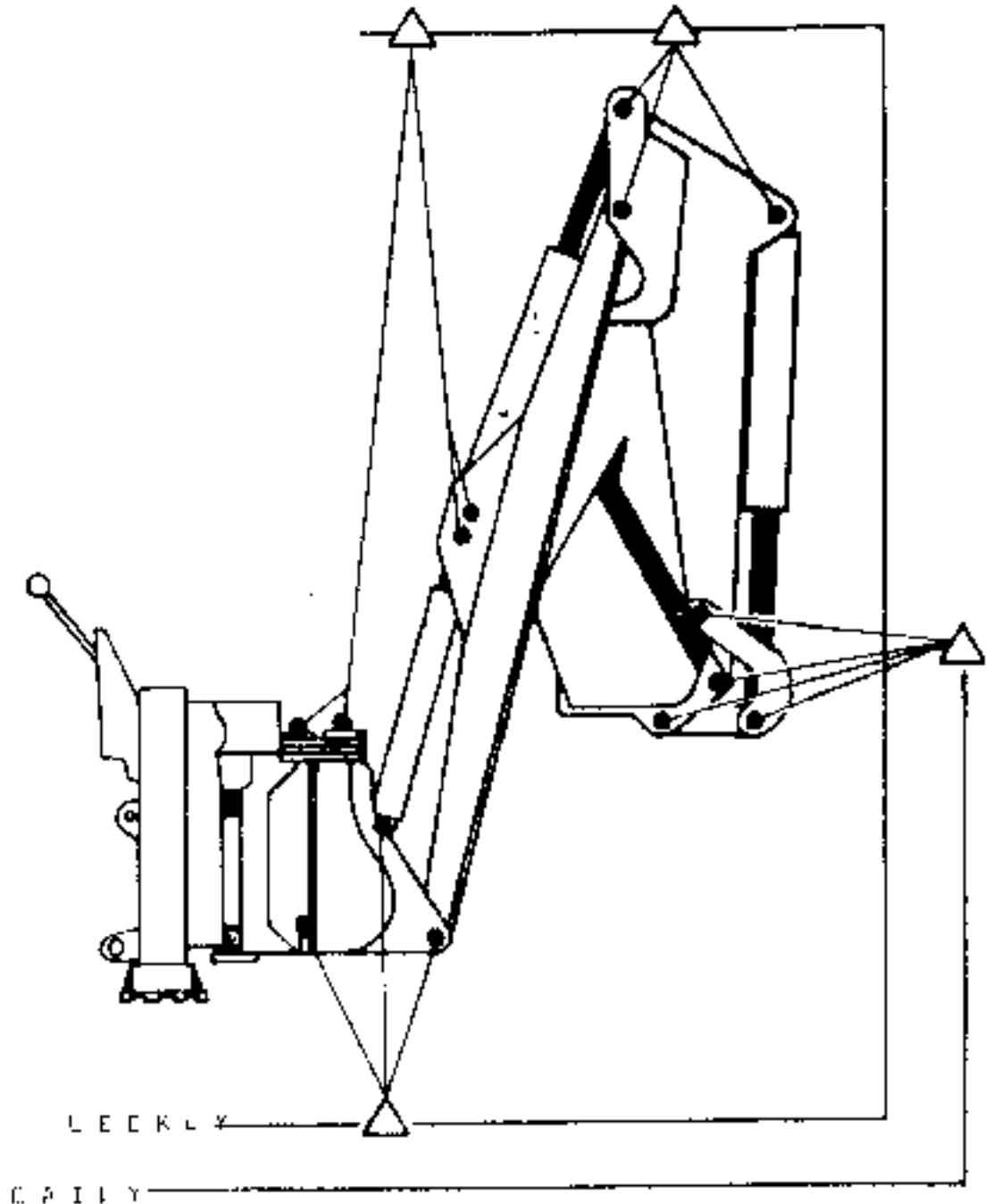

△ = GREASING

3. Replacement Limes

3.1 Hydraulic Oil

We recommend a constant hydraulic oil which retains its physical and chemical properties during use. This is the

SCHAEFF-Hydraulic Oil
E 1033

or a hydraulic oil with a viscosity of at least 12 cSt at 35^oK (91^oF) but not exceeding 1500 cSt at 235^oK (-15^oC).

The SCHAEFF Hydraulic Oil gives you the guarantee that you always have a product of the same quality and, as a result, always ensure the working safety and full capacity of your machine.

SCHAEFF Hydraulic Oil E 1033 can be obtained in containers of

20 ltr. Spare P. No. 4 312 205 753

50 ltr. Spare P. No. 4 312 205 79a

from our Spare Parts Department in Hothendorf a.H. or directly with our Customer Service Branch.

Hydraulic oil change

Under normal operating conditions the hydraulic oil should be changed in warm state at the following intervals:

1st. change after 500 op. hours

2nd change after 1200 op. hours

3rd subsequently after every 1200 operating hours
(at least once a year!)

3.2 Axles and Gear

Rear axle

Used is SAF 00 Hypoid oil.

Ambient temperature from -20^o to +40^o C

Oil filling approx. 8,3 ltr.

(use overflow plug)

Oil changes

1st change after 100 operating hours

2nd change after 1200 operating hours

3rd Subsequently after every 1200 operating hours

(at least once a year)

Front axle with facing gear

Used is SAF 90 Hypoid oil.

Ambient temperature from -20^o to +40^o C

Oil filling approx. 8,75 ltr.

(use overflow plug)

Oil changes

1st change after 100 operating hours

2nd change after 1200 operating hours

3rd Subsequently after every 1200 operating hours

(at least once a year)

3.3 Filter Change

Under normal operating conditions the intake filter cartridge is to be replaced at the following intervals:

- 1st change after 2000 operating hours
- 2nd change after 3000 operating hours
- 3rd change after 4000 operating hours
- 4th Subsequently after every 600 operating hours (at least once a year)

After a major repair of the hydraulic system, the filter cartridge is likewise to be renewed after the first test run.

Hydraulic oil filler- and breather filter

Check and if necessary clean the dirt from the screen of the breather filter before and after each filling.

3.4 Diesel engine

Maintenance work on the diesel engine like
 Engine oil change
 Air filter cleaning
 Fuel filter
 Injector pump etc.

are to be done according to the instructions of the engine manufacturer.

3.5 Brake fluid

The brake liquid is sensitive to dirt. Furthermore, it is exposed to the normal ageing process. When checking the liquid level, also the quality has to be examined. Compare old liquid with new one. Fresh brake fluid is light blue, smells as evaporated alcohol and when rubbing between fingers, a sticky film remains. Compared to it, used brake liquid is dark blue, almost scentless and has only little lubricity.

In that case, the hydraulic brake system has to be emptied, flushed and refilled newly.

Change: Once a year

Used is brake fluid according to SAE J 1703.

VI FAULT FINDING AND ELIMINATION

Towing of the machine

When the machine is to be towed - no matter for what reason - a high pressure limiting valve in the flushing block of the hydraulic motor has to be replaced by a blind plug (supplied). In this way the oil circuit is opened and the hydrostatic transmission no longer functions as a service brake.

IMPORTANT:

The machine should only be towed for a minimum distance (to clear a crossing or a road), otherwise the hydrostatic drive may run dry and breakdown. A tow bar must be used for towing the loader.

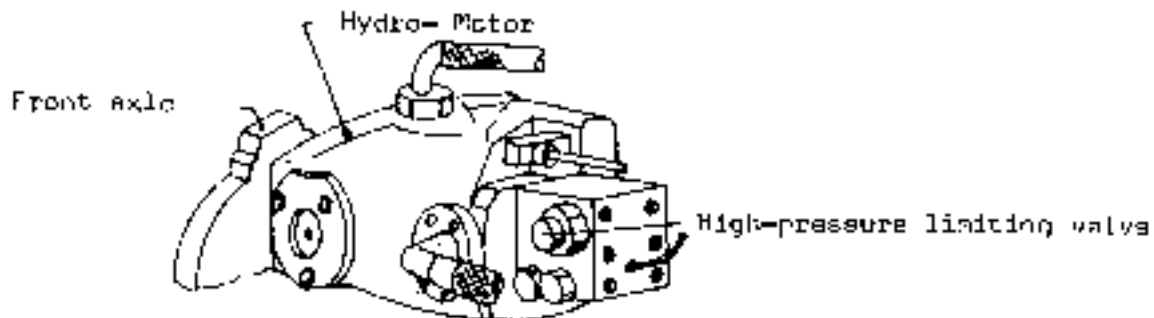

RE:

A maximum degree of cleanliness is very essential when repairing the hydraulic system!
When parking, the brake shoe should be placed under a wheel of the rear axle as a general rule.

Important:

If possible, let the Diesel engine run at idle speed while the machine is being towed. Maximum towing speed is 10 km/h

FAULT TABLE

The following fault table will help to detect and eliminate any faults quickly. However, the cause of the fault can only be localised quickly if one proceeds systematically.

I. Fuel / engine

see engine manual

II. General

<u>Fault</u>	<u>Possible cause</u>	<u>How to eliminate</u>
Hydraulic system gets too hot	1. Not enough oil	Fill up with oil to given level
	2. Oil cooler dirty	clean cooling fins
	3. Narrow pass in return line	hose or pipe buckled, align or replace
	4. Filter blocked up	replace filter cartridge
<u>III. Loader equipment</u>		
Neither lift nor dump cylinder moves	5. Oil feed to pump interrupted	Check intake line and eliminate trouble
	6. Main relief valve broken down	replace resp. adjust relief valve
	7. Hydraulic pump defect	replace hydraulic pump and establish cause
Lift frame drops	8. Sealing elements worn	replace sealing elements
Dumping cylinder fails to hold	9. Sealing elements worn	replace sealing elements

IV Hydraulic articulated Steering

No steering movement to right or left	10. Oil feed to pump interrupted	Check intake line and fix damage
	11. Foreign matter in the relief valve	only to be repaired by experienced fitter
	12. Hydraulic pump defect	Replace hydraulic pump and establish cause
	13. Articulation cylinder defect	Repair cylinder and establish cause

V. Hydrostatic drive

Machine does not travel neither forward nor reverse	14. Too little oil in tank	Fill up with oil to given level
	15. Oil feed to filling pump or meter pump interrupted	Check intake line and intake filter, replace filter cartridge
	16. Internal damage to pump esp. hydro-motor	Replace unit, establish cause by expert
Machine travels in one direction only	17. Electric direction selector defect	Check switch and wires
	18. One high pressure limiting valve does not close	Interchange both valves, in case machine travels in opposite direction, renew valve
Sluggish acceleration and delay in response to controls	19. Oil/air mixture in travel gear	check intake lines
	20. Inlet filter dirty	replace filter element
	21. Service valve vent blocked	disassemble valve and clean (only by expert)
	22. Internal damage to pump or motor	have expert establish cause
no travel range change	23. Electric travel range selector defect	check switch and wires replace magnetic valve on hydro motor.

V5 Backhoe

No movement of boom and bucket cylinder	24. Oil feed to pump interrupted	check intake line and repair damage
	25. Main relief valve broken down	adjust resp. replace main relief valve
	26. Hydraulic pump defect	replace hydraulic pump and have expert establish cause
	27. Defect hose connections	Pressure- and return line between pump and control valve and coupling is to be checked for correct fitting
Bucket stick, resp. boom drops	28. Secondary relief valve is set too low resp. defect	adjust valve correctly resp. replace
	29. Set of sleeves of cylinders worn	renew sleeve set
	30. Gate valve leaks	replace seals
bearing slide is moved	31. Hydraulic jamming defect	pipe connections or O-rings leak
	32. Jamming device defect oil flows	close ball valve and non-return valve is to be checked resp. replaced

UTI SAFETY REGULATIONS

+ WHEN USING THE MACHINE, THE ACCIDENT +
+ PREVENTION REGULATIONS OF THE LOCAL +
+ AND NATIONAL AUTHORITIES ARE TO BE +
+ CAREFULLY OBSERVED ! +

OPERATION AND MAINTENANCE OF THE MACHINE:

The customer or operator, respectively is to be instructed on the following points:

Operation and maintenance of the machine

1. Starting and switching off the engine
2. Operation with the front loader
3. Operation of the buckets
4. Driving controls
5. Mounting and detaching of buckets
6. Control and signal systems, lighting system
7. Running-in regulations +
8. Safety and weekly maintenance
9. Lubrication of the machine
10. Oil and Filter change (engine, transmission and hydraulic system).

Load travel and tool operation

1. Road travel, transport lock
2. Cross-country travel (operation stop)
3. Introduction to the hydrostatic travel drive
4. Towing of the machine
5. Work with loader and buckets (fields of application)
6. Effect of the torque to the drive wheels

General

1. Accident prevention regulations
2. Guarantee provisions
3. Inspection checks
4. Working over the operation: instructions and spare parts list with explanation of the main points to watch
5. Use of other spare parts
6. Do not forget to complete the working over card

+ see maintenance and care - SKB 800 Operating Instructions



SKB 800

MAINTENANCE AND INSPECTIONS PLAN

Careful maintenance is the best provision that your machine is always ready for operation. We recommend to carry out the following maintenance work in the proposed sequence while the engine is still warm.

The 1st and 3rd inspection at 100 and 600 operation hours has to be definitely carried out during the warranty period, as otherwise the guarantee cover will cease to apply.

Open delivery of the machine the operator has to be advised on the service of the diesel engine before the 1st inspection (100 hours).

The machine has to be cleaned before the inspection.

0 = Check, clean
X = replace

	OPERATIONS	Operating hours		
		100	300	500
1	Oil inspection and maintenance work on diesel engine is to be carried out according to the separate engine instructions	0	0	0
2	Check engine suspension	0	0	0
3	Check engine speed adjustment	0	0	0
4	Check exhaust system for leakage	0	0	0
5	Replace air filter cartridge	0	0	0
6	Check acid level and connections on battery	0	0	0
7	Check electric control and signal elements, lighting system	0	0	0
8	Check controls for axart functions	0	0	0
9	Check iso, replace bearing bushes and pins where necessary	0	0	0
10	Check axle and universal joint shaft mounting	0	0	0
11	Check axle lock	0	0	0
12	Check pins and connection of articulation	0	0	0
13	Check wheel nuts and tire pressure	0	0	0

	OPERATIONS	Operating hours		
		100	300	500
14	Frame and rear axle: check top, replace oil	X	0	0
15	Check clearance of wheels	0	0	0
16	Replace wheel hub grease			
17	Reduction gear: check top, replace oil	0	0	0
18	Check function of brakes and brake liners	0	0	0
19	Brake fluid	0	0	0
20	Check for leakage: pipe lines, hoses valve bank, hydraulic pumps, cylinder etc.	0	0	0
21	Replace hydraulic oil filter cartridge	X	X	X
22	Check top, replace hydraulic oil	0	0	0
23	Clean cooling fans and hydraulic oil cooler	0	0	0
24	Check backhoe mount	0	0	0
25	Check hydraulic functions and pressure of loader and backhoe	0	0	0
26	Grease machine according to schedule (see instruction manual)	0	0	0
27	Test run and test operation	0	0	0
28	Sign inspection card	0	0	0



Hydraulic Oil Recommendation Table for Schaeff Machines

In order to guarantee troublefree operation of our hydraulic machines at ambient temperatures of -10°C to $+40^{\circ}\text{C}$, besides following the instruction book it is essential to use the appropriate hydraulic oils. An excellent operation of our machines is *only* granted if the below-mentioned hydraulic oils or other ones with equivalent quality are used.

The limits of the hydraulic oils which are suitable for Schaeff machines are approx $12\text{ mm}^2/\text{s}$ (cSt) at 100°C and $1500\text{ mm}^2/\text{s}$ at -10°C . The hydraulic oils listed meet these requirements. In case machines operate at extremely low ambient temperatures (below -10°C), get in touch with our Service Department;

Notizen

Notes

Notices

Notizie

Noticias

SCHAEFF WARRANTY REGULATIONS

1. The warranty covers assured qualities and defects according in the current state of engineering. Alterations in design and version, which will take place in general on the goods before delivery, do not constitute a right to claim for compensation.
2. Warranty is provided for 6000 operating hours not exceeding 6 months from the date of delivery to the purchaser, respectively date of commencement for our products of regular dealer. The warranty is restricted to free of charge replacements or free of charge repairs for the parts which failed due to a material or design defect, whichever the manufacturer decides. The repair or replacement must be done by an authorized distributor at our expense, however transport costs ~~shall~~ be paid for by the purchaser.
3. Warranty claims ~~can~~ only be considered where they are claimed for formally ~~with~~ the manufacturer through the distributor immediately after the damage occurred and claims have to be submitted within ~~two~~ weeks.
4. The supply of the new part will be done as quickly as possible. No claims for compensation will be considered nor prolongation of the warranty term will be provided in the event of a delay in supplying.
5. Exempted from warranty are accessories and components which are not manufactured by SCHAEFF.
6. Warranty lapses where the failed part is repaired, even partly, altered or dismantled outside our authorized distributor repair shops. The same applies in the event that our instructions stated in our manuals or our advice have not been observed; this refers to application, maintenance, inspection intervals and operation. Also expiry of warranty in case of alterations done by the purchaser or by third parties, concerning the affected part or in case of change of ownerships.
7. We will review damages and their causes in any event. Replaced parts must be returned to the manufacturer and will become his property.
8. Any expenses that may be incurred for factual statements required by the purchaser and agreed with the supplier are to be carried by the purchaser.
9. There is no title to conversions or price reduction except the manufacturer fails to remedy the defect.
10. Compensation for consequential or immediate damage will not be granted.
11. No warranty is provided for special designs, for machine combinations which have not been tested and approved by SCHAEFF, and for implements assembled outside our factories except the assembly has been done with our written consent or under supervision of a person authorized by the manufacturer. But also in this event, approval from our side is required.
12. No warranty is provided by the supplier with the manufacturing of test implements (prototypes), except the warranty is expressed in writing by the supplier within the scope of the above mentioned warranty regulations, upon delivery. The same applies in the event the sample implement is sold to third parties with the written agreement by the manufacturer.
13. Exempted from warranty is normal wear and tear and damages due to faulty or careless operation.
14. We are not liable for any damages caused by natural phenomena, burglary, theft, fire and other unforeseen events or influences beyond one's control (force majeure) on the property of the purchaser which is in the works of the supplier.
15. We do not carry formal liability for statements concerning weight, capacity, consumption, performance or any other statements which are always approximate only. Cancellation of the contract cannot be claimed for by the purchaser or claims for compensation will not be considered in the events mentioned in this paragraph.