

VOLVO CONSTRUCTION EQUIPMENT

RECYCLING MANUAL

L60F, L70F, L90F, L110F, L120F



MORE CARE. BUILT IN.



Foreword

Foreword

Caring for the environment is one of Volvo's core values, along with quality and safety.

This brochure is for all those who work with dismantling and scrapping of a complete machine, both service workshops as well as dismantling companies and recycling companies. It can also be used for service work during the machine's lifetime, as a guide for handling used products that are replaced during repairs and service.

The purpose is to facilitate correct handling of hazardous waste or other equipment and components that may cause personal injury and environmental damage. It also serves as a material map to see which materials are included in the product.

The brochure does not include any instructions for recycling technicians since these will change with time, and an instruction from today may prove to be completely different in the future. There is also national legislation and a variety of local regulations that differ significantly.

The information in the brochure is developed for Volvo L60F, L70F, L90F, L110F, and L120F, and shall not be used in any way for other products.

Information and data included in the brochure are valid at the time of publication. We reserve the right to change specifications and equipment without prior notice.

This recycling manual is for a so-called 'basic machine'. When the machine is purchased, a variety of optional equipment may be selected and all of these are not included or described in this manual.

Overall perspective

Volvo Construction Equipment's overall perspective on how environmental aspects shall be fulfilled means that the company's products are regarded in a much greater context:

- Society works for common environmental legislation and facilitates good work planning and provides systems for recycling.
- Volvo and its sub-suppliers replace materials that have negative impact on man and the environment, and improve use of products and manufacturing methods.
- Dealers make sure that the customers get the right machines that are exactly adapted to their applications.
- Operators and owners handle the machines correctly with regards to use, service, and maintenance.
- Recycling is performed in a manner that is safe to both man and the environment. Scrapping and dismantling take place in a way that enables maximized reuse or recycling of the machine.

Safety

Safety

Volvo Construction Equipment AB assumes that work with our machines follows the safety and work instructions included in the Service manual and Operator's manual for the model in question.

Dismantling and recycling of machines shall be performed by personnel with sufficient knowledge, and in a professional manner in order to avoid personal injury and environmental damage.

If in effect, national legislation governing dismantling of machines is the primary legislation to be followed. This Recycling manual is only a supplement to the valid Service manual and Operator's manual for Volvo L60F, L70F, L90F, L110F, and L120F.

Recycling work

Work and recycling

A Volvo wheel loader consists of metals to approx. 80%. In general, metals are suitable for recycling. However, in certain cases the components' design and installation may make recycling impossible, both practically and economically, despite the included materials themselves being recyclable.

The recycling process has 5 readily identifiable steps, where one should strive to get the biggest fractions of the machine's material as high up as possible on the recycling steps.

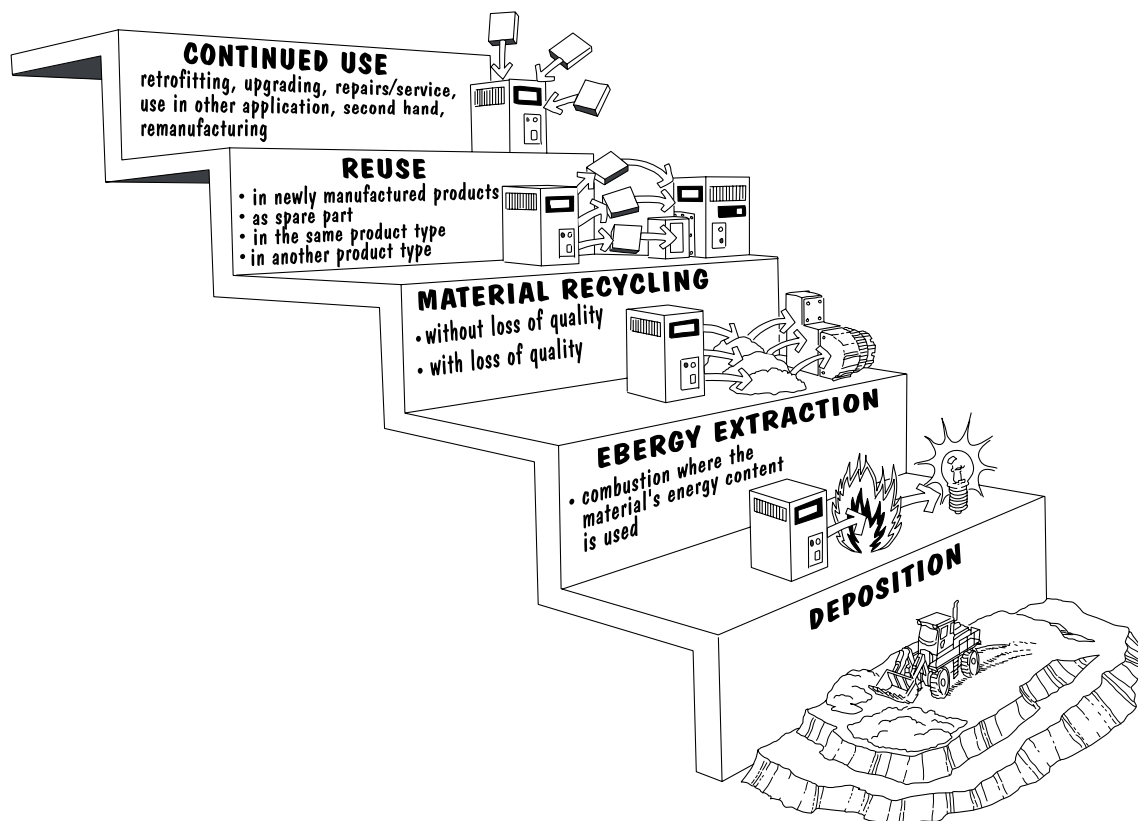

Recycling steps

Strive to get as much material as possible, as high as possible, on the steps.

Source: Thomas Magnusson IVF

Main work process when dismantling Volvo wheel loaders

This work process should be followed for dismantling work to proceed in an optimal way:

- 1 **Identify** the machine by reading signs and plates as well as the instructions in the manual.
- 2 **Check** governing regulations/legislation for recycling and producer responsibility. Also check if there are special safety aspects for dismantling.
- 3 **Decontaminate** the machine from fluids and specially marked components that have to be removed and sorted out for special handling.
- 4 **Dismantle** the machine in a safe and environmentally correct manner.
- 5 **Sort** the dismantled parts and components in fractions for recycling.

Sorting

Sorting

There is a number of thought fractions in which to sort the material, examples of these are found below. Handling of these fractions is governed by national legislation and local regulations, which shall be followed.

- Materials and components that can be reused as components in old and/or new machines. These may be in need of repairs or upgrades in order to meet quality requirements. For example, this may be engine, axles, transmission, and hydraulic cylinders.
- Materials that can be material-recycled with or without loss of quality. Examples of material recycling without loss of quality are metals and certain plastics. Loss of quality refers to, e.g., plastics that only can be given a dark colour when material-recycled.
- Materials for energy extraction are, among others, unsorted plastics and oils.
- Materials that have to be deposited mainly come from fragmentation and unsorted materials.

Producer responsibility

A number of the machine's components are governed by the principle of producer responsibility, which means that they shall be taken care of according to special instructions. These instructions may vary from one country to another. If you do not know what this includes or are unsure about applicable governing regulations, contact your Volvo dealer or Volvo directly.

Identifying

Identifying

Identifying the machines

This manual is only valid for the stated models; Volvo L60F, L70F, L90F, L110F, and L120F, see illustration below for identification marking. The machines have been manufactured in Sweden by Volvo Construction Equipment AB from the year 2007. The primary colour is yellow.

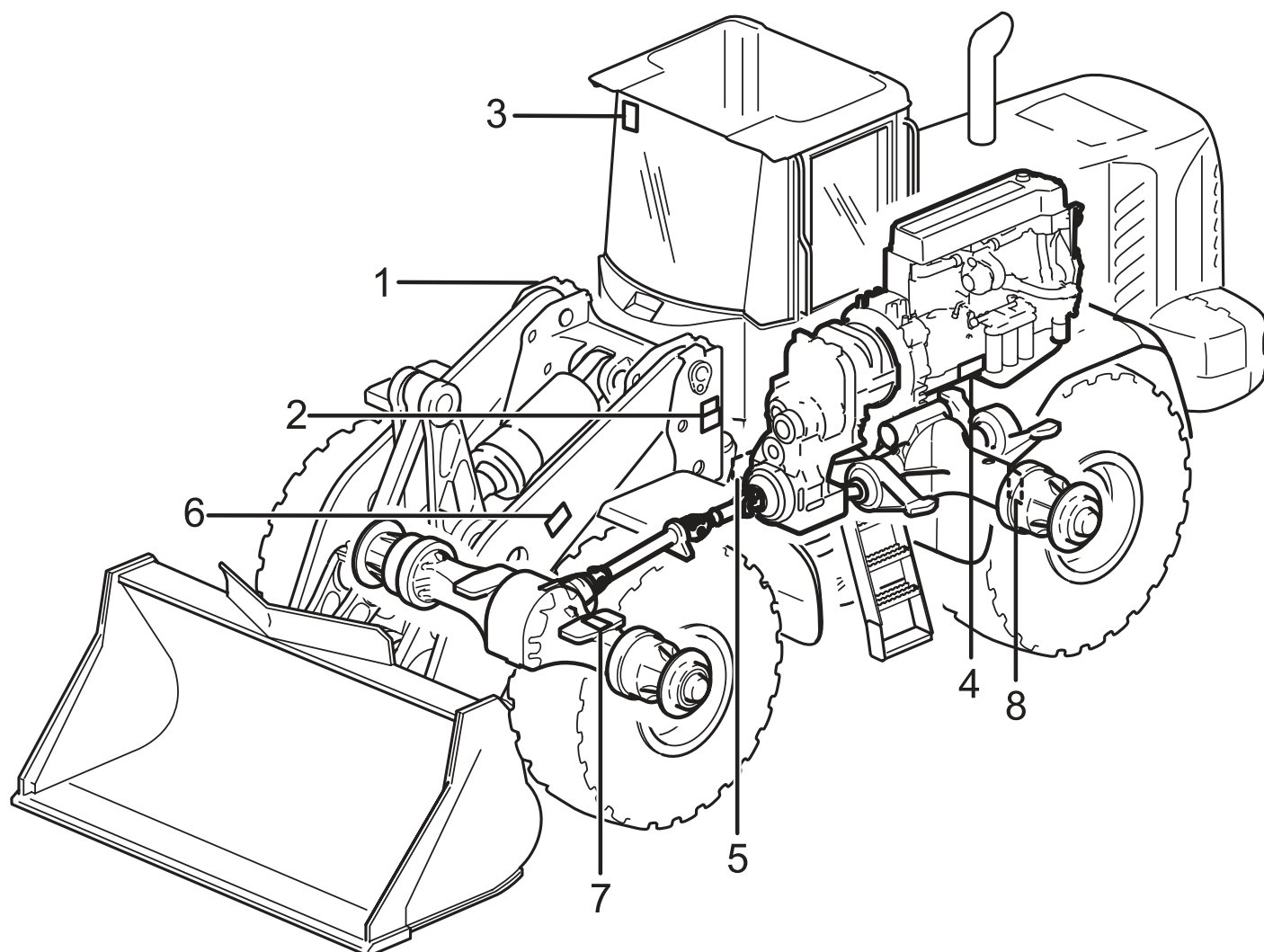

Identifying

- 1 Machine PIN, Product Identification Number (stamped on right side).
- 2 Product plate including, among other things, machine type and PIN. Additional plate with, among other things, CE-marking (only for country of origin within the EU), as well as an emission plate. A total of three plates.
- 3 Plate identifying that ROPS-test has been performed and approved.
- 4 CIN-plate (Component Identification Number) for engine.
- 5 CIN-plate for transmission
- 6 CIN-plate for boom
- 7 CIN-plate for front axle
- 8 CIN-plate for rear axle

Materials - Identifying

Marking - Standard

A marking system is used where all plastic parts are marked with a material code, making the materials easy to identify. Many materials can be granulated and reused, while other plastics are used for energy extraction by incineration. Certain plastics must be taken care of in a special way or destroyed, through some form of pre-treatment.

Volvo standards applicable to these machines are:

- Std 103-0002 Material identification and marking of components made of plastic or elastic material
- Std 5052,41 Material identification and marking of plastic parts
- Std 5052,411 Symbols and abbreviations
- Std 5052,412 Symbols for plastic containers

The following few examples show what the marking may look like:	
>ABS<	Part consisting of one material, in this case ABS-plastic.
>ABS+PC<	Part consisting of a mix of two materials.
>PVC,PUR,ABS<	Part consisting of 3 materials where PVD is the visible (coating) and PUR with inclusion of ABS. ABS is biggest by weight (underlined).
>PP - MD30<	Part containing reinforcing or filler material with 30 percent by weight.

continuation

For more complicated mixtures, see Std 103-0002.

Contact your Volvo dealer or Volvo directly to obtain these standards.

Decontamination

Draining fluids

Draining fluids

It is important that fluids are handled in a safe and correct manner, with regards to national legislation as well as local regulations. Follow instructions in the Service manual and Operator's manual for draining fluids in axles, tanks, and other containers and/or reservoirs.

The following table is intended to serve as a checklist.

Position	Total volume in litres				
	Machine type				
	L60F	L70F	L90F	L110F	L120F
Engine, including filters	20	20	20	21	21
Transmission and torque converter, including filters	20	20	21	38	38
Front axle, including hub reduction	24	35	35	36	36
Rear axle, including hub reduction	24	27	27	41	41
Hydraulic system	135	135	135	215	215
Hydraulic oil tank	90	90	90	133	133
Fuel tank	219	219	219	269	269
Cooling system	30	30	30	70	70
Oil bath pre-cleaner	5,5	5,5	5,5	9,1	9,1
Refrigerant (R134a)	2,1 kg	2,1 kg	2,1 kg	2,1 kg	2,1 kg
Washer fluid reservoir	5	5	5	5	5

Filter

Filter

There is a wide range of filters on the machine that, when dismantled, contain impurities and the medium which they filter. Note that there are special regulations for handling of filters.

Filter table. This table is intended to serve as a checklist.

Number	Position	Medium	Quantity	Comments
1	Transmission	Transmission oil	1	
2	Engine	Oil	3	
3	Engine	Coolant	1	
4	Hydraulic tank	Hydraulic fluid	1	
5	Rear axle	Oil	1	In comb. with axle oil cooling
6	Front axle	Oil	1	In comb. with axle oil cooling
7	Air cleaner	Air	2	Paper + filter
8	Cab	Air	2	Paper filter
9	Engine compartment	Diesel	2	
-	Breathing	Air / oil mist	5	Axles, transmission, hydraulic tank, and fuel tank

8 Components with special safety and environmental aspects

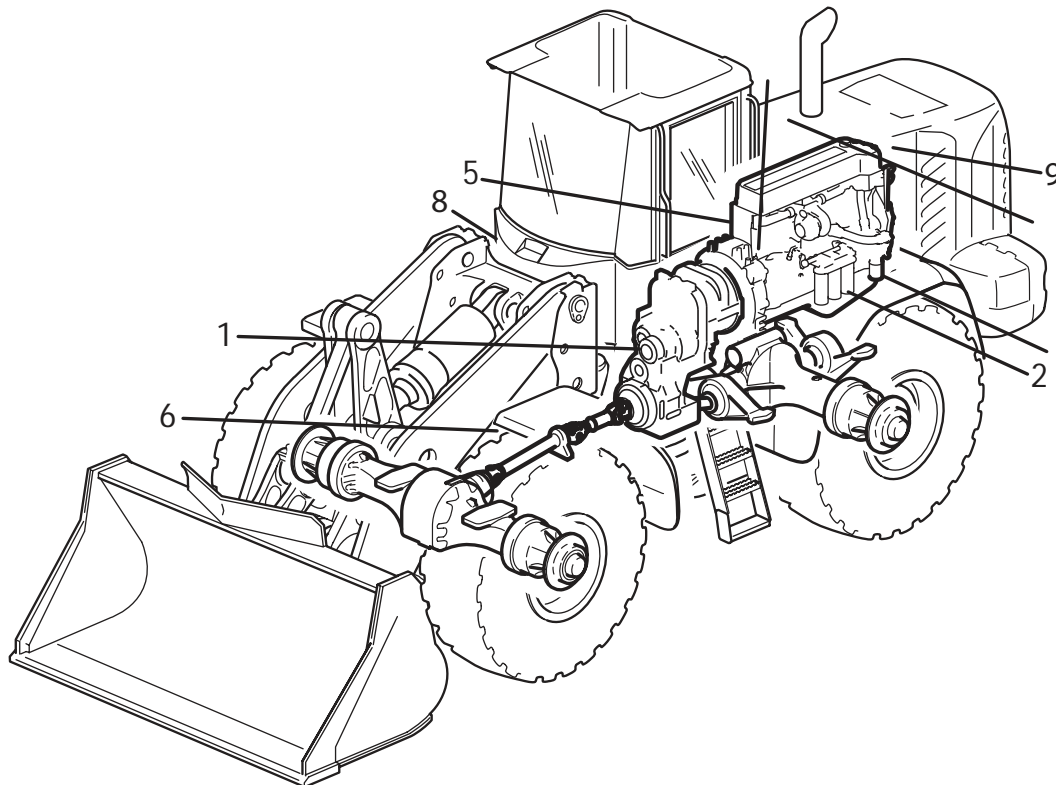

Components with special safety and environmental aspects

Components with special safety and environmental aspects

The following components shall be handled with the extreme care and highest safety. For handling, see Service manual and Operator's manual.

Number	Component	Aspect
1	Battery	Sulphuric acid
2	Accumulators for Boom Suspension System	Pressurized container
3	Accumulators for lowering load	Pressurized container
4	Accumulators for steering	Pressurized container
5	Accumulators for service brake	Pressurized container
6	Accumulators for P-brake	Pressurized container
7	Air conditioning unit	Refrigerant*
-	Gaskets of fluor rubber/fluor silicone (used to withstand high temperatures in, e.g., engines, transmissions, axles, hydraulic motors, and pumps)	Generate hydrogen fluoride and hydrofluoric acid when exposed to intense heat (fire). **

* Note that special regulations apply when working with refrigerant.

** Be extremely careful where you suspect presence of fluor rubber.

See Service manual and Operator's manual for more information.

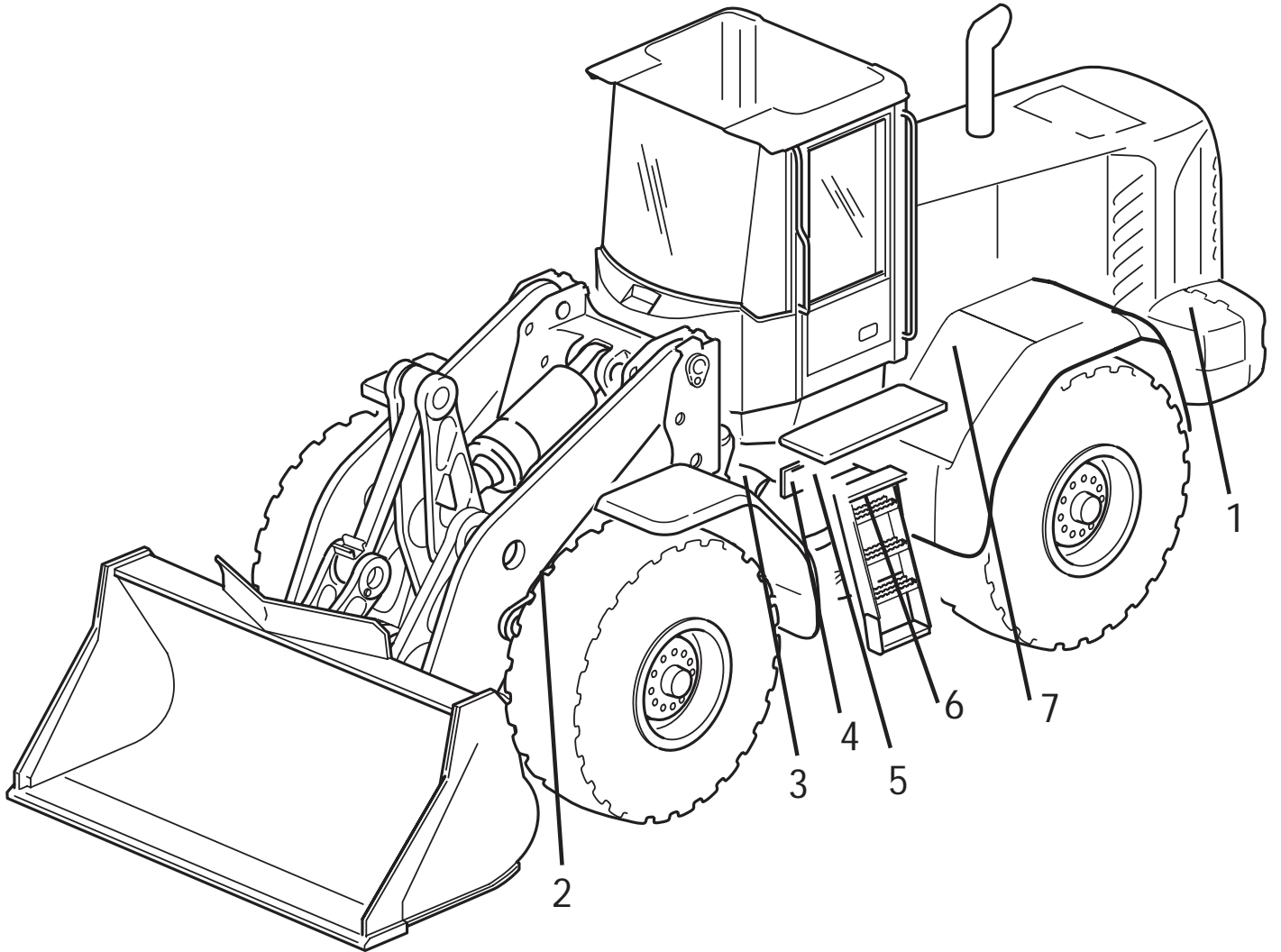

Dismantling

Material weights, complete machine

Material weights, complete machine

The following weights are approximate. They do not apply to machines with optional equipment.

Volvo's wheel loaders consist of metals to approx. 80%. In general, metals are suitable for material recycling.

Material	Weight in kg Machine type				
	L60F	L70F	L90F	L110F	L120F
Steel/iron	9350	10830	12830	14830	15770
Copper	43	43	43	43	43
Aluminium	38	38	38	86	86
Bronze bushings	18	18	27	32	33
Lead batteries	60	60	60	81	81
Glass	74	74	74	74	74
Polymer materials & rubber	140	140	140	160	160
Tires	880	880	880	1290	1520
Fluids, oils, and chemicals	410	420	430	620	620
Other	440	620	1010	810	820
Total*	11450	13120	15080	18030	19210
* Varies depending on equipment, e.g., tires and bucket.					

Components

Number	Component	Weight in kg				
		L60F	L70F	L90F	L110F	L120F
1	Transmission	473	473	478	830	830
2	Counterweight	730	1397	2369	1880	2780
3	Engine	565	565	565	685	685
4	Boom	713	930	990	1220	1250
5	Front axle, complete	602	911	911	1080	1080
6	Rear axle, complete	608	688	688	1270	1270
7	Front frame	885	988	1150	1475	1475
8	Rear frame	932	963	1102	1135	1135
9	Radiator for engine	72	72	72	737	737
10	Cab, complete	724	724	724	81	81
	• Steel	503	503	503	516	516
	• Plastics	81	81	81	81	81
	• Glass	74	74	74	74	74
	• Seat	36	36	36	36	36

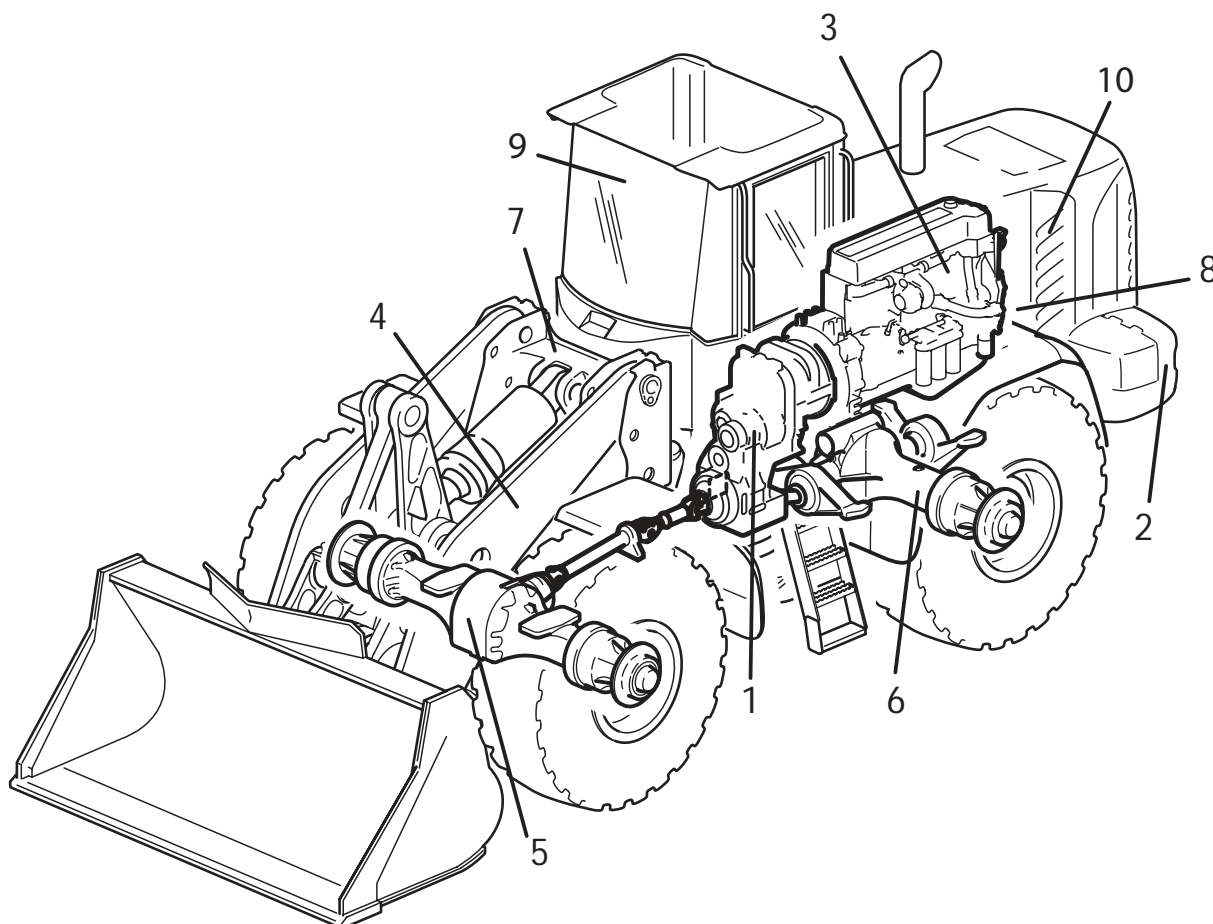

Electronics

Electronics

The machines have 4-6 so-called ECUs (Electronic Control Unit), and the number of ECUs depends on what equipment is installed on the machine. One is on the engine, one or two on the back wall in the cab, one in the instrument panel, and one or two on the right side in the cab. In the cab there are also two circuit boards, containing a number of relays and fuses. One circuit board is located on the back wall and the other one is on the right front pillar.

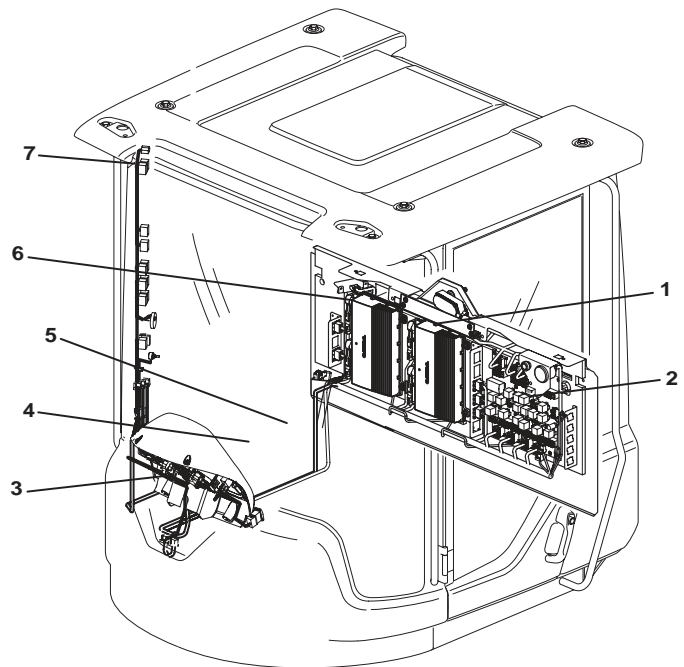

Position	Part	Material	Note
1	V-ECU	Circuit board + metal	
2	Circuit board	Circuit board	
3	I-ECU	Circuit board + plastic	Instrument panel
4	ECC	Circuit board + plastic	Climate control unit (AC)
5	W-ECU	Circuit board + plastic	CareTrack
6	V2-ECU	Circuit board + metal	CDC + electric servo
7	Circuit board	Circuit board	Control panel

Plastics

Plastics

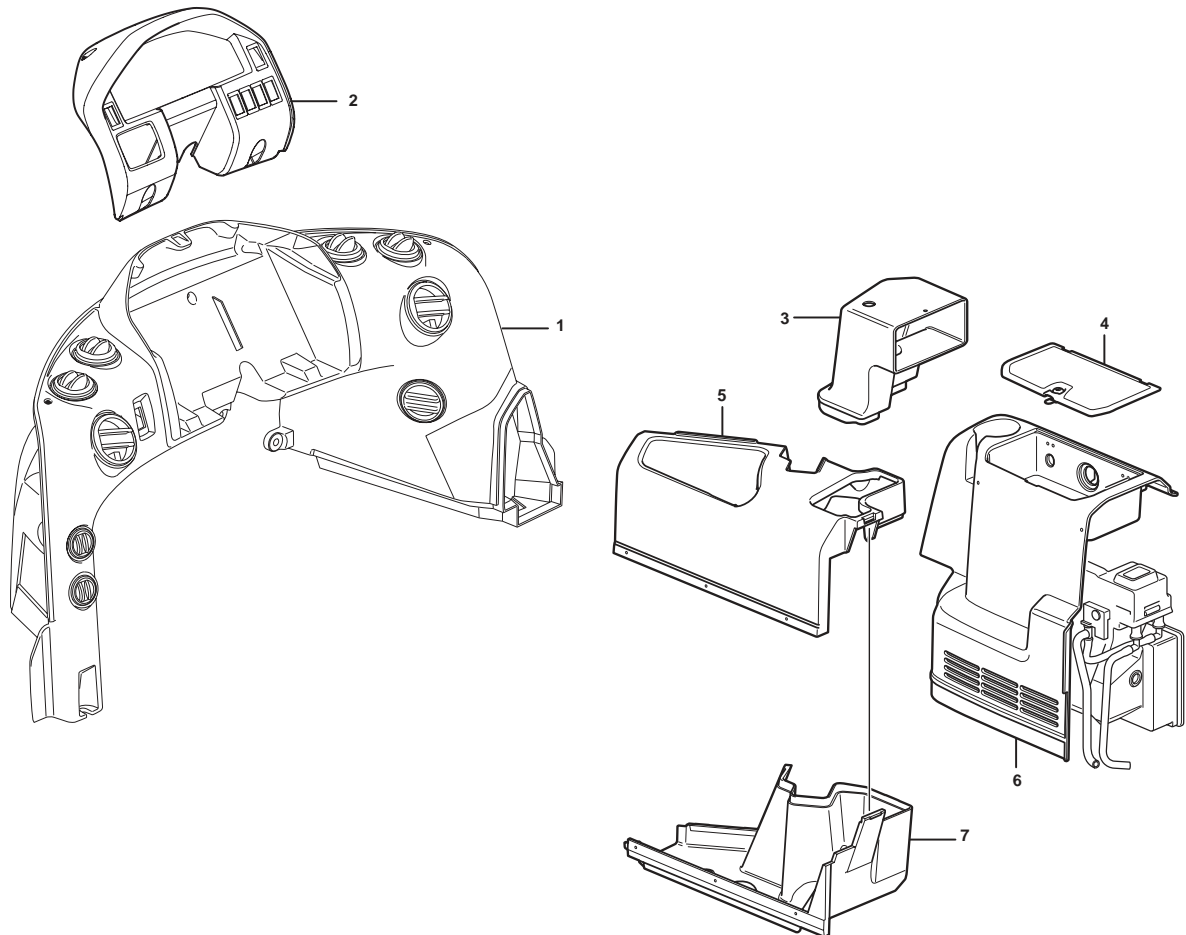

Number	Part	Material	Note
1	Air ducts	PP+elastic+mineral	
2	Instrument panel	PP+elastic+mineral	
3	Air duct	ABS	
4	Cover	PP	
5	Side panel	PP	
6	Air duct	PP+elastic+mineral	
7	Bottom part	PP+elastic+mineral	

Plastics

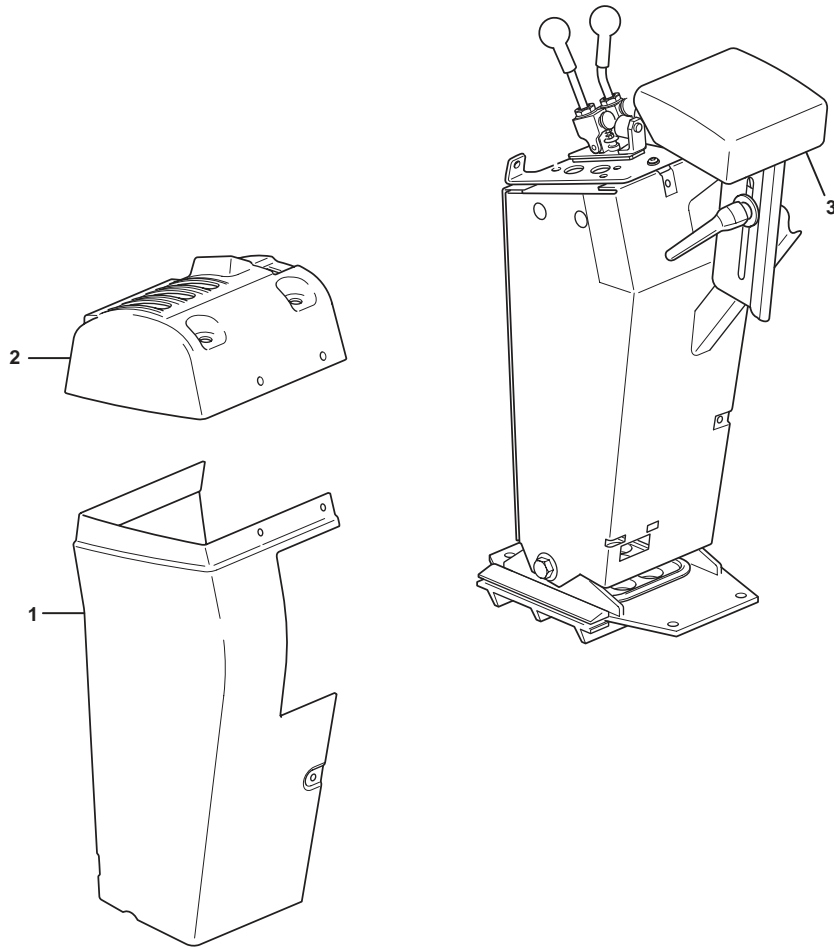

Number	Part	Material	Note
1	Casing	ABS	
2	Casing	PC+ABS	
3	Wrist support	PUR	

Plastics

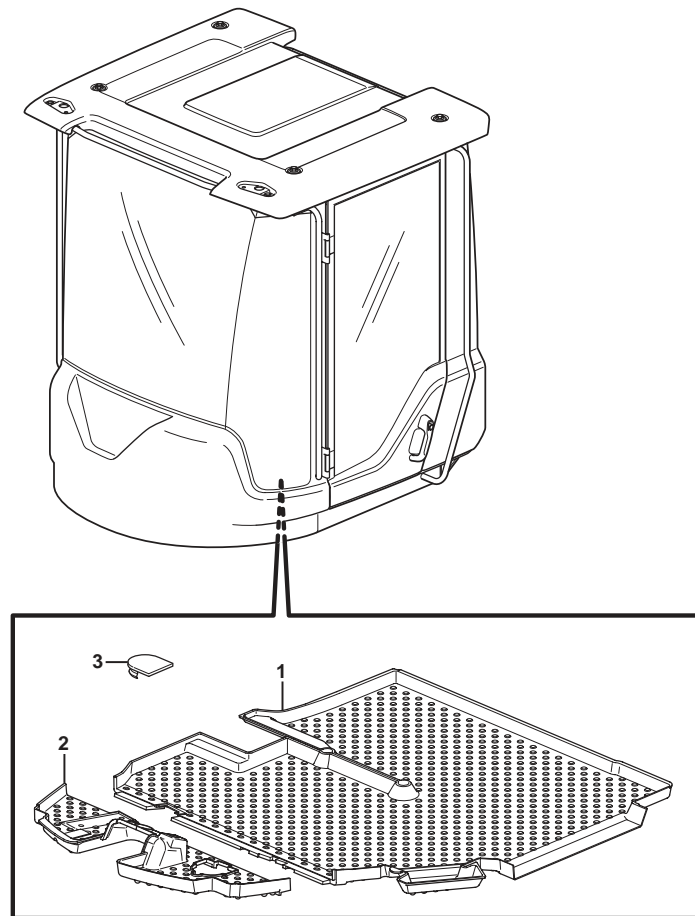

Volvo Construction
 Equipment
 1032102

Number	Part	Material	Note
1	Floor mat	PUR	
2	Floor mat	PUR	
3	Exterior roof	ABS + PMMA foil	

Plastics

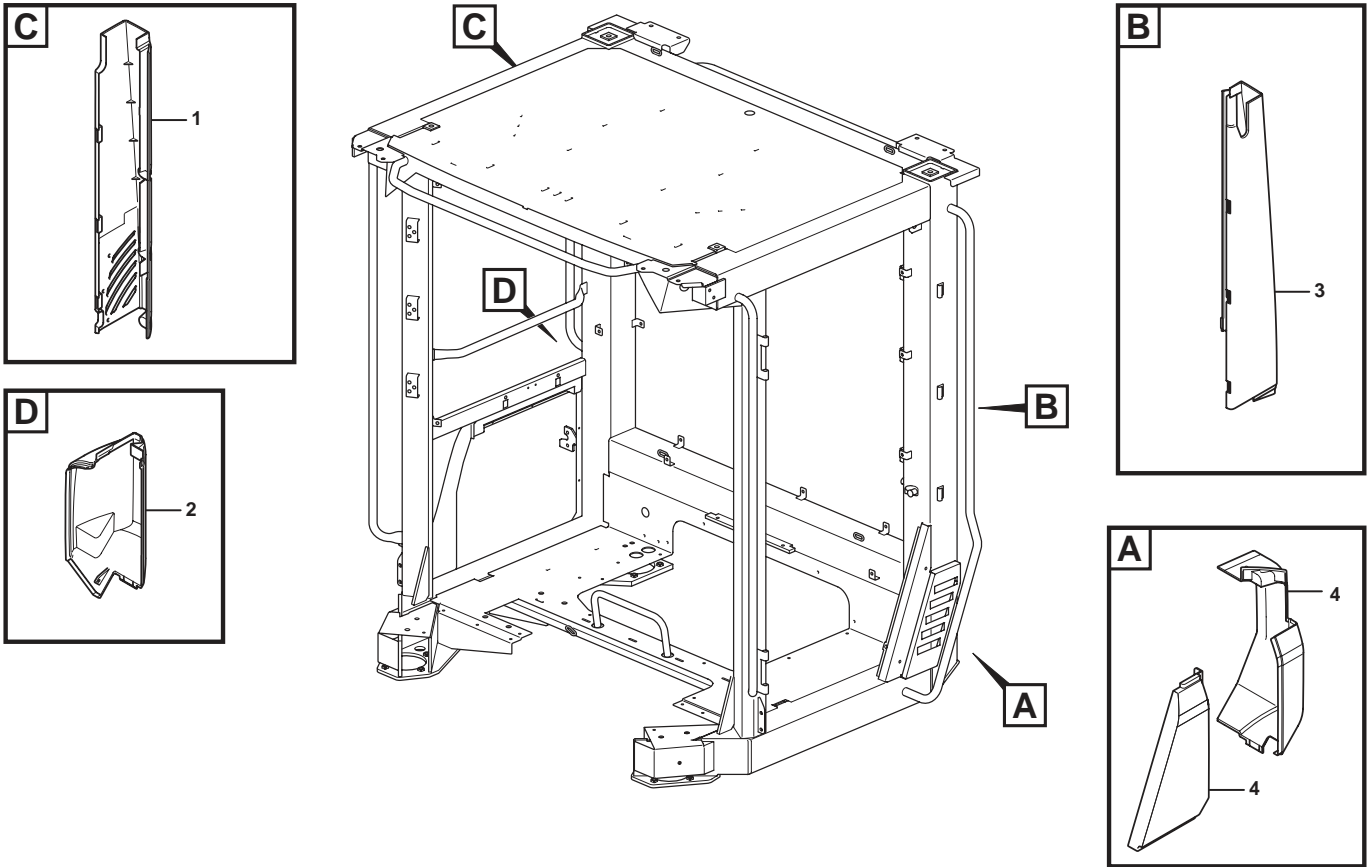

Number	Part	Material	Note
1	Exterior panel right	PP+elastic+mineral	
2	Cover right	PP+elastic+mineral	
3	Exterior panel left	PP+elastic+mineral	
4	Cover left	PP+elastic+mineral	2 parts

Plastics

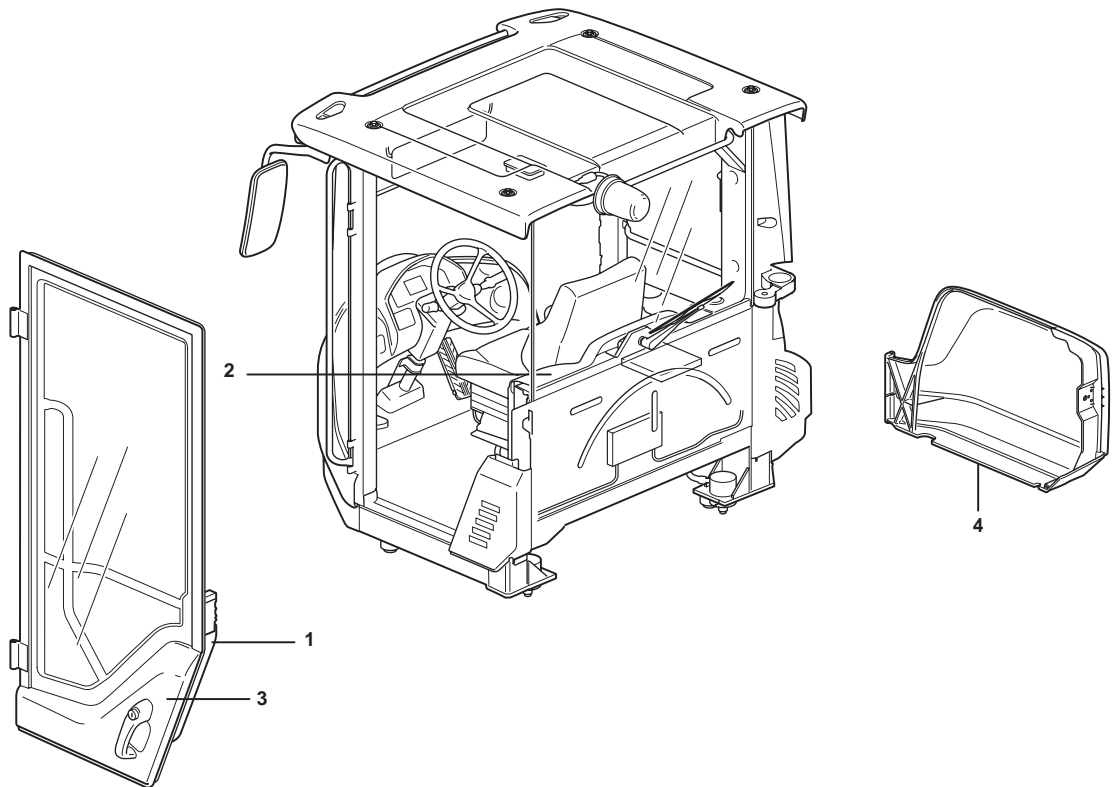

Number	Part	Material	Note
1	Panel inside door	ABS	
2	Panel inside rear	ABS	
3	Climate cover	PP+elastic+mineral	
4	Climate cover	PP+elastic+mineral	

Plastics

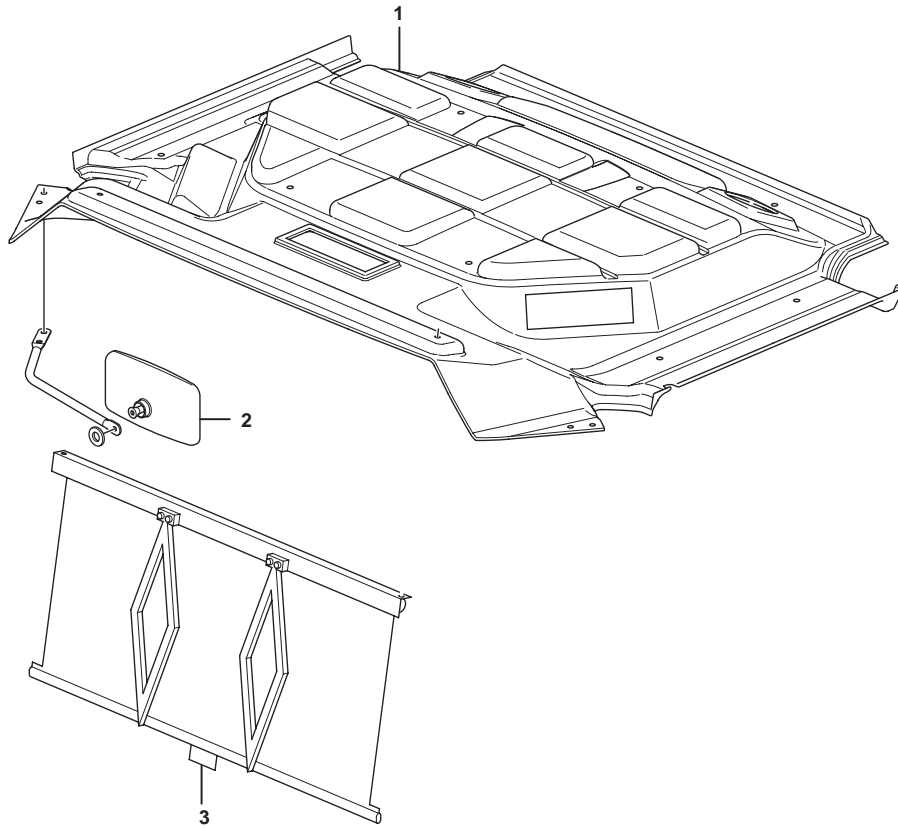

Number	Part	Material	Note
1	Ceiling (headlining)	Polyester	
2	Rearview mirror inside	ABS	2 pcs.
3	Sun visor	VELBEX	Contains PVC

Plastics

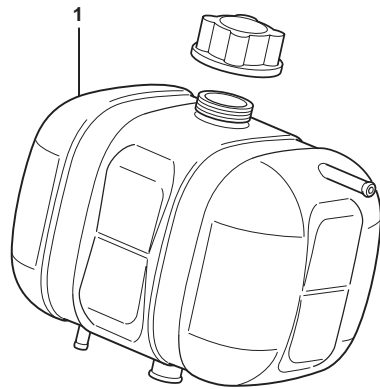

Number	Part	Material	Note
1	Expansion tank	PP	

Plastics

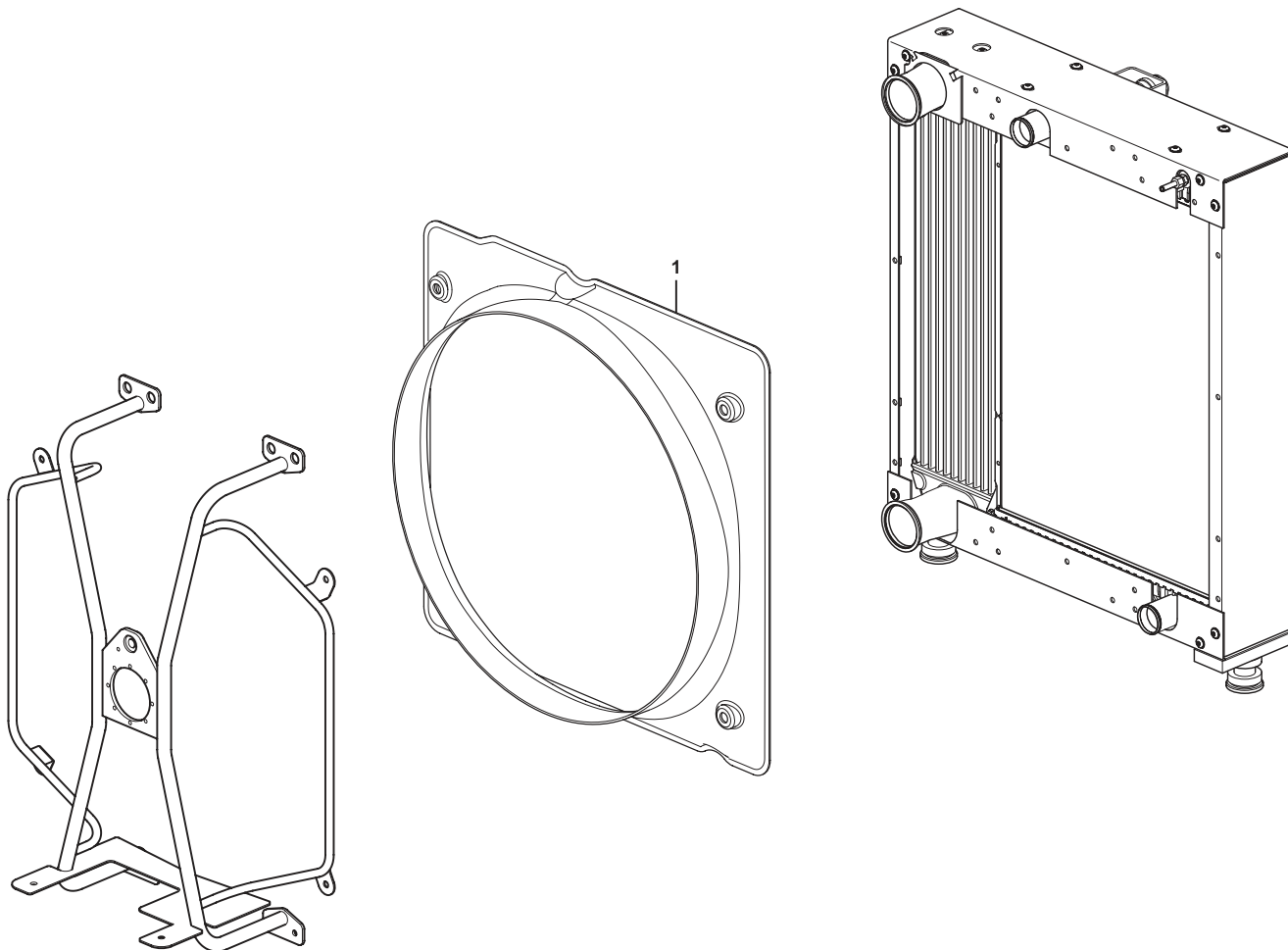

Number	Part	Material	Note
1	Fan shroud	PDCPD	

Plastics

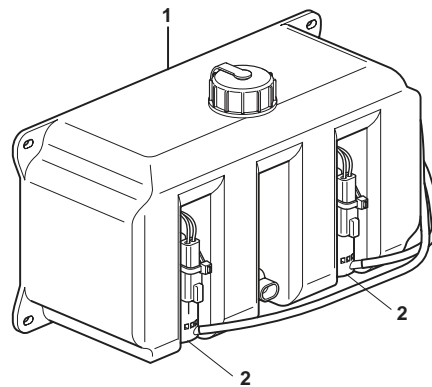

Number	Part	Material	Note
1	Washer fluid reservoir	PP	Motors (2) can easily be removed.

Plastics

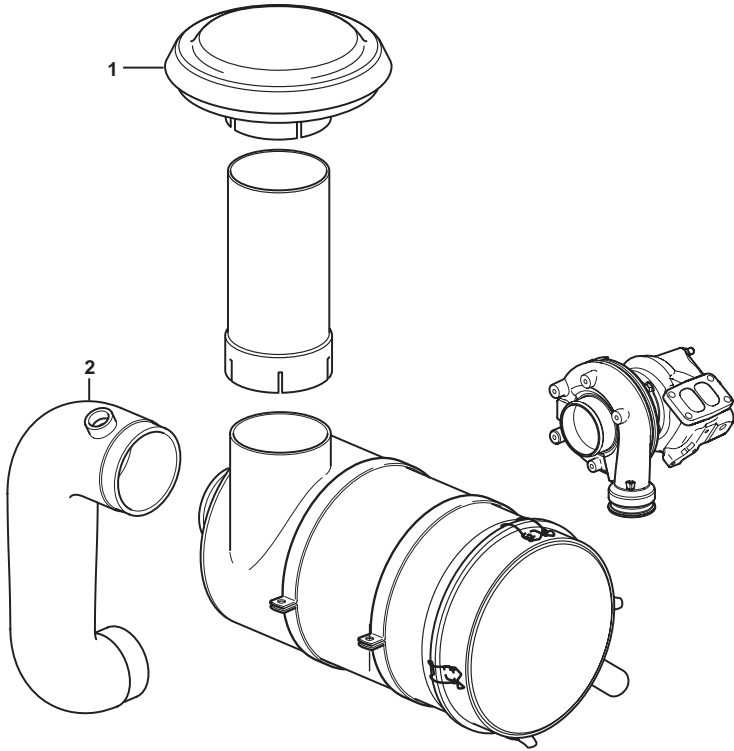

Number	Part	Material	Note
1	Cover for air cleaner	PP	
2	Hose for air cleaner	EPDM	

Plastics

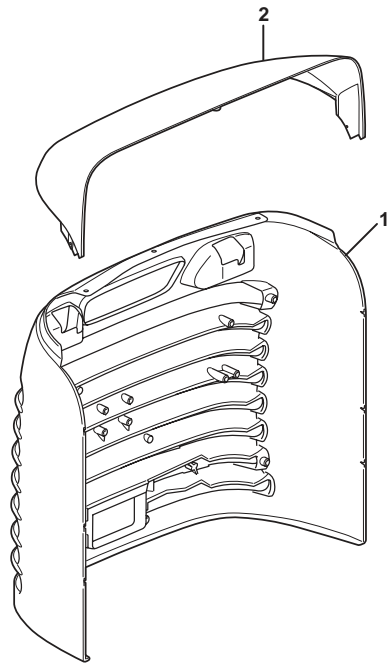

Number	Part	Material	Note
1	Grill	PDCPD	Embedded steel bushings
2	Top part	PDCPD	

Plastics

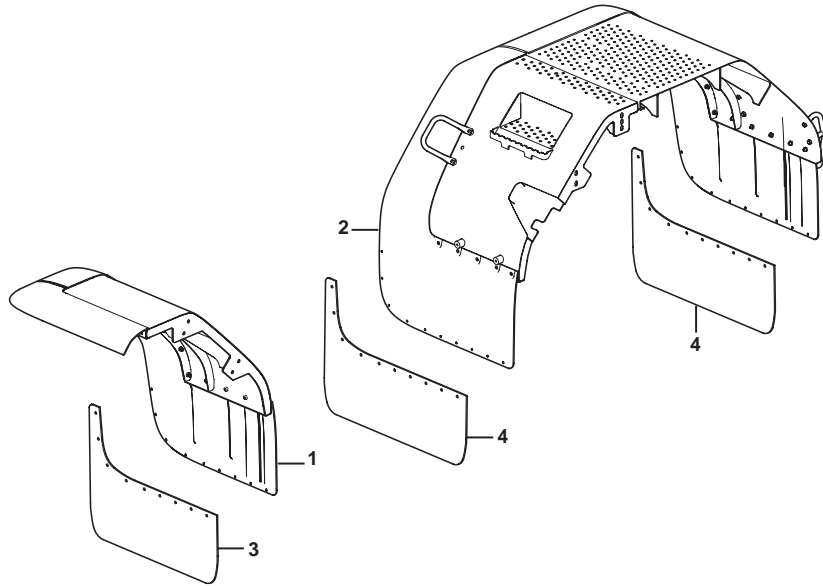

Number	Part	Material	Note
1	Fender widener, front	PP	
2	Fender widener, rear	PP	
3	Splash guard, front	Reinforced rubber cloth	
4	Splash guard, rear	Reinforced rubber cloth	2 pcs.

Plastics

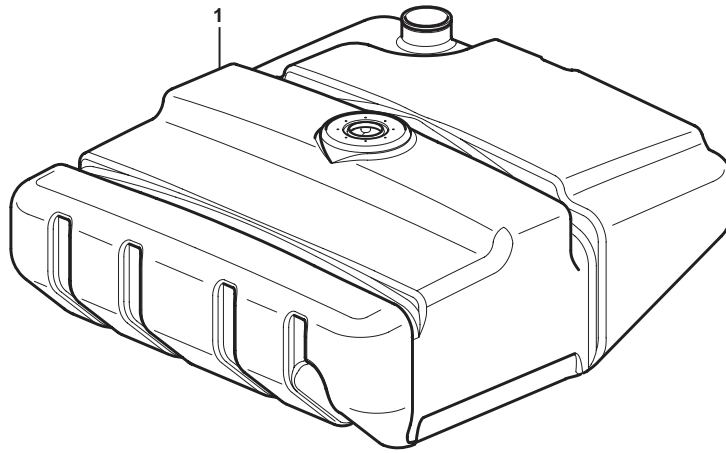

Number	Part	Material	Note
1	Fuel tank	HDPE	

Plastics

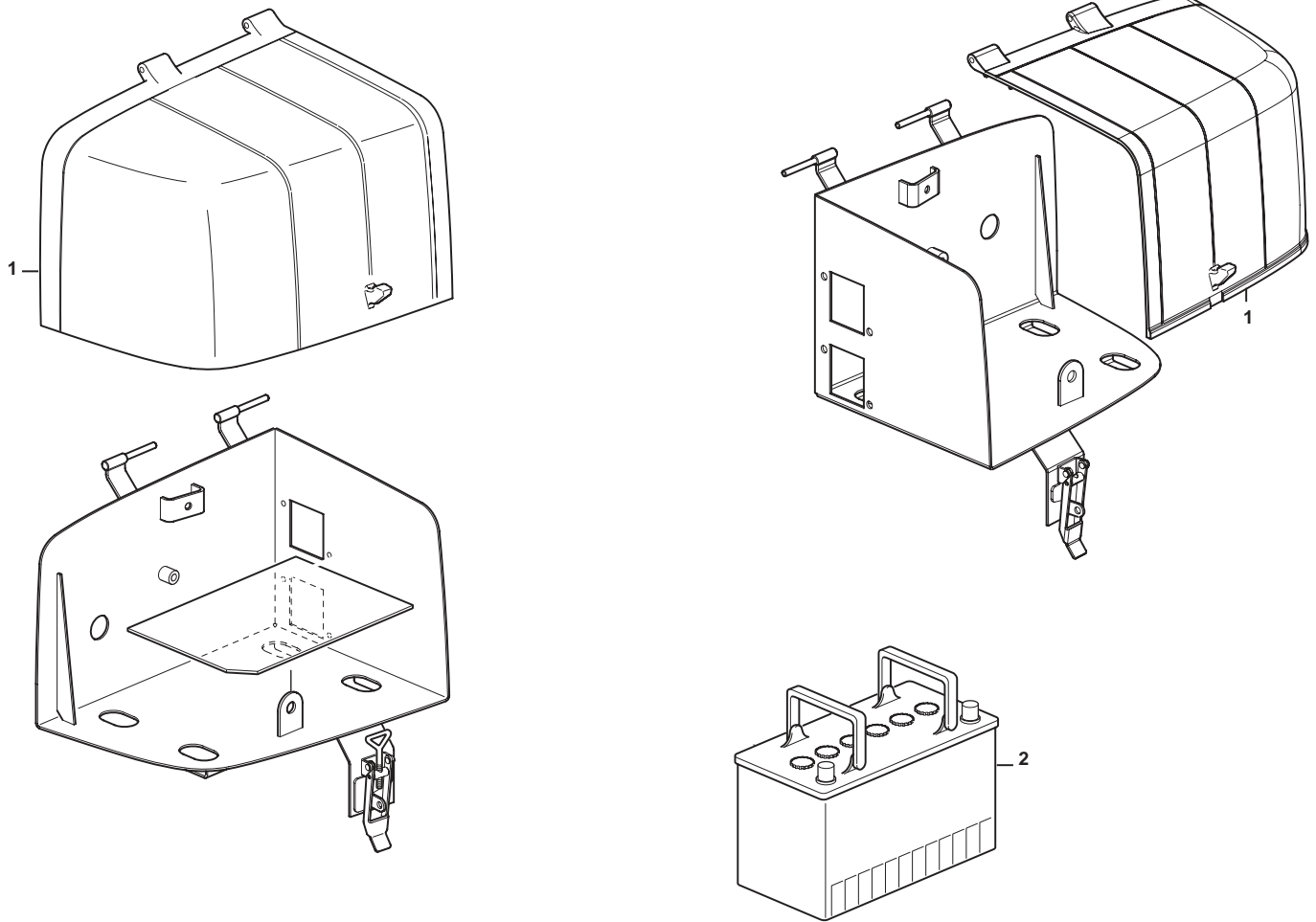

Number	Part	Material	Note
1	Cover for battery box	PP	2 pcs., one on each side
2	Battery		Contains sulphuric acid, special handling required

VOLVO

Construction Equipment

Web Version

Volvo, Eskilstuna

English
WLO