

Zetor

UTILIX CL

OPERATOR'S MANUAL

01/2021



45

55



Tractor is Zetor. Since 1946.

ZETOR



This Operator's Manual for the Zetor tractors, which we are presenting to you will help you to become familiar with the operation and maintenance of your new tractor.

Although many of you have rich experience with the operation of other tractors, please, read the information contained in this Operator's Manual very carefully.

In the Manual you will find a lot of new information and get a perfect overview of how to use the tractor with maximum efficiency during various kinds of work.

If you observe the rules of tractor operation and maintenance and driving safety, your new tractor will become your reliable and long-term friend.

The manufacturer of the tractor wishes you thousands of hours of satisfactory work.

ZETOR
Brno

The technical specifications and information about the design, equipment, material and appearance are valid at the time of print. The manufacturer reserves the right to implement changes.

Printing errors reserved

The instructions for use are a part of the machine.

CONTENTS

Location of serial numbers	7
Location of serial numbers	7
Tractor identification plate	7
Product Warranty.....	7
About this manual	9
Introduction & description	11
Instructions and Description	11
Description.....	12
Rops (roll over protection structures)	13
Roll-Over Protection Structure (ROPS).....	13
ROPS damage	14
Sliding Seat.....	15
Seat Back Reclining	16
Seat Suspension Adjustment	16
Safety instructions, Do's & Don'ts	17
Introduction to safety information	17
Signal words	17
Introduction to safety instructions Introduction to safety instructions.....	17
Protection children.....	17
Use of rops and seat belt	18
Precaution to avoid tipping	18
Safe parking of the tractor	18
Keep riders off tractor	18
Handle fuel safely-avoid fires	19
Stay clear of rotating shafts.....	19
Always use safety lights and devices	19
Practice safe maintenance	20
Avoid high-pressure fluids	20
Prevent battery explosions	20
Prevent acid burns.....	21
Battery disconnect	21
Service tractor safely	21
Work in ventilated area.....	22
Tractor runaway.....	22
Safety starter switch	22
Emergency exits	22
Safety precautions when using the loader	23
Towing safely.....	25
Falling Object Protective Structure (FOPS).....	25
Operator Protective Structure (OPS).....	25
Use of Hazardous Substances	25
Safe operation of your tractor	26
Safety Tips During Maintenance	26
Mounting and demounting implements	27
The following precautions are suggested to help prevent accidents	28
Diesel fuel.....	30
Do's and don'ts	31
Do's-for better performance.....	31
Don'ts - for safe operation	32
General informations	33
General safety information	33
Decals mounting location	33
Universal symbols	37
Tractor controls	39
Instruments and Switches	39
Key Switch.....	39
Combined Switch.....	40
Warning Lights Switch	40
Tachometer.....	40
Hour Meter	41
Fuel Gauge	41
Engine Coolant Temperature	41
Warning Indicator Lights.....	42

CONTENTS

Regeneration operation and cautions	43
Lamps related to exhaust gas control system	43
DPF Regeneration Switch	44
PTO Control Switches	45
Operation of Tractor Controls	47
Throttle Lever (Manual Control)	48
Accelerator pedal.....	48
Clutch pedal.....	48
Clutch cut-off arm	49
Brake Pedals	49
Parking Brake Lever	50
Air brakes of trailers and semi-trailers	50
Air pressure indication	50
The button for temporary deactivation of brakes of the trailer or semi-trailer	51
One-hose and two-hose brakes	52
One-hose brakes	52
Two-hose brakes	52
Reverse Shift Lever	53
Reduced and Road Gears Shift Lever	54
Gear shifting scheme.....	54
Differential Lock Pedal.....	55
Front Axle Drive Shift Lever (4WD)	55
Driver's Seat	56
Steering Wheel Adjustment Lever	56
PTO Shift Lever	57
Operating the hydraulics.....	57
Position control	58
Draft control	58
Three-Point Hitch Lowering Speed Control.....	59
Outer hydraulic circuit.....	59
Outer hydraulic circuit controls	60
Remote hydraulic control valve coupler connecting and disconnecting.....	60
Connection.....	60
Disconnection	60
Joystick Lever	61
Joystick lever lock.....	62
Connecting and Disconnecting Implement.....	62
Connection.....	62
Disconnection	62
Mounting Implement	63
Three-Point Hitch Control	64
Upper Link Adjustment	65
Retraction of the lower link (if it is the extendable type).....	66
Adjustment of the lift link on the lower link	66
Towing Equipment.....	67
Connection and disconnection of implements.....	67
Lower Hitch Disassembly	68
Multi-level hitch	68
Disassembly of the rear PTO cover	68
Height Adjustment and Disassembly of the Multi-level Hitch Attachment Tail Piece.....	69
*Front Three-point Hitch	69
Lifting force of the front three-point hitch	69
Controlling front three-point hitch	70
Hydraulic lock of the front three-point hitch	70
Working and transport position of the front three-point hitch	71
Driving with agricultural machines attached to the front three-point hitch.....	71
Trailer socket (seven terminal electrical socket type)	71
Front Fenders	71
Fixtion points of loader	71
Driving operation	73
Starting the Engine	73
Stopping the Engine	73
Engine Warm-up.....	73

CONTENTS

Engine Warm-up in Cold Weather.....	74
Warming Up Time.....	74
Engine Running-in Time.....	74
Driving the Tractor Off.....	74
Turning in the Field.....	75
Stopping and Parking.....	75
Drive Off on Steep Slope.....	75
Driving downhill.....	76
Driving to / from the Field.....	76
Operation of the diff lock.....	76
Warning for Driving on the Road.....	76
Operating Tips for Power Steering.....	76
Check During Driving.....	77
Oil Pressure Light.....	77
Battery Charging.....	77
Coolant.....	77
Fuel gauge.....	78
Maintenance.....	79
Check and service.....	79
Pre-start checks.....	79
Service inspections.....	79
Maintenance and adjustment schedule.....	80
Periodical check and service table.....	80
Tractor greasing plan.....	82
Fuels, coolants and lubricants used - amounts.....	83
Recommended ZETOR service fillings.....	83
Hood Opening.....	84
Opening the side cover.....	84
Check and Change of Coolant.....	85
Check of Coolant.....	85
Change of Coolant.....	85
Antifreeze.....	86
Check of Radiators for Clogging.....	86
Engine Oil and Filter Replacement.....	86
Engine Oil Check.....	86
Engine Oil Change.....	87
Engine Oil Filter Replacement.....	87
Transmission Oil and Filter Check and Replacement.....	88
Transmission Oil Check.....	88
Transmission Oil Change.....	88
Transmission Filter Maintenance.....	89
Front Axle Oil Check and Change.....	89
Check.....	89
Change.....	90
Fuel System.....	91
Cleaning/Replacement of the Fuel Filter Element.....	91
Fuel System Bleeding.....	92
Air Filter Check and Maintenance.....	92
Greasing the Tractor.....	93
Safety instructions for lubrication of the tractor.....	93
Controls Play Setting.....	94
Clutch Pedal Check and Adjustment.....	94
Brake Pedal Check and Adjustment.....	95
Adjusting the throttle lever.....	95
Adjusting toe-in.....	95
Alternator and fan belts inspect/adjust/replace.....	96
V-belt Check and Adjustment.....	96
Air conditioner compressor belt adjustment.....	96
Electric System Check.....	97
Alternator inspect.....	97
Battery Check and Charging.....	97
Battery Charging.....	97
Start with the Other Vehicle.....	98

CONTENTS

Battery Disconnecter	98
Removal of the knob	99
Refitting the knob	99
Electric Lines Check	99
Fuses Check and Replacement	100
Fuse Panel	101
Hoses and Connections Check	102
Tire Pressure	102
Tire inflation	102
Wheel Tread Setting	103
Service Prior to Daily and Short Terms Storage	104
For Daily or Short Term Storage	104
Long-term Shutdown	104
Re-use After Long Term Storage	104
Cabin system	105
Instruments and related parts	106
Doors	106
Rear Window	106
Side window	106
Work lights (front and rear)	107
Rearview Mirrors	107
Cab Ceiling	108
How to Control Cabin	108
Interior devices	108
Ventilation	108
Re-circulation inlets fully closed	108
Switch panel on the right pillar	108
Wiper control switch	109
Windscreen washer tank	109
Interior lamp	109
Blower control switch	110
Temperature control	110
Air conditioner switch	110
Circulation diffuser	110
Heating system	111
Compressor belt adjustment	111
Heating system configuration	111
Air conditioning system	112
Roof hatch (if equipped)	112
Cab air intake filter	112
Radio, CD player (if equipped)	113
Ash tray	113
Cigarette lighter	113
Air conditioning system troubleshooting	114
Troubleshooting	119
Engine Troubleshooting	119
Clutch, Brake and Hydraulic System Troubleshooting	120
Steering Wheel and Electric Instruments Troubleshooting	121
Towing the Tractor	122
Towing with the Engine Running	123
Towing with the Engine Off	123
Specification	125
Main technical parameters	125
Travel speeds	127
Noise levels	128
Vibration Referred to the Operator Position	129
Index	131

LOCATION OF SERIAL NUMBERS

Location of serial numbers

The engine number is stamped on the left side of the engine (1).

The chassis number (VIN) is stamped on the right side of the front axle console (2).

The tractor identification plate is located on the right side of the front axle console (3).

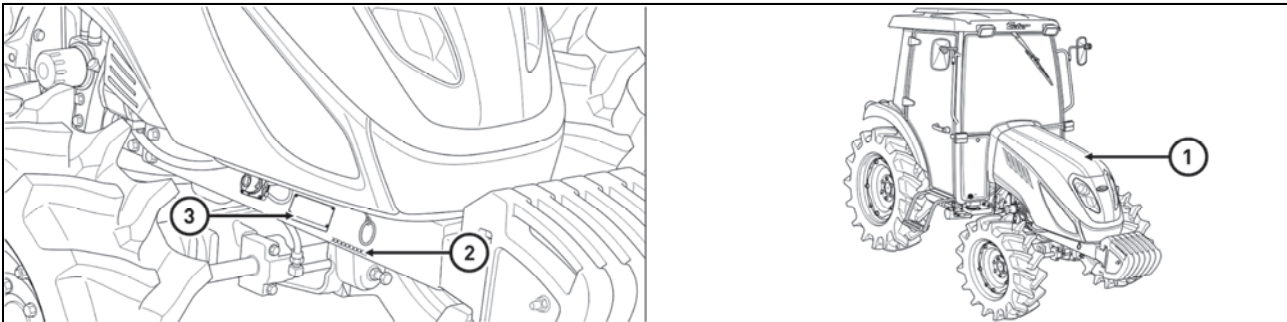

UCL18N023

Tractor identification plate

1 - Tractor VIN

2 - Table of weights and maximum permissible weights

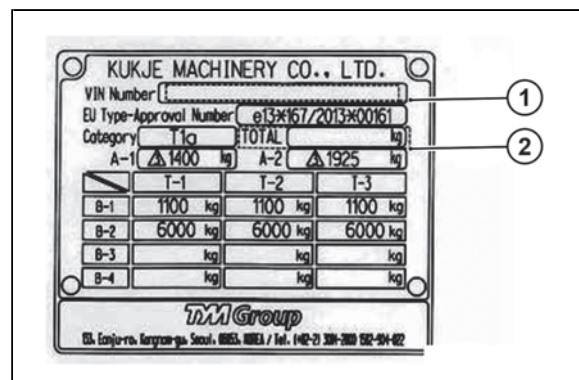

UCL18N041

Product Warranty

The manufacturer provides the warranty for this product. The warranty terms are set out in a separate document.

After-Sales Service

The objective of ZETOR TRACTORS a.s. company is complete customer satisfaction with the purchased product.

Any problems with your machine will be solved by your dealer / distributor service department.

Service

Service is available from any ZETOR TRACTORS a.s. dealer in the relevant area.

Spare Parts

To obtain spare parts, contact your nearest dealer and provide the following information:

- Tractor model
- Tractor serial number
- Tractor engine number
- Part number and description
- Quantity required

NOTES

ABOUT THIS MANUAL

This manual has been prepared to assist you in following / adopting the correct procedure for running-in operation and maintenance of your new ZETOR Tractor.

Your tractor has been designed and built to provide maximum performance, low fuel consumption and ease of use. To maintain the condition and ensure trouble-free performance, it is important that maintenance is performed at the recommended intervals as described in this manual.

Read this Manual carefully and keep it in a convenient place for future reference.

If at any time you require advice concerning your Tractor, do not hesitate to contact your Authorized ZETOR dealer / Distributor. He has trained personnel, genuine parts and necessary equipments to undertake all your service requirements.

All data given in this book is subject to production variations. Dimensions & weight are approximate only and the illustrations do not necessarily show Tractors in standard condition.

For exact information about any particular Tractor, please consult your ZETOR dealer / Distributor.

NOTES

INTRODUCTION & DESCRIPTION

Instructions and Description

The word 'tractor' is derived from 'traction', which means towing.

The tractor is required to tow or draw working equipment, an implement or a trailer that is attached to the body of the tractor by means of a suitable hitch.

The tractor can also be used as a drivetrain, thanks to a power output called a PTO or a PTO shaft.

This operating manual is prepared in accordance with the operating, maintenance and storage instructions for the relevant Zetor tractor model.

The manual has been designed to help you better understand the maintenance and efficient operation of this machine.

If you require any information not provided in this manual or require service from a trained mechanic, contact your local ZETOR TRACTORS a.s. dealer/distributor.

Dealers/distributors are kept informed about the latest service procedures for tractors. They have original spare parts in stock and have full service support from the machine manufacturer.

In this manual, the use of the terms LEFT, RIGHT, FRONT and REAR must be unified to avoid any confusion when following these instructions.

LEFT and RIGHT means the left and right sides of the tractor when looking from the driver's seat towards the front. The reference to FRONT means the end of the tractor radiator, while REAR means the end of the drawbar (see the picture).

When ordering spare parts, always specify the tractor and engine serial numbers when ordering.

This will make their delivery easier and faster and ensure that you receive the right spare parts for your particular tractor.

The tractor's serial number is stamped on a plate attached to the right side of the tractor (see the picture).

For easy reference, we recommend you to write this number in the space reserved for the owner's personal data.

- 1 - Turning Right (Clockwise)
- 2 - Right
- 3 - Front
- 4 - Left
- 5 - Rear
- 6 - Turning Left (Anticlockwise)

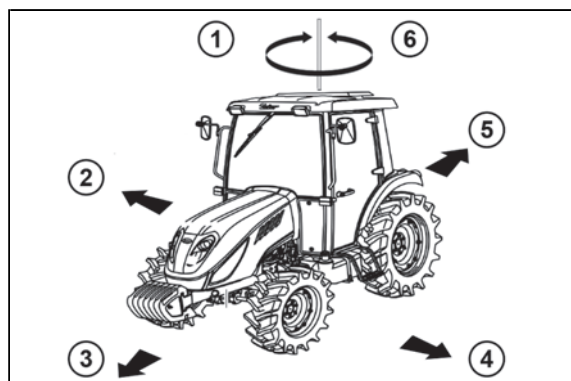

UCL18N002

(front, rear, left and right)

INTRODUCTION & DESCRIPTION

Description

Overall Design

The transmission case, clutch, clutch housing, engine and front axle support are bolted together to form a rigid unit.

Front Axle and Wheels

The front axle is a 4WD, center pivot type.

The front wheel drive mechanism is incorporated as a part of the axle. The front wheel drive power is taken from the rear-mounted transmission and transmitted to the front axle differential, where it is divided into right and left half axles and to the final drives.

In the final drives, the transmitted speed is reduced by the axle gears for front wheel drive.

This 4WD mechanism with axle gears allows a wider range of steering and longer service life of the mechanism.

Engine

The tractors are fitted with vertical, Water-cooled 4-cycle.

Clutch and transmission

A single plate dry clutch (10.24' diameter) is used on these tractors. Tractor with PTO (Power Take Off) are fitted with hydraulic clutch assy the transmission gear box has 16 forward & 16 revers specs of presently. Zetor tractors are fitted with partial synchro mesh type gears.

Brakes

Zetor tractors are equipped with disc brakes controlled by a foot pedal. There is a parking brake lever installed for parking.

Rear Axle and Wheels

It is mounted on ball bearings and is enclosed in a removable housing that is attached to the transmission case.

The rims and discs, assembled with the rear tires, are attached to the mounting points of the rear axle.

Hydraulic System and Hitches

Zetor tractors are equipped with active (i.e. the system is running) independent systems. A three-point hitch may be used for Type 1 (N) implement category.

Steering

Steering consists of a hydrostatic power steering system that has a hydraulic cylinder and a tandem hydraulic pump.

Electrical System

A 12 V battery is installed to start the motor using the starter.

The electrical system includes a horn, headlights, turn signal lights, tachometer, hour meter, brake lights, instrument lighting, hazard warning lights, generator or alternator, and a fuse box.

ROPS (ROLL OVER PROTECTION STRUCTURES)

Roll-Over Protection Structure (ROPS)

Zetor tractors are equipped with a frame to protect the operator.

On tractors with a cab, this frame is built into the cab structure.

The objective of the frame or the cab design is to protect the operator in the event of rolling over, they are designed to support the full weight of the tractor.

Each ROPS or cab structure, as well as any mounting brackets and screws or other fasteners, have been designed and tested to meet safety and government standards.

Danger



For the ROPS frames to effectively protect the tractor operator, the operator in the driver's seat must be wearing a seat belt. This will keep the driver inside the ROPS-protected area in the event of a rollover. Failure to use the seat belt can result in serious injury or death.

Some models of the ROPS frame can be folded, which can be used when entering low buildings, etc. Be careful when lowering the top part of the ROPS and be very careful when driving with the ROPS lowered.

Do not use the seat belt with the ROPS lowered and remember that the folding mechanism is intended for special use only and not for daily routine operation.



Using a tractor with the ROPS folded can cause serious injuries.

Since the ROPS frame or ROPS cab, together with the seat belt, have been designed to meet safety standards, they must be maintained in good order and in good condition.

For maximum safety, both the frame and seat belt must be regularly inspected (whenever the tractor is serviced).

If the seat belt is damaged or frayed, it must be replaced and if the ROPS frame or any part of its mounting structure is damaged or cracked, the defective part must be replaced by a new one.

Such a part must meet all test criteria of the original set.

The use of poor quality component(s) affects the certification of the entire ROPS and the effectiveness of the structure in the event of an accident.



Drilling or welding or making any unprofessional modifications of ROPS is prohibited.

ROPS (ROLL OVER PROTECTION STRUCTURES)

ROPS damage

If the tractor has rolled over or the ROPS has been damaged (for example, by hitting a low overhead object or during transport), the ROPS must be replaced to provide the guaranteed protection.

After an accident, check for damage on:

1. ROPS.
2. Seats
3. Seat belt and seat mountings.

Replace any damaged parts before operating the tractor.

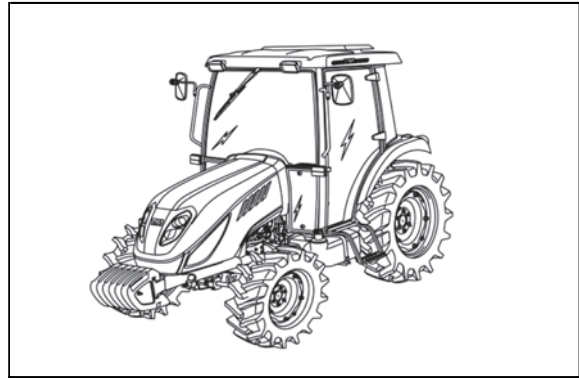

UCL18N003



Do not weld, drill or straighten the ROPS.



Warning: Never attach chains or ropes to the ROPS for towing; it will cause the tractor to roll over. Always use the points specified on the tractor for towing. Be careful when driving through open doors or under low overhead objects. Ensure sufficient overhead clearance for ROPS to avoid fatal injuries.



Warning: When removing or replacing the ROPS, ensure that the correct fasteners are used to replace the ROPS and that the fastening bolts are tightened to the recommended torque values.



Warning: If the tractor is equipped with ROPS, always use the seat belt.

ROPS (ROLL OVER PROTECTION STRUCTURES)

Sliding Seat

To adjust the seat position, move the adjustment lever and slide the seat towards or away from the instrument panel and controls.

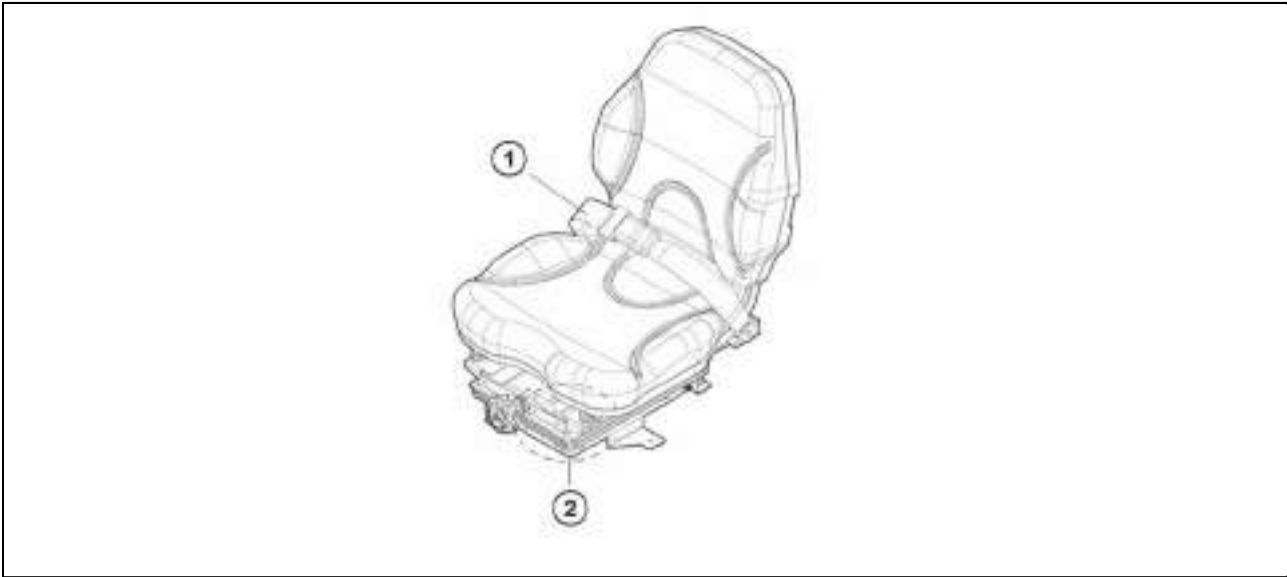

CCL25004

- 1 - Seat Belt
- 2 - Forward / Reverse Position Adjustment Lever

Before operating the tractor, it is important to adjust the seat to the most comfortable position and ensure that it is properly locked in its position.

NOTE:

Do not use solvents to clean the seat. Use warm water with detergent.



Warning: Do not place your hand between the seat and the guide rail when adjusting the seat. You may be injured.



Danger: Check that the seat is properly locked in its position before driving the tractor.



Danger: Always use the seat belt when the ROPS is installed/lifted. Do not use the seat belt if the ROPS is folded down or not installed. Check the seat belt regularly and replace it if it is frayed or damaged.

ROPS (ROLL OVER PROTECTION STRUCTURES)

Seat Back Reclining

To change the seatback angle, raise the lever on the left of the seat.

Then, adjust the seatback angle with the lever pulled. Release the lever after adjustment. Make sure that the lever is returned and the seat is firmly fixed after adjustment.

- 1 - Seat belt
- 2 - Backrest angle adjustment lever

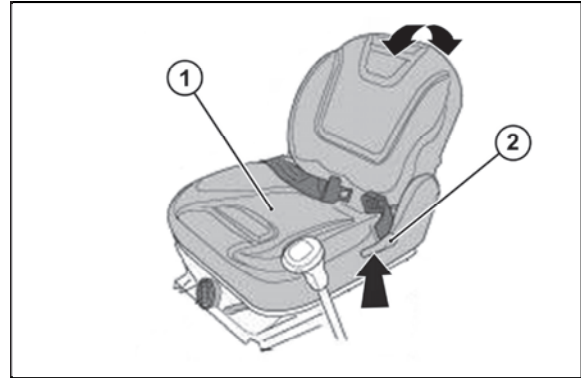

HODP008

Seat Suspension Adjustment

The seat cushion can be adjusted according to the driver's weight.

Turning the cushion adjustment knob counterclockwise towards 50 kg position will make the cushion softer.

By turning the knob clockwise towards 130 kg position, the cushion becomes harder.



CCL25005

- 1 - Seat Belt
- 2 - Knob for Weight Adjustment

SAFETY INSTRUCTIONS, DO'S & DON'TS

Introduction to safety information



This symbol means **ATTENTION! YOUR SAFETY IS INVOLVED**. The message that follows the symbol contains important information about safety. Carefully read the message.

Signal words

A signal word 'DANGER, WARNING OR CAUTION' is used with safety alert symbol. DANGER identifies the most serious hazards. Safety signs with signal Word 'DANGER OR WARNING' are typically near specific hazards. General precautions are listed on CAUTION safety signs.



DANGER



WARNING



CAUTION

Introduction to safety instructions Introduction to safety instructions

Carefully read all safety instructions given in this manual for your safety. Tempering with any of the safety devices can cause serious injuries or death. Keep all safety signs in good condition.

Replace missing or damaged safety signs.

Keep your tractor in proper condition and do not allow any unauthorized modifications to be carried out on the tractor, which may impair the function/safety and affect tractor life.

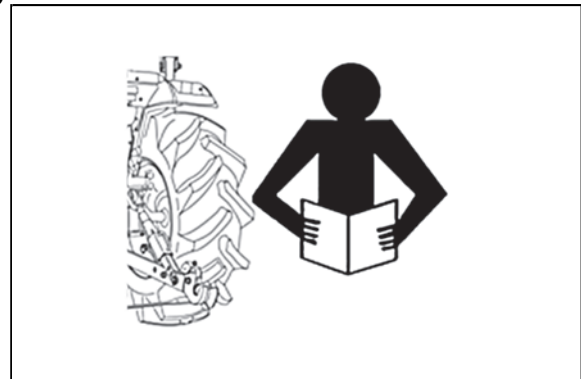

U18N134

Protection children

When using the tractor, prevent other persons from accessing the tractor.

Reverse travel

- Look around if someone is not behind the tractor.
- Do not allow anyone to ride on the tractor or implement.

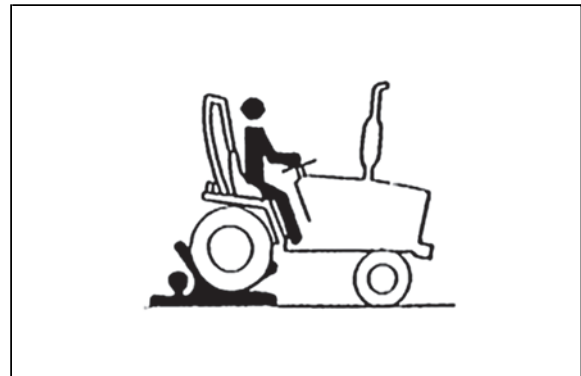

U18N135

SAFETY INSTRUCTIONS, DO'S & DON'TS

Use of rops and seat belt

The Roll Over Protective Structure (ROPS) has been certified to industry and/or government standards. Any damage or alternation to the ROPS, mounting hard-ware, or seat belt voids the certification and will reduce or eliminate protection for the operator in the event of a roll-over. The ROPS, mounting hardware, and seat belt should be checked after the first 100 hours of tractor and every 500 hours thereafter for any evidence of damage, wear or cracks. In the event of damage or alternation, the ROPS must be replaced prior to further operation of the tractor.

The seat belt must be worn during machine operation when the machine is equipped with a certified ROPS. Failure to do so will reduce or eliminate protection for the operator in the event of a roll over.



U18N136

Precaution to avoid tipping

Do not drive where the tractor could slip or tip. Stay alert for holes and rocks in the terrain, and other hidden hazards.

Slow down before you make a sharp turn.

Driving forward out of a ditch or mired condition could cause tractor to tip over backward. Back out of these situations if possible.

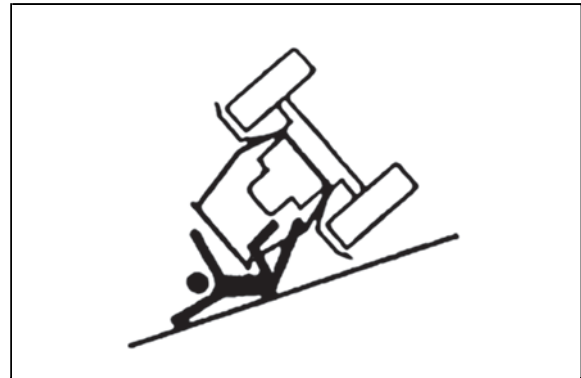

U18N137

Safe parking of the tractor

Before working on the tractor:
Lower all equipment to the ground.
Stop the engine and remove the key.

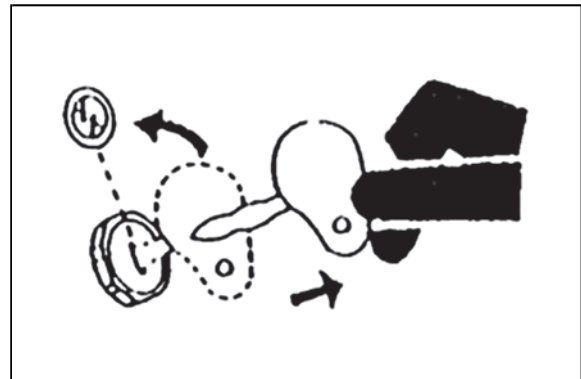

U18N138

Keep riders off tractor

Do not allow other persons to ride on the tractor besides the operator.

Persons on the tractor are exposed to the risk of injury, e.g. due to the impact of a foreign object or falling from the tractor.



U18N139

SAFETY INSTRUCTIONS, DO'S & DON'TS

Handle fuel safely-avoid fires

Handle fuel with care; it is highly flammable. Do not refuel the tractor while smoking or near open flame or sparks. Always stop engine before refueling tractors. Always keep your tractor clean of accumulated grease, and debris. Always clean up spilled fuel.



U18N140

Stay clear of rotating shafts

Entanglement in rotating shaft can cause serious injury or death. Keep PTO shield in place at all times. Wear close fitting clothing. Stop the engine and be sure PTO drive is stopped before making adjustments, connections, or cleaning out PTO driven equipment.



U18N141

Always use safety lights and devices

Use of hazard warning lights and turn signals are recommended when towing equipment on public roads unless prohibited by state or local regulations. Use slow moving vehicle (SMV) sign when driving on public road during both day & night time, unless prohibited by law.

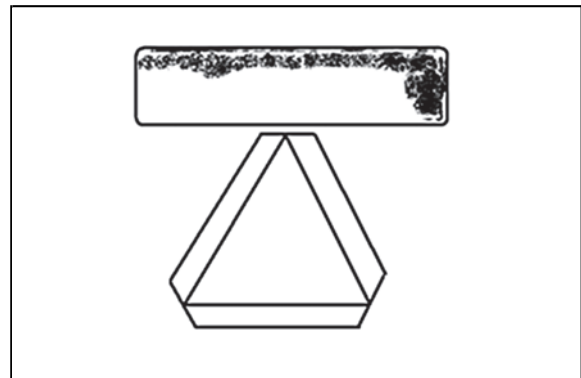

U18N142

SAFETY INSTRUCTIONS, DO'S & DON'TS

Practice safe maintenance

Be thoroughly familiar with the service procedure before performing work.

Keep the tractor area clean and dry.

Do not attempt to service the tractor while it is in motion.

Be careful not to let your body or clothing get into the rotating shaft.

Always lower all attached equipment on the ground. Turn off the engine.

Remove the ignition key. Let the tractor cool down before any repairs.

All parts of the tractor that need to be lifted for service work must be securely supported.

Keep all parts in good conditions and properly installed.

Replace worn or damaged parts. Replace damaged/missing plates.

Remove any accumulated excess grease or oil from the tractor.

Disconnect the battery ground cable (-) before making adjustments to electrical systems or performing welding work on the tractor.

Avoid high-pressure fluids

Liquid escaping under pressure can penetrate the skin and cause serious injury. Be especially careful when handling the injection elements - there is a risk of injecting liquids under high pressure under the skin of your hands or other parts of your body. If ANY liquid penetrates the skin, contact your doctor immediately.

Prevent battery explosions

Keep sparks, lighted matches, and open flame away from the top of battery. Battery gas can explode. Never check battery charge by placing a metal object across the poles.



U18N143



U18N144



U18N145

SAFETY INSTRUCTIONS, DO'S & DON'TS

Prevent acid burns

Protect the top of the battery from sparks, flammable materials and open flames. Accumulated battery fumes can explode. Never check the battery charge by connecting the battery terminals with a metal object.

Sulfuric acid in the battery electrolyte is hazardous to health. It is strong enough to burn the skin, burn through the clothing and cause blindness when it gets into the eyes.

To ensure adequate safety, always:

1. Refill the batteries in a well-ventilated place.
2. Wear eye protection and acid-resistant gloves.
3. Do not inhale the released vapors after the electrolyte has been added.
4. Do not add water to the electrolyte, as it may cause expansion and subsequent severe burns.

If you get stained with acid:

1. Rinse skin with water.
2. Rinse eyes with water for 10 - 15 minutes. Seek medical advice immediately.

Battery disconnect

1. When working with your tractors electrical components you must first disconnect the battery cables.
2. To ensure that there are no accidents from sparks you must first disconnect the negative battery cable.

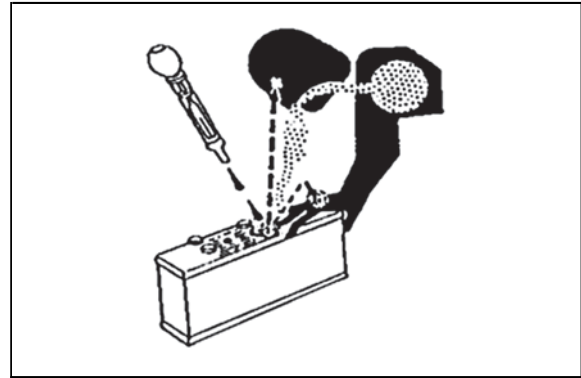

U18N146

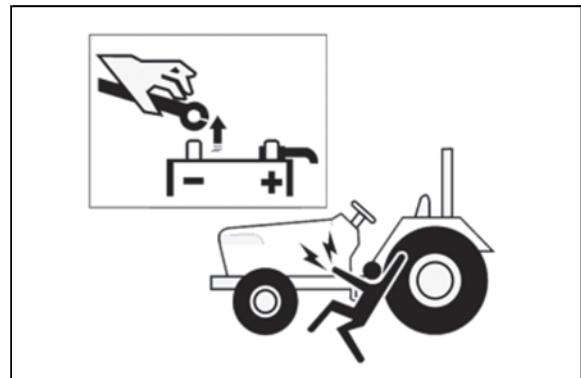

UCL18N007

Service tractor safely

Do not wear a tie, scarf or any other loose clothing when working near moving parts. If any of these garments is caught, a serious injury may occur.

Do not wear rings or other jewellery to avoid electrical short circuits and entanglement in moving parts.



U18N147

SAFETY INSTRUCTIONS, DO'S & DON'TS

Work in ventilated area

Do not start the tractor in an enclosed building unless the doors & windows are open for proper ventilation, as tractor fumes can cause sickness or death. If it is necessary to run an engine in an enclosed area remove the exhaust fumes by connecting exhaust pipe extension.



U18N148

Tractor runaway

1. The tractor may start when the gear is engaged, as a result of which the tractor may run uncontrolled and can cause serious injuries to people standing near the tractor.
2. When using the starter switch or other work on the tractor, the gearbox must be in the neutral position, the handbrake applied and the PTO lever disengaged.

Safety starter switch

1. Clutch operated safety switch is provided on all tractors which allow the starting system to become operational only when the clutch pedal is fully pressed.
2. Do not by-pass this safety starter switch or work on it. Only authorized dealers are recommended to work on safety starter switch.
3. On some models safety starter switch is provided on transmission high-low shifter lever and in PTO shifter lever. The tractor can be started only if High-low shifter lever is in neutral position.



Caution: *Safety starter switch is to be replaced after every 2 000 hours / 4 years, whichever is earlier.*

Emergency exits

If exit from the cab side doors is blocked (following an accident or vehicle overturn) the alternative safety exits are indicated by decals.

The possible safety exits are:

- Rear window hatch (all tractors)
- Front window (for versions with openable front window).

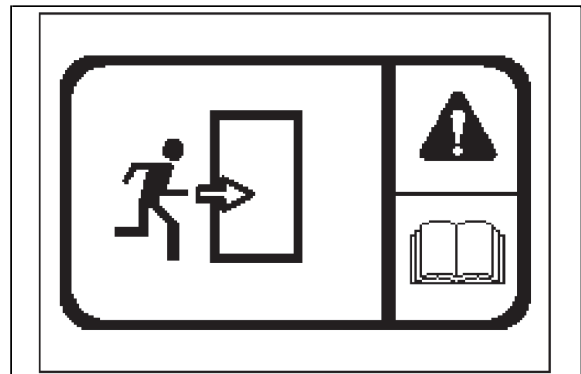

U18N005_1

SAFETY INSTRUCTIONS, DO'S & DON'TS

Safety precautions when using the loader

Do not allow persons to enter the attached loader adapter or the loader boom operating area. Failure to do so may result in serious injuries or even death.

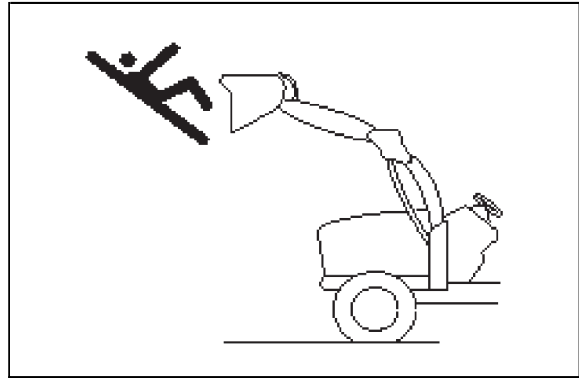

U18N005_2

Do not stay under the lifted loader or do not approach it. Lower the loader boom to the ground before leaving the tractor. Failure to do so may result in serious injuries or even death.

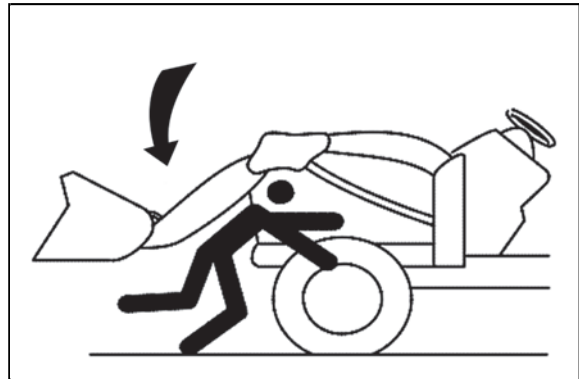

U18N005_3

When mounting or dismounting the loader, secure all parts that are attached to the adapter and the boom. The adaptor or the boom may unexpectedly drop, which can lead to injury or even death.

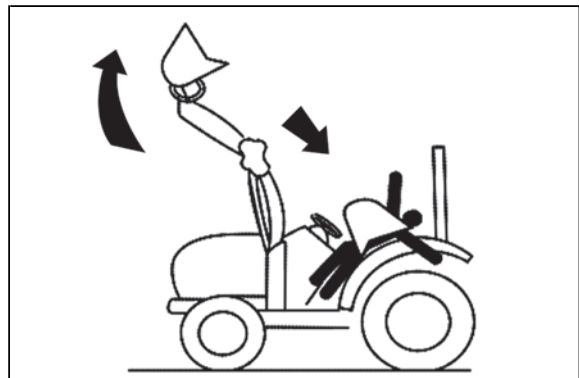

U18N005_8

SAFETY INSTRUCTIONS, DO'S & DON'TS

ROPS (roll-over protective structure), sun visor and cab are not FOPS protective structures (falling-object protective structure).

In no case does it serve to protect the operator from falling objects.

Avoid driving in dangerous areas, such as places where there is a danger of falling rocks, etc.

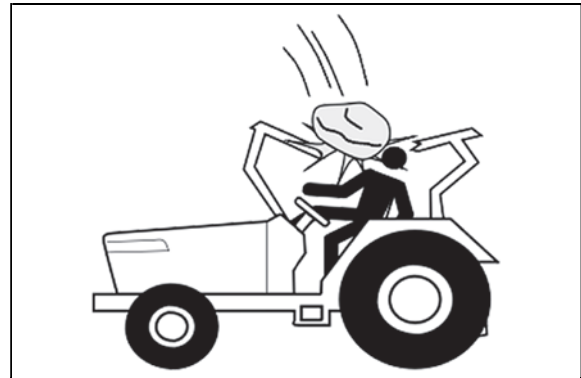

U18N005_5

Do not allow the boom or attached adapter or equipment to come into contact with electrical lines or other electrical equipment. Electric current causes serious injuries or death.

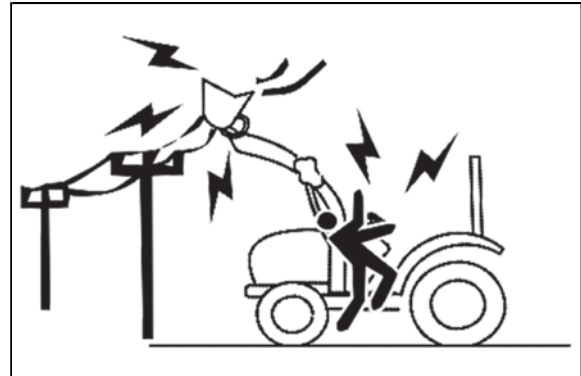

U18N005_6

For safe handling of loads, always use a suitable type of adapter for your work. While driving, keep the boom loaded with a load at a low position above the mat. Failure to do so may result in machine damage, serious injury or even death.

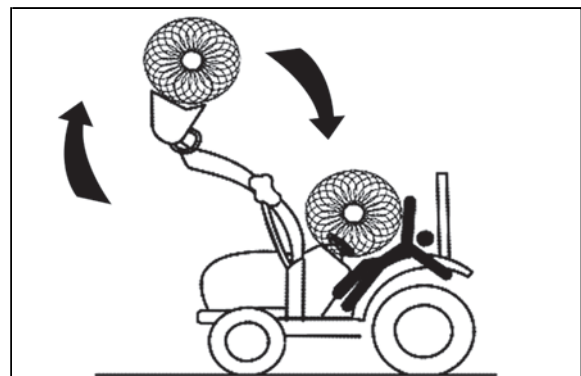

U18N005_7

SAFETY INSTRUCTIONS, DO'S & DON'TS

Towing safely

For the maximum permissible load of the hitch, see 'Maximum hitch load' in the Specifications section.

- Maintain a suitable speed taking into account the weight of the load towed or carried by the tractor and the inclination of the surrounding terrain, remembering that the braking distances will be greater than that of a unloaded tractor. Attached trailers or semi-trailers with or without brakes that exceed the specified technically permissible maximum authorized weight may cause loss of control of the tractor unit.
- Always take into account the total weight of the attached machine and its load.
- When semitrailers are attached to the tractor, remember to switch all controls to neutral position, lock the parking brake, turn off the engine, engage first gear (for mechanical transmission), and remove the ignition key before leaving the operator's seat. ALWAYS secure the wheels of the tractor and the trailer with wedges. The safest and recommended way to transport a damaged tractor is to transport it on a low-load trailer. Always attach the tractor to the low-load trailer with chains. Before transporting the tractor on a low-load trailer or on a railway wagon, make sure that the engine cover, door, openable roof (if available) and windows are closed and securely locked. Never tow the tractor at a speed higher than 10 km/h. In this case, the operator must remain in the operator's seat to drive and brake the tractor.



Caution: *When a trailers is hitched to the tractor, before you leave the driving seat remember to put all the controls in neutral, apply the handbrake, switch off the engine, engage first gear (if the tractor has a mechanical transmission) and remove the key from the starter switch. If the tractor is not parked on level ground, ALWAYS place chocks under the wheels of both the tractor and the trailer For further information on safe working procedures, refer to the chapter 'Parking the tractor' in the safe section of this manual.*

Falling Object Protective Structure (FOPS)

The term FOPS refers to a structure mounted on a tractor to reduce the risk of injury to the operator from falling objects.

Tractors equipped with a cab have a FOPS-certified roof.

Operator Protective Structure (OPS)

The term OPS refers to a protective structure installed on a tractor in order to minimize risk of operator injury caused by objects penetrating into the operator position area.



This tractor is not equipped with an OPS. If work must be carried out in areas where there is a risk of objects entering the driver's platform, consult your dealer before starting work on a suitable protective structure the tractor can be equipped with.

Use of Hazardous Substances

Below find the classification category, as determined according to ISO 14269-5, for the cab installed on this tractor series:

- Engine operating at rated speed
- Maximum amount of air blown from outside the cab (recirculation closed)
- With fan at maximum speed

Category of protection against hazardous substances	Category 1
---	------------

The cab does not provide any protection against hazardous substances.



Danger: *Use all personal protective equipment suitable for the relevant work and the relevant substances, in accordance with the requirements of the legislation applicable in your country.*

SAFETY INSTRUCTIONS, DO'S & DON'TS

Safe operation of your tractor

The manufacturer of your tractor has made every effort to make it as safe as is humanly possible. Beyond this point it is the responsibility of the operator to avoid accidents and we ask that you read and implement our suggestions for your safety.

Ensure that only trained and competent operators use this tractor and ensure that they are fully conversant with the machine and aware of all its control and safety features.

Operators should not operate a tractor or attached machines if they are not properly trained or if they are physically unfit to operate the machine.

To avoid accidents please ensure that the operator wears clothing which will not get entangled in the moving parts of the tractor or machine and protect him or her from the elements.

When spraying or using chemicals, please ensure that clothing and protective equipment is worn which prevents respiratory or skin problems.

For full details consult the manufacturer of the chemicals.

To avoid lengthy exposure to noise ensure that ear protection is worn.

If adjustment to the tractor or machinery need to be made ensure the tractor or machine are turned off beforehand.

Use of certified Roll Over Protection Structure (ROPS) is a must while operating a tractor.

Use of seat belt is a must while operating a tractor.

Under all circumstances, it is necessary to ensure the safety of the operator and others near the machine.

Ensure no one is between the tractor and a towed vehicle (trailer or implement).

Safety Tips During Maintenance

1. At least on a daily basis check all oil levels. Water level in the radiator and electrolyte level in the battery and perform services according to the service schedule.
2. Ensure tire pressure are even and the correct pressure for the job being done is maintained.
3. Check to ensure that the all controls and preventative mechanisms of the tractor and implement work correctly and effectively.
4. Ensure that an adequate set of the correct tools is available for maintenance and minor repairs.
5. Ensure that all service work and repairs are carried out on a flat area with a concrete or similar floor. Do not carry out service work on a tractor until it is switched off, and the parking brake applied and wheels chocked.
Where a tractor is started in a confined area, ensure that the area is well ventilated as exhaust gases are very harmful, and can cause death.
6. Do not work under raised implements.
7. When changing wheels or tires ensure that a suitable wheel stand is placed under the axle prior to removing the wheel and the wheels are chocked.
8. Where guards or shields need to be removed to perform a service or repair, ensure that the guard or shield is correctly reinstalled before starting the tractor.
9. Never refuel near a naked flame or with an overheated engine. Ensure to turn off Engine before refueling.
10. The cooling system operates under pressure, take care when removing the radiator cap on a hot engine to prevent being scalded by steam or hot water. Do not add water in the radiator when the engine is hot. Add water to the radiator only after the engine cools down completely.
11. To prevent fires keep the tractor including the engine clean and free from inflammable material and well away from fuels and other inflammable material.

SAFETY INSTRUCTIONS, DO'S & DON'TS

Mounting and demounting implements

1. Ensure that all assembly and disassembly of implements (attachments) is carried out on a secure, level surface. To prevent accidental injuries, ensure that no one is between the tractor and the implement or under the implement.
2. After mounting the implement, ensure that all hanging parts such as chains or hoses are properly secured and, where PTOs are used, properly fastened and secured.
3. Where heavy implements are used, ensure that the unit is well balanced, using suitable ballast to ensure this balance.
4. Before leaving the tractor, lower the implement onto the ground, deactivate the PTO, apply the parking brake and stop the engine.
5. When working with an implement that uses PTO, make sure that no other persons are near the moving parts and do not make any modifications to the implement while the machine is in operation.
6. A tractor equipped with a ROPS protective frame only performs its function in combination with a fastened seat belt.
7. If children are present in the immediate vicinity of the machine or unit, caution and anticipation of possible risks related to the movement and operation of the machine are necessary.
8. The tractor may only be used by trained operators who must ensure that no worker is injured. Extra caution is necessary in dusty environment with significantly reduced visibility.
9. Never start the tractor unless the transmission is in the neutral position, the operator is in the driver's seat, and there is no other danger when the engine is started up.
10. Only the operator sitting in the driver's seat can operate the tractor. Never turn or brake suddenly at high speed, as this may cause the tractor to roll over, resulting in serious injury or death.
11. When driving on public roads, observe all legal requirements of the country in which the tractor is operated, including the requirements for accompaniment. When driving with wide implements, use the warning devices specified by the applicable legislation in the country in which the machine is used.
12. When operating under adverse conditions, in hilly or bad terrain, adjust the speed of the tractor to the following conditions:
Never drive down the hill rashly or with the transmission in the neutral position.
Use engine braking capability together with service brakes.
Do not attempt to shift gears in a steep slope and engage a suitable gear before starting to drive the tractor.
13. When driving uphill with a heavy implement, be careful to prevent overloading and loss of front axle adhesion and consequent loss of control.
14. Never remove or modify the seat belt.
15. Never remove, modify or repair the ROPS protective frame.



Please remember that a little bit of extra care can prevent serious injury or death and avoid damage to your tractor.

SAFETY INSTRUCTIONS, DO'S & DON'TS

The following precautions are suggested to help prevent accidents

The best operator is the careful operator. Most accidents can be prevented by observing certain safety measures. Before using the tractor, read the following measures and observe them to avoid accidents. The tractor may only be operated by authorized persons who are properly trained for this operation.

Tractor

1. Read the operating and maintenance manual of the machine carefully before operating the tractor. Insufficient knowledge of machine operation can lead to accidents.
2. For safe operation, use an approved protective structure and seat belt. Roll-over of a tractor without a protective structure can result in serious injuries or even death.
3. **Do not remove the roll-over protective structure (ROPS).** Always use the seat belt.
4. The laminated roof of the tractor cab does not provide protection against the breakthrough of external objects with higher weight.
5. To avoid falling while entering and leaving the cab, keep the stairs and platform clean, free of mud and oil.
6. Do not allow anyone other than the operator to ride on the tractor. There is no safe seat or approved passenger seat on the tractor.
7. Replace any missing, illegible or damaged safety signs.
8. **Keep safety signs clean, free of dirt and grease.**

Tractor service

1. For your safety, keep the tractor in good operating conditions. An inadequately maintained tractor can be dangerous.
2. Stop the engine before servicing the tractor.
3. The cooling system operates under pressure. **If the engine and its cooling system are hot, it is dangerous to remove the cap.** Turn the cap slowly to the stop, then let the pressure escape before removing the cap.
4. **Do not smoke while refueling the tractor. Never refuel the machine near an open flame.**
5. The fuel in the injection system is under high pressure and can penetrate the skin. Unqualified persons must not disassemble or modify the fuel pump, injectors, nozzles or other parts of the fuel injection system. Failure to follow these instructions may result in serious injuries.
6. **To prevent fire or explosion, keep the battery and the cold start devices away from open flames.**
7. **Do not change or modify anything on the tractor and do not allow anyone to change or modify anything on the tractor or any part of the tractor or its function.**

SAFETY INSTRUCTIONS, DO'S & DON'TS

Tractor Operation

1. Before starting the tractor, apply the parking brake, set the PTO switch to the 'OFF' position, move the hydraulic control levers to neutral, the remote control levers to neutral (if fitted), and the transmission to neutral.
2. Do not start the engine or operate the tractor when standing next to the tractor. Always sit in the driver's seat when the engine is running or when operating the controls.
3. A safety switch is mounted on the tractor to prevent the tractor from starting accidentally. The tractor's starter system is connected via this switch, which only closes when the clutch pedal is depressed. On some models, the reverse lever and the PTO button must also be in the neutral position to close the starter circuit. It is forbidden to bypass the starter safety switch in any way. If the starter safety switch is defective, consult your Zetor tractor dealer/distributor.
4. Avoid accidental contact with the shift lever while the engine is running. Such contact can cause the tractor to move.
5. Do not get off or get on the tractor while it is moving.
6. Before leaving the tractor, stop the engine, remove the ignition key and apply the parking brake.
7. Do not operate the tractor in an enclosed building without adequate ventilation. Exhaust gases can cause death.
8. Do not park the tractor on a steep slope.
9. If the power steering or engine stops working, stop the tractor immediately.
10. Use only the lower swinging hitch or the draw bar connected to the 3-point hitch lower link in the down position. Always use a lockable pin to secure it. Attaching the drawbar to the rear axle bracket or any other point on the rear axle can cause the front axle to be lifted and the loss of control over the machine.
11. If the front of the tractor tends to lift when heavy working implement is attached to the three-point hitch, install the front ballast weights or front wheel weights. Do not operate the tractor with a light front axle.
12. Always use the hydraulic position control lever when attaching the implement and transporting the implement. Make sure that the hydraulic couplers are properly mounted and that they will disconnect safely in case of accidental detachment of implement.
13. Do not leave the implement in the lifted position.
14. Use the beacon, turn signal lights and slow moving vehicle (SMV) signs when driving on public roads during both day and night time, unless prohibited by law.
15. Dim the tractor lights when meeting approaching vehicles at night. Make sure that the lights are adjusted to avoid dazzling the eyes of the oncoming vehicle driver.
16. Emergency stop instruction: If the tractor does not stop after the brakes are applied, switch off the ignition switch (or switch off the key).

Tractor control

1. Watch where you drive, especially at the ends of the rows, the headlands, on the roads, around the trees and at obstacles hanging low to ground.
2. To prevent the tractor from rolling over, drive the tractor at a safe speed, especially when driving on uneven ground, when driving over ditches or slopes, and when turning in corners of areas and parcels.
3. When driving on the road, do not disconnect the two brake pedals of the tractor from each other to ensure better braking.
4. When driving downhill, shift the same gear in the tractor as uphill. Do not drive downhill with the engine stopped or idling.
5. For safety reasons, any towed vehicle and/or trailer, the weight of which exceeds the maximum towed weight, must be fitted with its own brakes.
6. If the tractor gets stuck or its tires are frozen to the ground, try to reverse to prevent the tractor from rolling over.
7. Always make sure you have enough space above you, especially when transporting the tractor.

SAFETY INSTRUCTIONS, DO'S & DON'TS

PTO operation

1. When operating a PTO driven implement, stop the engine and wait until the PTO stops before getting off the tractor and disconnecting the implement.
2. Do not wear loose clothing when operating the PTO or near a rotating equipment.
3. When operating PTO-driven stationary equipment, always secure the tractor with the tractor parking brake and secure the rear wheels from the front and rear side with wedges.
4. To avoid injury, always cover the PTO outlet. Do not clean, modify or repair the PTO-driven equipment while the tractor engine is running.
5. Always make sure that the PTO cover is installed and always install the PTO end piece cover whenever the PTO is not in use.

Diesel fuel



Diesel complies with EN 590 standard

IMPORTANT NOTE!

By using motor oil with elevated sulphur content, the service life of diesel particle filter can be significantly reduced.

1. Keep the equipment clean and properly maintained.
2. Under no circumstances should gasoline, alcohol or blended fuels be added to diesel fire or explosive hazard. Such blends are more explosive than pure gasoline. In a closed container, such as a fuel tank. **DO NOT USE THESE BLENDS.**
3. Never remove the fuel cap or refuel the tractor with the engine running.
4. Do not smoke while refueling or when standing near fuel.
5. Maintain control of the fuel filler pipe when filling the tank.
6. Do not fill the fuel tank to capacity. Allow room for expansion.
7. Wipe up spilled fuel immediately.
8. Always tighten the fuel cap securely.
9. If the original fuel tank cap is lost, replace it with genuine cap. A none approved cap may not be safe.
10. Do not drive equipment near open fire.
11. Never use fuel for cleaning purpose.
12. Arrange fuel purchases so that winter grade fuel are not held over and used in the spring.

Note: It is suggested that after repairs if any of the safety decal/sign is peeled/defaced, the same may be replaced immediately in interest of your safety.

SAFETY INSTRUCTIONS, DO'S & DON'TS

DO'S AND DON'T'S

DO'S-for better performance

YES Ensure that protective covers are returned immediately and they are in good conditions.

YES Read all operating instructions before operating the tractor

YES Perform all maintenance tasks completely and without error.

YES Keep the air filter clean.

YES Ensure that lubricating oils of the appropriate standard and quality are used and that they are refilled and changed at recommended intervals.

YES After replacing the filter elements, install new sealing rings.

YES Observe the warning light on the oil pressure gauge and if it lights up, check immediately for any abnormality.

YES Make sure the radiator is always filled with clean water and use antifreeze in cold weather. Drain the system only in case of emergency and refill before starting the engine.

YES Ensure the transmission is in the neutral position before starting the engine.

YES Store all fuel in clean environment and use a filter when filling the tank.

YES Perform minor adjustments and repairs as soon as necessary.

YES Allow engine to cool before removing radiator filler cap and adding water; remove the radiator cap slowly.

YES Engage a lower gear when going downhill steep slopes.

YES Connect the brake pedals together when driving on the road.

YES If the draft control lever is not in use, keep it in the lower limit position.

SAFETY INSTRUCTIONS, DO'S & DON'TS

Don'ts - for safe operation

DON'T- Run the engine with the air filter removed.

DON'T - Start the tractor in an enclosed building unless the windows and doors are open to ensure proper ventilation.

DON'T - Operate the tractor or engine while performing lubrication or cleaning.

DON'T - Allow the tractor to run out of diesel fuel, otherwise it will be necessary to bleed the system.

DON'T - Do not interfere in the injection pump - if the seal is broken, the warranty will be void.

DON'T - Allow the engine idle for an extended period of time.

DON'T - Run the engine when the fuel is not combusted in all cylinders.

DON'T - Do not drive with the brake or clutch pedal depressed. This will result in excessive wear of the brake linings, the driven clutch parts and the clutch release bearing.

DON'T - Use the disconnected brake pedals to turn the tractor on the road or at higher speeds.

DON'T - Refuel the tractor with the engine running.

DON'T - Get on or get off the tractor from the right side.

DON'T - Handle the upper stops of the control levers.

DON'T - Use the draft control lever to lift implements.

DON'T - Start the engine with the PTO engaged.

DON'T - Use the control lever (throttle lever) when driving on the road.

GENERAL INFORMATIONS

General safety information

IMPORTANT: This "General safety Information" should be kept with the machine at all times as reference data.



This symbol means **ATTENTION! YOUR SAFETY IS INVOLVED.** The message that follows the symbol contains important information about safety. Follow recommended precautions and safe operation practice.

Decals mounting location

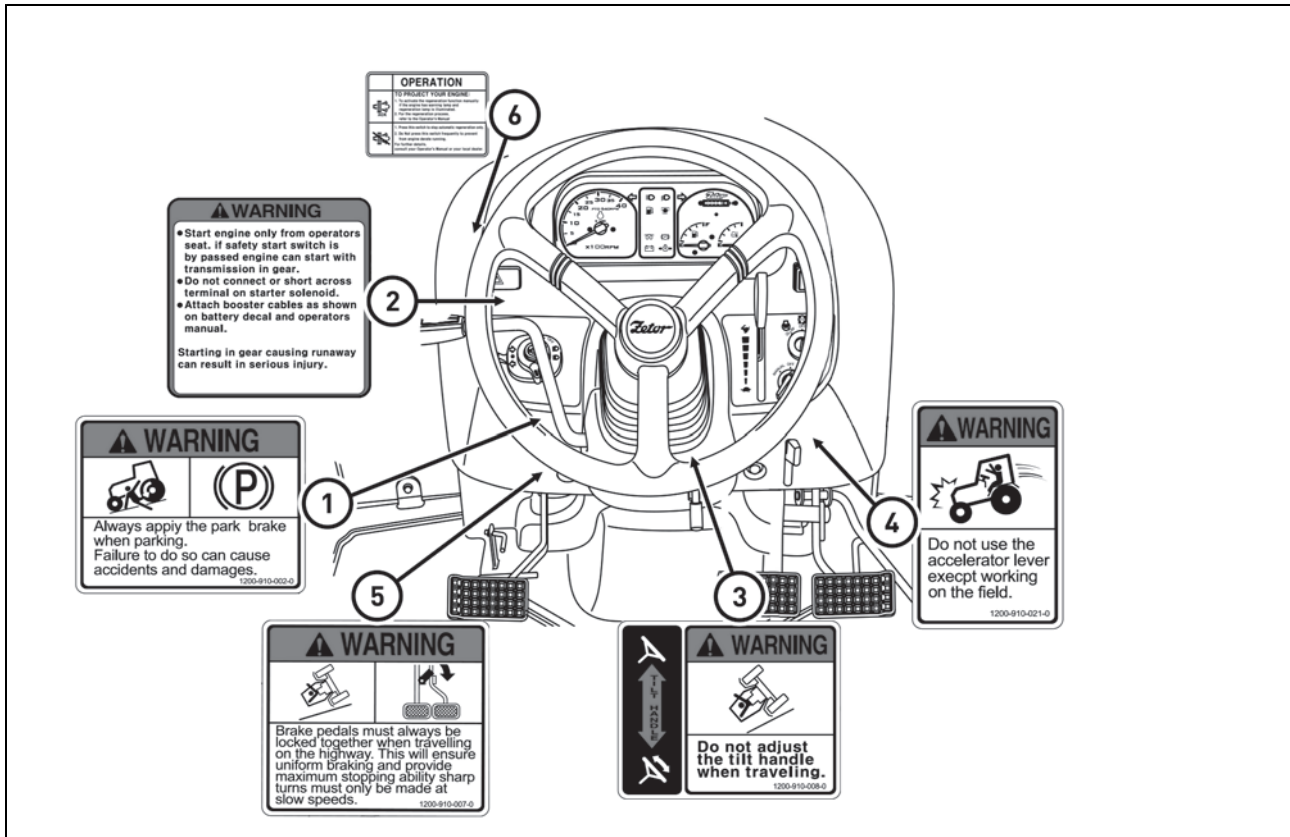

UCLS5N001

1 - Warning:

Always use the parking brake when parking.
Failure to do so may result in accidents and damage.

2 - Warning:

- Only start the engine from the operator's seat. If the safety start switch is disabled, the engine can start with a gear shifted.
- Do not connect the clamp to the starter solenoid.
- Connect the booster cables as shown on the battery plate and in the Operator's manual.

Starting with gear engaged can cause the vehicle to move and may cause serious injury.

3 - Warning:

Do not adjust the steering wheel tilt when driving.

4 - Warning:

Do not use the hand throttle lever except for field work.

5 - Warning:

The brake pedals must always be locked together when driving on the road.

This ensures even braking and maximum efficiency of stopping. Sharp turns must be performed only at moderate speeds.

6. Operation:

Particulate filter regeneration

GENERAL INFORMATIONS

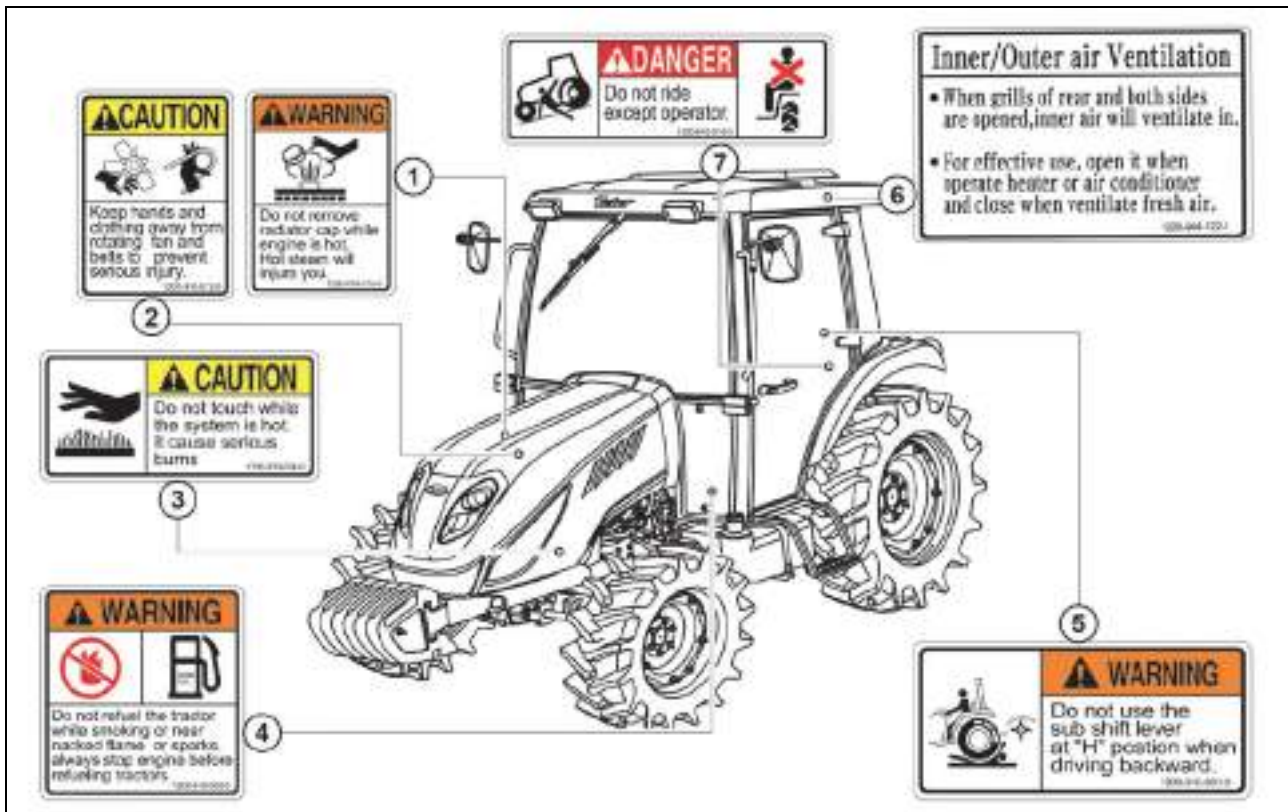

UCL18N009

1 - Warning:

Do not remove the radiator cap if the engine is hot. There is a risk of injury by hot steam.

2 - Caution:

Keep hands and clothing away from rotating fans and belts to avoid serious injuries.

3 - Caution:

Do not touch the engine and cooling system when it is hot. This may cause serious burns.

4 - Warning:

Do not refuel the machine while smoking or when near an open flame or sparks. Always stop the engine before refuelling.

5 - Warning:

Do not use the auxiliary shift lever in the 'H' position when reversing

6 - Internal/external air ventilation:

- When the grilles are opened at the rear and on both sides, the internal air is ventilated.
- For efficient use, open them when operating the heater or air conditioning system and close them during fresh air ventilation.

7 - Danger:

The tractor should only be driven by the operator.

GENERAL INFORMATIONS

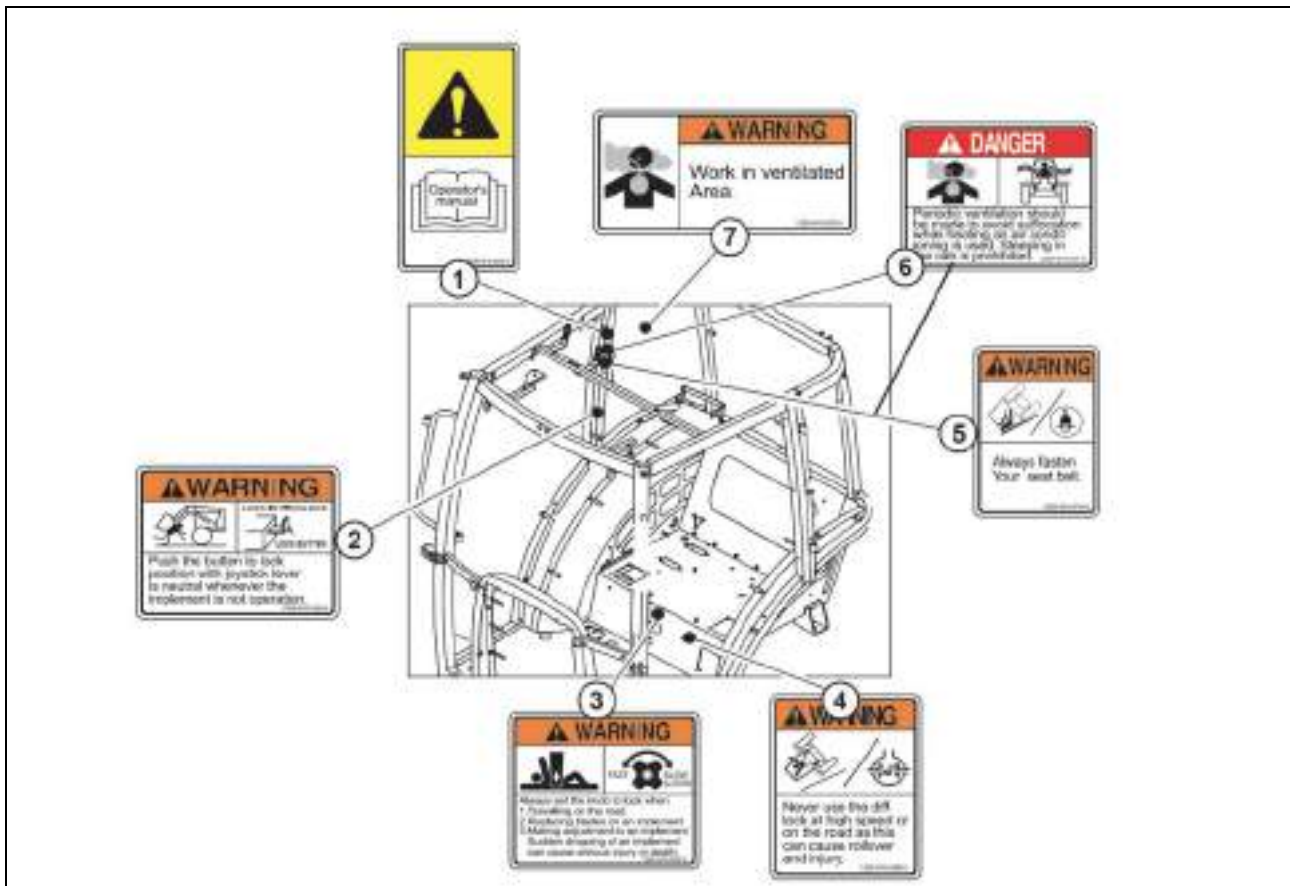

UCL18N010

1 - Operator's manual

2 - Warning:

Press the button to lock the neutral position of the joystick whenever these functions are not in operation.

3 - Warning:

Always lock the controller if

1. You drive on the road.
2. You perform maintenance / change working implements.
3. You set up the machine.
4. Sudden lowering of the implement can cause serious injuries or death.

4 - Warning:

Never use the differential lock at high speed or on the road, as it may cause damage to the machine, risk to road safety or cause accidents and injuries to persons.

5 - Warning:

Always drive with the seat belt fastened.

6 - Danger:

To avoid suffocation during heating or air conditioning, it is necessary to ventilate regularly. Sleeping in the cab is forbidden.

7 - Warning:

Work in ventilated areas

GENERAL INFORMATIONS

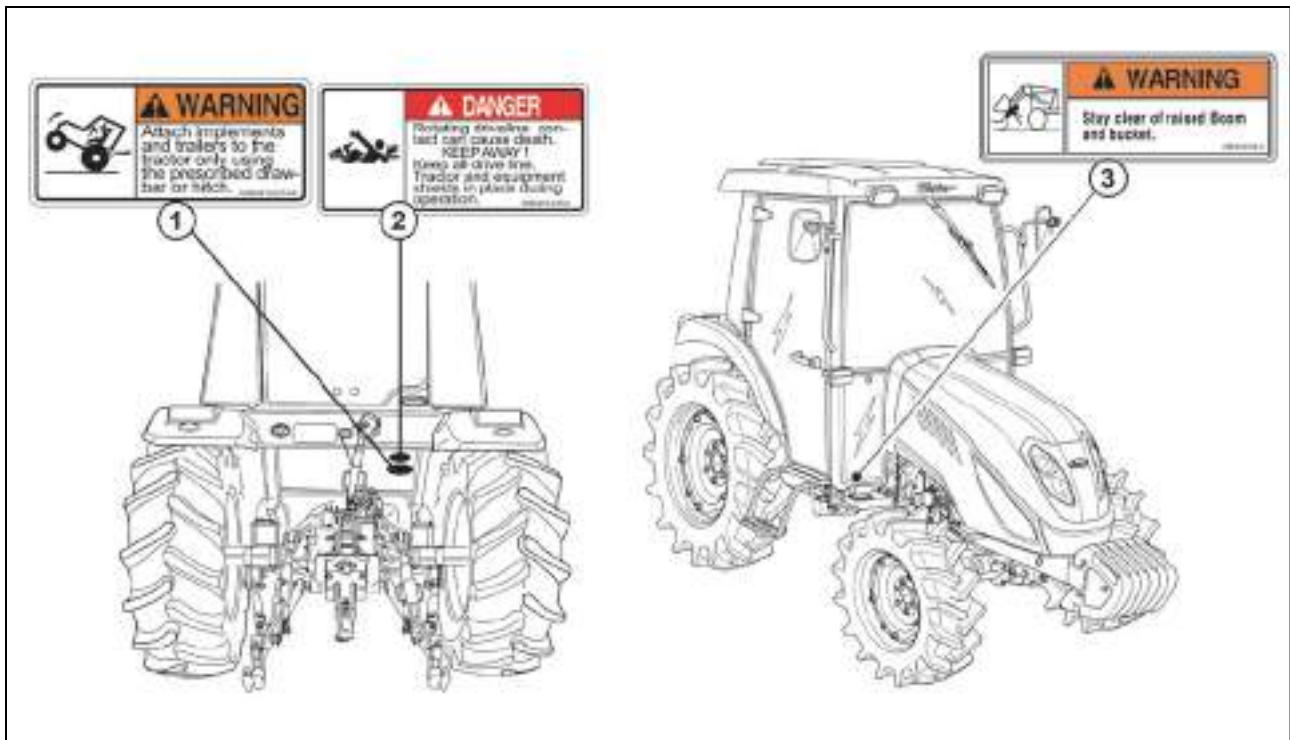

UCL18N011

1 - Warning:

Only attach implements and trailers to the tractor using the prescribed drawbar or hitch.

2 - Danger:

Contact with the rotating shaft may cause injuries or death.

Stay away!

When operating, keep all the covers of the shaft, tractor and connected implement mounted.































3 - Warning:

Keep away from lifted arms and other parts of the loaders and implements.

GENERAL INFORMATIONS

Universal symbols

Some of the universal symbols have been shown below with an indication of their meaning.

 Engine speed rev/minX100	 Pressured-open slowly	 Corrosive substance
 Hours, recorded	 Continuous variable	 "Tortoise" Slow or minimum setting
 Engine coolant temperature	 Warning	 "Hare" fast or maximum setting
 Fuel level	 Hazard warning	 Transmission oil pressure
 Engine stop control	 Neutral	 Turn signal
 Lights	 Fan	 Transmission oil temperature
 Horn	 Power take off engaged	 Parking brake
 Engine oil pressure	 Power take off disengaged	 Work lamps
 Air filter	 Lift arm/raise	 Differential lock
 Battery charge	 Lift arm/lower	 See operator's manual

NOTES

TRACTOR CONTROLS

Instruments and Switches

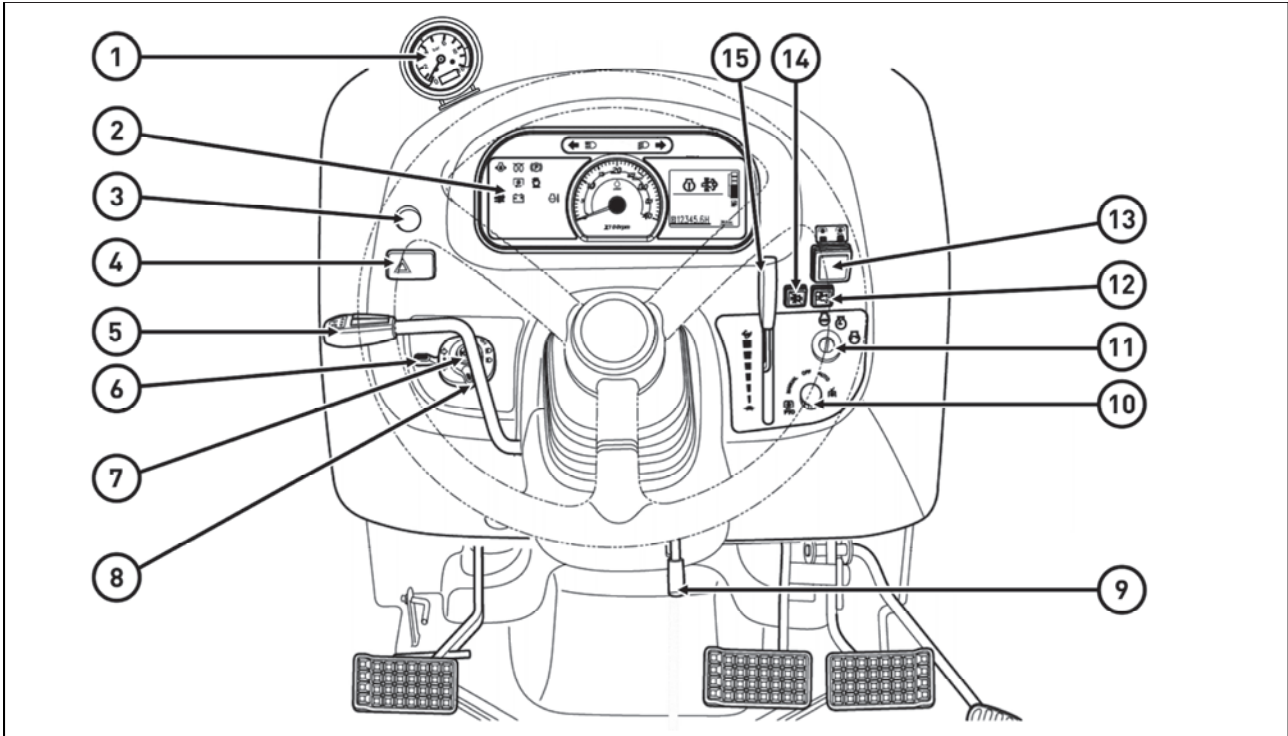

UCLS5N003

- 1 - Air Pressure Gauge, only for tractors equipped with trailer air brakes
- 2 - Dashboard
- 3 - Temporary Trailer Brake Deactivation Button, only for tractors equipped with trailer air brakes
- 4 - Warning Signal Switch
- 5 - Reverse Shift Lever
- 6 - Turn Signal Light Switch
- 7 - Horn Switch
- 8 - Headlight Switch
- 9 - Steering Wheel Tilt Lever
- 10 - PTO Mode Switch
- 11 - Key Switch
- 12 - DPF Regeneration Switch
- 13 - PTO On/Off Button
- 14 - DPF Regeneration Deactivation Switch
- 15 - Hand Throttle Lever

Key Switch

- OFF - The key can be inserted or removed.
- ON - The electrical circuit is closed.
- START - The engine starter is closed. When released, the key returns to the ON position.
- GLOW - Preheating of combustion chamber.

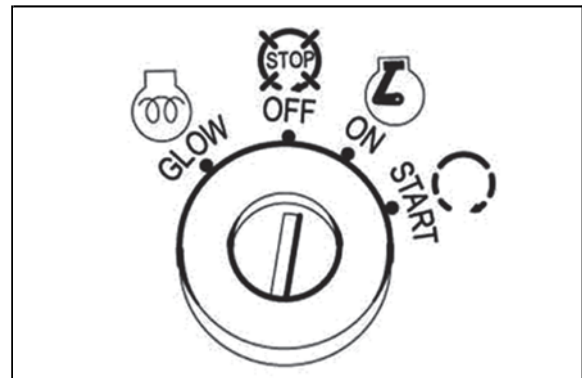

HODP042

TRACTOR CONTROLS

Combined Switch

Turn Signal Light Switch Lever

Press the turn signal lever (1) down to signal a left turn.
Press the turn signal lever (1) up to signal a right turn.

Headlights Switch (if Beacon Light is Installed, also Beacon Light Switch)

High beam and low beam lights are controlled by the lever (2) on the main switch.

Position 3 - High beam lights (Beacon)

Position 4 - Low beam lights (Beacon)

Horn

Press the red button (5).

- 1 - Turn Signal Light Switch Lever
- 2 - Headlight Switch
- 3 - High Beam Lights (Beacon Light)
- 4 - Low Beam Lights (Beacon Light)
- 5 - Horn

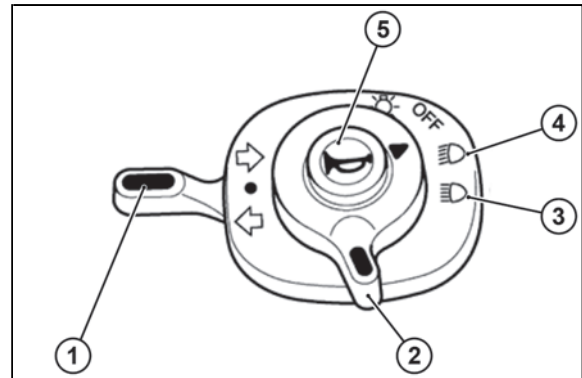

U18N012

Warning Lights Switch

Push the hazard warning signal once to operate the hazard warning light. (Left and right turn indicators flash).
Push the hazard warning light switch again to switch off the hazard warning lights.

- 1 - Hazard warning signal S/W

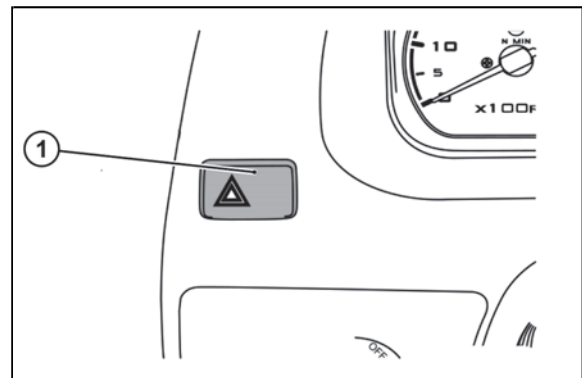

UCL18N015

Tachometer

Displays the number of engine or PTO revolutions per minute. At the highest gear also the speed.

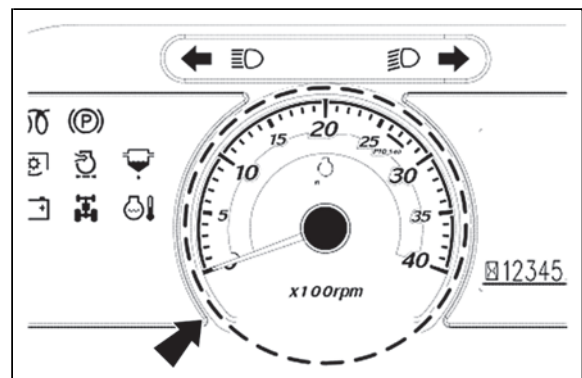

HODP044

TRACTOR CONTROLS

Hour Meter

Displays the total time the machine has been used. The last digit indicates the tenth of an hour (after the decimal point).

If the hour meter on the left is in operation, the indicator light below it flashes.

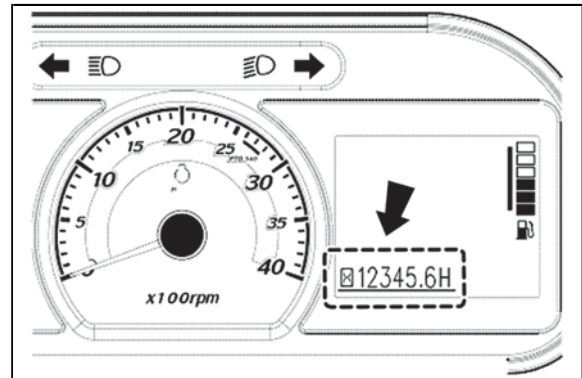

HODP045

Fuel Gauge

Displays the amount of fuel in the tank when the ignition switch is the ON position.



Notice: Poor fuel quality can damage the engine.

To make it easier to start the engine, use fuel intended for winter period in winter.

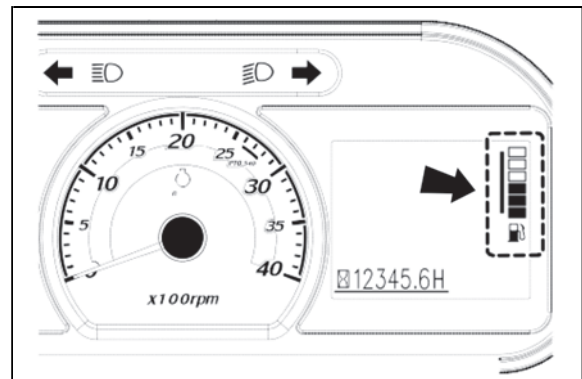

HODP046

Engine Coolant Temperature

Displays the coolant temperature when the ignition switch is in the ON position.

When this warning indicator light comes on while driving, it means the engine is overheated.



Operating the tractor at increased coolant temperatures can damage the engine.



HODP047

TRACTOR CONTROLS

Warning Indicator Lights

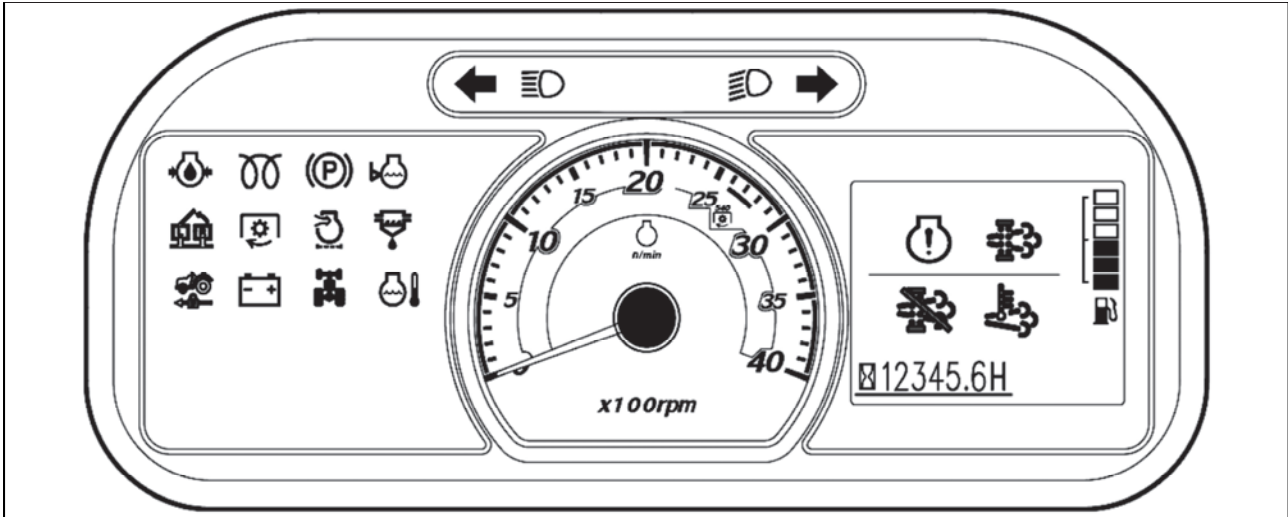

UCLS5N002



Turn signal lamp



High beam lamp



Low beam lamp



Fuel empty warning lamp



PTO monitor lamp This lamp will turn on when PTO is engaged.



Parking brake lamp This comes on when parking brake is engaged.



Glow signal lamp This lamp indicates pre-heating.



Charge lamp This lamp will go off as soon as the engine starts to run to indicate that the alternator is charging (Please note, as broken fan belt can cause the light to come on, please stop the engine as overheating can occur if not rectified immediately).



Oil pressure lamp This lamp will go out as soon as the engine starts if the oil pressure is correct. If it comes on while the engine is running, stop the engine and get expert advice.



Coolant temperature warning lamp This comes on when engine is overheated.



Water in fuel warning lamp When a certain amount of water is collected in the fuel filter, this lamp comes on. In this case, stop the engine and drain water from the fuel filter as soon as possible.



Air cleaner filter contamination indicator This comes on when the air cleaner is clogged by foreign materials.



DPF Regeneration Indicator The indicator light is on when DPF regeneration is in progress. Do not perform any work during regeneration

TRACTOR CONTROLS



DPF Warning Light This light flashes when the particulate filter is clogged. When this light flashes, start DPF regeneration using the relevant button.







Cruise control indicator This comes on while the cruise control (constant speed setting) is activated.)



One side brake warning lamp This comes on when brake interlock is not engaged.

Regeneration operation and cautions

Indicator lights

Indicator light	Funkcion
	DPF Warning Light
	Exhaust temp. lamp
	Engine warning lamp
	Regeneration Activation Button and indicator light
	Regeneration Emergency Stop Button

Lamps related to exhaust gas control system



MIL lamp comes on when DPF inlet temperature sensor system doesn't function properly.



Both MIL lamp and NCD lamp come on when either EGR sensor or air temperature sensor doesn't function properly.

Automatic regeneration



The regeneration process is automatically being performed when the exhaust temperature lamp comes on during work.

TRACTOR CONTROLS

DPF Regeneration Switch

During tractor operation, the particulate filter becomes clogged with solid particles generated during engine operation due to fuel combustion.

A clogged particulate filter is indicated by a flashing DPF regeneration light and an illuminated engine light. In this case, start regeneration of the DPF using the regeneration activation switch (ACK), whose indicator light also flashes.



Engine warning lamp



Regen request lamp

Activation (ACK)

1. Park the tractor on an even surface before performing DPF regeneration. Engage neutral, apply the parking brake and turn off the PTO.
2. Press the DPF regeneration activation button for three seconds. If regeneration of the DPF starts, the engine speed will increase to 2,200 rpm.
3. Regeneration takes approximately 30 - 40 minutes.
4. After successful regeneration of the DPF, the engine and DPF regeneration warning lights go out.



If the parking brake is not applied, the regeneration process will not start and the activation button will flash.



Regenerate the DPF in an open, well-ventilated area away from flammable substances.

Deactivation

Press the deactivation button only in an emergency. Do not press the deactivation button when the regeneration process is activated.

1. Regeneration Emergency Stop Button
2. Regeneration Activation Button (ACK)

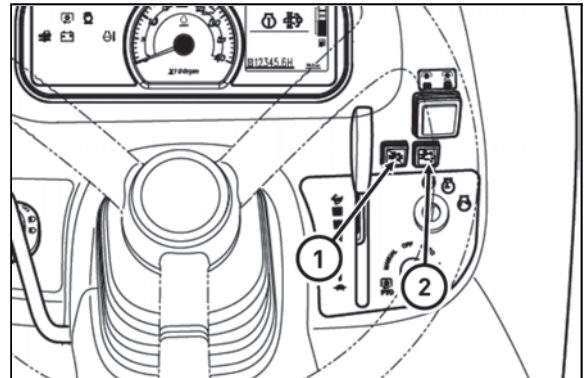

UCLS5N004

TRACTOR CONTROLS

PTO Control Switches

PTO Selector Switch

This switch is located near the starting key location on the dash panel. There are four positions marked for this switch.

1. **OFF** - The PTO shaft is stopped.
2. **Auto** - (Automatic) When the implement is raised to the preset height, the PTO shaft stops automatically.
3. **Manual** - The PTO shaft rotation status can be controlled by manually switching the PTO switch to the ON / OFF position.
4. **Intension mode** - On intension mode, PTO keep rotating even operator leaves from the seat.

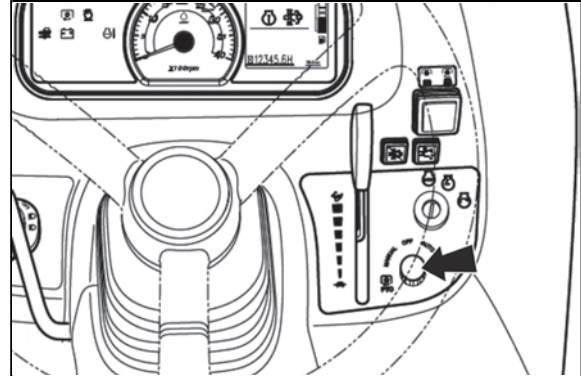

UCLS5N006

PTO Switch (ON/OFF)

It is used to turn the PTO on/off in conjunction with the PTO selector switch.

ON - Pressing the switch turns on the red indicator light and the PTO shaft rotates.

OFF - Pressing the switch again turns off the indicator light and the PTO shaft stops rotating.

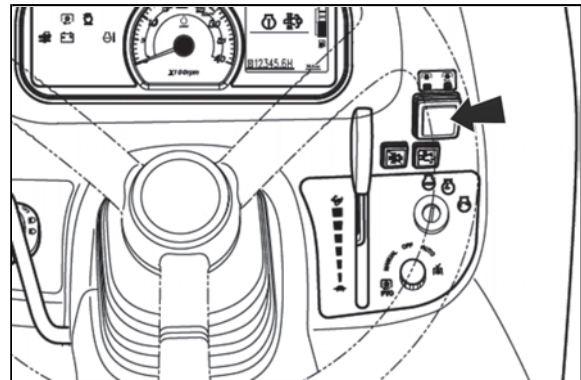

UCLS5N007



The **PTO indicator light** on the instrument panel indicates the PTO status.

1. If the indicator light is on: PTO rotates.
2. If the indicator light is off: PTO is off.
3. If the indicator flashes: PTO is not currently in motion, but shall be activated when the clutch pedal is released or the implement is lowered.

TRACTOR CONTROLS

The PTO does not rotate when one of the two switches is in the OFF position

The following table explains how the PTO operates in two different positions (Manual & Auto) of the PTO control switch with the PTO ON / OFF switch in the ON position.

PTO ON/OFF Switch	PTO Control Switch	Clutch Pedal	Hydraulic Position Control Lever	PTO Indicator Light on the Instrument Panel	PTO
ON	Manual mode	Depressed or released	Lifted or lowered	On	Rotates
ON	Auto mode	Depressed	Lifted or lowered	Flashes	Does not rotate
ON	Auto mode	Depressed or released	Lifted	Flashes	Does not rotate
ON	Auto mode	Released	Lowered	On	Rotates

- The table above shows the PTO safety features. When the indicator light on the dashboard flashes, it indicates to the operator that the PTO is in the 'ON' position, but does not temporarily rotate either because the clutch pedal is depressed or because the implement is lifted off the ground, or both. The PTO starts to rotate immediately when the clutch pedal is released and / or the implement is lowered to the working position.
- The operator must ensure that there are no persons in the operating area of the tractor due to possible bouncing of objects or particles from the rotating working parts of the implement and the intervention and injuries of persons near the working unit.
- Stopping the PTO, when lifting the implement from the ground together with a position check, prevents damage to the implement or PTO.



Warning:

- ***When the PTO control switch is in manual position the PTO does not stop rotating even if the clutch pedal is pressed. If working on hard soils, pavements with a rotary implement the PTO "ON/OFF" switch must be put to the "OFF" position to stop the PTO from rotating, If this is not done the rotating blades of the implement will push on the hard ground below and in turn push the tractor toward causing accident which can lead to serious injuries or death.***
- ***Extra precaution must be taken to clear the area of bystanders/onlookers when using PTO driven implements. The rotating blades of the implements can cause serious injuries on contact. The warning that is indicated by the blinking PTO monitor is to make the operator aware that the PTO is in on position and will instantly start rotating if the clutch pedal is released or implement is lowered or both.***
- ***In no case the specified rotating speeds indicated by the implement manufacturer be crossed as the same can lead to serious damage to the tractor/equipment and can lead to serious injuries to persons around.***

TRACTOR CONTROLS

Operation of Tractor Controls

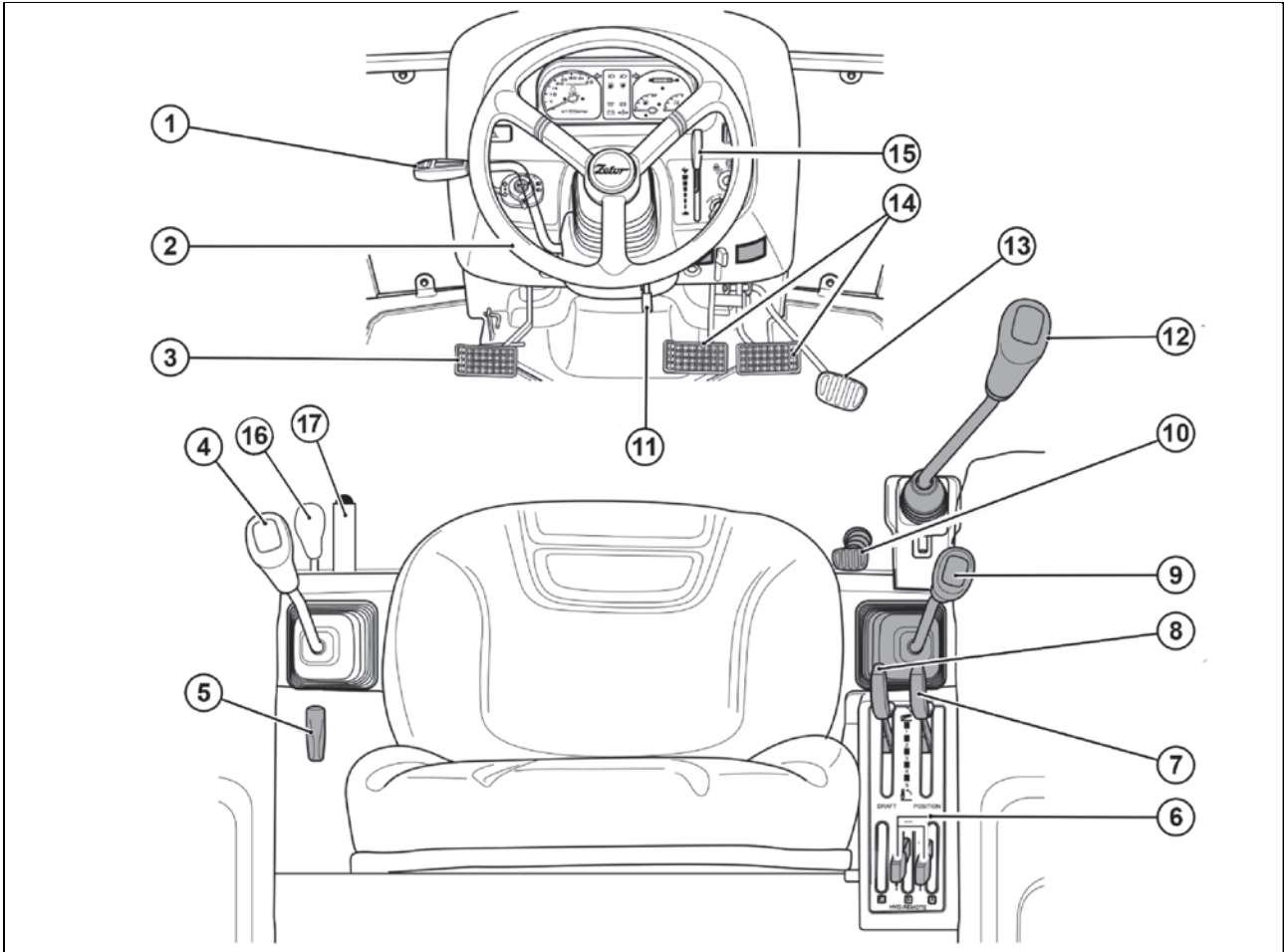

UCL18N019

- 1 - Reverse Shift Lever
- 2 - Steering Wheel
- 3 - Clutch Pedal
- 4 - Reduced Gears Shift Lever
- 5 - 4WD Shift Lever
- 6 - Sectional Directional Control Valve Control Lever
- 7 - 3-Point Hitch Position Regulation Lever
- 8 - 3-Point Hitch Draft Control Lever
- 9 - Main Shift Lever
- 10 - Differential Lock Pedal
- 11 - Steering Wheel Adjustment Lever
- 12 - Joystick Lever
- 13 - Accelerator Pedal
- 14 - Brake Pedal
- 15 - Hand Throttle Lever
- 16 - Rear PTO Speed Shift Lever
- 17 - Handbrake Lever

TRACTOR CONTROLS

Throttle Lever (Manual Control)

It is used to set the engine speed.



Pushing (away from the operator): speed increase.



Pulling (towards the operator): speed decrease.

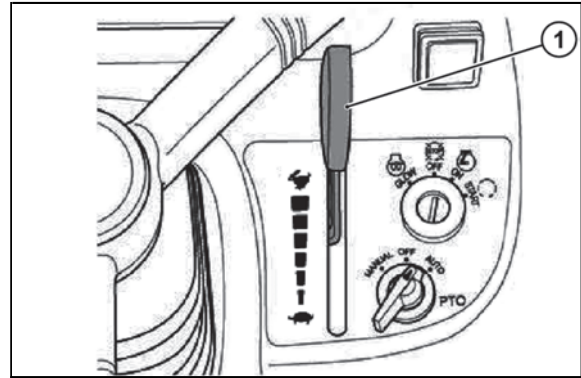

HODP055

Accelerator pedal

This pedal can override a fixed hand throttle setting.

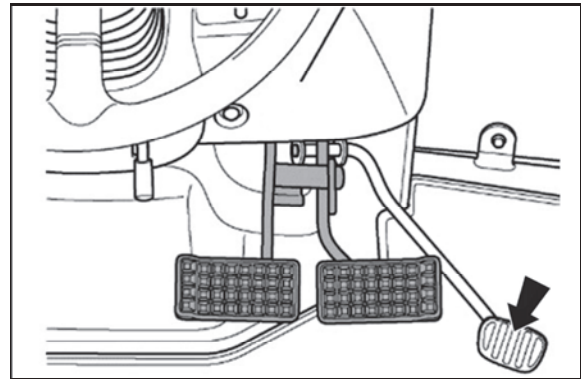

UCLS5N008

Clutch pedal

When the clutch pedal is depressed on models with manual transmissions, the drive is disengaged and the gear range and forward or reverse direction can be selected. Slowly release the pedal to start driving the tractor. Brake pedals control the rear wheel brakes.

1 - Clutch pedal

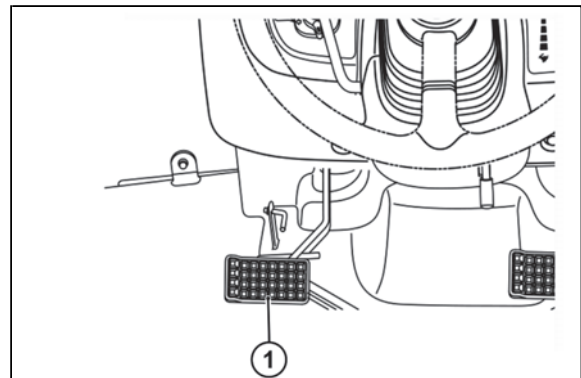

UCL18N021

TRACTOR CONTROLS

Clutch cut-off arm

For long term storage of the tractor it is possible to latch the clutch in the disengaged position. Push the clutch down and engage the latch to hold it there.



Warning: *Do not attempt to start engine when this arm is being used.*

- 1 - Clutch pedal
- 2 - Clutch pedal

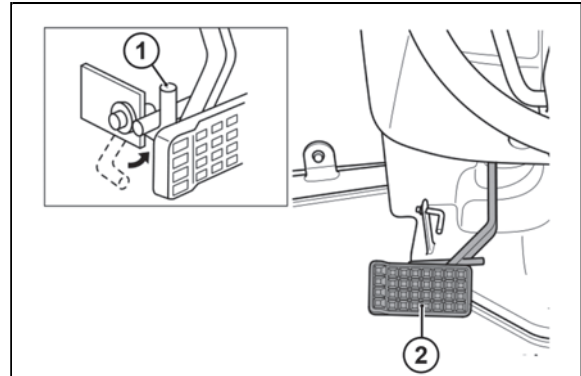

UCL18N022

Brake Pedals

The brake is used to force the vehicle to stop. This vehicle is equipped with separate brakes for its left and right side. The right and left brake pedals are designed to assist in turning the tractor in terrain and on unpaved surfaces.

A connecting latch is used to connect the left and right brake pedals.

When the brake pedals are disconnected, the warning light is on. When the brake pedals are connected, the warning light is off.

Driving on the road - Always connect both brake pedals, the brakes are applied simultaneously, the one-side brake indicator light is off.

Working in the field - Disconnect the brake pedals, only one side of the tractor is braking, the one-side brake indicator light is on.

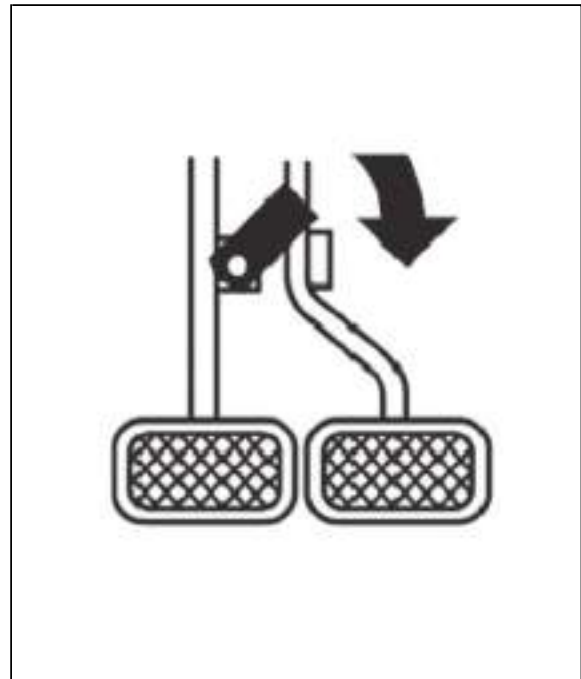

CCL25045



- **A connecting latch is available to connect the left and right brake pedals when driving at high speed or on the road.**
- **For safety reasons, always use it on the road or when driving at high speed, as braking on only one side can result in machine damage, serious accidents and serious injury or death.**
- **During tractor maintenance, make sure that the setting on both sides is the same.**

TRACTOR CONTROLS

Parking Brake Lever

The handbrake lever (1) is located on the left side of the driver's seat.

Pull the lever upwards up to the stop, to brake the tractor. The lever remains secured in the upper position with the latch.

To release the tractor, lift the handbrake lever slightly upwards, release the latch by pressing the button (2) at the end of the lever, lower the lever to the lower position and release the button (2).

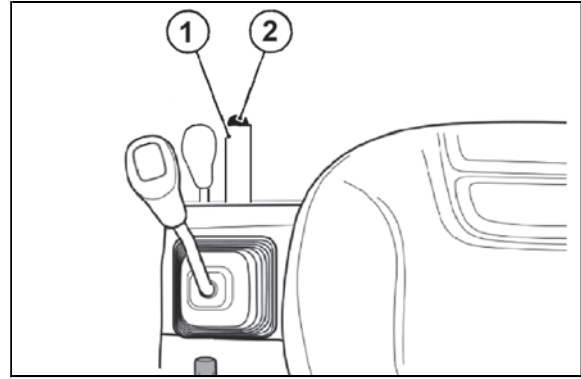

UCL18NN002



Important: *Traveling with the parking brake on will damage the brakes.*

Air brakes of trailers and semi-trailers

The control of the air brakes of trailers (semi-trailers) and the control of the tractor brakes is designed in such a way that the braking effect of both vehicles is synchronized.

Air pressure indication

The air pressure in the trailer or semi-trailer air brakes is indicated by an air pressure gauge located on the instrument panel.

If the air pressure gauge needle is in the red field, the air pressure in the trailer or semi-trailer air brake system is low.

If the air pressure gauge needle is in the green field, the value of the air pressure in the trailer or semi-trailer air brake system is correct.

If the air pressure gauge needle is in the yellow field, the air pressure in the trailer or semi-trailer air brake system is high, this is a malfunction, contact a service immediately. When driving a tractor with a trailer or semi-trailer with air brakes, the air pressure gauge needle must be in the green field.

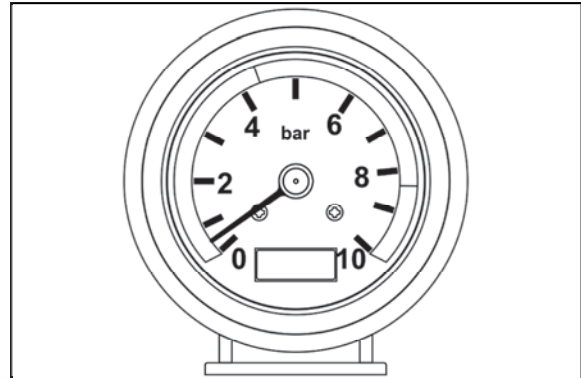

UCL18NN016



If the pressure gauge needle of a tractor with attached trailer or semi-trailer with air brakes drops into the red field, the tractor with trailer or semi-trailer with air brakes must not continue to travel. It is necessary to stop the unit and wait until the air pressure increases and the pressure gauge needle is within the green field of the pressure gauge.

TRACTOR CONTROLS

The button for temporary deactivation of brakes of the trailer or semi-trailer

The temporary trailer or semi-trailer brake deactivation button (1) is located on the dashboard panel.

The button for temporary deactivation of brakes of the trailer or semi-trailer can be used by the operator of the tractor with the connected trailer or semi-trailer to make sure that the effect of the parking braking system of the tractor with the connected trailer or semi-trailer when the tractor is braked with the hand brake is sufficient. If there is a tractor with the connected trailer or semi-trailer which is braked with the hand brake and the key in the switch box is in the position (I), and we press the button for temporary deactivation of brakes of the trailer or semi-trailer, the trailer or semi-trailer is deactivated for the time when the button is pressed (the trailer or semi-trailer does not brake). When the button for temporary deactivation of brakes of the trailer or semi-trailer is released, the brakes of the trailer or semi-trailer are activated (the trailer or semi-trailer brakes).

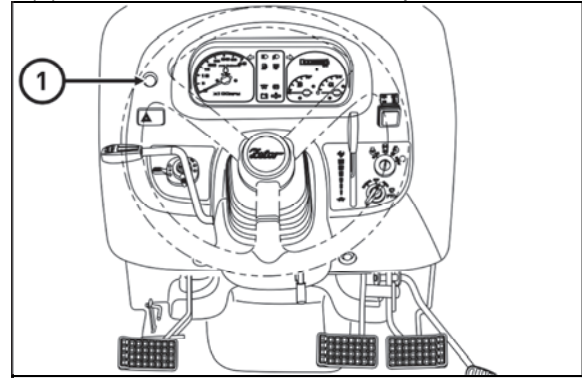

UCL18NN017



Prior to using the button for temporary deactivation of brakes of the trailer or semi-trailer, it is always necessary to provide sufficient space in front of the tractor and behind the connected trailer or semi-trailer where no obstacles or persons will be present for the case that the effect of the parking braking will not be sufficient and the combination of vehicles moves.



Only the air brakes are deactivated by the button for temporary deactivation of brakes of the trailer or semi-trailer.

TRACTOR CONTROLS

One-hose and two-hose brakes

1. clutch head of one-hose brakes
2. clutch heads of two-hose brakes



Clutch heads after disconnection or without a connected trailer, articulated trailer must be closed by a valve.

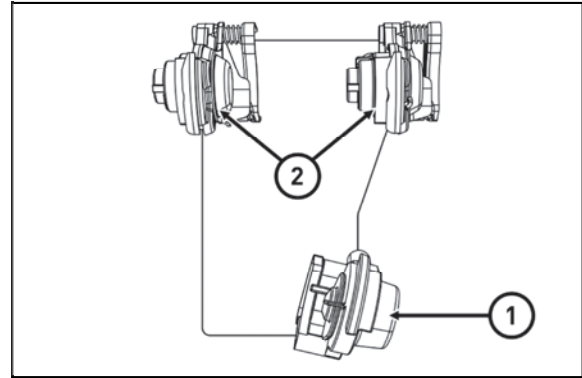

UCL18NN018

One-hose brakes

The coupling head of a single-hose air brake has a flap marked black.

The coupling head marked black serves both for filling and controlling for the single-hose air brake system of the trailer or semi-trailer.



The maximum permitted speed of the unit is given by the maximum permitted speed of the slower unit vehicle.

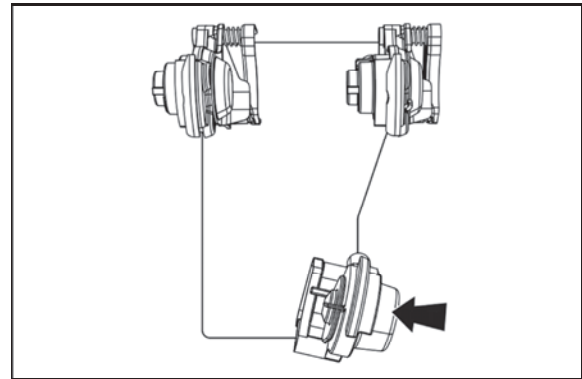

UCL18NN019

Two-hose brakes

The left-hand flap (1) is marked yellow (braking line), the right-hand flap (2) is red (filling line).



The maximum permitted speed of the unit is given by the maximum permitted speed of the slower unit vehicle .

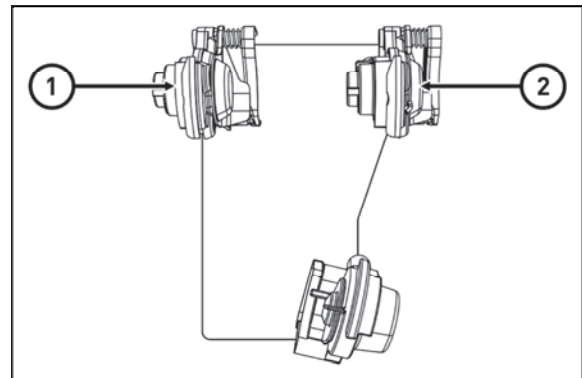

UCL18NN020

TRACTOR CONTROLS

Reverse Shift Lever

This control allows you to change the direction of travel from front to reverse and from reverse to front. When not in motion, move the lever to the 'N' position for neutral.

- Push the lever away from the driver to drive forward.
- Pull the lever towards the driver to reverse.

1. Reverse Shift Lever

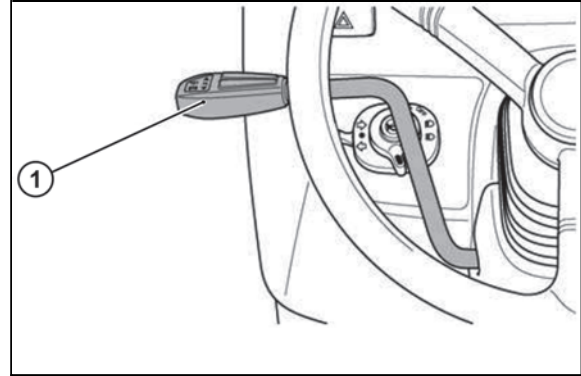

HODP061



Depress the clutch pedal fully before moving the reverse shift lever.

When changing the direction from front to reverse or reverse to front, make sure that the tractor is stopped before changing the direction. Failure to do so may result in damage to the machine or serious injury.



Warning:

- ***Only use the reverse shift lever when sitting in the tractor.***
- ***Do not use the reverse lever to start the tractor when towing or driving uphill, use the clutch instead.***
- ***Always stop before getting off the tractor.***



If the parking brake is applied during the starting off, it is signaled by an audible warning signal.

If the parking brake is applied during driving, the brakes will be damaged.

TRACTOR CONTROLS

Reduced and Road Gears Shift Lever

1. Road Gear Shift Lever

It is located on the right side of the driver's seat.

Shift gears with the clutch pedal depressed, both when the tractor is stationary and when it moves.

2. Reduced Gears Shift Lever

The lever is located on the left side of the driver's seat.

Shift the gears when the clutch pedal is depressed only when the tractor is stationary.

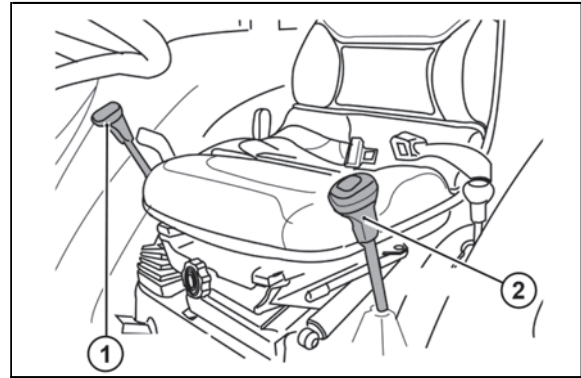

UCL18N024

Gear shifting scheme

1. Road Gear Shift Lever

2. Reduced Gears Shift Lever

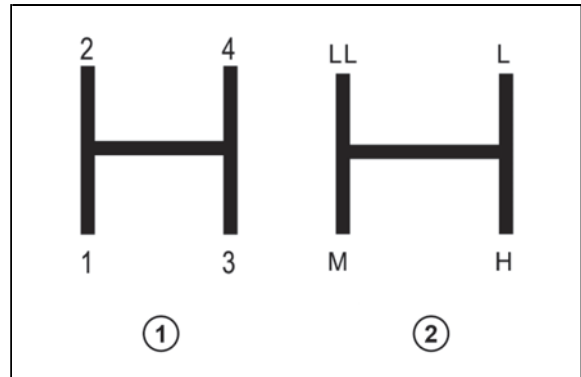

UCL18N025

The main shift lever provides four speed ranges. The Sub shift lever provides four gear positions. The Shuttle shift lever controls travel direction.

Use all three levers in different combinations to achieve Sixteen forward and Sixteen reverse speeds. Always select the correct speed range and gear for the job.



Select the proper speed range and gear for the job.

The machine maybe operated in any gear with engine speeds at 950-2600 rpm. Within these limits, the engine can be placed under varying load operations.

Never overload engine by lugging machine at low idle speeds.

Raise engine speed the match expected loads.If a slight increase engine rpm occurs simultaneously with moving hand throttle lever forward,the engine is not overloaded.



When you leave the tractor, be sure to apply the parking brake and stop the engine.

The torque of wheel axle is extremely high while creep speed is being used. Be sure to step down on the clutch pedal completely before applying the brakes, or they will not work.

When starting to operate the tractor, be sure to release the parking brakes. Misuse of the brakes may cause damage to the transmission.

TRACTOR CONTROLS

Differential Lock Pedal

The differential lock is a device for locking the differential system so that the left and right wheels rotate at the same speed. This function can be used when the rear wheels are slipping.

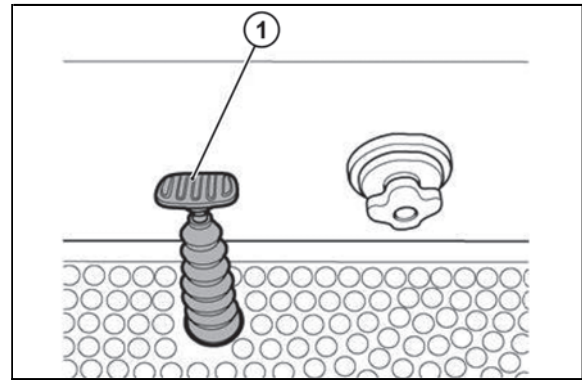

HODP066



Never use the differential lock at high speed or on the road, as this may cause the machine to roll over and cause injury.



It is difficult to turn the tractor when the differential lock is applied. To prevent damage to the mechanism, turn the differential lock off before turning the steering wheel.



Do not use high engine rpm with the differential lock engaged. If the differential lock is not released after removing the foot from the lock pedal, alternately brake with the left and right directional brake until it is released.

Front Axle Drive Shift Lever (4WD)

1 - Front Axle Drive Lever

In the ON position the front axle drive is connected and in the OFF position the front axle drive is disconnected. Activate and deactivate the front axle drive when driving straight at low engine speeds.

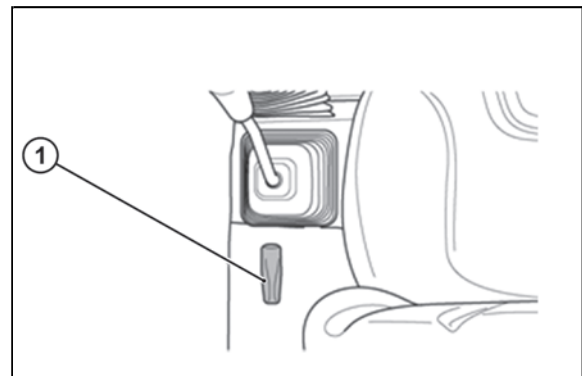

U18N031



Stop the tractor before shifting the front axle drive.



If it is not possible to engage the front axle drive, do not use excessive force. Instead, drive the tractor forward or backward slightly and try to engage the lever again. To reduce tire wear, do not use the front axle drive on the road.

TRACTOR CONTROLS

Driver's Seat

1. Seat belt, adjust the length of the belt as needed before driving and fasten it.
2. Seat adjustment, the seat can be adjusted by moving it forwards or backwards by pushing the seat movement lever located on the front of the seat. After adjustment, make sure that the seat is firmly secured.

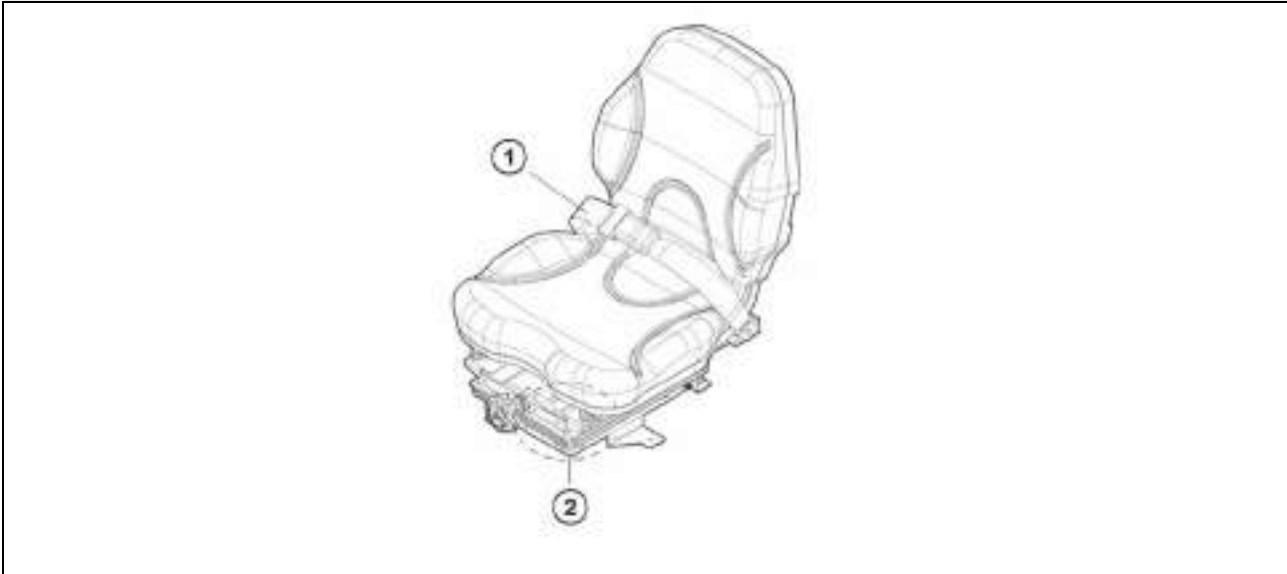

CCL25004

Steering Wheel Adjustment Lever

It is used to adjust the inclination of the steering wheel to the desired position (3 options).

1. Steering Wheel Adjustment Lever

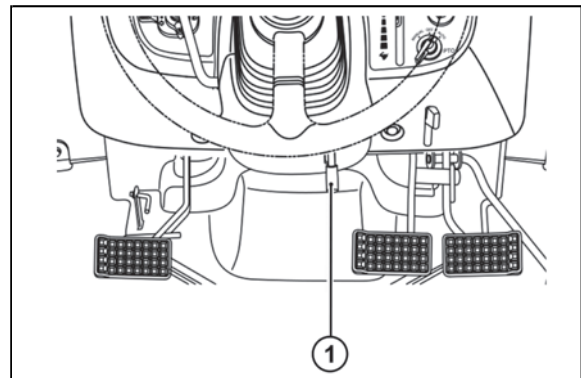

UCL18N028



Before starting the tractor, make sure that the steering wheel adjustment lever is locked.

TRACTOR CONTROLS

PTO Shift Lever

The rear PTO shift lever is located on the left side under the driver's seat and can be moved to the upper position (540 rpm) or to the lower position (1,000 rpm) from the center, neutral position, according to the specification of the attached implement.

In no case shall the specified speeds be exceeded, as this may result in serious damage to the tractor / attached implement.

When the PTO is not in use, the gear shift lever must be placed in the neutral position to prevent accidental lowering.

Your tractor is equipped with 2 Speed PTO to suit range of applications and conditions.

1 - PTO Shift Lever

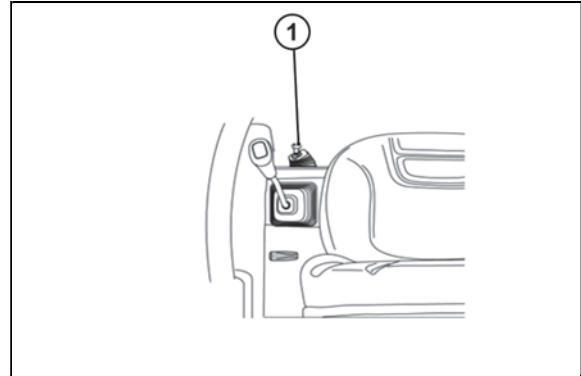

U18N032A



**Only move the PTO shift lever with the PTO switched off.
Always use the clutch when connecting or disconnecting the PTO shaft.**

Operating the hydraulics

The hydraulics are powered with an engine driven hydraulic pump and controlled with a position control lever mounted beside the driver.

1 - Position control lever

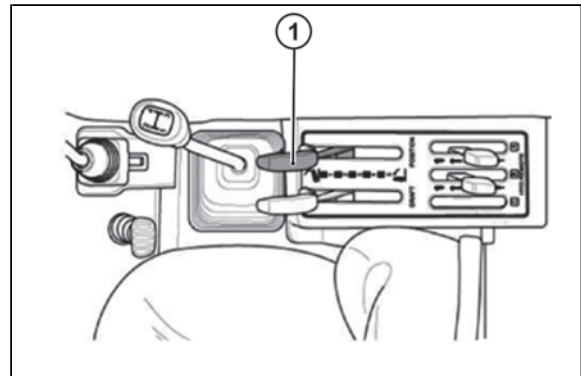

UCL18N029



Danger: When working with the three-point hitch, it is necessary to stay away from the radius of lift arms and all connected equipment. This eliminates the risk of injury in case of improper handling.

TRACTOR CONTROLS

Position control

1 - Position Regulation Lever

The implements can be raised and lowered using the position regulation lever and can be stopped at any position by stopping the lever shift.

To ensure a constant working depth, an adjustable stop can be used to ensure that the implement always returns to the same depth.

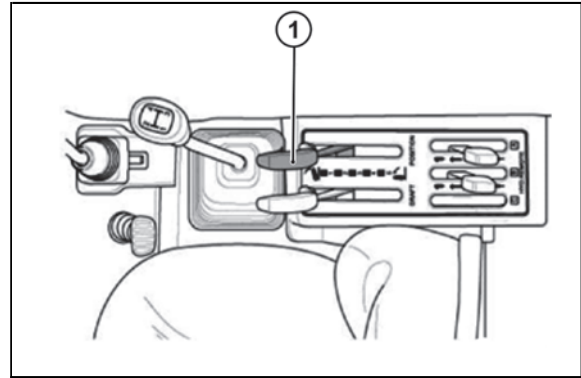

UCL18N029

To raise the implements: Pull the lever backwards

To lower the implement: Push the lever forwards.



Warning: After finishing the work, always lower the implement to the ground and switch off the engine, set the parking brake to avoid injuries and accidents.

Draft control

1 - Draft Control Lever

2 - Floating position

3 - Draft Control Range

4 - Lifting

For precise work, the soil tillage implement can be adjusted using draft control. When the lever is moved forward, the depth increases. When the lever is pulled back, the depth decreases.

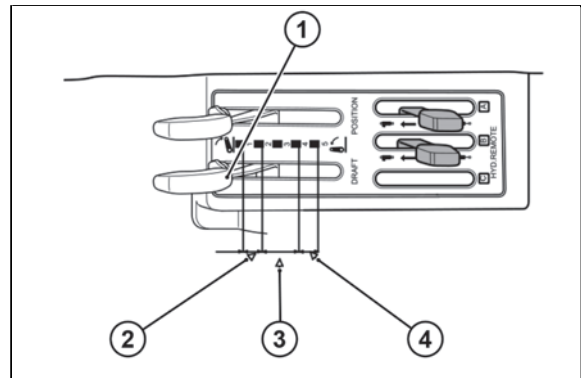

UCL18N030

TRACTOR CONTROLS

Three-Point Hitch Lowering Speed Control

It is used to set the lowering speed of the implement attached in the three-point hitch. It is located under the driver's seat.

1. Three-Point Hitch Speed Control

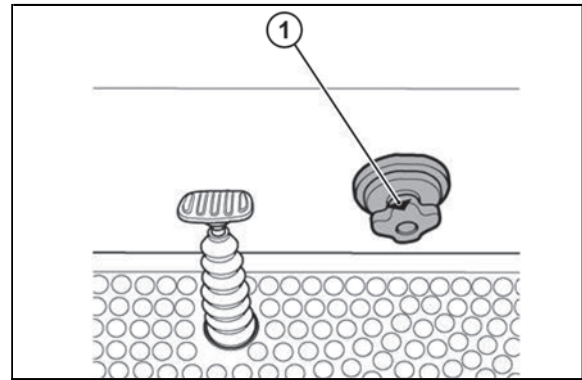

HODP073

To reduce the lowering speed of the three-point hitch arms, turn the control clockwise.

To increase the lowering speed of the three-point hitch arms, turn the control anticlockwise.

If the lowering speed control is turned clockwise to the stop, the arms of the rear three-point hitch cannot be lowered.

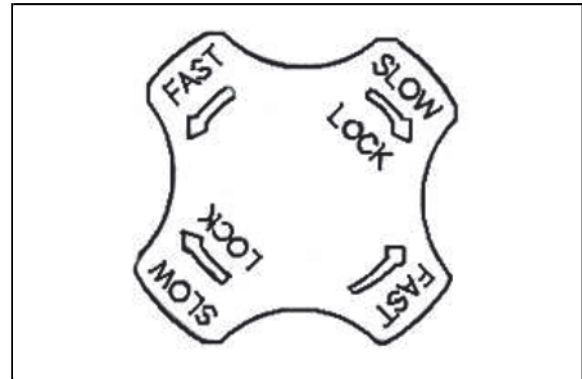

HODP074



Always lock the control when:

1. **Driving on the road.**
2. **Servicing or maintaining the implement attached in three-point hitch**

Outer hydraulic circuit

It supplies pressure oil for hydraulic devices on outer drives of hydraulics ended with couplers. Coupler sockets with 12.5 mm bore are in accordance with the international recommendation of ISO.

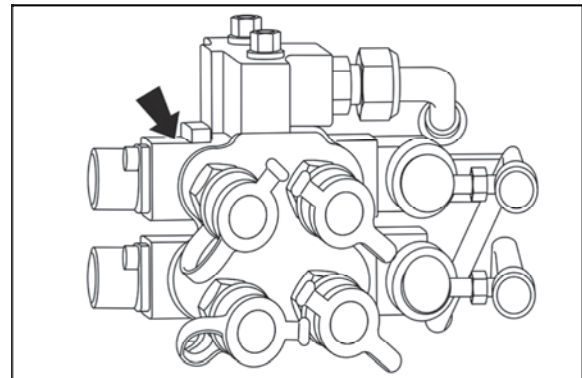

UCL18NN028

TRACTOR CONTROLS

Outer hydraulic circuit controls

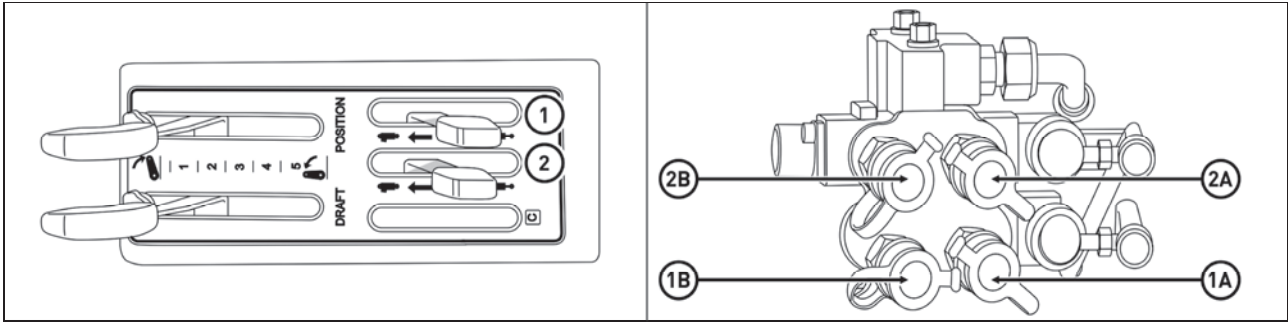

UCL18NN029

- By moving the lever (1) forward, pressure oil is supplied to the quick coupler (1A).
- By moving the lever (1) backwards, pressure oil is supplied to the quick coupler (1B).
- By moving the lever (2) forward, pressure oil is supplied to the quick coupler (2A).
- By moving the lever (2) backwards, pressure oil is supplied to the quick coupler (2B).

The SCVs quick couplers are operated by levers (1) and (2) located on the panel on the right side of the driver's seat.

Important:

As soon as the implement operated by the pressure oil from the quick couplers reaches the end of the stroke, return the lever to the middle (neutral) position, when there is no oil pressure in the quick couplers; otherwise the oil will flow through the relief valve. When the oil is pushed through the relief valve for a longer period of time, oil becomes overheated. When using the tractor hydraulic system to drive the front loader, do not use the SCVs and the loader at the same time.

Remote hydraulic control valve coupler connecting and disconnecting



When connecting and disconnecting the quick-couplers pay increased attention with regard to the residual oil that remains in the socket or on the plug of the quick-coupler. For environmental reasons after every disconnection of quick-couplers this residual oil must be removed with any textile material.

Connection

- 1) Do not forget to stop the engine before connecting the implement.
- 2) Move the lever of the double-acting valve forward and backward 4 to 5 times to release the pressure in the tractor's hydraulic lines. Otherwise it may be difficult to attach the couplers and hydraulic fluid may splash out of the hoses and strike the eyes when coupling.
- 3) Remove any dirt around the couplers. If dirt enters the hydraulic parts, the system may fail.
- 4) Open the dustproof clutch cover on the tractor and connect the implement coupler. You should hear a click when the coupler is engaged.
- 5) Pull the hydraulic hose to check that the couplers are correctly connected.
- 6) Start the engine and check for operation and leaks.

Disconnection

- 1) Do not forget to stop the engine before disconnecting the implement.
- 2) Relieve the residual pressure in the hydraulic hoses of the machine and the tractor by moving the lever of the double-acting valve 4 to 5 times backwards and forwards.
- 3) Remove any dirt around the quick couplers.
- 4) Keep the implement unloaded by removing all load (e.g. by lowering or placing the implement on the mat). If the hose is disconnected when the implement is loaded, it will be difficult to reconnect it in the future.
- 5) Disconnect the quick couplers by pulling them backwards.
- 6) Close the dustproof cover of the quick couplers of the tractor. Cover the quick coupler of the disconnected implement so that no dirt can penetrate.



Warning:

- **Never connect or disconnect the implement hydraulic hose while the pressure in it is not released or the engine is running. It is hard to connect and disconnect the hose and hydraulic fluid can be sprayed from the hose, and get into your eyes or skin.**
- **Stop the engine and wear protective glasses and gloves before work.**

TRACTOR CONTROLS

Joystick Lever

To control the front loader and the front three-point hitch, the joystick lever is used.

It allows to control the lifting, lowering and unloading of the front loader with one lever.

To lift the front loader: Pull the lever backwards.

To lower the front loader: Push the lever forwards.

To roll back the adapter: Push the lever to the left.

To dump (unload) the adapter: Push the lever to the right.

To control the third loader function, the button located on the joystick head is used.

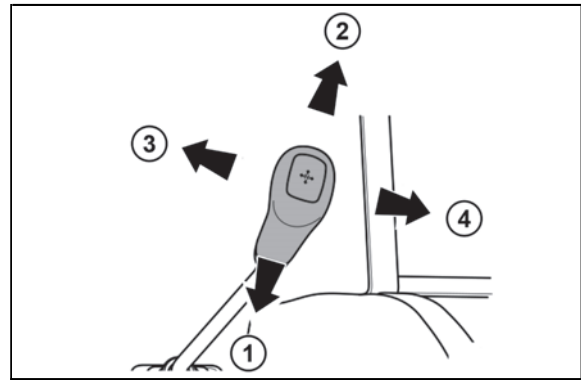

UCL 18N034

1. Lifting of the front loader boom
2. Lowering of the front loader boom
3. Rolling the front loader adapter back
4. Dumping the front loader adapter

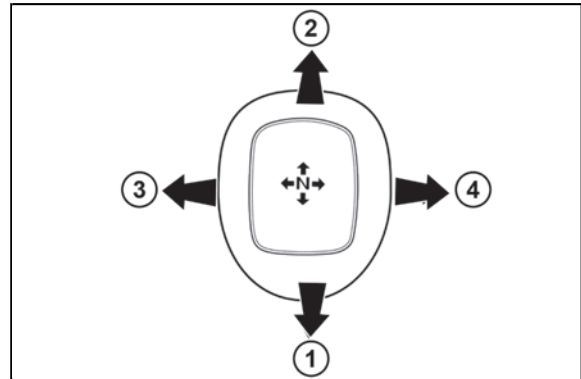

UCL 18N035



Do not operate the boom and adapter at the same time, the loader may not work properly due to insufficient oil flow.



Warning:

Hydraulic fluid escaping under pressure can have enough force to penetrate the skin.

Hydraulic fluid may also infect a minor cut or opening in the skin.

If injured by escaping fluid. See a doctor at once.

Serious infection or reaction can result if medical treatment is not given immediately. Make sure all connections are tight and that hoses and lines are in good condition before applying pressure to the system.

Release all pressure before disconnecting the lines or performing other work on the hydraulic system.

To find a leak under pressure use a small piece of cardboard or wood. Never use hands.

TRACTOR CONTROLS

Joystick lever lock

With this simple safety system, the joystick can be locked by pressing and unlocked by pulling the control.

- 1 - Locking the Joystick
- 2 - Unlocking the Joystick

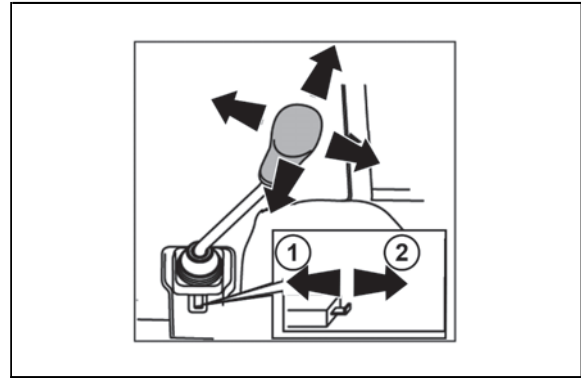

U18N040



Whenever the joystick lever is not used, lock it in the neutral position with the lock button. Otherwise, the implement may drop unexpectedly, in case the joystick lever is moved accidentally.

Connecting and Disconnecting Implement

Connection

1. Do not forget to stop the engine before connecting the implement.
2. Depressurize the external hydraulic circuit by repeatedly moving the control lever to the end positions. Otherwise the couplers may be difficult to connect or the oil may expand from the hoses when connecting.
3. Remove any dirt from the quick couplers. If contamination of the hydraulic circuit occurs, there might be a malfunction in the system.
4. Open the tractor quick coupler dust cover and insert the implement counterpart. You should hear a click when you connect the quick coupler.
5. Pull the hydraulic hose of the implement to check that the couplers are properly connected.
6. Start the engine and check for operation and leaks.

Disconnection

1. Do not forget to stop the engine before disconnecting the implement.
2. Release any residual pressure in the hydraulic hoses of the machine and tractor by repeatedly moving the control lever to the end positions.
3. Remove any dirt around the quick couplers.
4. Lower the implement on the ground. If the hose is disconnected when the implement is loaded, it will be difficult to reconnect it.
5. Disconnect the quick couplers by pulling them backwards.
6. Cover the quick couplers on the tractor and implement with dust plugs to prevent dirt from entering.



WARNING:

- **Never connect or disconnect the hydraulic hose of the implement when the pressure is not released or while the engine is running. Otherwise it is difficult to connect or disconnect the quick couplers and hydraulic fluid may splash out of the hoses and get into the eyes or penetrate the skin.**
- **Stop the engine and wear protective goggles and gloves before assembly / disassembly.**

TRACTOR CONTROLS

Mounting Implement

If the PTO is used, remove the safety cover (1) from the PTO shaft.

Connect the lower left link, then connect the lower right link using the adjusting handle, if necessary.

Connect the upper link.

Connect the PTO shaft to the tractor, if used, and make sure it is properly locked in place.

Adjust the stabilizer bars so that it corresponds to the implement and tighten the retaining nuts.

To disconnect the implement, proceed in the reverse order.

When not in use, lubricate the PTO shaft with grease and install a cap.

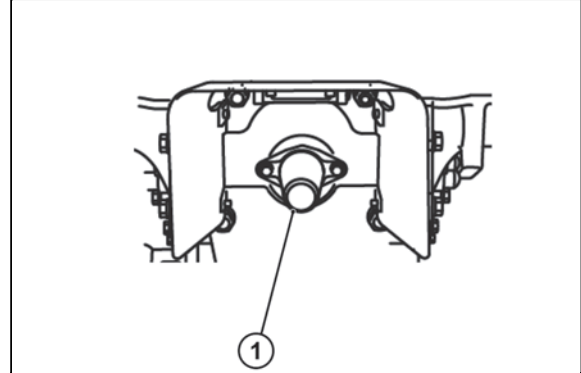

U18N048



Caution: Do not attach a PTO shaft with the engine running and ensure all safety shields are in place.



Under no circumstances should the rotational speeds specified by the implement manufacturer be exceeded, as this may result in serious damage to the tractor/equipment and serious injuries to bystanders.

Read the operating and maintenance manual of the implement carefully before operating it.



The measures must be taken to ensure that there are not bystanders around the tractor while working with a PTO-driven implement. Rotating blades of the implement can cause serious injuries. When not in use, install a protective cap on the PTO shaft.

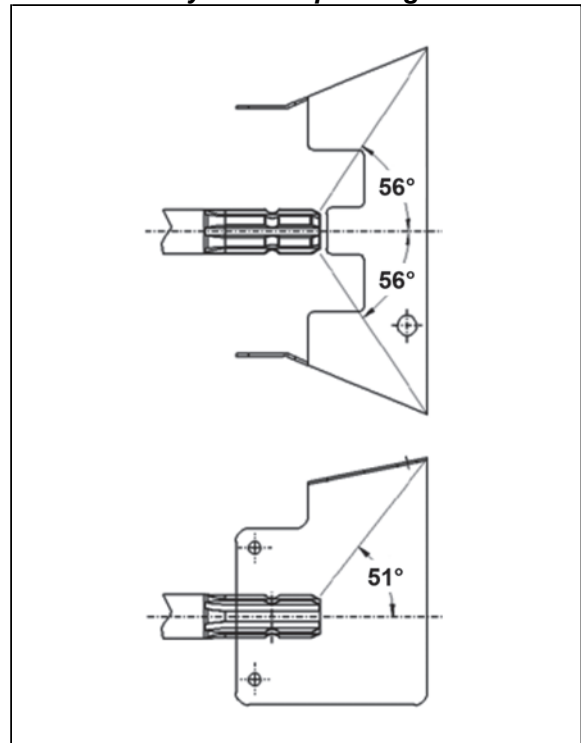

U18N055B

TRACTOR CONTROLS

Three-Point Hitch Control

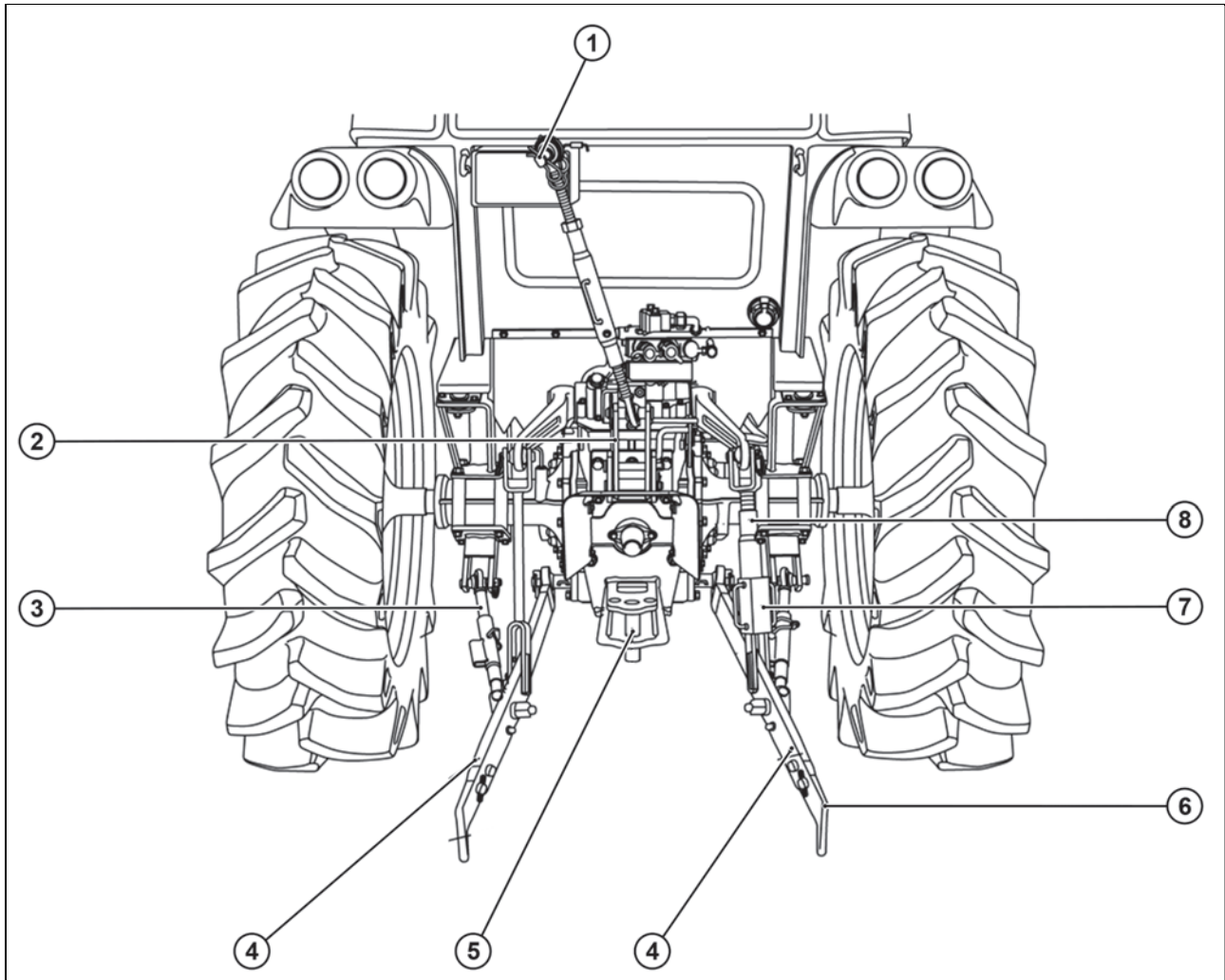

U18N041

- 1 - Upper Link
- 2 - Link Bracket
- 3 - Stabilizer bar
- 4 - Extendable Type of Lower Link
- 5 - Lower Swinging Hitch
- 6 - Lower Link
- 7 - Length Adjustment Handle of the Vertical Link
- 8 - Vertical Link

TRACTOR CONTROLS

Upper Link Adjustment

1 - Upper Link

2 - Length Adjustment Handle of the Upper Link. Extending or shortening the upper link changes the angle of the implement.

After adjustment, secure the adjustment handle with its mounting nut.

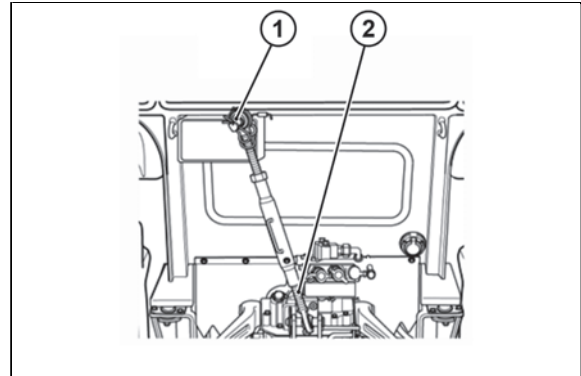

U18N043

The locating hole of the top link varies with the type of implement used.

1) The most common locations are the 1st and 2nd hole from the top (1).

2) For general implement: Use the Pin to **Position 3** point.

3) For Draft control: Use the Pin to **Position 2** point.

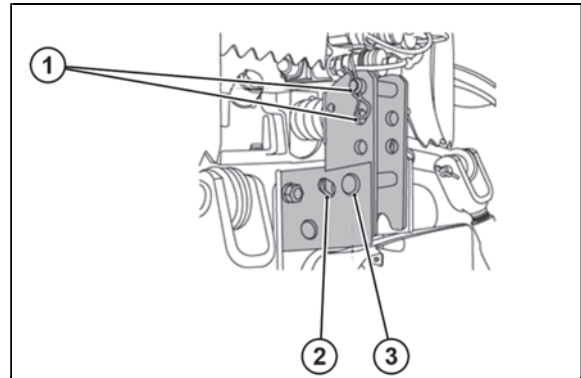

U18N044

Adjustment of the stabilizer bars

The stabilizer bars are designed to limit or prevent lateral movement of the implement.

No clearance is permitted when transporting implements and when working on slopes, with rollers, mowers, seeders, drills and similar implements (**position 1**).

However, a slight clearance (**position 2**) is necessary when working with plows, harrows, excavators, cultivators, etc., especially when working with draft control.

The length of the stabilizer bars is adjusted after removal of the pin by turning the tensioner through which the threaded plugs are connected.

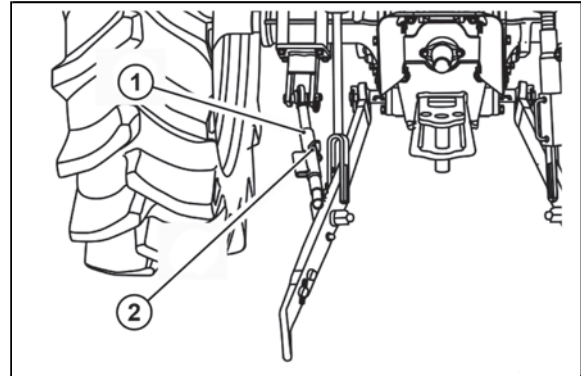

UCL 18N037

Adjustment of the lower links of the three-point hitch

1 - Vertical link

Adjustment is made using the adjustment handle of the right vertical link.

Turn the handle clockwise to retract and turn the handle counterclockwise to extend.

After proper adjustment, secure the handle against spontaneous rotation.

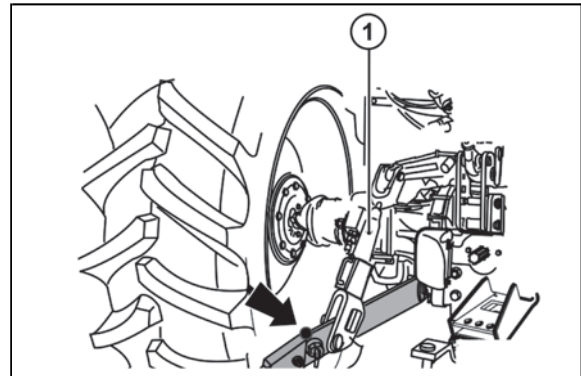

UCL 18N040

TRACTOR CONTROLS

Retraction of the lower link (if it is the extendable type)

Push the point area and pull the end of the lower link to adjust the length of lower link.

Adjustment of the lift link on the lower link

- 1 - Lifting Arm
- 2 - Lower Link
- 3 - Holes for Stabilizer Bar
- 4 - Extendable Type of Lower Link
- 5 - Position Holes of the Vertical Link
- 6 - Vertical link

For various applications, the lifting height of the lower links can be adjusted by adjusting the pins in the holes of the vertical links.

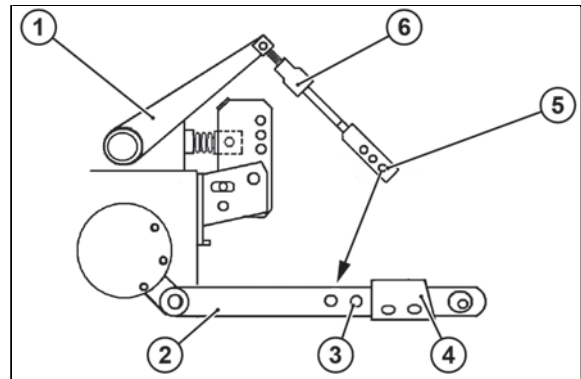

U18N046



When no implement is connected, secure the lower links with the stabilizer bars, so that the lower links do not touch the rear wheels.



Danger: Only use drawbar to tow and keep the 3 point linkage in raised position when toeing with the drawbar. Position can create unbalance causing the tractor to roll-over & result the death or serious injury.

TRACTOR CONTROLS

Towing Equipment

It is used to attach implements with a requirement for the lower hitch. When coupling the implement to the lower swinging hitch, make sure that there is no collision with the lower link arms of the 3-point hitch.

1. Locking Pin
2. Pin

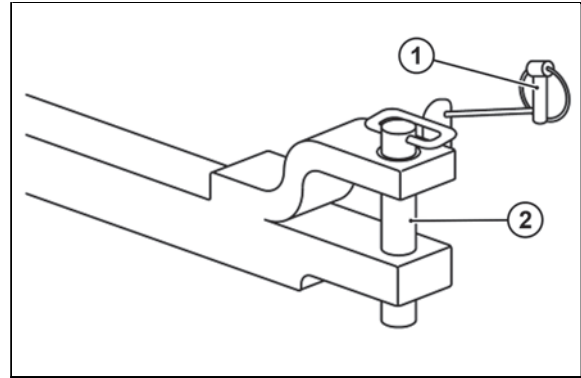

U18N050



Warning:

- **Always secure the hitch pin with a locking pin to prevent spontaneous disconnection and disassembly of the units, which may result in machine damage, accident, or serious injuries.**
- **Avoid anyone riding on the swinging hitch.**
- **For towing, use the lower hitch or drawbar for 3-point hitch, which is adjusted to the height of the lower hitch. In order to keep the operation safe and to maintain the traction capability, it is essential that the front axle is not lifted.**
- **Incorrect 3-point hitch height adjustment or incorrect mounting can cause machine damage, serious injury or death.**
- **The front towing equipment should be used for emergency towing of a trailer or for towing a tractor in the yard or an authorized service center.**

Connection and disconnection of implements

To connect implements in the lower hitch, proceed as follows

- Remove the locking pin 1
- Remove the pin 2
- Slowly reverse the tractor up to the implement
- Insert pin 2
- Secure the locking pin 1

TRACTOR CONTROLS

Lower Hitch Disassembly

After releasing the locking devices, remove the two pins (1).

Remove the lower hitch by pulling it backwards in the direction of the arrow.

Follow the reverse procedure to reassemble the lower hitch.

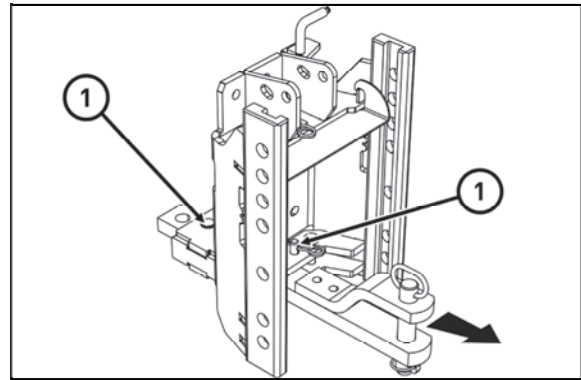

UCL18NN009

Multi-level hitch

Used to attach two-axle or lighter one-axle trailers. The guide tail piece is height adjustable. When working with various agricultural machines, it is necessary to adjust the height of the hitch or dismount it if necessary.



ATTENTION: To connect the attached equipment, the automatic tail piece (if equipped) is unlocked by the control lever of the hitch tail piece by lifting it to the upper position where it will automatically lock in the open position. When the drawbar is situated in the correct position in relation to the hitch, the machine is automatically locked, the machines are connected. Never place your hands or foreign objects in the tail piece with the control lever locked in the upper position. There is a risk of serious injury.

1. Multi-Level Hitch Console
2. Rear PTO Cover
3. Multi-level Hitch Attachment Tail Piece
4. Lower Swinging Hitch

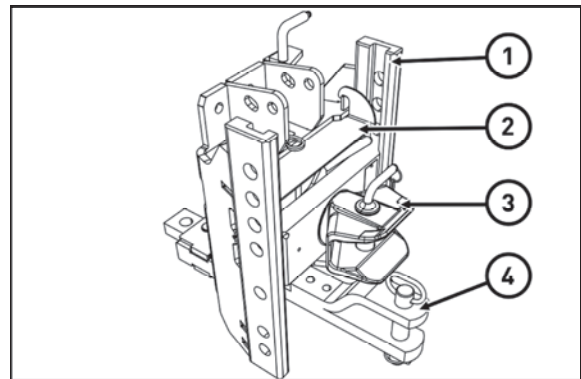

UCL18NN006

Disassembly of the rear PTO cover

Pull the locking device (1) towards yourself to remove it. Grasp the back of the cover and lift the cover in the direction of the arrow into the vertical position.

Pull the cover upwards to remove it from the hooks (2). Follow the reverse procedure to reassemble the cover.



When working with the rear PTO, the cover must always be installed.

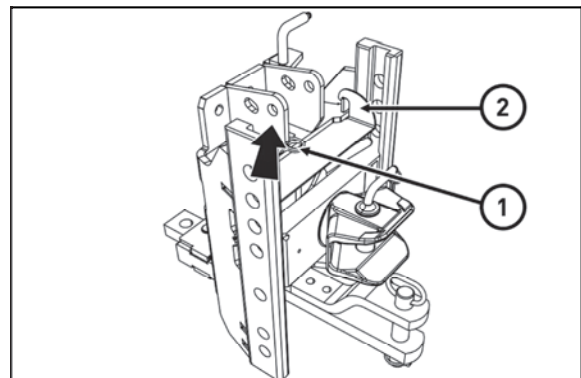

UCL18NN007

TRACTOR CONTROLS

Height Adjustment and Disassembly of the Multi-level Hitch Attachment Tail Piece

Remove the rear PTO cover and, if necessary, the lower hitch before handling the multi-level hitch attachment tail piece. Grasp the multi-level hitch attachment tail piece firmly. Moving the lever (1) in the direction of the arrow (upwards) engages the locking pins (2) and the tail piece is freely movable in the grooves of the multi-level console. Adjust the multi-level hitch attachment tail piece to a suitable height so that the locking pins (2) are aligned with the holes in the multi-level hitch console and release the lever (1); the locking pins (2) slide into the holes in the multi-level hitch console. Check that the pins (2) slightly overlap the outer edge of the multi-level console. Perform the disassembly of the multi-level hitch attachment tail piece after pulling the lever (1), by sliding the tail piece upwards out of the grooves of the multi-level console. Perform the assembly in the reverse order.

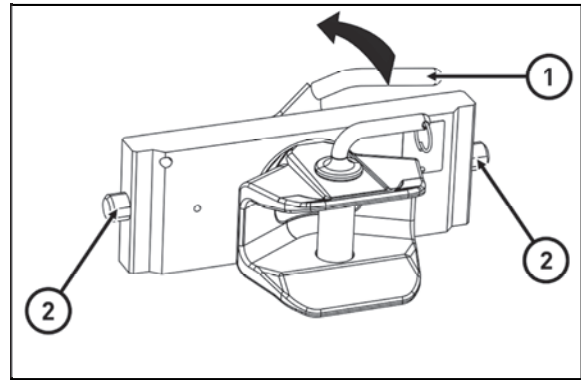

UCL18NN008

* Front Three-point Hitch

It is used for attachment of front mounted implements and tools with hitch points of category I according to ISO.

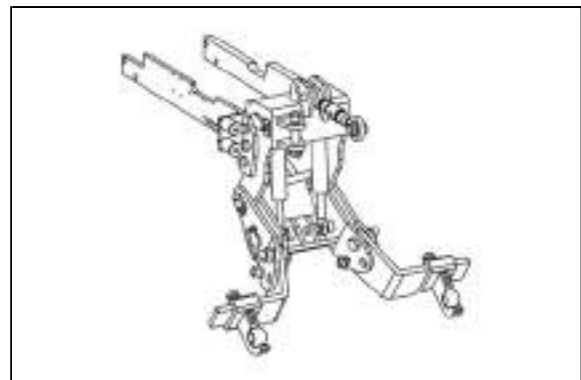

UCL18NN005



Note: The required width of the front hydraulic arms can be adjusted to a certain extent by adjusting the end points.
More information in the Operator's manual of the front three-point hitch manufacturer.

Lifting force of the front three-point hitch

Lifting force	
Front	700 kg

TRACTOR CONTROLS

Controlling front three-point hitch

The hitch is equipped with two hydraulic cylinders. Lifting and lowering is performed by the joystick lever located on the right side of the driver's seat.

- 1 - Lifting of Front Three-Point Hitch Arms
- 2 - Lowering of Front Three-Point Hitch Arms
- 3, 4 - Oil pressure release to the quick couplers of the SCV located on the front three-point hitch
- 5 - Joystick lever is locked
- 6 - Joystick lever is unlocked

The button on the joystick head is not functional in this case.

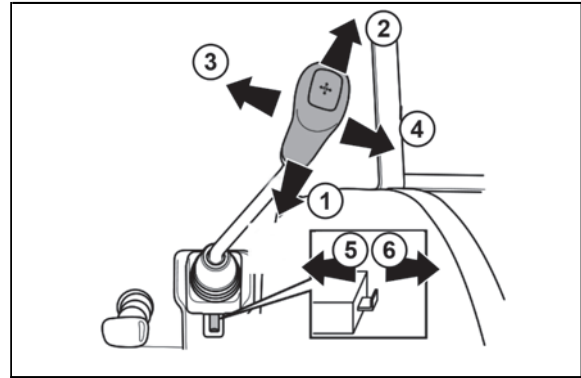

UCL18N036



After lowering or lifting the front three-point hitch arms to the required position, lock the joystick lever with the lock (5) to prevent it from moving when accidentally leaning against the joystick lever.

Hydraulic lock of the front three-point hitch

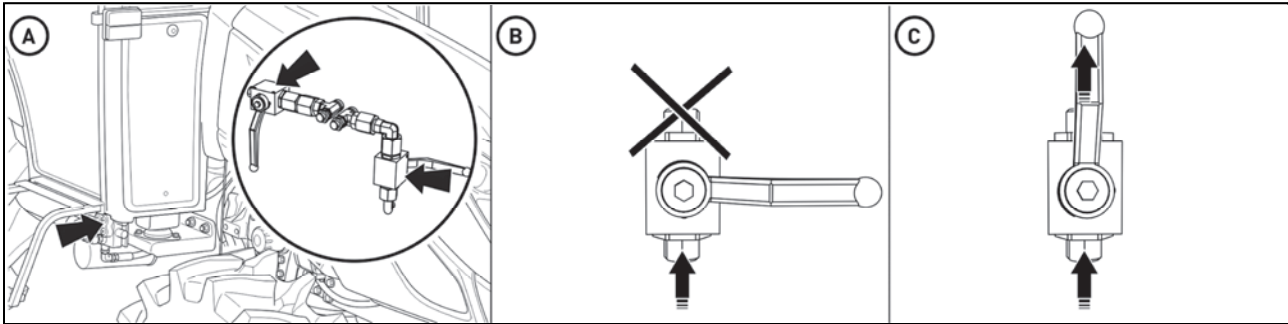

UCL18NN004

Hydraulic locking of the front three-point hitch is performed in any position of the hydraulic cylinders by two valves located on the right side of the tractor under the cab, in the area of the right footrest (A).

To close the valves (lock the movement of the arms), move the lever to the position shown in figure (B). To open the valves (unlock the movement of the arms), move the lever to the position shown in figure (C).



The locking or unlocking of the arm movement must always be performed on both valves. It is forbidden to have one valve open and the other closed during the operation of the tractor.



If the front three-point hitch is not used, both valves must be closed.



When transporting mounted implements, always lock the hitch in the raised position hydraulically, with valves located on the right side of the tractor under the cab.

This hydraulic lock is recommended even if no equipment is connected to the three-point hitch.

TRACTOR CONTROLS

Working and transport position of the front three-point hitch

A	Working position of the front three-point hitch
B	Transport position of the front three-point hitch

Changing the position of the draw-bars of the front three-point hitch:

1. Release and remove the pin (1) from the opening.
2. Lift the arm from position (A) to position (B).
3. Lock the arm by inserting the pin (2) in the opening (2) and secure the pin.

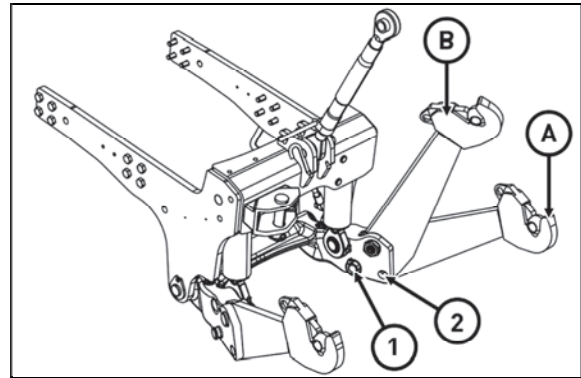

PCLPN062



Only insert the pin in the openings, never check whether the opening is free with your fingers!

Driving with agricultural machines attached to the front three-point hitch



The maximum permissible speed of the tractor with agricultural machines attached to the front three-point hitch is 15 km.h⁻¹. If no implement or weight is attached to the front three-point hitch, we recommend you to lift the lower lifting draw-bars to the transport position.

Trailer socket (seven terminal electrical socket type)

1 - Trailer socket

To operate the electrical systems of implements, trailer lighting, warning lamp etc.

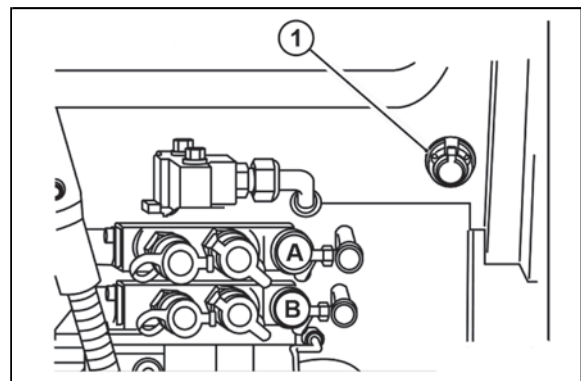

UCL18N048

Front Fenders

The front fenders can be fitted to the tractor as an option. It may be compulsory to fit them with regard to the relevant country's regulatory requirements.

Fixtion points of loader



For detailed information on the assembly and operation of the front loader, refer to the documentation supplied with your specific front loader.

1 - Right (front)

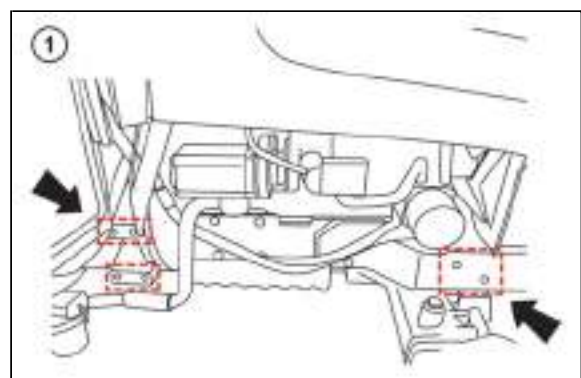

UCL18N050

TRACTOR CONTROLS

2 - Left (front)

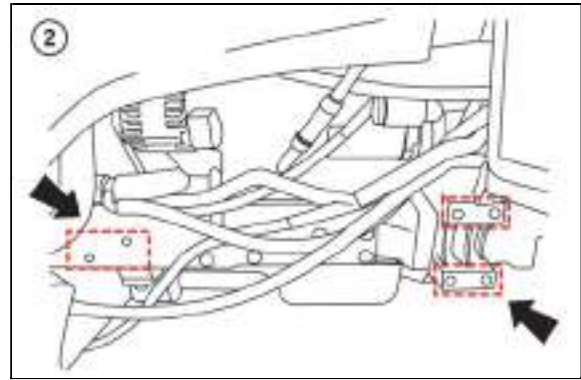

UCL18N051

3 - Right (rear)

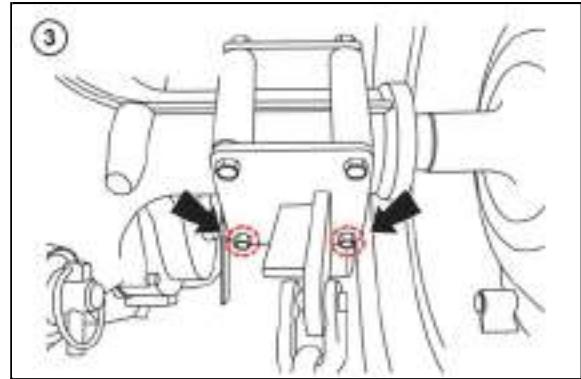

UCL18N052

4 - Left (rear)

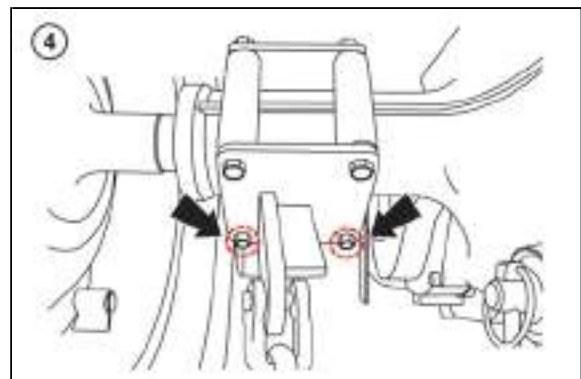

UCL18N053

	SPEC	Strength	No.	Remark
1	M16 x 2.0	9T	8	
2	M14 x 2.0	9T	4	
3	M12 x 1.75	7T	4	

DRIVING OPERATION

Starting the Engine

Before starting the engine, perform pre-operation check as described in the maintenance table.

1. Sit into the driver's seat and make sure the parking brake is applied.
2. Check that all shift levers and the PTO switch are in the neutral position.
3. Set the throttle lever halfway.
4. Depress the clutch pedal. Safety switch is activated.
5. Insert the key in the ignition switch and turn it to the left to the GLOW position to activate the combustion chamber heating. Preheating is indicated by the indicator light on the instrument panel.
6. When the indicator light goes out, turn the key to the ON position and make sure that the indicator lights on the instrument panel are working. Then turn the key to the START position to start the engine.
7. Make sure all warning lights switch off after the engine is started.



Never start the engine by connecting the starter terminals or with the safety switch deactivated, as the tractor may jump and cause an accident or injury.



Note:

- **The engine will not start unless the clutch pedal is depressed.**
- **The engine cannot be started unless the operator is sitting in the driver's seat.**
- **Do not turn the key to the start position when the engine is running.**
- **Do not keep the key in the start position for more than 10 seconds.**
- **If the engine does not start within 10 seconds, wait 30 seconds and try to start again.**

Stopping the Engine

1. Set the engine to idle speed.
2. Turn the key in the ignition switch to the OFF position.
3. Remove the key from the ignition switch.

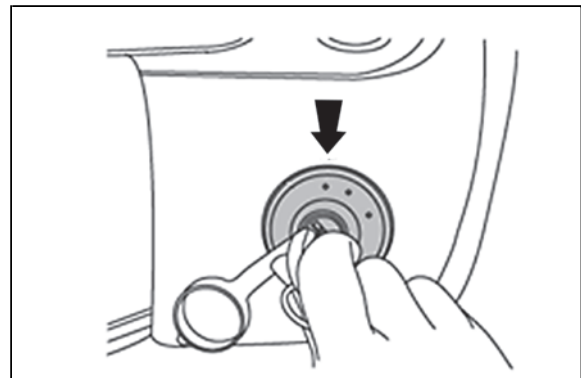

U18N049



Notice:

- **After prolonged or hard work, let the engine idle for 5-10 minutes before turning it off.**
- **Do not stop the engine at high speed.**

Engine Warm-up

After starting the engine, allow it to warm up to operating temperature by letting it idle for 5 to 10 minutes. At the same time, this provides lubrication for all engine components.



If the engine is loaded immediately after starting, it may be damaged.

DRIVING OPERATION

Engine Warm-up in Cold Weather

Cold weather changes the viscosity of the oil, resulting in a reduction in the performance of the engine oil pump, which can cause engine damage if oil is not heated properly.

At the same time, there may be problems with the hydraulic system and synchronization in the transmission.

Warming Up Time

Temperature	Time for warming up
Above 50 °F	5~10 min.
50 °F~32 °F	10~20 min.
32 °F~14 °F	20~30 min.
14 °F~-4 °F	30~40 min.
Below -4 °F	Over 40 min.



Make sure the parking brake is applied during warm-up.

Insufficient warm-up may cause problems or shorten the life of relevant components.

Never idle the engine in a poorly ventilated area. This can cause carbon monoxide poisoning.

Engine Running-in Time

For the initial 50 hours of operation, follow the instructions below.

1. Avoid stopping the engine suddenly.
2. Do not run the engine at high speed or with excessive load.
3. Only drive the tractor when the engine is warmed up to operating temperature.
4. Do not idle the engine at maximum speed.
5. Check all components and replace the prescribed operating fillings after 50 hours of operation, see section Maintenance.

Driving the Tractor Off

1. Make sure the left and right brake pedals are connected when not working in the field.
2. Lift the implement.
3. Move the main shift lever, speed range shift lever, and reverse shift lever to the desired positions.
4. Release the parking brake by depressing the brake pedal.
5. Slowly release the clutch pedal while depressing the fuel control pedal to increase engine speed.

When driving, change gears only with the (main) gear shift lever and always with the clutch pedal fully depressed.



Caution:

- ***Do not "ride" the clutch to control speed, use a lower gear.***
- ***Do not travel with your foot on the clutch pedal.***



Attention!

- ***The reverse speed is almost the same as the forward speed.***
- ***Never reverse with the speed range shift lever in H position.***

DRIVING OPERATION

Turning in the Field

Disconnect the latch connecting left and right brake pedals to allow the use of individual pedals.

To make a tight turn use both the steering wheel and the brake pedal at the same time.

For a left turns use the left pedal and a right turn the right pedal.

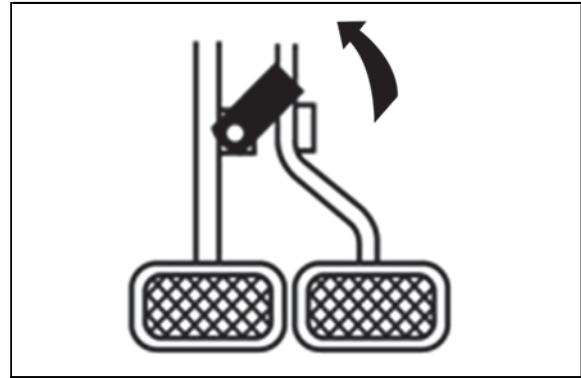

U18N050



Only use the brake pedals for turning at low speeds on unpaved surfaces.

At high speeds, the machine can roll over and cause very serious injury or death.

Note that when an implement is installed on the tractor, its overall length will increase. Pay extra attention when turning.

Stopping and Parking

Let the engine come back to idle and at the same time push in the clutch and brake simultaneously.

When the tractor has come to a halt, lower any implement to the ground, and put the main gear in neutral.

Apply the park brake, stop the engine, and remove the key.



UCL18N042



Always use the parking brake when parking.

When parking on a slope, secure the rear wheels with wedges.

Drive Off on Steep Slope

With the pedals connected, depress the brakes and depress the clutch.

Set all gear shift levers to low gears and throttle to medium engine speed.

Release the clutch and release the brake pedals when engaged.

Set the throttle to the required engine speed.

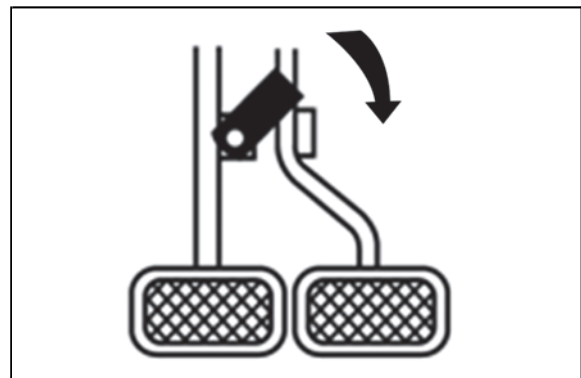

HODP085

DRIVING OPERATION

Driving downhill

Use the engine's ability to brake when traveling downhill.

Never rely on the brakes only and never travel downhill with the gears in neutral.



CAUTION:

- ***When working in hilly terrain, the risk of machine damage - rolling over and injury - is significantly increased. Environmental conditions must be taken into account.***
- ***When towing trailers and semi-trailers in hilly terrain, make sure that the brakes of these machines are in working order and in perfect condition. To drive down the hill, use the braking action of the engine in combination with a lower gear.***

Driving to / from the Field

Connect the left and right brake pedals.

It is dangerous to enter / leave the field if the field is well below the balk. Use ramps if necessary.

Move perpendicular to the balk.

To use full power, it is recommended to reverse into the field.

Operation of the diff lock

Although the differential lock is a very useful thing, caution is required when using it, as misuse can lead to hazardous situations.

The differential lock should only be used in situations where one of the rear wheels loses traction.



Warning: Use low engine revolutions when using the diff lock. If the diff lock does not release after removing the foot from the pedal use the left and right brake pedals in turn to release it. Do not try to engage or use the diff lock on tight turns as serious damage can result.

Warning for Driving on the Road

When changing the direction of travel on the road, always use turn signal lights.

Always keep the brake pedals connected.

When driving at night, switch off the work lights.

Dim the tractor lights when meeting another vehicle at night.

Make sure that the lights are adjusted to avoid dazzling the eyes of the oncoming vehicle driver.

No one but the driver may ride on the tractor.

Follow all applicable regulations and drive safely.

Operating Tips for Power Steering

1. The power steering is only active when the engine is running. Steering wheel operation can be more difficult at lower engine speeds.
2. In the event of a front axle load (loader work, weight aggregation), it may be harder to turn the steering wheel with the tractor stationary. In this case, turn the steering wheel while driving the tractor at low speed.
3. An audible sound is heard when the steering wheel is turned to the end position. Avoid holding the steering wheel in the end positions for a long time.
4. Unnecessary turning of the steering wheel to its end positions (with the tractor stationary) wears out the tires.
5. In winter, warm the engine sufficiently before driving.
6. Repair hydraulic components such as hoses or pipes in a clean environment. Prevent dirt from entering the system.
7. Keep your hands on the steering wheel while driving.



Releasing the steering wheel while driving can result in an accident and injury.

DRIVING OPERATION

Check During Driving

Constantly monitor the warning lights on the dash and if any comes on stop the tractor to determine the cause.

Oil Pressure Light

If the oil pressure light comes on check the oil level first of all.

If the oil level is OK ask a qualified dealer to check the reason for the light coming on.

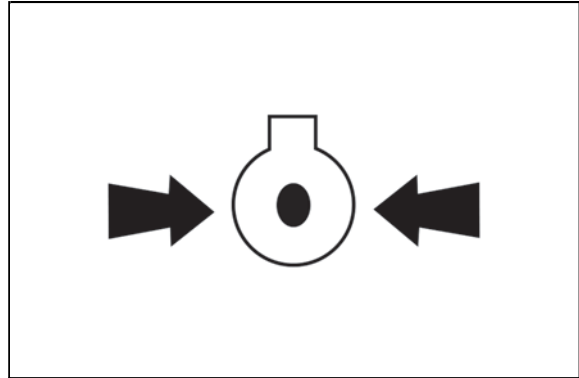

HODP086

Battery Charging

If the alternator indicator light comes on, check all connections and make sure the alternator V-belt is not damaged. If all connections and V-belt are OK, consult your dealer or an authorized service center to find out how to fix the problem.

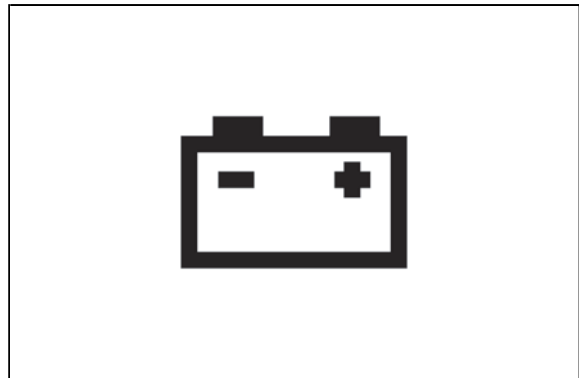

HODP087

Coolant

When this warning indicator light comes on while driving, it means the engine is overheated.

Stop the engine and allow it to cool, then check:

1. Coolant level in the radiator
2. The radiator fins are not clogged
3. Fan belt tension / damage

If everything is OK, consult your dealer or an authorized service center to find out how to fix the problem.



HODP047



Operating the tractor at increased coolant temperatures can damage the engine.

DRIVING OPERATION

Fuel gauge

To prevent excessive condensation in the fuel tank, refill the fuel at the end of each day and ensure that the level during the day does not fall to a level when the fuel system needs to be bled after refueling.

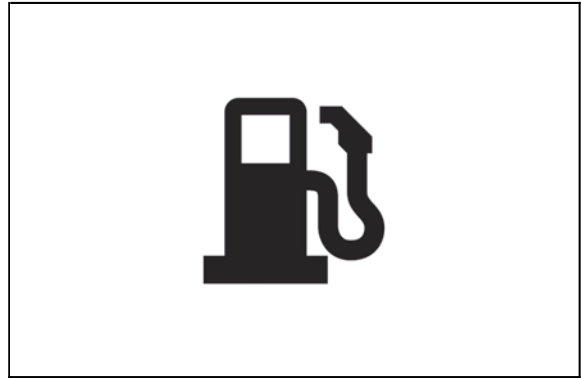

UCL18N046

MAINTENANCE

Check and service

This section gives full details of the service procedures necessary to maintain your tractor at peak efficiency while the lubrication and maintenance chart provides a ready reference to these requirements.

Pre-start checks

To avoid problems it is recommended that a range of checks be carried out daily before starting the tractor. For full details of the items and frequency please refer to the following tables - Periodical check and service tables.

Service inspections

Service inspections are performed as follows:

The first service inspection at the state of the engine hour counter of 50 EH maximum, but not later than 6 months after commissioning of the tractor. The second service inspection after covering another 200 EH (at the state of the engine hour counter of 250 EH maximum) but not later than 12 months after the first service inspection. Next service inspections always after covering another 250 EH but not later than 12 months after the previous service inspection. The service inspections are a part of tractor maintenance. The services authorized by Zetor will provide professional performance of service inspections according to the manufacturer's instructions.

MAINTENANCE

Maintenance and adjustment schedule



Caution: *These intervals are for operation under normal conditions and need to be reviewed under severe conditions to a greater frequency.*

O Check, refill, modify or clean

XX First Replacement

X Replace

Periodical check and service table

Division	Item	Daily	Service interval (hour meter, mark)												Comment
			50	100	150	200	250	300	350	400	450	500	1 Year	2 Years	
Engine	Engine oil& Cartridge	O	XX				X						X	X	Every 250 hours or 12 months
	Air cleaner			O		O		O					X		
	Radiator coolant	O												X	
	Fuel	O													Fill tank
	Fuel filter	O											X		
	Fan belt	O													
	Battery			O		O		O		O					
	Loose nuts and bolts	O													Tighten
	Radiator hose clamp	O													Tighten if required
Chassis	Transmission oil & HST Oil Filter		XX				X						X	X	Every 250 hours or 12 months
	Front axle oil		XX				X						X	X	
	State of both brake pedals	O													
	Operation of each lever	O													Smooth operation
	Free play of steering wheel	O													About 50mm (1.97in) of wheel circumference
	Toe-in						O							O	

MAINTENANCE

Division	Item	Daily	Service interval (hour meter,mark)												Comment		
			500	1000	1500	2000	2500	3000	3500	4000	4500	5000	1 Year	2 Years			
Chassis	Grease in front wheel hub						o										
	Check the steering wheel joint						o						o				
	Wheel nut fastening torque	o															
	Loose bolts and nuts	o															Tighten to proper torque
	Operation of the instrument	o															
	Grease each nipple		o	o	o	o	o	o	o	o	o	o	o				
	Oil of the 4WD front axle		xx				o						x	x			
	Check the electric wiring	o															Loose or broken terminals, missing wiring. Check correctly clamped
	Hydraulic hoses & pipes						o										

MAINTENANCE

Tractor greasing plan

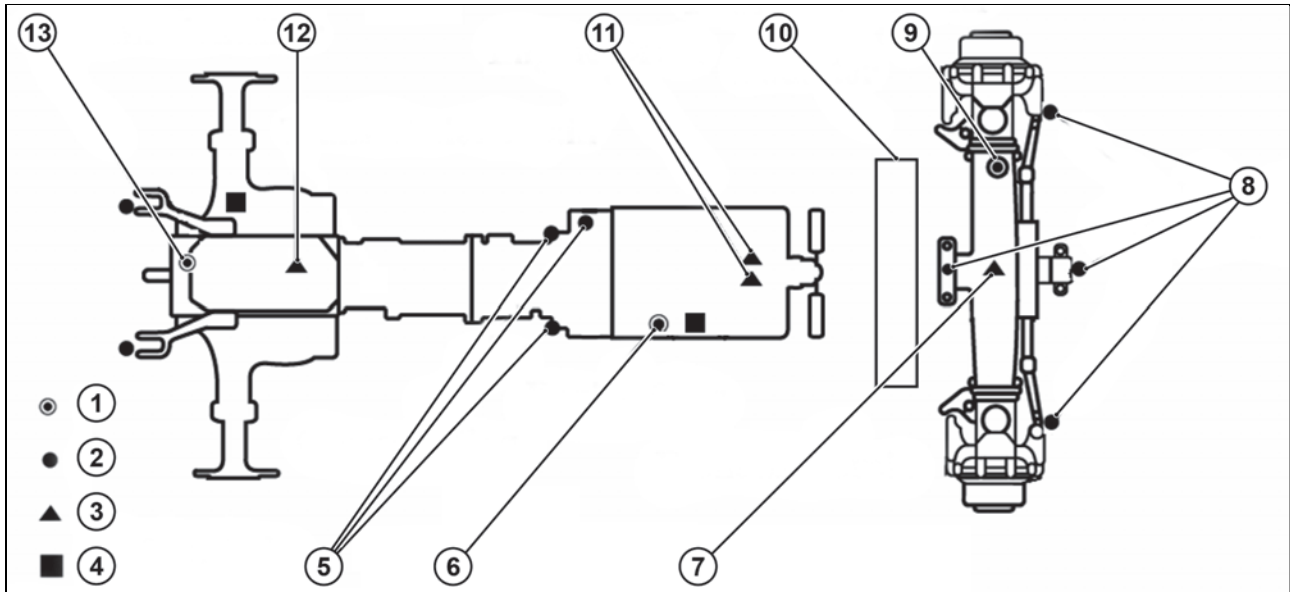

U18N067

- 1 - Oil Filler
- 2 - Lubrication Point
- 3 - Drain Plug
- 4 - Sight Gauge
- 5 - Grease Nipple
- 6 - Engine Oil Filler Neck
- 7 - Front-Wheel Axle Oil Drain Plug
- 8 - Front Axle Lubrication Point
- 9 - Front-Wheel Axle Oil Filler
- 10 - Radiator
- 11 - Engine Oil Drain Plug
- 12 - Transmission Oil Drain Plug
- 13 - Transmission Oil Filler

MAINTENANCE

Fuels, coolants and lubricants used - amounts

No.	Filling point	Fillings	Quantity liter (gal.)
	MODEL		UTILIX CL45/55
1	Radiator	50/50 : Ethylene glycol/Water (L.L.C) ASTM D4985 / D6210	9,3 l (2,5 US gal)
2	Engine	API : Grade CJ-4 (API ACEA E-6, JASO PH-2, Grade 10W30)	5,3 l (1,4 gal)
3	Transmission case	API GL-4 Grade Tractor transmission and hydraulic oil Below: -20 °C (-4 °F) ISO VG32 Above -20 °C (-4 °F) ISO VG46	35 l (9,24 US gal)
4	Front axle	(API GL-4 Grade) SAE 80W/90	10 l (2,64 US gal)
5	Final drive case(B)		
6	Clutch pedal shaft	Grease	As required
7	Ball joint	Grease	As required
8	Fuel tank	Diesel fuel (EN 590)	60 l (15,85 US gal)



The manufacturer does not take responsibility for any damages caused by the usage of service fillings that do not comply with requirements stated in this service manual.

Recommended ZETOR service fillings

Engine - ZETOR 10W-40 L-SAPS

Transmission - ZETOR EXTRA 10W-30 STOU (hydraulic gearboxes, summer operation)
- ZETOR HM 32 (winter operation)

Front axle - ZETOR LS 80W

Plastic lubricant - MOGUL LA 2

MAINTENANCE

Hood Opening

Unlock the hood by pulling the locking hook down. Pay attention to the wiring harness of the hood lights. After unlocking the hood, lift it with your hands. The hood is held in the raised position by means of a strut.

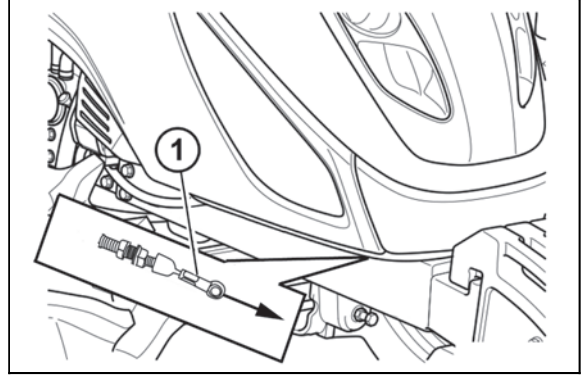

UCL18NN011



When the front hood is slammed shut, the headlight bulbs located in the front hood may be damaged.

Opening the side cover

To open it, grasp the side panel of the hood and pull the front panel upward to separate it from the guiding support pin (1). Then pull the hood side panel forward.

1 - Support Pin (1)

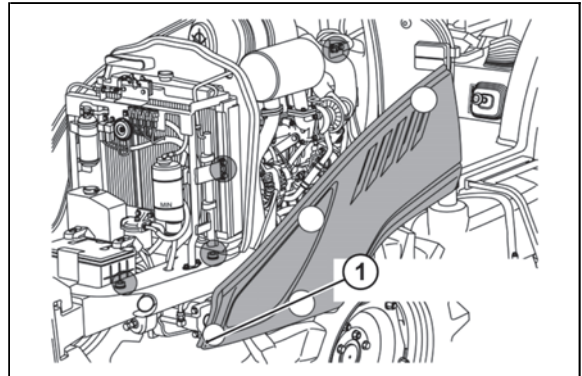

UCL18N061

MAINTENANCE

Check and Change of Coolant

Check of Coolant



Do not open the radiator cap if the engine is hot. Otherwise, hot steam can cause serious burns. Wait until the engine has cooled down sufficiently.

Remove the radiator cap and make sure that the coolant reaches up to the filler neck and that it is clean. Check that the correct antifreeze or anti-corrosion mixture is used.

- 1 - Radiator Cap
- 2 - Expansion Vessel

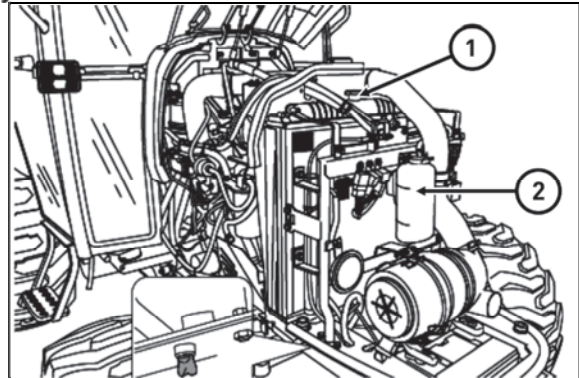

UCLS5N013

If corrosion of the cooling system is noticeable in the coolant color, completely drain the system and fill with the correct mixture of water and antifreeze or corrosion inhibitor.

- 1 - Drain Valve

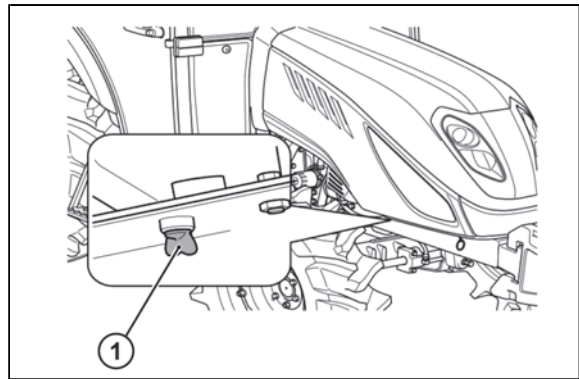

UCL18N055

Change of Coolant

1. Set the heating tap to the open position, open the drain tap.
2. At the same time, open the radiator cap.
3. For thorough cleaning, rinse the cooling circuit with running water.
4. Close the tap and fill the radiator with coolant, i.e. a mixture of water and an anti-corrosion inhibitor or antifreeze solution.
5. Start the engine and let it run for about 5 minutes, check the fluid level again and top up if necessary.

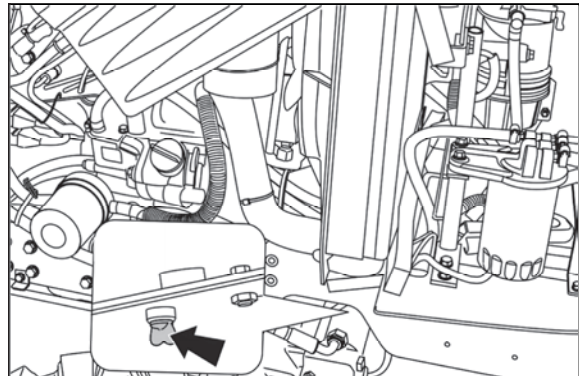

CCL3540040



Caution: Do not remove the radiator cap while the engine is hot. Allow the engine cool down and then turn the cap slowly to make sure that there is no excessive pressure in the radiator.

MAINTENANCE

Antifreeze

Frozen coolant can damage the engine.

Flush the radiator before changing the antifreeze.

Mix the antifreeze solution according to the instructions of the antifreeze brand and according to local climatic conditions.

Replace the solution in the cooling circuit.

If the solution is lost due to evaporation or overflow, top up in the original mixing ratio.



If engine coolant gets on your skin, it may cause skin irritation. Wash skin thoroughly with soap and water or hand cleanser.

Check of Radiators for Clogging

After working in a dusty environment, check the radiator fins for clogging. If they are clogged, clean the radiator fins with compressed air or water.



Important: Water or air under high pressure can distort the cooling fins on the radiator and thus reduce the efficiency of the radiator.

Engine Oil and Filter Replacement

Always use the oil types and classes according to relevant specifications and observe the oil change intervals. (see Tractor Maintenance chapter).

- 1 - Engine Oil Filter
- 2 - Engine Oil Dipstick

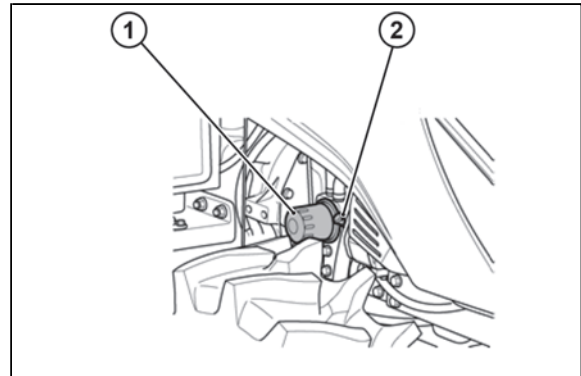

U18N059

Engine Oil Check

Remove the dipstick, wipe it and immerse in the oil pan. Make sure the oil level is between the upper and lower mark, near the upper mark. If the oil level is not as specified, top up with the specified oil.

- 1. Minimum Level
- 2. Maximum Level

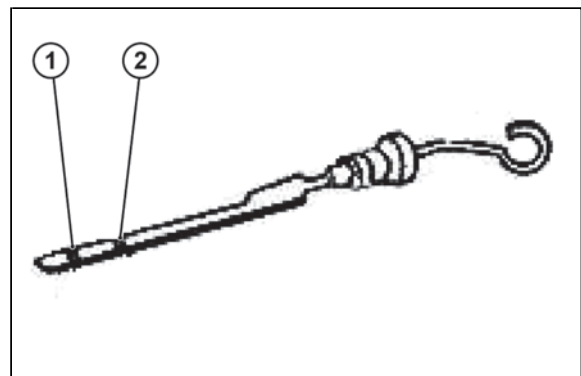

HODP096

MAINTENANCE

Engine Oil Change

Park tractor on level surface, shutoff engine. Remove sump plug & drain oil.

Replace and check the sump plug and refill the engine with oil to the correct level on the dipstick.



When changing the oil, always replace the filter as well.

Always use the prescribed oil, as using different types of oils or oils with different specifications can cause damage.

At the end of its service life, dispose of the oil in accordance with applicable regulations.



Do not overfill the crankcase with oil.

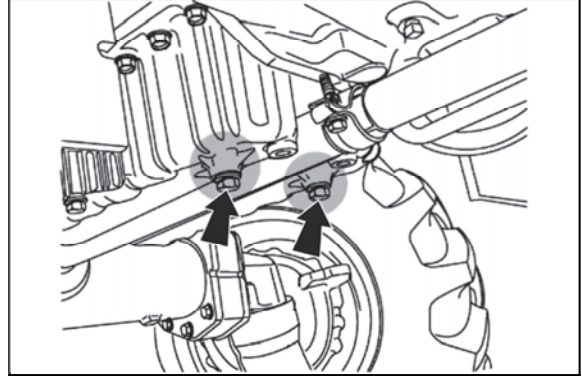

UCLS5N014

Engine Oil Filter Replacement

1 - Engine Oil Filter

2 - Engine Oil Dipstick

Using the oil filter wrench, screw the filter anticlockwise to remove it. Lightly lubricate the rubber seal ring on the new filter with oil, rotate clockwise until the seal reaches the sealing surface, and then rotate another 2/3 turn to tighten it properly.

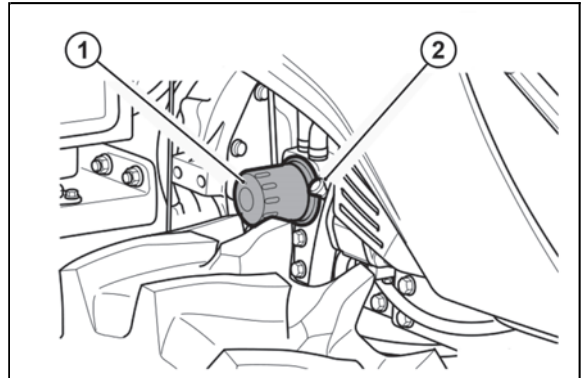

UCL18N067

MAINTENANCE

Transmission Oil and Filter Check and Replacement

Transmission Oil Check

Check the level using the dipstick at the top of the transaxle.
If the level is low, add more oil through the filler.



Caution: *Always ensure that you use the correct oil for topping up or oil changes.*

- 1 - Maximum Level
- 2 - Minimum Level

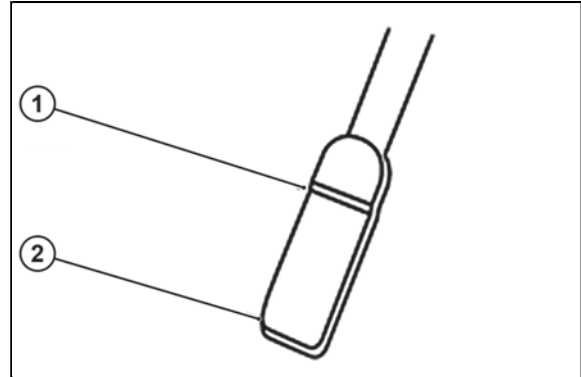

U18N061

- 1 - Oil dipstick
- 2 - Filler

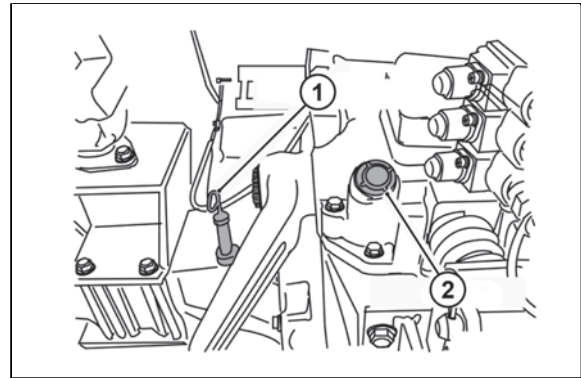

UCL18N057

Transmission Oil Change

Remove the drain plug from the bottom of the transmission and drain the oil.
After draining the oil, screw the drain plug back on.
Pour the prescribed transmission oil to the required level through the filling port.

- 1. Drain Plug

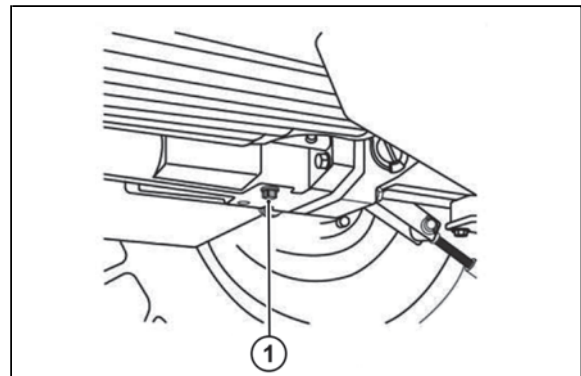

UCL18N064



When changing the oil, always replace the filter as well.

Always use the prescribed oil, as using different types of oils or oils with different specifications can cause damage.

Only add the prescribed amount of oil.

At the end of its service life, dispose of the oil in accordance with applicable regulations.

MAINTENANCE

Transmission Filter Maintenance

Remove the filter with a filter wrench.

To replace, apply oil or grease on the seal, fit by hand until seal contacts bare, then turn it 2/3rd turn further to tighten it check for leaks.

1. Hydraulic oil filter
2. Hydraulic control valve

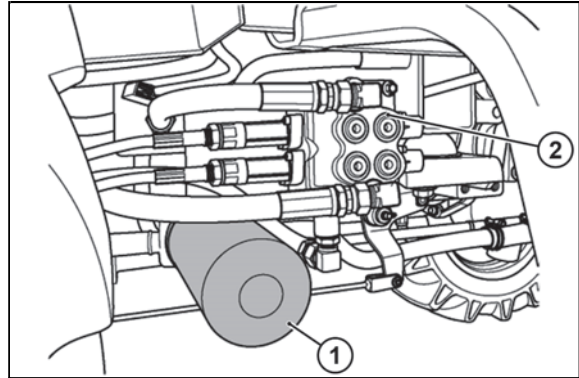

UCL18N069

Front Axle Oil Check and Change

Check

Remove the dipstick, wipe its end and insert it back. Then pull it out and check that the oil level is between the upper and lower mark.

In case of lack of oil, top up with the prescribed oil.

- 1 - Maximum
- 2 - Minimum

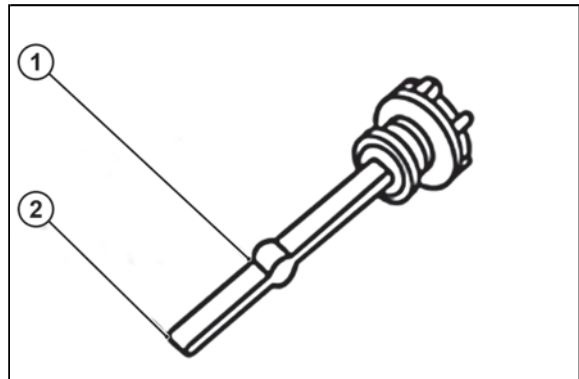

U18N078

MAINTENANCE

Change

To drain the oil from the front axle, unscrew the drain plugs on the bottom side of the axle and on the left/right reducer.

After draining the oil, screw the drain plugs back and tighten them, check for leaks.

Remove the front axle filler cap and fill with new oil that does not exceed the maximum level indicated by the mark.

- 1 - Level gauge & oil filler
- 2 - Front axle oil drain plug

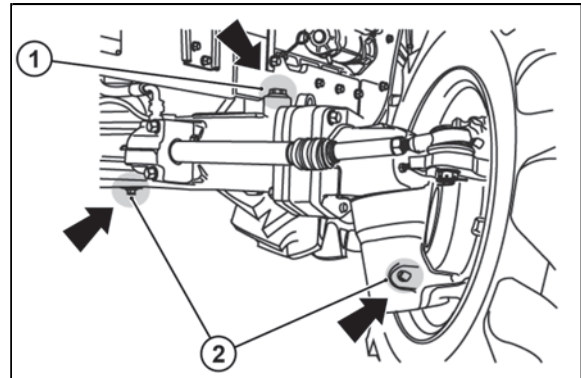

U18N079



Always use the prescribed oil, as using different types of oils or oils with different specifications can cause damage.

Only add the prescribed amount of oil.

At the end of its service life, dispose of the oil in accordance with applicable regulations.

- 1 - Top plug (Vent plug)

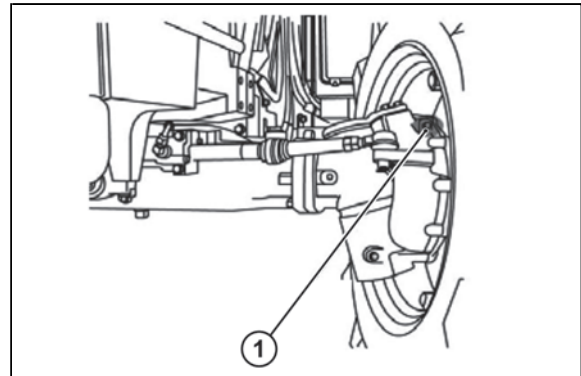

UCL18N066



Important:

After refilling the prescribed amount of new oil, the level measured by the dipstick may be higher than permitted - due to incomplete filling of the front-wheel axle drive mechanism - this discrepancy will disappear after being put back into operation. Unscrew the bleed plugs to accelerate the proper pumping of the oil by the front axle drive system.

MAINTENANCE

Fuel System

Use only low-sulfur diesel according to EN 590.



IMPORTANT: *The diesel fuel system is susceptible to dirt and water, so minimize the risk of system contamination.*

Cleaning/Replacement of the Fuel Filter Element

The fuel filter/water separator (if equipped) is not usually supplied by Yanmar.

The following text describes a typical fuel filter/water separator.

Place a tray under the fuel filter in order to catch any fuel that might spill. Clean up any spilled fuel immediately.

1. Close the fuel shutoff valve (if equipped).
2. Remove any contamination around the fuel system.

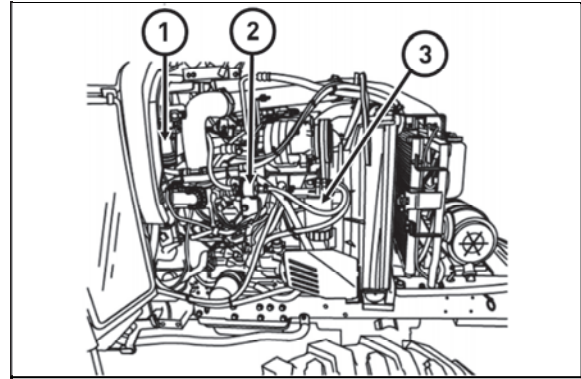

UCLS5N015

Note: If the fuel filter element is not equipped with a drain, remove cap. Remove the nylon insert in order to reduce the level of fuel in the fuel filter element. A reduction in the level of fuel in the fuel filter element will help prevent fuel from being spilled when the element is removed.

Notice: Do not use any tool to remove the fuel filter. If you attempt to remove the fuel filter with a filter wrench or a filter installation aid, the sealing ring may be damaged.

3. Hold fuel filter and rotate quick release collar counterclockwise. Removed and discarded.

Note: If the element is equipped with a sediment bowl, remove the sediment bowl from the element.

Thoroughly clean the sediment bowl. Inspect the O-ring seals. Install new O-ring seals, if necessary. Install the sediment bowl to the new element. Hand tighten the sediment bowl. Hand tightening is the only method that should be used.

Notice: Do not fill fuel filters with fuel before installing them. Contaminated fuel will cause accelerated wear to fuel system parts.

4. Make sure the bottom of the fuel filter is clean. Push the new filter element all the way into the bottom of the fuel filter.
5. Hold the fuel filter in its place. Attach the detent ring. Turn the detent ring clockwise to attach the fuel filter to the bottom part of the fuel filter.
6. Open the fuel shutoff valve (if equipped).



Important: *Never use petrol thinner or any similar flammable material to clean the coarse fuel filter. Always bleed the system after replacing the filter.*

MAINTENANCE

Fuel System Bleeding

The fuel system must be bled:

1. If the engine has stopped due to an empty fuel tank.
2. After replacement of the fuel filter or removal of the fuel line.

Procedure:

1. Fill the tank with fuel and turn the ignition key to on.
2. Loosen the air breather screw of the fuel filter two or three turns.
3. When fuel free from air flows (bubbles) from the air breather screw, tighten the Air breath screw.
4. The bleeding of the system is now finished.

1. Water separator
2. Fuel filter
3. Fuel pump

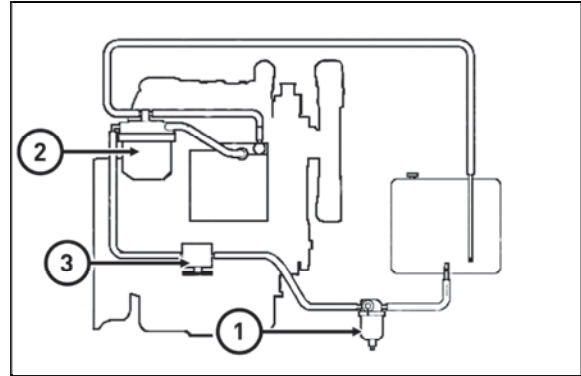

UCLS5026

Air Filter Check and Maintenance

Perform air cleaner maintenance:

- Daily when working with front-mounted machines or in a dusty environment
- Every 100 hours of operation

- 1 - Air cleaner body
- 2 - Element
- 3 - Cover

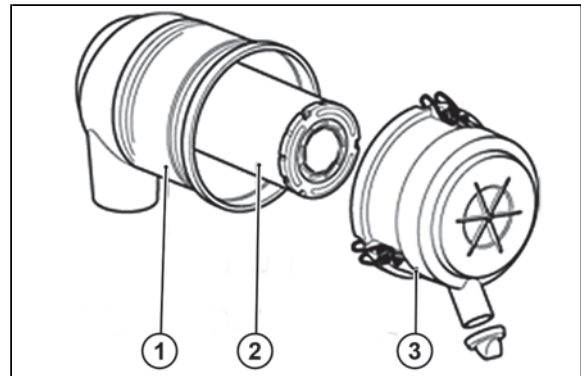

U18N099

To remove the dust from the evacuator valve squeeze it between thumb and fingers to let excess dust out and wipe around the valve to keep it clean from outside.

To clean the main element, remove the cover (3).

Remove the element (2).

Remove dust by blowing it out of the element with compressed air. Check the element to ensure it is not damaged. Reassemble the cover (3).



Replace the element after cleaning five times or if it is damaged.

Never clean the filter element by hitting it against a solid surface.

When reassembling, make sure all surfaces are properly sealed to prevent dust from entering.

MAINTENANCE

Greasing the Tractor

Grease the tractor according to the service schedule.

Ensure that grease nipples are cleaned well before any attempt is made to grease them.

Safety instructions for lubrication of the tractor

- The tractor maintenance may be performed only by the trained personnel thoroughly familiarized with operational and safety principles.
- During maintenance of the tractor wear appropriate (specified) personal protective equipment (occupational footwear, protective gloves, safety goggles, etc.).
- Prior to starting the work, secure the tractor against movement using manual brake.



Lubrication must be performed only when the engine is at standstill!

1 - Lubrication Point

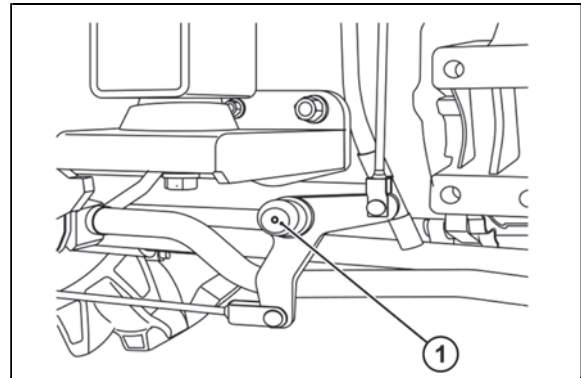

UCL18N070

1 - Lubrication Point

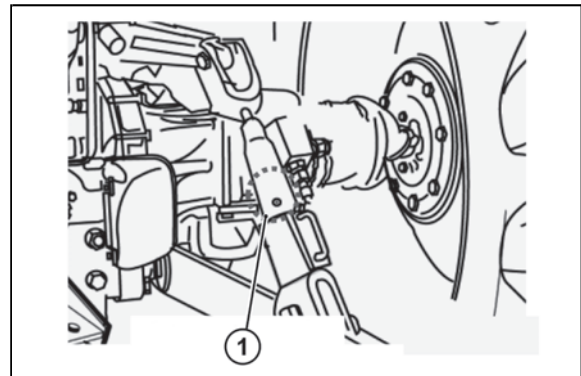

UCL18N071

1 - Lubrication Point

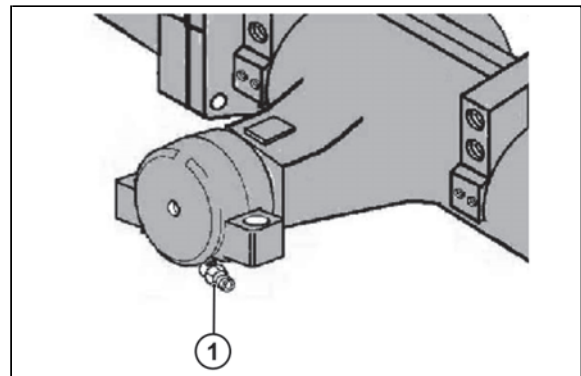

UCL18N072

MAINTENANCE

1 - Lubrication Point

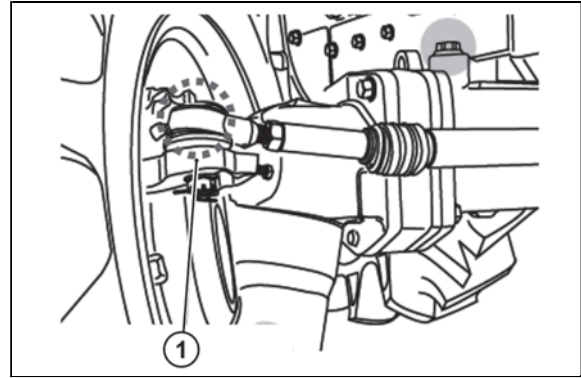

UCL18N073

Controls Play Setting

Slowly depress the pedal with your hand to check the play.

Clutch Pedal	Brake Pedal
20-30 mm (0.79-1.18 in.)	30-40 mm (1.18-4.57 in.)

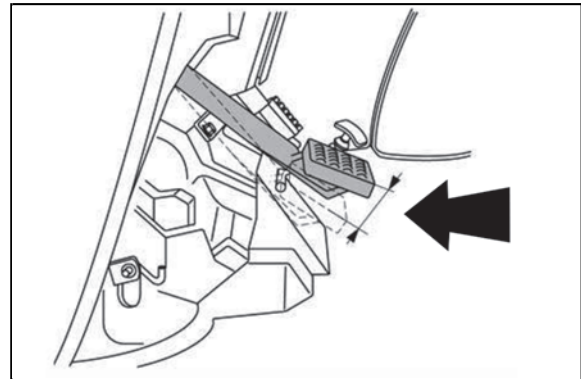

HODP132

Clutch Pedal Check and Adjustment

Using the clutch over a period of time will increase the free play.

The correct free play of the pedal is 20 - 30 mm

To adjust, loosen the locknut on the turnbuckle and adjust.

Check the adjustment and tighten the locknut if the free play is correct.

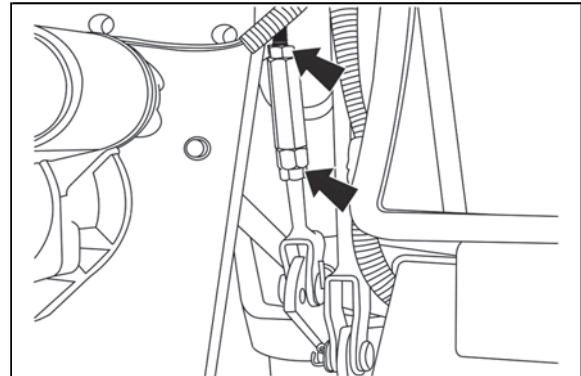

CCL3540053

MAINTENANCE

Brake Pedal Check and Adjustment

The operation changes the brake pedal play, as well as the alignment between the right and left pedals. The correct play of the brake pedal is 30 - 40 mm.

In case of excessive play or pedals asymmetry, adjust the brake pedals.

Adjustment:

1. Unscrew the lock nut and turn the adjusting nut to adjust the play.
2. Turning counterclockwise increases the play, while turning it clockwise decreases the play.
3. After adjustment, tighten the lock nut firmly.

Check that the play is correct and the same on both pedals for even braking effect.

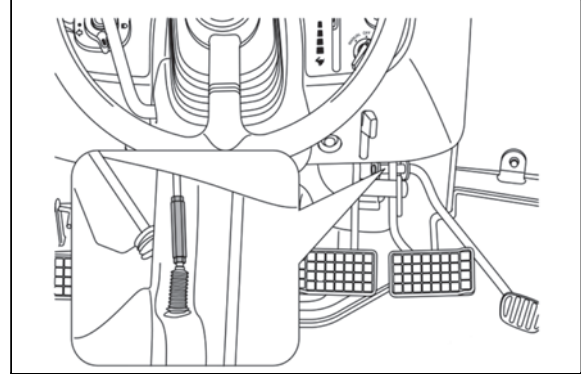

UCL18N074



Caution:

- ***Uneven adjustment of the left and right pedal will result in one sided braking when the pedals are connected and can cause serious accidents, especially at high speeds.***
- ***Double check to ensure free play is the same on both pedals.***

Adjusting the throttle lever

If this lever is loose or difficult to move, please contact an authorized service to help you solve the problem.

Adjusting toe-in

If the convergence is set incorrectly, it can cause severe vibration of both the steering wheel and the tractor. The correct convergence is 0.08 ~ 0.24 in. (2 ~ 6 mm). We recommend that this setting is carried out by an authorized service.

MAINTENANCE

Alternator and fan belts inspect/adjust/replace

For applications that require multiple drive belts, Replace the belts in matched sets. Replacing only one belt of a matched set will cause the new belt to carry more load because the older belt is stretched. The additional load on the new belt could cause the new belt to break. If the belts are too loose, vibration causes unnecessary wear on the belts and pulleys. Loose belt may slip enough to cause overheating. To accurately check the belt tension, a suitable gauge should be used.

Fit the gauge(1) at the center of the longest free length and check the tension. The correct tension is 535 N (120 lb). If the tension of the belt is below 250 N (56 lb) adjust the belt to 535 N (120 lb). If twin belts are installed, check and adjust the tension on the both belts.

1 - Burroughs gauge

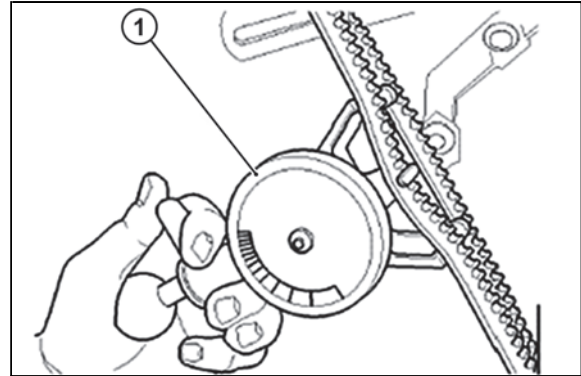

U18N097

V-belt Check and Adjustment

Regularly check and adjust the fan V-belt tension.

1. Slightly loosen the alternator mounting screw and adjust the tension by sliding the alternator.
2. Check belt tension. Press the middle of the belt with a weight of 6 - 7 kg (13.23 ~ 15.43 lbs). If the belt bends by 7 - 9 mm (0.28 ~ 0.35 in.), its adjustment is correct.

1 - 7~9 mm

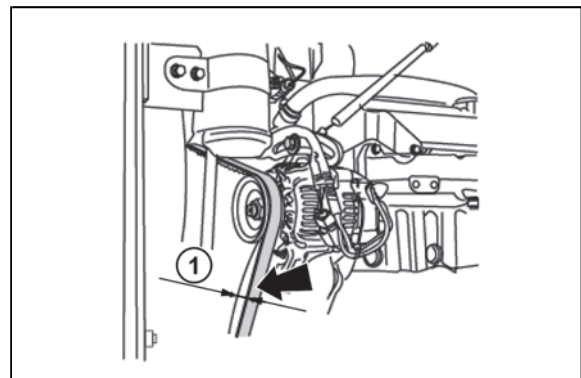

U18N096

Air conditioner compressor belt adjustment

1 - Tension Adjusting Bolt

Check the compressor belt tension regularly and adjust. If required. The correct tension is if the center of the belt is Pushed With a finger it moves in approx. 10 mm (0.39 in) as shown in the picture.

To adjust the belt, loosen the top bolt on the alternator, move the alternator to the desired position and tighten the bolt.

Also ensure that the bottom alternator bolts are tighten.

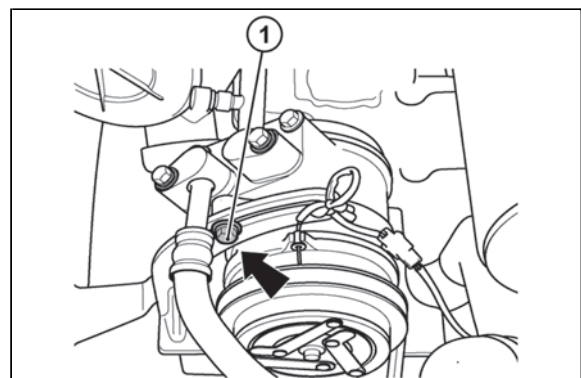

U18N098

MAINTENANCE

Electric System Check

Alternator inspect

Yanmar recommends a scheduled inspection of the alternator. Inspect the alternator for loose connections and proper battery charging. Inspect the ammeter (If equipped) during engine operation in order to ensure proper battery performance and/or proper performance of the electrical system. Make repairs, as required. Check the alternator and the battery charger for proper operation. If the batteries are properly charged, the ammeter reading should be very near Zero. All batteries should be kept warm because temperature affects the cranking power. If the battery is too cold, the battery will not crank the engine. When the engine is not run for long periods of time or if the engine is run for short periods. The batteries may not fully charge. A battery with a low charge will freeze more easily than a battery with a full charge.

Battery Check and Charging

Low temperatures affect battery performance, so pay special attention to them in winter.

Remove the battery and store it in a cool, dry place before prolonged shutdown.

If the battery remains in the tractor, disconnect the negative terminal.

If the batteries are not used for a long period of time, they will self-discharge.

If the battery contacts are oxidized, clean them with sandpaper or a steel brush.

1 - Control indicator

A battery charge indicator is available for the battery.

GREEN: Good condition

BLACK: Charging Required

WHITE: Replace the battery

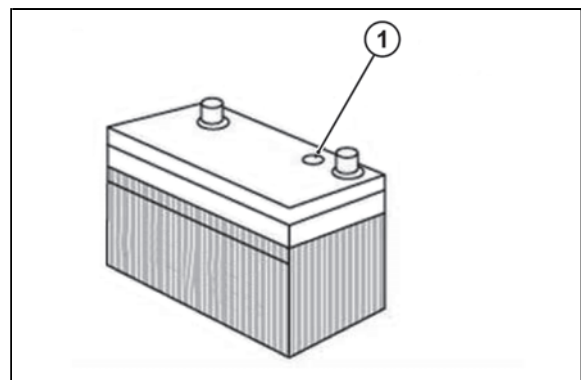

UCL18N075

Battery Charging

1. Turn the ignition switch to the 'OFF' position and remove the battery from the tractor.
2. Recharge the battery in a well-ventilated area.
3. Avoid charging the battery with a large charging current.
4. Properly connect the charger cables to the negative and positive terminals of the battery.
5. When using the charger, its charging current must be below 10 A.

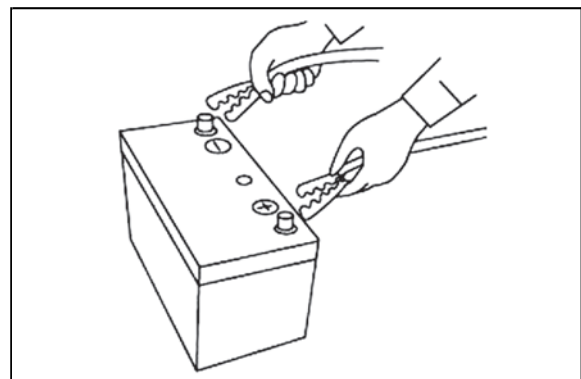

UCL18N076



Charge the battery only in a well-ventilated area.

The battery produces highly flammable hydrogen gases that can explode. Keep flammable objects and sparks away from the battery.

The electrolyte contains acid which can cause severe burns.



If the electrolyte battery gets in your eyes or on your skin, rinse them thoroughly with water. If swallowed, drink plenty of water and seek medical advice immediately.

MAINTENANCE

Start with the Other Vehicle

1. Switch off all electrical appliances.
2. Use a connecting cable to connect the positive terminals of battery of vehicles.
3. Use a connecting cable to connect the negative terminal of a standard battery to the tractor engine case with the discharged battery.
4. First start the engine of the vehicle with the charged battery. Then start the tractor engine with the discharged battery.
5. When the engine is started, disconnect the negative cable first. Then disconnect the positive cable.
6. After starting the engine, charge the discharged battery for about 30 minutes.

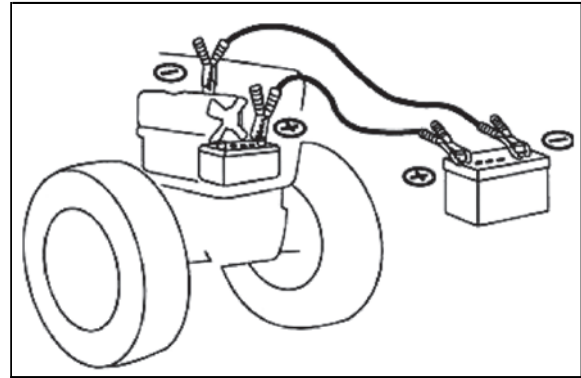

HODP136

Battery Disconnecter

The function of the battery disconnection switch is to disconnect the supply voltage from the electrical system by interrupting the connection to the battery. The main benefits of this solution are:

1. Short circuit protection of the electrical system;
2. Reduction of the battery spontaneous discharge, especially when the machine is shutdown for a long time;
3. Maintenance and repair work in safe conditions.

1 - Knob

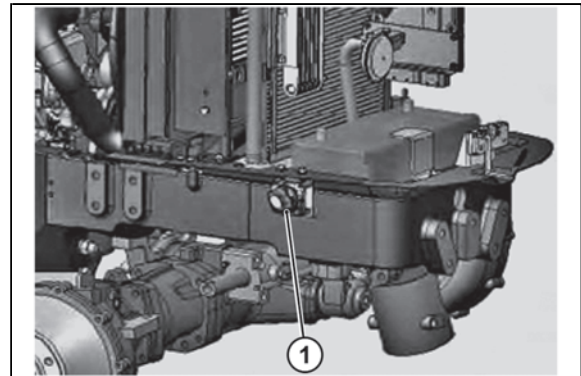

HODP137

Turn the knob to "OFF" to disconnect the battery and back to "ON" to resume normal operation. The battery disconnect knob 1 is located on a bracket to the right of the battery. Putting the battery disconnect in safety condition The battery disconnect knob may be removed for safety purposes in the manner described below.

MAINTENANCE

Removal of the knob

1. Turn the knob to the "off" position; the knob cannot be removed in this position.
2. Press the knob in and continue to turn it counter-clockwise as far as it will go.
3. Remove the knob.

1 - Knob

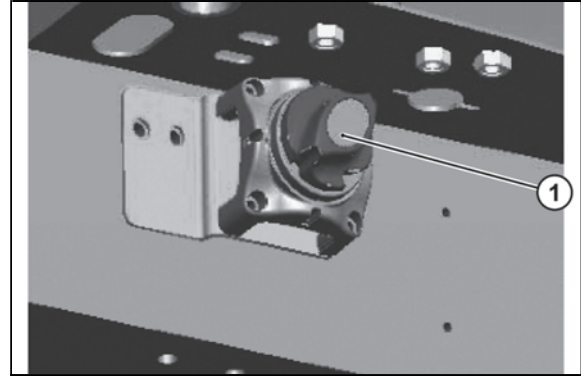

HODP138

Refitting the knob

1. Refit the knob
2. Press and turn the knob clockwise, positioning it at 45°

Electric Lines Check

Loose wire terminals can cause contact break and damaged wires can lead to poor electrical operation, short circuits and fire. Replace or repair worn and damaged wires.

If the insulation of any conductor is damaged, wrap this conductor with insulating plastic tape or replace it.

If the conductor clips or straps are damaged, secure the wires with new clips or straps.

Have the lines checked regularly once a year by an authorized service center to prevent fire.

MAINTENANCE

Fuses Check and Replacement

Fuses are installed in this tractor to prevent any possible accident in the event of a malfunction of the line circuit.

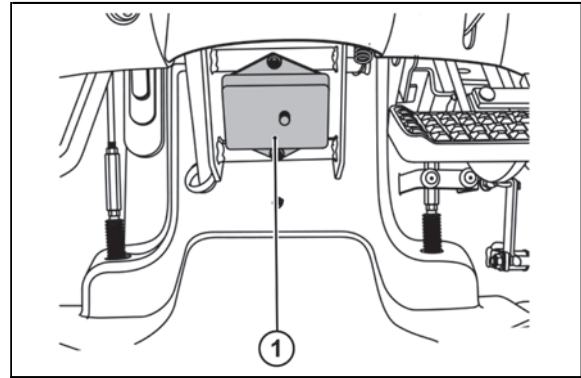

UCL18N078

If an electrical system does not function correctly while driving, check for a blown fuse:

1. Remove the fuse box cover.
2. Remove the blown fuse.
3. Insert a new fuse of the same rating.
4. The function and rating of each fuse is indicated on the fuse box cover.

- 1 - Normal condition
2 - Blown

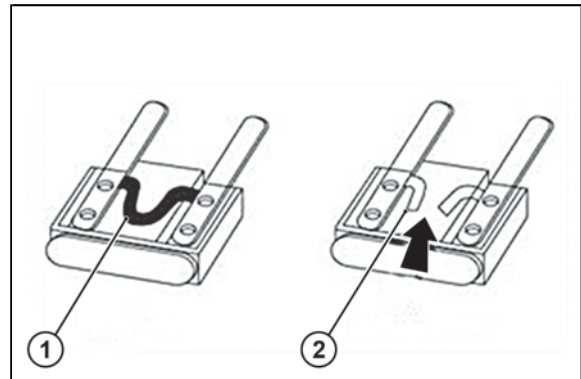

HODP141



Always eliminate the cause of the fuse blowing, otherwise a new fuse is likely to blow as well. Always use a fuse of the specified rating, never replace a blown fuse with a higher fuse rating or a wire.

MAINTENANCE

Fuse Panel

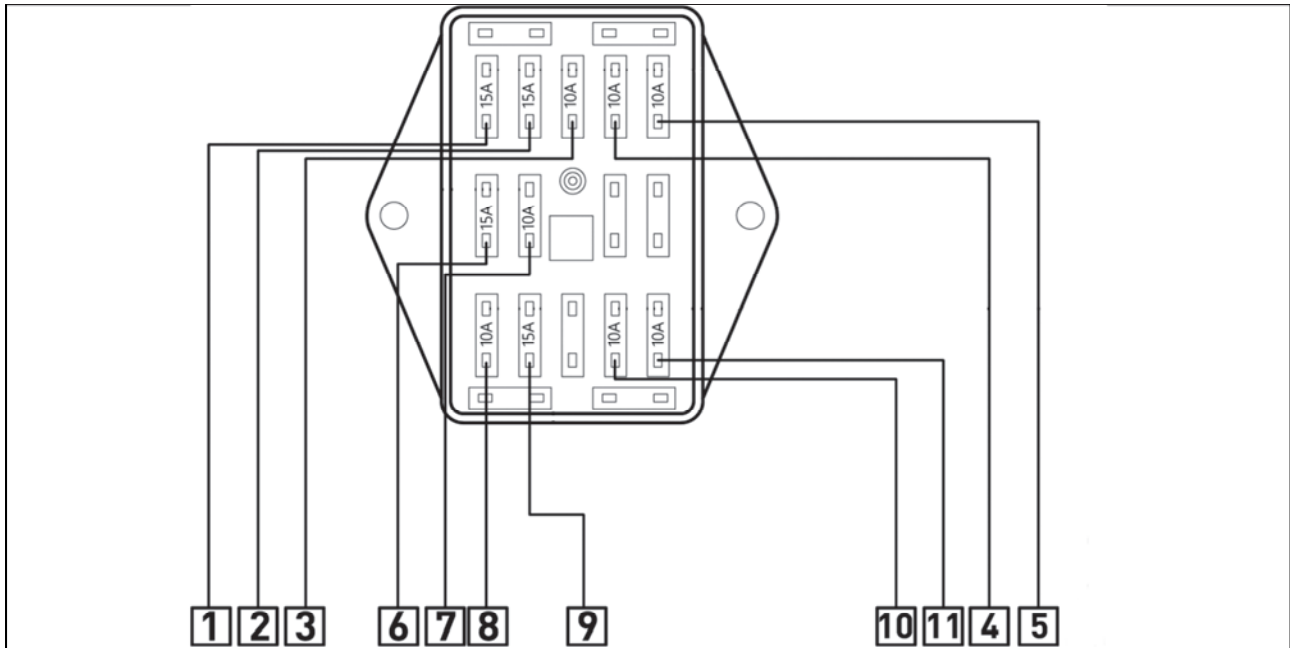

UCLS5N016

1. Panel (15A)
2. Light, Horn (15A)
3. Working light (10A)
4. Stop lamp (10A)
5. Turn signal (10A)
6. Controler (15A)
7. Engine stop (10A)
8. Fuel pump (10A)
9. Coupler (15A)
10. Auto rolling (10A)
11. Quick turn (10A)

MAINTENANCE

Hoses and Connections Check

Fuel lines, radiator hoses, hydraulic and rubber hoses are consumables that degrade with age and use. Check them regularly and replace defective ones.

1. Carry out the check with the engine sufficiently cooled down.
2. Check fuel lines, coolant hoses, and other rubber hoses for damage or leaks. Replace, if necessary
3. Check the tightening of the clamps.



ATTENTION: *Damaged fuel lines leak and may cause fire. Damaged radiator hoses can cause hot water burns and, in severe cases, damage the engine.*

Tire Pressure

Tire pressure has a direct impact on tire life and its off-road characteristics. Check the tire pressure visually before using the tractor, see the enclosed picture.

1. Over-inflated Tire
2. Correct Inflation
3. Under-inflated Tire

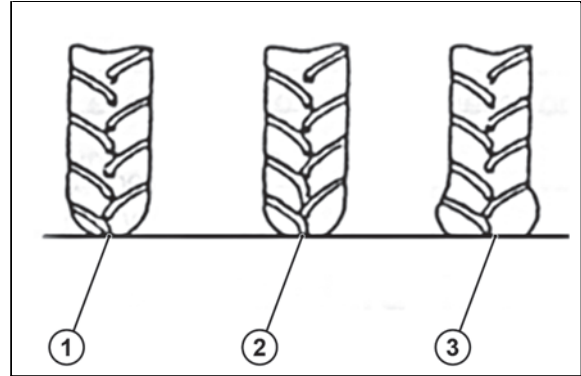

HODP104



IMPORTANT: *We recommend to check the tire pressure with a pressure gauge and not rely solely on a visual tire pressure check.*

Tire inflation

If the tractor is equipped with air brakes for trailers and semi-trailers, the tractor air pressure system can be used to inflate the tires.

Remove the cap (1) on the left compressed-air tank (accessible from the rear of the tractor) and screw the tire inflation hose onto the fitting (2).

Inflate the tires while the engine is running and the tractor is secured against movement by using the hand brake, if necessary by wedging the wheels.

When tire inflation is complete, remove the tire inflation hose and attach the cap (1) to the fitting (2).

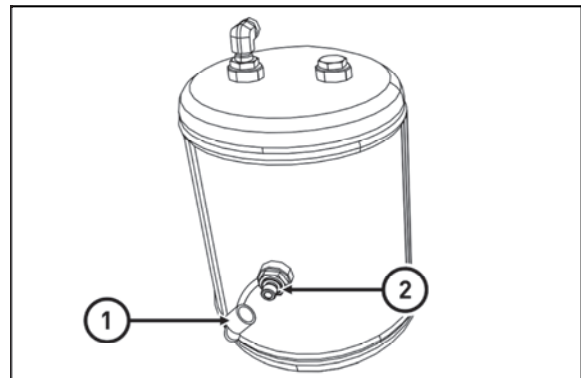

UCL18NN024

MAINTENANCE

Wheel Tread Setting

The front wheel track can be set in 2 positions. The rear track can be set in 5 positions as illustrated.

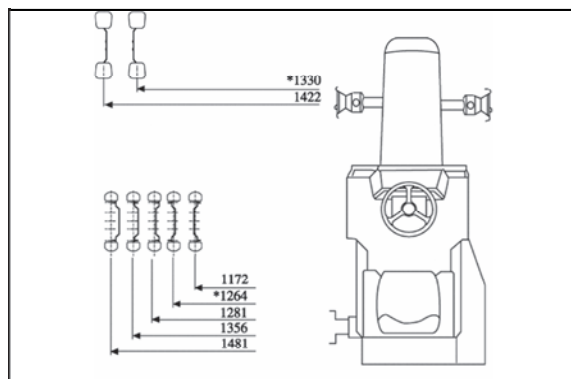

UCLS5N017

Model	Division	Tyre	Air pressure (kgf/cm ²)	Track adjustment (*) Marking is standart
Utilix CL45	Front	9.5-16-6PR	2,1	1330 mm
Utilix CL55	Rear	13.6-26-8PR	1,5	1264 mm



After adjusting the wheel tread, the width and turning radius of the vehicle change.

MAINTENANCE

Service Prior to Daily and Short Terms Storage

Wash the tractor and keep it clean.

Refuel the fuel tank to avoid condensation in the tank and corrosion of the fuel system.

Lower the attached implement to the ground before parking the tractor.

For Daily or Short Term Storage

Clean the tractor and remove all dirt.

Refuel the fuel tank to avoid condensation in the tank and corrosion of the fuel system.

Lower the power tool to the ground.

Park the tractor in a dry area with roof, if this is not possible we recommend covering the tractor with a solid material such as foil or tarpaulin. In very cold conditions, it is advisable to remove the battery and keep it in a warm environment to ensure functional starting. If the outside temperature is less than 32 °F (0 °C), replace the coolant completely or drain the coolant circuit to protect the engine from damage with frozen coolant.



IMPORTANT:

- ***When washing the tractor, make sure that water does not enter the tractor's electrical system or fuel and lubrication system.***
- ***To prevent short circuits remove the ignition key.***
- ***Do not wash the tractor when the engine is running.***

Long-term Shutdown

If the tractor will not be used for a long time, perform the cleaning as for the short term storage.

Drain and change the oil. Start the engine for approx. 5 minutes to refill the engine with new oil.

Drain the coolant from the radiator and remove the ignition key. Attach the 'NO COOLANT' sign to both the key and the steering wheel. If there is antifreeze in the cooling circuit, there is no need to drain the coolant.

Lubricate all lubrication points on the tractor.

Check pressure in tires, if necessary overinflate them slightly due to the machine being stationary for a long time.

Lower all attached implements on the ground or disconnect the unit if necessary.

Disconnect the clutch using the clutch release arm.

Place a wooden support under each tire to preserve its characteristics.

Refuel the fuel tank to avoid condensation in the tank and corrosion of the fuel system.

Recharge the battery every 2 months during long-term storage.



Important:

- ***After refilling the engine with the coolant run the engine for approx. 5-10 min. at 1,500-2,000 rpm every month as a corrosion prevention measure.***
- ***Either removes the battery or the negative terminal as mouse damage to wiring can cause short circuits and fires.***
- ***Remove the ignition key and store in a safe place.***

Re-use After Long Term Storage

Carry out a full check of all oils and coolant.

Refit the battery and run the engine at idle for 30 min. to ensure optimum engine life.

CABIN SYSTEM

The cab fully complies with international standards in terms of safety and sound insulation. It is equipped with ventilation, heating and air conditioning systems.



The cab is in full conformity with the international standards as to the cab's soundproofing. Be very careful when operating in small spaces and always protect your ears whenever other working equipment is generating dangerous noise levels.

- 1 - Air Filter
- 2 - Work lights (rear)
- 3 - Air Filter
- 4 - Rear Wiper
- 5 - Door Handle

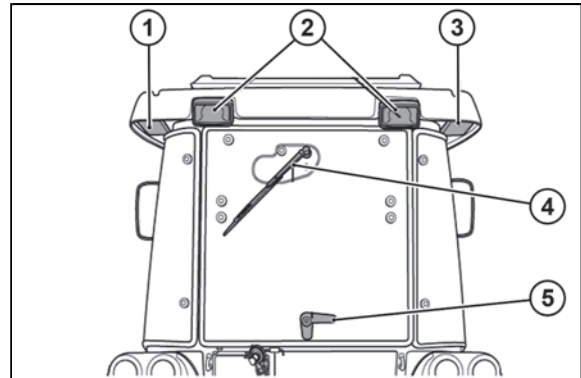

UCL18N081

- 1 - Rearview Mirror
- 2 - Work lights
- 3 - Roof Hatch
- 4 - Rearview Mirror
- 5 - Front Wiper

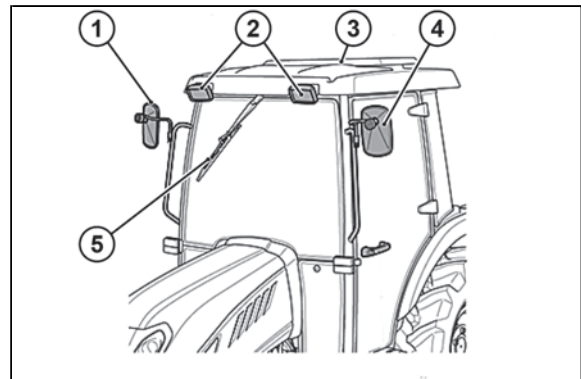

UCL18N082



Remember that steering, braking and operational performances are highly influenced by the implements mounted, the trailers transported and the ballasts applied to the tractor.



When transporting heavy loads (exceeding the weight of the tractor) reduce the speed under 15 km/h..



All the implements mounted onto the tractor must be safely secured.



Be very careful during implement hitching and unhitching operations. When using implement supports, be sure they are suitable and sufficiently strong.

CABIN SYSTEM

Instruments and related parts

Doors

The doors are provided with key locks.

To open from the outside, when unlocked, depress the push button.

To open from inside, push the lever downwards.

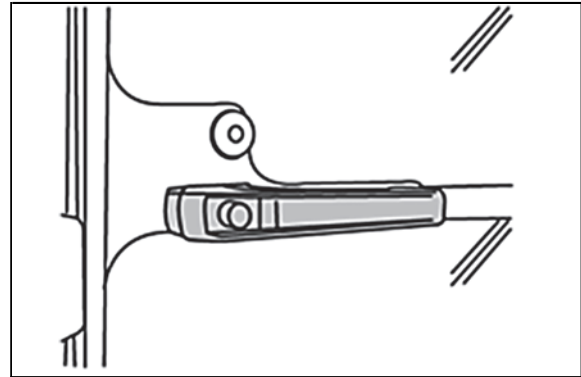

HODP146

Rear Window

The rear window is fitted with central handle for opening.

When opened it is held in place by two dampers.

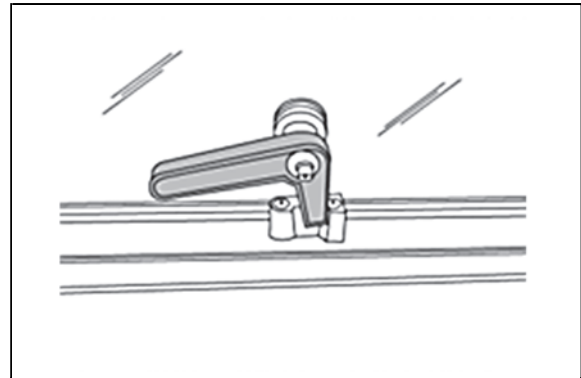

HODP147

Side window

The side window is fitted with central handle for opening.

When opened it is held in place by holder.

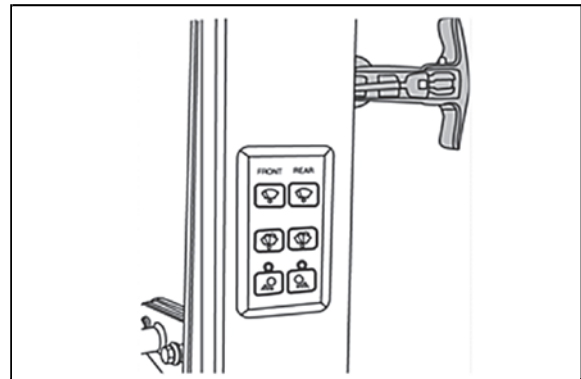

U18N109

CABIN SYSTEM

Work lights (front and rear)

The work lights are located on the cab roof (two at the front and two at the rear). They are switched on using separate switches on the roof console.

1 - Work lights

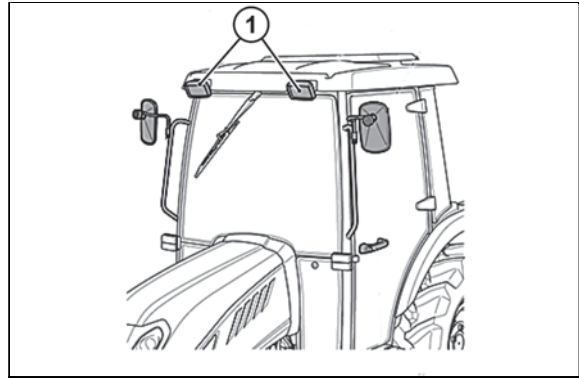

UCL18N083

1 - Work lights

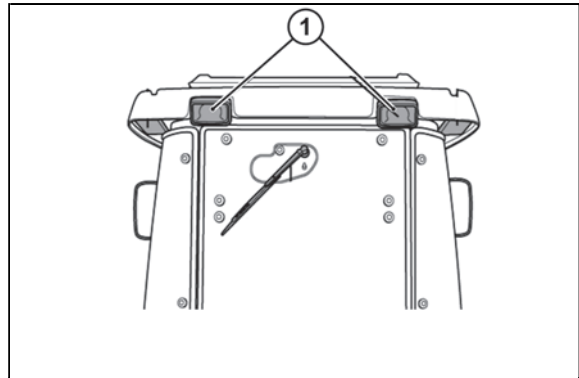

UCL18N084

Rearview Mirrors

The cab is provided with rearview mirrors on both sides. They can be adjusted and folded, whenever necessary, to avoid interference with external obstacles.

The mirrors have a telescopic arm to allow positioning for maximum convenience by the user.

Remember that mirrors must always be positioned in compliance with road traffic regulations when driving on a public highway.

CABIN SYSTEM

Cab Ceiling

The roof of the cab is lined with insulating material, the task of which is to retain thermal radiation in the cab and to maintain the cab temperature at a low temperature when working in hot sunny weather.

The cab platform is covered with a heavy-duty material in the most commonly used parts.

It is recommended to keep the floor clean, free of soil, mud, etc., so that the operator can enter and exit the tractor completely safely.

How to Control Cabin

Interior devices

- 1 - Roof Hatch
- 2 - Recirculation Input
- 3 - Player
- 4 - Rotary Diffuser
- 5 - Dome Lights
- 6 - Air conditioning unit, heating control

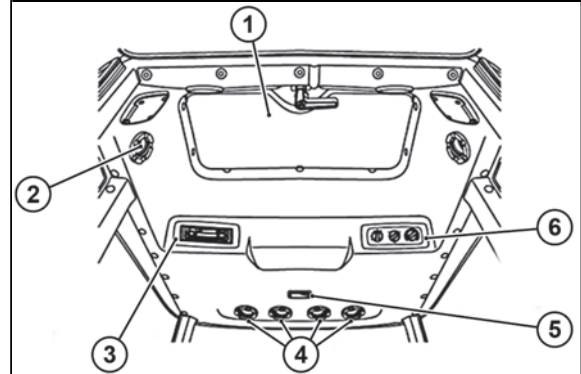

U18N112

Ventilation

The ventilation unit is housed in the cab ceiling.

To switch it on and adjust it, turn the electrical fan switch to the desired speed.

The cab becomes slightly pressurized when the ventilation system is in operation, so that the fresh air can enter only by way of the filter installed in the rear section of the cab roof.

The fan switch can be operated only after the ignition key is inserted.

The air flow can be regulated and directed by suitable positioning the air diffusers.

Air can be taken in fresh from outside or recirculated from within the cab by way of the relative side inlets.

Re-circulation inlets fully closed

Air is taken in entirely from outside the cab through the rear grille and filtered through a paper element positioned behind the grille.

Note: It is very important that the air diffusers never be completely closed so as to allow for a steady air flow. To obtain a greater pressurization inside the cab, it is necessary to take the air from the outside, therefore the inside air recirculation grille should be fully closed.

Switch panel on the right pillar

- 1 - Wiper switch
- 2 - Washer switch
- 3 - Working lamp switch

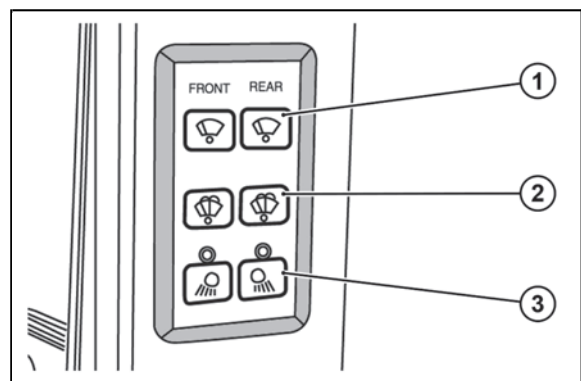

U18N113

CABIN SYSTEM

Wiper control switch

On switch

- Wind screen wiper operation.
- Continuous pushing button operates wiper and washer pump.

Off switch

- Wind screen wiper "Off" and operates washer pump.

Windscreen washer tank

Check the level of windscreen washer fluid in the plastic reservoir located on the rear side of tractor. During winter it is advisable to add a suitable antifreeze to the windscreen washer fluid.

1 - Washer tank

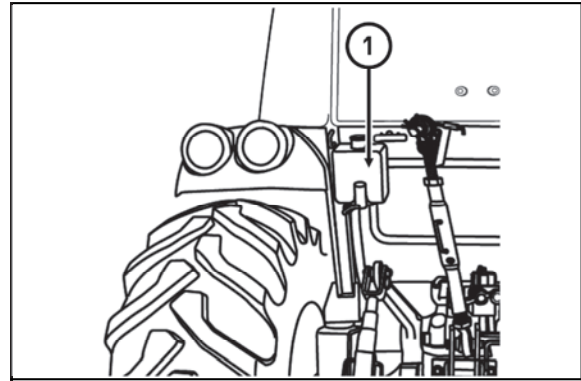

UCLS5N010

Interior lamp

Press the button to switch on.
To switch it off, press it again.

1 - Interior lamp

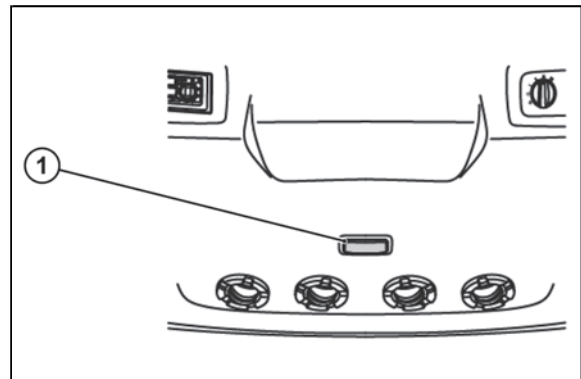

U18N115

CABIN SYSTEM

Blower control switch

Four-position rotary switch

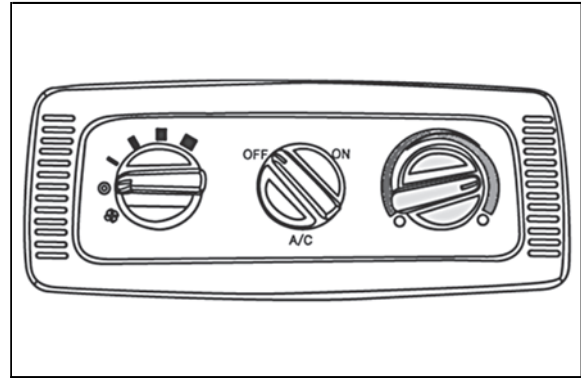

U18N116

Temperature control

Set temperature control as required fully clockwise.
For maximum cool and fully counterclockwise for heat.



U18N117

Air conditioner switch

To operate the air conditioner the blower must be on the blower speed temperature control and all vents must be adjusted to obtain the best cooling for the ambient temperature and dust conditions.

Under normal operating conditions, and the windows and doors closed, temperatures in the cab of 6 °C to 15 °C (10 °F to 25 °F) less than the ambient temperature will occur. When operating the air conditioner system, the moisture level is decreased.

Note:

- 1) During cold weather, with ambient temperature above 0 °C (32 °F) operate the air conditioner at least once per month for a period of 10 to 15 minutes. This will lubricate the seals to prevent them becoming brittle and help prevent the loss of refrigerant from the system.
- 2) The system is equipped with an environmentally safe refrigerant, R134a. Never recharge the air conditioning system with refrigerant other than R134a as this will result in loss of cooling and permanent damage to all air conditioning components.

Circulation diffuser

1 - Circulation diffuser

With the circulation vent set in any position outside Air will still be pulled into the cab.

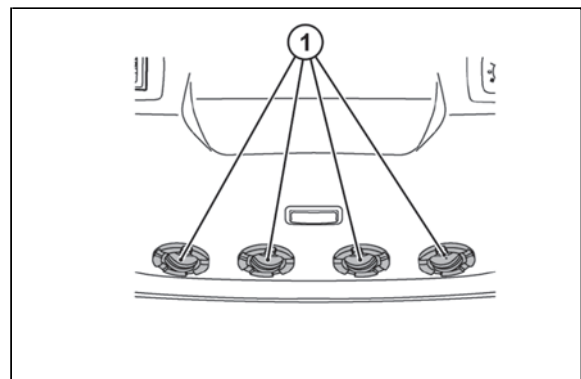

U18N118

CABIN SYSTEM

Heating system

The heater is switched on and adjusted by rotating the control knob at the roof console, then switching on the blower and setting the selector at the preferred speed.

To warm the cab up quickly, the knob should be rotated fully clockwise and the blower set to speed 3.

The screen is demisted or defrosted by air directed through a slot vent. For defrost or fast demist, all other vents should be closed off.

Important:

Ventilation is provided by a single blower unit serving both the heating system and the air conditioning system.

After reaching the desired temperature adjust the system to suit your needs.

Note: For ideal system operation, the engine must run at 1 000 rpm.



Warning: Before starting the engine, make sure the system is off (by turning off the ventilation fan) so as not to overload the battery.

After the system at full power for a long period of time, never turn it off suddenly but let it first idle for about 20 seconds.

- 1 - Heating Fan
- 2 - Electric heating
- 3 - Air Filter
- 4 - Recirculation connections
- 5 - Rotary Air diffuser

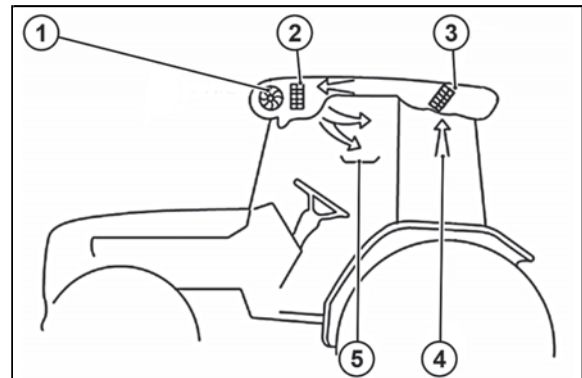

UCL18N085

Compressor belt adjustment

Check the compressor belt tension regularly and adjust if required.

The correct tension is if the center of the belt is pushed with a finger it moves in approx. 10mm (0.39 in) as shown in the picture.

To adjust the belt, loosen or tighten the nut (1).

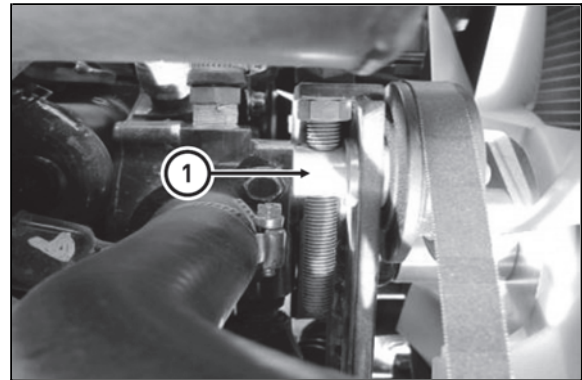

UCLS5N011

Heating system configuration

The heating system consist of two units:

1. Electric heater and blower unit installed behind roof console.
2. Power supplying set, consisting of an auxiliary alternator located front of the engine and driven by a belt directly linked to the engine pulley.
If the air does not come out from the diffusers right away as soon as the system is started, turn off immediately and identify the fault.

N.B: Never turn on the heating system when working in dusty environments.

CABIN SYSTEM

Air conditioning system

The system is designed to provide optimum temperature inside the cab and provide the operator with maximum comfort and safety. However, if you want to make repairs or adjustments, it is recommended to consult our specialist workshops. Do not approach to the system with open flames, as lethal and explosive gas can be generated when the media leaks from the circuit.

- 1 - Alternator
- 2 - Compressor
- 3 - Fan
- 4 - Electric heating
- 5 - Evaporator
- 6 - Air Filter
- 7 - Condenser
- 8, 9 - Air Diffusers
- 10 - Recirculation Ports

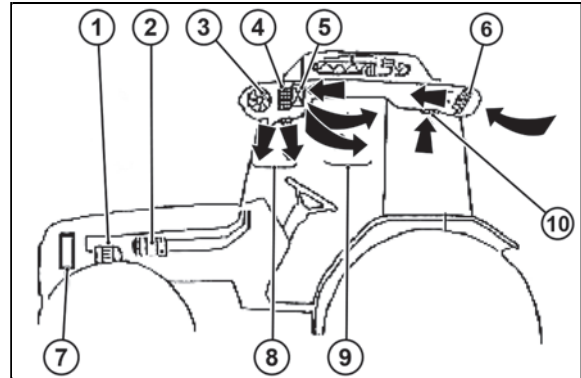

UCL 18N086

Roof hatch (if equipped)

- 1 - Roof hatch

Ventilation-push the latch towards the front of the tractor and then push the hatch up.
Emergency Exit-Push firmly upwards to release the support struts from the lower retainer clips.

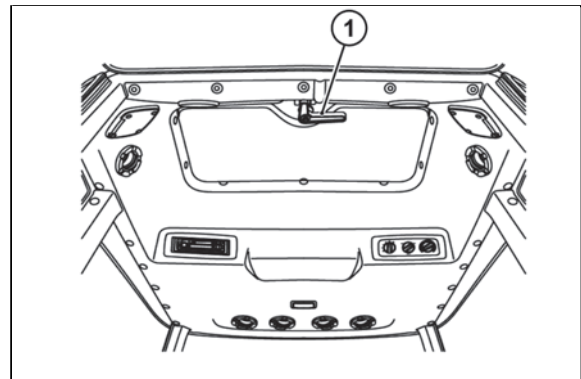

UCL 18N087

Cab air intake filter

The filter is not suitable for the treatment of pesticides and so must be replaced by an active carbon filter available optionally. Once the pesticide treatment is finished, it is necessary to once again replace the "ACTIVE CARBON" filter with the paper filter, since this is the only type suited for filtering foreign particles from the air. Optional ACTIVE CARBON FILTER is informed to parts Catalogue.

- 1 - Air intake filter

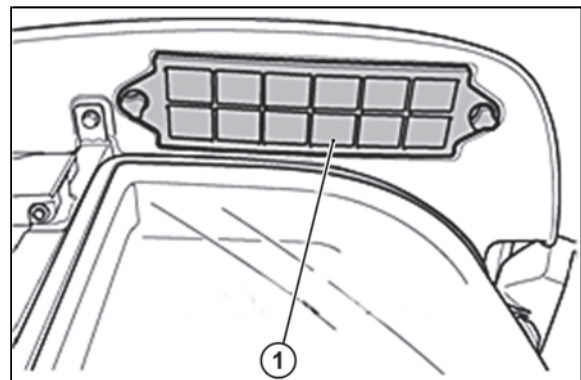

U18N123



Warning: Cab air filters remove dust in the air, but are not capable of removing chemicals used in spraying crops or in weed control. Many chemicals used for these purposes are toxic when improperly used and can be hazardous to operators and others in the area. Follow the instructions of manufacturers of both the equipment and the chemicals regarding prohibition of dust or spray, personal hygiene practices, and other precautions noted by the manufacturers.

CABIN SYSTEM

Radio, CD player (if equipped)

For operation refer to the radio, CD player manufacturers instructions.

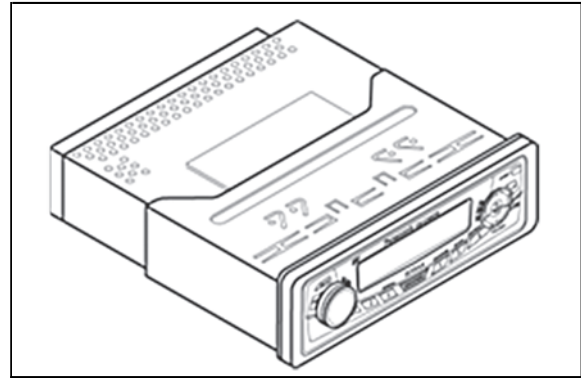

U18N124

Ash tray

Located at right side of near side window in cabin.

Cup holder

Put the bottles and personal belongings.

Cigarette lighter

Push the button. Use that is retune to original position.

- 1 - Cigarette lighter
- 2 - Ash tray
- 3 - Cup holder

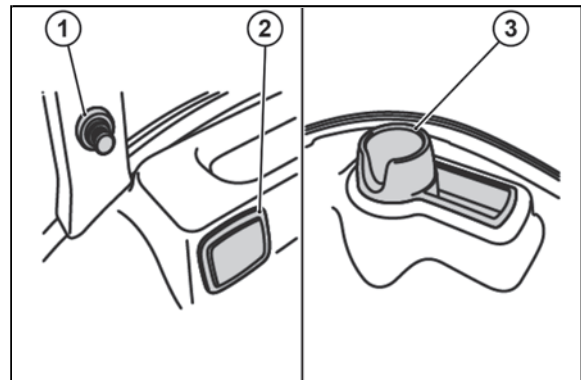

U18N125

CABIN SYSTEM

Air conditioning system troubleshooting

1. Check of the air-conditioning system.

1- High economy and gentle refrigerant: R134a 0,7~0,85 kg.

The presence of air and water in the system can harm its efficiency.

- Air is unnecessarily circulated by the compressor as it has practically no cooling effect.
- Moisture tends to rise to obstacles and joints, which significantly reduces cooling efficiency.

2- Check the belt tension; press your finger on the middle point between the two rollers.

3 - The radiator fins must always be properly cleaned using water or compressed air.

CABIN SYSTEM

2. Checking the air conditioning system charge

(1) Check the refrigerant charge.

- Run the engine at 1 500 rpm.
- Set the air conditioning system in the coldest for 5 minutes.
- Check the sight glass clear or cloud.



Caution:

- *If the air-con. is operated with not charged.*
- *The lubrication in the compressor can cause the damage.*

(2) Check the refrigerant with receive drier sight glass.

-	Bubbles or foam visible	Trouble shoot	
	<ul style="list-style-type: none"> • Bubbles flow and refrigerant gas disappeared like a fog flows. 	<ul style="list-style-type: none"> • Deficient of refrigerant replenish. • Nothing different temperature between H.L pipe. • High pressure of the pressure gauge needle indicates low pressure. 	Abnormal
	<ul style="list-style-type: none"> • Same bubble appeared occasionally. (1~2 sec. gap) 	<ul style="list-style-type: none"> • Replenish the refrigerant. • High pressure pipe is hot and low pressure pipe is a little cool. • H.L pressure of the pressure gauge needle indicates low pressure. 	Abnormal
	<ul style="list-style-type: none"> • No bubble shown high-pressure pipe is hot abnormally. H-L pressure of the pressure gauge needle indicates high pressure abnormally. 	<ul style="list-style-type: none"> • Too much of refrigerant deflate. • High pressure pipe is not abnormal. • H.L pressure of the pressure gauge needle indicates high abnormally. 	Abnormal
	<ul style="list-style-type: none"> • Refrigerant in the sight is shown clearly. • When engine RPM operates with high low some bubbles disappear slowly. 	<ul style="list-style-type: none"> • Normal refrigerant gas situation. • High pressure pipe is hot Low pressure pipe is cool. • High low pressure is normal with below. • Low : 1.5~2.0 kg/m² • High : 14.5~15 kg/m² 	Normal

CABIN SYSTEM

3. Diagnosing malfunctions

(1) Tracing faults

	FAULT	SYMPTOM	CAUSE	SOLUTION
1. Compressor	Unusual sound	Input sound Output sound	Lack of lubricant	Add
			Loose belt	Adjust
			Loose console	Tighten the screws
			Clutch failure	Check
	Abnormal speed	Input cause	Damaged parts	Check, replace
			Clutch slips	Check, replace
			No lubricant	Add
		Output cause	Belt loosened	Adjust
		Refrigerant or oil leakage	Refrigerant or oil leakage	Sealing washer damaged
	Loose screw on the head			Tighten
	O-Ring damaged			Replace
	Excessive pressure	Low, high pressure	Lack of refrigerant	Adjust
Compressor			Replace	

CABIN SYSTEM

	FAULT	SYMPTOM	CAUSE	SOLUTION
2. Engine	Low pressure or not working	Engine operation normal	Air supply clogged	Remove
			Evaporator freezes	Adjust the minimum pressure
			Fan switch damaged	Replace the switch
			Compressor	Replace
		Engine operation is not normal	Engine failure	Replace
			Broken wire	Replace
	Fan cannot be operated	Air leak	Pipe leak	Check, tighten
		Engine	Pneumatic control switch error	Check, tighten
3. Clutch	Noise	Regular noise	Collision with roller	Check the position of the compressor
		Irregular noise		
	Disengagement	Disengaged occasionally	Wire failure	Check the wire
		Always engaged	Large clutch play	Adjust
			Press by hand	Low voltage
		No wire defective	Malfunction	Replace
	Slippage	Slippage during rotation	Low voltage	Check the battery
			Clutch contaminated by oil	Clean
			Malfunction	Replace

(2) How to check the air conditioning system with the needle of high low gauge

To connect with manifold pressure gauge can find the cause of air conditioning system.

Because manifold pressure gauge is various sensibly (Ambient Temp. is based on 30~35 °C)

Caution: Operating E/G RPM 1 500~2 000 is must, and so to that you can check the correct cause and air conditioning. (In case below the figure of indicated pressure gauge has some clearance, confirm with approximate indicated needle data.)

Gauge pressure conversion

- $\text{lb/in}^2 = \text{PSI}$
- $1 \text{ kg/cm}^2 = 14.223 \text{ lb/in}^2$
(Ex) 200 PSI = 14 kgf/cm²

NOTES

TROUBLESHOOTING

Engine Troubleshooting

SYMPTOM		CAUSE	REMEDY
Engine	Turning the main switch will not operate the starter	Clutch not pushed in Battery flat Switch faulty	Push the clutch in Charge or replace the battery Contact dealer to repair or replace
	Starter operates but not enough to turn the engine	Low battery Bad earth Thick oil	Charge the battery Clean the earth lead and tighten Drain and replace with correct oil
	Starter operates OK but does not start the engine	Air in fuel system Clogged fuel filter No fuel being supplied Glow plug disconnected or not working	Bleed the system Clean or replace both filters Fill tank or turn tap on Contact dealer for repair
	Engine revolutions are irregular	Air in the fuel system Faulty injector Fuel pipe leak	Bleed the system Contact dealer for repair
	The engine stops at low revolution	Poor fuel injection Faulty injection pump Wrong valve clearance Wrong idle setting Faulty injector	Contact dealer for repair
	The engine stops suddenly	Lack of fuel Faulty injectors Seized engine due to lack of oil, the wrong oil or lack of coolant	Fill the tank and bleed the fuel system Contact dealer for repair Refill oil or coolant
	White smoking from the exhaust	Oil level too high Shortage of or faulty fuel	Reduce to correct quantity Contact dealer for repair

SYMPTOM		CAUSE	CORRECTIVE MEASURE
Engine	Engine is overheating	Lack of coolant Broken or incorrectly set fan belt Air filter plugged Clogged radiator Low oil level	Refill coolant Set or replace Clean or replace air filter Clean the radiator fins Refill the oil to the right level
	Reduced engine power	Injectors are clogged, carbonated and sticky Low compression Leaking valve Incorrect valve clearance adjustment Incorrect timing Lack of fuel Air filter plugged	Contact an authorized service Contact an authorized service Contact an authorized service Contact an authorized service Refill tank and check fuel quality Clean
	The oil indicator light comes on when the engine is running	Low oil level Unsuitable oil Indicator light or switch error Oil filter plugged	Refill to correct level Replace with correct oil Replace defective part Contact an authorized service
	The alternator indicator light comes on when the engine is running	Faulty wiring Defective alternator Low electrolyte level or defective battery Broken or loose fan belt	Contact an authorized service Contact an authorized service Add or replace Replace or adjust

TROUBLESHOOTING

Clutch, Brake and Hydraulic System Troubleshooting

SYMPTOM		CAUSE	CORRECTIVE MEASURE
Clutch	Clutch slips	Incorrect setting	Adjust the play
		Worn or burned lining	Contact an authorized service
	The clutch does not disengage	Incorrect setting Rusted lining	Adjust the play, Contact an authorized service
Braking system	Brakes do not work	Incorrect play, worn or burnt lining, left and right play are different	Adjust the play, Contact an authorized service
	Brake pedal does not return	Defective return spring Lack of lubricant in pivots	Replace the spring Remove corrosion and lubricate
Hydraulic system	Hydraulics does not lift	Engine speed too low Lack of transmission oil	Increase the engine speed. Refill the oil to the correct level
		Air leaking from the lines Suction filter plugged Defective pump Defective hydraulic valve	Repair or replace the lines or replace the O-ring on the joint and tighten Clean and change oil Contact an authorized service Contact an authorized service
	Oil leakage from lines	Loose line joints Cracked line	Contact an authorized service Contact an authorized service Contact an authorized service
	When lifting, the squealing of the bleed valve can be heard	Stop has slipped down	Tighten the joint Repair or replace the lines Set the stop
* For other hydraulic problems, contact an authorized service that has the correct equipment to perform diagnostics and repair the system.			

TROUBLESHOOTING

Steering Wheel and Electric Instruments Troubleshooting

SYMPTOM		CAUSE	SOLUTION
Steering wheel	Steering wheel vibrates	Poor convergence Uneven tire pressure Loose connection	Adjust the convergence Inflate both tires to the required pressure Tighten or replace in case of wear
	Excessive steering wheel play	Worn steering spindle Worn parts	Contact an authorized service
Electrical devices	Battery stops working	Defective wire Defective alternator Defective regulator Broken or loose fan belt	If necessary, repair, reconnect or tighten Contact an authorized service Contact an authorized service Replace or adjust
	First check the electrolyte level in the battery and the connections. If necessary, refill the electrolyte and clean or re-tighten the clamp		
	The headlights light is faint	Low battery Defective wire	Recharge or replace Repair or replace as needed
	Headlights fail to function	Fired bulb Blown fuse Defective contact	Replace the bulb Replace the fuse Repair or replace and check the grounding
	Horn fails to function	Defective horn button Defective wire Defective horn	Replace the button Repair or replace Replace
	Indicator light fails to function	Fired bulb Defective indicator light unit Defective wire	Replace the bulb Replace the unit Repair or replace

TROUBLESHOOTING

Towing the Tractor

The tractor can be towed only for short distances, such as, for example, from inside to outside a building.

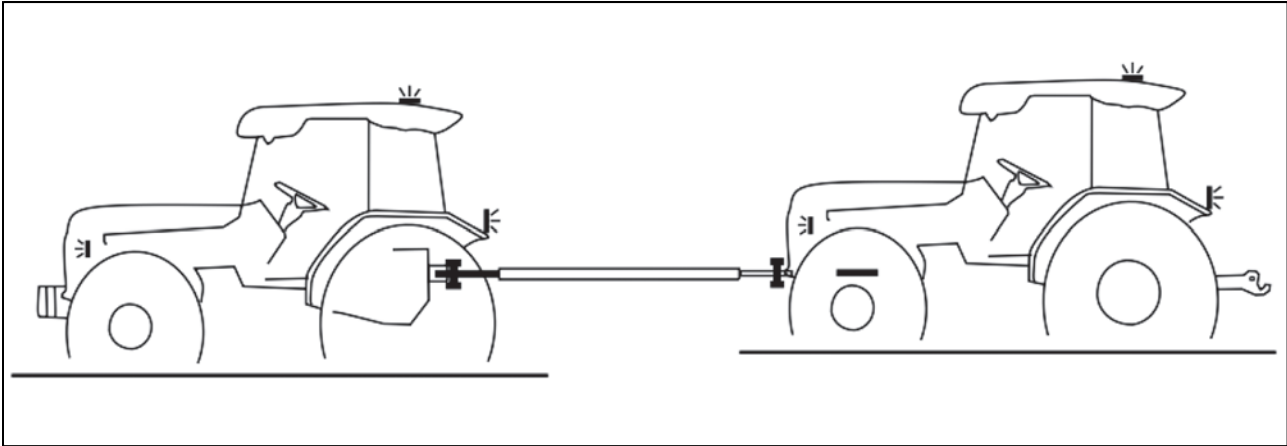

HODP164

A broken down tractor should be towed for the minimum indispensable distance to remove it from potentially dangerous conditions. Observe all legal provisions as envisaged in the highway code relative to national legislation regarding towing manoeuvres.



CAUTION: *We recommend transporting the tractor on a low loader in the case of longer transport distances. Comply with the maximum width and height regulations for road transport. Check that the loader is suitable for the weight of the tractor to be transported.*



CAUTION: *When towing the tractor, the operator must always sit in the driver's seat.*



DANGER: *Never allow unauthorized persons to access the driver's seat during towing.*

TROUBLESHOOTING

Towing with the Engine Running

Towing with the engine running is necessary due to forced lubrication of the gearbox, observe the following

- Engine speed between 1,200 - 1,300 rpm.
- Maximum towing speed 8 km/h
- Maximum towing distance 1 km

For towing the tractor use only a standard bar applied to the front towing hitch approved by the manufacturer. Make sure to use the correct pin for the towing hitch and that it is secured with its locking pin. Clean all lights required for road use, front and rear, and make sure they are in working order.

Before starting towing check the following conditions:

- Unhitch any implement from the tractor;
- Lock the two brake pedals together with the connecting latch;
- Disengage the power take-off and differential locks;
- Set the shuttle control lever and gear lever to neutral;
- Move the range lever to the "fast" position;
- Move the creeper lever to neutral;
- Display the SMV (Slow Moving Vehicle) sign and turn on the rotating beacon and hazard lights



WARNING: Turn on the warning lights and the beacon light. Attach suitable notice sign that the tractor is being towed. Check and comply with the applicable national legislation. Comply with the local safety regulations.

When driving on the road, observe the following:

- Wait for traffic to thin down before entering the road. Be very careful at intersections without traffic control.
- Slow down to have a clear view in both directions.
- Keep the vehicle in your lane and drive as close as possible to the right side of the road. If there are vehicles behind you, pull into a lay-by as soon as possible to allow the vehicles to pass.
- Apply the parking brake when the tractor is stopped (at any circumstances).
- The driving speed must always be such as to allow complete control of the vehicle or the unit and ensure its stability.



Danger: Never attempt to tow the tractor with ropes (including steel ropes) because rope breakage can cause serious injury.

Towing with the Engine Off



Important: With engine stopped and with forced gearbox lubrication system inoperative the tractor can be transferred to a service centre only when loaded onto a transporter.

With engine stopped and with forced gearbox lubrication system inoperative the tractor should not be towed except when safety is at risk.

NOTES

SPECIFICATION

Main technical parameters

Model		UTILIX CL45	UTILIX CL55	
Engine	Manufacturer	Yanmar	Yanmar	
	Model	4TNV88C-K	4TNV86CT-K	
	Type	Line, Water-Cooled Diesel	Line, Water-Cooled Diesel Turbo Charged	
	Number of Cylinders	4	4	
	Total Displacement cm ³	133.6(2190)	127.6(2091)	
	Gross Power kW (PS)	46 (34.3) / 2800	55.1 (41.1) / 2800	
	Maximum Torque	146	175	
Electrical System	Battery	12V80AH	12V80AH	
	Alternator	12V70A	12V70A	
Drive Train	Transmission Type	Sync/Shuttle	Sync/Shuttle	
	Number of Speeds	16 F / 16 R	16 F / 16 R	
	Brakes	Wet Disc	Wet Disc	
	Steering	Hydrostatic	Hydrostatic	
	Clutch	Dry Single Plate	Dry Single Plate	
Hydraulic System	Pump Capacity (Main) L/min	9.5(36.1)	9.5(36.1)	
	Pump Capacity (Power Steering) L/min	5.0(19.0)	5.0(19.0)	
	Number of standard remote valves (Additional Option)	2	2	
3 Point Hitch	Type	Category 1	Category 1	
	Lift Capacity	Lift Points (kg)	1503	1503
		24-in. Behind Lift Points (kg)	1336	1336
	Lift Control Type	Position/Draft	Position/Draft	

SPECIFICATION

Model		UTILIX CL45	UTILIX CL55	
PTO	Type PTO	Independent	Independent	
	Control	Electric/Hydro	Electric/Hydro	
	Mid (Option) (ot/min)	N/A	N/A	
	Rear PTO (ot/min)	540/1000	540/1000	
	Shaft Diameter PTO (mm)	1 3/8 (35)	1 3/8 (35)	
Fluid Capacities	Fuel Tank (l)	17(60)	17(60)	
	Cooling System (l)	9.0(8.5)	9.0(8.5)	
	Crankcase (with filter) (l)	7.1(6.7)	7.1(6.7)	
	Trans.& Hydr. System (l)	9.2(35)	9.2(35)	
	Front Axle (l)	10.5(10)	10.5(10)	
Dimensions	Overall length with 3-Point Hitch (mm)	3590	3590	
	Overall width (mm)	1620	1620	
	Overall height (mm)	2594 (ROPS) 2530 (Cabin)	2594 (ROPS) 2530 (Cabin)	
	Wheelbase (mm)	1935	1935	
	Min. Ground Clearance (mm)	350	350	
	Min. Turning Radius without brakes (mm)	3352	3352	
Weight with ROPS or Cab		3,184 (ROPS) 4,233 (Cabin)	3,184 (ROPS) 4,233 (Cabin)	
Tire	Front	Agricultural	9.5-16	9.5-16
		Turf	12-16.5	12-16.5
		Industrial	12-16.5	12-16.5
	Rear	Agricultural	13.6-16	13.6-16
		Turf	17.5L-24	17.5L-24
		Industrial	17.5L-24	17.5L-24

SPECIFICATION

Travel speeds

MODEL		UTILIX CL45 UTILIX CL55	
Range shift	Main shift	Traveling speed (Forward) km/h	Traveling speed (Reverse) km/h
LL	1	0.68	0.58
	2	0.87	0.76
	3	1.33	1.16
	4	1.57	1.37
L	1	1.87	1.64
	2	2.48	2.17
	3	3.79	3.31
	4	4.48	3.91
M	1	3.91	3.42
	2	5.19	4.53
	3	7.93	6.92
	4	9.35	8.17
H	1	12.40	10.82
	2	16.44	14.35
	3	25.10	21.91
	4	29.62	25.86

SPECIFICATION

Noise levels

The tractor is approved in accordance with the applicable EC Directives.

To avoid increased noise levels proceed as follows:

- After maintenance operations or repairs refit all the sound-deadening panels and materials correctly
- Do not make changes to the tractor that may lead to an increase in noise emissions.
- Beware of any anomalous noise or vibration if you notice anomalous noise or vibration, park the tractor in a safe position and perform the stopping procedure. Inform maintenance personnel of the situation. Avoid prolonged operation.

Reference norms for the measurement of noise levels:

- The maximum driver-perceived noise level, with the engine at normal operating temperature and measured in accordance with the test method described in the European Directive 1322/2014

UTILIX	CL 45		CL 55	
	ROPS	CAB	ROPS	CAB
Maximum inner noise level [dB(A)]	85,5	82,9	85,5	82,9

- The maximum noise level measured with the tractor in motion and the tractor stationary, measured in accordance with the method described in European directive 2018/985

UTILIX	CL 45		CL 55	
	ROPS	CAB	ROPS	CAB
Maximum external noise level with tractor moving, [dB(A)]	80,9	80,5	80,9	80,5
Maximum external noise level with tractor stationary, [dB(A)]	80,6	79,1	80,6	79,1

SPECIFICATION

Vibration Referred to the Operator Position

The value is referred to the amount of mechanical vibration transmitted by the tractor to WHOLE-BODY as defined by UNI ISO2631-1:2008.

Said value must be utilised for assessment of the vibration exposure risk, but it cannot cover all the possible conditions of use of the tractor since it may vary in accordance with parameters that are not always related to the tractor (terrain, implements, etc.). If the risk assessment cannot be considered to be exhaustive or if the risk may exceed the values defined in 2002/44/EC, the use of a vibration meter is prescribed.

The following best practices should be observed to minimize whole-body vibration

- Always use the most appropriate implement for the relevant type of work.
- Adjust the seat to match your weight and seating position.
- Check the cab suspension periodically and replace if damaged.
- Check tire pressure.
- Use the front axle suspension, if fitted.
- During transport, adjust the tractor speed to minimize vibration levels.

The seat vibration values, as obtained from the seat approval in compliance with 78/764/EEC (amended by 1999/57/EC) are shown in the following table.

Technical data

Input vibration : Category A, Class II

Ambient temperature : 23 °C

Seat type			Vibration level corrected for seat
W09SSS	Light driver	59 kg	1.241 m/sec ²
	Heavy driver	98 kg	1.122 m/sec ²

NOTES

INDEX

A		Driving to / from the Field	76
About this manual	9	Driving with agricultural machines attached to the front three-point hitch	71
Accelerator pedal	48	E	
Adjusting the throttle lever	95	Electric Lines Check	99
Adjusting toe-in	95	Electric System Check	97
Adjustment of the lift link on the lower link	66	Emergency exits	22
Air brakes of trailers and semi-trailers	50	Engine Coolant Temperature	41
Air conditioner compressor belt adjustment	96	Engine Oil and Filter Replacement	86
Air conditioner switch	110	Engine Oil Filter Replacement	87
Air conditioning system	112	Engine Oil Change	87
Air conditioning system troubleshooting	114	Engine Oil Check	86
Air Filter Check and Maintenance	92	Engine Running-in Time	74
Air pressure indication	50	Engine Troubleshooting	119
Alternator and fan belts inspect/adjust/replace	96	Engine Warm-up	73
Alternator inspect	97	Engine Warm-up in Cold Weather	74
Always use safety lights and devices	19	F	
Antifreeze	86	Falling Object Protective Structure (FOPS)	25
Ash tray	113	Fixtion points of loader	71
Avoid high-pressure fluids	20	For Daily or Short Term Storage	104
B		Front Axle Drive Shift Lever (4WD)	55
Battery disconnect	21	Front Axle Oil Check and Change	89
Battery Disconnecter	98	Front Fenders	71
Battery Charging	77	Front Three-point Hitch	69
Battery Charging	97	Fuel Gauge	41
Battery Check and Charging	97	Fuel gauge	78
Blower control switch	110	Fuel System	91
Brake Pedal Check and Adjustment	95	Fuel System Bleeding	92
Brake Pedals	49	Fuels, coolants and lubricants used - amounts	83
C		Fuse Panel	101
Cab air intake filter	112	Fuses Check and Replacement	100
Cab Ceiling	108	G	
Cabin system	105	Gear shifting scheme	54
Change	90	General informations	33
Change of Coolant	85	General safety information	33
Check	89	Greasing the Tractor	93
Check and Change of Coolant	85	H	
Check and service	79	Handle fuel safely-avoid fires	19
Check During Driving	77	Heating system	111
Check of Coolant	85	Heating system configuration	111
Check of Radiators for Clogging	86	Height Adjustment and Disassembly of the Multi-level Hitch Attachment Tail Piece	69
Cigarette lighter	113	Hood Opening	84
Circulation diffuser	110	Hoses and Connections Check	102
Cleaning/Replacement of the Fuel Filter Element	91	Hour Meter	41
Clutch cut-off arm	49	How to Control Cabin	108
Clutch pedal	48	Hydraulic lock of the front three-point hitch	70
Clutch Pedal Check and Adjustment	94	I	
Clutch, Brake and Hydraulic System Troubleshooting	120	Instructions and Description	11
Combined Switch	40	Instruments and related parts	106
Compressor belt adjustment	111	Instruments and Switches	39
Connecting and Disconnecting Implement	62	Interior devices	108
Connection	60	Interior lamp	109
Connection	62	Introduction & description	11
Connection and disconnection of implements	67	Introduction to safety information	17
Controlling front three-point hitch	70	Introduction to safety instructions Introduction to safety instructions	17
Controls Play Setting	94	J	
Coolant	77	Joystick Lever	61
D		Joystick lever lock	62
Decals mounting location	33	K	
Description	12	Keep riders off tractor	18
Diesel fuel	30	Key Switch	39
Differential Lock Pedal	55	L	
Disassembly of the rear PTO cover	68	Lamps related to exhaust gas control system	43
Disconnection	60	Lifting force of the front three-point hitch	69
Disconnection	62	Location of serial numbers	7
Don'ts - for safe operation	32	Location of serial numbers	7
Doors	106	Long-term Shutdown	104
Do's and don'ts	31	Lower Hitch Disassembly	68
Do's-for better performance	31	M	
DPF Regeneration Switch	44	Main technical parameters	125
Draft control	58	Maintenance	79
Drive Off on Steep Slope	75	Maintenance and adjustment schedule	80
Driver's Seat	56		
Driving downhill	76		
Driving operation	73		
Driving the Tractor Off	74		

INDEX

Mounting and demounting implements	27	Signal words	17
Mounting Implement	63	Sliding Seat	15
Multi-level hitch	68	Specification	125
N		Start with the Other Vehicle	98
Noise levels	128	Starting the Engine	73
O		Stay clear of rotating shafts	19
Oil Pressure Light	77	Steering Wheel Adjustment Lever	56
One-hose and two-hose brakes	52	Steering Wheel and Electric Instruments	
One-hose brakes	52	Troubleshooting	121
Opening the side cover	84	Stopping and Parking	75
Operating the hydraulics	57	Stopping the Engine	73
Operating Tips for Power Steering	76	Switch panel on the right pillar	108
Operation of the diff lock	76	T	
Operation of Tractor Controls	47	Tachometer	40
Operator Protective Structure (OPS)	25	Temperature control	110
Outer hydraulic circuit	59	The button for temporary deactivation of brakes of the trailer or semi-trailer	51
Outer hydraulic circuit controls	60	The following precautions are suggested to help prevent accidents	28
P		Three-Point Hitch Control	64
Parking Brake Lever	50	Three-Point Hitch Lowering Speed Control	59
Periodical check and service table	80	Throttle Lever (Manual Control)	48
Position control	58	Tire inflation	102
Practice safe maintenance	20	Tire Pressure	102
Precaution to avoid tipping	18	Towing Equipment	67
Pre-start checks	79	Towing safely	25
Prevent acid burns	21	Towing the Tractor	122
Prevent battery explosions	20	Towing with the Engine Off	123
Product Warranty	7	Towing with the Engine Running	123
Protection children	17	Tractor controls	39
PTO Control Switches	45	Tractor greasing plan	82
PTO Shift Lever	57	Tractor identification plate	7
R		Tractor runaway	22
Radio, CD player (if equipped)	113	Trailer socket (seven terminal electrical socket type)	71
Rear Window	106	Transmission Filter Maintenance	89
Re-circulation inlets fully closed	108	Transmission Oil and Filter Check and Replacement	88
Recommended ZETOR service fillings	83	Transmission Oil Change	88
Reduced and Road Gears Shift Lever	54	Transmission Oil Check	88
Refitting the knob	99	Travel speeds	127
Regeneration operation and cautions	43	Troubleshooting	119
Remote hydraulic control valve coupler connecting and disconnecting	60	Turning in the Field	75
Removal of the knob	99	Two-hose brakes	52
Rearview Mirrors	107	U	
Retraction of the lower link (if it is the extendable type)	66	Universal symbols	37
Re-use After Long Term Storage	104	Upper Link Adjustment	65
Reverse Shift Lever	53	Use of Hazardous Substances	25
Roll-Over Protection Structure (ROPS)	13	Use of rops and seat belt	18
Roof hatch (if equipped)	112	V	
Rops (roll over protection structures)	13	V-belt Check and Adjustment	96
ROPS damage	14	Ventilation	108
S		Vibration Referred to the Operator Position	129
Safe operation of your tractor	26	W	
Safe parking of the tractor	18	Warming Up Time	74
Safety instructions for lubrication of the tractor	93	Warning for Driving on the Road	76
Safety instructions, Do's & Don'ts	17	Warning Indicator Lights	42
Safety precautions when using the loader	23	Warning Lights Switch	40
Safety starter switch	22	Wheel Tread Setting	103
Safety Tips During Maintenance	26	Windscreen washer tank	109
Seat Back Reclining	16	Wiper control switch	109
Seat Suspension Adjustment	16	Work in ventilated area	22
Service inspections	79	Work lights (front and rear)	107
Service Prior to Daily and Short Terms Storage	104	Working and transport position of the front three-point hitch	71
Service tractor safely	21		
Side window	106		

Operator's manual
Utilix CL 45
Utilix CL 55

Edition: 1-100-2021
Publication No.: 222.213.600
03/2021
ZETOR TRACTORS a.s.
Department of Technical Documentation
Trnkova 111
628 00
Brno

Zetor



www.zetor.com
zetor@zetor.com



Made in EU