

Zetor

HORTUS HS CL

OPERATOR'S MANUAL

2/2019



65

Tractor is Zetor. Since 1946.

ZETOR



This Operator's Manual for the Zetor tractors, which we are presenting to you will help you to become familiar with the operation and maintenance of your new tractor.

Although many of you have rich experience with the operation of other tractors, please, read the information contained in this Operator's Manual very carefully.

In the Manual you will find a lot of new information and get a perfect overview of how to use the tractor with maximum efficiency during various kinds of work.

If you observe the rules of tractor operation and maintenance and driving safety, your new tractor will become your reliable and long-term friend.

The manufacturer of the tractor wishes you thousands of hours of satisfactory work.

ZETOR
Brno

The technical specifications and information about the design, equipment, material and appearance are valid at the time of print. The manufacturer reserves the right to implement changes.

The instructions for use are a part of the machine.

CONTENTS

General Information	9
Exterior View	9
Tractor Identification	12
Warranty of the Product.....	13
Parts	13
About This Manual.....	13
Introduction & Description	14
Tractor an Introduction	14
Description.....	15
General Construction.....	15
Front Axle & Wheels.....	15
Engine.....	15
Clutch and transmission	15
Brakes.....	15
Rear axle & wheels.....	15
Hydraulic System & Linkages.....	15
Steering	15
Electrical System.....	15
Owner assistance	16
ROPS (Roll Over Protective Structures)	16
Roll Over Protective Structures (ROPS)	16
Damage of the ROPS.....	17
Seat Sliding.....	17
Seat Back Reclining	18
Cunshion Strength Adjustment.....	18
Safety Precautions	19
Safety Instructions	19
Recognize Safety Information	19
Signal Words	19
Read Safety Instruction	19
Protection of persons.....	19
Use of ROPS and Seat Belt	20
Precaution to Avoid Tipping.....	20
Safe parking of the tractor	20
Handle Fuel Safely Avoid Fires	20
Keep Riders Off Tractor.....	21
Stay Clear of Rotating Shafts	21
Always Use Safety Lights and Devices	21
Practice Safe Maintenance.....	22
Avoid High-Pressure Fluids	22
Prevent Battery Explosions	23
Prevent ACID Burns	23
Battery Disconnect	23
Service Tractor Safely	24
Work in Ventilated Area.....	24
Safe starting	24
Safety Starter Switch	24
Emergency Exits.....	25
Safety Precautions When Using The Loader	25
Towing equipment	27
Falling object protective structure (FOPS)	27
Operator Protective Structure (OPS).....	27
Safe Operation of Your Tractor	28
Safety Tips During Maintenance	28
Mounting and Demounting Implements.....	29
The Following Precautions are Suggested to Help Prevent Accidents.....	30
The Tractor	30
Servicing the Tractor	30
Operating the Tractor	31
Driving the Tractor	31
Operating The PTO	32
Diesel Fuel.....	32
Do's and Don'ts	33

CONTENTS

Don'ts-For Safe Operation.....	34
Safety Signs	35
General Safety Information.....	35
Decals Mounting Location	35
Universal Symbols.....	41
Description of Tractor Controls	43
Instrument and switches.....	43
CL Model	43
HS Model.....	44
Main Switch	45
Headlights Switch (Beacon Light), Turn Signal Lights Switch and Horn Switch	45
Tachometer.....	46
Hour Meter.....	46
Fuel Gauge.....	46
Water Temperature	46
Warning Lights.....	47
Independent PTO	48
The PTO Monitor Lamp.....	48
PTO On / Off Switch.....	48
PTO Control Switch	48
Operation The Controls (CL MODEL)	50
Operation The Controls (HS Model).....	51
Hand Throttle (Throttle Lever)	52
Clutch Disconnecting Arm	52
Brake Pedal	52
Foot Operated Accelerator	53
Parking Brake	53
Parking Brake Lever	53
Shuttle Shift Lever - CL MODEL	54
Shuttle Shift Lever - HS Model	55
Gear Shift Lever	55
Sub Gear Lever (Linear Shift Lever)	56
Creep Shift Lever.....	57
Diff-Lock Pedal	58
Front Wheel Drive Lever (CL Model).....	58
Front Wheel Drive Lever (HS Model)	59
Driver's Seat	59
Tilt Lever.....	59
PTO Gear Selection Lever	60
Operation of the Hydraulic Circuit	60
Position Control	60
Lowering Speed Control Knob for The 3 Point Hitch	61
Exterior Hydraulic Lever (Optional)	62
Remote Hydraulic Control Valve Coupler Connecting and Disconnecting	62
Connecting.....	62
Disconnecting	62
Operating The 3 Point Linkage (TPI).....	63
Adjustment of the Stabilizer Bars	64
Adjustment of The Top Link.....	64
Adjustment of the Lift Link (left, right).....	64
Adjustment of the Lift Link on the Lower Link.....	65
Lower Swinging Hitch	65
Lower Hitch Disassembly	66
Multi-level hitch	66
Height Adjustment and Disassembly of the Multi-level Hitch Attachment Tail Piece	67
* Air Brakes.....	67
Air pressure indication	68
The button for temporary deactivation of brakes of the trailer or semi-trailer	68
* Front Three-point Hitch	69
Controlling front three-point hitch	69
Working and transport position of the front three-point hitch	70
Driving with agricultural machines attached to the front three-point hitch.....	70

CONTENTS

Operation	71
Starting the Engine.....	71
Stopping the Engine.....	71
Driving the Tractor.....	72
Warming Up.....	72
Warming Up in Cold Weather.....	72
Warming Up Time.....	72
Tight Turns in the Field.....	73
Normal Braking and Parking.....	73
Uphill Starts on a Steep Slope.....	74
Driving Downhill.....	74
Operation of the Diff-Lock.....	74
Check During Driving.....	75
Oil Pressure Light.....	75
Battery Charging.....	75
Fuel Gauge.....	75
Check During Driving.....	76
Connecting and Disconnecting Implement.....	77
Connection.....	77
Disconnection.....	77
Mounting Implement.....	78
Assembly of the Front Loader.....	79
Fixation Points of Loader.....	79
Joystick lever.....	80
Safety implement for joystick lever.....	80
Front Fenders.....	80
Maintenance	81
Checks and Service.....	81
General Information.....	81
Service inspections.....	81
Pre-Start Checks.....	81
Checking Engine Coolant.....	81
Inspection.....	81
Engine Oil.....	82
Transmission Oil.....	83
Fuel.....	84
Tire Pressure.....	84
Steering.....	84
Brake.....	84
Clutch.....	84
Electrical.....	84
Maintenance and Adjustment Schedule.....	85
Periodical Check and Service Table.....	85
Tire Size and Inflation Pressure.....	86
Filling Diagram & Capacity Table.....	87
Lubricants.....	87
ZETOR service fillings.....	88
Motor oils.....	88
Oil to gear systems of tractors.....	88
Oil for the front driving axle.....	88
Opening Method of Hood.....	88
Fuel.....	89
Bleeding the Fuel System.....	89
Changing the Oils in the Tractor.....	90
Changing Engine Oil.....	90
Changing the Transmission Oil.....	90
Changing Oil in the Front Axle.....	92
Cleaning and Changing Filters.....	93
Engine Oil Filter.....	93
Cleaning Oil Water Separator of Fuel Filter.....	93
Empty Water Tank.....	94
Change the Fuel Pre-Filter Insert.....	94
Vent the Fuel System.....	94

CONTENTS

Change the Fuel Filter Cartridge	95
Hydraulic Oil Filter and Engine Oil Filter Cartridge	95
Replacing coolant	96
Anti Freeze	96
Cleaning the Radiator	97
Greasing the Tractor	97
Setting the play of controls	98
Adjusting the Clutch	98
Adjusting the Brakes	98
Adjustment Method	98
Adjusting the Throttle Leve	99
Adjusting Toe-in	99
Battery Maintenance	99
Checking the Battery	99
Battery Maintenance	99
Battery Charging	100
Battery Disconnect	101
Removal of the knob	101
Refitting the knob	101
Other Maintenance	102
Checking the Belt Drive	102
Replace V-rib Belt	102
Check and Clean the Air Cleaner According to the Following Instructions	102
Cautions for inspection and service of air cleaner	103
Checking Hoses and Lines	103
Checking the Wiring Harness and Fuses	103
Replacing Fuses	104
Main Fuses	104
Position of the Fuse	105
Wiring Diagram of the Electric Instrument	106
Service Prior to Daily and Short Terms Storage	107
For Daily or Short Term Storage	107
Long-term Storage	107
Re-use After Long Term Storage	107
Fuel Saving Tips	108
Air Cleaning System	108
Engine	108
Clutch & Brakes	108
Oil System	108
Fuel System	108
Permissible Fuels	108
Winter Operation with Diesel Fuel	109
Cooling System	109
Water Quality	110
Cooling System Corrosion Protection Agent	110
Cabin System	111
Major Features	111
Instrument and Related Parts	112
Doors	112
Rear Window	112
Side Window	112
Roof Hatch (if equipped)	112
Working Lamps (Front and Rear)	113
Rerarview Mirrors	113
Cab Ceiling	113
How to Control Cabin	114
Interior Devices	114
Switches on the right cab column	114
Work Light Switches	114
Wiper Control Switch	114
On Switch	114
Off Switch	114
Windscreen Washer Tank	114

CONTENTS

Interior Lamp	115
Blower Control Switch	115
Temperature Control	115
Air Control Switch	115
Ventilation	116
External Circulation	116
Circulation Diffuser	116
Heating System	117
Heating System Configuration	117
Air-conditioning System	118
Cab Filter	118
Radio, CD Player (If Equipped)	119
Ash Tray	119
Cup Holder	119
Cigarette Lighter	119
Checking the Air Conditioning System	120
Checking the Air Conditioning System Charge	120
Diagnosing Malfunctions	121
1. Tracing Faults	121
2. Check of the air conditioning with a pressure gauge.	122
3. gauge pressure conversion	122
Specification	123
Technical data	123
Major Specifications	123
Permitted Towed Vehicle Weight	124
Traveling Speed	125
Noise Levels	126
Vibration Referred to the Operator Position	127
Troubleshooting	129
Engine Troubleshooting	129
Clutch, Brake and Hydraulic System Troubleshooting	132
Steering Wheel and Electric Instruments Troubleshooting	133
Towing the Tractor	134
Towing with the Engine Running	135
Towing with the Engine Off	135
Index	137

GENERAL INFORMATION

Exterior View

* The information in this manual is intended for HORTUS CL65 / HS65 model.

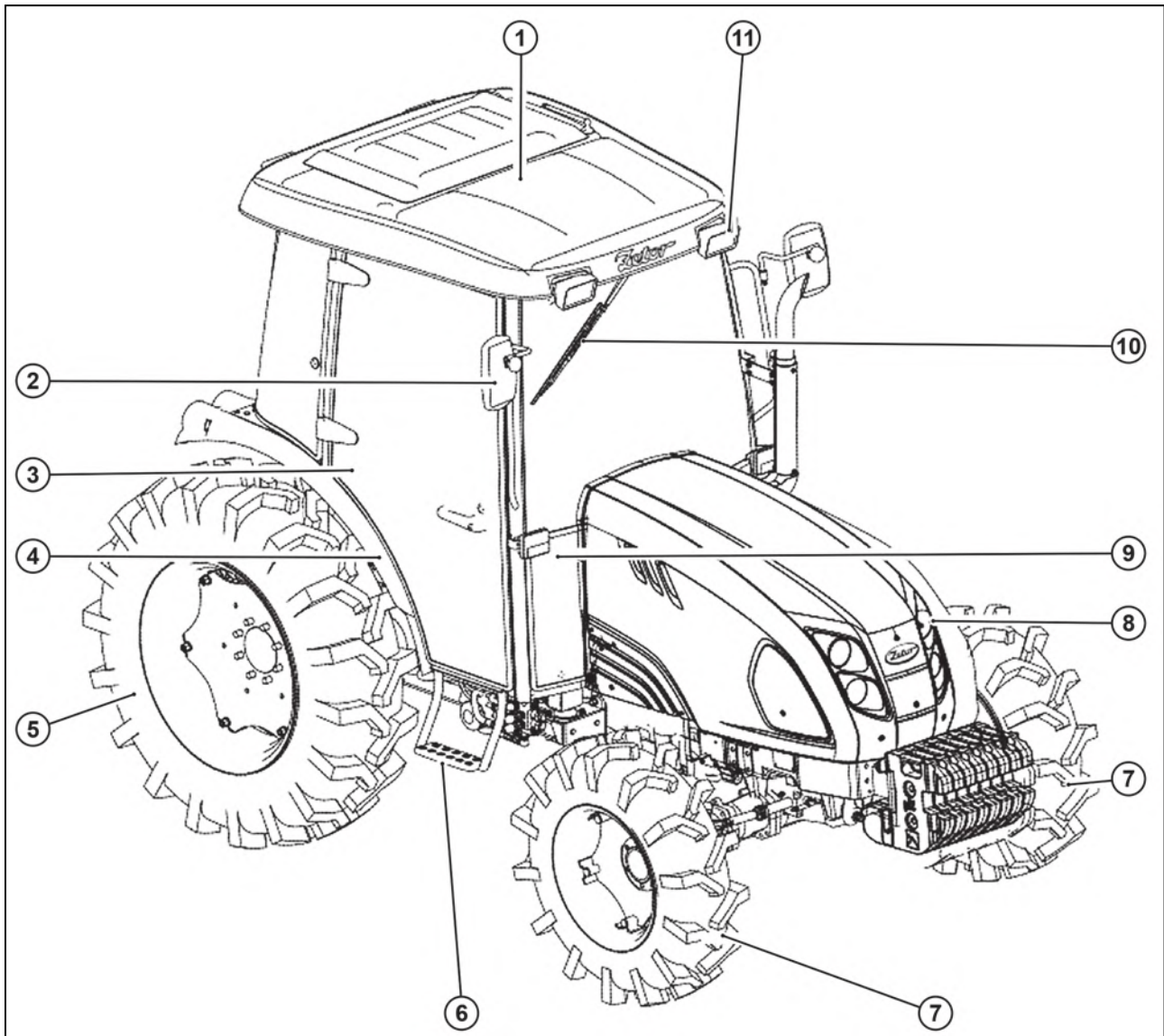

HODP001

- 1 - Roof
- 2 - Outside Rearview Mirror
- 3 - Right Door
- 4 - Rear Fender
- 5 - Rear Tire
- 6 - Step
- 7 - Front Tire
- 8 - Headlight
- 9 - Lower Windshield
- 10 - Front Wiper
- 11 - Work Light

GENERAL INFORMATION

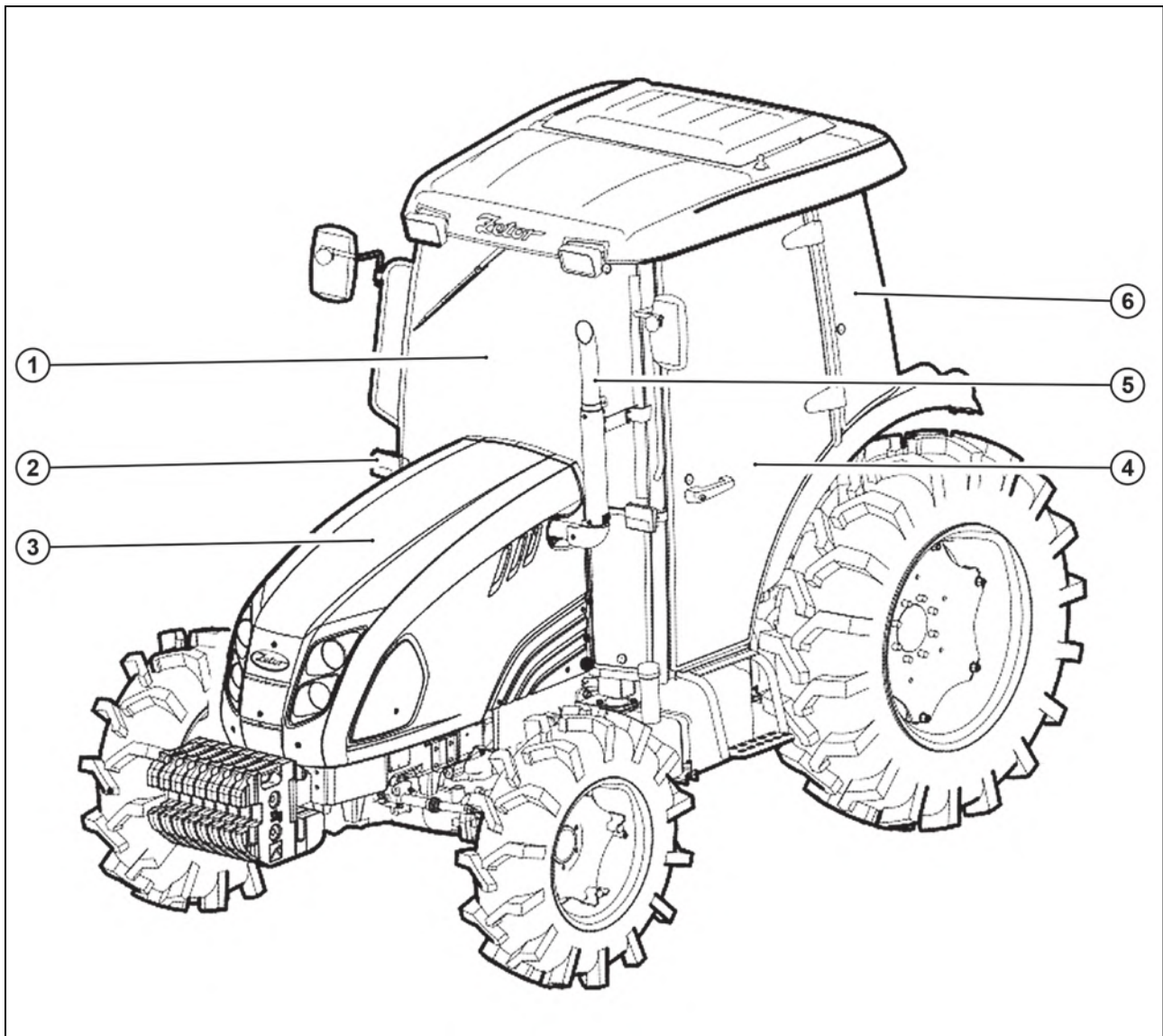

HODP002

- 1 - Windshield
- 2 - Direction Indicator and Position Light
- 3 - Hood
- 4 - Left Door
- 5 - Muffler
- 6 - Side Window

GENERAL INFORMATION

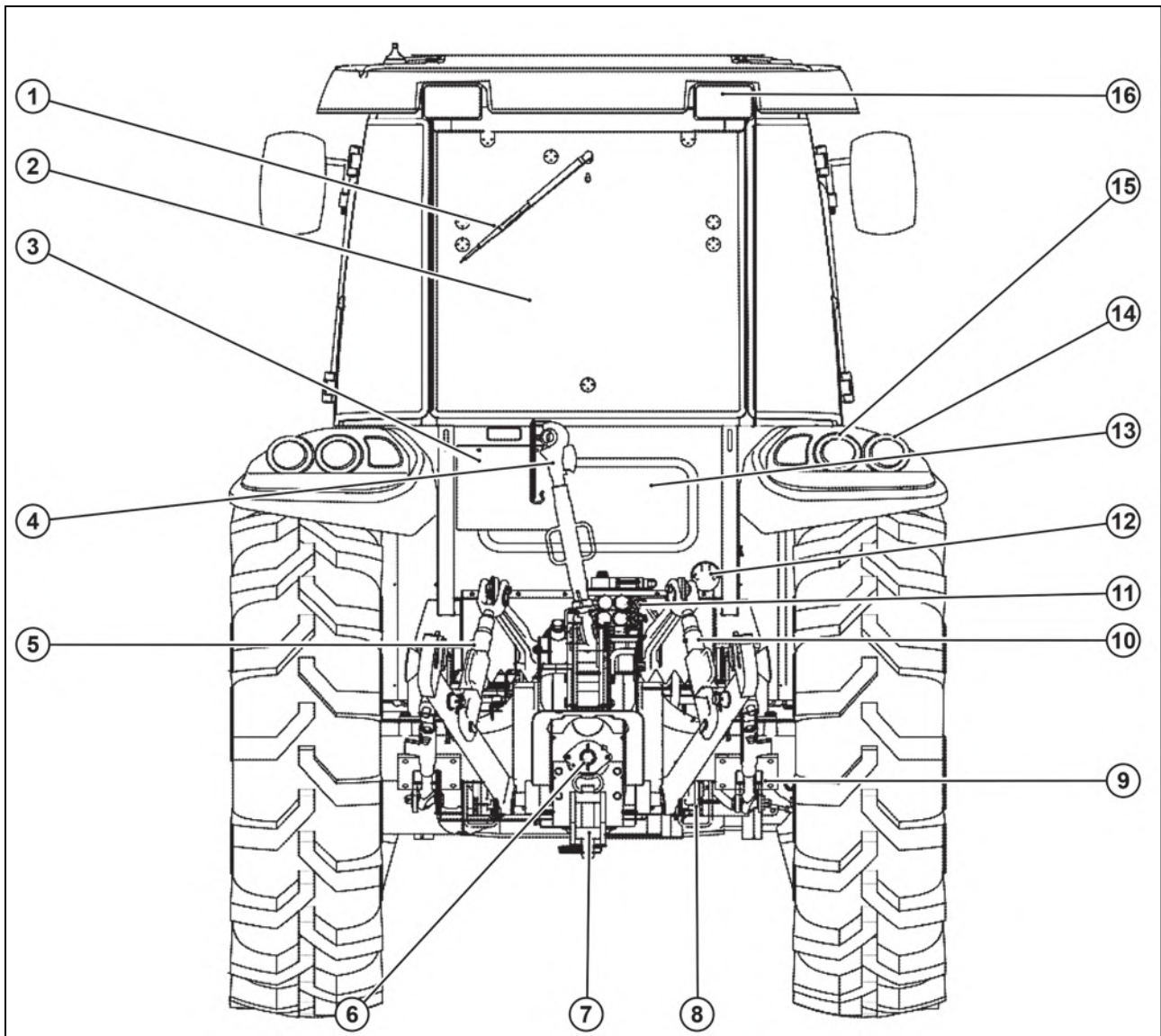

HODP003

- 1 - Rear Wiper
- 2 - Rear Window
- 3 - License Plate
- 4 - Top Link
- 5 - Left Lift Link
- 6 - PTO
- 7 - Lower Hitch
- 8 - Lower Link
- 9 - Stabilizer Bar
- 10 - Right Lift Link
- 11 - Outlet of External Hydraulic Circuits
- 12 - Light Socket for Trailers
- 13 - Lower Rear Window
- 14 - Direction Indicator
- 15 - Rear Headlight
- 16 - Rear Work Light

GENERAL INFORMATION

Tractor Identification

The engine number is stamped on the left hand side of the engine block.

The chassis number is shown on the left hand side of the tractor as shown in the drawing.

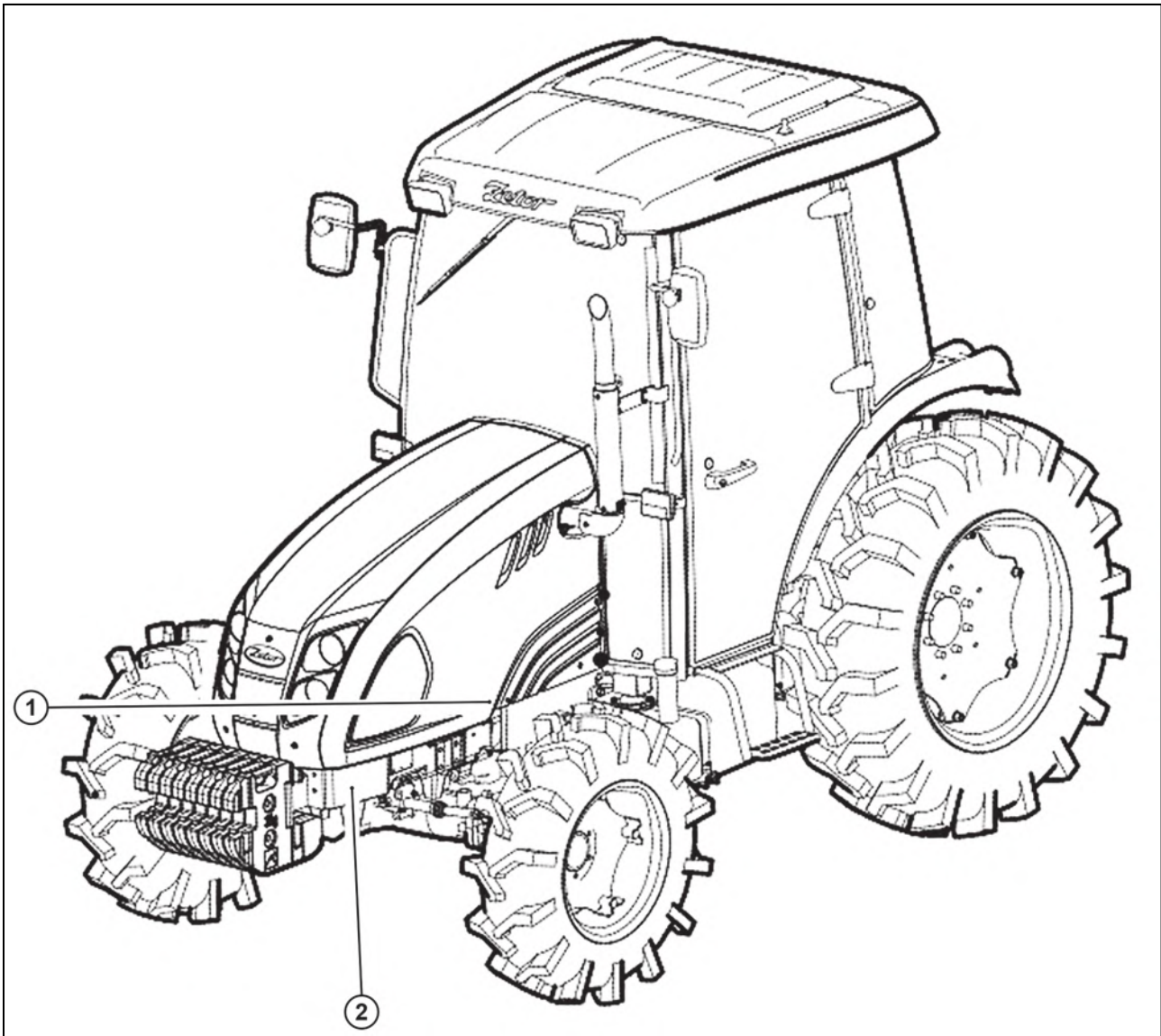

HODP004

- 1 - Carved position of the Engine type or Number
- 2 - Carved position of the chassis number

GENERAL INFORMATION

Warranty of the Product

The manufacturer warrants this product and full details of the warranty are provided on a separate warranty schedule.

Parts

To order any spare parts, please contact your nearest dealer or authorized service center and provide the details below.

- Tractor model
- Tractor serial number
- Tractor engine number
- Part number and description
- Quantity required

About This Manual

This manual has been prepared to assist you in following/adopting the correct procedure for running-in operation and maintenance of your new Zetor company (Here in after refer to Zetor) tractor.

Your tractor has been designed and built to give maximum performance, with good fuel economy and ease of operation under a wide variety of operating conditions. Prior to delivery, the tractor was carefully inspected, both at the factory and by your Zetor dealer/distributor, to ensure that it reaches you in optimum conditions. To maintain this condition and ensure trouble free performance, it is important that the routine services, as specified in this manual, are carried out at the recommended intervals.

Read this manual carefully and keep it in a convenient place for future reference. If at any time you need technical support concerning your tractor, feel free to contact your authorized Zetor dealer / distributor. They have trained staff, original parts and the necessary equipment to perform all service tasks.

Manufacturer's policy is one of continuous improvement, and the right to change prices, specifications or equipments at any time without notice is reserved.

All data given in this book is subject to production variations. Dimensions & weight are approximate only and the illustrations do not necessarily show tractors in standard condition. For exact information about any particular tractor, please consult your Zetor dealer/distributor.

GENERAL INFORMATION

Introduction & Description

Tractor an Introduction

This manual provides useful instructions for the operation, maintenance and storage of relevant Zetor tractor model. This user manual has been prepared for you to help you better understand the maintenance and efficient operation of the machine.

If you need information not provided in this manual or require services of a trained mechanic, please contact Zetor dealer / distributor at your location. Dealers / distributors are kept informed about the latest service procedures for our tractors. They have specific spare parts in stock and they are provided ZETOR TRACTORS a.s company support.

Through this manual. The use of the terms LEFT, RIGHT, FRONT and REAR must be understood, to avoid any confusion when following the introductions. The LEFT and RIGHT means left and right sides of the tractor when facing forward in the driver's seat, reference to the FRONT indicates the radiator end of the tractor, while the REAR, indicates the drawbar end.

When spare parts are required, always specify the tractor and engine serial number when ordering these parts. (See illustration A). This will facilitate faster delivery and help ensure that the correct parts for your particular tractor is received. The tractor serial number is punched on a plate attached to the left hand side of the engine body (Illust. A), for easy reference, we suggest you to write the number in the space provided in the owner's personal data.

- 1 - Turning Left (Anticlockwise)
- 2 - Right
- 3 - Front
- 4 - Left
- 5 - Rear
- 6 - Turning Right (Clockwise)

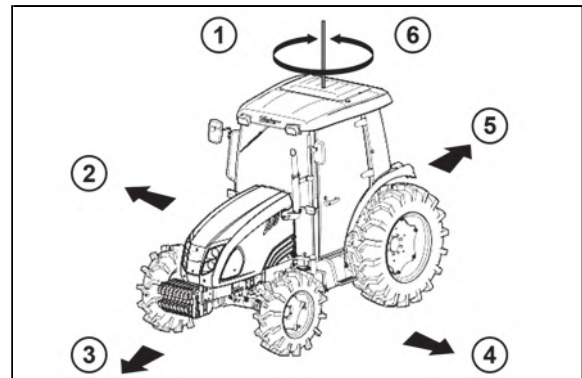

HODP005

GENERAL INFORMATION

Description

General Construction

The transmission case, clutch, clutch housing, engine and front axles are bolted together to form a complete unit.

Front Axle & Wheels

The front 4WD axle is the center pin axle. The front-wheel drive mechanism is a part of the axle. Front wheel drive power is taken from the rear transmission gearbox and is transmitted to the differential in the front axle, where the power is divided into right and left, and the respective final gears. In the final gears, the transmitted revolutions are reduced by means of the bevel gears to the front wheel drive. The 4WD bevel gear mechanism provides a wider steering angle and extended durability.

Engine

The tractors are fitted with fuel efficient Turbo charged engines with 4 cylinders of HORTUS HS65 designed by DEUTZ Engines Company.

Clutch and transmission

A single-disc dry clutch (diameter 11.81') is used on these tractors. The tractor with IPTO (independent rear Power Take-Off) is equipped with a hydraulic clutch assembly. The HORTUS HS65 transmission gear box has 24 forward and 24 reverse speeds in two high / low groups. At present, Zetor tractors are equipped with synchro mesh type gears.

Brakes

Zetor tractors are provided with independent disc brakes operated by two road travel. Hand brake lever is fitted for parking.

Rear axle & wheels

The rear axle is mounted on ball bearings which are bolted to the transmission case through housings. The rims and disc with rear tires are bolted to the outer flange of the rear axle.

Hydraulic System & Linkages

Zetor tractors are fitted with live (i.e. system is in operation even when clutch is disengaged.) independent, very touch of hydraulic System. Three point linkages can be used for category 2 type of implements.

Steering

It consists of a hydraulic cylinder and a tandem hydraulic pump.

Electrical System

A 12V lead acid propylene battery is used to start the engine, as well as to power the electrical system including horn, front headlights, side turn signal lights, attachment lighting, brake light, instrument panel lighting and warning lights. The fuse box is a part of the electrical system.



Warning: When operating the tractor at high speed, do not attempt to make sharp turns by using the brakes. This may result in overturning of the tractor causing serious injury or death.

GENERAL INFORMATION

Owner assistance

We at Zetor together with your dealer want you to be completely satisfied with your investment. Technical problems with your equipment shall be handled by the distributor / dealer service department. If you feel that your issue has not been resolved, we recommend you to contact the owner or director of an authorized dealership.

ROPS (Roll Over Protective Structures)

Roll Over Protective Structures (ROPS)

Zetor tractors are equipped with a frame for the protection of operators.

In the case of cab tractors the frame is incorporated in the cab structure.

The objective of the frame or cab structure is to protect the operator in the event of a roll over and they are designed to support the entire weight of the tractor in that event.

Each Zetor ROPS frame or cab structure is designed and has been tested to meet industry and or government standards.

Included in these tests were all mounting bases and bolts or other fasteners.



Danger: For ROPS frames to be effective and protect the operator, the seat belt provided must be worn in order to keep operators within the ROPS protected area in the event of a roll over. Failure to use the seat belt can still cause serious injury or death.

On some models, the ROPS has a fold down feature that can be used to enter low buildings, etc. Be careful when lowering the top part of the ROPS and be very careful when driving with the ROPS lowered.

Do not use the seat belt with the ROPS lowered and remember that the folding mechanism is intended for special use only and not for daily routine operation.



Use of the tractor with the ROPS lowered can cause fatal injuries!

As the ROPS frame or cab together with the seat belt was designed to meet certain standards, they must be maintained in good order and condition. To achieve this objective, both the structure and the seat belt should be inspected on a regular basis. (Every time the tractor is serviced)

If the seat belt is damaged or torn, it must be replaced and if the ROPS frame or any part of its mounting structure is damaged or cracked, the defective part must be replaced with a new part. Such a part shall meet all the test criteria of the original unit. Any installation or assembly of components or parts of inferior certification affects the certification of the entire ROPS structure and the effectiveness of the structure in the event of an accident. Drilling or welding or any other interference with the ROPS structure is prohibited.

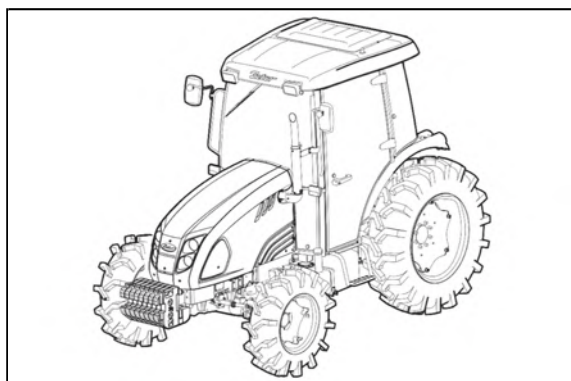

HODP006

GENERAL INFORMATION

Damage of the ROPS

If the tractor has rolled over or the ROPS has damaged (such as striking an overhead object during transport), it must be replaced to provide the original protection. After an accident, check for damages to the 1. ROPS. 2. Seat. 3. seat belt & seat mountings. Before you operate a tractor, replace all damaged parts.



Warning: *Do not weld, drill or straighten the ROPS.*



Never attach chains or towing ropes to the ROPS; this shall cause the tractor to roll over. Always use the points specified on the tractor for towing. Be careful when driving through open door or under low overhead objects. Ensure sufficient overhead clearance for ROPS to avoid fatal injuries.



Warning: *If the ROPS is removed or replaced, make certain that the proper hardware is used to replace the ROPS and the recommended torque values are applied to the attaching bolts.*



Warning: *Always wear your seat belt if the tractor is equipped with ROPS.*

Seat Sliding

To select seat position, move adjusting lever and slide seat closer to or away from dash panel and controls.

1 - Seat Belt

2 - Forward / Backward adjustment lever



HODP007

Before operating a tractor it is important to adjust the seat to the most comfortable position & check whether it is properly locked in its position.

Note: Do not use solvents to clean the seat. Use warm water with a little detergent added.



Caution: *Do not put a hand between the seat and the slides when adjusting the seat position. You can get injured unexpectedly.*



Danger: *Check whether the seat properly locked in its position before driving the tractor.*



Danger: *Always use the seat belt when the ROPS is installed. Do not use the seat belt if a foldable ROPS is down or there is no ROPS. Check the seat belt regularly and replace if frayed or damaged.*

GENERAL INFORMATION

Seat Back Reclining

To change the seatback angle, raise the lever on the left of the seat.

Then, adjust the seatback angle with the lever pulled. Release the lever after adjustment. Make sure that the lever is returned and the seat is firmly fixed after adjustment.

- 1 - Seat belt
- 2 - Backrest angle adjustment lever

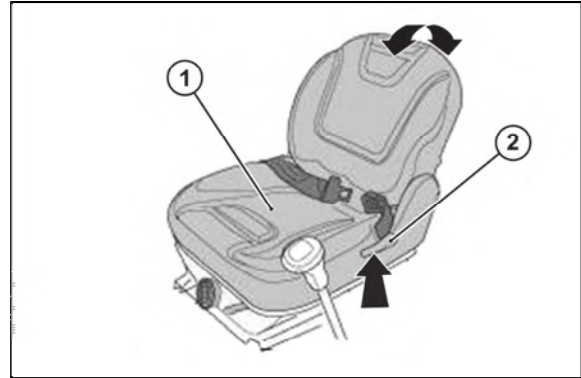

HODP008

Cunshion Strength Adjustment

The seat cushion can be adjusted according to the weight of the driver.

Turning the cushion adjustment lever counterclockwise to the 50 kg position makes the cushion lighter, and turning the lever clockwise to the 130 kg position makes the cushion heavier.

- 1 - Seat Belt
- 2 - Knob for weight adjustment



HODP009

SAFETY PRECAUTIONS

Safety Instructions

Recognize Safety Information



*This symbol means **ATTENTION! YOUR SAFETY IS INVOLVED.** The message that follows the symbol contains important information about safety. Carefully read the message.*

Signal Words



DANGER



WARNING



CAUTION

A signal word 'DANGER, WARNING OR CAUTION' is used with safety alert symbol. DANGER identifies the most serious hazards. Safety signs with signal Word 'DANGER OR WARNING' are typically near specific hazards. General precautions are listed on CAUTION safety signs.

Read Safety Instruction

To ensure your safety, read carefully all safety instructions in this manual. Careless handling of any of the safety devices can cause serious injury or death. Keep all safety signs in good condition. Replace missing or damaged safety signs.

Keep the tractor in good condition and avoid unauthorized modifications carried out on the tractor that could impair the function / safety and affect the tractor.

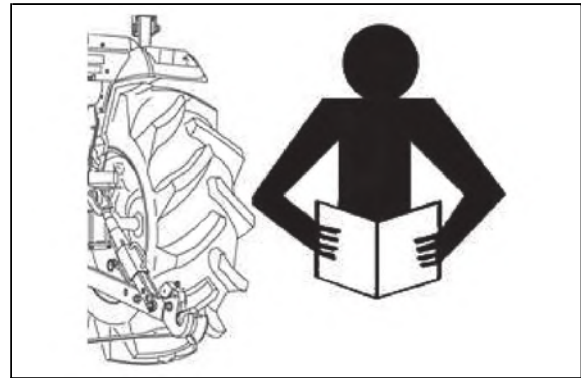

HODP010

Protection of persons

When using the tractor, prevent other persons from accessing the tractor.

Reverse drive

- Make sure there is no one behind the tractor.
- Do not allow anyone to ride on the tractor or implement.



HODP011

SAFETY PRECAUTIONS

Use of ROPS and Seat Belt

The Roll Over Protective Structure (ROPS) has been certified to industry and / or government standards. Any damage or alteration to the ROPS, mounting hardware, or seat belt voids the certification and will reduce or eliminate protection for the operator in the event of a roll-over. The ROPS, mounting hardware, and seat belt should be checked after the first 100 hours of tractor and every 500 hours thereafter for any evidence of damage, wear or cracks. In the event of damage or alteration, the ROPS must be replaced prior to further operation of the tractor.

The seat belt must be worn during machine operation when the machine is equipped with a certified ROPS. Failure to do so will reduce or eliminate protection for the operator in the event of a roll over.



HODP012

Precaution to Avoid Tipping

Do not drive the tractor to places where the tractor may get stuck or roll over.

Pay attention to holes and rocks in the terrain and all hidden dangers.

Slow down before making sharp turn.

If you try to drive the tractor from a ditch or waterlogged terrain where the tractor has got stuck, it may turn over. Try to avoid these situations.

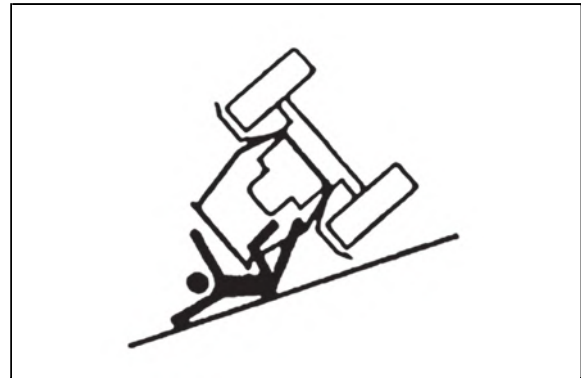

HODP013

Safe parking of the tractor

Before working on the tractor; Lower all equipment to the ground.

Stop the engine and remove the key.

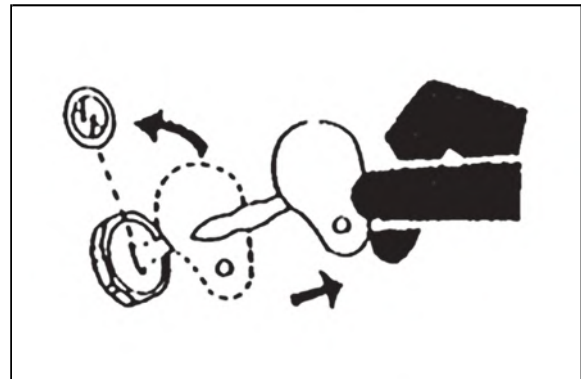

HODP014

Handle Fuel Safely Avoid Fires

Handle fuel with care; it is highly flammable. Do not refuel the tractor while smoking or near open flame or sparks.

Always stop engine before refueling tractors.

Always keep your tractor clean of accumulated grease, and debris. Always clean up spilled fuel.



HODP016

SAFETY PRECAUTIONS

Keep Riders Off Tractor

Do not allow other persons to ride on the tractor. Persons on the tractor are exposed to the risk of injury, e.g. due to the impact of a foreign object or falling from the tractor.



HODP015

Stay Clear of Rotating Shafts

Entanglement in rotating shaft can cause serious injury or death.

Keep PTO shield in place at all times.

Wear close fitting clothing. Stop the engine and be sure PTO drive is stopped before making adjustments, connections, or cleaning out PTO driven equipment.



HODP017

Always Use Safety Lights and Devices

Use of hazard warning lights and turn signals are recommended when towing equipment on public roads unless prohibited by state or local regulations.

Use slow moving vehicle (SMV) sign when driving on public road during both day & night time, unless prohibited by law.

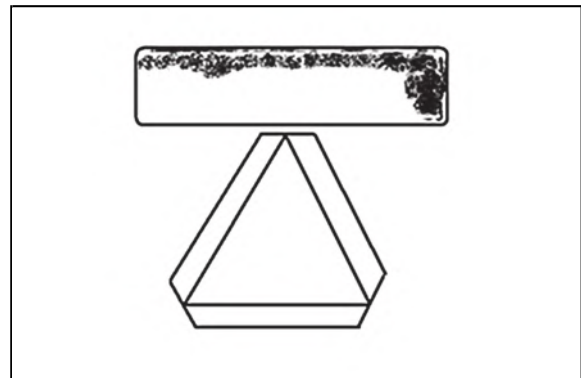

HODP018

SAFETY PRECAUTIONS

Practice Safe Maintenance

Before starting work, make sure you understand the work procedures.

Keep the tractor area clean and dry.

Do not attempt to repair the tractor while it is in motion.

Stay away (also keep your clothing away!) from the rotating shafts.

Always lower the attached implement on the ground. Stop the engine.

Remove the key. Let the tractor cool down before starting repair work.



HODP019

Securely support all tractor elements that must be lifted during service work.

Keep all machine parts in perfect condition.

Replace worn or broken parts. Replace damaged / missing plates.

Remove all grease and dirt from the tractor.

Disconnect the battery ground cable (-) before starting repair work on electrical systems or before welding work on the tractor.

Avoid High-Pressure Fluids

Leaking fluid under pressure can penetrate the skin and cause serious injuries. Be especially careful when handling the injection elements - there is a risk that the liquid under high pressure penetrated the skin. Seek medical attention immediately if any liquid penetrates your skin.



HODP020

SAFETY PRECAUTIONS

Prevent Battery Explosions

Keep all flammable materials, open flames or other sources of ignition (such as sparks) away from the battery. The gas released from the battery during charging may be explosive. Never attempt to check the battery charge by connecting its poles with a conductive object.



HODP021

Prevent ACID Burns

Sulfuric acid in battery electrolyte is poisonous. It is strong enough to burn skin, cause holes in clothing and cause blindness if found entry into eyes.

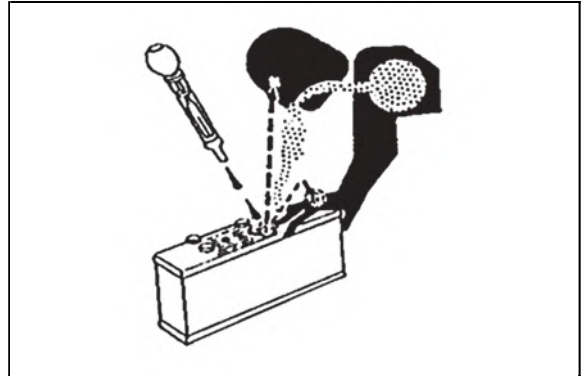

HODP022

For adequate safety always;

1. Fill batteries in a well-ventilated area.
2. Wear eye protection and acid proof hand gloves.
3. Avoid breathing direct fumes when electrolyte is added.
4. Do not add water to electrolyte as it may splash off causing severe burns.

If acid is spilled on a person:

1. In case of contact with skin, rinse the affected area with water.
2. In case of contact with eyes, rinse eyes with water for 10 - 15 minutes.

Always seek medical advice.

Battery Disconnect

1. When working with your tractors electrical components you must first disconnect the battery cables.
2. To ensure that there are no accidents from sparks you must first disconnect the negative battery cable.

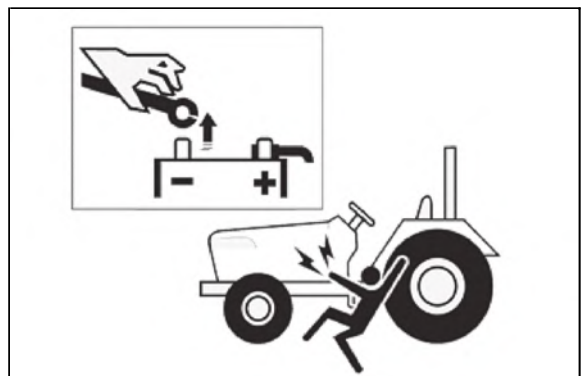

HODP023

SAFETY PRECAUTIONS

Service Tractor Safely

Do not wear ties, scarves, headscarves or any loose clothing when working near moving parts. Serious injury could occur if any of these items of clothing were caught by the rotating part.

Do not wear rings or other jewelry to prevent electrical shorts or avoid getting caught in moving parts.

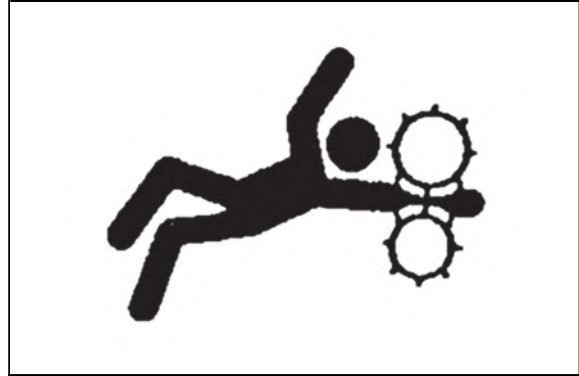

HODP024

Work in Ventilated Area

Do not run the tractor in an enclosed building unless proper ventilation is provided, as the exhaust fumes of the tractor may cause nausea, poisoning or death. If it is necessary to run the engine in an enclosed space, ensure sufficient ventilation or remove the exhaust fumes by connecting exhaust pipe extension.



HODP025

Safe starting

1. The tractor can be started even if the gear is shifted, which can cause the tractor to move and cause serious injury to the operator and bystanders.
2. For additional safety, secure the stop button (fuel shut off control) in the fully pulled out position. Transmission in the neutral position, parking brake engaged and PTO control lever in disengaged position when the starter safety switch is being engaged or performing other work on tractor.

Safety Starter Switch

1. Clutch operated safety switch is provided on all tractors which allow the starting system to become operational only when the clutch pedal is fully pressed.
2. Do not by-pass this safety starter switch or work on it. Only authorized dealers are recommended to work on safety starter switch.
3. On some models safety starter switch is provided on transmission high-low shifter lever and in PTO shifter lever. The tractor can be started only if high-low shifter lever is in neutral position.



Caution: Safety Starter Switch is to be replaced after every 2,000 hours / 4 years, whichever is earlier.

SAFETY PRECAUTIONS

Emergency Exits

If exit from the cab side doors is blocked (following an accident or vehicle overturn) the alternative safety exits are indicated by decals.

The possible safety exits are:

- Rear window hatch (all tractors)
- Front window (for versions with openable front window)

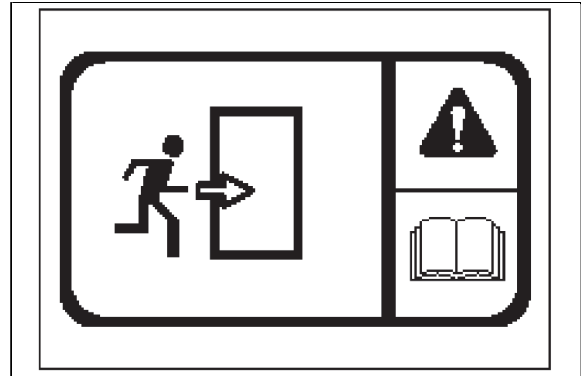

HODP027

Safety Precautions When Using The Loader

Do not allow persons to enter the attached loader adapter or the loader boom operating area. Failure to do so may result in serious injuries or even death.

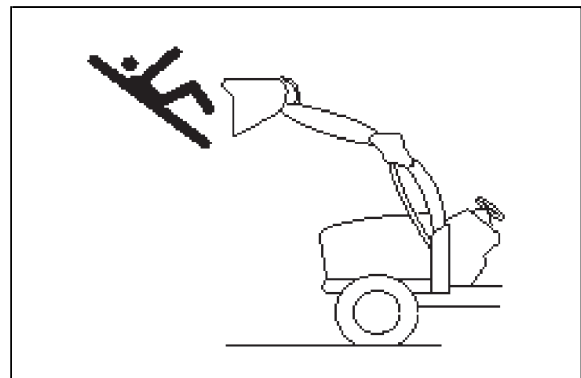

HODP028

Do not stand under the lifted loader or get close to it. Also, lower the loader arm onto the ground before leaving the tractor. Otherwise, it may lead to a fatal injury or even death.

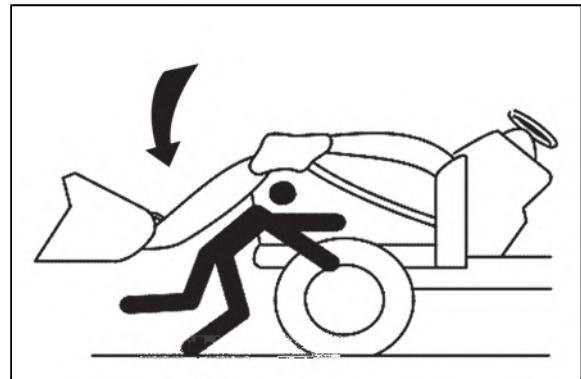

HODP029

When mounting or dismounting the loader, secure all parts that are attached to the adapter and the boom. The adapter or the boom may unexpectedly drop, which can lead to injury or even death.

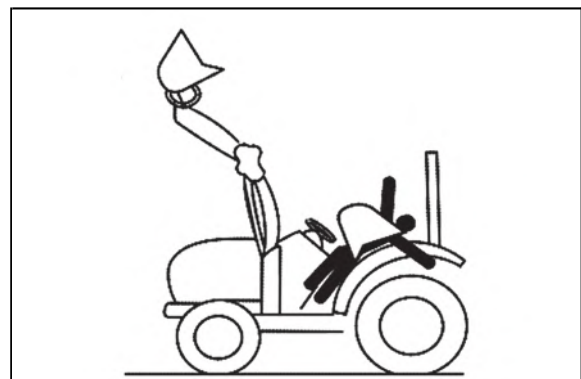

HODP030

SAFETY PRECAUTIONS



Important: ROPS (Roll Over Protective Structure), sun canopy or cabin are not a FOPS (Falling Object Protective Structure). It never can protect the riders against falling objects. Avoid driving the vehicle into a dangerous area such as falling rocks zone.

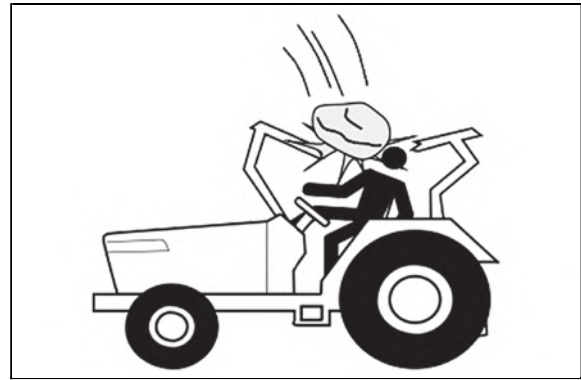

HODP031

Do not allow the boom or attached adapter to come into contact with electrical lines or other electrical equipment. Electric current causes serious injuries or death.

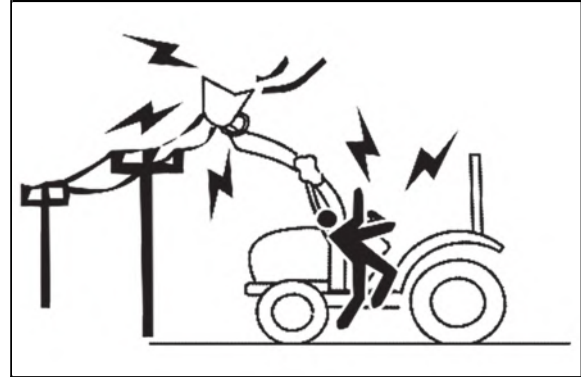

HODP032

For safe handling of loads, always use a suitable type of adapter for your work. Keep the transported object at a low height when driving. Failure to do so may result in serious machine damage, injury or even death.

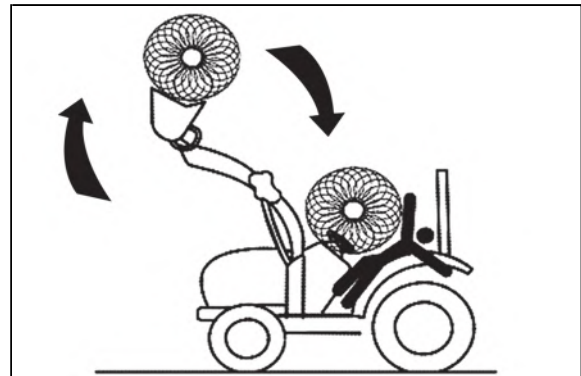

HODP033

When mounting or dismounting the loader, secure all parts that are attached to the adapter and the boom. The adapter or the boom may accidentally drop, which can lead to injury or even death.

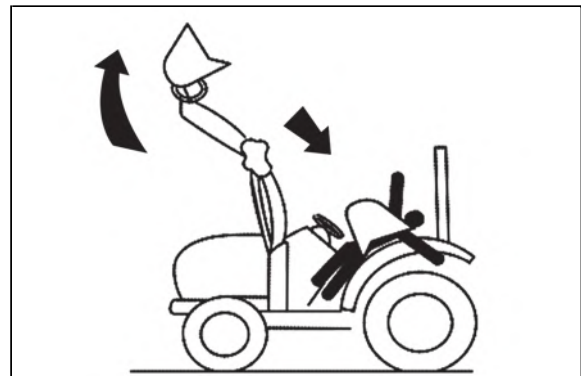

HODP034

SAFETY PRECAUTIONS

Towing equipment

For the maximum permissible load of the hitch, see 'Maximum permissible hitch load' chapter in the Specifications section.

- Maintain a suitable speed taking into account the weight of the load towed or carried by the tractor and the inclination of the surrounding terrain, remembering that the braking distances will be greater than that of a unloaded tractor. Towed semi-trailers or trailers with brakes or without brakes that exceed the specified technically permissible maximum authorized weight or that are towed at too high speed may cause the loss of the control of the unit.
- Always take into account the total weight of the implement and its load.



If any mounted implement or trailer / semi-trailer is attached to the tractor, make sure all controls are in the neutral position, the parking brake is applied, the engine is switched off, first gear is engaged (if the tractor has a mechanical transmission) and the key from the starter switch is removed, before leaving the driver's seat. If the tractor is not parked on level ground, ALWAYS secure the wheels of the tractor and the trailer with wedges. Further information on safe working procedures can be found in the 'Parking the tractor' chapter in the safety chapter in this manual

- The recommended way to transport a damaged tractor is to transport it on a low-load trailer. Always attach the tractor to the low-load trailer with a chain. Before transporting the tractor on a low-load trailer or on a railway wagon, make sure that the engine cover, door, openable roof (if available) and windows are closed and securely fastened. Never tow the tractor at a speed higher than 10 km/h. In this case, the operator must remain in the operator's seat to drive and brake the tractor.

Falling object protective structure (FOPS)

The term F.O.P.S refers to structure installed on the tractor intended to reduce the risk to the operator of injury from falling objects during normal use of the vehicle.



Important:

- ***This tractor is equipped with a FOPS.***
- ***The energy level of drop test is 1365J.***

Operator Protective Structure (OPS)

The term OPS refers to a protective structure installed on a tractor in order to minimise risk of operator injury caused by objects penetrating into the operator position area.



Danger: This tractor is not equipped with an OPS. If work must be performed in areas subject to the risk of the penetration of objects into the operator position, consult your dealer before starting work so that the tractor can be equipped with an appropriate protective structure.

SAFETY PRECAUTIONS

Safe Operation of Your Tractor

The manufacturer of your tractor has made every effort to make it as safe as is humanly possible. Beyond this point it is the responsibility of the operator to avoid accidents and we ask that you read and implement our suggestions for your safety.

Ensure that only trained and competent operators use this tractor and ensure that they are fully conversant with the machine and aware of all its control and safety features.

Operators should not operate a tractor or attached machines if they are not properly trained or if they are physically unfit to operate the machine.

To avoid accidents please ensure that the operator wears clothing which will not get entangled in the moving parts of the tractor or machine and protect him or her from the elements.

When spraying or using chemicals, please ensure that clothing and protective equipment is worn which prevents respiratory or skin problems.

For full details consult the manufacturer of the chemicals.

To avoid lengthy exposure to noise ensure that ear protection is worn.

If adjustment to the tractor or machinery need to be made ensure the tractor or machine are turned off beforehand.

Use of certified Roll Over Protection Structure (ROPS) is a must while operating a tractor.

Use of seat belt is a must while operating a tractor.

Under all circumstances, it is necessary to ensure the safety of the operator and others near the machine.

Ensure no one is between the tractor and a towed vehicle (trailer or implement).

Safety Tips During Maintenance

1. At least on a daily basis check all oil levels. Water level in the radiator and electrolyte level in the battery and perform services according to the service schedule.
2. Ensure tire pressure are even and the correct pressure for the job being done is maintained.
3. Check to ensure that the all controls and preventative mechanisms of the tractor and implement work correctly and effectively.
4. Ensure that an adequate set of the correct tools is available for maintenance and minor repairs.
5. Ensure that all service work and repairs are carried out on a flat area with a concrete or similar floor. Do not carry out service work on a tractor until it is switched off, and the parking brake applied and wheels chocked.
Where a tractor is started in a confined area, ensure that the area is well ventilated as exhaust gases are very harmful, and can cause death.
6. Do not work under raised implements.
7. When changing wheels or tires ensure that a suitable wheel stand is placed under the axle prior to removing the wheel and the wheels are chocked.
8. Where guards or shields need to be removed to perform a service or repair, ensure that the guard or shield is correctly reinstalled before starting the tractor.
9. Never refuel near a naked flame or with an overheated engine. Ensure to turn off Engine before refueling.
10. The cooling system operates under pressure, take care when removing the radiator cap on a hot engine to prevent being scalded by steam or hot water. Do not add water in the radiator when the engine is hot. Add water to the radiator only after the engine cools down completely.
11. To prevent fires keep the tractor including the engine clean and free from inflammable material and well away from fuels and other inflammable material.

SAFETY PRECAUTIONS

Mounting and Demounting Implements

1. Make sure all implements are mounted and removed on a safe, flat surface. Make sure that no one is between the tractor and the implement or under the implement to prevent accidental injury.
2. After mounting the implement, ensure that all components such as chains or hoses are correctly adjusted and, if PTO shafts are used, the shaft is correctly mounted and secured.
3. If heavy implements are used, make sure the unit is well balanced or use ballast weights for optimal weight distribution.
4. Before leaving the tractor, lower the implement on the ground or stop the PTO, apply the parking brake and switch off the engine.
5. Keep all bystanders away from moving parts while using the implements with the PTO and do not attempt to make adjustments while the machine is running.
6. Only the driver should ride on the tractor with a ROPS frame fitted and a seat belt correctly fastened.
7. If children are present in the immediate vicinity of the machine or unit, caution and anticipation of possible risks related to the movement and operation of the machine are necessary.
8. Tractors should only be operated by trained operators to ensure that other workers are not injured. In particular, they should be careful when working in dusty environment where visibility is substantially reduced.
9. Never start the tractor when the gear is engaged, the operator is not in the seat and the safety of the surroundings has not been thoroughly checked.
10. Only the operator sitting in the driver's seat can operate the tractor. Never turn or brake suddenly at high speed, as this may cause the tractor to roll over, resulting in serious injury or death.
11. When driving on public roads, make sure that the tractor and the driver meet all the legal requirements regarding safety and authorization. When working with wide implements, use the warning devices specified by the applicable legislation of the country in which the machine is operated and observe all legal requirements, including escort requirements.
12. When working in adverse conditions, on hilly terrain or on surfaces with reduced tire grip, adjust the tractor speed to suit the conditions; safety comes first. Never drive downhill at high speed or with the transmission in neutral. Brake with the engine as well as with the brakes. When driving down a steep slope, select the same gear used to drive up the hill. Never change gear going down the hill. Also, when driving up a steep hill, avoid shifting gear down at slow speeds - the unit may accidentally stop and start moving uncontrollably back.
13. Be careful when going uphill with a heavy implement, make sure that it does not overbalance, which would cause the loss of front axle grip and loss of control.
14. Never remove or modify the seat belt.
15. Never remove, modify or repair the ROPS frame.

Please remember that a little bit of extra care can prevent serious injury or death and avoid damage to your tractor.

SAFETY PRECAUTIONS

The Following Precautions are Suggested to Help Prevent Accidents

A careful operator is the best operator. Most accidents can be prevented by following safety precautions. Before operating the tractor, read the following measures and observe them to avoid accidents. The tractor may only be operated by authorized persons who are properly trained for this operation.

The Tractor

1. Read the operator's manual carefully before operating the tractor. Lack of operational knowledge can lead to accidents or injuries.
2. Use approved roll-over protection structure and seat belt for safe operation. Rolling the tractor over without ROPS can result in death or injury.
3. Do not remove the ROPS (Roll Over Protective Structure). Always wear seat belts.
4. The fiberglass roof does not provide protection against the breakthrough of heavy object.
5. To avoid falling while entering and leaving the cab, keep shoes and platform clean, free of mud and oil.
6. Do not allow anyone other than the operator to ride on the tractor. There is no safe seat or approved passenger seat on the tractor.
7. Replace any illegible, missing, or damaged safety signs.
8. Keep safety signs clean, free of dirt and grease.

Servicing the Tractor

1. For your safety, keep the tractor in good operating conditions. An inadequately maintained tractor can be dangerous.
2. Stop the engine before performing any maintenance or repair work on the tractor.
3. The cooling system operates under pressure which is controlled by the radiator cap. It is dangerous to remove this cap while the system is hot. First turn the cap slowly and let the pressure escape before removing the cap completely.
4. Do not smoke while refueling the tractor. Protect fuel and fuel circuit from all types of open flame.
5. The fuel in the injection system is under high pressure and can penetrate the skin. Unqualified persons must not disassemble or modify the fuel pump, injectors, nozzles or other parts of the fuel injection system.
6. To prevent fire or explosion, keep the battery and the cold start devices away from open flames.
7. Do not change or modify anything on the tractor and do not allow anyone to change or modify anything on the tractor or any part of the tractor or its function.

SAFETY PRECAUTIONS

Operating the Tractor

1. Before starting the tractor, apply the parking brake, place the PTO lever in the 'OFF' position, the hydraulic control lever in the lower position and put the gear shift lever in neutral position.
2. Do not start the engine or controls while standing next to the tractor. Always sit in the tractor seat when starting the engine or controls.
3. To prevent the tractor from starting accidentally, a safety switch is installed. The starter system of the tractor is connected via this switch, which allows starting the tractor only when the clutch pedal is depressed (on models equipped with a manual transmission). On some models, the reverse shift lever and the PTO button must also be in the neutral position to start the starter circuit. Do not bypass or disable the starter safety switch. If the safety switch fails, contact a Zetor authorized service / dealer for advice.
4. Avoid accidental contact with the shift lever while the engine is running. Such contact may cause the tractor to move unexpectedly.
5. Do not get off or climb the tractor while it is in motion.
6. Switch off the engine, remove the ignition key and apply the parking brake before leaving the tractor.
7. Do not use the tractor in an enclosed building without adequate ventilation. Exhaust fumes can cause intoxication or death.
8. Do not park the tractor on a steep slope.
9. If the power steering or engine is blocked, stop the tractor immediately.
10. Use only the lower swinging hitch or the draw bar connected to the 3-point hitch lower link in the down position. Always use a lockable pin to secure it. Attaching the drawbar to the rear axle bracket or any other point on the rear axle can cause the front axle to be lifted and the loss of control over the machine.
11. If the front part of the tractor tends to lift when a heavy implement is attached to the three-point hitch, install the front ballast weights or front axle ballast weights. Never operate a tractor with a lightweight front axle.
12. When attaching equipment / implements and transporting equipment, always use the hydraulics position control lever. Ensure that the hydraulic couplers are properly mounted and they disconnect safely if the implement is accidentally released.
13. Do not leave the equipment / implement in the raised position.
14. When driving on public roads during both day and night time, use warning lights, direction indicators / warning signs and slow moving vehicles (SMV) signs unless prohibited by law.
15. Dim the tractor lights when meeting another vehicle at night. Make sure that the lights are adjusted to avoid dazzling the eyes of the oncoming vehicle driver.
16. Emergency stop instructions: If the tractor does not stop after braking, pull out the fuel shut off control lever.

Driving the Tractor

1. Watch where you are going, especially at the side of the road, headlands, around trees and low obstacles.
2. To prevent the tractor from rolling over, drive the tractor at a safe speed, especially when driving on uneven ground, when driving over ditches or slopes, and when turning in corners of areas and plots.
3. When driving on the road, lock the tractor brake pedals together to ensure proper braking of the wheels.
4. When driving down a slope, shift the same the gear as when driving uphill. Driving downhill a slope without a gear shifted is prohibited.
5. Any towed vehicle and / or semi-trailer with the total vehicle weight exceeding that of the towing tractor, must be fitted with its own brakes for safe operation.
6. If the tractor gets stuck or its tires are frozen to the ground, try to reverse to prevent the tractor from rolling over.
7. Always check the overhead clearance, especially when transporting the tractor.

SAFETY PRECAUTIONS

Operating The PTO

1. When operating PTO driven equipment, shut off the engine and wait until the PTO stops before getting off the tractor and disconnecting the equipment.
2. Do not wear loose clothing when operating the power take-off or near rotating equipment.
3. When operating stationary PTO driven equipment, always apply the tractor parking brake and block the rear wheels from front and rear side.
4. To avoid injury, always move down flip part of PTO. Do not clean, adjust or service PTO driven equipment when the tractor engine is running.
5. Make sure the PTO master shield is installed at all times and always replace the PTO shield cap when the PTO is not in use.

Diesel Fuel



Diesel complies with EN 590 standard

IMPORTANT NOTE!

By using motor oil with elevated sulphur content, the service life of diesel particle filter can be significantly reduced.

1. Keep the equipment clean and properly maintained.
2. Under no circumstances should gasoline, alcohol or blended fuels be added to diesel fire or explosive hazard. Such blends are more explosive than pure gasoline. In a closed container, such as a fuel tank. **DO NOT USE THESE BLENDS.**
3. Never remove the fuel cap or refuel the tractor with the engine running.
4. Do not smoke while refueling or when standing near fuel.
5. Maintain control of the fuel filler pipe when filling the tank.
6. Do not fill the fuel tank to capacity. Allow room for expansion.
7. Wipe up spilled fuel immediately.
8. Always tighten the fuel cap securely.
9. If the original fuel tank cap is lost, replace it with genuine cap. A none approved cap may not be safe.
10. Do not drive equipment near open fire.
11. Never use fuel for cleaning purpose.
12. Arrange fuel purchases so that winter grade fuel are not held over and used in the spring.

*N.B: It is suggested that after repairs if any of the safety decal / sign is peeled / defaced, the same may be replaced immediately in interest of your safety.

SAFETY PRECAUTIONS

Do's and Don't's

- DO-** Ensure that the safety covers are in place and in good condition.
- DO-** Read all operating instructions before starting the operation of the tractor.
- DO-** Perform all maintenance tasks completely and faultlessly.
- DO-** Keep the air filter clean.
- DO -** Ensure that lubricating oils of the appropriate standard and quality are used and that they are changed at recommended intervals.
- DO-** Install the new sealing rings when changing the filter element.
- DO-** Watch the warning light on the oil pressure gauge and immediately check for any abnormality.
- DO-** Keep the radiator filled with clean water and use antifreeze mixture in cold weather. Drain the system only in emergencies and fill it before starting the engine.
- DO-** Make sure the transmission is in the neutral position before starting the engine.
- DO-** Store fuel in clean storage and use a filter when filling the tank.
- DO-** Perform minor adjustments and repairs as soon as necessary.
- DO-** Allow the engine to cool before removing the radiator filler cap and adding water, remove the radiator cap slowly.
- DO-** Shift a lower gear before driving down steep hills.
- DO-** Connect the brake pedals together when driving on the road.
- DO-** Keep draft control lever fully down when not in use.

SAFETY PRECAUTIONS

Don'ts-For Safe Operation

DON'T - Run the engine with the air cleaner disconnected.

DON'T - Start the tractor in an enclosed building unless the doors and windows are open for proper ventilation.

DON'T - Operate the tractor or engine while lubricating or cleaning.

DON'T - Allow the tractor to run out of diesel fuel otherwise it will be necessary to vent the system.

DON'T - Temper the fuel injection pump, if seal is broken the warranty becomes void.

DON'T - Allow the engine to run idle for a long period.

DON'T - Run the engine if it is not firing on all cylinders.

DON'T - Ride the brake or clutch pedal. This will result in excessive wear of the brake lining, clutch driven member and clutch release bearing.

DON'T - Use the independent brakes for making turns on the highway or at high speeds.

DON'T - Refuel the tractor with the engine running.

DON'T - Mount or dismount from the right side of the tractor.

DON'T - Temper the hydraulic control levers' upper limit stops.

DON'T - Use draft control lever for lifting of implements.

DON'T - Start the engine with the PTO engaged.

DON'T - Use the governor Control Lever (Hand throttle) while driving on roads.

DON'T - Move the hydraulic levers rearward.

SAFETY PRECAUTIONS

Safety Signs

General Safety Information



Important: *This "General safety Information" should be kept with the machine at all times as reference data.*



Caution: *This symbol means ATTENTION! YOUR SAFETY IS INVOLVED. The message that follows the symbol contains important information about safety. Follow recommended precautions and safe operating practice.*

Decals Mounting Location

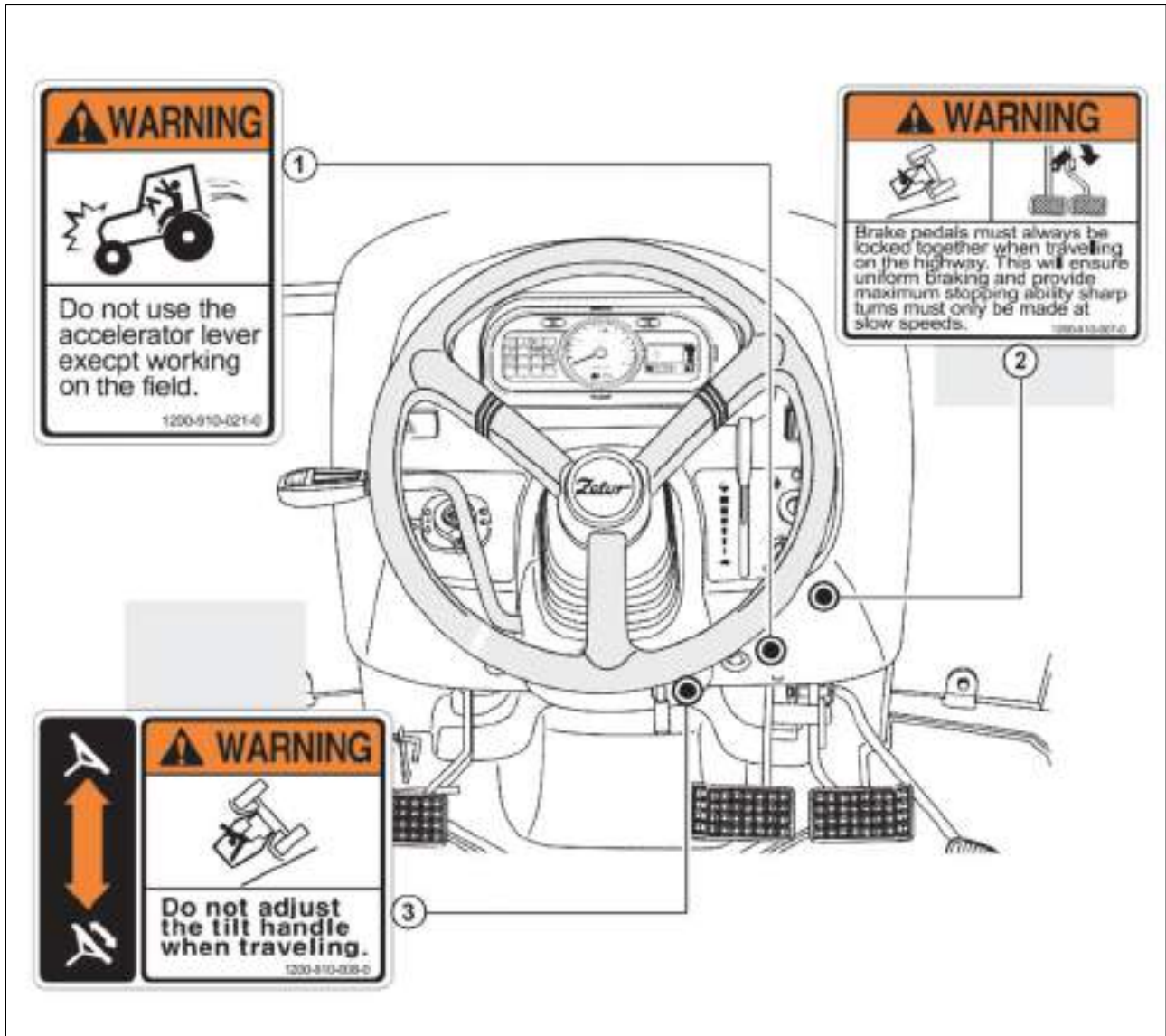

HODP035

1- Warning: Do not use the throttle lever except when working on the field (applies to models with manual transmission).

2- Warning: When driving on the road, brake pedals must always be locked together. This shall ensure even braking effect and provide maximum braking efficiency. Always make sharp turns at low speed.

3- Warning: Do not adjust the steering wheel position while driving.

SAFETY PRECAUTIONS

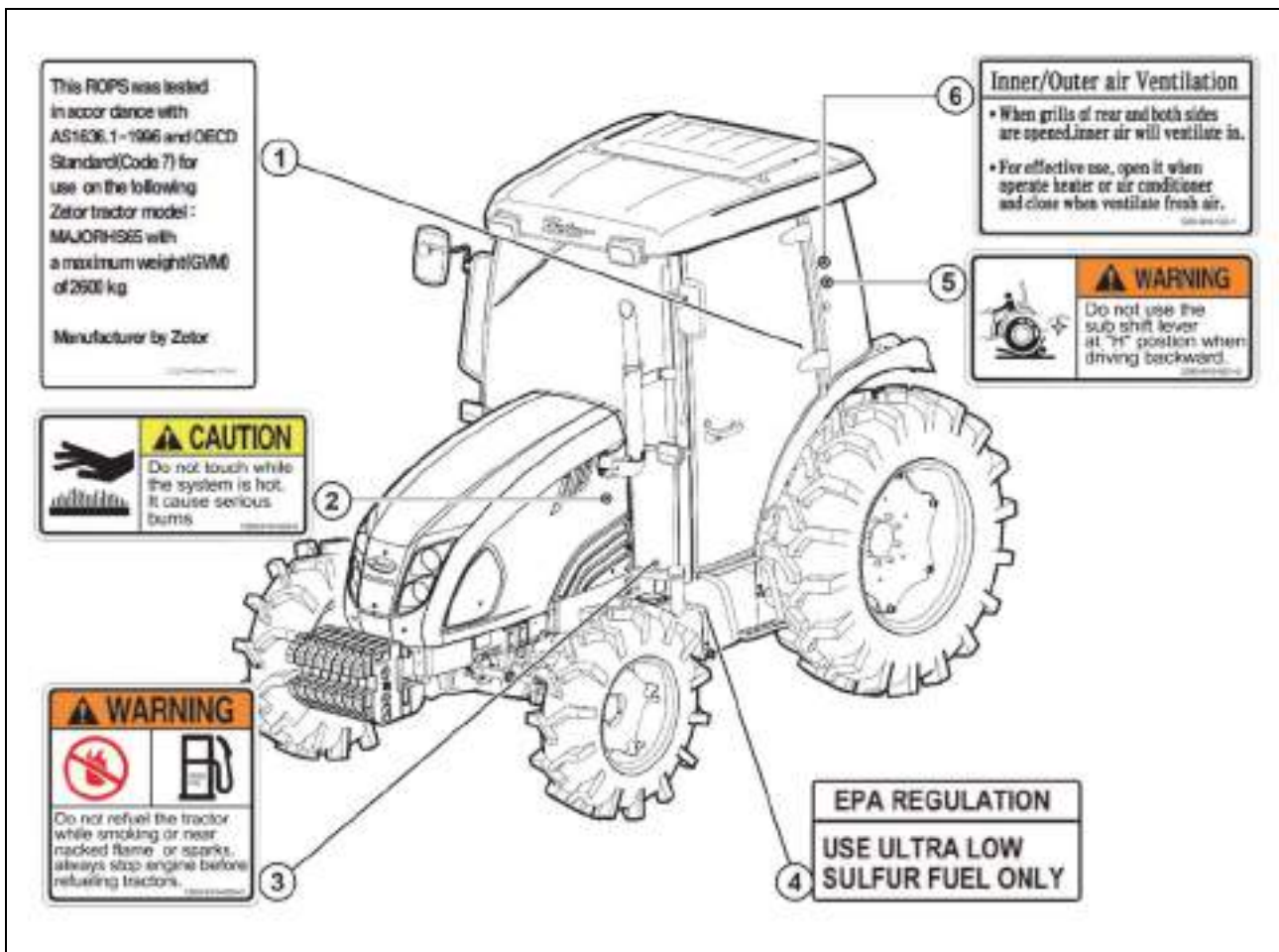

HODP036

1- ROPS was tested in compliance with AS1636.1-1996 and OECD Standard (Code 7) for use on tractors with the maximum weight (GVM) of 2,600 kg.

2- Caution:

Do not touch while the system is hot. It may cause severe burns.

3- Warning:

Do not refuel if you are smoking or if there is an open flame or spark source nearby. Always switch off the engine before refueling.

4- EPA regulation:

Only use fuels with a very low sulfur content.

5- Warning:

Do not use the reverse shift lever in the H position when reversing.

6 - Internal / external air ventilation:

- When the rear and both side grills are open, internal ventilation occurs.
- For maximum efficiency, open them when you want to switch on the heating or air-conditioning, and close them when you want to let the outside air in.

SAFETY PRECAUTIONS

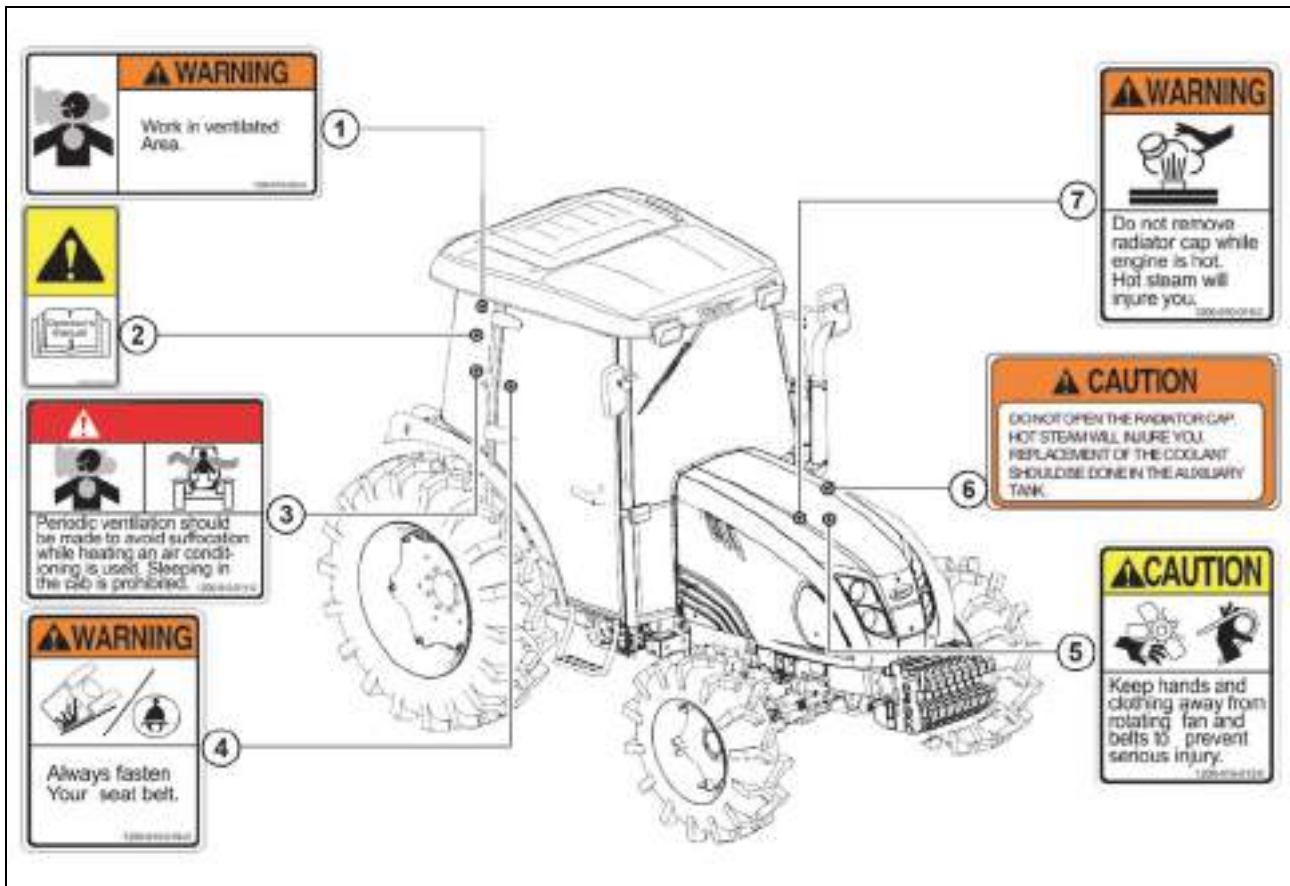

HODP037

1 - Warning: Work in ventilated Area.

2 - Operator's manual

3 - Danger: Periodic ventilation should be made to avoid suffocation while heating an air conditioning is used. Sleeping in the cab is prohibited.

4 - Warning: Always fasten Your seat belt.

5 - Caution: Keep hands and clothing away from rotating fan and belts to prevent serious injury.

6 - Caution: Do not open the radiator cap. Hot steam will injure you. Replacement of the coolant should be done in the auxiliary tank.

7 - Warning: Do not remove radiator cap while engine is hot. Hot steam will injure you.

SAFETY PRECAUTIONS

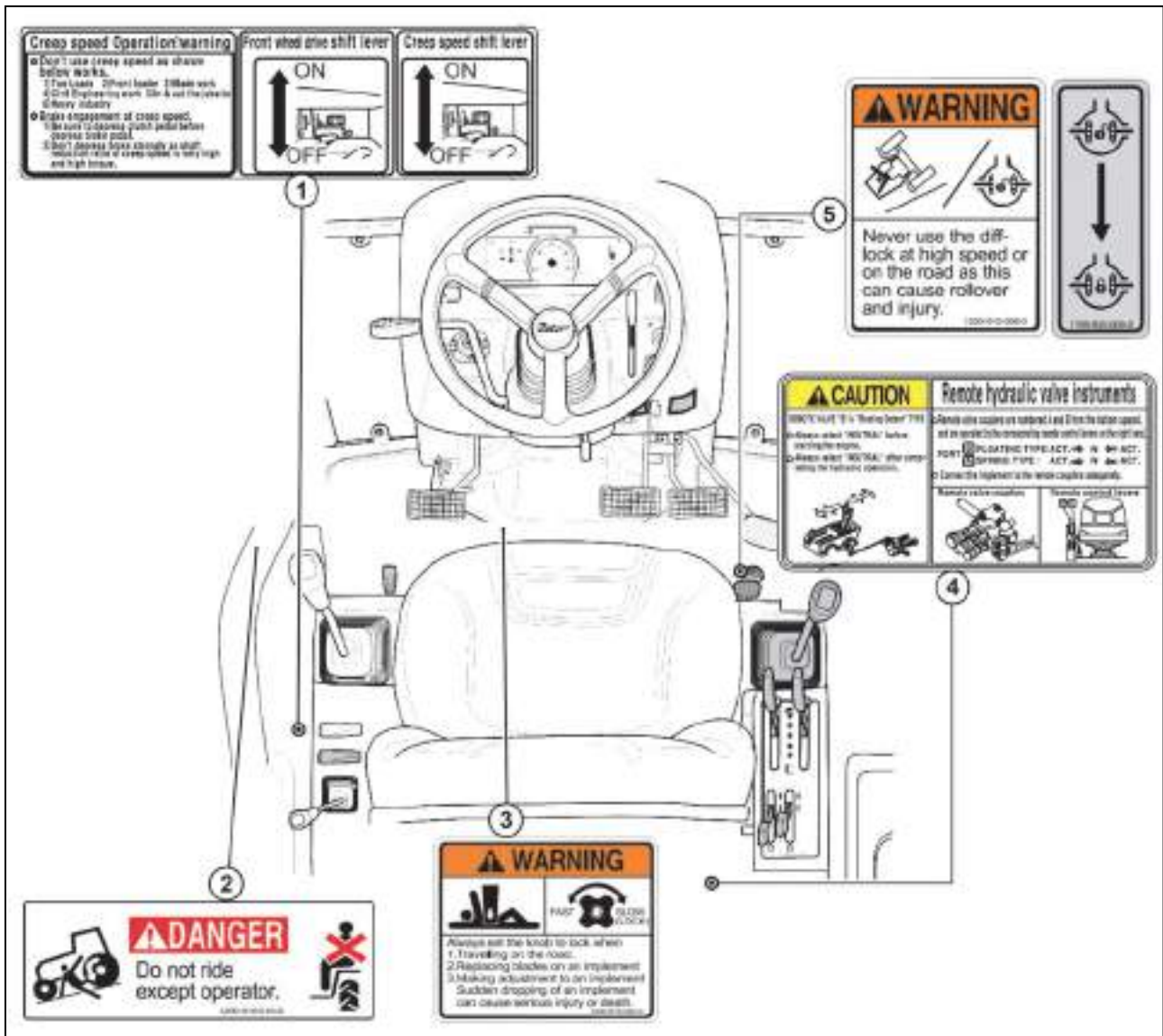

HODP038

1 - Creep speed operation! Warning:

- Do not use creep speed for the below listed tasks.
 - 1) Towing loads
 - 2) Working with front loader
 - 3) Working with blade
 - 4) Construction work
 - 5) Transporting the machine
 - 6) Heavy applications
- Braking at creep speed.
 - 1) Depress the clutch pedal before depressing the brake pedal.
 - 2) Do not depress the brake pedal too hard as the creep speed shaft reduction ratio is high as well as torque.

- Front wheel drive shift lever

- Creep speed shift lever

2 - Danger:

No one should drive on the tractor except the driver. 1200-910-016-0

SAFETY PRECAUTIONS

3- Warning:

Fast - Slow (Hydraulic Flow Lock)
Always lock when

1. Driving on the road.
2. Replacing blades on the implements.
3. Making adjustments on the implements. Sudden lowering of the implement can cause serious injuries or death.

4- Caution:

Selective control valve B is a floating stop valve.

- Always select Neutral before starting the engine.
- Always select Neutral after completing a hydraulic operation.

- SCV implements:

- The SCV couplers are marked A and B from bottom to top, and are operated by the corresponding lever on the right hand side.
Port - B - Floating type: ACT/ N/ ACT
- B - Spring type: ACT /N /ACT
- Connect the implement to the relevant couplers.

Removing couplers.

Removing control levers.

5- Warning:

Never use the differential lock when driving on the road or at high speeds; as it can cause damage to the machine, serious injury or accident.

SAFETY PRECAUTIONS

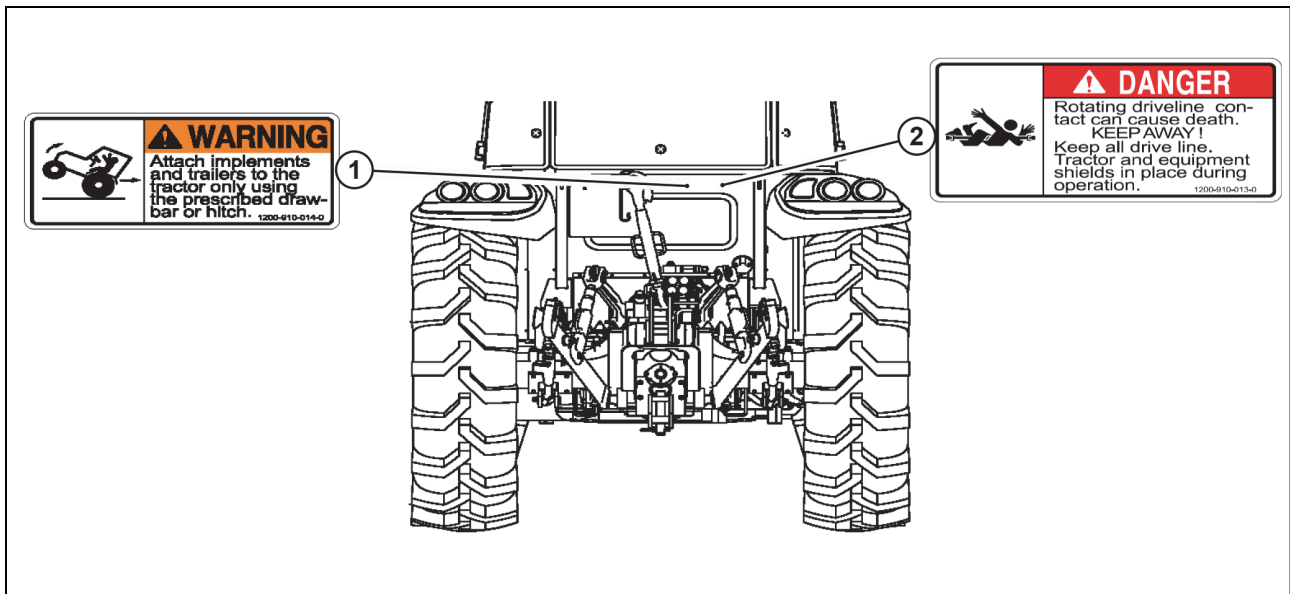

HODP039

1- Warning:

Use only the prescribed hitches when connecting trailers and implements.





























2 - Danger:

Contact with rotating parts can cause death. KEEP AWAY! Keep all protective equipment in place.

SAFETY PRECAUTIONS

Universal Symbols

Some of the universal symbols have been shown below with an indication of their meaning.

 Engine speed (rpm x 100)	 Air filter	 PTO engaged	 Parking brake
 Hours, recorded	 Battery charge	 PTO disengaged	 Work lights
 Engine coolant temperature	 Under pressure, open slowly	 3-point hitch arms / lifting	 Differential lock
 Fuel level	 Variator	 3-point hitch arms / lowering	 See Operator's manual
 Engine stop indicator light	 Warning	 Corrosive substance	-
 Position lights	 Danger warning	 Transmission oil pressure	-
 Horn	 Neutral	 Turn signal lights	-
 Engine oil pressure	 Fan	 Transmission oil temperature	-

NOTES

DESCRIPTION OF TRACTOR CONTROLS

Instrument and switches

The following pages in this section describe in detail the position and operation of the various tractor instruments, switches and controls. Even if you operate other tractors, you should read this section of the manual and make sure you really understand the location and use of all the features of your new tractor. Do not start or attempt to drive or operate the tractor until you are fully familiar with all the controls. It is too late to learn once the tractor is moving. If you have any doubts about any aspect of the tractor operation, consult your Zetor dealer / authorized Zetor service.

Particular attention should be paid to the recommendations for tractor running-in. These recommendations shall ensure reliable operation and long life of your tractor for which it was designed.

CL Model

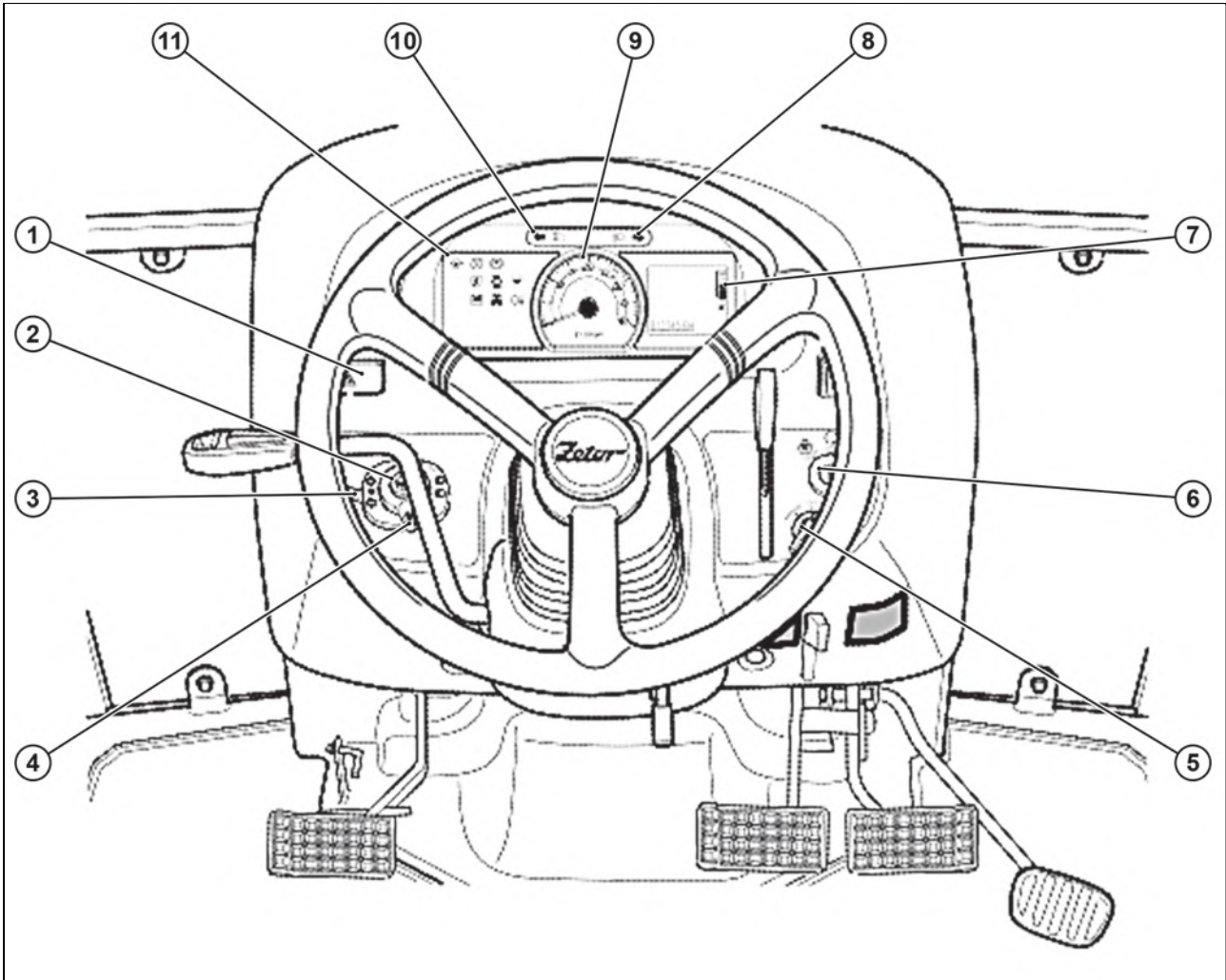

HODP040

- 1 - Hazard Warning Signal S/W
- 2 - Horn S/W
- 3 - Turn Signal S/W
- 4 - Head Lamp S/W
- 5 - PTO mode S/W
- 6 - Key S/W
- 7 - Fuel Gauge
- 8 - Right Turn Indicator Lamp
- 9 - Tachometer
- 10 - Left Turn Indicator Lamp
- 11 - Indicator Lamp

DESCRIPTION OF TRACTOR CONTROLS

HS Model

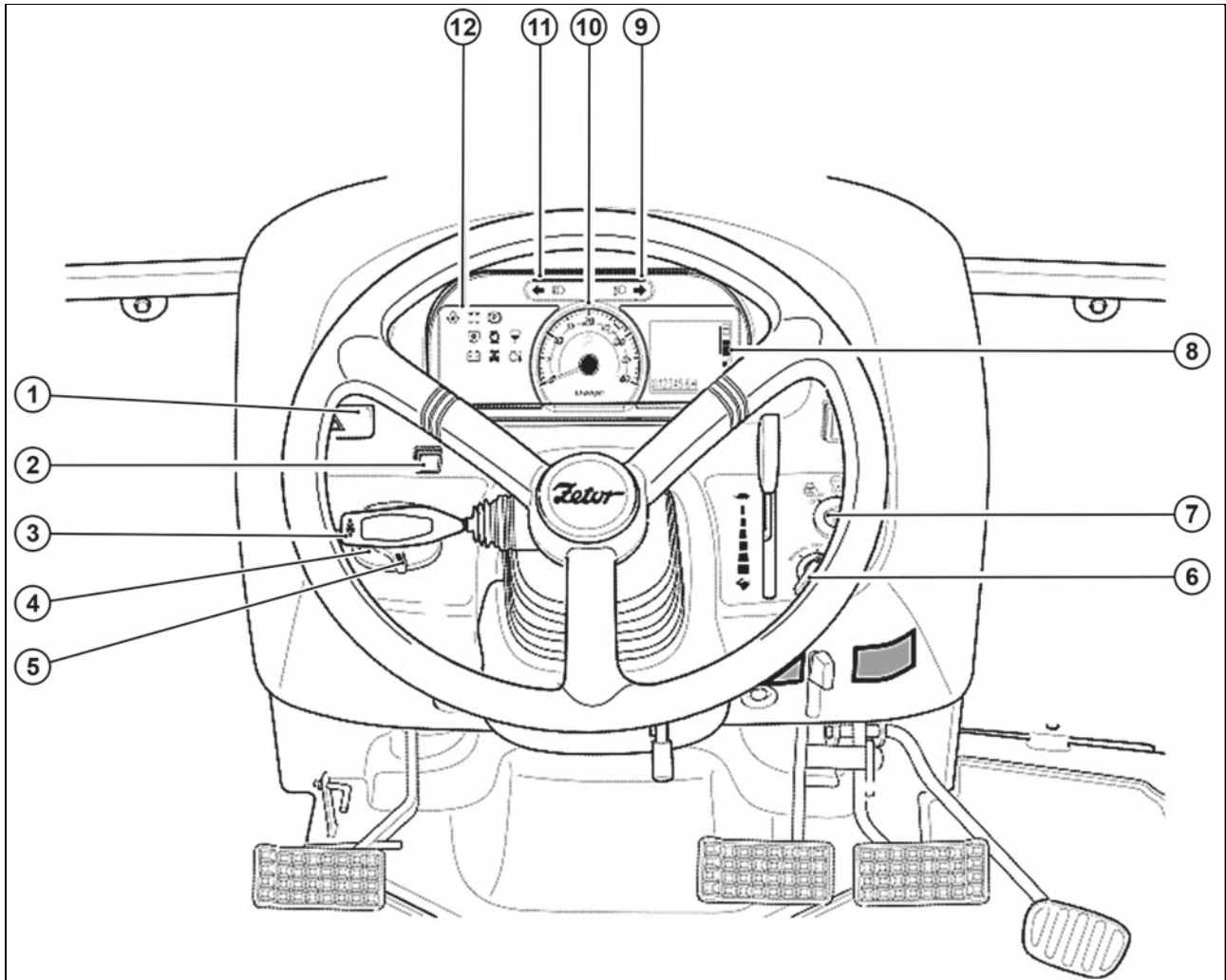

HODP041

- 1 - Hazard Warning Signal S/W
- 2 - 4WD (4-Wheel Drive) Switch
- 3 - Turn Signal S/W
- 4 - Horn S/W
- 5 - Head Lamp S/W
- 6 - PTO mode S/W
- 7 - Key S/W
- 8 - Fuel Gauge
- 9 - Right Turn Indicator Lamp
- 10 - Tachometer
- 11 - Left Turn Indicator Lamp
- 12 - Indicator Lamp

DESCRIPTION OF TRACTOR CONTROLS

Main Switch

- OFF - The key can be inserted or removed.
- ON - The electric circuit is on.
- START - The starter motor is engaged. When the key is released it will return to the ON position.
- GLOW - Glow plugs preheat the combustion chamber.

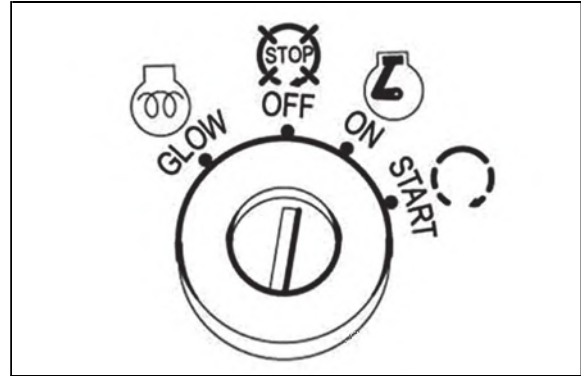

HODP042

Headlights Switch (Beacon Light), Turn Signal Lights Switch and Horn Switch



The beacon (if installed) is switched on simultaneously when the low beam lights or high beam lights are switched on.

Headlight Switch (if Beacon Light is installed, also Beacon Light Switch)

High beam and low beam lights are controlled by the lever (2) on the main switch

Position 3 - High beam lights (Beacon)

Position 4 - Low beam lights (Beacon)

Turn Signal Light Switch Lever

Press the turn signal lever (1) down to signal a left turn.

Press the turn signal lever (1) up to signal a right turn.

Horn

Press the red button (5).

- 1- Turn Signal Light Switch Lever
- 2 - Headlight Switch
- 3 - High Beam Lights (Beacon Light)
- 4 - Low Beam Lights (Beacon Light)
- 5 - Horn

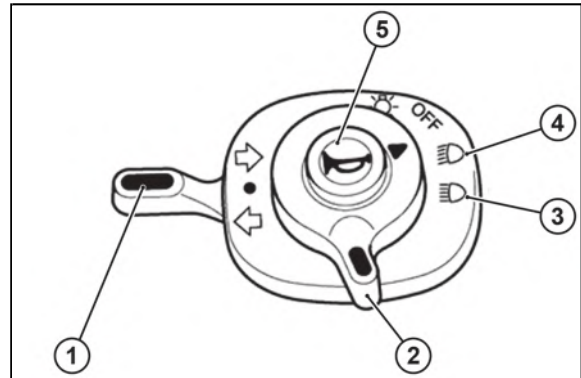

U18N012

DESCRIPTION OF TRACTOR CONTROLS

Tachometer

This meter shows the revolutions of the engine and the PTO shafts as well as the travel speed in top gear.

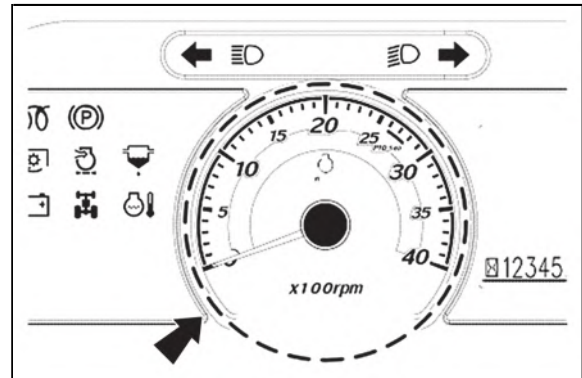

HODP044

Hour Meter

It indicates the total time of use. The last digit indicates one tenth hours. (decimal place) While the hour meter on the left most section is in operation, the lamp below it blinks.

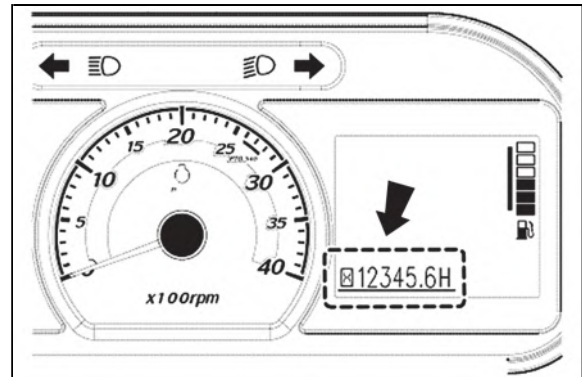

HODP045

Fuel Gauge

Shows the amount of fuel in the tank when the ignition switch is "ON".

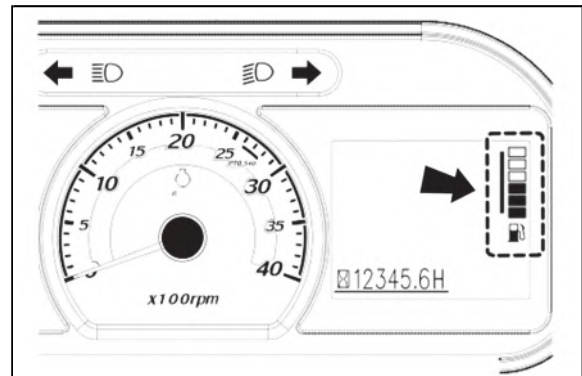

HODP046

Water Temperature

This indicates the coolant temperature after the key switch is turned to the "ON" position. When the lamp is comes on during driving, it means that the engine is overheated.



HODP047



Caution: Accelerating excessively rapaid the engine can damage the engine.

DESCRIPTION OF TRACTOR CONTROLS

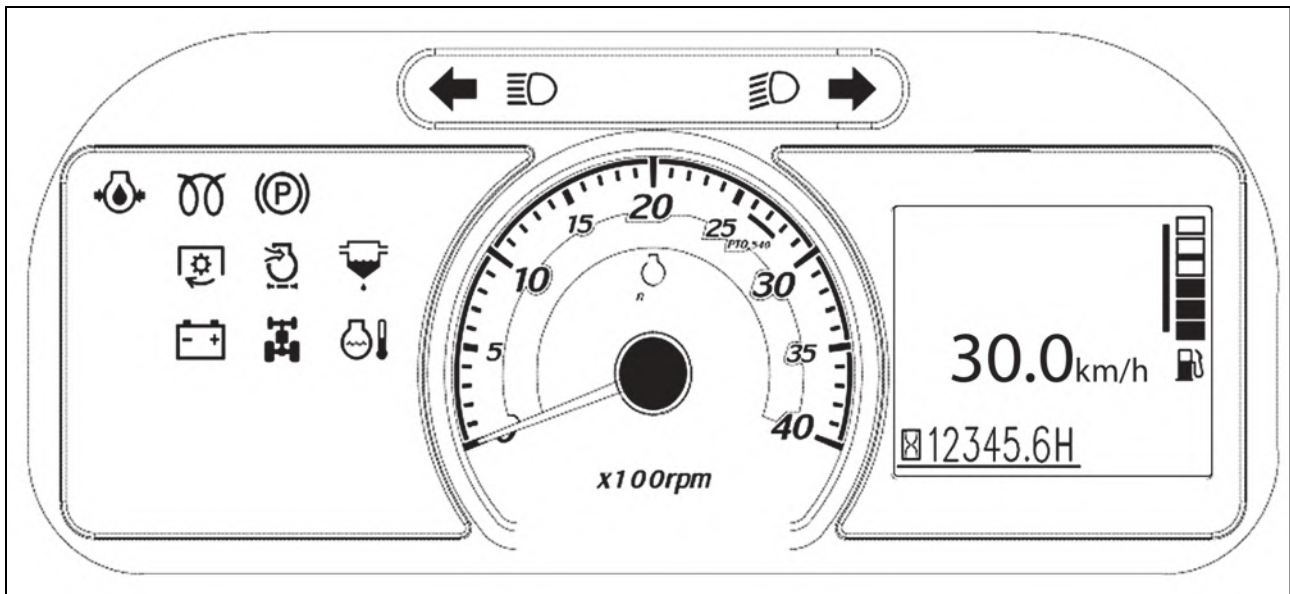

HODP048

Warning Lights



Charge Indicator Light

The indicator light goes off as soon as the engine is running and the alternator starts charging. (Note that a broken V-belt may cause the control indicator to come on, in such case stop the engine as overheating might occur if the defect is not rectified immediately.)



Oil Pressure Indicator Light

The light comes on when engine oil lubrication problems occur. Stop the engine and check the engine oil level, or have the engine repaired by an authorized service.



PTO Monitoring Indicator Light

Indicates PTO shaft activation. (see pages 3 - 6.)



Air Cleaner Filter Contamination Indicator Light This light comes on when the air cleaner is clogged with foreign materials. When it lights up, open the cover and clean the inside of the cleaner. Clean the filter element using compressed air, blow the compressed air through the filter in the intake air direction, or replace the filter with a new one.



The indicator light indicates that the high beam lights are activated.



The indicator light indicates that the low beam lights are activated.



The indicator light indicates that the parking brake activated.



Fuel level: if it comes on when the engine is running, refuel the tank.



Glowing indicator light: the illuminated light indicates operation of the pre-heating system.

DESCRIPTION OF TRACTOR CONTROLS

Independent PTO

It must be noted that the PTO shift lever on the LHS below the driver seat should be shifted to position 1 (540 RPM) Or 2 (750 RPM) depending upon the implement specification.

In no case the specified speeds be crossed as serious damage to the tractor / implement to person can result because of this.

When the PTO is not in use the shift lever must be put in neutral position to avoid unnecessary use or accidental use.

- 1 - PTO ON/OFF button
- 2 - Key S/W
- 3 - PTO Mode S/W

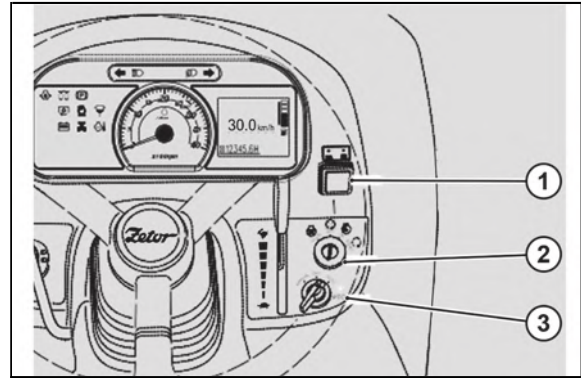

HODP049

The PTO Monitor Lamp

The PTO indicator light on the instrument panel indicates the PTO status.

1. If the indicator light is on: PTO rotates.
2. If the indicator light is off: PTO is off.
3. If the indicator flashes: PTO is not currently in motion, but shall be reactivated when the clutch pedal is released or the implement is lowered to the working position.

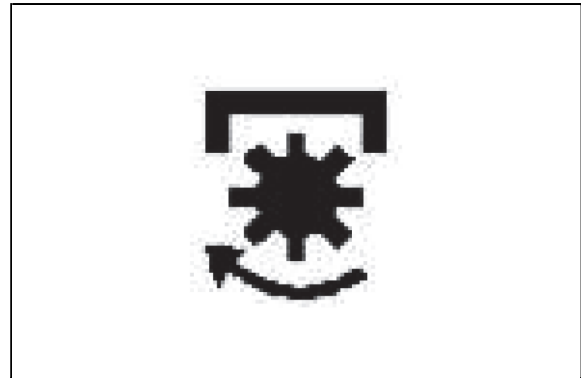

HODP050

PTO On / Off Switch

Two switches control the independent PTO.

PTO ON / OFF Switch: The PTO ON / OFF switch is located on the right side of the steering column and can be easily identified by the built-in red indicator light. When the switch is pushed down to engage the PTO, the PTO indicator light comes on to indicate that the switch and PTO are in the 'on' position. If the switch is pushed down again, the indicator turns off to indicate that the PTO is turned off.

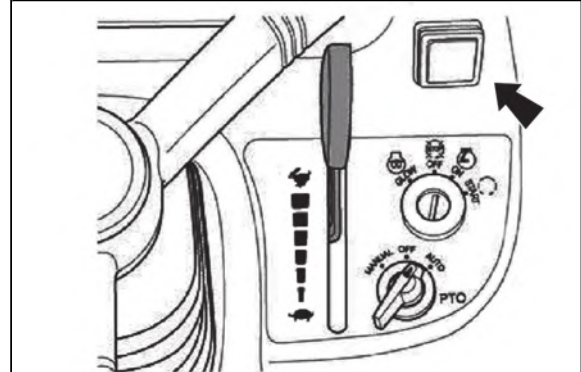

HODP051

PTO Control Switch

This switch is situated near the starting key location on the dash panel. There are three positions marked for this switch.

- "Off" at the center.
- "Manual" at the left.
- "Auto" at the right.

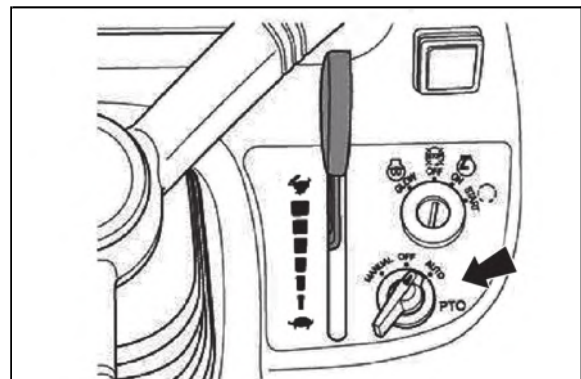

HODP052

DESCRIPTION OF TRACTOR CONTROLS

The PTO shaft will not rotate if either of the two switches is in "OFF" position. The following table explains how the PTO operates at the two different (Manual & Auto) positions of the PTO control switch with the PTO "On / Off" switch in the on position.

First select the specified speed for the PTO by using the PTO shifter on the LHS, below the driver seat.

PTO ON/OFF Switch	PTO Control Switch	Clutch Pedal	Hydraulic Position Control lever	PTO Monitor lamp on the dash panel	PTO Shaft
ON	Manual Mode	Either pressed or released	Either raised or lowered	Glows	Rotates
ON	Auto Mode	Pressed	Either raised or lowered	blinks	Stationary
ON	Auto Mode	Either pressed or released	Raised	blinks	Stationary
ON	Auto Mode	Released	Lowered	Glows	Rotates

- The table above shows the PTO safety features. When the indicator light on the dashboard is blinking, it indicates to the operator that the PTO is in the 'ON' position, but does not temporarily rotate either because the clutch pedal is depressed or because the implement is lifted off the ground, or both. The PTO starts to rotate immediately when the clutch pedal is released and / or the implement is lowered to the ground.
- The operator must ensure that there are no people in the area around the tractor when the indicator light is blinking, as rotating parts of some of the implements can cause injury to persons standing near the tractor.
- Stopping the PTO, when lifting the implement from the ground together with a position check, prevents damage to the implement or PTO.



WARNING: *If the PTO control switch is in the manual position, the PTO does not stop even when the clutch pedal is pressed. When working with a rotary implement on hard ground, the 'PTO ON / OFF' switch must be set to the 'off' position to stop the PTO. If it is not in the 'off' position, the rotating blades of the implement leaning against the hard surface can set the tractor into motion, so that an accident may occur, which can result in serious injuries or death.*



Warning:

- *Extra precaution must be taken to clear the area of bystanders / onlookers when using PTO driven implements. The rotating blades of the implements can cause serious injuries on contact. The warning that is indicated by the blinking PTO monitor is to make the operator aware that the PTO is in on position and will instantly start rotating if the clutch pedal is released or implement is lowered or both.*
- *In no case the specified rotating speeds indicated by the implement manufacturer be crossed as the same can lead to serious damage to the tractor / equipment and can lead to serious injuries to persons around.*

DESCRIPTION OF TRACTOR CONTROLS

Operation The Controls (CL MODEL)

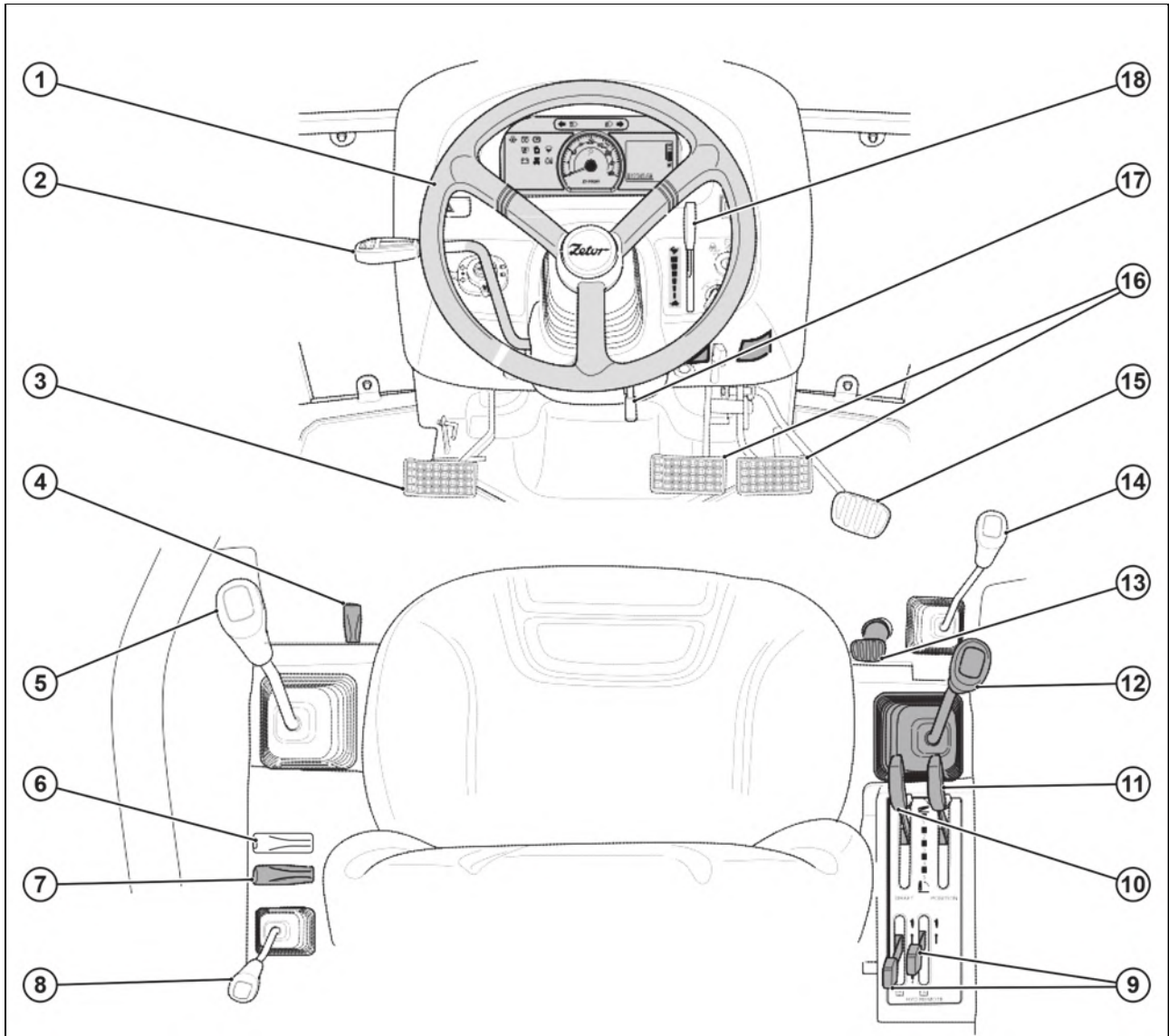

HODP053

1. Steering Wheel
2. Reverse Shift Lever
3. Clutch Pedal
4. Parking Brake Lever
5. Reduced and Road Gears Shift Lever
6. Creep Shift Lever
7. Front Axle Drive Lever
8. PTO Shift Lever
9. SCVs Control Levers
10. Draft Control Lever
11. Position Regulation Lever
12. Gear Shift Lever
13. Differential Lock Pedal
14. Joystick
15. Throttle Pedal
16. Brake Pedal
17. Steering Wheel Adjustment Lever
18. Throttle Lever

DESCRIPTION OF TRACTOR CONTROLS

Operation The Controls (HS Model)

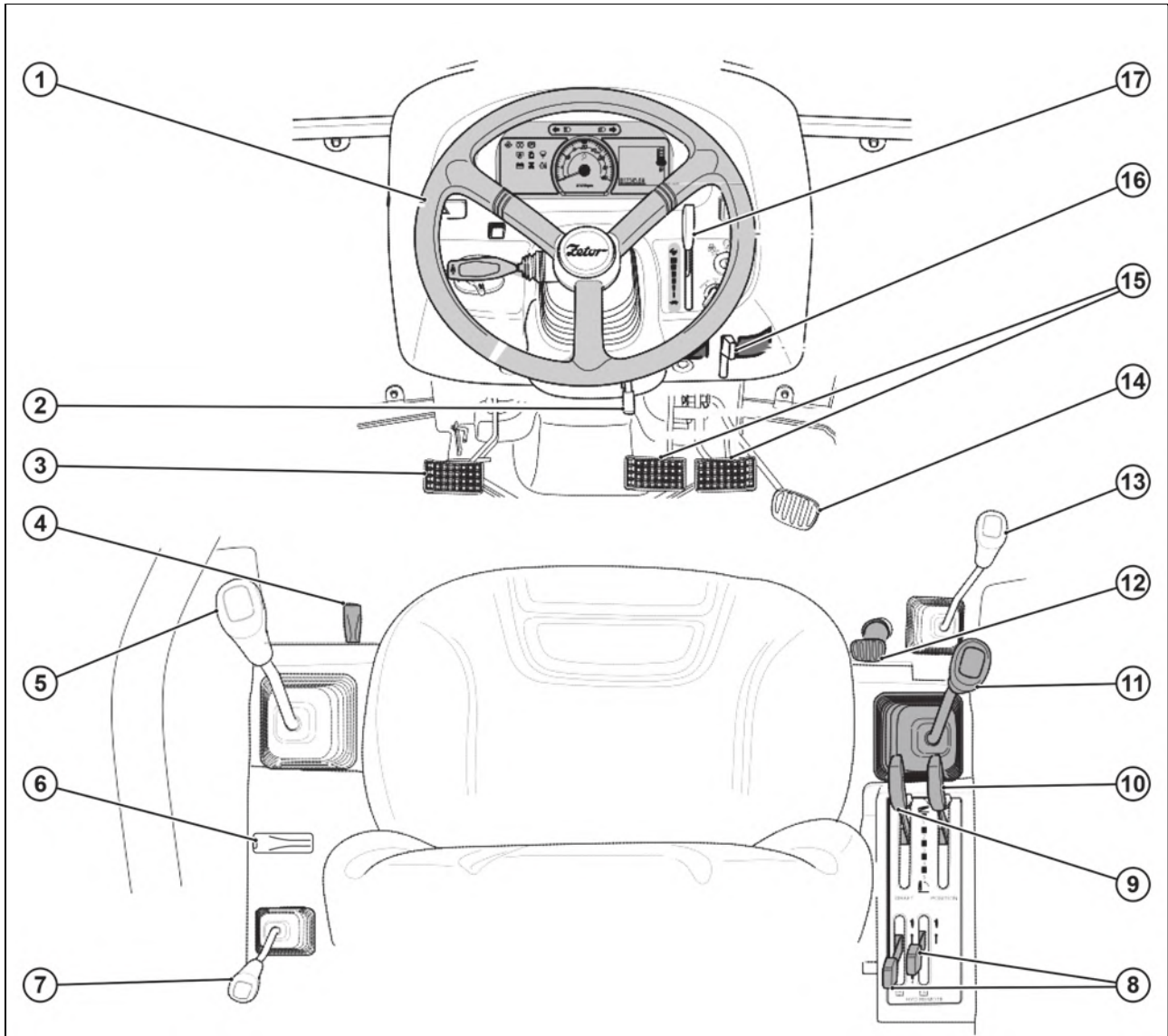

HODP054

1. Steering Wheel
2. Steering Wheel Adjustment Lever
3. Clutch Pedal
4. Parking Brake Lever
5. Reduced and Road Gears Shift Lever
6. Creep Shift Lever
7. PTO Shift Lever
8. SCVs Control Levers
9. Draft Control Lever
10. Position Regulation Lever
11. Gear Shift Lever
12. Differential Lock Pedal
13. Joystick Lever
14. Throttle Pedal
15. Brake Pedal
16. Parking Brake Lever
17. Throttle Lever

DESCRIPTION OF TRACTOR CONTROLS

Hand Throttle (Throttle Lever)

Pulling the hand throttle towards the driver increases revolutions.
Pushing it away from the driver decreases revolution.

1 - Throttle Lever

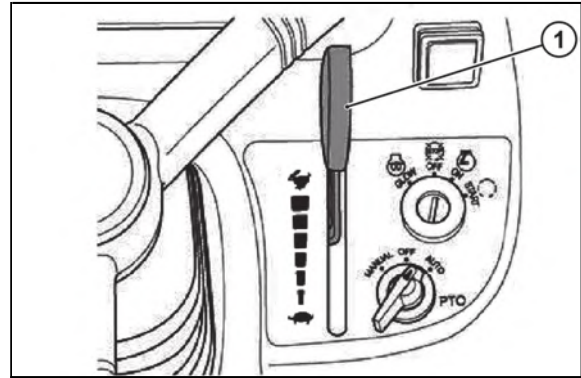

HODP055

Clutch Disconnecting Arm

For long term storage of the tractor it is possible to latch the clutch in the disengaged position.
Push the clutch down and engage the latch to hold it there.

1 - Clutch Pedal

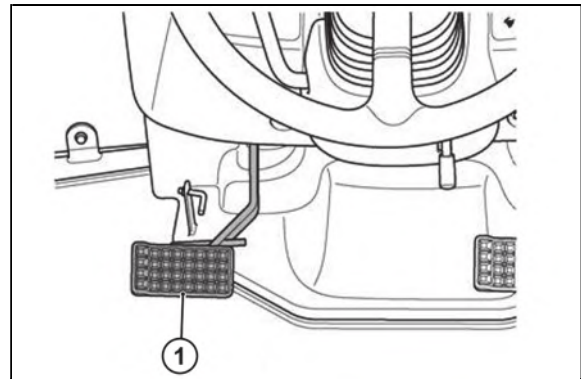

HODP056



Warning: *Do not attempt to start engine when this arm is being used.*

1 - Cut off arm

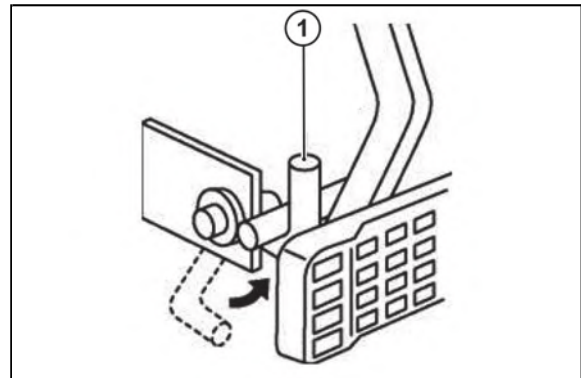

HODP057

Brake Pedal

Right and left brake pedals are provided to assist in turning the tractor in the field.



CAUTION:

- *A latch is available to connect the left and right brake pedals when driving at high speed or on the road.*
- *For safety reasons, always use it on the road or when driving at high speed, as braking on only one side can result in machine damage, serious accidents and serious injury or death.*
- *During tractor maintenance, make sure that the setting on both sides is the same.*

DESCRIPTION OF TRACTOR CONTROLS

Foot Operated Accelerator

This pedal can override a fixed hand throttle setting.

1 - Acceleration Pedal

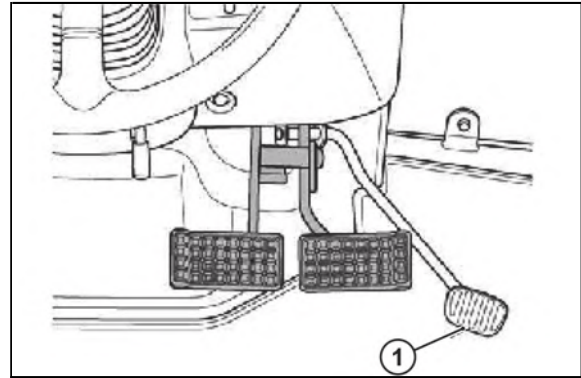

HODP058

Parking Brake

1. Pull the Lever fully up to engage the park brake.
2. Press the button on the end of the lever and lower the lever to release the brake.

1 - Parking brake Lever

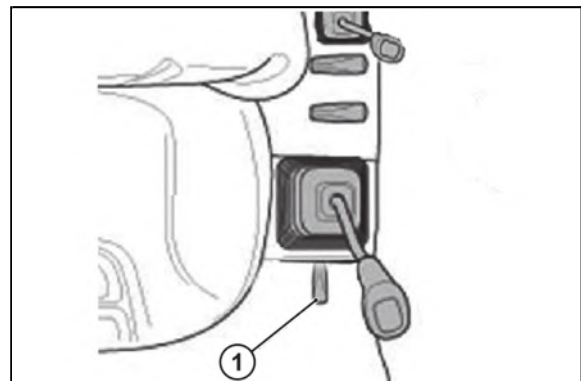

HODP059



Important: *Traveling with the park brake on will damage the brakes.*

Parking Brake Lever

1. With the left and right brake pedals interlocked, depress the brake pedal with a right foot firmly and pull up the parking brake lever to lock the pedals.
2. To release the parking brake, depress the brake pedal firmly.

1 - Parking brake lever

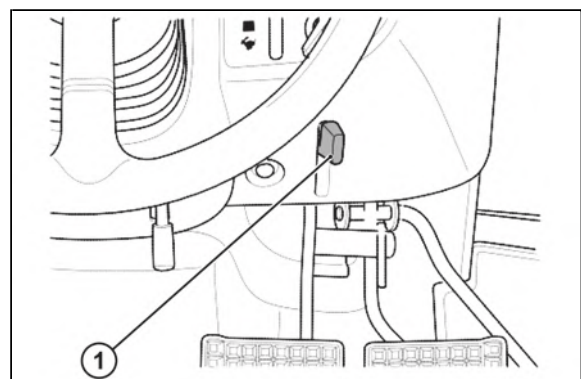

HODP060

Note: The brake discs can be worn prematurely if driving the vehicle with the parking brake engaged partially.

DESCRIPTION OF TRACTOR CONTROLS

Shuttle Shift Lever - CL MODEL

This control allows shifting from forward to reverse & reverse to forward. When stationary set the lever to "N" for neutral.

- Push the lever away from the driver engages forward.
- Pulling the lever towards the driver engages reverse.

1 - Shuttle Shift Lever

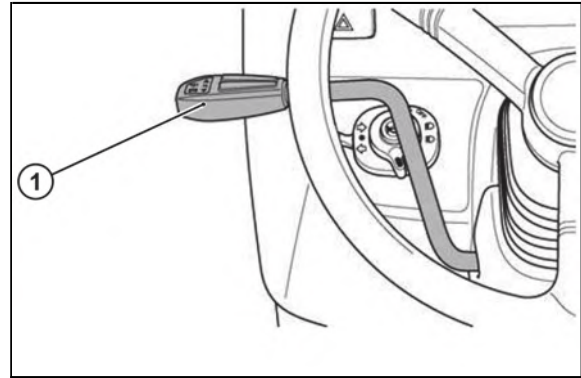

HODP061



Important: *Press clutch pedal fully before operating shuttle shift lever.*



Important: *When changing from forward to reverse or back to forward again while in high range make sure the tractor comes to a stop before changing direction. Failure to do so is likely to result in damage to the mechanism and place the driver at risk of injury.*



Caution:

- *Operate the shuttle shift only while seated on the tractor.*
- *Do not use the shuttle shift lever to start the tractor for towing or traveling uphill, use the clutch instead.*
- *Always stop the tractor before getting off.*

DESCRIPTION OF TRACTOR CONTROLS

Shuttle Shift Lever - HS Model

This lever is to switch between forward driving and reverse driving. Set it in the position N unless driving.

- Forward driving - Pull up the lever and push it forward to drive forwards.
- Reverse driving - Pull up the lever and pull it backward to drive backwards. Then, the reverse driving buzzer sounds.

1 - Shuttle Shift Lever

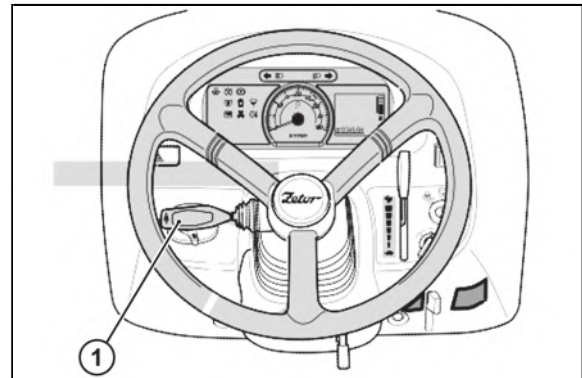

HODP062

Note: The vehicle can start off by operating the shuttle shift lever regardless of the position of the clutch pedal. Therefore, care should be taken.



Warning:

- **Do not operate the shuttle shift lever during driving. You can get injured by impact due to inertia. Change the driving direction after stopping the vehicle.**
- **Operate the shuttle shift lever only when seated in the driver's seat.**

Note: The response speed can vary as follows according to the operating speed or operating environment (temperature) of the hydraulic clutch:

- **Low operating oil temperature (in cold weather or initial tractor operation): The response may become faster (abrupt starting). Therefore, operate the clutch at a low speed, and operate the shuttle shift lever after warming up the engine sufficiently.**
- **High operating oil temperature (after prolonged use of the machine): The response may become slower, but this is normal.**

Gear Shift Lever

This lever can be shifted by using the clutch, both when the tractor is stationary or mobile. It is located on the R.H.S of the driver seat.

1. Seat Belts
2. Gear Shift Lever
3. Seat Adjustment Knob
4. Seat Adjustment Lever
5. Reduced and Road Gears Shift Lever

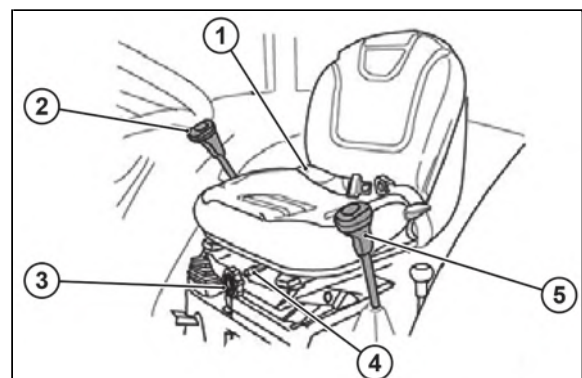

HODP063

DESCRIPTION OF TRACTOR CONTROLS

Sub Gear Lever (Linear Shift Lever)

Operate the sub gear lever using clutch to select the appropriate speed for different applications. It is located on the LHS of driver seat.

1. Seat Belts
2. Gear Shift Lever
3. Seat Adjustment Knob
4. Seat Adjustment Lever
5. Reduced and Road Gears Shift Lever

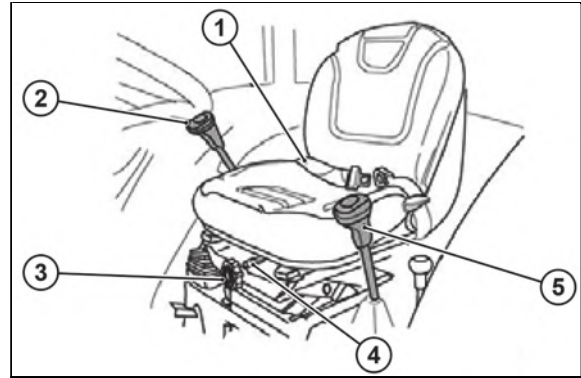

HODP064



Important: Avoid damage!

Select the proper speed range and gear for the job.

- **The machine maybe operated in any gear with engine speeds at 945 - 2,200 rpm. Within these limits, the engine can be placed under varying load operations.**
- **Never overload engine by lugging machine at low idle speeds.**
- **Raise engine speed the match expected loads. If a slight increase engine rpm occurs simultaneously with mobin hand throttle lever forward, the engine is not overloaded.**

The sub shift lever (A) provides three speed ranges. The main shift lever (B) provides four gear positions. The reverse lever (C) controls travel direction.

Use all three levers in different combinations to achieve twenty four forward and twenty four reverse speeds. Machine motion must stop and the clutch pedal must be depressed before changing ranges. Gear may be changed while machine is in motion if clutch pedal is completely depressed.

1. Choose a speed range to match work application:

A: Low speed / high power operations such as tilling hard soil, mowing high grass or positioning backhoe.
B: Operations including moderate tilling, hauling, and grass mowing.

2. Choose a gear that matches the immediate power / speed requirements

- 1st Gear: High power, low speed operations.
- 2nd Gear: Medium power, moderate speed operations.
- 3rd Gear: Low power, moderate speed operations.



Important: Do not operate gear levers without stopping the tractor & without using the clutch.

DESCRIPTION OF TRACTOR CONTROLS

Creep Shift Lever

1. Creep Shift Lever

Move the lever to 'OFF' for high speed and to 'ON' for low speed.

Shifting requires depressing the clutch.

1. Creep speed (achieved by shifting the creep speed lever to the ON position) should only be used to perform one of the following tasks

- Deep rotary tillage and plow work
- Planting, etc.

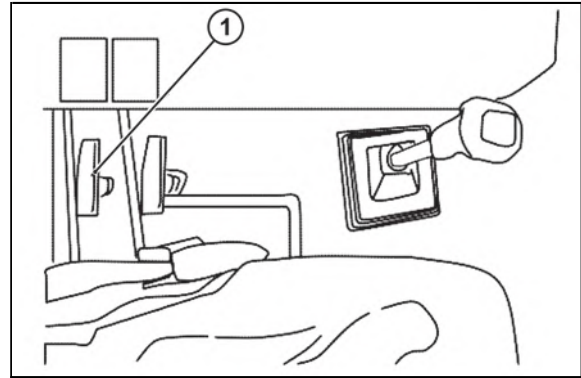

HODP065

2. Creep speed should not be used for any of the following activities

- Transport
- Front loader operation
- Front blade operation
- Reloading of soil
- Entry and exit of the field

3. To avoid injury:

- When leaving the tractor, make sure to apply the parking brake and switch off the engine
- When using brakes:

- The wheel axle torque is extremely high when using creep speed. Make sure you fully depress the clutch pedal before using the brakes, otherwise they may be damaged.

- Make sure that the parking brakes are released when starting to operate the tractor. Improper use of the brakes can cause damage to the transmission and is therefore unacceptable under Zetor warranty coverage.

4. The 'M' or 'H' reverse gear cannot be turned on when the creep speed is being used.



Important: Press the clutch pedal completely down and stop the tractor's motion before shifting the creep speed gear lever.

DESCRIPTION OF TRACTOR CONTROLS

Diff-Lock Pedal

1 - Diff-lock Pedal

In case of wheel slippage use the diff-lock by pushing down on the diff-lock pedal.
To release it remove the foot from the pedal.

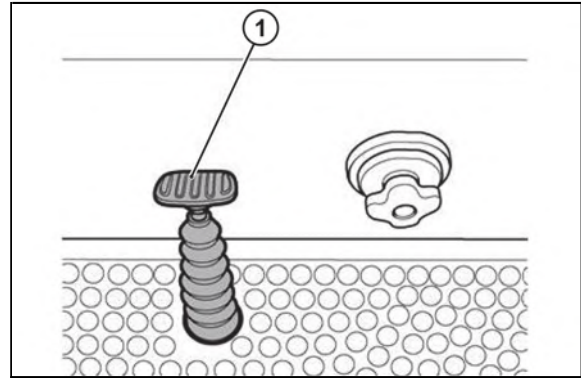

HODP066



DANGER: *It is difficult to turn the tractor when the differential lock is on. To prevent damage to the mechanism, turn the differential lock off before turning the steering wheel.*



IMPORTANT: *Do not use high engine rpm when engaging the differential lock. If the differential lock does not release after removing the foot from the lock pedal, alternately brake with the left and right directional brake until it is released.*



Caution: *Never use the diff-lock at high speed or on the road as this can cause roll over and injury.*

Front Wheel Drive Lever (CL Model)

1. Front Axle Drive Shift Lever

In the 'ON' position, the front axle drive is engaged and in the 'OFF' position disengaged.
Engage and disengage the front axle drive when the front wheels are in the straight position and at low engine rpm

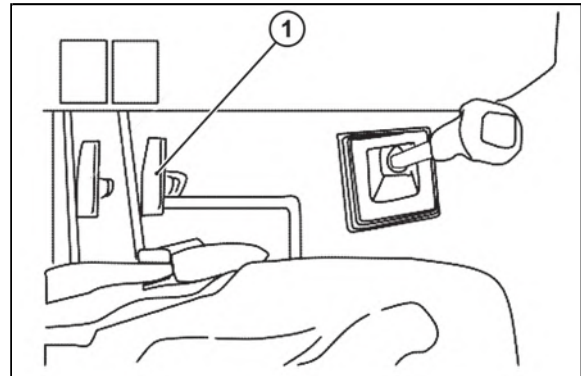

HODP067

DESCRIPTION OF TRACTOR CONTROLS

Front Wheel Drive Lever (HS Model)

1. Front Wheel Drive Switch

- ON - The front axle drive function is activated by pressing the top of the switch
- OFF - The front axle drive function is deactivated by pressing the bottom of the switch

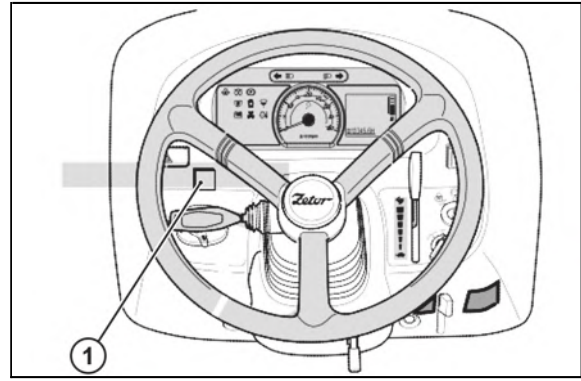

HODP068



IMPORTANT: Do not use the front axle drive at high speed or on a road, as the components shall prematurely wear out.



IMPORTANT: Always use the clutch when engaging and disengaging the front axle drive.

The use of front-wheel drive improves driveability on difficult terrain and tractor traction.

Driver's Seat



Caution: Check whether the seat properly locked in its position before driving the tractor.

1. Seat Belt
2. Seat Adjustment Knob
3. Seat Adjustment Lever

To adjust the seat forwards / backwards, raise the lever and adjust it to the desired position.

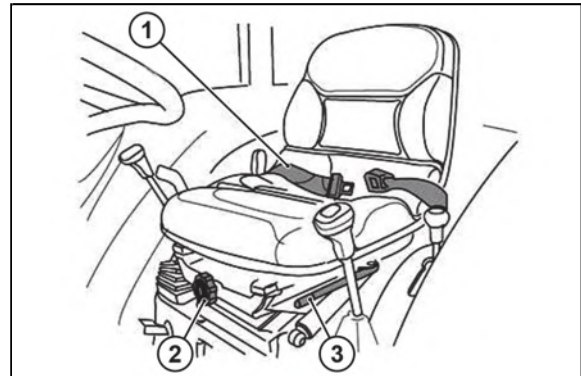

HODP069

Tilt Lever

1 - Tilt Lever

To adjust the inclination of the steering wheel with a 3 stages and set it to the desired position.

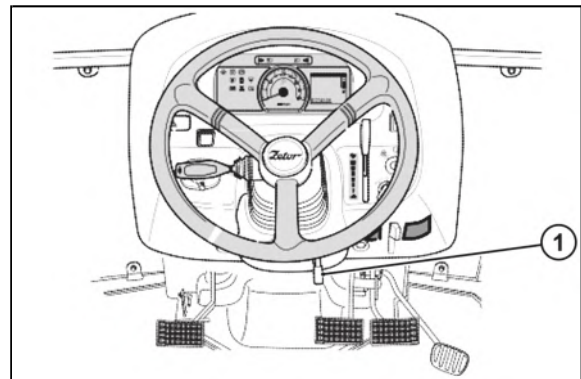

HODP070



Danger: Ensure that the tilt pedal has locked before moving the tractor.

DESCRIPTION OF TRACTOR CONTROLS

PTO Gear Selection Lever

Your tractor is equipped with 2 Speed PTO to suit range of applications and conditions.

1 - PTO Shift Lever

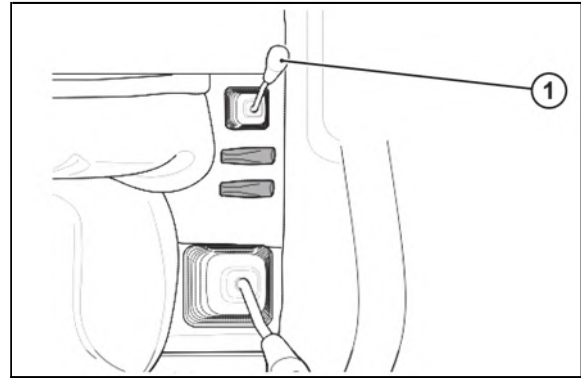

HODP071

MODEL	POSITION		
	1st	2nd	3rd
HORTUS CL65 / HS65	540	750	1,000



Important: *Always use the clutch when engaging or disengaging the PTO or changing PTO speed. Let the PTO driven implement come to a complete stop before changing.*

Operation of the Hydraulic Circuit

The external and internal hydraulic circuits are driven by an engine-driven hydraulic pump and controlled by a lever located next to the driver.

1. Position control lever

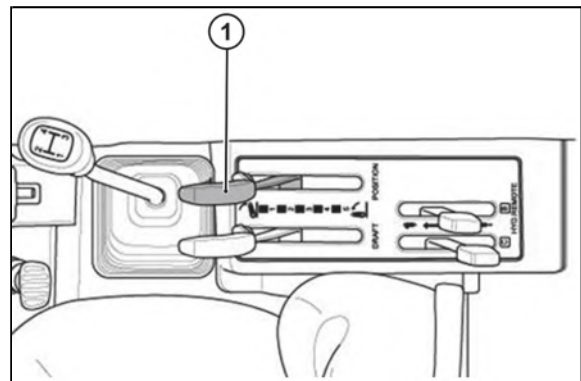

HODP072



Caution: *When working with the 3-point linkage, keep well clear of the operating radius of the lift arms and any attached implement. This is to avoid the risk of injury in the case of incorrect manoeuvres.*

Position Control

Implements can be raised and lowered with the hydraulic position control lever and can be stopped at any position by stopping the lever.

To ensure a consistent working depth the adjustable stop can be set to ensure that the implement returns to the same depth every time.

- To raise the implement: Pull the lever back.
- To lower the implement: Push the lever forward.



WARNING: *After finishing work, always lower the implement to the ground and switch off the engine. Apply the parking brake to prevent injuries and accidents.*

DESCRIPTION OF TRACTOR CONTROLS

Lowering Speed Control Knob for The 3 Point Hitch

This knob controls the downward speed of the hydraulics three point linkage and is positioned at the front of the driver's seat.

To slow the downward speed turn the knob clockwise.

1 - Adjusting knob of hydraulic decent speed

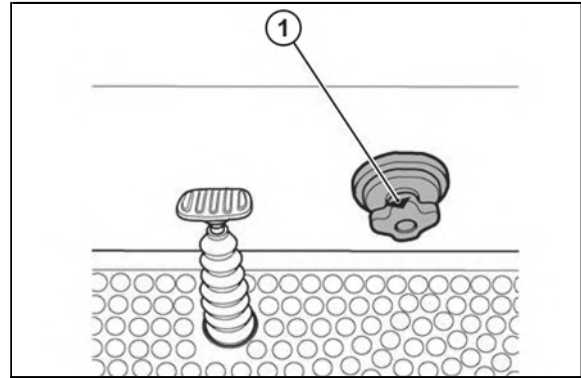

HODP073

To increase the downward speed, turn the knob anticlockwise.

To lock the knob clockwise. Do not over tighten the knob.

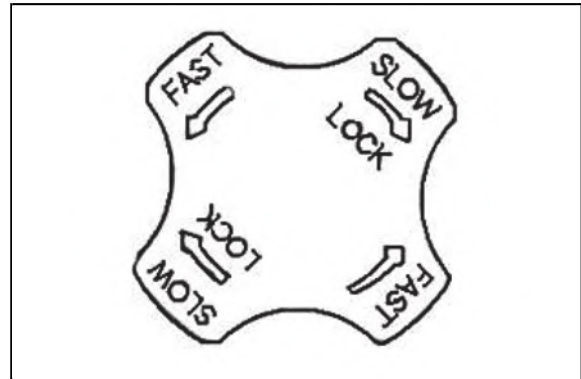

HODP074



CAUTION:

Always set the knob to lock when

- ***Driving on the road***
- ***Servicing or maintaining a machine attached in 3-point hitch***
- ***Sudden lowering of the implement due to a hydraulic defect can cause serious injury or death.***

DESCRIPTION OF TRACTOR CONTROLS

Exterior Hydraulic Lever (Optional)

Move the lever up or down and hold. This will raise or lower the implement. (Rotavator or hydraulic plow)
Lever will return to neutral by itself.

- 1 - Position B
- 2 - Position C

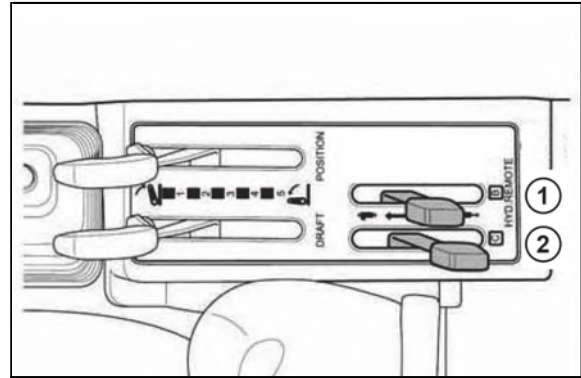

HODP075



IMPORTANT:

- **Do not hold the levers in Push or Pull position once the remote cylinder has reached the end of the stroke. This would cause oil to flow through the relief valve. The flow of oil through the relief valve for extended periods of time leads to overheating of the oil, its subsequent degradation and loss of functionality.**
- **When using the tractor hydraulic system to power the front loader, do not use two loader functions simultaneously.**

Remote Hydraulic Control Valve Coupler Connecting and Disconnecting

- 1 - Position B
- 2 - Position C

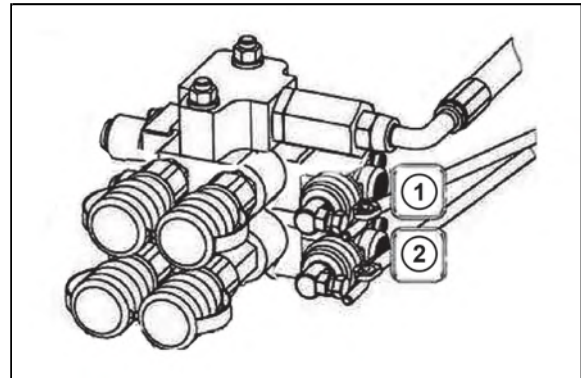

HODP076

Connecting

1. Clean both parts of the quick-couplers.
2. Remove the dust plugs
3. Insert the implement coupler into the tractor's hydraulic coupler.
4. Pull the implement coupler slightly to make sure the couplers are securely connected.

Disconnecting

1. First, lower the implement on the ground to release the hydraulic pressure in the hoses.
2. Clean the quick-couplers.
3. Relieve pressure by moving the hydraulic control levers while the engine is shut off. Pull the hose out of the hydraulic quick-coupler to release it.
4. Clean the oil and dust from the coupler, then insert the dust plugs

DESCRIPTION OF TRACTOR CONTROLS

Operating The 3 Point Linkage (TPI)

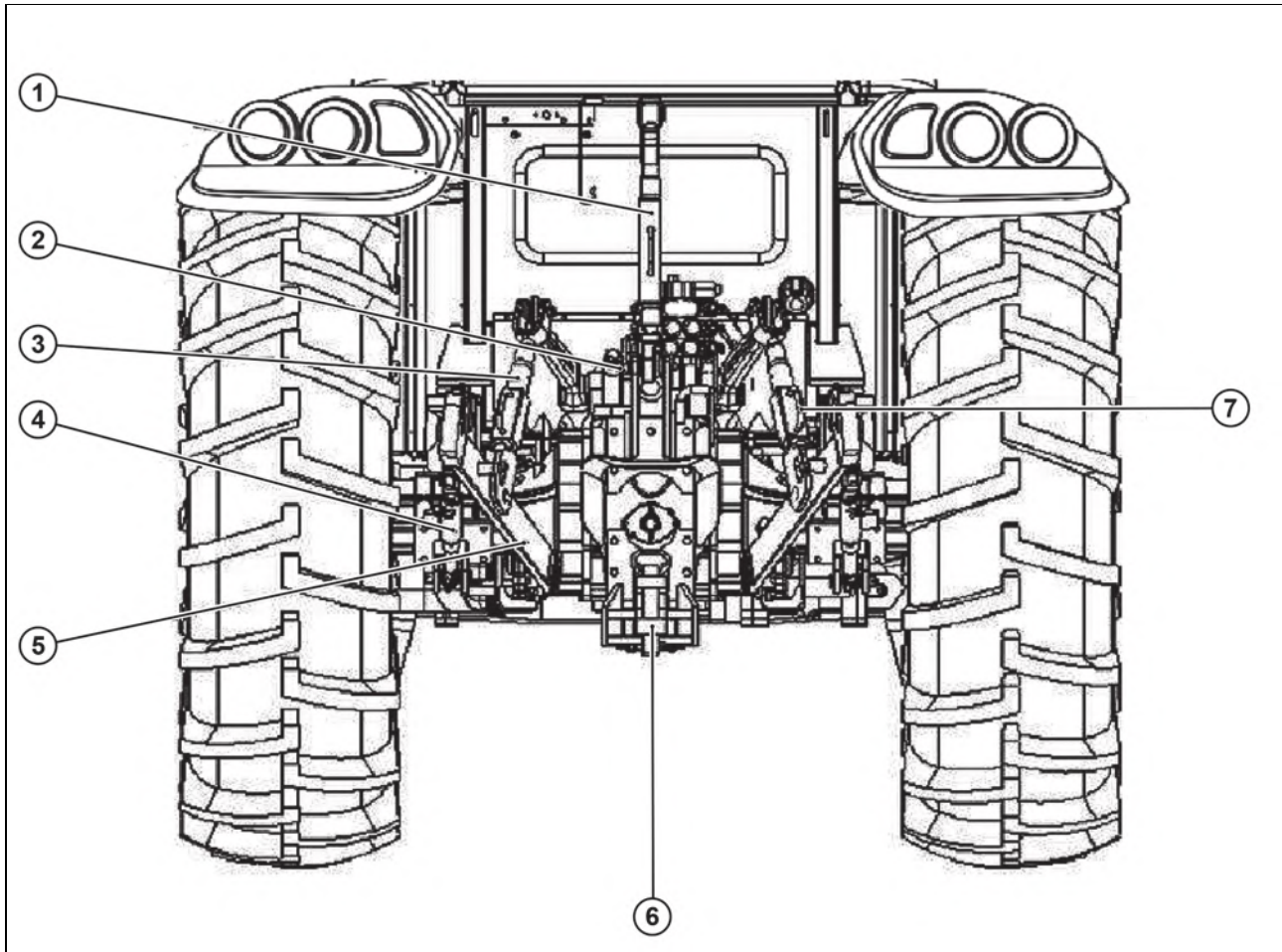

HODP077

1. Upper Link
2. Link Bracket
3. Lift Link
4. Stabilizer Bar
5. Lower Link Arm
6. Lower hitch
7. Length Adjustment of the Lift Link

DESCRIPTION OF TRACTOR CONTROLS

Adjustment of the Stabilizer Bars

The stabilizer bars are designed to limit or prevent lateral movement of the implement.

The length of the stabilizer bars is adjusted by removing the pin and rotating the turnbuckle nut by which the threaded ends are interconnected.

1. Turnbuckle
2. Pin

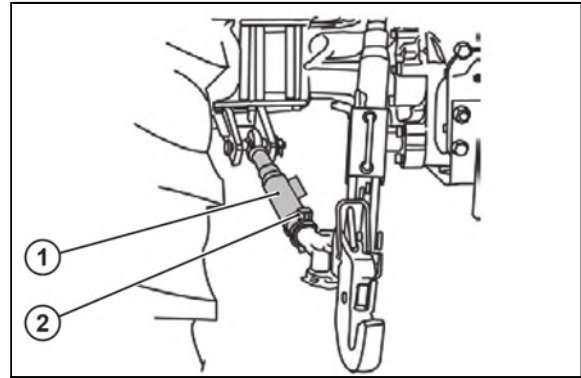

HODP078

Adjustment of The Top Link

Lengthening or shortening the top link will change the angle of the implement.

The locating hole of the top link varies with the type of implement used.

The most common locations are the 1st and 2nd hole from the top.

- For general implement: Use the Pin to "A": point
- For Draft control: Use the Pin to "B" point

1. Upper Link Length Adjustable Handle
2. Lock Nut
3. Upper Link Position
4. Position A
5. Position B

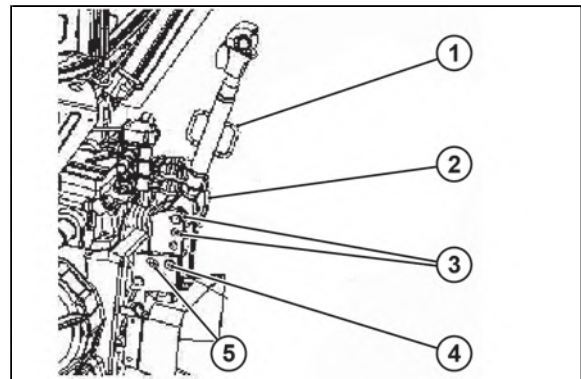

HODP079

Adjustment of the Lift Link (left, right)

Adjust the length of the lift link by screwing the adjustable handle to either side. Adjust the length of the lift link as required so that the connected implement is in its working position parallel to the ground.

- 1 - Lift Link Length Adjustment Handle

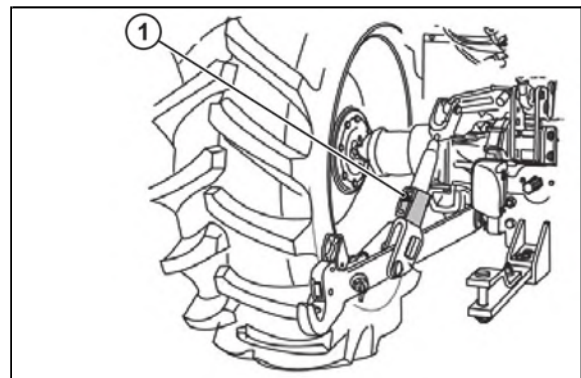

HODP080

DESCRIPTION OF TRACTOR CONTROLS

Adjustment of the Lift Link on the Lower Link

For various applications, the lift height change of the lower links can be adjusted by adjusting the pins in the holes of the lift links. There should be no clearance ('A' position) when transporting implements and working with seeders, drills, cutters and similar implements. However, a slight clearance (position 'B') is required when working with plows, excavators, cultivators and similar implements to control the adjustment of the towing machine.

- For common implements: Use the pin in 'A'
- For soil cultivation implements: Use the pin in 'B'

1. Lift Link
2. Lower Link
3. Hole A
4. Hole B

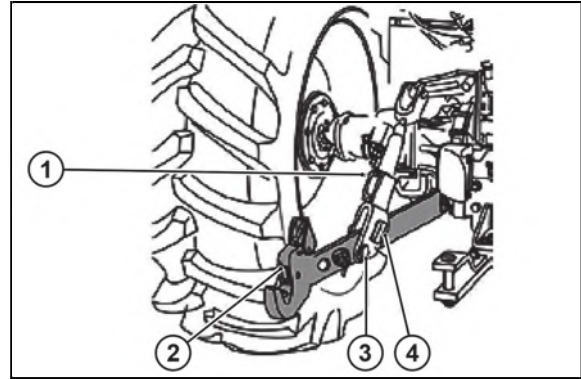

HODP081



DANGER:

- ***For towing, use the lower hitch or drawbar for 3-point hitch, which is adjusted to the height of the lower hitch. In order to keep the operation safe and to maintain the traction capability, it is essential that the front axle is not lifted.***
- ***Incorrect 3-point hitch height adjustment or incorrect mounting can cause machine damage, serious injury or death.***

Lower Swinging Hitch

It is used to attach implements with a requirement for the lower hitch. When coupling the implement to the lower swinging hitch, make sure that there is no collision with the lower link arms of the 3-point hitch. Always secure the hitch pin with a locking pin to prevent spontaneous disconnection and disassembly of the units, which may result in machine damage, accident, or serious injuries. Avoid anyone riding on the swinging hitch.

1. Locking pin
2. Pin

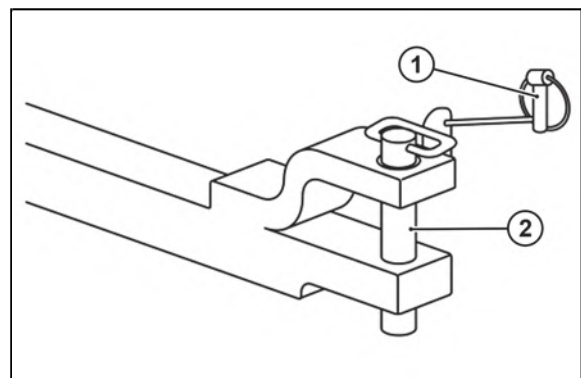

U18N050



Caution

- ***Maximum horizontal load (D) - 29.4 KN***
- ***Maximum vertical load - 500 kg***

DESCRIPTION OF TRACTOR CONTROLS

Lower Hitch Disassembly

After releasing the locking devices, remove the two pins (1).

Remove the lower hitch by pulling it backwards in the direction of the arrow.

Follow the reverse procedure to reassemble the lower hitch.

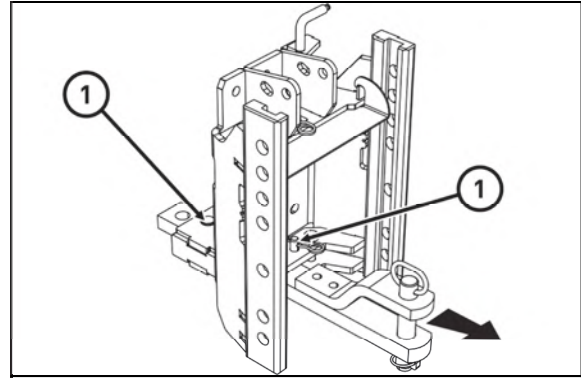

UCL18NN009

Multi-level hitch

Used to attach two-axle or lighter one-axle trailers. The guide tail piece is height adjustable. When working with various agricultural machines, it is necessary to adjust the height of the hitch or dismount it if necessary.



ATTENTION: To connect the attached equipment, the automatic tail piece (if equipped) is unlocked by the control lever of the hitch tail piece by lifting it to the upper position where it will automatically lock in the open position. When the drawbar is situated in the correct position in relation to the hitch, the machine is automatically locked, the machines are connected. Never place your hands or foreign objects in the tail piece with the control lever locked in the upper position. There is a risk of serious injury.

1. Multi-Level Hitch Console
2. Rear PTO Cover
3. Multi-level Hitch Attachment Tail Piece
4. Lower Swinging Hitch

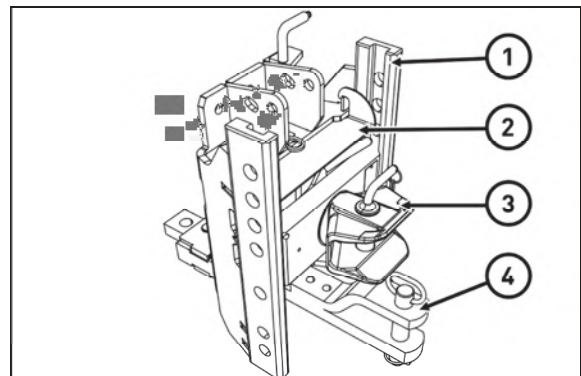

UCL18NN006

DESCRIPTION OF TRACTOR CONTROLS

Height Adjustment and Disassembly of the Multi-level Hitch Attachment Tail Piece

Remove the rear PTO cover and, if necessary, the lower hitch before handling the multi-level hitch attachment tail piece. Grasp the multi-level hitch attachment tail piece firmly. Moving the lever (1) in the direction of the arrow (upwards) engages the locking pins (2) and the tail piece is freely movable in the grooves of the multi-level console. Adjust the multi-level hitch attachment tail piece to a suitable height so that the locking pins (2) are aligned with the holes in the multi-level hitch console and release the lever (1); the locking pins (2) slide into the holes in the multi-level hitch console. Check that the pins (2) slightly overlap the outer edge of the multi-level console. Perform the disassembly of the multi-level hitch attachment tail piece after pulling the lever (1), by sliding the tail piece upwards out of the grooves of the multi-level console. Perform the assembly in the reverse order.

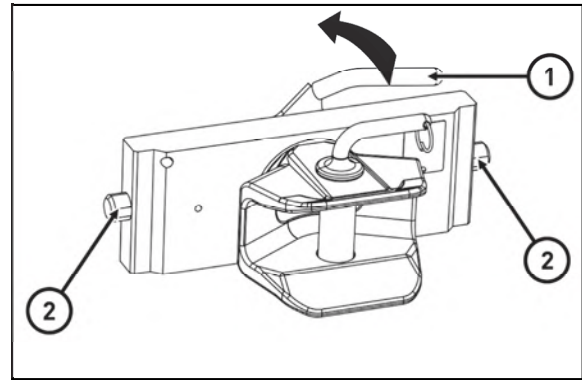

UCL18NN008



Caution

- **Maximum horizontal load (D) - 42.8 KN**
- **Maximum permitted vertical load - 1,200 kg**

* Air Brakes

On request, the tractor can be equipped with dual-hose air brakes. In this case it is necessary to connect both ends of the trailer air brakes to the corresponding counterparts (color coded). Always make sure the air brake hose ends are properly connected. Incorrect connection can result in serious accident and injury. If you have any doubts, contact your dealer / authorized service center.

Dual-hose Brakes

The left hose flap (1) is marked yellow (braking line), the right hose flap (2) is marked red (filling line).

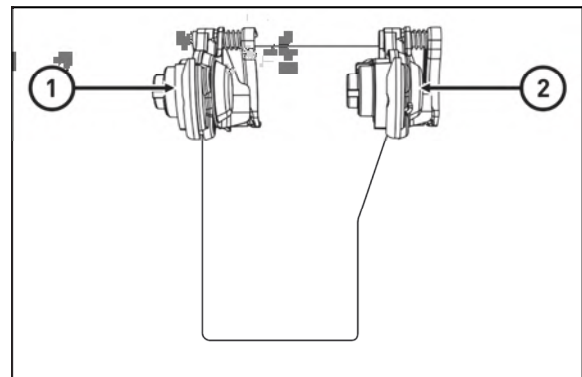

ATTENTION: Failure to connect or incorrectly connect the air brake hoses can result in serious injury and a traffic accident. Always check the correct connection.

DESCRIPTION OF TRACTOR CONTROLS

Air pressure indication

The air pressure in the trailer or semi-trailer air brakes is indicated by an air pressure gauge located on the instrument panel.

If the air pressure gauge needle is in the red field, the air pressure in the trailer or semi-trailer air brake system is low.

If the air pressure gauge needle is in the green field, the value of the air pressure in the trailer or semi-trailer air brake system is correct.

If the air pressure gauge needle is in the yellow field, the air pressure in the trailer or semi-trailer air brake system is high, this is a malfunction, contact a service immediately. When driving a tractor with a trailer or semi-trailer with air brakes, the air pressure gauge needle must be in the green field.

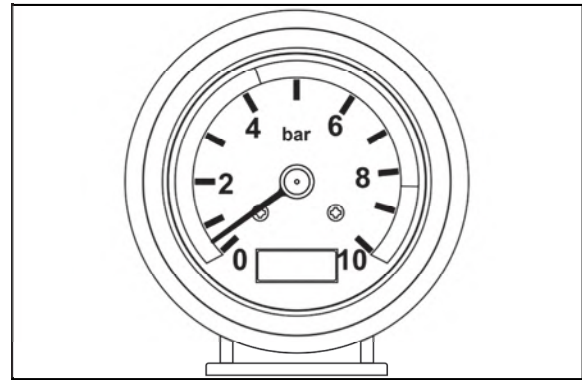

UCL18NN016



If the pressure gauge needle of a tractor with attached trailer or semi-trailer with air brakes drops into the red field, the tractor with trailer or semi-trailer with air brakes must not continue to travel. It is necessary to stop the unit and wait until the air pressure increases and the pressure gauge needle is within the green field of the pressure gauge.

The button for temporary deactivation of brakes of the trailer or semi-trailer

The temporary trailer or semi-trailer brake deactivation button (1) is located on the dashboard panel.

The button for temporary deactivation of brakes of the trailer or semi-trailer can be used by the operator of the tractor with the connected trailer or semi-trailer to make sure that the effect of the parking braking system of the tractor with the connected trailer or semi-trailer when the tractor is braked with the hand brake is sufficient. If there is a tractor with the connected trailer or semi-trailer which is braked with the hand brake and the key in the switch box is in the position (I), and we press the button for temporary deactivation of brakes of the trailer or semi-trailer, the trailer or semi-trailer is deactivated for the time when the button is pressed (the trailer or semi-trailer does not brake). When the button for temporary deactivation of brakes of the trailer or semi-trailer is released, the brakes of the trailer or semi-trailer are activated (the trailer or semi-trailer brakes).

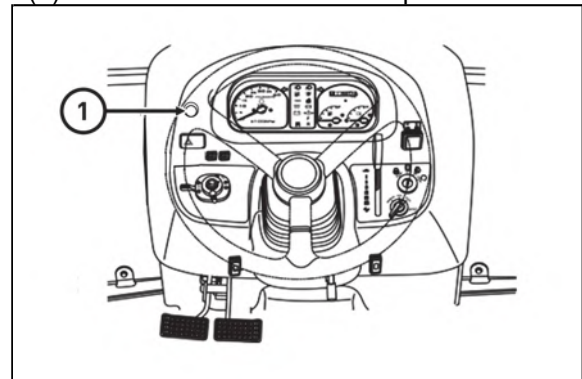

Prior to using the button for temporary deactivation of brakes of the trailer or semi-trailer, it is always necessary to provide sufficient space in front of the tractor and behind the connected trailer or semi-trailer where no obstacles or persons will be present for the case that the effect of the parking braking will not be sufficient and the combination of vehicles moves.



Only the air brakes are deactivated by the button for temporary deactivation of brakes of the trailer or semi-trailer.

DESCRIPTION OF TRACTOR CONTROLS

* Front Three-point Hitch

It is used for attachment of front mounted implements and tools with hitch points of category I according to ISO.

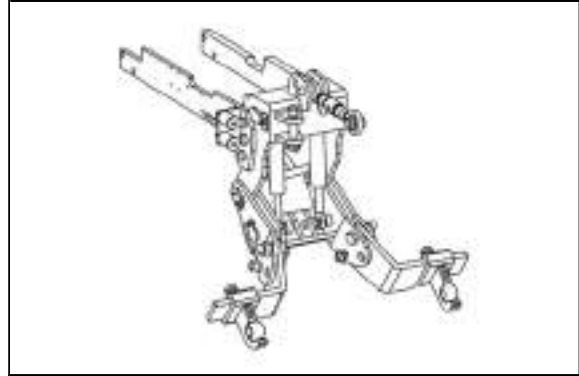

UCL18NN005



Note: The required width of the front hydraulic arms can be adjusted to a certain extent by adjusting the end points.
More information in the Operator's manual of the front three-point hitch manufacturer.

Controlling front three-point hitch

The hitch is equipped with two hydraulic cylinders. Lifting and lowering is performed by the joystick lever located on the right side of the driver's seat.

- 1 - Lifting of Front Three-Point Hitch Arms
- 2 - Lowering of Front Three-Point Hitch Arms
- 3, 4 - Oil pressure release to the quick couplers of the SCV located on the front three-point hitch
- 5 - Joystick lever is locked
- 6 - Joystick lever is unlocked

The button on the joystick head is not functional in this case.

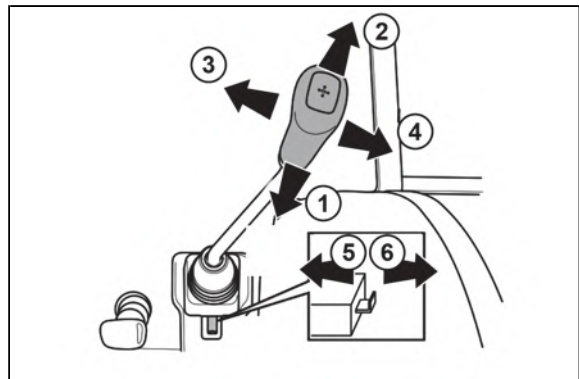

UCL 18N036



After lowering or lifting the front three-point hitch arms to the required position, lock the joystick lever with the lock (5) to prevent it from moving when accidentally leaning against the joystick lever.

DESCRIPTION OF TRACTOR CONTROLS

Working and transport position of the front three-point hitch

A	Working position of the front three-point hitch
B	Transport position of the front three-point hitch

Changing the position of the draw-bars of the front three-point hitch:

1. Release and remove the pin (1) from the opening.
2. Lift the arm from position (A) to position (B).
3. Lock the arm by inserting the pin (2) in the opening (2) and secure the pin.

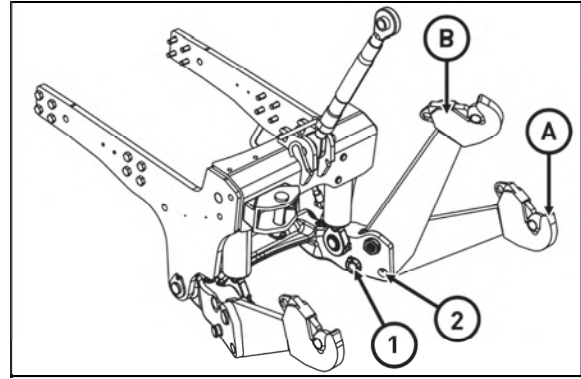

PCLPN062



Only insert the pin in the openings, never check whether the opening is free with your fingers!

Driving with agricultural machines attached to the front three-point hitch



The maximum permissible speed of the tractor with agricultural machines attached to the front three-point hitch is 15 km.h⁻¹. If no implement or weight is attached to the front three-point hitch, we recommend you to lift the lower lifting draw-bars to the transport position.

OPERATION

Starting the Engine

Before starting the engine, check it according to the chapter Safety instructions for the user.

1. Sit into the driver's seat.
2. Depress the foot brake.
3. Move the hydraulic control levers to the lower position.
4. Depress the clutch pedal to deactivate the safety switch.
5. Move the main gear shift lever to the neutral position (N).
6. Insert the ignition key into the ignition switch.
7. Turn the key anticlockwise to preheat the combustion chamber, which is indicated by the glow indicator light on the instrument panel. Release the key when the light goes out. Then turn the key clockwise to the 'ON' position where the wiring will be activated and check the operation of all indicators and indicator lights. To start the engine, further turn to the 'START' position, where the starter is switched on and the engine starts. At this point, turn the key back to the 'ON' position.
8. Make sure all warning lights switch off after the engine starts.

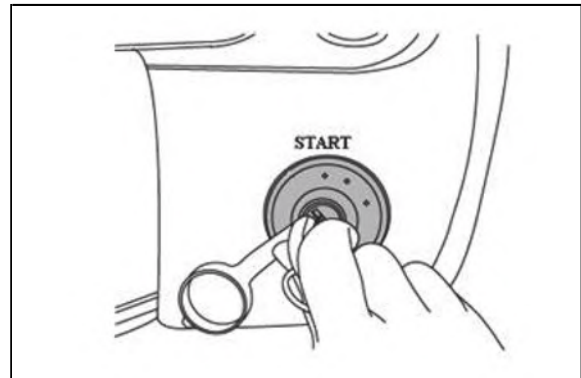

HODP082



Important:

- Never turn the key to the start position while the engine is running as this can cause serious damage to the starter and engine flywheel.
- Only engage the starter for a period of not more than 10 seconds.
- If Engine does not start, rest the starter for about 20 seconds and try again for a maximum of 10 seconds. If the engine does not start after repeated attempts, refer to the fault tracing guide.
- Especially in cold weather, always allow the tractor to idle for a while to warm up & build up sufficient oil pressure to ensure normal operating temperature for longer engine life.

Stopping the Engine

After light work let the engine idle for a while and turn the key off.



Important: *After long or heavy work allow the engine to idle for 5-10 minutes and turn the key off.*

OPERATION

Driving the Tractor

Warming Up

When starting the engine allow it to warm up to operating temperature by allowing it to idle 5-10 minutes to ensure full lubrication and operating temperature.

Failure to do so can shorten engine life substantially.

Warming Up in Cold Weather

Cold weather changes the viscosity of the oil, resulting in a reduction in the performance of the engine oil pump, which can cause engine damage if not heated properly.

At the same time, there may be problems with the hydraulic system and synchronization in the transmission.

Warming Up Time

Temperature	Time for warming up
Above 50 °F	5~10 min.
50 °F~32 °F	10~20 min.
32 °F~14 °F	20~30 min.
14 °F~-4 °F	30~40 min.
Below -4 °F	Over 40 min.



IMPORTANT:

- ***Make sure the parking brake is engaged during warm-up.***
- ***Insufficient warm-up may cause problems or shorten the life of the relevant components.***

When the engine is warmed up, depress the clutch and move both shift levers into the desired positions.

Depress the brake pedals and release the parking brake.

Increase engine speed and smoothly release clutch for smooth start.

When driving, change gears only with the (main) gear shift lever and always with the clutch pedal fully depressed.



Caution:

- ***Do not "ride" the clutch to control speed, use a lower gear.***
- ***Do not travel with your foot on the clutch pedal.***



Danger:

- ***Connect the brake pedals together when driving on the road.***
- ***Use only suitable hitches for towing.***
- ***Do not overload the tractor with an excessive load aggregation that is contrary to the applicable national legislation. The design braking performance of the brakes must be maintained.***
- ***Take special caution when towing or carrying excessive units and take into account the dimensions and weight of the unit. Use warning elements according to national legislation.***
- ***It is forbidden that another person rides on the unit.***
- ***Always observe local regulations and traffic rules.***

OPERATION

Tight Turns in the Field

Disconnect the latch connecting left and right brake pedals to allow the use of individual pedals.

To make a tight turn use both the steering wheel and the brake pedal at the same time.

For a left turns use the left pedal and a right turn the right pedal.

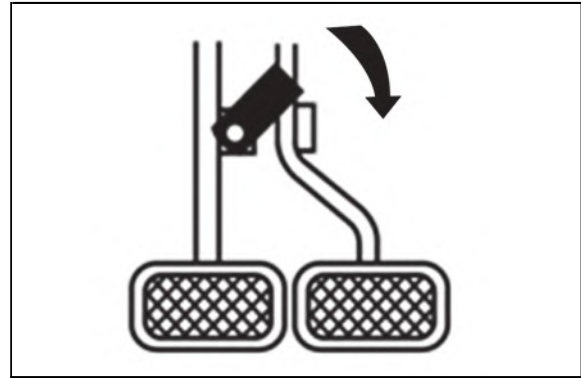

HODP083



Caution:

- ***Perform tight turns only at a slow safe speed.***
- ***Doing so at a high speed can cause rollovers and very serious injury or death.***

Normal Braking and Parking

Let the engine come back to idle and at the same time push in the clutch and brake simultaneously.

When the tractor has come to a halt, lower any implement to the ground, and put the main gear in neutral.

Apply the park brake, stop the engine, and remove the key.

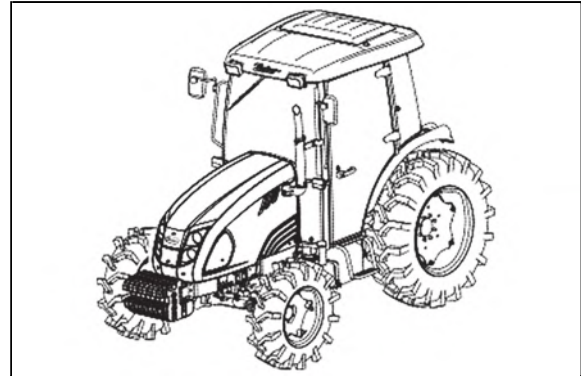

HODP084



Caution:

- ***Always apply the park brake when parking.***
- ***Failure to do so can cause accidents and damage.***
- ***As an extra precaution when parking on a slope, chock the rear wheels.***

OPERATION

Uphill Starts on a Steep Slope

With the pedals connected together push down on the brake pedals and push down the clutch.
Set all gear levers to low and the throttle to medium engine speed.
Release the clutch and as it engages release the brake pedals.
Adjust the throttle to the required speed.

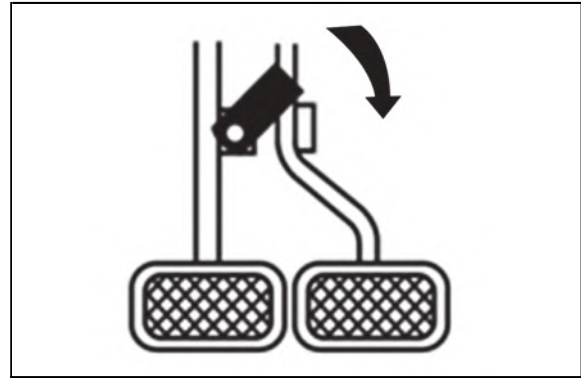

HODP085

Driving Downhill

Use the engine's ability to brake when traveling downhill.
Never rely on the brakes only and never travel downhill with the gears in neutral.



CAUTION:

- *When working in hilly terrain, the risk of machine damage - rolling over and injury - is significantly increased. Environmental conditions must be taken into account.*
- *When towing trailers and semi-trailers in hilly terrain, make sure that the brakes of these machines are in working order and in perfect condition. To drive down the hill, use the braking action of the engine in combination with a lower gear.*

Operation of the Diff-Lock

Although the differential lock is a very useful function, care should be taken to use it as improper use can lead to dangerous situations. The differential lock is only used in situations where one of the rear wheels does not have sufficient traction and the machine is on an unpaved surface.



WARNING

- *Only engage the differential lock at low engine speeds, direct driving and low speeds.*
- *If the differential lock is not disengaged when the pedal is released during driving straight, alternately brake with the left and right pedals until it is disengaged.*
- *Do not attempt to lock or use the differential lock in sharp turns, as this may cause serious damage to the mechanism.*

OPERATION

Check During Driving

Constantly monitor the warning lights on the dash and if any comes on stop the tractor to determine the cause.

Oil Pressure Light

If the oil pressure indicator light comes on, check the oil level first.

If the oil level is correct, ask your dealer / authorized service center to remove the cause of the defect.

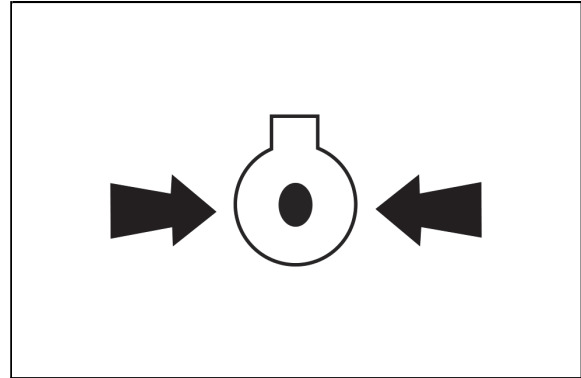

HODP086

Battery Charging

If the alternator indicator light comes on, check all connections and make sure the alternator V-belt is not damaged. If all connections and V-belt are OK, consult your dealer or an authorized service center to find out how to fix the problem.

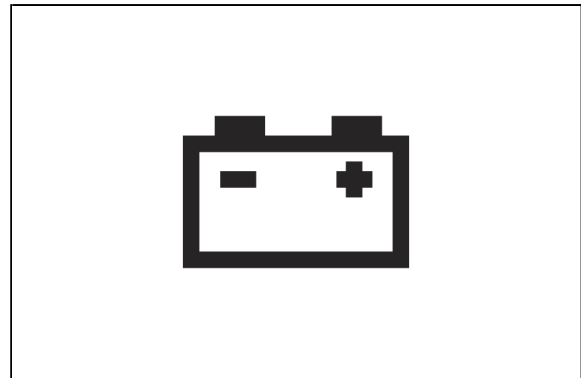

HODP087

Fuel Gauge

To prevent excessive water condensation in the fuel tank, refuel the fuel tank at the end of everyday work. When working, ensure that the fuel tank does not drop to a low level when the fuel system requires venting.

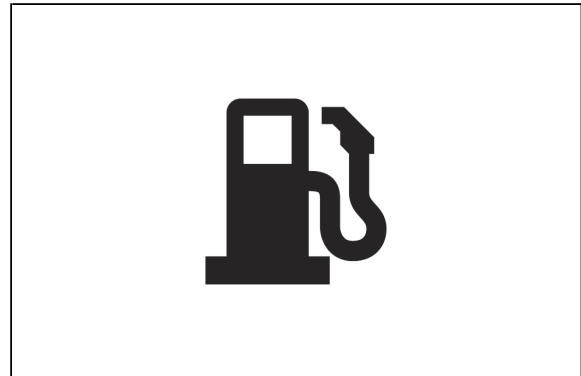

HODP088

OPERATION

Check During Driving

As HORTUS CL65 / HS65 models of Zetor are front wheel assist the front track can be set in 2 positions. The rear track can be set in 4 positions as illustrated.

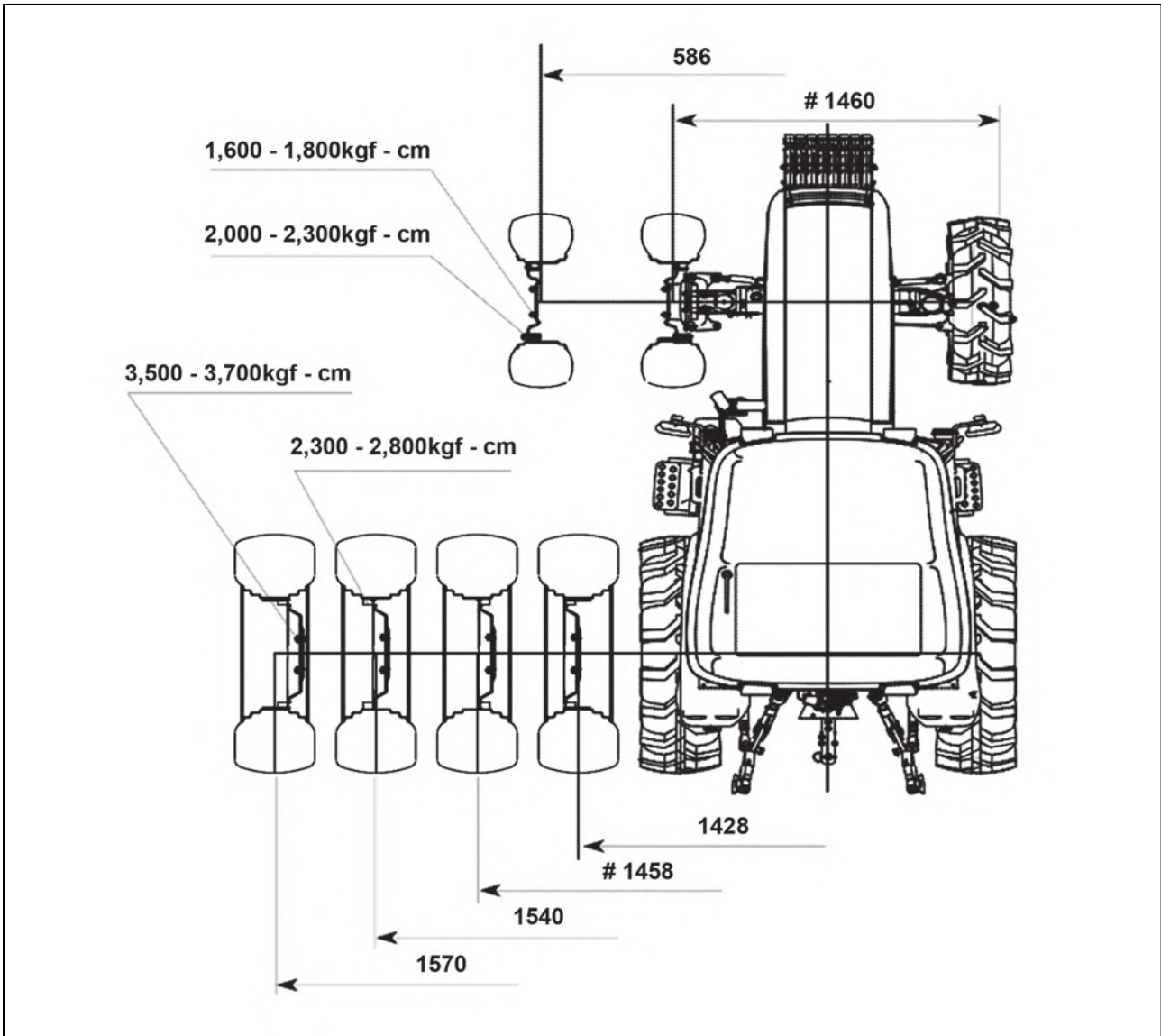

HODP089

OPERATION

Connecting and Disconnecting Implement

Connection

1. Do not forget to stop the engine before connecting the implement.
2. Depressurize the external hydraulic circuit by repeatedly moving the control lever to the end positions. Otherwise the couplers may be difficult to connect or the oil may expand from the hoses when connecting.
3. Remove any dirt from the quick couplers. If contamination of the hydraulic circuit occurs, there might be a malfunction in the system.
4. Open the tractor quick coupler dust cover and insert the implement counterpart. You should hear a click when you connect the quick coupler.
5. Pull the hydraulic hose of the implement to check that the couplers are properly connected.
6. Start the engine and check for operation and leaks.

Disconnection

1. Do not forget to stop the engine before disconnecting the implement.
2. Release any residual pressure in the hydraulic hoses of the machine and tractor by repeatedly moving the control lever to the end positions.
3. Remove any dirt around the quick couplers.
4. Lower the implement on the ground. If the hose is disconnected when the implement is loaded, it will be difficult to reconnect it.
5. Disconnect the quick couplers by pulling them backwards.
6. Cover the quick couplers on the tractor and implement with dust plugs to prevent dirt from entering.



WARNING:

- ***Never connect or disconnect the hydraulic hose of the implement when the pressure is not released or while the engine is running. Otherwise it is difficult to connect or disconnect the quick couplers and hydraulic fluid may splash out of the hoses and get into the eyes or penetrate the skin.***
- ***Stop the engine and wear protective goggles and gloves before assembly / disassembly.***

OPERATION

Mounting Implement

If the PTO is used, remove the safety cover from the PTO shaft.

Adjust the three-point hitch to allow trouble-free attachment of the implement.

1. PTO Cover

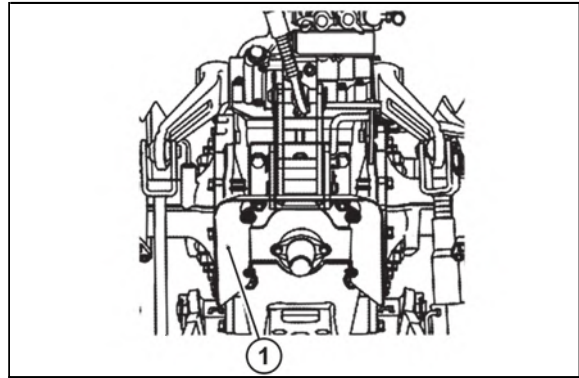

HODP090

Connect the PTO shaft to the tractor and make sure it is secure.

Adjust the three-point hitch and secure the set positions. To disconnect the implement, proceed in the reverse order.



Caution: Do not attach a PTO shaft with the engine running and ensure all safety shields are in place.

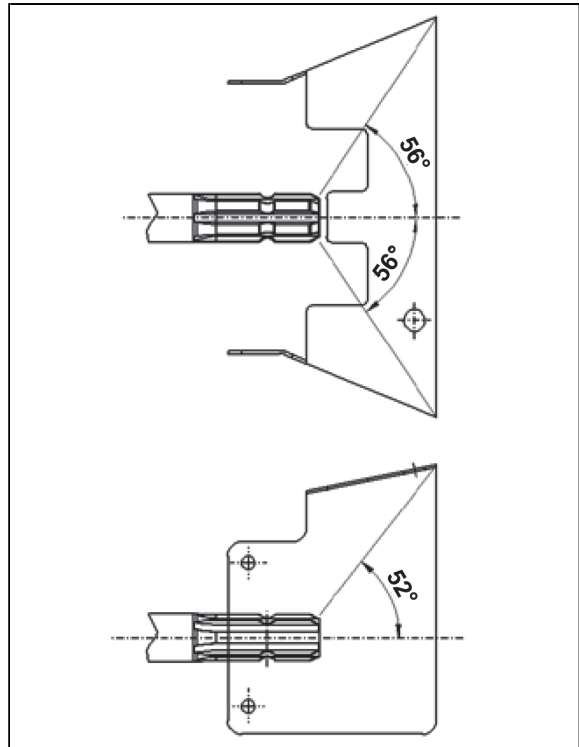

HODP091

OPERATION

Assembly of the Front Loader

For detailed information, see the instructions for assembly and operation of the specific loader.

Fixation Points of Loader

- Screw size: M16 X 2
- Screw strength: 9T
- Number: 20

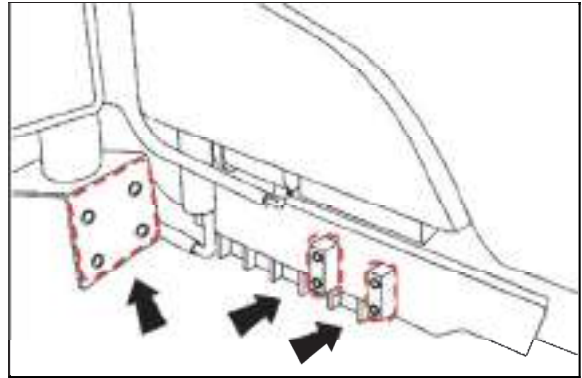

HODP092

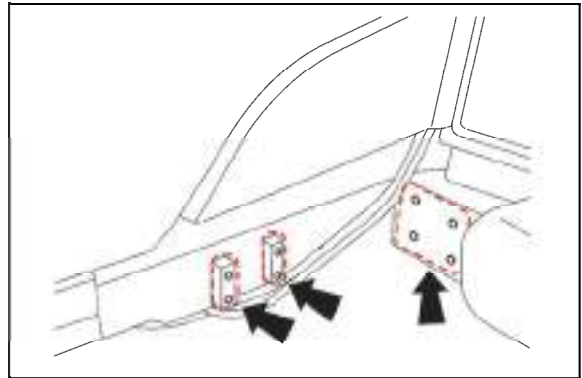

HODP093

OPERATION

Joystick lever

To control the front loader and the front three-point hitch, the joystick lever is used.

It allows to control the lifting, lowering and unloading of the front loader with one lever.

To lift the front loader: Pull the lever backwards.

To lower the front loader: Push the lever forwards.

To roll back the adapter: Push the lever to the left.

To dump (unload) the adapter: Push the lever to the right.

To control the third loader function, the button located on the joystick head is used.

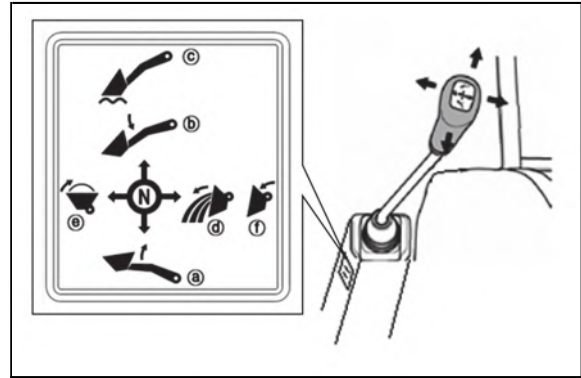

U18N038

1. Lifting of the front loader boom
2. Lowering of the front loader boom
3. Rolling the front loader adapter back
4. Dumping the front loader adapter

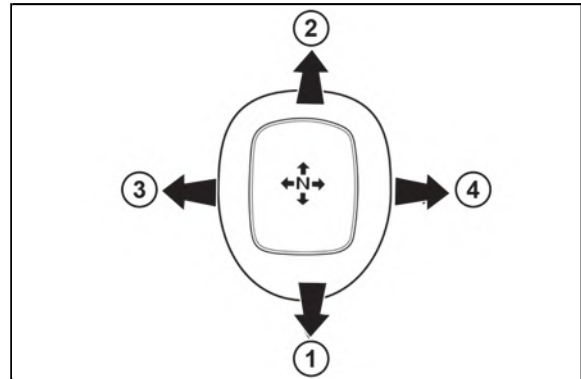

UCL 18N035

NOTE: The joystick can also be used for other applications if the front loader is not attached. 3rd function of the loader is controlled by the button on the joystick head.

Safety implement for joystick lever

- 1 - Lock
- 2 - Unlock

This simple **Safety** locking system can lock the joystick by pushing the Button and unlocked by pulling.

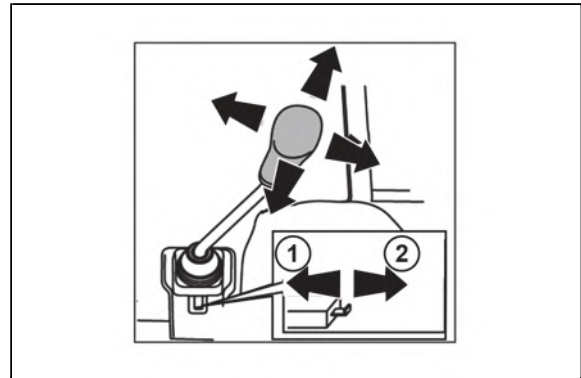

U18N040



Warning:

Hydraulic fluid escaping under pressure can have enough force to penetrate the skin.

Hydraulic fluid may also infect a minor cut or opening in the skin.

If injured by escaping fluid. See a doctor at once.

Serious infection or reaction can result if medical treatment is not given immediately. Make sure all connections are tight and that hoses and lines are in good condition before applying pressure to the system.

Release all pressure before disconnecting the lines or performing other work on the hydraulic system.

To find a leak under pressure use a small piece of cardboard or wood. Never use hands.

Front Fenders

The front fenders can be fitted to the tractor as an option. It may be compulsory to fit them with regard to the relevant country's regulatory requirements.

MAINTENANCE

Checks and Service

General Information

This section provides detailed information about the service procedures necessary to maintain trouble-free operation of the machine. Specific values for individual tasks can be found in the attached table.

Service inspections

Service inspections are performed as follows:

The first service inspection at the state of the engine hour counter of 50 EH maximum, but not later than 6 months after commissioning of the tractor. The second service inspection after covering another 450 EH (at the state of the engine hour counter of 500 EH maximum) but not later than 12 months after the first service inspection. Next service inspections always after covering another 500 EH but not later than 12 months after the previous service inspection. The service inspections are a part of tractor maintenance. The services authorized by Zetor will provide professional performance of service inspections according to the manufacturer's instructions.

Pre-Start Checks

To avoid problems it is recommended that a range of checks be carried out daily before starting the tractor.

Checking Engine Coolant

Inspection

Check that the coolant level in the tank is between MAX and MIN levels. If not sufficient, top up coolant.

1. Expansion Vessel Cap

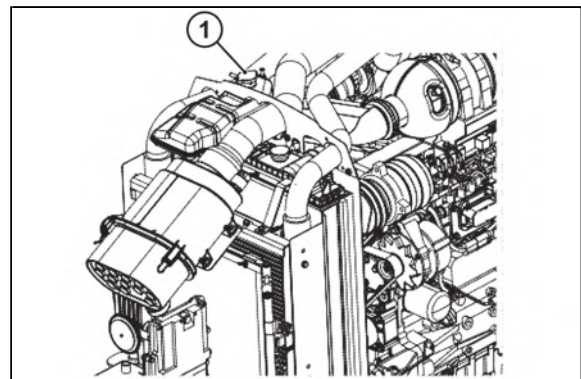

HODP094



Warning: Do not open the cap when the engine is hot. Otherwise, hot steam can burn you seriously. Wait until the engine is sufficiently cooled down.

If corrosion is evident in the coolant, completely drain the system and fill with a new mixture of water and antifreeze or corrosion inhibitor.

1. Drain Tap

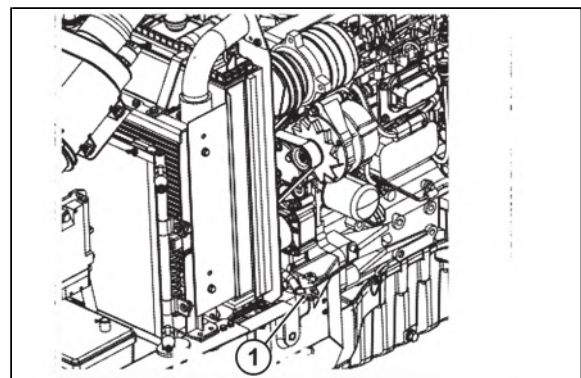

HODP095

MAINTENANCE

Engine Oil

Remove the dipstick, wipe it and immerse in the oil pan. Make sure the oil level is between the upper and lower mark, near the upper mark. If the oil level is not as specified, top up with the specified oil.

1. Minimum Level
2. Maximum Level

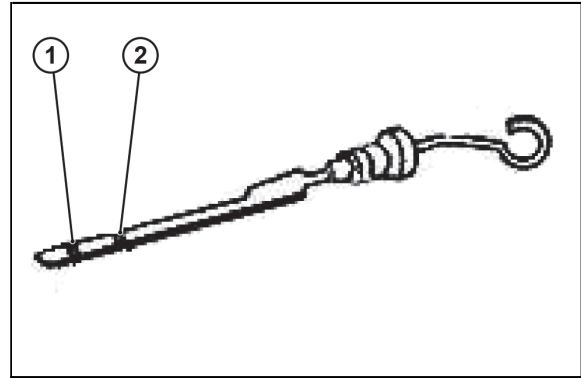

HODP096

1. Engine Oil Filler

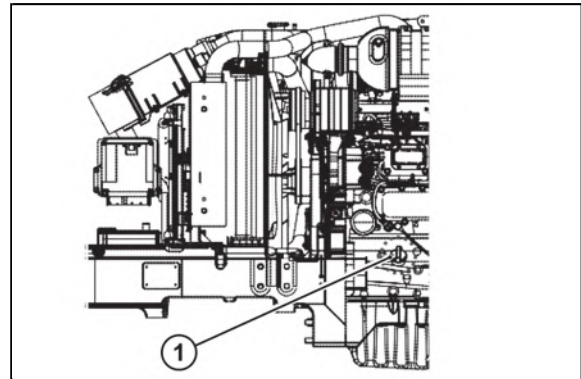

HODP097

- 1 - Engine oil gauge
- 2 - Engine oil drain plug

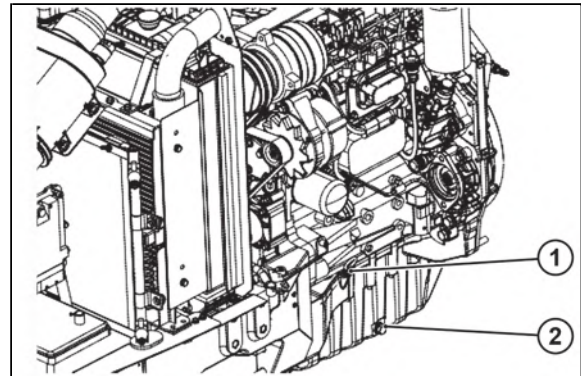

HODP098

Important: Do not overfill the crankcase with oil.

MAINTENANCE

Transmission Oil

Check the level using the dipstick at the top of the transaxle at the rear of the tractor.

If the level is too low, add oil to the specified level.

1. Maximum Level
2. Minimum Level

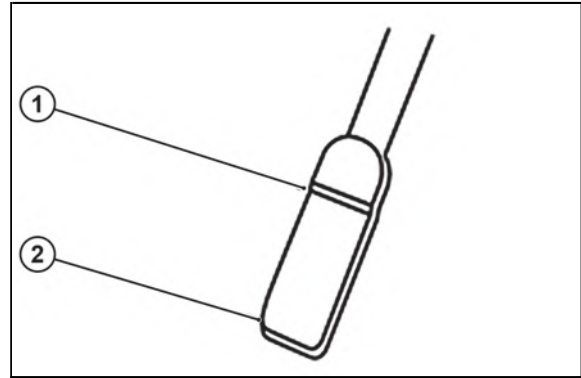

HODP099

1. Filler

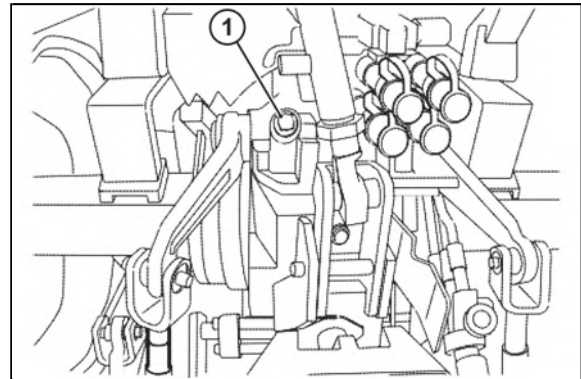

HODP100

1. Sight Gauge

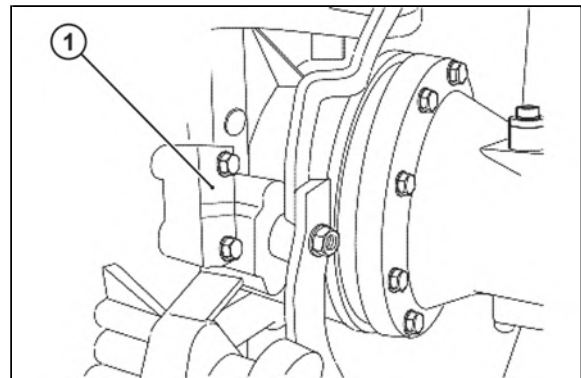

HODP101

- 1 - Drain plug

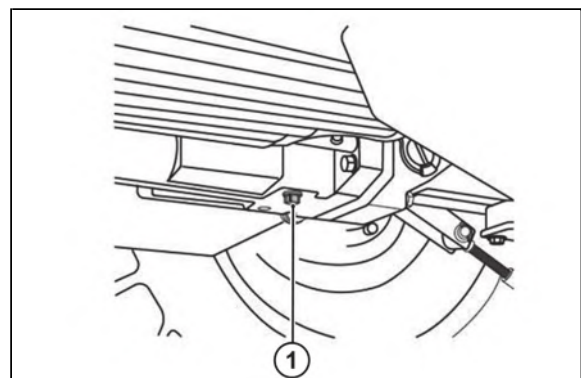

HODP102



Caution: Always ensure that you use the correct oil for topping up or oil changes.

MAINTENANCE

Fuel

Use the fuel gauge to check the fuel level and top up if too low.

It is a good practice to refill the tank immediately after use to avoid condensation.

- 1 - Fuel tank cap

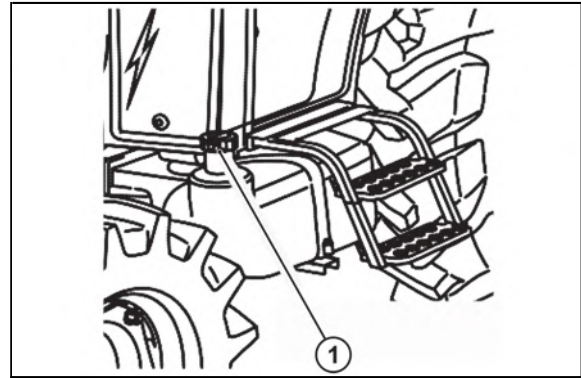

HODP103

Tire Pressure

Tire pressure has a direct impact on tire life and its off-road characteristics.

Make sure that the tire pressure is correct and in accordance with the table in the Tractor Maintenance chapter.

Check the tire pressure visually before using the tractor, see the enclosed picture.

1. Over-inflated Tire
2. Correct Inflation
3. Under-inflated Tire

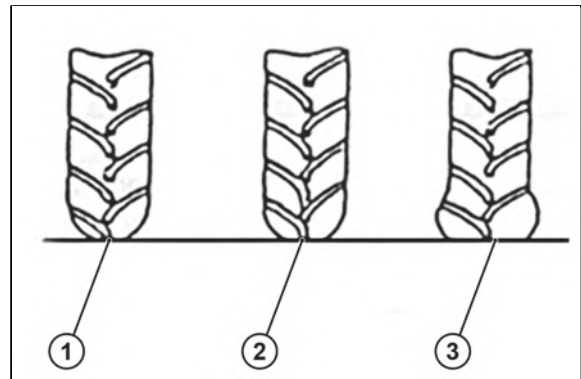

HODP104



IMPORTANT: *We recommend to check the tire pressure with a pressure gauge and not rely solely on a visual tire pressure check.*



Danger: *Excess tire pressure can cause accidents!*

Steering

Make sure that the steering wheel does not have excessive play (max. 50 mm sector perimeter).

Brake

Make sure the left and right brakes are correctly adjusted so that they can work with the same performance. The correct brake pedal play is 1.18 ~ 1.57 in. (30~40 mm).

Clutch

Ensure that the clutch is adjusted correctly.

Correct free play on the clutch pedal is 0.78~1.18 in. (20~30 mm)



Caution: *Incorrect clutch adjustment can cause excessive wear and reduced tractor performance.*

Electrical

Check the operation of all electrical appliances and indicators.

MAINTENANCE

Maintenance and Adjustment Schedule

Periodical Check and Service Table



Caution: *These intervals are for operation under normal conditions and need to be reviewed under severe conditions to a greater frequency.*

O Check, top-up or adjust,

X Replace,

XX First replacement

No.	Item	Daily	Serviceinterval (Hourmeter,Mark)										1 Year	2 Year	
			50	100	150	200	250	300	350	400	450	500			
1	Engineoil &Cartridge	O	xx										x	x	
2	Aircleaner					O							x		
3	Radiatorcoolant	O													x
4	Fuel	O													
5	Fuel filter (A) Main	O											x	x	
6	Fuel filter (B) Pre	O											x	x	
7	Fanbelt	O											O		
8	V-belt	O											O		
9	Battery			O											
10	Loosenuts and bolts	O													
11	Radiatorhose clamp	O													
12	Transmissionoil &car-tridge		xx					O					x	x	

MAINTENANCE

O Check, Top-up or Adjust,
 xx First Replacement
 x Replace, Clean or Wash

No.	Item	Daily	Service interval (Hourmeter, Mark)										1 Year	2 Year
			50	100	150	200	250	300	350	400	450	500		
13	Clutch pedal play	O												
14	State of both brake pedals	O												
15	Operation of each lever	O												
16	Free play of steering wheel	O												
17	Toe-in						O					O		
18	Grease in front wheel hub						O					O		
19	Check the steering wheel joint						O					O		
20	Wheel nut fastening torque	O												
21	Operation of the instrument	O												
22	Adjustment of the throttle pedal						O					O		
23	Grease each nipple	O	O	O	O	O	O	O	O	O	O	O		
24	Oil of the 4WD front axle		xx				O					x	x	
25	Check the electric wiring						O							
26	Hydraulic hoses & pipes						O							

Tire Size and Inflation Pressure

CLASS	DIVISION	SIZE	AIR PRESSURE	MODEL
Tire (Agro - Mitas)	Front	280/85 R20	34 PSI	HORTUS CL65/HS65
	Rear	380/85 R30	23 PSI	

MAINTENANCE

Filling Diagram & Capacity Table

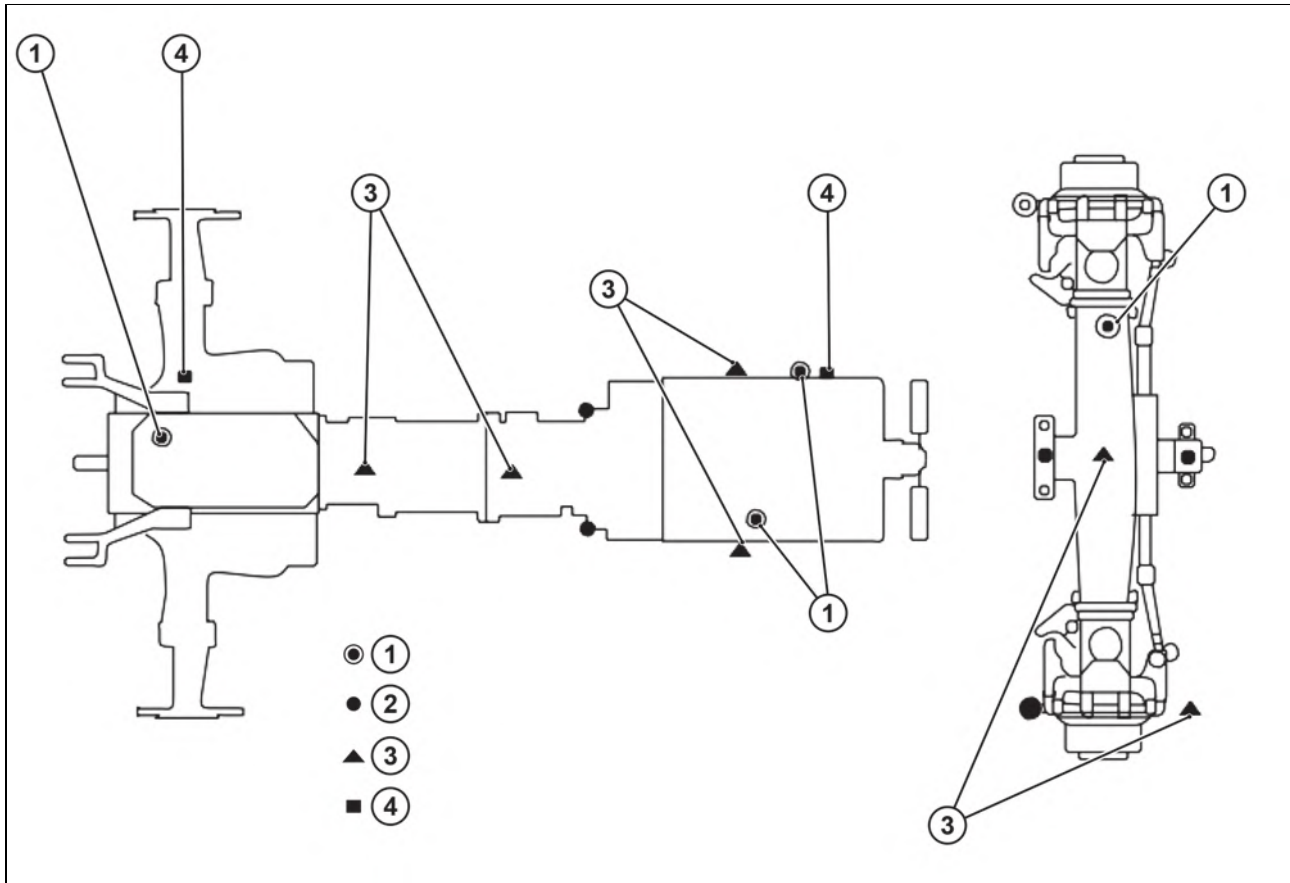

Lubricants

No.	Fillingpoint	Fillings	Quantity Liter(gal.)
1	Radiator	DQC CA-14, DQC CB-14, DQC CC-14 (Fresh clean water)	2.64 US gal (10L)
2	Engine	<ul style="list-style-type: none"> • Deutz quality class DQC III LA DQC IV LA API: CJ-4 grade Recommended SAE viscosity grades <ul style="list-style-type: none"> • A: Viscosity • B: Temperature 	8L
3	Transmission Case	SAE 80W / 90 API GL-4 Grade	11.1 US gal (42L)
4	Front Axle	SAE 80W / 90 API GL-4 Grade	4.33 US gal (16.4L)
5	Final Drive Case (B)	SAE 80W / 90 API GL-4 Grade	
6	Clutch Pedal Shaft	Grease	As required
7	Ball Joint	Grease	As required
8	Fuel Tank	Diesel fuel	18.48 US gal (70L)



The manufacturer does not take responsibility for any damages caused by the usage of service fillings that do not comply with requirements stated in this service manual.

MAINTENANCE

ZETOR service fillings

To maintain best operational characteristics of your tractor, original operational **Zetor** fillings are recommended to be used.

Motor oils

Motor oil **Zetor 10W40 L-SAPS**

Oil to gear systems of tractors

(gearbox with final drive housing, portals of the rear axle)

Oil for gearing mechanisms of tractors **ZETOR EXTRA 10W30 STOU**

Oil for the front driving axle

Oil for the front axle **ZETOR LS 80W**

Opening Method of Hood

With the hood up, the hook release lever can be removed by pulling left.

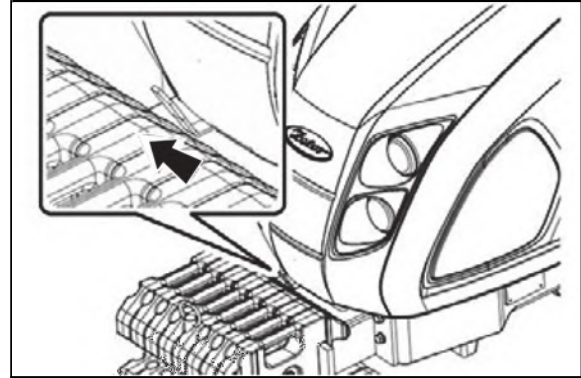

HODP106

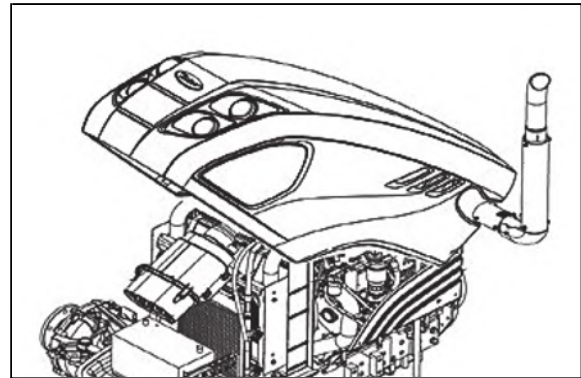

HODP107

MAINTENANCE

Fuel

Use clean diesel fuel only.



IMPORTANT: *The diesel fuel system is susceptible to dirt and water, so minimize the risk of system contamination.*

Bleeding the Fuel System

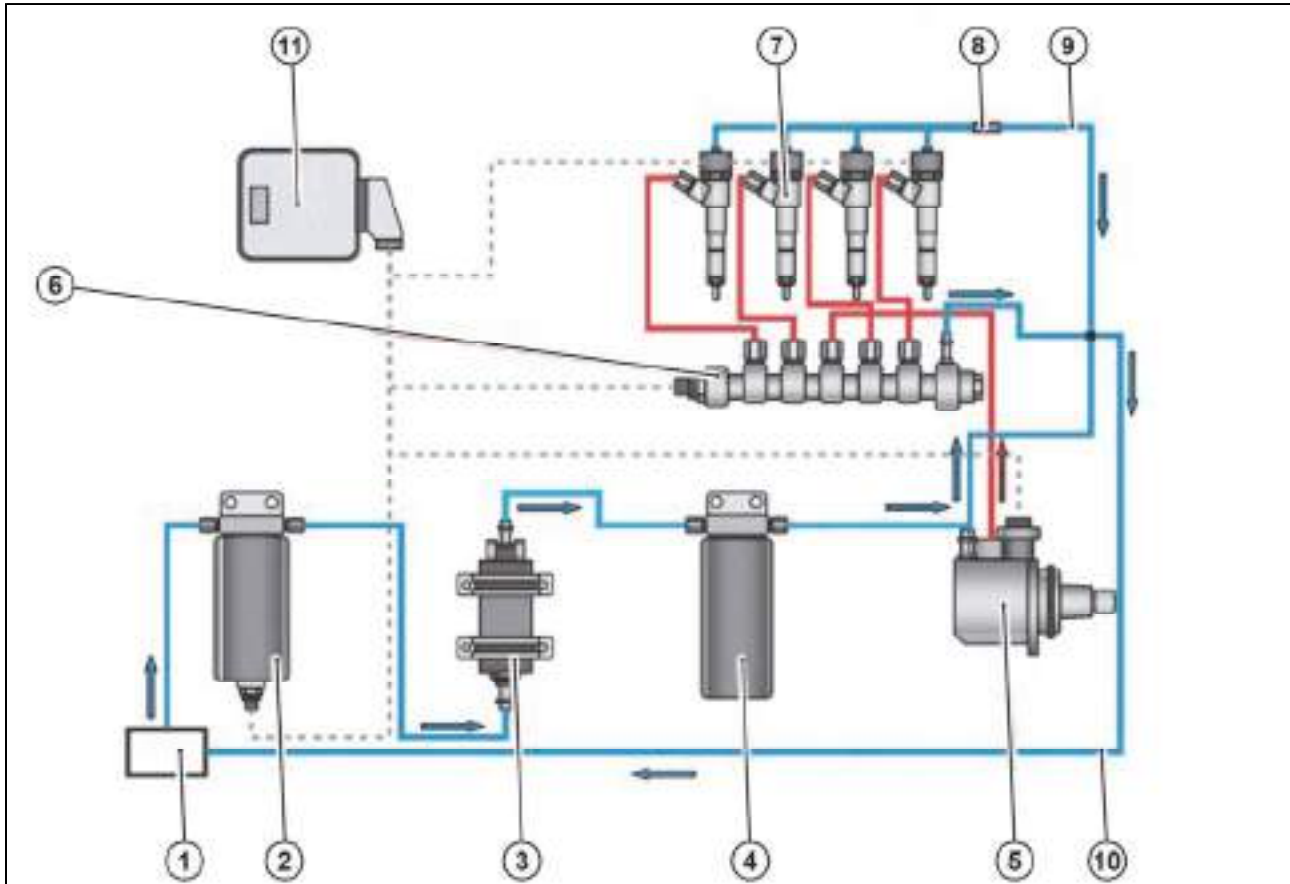

HODP108

- 1 - Fuel Tank
- 2 - Coarse Fuel Filter
- 3 - Supply Fuel Pump (Electrically Powered)
- 4 - Fine Fuel Filter
- 5 - High Pressure Pump with FCU Control Unit (Fuel Control Unit)
- 6 - High Pressure Rail (Rail)
- 7 - Injector
- 8 - Check Valve
- 9 - Return Line
- 10 - Fuel Return to Fuel Tank
- 11 - Engine Control Unit

MAINTENANCE

Changing the Oils in the Tractor

Always use the oil types and classes according to relevant specifications and observe the oil change intervals. (see Tractor Maintenance chapter).

1. Engine Oil Filler

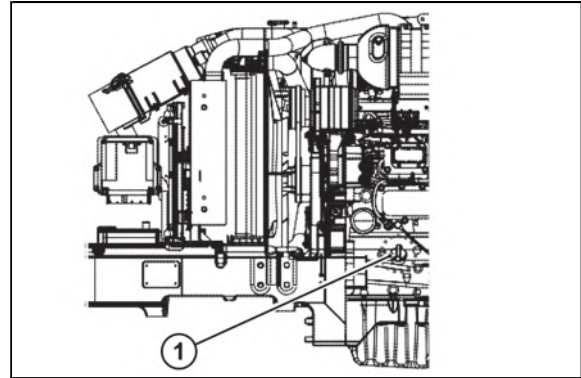

HODP109

1. Engine Oil Dipstick
2. Engine Oil Drain Plug

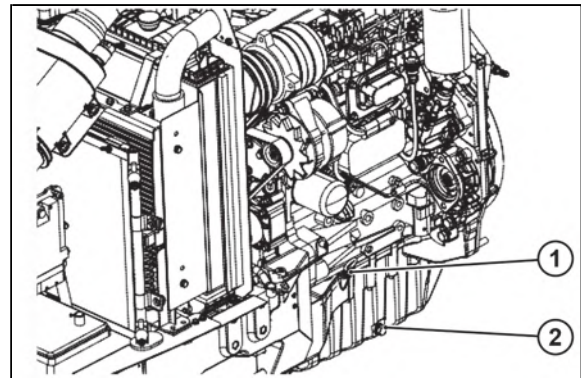

HODP110

Changing Engine Oil

Park tractor on level surface, shutoff engine. Remove sump plug & drain oil.

Replace and check the sump plug and refill the engine with oil to the correct level on the dipstick. (Approx. 2.11 gal)

Important:

- *When changing the oil always change the filter.*
- *Always use the same oil, as using different oils or specifications can cause damage.*
- *Dispose off the old oil as per local regulations.*

Changing the Transmission Oil

- 1 - Drain plug

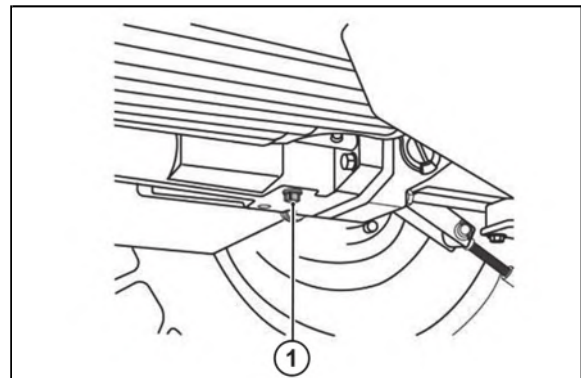

HODP111

MAINTENANCE

1. Maximum Level
2. Minimum Level

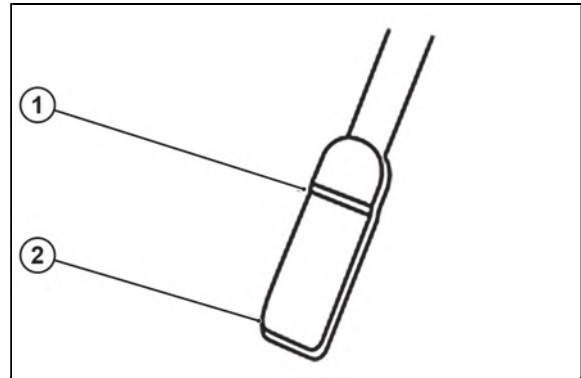

HODP113

Remove the drain plug from the bottom of the transmission and drain the oil.
Check and install the drain plug.
Fill the transmission oil to the correct level according to the dipstick.

- Capacity 18 US gal (68 L)

1. Filler

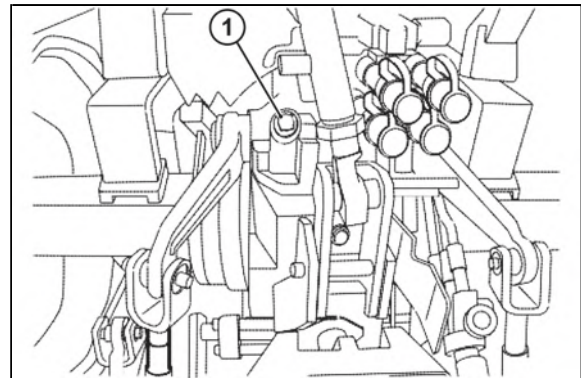

HODP113

1. Sight Gauge

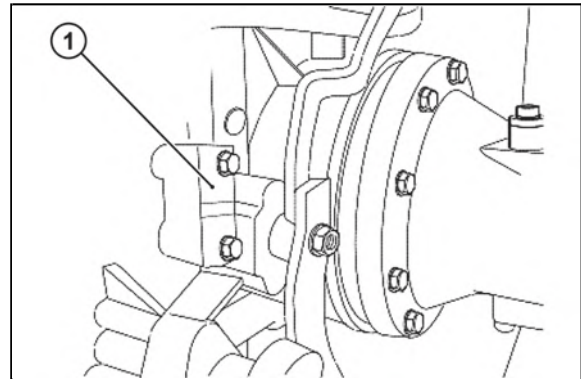

HODP114

IMPORTANT

- ***Always use the same oil grade and specification when changing the oil.***
- ***At the end of its service life, dispose of the oil in accordance with applicable regulations.***

MAINTENANCE

Changing Oil in the Front Axle

1. Maximum Level
2. Minimum Level

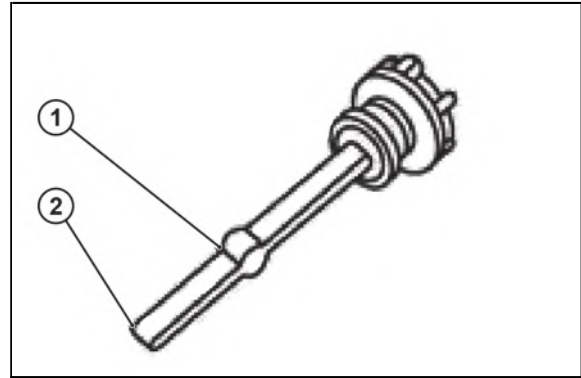

HODP115

Refill the transmission to the correct level on the dipstick with new oil.

- Capacity: 4.3 US gal (16.4L)

1 - Top Plug (Vent Plug)

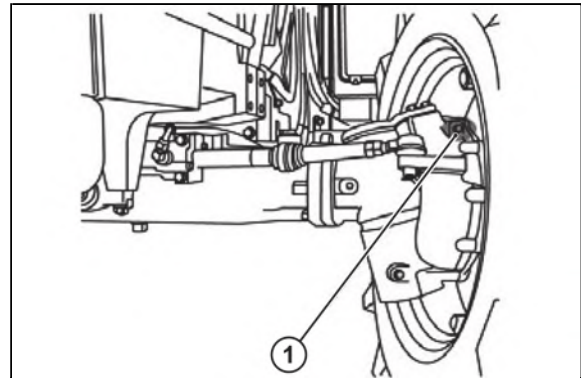

HODP116

1. Oil Dipstick
2. Drain Plug

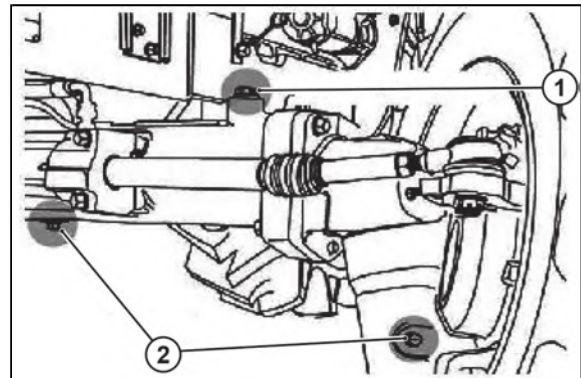

HODP117

IMPORTANT:

- **After refilling the prescribed amount of new oil, the level measured by the dipstick may be higher than permitted - due to incomplete filling of the front-wheel axle drive mechanism - this discrepancy will disappear after being put back into operation.**
- **Unscrew the vent plugs to accelerate the proper pumping of the oil by the front axle drive system.**

MAINTENANCE

Cleaning and Changing Filters

Engine Oil Filter

Using the oil filter wrench to loosen the filter, turn the filter anticlockwise to remove it. Lightly grease the new oil filter sealing to fix it in the correct position and perfect tightness. Turn clockwise until the sealing reaches the base, then rotate another 2/3 turn to tighten it properly.

1. Engine Oil Filter

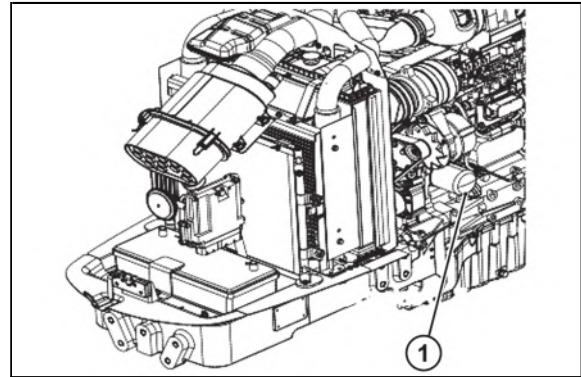

HODP118

Cleaning Oil Water Separator of Fuel Filter

- 1 - Fuel filter
- 2 - Main Fuel filter
- 3 - Pre Fuel filter

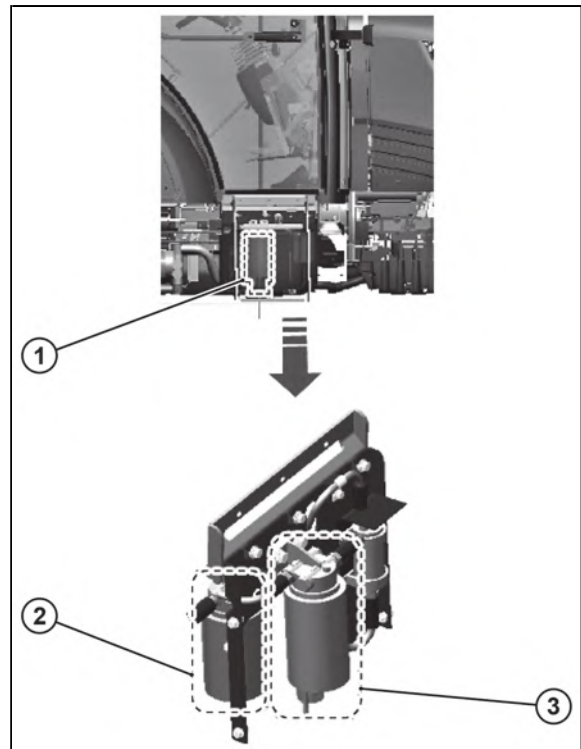

HODP119

Change / Vent Fuel Pre-Filter

1. Fuel Supply to the Pump
2. Venting Screw
3. Electrical Connection of the Water Level Sensor
4. Drain Plug
5. Filter Element
6. Fuel Supply from Fuel Tank

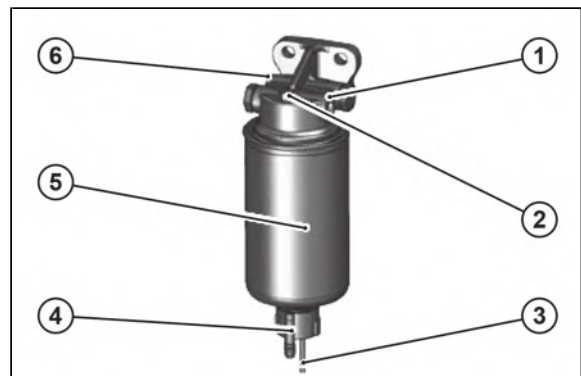

HODP120

MAINTENANCE

Empty Water Tank

- Turn off the engine.
- Place a suitable collection container under the filter.
- Electrical connection - Disconnect the cable connections.
- Loosen the drain plug.
- Drain the liquid until pure diesel fuel comes out.
- Mount the drain plug.
- Tightening torque of 1.6 ± 0.3 Nm
- Electrical connection - Connect the cable connections.

Change the Fuel Pre-Filter Insert

- Turn off the engine.
- Shut off the fuel supply to the engine.
- Place a suitable collection container under the filter.
- Electrical connection - Disconnect the cable connections.
- Remove the drain plug and drain the liquid.
- Remove the filter element.
- Clean any dirt from the sealing surfaces of the new filter element and the opposite side of the filter head.
- Apply a bit of fuel on the filter element sealing surfaces with fuel and screw it back on the filter head clockwise, tightening torque (17-18 Nm).
- Mount the drain plug.
- Tighten the drain plug with a torque of 1.6 ± 0.3 Nm
- Electrical connection - Connect the cable connections.
- Open the fuel supply and vent the system, see venting the fuel system.

Vent the Fuel System

The fuel system is vented through an electric fuel supply pump.

To avoid fuel system error messages, do not start the engine while venting the system.

This process is performed as follows:

- Ignition 'ON' The electronic fuel pump is switched on for 20 seconds to vent the fuel system and generate the desired fuel pressure. Wait until the electric fuel pump has disconnected from the control unit.
- Ignition 'OFF' Repeat this process at least twice until the fuel system has been vented.

MAINTENANCE

Change the Fuel Filter Cartridge



DANGER: *The filter element should never be pre-filled. There is a risk of the fuel system contamination.*

- Remove clamps when twist protection mounted (optional).
- Loosen and unscrew filter with tool (order no.: 0189 9142)
- Catch any escaping fuel.
- Clean the sealing surface of the filter support with a lint-free, clean cloth.



HODP121

- Lightly apply fuel on the sealing of the new original ZETOR filter element.
- Manually screw on the new filter until the sealing gets touches the sealing surface and tighten of: 10 - 12 Nm.
- Fasten clamps of the twist protection (optional).
- Vent the fuel system.

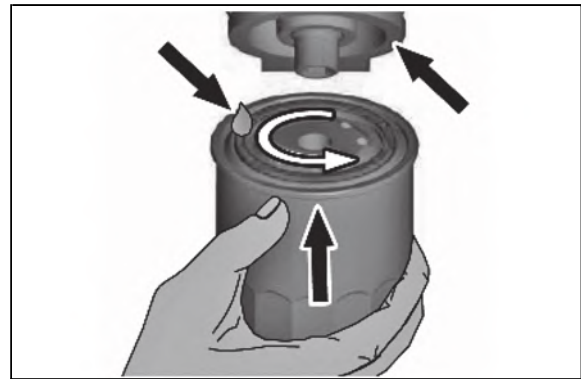

HODP122

Hydraulic Oil Filter and Engine Oil Filter Cartridge

Remove the filter with a wrench or a filter installation aid.

To replace it, apply oil on the sealing, manually place it until the sealing touches the sealing surface, and then rotate it another 2/3 turn to tighten. Check for leaks.

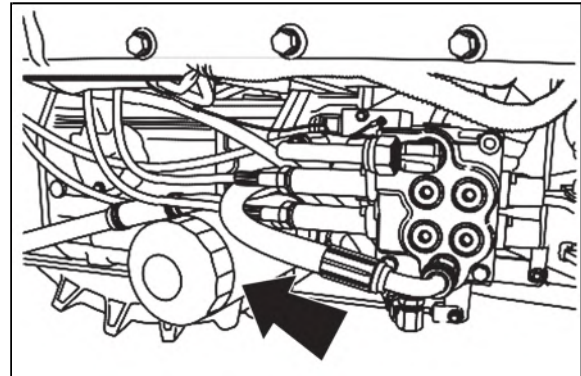

HODP123

1 - Engine oil filter

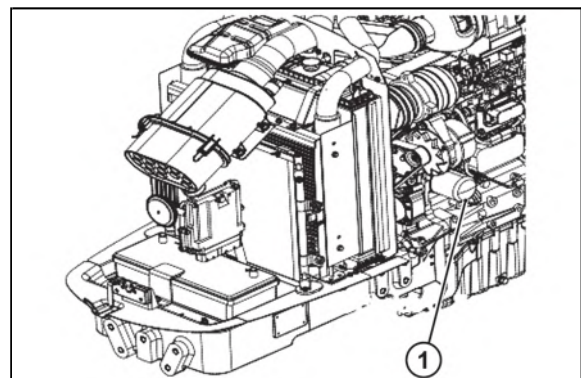

HODP124

MAINTENANCE

Replacing coolant

1. Open the drain tap in front of the engine oil filter to drain the coolant.
2. Open the coolant expansion vessel cap at the same time.
3. For thorough cleaning, rinse the cooling circuit with running water.
4. Close the drain tap and fill the radiator with a mixture of water and a corrosion inhibitor or antifreeze.
5. Start the engine and let it run for about 5 minutes, then check the water level again and add more if necessary.

1. Coolant Expansion Vessel Cap

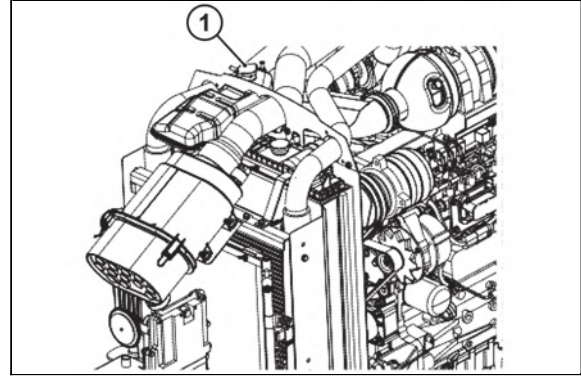

HODP125

1 - Drain Cock

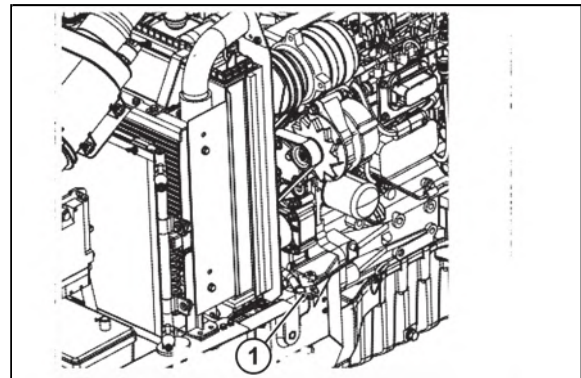

HODP126



Caution:

- **Do not remove the radiator cap on a hot engine.**
- **Allow the engine to cool down and then turn the cap slowly to ensure, that there is no excessive pressure in the radiator.**



Caution:

- **Serious burns, can result from the contents of pressurized, hot radiators.**
- **Allow the engine to cool down completely before opening radiator cap.**

Anti Freeze

Frozen cooling water can damage the engine.

Before replacing the anti freeze solution flush the radiator.

Mix the anti freeze solution in accordance with the instructions applicable to the brand of anti freeze and the locals climate.

Replace the solution in the radiator.

In case of loss of solution due to evaporation or overflow, replace with the original mixture ratio.

MAINTENANCE

Cleaning the Radiator

Insects, grass blades and dust can block the radiator and reduce its efficiency. Remove the radiator cover. Loosen the screw and pull out the cover. Then clean the radiator surface and fins.

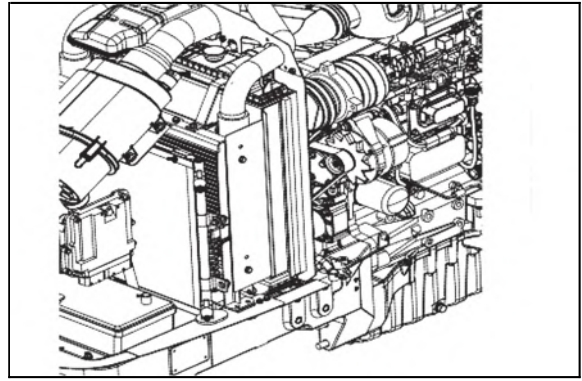

HODP165

IMPORTANT: *Water or air under high pressure can deform the cooling fins and reduce the efficiency of the radiator. Therefore, keep a reasonable distance when cleaning with water or air under high pressure.*

Greasing the Tractor

Grease the tractor according to the service schedule.

Ensure that grease nipples are cleaned well before any attempt is made to grease them.

1 - Lubrication Point

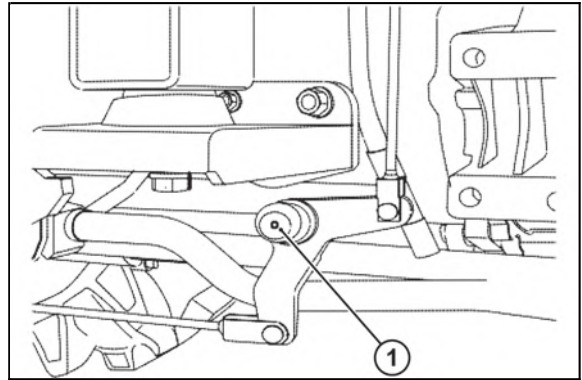

HODP166

1 - Lubrication Point

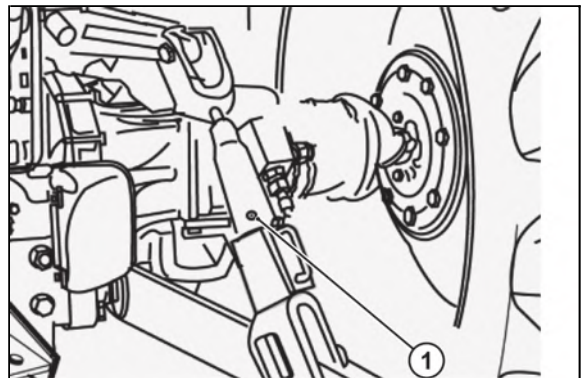

HODP129

1 - Lubrication Point

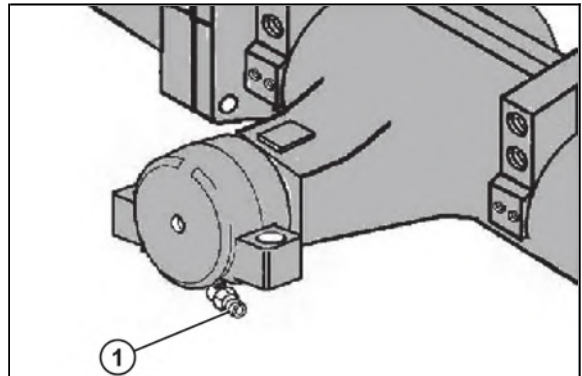

MAINTENANCE

Setting the play of controls

Adjusting the Clutch

Using the clutch over a period of time will increase the free play.

The correct free play of the pedal is 0.78~1.18 in. (20~30 mm).

To adjust, loosen the locknut on the turnbuckle and adjust. Check the adjustment and tighten the locknut if the free play is correct.

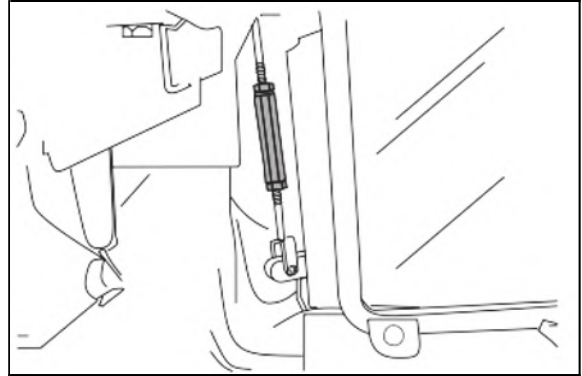

HODP131

Adjusting the Brakes

As is the case with the clutch, use of the brakes will change the pedal free play and the balance between the right and left pedal.

The correct pedal free play is 1.18~ 1.57 in. (30~40 mm).

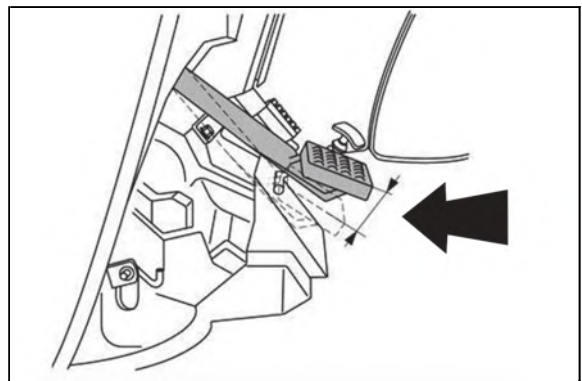

HODP132

Adjustment Method

Loosen the double locknuts to adjust the brake.

Turning it to increases the free play, or decreases it.

Tighten the double locknuts and confirm to fix the Nuts.

Check that the free play is correct and the same on both pedals to ensure even braking.

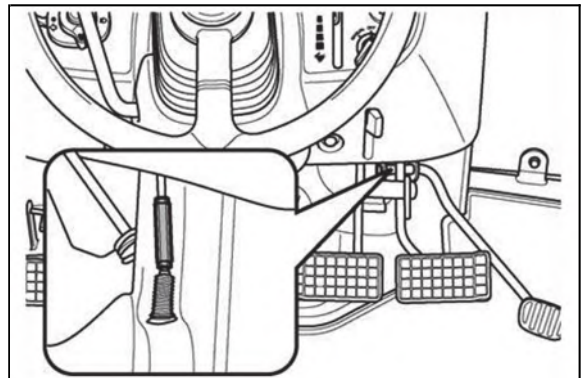

HODP133



Caution:

- **Uneven adjustment of the left and right pedal will result in one sided braking when the pedals are connected and can cause serious accidents, especially at high speeds.**
- **Double check to ensure free play is the same on both pedals.**

MAINTENANCE

Adjusting the Throttle Leve

If the hand throttle lever is loose or does not move properly, contact an authorized service center to solve the problem.

Adjusting Toe-in

If the convergence is set incorrectly, it can cause severe vibration of both the steering wheel and the tractor. The correct free play is 2 ~ 6 mm (0.08 ~ 0.24 in.). We recommend that this setting is carried out by an authorized service.

Battery Maintenance

Checking the Battery

To the battery there is an inspection charging indicator.

- GREEN: Good condition
- BLACK: Charging necessary
- WHITE: Replace battery

1 - Indicator

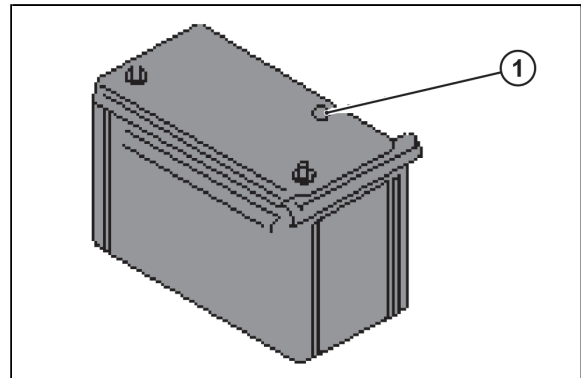

HODP134



Caution:

- ***Electrolyte contains acid and can cause serious burns.***
- ***Any spillage on skin should be washed off by running water immediately.***

Battery Maintenance

Low temperatures will affect the performance of batteries so take particular care of it in winter.

For longterm storage of the tractor remove the battery and keep it in a cool dry room.

If it is on the tractor while stored, disconnect the negative terminal.

Batteries will self discharge if left for a period of without use time.

To keep them in good condition charge them once a month in summer and every second month in winter.

When replacing the original battery, ensure that the replacement battery is the same size.

Failure to do so can cause problems with the electrical circuit.

MAINTENANCE

Battery Charging

A boost charge is only for emergencies. It will partially charge the battery at a high rate and in a short time.

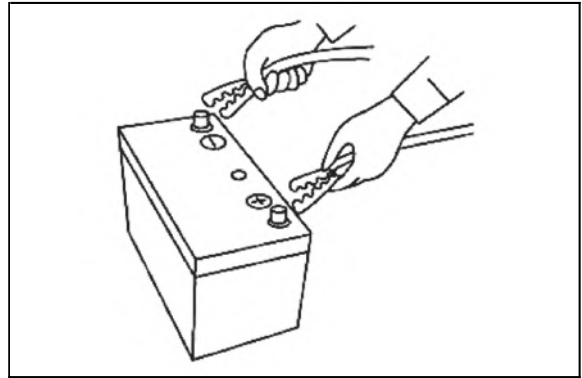

HODP135

When using the battery boost charge, it should be fully recharged as soon as possible. Failure to do so will shorten the service life of the battery.

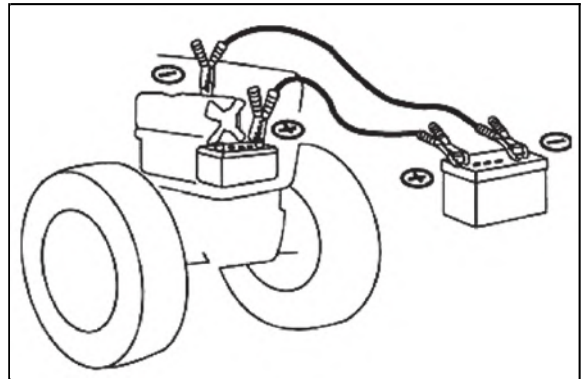

HODP136



Caution:

- ***Always disconnect the negative terminal first when removing the battery and always connect the positive terminal first when fitting the battery.***
- ***When connecting the battery leads make sure not to reverse the polarity.***
- ***Quick charging will reduce battery life.***
- ***Disconnect the terminals prior to charging the battery to avoid damage to the circuit and electrical instruments.***

MAINTENANCE

Battery Disconnect

The function of the battery disconnection switch is to disconnect the supply voltage from the electrical system by interrupting the connection to the battery. The main benefits of this solution are:

1. Short circuit protection of the electrical system;
2. Reduction of the battery spontaneous discharge, especially when the machine is shutdown for a long time;
3. Maintenance and repair work in safe conditions.

Turn the knob to "OFF" to disconnect the battery and back to "ON" to resume normal operation. The battery disconnect knob 1 is located on a bracket to the right of the battery. Putting the battery disconnect in safety condition The battery disconnect knob may be removed for safety purposes in the manner described below.

1 - Knob

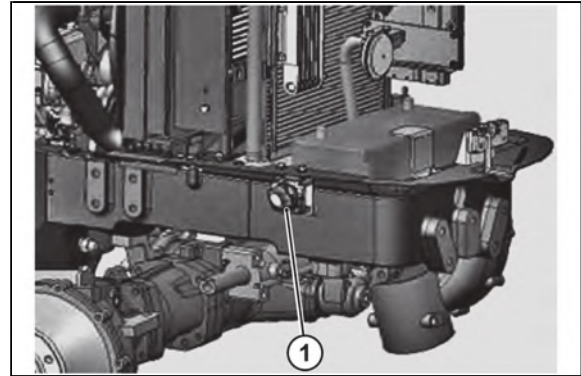

HODP137

Removal of the knob

1. Turn the knob to the "off" position; the knob cannot be removed in this position.
2. Press the knob in and continue to turn it counter-clockwise as far as it will go.
3. Remove the knob.

1 - Knob

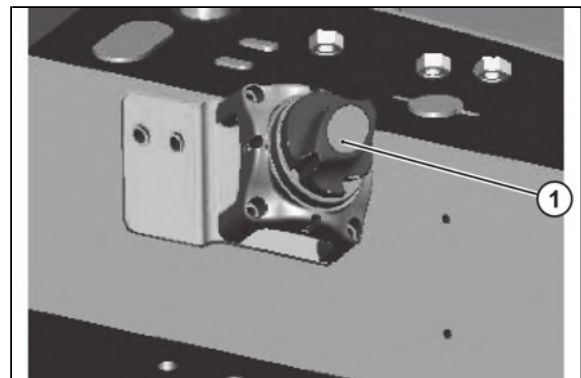

HODP138

Refitting the knob

1. Refit the knob
2. Press and turn the knob clockwise, positioning it at 45°

MAINTENANCE

Other Maintenance

Checking the Belt Drive



CAUTION:

- **Perform any maintenance only when the engine is at a standstill.**
- **After repair work: Check that all covers have been correctly installed and all tools have been removed from the engine.**

- Check the entire drive belt for damage.
- Replace the defective part.
- Reinstall the protective elements.
- Pay attention to the correct installation of the new belt, after 15 minutes of operation, check its correct tension.

If the machine is additionally equipped with a compressor for the trailer air brakes, it is necessary to regularly check its belt drive.

Replace V-rib Belt

- 1 - Tension pulley
- 2 - Retaining pin
- 3 - Assembly bore

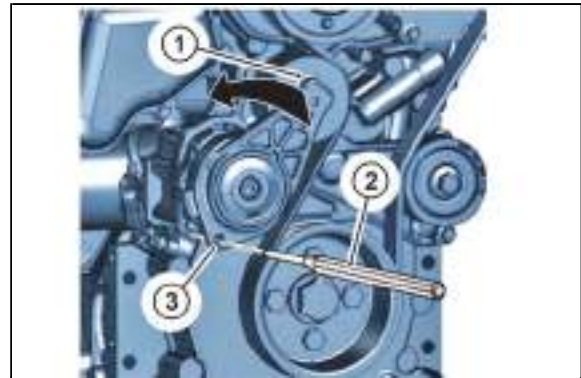

HODP139

- Press tensioning roller with socket wrench in the direction of the arrow until a retaining pin can be fixed in the assembly bore. The V-ribbed belt is now tension free.
- First pull the V-ribbed belt off the smallest roller or off the tensioning roller.
- Mount new V-ribbed belt.
- Retain tensioning pulley using the pin wrench and remove the holding pin.
- Tension V-ribbed belt using the tensioning roller and socket wrench. Check whether the V-ribbed belt is correctly in its guide.

Check and Clean the Air Cleaner According to the Following Instructions

- 1 - Filter Body
- 2 - Fine Filter
- 3 - Air Filter Element
- 4 - Ventilation

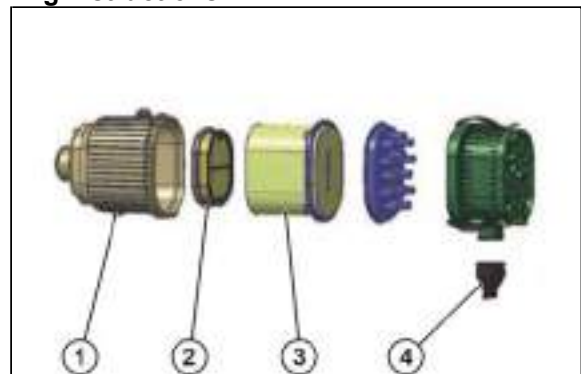

HODP140

MAINTENANCE

Cautions for inspection and service of air cleaner

- (1) Use the specified filter replacement parts.
- (2) Thoroughly remove dust from the cover.
- (3) Mount it firmly so that dust cannot enter under the cover.
- (4) Never drive with the element and the fine filter removed.
- (5) Replace the air cleaner filter and filter element according to their replacement plan or when the indicator light comes on, whichever comes first.

Note:

- Do not shake the element to clean it, use compressed air. Blow the filter element upstream of the engine. Be careful not to tear the filter element by air pressure.
- Make sure to install the element firmly.
- Tighten all parts of the air filter thoroughly to prevent dust and dirt from entering.

Replace the element after cleaning it 5 times or it is damaged.

Checking Hoses and Lines

The fuel lines, radiator hoses, hydraulic and rubber hoses are consumables, which deteriorate by age and use. Check them regularly and replace if faulty.



CAUTION:

- ***Damaged fuel lines leak and may cause fire.***
- ***Damaged radiator hoses can cause hot water burns and, in severe cases, damage the engine.***

Checking the Wiring Harness and Fuses

Loose wires make inferior connections and damaged wires can cause short circuits, fires burnt wiring or reduce efficiency of components.

Replace or repair any faulty wiring or insulation.

If a fuse burns out again after it has been replaced, do not replace it with wire or a high capacity fuse, find the cause and rectify it or get an auto electrician to do so.

Where insulation is chafed or peeled off, recover the area with a good quality insulation tape. Where wiring comes out of it's fitting replace it correctly with the standard fitting.

IMPORTANT

- ***Incorrect wiring or fuses can cause fire to both the tractor and the surrounding area, so have it checked annually by an authorized service.***
- ***Proceed similarly for fuel lines.***
- ***Ask an authorized service center to check them at least every 2 years and replace as necessary.***

MAINTENANCE

Replacing Fuses

- 1 - Normal condition
- 2 - Blown

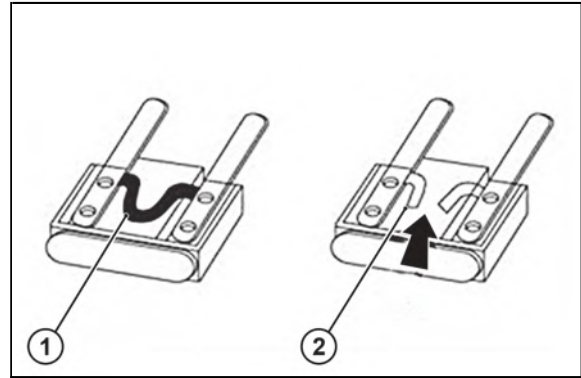

HODP141

The circuit has 8 blade type fuses in its wiring circuit. When a fuse has blown replace it with one of the same value. Using a large capacity fuse or wire burn out the wiring system. Use fuse tongs to replace fuses.

Main Fuses

The wiring harness is equipped with three main fuses to protect electrical devices. However, when the main fuse blows, the whole circuit does not work. Always check the reason and repair it before replacing the fuse for the fuse of the same value. To indicated the blown fuse, it will be discolored.

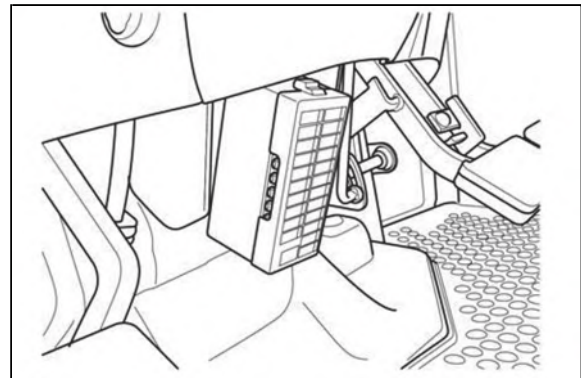

HODP142

Important:

- **Always check the reason for a blown fuse otherwise the new fuse is also likely to blow. Never ever use wire in place of correct grade fuse.**

MAINTENANCE

Position of the Fuse

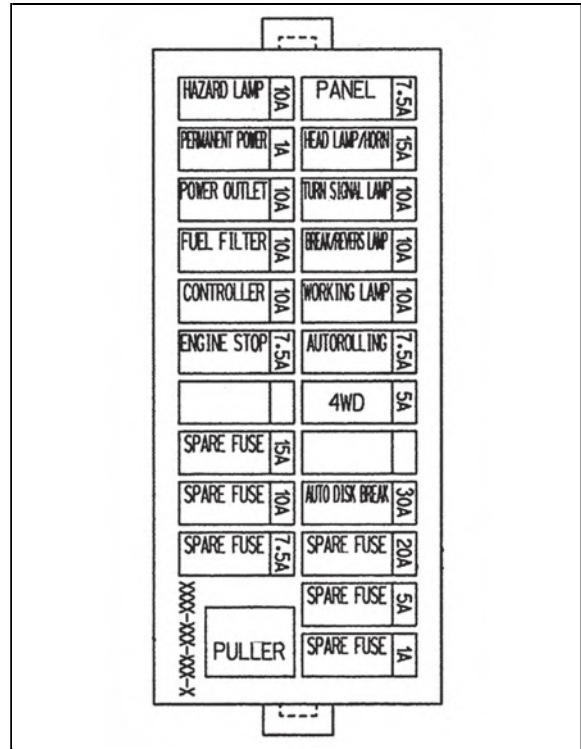

HODP163

MAINTENANCE

Wiring Diagram of the Electric Instrument

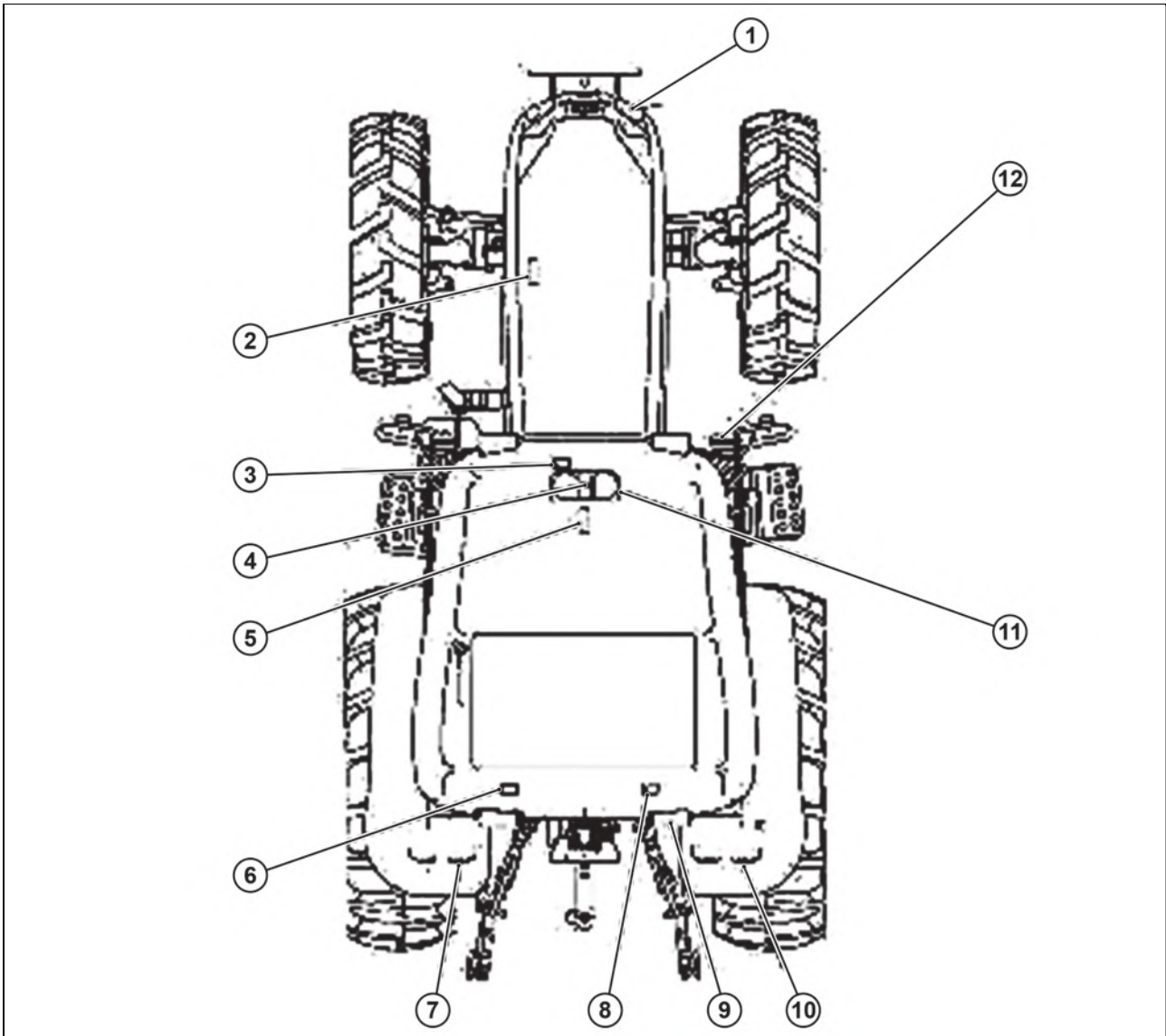

HODP166

1. Headlight (12V 55 W)
2. Fuse
3. Turn Signal Lights Relay
4. PTO Indicator Light
5. Fuse Box
6. Power Supply Fuse for Maximum Ampere Value
7. Rear Headlight (12V 21 W)
8. Trailer Coupling
9. Work Light (12V 35 W)
10. Turn Signal Lights (12V 21 W), Rear Brake Light (12V 21.5 W)
11. Instrument Panel Backlight (12V 3.4 W)
12. Turn Signal Lights (12V 21 W), Side Light (21V 5 W)

MAINTENANCE

Service Prior to Daily and Short Terms Storage

Wash the tractor and keep it clean.

Refuel the fuel tank to avoid condensation in the tank and corrosion of the fuel system.

Lower the attached implement to the ground before parking the tractor.

For Daily or Short Term Storage

Clean the tractor and remove all dirt.

Refuel the fuel tank to avoid condensation in the tank and corrosion of the fuel system.

Lower the power tool to the ground.

Park the tractor in a dry area with roof, if this is not possible we recommend covering the tractor with a solid material such as foil or tarpaulin. In very cold conditions, it is advisable to remove the battery and keep it in a warm environment to ensure functional starting. If the outside temperature is less than 32 °F (0 °C), replace the coolant completely or drain the coolant circuit to protect the engine from damage with frozen coolant.



IMPORTANT:

- ***When washing the tractor, make sure that water does not enter the tractor's electrical system or fuel and lubrication system.***
- ***To prevent short circuits remove the ignition key.***
- ***Do not wash the tractor when the engine is running.***

Long-term Storage

When the tractor will not be used for a long time perform the cleaning as for short term storage.

Drain and replace the oil. Start the engine for approx. 5 minutes to refill the engine with new oil.

Drain the coolant from the radiator and remove the ignition key.

Attach the 'NO COOLANT' sign to both the key and the steering wheel.

Lubricate all lubrication points on the tractor.

Check the tire pressures if necessary to overinflate slightly due to the machine being stationary for a long time.

Lower all attached implements on the ground or disconnect the unit if necessary.

Disconnect the clutch using the clutch release arm.

Place a wooden support under each tire to preserve its characteristics.

Refuel the fuel tank to avoid condensation in the tank and corrosion of the fuel system.



Important:

- ***After refilling the engine with the coolant run the engine for approx. 5-10 min. at 1,500-2,000 rpm every month as a corrosion prevention measure.***
- ***Either removes the battery or the negative terminal as mouse damage to wiring can cause short circuits and fires.***
- ***Remove the ignition key and store in a safe place.***

Re-use After Long Term Storage

Carry out a full check of all oils and coolant.

Refit the battery and run the engine at idle for 30 min. to ensure optimum engine life.

MAINTENANCE

Fuel Saving Tips

In order to save fuel and ensure maximum oil service life, observe the following:

Air Cleaning System

1. Clean the air cleaner regularly to prevent dust build-up.
2. Every 50 hours and every day in dusty conditions.
 - Clean the air filter element with compressed air.
 - If the rubber sealing is damaged or does not function, replace it with a new one. Check for leaks regularly.
 - Also check the air pipes of the filter, remove any leaks immediately.

Note: If air cleaning system is not properly maintained, it will lead to early wear of piston rings & sleeves. This will lead to problems like loss of engine power, excessive oil consumption fuel consumption.

Engine

1. Do not load the engine to the maximum after starting a cold engine. Observe the coolant temperature gauge to check engine warm-up (this will extend engine service life).
2. If there is excessive black smoke from the exhaust, check the air filter element and the high pressure fuel circuit.
3. Do not run the engine without load for more than 2 minutes. It is better to stop the engine rather than run it idle. This will reduce fuel consumption.

Clutch & Brakes

1. Do not use clutch slip to reduce speed or overcome momentary overload. Always shift to a lower gear.
2. If the tractor is to be parked for an extended period of time, it is recommended to shift the lever into neutral and release the clutch pedal.
3. Do not switch clutch and brake pedals.
4. When driving downhill, reduce engine throttle and use low gear. When decelerating, do not rely solely on the braking effect of the brakes.

Oil System

1. Always use the recommended grade and type of oil.
2. Every day before starting the engine, check the oil level using the dipstick and add fuel to the required level.
3. Regularly replace the engine oil according to the service interval. When replacing the fuel filter, replace the filter sealing at the same time.

Lubricating oils always consist of a base oil and additives adjusting the properties of the resulting lubricant, such as anticorrosive efficiency, acid neutralization, preventing the formation of carbon soot deposits.

Fuel System

1. Always use pure diesel only.
2. It is advisable to refuel the fuel tank after work to avoid water condensation in the tank.
3. If the engine power decreases, replace the filter. Do not change both filters at the same time. Failure to follow these instructions will shorten the service life of the fuel system. Also, it will lead to excessive black smoke and excessive diesel consumption.

Permissible Fuels



If other fuels are used which do not meet the requirements of the operating manual, the warranty will be voided.

MAINTENANCE

Winter Operation with Diesel Fuel

The winter operation of the diesel engine is subject to different demands (filterability) than the operation during other seasons.

Special demands are placed on the cold behaviour (temperature limit value of the filterability) for winter operation. Suitable fuels are available at filling stations in winter.



Important: For engines with common rail injection, the mixing of petroleum and adding of extra low additives is not permissible.

At low ambient temperatures paraffin discharges can lead to blockages in the fuel system and cause operating faults. Below 0 °C ambient temperature use winter diesel (down to -20 °C) (filling stations provide this in good time before the cold season starts).

- Special diesel fuels can be used for arctic climates to -44 °C.

Cooling System

1. Check the fan belt tension regularly. Adjust, if required.
2. Check the coolant level in the radiator fins always clean.
3. Replace the radiator cap with a genuine cap only, if required.
4. Do not remove the thermostat but replace with a new one, if required.
5. Do not change the radiator water often.



Caution: Never operate the engine without coolant, even for a short time!

In liquid-cooled engines, the coolant must be conditioned and monitored, otherwise the engine could be damaged by:

- Corrosion
- Cavitation
- Freezing
- Overheating

MAINTENANCE

Water Quality

The right water quality is important for the coolant correct operation. Clear, clean water within the following analysis values should be used:

Analysisvalues		min	max	ASTM
phvalue		6,5	8,5	D1293
Chlorine (Cl)	[mg/l]	-	100	D512 D4327
Sulphate (SO ₄)	[mg/l]	-	100	D516
Totalhardness (CaCO ₃)	[mmol/l]		3,56	D1126
	[mg/l]		356	
	[°dGH]		20,0	-
	[°e]		25,0	
	[°fH]		35,6	

Water quality specifications are carried out by local water authority bodies. If the water does not meet the above criteria, it must be brought to the required values.

Cooling System Corrosion Protection Agent



Caution: Health damaging nitrous amines form when nitritebased cooling system corrosion protection agents are mixed with amine-based agents!

Note:

- Cooling system corrosion protection agents must be disposed of in an environmentally friendly way.
- Observe the notes on the safety datasheet.

The conditioning of the coolant for liquid-cooled DEUTZ compact engines is performed by mixing an anti-freeze with corrosion protection inhibitors based on ethylene glycol into the water.

The cooling system must be monitored regularly.

This also includes checking the coolant system corrosion protection agent concentration in addition to checking the coolant level.

The cooling system corrosion protection agent concentration can be checked with conventional test instruments (e.g. refractometer).

Cooling system corrosion protection agent percentage	Water percentage	Cold protection up to
min.35 %	65%	-22 °C
40%	60%	-28 °C
45%	55%	-35 °C
min.50 %	50%	-41 °C

CABIN SYSTEM

Major Features

The cab fully complies with international safety and soundproofing standards.
The cab can be provided with ventilation, heating and air conditioning system.
The cab is available in the following versions:

- The cab with ventilation and heating system
- The cab with ventilation, heating systems and air conditioning.



CAUTION:

- **The cab is fully compliant with international standards regarding its soundproofing.**
- **Be very careful when working in small spaces and with specific (noisy) implements and protect your hearing by using appropriate protective equipment.**

- 1 - Cab Filter
- 2 - Work Lights (Rear)
- 3 - Rear Wiper
- 4 - Rear Window Handle

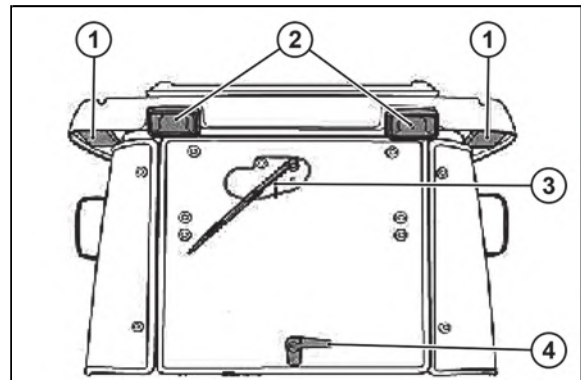

HODP144

- 1 - Rearview Mirror
- 2 - Work Lights (Front)
- 3 - Front Wiper
- 4 - Roof Hatch

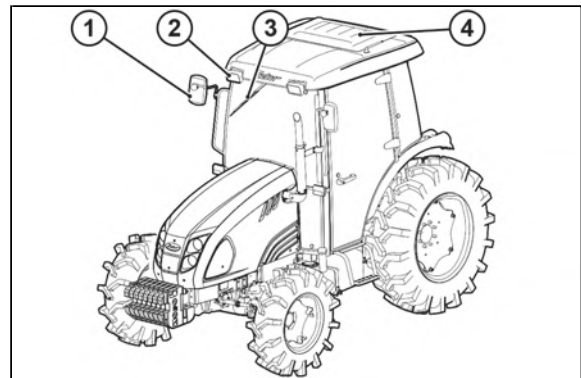

HODP143



Caution: *When transporting heavy loads (Exceeding the weight of the tractor) reduce the speed under 15 Km/h (9.32 m/h).*



ATTENTION: *Remember that steering, braking and operating performances are influenced by tractor load and attached implements (mounted / semi-mounted machines, trailers and semi-trailers).*



ATTENTION: *Each connected implement / equipment must be correctly attached and secured according to the operating instructions.*



ATTENTION: *Be very careful when attaching or removing implements. Make sure the supports and struts are in the correct positions and secured before disconnecting the machine.*

CABIN SYSTEM

Instrument and Related Parts

Doors

The doors are provided with key locks.
To open from the outside, when unlocked, depress the push button.
To open from inside, push the lever downwards.

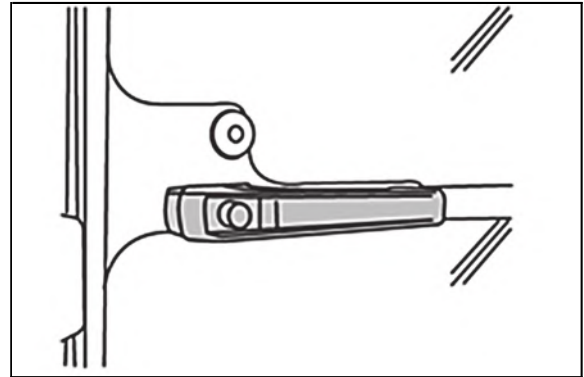

HODP146

Rear Window

The rear window is fitted with central handle for opening.
When opened it is held in place by two dampers.

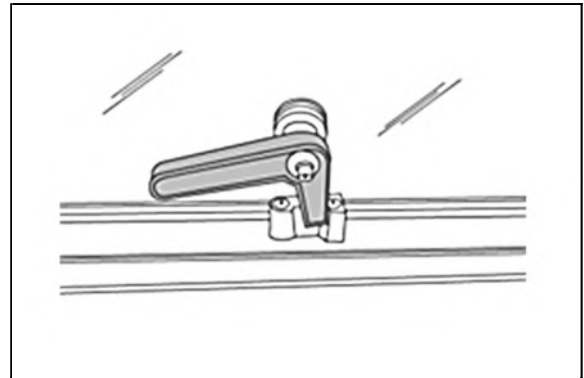

HODP147

Side Window

The side window is fitted with central handle for opening.
When opened it is held in place by holder.

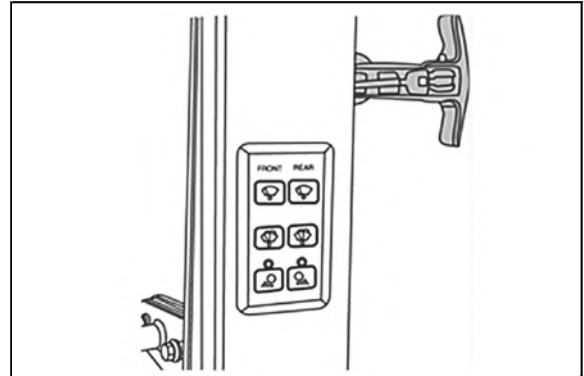

HODP148

Roof Hatch (if equipped)

Ventilation-push the latch towards the front of the tractor and then push the hatch up.
Emergency Exit-Push firmly upwards to release the support struts from the lower retainer clips.

1 - Roof hatch

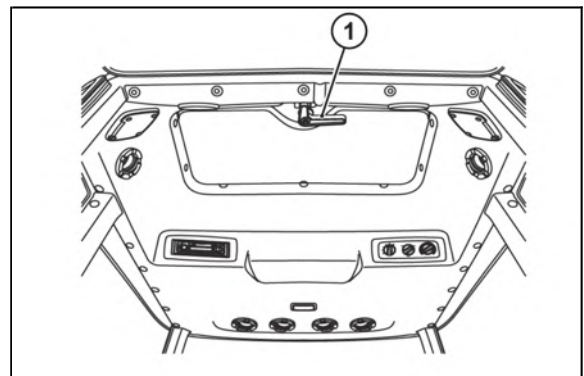

CABIN SYSTEM

Working Lamps (Front and Rear)

The working lamps are located on the cab roof (Two in the front and two in the rear). They are switched on by means of the special switches on the roof console.

1 - Working Lamp

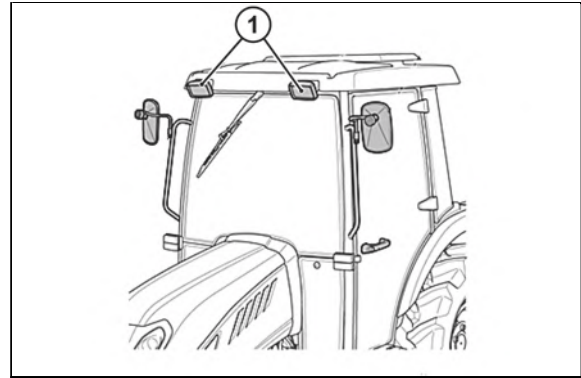

HODP149

1 - Working Lamp

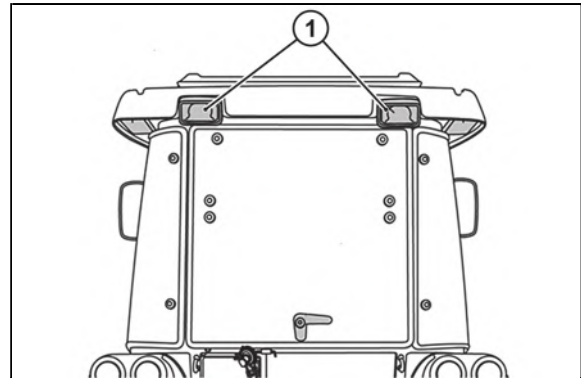

HODP150

Rearview Mirrors

The cab is provided with rearview mirrors on both sides. They can be adjusted and folded, whenever necessary, to avoid interference with external obstacles.

The mirrors have a telescopic arm to allow positioning for maximum convenience by the user.

Remember that mirrors must always be positioned in compliance with road traffic regulations when driving on a public highway.

Cab Ceiling

The ceiling is padded with insulation material to prevent heat radiation enter the cab and keep the temperature down when working in very sunny areas.

The cab floor is covered with a fixed carpet.

It is recommended to keep the floor clean for the operator to enter and exit the tractor safely.

CABIN SYSTEM

How to Control Cabin

Interior Devices

- 1 - Roof Hatch
- 2 - Air Recirculation
- 3 - Radio
- 4 - Rotary Vents
- 5 - Interior Lights
- 6 - Air Conditioning and Heating Control

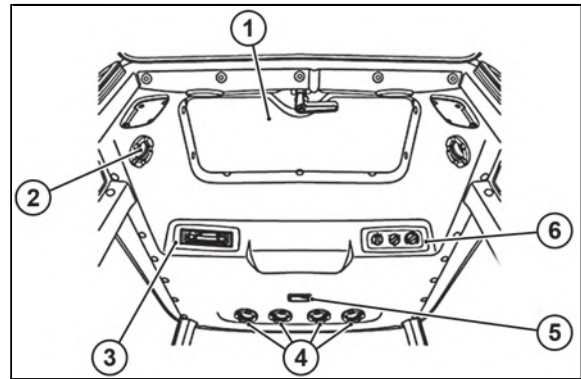

HODP151

Switches on the right cab column

- 1 - Wiper Switches
- 2 - Windscreen Washer Switches
- 3 - Work Light Switches

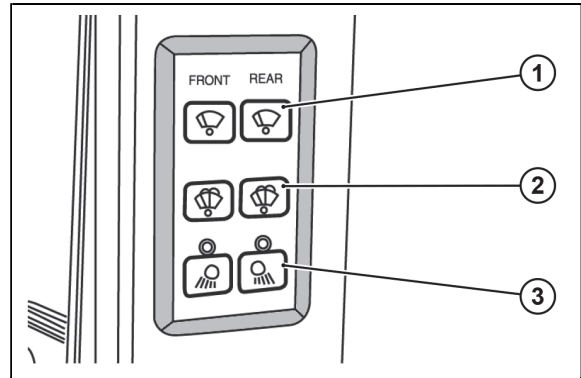

HODP152

Work Light Switches

The front and rear work lights come on when the corresponding button is pressed. The indicator light indicates that the relevant light is on.

Wiper Control Switch

On Switch

- Wind screen wiper operation.
- Continuous pushing button operates wiper and washer pump.

Off Switch

- Wind screen wiper "Off" and operates washer pump.

Windscreen Washer Tank

Check the level of windscreen washer fluid in the plastic reservoir located on the rear side of tractor. During winter it is advisable to add a suitable antifreeze or methyl alcohol to the windscreen washer fluid.

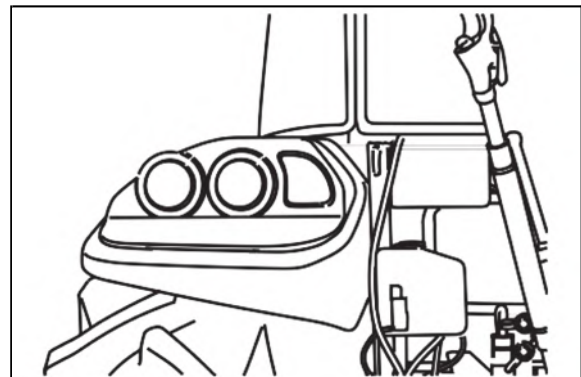

CABIN SYSTEM

Interior Lamp

Push the button to light on and push it again to light off.

1 - Interior Lamp

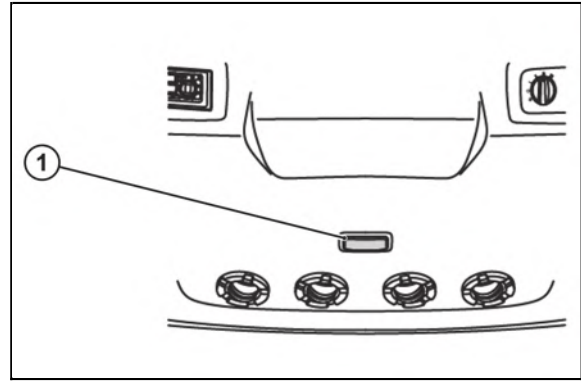

HODP152

Blower Control Switch

Three position rocker switch.

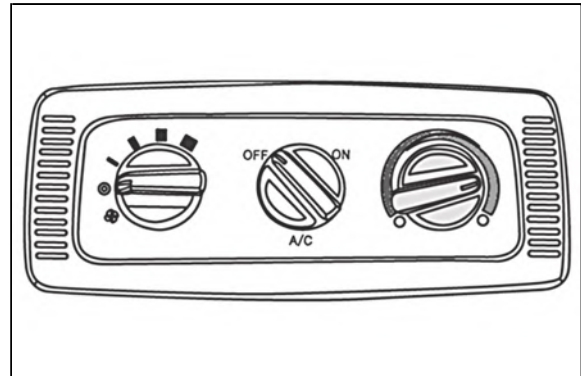

HODP155

Temperature Control

Set temperature control as required, fully clockwise.
For maximum cool and fully counterclockwise for heat.



HODP154

Air Control Switch

The fan must be turned on to operate the air conditioner. The fan speed control and all air vents must be adjusted to achieve the best possible interior cooling performance.

Under normal operating conditions and with doors and windows closed, the cab temperature is reduced by 6 °C to 15 °C (10 °F to 25 °F) compared to outside temperature. When operating the air conditioning system, the air humidity level of the cab interior is reduced.

Note:

- During cold weather, with ambient temperature above 32 °F (0 °C) operate the air conditioner at least once per month, for a period of 10 to 15 minutes. This will lubricate the seals to prevent them becoming brittle and help prevent the loss of refrigerant from the system.
- The system is equipped with an environmentally safe refrigerant, R134a. Never recharge the air conditioning system with refrigerant other than R134a as this will result in loss of cooling and permanent damage to all air conditioning components.

CABIN SYSTEM

Ventilation

The ventilation unit is housed in the cab ceiling.

To switch it on and adjust it, turn the electrical fan switch to the desired speed.

The cab becomes slightly pressurized when the ventilation system is in operation, so that the fresh air can enter only by way of the filter installed in the rear section of the cab roof.

The fan switch can be operated only after the ignition key is inserted.

The air flow can be regulated and directed by suitable positioning the air diffusers.

Air can be taken in fresh from outside or recirculated from within the cab by way of the relative side inlets.

External Circulation

The air is supplied from outside the cab through the rear grille and filtered through a cab filter located behind the grille.

*N.B: It is very important that the air diffusers never be completely closed so as to allow for a steady air flow. To obtain a greater pressurization inside the cab, it is necessary to take the air from the outside, therefore the inside air recirculating grille should be fully closed.

Circulation Diffuser

To recirculate the cab air, open the recirculated air inlets on the side of the cab ceiling.

1 - Rotary Vents

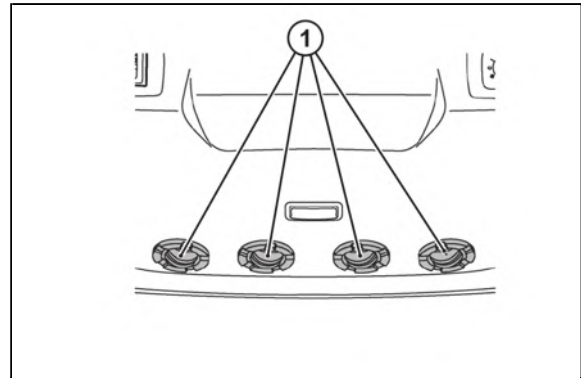

HODP157

CABIN SYSTEM

Heating System

The heating is switched on and set by rotating the control knob in the roof console, turning on the fan and setting the selector to the desired speed.

Warm the cab up quickly, the knob should be rotated fully clockwise and the blower set to speed 3.

The screen is demisted or defrosted by air directed through a slot vent. For defrost or fast demist, all other vents should be closed off.



Important:

- **Ventilation is provided by a single blower unit serving both the heating system and the air conditioning system.**
- **After reaching the desired temperature adjust the system to suit your needs.**

1. Fan
2. Electric Heater
3. Cab Filter
4. Recirculation Inlet
5. Rotary Air Vent

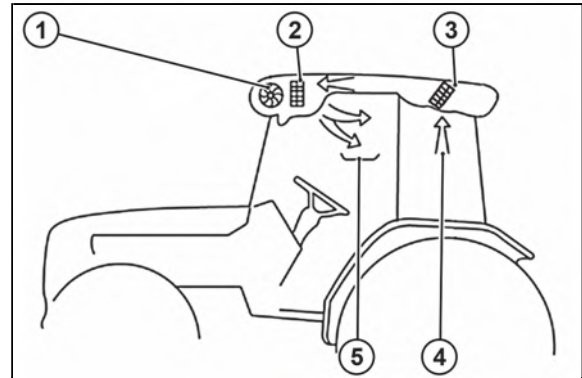

HODP158

Note: For ideal system operation, the engine must run at 1,000 rpm.



WARNING:

- **Before starting the engine, make sure that the system is off (by turning the fan off) to avoid overloading the battery.**
- **After long operation of the system at full power, never switch it off suddenly, but let it run for about 20 seconds lightly loaded, switch off the heating and let the system cool down.**

Heating System Configuration

The heating system consists of two units: 1. Heating and fan installed behind the roof console.

2. Power supplying set consisting of an air conditioning compressor located in front of the engine and driven by a belt directly connected to the engine pulley. If the air flow does not immediately start flowing from the diffusers when the system is activated, switch off the tractor immediately and determine the cause of the fault.

*N.B: Never turn on the heating system when working in dusty environments.

CABIN SYSTEM

Air-conditioning System

The system is designed to provide optimum temperature inside the cab, maximum operator's comfort and safety.

Any repairs and servicing of the system should be carried out in an authorized service center.

Do not approach the system with open flames, as any escape from the circuit may produce explosive gas.

1. Alternator
2. Air Conditioning Compressor
3. Fresh Air Fan
4. Electric Heater
5. Evaporator
6. Cab Filter
7. Condenser
- 8/9. Air Vent
10. Air Recirculation Flap

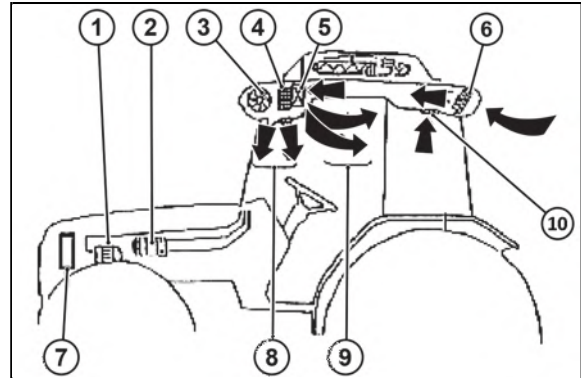

HODP159

Cab Filter

The paper filter element is not suitable for the treatment of pesticides and must therefore be replaced with an activated carbon filter. Once the treatment of pesticides has been completed, the activated carbon filter must be replaced by a paper filter suitable for normal operation.

- 1 - Cab Filter

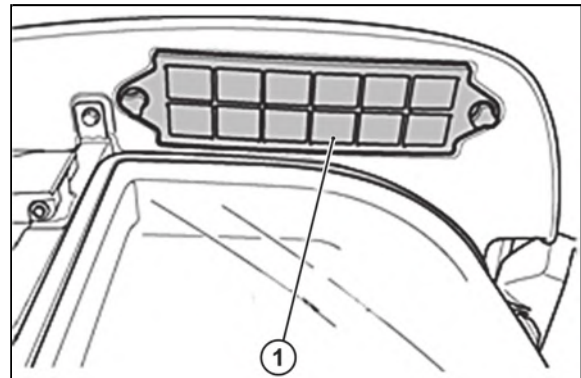

HODP161



Warning: Cab air filters remove dust in the air, but are not capable of removing chemicals used in spraying crops or in weed control. Many chemicals used for these purposes are toxic when improperly used and can be hazardous to operators and others in the area. Follow the instructions of manufacturers of both the equipment and the chemicals regarding prohibition of dust or spray, personal hygiene practices, and other precautions noted by the manufacturers.

CABIN SYSTEM

Radio, CD Player (If Equipped)

For operation refer to the Radio, CD player manufacturers instructions.

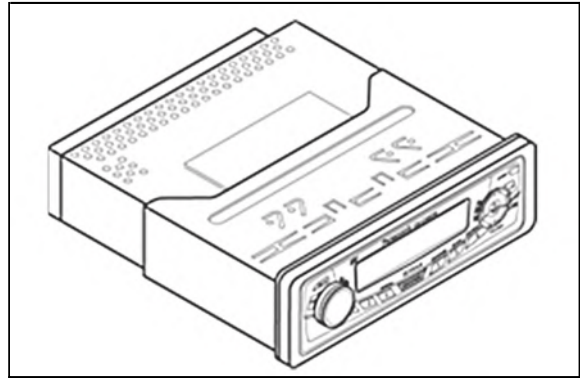

HODP162

Ash Tray

Located at right side of near side window in cabin.

- 1 - Cigarette Lighter
- 2 - Ash Tray
- 3 - Cup Holder

Cup Holder

It serves for storing drinks and small objects.

Cigarette Lighter

Press it to turn it on. Press again to turn off.

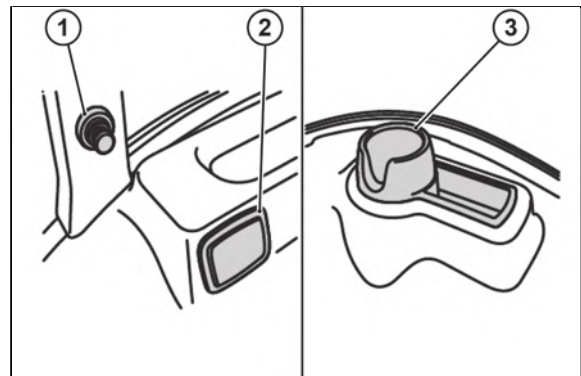

HODP163

CABIN SYSTEM

Checking the Air Conditioning System

1. Environment-friendly refrigerant: R134a (0.7 ~ 0.85 kg)

The presence of air and water in the system could jeopardize its efficiency.

- The air is uselessly compressed by the compressor and no cooling effect is produced.
- The moisture has a tendency rise to obstructions which prevent the cooling efficiency.

2. Check belt tension; when finger pressure is applied to the mid-point between both pulleys.

3. Condenser fins must always be duly clean using water or an air set.

Checking the Air Conditioning System Charge

1. Check the refrigerant charge.

- Run the engine at 1,500 rpm.
- Set the air conditioning system in the coldest for 5 minutes.
- Check the sight glass clear or cloud.



Caution:

- ***If the air-con. is operated with not charged.***
- ***The lubrication in the compressor can cause the damage.***

2. Check the refrigerant with receive drier sight glass.

CABIN SYSTEM

Diagnosing Malfunctions

1. Tracing Faults

	PROBLEM	CONDITION	CAUSE	CORRECTIVE MEASURE
1. Compressor	Abnormal sound	Inlet sound	Insufficient lubrication	Replenish
			Outlet sound	Insufficient belt tension
		Released holder		Tighten connections
		Clutch failure	Check	
	Abnormal revolutions	Drive interruption	Damaged parts	Check, replace
			Clutch slipping	Check, replace
			Lack of lubricant	Replenish
			Belt tension released	Adjust
	Refrigerant or oil leakage	Refrigerant or oil leakage	Damaged sealing	Replace
			Head screw is loosened	Tighten the screws
			D-ring damaged	Replace
	Abnormal pressure	Too low / high pressure	Insufficient cooling	Adjust
			Compressor	Replace
2. Engine	Low pressure or not working	Normal engine operation	Air inlet is blocked	Remove
			Evaporator freezing	Minimum pressure control
			Fan switch damaged	Replace the switch
			Compressor	Replace
		Abnormal motor operation	Engine failure	Replace
		Broken wire	Replace	
	Air leak	Tube leak	Check, tighten	
	Fan cannot be operated	Engine	Switch failure	Check, tighten
Abnormal motor operation		Engine failure	Replace	

	PROBLEM	CONDITION	CAUSE	CORRECTIVE MEASURE
3. Clutch	Noise	Regular / irregular noise	Interference with pulley	Check the position of the compressor
	Disengaged	Engaged sometimes	Wire defect	Check the wire
		Engaged by pushing by hand	Large clutch gap	Adjust
			Low voltage	Check the battery
	Without a faulty conductor	Defect	Replace	
	Slipping	Slipping during rotation	Low voltage	Check the battery
			Greasy bar on clutch	Clean
Defect			Replace	

CABIN SYSTEM

2. Check of the air conditioning with a pressure gauge.

To connect with manifold pressure gauge can find the cause of air conditioning system. Because manifold pressure gauge is various sensibly. (Ambient Temp. is based on 30~35 °C)



Caution: Operating E/G RPM 1500~2000 is must, and so to that you can check the correct cause and air conditioning. (In case below the figure of indicated pressure gauge has some clearance, confirm with approximate indicated needle data.)

3. gauge pressure conversion

- $\text{lb/in}^2 = \text{PSI}$
- $1 \text{ kgf/cm}^2 = 14.22 \text{ lb/in}^2$ (Ex) $200 \text{ PSI} = 14 \text{ kgf/cm}^2$

SPECIFICATION

Technical data

Major Specifications

Model		HORTUS CL65	HORTUS HS65
Engine	Manufacturer	Deutz	Deutz
	Model	TCD2.9L4	TCD2.9L4
	Type	CRDI, vertical, water-cooled, 4-cycle, diesel	CRDI, vertical, water-cooled, 4-cycle, diesel
	Number of cylinders	4	4
	Total displacement, cm ³	2,925	2,925
	Nominal power kW (PS)	50.0 (67.9) @ 2,200 rpm	50.0 (67.9) @ 2,200 rpm
	Rated speed (rpm)	2,200 rpm	2,200 rpm
	Maximum torque Nm @ rpm	272 @ 1600 rpm	272 @ 1600 rpm
Electrical System	Battery	12V 110AH	12V 110AH
	Alternator	12V 95A	12V 95A
Drivetrain	Transmission	Mechanical reversal	Mechanical reversal
	Number of speeds	F24 / R24	F24 / R24
	Brakes	Wet disc	Wet disc
	Steering	Hydrostatic	Hydrostatic
	Clutch	Dry single-disc	Wet multi-disc
Hydraulic System	Pump capacity (Main) L / min	39.1	39.1
	Pump capacity (Power Steering) L / min	22	22
	Number of SCV	2(3)	2(3)
Rear Three-point Hitch	Type	Category II	Category II
	Lift Capacity	Lift Points	1,517
		640 mm behind Lift Points	974
	Lift Control Type	Mechanical - Position / Draft	Mechanical - Position / Draft
Front Three-point Hitch	Type	Category I	Category I
	Lift (mm)	500	500
	Capacity (kg)	1,100	1,100
	Control - SCV Joystick	Mechanical	Mechanical

SPECIFICATION

Model		HORTUS CL65	HORTUS HS65
PTO	Type	Independent	Independent
	Control	Electrohydraulic	Electrohydraulic
	Rear	rpm 540/750/1000	540/750/1000
	Diameter	mm 35 mm, 6 splines	35 mm, 6 splines
Volumes of Liquids	Fuel tank	L 72	72
	Cooling system	L 10	10
	Crankcase with filter	L 8	8
	Transmission and hydraulic system	L 42	42
	Front axle	L 16.4	16.4
Dimensions	Total Length with 3-point Hitch	mm 3,982	3,982
	Overall width	mm 1,840	1,840
	Overall height (without / with beacon)	mm 2,575/2,619	2,575/2,619
	Wheelbase	mm 2,155	2,155
	Min. Ground Clearance (mm)	mm 420	420
	Min. Turning Radius without Brakes	mm 3,930	3,930
Weight with ROPS or Cab		2,615	2,615
Tires	Front	280/85 R20	280/85 R20
	Rear	380/85 R30	380/85 R30

Permitted Towed Vehicle Weight

Unbraked trailers / semi-trailers	1,100 kg
With overrun brake	6,000 kg
With pneumatic brakes	17,000 kg

SPECIFICATION

Traveling Speed

Operating the Lever			Traveling speed	
Creep	Rangeshift	Mainshift	Forward	Reverse
On	L	1	0.39 (0.28)	0.28 (0.20)
		2	0.57 (0.40)	0.42 (0.30)
		3	0.82 (0.58)	0.6 (0.43)
		4	1.09 (0.77)	0.79 (0.56)
	M	1	1.24 (0.88)	0.90 (0.64)
		2	1.82 (1.29)	1.33 (0.94)
		3	2.61 (1.85)	1.9 (1.35)
		4	3.48 (2.47)	2.54 (1.80)
	H	1	3.95 (2.80)	2.88 (2.04)
		2	5.82 (4.13)	4.24 (3.01)
		3	8.35 (5.92)	6.09 (4.32)
		4	11.13 (7.90)	8.12 (5.76)
Off	L	1	1.28 (0.91)	0.94 (0.67)
		2	1.89 (1.34)	1.38 (0.98)
		3	2.71 (1.92)	1.98 (1.40)
		4	3.62 (2.57)	2.64 (1.87)
	M	1	4.1 (2.91)	2.99 (2.12)
		2	6.04 (4.29)	4.41 (3.13)
		3	8.66 (6.14)	6.32 (4.48)
		4	11.55 (8.20)	8.43 (5.98)
	H	1	13.13 (9.32)	9.58 (6.80)
		2	19.33 (13.72)	14.10 (10.00)
		3	27.73 (19.68)	20.23 (14.35)
		4	36.97 (26.23)	26.97 (19.14)

* The specifications are subject to change for improvement without notice.

SPECIFICATION

Noise Levels

The tractor is approved in accordance with the applicable EC Directives.

To avoid increased noise levels proceed as follows:

- After maintenance operations or repairs refit all the sound-deadening panels and materials correctly
- Do not make changes to the tractor that may lead to an increase in noise emissions.
- Beware of any anomalous noise or vibration if you notice anomalous noise or vibration, park the tractor in a safe position and perform the stopping procedure. Inform maintenance personnel of the situation. Avoid prolonged operation.

Reference standards for the measurement of noise levels:

- The maximum driver-perceived noise level, with the engine at normal operating temperature and measured in accordance with the test method described in the European Directive 2009/76EC.

Model	Noise Levels	
	Maximum noise level in CAB with Doors open(Roof hatch and front and rears windows open), db(A)	Maximum noise level in CAB with doors closed, db(A)
HORTUS HS65	81.5	82

- The maximum noise level measured with the tractor in motion and the tractor stationary, measured in accordance with the method described in European directive 2009/63/EC.

Model	Noise Levels	
	Maximum external noise level with tractor moving, db(A)	Maximum external noise level with tractor stationary, db(A)
HORTUS HS65	80	77.5

SPECIFICATION

Vibration Referred to the Operator Position

The value is referred to the amount of mechanical vibration transmitted by the tractor to WHOLE-BODY as defined by UNI ISO2631-1:2008.

Said value must be utilised for assessment of the vibration exposure risk, but it cannot cover all the possible conditions of use of the tractor since it may vary in accordance with parameters that are not always related to the tractor (terrain, implements, etc.). If the risk assessment cannot be considered to be exhaustive or if the risk may exceed the values defined in 2002/44/EC, the use of a vibration meter is prescribed.

The following best practices should be observed to minimize whole-body vibration

- Always use the most appropriate implement for the relevant type of work.
- Adjust the seat to match your weight and seating position.
- Check the cab suspension periodically and replace if damaged.
- Check tire pressure.
- Use the front axle suspension, if fitted.
- During transport, adjust the tractor speed to minimize vibration levels.

The seat vibration values, as obtained from the seat approval in compliance with 78/764/EEC (amended by 1999/57/EC) are shown in the following table.

Input vibration : Category A, Class I and Class II
Ambient temperature: 23 °C

Seat type			Corrected vibration level on seat
WOOCHANG W2100	Light driver	59 kg	1.18 m/s ²
	Heavy driver	98 kg	0.95 m/s ²
Grammer DS 44/1HB	Light driver	59 kg	See EEC certificate: e1-100506
	Heavy driver	98 kg	

NOTES

TROUBLESHOOTING

Engine Troubleshooting

TROUBLE		PROBABLE CAUSE	SOLUTION
ENGINE	Starter does not work	<ul style="list-style-type: none"> ● Clutch pedal released 	<ul style="list-style-type: none"> ● Depress the clutch pedal
		<ul style="list-style-type: none"> ● PTO switch set to ON position ● Defective safety switch ● Dead battery ● Loose contact ● Defective switch ● Defective starter 	<ul style="list-style-type: none"> ● Set the PTO switch to the OFF position ● Have it repaired by an authorized service ● Charge the battery ● Check for loose contacts and corrosion. Clean, tighten ● Have it repaired by an authorized service ● Have it repaired by an authorized service
	Low starter speed	<ul style="list-style-type: none"> ● Low battery ● Poor grounding ● Incorrect engine oil viscosity 	<ul style="list-style-type: none"> ● Charge the battery ● Clean and tighten the contacts ● Replace with engine oil of the correct viscosity
	The starter works, but the engine does not start	<ul style="list-style-type: none"> ● Air in the fuel system ● Clogged fuel filter ● No fuel supply ● Defective engine ● Defective key switch 	<ul style="list-style-type: none"> ● Bleed the system ● Clean or replace the filter ● Open the fuel tap ● Have it repaired by an authorized service ● Have it repaired by an authorized service
	Irregular engine operation	<ul style="list-style-type: none"> ● Air in the fuel system ● Clogged fuel filter 	<ul style="list-style-type: none"> ● Bleed the system ● Clean or replace the filter

TROUBLESHOOTING

TROUBLE		PROBABLE CAUSE	SOLUTION
Engine	Irregular engine operation	<ul style="list-style-type: none"> • Clogged injection nozzle 	<ul style="list-style-type: none"> • Have it repaired by an authorized service
		<ul style="list-style-type: none"> • Fuel system leaks 	<ul style="list-style-type: none"> • Tighten the connections, replace the pipe and sealing washers
		<ul style="list-style-type: none"> • Fuel injection malfunction 	<ul style="list-style-type: none"> • Have it repaired by an authorized service
	Engine stops at low rpm	<ul style="list-style-type: none"> • Defective injection pump 	<ul style="list-style-type: none"> • Have it repaired by an authorized service
		<ul style="list-style-type: none"> • Incorrect valve clearance 	<ul style="list-style-type: none"> • Have it repaired by an authorized service
		<ul style="list-style-type: none"> • Low idle speed 	<ul style="list-style-type: none"> • Set to standard
		<ul style="list-style-type: none"> • Defective nozzle 	<ul style="list-style-type: none"> • Have it repaired by an authorized service
	Engine overruns	<ul style="list-style-type: none"> • Limited regulator operation 	<ul style="list-style-type: none"> • Have it repaired by an authorized service
		<ul style="list-style-type: none"> • Rising oil level 	<ul style="list-style-type: none"> • Have it repaired by an authorized service
	The engine stops suddenly	<ul style="list-style-type: none"> • Low fuel level 	<ul style="list-style-type: none"> • Refuel and bleed the system
		<ul style="list-style-type: none"> • Defective nozzle 	<ul style="list-style-type: none"> • Have it repaired by an authorized service
		<ul style="list-style-type: none"> • Engine seizure due to insufficient oil volume or poor lubrication 	<ul style="list-style-type: none"> • Have it repaired by an authorized service
	The engine is overheated	<ul style="list-style-type: none"> • Insufficient coolant amount 	<ul style="list-style-type: none"> • Add coolant
<ul style="list-style-type: none"> • Damaged fan belt 		<ul style="list-style-type: none"> • Replace belt 	
<ul style="list-style-type: none"> • Clogged radiator 		<ul style="list-style-type: none"> • Clean the radiator 	
<ul style="list-style-type: none"> • Lack of engine oil 		<ul style="list-style-type: none"> • Check and refill 	

TROUBLESHOOTING

TROUBLE		PROBABLE CAUSE	SOLUTION
Engine	The engine produces white smoke	<ul style="list-style-type: none"> ● Clogged air cleaner 	<ul style="list-style-type: none"> ● Check and clean it
		<ul style="list-style-type: none"> ● Excessive engine oil amount 	<ul style="list-style-type: none"> ● Check and set it to the proper amount
		<ul style="list-style-type: none"> ● Insufficient fuel supply amount 	<ul style="list-style-type: none"> ● Have it repaired by workshop
	The engine produces black smoke	<ul style="list-style-type: none"> ● Low quality fuel 	<ul style="list-style-type: none"> ● Add the specified fuel
		<ul style="list-style-type: none"> ● Excessive fuel amount delivery 	<ul style="list-style-type: none"> ● Have it repaired by workshop
		<ul style="list-style-type: none"> ● Insufficient nozzle pressure 	<ul style="list-style-type: none"> ● Have it repaired by workshop
	The engine does not produce sufficient power	<ul style="list-style-type: none"> ● Clogged or carbon on nozzle tip 	<ul style="list-style-type: none"> ● Have it repaired by workshop
		<ul style="list-style-type: none"> ● Insufficient compression or gas leak from valve seat 	<ul style="list-style-type: none"> ● Have it repaired by workshop
		<ul style="list-style-type: none"> ● Improperly adjusted valve clearance 	<ul style="list-style-type: none"> ● Have it repaired by workshop
		<ul style="list-style-type: none"> ● Incorrect injection timing 	<ul style="list-style-type: none"> ● Have it repaired by workshop
		<ul style="list-style-type: none"> ● Low fuel level 	<ul style="list-style-type: none"> ● Add fuel
		<ul style="list-style-type: none"> ● Clogged air cleaner 	<ul style="list-style-type: none"> ● Clean the element
The oil warning lamp comes on during driving	<ul style="list-style-type: none"> ● Low engine oil level 	<ul style="list-style-type: none"> ● Add to the specified level 	
	<ul style="list-style-type: none"> ● Low viscosity of engine oil 	<ul style="list-style-type: none"> ● Change engine oil with proper viscosity 	
	<ul style="list-style-type: none"> ● Faulty pressure switch 	<ul style="list-style-type: none"> ● Replace the switch 	

TROUBLE		PROBABLE CAUSE	SOLUTION
Engine	The oil warning lamp comes on during driving	Defective oil pump	Have it repaired by workshop
		Clogged oil filter element	Replace the oil filter
	The charge warning lamp comes on during driving	Defective wiring	Check for loose or missing terminal, short circuit and poor ground and repair as necessary
		Defective alternator	Have it repaired by workshop
		Defective battery	Replace the battery
		Damaged fanbelt	Replace the belt

TROUBLESHOOTING

Clutch, Brake and Hydraulic System Troubleshooting

PROBLEM		CAUSE	CORRECTIVE MEASURE	
Clutch	Clutch slips	<ul style="list-style-type: none"> ● Incorrect adjustment 	<ul style="list-style-type: none"> ● Adjust the clearance 	
		<ul style="list-style-type: none"> ● Worn or burned lining 	<ul style="list-style-type: none"> ● Have it repaired by an authorized service 	
	The clutch does not disengage	<ul style="list-style-type: none"> ● Incorrect adjustment, rusty lining 	<ul style="list-style-type: none"> ● Adjust the clearance, contact an authorized service center 	
Brake	Brakes do not work	<ul style="list-style-type: none"> ● Incorrect clearance adjustment, worn or burnt lining 	<ul style="list-style-type: none"> ● Adjust the clearance, contact an authorized service center 	
	Brake pedal does not return	<ul style="list-style-type: none"> ● Defective return spring, lack of lubricant in the bearings 	<ul style="list-style-type: none"> ● Replace the spring ● Remove rust and lubricate 	
Hydraulic System	Hydraulics does not lift	<ul style="list-style-type: none"> ● Engine speed is too low ● Lack of transmission oil ● Air leaks from the lines ● Suction filter clogged ● Defective pump ● Defective hydraulic distributor ● Defective hydraulic valve 	<ul style="list-style-type: none"> ● Increase the engine speed ● Refill the oil to the correct level ● Tighten the connections, or replace the pipe and sealing O-ring ● Clean the filter and change oil ● Contact an authorized service center ● Contact an authorized service center ● Contact an authorized service center 	
		Oil leaks from lines	<ul style="list-style-type: none"> ● Loose line connections, cracked lines 	<ul style="list-style-type: none"> ● Tighten the connections ● Repair or replace the lines
		Whistling sounds when lifting	<ul style="list-style-type: none"> ● Incorrectly adjusted limiter 	<ul style="list-style-type: none"> ● Adjust the limiter

* For other hydraulic problems, contact an authorized service that has the correct equipment to perform diagnostics and repair the system.

TROUBLESHOOTING

Steering Wheel and Electric Instruments Troubleshooting

SYMPTOM		CAUSE	REMEDY
Steering wheel	Steering wheel shaking	<ul style="list-style-type: none"> • Wrong toe-in • Unequal tire pressure • Loose component 	<ul style="list-style-type: none"> • Adjust toe-in • Inflate both to correct pressure • Tighten or replace if worn
	Excessive play in the steering	<ul style="list-style-type: none"> • Worn steering shaft • Worn components 	<ul style="list-style-type: none"> • Contact dealer for repair • Contact dealer for repair
Electric instruments	Flat battery	<ul style="list-style-type: none"> • Faulty wiring • Faulty alternator • Faulty regulator • Broken or loose fan belt 	<ul style="list-style-type: none"> • Repair, reconnect or tighten as needed • Contact dealer for repair • Contact dealer for repair • Replace or adjust
	Before anything else, check the electrolyte level of the battery and the connections. Top up if required and clean and retighten the terminal		
	Dim head lights	<ul style="list-style-type: none"> • Low battery • Faulty wiring 	<ul style="list-style-type: none"> • Charge or replace • Repair or replace as needed
	Headlights not working	<ul style="list-style-type: none"> • Blown bulb • Blown fuse • Faulty contact 	<ul style="list-style-type: none"> • Replace bulb • Replace fuse • Repair or replace and check the earth
	Horn not working	<ul style="list-style-type: none"> • Faulty horn button • Faulty wiring • Faulty horn 	<ul style="list-style-type: none"> • Replace button • Repair or replace • Replace
	Indicator not working	<ul style="list-style-type: none"> • Blown bulb • Faulty flasher unit • Faulty wiring 	<ul style="list-style-type: none"> • Replace bulb • Replace unit • Repair or replace

TROUBLESHOOTING

Towing the Tractor

The tractor can be towed only for short distances, such as, for example, from inside to outside a building.

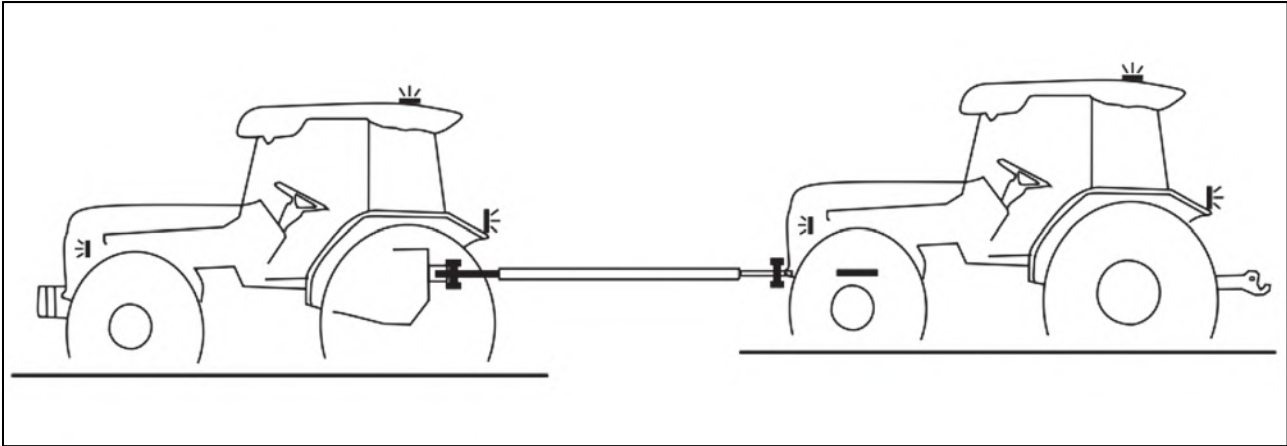

HODP164

A broken down tractor should be towed for the minimum indispensable distance to remove it from potentially dangerous conditions. Observe all legal provisions as envisaged in the highway code relative to national legislation regarding towing manoeuvres.



CAUTION: *We recommend transporting the tractor on a low loader in the case of longer transport distances. Comply with the maximum width and height regulations for road transport. Check that the loader is suitable for the weight of the tractor to be transported.*



CAUTION: *When towing the tractor, the operator must always sit in the driver's seat.*



DANGER: *Never allow unauthorized persons to access the driver's seat during towing.*

TROUBLESHOOTING

Towing with the Engine Running

Towing with the engine running is necessary due to forced lubrication of the gearbox, observe the following

- Engine speed between 1,200 - 1,300 rpm.
- Maximum towing speed 8 km/h
- Maximum towing distance 1 km

For towing the tractor use only a standard bar applied to the front towing hitch approved by the manufacturer. Make sure to use the correct pin for the towing hitch and that it is secured with its locking pin. Clean all lights required for road use, front and rear, and make sure they are in working order.

Before starting towing check the following conditions:

- Unhitch any implement from the tractor;
- Lock the two brake pedals together with the connecting latch;
- Disengage the power take-off and differential locks;
- Set the shuttle control lever and gear lever to neutral;
- Move the range lever to the "fast" position;
- Move the creeper lever to neutral;
- Display the SMV (Slow Moving Vehicle) sign and turn on the rotating beacon and hazard lights



WARNING: Turn on the warning lights and the beacon light. Attach suitable notice sign that the tractor is being towed. Check and comply with the applicable national legislation. Comply with the local safety regulations.

When driving on the road, observe the following:

- Wait for traffic to thin down before entering the road. Be very careful at intersections without traffic control.
- Slow down to have a clear view in both directions.
- Keep the vehicle in your lane and drive as close as possible to the right side of the road. If there are vehicles behind you, pull into a lay-by as soon as possible to allow the vehicles to pass.
- Apply the parking brake when the tractor is stopped (at any circumstances).
- The driving speed must always be such as to allow complete control of the vehicle or the unit and ensure its stability.



Danger: Never attempt to tow the tractor with ropes (including steel ropes) because rope breakage can cause serious injury.

Towing with the Engine Off



Important: With engine stopped and with forced gearbox lubrication system inoperative the tractor can be transferred to a service centre only when loaded onto a transporter.

With engine stopped and with forced gearbox lubrication system inoperative the tractor should not be towed except when safety is at risk.

NOTES

INDEX

1. Tracing Faults	121	Cooling System Corrosion Protection Agent	110
2. Check of the air conditioning with a pressure gauge.	122	Creep Shift Lever	57
3. gauge pressure conversion	122	Cunshion Strength Adjustment	18
A		Cup Holder	119
About This Manual	13	D	
Adjusting the Brakes	98	Damage of the ROPS	17
Adjusting the Clutch	98	Decals Mounting Location	35
Adjusting the Throttle Leve	99	Description	15
Adjusting Toe-in	99	Description of Tractor Controls	43
Adjustment Method	98	Diagnosing Malfunctions	121
Adjustment of the Lift Link (left, right)	64	Diesel Fuel	32
Adjustment of the Lift Link on the Lower Link	65	Diff-Lock Pedal	58
Adjustment of the Stabilizer Bars	64	Disconnecting	62
Adjustment of The Top Link	64	Disconnection	77
Air Brakes	67	Don'ts-For Safe Operation	34
Air Cleaning System	108	Doors	112
Air Control Switch	115	Do's and Don'ts	33
Air pressure indication	68	Driver's Seat	59
Air-conditioning System	118	Driving Downhill	74
Always Use Safety Lights and Devices	21	Driving the Tractor	31
Anti Freeze	96	Driving the Tractor	72
Ash Tray	119	Driving with agricultural machines attached to the front three-point hitch	70
Assembly of the Front Loader	79	E	
Avoid High-Pressure Fluids	22	Electrical	84
B		Electrical System	15
Battery Disconnect	23	Emergency Exits	25
Battery Disconnect	101	Empty Water Tank	94
Battery Charging	75	Engine	15
Battery Charging	100	Engine	108
Battery Maintenance	99	Engine Oil	82
Battery Maintenance	99	Engine Oil Filter	93
Bleeding the Fuel System	89	Engine Troubleshooting	129
Blower Control Switch	115	Exterior Hydraulic Lever (Optional)	62
Brake	84	Exterior View	9
Brake Pedal	52	External Circulation	116
Brakes	15	F	
C		Falling object protective structure (FOPS)	27
Cab Cailing	113	Filling Diagram & Capacity Table	87
Cab Filter	118	Fixation Points of Loader	79
Cabin System	111	Foot Operated Accelerator	53
Cautions for inspection and service of air cleaner	103	For Daily or Short Term Storage	107
Change the Fuel Filter Cartridge	95	Front Axle & Wheels	15
Change the Fuel Pre-Filter Insert	94	Front Fenders	80
Changing Engine Oil	90	Front Three-point Hitch	69
Changing Oil in the Front Axle	92	Front Wheel Drive Lever (CL Model)	58
Changing the Oils in the Tractor	90	Front Wheel Drive Lever (HS Model)	59
Changing the Transmission Oil	90	Fuel	84
Check and Clean the Air Cleaner According to the Following Instructions	102	Fuel	89
Check During Driving	75	Fuel Gauge	46
Check During Driving	76	Fuel Gauge	75
Checking Engine Coolant	81	Fuel Saving Tips	108
Checking Hoses and Lines	103	Fuel System	108
Checking the Air Conditioning System	120	G	
Checking the Air Conditioning System Charge	120	Gear Shift Lever	55
Checking the Battery	99	General Construction	15
Checking the Belt Drive	102	General Information	9
Checking the Wiring Harness and Fuses	103	General Information	81
Checks and Service	81	General Safety Information	35
Cigarette Lighter	119	Greasing the Tractor	97
Circulation Diffuser	116	H	
CL Model	43	Hand Throttle (Throttle Lever)	52
Cleaning and Changing Filters	93	Handle Fuel Safely Avoid Fires	20
Cleaning Oil Water Separator of Fuel Filter	93	Headlights Switch (Beacon Light), Turn Signal Lights Switch and Horn Switch	45
Cleaning the Radiator	97	Heating System	117
Clutch	84	Heating System Configuration	117
Clutch & Brakes	108	Height Adjustment and Disassembly of the Multi-level Hitch Attachment Tail Piece	67
Clutch and transmission	15	Hour Meter	46
Clutch Disconnecting Arm	52	How to Control Cabin	114
Clutch, Brake and Hydraulic System Troubleshooting	132	HS Model	44
Connecting	62	Hydraulic Oil Filter and Engine Oil Filter Cartridge	95
Connecting and Disconnecting Implement	77	Hydraulic System & Linkages	15
Connection	77		
Controlling front three-point hitch	69		
Cooling System	109		

INDEX

I		Recognize Safety Information	19
Independent PTO	48	Refitting the knob	101
Inspection	81	Remote Hydraulic Control Valve Coupler Connecting and Disconnecting	62
Instrument and Related Parts	112	Removal of the knob	101
Instrument and switches	43	Replace V-rib Belt	102
Interior Devices	114	Replacing coolant	96
Interior Lamp	115	Replacing Fuses	104
Introduction & Description	14	Rearview Mirrors	113
J		Re-use After Long Term Storage	107
Joystick lever	80	Roll Over Protective Structures (ROPS)	16
K		Roof Hatch (if equipped)	112
Keep Riders Off Tractor	21	ROPS (Roll Over Protective Structures)	16
L		S	
Long-term Storage	107	Safe Operation of Your Tractor	28
Lower Hitch Disassembly	66	Safe parking of the tractor	20
Lower Swinging Hitch	65	Safe starting	24
Lowering Speed Control Knob for The 3 Point Hitch	61	Safety implement for joystick lever	80
Lubricants	87	Safety Instructions	19
M		Safety Precautions	19
Main Fuses	104	Safety Precautions When Using The Loader	25
Main Switch	45	Safety Signs	35
Maintenance	81	Safety Starter Switch	24
Maintenance and Adjustment Schedule	85	Safety Tips During Maintenance	28
Major Features	111	Seat Back Reclining	18
Major Specifications	123	Seat Sliding	17
Motor oils	88	Service inspections	81
Mounting and Demounting Implements	29	Service Prior to Daily and Short Terms Storage	107
Mounting Implement	78	Service Tractor Safely	24
Multi-level hitch	66	Servicing the Tractor	30
N		Setting the play of controls	98
Noise Levels	126	Shuttle Shift Lever - CL MODEL	54
Normal Braking and Parking	73	Shuttle Shift Lever - HS Model	55
O		Side Window	112
Off Switch	114	Signal Words	19
Oil for the front driving axle	88	Specification	123
Oil Pressure Light	75	Starting the Engine	71
Oil System	108	Stay Clear of Rotating Shafts	21
Oil to gear systems of tractors	88	Steering	15
On Switch	114	Steering Wheel and Electric Instruments	
Opening Method of Hood	88	Troubleshooting	133
Operating The 3 Point Linkage (TPI)	63	Stopping the Engine	71
Operating The PTO	32	Streering	84
Operating the Tractor	31	Sub Gear Lever (Linear Shift Lever)	56
Operation	71	Switches on the right cab column	114
Operation of the Diff-Lock	74	T	
Operation of the Hydraulic Circuit	60	Tachometer	46
Operation The Controls (CL MODEL)	50	Technical data	123
Operation The Controls (HS Model)	51	Temperature Control	115
Operator Protective Structure (OPS)	27	The button for temporary deactivation of brakes of the trailer or semi-trailer	68
Other Maintenance	102	The Following Precautions are Suggested to Help Prevent Accidents	30
Owner assistance	16	The PTO Monitor Lamp	48
P		The Tractor	30
Parking Brake	53	Tight Turns in the Field	73
Parking Brake Lever	53	Tilt Lever	59
Parts	13	Tire Pressure	84
Periodical Check and Service Table	85	Tire Size and Inflation Pressure	86
Permissible Fuels	108	Towing equipment	27
Permitted Towed Vehicle Weight	124	Towing the Tractor	134
Position Control	60	Towing with the Engine Off	135
Position of the Fuse	105	Towing with the Engine Running	135
Practice Safe Maintenance	22	Tractor an Introduction	14
Precaution to Avoid Tipping	20	Tractor Identification	12
Pre-Start Checks	81	Transmission Oil	83
Prevent ACID Burns	23	Traveling Speed	125
Prevent Battery Explosions	23	Troubleshooting	129
Protection of persons	19	U	
PTO Control Switch	48	Universal Symbols	41
PTO Gear Selection Lever	60	Uphill Starts on a Steep Slope	74
PTO On / Off Switch	48	Use of ROPS and Seat Belt	20
R		V	
Radio, CD Player (If Equipped)	119	Vent the Fuel System	94
Read Safety Instruction	19	Ventilation	116
Rear axle & wheels	15		
Rear Window	112		

INDEX

Vibration Referred to the Operator Position	127	Winter Operation with Diesel Fuel	109
W		Wiper Control Switch	114
Warming Up	72	Wiring Diagram of the Electric Instrument	106
Warming Up in Cold Weather	72	Work in Ventilated Area	24
Warming Up Time	72	Work Light Switches	114
Warning Lights	47	Working and transport position of the front three-point hitch	70
Warranty of the Product	13	Working Lamps (Front and Rear)	113
Water Quality	110	Z	
Water Temperature	46	ZETOR service fillings	88
Windscreen Washer Tank	114		

Operator's manual
Hortus HS 65
Hortus CL 65

Edition: 2-100-2019
Publication No.: 222.213.537
2/2020
ZETOR TRACTORS a.s.
Department of Technical Documentation
Trnkova 111
628 00
Brno

Zetor



www.zetor.com
zetor@zetor.com



Made in EU