

**OPERATOR'S MANUAL**

# **KUBOTA TRACTOR**

**MODELS B2710 · B2910 · B7800**



F-11800

*READ AND SAVE THIS MANUAL*

**Kubota**

# ABBREVIATION LIST

Abbreviations	Definitions
2WD	Two Wheel Drive
4WD	Four Wheel Drive
API	American Petroleum Institute
ASAE	American Society of Agricultural Engineers, USA
ASTM	American Society of Testing and Materials, USA
DIN	Deutsches Institut für Normung, GERMANY
DT	Dual Traction [4WD]
fpm	Feet Per Minute
GST	Glide Shift Transmission
Hi-Lo	High Speed-Low Speed
HST	Hydrostatic Transmission
m/s	Meters Per Second
PTO	Power Take Off
RH/LH	Right-hand and left-hand sides are determined by facing in the direction of forward travel
ROPS	Roll-Over Protective Structures
rpm	Revolutions Per Minute
rps	Revolutions Per Second
SAE	Society of Automotive Engineers, USA
SMV	Slow Moving Vehicle

California Proposition 65

## **▲ WARNING ▲**

The engine exhaust from this product contains chemicals known to the State of California to cause cancer, birth defects or other reproductive harm.

# UNIVERSAL SYMBOLS

As a guide to the operation of your tractor, various universal symbols have been utilized on the instruments and controls. The symbols are shown below with an indication of their meaning.



 Safety Alert Symbol	 Draft Control-Shallow Position
 Diesel Fuel	 Draft Control-Deep Position
 Fuel-Level	 3-Point Lowering Speed Control
 Engine-Rotational Speed	 Remote Cylinder-Retract
 Hourmeter/Elapsed Operating Hours	 Remote Cylinder-Extend
 Engine Coolant-Temperature	 Steering Wheel-Tilt Control
 Parking Brake	 Hazard Warning Lights
 Battery Charging Condition	 Headlight
 Engine Oil-Pressure	 Four-Wheel Drive-On
 Turn Signal	 Four-Wheel Drive-Off
 Engine-Stop	 Fast
 Engine-Run	 Slow
 Diesel Preheat/Glow Plugs(Low Temperature Start Aid)	 Creep
 Starter Control	 Rear Operator's Manual
 Power Take-Off Control-Off Position (Disengaged)	 Tractor-Forward Movement-Overhead View of Machine
 Power Take-Off Control-On Position (Engaged)	 Tractor-Rearward Movement-Overhead View of Machine
 Differential Lock	 Engine Speed Control
 Position Control-Raised Position	
 Position Control-Lowered Position	

# FOREWORD

You are now the proud owner of a KUBOTA Tractor. This tractor is a product of KUBOTA quality engineering and manufacturing. It is made of fine materials and under a rigid quality control system. It will give you long, satisfactory service. To obtain the best use of your tractor, please read this manual carefully. It will help you become familiar with the operation of the tractor and contains many helpful hints about tractor maintenance. It is KUBOTA's policy to utilize as quickly as possible every advance in our research. The immediate use of new techniques in the manufacture of products may cause some small parts of this manual to be outdated. KUBOTA distributors and dealers will have the most up-to-date information. Please do not hesitate to consult with them.

## SAFETY FIRST

This symbol, the industry's "Safety Alert Symbol", is used throughout this manual and on labels on the machine itself to warn of the possibility of personal injury. Read these instructions carefully. It is essential that you read the instructions and safety regulations before you attempt to assemble or use this unit.

-  **DANGER :** Indicates an imminently hazardous situation which, if not avoided, will result in death or serious injury.
-  **WARNING :** Indicates a potentially hazardous situation which, if not avoided, could result in death or serious injury.
-  **CAUTION:** Indicates a potentially hazardous situation which, if not avoided, may result in minor or moderate injury.
- IMPORTANT :** Indicates that equipment or property damage could result if instructions are not followed.
- NOTE :** Gives helpful information.

# CONTENTS

## **▲ SAFE OPERATION ..... 1**

SERVICING OF TRACTOR ..... 9

SPECIFICATIONS ..... 10

SPECIFICATION TABLE ..... 10

TRAVELING SPEEDS ..... 11

IMPLEMENT LIMITATIONS ..... 12

### Operation Section

INSTRUMENT PANEL AND CONTROLS . 14

PRE-OPERATION CHECK ..... 17

DAILY CHECK ..... 17

OPERATING THE ENGINE ..... 18

STARTING THE ENGINE ..... 18

STOPPING THE ENGINE ..... 20

WARMING UP ..... 20

JUMP STARTING ..... 21

OPERATING THE TRACTOR ..... 22

OPERATING NEW TRACTOR ..... 22

OPERATING FOLDABLE ROPS

(OPTION) ..... 22

STARTING ..... 24

STOPPING ..... 29

CHECK DURING DRIVING ..... 29

PARKING ..... 30

OPERATING TECHNIQUES ..... 31

PTO ..... 33

PTO OPERATION ..... 33

THREE-POINT HITCH & DRAWBAR ..... 35

3-POINT HITCH ..... 36

DRAWBAR ..... 38

HYDRAULIC UNIT ..... 39

3-POINT HITCH CONTROL SYSTEM ... 39

AUXILIARY HYDRAULICS ..... 39

TIRES, WHEELS AND BALLAST ..... 42

TIRES ..... 42

WHEEL ADJUSTMENT ..... 42

BALLAST ..... 44

### Maintenance Section

MAINTENANCE ..... 45

SERVICE INTERVALS ..... 45

LUBRICANTS ..... 46

PERIODIC SERVICE ..... 47

HOW TO OPEN THE HOOD ..... 47

DAILY CHECK ..... 48

EVERY 50 HOURS ..... 51

EVERY 100 HOURS ..... 53

EVERY 200 HOURS ..... 58

EVERY 300 HOURS ..... 60

EVERY 400 HOURS ..... 62

EVERY 800 HOURS ..... 62

EVERY 1500 HOURS ..... 62

EVERY 3000 HOURS ..... 62

EVERY 1 YEAR ..... 62

EVERY 2 YEARS ..... 63

SERVICE AS REQUIRED ..... 64

STORAGE ..... 66

TRACTOR STORAGE ..... 66

REMOVING THE TRACTOR

FROM STORAGE ..... 66

TROUBLESHOOTING ..... 67

ENGINE TROUBLESHOOTING ..... 67

OPTIONS ..... 68



# SAFE OPERATION

Careful operation is your best insurance against an accident.

**Read and understand this section carefully before operating the tractor.**

All operators, no matter how much experience they may have had, should read this and other related manuals before operating the tractor or any implement attached to it. It is the owner's obligation to instruct all operators in safe operation.

## 1. BEFORE OPERATING THE TRACTOR

1. Know your equipment and its limitations. Read this entire manual before attempting to start and operate the tractor.
2. Pay special attention to the danger, warning and caution labels on the tractor itself.
3. KUBOTA recommends the use of a Roll Over Protective Structures (ROPS) and seat belt in almost all applications. This combination will reduce the risk of serious injury or death, should the tractor be upset.

If the ROPS is loosened or removed for any reason, make sure that all parts are reinstalled correctly before operating the tractor.

Never modify or repair a ROPS because welding, bending, drilling, grinding, or cutting any portion may weaken the structure.

A damaged ROPS structure must be replaced, not repaired or revised. If any structural member of the ROPS is damaged, replace the entire structure at your local KUBOTA Dealer.



F-13724A

(1) ROPS

(2) Seat belt

4. Always use the seat belt when any ROPS is installed. Do not use the seat belt if a foldable ROPS is down or there is no ROPS. Check the seat belt regularly and replace if frayed or damaged.
5. Do not operate tractor or any implement attached to it while under the influence of alcohol, medication, or other substances or while fatigued.
6. Carefully check the vicinity before operating tractor or any implement attached to it. Check for overhead clearance which may interfere with a ROPS. Do not allow any bystanders around or near tractor during operation.
7. Before allowing other people to use your tractor, explain how to operate and have them read this manual before operation.
8. Never wear loose, torn, or bulky clothing around tractor. It may catch on moving parts or controls, leading to the risk of accident. Use additional safety items, e.g. hard hat, safety boots or shoes, eye and hearing protection, gloves, etc., as appropriate or required.
9. Do not allow passengers to ride on any part of the tractor at anytime. The operator must remain in the tractor seat throughout operation.
10. Check brakes, clutch, and other mechanical parts for improper adjustment and wear. Replace worn or damaged parts promptly. Check the tightness of all nuts and bolts regularly. (For further details, see "MAINTENANCE" section.)
11. Keep your tractor clean. Dirt, grease, and trash accumulations contribute to fires and lead to personal injury.
12. Use only implements meeting the specifications listed under "IMPLEMENT LIMITATIONS" in this manual and use only implements approved by KUBOTA.
13. Use proper weights to front or rear of tractor to reduce the risk of upsets. When using the front loader, put the implement or ballast on 3-point hitch to improve stability. Follow the safe operating procedures specified in the attached manual to the equipment.
14. Do not modify the tractor. Unauthorized modification may affect the function of the tractor, which may result in personal injury.

## 2. OPERATING THE TRACTOR

1. Never start engine or operate levers from anywhere other than the seat.
2. Before starting the engine, make sure that all levers (including auxiliary control levers) are in their neutral positions, that the parking brake is engaged, and that both the clutch and the Power Take-Off (PTO) are disengaged (OFF).  
Fasten the seat belt if the tractor has a ROPS.
3. Do not start engine by shorting across starter terminals or bypassing the safety start switch. Machine may start in gear and move if normal starting circuitry is bypassed.
4. Pull only from the drawbar. Never hitch to axle housing or any other point except drawbar; such arrangements only increase the risk of serious personal injury or death due to a tractor upset.

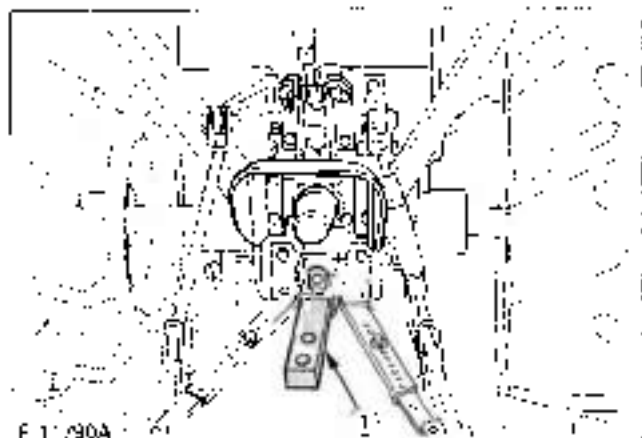

(1) Drawbar

5. Do not operate or idle engine in a non-ventilated area.  
Carbon monoxide gas is colorless, odorless, and deadly.
6. Keep all shields and guards in place. Replace any that are missing or damaged.
7. Avoid sudden starts. To avoid upsets, slow down when turning, on uneven terrain, and before stopping.
8. The tractor cannot turn with the differential locked and attempting to do so could be dangerous.
9. Do not operate near ditches, holes, embankments, or other terrain features which may collapse under the tractor's weight. The risk of tractor upset is even higher when the ground is loose or wet.
10. Driving forward out of a ditch or mired condition or up a steep slope risks a tractor to be upset backward. Always back out of these situations. Extra caution is required with four-wheel drive models because their higher traction can give the operator false confidence in the tractor's ability to climb slopes.
11. To avoid upsets, always back up steep slopes. Stay off hills and slopes too steep for safe operation.

12. Watch where you are going at all times. Watch for and avoid obstacles. Be alert at row ends, near trees, and other obstructions.
13. When working in groups, always let the others know what you are going to do before you do it.
14. Never "freewheel". Disengaging the clutch or shifting into neutral while descending a slope could lead to a loss of control.
15. Never try to get on or off a moving tractor.
16. Check before each use that operator presence controls are functioning correctly. Test safety systems. (See "EVERY 50 HOURS, Checking Engine Start System" in "PERIODIC SERVICE" section.)  
Do not operate unless they are functioning correctly.

### ◆ Safety for children

Tragedy can occur if the operator is not alert to the presence of children. Children generally are attracted to machines and the work they do.

16. Never assume that children will remain where you last saw them.
17. Keep children out of the work area and under the watchful eye of another responsible adult.
18. Be alert and shut your machine down if children enter the work area.
19. Never carry children on your machine. There is no safe place for them to ride. They may fall off and be run over or interfere with your control of the machine.
20. Never allow children to operate the machine even under adult supervision.
21. Never allow children to play on the machine or on the implement.
22. Use extra caution when backing up, look behind and down-make sure area is clear before moving.
23. When parking your machine if at all possible park on a firm, flat and level surface; if not, park across a slope. Set the parking brake(s), lower the implements to the ground, remove the key from the ignition and lock the cab door (if equipped) and chock the wheels.



### 3. DRIVING THE TRACTOR ON THE ROAD

1. Lock the two brake pedals together to help assure straight-line stops. Uneven braking at road speeds could cause the tractor to tip over.

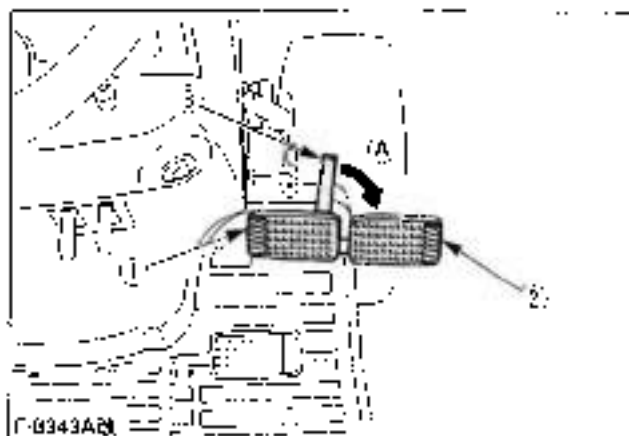

(1) Brake pedal (LH) (A) Whenever traveling on the road  
 (2) Brake pedal (RH)  
 (3) Brake pedal lock

2. Always slow the tractor down before turning. Turning at high speed may tip the tractor over.
3. Make sure that the Slow Moving Vehicle (SMV) sign is clean and visible. Use hazard lights as required.

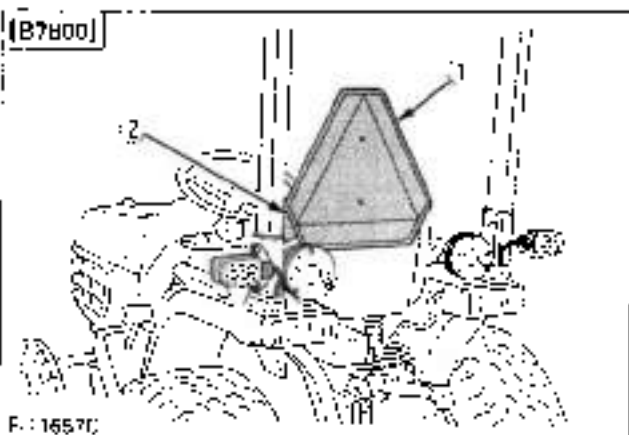
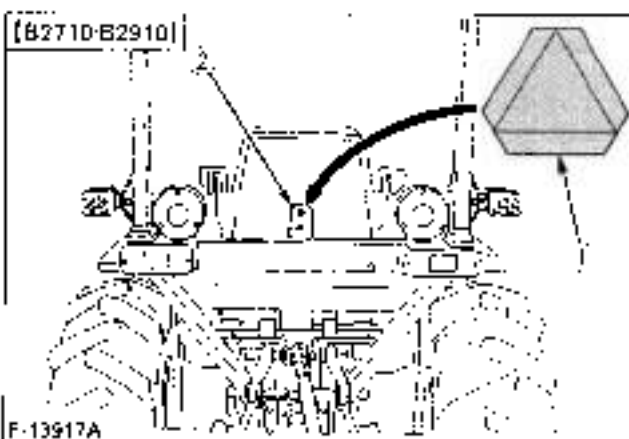

(1) SMV emblem  
 (2) Bracket

4. Observe all local traffic and safety regulations.
5. Turn the headlights on.
6. Drive at speeds that allow you to maintain control at all times.
7. Do not apply the differential lock while traveling at road speeds. The tractor may run out of control.
8. Avoid sudden motions of the steering wheel as they can lead to a dangerous loss of stability. The risk is especially great when the tractor is traveling at road speeds.
9. Do not operate an implement while the tractor is on the road. Lock the 3-point hitch in the raised position.
10. When towing other equipment, use a safety chain and place an SMV emblem on it as well.

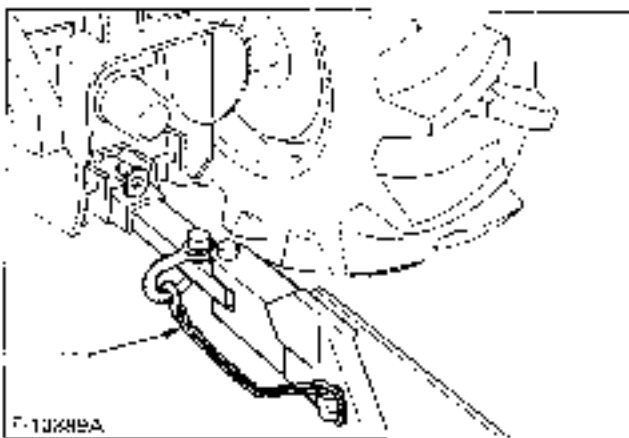

(1) Safety chain

### 4. PARKING THE TRACTOR

1. Disengage the PTO, lower all implements to the ground, place all control levers in their neutral positions, set the parking brake, stop the engine, and remove the key.
2. Make sure that the tractor has come to a complete stop before dismounting.

## 5. OPERATING THE PTO

1. Wait until all moving components have completely stopped before getting off the tractor, connecting, disconnecting, adjusting, cleaning, or servicing any PTO driven equipment.
2. Keep the PTO shaft cover in place at all times. Replace the PTO shaft cap when the shaft is not in use.

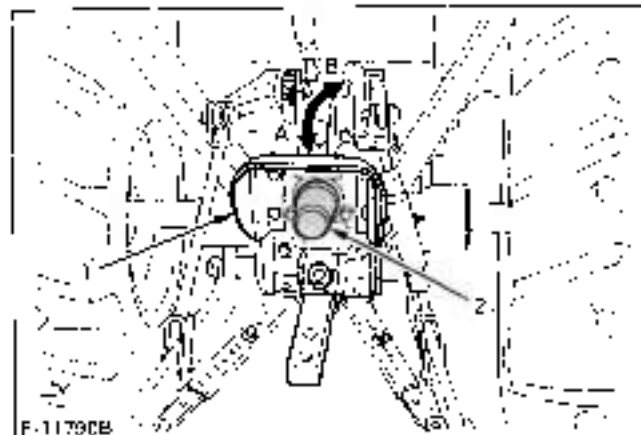

F-1179CB

(1) PTO shaft cover

(2) PTO shaft cap

(A) "NORMAL POSITION"

(B) "RAISED POSITION"

3. Before installing or using PTO driven equipment, read the manufacturer's manual and review the safety labels attached to the equipment.
4. When operating stationary PTO driven equipment, always apply the tractor parking brake and place chocks behind and in front of the rear wheels. Stay clear of all rotating parts.

## 6. USING 3-POINT HITCH

1. Use the 3-point hitch only with equipment designed for 3-point hitch usage.
2. When using a 3-point hitch mounted implement, be sure to install the proper counterbalance weight on the front of the tractor.
3. When transporting on the road, set the 3-point hitch lowering speed knob in the "LOCK" position to hold the implement in the raised position.

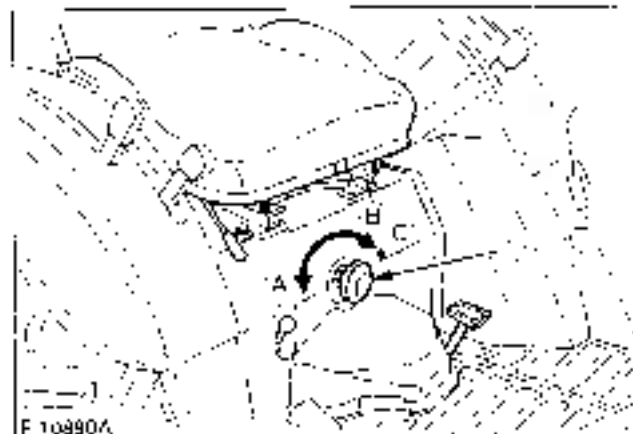

F-10890A

(1) 3-point hitch lowering speed knob

(A) "FAST"

(B) "SLOW"

(C) "LOCK"

## 7. SERVICING THE TRACTOR

Before servicing the tractor, park it on a firm, flat and level surface, lower all implements to the ground, set the parking brake, place the gear shift lever in neutral and stop the engine.

1. Allow the tractor time to cool off before working on or near the engine, muffler, radiator, etc.
2. Always stop the engine and remove the key before refueling. Avoid spills and overfilling.
3. Do not smoke when working around battery or when refueling. Keep all sparks and flames away from battery and fuel tank. The battery presents an explosive hazard because it gives off hydrogen and oxygen -- especially when recharging.
4. Before "jump starting" a dead battery, read and follow all of the instructions. (See "JUMP STARTING" in operating the engine section)
5. Keep first aid kit and fire extinguisher handy at all times.
6. Do not remove radiator cap while coolant is hot. When cool, slowly rotate cap to the first stop and allow sufficient time for excess pressure to escape before removing the cap completely. If the tractor has a coolant recovery tank, add coolant there instead of to the radiator.
7. Disconnect the battery's ground cable before working on or near electric components.
8. Do not use or charge the refillable type battery if the fluid level is below the LOWER (lower limit level) mark. Otherwise, the battery component parts may prematurely deteriorate, which may shorten the battery's service life or cause an explosion. Check the fluid level regularly and add distilled water as required so that the fluid level is between the UPPER and LOWER levels.
9. To avoid sparks from an accidental short circuit, always disconnect the battery's ground cable -- first and connect it last.

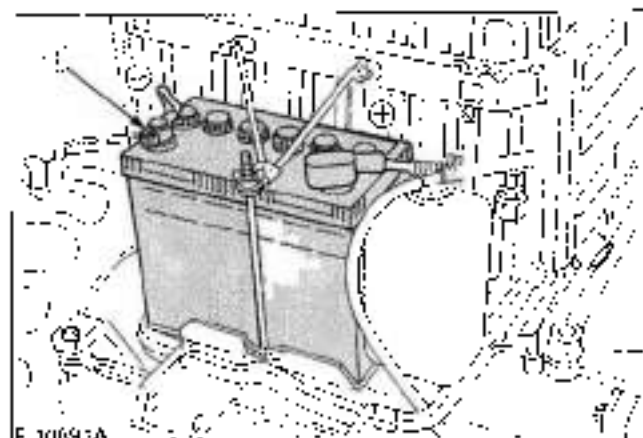

F-10891A

(1) Battery

10. Do not attempt to mount a tire on rim. This should be done by a qualified person with the proper equipment.

11. Always maintain the correct tire pressure. Do not inflate tires above the recommended pressure shown in the operator's manual.

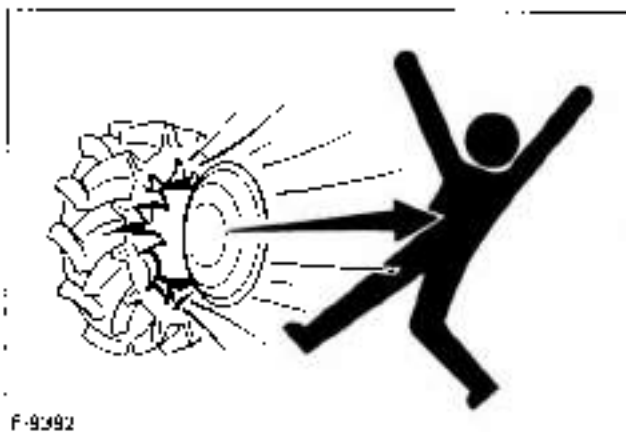

F-9392

12. Securely support the tractor when changing wheels or the wheel tread width.  
 13. Make sure that wheel bolts have been tightened to the specified torque.  
 14. Escaping hydraulic fluid under pressure has sufficient force to penetrate skin, causing serious personal injury. Before disconnecting hydraulic lines, be sure to release all residual pressure. Before applying pressure to the hydraulic system, make sure that all connections are tight and that all lines, pipes, and hoses are free of damage.

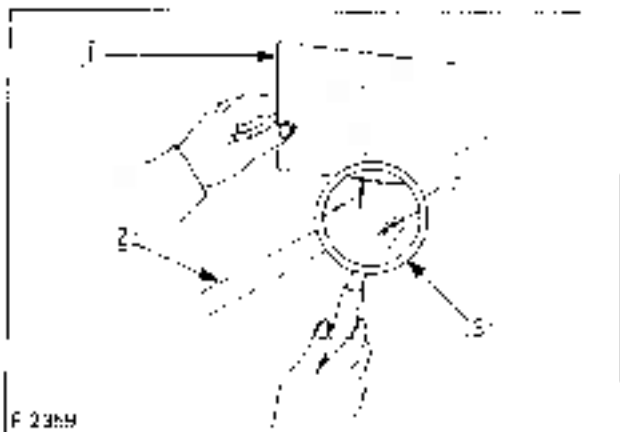

F-2359

- (1) Cardboard  
 (2) Hydraulic line  
 (3) Magnifying glass

Fluid escaping from pinholes may be invisible. Do not use hands to search for suspected leaks; use a piece of cardboard or wood, instead. Use of safety goggles or other eye protection is also highly recommended. If injured by escaping fluid, see a medical doctor at once. This fluid will produce gangrene or severe allergic reaction.

## 8. DANGER, WARNING AND CAUTION LABELS

11) Part No. 6C090-4965-1

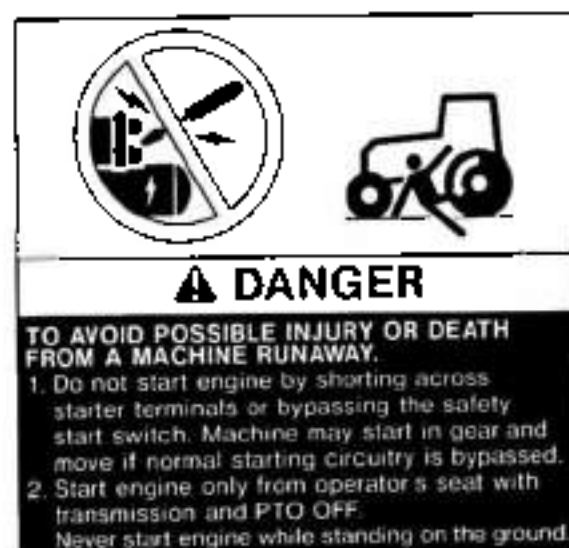

12) Part No. TA040-4959-3

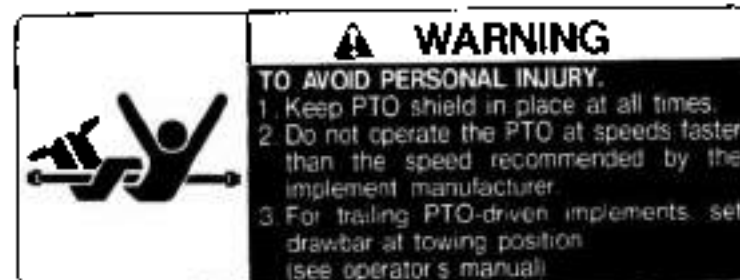

13) Part No. 6C040-4741-2

No fire



14) Part No. 6C140-4744-1

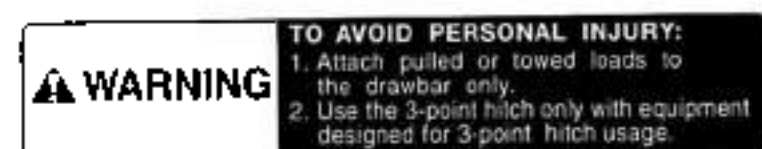

16) Part No. TA040-4958-1

Do not touch hot surface like muffler, etc.

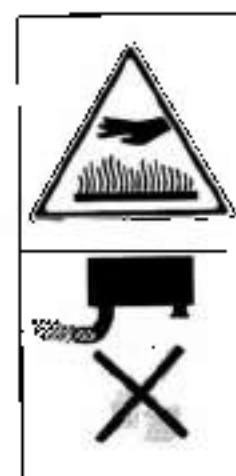

15) Part No. 6C150-4743-1

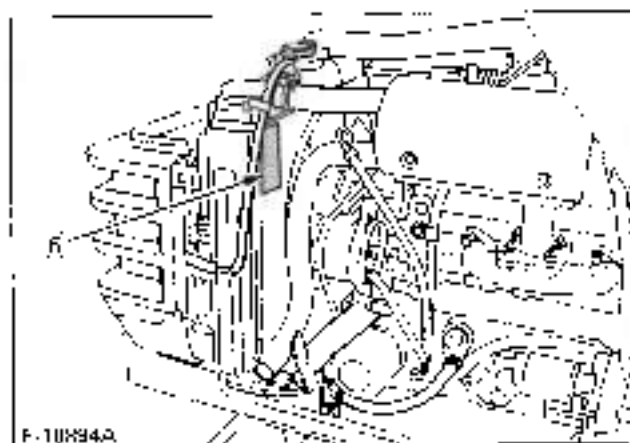
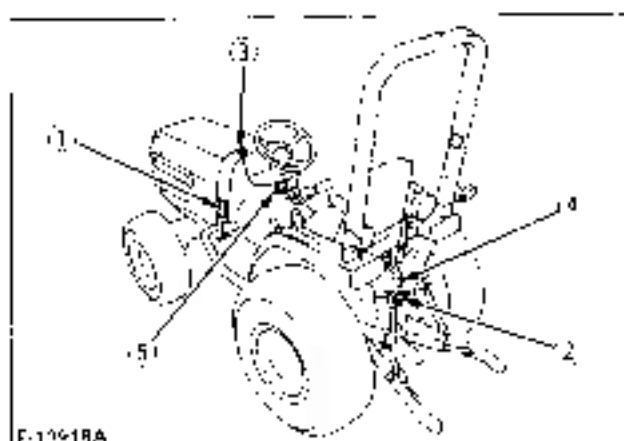



## 17) Part No. TA040-4932-2 [Rigid ROPS type]

<b>▲ WARNING</b>	<b>TO AVOID PERSONAL INJURY OR DEATH FROM ROLL-OVER:</b>
	1. Kubota recommends the use of a Roll-Over Protective Structures (ROPS) and seat belt in almost all applications.
	2. Remove the ROPS only when it substantially interferes with operation or itself presents a safety risk. (Examples include work in orchards and vineyards.) <b>ALWAYS REINSTALL IT BEFORE USING THE TRACTOR IN OTHER APPLICATIONS.</b>
	3. Never use just the seat belt or just the ROPS. They must be used together. For further details, consult your Operator's Manual or your local dealer.

18. Part No. 32751-495H-1  
Stay clear of engine fan and fanbelt.

## 17) Part No. TA240-9848-1 [Foldable ROPS type]

	<b>▲ WARNING</b>
	<b>TO AVOID INJURY OR DEATH FROM ROLL-OVER:</b>
	<ul style="list-style-type: none"> <li>• Keep Roll-Over Protective Structures (ROPS) in the upright and locked position.</li> <li>• Fasten SEAT BELT before operating.</li> </ul>
<b>THERE IS NO OPERATOR PROTECTION WHEN THE ROPS IS IN THE FOLDED POSITION:</b>	
<ul style="list-style-type: none"> <li>• Check the operating area and fold the ROPS only when absolutely necessary.</li> <li>• Do not wear SEAT BELT if ROPS is folded.</li> <li>• Raise and lock ROPS as soon as vertical clearance allows.</li> <li>• Read ROPS related instructions and warnings.</li> </ul>	

## 19) Part No. 6C070-4742-2

<b>▲ CAUTION</b>
<b>TO AVOID PERSONAL INJURY:</b>
<ol style="list-style-type: none"> <li>1. Read and understand the operator's manual before operation.</li> <li>2. Before starting the engine, make sure that everyone is at a safe distance from the tractor and that the PTO is OFF.</li> <li>3. Do not allow passengers on the tractor at any time.</li> <li>4. Before allowing other people to use the tractor, have them read the operator's manual.</li> <li>5. Check the tightness of all nuts and bolts regularly.</li> <li>6. Keep all shields in place and stay away from all moving parts.</li> <li>7. Lock the two brake pedals together before driving on the road.</li> <li>8. Slow down for turns, or rough roads, or when applying individual brakes.</li> <li>9. On public roads use SMV emblem and hazard lights, if required by local traffic and safety regulations.</li> <li>10. Pull only from the drawbar.</li> <li>11. Before dismounting, lower the implement to the ground, set the parking brake, stop the engine and remove the key.</li> <li>12. Securely support tractor and implements before working underneath.</li> </ol>

## 20) Part No. 6C040-5559-1

<b>DANGER EXPLOSIVE GASES</b>
<small>Cigarettes, flames or sparks could cause battery to explode. Always shield eyes and face from battery. Do not charge or use booster cables at adjust port connections without proper instruction and warning.</small>
<b>KEEP VENT CAPS TIGHT AND LEVEL</b>
<b>POISON CAUSES SEVERE BURNS</b>
<small>Contaminants will burn on contact with skin. Avoid contact with skin. In event of accident flush with water and call a physician immediately.</small>
<b>KEEP OUT OF REACH OF CHILDREN</b>

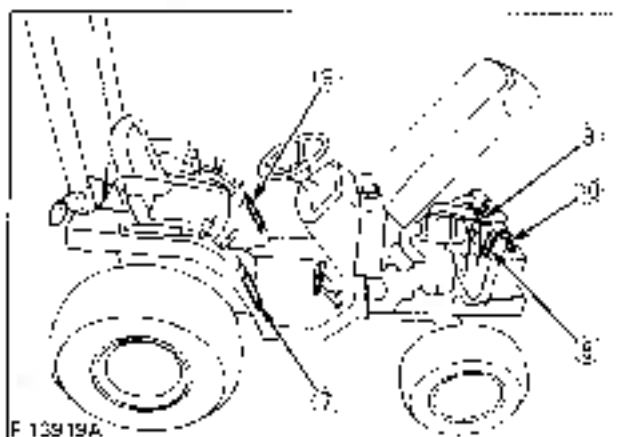

(1) Part No. 6C140-4746-1 [Rigid ROPS type]



(2) Part No. 3A111-9554-1 [Foldable ROPS type]

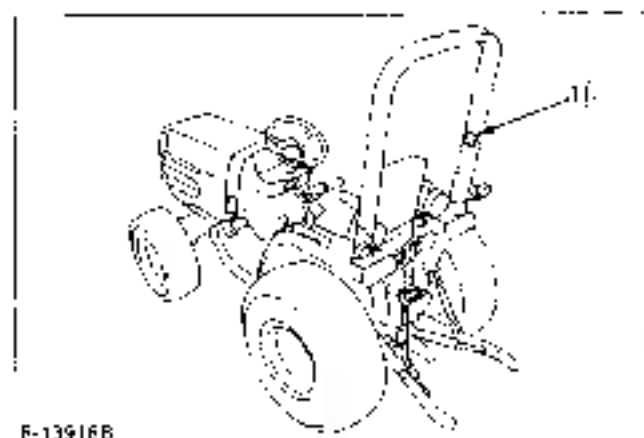
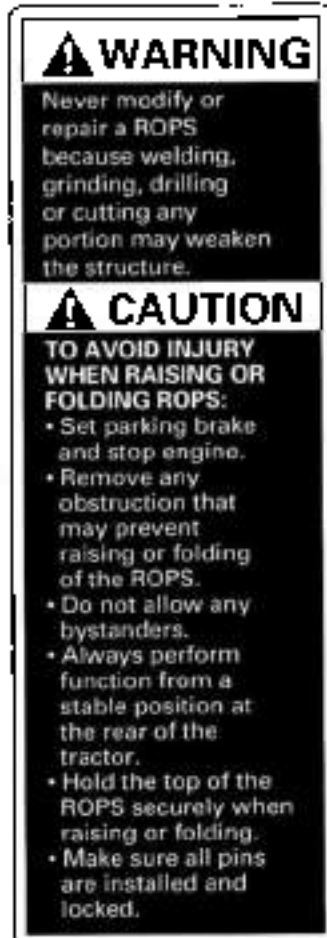

F-1391EB

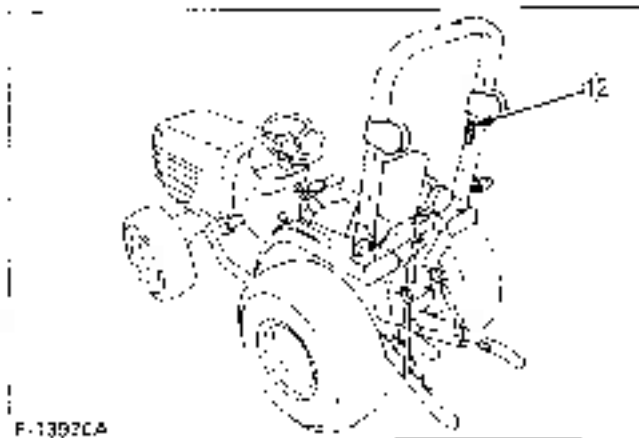

F-1392CA

## 9. CARE OF DANGER, WARNING AND CAUTION LABELS

1. Keep danger, warning and caution labels clean and free from obstructing material.
2. Clean danger, warning and caution labels with soap and water, dry with a soft cloth.
3. Replace damaged or missing danger, warning and caution labels with new labels from your local KUBOTA Dealer.
4. If a component with danger, warning and caution label(s) affixed is replaced with new part, make sure new label(s) is(are) attached in the same location(s) as the replaced component.
5. Mount new danger, warning and caution labels by applying on a clean dry surface and pressing any bubbles to outside edge.

# SERVICING OF TRACTOR

Your dealer is interested in your new tractor and has the desire to help you get the most value from it. After reading this manual thoroughly, you will find that you can do some of the regular maintenance yourself.

However, when in need of parts or major service, be sure to see your KUBOTA Dealer.

For service, contact the KUBOTA Dealership from which you purchased your tractor or your local KUBOTA Dealer.

When in need of parts, be prepared to give your dealer both the tractor and engine serial numbers.

Locate the serial numbers now and record them in the space provided.

	Type	Serial No.
Tractor	_____	_____
Engine	_____	_____
Date of Purchase	_____	
Name of Dealer	_____	

(To be filled in by purchaser.)

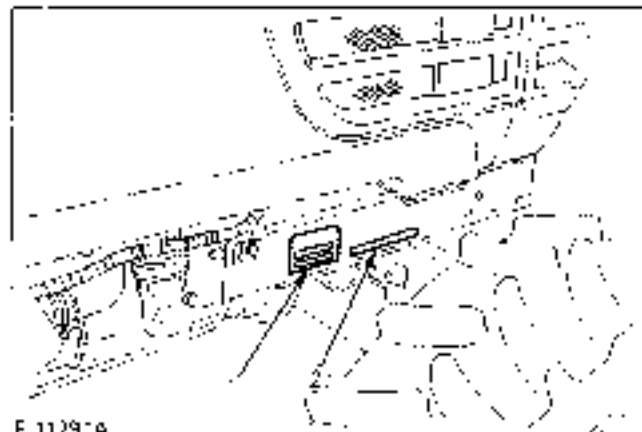

F 1179 A

(1) Tractor identification plate

(2) Tractor serial number

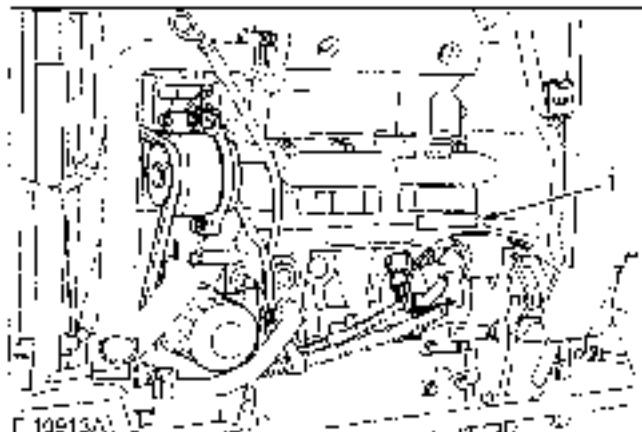

F 10913 A

(1) Engine serial number

# SPECIFICATIONS

## SPECIFICATION TABLE

Model		B2710 HSD	B2910 HSD	B7800 HSD
PTO power kW (HP)		14.9 (20.0) *	16.4 (22.0) *	
Maker		KUBOTA		
Model		V1305-E-D12	V1505 E-D16	
Type		Indirect Injection, Vertical, water-cooled, 4-cycle diesel		
Number of cylinders		4		
Bore and stroke mm (in.)		ø76X73.6(ø3.0X2.9)	ø78X78.4(ø3.1X3.1)	
Total displacement cm <sup>3</sup> (cu. in.)		1335 (81.5)	1498 (91.5)	
Engine gross power kW(HP)		23.1 (31.0) *	22.3 (30.0) *	
Rated revolution rpm		2600		
Maximum torque N·m(lb-ft)		79 (58)	89 (66)	
Battery		12V, RC : 79 min. CCA : 433 A		
Fuel		Diesel fuel No.2 (above -10°C/14°F), Diesel fuel No.1 (below -10°C/14°F)		
Fuel tank L (U.S. gals.)		26 (6.9)		
Engine crankcase (with filter) L (U.S. qts.)		4.1 (4.3)		
Engine coolant L (U.S. qts.)		4.5 (4.7)		
Transmission case L (U.S. gals.)		14.5 (3.83)		
Overall length (without 3rd main) mm (in.)		2520 (99.2)		
Overall width (min. tread) mm (in.)		1366 (53.8)		
Overall height (with ROPS) mm (in.)		1995 (78.5)		
Overall height (Top of Seat) mm (in.)		1365 (53.7)		
Wheel base mm (in.)		1666 (65.6)		
Min. ground clearance mm (in.)		370 (14.6)		
Tread		Front mm (in.) 935 (36.8) Rear mm (in.) 1050 (41.3)		
Weight (with ROPS) kg (lbs.)		790 (1740)	800 (1763)	790 (1740)
Clutch		Dry single plate		
Tires		Front 7-12 Rear 12.4-16		
Steering		Integral type power steering		
Transmission		Main-hydrostatic transmission, 3 range gear shift (3 forward, 3 reverse)		
Brake		Wet disk type		
Min. turning radius (with brake) m (feet)		2.1 (6.9)		
Hydraulic control system		Position Control	Quarter Inching Valve	
Pump capacity L/min (gals./min.)		3P, 24.4 (6.4), Power steering: 11.7 (3.1)		
Three point hitch		SAE Category I		
Max. lift force		At lift points kg(lbs.) 750 (1655) 24m behind lift points kg(lbs.) 590 (1300)		
Rear-PTO		SAE 1-3/8, 6 splines		
Revolution		1 speed (540 rpm) at 2600 engine rpm		
Mid-PTO (if equipped)		USA No.5 (KUBOTA 10-tooth) involute spline		
Revolution		1 speed (2500 rpm) at 2578 engine rpm		

**NOTE** \* Manufacturer's estimate. The company reserves the right to change the specifications without notice.



## TRAVELING SPEEDS

(At rated engine rpm)

Model		B2710 · B2910 · B7800			
Tire size (Rear)		12.4 - 16 Farm		13.6 - 16 Turf	
	Range gear shift lever	km/h	mph	km/h	mph
Forward	Low	0 to 5.0	0 to 3.1	0 to 5.1	0 to 3.2
	Middle	0 to 8.8	0 to 5.3	0 to 8.8	0 to 5.5
	High	0 to 19.1	0 to 11.9	0 to 19.6	0 to 12.2
Reverse	Low	0 to 4.0	0 to 2.5	0 to 4.1	0 to 2.6
	Middle	0 to 6.9	0 to 4.3	0 to 7.1	0 to 4.4
	High	0 to 15.2	0 to 9.4	0 to 15.5	0 to 9.7

The company reserves the right to change the specifications without notice.

# IMPLEMENT LIMITATIONS

The KUBOTA Tractor has been thoroughly tested for proper performance with implements sold or approved by KUBOTA. Use with implements which are not sold or approved by KUBOTA and which exceed the maximum specifications listed below, or which are otherwise unfit for use with the KUBOTA Tractor may result in malfunctions or failures of the tractor, damage to other property and injury to the operator or others. [Any malfunctions or failures of the tractor resulting from use with improper implements are not covered by the warranty.]

	Tread (max. width) with farm tires		Lower link end max. loading weight $W_0$
	Front	Rear	
B2710 B2910 B7800	935 mm (36.8 in.)	1050 mm (41.3 in.)	360 kg (800 lbs.)

	Actual figures		
	Implement weight $W_1$ and/or size	Max. Drawbar Load $W_2$	Trailer loading weight $W_3$ Max. capacity
B2710 B2910 B7800	As in the following list (Shown on the next page)	500 kg (1100 lbs.)	1500 kg (3300 lbs.)

Lower link end max. loading weight... The max. allowable load which can be put on the lower link end :  $W_0$   
 Implement weight..... The implement's weight which can be put on the lower link :  $W_1$   
 Max. drawbar load.....  $W_2$   
 Trailer loading weight..... The max. loading weight for trailer (without trailer's weight):  $W_3$

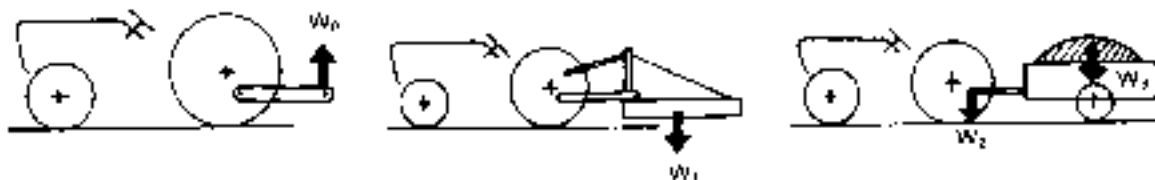

## NOTE:

- Implement size may vary depending on soil operating conditions.

Implement		Remarks		B2710 · B2910 · B7800
Mower	Mid-mount	Max. cutting width	mm(in.)	1830 (72)
		Max. weight	kg(lbs.)	205 (451)
	Rotary-cutter (1 Blade)	Max. cutting width	mm(in.)	1220 (48)
		Max. weight	kg(lbs.)	227 (500)
	Rear-mount (2 or 3 Blades)	Max. cutting width	mm(in.)	1830 (72)
Max. weight		kg(lbs.)	227 (500)	
Flail-mower	Max. cutting width	mm(in.)	1220 (48)	
	Sickle bar	Max. tilling width	mm(in.)	1524 (60)
Rotary tiller		Max. weight	mm(in.)	1270 (50)
		Max. weight	kg(lbs.)	250 (550)
Bottom plow		Max. size	mm(in.)	305 (12) x 2
Disc plow		Max. size	mm(in.)	559 (22) x 2
Cultivator		Max. size	mm(in.)	1524 (60) 1 Row
Disc harrow		Max. harrowing width	mm(in.)	1676 (66)
		Max. weight	kg(lbs.)	250 (550)
Sprayer		Max. tank capacity	LIU.S.gals.	246 (65)
Front blade		Max. cutting width	mm(in.)	1676 (66)
		Sub frame		Necessary
Rear blade		Max. harrowing width	mm(in.)	1676 (66)
		Max. weight	kg(lbs.)	250 (550)
Front loader		Max. digging depth	kg(lbs.)	400 (880)
		Max. weight	mm(in.)	1524 (60)
		Sub frame		Necessary
Box blade		Max. cutting width	mm(in.)	1372 (54)
		Max. weight	kg(lbs.)	227 (500)
Back hoe		Max. digging depth	mm(in.)	1830 (72)
		Max. weight	kg(lbs.)	363 (800)
		Sub frame		Necessary
Snow blower		Max. working width	mm(in.)	1524 (60)
		Max. weight	kg(lbs.)	227 (500)
Trailer		Max. load capacity	kg(lbs.)	1500 (3300)
		Max. drawbar load	kg(lbs.)	360 (800)

**NOTE:**

- Implement size may vary depending on soil operating conditions.

# INSTRUMENT PANEL AND CONTROLS

## Instrument Panel, Switches and Hand Controls

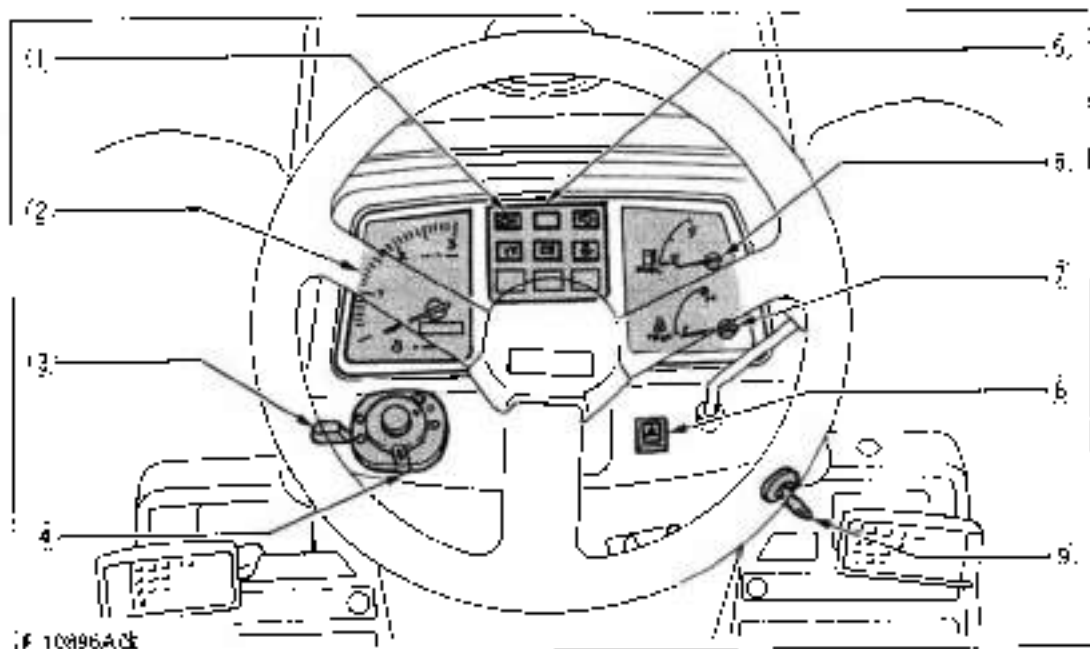

### ILLUSTRATED CONTENTS

(1) Turn signal / Hazard light indicator	25
(2) Hourmeter / Tachometer	30
(3) Turn signal light switch	25
(4) Head light switch	25
(5) Easy Checker™	20, 29
(6) Fuel gauge	30
(7) Coolant temperature gauge	30
(8) Hazard light switch	25
(9) Key switch	19

## Pedal Location Label

The label is located on the cover under seat

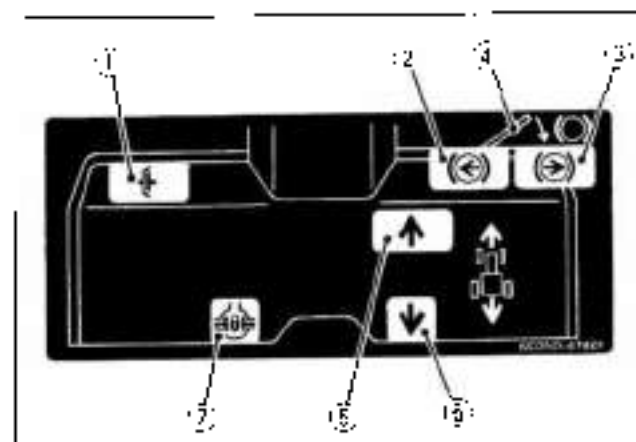

- (1) Clutch pedal
- (2) Brake pedal (left)
- (3) Brake pedal (right)
- (4) Brake pedal lock
- (5) Speed control pedal (forward)
- (6) Speed control pedal (reverse)
- (7) Differential lock pedal

■ Foot and Hand Controls

◆ B2710 · B7800

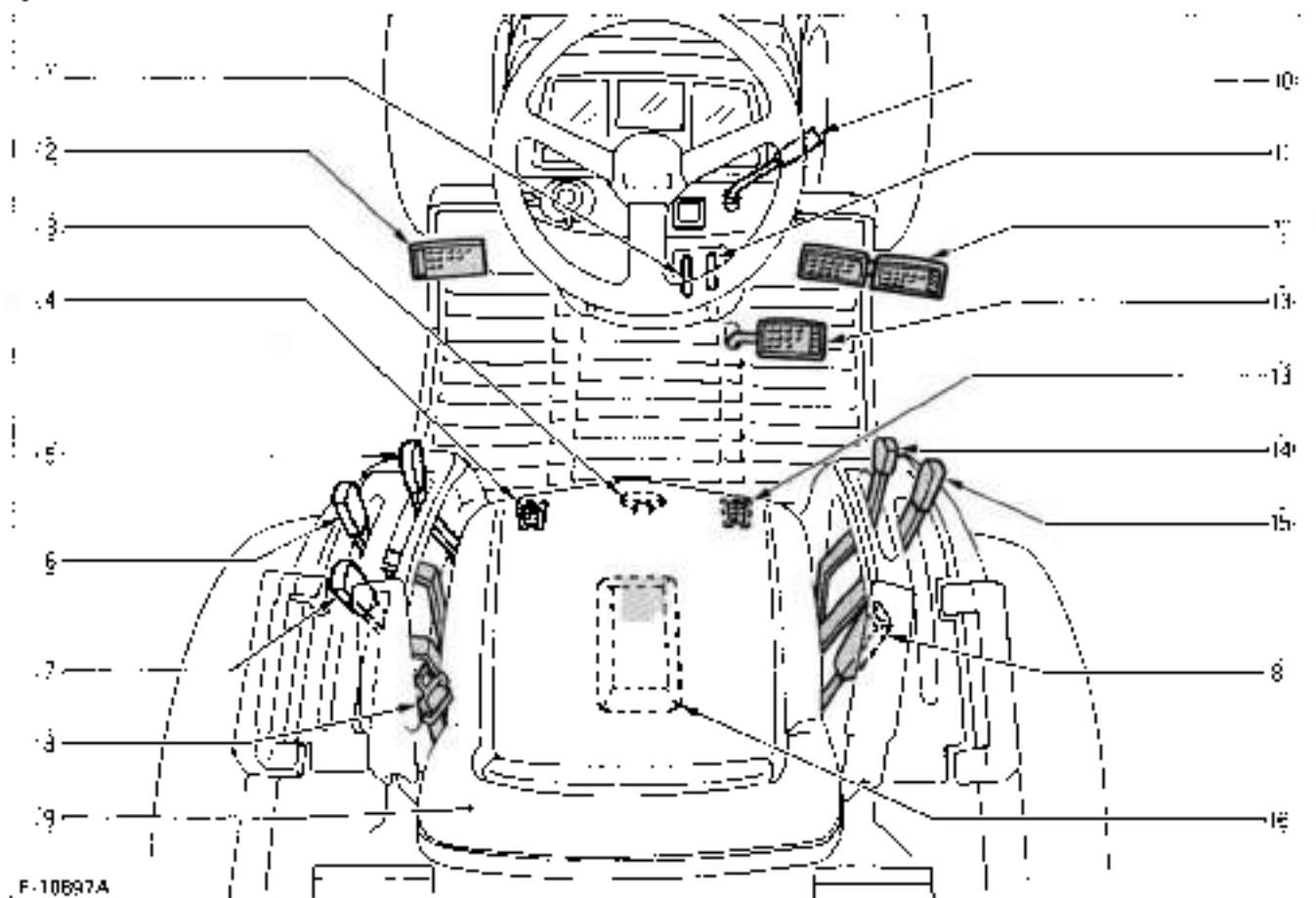

ILLUSTRATED CONTENTS

(1) Speed set lever	28
(2) Clutch pedal	26
(3) 3-Point hitch lowering speed knob	39
(4) Differential lock pedal	31
(5) Mid PTO gear shift lever (if equipped)	18, 34
(6) Range gear shift lever	27
(7) Rear PTO gear shift lever	18, 33
(8) Seat belt	24
(9) Operator's seat	24
(10) Hand throttle lever	19, 27
(11) Parking brake lever	18, 28, 30
(12) Brake pedal	25
(13) Speed control pedal	18, 28
(14) Front wheel drive lever	27
(15) Position control lever [92 / 10]	19, 39
Hydraulic control lever (B7800)	19, 39
(16) Tool box	—

◆B2910

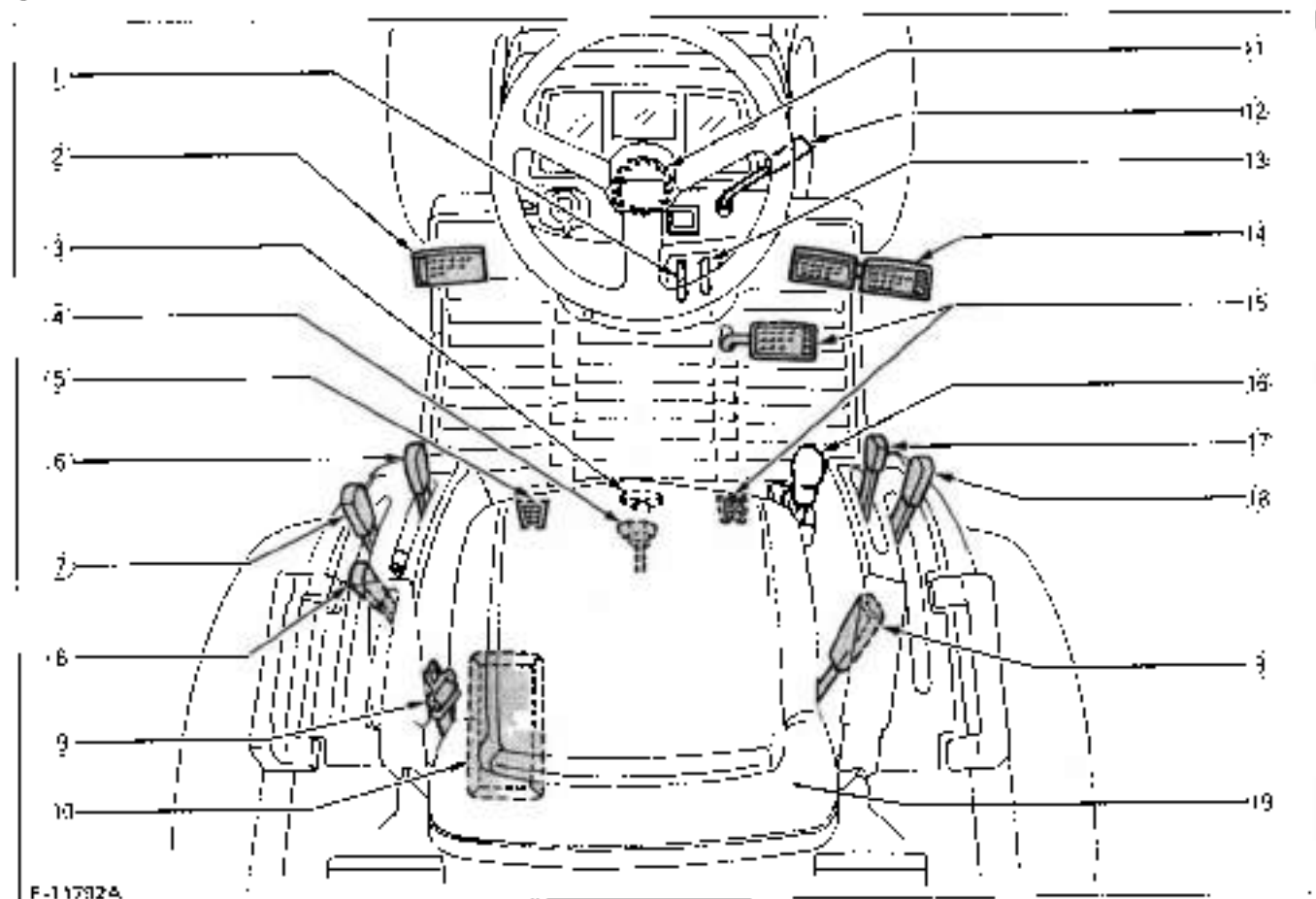

F-11792A

ILLUSTRATED CONTENTS

(1) Steering wheel tilt lever .....	24
(2) Clutch pedal .....	26
(3) 3-Point hitch lowering speed knob .....	38
(4) Suspension adjust knob .....	24
(5) Differential lock pedal .....	31
(6) Mid-PTO gear shift lever .....	19, 33
(7) Range gear shift lever .....	27
(8) Rear-PTO gear shift lever .....	13, 33
(9) Seat belt .....	24
(10) Tobi-box .....	-
(11) Steering wheel telescope hub .....	24
(12) Hand throttle lever .....	19, 27
(13) Parking brake lever .....	18, 28, 30
(14) Brake pedal .....	25
(15) Speed control pedal .....	19, 28
(16) Cruise control lever .....	28, 29
(17) Front wheel drive lever .....	27
(18) Pashinn control lever .....	19, 33
(19) Operator's seat .....	24

# PRE-OPERATION CHECK

## DAILY CHECK

To prevent trouble from occurring, it is important to know the condition of the tractor. Check it before starting.



### CAUTION

To avoid personal injury:

- Be sure to check and service the tractor on a firm, flat, and level surface with the engine stopped, all implements lowered to the ground and the parking brake "ON".

### Check item

- Walk around inspection
- Check engine oil level
- Check transmission oil level
- Check coolant level
- Clean grill and radiator screen
- Check air cleaner evacuator valve  
(When used in dusty conditions)
- Check brake and clutch pedal
- Check indicators, gauges and meter
- Check wire harness
- Check lights
- Check seat belt and ROPS
- Refuel  
(See "DAILY CHECK" in periodic service section.)
- Care of danger, warning and caution labels  
(See "DANGER, WARNING AND CAUTION LABELS" in safe operation section.)

# OPERATING THE ENGINE



## CAUTION

To avoid personal injury:

- Read "Safe Operation" in the front of this manual.
- Read the danger, warning and caution labels located on the tractor.
- To avoid the danger of exhaust fume poisoning, do not operate the engine in a closed building without proper ventilation.
- Never start engine while standing on ground. Start engine only from operator's seat.
- Make it a rule to set all shift levers to the "NEUTRAL" positions and to place PTO lever in "OFF" position before starting the engine.

## IMPORTANT:

- Do not use starting fluid or ether.
- To protect the battery and the starter, make sure that the starter is not continuously turned for more than 30 seconds.

## STARTING THE ENGINE

### 1. Make sure the parking brake is set.

1. To set the parking brake:
  - 1) Interlock the brake pedals.
  - 2) Depress the brake pedals.
  - 3) Latch the brake pedals with the parking brake lever.
2. To release the parking brake, depress the brake pedals again.

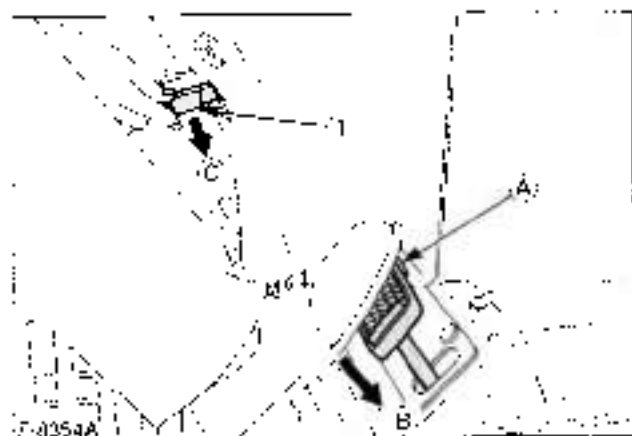

(1) Parking brake lever

- (A) Interlock the brake pedals  
(B) "DEPRESS"  
(C) "PUSH-DOWN"

2. Place the Rear-PTO gear shift lever in "OFF" (Disengaged) position.
3. Place the Mid-PTO gear shift lever in "OFF" (Disengaged) position. (if equipped)
4. Place the speed set lever in "OFF" position. [B2710-B7800]  
Place the cruise control lever in "OFF" position. [B2910]  
Place the speed control pedal in "NEUTRAL" position.  
Place the range gear shift lever in "NEUTRAL" position.

### ◆B2710-B7800

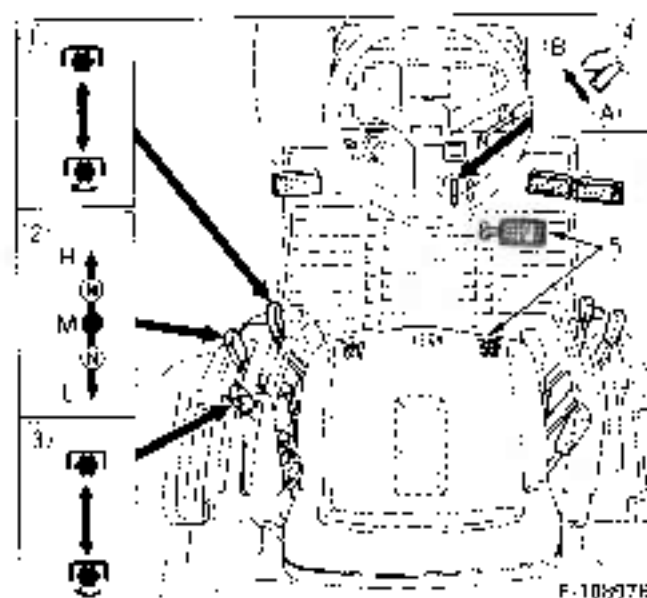

- (1) Mid-PTO gear shift lever
- (2) Range gear shift lever (L, M, H)
- (3) Rear-PTO gear shift lever
- (4) Speed set lever
- (5) Speed control pedal
- (A) "ON"  
(B) "OFF"  
(H) "HIGH"  
(M) "MIDDLE"  
(L) "LOW"  
(N) "NEUTRAL POSITION"
- ☐ "ON" (Engaged)  
☐ "OFF" (Disengaged)

## NOTE:

- The speed control pedal automatically returns to neutral when the operator's foot is released from the pedal.



◆B2910

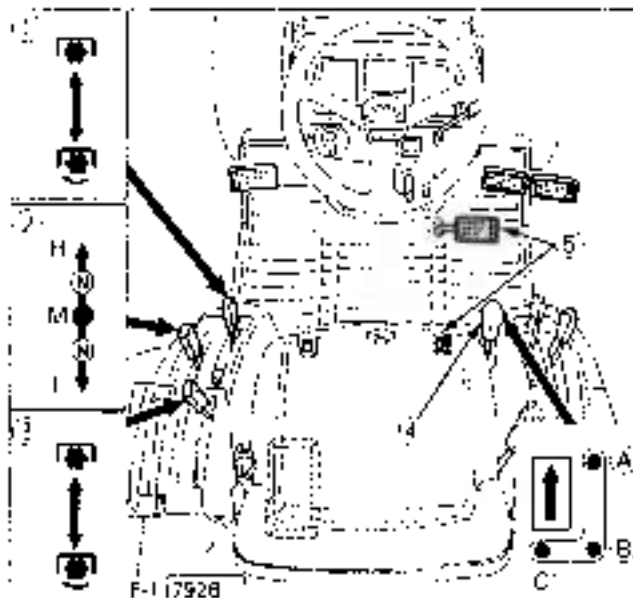

- (1) Mid-PTO gear shift lever
- (2) Range gear shift lever (L-M-H)
- (3) Rear-PTO gear shift lever
- (4) Cruise control lever
- (5) Speed control pedal
- (A) "INCREASE"
- (R) "DECREASE"
- (C) "OFF" position
- (H) "HIGH"
- (M) "MIDDLE"
- (L) "LOW"
- (N) "NEUTRAL POSITION"
- ☑ "ON" (Engaged)
- ☐ "OFF" (Disengaged)

NOTE:

- The speed control pedal automatically returns to neutral when the operator's foot is released from the pedal.

5. Place the position control lever in "LOWEST" position. [B2710-B2910]  
Place the hydraulic control lever in "NEUTRAL" position. [B7800]

[B2710-B2910]

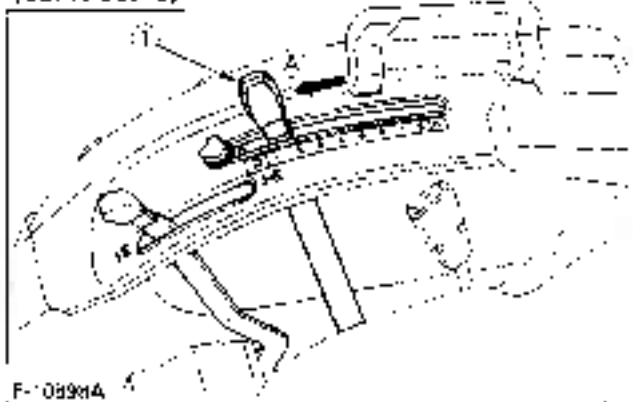

(1) Position control lever (A) "Down"

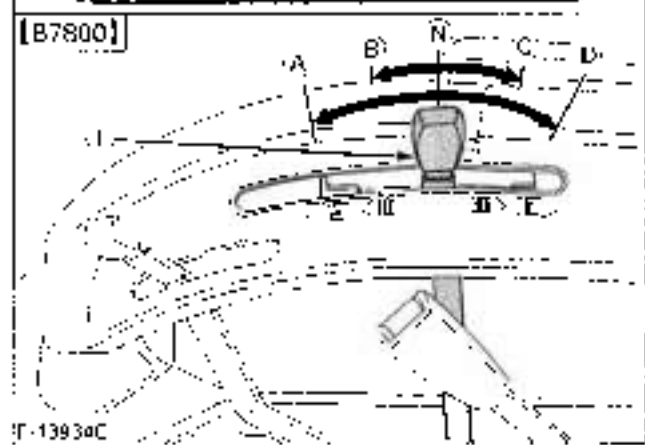
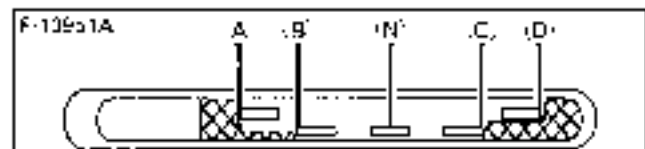

(1) Hydraulic control lever  
(A) "DOWN"  
(B) "SLOW DOWN"  
(N) "NEUTRAL"  
(C) "SLOW UP"  
(D) "UP"

6. Set the throttle lever to about 1/2 way.

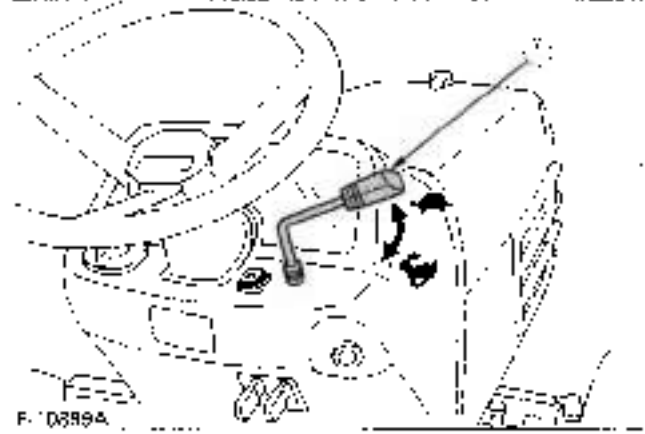

(1) Hand throttle lever  
☑ "INCREASE"  
☐ "DECREASE"

7. Insert the key into the key switch and turn it "ON".

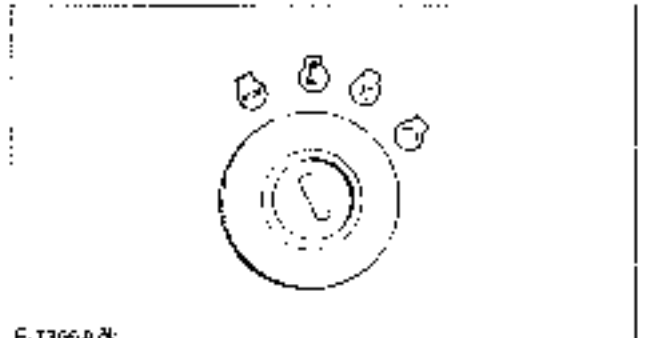

(1) Key switch  
☑ "OFF"  
☑ "ON"  
☑ "PREHEAT"  
☑ "START"

### ◆ Check Easy Checker™ lamps:

- When the key is turned "ON", lamps (3)-(4) should come on. If trouble should occur at any location while the engine is running, the warning lamp corresponding to that location comes on.

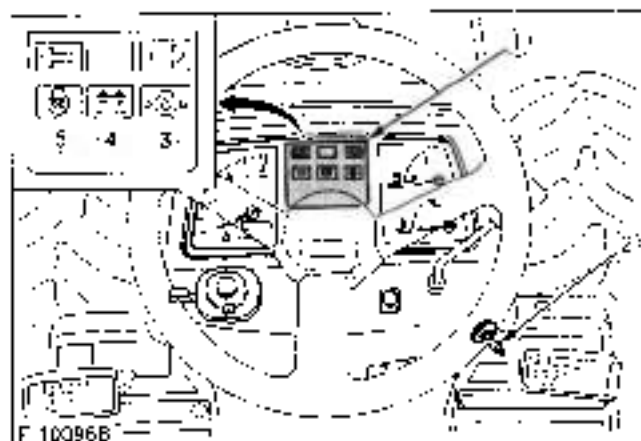

- (1) Easy checker™  
 (2) Key switch  
 (3) Engine oil pressure  
 (4) Electrical charge  
 (5) Glow plug indicator

### IMPORTANT:

- Daily checks with the Easy Checker™ only are not sufficient. Never fail to conduct physical daily checks carefully by referring to Daily Check section. (See "DAILY CHECK" in Periodic Service section)

8. Fully depress the clutch pedal, turn the key to "PREHEAT" position and hold it for about 2 to 3 seconds.

For the appropriate preheating time, refer to the table below:

Temperature	Preheating Time
Over 0°C (32°F)	2 to 3 sec.
0 to -5°C (32 to 23°F)	5 sec.
5 to -15°C (23 to 5°F)	10 sec.

### NOTE:

- Glow plug indicator (5) comes on while engine is being preheated.

9. Turn the key to "START" position and release when the engine starts.

### ◆ Cold Weather Starting

When the ambient temperature is below -5°C (23°F) and the engine is very cold. If the engine fails to start, turn off the key for 30 seconds. Then repeat steps 8 and 9. To protect the battery and the starter, make sure that the starter is not continuously turned for more than 30 seconds.

### ■ Block Heater (Option)

A block heater is available as an option from your dealer. It will assist you in starting your tractor when the ambient temperature is below -15°C (5°F).

### IMPORTANT:

- The engine will not start unless the clutch pedal is fully depressed, and the speed control pedal and the Rear-PTO gear shift lever and Mid-PTO gear shift lever are in the "NEUTRAL" position.

10. Check to see that all the lamps on the Easy Checker™ are "OFF".

If a lamp is still on, immediately stop the engine and determine the cause.

11. Release the clutch pedal.

## STOPPING THE ENGINE

1. After slowing the engine to idle, turn the key to "OFF".
2. Remove the key.

## WARMING UP



### CAUTION

To avoid personal injury:

- Be sure to set the parking brake during warm-up.
- Be sure to set all shift levers to the "NEUTRAL" positions and to place PTO lever in "OFF" position during warm-up.

For five minutes after engine start-up, allow engine to warm up without applying any load, this is to allow oil to reach every engine part. If load should be applied to the engine without this warm-up period, trouble such as seizure, breakage or premature wear may develop.

## ■ Warm-up Transmission Oil at Low Ambient Temperatures

Hydraulic oil serves as transmission fluid. In cold weather, the oil may be cold with increased viscosity. This can cause delayed oil circulation or abnormally low hydraulic pressure for some time after engine start up. This in turn can result in trouble in the hydraulic system. To prevent the above, observe the following instructions:

Warm up the engine at about 50 % of rated rpm according to the table below:

Ambient temperature	Warm-up time requirement
Above 0°C (32°F)	At least 5 minutes
0 to -10°C (32 to 14°F)	5 to 10 minutes
-10 to -20°C (14 to -4°F)	10 to 15 minutes
Below -20°C (-4°F)	More than 15 minutes

### IMPORTANT:

- Do not operate the tractor under full load condition until it is sufficiently warmed up.

## JUMP STARTING



### CAUTION

To avoid personal injury:

- Battery gases can explode. Keep cigarettes, sparks, and flames away from battery.
- If tractor battery is frozen, do not jump start engine.
- Do not connect other end of negative (-) jumper cable to negative (-) terminal of tractor battery.

When jump starting engine, follow the instructions below to safely start the engine.

- Bring helper vehicle with a battery of the same voltage as disabled tractor within easy cable reach. "THE VEHICLES MUST NOT TOUCH".
- Engage the parking brakes of both vehicles and put the shift levers in neutral. Shut both engines off.
- Put on safety goggles and rubber gloves.
- Ensure the vent caps are securely in place, if equipped!
- Cover vent caps with damp rags. Do not allow the rag to touch the battery terminals.
- Attach the red clamp to the positive (red, + or pos.) terminal of the dead battery and clamp the other end of the same cable to the positive (red, + or pos.) terminal of the helper battery.
- Clamp the other cable to the negative (black, - or neg.) terminal of the helper battery.

- Clamp the other end to the engine block or frame of the disabled tractor as far from the dead battery as possible.
- Start the helper vehicle and let its engine run for a few moments. Start the disabled tractor.
- Disconnect the jumper cables in the exact reverse order of attachment. (Steps 8, 7 and 6).
- Remove and discard the damp rags.

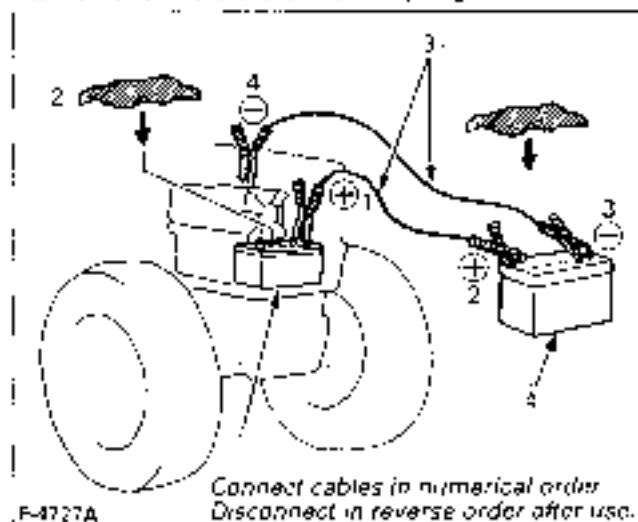

F-4727A

Connect cables in numerical order. Disconnect in reverse order after use.

(1) Dead battery

(2) Lay a damp rag over the vent caps

(3) Jumper cables

(4) Helper battery

### IMPORTANT:

- This machine has a 12-volt negative (-) ground starting system.
- Use only same voltage for jump starting.
- Use of a higher voltage source on tractor's electrical system could result in severe damage to tractor's electrical system. Use only matching voltage source when "Jump starting" a low or dead battery condition.

# OPERATING THE TRACTOR

## OPERATING NEW TRACTOR

How a new tractor is handled and maintained determines the life of the tractor.

A new tractor just off the factory production line has been, of course, tested, but the various parts are not accustomed to each other, so care should be taken to operate the tractor for the first 50 hours at a slower speed and avoid excessive work or operation until the various parts become "broken-in." The manner in which the tractor is handled during the "breaking-in" period greatly affects the life of your tractor. Therefore, to obtain the maximum performance and the longest life of the tractor, it is very important to properly break-in your tractor. In handling a new tractor, the following precautions should be observed.

### Do not Operate the Tractor at Full Speed for the First 50 Hours.

- Do not start quickly nor apply the brakes suddenly.
- In winter, operate the tractor after fully warming up the engine.
- Do not run the engine at speeds faster than necessary.
- On rough roads, slow down to suitable speeds. Do not operate the tractor at fast speed.

The above precautions are not limited only to new tractors, but to all tractors. But it should be especially observed in the case of new tractors.

### Changing Lubricating Oil for New Tractors

The lubricating oil is especially important in the case of a new tractor. The various parts are not "broken-in" and are not accustomed to each other; small metal grit may develop during the operation of the tractor, and this may wear out or damage the parts. Therefore, care should be taken to change the lubricating oil a little earlier than would ordinarily be required.

For further details of change interval hours, see "MAINTENANCE" section.

## OPERATING FOLDABLE ROPS (OPTION)



### CAUTION

To avoid personal injury:

- When raising or folding the ROPS, apply parking brake, stop the engine and remove the key.
- Always perform function from a stable position at the rear of tractor.

- Fold the ROPS down only when absolutely necessary and fold it up and lock it again as soon as possible.
- Before proceeding to fold ROPS, check for any possible interference with installed implements and attachments. If interference occurs, contact your KUBOTA Dealer.

### To Fold the ROPS

1. Remove both set bolts.

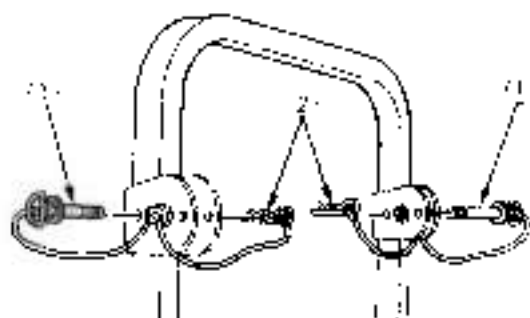

F-10522A28

- (1) Set bolt
- (2) Hair pin

2. Fold the ROPS.



### CAUTION

To avoid personal injury:

- Hold the ROPS tightly with both hands and fold the ROPS slowly and carefully.

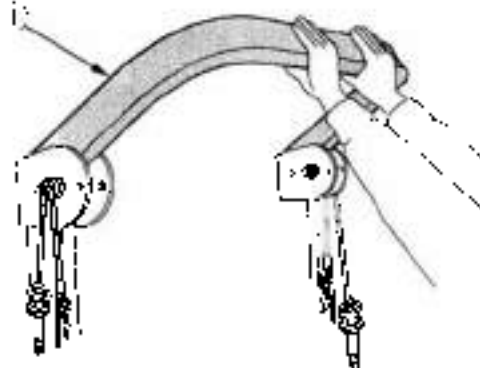

F-10523A28

- (1) ROPS

- Align set bolt holes and insert both set bolts. Slightly tighten the set bolts and secure them with the hair pins.

**CAUTION**

To avoid personal injury:

- Make sure that both set bolts are properly installed and secured with the hair pins.

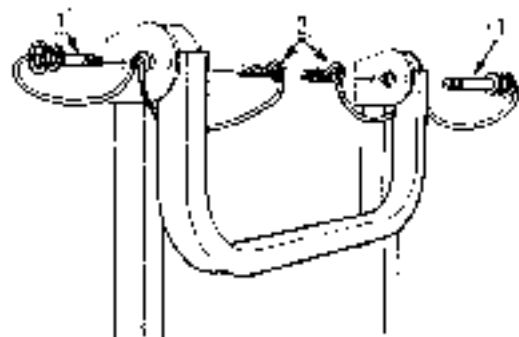

F-11695A (2)

- (1) Set bolt  
(2) Hair pin

### ■ To Raise the ROPS to Upright Position

- Remove both hair pins and set bolts.

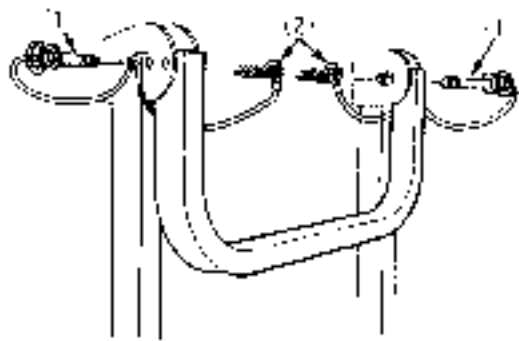

F-11695A (3)

- (1) Set bolt  
(2) Hair pin

- Raise ROPS to the upright position.

**CAUTION**

To avoid personal injury:

- Raise the ROPS slowly and carefully.

- Align set bolt holes, insert both set bolts. Slightly tighten the set bolts and secure them with the hair pins.

**CAUTION**

To avoid personal injury:

- Make sure that both set bolts are properly installed as soon as the ROPS is in the upright position and secured with the hair pins.

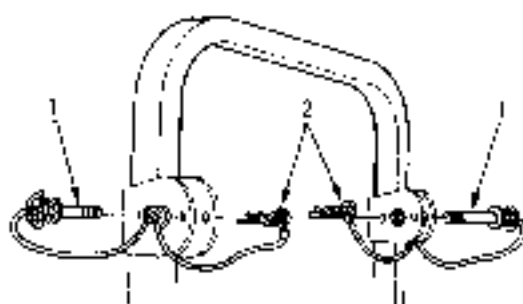

F-105216B

- (1) Set bolt  
(2) Hair pin

### ■ Adjustment of Foldable ROPS

- Adjust free fall of the ROPS upper frame regularly.
- If you feel less friction when folding the ROPS, remove the cotter pin (1), tighten the nut (2) until you feel the right friction in the movement and then replace the cotter pin.

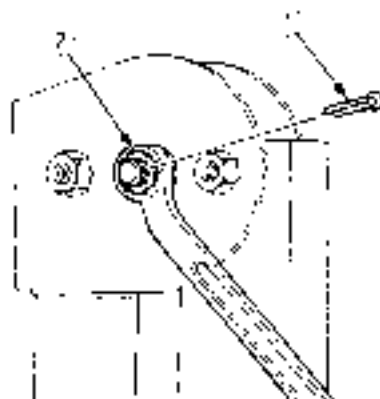

F-10525A

- (1) Cotter pin  
(2) Nut

## STARTING

### 1. Adjusting the Operator's Position.

#### Operator's Seat



#### CAUTION

To avoid personal injury:

- Make sure that the seat is completely secured after each adjustment.
- Do not allow any person other than the driver to ride on the tractor.

#### ◆ Position adjustment

Pull in the position adjust lever and slide the seat backward or forward, as required. The seat will lock in position when the lever is released.

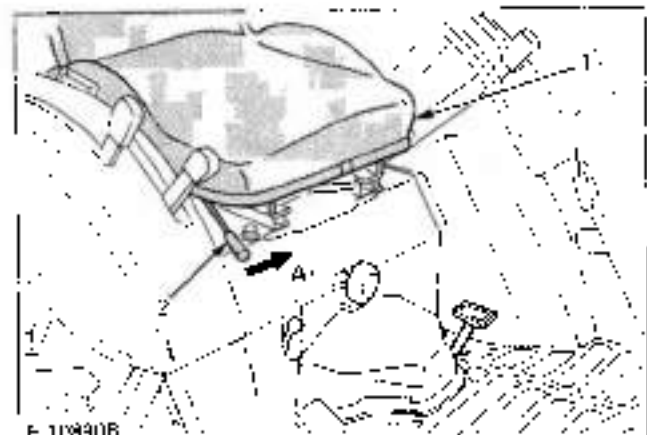

(1) Seat

(2) Position adjust lever

(A) "PULL IN"

#### IMPORTANT

- After adjusting the operator's seat, be sure to check that the seat is properly locked.

#### ◆ Suspension adjustment [B2910 only]

Turn the suspension adjust knob to achieve the optimum suspension setting.

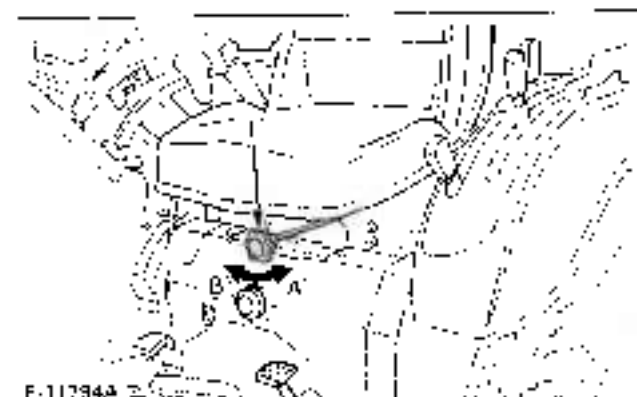

(1) Suspension adjust knob

(A) To decrease tension  
(B) To increase tension

#### Seat Belt



#### CAUTION

To avoid personal injury:

- Always use the seat belt when the ROPS is installed.
- Do not use the seat belt if a foldable ROPS is down or there is no ROPS.

Adjust the seat belt for proper fit and connect to the buckle. The seat belt is auto-locking retractable type.

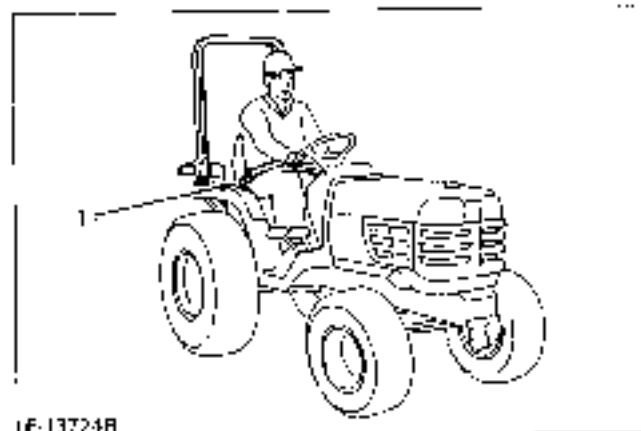

F-13724B

(1) Seat belt

#### Tilt and Telescopic Steering Wheel Adjustment [B2910 only]



#### CAUTION

To avoid personal injury:

- Do not adjust the steering wheel while the tractor is in motion.
- Make sure the steering wheel is locked after adjusting.

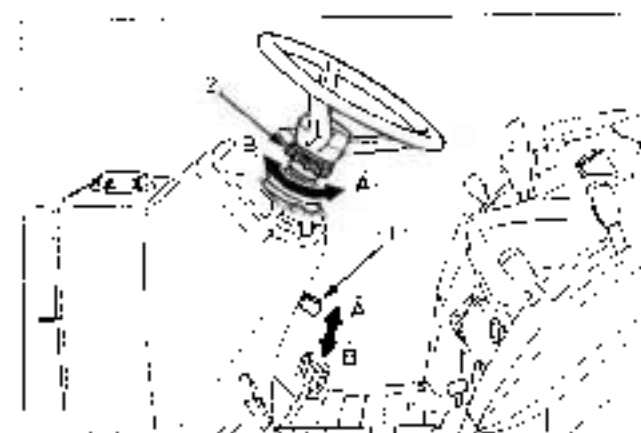

F-11824A

(1) Tilt lever

(2) Telescope hub

(A) "UNLOCK"

(B) "LOCK"

#### ◆ To tilt the steering wheel

1. Pull up the tilt lever.
2. Move the steering wheel fore and aft to the desired position.
3. Push down the tilt lever to lock the steering wheel.



#### ◆ To telescope the steering wheel

1. Turn the telescope hub counter-clockwise.
2. Raise or lower the steering wheel to the desired position.
3. Turn the telescope hub clockwise to lock the steering wheel.

## 2. Selecting Light Switch Positions.

### ■ Head Light / Turn Signal / Hazard Light Switch

#### ◆ Head Light Switch

- (A)  --- Head lights OFF.  
 (B)  --- Head lights ON.

#### ◆ Hazard Light

- When hazard light switch is pushed, the hazard lights flash, along with the L/H and R/H indicators on the instrument panel.
- Push hazard light switch again to turn off the hazard lights.

#### ◆ Turn Signal with Hazard Light Switch On.

- To indicate a right turn with the hazard lights already flashing (hazard switch on), turn the turn signal switch clockwise.
- To indicate a left turn with the hazard lights already flashing, turn the turn signal switch counterclockwise.
- When the left or right turn signal is activated in combination with the hazard lights, the indicated turning light will flash and the other will stay on.

#### ◆ Turn Signal with Hazard Light Switch Off.

- To indicate a right turn without hazard lights (hazard switch off), turn the turn signal switch clockwise.
- To indicate a left turn without hazard lights, turn the turn signal switch counterclockwise.
- When the left or right turn signal is activated without the hazard lights, the indicated turning light will flash and the other will stay on.

#### NOTE:

- The hazard light switch is operative when the key switch is in either the "ON" or "OFF" positions.
- The turn signal light switch is only operative when the key switch is in the "ON" position.
- The indicator in the hazard light switch will light up when the head light switch is turned on.
- Be sure to return the turn signal switch to center position after turning.



- (1) Turn signal light switch  
 (2) Head light switch  
 (3) Hazard light switch  
 (4) Hazard / Turn signal indicator

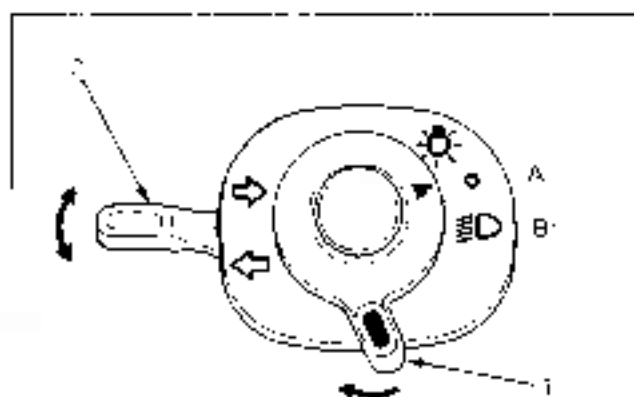

F-10900A

- (1) Head light switch (A) "OFF"  
 (2) Turn signal light switch (B) "ON"

## 3. Checking the Brake Pedal.

### ■ Brake Pedals (Right and Left)



#### WARNING

To avoid personal injury:

- Applying only one rear wheel brake at high speeds could cause the tractor to swerve or roll-over.



#### CAUTION

To avoid personal injury:

- An accident may occur if the tractor is suddenly braked, such as by heavy towed loads shifting forward or loss of control.
- The braking characteristics are different between two and four wheel drive tractor models. Be aware of the difference and use carefully.
- When driving on icy, wet or loose surfaces, make sure the tractor is correctly ballasted to avoid skidding and loss of steering control. Operate at reduced speed.

- Before operating the tractor on the road or before applying the parking brake, be sure to interlock the right and left pedals as illustrated below.
- Use individual brakes to assist in making sharp turns at slow speeds (Field Operation Only). Disengage the brake pedal lock and depress only one brake pedal.

3. Be sure brake pedals have equal adjustment when using locked together.



F-1134392

(A) "LOCK"  
(B) "RELEASE"

4. Raise the Implement. (see "HYDRAULIC UNIT" section)

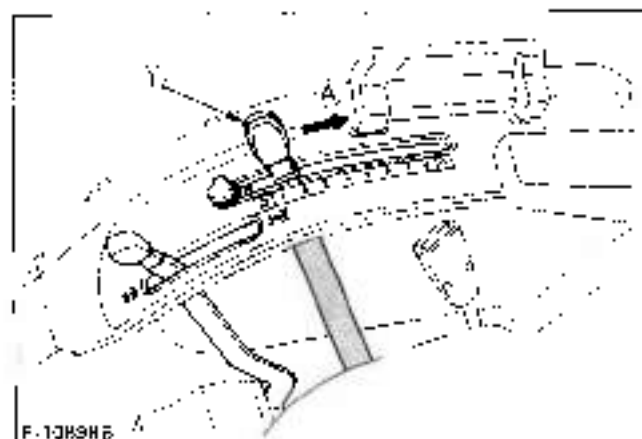

F-108985

(1) Position control lever [B2710-B2910]

(A) "UP"

[B7800]



F-113934A

(1) Hydraulic control lever [B7800]

(A) "UP"

5. Depress the Clutch Pedal.

#### Clutch Pedal



#### CAUTION

To avoid personal injury:

- Sudden release of the clutch may cause the tractor to lunge in an unexpected manner.

The clutch is disengaged when the clutch pedal is fully pressed down.

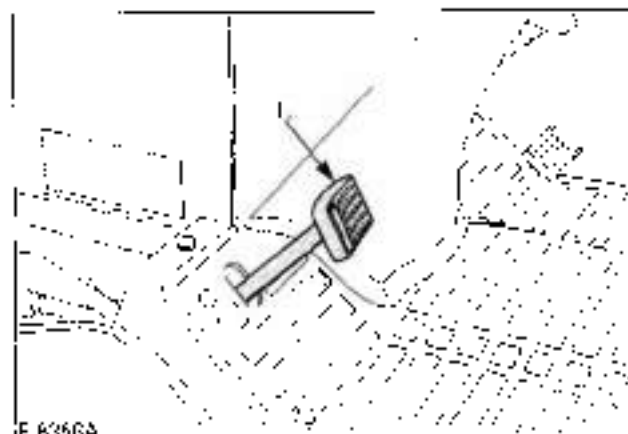

F-10368A

(1) Clutch pedal

#### IMPORTANT:

To help prevent premature clutch wear:

- The clutch pedal must be quickly disengaged and be slowly engaged.
- Avoid operating the tractor with your foot resting on the clutch pedal.
- Select proper gear and engine speed depending on the type of job.

6. Selecting the Travel Speed.

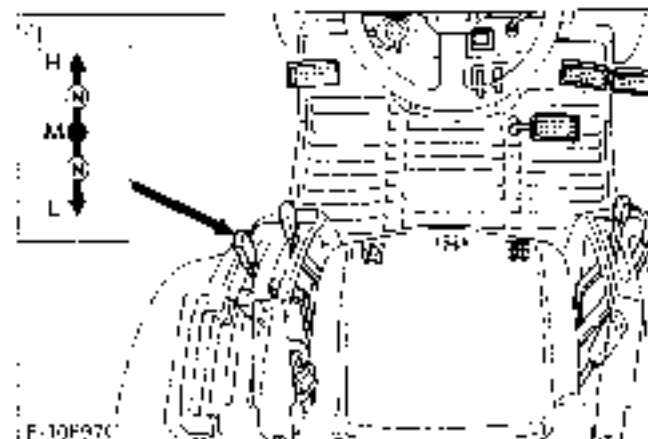

F-108970

(1) Range gear shift lever  
(L-M-H)

(H) "HIGH"

(M) "MIDDLE"

(L) "LOW"

(N) "NEUTRAL POSITION"



### Range Gear Shift Lever (L-M-H)

The range gear shift can only be shifted when tractor is completely stopped and the clutch pedal is depressed.

#### IMPORTANT:

Depress the clutch pedal and stop the tractor. Do not force the range gear shift lever.

- If it is difficult to shift the range gear shift lever into neutral position:
  1. Depress the brake pedals firmly for several seconds.
  2. Without reducing the brake pedal force, depress the clutch pedal and then shift the range gear shift lever.
- If it is difficult to shift the range gear shift lever into L, M, or H from neutral position:
  1. Release the clutch pedal.
  2. Slightly depress the speed control pedal to rotate the gears inside of transmission.
  3. Release the speed control pedal to neutral position.
  4. Depress the clutch pedal and then shift the range gear shift lever.

### Front Wheel Drive Lever



#### CAUTION

To avoid personal injury:

- Do not engage the front wheel drive when traveling at road speed.
- When driving on icy, wet or loose surfaces, make sure the tractor is correctly ballasted to avoid skidding and loss of steering control. Operate at reduced speed and engage front wheel drive.
- An accident may occur if the tractor is suddenly braked, such as by heavy towed loads shifting forward or loss of control.
- The braking characteristics are different between two and four wheel drive. Be aware of the difference and use carefully.

Use the lever to engage the front wheels with the tractor stopped. Shift the lever to "ON" to engage the front wheel drive.

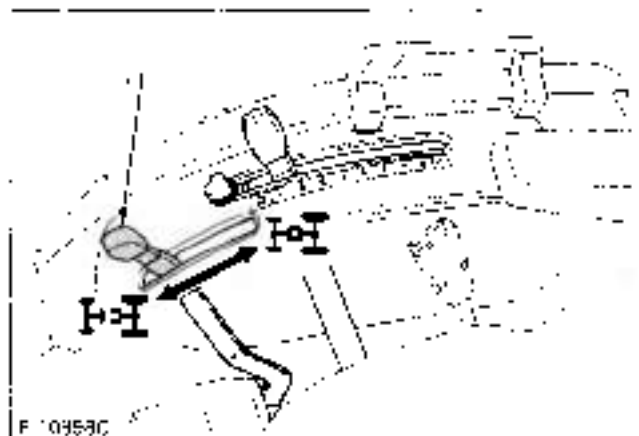

(1) Front wheel drive lever: "OFF" "ON"

#### IMPORTANT:

- Depress the clutch pedal before engaging the front wheel drive lever.
- Tires will wear quickly if front wheel drive is engaged on paved roads.

#### ◆ Front wheel drive is effective for the following jobs:

1. When greater pulling force is needed, such as working in a wet field, when pulling a trailer, or when working with a front end loader.
2. When working in sandy soil.
3. When working on a hard soil where a rotary tiller might push the tractor forward.
4. Additional braking at reduced speeds.

## 7. Accelerate the Engine.

### Hand Throttle Lever

Pulling the throttle lever back increases engine speed, and pushing it forward decreases engine speed.

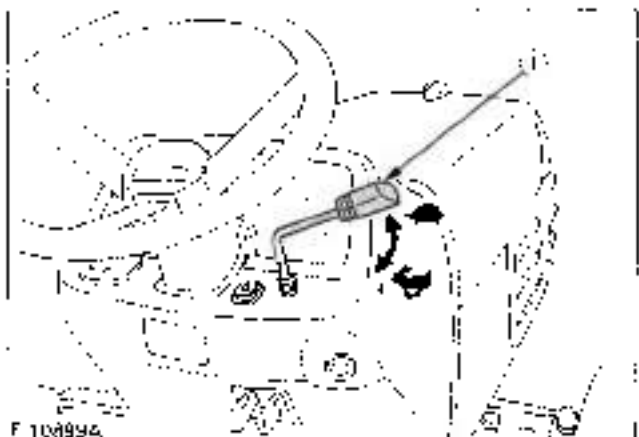

(1) Hand throttle lever

↑ "INCREASE"  
↓ "DECREASE"

## 8. Unlock the Parking Brake and Slowly Release the Clutch.

### ■ Parking Brake Lever

To release the parking brake, depress the brake pedals again.



F-8363A  
(1) Brake pedals

## 9. Depress the Speed Control Pedal.

### ■ Speed Control Pedal



#### WARNING

To avoid personal injury:

- Do not operate if tractor moves on level ground with foot off Speed Control Pedal.

#### Forward Pedal

Depress the forward pedal with the toe of your right foot to move forward.

#### Reverse Pedal

Depress the reverse pedal with the heel of your right foot to move backward.

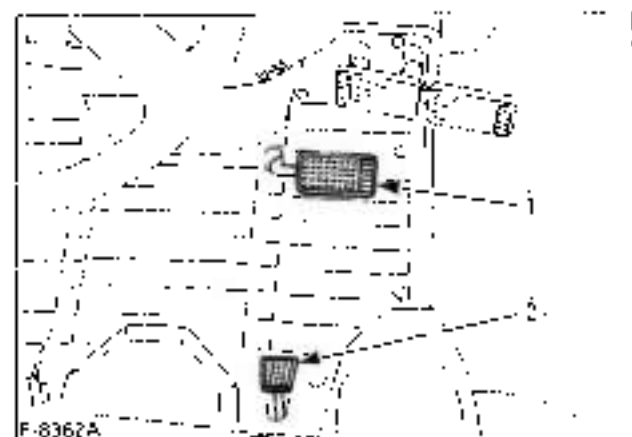

F-8362A  
(1) Forward Pedal  
(2) Reverse Pedal

#### IMPORTANT:

- To prevent the damage of speed set device, do not depress the reverse pedal when the speed set device is engaged.

### ■ Speed Set Device [B2710-B7800]

The Speed Set Device is designed for tractor operating efficiency and operator comfort. This device will provide a constant forward operating speed by mechanically holding the speed control pedal at a selected position.

#### ◆ To engage Speed Set Device

- Accelerate speed to desired level using Speed Control Pedal, and push the speed set lever down to the "ON" position
- Release Speed Control Pedal and desired speed will be maintained

#### ◆ To disengage Speed Set Device

- Pull the speed set lever upward.
- Depress both brake pedals.

#### NOTE:

- If you step on the pedal on the forward acceleration side, the speed set device will disengage.
- The speed set device does not disengage when the individual right or left brake is applied.
- Speed set device will not operate in reverse

#### IMPORTANT:

- To prevent the damage of speed set device, do not depress the reverse pedal when the speed set device is engaged.



F-8361A  
(1) Speed set lever (A) "ON" (C) "Increase"  
(2) Speed control pedal (B) "OFF" (D) "Decrease"

#### NOTE: [B7800]

- When you stand up from the seat with the speed control pedal stepped on or the speed set lever engaged (ON), the engine will stop regardless of whether the machine is moving or not. This is because the tractor is equipped with Operator Presence Control system (OPC).

## ■ Cruise Control Device (B2910)

Cruise control is designed for tractor operating efficiency and operator comfort. This device will provide a constant forward operating speed by mechanically holding the speed control pedal at the selected position.

### ◆ To engage Cruise Control Device

1. The proper forward speed will be maintained if you apply the cruise control lever at any position.
2. To operate faster than the set speed, depress the speed control pedal further down in this condition. The set speed will be resumed if you release the pedal.

### ◆ To disengage Cruise Control Device

- Move the lever all the way back and then to "OFF" position to release the cruise control.
- Depress both brake pedals.

### NOTE:

- Cruise control device will be disengaged automatically when both brake pedals are depressed.
- The cruise control device does not disengage when the individual right or left brake is applied.
- Cruise control device will not operate in reverse.

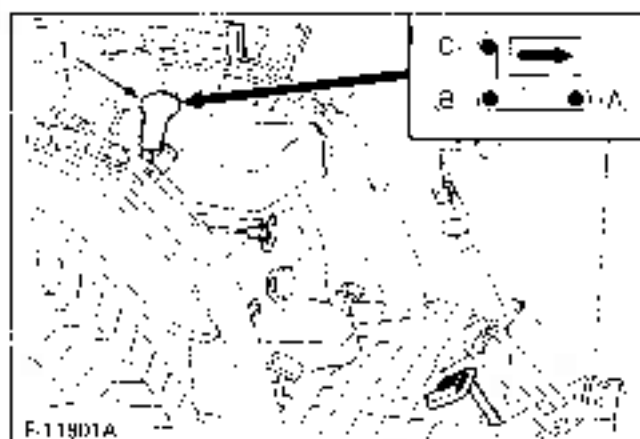

(1) Cruise control lever

(A) "INCREASE"

(B) "DECREASE"

(C) "OFF" position

## STOPPING

### ■ Stopping

1. Slow the engine down.
2. Step on the clutch and brake pedal.
3. After the tractor has stopped, disengage the PTO, lower the implement, shift the transmission to neutral, release the clutch pedal, and set the parking brake.

## CHECK DURING DRIVING

### ■ Immediately Stop the Engine if:

- The engine suddenly slows down or accelerates.
- Unusual noises suddenly are heard.
- Exhaust fumes suddenly become very dark.

While driving, check the following checks to see that all the parts are functioning normal y

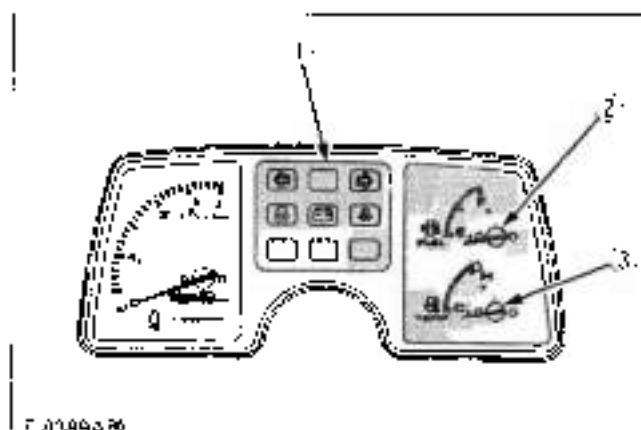

(1) Easy checker™

(2) Fuel gauge

(3) Coolant temperature gauge

### ■ Easy Checker™

If the warning lamps of the Easy Checker™ come on during operation, immediately stop the engine, and find the cause as shown below.

Never operate the tractor while Easy Checker™ lamp is on.

#### ⚠ Engine oil pressure

If the oil pressure in the engine goes below the prescribed level, the warning lamp in the Easy Checker™ will come on.

If this should happen during operation, and it does not go off when the engine is accelerated to more than 1000 rpm, check level of engine oil. (See "Checking Engine Oil Level" in daily check in periodic service section.)

#### ⚠ Electrical charge

If the alternator is not charging the battery, the warning lamp in the Easy Checker™ will come on.

If this should happen during operation, check the electrical charging system or consult your local KUBOTA Dealer.

### NOTE:

- For checking and servicing of your tractor, consult your local KUBOTA Dealer for instructions.

## Fuel Gauge

When the key switch is on, the fuel gauge indicates the fuel level.

Be careful not to empty the fuel tank. Otherwise air may enter the fuel system.

Should this happen, the system should be bled (See "Bleeding Fuel Systems" in Periodic Service section.)

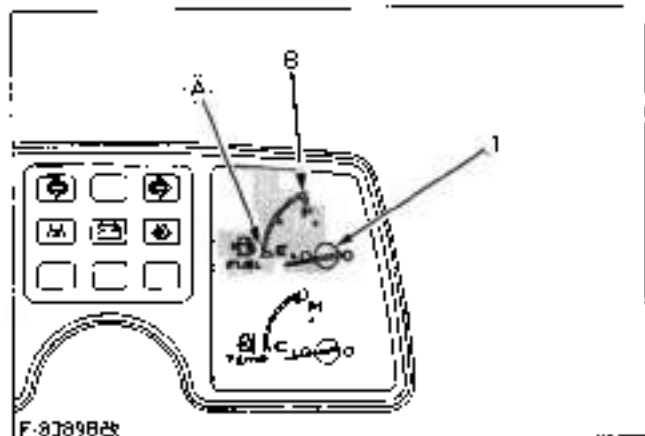

(1) Fuel gauge

(A) "EMPTY"  
(B) "FULL"

## Coolant Temperature Gauge



### CAUTION

To avoid personal injury:

- Do not remove radiator cap until coolant temperature is well below its boiling point. Then loosen cap slightly to the stop to relieve any pressure before removing cap completely.

- With the key switch at "ON", this gauge indicates the temperature of the coolant. "C" for "cold" and "H" for "hot".
- If the indicator reaches the "H" position (red zone), engine coolant is overheated. Check the tractor by referring to "TROUBLESHOOTING" section.

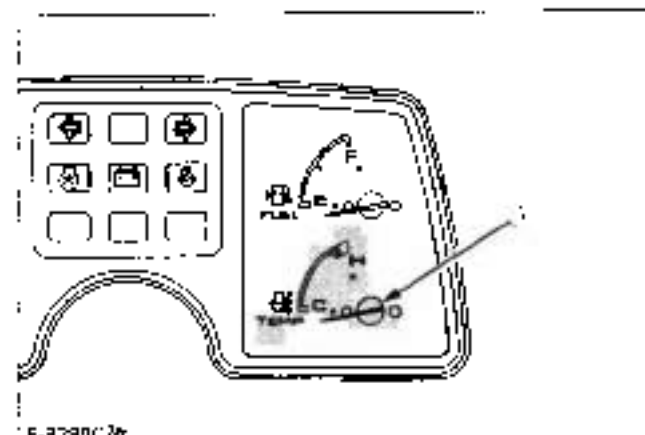

F-8389C2

(1) Coolant temperature gauge

## Hourmeter/Tachometer

This meter gives readings for engine speed, PTO shaft speed and the hours the tractor has been operated.

- The tachometer indicates the engine speed and the 540 PTO shaft speed location on the dial.
- The hourmeter indicates in five digits the hours the tractor has been used; the last digit indicates 1/10 of an hour.

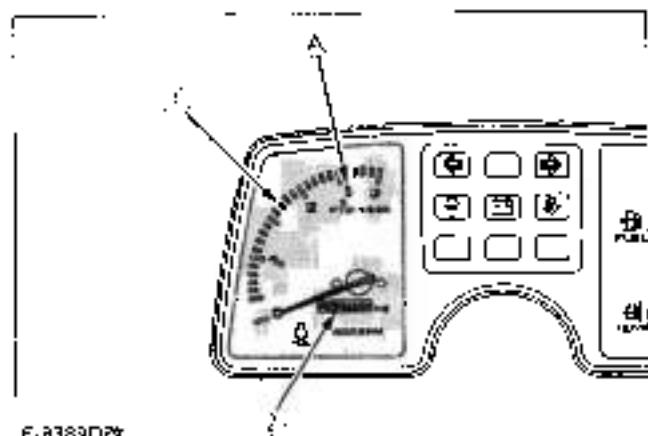

F-8389D2

(1) Engine revolution  
(2) Hours used

(A) PTO: 540rpm

## PARKING

### Parking



### CAUTION

To avoid personal injury:

- Always set the parking brake, stop the engine and remove the key before leaving the tractor seat.

- When parking, be sure to set the parking brake.
  - set the parking brake.
  - Interlock the brake pedals.
  - Depress the brake pedals.
  - Latch the brake pedals with the parking brake lever.



F-8354A

(1) Parking brake lever

(A) Interlock the brake pedals  
(B) "DEPRESS"  
(C) "PUSH-DOWN"

- Before getting off the tractor, disengage the PTO, lower all implements to the ground, place all control levers in their neutral positions, set the parking brake, stop the engine and remove the key.
- If it is necessary to park on an incline, be sure to chock the wheels to prevent accidental rolling of the machine.

## OPERATING TECHNIQUES

### Differential Lock



#### WARNING

To avoid personal injury due to loss of steering control:

- Do not operate the tractor at high speed with differential lock engaged.
- Do not attempt to turn with the differential lock engaged.
- Be sure to release the differential lock before making a turn in field conditions.

If one of the rear wheels should slip, step on the differential lock pedal. Both wheels will then turn together, reducing slippage.

Differential lock is maintained only while the pedal is depressed.

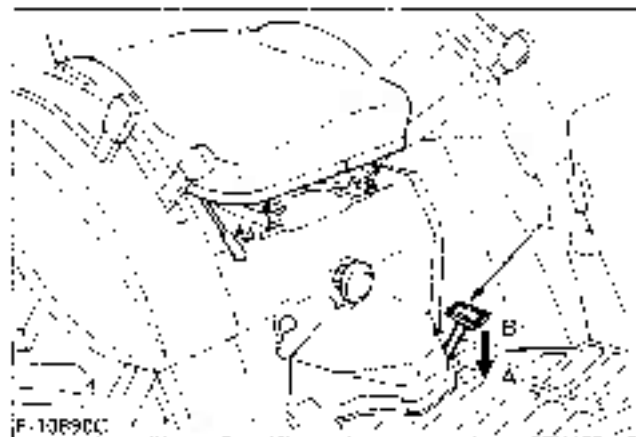

F-13B90C

- (1) Differential lock pedal (A) Press to "ENGAGE"  
(B) Release to "DISENGAGE"

#### IMPORTANT:

- When using the differential lock, always slow the engine down.
- To prevent damage to power train, do not engage differential lock when one wheel is spinning and the other is completely stopped.
- If the differential lock cannot be released in the above manner, step lightly on the brake pedals alternately.

### Operating the Tractor on a Road



#### CAUTION

To avoid personal injury:

- To help assure straight line stops when driving at transport speeds, lock the brake pedals together. Uneven braking at road speeds could cause the tractor to roll-over.
- When traveling on road with 3-point hitch mounted implement attached, be sure to have sufficient front weight on the tractor to maintain steering ability.
- Towed equipment (without brake) must not exceed 1.5 times the tractor weight when traveling on roads or at high speeds.

Be sure SMV emblem and hazard light are clean and visible. If towed or rear-mounted equipment obstructs these safety devices, install SMV emblem and hazard light on equipment.

Consult your local KUBOTA Dealer for further details.

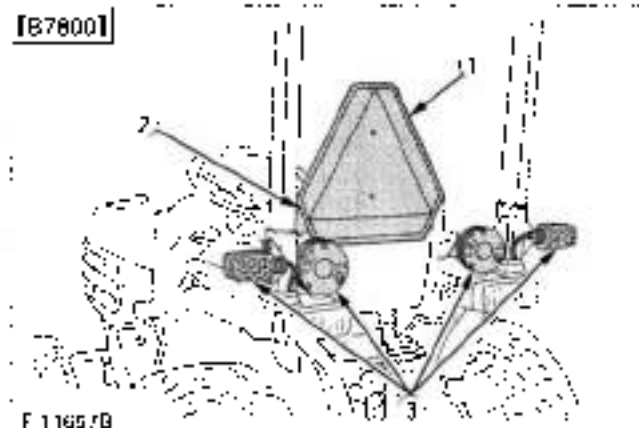
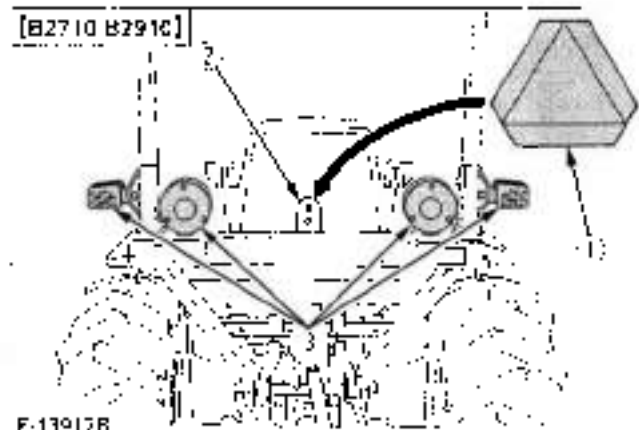

- (1) SMV emblem  
(2) Bracket  
(3) Hazard light

## ■ Operating on Slopes or Rough Terrain



### CAUTION

To avoid personal injury:

- Always back up when going up a steep slope. Driving forward could cause the tractor to tip over backward. Stay off hills and slopes too steep for safe operation.
- Avoid changing gears when climbing or descending a slope.
- If operating on a slope, never disengage the clutch or shift levers to neutral. Doing so could cause loss of control.
- Do not drive the tractor close to the edges of ditches or banks which may collapse under the weight of the tractor. Especially when the ground is loose or wet.

1. Be sure wheel tread is correct to provide proper stability.  
(See "WHEELS" in tires, wheels and ballast section.)
2. Slow down for slopes, rough ground, and sharp turns, especially when transporting heavy, rear mounted equipment.
3. Before descending a slope, shift to a gear low enough to control speed without using brakes.

## ■ Directions for Use of Power Steering

1. Power steering is activated only while the engine is running. Slow engine speeds make the steering a little heavier. While the engine is stopped, the tractor functions in the same manner as tractors without power steering.
2. When the steering wheel is turned all the way to the stop, the relief valve is activated. Do not hold the steering wheel in this position for a long period of time.
3. Avoid turning the steering wheel while the tractor is stopped, or tires may wear out sooner.
4. The power steering mechanism makes the steering easier. Be careful when driving on a road at high speeds.

# PTO

## PTO OPERATION



### WARNING

To avoid personal injury:

- Before operation, be sure to select the correct PTO lever (mid/rear).



### CAUTION

To avoid personal injury:

- Disengage PTO, stop engine, and allow all rotating components to come to a complete stop before connecting, disconnecting, adjusting, or cleaning any PTO driven equipment.

### ■ Rear-PTO Gear Shift Lever

1. The tractor has a 540 rpm speed position.
2. PTO shifting needs clutch operation. Press the clutch pedal down completely to stop the tractor movement and any PTO driven equipment movement before shifting the Rear-PTO gear shift lever.

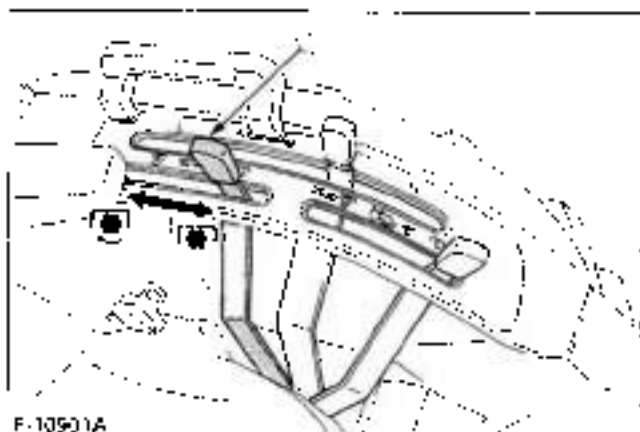

F-10501A

(1) Rear-PTO gear shift lever

☑ "ON" "ENGAGE"  
☐ "OFF" "DISENGAGE"

### IMPORTANT:

- To avoid shock loads to the PTO, reduce engine speed when engaging the PTO, then open the throttle to the recommended speed.
- To avoid damage of transmission, before shifting the Rear PTO gear shift lever, fully disengage the main clutch.

Engine Speed	rpm	2000
Shaft		6-spline
PTO Speed	rpm	540

### NOTE:

- There is a PTO-1 (540rpm) indicator mark on the tachometer face.
- Tractor engine will not start if Rear PTO gear shift lever is in the engaged ("ON") position.

### ■ Mid-PTO Gear Shift Lever (if equipped)

1. The tractor has a 2500 rpm speed position.
2. PTO shifting needs clutch operation. Press the clutch pedal down completely to stop the tractor movement and any PTO driven equipment movement before shifting the Mid-PTO gear shift lever.

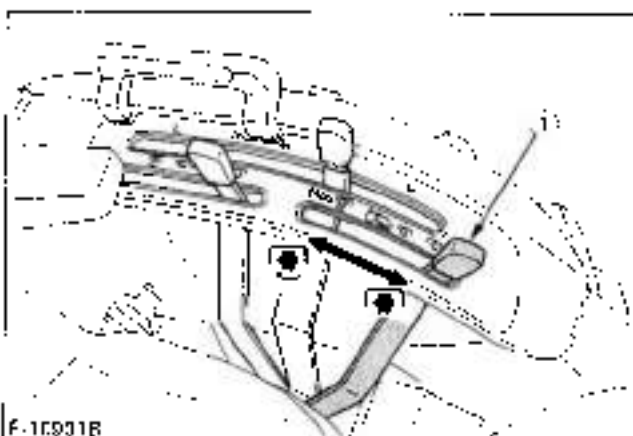

F-10501B

(1) Mid-PTO gear shift lever

☑ "ON" "ENGAGE"  
☐ "OFF" "DISENGAGE"

### IMPORTANT:

- To avoid shock loads to the PTO, reduce engine speed when engaging the PTO, then open the throttle to the recommended speed.
- To avoid damage of transmission, before shifting the Rear and Mid-PTO gear shift levers, fully disengage the main clutch.

### ◆ Mid-PTO speed

Engine Speed	rpm	2578
PTO Speed	rpm	2500

### NOTE:

- Tractor engine will not start if Mid PTO gear shift lever is in the engaged ("ON") position.

### ◆ Mid-PTO

The Mid-PTO is available for KUBOTA approved implements.

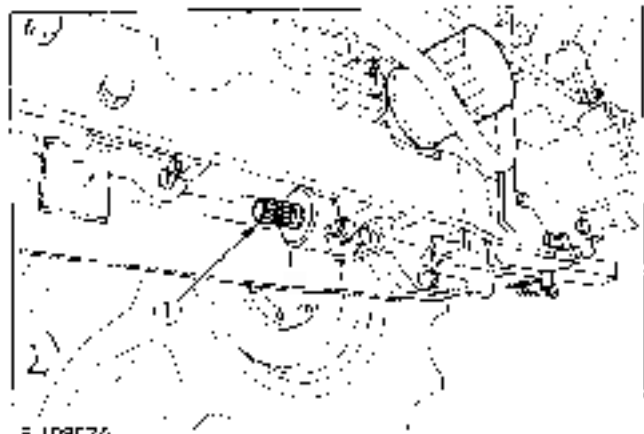

F-109C24

(1) Mid-PTO

### ■ PTO Shaft Cover and Shaft Cap

Keep the PTO shaft cover in place at all times. Replace the PTO shaft cap when the PTO is not in use. Before connecting or disconnecting a drive shaft to PTO shaft, be sure engine is "OFF" and raise up the PTO shaft cover.

Afterward be sure to return the PTO shaft cover to the "NORMAL POSITION".

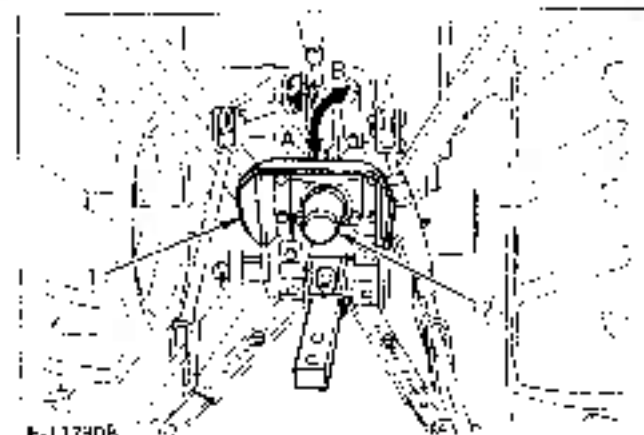

F-11790B

(1) PTO shaft cover

(2) PTO shaft cap

(A) "NORMAL POSITION"

(B) "RAISED POSITION"

### ■ Stationary PTO

To park the tractor and use the PTO system (for chipper or pump, for example), start the PTO system in the following steps

1. Apply the parking brakes and place blocks at the tires.
2. Make sure the shift levers are at NEUTRAL, and start the engine.
3. Tilt the operator's seat forward.
4. Fully depress the clutch pedal.
5. Shift the rear-PTO gear shift lever to "ON" (Engaged) position.

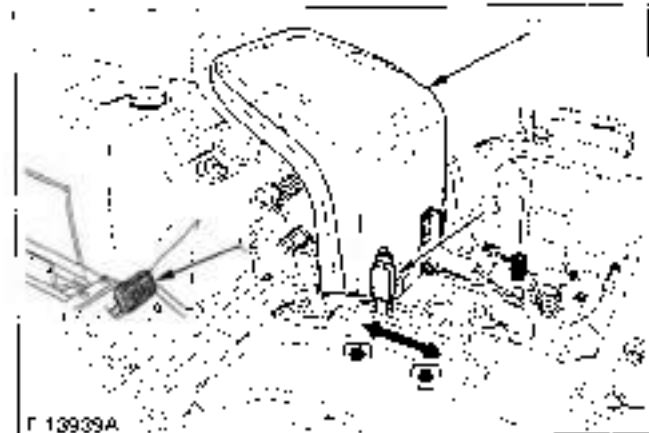

F-13939A

(1) Seat

(2) Clutch pedal

(3) Rear-PTO gear shift lever

ON  
OFF

#### NOTE:

- Suppose that the PTO system is engaged but you stand from the seat or the seat is not tilted forward. In such case, the engine stops itself.



# THREE-POINT HITCH & DRAWBAR

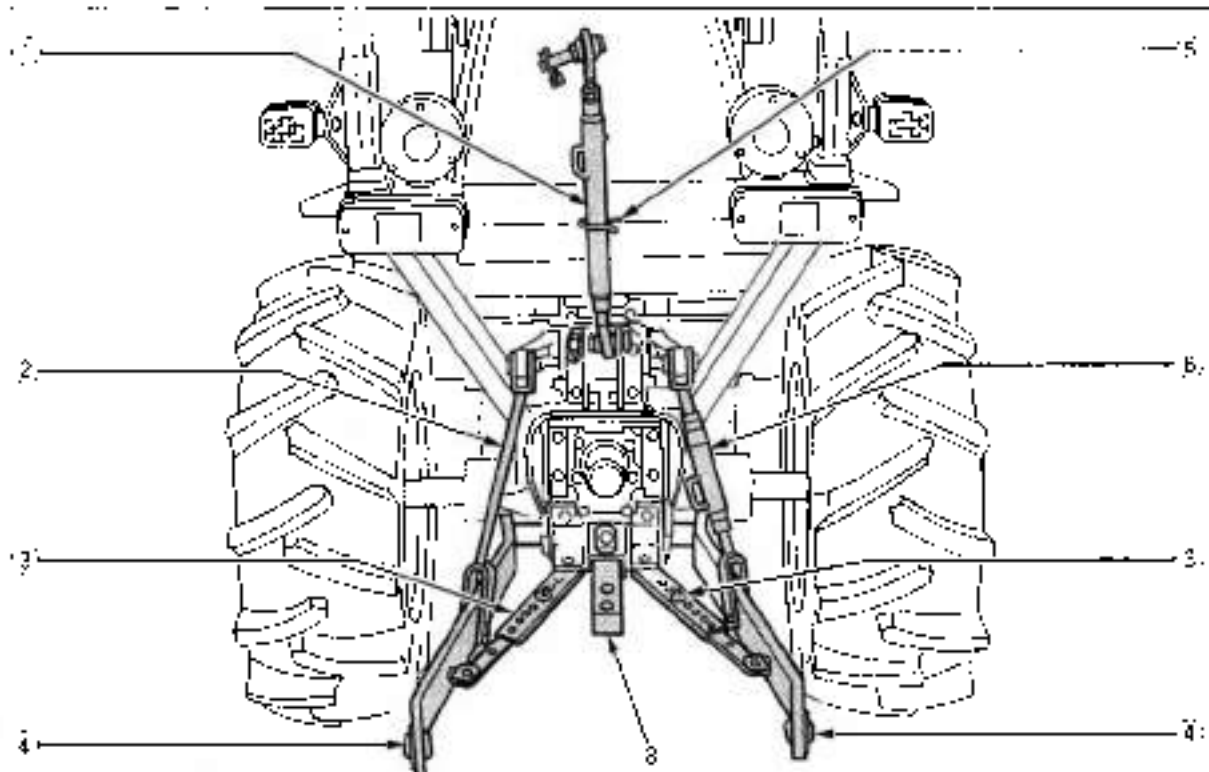

F 13821A

- (1) Top link
- (2) Lifting rod (left)
- (3) Telescopic stabilizers  
Check chains (B7800)
- (4) Lower link (B2710-B7800)  
Lower link / Telescopic type! (B2910)
- (5) Top link holder  
Top link holder (B7800)
- (6) Lifting rod (right)
- (7) Lifting rod (right, Hatcher type) (B2910)
- (8) Drawbar

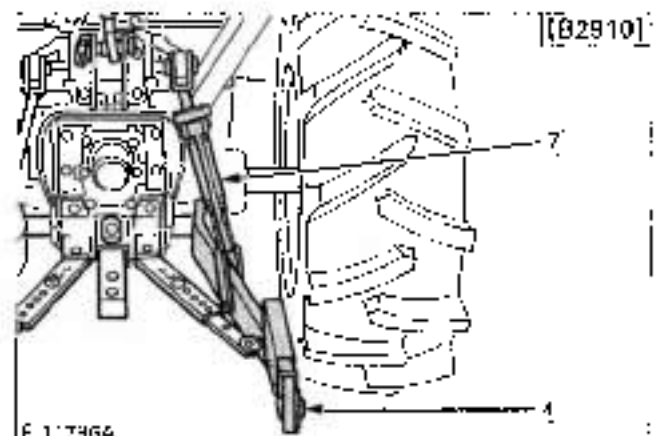

F 17366

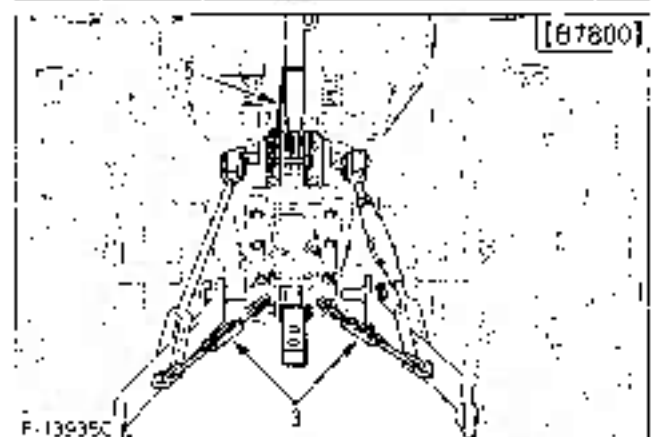

F-13935C

## 3-POINT HITCH

### 1. Make preparations for attaching implement.

#### ■ Selecting the holes of lifting rods and lower links

There are two holes in the lower links. For most operations the lifting rods should be attached to the (A) holes.

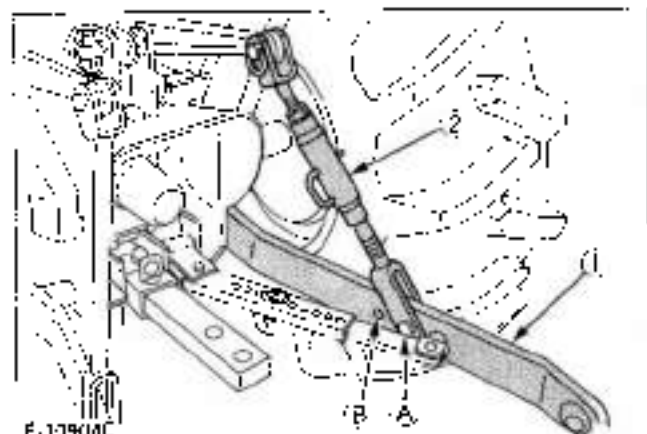

F-10904C

(1) Lower link  
(2) Lifting rods

holes: (A), (B)

#### NOTE:

- The lifting rods may be attached to (B) hole for higher lifting height (with reduced lifting force)

#### ■ Selecting the Top Link Mounting Holes

Select the proper set of holes by referring to the "Hydraulic Control Unit Use Reference Chart" in Hydraulic Unit section.

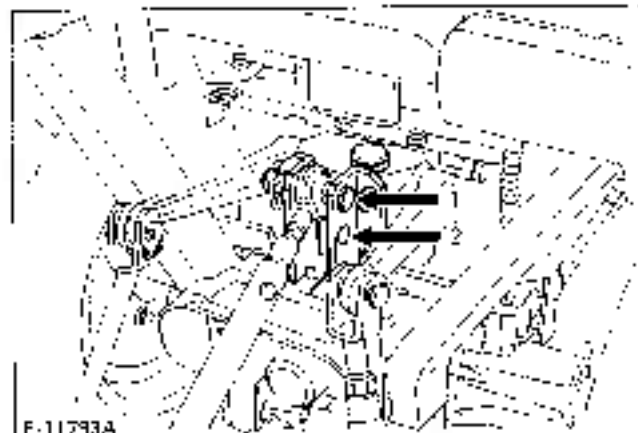

F-11793A

#### ■ Drawbar

Remove the drawbar if a close mounted implement is being attached.

## 2. Attaching and detaching implements



#### CAUTION

To avoid personal injury:

- Be sure to stop the engine and remove the key.
- Do not stand between tractor and implement unless parking brake is applied.
- Before attaching or detaching implement, locate the tractor and implement on a firm, flat and level surface.
- Whenever an implement or other attachment is connected to the tractor 3-point hitch, check full range of operation for interference, binding or PTO driveline separation

#### ■ Lifting Rod (Right) [B2710-B7800]

Level a 3-point mounted implement from side to side by turning the adjusting handle to shorten or lengthen the adjustable lifting rod with the implement on the ground.

After adjustment, tighten the lock nut securely.

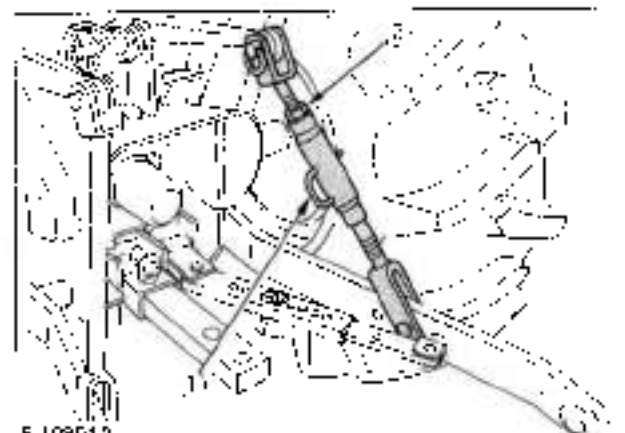

F-10904A

(1) Adjusting handle  
(2) Lock nut

### ■ Lifting Rod (Right, Ratchet type) (B2910)

To level a 3-point mounted implement.

1. Press the up and down changing lever.
2. Turn the adjusting handle from side to side to shorten or lengthen the adjustable lifting rod with the implement on the ground.

#### IMPORTANT.

- After adjustment, be sure to lock the adjusting handle with the handle stopper.

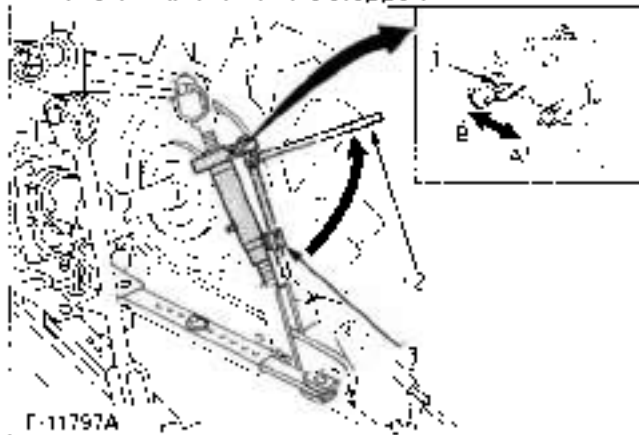

F-11797A

- (1) Up and down changing lever (A) To shorten the lifting rod  
 (2) Adjusting handle (B) To lengthen the lifting rod  
 (3) Handle stopper

### ■ Top Link

1. Adjust the angle of the implement to the desired position by shortening or lengthening the top link.
2. The proper length of the top link varies according to the type of implement being used.

### ■ Telescopic Stabilizers (B2710-B2910)

Adjust the telescopic stabilizers to control horizontal sway of the implement.

After aligning satisfactorily, insert the set-pin through any one of the eight holes on the outer tube that align with one of the holes on the inner bar, both stabilizers will be locked. If the set pin is inserted through the slot to engage one of the holes on the inner bar, a limited degree of sway will be permitted.

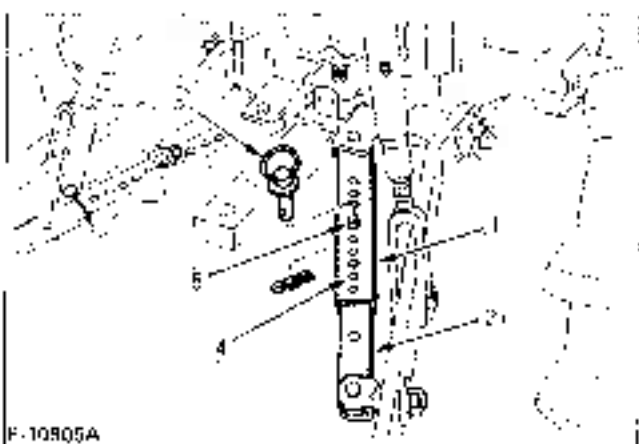

F-10805A

- (1) Outer tube (4) Hole  
 (2) Inner bar (5) Slot  
 (3) Set-pin

### ■ Check Chains (B7800)

Remove the snap pin and adjust the turnbuckle to control horizontal sway of the implement.

After adjustment, re set the snap pin.

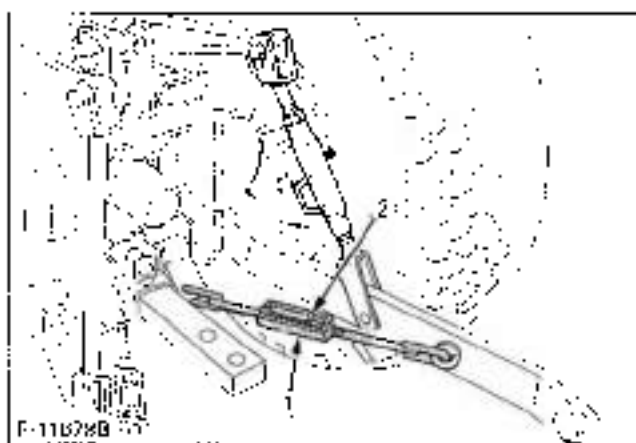

F-11629B

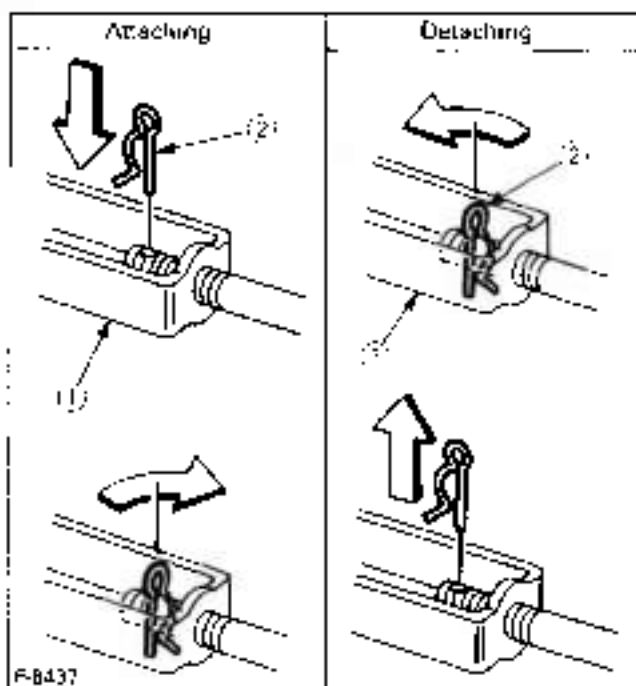

F-8437

- (1) Turnbuckle  
 (2) Snap pin

### ■ Telescoping Lower Links [B2910]

To attach an implement, follow the instructions below:

1. Push the levers, pull out the lower link ends and attach to the implement.
2. Back up the tractor slightly to make sure the lower links are pushed in securely.

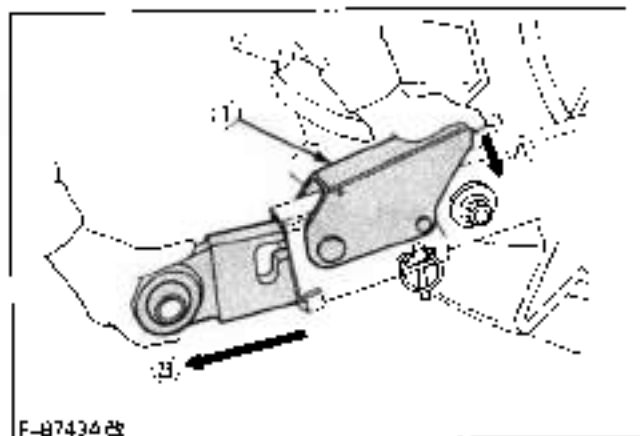

F-B7434 25

(1) Lever

(A) "PUSH"

(B) "PULL OUT"

## DRAWBAR



### WARNING

To avoid personal injury or death:

- Never pull from the top link, the rear axle or any point above the drawbar. Doing so could cause the tractor to tip over rearward causing personal injury or death.

### ■ Adjusting Drawbar Length

When towing an implement, use of (B) hole in drawbar is recommended.

The acceptable drawbar load is provided in the "IMPLEMENT LIMITATIONS" section.

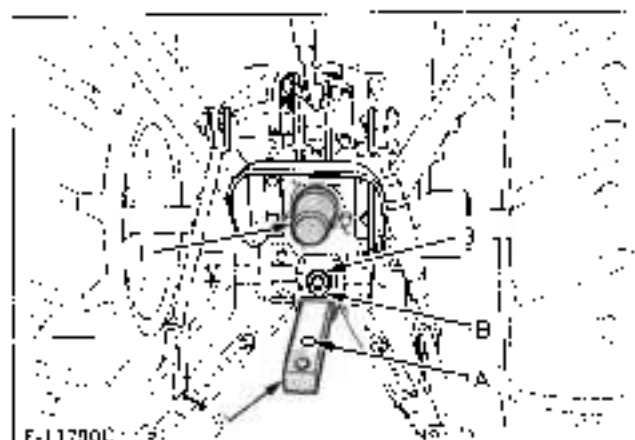

F-11790L

(1) Rear-PTO shaft

Holes: (A), (B)

(2) Drawbar

(3) Drawbar pin

# HYDRAULIC UNIT

## 3-POINT HITCH CONTROL SYSTEM

### ■ Position Control [B2710-B2910]

This will control the working depth of 3-point hitch mounted implement regardless of the amount of pull required.

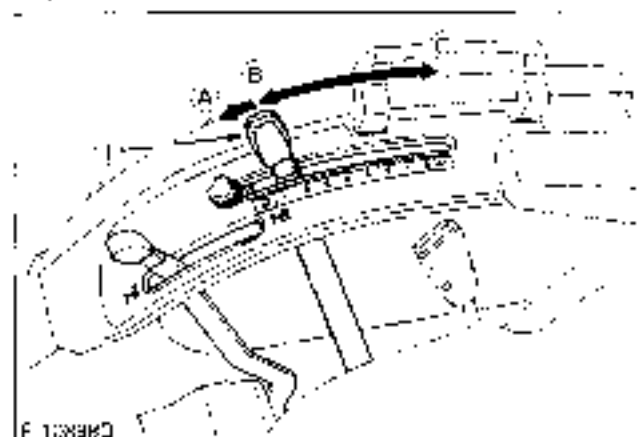

F-10389D

(1) Position control lever

(A) "FLGAT"  
(B) "DOWN"  
(C) "UP"

### ■ Quarter Inching Valve [B7800]

Operating the hydraulic control lever actuates the hydraulic lift arm, which controls the elevation of 3-point hitch mounted implement.

To lower implement, push the lever forward; to raise it, pull the lever back.

The lever position (C) enables you to control the valve with ease in increments of approximately 1/4 inches at the lower link end.

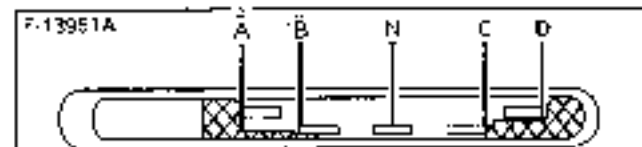

F-13951A

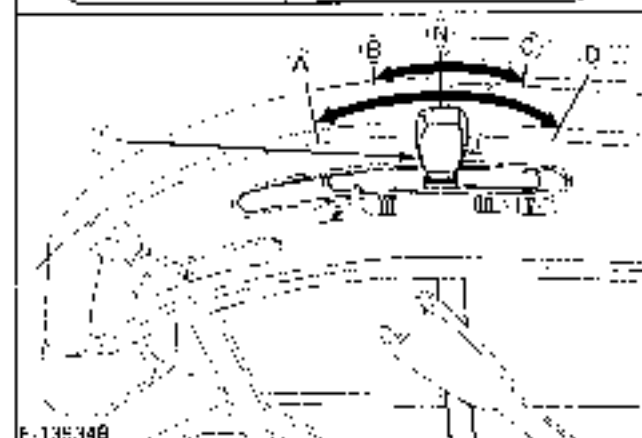

F-13954B

(1) Hydraulic control lever

(A) "DOWN"  
(B) "SLOW DOWN"  
(C) "SLOW UP"  
(D) "UP"

### IMPORTANT:

- If the 3-point hitch can not be raised by setting the hydraulic control lever to the UP position after long term storage or when changing the transmission oil, turn steering wheel to the right and left several times to bleed air from the system.
- Do not operate until the engine is warmed up. If operation is attempted when the engine is still cold, the hydraulic system may be damaged.
- If noises are heard when implement is lifting after the hydraulic control lever has been activated, the hydraulic mechanism is not adjusted properly. Unless corrected the unit will be damaged. Contact your KUBOTA Dealer for adjustment.

### ■ 3-point Hitch Lowering Speed



#### CAUTION

To avoid personal injury:

- Fast lowering speed may cause damage or injury. Lowering speed of implement should be adjusted to two or more seconds.

The lowering speed of the 3-point hitch can be controlled by adjusting the 3-point lowering speed knob.

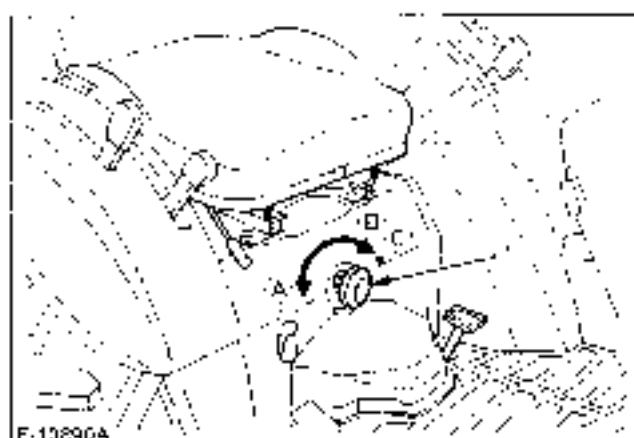

F-13890A

(1) 3-Point lowering speed knob

(A) "FAST"  
(B) "SLOW"  
(C) "LOCK"

## AUXILIARY HYDRAULICS

Two hydraulic outlets (mid and rear) are provided on the tractor.

### ■ Hydraulic Block Type Outlet

Hydraulic block type outlet is useful when adding hydraulically operated equipment such as front end loader, front blade, etc.

When implement is attached

1. Remove the block cover.
2. Attach the block outlet cover. (optional)

## [Mid outlet]

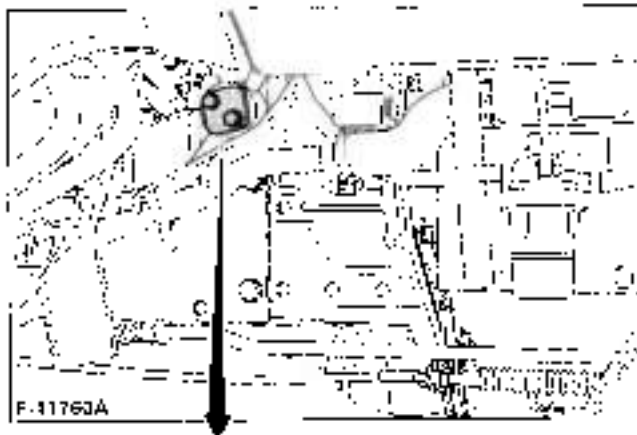

When implement is not attached

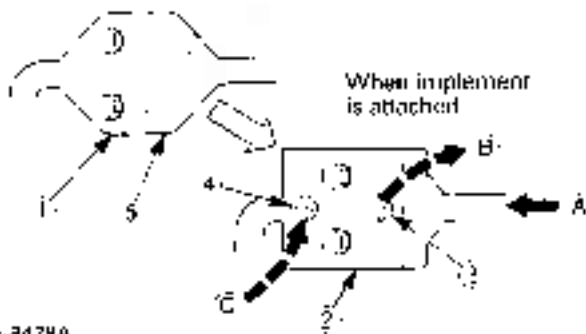

When implement is attached

F-8439A

- |                                   |   |
|-----------------------------------|---|
| (1) Block cover                   | (A) From gear pump                      |
| (2) Block outlet cover (optional) | (B) To implement inlet                  |
| (3) Outlet                        | Max. flow                               |
| (4) Inlet                         | 24.4 L/min                              |
| (5) Hydraulic block               | (6.4 U.S.gals./min)                     |
|                                   | No relief valve in the hydraulic block. |
|                                   | (C) From implement outlet               |

**IMPORTANT:**

- For mid outlet, be sure to use the control valve of the "Power beyond type" (with relief valve) that has a third line return to tank.

**NOTE:**

- The "tank" port flow from implement valve should be connected to the port located on the right hand side of transmission case.

## [Rear outlet] [Except B7800]

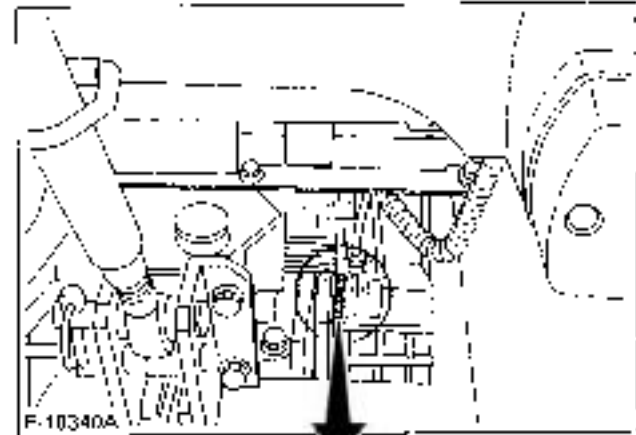

When implement is not attached

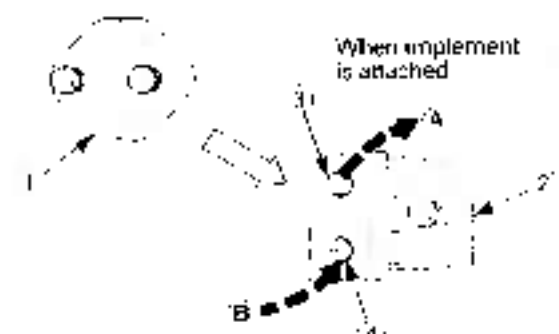

When implement is attached

F-3328A

- |                                   |                                |
|-----------------------------------|--------------------------------|
| (1) Block cover                   | (A) To implement inlet         |
| (2) Block outlet cover (optional) | Max. flow                      |
| (3) Outlet                        | 24.4 L/min                     |
| (4) Inlet                         | (6.4 U.S.gals./min)            |
|                                   | Max. pressure                  |
|                                   | 13.2 to 13.7 MPa               |
|                                   | 135 to 140 kgf/cm <sup>2</sup> |
|                                   | 1920 to 1992 psi               |
|                                   | (B) From implement outlet      |

**NOTE:**



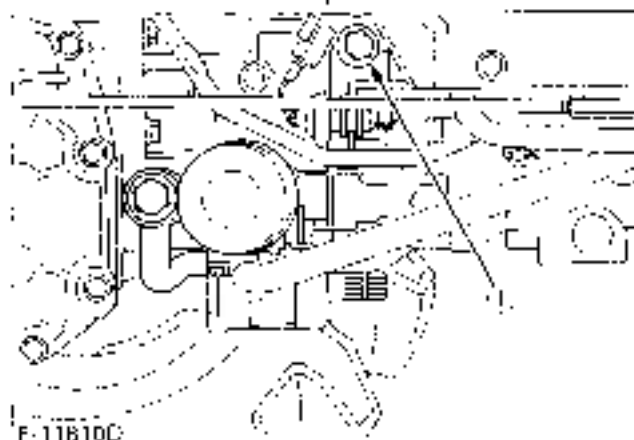

- If the implement control valve has a relief valve, the tank port flow from implement should be connected to the port located on the right hand side of transmission case.



(1) Return port

### Hydraulic Control Unit Use Reference Chart

In order to handle the hydraulics properly, the operator must be familiar with the following. Though this information may not be applicable to all types of implements and soil conditions, it is useful for general conditions.

Implement	 <p>F-9000 Top link mounting holes</p>	 <p>F-0430E (1) Position control lever / Hydraulic control lever</p>	 <p>F-700A Gauge wheel</p>	 <p>F-10904B (1) Telescopic stabilizers [B2710-B2910] (1) Check chain [B7800]</p>	Remarks
Soil condition:  Light soil Medium soil heavy soil	(1) is standard.  (2) is used only when there is some obstacle that prevents you from using the standard.	YES/NO	Loose	Insert the set-pin through the slot on the outer tube that align with one of the holes on the inner bar.  For implements with gauge wheels, lower the implements to the ground	
Disc plow  Harrower (spike, springtooth, disc type)  Subsoiler  Weeder, ridger.....  Earthmover, digger, scraper, manure fork, rear carrier.....  Mower (mid-and rear-mount type), hayrake, tedder.....		YES/NO	Tighten	Telescopic stabilizer should be tight enough to prevent excessive implement movement when implement is in raised position.  For implements with gauge wheels, lower the implements to the ground.	

# TIRES, WHEELS AND BALLAST

## TIRES



### WARNING

To avoid personal injury:

- Do not attempt to mount a tire on a rim. This should be done by a qualified person with the proper equipment.
- Always maintain the correct tire pressure. Do not inflate tires above the recommended pressure shown in the operator's manual.

### IMPORTANT:

- Do not use tires other than those approved by KUBOTA.

### ■ Inflation Pressure

Though the tire pressure is factory set to the prescribed level, it naturally drops slowly over the course of time. Thus, check it regularly and inflate as necessary.

	Tire sizes	Inflation Pressure
Rear	12.4-16, 4PR	110kPa ( 1.1 kgf/cm <sup>2</sup> , 16psi )
	13.6-16, 4PR	100kPa ( 1.0 kgf/cm <sup>2</sup> , 14psi )
	12.4-16Ind, 4PR	138kPa ( 1.4 kgf/cm <sup>2</sup> , 20psi )
Front	A6 12, 4PR	200kPa ( 2.0 kgf/cm <sup>2</sup> , 28psi )
	7-12, 4PR	170kPa ( 1.7 kgf/cm <sup>2</sup> , 24psi )
	23x8.50-12, 4PR	150kPa ( 1.5 kgf/cm <sup>2</sup> , 22psi )
	24x8.50-14, 4PR	150kPa ( 1.5 kgf/cm <sup>2</sup> , 22psi )
	23x8.50-14Ind, 4PR	241kPa ( 2.5 kgf/cm <sup>2</sup> , 35psi )
	24x8.50-12 4PR	160kPa ( 1.6 kgf/cm <sup>2</sup> , 23psi )

### NOTE:

- Maintain the maximum recommended pressure in the front tires, when using a front loader or equipped with a full load of front weights.

## WHEEL ADJUSTMENT



### CAUTION

To avoid personal injury:

- When working on slopes or when working with a trailer, set the wheel tread as wide as practical for maximum stability.
- Support tractor securely on stands before removing a wheel.
- Never operate tractor with a loose rim, wheel, or axle.

### ■ Front Wheels

Front tread width can not be adjusted.

### IMPORTANT:

- Do not turn front discs to obtain wider tread.
- In setting up the front wheels, make sure that the inflation valve stem of the tires face outward







### ■ Rear Wheels

Rear tread width can not be adjusted.

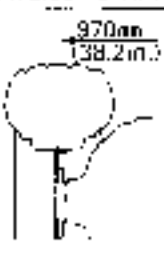

**Treads**

◆ **USA models**

Front	7-12 Farm  F-8440	23 x 8.50-12 Turf  F-8440	24 x 8.50-14 Turf  F-13950	23 x 8.50-14 Ind.  F-7776
	Rear	12.4-16 Farm  F-2492	13.6-16 Turf  F-7776	12.4-16 Ind.  F-7776

◆ **Except USA models**

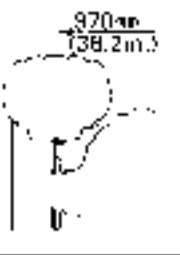
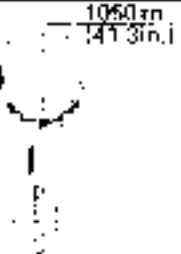
Front	A6-12 Farm 	24 x 8.50-12 Turf 
	Rear	12.4-16 Farm 

## BALLAST



### CAUTION

To avoid personal injury:

- Additional ballast will be needed for transporting heavy implements. When the implement is raised, drive slowly over rough ground, regardless of how much ballast is used.
- Do not fill the front wheels with liquid.

### Front Ballast

Add weights if needed for stability and improving traction.

Heavy pulling and heavy rear mounted implements tend to lift front wheels. Add enough ballast to maintain steering control and prevent tip over. Remove weight when no longer needed.

### Front End Weights (option)

The front end weights can be attached to the bumper. Consult your local KUBOTA Dealer for use.

### NOTE:

- Besides the weight, a mounting kit is also required.

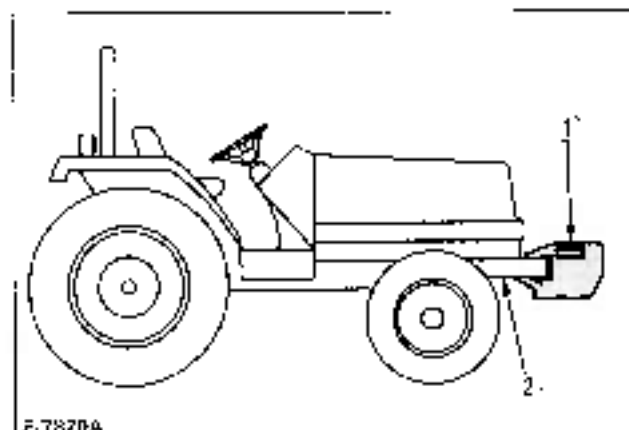

F-7829A

(1) Front end weights

(2) Bumper

### IMPORTANT:

- Do not overload tires.
- Add no more weight than indicated in chart.

Maximum weight	25 kg x 5 pieces ( 275 lbs.)
----------------	---------------------------------

### NOTE:

- 3 weights can be attached to the bumper. (Mounting kit is required.)  
The optional stay kit is required to mount 2 more weights if additional weight is needed.

### Rear Ballast

Add weight to rear wheels if needed to improve traction or for stability. The amount of rear ballast should be matched to job and the ballast should be removed when it is not needed.

The weight should be added to the tractor in the form of liquid ballast.

### Liquid Ballast in Rear Tires

Water and calcium chloride solution provides safe economical ballast. Used properly, it will not damage tires, tubes or rims. The addition of calcium chloride is recommended to prevent the water from freezing. Use of this method of weighting the wheels has the full approval of the tire companies. See your tire dealer for this service.

Liquid weight per tire (75 Percent filled)

Tire sizes	12.4-16
Slush free at -10°C (-14°F) Solid at -30°C (-22°F) (Approx. 1 kg (2 lbs.) CaCl <sub>2</sub> per 4 l (1 gal) of water)	85 kg (187 lbs.)
Slush free at -24°C (-11°F) Solid at -47°C (-52°F) (Approx. 1.5kg (3.5lbs.) CaCl <sub>2</sub> per 4 l (1 gal) of water)	89 kg (196 lbs.)
Slush free at -47°C (-52°F) Solid at -52°C (-62°F) (Approx. 2.25kg (5 lbs.) CaCl <sub>2</sub> per 4 l (1 gal) of water)	94 kg (207 lbs.)

### IMPORTANT:

- Do not fill tires with water or solution more than 75% of full capacity (to the level of valve stem at 12 o'clock position).

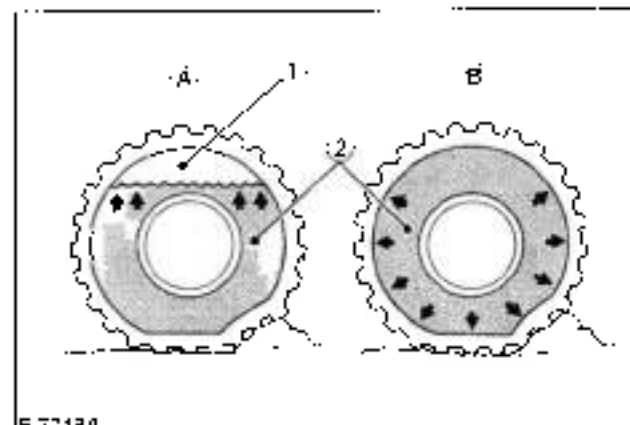

F-7743A

(1) Air

(2) Water

(A) Correct: 75% Full

Air compresses like a cushion

(B) Incorrect: 100% Full

Water can not be compressed

# MAINTENANCE

## SERVICE INTERVALS

No	Items	Period	Indication on hour meter													Since then	Refer-ence page			
			50	100	150	200	250	300	350	400	450	500	550	600	650					700
1	Engine oil	Change	○	○													every 100 Hr	54		
2	Engine oil filter	Replace	○														every 200 Hr	58		
3	Transmission oil filter	Replace	○														every 300 Hr	61		
4	Transmission fluid	Change	○														every 300 Hr	60		
5	Transmission strainer	Clean															every 300 Hr	61		
6	Front axle case oil	Change															every 300 Hr	62		
7	Front axle pivot	Adjust															every 400 Hr	62		
8	Engine start system	Check	○	○	○	○	○	○	○	○	○	○	○	○	○	○	every 50 Hr	51		
9	Greasing	—	○	○	○	○	○	○	○	○	○	○	○	○	○	○	every 50 Hr	52		
10	Wheel bolt torque	Check	○	○	○	○	○	○	○	○	○	○	○	○	○	○	every 50 Hr	53		
11	Battery condition	Check	○	○	○	○	○	○	○	○	○	○	○	○	○	○	every 100 Hr	53,54	*5	
12	Air cleaner element (Double type)	Primary element	Clean	○	○	○	○	○	○	○	○	○	○	○	○	○	every 100 Hr	55	*1	@
		Secondary element	Replace														every 1 year	62	*2	
13	Fuel filter element	Clean	○	○	○	○	○	○	○	○	○	○	○	○	○	○	every 100 Hr	56		@
		Replace															every 400 Hr	62		
14	Fan belt	Adjust	○	○	○	○	○	○	○	○	○	○	○	○	○	○	every 100 Hr	56		
15	Clutch	Adjust	○	○	○	○	○	○	○	○	○	○	○	○	○	○	every 100 Hr	57		
16	Brake	Adjust	○	○	○	○	○	○	○	○	○	○	○	○	○	○	every 100 Hr	57		
17	Radiator hose and clamp	Check	○	○	○	○	○	○	○	○	○	○	○	○	○	○	every 200 Hr	58		
		Replace															every 2 years	64		
18	Fuel line	Check	○	○	○	○	○	○	○	○	○	○	○	○	○	○	every 100 Hr	55		@
		Replace															every 2 years	64		
19	Intake air line	Check	○	○	○	○	○	○	○	○	○	○	○	○	○	○	every 200 Hr	59		@
		Replace															every 2 years	64	*3	
20	Toe-in	Adjust	○	○	○	○	○	○	○	○	○	○	○	○	○	○	every 200 Hr	59		
21	Engine valve clearance	Adjust															every 800 Hr	62	*4	
22	Fuel injection nozzle Injection pressure	Check															every 1500 Hr	62	*4	@
23	Injection pump	Check															every 3000 Hr	62	*4	@
24	Coilng system	Flush															every 2 years	63		
25	Coolant	Change															every 2 years	63		
26	Fuel system	Bleed																64		
27	Clutch housing water	Drain															Service as required	64		
28	Fuse	Replace																65		
29	Light bulb	Replace																65		

**IMPORTANT:**

- The jobs indicated by (X) must be done after the first 50 hours of operation.
- \*1 Air cleaner should be cleaned more often in severe dusty conditions.
- \*2 Every year or after 6 cleanings.
- \*3 Replace only if necessary.
- \*4 Consult your local KUBOTA Dealer for this service.
- \*5 When the battery is used for less than 100 hours per year, check the fluid level annually.
- The items listed above (@ marked) are registered as emission related critical parts by KUBOTA in the U.S.EPA nonroad emission regulation. As the engine owner, you are responsible for the performance of the required maintenance on the engine according to the above instruction. Please see the Warranty Statement in detail.

**LUBRICANTS**

No.	Locations	Capacities		Lubricants						
		B2710-B2910-B7800								
1	Fuel	26 L (6.9 U.S.gals.)		No.2-D diesel fuel No.1-D diesel fuel if temperature is below -10°C (14°F)						
2	Coolant (with recovery tank)	4.5 L (4.7 U.S.qts.)		Fresh clean water with anti-freeze						
3	Engine crankcase	4.1 L (4.3 U.S.qts.)		• Engine oil : API Service Classification CD, CE or CF  <table border="1" style="margin-left: 20px;"> <tr> <td>Above 25°C (77°F)</td> <td>SAE 30, SAE 10W-30 or 10W-40</td> </tr> <tr> <td>0 to 25°C (32 to 77°F)</td> <td>SAE 20, SAE 10W-30 or 10W-40</td> </tr> <tr> <td>Below 0°C (32°F)</td> <td>SAE 10W, SAE 10W-30 or 10W-40</td> </tr> </table>	Above 25°C (77°F)	SAE 30, SAE 10W-30 or 10W-40	0 to 25°C (32 to 77°F)	SAE 20, SAE 10W-30 or 10W-40	Below 0°C (32°F)	SAE 10W, SAE 10W-30 or 10W-40
Above 25°C (77°F)	SAE 30, SAE 10W-30 or 10W-40									
0 to 25°C (32 to 77°F)	SAE 20, SAE 10W-30 or 10W-40									
Below 0°C (32°F)	SAE 10W, SAE 10W-30 or 10W-40									
4	Transmission case	14.5 L (3.83 U.S.gals.)		• KUBOTA UDT or SUPER UDT fluid*						
5	Front axle case	4.5 L (4.7 U.S.qts.)		• KUBOTA UDT or SUPER UDT fluid* or SAE80-SAE90 gear oil						
6	Greasing	No. of greasing points		Capacity	Type of grease					
	Top link	1		Until grease overflows.  moderate amount	Multipurpose type grease					
	Lift rod (RH)	1								
	Speed control pedal	1								
	Battery terminal	2								

**NOTE.** \* KUBOTA UDT or SUPER UDT fluid ---KUBOTA Original Transmission hydraulic fluid

**NOTE:**

- Engine oil:  
Oil used in the engine should have an American Petroleum Institute (API) service classification and Proper SAE Engine Oil according to the ambient temperatures as shown above:
- Transmission oil:  
The oil used to lubricate the transmission is also used as hydraulic fluid. To insure proper operation of the hydraulic system and complete lubrication of the transmission, it is important that a multi-grade transmission fluid be used in this system. We recommend the use of **KUBOTA SUPER UDT fluid** for optimum protection and performance (Consult your local KUBOTA Dealer for further detail.)  
Do not mix different brands or grades.
- Indicated capacity of water and oil are manufacturer's estimate.

# PERIODIC SERVICE

## HOW TO OPEN THE HOOD



### CAUTION

To avoid personal injury from contact with moving parts:

- Never open the hood or engine side cover while the engine is running.
- Do not touch muffler or exhaust pipes while they are hot; Severe burns could result.
- Support hood with other hand while unlocking support link.

### ■ Hood

To open the hood, twist the mascot to release the latch and open the hood.

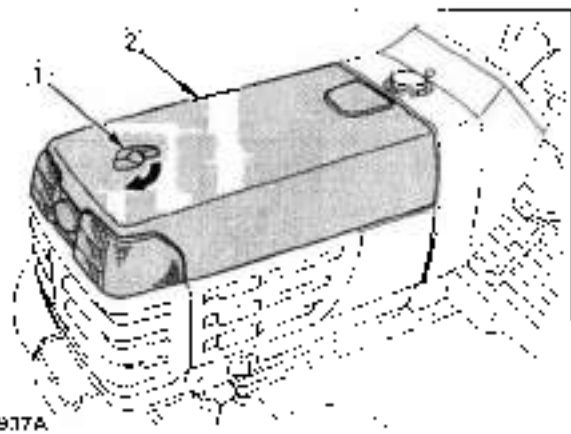

F-10937A

(1) Mascot

(2) Hood

### NOTE:

- To close the hood, hold the hood and release the support rod.

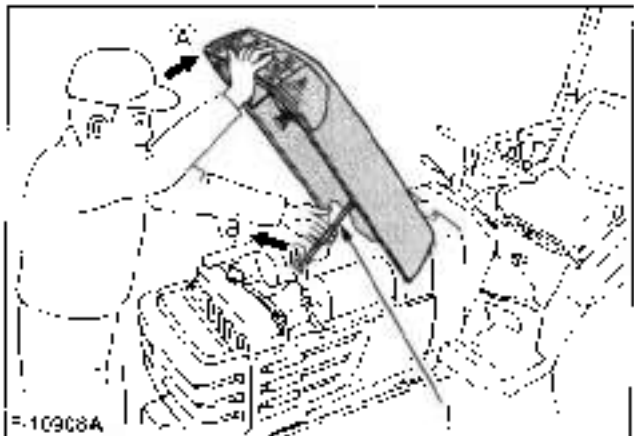

F-10908A

(1) Support rod

(A) "HOLD"

(B) "PULL"

### ■ Engine Side Cover and Front Grill

To remove the engine side cover and front grill, pull outward as indicated by arrows, and then lift cover off.

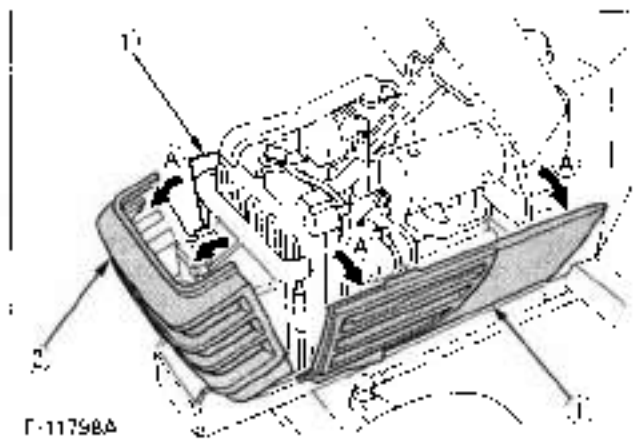

F-11798A

(1) Side cover

(2) Front grill

(A) "PULL"

## DAILY CHECK

For your own safety and maximum service life of the machine, make a thorough daily inspection before starting or operating the machine.



### CAUTION

To avoid personal injury:

- Be sure to check and service the tractor on a firm, flat and level surface with the engine stopped, the parking brake "ON" and implements lowered to the ground.

### Walk Around Inspection

Look around and under the tractor for such items as loose bolts, trash build-up, oil or coolant leaks, broken or worn parts.

### Checking and Refueling



### CAUTION

To avoid personal injury:

- Do not smoke while refueling.
- Be sure to stop the engine and remove the key before refueling.

1. Turn the key switch to "ON", check the amount of fuel by fuel gauge.
2. Fill fuel tank when fuel gauge shows 1/4 or less fuel in tank.
3. Use grade No.2-Diesel fuel at temperatures above -10°C (14°F).  
Use grade No.1-Diesel fuel at temperatures below -10°C (14°F).

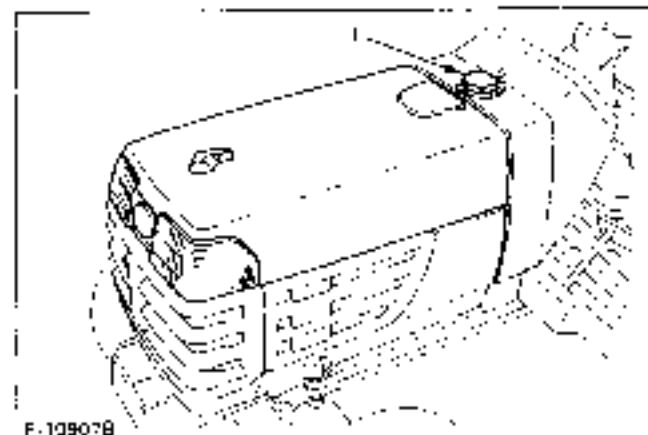

F.109078

(1) Fuel tank cap

Fuel tank capacity	26 L   6.9 U.S.gals.
--------------------	----------------------

### IMPORTANT:

- Do not permit dirt or trash to get into the fuel system.
- Be careful not to let the fuel tank empty completely, otherwise air will enter the fuel system, necessitating bleeding before engine will start.
- Be careful not to spill during refueling. If a spill should occur, wipe it off at once, or it may cause a fire.
- To prevent condensation (water accumulation) in the fuel tank, fill the tank before parking overnight.

### NOTE:

- No.2-D is a distillate fuel of lower volatility for engines in industrial and heavy mobile service.
- Grade of Diesel Fuel Oil According to ASTM D975 (SAE J313 JUN87)

Flash Point C(°F)	Water and Sediment, volume %		Carbon Re- sidue on 10 percent Re- sidual, %	Ash, weight %
	Min	Max		
52 (125)		0.05	0.35	0.01

Distillation Temperatures °C(°F) 90% Point:		Viscosity Kinematic cSt or mm <sup>2</sup> /s at 40°C		Viscosity Saybolt, SUS at 100°F		Sulfur weight %	Copper Strip Corrosion	Cetane Number
Min	Max	Min	Max	Min	Max			
282 (540)	338 (640)	1.9	4.1	32.8	40.1	0.50	No.3	40

## ■ Checking Engine Oil Level



### CAUTION

To avoid personal injury:

- Be sure to stop the engine and remove the key before checking the oil level.

1. Park the machine on a firm, flat and level surface.
2. Check engine oil before starting the engine, or, wait 5 minutes or more after the engine has been stopped.
3. To check the oil level, draw out the dipstick, wipe it clean, replace it, and draw it out again. Check to see that the oil level is between the two notches. If the level is too low, add new oil to the prescribed level at the oil inlet.  
(See "LUBRICANTS" in maintenance section.)

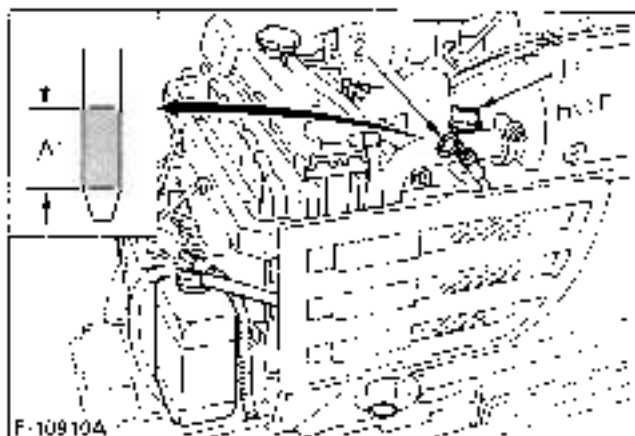

F-109104

(1) Oil inlet (A) Oil level is acceptable within this range  
(2) Dipstick

### IMPORTANT:

- When using oil from a different manufacturer or viscosity, remove all of the old oil and oil filter. Never mix two different types of oil.
- If oil level is low, do not run engine.

## ■ Checking Transmission Fluid Level

1. Park the machine on a firm, flat and level surface, lower the implement and stop the engine.
2. To check the oil level, draw out the dipstick, wipe it clean, replace it, and draw it out again. Check to see that the oil level is between the two notches. If the level is too low, add new oil to the prescribed level at the oil inlet.  
(See "LUBRICANTS" in maintenance section.)

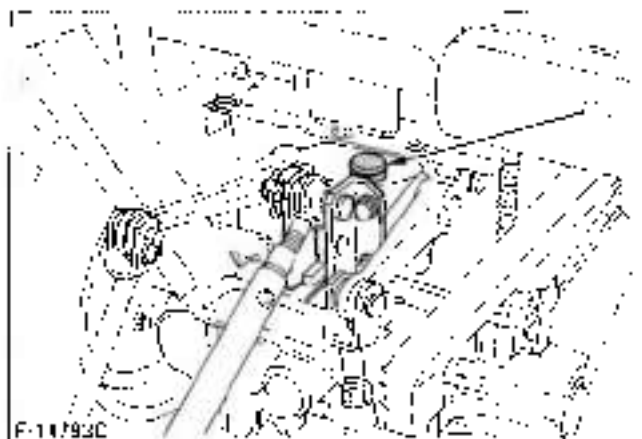

F-117920

(1) Oil inlet



F-138800

(1) Dipstick (A) Oil level is acceptable within this range

### IMPORTANT:

- If oil level is low, do not run engine.

## ■ Checking Coolant Level



### CAUTION

To avoid personal injury:

- Be sure to stop the engine and remove the key.
- Do not remove the radiator cap while coolant is hot. When cool, slowly rotate cap to the first stop and allow sufficient time for excess pressure to escape before removing cap completely.

1. Check to see that the coolant level is between the "FULL" and "LOW" marks on the recovery tank.
2. When the coolant level drops due to evaporation, add water only up to the full level. In case of leakage, add antifreeze and water in the specified mixing ratio up to the full level. (See "Flush, Cooling System and Changing Coolant" in every 2 years maintenance.)

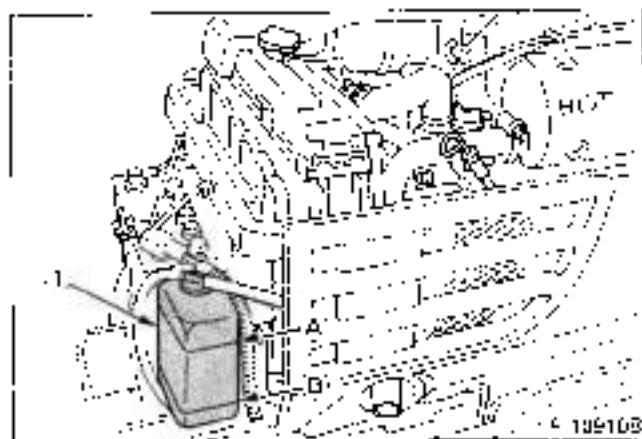

(1) Recovery tank

(A) "FULL"  
(B) "LOW"

### IMPORTANT:

- If the radiator cap has to be removed, follow the above "CAUTION" and securely retighten the cap.
- Use clean, fresh water and anti-freeze to fill the recovery tank.
- If coolant should leak, consult your local KUBOTA Dealer.

## ■ Cleaning Grill and Radiator Screen



### CAUTION

To avoid personal injury:

- Be sure to stop the engine and remove the key before removing the screen.

1. Check front grill and side screens to be sure they are clean of debris.
2. Detach the screen and remove all foreign materials and clean the front of radiator completely.

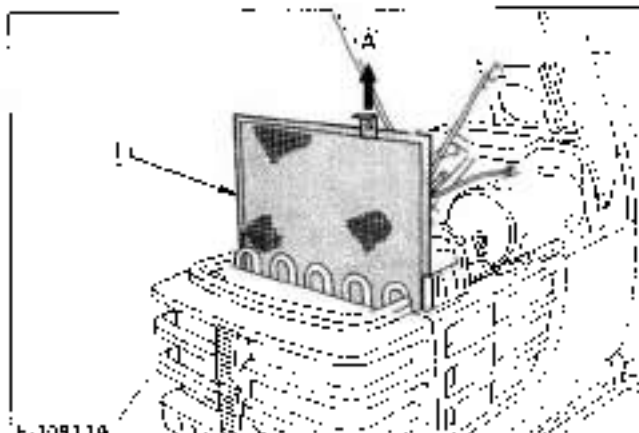

F-13911A

(1) Radiator screen

(A) "DETAACH"

### IMPORTANT:

- Grill and screen must be clean from debris to prevent engine from overheating and to allow good air intake for the air cleaner.

### NOTE:

- If the dust or chaff has accumulated between the battery and radiator, open the shutter plate and clean the front of radiator completely.

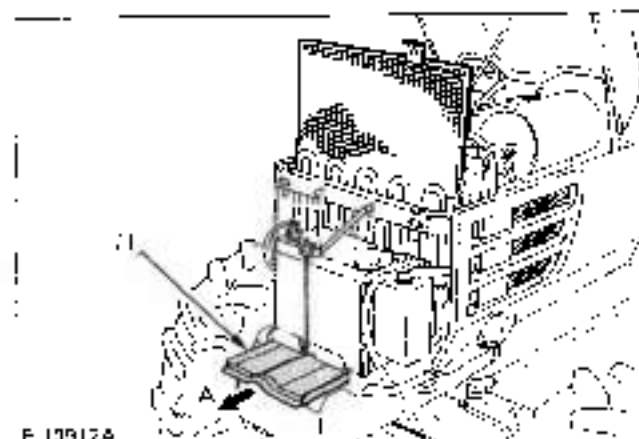

F-13912A

(1) Shutter plate

(A) "PULL"



### ■ Checking Brake Pedals and Clutch Pedal

1. Inspect the brake and clutch pedals for free travel and smooth operation.
2. Adjust if incorrect measurement is found: (See "Adjusting Clutch and Brake Pedal" in every 100 hours maintenance.)

#### NOTE:

- Brake pedals should be equal when depressed.

### ■ Checking Gauges, Meters and Easy Checker™

1. Inspect the instrument panel for broken gauge(s), meter(s) and Easy Checker™ lamps.
2. Replace if broken.

### ■ Checking Head Light, Hazard Light etc.

1. Inspect the lights for broken bulbs and lenses.
2. Replace if broken.

### ■ Checking and Cleaning of Electrical Wiring and Battery Cables



#### CAUTION

To avoid personal injury:

- A loosened terminal or connector, or damaged wire may affect the performance of electrical components or cause short circuits. Leakage of electricity could result in a fire hazard, a dead battery or damage to electrical components.
- Replace damaged wires or connections promptly.
- If a fuse blows soon after replacement, **DO NOT USE A LARGER THAN RECOMMENDED FUSE OR BYPASS THE FUSE SYSTEM.**
- Many wiring connections are protected by waterproof plugs, plug and unplug these connections carefully and make sure they are sealed correctly after assembly.
- Accumulation of dust, chaff or spilled fuel deposits around the battery, electrical wiring, engine or exhaust system are a fire hazard. **CLEAN THESE AREAS BEFORE STARTING WORK.**  
To avoid premature electrical malfunctions **DO NOT APPLY** high pressure water directly to battery, wiring, connectors, electrical components or instrument panel.

#### Inspect the following Regularly:

1. Check wiring for chafed or cracked insulation.
2. Check wiring harness clamps. Replace if necessary.
3. Check connectors and terminals for looseness, contamination or overheated (discolored) connections.
4. Check instrument panel for correct operation of switches and gauges.

Consult your KUBOTA Dealer regarding maintenance, diagnosis and repair.

### ■ Checking Seat Belt and ROPS

1. Always check condition of seat belt and ROPS attaching hardware before operating tractor.
2. Replace if damaged.

## EVERY 50 HOURS

### ■ Checking Engine Start System



#### CAUTION

To avoid personal injury:

- Do not allow anyone near the tractor while testing.
- If the tractor does not pass the test do not operate the tractor.

#### ◆ Preparation before testing

1. Sit on operator's seat.
2. Set the parking brake and stop the engine.
3. Shift the range gear shift lever in "NEUTRAL" position.
4. Place the speed control pedal in "NEUTRAL" position.
5. Shift the rear-PTO gear shift lever and Mic-PTO gear shift lever to "OFF" (Disengaged) position.
6. Fully depress the clutch pedal.

#### ◆ Test 1:

1. Release the clutch pedal.
2. Turn the key to "START" position.
3. The engine must not crank.

#### ◆ Test 2:

1. Fully depress the clutch pedal.
2. Depress the speed control pedal.
3. Turn the key to "START" position.
4. The engine must not crank.

#### ◆ Test 3:

1. Fully depress the clutch pedal.
2. Place the speed control pedal in "NEUTRAL" position.
3. Shift the rear-PTO gear shift lever to "ON" (Engaged) position.
4. Turn the key to "START" position.
5. The engine must not crank.

## ◆ Test 4:

1. Shift the rear-PTO gear shift lever to "OFF" (Disengaged) position.
2. Shift the Mid-PTO gear shift lever to "ON" (Engaged) position.
3. Turn the key to "START" position.
4. The engine must not crank.

## [B7800 only]

## ◆ Test 5: Switch for the Operator's seat.

1. Sit on operator's seat.
2. Start the engine.
3. Fully depress the clutch pedal.
4. Shift the rear-PTO gear shift lever to "ON" (Engaged) position.
5. Stand up. (Do not get off the machine.)
6. The engine must shut off after approximately 1 second.
7. If it does not stop, consult your local KUBOTA Dealer for this service.

## NOTE:

- If the engine cranks during any of these tests, consult your local KUBOTA Dealer to have unit checked before operating.

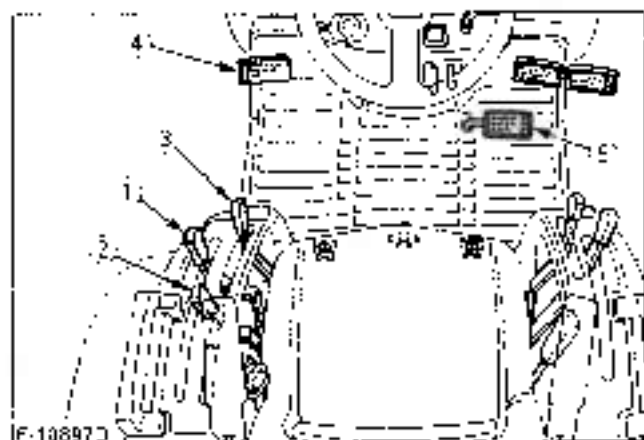

F-10897D

- (1) Range gear shift lever
- (2) Rear-PTO gear shift lever
- (3) Mid-PTO gear shift lever
- (4) Clutch pedal
- (5) Speed control pedal

## ■ Lubricating Grease Fittings

Apply a small amount of multipurpose grease to the following points every 50 hours:

If you operated the machine in extremely wet and muddy conditions, lubricate grease fittings more often.

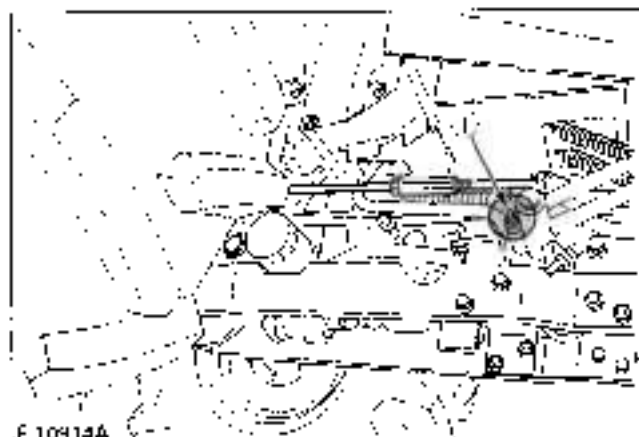

F-10914A

- (1) Grease fitting (Speed control pedal)

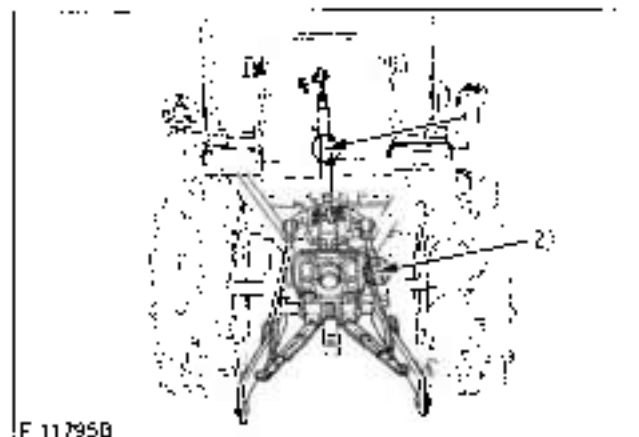

F-11795B

- (1) Grease fitting (Top link)
- (2) Grease fitting (Lifting rod) [RH]

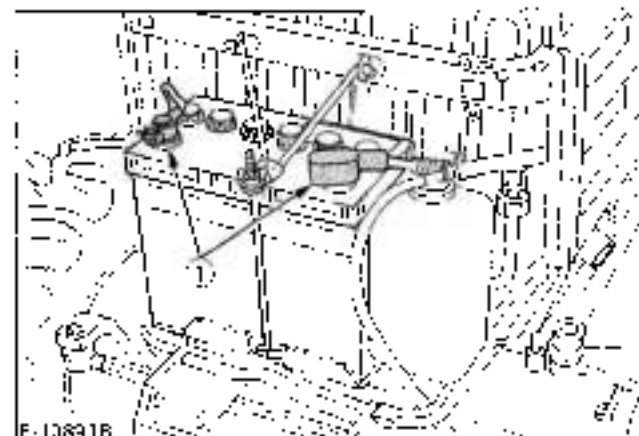

F-10891B

- (1) Battery terminals

## ■ Checking Wheel Bolt Torque



### CAUTION

To avoid personal injury:

- Never operate tractor with a loose rim, wheel, or axle
- Any time bolts and nuts are loosened, retighten to specified torque.
- Check all bolts and nuts frequently and keep them tight.

Check wheel bolts and nuts regularly especially when new. If they are loose, tighten them as follows.

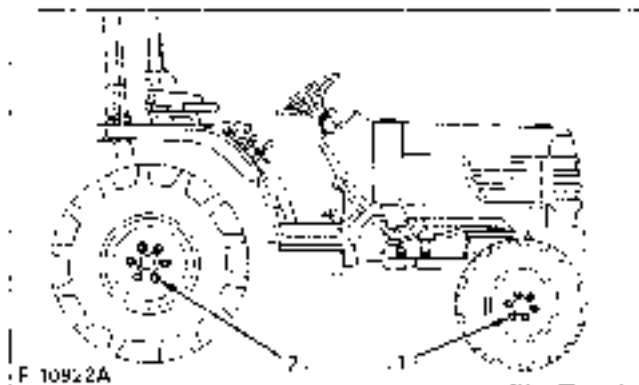

F 10922A

(1) Nut: 77 to 90 N·m ( 9 to 9.2 kgf·m, 57 to 67 ft·lbs. )

(2) Bolt: 196 to 225 N·m ( 20 to 23 kgf·m, 145 to 166 ft·lbs. )

Nut: 167 to 191 N·m ( 17 to 19.5 kgf·m, 123 to 141 ft·lbs. )

## EVERY 100 HOURS

### ■ Battery



### DANGER

To avoid the possibility of battery explosion: For the refillable type battery, follow the instructions below.

- Do not use or charge the refillable type battery if the fluid level is below the LOWER (lower limit level) mark. Otherwise, the battery component parts may prematurely deteriorate, which may shorten the battery's service life or cause an explosion. Check the fluid level regularly and add distilled water as required so that the fluid level is between the UPPER and LOWER levels.



### CAUTION

To avoid personal injury:

- Never remove the vent caps while the engine is running.
- Keep electrolyte away from eyes, hands and clothes. If you are splattered with it, wash it away completely with water immediately and get medical attention.
- Wear eye protection and rubber gloves when working around the battery.

Mishandling the battery shortens the service life and adds to maintenance costs.

The original battery is maintenance free, but needs some servicing.

If the battery is weak, the engine will be difficult to start and the lights will be dim. It is important to check the battery periodically.

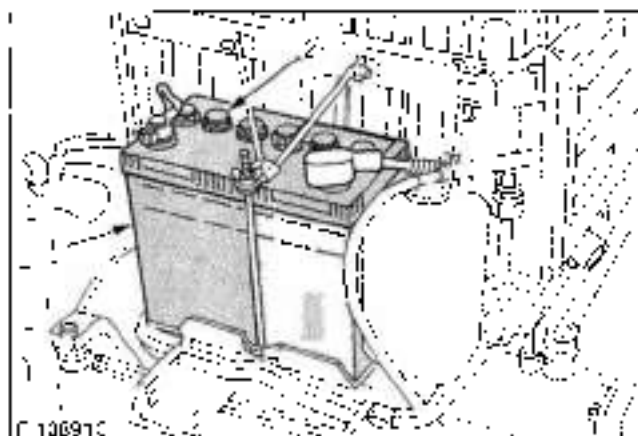

(1) Battery

(2) Vent cap

### ◆ Battery Charging



### CAUTION

To avoid personal injury:

- When the battery is being activated, hydrogen and oxygen gases in the battery are extremely explosive. Keep open sparks and flames away from the battery at all times, especially when charging the battery.
- When charging the battery, ensure the vent caps are securely in place (if equipped).
- When disconnecting the cable from the battery, start with the negative terminal first. When connecting the cable to the battery, start with the positive terminal first.
- Never check battery charge by placing a metal object across the posts. Use a voltmeter or hydrometer.

1. Make sure each electrolyte level is to the bottom of vent wells, if necessary add distilled water in a well ventilated area.

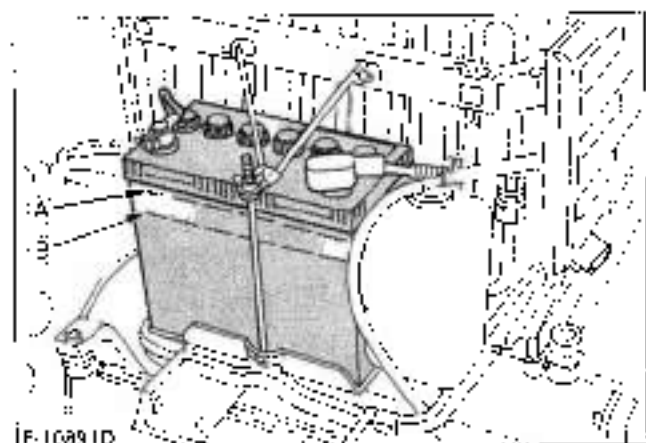

(A) Upper level  
(B) Lower level

2. The water in the electrolyte evaporates during recharging. Liquid shortage damages the battery. Excessive liquid spills over and damages the tractor body.
3. To slow charge the battery, connect the battery positive terminal to the charger positive terminal and the negative to the negative, then recharge in the normal manner.
4. A boost charge is only for emergencies. It will partially charge the battery at a high rate and in a short time. When using a boost-charged battery, it is necessary to recharge the battery as early as possible. Failure to do this will shorten the battery's service life.
5. When the specific gravity of electrolyte is between 1.27 and 1.29 the charging is completed.
6. When exchanging an old battery for a new one, use battery of equal specification shown in table 1.

Table 1

Battery Type	Volts (V)	Capacity at 54.8	Reserve at (min)	Cold Cranking Amps	Normal Charging Rate (A)
55B24L(S) MF	12	36	79	433	4.5

#### ◆ Battery Storage

1. When storing the tractor for a long period, remove the battery from tractor, adjust the electrolyte to the proper level and store in a dry place out of direct sunlight.
2. The battery self-discharges while it is stored. Recharge it once every three months in hot seasons and once every six months in cold seasons.

## ■ Changing Engine Oil



### CAUTION

To avoid personal injury:

- Be sure to stop the engine and remove the key.
- Allow engine to cool down sufficiently, oil can be hot and can burn.

1. To drain the used oil, remove the drain plug at the bottom of the engine and drain the oil completely into the oil pan. All the used oil can be drained out easily when the engine is still warm.
2. After draining reinstall the drain plug.
3. Fill with the new oil up to the upper notch on the dipstick. (See "LUBRICANTS" in maintenance section.)
4. Properly dispose of used oil.

Oil capacity with filter	4.1 L (4.3 U.S.qts.)
--------------------------	----------------------

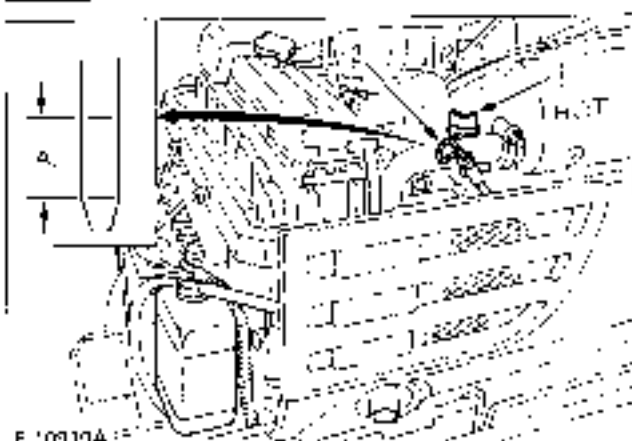

F 10910A

- (1) Oil inlet (A) Oil level is acceptable within this range  
(2) Dipstick



F 10923A

- (1) Drain plug (Both sides)

## ■ Cleaning Air Cleaner Primary Element



### CAUTION

To avoid personal injury:

- Be sure to stop the engine and remove the key.

1. Remove the air cleaner cover and primary element.
2. Clean the primary element:
  - 1) When dry dust adheres to the element, blow compressed air from the inside, turning the element. Pressure of compressed air must be under 490kPa (5kgf/cm<sup>2</sup>, 71psig).
  - 2) When carbon or oil adheres to the element, soak the element in detergent for 15 minutes then wash it several times in water, rinse with clean water and dry it naturally. After element is fully dried, inspect inside of the element with a light and check if it is damaged or not.
3. Replace air cleaner primary element:  
Every year or after 6 cleanings, whichever comes first.

### NOTE:

- Check to see if the evacuator valve is blocked with dust.

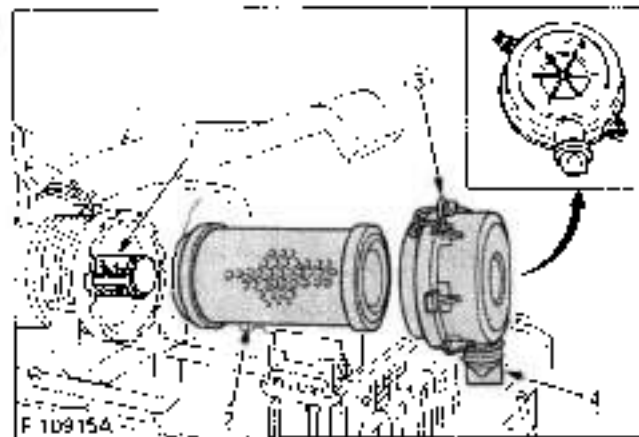

- F 109154
- (1) Secondary (safety) element
  - (2) Primary element
  - (3) Cover
  - (4) Evacuator valve

### IMPORTANT:

- The air cleaner uses a dry element, never apply oil.
- Do not run the engine with filter element removed.
- Be sure to refit the cover with the arrow ↑ (on the face of cover) upright. If the cover is improperly fitted, evacuator valve will not function and dust will adhere to the element.
- Do not touch the secondary element except in cases where replacing is required.

### ◆ Evacuator Valve

Open the evacuator valve once a week under ordinary conditions or daily when used in dusty conditions to get rid of large particles of dust and dirt.

## ■ Checking Fuel Line



### CAUTION

To avoid personal injury:

- Be sure to stop the engine and remove the key.

1. Check to see that all lines and hose clamps are tight and not damaged.
2. If hoses and clamps are found worn or damaged, replace or repair them at once.

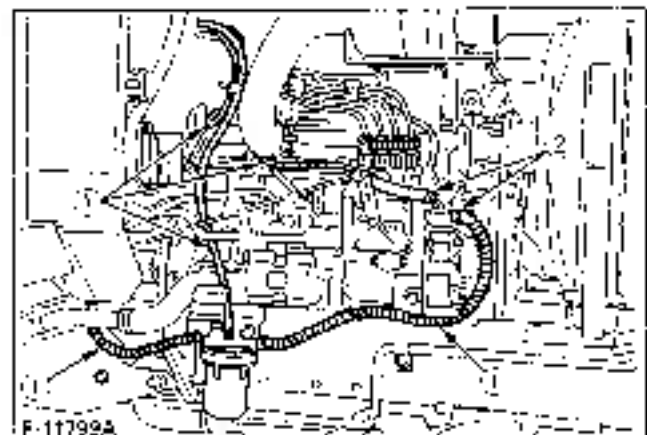

- F-11799A
- (1) Fuel lines
  - (2) Hose clamps

### NOTE:

- If the fuel line is removed, be sure to properly bleed the fuel system.  
(See "Bleeding Fuel System" in "SERVICE AS REQUIRED")

## ■ Cleaning Fuel Filter

This job should not be done in the field, but in a clean place.

1. Loosen and remove the filter bowl, and rinse the inside with kerosene.
2. Take out the element and dip it in the kerosene to rinse.
3. After cleaning, reassemble the fuel filter, keeping out dust and dirt.
4. Bleed the fuel system.  
(See "SERVICE AS REQUIRED" in Periodic service section.)

### NOTE:

- When the fuel filter bowl has been removed, fuel stops flowing from the fuel tank. If the fuel tank is almost full, however, the fuel will flow back from the fuel return pipe to the fuel filter. Before checking, make sure the fuel tank is less than half-full.

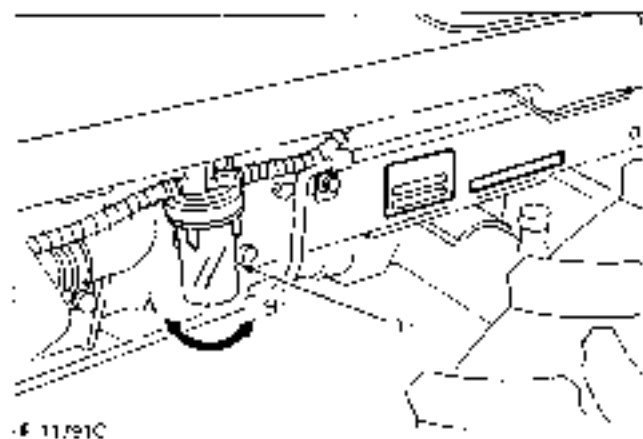

F-11791C

(1) Fuel filter bowl

(A) "LOOSEN"

(B) "TIGHTEN"

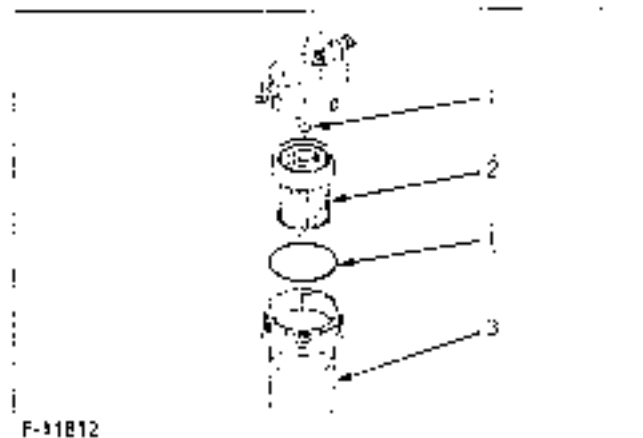

F-11812

(1) O ring

(2) Filter element

(3) Filter bowl

### IMPORTANT:

- If dust, dirt or water enters the fuel system, the fuel pump and injection nozzles are subject to premature wear. To prevent this, be sure to clean the fuel filter bowl and element periodically.

## ■ Adjusting Fan belt Tension



### CAUTION

To avoid personal injury:

- Be sure to stop the engine and remove the key.

Proper fan belt tension

A deflection of between 7 to 8mm (1/4 to 3/8 in.) when the belt is pressed in the middle of the span.

1. Stop the engine and remove the key.
2. Apply moderate thumb pressure to belt between pulleys.
3. If tension is incorrect, loosen the alternator mounting bolts and, using a lever placed between the alternator and the engine block, pull the alternator out until the deflection of the belt falls within acceptable limits.
4. Replace fan belt if it is damaged.

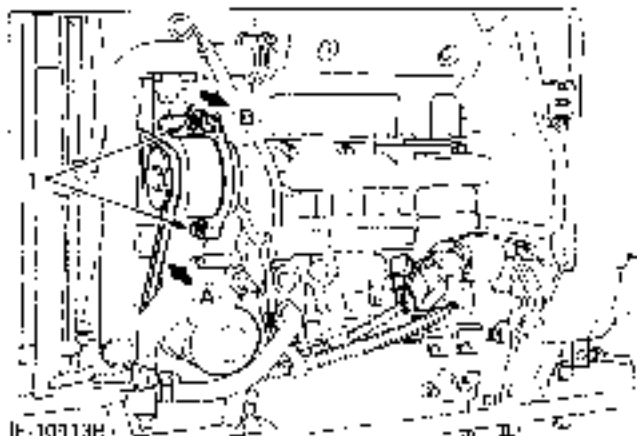

F-10313B

(1) Bolt

(A) Check the belt tension

(B) To tighten

## ■ Adjusting Clutch Pedal

Proper clutch pedal free travel	20 to 30 mm (13/16 to 1-3/16 in.) on the pedal
---------------------------------	--

1. Stop the engine and remove the key.
2. Slightly depress the clutch pedal and measure free travel at top of pedal stroke.
3. If adjustment is needed, loosen the lock nut and turn the clutch rod to adjust the rod length within acceptable limits.
4. Retighten the lock nut.
5. After adjusting, release the clutch pedal and check the clearance (B). If adjustment is needed, adjust the clearance (B) with bolt (3).

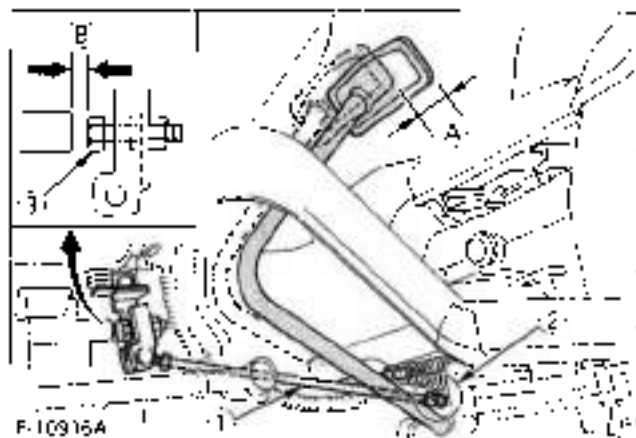

F-10915A

- (1) Clutch rod  
(2) Lock nut  
(3) Bolt

- (A) Free travel  
(B) 8.5mm (1/32 in.)

## ■ Adjusting Brake Pedal



### CAUTION

To avoid personal injury:

- Stop the engine and chock the wheels, remove the key, lower the implement the ground.

Proper brake pedal free travel	30 to 40 mm (1-3/16 to 1-19/32 in.) on the pedal
	Keep the free travel in the right and left brake pedals equal.

1. Release the parking brake.
2. Slightly depress the brake pedals and measure free travel at top of pedal stroke.
3. If adjustment is needed, loosen the lock nut and turn the turnbuckle to adjust the rod length within acceptable limits.
4. Retighten the lock nut.

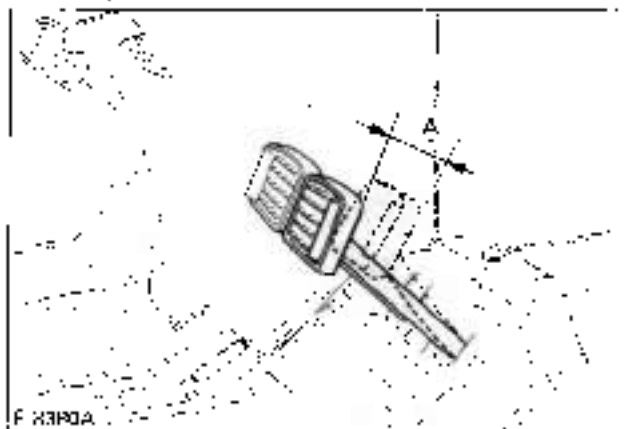

F-8380A

- (A) Free travel

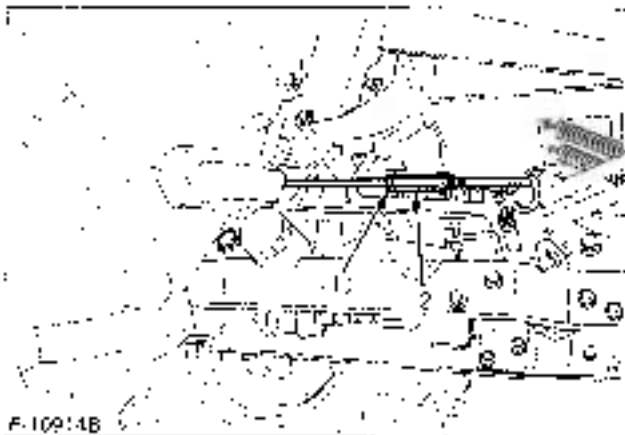

F-10914B

- (1) Lock nut  
(2) Turnbuckle

## EVERY 200 HOURS

### ■ Replacing Engine Oil Filter



#### CAUTION

To avoid personal injury:

- Be sure to stop the engine and remove the key.
- Allow engine to cool down sufficiently, oil can be hot and can burn.

1. Remove the oil filter.
2. Put a film of clean engine oil on the rubber seal of the new filter.
3. Tighten the filter quickly until it contacts the mounting surface.  
Tighten filter by hand an additional 1/2 turn only.
4. After the new filter has been replaced, the engine oil normally decreases a little. Make sure that the engine oil does not leak through the seal and be sure to check the oil level on the dipstick. Then, replenish the engine oil up to the prescribed level.
5. Properly dispose of used oil.

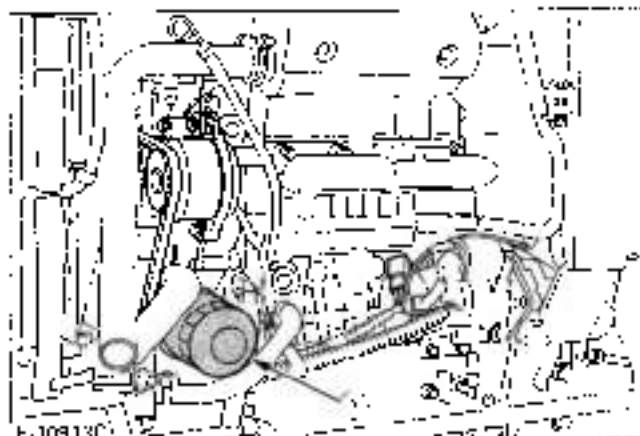

(1) Engine oil filter

#### IMPORTANT:

- To prevent serious damage to the engine, use only a KUBOTA genuine filter.

### ■ Checking Radiator Hose and Clamp



#### CAUTION

To avoid personal injury:

- Be sure to stop the engine and remove the key.

Check to see if radiator hoses are properly fixed every 200 hours of operation or six months, whichever comes first.

1. If hose clamps are loose or water leaks, tighten clamps securely.
2. Replace hoses and tighten hose clamps securely, if radiator hoses are swollen, hardened or cracked.
3. Properly dispose of used coolant

Replace hoses and hose clamps every 2 years or earlier if checked and found that hoses are swollen, hardened or cracked

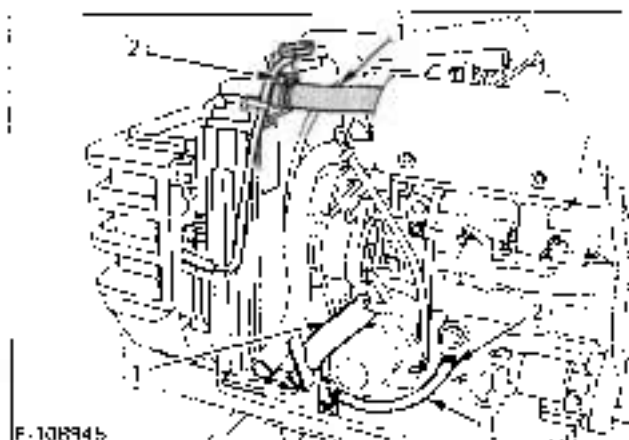

F-108945

(1) Radiator hose (5 hoses)

(2) Hose clamps (10 clamps)

#### ◆ Precaution at Overheating

Take the following actions in the event the coolant temperature be nears the boiling point, what is termed "Overheating".

1. Stop the machine operation in a safe place and keep the engine unloaded and idling.
2. Don't stop the engine suddenly, but stop it after about 5 minutes of unloaded idling.
3. Keep yourself well away from the machine for an additional 10 minutes or until the steam has blown out.
4. After carefully checking that there is no danger of being burned, eliminate the causes of overheating according to the manual, see "TROUBLESHOOTING" section, and restart the engine.



## ■ Checking Intake Air Line



### CAUTION

To avoid personal injury

- Be sure to stop the engine and remove the key.

1. Check to see that hoses and hose clamps are tight and not damaged.
2. If hoses and clamps are found worn or damaged, replace or repair them at once.

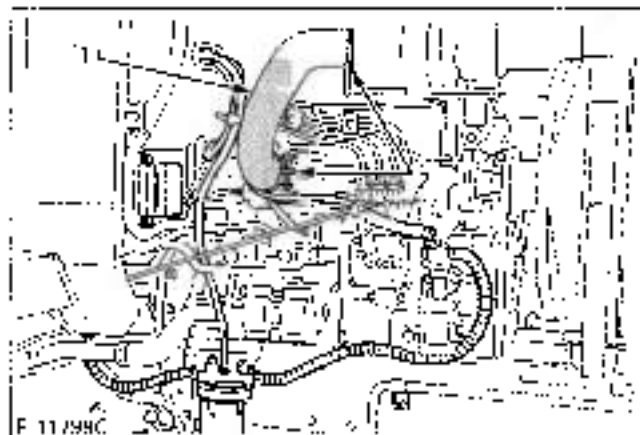

(1) Hose

(2) Hose clamps

## ■ Adjusting Toe-in

1. Park tractor on a firm, flat and level surface.
2. Turn steering wheel so front wheels are in the straight ahead position.
3. Lower the implement to the ground, set the park brake, stop the engine and remove the key.
4. Measure distance between tire beads at front of tire at hub height.
5. Measure distance between tire beads at rear of tire, hub height.
6. Front distance should be 1 to 5mm (1/16 to 3/16 in.) less than rear distance. If not, adjust tie rod length.

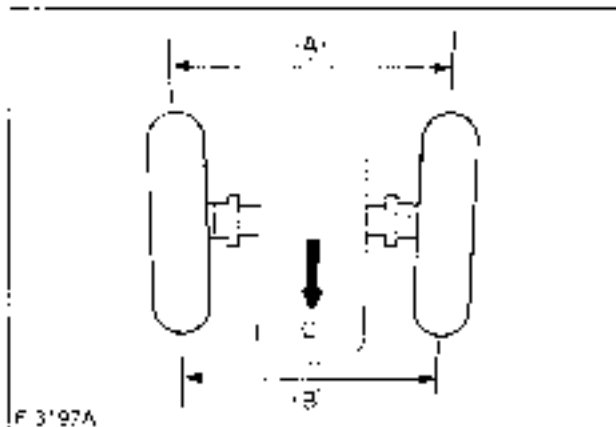

(A) Wheel to wheel distance at rear

(B) Wheel to wheel distance at front

(C) "FRONT"

### ◆ Adjusting procedure

1. Loosen the lock nut and turn the tie rod to adjust the rod length until the proper toe in measurement is obtained.
2. Retighten the lock nut.

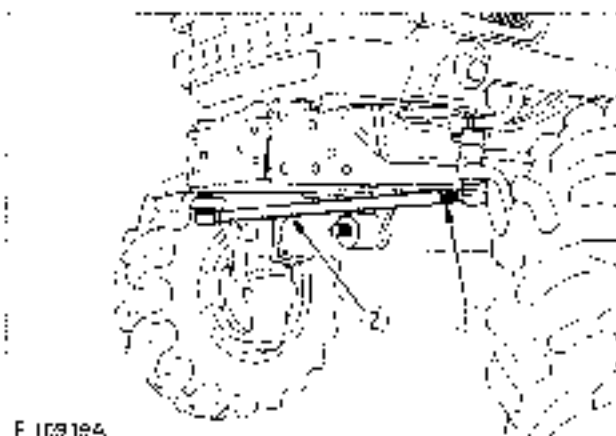

(1) Lock nuts

(2) Tie rod

## EVERY 300 HOURS

### Changing Transmission Fluid



#### CAUTION

To avoid personal injury:

- Allow engine to cool down sufficiently. Oil can be hot and can burn.

1. To drain the used oil, remove the drain plug at the bottom of the transmission case and drain the oil completely into the oil pan.
2. After draining reinstall the drain plug.
3. Clean the transmission strainer.
4. Fill with new KUBOTA SUPER UDT fluid up to the upper notch on the dipstick. (See "LUBRICANTS" and "DAILY CHECK" in maintenance section.)
5. After running the engine for a few minutes, stop it and check the oil level again; add oil to prescribed level.
6. Properly dispose of used oil.

Oil capacity	14.5 L (3.83 U.S.gals.)
--------------	-------------------------

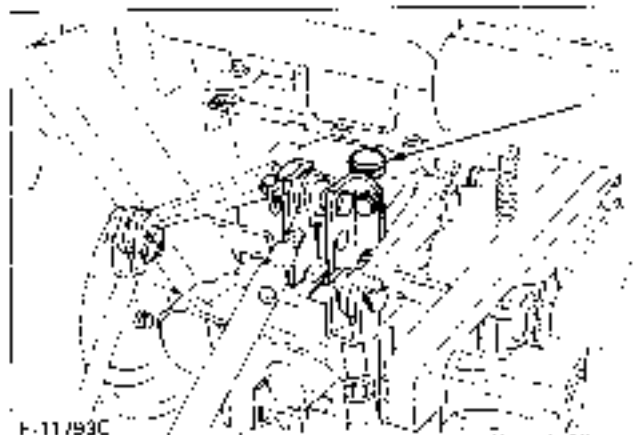

F-11793C

(1) Oil inlet



F-10806D

(1) Dipstick

(A) Oil level is acceptable within this range.

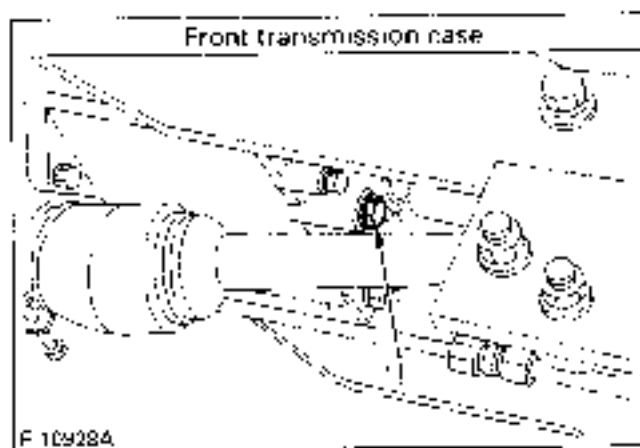

F-10928A

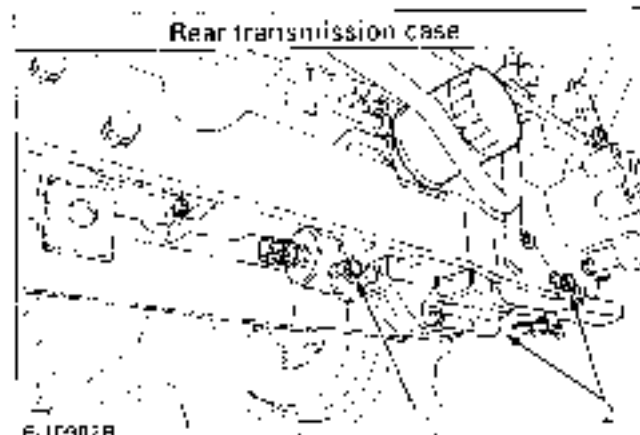

F-10907B

(1) Drain plug

(2) Drain plugs (Both sides)

#### IMPORTANT:

- If the 3-point hitch can not be raised by setting the hydraulic control lever to the UP position after long term storage or when changing the transmission oil, turn steering wheel to the right and left several times to bleed air from the system.
- Do not operate the tractor immediately after changing the transmission fluid or cleaning transmission strainer.

### ◆ Cleaning Transmission Strainer

When changing the transmission fluid, disassemble and rinse the strainer with nonflammable solvent to completely clean off filings. When reassembling be careful not to damage the parts.

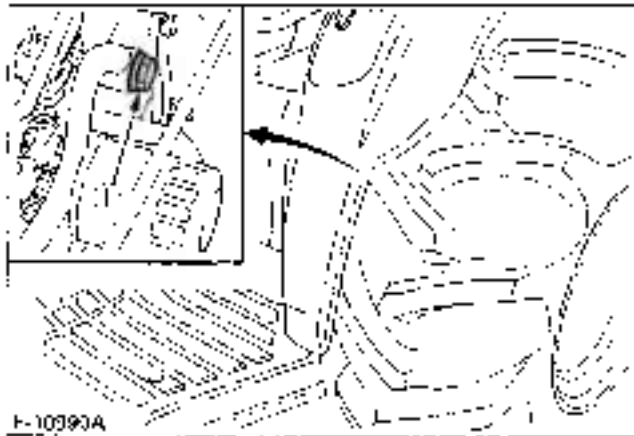

F-10990A

(1) Strainer

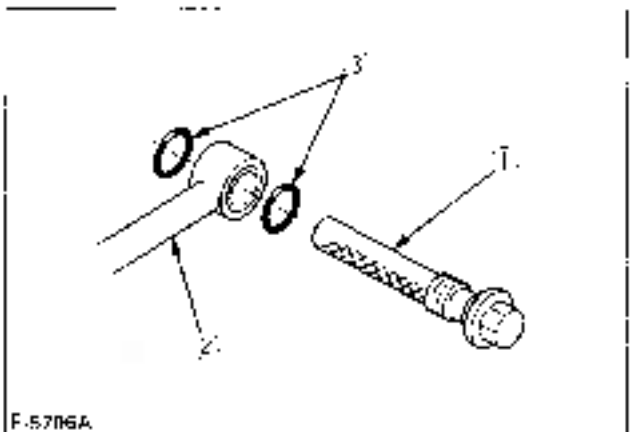

F-5706A

(1) Strainer

(2) Suction line

(3) O-ring

#### NOTE:

- Since the fine fillings in the oil can damage the precision component parts of the hydraulic system, the end of the suction line is provided with an oil strainer.

### ■ Replacing Transmission Oil Filter



#### CAUTION

To avoid personal injury:

- Allow engine to cool down sufficiently, oil can be hot and can burn.

1. Remove the oil filter.
2. Put a film of clean transmission oil on rubber seal of new filter.
3. Tighten the filter quickly until it contacts the mounting surface.  
Tighten filter by hand an additional 1/2 turn only.
4. After the new filter has been replaced, the transmission fluid level will decrease a little. Make sure that the transmission fluid does not leak through the seal, and check the fluid level. Top up if necessary.
5. Properly dispose of used oil.

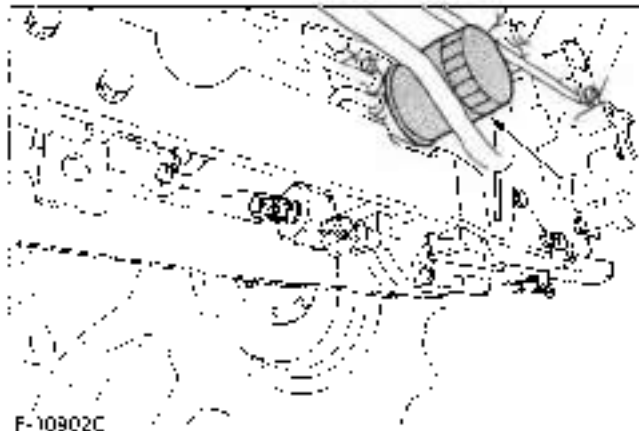

F-10902C

(1) Filter

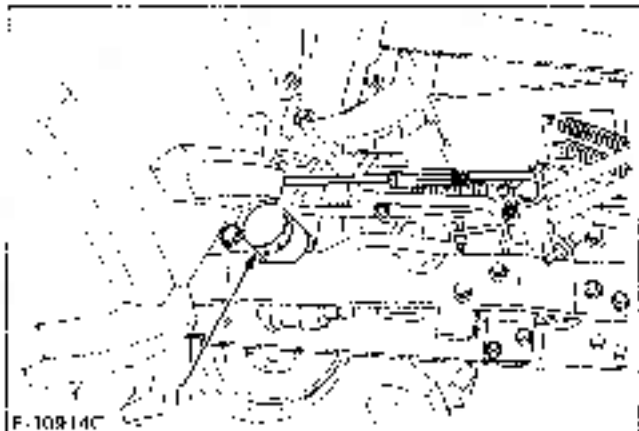

F-10814C

(1) Filter

#### IMPORTANT:

- To prevent serious damage to the hydraulic system, use only a KUBOTA genuine filter.

### ■ Changing Front Axle Case Oil

1. Park the tractor on a firm, flat and level surface.
  2. To drain the used oil, remove the right and left drain plugs and filling plug at the front axle case and drain the oil completely into the oil pan.
  3. After draining, reinstall the drain plugs.
  4. Fill with new oil up to the upper notch on the dipstick.  
(See "LUBRICANTS" in maintenance section.)
  5. Properly dispose of used oil.
- IMPORTANT:**
- After ten minutes, check the oil level again; add oil to prescribed level.
6. After filling, reinstall the filling plug.

Oil capacity	4.5 L (4.7 U.S.qts.)
--------------	----------------------

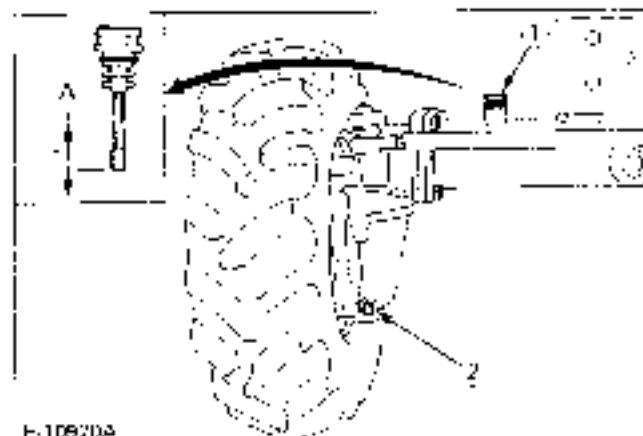

F-10920A

(1) Filling plug with dipstick

(A) Oil level is acceptable within this range

(2) Drain plug

### EVERY 400 HOURS

#### ■ Adjusting Front Axle Pivot

If the front axle pivot pin adjustment is not correct, front wheel vibration can occur causing vibration in the steering wheel.

##### ◆ Adjusting procedure

Loosen the lock nut, tighten the adjusting screw (tightening torque: 20 N·m, 2.0 kgf·m, 15 ft·lbf) then loosen the screw by 1/8 turn. Retighten the lock nut.

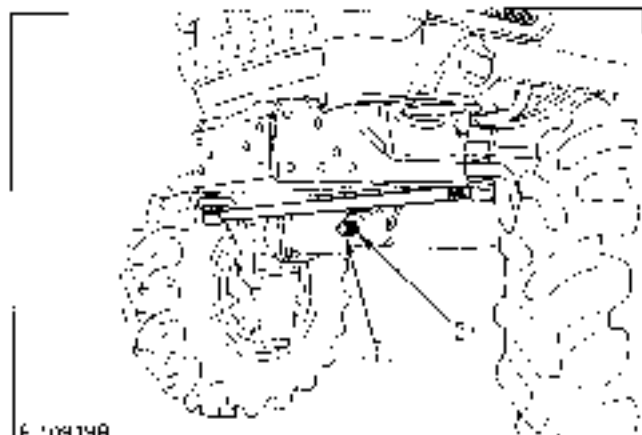

E-10919B

(1) Adjusting screw

(2) Lock nut

#### ■ Replacing Fuel Filter Element

(See "Cleaning fuel filter" in every 100 hours maintenance.)

### EVERY 800 HOURS

#### ■ Adjusting Engine Valve Clearance

Consult your local KUBOTA Dealer for this service.

### EVERY 1500 HOURS

#### ■ Checking Fuel Injection Nozzle Injection Pressure

Consult your local KUBOTA Dealer for this service.

### EVERY 3000 HOURS

#### ■ Checking Injection Pump

Consult your local KUBOTA Dealer for this service.

### EVERY 1 YEAR

#### ■ Replacing Air Cleaner Primary Element and Secondary Element

(See "Cleaning Air Cleaner Primary Element" in every 100 hours maintenance.)

## EVERY 2 YEARS

### Flush Cooling System and Changing Coolant



#### CAUTION

To avoid personal injury:

- Do not remove the radiator cap while coolant is hot. When cool, slowly rotate cap to the first stop and allow sufficient time for excess pressure to escape before removing cap completely.

- Stop the engine, remove the key and let cool down.
- To drain the coolant, open the radiator drain cock and remove radiator cap. The radiator cap must be removed to completely drain the coolant.
- After all coolant is drained, close the drain cock.
- Fill with clean water and cooling system cleaner.
- Follow directions of the cleaner instruction.
- After flushing, fill with clean water and anti-freeze until the coolant level is just below the radiator cap. Install the radiator cap securely.
- Fill with coolant up to the "FULL" mark of recovery tank.
- Start and operate the engine for few minutes.
- Stop the engine, remove the key and let cool.
- Check coolant level of recovery tank and add coolant if necessary.
- Properly dispose of used coolant.

Coolant capacity (with recovery tank)	4.5 L (4.7 U.S. qts.)
--	-----------------------

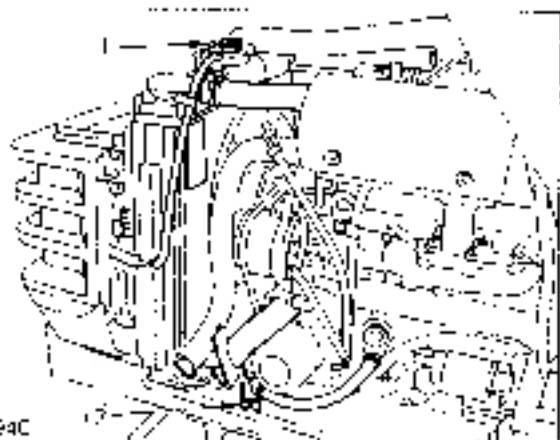

F-0894C

- (1) Radiator cap  
(2) Drain cock

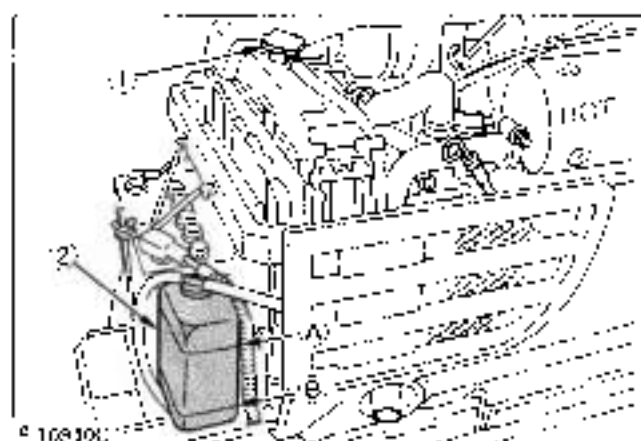

F-10810C

- (1) Radiator cap  
(2) Recovery tank

- (A) "FULL"  
(B) "LOW"

#### IMPORTANT:

- Do not start engine without coolant.
- Use clean, fresh water and anti-freeze to fill the radiator and recovery tank.
- When the anti-freeze is mixed with water, the anti-freeze mixing ratio must be less than 50%.
- Securely tighten radiator cap. If the cap is loose or improperly fitted, coolant may leak out and the engine could overheat.

### ■ Anti-Freeze

If cooling water freezes, it can damage the cylinders and radiator. It is necessary, if the ambient temperature falls below 0°C (32°F), to remove cooling water after operating or to add anti-freeze to it.

1. There are two types of anti freeze available: use the permanent type (P.F.) for this engine.
2. Before adding anti-freeze for the first time, clean the radiator interior by pouring fresh water and draining it a few times.
3. The procedure for mixing of water and anti-freeze differs according to the make of the anti freeze and the ambient temperature, basically it should refer to SAE J1034 standard, more specifically SAE J814c.
4. Mix the anti-freeze with water, and then fill into the radiator.

Vol % Anti-freeze	Freezing Point		Boiling Point*	
	°C	°F	°C	°F
40	-24	-12	106	222
50	-37	-34	108	226

\* At 760mmHg pressure (atmospheric). A higher boiling point is obtained by using a radiator pressure cap which permits the development of pressure within the cooling system.

#### NOTE.

- The above data represents industry standards that necessitate a minimum glycol content in the concentrated anti-freeze
- When the cooling water level drops due to evaporation, add water only. In case of leakage, add anti-freeze and water in the specified mixing ratio
- Anti-freeze absorbs moisture. Keep unused anti-freeze in a tightly sealed container.
- Do not use radiator cleaning agents when anti-freeze has been added to the cooling water. (Anti-freeze contains an anti-corrosive agent, which will react with the radiator cleaning agent forming sludge which will affect the engine parts.)

### ■ Replacing Radiator Hose (Water pipes)

Replace the hoses and clamps.  
(See "Checking Radiator Hose and Clamp" in every 200 hours maintenance.)

### ■ Replacing Fuel Hose

Replace the hoses and clamps.  
(See "Checking Fuel Line" in every 100 hours maintenance.)

### ■ Replacing Intake Air Line

Consult your local KUBOTA Dealer for this service.

## SERVICE AS REQUIRED

### ■ Bleeding Fuel System

Air must be removed:

1. When the fuel filter or lines are removed.
2. When tank is completely empty.
3. After the tractor has not been used for a long period of time.

#### ◆ Bleeding procedure is as follows:

1. Fill the fuel tank with fuel.
2. Start the engine and run for about 30 seconds, and then stop the engine

### ■ Draining Clutch Housing Water

The tractor is equipped with drain plug under the clutch housing.

After operating in rain, snow or tractor has been washed, water may get into the clutch housing. Remove the drain plug and drain the water, then install the plug again.



(1) Water drain plug

## Replacing Fuse



### CAUTION

To avoid personal injury:

- Be sure to stop the engine and remove the key.

The tractor electrical system is protected from potential damage by fuses.

A blown fuse indicates that there is an overload or short somewhere in the electrical system.

If any of the fuses should blow, replace with a new one of the same capacity.

### IMPORTANT:

- Before replacing a blown fuse, determine why the fuse blew and make any necessary repairs. If fuse continues to blow, do not short circuit. Failure to follow this procedure may result in serious damage to the tractor electrical system. Refer to the troubleshooting section of this manual or your local KUBOTA Dealer for specific information dealing with electrical problems. If any of them should blow, replace with a new one of the same capacity.

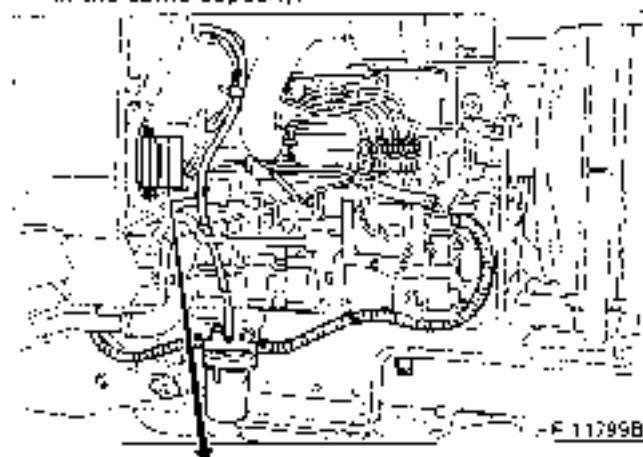

[B2710-B2910]

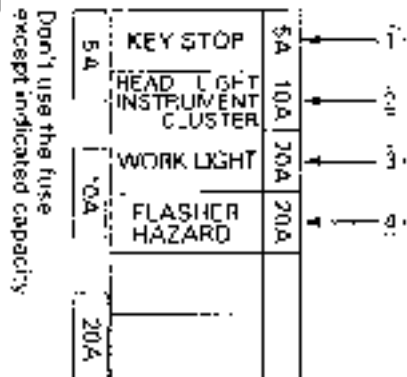

[B780G]

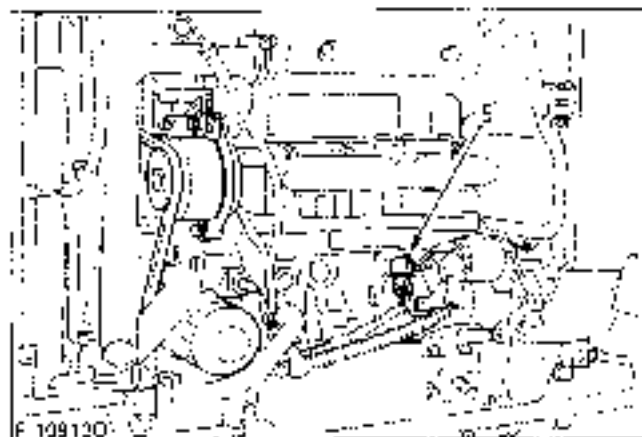
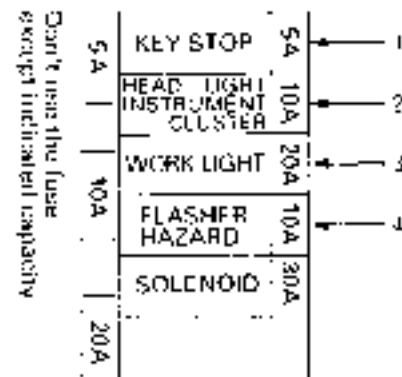

### Protected circuit

FUSE No.	CAPACITY (A)		Protected circuit
	B2710 B2910	B780G	
1	5		Key stop
2	10		Head light
3	20		Work light
4	20	10	Flasher / Hazard light
5	Slow blow fuse		Check circuit against wrong battery connection.

## Replacing Light Bulb

- Head lights :**  
Take the bulb out of the light body and replace with a new one.
- Other lights :**  
Detach the lens and replace the bulb.

Light	Capacity
Head light (B2710 B7910; B780G)	23W / 15W
Tail light:	8W
Turn Signal / Hazard light	27W and 20W
Instrument panel light:	1.7W
Hazard light switch indicator	0.6W

# STORAGE



## CAUTION

To avoid personal injury:

- Do not clean the machine with engine running.
- To avoid the danger of exhaust fume poisoning, do not operate the engine in a closed building without proper ventilation.
- When storing, remove the key from the key switch to avoid unauthorized persons from operating the tractor and getting injured.

## TRACTOR STORAGE

If you intend to store your tractor for an extended period of time, follow the procedures outlined below. These procedures will insure that the tractor is ready to operate with minimum preparation when it is removed from storage.

1. Check the bolts and nuts for looseness, and tighten if necessary.
2. Apply grease to tractor areas where bare metal will rust also to pivot areas.
3. Detach the weights from the tractor body.
4. Inflate the tires to a pressure a little higher than usual.
5. Change the engine oil and run the engine to circulate oil throughout the engine block and internal moving parts for about five minutes.
6. Keep the clutch disengaged. If the clutch is left engaged for a long period of time, the clutch plate may rust, making clutch disengagement impossible at the next operation.

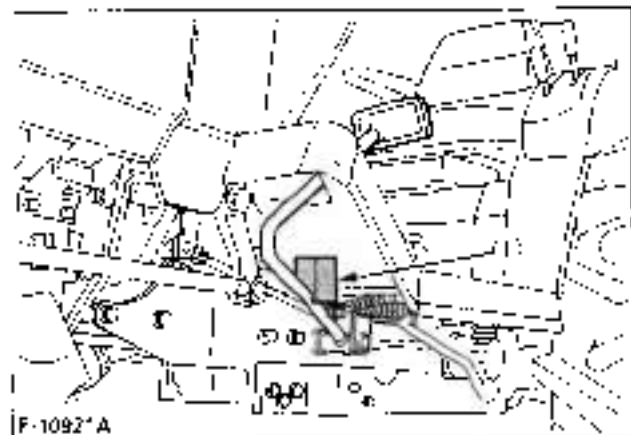

(1) Wooden block

7. With all implements lowered to the ground, coat any exposed hydraulic cylinder piston rods with grease.

8. Remove the battery from the tractor. Store the battery following the battery storage procedures (See "Battery condition" in every 100 hours in maintenance.)
9. Keep the tractor in a dry place where it will be sheltered from the elements. Cover the tractor.
10. Store the tractor indoors in a dry area that is protected from sunlight and excessive heat. If the tractor must be stored outdoors, cover it with a waterproof tarpaulin.  
Jack the tractor up and place blocks under the front and rear axles so that all four tires are off the ground. Keep the tires out of direct sunlight and extreme heat.

## IMPORTANT:

- When washing the tractor, be sure to stop the engine. Allow sufficient time for the engine to cool before washing.
- Cover the tractor after the muffler and the engine have cooled down.

## REMOVING THE TRACTOR FROM STORAGE

1. Check the tire air pressure and inflate the tires if they are low.
2. Jack the tractor up and remove the support blocks from under the front and rear axles.
3. Install the battery. Before installing the battery, be sure it is fully charged.
4. Check the fan belt tension.
5. Check all fluid levels (engine oil, transmission/hydraulic oil, engine coolant and any attached implements).
6. Start the engine. Observe all gauges. If all gauges are functioning properly and reading normal, move the tractor outside. Once outside, park the tractor and let the engine idle for at least five minutes. Shut the engine off and walk around tractor and make a visual inspection looking for evidence of oil or water leaks.
7. With the engine fully warmed up, release the parking brake and test the brakes for proper adjustment as you move forward. Adjust the brakes as necessary.



# TROUBLESHOOTING

## ENGINE TROUBLESHOOTING

If something is wrong with the engine, refer to the table below for the cause and its corrective measure.

Trouble	Cause	Countermeasure	
Engine is difficult to start or won't start	<ul style="list-style-type: none"> <li>No fuel flow.</li> </ul>	<ul style="list-style-type: none"> <li>Check the fuel tank and the fuel filter. Replace filter if necessary.</li> </ul>	
	<ul style="list-style-type: none"> <li>Air or water is in the fuel system.</li> </ul>	<ul style="list-style-type: none"> <li>Check to see if the fuel line coupler bolt and nut are tight.</li> <li>Bleed the fuel system (See "Bleeding Fuel system" in as required maintenance). Remove water from the system and replace the fuel filter.</li> </ul>	
	<ul style="list-style-type: none"> <li>In winter, oil viscosity increases, and engine revolution is slow.</li> </ul>	<ul style="list-style-type: none"> <li>Use oils of different viscosities, depending on ambient temperatures.</li> <li>Use engine block heater. (Optional)</li> </ul>	
	<ul style="list-style-type: none"> <li>Battery becomes weak and the engine does not turn over quick enough.</li> </ul>	<ul style="list-style-type: none"> <li>Clean battery cables and terminals.</li> <li>Charge the battery.</li> <li>In cold weather, always remove the battery from the engine, charge and store it indoors. Install it on the tractor only when the tractor is going to be used.</li> </ul>	
Insufficient engine power.	<ul style="list-style-type: none"> <li>Insufficient or dirty fuel.</li> <li>The air cleaner is clogged.</li> </ul>	<ul style="list-style-type: none"> <li>Check the fuel system.</li> <li>Clean or replace the element.</li> </ul>	
Engine stops suddenly.	<ul style="list-style-type: none"> <li>Insufficient fuel.</li> </ul>	<ul style="list-style-type: none"> <li>Refuel.</li> <li>Bleed the fuel system if necessary.</li> </ul>	
Exhaust fumes are colored.	Black	<ul style="list-style-type: none"> <li>Fuel quality is poor.</li> <li>Too much oil.</li> <li>The air cleaner is clogged.</li> </ul>	<ul style="list-style-type: none"> <li>Change the fuel and fuel filter.</li> <li>Check the proper amount of oil.</li> <li>Clean or replace the element.</li> </ul>
	Blue white	<ul style="list-style-type: none"> <li>The inside of exhaust muffler is damped with fuel.</li> <li>Injection nozzle trouble.</li> <li>Poor quality fuel.</li> </ul>	<ul style="list-style-type: none"> <li>Heat the muffler by applying load to the engine.</li> <li>Check the injection nozzle.</li> <li>Change the fuel and fuel filter.</li> </ul>
Engine overheats	<ul style="list-style-type: none"> <li>Engine overloaded</li> <li>Low coolant level</li> </ul>	<ul style="list-style-type: none"> <li>Shift to lower gear or reduce load.</li> <li>Fill cooling system to the correct level, check radiator and hoses for loose connections or leaks.</li> </ul>	
	<ul style="list-style-type: none"> <li>Loose or defective fanbelt</li> <li>Dirty radiator core or grille screens</li> <li>Coolant flow route corroded.</li> </ul>	<ul style="list-style-type: none"> <li>Adjust or replace fanbelt.</li> <li>Remove all trash.</li> <li>Flush cooling system.</li> </ul>	

If you have any questions, contact your local KUBOTA Dealer.

# OPTIONS

Consult your local KUBOTA Dealer for further detail.

- **Rear Work Light [Except B7800]**  
High visibility for night work
- **Front end weights**  
For front ballast
- **Mounting Kit (Front end weights)**  
To mount Front end weights
- **Engine Block Heater**  
For extremely cold weather starting
- **Mid-PTO kit [B7800]**



## KUBOTA Corporation is . . .

Since its inception in 1890, KUBOTA Corporation has grown to rank as one of the major firms in Japan.

To achieve this status, the company has through the years diversified the range of its products and services to a remarkable extent. Nineteen plants and 16,000 employees produce over 1,000 different items, large and small.

All these products and all the services which accompany them, however, are unified by one central commitment. KUBOTA makes products which, taken on a national scale, are basic necessities. Products which are indispensable. Products which are intended to help individuals and nations fulfill the potential inherent in their environment. KUBOTA is the Basic Necessities Giant.

This potential includes water supply, food from the soil and from the sea, industrial development, architecture and construction and transportation.

Thousands of people depend on KUBOTA's know-how, technology, experience and customer service. You too can depend on KUBOTA.

---

# Kubota®

## KUBOTA TRACTOR CORPORATION

**CORPORATE OFFICE:** 3401 DEL AMO BOULEVARD, TORRANCE, CA 90503

**WESTERN DIVISION:** 1175 S. Guild Ave., Lodi, CA 95240 • (209) 334-9910

**CENTRAL DIVISION:** 14855 F.A.A. Blvd., Fort Worth, TX 76155 • (817) 871-0900

**NORTHERN DIVISION:** One Kubota Way, Groveport, OH 43125 • (614) 835-1100

**SOUTHEAST DIVISION:** 1025 Northbrook Parkway, Suwanee, GA 30024 • (770) 995-8855

---



英語(U.S.A.)  
PRINTED IN JAPAN  
REPRINTED IN U.S.A.

March 2003  
Code No. 6C170 6311-3

