

SOLIS



SOLIS 50

OPERATOR MANUAL

A Product of

SONALIKA
INTERNATIONAL

OPERATOR MANUAL

SOLIS - 50

The logo for SOLIS is rendered in a bold, stylized, outlined font. The letters are thick and have a double-line outline. The 'S' is a simple, rounded shape. The 'O' is a circle with a horizontal line through the middle. The 'L' is a vertical bar with a horizontal base. The 'I' is a vertical bar with a horizontal top bar. The 'S' at the end is a simple, rounded shape.

**INTERNATIONAL TRACTORS LIMITED
HOSHIARPUR
INDIA**

PART NO :— 10071297AA

OWNERSHIP AND TRACTOR DETAILS

OWNER'S NAME & ADDRESS	----- ----- ----- TEL No. -----
-----------------------------------	--

Model :	Delivery Date :
Chassis No.	Bill No. / Date :
Engine No.	Alternator Make / Sr. No.
Battery Make / Sr. No.	Starter Motor Make / Sr. No.
FIP Sr. No. :	Hydraulic Pump Make / Sr. No. :

Tire	Make	Size	Sr. No.
Front (Left)			
Front (Right)			
Rear (Left)			
Rear (Right)			

I have understood all the terms & conditions of the maintenance of the tractor, terms of warranty, systems, Scheduled services & understood operation of tractor in the field and other operations

Received a new defect free tractor Chassis No. Engine No.

& fully satisfied with the transaction.

OWNER SIGNATURE	DEALER STAMP & SIGNATURE
	PH. No. DATE :

* **IMPORTANT INFORMATION TO CUSTOMER:** For any assistance with regard to our product, please contact our authorized dealer or authorized service center.

OWNERSHIP AND TRACTOR DETAILS

OWNER'S NAME & ADDRESS	----- ----- ----- TEL No. -----
-----------------------------------	--

Model :	Delivery Date :
Chassis No.	Bill No. / Date :
Engine No.	Alternator Make / Sr. No.
Battery Make / Sr. No.	Starter Motor Make / Sr. No.
FIP Sr. No. :	Hydraulic Pump Make / Sr. No. :

Tire	Make	Size	Sr. No.
Front (Left)			
Front (Right)			
Rear (Left)			
Rear (Right)			

I have understood all the terms & conditions of the maintenance of the tractor, terms of warranty, systems, Scheduled services & understood operation of tractor in the field and other operations

Received a new defect free tractor Chassis No. Engine No.

& fully satisfied with the transaction.

OWNER SIGNATURE	DEALER STAMP & SIGNATURE
	PH. No. DATE :

* **IMPORTANT INFORMATION TO CUSTOMER:** For any assistance with regard to our product, please contact our authorized dealer or authorized service center.



PREFACE

Dear Customer, we welcome you with great pleasure in your joining the **ITL** family and thank you for the faith and trust you have placed in the careful selection of your tractor.

Before using this tractor it is highly recommended to read this manual thoroughly. Any person who regularly or occasionally uses your tractor should be encouraged to read these instructions.

Daily and routine maintenance operations can be easily performed with the use of this manual. Our dealers would be pleased to assist you in the maintenance of your tractor and help economical operation.

Use only genuine ITL spare parts from dealers/stockist. It would fetch you a reliable and durable performance.

Information provided in this operator manual is accurate at the time of printing. Improvement and modifications is a continuous process at **International Tractor Limited (ITL)**, be reserve the right to modify at any time without prior notice.

You are the proud owner of the best product for your prosperity. In case of any help/support required please feel free to call our dealership with the tractor details like Engine number and Chassis number. We wish your prosperity and our growth.

Export Department

INTERNATIONAL TRACTORS LIMITED

Vill.-Chak Gujran, P.O. Piplanwala 146022

Jalandhar Road, Hoshiarpur, Punjab, India.

Phone: +91-1882-302-525/526

E-mail: exports@sonalika.com

YOUR RIGHTS

While taking delivery of new "ITL" Tractor, kindly ask the dealer to give following items free of cost:

1. Tool kit which includes

Grease gun (4 Cylinder)	1pc
Cutter plier 8"	1pc
Screw driver 5"	1pc
D-spanner 10 X 11	1pc
D-spanner 12 X 13	1pc
D-spanner 14 X 17	1pc
D-spanner 18 X 19	1pc
D-spanner 20 X 22	1pc
D-spanner 30 X 32	1pc
Ring spanner 16 X 17	1pc
Ring spanner 24 X 27	1pc
Battery Guarantee card	1pc
Hydraulic Jack (Optional)	1pc
Rear Wheel Spanner Kit (Optional)	1pc

2. Farmer Kit

Diesel Filter(Primary)	3pc
Diesel Filter(Secondary)	3pc
Lub. Oil Filter	2pc
Fan Belt	1pc
Cap Radiator	1pc
Cap Fuel Tank	1pc
Linch Pin	3pc
Fuse Box	1pc
Tyre pressure gauge	1pc

3. To avail the services.

4. To call dealers any time for any breakdown.

CONTENTS

Sr. No.	DESCRIPTION	PAGE NO.
	IDENTIFICATION OF TRACTORS	11
	SAFETY NOTES	13
1	INSTRUMENT PANEL AND ELECTRICAL CONTROLS AND TOOP HOOD	36
	1.1. INSTRUMENT PANEL	36
	1.2. ELECTRICAL CONTROLS	40
	1.3. PROCEDURE TO OPEN THE TOP HOOD	41
	1.4. REAR VIEW MIRROR	41
	1.5. COLD START UNIT	41
2	ELECTRICAL EQUIPMENTS	42
	2.1. BATTERY	42
	2.2. ALTERNATOR	44
	2.3. STARTER MOTOR	44
	2.4. GENERAL MAINTENANCE OF ELECTRICAL SYSTEM	44
3	ENGINE	45
	3.1. STARTING THE ENGINE	45
	3.2. STOPPING THE ENGINE	45
	3.3. RUNNING IN ENGINE	45
	3.4. FUEL SYSTEM	46
	3.5. ENGINE LUBRICATION SYSTEM	46
	3.6. GENERAL MAINTENANCE	46
	3.7. AIR CLEANER	48
	3.8. RADIATOR	50
4	CONTROLS	52
	4.1. HAND CONTROLS	52
	4.2. FOOT CONTROLS	54
	4.3. SEVEN PIN SOCKET	56
5	HYDRAULIC	57
	5.1. HYDRAULIC SYSTEM	57
	5.2. HYDRAULIC CONTROL OPERATIONS	57
	5.3. THREE POINT LINKAGE	58
	5.4. GENERAL MAINTENANCE	59
6	WHEELS AND TYRES	61
	6.1. IN FIELD OPERATIONS	61
	6.2. ON ROAD OPERATIONS	62
	6.3. BALLASTING OF TRACTOR	62
	6.4. RECOMMENDED LOAD CARRYING CAPACITY PER TYRE W.R.T. ITS SIZE	64
	6.5. TRACK WIDTH ADJUSTMENT	64
	6.6. TIPS FOR PROPER HANDLING AND DURABILITY OF TYRES	66
	6.7. GENERAL SUGGESTIONS	67
	6.8. CHECK WHEEL NUT BOLT	67
7	FRONT AXLE 4WD (OPTIONAL)	68
	7.1. FRONT AXLE 4WD	68

CONTENTS

	7.2	SWINGING DRAW BAR	68
	7.3	ROLL OVER PROTECTION	68
	7.4	PNEUMATIC TRAILER BRAKES (OPTIONAL)	69
	7.5	PNEUMATIC TRAILER BRAKE COMPONENTS	69
	7.6	HYDRAULIC TRAILER BRAKE	70
	7.7	HYDRAULIC TRAILER BRAKE FREE PLAY ADJUSTMENT	70
	7.8	HYDRAULIC TRAILER BRAKE COUPLER	70
8		OTHERS	72
	8.1	REGISTRATION PLATE	72
	8.2	LIGHTS	72
	8.3	REFLECTOR	72
	8.4	EXHAUST MUFFLER	72
	8.5	HEAT INSULATION SHEET	72
	8.6	PTO GUARD	73
	8.7	DRIVER SHEET (E-MARKED)	73
	8.8	RECOMMENDED SCHEDULE FOR MAINTENANCE SERVICE	74
	8.9	ELECTRICAL WIRING CIRCUIT DIAGRAM	76
	8.10	RECOMMENDED GRADE OF LUBRICANTS & GREASES	77
	8.11	GREASING POINT ON TRACTORS	77
9		WARRANTY POLICY	79
10		TROUBLE SHOOTING	81
11		SPECIFICATION	84
12		FREE SERVICE COUPON	87
13		SERVICE RECORDS	95
14		NOTES	96
15		FEEDBACK CARD	97

IDENTIFICATION OF TRACTOR

1. In this manual it is written many times **front portion, rear portion, left side, right side**, understand these terms as per reference Fig.
2. While ordering spare parts always mention the chassis number of the tractor and engine. These numbers are punched on the data plate which is riveted on left hand fender. By giving these numbers correctly you will get delivery of the right parts at right time. Refer Fig. Fordata plate.
3. The serial No for E Marked ROPS is also riveted on the left side of the ROPS refer Fig.

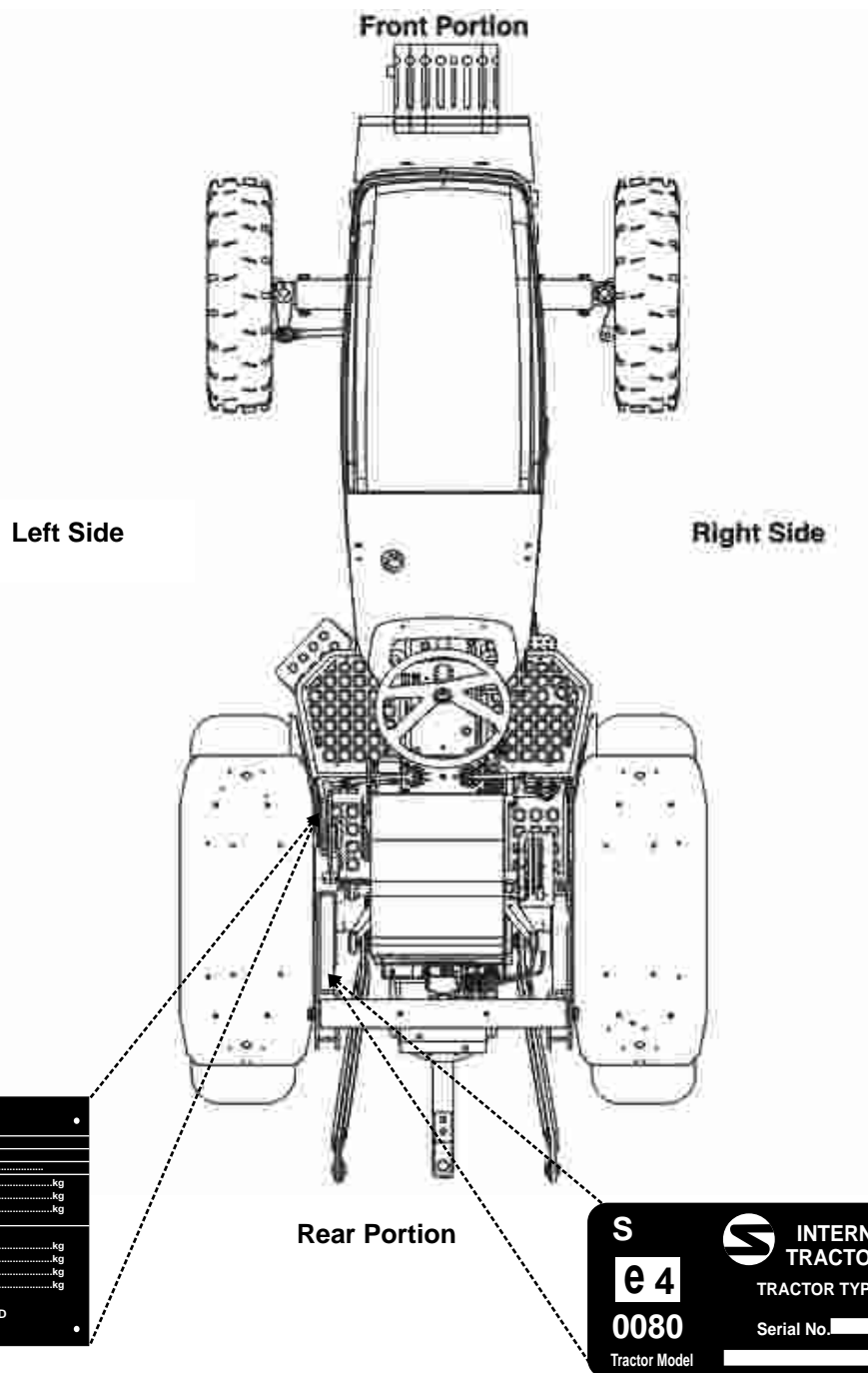

SONIKA INTERNATIONAL TRACTORS LTD.	
Type:
ECE number:
Identification number:
Total permissible mass (*):to.....kg
Permissible front axle load (*):to.....kg
Permissible rear axle load (*):to.....kg
(* depending on the tyres.	
Permissible towable mass:	
Unbraked towable mass:kg
Independently-braked towable mass:kg
Inertia-braked towable mass:kg
Towable mass fitted with an assisted braking system (hydraulic or pneumatic):kg
INTERNATIONAL TRACTORS LIMITED HOSHARPUR, PUNJAB (INDIA)	

S	INTERNATIONAL TRACTOR LIMITED
e 4	
0080	TRACTOR TYPE T 1
Tractor Model	Serial No. _____

WHOLE VEHICLE TYPE APPROVALS FOR TRACTOR

TRACTOR EC TYPE APPROVAL NO	TRACTOR MODEL
e4*2003/37*0057*01	SOLIS 50 4WD Including all variants with up Draft/ Down Draft, Power Steering/ Mechanical Steering, Radial Tyres, Air Trailer Brake/Hydraulic Trailer Brake
e4*2003/37*0051*03	SOLIS 50 2WD Including all variants with up Draft/ Down Draft, Power Steering/ Mechanical Steering, Radial Tyres, Air Trailer Brake/Hydraulic Trailer Brake

E-marked Components

Sr. No.	Name of Device	Component Type approval No.
1	Main Beam Head Lamp	E4-112R-000223
2	Dim Beam Head Lamp	E4-112R-000223
3	Front Direction Indicator	E4-6R-0111359
4	Front Position Lamp	E4-7R-0211359
5	Rear Direction Indicator	E4-6R-0111358
6	Stop Lamp	E4-7R-0211358
7	Rear Position Lamp	E4-7R-0211358
8	Registration Plate Lamp	E4-4R-004125
9	Reflector	E4-3R-023232
10	Driver Seat	e4*78/764*1999*/57*0009*00
11	Audible Warning Device	E4-28R-000153
12	Rear View Mirror	E4-46R-022764
13	ROPS	e4*2009/75*2009/75*0080*00
14	Swinging Drawbar	e4*2009/144*2010/62*0049*00

SAFETY NOTES

A. SAFETY ALERT SYMBOLS AND TERMS

This safety alert symbol means ATTENTION! BECOME ALERT! YOUR SAFETY IS INVOLVED!



The safety alert symbol identifies important safety messages on machines, safety signs, in manuals or elsewhere. When you see this symbol, be alert to the possibility of personal injury or death.

Why is SAFETY important to you? *ACCIDENT DISABLE and KILL*

*** ACCIDENTS are COSTLY ** ACCIDENTS can be AVOIDED***

SAFETY: TRACTOR and IMPLEMENT

- ◆ The tractor is a source of power: Both mechanical and hydraulic.
- ◆ On its own, the tractor is of little practical value. Only when used in conjunction with an implement or other attachment does it become a working unit.
- ◆ This instruction book is compiled to cover those safe working practices that are associated with the base tractor operation.
- ◆ It does not cover all operation and safety instructions relevant to all known implements and attachments that may be fitted at the time of tractor delivery or at some future date.
- ◆ It is essential that operators use and understand the relevant instruction manual of such implements and attachments.

B. SAFETY: INTRODUCTION

This safety section of your Operator Instruction book is intended to point out some of the basic safety situations which may be encountered during the normal operation and maintenance of your PLATFORM, and to suggest possible ways of dealing with these situations. This section is NOT a replacement for other safety practices featured in other sections of this book.

Additional precautions may be necessary depending on attachments used and conditions at the work site or in the service area. The tractor manufacturer has no direct control over tractor application, operation, inspection, lubrication or maintenance. Therefore it is YOUR responsibility to use good safety practices in these areas.

C. SAFETY: A WORD TO THE OPERATOR

It is YOUR responsibility to read and understand the safety section in this manual before operating your tractor. You must follow these safety instructions that

In reading this section, you will note that illustrations have been used to highlight certain situations. Each illustration is numbered and the same number appears in the text in parenthesis. This number is placed at the end of the written text that refers to the illustration and is made up of two digits, separated by a hyphen: the first digit designates the chapter, the second one of the figure number in that chapter, Remember that YOU are the key to safety. Good safety practices not only protect you, but also the people around you. Study the features in this manual and make them a working part of your safety program. Keep in mind that this safety section is written only for this type of machine. Practice all other usual and customary safe working precautions, and above all REMEMBER: SAFETY IS YOUR RESPONSIBILITY. YOU CAN PREVENT

D. SAFETY: DANGER, WARNING and CAUTION

Whenever you see the words and symbols shown below, used in this book and on decals, you **MUST** take note of their instructions as they relate to personal safety.



DANGER: The symbol and the word **DANGER** indicates an imminently hazardous situation, which, if not avoided, will result in **DEATH OR VERY SERIOUS INJURY**.



WARNING: The symbol and the word **WARNING** indicate a potentially hazardous situation. If the instructions or "procedures are not correctly followed it could result in **DEATH OR SERIOUS INJURY**.



CAUTION: The symbol and the word **CAUTION** indicate a "potentially hazardous situation, which, if not avoided, may result in **MINOR INJURY**.

IMPORTANT: The word **IMPORTANT** is used to identify special instructions or procedures which, if not strictly observed, could result in damage to, or destruction of the machine, process or its surroundings.

NOTE: The word **NOTE** is used to indicate point of particular interest for more efficient and convenient repair or operation.

SAFETY: DECALS



WARNING: DO NOT remove or obscure Danger, Warning, Caution or Instruction decals.

Replace any Danger, Warning, Caution or Instruction Decals that are not readable or are missing. Replacement decals are available from your Dealer in the event of loss or damage. The actual location of these safety Decals is illustration at the end of this section.

If a used tractor has been purchased, refer to the illustration at the end of this section to ensure that all the safety warning decals are in the correct position and are readable.

E. SAFETY: FOLLOW A SAFETY PROGRAM

For safe operation:

For safe operation of an agricultural tractor, you must be a qualified and authorized operator. To be qualified you must understand the written instructions supplied in this Operator Instruction Book, have training, and know the safety rules and regulations for the job.

Some regulations specify, for example, that no one under the age of 18 years (according to European Rules) may operate power machinery. This includes tractor, it is your responsibility to know what these regulations are, and obey them, in the operating area of situation.

These will include, but are not limited to, the following instructions for safe tractor operations:



WARNING : An operator should not use alcohol or drugs which can change his/her alertness or co-ordination. An operator on prescription or 'over the counter' drugs needs medical advice on whether or not he or she can properly operate machines.

Observe the following precautions:

- ◆ NEVER allow children or unqualified persons to operate your tractor. Keep others away from your area of work.
- ◆ Securely fasten your seat belt when the tractor has a safety frame in the upright position.
- ◆ Where possible, avoid operating the tractor near ditches, embankments and holes. Reduce speed when turning, crossing slopes, and on rough, slippery, or muddy surfaces.
- ◆ Stay off slopes too steep for safe operation.
- ◆ Watch where you are going, especially at row ends, on roads, and around trees.
- ◆ DO NOT permit others to ride on the tractor or the implement unless an approved passenger seat is fitted.
- ◆ Hitch only to the drawbar and recommended hitch points, and never above the center line of the rear axle.
- ◆ Operate the tractor smoothly - no jerky turns, starts or stops, when the tractor is stopped, apply the parking brakes securely.
- ◆ Never modify or remove any part of the equipment.

F. SAFETY FRAME

A Safety Structure and seat belt is fitted as standard equipment to the platform tractor at the time of factory assembly. If the safety frame was deleted by the original purchaser or has been removed, it is recommended that you equip your tractor with a Safety Structure and a seat belt. Safety frames are effective in reducing injuries during overturn accidents. A tractor overturning without safety frame can result in serious injury or death.

Depending on laws in force in the various markets, a seat may be installed. Always raise the safety frame before it may be installed. Always raise the safety frame before fastening the seat belt.

If a fold-down safety frame is installed. **DO NOT** wear a seat belt when the safety frame is in folded down position. **NEVER** keep the safety frame in the folded down position when working with the tractor.

Operation:

- ◆ Before using the tractor ensure that the safety frame is not damaged, that it is securely fastened to the tractor, and, if a hinged section is fitted, that it is in the raised position and secured.
- ◆ If the safety frame has been removed from the tractor, or folded down for a specific operation, it must be refitted or erected immediately using the proper hardware and applying the recommended torque value.
- ◆ **DO NOT ATTACH** chains, ropes or cables to the safety frame for pulling purposes; this will cause the tractor to tip backwards. Always pull from the tractor drawbar.
- ◆ If a seat belt is installed, always wear your seat belt-adjusted snugly except when operating with a folded down safety frame or if the safety frame has been removed.
- ◆ Check the seat belt for damage. A damaged seat belt must be replaced.

Damage to the safety frame

If the tractor has rolled over or the safety frame has been damaged (such as striking an overhead object during transport), the safety frame must be replaced to provide the original degree of protection.

After an accident, check for damage to the safety frame operator's seat, seat belt and seat mountings. Before you operate the tractor, replace all damaged parts.

DO NOT WELD, DRILL, BEND OR STRAIGHTEN THE SAFETY FRAME. IF DONE, reduce the protection it offers.

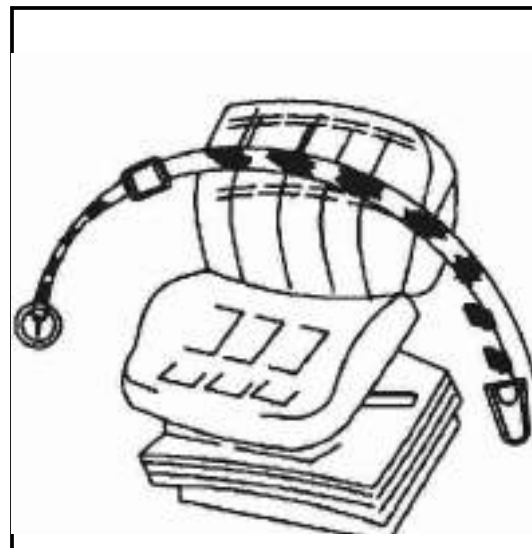
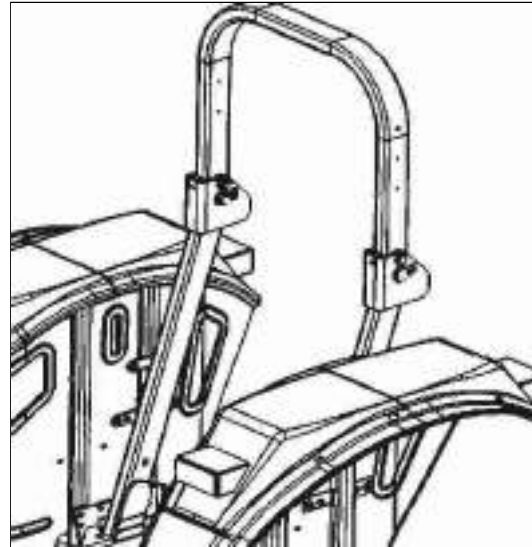

G. SAFETY: PREPARE FOR SAFE OPERATION

Protect yourself:

Wear all the protective clothing and personal safety devices issued to you or called for by job conditions. Don't take risk hence you may carry/wear the following

- (a) A hard hat.
- (b) Safety glasses, goggles or face shield.
- (c) Hearing protection.
- (d) Respirator or filter mask.
- (e) Inclement weather clothing.
- (f) Reflective clothing.
- (g) Heavy gloves (neoprene for chemical, leather for rough work).
- (h) Safety shoes.

DO NOT wear loose clothing, jewellery or other items and tie up long hair which could catch on controls or other parts of the tractor.

Learn where fire extinguishers and first aid or emergency equipment is kept and where to get help in a hurry. Make sure you know how to use this equipment.



(a)



(b)



(c)



(d)



(e)



(f)



(g)



(h)

H. Know your equipment:

Know your tractor. Know how to operate all equipment on your machine and the implements and attachments used with it. Know the purpose of all the controls, gauges and dials. Know the rated load capacity, speed range, braking and steering characteristics turning radius and operating clearances.

Keep in mind that rain, snow, ie, loose gravel, soft ground, etc. can change the way your tractor operates. ***Under poor conditions, slow down and be extra careful, engage four wheel drive, if fitted.***

Study the DANGER, WARNING or CAUTION safety signs on your tractor and the information signs also. read this operator instruction book before starting the engine.

study it before you start the work.

if there is something in the manual you don't understand, ask someone (such as your equipment dealer) to explain it to you.

IMPORTANT: This manual covers general safe practices for agricultural tractor it must always be kept with the tractor. For further copies contact your Dealer.

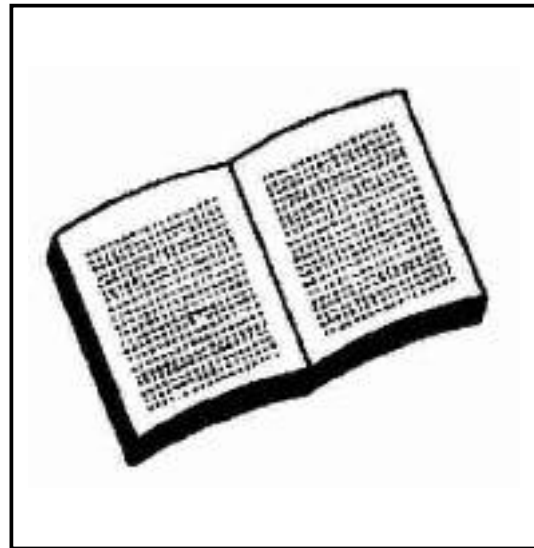

I. Use all available protective devices

Keep all protective devices in place and securely fastened. Make certain all guards, shields safety signs are properly installed, as specified, and are in good condition.

IMPORTANT: To help keep you and others around you safe, your tractor should be equipped with:

Safety belt. It must always be mounted in protection position. A seat belt is recommended according to law requirements on the respective market when ROPS is erected.

Tractors PTO shield.

Your tractor may also need:

- Rear view mirrors.
- Fire extinguisher.

SMV (Slow Moving Vehicle) emblem, Additional guards, lights or decals and additional alarm.

Know which devices are required for safe operation of your tractor. Use them. Make sure they are in place and in good condition. NEVER remove or disconnect any safety device.

Check the equipment:

Before you begin your working day, take time to check your tractor and ensure that all systems are in good operational condition.

DO NOT smoke while refueling the tractor. Keep any type of open flame away

Check for loose, broken, missing, or damaged parts. Have everything put into good repair. Make certain all safety devices are in place.

Check safety frame and seat belt for damage. A damage safety frame or seat belt MUST be replaced. Ensure that implements and attachments are properly installed and that the tractor and implement PTO RPM ratings match.

Check the tires for cuts, bulges and correct pressure. Replace worn or damaged tires. Check foot and parking brakes for proper operation. Adjust if necessary.

AREA FOR REFILLING FUEL



- ◆ Stop the engine and wait for it to cool before refueling. Check the engine oil level and add oil if required.
- ◆ Perform all maintenance procedures outlined in the maintenance and adjustment section of this manual.
- ◆ Check that the PTO drive locking devices are latched.
- ◆ Check that the tractor PTO shield and driveline guards are in place and operating properly.
- ◆ Check the tractor and implement hydraulic system. Have any leaks or damaged parts repaired or renewed.



WARNING: Diesel fuel or hydraulic fluid under pressure can penetrate the skin or eyes and cause serious personal injury, blindness or death. Fluid leaks, under pressure, may not be visible. Use a piece of cardboard or wood to find leaks. Never use your bare hand. Wear safety goggles for eye protection. If any fluid is injected into the skin, it MUST be surgically removed within a few hours by a doctor familiar with this type of injury

Before applying pressure to the fuel or hydraulic system, be sure all connections are tight and that lines, pipes, and hoses are not damaged. Before disconnecting fuel or hydraulic lines, be sure to relieve all pressure.

Make sure that all hydraulic lines are correctly installed and not tangled.



WARNING : Liquid cooling systems build up pressure as the engine gets hot. Before removing the radiator cap, stop the engine and let the system cool.

Check the engine cooling system and add coolant as required.

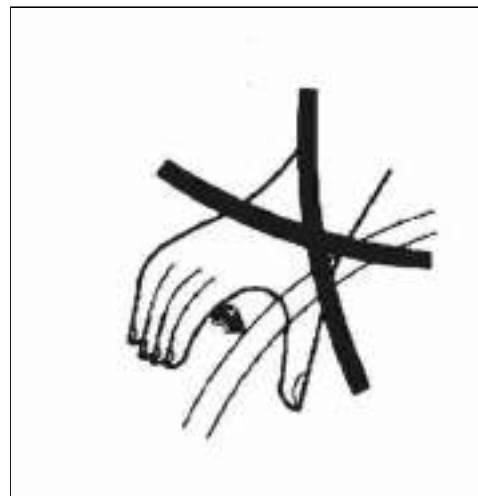

J. Clean the tractor:

- ◆ Keep work surfaces and engine compartments clean.
- ◆ Before cleaning the machine, always lower implements to the ground, place transmission in neutral, engage the parking brake, shut off the engine and remove the key.
- ◆ Clean steps, pedals and floor. Remove grease or oil, Brush away dust or mud. In winter, scrape away snow and ice. Remember-slippery surfaces are dangerous.
- ◆ When plastic parts need to be cleaned (such as console, instrument panel, monitors, indicators etc.), do not use petrol, paraffin, diluents etc.
- ◆ They could cause discoloration, cracking or warping of the cleaned parts.
- ◆ These parts should ONLY be cleaned with water, neutral soap and a soft cloth..
- ◆ Remove and store implements, keys, hitches etc. in their proper places.

K. Protect the environment:

It is illegal to pollute drains, water courses or soil. Use authorized waste disposal facilities, including civic amenity sites and garages providing facilities for disposal of used oil. If in doubt, contact your local authority for advice.

To get to know the correct methods to dispose of oils, filters, tyres etc. contact your Dealer or the local agency for waste recycling.

L. Only for North America:

The safety sheets of each material give information on chemicals contained in a product, procedures to use it safely, first-aid and procedure to be followed in case of leakage or spills. In all North America such safety sheets are available at the Dealer's.

Before any maintenance on the machine refer to the above mentioned safety sheets for fluids, oils etc. used in this machine. The sheets inform about risks and safe maintenance procedures. We strongly recommended following these indications during any maintenance operations.

Disposal of the tractor: The tractor is made up of parts subjected to rules and laws for their disposal. When the tractor is not used any more, it must be disposed of through proper agencies according to such rules. Do not pollute the environment with the tractor or its parts.

M. SAFETY: SERVICING THE TRACTOR

DO NOT service the tractor while the engine is running or hot, or if the tractor is in motion

Before making adjustments to, or servicing the electrical system, disconnect the battery cables, negative (-) cable first.

To prevent fires or explosions keep open flames away from the battery to cold weather starting aids. To prevent sparks which could cause explosion use jumper cables according to instructions.

When making repairs or adjustments it is recommended that you consult your Dealer, and have the work carried out by trained personnel.

The implement and/or tractor must be supported on suitable wooden blocks or stands, NOT a hydraulic jack.

Check all nuts and bolts periodically for tightness especially wheel hub and rim nuts. Tighten to the prescribed torque values.

Check the power steering reservoir regularly and top up as necessary with approved oil.

Check the brakes regularly, top up the reservoir and/or adjust where necessary. Make sure that the brakes are evenly adjusted.

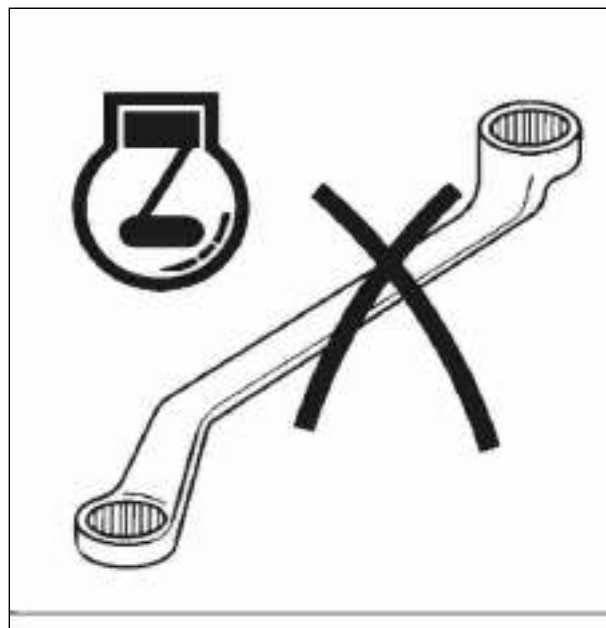

N. SAFETY: STARTING

Warn bystanders before starting:

Before starting, Walk all around the tractor and any attached equipment. Make sure that no one is under it, on it, or close to it. Let other workers and bystanders know you are starting up and don't start until everyone is clear of the tractor, implements and towed equipment.

Ensure that all bystanders, particularly children are in a safe position before starting the engine.

Mount and dismount properly:

Always use 'three point contact' with the machine, and face the machine when you mount it. Three point contact means both hands and one foot or one hand and both feet are in contact with the machine at all times during mounting and dismounting.

Clean the soles of your shoes and wipe your hands before climbing on. Use handrails, grip handrails, ladders or steps (as provided) when mounting or dismounting.

NEVER use control levers as a hand hold and NEVER step on foot controls when mounting or dismounting.

NEVER attempt to mount or dismount from a moving tractor. NEVER jump off a tractor in any circumstances.

Start safely.



WARNING : Before starting the engine, make sure there is plenty of ventilation. Never operate the engine in a closed building. The exhaust fumes may cause asphyxiation.

Always start the engine from the operator's seat with all the transmission levers and PTO lever in neutral.

Make sure that the tractor dual brake pedals are locked together at all times unless you are making turns in the field which require independent use of the brakes. Make sure the brakes are properly adjusted so that both brakes engage at the same time.

Adjust the seat, fasten the seat belt (where applicable as outlined in this manual), apply the parking brake and put all controls in neutral before starting up.

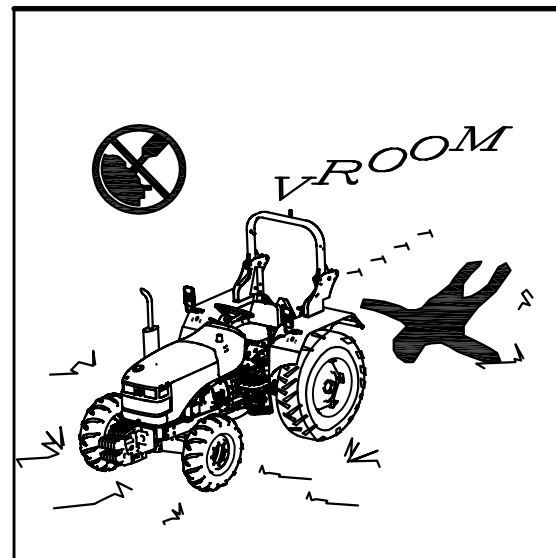
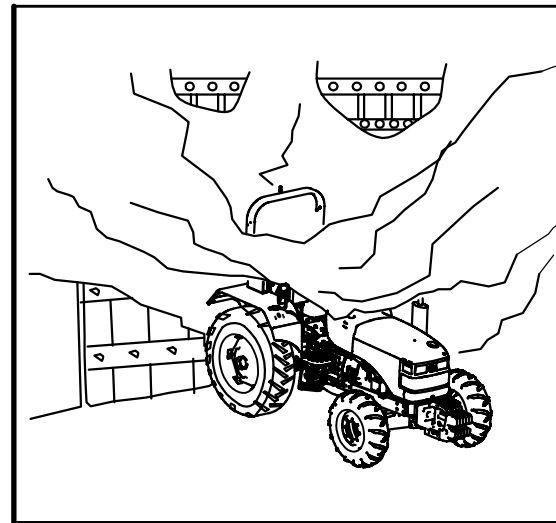

DANGER : Start the engine, with the starter key, from the operator's seat only. Never attempt to start the engine by shorting across the starter terminals. The machine will start in gear if the neutral start circuit bypassed. This could cause serious injury or death to anyone near the tractor.

O. Follow recommended starting procedures

Follow the starting procedures recommended in the operation section of this Operator instruction Book. This includes normal starting, cold starting and use of starting fluids.

Test the controls

After starting, recheck all gauges and lights. Make sure everything is functioning correctly. If the tractor does not respond correctly which each control is operated, DO NOT use the machine until the fault is rectified

Ensure that the starter solenoid cover is always in position.

Starting fluid



WARNING : It is very important that you read the label on the can before using starting fluid. DO NOT use aerosol can of starting aid on tractors with the thermostat connected to the electrical system. Ether combined with thermostat can cause an explosion with damage to engine, personal injury or both.

Handle starting fluid correctly. Starting fluid must only be used when an ether start aid is fitted as original equipment by the manufacturer or when installed by a Dealer as an accessory, in case of tractors being fitted with glow plugs or thermostat ,this must be removed prior to the installation.

If aerosol cans of starting fluid are to be used the thermostat must be disconnected. Remove the wire from the thermostat unit which will be found on the induction manifold. Tape the end of wire to prevent an electrical short circuit.

Before starting the tractor, ensure that no persons or hindrances are present in its range.

P. SAFETY: WORK SAFETY



WARNING : An unbalanced tractor could overturn and cause injury or death. Make sure front frame counterweights, wheel weights and wheel ballast are used as recommended by the manufacturer. NEVER add extra counter weights to compensate for an overload, better to reduce the load.



WARNING : Keep all parts of your body inside the operator's compartment while operating the tractor.

Q. Make the right moves

Make sure your tractor is ready for the job it must do. Know the rated load capacities of your tractor and never exceed them. Be certain that any equipment or implements you intend to use DO NOT exceed the load rating of your tractor. Be sure the tractor and implement PTO rev/min match.

Keep in mind that tractors normally operate on uneven, unpaved, and often bumpy or sloping surfaces. Operating conditions can reduce the amount of weight you should carry or pull.

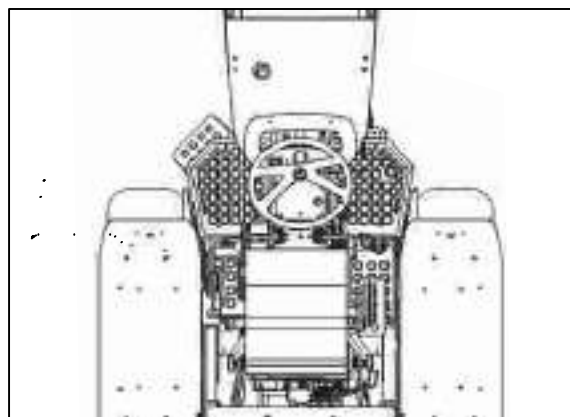
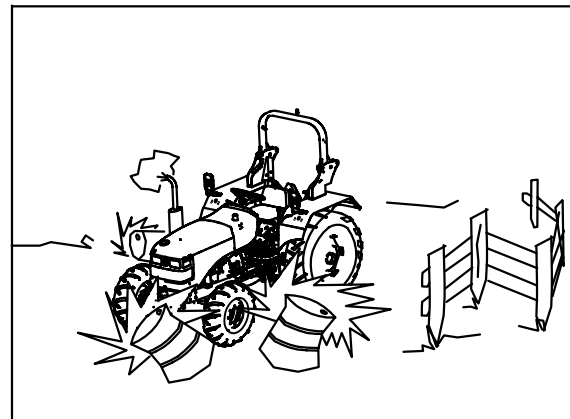
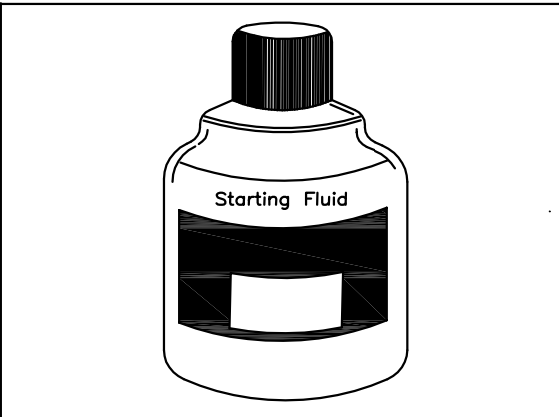

WARNING: Do not start the tractor without ensuring a perfect command of speed and steering controls

R. Follow safe operating practices:

- ◆ **Operating the controls smoothly: don't jerk the steering wheel or other controls.**
- ◆ **DO NOT get on or off a moving tractor, keep a firm grip on the steering wheel at all times, with the thumbs clear the spokes when driving the tractor.**
- ◆ **Make sure you have adequate clearance in all directions for tractor, safety frame and implement.**
- ◆ **NEVER play games with a tractor or equipment.**
- ◆ **NEVER attempt to work the controls expect from the operator's seat.**
- ◆ **Before getting off the tractor, always disengage the PTO, lower all attachments and implements to the ground, place the tractor in neutral, engage parking brake, shut off the engine and remove the key.**

Before starting, inspect the work area to establish the best and safest procedure. Plan your work so that you drive as straight as possible forward. Beware of trenches, pits, ditches, slopes, trunks or stumps, ponds etc. Watch for any possibly dangerous condition. If you are using a front loader or foldable implements or implements with high components, watch out for obstacle in the tractor's way.

DO NOT touch, lean on, or reach through any implement mechanism or permit others to do so.

Stay alert. Should something break, come loose, or fail to operate in your equipment, stop work, shut off the engine, inspect the machine and have repairs or adjustments made before resuming operation.

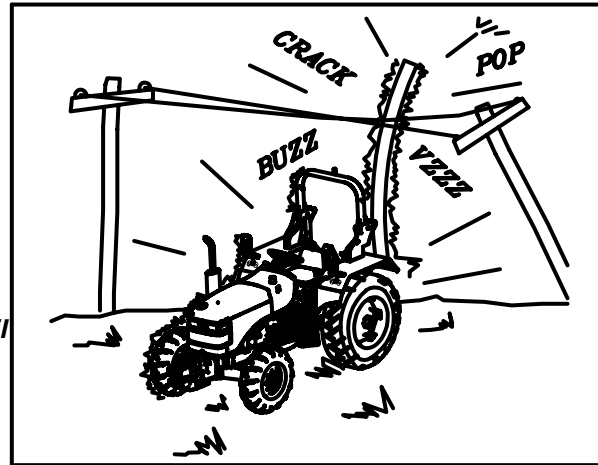

S. Watch out for others

Be aware of what is going on. Never allow an untrained or unqualified person to operate your tractor. They could injure themselves or someone else.



WARNING: Your tractor is a one person machine. DO NOT permit others to ride on the tractor or the implement . In some countries a passenger seat must be fitted to carry passengers. Never allow anyone to ride on the implements or other equipment including trailers, except on certain harvesting equipment, specially designed for riders during the actual harvest operation only (not during transport). Such equipment must have provision for a safe riding area. NEVER allow children on a tractor.



WARNING: Accidental contact with high-voltage, lines cause death. In case of contact with high -voltage conductors DO NOT leave the tractor, bid move the tractor and/or the loader in such a way as to eliminate the contact and reach a safe distance



WARNING: Be certain you can control both speed and direction before moving. Move slowly until you are sure that everything is operating properly. After starting, recheck the steering, right and left. Be certain you have full steering and brake control. If differential is locked, DO NOT operate at high speed or turn the tractor until the differential lock is disengaged.

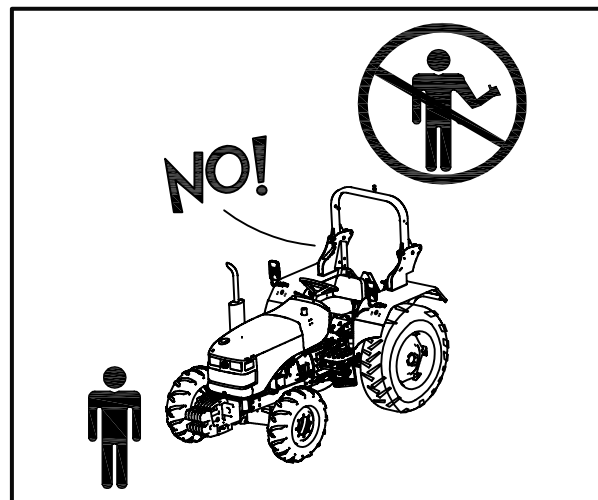

! WARNING : Never lift a load over anyone

- ◆ Keep others away from your operation. Never allow anyone to stand or pass under a raised implement
- ◆ DO NOT lift object that cannot be contained safely in the bucket, get the appropriate attachment. Never allow anyone to stand on the safety frame or fenders,.
- ◆ When using a loader, avoid sudden stops, starts, turns, or change of direction. Keep loads as near to the ground as possible.
- ◆ **Never stand (or allow anyone else to stand) in front of, under, or behind loaded or loading equipment.** Never drive a tractor up to someone standing in front of a fixed object.
- ◆ Keep others away from articulation joints, hitches, drawbar, lift arm, PTO drive, cylinders, belts, pulleys, and other moving parts. Keep all shields and guards in place.



WARNING : NEVER stand, or allow anyone else stand between the tractor and implement unless the engine is turned off parking brakes is engaged, the transmission is in neutral, and all attachments or implements are lowered to the ground.

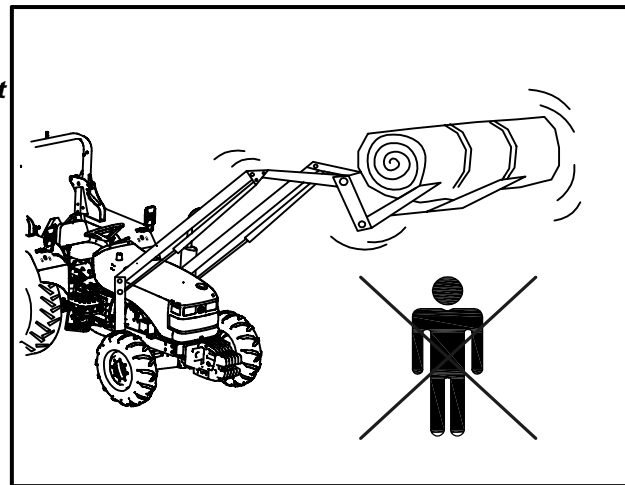

T. Risk of overturning

For your safety, it is recommended that all platform tractors are fitted with safety frame and seat belts

In the event of overturning with a tractor fitted with a safety frame, hold the steering wheel firmly and DO NOT attempt to leave the seat until the tractor has come to rest.

U. To avoid side overturns:

- ◆ Set the wheel track at the widest setting suitable for the job being done.
- ◆ Lock the brake pedals together before driving at transport speeds.
- ◆ Reduce speed to match operating conditions. If the tractor is equipped with a front end loader, carry the bucket and load as low as possible.
- ◆ Make wide slow turns at reduced speed. DON'T let your tractor bounce. You may loose steering control.
- ◆ DON'T pull a load too heavy for your tractor. It could run away on the down slope or the tractor could jackknife around a towed load.
- ◆ DON'T brake suddenly. Apply brakes smoothly and gradually.
- ◆ When going down a slope use the throttle to slow the tractor engine and use the same gear you would use to up the slope. Shift into gear before you start downhill.
- ◆ Engine four-wheel drive (if fitted), this will give four- wheel braking.

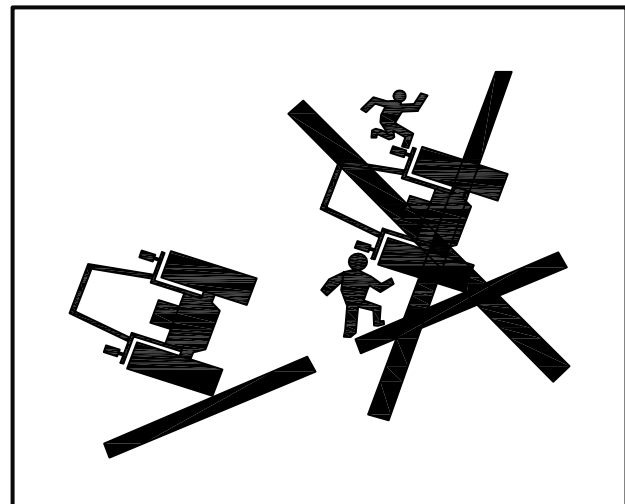



WARNING : NEVER disengage the clutch or attempt to shift gear after you have started downhill.

- ◆ It is always preferable to straight up or down a steep slope rather than across it.
- ◆ Avoid crossing steep slopes if possible. If you must do so, avoid any holes or depressions on the downhill side. Avoid any stumps rocks, bumps or raised areas on the uphill side. When operating near ditches or banks, always keep your tractor behind the shear line .

If it is necessary to cross a steep slope, avoid turning uphill, slope down and make a wide turn. Travel directly up or down the slope, never across it. When traveling up or down a slope, keep the heavy end of the tractor pointed uphill.

When traveling across a slope with side mounted implements, keep the implement on the uphill side. Don't raise the implements, keep them as low to the ground as possible when crossing a slope.

Avoid crossing steep slopes if possible. If you must do so, avoid any holes or depressions on the downhill side. Avoid any stumps, rocks, bumps or raised areas on the uphill side.

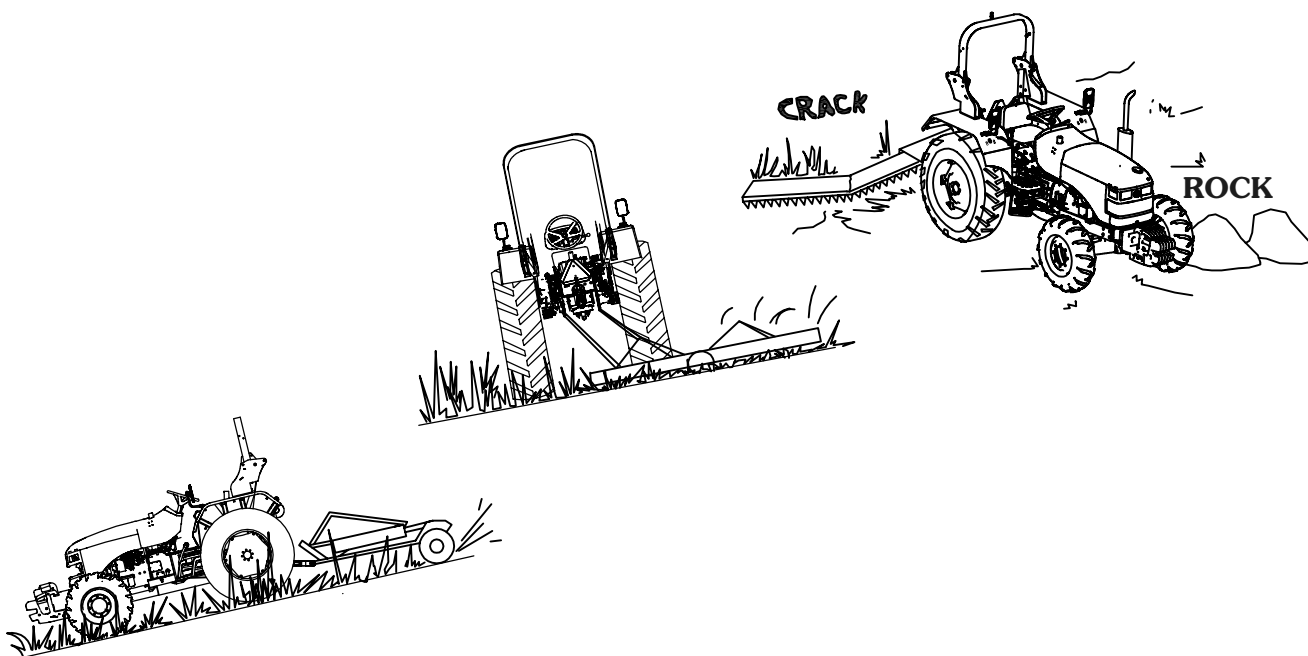
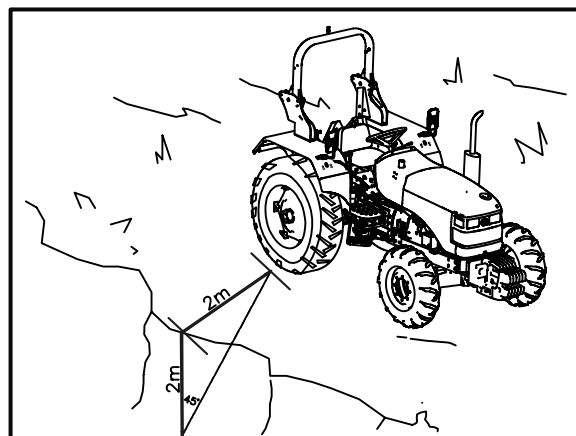
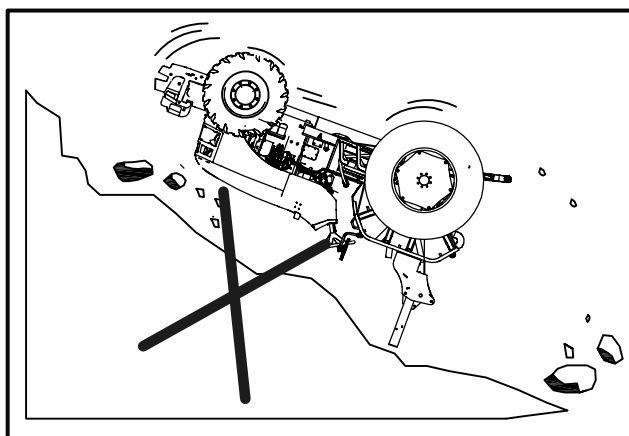

V. To avoid rear overturns



WARNING : *Hitching to the rear axle, or any other point above the swinging drawbar, can cause a rear overturn.*

DO NOT pull anything using the top link connection, or from any point above the centre line of the rear axle. Always use an approved drawbar, and only use a drawbar pin that locks into place.

High hitching can cause rear overturn, which may cause serious injury or death. Hitch loads to the drawbar only.

When using a three-point linkage drawbar, the stays must be fitted and kept in the down position.

Use front counterweights to increase tractor stability when towing a heavy load or to counterbalance a heavy rear mounted implement

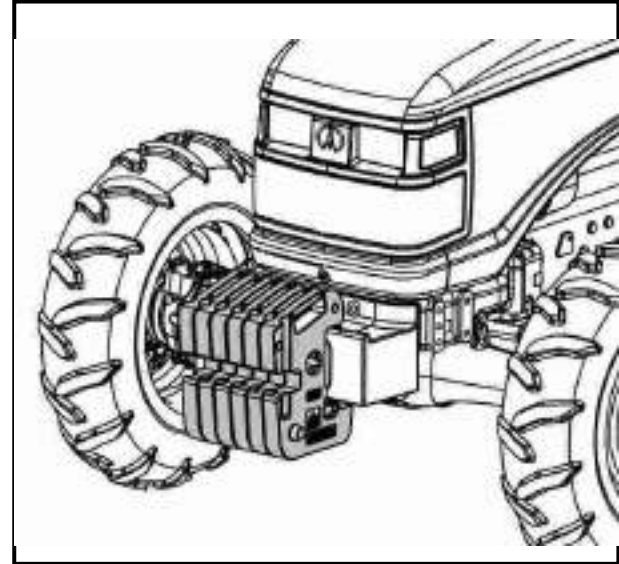

DO NOT overload your tractor and DO NOT ballast it beyond its carrying capacity. Never add ballast weight to counterbalance an overload. Reduce the load instead.



WARNING : *An overload is always dangerous. Check the loading capacity of your tractor and NEVER overload*

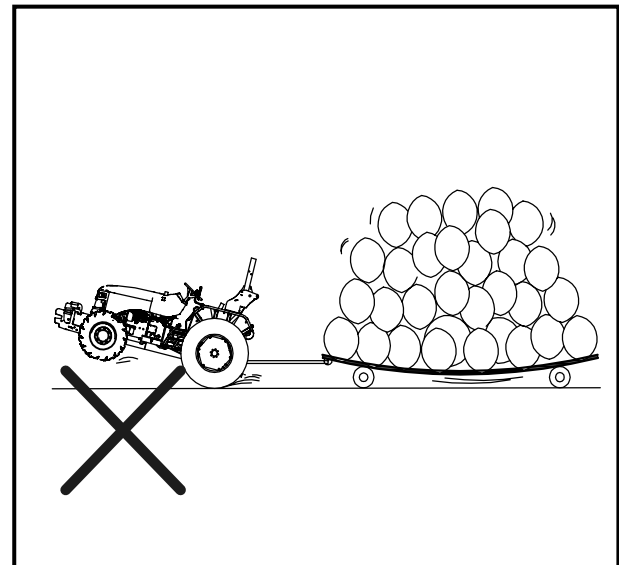

If the front end of the tractor starts to lift, reduce your speed and, if necessary, disengage the clutch .

If your tractor is bogged down in the mud or frozen to the ground, DO NOT attempt to drive forwards. The tractor can rotate around its rear wheels and overturn .Lift any attached implement and attempt to BACK OUT. If this is not possible, tow it out with another vehicle.

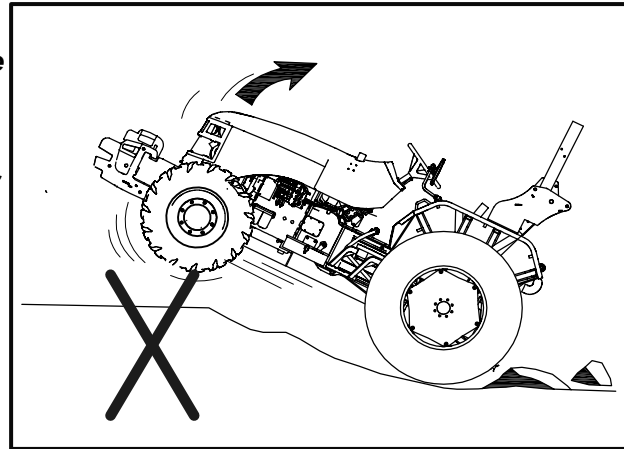

Start forward slowly and gradually increase your speed. DO NOT rev the engine or drop the clutch. If the tractor is attached to a heavy load, or immovable object, improper clutching may cause overturn

If you get stuck in a ditch, BACK OUT, if possible. If you must go forward, do it slowly, and carefully.

A bare tractor or a tractor with rear mounted attachments should be backed up the slope in reverse and travel forward downhill.

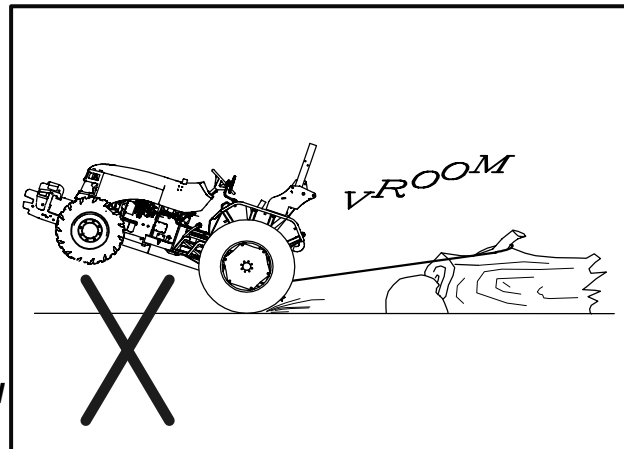

A tractor with a loaded front end bucket should be backed down the slope and travel forward uphill. Keep the loader bucket as low as possible.

Always keep the tractor in gear when going down hill Never permit the tractor to coast with clutch disengaged or transmission in neutral

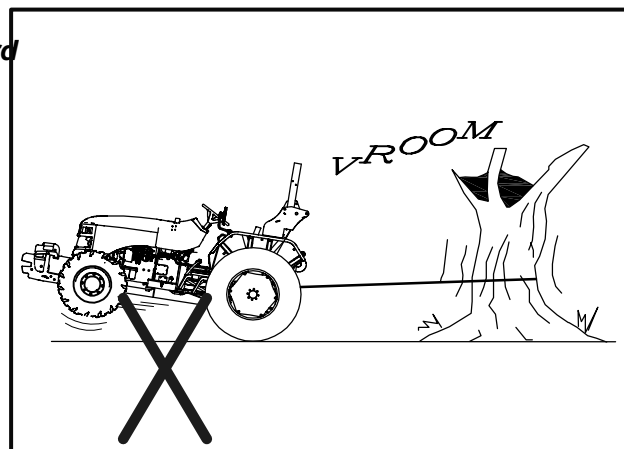

W. General operating hazards

Ensure that the PTO shield (1) is in plane and that the cap (2) is fitted when the PTO driveline is not in use

Before attaching, detaching, cleaning or adjusting PTO driven implements, disengage the PTO, stop the engine remove the key, and make sure that the PTO driveline has stopped.

Ensure that all the PTO driveline guards are in place and observe all safety signs .

Be sure everyone is clear of your machine before engaging the PTO. For stationary PTO operation, always place transmission in neutral, engage parking brake and lock both tractor and implement wheels.

When operating mobile PTO driven equipment, never leave the tractor seat until the PTO drive is disengaged, the transmission is in neutral, the parking brake is engaged, the engine shut off and the key removed.

DO NOT use PTO adaptors, reducers or extensions as they extend the PTO coupler and universal joint out beyond the protection offered by the PTO shield. The top link rods must not be extended beyond the point where threads begin to show. Fig.



WARNING : NEVER attempt to unplug the hydraulic connections, or adjust an implement with the engine running or the PTO drive in operation. To do so may result in serious injury or death.

When using chemicals, carefully follow the chemical manufacturer's instructions for use, storage and disposal. Also follow the chemical application equipment manufacturer's instructions.

When operating under poor visibility conditions, or in the dark, use your ground speed. (DO NOT use your field lights when traveling on a roadway because rear pointed white lights are illegal except when reversing and may confuse following drivers).

Operate your tractor with the wheels set the widest setting possible, consistent with the particular task you are performing. To adjust wheel settings refer to Maintenance and Adjustment section.

Reduce your speed when operating over rough or slippery ground when foliage restricts your view of hazards.

DO NOT make sharp turns at high speed.

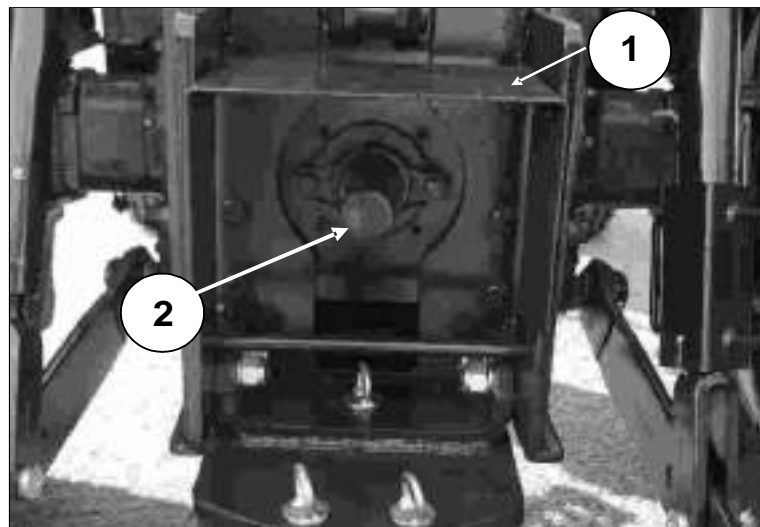



WARNING : A front-end loader (bucket or forks) must be equipped with a suitable restraining device to prevent the load, bales, fence posts, rolls of fence, wires etc.) from rolling down the lift arms into the operator's compartment and crushing the driver when the loader is raised. Inadequately secured objects could also fall and injure bystanders. Do not use implements for different purpose or to handle materials they are not expected to . For the operation of front loaders and relative safety rules, please refer to the Operation Manual of the loader.

Threepoint hitch and side mounted implements make a much larger arc when turning that towed equipment. Make certain to maintain sufficient clearance for safe turning.

When using attachments or implements with the tractor, be sure to thoroughly read the Operator Instruction Book for that attachment or implement and follow its safety instructions.

Pull only from the approved drawbar. Towing or attaching to other locations may cause the tractor to overturn.

Improper use of the drawbar, even if correctly positioned, may cause the tractor to overturn to the back.

DO NOT overload an attachment or towed equipment Use proper counterweights to maintain tractor stability. Hitch loads to the drawbar only.

X. Road Transport

Before operating your tractor on a public road, a number of precautions must be taken.

Familiarize yourself - and comply - with all local bylaws, and national laws appropriate to your tractor.

Lock your brake pedals together.

Raise all implements to their transport position and lock them in place.

Place all implements into their narrowest transport configuration.

Disengage the PTO and differential lock.

Make sure tractor and equipment are equipped with slow moving vehicle (SMV) signs or beacon if the law requires them and that loads do not obscure them or other lights.

Make sure any required clearance flags or hazard lights are in place and in working order.

Make sure you use a proper hitch pin with a clip retainer.

Clean off all reflectors and road lights, front and rear, and be certain they are in working order.

Implements mounted on the 3-point hitch and mounted implements projecting from the side need a wider turn radius than trailed implements. Always be sure to keep enough clearance when making a turn.

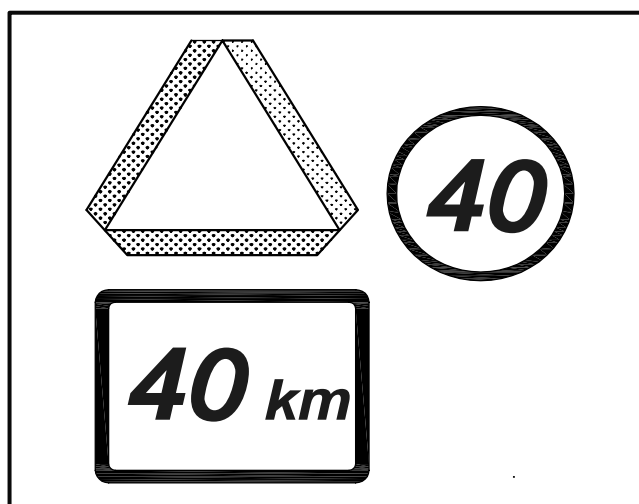
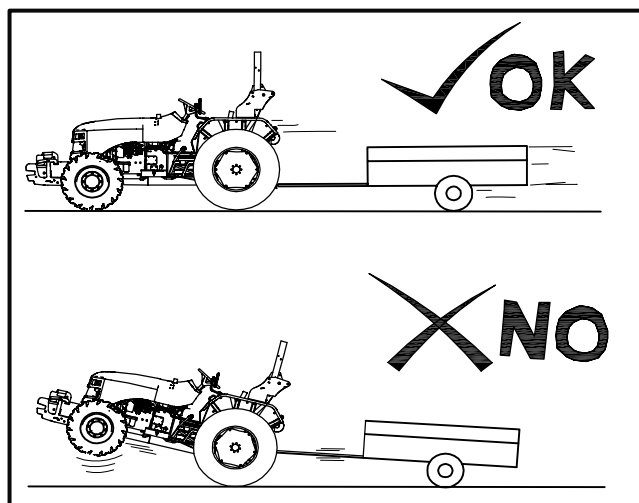

Use the symbol valid in your country.

Y. Road regulations

When operating your tractor on a public road a number of precautions must be taken.



WARNING : DO NOT allow any passengers on the tractor or towed equipment.

Know the route you are going to travel.

Use flashing lights or beacon when traveling on roads, day or night, unless prohibited by law .

Use caution when towing a load at transport speeds especially if the towed equipment is NOT equipped with brakes.

Observe all local or national regulations regarding the road speed of your tractor.

Use extreme caution when transporting on snow-covered or slippery roads.

Wait for traffic to clear before entering a public road.

Beware of blind intersections. Slow down until you have a clear view.

DO NOT attempt to pass at any intersection. Slow down for turns and curve

- ◆ **Make wide, gentle turns.**
- ◆ **Signal your intent to slow, stop or turn.**
- ◆ **Shift to lower gear before going up or down hills.**
- ◆ **Keep tractor in gear. Never coast with the clutch disengaged or transmission in neutral.**
- ◆ **STAY OUT of the path of oncoming traffic.**
- ◆ **Drive in your correct lane keeping as near to the kerb as possible.**
- ◆ **If traffic builds up behind you, pull off the road and let the road and let it go by.**
- ◆ **Drive defensively. Anticipate what other drivers might do.**
- ◆ **When towing a load, start braking sooner than normal and slow down gradually.**
- ◆ **Watch out for overhead obstructions.**

Z. SAFETY-AFTER OPERATION

When stopping at any time, bring the tractor to a secure halt (**DO NOT** park on a slope), apply the parking brake, engage the Park-Lock (if installed), disengage the PTO, place all gear shift levers in neutral, lower the implement to the ground, stop the engine and remove the key **BEFORE** leaving the seat.

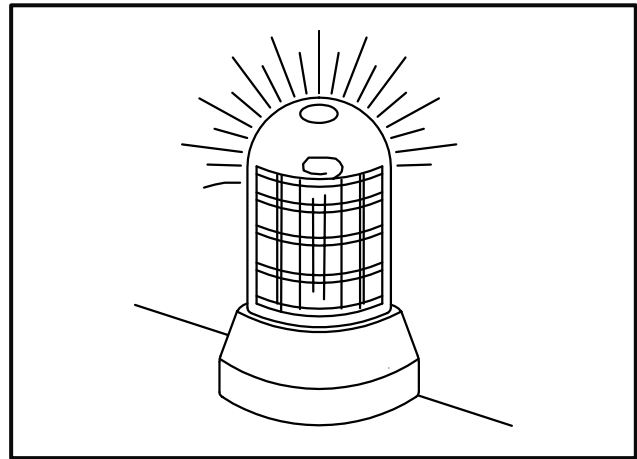

AA. Risks deriving from exposure to noise:

Noise characteristics and measurement

Noise is a pressure variation in an elastic medium, generally the air, produced by the variation of a material body (source) that determines an undesired and often annoying acoustic sensation. Noise is mainly characterized by;

- ◆ **Sound intensity or level:** expresses the entity of the pressure variation due to the sound wave. Measured in decibels (dB), It doubles the sound intensity and, thus, the energy that reaches the ear.
- ◆ **Frequency:** expresses the number of pressure variations of the wave per second and is measured in Hertz (Hz)- acute noises have high frequencies (2000-4000 Hz or more) while low-pitched noises have low frequencies (250 Hz or less).
- ◆ **How the risk is evaluated:** The higher the sound level and exposure time, the greater the noise risk will be:
- ◆ **LAeq:** (Equivalent continuous weighted level A): this is a sound level measurement that takes into account noise fluctuations and the varying sensitivity of the ear to the frequencies: LAeq is measured with a sound level meter;
- ◆ **PEL** (Personal Exposure Level): this is a measurement that takes the various noise levels into account along with the time the worker remains on the individual machines or working at determined processes: PEL is calculated mathematically.

Noise pathologies

Damage to the hearing

Noise causes hyperdulia or deafness because it destroys the acoustic receptors, nervous cells able to transform the mechanical sound vibrations into nervous impulses that, on reaching the brain, determine the aural sensation. These receptors are irreplaceable if they are destroyed and the resulting damage is irreversible: hyperdulia worsens if exposure to noise continues and does not improve even if this terminates.

Moreover, it is also bilateral since it can be accompanied by annoying buzzing and whistling sounds, and by intolerance to loud noise.

The damage is insidious since it proceeds slowly and unexpectedly: in the initial phase, when it is limited to a diminished ability to perceive acute sounds (music, bells) or the spoken voice when there is a background noise, it can only be detected by means of an

audiometric test. Pulsating noises of great intensity lasting a very short time are highly damaging since the ear is unable to actuate any physiological protective measures in time. Hyperdulia from noise generally arises after several years of exposure and depends on the PEL (risk almost null below 80 dBA) and on individual characteristics. It is an incurable disease: the only efficacious means of protection against it is prevention.

Other effects

Noise does not just determine aural sensation. For levels exceeding* 70dBA, it causes stress by means of the cerebral integration centers and determines a specific neurovegetative reaction responsible for effects that lead to cardio circulatory and gastro enteric diseases. Amongst these, it is worthwhile noting: an increase in gastric acidity, a decrease in the heart rate, visual range and reflex speed; a sensation of discomfort and weariness with an increased sense of fatigue.

These effects are dangerous because they also increase the risk of accidents.

Personal equipment to protect against noise

Individual protective equipment attenuates the sound energy transmitted to the ear through the air. This equipment is used when dangerous exposure cannot be avoided in any other way.

There are different types of devices with different attenuating capacities: helmets, ear muffs, ear plugs. Helmets and ear muffs offer the greatest protection but they are bulky and inconvenient to wear. They are therefore only of use for exposure to high noise levels but for short periods of time (max. 2 hours).

Ear plugs are generally tolerated to a greater extent and are of particular use in the case of lengthy exposure to noise of a lesser intensity.

Always use adequate individual protective equipment to safeguard the hearing when the personal daily level of exposure to noise is 85 dBA or more. Consult the "specifications" chapter of this manual in relation to tractor noise measured in instantaneous conditions in compliance with the laws in force.

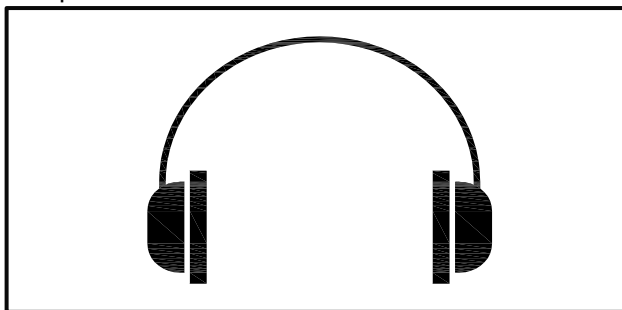

POSITION OF DECALS ON TRACTOR

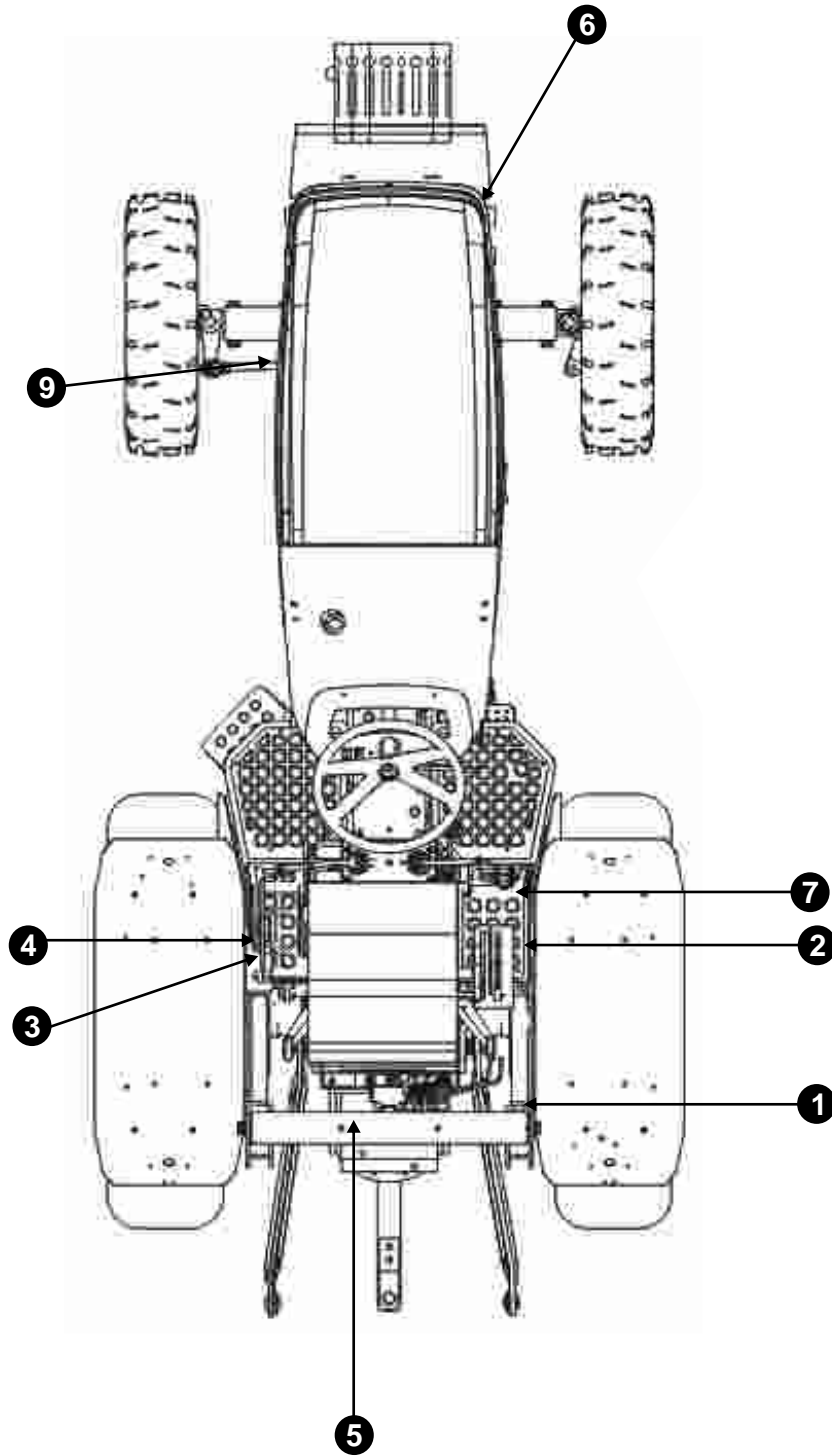

1.



SAFETY INSTRUCTION

- It is essential to read The Manual carefully.
- Do not take off belt or Adjustment while Tractor is Running.
- Do not dismantle or assemble from the Tractor while is in motion except in an emergency.
- Do not stand in-between the Tractor and Equipment when operating control.
- Keep clothing hand and feet away from moving parts.
- Do not make any adjustment when tractor is in operation.
- Wear adequate Footwear and snug-fitting clothing.
- Do not sit or stand on unsafe place when Tractor is moving.
- Keep Display Boards, Handles and Drivers Position Clean.
- Keep All Safety Guards in place While working.
- Make sure that no trains are coming before crossing the unguarded railway crossing.

PART No. 20002577

2.



CAUTION

DO NOT OPERATE
UNTIL YOU READ THE
OPERATOR'S MANUAL
TO UNDERSTAND
THE IMPORTANT
FUNCTIONS AND
CONTROLS.

PART NO. 20002580

3.



CAUTION

FOLLOW THE GENERAL
INSTRUCTIONS AND ROUTINE
MAINTENANCE AS GIVEN
IN THE MANUAL

PART NO. 20002739

4.



WARNING

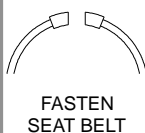

SEAT BELT MUST BE
WORN BECAUSE THIS
TRACTOR IS EQUIPPED
WITH ROLL OVER
PROTECTION.

FAILURE TO FASTEN SEAT BELT COULD
RESULT IN SERIOUS INJURY OR DEATH.

PART NO. 20002591

5.



WARNING

- PULL ONLY FROM DRAWBAR. PULLING FROM ANY OTHER POINT CAN CAUSE REAR OVERTURN.
- DO NOT OPERATE THE PTO WITHOUT GUARD.
- USE SAFETY CHAIN WHEN TOWING EQUIPMENT.

FAILURE TO FOLLOW ANY OF THE ABOVE
INSTRUCTIONS, CAN RESULT IN SERIOUS INJURY
TO OPERATOR OR OTHER PERSON.

PART NO. 20002587

6. 

⚠ DANGER

- KEEP FLAMES AWAY FROM BATTERY.
- DISCONNECT -ve CABLE OF BATTERY BEFORE ANY WELDING OPERATION.
- PROTECT YOURSELF FROM BATTERY, FLAME BURNS CAN RESULT FROM BATTERY ACID.
- IN CASE OF CONTACT WITH ACID, FLUSH WITH PLENTY OF WATER IMMEDIATELY.
- DO NOT JUMP START THE TRACTOR BY SHORTING ACROSS STARTER TERMINALS, TRACTOR WILL MOVE IF IN GEAR.

PART NO. 20002583

7. 

⚠ WARNING

- READ THE OPERATING MANUAL CAREFULLY BEFORE STARTING THE TRACTOR. FOR QUERIES CONTACT AUTHORIZED DEALER.
- CLEAR THE AREA OF BYSTANDERS.
- UNDERSTAND OPERATION AND LOCATION OF CONTROLS.
- START ENGINE ONLY FROM DRIVER SEAT WITH GEAR LEVER IN NEUTRAL POSITION BY PRESSING CLUTCH PEDAL.
- WHILE DRIVING ON ROAD, BRAKE PEDALS SHOULD BE LOCKED TOGETHER, USE SLOW MOVING VEHICLE EMBLEM AND WARNING LIGHTS.
- DO NOT LEAVE THE ENGINE RUNNING IN CLOSED CONDITIONS.
- DO NOT USE DIFFERENTIAL LOCK ON ROAD AND BEND, USE IT ON SLIPPERY SURFACES.
- DO NOT RUN FAST ON ROUGH GROUND, TURNS AND SLOPES TO AVOID JERKS.
- SITTING IS PROHIBITED ON FENDERS IF THERE IS NO SPECIFIC SEAT PROVIDED.
- DISENGAGE PTO AND STOP ENGINE BEFORE ATTACHING OR DETACHING IMPLEMENTS.
- BEFORE LEAVING THE TRACTOR SEAT, LOWER THE EQUIPMENT, POSITION GEAR LEVER IN NEUTRAL, STOP ENGINE AND APPLY PARKING BRAKE.

PART NO. 20002584

8. 

⚠ WARNING

KEEP CLOTHING AND HANDS AWAY FROM BELTS AND FAN TO AVOID SERIOUS INJURY.

PART NO. 20002589













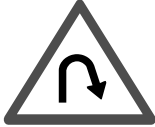

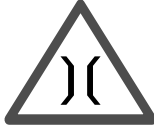



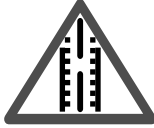













⚠ WARNING

- COOLING SYSTEM REMAINS UNDER PRESSURE.
- DO NOT REMOVE RADIATOR CAP WHEN SYSTEM IS HOT.
- ALWAYS TURN THE CAP SLOWLY AND ALLOW PRESSURE TO ESCAPE BEFORE REMOVING THE CAP COMPLETELY.
- WHEN OPERATING BELOW 32°F, USE SUITABLE ANTIFREEZE WITH WATER.

PART NO. 20002590

9. 

ROAD SAFETY SIGN

 Right Hand Curve	 Left Hand Curve	 Right Hair Pin Bend	 Left Hair Pin Bend	 Narrow Bridge	 Pedestrian Crossing
 School Ahead	 Men at Work	 Cross Road	 Gap in Median	 Side Road Right	 Side Road Left
 Staggered Intersection	 No Parking		 No Stopping or Standing		 Staggered Intersection
 Staggered Intersection	 Major Road Ahead	 Right Reverse Bend	 Left Reverse Bend	 Narrow Road Ahead	 Road Widens Ahead
 Cattle	 Ferry	 One way signs Vehicles Prohibited in One Direction	 One way signs Vehicles Prohibited in One Direction	 Y-Intersection	 Y-Intersection
 Y-Intersection	 T-Intersection	 Straight Prohibited or No Entry	 Right Turn Prohibited	 Left Turn Prohibited	 U-turn Prohibited

1. INSTRUMENT PANEL, ELECTRICAL CONTROLS AND SHEET METAL

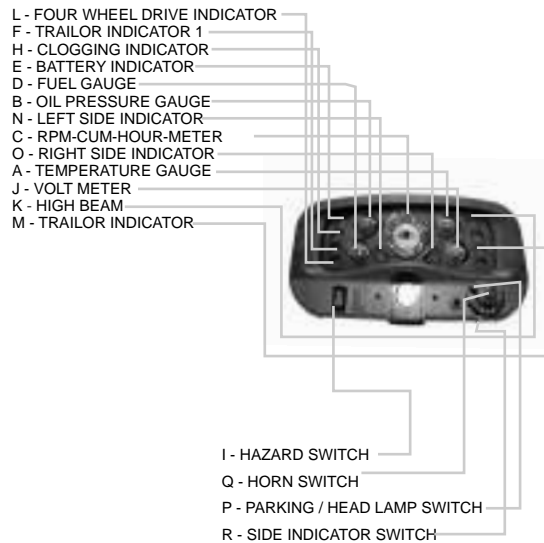

A. TEMPERATURE GAUGE:

This gauge indicates temperature of engine coolant. GREEN zone indicates normal temperature and RED Zone indicates engine overheating. If the needle moves beyond normal range, towards RED zone, follow the procedure:

- I Drive safely to the side of road and stop your tractor.
- II Allow the engine to run idle.
- III If the temperature does not go down, shut it off and allow sufficient time for it to cool.
- IV Visually inspect the fan belt for looseness, breakage and all water hose connections for leak.
- V If the fan belt is OK and no coolant leak is noticed, check the coolant level.
- VI Add coolant if required.

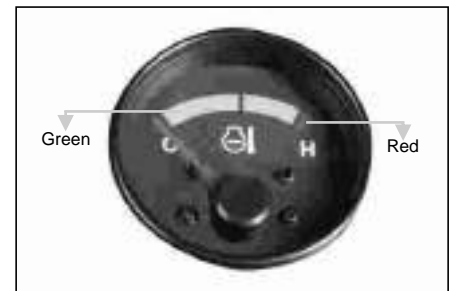

WARNING

Do not remove the radiator cap when the engine and radiator are hot. Boiling hot coolant and steam may blow out under pressure, which could cause serious injury. The cap should only be taken off when the coolant temperature has lowered. Necessary precaution to be taken while opening the radiator cap.

B. OIL PRESSURE GAUGE

This gauge indicates pressure of lubricating oil in the engine. If the needle enters in RED zone, stop the engine and follow the procedure

- I Stop your tractor to the side of road on leveled surface
- II Wait for minimum 10 minutes after stopping the engine.
- III Pull out the dipstick, wipe oil off with a clean cloth, insert & tighten the dipstick all the way into engine, and then remove it again. The oil on dipstick should be between the UPPER and LOWER limits.
- iv If the oil level is below the lower limit, then top up with oil.
- V Start the engine, allow it to run idle and don't race it immediately.



CAUTION

Do not operate the engine if there is no oil pressure indication.

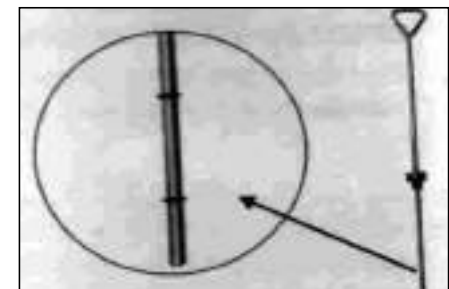

C. RPM CUM HOUR METER

Needle of this meter indicates speed of engine in Revolution per minute and the recorder meter indicates number of hours clocked by the engine. GREEN zone indicates economical speed.



D. FUEL GAUGE

Fuel gauge gives an approximate indication of the amount of fuel in fuel tank. If the needle enters in RED zone, refill the fuel tank.

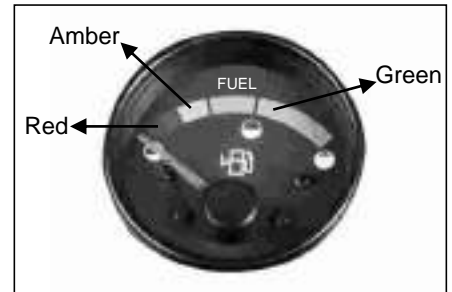

E. BATTERY CHARGE INDICATOR

If the indicator glow, it means that battery is not being charged. If the indicator remains 'OFF' battery is being charged.

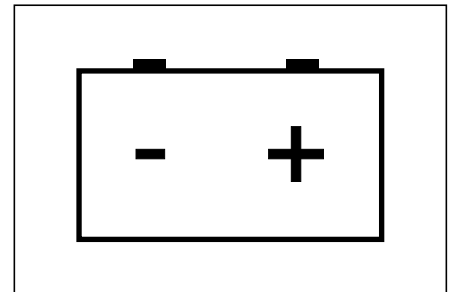

F. TRAILER INDICATOR-1

It indicates the working of left side trailer indicator & will work if auxiliary trailer is hitched & electrical connection is made with auxiliary electrical socket.

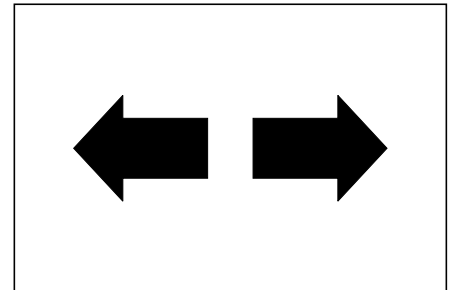

G. MOBILE CHARGER POINT

This point is provided to charge the mobile phone.



H. CLOGGING SENSOR INDICATOR

This light will glow when the air filter get choked. Clean the cleaner immediately if this light visible.

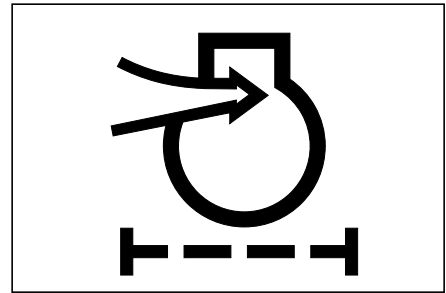

I. HAZARD LIGHT SWITCH

Pressing this switch will turn on all four indicator lights. To be used if tractor is stopped on the road or if some breakdown if there.



J. VOLTMETER

It shows the voltage of battery.



K. HIGH BEAM

It glows when high beam of head light is used.

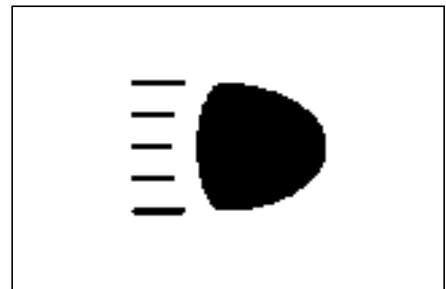

L. FOUR WHEEL DRIVE INDICATOR (OPTIONAL)

It indicates the engagement of 4WD if equipped

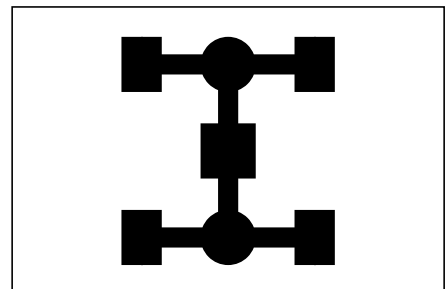

M. TRAILER INDICATOR-2 TURN

It indicates the working of right side trailer indicator.

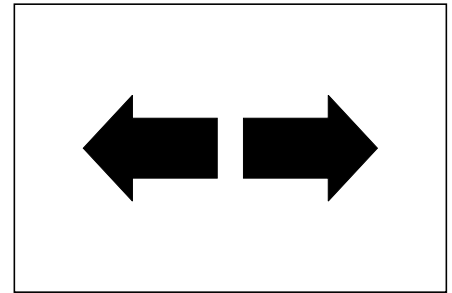
**N. LEFT SIDE INDICATOR**

It glows when left side indicator is switched ON.

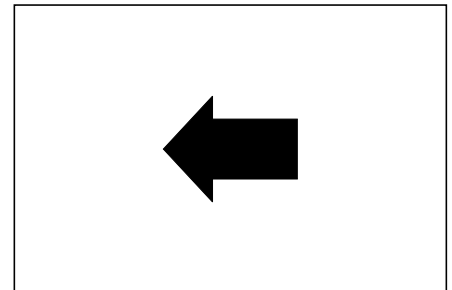
**O. RIGHT SIDE INDICATOR**

It glows when right side indicator is switched ON.

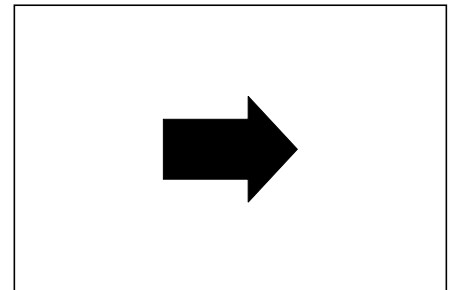
**P. PARKING / HEAD LAMP SWITCH**

This switch is provided to switch 'ON' or 'OFF' the parking lights & head light of the tractor.

**Q. HORN SWITCH**

The switch is used for blowing the horn



R. SIDE INDICATOR SWITCH

This switch is used for indicating vehicle turn either left or right. Toggle the switch(R) left or right for respective indication.

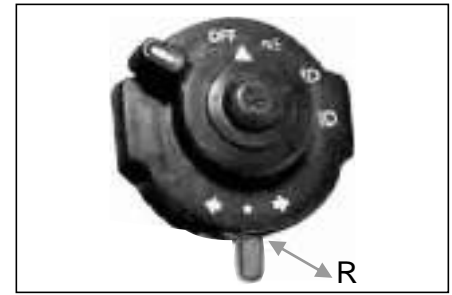

1.2 ELECTRICAL CONTROLS (WITH COMBINATION SWITCH)

1. Starting key switch.
2. Hazard light switch.
3. Engine Stop knob.
4. Combination switch.
5. Fuse Box.

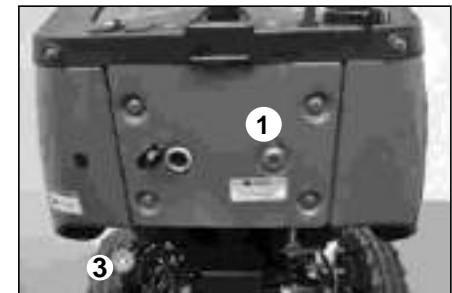

11. STARTING KEY SWITCH: Insert the key into the starting switch and rotate it in clockwise direction until engine starts. Do not keep the starter engaged for more than ten second. If engine stalls & falters in starting, wait 5 to 10 seconds before re-enganging the starter, otherwise you may damage it. Refer Page No. 22 for cold starting instruction for starting engine in cold weather.

2. HAZARD LIGHT SWITCH: push this switch to blink all indicators in hazard situation to alert Purpose of the hazard switch is as follows.

1. All the four lights blinking Indicates that driver has no control on tractor.
2. Mechanical defects in the tractor.
3. The driver is in distress maybe calling for a help or coming vehicle should take care of it self.

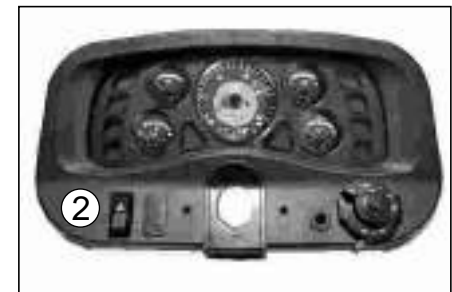

3. ENGINE STOP KNOB: To stop the engine release the accelerator lever and pull the stopping knob. After stopping the engine push it back to its original position.

4. COMBINATION SWITCH

R. SIDE INDICATOR SWITCH: This switch is used for indicating the vehicle turn. Move turn signal lever left to indicate left (L) hand turn or right (R) for right hand turn. Indicator lights n hour meter will flash according.

Q. HORN SWITCH: This switch is used for blowing the horn.

P. HEAD LIGHT AND PARKING LIGHT SWITCH: This switch has four positions in clockwise direction.

- 1st position : All lights are off.
- 2nd position (clockwise) : Parking lights, Instrument panel lights, tail lights will glow.
- 3rd position (clockwise) : Head lights (low beam), Instrument panel lights, Parking lights, tail light will glow.
- 4th position (clockwise) : Head lights (High beam) Instrument panel lights, Parking lights, tail light will glow.

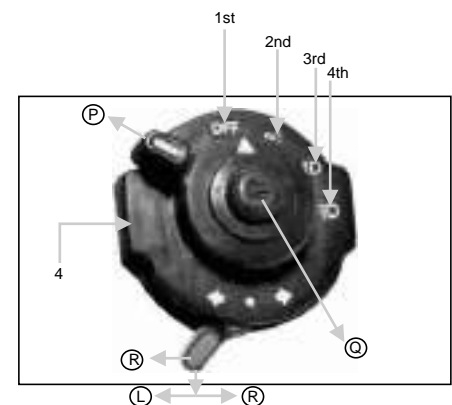

V. FUSE BOX: Fuse box is mounted on the dashboard. Remove the cover of fuse box by pressing the fuse box in lateral direction, as it will come of from locking clamp . Replace the fuse whichever need replacement (Never install a wire instead of proper fuse. Use only specified fuses) as mentioned on box.



1.3 PROCEDURE TO OPEN THE TOP HOOD

I. Insert the key (1) and rotate it clock wise to unlock the bonnet lock, than lift the handle (2) to open the bonnet.



II. Slightly lift the top hood upwards raising and it will raise of up by it sell with gas spring installed, to open it fully.



III. Use stay rod as shown in fig. to keep the hood in open condition for prolonged duration, in case of any repair.



1.4. REAR VIEW MIRROR

Both side rear view mirror installed for better rear side visibility

Side view mirror



1.5. COLD START UNIT

Cold start unit is fitted for ease in engine starting under cold weather.

Cold Start Unit

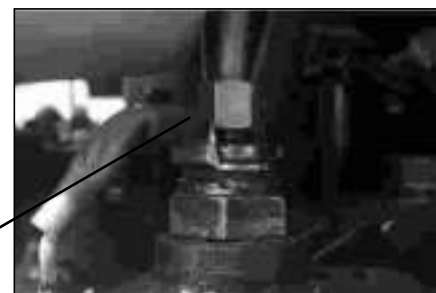

2. ELECTRICAL EQUIPMENTS

2.1 BATTERY

12V, 88Ah

I. Battery Access

Battery is located in front of the radiator.

To gain access:

1. Raise the hood as per procedure to open the top hood refer page no. 41

II. Removing Battery



CAUTION

To avoid sparks, disconnect negative (ground) cable first and connect it last.

1. Remove negative (ground) battery cable (B) and remove the cable connection. Then remove positive cable (A) and connection.
Loosen nuts securing battery hold-down and rotate the holder down, freeing the battery.
2. Lift and slide the battery from the battery tray.

III. Checking Battery Condition

- a. Battery gas can explode. Keep sparks and flames away from batteries. Use a flashlight to check battery electrolyte level.
- b. Never check battery charge by placing a metal object across the posts. Use a voltmeter or hydrometer.
- c. Always remove grounded (—) battery clamp first and replace it last.

Charging Battery

Keep battery fully charged, especially during cold weather.



CAUTION

Gas given off by battery is explosive. Keep sparks and flames away from battery. Before connecting or disconnecting a battery charger, turn charger off. Make last connection and disconnection at a point away from battery.

1. With charger off, attach positive battery charger lead to positive (+) battery terminal (A). Attach negative charger lead to tractor frame away from the battery.
2. Turn charger on and recharge the battery following battery manufacturer's instructions for using charger. Check battery condition as described below.
3. To disconnect battery charger, turn charger off. Remove negative charger lead first, follow by positive charger lead.

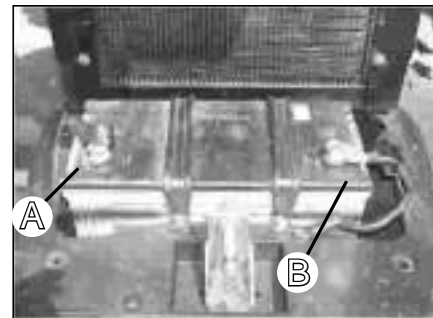

A—Positive (+) Cable Nut
B—Negative (—) Cable Nut

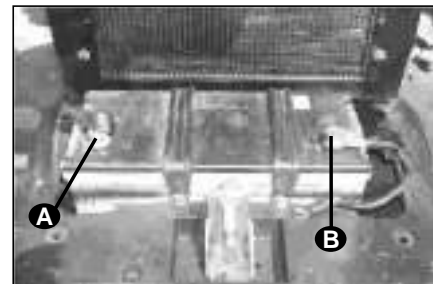

A—Positive (+) Battery Terminal
B—Negative (—) Battery Terminal

Servicing Battery

1. Keep battery clean by wiping with a damp cloth. Keep all connections (A and B) clean and tight. To remove any corrosion, wash terminals with a solution of four parts water to one part baking soda.



To avoid sparks, connect negative (ground) (—) cable last and disconnect it first.

2. Keep battery fully charged, especially during cold weather. If a battery charger is connected, attach a positive cable to the positive battery terminal (A). Connect the negative battery charger lead to a good ground on tractor frame.



Sulfuric acid in battery electrolyte is poisonous. It is strong enough to burn skin, eat holes in clothing, and cause blindness if splashed into eyes.

Avoid the hazard by:

1. Filling batteries in a well-ventilated area.
2. Wearing eye protection and rubber gloves.
3. Avoiding breathing fumes when electrolyte is added.
4. Avoiding spilling or dripping electrolyte.
5. Use proper jump start procedure.

If you spill acid on yourself:

1. Flush your skin with water.
2. Apply baking soda or lime to help neutralize the acid.
3. Flush your eyes with water for 15-30 minutes. Get medical attention immediately.

If acid is swallowed:

1. Do not induce vomiting.
2. Drink large amounts of water or milk, but do not exceed 2L (2 quarts).
3. Get medical attention immediately.

IMPORTANT: DO NOT add water in freezing weather unless tractor will be run at least 30 minutes to assure thorough mixing.

3. Check level of electrolyte in each cell (A) at least every 250 hours. If low, fill to bottom of filler necks with CLEAN, SOFT water. DO NOT OVERFILL.
4. Coat terminals with a small amount of grease.

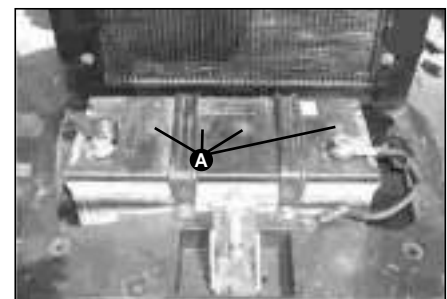
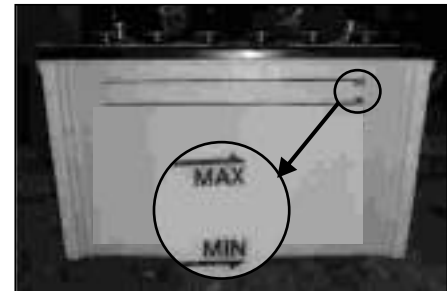
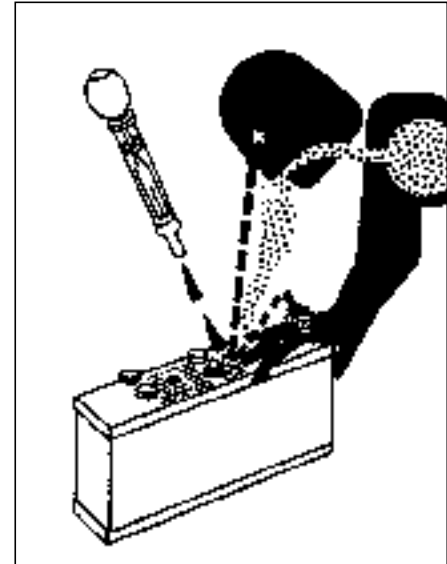

A- Battery Cells

2.2 ALTERNATOR

Alternator generate current which charges battery for healthy electrical backup. Rating: 12V, 36KW

I. ADJUSTMENT

To adjust the fan belt tension loosen the nuts (A) and (B). Move the alternator outwards to obtain proper belt tension then re-tighten the nuts (A & B)

Always do routine check for fan belt tension as per service schedule refer page no. 72

Drive belt deflection	
New	Old
9-10 mm	10-11 mm

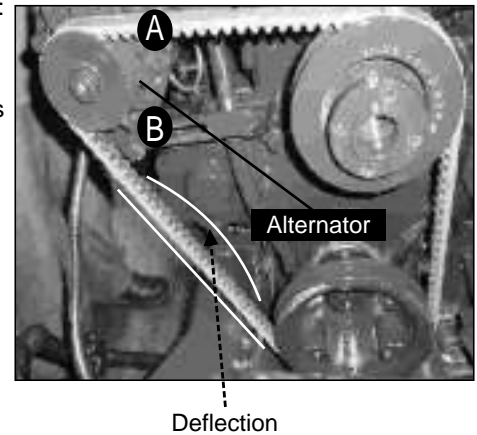

2.3 STARTER MOTOR

The starting motor rotates the flywheel for engine starting.

Capacity and Rating: 12V, 2.7KW

2.4 GENERAL MAINTENANCE OF ELECTRICAL SYSTEM

Never Patch up the electrical circuits.

Never replace a blown fuse by a higher capacity fuse. It could cause a fire.

Never work on components such as the alternator or starter motor when the engine is running.

Lastly when you are cleaning the tractor and using high-pressure spray, take care not to damage the connections on the various electrical cable.

2.4.1 PRECAUTIONS BEFORE CONNECTING WELDING APPARATUS:

In case of any electrical welding on tractor, first disconnect battery earth connection.

3. ENGINE

3.1 STARTING THE ENGINE

I. STARTING ENGINE IN HOT WEATHER

Ensure Gear levers at neutral Position.

Ensure hand throttle lever is at low idle position.

Press the clutch pedal and turn the starting switch clockwise to start the engine. Do not crank the starter motor more than 10 second.

Ensure that all gauges on dash board are working.

Note: The tractor is equipped with neutral safety switch . The tractor will not start if gear is not in neutral position.

II. STARTING ENGINE IN COLD WEATHER

Ensure Gear levers at neutral Position.

To start the tractor after long period, pump the fuel feed pump up to 20 times before attempt to start.

To start , keep hand throttle lever in low idle position and rotate the key just before cranking position for 10 sec and then further rotates the key to start the engine. This will turn on the cold starter flame glow device installed on air intake manifold & heat up the air coming inside the engine cylinder .

If engine does not start, repeat the procedure after 2-3 minutes of interval.

When the engine started, keep hand throttle lever in its original position and check for water temperature, pressure gauge are in normal condition.

Tractor cooling system is based on pressurized cooling. Hence without radiator cap do not run the engine.

Do not cover radiator in cold weather.

3.2 STOPPING THE ENGINE

Let the engine run on idling for 1 or 2 minutes then pull the fuel cut off lever till engine stops.

3.3 RUNNING IN ENGINE

During initial 50 hours, follow all instruction to get effective and trouble free long life of tractor.

Don't put load when engine is cold.

Don't over load the engine.

I. OPERATING TEMPERATURE

Run the engine at half speed for 10 minutes to attain normal operating temperature. The engine is designed to operate constantly at near full load. Put the Load on the engine only after maintaining operating temperature, (needle in green zone).

NOTE: Avoid running your engine for long periods in idle mode (greater than 20-30 minutes).

3.4 FUEL SYSTEM

I. FUEL SAVING TIPS

- Maintain your tractor. Badly maintained tractor waster 25% of precious fuel
- Always top up tank at the end of day to avoid water contamination in fuel tank due to moisture.
- Change fuel filter regularly as per maintenance schedule. Use genuine fuel filter available at authorized dealer. Also clean feed pump, filter and drain out water from filters as per schedule.
- Prevent fuel leakage.
- For better performance of tractor follow running in process mentioned in this manual.
- Do not over ride the clutch.
- Run tractor with appropriate speed and gear combination.
- Do lengthwise field operation.
- Always keep the specified tyre pressure for road and field operation.
- Switch off the engine when the tractor is not in use.
- Avoid wheel slippage
- Attached tractor trolley at appropriate height.
- Do not over load tractor beyond capacity

For Better Engine life
use only

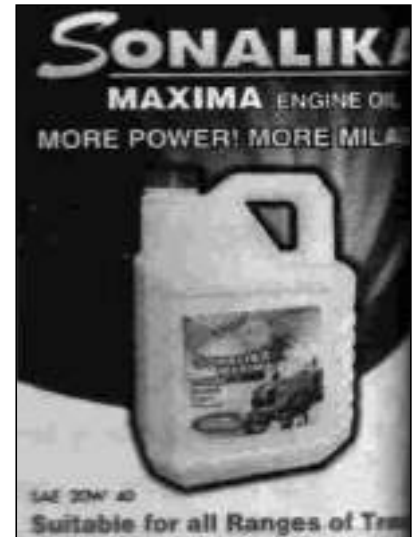

3.5 ENGINE LUBRICATION SYSTEM

We recommend the grade SAE20W/40 (**Sonalika Maxima Engine Oil**) of as mentioned in service schedule

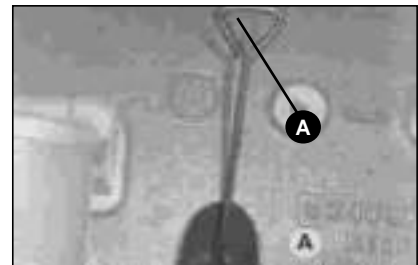

3.6 GENERAL MAINTENANCE

I. CHECK ENGINE OIL LEVEL

- Before checking the oil level, ensure that tractor is parked on leveled ground. Stop the engine and wait for some time, as all oil should return to oil sump.
- Check the oil level by unscrewing dipstick (A) Top up the oil level if the level is below the minimum level(1) mark. Do not over fill than maximum level(2) mark.

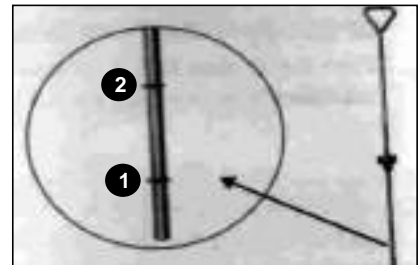

II. Fuel System Components

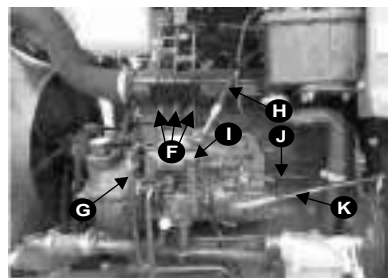
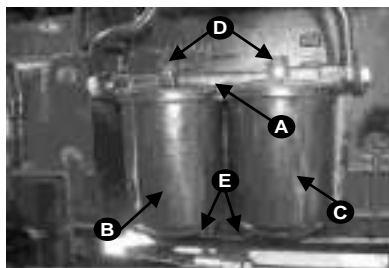

- | | | |
|-------------------------|-------------------------------|-----------------------|
| A—Fuel filter Assembly | E—Sediment Drain Screws-2 Nos | I—Hand Priming Pump |
| B—Primary Filter | F—Fuel Injection Lines | J—Fuel Shut Off Lever |
| C—Secondary filter | G—Fuel Line to Pump | K—Acclerator |
| D—Bleeding Screws-2 nos | H—Fuel return line | |

III. Replace Fuel Filter Elements

1. Remove cap screw (A) and filter element bowl (B).
2. Take out filter element (C).
3. Drain the fuel and clean the bowl.
4. Install new filter element.
5. Reinstall the bowl (B) and tighten screw (A) and washer (D).
6. Bleed the system from bleed screw (E).

IMPORTANT: Change primary and secondary filter elements alternatively. Never change both filter elements simultaneously. Always use new O-ring which comes filter elements

- A—Cap Screw
- B—Filter Element Bowl
- C—Filter element
- D—Washer
- E—Bleed Screw

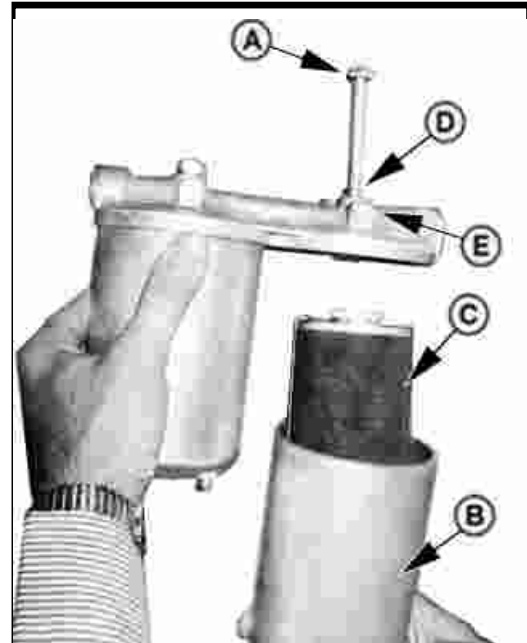

IV. Bleeding Fuel System

1. Loosen fuel return line (A).
2. Unscrew hand primer (B) on fuel supply pump until it can be pulled by hand.
3. Operate the hand primer until fuel flow is free from air bubbles.
4. Simultaneously stroke the hand primer down and close the fuel return port. This prevents air from entering the system. Tighten securely.
5. Lock hand primer in position.

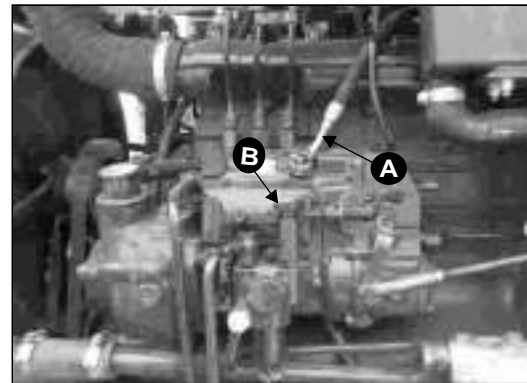

A-Fuel Return Line
B-Hand Primer

V. Bleed Fuel System At Fuel Injection Nozzles

If engine will not start after the bleeding procedures described above, continue as follows:

1. Place throttle lever in fast idle position.
2. Using two open-end wrenches, loosen fuel line on at least three nozzles.
3. Turn over engine with starter motor until fuel flows free from bubbles out of loosened fuel nozzle connections. Retighten connections.



VI. Water Separator Bowl

1. The water separator is used to obtain the better functioning of fuel system
2. Drain water and contaminants from clear water separator sediment bowl by opening drain screw (C).

A-Water Separator
 B-Indicator Ring
 C-Drain Screw

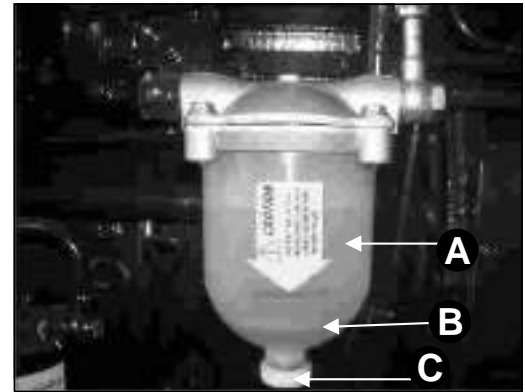

CAUTION

Drain the water from drain screw, if the indicator ring floats up to the level as marked on the water separator (A).

VII. CLEANING OF FUEL FEED PUMP STRAINER

Shut off fuel cock for cleaning the strainer remove it from bowl by loosening the screw provided at bottom. Clean the element of strainer and fit it again. Be sure that part of strainer bowl is fitted properly. Any minor leakage in this may cause air trapping in fuel system.

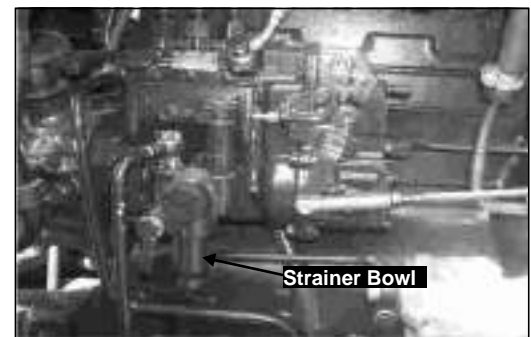

VIII. CHANGING OF ENGINE OIL

Park the tractor on leveled surface. Warm up the engine up to operating temperature and shut down, drain the oil by removing the plug. Fit drain plug (A) and fill the clean oil through filter cap (B). Start the engine for a while. Wait for a while, check the dipstick oil level. Always keep oil level between maximum and minimum oil level.

At the time of oil pouring always avoid overflow condition from filter cap to do so use proper size of funnel..

Do not fill oil over the maximum oil level mark. It may cause excessive oil consumption.

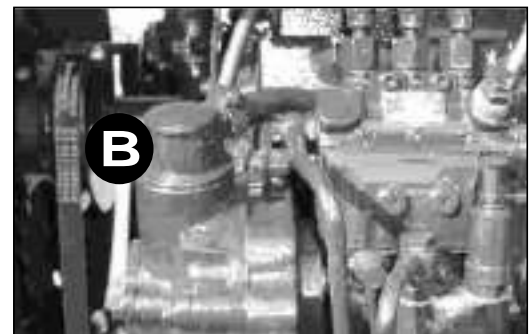

3.7 AIR CLEANER

I. GUIDELINES FOR DRY AIR CLEANER

Clean the primary element after every 300 hrs of operation or when ever choke indicator glows on dashboard.

Replace primary element after 3 cleaning or 900 hrs (whichever earlier).

Secondary element to be replaced after every three replacement of primary filter.

Use clean cloth to wipe sealing areas of primary filter.

Ensure proper seating of filter into housing before latching the cover. Do not use latches on the cover to force the filter into air cleaner that could cause damage to housing and will void the warranty.

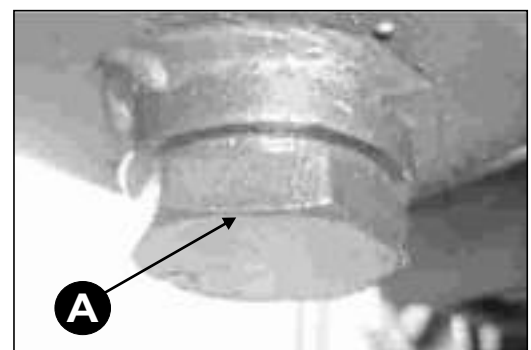

II. Replace Air Cleaner Elements

1. Open the bonnet hood. Refer page No.20 for procedure to open the hood
2. Release clips (A).
3. Remove cover (B).
4. Remove primary element (C).
5. Clean out any dirt in canister taking care not to damage the secondary filter element.

IMPORTANT: Remove secondary element (inner element) **ONLY** if it is to be replaced. **DO NOT** attempt to clean secondary element.

If secondary element is replaced, install new element immediately to prevent dust from entering air intake system.

6. Removal of the secondary element (D) is similar to removal of the primary element.

NOTE: When installing the air cleaner canister, make sure that the dust unloader valve (E) is facing down.

7. Install secondary element, primary element and cover.

A—Clips
B—Cover
C—Primary Element
D—Secondary Element
E—Unloader Valve

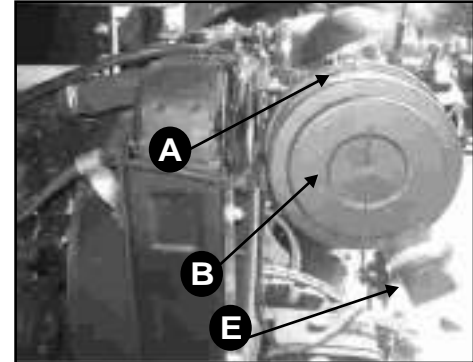

III. Cleaning Primary Element

1. Pat sides of element gently to loosen dirt. **DO NOT** tap element against a hard surface.
2. Clean element with compressed air (below 690 kPa or 100 psi). Hold nozzle next to inner surface, and move up and down pleats.

IMPORTANT: **DO NOT** direct air against outside of element, as it might force dirt through to inside.

3. Inspect element before reinstalling.

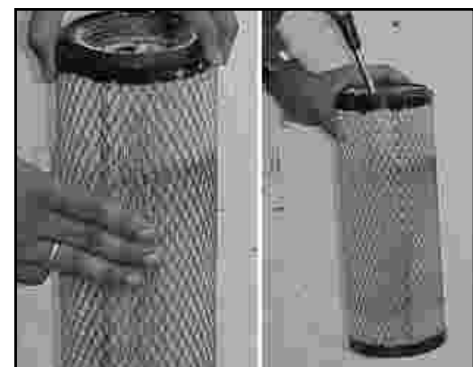

IV. Inspecting Element

1. Hold a bright light (A) inside element (B) and check carefully for holes. Discard any element which shows the slightest hole.
2. Be sure outer screen is not dented. Vibration would quickly wear a hole in filter.
3. Be sure rubber sealing surfaces (C) are in good condition on both ends. If damaged, replace element.

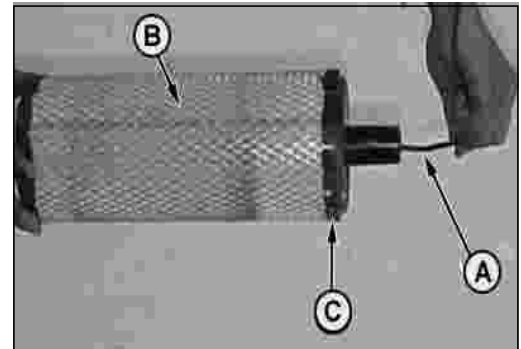

A—Light Source
 B—Element
 C—Rubber Sealing Surface



CAUTION

It the tractor is utilized in the dusty condition the cleaning interval should be decreased accordingly .

3.8 RADIATOR

I. COOLANT LEVEL IN RADIATOR (HOT)

Slowly unscrew the radiator cap up to the safety hatch (about 1/4 turn). Wait to allow the steam to escape. Continue unscrewing the cap, press it down firmly to release the safety hatch. The level of coolant should just touch the tab located in the filling spout (E). If the level has dropped, check the entire cooling system for external leakage (radiator, hoses etc.) If there is no external leak, top up the coolant.

Important check :-

1. Check for coolant level (Cold) in recovery tank (C). It should be at cold level as indicated on coolant recovery bottle.
2. Keep the radiator (B) topped up with coolant as per level up to filling spout (E)

IMPORTANT : Never pour cold water into the cooling system of a hot engine, as it might crack cylinder block or head. Do NOT operator engine without coolant for even a few minutes

A-Radiator Cap
 B-Radiator
 C-Coolant Recovery Tank
 D-Upper Radiator Hose
 E-Filling Spout

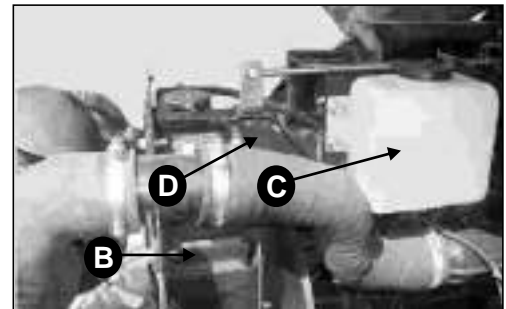
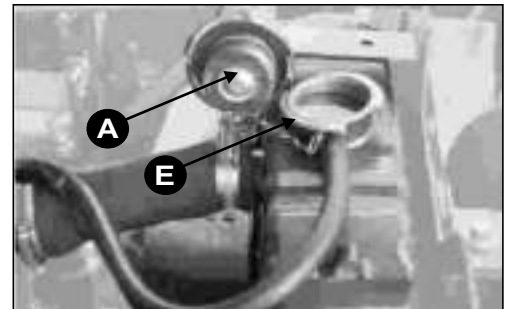

II. ANTI FREEZING PRECAUTIONS (FOR COLD COUNTRIES) BELOW 0°C TEMP.

Precautions against damage by freezing should be taken if the engine is to be left exposed to temperature below 0°C either by adequately draining the water system or by addition of an anti-freeze solution of reputed make and incorporating suitable corrosion inhibitor. The coolant solution containing 40% anti-freeze in water in a properly maintained engine should maintain its anti-freeze and anti-corrosive properties through out the winter season and in general, a safe life of 12 months maybe reasonable expected. When draining the water circulating system, it is not enough merely to open the radiator drain cock. The cap on the cylinder block must also be opened. This cap is on the rear side of the cylinder block where a pressurized radiator filler cap is fitted this should be removed before draining the cooling system. When draining the cooling system ensures that the engine is on level. When the engine is drained, in the majority of applications the water pump is also drained, but rotation of the pumping may be prevented by locking of the impeller by ice due to the pump drain hole being locked by sediment and or by locking of the seal through the freezing of moisture between the seal and gland. clean & check the same. 40% antifreeze should be used up to -20°C ambient temperature. Please use below mentioned antifreeze mixing ratio according to ambient temperature.

% Vol of Antifreeze	10	20	30	40	50
Freezing Point	-3	-9	-18	-25	-37

III. PRECAUTIONS TO BE TAKE WHILE WORKING BELOW FREEZING POINT.

Before starting the engine, turn the fan and water pump by hand this will indicate if freezing has taken place. This should free of any ice formation. If it is impossible to turn the pump by hand, the radiator and engine should be filled with warm water. After the anti-freeze solution has been used, the cooling system should be thoroughly flushed in accordance with the manufacturer's precautions before refilling the normal coolant.

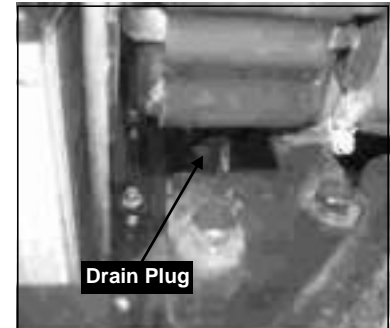

IV. RADIATOR DRAINING (When Cold)

Drain the radiator by unscrewing the drain plug of radiator and hose pipe connections must be removed before draining.



4. CONTROLS

4. CONTROLS

4.1 HAND CONTROLS

I. GEAR SHIFTER LEVERS

a. MAIN GEAR SHIFTER LEVER

In transmission 8-forward and 2- reverse gears are available. Main gear lever (A) allows changing gear while tractor is moving. Release accelerator pedal and declutch. Select required gear, release the clutch progressively and accelerate the engine. Before changing the tractor movement from forward to reverse or reverse to forward direction wait for the tractor to stop.

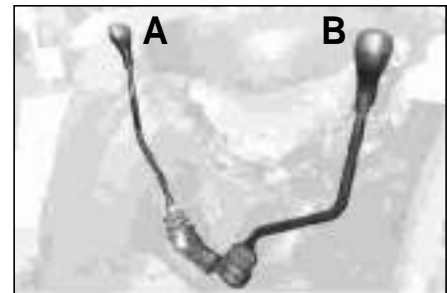

Side Gear

b. HIGH-LOW LEVER

This lever (B) is used to change the low speed into high speed or vice versa when tractor is moving. According to requirement you can use it with combination with main gear lever. Move the lever forward for high gear & vice verse for low gear speed.



Main Gear
Lever Knob



Hi-Low
Lever Knob

NOTE: When traveling downhill always remain in gear. Never declutch. The gear selected should be same as would be used to Climb. For engaging / disengaging gear always depress the clutch. Always use low gear while moving down slope.

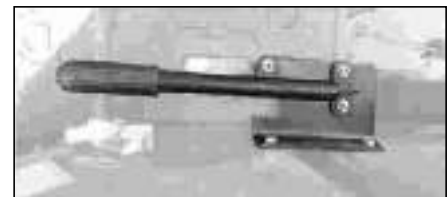

II. PARKING BRAKE

Parking brake lever is mounted at left hand side of the driver (as per different models). By pulling it upwards, you can apply parking brake to your tractor. It is used while your tractor is in parking condition.



Before driving tractor, parking brake should be released.

III. HAND THROTTLE LEVER

Hand throttle lever mounted on dashboard (Panel) is used in field application. To increase the speed of engine, pull down the lever and to decrease pull up the lever.

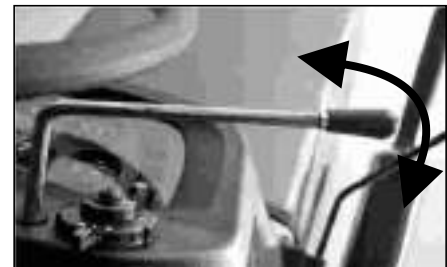

Panel Mounted



Never use hand throttle while driving the tractor on road use foot accelerator only.

IV. 4WD ENGAGE & DISENGAGE LEVER

Shift 4WD engage & disengage lever backward for 2 Wheel Drive (2WD) option & forward for 4 Wheel Drive (4WD) Option.



V. POWER TAKE OFF

Power take off is mounted at rear side of tractor. This is used for supplying rotary power directly to implement from engine. Power take off shaft has standard 06 Spline on 540rpm. PTO can be engaged or disengaged by PTO shifter lever.



a. POWERTAKE OFF SHIFTER LEVER

There are two positions for PTO lever. One Position is Neutral and Other position is Live PTO. When PTO lever is engaged in backward direction it is called Live or Direct PTO.

In Live or Direct PTO the speed directly depend on engine speed.

For engaging PTO set the engine to idle speed, declutch the engine and pull the lever to backward for direct PTO

540 RPM Obtained at 1600 Engine RPM



NOTE: When the PTO is not being used put the PTO in neutral.

b.. OPERATION WITH PTO

To mount PTO driven implements following steps are followed.

- a. Be sure that both gear shifter levers are in neutral position and PTO lever is also in neutral position.
- b. Stop the engine, hitch or mount the implement on three-point linkage.
- c. Remove PTO shaft cap and keep it to toolbox. Join the implement with PTO shaft directly or with the help of carden shaft as per provision of implement. Follow the instruction of implement manufacturer



CAUTION

- ➔ Do not wear loose clothes while operating PTO driven implement. If engine is in running condition do not go near the implement. For repairing or cleaning stop the engine and wait till the implement stop rotating. Do not pass between tractors and implement.
- ➔ Start the engine, depress the clutch, engage PTO as per requirement (operation) direct . Accelerate the engine at desired speed and then release clutch pedal slowly.
- ➔ While using PTO operated implement in stationary condition, apply parking brake, neutral both the gearshift lever and lock all the four wheel.

VI. DRIVER SEAT

Driver seat can be adjusted according to your conveyance in following ways.

a. TRAVEL ADJUSTMENT

- i By Pulling up the lever A (Located under the driver Seat) the driver Seat can be slided and adjusted according to requirement.

By unscrewing the two knobs (R) and loosening the bolt (C) the crive seat can be moved up and down.

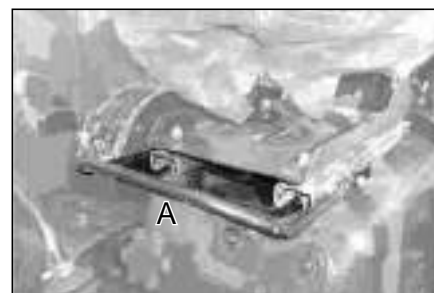

b. SUSPENSION WEIGHT ADJUSTMENT

The Seat can be adjusted for better suspension according to driver weight. This can be done by knob as shown. If you want hard suspension turn the knob (1) clockwise and if you want soft suspension turn it to anti clockwise. When the indicator (2) indicates the weight (approx. your weight) then the adjustment of suspension setting is at best position.

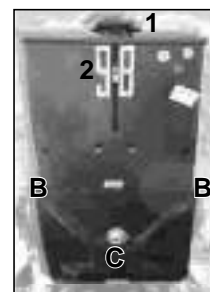

VII. HYDRAULIC LEVERS

a. POSITION CONTROL LEVER (A)

It is Black Colour handle located towards the driver side which enables raising or lowering the implement / lift. It is used when implement operation demands stable / fixed position e.g. carrying goods in a bucket attached on three point linkage.

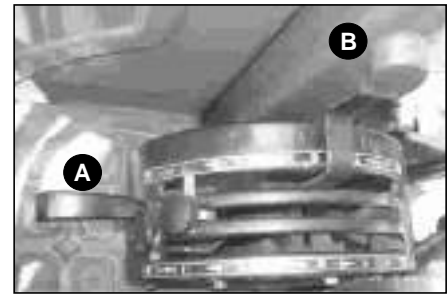

b. DRAFT CONTROL LEVER (B)

It is Red Colour handle locate towards right fender side which is used to control the draft of soil on implement. By controlling the draft, the implement and tractor can be prevented from overloading.

c. EXTERNAL HYDRAULIC CONTROL LEVER (C & D)

Used to control the oil flow into the auxiliary hydraulic circuit, either single acting or double acting.

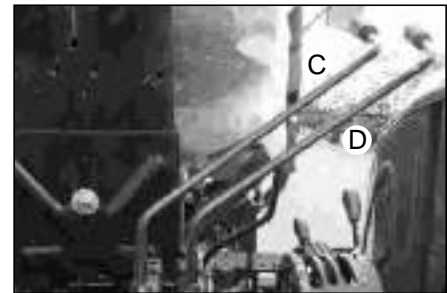

VII. DIRECTION CONTROL VALVES (DCV)

The DCV equipped is operated by two lever. Lever "C" is controlling Double Acting (DA) DCV and Lever "D" is controlling convertible Double Acting (DA) Single Acting (SA) DCV. We can convert the Convertible DCV into Double Acting (DA) by tightening the converting screw and vice-versa for SA.

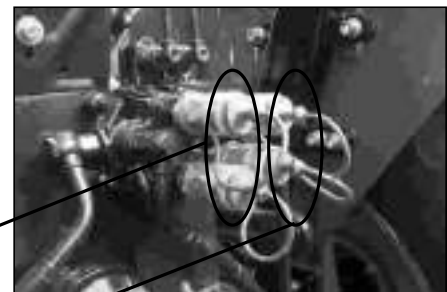

DA QRC

SA - Single Acting

DA - Double Acting

DA / SA QRC

Converting Screw



4.2 FOOT CONTROLS

I. CLUTCH PEDAL

By depressing clutch pedal (C) the motion and power of engine will be disengage from gearbox. Releases the clutch pedal slowly for transfer the engine power to gearbox.

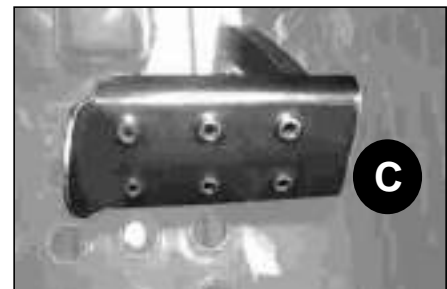

a. METHOD TO CHECK CLUTCH PEDAL FREE PLAY

Press down the clutch pedal and measure the distance between the footrest and pad. The distance should be 25 to 35 mm. If the distance is less than 25mm or higher than 35mm then get it adjusted. The adjustment can be done by the clutch pedal tie rod as it is having adjustable nut.

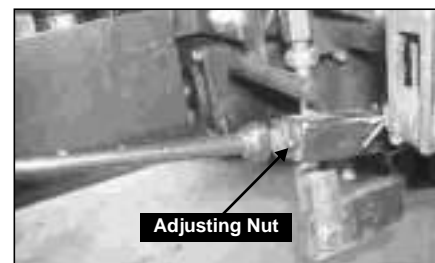

Do not keep foot on clutch pedal while tractor is in running condition. It may cause excessive wear of clutch and clutch fails before its lifetime.

II. DIFFERENTIAL LOCK

The differential lock mechanically locks the rear axle shaft together so that both wheels are coupled together so that both wheels are coupled together. This is an important aid when operating in muddy conditions as it provides increased traction, reduces wheel slip and prevent tyre wear.

If a rear wheel starts to slip - Engage the Differential Lock.

To Engage the Differential Lock

- 1 Fully depress the clutch pedal.
- 2 Push down the differential lock pedal with your heel and this engages the differential lock pedal
- 3 Release the clutch pedal slowly, while maintaining foot pressure on the differential lock pedal

To Disengage the differential lock, release the pedal. If the lock fails to disengage steer slightly to either left or right.

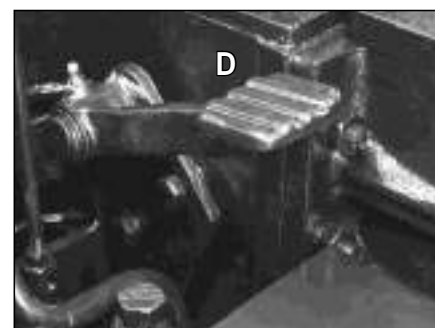

Do not apply differential lock while tractor speed is more than 6 kmph on turning
Do not attempt to sheer the tractor with the differential lock in the engaged position.

III. FOOT BRAKE PEDALS (E)

Use independent brake in the field operations. In field you will turn more sharply by pressing brake pedal for the side wheel on the turn. The pedals must be locked for road use. Use the lock by sliding the lever (A) side ways.

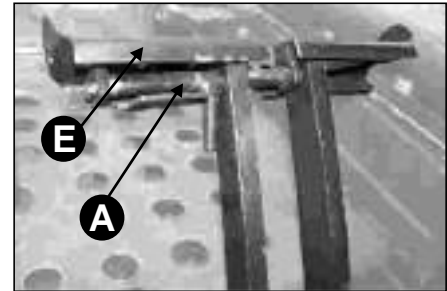

a. METHOD TO CHECK BRAKES

Release the hand brake. Uncouple the two pedals

Press down the right hand pedal and measure the distance between the pads & footrest. The distance should be between 55-65mm

If the free play is less than 55mm or higher than 65mm then adjust the both hex nut on actuator tie rod until free play comes to 55 to 65 mm. Now, press down the left hand pedal. If the values are not equal with the right hand pedal then repeat the same procedure until values become equal.

NOTE: Difference in the free play will lead to unbalanced brakes. the tractor can slew, in the event of violent braking. the wheel on Which the brakes are applied locks and the tyre wears out quickly. During Road Operations Both the brake Pedals should be locked.

IV. FOOT ACCELERATOR (F)

Food accelerator is used for control the tractor speed as per requirement. Only use foot accelerator while moving on road.

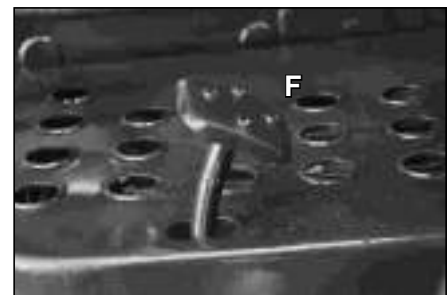

4.3 Seven Pin Socket

7 Pin socket is attached for trailer connection as per following Connectors.

- | | |
|-------------------------|------------------|
| 1. Earth | 2. Working light |
| 3. Left Indicator | 4. Parking light |
| 5. Right Indicator | 6. Brake light |
| 7. For Extra Connection | |

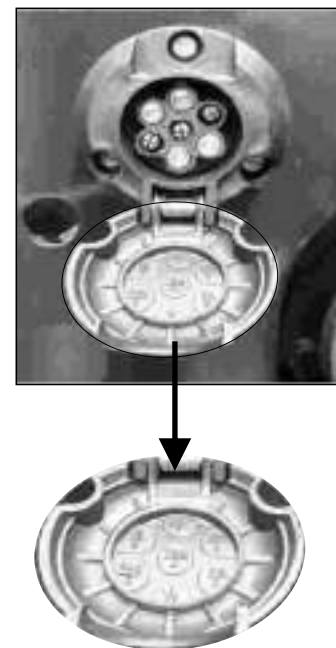

5. HYDRAULIC

5.1 HYDRAULIC SYSTEM

In this tractor live hydraulic system is provided. In which hydraulic pump is driven by engine and mounted with timing gear of engine. As the engine run, the hydraulic pump also starts working. Transmission lubrication oil is coming with hydraulic oil. Hydraulic system senses the load on implement through draft sensor provided at top link Mounting bracket of three- point linkage. You can operate position control, draft control or mixed control.

5.2 HYDRAULIC CONTROLS OPERATIONS

5.2.1 POSITION CONTROL OPERATION

Position control (A) is used to raise hold and lower three point linkage for mounted implements during tillage/field operation e.g. Mounted Disc Harrow, Seed Drill, Rotavator, Disc Plough, Ripper etc., which works above the ground. Once the height of implement is set, position lever maintains it. Always use Position lever for transporting the implement. One adjustable locking knob is provided for maintaining the specific position.

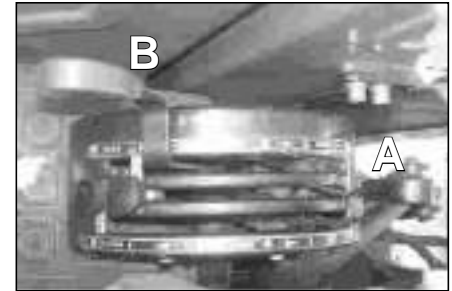

5.2.2 DRAFT CONTROL OPERATION

Automatic Draft Control(B) is designed to respond at the time of sudden resistance faced by the mounted dragging type implements i.e. Cultivator, Plough, and Reversible Plough etc. while working in the field. Keep both position and draft lever(Black & Red) in lower most position (implement grounded) now move the draft lever (Red) towards up side position on sector as implement starts rising move back the lever by few mm. Prevents: Overloading of engine, breakage of implements, clutch slippage, tyre slippage, and excess fuel consumption.

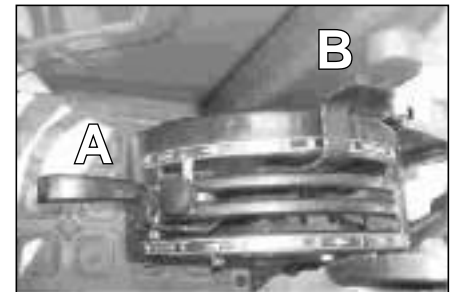

5.2.3 MIXED CONTROL OPERATION

Simultaneous use of position control and draft control lever is called mix control. If the ground is not uniform and has soft areas where the implement can sink too deep then mix control is performed because in this situation draft control does not function properly. Use the same. Procedure as for work in draft control then draw a furrow up the field, when the ground becomes sandy, the implement tends to sink in deeply. In this case, bring the position control lever backward to limit the working depth. Now set the position lever in this position.

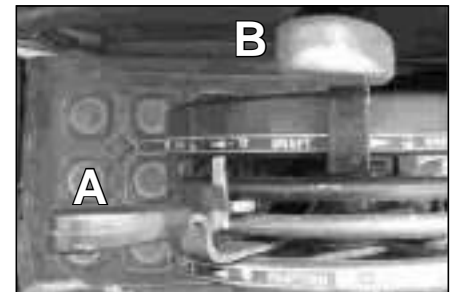

NOTE: At the end of the furrow, bring the position lever backward to raise implement fully. To bring implement is working position lower the position lever to the previous position marked on the position sector by knob.
Always use position lever while joining the implement and transporting the implement.
During transportation while holding implement in raised position, always close the response valve to prevent any accident.

5.2.4 DIRECTION CONTROL VALVE OPERATION

This operation is performed when external hydraulic cylinders are operated by tractor. To full the external cylinder shift the operating lever in forward and for draining the cylinder set the DCV Lever down in backward direction.



5.2.5 RESPONSE VALVE

It acts as safety device during transportation of implements and helps in its smooth lowering. It is located on front end side of Hydraulic Rear Cover below driver seat.

Rotate anti clockwise to lock the hydraulic lift & rotate clockwise to control the lifting response time of lift.





Response Valve should always be closed during implements transportation.

5.3 THREE POINT LINKAGE

Three-point linkage is used for mount the implement, which is fully mounted, or semi-mounted and used for different field operation. Three-point linkage is controlled by hydraulic lever with the help of position and draft lever. In this two lower link are available, of which one side of the lower link is attached with differential housing and other is used to hitch the lower pin of the implement. Lift rods are mounted on lift arm that is operated through rockshaft. Right side lift rod is an adjustable for convenience to mount a implement in three point linkage. Loose side of Top link is used for attaching upper hitch pin of implement. Top link is adjustable for proper setting of implement and ease at the timing of joining.

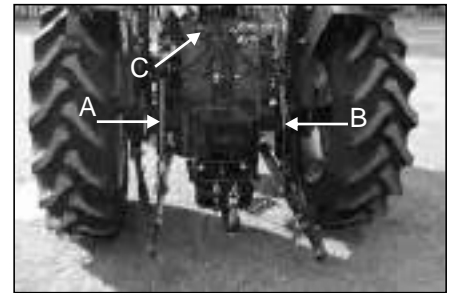

5.3.1 LEFT LIFT ROD (A)

If lift rod is fitted with lift arm and lower link, the length of lift rod cannot be adjusted. For adjustment of length, remove the safety pin, which is attached with lift arm, and turn lift rod for increase or decrease the length.

5.3.2 RIGHT LIFT ROD (B)

For adjustment of length unlock the lever of -adjustment box and turn it clockwise for decreasing the length or turn it to anticlockwise for increasing the length.

5.3.3 TOP LINK (C)

For length adjustment of top link, fix the top link other end and turn the lever for increasing or decreasing the length. During field operation lock the tube to avoid unnecessary turning.

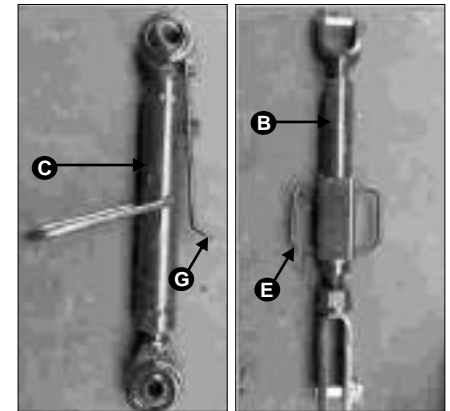

5.3.4 ROCKER LINK ASSEMBLY (D)

While using draft control, the sensing from top link to control valve is transferred by rocker link assembly. Three different mounting holes have been provided, for

1	Top Hole	Soft Soil
2	Middle Hole	Medium Soil
3	Bottom Hole	Hard Soil

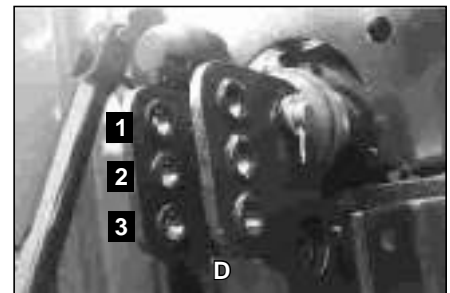

5.3.5 LOWER LINKS (E)

Lower Links are provided for hitching the implement.

5.3.6 STAY BARS (F)

Stay Bars controls the swing of implement during transport and field operations. Stay Bar are provided between side of lower link and differential housing.

5.3.7 SWINGING DRAWBAR (G)

Swinging Drawbar fitted on rear side of the differential housing is used for trailer towing the haulage operation.

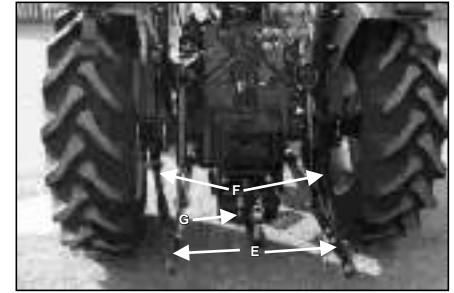
**5.3.8 ATTACHING IMPLEMENT TO 3 POINT LINKAGE**

Position the tractor to align corresponding linkage with the hitch points of implements. Keep the implement on hard & leveled surface and attach as per given below instructions

First attach with Left Lift Rod (A)

Attach with Right Lift Rod (B)

Then at Last attach with Top Link (C)

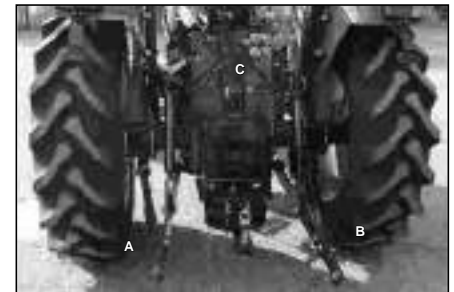
**5.4 GENERAL MAINTENANCE****5.4.1 TRANSMISSION/HYDRAULIC OIL LEVEL**

Keep oil level up to maximum oil level mark.

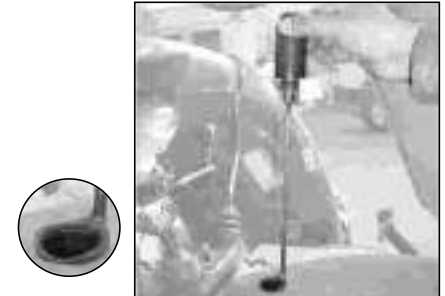
**5.4.2 HYDRAULIC OIL FILTER**

Hydraulic oil filter is fitted at right hand side of tractor. Remove the old filter and change with new one dully filled with clean oil. Apply small amount of oil on rubber seal of filter and fit it. Do not over tight the filter.

**5.4.3 CHECK TRANSMISSION OIL BREATHER**

The breather is located on top of the rear cover, beneath the driver seat.

Remove the breather by unscrewing it. Clean it with diesel and check it for proper working and fit it again.

Oil Breather

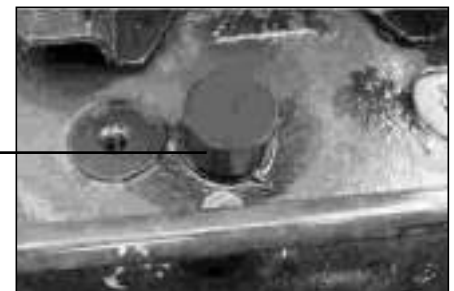

NOTE: Use proper genuine transmission oil.

5.4.4 CHANGE TRANSMISSION OIL

Before draining the oil, heat up by running engine, transmission and hydraulic system. Park the engine on level ground, turn off the engine and then drain the oil by opening the drain plug provided at bottom of gear box and differential housing. Fill the new oil. Check the level by dipstick. Tighten the drain plug with torque of 90 NM.



5.4.5 CHANGE STEERING GEAR BOX OIL(MECH. STG. - OPTIONAL)

Drain out the oil by removing the drain plug of steering gear box assembly. Keep oil level up to level plug.

Steering oil capacity 600 ml (approx.)

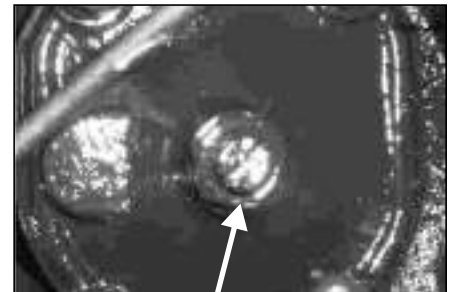

Mechanical Steering Gear Level Screw

5.4.6 POWER STEERING

Power stg consists of following components

- A) Power stg oil tank
- B) Dip stick cum breather
- C) Power Stg. oil tank filter

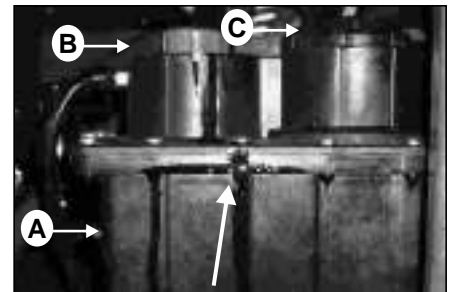

Power stg oil tank full

5.4.6.1 POWER STG OIL TANK

Steering oil in the power steering system is 3.5 lit. Resorvoir tank capacity 1.75 lit.

5.4.6.2 POWER STG. OIL TANK FILTER

Open the power stg. oil tank filter (C) by opening the locking screw. Clean the filter after every 150 hour .



Dip Stick Cum Breather

5.4.6.3 POWER STG OIL LEVEL

Power steering tank oil level should be in "FULL" as Indicated in the dipstick.

5.4.6.4 STICKER

Sticker provided in the steering tank in which power stg oil grade mentioned. Recommended oil grade is DEXRON-IIID



6. WHEELS AND TYRES

Tyres play vital role in transportation and agriculture operations so their importance became a necessity tractor/ automobiles. Here we will discuss only pneumatic tyres.

On any tyre there is some marking which represents its size & capacity e.g. Tyre marking is 13.6x28, 12 ply rating i.e. 13.6 inch is the section width, 28 inch is the bead diameter. Ply rating doesn't show that the same No. of plies are inserted in tyre. It is only comparative measure of the load carrying capacity (L.C.C) of tyre. As more ply rating shows more L.C.C. at the same time as L.C.C. increases the shocks absorption capacity decreases.

It is the most important factor in the efficient performance of tractor it should be used only as per company recommendation. In general, tractor is considered for two types of work:

- 1 Work on soft soil where maximum adhesion is needed. In this case there will be use of lowest pressure compatible with the load carried.
- 1 Work on hard ground and roads, towing etc; In this case there will be use of maximum pressure.

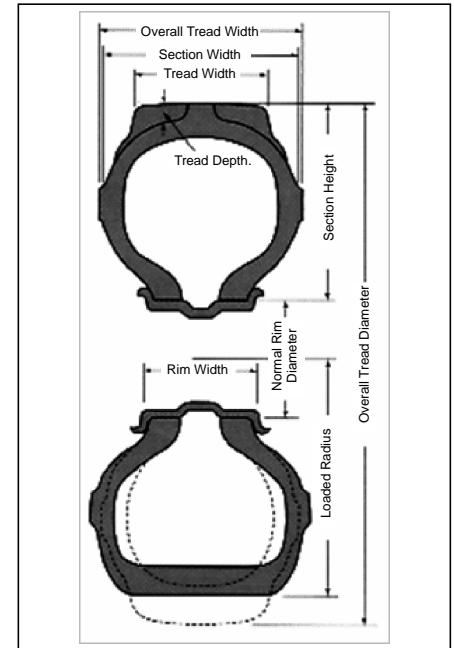

6.1 IN FIELD OPERATIONS

6.1.1 Correct Pressure

- Good adherence by dirt grousers.
- Good cleaning of the tread

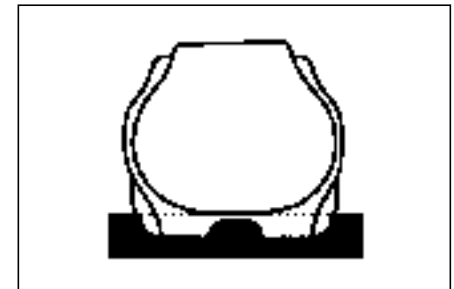

6.1.2 Insufficient Pressure

- Reduce adherence through lack of tyre grip.
- Deterioration of tyre casing by traction forces.

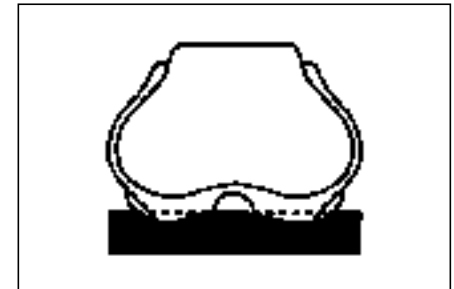

6.1.3 Over Pressure

- Reduce grip due to lack of cleaning
- Deterioration due to compacted ground.

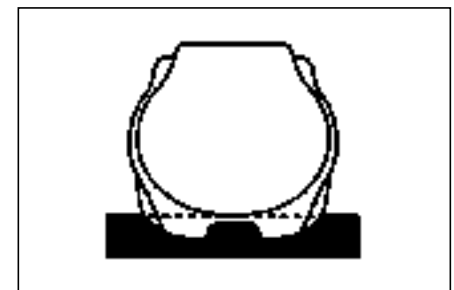

6.2 ON ROAD OPERATIONS

6.2.1 Correct Pressure

Resistance to Wear

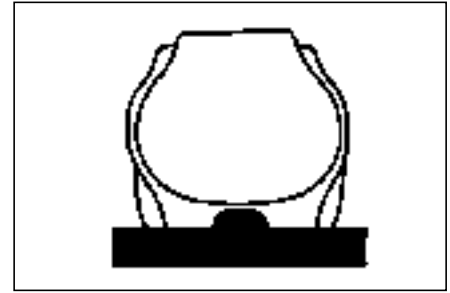

6.2.2 Insufficient Pressure

Reduce through lack of tyre grip.

Deterioration of tyre casing by traction forces.

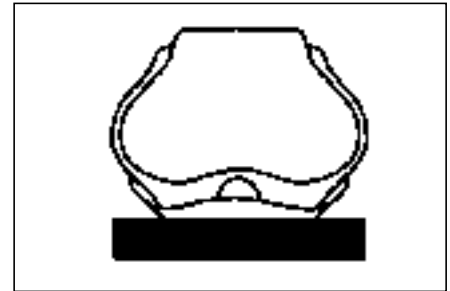

6.2.3 Over Pressure

Reduce grip due to lack of cleaning

Deterioration due to compacted ground.



NOTE: Tyre pressure should never maximum pressure as recommended the tyre could burst. Change / repair any worn or faulty tyre (cuts, cracks etc.) immediately to prevent the problem become more severe.

6.3 BALLASTING OF TRACTOR

Proper ballasting is an important factor in tractor performance. For better performance of tractor, the weight of tractor can be decreased or increased as per requirement. Maximum productivity can be achieved only if tractor weight is appropriate for the job. Ballast is required for traction and stability. Following factors determine amount of ballast.

- Soil surface either loose or firm
- Type of implement
- Travel speed and tractor power output either partial or full load.

I. FRONT END BALLASTING

Add extra removable weight to front end. Heavy pulling and heavy rear- mounted implements tends to lift front wheels. Add enough ballast to maintain steering control. Six 31Kg. removable weights are already supplied with the tractor.



II. REAR END BALLASTING

a. WHEELS AND TYRES

Ballasting of rear wheel required for proper traction for heavy implements. Ballasting can be done by water or cast iron weight. You can water ballast the Tyre up to 75%. It is most convenient way of ballasting. For the normal atmosphere region you can use ordinary water for ballasting. For tractors working in cold climate precautions must be taken to avoid the water freezing.

b. PRINCIPLE

The type inner tubes on the driving wheels are fitted with air and water valves to allow inflation with air and ballast with water. A special connections is required to connect the water supply to the valve or filling with 75% water (Air + Water) the set retains almost the same flexibility as when inflated with air only as the remaining spaces filled with air at the pressure normally used for the load carried and the size of tyre.

c. PROCESS OF WATER FILLING IN THE TYRE

Action:-

1. Jack up wheel & remove valve from the tube.
2. Deflate the tube.
3. Turn the wheel so that valve is on top/ 12 o'clock position.
4. Attach the hose to the valve body by till it details flowing back means of a special adopter.
5. Allow water to flow in.
6. Fill water up to upper rim level.
7. Take out the adopter and rotate the tyre to bring it to 11 o'clock position & replace the valve. Allow water to flow out, and replace the valve. Bring in the tyre to 12 o'clock position again.
8. Fill in air to its normal working pressure of 10-12 psi.
9. Check the valve for proper tightness / leakage.
10. Remove the jack.

*While filling water in tube it is said that water should be filled up to upper rim level i.e. 75% of its space, rest should be filled with air. Presence of air is necessary for cushioning effect and to absorb shock.

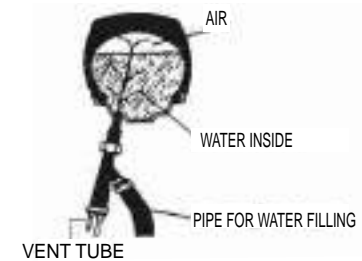
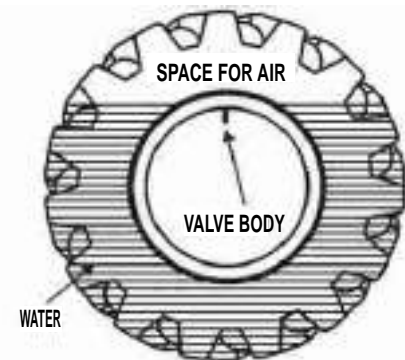

Chart shows water-ballasting capacity per Tyre.

TYRE SIZE	WATER IN LITERS
NOTE: Ballast should be limited by either Tyre capacity or tractor capacity. Each Tyre has a recommended load carrying capacity, which should not be exceeded. If a greater amount of weight is needed for traction then a larger. Tyre should be considered.	

6.3.2.2 USING CAST IRON WEIGHT (REAR)

Cast iron weight are available in a 34 kg size. Weight can be installed on the outside of wheel. Use these weights as per recommendation. The tractor is already supplied with one set of casting rear weight.

6.3.2.2.1 INSTALLING CAST IRON WEIGHT

Cast iron weight can be attached to wheel by means of bolt. One or two weight can be attached. Tighten the bolts according to specified torque of 230 Nm.



6.4 RECOMMENDED LOAD CARRYING CAPACITY PER TYRE W.R.T ITS SIZE

Tyre Size	Pressure lbs/in ²	Load Carrying Capacity in Kgs per Tyre at PSI (ON ROAD)													
		15	17	18	19	20	22	24	25	26	27	29	31	33	34
13.6 x 28	Ply Rating 6 Ply	1100	1165	1220	1270	1325	1375	1430							
	8 ply & above								1480	1530	1585	1645			

NOTE : Load can be increased by 20% without increasing inflation pressure if the tractor is operated at speed upto 16 Kmph.

FRONT TYRES

Tyre Size	Pressure Kg/CM ² lbs/in ²	1.2	1.7	2.0	2.25	2.25	2.8	3.1	3.4
		20	24	28	32	36	40	44	48
6.0 x 16 (2WD)	Load Capacity (kgs) per Type	340	380	415	450	485	515	545	570
9.5x20 (4WD)					850				

6.5 TRACK WIDTH ADJUSTMENT

I. FRONT TRACK WIDTH (2WD)

For adjusting the front track wheel telescopic section is provided in hollow beam of the front axle. For adjustment on telescopic section four holes are provided at a distance of 50-mm. By this you can obtain three positions of track width and also the rims of front wheel offset. By reversing it you can adjust track width. Thus you can get 6-track width for front axle.

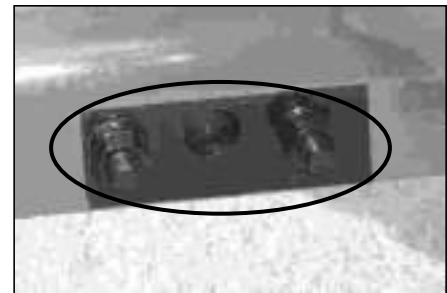

a. FRONT WHEEL TOE IN

After setting the track width it is necessary to adjust toe in of the front axle.

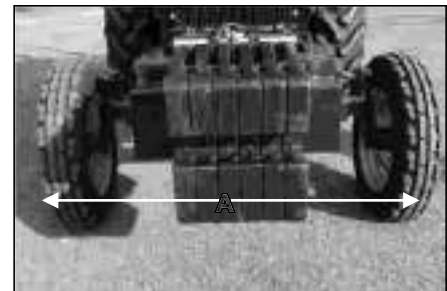

b. CHECKING AND ADJUSTMENT OF TOE-IN

Firstly park the tractor on level surface. Turn the steering wheel so that front wheels are in the straight-ahead position. Stop the engine. Measure distance (A) between tyres at hub level in front of axle. Record measurement and mark the points on tyres. Move tractor back about 1 meter, so that mark on the tyre is at hub level behind the axle.

Again measure distance between tyres at same point on tyre. Record the measurement. Determine the difference between front and rear measurement. If the front measurement is smaller toe is 'in'. If the rear is smaller, toe is 'out'. Distance (A) at front of tyres should be 3-6 mm less than distance measured at rear of tyres.

Adjust toe-in if necessary. For adjusting toe-in loosen the lock nuts (B) on both sides. Turn the tie rod (C) and adjust toe in to 3-6 mm. After adjusting torque the lock nut (B) to 100 NM.

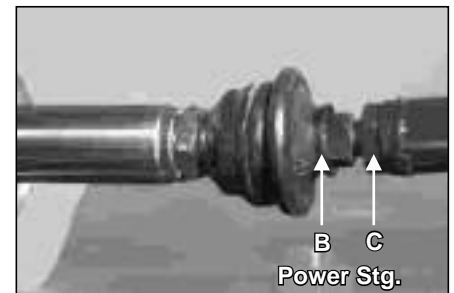
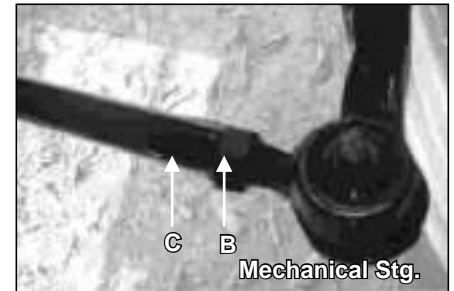

NOTE: If toe in of the front wheel is not proper, wear out of front wheel will increase.

6.5.2 REAR WHEEL TRACK WIDTH ADJUSTMENT

Track width of the rear axle can be adjusted by repositioning or exchanging the rims or by reversing the wheel discs. Track width can also be adjusted by exchanging the complete wheel to the opposite side of tractor. This maneuver permits the change from disc dished in to disc dished out operations without disassembling the wheel. When changing rear wheels from one side to the other, the arrow on sidewall of tyre points in the direction of forward rotation. A study of following diagram, from attempting to change track width setting will save unnecessary labour.

6.5.2.1 WHEEL BODY TOWARDS INSIDE

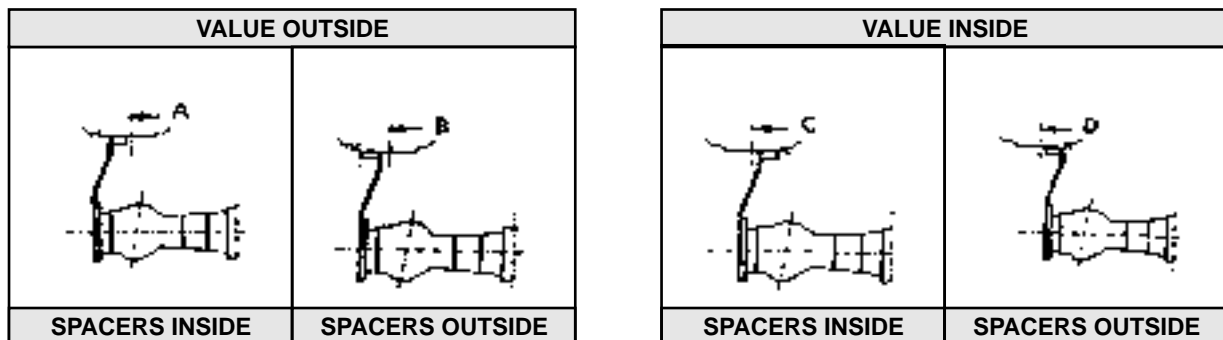

6.5.2.2 WHEEL BODY TOWARDS OUTSIDE

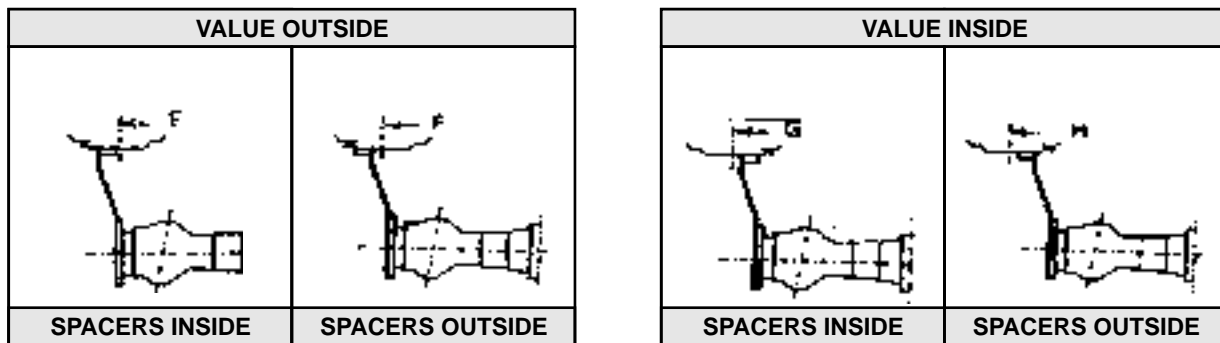

TRACTOR SIDE	TRACK WIDTH (mm)		
	MAXIMUM	MINIMUM	STANDARD
Rear	1814	1420	1420
Front (2WD)	1675	1290	1310
Front (4WD)	1530	1530	1530

NOTE: Track widths are measured at bottom of centerline Some combinations not possible due to fouling with fenders.

6.6. TIPS FOR PROPER HANDLING AND DURABILITY OF TYRES

Some ignorance and improper handling reduce the life span of tyres. In this topic we mention about the tractor that are account for proper handling and more durability of tyres. There are some factors that are mention as follow.

Problems	Factor Effecting	Corrective action
Alternate wear tread	<ul style="list-style-type: none"> ● Inappropriate pressure in tyres. ● Continuous use of tyres for excessive load on road with two-tyre trailer. ● Incorrect matching of tractor with trailer. 	<ul style="list-style-type: none"> ● Maintain appropriate pressure in tyres. ● There should be check up of tyres pressure time to time. ● There should be correct matching of tractor trailer.
Sidewall or Shoulder damage	<ul style="list-style-type: none"> ● Damage by sharp edges things like stones, pieces of glass etc. ● Tyres damage with linkages while turning. 	<ul style="list-style-type: none"> ● Maintain appropriate pressure in tyres. ● Never turn the tractor instantly.
Scoop or wear from high center tread	<ul style="list-style-type: none"> ● Excessive pressure led to early wear of tyres. ● Use of tractor in transportation for longer period. 	<ul style="list-style-type: none"> ● Proper inflation and ballasting of tyres during agricultural and transportation purpose.
Puncture of tyre again and again:	<ul style="list-style-type: none"> ● Places where Crops like Sunflower, Sugarcane & Cotton etc that are with sharp edges stem and deep roots have more probability to cause damage to tyre. 	<ul style="list-style-type: none"> ● To over come this problem, wheel track should be adjust according to rows difference of crops.
Damage to tread/crown of tyre	<ul style="list-style-type: none"> ● Merging of sharp edges things in tread/ crown area. ● Contact with stones, pieces of glass, steel or crops with sharp edges stem and deep roots etc. ● Excess pressure of tyre may cause damage to tread/crown area. 	<ul style="list-style-type: none"> ● Don't run the tractor with high speed on sharp edges areas. ● Maintain appropriate pressure in tyres.
Damage of tyre due to less pressure	<ul style="list-style-type: none"> ● Less inflation pressure of tyre. ● Overload 	<ul style="list-style-type: none"> ● According to the load, pressure should be the tyres. ● Maintain appropriate pressure in tyres.

6.7 GENERAL SUGGESTIONS

- Always maintain proper inflation of tyres.
- Tyre should be ballast to over come the problem of slippage.
- Tractor should be park in shed area in order to avoid the direct contact of sun rays with tyres.
- If tractor is not in use for longer period then tyre should be jacked
- Avoid the contact of oil & grease with tyres.

6.8 CHECK WHEEL NUT BOLT

Check wheel nut of the front and rear wheel. Torque it as per specification.

- Wheel body on hub
- Rearwheel: 250 NM
- Front wheel: 150 NM

7. FRONT AXLE 4WD (OPTIONAL)

7.1 FRONT AXLE 4WD

The tractor is equipped with front live axle (Optional) for better traction and pulling where even required. The live 4WD axle is having a limited slip differential with final epicyclic hub reduction for durability. The 4WD engagement can be done by mechanical actuation of lever located on the lift side of operator seat. Ensure proper oil levels in differential & hubs during routine maintenance check as also specified in service intervals.

a. FILLING & REPLACING FRONT AXLE OIL

Align the hubs in horizontal position as marked on the hub (A) for filling & replacing front axle oil.

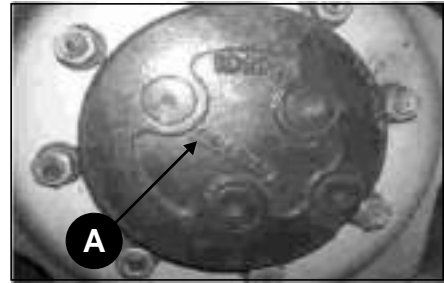

 WARNING	Do not operate 4WD axle high speeds.
--------------------	--------------------------------------

7.2 SWINGINING DRAW BAR

The tractor is equipped with swingining drawbar as conforming to ECE standard. Use correct position of bar i.e. it can be adjusted either telescopic way or can be tilted left or right. Remove the locking pins(1) to adjust the same.

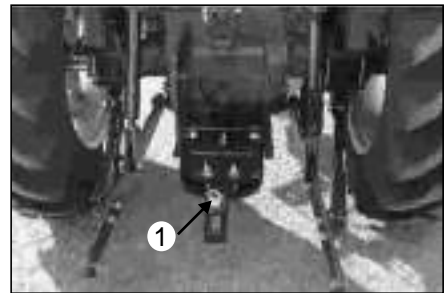

 CAUTION	For trail type implements always use the swingining bar to hitch them.
--------------------	--

7.3 Roll Over Protection

The objective of the frame is to protect the operator in the event of a roll over and they are designed to support the entire weight of the tractor in that event.

ROP frame is designed and has been tested to meet industry and or Government standards including ECE Norms.

Included in these tests were all mounting bases and bolts or other fasteners.

The ROPS frame has a fold down feature, which can be used to enter low buildings etc.

Take care when lowering the upper section of the ROPS frame and take extreme care while driving the tractor with the ROPS frame lowered.

Each ROPS has a separate serial no. Punch on the data plate which is affixed on the ropsframe as per ECE Norms.



7.4 Pneumatic trailer brakes (optional)

The tractor is equipped with Single line pneumatic brake system: i.e. when the braking is done via tractor service brakes, the air pressure in single line is cut off, the palm coupling end is connected to trailer end.



7.5 Pneumatic trailer brake components:

Compressor: - The compressor is mounted on engine and is reciprocating type.

Shut down the compressor when you are not using the trailer in order to increase the efficiency of engine.

Unloader valve: Unloader valve regulates the pressure in the system and maintains it at 8 bar.



Caution: Donot temper with unloader valve, get the pressure setting adjusted through authorized service centre or dealer only if there is any non-working of the valve.

Tank: - Before draining the water content, park the tractor on level ground then drain the water contents by opening the drain plug provided at bottom of tank.



Line filter: - Clean the filter depending on operating conditions - normally every 3 to 4 months. This requires taking the filter cartridge out and blowing it out with compressor air. Donot over tight the filter replaced the damaged filter cartridge.



7.6 HYDRAULIC TRAILER BRAKE (If Equipped)

This is mounted on RH side of tractor in front of brake pedal. This is provided to operate the Hydraulic bakes of trailer. It is actuated by the braked pedals of the tractors.

The adjuster nut can be adjusted for sensitivity of the trailer valve.



7.7 HYDRAULIC TRAILER BRAKE FREE PLAY ADJUSTMENT

Adjust the Actuator adjustor in such a way "that Actuator adjustor pin remain at lower side in slot of brake pedal and spherical pushing pin should remain in touch with Spool of Brake valve and finally fit split pin and plain washer after adjustment.

Note : During adjustment brake pedal should be in unoperating condition as well as there should not be any pressure on Spool of Brake valve.

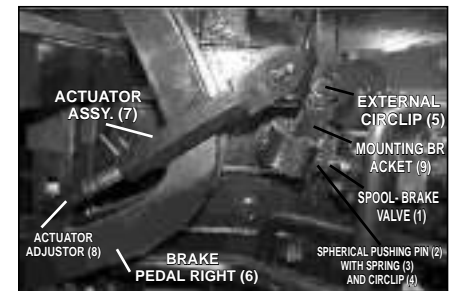

7.8 HYDRAULIC TRAILER BRAKE COUPLER

The Coupler is provided at the rear end of the tractor. The Trailer male Couple Should be attached at left side below seven pin socket with the female tractor coupler while the trailer is being towed on the road.

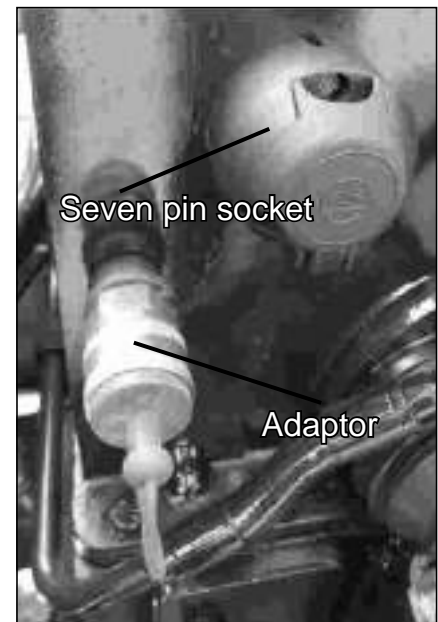

Always de couple the hydraulic trailer brake coupler before unhitching the trailer.

Gate valve: - Turn off the gate valve when you are not using the trailer



Palm coupling: - Make sure that the washer is clean and undamaged when connection is made. After that check the connection for proper seal.



Check points:- Check out the air leakage at specific joints, if present contact your authorized service station.

Air leakage in braking circuit will lead to unbalanced brakes and tyres wears out quickly.

Note:-

Make sure that before operating the trailer brake runs the engine idle for at least 15 minutes. Unloading valve is used to set the required pressure do not temper with it, on finding some disturbance contact your authorized service station.

8. OTHERS

8.1 REGISTRATION PLATE

A vehicle registration plate, usually called license plate or number plate for official identification purposes is mounted at the top of tail light of left/right side fender as per country rule.



8.2 LIGHTS

The vehicle is equipped with E marked front and rear tail lights.



8.3 REFLECTOR

A pair of rear tail reflections as per specification listed in the ECE standards.



8.4 EXHAUST MUFFLER

An under hood muffler with down ward/upward displacement exhaust pipe is fitted on the tractor.



8.5 HEAT INSULATION SHEET

The front hood is having a heat insulation/noise absorbing sheet fixed on the inner side of the bonnet for insulating the bonnet from the heat generated by engine.



8.6 PTO GUARD

For the operator safety the PTO is having guard with safety cover.

**8.7 DRIVER SEAT (E MARK)**

The operator seat conforms to the ECE standard and is having both horizontal as well as vertical adjustments. Further the safety belt is mounted on the seat.



8.8 RECOMMENDED SCHEDULE FOR MAINTENANCE SERVICE

MAINTENANCE INTERVAL (HRS)	EVERY 10	50	250	500	750	1000	1250	1500
SERVICE ITEM								
GENERAL								
COMPLETE WASHING	–	W	W	W	W	W	W	W
NIPPLE GREASING	–	G	G	G	G	G	G	G
COOLANT LEVEL & Top Up	C	C&P	C&P	C&P	C&P	C&P	C&P	C&P
AIR CLEANER								
AIR CLEANER OIL	C	R	R	R	R	R	R	R
AIR CLEANER ELEMENT(WET)	–	K	K	K	K	K	K	K
AIR CLEANER ELEMENT(PRIMARY)	–	K	K	R	K	R	K	R
AIR CLEANER ELEMENT(SECONDARY)	–	K	K	K	K	K	K	K
AIR INTAKE HOSE CLAMPS	T	T	T	T	T	T	T	T
ENGINE								
ENGINE VALVE CLEARANCE	–	A	A	A	A	A	A	A
ENGINE OIL	–	R	R	R	R	R	R	R
ENGINE OIL FILTER	–	R	R	R	R	R	R	R
ENGINE IDLE SPEED	–	C	C	C	C	C	C	C
FUEL INJECTION TIMING	–	C	C	C	C	C	C	C
BELL HOUSING NUT & BOLTS	–	I	I	I	I	I	I	I
COOLING SYSTEM								
FAN BELT TENSION	C	C&A	C&A	C&A	C&A	C&A	C&A	C&A
COOLANT SYSTEM FLUSHING	–	–	–	–	R	–	–	R
CLUTCH								
CLUTCH OPERATION & PEDAL FREE PLAY	C	C&A	C&A	C&A	C&A	C&A	C&A	C&A
TRANSMISSION/HYDRAULIC								
OPERATION OF GEARS	–	C	C	C	C	C	C	C
TRANSMISSION HYDRAULIC OIL	–	C	C	C	C	C	C	C
TRANSMISSION / HYDRAULIC OILFILTER	–	R	R	R	R	R	R	R
HYDRAULIC OIL STRAINER	-	K	K	K	R	K	K	R
TRANSMISSION BREATHER	K	K	K	K	K	K	K	K
OPERATION OF LIFT	–	C	C	C	C	C	C	C

MAINTENANCE INTERVAL (HRS)	EVERY 10	50	250	500	750	1000	1250	1500
SERVICE ITEM								
FUEL SYSTEM								
PRIMARY FUEL FILTER	–	–	R	–	R	–	R	–
SECONDARY FUEL FILTER	–	–	–	R	–	–	–	R
FIP FEED PUMP BOWL	K	K	K	K	K	K	K	K
FUEL SEDIMANTOR	D	D	D	D	D	D	D	D
INJECTOR PRESSURE & SPRAY	–	–	–	–	C	–	–	C
BRAKES								
BRAKE OPERATION & PEDAL								
FREE PLAY	C	C	C	C	C	C	C	C
BRAKE HOUSING/LINING	–	K	K	K	K	K	K	K
STEERING								
STEERING OPERATION	–	C	C	C	C	C	C	C
STEERING GEAR OIL LEVEL (MECH. & POWER STG.)	–	C&P	C&P	C&P	C&P	C&P	C&P	C&P
POWER STG. OIL TANK FILTER	–	R	K	K	K	R	K	K
POWER STG. OIL CHANGE	–	R	–	–	–	R	–	–
LINKAGES FOR PLAY	–	C	C	C	C	C	C	C
KING PIN	–	C	C	C	C	C	C	C
TOE IN	–	C&A	C&A	C&A	C&A	C&A	C&A	C&A
WHEELS & TYRES								
WHEELS NUTS & BOLTS	–	T	T	T	T	T	T	T
TYRES INFLATION	–	C	C	C	C	C	C	C
FRONT & REAR AXLE								
STUB AXLE GREASE	–	G	G	G	G	G	G	G
WHEEL BEARING GREASE	–	G	G	G	G	G	G	G
BATTERY								
BATTERY ELECTROLYTE LEVEL	C	C	C	C	C	C	C	C
BATTERY TERMINAL GREASE	–	G	G	G	G	G	G	G
ELECTRICALS								
FUNCTIONING OF OIL GAUGE	C	C	C	C	C	C	C	C
FUNCTIONING OF TEMPERATURE GAUGE	C	C	C	C	C	C	C	C

LEGANDS**A : ADJUST****K : CLEAN****D : DRAIN****T : TIGHTEN****P : TOP UP****C : CHECK****R : REPLACE****G : GREASE****W : WASHING**

Ü Engine Oil Grade should be selected as per operating Temperature condition

Ü Anti freeze should be used as per ambient temp.

Ü Clean Air cleaner element as and when required

8.9

ELECTRICAL WIRING CIRCUIT DIAGRAM

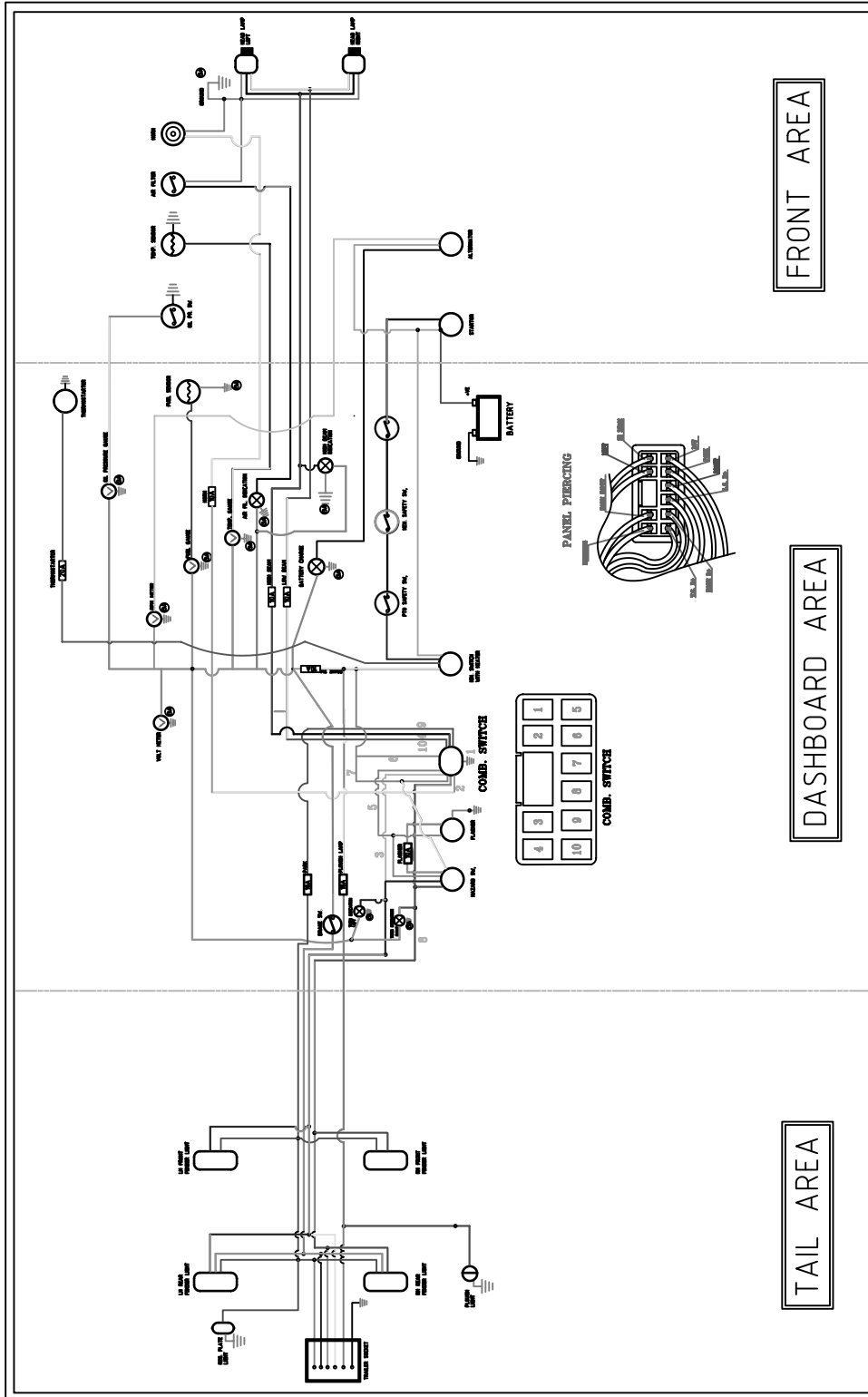

8.10 RECOMMENDED GRADE OF LUBRICANTS & GREASES

TRACTOR MODEL	SOLIS 50
DRIVE	2WD/4WD
ENGINE OIL	
QUANTITY (In Liters)	8.2
GRADE	(Sonalika Maxima Engine Oil) SAE 20W40
MANUFACTURER	Recommend by ITL
AIR CLEANER	DRY AIR CLEANER WITH CLOGGING SENSOR
BRAKES	
MAIN BRAKE	OIL IMMERSED BRAKE
HYDRAULIC SYSTEM & TRANSMISSION OIL	
QUANTITY (In Liters)	61
GRADE	ELF 2412
VENDOR	VALVOLINE / ELF
GREASE	
QUANTITY (In Kg.)	0.75

NOTE :- At level than gradient 18°, level of transmission oil should be increased by 5 ltr or as per requirement.

8.11 GREASING POINTS ON TRACTOR

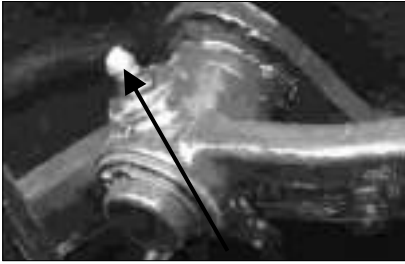

Center Pin (01pt.)

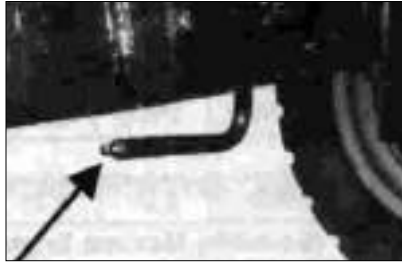

Center Pin

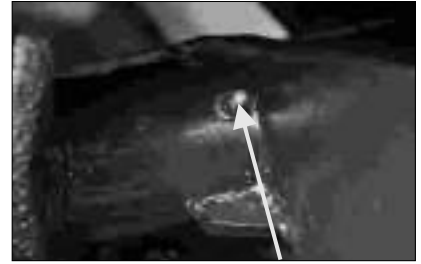

King Pin (Left / Right)



Front Wheel Hub (Left / Right)



Tie Rod (02pt.) (Left / Right)

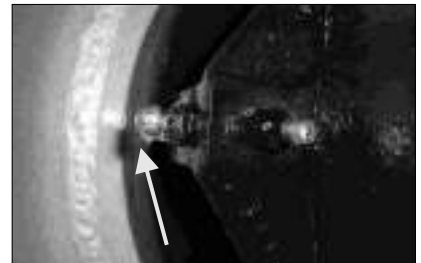

Trumpet plate cover (left(01pt.)
Right (02pt.)



Steering Arm (Left)



Steering Arm (Right)



Lift rod (Left lift rod (01pt) &
Right Lift Rod (01pt.)



Clutch actuator shaft (left (01pt.) Right (01Pt.)



Differential pedal (01pt.)

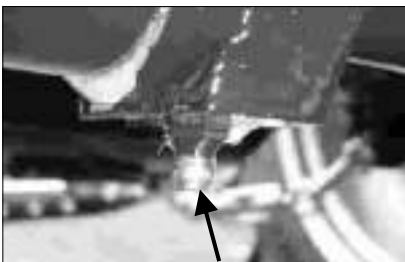

Brake Rod (05pt.) (Left)



Brake Rod (05 pt.) (Right)

9. WARRANTY POLICY

M/S International Tractor Limited, India warrant, subject as hereinafter provided that all new goods supplied by it are free from defects in material and workmanship. Its liability under such warranty being limited to making good any part or parts which shall within 42 Months from date of Bill of lading or 36 Months from date of delivery to first original retail purchaser or 2000 Hours which ever is earlier, which includes 12 months or 1000 Hours on complete tractor & additional 24 months or 1000 Hours on power train (Engine, gearbox, transmission & hydraulics). Warranty for proprietary items will be up to 12 months or 1000 working hours whichever appears earlier from the date of delivery to the first original retail purchaser. Claims will be settled against manufacturing defects by ITL as per their published warranty policy.

(A) TERMS AND CONDITION:

- ❖ During warranty period the Authorized Distributor will repair the Tractor by replacing the failed parts from their stock which are supplied by ITL against their order and lodge the claim within 60 days from the date of repair of Tractor.
- ❖ The claim will be settled as per ITL warranty policy.
- ❖ If any work is out sourced like welding, machining operation, transportation, labor charges etc will not be covered under warranty.

(B) EXCEPTIONS TO WARRANTY:

- ❖ Electrical fitment like Bulbs and Glasses do not come under warranty. At the time of delivery the customer should ensure that these things are in proper order because after that customer himself is responsible.
- ❖ Policy does not include replacement of Oil and Fuel filters, Oil and Lubricants, Nuts & Bolts, Plastic Material,
- ❖ Warranty for propriety articles like Fuel Injection Equipments Self starter, Alternator, Batteries, Tyres & Tube will be up to 12 months or 1000 working hours whichever appears earlier from date of sale to the original retail customer & shall be settled as per terms & conditions of the concerned manufacturer provided the repairable items have not been repaired from any other sources.
- ❖ Distributor will deliver the tractor with complete oil level as per standard. In case of any seal leakage, customer will have to bear the cost of oil.
- ❖ Warranty of normal wear and tear of the components; however ITL will discuss premature or epidemic on case by case basis.
- ❖ Parts lost in field are not covered under warranty.
- ❖ Warranty is not applicable
 - o If tractor used overloaded, over heated, driver negligence, unauthorized modification, untimely servicing, poor maintenance or tractor met with an accident.
 - o Tractor has crossed the warranty period.
 - o In case of late submission of warranty claim. (The claim must be submitted within 60 days from the date of repair).
 - o If defective parts not available inspection. ITL can request parts within 90 days from date of submission of warranty claims.
- ❖ Once a Tractor is purchased / delivered, it will not be returned or replaced. It will be repaired only as per ITL warranty policy.
- ❖ Warranty applicable only to first retail purchaser.
- ❖ This policy ceases if the components show mishandling, modification, neglect of slight defect, overloading, overheating, poor maintenance or use of incorrect grade of oil.
- ❖ The warranty becomes inoperative if the tractor is repaired/ dismantled in an unauthorized workshop and use of replacement parts, not supplied/approved by ITL.
- ❖ ITL's responsibility is limited to the terms of the warranty and it shall not be answerable for personal injuries or consequential or resulting liability, damage or loss arising from any defects.

(C) - WARRANTY CLAIMS SUBMISSION: -

Authorized Distributor will submit the warranty claim form by filling all column duly signed & seal by Distributor with customer signature, along with following documents:

1. Photograph of failed component with Chassis/Engine number written with paint
- ❖ Claims will not be entertained under warranty if received with incomplete information and without supporting documents.
 - ❖ All warranty claims along with supporting documents must reach Exports Department within 60 days from date of repair of Tractor thru courier/ e-mail.
 - ❖ As a proof of repair / replacement being carried out, a computer print out of buyer acceptance is a must & the distributor needs to keep an acceptance letter duly signed by buyer in their records for 6 months to be cross checked by ITL randomly for audit purpose
 - ❖ Distributor must provide the Installation certificate copy with in 30 days from the date the tractor is delivered to customer, for reference of ITL during warranty settlement. The claim of tractor for which installation certificate is not submitted, warranty claim shall not be settled.

(D) - STORAGE OF DEFECTIVE PARTS: -

All failed parts pertaining to warranty replacement are property of ITL & must be retained with distributor at least for 90 days from date of submission of warranty claims with proper tagging & packing for further Inspection/investigation by ITL Engineer. These can be called back to ITL works if necessary for investigation at ITL expense.

(E) - SETTLEMENT OF WARRANTY CLAIM: -

Claim will be settled within 30 days from date of submission of warranty claim as per ITL warranty policy by our warranty division and reimbursement of parts value as per latest prices (applicable import price at the time of repair of tractor) + 10% as freight component will be credited in Distributor account within 45 days of submission of warranty claim.

Address for submission of warranty claims: -

**To,
Exports Department
INTERNATIONAL TRACTORS LTD,
Village- Chak Gujran,
P.O.- Piplanwala-146022.
Jalandhar Road,
HOSHIARPUR (Punjab) INDIA.
Tel No +91-1882-302525 / 526
E- Mail exports@sonalika.com**

10. TROUBLE SHOOTING

PROBLEM	POSSIBLE CAUSE	REMEDY
ENGINE		
Engine not starting	Wrong way of starting engine	Use proper way of starting
	No fuel	Check oil level
	Air trapped in fuel system	Bleed the fuel system
	Checking of fuel system	Contact your dealer
	Fuel injector faulty	Replace
	Pull to lever knob in pulling condition	Return it to its proper position
	Fuel filter choke	Replace filters
Engine not run in proper way	Fuel filter choke	Replace filters
	Low quality of oil	Drain diesel from tank and fill clean diesel
	Choking of fuel system	Check fuel system
	Fuel injectors faulty	Replace fuel injector
More oil consumption	Oil level is more than maximum level	Keep oil level up to mark
	Oil quality is not good	Use genuine oil
Engine not giving maximum power	Leakage of oil	Check and repair
	Heavy load on engine	Decrease load or shift in low gear
	Air cleaner dirty	Clean air cleaner
	Fuel filter choke	Replace filter
	Engine overheating	Check cooling system
	Engine operating temperature is less	Check thermostat
	Valve clearance not proper	Adjust through authorized dealer.
	Throttle system not working properly	Check & repair through authorized dealer.
Engine abnormal noise	Oil level less	Top up
	Oil pressure less	Check through authorized dealer
	Engine is overheated	Check and find reason
	Improper tappet setting	Adjust through authorized dealer
Oil pressure gauge shows warning	Oil level is less	Top up oil up to level
	Oil quality is not good	Use genuine engine oil
	Oil pump not working	Check and repair through authorized dealer
Engine Over Heating	Radiator cap faulty	Replace with new one
	Choked radiator fins	Clean it
	Engine gets overload	Decrease load or shift to low gear
	Oil level is less	Top up to level
	Coolant level is less	Check level and leakage of system and top up
	Slippage of fan belt	Check belt tension
	Thermostat faulty	Replace
	Choking of cooling system	Clean the cooling system
	Water temp. Gauge not working	Check through dealer and faulty replace

PROBLEM	POSSIBLE CAUSE	REMEDY
ENGINE		
More Fuel Consumption	Air cleaner is dirty / choked	Clean air cleaner
	Overloading of engine	Reduce load or shift to low gear
	Improper valve clearance	Check and adjust
	Implement setting improper	Adjust it and take instrument from dealer for right option.
	Less engine temp	Check cooling system
	Fuel injection nozzle faulty	Check and service through dealer
HYDRAULIC		
Excessive Heating Of Oil	Improper inflation pressure	Check and adjust according to specified
	Oil level is high or less	Check and maintain proper level
	Hydraulic filter element choked	Replace
	Mechanical linkage may faulty	Contact your authorized dealer
Linkage Goes Down Slowly	Bush tight	Contact your authorized dealer
	Response valve setting improper	Contact your authorized dealer
Linkage Not Lift Fully	Improper lift arm setting	Contact your authorized dealer
	Improper internal adjustment	Contact your authorized dealer
Three Point Linkage Not Respond To Lifting While Operating Hydraulic Lever	Linkage connection not joint properly	Contact your authorized dealer
	Heavy load on linkage	Contact your authorized dealer
Draft Control Fast	Draft / position control setting wrong	Contact your authorized dealer
	Implement not working well	Make correct adjustment of implement.
Hydraulic System Not Working Properly	Response valve setting very low	Check valve by your dealer.
	Oil level low	Check and top up
	Hydraulic filter choked	Replace filters
	Hydraulic system faulty	Check through authorized dealer
Draft Control Fast	Hydraulic pump not working	Contact your authorized dealer
Draft Control Fast	Draft / position control setting wrong	Contact your authorized dealer and check system
BRAKES		
Brakes Noisy While Applying Brakes Tractor Goes In One Side	Wrong adjustment of brakes	Check
	Both brakes are not set properly	Adjust

PROBLEM	POSSIBLE CAUSE	REMEDY
Brakes Works When Fully Pressed	Wrong adjustment of brake pedal	Check and Adjust.
ELECTRICAL		
Electrical System Not Working.	Battery terminal loose or rusting of terminal	Clean and tight the terminals
	Less specific gravity	Replace or fill electrolyte up to level
Starter Motor Not Working.	Battery terminal loose	Tightened
	Battery discharged fully	Recharge or replace battery
	Faulty starter motor	For repair contact your dealer
Battery Not Charging	Loose or rusted terminals	Clean and tight terminal
	Belt loose	Check belt tension
	Faulty battery	Replace

11. SPECIFICATION

S.No.	AREA	MAIN TECHNICAL DATA	
		SOLIS 50 2WD (Mech/Power Stg.)	SOLIS 50 4WD
1.	ENGINE		
	MAKE	SONALIKA	
	MODEL:	3102EL	
	TYPE	4 STROKE, DIRECT INJECTION,NA	
	CYLINDERS	3	
	DISPLACEMENT (CC)	2893 CC	
	BORE/STROKE	102/118 MM	
	MAXIMUM POWER Kw (Hp)	35.0 (46.91)	
	RATED SPEED	2100 RPM	
	IDLE SPEED	750(+/-50) RPM	
	MAX NO LOAD SPEED	2300(-50) RPM	
	MAX TORQUE SPEED	1200(+/-100)RPM	
	COOLING SYSTEM	WATER COOLED	
	FUEL INJECTION SYSTEM	DIRECT INLINE	
	AIR CLEANER	DRY AIR CLEANER WITH CLOGGING SENSOR	
SILENCER	DOWN DRAFT/ UPDRAFT UNDER HOOD MUFFLER		
EMISSION COMPLIANCE	TO MEETS CURRENT LEGISLATION OF EUROPEAN UNION STAGE III A		
2.	CLUTCH		
	TYPE	DUAL CLUTCH	
	DISC FACING	CERAMIC FOR DC	
	DISC SIZE	DUAL 280	
3.	TRANSMISSION		
	TYPE	CONSTANT MESH	
	REDUCTION TYPE	BULL PINION	
	NO OF SPEEDS	8+2	
	SPEEDS AT RATED ENGINE SPEED WITH 13.60X28 REAR TYRES & GEAR RATIO	GEAR	SPEED (Km/hr)
	FORWARD	LOW-1	1.77
		LOW-2	2.58
		LOW-3	4.34
		LOW-4	7.26
		HIGH-1	7.56
		HIGH-2	10.99
		HIGH-3	18.49
		HIGH-4	30.92
	REVERSE	LOW	2.27
	HIGH	9.68	
4.	POWER TAKE OFF		
	TYPE	TYPE I	
	MAX PTO POWER (KW/HP)	30.52/40.91	

S.No.	AREA	MAIN TECHNICAL DATA	
		SOLIS 50 2WD (Mech/Power Stg.)	SOLIS 50 4WD
5.	HYDRAULICS		
	PUMP CAPACITY	23.1 LIT/MIN FOR HYD AT RATED ENGINE RPM	
	LIFT TYPE	POSITION AND AUTOMATIC MIX CONTROL	
	LIFT CAPACITY (KG)	1200 AT THE ENDS OF LOWER LINK	1600
	AUXILIARY HYDRAULIC	HYDRAULIC TRAILER BRAKES 2 DA/ CONVERTIBLE TO SA	
6.	THREE POINT LINKAGE		
	TYPE	CAT 2	
	STABILIZERS	ADJUSTABLE STAY BAR	
7.	STEERING		
	TYPE	MECHANICAL / POWER STG.	POWER STG.
	STEERING WHEEL DIA (MM)	434	
	TURNING RADIUS		
	WITH BRAKES (M)	2.95	
	WITHOUT BRAKES (M)	3.64	4.72
8.	BRAKES		
	SERVICE BRAKE		
	TYPE	OIB (STD)	
	OPERATION	MECHANICALLY OPERATED	
	PARKING BRAKE		
	TYPE	MECHANICAL TYPE	
	OPERATION	HAND OPERATED	
9.	BODY & ERGONOMICS		
	PEDALS	CLUTCH AND BRAKE PEDAL FOOT OPERATED	
	GEAR SHIFT LEVERS	SIDE SHIFTER	
	DRIVER SEAT	E-MARKED ADJUSTABLE TYPE	
10.	ELECTRICALS		
	TYPE	12 V	
	BATTERY	12V, 88Ah	
	ALTERNATOR	12V, 36 Kw	
	STARTER MOTOR	12V, 2.7 KW	
	HEAD LAMPS	HIGH 60W / LOW 55W	
	PLOUGH LAMP	35W	
	GAUGES	CLUSTER WITH ELECTRICAL HOUR METER/RPMMETER, ELECTRICAL OIL PRESSURE GAUGE, VOLTMETER, ELECTRICAL TEMP GAUGE, FUEL GAUGE, INDICATOR SWITCH FOR HIGH BEAM ETC.	
11.	FRONT AXLE		
	TYPE	ADJUSTABLE TYPE	FIXED TYPE
	MAX PERMISSIBLE LOAD (KG)	1350	2080
12.	WHEELS & TYRES		
	FRONT	6.00 X 16	9.50x20
	REAR	13.6 X 28	
13.	INFLATION PRESSURE OF TYRES		
	IN kPa		
	FRONT (kPa)	250	
	REAR (kPa)	150	

S.No.	AREA	MAIN TECHNICAL DATA	
		SOLIS 50 2WD (Mech/Power Stg.)	SOLIS 50 4WD
14.	HEIGHTS(Kg) AND DIMENSIONS IN mm		
	OVERALL LENGTH (WITH LINKAGE)	3820	3780
	OVERALL WIDTH OF STANDARD TRACTOR	1790	1800
	GROUND CLEARANCE	441	330
	HEIGHTS MM		
	AT REAR VIEW MIRROR (WITH DOWN DRAFT SILENCER)	1840	1860
	WITH UP DRAFT SILENCER	2200	2340
	WHEEL BASE	1980	2175
	STD./MAX. FRONT TRACK (STD. TRACTOR)	1310	1530
	STD./MAX. REAR TRACK (STD. TRACTOR)	1420	1420
	WEIGHT (WITHOUT BALLAST)		
	FRONT	830	990
	REAR	1615	1680
	TOTAL	2445	2670
	RECOMMENDED MAX BALLAST (BALLAST WEIGHTS ARE NOT A PART OF STANDARD TRACTOR BUT CAN BE ORDERED AS OPTIONAL)	258 Kg. 6No's OF 31 Kg ON REAR SIDE & 72 Kg. ON FRONT SIDE	Front - 326 kg. cast iron 6 numbers of 31 kg. each, one no. of 72 kg. Rear - 2 no. of 34 kg. each
15.	CAPACITIES IN LITERS		
	FUEL TANK		55 HSD
	ENGINE SUMP		8.2
	AIR CLEANER		DRY TYPE
	TRANSMISSION CUM HYDRAULIC FLUID		60
	STEERING		0.6
	BARE RADIATOR CAPACITY		4.5
	TOTAL COOLANT		10.5
16.	RECOMMENDED IMPLEMENTS		
	1.		CULTIVATOR 11 TYNE
	2.		HARROW 8X8
	3.		MB PLOUGH TWO BOTTOM
	4.		DISC PLOUGH TWO BOTTOM
	5.		ROTAVATOR 5(FEET)
	6.		SINGLE TRAILER DOUBLE / SINGLE AXLE 5(TONNE)

* COMPANY RESERVE THE RIGHT TO CHANGE SPECIFICATIONS AND/OR FEATURES OF PRODUCTS WITHOUT NOTICE AT ANY TIME



International Tractors Limited
 Jalandhar Rd. Hoshiarpur- (Pb). 146 001
 Phones: +91-1882- 302220, 302221, 302223

1st First Service (Hours: 50-60) / (One Month)

Date: _____
 Dealer Code: _____
 Model: _____
 Chassis No. _____
 Engine No. _____
 HMR _____

I here by certify that the service has been carried out to my entire satisfaction as per company recommended schedule.

Owner / Operator signature
 Owner / Operator Name

Dealer stamp & signature:.....

Payment towards all consumables (All lub. /oils, bulb, etc.) will be borne by customer



International Tractors Limited
 Jalandhar Rd. Hoshiarpur- (Pb). 146 001
 Phones: +91-1882- 302220, 302221, 302223

2nd Second Service (Hours : 250-260)

Date: _____
 Dealer Code: _____
 Model: _____
 Chassis No. _____
 Engine No. _____
 HMR _____

I here by certify that the service has been carried out to my entire satisfaction as per company recommended schedule.

Owner / Operator signature
 Owner / Operator Name

Dealer stamp & signature:.....

Payment towards all consumables (All lub. /oils, bulb, etc.) will be borne by customer



International Tractors Limited
 Jalandhar Rd. Hoshiarpur- (Pb). 146 001
 Phones: +91-1882- 302220, 302221, 302223

1st First Service (Hours: 50-60) / (One Month)

Date: _____
 Dealer Code: _____
 Model: _____
 Chassis No. _____
 Engine No. _____
 HMR _____

I here by certify that the service has been carried out to my entire satisfaction as per company recommended schedule.

Owner / Operator signature
 Owner / Operator Name

Dealer stamp & signature:.....

Payment towards all consumables (All lub. /oils, bulb, etc.) will be borne by customer



International Tractors Limited
 Jalandhar Rd. Hoshiarpur- (Pb). 146 001
 Phones: +91-1882- 302220, 302221, 302223

2nd Second Service (Hours : 250-260)

Date: _____
 Dealer Code: _____
 Model: _____
 Chassis No. _____
 Engine No. _____
 HMR _____

I here by certify that the service has been carried out to my entire satisfaction as per company recommended schedule.

Owner / Operator signature
 Owner / Operator Name

Dealer stamp & signature:.....

Payment towards all consumables (All lub. /oils, bulb, etc.) will be borne by customer

JOB TO BE PERFORMED DURING 60 HOURS SERVICE

Operations	Check Points	Tick
Washing	Complete Tractor.	
Lubrication	Lubricate all grease nipples.	
Oil Change	(Sonalika Maxima) Engine Oil. Air cleaner oil.	
Check & Top up	Coolant Level. Electrolyte level of battery. Oil level in steering box.	
Check & Adjust	Tappet clearance. Brake & Clutch pedal free play. Belt Tension(10mm) Idle RPM/Max RPM.	
Check	Toe-In & Tyre pressure. Functioning of oil & temp. gauge. Air cleaner Oil /Air Filter Tightness of all bolts & nuts.	
Clean	FIP feed pump bowl. Vent plugs & terminals of battery. Air cleaner element Wet / Dry. Fuel Cock strainer. Water separator Lubrication oil filter & hyd. oil filter.	
Change	Engine & Bell Hsg M12*1.75*40	
Torquing	/M10*1.5 70/40 Nm Front axle bolts 140 to 150 NM	

JOB TO BE PERFORMED DURING 60 HOURS SERVICE

Operations	Check Points	Tick
Washing	Complete Tractor.	
Lubrication	Lubricate all grease nipples.	
Oil Change	(Sonalika Maxima) Engine Oil. Air cleaner oil.	
Check & Top up	Coolant Level. Electrolyte level of battery. Oil level in steering box.	
Check & Adjust	Tappet clearance. Brake & Clutch pedal free play. Belt Tension(10mm) Idle RPM/Max RPM.	
Check	Toe-In & Tyre pressure. Functioning of oil & temp. gauge. Air cleaner Oil /Air Filter Tightness of all bolts & nuts.	
Clean	FIP feed pump bowl. Vent plugs & terminals of battery. Air cleaner element Wet / Dry. Fuel Cock strainer. Water separator Lubrication oil filter & hyd. oil filter.	
Change	Engine & Bell Hsg M12*1.75*40	
Torquing	/M10*1.5 70/40 Nm Front axle bolts 140 to 150 NM	

JOB TO BE PERFORMED DURING 260 HOURS SERVICE

Operations	Check Points	Tick
Washing	Complete Tractor.	
Lubrication	Lubricate all grease nipples.	
Oil Change	(Sonalika Maxima) Engine Oil. Air cleaner oil.	
Check & Top up	Coolant Level. Electrolyte level of battery. Oil level in steering box.	
Check & Adjust	Tappet clearance. Brake & Clutch pedal free play. Belt Tension (10mm) Idle RPM/Max RPM.	
Check	Toe-In & Tyre pressure. Functioning of oil & temp. gauge. Air cleaner Oil/Air Filter Tightness of all bolts & nuts.	
Clean	FIP feed pump bowl. Vent plugs & terminals of battery. Air cleaner element Wet / Dry. Fuel Cock strainer. Water separator Lubrication oil filter & hyd. oil filter.	
Change	Engine & Bell Hsg M12*1.75*40	
Torquing	/M10*1.5 70/40 Nm Front axle bolts 140 to 150 NM	

JOB TO BE PERFORMED DURING 260 HOURS SERVICE

Operations	Check Points	Tick
Washing	Complete Tractor.	
Lubrication	Lubricate all grease nipples.	
Oil Change	(Sonalika Maxima) Engine Oil. Air cleaner oil.	
Check & Top up	Coolant Level. Electrolyte level of battery. Oil level in steering box.	
Check & Adjust	Tappet clearance. Brake & Clutch pedal free play. Belt Tension (10mm) Idle RPM/Max RPM.	
Check	Toe-In & Tyre pressure. Functioning of oil & temp. gauge. Air cleaner Oil/Air Filter Tightness of all bolts & nuts.	
Clean	FIP feed pump bowl. Vent plugs & terminals of battery. Air cleaner element Wet / Dry. Fuel Cock strainer. Water separator Lubrication oil filter & hyd. oil filter.	
Change	Engine & Bell Hsg M12*1.75*40	
Torquing	/M10*1.5 70/40 Nm Front axle bolts 140 to 150 NM	



International Tractors Limited
 Jalandhar Rd. Hoshiarpur- (Pb). 146 001
 Phones: +91-1882- 302220, 302221, 302223

3rd

Third Service (Hours: 500-510)

Date: _____
 Dealer Code: _____
 Model: _____
 Chassis No. _____
 Engine No. _____
 HMR _____

I here by certify that the service has been carried out to my entire satisfaction as per company recommended schedule.

Owner / Operator signature
 Owner / Operator Name

Dealer stamp & signature:.....

Payment towards all consumables (All lub. /oils, bulb, etc.) will be borne by customer



International Tractors Limited
 Jalandhar Rd. Hoshiarpur- (Pb). 146 001
 Phones: +91-1882- 302220, 302221, 302223

4th

Fourth Service (Hours : 750-760)

Date: _____
 Dealer Code: _____
 Model: _____
 Chassis No. _____
 Engine No. _____
 HMR _____

I here by certify that the service has been carried out to my entire satisfaction as per company recommended schedule.

Owner / Operator signature
 Owner / Operator Name

Dealer stamp & signature:.....

Payment towards all consumables (All lub. /oils, bulb, etc.) will be borne by customer



International Tractors Limited
 Jalandhar Rd. Hoshiarpur- (Pb). 146 001
 Phones: +91-1882- 302220, 302221, 302223

3rd

Third Service (Hours: 500-510)

Date: _____
 Dealer Code: _____
 Model: _____
 Chassis No. _____
 Engine No. _____
 HMR _____

I here by certify that the service has been carried out to my entire satisfaction as per company recommended schedule.

Owner / Operator signature
 Owner / Operator Name

Dealer stamp & signature:.....

Payment towards all consumables (All lub. /oils, bulb, etc.) will be borne by customer



International Tractors Limited
 Jalandhar Rd. Hoshiarpur- (Pb). 146 001
 Phones: +91-1882- 302220, 302221, 302223

4th

Fourth Service (Hours : 750-760)

Date: _____
 Dealer Code: _____
 Model: _____
 Chassis No. _____
 Engine No. _____
 HMR _____

I here by certify that the service has been carried out to my entire satisfaction as per company recommended schedule.

Owner / Operator signature
 Owner / Operator Name

Dealer stamp & signature:.....

Payment towards all consumables (All lub. /oils, bulb, etc.) will be borne by customer

JOB TO BE PERFORMED DURING 510 HOURS SERVICE

Operations	Check Points	Tick
Washing	Complete Tractor.	
Lubrication	Lubricate all grease nipples.	
Oil Change	(Sonalika Maxima) Engine Oil. Air cleaner oil.	
Check & Top up	Coolant Level. Electrolyte level of battery. Oil level in steering box.	
Check & Adjust	Tappet clearance. Brake & Clutch pedal free play. Belt Tension(10mm) Idle RPM/Max RPM.	
Check	Toe-In & Tyre pressure. Functioning of oil & temp. gauge. Air cleaner Oil /Air Filter Tightness of all bolts & nuts.	
Clean	FIP feed pump bowl. Vent plugs & terminals of battery. Air cleaner element Wet / Dry. Fuel Cock strainer. Water separator Lubrication oil filter & hyd. oil filter.	
Change	Engine & Bell Hsg M12*1.75*40	
Torquing	/M10*1.5 70/40 Nm Front axle bolts 150 to 180 NM	

JOB TO BE PERFORMED DURING 510 HOURS SERVICE

Operations	Check Points	Tick
Washing	Complete Tractor.	
Lubrication	Lubricate all grease nipples.	
Oil Change	(Sonalika Maxima) Engine Oil. Air cleaner oil.	
Check & Top up	Coolant Level. Electrolyte level of battery. Oil level in steering box.	
Check & Adjust	Tappet clearance. Brake & Clutch pedal free play. Belt Tension(10mm) Idle RPM/Max RPM.	
Check	Toe-In & Tyre pressure. Functioning of oil & temp. gauge. Air cleaner Oil /Air Filter Tightness of all bolts & nuts.	
Clean	FIP feed pump bowl. Vent plugs & terminals of battery. Air cleaner element Wet / Dry. Fuel Cock strainer. Water separator Lubrication oil filter & hyd. oil filter.	
Change	Engine & Bell Hsg M12*1.75*40	
Torquing	/M10*1.5 70/40 Nm Front axle bolts 150 to 180 NM	

JOB TO BE PERFORMED DURING 760 HOURS SERVICE

Operations	Check Points	Tick
Washing	Complete Tractor.	
Lubrication	Lubricate all grease nipples.	
Oil Change	(Sonalika Maxima) Engine Oil. Air cleaner oil.	
Check & Top up	Coolant Level. Electrolyte level of battery. Oil level in steering box.	
Check & Adjust	Tappet clearance. Brake & Clutch pedal free play. Belt Tension(10mm) Idle RPM/Max RPM.	
Check	Toe-In & Tyre pressure. Functioning of oil & temp. gauge. Air cleaner Oil /Air Filter Tightness of all bolts & nuts.	
Clean	FIP feed pump bowl. Vent plugs & terminals of battery. Air cleaner element Wet / Dry. Brake housing / lining. Fuel Cock strainer. Water separator	
Change	Lubrication oil filter & hyd. oil filter.	
Torquing	Engine & Bell Hsg M12*1.75*40 /M10*1.5 70/40 Nm Front axle bolts 150 to 180 NM	

JOB TO BE PERFORMED DURING 760 HOURS SERVICE

Operations	Check Points	Tick
Washing	Complete Tractor.	
Lubrication	Lubricate all grease nipples.	
Oil Change	(Sonalika Maxima) Engine Oil. Air cleaner oil.	
Check & Top up	Coolant Level. Electrolyte level of battery. Oil level in steering box.	
Check & Adjust	Tappet clearance. Brake & Clutch pedal free play. Belt Tension(10mm) Idle RPM/Max RPM.	
Check	Toe-In & Tyre pressure. Functioning of oil & temp. gauge. Air cleaner Oil /Air Filter Tightness of all bolts & nuts.	
Clean	FIP feed pump bowl. Vent plugs & terminals of battery. Air cleaner element Wet / Dry. Brake housing / lining. Fuel Cock strainer. Water separator	
Change	Lubrication oil filter & hyd. oil filter.	
Torquing	Engine & Bell Hsg M12*1.75*40 /M10*1.5 70/40 Nm Front axle bolts 150 to 180 NM	



International Tractors Limited
 Jalandhar Rd. Hoshiarpur- (Pb). 146 001
 Phones: +91-1882- 302220, 302221, 302223

5th Fifth Service (Hours: 1000-1010)

Date: _____
 Dealer Code: _____
 Model: _____
 Chassis No. _____
 Engine No. _____
 HMR _____

I here by certify that the service has been carried out to my entire satisfaction as per company recommended schedule.

Owner / Operator signature
 Owner / Operator Name

Dealer stamp & signature:.....

Payment towards all consumables (All lub. /oils, bulb, etc.) will be borne by customer



International Tractors Limited
 Jalandhar Rd. Hoshiarpur- (Pb). 146 001
 Phones: +91-1882- 302220, 302221, 302223

6th Sixth Service (Hours : 1250-1260)

Date: _____
 Dealer Code: _____
 Model: _____
 Chassis No. _____
 Engine No. _____
 HMR _____

I here by certify that the service has been carried out to my entire satisfaction as per company recommended schedule.

Owner / Operator signature
 Owner / Operator Name

Dealer stamp & signature:.....

Payment towards all consumables (All lub. /oils, bulb, etc.) will be borne by customer



International Tractors Limited
 Jalandhar Rd. Hoshiarpur- (Pb). 146 001
 Phones: +91-1882- 302220, 302221, 302223

5th Fifth Service (Hours: 1000-1010)

Date: _____
 Dealer Code: _____
 Model: _____
 Chassis No. _____
 Engine No. _____
 HMR _____

I here by certify that the service has been carried out to my entire satisfaction as per company recommended schedule.

Owner / Operator signature
 Owner / Operator Name

Dealer stamp & signature:.....

Payment towards all consumables (All lub. /oils, bulb, etc.) will be borne by customer



International Tractors Limited
 Jalandhar Rd. Hoshiarpur- (Pb). 146 001
 Phones: +91-1882- 302220, 302221, 302223

6th Sixth Service (Hours : 1250-1260)

Date: _____
 Dealer Code: _____
 Model: _____
 Chassis No. _____
 Engine No. _____
 HMR _____

I here by certify that the service has been carried out to my entire satisfaction as per company recommended schedule.

Owner / Operator signature
 Owner / Operator Name

Dealer stamp & signature:.....

Payment towards all consumables (All lub. /oils, bulb, etc.) will be borne by customer

JOB TO BE PERFORMED DURING 1010 HOURS SERVICE

Operations	Check Points	Tick
Washing	Complete Tractor.	
Lubrication	Lubricate all grease nipples.	
Oil Change	(Sonalika Maxima) Engine Oil.	
	Transmission oil	
	Air cleaner oil.	
Check & Top up	Coolant Level.	
	Electrolyte level of battery.	
	Oil level in steering box.	
Check & Adjust	Tappet clearance.	
	Brake & Clutch pedal free play.	
	Belt Tension 10mm	
	Idle RPM/Max RPM.	
Check	Toe-In & Tyre pressure.	
	Functioning of oil & temp. gauge.	
	Air cleaner, Oil/Air Filter	
	Tightness of all bolts & nuts.	
Clean	FIP feed pump bowl.	
	Vent plugs & terminals of battery.	
	Air cleaner element Wet / Dry.	
	Fuel Cock strainer.	
	Water separator	
Change	Lubrication oil filter & hyd. oil filter	
Change	Engine & Bell Hsg M12*1.75*40	
Torquing	/M10*1.5 70/40 Nm	
	Front axle bolts 150 to 180 NM	

JOB TO BE PERFORMED DURING 1010 HOURS SERVICE

Operations	Check Points	Tick
Washing	Complete Tractor.	
Lubrication	Lubricate all grease nipples.	
Oil Change	(Sonalika Maxima) Engine Oil.	
	Transmission oil	
	Air cleaner oil.	
Check & Top up	Coolant Level.	
	Electrolyte level of battery.	
	Oil level in steering box.	
Check & Adjust	Tappet clearance.	
	Brake & Clutch pedal free play.	
	Belt Tension 10mm	
	Idle RPM/Max RPM.	
Check	Toe-In & Tyre pressure.	
	Functioning of oil & temp. gauge.	
	Air cleaner, Oil/Air Filter	
	Tightness of all bolts & nuts.	
Clean	FIP feed pump bowl.	
	Vent plugs & terminals of battery.	
	Air cleaner element Wet / Dry.	
	Fuel Cock strainer.	
	Water separator	
Change	Lubrication oil filter & hyd. oil filter	
Change	Engine & Bell Hsg M12*1.75*40	
Torquing	/M10*1.5 70/40 Nm	
	Front axle bolts 150 to 180 NM	

JOB TO BE PERFORMED DURING 1260 HOURS SERVICE

Operations	Check Points	Tick
Washing	Complete Tractor.	
Lubrication	Lubricate all grease nipples.	
Oil Change	(Sonalika Maxima) Engine Oil.	
	Air cleaner oil.	
Check & Top up	Coolant Level.	
	Electrolyte level of battery.	
	Oil level in steering box.	
Check & Adjust	Tappet clearance.	
	Brake & Clutch pedal free play.	
	Belt Tension(10mm)	
	Idle RPM/Max RPM.	
Check	Toe-In & Tyre pressure.	
	Functioning of oil & temp. gauge.	
	Air cleaner Oil /Air Filter	
	Tightness of all bolts & nuts.	
Clean	FIP feed pump bowl.	
	Vent plugs & terminals of battery.	
	Air cleaner element Wet / Dry.	
	Fuel Cock strainer.	
	Water separator	
Change	Lubrication oil filter & hyd. oil filter.	
Change	Engine & Bell Hsg M12*1.75*40	
Torquing	/M10*1.5 70/40 Nm	
	Front axle bolts 150 to 180 NM	

JOB TO BE PERFORMED DURING 1260 HOURS SERVICE

Operations	Check Points	Tick
Washing	Complete Tractor.	
Lubrication	Lubricate all grease nipples.	
Oil Change	(Sonalika Maxima) Engine Oil.	
	Air cleaner oil.	
Check & Top up	Coolant Level.	
	Electrolyte level of battery.	
	Oil level in steering box.	
Check & Adjust	Tappet clearance.	
	Brake & Clutch pedal free play.	
	Belt Tension(10mm)	
	Idle RPM/Max RPM.	
Check	Toe-In & Tyre pressure.	
	Functioning of oil & temp. gauge.	
	Air cleaner Oil /Air Filter	
	Tightness of all bolts & nuts.	
Clean	FIP feed pump bowl.	
	Vent plugs & terminals of battery.	
	Air cleaner element Wet / Dry.	
	Fuel Cock strainer.	
	Water separator	
Change	Lubrication oil filter & hyd. oil filter.	
Change	Engine & Bell Hsg M12*1.75*40	
Torquing	/M10*1.5 70/40 Nm	
	Front axle bolts 150 to 180 NM	



International Tractors Limited
 Jalandhar Rd. Hoshiarpur- (Pb). 146 001
 Phones: +91-1882- 302220, 302221, 302223

7th **Seventh Service (Hours: 1500)**

Date: _____
 Dealer Code: _____
 Model: _____
 Chassis No. _____
 Engine No. _____
 HMR _____

I here by certify that the service has been carried out to my entire satisfaction as per company recommended schedule.

Owner / Operator signature
 Owner / Operator Name

Dealer stamp & signature:.....

Payment towards all consumables (All lub. /oils, bulb, etc.) will be borne by customer



International Tractors Limited
 Jalandhar Rd. Hoshiarpur- (Pb). 146 001
 Phones: +91-1882- 302220, 302221, 302223

7th **Seventh Service (Hours: 1500)**

Date: _____
 Dealer Code: _____
 Model: _____
 Chassis No. _____
 Engine No. _____
 HMR _____

I here by certify that the service has been carried out to my entire satisfaction as per company recommended schedule.

Owner / Operator signature
 Owner / Operator Name

Dealer stamp & signature:.....

Payment towards all consumables (All lub. /oils, bulb, etc.) will be borne by customer

JOBS TO BE PERFORMED DURING 1500 HOURS SERVICE

Operations	Check Points	Tick
Washing	Complete Tractor.	
Lubrication	Lubricate all grease nipples.	
Oil Change	(Sonalika Maxima) Engine Oil.	
	Air cleaner oil.	
Check & Top up	Coolant Level.	
	Electrolyte level of battery.	
	Oil level in steering box.	
Check & Adjust	Tappet clearance.	
	Brake & Clutch pedal free play.	
	Belt Tension(10mm)	
	Idle RPM/Max RPM.	
Check	Toe-In & Tyre pressure.	
	Functioning of oil & temp. gauge.	
	Air cleaner Oil /Air Filter	
	Tightness of all bolts & nuts.	
Clean	FIP feed pump bowl.	
	Vent plugs & terminals of battery.	
	Air cleaner element Wet / Dry.	
	Brake housing / lining.	
	Fuel Cock strainer.	
Change	Water separator	
	Lubrication oil filter & hyd. oil filter.	
Torquing	Engine & Bell Hsg M12*1.75*40	
	/M10*1.5 70/40 Nm	
	Front axle bolts 150 to 180 NM	

JOBS TO BE PERFORMED DURING 1500 HOURS SERVICE

Operations	Check Points	Tick
Washing	Complete Tractor.	
Lubrication	Lubricate all grease nipples.	
Oil Change	(Sonalika Maxima) Engine Oil.	
	Air cleaner oil.	
Check & Top up	Coolant Level.	
	Electrolyte level of battery.	
	Oil level in steering box.	
Check & Adjust	Tappet clearance.	
	Brake & Clutch pedal free play.	
	Belt Tension(10mm)	
	Idle RPM/Max RPM.	
Check	Toe-In & Tyre pressure.	
	Functioning of oil & temp. gauge.	
	Air cleaner Oil /Air Filter	
	Tightness of all bolts & nuts.	
Clean	FIP feed pump bowl.	
	Vent plugs & terminals of battery.	
	Air cleaner element Wet / Dry.	
	Brake housing / lining.	
	Fuel Cock strainer.	
Change	Water separator	
	Lubrication oil filter & hyd. oil filter.	
Torquing	Engine & Bell Hsg M12*1.75*40	
	/M10*1.5 70/40 Nm	
	Front axle bolts 150 to 180 NM	

CUSTOMER FEEDBACK CARD

Customer Name :

Address :

..... Phone (S).....

Chassis No. Engine No. Model :

Delivery Dealer Name

Delivery Dealer Code Delivery Date.....

S.No.	ANY PROBLEMS FACED WITH THE TRACTOR	Rectified (Yes/No)
1.		
2.		
3.		
4.		
5.		
6.		

2. EXPERIENCE WHILE TAKING DELIVERY FROM SHOW ROOM

	GOOD	FAIR	POOR
Hospitality	<input type="checkbox"/>	<input type="checkbox"/>	<input type="checkbox"/>
Clear explanation by Dealer's Staff on operation, features and maintenance of the Tractor	<input type="checkbox"/>	<input type="checkbox"/>	<input type="checkbox"/>
Cleanliness of Tractor at delivery	<input type="checkbox"/>	<input type="checkbox"/>	<input type="checkbox"/>
		YES	NO
Was there any undue delay in handing over your Tractor on the day of delivery		<input type="checkbox"/>	<input type="checkbox"/>

3. EXPERIENCE IN WORKSHOP

Name of Workshop : _____

City _____

	GOOD	FAIR	POOR
Hospitality	<input type="checkbox"/>	<input type="checkbox"/>	<input type="checkbox"/>
Quality of repair/Service	<input type="checkbox"/>	<input type="checkbox"/>	<input type="checkbox"/>
		YES	NO
Tractor delivered at promised time		<input type="checkbox"/>	<input type="checkbox"/>
Was post service follow up done		<input type="checkbox"/>	<input type="checkbox"/>

Suggestion if Any :

TO OPEN CUT HERE

INLAND LETTER CARD



TO OPEN CUT HERE

TO OPEN CUT HERE

SONALIKA INTERNATIONAL TRACTORS LIMITED

**Works : Village Chak Gujran, P.O. Piplanwala,
Jalandhar Road, Hoshiarpur, PUNJAB (INDIA)**

Phone : +91 1882 302-525/526

www.sonalika.com

(Do not write or print below this line) _____ PIN

1	4	6	0	2	2
---	---	---	---	---	---

SECOND FOLD

NO ENCLOSURES ALLOWED
WRITE PIN CODE IN ADDRESS
SENDER'S NAME AND ADDRESS

PIN

--	--	--	--	--	--

FIRST FOLD

International Tractors Limited

H.O.: Pankaj Plaza-1, Plot No.2, Karkardooma,
Commercial Complex, Delhi - 110 092, INDIA

Ph.: +91-11-45192200, 22373785

Works : Jalandhar Road, Hoshiarpur-146 022 (Pb.) India

Phone : +91-1882-302-525/526

web.: www.sonalika.com, E-mail : exports@sonalika.com