

**LOVOL TD Series wheeled tractor**

TD750/TD754/TD800/TD804/TD820/TD824/TD850/TD854/TD900/TD904/TD950/TD954/

TD1000/TD1004/TD1100/TD1104

**Operation Manual**

The People's Republic of China  
LOVOL HEAVY INDUSTRY CO., LTD.

## Product Identification Record Form

Product Grade	
Product model	
Factory No. of Complete Machine	
Engine Model	
Engine Factory No.	
Date of Purchase	
Place of Purchase and Contact Information	
User's Name	
Name of Manufacturing Plant	LOVOL HEAVY INDUSTRY CO., LTD.
Address of Manufacturing Plant	No.192, South Beihai Road, Fangzi District, Weifang, Shandong
TEL of Manufacturing Plant	

**Note:** 1. The user should fill in this form carefully when purchasing;  
2. The numbers in the table should be recorded fully (including letters).

LOVOL TD Series wheeled tractor

TD750/TD754/TD800/TD804/TD820/TD824/TD850/TD854/TD900/TD904/TD950/TD954/TD1000/TD1004/TD1100/TD1104

Operation Manual

LOVOL HEAVY INDUSTRY CO., LTD. of The People's Republic of China

\* \* \*

Format: 880×1230 1/16 No.: TL2-SM-02

Jan. 2015 Version 10 • Jan. 2015 First Printing.

# Instruction to the User

---

## User Notices

Dear users:

Thanks for your trust in our company and select our **LOVOL TD series wheeled tractors**. Please pay attention to the important information below for your correct, reasonable and efficient use of this machine.

1. It is necessary to read this manual carefully whether you have relevant driving experience or not before using this tractor and this will help you to operate it more reasonably and efficiently.
2. In order to bring you more economic benefits and prolong the machine's service life, please read carefully this Instruction together with the operation manual of engine and farm implements before using this machine. The specifications stipulated in the manual shall be strictly implemented to operate, maintain, service the tractor well for fully achieving the machine's operating performance.
3. It is prohibited to modify the machine randomly for this may affect its performance or cause accidents, and will lead to failure to provide after-sales service of repair, replacement or compensation.
4. Due to great differences in agricultural conditions from place to place, there may be differences in application, parameter and operating efficiency recommended in this Instruction, so please make a suitable selection according to actual situation.
5. This tractor can only be operated, maintained and repaired by those familiar with machine's characteristics and with relevant safe operation knowledge.
6. The driver must hold an applicable driver's license for agricultural vehicle and tractor issued by local traffic department.
7. Abide by the local safety regulations and road traffic rules at any time to avoid accidents.
8. Do not use the tractor beyond the regulations in this operation manual, otherwise, performance degradation or fault may occur.
9. This manual will help the driver gain high level operation and is not quality guarantee, of which content such as data, illustration and description etc. is only limited to operation, maintenance and repair.
10. In order to improve quality, working and safety performance of the machine, we will make relevant change in the design of certain parts when applicable, so the details and figures herein may be different from those of the physical object. Please understand that this manual is subject to change without prior notice.

#### Warranty Statement:

LOVOL's responsibilities under limited warranty

LOVOL H. I. has the responsibility and obligation to manufacture high-performance products, which, however, does not mean no material or process problems will occur. If the products from authorized dealers of LOVOL incur any quality or process problems during the warranty period, LOVOL H. I. and its authorized dealers will offer free repair services. Since products are used for different purposes in different regions, the specific warranty period shall be subject to the dealers' promises.

This chapter focuses on the illustration of the users' responsibilities and the manufacturer's disclaimers that apply to the users' operation of LOVOL H.I. equipment. You are advised to read this chapter carefully. For any doubt, please consult local authorized dealer.

#### User responsibilities:

1. Users shall timely inform LOVOL H. I. of the faults in the warranty period, and independently assume the expenses, so as to make the product stay in the "To be repaired" state;
2. Use and operate products correctly, and use the products within the specified capacity quota and application scope;
3. Maintain the products correctly.
4. Render complete purchase voucher and duplicate of delivery training sheet when applying for the warranty.

#### Disclaimer:

- 1) Premature abrasion and fault arising from improper operation and maintenance that exceed the specified operation scope of the instruction.
- 2) Fault and damage resulting from unauthorized refitting and improper disassembling.
- 3) Fail to render purchase voucher and duplicate of delivery training sheet.
- 4) Traffic accident and operation safety accident resulting from improper drive, operation and use, or associated losses incurred therein, such as property loss and casualties.
- 7) Damage due to force majeure.
- 8) Unauthorized repair
- 9) Faults resulting from use of other manufacturers' components in repair.
- 10) In principle, the wear parts or servicing parts (except defects before shipment) include but are not limited to parts below:

Clutch and brake frictionlining, filter (air, oil, fuel), bulb, glass products, lubricating & cooling fluid (except the use in authorized repair), belt, cutter blade, bucket tooth, injection nozzle, cover tire, and inner tube.

11) Those renovated products that have been determined as “totally damaged product”.

# Overview

---

## Overview

This operation manual introduces safety precautions, running-in of each part, use, technical maintenance, adjustment, failure and trouble shooting of **LOVOL-TD series wheeled tractors** in order to provide reference for the driver and maintenance personnel.



In this manual the safety warning symbol  represents important safety information. When this symbol appears, it warns you of the potential injuries; please read carefully the following information and inform other operators.



**Warning: it means the potential dangerous conditions which may cause death or serious injury if it is not avoided;**



**Attention: it means the potential dangerous conditions which may cause slight or moderate injury if it is not avoided;**

**Important: The items that may damage the machine or the environment.**

**Note: Gives the supplementary information.**

This Manual is an integral part of the product, and will be provided to the user along with the tractor. Please keep it properly.

When anything is unclear during application of this Manual, please call service hotline to consult.

Hotline: +86(536)7638885

## Intended Use

This **LOVOL-TD series wheeled tractor** is a type of multipurpose large-sized farm-oriented tractor, which is characterized by compact structure, handiness, flexible steering, big traction force, widely use and easy maintenance. It can be used for plowing, harrowing, sowing, harvesting and other operations if equipped with the appropriate farm tools, for agricultural transportation if equipped with a trailer with a trailer-tractor ratio (the ratio of the total mass of trailer to that of the tractor)  $\leq 3$ , for returning straw to field through its PTO shaft connected to a field straw chopper, and for motive power of a pumper or thresher. Follow the

## Overview

---

requirements of this manual to equip agricultural implements (see Appendix 11-6) to obtain maximum economic benefits. The user shall strictly comply with the condition of use, maintenance and repair specified by the manufacturer as well as the basic requirements of the intended use. To use the machine in other operation is to violate the intended use of the tractor.

This tractor can only be operated, maintained and repaired by those familiar with machine's characteristics and with relevant safe operation knowledge.

Abide by rules and other safety regulations and road traffic rules at any time to avoid accidents.

The manufacturer is not responsible for reduced reliability, tractor damage or personal injury caused by any unauthorized restructuring or any operation contrary to the intended use of your tractor.

# Content

---

## Content

1 Safety precautions -----	1
1.1 General -----	1
1.2 Safety warning mark-----	11
2 Product Mark -----	17
3 Operation instruction -----	18
3.1 Product description -----	18
3.2 Tractor operation mechanism and instrument -----	18
3.3 Start of engine -----	26
3.4 Starting of tractor -----	28
3.5 Tractor Steering -----	29
3.6 Tractor gear shift-----	29
3.7 Operation of differential lock -----	31
3.8 Use of front drive axle -----	32
3.9 Brake of tractor -----	32
3.10 Tractor parking and engine flameout -----	33
3.11 Adjustment of wheel track -----	34
3.12 Use and disassembling of tires -----	39
3.13 Use of counterweight -----	40
3.14 Adjustment of Driver's seat -----	41
3.15 Tractor covering parts -----	42
3.16 Usage of tractor operation device-----	46
3.17 Running-in of tractor -----	65
3.18 Common fault and troubleshooting for tractor -----	69
4 Accessories, spare parts and quick-wear part -----	79
4.1 Accessories -----	79
4.2 Spare parts -----	80
4.3 Quick-wear Part -----	85
5 Maintenance instructions -----	87
5.1 Technical maintenance procedures -----	87
5.2 Technical maintenance operation -----	89



# 目录



---

5.3 Adjustment of Tractor Chassis .....	100
5.4 Adjustment of hydraulic suspension system .....	110
5.5 Precautions for use of full hydraulic steering system .....	115
6 Storage .....	117
<b>6.1 Causes of the damage during storage of the tractor .....</b>	<b>117</b>
6.2 Sealing up of tractor .....	117
6.3 Maintenance during the tractor's seal-up .....	118
6.4 Unpacking of tractor .....	118
7 Delivery, acceptance and transportation.....	120
7.1 Delivery and acceptance .....	120
7.2 Transportation .....	120
8 Technical specifications .....	122
8.1 Product model .....	122
8.2 Product Technical Specifications .....	122
9 Disassembly and disposal .....	131
10 Warranty item .....	132
10.1 Product warranty basis .....	132
10.2 Cases not covered by the warranty .....	132
11 Appendix .....	133
11.1 Oil and solution used on the tractor .....	133
11.2 Tightening torque table for main bolt and nut .....	135
11.3 Framework oil seal .....	136
11.4 Rolling bearing .....	136
11.5 Rubber O-ring .....	138
11.6 Supporting farm implements for LOVOL TD series tractor .....	139
User Information Feedback Form .....	144
Delivery training sheet –tractor .....	146
Compulsory warranty service sheet –tractor .....	150

# 1 Safety precautions

## 1.1 General

Before using this machine, the operating manual must be read carefully and completely understood in order to guarantee safety during operation. After mastering the using method, and then perform actual operation. Attention must be paid to the notices mentioned below and the important items related to safety such as

 Warning,  Attention, Important reminder and Note" etc.

### Read before operation

1. The driver must read and completely understand the operation manual and
2. The driver must remember correct operating and working methods.



Fig 1-1 Read before operation

### Qualified operator

1. When the driver operates the machine, he must have the ability of judgment.
2. Those who feel unwell, drunk, sleepy, pregnant, color-blind and below 18 years old are not allowed to operate this machine.
3. The driver must be specially trained, and has been granted with driving license and regular verification; He should strictly observe the traffic rules during driving.
4. For initial operator, please operate the machine at a low speed before being skilled



Fig 1-2 Qualified operator

### Driver's clothes

1. When operating, the driver is not allowed to wear proper tight overalls, loose coat and shirt, tie, scarf or necklace. If a female driver has long hair, please tie it up.
2. When working near the operating tractor or components, please tie hair up, and do not wear tie, scarf or necklace for personal injury may be caused if these items are entangled. Personal injury may be caused if these items are entangled.
3. Wear safety helmet, safety goggles and gloves, safety shoes and so on as needed.



Fig 1-3 Driver's clothes

### Use of Fuel

1. Fuel is inflammable. Stay away from fire when fueling.
2. Engine must be stopped before adding fuel into the fuel tank.
3. When fueling and checking the fuel system, it is prohibited to smoke or be close to the fire.
4. Keep the machine free of accumulated dirt, grease and scrap; when fuel or engine oil overflows, please wipe it with a clean rag.
5. Fuel and lubricating oil quality must strictly comply with the requirements set out in the “Appendix”.



Fig. 1-4 Usage of fuel

### Safely replace the work fluid

1. Work fluid is dangerous, which may lead to personal injury, such as high pressure hydraulic oil , brake fluid and engine oil.
2. Shutdown the engine before replacing work fluid. Don't set off firework and smoke. Please wipe the overflowed work fluid with a clean rag.
3. Replace the work fluid according to the specified grade.
4. Replaced working fluid is waste oil which cannot be discarded at will.

### Precautions on tire maintenance

1. Installing and removing tires not according to regular operation process may lead to explosion, causing severe injuries. If you have not proper equipment and safety work experience, do not install or remove the tire.
2. Tire charging pressure must be kept correctly, and it should not exceed the specified max charging pressure. Otherwise, crack of tire edge or even explosion can occur. When it reaches the recommended charging pressure, if the tire edges on both sides are still not fixed, air must be bled. Then refix the tire, lubricate the edges and charge the tire again.
3. Regularly inspect, retighten the tightening torques of fixing nuts and bolts of front and rear rims to avoid that the machine may turn over or be excessively damaged and the operator may be severely injured due to tire's dropping off.

### Disposal of waste oils and wastes

1. Improper handling of the waste oil and material may damage the environment and ecology.
2. When discharging the waste oil, leak-proof container shall be used. It is prohibited to use packaging food and drink container so as not to drunk by mistake to cause accident injury.
3. It is prohibited to pour the waste oil on the ground or into the sewer, or discharge it into other water sources.
4. Do not discard engine oil, fuel, coolant, brake fluid, filter element or battery that has potential hazard

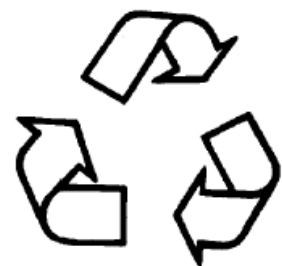

Fig. 1-5 Disposal of wastes

randomly. Please consult the local environmental protection department or recycling centre to recycle or dispose the waste in the right way.

### **Under electric wire of power for life and industry**

1. Ensure that each part of the machine has been fixed securely so as to prevent it from looseness or electric shock.
2. When passing through the electric wire of power for life and industry at a low speed, ensure that the highest point of the machine conforms to the allowable safety height of electric wire to avoid scraping and electric shock.
3. The machine is prohibited to impact the high tension line when it is under transportation, working or shutdown status so as to avoid electric shock.

### **Correct Support of the Tractor**

1. To lower parts or appliances to the ground; if the tractor or its components must be raised, it needs to secure the support.

2. Do not use coal slag, (hollow) bricks, hollow tiles or other supporters which are possible to fragment under sustained pressure to support the machine.

3. Do not work under the tractor supported by one jack only.

4. Before operating the jack, you need to read and understand the entire contents of the manual. The overloading is strictly prohibited, and it can be used only on the rigid support surface to prevent personal injury or property damage.

5. When using the jack, it can only be supported on the left and right half shaft housings of the tractor rear axle and just below the front bracket, and cannot be supported on other parts.

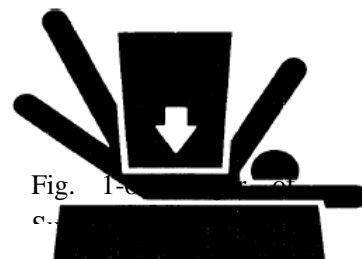

Fig. 1-7

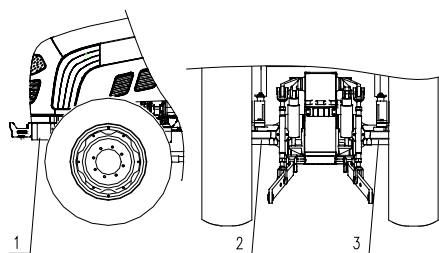

Fig. 1-7 Supported Parts of Jack

1. Front Bracket; 2. Left half shaft housing; 3. Right half shaft housing

### **Emergency exits in the Cab**

There are three emergency exits in the cab, namely the left and right doors and rear window. In case of emergency, you can lift the door unlock handle to open the door or rotate the rear window unlock handle clockwise, and open the rear window to leave the cab.

### **Avoid touching the running parts**

1. When the machine is running, do not lubricate, maintain, repair or adjust the machine; the above operations can be proceeded only after all the rotating machines stop moving.
2. Keep your hands, feet and clothes away from running transmission parts.



Fig. 1-8 Do not get close to the

### **Pay attention to the hydraulic pipelines**

1. The high-pressure hydraulic fluid has sufficient strength to penetrate and injure your hands, eyes and skins, so before inspecting and repairing hydraulic pipelines, you should relieve pressure on the hydraulic system, and then use cardboards or wood boards to check suspicious leaks so as to prevent your hands and body from being hurt by the high-pressure liquid.

2. If you are injured by the leaking hydraulic oil, immediately go to hospital for treatment. Failure to do so may cause serious infections and reactions.

3. Heating near the liquid pipelines with pressures will produce flammable sprays which will cause serious burns to you or bystanders. Do not heat near the pipeline. Use of electric welding, gas welding or welding torch for heating is prohibited in the vicinity of the pressurized fluid pipeline or other combustible materials, and heat radiation except for flame will cause accidental damage to the pipeline.

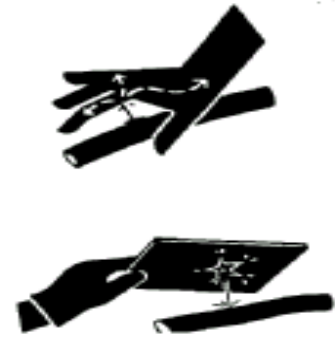

Fig 1-9 Leakage of hydraulic pipeline

### **Take Other Personnel Aboard**

1. It only allows the driver to operate on the machine; the machine without secondary seat is not allowed to take other personal, and the machine with secondary seat is allowed to take one other person aboard, but it should not appear any situation that interferes, influences or obstructs the driver's manipulative behavior.

2. Under the starting and working conditions of the machine, personals are not allowed to climb the machine up and down, and they should stay away from the machine to avoid being hurt.

### **Dealing with Emergency events**

1. In case of brake failure, it's required to stabilize the steering wheel, drive the vehicle to a safe place and shut down the engine immediately.

2. In case of steering wheel failure, it's required to depress the brake immediately and then shut down the engine.

3. A first-aid kit shall be kept near you at all times, and the emergency telephone numbers of emergency center, hospital and fire department shall be available at any time. Once an accident occurs, call the emergency center, hospital and fire department depending on the circumstance.

4. In order to ensure the personal safety of you and others, please don't risk driving or operating. Under the circumstance of the machine is well repaired and the surrounding environment is safe, the operator shall restart and have it move slowly.

5. In case of fire, you must shut down the engine immediately. Use fire extinguisher, if any, to spray towards the root of the flame; if no any fire extinguisher, the sands can be used for fire fighting.

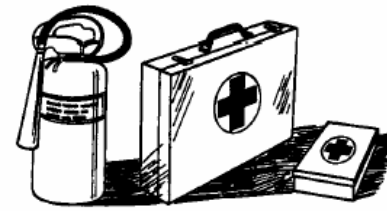

Fig. 1-10 Disposal of  
Emergency

### **Upon connecting with other devices or changing components for tractor**

1. When replacing the components, you must shut off the engine and stop the tractor in a safe place. Carefully read the safety warning mark and operating manual before replacing and ask the professional personnel to replace the components if necessary.

2. When the tractor is connected with other devices, the personal injury may be caused if lack of necessary experiences, therefore, the professional personnel shall be invited to execute such connection if necessary.

## Correct use of battery

1. The gas overflowing from the battery is dangerous, therefore, the battery shall be kept away from open fire (fire from match, lighter or cigarette, etc); the electric line shall not have a short circuit and generate spark.

2. The battery is only for starting the engine and not for other purposes.

3. When the battery is charged or changed, please read the notice label on the battery.

4. When the battery is removed, the bond strap connecting with negative terminal (-) shall be removed first. After battery is mounted, the cable connecting with positive terminal (+) shall be installed first.

5. When the battery is charged, it shall be removed from the machine.

6. Prior to charging, please check whether the vent hole on the battery cover is well ventilated, with ventilated surrounding environment.

7. Properly select charging current according to rated capacity of battery. After charging, please disconnect charging source first and disconnect cable from the terminal of battery in case the battery is detonated by electric firing.

8. Please don't use any other batteries other than the one designated by the machine.

9. It's very dangerous to contact electrolyte (dilute sulphuric acid). Promptly cleanse the eyes, skin & clothes with clean water in case of contacting the electrolyte solution; Flush the eye with water if it enters into the eyes and then go to the doctor immediately. The following measures shall be taken in order to avoid damage:

- ① Wear safety goggles and rubber gloves.
- ② Avoid breathing smoke generated by the electrolyte;
- ③ Prevent the electrolyte solution splashing or leaking.
- ④ Use correct parallel starting procedures.



Fig. 1-11 Use of battery



Fig 1-12 Danger of electrolyte

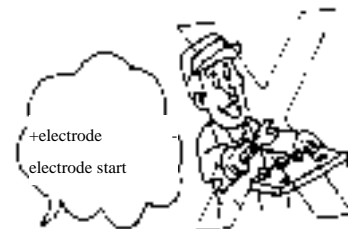

Fig. 1-13 Inspection of storage battery

## Ensure the correct installation of anti-turnover bracket

If the anti-turnover bracket is disengaged or removed due to any reason, please make sure that all the parts and components are reinstalled correctly. Tighten the fixed bolt to its correct torque. If the structure of anti-turnover bracket is damaged due to overturn accident and bending, its protection function will be influenced, so the damaged anti-turnover bracket must be replaced and not be used any more.

### **Correctly use the foldable anti-turnover bracket and safety belt**

1. If the tractor has foldable anti-turning rack, you must keep the anti-turning rack at full extending and lock position. If the anti-turnover bracket is working in the fold position, you must drive the tractor with care. If anti-turnover bracket in the fold position, seat belt is prohibited to be used.
2. When the tractor returns to normal operating condition, you must timely lift the anti-turning rack to full extending position and fix it. When the anti-turnover bracket is at full extending or lock position, you must use safety belt.
3. If damage appears on the fastener, buckle or shrinker, the safety belt must be replaced.
4. You shall always check the safety belt and its fastener. Check whether the fastener is loose or the safety belt is damaged, such as cutting port, scratch, and abnormal spoilage and wear.
5. If tractor doesn't have anti-turnover bracket or cab, safety belt is prohibited to be used.



Warning:

1. **Please operate safely for sake of your life, property security and family happiness.**
2. **When the tractor starts up, the attention should be paid to whether there is obstacle on path, anyone present between tractor and farm implements or trailer, to prevent from the sudden start of tractor, action out of control, which will cause the unexpected danger.**
3. **Do not leave the driver seat to start and operate the tractor. Ensure that various gear shift levers stay in the neutral position prior to the startup, and the power output shaft control handle and front drive axle control handle stay at the disconnecting position, the lifter control handle put in the neutral position, to prevent from the sudden start, which will cause the unexpected danger .**
4. **Do not start up the engine by the way of bridging over short circuit terminals, otherwise, the tractor will automatically lose control on driving and cause the accidental danger when the gearbox is engaged.**
5. **The pedal action should not have any hindrance; all the pedals must be free from obstacles and able to back on home position. On the floor and under the pedal, there must not be any things hindering the pedal travel. No rolling or slip objects may lay aside when stepping on the pedals. The extra foot blanket or other mats are not allowed to lay around the pedals, so as to avoid the influence on the pedal movement and cause the accidental risk.**
6. **While the tractor is moving, persons are not allowed to get on and off. During the running of engine, no check and repair by crawling under the bottom of the tractor are permitted to prevent from the accidental risk.**
7. **After parking and before getting down from the tractor, the driver must take out the key, set all shift levers on the neutral position, and lock up the parking-brake handle to prevent the tractor from the sudden startup, action out of control and accidental risk.**
8. **During the transportation, the L/R brake pedals must be interlocked together and control the speed reasonably. When crossing the tunnels and the bridges, full attention must be paid to whether the load is over the limited height. The sufficient deceleration must be made in advance while turning to avoid the accident, overturn and collision.**



9. When going uphill or downhill, the lowest gear must be used and reasonably use the accelerator to control . It is strictly prohibited for the tractor to shift on neutral gear or to glide downhill by stepping on the clutch pedal. It is strictly prohibited to shift the gear on an up and down slope so as to avoid the danger of overturn.

10. The sudden turn is not allowed while the tractor drives at high speed. Do not make the sudden turn by the unilateral braking so as to avoid the danger of overturn.

11. When driving the tractor on the road, attention should be paid to the traffic sign and the traffic law and rules should be strictly observed so as to avoid the accident.

12. In case of tractor displacement, the traffic rules should be strictly observed and the distance between two vehicles should be kept at least 60m to avoid the collision resulting from accident.

13. The roadbeds near ditches, caves and dams are more fragile, the tractor's weight possibly causes their crushes, please make a detour, and otherwise the accidental danger may arise.

14. The tractor is not allowed to be overloaded and overburdened. It is prohibited to run over limit duty, which may cause the machine damage, even the casualty of present persons.

15. When tractor works at night, the good lighting equipment must be provided so as not to influence the work efficiency of tractor and cause accidents.

16. When the tractor carries on the harvest or backyard work, the spark extinguish device must be fixed on the exhaust pipe, in order to avoid fire accident.

17. When working on a rainy day, the operation speed must be reduced to avoid the rollover risks due to the slippery path and ground.

18. When power output is working, the reliable connection and protection must be guaranteed to prevent the moving parts from shaking off and hurting persons.

19. When hitching and towing the attached tools, the reliable and fast connection of each pin roll must be guaranteed to prevent them from shaking off and causing the danger of collision. When disconnecting the hitching and towing tools, ensure that all pin rolls are in disengaged status to avoid the damage on the machine and human safety danger due to the misconnection.

20. When lifting, pay attention to the control of the engine throttle to avoid fast hoisting speed, which may damage the machine or endanger the personal safety.

21. During the battery charge, make sure that the air vent of filling plug is unimpeded and far away from the open fire. After charging, the power should be first cut off to avoid explosion.

22. The installation height allowed by the high voltage transmission line must be strictly observed, in order to avoid dangerous accident!

23. When the tractors is used for harvest ,threshing and inflammable goods transportation, it must be equipped with fire extinguisher so as not to avoid fire accident.

24. When tractor carries out transport operation, the user shall equip with fault warning marking board. When the tractor has present fault and needs to carry out repair, please place the warning marking board at least 30m behind the fault tractor to warn other vehicle for vehicle repair in the front so as not to occur danger.

**▲ Attention:**

1. Bolts, nuts and easy loose components on each joint, e.g. the nuts on the front/rear drive wheels and connecting nut of the steering draw rod should be frequently checked. If loose, screw it tightly to avoid dangerous accident.
2. When the power output shaft is working, the safety shield of power takeoff shaft has to be installed. Persons are strictly prohibited to approach the power takeoff shaft. When the power takeoff shaft is on load, the tractor is not allowed to make the sudden turn in order to avoid the damage on the universal joint or the power takeoff shaft; When the Power takeoff shaft is not in use, the handle should be made on separate position to avoid dangerous accident.
3. After stopping the tractor, the driver cannot leave the tractor before the engine is shut down, in order to avoid sudden start of the tractor, action out of control which may lead to accident.
4. When parking the tractor on the slope, the hand brake handle should be in active state, let the engine shut down, put on gear (Uphill position on front gear, downhill on reverse gear position), the parking brake must be used with triangle block chocking the rear wheels so as to prevent from tractor!/'s action out of control and the accidental risk.
5. The installation and adjustment of tires can be carried out by the experienced persons with special tool. The wrong installation of tires may cause serious accident.
6. When cleaning the water tank, clean work should be made after cooling down of water tank and engine flameout so as not to cause the scalding accident and damage to water tank.
7. Before the installation and use of optional parts, replacement parts or hitching implements, please be careful and carefully read the safety warning mark and the operation manual.

**Important:**

1. For the tractor from the new production or after the overhaul, the running-in has to be made according to the requirements of tractor's running-in so as to avoid affecting the normal service life of tractor.
2. The tractor should use various kinds of solution strictly according to the requirements. The fuel must be subject to at least 48h's (hours) sediment and purification process. Only having passed through the filtration by filter at the same precision as oil absorption filter of lifter, the lubricating oil in the transmission system can be added so as not to affect the service life of related part and operating performance of tractor.
3. Prior to the startup of tractor, the oil system, electric circuit and coolant have to be examined; After the startup, the attention has to be paid anytime to the readout of various instruments and the normal operation of each part.
4. Before the power takeoff shaft actuates the farm implements, the matching rationality between the tractor and driven farm implements should be inspected. When tillage is performed, the included angle between the power takeoff shaft and the universal joint drive shaft should not be bigger than 15° (degree); When the hydraulic operating control is normal, and after the farm implements has been lifted at the curve of field edge, the included angle between the power takeoff shaft and the universal joint

drive shaft should not be bigger than 20° (degree); It is prohibited to dig the rototiller into field prior to the power takeoff connection, for this will severely damage the rototiller and the tractors!/  
clutch [To increase the work efficiency, the power supply can not be shut off at the time of turning, however, the lifting height of tools must be maintained at ca. 200mm(millimeter) above the ground].

5. When the temperature in winter is lower than 0 (degree Celsius), the used so as not to freeze water tank, engine and etc.

6. The front drive axle of tractor can be used only at the time of farmland work, on muddy road and skidded tires; the use on other cases is not allowed, and otherwise it is easily to cause the premature wear of tire and the transmission system.

7. During the running process of tractor, the driver's feet are not allowed to place on the brake pedal or the clutch pedal so as to avoid the premature wear of the brake or the clutch.

8. When the tractor displaces with attached agricultural machinery, the upper lever of the suspension unit should be adjusted to the shortest condition, and the limit lever adjusted to prevent the agricultural machinery from swinging. At the meantime, the locking nuts of upper and limit levers must be tightly screwed to ensure driving security and avoid the damage risk on the machine and agricultural machinery.

9. When the tractor shifts with the farm implements hanging on it, the farm implements position should be fixed. The farm implements must be lowered to the ground when the driver leaves the tractor in order to avoid the damage risk on the machine and farm tools.

10. For the tractor maintenance, the qualified parts must be used so as not to affecting the normal service life of tractor.

### Twist off the radiator cap

When the engine remains on warm state, twist off the radiator cap with care. After several minutes idling, shut off the engine and cool it down, twist the radiator cap to the first gear position, and then take it out after the pressure has been reduced.



Fig.1-14 Twist off the radiator cap

### Maintenance of electric parts

1. Take out the electrical locking switch key.
2. Cut off the master switch of battery power and then repair the electric parts.
3. When using electric welding to repair the tractor, disconnect the battery ground wire. Unplug the big connecting wire of computer controller of engine hydraulic part, otherwise it may easily damage the battery, controller and combination instrument.



Fig. 1-15 Maintenance of electric parts

### In case of abnormal phenomenon occurring on the tractor

1. The tractor is not allowed to work “with defects”. In particular, when lack of oil pressure, excessively low oil pressure, over-high water temperature or unusual sound and smell occur, stop the machine in time for check and troubleshooting.
2. During the lubrication maintenance and adjustment on field, the engine should be shut down.



Fig. 1-16 In case of abnormal phenomenon occurring on the tractor

### Safety rules of unattended tractor

- 1 Shift to neutral position and move the hydraulic control handle to middle position.
2. Lifting device or traction articulated device is placed at the lowest position.
3. Engage parking brake.
4. Take down engine switch key.
5. If the tractor is stopped on the slope, a triangle stopper must be used to stop the rear tire.

## 1.2 Safety warning mark

 Warning:

1. The safety warning marks should remain clear and easy to read. When dirty, wash them with soapy water and clean them with soft rag;
2. When the safety warning marks are lost or unclear, it is necessary to contact the sales department or the manufacturer in time for replacement.
3. In case of replacing the parts with attached safety warning mark, the replacement of safety warning mark should be made at the meantime.
4. The safety warning mark, where the prompts involve to the personal safety, must be strictly complied.



Meaning: When the tractor is working, keep away from its hot surfaces to avoid personal injury;

Pasting position: Outer side of damper, flank of water tank.

Fig 1-17 Safety warning mark IV



Meaning: Keep a safe distance from the tractor to avoid personal injury;  
Pasting position: rear side of mudguard.

Fig 1-18 Safety warning mark II



Meaning: Do not ride in a place other than passenger seat to avoid obstructing the driver's line of sight, causing personal injury;

Pasting position: Front side of the left and right mudguard.

Fig 1-19 Safety warning mark VI



Meaning: When the lifting rod control mechanism works, stay far away from the effective space of lifting lever, so as to avoid personal injuries!

Pasting position: rear side of mudguard.

Fig 1-20 Safety warning mark III



Meaning: Before repair, maintenance and adjustment, shut off the engine and remove the ignition key in accordance with the requirements of the operation manual to avoid personal injury;

Pasting position : the front of the instrument panel

Fig 1-21 Safety warning mark I

Meaning: when the engine is running, do not open or remove the protective cover and do not reach into the working area to avoid personal injury;



Pasting position: on the engine hood

Fig 1-22 Safety warning mark IX



Meaning: The driver must start the engine on the driver's seat. Do not start the engine in a short-circuited manner at the starter to avoid injury;  
Pasting position : the front of the instrument panel

Fig 1-23 Safety startup mark



Meaning: Please read the manual to understand the meaning of the non-lettered safety symbol so as to avoid personal injuries.  
Pasting position : the front of the instrument panel

Fig 1-24 Read the manual mark

Meaning: Only when all parts of machine have fully stopped can it be contacted so as not to cause personal injury.



Pasting position: On the PTO protective cover.

Fig 1-25 PTO safety mark



Meaning: When maintaining the battery, please refer to the operation manual for correct maintenance process to avoid personal injury.  
Pasting position: On the surface of the battery

Fig 1-26 Battery mark

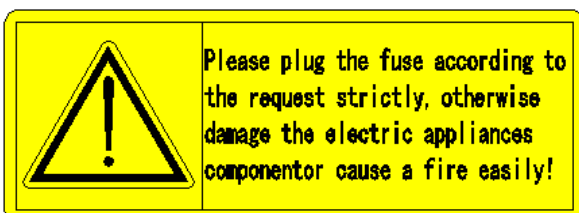

Meaning: See Fig. 1-27

Pasting position: Near the electric box

Fig 1-27 Fuse safety warning mark



Guard against fire:  
1. Don't fuel at the working site or the tractor running.  
2. Please keep away the fire when fueling.  
3. Please clear the oil stains on the tank surface.  
4. When the harvester is mounted on the tractor, don't smoke at the working site and on the tractor.

Meaning: See Fig. 1-28

Pasting position: Near the oil filler of fuel tank

Fig 1-28 Fuel filling anti-fire mark



To avoid personal injury, install safety cover or PTO while it is not used

Meaning: See Fig. 1-29

Pasting position: Near the power output shaft

Fig 1-29 PTO safety mark



For avoiding failure of brake apparatus, when the tractor works over 50 hours, please drain out the wasted water from the air vessel.

Meaning: See Fig. 1-30

Pasting position: Surface of air brake tank

Fig 1-30 Air brake warning mark



Meaning: See Fig. 1-31

Pasting position: Rear transverse board, floor

Fig 1-31 Safety warning mark IX



Meaning: See Fig. 1-32

Pasting position: Near the steering fluid tank

Fig. 1-32 Fluid level marking



Meaning: See Fig. 1-33;

Pasting position : the front of the instrument panel

Fig 1-33 Safety starting warning mark IX



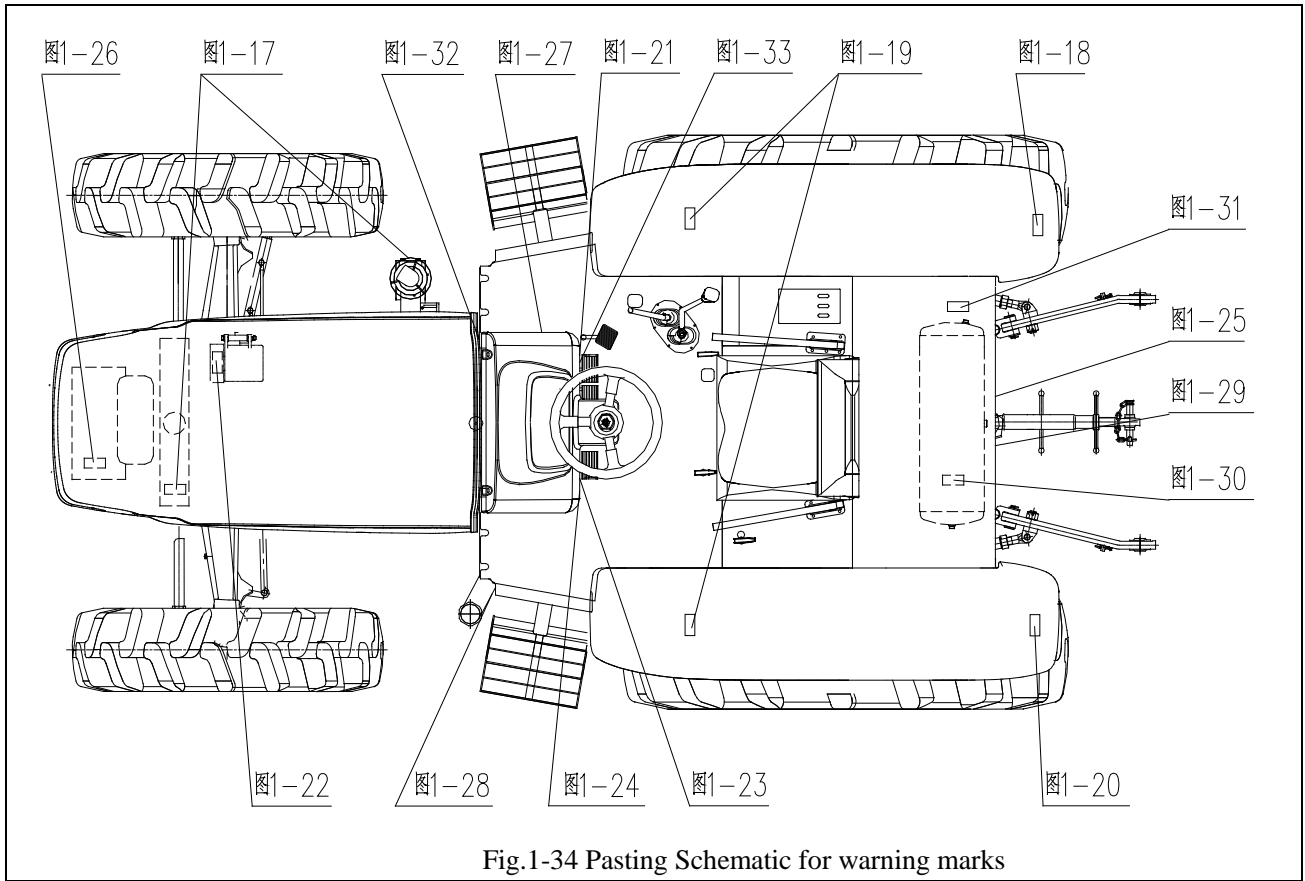

# Product Mark

## 2 Product Mark

### Product nameplate

The product nameplate is an important valid identification for tractor, and it is located at the left of instrument panel. When receiving the after-sales service, the service staff shall check the nameplate, so please don't damage or lose it, and do keep its content clear.



1. Product nameplate  
Fig. 2-1 Product

### Engine information

The nameplate of the engine, an important and valid identification mark for the tractor's supporting power unit, is located under the tractor hood, as shown in the figure. When receiving after-sale service, the service staff may check the nameplate, so please don't damage or lose it, and do keep its content clear.



1- Engine nameplate  
Fig. 2-2 Engine nameplate

### Type and factory No. of complete machine

As the tractor leaves the factory, the model and factory No. of the complete machine should be engraved or printed at the left side of gearbox housing, the detailed position is as shown in the figure.



1-Complete machine No.  
Fig. 2-3 Factory No.

# Operation Instructions

## 3 Operation instruction





**Attention: Correct operation of the tractor can give full play to its efficiency, reduce wears and prevent accidents so that the operator could achieve high-quality, efficient, low-cost and safe field and road work.**

Table 3-1 Commonly Used Symbols

Symbol	Meaning	Symbol	Meaning	Symbol	Meaning
	Safety alert symbol		Four-wheel drive		Horn
	High beam lamp		Low beam lamp		Fast
	Engine oil pressure		Battery charging condition		Slow
	Steering indicator		Scrubber		Position lamp
	Engine preheating		Rear wiper		Wiper
	Air filter blocking alarm		Oil filter blockage alarm		Air brake failure / fault
	Engine coolant temperature		Fuel level		Parking brake

## Operation Instructions

	Differential lock		Hazard indicator light		Brake fluid level alarm
---	-------------------	---	------------------------	---	-------------------------

### 3.1 Product description

This manual introduces the use, technical maintenance, adjustment, faults and troubleshooting of the **LOVOL-TD wheeled tractor**.

**LOVOL-TD series wheeled tractor** is a multi-purpose large scale agriculture tractor. It is featured with compact structure, easy operation, flexible steering, high towing force and convenient maintenance etc.

### 3.2 Tractor operation mechanism and instrument

#### 3.2.1 Tractor operation mechanism

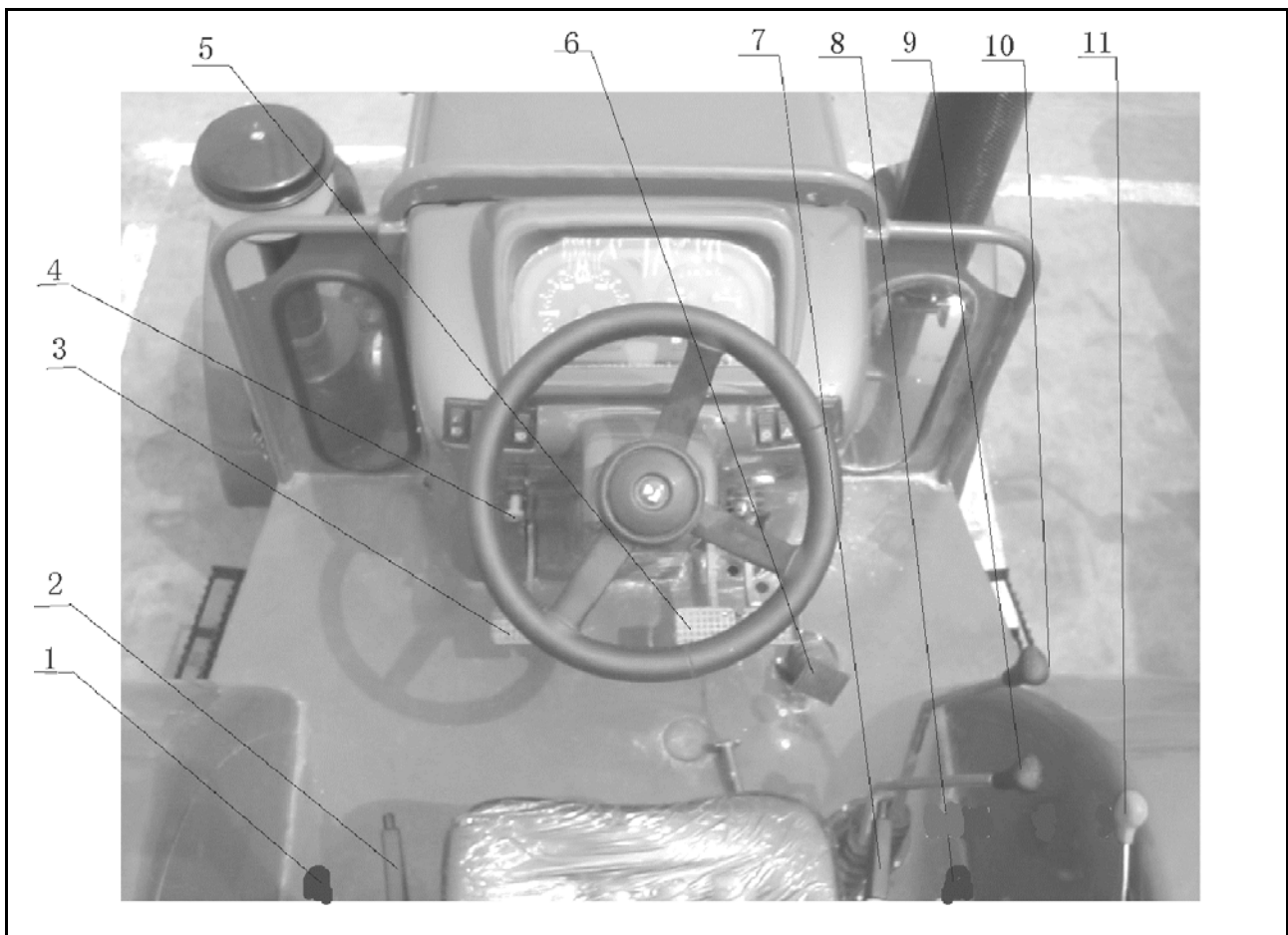

Fig. 3-1 Tractor operation mechanism

1. PTO control handle;
2. Parking brake control handle;
3. Main clutch pedal;
4. Flameout pull wire handle
5. Right and left brake pedal;
6. Foot accelerator control pedal;
7. Auxiliary clutch control handle;
8. Distributor control handle
9. Main gear lever;
10. Auxiliary gear lever;
11. Hand accelerator control pedal;

# Operation Instructions

## 3.2.2 Instrument and switches

### Instrument and switches

The instrument cluster includes a water temperature gauge, a fuel indicator, an engine tachometer, an engine oil pressure meter, and a steering indicator lamp, high-beam and low-beam indicator lamps, a position indicator lamp, a charging alarm lamp, an air pressure warning lamp for easy monitoring of vehicle operating condition at any time.



Ordinary

Practical power



- 1. Combination instrument assembly
- 2. Right side rocker switch combination
- 3. Ignition lock
- 4. Left side rocker switch combination

Fig. 3-2 Instrument and switches

### Important

**While the tractor is working, the driver should always pay attention to the various instruments and indicator lamps, and if any abnormality occurs, stop it immediately for maintenance.**

### Engine Tachometer

After starting the engine, the indicated value shows operating speed of the engine while that in the box shows operating hours of the engine.

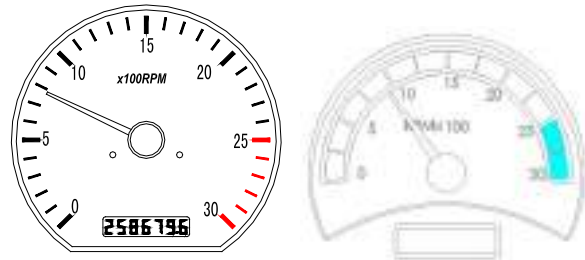

Ordinary

Practical power

Fig. 3-3 Engine Tachometer

### Water temperature gauge

It indicates engine coolant temperature with scales with from left to right. The red area is high temperature area.

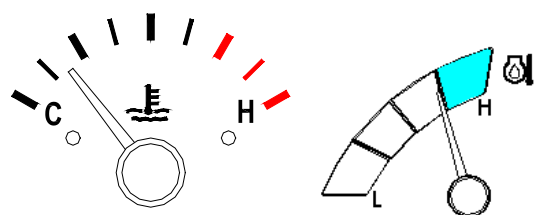

Ordinary

Practical power

Fig. 3-4 Water temperature gauge

## Operation Instructions

### Fuel gauge

Fuel gauge indicates fuel volume in the fuel tank with scales. When the pointer pointing at the rightmost position, it is indicated that the fuel tank is filled with fuel; when the pointer pointing at the left red area, it is indicated that there is insufficient fuel in the tank and please refuel immediately.

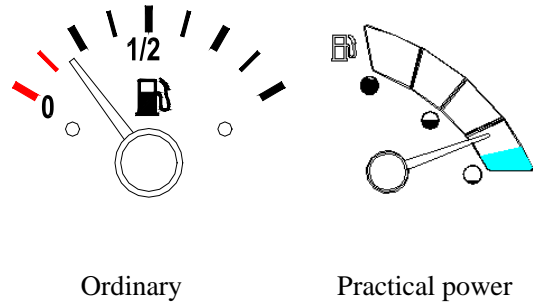

Fig. 3-5 Fuel gauge

### Oil pressure gauge

Oil pressure gauge indicates oil pressure with scales. When the pointer pointing at silver gray area in the middle, it is indicated that oil pressure is normal; when the pointer pointing at red area, it is indicated that oil pressure is abnormal and carry out overhaul immediately.

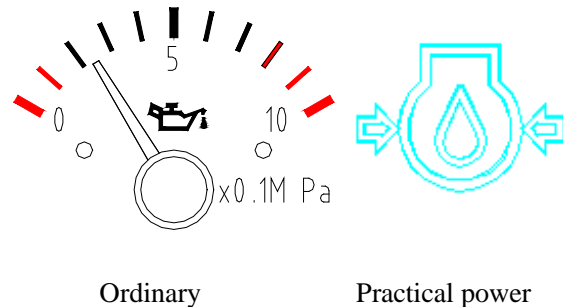

Fig. 3-6 Oil pressure gauge

### Charging indicator lamp (red)



After starting the engine, this lamp should go out to indicate the battery charge is normal. If the indicator lamp does not go out, carry out overhaul accordingly.

Fig. 3-7 Charging indicator lamp

### Air pressure warning lamp (red)

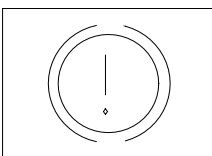

Fig. 3-8 Air pressure warning lamp

In the case of a model with an air brake, when the air brake system pressure is lower than 0.4MPa(Megapascal), this lamp lights up to indicate brake air circuit faults or air pressure warning breakdown which should be overhauled at once. Switch on the key with the engine shutdown, if the pressure is insufficient, the lamp will light up normally.

**Important: Before the engine working, the ignition key should be at ignition position and check whether the above two lamps come on. Otherwise, the bulb is damaged or circuit failure will occur, please immediately repair.**

## Operation Instructions

### Position indicator lamp (green)

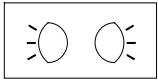

In the case of tractor stopping during running on a highroad at night, it is necessary to turn on clearance lamps and place the lighting switch at position “1” to guarantee driving safety and remind drivers in vehicles in front and behind of the parking tractor. At the moment, clearance lamps of position indicator lamps light up.

Fig. 3-9 Position indicator lamp

### Parking brake indicator lamp (red)



When pulling up the hand brake, the lamp comes on, and when pulling down the hand brake, the lamp comes off.

Fig. 3-10 Parking brake indicator lamp

### Brake oil pot oil level low alarm lamp (red)



The lamp turns on. It indicates that the oil level in the brake oil pot is low, so it is required to refill brake oil in time.

Fig 3-11 Brake oil pot oil level low alarm lamp

### Headlamp high beam indicator lamp (blue)



When the lighting switch and dimmer switch are locating at position “2”, this lamp lights up. It indicates that operating headlamps are high beams at the moment.

Fig. 3-12 Headlamp high beam indicator lamp

### Left turn signal lamp (green)

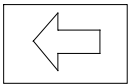

In the case of left turn of the tractor, switch on the left turn signal switch, this lamp lights up.

Fig. 3-13 Left turn signal lamp

### Right turn signal lamp (green)

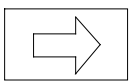

In the case of right turn of the tractor, switch on the right turn signal switch, this lamp lights up.

Fig. 3-14 Right turn signal lamp

## Operation Instructions

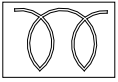

### Preheating indicator lamp (yellow)

This lamp light up during tractor preheating.

Fig. 3-15 Preheating indicator lamp

### Left rocker switch combination

1. Dimmer switch
2. Lighting switch
3. Ceiling and rear lamp switch
4. Wiper switch (for the model with cab)

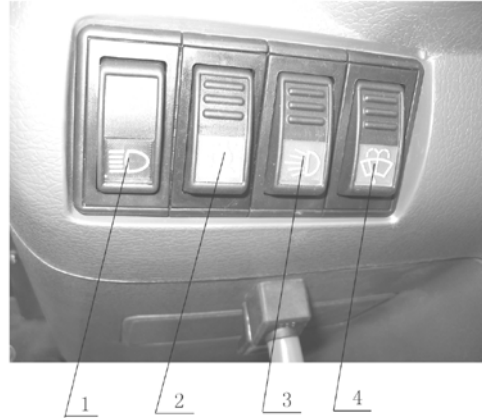

Fig. 3-16 Left rocker switch combination

### Dimmer switch



Position "2": high beams light up. Position "0": low beams light up. Position "1": standby. Change-over between high beams and low beams are controlled by the lighting switch.

Fig. 3-17 Dimmer switch

### Lighting switch



When it is locating at Position "0", power supply is cut off. Position "1": position lamp lights up. Position "2": headlamps are power-on, when the switch is located at this position, headlamps can be controlled by the dimmer switch for high beam and low beam change-over.

Fig. 2-15 Fig. 3-18 Lighting switch

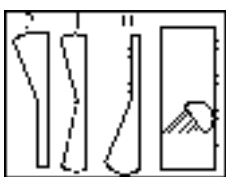

### Switch for ceiling lamp and rear lamp

Position "0", power supply is cut off. "1" position: The ceiling lamp is on (Being used where a cab is provided). Position "2": rear lamps light up.

Fig. 3-19 Ceiling and rear lamp switch



# Operation Instructions

## Wiper switch

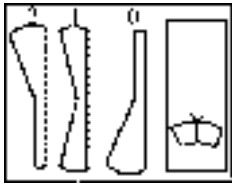

Position “2”, wiper operates quickly; Position “1”, wiper operates slowly; Position “0”, wiper is reset and stops operating.

Fig. 3-20 Wiper switch

**The right side rocker switch assembly consists of the following two kinds of switches.**

## Right side rocker switch combination

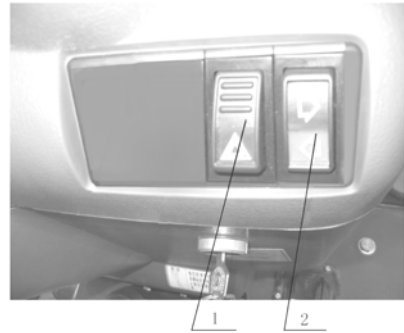

Fig. 3-21 Right side rocker switch combination  
1. Hazard warning switch 2. Turn signal switch

## Hazard warning switch

Position "1": All the front, rear, left and right steering lamps, the right and left steering lamps on the instrument and the indicator on the hazard warning switch will light up. When the tractor stops on the road due to failures or it needs warning vehicles and pedestrians around due to other reasons, this function should be used in order to avoid accidents.



Fig. 3-22 Hazard warning switch

## Steering switch

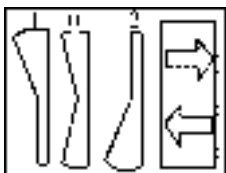

Position 2: The right steering lamps will be switched on; Position 0: Cut off power;  
Position 1: The left steering lamps will be switched on.

Fig. 3-23 Steering switch

**Horn switch:** The horn switch is located on the steering wheel. When using the horn, press down the center cover plate of the steering wheel to switch on the horn switch.

## Operation Instructions



**Alarm lamp switch:** The alarm lamp switch of of cab model is located on the right of air conditioner switch of top left, and the alarm lamp switch of safety frame model is located on the right rocker switch. It is only necessary to press the switch when using the

Fig. 3-24 Alarm lamp switch

switch of alarm lamp.

### Ignition lock:

Insert the key into ignition lock and turn the key clockwise to positions as follows:

- Turn it to OFF position (power-off)to switch off the vehicle circuit power supplyand the key can be inserted or pulled out;
- Turn it to ACC position (auxiliary component control) to power

on auxiliary electrical components (such as: air heater, wiper, fan, horn switch, etc.) and the auxiliary electrical component circuit is power-on;

- Turn it to ON position (ignition position) to switch on the vehicle power supply and the vehicle circuit is power-on;
- Turn it to H position (preheating position) and the engine glow plug (or preheating system ) starts to operate;

Turn it to ST position (start position) to start the engine; after starting the engine, release it immediately and the key returns to ON position automatically. At the moment, ON position and ACC position are connected simultaneously and vehicle circuit is power-on;

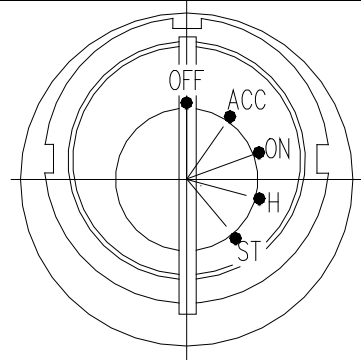

Fig. 3-25 Ignition lock

### Main power switch:

- During startup of the tractor, turn the operating handle of the main power switch in clockwise direction, turn on the main power switch for energization; otherwise, the complete vehicle cannot be started;
- After flame-out of the tractor, turn the operating handle of the main power switch in counter-clockwise direction to disconnect the power supply to avoid self-discharging of the battery. During maintenance of the vehicle, the switch must be off.



Fig. 3-26 Main power switch

## Operation Instructions

### 3.3 Start of engine



**Note: Before use, serious and comprehensive inspection shall be made on the tractor to eliminate the hidden dangers and effectively avoid dangerous accidents.**

#### 3.3.1 Preparations before engine start

- Before start, careful checks should be made to ensure that all parts are reliably tightened, all controls work normally and all tube joints are tightened without any oil, water or gas leakage;

- Check the lubricant level in the engine oil sump, gearbox, rear axle and hydraulic system. Fill the radiator up with cooling water. Fill the fuel tank up.

- Check the gearbox control handle, PTO handle. Position the main gear lever, PTO handle, front drive shaft control handle respectively to neutral gear position. Position the distributor control handle to lowering position

- Pull the locking device of the flameout cable to loosen the wire, and at this time, the injection pump is at the position of oil supply;

- Position the hand accelerator at half state, as shown in fig.3-25.

- As to the new, overhauled or long-period storage tractor, before starting, please empty the air in oil (fuel) pipe to ensure diesel engine smooth starting.

The method is as follows: loosen the air bleeding screw on the diesel filter, use hand pump to empty the air of fuel pipe from the fuel tank to diesel filter until there is no bubble emerged in drained fuel. Then, tighten the bleeder screw of the diesel filter, unscrew the bleeder screw on the injection pump and deflate similarly as above until the discharged fuel is free from any bubble.



Fig. 3-27 Hand accelerator

#### **Important:**

1. The debris should be regularly cleaned from the water tank meshes, so as to avoid engine failure due to poor heat dissipation;

2. After the tractor is equipped with a knapsack type harvester, it is recommended that an auxiliary cooling device will be installed at the proper position so that the engine could be able to continuously work for a long time because of the poor heat dissipation.

#### 3.3.2 Start of engine

## Operation Instructions



### Attention:

Before starting, please ensure the main/auxiliary gear lever and front drive control lever are positioned at neutral position, the distributor control lever should be positioned at lowering position to avoid tractor suddenly starting.

### Important:

1. After starting, please immediately let your hand go to allow the ignition key automatically return back to ON (see ignition lock picture). Otherwise, started engine will reversely make the starting motor started, causing damage of starting motor.

2. Engine should be of good starting performance. If ambient temperature is not less than  $-5^{\circ}\text{C}$ , the engine starting time should be within 5s. At any state, engine starting time should not be more than 15s. During repeatedly starting, each interval should not be less than 2 min. If the engine could not be started for successively 3 times, please find out cause and start again.

### 3.3.2.1 Battery starting:

- Starting at ambient temperature ( at  $-5^{\circ}\text{C}$  or more): turn the ignition key clockwise to “ON” to turn on the circuit. Then rotate it again to “ST” to start engine. After engine starting, please immediately let your hand go, the key will automatically return back to “ON”. If equipped with safe starting switch, please depress down the main clutch pedal and then rotate the ignition key to start the engine.

- Start at a low temperature**

Start at a low temperature [when the ambient temperature is lower than  $-5^{\circ}\text{C}$  (centigrade)],

start the engine according to operations as follows:

- For the tractor which is not equipped with a preheating circuit and does not apply antifreeze, pour hot water at  $90^{\circ}\text{F}$  and above into the water tank before starting the engine in cold weather, until you can see hot water outflow from the drain valve on the cylinder block. Then, close the drain valve, and then fill the entire cooling system with hot water. Drain the oil in the oil pan (preferably when it is hot at the last stall) into an appropriate container. Heat the oil in the covered container to  $70 \sim 90^{\circ}\text{C}$  and then re-pour it into the oil pan. Do not grill oil pan by using fire. Place the hand throttle at its large opening position and turn the key clockwise to ST position (start position) to start the engine; Release the key immediately after starting the engine and the key returns to ON position (ignition position) automatically. Then, place the hand throttle at its small opening position.

- For the tractor with a preheating circuit, start the engine according to operations as follows:



Fig 3-28 Battery starting  
1. Ignition lock key

## Operation Instructions

Place the hand throttle at large opening position and turn the key clockwise to H position (preheating position ) and hold for (15~20) s (second) and then turn the key to ST position (start position) to start the engine; Release the key immediately after starting the engine and the key returns to ON position (ignition position) automatically. Then, place the hand throttle at its small opening position.

### Tow start:

If starting engine by towing tractor, you should engage 3-gear or 4-gear of high-speed gear. To ensure safety, the speed of towed tractor should not be higher than 15km/h.

**Important: When a towing tractor is used for starting, immediately step down the main clutch pedal once the engine starts working, and narrow the accelerator to prevent engine flameout.**

### 3.3.3 Operation of engine

- After engine starting, please immediately decrease the accelerator to allow the engine at idle state. At this time, check the engine oil pressure and ensure it is not less than 98kPa, then the oil pressure indicating lamp will go out.

- Once the engine starts, do not let it run under full load immediately, but under no load at a medium speed to warm up. Only when the coolant temperature is above 60°C can you use the maximum speed for full-load work.

- You should slowly increase or decrease the engine speed and load, especially when the engine has just been started, it is prohibited to force the accelerator for high-speed operation.

- During engine running, please frequently check the oil pressure and coolant temperature. At normal work, the coolant temperature should be within (85~95) °C, and oil pressure should be within (0.3~0.5) MPa.

**Important: At any state, oil pressure should not be less than 0.1MPa to avoid damage of engine.**

### 3.4 Starting of tractor

- When the engine is at low speed status, step down the clutch pedal, and then place the transmission gear lever to the desired gear;

- Push the hand brake handle downward, loosen the parking brake;

- Sound the horn and make sure there is no barrier around.

- Increase the engine speed gradually, and release the clutch pedal gradually to allow the tractor to start smoothly. After starting, release the clutch pedal quickly to prevent the clutch from being ground;

- Speed up the engine gradually until the tractor reaches the desired operating speed;

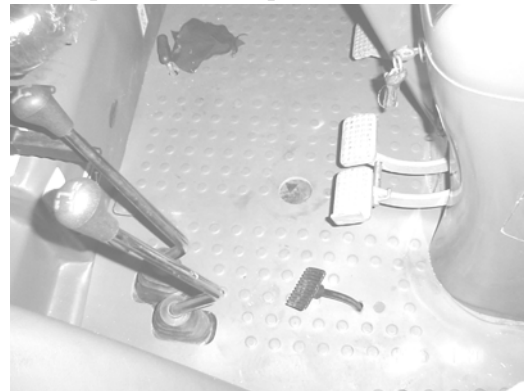

Fig. 3-29 Starting of tractor

## Operation Instructions

• Do not slow down the tractor by engaging the clutch half. When the tractor is moving, when you are not shifting, do not rest your foot on the clutch pedal. This can cause your release lever and friction plates to wear out faster.

### **Important:**

- 1. It is not allowed to start with high gears engaged to avoid gear impact of the gearbox drive gear and clutch early wears.**
- 2. Prior to starting, it is necessary to release the parking brake to avoid operating component damages.**
- 3. It is necessary to release the main clutch via depressing the clutch pedal in the case of gear engagement or gear shift to avoid gear impact of the gearbox drive gear and clutch early wears.**

### **3.5 Tractor Steering**

If tractor steering on the road, firstly press the horn switch on the core of steering wheel to sound warning, then do the steering. If the speed is high, firstly slow down, slowly and early turn the steering wheel with less times of returning back steering wheel. If sharp turning, lately and quickly turn the steering wheel with more times of returning back steering wheel.

In the case of tractor small turning or turning on soft ground, there may be steering failure due to front wheel sideslip. At the moment, turn the steering wheel and depress the brake pedal at the corresponding side simultaneously to help steering.



### **Warning:**

- 1. It is not allowed apply single-side brake for a sharp turn when the tractor is running with a high speed;**
- 2. When turning the front wheel at smooth angle, if steering relief valve sounds squeak during acting, slightly return the steering wheel back to avoid hydraulic system damage which is caused by overload for long period, resulting in steering failure occurs.**
- 3. Before turning or backing in the field work, first do have the underground parts of the agricultural machinery rise out of the ground so as not to damage the farm implements or cause casualty accidents.**

### **3.6 Tractor gear shift**

Main and auxiliary gear shift is respectively controlled by 2 pieces of control handle. Main gear lever A can get 4 gears (1,2,3,4) and auxiliary gear lever B can get 2 forward speed section (L is low speed section, H is high speed section) and 1 reverse speed section R.

## Operation Instructions

### 3.6.1 8+4 gears and 16+8 creeper gears:

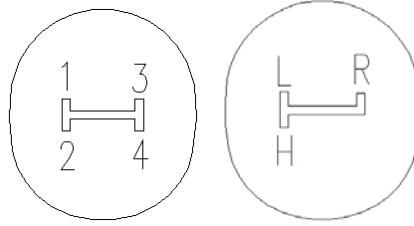

Main gear lever A      Auxiliary gear lever B

Fig 3-30 Tractor gear shift

Depress down the main clutch pedal and push the auxiliary gear lever B from the neutral gear to the left. If continuously pushing forward, you can get low speed section L. If continuously pushing backward, you can get high speed section H. If you push the auxiliary gear lever B from the neutral position to the right and then to the forward, you can engage the reverse gear R.

Depress down the main clutch pedal and push the main gear lever A from the neutral gear to the left. If continuously pushing forward, you can engage 2nd gear. If continuously pushing right from the neutral position, then backward, you can get 3rd gear. Push forward, you can engage 4th gear.

If your tractor is equipped with creeper gear, the high/low speed handle is mounted on the center-right side of floor with the center gear position as neutral gear. If pulling the creeper gear handle upward, you can get low speed gear. If pressing the creeper gear handle downward, you can engage the high speed gear. If combined with said main and auxiliary gear levers, you can get 16 forward gears and 8 reverse gears.

### 3.6.2 16+8 shuttle type gear shift:

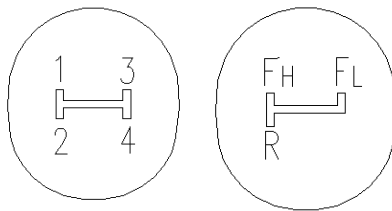

Main gear lever A      Auxiliary gear lever B

Fig 3-31 Tractor gear shift

Depress down the main clutch pedal and push the auxiliary gear lever B from the neutral gear to the left. If continuously pushing forward, you can get high speed section H. If continuously pushing backward, you can get reverse gear R. If you push the auxiliary gear lever B from the neutral position to the right and then to the forward, you can get the low speed section L.

Depress down the main clutch pedal and push the main gear lever A from the neutral gear to the left. If continuously push forward, you can engage 1st gear. If continuously push forward, you can get 2nd gear. If you push from the neutral position to the right and then to the backward, you can engage the 4th gear.

## Operation Instructions

A high/low speed handle is provided at right part of the floor. The middle position is neutral gear. Pulling the handle upward has the tractor engaged in the low speed gear, and pushing the handle downward has the tractor engaged in the high speed gear. If combined with said main and auxiliary gear levers , you can get 16 forward gears and 8 reverse gears.

By selecting correctly the working speed of tractor, we can not only obtain the best productivity and economy, but also extend the service life. While in work, we should not frequently overload the tractor, but give the engine a certain power reserve. For the selection of speed for tractor field operations, it is preferred to keep the engine running with the load of 80% of its rated one approximately. If the tractor works with light load at a comparatively low working speed, we can choose a higher Gear-1 speed at a small accelerator to save fuel.

### Important:

1. When the engine is running, have the main clutch pedal depressed thoroughly before gearshift, and after several seconds, change the gear again, so as to avoid "gear crush" resulted from poor engagement of the engagement sleeve of the gearbox,
2. Only the tractor is motionless, you may engage the reverse gear.
3. Do not place your hand on the gear lever during tractor running or pressure from the hand may be delivered to the shift fork in the gearbox and this will lead to premature wears of the shift fork.

### 3.7 Operation of differential lock

#### Differential lock operation

During driving or operating, if the tractor cannot move forward due to trapping or unilateral drive slipping, follow the steps below to engage the differential lock so that the left and right drive shafts could be rigidly connected and rotated at the same speed to have the tractor move forward away from the slippery section.

- Depress the main clutch pedal and put the gear lever to a lower gear;
- Pull the throttle control lever to the position of the maximum oil supply;
- Depress the differential lock control pedal with your right foot;
- Release the clutch pedal gradually to allow the tractor to start smoothly.
- After driving out of the slippery district, release the differential lock pedal and unlock the differential lock automatically.

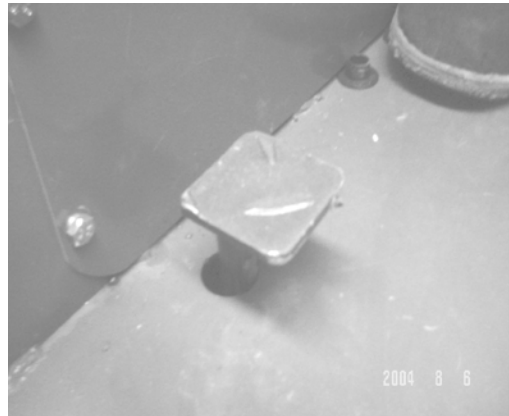

Fig 3-32 Operation of differential lock

**Important: In normal running and turning, it shall be strictly prohibited to use the differential lock so as**



## Operation Instructions

to avoid mechanical damages and accelerated tire wears.

### 3.8 Use of front drive axle

In the case of heavy-duty operation in the field or operation in the soft wet soil, the 4WD tractor may be unable to provide a sufficient traction only relying on the rear-wheel drive. Then, to increase the traction, engage the front drive axle to reduce slippage, thereby enhancing the adaptability of the tractor operation. In order to connect and separate the front drive axle, the following control procedure should be abided by:

#### 3.8.1 Attachment of front drive axle

Depress the main clutch pedal and shift the transmission into the desired gear, and then release the clutch pedal gradually. Wait until the tractor moves slightly, and then pull up the control lever of the front drive axle to make the 2WD change into 4WD.

#### 3.8.2 Disconnection of front drive axle

Depress down the main clutch pedal, push the front drive axle control handle downward to make the 4DW change into 2DW.

### Important:

**1. Important: when tractor works on hard ground, front drive axle is not allowed to be connected, otherwise it can cause the premature wear of front tires and increase fuel consumption. Engage the front drive axle only when driving on slippery roads in rainy and snowy weather, as well as on a deep uphill which can cause the rear tires to slip. When tractor is driven out of difficult section, front drive axle should be separated.**

**2. During transport operation, the tractor!/'s front tires wear out faster and left and right tread patterns wear unevenly. Therefore, you can rotate the left and right tires as the circumstances may require.**

### 3.9 Brake of tractor

In general case, we should reduce the throttle firstly, depress the clutch pedal, and then gradually depress the brake pedal to make the tractor stop steadily.

In case of emergency stop, we should depress the clutch and brake pedal at the same time, instead of stepping down the brake pedal alone to avoid the sharp abrasion of the brake friction plates or the engine flameout.

When applying the brake with a trailer, adjust the length of the brake valve rod, and then brake the trailer before braking the tractor.

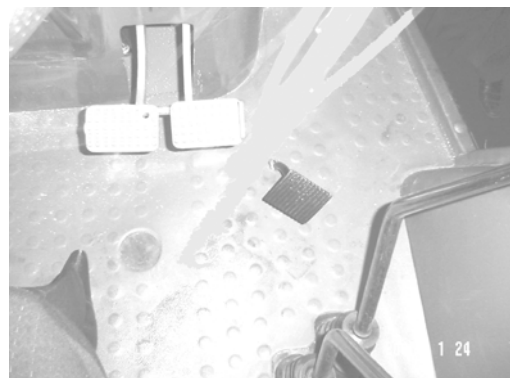

## Operation Instructions

### Left/right brake pedal interlock

In normal running, an interlocking plate should be applied to lock the left and right brake pedals together.

Fig. 3-33 Brake of tractor



#### Warning:

1. It is necessary to check the brake oil reservoir for sufficient oil volume and check brake line for oil leakage prior to every driving. If there is little oil in the oil reservoir or oil leakage in the line, find out the cause and troubleshoot timely. Otherwise, there will be major accidents like brake failures.

2. In the case of normal tractor running, left and right brake pedals should be interlocked to avoid tractor deviation and even rollover.

### 3.10 Tractor parking and engine flameout

- Decrease the accelerator to reduce the running speed;
- Depress the clutch pedal and brake pedal at the same time, lock up the brake handle, and put shift lever to neutral position after the tractor is stopped;
- Release the clutch and brake pedals, and decrease the accelerator to idle the engine;
- Pull the flameout rod backward, the oil pump will stop feeding, the engine will stop immediately, and then push back to the position of oil feeding;
- Turn the ignition key to OFF to switch off all the power supplies.



#### Attention:

1. After stopping the tractor, the driver cannot leave the tractor before the engine is shut down, in order to avoid sudden start of the tractor, action out of control which may lead to accident.

2. When it is inevitable to park on a slope, implement gear engagement (for upslope position, apply forward gear engagement while for downslope position, apply reverse gear engagement) and make sure to apply parking brake and wedge rear wheels with triangle wedge blocks to avoid tractor sudden start and out of control as a result of self actions which may bring unexpected dangers.

#### Important:

1. When air temperature is lower than 0°C (centigrade) in winter, for the tractor without antifreeze, its water tank should be drain valve should be opened under the condition of engine idling and water coolant for the engine should be drained completely through the drain cock and then shut down the engine to avoid frost cracks of the engine body as a result of water coolant freezing.

2. If the outlet of radiator is higher than inlet of water pump, it is recommended to open the drain switch to avoid the remained water in the outlet pipe of radiator freezing the pipe. Meanwhile position

## Operation Instructions

the flameout position to off, and then use battery to drag engine running for 2-3times with less than 15s each time and interval of 2-3min to drain the water in the pipe.

### 3.11 Adjustment of wheel track

#### 3.11.1 Front wheel track adjustment (non-stepless adjustable wheel track type)

● Front wheel track adjustment of 2DW tractor: put the tractor front axle on the jack stand, dismantle the lock bolt 1,2 from the left and right main and auxiliary sleeves.

Then remove the lock bolt 4 and cylinder mounting bolt 3. Adjust the auxiliary sleeve, cylinder position and tie rod to desired location. At last reinstall and lock all removed bolts. There are 4 kinds of front wheel track to be selected: 1385mm, 1485mm, 1585mm, 1685mm.

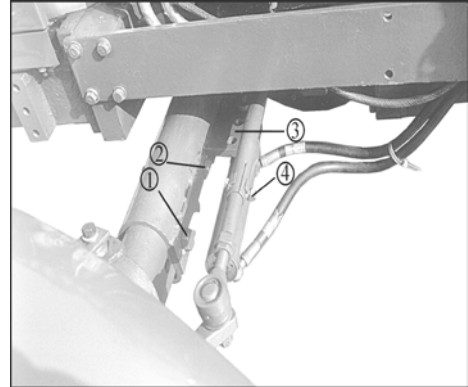

Fig.3-34. Tractor front axle

● The front wheel track of 4DW could be adjusted by changing joint position of rim and spoke. You can get 4 kinds of wheel track 1610mm, 1710mm, 1810mm, 1950mm.

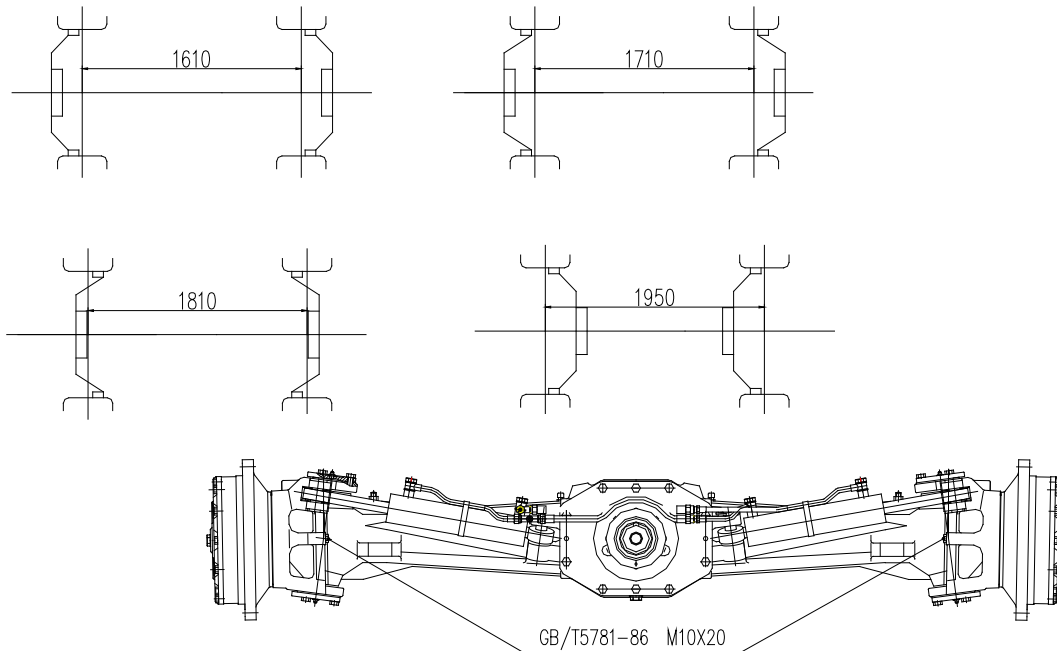

Fig.3-35 Front wheel track adjustment (unit: mm)

When the front wheel track is adjusted to the minimum value, the front axle should be adjusted as follows accordingly:

- Remove the front wheel mudguard;
- As shown in Figure 3-33, screw a M10×20 bolt into the adjusting threaded holes of the left/right steering knuckle of the front axle, respectively, so as to limit steering angle of the front wheels by adjusting

## Operation Instructions

screw-in length of the bolts; the front wheel□´

### 3.11.2 Rear wheel track adjustment (non-stepless adjustable wheel track type)

Adjusting method: the 5 wheel tracks could be obtained via different connections of spoke, hub and rim.

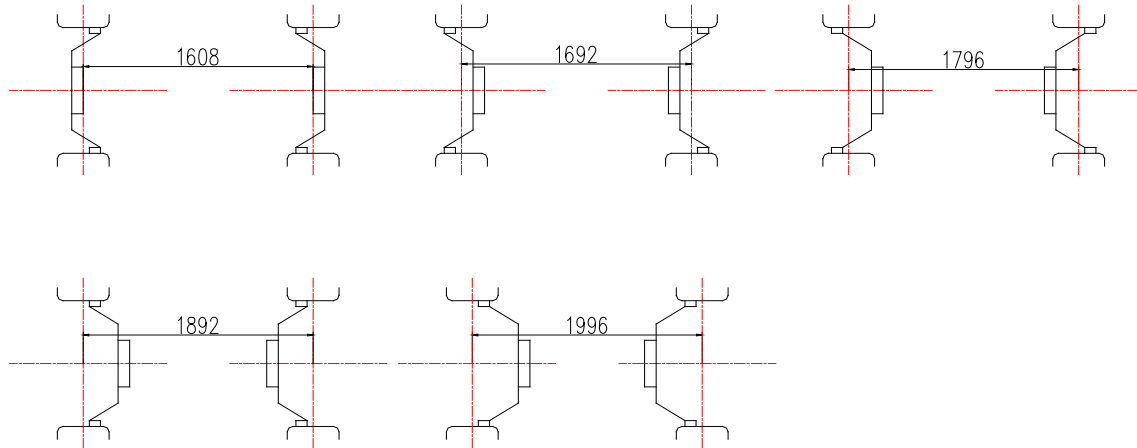

Fig.3-36 Rear wheel track adjustment (unit: mm)

**Note:** When the rear wheel track is adjusted from 1608 mm to another value, the rear counterweight cannot be used, and the user should select a rear wheel track value according to actual working conditions.

### 3.11.3 Adjusting wheel track of the vehicle model with stepless wheel track adjustment.

#### 3.11.3.1 Adjustment of front wheel track

● 2DW tractor: put the tractor front axle on the jack stand, dismantle the lock bolt 1,2 from the left and right main and auxiliary sleeves. Then remove the lock bolt 4 and cylinder mounting bolt 3. Adjust the auxiliary sleeve, cylinder position and tie rod to desired location. At last reinstall and lock all removed bolts. 6 kinds of wheel track are available for selection by changing the bolt position instead of turning the spoke over:

1595mm、1695mm、1795mm、1895mm、1995mm、2095 mm.

Further 6 kinds of wheel track i.e. 1651mm, 1751mm, 1851mm, 1951mm, 2051mm, 2151mm are available for selection by turning the spoke over and changing the bolt position.

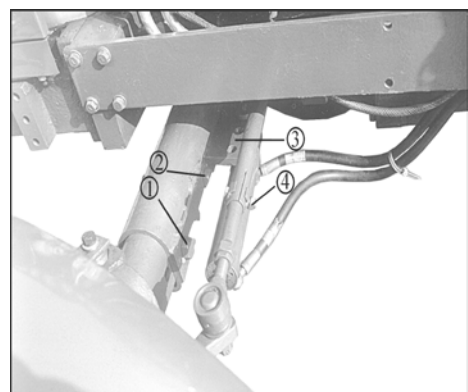

Fig.3-37 Front axle of stepless adjustable wheel track type

## Operation Instructions

● As to 4DW type, there are 6 kinds of wheel tracks by adjusting the joint position of rim and spoke: 1610mm, 1710mm, 1750mm, 1810mm, 1850mm, 1970mm. At each joint condition of wheel track, you can obtain another 6 kinds of front wheel track 1880mm,1980mm,2020mm,2080mm,2120mm,2240mm by adding drive axle connecting sleeve between the rim and front axle and accordingly increasing wheel track of 270mm.

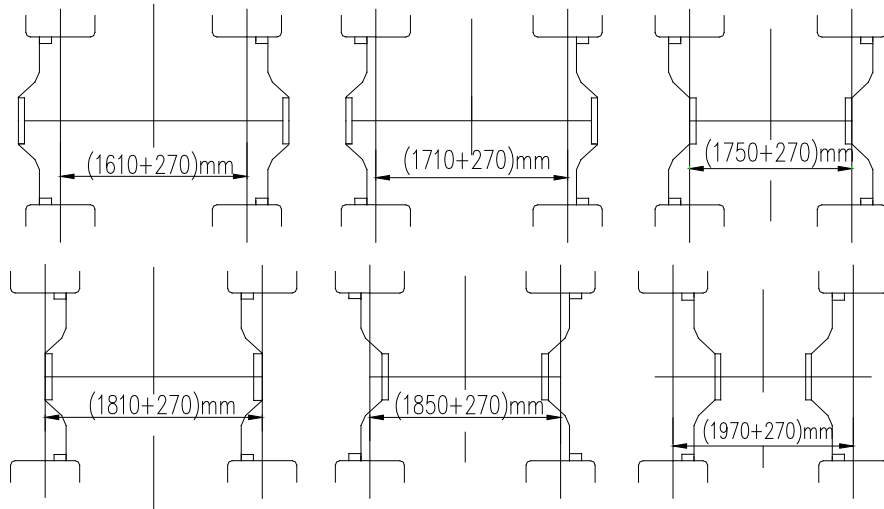

Fig.3-38 Adjustment of front wheel track for the model with stepless wheel track adjustment

## Operation Instructions

### 3.11.3.2 Adjustment of rear wheel track (13.6-38 tire)

The wheel track is usually 1620mm. 7 kinds of wheel track position can be obtained by changing connecting positions of the spoke, hub and rim. At each position, it is possible to obtain further 7 kinds of wheel track adjustment range by adjusting the hub and the "hub seat.

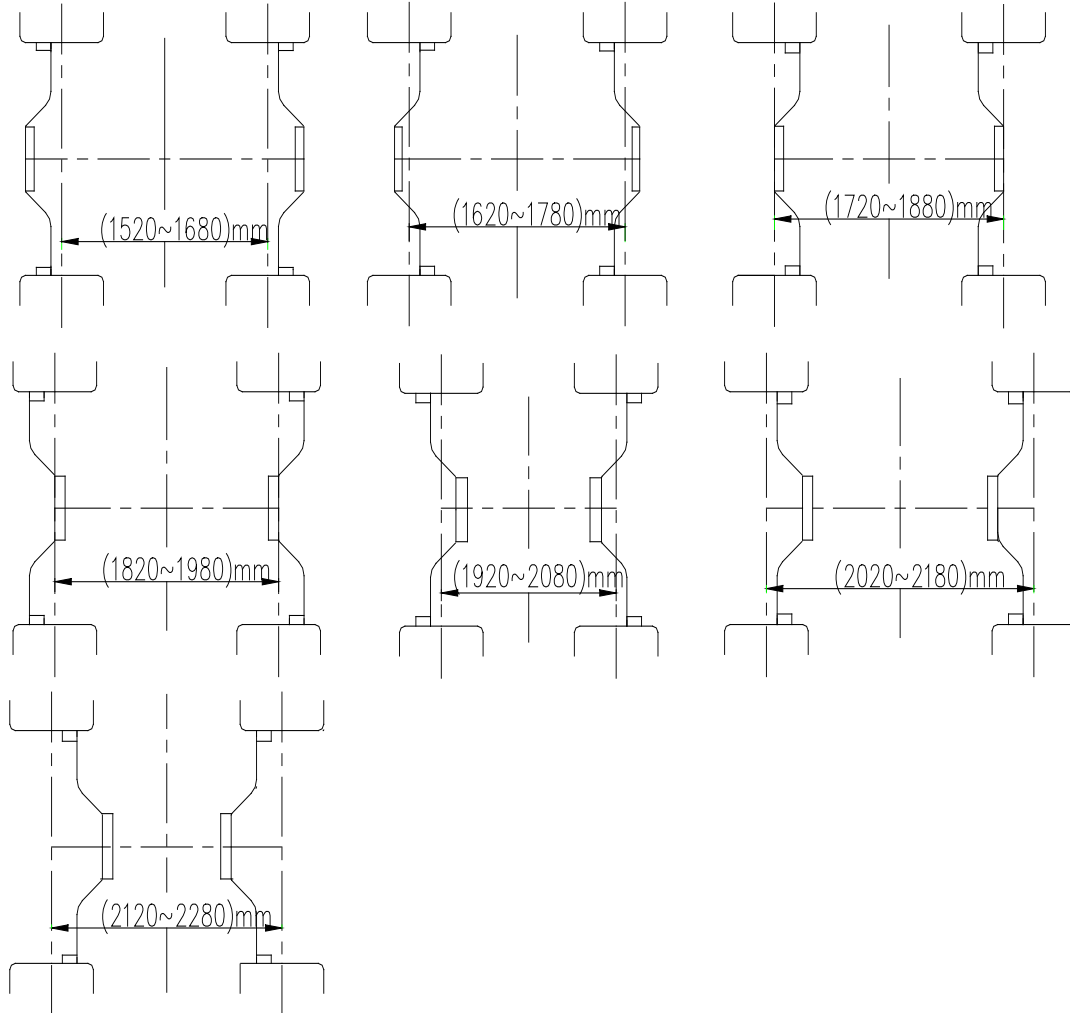

Fig. 3-39 Rear wheel track adjustment (13.6-38 tires) (unit: mm)

## Operation Instructions

### 3.11.3.3 Adjustment of rear wheel track (16.9-34 tire)

The wheel track is usually 1600mm. 7 kinds of wheel track position can be obtained by changing connecting positions of the spoke, hub and rim. At each position, it is possible to obtain further 7 kinds of wheel track adjustment range by adjusting the hub and its pedestal.

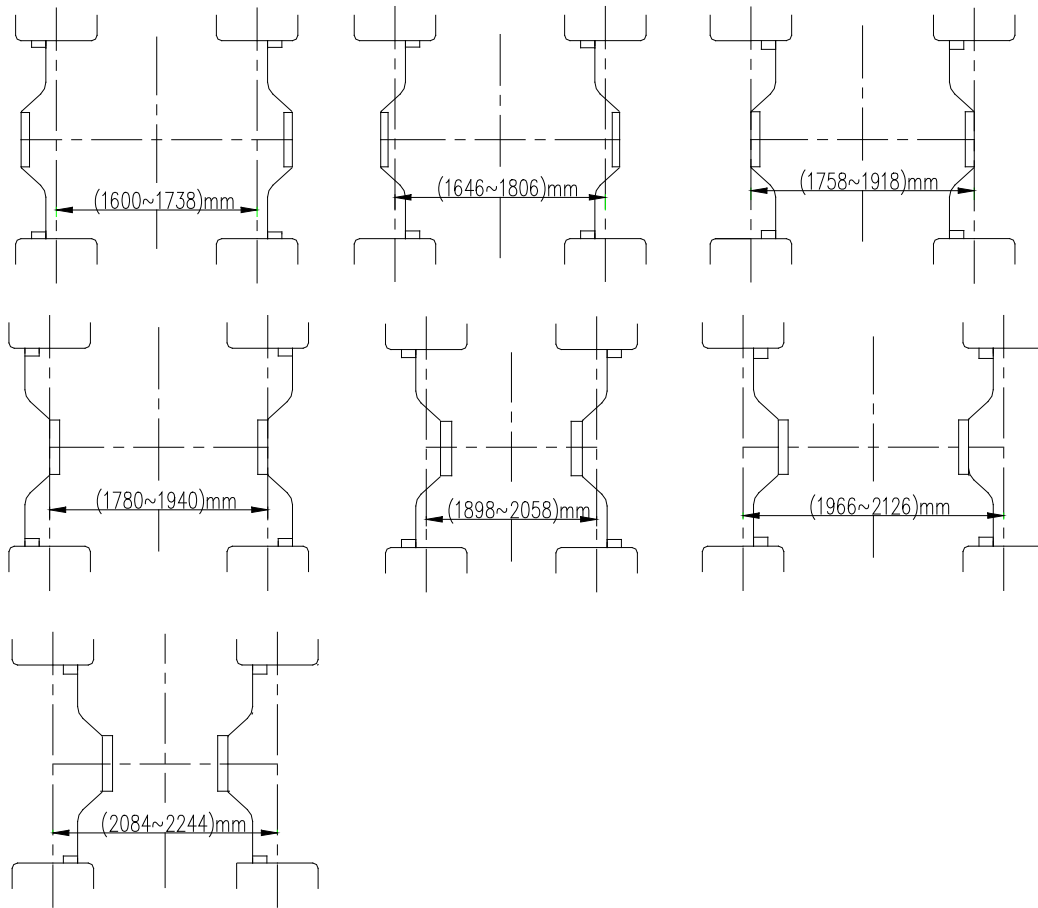

Fig. 3-40 Rear wheel track adjustment (16.9-34 tires) (unit: mm)

**Important:** During adjusting the rear wheel track, be sure the tire side arrow or the tip of herringbone is in line with tractor forward direction. Always ensure the 2 front wheels and rear wheels are symmetric to tractor center line to prevent the machine from early wearing. During adjusting, firstly select proper rear wheel track and then select front wheel. During adjustment, first select the most appropriate rear wheel track, and then the front wheel track.

### 3.11.4 Adjustment of the toe-in of front wheel

## Operation Instructions

Park the tractor at horizontal ground to enable the front wheel to be at straight driving position, shown in Figure 3-39. By adjusting length of the tie rod 2, obtain the toe-in value by subtracting B from A. Pay attention that, after adjustment of the toe-in, the locknut 1 at both ends of the tie rod should be tightened, respectively.

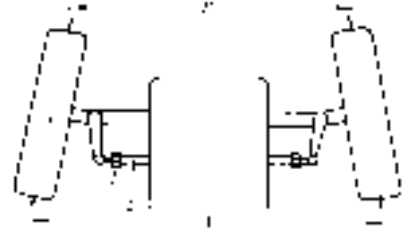

Fig. 3.-41 Adjustment of the toe-in of front wheel

1. Locknut; 2. Tie rod

### 3.12 Use and disassembling of tires

#### 3.12.1 Use of tire

Tires are the main quick-wear parts of a tractor, so attention must be paid to the use and maintenance of tires in order to prolong its service life as far as possible.

All tires have rated load values, overload will cause excessive deformation, the tire side will fracture easily due to overbending, the tire fabrics and the buffer layers are also easily degummed so that the fabric layer will loose until the tire is broken, and especially on the uneven pavement or due to obstacle impact, the tire is more prone to rupture.

The tire charging pressure must comply with the provision, and too high or too low pressure will affect the service life. Too-low pressure may result in excessive deformation to quicken the tread wear, even make the inner and cover tires quickly damaged and have the inflating valve cut off; and simultaneously have the running resistance increased. If the front tire pressure is too low, the manipulation will be strenuous; if too high, the tire fabrics will fracture due to excessive stretch, the tread will be worn quickly, and the body vibration will be increased. In the field work, the tire pressure may be a little lower, but higher in long-term highway transportation. The tire pressure should be checked with a barometer at the room temperature, so as to avoid inaccurate measurement after the tire is heated due to work. Improper operation will also result in earlier wear or damage of the tires. During running, crossing obstacles at a high speed, sudden brake or sharp turn should be avoided. Driving on the gravel roads, the tire track slip should be avoided as much as possible.

During operation, do keep the tires away from oil, acid or alkali and other corrosive chemicals, and avoid exposure to hot sun to prevent rubber from aging and deterioration. Front wheel alignment and front toe-in must be frequently checked so as to avoid eccentric wear of the tires. If the tires have uneven wear, the left and right tires may be exchanged.

**Important: Charging pressure of front and rear tires of four-wheel drive type tractor should be same so as to avoid abnormal wear of tires.**

#### 3.12.2 Tire disassembling

##### Tire disassembling

Do use special tools to dismount tires, but do not use sharp and hard tools (for example, screwdrivers) or hammers to knock the tires disorderly, so as not to puncture the tire or damage the tire margins or rims.



## Operation Instructions

When disassembling tires, do deflate firstly, press the tire margins of the cover tire into the rim groove, then use crowbars to force the tire margin near the inflating valve on one side out of the rim, and then use two crowbars alternatively to force the tire margin out. After the inner tube is taken out, then do as above to force the tire margin on the other side out and then remove the cover tire.



Fig.3-42 Tire disassembling

### Tire installation

When installing the tire, the rim should match with tire. There should not be rug, serious distortion and rust on the rim edge. When installing, first clean the parts and then coat a thin layer of talc between the inner tube and cover tires. Put the rim flat, mount the cover tire, and force it into the rim.



Fig.3-16 Tire installation

Install inner tube (slightly underlay the outer tube), use lead wire to fix the core into the core hole of rim to avoid it slipping. Use crowbar to lever the other side of outer tube into rim (you may apply greater force at last phase and you can use hammer to gently hitting crowbar, as shown in figure.). Finally check whether the inflating valve is positioned askew, and whether the tire edge fits the rim tightly. Moreover, check whether the inner tube is broken and hammer the cover tire when inflating. It is better to bleed the air by half when inflated to the specified pressure, and then inflate it once again, so as to have the inner tube normally expanded and eliminate its wrinkles. If installing tires, please note the tread pattern direction. Otherwise it will affect the gripping performance and resistance to corrosion. Moreover the mud is prone to be accumulated.



**Warning: Never remove the bolts attaching tire/hub to wheel rim or attaching spoke to rim in inflation state. Otherwise the bolts may rush out to hurt people.**

### 3.13 Use of counterweight

#### 3.13.1 Rear counterweight

When the tractor is working in the field, the counterweight can be selected according to appropriate working type to improve working performance of the tractor.

- 6 pieces of counterweights can be installed for large load plowing area;
- 2 pieces of counterweights or no counterweight can be installed for rotary tillage area;
- 4 pieces of counterweights can be installed for ordinary plowing area;



Fig. 3-44 Rear counterweight



### **Attention:**

**Before removing the rear wheels with rear counterweights from the tractor, it is necessary to remove those rear counterweights from tires first to avoid the hazard of instability.**

### **3.13.2 Front counterweight**

In order to balance the front and rear masses, it is necessary to install front counterweight in front of tractor. When large load plowing activities is carried out or a large-size seeding implement is suspended, front counterweights with enough weight must be installed to ensure that no rear-up occurs and ensure safe driving and high performance. The tractor can be equipped with 11 pieces of front counterweight of cast iron at bridge.



Fig. 3-45 Front counterweight



### **Warning:**

**When the rear part of the tractor is equipped with a large-size implement, front counterweights with enough weight must be equipped to ensure your safety; otherwise, it may result in roll-over risk!**

### **3.14 Adjustment of Driver's seat**

## Operation Instructions

### 3.14.1 Front and rear adjustment of driver's seat

The seat can be adjusted forward and backward according to the operator's height and by adjusting the seat forward/backward handle at lower right side of the seat.



Fig 3-46 Front and rear adjustment of driver's seat

### 3.14.2 Front and rear adjustment of driver's seat

Adjust the operator's hand-wheel according to the operator's height and weight.



Fig. 3-47 Rigidity adjustment of driver's seat



#### Attention:

1. For safety, the seat should be adjusted when the tractor is at static to avoid potential hazard.
2. The seat rigidity should not be adjusted to excessive softness, especially on the irregular pavement. This could prevent potential accidents occurring.

## 3.15 Tractor covering parts

It mainly including: hood, cab, mudguard, dashboard, floor and accessories etc.

### 3.15.1 Hood

The engine hood adopts elegant-appearance stream-line metal plate structure. Pull the opening handle of hood lock located at the left side of the lower-front wall of the hood to open the hood lock. Then gently lift the hood up from the lower side and the hood automatically open under the pushing force of the 2 air springs separate. If pulling the hood from the lower point to a certain angle, the hood lock will automatically close and



Fig. 3-48 Hood

## Operation Instructions

lock.

### 3.15.2 Instrument panel:

The electric control switch and combined instrument of the tractor are installed on the instrument panel. The instrument panel plays a role of controlling switch support, decorating and sealing.



1

Fig. 3-49 Instrument panel:  
1. Instrument panel

**3.15.3 Cab (optional):** The tractor cab is a frame welded by tubular profiled bars and is inlaid with a large area of space curved glass.

### 3.15.4 Cab fan

The cab fan was shown as the figure.



Fig.3.50 Cab fan

### 3.15.5 Cab interior trims

The interior trims in the cab include mudguard trim, floor mat, instrument console, internal ceiling lining and etc., shown as following figure.



Fig. 3-51 Cab interior trims

# Operation Instructions

## 3.15.6 Doors

The tractor doors adopt profiled door frame, inlaid with monoblock curve glass. Integrating with the streamline cab not only shows the spacious and comfortable driving room, but also greatly improves the elegance appearance of the tractor.

Door opening steps are as follows: clockwise rotate the door key by 90°, after taking out the key, grasp the door handle with thumb pushing the pressing piece 2, meanwhile pull the handle outward to open the door. Lock the door in reverse order of the above mentioned.



Fig.3-52 Cab door lock

- 1. Door key
- 2. Door lock
- 3. Push rod
- 4. Locking plate
- 5. Unlocking handle
- 6. Door handle

## 3.15.7 Left and right side windows

All-glass structure is adopted. In the case side window open, lift lock-up handle and push the window outward simultaneously until it is stuck and then lift the lock-up handle gently so as to open the side window and limit to a certain place. Besides, the max. side window distance is the effective length for the lock-up handle.

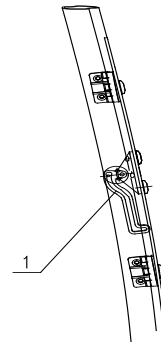

Fig. 3-53 Left and right side windows

- 1. Lock-up handle

## 3.15.8 Rear window

Tractor rear window is semi-automatic. It can open upwards to two positions: normal and maximum.

- Normal state: Rotate handle, Push handle outward when projection in the front of the handle slips off its groove until the projection in the rear of the handle reaches the groove and then rotate the handle once again to slip the rear projection into the groove so as to keep the rear window open and maintain a certain opening angle.

In its closing, operate in the reverse order.

- Max. state: Place the handle. Push handle outward when projection in the front of the handle slips off its groove until the pulling force from air spring is overcome. Then, air spring is changed from “pulling” into outward “pushing”. Then, the rear window reaches its opening position automatically. In the case of its closing, pull the handle inward to overcome “pushing” force from air spring and then air spring is changed

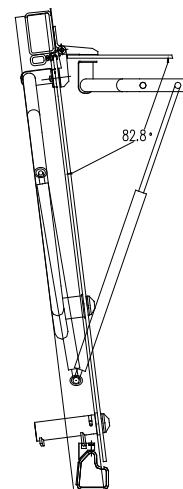

Fig. 3-54 Rear window

## Operation Instructions

from outward “pushing” into inward “pulling” and then the rear window closes automatically. Rotate the handle once again to slip the front projection into its groove for its lock-up state.

### 3.15.9 Sun roof

The sun roof adopts glass reinforced plastic structure. In the case of sun roof open, hold the handle and press the sun roof lock with your thumb simultaneously and then the lock will be unlocked automatically. Push the sun roof outward gently and it opens automatically with the effect of left and right air springs. In its closing, operate in the reverse order.



Fig. 3-55 Sun roof

### 3.15.10 Cab HVAC (heating ventilation and air conditioning) (optional)

The dual-purpose air conditioner possesses 2 air outlets in the cab. You can rotate cover plates for these air outlets to adjust air volume and blowing direction; At the leftmost side of the HVAC is its control panel which possesses control modes as follows:



Fig. 3-56 Air conditioner

#### 3.15.10.1 Separate ventilation control

- Turn off water inlet and outlet switch for the air heater on the engine;
- Rotate air speed switch in the middle of the control panel to adjust air speed so as to obtain natural wind.

#### 3.15.10.2 Air conditioner control

- Turn off water inlet and outlet switch for the air heater on the engine;
- Turn on the compressor switch on the leftmost of control panel to make the compressor filled with refrigerant begin to work. The cold air could be blown into cab to reduce the temperature.
- Rotate HVAC temperature control switch at the right side of the control panel to adjust the interior temperature
- Rotate air speed switch in the middle of the control panel to adjust the air speed..

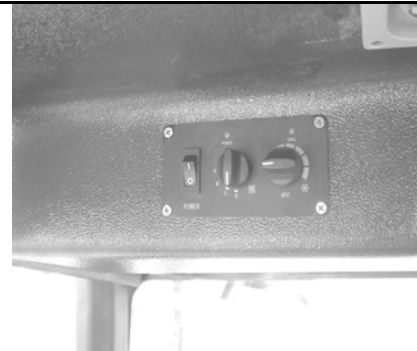

Fig. 3-57 HVAC control panel

## Operation Instructions

### 3.15.10.3 Air heater control

- Turn off compressor switch at the leftmost side of the control panel
- Turn on water inlet and outlet switch of the air heater on the engine and warm water starts to its circulation in the air heater. Heated air can be provided to the interior of the cab to increase interior temperature.
- Rotate air speed switch in the middle of the control panel to adjust the air speed

### 3.15.11 Safety rack

Tractor safety rack is a frame welded by rectangular tubes and it can be overturned and folded.

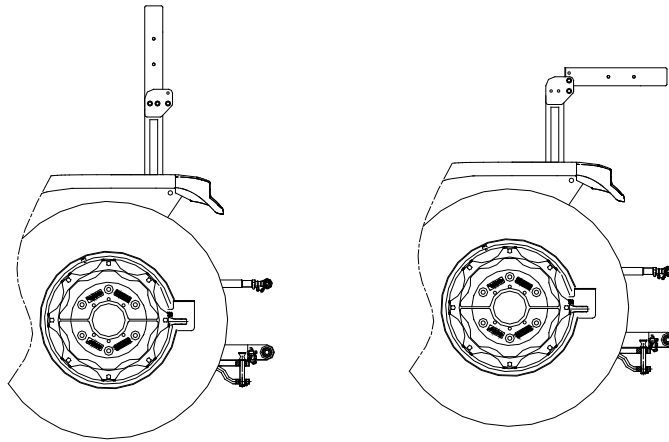

Safety rack extension position schematic diagram

Safety rack nfoldment position schematic diagram

Fig. 3-58 Safety frame

### 3.16 Usage of tractor operation device

This tractor series is mainly composed of the following working devices:( optional for some devices)

- Hydraulic lifter: the force-position combined adjustment shall be preferred when plowing operation is added so as to ensure operation effect;
- Simply hydraulic output: mainly used for hydraulic trailer etc.
- Hydraulic output device: used for hydraulic reversible plough, hydraulic harrow etc.
- Suspension mechanism: mainly used for hooking agricultural implement etc.
- PTO device: Mainly used for power needed agricultural implement etc.
- Pendulum towing device: mainly used for harrow, mower, tractor-powered seeder etc.
- Towing rack: mainly used for signal-axle trailer and double-axle trailer etc.

Select farm implements for the tractor

Important: Select agricultural implements for the tractor Overly high power might result in damage of agricultural implements, and oversize agricultural implements may lead to damage of the tractor. (Before installation the agricultural implements, refer to your agricultural implement manual for the agricultural

## Operation Instructions

implements' maximum and minimum power, so as to make the agricultural implement match your tractor)

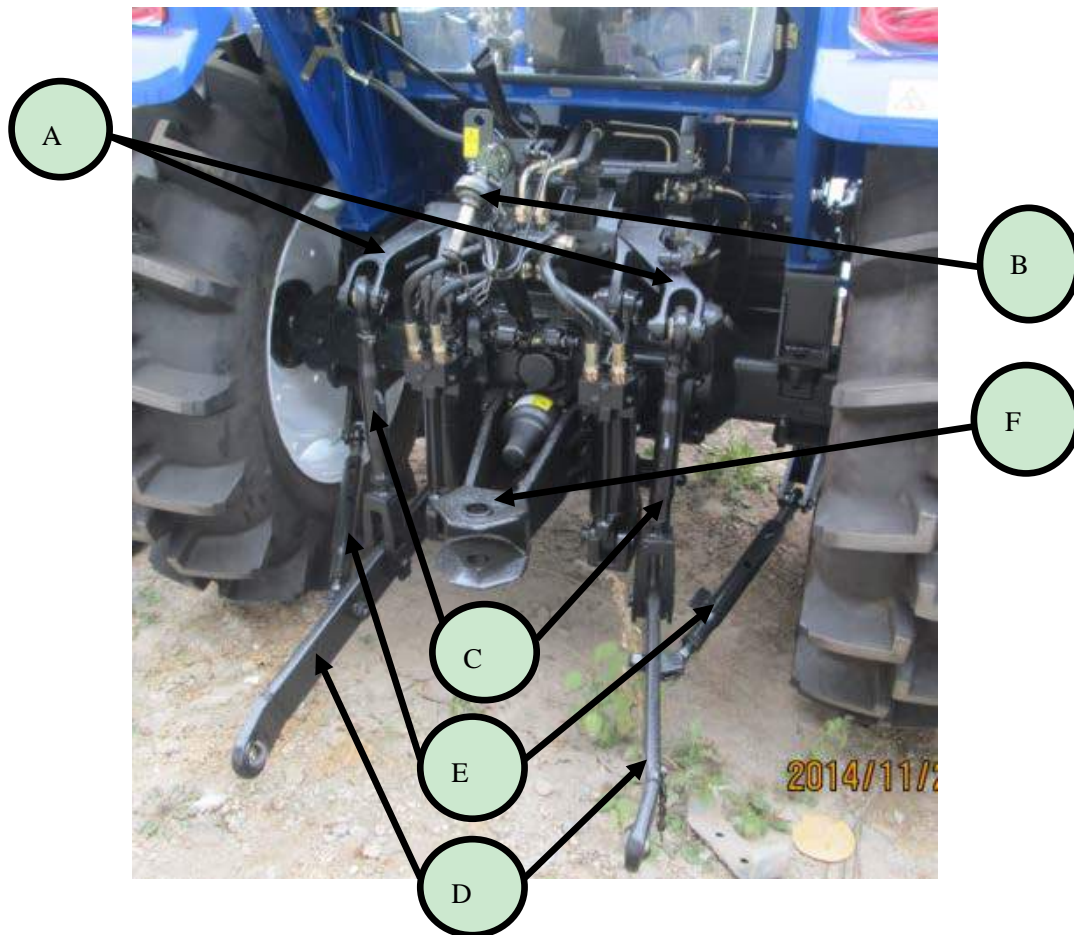

Fig. 3-59 Suspension mechanism

A. Lift arm    B. Upper link    C. Lift link    D. Lower link    E. Stop link    F. Traction

### 3.16.1 Operation of hydraulic lifter

#### 3.16.1.1 Semi-separated hydraulic lifter control type

Semi-separated hydraulic lifter is functioned by position control, force and position control and floating control etc. When the hydraulic lifter working, its handle is used for lifting/lowering agricultural implement to



## Operation Instructions

control the tilling depth.

- Position control: when the tractor begins to rotary tilling, mowing and harvesting etc with the agricultural implement, the upper pull rod is pulled, causing force control spring out of function. At this time, please adopt the position control.

Within position control, the lifting/lowering amount of agricultural implement is proportional to forward/backward moving amount of control handle. The more the control handle

moves forward (lowering direction), the more the agricultural implement lowers. Inversely, the more the control handle moves backward (raising direction), the more the agricultural implement rises.

- Force-position combination control: The force-position combination control is that the force control and position control is activated simultaneously to control the plowing depth of the implement, which is suitable for plowing the soil with a large soil specific resistance. It is able to prevent the deep soil from being plowed to ground surface due to sudden descending of the implement resulting from sudden decrease in soil specific resistance during plowing. During plowing, the control handle is used to control plowing depth. Within the combination control range, the further the control handle moves toward (down direction), the bigger the plowing depth is, vice versa. When it is adjusted to the required plowing depth, loosen the wing nut on the control plate, and move the stop block to the control handle, and then tighten the wing nut. This can ensure that the control handle is stopped at the stop block every time the implement is lowered, so as to keep the plowing depth unchanged basically.

- Floating control: When an implement with a depth roller, the floating control should be adopted. Have the control handle placed at the floating position, and at this moment, the hydraulic system is in floating status and the lifting arm can be swung freely. Then the lifting arm could sway freely. The tilling depth is controlled by depth roller, with ground profiling.

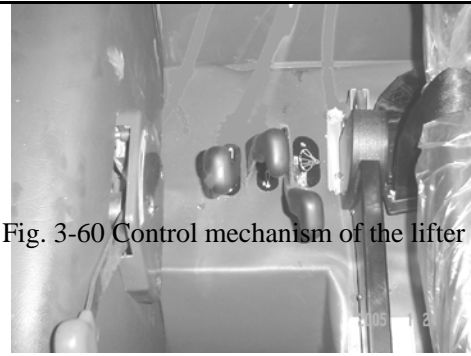

Fig. 3-60 Control mechanism of the lifter

### 3.16.1.2 Use of the separated hydraulic lifter

- When the control handle is pulled back to the rearmost position from the "Neutral" position (it is obviously felt that the control handle is locked), the suspension mechanism starts lifting up; when it reaches the terminal position, the control handle returns automatically (it means return to "Neutral" position).

- When holding the control handle by hand and pulling it forward from the "Neutral" position (the control handle is not at the foremost position at this moment), the suspension mechanism starts descending; and at this moment, in case of releasing the control handle, the control handle can be returned to the "Neutral" position immediately, and stops descending;

- When the control handle is pulled to the foremost position from the "Neutral" position (it is obviously

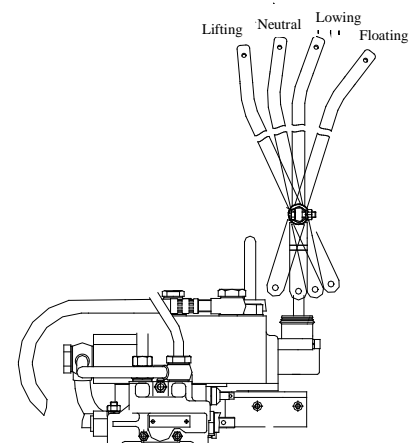

Fig. 3-61 Use of the separated hydraulic lifter

## Operation Instructions

felt that the control handle is positioned), the suspension mechanism is at "Floating" status after being descended to the terminal position.

### 3.16.1.3 Control of the implement descending speed (Semi-separated type hydraulic lifter)

To adjust the descending speed of the implement and lock the implement at required position, a descending speed control hand-wheel "A" is provided (See Figure 3-58). When turning the hand-wheel in counterclockwise direction, the descending speed of the implement slows; when turning the hand-wheel in clockwise direction, the descending speed of the implement increases. During use, an appropriate descending speed of the implement is selected according to quality and size of the implement and ground hardness, so as to avoid damage to the implement resulted from too fast descending speed.

When the tractor with an implement is transported, the implement should be lifted to the highest position, and then the descending speed control hand-wheel is screwed out in counterclockwise direction to enable the implement not to descend, and at this moment, the implement is locked at the highest position to activate the hydraulic lock to safely transport the tractor with the implement.

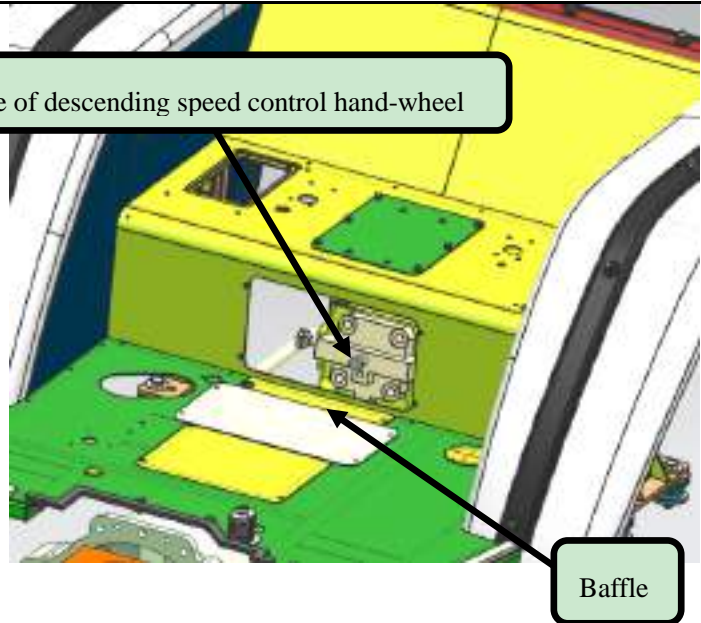

Fig. 3-62 Use of descending speed control

**Note: The lifter and simple hydraulic output cannot be used simultaneously. When the simple hydraulic output is not required, dismantle the hydraulic output pipeline, re-tighten the sleeve and hollow bolt onto the cylinder head, and turn the descending speed control hand-wheel in counterclockwise direction, open the oil line to the lifter cylinder, so that the lifter can work again.**

### 3.16.2 Simple hydraulic output (Semi-separated type hydraulic lifter)

## Operation Instructions

When the hydraulic output is required, the following steps should be carried out:

- Push the control handle to the down position to lower the suspension lever part at the lowest position;
- Thoroughly tighten the descending speed control hand-wheel "A" in clockwise direction to close the oil line to the lifter cylinder.

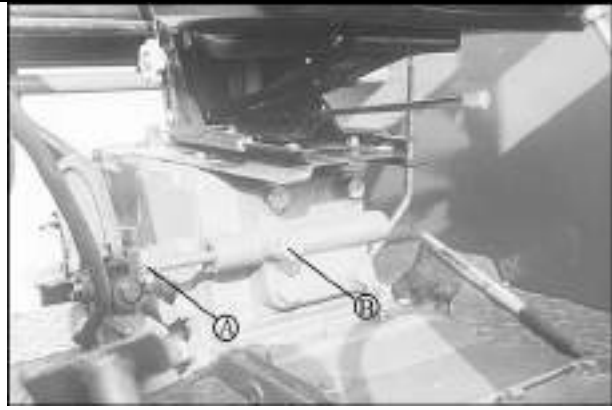

Fig. 3-63 Simple hydraulic output

- Unscrew the hollow bolt "B" of the hydraulic output from the cylinder head, remove the sleeve, connect the high-pressure oil pipe, set the control handle to "Up" position, so that the pressure oil can enter the hydraulic output device for hydraulic output. If the oil is returned via the hydraulic output device, only the control handle can be set to Down position.

**Important: When an implement with a power take-off is required, it is required that the implement be lifted above the ground and the lifting height having no influence on steering of the tractor in the field be guaranteed, for the purpose of preventing excessive lifting height of the implement resulting in damage to the drive shaft that is connected from the PTO shaft to the implement.**

### 3.16.3 Operation and use of hydraulic output device

The tractor can be installed with 1 or 2 optional spool valve type hydraulic output multi-way valve as required. Two valves are controlled by C and D operating handle, respectively, so as to control two double-action oil cylinder on the implement. Use 4 M10 bolts to fix the multi-way valve onto the multi-way valve fixing plate. The fixing plate is connected with the housing of the rear axle half shaft. The oil inlet and oil return port of the multi-way valve are connected with the gear pump and lifter, respectively, and the oil outlet is connected to the oil inlet of the distributor. Each control valve has female connection A1 and B1 and A2 and B2 of 2 M22×1.5 quick-change connectors (as shown in Figure

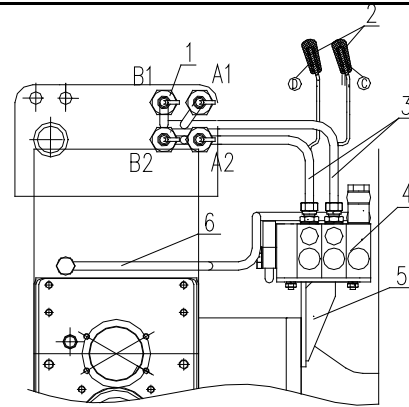

Fig. 3-64 Hydraulic output device

1. Quick-change connector
2. Control-handle
3. Multi-way valve pipeline
4. Multi-way valve assembly
5. Multi-way valve fixing plate
6. Oil return pipe assembly.

3-60). When the connection is not used, have it sealed with a sealing cover. During use, connect the spare male connection (placed in the spare parts box) to the oil inlet and outlet of the hydraulic implement, and then connect the female connection of the quick-change connector. The control handle "C" is used to control the first hydraulic output A1 and B1, and the control handle "D" is used to control the second hydraulic output A2 and B2. If a single-action cylinder is connected, the oil pipe of the oil cylinder is connected the first output A1 or second output A2. Operating the control handle "C" and "D" upward and downward, and operating the

## Operation Instructions

single-action or double-action oil cylinder can complete corresponding action. Two hydraulic output valves can realize single-action hydraulic output or double-action hydraulic output by screwing in or screwing out the single- and double-action screw "E" on the multi-way valve (Shown as Figure 3-61). Unscrew the screw "E" in counterclockwise direction to realize single-action hydraulic output. On contrary, screwing in the screw "E" is able to realize double-action hydraulic output.

When using quick-change coupler, please firstly complete the following work, and then insert the positive pole of agricultural implement into negative pole.

- Stop the engine
- Lower the hitched agriculture tool
- Forward or backward moving the hydraulic output control handle could eliminate the pressure in the hydraulic quick-change connector block
- Remove the sealing cover on the quick-change negative connector and clean the quick-change connector.

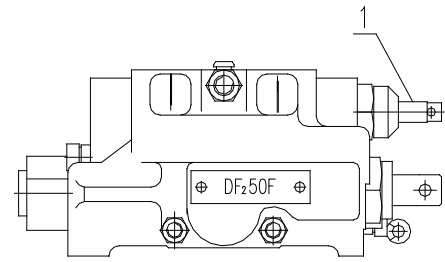

Fig. 3-65 Multi-way valve assembly  
1. Single/double action switching screw "E"

### Important:

1. When not in use of quick-change coupler, its hole should be covered by dust cover.
2. After hydraulically output device is operated over, its operating handle should be set to neutral position, otherwise, it may cause hydraulic system overheat;

### Important:

1. If the tractor with agricultural implement transferring for a long distance, please shorten the upper pull rod and adjust the limit rod to avoid swinging of agricultural implement. Whilst tighten the nuts from the upper pull rod and limit rod to avoid damaging machine caused by excessive swing.
2. Please lift the agriculture implement to steer the tractor if needed at the field edge. Doing so could avoid damaging machine. You can lower the agricultural implement after straight traveling.

### 3.16.4 Use of suspension mechanism

## Operation Instructions

Lovol Oubao TD Series Tractors adopt a rear three-point suspension device to couple the implement. The maximum lifting travel of the lower draw bar (factory status: the lifting lever is connected with the "B" hole) is 635mm for the semi-split type, and 660mm for the split type.

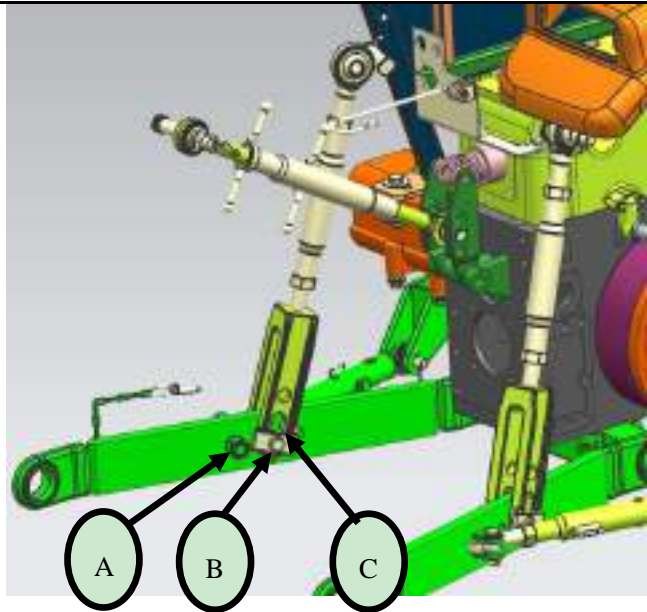

Fig. 3-66 Lower tied

3.16.4.1 Before connecting, please check the swing type towing rod or other possible objects for interference. Move it forward or remove it as needed.

3.16.4.2 The tractor runs to the agricultural direction to align with the towing point. Place the main gear lever to neutral position, depress the brake pedal and simultaneously lift the hand brake.

3.16.4.3 Place the hand accelerator to the lowest position to idle for 1-2min, then shut down engine to connect the agricultural implement.

### 3.16.4.4 Lower tied rod connection

The lower tie rod and the lifting lever have two connecting holes, i.e. front hole "C" and middle hole "B". During normal operation, the middle hole "B" is connected usually, but when long-distance transportation of the implement to be suspended is required, the front hole "C" should be connected.

The hole connecting the lower draw bar to the limit rod is the rear hole "A".

### 3.16.4.5 Connection of lifting rod

Generally, length of the lifting rod should be adjusted to its intermediate length. Generally, length of the lifting rod should be adjusted to its intermediate length. The left and right lifting rods can be adjusted by turning the guide pipe weld unit of the middle lifting rod. Adjustment of the lifting rod mainly refers to adjustment of horizontal position of the implement. The following instructions are given by taking the plough adjustment as an example:

- Regulation of left level and right level of plough frame: Regulate length of right lifting lever to make plough frame keep level, so as to guarantee the consistent tilling depth. Unscrew the nuts at both ends of spiral pipe, rotate the regulation plate of right lifting lever clockwise, extend the right lifting lever, make the tilling depth of the first bottom plough become deeper, and then shorten the lifting lever by rotating regulation plate counterclockwise. Generally, it is not necessary to regulate the left lifting lever, and only when the regulation amount of right lifting lever is not enough, can the left length be regulated to meet requirements. After the regulation is completed, screw down nuts at both ends of spiral pipe of lifting lever, so as to avoid position change during the using.

## Operation Instructions

- Adjustment of front and rear level: adjust the upper draw bar of the suspension mechanism, and when front furrow depth or rear plough heel leaves the bottom of ditch, extend the upper draw bar, and for rear furrow depth, shorten the upper draw bar to keep□□
- Adjustment of tilling width: the adjustment of tilling width is achieved mainly by adjusting the tilling width adjuster of plough. Front and rear relative positions of left and right lower suspension points can be changed by adjusting the tilling width adjuster. If the right lower suspension point is moved forward, the tilling width will be increased; otherwise, the tilling width will be reduced. The normal position of plough frame can be guaranteed by adjusting the tilling width adjuster to avoid any repeated plough or missed plough.

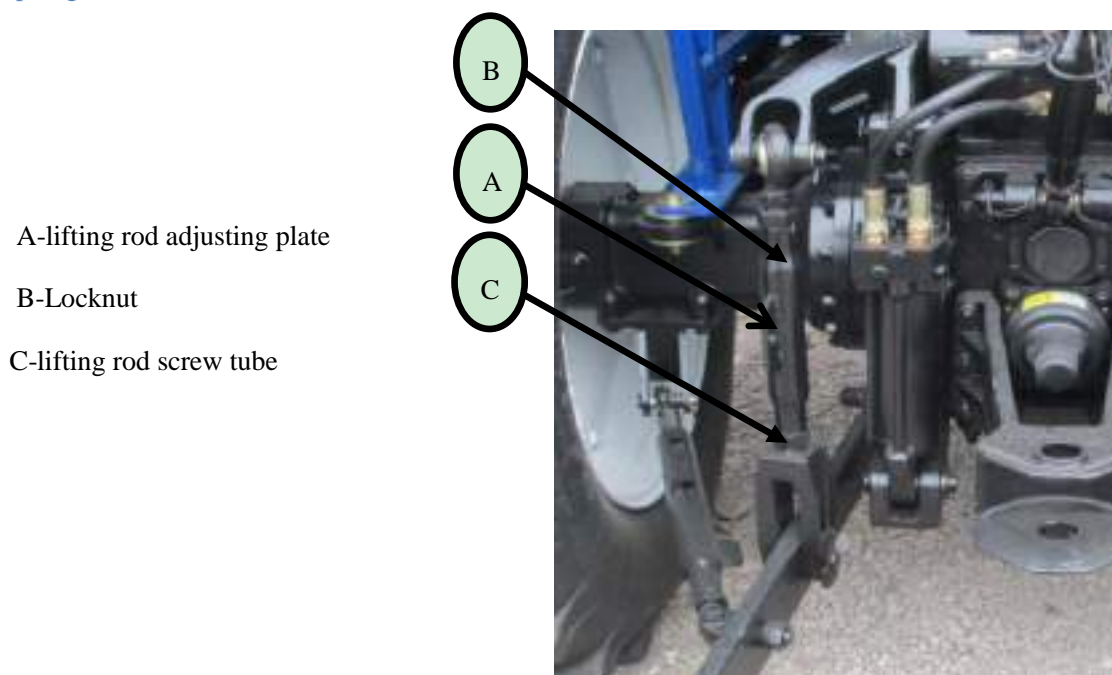

### 3.16.4.6 Upper draw bar connection

Fig. 3-67 Regulation of

The upper link is connected with the support via 3 holes. An appropriate position is selected according to the post height of the implement. Generally, when the post height is equal to or less than 510mm, select the lower hole; when the post is between 510~610mm, select the middle hole; when the post height is equal to or more than 610mm, select the upper hole. Adjustment can also be conducted according to actual conditions. Adjustment of the upper link is mainly carried out to adjust the longitudinal and horizontal position of the implement, and adjust consistency in the front and rear plowing depth.

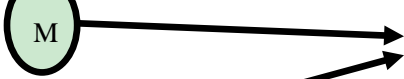

### 3.16.4.7 Adjustment of limit rod

The limit rod is mainly used to limit lateral oscillation of the implement (i.e. the lower tie rod). Insert the pin into the long hole of the limit sleeve so that the limit rod can be moved with a certain range; when the pin is inserted into the front hole of the limit sleeve, the limit rod can be kept standstill. Turning the threaded limit sleeve can adjust length of the limit rod. The rear hole is used to receive the pin when adjusting length of the limit rod.

The movement of the limit rod is selected according to working type of the implement. The limit rod should be moved within a certain range when the tractor with a plough or harrow is working, so that the tractor has excellent operating performance. The limit rod should be fixed when the tractor with a rotary plough or mower is working.

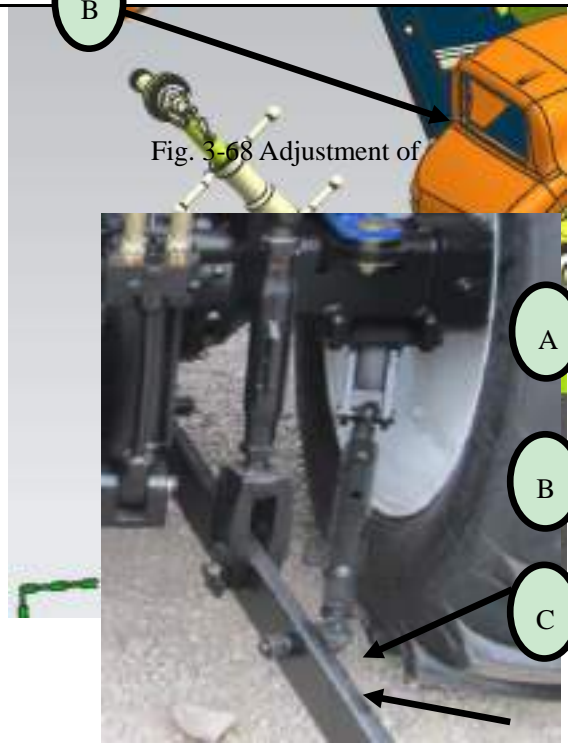

Fig. 3-69 Adjustment of limit rod  
A-Limit rod extension guide lever B-Limit rod pin  
C-Limit rod sleeve

# Operation Instructions

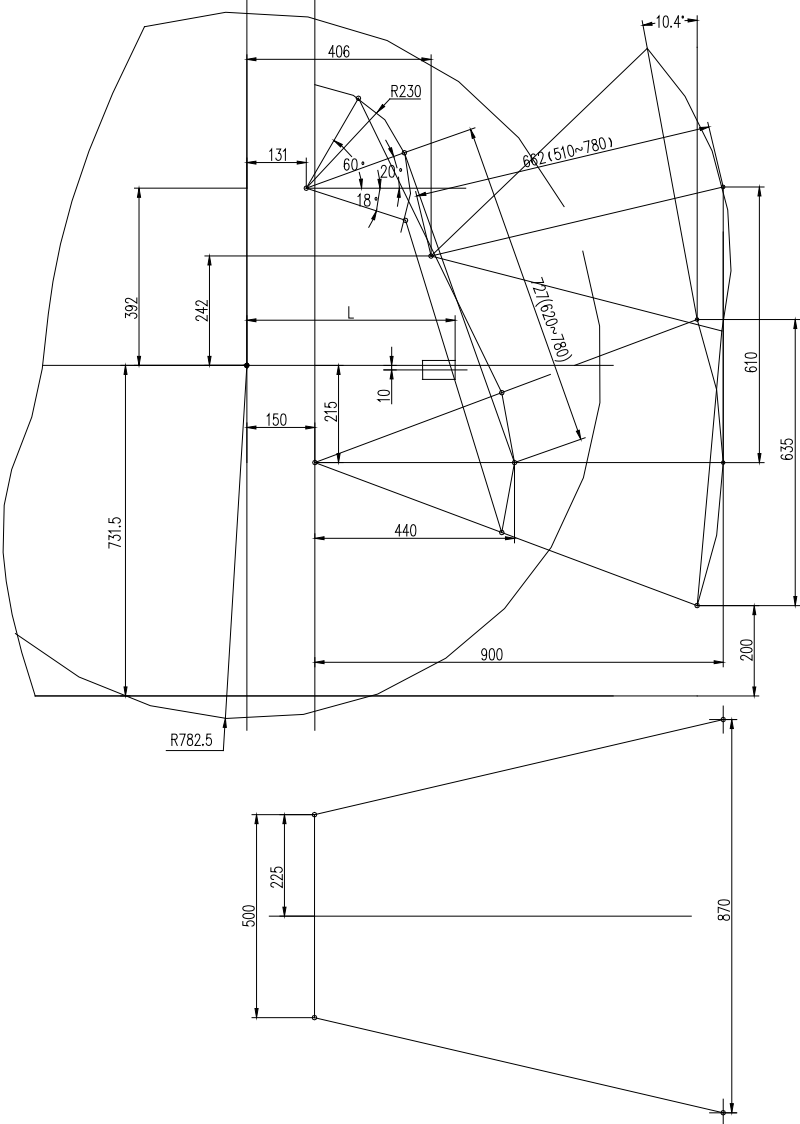

Fig. 3-70 Diagram for Movement of Suspension Mechanism for the Vehicle Model  
with a Semi-separated Type Lifter



# Operation Instructions

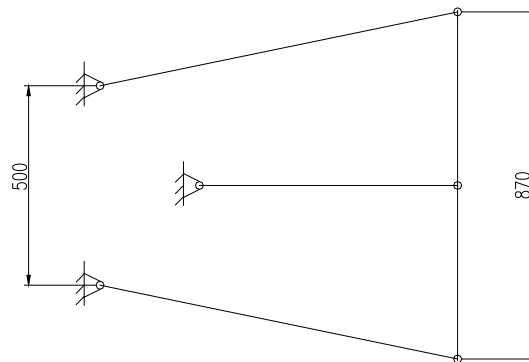
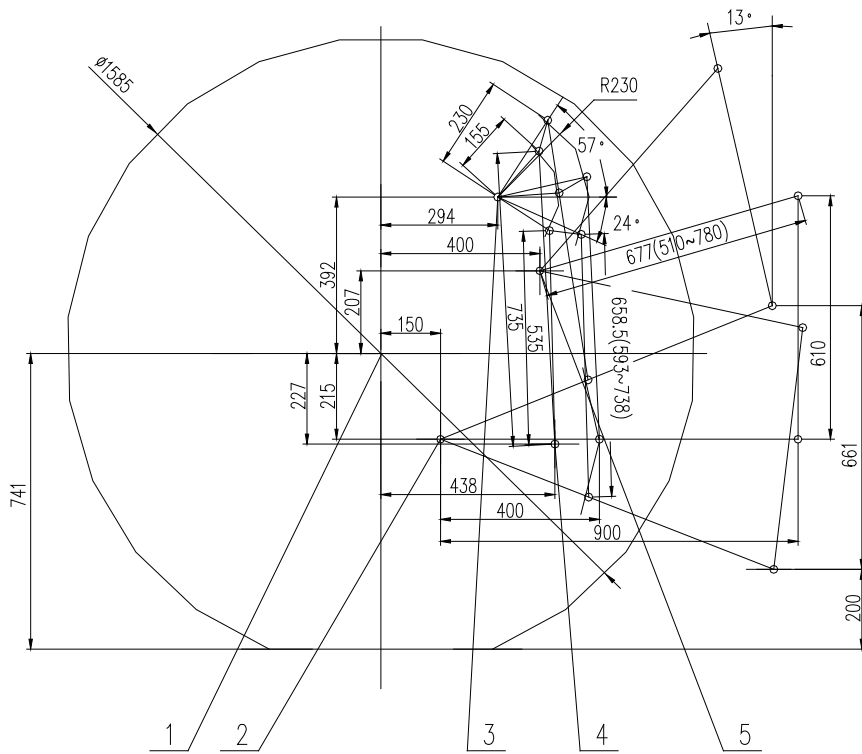

Fig. 3-71 Diagram for Movement of Suspension Mechanism for the Vehicle Model  
with a Semi-separated Type Lifter

1. Driving wheel center
2. Lower hinging point
3. Connecting point of lift shaft
4. Supporting point of oil cylinder
5. Upper hinging point

## Operation Instructions



### Attention:

1. After adjusting the suspension rod's length, tighten the locknut in time, so as to avoid premature damage of the rod pieces and other damages;
2. In case the tractor is not equipped with farm implement and trailer, etc., securely lock the left and right lower draw bars with link chain, and insert limit rod lock pin into the limit rod's round hole, so as to avoid collision with other parts.

### 3.16.5 Operation of PTO

The PTO shaft of the **LOVOL-TD series tractors** is an independent type. The tractor is able to carry out working in a mobile manner or in a fixed manner. The PTO works independently. By depressing the main clutch pedal, the tractor stops forward movement, and the PTO shaft is able to continue working. If the auxiliary clutch control handle is pulled, the PTO shaft stops working, but the tractor can continue to drive forward. When the supporting implement of the tractor requires PTO, the operation should be carried out according to following steps:

- Have the implement coupled with the suspension mechanism;
- Pull the auxiliary clutch control handle, and set the PTO control handle to the neutral position;
- Unscrew the PTO shaft sleeve, and then couple the upper cardan joint of the implement with the PTO shaft;
- Install the PTO protective cover;
- Set the control handle of the lifter to "Lift" position to lift the implement.
- Pull the auxiliary clutch control handle again, and select the PTO speed as required. Push the PTO control handle downward to engage the high speed gear of 1000r/min (or 850r/min); if it is pulled upward, it is engaged at low speed gear of 760r/min (or 540r/min). When PTO is not required, the PTO control handle should be in the neutral position, and the PTO shaft sleeve should be re-installed and tightened.



**Warning: When engaging PTO, nobody should be close to the agricultural machine so as to avoid injury.**

### 3.16.6 Use of trailing equipment

#### 3.16.6.1 Swing type draw bar

The swing type draw bar is only used for the pull-type implement. The rear end of the draw-bar is connected with the implement via the draw bar pin. The draw-bar can be oscillated laterally, and the implement should be coupled easily. During operation, the draw bar can swing from side to side, but when the tractor

## Operation Instructions

draws the implement in reverse direction, the 2 dowel pins must be inserted into the hole of the drawplate to keep the drawbar standstill.

Turning the draw bar over can change height of the towing point to obtain a towing height suitable for the supporting implement.

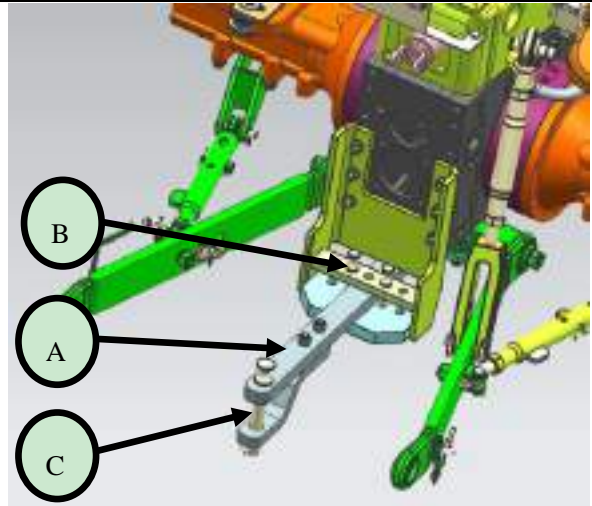
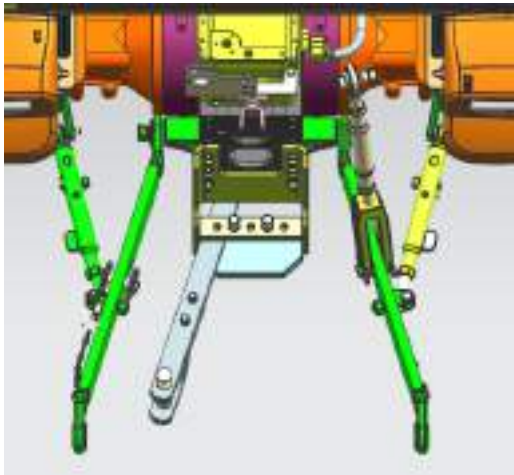

Fig. 3-72 Use of draw bar (delivery status of the complete vehicle)

A-Swing Lever    B-Locating Pin    C-Traction Pin



The traction lever swings to left  
(with swing angle of 15°).



The traction lever swings to right  
(with swing angle of 15°)

### 3.16.6.2 Towing frame

The towing frame is suitable for various types of trailers, and cannot be installed together with the swing draw bar.

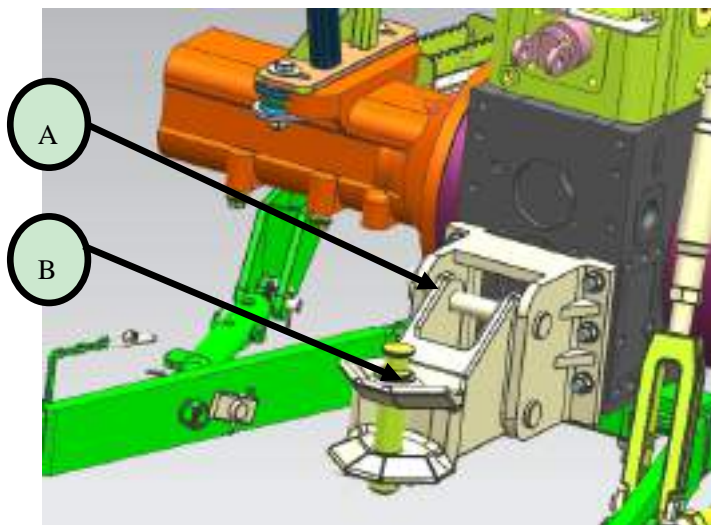

Figure 3-73 Towing

A-Towing Frame    B-Towing Pin

## Operation Instructions



### Warning:

1. Do not exceed the limit load during towing or with trailer. Otherwise the machine life will be shortened or even serious accidents may occur.
2. When braking, apply trailer brake before tractor brake. Otherwise rollover accident may occur.

### 3.16.7 Operation of the trailer brake system

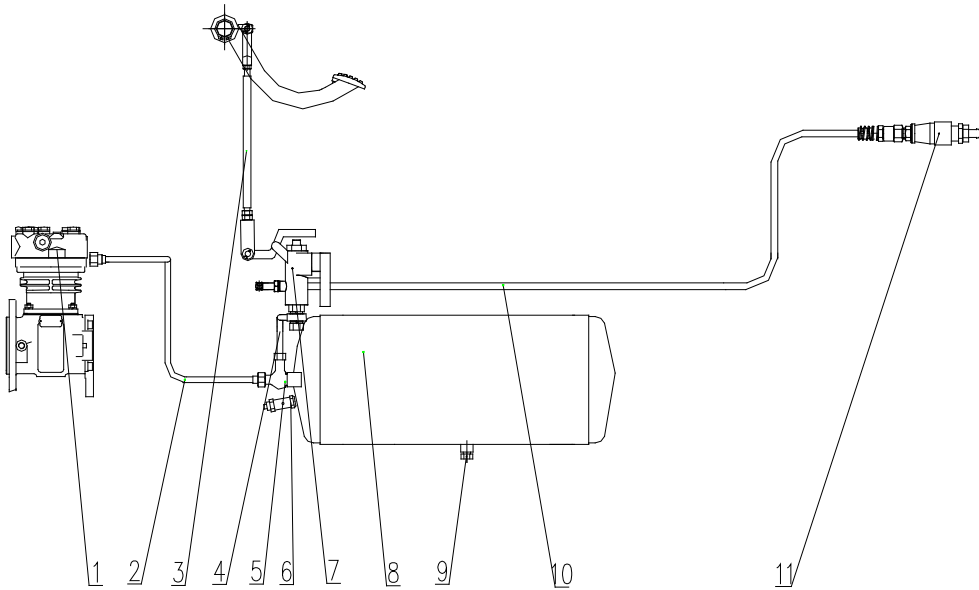

Fig 3-74 Trailer brake system

- 1 Air compressor 2. Air receiver inlet pipe 2. Push rod 4. Air delivery pipe 5. Tee union 6. Safety valve assembly 7. Shut-off brake valve 8. Air receiver 9. Plug 10. Brake valve air outlet 11. Quick coupler

The trailer air brake system is a "shut-off" control system. It is required that its supporting trailer must be equipped with a complete "shut-off" control device. For the trailer that is only equipped with a "air supply" control brake device having a brake air chamber and controller, the "air supply" control system must be modified with a "shut off" control system.

- If the tractor transporting with trailer, please take note the air pressure indicator lamp. The air pressure in the air reservoir should not be less than 0.45MPa. Otherwise, you are allowed to drive the tractor only raising the air pressure to set value.

- Generally, the balance pressure in the air reservoir should not be less than 0.70MPa. When the engine is stopped, if the barometer reading drops rapidly, it indicates that there is an air leak. Check and remove it in time.

## Operation Instructions

- The opening pressure of air reservoir safety valve is (0.75~0.8) MPa, and if the air pressure alarm alarms when using, make adjustment timely.
- During use, if the pressure of tractor air reservoir is normal while the pressure of trailer air reservoir is lower (represented by that effective braking of trailer cannot be guaranteed), only adjust the adjusting screw on the left of the brake valve.
- If the air pressure is always within (0.75~0.8)MPa or more, it indicates the relief valve will not work. Please timely clean or replace the relief valve.
- If the tractor transporting with trailer, please check the whole braking system to ensure the trailer braking is synchronizing with tractor braking or is slightly in advance rather than lag behind. You can adjust the adjusting screw on the brake valve to satisfy the requirements if necessary. If necessary, adjust the adjusting screw of brake valve to meet the above requirements.



**Warning:**

- 1. If the trailer braking lags behind the tractor braking, rollover may occur.**
- 2. The two adjusting screws of brake valve pull rod are already adjusted on the exclusive test bed when delivery, and coated with red mark. Do not screw it at will to avoid invalid braking.**
- 3. After each 50h, open the drain valve to drain the deposited water in the reservoir to ensure braking system normal work.**

### 3.16.8 Use and adjustment of electrical system

The electric system of **LOVOL-TD Series tractors** adopts a double-wire system at voltage of 12V, with negative pole of the silicon rectification generator being bonded. It is composed of engine startup equipment and lighting signal devices. The engine startup equipment include starter motor and silicon rectification generator. For details about use and maintenance of the equipment mentioned above, see the instructions for engine operation and maintenance. The lighting and signal unit is composed of front combination lamp, reversing lamp, cab ceiling lamp, handrail lamp (steering and position), rear tail-lamp (steering, position and braking), and central electric box.

The diagram for electric circuit of **LOVOL-TD Series tractors** is shown in Figure 3-69. For details on electric circuit number, nominal sectional area and conductor color, see Table 3-2.

Table 3-2 LOVOL TD series tractor wire No., nominal sectional area and wire color

Wire NO.	Nominal cross section	Wire Color	Wire number	Nominal Cross section	Wire Color	Wire number	Nominal Cross section	Wire Color	Wire number	Nominal Cross section	Wire Color

## Operation Instructions

1	4.0	Red (R)	13	0.75	Green Blue (GL)	26	0.75	Orange (O)	39	4.0	Brown (Br)
1b	2.5	Red (R)	14	1.0	White red (WR)	27	0.75	Green black (GB)	40	0.75	Gray
2	1.5	Pink (V)	15	1.5	Blue red (LR)	28	0.75	Orange blue (OL)	42	2.5	Black (B)
3	4.0	Red white (RW)	16	1.0	Red white (RW)	29	0.75	Green Gray (GS)	50	1.0	Pink (V)
4	1.5	Yellow (Y)	17	0.75	Pink Green (VG)	30	0.75	Brown Yellow (BrY)	51	1.0	Pink White (VR)
5	1.0	Green (G)	18	0.75	Brown (Br)	31	0.75	White (W)	53	0.75	Red Brown (RBr)
6	1.5	Blue (L)	19	0.75	Light Blue (LU)	32	0.75	Brown white (BrW)	54	0.75	Blue Green (LG)
7	1.0	Yellow Black (YB)	20	0.75	Red white (RW)	33	0.75	Red Green (RG)	55	0.75	Red Gray (RS)
8	0.75	Gray White (SW)	21	0.75	Blue Black (LB)	34	1.0	White Blue (WL)	56	0.75	Light Green (LuG)
9	1.0	Red Blue (RL)	22	0.75	Red Black (RB)	35	0.75	Green Red (GR)	57	0.75	Gray Black (SB)
10	1.5	Yellow Red (YR)	23	1.0	Purple (P)	36	0.75	Purple Black (PB)	10a	0.75	Yellow Red (YR)
11	1.0	Red Yellow (RY)	24	1.5	Green White (GW)	37	1.0	Purple Yellow (PY)	42a	0.75	Black (B)
12	1.0	Yellow Blue (YL)	25	0.75	Brown Red (BrR)	38	0.75	Brown Green (BrG)			

### Rear lamp and rear tail lamp

Position drawing for rear lamp and rear tail lamp (steering, position, braking).



Fig.3-75 Rear lamp and rear tail lamp

## Operation Instructions

### Plug socket of rear trailer

The rear trailer connector socket is wired at the position shown as Figure 3-67. The wiring instructions are as follows:

Contact point 1: connect with the left steering lamp

Contact point 2: naught

Contact point 3: ground wire

Contact point 4: connect with the right steering lamp

Contact point 5: connect with right

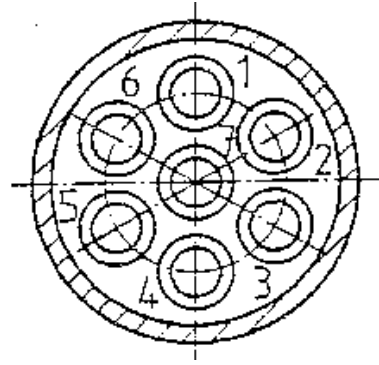

Fig. 3-76 Trailer socket

### Roof lamp

There are four cab roof lamps, which are positioned at front upper part and rear upper part of the cab. The front roof lamps of the cab are shown as the right figure.

The roof lamp body can be turned to right/left as required during working, so as to meet requirement for change in light direction.



Fig. 3-77 Roof lamp

### Central electrical control box

A main power supply relay, electronic flash indicator, light relay and other electric circuit control components are set in the central electric box. And, there are 15-way fuses. Working current and electric apparatuses protected at each gear are shown in Table 3-3. When the electric components are disconnected, first inspect the fuse in the electric box; in case that the fuse is damaged, remove a spare fuse with same current rating for displacing the damaged one immediately, so as to ensure no damage to the electric components.

## Operation Instructions



Fig. 3-78 Central  
electrical control box

Table 3-3 Working current of each way and protected electrical elements

Unit: A

Range of the fuse box	I	II	III	IV	V	VI	VII	VIII	IX
Rated working current	10	10	20	10	10	20	5	20	15
Protected electric apparatus	Brake lamp and horn	Steering lamp alarm	Wiper and air conditioner	Dipped beam of headlamp	Far beam of headlamp	Accessories power supply	Position lamp	Roof lamp	Light relay



# Operation Instructions

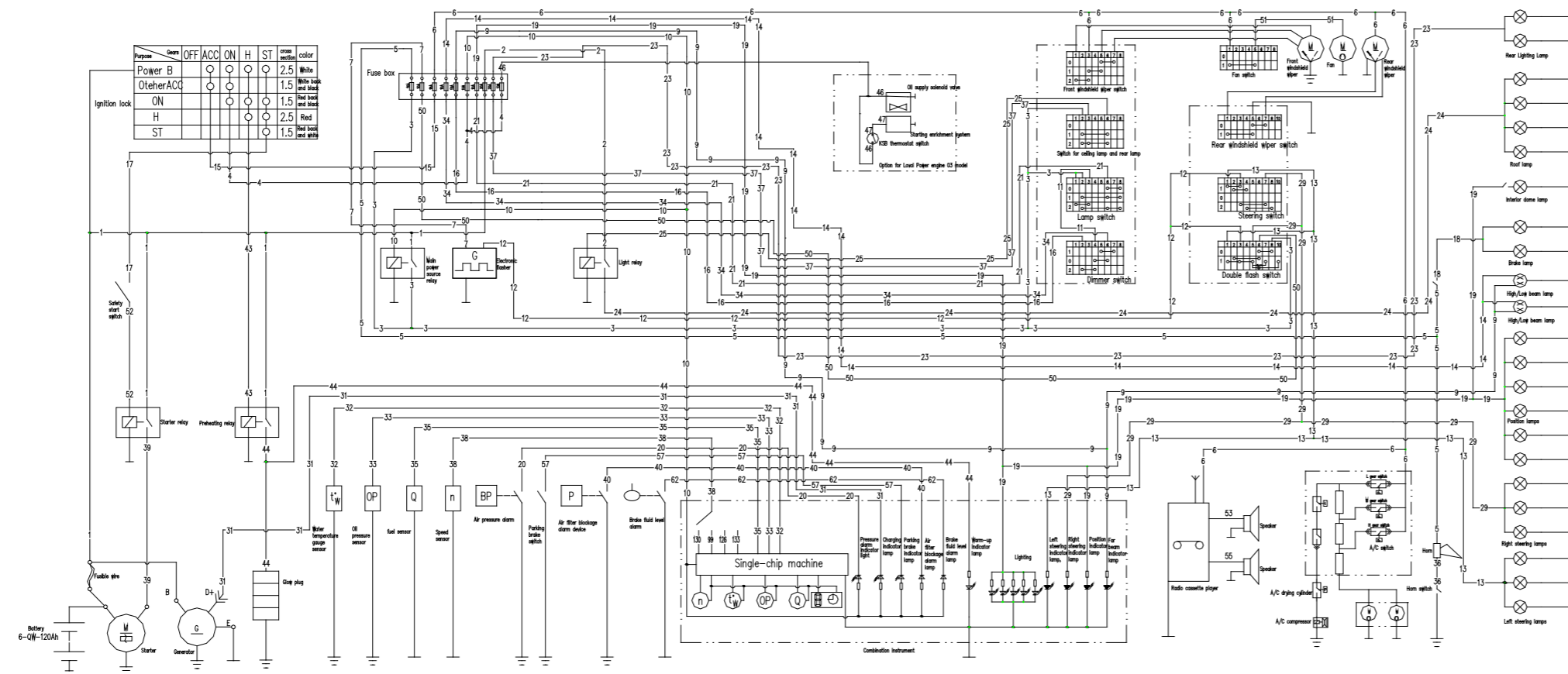

Fig.3-77 electrical schematic diagram

## Operating Instructions

### 3.17 Running-in of tractor

A series of work called running-in should be done to a tractor before use, i.e., make it run under specified lubrication, speed, and load conditions for some time, and at the meanwhile conduct necessary inspection, adjustment and maintenance to normalize.

#### 3.17.1 Preparations before running-in

- During running-in period, perform technical maintenance on the tractor every shift and every 50 hours.

(See the Maintenance Instructions in the Section 5 of this manual.)

- Check and tighten the tractor external bolts, nuts and screws.
- Add lubricating grease in the oil cups of the front hub, front drive axle pin and the water pump shaft.

Check the oil levels of engine oil pan, transmission and lifter, the central and final drive of the front drive axle.

Fill as required.

- Fill fuel oil and coolant conformed to label.
- Check whether tire pressure is normal.
- Check whether electrical circuit is normal and reliable.
- Each control handle is placed at neutral position.

#### 3.17.2 Engine idle running

Keep the engine at idle running for 15 minutes. After its startup, keep the engine running at low-speed (Low accelerator), medium-speed (Medium accelerator), and finally high-speed (High accelerator), each for 5min (minutes) in the order as specified in "Operation and Maintenance Instructions for Diesel Engine".

In the process of engine's idle running, check carefully the working conditions of engine, air compressor and hydraulic pump to observe whether there are any anomalies and sound, leakages of water, oil and air. Inspect if the instrument works properly. In case of any off-normal occurrence, immediately shut it down and start running-in after troubleshooting.

Conduct the following running-in after ensuring that the engine could work perfectly and normally.

#### 3.17.3 Power output shaft running-in with no load

Place the engine accelerator control lever in the medium accelerator position to enable the engine running at medium speed. Keep the power output shafts rotate at low speed and high-speed respectively, each for 5minutes, and check for anomalies. After running-in, make sure the PTO shaft is in neutral position.

## Operating Instructions

### 3.17.4 Hydraulic system running-in

Start the engine to operate with the accelerator being placed on the accelerator position, maneuver dispenser handle to lift and drop suspension mechanism several times to observe whether there is any anomaly. Then hang a mass of about 800kg (kg) weight or mating farming tools of the same weight on the suspension mechanism, let the engine operate in the large accelerator position, manipulate dispenser handle to make the suspension mechanism rise and fall at whole stroke not less than 20 times. Check whether the hydraulic suspension mechanism can be fixed at the highest position or desired position, the lifting time and whether there is any leakage.

Keep the tractor stand still and the engine operate at low, medium and high-speed, steer the steering wheel smoothly to the left and right for 10 times respectively, and observe the follow-up conditions of the tractor! front wheel steering, whether the sound is normal, and the steering wheel manipulation is light and smooth.

If any fault is found in running-in, a timely analysis of the causes should be made and ruled out.

### 3.17.5 Tractor Running without Load and Running-in with Load

After idling running-in of the engine and running-in of the PTO shaft and hydraulic system, the complete machine can be subject to running-in only after confirming that technical status of the tractor is fully normal. The running-in sequence and time is as follows: When being idle running-in, exercise turning and use unilateral brake properly at low speed, and test emergency braking at high speed.

Only when the technical state of the tractor is completely normal after the idle running-in, can load running-in be carried out with load increasing from small to large, gear position changing from low to high. The tractor having an optional creeper gear can be engaged in the creeper gear for running-in operation. When the four-wheel drive tractor can be engaged in the I~IV gear for run-in operation, the front drive axle can be engaged; when the tractor is engaged, Attention should be paid in the running-in process to:

- Observe whether the readings of electrical equipment and various instruments are normal
- Whether the engine is running properly.
- Whether clutch engagement is smooth and separation is complete.
- Whether gearbox shifting is light and flexible, whether there is any random gear change or spontaneous out-of-gear.

- Whether the brake works reliably.
- Whether engagement and separation of the differential locks is reliable.
- Whether the engagement and separation of front drive axle is reliable.

Faults should be excluded when found before running-in continues.

## Operating Instructions

### 3.17.6 Technical maintenance after running-in

After running in the tractor, there will be metal filing or dirt in the lubricating oil of the drive system, lubricating system and hydraulic system. Therefore, be sure to drain the oil in such systems and pour new oil in them. Perform the necessary technical maintenance on the tractor before putting it into normal operation.

The technical maintenance after running-in is as follows:

- Discharge the engine oil in the engine oil pan and the steering system while hot after the shutdown, clean the oil pan, oil filter screen, air filter and filter screen in the steering tank, replace the filter element of diesel filter and oil filter, and then fill in new lubricating oil according to the technical requirements.
- Drain the oil in the drive system, hydraulic system, steering system and front drive axle when it is hot, and add some light diesel oil or kerosene properly. Without starting the engine, drag the tractor slowly forward or backward for about 3 min (minutes) or with the front and rear wheels of the tractor off the ground, turn the front and rear tires in two directions for about 3 min (minutes), and then drain the cleaning fluid immediately. Meanwhile, remove the suction filter of the lifter and clean or replace it. Re-install the suction filter, and then add new oil to the power train system, hydraulic system, steering system and the front drive axle as required.
- When conducting first maintenance of the hydraulic system with an independent oil supply, its hydraulic oil may not be changed, but only cleaning or replacing the filter element is required.
- Maintain the diesel engine according to "Operation and Maintenance Instructions for Diesel Engines".
- Drain the coolant. Clean the engine cooling system with fresh water, and then add new coolant.
- Check the toe-in of front wheels, and free travels of the clutch and brake. If necessary, adjust them.
- Check and tighten all external bolts, nuts and screws.
- Fill lubricating grease to each tractor parts according to Maintenance and Service Schedule.

### Important:

**1. The newly-made or overhauled tractors can only be put into normal use after the running-in; Otherwise, the service life of the tractor will be shortened.**

**2. The driver must first learn and be familiar with the manipulation and use of tractor prior to the running in.**

Table 3-4 LOVOL TD series tractor running-in specification [8F+4R or 16F+8R (creeper gear optional) ]

Traction Load (kN)	0	3~4	7~8	10.5~11.5
Equivalent operating items	Empty Driving	Transportation with 4t goods in trailer	Equipped with plough, the sand soil with specific resistance of 30 ~ 35kPa, tilling depth of 18~20cm.	Equipped with plough, the clayed soil with specific resistance of 45 ~ 50kPa, tilling depth of 20cm.
Throttle opening	3/4	3/4	Fully-open	Fully-open

## Operating Instructions

Direction	Creeper gear	Auxiliary gearshift	Main gearshift				
Forward gear	Low speed gear	Low speed gear	1	0.5			
			2				
			3				
			4				
		High speed gear	1				
			2	0.5			
			3				
			4				
	High speed gear	Low speed gear	1	0.5			
			2	0.5			
			3	0.5	2	10	8
			4	0.5	2	11	15
		High speed gear	1	0.5	4	11	15
			2	0.5	4	4	
			3	0.5	4		
			4	0.5	3		
Reverse gear	Low speed gear	Reverse gear	1				
			2				
			3				
			4				
	High speed gear	Reverse gear	1	0.5			
			2	0.5			
			3	0.5			
			4	0.5			
Total hour numbers h				7	19	36	38

Table3-5 Lovol-TD series tractor running-in specification (16F+8R shuttle type gear shift)

Traction Load (kN)				0	3~4	7~8	10.5~11.5
Equivalent operating items				Empty Driving	Transportation with 4t goods in trailer	Equipped with plough, the sand soil with specific resistance of 30 ~ 35kPa, tilling depth of 18~20cm.	Equipped with plough, the clayed soil with specific resistance of 45 ~ 50kPa, tilling depth of 20cm.
Throttle opening				3/4	3/4	Fully-open	Fully-open
Direction	Creeper gear	Auxiliary gearshift	Main gearshift				

## Operating Instructions

Traction Load (kN)				0	3~4	7~8	10.5~11.5
Equivalent operating items				Empty Driving	Transportation with 4t goods in trailer	Equipped with plough, the sand soil with specific resistance of 30 ~ 35kPa, tilling depth of 18~20cm.	Equipped with plough, the clayed soil with specific resistance of 45 ~ 50kPa, tilling depth of 20cm.
Throttle opening				3/4	3/4	Fully-open	Fully-open
Direction	Creeper gear	Auxiliary gearshift	Main gearshift				
Forward gear	Low speed gear	Low speed gear	1	0.5			
			2				
			3				
			4			6	5
		High speed gear	1				
			2	0.5			
			3				
			4			10	15
	High speed gear	Low speed gear	1	0.5		10	18
			2	0.5			
			3	0.5	2		
			4	0.5	2		
		High speed gear	1	0.5	4	10	
			2	0.5	4		
			3	0.5	4		
			4	0.5	3		
Reverse gear	Low speed gear	Reverse gear	1				
			2				
			3				
			4				
	High speed gear	Reverse gear	1	0.5			
			2	0.5			
			3	0.5			
			4	0.5			
Total hour numbers h				7	19	36	38

### 3.18 Common fault and troubleshooting for tractor

#### 3.18.1 Chassis fault and troubleshooting

##### 3.18.1.1 Clutch fault and troubleshooting

## Operating Instructions

Table 3-6 Clutch fault and troubleshooting

Problems	Causes	Troubleshooting
1.Clutch slipping	(1) Oil stains on the friction plate and pressure plate (2) Excessive wear or burn on the friction plate (3) Butterfly spring pressure is too low. (4) Pedal free stroke is small or none (5) Serious deformation of clutch driven disk	(1) Wash with gasoline, and troubleshoot oil leakage fault (2) Replace friction plate (3) Replace butterfly spring (4) Readjust free stroke of pedal according to requirements (5) Replace the clutch driven disk.
2.Clutch is not disengaged completely or gear has sound.	(1) Pedal free stroke is too large and working stroke is too small. (2) Clutch driven disk over bending (3) 3 disengaging lever heads are not on the same plane	(1) Adjust free travel of the pedal to 28~40 mm (2) Replace the driven disk. (3) Adjust according to requirements
3. The tractor starting is wobbling	(1) 3 disengaging lever heads are not on the same plane (2) Oil stains on the friction plate and driven disk (3) Driven disk over bending (4) Fastening screw of flywheel and clutch shell is loose.	(1) Adjust according to requirements (2) Clean the friction plate and driven disk. (3) Replace the driven disk. (4) Promptly park and check to troubleshoot fault

### 3.18.1.2 Gearbox fault and troubleshooting

Table 3-7 Gearbox fault and troubleshooting

Problems	Causes	Troubleshooting
1. It is difficult to shift gears or can not put into gear.	(1) Clutch is not disengaged completely. (2) The gearshift interlocking link is too long. (3) Gear shift lever head severely wears. (4) Engaging sleeve end face and gear end face was worn or damaged.	(1) Remove according to clutch trouble shooting method (2) Shorten the gearshift interlocking link (3) Replace the shift lever. (4) Replace or repair
2.Disengage automatically	(1) The gearshift interlocking link is too short (2) Locating slot of fork shaft is severely worn. (3) Inadequate interlock pin spring pressure. (4) The bearing on the gear shaft is worn, making the shaft incline.	(1) Shorten the gearshift interlocking link (2) Replace the fork shaft. (3) Adjust or replace the interlock pin spring. (4) Replace bearings
3. Gear disorder	(1) Gear shift lever head is worn. (2) Gear-shifting guide groove is badly worn. (3) Grooves of shift fork and engaging sleeve are worn.	(1) Repair or replace the shift lever. (2) Replace the gear-shifting guide. (3) Replace the shift fork and engaging sleeve.

## Operating Instructions

Problems	Causes	Troubleshooting
	(4) The locating groove of the interlocking pin and shift fork shaft is worn.	(4) Replace the interlocking pin and shift fork shaft.
4. Oil leaks from the inspection window cover at bottom of the transmission.	(1) The rear oil seal of the engine crankshaft is failed. (2) The input shaft oil seal of the transmission is failed. (3) Oil leaks from the input shaft bearing pedestal of the transmission.	(1) Replace the oil seal. (2) Replace the oil seal. (3) Re-install it after being applied with glue.
5. Noise or knocking sound in the gearbox	(1) Excessive gear wear, spalling of tooth surface or gear tooth broken (2) Severe wear or damage of the bearing (3) Inadequate or unqualified lubricant	(1) Replace the gear. (2) Replace bearings (3) Add or replace the lubricant.

### 3.18.1.3 Rear axle and brake fault and troubleshooting

Table 3-8 Fault and troubleshooting of rear axle and brake

Problems	Causes	Troubleshooting
1. The noise of central transmission increases.	(1) Clearance of small bevel gear bearing is too large. (2) Gear mesh is. abnormal. (3) Bevel gear countershaft bearing or gear is damaged. (4) Wear and scuffing of the differential shaft. (5) Planetary gear or gasket is worn. (6) Differential bearing is worn or damaged.	(1) Adjust according to requirements (2) Readjust according to requirements (3) Replace the bearing or gear. (4) Replace differential shaft (5) Replace planetary gear or gaskets (6) Replace the differential bearing.
2. Overheat of small bevel gear bearing and differential bearing	(1) Excessive preload (2) Poor lubrication (3) Bevel gear backlash is too small.	(1) Readjust the bearing preload. (2) Check the lubricating oil level and add it if necessary. (3) Readjust the backlash.
3. Final transmission sounds unusual	(1) The planetary carrier fixing bolt is loosened, and the thrust gasket is damaged. (2) Bearings, gears or shafts are damaged.	(1) Tighten the planetary carrier fixing bolt as required, and replace the thrust gasket. (2) Replace bearings, gears or shaft.



## Operating Instructions

Problems	Causes	Troubleshooting
4. Brake failure	<ul style="list-style-type: none"> <li>(1) There is air in the brake pipeline.</li> <li>(2) The brake fluid is insufficient, and oil leaks from the pipeline.</li> <li>(3) Free stroke of brake pedal is too large.</li> <li>(4) Friction plate with severe wear or inclining wear</li> <li>(5) The brake pump is blocked.</li> </ul>	<ul style="list-style-type: none"> <li>(1) Exhaust the air from the pipeline.</li> <li>(2) Handle the oil leakage, and refill brake fluid.</li> <li>(3) Readjust free stroke of pedal</li> <li>(4) Replace friction plate</li> <li>(5) Clean the brake pump.</li> </ul>
5. Tractor is off tracking when braking.	<ul style="list-style-type: none"> <li>(1) Free strokes of left and right brake pedal are different.</li> <li>(2) Damaged brake friction plates on one side.</li> <li>(3) Oil leakage occurs from the single side of the brake pipeline.</li> <li>(4) Air intake occurs from the single side of the brake pipeline.</li> <li>(5) Pressure of both rear tires are not same.</li> </ul>	<ul style="list-style-type: none"> <li>(1) Adjustment</li> <li>(2) Replace friction plate</li> <li>(3) Exclude oil leakage points.</li> <li>(4) Air exhaust</li> <li>(5) Check and inflate the tire as required.</li> </ul>

### 3.18.1.4 Driving system fault and troubleshooting.

Table 3-9 Driving system fault and troubleshooting

Problems	Causes	Troubleshooting
1. Front tires are badly worn.	<ul style="list-style-type: none"> <li>(1) Front wheel rim or wheel spoke deforms seriously.</li> <li>(2) Improper toe-in adjustment.</li> <li>(3) Two pins of steering knuckle and cylinder are severely worn.</li> <li>(4) Insufficient tire pressure during the transport operations.</li> <li>(5) The front drive axle is still engaged during transport operation.</li> <li>(6) Reverse installation of front drive tire tread.</li> </ul>	<ul style="list-style-type: none"> <li>(1) Adjust front wheel rim or wheel spoke</li> <li>(2) Adjust the toe-in.</li> <li>(3) Replace the pins.</li> <li>(4) Check and inflate the tire as required.</li> <li>(5) Disengage the front drive axle.</li> <li>(6) Reinstall the tires as required.</li> </ul>
2. Front wheels swing	<ul style="list-style-type: none"> <li>(1) Fastening nuts and bolts of ball pin, cylinder, steering arm are loose.</li> <li>(2) Improper toe-in adjustment.</li> <li>(3) Bearing clearance is too large or badly worn.</li> <li>(4) Steering kingpin is badly worn.</li> <li>(5) Front wheel rim is badly deformed.</li> </ul>	<ul style="list-style-type: none"> <li>(1) Check the fastening.</li> <li>(2) Adjust the toe-in.</li> <li>(3) Adjust or replace the bearings.</li> <li>(4) Replace the steering kingpin.</li> <li>(5) Correct the front wheel rim.</li> </ul>
3. Loud noise (4WD tractor)	<ul style="list-style-type: none"> <li>(1) Poor meshing mark of the front central transmission gear.</li> <li>(2) Excessive gap or damage of the central transmission bearing</li> <li>(3) Differential shaft is worn or damaged.</li> <li>(4) Planetary gear or gasket is worn.</li> <li>(5) Poor meshing of final planetary gear</li> </ul>	<ul style="list-style-type: none"> <li>(1) Readjust the meshing marks.</li> <li>(2) Adjust or replace.</li> <li>(3) Replace differential shaft</li> <li>(4) Replace planetary gear or gaskets</li> <li>(5) Replace the planetary transmission gear.</li> </ul>

## Operating Instructions

Problems	Causes	Troubleshooting
4. Transmission shaft and protecting bush heating (4WD tractor)	(1) Over bending and deformation of transmission shaft, resulting in friction. (2) The middle supporting bearing pedestal is loosened.	(1) Correct or replace the transmission shaft. (2) Adjust according to requirements
5. Transfer case with loud noise (4WD tractor)	(1) Excessively high speed gear (2) Badly-worn bearing or gear	(1) Shift into a low speed gear (2) Replace or repair

### 3.18.1.5 Hydraulic steering system fault and troubleshooting

Table 3-10 Hydraulic steering system faults and troubleshooting

Problems	Causes	Troubleshooting
1. Oil leakage	(1) Rubber rings of each pipe joint are damaged or bolts are loose. (2) Damaged rubber rings between hydraulic steering valve, separation disc, stator and rear cover joint surfaces (3) Rubber rings of journal are damaged. (4) Bolts of steering gear binding site are loose.	(1) Replace aprons or tighten bolts. (2) Clean and replace rubber rings. (3) Replace rubber rings. (4) Tighten bolts.
2. Hard steering	(1) Insufficient oil supply of gear oil pump, inner leakage of steering gear pump or clogging in the steering tank strainer, light slow steering and hard fast steering. (2) There is air in steering system. When rotating the steering wheel, the cylinder moves sometimes. (3) Oil level in steering oil reservoir is insufficient. (4) Safety valve spring force weakens, or the ball is not sealed, light steering with light loads and hard steering with increased loads. (5) Oil viscosity is too large. (6) Steel ball check valve of valve body fails, with hard slow and quick steering, and the steering is weak. (7) Steering system oil leakage exists, including inner leakage (cylinder) and outer leakage.	(1) Check whether the gear oil pump works normally and clean the strainer. (2) Drain off the air in the system and check whether there is air intake in the oil lines. (3) Fill oil to specified level. (4) Clean safety valve and adjust the spring pressure of safety valve. (5) Use specified oil. (6) Clean, maintain or replace parts. (7) Check and exclude oil leakage points.
3. Steering failure	(1) Cycloid pin is broken or deformed. (2) Linkage axis orifice is broken or deformed. (3) Swap positions of rotor and linkage axis. (4) Steering cylinder piston or piston seal ring is damaged.	(1) Replace the cycloid pin. (2) Replace the linkage axis. (3) Reassembly. (4) Replace the piston or seal ring.
4. No manual steering	(1) The clearance between rotor and stator is too large (2) The sealing of cylinder piston is too bad. With power steering, the cylinder piston reaches to the extreme position, yet the driver has a dull feeling of the endpoint; with manual steering, steering wheel rotates, whereas the cylinder remains motionless.	(1) Replace the rotor and stator. (2) Replace the piston seal ring.

## Operating Instructions

Problems	Causes	Troubleshooting
5. Insensitive steering	(1) The clearance between valve core and sleeve is too large. (2) The clearance between linkage axis and cycloid pin is too large. (3) The clearance between couple axle and rotor is too large. (4) Return spring pieces is broken or too soft.	(1) Replace (2) Replace (3) Replace (4) Replace

### 3.18.1.6 Hydraulic suspension system fault and troubleshooting

Table 3-11 Hydraulic suspension system faults and troubleshooting

Problems	Causes	Troubleshooting
1. Regardless of its weight, the load cannot be lifted.	(1) The oil level in the lifter housing is too low. (2) Oil filter strainer is seriously clogged. (3) Air in oil lines. (4) Gear oil pump fails. (5) Falling off of the spring pin used to control the external or internal end of the handle spindle (6) Falling off of the swinging lever in the distributor (7) Main control valve seized at the neutral or descending position, or oil return valve seized at the opening position. (8) Main control valve seized. (9) Descending valve seized. (10) The pin gets shorter or the descending valve assembly becomes loose and comes out, so that the descending valve cannot be opened. (11) Blocked oil line to the cylinder in the cylinder head	(1) Fill oil to specified level. (2) Clean or replace the oil filter strainer. (3) Check the oil line connections. (4) Check, repair or replace the gear oil pump. (5) Re-install the spring pin. (6) Disassemble the distributor and install the swinging lever in place. (7) Disassemble the distributor, clean the valves. (8) Clean the main control valve. (9) Clean the descending valve. (10) Remove the descending valve plug, and re-adjust the clearance of the descending valve pin or tighten the descending valve assembly. (11) Open oil line
2. The implement can be lifted at light load, but cannot be lifted or lifted slowly at heavy load.	(1) Suction or air intake in oil lines. (2) System safety valve setting pressure is too low (3) Cylinder safety valve setting pressure is too low. (4) Gear oil pump is badly worn with insufficient pressure. (5) There is oil leakage in the cylinder seal.	(1) Check oil lines and oil filters. (2) Adjust or replace system safety valve. (3) Adjust or replace cylinder safety valve (4) Repair or replace gear oil pump. (5) Replace cylinder seals.
3. The implement wiggles during lifting, or is lifted slowly.	(1) Oil filter is clogged. (2) Air in oil lines. (3) Gear oil pump fails. (4) Hydraulic oil level is too low.	(1) Clean or replace the filter element. (2) Eliminate joints and O-ring leakages. (3) Replace the gear oil pump. (4) Add lubricant as required.

## Operating Instructions

Problems	Causes	Troubleshooting
4. Frequent “nodding” after the farm implements being lifted, and quick settling after the engine flameout.	<ul style="list-style-type: none"> <li>(1) Poorly-sealed check valve of the distributor</li> <li>(2) Poorly-sealed descending valve</li> <li>(3) Cylinder safety valve is with oil leakage or improperly adjusted.</li> <li>(4) Cylinder piston O-ring is damaged with oil leakage.</li> <li>(5) Falling off or damage of the poorly-installed seal ring between the distributor or cylinder head and the oil inlet hole of the lifter housing</li> </ul>	<ul style="list-style-type: none"> <li>(1) Clean the check valve. Grind it in pair with fine abrasive pastes if necessary.</li> <li>(2) Clean the descending valve or grind it in pair.</li> <li>(3) Repair or readjust the cylinder safety valve.</li> <li>(4) Replace the O-ring.</li> <li>(5) Check and replace the seal ring.</li> </ul>
5. The distributor sounds sharply when the handle is at the lifting position.	<ul style="list-style-type: none"> <li>(1) Due to incorrect adjustment, the internal lift arm jacks up the lifter housing so that the safety valve is opened.</li> </ul>	<ul style="list-style-type: none"> <li>(1) First, measure the lifting height of the farm implements, and then re-adjust or shorten the force position adjusting lever until the highest lifting position is lower than the original position.</li> </ul>
6. No hydraulic pressure output or weak output from the cylinder head	<ul style="list-style-type: none"> <li>(1) Inlet oil line of the cylinder is not cut off.</li> <li>(2) Poorly-sealed front cone and taper hole of the descending speed control valve</li> <li>(3) The lifter is in the neutral position of lifting.</li> </ul>	<ul style="list-style-type: none"> <li>(1) Tighten the descending speed control hand wheel clockwise.</li> <li>(2) Repair the front cone and taper hole of the descending speed control valve in pair, or replace the descending speed control valve.</li> <li>(3) Pull the lifter control lever to the descending position to allow the external lift arm to fall to the lowest position and cut off the inlet oil-line of the cylinder. Then, pull the control lever to the lifting position.</li> </ul>

### 3.18.1.7 Air Brake System Fault and Troubleshooting

Table 3-12 Air Brake System Fault and Troubleshooting

Problems	Causes	Troubleshooting
1. Insufficient pressure	<ul style="list-style-type: none"> <li>(1) Air line leaks.</li> <li>(2) Inlet/exhaust valve of air pump or spring is damaged</li> <li>(3) Piston ring of air pump and cylinder liner are worn seriously</li> <li>(4) Safety valve is not closed completely</li> </ul>	<ul style="list-style-type: none"> <li>(1) Check the leak and troubleshoot</li> <li>(2) Replace</li> <li>(3) Replace the piston ring and the cylinder liner</li> <li>(4) Check or replace the safety valve</li> </ul>
2. Air brake valve cannot return	<ul style="list-style-type: none"> <li>(1) Dust has been in air brake valve</li> <li>(2) Oil or water has been in air brake valve</li> </ul>	<ul style="list-style-type: none"> <li>(1) Clean air brake valve</li> <li>(2) Discharge oil or water in air brake valve and clean it</li> </ul>

## Operating Instructions

3. Air brake valve does not exhaust	(1) Tappet is stuck (2) Return spring is broken or spring force is weak	(1) Repair and make tappet move flexibly without jam (2) Replace the return spring.
-------------------------------------	--	--

### 3.18.2 Electrical system fault and troubleshooting

#### 3.18.2.1 Starter motor faults and troubleshooting

Table 3-13 Starter motor fault and troubleshooting

Problems	Causes	Troubleshooting
1. Starter motor does not run	(1) Lack of battery capacity. (2) Dirty battery poleor loose cables. (3) Cable connector gets loose, or bond strap is corroded. (4) Starting switch and other control circuit are broken (5) Poor contact of carbon brush and commutator. (6) Internal open-circuit and short-circuit in the starter motor	(1) Charge the battery as required. (2) Clean dirt and tighten the connector. (3) Tighten the joint and remove the corrosion. (4) Check the circuits to have reliable connections. (5) Adjust the spring pressure of the carbon brush, and clean the commutator. (6) Check and repair the starter motor.
2. The starter motor is not powerful enough to start the engine.	(1) Lack of battery capacity. (2) Poor wire contact (3) Commutator surface is burnt or with oil. (4) The carbon brush is worn excessively, or the carbon brush spring pressure is insufficient, so that it is in poor contact with the commutator. (5) The main contact of the electromagnetic switch is burnt out, resulting in poor contact. (6) Badly-worn bearing, causing the armature rubs the housing.	(1) Charge the battery. (2) Tighten the wire connector. (3) Polish the commutator surface or remove the oil dirt. (4) Replace or adjust. (5) Polish it with non-metallic abrasive paper (No. 0). (6) Replace bearings
3. The engine starts, but the starter motor keeps rotating and sounds sharply.	(1) The copper contact disc in the starter motor relay is adhered to two contacts. (2) The starter motor lever decouples or the eccentric screw becomes loose. (3) The lever return spring is broken or loses elasticity. (4) The starter motor armature shaft is broken or bent. (5) The tooth surface becomes galling and gets stuck.	(1) Check the circuit and repair the contact. (2) Readjust and fix it. (3) Replace the spring. (4) Replace the starter motor. (5) Replace the tooth surface.

#### 3.18.2.2 Generator faults and troubleshooting

Table 3-14 Generator fault and troubleshooting

## Operating Instructions

Problems	Causes	Troubleshooting
Generator produces no power.	(1) Wiring fault, broken wiring or poor contact (2) Rotor coil open circuited (3) Rectifier diode is damaged (4) Poor contact of carbon brush (5) Regulator damaged	(1) Maintain the lines (2) Maintain or replace generator assembly (3) Replace the diode (4) Remove dirt or replace the carbon brush (5) Repair or replace the regulator.
2. Undercharge of generator	(1) The V-shaped transmission belt becomes loose. (2) Poor contact of carbon brush and slip ring with oil stain. (3) Regulator damaged (4) Lack of battery electrolyte or seriously vulcanized plates, or ageing	(1) Adjust the tension of V-shaped transmission belt. (2) Adjust the carbon brush, and clean the slip ring. (3) Replace the regulator. (4) Repair or replace battery
3. Charging current of generator is too high, easy to burn the lamp	(1) Regulating voltage of regulator is too high (2) The magnetizing coil of the regulator is sealed off to loose regulation action.	(1) Regulate the voltage to a suitable value as required. (2) Inspect the magnetizing coil, and re-weld the soldering point firmly.

### 3.18.2.3 Battery fault and troubleshooting

Table 3-15 Battery fault and troubleshooting

Problems	Causes	Troubleshooting
1. Battery capacity is insufficient and causes starting of the engine difficulty.	(1) Low electrolyte level (2) Short circuit between the plates (3) Plate vulcanization (4) Poor contact of circuit joints, too much oxides on terminal post, and undercharge.	(1) Repair or replace battery (2) Remove the sediment and replace the electrolyte. (3) Repeatedly charge and discharge to remove the vulcanization. (4) Connect and tight the cables. Remove the oxide. Apply a layer of Vaseline on the terminal posts.
2. Over self-discharge	(1) The electrolyte contains impurities. (2) There is short circuit at battery external wires. (3) There are electrolyte spills on the battery surface, causing a short circuit between the positive and negative poles. (4) Metal tools or rods are placed between the positive and negative poles, resulting in a severe short circuit. (5) Active materials on the plates peel off and too many deposits lead to a short	(1) Repair or replace battery (2) Check the short circuit and troubleshoot. (3) Rinse the battery surface and terminal posts with alkaline water or warm water to keep their surface clean. (prevent alkaline water or warm water from leaking into the battery.) (4) It is prohibited to place metal rods or tools on the battery surface.

## Operating Instructions

	<p>circuit between the plates; Separator damage causes short circuit of plates; plate warping leads to a short circuit of positive and negative poles.</p>	
--	--	--

### 3.18.2.4 Instrument fault and troubleshooting

Table 3-16 Instrument fault and troubleshooting

Problems	Causes	Troubleshooting
1. The water temperature gauge pointer always points low temperature.	(1) Open circuit, poor contact of connectors (2) Coolant temperature sensor damaged	(1) Service the circuit, remove the dirt from the connectors. (2) Replace the water temperature sensor.
2. The water temperature gauge pointer always points low temperature.	(1) Coolant temperature sensor short circuited and damaged (2) Short circuit	(1) Replace the water temperature sensor. (2) Service the short circuit fault.
3. The oil pressure gauge is functioning improperly.	(1) Open circuit and short circuit (2) Open circuit, short circuit and/or poor contact of sensor	(1) Maintain I and troubleshooting (2) Maintain or replace the sensor

### 3.18.2.5 Lighting fault and troubleshooting.

Table 3-17 Lighting fault and troubleshooting

Problems	Causes	Troubleshooting
1. Headlamps without high/low beam	(1) Circuit breaks; a short circuit blows the fuse. (2) Poor contact or damage of rear lamp switch. (3) Filament is burnt out	(1) Repair and connect. (2) Repair and replace. (3) Replace with a bulb of good quality.
2. Rear lamp is off	(1) Open circuit (2) Poor contact or damage of rear lamp switch.	(1) Repair and connect. (2) Repair or replace.

## Accessories, spare parts and quick-wear part

### 4 Accessories, spare parts and quick-wear part

#### 4.1 Accessories

The tractor accessories includes heater, mudguard mat, floor mat and sway-type tow bar etc.

##### 4.1.1 Air heater (optional):

The air heater on the tractor is installed on front top of cab, on which the switch is set up. When turning on the power, the air heater can start operation immediately. It is necessary to ensure a comfortable working temperature in the cab.

If the ventilation in cab is needed (especially in summer), it is only necessary to shut down the outlet valve of hot cycling water on the heater, then turn on the heater switch. At this time, the heater fan begins to rotate.

Two small flap gates on the right of left of heater are used to adjust the air cycle in cab.

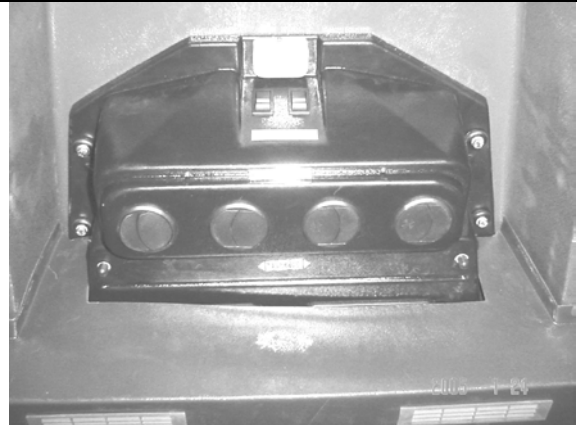

Fig. 4-1 Air heater

##### 4.1.2 Floor mat (for the model with a cab):

The floor mat is formed by use of a soft and comfortable rubber die, and is 10mm thick, and is fastened to the floor by use of a boundary beam hold-down strip.

##### 4.1.3 Mudguard mat (for the model with a cab):

It is made of PVC foaming surface absorption material, and formed by a die. The whole mudguard mat is fastened to the left/right mudguard by use of the boundary beam hold-down strip, and is usually not removed.

##### 4.1.4 Swing-type drawbar (optional):

Only for trail-type farm implements. The rear end of the drawbar is connected to the farm implements with the traction pin. The drawbar can swing laterally, which can attach the farm implements more conveniently. The drawbar can swing from side to side when working. But when the tractor drags the farm implements backward, be sure to insert the positioning pin (1) into the hole on the traction plate to prevent the drawbar (2) from swinging.

Turning the drawbar over can change height of the towing point to obtain a towing height suitable for the supporting implement.

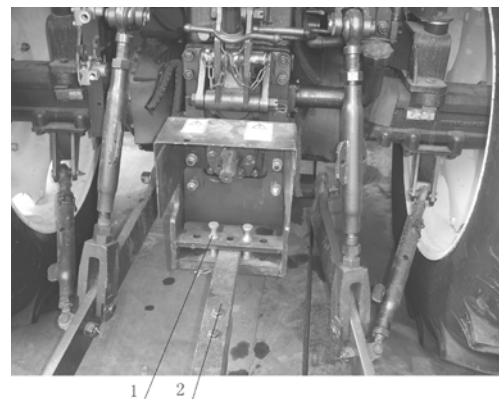

Fig. 4-2 Swing-type drawbar

1. Positioning pin 2. Drawbar

**Important note: For the tractor with a heating air fan or an air conditioner, the cooling system of the engine must use anti-freeze fluid in winter, so as to avoid cracking of the heater or air conditioner.**



## Accessories, spare parts and quick-wear part

### 4.2 Spare parts

#### 4.2.1 Spare parts

Table 4-1 List of Onboard Spare Parts

SN..	Code	Name	Quantity	Remark
1		Engine Onboard Spare Parts	1 set	Provided by the supporting plant
2	TD9600000500	Ordinary fuse (5A)	2	
3	TD9600000700	Ordinary fuse (10A)	2	
4	TD9600000800	Ordinary fuse (15A)	2	
5	TD9600000900	Ordinary fuse (20A)	2	
6	TD800.482.2	Working light connector plug	1	
7	TA600.96-02	Return oil filter element	1	Optional, only used for split type lifter model
8	TD800.96-01	Absorption filter element	1	
9	TD900.484.3	Plug pin of rear trailer	1	
10	TD800.481.2	Fusible link (1.0mm <sup>2</sup> )	1	
11	FT65.80.018	Quick coupler	1	Optional, only used for the model with an air brake system
12	FT354.58A.030	Quick change coupler	1	Optional, used for the model with a simple hydraulic output, and imperial system connector of the semi-split type lifter.
			3	Optional, used for the model with a simple hydraulic output unit and single-way valve output, and imperial system connector of the semi-split type lifter.
			5	Optional, used for the model with a simple hydraulic output unit and multi-way valve output, and imperial system connector of the semi-split type lifter.
			2	Optional, used for the model with single-way valve output, and imperial system connector of the split type lifter.
			4	Optional, used for the model with multi-way valve output, and imperial system connector

### Accessories, spare parts and quick-wear part

SN..	Code	Name	Quantity	Remark
				of the split type lifter.
13	FT654.58.010a	Quick change coupler	1	Optional, used for the model with a simple hydraulic output, and metric system connector of the split type lifter.
			3	Optional, used for the model with a simple hydraulic output unit and single-way valve output, and metric system connector of the split type lifter.
			5	Optional, used for the model with a simple hydraulic output unit and single-way valve output, and metric system connector of the semi-split type lifter.
			2	Optional, used for the model with single-way valve output, and metric system connector of the split type lifter.
			4	Optional, used for the model with multi-way valve output, and metric system connector of the split type lifter.
14	FT800.38.234	Breather element	2	For chassis and oil tank breather
15	FT650.40.162	Breather element	2	For steering and hydraulic system breather
16	FT700.55D.109	Breather element	1	
17	FT804.32C.108	Connecting sleeve of drive axle	2	Optional, only used for the model with stepless adjustable wheel track
18	FT804.32C.106	Bolt M16×1.5×175	16	
19	FT654.32.104	Washer	16	
20	FT800A.41.012	Safety protection guard weld unit of PTO shaft	1	Optional, only used for the model with split type lifter and trailer
21		Engine lifting lug	1	
22		Repairing kit for lifter cylinder	2	Optional, only used for the model with split type lifter , provided by cylinder factory
23		Repairing kit for lifter	2	Optional, only used for the model with semi-split type lifter , provided by lifter factory
24	QC/T 350	Plastic split rivet-6	5	Optional, only used for the model with cab
25	QC/T 350	Plastic split rivet-8	5	

### Accessories, spare parts and quick-wear part

SN..	Code	Name	Quantity	Remark	
26	FT800.37.172	Adjusting shim, the thickness is 0.1	4	For main and auxiliary gearshift assembly	
		Adjusting shim, the thickness is 0.2	4		
		Adjusting shim, the thickness is 0.5	4		
27	FT800.37.206	Adjusting shim, the thickness is 0.1	4		
		Adjusting shim, the thickness is 0.2	4		
		Adjusting shim, the thickness is 0.5	4		
28	FT804.42.109	Adjusting shim, the thickness is 0.1	4		
		Adjusting shim, the thickness is 0.2	4		
		Adjusting shim, the thickness is 0.5	4		
29	FT800.38.208	Adjusting shim, the thickness is 0.1	4		Used for rear axle assembly
		Adjusting shim, the thickness is 0.2	4		
		Adjusting shim, the thickness is 0.5	4		
30	FT800.38.221	Adjusting shim, the thickness is 0.1	4		
		Adjusting shim, the thickness is 0.2	4		
31	FT800.39.117a	Adjusting shim, the thickness is 0.1	4	Used for final drive assembly	
		Adjusting shim, the thickness is 0.15	4		
		Adjusting shim, the thickness is 0.5	4		
32	FT800A.41.152	Adjusting shim, the thickness is 0.1	4	For PTO gear assembly	
		Adjusting shim, the thickness is 0.15	4		

## Accessories, spare parts and quick-wear part

SN..	Code	Name	Quantity	Remark
		Adjusting shim, the thickness is 0.5	4	
33	FT804.42.109	Adjusting shim, the thickness is 0.1	4	For transfer case assembly
		Adjusting shim, the thickness is 0.2	4	
		Adjusting shim, the thickness is 0.5	4	

### 4.2.2 Onboard tools

Table 4-2 Onboard tools

SN..	Code	Name	Quantity	Remark
1	QB/T 2564.4	Screwdriver for slotted head screws 1×5.5×125P	1	
2	TD800.96-08	Screwdriver for recessed head screws 6×150P	1	
3	GB/T 3390.1	Socket, manual socket wrench 18×12.5L	1	
4	GB/T 3390.1	Socket, manual socket wrench 21×12.5L	1	
5	GB/T 3390.1	Socket, manual socket wrench 24×12.5L	1	
6	GB/T 3390.1	Socket, manual socket wrench 27×12.5L	1	
7	GB/T 3390.1	Socket, manual socket wrench 30×12.5L	1	
8	GB/T 3390.3	Handle, manual socket wrench H12.5	1	
9	GB/T 3390.4	Extension bar, manual socket wrench 204×12.5×250a	1	
10	JB/T 7942.1	Lever-type grease gun A200	1	
11	JB/T 3411.47	Installing tong for circlip for shaft B2.5	1	
12	JB/T 3411.48	Installing tong for circlip for hole A2.5	1	
13	TD800.96-09	Hexagonal wrench 8×160	1	
14	GB/T 4388	Double open end wrench 8×10×119	1	

### Accessories, spare parts and quick-wear part

SN..	Code	Name	Quantity	Remark
15	GB/T 4388	Double open end wrench 10×12×135	1	
16	GB/T 4388	Double open end wrench 13×16×159	1	
17	GB/T 4388	Double open end wrench 16×18×183	1	
18	GB/T 4388	Double open end wrench 18×21×199	1	
19	GB/T 4388	Double open end wrench 21×24×223	1	
20	GB/T 4388	Double open end wrench 24×27×247	1	
21	GB/T 4388	Double open end wrench 30×34×295	1	
22		Engine onboard spare parts	1 set	Provided by the engine supporting plant

#### 4.2.3 Self-provide Tool

Table 4-3 Self-provide Tool

SN..	Code	Name	Quantity	Remark
1	GB/T 6295.1	Cutting pliers	1	
2	GB/T 4440	Universal screw-wrench 300×36	1	
3	SG 216	Fitter's hammer with weight of 1 pound	1	

#### 4.2.4 List of Onboard Document

Table 4-4 List of Onboard Document

SN..	Document name	Quantity	Remark
1	Onboard technical document for engine	1	Provided by the engine supporting plant
2	Product Qualification Certificate	1	Store in file cover
3	Warranty Card	1	Store in file cover
4	Operation Manual for air-condition	1	Optional, only used for the model with air-condition
5	Operation Manual for air heater	1	Optional, only used for the model with air heater
6	Instructions for operation of radio cassette player	1	Optional, only for the model with a radio cassette player
7	Tractor Parts Atlas	1	Store in file cover

## Accessories, spare parts and quick-wear part

8	Engine Qualification Certificate	1	Provided by the engine supporting factory, and stored in file cover
9	Tractor Operation Manual	1	Store in file cover
10	Packing list of onboard items	1	

**Note: Please check and accept the engine onboard tools, spare parts and documents according to the packing list of the diesel engine.**

### 4.3 Quick-wear Part

Quick-wear parts of **LOVOL-TD Series tractors** include: all fuses and bulbs used in the complete machine, shown as Table 4-5.

Table 4-5 Quick-wear part list

SN..	Code	Name	Qty/Unit	Position for use
1	TD9600000500	Ordinary fuse (5A)	2	Central electric box
2	TD9600000700	Ordinary fuse (10A)	8	Central electric box
3	TD9600000800	Ordinary fuse (15A)	2	Central electric box
4	TD9600000900	Ordinary fuse (20A)	3	Central electric box
5	12V-H4-55/60W	Double- filament bulbs of low and high beams	2	Headlamp
6	12V-21W	Steering bulb	6	Headlamp, handrail lamp (model with cab), rear tail-lamp
7	12V-5W	Position lamp (front)	4	Headlamp, handrail lamp (model with cab)
8	12V-10W	Position lamp (rear)	2	Rear tail-lamp
9	12V-H3-55W	Rear working bulb	2	Rear working lamp
10	12V-35W	Top working bulb	4	Top working lamp
11	12V-21W	Brake bulb	2	Rear tail-lamp
12	TD800.481.2	Fusible link (1.0)	1	Engine harness

#### **Important:**

**1. Various spare parts, tools and quick-wear parts listed above are specifically designed for this tractor. Please keep them in a safe place to prepare for use, maintenance and service of the tractor. Failure to do so can affect the use of the tractor's function.**

**2. Only use the formal LOVOL parts to perform maintenance on your tractor. Failure to do so can affect the tractor's functions, performance and service life.**



# Maintenance instructions

## 5 Maintenance instructions

Technical maintenance is a series of technical maintenance measures which include cleaning, checking, lubricating, fastening, and adjusting each part of the tractor or replacing some parts regularly. Regular maintenance can avoid technical conditions of each part from deteriorating rapidly, reduce failure rate and prolong its service life, and keep the tractor working in good conditions.

### **Important:**

- 1. All maintenance work should be carried out by the trained and qualified persons, who are familiar with the tractor performances so as not to damage the tractor.**
- 2. In order to keep the tractor running in a normal operation and prolong its service life, the technical maintenance procedures should be strictly observed.**
- 3. Within the warranty period, if any damage occurs arising from any operator who is unspecialized or not familiar with the tractor performances, or the maintenance which is not made by ruled within the specified period from the manufacturer, the relative warranty will be invalid.**
- 4. It is prohibited to adjust the relief valve opening pressure of engine, hydraulic system and air brake system, safety overflow pressure of constant overflow pump overflow valve and opening pressure of radiator cap without permission. Otherwise it can cause damage to the tractor, affect the performance of tractors and lose the relative service right of warranty of tractors.**

### 5.1 Technical maintenance procedures

Service period of FOTON-TD wheeled tractor is calculated according to cumulative working hours including technical maintenances of every shift [every 10h], every 50h, every 200h, every 400h, every 800h, and every 1600h, as well as special maintenance in winter and maintenance for long-time storage.

#### 5.1.1 Technical maintenance of every shift

- Dusts and greasy dirt on tractor shall be cleared away.
- Check and secure all fasteners outside of tractor if needed, especially the fixing nuts from the front and rear wheel;
- Check the fluid level in the oil sump, radiator, fuel tank, hydraulic steering oil reservoir, service brake oil reservoir and hydraulic lifter etc and fill them if necessary. If checking the level in oil sump, please park the tractor on the flat ground and go ahead after 15min of stopping.
- Lubricating grease shall be added according to Maintenance and Service Schedule 5-1;
- Pressures of front and rear wheels shall be checked and inflated as required when there is any insufficiency;
- Check the free travel of the main / auxiliary clutch pedal and the brake pedal respectively.
- "Three leakage"-air leakage, oil leakage and water leakage of the tractor shall be checked and removed;
- Maintain the diesel engine according to "Technical maintenance of daily shift".



## **Maintenance instructions**

---

### **5.1.2 Technical Maintenance for Every 50 Hours**

- All contents of technical maintenance of every shift shall be done;
- Lubricating grease shall be added according to Maintenance and Service Schedule 5-1;
- Check the oil level of the oil bath type air filter and dedust it.
- Maintain the diesel engine according to Level-1 Technical Maintenance".

### **5.1.3 Technical Maintenance for Every 200 Hours**

- All contents of technical maintenance of every 50 hours shall be done;
- Change the lubricant in engine oil pan.
- Clean and maintain the oil pan of the oil bath type air filter;
- Clean the hydraulic fluid filter of the lifter. If necessary, replace the filter element.
- Maintain the diesel engine according to Level-2 Technical Maintenance".

### **5.1.4 Technical Maintenance for Every 400 Hours**

- All contents of technical maintenance of every 200 hours shall be done;
- Lubricating grease shall be added according to Maintenance and Service Schedule 5-1;
- Inspect oil level of the main drive and final drive of the front drive axle, and refill oil if necessary;
- Inspect oil level of the transmission system and lifter, and refill oil if necessary;
- Inspect free travel of the parking brake handle, and adjust it if necessary;
- Clean and maintain the filter of the hydraulic steering oil tank;
- Maintain the diesel engine according to Level-2 Technical Maintenance".

### **5.1.5 Technical Maintenance for Every 800 Hours**

- All contents of technical maintenance of every 400 hours shall be done;
- Replace the hydraulic oil for the hydraulic steering system;
- Replace the hydraulic oil for the transmission and lifter;
- Check valve clearance of diesel engine
- Check and adjust the injection pressure of the fuel injection pump.
- Conduct cleaning and maintenance of the fuel tank;
- Maintain the diesel engine according to Level-3 Technical Maintenance".

### **5.1.6 Technical Maintenance for Every 1600 Hours**

- All contents of technical maintenance of every 800 hours shall be done;
- Clean and maintenance the diesel engine cooling system;
- Replace the lubricating grease for the central and final transmission of the front drive axle;
- Checking, adjustment and maintenance of the starter motor.
- Maintain the diesel engine according to Level-3 Technical Maintenance".

## Maintenance instructions

### 5.1.7 Special maintenance in winter

- Change with the lubricant and fuel for winter;
- The antifreeze should be adopted if temperature is below 0°C in winter.
- Before working each shift, please follow the requirements for winter to start the engine.
- In winter, the battery discharging rate of battery should not be more than 25%, please keep higher charging rate.
- If operation completed, please park it in windshield warm shed.

### 5.1.8 Technical maintenance of Tractor's Long-term Storage

If the tractor has been stored for less than one month, and the time does not exceed 100 hours since the engine oil was replaced, special technical maintenance is not required. If the tractor has been stored for more than one month, special technical maintenance shall be done according to Section 6 Storage specified in this Manual.

## 5.2 Technical maintenance operation

### 5.2.1 Tractor Maintenance

Table 5-1 Maintenance of FOTON-TD Series Tractor

SN..	Maintenance parts	Operation contents	Times	Maintenance period
1	Engine oil pan	Checking liquid level	1	Every shift
2	Oil bath type air filter	Checking liquid level	1	Every shift
3	Battery	Checking liquid level	1	Every shift
4	hydraulic steering oil tank	Checking liquid level	1	Every shift
5	Radiator (Water Tank)	Checking liquid level	1	Every shift
6	Water Pump Shaft of Engine	Adding lubricating grease	1	Every shift
7	Fuel Injection Pump	Checking liquid level	1	Every shift
8	Brake oil tank	Checking liquid level	1	Every shift

## Maintenance instructions

9	Rear wheel hub	Adding lubricating grease	2	Every shift
10	Main Clutch	Adjusting free stroke	1	Every shift
11	Auxiliary clutch	Adjusting free stroke	1	Every shift
12	Driving brake	Adjusting free stroke	2	Every shift
13	Fan belt	Checking tensity	1	Every 50 work hours
14	Steering cylinder	Adding lubricating grease	1	Every 50 work hours
15	Front axle kingpin bushing	Adding lubricating grease	2	Every 50 work hours
16	Front axle swing shaft, 4WD	Adding lubricating grease	2	Every 50 work hours
17	Central swing pin bushing of front axle	Adding lubricating grease	1	Every 50 work hours
18	Rocker shaft of main and auxiliary clutches	Adding lubricating grease	4	Every 50 work hours
19	Diesel Filter	Replacing filter Element	1	Every 200 operating hours after the run-in period is finished.
20	Rotary oil filter	Replacing filter	1	Every 200 operating hours after the run-in period is finished.
21	Hydraulic oil absorption filter of lifter	Clean or replace the filter element.	1	Every 200 work hours
22	Hydraulic oil return filter of lifter	Clean or replace the filter element.	1	Every 200 work hours
23	Fuel Injection Pump	Replace the lubricant	1	Every 200 work hours
24	Engine oil pan	Replace the lubricant	1	Every 200 work hours
25	Oil pan of oil bath type air filter	Cleaning and maintenance	1	Every 200 work hours
26	Power train and lifter	Check the oil level	1	Every 400 work hours

## Maintenance instructions

27	Parking brake	Adjusting free stroke	1	Every 400 work hours
28	Breather element	Clean filter element	2	Every 400 work hours
29	Front Wheel	Adding lubricating grease	2	Every 400 work hours
30	Central transmission of the front drive axle	Check the oil level	1	Every 400 work hours
31	Oil cup of kingpin of front drive axle	Adding lubricating grease	2	Every 400 work hours
32	Final transmission of the front drive axle	Check the oil level	2	Every 400 work hours
33	Hydraulic steering oil tank filter	Clean and maintain	1	Every 400 work hours
34	hydraulic steering oil tank	Replace the lubricant	1	Every 800 work hours
35	Fuel Tank	Clean and maintain	1	Every 800 work hours
36	Intake/Exhaust Valve of Engine	Adjusting valve clearance	8	Every 800 work hours
37	Fuel injector	Adjusting the pressure of injection pump	4	Every 800 work hours
38	Power train and lifter	Replace the lubricant	1	Every 800 work hours
39	Engine cooling system	Clean and maintain	1	Every 1600 work hours
40	Engine cooling system by using antifreeze solution	Replacing antifreeze solution	1	2 years or every 1600 work hours
41	Central transmission of the front drive	Replace the lubricant	1	Every 1600 work hours
42	Final transmission of the front drive axle	Replace the lubricant	1	Every 1600 work hours
43	Brake fluid for the brake system.	Replace the brake fluid	1	Half a year

### 5.2.2 Technical maintenance operation

#### 5.2.2.1 Battery Maintenance

- Service of maintenance-free battery

## Maintenance instructions

Usually, the maintenance-free battery does not need to be maintained specially. Observe the color shown in the hydrometer observation hole. Green indicates the battery is fully charged. Black indicates the battery is short of power. White indicates the battery almost runs down. If the observation hole shows black, charge the battery immediately. If the observation hole shows white, replace the battery.



Fig 5-1 Inspection of battery condition



### Warning:

**The battery contains electrolyte which is highly corrosive. Do not get electrolyte in your eyes or on your skins or clothing. If so, rinse your eyes or skin with large quantities of water. Call a physician immediately to avoid serious burns.**

#### ● Cautions for Use and Service of Maintenance-free Battery

1. Store the battery in a dry, clean and well-ventilated place at 5~40 °C.
2. Do not expose the battery to direct sunlight, and keep it away from any heat source (heating equipment, etc.) for at least 2m.
3. Avoid rain and dust and other impurities, and prevent the battery from discharging due to external short circuit.
4. Do not put the battery upside down or let it lie down to avoid any mechanical shock or great pressure
5. To store the battery, make sure it is fully charged.
6. Avoid tilting the battery when placing it. Do not put the battery upside down or bump it.
7. Check the battery voltage once every 3 months. When its voltage is below 12.5V, charge the battery in time. Failure to do so can cause the battery to be charged difficultly after long-term storage, and affect the battery service life.
8. When the battery is used or stored, always make sure its vent hole is unblocked to prevent the battery from deformation or explosion.
9. In the process of charge and discharge, make sure the battery is in a well-ventilated environment to eliminate the acid mist and combustible gases generated during charging and to keep the indoor air fresh to reduce the erosion of acid molecules to the personnel and equipment and to avoid ignition of combustible gases.
10. Always check the color of the charge density meter on the battery cover plate, and according to the

## Maintenance instructions

color, perform service, maintenance and replacement on the battery.

- Charging mode

Usually, there are constant-current charging, constant-voltage current-limiting charging and other charging mode. We recommend you using the constant-voltage current-limiting charging mode.

1. Constant-current charging

Charge your battery at  $0.1C_{20}A$  (i.e., 12A) to 16V, and then continue to charge it at  $0.05C_{20}A$ . When the battery voltage can keep unchanged for 1 to 2 hours, you can finish charging it (with a voltage difference between the two times  $<0.03V$ ), or when the battery continues to be charged for 3-5 hours after its voltage reaches 16V, you can finish it.

2. Constant-voltage charging

With a constant voltage between 14.8V~15.5V, and the maximum current  $0.25C_{20}A$  (i.e., 30A), after the charging current  $\leq 0.5A$ , you can continue to charge the battery for 3 hours. The total charging time should be controlled within 24 hours.

- Charging cautions

1. Be sure to connect the positive battery terminal to the positive pole of the charger and connect the negative battery terminal to the negative pole of the charger.
2. Lay the battery level and make sure the charging connections are secure and firm.
3. When charging, make sure the battery temperature does not exceed  $45^{\circ}C$ . Otherwise, cool the battery through water bath or reduce the charging current temporarily or reduce the charging voltage and other measures.
4. Be sure to charge the battery in a well-ventilated room. The battery gives off explosive hydrogen during normal charging. If the hydrogen accounts for 4%~7% of the gases in the room, a spark or flame can cause explosion. Especially, there should be no smoking or open fire in the charging room.
5. When connecting the charging cables, be sure to avoid short-circuit.

### 5.2.2.2 Check and maintenance of service brake oil tank

The service brake oil tank is set on right side of the bonnet support. The brake fluid should be 10~15mm above the boss in normal condition. When the brake fluid level is less than the value, it is required to find out the oil leakage causes, and handle the problem, as well as replenish the oil.



#### Attentions:

1. Correct brake fluid level is critical to normal operation of the brake system; Excessively low

## Maintenance instructions

brake fluid level will result in failure of the brake and major safety hazard accidents;

2. The hydraulic brake oil must be synthetic oil, and brake oil containing alcohol cannot be used or other machine oil is used in place of the same brake oil, so as to avoid occurrence of unexpected safety hazard accidents resulted from brake failure.

### 5.2.2.3 Check and maintenance of hydraulic steering oil tank

Hydraulic steering oil tank is mounted on the upper side of the engine. Open the cap (with dipstick) to check whether there is oil trace. If there is no oil trace, it indicates the oil level is insufficient. Find out the cause and then add oil to middle scale of dipstick by removing oil tank. Then reinstall again. Be sure there is no leakage of hydraulic steering oil tank, oil pipe and connections. Otherwise, steering failures will occur. Regularly clean and replace the hydraulic oil filter screen.

When checking the oil level, please check whether the vent valve (rivet shaped) on the center of oil reservoir cap could lift or lower smoothly. if any oil contamination, please remove it.

### 5.2.2.4 Maintenance of oil bath type air filter

By opening the locking hook at lower part of the filter, dismantle the oil basin at its bottom, empty the contaminated oil, and clean it with kerosene or diesel, as well as clean the filter element at the same time; then, refill new oil to the specified oil level, and re-install it properly.

### 5.2.2.5 Use and maintenance of dry-type air filter

When the air filter blockage alarm lamp is on, must conduct maintenance of the dry type air filter element.

The air filter should be maintained frequently according to the dust conditions in the operating environment. It is recommended that it is maintained every shift in dusty environment.

The equipment should be inspected every day or when refilling fuel, so as to ensure all connections between the air filter and engine are sealed properly, including all hose fittings, and end cover of the air filter housing. In case of discovering any crack, have it repaired immediately, and record it in the machine maintenance records.

The built-in dry air filter element is divided into two stages: i.e. primary filter element and safety filter element.

During maintenance, the primary filter element should be dismantled carefully to prevent dust from ingress into the filter housing.

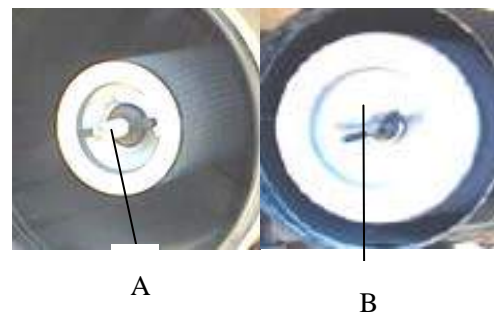

Fig.5-2 Dry-type Air Filter  
A. Safety filter element; B. Primary filter element

## Maintenance instructions

It is recommended that the safety filter element should be replaced when the primary filter element has been replaced for more than three times. If the safety filter sounds very clean and before the replacement date, do not loosen the wing locknut, and do not change mounting status of the safety filter element.

When it is found that replacement of the safety filter element is required, inspect the wing locknut to ensure it is tightened securely. At this moment, do not loosen the locknut. When the safety filter element has not been replaced, clean the filter housing, and remove dust accumulated in the housing. Do not use compressed air to clean the air filter housing.

During replacement of the safety filter element, dismantle the wing locknut and washer, and carefully remove the filter element from the housing. Prior to installation of a new safety filter element, use a piece of clean and wet cloth to wipe the mounting surface of the safety filter element.

Inspect each new filter, and ensure that the new filter model is correct. Inspect the filter is cracked/damaged or wrinkled, and its lining is cracked/damaged, or the washer is damaged. If damage to any part is found, discard the damaged part, install a new filter element, and use a washer and wing locknut to tighten it. Ensure that the new filter rubber washer is mounted between the wing locknut and filter element, and simultaneously ensure an air intake resistance indicator is mounted.

Re-assemble an air filter as per reverse dismantling sequence. Mount the end cover, and before fixing the clamp or wing locknut, ensure that the end cover is located and seated accurately.

**Important: Correct use and maintenance of air filter is directly related to the service life of engine, therefore it must be kept clean all the time. During farmland operation, be sure to check, clean the oil after each shift. After maintenance, must ensure that the air filter element is tightly against the air filter to prevent presence of a gap between the two parts, so as to avoid ingress of dust or mud into the engine resulting in engine scuffing, abnormal wear and downward exhaust and other faults!**

### 5.2.2.6 Adjustment of fan belt tension

Pressing the central part of the fan adhesive tape with thumb by applying a force of (29.4~49.0)N gives a press distance of (15±3)mm. If these requirements cannot be met, perform adjustment as follows:

Loosen the retaining nut on the generator bracket and pull the generator outward to tension the belt, and then tighten the retaining nut.

### 5.2.2.7 Inspection of oil level in engine oil pan and replacement of oil

Pull out the dipstick A on the front left of the oil pan. Check whether the oil level is between the UPPER and LOWER marks. If the oil level is under the lower scale line, remove the oil filler cap on the engine timing gear housing cover.

During maintenance and oil replacement, unscrew the oil drain plug at lower part of the oil sump to empty the contaminated oil and clean it, and then re-inject new oil.



## Maintenance instructions

### 5.2.2.8 Protection of front axle

Add grease to the kingpin sleeve, front axle main balance pin sleeve, the ball joint at the both ends of steering cylinder and ball joint of tie-rod. Check whether the nuts from both tie-rod ball pin and pin at the both ends of cylinder are loose.

### 5.2.2.9 Maintenance of fuel filter

For the fuel filter, see the figure. The engine adopts 2 stage of filters connected in series, of which the left filter is the 1st stage filter, and the right filter is the 2nd stage filter. Cleaning of the paper filter element is not allowed. After run-in period is finished, the 1st filter element should be replaced every 200 operating hours of the engine. During replacement, the 2nd filter element is installed in the 1st stage, and the 2st filter element is replaced with a new one.

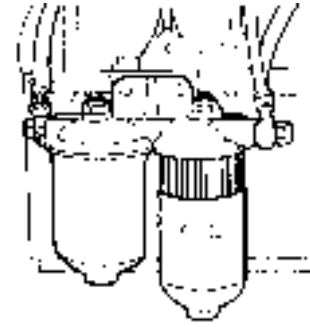

Fig. 5-3 Fuel filter

### 5.2.2.10 Maintenance of the rotary oil filter

The rotary oil filter is located at lower left side of the engine, and should be replaced according to technical requirements every 200 operating hours after run-in period.

The rotary oil filter is replaced as a whole, and must be tightened during installation.

### 5.2.2.11 Maintenance of hydraulic oil filter

The hydraulic oil absorption filter of the lifter is located at the lower right part of the engine. It is maintained as per technical requirements. The method is as follows: unscrew the rear end cover of the hydraulic filter, remove the net type filter element, and use gasoline to clean it and use compressed air to purge it. When it is difficult to clean the filter element or the filter element is damaged, it should be replaced with a new one. The oil return filter is located on the left side of the lifter housing, and should be cleaned every 200 operating hours. When it is difficult to clean the filter element or the filter element is damaged, it should be replaced with a new one.

### 5.2.2.12 Inspection of oil level at end of the front drive axle

The screw plug for inspection of drive oil level at end of the front drive axle is located at the front wheel hub, so that the screw plug port is at horizontal position and the new oil is injected to the screw plug port.

### 5.2.2.13 Oil level inspection of the front drive housing

## Maintenance instructions



Fig. 5-4 Oil level inspection of the front drive housing

When inspecting oil level of the front drive housing (see Figure 5-4), the screw plug "A" should be removed, and the oil level should reach the screw plug port; otherwise oil should be injected. During replacement of the oil, empty the dirty oil from the screw plug "B", and tighten the screw plug "B", and inject new oil from the screw plug "A".

### 5.2.2.14 Injection of the front wheel lubricating oil

Lubricating grease of the front wheel of FOTON-TD Series tractors is injected from the hub oil cup inside the front wheel.

### 5.2.2.15 Lubrication of the front drive axle kingpin

1 oil cup is at both ends of the middle pendulum shaft of the front drive axle of the FOTON-TD Series tractors, respectively. The lubricating grease should be filled on a regular basis, and is usually re-filled every 50 operating hours.

### 5.2.2.16 Maintenance of Power train

When checking the oil level, please park the tractor on the flat ground. Shut down the engine. Screw out and clean the dipstick on the right side of rear axle housing. Insert the dipstick to check the oil level. If the oil level is below the lower scale of dipstick, please fill the drive oil to the zone between the upper and lower scales (measurement should be taken after 5min when filling oil is over). When replacing the lubricant, please remove the drain plug located on the bottom of transfer case housing to drain the used oil. Moreover, use the diesel oil to clean it. Tighten the drain plug and add the new oil.

### 5.2.2.17 Maintenance of Lifter

Park the tractor on the flat ground and lower the lifting arm to lowest position. Shut down engine and screw out the dipstick on the lifter cover to check the oil level. If the level is below lower scale, please fill it to the zone between upper and lower scales. To change the hydraulic oil, remove the drain plug to drain the used oil. Then clean and fill new oil as required.

### 5.2.2.18 Maintenance of Fuel Tank

## Maintenance instructions

Park the tractor on level ground and shut off the engine, and then remove the drain plug at the bottom of the fuel tank and drain its deposition.

The fuel tank diesel filter is functioned for filtrating fuel, depositing moisture and foreign material. Please regularly check or clean it.

### 5.2.2.19 Inspection of Tire Inflation Pressure

Check the tire pressure with a barometer. For the tire pressure, see the Tractor Technical Specifications. Too high or too low of tire pressure will cut down tire service life, and have an impact on driving and handling the tractor, resulting in accidents.

### 5.2.2.20 Maintenance of engine cooling system

Engine coolant can be boiled water or antifreeze. Validity period of antifreeze is 2 years or 1600 h. Antifreeze shall be drained and the cooling system shall be washed if beyond the time limit, then new freeze shall be added.

Precautions for use of the radiator:

- Before starting, please check whether coolant is filled up in the radiator and whether there is any leak.

Check whether the radiator cap is tightened.

- Frequently check whether there is weed, dust or oil contamination in the radiator core. Remove it if necessary.
- Periodically clean the scale in the cooling system to maintain the thermal dissipation on the heat exchange surface.
- Periodically look over the thermostat that will affect the cooling water cycling and therefore cooling effect.

Cleaning of the cooling system:

During external cleaning of the radiator, remove weeds foreign bodies before cleaning, and use hot water (or water vapor) to wet its core, and dry it with compressed air.

During removal and cleaning, have it soaked in water solution with 1~2% detergent. The solution temperature should be 80~100°C. The radiator should be shook in the solution to remove contaminant, and wash clean it with clear water.

Cleaning of scale in the cooling system: in the shift before maintenance, the cooling system shall be filled with a solution, whose proportion is adding 750 g caustic soda and 150 g kerosene in 10 L water. Let the engine run at medium speed for 5 ~ 10 minutes and let the cleaning solution sit for 10~12h (Note: Be sure to keep the engine warm to prevent freezing in winter.), and then, stop the engine and drain the cleaning solution after the engine is re-started to operate at middle speed for 20 min. After the engine gets cool, insert a water pipe into the water tank for flushing, and at this moment, the water drain valve at bottom of the water tank should be opened. After rinsing, turn off the drain valve, and add water to let the engine run for 20 minutes, and then drain the water. After the engine is cooled down, new antifreeze or cooling water shall be added according to

## Maintenance instructions

regulations.

### Important:

1. In winter, frequently check the antifreeze concentration according to ambient temperature. If necessary, timely recover to normal concentration. For the tractor without antifreeze, wait until the cooling water temperature drops below 70°C, and then drain the cooling water while the engine idling to prevent the cooling water from being frozen, cracking the engine block.

2. To prevent blockage of the water pipe of the radiator core and water deposit in the same pipe must use anti-freeze fluid produced by specified manufacturers.

3. The heat radiator cannot be in contact with any acid, alkali or other corrosive substances, so as to avoid corrosion of the heat radiator;

4. During installation and cleaning of the heat radiator, pay attention to prevent damage to the radiator strap and collision with the radiating pipe.

### 5.2.2.21 Maintenance and care of individual breathers

After shutdown of the tractor, remove individual breathers one by one, use clean diesel for cleaning, and after cleaning, re-install them back to the tractor. During assembling, pay attention to remove air trapped in the oil line.

### 5.2.2.22 Exhaust of fuel system

Prolonged tractor storage or replacing the diesel oil filter, as well as emptying the fuel tank, can cause air in the fuel lines. Air in the fuel system will make the engine difficult to start. Bleed the air by observing the

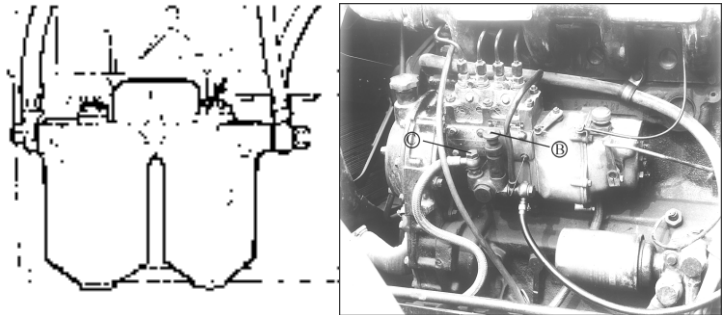

Fig. 5-5 Exhaust of engine fuel system

following steps when the tank is full of fuel and the fuel line switch is turned on: Loosen the bleed screw A of the fuel filter, and pull the draw knob B of the fuel delivery pump up and down, until the diesel oil spills from the bleed screw hole without bubbles. Tighten the bleed screw A again, and loosen the bleed screw on the injection pump and pull up and down the draw knob B of the hand pump of the fuel delivery pump, until the diesel oil spills from the bleed screw hole without bubbles, and then tighten the bleeder screw C.

## Maintenance instructions

### Important:

1. Only apply the qualified high-quality light oil to the engine, generally No. 0 light diesel oil in summer, and No. -10 light diesel oil in winter (For details see the operation manual of diesel engine); The diesel oil must be pure. Be sure to precipitate and purify it for at least 48h before use. Failure to do so can damage the engine

2. Frequently check the lubricant level for the ZHB fuel injection pump. Fill to scale position if necessary. Change the lubricant every 200h. The lubricant grade used in injection pump should be same as that used in diesel engine to avoid affecting fuel injection pump performance and service life.

### 5.2.2.23 Air bleeding of the brake system

After dismantling the oil pipe of the brake system or conducting inspection and adjustment of the brake smoothness (synchronism), must remove air trapped in the brake system.

The air removal of the brake system should be carried out by a trained, skilled and experienced personnel according to following steps: first have the brake oil tank full of oil, slowly depress the left brake pedal

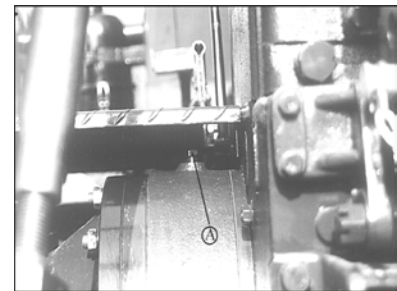

Fig. 5-6 Exhaust of brake

to build brake pressure. Unscrew the air bleed plug "A" above the brake housing by half turn. Tighten the air bleed plug "A", and repeat the above-mentioned operation until the spilled oil is free from air bubbles.

Depress the brake pedal again to build oil pressure. When the pedal reaches the normal travel, the oil pressure is built completely (reach the specified pressure). Note: Finally, wipe away the oil spilled onto the half shaft housing to prevent coming-off of the paint. Conduct air bleeding of the brake on other side in the above-mentioned sequence. Finally, inject oil into the brake oil tank to the specified oil level.



Warning: If the air is not bled thoroughly, the brake system may be failed!

## 5.3 Adjustment of Tractor Chassis:

### 5.3.1 Adjustment of clutch

- The main clutch control mechanism is adjusted according to following steps:
  - a. Adjust jointing length of the middle lever 6 to obtain a 28~40mm free travel of the main clutch pedal, and then tighten the tie rod nut 5.
  - b. Adjust extension length of the limit screw 3 to limit full travel of the main clutch pedal within

## Maintenance instructions

140~150mm, so that the main clutch is disengaged thoroughly, the tractor can be shifted between gears flexibly, and then the limit screw is tightened with a nut.

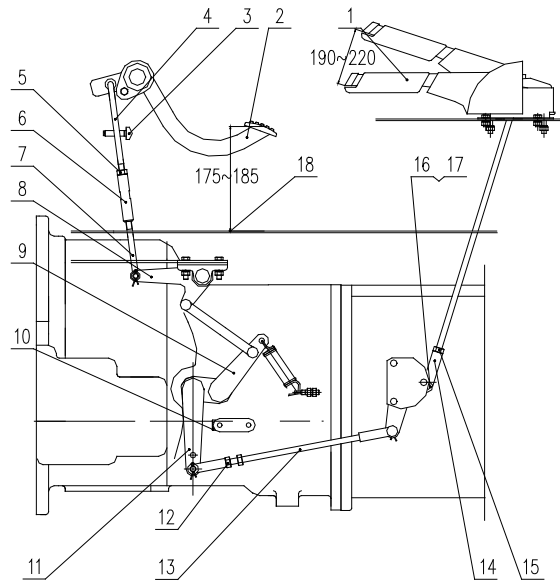

Fig. 5-7 Adjusting free travel of the clutch pedal

1. Auxiliary clutch control handle	2. Pedal	3. Limit screw	4. Upper draw bar	5. Nut
6. Middle lever	7. Lower draw bar	8. Transition lever	9. Main clutch rocker arm	10. Limit screw
11. Auxiliary clutch rocker arm	12. Nut	13. Auxiliary clutch pull rod	14. Pull rod fork	15. Nut
16. Cotter pin	17. Pin	18. Floor		

- The auxiliary clutch control mechanism is adjusted according to following steps:

a) Adjust length of the auxiliary clutch pull rod 13 to obtain a 45mm~55mm free travel of the auxiliary clutch control handle 1, and then tighten the pull rod nut.

b) Adjust length of limit screw 10 on right side of the gearbox, limit full travel of the auxiliary clutch control handle 1 within 255mm~270mm to get the auxiliary clutch disengaged thoroughly; the PTO can change gear flexibly, and then limit screw 10 is tightened with a nut.

- **Internal adjustment**

The clutch has been adjusted before delivery, and no adjustment is usually required. If desired to conduct adjustment, it can be adjusted by following method:

Adjustment of main clutch: Unscrew the nut 18 and turn the limit screw 17 to obtain a clearance of 2~2.5mm between the end B of the main clutch release lever 14 and the release bearing, and then tighten the nut

## Maintenance instructions

18. When it is adjusted by this method, must ensure that the end of 3 main clutch release levers is in the same vertical plane, and use a feeler gauge for inspection. The deviation should not be more than 0.2mm.

b. Adjustment of auxiliary clutch: Unscrew the small hex self-locking nut 4 to obtain a clearance of 2~2.5mm between the end A of the auxiliary clutch release lever 8 and the auxiliary clutch release plate. Then, firmly clamp the round end of the small hex self-locking nut 4, so that the nut is locked firmly. During adjustment, must ensure that the end of 3 clutch release levers is in the same vertical plane, and use a feeler gauge for inspection. The deviation should not be more than 0.2mm.

Adjustment of the release lever position is shown in Figure 5-8. When re-installing the clutch assembly, the distance between the end A of the main clutch release lever and the end surface of the auxiliary clutch driven plate assembly 2 must be  $103\pm 0.5\text{mm}$  [For the 11" clutch, the distance should be  $96\pm 0.5\text{mm}$ ]; the distance between the end B of the auxiliary clutch release lever 8 and the end surface of the auxiliary clutch driven plate assembly must be  $137\pm 0.5\text{mm}$  [For the 11" clutch, the distance must be  $121\pm 0.5\text{mm}$ ].

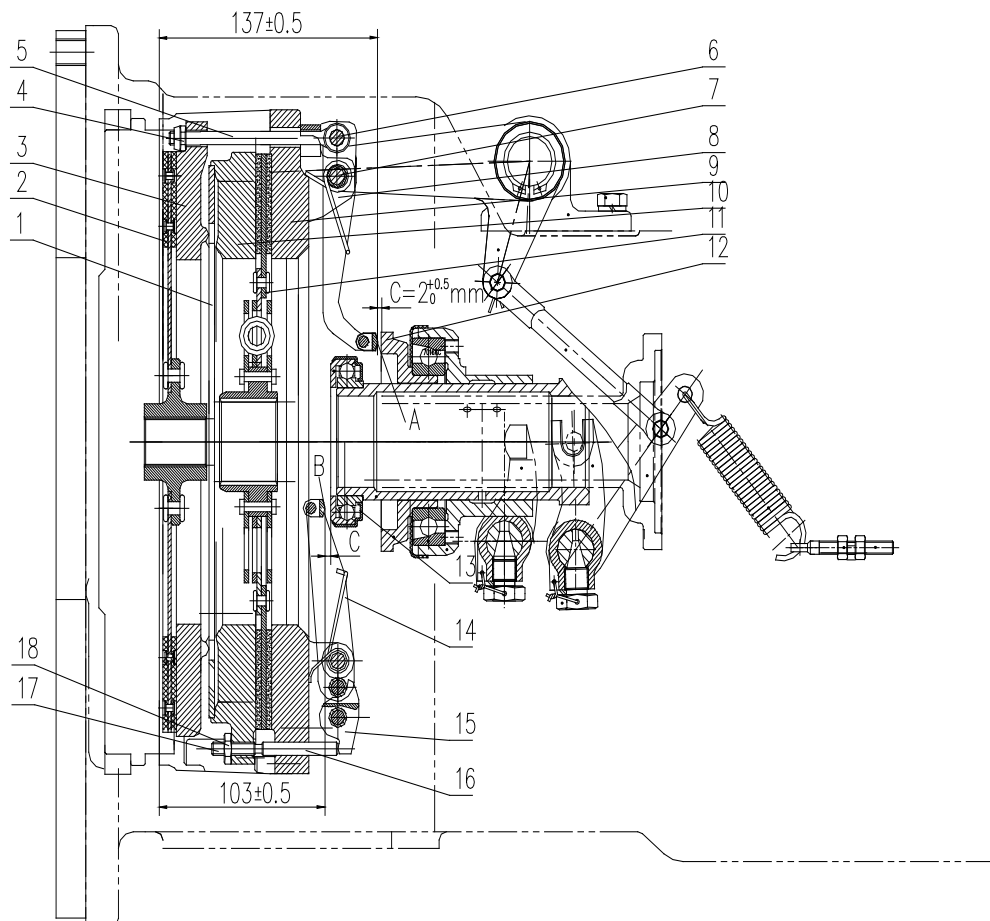

Fig. 5-8 12" clutch mounting

1. Disc spring 2. Auxiliary clutch driven plate assembly 3. Auxiliary clutch pressure plate unit 4. Small hex self-locking nut 5. Coupling lever 6. Short pin 7. Long pin 8. Auxiliary clutch release

## Maintenance instructions

lever 9. Clutch cover 10. Main clutch pressure plate unit 11. Main clutch driven plate assembly 12. Auxiliary clutch release plate 13. Main clutch release bearing 14. Main clutch release lever 15. Lever unit 16. Pin 17. Limit screw 18. Nut

**Important:** The free travel of the clutch should be inspected and adjusted frequently to ensure that the free travel of the pedal is within 28~40mm, so as to avoid abnormal wear of the clutch.

**Important:**

1. During use of the clutch, must note that the clutch is disengaged rapidly and thoroughly, and be engaged smoothly, so as to avoid early damage to the clutch.
2. During driving of the tractor, do not place your foot on the clutch pedal. Semi-engagement of the clutch is not allowed to reduce driving speed of the tractor, and sudden engagement of the clutch is not allowed for climbing or overpassing a barricade, so as to avoid damage to the clutch.
3. The clutch lining surface should be free from oil stains. In case that the clutch lining surface is oil-stained, it should be cleaned with gasoline, and should not put into service until it gets dry, so as to avoid early damage to the clutch.
4. Every 50 hours, inject appropriate quantity of lubricating grease into the oil cup on the left/right front connecting supports, respectively, so as to lubricate the main/auxiliary clutch rocker arm shaft, ensuring that the rocker arm shaft rotates flexibly.

### 5.3.2 Adjustment of brake control mechanism



## Maintenance instructions

For adjustment of the brake, see Figure

By adjusting the limit screw 11, the height from the floor to the pedal center should be within 175~185mm; By adjusting the limit screw 3, ensure that the clearance between the limit screw 3 and the brake pump is within 3~4mm, so that the free travel of the pedal is within 12~16mm; the working travel is within 110~130mm. The working travel of the hand brake control handle is within 220~250mm. By adjusting length of the hand brake pull rod, ensure that parking braking is realized reliably within specified working travel. The specific adjustment method is as follows: Set the hand brake control handle to the initial position (horizontal position of the control lever), remove the cotter pin, withdraw the pin 7, loosen the nut 9, turn the pull rod 8 to adjust effective length of the hand brake pull rod until the working travel meets requirements.

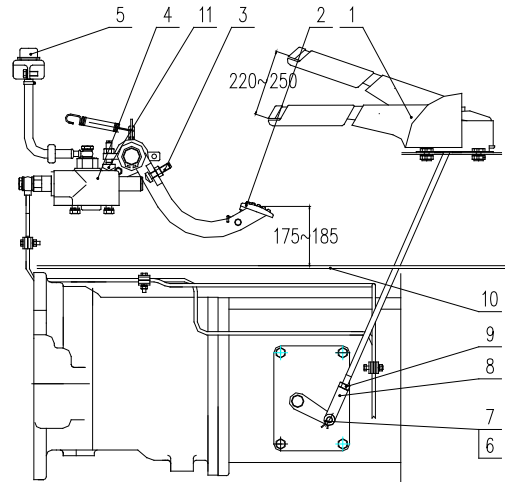

Fig. 4-8 Adjustment of brake control

Fig. 5-9 Adjustment of

1. Hand brake control handle 2. Pedal 3. Limit screw 4. Brake pump 5. Brake oil tank
6. Cotter pin 7. Pin 8. Pull rod fork
9. Nut 10. Floor 11. Limit screw



Attentions:

**1. The free travel of the left/right brake pedal of the tractor must be adjusted consistently; otherwise, the tractor will deflect toward one side during emergency braking, resulting in dangerous accident;**

**2. For the purpose of reliability, the brake test should, after adjusting the brake control mechanism, be carried out by following steps: have the right/left brake pedals interlocked, and move the tractor to a dry and flat road; after the main clutch is disengaged in high speed straight driving conditions, use the brake for emergency braking, and then park the vehicle to inspect sliding imprints of the drive wheels on the road. If the imprints of the left/right drive wheels on the road are consistent (the imprints on both sides are straight, in parallel with each other, and equal in their length), it indicates that it is adjusted properly; otherwise, it should be adjusted again. If it cannot be adjusted properly for several times, it is required to inspect the interior of the brake.**

### 5.3.3 Adjustment of the rear axle

#### 5.3.3.1 Adjustment of the bevel pinion shaft bearing

Adjustment of the bevel pinion shaft bearing is shown in figure.

The conical roller bearing 3 and 5 on the bevel pinion shaft 6 are pre-tightened. During use, wear of the bearing may result in end-play of the bevel

pinion shaft. During repeated adjustment, a

pre-tightening resisting moment of 1.5~2.5N·m

[Have a rope wound onto the active arc splined shaft by 2-3 turns, and use a spring balance to pull

the rope to have the active arc rotated. The spring

balance pulling force is 62.5~104N] is produced when separately turning the bevel pinion after the round nut 1

is tightened firmly; by screwing in or screw out the round nut, adjust the conical bearing pre-tightening force to

the specified range; after adjustment, tighten the two round nuts with a tightening torque of 300~350N·m under

the premise of ensuring that the bevel pinion shaft (No. 6) does not rotate in relation to the round nut close to

the bearing (No. 3); finally, tap a locking lug of the stop washer (No. 2) into the external round nut groove, so

as to lock the external nut.

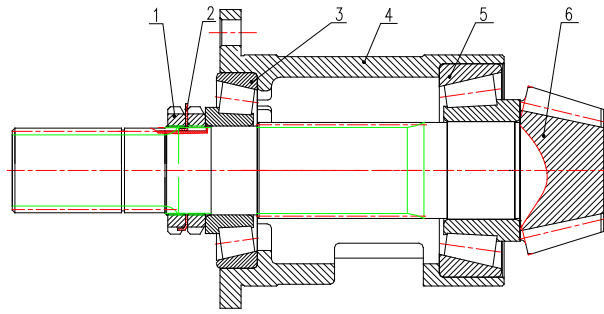

Fig. 5-10 Adjustment of the bevel pinion shaft

1. Round nut 2. Stop washer 3. Conical roller bearing 4. Bearing block 5. Conical roller bearing 6. bevel pinion shaft bearing

#### 5.3.3.2 Adjustment of Differential Bearing

## Maintenance instructions

For details on adjustment of the differential bearings, see the Figure. The left/right bearing 2 and 4 of the differential are also pre-tightened, and wear of the bearings during operation may result in increase in end-play of the bevel wheel gear 3 and decrease in its pre-tightening force. Therefore, it should be inspected and adjusted regularly. During adjustment, first dismantle the active arc assembly, and separately measure the friction frictional resistance moment of 1.5~2.5N·m required for rotation of the differential assembly [Have a rope wound onto the differential housing  $\varnothing 160$  by 2~3 turns, and use a spring balance to pull the rope to rotate the differential assembly.

The spring balance pulling force should be 18.5~31.5N]; if the pre-tightening force is less than 18.5N or more than 31.5N, same quantity of adjusting shims should be added or reduced on both sides of the left/right bearing carriers until the pre-tightening force is adjusted to the specified range. After adjusting the pre-tightening force of the differential, the dismantled active arc assembly should be re-assembled onto the differential housing.

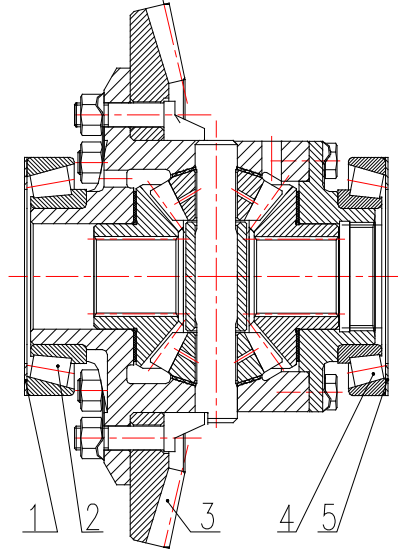

Fig 5-11 Adjustment of

1. Adjusting shim 2. Bearing 3. Bevel wheel shaft 4. Bearing 5. Adjusting

### 5.3.3.3 Engagement Adjustment of main drive bevel gear

For details on engagement adjustment of main drive bevel gear, see the Figure.

The increased backlash caused by gear surface wear will not affect the gear performance. If the bearing wear makes the bevel gear away from the initial meshing position, it is not necessary to adjust it as long as it does not affect the gear normal work. But, do adjust the meshing gears if doing the overhauling, the gear can not normally work or replacing bearing (differential bearing and bevel pinion bearing) and spiral bevel gearset.

- Inspect the backlash

## Maintenance instructions

Insert a lead sheet into the non-working flanks of the bevel wheel and pinion gears, respectively, and turn the gear to squeeze the lead sheet. Then, remove the lead sheets, and measure the sum of the thinnest thickness of the two lead sheets (i.e. backlash). The sum of the thinnest thickness of the two lead sheets should be 0.2~0.4mm. The measurement should be carried out at three points on the whole circumference of the gear, and the three measured values should be averaged. If the meshing clearance does not meet requirements, the adjusting shim 5 of the differential bearing pedestal 7 can be increased or reduced.

When the clearance is big, withdraw the right shim shown in Figure 5-11, and insert it on the left side, vice versa.

- Check the meshing mark

Apply a layer of thin and even red lead at raised surface of the bevel wheel gear 6. At this moment, the recessed surface of the bevel pinion shaft 4 is subject to force, so as to rotate the gear and obtain a meshing imprint on the bevel pinion gear. Correct meshing imprint should be in the vicinity of the pitch cone at middle part of the tooth height and slightly higher than the small end and should be at distance not less than 3~4mm from the end edge, whose length should not be less than 60% the tooth length, and height should not be less than 55% the tooth height. During adjustment, move the bevel pinion gear shaft in axial direction by changing thickness of the adjusting shim 2, and move the bevel wheel gear in circumferential direction by changing thickness of the adjusting shim 5. To avoid influence on pre-tightening of the differential bearing, must add the shims removed from the side bearing pedestal into the bearing pedestal on the other side to keep total thickness of adjusting shims for the left/right bearing pedestal unchanged.

During adjustment, when the meshing clearance is contradictory to the meshing imprint (i.e. the meshing imprint is appropriate, and the clearance is not appropriate, or vice versa), the meshing imprint prevails, but the meshing clearance should not be less than 0.2mm. During dismantling, inspection and adjustment, pay attention to position and quantity of the adjusting shims; after the adjustment is finished, store the dismantled remaining shims for future use.

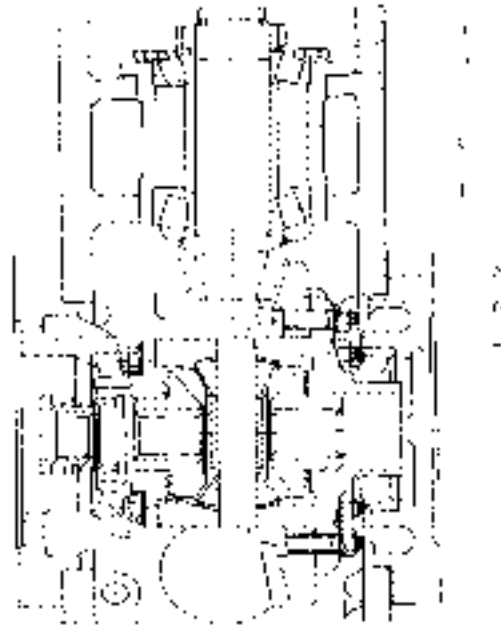

Fig. 5-12 Engagement Adjustment of

1. Blot 2. Adjusting shim 3. Front bearing pedestal 4. Bevel pinion shaft 5. Adjusting shim 6. Bevel wheel shaft 7. Differential bearing pedestal

## Maintenance instructions

### 5.3.4 Adjustment of Final Drive

For adjustment of the final drive of the front drive axle, see the figure. The 2 conical roller bearings 7 of the final drive of the front drive axle are pre-tightened. During inspection and adjustment, first dismantle the bolt 1, remove the planetary carrier 2, tighten the adjusting nut 3, and then turn the nut back by  $1/10 \sim 1/6$  turn to enable the front wheel hub to rotate flexibly, and finally re-assemble and tighten the dismantled parts. The clearance  $G$  between the planetary carrier 6 and bearing 1 is equal to  $0.075 \sim 0.125$  mm. During assembling of the tractor, the clearance has been adjusted, so that no adjustment is carried out during operation. However, adjustment should be carried out during overhaul or when replacing the planetary gear mechanism.

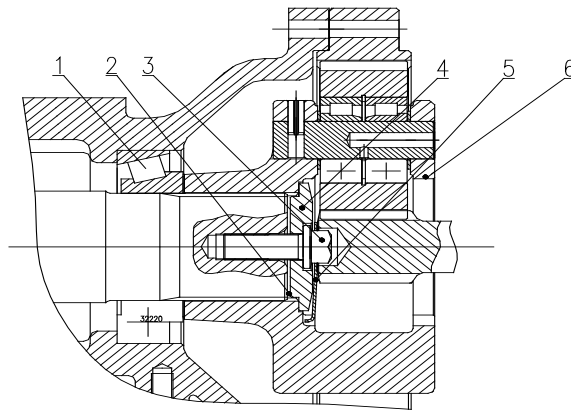

Fig. 5-13 Adjustment of Final Drive

1. Bearing    2. Washer    3. Bolt    4. Planetary carrier pressure plate    5. Stop washer    6. Planetary carrier

During adjustment, use a padding tool to support the planetary carrier assembly and pressure plate 4, so that the end surface of the planetary carrier pressure plate is firmly against the end surface of the planetary carrier, and measure the distance  $A$  from the end surface of the planetary carrier pressure plate 4 to the end surface of the planetary carrier 6; then, measure the depth  $B$  from the end surface of the drive shaft and bearing 1, so that thickness  $\delta$  of the adjusting shim 2 is equal to  $A - B + (0.075 \sim 0.125)$  mm. When inserting adjusting shims, the adjusting shims should be arranged from the thicker shim to thinner shim, and the number of adjusting shims should be minimized. Place the selected adjusting shim 2 at the position shown at the figure, and align the planetary carrier assembly with the drive shaft spline, and have it installed onto the shaft; then, tighten the mounting bolt 3 of the planetary carrier pressure plate, and use a stop washer 5 to lock it.

### 5.3.5 Adjustment of front wheel hub bearing

## Maintenance instructions

Normal clearance between the front wheel hub bearings of the FOTON-TD Series two-wheel drive tractor models is 0.05~0.15mm. Due to bearing wear during operation, the clearance increases gradually; when the clearance exceeds 0.4mm, it should be adjusted accordingly. During adjustment, use a jack to support the front axle to enable the front wheels to be above ground, so as to remove the screw 2, bearing cover 3 and cotter pin 4 in sequence, and screw in the adjusting nut 5 until the bearing clearance is eliminated, and then turn the nut back by 1/30~1/10 turn. At this moment, the front wheels should be able to rotate flexibly. Then, insert the cotter pin 4 and install the bearing cover 3.

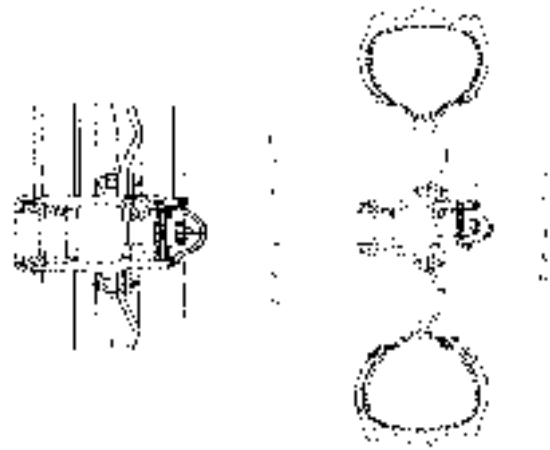

Fig. 5-14 Adjustment of front wheel hub

1. Oil cup; 2. Screw; 3. Bearing cover; 4. Cotter pin; 5. Adjusting nut; 6. Bearing

### 5.3.6 Adjustment of front drive axle (4WD tractor)

#### 5.3.6.1 Adjustment of central drive of the front drive axle

For adjustment of the central drive of the front drive axle, see the figure.

Both the two tapered roller bearings on the bevel pinion shaft of the front drive axle and the two tapered roller bearings on the differential case are preloaded. When in use, due to bearing's wear, an axial clearance appears between the bevel pinion shaft and the differential case. Be sure to check it for every 1600h. Bevel pinion shaft bearing is adjusted by the adjusting nut 1. When adjusting, firstly tighten the nut 1 and return it back by 1/10~1/6 circle. At last lock the nut. As to the adjustment of differential housing bearing, the left and right helicoidal should be adjusted simultaneously to keep the meshing clearance between the main drive bevel gearset within (0.15~0.3)mm. Use the locking sheet to lock the adjusting helicoidal. The detection method for the backlash and contact pattern is the same as that of the central transmission of the rear axle.

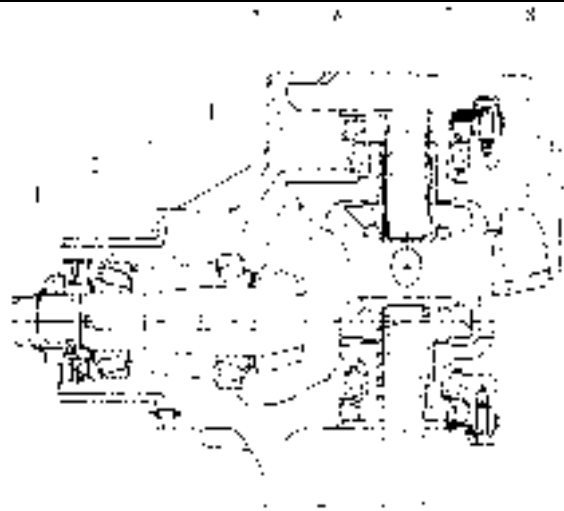

Fig 5-15 Adjustment of central drive of the

1. Adjusting nut; 2. Tapered roller bearing; 3. Bevel pinion shaft; 4. Adjusting shim; 5. Bevel wheel gear 6. Adjusting ring; 7. Locking plate; 8. Blot

## Maintenance instructions

### 5.3.6.2 Adjusting the final drive of the front drive axle

For adjustment of the final drive of the front drive axle, see the figure. The 2 conical roller bearings 7 of the final drive of the front drive axle are pre-tightened.

During inspection and adjustment, first dismantle the bolt 1, remove the planetary carrier 2, tighten the adjusting nut 3, and then turn the nut back by 1/10~1/6 turn to enable the front wheel hub to rotate flexibly, and finally re-assemble and tighten the dismantled parts.



Fig 5-16 Adjusting the final drive of the front drive axle

1. Bolt; 2. Planetary carrier; 3. Adjusting nut;
4. Drive shaft; 5. Sun wheel; 6. Front wheel hub; 7. Tapered roller bearing

## 5.4 Adjustment of hydraulic suspension system

### 5.4.1 Adjustment of lifter

## Maintenance instructions

During delivery of the tractor, the lifter has been adjusted properly, and no adjustment by the user is required. However, due to wear of the drive pairs of the lever parts and looseness of the fasteners, the original adjustment status of the lifter is impaired, resulting in abnormal operation of the lifter, or when assembling the lifter after being repaired, the lifter should be adjusted. The lifter is adjusted by following method and sequence (See Figure 5-17):

- Pull the distributor control handle 6 to the lowest down position and keep it standstill.

- Start the engine, and slowly move the control handle 6 toward the up position.

At this moment, the external lifting arm 2 is moved toward the lifting direction constantly.

- If the control handle 6 is moved to the highest lifting position, but the external lifting arm 2 does not reach the highest position, it is required to adjust the threaded sleeve 4 to enlarge the distance between the distributor feedback arm and the middle arm, so as to enable the external lifting arm to turn upward until an angle of  $60^\circ$  is formed between the lifting arm and the horizontal line. Lock the nut 5, and at this moment, the marking line of the external lifting arm is in line with that of the lifter case. Lift the lifter up and down for 3 times; if the lifter operates normally, the adjustment is finished.

- If the control handle 6 does not move to the highest position, but the external lifting arm 2 has reached the highest position, it is required to adjust the adjusting threaded sleeve 4 to reduce the distance between feedback arm and the middle arm. When the control handle 6 is moved to the highest position and the external lifting arm 2 reaches the highest position, tighten the locknut 5. Lift the lifter up and down for 3 times; if the lifter operates normally, the adjustment is finished.

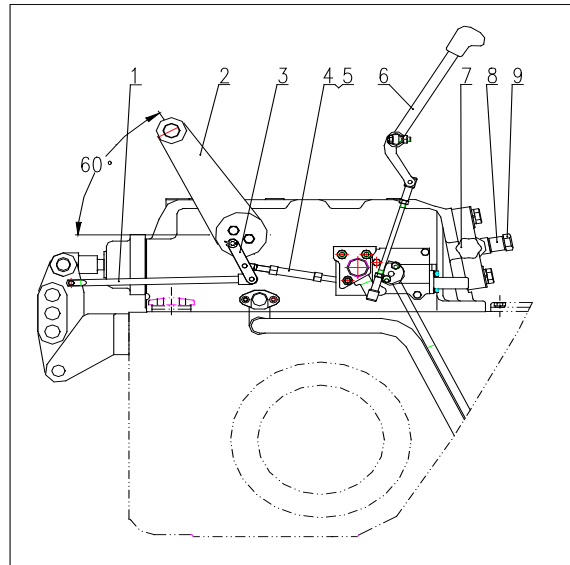

1. Connecting link; 2. Outer lift arm; 3. Middle arm; 4. Adjusting threaded sleeve; 5. Nut; 6. Control lever; 7. Descent speed control handle 8. Sleeve; 9. Hollow bolt

**Important: When an implement with a power take-off is required, it is required that the implement be lifted above the ground and the lifting height having no influence on steering of the tractor in the field be guaranteed, for the purpose of preventing excessive lifting height of the implement resulting in damage to the drive shaft that is connected from the PTO shaft to the implement.**



## Maintenance instructions

### 5.4.2 Adjustment of the distributor

#### 5.4.2.1 Inspect travel of the lowering valve

- Unscrew the lowering valve plug 8;
- Set the control handle (See Figure 5-17, No. 6) at

the highest ascending position (i.e. the control valve is placed at ascending position), and measure the distance H1 from the steel ball 6 to the upper end surface of the lowering valve pocket 2;

- Set the control handle at the descending position (i.e. the main control valve is placed at descending position), and measure the distance H2 from the steel ball 6 to the upper

end surface of the lowering valve pocket 2;

- In case of  $H1 - H2 = (2 \pm 0.2) \text{mm}$ , it indicates that it is adjusted properly. Otherwise, the adjustment dimension can be obtained by

- Tighten the lowering valve plug.

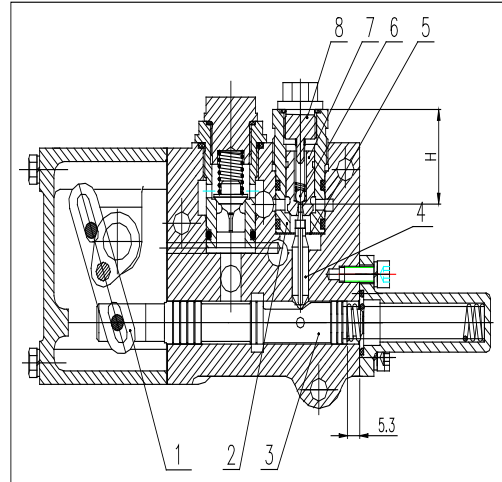

Fig. 5-18 Adjustment of the distributor

1. Swing rod; 2. Lowering valve pocket ; 3. Main control valve; 4. Push pin; 5. Adjusting shim; 6. Steel ball; 7. Lowering valve; 8. Lowering valve plug

#### 5.4.2.2 Adjusting the safety valve of the distributor

##### Note:

1. The safety valve of the distributor has been adjusted properly during delivery, and the user does not need to conduct adjustment; if required to adjust it, the adjustment must be carried out on a test table;

2. Opening pressure of the safety valve of the distributor is 17.5~18 MPa;

3. The distributor is a precision part, and usually, no dismantling is allowed; if the distributor must be dismantled, it should be dismantled at a clean place, and cleaned with clean gasoline or kerosene.

## Maintenance instructions

### 5.4.3 Adjusting the split type hydraulic system

#### 5.4.3.1 Adjusting the height limit of the split type lifter

● The function of and structural diagram for the height limit device of the FOTON-TD Series tractors are as follows:

Through adjusting the limit device (See the adjusting method), it is possible to control lifting height of the implement. To prevent occurrence of PTO shaft breakage due to excessive lifting height of the implement arising out of improper operation, the user should conduct adjustment by referring to the following figure and by the method set forth in Clause 2.

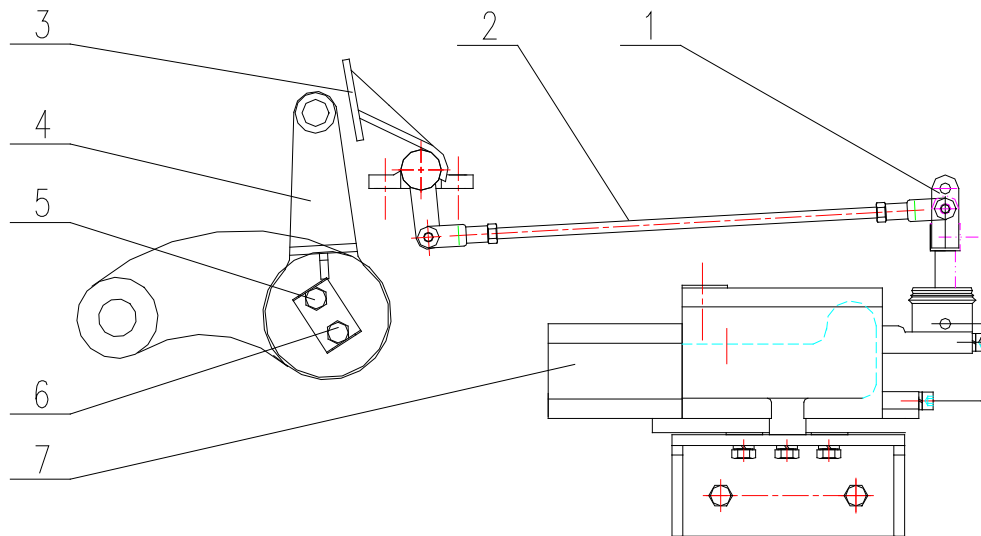

Fig. 5-19 Adjusting the height limit of the split type lifter

1. Control device; 2. Feedback lever; 3. Height limit feedback lever; 4. Limit plate; 5. Nut 1; 6. Nut 2; 7. Distributor

● Adjusting method and requirements:

1. Adjust the height by adjusting the limit plate at right end of the lifting shaft, and loosen the nut 1 and 2 and adjust the limit plate in counterclockwise direction to increase the lifting height, vice versa;

2. Adjusting lifting height during turning in the field when the implement is working: It is required that the implement is 150~250mm above the ground after it is lifted up, so as to confirm length of the limit plate;

3. Adjustment during long-distance transfer or road transportation: Adjust position of the limit plate. The lifting height must meet the requirements that the lowest point of the implement is 250mm above the ground;

4. After adjustment, tighten fasteners.

## Maintenance instructions

### 5.4.3.2 Adjusting the oil cylinder of the split type lifter

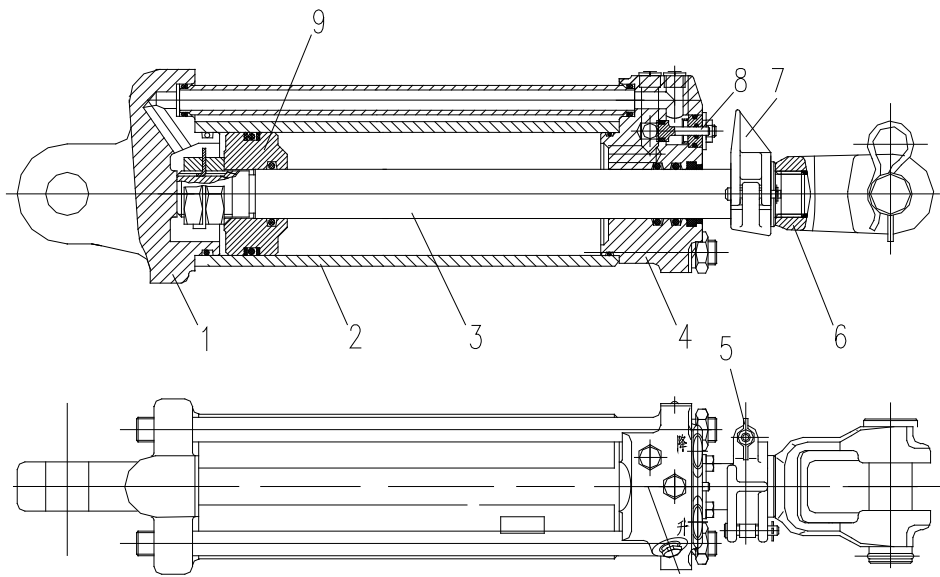

Fig. 5-20 Adjusting the oil cylinder of the split type lifter

1. Lower cover; 2. Cylinder body; 3. Piston rod; 4. Upper cover; 5. Wing nut; 6. Piston rod connecting fork; 7. Positioning clamp; 8. Positioning valve; 9. Piston

To ensure safety and reliability during transportation of the implement, the positioning clamp should be adjusted to press the positioning valve 9 to the limit position when the implement is lifted up to the highest point. Through the positioning valve, the oil line of the lower chamber of the oil cylinder is closed so that it cannot be lowered any more.

### 5.4.4.3 Adjusting lowering height of the oil cylinder

The lowering height is controlled by the positioning valve and positioning clamp stop block on the oil cylinder. The positioning clamp stop block can be adjusted upward or downward on the piston rod. The lower the positioning clamp stop block is, the smaller the lowering height is, vice versa. In the lowering process, the oil cylinder stops lowering when the positioning clamp stop block presses the positioning valve.

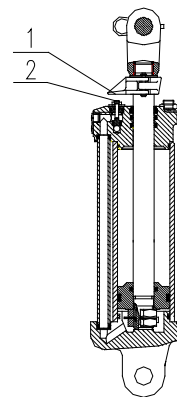

Fig. 5-21 Oil cylinder assembly

1. Positioning clamp stop block; 2. Positioning valve

## Maintenance instructions

**Important:** When adjusting the distance between the positioning clamp stop block and the positioning valve, must keep consistency in adjustment of the two oil cylinders, with deviation of  $0 \sim 0.5\text{mm}$ .

### 5.5 Precautions for use of full hydraulic steering system

FOTON-TD Series tractors adopt a full hydraulic steering system. The structure of the full hydraulic steering gear is as follows. The steering system has been adjusted properly in the factory. Attention should be paid to the following matters during the course of using:

- Frequently inspect the joint of each screw thread which shall be tightened if it is loose. Make sure there is no leak at any joint when the full hydraulic steering system is operating.

- Frequently check the level in the oil reservoir, add it if necessary.

- If the steering is found to be turning heavily or out of order, it is required to carefully find the cause. It is not allowed to pull the steering wheel

blindly or simply disassemble the steering gear in case of the part damage. Turning the steering wheel with two people is strictly prohibited.

- Ensure that the steering gear is in the same axle with the steering axle and the clearance shall exist in the axial during the installation of the full hydraulic steering system. Inspect whether the steering wheel can be returned flexibly after installation.

- Ensure the oil is clean. For this purpose, it is required to frequently inspect the filter element and the oil in the filter. Inspection method: Drop one drop of the oil on the blotting paper, then if a black center is found in the oil stains, the oil shall be replaced.

- The gas in the fuel cylinder shall be exhausted after replacing with new engine oil. Exhausting method: Loosen the steering cylinder bolt head and let the oil pump run at low speed to bleed the air until no bubbles appear in the effluent oil.

Disassemble the connection between the piston rod of the steering fuel cylinder and the steering wheel, turn the steering wheel to make the piston reach the left end or right end (Never stop in the two extreme positions), and then add oil to the highest level.

Tighten all threaded connection (do not tighten it under pressure condition). Connect the piston. Check the steering system for normal work at all kinds of working state.

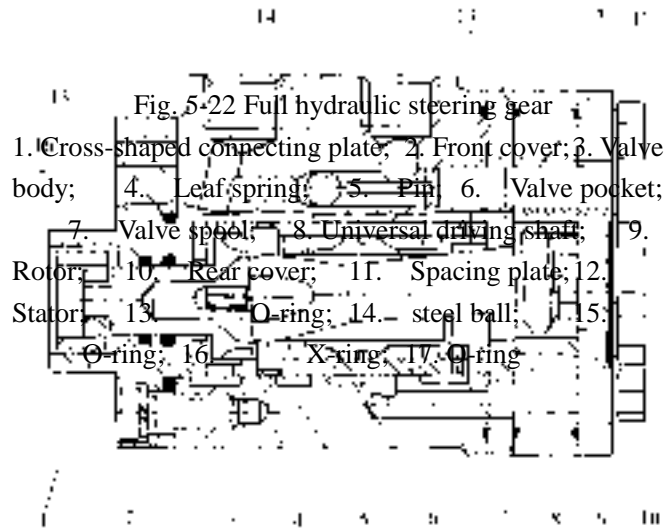

## Maintenance instructions

### **Important:**

1. Before delivery, a safe overflow pressure of the overflow valve for the constant-flow overflow pump has been adjusted, and cannot be dismantled for adjustment, so as to avoid operation of the system;

2. The constant-flow overflow pump is a precision part, and is usually cannot be dismantled, usually; it should be dismantled at a clean place, and washed with clean gasoline or kerosene.

## Storage

### 6 Storage

When the tractor is to be out of use for a longer time (more than one month) or after the completion of farm work, it must be kept in proper storage and sealed up. The tractor should be kept under sound condition to prevent the machine from rusting, aging and distortion.

Before the tractor's seal-up, it must undergo the thorough cleaning, adjustment and tightening of various joint parts, subject to the technical maintenance in operate time so as to make the tractor remain in good technical condition

**Important: During the long period out of use, it is very important to store and maintain the tractor in a scientific way. Otherwise, the deterioration speed of tractor technical condition is quicker than its work time.**

#### 6.1 Causes of the damage during storage of the tractor

- 6.1.1 Rust and pollution: During the storage period, the dust and moisture in the air easily immerse into the machine through the slits, orifices etc., polluting and rusting the components. As the pistons, valves, bearing and gears etc. stay for long time
- 6.1.2 Aging: Components made from rubber and plastic will get aged, deteriorated, and brittle under the ultraviolet of sunlight, resulting in corrosion or rot.
- 6.1.3 Deformation: Components such as drive belt and tires etc under stress for a long time may have plastic deformation.
- 6.1.4 Others: The electric appliance parts are affected with damp and the battery self-discharges etc.

#### 6.2 Sealing up of tractor

- 6.2.1 Prior to the seal-up, checks carefully the tractor, eliminates the failures and keeps it in sound technical condition. Clean up the exterior of tractor.
- 6.2.2 Drain the antifreeze and rust-proof liquids in the radiator, cylinder block and water pump, as well as the lubricating oil in the drive train and the oil in the hydraulic system.
- 6.2.3 Remove the battery, coat the lubricant grease on the terminal and store it in a dark and ventilated room, where the temperature is not lower than 10 °C.
- 6.2.4 Discharge the engine oil before it becomes cool, refuel the fresh oil, and keep the engine running for several minutes by reducing throttle, which will make the oil cling evenly on the surfaces of various moving parts.
- 6.2.5 To add the lubricant grease into various lubrication points.
- 6.2.6 Coat the contact points of electric appliance, connector and non-painted metal parts with dehydrated Vaseline [heated up to (100~200)°C (degree Celsius)].
- 6.2.7 Loosen the engine fan belt, take it down if necessary, wrap it securely and store it separately, spray a coating of rust-proof agent into the pulley groove. The makeup painting should be made on the paint

## Storage

flakes on the exterior of tractor.

6.2.8 Discharge the diesel oil from the tank and clean up the oil tank.

6.2.9 Seal the open orifice of engine such as intakes/outlets with the protective material (e.g. canvas, waterproof cloth or oiled paper etc.) to prevent the foreign matter, dust and moisture from entry.

6.2.10 Place all control handles on the neutral gear position (including electrical system switch), put positively the tractor front wheel, and the suspension rod on the lowest position.

6.2.11 Support the tractor with the wooden stands, and unload the tires. Check regularly the tire pressure.

6.2.12 The tractor should park in the hangar or the shed, where the environment should be dry and drafty. It is strictly prohibited to store it together with the corrosive goods and gas. If such conditions are not available and it is forced to park on open air, a dry terrace on higher land must be selected for parking with the rainproof cloth covering on the tractor.

6.2.13 Parts disassembled from the tractor and onboard tools should be cleaned up, well wrapped and preserved in the dry storehouse.

### 6.3 Maintenance during the tractor's seal-up

6.3.1 During the storage period, the above mentioned requirements relevant to the tractor's storage must be met.

6.3.2 Monthly check the tractor and parts to see whether there are abnormal phenomena such as rust, corrosion, aging and distortion etc. The problems should be removed promptly.

6.3.3 Revolve the crankshaft of engine (10-15r) to prevent the interior rust every 2 months. For the location necessary to add lubricant, the old lubricant should be removed for new replacement.

6.3.4 It is necessary to start up the tractor, drive it at low speed (20~30) min, and check whether there are abnormal phenomena on each part every 3 months.

6.3.5 Remove the dust from the top surface of the battery regularly with a dry cloth. Inspect status of the battery as per requirements specified in 5.2.2.1 "Maintenance of Battery", and then install the battery. Even if out-of-service, the battery will self-discharge. Be sure to charge the battery every 3 month.

**Important: if user has not rust-proof treatment condition and tractor need idle for several months or a long time, replace engine oil and engine oil filter and start one time every other month, driving it at low speed of (20~30)min, check whether each part is normal. Keep the outside of the tractor clean and dry.**

### 6.4 Unpacking of tractor

6.4.1 Remove the grease used for anti-rusting

6.4.2 Open various sealed up nozzles. Clean up the tractor.

6.4.3 Add the coolant, machine oil, diesel oil and lubricate every lubrication points according to the provisions.

6.4.4 Inspect status of the battery as per requirements specified in 5.2.2.1 "Maintenance of Battery", and then install the battery.

## Storage

6.4.5 Remove the remainder anti-rust agent in the belt grooves of fan and installs the belt. Adjusts the transmission belt tension according to the specification (See Operation and maintenance manual of engine)

6.4.6 Set the battery, and coat the vaseline on the terminals.

6.4.7 Check the tightening of the circuit and pipeline.

6.4.8 Control the tractor according to the requirements of manual.

**Note: Please refer to the Operation and maintenance manual of engine for details of engine's sealing and unsealing.**



# Delivery, acceptance and transportation

## 7 Delivery, acceptance and transportation

### 7.1 Delivery and acceptance

When purchasing the tractor, the user should carry out the acceptance testing on the purchased machine with the emphasis laid on several aspects as follows:

- Whether the on-board documents are completely provided

The attached documents include: Operation Manual, Product Certificate, Three-Guarantee Service Certificate, Pack List of Vehicle Items, Air heater operation manual (equipped on machine with heater), The Air conditioner operation manual (equipped on machine with air conditioner), The radio cassette player operation manual (equipped on machine with radio cassette player) and “Technical Document for Engine” (from the engine manufacturer), Tractor Parts and Components Schematics. Check whether the numbers of the "Product Qualification Certificate", "3R Warranty Card" and "Engine On-board Technical Document" comply with those of the physical object.

- Whether the on-board articles are fully provided

Carries out the verification on the machine attachments according to the "Packing list of Onboard Articles", which includes onboard spare parts and tools. The "Engine Onboard Technical Document" should be taken as valid for onboard articles (In case of questions, if any, please contact the dealer).

- Whether the machine is in good condition

The operational conditions of machine may be probably changed after the consignment or shipment, When purchasing, the user may further verify the machine conditions.

### 7.2 Transportation

In case of tractor displacement, if the tractor is displaced by self-drive, the traffic regulations should be strictly observed and the distance between two vehicles should be kept at least 60m to avoid the collision by accident; If the load transport selected, the following points should be satisfied:

- For the loading and unloading of the tractor, a smooth place should be selected.
- By unloading the machine, a special unloading platform should be used.
- An assistant should be available on the spot for guiding and the approach of persons not concerned is not allowed.
- After loading the tractor, put the suspension rods to the lowest position, set the parking brake, move the shift lever into Reverse, pull out the ignition key, lock the door and turn off the main switch of the power supply.
- The front and rear four tires will be fixed with the iron wire on form of the number "8", the tires ahead and behind reliably forelocked with wedges and rear axle hauled with iron wire..
- Pull the rear view mirrors inward as much as possible. If necessary, remove them. Meanwhile, make sure the engine hood and doors and windows of cab are closed. For model with safety frame, if necessary, place the safety frame on folded position and screw it.

## **Delivery, acceptance and transportation**

- When passing tunnels and the bridges, pay attention to the load height, and slow down the speed sufficiently while a turn is made.
- While unloading, the hand brake should be first released; the drive gear should be shifted on and slowly driven down at lowest speed.



### **Attentions:**

**1. While the tractor is loaded/unloaded, the truck-trailer should be fully braked to stop. The front/rear wheels should be safely forelocked so as to prevent the tractor and driver from the danger of overturn or fall-off.**

**2. While loading and unloading, the tractor should be driven at the lowest speed. To avoid the tractor overturning or falling caused by high speed.**

# Technical specifications

## 8 Technical specifications

### 8.1 Product model

LOVOL TD series tractor product model has the following meanings:

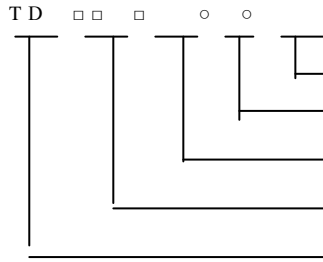

Distinctive emblem, Use a capital form of Latin letter to represent it.

Function code, None represents general agriculture mode, T represents transport mode.

Model code, “0” means rear wheel drive four-wheel drive; “4” means four wheel drive.

Power code, expressed by the integer around the value of engine rated power times 1.36.

Series Code

The corresponding power values are as follows:

Corresponding power values to the product type:

TD750/TD754 wheeled tractor's rated power of 55 kw (75 PS)

TD800/TD804 wheeled tractor's rated power of 59 kw (80 PS)

TD820/TD824 wheeled tractor's rated power of 60.3 kw (82 PS)

TD850/TD854 wheeled tractor's rated power of 62.5 kw (85 PS)

TD900/TD904 wheeled tractor's rated power of 66.2 kw (90 PS)

TD950/TD954 wheeled tractor's rated power of 70.0 kw (95 PS)

TD1000/TD1004 wheeled tractor's rated power of 73.5 kw (100 PS)

TD1104/TD1104 wheeled tractor's rated power of 81 kw (110 PS)

Product Standard: Q/LWZ 001 **LOVOL Wheeled Tractor**

### 8.2 Product Technical Specifications

Table 8-1 Main Technical Specifications of **TD Series Tractor**

Item	Unit	Technical parameter	
		TD750/TD800/TD820/TD850/ TD900/TD950/TD1000/TD1100	TD754/TD804/TD824/TD854/ TD904/TD954/TD1004/TD1104
Type	——	4×2 wheel type	4×4 wheel type
Rated Traction Force	kN	14.6/15.5/15.8/16.3/ 17.7/18.7/19.7/21.7	17.3/18.6/19/19.7/ 21.3/22.5/23.7/25
PTO Shaft power	kW	46.7/50.2/51.3/53.1/ 56.3/59.5/62.5/68.8	46.7/50.2/51.3/53.1/ 56.3/59.5/62.5/68.8
Overall Dimension	Length (Including Rear Overhang)	mm	4530 (Including front counterweight)
	Width (Common track, outside of common tire)	mm	1986
	Height (to the top of muffler)	mm	2760
Wheel base		mm	2195/2366
Track (comm)	Front Wheel	mm	1385~1685(Factory 1485)
			1610~1950(Factory 1610/1710) ①

## Technical specifications

	Item	Unit	Technical parameter			
			TD750/TD800/TD820/TD850/ TD900/TD950/TD1000/TD1100	TD754/TD804/TD824/TD854/ TD904/TD954/TD1004/TD1104		
on tire)	Adjusting way of front wheel	—	Adjustable	Adjustable		
	Rear Wheel	mm	1608~1996(Factory 1608)	1608~1996(Factory 1608)		
	Adjusting way of rear wheel	—	Adjustable or stepless	Adjustable or stepless		
Ground Clearance	Min. Ground Clearance	mm	420 (Bottom of oil tank) 375 (Bottom of oil cylinder base)	405 (Lower edge of front drive axle)		
	Agronomic clearance	mm	495	420		
Turning radius	Unilateral brake	m	3.6±0.2	4.2±0.3 4.6±0.3 (Front wheel: 13.6-24)		
	Non-unilateral brake	m	4.0±0.2	4.9±0.3 5.2±0.3 (Front wheel: 13.6-24)		
Structural Quality	Model with cab	kg	3560	3915		
	Model without cab		3260	3615		
Min. Service Quality	Model with cab	kg	3800	4155		
	Model without cab		3500	3855		
Mass Distribution Ratio	Front axle	With cab	kg	1400	1565	
		Without cab		1290		1450
	Rear axle	With cab		2400	2590	
		Without cab		2210	2405	
Counterweight	Front counterweight(optional)	kg	310	242 or 310 nor 440		
	Rear counterweight(optional)	kg	320 or 360 or 480 or 540	320 or 480		
Transmission system	Clutch		—	Single plate, dry-type, double-acting clutch		
	Gearbox		—	It is combination type 4×(2+1), i.e. 8 forward gears and 4 reverse gears; when it is installed with optional creeper gear or shuttle type gear shift mechanism, it is 4×(2+1)×2, i.e. 16 forward gears, 8 reverse gears. The main/auxiliary gearshift device adopts a straight-tooth engaging sleeve for gear shift.		
	Rear axle	Central transmission	—	Spiral bevel gear		
		Differential	—	Closed, 4 planetary gears		
		Differential lock	—	Splined sleeve type		
Rear final drive		—	Single-stage planetary gear type, exterior to both sides of the rear axle box			

## Technical specifications

Item		Unit	Technical parameter		
			TD750/TD800/TD820/TD850/ TD900/TD950/TD1000/TD1100	TD754/TD804/TD824/TD854/ TD904/TD954/TD1004/TD1104	
Front drive axle	Drive Shaft	—	—	Middle-set drive Shaft	
	Front central drive	—	—	Spiral bevel gear	
	Front differential	—	—	Closed, 2 planetary gears	
	Front final drive	—	—	Single-stage planetary gear type	
Traveling system	Rack		Frameless		
	Front Suspension		Rigid suspension type	—	
	Front axle		Telescopic type	—	
	Toe in of front wheel		mm	5~10	0~5
	Tire pressure	Front Wheel	kPa	200~250	150~180
		Rear Wheel	kPa	150~180/ 120~150 (11-32 Paddy)	
	Tire Specification	Standard: front wheel/rear wheel	—	6.5-20/14.9-30	11.2-24/16.9-34
		Optional: front wheel/rear wheel	—	7.5-20/14.9-30 6.5-20 or 7.5-20/16.9-34; 6.5-20 or 7.5-20/13.6-38; 6.5-20 or 7.5-20/18.4-30;	11.2-24/18.4-30 11.2-24/13.6-38 12.4-24/16.9-34 12.4-24/18.4-30 12.4-24/13.6-38 13.6-24/16.9-34 13.6-24/18.4-30 13.6-24/13.6-38
Steering System	Method		Front wheel hydraulic steering		
	Steering Gear		Swing line rotary valve type full hydraulic steering gear		
Brake system	Driving brake		Wet type, disc type, hydrostatic control		
	Parking brake		Independent hand brake		
	Trailer brake		Air brake, shot-off		
Working devices	Hydraulic system type		Open, semi-split type or split type		
	Hydraulic oil pump		Semi-split type: gear pump CB-F316L; Split type: gear pump CB-F320L or CB-F325L		
	Distributor		Sliding valve type		
	Cylinder	Diameter × stroke	mm	φ110×128 (single acting) /φ80×200(double acting)	
		Form	—	Single acting (semi-split type)/double acting (split type)	
	Suspension mechanism		mm	Rear three-point linkage, type 2 Upper suspension point joint hole × width: φ25.5×51; Lower suspension point joint hole × width: φ28.7×45;	
Tilling depth adjustment method		—	Semi-split Type Lifter: Force-position adjustment, floating control or split Type Lifter: Height adjustment, floating control		

## Technical specifications

Item		Unit	Technical parameter	
			TD750/TD800/TD820/TD850/ TD900/TD950/TD1000/TD1100	TD754/TD804/TD824/TD854/ TD904/TD954/TD1004/TD1104
System max. lifting force (610mm after suspension point)		kN	Semi-split Type: $\geq 15$ Split Type: $\geq 20$	
Open pressure of system safety valve		MPa	17.5~18.0	
Hydraulic Output	Form	—	Simple hydraulic output or Multi-way valve	
	Quantity	—	Semi-split Type Lifter: 1-way (Simple hydraulic output) or 1 pair or 2 pairs (Multi-way valve ); Split Type Lifter: 1 pair or 2 pairs (Multi-way valve )	
	Specification	—	M18×1.5	
PTO shaft	Form	—	Rear-mounted, independent	
	Specification	—	$\phi 35$ 6-tooth rectangular spline shaft (may select $\phi 38$ 8-tooth rectangular spline shaft or $\phi 35$ 21-tooth involute spline shaft)	
	Revolving Speed	r/min	540/1000 ( optional 760/1000,540/760, 760/850 )	
Towing trailer	Towing device	Form	Swing rod type	
		Road clearance	mm	367
	Trailer trailer	—	U-hook	
Cab		—	As an option which is simple and comfortable, and equipped with hot air fan, or a fan or an air conditioner.	
Safety frame		—	2-pillar (model without cab ), optional	
Drive seat		—	Mechanical suspension type, PVC surface layer with adjustable height, forward/backward position and seat back	
Electric instrument system	Electrical system type	V	Double wire system of 12V negative pole grounding	
	Generator	Model	—	For details see the operation manual of engine
		Voltage	V	14
Power	Power	kW	0.65/0.75	
	Adjuster	Model	—	For details see the operation manual of engine
Adjust voltage		V	14	
Start motor		Model	—	For details see the operation manual of engine
	Voltage	V	12	
	Power	kW	3.7	
Electric instrument system	Battery	Model	—	6-QW-120
		Voltage	V	12
		Volume	A·h	120
		Quantity	—	1
Lighting and	Headlamp	V W	12V, 55/60W,combined type	
	Front steering lamp	V W	12V, 21W, 2 ( model without cab ) or 4 ( model with cab )	

## Technical specifications

Item		Unit	Technical parameter		
			TD750/TD800/TD820/TD850/ TD900/TD950/TD1000/TD1100	TD754/TD804/TD824/TD854/ TD904/TD954/TD1004/TD1104	
signaling devices	Position lamp (front)	V W	12V, 5W, 2 (model without cab) or 4 (model with cab)		
	Rear combination lamp	W	Position lamp (rear) 10W, steering lamp 21W, Brake lamp 21W, reflector lamp (red) each 1piece at right and left		
	Rear working lamp	V W	12V, 55W, 2		
	Trailer socket	—	7-hole trailer socket, 1 piece.		
Monitoring and warning device	Combination instrument	—	With tachometer, water temperature, oil pressure gauge, fuel gauge, 1		
	Warning device	—	Instrument alarm indicator lamp: Brake fault (as an option for the model with an air brake system), left/right steering indicator lamp, dipped beam indicator lamp, charging indicator lamp, warm-up indicator lamp (as an option for the model with a pre-heater), position indicator lamp, parking brake indicator lamp, brake fluid level alarm; Signal lamps and devices: Brake lamp, left/right steering lamp, front/rear position lamp, reflector lamp; Air filter blockage alarm and safety warning markings		
Injection volume	Radiator	L	14		
	Fuel Tank	L	145		
	Engine oil pan	L	According to the operation manual of engine		
	Oil bath type air filter	L	Fill the specified oil level as needed		
	Hydraulic steering oil	L	2.5		
	Brake oil	L	0.6		
	Drive drain oil	L	38		
	Lifter oil	L	18 (semi-split type) /28 (split type)		
	Central transmission of the front drive axle	L	—	6.1	
	Final drive of the front drive axle	L	—	1.2 (each side)	

Note: For the items marked with installed, and the content after the slash is parameter when a replacement bonnet is installed.

## Technical specifications

Table 8-2 Main Technical Specifications of TD Series Tractor Engine

Item		Unit	Technical parameter									
E n g i n e	Model	—	1004-4 TRT Lovol Power	1004C -P4T Lovol Power	1004C -P4TW Lovol Power	1004C -P4TA Lovol Power	1104C- P4TA Lovol Power	1004-4 TWRT Lovol Power	1004-4 TART Lovol Power	1004D -4TAR T Lovol Power	1104 D-44 T Britis h Perki ns	
	Emission Standards	—	Natio nal I	Nation al II	Nation al II	Nation al II	Nation al II	EPA I	EPA II , EuroSt age II	EPATie r III EuroSt age III A	EPATie r III EuroSt age III A	
	Connect ing method of the engine and transmis sion	—	Direct connection									
	Type	—	Water- Coolin g, In-line, four-str oke	Water- Coolin g, In-line, four-str oke	Water inter-c ooler, In-line, four-str oke	Air inter-c ooler, In-line, four-str oke	Air inter-c ooler, In-line, four-str oke	Water inter-c ooler, In-line, four-str oke	Air inter-c ooler, In-line, four-str oke	Air inter-c ooler, In-line, four-str oke	Air inter- cooler , In-lin e, four-s troke	
	Number of cylinder	—	4									
	Cylinder Bore × Stroke	mm	100×1 27	100×1 27	100×1 27	100×1 27	100×1 27	100×1 27	100×1 27	100×1 27	100×1 27	105× 127
	Rated power	kW	55.0/6 0.3/66. 2/70.0	55.0/5 9/ 60.3/6 2.5/ 66.2/7 0.0	73.5/8 1	81	81	60.3	60.3/6 6.2	60.3/6 6.2	60.3/6 6.2	
	Namepl ate power/s peed	kW r/min	55.0/2 300 60.3/2 300 66.2/2 300 70.0/2 300	55.0/2 200 59/220 0 60.3/2 200 62.5/2 200 66.2/2 200 70.0/2 200	73.5/2 200 81/220 0	81/220 0	81/220 0	60.3/2 300	69/2 300 74/2 300	69/2 200 74/220 0	68/23 00 72/23 00	
	Rated Speed	r/min	2300	2200	2200	2200	2200	2300	2300	2200	2300	



## Technical specifications

Item	Unit	Technical parameter
Max Torque/ RPM	N·m/ (r/min )	$\geq 263/1500\sim 1700$ (TD750/TD754) $\geq 335/1500\sim 1700$ (TD800/TD804) $\geq 288/1500\sim 1700$ (TD820/TD824) $\geq 340/1500\sim 1700$ (TD850/TD854) $\geq 350/1500\sim 1700$ (TD900/TD904) $\geq 360/1500\sim 1700$ (TD950/TD954) $\geq 380/1500\sim 1700$ (TD1000/TD1004) $\geq 404/1500\sim 1700$ ( 1004C-P4TW ) /1400~1600 (1104C-P4TA/1004C-P4TA) (TD1100/TD1104)
Fuel Consumption Rate under Rated Working Condition	g/kW·h	$\leq 260$
Rated Working Condition Oil Consumption Rate	g/kW·h	$\leq 2.1$
Lubricating way		Pressure type
Starting method		Electric starting
Air filter type		Dry type or wet type
Cooling system type		Water-Cooling, Water inter-cooler, Air inter-cooler

## Technical specifications

Table 8-3 Theoretical speed of **LOVOL-TD series tractor (I)**

Unit: km/h

Model				TD750/TD800/TD820/TD850/TD900/TD950/TD1000/TD1100 TD754/TD804/TD824/TD854/TD904/TD954/TD1004/TD1104	
Gear				16F+8R (creeper gear) - rear tire 16.9-34 or 14.9-30 (2WD Tractor)	16F+8R (Shuttle gearshift) - rear tire 16.9-34 or 14.9-30 (2WD Tractor)
Dir ecti on	High/ low shift	Auxiliar y gearshif t	Main gearshi ft		
For war d gea r	Low shift	Slow shift	1	0.4/0.5	1.5/1.6
			2	0.7/0.7	2.0/2.1
			3	1.1/1.2	2.6/2.7
			4	1.5/1.6	5.1/5.3
		Fast shift	1	1.9/2.0	2.2/2.3
			2	3.0/3.1	3.0/3.1
			3	4.8/5.0	3.9/4.0
			4	6.7/7.0	7.5/7.9
	High shift	Slow shift	1	2.2/2.3	6.5/6.8
			2	3.4/3.6	8.6/9.0
			3	5.5/5.8	11.2/11.7
			4	7.7/8.0	21.8/22.8
		Fast shift	1	9.6/10.0	9.6/10.0
			2	14.9/15.6	12.8/13.4
			3	23.9/25.0	16.6/17.3
			4	33.3/34.9	32.2/33.7
Rev erse gea r	Low shift	Reverse gear	1	0.6/0.6	2.3/2.4
			2	0.9/1.0	3.1/3.2
			3	1.5/1.6	4.0/4.2
			4	2.1/2.2	7.7/8.1
	High shift	Reverse gear	1	3.0/3.1	9.9/10.3
			2	4.6/4.8	13.1/13.7
			3	7.4/7.7	17.1/17.8
			4	10.3/10.8	33.2/34.7

## Technical specifications

Table 8-4 Theoretical speed of **LOVOL-TD series tractor (II)**

Unit: km/h

Model			TD750/TD800/TD820/TD850/TD900/TD950/TD1000/TD1100 TD754/TD804/TD824/TD854/TD904/TD954/TD1004/TD1104
Gear			8F+4R-rear tire 16.9-34 or 14.9-30 (2WD Tractor)
Direction	Auxiliary gearshift	Main gearshift	
Forward gear	Slow shift	1	2.2/2.3
		2	3.4/3.6
		3	5.5/5.8
		4	7.7/8.0
	Fast shift	1	9.6/10.0
		2	14.9/15.6
		3	23.9/25.0
		4	33.3/34.9
Reverse gear	Reverse gear	1	3.0/3.1
		2	4.6/4.8
		3	7.4/7.7
		4	10.3/10.8

**Note:**

- 1、 The number before and after "/" in the theoretical speed is 2200 r/min and 2300 r/min, respectively, where the vehicle model is equipped with 16.9-34 or 14.9-30 (two-wheel drive model) standard rear wheel tires.
- 2、 If equipped with other rear tires, the parameter in above sheet should be multiplied respective coefficient "a".
  - If equipped with 13.6-38 common rear tires, a=0.987;
  - If equipped with 18.4-30 common rear tires, a=0.978;

## Disassembly and disposal

### 9 Disassembly and disposal

After the machine reaches its due service life, for your personal safety and the protection of social environment, please deliver it to the licensed recycling company specialized in disassembly.

When disassembling, do it from top to bottom and from outside to inside. To disassemble a bulky or heavy object, use a special sling. The battery should be recycled by professional battery recycling company #, waste oil and so on should be treated properly. Do not reject them randomly for they may cause the pollution risk to the environment.



**WARNING: The battery contains electrolyte which is highly corrosive. Do not get electrolyte in your eyes or on your skins or clothing. If so, flush your eyes or skin with large quantities of water and go to hospital immediately to avoid accidental burns.**

#### **Important:**

- 1. The replaced battery acid liquor cannot be disposed at any place, so as to avoid environmental pollution.**
- 2. The used oil belongs to waste oil. To avoid environment pollution, do not discard it in a trash bin**

We kindly remind you, the improper placement will cause the personal injury on lack of special removal tools and practical experience in disassembly and after disassembly



**Warning: When disassembling the large or heavy mass object, the special hoisting mechanism must be used. Pay attention to personal safety.**

## Warranty item

---

### 10 Warranty item

#### 10.1 Product warranty basis

LOVOL-TD series wheeled tractor is covered by the warranty based on the following documents and regulations.

The liability of Repair, Replacement, Return of Agricultural Machinery, [directive 126 of General Administration of Quality Supervision, Inspection and Quarantine of P.R.C](#)

Law of the People's Republic of China on Product Quality

Law of the People's Republic of China on the Protection of Consumer Rights and Interests

#### 10.2 Cases not covered by the warranty

According to relevant laws and regulations, some conditions are excluded from the range of guarantee. For details, please refer to Chapters involved with Three-Guarantee Service Certificate.

**Note: Some behaviors will possibly invalidate the warranty condition. For details, see the Warranty Card.**

**Note: If the user refits the tractor or uses it for purposes other than those stipulated in the manual, it will not be covered by the warranty scope of manufacturer, to which we kindly ask you to pay attention.**

**Note:**

1. When user accepts warranty, he must show the Warranty Card, please keep the card properly.
2. If the machine fails, when contracting for warranty, you must inform dealer of the following information: machine model, factory No, model and type of engine and other content on the nameplate; used time and detail description of fault.
3. Description of 3R Repair part supply year limit: ensure continued supply of products and repaired 3R parts for five years after stopping production, but delivery time of special part shall be decided after negotiation. If 3R parts are beyond the deadline, □®
4. Please use special spare parts and engine oil of product.

# Appendix

## 11 Appendix

### 11.1 Oil and solution used on the tractor

Table 11-1 Oil and solution for tractor

Application locations of oils and solutions	Oils and solutions								
Fuel Tank	Domestic standard	Light diesel oil conforming to GB 252	Over 20 °C	(4~20) °C	(-5~4) °C	(-14~-5) °C	(-29~-14) °C	(-44~-29) °C	
			NO. 10	NO. 0	NO. -10	NO. -20	NO. -35	NO. -50	
	International standard	Adopt ASTM D-975 fuel oil. Under general air temperatures, use 2-D grade oil; when ambient temperature is below 5 °C, use 1-D grade oil.							
Engine oil pan	Domestic standard	Add oil in accordance with the Engine Manual.							
	International standard	Society of Automotive Engineers(SAE) viscosity classification Use SAE10W-40 when the temperature is below -5 °C Above -5 °C, use SAE15W-40 oil in the four seasons. Shell Rimula R2 15W/40 diesel engine or Mobil Delvac Super 15W/40. Quality grade should comply with API CD grade standard.							
Engine radiator	If ambient temperature is 4 °C or more, use soft water for tractor cooling system. If ambient temperature is 4 °C or less, use anti-freeze. If Min. ambient temperature is -15 °C or more, adopt 25# long effective antifreeze(SH/T0521); If Min. ambient temperature is -25°C or more, adopt 35# long effective antifreeze(SH/T0521); If Min. ambient temperature is -35 °C or more, adopt 45# long effective antifreeze(SH/T0521); If Min. ambient temperature is -45 °C or more, adopt 55# long effective antifreeze(SH/T0521);								
Bath-type air filter	Domestic standard	Below -5 °C: use 10w/30, above -5 °C: use 15w/40 multi CC grade or CD grade in the GB 11122-2006							
	International standard	Society of Automotive Engineers(SAE) viscosity classification Use SAE10W-40 when the temperature is below -5 °C Above -5 °C, use SAE15W-40. Shell Rimula R2 15W/40 diesel, Mobil Delvac 15W-40. Quality grade should comply with API CD grade standard.							
Gearbox - rear axle, hydraulic lifter, front drive axle	Domestic standard	N100D drive hydraulic dual-purpose oil, executive standard: Q/LWZ B119.							
	International standard	MF1135 of Massey Ferguson Or M2C 86A of Ford							

## Appendix

Application locations of oils and solutions	Oils and solutions	
		Or HY-GARDTM or J20A、J20B、J20C from John Deer  Shell Spirax S3 TLV
Steering cylinder	Domestic standard	N100D drive hydraulic dual-purpose oil, executive standard: Q/LWZ B119.
	International standard	QUATROL or other oil can be used, subject to John Deere JDMJ20A or JDMJ20B, and the temperature is blow -40 °C, 40 °C, polar oil. Shell Tellus 32 hydraulic oil, Spirax S3 TLV, Mobil Nuto H32 Anti-wear hydraulic oil.
Oil cup	Domestic standard	General lithium base grease conforming to GB/T 7324.
	International standard	SAE general purpose grease is added with 3~5% molybdenum sulfide. Use polar region grease (MIT-G-10924C)if below -30 Institute NJGI grease D-217 with 2 viscosity grade.  Shell Gadus S2 V100 3 Lubricating grease; Mobil LUX ep 3.
Brake system	Domestic standard	Triple-purpose oil used for drive, hydraulic and brake systems. Executive standard: Q/LWZ B119.
	International standard	SAE10W-40 engine oil Shell Spirax S3 TLV
Windshield	Used for the windshield washer. -45# anti-freezing cleaning solution (SH/T0521) should be used at -10 °C temperature.	

### Important:

- 1. Drive hydraulic dual-purpose oil, diesel oil and diesel engine oil must be deposited for at least 48h and then can be filled for use so as not to reduce cleanness to impact performance of machine.**
- 2. When the engine is running, do not add oil into the fuel tank. If the tractor is working under the torridity or sunlight, oil tank cannot be fully filled; once fuel runs over, wipe it immediately.**
- 3. Do not mix oils of different brands or different manufacturers! Failure to do so can affect the engine performance.**
- 4. For the tractor with a heating air, the cooling system of the engine must use anti-freeze fluid in winter, so as to avoid cracking of the heater or air conditioner.**

## Appendix

### 11.2 Tightening torque table for main bolt and nut

Table 11-2 Tightening torque table for main bolt and nut

Name and mounting part	Thread specification	Tightening torque [N·m(Newton·meter)]
Bolt for connecting engine to gearbox housing	Stage M10-10.9	58~71
Bolt for connecting engine to gearbox housing	Stage M12-10.9	105~128
Bolt for connecting engine to gearbox housing	Stage M16-10.9	247~290
Spirallock nut for connecting gearbox to rear axle casing	Stage M12×1.5-10	130~150
Spirallock nut for connecting gearbox to rear axle casing	Stage M16×1.5-10	337~412
Nuts for coupling driven shaft housing with rear axle housing	Stage M14×1.5-8	126~154
Nuts for connecting driving wheel hub to spoke board	Stage M20×1.5-10	540~596
Nuts for connecting front wheel hub to spoke board	Stage M16×1.5-10	265~311
Connecting bolts between bracket and engine	Stage M16-10.9	247~290
Nuts for connecting steering wheel to steering column	Stage M16×1.5-8	199~243
Fastening bolts on internal and external sleeve joints	Stage M20-8.8	265~320
Bolt connecting the differential housing to the driven arc tooth bevel gear	Stage M14×1.5-8	126~154
Bolt connecting the differential housing to the differential chamber	Stage M12-8.8	73~89
Round locknut at rear end of the PTO drive shaft	GB/T812-M48×1.5	300~350
Locknuts on rear center pinion gear shaft	M50×1.5(FT800.38.207)	300~350



## Appendix

**Note: To tighten main bolts on the tractor, you must use torque wrench.**

### 11.3 Framework oil seal

Table 11-3 Framework oil seal

Mounting position	Specification	Standard No.	Piece/set
Transfer case bearing seat	FB30×52×7D	GB/T 9877.1	2
Gearbox input shaft bearing carrier	FB50×72×8D	GB/T 9877.1	2
PTO shaft	SG60×90×12	JB2600	2
Vertical shaft of steering knuckle	SD65×90×12	JB2600	8
Bearing carrier of half axle housing	FB100×130×12D	GB/T 9877.1	4
Intermediate support base of front axle drive shaft	FB30×52×7D	GB/T 9877.1	2
Wheel hub on front drive axle	165×190×7	5137109	2
Front drive axle shaft	40×62×12	5136002	2
Front drive fork shaft	42×62×17	5133799	2
Bevel pinion shaft of front drive axle	45×75×10	5135294	1
Kingpin hole of front drive axle housing	56×70×7.5	5121471	2
Oil seal on the head of PTO shaft	FB70×90×10D	GB/T 9877.1	2

### 11.4 Rolling bearing

Table 11-4 Rolling bearing

Mounting position	Bearing name	Model	Bearing	Piece/se
Gearbox input shaft bearing	Single-row radial ball	6310	GB/T 276	1
Rear end of gearbox input shaft	Single-row cylindrical	20209	Special	1
Front end of auxiliary gearshift	Single-row radial ball	NUP1014	Special	1
Rear end of auxiliary gearshift	Single-row radial ball	6408N	GB/T 276	1
Middle section of PTO drive	Single-row radial ball	6306	GB/T 276	1
Inner side of rear drive shaft	Conical roller bearing	30214	GB/T 297	2
Outer side of rear drive shaft	Conical roller bearing	30215	GB/T 297	2
Planetary wheel shaft of rear	Rolling needles	8×23.8	GB/T 309	252
Front end of PTO drive shaft	Single-row radial ball	6309	GB/T 276	1

## Appendix

Mounting position	Bearing name	Model	Bearing	Piece/se
Rear end of PTO drive shaft	Single-row radial ball	6210	GB/T 276	1
Rear end of PTO shaft	Single-row radial ball	6310	GB/T 276	1
Front end of PTO shaft	Single-row radial ball	6308	GB/T 276	1
Right side of differential	Conical roller bearing	32216	GB/T 297	1
Left side of differential	Conical roller bearing	30216	GB/T 297	1
Rear end of rear axle bevel	Conical roller bearing	32311	GB/T 297	1
Middle end of rear axle bevel	Conical roller bearing	30310	GB/T 297	1
Rear end of gearbox output shaft	Single-row radial ball	6211N	GB/T 276	1
Front end of gearbox output	Needle bearing	K323920	JB/T 7918	1
Rear end of transmission	Single-row radial ball	6211	GB/T 276	1
Front end of transmission	Single-row radial ball	6210N	GB/T 276	1
Intermediate gear shaft of	Cylindrical roller	42305E	GB/T 283	2
Rear end of transfer case drive	Single-row radial ball	6306E	GB/T 276	2
Middle section of front drive	Single-row radial ball	6006E	GB/T 276	1
Rear end of front drive bevel	Conical roller bearing	32207	Special	1
Front end of front drive bevel	Conical roller bearing	802048	Special	1
Front drive differential	Conical roller bearing	2007112E	GB/T 297	2
Middle section of front drive	Single-row radial ball	6007	GB/T 297	2
Front wheel hub bearing	Conical roller bearing	819310	Special	4
Planetary gear shaft of front final	Rolling needles	5×23.8	GB/T 309	
Inner side of steering knuckle	Conical roller bearing	32209	GB/T 297	2
Outer side of steering knuckle	Conical roller bearing	32307	GB/T 297	2
Kingpin of steering knuckle	Flat-bottom thrust ball	51210	GB/T 301	2
Auxiliary clutch bearing carrier	Angle contact ball	7016AC	GB/T 292	1
Main clutch release bearing block	Angle contact ball	996712	Special	1
Bearing carrier of steering gear	Single-row radial ball	6004	GB/T 276	1
Inner hole of drive gear for gear	Needle bearing	KK64×74×41	JB/T 7918	1
Inner hole of drive gear for gear	Needle bearing	KK64×74×41	JB/T 7918	1
Inner hole of drive gear for gear	Needle bearing	KK64×74×41	JB/T 7918	1
Inner hole of auxiliary gearshift	Needle bearing	KK55×65×43	JB/T 7918	1
Front end of PTO driven shaft	Bearing	6210	GB/T 276	1

## Appendix

Mounting position	Bearing name	Model	Bearing	Piece/se
Rear end of PTO drive shaft	Conical roller bearing	7212E	GB/T 297	2
Rear end of PTO drive duplex	Conical roller bearing	7210E	GB/T 297	2

### 11.5 Rubber O-ring

Table 11-5 Rubber O-ring

Mounting position	Specification	Standard No.	Piece/set
Handle shaft of distributor	9.5×2.65G	GB/T 3452.1	1
Feedback shaft of distributor	9.5×2.65G	GB/T 3452.1	1
Interlocking shaft	13.2×1.8G	GB/T 3452.1	1
Lowering valve plug of distributor	16×1.8G	GB/T 3452.1	1
Safety valve of the distributor	19×2.65G	GB/T 3452.1	2
Safety valve of distributor clogged	11.8×2.65G	GB/T 3452.1	1
Main valve front cover of distributor	19×2.65G	GB/T 3452.1	1
Descending valve of distributor	19×2.65G	GB/T 3452.1	1
One-way valve of distributor	19×2.65G	GB/T 3452.1	2
One-way valve plug of distributor	20×1.8G	GB/T 3452.1	1
Brake pump plug	20×2.65G	GB/T 3452.1	2
Oil return valve of distributor	21.2×2.65G	GB/T 3452.1	1
Oil inlet of steering oil pump	19×2.65G	GB/T 3452.1	1
One-way valve of distributor	25.7×2.65G	GB/T 3452.1	1
Brake pump valve stem	25×3.55G	GB/T 3452.1	2
Oil outlet pipe fitting of brake pump	30×3.55G	GB/T 3452.1	2
Lifting shaft of lifter	54.5×5.3G (old structure)	GB/T 3452.1	
Lifter piston	100×5.3G	GB/T 3452.1	1
Oil inlet port of lifter cylinder head	12.5×2.65G (old structure)	GB/T 3452.1	2
Lifter cylinder head	103×3.55G (old structure)	GB/T 3452.1	1
Lifter cylinder	118×3.55G	GB/T 3452.1	1
Brake piston	260×3.55G	FT800.43.149	2
Brake piston	300×3.55G	FT800.43.150	2
PTO control handle shaft	17×1.8G	GB/T 3452.1	1

## Appendix

Mounting position	Specification	Standard No.	Piece/set
External casing of front axle drive	45×3.55G	GB/T 3452.1	4
Transfer case control shaft	17×1.8G	GB/T 3452.1	2
Bevel pinion shaft of front drive	31.5×1.8G	GB/T 3452.1	1
Half shaft bearing carrier of front	80×2.62G	4966231	2
Rear mounting base of front drive	99.6×5.3G	GB/T 3452.1	2
Front mounting base of front drive	52.6×3.55G	GB/T 3452.1	1
Oil inlet joint of distributor	12.5×2.65G	GB/T 3452.1	1
Hand brake camshaft	15×2.65G	GB/T 3452.1	2
Steering axle	15×2.65G	GB/T 3452.1	1
Angular pipe union of oil pump	20×2.65G	GB/T 3452.1	1
Differential lock fork shaft	20×2.65G	GB/T 3452.1	1
Connecting plate of oil pump inlet	21.2×2.65G	GB/T 3452.1	1
Differential lock fork shaft support	30×2.65G	GB/T 3452.1	1
Front axle balance pin	50×5.3G	GB/T 3452.1	2
Angular pipe union of oil pump	15×2.65G	GB/T 3452.1	1
Connecting plate of oil pump inlet	21.2×1.8G	GB/T 3452.1	1
Mating surface between oil	26.5×2.65G	GB/T 3452.1	1
Mating surface between oil	32.5×2.65G	GB/T 3452.1	1

### 11.6 Supporting farm implements for LOVOL TD series tractor

Table 11-6 Supporting farm implements for LOVOL TD series tractor

Category	Tractor model	Name of supporting Farm implements	Agricultural machinery model	Main technical parameter	Company
Tillage machinery	TD750/TD754 TD800/TD804 TD820/TD824 TD850/TD854	Three-share mounted plough	1L-335	Tilling depth (22~28)cm	Baoding Shuangying Agricultural Machinery Co., Ltd. Kuhn Company Besson Company
		Suspension turnover three-furrow plough	1LF-335		
		Suspension regulating three-furrow plough	1LT-335	Tilling depth(22~28)cm	
		Five-share	1L-525	Tilling depth(1~	

## Appendix

Category	Tractor model	Name of supporting Farm implements	Agricultural machinery model	Main technical parameter	Company
Tillage machinery		mounted plough		24)cm	
		Six-share mounted plough	1L-627	Tilling depth(16~20)cm	
		Seven-share mounted plough	1L-727	Tilling depth(16~20)cm	
		Hydraulic turnover plough	1LF-430/335	Tilling depth(20~26)cm	
		悬挂四铧犁	1LH-430	Tilling depth(26~30)cm	
		Four-share mounted plough	1LH-338	Tilling depth(30~35)cm	
		Deep-scarification and shallow-ploughing plough	1LH-435	Tilling depth30cm	
		Deep-scarification and shallow-ploughing plough	1FSL-435	Tilling depth(30~35)cm	
	TD900/TD904 TD950/TD954 TD1000/TD1004 TD1100/TD1104	Hydraulic turnover plough	1LF-435/430	Tilling depth(22~28)cm	
		Deep-scarification and shallow-ploughing plough	1FSL-435	Tilling depth(30~35)cm	
	TD750/TD754 TD800/TD804 TD820/TD824 TD850/TD854	Rotary cultivator	1GQN-200/210J	Tilling depth(12~15)cm	Dingzhou Dingyuan Machinery Manufacturing Co., Ltd. Xian Yaa Rotary Seeding Machine Factory
		Variable speed rotary plough	1GQNB-200/230	Supporting overhead tank for large-size tire model	
		Rotary cultivator	1GQN-200/230J	Center height of 45-51cm	
TD900/TD904 TD950/TD954 TD1000/TD1004 TD1100/TD1104	Variable speed rotary plough	1GQNB-200/230		Maschio (qingdao) Agricultural Machinery Co., Ltd	
	Drive harrow	DS2000	Tilling depth(12~20)cm		
Scarification mac	Full series	20-disc Medium mounted harrow	1BJX-2.2	耙深(12~14)cm	Jiamusi North Machinery Manufacturing Co., Ltd.
		24-disc Medium	1BJBX-2.5	耙深(12~14)cm	

## Appendix

Category	Tractor model	Name of supporting Farm implements	Agricultural machinery model	Main technical parameter	Company
hine ry		semi-mounted harrow			Heilongjiang Nenjiang Agricultural Machinery Factory
		28-disc Medium semi-mounted harrow	1JBX-3.1	耙深(12~14)cm	
		72-disc flap type light harrow	1BY-7.2	耙深(8~10)cm	
		24-disc hydraulic offset heavy harrow	1BZBX-2.0/2.5	耙深(14~16)cm	
		Combined land preparation machine	1LZ-3.0/3.6/ 1LZ-4.2	耕深(8~10)cm	
Scar ifica tion mac hine ry	Full series	Hydraulic middle harrow	1BJ-3.4	耙深(12~14)cm	
		Hydraulic middle harrow	1BJ-4.0		
Sow and ferti lizer mac hine ry	Full series	Fertilization and seeding machine	2BF-24A	24 wheat seeding rows	Dingzhou Dingyuan Machinery Manufacturing Co., Ltd. Heilongjiang Nenjiang Agricultural Machinery Factory Xinjiang Farming Machinery Factory Aksuli Farming Machinery Manufacture Co., Ltd
		Fertilization and seeding machine	2BF-24C		
		Combined machine for membrane paving and seeding	2BML-12	12 cotton seeding rows	
		Combined machine for seeding and fertilization	2BM-8	Corn, soybean Seeding capacity: 8 rows	
		Sow and fertilizer machinery	2BFXZ-24	24 wheat seeding rows	
Sow and fertilizer machinery	2BFXZ-24				

## Appendix

Category	Tractor model	Name of supporting Farm implements	Agricultural machinery model	Main technical parameter	Company
		Air-absorbed precision seeding machine	2BQ-7/8	Corn, soybean Seeding capacity: 7/8 rows	
Spraying machine	Full series	Suspension-type pesticide sprayer	3W-1200/21	Medical kit volume: 1200L Spraying width: 21m	Handan Chenggong zhong Zhibao achinery Plant Heilongjiang Nenjiang gricultural Machinery ctory
Returning machine	TD750/TD754 TD800/TD804 TD820/TD824 TD850/TD854 TD900/TD904	Straw shattering and returning machine	1JH-165/172	Working width: 1.8 m/1.72 m	Dingzhou Dingyuan Machinery Manufacturing Co., Ltd. Shijiazhuang Agricultural Machinery Co., Ltd. Dezhou Huabei Agricultural Equipment Co., Ltd.
	TD950/TD954 TD1000/TD1004 TD1100/TD1104		1JH-180/185	Working width: 1.8 m/2.0m Stubble height (2~8)cm	
Duplex implement	TD750/TD754 TD800/TD804 TD820/TD824 TD850/TD854	Stubble ploughing rotary ridge repression machine	SGTN-200/210	Three-ridge straw cutting and three-ridge preparation; large-tire model: center height of tank up to 450-510 mm	Dingzhou Dingyuan Machinery Manufacturing Co., Ltd.
	TD900/TD904 TD950/TD954 TD1000/TD1004 TD1100/TD1104		SGTN-210/240		
	TD950/TD954 TD1000/TD1004 TD1100/TD1104	Stubble ploughing ridge repression machine	STGN-240/210	Three/four-ridge straw cutting and three/four-ridge preparation; large-tire model: center height of tank up to 450-510 mm (high-tank model)	Shenyang Huayuan Agricultural Machinery Co., Ltd.
Harvest machinery	Full series	Wheat backpack machine	4L-2.5	Feeding capacity: 2.5kg/s Harvesting width: 2.2m	Shijia Zhuang Shuangjian King Guilin harvester plant
		Corn backpack machine	4Y-3	Three-row cutting	Yanzhou Yu Feng, Yanzhou Feng
Road machinery	Full series	Highway mixing machine	LBJ-180/200	Operating width 1.8 m/2.0m	Shandong yanzhou road machinery research institute

## Appendix

Category	Tractor model	Name of supporting Farm implements	Agricultural machinery model	Main technical parameter	Company
Trailer	Full series	Farm trailer	7C-7	Dead weight capacity 7t	Qingdao Yakai Machinery Factory He Nan Jin Da Chuan Machinery Co., Ltd
		Farm trailer	7C-7		
		Hydraulic side-discharge trailer	7CC-7		



**Attention:** before using matching farm machinery, operator shall carefully read "Operation and Maintenance Manual" for agricultural machinery. Familiar with structure, performance, operating method, proper matching so as not to damage agricultural implement and personal accidents.

### Important:

**1. Before selecting agricultural machinery, refer to the reference list of operating condition of operating area (soil resistance, agriculture requirement) and first select the category of matching agricultural machinery and consult the dealer.**

**2. In accordance with the model of purchased tractor (watt level), combining with operating condition of operating area (soil resistance, agriculture requirement), refer to the advisory opinion and determine the main technical parameter of agricultural machinery. If matching is not proper, the machine may be adversely affected.**

**3. Under different operating conditions (soil resistance, agriculture requirement), the working performance and effect of the same machine is different. The user should determine the operating speed, operating width and etc. according to the local geographical conditions.**



Dear users,

Thank you for your patronage and welcome to select and use **LOVOL-TD series wheeled tractor**. We'd like to provide you with wholehearted service and solve your problems during tractor application timely and effectively to fulfill your demand to the greatest extent and provide excellent customer service.

We currently send the "Users Information Feedback" with operation manual to you, and please fill in it with regular script, then send it to the Information Center of farming business department, **LOVOL Heavy Industry Co., Ltd.** in 192 North South Road, Fangzi district, Weifang City, Shandong Province, postal code: 261206. Our Company will input your Users Information Feedback into the computer to conveniently carry out the "3 Guarantees" service for you.

We sincerely appreciate your coordination and vigorous support!

### User Information Feedback Form

Product model		Factory No. of Tractor		Engine Manufacturer	
Engine Number		Date of Manufacture		Date of Purchase	
User's Name		Age		Degree of Education	Driving Years
Home Address			Telephone Number		Postal Code
Main Use for Purchase of Machine			Tractor Load		
Time and Cause of Fault					
Name and Condition of Damaged Parts					

Improvement Opinion and Suggestion	
--	--

**Note: This feedback shall be filled in by the machine owner (or machine operator) with true information so as to understand the service condition of the tractor and provide great service for users. Copy of this user information feedback sheet is accepted.**

## Delivery training sheet –tractor

<b>FOTON LOVOL</b>		<b>Tractor delivery training sheet</b>			
* Machine model		*VIN		* Engine serial number	
Country		Dealer name			
<b>Owner information</b>					
*Name of Contact Person		* Tel. of Contact Person		Industry type	
* Contact person address					
* Delivery date			* Name of the delivery clerk		
Evaluation (tick <input type="checkbox"/> with “√” )	<input type="checkbox"/> Satisfied <input type="checkbox"/> So-so <input type="checkbox"/> Dissatisfied		* Signature by the user		
<b>Delivery training items</b>					
After receiving the training, customer shall master the knowledge below (tick the item with “√” for confirmation)					
1. introduce the complete equipment’s nameplate information and count the accompanying spare parts, tools, and technical documents, etc.					
2. Inform users of the warranty application flow, requirements, and considerations					
3. Introduce the complete machine’s safety operation attentions, in addition to the safety markers’ connotations					
4. Introduce the oil type required by the manufacturer					
5. Introduce the name, function, and mounting position of the product’s major parts					
6. Introduce the tractor’s correct operation method					
7. Introduce the tractor’s correct running-in method and the servicing requirements after the running-in					
8. Introduce the daily tractor servicing content, method, and considerations					
<b>Attentions:</b> 1、 Items marked with red color on the delivery training sheet shall be filled, and the information filled shall be authentic. 2、 Refer to the accompanying servicing instruction for detailed training contents.					

SN..	Item	Content	Ordinary items	Key items
1	Accompanying materials	Verify the complete equipment information.		■
		Count the accompanying spare parts, accompanying tools, certificate of conformity, operation instruction, and parts catalogue.	■	
2	Safety	Silencer, differential lock control, PTO control handle, hydraulic control handle warning signs.	■	
		Warning signs at radiator, instrument desk, fender, and PTO shaft.		■
3	Product introduction	1. According to the complete equipment's actual configuration, give a brief introduction of the complete equipment's major parts, such as engine hood, radiator, engine, floor, protecting brace, cab, gearbox, and rear axle. 2. Give a brief introduction of the operation of air conditioning, heater, seat, electrical switch, wiper, car audio, alarm lamp, and battery, and the adjustment to protecting brace.	■	
		1. Operation of shuttle-type gearshift, basic transmission/splitter, 4WD, brake, clutch, PTO, differential lock, multi-way valve, lifter (ordinary, forced, and electrical), in addition to the suspension operation and considerations; 2. Operation and considerations of the instrument's oil pressure, water temperature, recharging, rotating speed, and hour meter.		■
4	Running-in	1. Checking before the running-in: 1.1. Check the external fastener; 1.2. Check the oil level; 1.3. Check the tire pressure; 1.4. Add lubricating grease. 2. Expound the running-in time for users according to the instruction. 2.1. Engine running-in in racing (high, middle, and low speed); 2.2. PTO running-in (high and low speed); 2.3. Hydraulic system's running-in (loading); 2.4 Tractor running-in (neutral travelling and loading) 3. Cautions for running-in: Whether the engine, chassis, hydraulic system, operation system and electrical appliance are working normally, and how to deal with the faults.	■	
5	Servicing after running-in	Discharge the oil when the oil temperature is relatively high (about 60 degrees Celsius), clean the drain plug, and add new oil according to needs. Replace the engine oil and fuel filter element, clear up or clean the air filter element, oil return filter element, and oil suction filter element;		■

		Inspection after the running-in shall be performed according to the inspection steps before the running-in.		
6	Regular servicing	<p>Daily servicing: cleaning, inspection, adjustment, and tightening.</p> <p>Preventive servicing on a regular basis: 50h(weekly), 200h(monthly), 400h(quarterly), 800h(semiannually), and 1600h(annually).</p> <p>50h servicing: clean the air filter, and check the main/assistant clutch and brake's stroke;</p> <p>200h servicing: smear lubricating grease on the frequently rotating parts, replace engine oil and filter element, and replace fuel filter element and maintain the air filter;</p> <p>400h servicing: Check the chassis, front axle, and hydraulic system's oil level, add lubricating grease, and clean the steering oil tank's filter element ;</p> <p>800h servicing: replace hydraulic oil, steering oil, and chassis oil, clean the fuel tank, and check the valve clearance and injector's injection pressure;</p> <p>1600h servicing: clean the cooling system, and replace the front axle oil and brake fluid.</p>		■
7	Main servicing method	<ol style="list-style-type: none"> <li>1. Know how to drain the oil in engine, gearbox, rear axle, transfer case, final drive, front drive axle, steering gear, and hydraulic system;</li> <li>2. Give a brief introduction of the method to clear up or clean the filter element;</li> <li>3. Toe-in inspection and adjustment method;</li> <li>4. Brake and clutch stroke adjustment method;</li> <li>5. Lubricating grease adding requirements.</li> </ol>		■
8	Service flow	After-sales flow	■	

**Compulsory warranty service sheet –tractor**

<b>FOTON LOVOL</b>		<b>Forced Assurance Service Sheet of Tractor</b>			
* Machine model		*VIN		* Engine serial number	
Country		Dealer name			
* Name of Contact Person		* Tel. of Contact Person		Industry type	
Contact person address					
* Servicing date		* The complete vehicle's working hours (by now)		Name of the delivery clerk	
Evaluation (tick <input type="checkbox"/> with “√”)	<input type="checkbox"/> Satisfied <input type="checkbox"/> So-so <input type="checkbox"/> Dissatisfied			* Signature by the user	
<b>Servicing item</b>					
1. Replace the engine oil and filter element according to requirements, and clean relevant parts;					
2. Replace gearbox, front axle, lifter oil according to requirements, as well as clean relevant parts;					
3. Maintain the diesel engine according to "Operating and Maintenance Instructions for Diesel Engines".					
4. Clean the engine cooling system according to requirements, as well as replace the coolant;					
5. Check the toe-in of front wheels, and free travels of the clutch and brake. If necessary, adjust them.					
6. Check and tighten all external bolts, nuts and screws.					
7. Fill lubricating grease to each tractor parts according to Maintenance and Service Schedule.					
<p>1. After each servicing operation is completed, tick the blank with√</p> <p>2. Items marked with red color on the delivery training sheet shall be filled, and the information filled shall be authentic.</p> <p>3. Refer to the accompanying servicing instruction for detailed training contents.</p>					

Sales Tel:

Sales Fax:

Service Hotline:

Tel: (for spare parts)

Fax: (for spare parts)

Postal Code: 261206

Website: <http://www.fotonlovol.com>

E—mail: [nzyx@lovol.com.cn](mailto:nzyx@lovol.com.cn)

Address: No.192, South Beihai Road, Fangzi  
District, Weifang, Shandong