

REPAIR - OVERHAUL AGRICULTURAL TRACTORS

mod. **75** mod. **76**

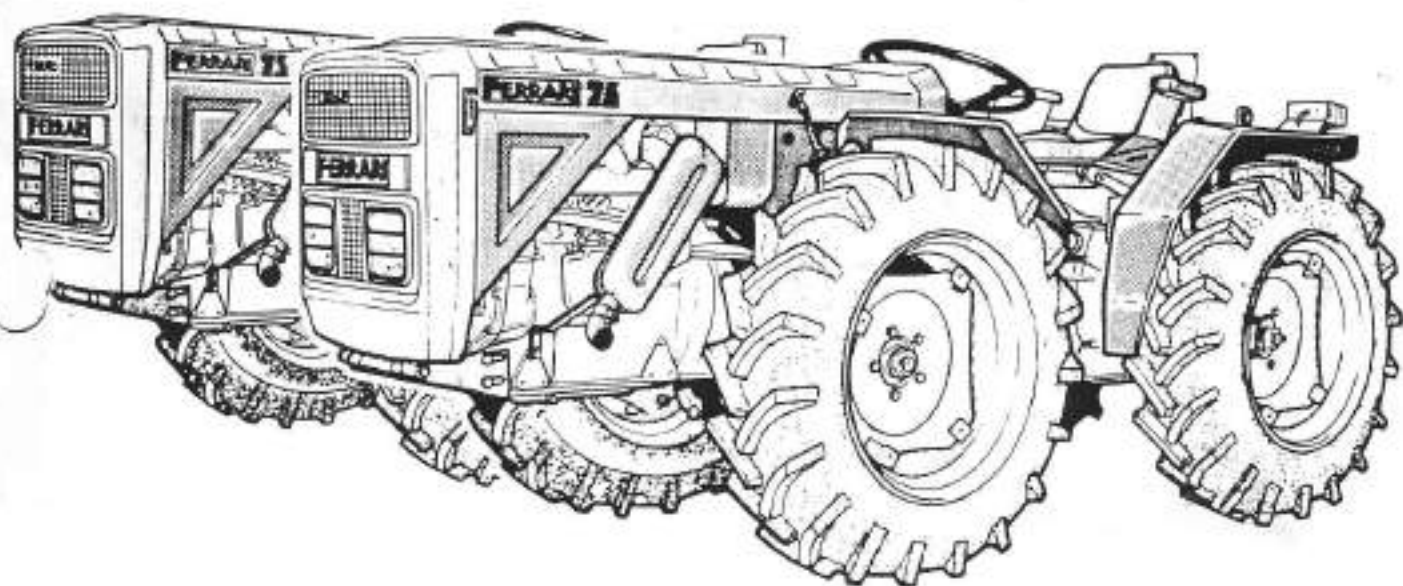

FERRARI

MACCHINE
AGRICOLE

MAIN OFFICE
42045 LUZZARA (Reggio Emilia) - ITALY
Tel. (0522) 835113/216/298

INDEX

		Page
CHAPTER I	— INTRODUCTION — DESCRIPTION AND TECHNICAL CHARACTERISTICS	
	INTRODUCTION	1-1
	IDENTIFICATION OF THE TRACTORS	1-1
	— SPECIAL NOTES	1-1
	TECHNICAL CHARACTERISTICS OF THE TRACTORS	1-1
CHAPTER II	PRINCIPAL ADJUSTMENTS — GENERAL	
	INTRODUCTION	2-1
	ADJUSTMENT OF THE ACCELERATOR CONTROL AND OF THE ENGINE SHUT-DOWN CONTROL	2-1
	— ACCELERATOR CONTROL	2-1
	— ENGINE SHUT-DOWN CONTROL	2-1
	ADJUSTMENT OF THE CLUTCH CONTROL PEDAL	2-1
	ADJUSTMENT OF THE FOOT BRAKE PEDAL AND THE HAND BRAKE	2-1
	— ADJUSTMENT OF THE FOOT BRAKE PEDAL (Mod. 75)	2-1
	— ADJUSTMENT OF THE HAND BRAKE (Mod. 75)	2-1
	— ADJUSTMENT OF THE FOOT BRAKE PEDAL AND THE HAND BRAKE (Mod. 76)	2-2
	— ADJUSTMENT OF THE SHOE — OPENING CAM	2-2
	ADJUSTMENT OF THE DIFFERENTIAL LOCK CONTROL	2-2
	ELECTRICAL SYSTEM	2-2
	— LIGHT SYSTEM	2-2
	— MAINTENANCE OF THE BATTERY	2-2
CHAPTER III	OVERHAUL OF THE TRACTORS	
	DISMOUNTING OPERATION	3-1
	RECOUNTING OPERATION	3-1
	TROUBLES AND REMEDIES	3-1
— Section I	CLUTCH	
	Overhaul	3-3
	Dismounting the clutch spring disk and friction disk	3-3
	Remounting	3-3
	— Replacement of the engine oil seal	3-4
	— Adjustment of the stroke of the clutch fork	3-5
	Troubles and remedies	3-5
— Section II	FRONT — DIFFERENTIAL AND TRANSMISSION UNIT	
	— Special note	3-7
	Overhaul	3-7
	Dismounting part I — front gear train	3-9
	Dismounting part II — front differential	3-10
	Remounting part II — front differential	3-13
	— Remounting part II — gears	3-14
	— Remounting part II — differential	3-14
	Remounting part I — front gear train	3-14
	Troubles and remedies	3-16

	Page
- Section III ARTICULATED JOINT	
Overhaul	3-19
Dismounting	3-19
Remounting	3-19
- Section IV REAR DIFFERENTIAL	
Overhaul	3-21
Dismounting	3-21
- Dismounting of the differential bevel gears	3-21
- Dismounting of the power take-off reduction gear box	3-21
Remounting	3-22
- Section V WHEEL HUBS	
Overhaul (tractor Mod. 75)	3-25
Dismounting	3-25
Remounting	3-25
Overhaul (tractor Mod. 76)	3-25
Dismounting the wheel hubs	3-25
- Dismounting the wheel reduction gear	3-27
Remounting	3-27
- Section VI STEERING (Mechanical)	
Overhaul	3-29
Dismounting of the steering box	3-29
Dismounting of the articulating arms	3-30
Remounting of the articulating arms	3-30
Remounting of the steering box	3-31
- Section VII HYDRAULIC SYSTEM	
Overhaul	3-33
Introduction	3-33
Checking operating pressure values	3-33
- Steering wheel working pressure values	3-33
- Hydraulic power lift working pressure values (Mod. 75)	3-33
- Hydraulic power lift working pressure values (Mod. 76)	3-34
- Checking bypass valve pressure	3-34
Replacement of the hydraulic return filter cartridge	3-35
Hydraulic system schematics	3-35
- Section VIII HYDRAULIC POWER LIFT	
Overhaul	3-39
Dismounting	3-39
Remounting	3-39
Troubles and remedies (Mod. 75) (Mechanical steering)	3-40
Troubles and remedies (Mod. 75 and Mod. 76) with hydraulic steering	3-41

CHAPTER I

INTRODUCTION

DESCRIPTION AND TECHNICAL CHARACTERISTICS

INTRODUCTION

This publication is the Repair and Overhaul Manual for the agricultural tractors "Ferrari 75" and "Ferrari 76", manufactured by the FERRARI Company - Agricultural Machines - Luzzara, Reggio Emilia (RE), Italy. This publication contains the instructions for the dismounting of the principal parts of the tractor, for the principal adjustments and any other similar operation. As a general practice in the various operations of dismounting, remounting or adjustment, the machines have been subdivided into the following eight groups:

- CLUTCH
- FRONT DIFFERENTIAL AND GEARS
- ARTICULATED JOINT
- REAR DIFFERENTIAL
- WHEEL HUBS
- STEERING (mechanical)
- HYDRAULIC SYSTEM
- HYDRAULIC POWER LIFT

Note

Unless otherwise indicated the data and instructions contained herein are valid for both machines.

IDENTIFICATION OF THE TRACTORS

The serial number of the machine is stamped on the right side of the gear box (see figure 1-1).

Note

When replacement parts are ordered, always state the model and serial number of the tractor concerned.

SPECIAL NOTES

- The term RIGHT and LEFT, as used in this manual to locate the various components, are referenced to the tractor as viewed by the operator seated in the driver's seat.

- The manufacturer reserves the right to modify the machine, whenever required by commercial construction characteristics, without any obligation to immediately update this manual.

TECHNICAL CHARACTERISTICS OF THE TRACTORS

Qualifying technical characteristics: These are agricultural tractors, centrally articulated for total traction on four wheels of equal diameter.

Engine: Diesel, 4 stroke, air cooled.

Clutch: Single dry plate, adjustable.

Gears: 7 forward speeds, 3 reverse; all controlled by one lever.

Final reduction gears: On all four wheels (only for Mod. 76).

Steering: Mod. 76, Danfoss hydraulic system: with perfect maneuverability even under adverse conditions. Mod. 75, hydraulic or mechanical worm steering gear with a steering angle of 35°.

Wheels: 4-wheel drive with pneumatic tires 7.50-18 or 9.5-20 for Mod. 76, and 6.00-16 or 7.50-16 for Mod. 75.

Differential: On both axles with locking on rear and front axles for Mod. 76 and on the front only for Mod. 75.

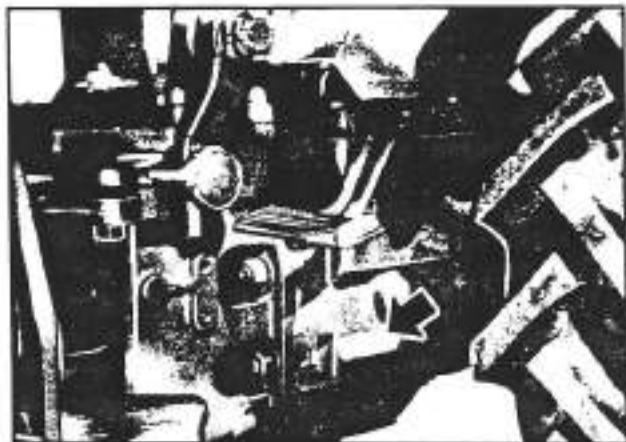

Fig. 1-1. Identification of the tractors

Service brake (foot brake - pedal): Operates on all 4 wheels for Mod. 76. Operates only on the front wheels for Mod. 75.

Emergency and parking brake (hand brake - lever): Operates on the rear wheels for Mod. 76 and the front wheels for Mod. 75.

Electrical system: 12 Volts for starting and lights. Rechargeable battery, permanent magnet alternator with charging at minimum revolutions. Horn - headlights. Directional signals and brake lights only for Mod. 76.

Power take-off: Standard 1-3/8 inch for connecting tools at two clockwise speeds independent of the forward speed, range of use from 540 to 630 RPM's and from 790 to 910 RPM's for Mod. 76 and range of use from 550 to 640 RPM's and from 800 to 930 RPM's for Mod. 75. If requested, synchronized power take-off at all speeds (forward and reverse) for wheel-driven trailers may be installed.

Tool lifting: Hydraulic, with automatic adjustment for depth and stress with connections at 2 and 3 points.

Trailer coupling: Road usable approved for Class B, towing of single axle trailers.

Instruments: Hour meter, tachometer (engine and power take-off), warning lights: insufficient oil pressure, generator, lights, reserve fuel.

Optional equipment: Cultivator width from 100 to 120 cm, fixed hood with upper opening, 6 tilling elements, 24 hoes.

- Plough: one-furrow - two furrows - swivel.
- Towed or wheel driven trailer.
- Back cutting mower bar.
- Towed sprayers.
- Spading machine
- Irrigation pump.
- Spray pump.

CHAPTER II

PRINCIPAL ADJUSTMENTS – GENERAL

INTRODUCTION

Some of the principal adjustments can be made from outside the machine without dismantling of any components. The following paragraphs contain the instructions for such adjustments.

ADJUSTMENT OF THE ACCELERATOR CONTROL AND OF THE ENGINE SHUT-DOWN CONTROL

If there is a malfunction of the accelerator or engine shut-down controls, proceed with the adjustment of the cables (1, 2; fig. 2-1) in the following way.

ACCELERATOR CONTROL

Adjust the screw (3, fig. 2-1) after having loosened the respective locknut.

ENGINE SHUT-DOWN CONTROL

Adjust the screw (4) after having loosened the respective locknut.

Note

Ascertain, after the adjustment has been made, that there exists approximately 10 mm of play between the ratchet (5) and the limit stop (6).

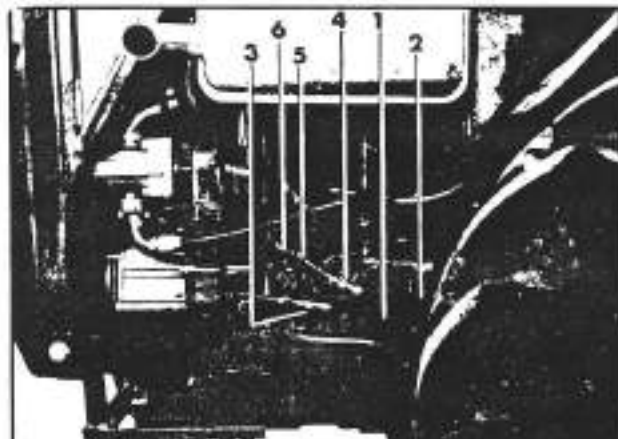

Fig. 2-1. Adjustment of the accelerator control and of the engine shut down control

ADJUSTMENT OF THE CLUTCH CONTROL PEDAL

If the clutch does not release completely or if the idle stroke becomes excessive (more than 15 mm), adjust the control rod by acting thereon until the idle stroke of the pedal is slightly less than 15 mm; then fasten the locknut securely. If the adjustment in the play of the clutch pedal is not sufficient to establish perfect functioning conditions, see Chapter III under item CLUTCH OVERHAUL.

ADJUSTMENT OF THE FOOT BRAKE PEDAL AND THE HAND BRAKE

ADJUSTMENT OF THE FOOT BRAKE PEDAL (Tractor Mod. 75)

If the brakes slip or if the idle stroke of the pedal becomes excessive (more than 20 mm), adjust the control rods (4, fig. 2-2) as follows:

- a. Loosen the locknut (2, fig. 2-2).
- b. Tighten the adjusting nut (1, fig. 2-2) until the idle stroke of the pedal is less than 20 mm.
- c. Tighten the locknut (2, fig. 2-2).

ADJUSTMENT OF THE HAND BRAKE (Tractor Mod. 75)

If the action of the hand brake is inefficient, adjust the control rods (3, fig. 2-2) as follows:

- a. Loosen the locknut (2, fig. 2-2).
- b. Tighten the adjusting nut (1, fig. 2-2) until the lever of the hand brake starts the braking action after the idle stroke over the first two teeth of the ratchet.

Note

Adjustment of the rods (3, 4; fig. 2-2) must be made simultaneously when regulating the brakes.

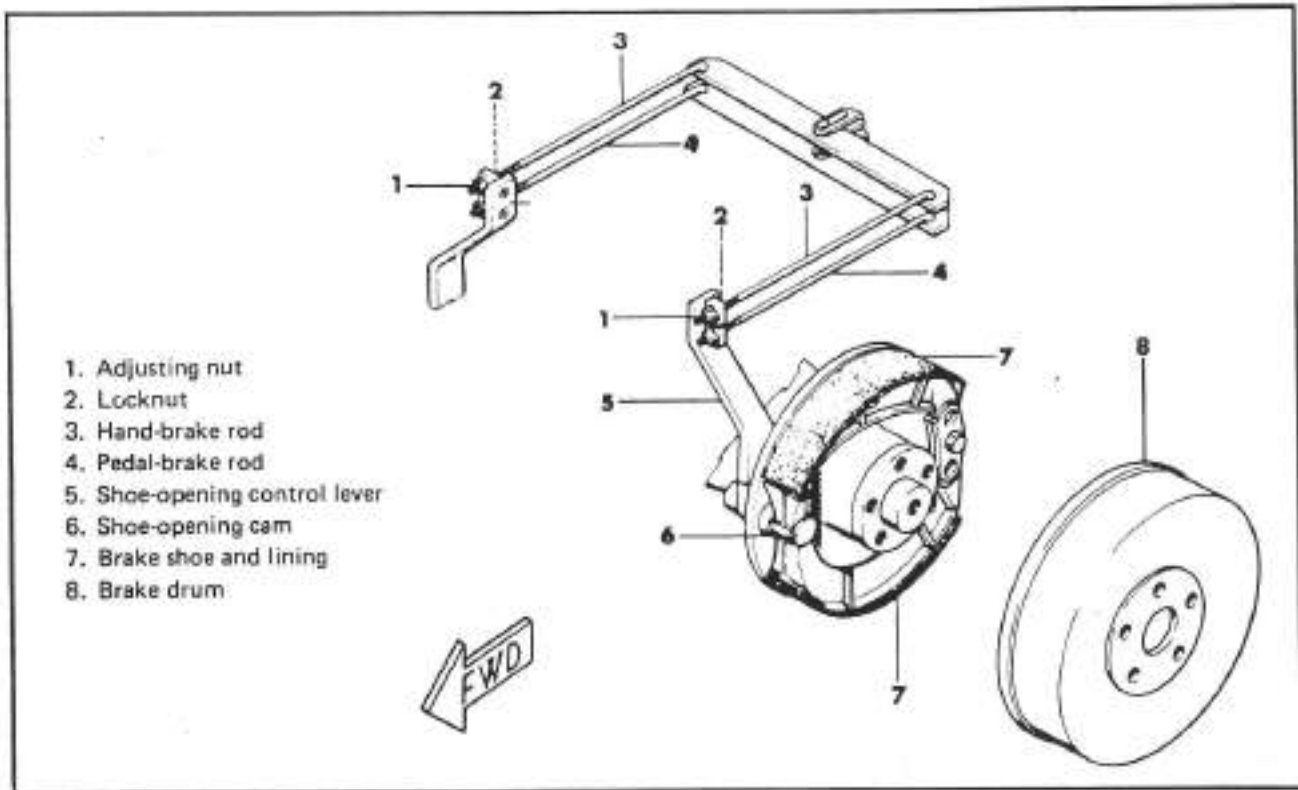

1. Adjusting nut
2. Locknut
3. Hand-brake rod
4. Pedal-brake rod
5. Shoe-opening control lever
6. Shoe-opening cam
7. Brake shoe and lining
8. Brake drum

Fig. 2-2. Adjustment of the brakes (tractor Mod. 75)

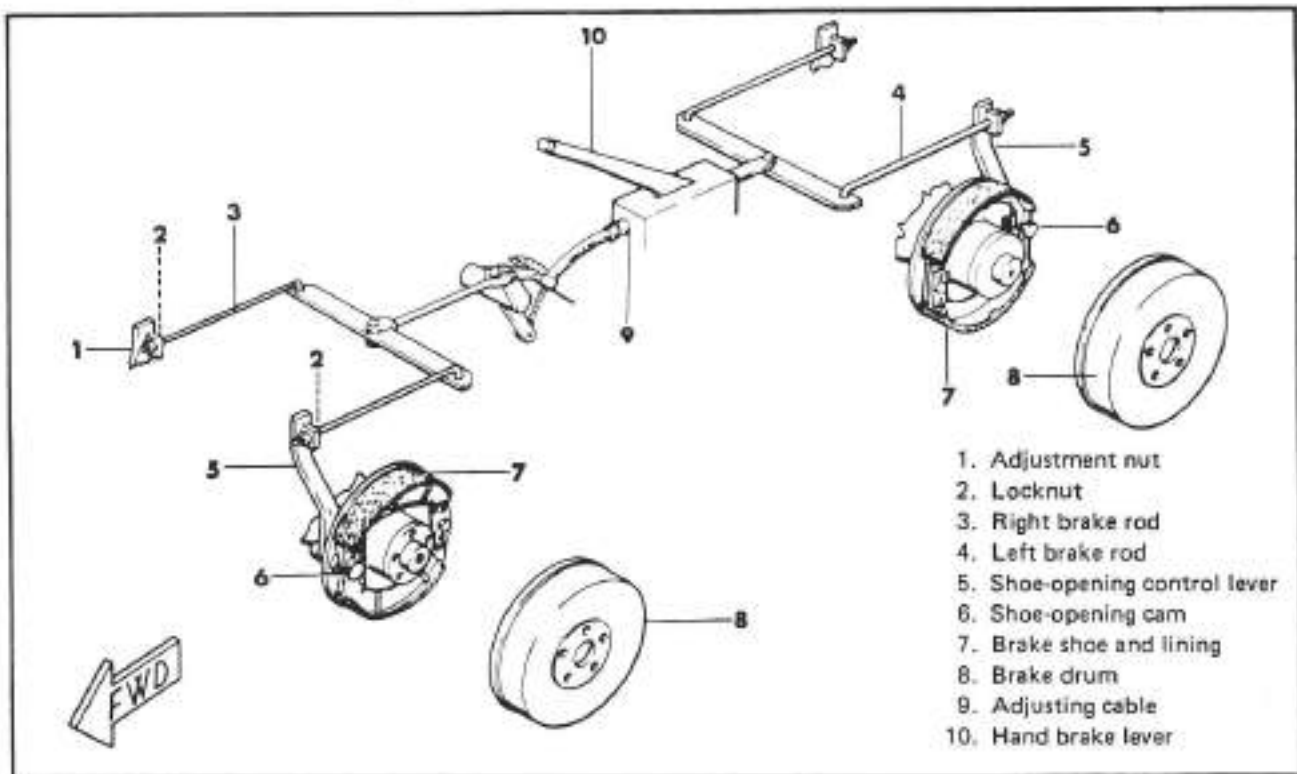

1. Adjustment nut
2. Locknut
3. Right brake rod
4. Left brake rod
5. Shoe-opening control lever
6. Shoe-opening cam
7. Brake shoe and lining
8. Brake drum
9. Adjusting cable
10. Hand brake lever

Fig. 2-3. Adjustment of brakes (tractor Mod. 76)

ADJUSTMENT OF THE FOOT BRAKE PEDAL AND THE HAND BRAKE

(Tractor Mod. 76)

The adjustment is the same as for tractor Mod. 75 by use of the nut (1; fig. 2-3) and the locknut (2; fig. 2-3).

Note

Adjustment of the hand brake is effected simultaneously when the foot brake adjustment is made.

WARNING

After adjustment, if the front wheels of the tractor have more braking action than the rear wheels or vice versa, adjust the brake cable (9; fig. 2-3) for the rear wheels. See also figure 2-4.

ADJUSTMENT OF THE SHOE-OPENING CAM

(Tractor Mod. 75 and Mod. 76)

Whenever adjustment of the rods (3, 4; fig. 2-2 or 3; fig. 2-3) is not sufficient to establish a correct braking action (the locknut (2; fig. 2-2 or fig. 2-3) has reached the last thread) it will be necessary to remove the brake drum (8; fig. 2-2 or fig. 2-3) and check the wear on the brake lining. If the wear on the lining is excessive, replace the brake shoes (7; fig. 2-2 or fig. 2-3); otherwise adjust the shoe-opening cam as follows:

- a. Release the shoe-opening control lever (5) from the rods (3, 4).
- b. Loosen the shoes (7) from the shoe-opening cam (6).
- c. Rotate the cam (6) one tooth in the direction of the shoe-opening control lever (5) while keeping the said control lever stationary.
- d. Reconnect the rods (3, 4) and readjust the brakes so that the brake pedal has an idle stroke of less than 20 mm.

ADJUSTMENT OF THE DIFFERENTIAL LOCK CONTROL

If it is difficult to engage the locking device of the differential, regulate the control cables by properly

adjusting the nuts (1, 2; fig. 2-4) after having previously loosened the respective locknuts. If the adjustment is not sufficient to establish the condition of perfect functioning, see Chapter III, under item TROUBLES AND REMEDIES - FRONT DIFFERENTIAL AND TRANSMISSION UNIT.

ELECTRICAL SYSTEM

The electrical system of the tractor is supplied current from one 12 V, 45Ah, battery. The figures 2-5 and 2-6 show the wiring diagrams for tractor Mod. 75 and Mod 76 respectively.

LIGHT SYSTEM

If the headlights, position lights or direction lights should not function, verify the condition of the respective fuses (refer to the scheme for the respective tractor). The fuses are located in a box in the battery space under the hood.

MAINTENANCE OF THE BATTERY

The battery is accessible by lifting the hood of the machine. To insure efficient output from the battery it is necessary to verify periodically the level of the electrolyte, refill with distilled water and protect the terminals with a coating of vaseline.

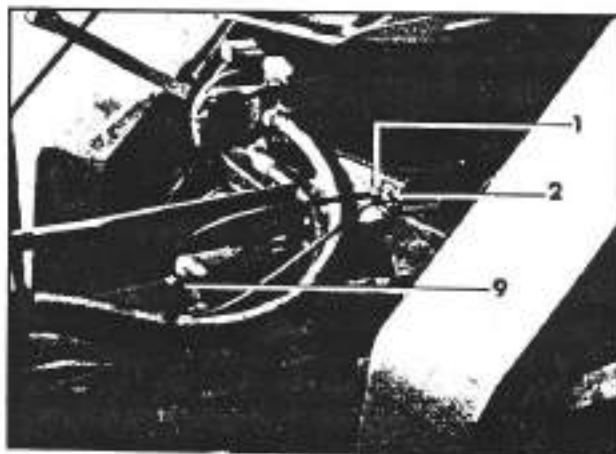

Fig. 2-4. Adjustment of the differential lock control

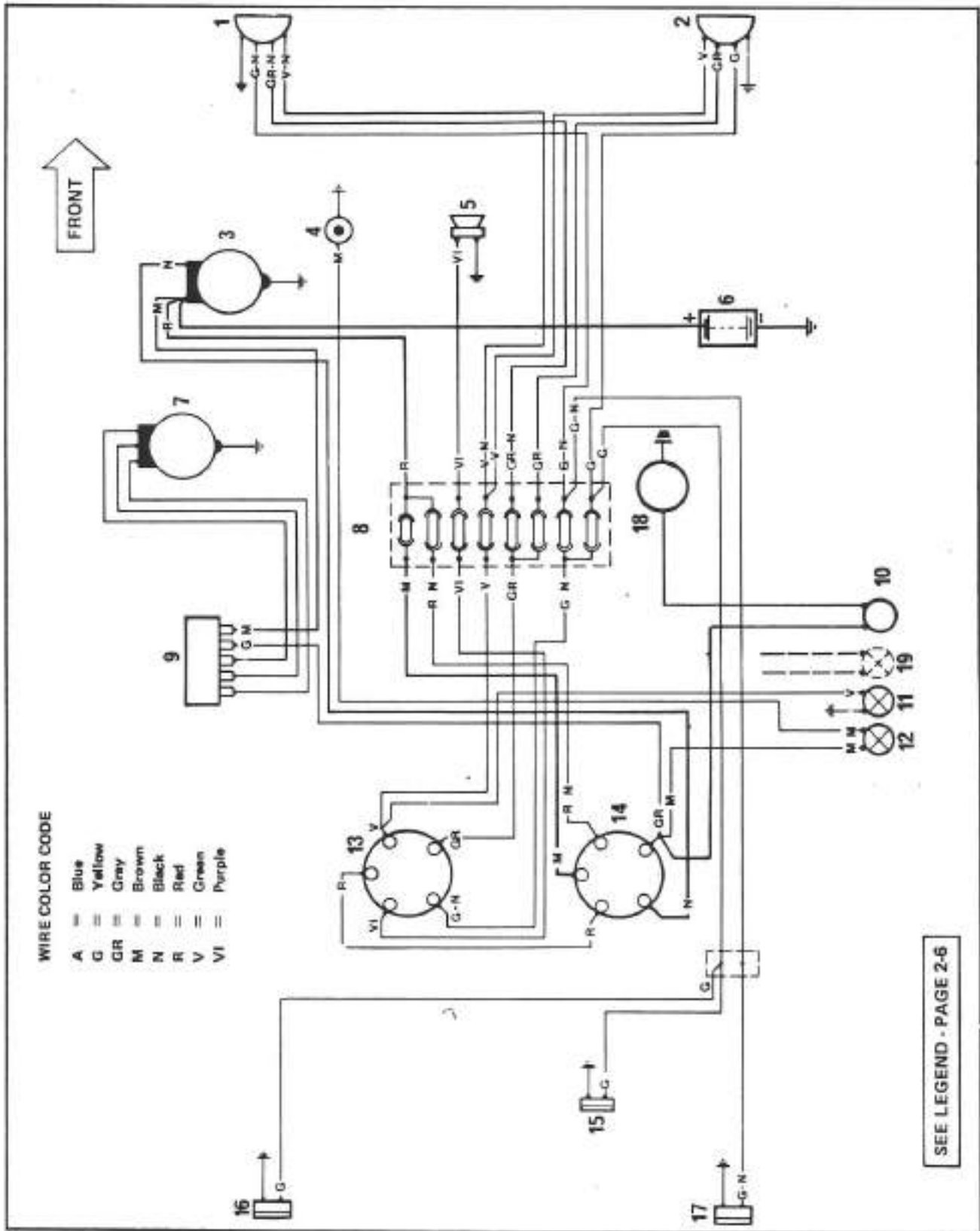

Fig. 2-5. Wiring schematic (tractor Mod. 75)

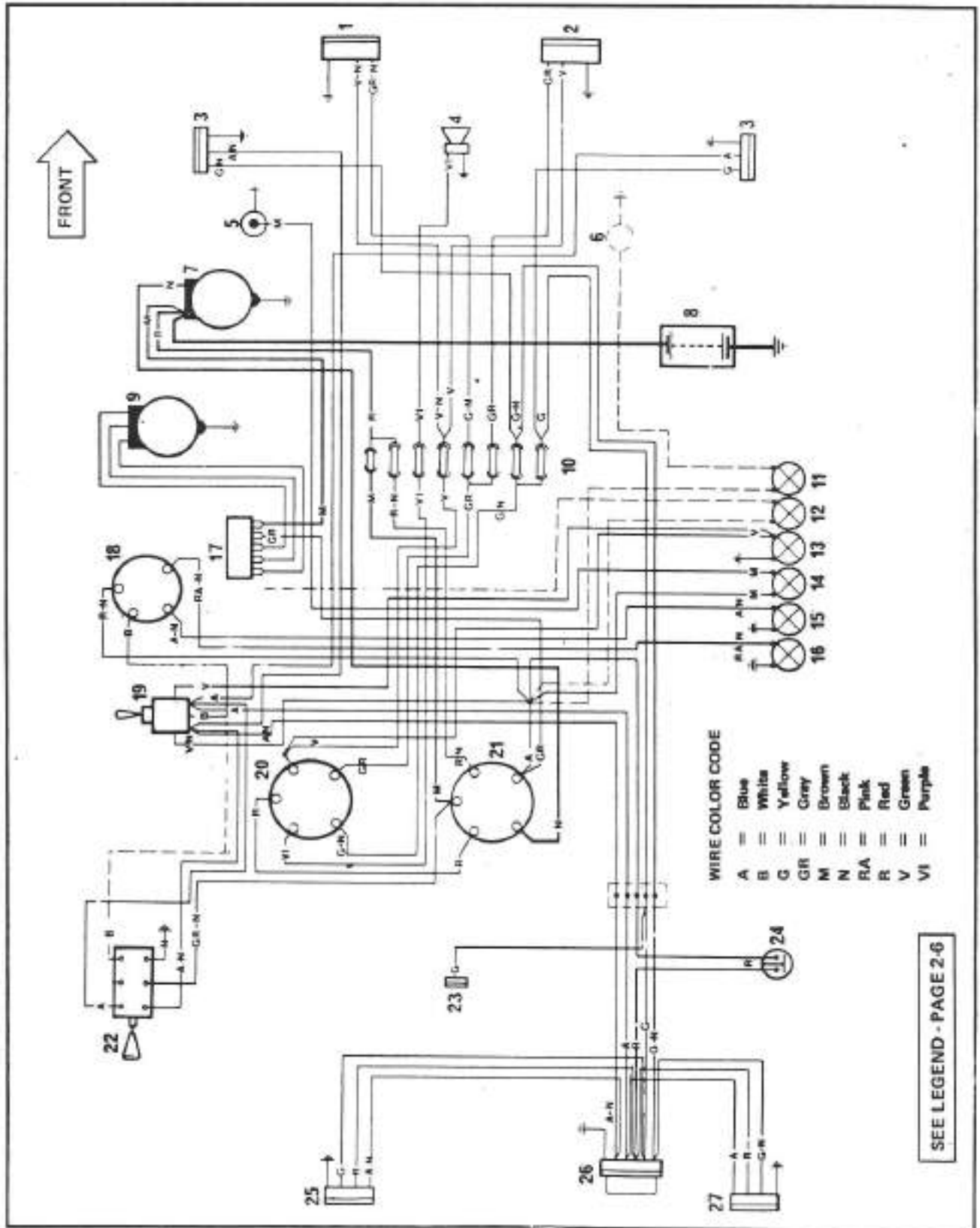

Fig. 2-6. Wiring schematic (tractor Mod. 75)

SEE LEGEND - PAGE 2-6

LEGEND FOR WIRING DIAGRAM Mod. 75
(See fig. 2-5)

- | | |
|-------------------------------------|--|
| 1. Left headlight | 11. Headlight signal |
| 2. Right headlight | 12. Insufficient oil pressure signal |
| 3. Starting motor | 13. Switch for lights and horn |
| 4. Engine oil pressure gauge switch | 14. Key switch for ignition, setting of services and engine starting |
| 5. Horn | 15. License-plate light |
| 6. Battery | 16. Left tail light |
| 7. Alternator | 17. Right tail light |
| 8. Fuses | 18. Fuel reserve signal switch |
| 9. Voltage regulator | 19. Spare signal for special installations |
| 10. Fuel reserve signal | |

LEGEND FOR WIRING DIAGRAM Mod. 76
(See fig. 2-6)

- | | |
|---|---|
| 1. Left headlight | 16. Signal showing tractor direction indicators operating |
| 2. Right headlight | 17. Voltage regulator |
| 3. Turn indicators | 18. Flasher |
| 4. Horn | 19. Switch for turn indicators and flashing light |
| 5. Engine oil pressure gauge switch | 20. Switch for lights and horn |
| 6. Fuel reserve signal switch | 21. Key switch for ignition, setting of services, and engine starting |
| 7. Starting motor | 22. Switch for right and left emergency lights |
| 8. Battery | 23. License-plate light |
| 9. Alternator | 24. Switch for stop-lights |
| 10. Fuses | 25. Left tail light |
| 11. Fuel reserve signal | 26. Socket for trailer |
| 12. Spare signal for special installations | 27. Right tail light |
| 13. Headlight signal | |
| 14. Signal showing insufficient engine oil pressure | |
| 15. Signal showing trailer direction indicators operating | |

CHAPTER III

OVERHAUL OF THE TRACTORS

DISMOUNTING OPERATION

It is suggested that the operations, as indicated in the following paragraphs, be carefully followed. Avoid use of wrenches, hammers, chisels and improvised tools of any other kind. Only by using the proper tools and equipment, and only by using them for their proper purpose, is it possible to effectively overhaul the machine without damage and with speed and safety.

- When dismantling any part of the machine, be sure to lay out each part in the same sequence as it was dismantled to prevent confusion when remounting. Also be sure to keep the parts of one machine separated from the parts of any other machine.
- In the operations of dismantling or remounting observe the utmost cleanliness. It would be wise to use two containers with either kerosene or gasoline; using the first container to wash them in and the second container to rinse them in.

in the overhaul, particular care should be used to allow for eventual adjustments which may have to be made as indicated.

The pieces must be washed, as indicated in the paragraph under "DISMOUNTING OPERATION", and dried with clean, lintless cloths or with an air hose.

If the remounting of one group has to be put aside for a period of time, it is necessary to preserve and protect this group by placing it in a dust-proof container. In every remounting always use new gaskets, cotter pins, and seals and replace other parts showing wear or which may have been damaged during the dismantling operation.

Note

In the remounting operation, it may be necessary to consult the GENERAL CATALOG OF SPARE PARTS for the specific tractor.

REMounting OPERATION

In the remounting operation proceed, if possible, in the inverse order to that used for dismantling. To avoid damage or excessive wear to the component, concerned

TROUBLES AND REMEDIES

The most probable troubles have been summarized and the operations necessary to avoid the causes of such troubles have been listed. Generally, the most usual causes of troubles have been omitted because the operator may easily identify them.

SECTION I	→	CLUTCH
SECTION II	→	FRONT DIFFERENTIAL AND TRANSMISSION UNIT
SECTION III	→	ARTICULATED JOINT
SECTION IV	→	REAR DIFFERENTIAL
SECTION V	→	WHEEL HUBS
SECTION VI	→	STEERING (mechanical)
SECTION VII	→	HYDRAULIC SYSTEM
SECTION VIII	→	HYDRAULIC POWER LIFT

SECTION I

CLUTCH

OVERHAUL

PRELIMINARY OPERATIONS

In order to reach the clutch bell-housing follow the operation listed below.

- a. Lift the hood of the tractor and disconnect one of the battery cables.
- b. Disconnect the headlights.
- c. Remove the oil tank and the air filter cartridge for the engine (only for Mod. 75 which is provided with the Sianzi engine).
- d. Remove the hood.
- e. Disconnect all of the electrical connections - starter, grounding wire, etc. - fixed to the engine body.
- f. Remove the electrical cable of the pressure switch and the two cables of the voltage regulator.
- g. Disconnect the horn and fuel reserve indicator connections.
- h. Disconnect the hour meter/tachometer cables.
- i. Disconnect the inlet and outlet hydraulic tubes and collect (in a clean basin for later re-use) the hydraulic fluid coming from the tubes and the tank.

Note

In the event that it is unnecessary to remove the oil from the tank, disconnect the inlet and outlet tubes and raise the open ends above the level of the fluid in the tank.

Temporarily secure these tubes in this position by means of a string, wire, or other device.

- j. Disconnect the cables for the accelerator and the engine shut-down.
- k. Remove the coil spring of the clutch pedal.
- l. Attach a lifting hoist to the engine to keep it in position. Then remove the six (6) bolts of the clutch bell housing. Remove the engine.

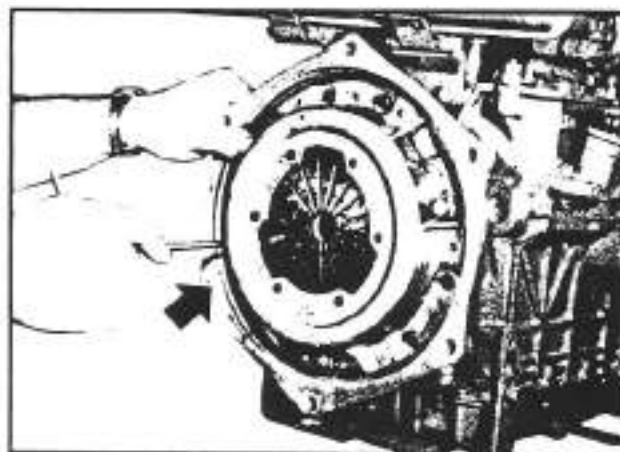

Fig. 3-1. Removal of the spring disk

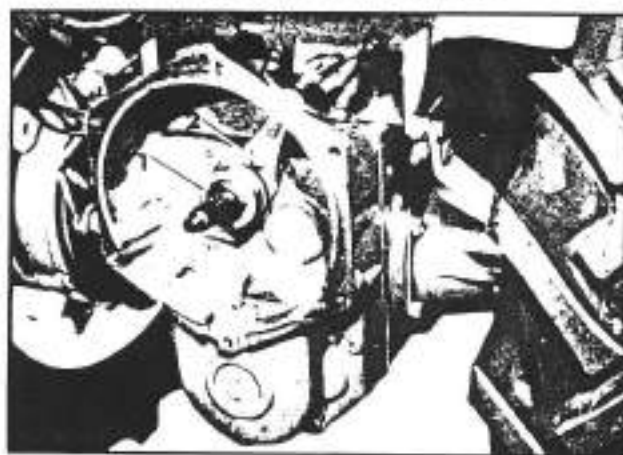

Fig. 3-2. Removal of the clutch fork and bearing

DISMOUNTING THE CLUTCH SPRING DISK AND FRICTION DISK

- m. This operation does not require any particular knowledge. It is only necessary to remove the six bolts which hold the spring disk in place (see figure 3-1).

REMountING

The remounting operation must be conducted with

much care in order to avoid damage to or rapid wear of the thrust bearing (1; fig. 3-2) and of the clutch disk (1; fig. 3-3). It is absolutely necessary to center the clutch disk (1, fig. 3-3) and the spring disk (2; fig. 3-3) before inserting and tightening the bolts.

In order to perform this operation correctly, it is necessary to have for centering a spare main shaft (3; fig. 3-3).

Note

It is possible to replace the spare main shaft with a centering pin dimensioned as indicated in figure 3-4.

Replacement of the engine oil seal

- Remove the thrust bearing (1; fig. 3-2) and the clutch fork (2; fig. 3-2).
- Position the puller (1; fig. 3-5) on the engine pinion and fully tighten the nut (2; fig. 3-5). Turning the puller end (3; fig. 3-5) extract the oil seal (4; fig. 3-5).

Note

The puller for the oil seal can only be obtained from FERRARI.

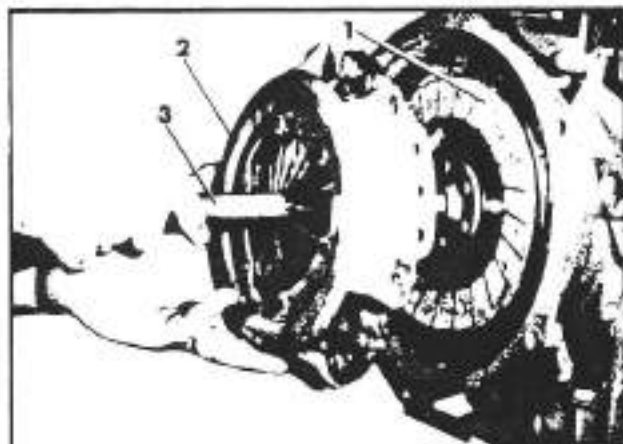

Fig. 3-3. Mounting the spring disk

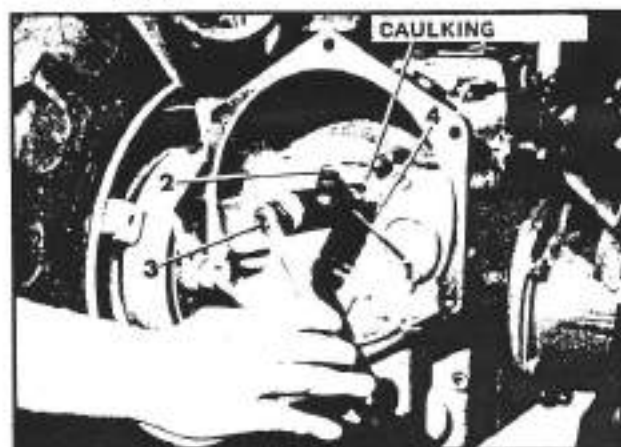

Fig. 3-5. Removal of the engine oil seal

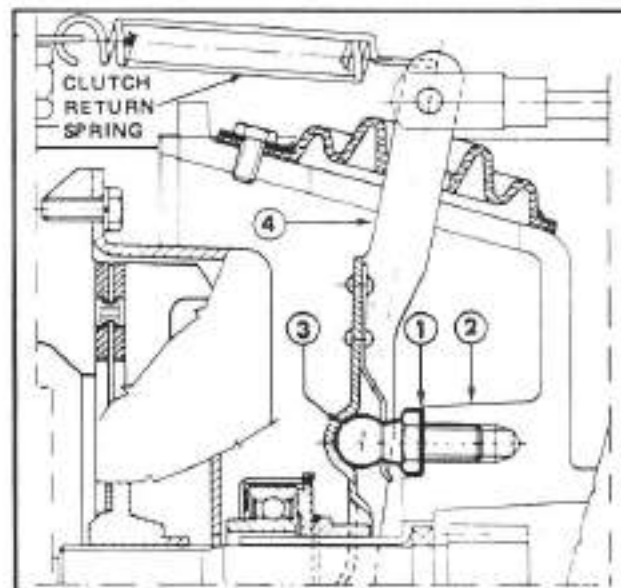

Fig. 3-6. Adjustment of the stroke of the clutch fork

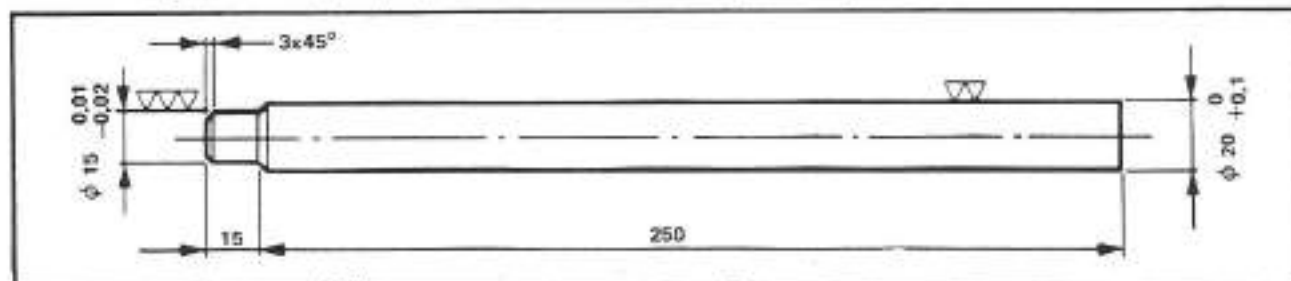

Fig. 3-4. Pin for centering the clutch disk

Adjustment of the stroke of the clutch fork

If the clutch does not completely disengage and the idle stroke of the clutch pedal is insufficient to re-establish perfect functioning conditions, insert a shim (1; fig. 3-6) between the clutch bell housing (2; fig. 3-6) and the

spherical headed clutch release pin (3; fig. 3-6) in order to extend the stroke of the clutch fork (4, fig. 3-6).

Note

Also see figure 3-5 for more details.

TROUBLES AND REMEDIES

TROUBLE	PROBABLE CAUSE AND REMEDY
Clutch disk slipping.	<ol style="list-style-type: none"> 1. Insufficient idle stroke of the clutch pedal. Reestablish the idle stroke by adjustment of the control lever nut (maximum pedal idle stroke, 20 mm). 2. Oil in the clutch bell housing. Wash the inside of the housing and replace the oil seal of the engine pinion or of the shaft.
	<p>Note</p> <p>Eventually it may also be necessary to replace the clutch disk.</p>
	<ol style="list-style-type: none"> 3. Clutch disk too worn or damaged (dirty inserts). Replace. 4. Damaged spring disk. Replace. 5. Incorrect mounting of the clutch disk. Remount correctly.
Incomplete disengagement.	<ol style="list-style-type: none"> 1. Excessive clutch pedal idle stroke. Reestablish the idle stroke (about 20 mm).
	<p>Note</p> <p>If the clutch pedal idle stroke is not sufficient to reestablish perfect functioning conditions, it means that the stroke of the clutch fork (4; fig. 3-6) is too short. Extend the stroke of the clutch fork by properly inserting a shim (1; fig. 3-6) between the clutch bell housing (2; fig. 3-6) and the spherical headed clutch release pin (3; fig. 3-6).</p>
	<ol style="list-style-type: none"> 2. Damaged disk. Replace the disk.
Noises in the clutch bell housing.	<ol style="list-style-type: none"> 1. Damage to the thrust bearing caused by the infiltration of dust. Wash the inside of the clutch bell housing and replace the bearing and the friction disk.

Note

Eventually it may be necessary to replace the bellows.

SECTION II

FRONT-DIFFERENTIAL AND TRANSMISSION UNIT

SPECIAL NOTE

For clarity and brevity the "Front-Differential and Transmission Unit" consisting of the following two parts, physically separated as to defining components by the intermediate plate, will be set forth herein as follows:

- Part I, or the front gear train (the defining components of which are the reverse gear and the idling gear).
- Part II, or the front-differential (the defining components of which are the differential, gear shift forks and levers).

OVERHAUL

Preliminary operations

- a. Separate the engine (see preliminary operation under clutch overhaul).
- b. After removal of the small cover, take off the steering wheel by using a puller as shown in figure 3-7.
- c. Disconnect the electrical connections to the dash panel. Particular attention should be paid to the dismantling of the light switches, the horn and the ignition switch. Remove the dash panel (see figure 3-8).
- d. Disconnect the brake control rods (1; fig. 3-9) as indicated.
- e. Remove the cotter pin from the hand brake lever and extract the lever.
- f. Take out the four set screws of the battery casing and remove it together with the attached hydraulic fluid tank (1; fig. 3-10), after having drained the tank and tubes.
- g. Remove the clutch control rod (1; fig. 3-11) and the differential lock (2; fig. 3-11).
- h. Take off the battery case brackets and take out the gear box cover set screws (see figure 3-12).
- i. Remove the gear box cover (see figure 3-13).
- j. Lift the tractor and place it on wooden blocks. Remove the wheels.



Fig. 3-7. Removal of the steering wheel

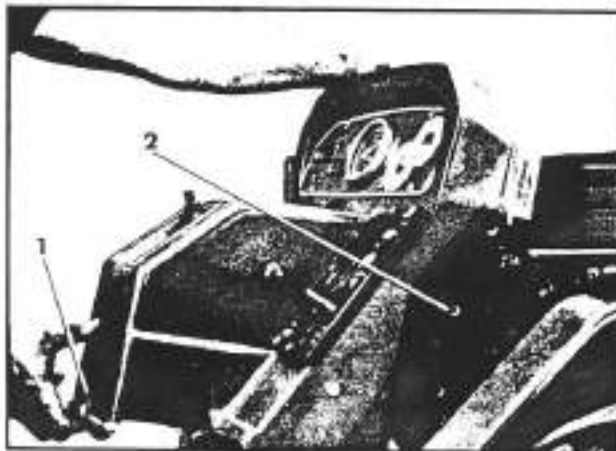

Fig. 3-8. Removal of the dash panel

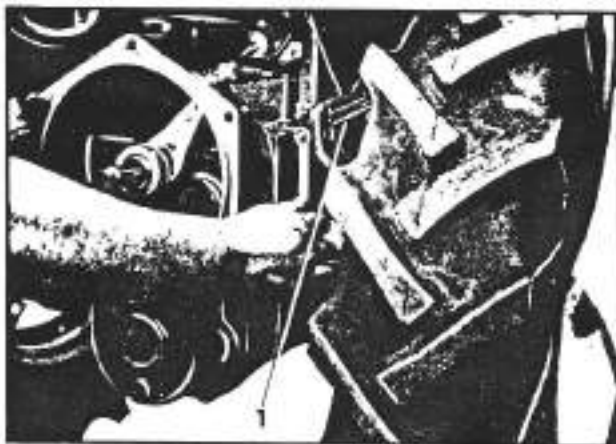

Fig. 3-9. Removal of the brake control rod

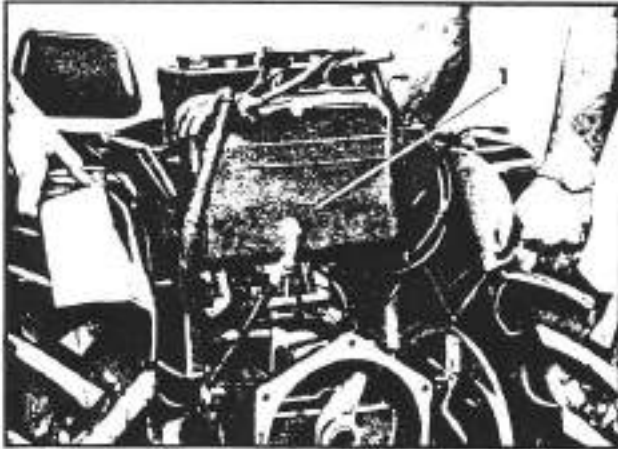

Fig. 3-10. Removal of the hydraulic fluid tank and battery case

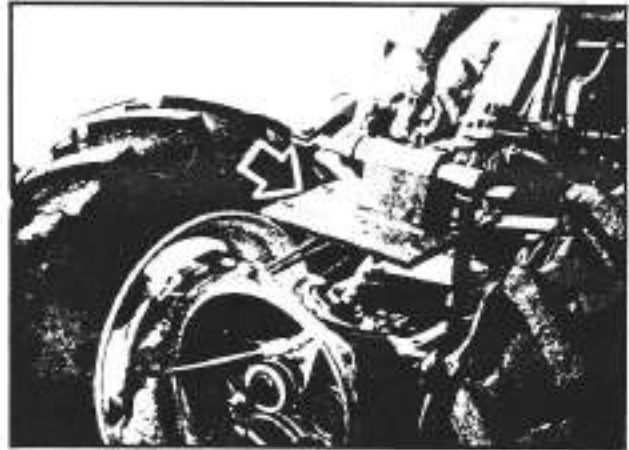

Fig. 3-13. Removal of the gear box cover

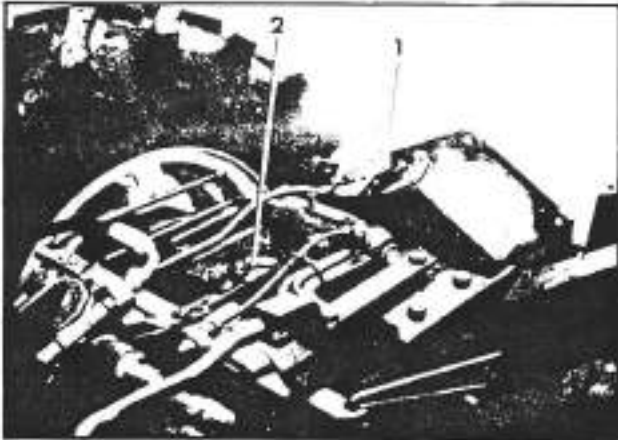

Fig. 3-11. Extraction of the clutch and differential controls

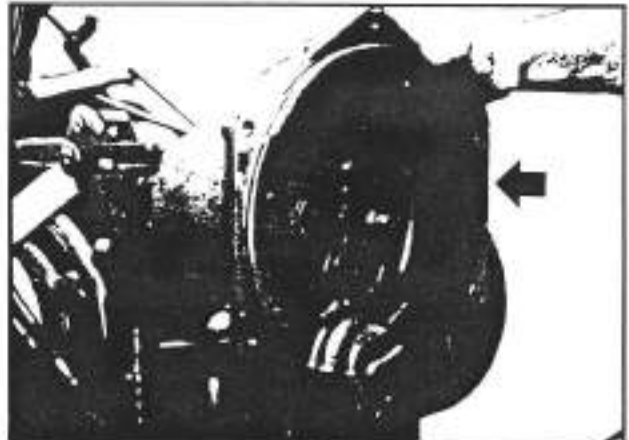

Fig. 3-14. Removal of the clutch bell housing

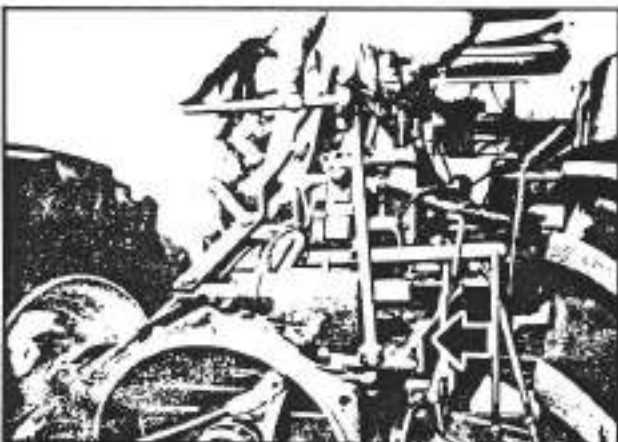

Fig. 3-12. Removal of the brackets for the battery case

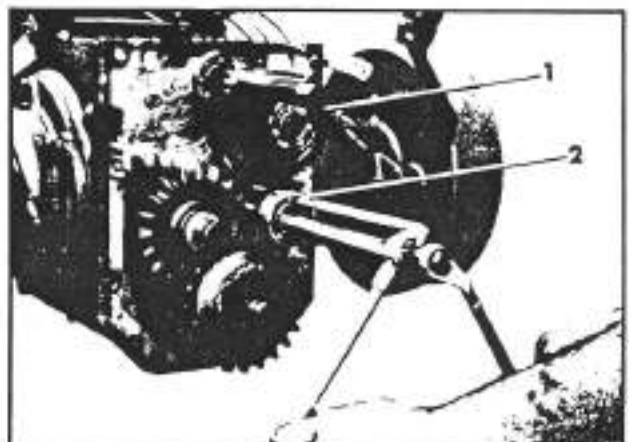

Fig. 3-15. Extraction of the main drive shaft bearing and the idling gear bearing

DISMOUNTING PART I – FRONT GEAR TRAIN

- k. After having drained the oil from the housing and after having removed the respective eight set screws, take off the clutch bell housing (see figure 3-14). Use a wooden mallet.

Note

- If the wooden mallet is not sufficient to remove the clutch bell housing, use a heavier tool with caution to avoid damaging the bell housing itself.
- If the gear bearing at the reduction end of the bell housing remains in place, break through the cap nut to extract it.

- l. Remove the main drive shaft bearing (1; fig. 3-15) and the idling gear bearing (2; fig. 3-15) as indicated.
- m. Ease out the reduction bell gear (1; fig. 3-16) and the reverse gear (1; fig. 3-17) with its relative washer (2; fig. 3-17).
- n. Extract, as indicated in figure 3-18, the gear (1; fig. 3-18) and the gear (1; fig. 3-19). Ease out the driving pinion (2, fig. 3-19) with its bearing.
- o. Loosen the lock nut of the control fork of the Part I sliding gear as indicated in figure 3-20 and extract the entire group.
- p. As shown in figure 3-21, ease out the double idling gear (1; fig. 3-21).
- q. Loosen the two lock nuts (1; fig. 3-22) of the support of the control rod (2, fig. 3-22).
- r. Take out the two lock nuts of the intermediate plate (1, fig. 3-23) and remove it with its respective gasket.

Note

Replace this gasket during the remounting operation.

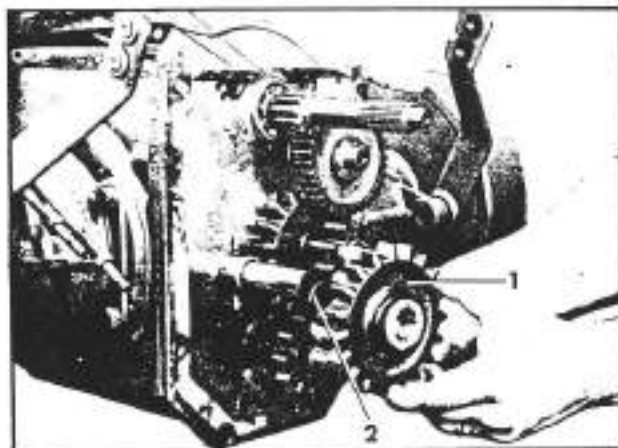

Fig. 3-17. Removal of the reverse gear and washer

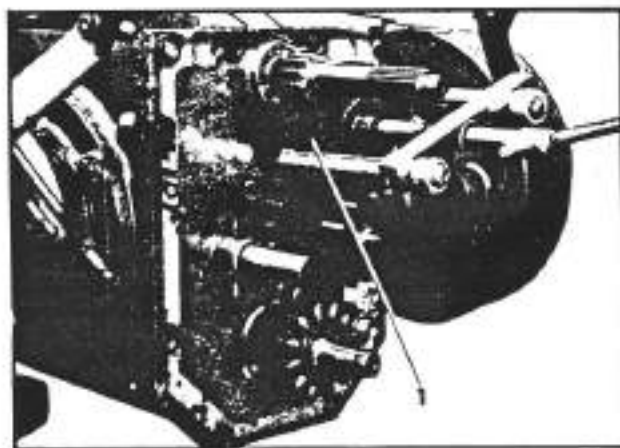

Fig. 3-18. Removal of the main drive shaft gear

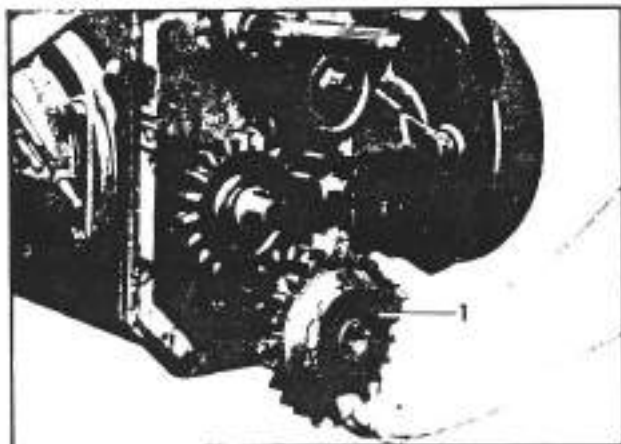

Fig. 3-16. Removal of the reduction bell gear

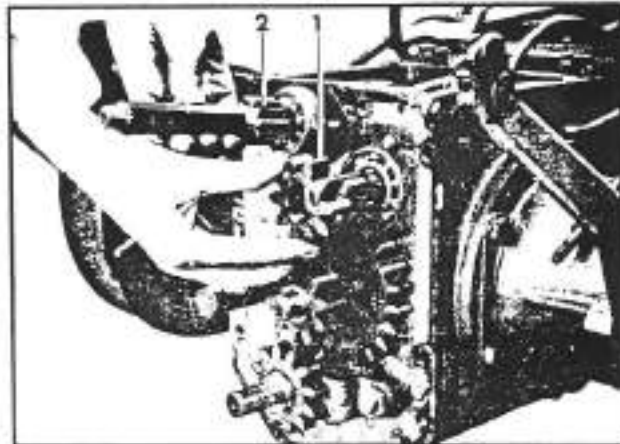

Fig. 3-19. Removal of the idling gear and the driving pinion

DISMOUNTING PART II – FRONT DIFFERENTIAL

- a. Take off the cover, opposite the wheel hub, after having removed the eight set screws.
- b. Take off the wheel hubs (see figure 3-24).
- c. Extract the differential group (see figure 3-25).

Note

In this case, the complete differential group can be removed from the top or through the front opening. In figure 3-25, the removal of the group is shown as for the case in which the overhaul does not include the removal of any other part such as the intermediate plate, or the housing cover.

- d. Only loosen the bolts holding the gear box to the articulated joint (1; fig. 3-26); carefully separate the gear box and the articulated joint and then remove the socket-head bolts (1; fig. 3-27). Then take out the bolts (1; fig. 3-28) and detach the complete

- transmission from the tractor.
- e. Take off the nuts (1; fig. 3-28) from the speed selector rods and remove the respective forks (2; fig. 3-28).
- f. Extract the speed selector rods (1; fig. 3-29).

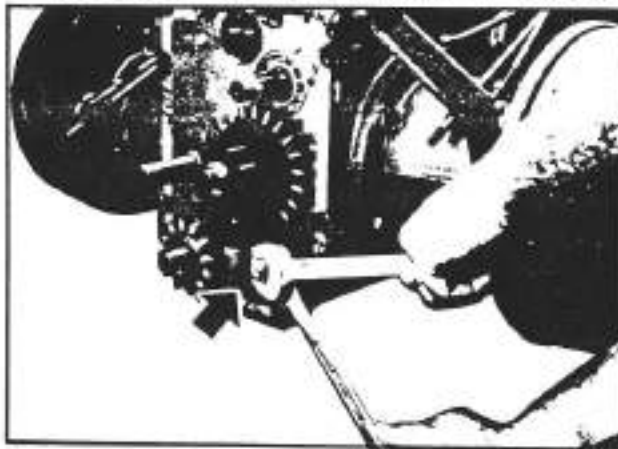

Fig. 3-20. Removal of the control fork group.

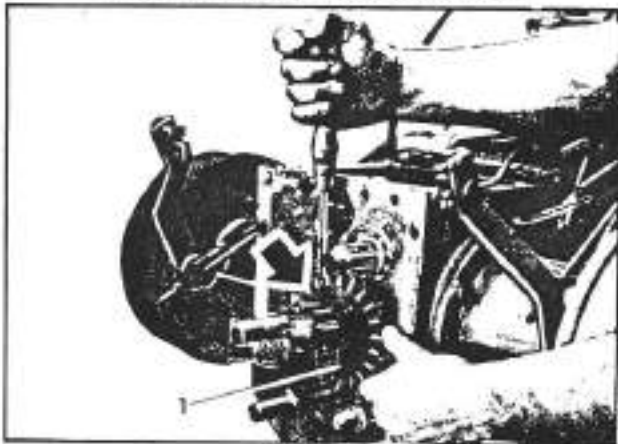

Fig. 3-21. Removal of the double idling gear

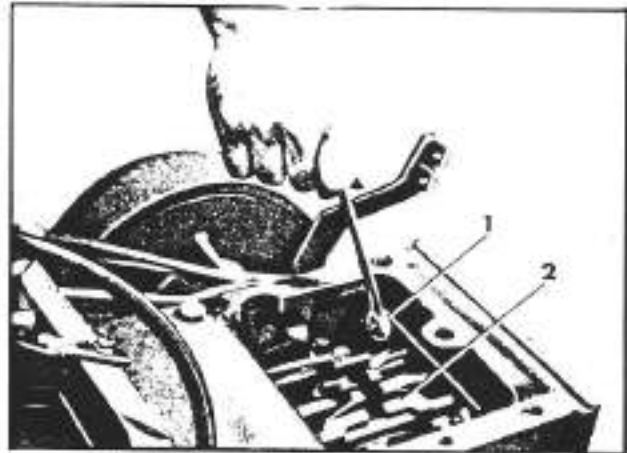

Fig. 3-22. Removal of the support of the speed selector control rods

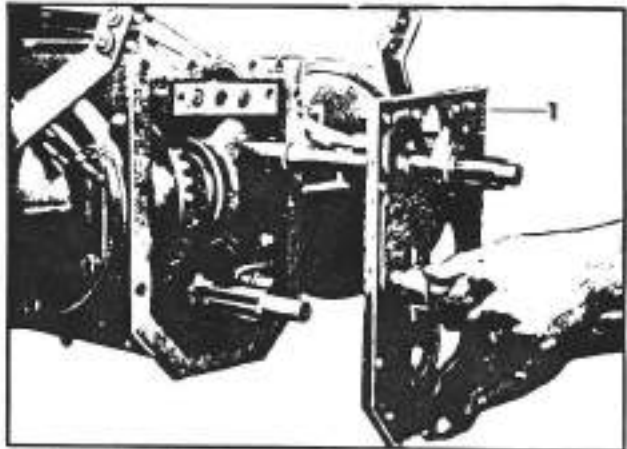

Fig. 3-23. Removal of the intermediate plate

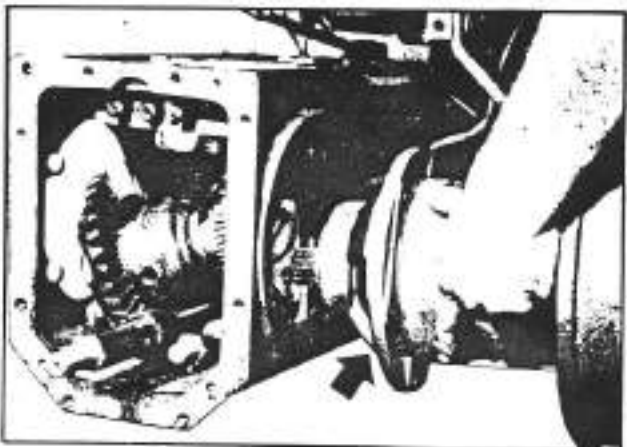

Fig. 3-24. Removal of the wheel hubs

Note

Pay particular attention that the springs and poppet balls located in the holes indicated in figure 3-26, immediately over the respective rods are not lost.

- g. Break out the small cap at the end of the main drive shaft (1; fig. 3-30), extract the retaining ring (2; fig. 3-30), remove the roller bearing (3, fig. 3-30), and take out the shaft (1; fig. 3-30).
- h. Take off the spacer (1; fig. 3-31) and the retaining ring (2, fig. 3-31).

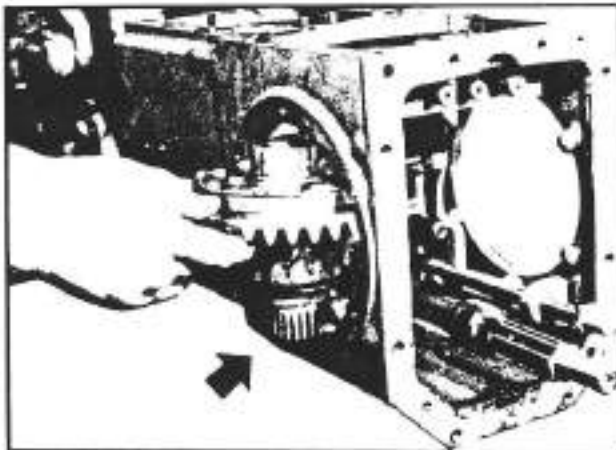

Fig. 3-25. Removal of the differential gear

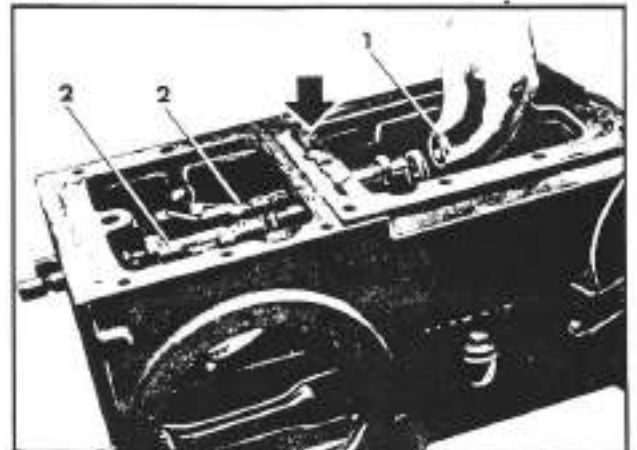

Fig. 3-28. Removal of the selector rod forks

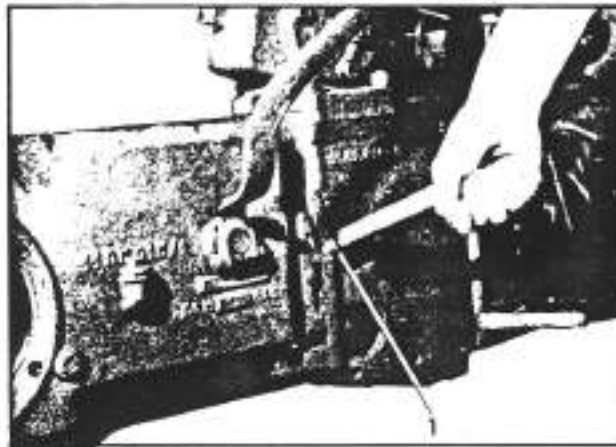

Fig. 3-26. Loosening of the lock nuts of the articulated joint

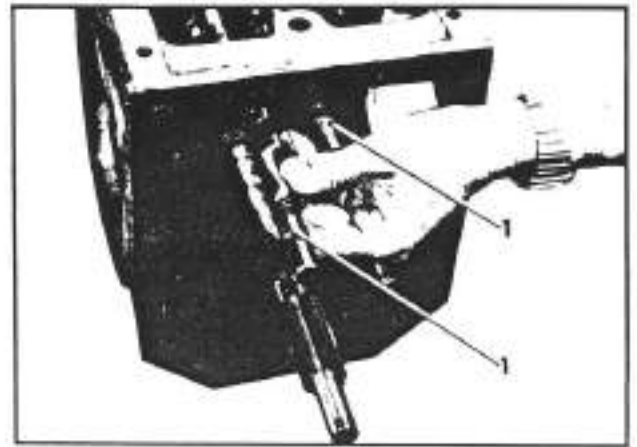

Fig. 3-29. Removal of the speed selector rods

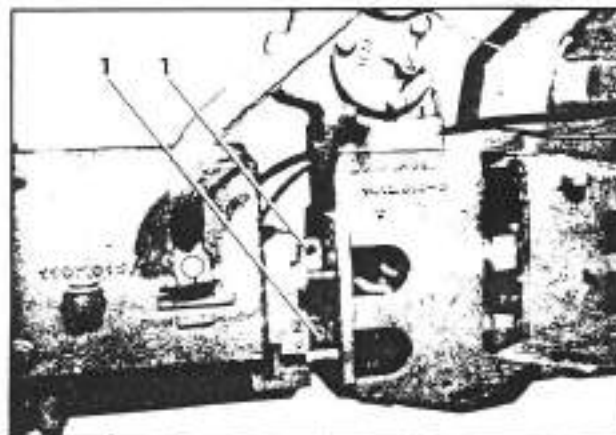

Fig. 3-27. Removal of the bolts from the articulated joint

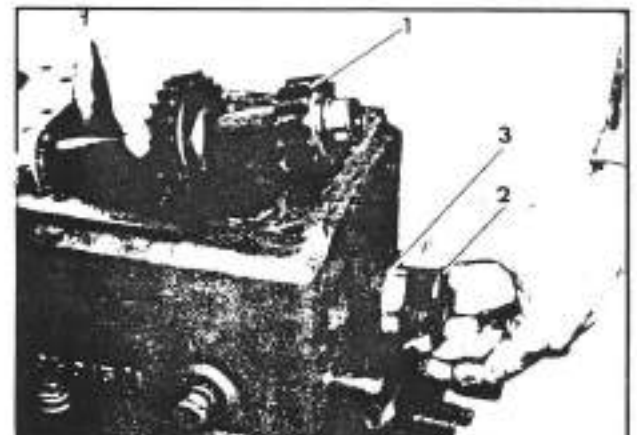

Fig. 3-30. Removal of the main drive shaft

- i. Extract both the retaining ring located behind the first gear and the retaining ring located behind the last gear (see figure 3-32).
- j. Using a wooden mallet, remove the shaft with the complete gear train and extract it through the top (see figure 3-33).
- k. Remove the counter shaft (see figure 3-34).
- l. Unscrew the nuts (1; fig. 3-35) and remove the forks (2; fig. 3-35) of the power take-off rod on each side of the relative spacer (3; fig. 3-35).
- m. Unscrew the nuts (1, 2; fig. 3-36) and remove the springs and poppet balls of both the power take-off control rod and the front-differential and transmission unit control rod. Take out both rods.
- n. Remove the oil seal (1; fig. 3-37) and the retaining ring (2; fig. 3-37) from the power take-off shaft (3; fig. 3-37) and, tapping with a wooden mallet from the inside, extract the shaft with its relative bearing (4; fig. 3-37).

Note

The bearings located on the other end of the shaft will remain in place and may be extracted from the top together with the low gear for the implement power take-off which remains inside.

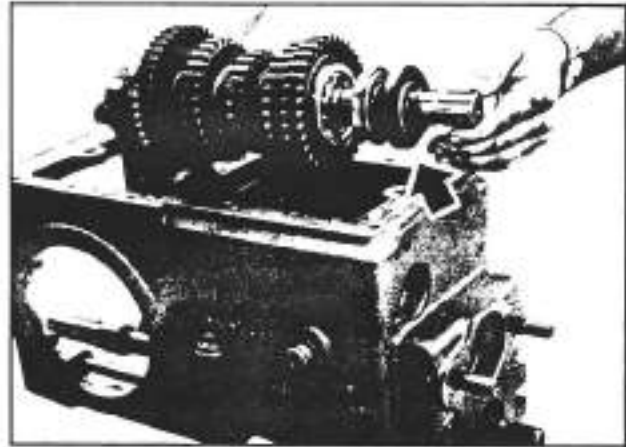

Fig. 3-33 Removal of the pinion shaft with the complete gear train

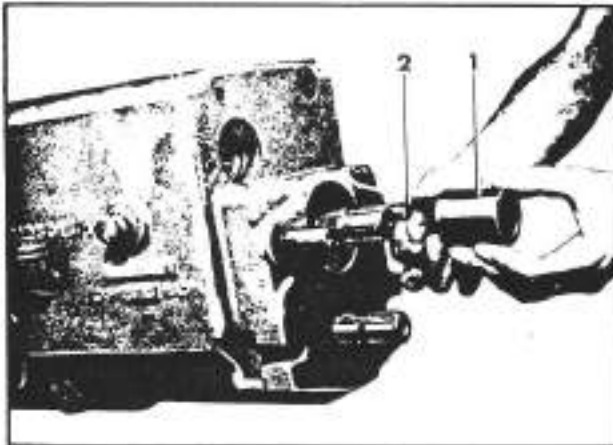

Fig. 3-31. Removal of the spacer and retaining ring

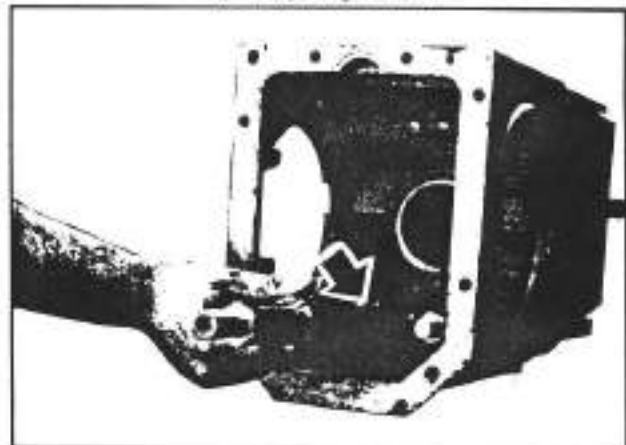

Fig. 3-34. Removal of the counter shaft

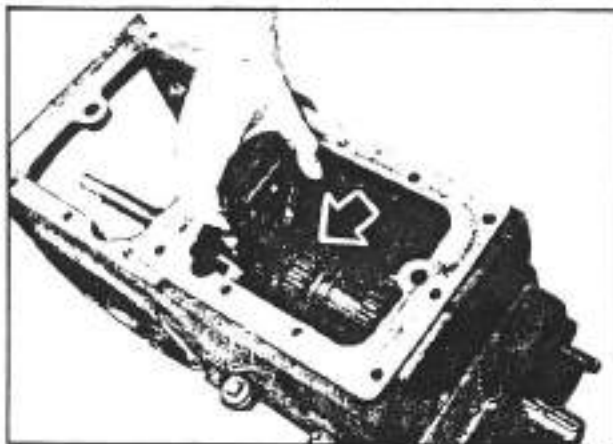

Fig. 3-32. Removal of the lock rings

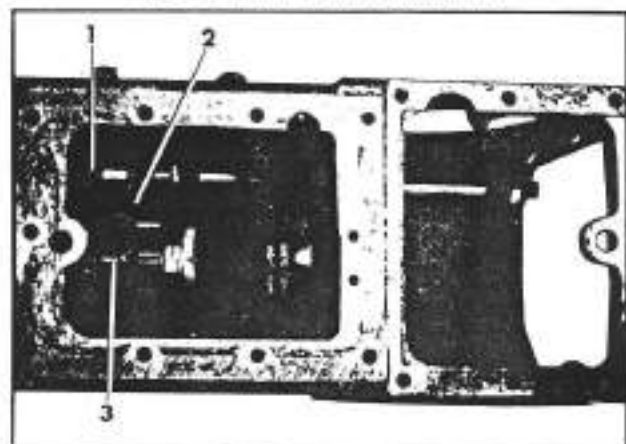

Fig. 3-35. Removal of the power take-off control rod forks

REMountING PART II – FRONT DIFFERENTIAL

Remounting operations should be performed, insofar as

possible, in the reverse order to that indicated for dismounting. Always replace, grommets, seals, and any other components showing operational wear or which have been damaged during dismounting. During remounting, pay particular attention to the following:

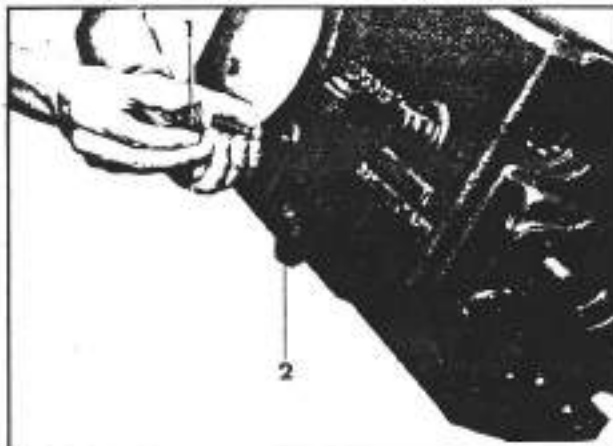

Fig. 3-36. Removal of the poppets of the control rods

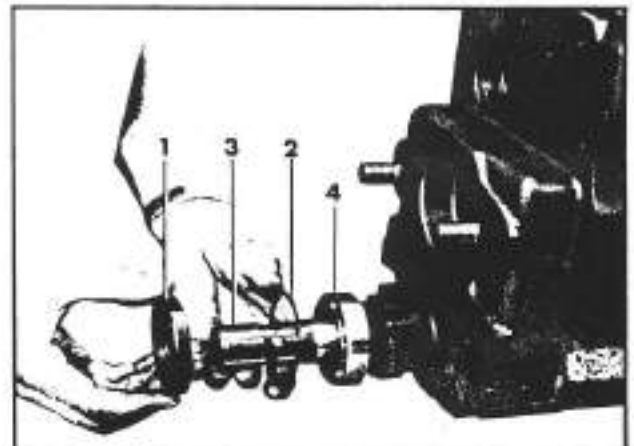

Fig. 3-37. Removal of the power take-off shaft

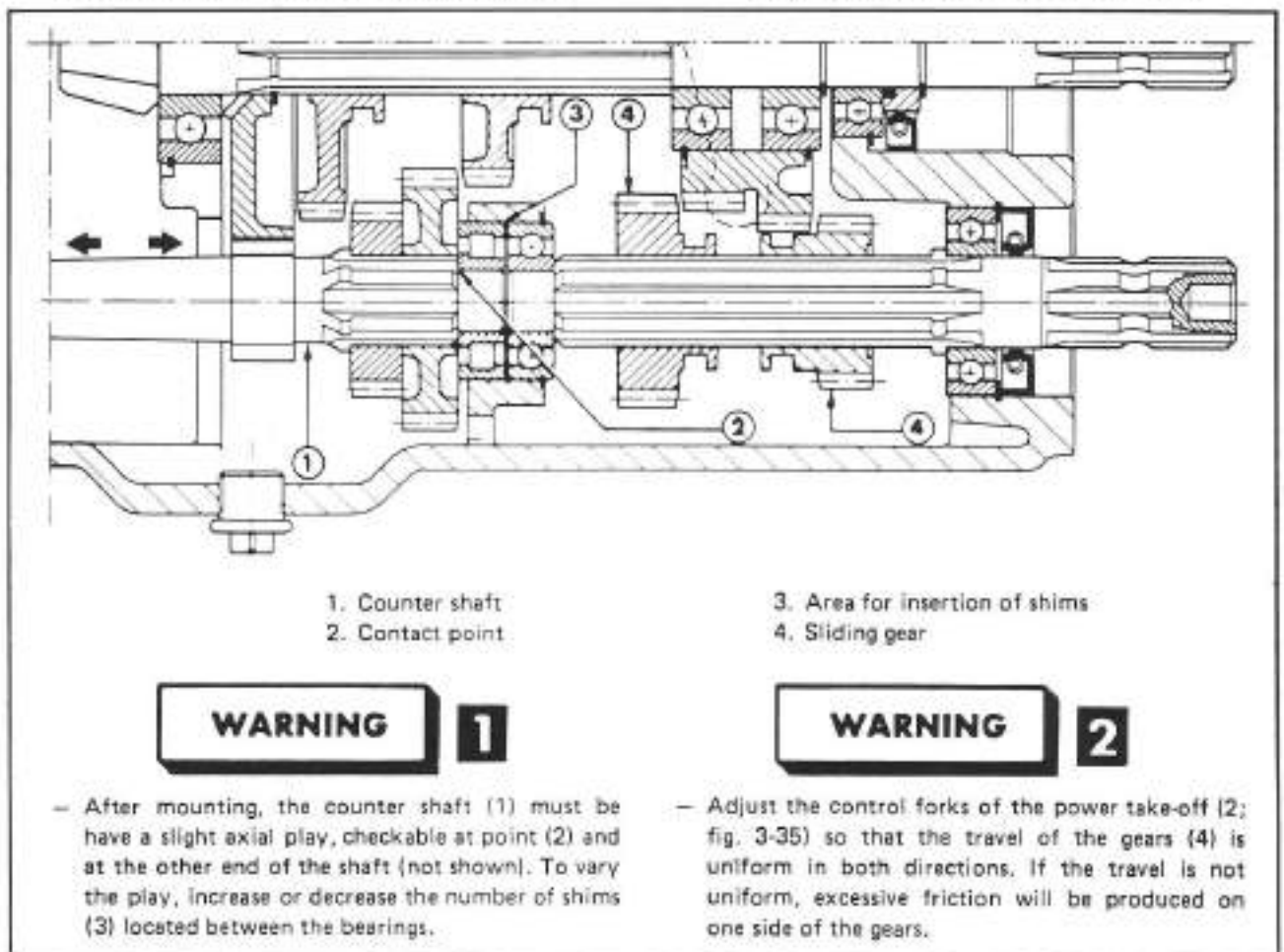

Fig. 3-38. Adjustment of the counter shaft and the control forks of the power take-off

REMountING PART II – GEARS

- The counter shaft (see figure 3-34), must have a slight amount of play as indicated in figure 3-38. If such play cannot be obtained normally, it will be necessary to vary the number and/or thickness of the shims between the ball bearing and the roller bearing. (**WARNING 1**).
- Adjust the control forks (2; fig. 3-35) of the power take-off as indicated in figure 3-38. (**WARNING 2**)

REMountING PART II – DIFFERENTIAL

- Mount the two wheel hubs and tighten the respective lock bolts. Inspect to see the number of shims that it may be necessary to use between the bearing (1; fig.

3-39) and the differential housing (2; fig. 3-39) or between the bearing and the retaining ring (3; fig. 3-39).

REMountING PART I – FRONT GEAR TRAIN

Observe the general rules for remounting previously stated, with particular attention to the following:

- The main drive shaft (see figure 3-15) must always be mounted with the longest end toward the clutch bell housing and the shortest end inside the gearbox.

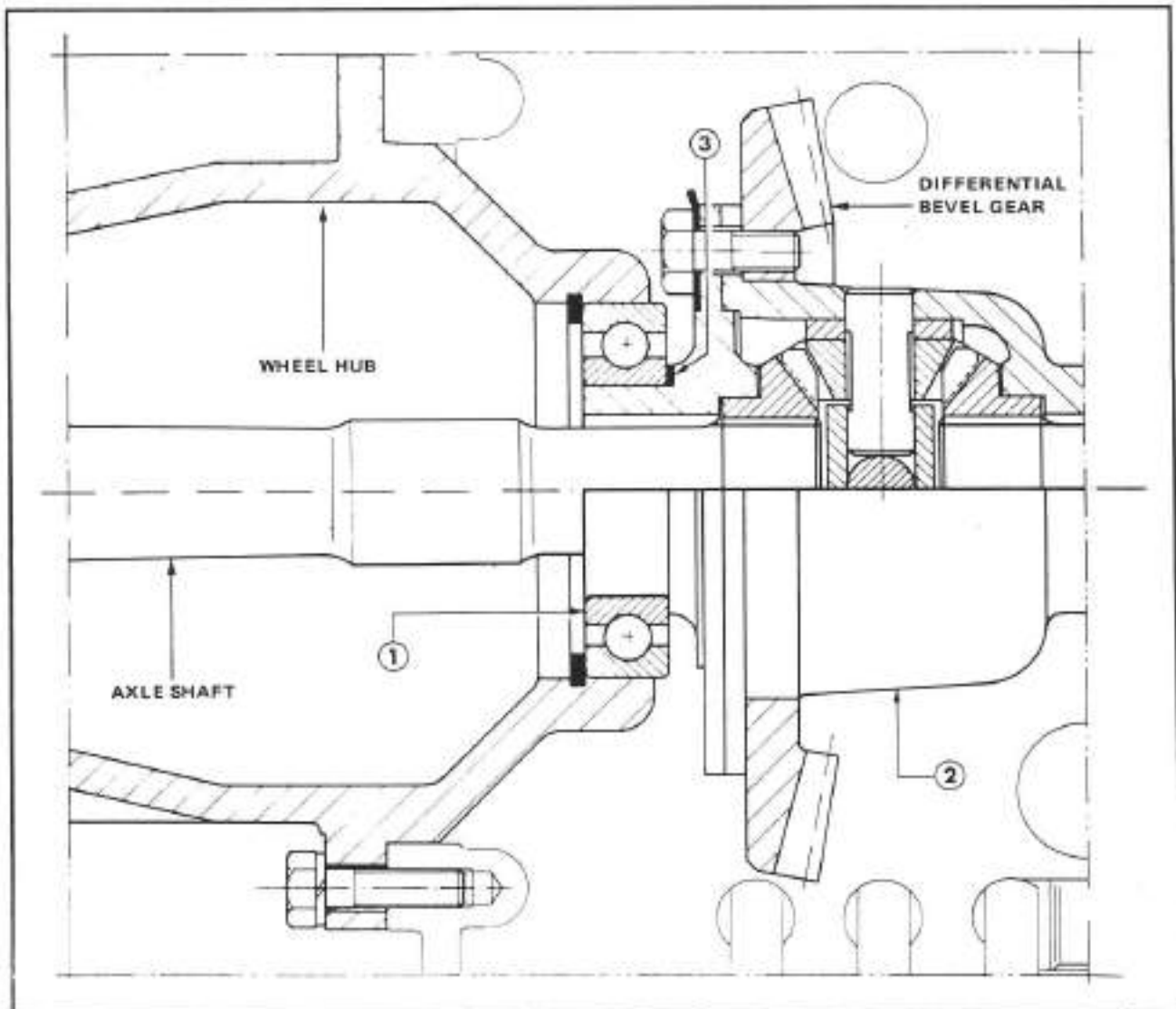

Fig. 3-39. Adjustment of the play of the differential bevel gear and the bevel pinion

- Ascertain that, after assembly, the reverse gear (see figure 3-20), slides easily along the shaft, and that the reduction bell gear (1; fig. 3-16) meshes perfectly with the idling gears (1; fig. 3-21).
- Adjust the control forks of the sliding gear as indicated in Figure 3-39a.
- Mount the reverse gear (1; fig. 3-17) so that the collar of the bushing faces the clutch bell housing.

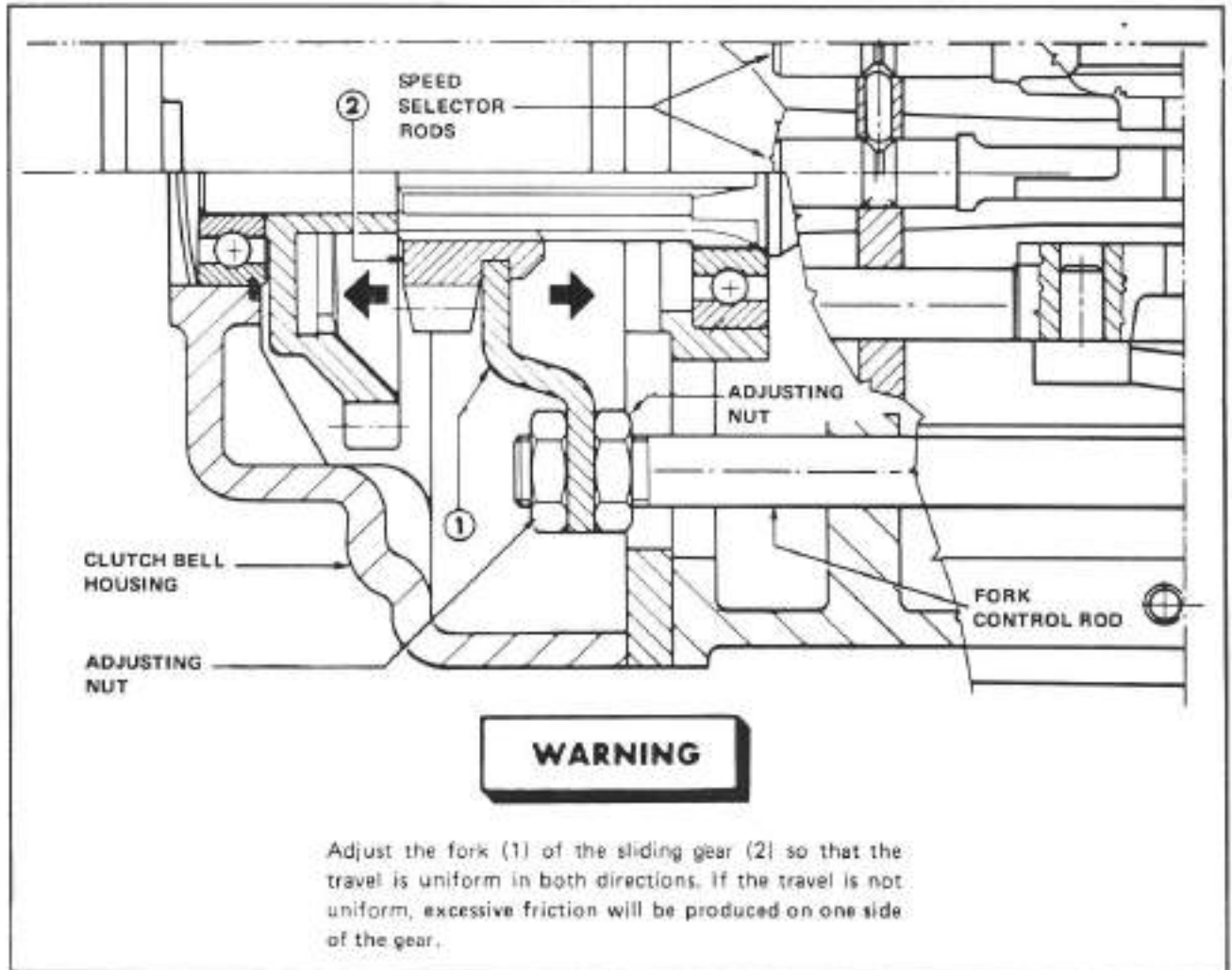

Fig. 3-39a. Adjustment of the control forks of the sliding gear

TROUBLES AND REMEDIES

TROUBLE	PROBABLE CAUSE AND REMEDY
<p>Difficulty in gear shifting.</p>	<p>1. Deformed gear shift lever. Replace the lever.</p> <p style="text-align: center;">Note</p> <p>The lever is deformed when the neutral position does not exactly correspond to the selector indicator. With the lever deformed, it is not possible to engage the LO or HI ranges of speed.</p> <p>2. Excessive play between the gear shift lever and the small selector control lever. Replace both levers.</p>
<p>During regular use the gears shift normally but when submitted to excessive stress (during work) the drive gear disengages.</p>	<p>1. Deformed selection control lever. Replace the lever.</p> <p style="text-align: center;">Note</p> <p>The lever is deformed when the neutral position does not correspond exactly to the selector indication. With the lever deformed, it is not possible to engage the HI or LO ranges of speed.</p> <p>2. The poppet ball of the selector rod is not sufficiently loaded by the relative spring. Replace the spring.</p>
	<div style="border: 2px solid black; padding: 5px; width: fit-content; margin: 0 auto;">WARNING</div> <p>When replacing the loading spring for the poppets, because the springs are worn or broken, be sure the new springs are of the proper length.</p>
	<p>3. Excessive wear of a bearing or a bushing. Replace the bearing or bushing.</p> <p style="text-align: center;">Note</p> <p>If the foregoing problem occurs too often, it will be necessary to dismount the gear set involved and replace them.</p>
<p>Stiffness of the speed selector control lever.</p>	<p>1. Lack of grease. Lubricate using the correct grease gun.</p> <p>2. Seizing of the selector rod control pin. Dismount the lever and the control pin. Clean by removing the rust which has formed and lubricate.</p> <p style="text-align: center;">Note</p> <p>Pay particular attention to the lubrication of the pin because excessive grease may cause the failure of the lubricating tube.</p>
<p>Traction only by front or rear wheels.</p>	<p>1. Failure of the axle shaft. Replace it.</p> <p>2. Failure of bevel gear. Replace it.</p> <p>3. Failure of the differential housing. Replace it.</p>

TROUBLE	PROBABLE CAUSE AND REMEDY
The differential cannot be locked.	<ol style="list-style-type: none"><li data-bbox="706 325 1539 380">1. Control cable broken or loose. Check the tension of the cable and reset it or replace the cable.<li data-bbox="706 394 1539 422">2. Failure of the splined coupling of the differential box. Replace the box.
The differential cannot be unlocked.	<ol style="list-style-type: none"><li data-bbox="706 472 1463 499">1. Failure of the return spring of the control lever. Replace the spring.<li data-bbox="706 506 1463 527">2. Deformed axle shaft. Replace the axle shaft.

SECTION III

ARTICULATED JOINT

OVERHAUL

Preliminary operation

- a. Remove the complete front differential and gear box. (See paragraph "DISMOUNTING PART II - FRONT DIFFERENTIAL", operation "d").
- b. Remove the rear differential, taking out the six socket head bolts of the articulated joint.

Note

The socket head bolts can be removed from the inside of the joint without dismantling any other components of the joint itself. Use a wrench for socket head bolts of appropriate length (about 2 feet).

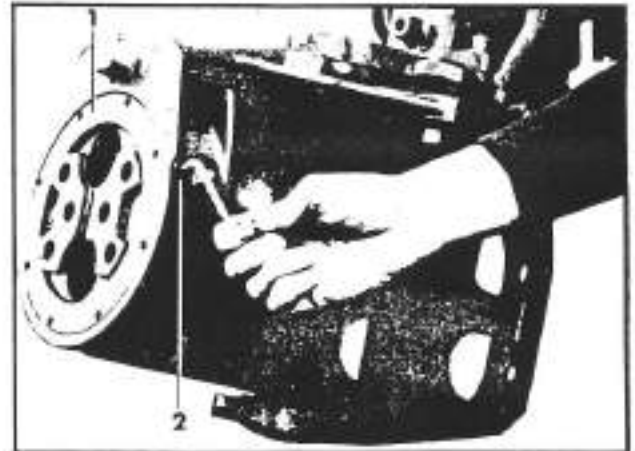

Fig. 3-40. Preliminary operation - removal of the threaded ring

DISMOUNTING

- c. Take off the two footboards from the body of the articulated joint removing the four lock bolts.
- d. Operating as indicated in figure 3-40, loosen the lock nut (2; fig. 3-40) then remove the set screw that retains the threaded ring (1). Take off the threaded ring (1) as shown in figure 3-41.

Note

Pay attention, when removing the threaded ring, (1; fig. 3-41), not to lose the balls placed in its seat.

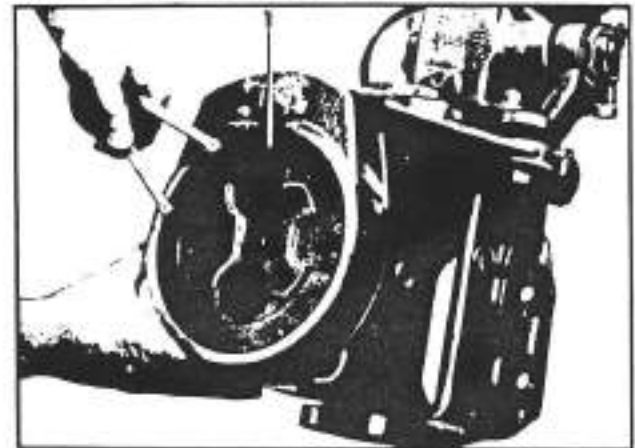

Fig. 3-41. Removal of the threaded ring

- If further disassembly is required, take off the cover (1; fig. 3-42) and remove the retaining ring (2; fig. 3-42), the bearing (3; fig. 3-42), and the pin (4; fig. 3-42). Perform the same operation on the group on the other side.

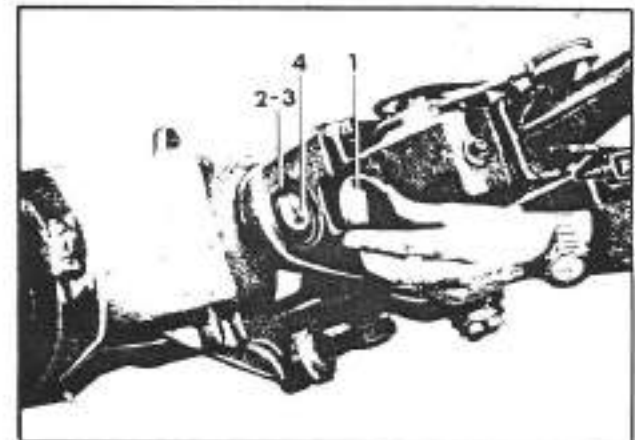

Fig. 3-42. Further dismantling of the articulated joint

REMOUNTING

Observe the general rules for remounting, as previously stated, paying particular attention to the following:

- Before tightening the set screw (see figure 3-40) of the threaded ring, ascertain that the threaded ring is securely bedded and that no play exists.

SECTION IV

REAR DIFFERENTIAL

OVERHAUL

Preliminary operation

- a. Remove the seat and the fenders from the tractor and all components of the hydraulic power lift for access to the rear differential. (See paragraph "HYDRAULIC POWER LIFT - DISMOUNTING").
- b. Remove completely the hitch linkage support arms (1; fig. 3-43).
- c. Remove the cover of the rear differential (see figure 3-44).
- d. Detach the rear differential casing, as indicated in paragraph "ARTICULATED JOINT - DISMOUNTING", after having detached the articulated joint from the transmission casing (see paragraph "DISMOUNTING PART II - FRONT DIFFERENTIAL", operation "d").
- e. Remove the tractor wheels and take off the hubs. Remove, from the top, the complete differential (1; fig. 3-44).

Note

For access to the differential of tractor Mod. 76, after having removed the entire wheel hubs, it will be necessary to remove the wheel reduction gearboxes.

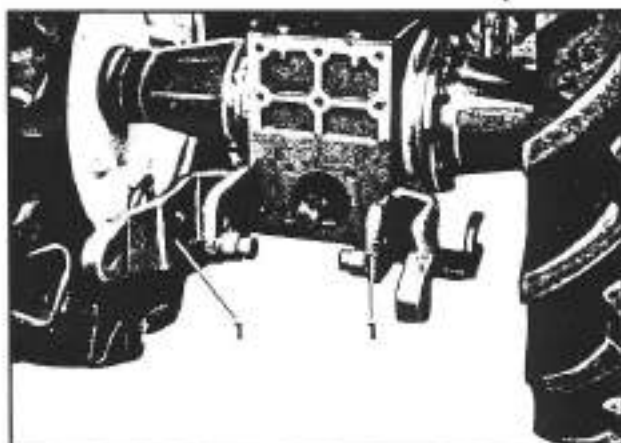

Fig. 3-43. Removal of the hitch linkage support arms



Fig. 3-44. Removal of the rear differential cover

DISMOUNTING

DISMOUNTING OF THE DIFFERENTIAL BEVEL GEARS

- a. Bend back the opening-tabs of the lock washer (1; fig. 3-45) and remove the nut (2; fig. 3-45), the spacer (3; fig. 3-45), and seals (4; fig. 3-45).
- b. Remove the shaft (5; fig. 3-45) using a wooden mallet.

DISMOUNTING OF THE POWER TAKE OFF REDUCTION GEARBOX

(Only for tractor Mod. 76)

- a. Take out the 4 bolts (1; fig. 3-46) of the box of the power take-off reduction gearbox (2; fig. 3-46). Remove the gearbox.

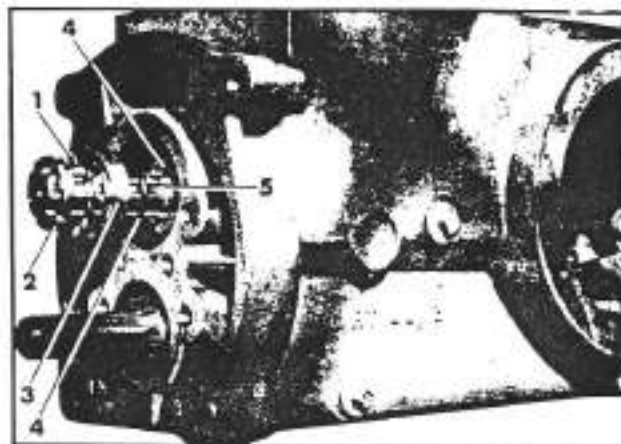

Fig. 3-45. Removal of the components and the bevel pinion shaft

- b. Extract the power take-off shaft (1; fig. 3-47) with its bearing (2; fig. 3-47) by tapping with a punch from the opposite end.

DISASSEMBLY OF THE POWER TAKE OFF REDUCTION GEARBOX
(Only for tractor Mod. 76)

- a. Take off the oil seal (1; fig. 3-48), the retaining ring (2; fig. 3-48) and the split retainer ring (3; fig. 3-48).
- b. Extract the pinion shaft assembly (1; fig. 3-49).

Note

Pay great attention to the extraction of the pinion shaft (1; fig. 3-49) from the box so that no needles are lost or damaged. The exact (2; fig. 3-49) number of needles is 108.

REMountING

Observe the general rules for remounting, as cited

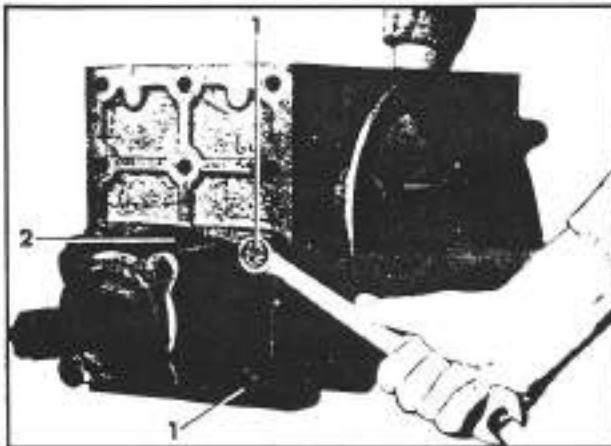

Fig. 3-46. Removal of the power take-off reduction gearbox

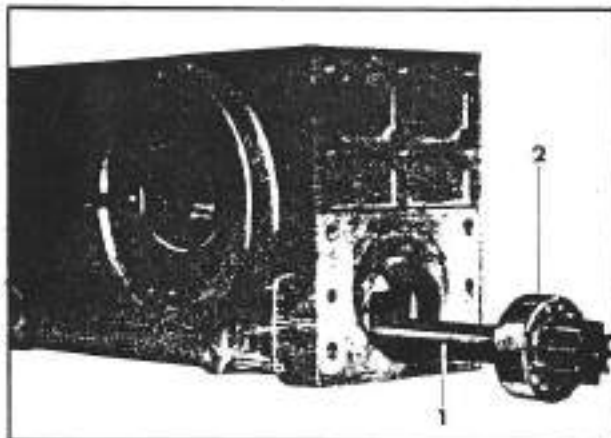

Fig. 3-47. Removal of the power take-off shaft

previously, paying particular attention to the following:

- After remounting the rear differential, ascertain that there is a play of approximately 0,1 mm (0.04 in) between the pawl (1; fig. 3-50) and the differential ring gear (2; fig. 3-50). In the event that adjustment is necessary, loosen the lock nut (3; fig. 3-50) and move the pawl as required.
- When installing the bevel pinion (5; fig. 3-45) after having tightened the lock nut (2; fig. 3-45), be sure to ascertain that the tapered bearings are well set by tapping both ends of the shaft with a wooden mallet or rawhide or plastic mallet. Afterwards bend the nearest tab of the lock washer (1; fig. 3-45), into one of the slots of the lock nut (2; fig. 3-45).
- Adjust the rear differential bevel gear set using the same procedure as for the adjustment of the front differential bevel gear set.

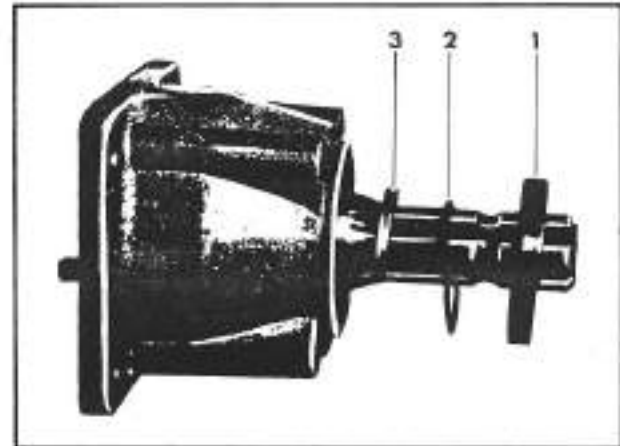

Fig. 3-48. Dismounting of the power take-off reduction gearbox (tractor Mod. 76)

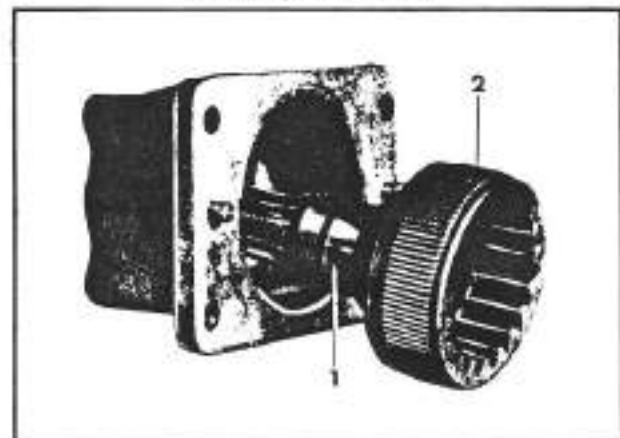

Fig. 3-49. Removal of the power take-off reduction gear drive shaft (tractor Mod. 76)

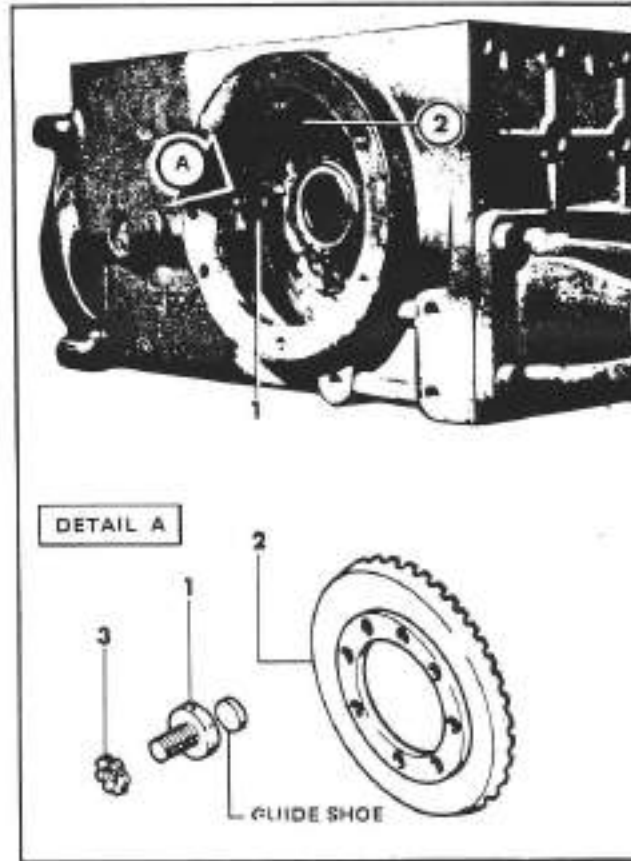

Fig. 3-50. Adjustment of the play of the differential bevel ring gear

SECTION V

WHEEL HUBS

OVERHAUL

(Tractor Mod. 75)

Preliminary operation

- a. Lift the tractor. Place it on blocks and remove the wheels.
- b. Take off the brake drums.
- c. Remove the bolts (1; fig. 3-51), the shackle (2; fig. 3-51), and take off the brake shoes by moving the lever (3; fig. 3-51).

DISMOUNTING

- d. Drain the oil from the transmission housing and take off the wheel hubs after having removed the six bolts

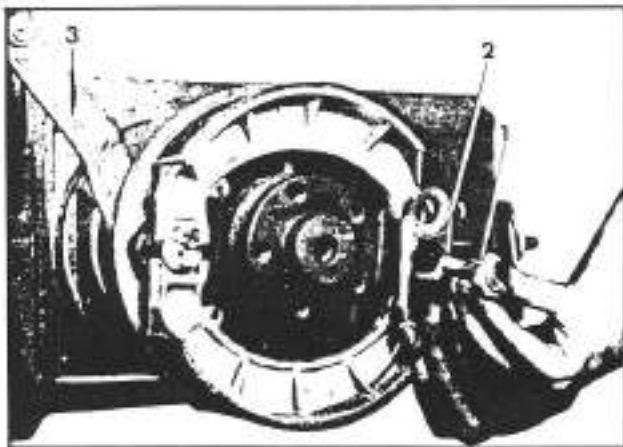

Fig. 3-51. Removal of the brake shoes

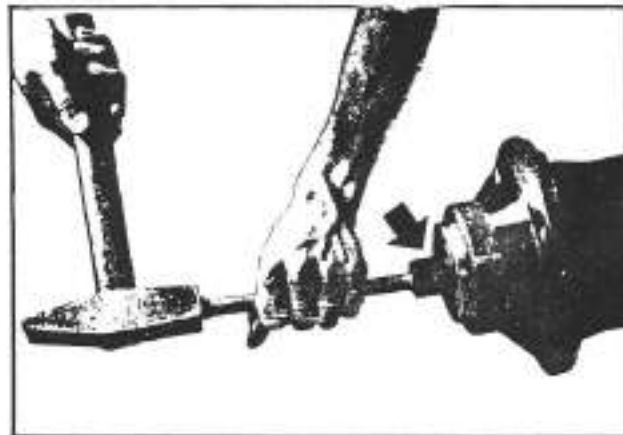

Fig. 3-52. Extraction of axle shaft

from the housing.

- e. Using a hammer and a punch (see figure 3-52) push out the axle shaft and locking ring (1; fig. 3-53) which should have come off and fallen inside the hub.
- f. From the same side, extract the bearing and take off the retaining ring.
- g. From the opposite side of the hub (see figure 3-54) take off in order: the oil seal, the retaining ring and the bearing.

REMountING

Observe the normal rules, paying particular attention to the following:

- In order to remount the locking ring (1; fig. 3-53) it is necessary to heat it to a temperature of 180 to 200°C (355 to 390°F) (blue color). Put the locking ring over the axle shaft and let it fall in place (see figure 3-55). Using a hammer and a piece of metal tube (see figure 3-56) of the correct diameter, align the ring perfectly on the axle shaft, in contact with the bearing. Let cool.

OVERHAUL

(Tractor Mod. 76)

Preliminary operation

Follow the preliminary operation as described for the overhaul of the wheel hubs for tractor Mod. 75.

DISMOUNTING THE WHEEL HUBS

Isolate the wheel hub that needs overhaul and remove the eight bolts which attach the hub to the wheel reduction gear (see figure 3-57) and proceed with the following operations:

- a. Loosen and remove the nut (1; fig. 3-58). Take off the washer (2; fig. 3-58) and the seals (3; fig. 3-58).
- b. Mount on the flange (1; fig. 3-59), by means of five bolts (2; fig. 3-59), the proper pulling tool (3; fig. 3-59).

Note

The puller tool (3; fig. 3-59) for the removal of the wheel hub flange (1; fig. 3-59), can only be obtained from FERRARI Company.

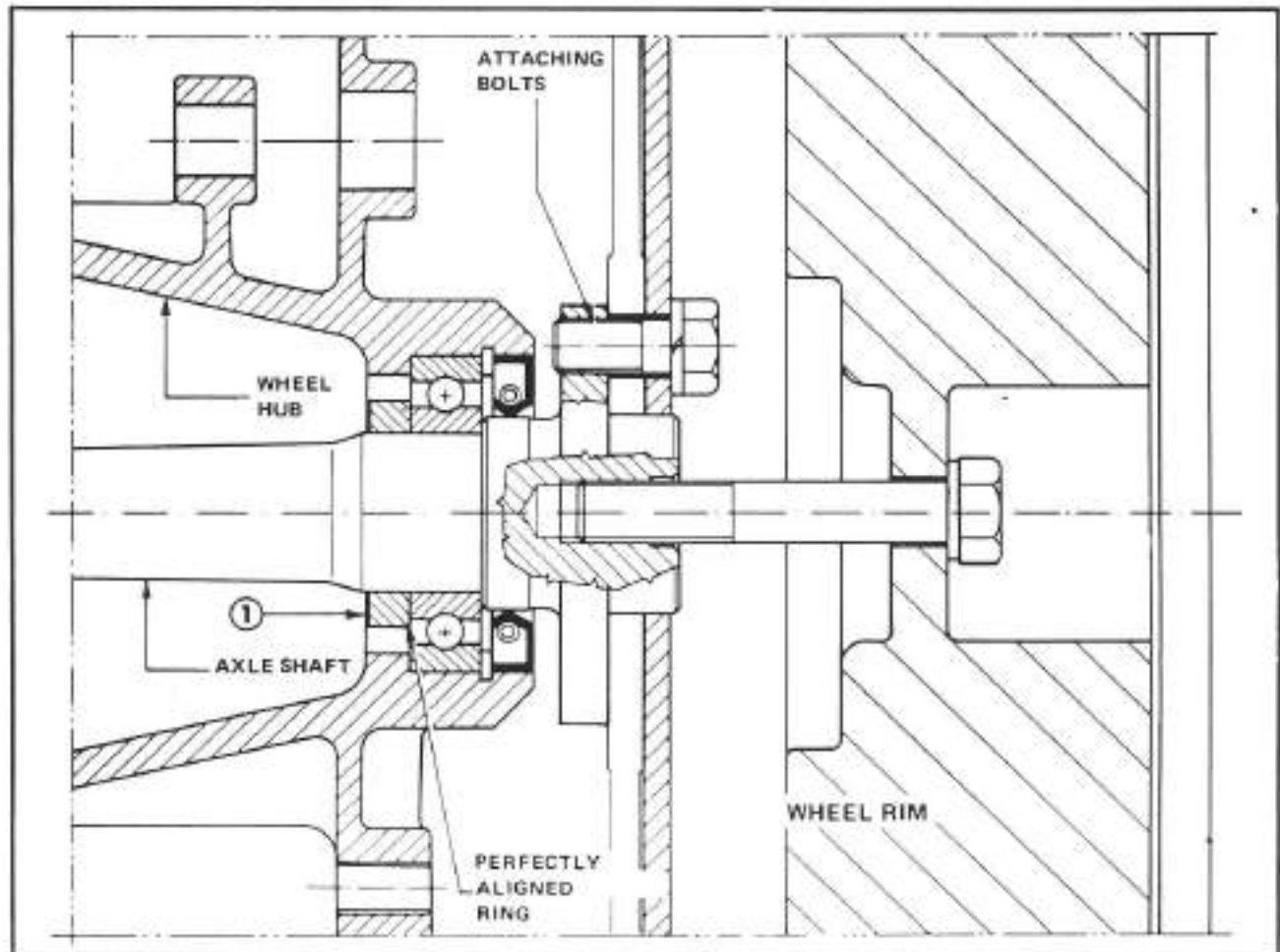

Fig. 3-53. Axle shaft locking ring

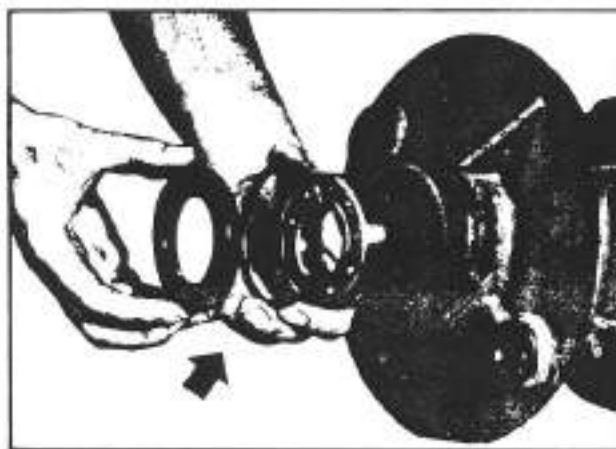

Fig. 3-54. Removal of the axle shaft components

- c. Turn the hexagonal head of the puller tool (4; fig. 3-59) in a clockwise direction and extract the flange (1; fig. 3-59). Separate the flange from the puller tool.
- d. To remove the axle shaft and reduction gear assembly



Fig. 3-55. Remounting the locking ring on the axle shaft
(fig. 1 of 2)

(1; fig. 3-60), gently tap the part opposite the hub with a mallet.

DISMOUNTING THE WHEEL REDUCTION GEAR

- a. Take out the mounting bolts from the reduction gear casing (see figure 3-57) and remove the unit.
- b. Take off the retaining ring (1; fig. 3-61), located on the opposite side of the bearing, and take out the reduction gear shaft (2; fig. 3-61).

REMountING

Observe the normal rules, paying particular attention to the following:

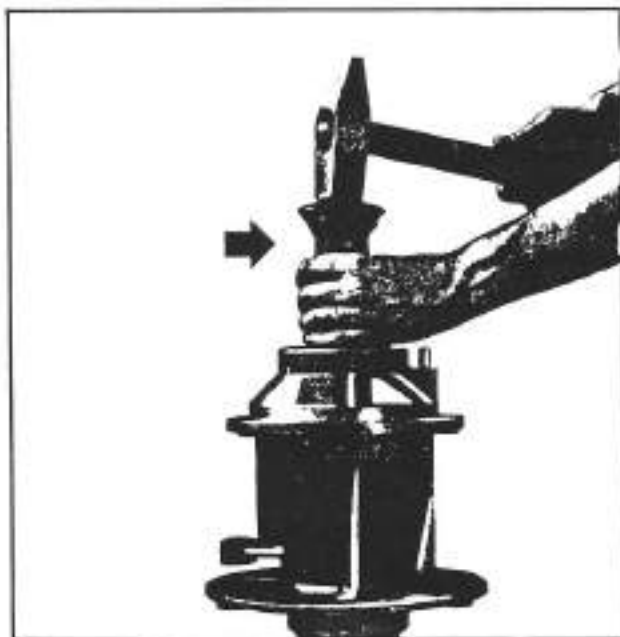

Fig. 3-56. Remounting of the locking ring on the axle shaft
(fig. 2 of 2)

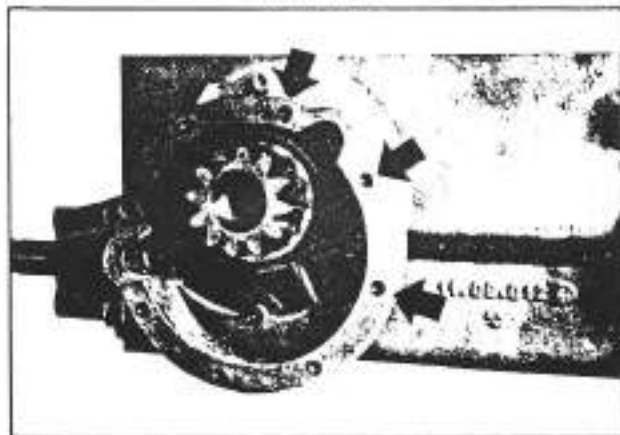

Fig. 3-57. Removal of the wheel hub

- For remounting the wheel hub flange (1; fig. 3-59), the flange must be heated to a temperature between 150 and 200°C (300 and 390°F). Place the flange on the shaft and seat it properly. Let cool.

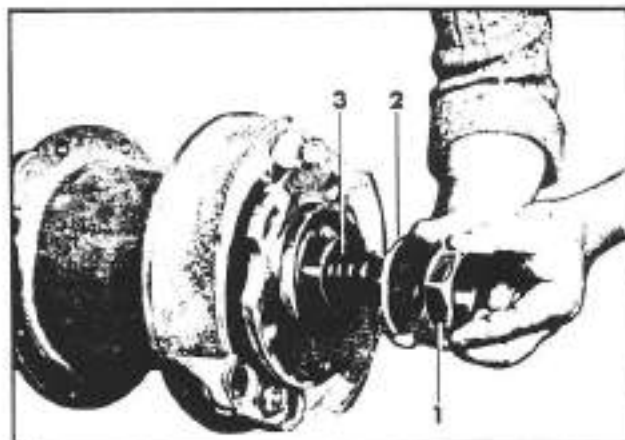

Fig. 3-58. Removal of the flange retaining components

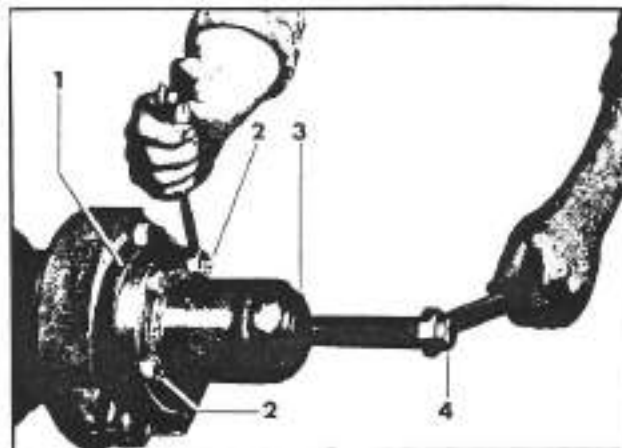

Fig. 3-59. Removal of the wheel hub flange

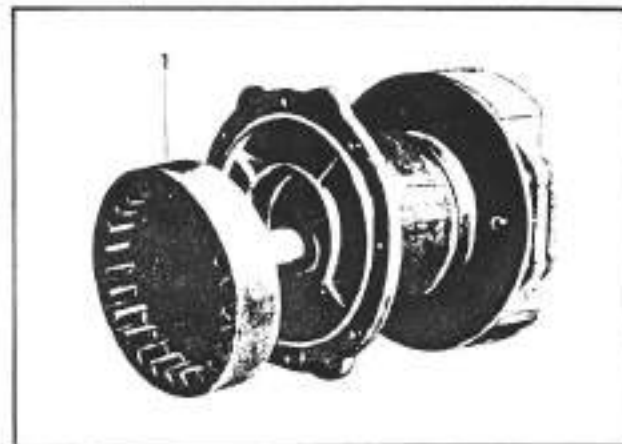

Fig. 3-60. Removal of axle with reduction gear



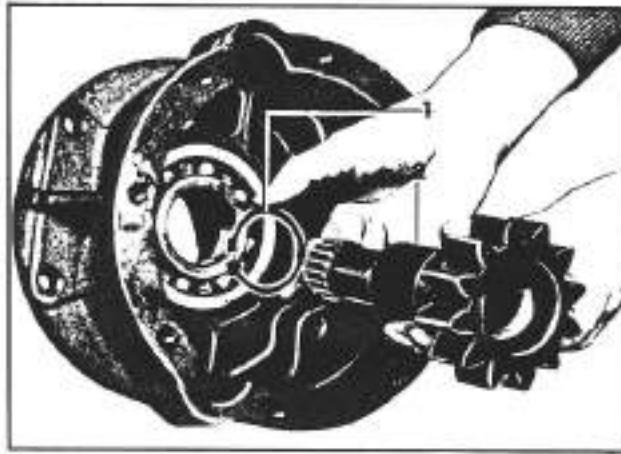

Fig. 3-61. Removal of the reduction gear shaft

SECTION VI
STEERING
 (Mechanical)

OVERHAUL

(Mechanical steering, tractor Mod. 75)

Preliminary operation

- a. Take off the cover of the steering wheel and remove the steering wheel itself using a puller tool (see figure 3-7).
- b. Disconnect all of the electrical connections to the instrument panel paying particular attention to the dismantling of the horn, lights, and starter switches.
- c. Take out the central mounting bolt (1; fig. 3-8) and the six screws (2; fig. 3-8) on the side of the instrument panel. Remove the panel.

DISMOUNTING OF THE STEERING BOX

- d. After having removed the cotter pin, remove the castellated nut (1; fig. 3-67) from the steering arm shaft.
- e. By means of a pulling tool (1; fig. 3-63) take the arm (2; fig. 3-63) off of the shaft (3; fig. 3-63) of the steering box.
- f. Take out the flange (1; fig. 3-67) mounting bolts; remove the flange and drain the oil from the steering box.
- g. Take out the four mounting bolts of the steering column (2; fig. 3-64) and remove it.
- h. Take out the steering worm shaft (1; fig. 3-65) being careful not to lose the shims (2; fig. 3-65).



Fig. 3-63. Removal of the steering arm

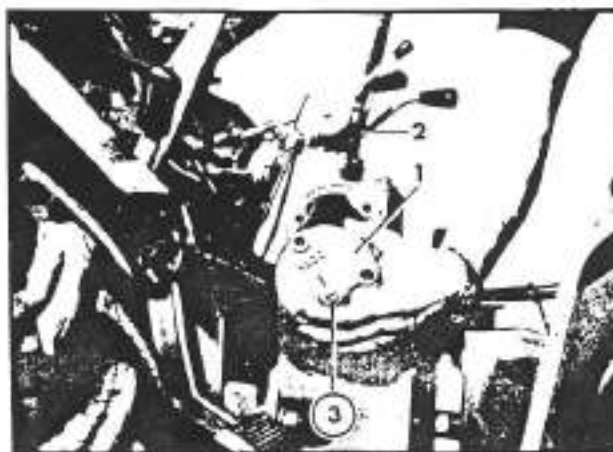

Fig. 3-64. Removal of the flange from the steering box.



Fig. 3-62. Removal of the steering arm nut

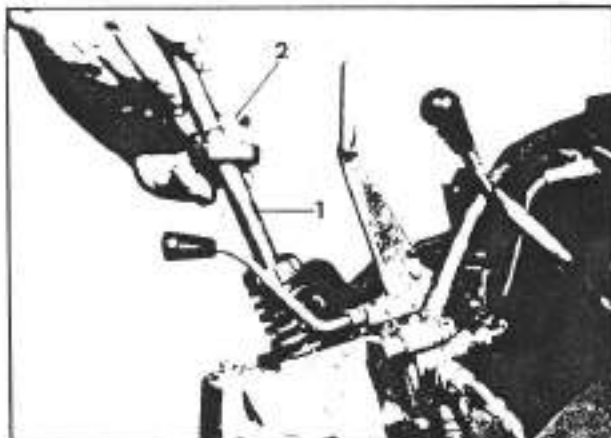

Fig. 3-65. Removal of the steering worm shaft

- i. Take out the steering shaft and sector gear assembly (1; fig. 3-66) using a wooden mallet.

DISMOUNTING OF THE ARTICULATING ARMS

- j. By means of a punch and a hammer (1, 2; fig. 3-67) pry loose and take off the cover (3; fig. 3-67) of the articulating arms.
- k. Remove the retaining ring (1; fig. 3-68) and take off the arm (2; fig. 3-68) using a puller tool as indicated.

Note

For the dismantling of the other arm (3; fig. 3-68) follow the same procedure.

WARNING

After dismantling, take out the pivot pin (1; fig. 3-69) by use of a punch. If the ball joint (2; fig. 3-69) has to be replaced, also replace the bushing (3; fig. 3-69). After mounting the new bushing, caulk around the entire circumference on both sides. The caps must always be replaced and pressure mounted with appropriate caulking to retain them in position.

REMOVING OF THE ARTICULATING ARMS

No particular attention is required for the remounting of the articulating arms.

SPECIAL NOTE

After installation of the articulating arms make sure that, when the arms have been mounted and with the wheels

perfectly aligned, the number of turns of the steering wheel rotating to the right is equal to the number of turns of the steering wheel to the left.



Fig. 3-67. Removal of the articulating arm cap



Fig. 3-68. Removal of the articulating arm

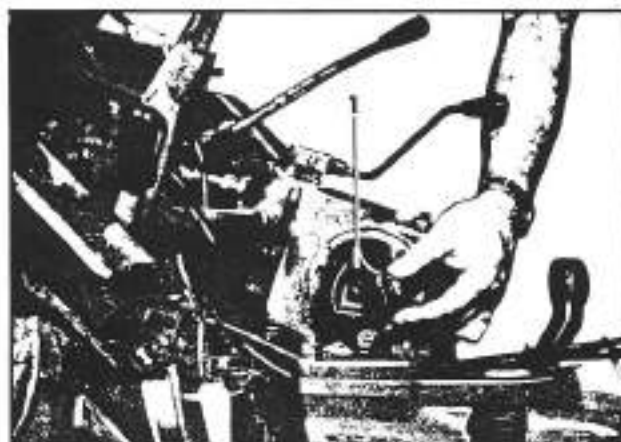

Fig. 3-66. Removal of the steering shaft and sector gear



Fig. 3-69. Dismounting of the steering shaft pin, bushing and ball joint

RE-MOUNTING OF THE STEERING BOX

Re-mount the steering box in the inverse order to that indicated for dismounting. Pay particular attention to the mounting of the steering column in the box.

- If necessary increase the number of shims (2; fig. 3-65) so that, after final installation of the steering column (2; fig. 3-64), no vertical play exists at the shaft (1; fig. 3-65).
- After completing the mounting of the steering shaft and sector gear (1; fig. 3-66), turn the screw (3; fig. 3-64) to tighten the flange against the box, to eliminate the axial play of the steering shaft and to insure the best meshing between the sector gear and the steering worm gear.

SECTION VII

HYDRAULIC SYSTEM

OVERHAUL

INTRODUCTION

The hydraulic system of the tractor does not require any particular instructions for dismantling of the components to effect an overhaul.

Generally, after having found the cause of the failure, it is sufficient to clean the line, filter, etc., and/or replace the damaged pump, hydraulic cylinder, etc. As the hydraulic system of the tractor is complex, and when any doubt arises, it is suggested that the help of an expert be requested or that the manufacturing company be contacted directly.

Below are described the necessary operations to check the system, to be sure it is in perfect working order, and to calibrate the valves. Pay scrupulous attention to the following.

CHECKING OPERATING PRESSURE VALUES

Preliminary operations

- a. Install, on the outlet fitting of the hydraulic pump, a manometer with a scale of at least 250 Atm. (See figure 3-70).

Note

The flange of the hydraulic pump can be located in a different position, on the engine body, than that indicated in figure 3-70. The position may vary according to the engine installed in the tractor.

- b. Start the engine of the tractor and maintain approximately 2000 RPM.

STEERING WHEEL WORKING PRESSURE VALUES

- a. Turn the steering wheel until the wheels are as far left or right as they can go (steering gear jack completely extended or retracted).
- b. Check to see that the manometer shows a pressure between 100 and 105 Atm. If the pressure does not

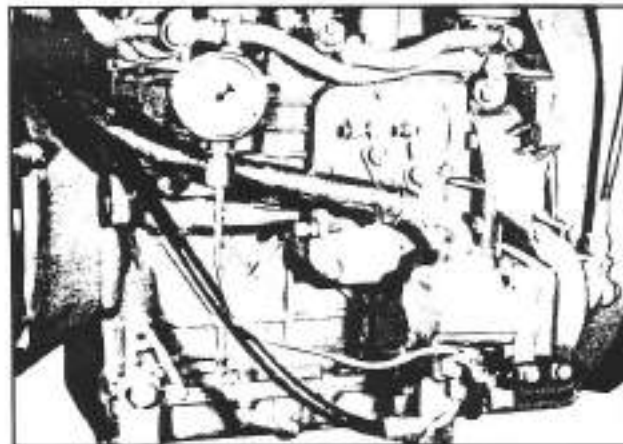

Fig. 3-70. Installation of the manometer on the hydraulic pump outlet

read between 100 and 105 Atm, tighten or loosen the regulating screw (2, fig. 3-71) on the hydraulic valve (1; fig. 3-71) for the hydraulic steering.

Note

For access to the regulating screw, remove the rubber insert (7; fig. 3-71) located on the instrument panel.

- c. If the operating pressure value is correct, but the steering movement is still irregular after having ascertained that the steering gear jack functions perfectly, replace the springs (5; fig. 3-71) of the hydraulic valve (1; fig. 3-71).

HYDRAULIC POWER - LIFT PRESSURE VALUES
(Tractor Mod. 75 with mechanical steering)

- a. Place in lift position the distributor control lever (1; fig. 3-72) of the hydraulic power - lift and hold there while ascertaining that the manometer indicates a pressure between 80 and 100 Atm.
- b. If the pressure is not obtained, remove the protecting cap and tighten or loosen the regulating screws of the pressure relief valve (2; fig. 3-72).

Note

For more complete access to the valve, it may become necessary to remove the instrument panel.

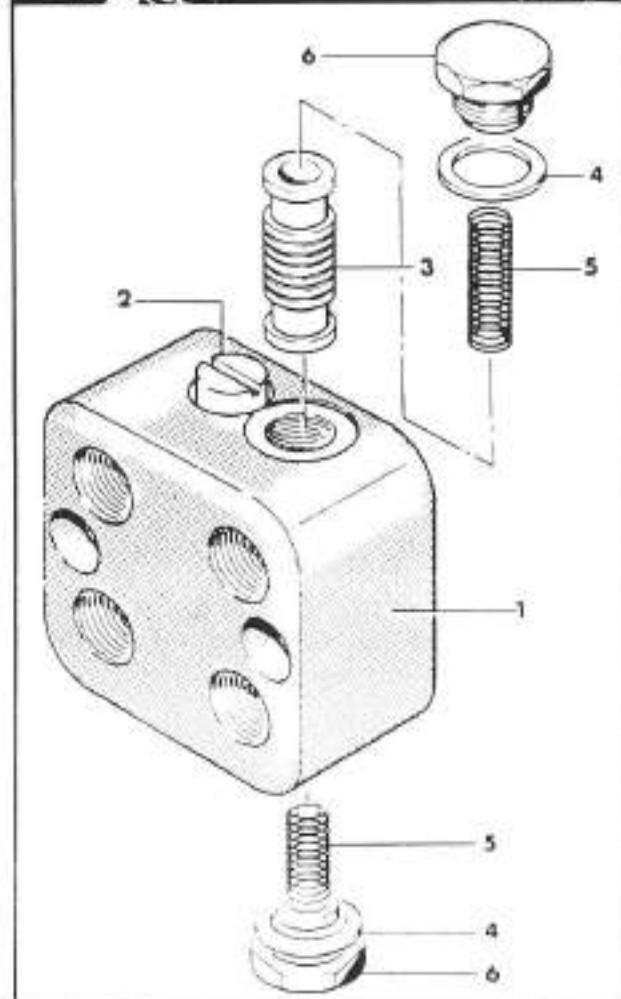
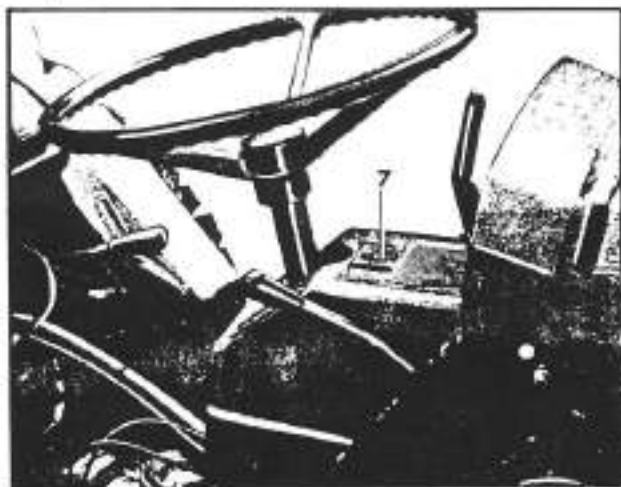

Fig. 3-71. Power steering valve

HYDRAULIC POWER - LIFT PRESSURE VALUES
(Tractor Mod. 76)

- Place in "LIFT" position the distributor control levers (1, 5; fig. 3-73) of the hydraulic power - lift.
- Push the lever (2; fig. 3-73) as far from vertical as it will go, as shown in the figure, and maintain it in that position. Ascertain that the manometer indicates a pressure between 80 and 100 Atm.
- If this pressure is not obtained, and after checking to be sure that there are no evident oil leakages from the distributor, disassemble the valve (3; fig. 3-73) and clean.

WARNING

Do not touch the regulating nut (4; fig. 3-73) of the distributor.
THIS ADJUSTMENT HAS BEEN SET BY THE MANUFACTURING COMPANY DURING THE MOUNTING OPERATION.

CHECKING BYPASS VALVE PRESSURE
(Only for tractors with hydraulic steering)

- Push the lever (2; fig. 3-73) as far as it will go from vertical in the indicated direction and maintain it in this position.
- Turn the wheels completely to the right or left (steering jack completely extended or retracted). Check that the manometer indicates a pressure between 130 and 140 Atm.
- If this pressure is not obtained, remove the cap of the hydraulic system bypass valve and tighten or loosen the regulating screw with a screw driver. See figure 3-74 for tractor Mod. 75 and figure 3-75 for tractor Mod. 76.



Fig. 3-72. Calibration for the hydraulic power lift pressure relief valve (tractor Mod. 75)

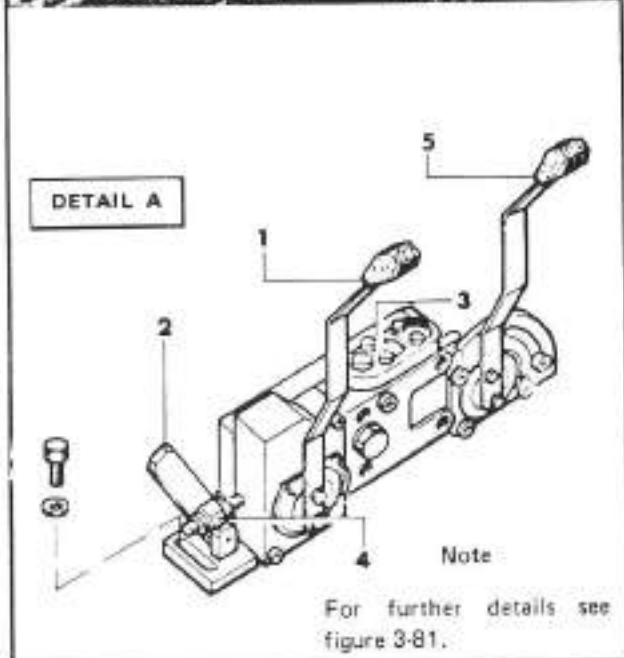
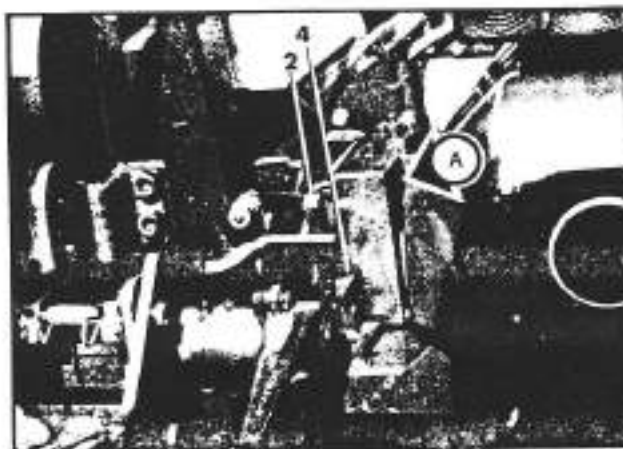

Fig. 3-73. Checking pressure of the hydraulic power lift (tractor Mod. 76)

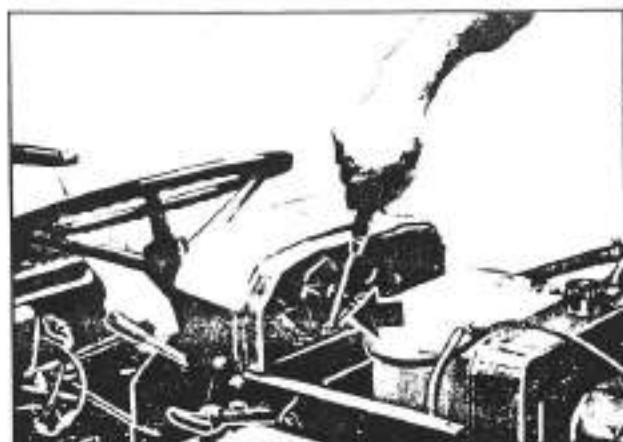

Fig. 3-74. Calibration of the bypass valve (tractor Mod. 75)

REPLACEMENT OF THE HYDRAULIC RETURN FILTER CARTRIDGE

- Loosen the clamp on the return tube (1; fig. 3-76) of the hydraulic fluid and detach the tube.
- Take out the mounting screws of the flange (2; fig. 3-76).
- Take out the filter, dismount the cartridge (3; fig. 3-76) and replace with a new cartridge.

HYDRAULIC SYSTEM SCHEMATICS

The schematics of the tractor hydraulic systems for Mod. 75 with mechanical steering and for Mod. 76 are illustrated in figures 3-77 and 3-78 respectively.



Fig. 3-75. Calibration of the bypass valve (tractor Mod. 76)

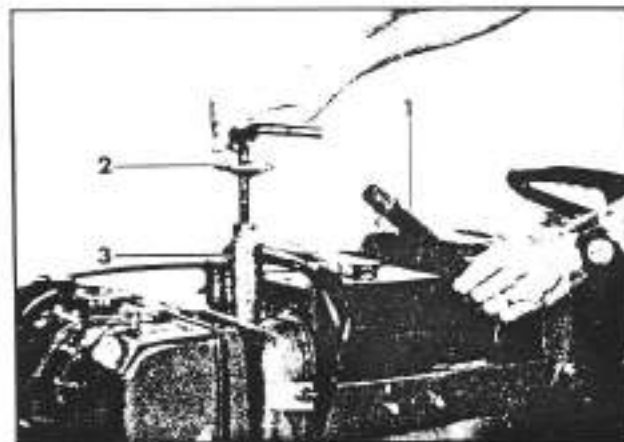
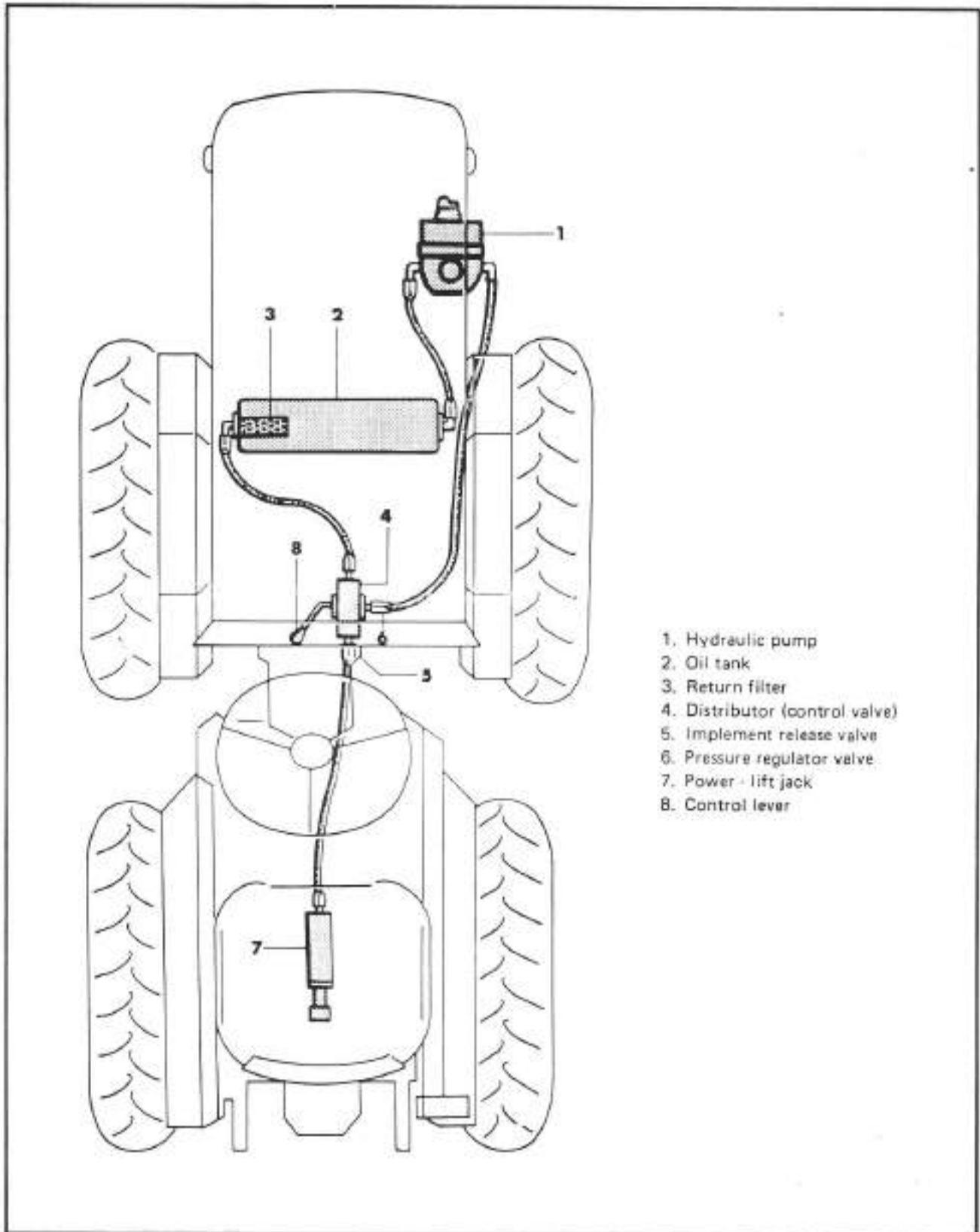
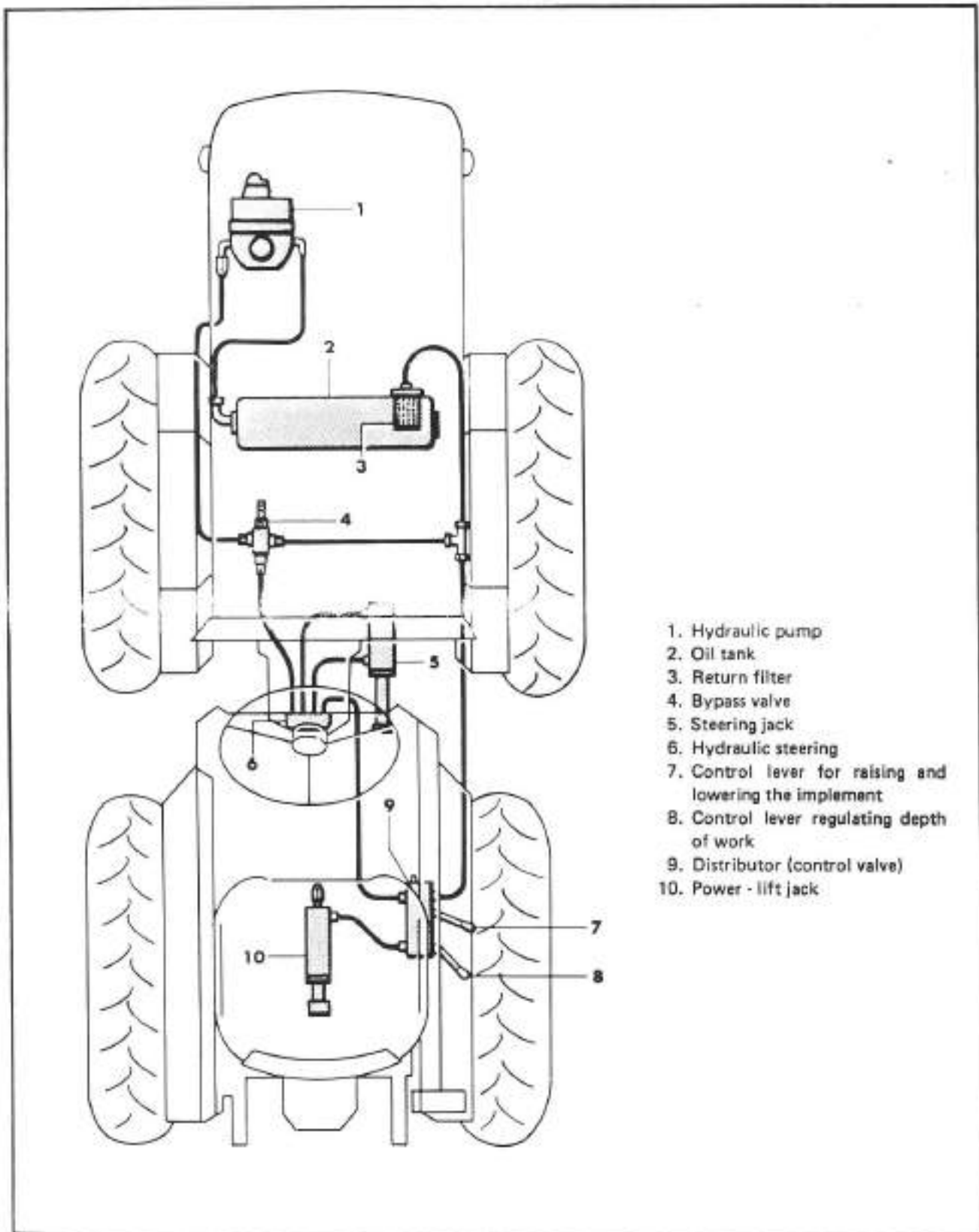

Fig. 3-76. Replacement of the return filter cartridge



- 1. Hydraulic pump
- 2. Oil tank
- 3. Return filter
- 4. Distributor (control valve)
- 5. Implement release valve
- 6. Pressure regulator valve
- 7. Power - lift jack
- 8. Control lever

Fig. 3-77. Schematic of the hydraulic system - tractor Mod. 75



1. Hydraulic pump
2. Oil tank
3. Return filter
4. Bypass valve
5. Steering jack
6. Hydraulic steering
7. Control lever for raising and lowering the implement
8. Control lever regulating depth of work
9. Distributor (control valve)
10. Power - lift jack

Fig. 3-78: Schematic of the hydraulic system - tractor Mod. 76

SECTION VIII

HYDRAULIC POWER - LIFT

OVERHAUL

Preliminary operations

- a. Remove the seat and the fender from the tractor.
- b. Remove the protective cover from the jack (located under the seat).

DISMOUNTING

- c. Remove the two socket head screws from the two lifting arms of the power - lift (1; fig. 3-79) and take off the two arms (2; fig. 3-79).
- d. Detact the outlet connector (1; fig. 3-80) of the hydraulic fluid and take out the pivot pin located at the rear of the jack. Take out the jack.

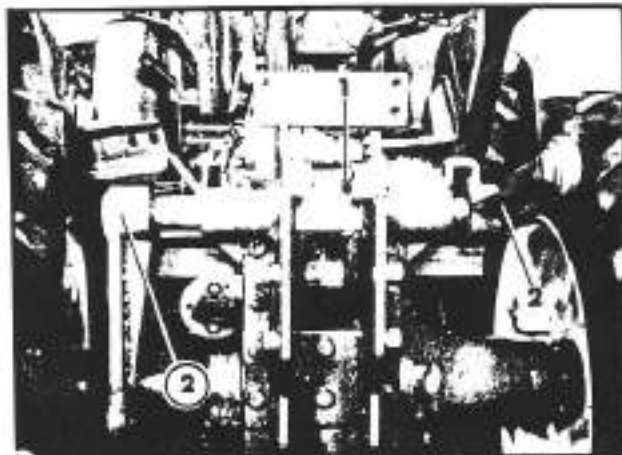

Fig. 3-79. Removal of the lifting arms

REMOUNTING

Follow the general rules previously drescribed.

HYDRAULIC POWER - LIFT

(Tractor Mod. 75, mechanical steering)

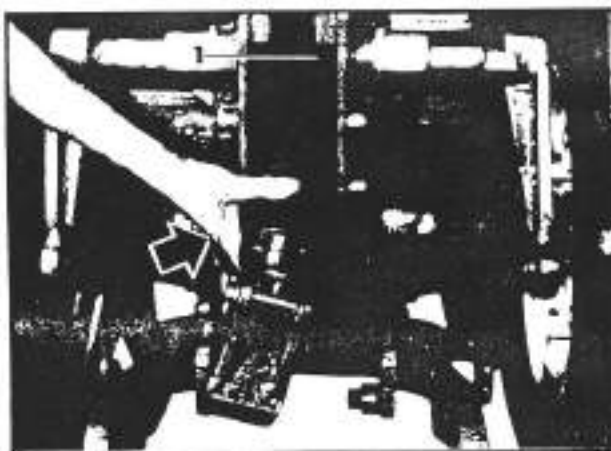

Fig. 3-80. Removal of the power - lift jack

HYDRAULIC POWER-LIFT (Tractor Mod. 75, mechanical steering)

GENERAL NOTE

If the hydraulic power - lift functions irregularly it may sometimes be caused by the quality of the oil or the impurities contained in the oil. When changing or adding oil, it is recommended that scrupulous attention be given to cleanliness and prescribed handling as indicated by the manufacturer.

TROUBLES AND REMEDIES

TROUBLE	PROBABLE CAUSE AND REMEDY
The implement does not lift or lifts with difficulty.	<ol style="list-style-type: none"> 1. Insufficient hydraulic fluid in the tank. Restore fluid to proper level. 2. Insufficient pressure. After removing the protective cap, tighten the regulating screw of the pressure relief valve of the distributor to increase the pressure. 3. Oil leakage from the distributor. Replace the distributor. 4. Oil leakage from the jack. Overhaul the jack or replace it. 5. Damaged hydraulic pump. Replace the pump.
Note	
<p>The hydraulic pump is damaged when it does not supply or maintain proper pressure. See the paragraph "HYDRAULIC POWER - LIFT PRESSURE VALUES" for the respective tractor involved.</p>	
Slow implement lifting speed.	<ol style="list-style-type: none"> 6. Unsuitable type of hydraulic fluid. Replace with fluid indicated by the manufacturer. 1. Inadequate calibration of the pressure relief valve. See preceding point 1. 2. Air infiltration in the suction tube of the pump. Replace the tube and, after having carefully tightened the clamp, ascertain that the lift has been reestablished to proper working conditions. 3. Damaged pump. Replace the pump.
The implement lift works unevenly.	<ol style="list-style-type: none"> 1. Insufficient hydraulic fluid in the tank. Restore fluid to proper level. 2. Clogging of the suction tube caused by the failure of the return filter cartridge. See paragraph "REPLACEMENT OF THE RETURN HYDRAULIC FLUID FILTER CARTRIDGE". 3. Damaged pump. Replace the pump.
Oil leakage from the power - lift.	<ol style="list-style-type: none"> 1. Threaded plug loosened. Retighten without lubricating the threads. Eventually replace the plug. 2. Damaged washer and oil seal. Replace them.

HYDRAULIC POWER-LIFT (Tractor Mod. 76 and Mod. 75 with hydraulic steering)
Refer to figure 3-81.

TROUBLES AND REMEDIES

TROUBLE	PROBABLE CAUSE AND REMEDY
The lift does not raise even without a load.	<ol style="list-style-type: none"> 1. Lack of oil. Restore the oil level. 2. Jamming pilot valve (14; fig. 3-81) caused by impurities contained in the oil. Unscrew the four screws holding the cover (26) then unblock and clean the valve. To prevent the repetition of this problem, carefully clean the return oil filter cartridge (figure 3-76).
The power - lift does not lower. (This problem may occur in a new apparatus if it has remained inoperative for sometime after the final test).	<ol style="list-style-type: none"> 1. Jamming of the shaft (3). Dismount the cover (22); place the control lever in down position. Unblock the shaft with light blows.
The power - lift pumps during raising.	<ol style="list-style-type: none"> 1. Insufficient oil. Restore the oil level. 2. Infiltration of air into the suction line. Check the connectors for proper tightening and replace the packings. Bleed the tube by squeezing. 3. Air drawn through the oil seal of the pump. Replace the oil seal of the pump.
The hydraulic power - lift does not remain in position but rises or falls with jerking action or with the engine off the power - lift creeps down.	<ol style="list-style-type: none"> 1. Leaking check valve (16). Take off the cover (26), extract the valve and clean the valve seat. If the valve and valve seat are in good condition and if this trouble repeats, change or filter the oil and clean the cartridge. 2. Oil seepage through the piston seal or through the cylinder cap seals, or through the seals between the body of the distributor block and the housing. Replace the respective oil seal.
The hydraulic power - lift does not have sufficient lifting power. Usually this trouble is accompanied by abnormal heating of the system.	<ol style="list-style-type: none"> 1. The pump fails to develop full output. Overhaul or replace the pump. 2. Improper setting of the relief valve (9, 10). Take off the cover (26) and replace the spring (8). 3. Damage to the valve plunger (9) and its seat (10) permitting oil seepage. Replace the valve. 4. Contamination of the pilot valve seat (14). Take off the cover (26), extract the valve and clean the valve seat. 5. Excessive wear of the seat of the pilot valve (14). Overhaul the whole distributor block.
When the arms of the hydraulic power - lift are in full "up" position, the relief valve cuts-in.	<ol style="list-style-type: none"> 1. Jammed poppet (3). Dismount the cover (22), place the control lever in down position and free the poppet by tapping lightly. 2. Improper setting of the raise limit "stop". Temporarily, so as to prevent damage to the system, tighten the wing screw (located at the upper part of the control quadrant) so that the travel does not pass the point where the relief valve cuts-in. However, have this travel "stop" adjusted by the manufacturer or the local representative as soon as possible.

TROUBLE

PROBABLE CAUSE AND REMEDY

Escape of aerated oil through the breather plug.

1. Oil level too high or too low. Restore the oil to its proper level.
2. Air drawn into the suction line. Tighten the fittings; inspect the welds; replace the gaskets.
3. Air down through the oil seal of the pump. Replace the oil seal.

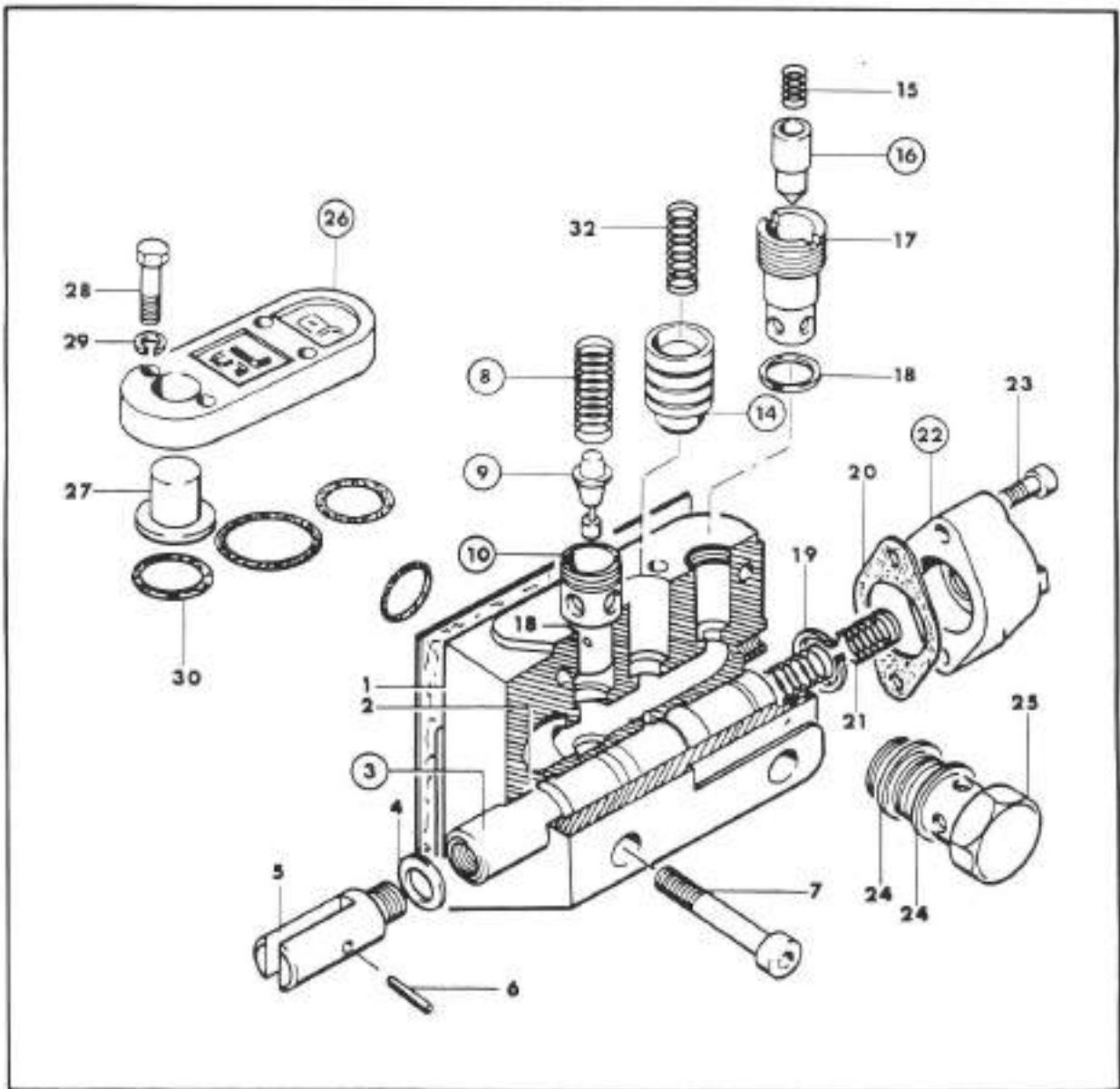

Fig. 3-81. Power - lift distributor - tractor Mod. 75