

OPERATION MANUAL



HHJM-254E/454E

HHJM

JM

JINMA

HUANGHAIJINMA



Jiangsu Yueda Intelligent Agricultural Equipment CO.,LTD.

Preface

Thank you for your trust on our HHJM-254E and HHJM-454E series wheel tractors . This series is reasonable in structure, excellent in materials and completed in performance. They are applicable for a wide range of gardening or field work, not for forestry application. In order to help customres operate, adjust , repair and maintain the products in a better way, and for better performance of this series, we compile this operation manual. As for the operation & maintenance manue of engines, please refer to diesel engine manual.

With technical development and requirements from our customers, descriptions in the manual may differ from the real structure of your tractors and the differences will be involved in the next version. If what you want to know is beyond this book, please contact the agent or the manufactuer.

“  ” **Precaution Symbol**

In this manual, this precaution symbol means some important safety information. Seeing this symbol, you should read the contents below it carefully and inform other operators to protect from possible hurts.

"Warning " and **"Attention "**: These focus on correct steps or techniquis in operations. Driver or stander-bys will be hurt or even die due to ignore.

"Important" : These focus on correct steps or techniquis in operations. Your ignore can result in the damages to tractors or equipments.

Contents

Preface	
Chapter One Precautions for Safe Operations-----	1
Chapter Two General Description-----	11
Chapter Three Key Technical Specifications of the Tractors-----	12
3.1 Parameters of whole unit-----	12
3.2 Engine Parameter-----	13
3.3 Transmission system-----	14
3.4 Travel, steering and braking systems-----	15
3.5 Working unit-----	16
3.6 Electrical system-----	17
3.7 Liquid filling capacity-----	17
Chapter Four Operation of Tractor-----	18
4.1 The fuel and lubricating oil of the tractor-----	18
4.2 Water using-----	19
4.3 Running-in-----	19
4.4 Steering mechanism and meters-----	21
4.5 Control and drive-----	22
4.6 Operation and use of the working units of tractor-----	25
4.7 Operation of electrical equipments-----	28
Chapter Five Technical Maintenance of the Tractor-----	31
5.1 Technical service of every shift-----	31
5.2 Class-I technical service-----	31
5.3 Class-II technical service-----	32
5.4 Class-III technical service-----	32
5.5 Class-IV technical service-----	32
5.6 Technical service in winter-----	33
5.7 Technical service for long-time storage-----	33

Chapter VI main Adjustments on Tractor-----	34
6.1. Adjustment on clutch -----	34
6.2 Adjustment on central transmission -----	35
6.3 Adjustment on differential lock -----	37
6.4 Adjustment on brakes-----	39
6.5 Adjustment on front axle-----	39
6.6 Adjustment on fore driving axle-----	41
6.7 Adjustment on rear wheel tread-----	43
6.8 Adjustment and operation of steering device-----	43
6.9 Structure and adjustment of hydraulic suspension system-----	46
6.10 Service and repair of eletrcal system: -----	54
6.11 Intake and exhaust system-----	55
6.12 Operator Seat -----	56
6.13 Roll Over Protective Structure (ROPS) -----	57
6.14 Swinging Drawbar -----	58
6.15 The plate of the tractor -----	59
6.16 Angle of the cardan -----	59
Chapter VII Main Troubles and Solutions-----	61
7.1 Diesel-----	61
7.2 Transmission system-----	63
7.3 Brakes-----	63
7.4 Steering unit and traveling system-----	64
7.5 Hydraulic suspension system-----	65
7.6 Electrical system-----	65
Chapter VIII Appendix-----	68
8.1 Electric wiring map-----	68
8.2 Optional accessories with additional payments-----	70
8.3 Oil seal specification for tractor chassis -----	70
8.4 Attached tools-----	71
Appendix I -----	72
Appendix II -----	73

Chapter One Precautions for Safe Operations



1.1 Only after reading the manual carefully, can the driver who has got special training and driving licence with a full survey record operate the tractor. Tractor cannot be operated without licenses.





1.2 This machine only can be operated, maintained and repaired by the persons who are familiar to its features and know the related safe operation rules.







1.3 Driver should pay especial attention to the precaution symbol on the machine.





1.4 It is forbidden to drive tractors after being drunk, tired or taking some antipsychotic.







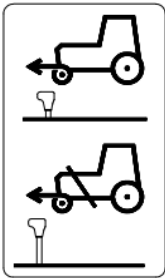
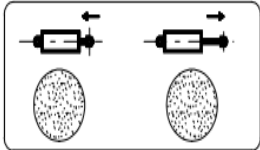

1.5 During operating the tractor, driver should strictly complies with the informed steps accroding to the presauion symbols to avoid accidents. When the symbols are lost, poluted or abraded, they should be replaced in time.(See Fig.1--1~Fig. 1-19 for precaution and operation symbols)

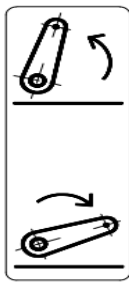

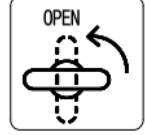
REF	MEANNING	LOCATION	Q.TY
1-1		Danger: Engine fan	On the two sides of radiator wind scooper clearly. 2
1-2		Danger: Hot parts	Near to muffler. 1

1-3		Danger: Engine belt pulley	Near to belt pulley	1
1-4		Manual before operating the machine	On the right of meter	1
1-5		Danger:PTO shaft	Upper side PTO protective cover	1
1-6		Do not stand between tractor and equipment while operating hydraulic lift	At the central site of the machine end.	1
1-7		Always lock ROPS in upright position unless it has to be allow operation underneath trees or bushes	On the left of ROPS	1

1-8		Danger: Hot parts	On the two sides of radiator wind scooper clearly.	2
1-9		Danger: Maintain	On the right of meter	1
1-10		Danger: It is prohibited to sit in the position of non-occupant.	On the both of the fender.	2
1-11		Danger: Use safety belts	On the right of the inside of ROPS	1
1-12		Diesel	On the front end of oil tank	1
1-13		Starter control	Above starting switch	1

1-14		Engine shut-off control	Above choke line	1
1-15		Parking brake control	Near hand throttle assembly	1
1-16		2WD& 4WD	Near front drive handle	1
1-17		Hydraulic output	Near single-way valve	1
1-18		Differential lock	Near to differentiallock pedal	1
1-19		Refuel	Engine refueling Front drive refueling	2

1-20		Control PTO	Near to PTO control lever	1
1-21		Control lifter	Near to the lifter handle	1
1-22		HYDRAULIC OIL	On the oil tank	1
1-23		Open the hood lock	Near to the hood lock	2
1-24		Dipped-beam headlamps control	On the surface of head lamps	1
1-25		Starter control	Above starting switch	1
1-26		Engine shut-off control	Above choke line	1
1-27		Differential lock control	Above pedal of differential lock	1
1-28		Engine rotary variations	On cover plate of hand throttle assembly	1

1-29		Three-point lifting mechanism control	At the starting and ending positions of lifter control lever	1
1-30		Parking brake control	Near hand throttle assembly	1
1-31		ENGINE ROTARY VARIATIONS	On cover plate of hand throttle assembly	1

1.6 Before operation, a new tractor should have a running-in following the related regulations. And then normal loaded work can be done.

1.7 Before the tractor moves, on its path should be no any barrier, and no people between the tractor and the rear implement or trailer.

1.8 Don't leave driver's seat to start or control the tractor. Each gear shifter should be placed at the "neutral gear" before starting or getting off the tractor.

1.9 Don't get on or off the tractor during its running, Before repairing the tractor, the machine should be stopped and the key should be taken off. Repair or check under the tractor is forbidden when the engine runs.

1.10 To avoid turn-over, only low gears can be used, especially going on high slopes or muddy path. When going downslope, clutch engaging or neutral gear is not allowed. Let the running tractor not too near to any ditch, to avoid damage due to broken trenches.

1.11 In transportation, the left and the right brake pedals should be joined and locked together. Move PTO handle to the "Apart" position.

1.12 When the suspended implement of the tractor is transferred, hydraulic lifter should be at the position of "neutral".

1.13 No sharp turn is permitted while driving at a high speed. Sharp turn with the help of one side brake is prohibited either to avoid turn-over or parts damaging.

1.14 You'd better check and fasten bolts of wheel radial plates and the bolts or nuts in other key positions.

1.15 When operating 3-Point Suspension, the people must far away from the area that may cause hurt; When transferring to another field or operating with hung farm implements, high speed is forbidden to avoid the damage to parts of lifting system and suspending system.

Before leaving the tractor or taking down the farm implements, driver should drop down its farm to the ground first, stop the engine and take off the key to prevent others from starting the tractor.

1.16 Before starting the tractor, you'd better check oil duct, electric circuit and cooling water. In any case, it is not allowed to fill the fuel that has not been precipitated or filtrated into tank. After starting the machine, you'd better pay attention to all indicators and meters.

1.17 Before filling fuel into tank, you'd better stop the engine; Smoking is prohibited during fuel filling and check & repair for fuel system.

1.18 When deep treaded tires working or transferring in fields, high speed is not allowed; Deep treaded tires can't be used for transportation.

1.19 Tractor cannot be used with over load to avoid damage to organs. Load limit of the trailer is 3 tons. The traier of the tractot can equip with unbrake, independently-brake, inertial-brake.

when the matched trailer or farm implements have not assembled, please don't do any oprations, equipped with different farm implements should accord with max endured mass of the tractor ,the front axle and rear axle, tyres .

1.20 Dirts should be eliminated from radiating water tank to guarantee its heat radiating performance. When the water tank is too hot, you can't water the engine or water tank with cold water to avoid breaking the tank. You should reduce its load and only after the water is not so hot can cooling water be filled with the engine running.

1.21 You should tell your next shift about any troubles of the tractor. During operation in night, fine lightings are necessary.

1.22 When it works below 0°C in winter, exhaust all the water in the case of idling operation to avoid organs freezing caused by remained water.

1.23 Manufacturer is not responsible for any reduced raliability of the machine, personnel hurt or damaged machine due to any unauthorized reform on the tractor.

1.24 During running or working, if one of the tractor's driving wheel is found severe wheelspin, you can use the differential lock following its instruction. The differential lock is forbidden to use in any other case to avoid machine

1.25 During harvesting or operating in field yard, a spark extinguisher should be installed on air exhaust .

1.26 Exhaust elbow and muffler are high temperature components. within a half hour after starting or stoping the engine, anyone is not allowed to get near to avoid burn. damaging or other accidents.

1.27 Faulted tractor cannot be put into use, especially when oil pressure is zero or too low , water is too hot or abnormal sound or smell come. The machine should be stopped for check and the trouble should be shot in time.

1.28 Only after taking earth wire off from the battery can electric parts be repaired.

1.29 when the area with hills or steeps,or the ramp is too big ,the driver shouldn't operation tractor.Don't stop the tractor on a big slop. When the driver need to use the lifting jack to repair the tractor, the lifting jack can place on the position of the front driving shaft housing or the rear driving shaft housing, its park brakes should be used and a triangle should be stuck under the rear wheels.



Front lifting
jack position



Rear lifting
jack position

1.30 The protecting components for driver is not indispensable. However when installing safety frame on the tractor, a seat belt is necessary; when removing the fram from the tractor, the seat belt should be removed too to avoid ues by mistake.

1.31 When working in fields or muddy area, you'd better remove the dirt from your shoes and keep the pedals clean.Catcj the armrest carefull when getting on or off the tractor.

1.32 When driving along the road, you'd better follow the local traffic rules

1.33 In any case kids or no-drivers should be kept far away from the machine ,Keep the people away from the area between the tractor and the trailer,because it can cause serious injuries or death.

1.34 Before using PTO, a protecting cover need be installed.

1.35 Before operating the tractor, please read operation manual; Please be sure to sit on the seat ,then you can start and operate the tractor.

1.36 It is forbidden to put down the roll bar when you are starting and using the tractor normally!

1.37 You can use the differential lock only when the tractor skid on the muddy road; when the tractor skids, please press the handle of the differential lock, then the differential lock works, and it makes lef-right jaw of the drive shaft meshing to be one, and then makes the tractor driving out of the muddy road; At the same time release the handle back to the position!

1.38 Only one driver is allowed on the tractor. No one is allowed to ride.

1.39 Being involved in a rotating drive mechanism may lead to personal injury or death.

The transmission shield must always be in place.

1.40 Be careful when cleaning the tractor, especially when using a water cannon. Even if all precautions are taken to protect electronic components and joints, the pressure of some cleaning machines may still be too much to ensure full water resistance. When using water cannon, do not get too close to the tractor. Do not use a cooling water to wash engine or exhaust pipe directly.

1.41 If you need to use and maintain the machine in high altitude, please use the installed pedals and handrails correctly. Do not stand on the surface out of the foot pedal or platform. Do not use the machine as a crane or ladder when working at high altitude.

1.42 Check the hydraulic hose at least half a year for oil leakage, knot, incision, crack, abrasion, rust, wire leakage or any other damage.

1.43 It is forbidden to weld or heat the high pressure liquid pipeline or other combustible materials. If the heat is beyond the heating zone, the high pressure liquid pipeline will burst.

1.44 When pulling a tractor, try to pull a short distance as far as possible, such as pulling out from buildings. Do not pull tractors or transport tractors on highways. Use the trailer lever when pulling the tractor, and keep the minimum speed.

1.45 There is a danger of explosion from the gas that overflows from the battery, so the battery cannot be close to the open fire (matches, lighters or cigarette fire, etc.); Don't short-circuit the wires. Contact with electrolyte is very dangerous, if eyes, skin or clothes contact with electrolyte, should be washed with water immediately, or ask a doctor to treat.

1.46 When charging the battery, it should ensure that the vent hole of the filling plug is unblocked, keep away from the open fire, and then power off the power to prevent the explosion.

1.47 The ramp is a major cause out of control and rollover accidents, which can cause serious injury or death. Be careful on the ramp. It is not possible to enumerate every possible condition that may cause a tractor to turn over, and it must be noted for each case that may affect stability.

1.48 The engine, radiators, exhaust parts and hydraulic pipes may become hot during the operation. Be careful when maintaining these parts. Please handle or disconnect the high temperature parts after cooling. Wear protective equipment in due course.

1.49 When excavating or using the ground operation equipment, please pay attention to the buried cable or other service facilities. Please contact the utility department to determine the location of the cable equipment. Pay attention to the overhead wires and hanging obstacles, and to be safe, you need to keep a large distance from the high pressure line.

1.50 Do not operate the machine during thunder and lightning. If you are standing on the ground, stay away from the machine and hide in a permanently protected building.

1.51 When the tire is installed and disassembled, it is not easy to operate according to the prescribed procedures. There may be an explosion, which may cause serious casualties. Do not disassemble tyres without proper equipment and safety work experience.

1.52 Must keep the right tire inflation pressure, do not exceed the stipulated by the tire inflation pressure, if exceed the maximum pressure, tire edge crack happens, even an explosion.

1.53 Do not use heavy machinery on high places, or it will reduce the stability of the tractor.

Chapter Two General Description

HHJM-254E and HHJM-454E series wheel tractors are a new series developed by ourselves according to Europe farming machinery markets.

HHJM-254E and HHJM-454E series wheel tractors are newly developed with kinds of new technologies, new processes and new structures, together with years' production experiences. The new series has more reasonable structures and better improved performance. They are more powerful, economical in oil consumption, high efficiency, nice in appearance, easy in operation and maintenance, convenient for being supported, economical in use and perfect in integrated performance.

HHJM-254E and HHJM-454E tractor's muffler assembly is upset, that means Exhaust muffler upwards, HHJM-254E and HHJM-454E tractor's muffler assembly is downward, from the feet under the floor back exhaust, the left side of the pedal tractor boarding, please get on the tractor from the left side of the tractor.

HHJM-254E and HHJM-454E series wheel tractors are equipped with 25hp and 45hp vertical and oil-saving diesels respectively. Direct transmission is used between the engine and the transmission system and an 8-gear gear box is installed for the work of rototilling, ploughing, harvesting, transportation and so on. They have a hydraulic suspending system with perfect performance, low-pressure broad driving wheel tires with fine adhesion, and airbraking device with reliable performance. Besides, customers can select different types of tractors according to their own requirements and economic situations. The series include dual-acting clutch, 4-wheel driving, mechanical steering and entirely hydraulic steering.

HHJM-254E and HHJM-454E series tractor according to the agronomic requirements of different, choose different equipment for rotary tillage, plowing, mowing, loading, irrigation, transportation and other operations.

Warning :

1. Manufacturer is not responsible for any reduced reliability of the machine, personnel hurt or machine damaging due to any unauthorized reform on the tractor or any operation that doesn't follow related technical requirements.

2. You can only use the implements specially designed for this series. Customers should try to avoid possible damages to the machines caused by the farm implements that don't follow the configuring regulations.

Chapter Three Key Technical Specifications of the Tractors

3.1 Parameters of whole unit

tractor type		JINMA/HHJM 254E	JINMA/HHJM 454E
parameter			
mode		4 × 4 (4WD)	
external size mm	L	3360	3375
	W	1440 ~ 1640	1525 ~ 1725
	H	2450	2510
wheelbase mm		1755	1835
usual tread of front wheels mm		1050	1050
usual tread of back wheels mm		1040~1200(adjustable with steps)	1080~1240(adjustable with steps)
Min. ground clearance mm		320	330
radius of turning circle m		3.6	4.0
towable mass without braking kg		1400	1500
towable mass with independent braking kg		3000	
towable mass with inertia braking kg		3000	
towable mass with hydraulic or pneumatic braking kg		/	
external sound levels dB(A) 2009/63/EC		≤ 89	≤ 89
driver-perceived sound levels dB(A) 2009/76/EC Annex II		≤ 86	≤ 86
Vibration of the seat (awS ≤ 1.25m/sec ²) 78/764/EEC		Light driver (59 ± 1 kg)	0.60
		Heavy driver (98 ± 5kg)	1.15
Vibration of the seat (awS/awB ≤ 2) 78/764/EEC		Light driver (59 ± 1 kg)	0.996
		Heavy driver (98 ± 5kg)	1.070

Theoretical velocity km/h								
1.Rated engine speed: 2400r/min								
2.Tyre code of rear driving wheels: 254E: 9.5-24, 454E: 11.2-24								
3.Max. impetus radius of rear driving wheels: 254E: 491mm, 454E: 517mm								
tracto r model theoretical velocity gear	JINMA/HHJM-254E				JINMA/HHJM-454E			
	Creep er		Shuttle		Creep er		Shuttle	
	Quick	Creep	Forwar d	Revers e	Quick	Creep	Forwar d	Revers e
L- I	1.77	0.33	1.77	1.70	1.86	0.35	1.86	1.79
L- II	2.70	0.50	2.70	2.60	2.84	0.53	2.84	2.73
L- III	4.23	0.79	4.23	4.08	4.45	0.83	4.45	4.29
L- IV	5.83	1.09	5.83	5.62	6.14	1.14	6.14	5.91
H- I	8.18	1.53	8.18	7.88	8.61	1.61	8.61	8.29
H- II	12.46	2.32	12.46	12.01	13.12	2.45	13.12	12.64
H- III	19.56	3.65	19.56	18.84	20.58	3.84	20.58	19.83
H- IV	26.96	5.03	26.96	25.97	28.37	5.29	28.37	27.33
R- I	2.33	0.43	/	/	2.45	0.46	/	/
R- II	11.23	2.10	/	/	11.84	2.21	/	/

3.2 Engine Parameter

Type Engine Data	JINMA/HHJM-254E	JINMA/HHJM-454E
Model	3LS25B	4L45B
Type	Three(Four)-cylinder,In-line Water-cooled,Four-stroke,Swirl chamber	
Bore of cylinder mm	90	95
Stroke of piston	95	100
Tated power/speed kW/rpm	18.4/2400	33.1/2400
Max. torpue/speed N·m/rpm	112/1800	202/1800
Maximum allowable intake depression kPa	6.2	6.2
Maximum allowable back pressure kPa	10.0	10.0
Compression ratio	18: 1	18: 1
Displacement L	1.813	2.83

Engine parameter		Type	JINMA/HHJM-254E	JINMA/HHJM-454E
Model			3LS25B	4L45B
Firing order			1-3-2	1-3-4-2
Oil pressure	At idle speed kPa		≥ 50	≥ 50
	At rated speed kPa		200 ~ 400	200 ~ 400
Valve timing phase	Intake valve open(before T.D.C)		12 CA	12 CA
	Intake valve close (after B.D.C)		38 CA	38 CA
	Exhaust valve open(before B.D.C)		50 CA	50 CA
	Exhaust valve close(after T.D.C)		14CA	14CA
Valve clearance	Intake valve mm		0.25 ~ 0.30	0.25 ~ 0.30
	Exhaust valve mm		0.25 ~ 0.30	0.25 ~ 0.30
Temperature °C	Cooled water		80 ~ 90	80 ~ 90
	Oil		≤ 105	≤ 105
	Exhaust pipe		≤ 600	≤ 600
Starting method			Electric starting	Electric starting
Lubricating method			Pressure & splash	Pressure & splash
Cooling method			Water cooling	Water cooling
Overall dimension (L × W × H) mm			643 × 562 × 781	780 × 516 × 689
Net weight kg			230	260

3.3 Transmission system

Part names	Type	JINMA/HHJM-254E	JINMA/HHJM-454E
Clutch		dual-acting, dry and constantly-engaged friction type	
Gearbox		two-axial, direct teeth (4+1) × 2combination type	
Central Drive		spiral taper gear	
Differential		two planetary gear teeth, bevel gear type (with differential lock)	
Final Drive		external gearing direct teeth type	
Fore Drive Axle		whole-sealed bevel gear type	
Transfer Case		spur gear	

3.4 Travel, steering and braking systems

tractor type		JINMA/HHJM-254E		JINMA/HHJM-454E		
parts and parameters						
Frame Type		semi-frame type				
Type of Fore Shaft(Fore Drive Axle)		tri-sensor separable axle housing of conic reducer				
Fore Axle Tilt Angle		$\pm 8^\circ$				
Toe-in of Front Wheels mm		4~10				
Toe-out of Front Wheel		3.5°				
Tumble Home of Main Shaft		8°				
agricultural tyre	fore wheels	tyre code	6.00-16-6PR		6.50-16-6PR	
		air pressure / load Pa/kg	120/290		120/300	
			200/390		200/430	
			250/495		250/565	
	back wheels	tyre code	9.5-24		11.2-24	
		air pressure / load Pa/kg	6PR	8PR	8PR	10PR
			120/600	120/640	120/680	120/760
			180/765	200/880	180/940	200/1080
			210/940	280/1100	240/1225	300/1380
lawn tyres	front wheels	tyre code	$26 \times 7.5-12-4PR$			
		air pressure / load Pa/kg	120/290			
			150/330			
			180/370			
	back wheels	tyre code	$11.2-20-4PR$			
		air pressure / load Pa/kg	70/525			
			100/650			
			130/758			
model of hydraulic steering device		101S-1-50-12-A				
model of constant flow pump		CBT-F306(coupling by levogyrate splines)				
brake		disk brake				

3.5 Working unit

Tractor model		JINMA/HHJM-254E/454E	
parts and parameters			
Lifter type		Semi-divided positioned Type	
Model of Gear Pump		CBN-F310(coupling by dextrogyrate splines)	
Model of Dispenser		Outlaid Unload Control	
cylinder (diameter × stroke) mm		70 × 100	
Safety Valve Type of System and Oil Cylinder		Damping Valve Direct Action Type and Cone Valve Direct Action	
System Pressure MPa		16 ± 0.5	
Opening Pressure of Safety Valve MPa		16 ± 0.5	
Plowing Depth Control		combination control	
Max Lift Force in the Position of 610mm back from Lower Hook Station kN		4200/7500	
Hydraulic-pressure Output Joint	Specification of Diameter		M18 × 1.5
	Quantity		1
	Output Discharge l/min		12
Type of Hanging Device		Rear Three-point Suspending	
Hanging Connection Triangle mm		410 × 594 ± 15(W × H)	
Connecting Aperture of Upper Suspending Point mm		Φ19	
Connecting Aperture of Lower Suspending Point mm		Φ22	
Mode of PTO Shaft		combined type	
speed r/min		540/1000	
Circumrotation Direction		Clockwise(Facing the head-ward of Tractor)	
Shaft Extension		I type/ square spline (6-35 × 28.91 × 8.69)	
pull unit	Diameter of Joint Pin mm		Φ30
	20Ground Clearance of Joint Pin(Midpoint) mm	Swing drawbar	281
			370
		Clevis	491

3.6 Electrical system

Parts \ Model	JINMA/HHJM-254E/454E
electrical system	minus earthsingle-wire system12V
starting motor	QDZ157Y(12V,3.2kW)
generator	ZFW13C1(14V,350W)
battery	C603-6QA-80AH/90Ah
gauges	C110-050(oil pressure gauge, fuel gauge, water thermometer, chronometer,speed indicator)
head lamp	C201-025/C201-026
rear working lamp	C203-012
front signal lights	C202-007
tail lamp	400E.48.021
rear license light	C209-001
horn	C502-50F
fuse box	C702-010
combined switch	400.48.018A-1&400.48.019A-1
7-hole socket	C604-014
starting switch	C402-003A
speed sensor	C304-013
oil mass sensor	C302-021
oil pressure sensor	C303-007
water-temperature sensor	C301-008
starting interlock switch	250.48.361
braking interlock switch	C402-036
cigarette lighter	C801-001

3.7 Liquid filling capacity

Parts and parameters \ Tractor model	JINMA/HHJM-254E	JINMA/HHJM-454E
fuel tank L	46	
gearbox, rear axle, final transmission of dispenser L	14	
front driving axle L	6	
hydraulic steering L	2.5	
lifter L	12	
cooling liquid L	10	12

Chapter Four Operation of the Tractor

4.1 The fuel and lubricating oil of the tractor

See Fig. 4-1 for The fuel and lubricating oil of the tractor.

Fig. 4-1 The fuel and lubricating oil of the tractor

Site	Season and Environmental Temperature	Oil Specification
Fuel Tank	Summer (Above 10°C)	0#, -10 # solar oil (GB/T 252-2000)
	Winter (Below 10°C)	-10# solar oil (GB/T 252-2000)
Oil pan of engine, hydraulic-pressure steering gear of lifter, oil pan of air filter, and injection pump	Below 0°C	20# 40# diesel oil (GB/T 5323-1994)
	Between 0°C-25°C	30# diesel oil (GB/T 5323-1994)
	Above 25°C	40# diesel oil (GB/T 5323-1994)
Gear box, transfer case, front driving axle, mechanical steering device	Summer (Above 10°C)	40# diesel oil (GB/T 5323-1994)
	Winter (Below 10°C)	30# diesel oil (GB/T 5323-1994)
Each grease nipple	For all seasons	ZFG2# complex calcium lubricating grease(SH0370-1992)
engine, starter, bearing6203-E	For all seasons	ZFG2# complex calcium lubricating grease(SH0370-1992)



Warning:

1. Before filling fuel into tank, you'd better stop the engine; Smoking is not allowed during fuel filling and check & repair for fuel system.
2. In no case can gasoline or alcohol be filled in diesel oil. This mixture can lead to fire or explosion because it is more detonable than pure gasoline in fuel tank. Different grade oil can't be mixed for use.

● Important:

1. Only very clear fuel can be used. Fuel should be precipitated for above 48 hours and then only the middle and top fuel can be filled into the tank with a filter. No full fuel for volatilization and screw down the tank cover after filling.
2. Fill fuel before the tank is empty. To fill fuel after the oil is used out in the supplying system, air must be exhausted from the supplying system firstly.
3. Do use a clean filling tool. Don't wash or wipe with diesel oil. Wipe the overflowed diesel oil at once.
4. Wash fuel tank regularly, discharge precipitated oil, and wash diesel oil filter.
5. Don't use open oil drum to transport fuel.
6. Put all cloth with oil into containers with covers. No dog-end can touch it.
7. You'd better check the engine oil on each lubricated site very often. Fill oil at the sites in time. Fill grease into grease nipples regularly.

4.2 Water using

4.2.1 Only clear and soft water can be filled into water cooling tank to avoid inefficient performance caused by scale incrustation.

4.2.2 Hard water(in well, spring and so on) should be softened and then be used. Follow the steps below to soften the hard water:

1. Boil up hard water, precipitate and filter it.
2. Use caustic soda to treat hard water at a rate of 1.5g/l

Working in cold areas, anti-icing fluid can be used for cooling water.

Attention:

When the engine works or just after it is stopped, the water tank has a high temperature, so it is dangerous to open the tank cover at that time. Only after the tank is cooled down can it be opened. To open it , you can loose the cover first to release its inside air pressure.

● **Important:**

1. Dirt should be eliminated from radiating water tank to guarantee its heat radiating performance. When the water tank is too hot, you can't water the engine or the tank to avoid breaking the tank. You should reduce its load and only after the water is not so hot can cooling water be filled with the engine running. Check cooling water in the tank that should be kept full. Cooling water can' t be less than 2/3 of the tank volume.

2. When the water in tank is over 100 °C , stop the engine immediately. Have a necessary check and repair on the water tank after it is cooled.

3. When operation in the cold area with a temperature under 0 °C is over, you should discharge all the water with tractor idling.

4.3 Running-in

To put into use, new tractors or heavily repaired tractors must run in first, because newly manufactured parts have more or less tool marks on the surfaces. If you use the tractor with a heavy load without running-in, abrasion on the parts will be more severe and the parts can even be stuck and damaged to shorten the tractor life.

4.3.1 Preparation before Running-in

1. Wash the housing of the engine.
- 2, Check and tighten the external bolts and nuts.
3. Check the oil level in each lubricating box, refill oil if not enough.
4. Fill grease to every oil site.
5. Fill fuel and cooling water.
6. Check the toe-in of front wheel (4-10mm); Check air pressure of the front and the rear tires and adjust the pressure to the rated value.
7. Check batteries and connections of the electric circuit in electric system.
8. Put shifter at neutral gear, hand throttle in idle-speed position and hydraulic hand in dropping position.

4.3.2 Running-in of the engine without load

After starting the engine according to stipulated steps, you should listen to the engine carefully. Make sure there is no water leak, oil leak or gas leak. Read all indicators to see if all are OK. Do next running-in step after making sure that the engine works normally. Run the engine from low speed to middle speed and then high speed for 7 minutes, 5 minutes and 3 minutes respectively, totally running-in of the engine without load costs 15 minutes.

4.3.3 Tractor's free and load running-in

Running-in for tractor running-in should be carried out at rated engine speed. Follow the following rules for running-in steps and time.

Fig. 4-2 Running-in rules

running-in mode	load	running-in time for each gear (hours)								sub-total	total
		I	II	III	IV	V	VI	reverse I	reverse II		
running-in without loads	free load	1	1	1	2	0.5	0.5	0.5	0.5	6	31
load	road transportation with towed vehicle and 1.2 tons goods on it;	1	2	4	4	2	2			15	
running-in	4-inch shallow furrow in light soil with suspended plow.	1	2	4	3					10	

During running-in, if abnormal situations or malfunction happen, find out the causes at once and then go on running in.

After the running-in is finished, do the following maintenance and then the tractor can be put into use.

1. After the machine is stopped, discharge the lubricating oil from the oil pan of diesel engine. Wash oil pan, engine oil filter cloth and engine oil cleaner, and fill new lubricating oil to rated level.
2. Discharge the lubricating oil from gear box, hydraulic system and front driving axle when it is hot. Fill in some diesel oil, travel for 2-5 minutes at II-gear and reverse I-gear, wash it, let out the washing oil and fill in new lubricating oil.
3. Wash diesel oil cleaner (including the filter cloth in fuel box) and air filter.
4. Discharge cooling water, wash the cooling system of the engine with clean water.
5. Check and adjust the free travels of the clutch pedal and brake pedal, and the operating of the brake.
6. Check and tighten the bolts and nuts at every key connecting sites.
7. Check oil nozzle and valve clearance. Adjust them if necessary.
8. Check the work of electric system.
9. Check and adjust toe-in of the front wheels.
10. Fill lubricating grease to every grease nipple sites.

● Important:

1. See if the operation of engine is right.
2. See if clutch adjustment normal and its separation is thorough.
3. See if gear shifting of gear box including front driving handle, crawling gear shifting are

flexible and easy. Pay attention to possible spontaneous out-of-gear or failure interlock.

4. See if brake adjustment is proper and the performance is reliable.
5. See if steering control is flexible.
6. See if electric units and meters work normally and reliably.

4.4 Steering mechanism and meters



Fig. 4-1 Control devices and indicators

control devices and indicators well and their locations on tractors (fig.4-1). This is necessary for operating tractor correctly.

- (1) Assistant gear shifter lever: control the assistant gear shifter to shift gears (refer to figure).
- (2) Master gear shifter lever: control the master gear shifter to shift gears (refer to figure).
- (3) Differential lock control lever: to move the right jaw to disengage or engage it to bring the driving wheels on both sides differential speed or no differential speed.
- (4) Foot throttle control device:Foot Step it down to increase oil pully; release pedal to reduce oil supply.
- (5) Hand throttle control device:Push ahead, and the oil supply will be increased; pull hack, it will be reduced.Hand throttle is forbidden for road traveling.
- (6) Hand braking unit: Pull hand brake handle upward for emergent braking or park braking.

Before starting the vehicle, check the hand brake to see if it is in the separated position.

(7) front driving disengaging lever: to stop power of front driving axle during engagement to carry out 4-wheel driving or 2-wheel driving.

(8) Control handle for creeping gears: to control and shift normal gears or creeping gears.

(9) clutch pedal: step down the pedal to separate driving power.

(10) left and right brake pedals: pull the linking braking plate to the right side to synchronize the braking performance of the left and the right pedals; separate the lining plate and the left or the right single-side braking can be done for single-side braking steering.

(11) Preheating starting control device: Preheating starting control unit: Insert key into the switch, position "OFF" means the electric circuit not through; turn clockwise to the position "ON", all electric circuits except starting and warming-up electric circuits are energized (after starting, the key should be kept in this position); turn to position "H", heater plug is energized; turn to the position of "ST", starting circuit is alive. Turn anti-clockwise to the position "ST" and it can be started directly.

(12) Combined gauges: Combined gauges include oil-pressure gauge, oil volume indicator, water-temperature indicator, chronometer, rotation speed gauge, warning light and indicator light.

(13) Combined switches include: dipped headlight switch of head lamp, switch of front turn lights, switch of rear turn lights, switches of the front signal light and the front license light, the rear signal light and license light, switches of rear working lights, horn button, switch of emergent light.

(14) PTO releasing lever: to engage or separate power of PTO shaft

(15) Distributor control handle: Handle at the retroverted, pitched and vertical positions can respectively control the farming implement at the lifting, dropping and neutral states.

4.5 Control and drive

Warning:

1. Only after reading the manual carefully, can the driver who has got special training and driving license with a full survey record can operate the tractor. Tractor cannot be operated without licenses. Overload is forbidden.

2. drivers should pay especial attention to the safety & warning symbols and understand them correctly.

3. It is forbidden to drive tractors after being drunk, tired or taking some antipsychotic.

4. Don't leave driver's seat to start or control the tractor. Before starting the tractor, every gear shift lever should be placed in the position of "neutral gear". To get off the tractor, every gear shift lever should be placed in the position of "neutral gear".

5. Before the tractor moves, its path should be no any barrier, and no people between the tractor and the rear implement or trailer.

6. Don't getting on or off the tractor when it is running. No repair or check under the tractor is allowed when the engine runs. People are forbidden to sit on the fender apron. Casualty accident can happen when it parks, so parking brake is necessary.

7. To go on an abrupt slope, you'd better select a proper gear. It is not allowed to shift

gears on an abrupt slope. When going down the slope, it is forbidden to stop the engine or out-of-gear or turn sharply. For emergency stop, you should step down the clutch pedal and the brake pedal at the same time. Don't just step down the brake pedal, or some mechanical parts will be damaged.

8. For transportation operation, the right and the left brake pedals should be locked together. For high-speed driving or full-load operation, it is strictly forbidden to use unilateral brake to get a sharp turn.

9. High speed is not allowed when operating or transferring to other field with hung farm implements. Lift the working units of farm implements out of the earth to avoid damages to the parts of lifting system and suspending system. When leaving the tractor, driver should drop farm implements to the ground, stop the engine and take off the keys to avoid others' starting tractor.

10. For emergency parking, you should step down the clutch pedal and brake pedal at the same time. Don't only step down the brake pedal, or the brake will be damaged.

11. Driving on road, you should follow the local traffic rules.



Notice:

1. Carefully check and listen to the engine and all parts of the tractor when they are working to see if there are abnormal sound and noise, especially check the technical situations of clutch and brake, check and tighten the bolts and nuts at every key site of the tractor. Check air pressure of the tires, aerate the tires if necessary.

2. When the machine is turnup during operation, shift to a low gear, release the clutch and discharge the load to avoid lengthways turn-over.

3. When engine is over speed, unloading is not allowed. You'd better immediately pull shut-down lever, and turn the decompression rod to the decompression position or keep air away from entering engine or cut off the oil way.

4. Watch the color of the exhausted air. Too much black smoke is not allowed to avoid overload of the engine. If the clutch slides or cannot separate thoroughly or brake doesn't work well, the machine should be stopped for check.

Operations during nights need complete lighting equipments.

6. When 4-wheel driving tractors travel without load or are engaged in transportation, the front driving lever should be placed in the neutral position.

7. To avoid turn-over, especially travel on steep slope and muddy roads. Only low gears are allowed. When going down the slope, it is forbidden to step down the clutch and slide with neutral gear.

8. To avoid the pollution caused by the exhaust gas don't start the diesel in a room that is closed without fine ventilated conditions. When a diesel transfers, keep human and animals far away from the exhaust gas.

4.5.1 Starting the Engine

Before starting, check fuel, lubricating oil and cooling water; check and guarantee that all parts and electrical circuitries work normally; oil circuitries are through without air; gear shifting lever has been put in neutral position and PTO declutching lever has been in disengaging state. In case hydraulic

system is mounted, pay special attention on the hydraulic oil in the lifter to see if it is full.

When the preparation is done, the driver should sit and step on the clutch pedal, then tractor can be started.



Attention:

To start the tractor should meet four conditions: ① the driver must sit on the seat; ② the driver should step on the clutch pedal; ③ main gear shift level should be put in the neutral; ④ PTO level should be put in the neutral;

(1) When using electric starting, turn the starting switch clockwise to I gear and the electric starter drives the engine. Starting time of electric starter does not exceed 5~10 seconds each time and the interval between starting should not be less than 2 seconds.

(2) Turn the switch to III gear, Once the engine begins working, the key to starting switch should be turned withershins immediately to the battery charging position.

(3) When using electric starting in Summer, decompress is not necessary; starting in winter is difficult, so use prehearing device (II gear) is necessary.

4.5.2 Starting moving of the tractor

After starting the engine, preheat the engine at the middle rotary speed for 5~10minutes, start the tractor according to the steps below when the water is heated to 70°C or the above:

(1) Lift the suspending farming implement.

(2) Step down clutch pedal, put the gear shifting lever to the needed low gears and uncouple the brake pedal locking pawl.

(3) Watch out and see if there are barriers. use horn to warn people around.

(4) Release clutch pedal slowly, gear up gradually and the tractor will begin moving.

4.5.3 Driving of tractor

(1) When the tractor works, care the readings on all meters to see if they are normal.

(2) During tractor operating, driver is forbidden to put foot on clutch pedal to avoid clutch in constant semi-engagement, or it will be burnt due to overheating.

(3) During transportation or traveling, the left and the right braking pedals should be locked up with link locks.

(4) When operating in fields, single-side braking can minus turning radius. However single-side braking is forbidden to use for sharp turning during high-speed operation or road transportation.

(5) When tractor works, you should select right gear accordingly to get the highest production and economical efficiency.

When tractor works, its uses of gears are shown in Fig. 4-3.

Table 4-3 Functions of tractor gears

gear	low gear I	low gear II	low gear III and low gear IV	high gear I	high gear II	high gear III and high gear IV	reverse gear I	reverse gear II
item	rotary tillage	rotary tillage, transplant	ploughing, harrowing and seeding	ploughing, harrowing and seeding	transportation	transportation	hanging with farming implement	hanging with farming implement

4.5.4 Parking

1. Lower down the gear for a slower moving
2. Step down the clutch pedal quickly and push the main gear shifting lever to the neutral position.
3. Release the clutch pedal to make the engine freely run with a low speed.
4. step down brake pedal to park the tractor stably and lock up with locating pawl.
5. In case parking for a longtime, stop the engine. After the engine is unloaded, run at low speed for a while until the cooling water is cooled down to 70°C and the below. Pull stopping chock lever to stop engine oil supply for parking.
6. Put the starting switch at "0" position and take down key. Parking for a lone time needs switching off the fuel tank.
7. In case parking under a temperature below 0°C, open the cover of water tank, turn off the water discharge valve and discharge the water inside completely in a situation of engine running at an idle speed to avoid frozen machine body and water tank. (except adding anti-icing fluid)

● Important:

1. When working in fields or muddy area, you'd better remove the dirt from your shoes and keep the pedals clean. Catch the armrest careful when getting on or off the tractor.
2. You should tell your next shift about the troubles and malfunctions you found.
3. Try to avoid barriers on roads when driving tractors.
4. Driving on roads, farm implements cannot be put into use.

4.6 Operation and use of the working units of tractor

4.6.1 Operation and use of PTO shaft

PTO shaft Power is engaged and cut off through controlling the PTO shaft handle at the right side of transmission case.

Rev of PTO shaft is 540 r/min. or 1000r/min.

PTO shaft is engaged when push down the controlling handle from front-top and disengaged when pull up the controlling handle. Its operation method is as following:

- (1) Disassemble the protection hood of PTO shaft and dragging plate, assemble the farming implement.
- (2) Put the main shifting lever in neutral position.
- (3) Step down the pedal of clutch to disengage it, and pull the controlling handle of PTO shaft to "engaging" position.
- (4) Release the pedal of clutch slowly, and run at low speed with low gear levels . Check whether it works in normal condition, and then can operate it normally.

4.6.2 Operation and utilization of the dual-speed PTO shaft of tractor

Engaging and dis-engaging of the dual-speed PTO shaft are realized through controlling the dual-speed PTO shaft handle at the right-back of transimmission box. The dis-engaging handle are divided into high-gear, low-gear and neutral-gear position.

The revolution of dual-speed PTO shaft is 540r/min and 1000 r/min .

When controlling handle is in neutral position, the PTO shaft is in dis-engaging situation. When pull up the controlling handle from neutral-gear position, it is in high-gear, and when pull down it is in low-gear position.

 **Warning:**

1. When using PTO shaft, a safety protecting cover should be installed. People are not allowed to stand on the protecting cover. When the operation is over, an axial sleeve is needed to cover the PTO shaft.

2. When selecting implements, you make rotating speed of the farm implement match that of PTO shaft;

3. Stop the engine to couple farm implements.

4. Coupling with the PTO shaft, cardan joint can't have a too big deviation angle;

5. To couple with cardan joint, the clutch should be released thoroughly first.

6. When the machine travels for a long distance, the control handle should be at the neutral position. Cut off power to avoid breaking farm implements and personnel hurts.

7. When the PTO shaft is being coupled, only work staff can be near to the farm implements to guarantee personnel safety.

8. When the engine works, to engage or separate the PTO shaft, you should step down the clutch pedal.

4.6.3 Control and utilization of the hydraulic suspension system

(1) Position adjustment

When utilizing position adjustment, the liftable position of farming implement is controlled and realized by pulling the distributor controlling handle and adjusting the position of limit block on return-rod. When utilizing requirement is achieved, tighten the stopper on rod with bolts.

Adjustment of cultivating depth can be carried out during cultivating. When position adjustment is used, the ground-wheel need not to be installed for farming implement.

(2) Height adjustment

For dry land cultivation, the height adjustment can be adopted. When using the height adjustment, the farming implement need to install ground-wheel. During cultivating, the controlling handle of distributor shall be in lowering position (viz. controlling handle of distributor is lowered to returning-stopper and shall not return to neutral position). At this time the hydraulic oil circuit is in "floating" situation.

When using the height adjustment, the cultivating-depth is controlled through adjusting the height of ground-wheel from the ground. By this way the uniformed cultivating-depth can be obtained for the soil with big variable specific-resistance.

(3) Lowering speed adjustment

The rapidness of farming implement lowering can be controlled by adjusting lowering speed. Select the appropriate lowering speed of farming implement in order to avoid the heavy impact when farming implement contacts the land and therefore avoid to damage farming implement. It shall be selected according to the weight of farming implement and hardness of land.

Turn the adjusting hand-wheel clockwise, the lowering speed of farming implement will be decreased. And turn the adjusting hand-wheel anticlockwise, the lowering speed of farming implement will be increased.

(4) Utilization of suspension mechanism

Before coupling farming implement to tractor suspension mechanism, the necessary adjustment shall be carried out according to the Instruction Manual of farming implement.

During cultivating, adjust the plough longitudinally and crossly in order to keep the same cultivating depth of front and rear plough.

① Longitudinal horizontally adjustment

Adjust the length of top drawbar of suspension mechanism in order to keep the plough frame horizontally and achieve the same cultivating depth of ploughs. When the front plough is deep and rear plough or plough heel leaves the channel bottom, it shall elongate the top drawbar; and when the front plough is low, and rear plough is deep or plough heel press the channel bottom tightly, it shall shorten the top drawbar.

② Cross horizontally adjustment

Adjust the length of right liftable rod to keep the plough frame cross horizontally. When elongating the right liftable rod, the cultivating depth of the first plough will be increased; and when shortening right liftable rod, the cultivating depth of the first plough will be decreased. In general condition, the left liftable rod will not be adjusted. Only when the adjustment of right liftable rod is not enough, it will adjust the left liftable rod in order to keep the same cultivating depth of each plough.

In actual utilization, it is also need to adjust the cultivating range according the Instruction Manual of plough in order to achieve good cultivating quality and ensure the re-cultivating and miss-cultivating will not happened. Because the above-mentioned adjustments are inter-related, the good cultivating result can only be obtained by cooperated adjustments according to actual condition.

The limit chain can make the tractor set owning good controllability during cultivating. It can protect the rear wheel of tractor from being impacted by farming implement due to big swing when lifting the farming implement and turning the tractor at the edge of land. When farming implement is in cultivating position, the limit chain is in loose situation. It allows a certain swing range between tractor and farming implement. It is forbidden to adjust the slanting-drawing of the farming implement by tightening the limit chain.

③ When using the driving-type farming implement, it should pay attention to the length of universal joint transmission shaft. After coupling, around 10mm of axial gap between front and rear transmission shafts shall be kept.



Attention:

- 1. Keep people far away from the lifting area of the lifter when operating hydraulic lifters**
- 2. 3-point suspending unit is only for the farm tools especially designed for 3-point suspending devices.**
- 3. High speed is not allowed when operating or transferring to other field with hung farm implements. Lift the working units of farm implements out of the earth to avoid damages to the parts of lifting system and suspending system.**
- 4. With heavy farm tools connected, the lifting control handle should move up slowly to avoid turn-over.**
- 5. Trailer should be connected to the drawing plate.**

4.6.4 Differential Lock

During the travel or operation of the tractor, if one of the driving wheels is found too severely sliding to stop the tractor from moving, you can control the differential lock as the following steps:

1. Step down the pedal of the differential lock, shift to a low gear.
2. Turn the hand throttle to the max. position.

3. Press the control lever of the differential lock at the low right position of the driver's seat. Release the clutch pedal slowly to engage the clutch. Now the two driving wheels of the tractor drives at the same time to let the tractor out of the sliding area.

4. After driving from the sliding area, the tractor cannot turn, or it is possible to damage the mechanical parts.



Attention:

1. During normal driving and direct changing of the tractor, the differential lock should be forbidden to use, or the differential lock will stop the tractor from turning and this will lead to breaking parts and enhancing the abrasions of the tires.

2. If one of the rear wheel has wheelspin, speed down the engine before stepping down the differential lock to avoid impact on the transmission box.

3. When the differential lock is engaged, release the control lever of the differential lever immediately to let it reset.

4.6.5 Control and operation of belt wheel during its fixed operation

When the tractor is used for stationary working with belt wheel, its operation procedure is as following:

(1) Remove the protection hood of PTO shaft, top drawbar, lifting rod, bottom drawbar, dragging plate.

(2) Install the belt wheel assembly on the PTO shaft.

(3) Push auxiliary gear lever to "neutral gear" position, and put the main gear lever in 1 gear position or 2 gear position (the purpose is to let the front bearing of transimmission box first shaft being lubricated sufficiently). Put the PTO shaft handle in "engaging" position, and put the PTO shaft handle in low-speed position in case dual-speed output, then test-run the belt wheel at low speed.

(4) Drive the tractor to the appropriate position, stop the engine and put the PTO shaft handle in "neutral" position.

(5) Install the stationary mechanism, align the belt wheel and let the belt in appropriate tension situation. It can move the mechanism or tractor when necessary.

(6) Pull the belt with hand and check the installation condition, and then fixed the mechanism and tractor.

(7) Start the engine and drive belt wheel, first at low speed and then at high speed to check its working condition.

(8) When the unit is in normal working condition, it can adjust the unit to requiried speed by adjusting the throttle manually. But it is unsuitable to decrease the speed excessively because the output power decreases as revolution decreasing.



Warning:

(1) Stop the engine and remove the key before install belt wheel.

(2) Following the operation procedure of PTO shaft strictly.

4.7 Operation of electrical equipments

The electric equipments of tractor are used to start tractor and meet the requirments of sending out signal from tractor and lighting at night etc. The electric system of this tractor is negative-grounded 12V single wire schedule.

4.7.1 Accumulator

The type of accumulator is 6-Q (A) -80 or 6-Q (A) -100 with rated voltage 12V and rated volume 80 or 100A. Some types of tractor are equipped with 2 accumulators with type of 3-Q (A) - 100 100A. The accumulator is used to store redundant power from generator. When the generator is not working or running at low speed, it can supply its power to start the tractor and other power consumers. When the engine is over-loaded at short time, it also assist to supply power.

Check and maintain the tractor regularly according to the Technical Maintenance of tractor during daily utilization.

(1) For the new accumulator, fill the electrolyte liquid to required level according to the stipulations of table 4-4, and it can be used after a rest of 15 minutes. It is better to charge the accumulator after 1-2 hours of engine's starting, this will benefits to improve the service life of accumulator.

Table 4-4 Electrolyte Density Table

temperature of electrolyte (0°C)	0~5	5~10	10~15	15~20	20~25	25~30	30~35	35~40	40~45
density (g/cm ³)	1.305	1.300	1.295	1.290	1.285	1.280	1.275	1.270	1.265

(2) Clean the dust and dirty on the accumulator case regularly in order to avoid the creepage. Check whether there is crack or electrolyte leakage and maintain the pole and wire contactor in good contacting condition. The blowhole of plastic cover shall be kept unblocked in order to avoid explosion.

(3) Check electrolyte level and its specific gravity. It shall refill distilled water in case the electrolyte liquid level exceeding the pole plate less than 10-15mm during noral utilization. Water from well and river is not allowed to be used in order not to mix the impurity. In case the electrolyte liquid overflows excessively due to accidents, it can refill electrolyte. The density of electrolyte inside accumulator shall be no less than 1.2g/m³, it shall charge in case over-low dendisty.

(4) Each starting time shall not over 10 seconds in order to avoid discharging excessively. Accumulator shall be charged timely. The single battery voltage shall be 2--2.1V after being charged.



Warning:

(1) **When engine is running, it is absolutely forbidden to disassembel accumulator cover. Don't let eye, hand or clothe being touched by electrolyte. In case being touched by it, wash with clean water completely.**

(2) **Maintenance of electric equipments can only be carried out after disconnecting the ground cable and accumulator.**

(3) **Gas emitted from accumulator is explosive. Keep the accumulator far away from electric spark in order to avoid damaging the accumulator.**

(4) **Don't discharge in enclosure enviroment. Approviate ventilation can protect the build-up gas from explosion.**

● Important :

(1) Improper use of accumulator can decrease its service life and increase its maintenance cost. It shall be used properly and exert its full performances.

(2) The positive and negative poles of accumulator shall not be connected reversedly. Reversed connection of positive and negative will cause failure of accumulator and electrocircuit.

(3) Disconnecting the wire of accumulator from negative pole and connecting it from positive pole.

4.7.2 Operation of generator and regulator

(1) Use of generator must mach with regulator.

(2) Silicon recitifying generator is negative grounded. It shall not connect wrongly the positive pole and negative pole of generator, relay and accumulator, otherwise it will damage generator and regulator.

(3) It is forbidden to check whether generator generating power with the method of ground ignition. It is not allowed to to check insulaton of generator with trameggar or AC power over than 100V. It can only be checked with multimeter with high inner-resistance, otherwise the diode will be destroyed.

(4) When parking, it should remove the key in order to disconnect the motor field winding and accumulator, and ensure the accumulator will not discharging in long term.

4.7.3 Use of starter

(1) During using, keep regularly the start-motor clean, all contacting points of wire being tightened tightly and in good contacting condition.

(2) Each starting time shall not be over 10 seconds, the time between two starting shall be less than 2 minutes. Find the reason and eliminate them in case fail to start several times.

(3) Pre-heating the engine and then use the start-motor when starting in cold weather.

4.8. Tractor's entering and leaving station

When driver will control the tractor , you'd better to grasp the handrail , then you can enter or leave from the left side of tractor.

4.9. The information of drawing the tractor

When the driver need to draw the tractor, you can draw the tractor from front drawbar or swinging drawbar.



Chapter Five Technical Maintenance of the Tractor

For continuous normal work and a longer life of the tractor, technical maintenance rules should be strictly followed and technical maintenance should be often done to see the technical situation of the tractor.

Table 5-1 Technical Maintenance Schedule

Maintenance Class	Working hours of tractor (h)
Shift technical maintenance	After every shift or 10-12 hours of working
First class technical maintenance	50
Second class technical maintenance	250
Third class technical maintenance	500
Fourth class technical maintenance	1000

It can add and improve the content and method of maintenance depending on the actual situation during utilization.

5.1 Technical service of every shift

Make the following maintenances after each shift's work or every 10-12 hours of work.

(1) Clean the dust and mud from tractor and farming implement. The air filter should be cleaned in case working in the environment with heavy dust and sand.

(2) Check the tightening bolts and nuts of every main part of tractor exterior, especially whether the connecting bolts and nuts of front and rear wheels are loose or not, tighten it when necessary.

(3) Inspect the liquid level of oil pan of diesel, water box, oil tank and lifter. Refill it when necessary. Inspection of oil pan level should be carried out after 15 minutes when engine stops.

(4) Inspect whether there are air leakage, oil leakage and water leakage etc. Eliminate it in case any of them happened.

(5) Inspect whether water in radiator is full, wash and clean the sundries between radiating fins in order to avoid decreasing the radiating effect.

(6) Inspect whether there are dirt and water in the fuel oil depositing cup. Eliminate them and get rid of the air in the oil circuit when necessary.

(7) Check the pressure of front and rear tires.

(8) Fill grease according to the stipulations in table 4-1 <Fuel oil and lubrication oil of tractor>. All the muddy water inside lubricating position should be squeezed out until the grease comes out when filling grease.

(9) Check whether the means along with the tractor is complete or not.

5.2 Class-I technical service

Make the following maintenances after every 50 hours of working

(1) Complete the shift maintenance items.

(2) Wash the air filter, replace the machine oil inside the oil pan.

(3) Check the tightness of the fan belt. Push the middle of belt at the longest side with hand. It is appropriate that the belt will be sagged 15~25mm at the pressure of around 10N. Adjust it when necessary.

(4) Check and adjust free stroke of the clutch pedal and brake pedal.

(5) Check the oil level of transmission box and front driving-axle. Refill it in case insufficient.

(6) Clean the accumulator with cloth and check the electrolyte level inside accumulator. It is required that the electrolyte level should be 10-15mm over the pole plate. Refill with distilled water when insufficient, and coat the grease on pole connector in order to avoid corrosion.

5.3 Class-II service

Make the following maintenances after every 250 hours of working

(1) Complete the first class technical maintenance items.

(2) Replace machine oil inside the diesel oil pan, wash oil pan and absorbing pan and oil filter.

5.4 Class-III technical service

Make the following maintenance after every 500 hours of working.

(1) Complete the secondary technical maintenance items.

(2) Check and adjust the throttle gap, nozzle pressure and automatization condition according to the Instruction Manual.

(3) Wash the fuel oil tank and filter.

(4) Wash the transmission box and replace lubrication oil.

(5) Wash the filter of hydraulic lifter, check the cleanness of oil. Wash the internal bore of lifter case and replace with new oil when necessary.

(6) Check and adjust the front wheel toe-in (required toe-in 4-10mm). Check the tightness of front wheel bearing and adjust it when necessary. Replace the grease in the front wheel hub.

(7) Check the idle-running angle of steering wheel (required idle angle less than 15°), adjust it when necessary.

(8) Check the oil level inside the steering gear, refill it when insufficient.

5.5 Class-IV technical service

Make the following maintenances after every 1000 hours of working.

(1) Complete the third class technical maintenance items.

(2) Carry out the relative maintenance items according to the Instruction Manual of diesel.

(3) Wash the oil tank completely with 25% hydrochloric acid, and then wash with clean water.

(4) Disassemble the generator and start-motor, wash off the grease inside bearing and replace with new grease. In the mean time check the drive gear of start-motor.

(5) Clean off the carbon deposit in exhaust pipe and silencer.

(6) Soak the bearings dissembled from clutch into the molten high-temperature grease, and refill the lubrication grease.

(7) Check and adjust the engaging clearance and contacting moulage of central driving bevel gear, and clearance and pre-tension of the bevel gear

(8) Wash the filter of hydraulic lifting system., replace oil of the system.

(9) Wash steering gear, replace the lubrication grease inside the case.

(10) Checking the hydraulic pipe after every 1000 hours of working.

(11) Carry out test running in short-term, check whether all parts works in good condition.

5.6 Technical service in winter

When operating tractors under a temperature below 5 °C , special technical maintenance is necessary. Now besides shift technical maintenance, you should follow the rules below:

1. Engine can't be started without water in cooling system. You can fill 60~80°C water into the water tank.
2. After being cold started, the engine should be preheated for a while until the water is above 60 °C.
3. When the tractor operation is over and it rests for a long time, all the water in cooling system will be discharged (without anti-icing fluid), and discharged water has the temperature of 50~55°C.
4. Fuel and lubricating oil selections depend on air temperatures or seasons.
5. In severely cold seasons, for easily starting the engine, you'd better store the tractor in a warm garage

5.7 Technical service for long-time storage

The tractor that is to be stored for a long time should get a thorough check and test for its technical situation before its storage.

1. You'd better store the tractor in a dry garage, and support it's front and rear wheels with wood blocks to leave ground. If you have to park in an open area, a tarp is necessary to cover the tractor with drainage lead around it.

The storing area should be far from fire resources such as oil store and kitchen.

2. Wash and clean the tractor body before its storage. Oil the sites that need lubricating following Fig. 4-1 <<Fuel and Lubricating Oil of Tractor>>.
3. After parking, the cooling water should be discharged from the diesel; disassemble the batteries for another storage; cover air exhaust mouths.
4. Start the engine once every three months, and let it running for 20 minutes at various rev. Watch abnormal performances.



Attention:

1. Only the persons who are familiar to the features of the machine and have related safe-operation skills can maintain and repair the machine.
2. Read the parts book relative to this manual and the manual for diesel before maintenanc

Chapter VI Main Adjustments on Tractor

6.1 Adjustment on clutch

During operation, clutches will have sliding or inexhaustive release caused by continuous part wearing, which can lead to malfunctions. So adjustments should be done in time

6.1.1 Adjustments on dual clutch:

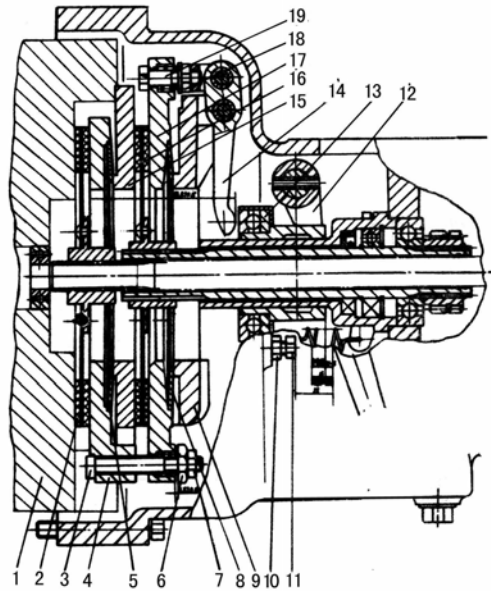

1. flying wheel 2. assistant clutch driven disk 3. drawbar 4. assistant clutch pressure plate 5. disk spring 6. adjusting nut 7. nut 8. disk spring 9. clutch cover 10. nut 11. adjusting bolt 12. clutch shifter 13. release bearing 14. releasing lever 15. fixed pressure plate 16. master clutch driven disk 17. master clutch pressure plate 18. nut 19. adjusting bolt

Fig 6-1 shows dual clutch of united-control type. It consists of three main units: driving unit, driven unit and control unit. Driving unit rotates along with engine flywheel, while only when clutch is engaged will the driven unit rotate together with engine.

Dual clutch should be adjusted on a clamp, following the steps: adjust the length of bolt 11 to get a distance of 96.8mm between the three releasing levers 14 and the end surface of assistant clutch press disk 4 with a difference value of 0.1 mm allowed. After adjustments, lock it up with M10×1 nut .

Adjust the free travel of clutch pedal . First length of the clutch push rod is adjusted to guarantee a gap of 2.5 ± 0.5 mm between the end face of the three releasing levers of the master clutch and releasing bearing .(to guarantee a free travel of 5.5-7mm of the clutch rocker). After the adjustments, lock up the nut .



Attention :

- 1) **With safety considered, the engine cannot be started without clutch released.**
- 2) **When you released the clutch pedal, your action should be quick and when you engage it,**

action should be slow. Before speed changing, the clutch pedal should be stepped down completely.

3) During operation, don't put your feet on the clutch pedal, or the abrasion of the clutch is increased.

6.2 Adjustment on central transmission

6.2.1 Adjustment for pretension of bevel bearing

To reduce the axial movements and increase their supporting stiffness of spiral bevel gear pair during operation, the two 32011 cone bearings 3 on the two ends of differential and the two 31305 cone bearings 10 (fig. 6-3) on the secondary shaft of gear box (that is central drive small bevel gear shaft) 9 should contain some pretension force when it is assembled. After some working time, the original pretension force will be reduced gradually due to the cone bearing's wearing. Then free play will come between the two cone bearings. In case the play is over 0.1mm, a second pretension should be done for the bevel springs.

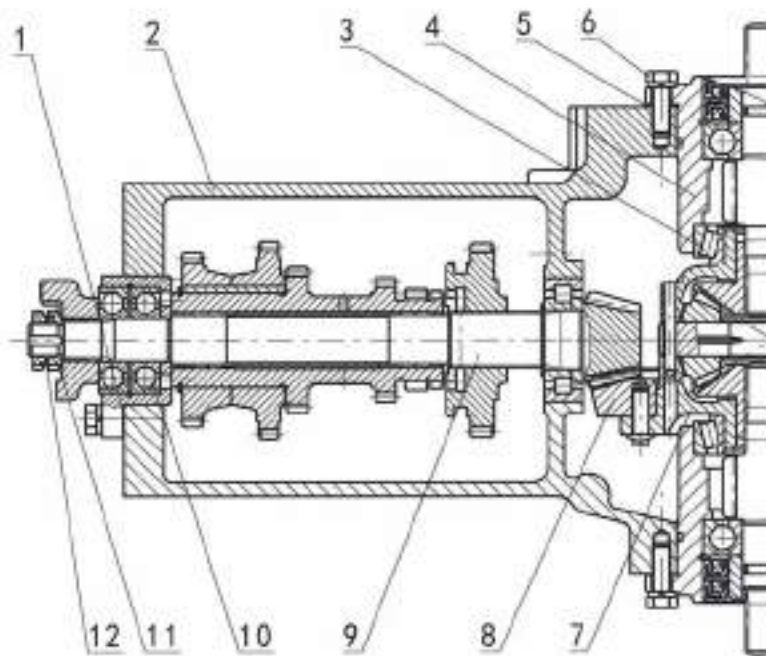

Fig. 6-3 Central transmission

1 adjusting washer 2 transmission case body 3 taper bearing 32011 4 bearing base
5 adjusting washer 6 bolt 7 differential housing 8 driven bevel gear 9 secondary
shaft 10 taper bearing 73058/08 11 locking nut 12 locking plate









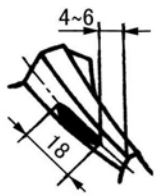

(1) Adjustment for the pretension of bevel bearing of the secondary shaft

Adjust the tightening level of the locking nut 11 near bearing to get a torque of 0.7~1.1N·m to rotate the secondary shaft. After adjustment, put in locking washer 12 and tighten the second locking nut 11.

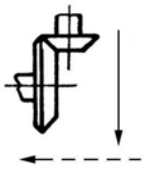
(2) Adjustment for the pretension of bevel bearing of the differential

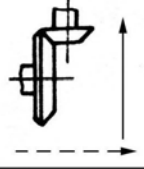
Adjusting washers 5 are inserted between the two sides of the transmission case body and bearing bases 4 of cone bearing. Tighten bolts 6 of two bearing bases. Turn secondary shaft 9. If the rotating torque is 0.4~0.76N·m stronger than that before installing differential, it means the pretension is proper. Here push and press the big bevel gear axially should not cause any free play.

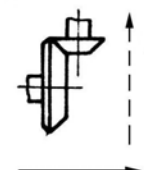
Fig6-1 Adjustment on the imprints of central transmission small curved-tooth bevel gears

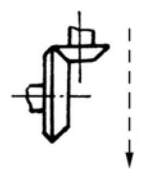
前进档		倒退档		Adjustment	
				Right Imprints	<p>During forwarding gears in operations, concave of small curved-tooth bevel gear should get imprints of concavenot not less than 60% of the tooth width and 50%of the tooth height. The imprints should be distributed near the smaller end of the tooth height; During reverse gears in operation, the imprints of the convex surfaces of small curved bevel gears are the same as the above.</p>
					<p>Reduce the adjusting washers 1 of the second shaft to move small curved-tooth bevel gears back (fig.6-3)</p> 
				abnormal imprints	<p>Add the adjusting washers 1 of the 2nd shaft to move small curved -tooth bevel gears forward. (Fig.6-3)</p> 
					<p>Add adjusting washers 5 of large curved-tooth bevel gear on the right , and reduce adjusting washers of the same amount on the left to drive large curved-tooth bevel gear right (fig. 6-3)</p> 
					<p>Add adjusting washers 5 of the large curved-tooth bevel gears on the left and reduce washers of the same amount on the right to drive the bevel gear left (fig. 6-3)</p> 
<p>Note: solid arrow means adjusting imprints while dotted arrow means adjusting engagement clearance</p>					

6.2.2 Adjustment for gear tooth clearance and imprints of bevel gear pair

(1) Standards of gear tooth clearance and imprints

Tooth clearance of bevel gear is required to be 0.10~0.25mm. Ideal imprints are distributed in the middle section of working gear flank close to the smaller end. Imprints look like spots with a length over 60% of that of gear tooth and a height over 50% of that of tooth.

(2) Check tooth clearance and imprints

① Check tooth clearance

There are two ways to check the clearances: You can check with a dial indicator. Put contactor of a dial indicator onto the gear tooth flank of the big end of big bevel gear, fix small bevel gear and swing the big bevel gear following the rotating direction. If the dial indicator reads 0.14~0.3mm, it means the tooth clearance is right; You can also use a 15~20mm long and 0.5mm thick lead sheet or “∞” - shaped fuse. Put the sheet or fuse between the unengaged tooth flanks (that is between the convex surface of small bevel gear and the concave surface of the large bevel gear). Turn the gear, then the pressed thickness of the big lead sheet end suggests the normal tooth clearance of this site. The clearance value should be 0.1~0.25mm (normal clearance). It is proper to have three or more spots equally distributing around the gear.

② Check flank imprints

Use chromatic way to check imprints of gear flanks. Paint the tooth flank of the big bevel gear with a thin and equal red lead coat. Rotate gear for several rounds, and the imprints left on the small bevel gear surface are touch imprints. As the small bevel gear is right spiral, the concave surface of the gear bears force when tractor goes forward. Here the big bevel gear's convex surface should be painted with red lead; when tractor move backward, the convex surface of the small bevel gear will bear force, and the concave surface of the big bevel gear should be painted with red lead.

③ Adjustments for tooth clearance and tooth flank imprints (fig. 6-1 shows the adjusting methods)

During adjustments, axial play of large and small bevel gears will make tooth clearance and tooth flank imprints have changes. If imprint and tooth clearance are inconsistent, correct imprints have priority, while the adjusting range of tooth clearance can be enlarged properly. Especially when a new adjustment is done after gear and bearing are abraded, the tooth clearance cannot be less than 0.1mm.

During normal operation, tooth clearance and tooth flank imprints will both have changes. In this case, if the tooth touch imprints are normal while tooth clearance is increased, no new adjustment is needed. However, when the tractor is heavily repaired or when it is replaced with a new pair of central driving gear or cone bearing, careful adjustments must be carried out to guarantee right tooth clearance and tooth flank imprints at the same time.

● Important:

The central transmission big and small gears are a pair of matched gears. Make sure that they are fixed correctly. It's better that they are replaced together with the bearing, otherwise the service life will be shortened.

6.3 Adjustment on differential lock

Differential lock is adjusted through adjusting bolt 3 and nut 4. During adjustment, right jaw 7 and left jaw 9 will have a clearance of about 2mm. When bolt is screwed in, the clearance is increased while when it is screwed out, the clearance is reduced. After adjustment, lock up bolt 3 with nut 4 (fig. 6-4).

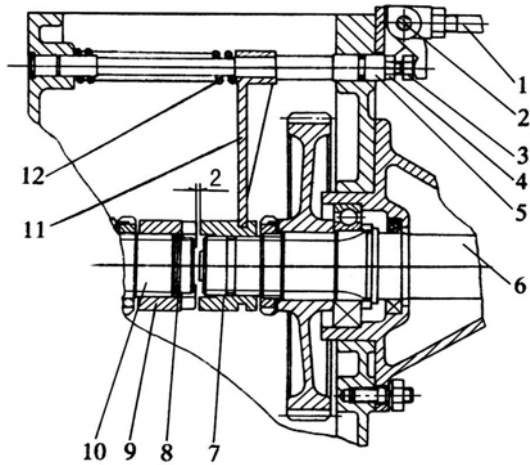
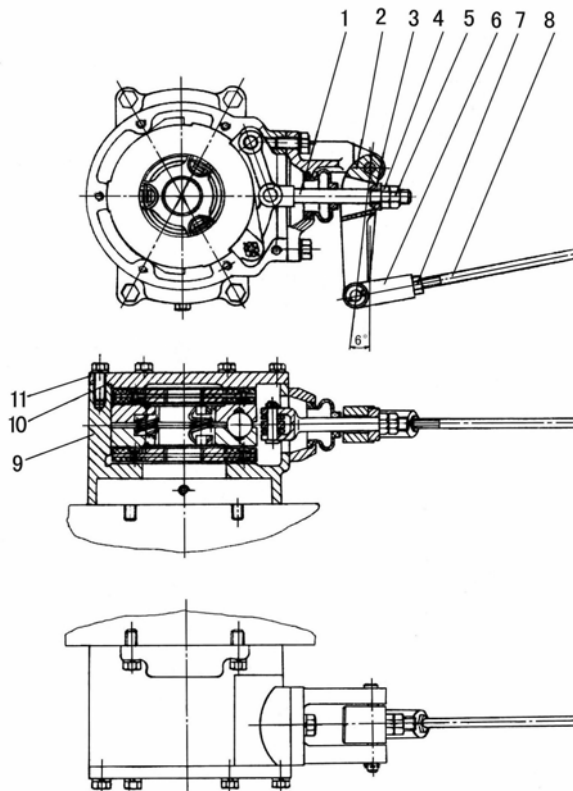

Fig. 6-4 differential lock

1 control stick of differential lock 2 pin 3 adjusting bolt 4 locking nut 5 fork shaft of differential lock 6 right driving axle 7 right jaw 8 roundwire snap ring 9 left jaw 10 left driving axle 11 shifter of differential lock 12 spring of differential lock

6.4 Adjustment on brakes



After some working time, abrasion of friction plate enlarges the clearances between friction plate and brake drum or between friction plate and brake housing and brake cover, which can influence brake performance. Overlarge free travel will cause ineffective braking. So brake should be adjusted frequently to guarantee safe traveling.

For both new and old tractors, when any of the following happens, adjustment should be done:

- ① Too large free travel of brake pedal leads brake malfunction;
- ② Too small free travel of brake pedal make brake constantly in half-braking state and the brake housing is heated.
- ③ Inconsistent braking force on the left and the right pedals can cause crooked running.

Fig. 6-6 disk brake

1 adjusting lever 2 rocker 3 self-alignment washer 4 nutM10 5 nutM10 6 adjusting fork of brake lever 7 nutM8 8 brake drawbar 9 brake housing 10 spacer of brake housing 11 brake housing

6.4.2 Adjustments on disk brake:

(1) Adjustment for free state of brake

Release M10 locking nut 5 on the outer end of the adjusting lever 1. rotate M10 nut 4 at the inside end. Self-alignment block 3 will have longitudinal movement, which can change the installation angle of rocker 2. The upper and the low holes 's central tie-line should be 6° backward from plumb line. After adjustment, lock up locking nut 5 (fig. 6-6)

(2) Adjustment for travel of brake pedal

Release locking nut 7 of adjusting fork of brake 6, rotate adjusting fork of brake to change the length of brake lever 8. The brake pedal 's movement should be limited in a range of 85~95mm from its top position to the friction plats completely braked.

In case the free state and braking state of the brake can not be achieved through adjusting within above adjustment range, it can be adjusted by increasing/decreasing the quantity of spacers between the brake cover 11 and brake housing 9. In case braking stroke is too small, it can be solved through incresing the quantity of these spacers. In case braking stroke is too big, then decrease or remove these spacers. (fig.6-6).

(3) Adjustment for brake "deviation"

In case the adjustment of left and right brake is inconsistent, the braking imprints on right and left tires are different and tractor's deviation will happen when braking the tractor running in high speed promptly. In this case the length of brake lever on the long imprint side shall be increased appropriately, or decrease the length of brake lever on the short imprint side until the length of left and right tire imprints are basicly the same and can guarantee the reliable braking. After that, tighten the lock nut, first check with III gear, then check with IV gear after adjustment.



Warning :

Before starting, interlock left and right brake pedal. Single-side braking can cause sharp turn and leads to turn over.



Important:

Free travel of the left brake pedal of tractor must be identical with that of the right one; otherwise tractor will deviate from its course and lead to accident in case of emergency brake.

When the operator leaves the driving seat or the tractor is parked, the operator must open the hand brake self-locking device, otherwise the alarm device will be triggered and the buzzer will ring.

6.5 Adjustment on front axle

6.5.1 Adjustment for axial clearance of front wheel bearing

Normal axial clearance of front wheel bearing 8 and 9 is 0.1~0.2 mm (fig.6-7). When its clearance is more than 0.4mm the the front wheels will wigwag right-and-left during the tractor running, and the bearings are easily damaged due to impact load, therefore it shall be adjusted in time. When adjusting, first rise and support the front wheel and keep it from ground, then remove the bearing cover and pull the split pin from nut 6, after that first tight the nut 6 until the bearing clearance being elimiated, then untight the nut 6 $1/15\sim 1/7$ turn, and tighten the nut with split pin, finally install the bearing cover.

6.5.2 Adjustment on front wheel toe-in

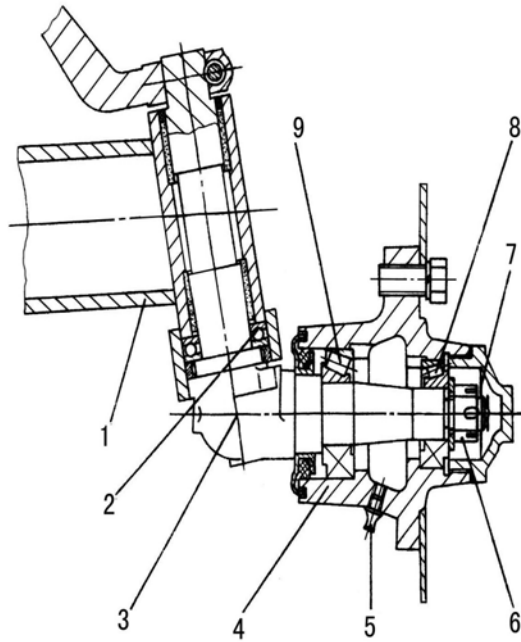

Fig. 6-7 front wheel hub and steering knuckle

1. front axle 2. thrust bearing 51106 3. steering knuckle 4. front wheel hub 5. oil cup 6. nut 7. split pin 8. bearing 30205 9. bearing 30206

During the use of tractor, the front wheel toe-in changes due to deformation and wearing of steering gear and front axle. It will speed up the wearing of front wheel tire if it is not adjusted properly in time. Toe-in adjusting should follow the following steps:

- (1) Park the tractor on the ground and put the front wheels in beeline running direction.

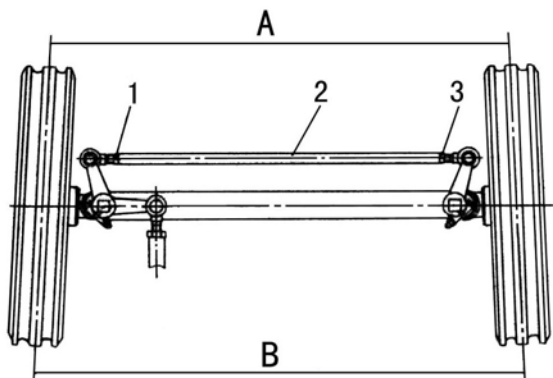

Fig. 6-8 adjustment of toe-in of front wheel

1. right handed nut 2. drawbar
3. left handed nut

- (2) Measure the distance A and B between front side and back side of two wheels at the height of front wheel center.

(3) Loose the lock nuts 1 and 3 at the two sides of drawbar 2, rotate the drawbar until $B - A = 4 \sim 10$ mm, and then tighten drawbar 2 with nut 1 and 3.

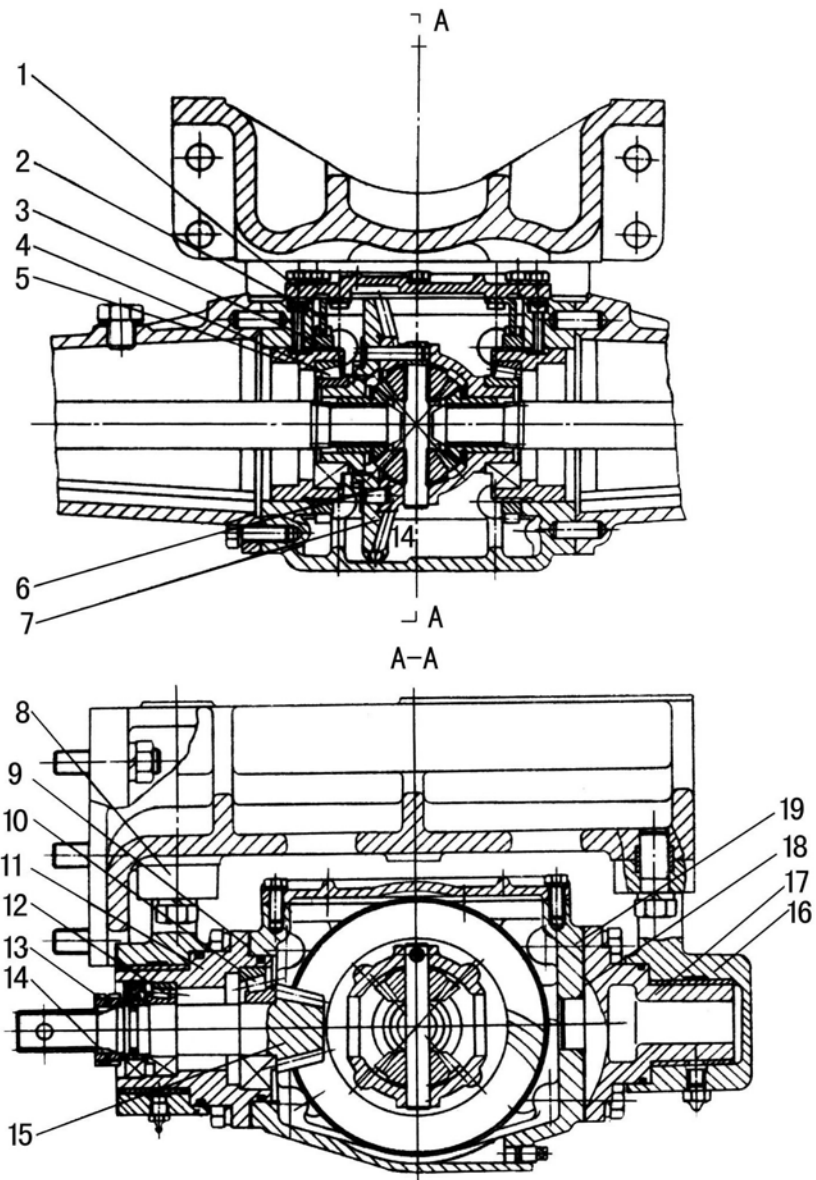

Fig. 6-9 central transmission of fore driving axle and differential assembly

1. upper cover of final transmission case 2. locking plate 3. adjusting nut 4. rolling bearing 32009 5. bearing base 6. differential housing 7. driven bevel gear 8. rear stand assembly 9. bearing base washer 10. rolling bearing 31306 11. driving bevel gear bearing base 12. rolling bearing 32006 13. round nut 14. lock washer 15. driving bevel gear 16. front supporting base 17. front sway shaft 18. washer of front sway shaft 19. main driving housing

6.6 Adjustment on fore driving axle

6.6.1 Adjustment of central transmission (fig.6-9)

For assembling, fit the driving bevel gear bearing base washer 9 and adjust nuts 3 at two sides, keep the backlash of central transmission gear pair within 0.15~0.30 mm. In the mean time, ensure no axial float of the bearings at two sides of differential and free running of the differential assembly.

Adjust the position of flute on nut, it shall ensure that positioning piece can be inserted smoothly to

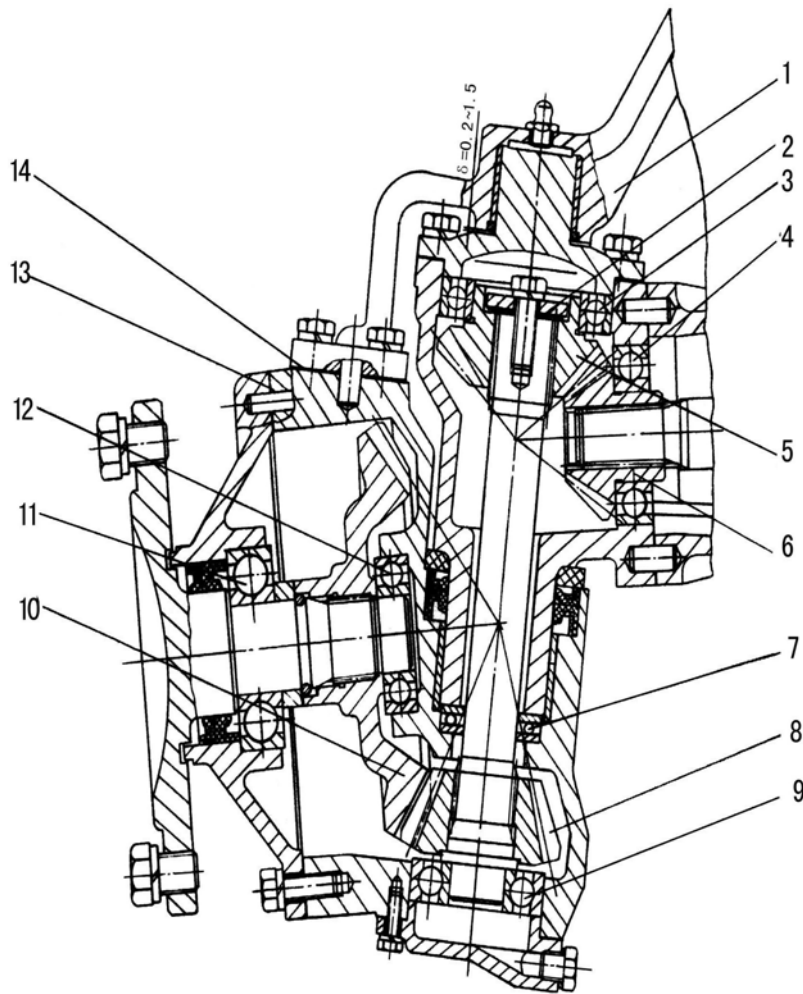

Fig. 6-10 final drive of front driving axle

1. left steering arm 2.adjusting washers of vertical axle 3. rolling bearing 6010 4. rolling bearing 6207 5. driven gear of central drive 6. driving gear of central drive 7. rolling bearing 51106 8. driving gear of final drive 9. rolling bearing 6305 10. driven gear of final drive 11. rolling bearing 6307 12. rolling bearing 6206 13. washers of driving shaft cap 14. adjusting washers

lock the nut.

6.6.2 Adjustment of side reduction gear pair (fig.6-10)

For assembling, fit the driving shaft cap washers 13 to keep backlash of side reduction gear pair within the range of 0.2~0.4 mm and ensure imprints of contacting area.

6.6.3 Adjustment on inter-transmission gear pair (fig.6-9)

For assembling, fit the adjusting washers 2 of vertical shaft to keep backlash of inter-transmission gear pair within the range of 0.2~0.4 mm and ensure imprints of contacting area.

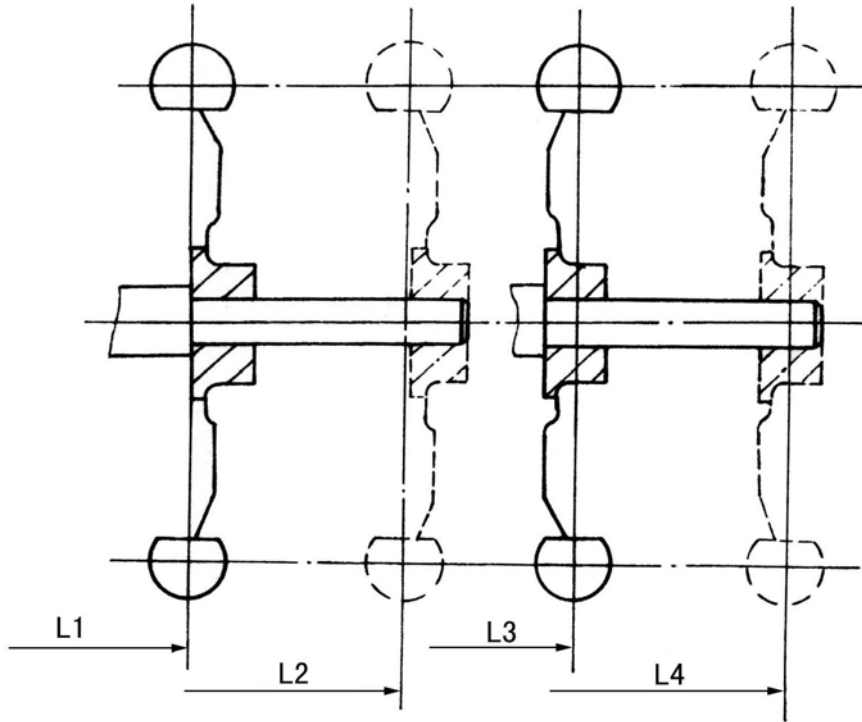

Fig.6-11 tread adjustment for rear wheels

6.7 Adjustment on wheel tread

6.7.1 Adjustment on front wheel tread

The front wheels tread of Jinma series wheel-type tractors has two kind of structures with adjustable wheels tread and unadjustable wheels tread respectively. Adjustable wheels tread structure utilize telescopic sleeve to carry out step-by-step regulation. Regulating range is 970~1270 mm and each step gap is 100 mm.

6.7.2 Adjustment on rear wheel tread :

Rear wheels tread can be adjusted steplessly by changing and turning the fixed position of driving wheel hub on driving shaft. It can also carry out step-by-step regulation by turning rim assembly or exchanging right and left driving wheels. Adjusting range of the first step tread is L1~L2 and the L2 is the normal tread used. Adjusting range of the second step tread is L3~L4 (see fig.6-11). Values of L1~L4 see chapter 1 <Main Technical Specification of Tractor>.



Attention:

- (1) Don't use the tire with size bigger than specified size in the manual.
- (2) Qualified workers with appropriate means are needed to disamble and change tire or adjust tread. During working, pay attention to the inclination of tractor or tires due to its gravity.
- (3) Tight the connection bolts of tire and plates to required torque and inspect them periodically.

6.8 Adjustment and operation of steering device

6.8.1 Hydraulic steering control unit (SCU)

Model: 101S-1-50-12-A

Hydraulic Steering Control Unit (SCU) series 101S-1 is integrate hydraulic orbital steering control unit, CU series 101S-1, based upon series 101-1, incorporates relief valve, shock valve, suction valve and check valve inside the steering unit. They inherit the same feature as series 101-1, meanwhile they can also control the steering pressure , and provide the oil cylinder with shockproof and oil

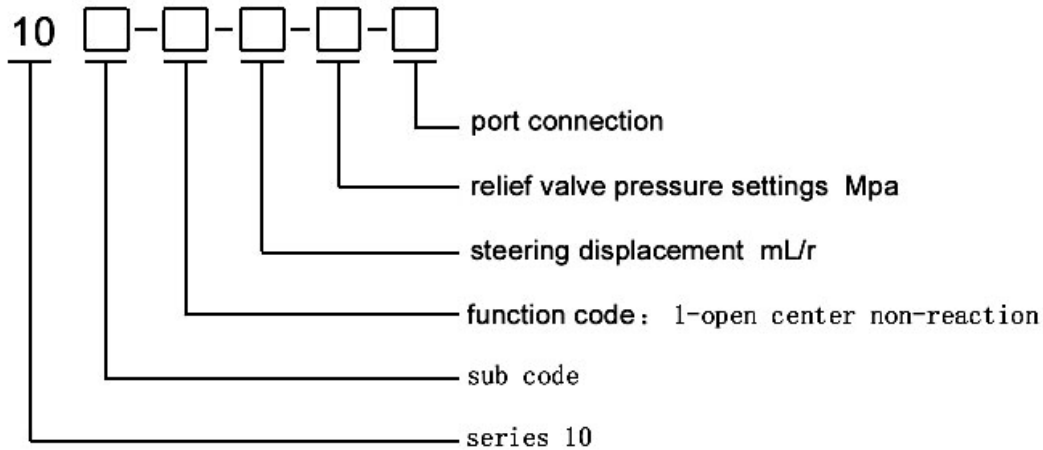

FIG 6-10 Model code

suction protection, to avoid the oil flowing backward。

1、 Model Code (fig. 6-10)

2、 Drawing (fig. 6-11)

3、 Issues needing attention

(1) For mounting

① the mounting data of SCU should conform with the coaxal requirement between the steering control unit and the steering column, meanwhile there should be about 1 mm clearance in the axial direction between the steering column and the steering control unit.

② The depth of the bolt that fastens the steering column, screwing inside the steering thread hole, should be $\leq 17\text{mm}$, the fastening torque should be $\geq 30\text{N.m}$.

③ After mounting, the steering control unit should be checked whether the steering wheel can return to the neutral position smoothly, to ensure the flexibility

④ Pipe connecting: Port P should be connected with supply pipe of the pump, Port T should be connected with pipe to oil tank. Port A and B should be connected separately with the left and the right pipe.

(2) For oil flow speed

① For the oil supply pipe to be connected with the Port P, it's recommended that the oil flow

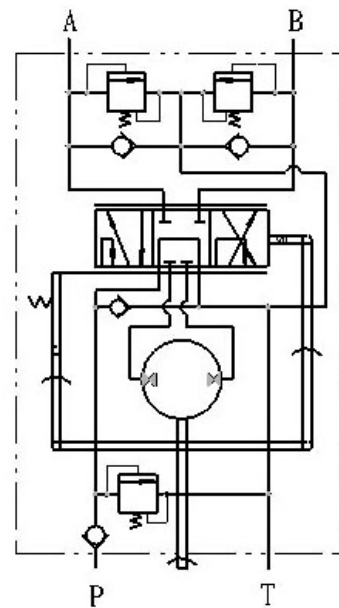

FIG 6-11 Drawing

speed inside the pipe be $\leq 1.5\text{m/s}$ 。

② For the cylinder pressure pipe to be connected with Port A and Port B, it's recommended that the oil flow speed inside the pipe be $\leq 4\sim 5\text{m/s}$ 。

(3) For others

① The diameter of the steering wheel should not exceed 500mm。

② A filter, the filtering precision of which is $30\mu\text{m}$, should be installed on the way to Port T. The tank position should be mounted generally higher than the SCU mounting position, and the backward flowing pipe should be put under the oil, then during the manual steering, the suction can be supplied, meanwhile the air can be prevented to go inside the oil pipe

③ The viscosity of the oil for the steering is 17 cst \sim 33 cst. It is recommended to use low condensate hydraulic oil. The scope of oil operational temperature is $-30\text{ }^{\circ}\text{C}\sim 100\text{ }^{\circ}\text{C}$ and the normal oil temperature should be $20\sim 80\text{ }^{\circ}\text{C}$

④ The steering should be executed under test operation after mounting: Before running, clean the tank and fill the oil to the maximum level. Loosen the cylinder thread screw, to make the pump run at low speed to deflate, until the oil flowing outward doesn't produce any foam. Disassembling the link of the piston rod and the steering wheel, and turning steering wheel to make the piston to the extreme left or right (don't stop between the extreme ends), then filling oil up to the stipulated level. Fastening all the thread joints(don't fasten on the condition of pressure), link the piston rod, and then check whether steering unit operates normally or not under different conditions.

⑤ It's necessary to keep oil clean, to prevent the internal part of the steering unit from being locked by any dirty fragment, resulting in malfunction of steering. Therefore, the filter and the oil should be frequently inspected(the oil should be changed under the condition that there appears the black center on the blotter, if one drop of oil is put on the paper.

⑥ If the operator feels the steering unit heavy or malfunction during the operation, the operator should check carefully and check the reason, it's forbidden to turn the steering wheel rudely, or disassembly the steering unit to prevent parts being damaged. It's forbidden that two operators turn steering wheel at the same time

4、Disassembly and Assembly

(1) Disassembly

① Disassembly Order:

End Cap—Spacer—Stator—Rotor—Drive shaft—Spacer Plate— Pin + Steel Ball—valve Spool & Sleeve—Pin—Spring—backup ring—Bearing—backup ring—Housing

Plug of Relief Valve—Lock Bolt—Spring base—Spring—Spool of Relief Valve—Base of Relief Valve

Plug of Shock Valve—Shockproof and Pressure adjustment Bolt—Spring of Shock Valve—Base of Steel Ball—Steel Ball—Base of Shock Valve

② Attentions

Don't damage or scrape the surface and end of parts.

Don't dip or soak in petrol the rubber ring which is disassembled from SCU. Otherwise it will cause distortion and deterioration. Pay attention to the right position of the steel ball, after it's disassembled.

③ SCU is a kind of high precision product. The user doesn't have the test tool, thus So we don't suggest that the user disassemble it himself.

(2) Assembling

① Assembling Order

Valve Spool—valve Sleeve—Pin—Spring—Big backup ring—Bearing—small backup ring—Housing—Steel Ball+ Pin—Spacer Plate—Drive shaft—Rotor—Stator—Spacer—End Cap

Base of Relief Valve—Spool of Relief Valve—Spring—Spring Base—Locked Bolt—Plug of Relief Valve

Base of Shock Valve—Steel Ball—Base of Steel Ball—Spring of Shock Valve—Shockproof and pressure Adjustment Bolt—Plug of Shock Valve

② Attentions

I . Please clean all the parts (except the rubber ring) with petrol or coal oil before assembly. If there is paint with the connection surface, it should be cleaned by acetone. Please clean with soft brush or silk ,it' s forbidden to clean with any cotton or clout. And the best cleaning method is to blow by compressed air.

After finishing assembly, the operator should put 50-100 mL hydraulic pressure oil into the input port , and turn the valve spool left or right . If there is no problem , it can be installed in the vehicle.

II . Keep clean the connection surface of Housing ,Spacer Plate, Stator and End Cap. Do not be scraped or broken.

III . There is a mark both on the end surface of the rotor and on the drive shaft, the mark of the drive shaft should be meshed against the tooth vale of inner spline. Pay attention to the right position while assembling.

IV . For the bolt of the end cap, the qualified complex washer has to be used

V . While fastening seven bolts in the end cap, one bolt should be fastened every two bolts in sequence, fasten gradually, and the fastening torque is around 40-50N.m;

VI . To avoid scraping during assembly, bit Lithium-based lube grease can be used.

6.9 Structure and adjustment of hydraulic suspension system

Hydraulic suspension system is made up of hydraulic system and suspension device. Hydraulic system is open oil circulating pipe system for oil pressing control. Suspension device is rear-installed three-point suspending. Hydraulic system mainly consists of semi-distribution type hydraulic lifter,

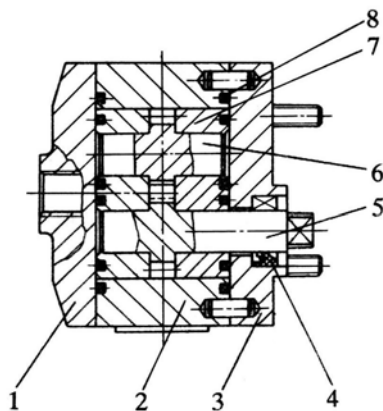

Fig.6-15 CBN-E306 gear pump

- 1 rear cover 2 pump body 3 front cover
- 4 reinforced seal 5 driving gear 6 driven gear
- 7 axial sleeve 8 seal ring

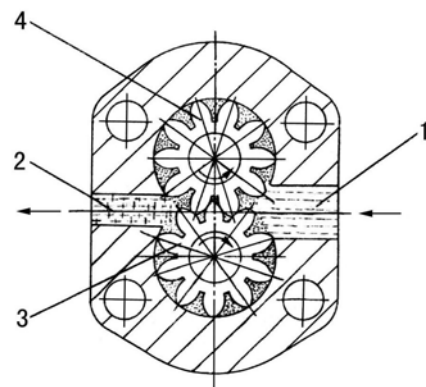

Fig. 6-16 working principal of gear pump

- 1 oiltaking chamber 2 oilpressing chamber
- 3 driving gear 4 driven gear

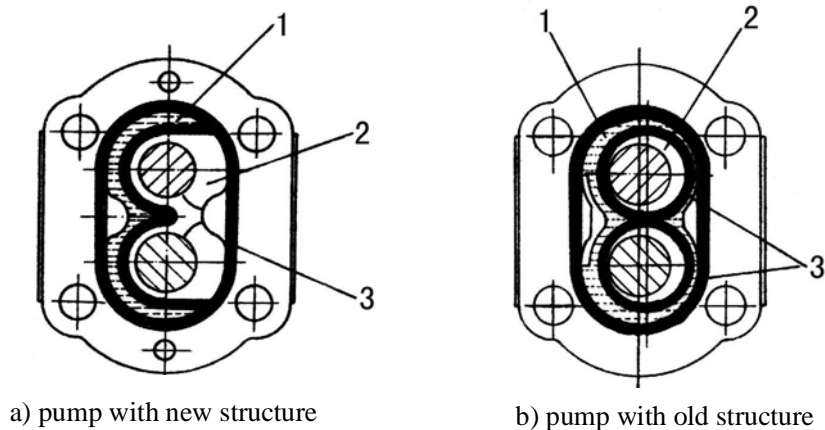

Fig.6-17 hydraulic compensation
 1 high-pressure area 2 low-pressure area
 3 seal ring pressed area

gear pump, oil filter and connecting pipes etc.

6.9.1 Working principle of gear pump

Gear pump for Jingma series wheel-type tractor is CBN volume-type external engaged gear pump (see fig.6-15). The gear pump is installed on right rear side of the gear chamber in front of diesel engine and driven directly by diesel engine. The gear pump mainly includes a pair of external-engaged shaft gears 5 and 6, and pump body 2 containing this pair of gears, sleeve 7, front and rear covers 1 and 3 etc.

Working principle of gear pump is indicated on drawing 6-16. Take left-rotating pump as a example, when the diesel engine starts, the driving gear of gear pump will rotates counterclockwise, and the oil from oil absorbing chamber will be filled in-between the gears. Oil entered into the pump is contained by axial sleeves of both side, engaged gears and pump body, and formed two oil chambers which are not open to each other, viz. oil absorbing chamber and oil pressing chamber. When gear rotates, gears in right chamber (oil absorbing chamber) disengae and space between gears enlarges, and it formed partial vacuum, then oil in oil tank is absorbed in. In the mean time, gears in left chamber (oil pressing chamber) enters into engagement, its teeth meshed with each other and thus press the oil in-between teeth outside the oil pump. Oil inside the oil chamber will flow to lifter continuously through gear pump.

During working, a certain pressure difference exists between oil absorbing chamber and oil pressing chamber inside gear pump. The high pressure oil in oil pressing chamber will leak back to oil absorbing chamber through gaps between two sides of gear and axle sleeve, gaps between teeth addendum and pump body and gaps due to bad engagement of gears, and cause the loss of volume, then the hydraulic system will be heated. Excessive volume loss can result that the normal working pressure of gear pump can not be set up, it can not lift farming implement in serious condition.

In order to reduce volume loss, oil pump adops integral-floating axle sleeve, and has hydraulic automatic compensation and axial balance structure. Axle sleeve floats inside pump body during working. Its position is determined by the force on it. The width of pump body is 0.09~0.18mm bigger than the total width of gear and two axle sleeves. After assembling, the front and rear cover is pressed

tightly on the pump body by bolts, and the seal rings between them are compressed. It make the axle sleeve being pressed tightly on two sides of gear, at this time a space which is not big is formed between axle sleeves and front and rear cover. Oil pressure is imposed on back face of sleeve through this gap (see 6-17), and then ensure good matchment between sleeve and gear joint face. This function is named as hydraulic automatic compensation.

Fig..6-23 Hydraulic Steering Pipe

1.Hydroulic steering control units :101S-1-100-12-AH;

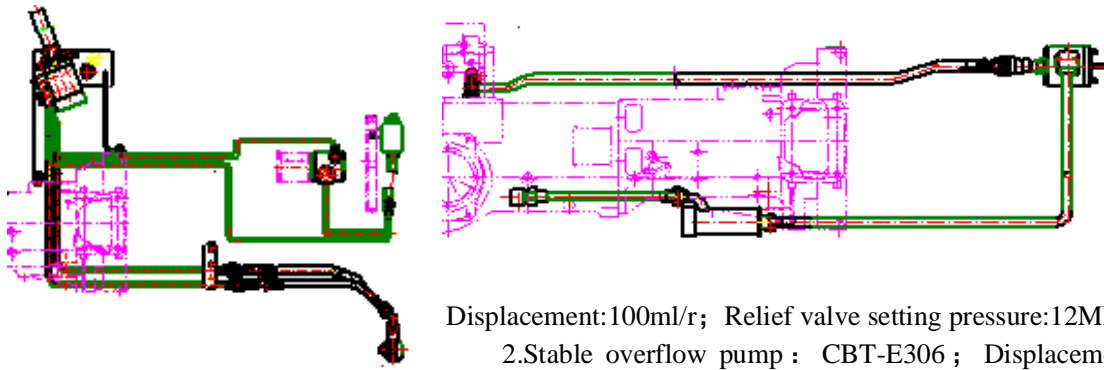

Displacement:100ml/r; Relief valve setting pressure:12MPa

2.Stable overflow pump : CBT-E306 ; Displacement: 6ml/r; Pressure: 6MPa

Fig..6-24 Hydraulic Lift Pipe.

1.Gear pump: CBN-E314; working pressure: 16MPa; Nominal flow rate: 28L/min

6.9.2 Lifter

(1)Working principle of distributor (simple reversing valve)

The working principle of distributor (simple reversing valve) is indicated on fig.6-19. Pull the control handle 5 can put it in three different working positions named as lifting, neutral and dropping. When main control valve 1 is in neutral position (fig.6-19b), the oil fed to revising valve by oil pump flows back to oil tank through oil returning port A following arrow indication on the drawing. At this time the oil inlet port B and oil returning port C are closed by main control valve, and oil cylinder is under a closed situation, therefore the farming implement is kept in a fixed position.

When the main control valve 1 is pushed from neutral position to dropping position (fig.6-19d), oil returning port C of cylinder is opened, and the oil inside cylinder is forced back to oil tank through oil returning port C following arrow direction indicated on fig.(6-19d) by self-weight of farming implement, therefore the farming implement begins dropping. At this time, the oil of the input revising valve of oil pump still flow back to oil tank through oil returning port A.

When the main control valve is pushed from neutral position to lifting position (fig.6-19c), oil returning port A of cylinder is closed and oil inlet port B of cylinder is opened. At this time oil of pump input reversing valve flows into oil tank through oil port B following arrow direction indicated on the fig.and push the piston, then the farming implement begins lifting. In order to prevent the hydraulic elements from being damaged by over-load arisen from farming implement lifting, a system safety valve is added inside the reversing valve.

(2)Working principle of lifter

Fig.6-20 is simple position adjustment principle diagram of lifter with height adjusting performance. In the drawing the main control valve 6 is in neutral position.

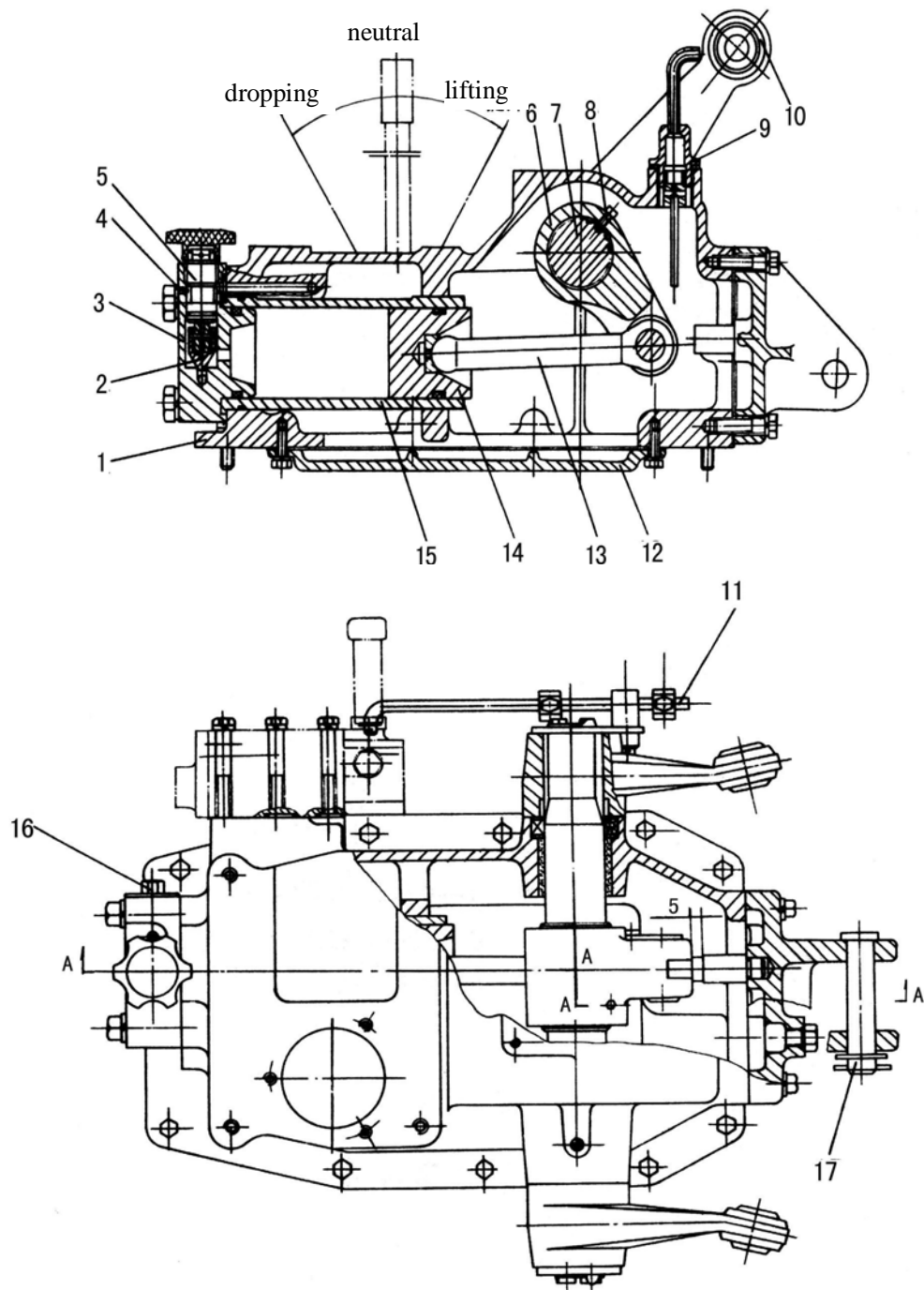
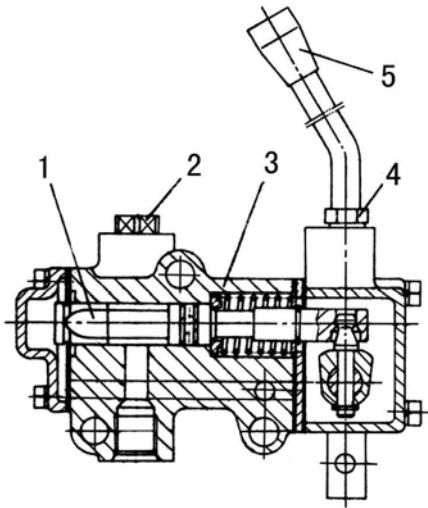
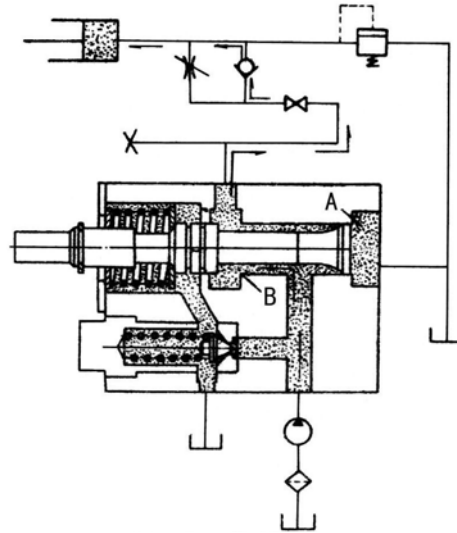

Fig. 6-118 Lifter

- 1 lifter housing 2 adjusting valve 3 cylinder head 4 fixing bolt 5 bolts of adjusting valve
 6 inner lifting arm 7 lifting shaft 8 fixing bolt of inner arm 9 air plug and oil dipstick
 10 outer lifting arm 11 return push lever of handle 12 oil sump 13 fixing bolts of inner arm
 14 piston 15 cylinder 16 hydraulic output plug 17 front connecting pin of top link



a) simple reversing valve



c) lifting position

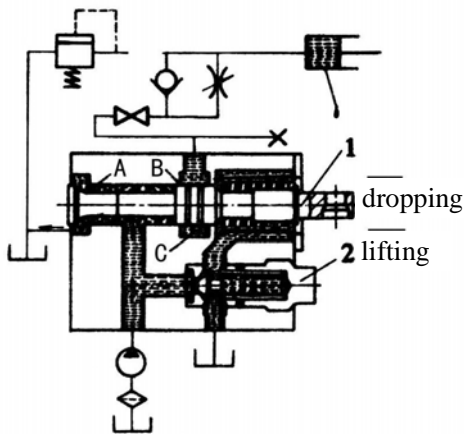

b) neutral position

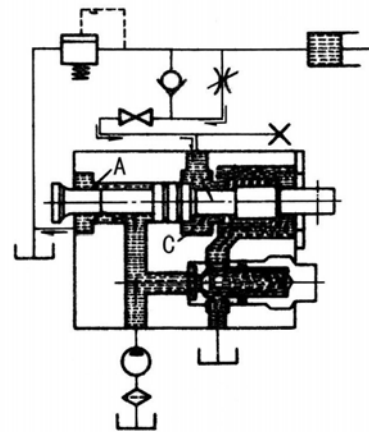

d) dropping position

Fig. 6-19 simple reversing valve and its working principle

- 1 main control valve 2 safety valve press screw plug 3 valve body
4 handle fixing device 5 control device 6 cylinder

Pull the control handle 10 to the dropping position, locking ball 8 drops to the drop locking locating slot B on the locating block 7. Master control valve 5 moves right to the dropping position at the same time. Oil in cylinder flows back to oil tank through master control valve and the farming implement begins dropping. Along with the implement dropping step by step, backing pin 2 fixed on lifter shaft baffle does laevorotation around the lifting shaft and slide along return push lever 4. When it slides and touches drop limit stop 3 fixed on return push lever, it will drive return push lever 4 to move right and turn control handle at the same time until locating steel ball 8 is pushed out of locating slot 8. Now under the tensile force of master control valve return spring 6, control handle 10 and master control valve 5 jump back to the neutral position at the same time. Cylinder stops oil returning and so implement stops dropping. Therefore, implement dropping location depends on the fixed location of

dropping return block 3 on return push lever 4. That is, the closer dropping return baffle is from control handle the lower position the implement can go. Loosen the locking bolt of the dropping return baffle, the return push lever cannot return the control handle to the neutral position. The master control valve will stay at the dropping position all the time. Now cylinder will work in "floating" state.

To lift farming implement, push the control handle 10 to the lifting position. Now the locating steel ball will drop into locating slot A (fig. 6-20) and master control valve 5 move left to lifting position. Then farming implement begins rising. Along with farming implement's rising step by step, return baffle pin 2 rotates clockwise. When the baffle pin slides and touches lifting block 1, it drives return push lever to move left. Rotate control handle 10 at the same time until locating steel ball 8 is pulled out of locating slot A. Now under the tensile force of return spring 6, control handle 10 and master control valve 5 jump back to the neutral position at the same time. Oil pump stops supply cylinder with oil and the farming implement stops rising accordingly. The rise height of the farming implement depends on the fixed position of lifting return baffle 1 on return push lever 4. The closer the return block 1 is from return push lever, the farm implement will rise higher.

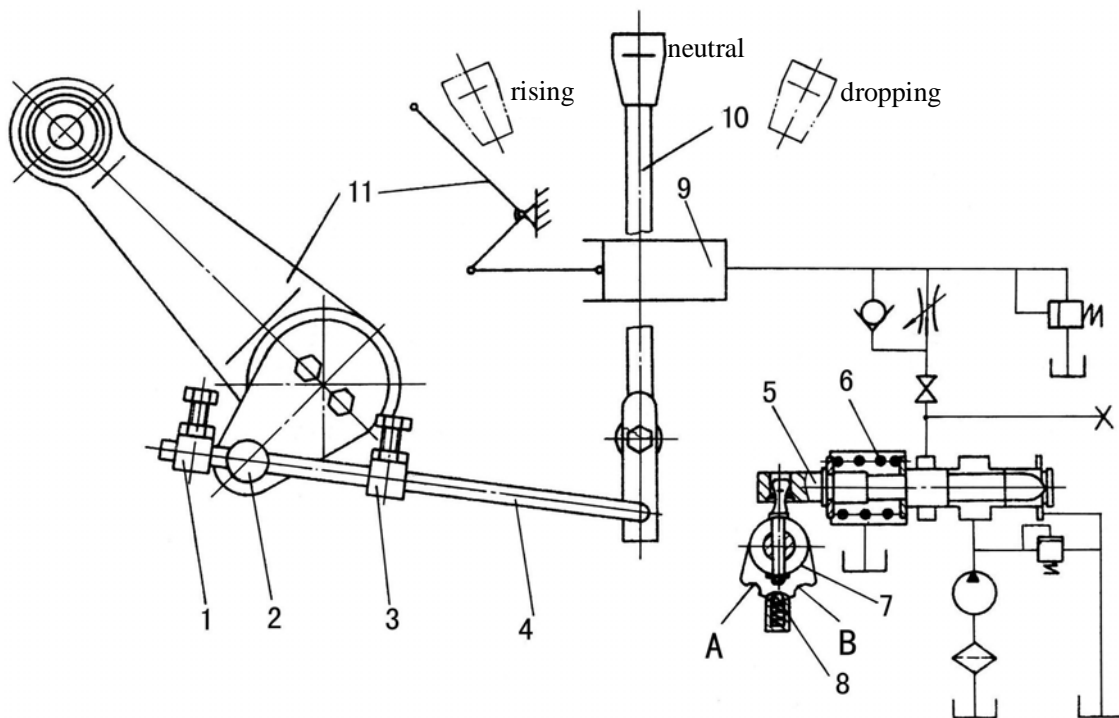

Fig.6-20 lifter working principle

- 1 return block for lifting 2 return pin 3 return block for dropping 4 handle returning rod
 5 master control valve 6 return spring of slide valve 7 handle fixing block 8 fixing steel ball
 9 cylinder 10 control handle 11 outer lifting arm

● **Important:**

During operation, improper adjustment can keep control handle from returning in time, which will lead to overload of hydraulic system and damaging the machine.

(3) Adjustments on hydraulic lifter

① Adjustment for Max. lifting position

Put control handle 1 at the neutral position in Fig. 6-21, turn lifting arm assembly 2 to the rising side to get a distance of not less than 5mm between the top of the lifting arm 3 and limit pin 4 (insert a pad at the site of air plug 5 to control this size). Adjust distance L of 9~10mm between baffle plate 6 and baffle pin 7. Fix the baffle plate on the return push lever 8 with bolts and nuts.

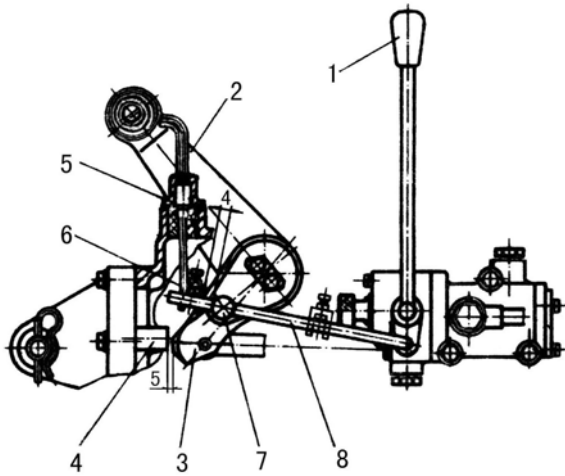

Fig. 6-21 adjustment for lifting position
1 control handle 2 lifting arm assembly
3 inner lifting arm 4 spacer pin 5 air plug
6 block 7 pin 8 return rod

② Adjustment for dropping position

Put control handle 1 at the neutral position, turn lifting arm assembly 2 to the dropping side. When it reaches dropping location, adjust the distance L of 9-10 mm between fixing block 3 and pin 4. Location adjustment should be done during traveling. After the farming implement dives into earth, fix block 3 on return lever 5 with bolts and nuts (Fig. 6-22). Then lift farming implement and repeat tests and check the adjustments.

If operate farming implement with land wheels, use height adjustment. Now block for dropping 3 should be adjusted to keep distributor control handle 1 from returning to the central position.

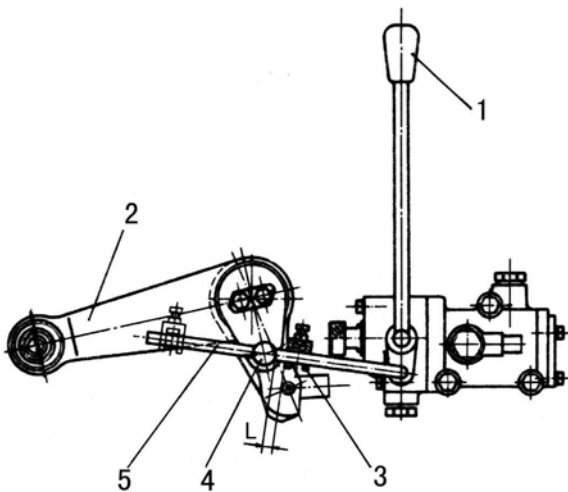

Fig. 6-22 adjustment for dropping position
1 control handle 2 lifting arm assembly
3 fixing block 4 pin 5 return rod

③ Adjustments for dropping speed

During adjustments, turn adjusting valve screw bolt 5 (Fig. 6-18) to control the dropping speed of farming implement. When dropping speed is adjusted to a proper value, limit the move range of

adjusting valve bolt with limiting screw 4 .

④Adjustments on safety valve

Safety valve has been adjusted when machine is delivered from factory. During operation, it cannot be dismantled in common conditions. When it needs new adjusting, the adjustment should be done on a special pressure adjusting bench. Test oil is HC-8 (SY1152-77) and oil temperature is controlled at $65^{\circ}\text{C} \pm 5^{\circ}\text{C}$. When safety valve presses screw plug and turns clockwise, opening pressure is increased. Otherwise, the opening pressure will be reduced. (Fig. 6-18)

In Hydraulic system, most components have high precision and their assembled parts have not careful debugging on test table. Therefore, during operation, service and trouble shooting, you should care the hydraulic oil, oil for washing and clean environment around. In common conditions, no dismantling at random is allowed.

 **Attention :**

(1) Before checking hydraulic system, turn off engine and push hydraulic handle to decrease pressure inside the system.

(2)High-pressure oil will soak into skin and cause hurts. So pay much attention to the high-pressure oil. Don't let the high-pressure oil spray to eyes and such other site.

(3)Only after filling fully hydraulic oil into the shell of hydraulic lifter according to rules, can the engine be started to burn out the hydraulic gear pump.

(4)When tractor transfers with farming implements suspended, hydraulic lifter handle should be at the position of "neutral". When it transfer to a new field or operates with farming implement suspended, no high speed is allowed to avoid damaging parts of suspending system and lifting system. When driver leaves tractor, the farming implement must be dropped to the ground.

6.10 Operation of electrical equipments

The electric equipments of tractor are used to start tractor and meet the requirements of sending out signal from tractor and lighting at night etc. The electric system of this tractor is negative-grounded 12V single wire schedule.

6.10.1 Accumulator

When the type of accumulator 6-QW-80 has a rated voltage of 12V and a rated capacity of 80 ampere hour, the accumulator is used to store redundant power from generator. When the generator is not working or running at low speed, it can supply its power to start the tractor and other power consumers. When the engine is over-loaded at short time, it also assists to supply power.

Check and maintain the tractor regularly according to the Technical Maintenance of tractor during daily use.

(1) For a new accumulator, charge it for 1—2 hours before using it, which can prolong the service life of the accumulator.

(2) Clean the dust and dirt on the accumulator case regularly in order to avoid the leakage. Check whether there is crack or electrolyte leakage and maintain the pole and wire contactor in good contacting condition. The blowhole of plastic cover shall be kept unblocked in order to avoid explosion.

(3) Each starting time shall not be over 10 seconds and interval between starting should not be less than 2 minutes in order to avoid over discharging. Accumulator shall be charged timely. The single battery voltage shall be 12.6V after being charged.

(4) Before the tractor is to be stored for a long term, cathode cable should be dismantled to avoid self-discharging of the battery. When the battery is in long-term use, charge it before next use. It is forbidden to start the tractor in the deficient power state of battery.



Warning :

(1) When engine is running, it is absolutely forbidden to disassemble accumulator cover. Don't let eye, hand or clothe being touched by electrolyte. In case being touched, wash with clean water completely.

(2) Maintenance of electric equipments can only be carried out after disconnecting the ground cable and accumulator.

(3) Gas emitted from accumulator is explosive. Keep the accumulator far away from electric spark in order to avoid damaging the accumulator.

(4) Don't discharge in enclosure environment. Appropriate ventilation can protect the build-up gas from explosion.

● Important:

(1) Improper use of accumulator can decrease its service life and increase its maintenance cost. It shall be used properly and exert its full performances.

(2) The positive and negative poles of accumulator shall not be connected reversedly. Reversed connection of positive and negative will cause failure of accumulator and electrocircuit.

(3) Disconnecting the wire of accumulator from negative pole and connecting it from positive pole.

6.10.2 Operation of generator

(1) It is forbidden to check whether generator generating power with the method of ground ignition. It is not allowed to check insulation of generator with tramegger or AC power over 100V. It can only be checked with multimeter with high inner-resistance, otherwise the diode will be destroyed.

(2) When parking, it should remove the key in order to disconnect the motor field winding and accumulator, and ensure the accumulator will not discharging in long term.

6.10.3 Use of start motor

(1) During using, keep regularly the start-motor clean, all contacting points of wire being tightened tightly and in good contacting condition.

(2) Each starting time shall not be over 10 seconds, the time between two starting shall be less than 2 minutes. Find the reason and eliminate them in case fail to start several times.

(3) Pre-heating the engine and then use the start-motor when starting in cold weather.

6.11 Intake and exhaust system

The air cleaner adopts K1317 dry paper filtrate core, whose structure and air flowing chart are shown in Fig. 6-39. Air is absorbed in from the intake port on the upper part of air filter. The torsion angle makes the air whirling. The bigger particle is thrown off to the bottom because of the centrifugal force and files up. The briefly cleaned air will be cleaned again through the paper filtrate core before it is absorbed into the cylinder so that it can prolong the cylinder sleeve and piston unit's service life.

According to the dust level of the environmental air, the filtrate element need to be maintained after being used for some time according to tractor service requirements (If in dusty environment, it needs to be maintained more early). Take out the filtrate element, remove the dust with a soft brush (Fig. 6-40) and knock on the surface gently. If condition permits, airproof the two ends of the filtrate element, blow it from the inside to the outside with compressed air. Never clean it with oil or water.

The muffler is fixed on the exhaust elbow. The waste gas enters the muffler and moves on through

the eyelets on the down-side to the muffler cavum, and then goes out through the eyelets on the up-side of the filtrate element. After several times ' swerve, blocking and inflation, the noise is greatly reduced. After being used for about 1000 hours, the dust need to be removed by knocking at the outside of the muffler in order not to block up or affect the engine' s function.

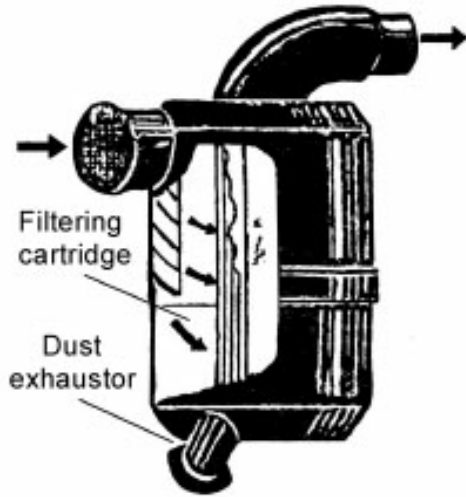

Fig. 6-39 air filter



Fig. 6-40 service and clean filter core

6.12 Operator Seat

The operator's seat can be adjusted for position and weight of operator. These adjustments are to be done prior to starting the engine.

Adjusting Seat Position

The seat can be adjusted fore and aft upto 6 inch. To adjust the position of seat, proceed as follows:

1. Sit on the operator seat.
2. Shift the Lever (B) to left side
3. Move the seat fore-and-aft to adjust the seat to desired position.
4. Ensure that all controls can be accessed easily.
5. Release the Lever. Ensure that the pin of lever is engaged in groove.
6. Loosen the knobs of (E) lift the seat up and down to desired height and lock tightly.



Weight Adjustment

Optimum seat suspension can be adjusted as per the weight of operator. Turn the knob (D) in clockwise or counterclockwise direction according to the weight of operator.

Using Seat belt

Use a seat belt when you operate with Roll over protective structure (ROPS) to minimize chance

of injury from an accident such as an overturn. Do not jump if machine tips.

Fasten Seat belt

1. Pull belt end (C) across operator lap.

2. Install tab into buckle (A).

Release Seat belt

Press red button, the seat belt will automatically retract.



A CAUTION

Attempting to adjust the seat while driving the tractor may cause the operator to lose control of the tractor

A WARNING

Do not use seat belt if operating without a ROPS or with an optional folding ROPS in the folded position.

6.13 Roll Over Protective Structure (ROPS)

The tractors are fitted with a frame for the protection of tractor operators to minimize serious operator injury resulting from accidental roll over. These frames, known as ROPS, form a safety zone within which the operator is offered some protection in the event that the tractor turns over. It is necessary that the tractor operator fasten the seat belt around him/her to be protected by the ROPS.

The mounting structure and fasteners forming the mounting connection with the tractor are part of the ROPS.

(ROPS) Maintenance and Inspection

The ROPS has been certified to industry and/or government standards. Any damage or alteration to the ROPS, mounting hardware or seat belt voids the certification and will reduce or eliminate protection for the operator, in the event of a roll-over.

The ROPS, mounting hardware and seat belt should be checked after the first 100 hrs. of machine operation and every 500 hours thereafter for any evidence of damage, wear or cracks. In the event of damage or alteration the ROPS must be replaced



prior to further operation of the machine. The seat belt must be worn during machine operation when it is equipped with a certified ROPS. Failure to do so will reduce or eliminate protection of the operator in the event of a roll-over.

Substitution of mounting hardware, seat belt etc. with components not equal to or superior to the original certified components will void the certification and will reduce or eliminate protection for the operator in the event of a rollover.

Damage of the ROPS

If the Tractor has rolled over or the ROPS has been damaged (such as striking an overhead object during transport), it must be replaced to provide the original protection. After an accident, check for damages to the 1. ROPS 2. Seat 3. Seat belt & seat mountings.

Before you operate a Tractor, replace all damaged parts.

AWARNING

Never attach chains or ropes to the ROPS for pulling purposes; this will cause the tractor to tip backwards. Always pull from the tractor drawbar. Be careful when driving through door openings or under low overhead objects. Make sure there is sufficient overhead clearance for the ROPS. If the ROPS is removed or replaced, make certain that the proper hardware is used to replace the ROPS and the recommended torque values are applied to the attaching bolts. Always wear your seat belt if the tractor is equipped with a ROPS.

AWARNING

When improperly operated, a tractor can roll over. For low clearance storage only, the roll bar may be folded. No protection is provided when the tractor is operated with the roll bar in the folded position. Always raise the roll bar immediately after low clearance storage. Always use the seat belt when the roll bar is raised. Seat belts save lives when they are used. Do not use the seat belt when the roll bar is lowered.

6.14 Swinging Drawbar

Tractor can be equipped with a drawbar for connecting to pull behind implements. It can swing from side to side and can be adjusted fore and aft. It can be set at various positions. The distance between end of PTO shaft and implement / attachment pinhole can be set at two positions. In each position the dimensions achieved are as per chart.

Certain heavy equipment such as a loaded single axle trailer can place excessive strain on the drawbar. Strain is greatly increased by rough road and high speed. Static vertical load on drawbar should not exceed as stated in chart.

The drawbar can also be offset from the center on both sides. See your implement operator's manual for drawbar positions.

The drawbar must be locked in center position when
1. Operating a drawbar pulled PTO driven implemen





pig 6.15



pig 6.16

Chapter VII Main Troubles and Solutions

7.1 Diesel

7.1.1 Diesel has difficulty in starting

causes	soluitons
1. too low temperature 2. Diesel oil cannot flow smoothly. 3. air enters fuel pipes 4. Such couple units as fuel injection nozzle and injection pump are blocked or abraded. 5. Intake and exhaust ports have leakage, washer of air cylinder cover is damaged, piston rubber ring is abraded, or the air port has no clearance. These cause inefficient pressure. 6. Insufficient battery voltage	Fill hot water into radiator, or preheat engine oil and then fill into crankcase Check and wash fuel pipes and filter core Exhaust air from fuel pipes and tighten every joint. Wash, repair or replace couple units. Grind intake and exhaust port, adjust air port clearance, replace air cylinder cover washer and piston ring. Charge battery or replace with a new one.

7.1.2 Insufficient power

causes	solutions
1. Air filter or diesel oil filter is jammed. 2. Wrong advance angle of fuel supply 3. Diesel contains moisture. 4. Oil injector needle valve is binded or jet orifice is jammed. 5. Intake & exhaust air port has leakage or air port has wrong clearance. 6. Main bearing or connecting rod bearing shell is over abraded or burnt out. 7. Two diesel cylinders cannot equally work	Wash filter core with diesel oil or coal oil. Reregulate to stated value. Eliminate moisture or replace diesel oil. Check, repair or replace couple pieces of oil injecting port Grinding air port; adjust air port clearance. Check, repair or replace it. Check and adjust two cylinders of oil injecting pump for oil supply and injecting pressure to improve the equality.

7.1.3 Engine has sudden stop

(1) Rotate diesel with handle to see if it can normally turn. If the crank cannot move, check the following aspects:

① Crank is seized with bearing

Repair or replace crank and bearing

causes	solutions
1. Insufficient or halt engine oil 2. Machine oil is too watery or goes bad after long-term use. 3. Oil pump loses effects suddenly or oil filter is jammed; safety and by-pass valve don't work well.	Check the oil level in oil pan. If the level is too low, supplement machine oil in time. Replace with new machine oil. Check oil injecting pump post pair to see if too much diesel oil leakage dilute machine oil. If so, do repair. Check, repair or replace machine oil pump and filter.

② Piston is seized with air cylinder Repair or replace such parts as air cylinders and pistons

causes	solutions
1. Diesel lacks water and is so hot that seizes cylinder 2. Too much water scale in cylinder water jacket makes cylinder over hot. 3. Engine works with over loads 4. Fan belt is too loose.	Supplement cooling water Eliminate water scale. Strictly comply with operation rules Adjust belt tautness or replace belt.

(2) If crank can joggle easily, pay attention to the following aspects:

causes	solutions
1. Diesel oil in fuel tank is used out or fuel pipe breaks. 2. Air is absorbed in fuel pipes 3. Diesel oil filter or pipes are jammed. 4. Oil injecting pump plunger spring is broken.	Fill in diesel oil or replace fuel pipes Eliminate air from fuel pipes. Wash diesel filter core or fuel pipes. Replace with new plunger spring.

7.1.4 Abnormal fume exhaust

causes	solutions
1. Diesel works with over loads. 2. Much smoke comes with exhaust, which is caused by the secondary air ring is wrongly mounted or oil ring is severely abraded. 3. White smoke in exhaust is caused by water in fuel, or bad atomization of oil injector, or too low oil injecting pressure.	Minus loads. Adjust until requirements are met. Re-mount air ring. Make the surface with symbol "上" face piston top or replace oil ring. Wash oil tank, diesel filter, replace diesel, repair oil injecting pairs and adjust oil injecting pressure.

7.1.5 Over hot diesel

causes	solutions
1. Fan belt is too loose 2. Diesel works with overload for a long term. 3. Oil supply is too late or oil injector drops oil to make exhaust test too high.	Adjust belt tautness or replace with belt. Reduce diesel loads Check and repair.

7.2 Transmission system

7.2.1 Clutch slides

causes	solutions
1. Friction plate surface is oil stained 2. Pressure spring has no full force or is broken. 3. Free travel is small or zero. releasing levers are not in a plane. 4. Friction plates are severely abraded.	Wash with diesel oil. Eliminate oil leakage. Replace spring Re-adjust according to rules. Replace friction plates.

7.2.2 Clutch cannot be released completely. Gear lever has difficult for gear shifting.

causes	solutions
1. Too large free travel or too small working travel 2. Clearance between three releasing levers and releasing bearing.	Re-adjust according to requirements. Re-adjust according to requirements.

7.2.3 Transmission case sounds abnormally.

causes	solutions
1. Tooth flank of gear is severely abraded or peeled off. 2. Gear tooth is broken. 3. Bearing is severely abraded or damaged. 4. Engage clearance of central drive gear is broken.	Replace gear. replace gear replace bearing re-adjust to stated value.

7.2.4 Transmission case is too hot. (oil temperature is over 90°C)

causes	solutions
1. Bearing clearance or bevel gear's engaging clearance is too small. 2. Insufficient oil volume 3. Bad oil quality	Re-adjust to stated value. Add lubrication oil to stated oil level. Wash with diesel and then fill in proper lubricating oil.

7.3 Brakes

7.3.1 Brakes don't work well

causes	solutions
1. Brake shoe bears too much abrasion on friction belt. 2. Friction belt on brake shoe contains oil. 3. Improper adjustment.	Replace with new brake shoe. Wash it with gasoline and eliminate leakage. Re-adjust according to requirements.

7.3.2 Crooked running during braking

causes	solutions
1.The left and the right brake pedals have inconsistant travel.	Re-adjust until consistency.
2. Friction belt on single -side brake shoe is stained with oil.	Wash with gasoline and elimilate leakage.
3.Abrasion of friction belt on the left and the right braking shoes are not consistent.	Re-adjust or replace with new braking shoe.

7.3.3 Uncomplete release ; high temperature

causes	solutions
1.Brake sho return spring has no full force.	Replace spring
2.Clearance between the friction belt and drum on brake shoe is too small.	Adjust free travel of pedals.

7.4 Steering unit and traveling system

7.4.1 Hard steering

causes	solutions
1.Too low air pressure of front tires;	Charge accroding to requirements.
2.Insufficient oil supply of oil pump;	Select proper oil pump or check oil pump for its normal performance.
4.Steering system contains air.	Eliminate air from exhaust system and check oil absornering pipes.
4.Oil tank is not full.	Fill oil to stated level.

7.4.2 Tractor automatically goes to one side.

causes	solution
1. Air pressure of the left and the right tires are not consistent.	Adjust for consistance.
2.Wheel treads of the left and the right tires are not ot consistent	Replace tires

7.4.3 Front wheels swing

causes	solutions
1.Bearing clearance of front wheel shaft is too large or severely abraded.	Adjust clearance or replace bearing.
2.Round-head pin or round-head base is severely abraded.	Replace round-head pin or round-head base.
3.Sleeve of swing shaft is abraded.	Replace axle sleeve.
4.Steering knuckle sleeve is abraded.	Replace axle sleeve.

7.4.4 Initial abrasion of tires

causes	solutions
1.Improper adjustments on toe-in of front wheels. 2. Low tire pressure 3.Driving wheels are installed wrongly.	Re-adjust to stated value. Inflate according to rules. Re-install it.

7.5 Hydraulic suspension system

7.5.1 Farming Implements cannot rise or drop.

causes	solutions
1.adjusting valve is locked up.	Release adjusting valve.

7.5.2 Implement has too quick static dropping

causes	solutions
1.Oil cylinder and piston are severely abraded. 2.Oil seal on piston is damaged. 3.Slide valve of distributor is damaged.	Repair or replace oil cylinder piston assembly Replace oil seal. replace distributor.

7.6 Electrical system

7.6.1 Starter

causes	solutions
1. Starter cannot turn. ①Connecting wire is broken or cannot contact well. ②Battery has insufficient charging ③E-brush cannot contact commutators well. ④ Starter has inside short or open circuit . 2.Starter freely rotates without starting power. ①E-Brush cannot contact commutators well. ②Commutator surface is burnt or has oil stain . ③Connector cannot work well. ④ Electromagnet switch doesn't work well ⑤ Insufficient battery charging. 3. Starting small gears are not engaged and the starter turns, so gears impact against each other. Electromagnet switch armature has too small travel.	Weld or screw connecting points tightly. Supplement electric charging or replace batteries. Clean commutators surface or replace brush. Check and repair. Clean commutators' intersurfaces. Restore commutator with sand cloth or clean oil stain. Clean and screw up contact points. Check and repair switches. Check and charge Turn electromagnet switch armature connecting screws in for 2-3 teeth.

7.6.2 Silicon rectification generator

Causes	solutions
<p>1. Generators cannot generate electricity.</p> <p>① Wire splicing is loose, broken, short circuit or wrong connected.</p> <p>② Diode is damaged or has short or open circuit.</p> <p>③ Rotor and stator coil has short or open circuit or bonding.</p> <p>④ Adjustor has too low adjusting voltage.</p> <p>⑤ Adjustor contact points are burnt or have open wire inside.</p>	<p>Check and repair.</p> <p>Repair or replace.</p> <p>Repair or replace.</p> <p>Increase voltage properly.</p> <p>Check and repair.</p>
<p>2. Generator has no sufficient output current</p> <p>① Partial stators and rotators coils have short or open circuit .</p> <p>② One or two diode are damaged.</p> <p>③ Generator belt is too loose.</p>	<p>Repair or replace.</p> <p>Replace</p> <p>Tighten belt.</p>
<p>3. Charging current is not stable.</p> <p>① Generator belt slides.</p> <p>② Charging circuits have malfunctions.</p> <p>③ Stator and rotator coils are to have short or open circuit.</p> <p>④ Adjustor has malfunction.</p>	<p>Eliminate oil stain or tighten belt.</p> <p>Check and eliminate troubles.</p> <p>Repair or replace.</p> <p>Repair and replace adjustor.</p>
<p>4. Generator sounds abnormal</p> <p>① Improper generator installation cause interference between rotating part and fixed part.</p> <p>② Bearing is damaged.</p> <p>③ Rotator touches stator</p>	<p>Find out interference sites and adjust installation positions.</p> <p>Replace it.</p>
<p>5. Generator has scorch smell.</p> <p>① Damaged diode causes one-phase or biphasic burnt.</p> <p>② Touch between stator and rotator iron core burns stator coil and causes short circuit in rotator coils.</p> <p>③ Adjustor has malfunction or voltage is too high and bears overloads for a long time.</p>	<p>Repair it.</p> <p>Replace it.</p> <p>Repair or replace coil.</p> <p>Replace and adjust.</p>
<p>6. Too large charging currents</p> <p>① Single case of battery has short circuit.</p> <p>② Adjustor voltage is too high</p> <p>③ Adjustor has bad bonding.</p> <p>④ Contact of adjustor has malfunction or is stained.</p>	<p>Replace</p> <p>Lowerdown voltage.</p> <p>Check and repair.</p> <p>Repair and wash.</p>

7.6.3 Battery

causes	solutions
<p>1. Battery often has no sufficient electric storage.</p> <p>① Generator or adjustor has malfunction and produce no charging current.</p> <p>② Connecting wire of charging circuit is loose or rusted, which cause increased resistance.</p> <p>③ Pole plate has short circuits.</p> <p>2. Battery has self-discharging; Material of pole plate has too much impurities or the electrolyte is not pure.</p> <p>3. Battery capacity is obviously reduced (low discharging voltage, high charging voltage, electrolyte density is low) and pole plate is vulcanized.</p> <p>① Charging is always no sufficient.</p> <p>② Discharging with low current for a long term doesn't get charging in time.</p> <p>③ Electrolyte surface is too low and the upper part of the pole plate is bared from liquid.</p>	<p>Repair generator or adjustor.</p> <p>Check post clamping chuck and connecting bolts. If they are loose, screw it up or eliminate rusts.</p> <p>Repair it.</p> <p>Discharge batteries completely or do overdischarging to make pole plate impurity enter electrolyte and then discharge electrolyte, wash it with distilled water. poure new electrolyte to charge again.</p> <p>Charging with low current for long time, or do fully -charging & fully-discharging circulations to react the active elements, or do desulfurized charging to supplement electrolyte.</p>

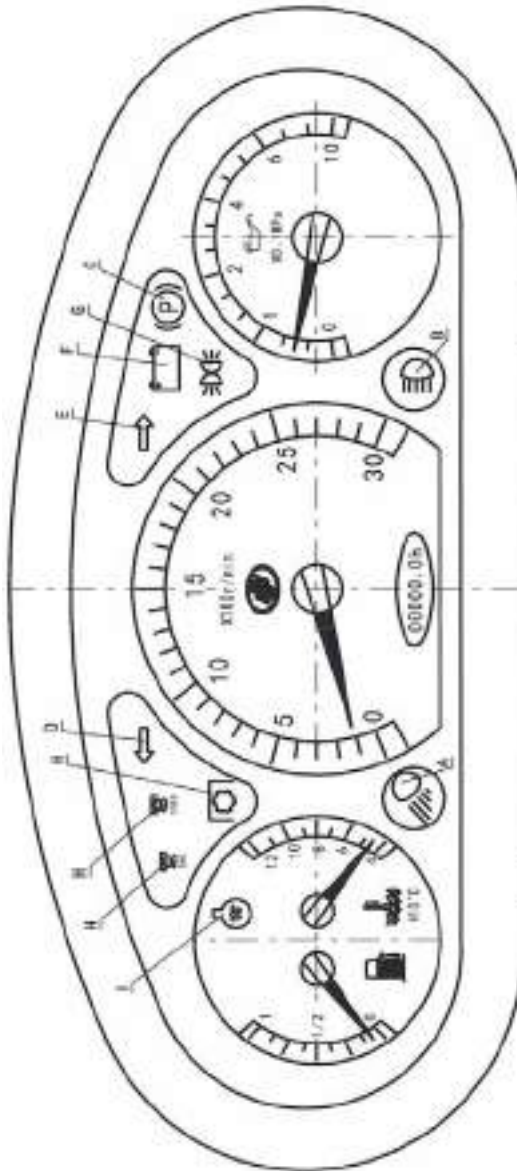

- I: Left Right turn switch
- II: Front light switch
- III: Width light switch
- IV: Rear working lamp switch
- V: Horn button
- VI: Hazard warning switch

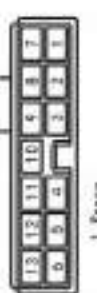
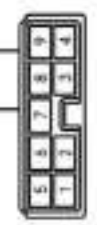
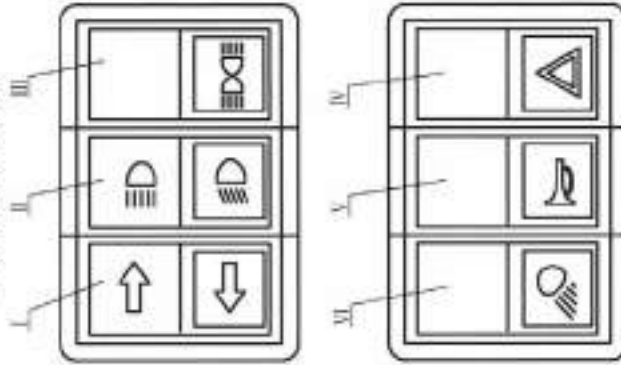

- 1. Spare
- 2. Spare
- 3. Instrument negative wire
- 4. Instrument positive wire
- 5. Mark indicator
- 6. H. T coolant lamp
- 7. RPM
- 8. Fuel
- 9. PTO indicator
- A. Mark indicator
- B. High beam indicator
- C. Chavo indicator
- D. Left turn indicator
- E. Right turn indicator
- F. Charge indicator
- G. Position indicator
- H. PTO indicator
- I. Electrical preheat
- 1. Spare
- 2. Charger indicator
- 3. Spare
- 4. Spare
- 5. Spares
- 6. Spare
- 7. Left turn indicator
- 8. Right light indicator
- 9. High beam indicator
- 10. Right turn indicator
- 11. Break indicator
- 12. Low oil pressure indicator
- 13. Spare

8.2 Optional accessories with additional payments

Customers can order accessories listed below if necessary:

No.	Name	Quantity	Use
1	deep treaded tire	one pair	used in paddy fields
2	larwn tire	one pair for front and back wheels respectively	for gardening operation
3	cab	1	to improve driver's operation condition
4	safety frame	1	protect driver's safety
5	pulley	1	for fixing operation

8.3 Attached Tools

No.	Code	Name	Volume
1	160.49.001-1	toolbox assembly	1piece
5		open-ended spanner	1set
6		consumable seals	1bag
7	JM25~45E	manual	1
8	JM25~45E	Part drawings collection	1
9		diesel fittings and toolbox	1set

8.4 Oil seal specification for tractor chassis

Part	Specifications	Sites	volume	
transmission case	GB/T9877.1 Rotary shaft lip seals	FB35×55×8	front end of the first shaft	1
		FB35×55×10	inside bearing cover of PTO shaft	1
		FB50×72×12	outer end of driving shaft sleeve	4
		FB50×80×12	outer end of final drive bearing base	4
		FB55×75×12	inside drive axle sleeve	2
	GB 3452.1 O-ring	11.8×1.8	PTO fork shaft	1
		15×2.65	assistant gear shifter rod	2
		15×2.65	declutch shift shaft of differential lock	1
		22.4×2.65	outer end of reverse gear shaft	1
		28×2.65	driving gear shaft of final drive	2
creeping gear	GB 3452.1 O-ring	67×3.55	front bearing base of secondary shaft	1
		103×3.55	outer round of bearing base	2
		112×3.55	inside end of drive shaft sleeve	2
transfer case	GB/T9877.1 Rotary shaft lip seals	9.5×2.65	declutch shift shaft of creeping gears	1
		10×2.65	transfer case power shift shaft	1
	11.2×2.65	creeping shifter lever	2	
transfer case	GB/T9877.1 Rotary shaft lip seals	FB25×40×8	oil seal base of transfer case	2
		FB25×47×7	254 tractor transfer case oil seal base	1
	GB 3452.1 O-ring	15×2.65	idler shaft	1
		58×3.55	transfer case oil seal base	1
dual clutch	GB/T9877.1 Rotary shaft lip seals GB 3452.1-1992 O-ring	54.5×3.55	front fixing base	1
		19×2.65	transfer case oil seal case	1
brake	GB 3452.1 O-ring	15×2.65	front fixing base	1
		15×2.65	brake camshaft	2
front shaft	non-standard vertical shaft oil seal	40×48×6.5	releasing bearing base support	1
	non-standard vertical shaft oil seal	38×62×11.5	master clutch shaft	2
	GB 3452.1 O-ring	30×3.55	upper ends of left and right knuckles	2
			two ends of swing shaft	2

Appendix I: Standards, commands and laws

1. GB/T18447.1 Agriculture tractors Safety requirements
2. GB/T3871 Agriculture tractors test method
3. GB/T6376 Tractors limited of sound levels
4. GB/T19040 Steering requirements for Agriculture tractors
5. GB/T9840 The rules of operation manual for Agriculture tractors
6. (EU) NO 167/2013
7. (EU) NO 2015/208
8. (EU) NO 1322/2014
9. (EU) NO 2015/96
10. (EU) NO 2015/68
11. (EU) NO 2015/504

Appendix II: key words Contents

Adjustments on Tractor ----	Page 34
Appendix ----	Page 68
Brakes ----	Page 38
Central transmission ----	Page 35
Clutch ----	Page 34
Differential lock ----	Page 37
Driving axle ----	Page 41
Electric system ----	Page 54
Hydraulic suspension system ----	Page 47
Intake and exhaust system ----	Page 55
Maintenance of the Tractor ----	Page 27
Oil ----	Page 18
Operation of the Tractor ----	Page 18
Operator Seat ----	Page 56
Rear wheel tread ----	Page 42
Roll Over Protective Structure (ROPS) ----	Page 57
Running-in----	Page 19
Safe Operations ----	Page 1
Steering device ----	Page 43
Swinging Drawbar ----	Page 58
Technical Specifications ----	Page 12
Troubles and Solutions ----	Page 61
Water using----	Page 18



Jiangsu Yueda Intelligent Agricultural Equipment CO.,LTD.

Add: 9,NenJiang Road Economic Developing Zone,

YanCheng JiangSu, PRC

Tel: 0086-515-68823978/ 68829666

Fax: 0086-515-68822692

Postcode: 224002

Edition number:454E-2018-001

Publish date : 2018-04-10