

DONG FENG

Tractor Parts Manual

DF354



CONTENT

1	油门操纵机构总成 Throttle Control Mechanism	1
2	离合器总成 Clutch	3
3.1	机架总成(2WD 配 390 发动机) Frame (2WD For 390 engine)	6
3.2	机架总成(2WD 配 395 发动机) Frame (2WD For 395 engine)	8
3.3	机架总成(2WD 配 490 发动机) Frame (2WD For 490 engine)	10
4	前轴总成 Front Axle	12
5.1	导向轮和驱动轮总成 Directive Wheel and Drive Wheel	16
5.2	草比胎后轮 Rear Wheel (Turf tyre)	18
5.3	后轮总成(工业胎) Rear Wheel (Industrial tyre)	20
6	变速箱总成(A) Gearbox(A)	22
7	变速箱总成(B) Gearbox(B)	26
8	后桥总成(A) Rear Axle(A)	29
9	后桥总成(B) Rear Axle(B)	31
10	差速锁总成 Differential Lock	34
11	最终传动总成 Final Transmission	36
12	转向器总成 Steering Gear	38
13	动力输出轴总成 PTO	41
14.1	座椅总成(减震) Seat (Absorber)	45
14.2	座椅总成 Seat	47
15	遮阳棚总成 Scushade	49
16	折叠式安全架 Folding Safety Frame	51
17	机罩仪表罩总成(AU07) Hood and Panel (AU07)	53
18	橡胶挡板总成 Foot Mat Shields Rest	56
19	电瓶架 Battery Bracket	59
20	电气系统总成(配 AU07 机罩) Electrical System(For AU07 hood)	61

21. 工具箱总成 Toolbox	64
22. 燃油箱总成 Fuel Tank	66
23. 摆式牵引杆总成 Swing Drawbar Frame	68
24. 分配器总成 Hydraulic Oil Distributor	70
25. 提升器总成 Hydraulic Power Lift	73
26. 悬挂装置总成 Suspension Mechanism	77
27. 前配重总成 Front Balance Weight	80
28. 前置空管气刹装置总成 Air Brake Installations for Trailer	82
29.1 机架总成(4WD 配 390 发动机) Frame(2WD For 390 engine)	85
29.2 机架总成(4WD 配 395 发动机) Frame(2WD For 395 engine)	87
29.3 机架总成(4WD 配 490 发动机) Frame(2WD For 490 engine)	89
30.1 前驱动桥总成 Front Drive Wheel	91
30.2 草胎胎花轮 Front Wheel (Turf tyre)	93
30.3 前轮总成(工业胎) Front Wheel (Industrial tyre)	95
31. 前驱动桥总成(中) Front Wheel Drive Axle (middle)	97
32. 前驱动桥总成(左边减速) Front Wheel Drive Axle (Left Side-Slowdown)	100
33. 前驱动桥总成(右边减速) Front Wheel Drive Axle (Right side-Slowdown)	104
34. 前驱动桥总成(304.31.022-1 部件) Front Wheel Drive Axle (304.31.022-1 Assembly)	107
35. 前驱动桥总成(304.31.014A) Front Wheel Drive Axle (304.31.014A Assembly)	109
36. 传动轴总成 Transmission shaft	111
37.1 液压转向系统总成(配 390 发动机) Full Hydraulic Power Steering Gear(For 390 engine)	114
37.2 液压转向系统总成(配 395 发动机) Full Hydraulic Power Steering Gear(For 395 engine)	113
37.3 液压转向系统总成(配 490 发动机) Full Hydraulic Power Steering Gear(For 490 engine)	122
38. 分动箱总成 Transfer case	125
39.1 油泵滤油器油管总成(配 390 发动机) Oil Pump, Filter, Pipe and Fittings(For 390 engine)	129
39.2 油泵滤油器油管总成(配 395 发动机) Oil Pump, Filter, Pipe and Fittings(For 395 engine)	132
39.3 油泵滤油器油管总成(配 490 发动机) Oil Pump, Filter, Pipe and Fittings(For 490 engine)	135

40.1	空滤器总成(配 390 发动机) Air Filter(For 390 engine)	138
40.2	空滤器总成(配 395 发动机) Air Filter(For 395 engine)	140
40.3	空滤器总成(配 490 发动机) Air Filter(For 490 engine)	142
41.1	散热器总成(配 390 发动机) Radiator(For 390 engine)	144
41.2	散热器总成(配 395 发动机) Radiator(For 395 engine)	146
41.3	散热器总成(配 490 发动机) Radiator(For 490 engine)	148
42.1	排气管总成(配 390/395 发动机) Exhaust pipe(For 390/395 engine)	150
42.2	排气管总成(配 490 发动机) Exhaust pipe(For 490 engine)	152
42.3	排气管总成(防火星、配 390/395 发动机) Exhaust pipe(Prevent fire, For 390/395 engine)	154
42.4	排气管总成(防火星、配 490 发动机) Exhaust pipe(Prevent fire, For 490 engine)	156
43	电机防护罩 Protective shield	158
44	盘式制动器总成 Disc Brake	160
45	盘式制动器操纵机构总成 Disc Brake Operation Mechanism	165
46	304.40.033 转向油缸总成 Steering cylinder assy	166
47	CBN-F306B 齿轮泵 Gear Pump	168
48	CBN-E314B 齿轮泵 Gear Pump	170
49	BZ71-E80 转向器总成 Hydraulic Steering Gear	172
50	FLD-F6-H 分流阀总成 Distributary valve assy	174
51	HLCB-D006/06 恒流泵总成 Constant Flow Pump	176

1 油门操纵机构 Throttle Control Mechanism

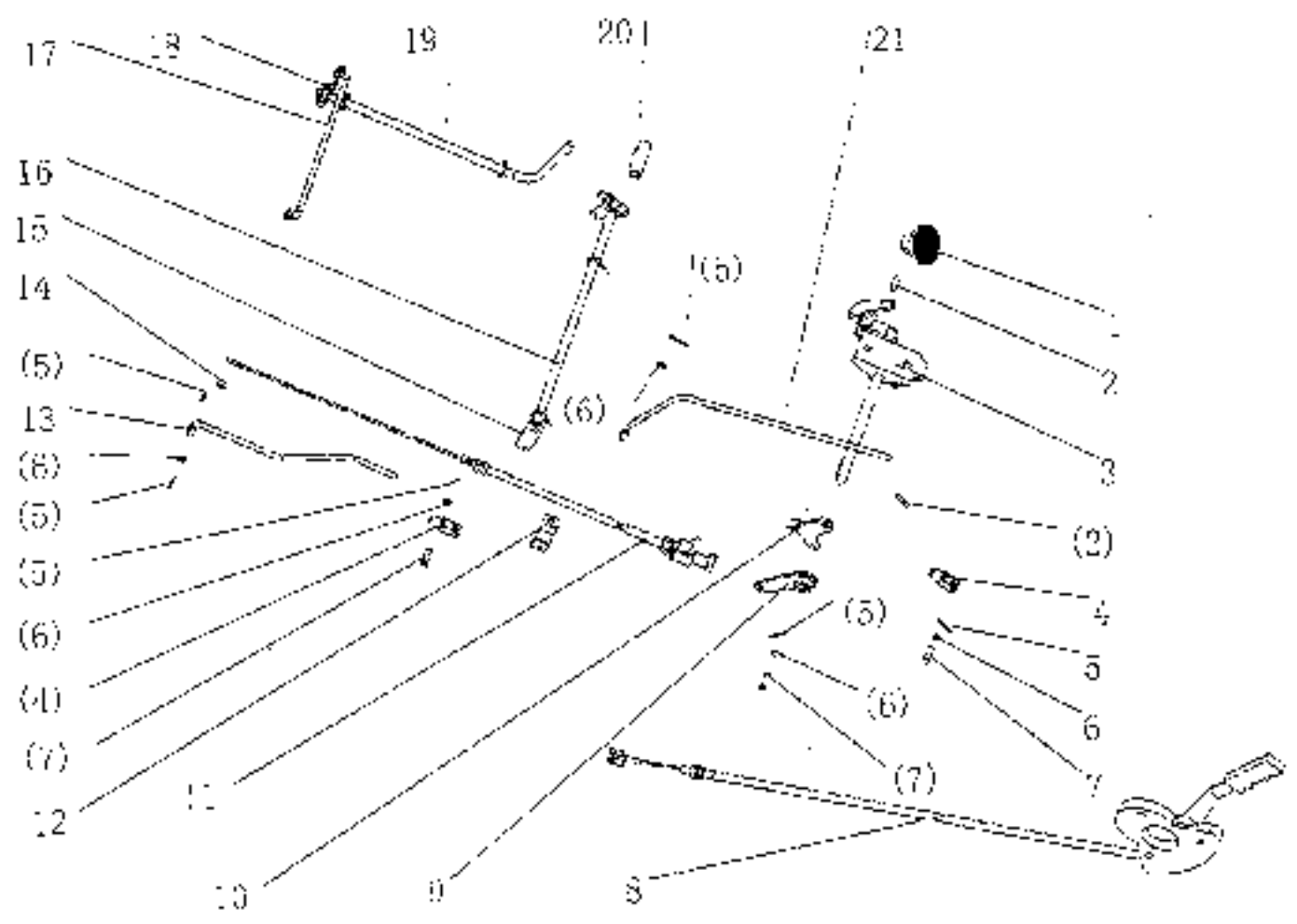

1 油门操纵机构总成 Throttle Control Mechanism

序号 Ser. No.	代号 Part No.	名称及规格	Name & Specifications	数量 Quantity	备注 Remarks
1	550.20.104-1	油门踏板	Throttle lever	1	
2	GB879-86	销5x20	Slotted spring pin 5x20	2	
3	354-5.20.016	油门拉杆总成	Pull rod, throttle	1	
4	300.20.101	连接叉	Rod clevis	2	
5	GB 91-86	销 2x16	Split pin 2x16	7	
6	GB97.1-85	垫圈 6	Plain washer 6-140HV	6	
7	GB883-86	销轴B6x22	Clevis pin with head B6x22	3	
8	550.20.014-2	手油门总成	Hand throttle	1	
9	550.20.015-1	摇臂焊合件	Rocker	1	
10	550.20.013-1	手油门摇臂	Hand accelerograph rocker	3	
11	350.20A.015	熄火拉线总成	Stop control thread, engine	1	
12	350.20A.101	熄火拉线座	Stop control thread, engine base	1	
13	350.20.013	油门拉杆焊合件	Accelerograph pull rod weldment	2	
14	GB97.1-85	垫圈 5	Plain washer 5-140HV	1	
15	300.20.012	摇臂焊合件	Rocker	1	
16	300.20A.012	油门传动轴焊合件	Throttle transition weldment	1	
17	350.20.017	减压拉杆焊合件	Decompressor pull rod weldment	1	
18	300.20.018	减压摇臂焊合件	Decompressor rocker weldment	1	
19	300.20.127	减压连杆	Decompressor pull rod	1	
20	300.20A.101	套套	Bush	1	
21	500.20.015-1	脚踏油门拉杆焊合件	Foot accelerograph pull rod weldment	1	

2 离合器总成 Clutch

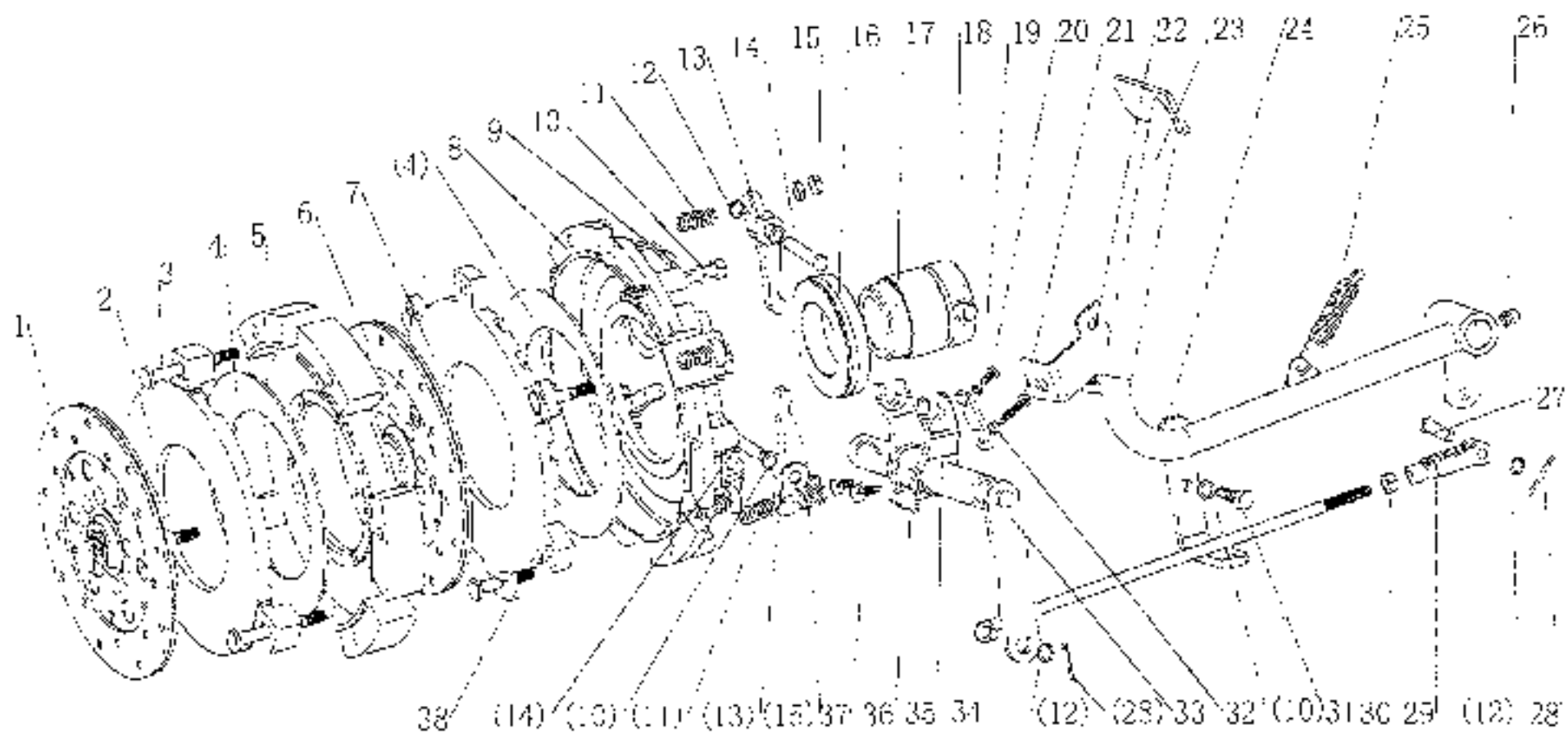

2 离合器总成 Clutch

序号 Ser.No	代号 Part No.	名称及规格	Name & Specifications	数量 Quantity	备注 Remarks
1	300.21C.015	主离合器从动盘总成	Driven plate, main clutch	1	
2	300.21C.103-1	主离合器压盘	Pressure plate, main clutch	1	
3	300.21C.114-1	调整螺栓	Adjusting bolt	3	
4	300.21A.102-2	碟形弹簧	Disc spring	2	
5	300.21C.104	离合器固定压盘	Fixed pressure plate, clutch	1	
6	300.21C.012	PTO 离合器从动盘总成	Driven plate, PTO clutch	1	
7	300.21C.106-1	PTO 离合器压盘	Pressure plate, PTO clutch	1	
8	300.21C.107-1	离合器盖	Clutch cover	1	
9	GB5782-86	螺栓 M10×90	Hex. head bolt M10×90	6	
10	GB93-87	垫圈 10	Spring lock washer 10	8	
11	300.21C.115	回位弹簧	Return spring	6	
12	GB97.1-85	垫圈 10	Plain washer 10	16	
13	300.21C.116-1	主分离杠杆	Main release lever	3	
14	300.21B.157	分离杠杆销轴	Clevis pin with head	3	
15	GB6173-86	螺母 M10×1	Fine thread hex. nut M10×1	6	
16		分离轴承 65TNK20	Release bearing 65TNK20	1	For export
		分离轴承 688713	Release bearing 688713	1	
17	300.21C.108	分离轴承座	Release bearing seat	1	
18	300.21C.131	安全开关顶板	board for safety switch	1	
19	GB93-87	垫圈 6	Spring lock washer 6	1	
20	GB5782-86	螺栓 M6×12	Hex. head bolt M6×12	1	
21	300.21C.133	调整螺栓	Adjusting bolt	1	
22	300.21C.152	安全开关支架	safety switch bracket	1	
23	300.21C.017	脚踏板焊合件	Pedal weldment	1	
24	280.21.119-1	脚踏限位板	Limit stop	1	

2 离合器总成 Clutch

续表

序号 Ser. No.	代号 Part No.	名称及规格	Name & Specifications	数量 Quantity	备注 Remarks
25	300.21A.147-1	弹簧	Extension spring	1	
26	GB1153-86	油杯 45° M10X1	Angle grease nipple 45° M10X1	1	
27	GB882-86	销轴 B10×30	Clevis pin with head B10×30	1	
28	GB91-86	开口销 3×25	Split pin 3×25	2	
29	300.21A.148	轴叉叉头	Rod clevis	1	
30	GB6171-86	螺母 M10×1	Fine thread hex. nut M10×1	4	
31	GB5783-86	螺栓 M10×25	Hex. head bolt M10×25	2	
32	GB6170-86	螺母 M6	Hex. nut M6	1	
33	300.21C.015-A	分离轴总成	Release shaft	1	For export
	300.21C.015	分离轴总成	Release shaft	1	
34	300.21A.019	下分离轴总成	Lever release pull rod	1	
35	300.21C.110	离合器拨叉	Release fork	1	
36	GB3081-82	热镀锌铁丝 1-2	Hot galvanized steel wire 1-2	2	
37	300.21A.146	限位螺钉 II	Set screw with dog point II	2	
38	300.21C.113-1	调整螺栓	Adjusting bolt	3	

3.1 机架总成(2WD 配390发动机) Frame(2WD For 390 engine)

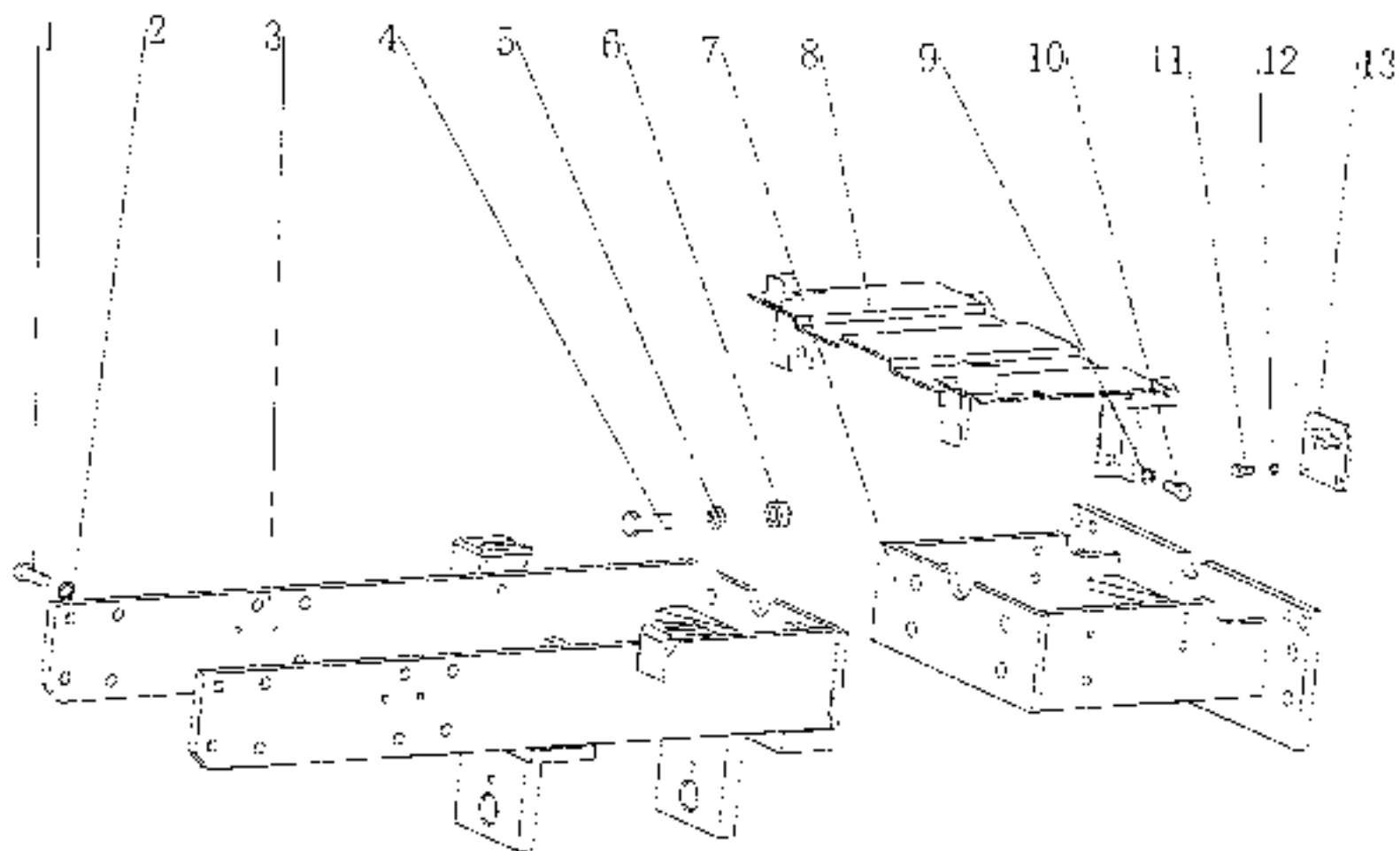

3.1 机架总成(2WD 配390发动机)

Frame (2WD For 390 engine)

序号 Ser.No.	代号 Part No.	名称及规格	Name & Specifications	数量 Quantity	备注 Remarks
1	GB11783-86	螺栓M12x35	Hex head bolt M12x35	6	8.8级
2	GB93-87	弹簧垫圈12	Spring Lock washer12	10	
3	30030A.011	机架总成件	Frame	1	
4	GB5783-86	螺栓M16x45	Hex head bolt M16x45	4	
5	GB93-87	弹簧垫圈16	Spring Lock washer16	4	
6	GB6170-86	螺母M16	Hex nut M16	4	
7	304.30A.012	副重架总成件	Assistant weight support	1	
8	284.30B.013	电瓶架总成件	Battery bracket	1	
9	GB5783-86	螺栓M10x25	Hex head bolt M10x25	6	
10	GB93-87	弹簧垫圈10	Spring Lock washer10	6	
11	GB5783-86	螺栓M8x16	Hex head bolt M8x16	1	
12	GB93-87	弹簧垫圈8	Spring Lock washer8	1	
13	250.30.116	手摇启动支承板	Starting crank gate	1	

3.2 机架总成(2WD 配395发动机) Frame(2WD For 395 engine)

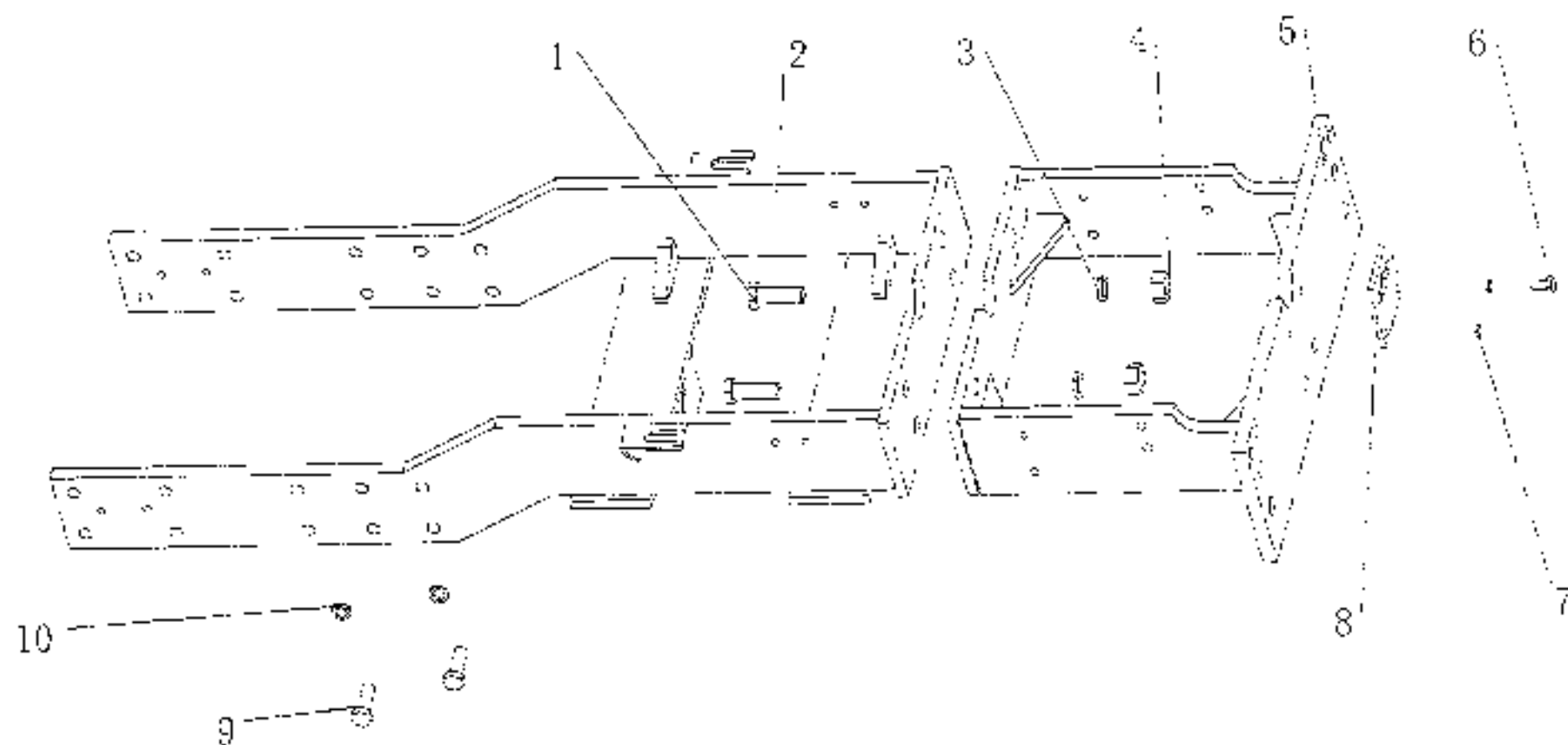

3.2 机架总成(2WD 配395发动机) Frame(2WD For 395 engine)

序号 Ser.No	代号 Part No.	名称及规格	Name & Specifications	数量 Quantity	备注 Remarks
1	GB5783-85	螺栓M16x45	Hex.head bolt M16x45	4	8.8级
2	350.30A.011	机架铸件	Frame	1	
3	GB93-87	垫圈16	Spring Lock washer16	4	
4	GB6170-86	螺母M16	Hex. nut M16	4	8级
5	354.30A.012	副重架铸件	Assistant weight support	1	
6	GB5783-86	螺栓M8x16	Hex.head bolt M8x16	2	
7	GB93-87	垫圈8	Spring Lock washer8	2	
8	250.30.116	手摇启动支承板	Starting crank gate	1	
9	GB5783-86	螺栓M12x35	Hex. head bolt M12x35	16	8.8级
10	GB93-87	垫圈12	Spring Lock washer12	16	

3.3 机架总成(2WD 配490发动机) Frame(2WD For 490 engine)

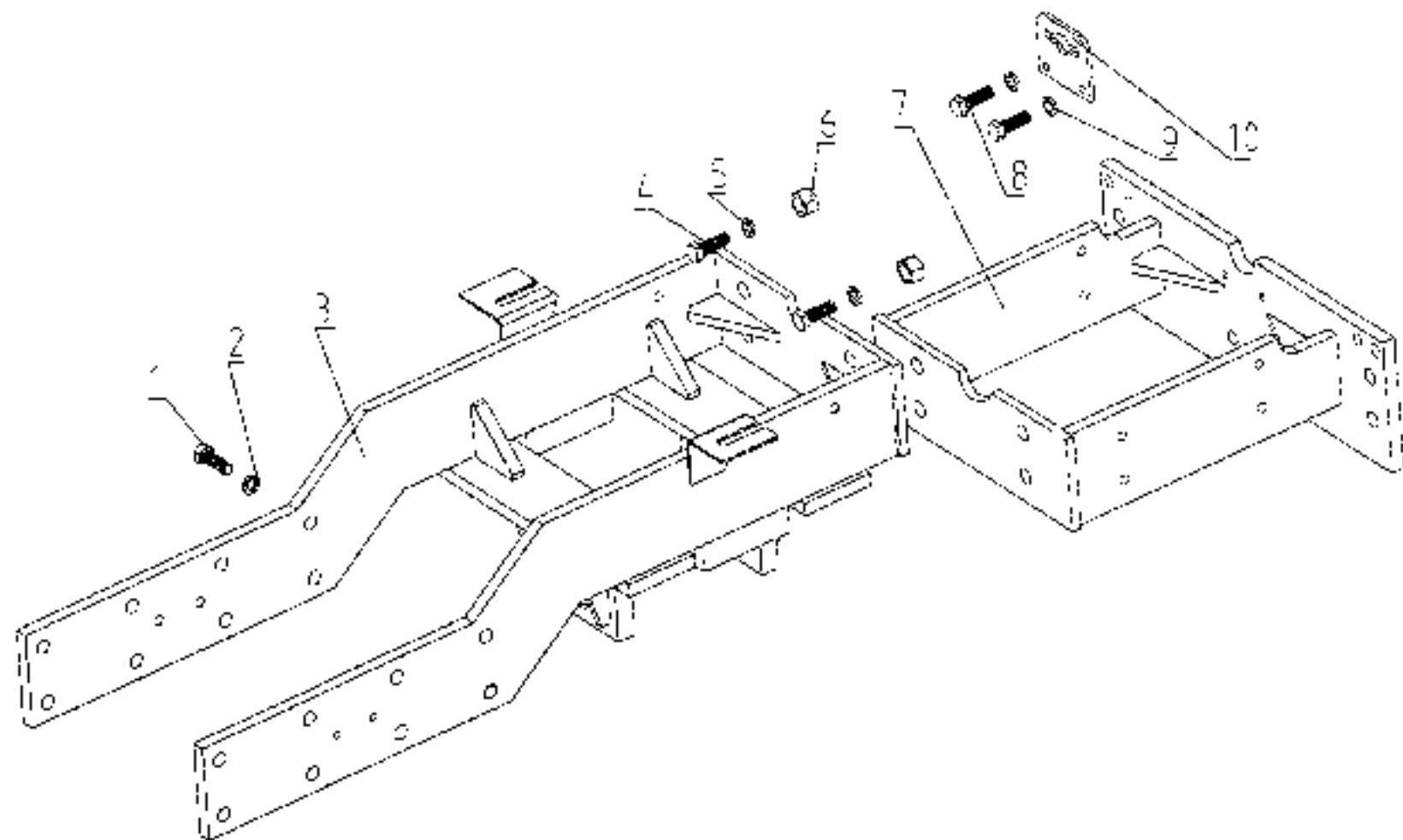

3.3 机架总成(2WD 配490发动机)

Frame(2WD For 490 engine)

序号 Ser.No.	代号 Part No.	名称及规格	Name & Specifications	数量 Quantity	备注 Remarks
1	GB5783-86	螺栓M14x35	Hex.head bolt M14x35	16	8.8级
2	GB93-87	垫圈14	Spring Lock washer14	16	
3	400.30A.011	机架焊合件	Frame	1	
4	GB5782-86	螺母M16x45	Hex.head bolt M16x45	4	
5	GB93-87	垫圈16	Spring lock washer16	4	
6	GB6170-86	螺母M16	Hex nut M16	4	
7	404R.30A.012	平衡架焊合件	Balance weight frame	1	
8	GB5783-86	螺栓M8x16	Hex.head bolt M8x16	2	
9	GB93-87	垫圈8	Spring Lock washer8	2	
10	750.30.116	手油门轴支承板	Starting crank gate	1	

4 前轴总成 Front Axle

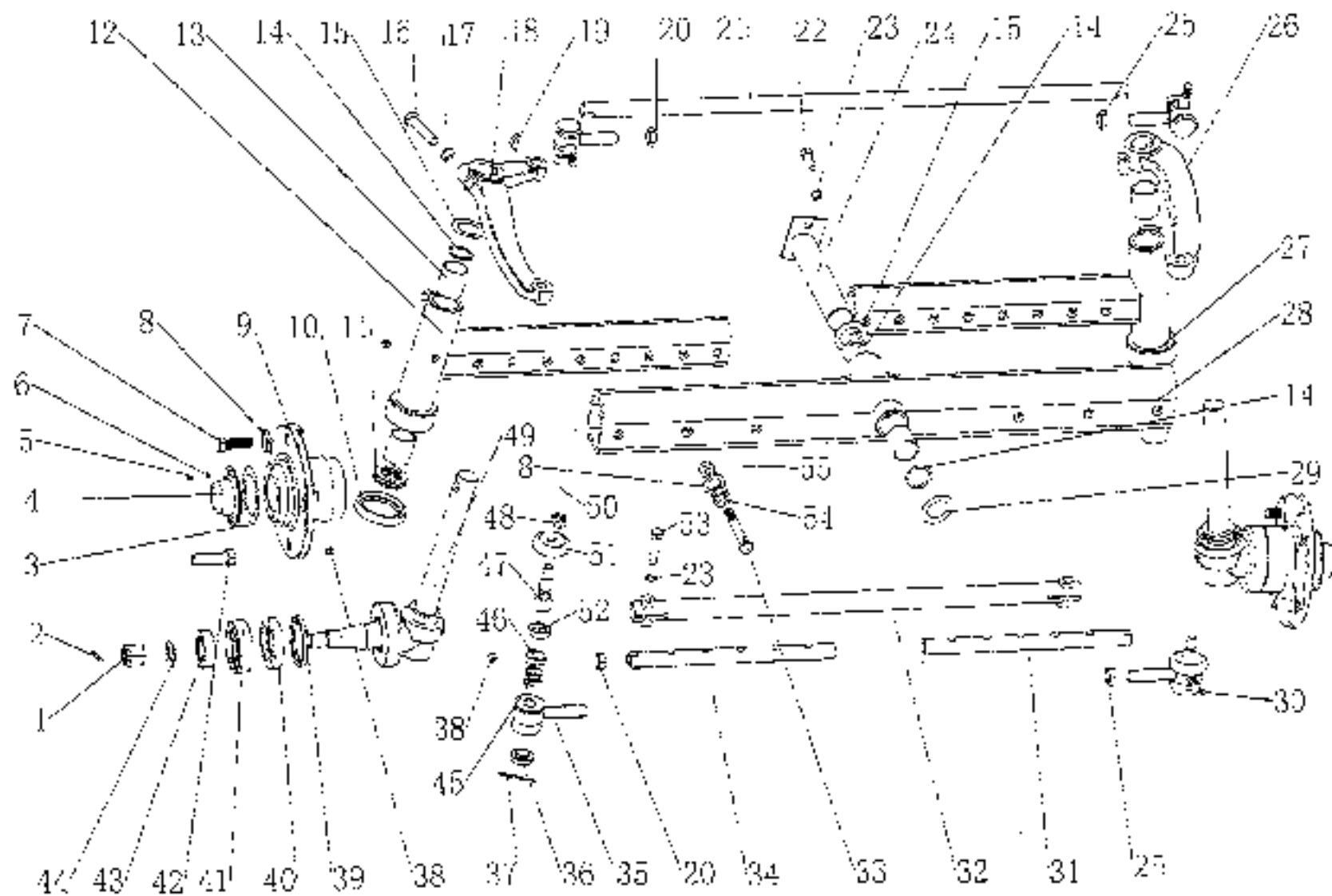

4 前轴总成 Front Axle

序号 Ser.No.	代号 Part No	名称及规格 Name & Specifications	数量 Quantity	备注 Remarks
1	GB6180-86	螺母M20	2	
2	GB91-86	销4x30	2	
3	200.31.135	密封衬垫	2	
4	200.31.124	前轮轮毂盖	2	
5	GB818-85	螺钉M5x10	8	
6	GB93-87	垫圈5	8	
7	GB5782-86	螺栓M14x30	6	
8	GB93-87	垫圈14	16	
9	200.31B.123	前轮轮毂	2	
10	HG4-692-67	油封SD45x62x12	2	
11	GB301-84	轴承8106	2	
12	300.31.024	左主转向节组合件	1	
13	200.31.114-2	主销衬套	6	
14	GB5452.1-82	O型圈30x2.65	4	
15	200.31.126	防尘圈	4	
16	GB5782-86	螺栓M12x1.5x55	2	
17	GB93-87	垫圈12	2	
18	300.31.106	左转向节臂	1	
19	GB1099-79	键8x28	2	
20	GB6173-86	螺母M16x1.5(左)	2	
21	300.31.176-1	纵拉杆	1	For 390 engine
	350.31.176-1	纵拉杆	1	For 395 engine
	400B.31.101	纵拉杆	1	For 490 engine
22	GB5783-85	螺栓M10x30	1	
23	GB93-87	垫圈10	3	
24	300.31.018	摆振轴组合件	1	
25	GB6173-86	螺母M16x1.5(右)	2	

4 前轴总成 Front Axle

续表:					
序号 Ser.No.	代号 Part.No.	名称及规格	Name & Specifications	数量 Quantity	备注 Remarks
26	300.31.108	右转向臂	Right steering arm	1	
27	300.31.025	右立轴套管总成	Right telescopic beam assy	1	
28	300.31B.023	前轴总成	Front Axle	1	
29	200.31.160	调整垫片	Adjust shim	1组	
30	300.31.164	转向节头(右)	Pull rod joint (right)	2	
31	300.31B.129	副横拉杆(右)	Assistant tie rod (right)	1	
32	300.31B.028	横拉杆总成	Tie rod assy	1	
33	GB5782-86	螺栓M14x90	Hex.head bolt M14x90	6	
34	300.31B.138	副横拉杆(左)	Assistant tie rod (left)	1	
35	300.31.163	转向接头(左)	Pull rod joint (left)	2	
36	300.31.170	密封盖	Seal cover	4	
37	GB91-86	销3.2x50	Split 3.2x50	4	
38	GB1152-79	油杯M10x1	Grease nipple M10x1	5	
39	HG4-692-67	油封W50x72x7	Oil seal WD50x72x7	2	
40	HG4-692-67	油封PD50x72x12	Oil seal PD50x72x12	2	
41	GB297-84	轴承7507	Bearing 7507	2	
42	200.31.161	螺柱	Stud	4	
43	GB297-84	轴承7205	Bearing 7205	2	
44	GB97.2-85	垫圈20-140HV	Plain washer 20-140HV	2	
45	200.31.169	球头销	Ball stud	4	
46	300.31.168	球头销总	Pull rod joint (left)	4	
47	300.31.165	球头销	Ball stud	4	
48	GB6181-86	螺母M12	Slotted Hex.nut M12	4	
49	200.31.014	转向节总成	Steering knuckle assy	2	
50	GB91-86	销3.2x24	Split 3.2x24	4	

4 前轴总成 Front Axle

续表						
序 号	代号	名称及规格	Name & Specifications	数量	备注	
Seq. No.	Part No.			Quantity	Remarks	
51	300.31.166	球头衬套	Ball stud seat	4		
52	300.31.167	球头销套	Hex.head.bolt M10x45	2		
53	GB5782-86	螺母 M10	Secm ring pad	4		
54	300.31.134	压簧套	Hex nut M10	6		
55	GB6170-86	螺母 M10				

5.1 导向轮和驱动轮总成 Directive Wheel and Drive Wheel

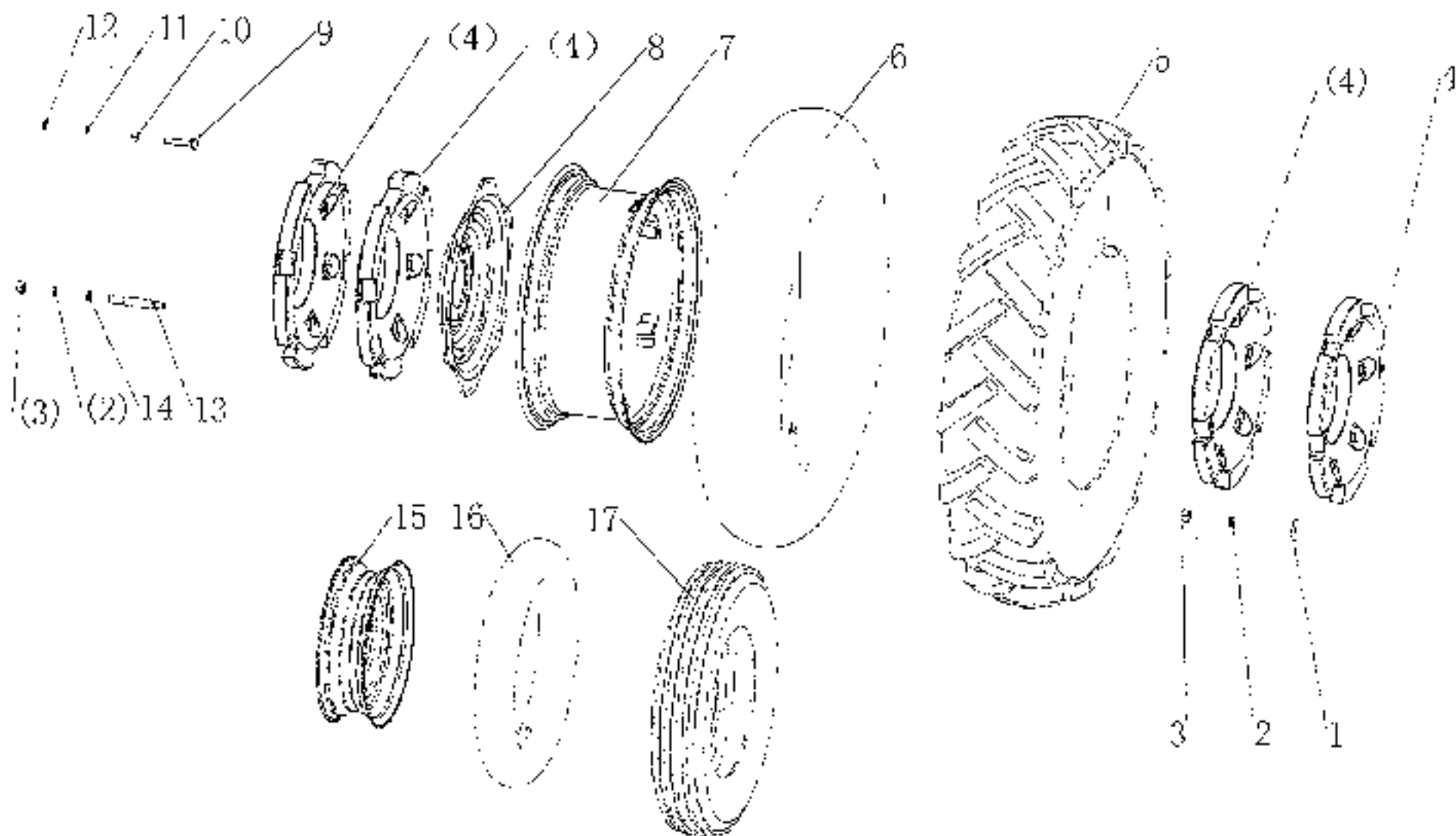

5.1 导向轮和驱动轮总成 Directive Wheel and Drive Wheel

序号	Ser.No.代号	Part No.	名称及规格	Name & Specifications	数量	Quantity	备注	Remarks
1		GB96-85	垫圈 16	Large plain washer 16	6x2		Optional while placing order	
2		GB93-87	垫圈 16	Spring lock washer 16	6x2		Optional while placing order	
3		GB6170-86	螺母 M16	Hex. nut M16	6x2		Optional while placing order	
4		300-34-101-2	后轮盖	Rear wheel ballast	4x2		Optional while placing order	
5		GB2979-91	驱动轮外胎 11.2-24	Tire 11.2-24	1x2			
		GB2979-91	驱动轮外胎 12.4-24	Tire 12.4-24	1x2		For 490 engine	
		GB2979-91	驱动轮外胎 9.5-24	Tire 9.5-24	1x2		高花紋轮胎 High lug tyre	
6		GB2979-91	驱动轮内胎 11.2-24	Tube 11.2-24	1x2			
		GB2979-91	驱动轮内胎 12.4-24	Tube 12.4-24	1x2		For 490 engine	
		GB2979-91	驱动轮内胎 9.5-24	Tube 9.5-24	1x2		高花紋轮胎 High lug tyre	
7		300-34-011	驱动轮轮毂总成	Wheel rim	1x2			
		300-34A-011	驱动轮轮毂总成	Wheel rim	1x2		配有花紋轮胎 For High lug tyre	
8		300-34-103-1	驱动轮轴板	Wheel disc	1x2			
9		200-34-115	轮毂螺栓	Attachment bolt	6x2			
10		GB6176-86	螺母 M14x1.5	Fine thread hex. nut M14x1.5	12x2			
11		GB93-87	垫圈 14	Spring lock washer 14	12x2			
12		GB97.1-85	垫圈 14	Plain washer 14	12x2			
13		300-34-102-2	轴盖螺栓	Bolt for ballast	6x2		Optional while placing order	
14		GB97.1-85	垫圈 16	Plain washer 16	6x2		Optional while placing order	
15		300-32-011	导向轮轮毂总成	Directive wheel rim	1x2			
16		GB2979-91	导向轮内胎 5.0-15	Tube 5.0-15	1x2			
17		GB2979-91	导向轮外胎 5.0-15	Tire 5.0-15	1x2			

5.2 草地胎前轮 Front Drive Wheel (Turf Tyre)

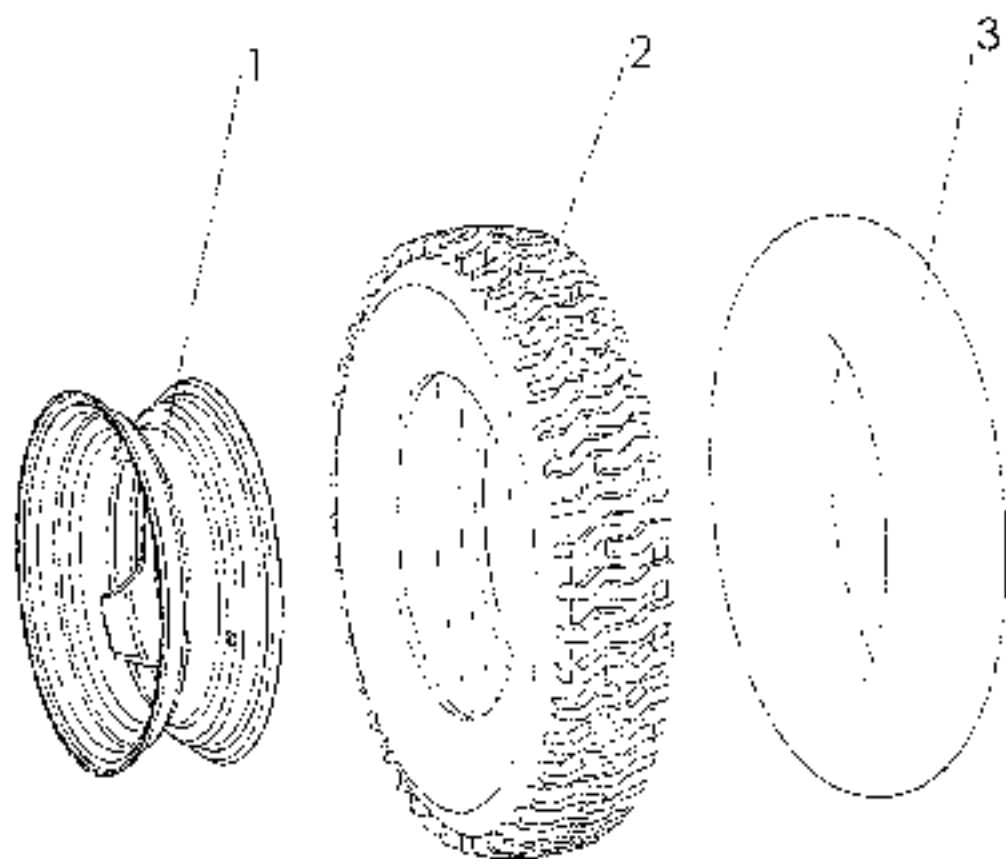

5.2 草地胎后轮 Rear Wheel (Turf tyre)

序号 Ser.No.	代号 Part No.	名称及规格	Name & Specifications	数量 Quantity	备注 Remarks
1	GB2979-91	外胎 11.2-24	Tire 11.2-24	1×2	
2	GB2979-91	内胎 11.2-24	Tube 11.2-24	1×2	
3	300.34.011	轮架总成 (24×W10)	Wheel rim (24×W10)	1×2	
4	GB5785-86	螺母 M14×1.5×80	Hex head bolt M14×80	2×6	
5	GB97.1-85	垫圈 14	Large plain washer 14-1005IV	2×6	
6	300.34.103-1	碟板	Wheel disc	1×2	
7	GB93-87	垫圈 14	Spring lock washer 14	2×6	
8	GB6176-86	螺母 M14×1.5	Fine thread hex. nut M14	2×6	

5.3 后轮总成 (工业胎) Rear Wheel (Industrial tyre)

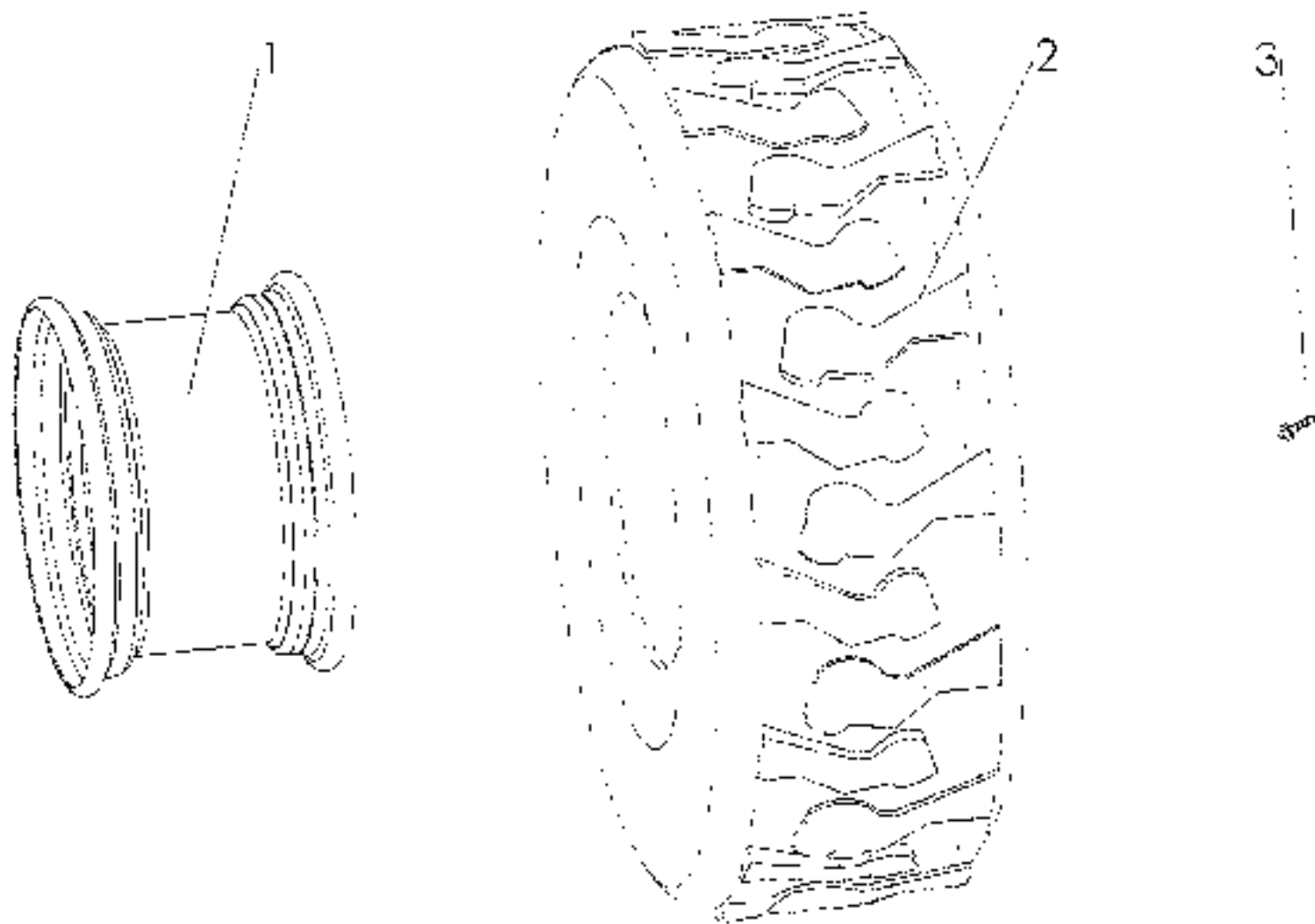

5.3 后轮总成（工业胎） Rear Wheel (Industrial tyre)

序号 Ser No	代号 Part No	名称及规格	Name & Specifications	数量 Quantity	备注 Remarks
1	354.54.351	轮制总成	Front wheel rim	1×2	
2	16.5-22 SNHS	工业后轮胎	Industrial tyre	1×2	
3	1R501	气门嘴	Valve	1×2	

6 变速箱总成 (A) Gearbox (A)

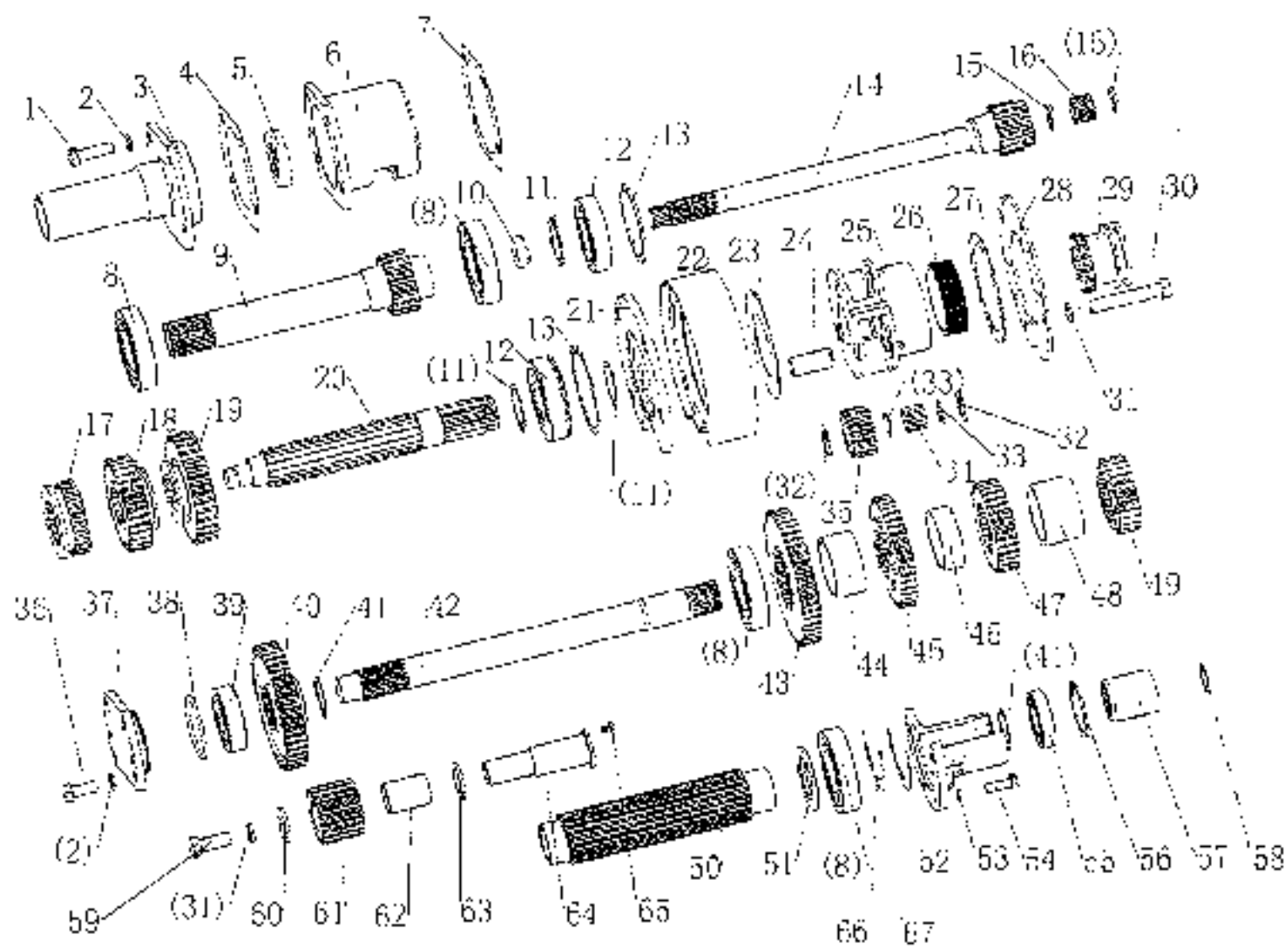

6 变速箱总成(A) Gearbox(A)

序号 Ser.No	代号 Part No.	名称及规格	Name & Specifications	数量 Quantity	备注 Remarks
1	GB5783-86	螺栓 M10×35	Hex. head bolt M10×35	4	
2	GB93-87	垫圈 10	Spring lock washer 10	15	
3	300.37.104-1	一轴前轴承盖	Front bearing cover, shaft I	1	
4	300.37.105-1	一轴前轴承盖衬垫	Bearing cover gasket, shaft I	1	
5	JB2600-80	油封 5035×55×10	Oil seal 5035×55×10	1	
6	300.37.143-2	一轴前轴承座	Front bearing seat, shaft I	1	
7	300.37.106-1	一轴前轴承座衬垫	Bearing seat gasket, shaft I	1	
8	GB276-89	轴承 208	Ball bearing 208	2	
9	300.37.103-1	输入轴	Input shaft	1	
	300.37.103-A	输入轴(1000/540)	Input shaft (1000/540)	1	For PTO (1000/540)
	300.37.103-B	输入轴(730/540)	Input shaft (730/540)	1	For PTO (730/540)
10	300.37.107-2	输入轴油封	Oil seal	1	
11	GB894.1-86	挡圈 35	Circ lip for shaft 35	3	
12	GB277-89	轴承 50207	Snap ring ball bearing 50207	2	
13	GB305-89	止动环 80	Snap ring 80	2	
14	300.37.102-3	一轴常啮合齿轮	Constant-mesh gear, shaft I	1	
15	200.37.105	滚针止推圈	Thrust washer roller	2	
16	GB309-89	滚针 2.5×19.8	Needle roller 2.5×19.8	28	
17	300.37.115-1	二轴三四档齿轮	3rd & 4th speed gear, shaft II	1	
18	300.37.116-1	二轴二档齿轮	2nd speed gear, shaft II	1	
19	300.37.117-1	二轴一档齿轮	1st speed gear, shaft II	1	
20	200.37.157	二轴	shaft II	1	
21	200.37.120	二轴后轴承盖	Rear bearing cover, shaft II	1	
22	200.37.203	齿圈	Ring gear	1	
23	200.37.201	行星架前垫片	Front shim, planet carrier	1	
24	200.37.202	行星齿轮轴	Planet gear shaft	3	
25	200.37.209	行星齿轮架	Planet carrier	1	

6 变速箱总成(A) Gearbox(A)

续表

序号 Ser No.	代号 Part No.	名称及规格	Name & Specifications	数量 Quantity	备注 Remarks
26	200.37.210	行星轮架花键套	Spined ring, planet carrier	1	
27	200.37.205	行星架后垫片	Rear shir., planet carrier	1	
28	200.37.206	行星轮架后盖	Rear cover, planet carrier	1	
29	200.37.212	接合齿套	Sliding gear	-	
30	GB5782-86	螺栓 M12x70	Hex. head bolt M12x70	4	
31	GB93-87	垫圈 12	Spring lock washer 12	5	
32	200.37.204	行星轮垫片	Shur. Planet gear	6	
33	200.37.203	行星轮滚针挡瓦	Needle bearing retainer	6	
34	GB309-89	滚针 3x19 8	Needle roller 3x19.8	66	
35	200.37.207	行星齿轮	Planet gear	3	
36	GB5783-86	螺栓 M10x25	Hex head bolt M10x25	4	
37	300.37.152-1	中间轴前轴承盖	Front bearing cover, counter-shaft	1	
38	GB3452.1-82	O形圈 54.5x3.55	O-ring seal 54.5x3.55	1	
39	GB276-89	轴承 305	Ball bearing 305	1	
40	300.37.149-1	动力输出传动齿轮	PTO transmission gear	1	
	300.37.149-A	动力输出传动齿轮(1000/540)	PTO transmission gear (1000/540)	1	For PTO(1000/540)
	300.37.149-D	动力输出传动齿轮(730/540)	PTO transmission gear (730/540)	1	For PTO(730/540)
41	GB894-1-86	挡圈 30	Circlip for shaft 30	2	
42	300.37.134-1	动力输出传动轴	PTO transmission shaft	1	
	300.37.134-1	动力输出传动轴(带孔)	PTO transmission shaft	1	轴头带孔4WD用
43	300.37.146-1	中间轴常啮合齿轮	Constant-mesh gear, counter-shaft	1	
44	300.37.145-1	中间轴前隔套	Front spacer sleeve, counter shaft	1	
45	300.37.143-2	中间轴三档齿轮	3rd speed gear, counter shaft	1	
46	300.37.142-1	中间轴十档隔套	Middle spacer sleeve, counter-shaft	1	
47	300.37.140-1	中间轴二档齿轮	2nd speed gear, counter-shaft	1	
48	300.37.138	中间轴后隔套	Rear spacer sleeve, counter shaft	1	

6 变速箱总成(A) Gearbox(A)

序号 Ser.No	代号 Part No	名称及规格	Name & Specifications	数量 Quantity	备注 Remarks
49	300.37.137-1	中间轴一档齿轮	1st speed gear I gear, counter-shaft	1	
50	280.37.112	中间轴	Counter-shaft	1	
51	280.37.111	中间轴后轴承盖	Rear Retaining ring, counter-shaft	1	
52	280.37.110	中间轴后轴承盖	Rear bearing cover, counter shaft	1	
53	GB93-87	弹簧 8	Spring lock washer 8	4	
54	GB5783-86	螺栓 M8×25	Hex. head bolt M8×25	2	
55	GB276-89	轴承 106	Ball bearing 106	1	
56	GB893.1-86	挡圈 55	Circlip for hole 55	1	
57	300.37.132-1	输出轴接合套	Splined sleeve	1	
58	GB593.1-86	挡圈 23	Circlip for hole 23	1	
59	GB5785-86	螺栓 M12×30	Hex. head bolt M12×30	1	
60	200.37.111	倒档齿轮衬套	Retaining ring, reverse gear	1	
61	300.37.169-1	倒档齿轮	Reverse gear	1	
62	200.37.146	倒档齿轮衬套	Bush, reverse gear	1	
63	200.37.114	倒档齿轮止推垫	Thrust ring, reverse gear	1	
64	200.37.116	倒档轴	Reverse gear shaft	1	
65	GB65-85	螺钉 M6×8	Cheese head screw M6×8	1	
66	280.37.200	调整垫片	Adjusting shim	1	
67	280.37.201	调整垫片	Adjusting shim	1	

7 变速箱总成 (B) Gearbox (B)

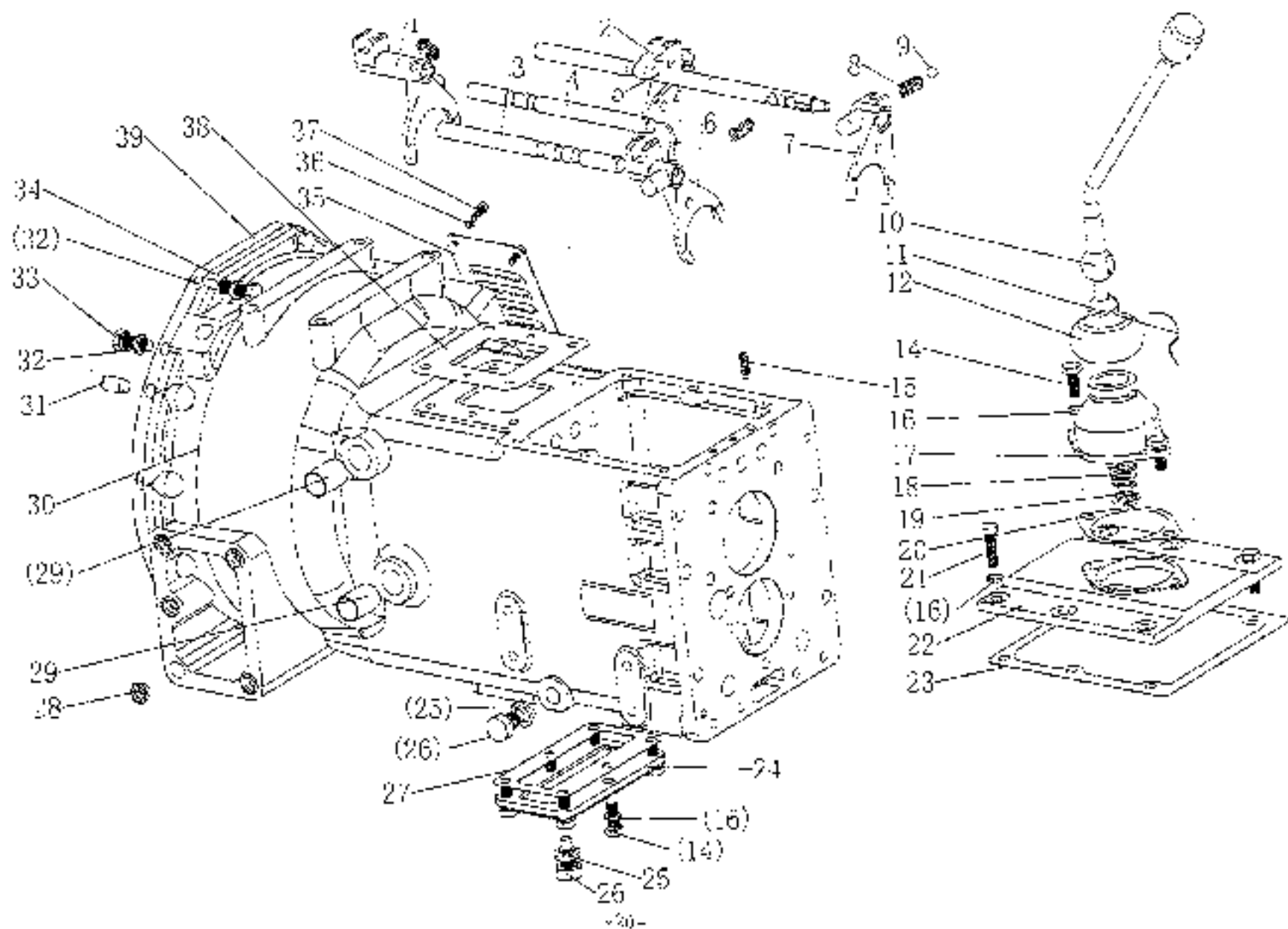

7 变速箱总成(B) Gearbox(B)

序号 Ser.No.	代号 Part No	名称及规格	Name & Specifications	数量 Quantity	备注 Remarks
1	300.37.128	中拨叉	Middle shift fork	1	
2	300.37.126	右拨叉	Right shift fork	1	
3	300.37.129-2	左拨叉轴	Shaft, left shift fork	1	
4	300.37.127-2	中拨叉轴	Shaft, middle shift fork	1	
5	300.37.125-2	右拨叉轴	Shaft, right shift fork	1	
6	300.37.130	左拨叉	Left shift fork	1	
7	200.37.211	高低档拨叉	Shift fork, Hi-low speed range	1	
8	200.37.127-1	拨叉定位弹簧	Positioning spring, shift fork	4	
9	GB308-84	钢球9.5	Steel ball 9.5	4	
10	200.37.013-1	换挡杆总成	Gear-shift lever	1	200.37.013A
11	GB343-82	冷拉钢丝1.4×160	Cold drawn steel wire ϕ 1.4×160	1	
12	200.37.153	防尘罩	Dust boot	1	
13	GB75-85	螺钉M8×12	Set screw with dog point M8×12	2	
14	GB5783-86	螺栓M10×25	Hex. head bolt M10×25	8	
15	300.37.155	定位螺钉	Positioning screw	3	
16	GB93-87	垫圈10	Spring lock washer 10	15	
17	300.37.114	换挡杆座	Seat, gear shift lever	1	
18	200.37.112	变速杆弹簧	Spring, gear shift lever	1	
19	300.37.113	换挡杆弹簧挡圈	Spring stopper, gear shift lever	1	
20	200.37.134	换挡座衬垫	Seat gasket, gear shift lever	1	
21	GB5783-86	螺栓M10×35	Hex. head bolt M10×35	4	
22	300.37.116	变速箱盖	Gearbox cover	1	
23	300.37.120	变速箱盖衬垫	Gasket, gearbox cover	1	
24	300.37.150	底盖	Bottom cover	1	
25	12.37.149	组合密封圈	Combined seal washer	2	

7 变速箱总成(B) Gearbox(B)

序号 Ser.No	代号 Part No	名称及规格 Name & Specifications	数量 Quantity	备注 Remarks
1	300.37.128	中拨叉 Middle shift fork	1	
2	300.37.126	右拨叉 Right shift fork	1	
3	300.37.129-2	左拨叉轴 Shaft, left shift fork	1	
4	300.37.127-2	中拨叉轴 Shaft, middle shift fork	1	
5	300.37.125-2	右拨叉轴 Shaft, right shift fork	1	
6	300.37.130	左拨叉 Left shift fork	1	
7	200.37.211	高低档拨叉 Shift fork, Hi-low speed range	1	
8	200.37.127-1	拨叉定位弹簧 Positioning spring, shift fork	4	
9	GB308-84	钢球9.5 Stee. ball 9.5	4	
10	200.37.013-1	换挡杆总成 Gear-shift lever	1	200.37.013A
11	GB543-82	冷拉钢丝1.4×160 Cold drawn steel wire ϕ 1.4×160	1	
12	200.37.153	防尘罩 Dust boot	1	
13	GB75-85	螺钉M8×12 Set screw with dog point M8×12	2	
14	GB5783-86	螺栓M10×25 Hex. head bolt M10×25	3	
15	300.37.155	定位螺钉 Positioning screw	3	
16	GB93-87	垫圈10 Spring lock washer 10	15	
17	300.37.114	换挡杆座 Seat, gear shift lever	1	
18	300.37.112	变速箱弹簧 Spring, gear shift lever	1	
19	300.37.113	换挡杆弹簧挡块 Spring stopper, gear shift lever	1	
20	200.37.134	换挡座衬垫 Seat gasket, gear shift lever	1	
21	GB5783-86	螺栓M10×35 Hex. head bolt M10×35	4	
22	300.37.119	变速箱盖 Gearbox cover	1	
23	300.37.120	变速箱盖纸垫 Gasket, gearbox cover	1	
24	300.37.150	底盖 Bottom cover	1	
25	12.37.149	出油密封圈 Combined seal washer	2	

8 后桥总成(A) Rear Axle(A)

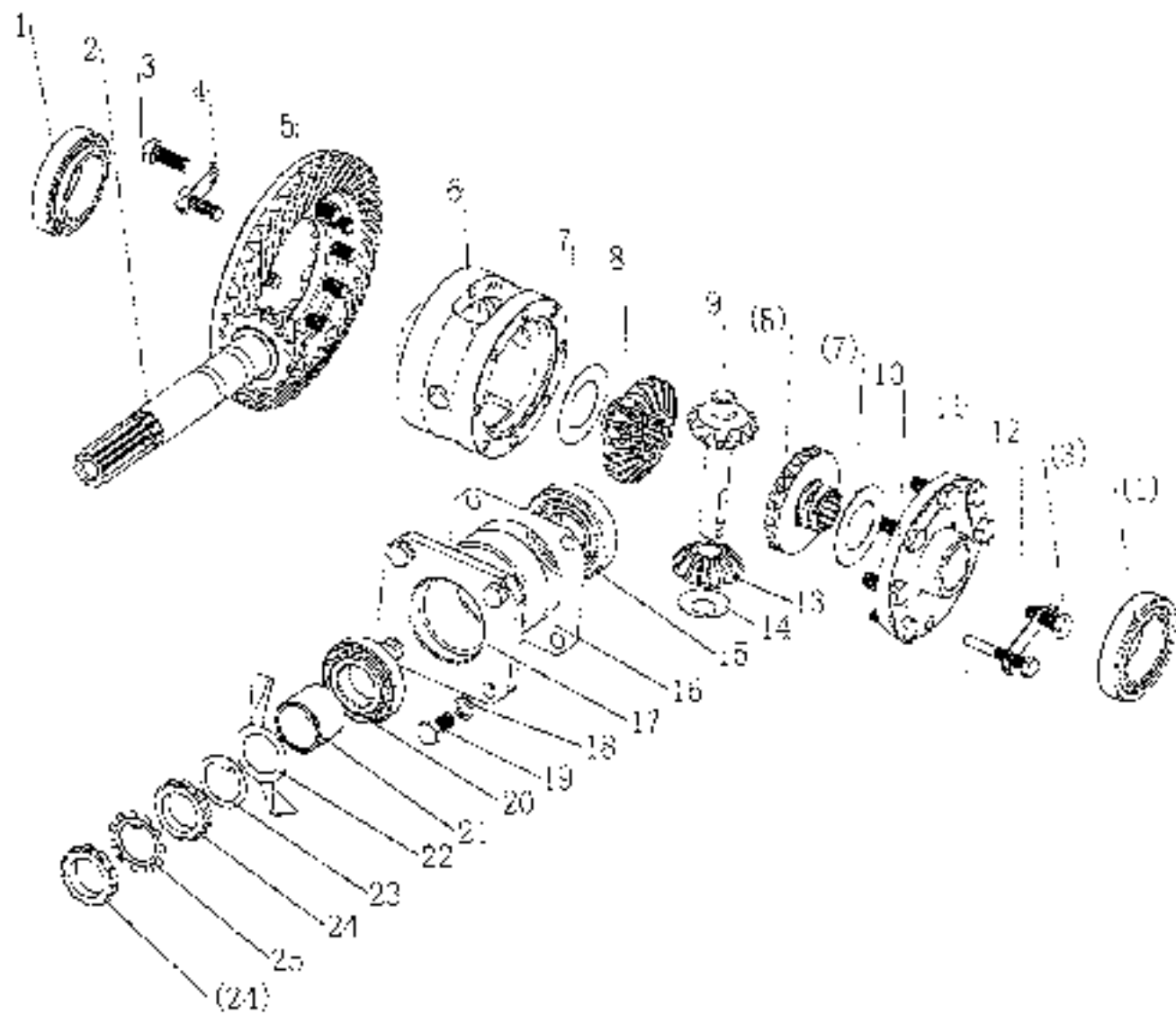

8 后桥总成 (A) Rear Axle(A)

序号 Ser. No.	代号 Part No.	名称及规格 Name & Specifications	数量 Quantity	备注 Remarks
1	GB297-84	滚动轴承2007111	2	
2	300.38.129	主传动主动圆锥齿轮	1	
3	GB5785-86	螺栓M10×1×30	19	
4	300.38.139	锁紧垫片	6	
5	300.38.140	主传动被动圆锥齿轮	1	
6	300.38.158	差速器壳体	1	
7	300.38.147	半轴齿轮垫片	2	
8	300.38.141	半轴齿轮	2	
9	300.38.143	行星轴	1	
10	300.38.148	差速器盖	1	
11	300.38.144	行星轴固定螺钉	1	
12	300.38.146	锁紧垫片	4	
13	300.38.142	行星齿轮	2	
14	300.38.145	行星齿轮垫片	2	
15	GB297-84	滚动轴承7307	1	
16	200.38.104	主传动主动圆锥轮调整垫片	1	
17	300.38.135	主动圆锥轮轴承座	1	
18	GB93-87	弹簧12	4	
19	GB5786-86	螺母M12×1.5×35	4	
20	GB297-84	滚动轴承7207	1	
21	300.38.134	短套筒	1	
22	200.38.145	油封片	1	
23	200.38.134	锁片	1	
24	200.38.150	锁紧螺母	2	
25	200.38.131	止退垫片	1	

9 后桥总成 (B) Rear Axle (B)

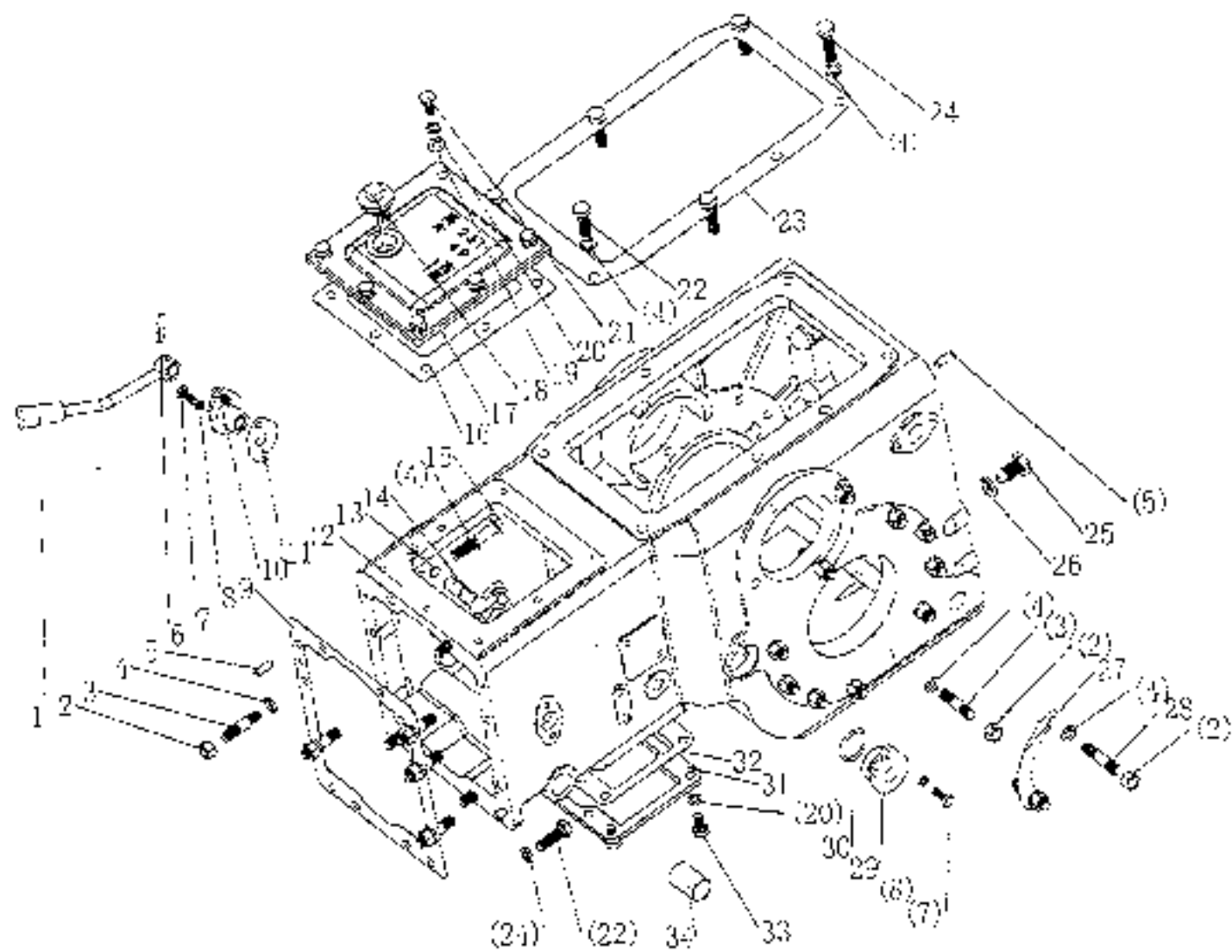

9 后桥总成 (B) Rear Axle(B)

序号 Ser.No	代号 Part No.	名称及规格 Name & Specifications	数量 Quantity	备注 Remarks
1	200.38.020	高低档换挡杆总成	1	
2	GB6170-86	螺母M12	31	
3	GB898-88	螺柱AM12x35	23	
4	GB93-87	垫圈12	46	
5	GB119-86	销B8x22	4	
6	GB879-86	销5x28	1	
7	GB5783-86	螺栓M8x20	3	
8	GB93-87	垫圈8	3	
9	200.38.102	变速箱与后桥联接纸垫		
10	200.38.113	操纵轴衬套	1	
11	200.38.111	操纵轴衬套纸垫	1	
12	200.38.101-2	后桥壳体	1	
	300.38.101-2A	后桥壳体	1	马其顿号用
13	GB3452.1-82	O型密封圈10.6x2.65	1	
14	300.38.103	高低档拨销	1	
15	GB5782-86	螺栓M10x50	2	
16	300.38.112	上盖板纸垫	1	
17	300.38.113B	上盖板	1	U.S
	300.38.113A-1	上盖板	1	
18	200.38.014	油尺总成	1	
	200.38.014A	油尺总成	1	马兴西亚
19	GB97.2-85	垫圈10	7	
20	GB93-87	垫圈10	13	
21	GB5783-86	螺栓M10x20	7	
22	GB5786-86	螺栓M12x1.5x35	6	

9 后桥总成 (B) Rear Axle(B)

序号 Ser.No	代号 Part No.	名称及规格	Name & Specifications	数量 Quantity	备注 Remarks
23	300.38.114	提升器壳体纸垫	Paper gasket,lift housing	1	
24	GB5782-86	螺栓M12×45	Hex. head bolt M12x45	5	
25	200.38.024	放油螺塞总成	Oil drain plug	1	
26	12.37.149	组合密封垫圈	Combiness seal washer	1	
27	300.38.116	主传动轴啮合齿隙调整垫片	Adjusting shim,spiral crown gear	4组	
28	GB898-88	螺栓AM12×40	Double end stud AM12x40	8	
29	200.38.160	端盖	End cover	1	
30	GB3452.1-82	O型密封圈33.5×3.35	O-ring seal 33.5x3.35	1	
31	300.38.108	小盖板	Small cover	1	
32	300.38.109	小盖板纸垫	Paper gasket,small cover	1	
33	GB5783-86	螺栓M10×25	Hex head bolt M10x25	6	
34	200.38.144	衬套	Bush	2	

10 差速锁总成 Differential Lock

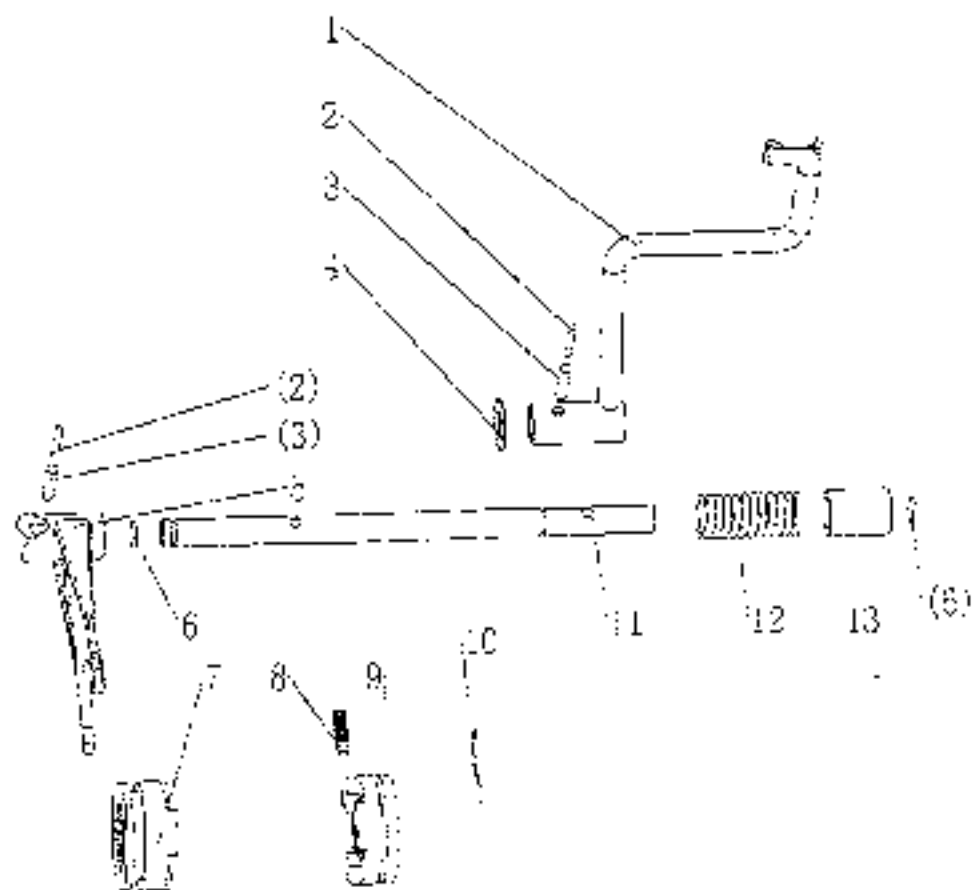

10 差速锁总成 Differential Lock

序号 Ser. No.	代号 Part No.	名称及规格	Name & Specifications	数量 Quantity	备注 Remarks
1	300.38.020-1	脚踏操纵杆	Foot control lever	1	
2	GB879-86	销5×35	Slotted spring pin 5x35	2	
3	GB879-86	销8×35	Slotted spring pin 8x35	2	
4	GB97.2-85	垫圈20	Chartered plain washer 20-14 V	1	
5	300.38.154	拨叉	Shift fork	1	
6	GB3452.1-82	O型密封圈15×2.65	O ring seal 15x2.65	2	
7	300.38.169	左接合套	Left splicing sleeve	1	
8	GB75-85	螺钉M10×25	Set screw with dog point M10x25	2	
9	300.38.170-1	右接合套	Right splicing sleeve	1	
10	GB3051-82	热镀锌铁丝 1-1.40×260	Galvanized steel wire 1-1.40x260	1	
11	300.38.155-1	拨叉轴	Shift fork shaft	1	
12	300.38.151-1	弹簧	Spring	1	
13	300.38.152-1	衬套	Sleeve	1	

11 最终传动总成 Final Transmission

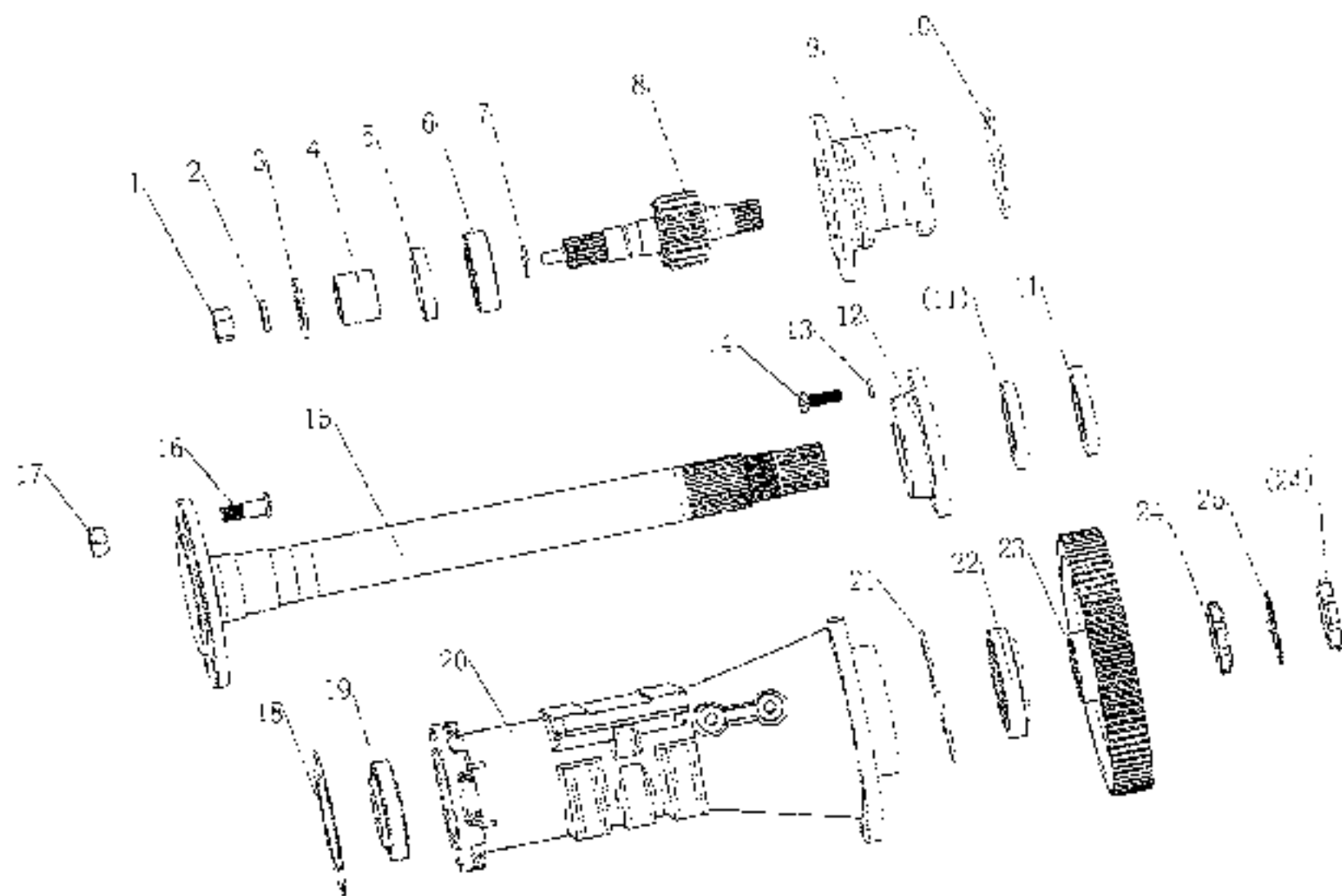

11. 最终传动总成 Final Transmission

序号 Ser.No	代号 Part No	名称及规格	Name & Specifications	数量 Quantity	备注 Remarks
1	GB6170-86	螺母M20	Hex. nut M20	1	
2	GB93-87	垫圈20	Spring lock washer 20	1	
3	GB97.1-85	垫圈20	Plain washer 20	1	
4	300.39.108	衬套	Spacer sleeve	1	
5	HC4-692-67	油封PD50×70×12	Oil seal PD50×70×12	1	
6	GB276-89	轴承307	Ball bearing 307	1	
7	GB3452.1-82	O型密封圈26.5×2.65	O ring seal 26.5×2.65	1	
8	300.39.107-1	主动齿轮	Drive gear	1	For Shoe brake
	300.39A.101	主动齿轮	Drive gear	1	For Disc brake
9	300.39.109	轴承座	Bearing seat	1	
10	GB3452.1-82	O型密封圈103×3.55	O-ring seal 103×3.55	1	
11	HC4-692-67	油封SD60×90×12	Oil seal SD60×90×12	2	
12	300.39.102	轴承盖	Bearing cover	1	
13	GB93-87	垫圈12	Spring lock washer 12	6	
14	GB5783-86	螺母M12×35	Hex. head bolt M12×35	6	
15	300.39.103-3	半轴	Half axle shaft	1	
16	300.39.102	后轮毂螺栓	Rear hub bolt	8	
17	300.39.102	后轮毂螺母	Rear hub nut	6	
18	300.39.110	纸垫	Paper gasket	1	
19	GB297-84	滚子轴承7211	Tapered roller bearing 7211	1	
20	300.39.105-1/106-1	左、右半轴套	Right/left half shaft housing	1	
21	GB3452.1-82	O型密封圈128×3.55	O-ring seal 128×3.55	1	
22	GB297-84	滚子轴承2007114E	Tapered roller bearing 2007114E	1	
23	300.39.110-3	被动齿轮	Driven gear	1	
24	300.39.114	锁紧螺母	Lock nut	2	
25	300.39.115	锁紧垫片	Lock piece	1	

12 转向器总成 Steering Gear

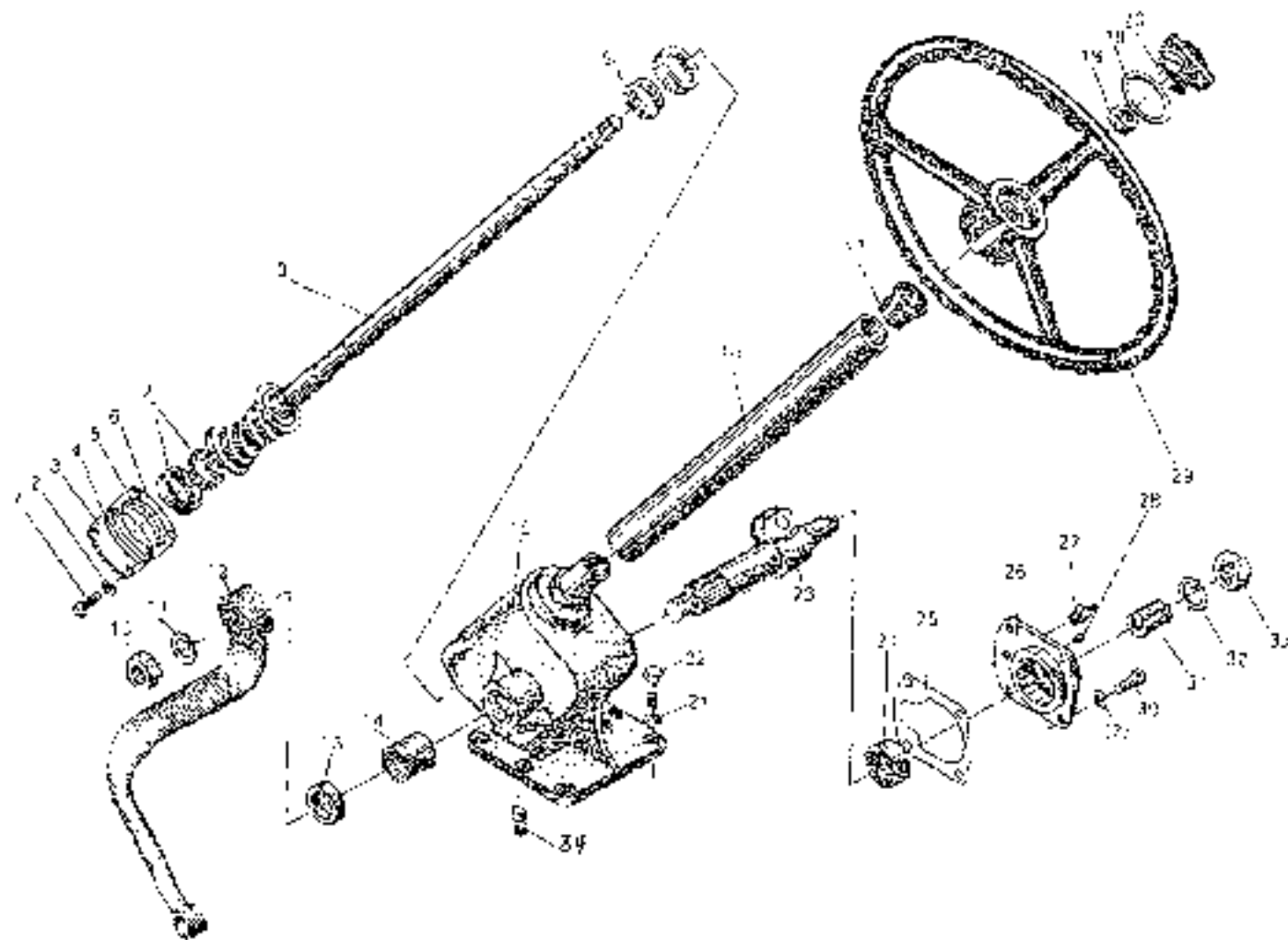

12 转向器总成 Steering Gear

序号 Ser.No.	代号 Part No.	名称及规格	Name & Specifications	数量 Quantity	备注 Remarks
1	GB5782-86	螺栓 M8x20	Hex head bolt M8x20	4	
2	GB93-87	垫圈8	Spring lock washer 8	8	
3	ZS.40.103	转向器下盖	Steering gear lower cover	1	
4	ZS.40.209/210	转向器下盖调整衬垫	Lower cover adjusting shim	按需 (need)	
5	ZS.40.211	转向器下盖调整衬垫	Lower cover adjusting shim	按需 (need)	
6	ZS.40.213	转向器下盖纸垫	Paper gasket	1	
7		滚动轴承977007K	Taper roller bearing 977007K	1	
8		转向轴带转向蜗杆总成	Steering shaft with worm	1	
9		滚动轴承977007	Taper roller bearing 977007	1	
10	GB6173-86	螺母M22x1.5-7H	Fine pitch hex.thin nut M22x1.5-7	1	
11	GB93-87	垫圈22	Spring lock washer 22	1	
12	300.31.101	转向盘臂	Steering arm	1	
13	JB2600-80	油封32x45x10	Oil seal 32x45x10	1	
14	ZS.40.110	转向衬套	Steering arm bush	1	
15	ZS.40.109	转向器壳体	Steering gear case	1	
16	300.40.102A	转向套管	Steering-column case	1	
17	TY1205.40.109	下油封	Lower oil seal	1	
18	GB6173-86	螺母M16x1.5	Fine pitch hex.thin nut M16x1.5	1	
19	ZS.40.106	橡胶垫	Rubber pad	1	
20	ZS.40.107	转向轴盖	Steering wheel centre cap	1	
21	GB93-87	垫圈8	Spring lock washer 8	8	
22	GB6173-86	螺栓M10x30	Hex. head bolt M10x30	4	
23	ZS.40.013A	转向器臂轴总成	Steering arm shaft	1	
24		轴承922205	Bearing 922205	1	
25	ZS.40.208	转向器侧盖衬垫	Side cover gasket	1	

12 转向器总成 Steering Gear

续表

序号 Ser.No	代号 Part No.	名称及规格	Name & Specifications	数量 Quantity	备注 Remarks
25	25.40.207A	转向器侧盖	Side cover	1	
27	GB1152-86	油杯 M10x1	Grease nipple M10x1	1	
28	GB119-86	销 B5x8	Parallel pin B5x8	1	
29	300.40.012	方向盘组件	Steering wheel	1	
30	GB5782-86	螺母 M8x16	Hex. head bolt M8x16	1	
31	25.40.202	转向摇臂轴调整螺钉	Adjusting screw	1	
32	25.40.206	摆臂轴调整螺钉锁紧垫圈	Lock washer	1	
33	GB53-76	螺母 M24x1.5	Fine pitch hex.nut M24x1.5	1	
34	GB119-86	销 B8x16	Parallel pin B8x16	2	

13 动力输出总成 FTO

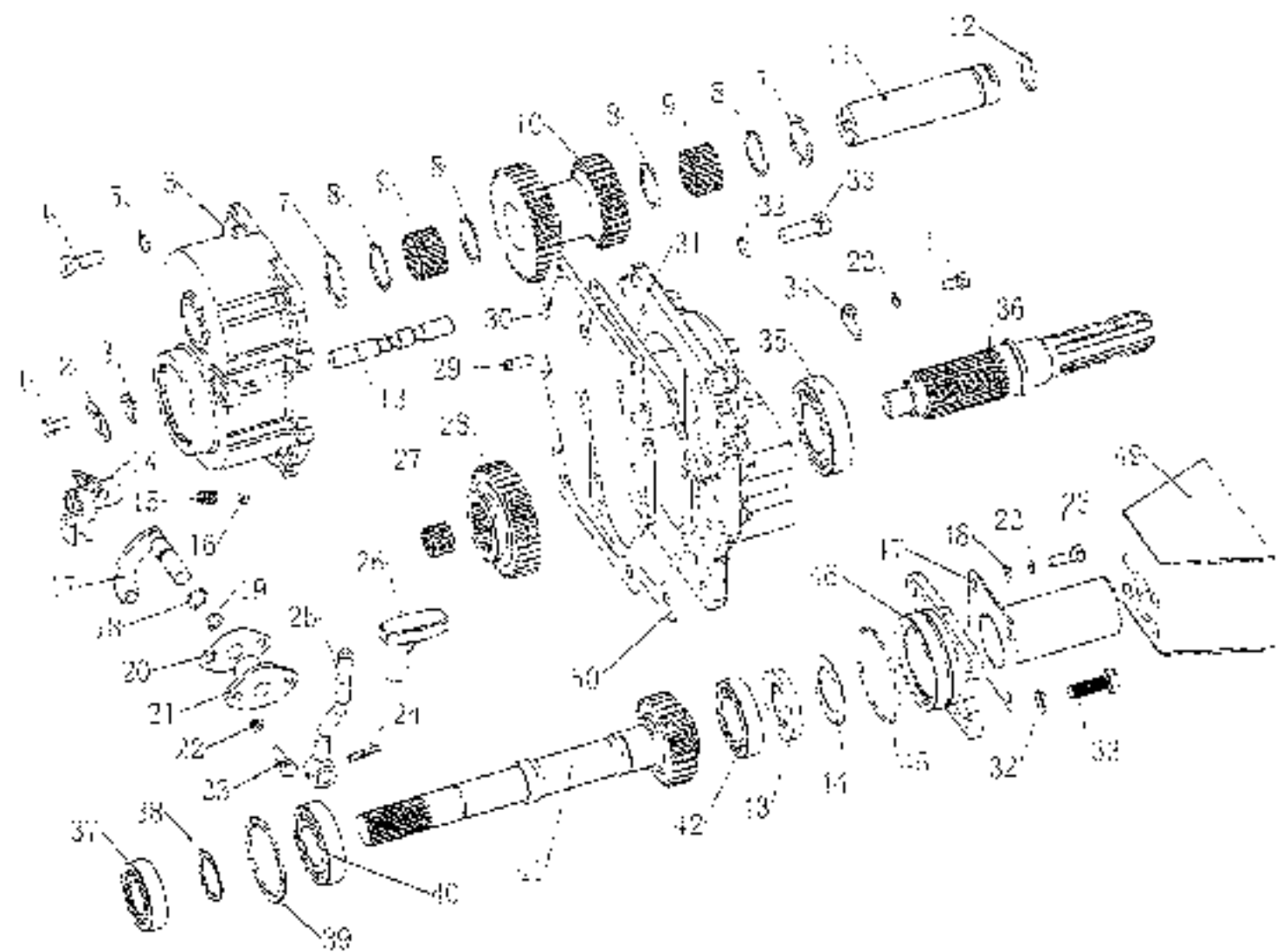

13 动力输出总成 PTO

序号 Ser No	代号 Part No	名称及规格	Name & Specifications	数量 Quantity	备注 Remarks
1	GB5783-86	螺栓 M8×16	Hex. head bolt M8×16	2	
2	300.41B.122	锁紧垫片	Lock washer	1	
3	300.41B.101	拨叉轴定位板	Locating plate of shift fork shaft	1	
4	GB5783-86	螺栓 M10×30	Hex. head bolt M10×30	8	
5	GB93-87	垫圈 10	Spring lock washer 10	8	
6	400B.41.102-1	双速输出齿轮壳体	PTO gear housing	1	
7	300.41B.103	挡圈	Blocking ring	2	
8	300.41B.104	挡圈	Blocking ring	4	
9	GB309-84	滚针 3×23.8	Needle roller 3×23.8	78	
10	400B.41.106	中间齿轮(540/1000)	Middle gear (540/1000)	1	for 540/1000rpm
	400B.41.106A	中间齿轮(540/730)	Middle gear (540/730)	1	for 540/730rpm
11	300.41B.107	双速输出中间轴	Middle shaft	1	
12	GB3452.1-82	O形圈 30×2.65	O-ring seal 30×2.65	1	
13	300.41B.111	拨叉轴	Shift fork shaft	1	
14	400B.41.112-1	拨叉	Shift fork	1	
15	300.37.127-1	拨叉定位弹簧	Shift fork positioning spring	1	
16	GB308-89	钢球 9.5	Steel ball 9.5	1	
17	400B.41.011-1	控制轴零件	controlling shaft	1	
18	GB894.1 86	挡圈 15	Circlip for shaft 15	1	
19	GB3452.1-82	O形圈 10.6×2.65	O-ring seal 10.6×2.65	1	
20	200.38.111	操纵轴衬套纸垫	bushing gasket	1	
21	200.38.113	操纵轴衬套	Controlling shaft bushing	1	
22	GB93-87	垫圈 8	Spring lock washer 8	7	
23	GB5783-86	螺栓 M8×25	Hex. head bolt M8×25	6	
24	GB879-86	销 6×28	Slotted spring pin 6×28	1	
25	350-1.41.011	动力输出操纵杆零件	PTO control lever	1	

续表

13 动力输出总成 PTO

序号 Ser.No	代号 Part.No	名称及规格	Name & Specifications	数量 Quantity	备注 Remarks
	350-1.41.011A	动力输出操纵杆焊合件	PTO control lever	1	
26	280.41.122-1	动力输出操纵杆手柄	PTO control handle	1	
	280.41.122A-1	动力输出操纵杆手柄	PTO control handle	1	
27	GB5846-86	轴承 K223020	Bearing K223020	1	
28	400B.41.117	换挡齿轮(540/1000)	Shifting gear (540/1000)	1	for 540/1000rpm
	400B.41.117A	换挡齿轮(540/730)	Shifting gear (540/730)	1	for 540/730rpm
29	GB119-86	销 B8×26	Straight pin B8×26	2	
30	400B.41.116	双轴输出齿轮壳体垫片	Gasket of rear cover	1	
31	400B.41.108	后轴盖板	Rear cover of rear axle	1	
32	GB93-87	垫圈 12	Spring lock washer 12	12	
33	GB5783-86	螺栓 M12×35	Hex. head bolt M12×35	12	
34	300.41B.109	中间轴定位板	Locating plate of middle shaft	1	
35	GB276-89	轴承 209	Ball bearing 209	1	
36	300.41B.114	动力输出轴(6齿)	PTO shaft (of 6 teeth)	1	
	300.41B.114A	动力输出轴(8齿)	PTO shaft (of 8 teeth)	1	
37	GB276-89	轴承 206	Ball bearing 206	1	
38	GB894.1-86	挡圈 35	Circlip for shaft 35	1	
39	GB893.1-86	挡圈 80	Circlip for hole 80	1	
40	GB276-89	轴承 307	Ball bearing 307	1	
41	400B.41.124B	传动齿轮轴(540/730)	Driving gear shaft (540/730)	1	for 4DW
	400B.41.124	传动齿轮轴(540/730)	Driving gear shaft (540/730)	1	
	400B.41.123A	传动齿轮轴(540/1000)	Driving gear shaft (540/1000)	1	for 4DW
42	GB276-89	轴承 103	Ball bearing 103	1	
43	GB13871-92	油封 FB40×62×8	Oil seal FB40×62×8	1	
44	300.41B.125	注油挡圈	Oil seal blocking ring	1	

续表

13 动力输出总成 PTO

序号 Ser.No.	代号 Part No.	名称及规格	Name & Specifications	数量 Quantity	备注 Remarks
45	GB3452.1-82	O形圈 80×2.65	O-ring seal 80×2.65	1	
	400B.41.123	传动齿轮轴(540/1000)	Driving gear shaft (540/1000)	1	
46	300.41B.115-1	动力输出盖板	Cover	1	
47	300.41.011	防尘罩	PTO shaft shield	1	
48	GB97.1-85	垫圈 3-140HV	Plain washer 3-140HV	4	
49	300.41.012	动力输出护罩	PTO shaft safety cover	1	
50	400B.41.105-1	动力输出轴承座垫片		1	

14.1 座椅总成 (減震) Seat (Absorber)

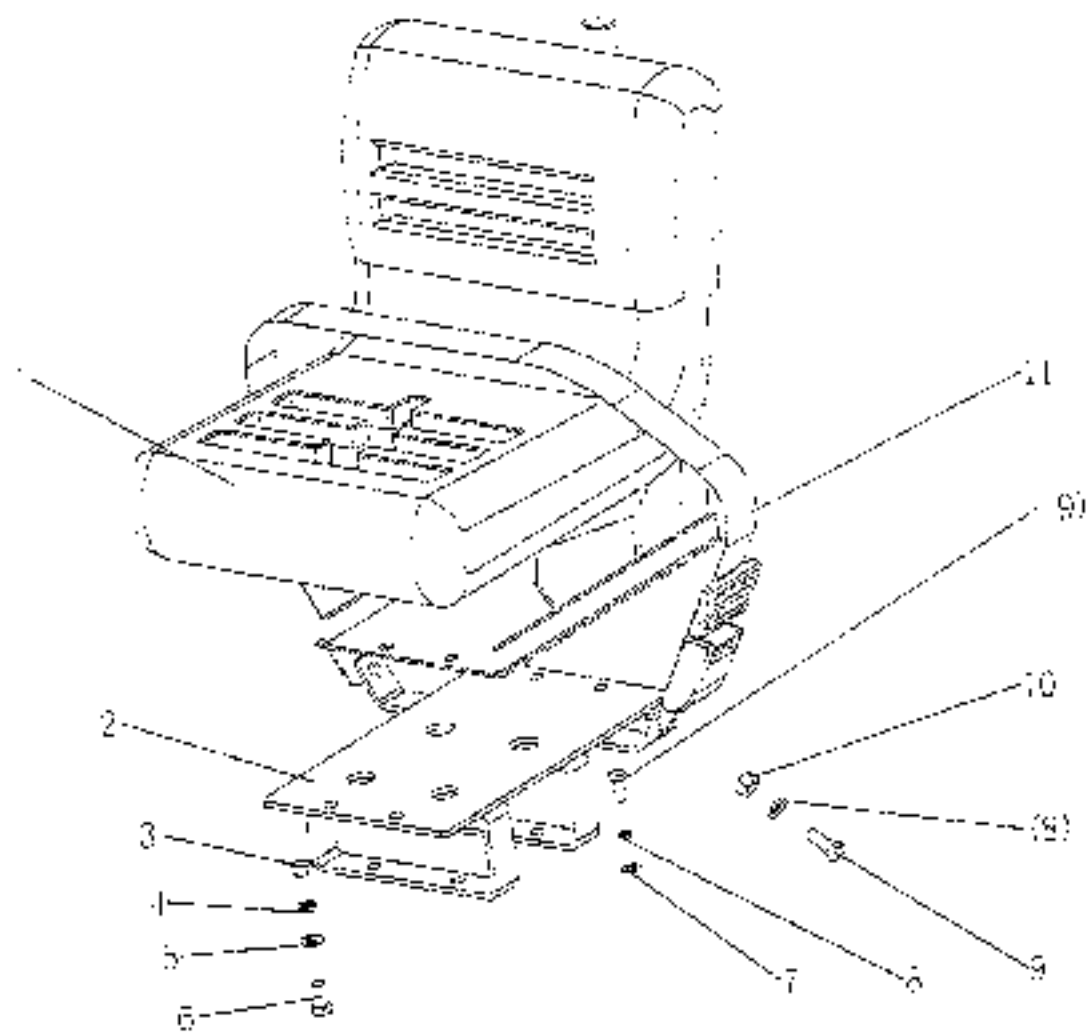

14.1 座椅总成(減震) Seat (Absorber)

序號 Ser.No	代號 Part No	名稱及規格	Name & Specifications	數量 Quantity	備註 Remarks
1	280.44B.101	座椅	Seat	1	
2	300.44B.011	座椅支架焊合件	Seat bracket weldment	1	
3	GB6170-86	螺絲 M8	Hex. nut M8	4	
4	GB97.1 85	墊圈 8	Plain washer 8	6	
5	GB93-87	彈圈 8	Spring lock washer 8	6	
6	GB5783-86	螺栓 M8×20	Hex. head bolt M8×20	6	
7	GB97.1 85	墊圈 10	Plain washer 10	2	
8	GB93-87	彈圈 10	Spring lock washer 10	4	
9	GB5783-86	螺栓 M10×20	Hex. head bolt M10×20	4	
10	GB6170 86	螺母 M10	Hex. nut M10	2	
11	300.44B.012	安全帶	Safety belt	1	

14.2 座椅总成 Seat

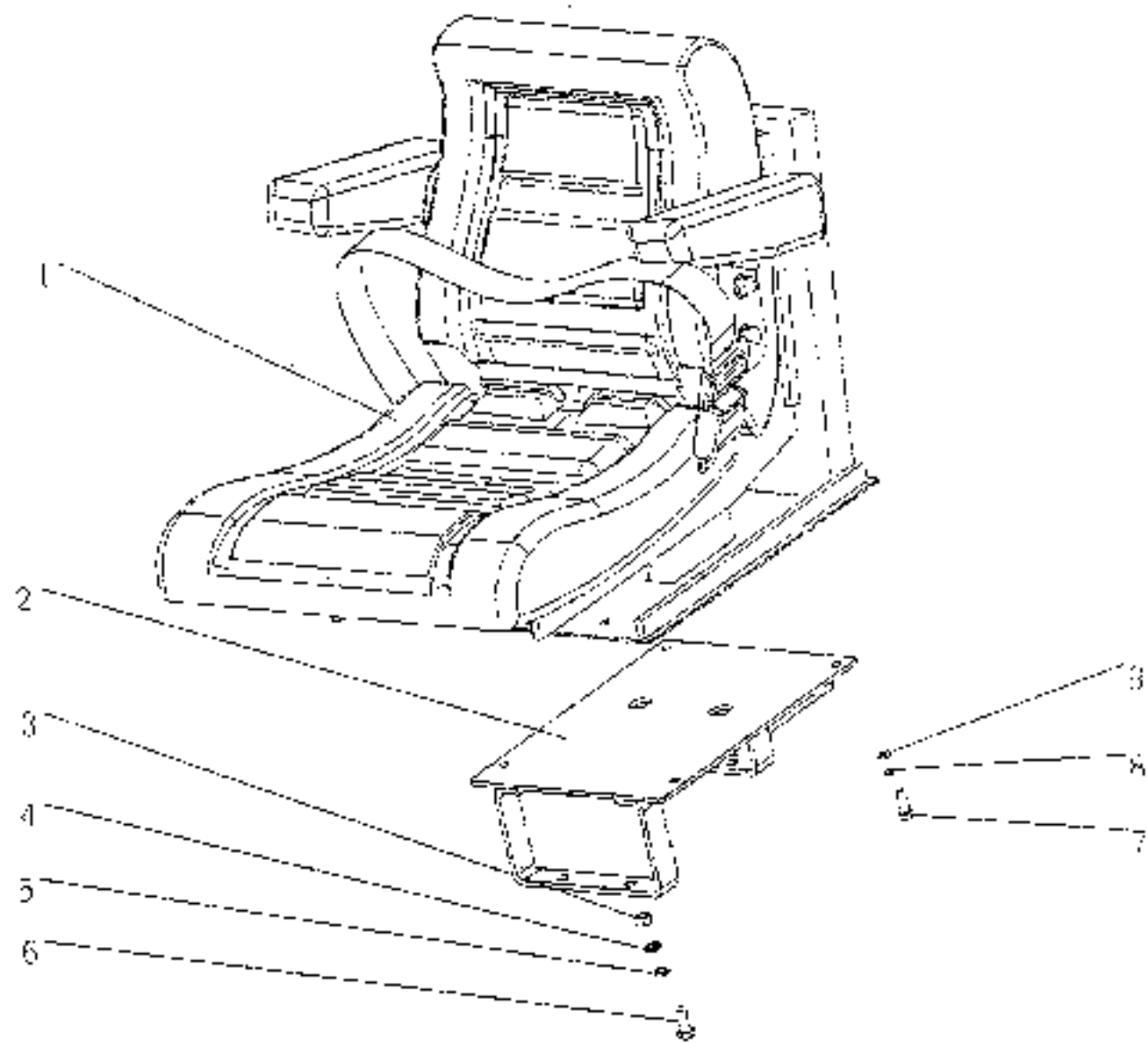

14.2 座椅总成 Seat

序号 Ser. No.	代号 Part No.	名称及规格	Name & Specifications	数量 Quantity	备注 Remarks
1	550.44D.001	座椅	Seat	1	
2	354-5.44.011-1	座椅支架焊合件	Seat bracket weldment	1	
3	GB6170-86	螺母 M10	Hex nut M10	4	
4	GB97.1-85	垫圈 10	Plain washer 10	4	
5	GB93-87	弹簧 10	Spring lock washer 10	4	
6	GB5783-86	螺栓 M10×20	Hex head bolt M10×20	4	
7	GB5783-86	螺栓 M8×20	Hex head bolt M8×20	1	
8	GB93-87	弹簧 8	Spring lock washer 8	4	
9	GB97.1-85	垫圈 8	Plain washer 8	2	

15 遮阳棚总成 Sunshade

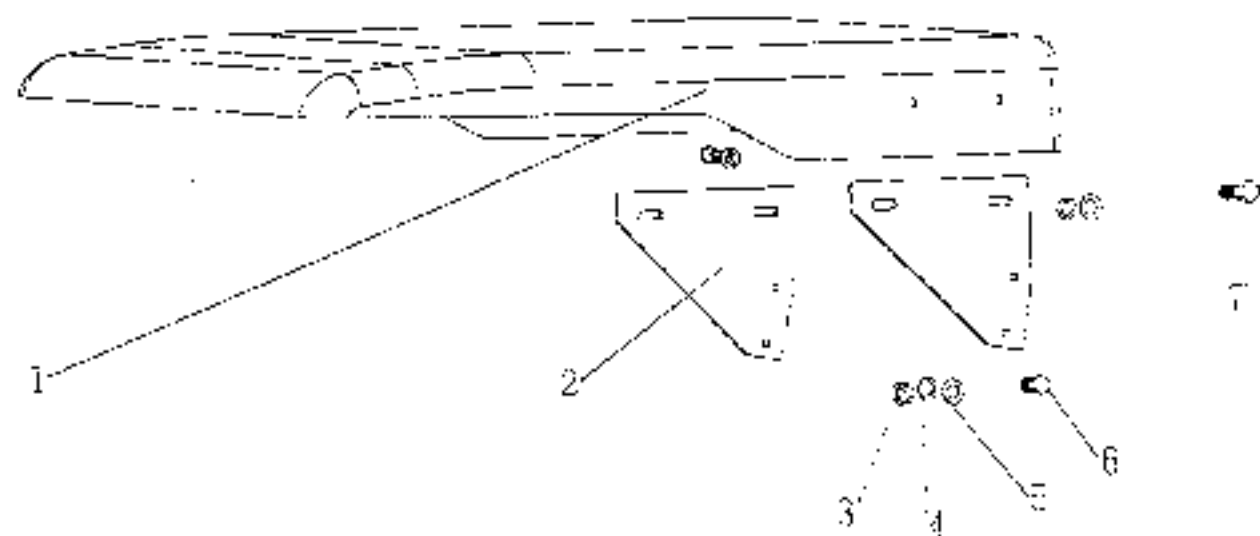

15 遮阳棚总成 Sunshade

序号 Ser.No	代号 Part No.	名称及规格	Name & Specifications	数量 Quantity	备注 Remarks
1	300.45.011	遮阳板钣金件	Sunshade	1	
2	300.45.102	连接板	Connecting board	2	
3	GB6170-85	螺母M12	Hex nut M12	8	
4	GB93-87	垫圈12	Spring lock washer 12	8	
5	GB97.1-85	垫圈12-140HV	Plain washer 12-140HV	16	
6	GB5782-86	螺栓M12×E5	Hex head bolt M12×E5	4	
7	GB5782-86	螺栓M12×2b	Hex head bolt M12×3b	4	

16 折叠式安全驾总成 Folding Safety Frame

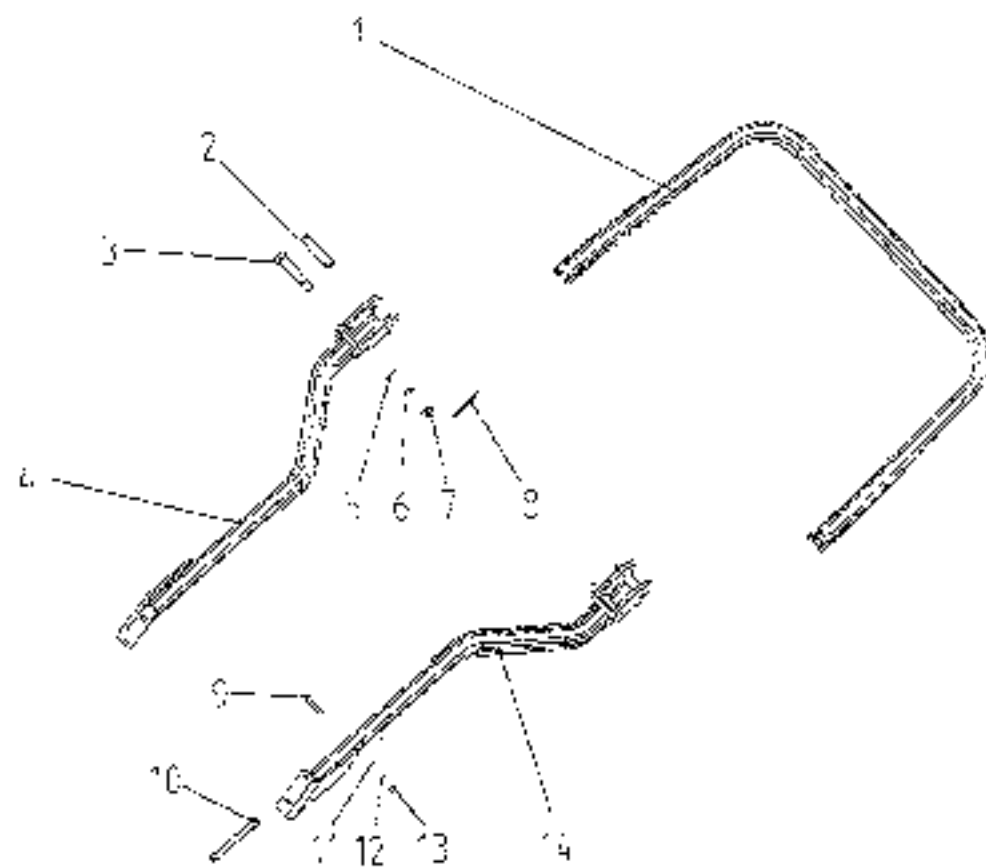

16 折叠式安全架总成 Folding Safety Frame

序号 Ser. No.	代号 Part No.	名称及规格	Name & Specifications	数量 Quantity	备注 Remarks
1	280.46D.012	安全架上框焊合件	Upper frame weldment	1	
2	280.46D.105	锁销	Lock Pin	1	
3	GB5782-86	螺栓M24x100	Hex. head bolt M24x100	2	
4	354-5 46.011	安全架左撑杆焊合件	Left support frame	1	
5	GB97.1-85	垫圈24	Plain washer 24	2	
6	GB93-87	垫圈24	Spring lock washer 24	2	
7	GB6170-86	螺母24	Hex. nut M24	2	
8	300.46D.114	弹簧铁销	Spring lock pin	2	
9	GB5783-86	螺栓M12x60	Hex. head bolt M12x60	6	
10	GB5782-86	螺栓M16x175	Hex. head bolt M16x175	4	
11	GB97.1-85	垫圈12	Plain washer 12	6	
12	GB93-87	垫圈12	Spring lock washer 12	6	
13	GB6170-86	螺母12	Hex. nut M12	6	
14	354-5 46.012	安全架右撑杆焊合件	Right support frame	1	

17 机岸仪表罩总成 (AJ07) Hood and panel (AU07)

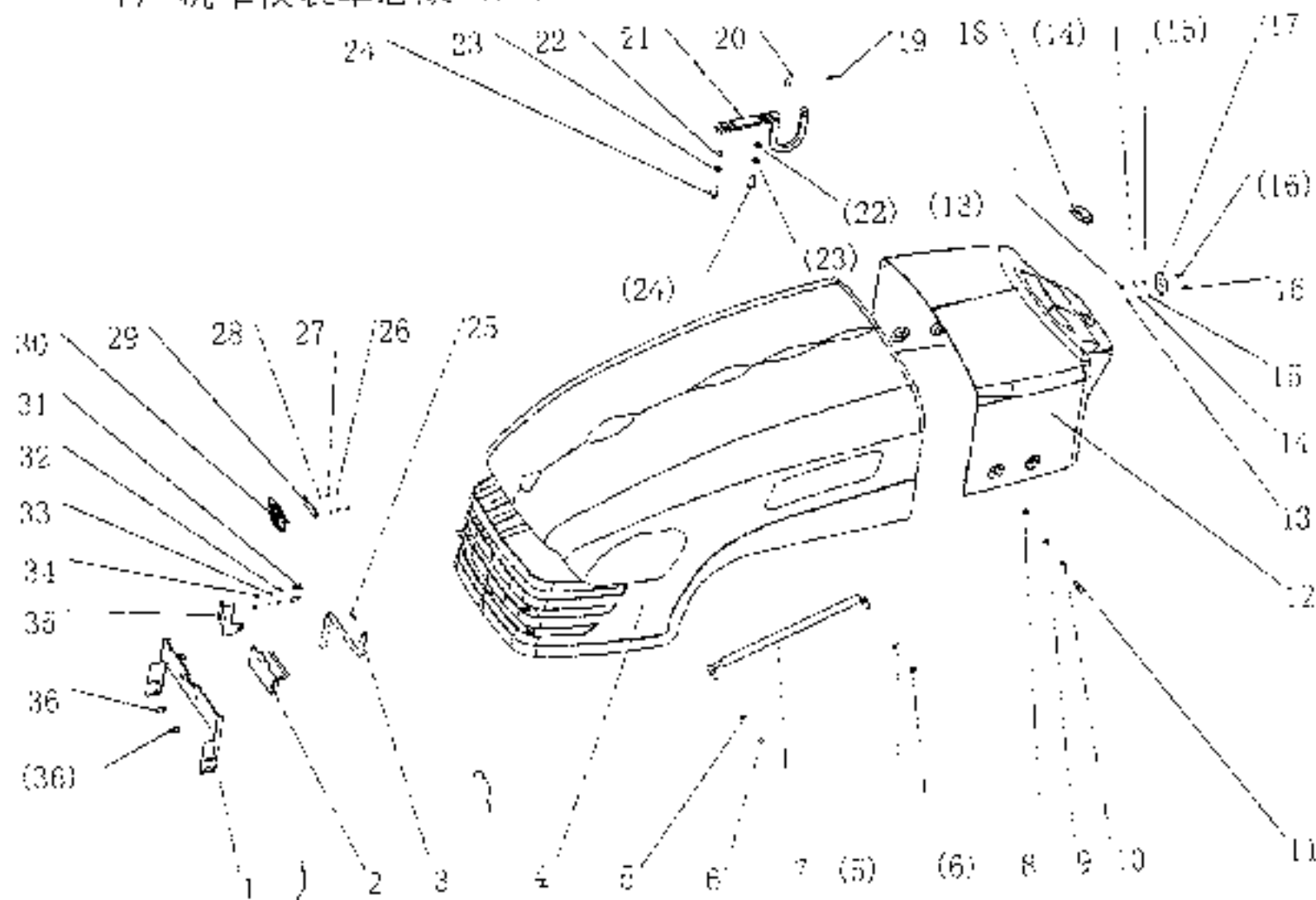

17 机罩仪表罩总成 (AU07) Hood and Panel (AU07)

序号 Ser.No.	代号 Part No.	名称及规格	Name & Specifications	数量 Quantity	备注 Remarks
1	300-6.47.014	锁安装架焊合件	Lock bracket	1	For 390/490 engine
	354-5.47.015	锁安装架焊合件	Lock bracket	1	For 395 engine
2	800.47.026	机罩锁	Hood lock	1	
3	254G2.47C.101	机罩开闭杆	Hood open haalm	1	For 390/490 engine
	354-1.47A.101	机罩开闭杆	Hood open haalm	1	For 395 engine
4	354.5.47.011	机罩合件	Engine Hood	1	For 390/395 engine
	404-5.47.011	机罩合件	Engine Hood	1	For 490 engine
5	GB93-87	垫圈8	Spring Lock washer8	2	
6	GB6170-86	螺母M8	Hex nut M8	2	
7	QD16-690x290x200-BB	气弹簧总成	Gas spring	2	
8	GB6170-86	螺母M8	Hex nut M8	2	
9	GB93-87	垫圈8	Spring Lock washer8	2	
10	GB97.1-85	垫圈8	Plain washer 8	4	
11	GB5783-86	螺栓M8x30	Hex head bolt M8x30	4	
12	354-5.47.012	仪表罩合件	Engine Hood	1	
13	GB6170-86	螺母M5	Hex nut M5	2	
14	GB93-87	垫圈5	Spring Lock washer5	2	
15	GB97.1-85	垫圈5	Plain washer 5	2	
16	GB818-85	螺钉 M5x25	Phillips pan head screw M5x25	2	
17	230.47B.118	电锁安装板	Installation plate switch	1	
18	700.47.120	橡胶圈	Rubber ring	1	
19	GB91-86	销 3.2x30	Split pin 3.2x30	1	
20	GB882-86	销 B10x35	Split pin B10x35	1	
21	250-1.47A.014	机罩铰链合件	Hood gemel bracket	1	
22	GB97.1-85	垫圈10	Plain washer 10	2	

续表

17 机罩仪表罩总成 (AU07) Hood and Panel (AU07)

序号 Ser.No.	代号 Part No.	名称及规格	Name & Specifications	数量 Quantity	备注 Remarks
23	GB93-87	垫圈10	Spring Lock washer 10	8	
24	GB5783-86	螺栓M10x25	Hex head bolt M10x25	4	
25	GB91-86	销 1.6x20	Split pin 1.6x20	1	
26	GB6170-86	螺母M5	Hex nut M5	2	
27	GB93-87	垫圈5	Spring Lock washer 5	2	
28	GB97.1-85	垫圈5	Plain washer 5	2	
29	300.47.113	标牌安装板	Scutcheon bracket	1	
30	300.47.106A 1	东仪标牌	Dong ying scutcheon	1	
31	GB5783-86	螺栓M6x20	Hex head bolt M6x20	2	
32	GB97.1-85	垫圈6	Plain washer 6	2	
33	GB93-87	垫圈5	Spring Lock washer 6	6	
34	GB6170-86	螺母M6	Hex nut M6	6	
35	254G2.47C.105	固定座	Immobility	1	
36	GB5783-86	螺栓M6x35	Hex head bolt M6x35	4	

18 地板挡泥板总成 Foot Mud Shields Rest

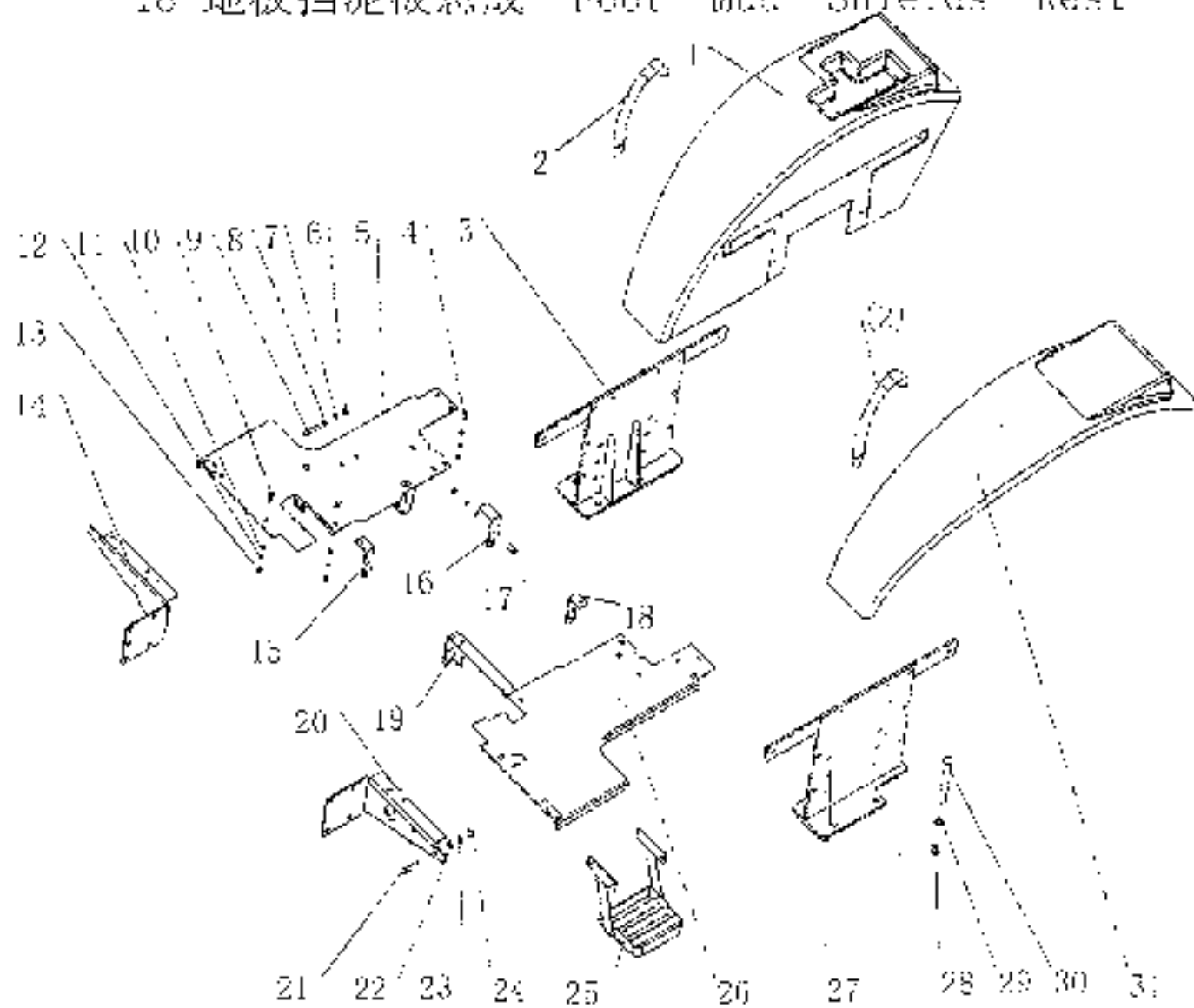

18 地板挡泥板总成 Foot Mud Shields Rest

序号	Ser.No.	代号 Part No.	名称及规格	Name & Specifications	数量	Quantity	备注 Remarks
1		354-7.51.101	右后脚支架总成	Right-front foot bracket rest	1	1	
2		GB5783-86	螺栓M8X30	Hex.head bolt M8x30	4	4	
3		GB97.1-85	垫圈3	Plain washer 3	27	27	
4		GB93-87	弹簧垫圈8	Spring lock washer 8	27	27	
5		GB6170-86	螺母M8	Hex. nut M8	15	15	
6		354-7.51.014	右地板总成	Right foot rest	1	1	
7		354-7.51.114	右地板橡胶板	Plank of right floor rubber	1	1	
8		354-7.51.106	右前支承板	Right-front bracket joint	1	1	
9		GB5783-86	螺栓M8X20	Hex.head bolt M8x20	8	8	
10		GB5783-86	螺栓M8X25	Hex head bolt M8x25	7	7	
11		354-7.51.109	右盖板防护罩	Right cover plate protection hood	1	1	
12		354-7.51.107	右后支架板	Right-back bracket joint	1	1	
13		354-7.51.031	右支架总成	Right bracket rest	1	1	
14		354-7.51.104	挡板(二)	Limit blank(II)	1	1	
15		GB5783-86	螺栓M6X14	Hex.head bolt M6x14	12	12	
16		GB97.1-85	垫圈6	Plain washer 6	15	15	
17		GB93-87	弹簧垫圈6	Spring lock washer 6	15	15	
18		GB6170-86	螺母M6	Hex nut M6	15	15	
19		354-7.51.106	固定板(II)	Fix the plank(II)	2	2	
20		354-7.51.105	固定板(I)	Fix the plank(I)	2	2	
21		354-7.51.101	座椅架	Seat bracket	1	1	
22		354-7.51.102	座椅架连接垫板	Seat bracket weldment	1	1	
23		354-7.51.017	圆板支架总成	Round the plank bracket joint	1	1	
24		GB5783-86	螺栓M12X45	Hex head bolt M12x45	16	16	
25		GB97.1-85	垫圈12	Plain washer 12	16	16	
26		GB93-87	弹簧圈 12	Spring lock washer 12	16	16	

18 地板挡泥板总成 Foot Mud Shields Rest

续表

序号	Serial No.	代号 Part No.	名称及规格	Name & Specifications	数量 Quantity	备注 Remarks
27		GB6170-86	螺母M12	Hex nut M12	3	
28		GB5783-86	螺栓M8X16	Hex head bolt M8x16	3	
29		GB5783-86	螺栓M16X175	Hex head bolt M16x175	3	
30		GB97.1-85	垫圈16	Plain washer 16	3	
31		GB93-87	垫圈16	Spring lock washer 16	3	
32		GB6170-86	螺母M16	Hex nut M16	3	
33		354-7.51.103	挡板(一)	Limit blank(I)	1	
34		GB5783-86	螺栓M6X20	Hex head bolt M6x20	3	
35		354-7.51.021	左支架焊合件	Left bracket rest	1	
36		354-7.51.104	挡板(二)	Limit blank(II)	1	
37		354-7.51.110	左盖板防护罩	Left cover plate protection hood	1	
38		354-7.51.108	左后支承板	Left-back bracket joint	1	
39		354-7.51.113	左地板橡胶板	Plank of left floor rubber	1	
40		354-7.51.018	左前支承板焊合件	Left-front bracket joint	1	
41		354-7.51.013	左踏板焊合件	Left foot rest	1	
42		354-7.51.012	左地板前支架焊合件	Left-front foot bracket joint	1	
43		254-7.51.019	左挡泥板	Left mud shields rest	1	
44		254-7.51.018	右挡泥板	Right mud shields rest	1	

19 电瓶架 Battery Bracket

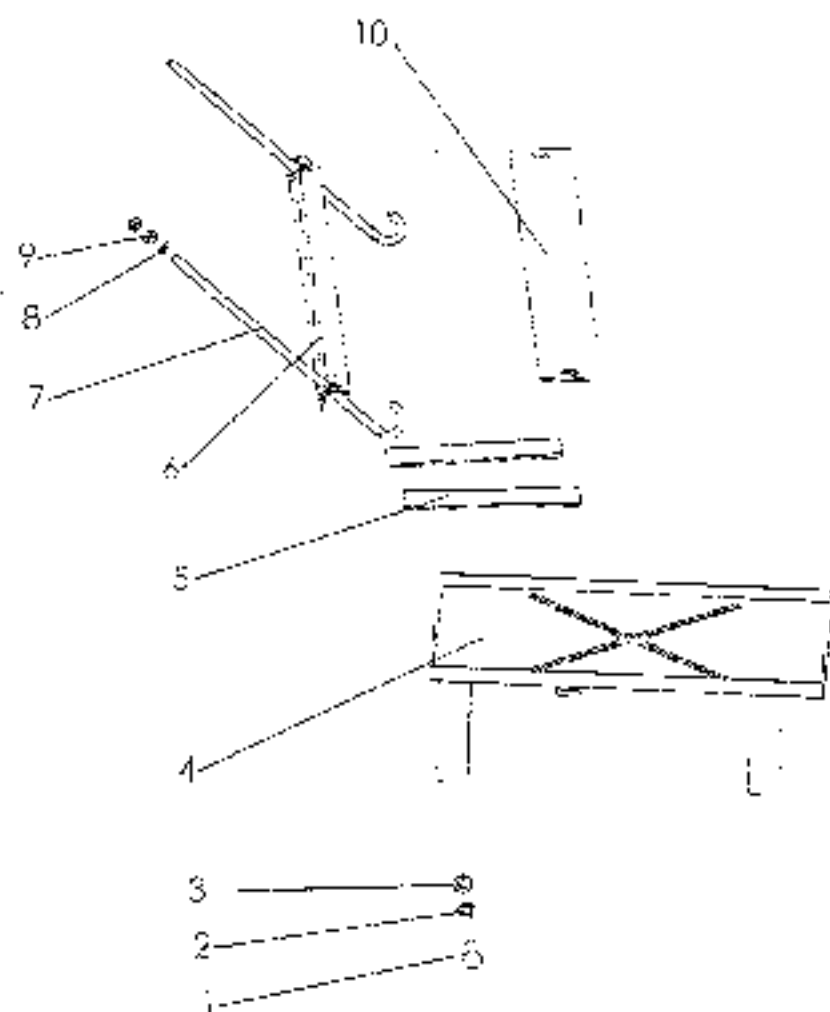

19 电瓶架 Battery Bracket

序号 Ser.No.	代号 Part No	名称及规格 Name & Specifications	数量 Quantity	备注 Remarks
1	GB5735-86	螺栓 M10x20	5	
2	GB93-87	弹簧垫圈 10	6	
3	GB97.1-85	平垫圈 8	6	
4	284.30B.013-1	电瓶架零件	1	For 390 engine
	330.47.013C	电瓶架零件	1	For 395 engine
	400B.47.013-2	电瓶架零件	1	For 490 engine
5	300.47.143	电瓶胶垫	2	
6	300.47.019	电瓶夹箍	1	
7	300.47.139	电瓶螺栓	2	
8	GB97.1-85	垫圈 8	4	
9	GB6170-86	螺母 M8	4	
10	300.47.142	电瓶胶垫	1	

20 电气系统总成(型AU07机罩) Electrical System For AU07 Hood

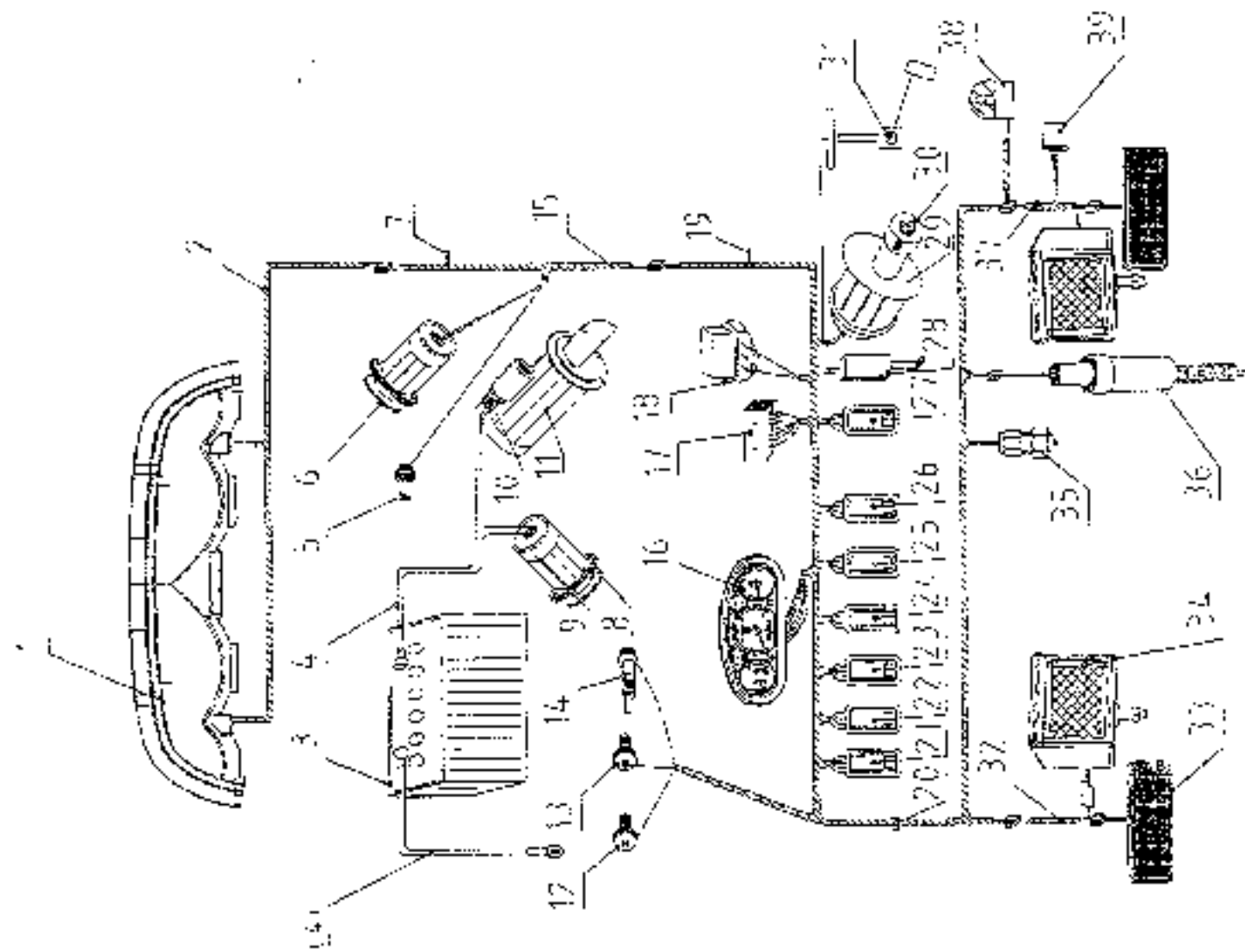

20 电气系统总成 (配AU07机罩)

Electrical System (For AU07 hood)

序号	Ser No	代号 Part No	名称及规格	Name & Specifications	数量 Quantity	备注 Remarks
1		254-5.48.101	DY组合前照灯	DZ550 combination head lamp	1	
2		354-1.48.011	前线束	Front wiring harness	1	
3		6-QW-80L	免维护蓄电池	Battery	1	
4		350.45B.015	蓄电池电缆线	Battery cable	1	
5			水温传感器	Water temperature sensor	1	From combination meter
6			发电机	Generator	1	From engine
7		ZD300X8	可松开式锁式扎带	Clingulum	2	
8		192A	起动继电器	Starting relay	1	
9		250-1.48A.110	继电器托板	Relay splint	1	
10		250D.48.101	电缆接头护套	Cable splice jacket	1	
11			起动电机	Starting motor	1	From engine
12			转速传感器 (K10X1.5)	Rotation speed sensor	1	From combination meter
13			油压传感器	Oil pressure sensor	1	From combination meter
14		10-12-35	电热塞	Pre-heating plug	1	From engine
15		354-1.48A.012	主线束	Main wiring harness	1	
16		300-6.48.027	ZB103-7A组合仪表 (109齿)	ZB103-7A Combination meter	1	
17		AX103	保险丝盒	Fuse box	1	
18		FT111	电压调节器	Voltage regulator	1	
19		ZD150X8	可松开式锁式扎带	Clingulum	10	
20		200.48B.108	线夹	Wire clip	3	
21		JK938A	前照灯开关	Head lamp switch	1	
22		JK938A	驻车闪光开关	Parking flasher	1	
23		JK938A	慢速警报灯开关	Slow caution light switch	1	
24		JK938A	左转向灯开关	Left turning switch	1	
25		JK938A	右转向灯开关	Right turning switch	1	

20 电气系统总成 (配AU07机罩)

Electrical System (For AU07 hood)

序号	Ser.No.	代号 Part No	名称及规格	Name & Specifications	数量 Quantity	备注 Remark
26		JK938A	后尾灯开关	Tail lamp switch	1	
27		JK938A	后转向灯	Tail lamp switch	1	
28		SG152	电子闪光器	Flasher	1	
29		300.48B.107	启动开关按钮	Starting switch	1	
30		JK406B	预热启动开关	Pre-heating starting switch	1	
31			油量传感器	Oil level sensor	1	
32		354-1.43A.013	左挡泥板线束	Left-rear wiring harness	1	
33		450-48A.019	052型组合后灯	Combination rear signal lamp	2	
34		250D.43.018	后尾灯	Tail lamp	2	
35		JB1041	启动安全开关	Security switch	1	
36		JK251B	制动灯开关	Brakelight switch	1	
37		354-1.43A.014	右挡泥板线束	Right-rear wiring harness	1	
38		300-6.48.018	02型警示灯	Caution light	1	
39		1B3762-84	拖车插座	Trailer socket	1	送装

21 工具箱总成 Tool Box

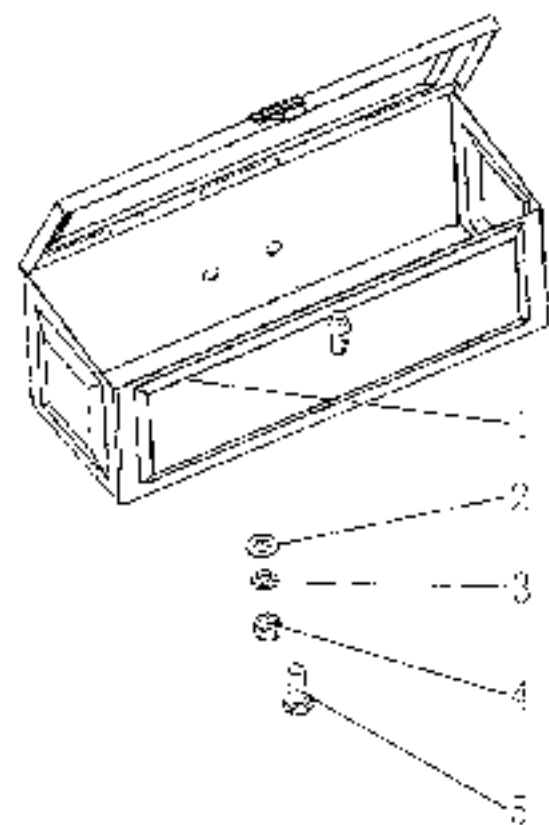

21 工具箱总成 Toolbox

序号 Ser. No.	代号 Part No.	名称及规格	Name & Specifications	数量 Quantity	备注 Remarks
1	450 49.001	工具箱	Toolbox	1	
2	GB97.1-85	垫圈 10	Plain washer 10-140HV	2	
3	GB93-87	垫圈 10	Spring lock washer 10	2	
4	GB6170-86	螺母 M10	Hex. nut M10	2	
5	GB5783-86	螺栓 M10×20	Hex. head bolt M10×20	2	

22 燃油箱总成 Fuel tank

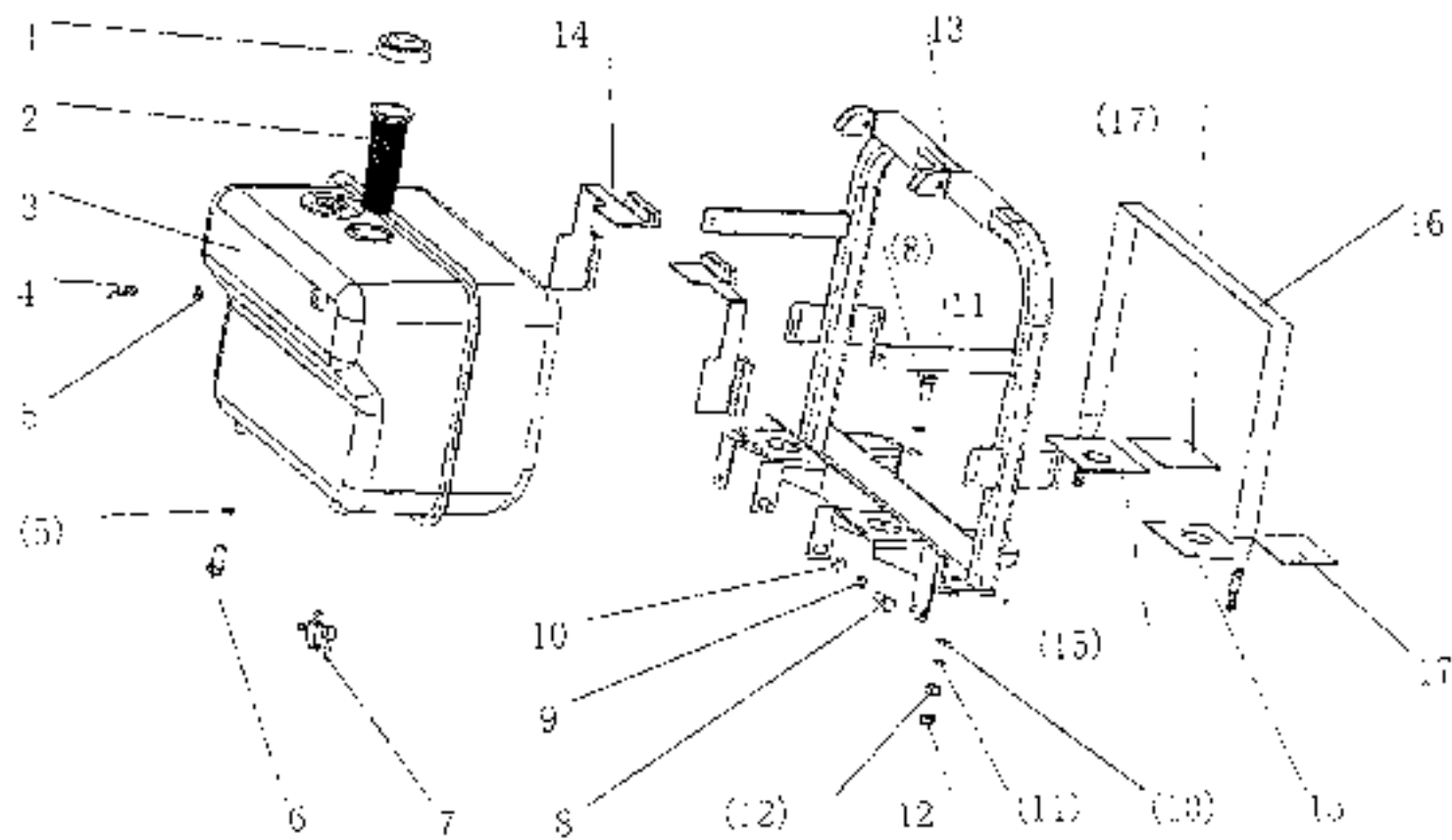

22 燃油箱总成 Fuel Tank

序号 Ser. No.	代号 Part No.	名称及规格	Name & Specifications	数量 Quantity	备注 Remarks
1	200.50.011	油桶盖组合件	Fuel tank cap	1	
2	200.50.012	滤网杯总成	Fuel strainer	1	
3	354-1.50.014	燃油箱壳体件	Fuel tank	1	
4	GB3451-83	铰接螺栓 M12×1.25	Hollow hex.head bolt M12×1	1	
5	GB3541-83	垫圈 12	Washer 12	4	
6	GB5786-86	螺栓 M12×1.25×16	Hex.head bolt M12×1.25×16	1	
7	300.50.015A	燃油供给管路总成	Fuel delivery pipe	1	
8	GB5783-86	螺栓 M10×20	Hex. head bolt M8×20	4	
9	GB93-87	弹簧 10	Spring lock washer 10	4	
10	GB97.1-85	垫圈 10-40HV	Plain washer 10	6	
11	GB6172-86	弹簧 10	Spring lock washer 10	2	
12	GB6170-86	螺母 M10	Hex. nut M10	4	
13	354-1.50.012A	托板组合件	Fuel tank cradle	1	
14	200.50.101	上座胶垫	Upper Rubber pad	2	
15	200.50.106	前缘胶垫	Front rubber pad	2	
16	354-1.50.022A	捆绑带组合件	Fuel tank strap	1	
17	200.50.107	橡胶垫	Rubber pad	2	

23 摆式牵引杆总成 Swing Drawbar Frame

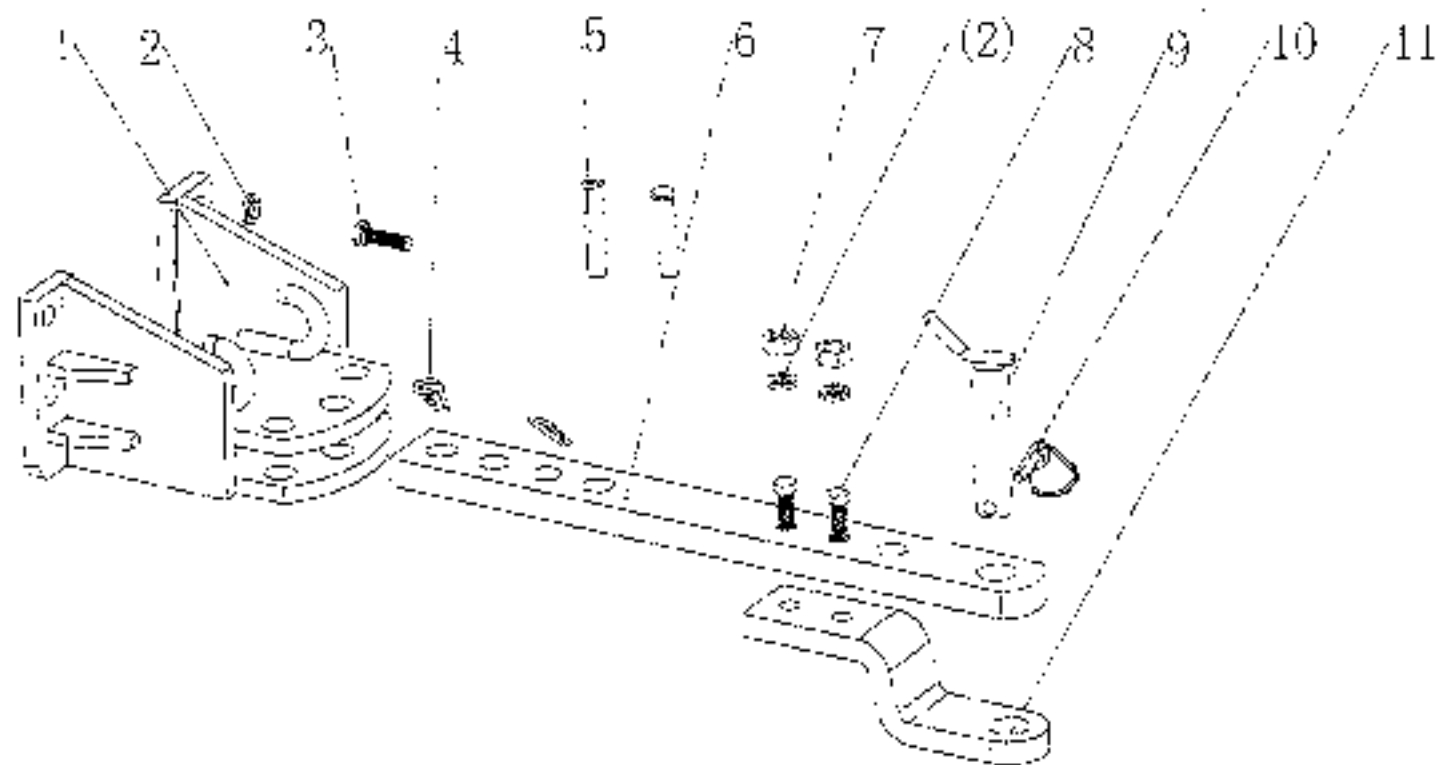

23 摆式牵引杆总成 Swing Drawbar Frame

序号	图号	代号 Part No.	名称及规格	Name & Specifications	数量 Quantity	备注 Remarks
1		300.53A.012	摆杆式牵引杆总成	Rocker drawbar frame	1	
2		GB95-87	垫圈 16	Spring lock washer 16	6	
3		GB5783-86	螺栓 M16×40	Hex. head bolt: M16×40	4	
4		300.53.102	牵引 R 销	R-pin	2	
5		GB882-86	衬套 B16×75	Spindle B16×75	2	
6		300.53A.103	牵引板	Drawbar plate	1	
7		GB6170-86	螺母 M16	Hex. nut: M16	2	
8		GB5782-86	螺栓 M16×65	Hex. head bolt: M16×65	2	
9		300.53.011	轴销焊合件	Spindle	1	
10		200.56.023	锁销总成	Lock pin	1	
11		300.53.104-1	牵引卡	Drawbar clamping plate	1	

24 分配器总成 Hydraulic Oil Distributor

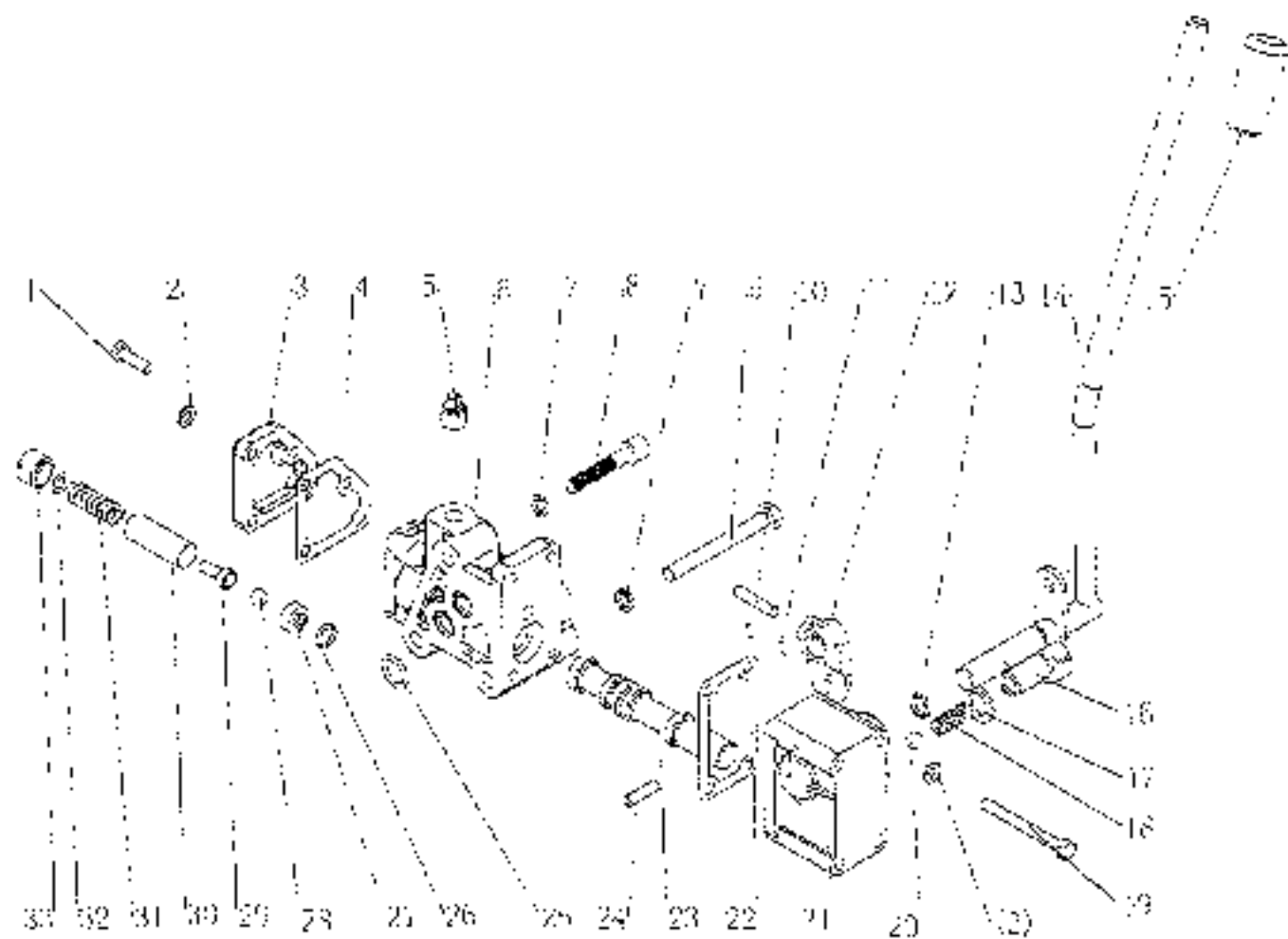

24 分配器总成 Hydraulic Oil Distributor

序号	Serial No.	代号 Part No.	名称及规格	Name & specifications	数量	Quantity	备注	Remarks
1		GB5783-86	螺栓M6x20	Hex head bolt M6x20	1	1		
2		GB97.1-85	垫圈6-140HV	Plain washer 6-140HV	8	8		
3		200.55.131	端盖	End cover	1	1		
4		200.55.132	端盖纸垫	Paper gasket	1	1		
5		GB3289.31-82	外方管销R1/4	Square head oil pin R1/4	1	1		
6		200.55.126-A	分配器壳体	Distributor body	1	1		
7		GB93-87	垫圈8	Spring lock washer 8	3	3		
8		GB70-85	螺钉M6x25	Hex socket cap screw	2	2		
9		GB5782-86	螺栓M8x75	Hex head bolt M8x75	1	1		
10		GB880-86	销6x30	Pin 6x30	1	1		
11		GB91-86	销1.6x10	Split pin 1.6x10	2	2		
12		700.55.128	拨叉	Fork	1	1		
13		GB3452.1-82	O形圈10.6x1.8	O-ring seal 10.6x1.8	1	1		
14		200.55.018-1	手柄总成	Handle assy	1	1		
15		200.55.149	手柄	Handle	1	1		
16		700.55.130	定位螺钉	Positioning bolt	1	1		
17		GB3541-83	垫圈14	Copper washer 14	1	1		
18		700.55.135	定位弹簧	Positioning spring	1	1		
19		GB5782-86	螺栓M6x60	Hex head bolt M6x60	1	1		
20		GB308-85	钢球9.5	Steel ball 9.5	1	1		
21		200.55.123	拨叉套	Fork box	1	1		
22		200.55.125	拨叉盒纸垫	Paper gasket	1	1		
23		200.55.127	滑动阀	Sliding valve	1	1		
24		GB879-86	销6x22	Slotted spring pin 6x22	1	1		
25		GB3452.1-82	O形圈15x2.65	O-ring seal 15x2.65	2	2		

续表

24 分配器总成 Hydraulic Oil Distributor

序号	Serial No.	代号 Part No.	名称及规格	Name & specifications	数量 Quantity	备注 Remarks
26		GB3452.1-82	O形圈 10.8x2.55	O-ring seal 10.8x2.55	1	
27		200.55.138	垫块	Pad	1	
28		GB308-84	钢球9	Steel ball dia 9	1	
29		200.55.137	球座	Ball seat	1	
30		200.55.136	套筒	Sleeve	1	
31		200.55.135	安全阀弹簧	Safety valve Spring	1	
32		200.55.134	调节垫片	Adjusting shims	2 ~5	
33		200.55.133	螺塞	Plug	1	

25 提升器总成 Hydraulic Power Lift

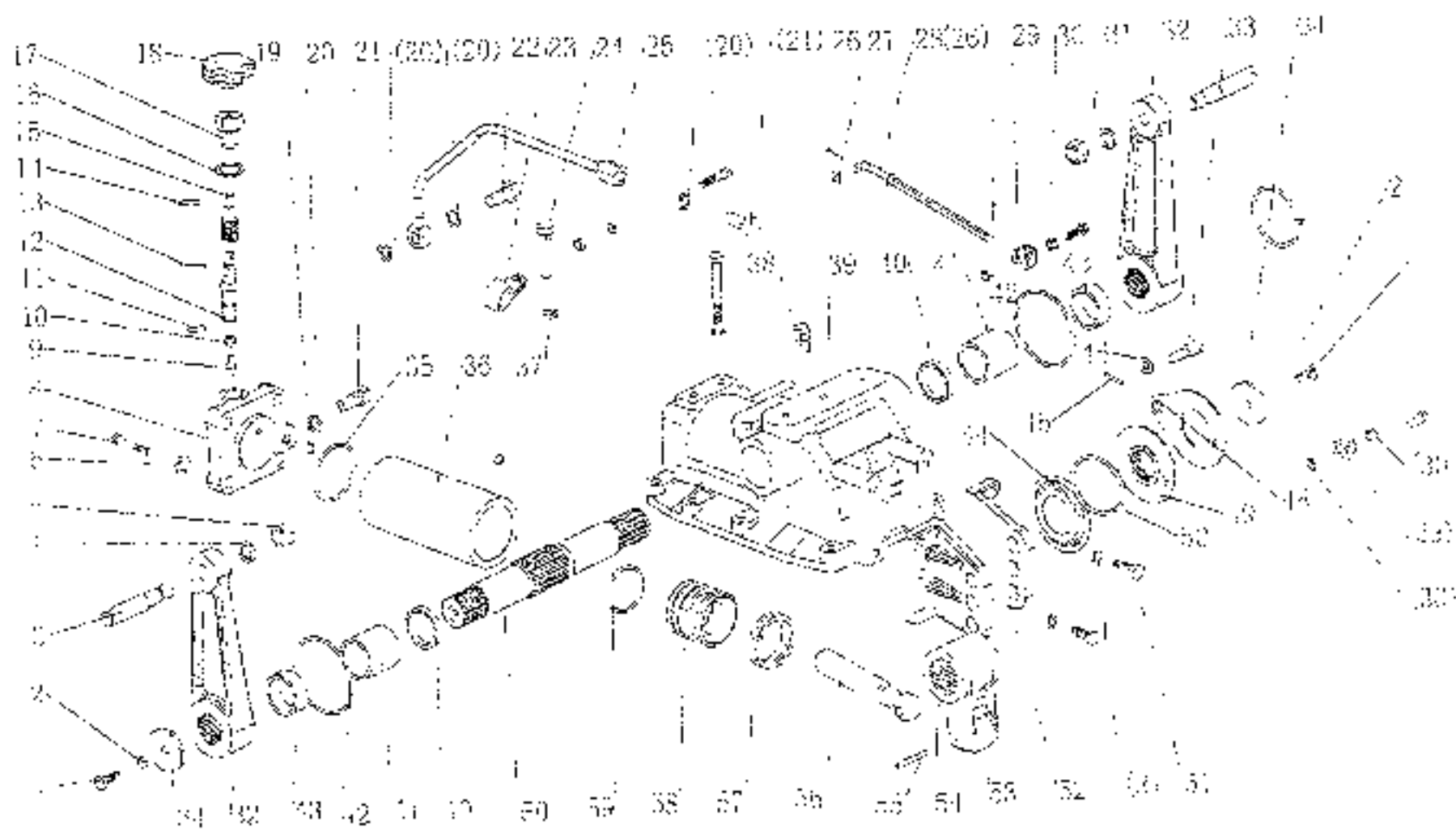

25 提升器总成 Hydraulic Power Lift

序号 Ser No	代号 Part No.	名称及规格	Name & Specifications	数量 Quantity	备注 Remarks
1	GB5783-86	螺栓 M10×25	Hex. head bolt M10×25	2	
2	GB93-87	垫圈 10	Spring washer 10	6	
3	200.55.105	提升臂杆	Lift arm pin	2	
4	GB93-87	垫圈 16	Spring washer 16	2	
5	GB6170-86	螺母 M16	Hex. nut M16	2	
6	GB93-87	垫圈 14	Spring washer 14	4	
7	GB5782-86	螺栓 M14×45	Hex. head bolt M14×60	4	
8	300.55.114-1	油缸盖	Cylinder cover	1	
9	300.55.126	调节阀	adjust valve	1	
10	GB3452.1-82	O形密封圈 11.8×2.65	O-ring seal 11.8×2.65	2	
11	GB119-76	销4×12	Pin 4×12	1	
12	300.55.127	调节阀杆下端	The lower end of adjust valve	1	
13	GB879-86	销4×16	Slotted spring pin 4×16	1	
14	GB879-86	销5×24	Slotted spring pin 5×24	1	
15	300.55.122	调节阀杆上端	The lower top of adjust valve	1	
16	JB1002-77	垫圈 22	Washer 22	1	
17	300.55.130	阀杆螺母	Valve-gate nut	1	
18	300.55.020	手轮胶合套	Handwheel	1	
19	GB3452.1-82	O形密封圈 10.6×1.8	O-ring seal 10.6×1.8	2	
20	GB3541-83	垫圈 14	Washer 14	4	
21	JB1000-77	塞套 M14×1.5	Plug M14×1.5	2	
22	200.55.124	铰接螺栓 M14×1.5	Hex. head bolt M14×1.5	1	
23	200.55.165	夹条板	Pressing Plate	1	
24	GB5782-86	螺栓 M12×50	Hex. head bolt M12×50	1	
25	200.55.022-1	出口油管总成	Out-let pipe	1	

25 提升器总成 Hydraulic Power Lift

序号 Ser.No.	代号 Part No.	名称及规格	Name & Specifications	数量 Quantity	备注 Remarks
26	GB91-86	销 2×16	Split pin 2×16	2	
27	GB97.1-85	垫圈 8-140HV	Plain washer 8-140HV	1	
28	200.55.013	联动杆焊合件	Linkage rod	1	
29	200.55.119-1	限位	Limit stop	2	
30	GB6170-86	螺母 M8	Hex nut M8	3	
31	GB5783-86	螺栓 M8×25	Hex head bolt M8×25	2	
32	200.55.106	外提升臂	Lift arm	2	
33	200.55.120	联动销	Linkage pin	1	
34	200.55.107	压板	Clamping plate	2	
35	GB3452.1-82	O形密封圈 92.5×5.3	O-ring seal 92.5×5.3	1	
36	300.55.115	缸缸	Cylinder	1	
37	GB93-87	垫圈 12	Spring washer 12	1	
38	200.55.111-1	进气管	Vent tube	1	
39	300.55.101-1	提升器壳体	Lift case	1	
40	200.55.102	隔套	Spacer sleeve	2	
41	200.55.103-1	衬套	Bush	2	
42	GB3542.1-82	O形密封圈 38.7×5.3	O-ring seal 38.7×5.3	2	
43	200.55.104	挡圈	Retainer ring	2	
44	200.55.122	挡盘	Retainer plate	1	
45	GB91-86	销 3.2×20	Split pin 3.2×20	1	
46	GB97.1-85	垫圈 10-140HV	Plain washer 10-140HV	1	
48	200.55.014	驱动焊合件	Driven plate	1	
49	200.55.016	传动焊合件	Drive plate weldment	1	
50	200.55.121	弹簧	Tension spring	1	

25 提升器总成 Hydraulic Power Lift

续表					
序号 Ser. No.	代号 Part No.	名称及规格	Name & Specifications	数量 Quantity	备注 Remarks
51	GB5783-86	螺栓 M10×30	Hex. head bolt M10×30	4	
52	300.55.024	右连接板零件	Right Hitching plate	1	
53	200.55.108-1	内提升臂	Inner lift arm	1	
54	300.55.025	左连接板零件	Left Hitching plate	1	
55	GB879-86	销 6×50	Slotted spring pin 6×50	1	
56	200.55.109	活塞顶杆	Piston push rod	1	
57	200.55.117-1	YX形密封圈 D65	YX-seal D65	1	
58	200.55.116	活塞	Piston	1	
59	GB3452.1-82	O形密封圈 69×3.55	O-ring seal 69×3.55	1	
60	200.55.110	提升轴	Lift shaft	1	

26 悬挂装置总成 Suspension Mechanism

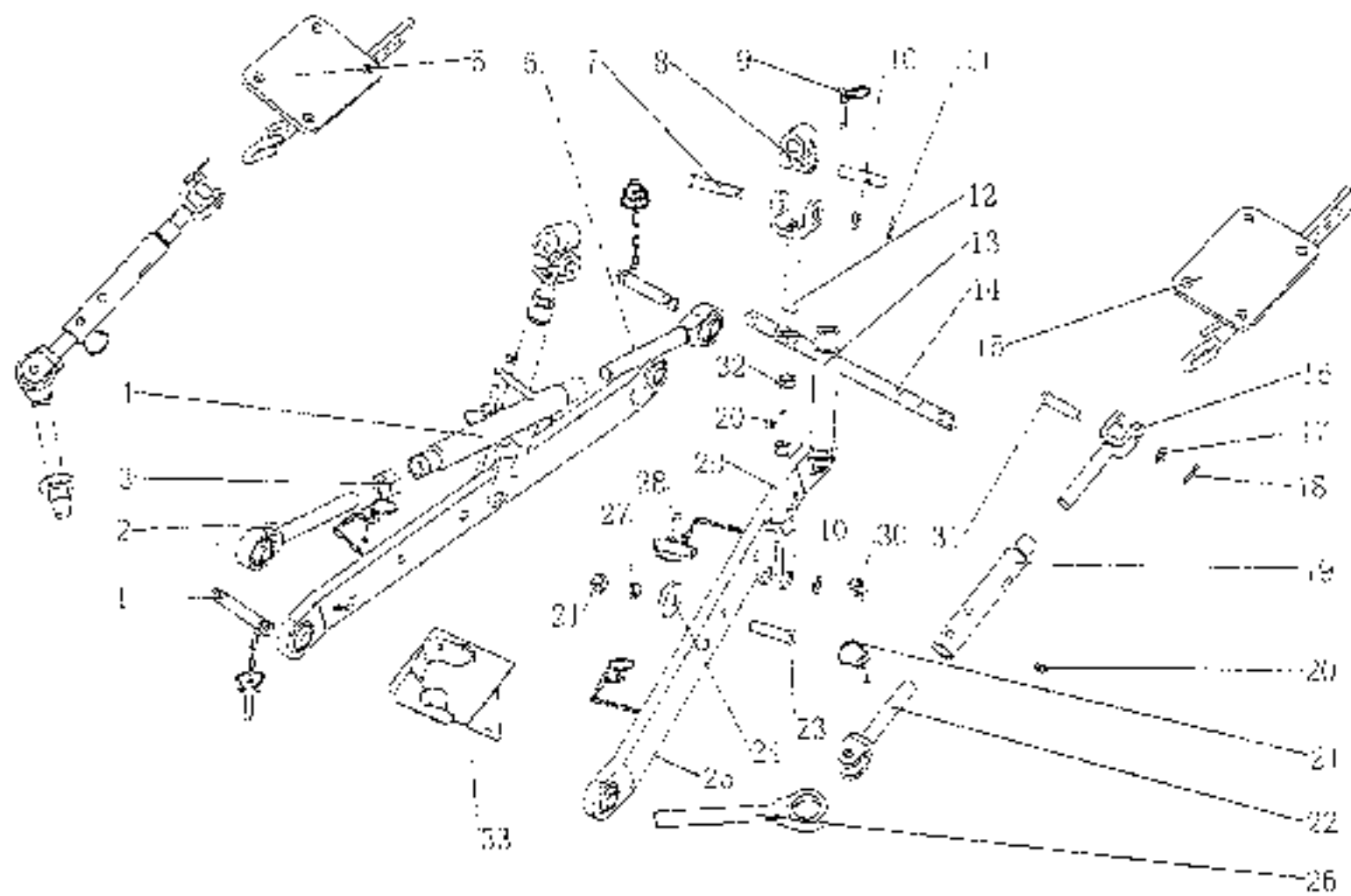

26 悬挂装置总成 Suspension Mechanism

序号 Ser. No.	代号 Part No.	名称及规格 Name & Specifications	数量 Quantity	备注 Remarks
1	200.56.016	上拉杆连接销总成	2	
2	300.56.020-1	上拉杆后调节杆总成	1	
3	GB6170-86	螺母 M24	1	
4	300.56.019	转向螺母焊合件	1	
5	300.56.029-1	左前限位链焊合件	1	
6	300.56.018-1	上拉杆前调节杆总成	1	
7	GB882-86	销16x80	2	
8	300.56.113	提升杆十字接头	2	
9	200.56.041	限位销焊合件	2	
10	GB97.1-85	垫圈 16	2	
11	GB91-86	开口销 3.2x26	2	
12	300.56.022-1	提升杆上端耳焊合件	2	
13	300.56.034	提升杆螺母焊合件	2	
14	200.56.103	下拉杆轴销轴	1	
15	300.56.026-1	右前限位链焊合件	1	
16	300.56.032-1	限位限位焊合件	2	
17	GB97.1-85	垫圈 12	2	
18	GB91-86	开口销 4x20	2	
19	300.56.155-1	调节套	2	
20	GB1152-89	衬套 F10x1	4	
21	GB6170-86	螺母 M16	4	
22	300.56.027-2	限位限位焊合件	2	
23	GB5782-86	螺母 M16x65	2	
24	300.56.157	衬套	2	
25	300.56.020	下拉杆焊合件	2	

26 悬挂装置总成 Suspension Mechanism

序号 No.	代号 Part No.	名称及规格 Name & Specifications	数量 Quantity	备注 Remarks
26	300.56.102	弹簧 Spring	2	
27	GB90-87	弹簧垫圈 Spring lock washer 16	2	
28	GB882-86	销轴 16×65 Clevis pin with head B16×65	2	
29	300.56.024.1	提升机下限位块零件 Lower clevis of lift rod	2	
30	300.56.101-1	R销 R-pin	2	
31	GB882-86	销轴 12×45 Clevis pin with head B12×45	2	
32	GB6173-86	螺母 M20×2 Hex.nut M20x2	2	

27 前配重总成 Front Balance Weight

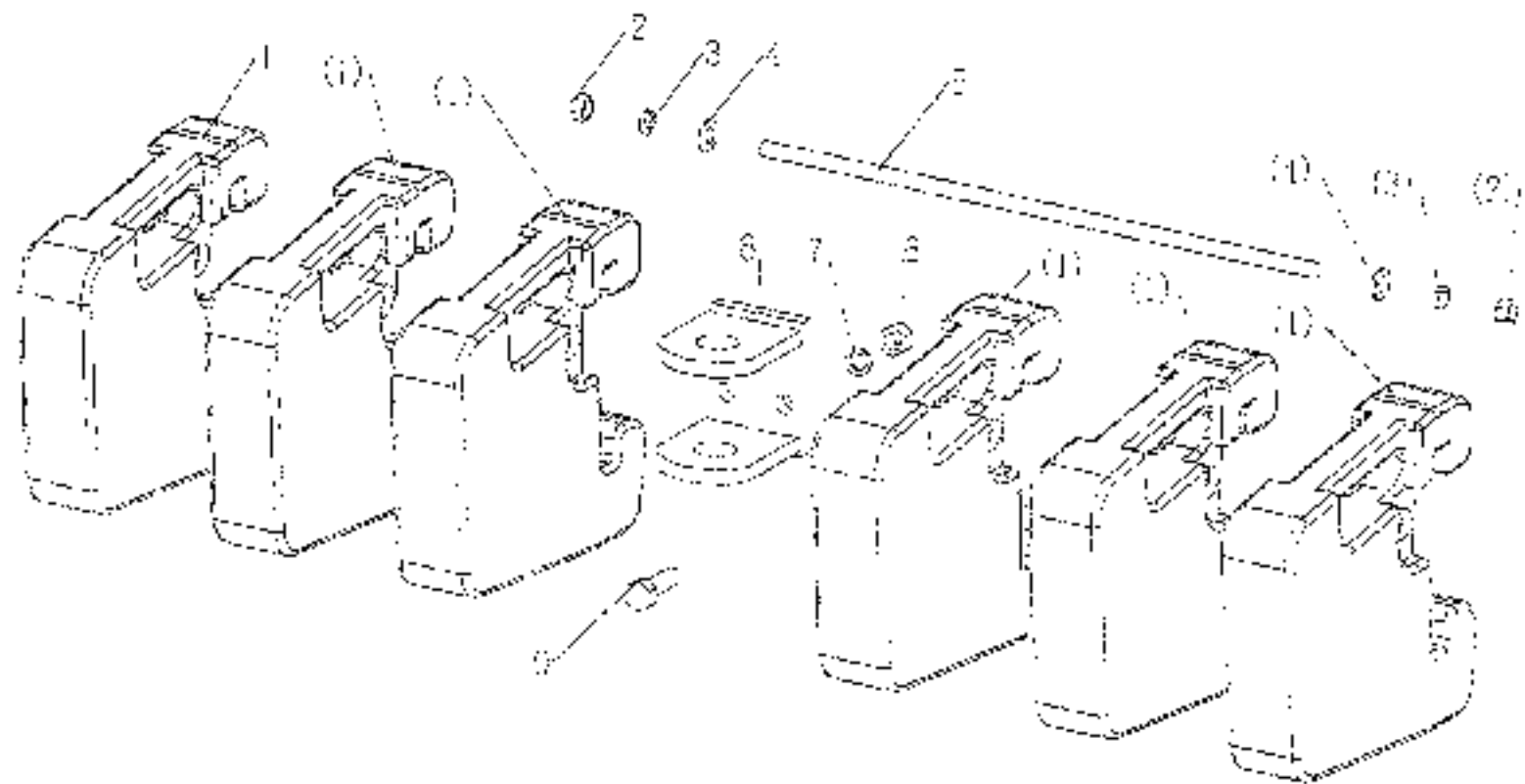

27 前配重总成 Front Balance Weight

序号 Ser. No.	代号 Part No.	名称及规格	Name & Specifications	数量 Quantity	备注 Remarks
1	250.73.101-1	砊重	Balance weight block	6	
2	GB6170-86	螺母M12	Hex.nut M12	2	
3	GB93-87	垫圈12	Spring lock washer 12	2	
4	GB97.1-85	垫圈12	Plain washer 12	2	
5	GB953-88	等长双头螺柱M12x48	Clamping type double stud M.12x48	1	
6	GB6170-86	螺母M14	Hex.nut M14	1	
7	GB93-87	垫圈14	Spring lock washer 14	1	
8	300.73.011	牵引板焊合件	Front drawbar weldment	1	
9	GB5783-86	螺母M12x45	Hex.bolt M12x45	1	

28 前置式挂车气刹装置总成

Air Brake Installations for Trailer

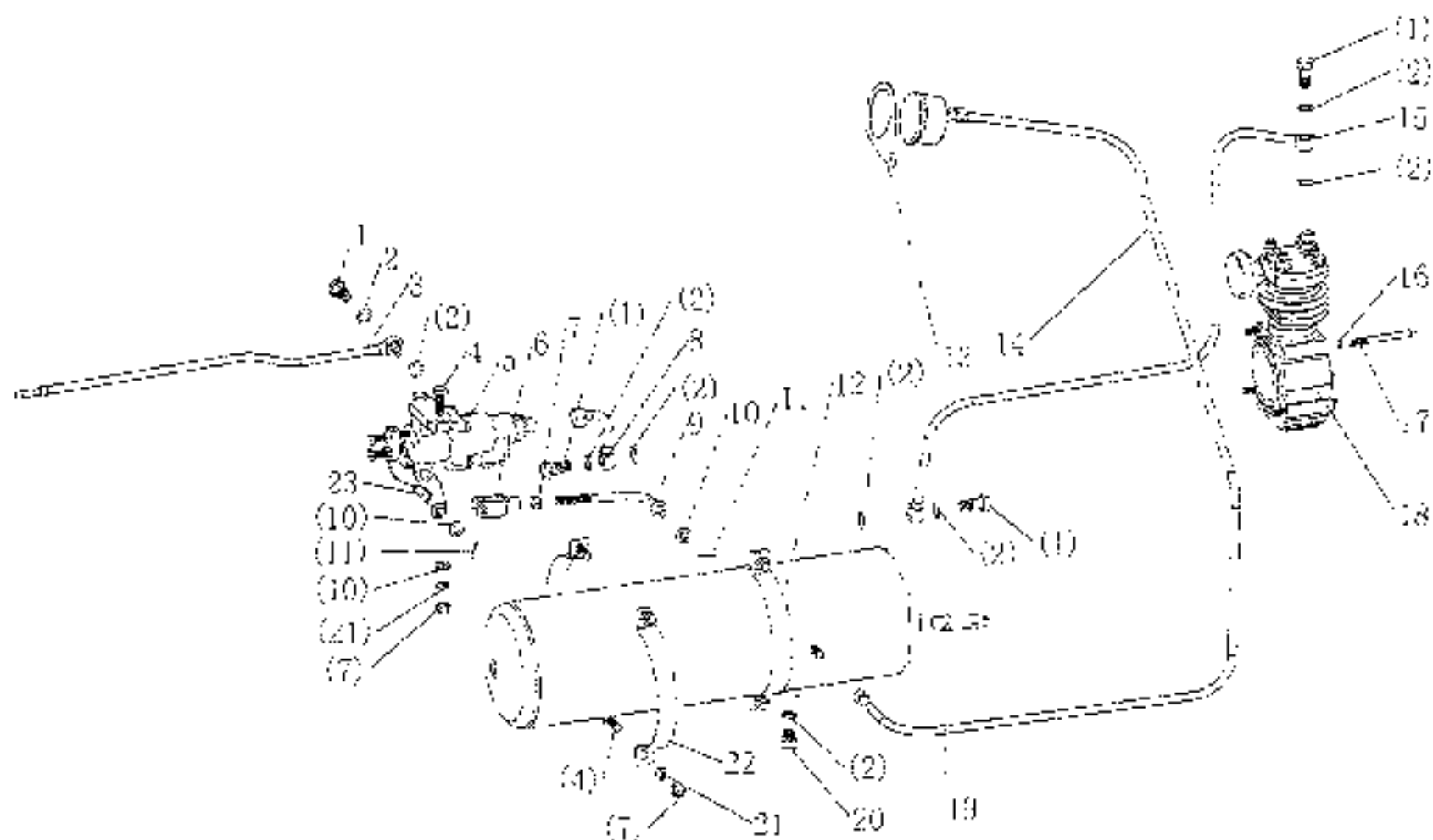

28 前置式挂车气刹装置总成

Air Brake Installations for Trailer

序号	Ser. No.	代号 Part No.	名称及规格	Name & Specifications	数量 Quantity	备注 Remarks
1		300.80.101	管接头螺母	Hollow Bolt	4	
2		300.80.102	铝垫片	Aluminum washer	9	
3		300.80.018	制动阀出气管零件总成	Outlet pipe, brake valve	1	
4		GB5783-86	螺栓M10×30	Hex. head bolt M10×30	6	
5		300.80.016	制动阀总成	Brake valve	1	Aerate Brake
		YZ50-80	制动阀总成	Brake valve	1	Expire Brake
6		300.80.014	控制阀拉杆叉	Rod clevis, brake valve	1	
7		GB6170-86	螺母M10	Hex nut M10	7	
8		300.80.014	储气筒与气管焊合件	Outlet pipe, air tank	1	
9		300.80.015	拉杆焊合件	Handspike	1	
		300.80.015A	拉杆焊合件	Handspike	1	
		300.80B.015	拉杆焊合件	Handspike	1	Expire Brake
10		GB97.1-85	垫圈10	Plain washer 10	4	
11		GB91-86	销3.2×20	Split pin 3.2×20	2	
12		300.80.012	储气筒总成	Air tank	1	012A is short
		300.80B.012	储气筒总成	Air tank	1	
13		300.80.125	气压表支架	Bracket, air pressure gauge	1	Original
14		300.80.013	气压表总成	Air-pressure gauge YTG-60	1	
15		300.80.011/011A	气泵出气管焊合件	Outlet pipe, air pump	1	Used for 390 engine
		350.80.011/011A	气泵出气管焊合件	Outlet pipe, air pump	1	Used for 395 engine
		400B.80.011	气泵出气管焊合件	Outlet pipe, air pump	1	Used for 490 engine
16		GB93-87	垫圈8	Spring lock washer 8	6	
17		GB5782-86	螺栓M8×95	Hex. head bolt M8×95	4	
18		300.80.010	空气压缩机总成	Air pump	1	
19		300.80.017	安全阀总成	Safety valve	1	
20		300.80.103	放水阀	Water drain plug	1	

28 前置式挂车气刹装置总成

Air Brake Installations for Trailer

纸表

序号 Ser. No.	代号 Part No.	名称及规格	Name & Specifications	数量 Quantity	备注 Remarks
21	GB90-87	垫圈 10	Spring lock washer 10	6	
22	300.80.105	储气筒包箍	Air tank hoop	4	
23	GB882-86	销轴 B10×30	Clevis pin with head B10×30	1	

29.1 机架总成(4WD 配390发动机) Frame(4WD for 390 engine)

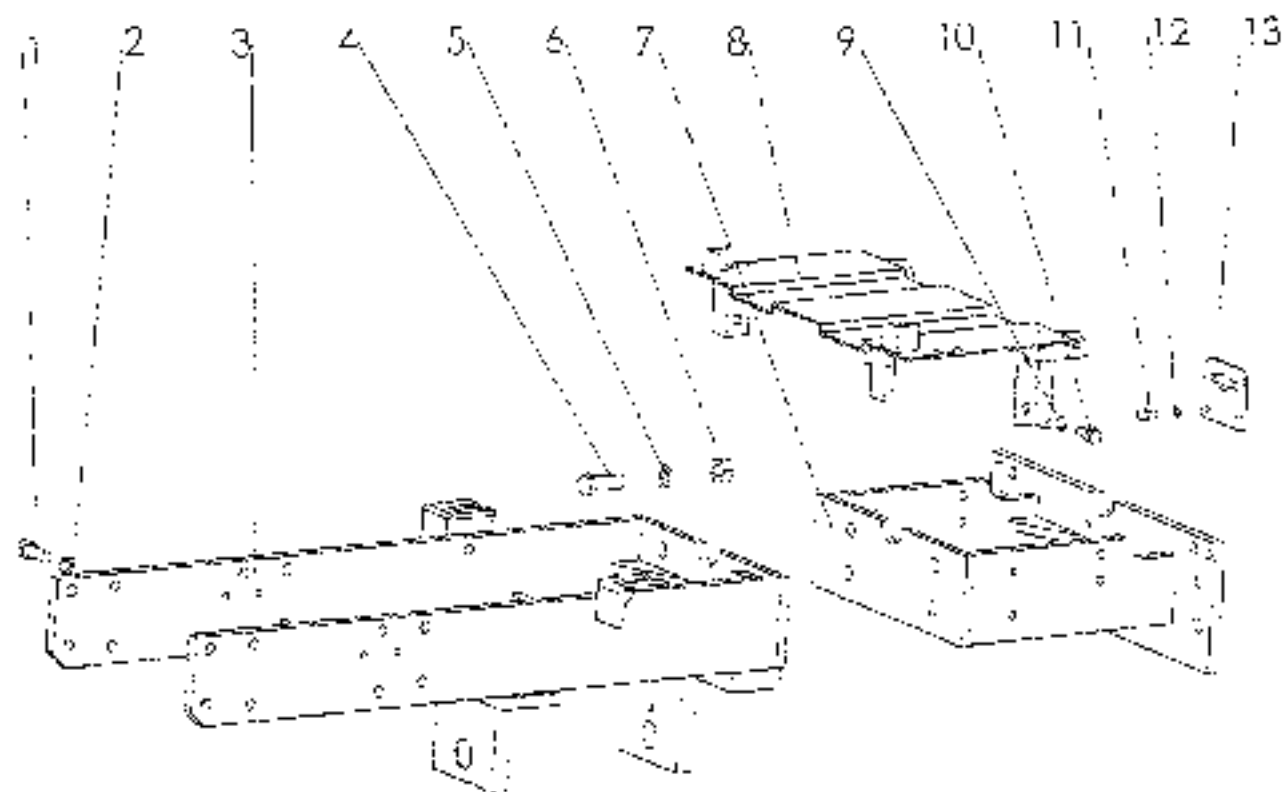

29.1 机架总成(4WD 配390发动机) Frame(4WD For 390 engine)

序号 Ser No.	代号 Part No.	名称及规格	Name & Specification	数量 Quantity	备注 Remarks
1	GB5783-86	螺栓M12x35	Hex head bolt M12x35	16	S.8級
2	GB97-87	弹簧垫圈	Spring Lock washer 12	16	
3	304.30A.011	机架总成件	Frame	1	
4	GB5783-86	螺栓M16x45	Hex head bolt M16x45	4	
5	GB93-87	弹簧垫圈	Spring Lock washer 16	4	
6	GB6170-86	螺母M16	Hex nut M16	4	
7	304.30A.012	配重块零件	Assistant weight support	1	
8	284.30B.013	电瓶架零件	Battery bracket	1	
9	GB5783-86	螺栓M10x25	Hex head bolt M10x25	6	
10	GB93-87	弹簧垫圈	Spring Lock washer 10	6	
11	GB5783-86	螺栓M8x16	Hex head bolt M8x16	1	
12	GB93-87	弹簧垫圈	Spring Lock washer 8	1	
13	250.30.115	手摇起动机支架	Starting crank gate	1	

29.2 机架总成(4WD 配395发动机) Frame(4WD For 395 engine)

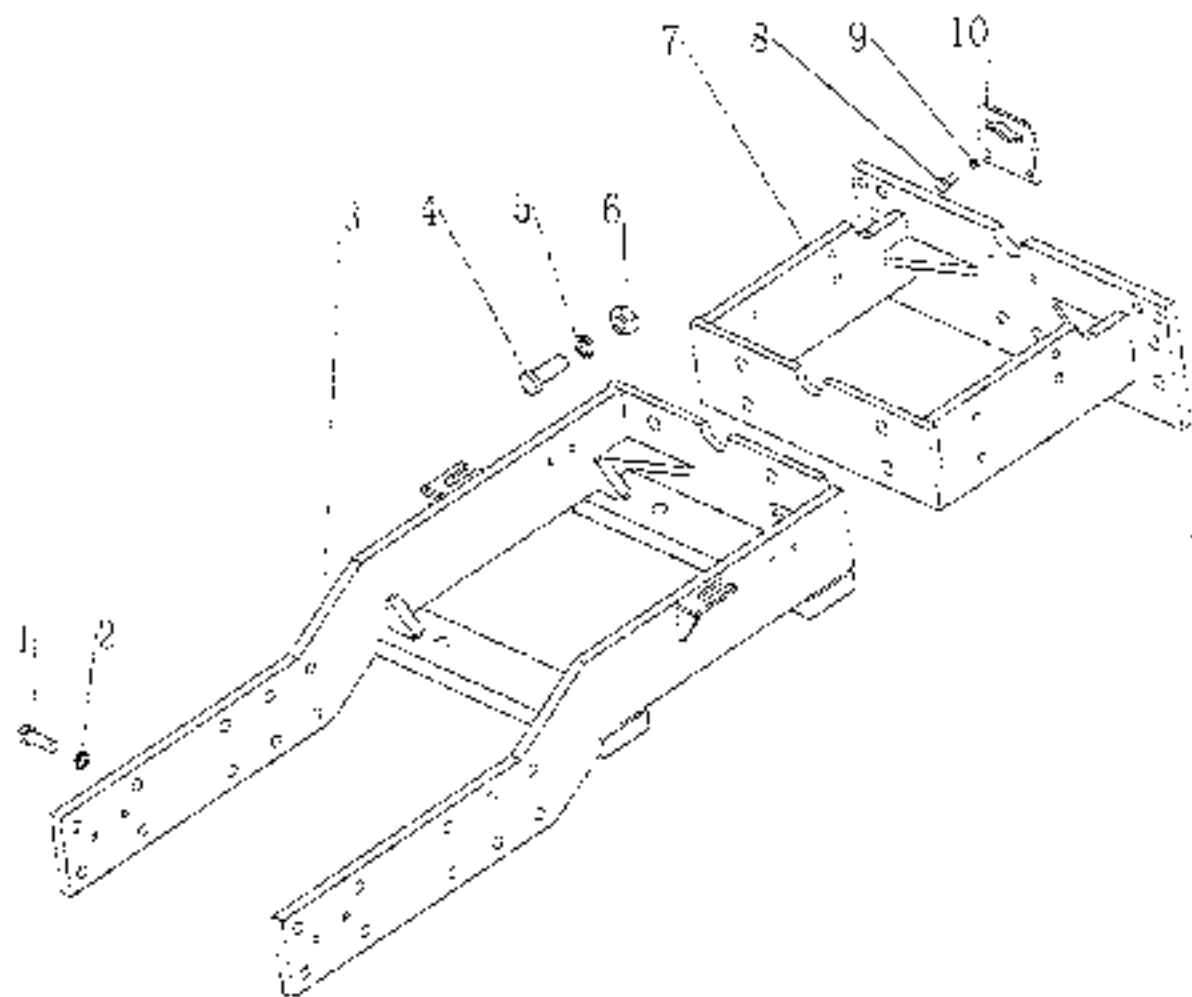

29.2 机架总成 (4WD 配395发动机) Frame(4WD for 395 engine)

序号 Ser. No.	代号 Part No.	名称及规格	Name & Specifications	数量 Quantity	备注 Remarks
1	GB5783-86	螺栓M12x35	Hex head bolt M12x35	16	3.5级
2	GB93-87	垫圈12	Spring Lock washer12	16	
3	354.30A.011	机架焊合件	Frame	1	
4	GB5783-86	螺栓M16x45	Hex head bolt M16x45	4	
5	GB93-87	垫圈16	Spring Lock washer16	4	
6	GB6170-86	螺母M16	Hex nut M16	4	
7	354.30A.012	配重架焊合件	Assistant weight support	1	
8	GB5783-86	螺栓M8x16	Hex head bolt M8x16	1	
9	GB93-87	垫圈8	Spring Lock washer8	1	
10	250.30.115	手推自动换挡板	Starting crans gate	1	

29.3 机架总成(4WD 配490发动机) Frame(4WD For 490 engine)

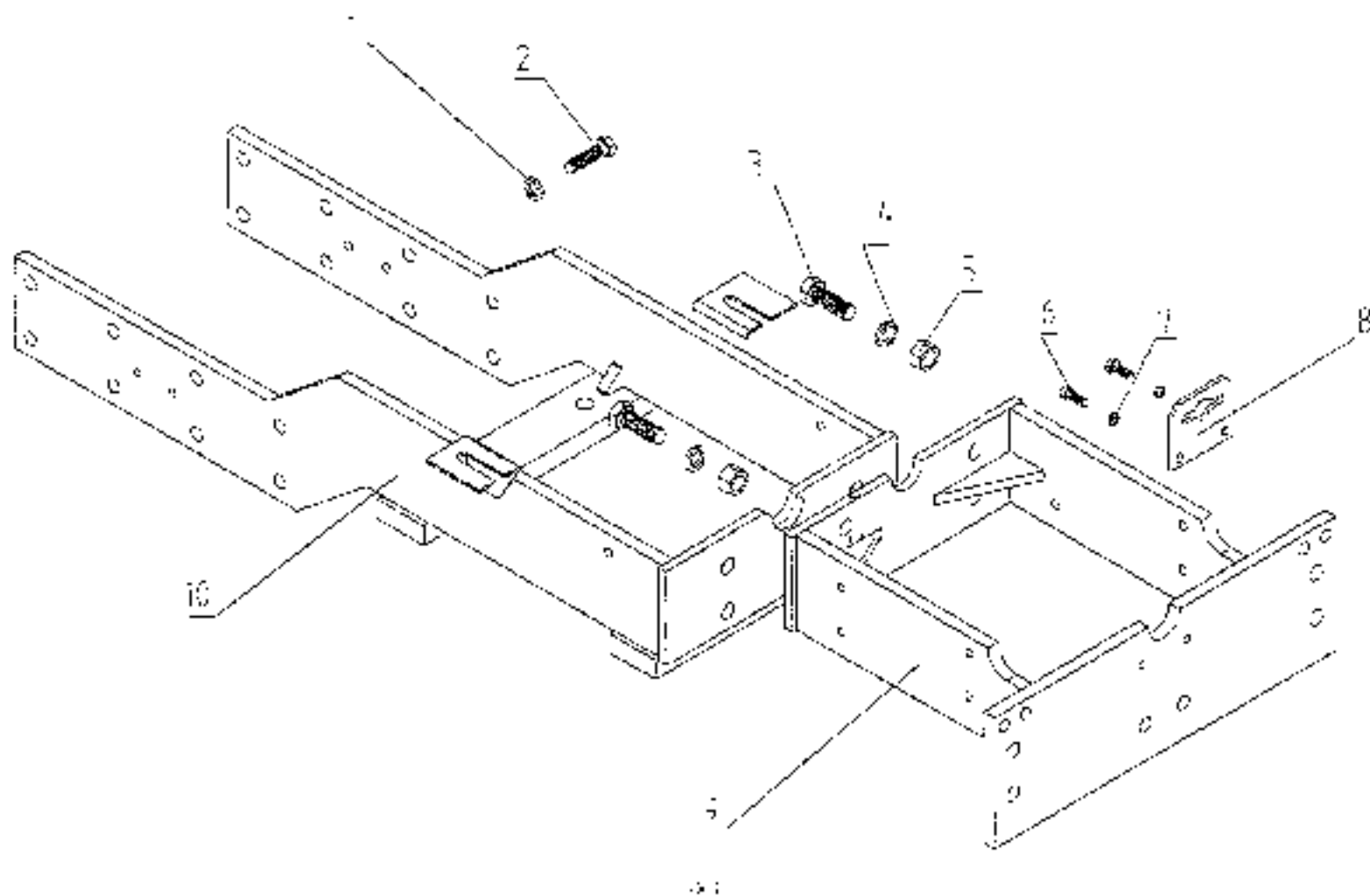

29.3 机架总成(4WD 配490发动机) Frame (4WD For 490 engine)

序号 Ser.No.	代号 Part No.	名称及规格	Name & Specifications	数量 Quantity	备注 Remarks
1	GB93-87	垫圈14	Spring lock washer 14	6	
2	GB5783-86	螺栓M14x35	Hex.head bolt M14x35	5	3.8级
3	GB5783-86	螺栓M16x45	Hex.head bolt M16x45	4	3.8级
4	GB93-87	垫圈16	Spring lock washer 16	4	
5	GB6170-86	螺母M16	Hex.nut M16	4	8级
6	GB5783-86	螺栓M8x16	Hex.head bolt M8x16	2	
7	GB93-87	垫圈8	Spring Lock washer 8	2	
8	250.30.116	手操启动叉总成	Starting crank gear	1	
9	40-B.30A.G12	配重架零件	Balance weight frame	1	
10	400.30A.011	机架零件	Frame	1	

30.1 前驱动轮总成 Front Drive Wheel

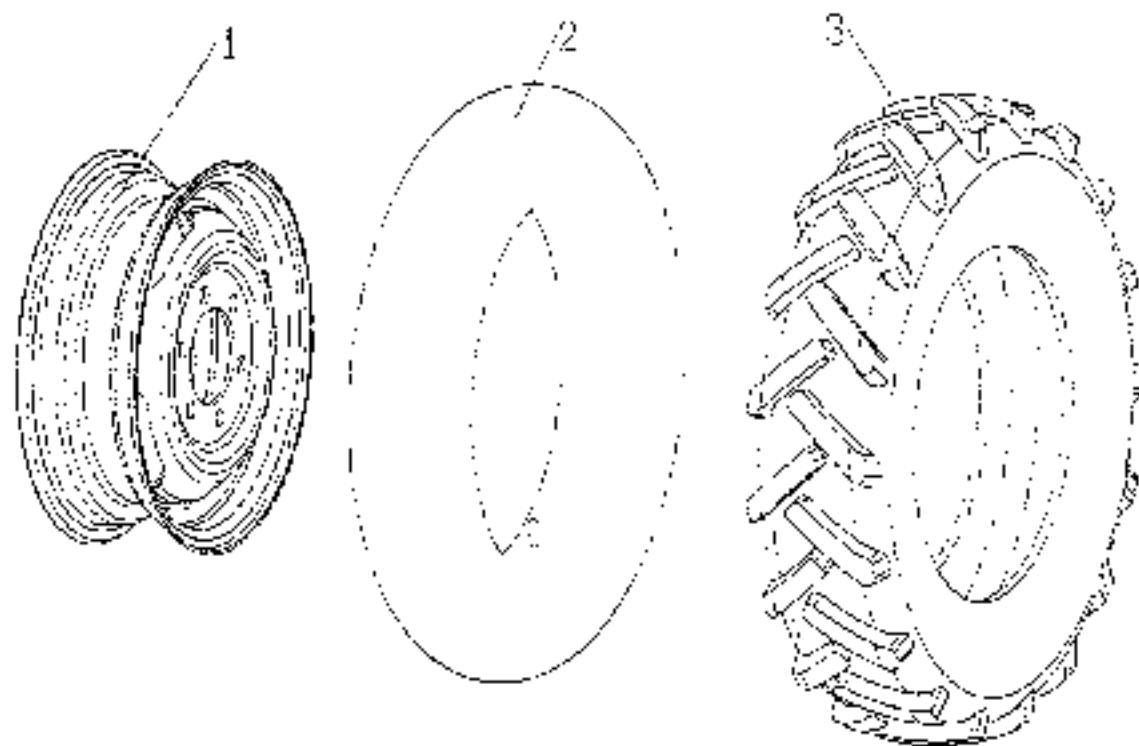

30.1 前驱动轮总成 Front Drive Wheel

序号	Seq. No.	代号 Part No.	名称及规格	Name & Specifications	数量 Quantity	备注 Remarks
1		304.32.01	前驱动轮总成	Min. Front drive wheel	1×2	
2		GB/T2919-1999	驱动轮内胎 6.5-16	Inner Tube 6.5-16	1×2	Used for 490 engine
			驱动轮内胎 7.5-16	Inner Tube 7.5-16	1×2	
3		GB/T2919-1999	驱动轮外胎 6.5-16	Tyre 6.5-16	1×2	Used for 490 engine
			驱动轮外胎 7.5-16	Tyre 7.5-16	1×2	

30.2 驱动轮总成 (草地胎) Drive Wheel (Turf tyre)

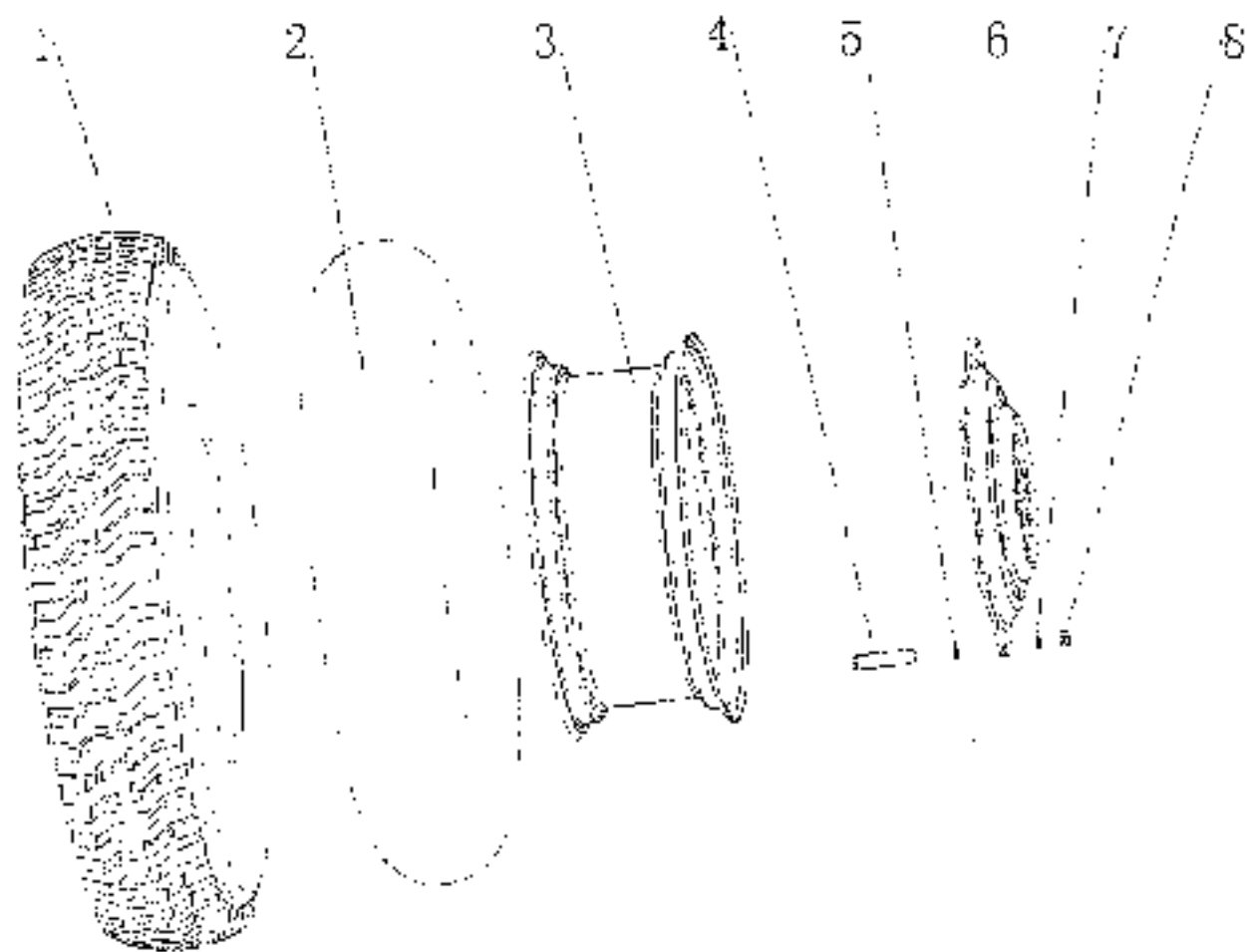

30.2 草胎胎前轮 Front Wheel (Turf tyre)

序号 Ser.No	代号 Part No.	名称及规格	Name & Specifications	数量 Quantity	备注 Remarks
1	304.52.011	轮胎总成 (16x5.00F)	Front wheel (16x5.00F)	1x2	
2	GB2979-91	外胎 7.5-16	Tire 7.5-16	1x2	
3	GB2979-91	内胎 7.5-16	Tube 7.5-16	1x2	

30.3 前轮总成 (工业胎) Front Wheel (Industrial tyre)

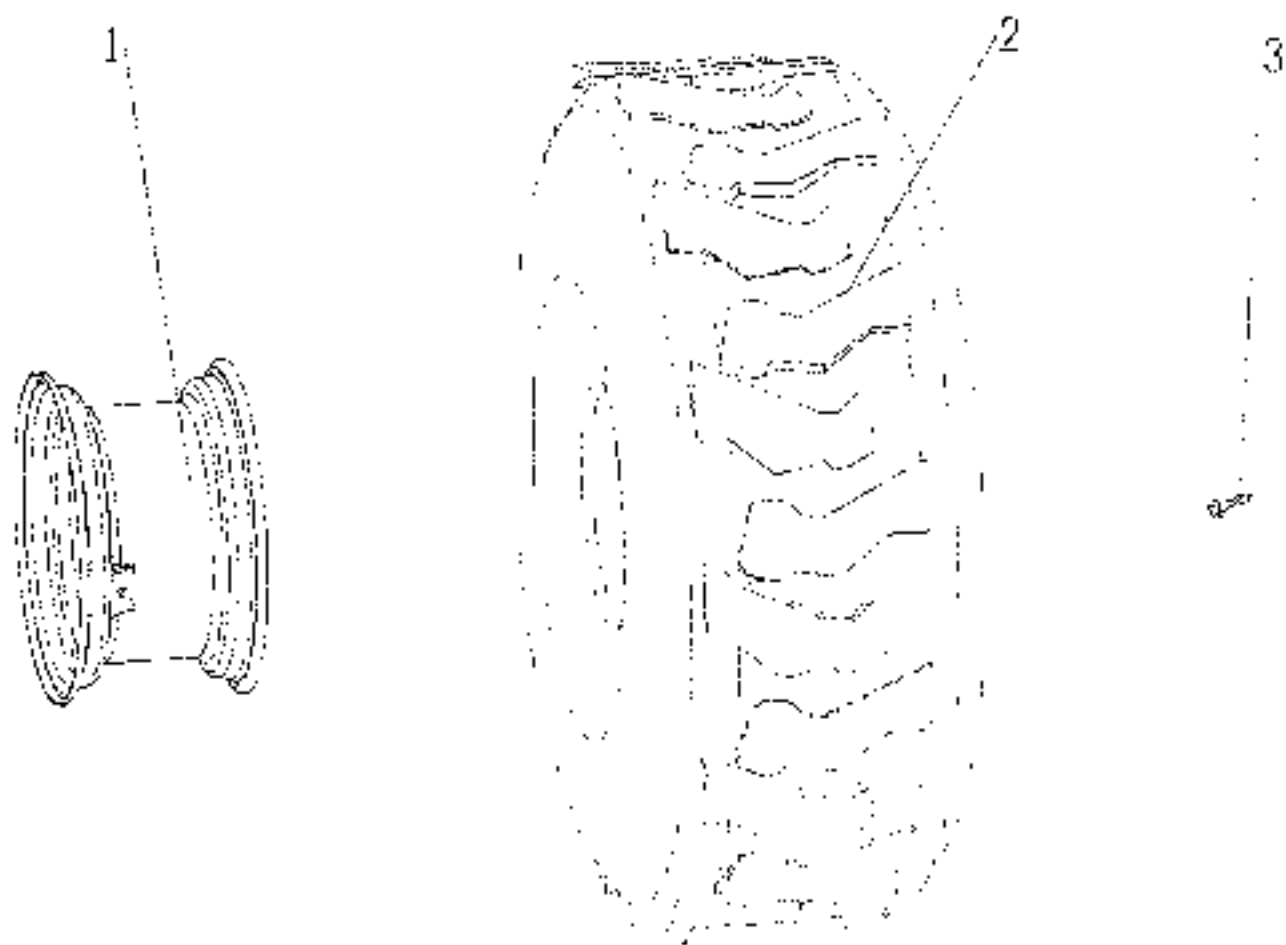

30.3 前轮总成 (工业胎) Front Wheel (Industrial tyre)

序号 Ser.No.	代号 Part No	名称及规格	Name & Specifications	数量 Quantity	备注 Remarks
1	354.32.011	轮辋总成	Front wheel rim	1x2	
2	10-16.5	工业前轮胎	Industrial tyre	1x2	
3	TR501	气门嘴	Valve	1x2	

31 前驱动桥总成 (中) Front Wheel Drive Axle(middle)

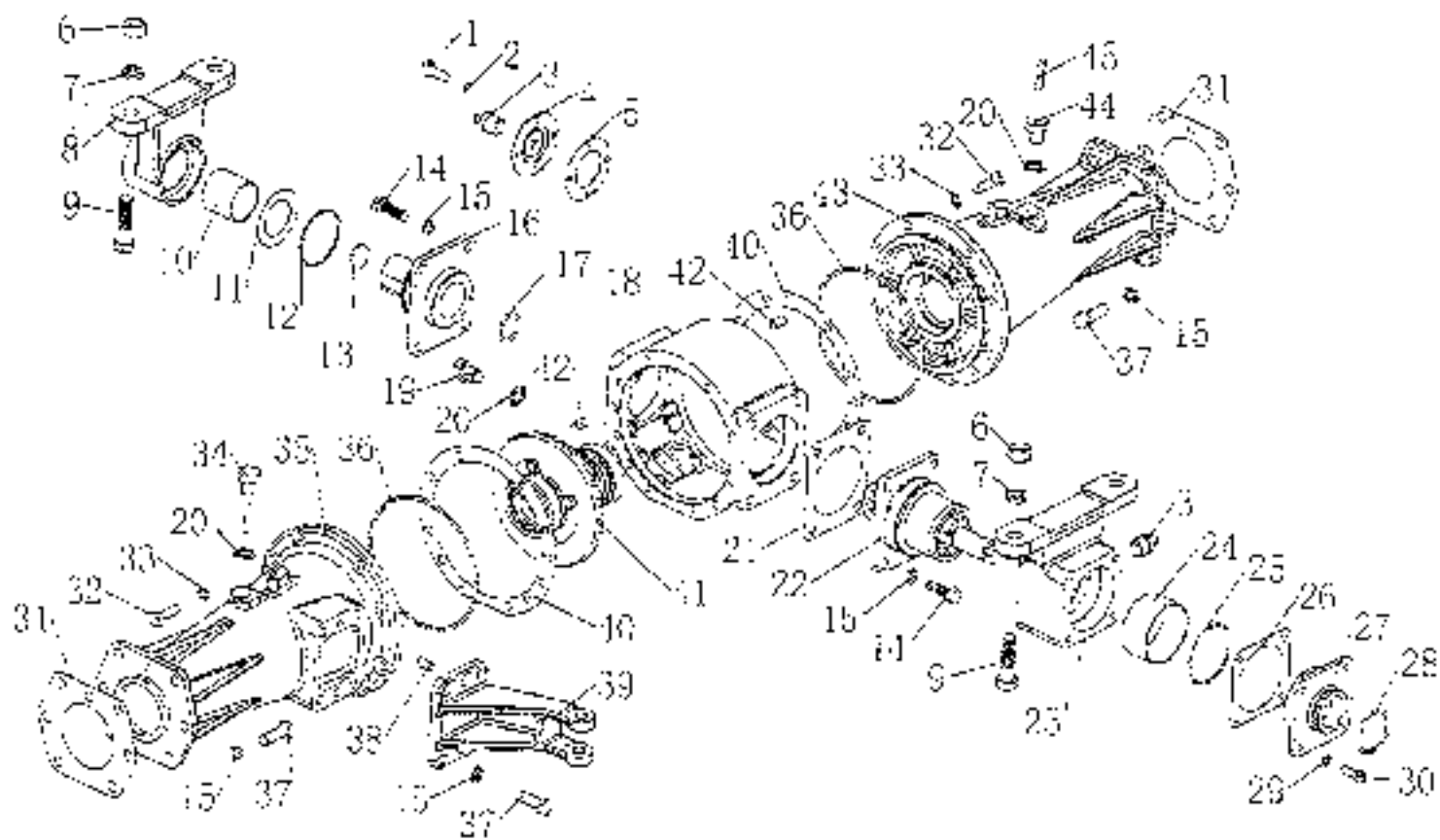

31 前驱动桥总成 (中) Front Wheel Drive Axle (middle)

序 号	件 号	名 称 及 规 格	Name & Specifications	数 量	备 注
1	GB5783-86	螺母 M6x12	Hex. head bolt M6x12	4	
2	GB993-87	弹簧垫圈 6	Spring lock washer 6	4	
3	GB1152-89	油封 M10x1	Grease seal M 10x1	2	
4	304.31.1019	前驱动桥壳组合件	End cover of front pedestal	1	
5	304.31.123	前壳垫片	End cover gasket	1	
6	GB6170-86	螺母 M16	Hex. nut M16	4	
7	GB93-87	垫圈 16	Spring lock washer 16	4	
8	304.31.220-2	前叉座	Front pedestal	1	
9	GB27-88	螺栓 M15x65	Hex. head bolt M15x65	4	
10	304.31.219-1	前叉座衬套	Front pedestal bush	1	
11	304.31.123-1	前摆轴垫片	Shims for front swing axle	1组	每组各2片 one pos. for each axle
12	GB3452.1-82	O型圈 65x2.65	O-ring seal 65x2.65	1	
13	ZB T32005-88	防尘盖片 24	Casing cap	1	
14	GB5786-86	螺栓 M12x1.5x35	Hex. head bolt M12x1.5x35	8	
15	GB93-87	垫圈 12	Spring lock washer 12	24	
16	304.31.124-2	前摆轴	Front swing axle	1	
17	GB3452.1-82	O型圈 69x3.55	O-ring seal 69x3.55	1	
18	304.31.116-2	主传动壳体	Main drive case	1	
19	200.38.024	放油螺塞总成	Oil drain plug	1	
20	12.37.149	组合密封垫圈	Combined seal washer	3	
21	304.31.125-1	轴承座垫片	Shims for bearing seat	1组	每组各2片 two pos. for each side
22	304.31.022-1	主驱动桥壳总成	Bevel drive pinion assembly	1	
23	304.31.222-2	后叉座	Rear pedestal	1	
24	304.31.231-1	后叉座衬套	Rear pedestal bush	1	

附表

31 前驱动桥总成(中) Front Wheel Drive Axle (middle)

序号 Ser No.	代号 Part No.	名称及规格 Name & Specifications	数量 Quantity	备注 Remarks
25	GB3452.1-82	O型圈 69×2.65	1	
26	304.31.026	后支轴盖垫片	1	
27	304.31.027-1	后支轴盖	1	
28	GB3452.1-82	O型圈 48.7×3.55	1	
29	GB93-87	垫圈 8	4	
30	GB5783-86	螺栓 M8×25	4	
31	304.31.028-1	左半轴套管垫片	2	
32	GB5783-86	螺栓 M10×35	20	
33	GB93-87	垫圈 10	20	
34	304.31.013-1	油尺总成	1	
35	304.31.233-1	左半轴套管	1	
36	GB3452.1-82	O型圈 160×3.55	2	
37	GB5783-86	螺栓 M12×35	16	
38	GB119-86	销 A10×20	2	
39	304.31.234	转向油缸座	1	
40	304.31.117-1	主传动壳外垫片	2套 two set	1套每桥各1 Two pcs for each axle
41	304.31.014-1	差速器总成	1	with two Planet gear
	304.31.014A	差速器总成	1	with four Planet gear
42	GB119-86	销 A10×16	2	
43	304.31.113-1	右半轴套管	1	
44	304.31.118-1	通气螺塞	1	
45	304.31.119-1	通气管	1	

32 前驱动桥总成 (左边减速)
 Front Wheel Drive Axle (Left Side Slowdown)

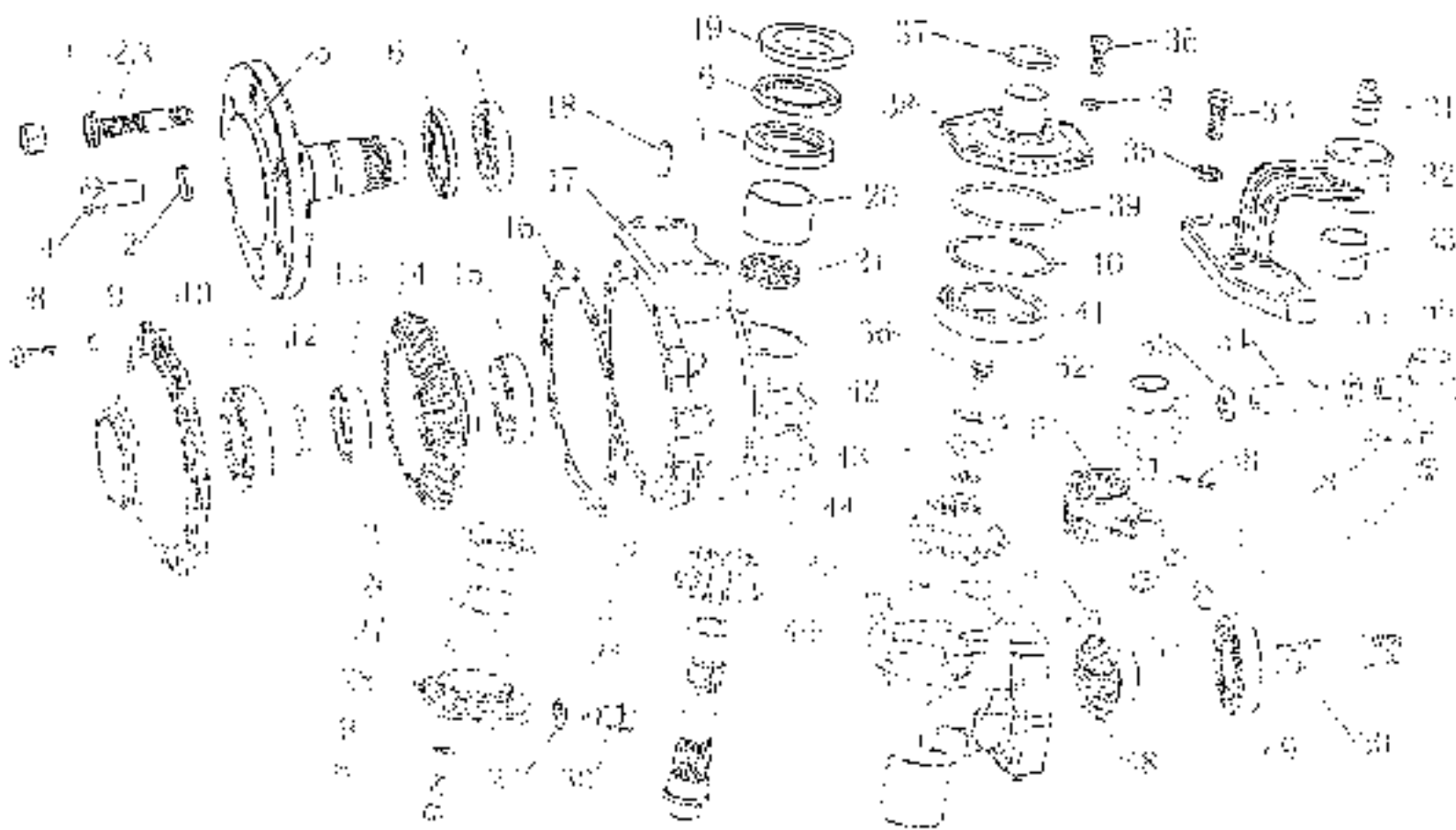

32 前驱动桥总成 (左边减速) Front Wheel Drive-Axle (Left Side-Slowdown)

序号 Ser. No.	代号 Part No.	名称及规格	Name & Specifications	数量 Quantity	备注 Remarks
1	GB6176-85	螺母 M18×1.5	Hex nut M18×1.5	2	
2	GB93-87	垫圈 18	Spring lock washer 18	6	
3	304.31.179	螺柱	Double screw bolt	2	
4	GB5786-86	螺栓 M18×1.5×35	hex. head bolt M18×1.5×35	4	
5	304.31.101-2	驱动轴	Drive shaft	1	
6	HG4-692-67	油封 W50×72×7	Oil-seal W50×72×7	2	
7	HG4-692-67	油封 PD50×72×12	Oil-seal PD50×72×12	2	
8	GB5783-86	螺栓 M10×30	Hex. head bolt M10×30	20	
9	GB93-87	垫圈 10	Spring lock washer 10	26	
10	304.31.104-3	驱动轴盖	Drive shaft cover	1	
11	GB276-89	轴承 209	Ball bearing 209	1	
12	304.31.102-2	驱动轴固定套	Fixing ring of drive shaft	2	
13	304.31.103-2	驱动轴套圈	Drive shaft sleeve	1	
14	304.31.132-2	末减速被动齿轮	Driven bevel gear of final drive	1	
15	GB276-89	轴承 207	Ball bearing 207	1	
16	304.31.105-1	驱动轴衬套片	Gasket for drive shaft cover	1	
17	304.31.228-4	左边减速壳体	Left final drive housing	1	
18	GB119-86	销 A10×28	Straight pin A10×28	2	
19	304.30.130	毛毡圈	Felt washer	1	
20	304.31.217-1	边减速壳体衬套	Final drive housing bushing	1	
21	GB501-84	轴承 8106	Thrust ball bearing 8106	1	
22	304.31.131-2	末减速主动齿轮	Driving bevel gear of final drive	1	
23	304.31.140	隔套	Spacer	1	
24	304.31.107-3	立轴	Upright shaft	1	
25	GB276-89	轴承 305	Ball bearing 305	1	
26	304.31.139	不同传动调整垫片	Adjusting shims for final drive	1组 one set	1组两种各2片 Two pcs for each size

附表 32 前驱动桥总成 (左边减速) Front Wheel Drive Axle (Left Side-Slowdown)

序号 Ser. No.	代号 Part No.	名称及规格 Name & Specifications	数量 Quantity	备注 Remarks	
27	GB3452.1-82	O形圈 56×2.65	O-ring seal 56×2.65	1	
28	304.31.137-2	下轴承盖	Lower bearing cover	1	
29	12.37.149	组合密封垫圈	Combined seal washer	1	
30	200.38.024	放油螺塞总成	Oil drain plug	1	
31	GB1152-89	衬杯 M10×1	Grease cup M10×1	1	
32	304.31.201-3	左转向臂	Left steering arm	1	
33	304.31.202-1	联接臂可调衬套	Steering arm bushing	1	
34	GB5783-86	螺栓 M12×40	Hex. head bolt M12×35	4	
35	GB93-87	垫圈 12	Spring lock washer 12	4	
36	GB5783-86	螺栓 M10×25	Hex. head bolt M10×25	7	
37	GB3452.1-82	O形圈 34.5×2.65	O-ring seal 34.5×2.65	1	
38	304.31.111-3	上轴承盖	Upper bearing cover	1	
39	GB3452.1-82	O形圈 85×2.65	O ring seal 85×2.65	1	
40	304.31.133	中间传动调整垫片	Adjusting shims for the first drive	1张 one set	1张每轴各2片 Two pcs for each size
41	GB276-89	轴承 111	Ball bearing 111	1	
42	304.31.135	锁紧垫片	Lock washer	1	
43	304.31.110-1	立轴衬套	Blocking ring of upright shaft	1	
44	304.31.112-2	调整垫片	Adjusting shims	1张 one set	1张每轴各2片 Two pcs for each size
45	304.31.113-1	中间传动轴驱动锥壳	Driven bevel gear of the first drive	1	
46	304.31.108-3	立轴套管	Upright shaft housing	1	
47	GB119-86	轴 A10×20	Straight pin A10×20	1	
48	304.31.129-1	中间传动主动锥壳	Driving bevel gear of the first drive	1	
49	GB276-89	轴承 208	Ball bearing 208	1	
50	304.31.114-2	半轴	Half shaft	1	
51	304.31.120-2	左梯形臂	Left steering trapezoid arm	1	

表 32 前驱动桥总成 (左边减速) Front Wheel Drive Axle (Left Side-Slowdown)

序号 Ser. No.	代号 Part No.	名称及规格 Name & Specifications	数量 Quantity	备注 Remarks
52	200.31.026	转向接头总成(左) Linkage ball joint (Left)	1	
53	GB6173-86	螺母 M16×1.5-左 Hex. thin nut M16×1.5-Left	1	
54	304.31.232	横拉杆 Steering tie rod	1	
55	GB6173-86	螺母 M16×1.5 Hex. thin nut M16×1.5	1	
56	300.31.027	转向接头总成(右) Linkage ball joint (Right)	1	
57	GB6181-86	螺母 M12 Hex. thin slotted nut M12	2	
58	GB91-86	销 3.2×22 Split pin 3.2×22	2	

33 前驱动桥总成 (右边减速)
 Front Wheel Drive Axle (Right side Slowdown)

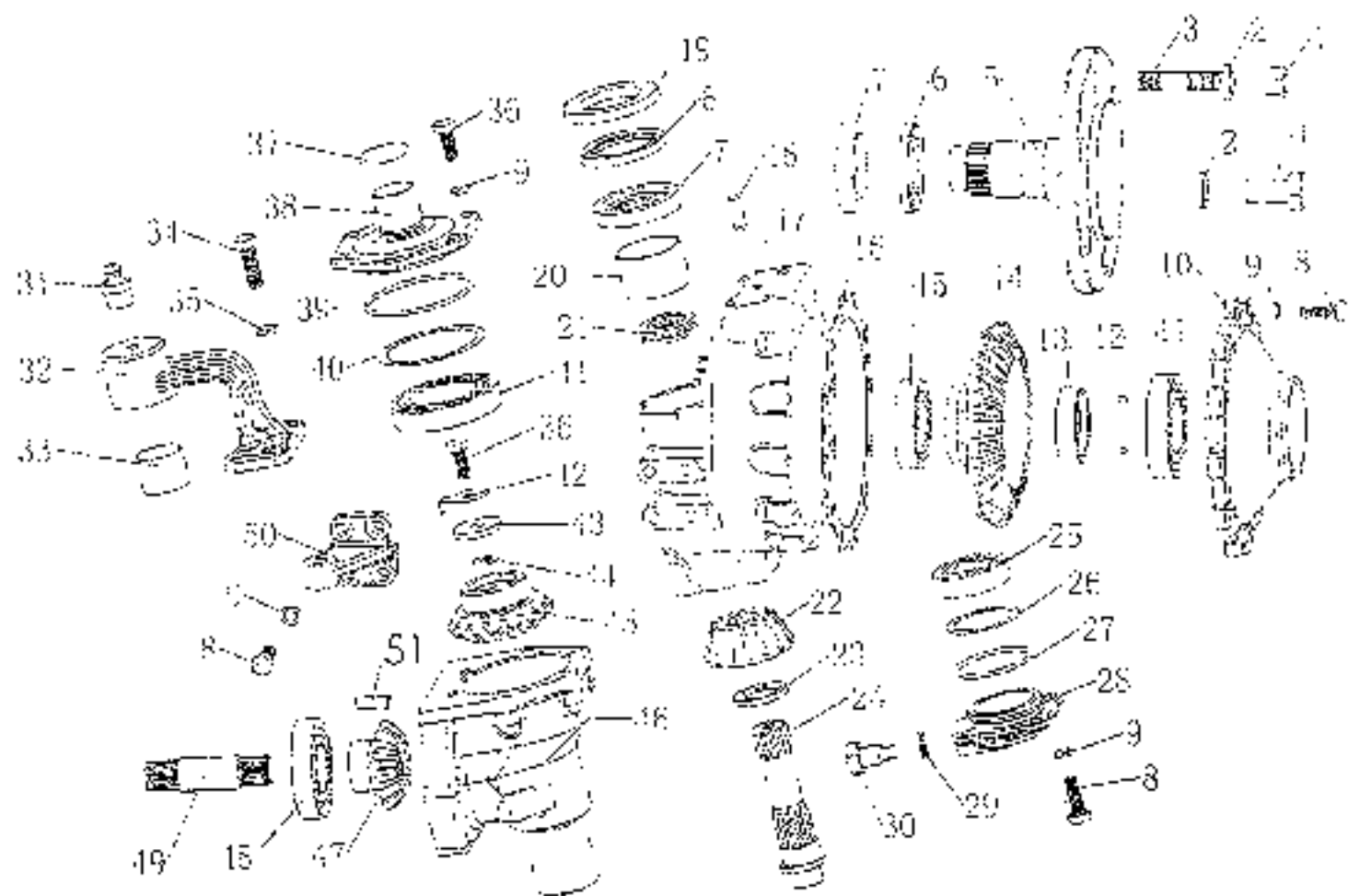

33 前驱动桥总成 (右边减速) Front Wheel Drive Axle (Right side-Slowdown)

序号 Ser. No.	代号 Part No.	名称及规格	Name & Specifications	数量 Quantity	备注 Remarks
1	GB6176-86	螺母 M18×1.5	Hex. nut M18×1.5	2	
2	GB93-87	垫圈 18	Spring lock washer 18	6	
3	304.31.119	螺帽	Double screw hat	2	
4	GB5785-86	螺栓 M18×1.5×35	hex. head bolt M18×1.5×35	4	
5	304.31.101-2	驱动轴	Drive shaft	1	
6	HG4-692-67	油封 W50×72×7	Oil-seal W50×72×7	3	
7	HG4-692-67	油封 PD50×72×12	Oil-seal PD50×72×12	2	
8	GB5783-86	螺栓 M10×30	Hex. head bolt M10×30	20	
9	GB93-87	垫圈 10	Spring lock washer 10	26	
10	304.31.104-3	驱动轴盖	Drive shaft cover	1	
11	GB276-89	轴承 209	Ball bearing 209	1	
12	304.31.102-2	驱动轴固定套	Fixing ring of drive shaft	2	
13	304.31.103-7	驱动轴套套	Drive shaft sleeve	1	
14	304.31.132-2	末减速被动齿轮	Driven bevel gear of final drive	1	
15	GB276-89	轴承 207	Ball bearing 207	1	
16	304.31.105-1	驱动轴盖垫片	Gasket for drive shaft cover	1	
17	304.31.216-4	右边减速壳外	Right final drive housing	1	
18	GB119-86	销 A10×28	Straight pin A10×28	2	
19	304.30.130	平垫圈	Flat washer	1	
20	304.31.217-1	边减速壳体衬套	Final drive housing bushing	1	
21	GB301-84	轴承 8106	Thrust ball bearing 8106	1	
22	304.31.131-2	末减速主动齿轮	Driving bevel gear of final drive	1	
23	304.31.140	隔套	Spacer	1	
24	304.31.107-3	立轴	Upright shaft	1	
25	GB276-89	轴承 305	Ball bearing 305	1	
26	304.31.139	末轴传动调整垫片	Adjusting shims for final drive	1副 one set	1组零件各2片 Two pcs. for each

附表 33 前驱动桥总成（右边减速）Front Wheel Drive Axle (Right side-Steer)

序号 Ser.No.	代号 Part No.	名称及规格	Name & Specifications	数量 Quantity	备注 Remarks
27	GB3452.1-82	O形圈 56×2.65	O ring seal 56×2.65	1	
28	304.31.137-2	下轴承盖	Lower bearing cover	1	
29	12.37.149	组合密封垫圈	Combined seal washer	1	
30	200.38.024	放油螺塞总成	Oil drain plug	1	
31	GB1152-89	油杯 M10×1	Grease cup M10×1	1	
32	304.31.215-3	右联接臂	Right linking arm	1	
33	304.31.202-1	联接转向臂衬套	Steering arm bushing	1	
34	GB5783-86	螺栓 M12×35	Hex. head bolt M12×35	4	
35	GB93-87	垫圈 12	Spring lock washer 12	4	
36	GB5783-86	螺栓 M10×25	Hex. head bolt M10×25	7	
37	GB3452.1-82	O形圈 34.5×2.65	O-ring seal 34.5×2.65	1	
38	304.31.111-5	上轴承盖	Upper bearing cover	1	
39	GB3452.1-82	O形圈 85×2.65	O-ring seal 85×2.65	1	
40	304.31.135	中间传动调整垫片	Adjusting shims for the first drive	1组 one set	1组每科各2片 Two pcs for each
41	GB276-89	轴承 111	Ball bearing 111	1	
42	304.31.138	锁紧垫片	Lock washer	1	
43	304.31.110-1	定位挡圈	Blocking ring of upright shaft	1	
44	304.31.112-2	调整垫片	Adjusting shims	1组 one set	1组每科各2片 Two pcs for each
45	304.31.113-1	驱动传动从动齿圈	Driven bevel gear of the first drive	1	
46	304.31.108-3	立轴套筒	Upright shaft housing	1	
47	304.31.129-1	中间传动主动齿圈	Driving bevel gear of the first drive	1	
48	GB276-89	轴承 208	Ball bearing 208	1	
49	304.31.114-2	半轴	Half shaft	1	
50	304.31.121-2	右梯形臂	Right steering trapezoidal arm	1	
51	GB119-86	销 A10×20	Straight pin A10×20	2	

34 前驱动桥总成 (304.31.022-1 部件)
Front Wheel Drive Axle (304.31.022-1 Assembly)

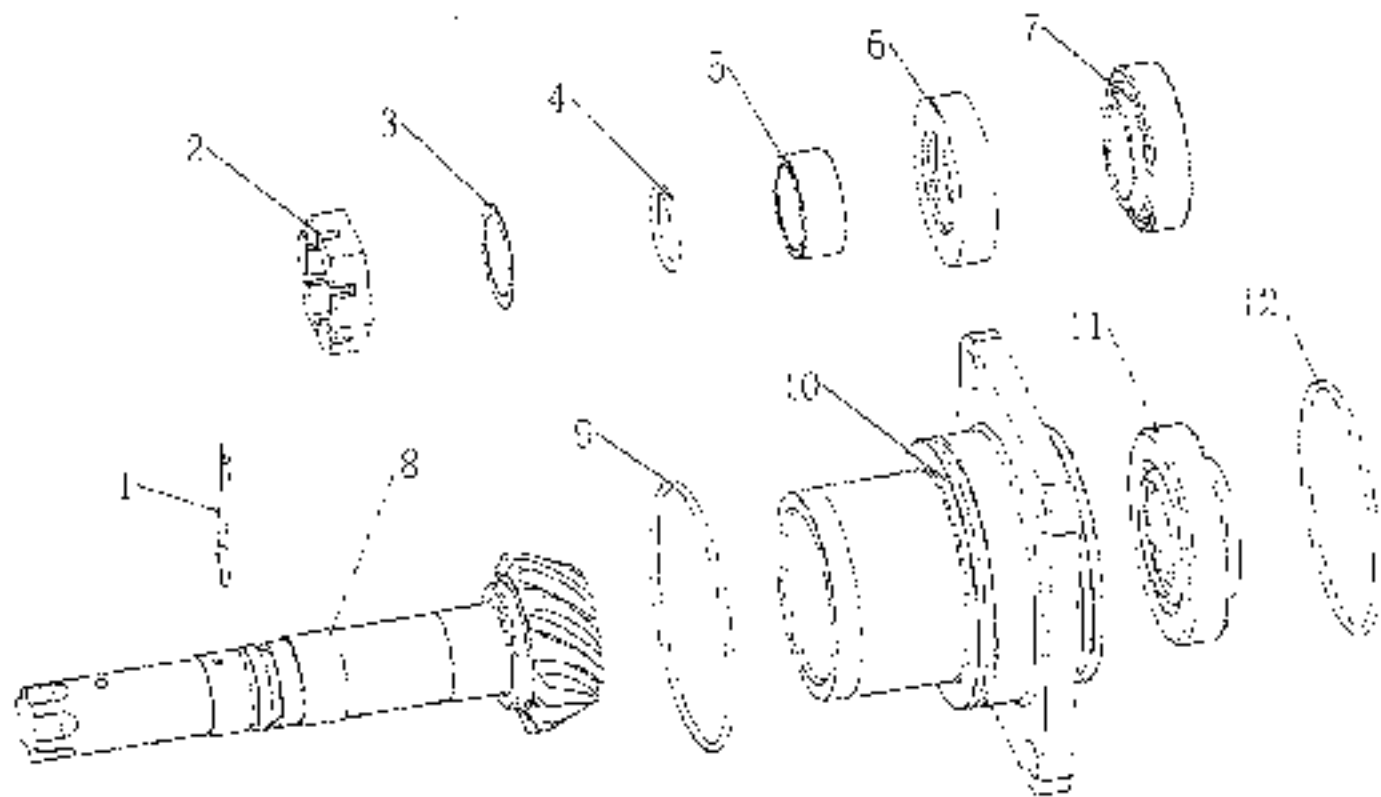

34 前驱动桥总成 (304.31.022-1 部件) Front Wheel Drive Axle (304.31.022-1 Assembly)

序号	Serial No.	代号	Part No.	名称及规格	Name & Specifications	数量	Quantity	备注	Remarks
1		GB91-86		销 3.2×50	Split pin 3.2×50	1			
2		304.31.223-1		锥形螺母	Castle nut	1			
3		304.31.224-1		调整垫片	Adjusting shims	1套	one set		双向各一片 one pcs for each
4		GB3452.1-82		O形圈 23.6×2.65	O-ring seal 23.6×2.65	1			
5		304.31.225-1		主动锥齿轮轴衬套	Oil-seal seat	1			
6		HG4-692-67		油封 SD35×56×12	Oil seal SD35×56×12	1			
7		GB297-84		轴承 2007106	Taper roller bearing 2007106	1			
8		304.31.227		主动圆锥齿轮	Bevel drive pinion	1			
9		GB3452.1-82		O形圈 85×2.65	O-ring seal 85×2.65	1			
10		304.31.226		主动锥齿轮轴承座	Bearing seat	1			
11		GB297-84		轴承 27306	Taper roller bearing 27306	1			
12		GB3452.1-82		O形圈 80×2.65	O-ring seal 80×2.65	1			

35 前驱动桥总成 (304.31.014A 部件)
Front Wheel Drive Axle (304.31.014A Assembly)

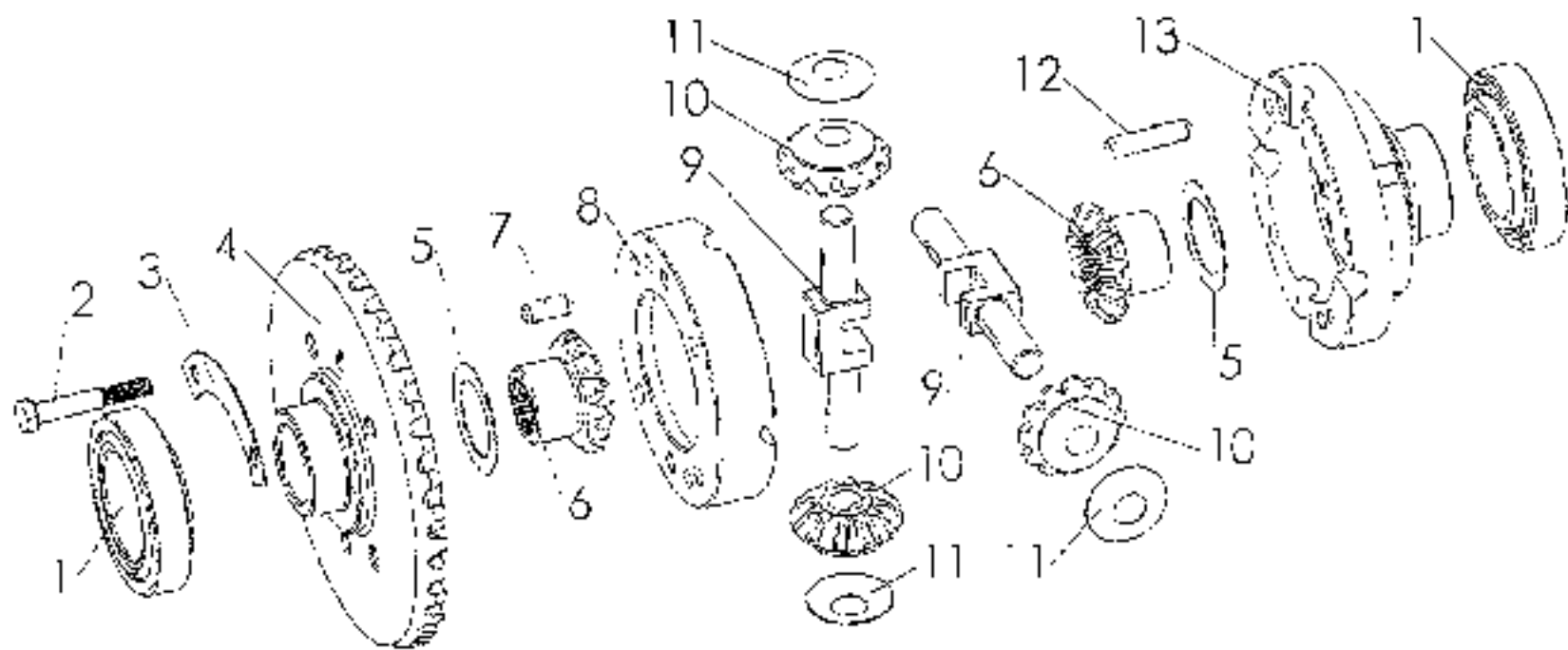

35 前驱动桥总成 (304.31.014A 部件) Front Wheel Drive Axle (304.31.014A Assembly)

序号	Serial No.	代号	Part No.	名称及规格	Name & Specifications	数量	Quantity	备注	Remarks
1		GB297-84		锥滚 2007109	Taper roller bearing 200710	2			
2		GB5782-86		螺栓 M8×50	Hex head bolt M8×50	4			
3		304.31.205		锁紧圆锥齿轮垫片	Lock washer for crown gear	2			
4		304.31.207		蜗轮圆锥齿轮	Crown gear	1			
5		304.31.210A		半轴齿轮垫片	Half shaft gear washer	2			
6		304.31.211A		差速器半轴齿轮	Half shaft gear	2			
7		GB119-86		销 A8×20	Straight pin A8×20	2			
8		304.31.235		左差速器壳体	Left differential housing	1			
9		304.31.208A		行星齿轮轴	Planet gear shaft	2			
10		304.31.205A		差速器行星齿轮	Planet gear	4			
11		304.31.209A		行星齿轮垫圈	Planet gear washer	4			
12		GB119-86		销 A8×35	Straight pin A8×35	2			
13		304.31.236		右差速器壳体	Right differential housing	1			

36 传动轴总成 Transmission shaft

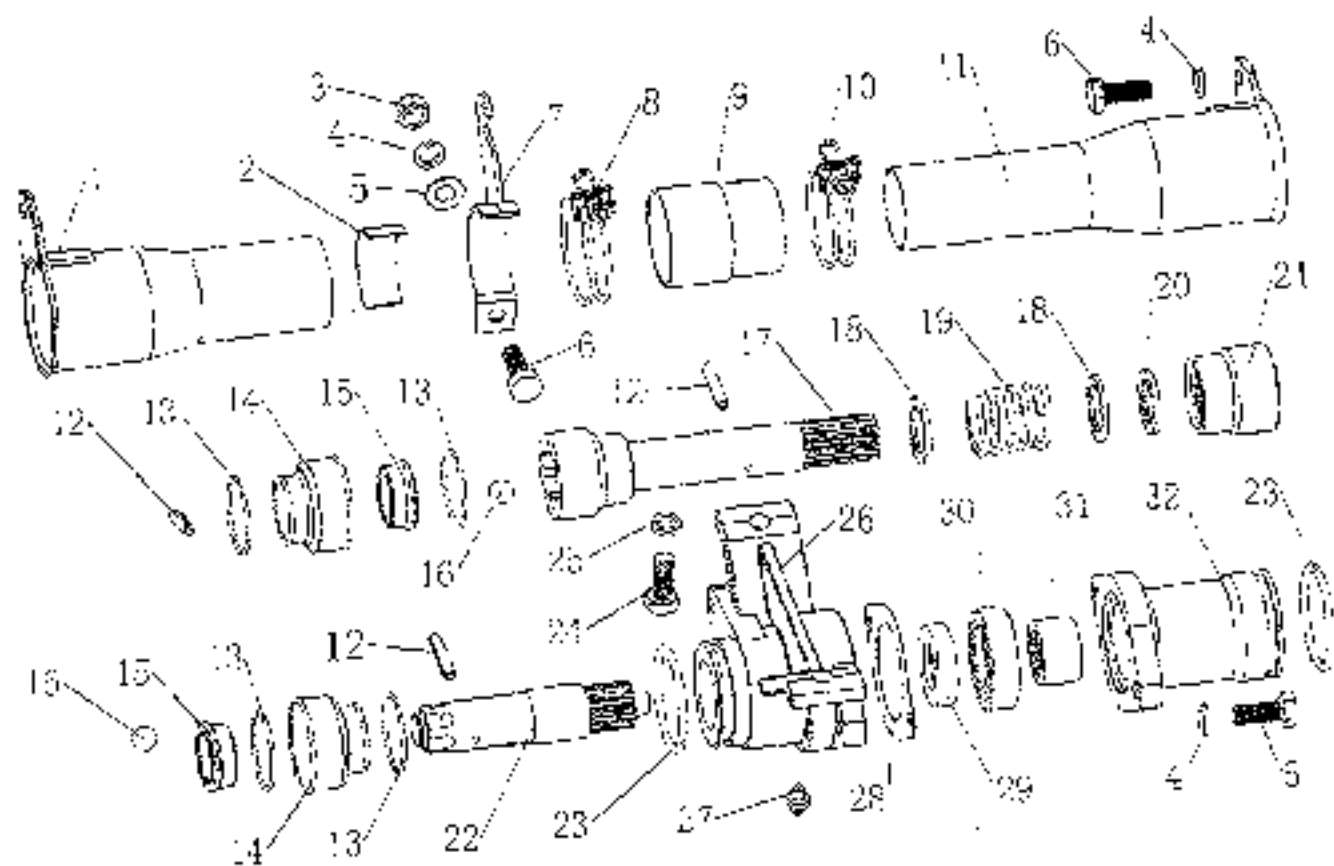

36 传动轴总成 Transmission shaft

序号 Ser.No	代号 Part No.	名称及规格 Name & Specifications	数量 Quantity	备注 Remarks
1	304.36.012	前套管焊合件	1	Used For 390 engine
	354.36.012	前套管焊合件	1	Used For 395 engine
	404.36.012	前套管焊合件	1	Used For 490 engine
2	304.36.114	橡胶垫	1	
3	GB6170-86	螺母 M8	1	
4	GB93-87	垫圈 8	4	
5	GB97.1-85	垫圈 8-140HV	1	
6	GB5783-86	螺栓 M8×25	4	
7	304.36.013-1	固定架焊合件	2	
8	304.36.014	环箍 φ53总成	1	
9	304.36.103	密封套	1	
10	304.36.015	环箍 φ48总成	1	
11	304.36.016	后套管焊合件	1	
12	GB879-86	销 4×30	3	
13	GB3081-82	热镀锌铁丝 I-1.4	按图 need	
14	304.36.108	橡胶护套	2	
15	304.36.101	支承套	2	
16	GB308-89	钢球 9	12	
17	304.36.011	传动轴焊合件	1	Used For 390 engine
	354.36.011	传动轴焊合件	1	Used For 395 engine
	404B.36.011	前球形连接套焊合件	1	Used For 490 engine
18	304.36.104	挡圈 (二)	2	
19	304.36.105	弹簧	1	
20	304.36.106	密封挡圈	1	
21	304.36.107	后球形连接套	1	
22	304.36.112	后中轴	1	

续表

36 传动轴总成 Transmission shaft

序号 Ser. No.	代号 Part No.	名称及规格	Name & Specifications	数量 Quantity	备注 Remarks
23	GB3452.1-86	O形环 48.7×3.55	O ring seal 48.7x3.55	2	
24	GB5783-86	螺母 M10×25	Hex. head bolt M10x25	2	
25	GB9338-7	弹簧 10	Spring lock washer 10	2	
26	304.36.109	中轴套	Mid-shaft seat	1	
27	GB1154-89	油杯 M10×1	Grease cup M10x1	1	
28	304.26.110	纸垫	Paper gasket	1	
29	HG4-692-67	油封 PG25×42×10	Oil seal PG25x42x10	1	
30	GB278-89	轴承 60205	Ball bearing with shields 60205	1	
31	304.36.113	接合套	Connecting sleeve	1	
32	304.36.111	中轴套管	Mid-shaft housing	1	

37.1. 液壓轉向系統總成(配390發動機)
 Full-Hydraulic Power Steering Gear (For 390 engine)

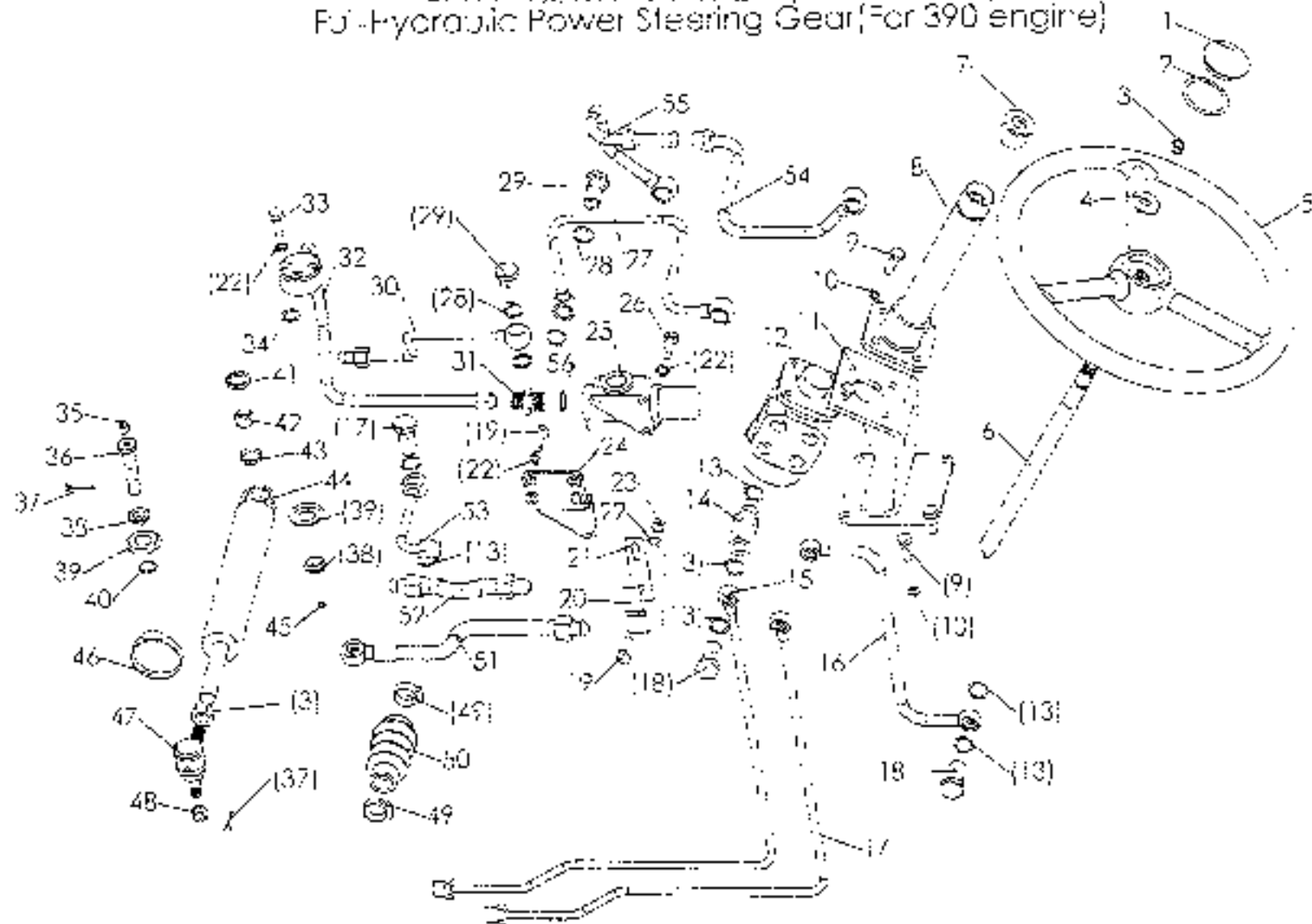

37.1 液压转向系统总成(配390发动机) Full Hydraulic Power Steering Gear(Far 390 engine)

序号 Ser.No	代号 Part No.	名称及规格	Name & Specifications	数量 Quantity	备注 Remarks
1	200.40.111	螺盖	Screw cover	1	
2	200.40.112	橡胶垫圈	Rubber washer	1	
3	GB6173-86	螺母 M16×1.5	Hex. nut M16×1.5	2	
4	GB97.2-85	平垫 16	Plain washer 16	1	
5	300.10.012	方向盘总成	Steering wheel assy	1	
6	304.40.113	转向轴	Steering shaft	1	
7	304.40.112	橡胶护套	Rubber sleeve	1	
8	304.40.026	转向管柱总成	Steering column weldment	1	
9	GB5783-86	螺栓 M10×30	Hex. head bolt M10×30	8	
10	GB93-87	弹簧 10	Spring lock washer 10	8	
11	304.40.027-1	转向器支架总成	Bracket weldment	1	
12	BZZ1-E80	转向器总成	Full hydraulic steering gear	1	
13	JB982-1977	垫圈 16	Washer 16	14	
14	304.40A.102	接管	Connector	4	
15	304.40A.014	转向油缸油管焊合件 (一)	Steering cylinder pipe(1)	1	
16	304.40A.012	转向器油管总成	Oil return pipe assy	1	
17	304.40A.015	转向油缸油管焊合件 (二)	Steering cylinder pipe(2)	1	
18	250D.40.150	铰接螺栓 M16×1.5	Hollow bolt M16×1.5	7	
19	GB5783-86	螺栓 M8×25	Hex. head bolt M8×25	7	
20	304.40A.104	固定夹压板	Pressure plate of fixed clip	1	
21	304.40A.105	固定夹底板	Base plate of fixed clip	1	
22	GB93-87	垫圈 8	Spring lock washer 8	13	
23	GB6170-86	螺母 M8	Hex. nut M8	1	
24	301.40.109.1	垫板	Pad	1	

37.1 液压转向系统总成(配390发动机)

Full Hydraulic Power Steering Gear(For 390 engine)

续表

序号 Ser.No.	代号 Part No	名称及规格	Name & Specifications	数量 Quantity	备注 Remarks
25	FLD-T6-11	分流阀总成	Distributary valve assy	1	
26	GB5782-86	螺栓 M8×50	Hex. head bolt M8×50	3	
27	304.40A.013	转向器进油管总成	Oil delivery pipe weldment	1	
28	JB982-1977	垫圈 20	Copper washer 20	3	
29	Z54D.40.165	连接螺栓 M20×1.5	Hollow bolt M20×1.5	2	
30	304.40A.016	分流阀出油管总成	Out-let pipe assy	1	
31	304.40A.103	油管接头	Connector	1	
32	304.40A.018	分流阀进油管总成	Inlet pipe assy	1	
33	GB5783-86	螺栓 M8×35	Hex. head bolt M8×35	2	
34	GB3-52.1-82	O形圈 18×2.65	O-ring seal 18×2.65	1	
35	GB1153-89	油杯 45°M10×1	Grease nipple 45° M10×1	1	
36	304.40.127	销	Pin	1	
37	GB91-36	销 2.2×24	Split pin: 2×12	2	
38	304.40.120	挡圈	Circlip stop ring	2	
39	304.40.128	防尘罩	Dustproof cover	2	
40	GB893.1-86	挡圈 30	Circlip for shaft 30	1	
41	304.40.126	上球头座	Upper ball seat	1	
42	304.40.129	球接头	Ball connector	1	
43	304.40.125	下球头座	Lower ball seat	1	
44	304.40.033	转向器缸总成	Steering cylinder assy	1	
45	GB9459-88	螺母 M14×1.5	Hex. nut M14×1.5	1	
46	JB/T8870-99	螺栓 2A (44-64)	Hex: 2A (44-64)	1	
47	300.51.027	转向接头总成(右)	Connector assy (Right)	1	

37. 液压转向系统总成(配390发动机) Full Hydraulic Power Steering Gear(for 390 engine)

件名

序号 Part No.	代号 Part No.	名称与规格	Name & Specifications	数量 Quantity	备注 Remarks
48	GB6181-86	螺母 M12	Nut M12	1	
49	JR/T8370-93	双管 2A (13-20)	Hoop 2A (13-20)	2	
50	304.40A.132	橡胶护套	Rubber jacket	1	
51	304.40A.011	软管总成	Hose assy	1	
52	304.40A.017	软管总成	Hose assy	1	
53	304.40A.019	转向油缸引伸油管总成	Extended pipe	1	
54	304.40A.025	转向供油管前段总成	Oil delivery pipe-front part	1	
55	304.40A.024	转向供油管后段总成	Oil delivery pipe-rear part	1	
56	GB3541-85	垫圈 24	Copper washer 24	1	

Remark: Parts No. 54,55 can replace part No. 27.

37.2 液壓轉向系統總成(配395發動機)

[Full] Hydraulic Power Steering Gear (For 395 engine)

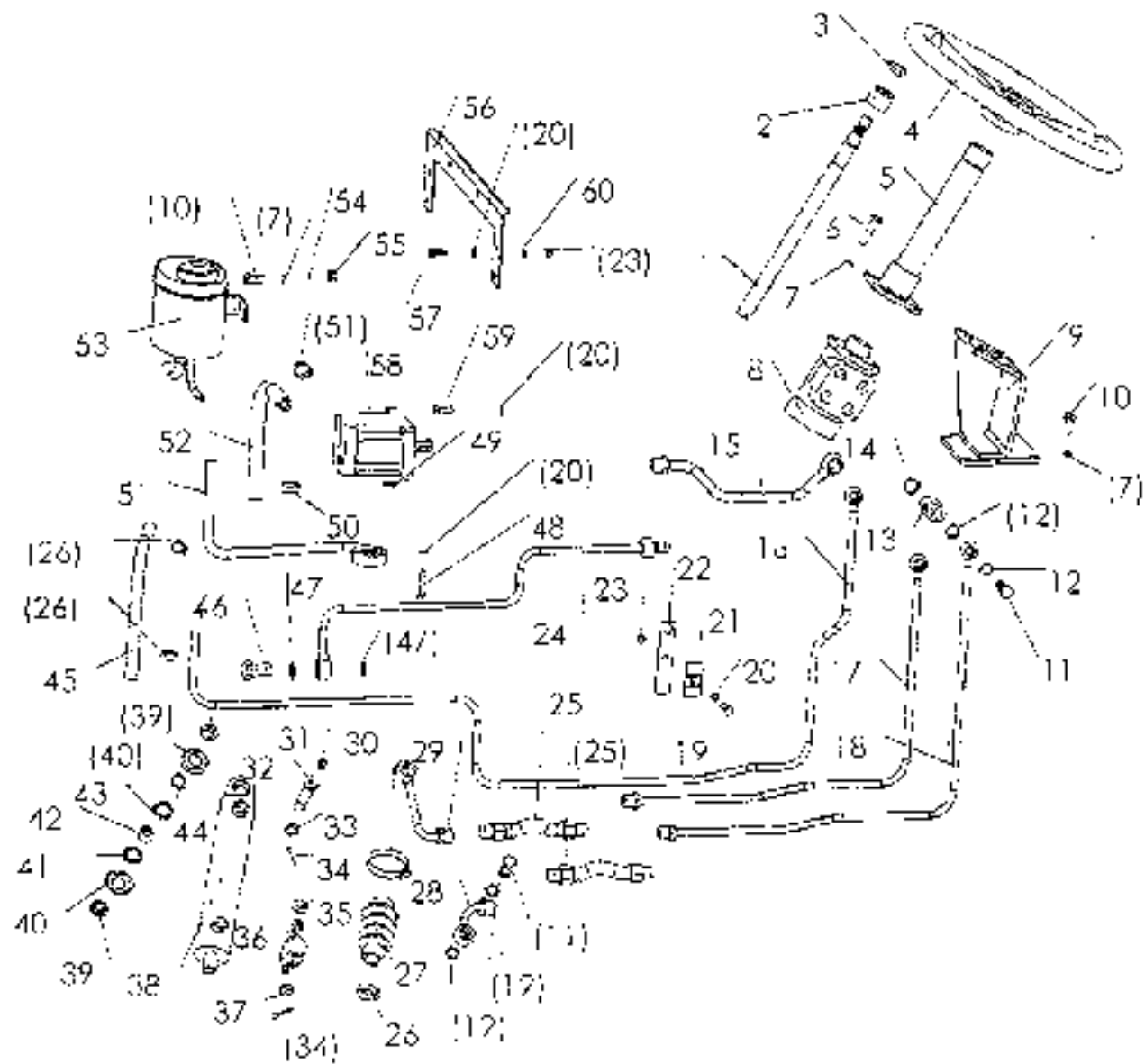

37.2 液压转向系统总成(配395发动机) Full Hydraulic Power Steering Gear System(For 395 engine)

序号 Ser.No	代号 Part No	名称及规格	Name & Specifications	数量 Quantity	备注 Remarks
1	304.40.113	转向轴	Steering shaft	1	
2	304.40.112	橡胶衬套	Rubber sleeve	1	
3	GB6171-86	螺母 M16X1.5	Hex. nut M16X1.5	1	
4	300.40.012	方向盘总成	Steering wheel assy	1	
5	304.40.020	转向管柱焊合件	Steering column weldment	1	
6	GB5783-86	螺母 M10X30	Hex. head bolt M10X30	4	
7	GB93-87	垫圈 10	Spring lock washer 10	10	
8	BZZ1-ES0	转向器总成	Full hydraulic steering gear	1	
9	304.40.027-1	转向支架焊合件	Bracket weldment	1	
10	GB5783-86	螺母 M10X25	Hex. head bolt M10X25	6	
11	Z50D.4E.150	铰接螺栓 M16X1.5	Hollow bolt M16X1.5	5	
12	JB982-1977	垫圈 16	Washer 16	12	
13	304.40A.102	接管	Connector	1	
14	JB982-1977	垫圈 20	Washer 20	4	
15	354.40A.024	转向器进油管后段焊合件	Oil delivery pipe back weldment	1	
16	354.40C.015	转向器回油管焊合件	Oil return pipe assy	1	
17	304.40A.014	转向缸前油管焊合件(一)	Steering cylinder pipe(1)	1	
18	304.40A.015	转向缸前油管焊合件(二)	Steering cylinder pipe(2)	1	
19	GB5783-86	螺母 M8X25	Hex. head bolt M8X25	1	
20	GB93-87	垫圈 8	Spring lock washer 8	12	
21	304.40A.104	固定夹板	Pressure plate of fixed clip	1	
22	354.40A.101	固定夹底板	Base plat of fixed clip	1	
23	GB6170-86	螺母 M8	Hex. nut M8	5	
24	354.40C.021	转向器进油管前段焊合件	Oil delivery pipe before weldment	1	
25	304.40A.017	软管总成	Hose assy	1	

37.2 液压转向系统总成(配395发动机) Full Hydraulic Power Steering Gear System(For 395 engine)

续表

序号 Ser No.	代号 Part No.	名称及规格	Name & Specifications	数量 Quantity	备注 Remarks
26	JB/T8870-99	喉箍 2A (13-20)	Hoop 2A (13-20)	2	
27	304.40A.132	橡胶护套	Rubber jacket	1	
28	304.40A.020	转向缸进油管管接头(二)	Extended pipe	1	
29	304.40A.019	转向缸回油管管接头(一)	Extended pipe	1	
30	JB/T8870-99	喉箍 2A (44-64)	Hoop 2A (44-64)	1	
31	GB1153-89	丝杯45° M10×1	Grease nipple 45° M10×1	1	
32	304.40.127	销	Slotted spring pin	1	
33	GB9459-88	螺母 M14×1.5	Hex. nut M14×1.5	1	
34	GB91-86	销 3 2×24	Spir. pin 3 2×24	2	
35	GB6175-86	螺母 M16×1.5	Hex. nut M16×1.5	1	
36	300.31.027	转向接头总成(右)	Connector assy(Right)	1	
37	GB6181-86	螺母 M12	Hex. nut M12	1	
38	304.40.033	转向油缸总成	Steering cylinder assy	1	
39	304.40.130	挡圈	Circlip stop ring	2	
40	304.40.128	防尘罩	Dustproof cover	2	
41	304.40.125	下球头座	Lower ball seat	1	
42	304.40.129	球接头	Ball connector	1	
43	304.40.126	上球头座	Upper ball seat	1	
44	GB893.1-86	挡圈 30	Circlip for hole 30	1	
45	JB/T6015-1992	胶管 10-390	Rubber pipe 10-390	1	
46	250D.58.118	铰接螺栓 M18×1.5	Hollow bolt M18×1.5	1	
47	JB982-1977	垫圈 18	Washer 18	2	
48	GB5783-86	螺栓 M8×30	Hex. head bolt M8×30	2	
49	GB3542.1-82	O形圈 18×2.65	O-ring seal 18×2.65	1	
50	JB/T8870-99	喉箍 2A (16-25)	Hoop 2A (16-25)	2	
51	354.40C.011	进油管管接头	Inlet pipe assy	1	

37.2 液壓轉向系統總成(配395發動機) Full Hydraulic Power Steering Gear System(For 395 engi

零件

序號 Ser.No.	代號 Part No	名稱及規格	Name & Specifications	數量 Quantity	備註 Remark
52	D6770015-1992	液管13-390	Rubber pipe 13-390	1	
53	354 40B 011-1	轉向油缸總成	Steering tonix assy	1	
54	GB97.1-85	墊圈 10	Flat washer 10	2	
55	GB6170-86	螺母 M10	Hex. nut M10	2	
56	354 40B 10J	油箱連接板	Tank connect board	1	
57	GB5783-86	螺栓M8×20	Hex. head bolt M8×20	4	
58	HLCB-D08/06	直流電液泵	Compound gear pump	1	右旋花齒
59	GB5783-86	螺栓M8×35	Hex. head bolt M8×35	4	
60	GB97.1-85	墊圈 8	Flat washer 8	4	

37.3 液压转向系统总成(配490发动机) Full Hydraulic Power Steering Gear System(For 490 engine)

序号 Ser. No.	代号 Part No.	名称及规格	Name & Specifications	数量 Quantity	备注 Remarks
1	304.40.113	转向轴	Steering shaft	1	
2	304.40.112	橡胶衬套	Rubber sleeve	1	
3	GB6171-86	螺母 M16X1.5	Hex. nut M16X1.5	1	
4	304.40.012	方向盘总成	Steering wheel assy	1	
5	304.40.026	转向管柱焊合件	Steering column weldment	1	
6	GB5783-86	螺栓 M10x30	Hex. head bolt M10x30	4	
7	GB93-87	垫圈 10	Spring lock washer 10	10	
8	BZZ1-ES0	转向器总成	Full hydraulic steering gear	1	
9	304.40.027-1	转向支架焊合件	Bracket weldment	1	
10	GB5783-86	螺栓 M10x25	Hex. head bolt M10x25	3	
11	2502-00-150	空心螺母 M16x1.5	Hollow nut M16x1.5	2	
12	JB982-1977	垫圈 16	Washer 16	12	
13	304.40A-102	接头	Connector	4	
14	JB982-1977	垫圈 20	Washer 20	4	
15	304.40A-024	转向器进油管焊合件	Oil delivery pipe back weldment	1	
16	404B.40.012	转向器回油管焊合件	Oil return pipe assy	1	
17	404B.40.011	转向缸进油管焊合件 (1)	Steering cylinder pipe(1)	1	
18	404B.40.013	转向缸回油管焊合件 (1)	Steering cylinder pipe(2)	1	
19	GB5783-86	螺母 M8x25	Hex. head bolt M8x25	1	
20	GB93-87	垫圈 8	Spring lock washer 8	4	
21	304.40A-104	固定夹板	Pressure plate of fixed clip	1	
22	404B.40.118	固定夹板	Base plat of fixed clip	1	
23	GB6170-86	螺母 M8	Hex. nut M8	1	
24	404B.40.021	转向器进油管前段焊合件	Oil delivery pipe before weldme	1	

37.3. 液压转向系统总成(配490发动机) Full Hydraulic Power Steering Gear System(For 490 engine)

续表

序号 Ser No	代号 Part No	名称及规格	Name & Specifications	数量 Quantity	备注 Remarks
25	304.40A.017	软管总成	Hose assy	1	
26	JB/T8870-89	喉箍 2A (13-20)	Hoop 2A (13-20)	3	
27	304.40A.102	橡胶护套	Rubber jacket	1	
28	304.40A.020	转向油缸引伸油管焊合件(二)	Extended pipe	1	
29	304.40A.019	转向油缸引伸油管焊合件(一)	Extended pipe	1	
30	JB/T8870-89	喉箍 2A (44-64)	Hoop 2A (44-64)	1	
31	GB1153-89	活头 45° M10×1	Grease nipple 45° M10×1	1	
32	304.40.127	销	Slotted spring pin	1	
33	GB9459-88	螺母 M14×1.5	Hex. nut M14×1.5	1	
34	GB91-86	销 3.2×24	Split pin 3.2×24	2	
35	GB6173-86	螺母 M16×1.5	Hex. nut M16×1.5	1	
36	300.31.027	转向接头总成(右)	Connector assy(Right)	1	
37	GB5181-86	螺母 M12	Hex. nut M12	1	
38	304.40.033	转向缸总成	Steering cylinder assy	1	
39	304.40.130	挡圈	Circlip stop ring	2	
40	304.40.128	防尘罩	Dustproof cover	2	
41	304.40.125	下球头座	Lower ball seat	1	
42	304.40.129	球接头	Ball connector	1	
43	304.40.126	上球头座	Upper ball seat	1	
44	GB393.1-86	挡圈 30	Circlip for hole 30	1	
45	JB/T6015-1997	胶管 10-390	Rubber pipe 10-390	1	
46	JB982-1977	垫圈 18	Washer 18	3	
47	404B.40.115	接管	Connector	1	
48	250D.58.118	铰接螺栓 M18×1.5	Hollow bolt M18×1.5	1	
49	GB5783-86	螺栓 M8×40	Hex. head bolt M8×40	3	

37.3. 液压转向系统总成(配490发动机) Full Hydraulic Power Steering Gear System(For 490 engine)

续表

序号 Ser No.	代号 Part No.	名称及规格	Name & Specifications	数量 Quantity	备注 Remarks
50	GB3542-1-82	O形圈18×2.65	O-ring seal 18×2.65	1	
49	GB5783-86	螺栓M8×40	Hex. head bolt M8×40	3	
50	GB3542-1-82	O形圈18×2.65	O-ring seal 18×2.65	1	
51	JR/T8870-99	喉箍 2A (16-25)	Hoop 2A (16-25)	2	
52	40×B 40.013	油泵进油管焊合件	Inlet pipe assy	1	
53	JR/T6015-1992	胶管13-390	Rubber pipe 13-390	1	
54	354.40B.011-1	转向储油总成	Steering tank assy	1	
55	GB97.1-85	挡圈 10	Flat washer 10	2	
56	GB6170-86	螺母 M10	Hex. nut M10	2	
57	HLCB-D08/06	恒流溢流泵	Compound gear pump	1	右是原厂
58	GB5783-86	螺栓M8×35	Hex. head bolt M8×35	1	

38 分动箱总成 Transfer case

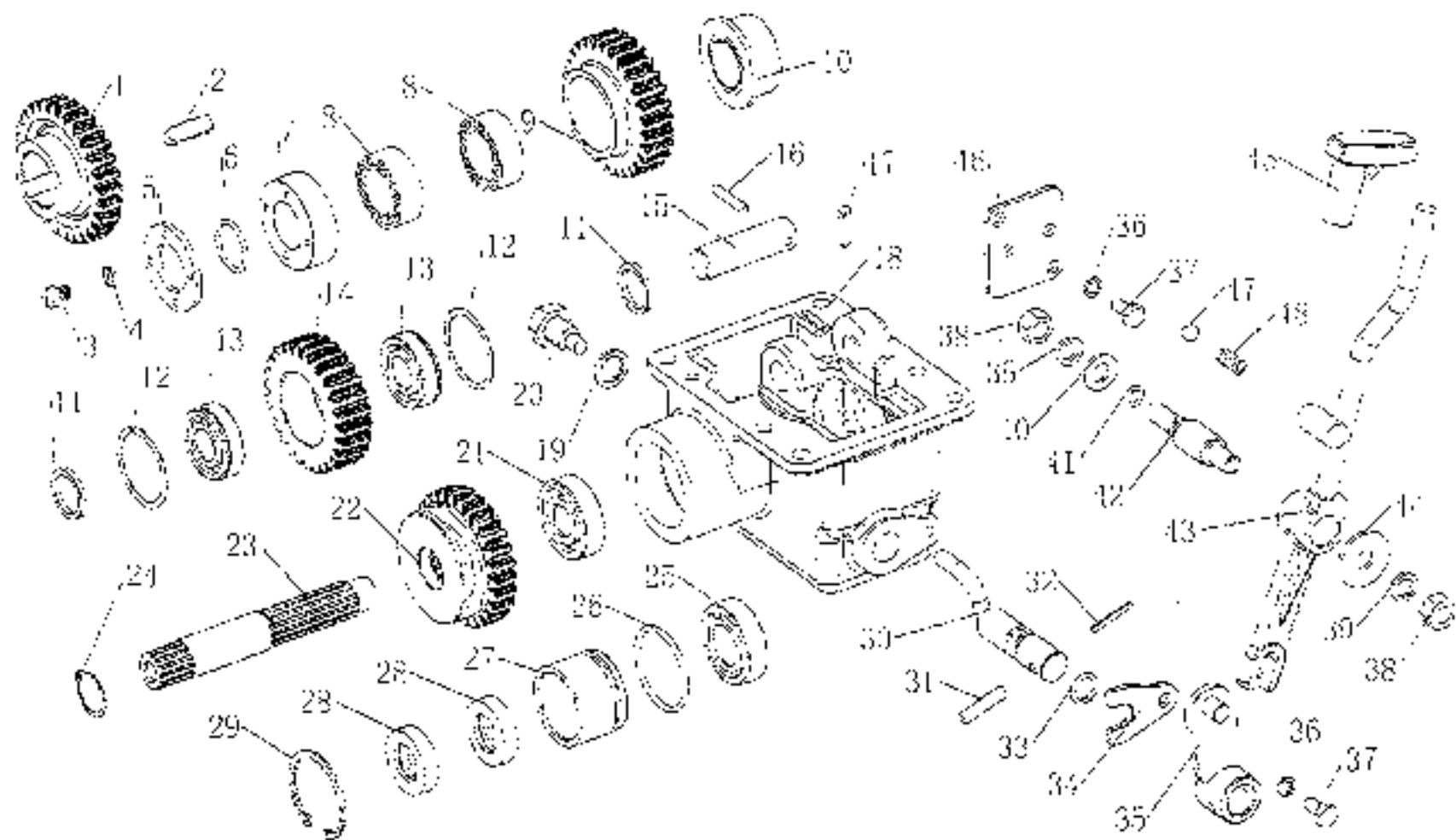

38 分动箱总成 Transfer case

序号 Ser No.	代号 Part No.	名称及规格 Name & Specifications	数量 Quantity	备注 Remarks
1	304.42.103/101A	一大传动分动齿轮 Power Transfer gear	1	101A used for Malaysia wide tyre
2	GB1096-79	键 C10×32 Flat key C10×32	1	
3	GB65-85	螺钉 M5×16 Cheese head screw M5×16	4	
4	GB93-87	垫圈 5 Spring lock washer 5	4	
5	304.42.155-1	限位板 Locating plate	1	
6	GB895.2-86	衬套 30 Circlip for shaft 30	1	
7	304.42.104-1	前隔套 Front spacer	1	
8	GB5801-86	轴承 4524906 Needle bearing 4524906	2	
9	304.42.105/105A	分动上边轮 Upper idler	1	105A used for Malaysia wide tyre
10	304.42.103	后隔套 Rear spacer	1	
11	304.42.116	隔套 Spacer	2	
12	GB305-89	上轴环 52/57.9 Locking snap ring 52/57.9	2	
13	GB277-89	轴承 50205 Ball bearing with snap ring groove 50	2	
14	304.42.117/107A	分动下边轮 Lower idler	1	107A used for Malaysia wide tyre
15	304.42.118	小轴 Lower idler shaft	1	
16	GB879-86	销 6×50 Slotted spring pin 6×50	1	
17	GB119-86	销 A8×30 Straight pin A8×30	2	
18	304.42.109-1	分动箱体 Transfer case housing	1	
19	12.37.149	组合密封垫圈 Combined seal washer	1	
20	200.38.024	放油螺塞总成 Oil drain plug	1	
21	GB276-82	轴承 304 Ball bearing 304	1	
22	304.42.106-1/106A	分动滑动齿圈 Sliding gear	1	106A used for Malaysia wide tyre
23	304.42.107	分动轴 Transfer case shaft	1	

續表

38 分動箱总成 Transfer case

序号 Ser No.	代号 Part No	名稱及規格 Name & Specifications	數量 Quantity	备注 Remarks
24	GB894-1-86	卡簧 24 Circlip for shaft 24	1	
25	GB276-89	鋼球 205 Ball bearing 205	1	
26	GB3452.1-82	O形圈 45×33.55 O-ring seal 45×33.55	1	
27	304.42.103	油封座 Oil seal seat	1	
28	HG4 692-67	油封 PG25×42×10 Oil seal PG25×42×10	2	
29	GB893.1-86	卡簧 55 Circlip for hole 55	1	
30	304.42.012-1	撥片軸套 Shifter peg	1	
31	GB879-86	銷 8×32 Slotted spring pin 8×32	1	
32	GB879 86	銷 5×32 Slotted spring pin 5×32	1	
33	GB3452.1 82	O形圈 15×2.65 O-ring seal 15×2.65	1	
34	304.42.111	定位板 Locating plate	1	
35	304.42.013-1	搖臂總成 Rocker arm	1	
36	GB93-87	彈簧墊圈 8 Spring lock washer 8	3	
37	GB5783 86	螺絲 M8×16 Hex. head bolt M8×16	3	
38	GB6170-86	螺絲 M12 Hex. nut M12	2	
39	GB93-87	彈簧 12 Spring lock washer 12	2	
40	GB97.1-85	墊圈 12-140HV Plain washer 12-140HV	1	
41	GB3452.1-82	O形圈 9×2.65 O-ring seal 9×2.65	1	
42	304.42.113	支承軸 Pivot shaft	1	
43	304.42.014-1	操縱杆總成 Control lever	1	
44	GB96-85	墊圈 12-140HV Plain washer 12-140HV	1	
45	304.42.134	分動箱操縱杆手柄 Transfer control handle	1	
46	304.42.115	墊板 Positioning plate	1	
47	GB208-84	鋼球 10 Steel ball 10	1	
48	304.42.114	彈簧 Spring	1	

39.1 油泵、滤油器、油管总成(配390发动机)

Oil Pump, Filter, Pipe and Fittings (For 390 engine)

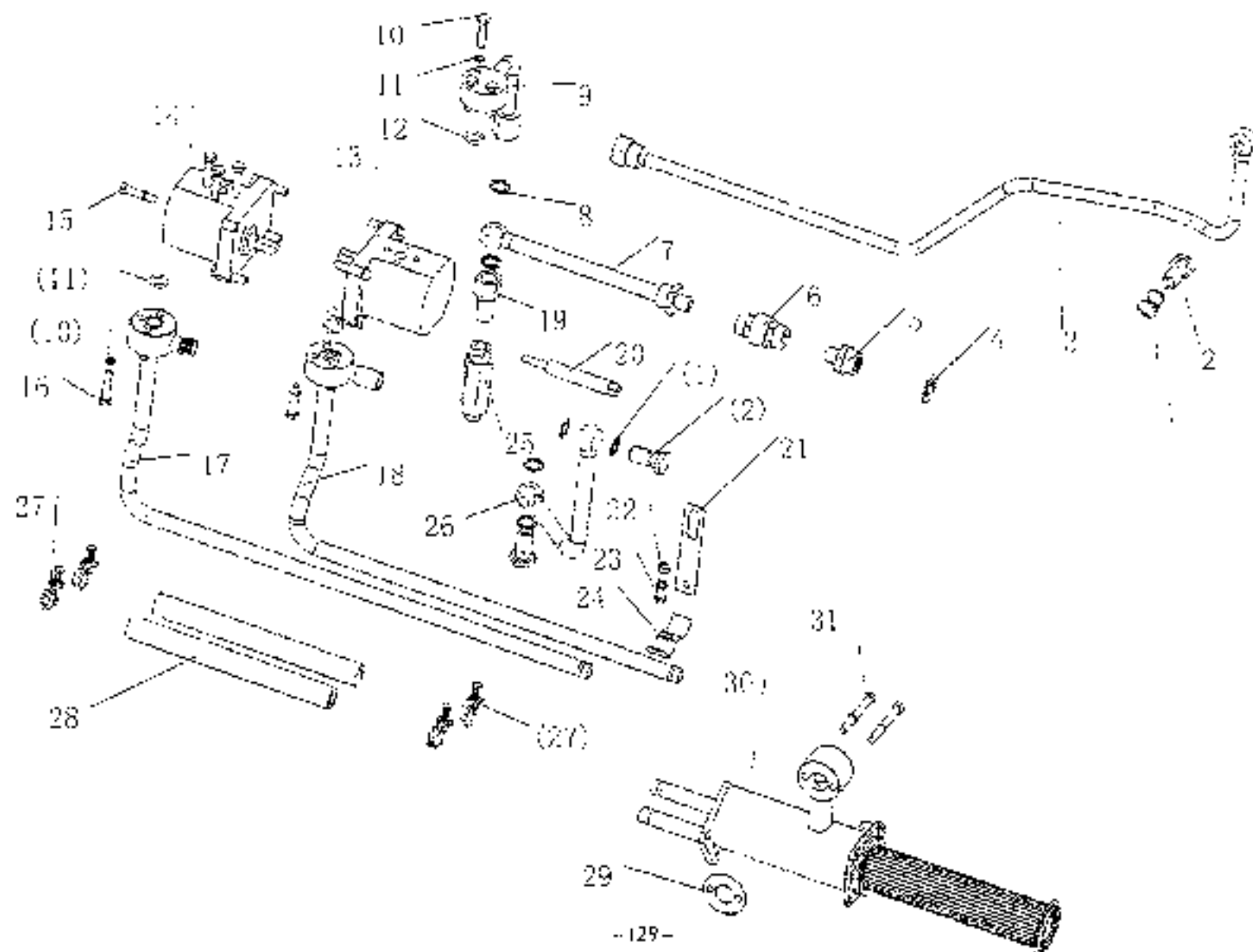

39.1 油泵、滤油器、油管总成(配390发动机) Oil Pump, Filter, Pipe and Fittings(For 390 engine)

序号 No.	代号 Part No	名称及规格	Name & Specifications	数量 Quantity	备注 Remarks
1	1B982-1977	垫圈 14	Washer 14	1	
2	200.58.124	空心螺栓 M14x1.5	Hollow bolt M14x1.5	2	
3	354-1.58A.011	分配器进油管总成	Distributor inlet pipe assy	1	
4	300.58.127	尼龙垫圈	Nylon washer	1	
5	300.58.120-1	固定接头	Fixed joint	1	
6	100UBM114-1991	快换接头	Quick connector	1	
7	354-1.58A.016	联接软管总成	Hose assy	1	
8	1B982-1977	垫圈 18	Washer 18	2	
9	304G2.58.011-1	出油口接头总成	Flange connector weldment	1	
10	GB3787-86	螺栓 M8x40	Hex. head bolt M8x40	6	
11	GB93-87	垫圈 8	Spring lock washer 8	24	
12	GB3457.1-82	O形圈 16x2.65	O-ring seal 16x2.65	4	
13	CBN-E314B	齿轮泵	Gear pump	1	左旋 Left circle
14	CBN-E300B	齿轮泵	Gear pump	1	右旋 Right circle
15	GB5783-85	螺栓 M8x35	Hex. head bolt M8x35	7	
16	GB5783-86	螺栓 M8x45	Hex. head bolt M8x45	3	
17	304.58A.011-1	吸油管总成(右)	Inlet pipe weldment(right)	1	
18	304-5.58.011	吸油管总成(左)	Inlet pipe weldment	1	
19	25402.58.101	安全阀接头	safety valve connector	1	
20	300.58.102	紧固螺栓	Fastening bolt	1	
21	300.58.119	固定夹	Base plate of fixed clip	1	
22	GB6170-86	螺母 M3	Hex nut M3	1	
23	GB5783-86	螺栓 M8x25	Hex. head bolt M8x25	1	
24	300.58.118	固定夹(左)	Pressure plate of fixed clip	1	

39.1 油泵、滤油器、油管总成(配390发动机) Oil Pump, Filter, Pipe and Fittings(For 390 engine)

续表

序号 Ser No.	代号 Part No.	名称及规格	Name & Specifications	数量 Quantity	备注 Remarks
25	254G2.58.013	安全阀总成	safety valve assy	1	
26	GB35-2-83	输油胶管10A-A-210	Hose 10A-A-210	1	
27	200.58A.012	管接头夹组合件	Hose clip	4	
28	HG4-761-74	输油胶管10×27×200	Hose 10×27×200	2	
29	304.58A.101	纸垫	Paper gasket	1	
30	304.58A.013-1	滤油器总成	Filter assy	1	
31	GB5783-86	螺栓 M8×55	Hex. head bolt M8×55	2	

39.2 油泵、过滤器、进管总成(配395发动机)
 Oil pump, Filter, Pipe and Fittings (For 395 engine)

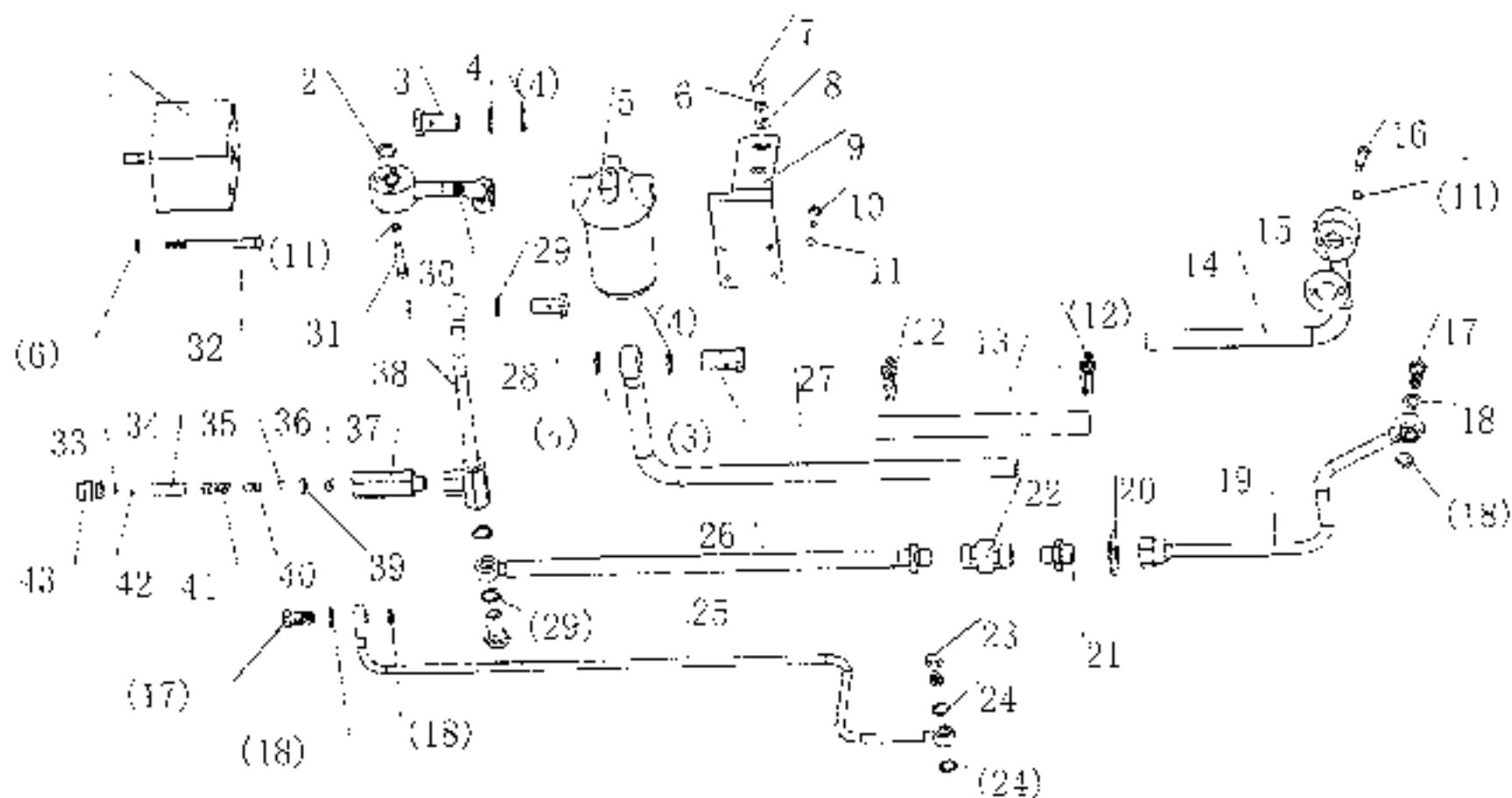

39.2. 油泵、滤油器、油管总成(配395发动机) Oil Pump, Filter, Pipe and Fittings(For 395 engine)

序号 Ser.No.	代号 Part No.	名称及规格	Name & Specifications	数量 Quantity	备注 Remarks
1	CBN 6314.	齿轮泵	Gear pump	1	左侧 Left end
2	GB3452.1-87	O型圈 18×2.65	O-ring seal 18×2.65	1	
3	320.58.103	双头螺栓 M22×1.5	Ho low bolt M22×1.5	2	
4	JB982-1977	垫圈 22	Washer-22	4	
5	YX0811A-0030	滤油器总成	Filter	1	
6	GB95-87	垫圈 10	Spring lock washer 10	4	
7	GB5783-86	螺栓 M10×20	Hex. head bolt M10×20	2	
8	GB97-1-85	垫圈 10	Spring lock washer 10	2	
9	354.58B.116-1	滤油器支架	Filter plate	1	
10	GB5783-86	螺栓 M8×25	Hex. head bolt M8×25	4	
11	GB93-87	垫圈 8	Spring lock washer 8	9	
12	J8-T8970-99	胶圈 2A (25-38)	Hoop 2A (25-38)	2	
13	HG4-761-74	输油胶管 19×30×270	Hose 19×30×270	1	
14	354.58B.015	滤油器进油管焊合件 (一)	Filter inlet pipe weldmen.(one)	1	
15	304.58A.101	纸垫	Paper gasket	1	
16	GB5783-86	螺母 M8×55	Hex. head bolt M8×55	2	
17	200.55.124	空心螺栓 M14×1.5	Hollow bolt M14×1.5	2	
18	JB982-1977	垫圈 14	Washer 14	4	
19	300.58.020	分配器进油管焊合件 1	Distributor inlet pipe	1	
	354.58C.022	多路阀进油管焊合件	Sandwich multiple control valve	1	造竣
20	300.58.121	尼龙垫圈	Nylon washer	1	
21	300.58.120-1	固定接头	Fixed joint	1	
22	10Q/JBM114-1991	快换接头	Quick connector	1	

39.2. 油泵、滤油器、油管总成(配395发动机) Oil Pump, Filter, Pipe and Fittings(For 395 engine)

续表					
序号 Ser.No	代号 Part No.	名称及规格	Name & Specifications	数量 Quantity	备注 Remarks
23	25GD 40.150	铰接螺栓 M16×1.5	Hollow bolt M16×1.5	1	
24	JB982-1977	垫圈 16	Washer 16	2	
25	354.58F.011	安全返回油管焊合件	Relief valve return pipe	1	
26	354-1.58A 015	联接软管总成	Hose assy	1	
27	354.58B.016	滤清器进油管焊合件 (二)	Filter inlet pipe weldment (two)	1	
28	250D.58.113	铰接螺栓 M18×1.5	Hollow bolt M18×1.5	2	
29	JB982-1977	垫圈 18	Washer 18	4	
30	354.58F.013	油泵吸油管焊合件	Suction pipe assy of gear pump	3	
31	GB5783-86	螺母 M8×45	Hex. head bolt M8×45	3	
32	GB5782-86	螺栓 M10×115	Hex. head bolt M10×115	2	
33	200.55.134	调整垫片	Adjusting shims	2~5	
34	200.55.136	套管	Sleeve	1	
35	GB308-84	钢球φ	Steel ball dia.9	1	
36	GB3452.1-82	O形圈10.6×2.65	O-ring seal 10.6×2.65	1	
37	254G2.58.101	阀体	Valve body	1	
38	354.58C.015	油泵出油管焊合件	Suction pipe weldment	1	
39	200.55.138	垫块	Pad	1	
40	200.55.137	球座	Ball seat	1	
41	200.55.135	安全阀弹簧	Safety valve Spring	1	
42	GB3452.1-82	O形圈16×2.65	O-ring seal 16×2.65	1	
43	254G2.58.110	安全阀螺塞	Relief valve plug	1	

39.3 油泵 滤油器 油管总成(配490发动机)
 Oil Pump, Filter, Pipe and Fittings(For 490 engine)

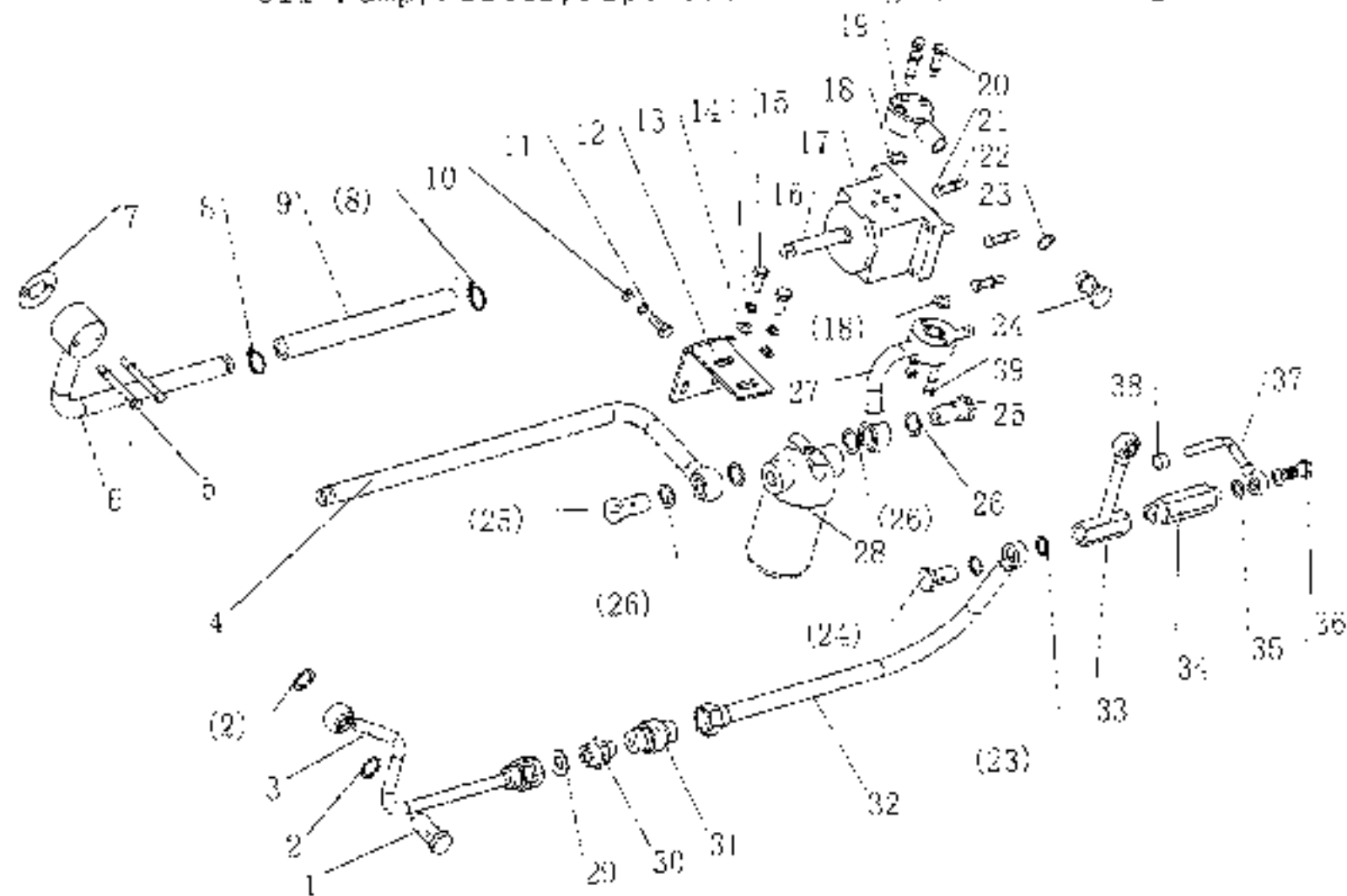

39.3 油泵、滤油器、油管总成(配490发动机) Oil Pump, Filter, Pipe and Fittings(For 490 engine)

序号 Ser.No.	代号 Part No.	名称及规格	Name & Specifications	数量 Quantity	备注 Remarks
1	354.51.101	铰接螺栓	Hollow bolt	1	
2	354.51.102	弹簧	Spring lock washer	2	
3	404-1.58.016	多路阀进油管总成	Inlet pipe weldment	1	配多路阀
4	404B.58.015	滤清器进油管前段焊合件	Filter inlet pipe weldment	1	
5	GB5783-86	螺栓 M8×55	Hex. head bolt M8×55	2	
6	404B.58.013	滤清器进油管后段焊合件	Filter inlet pipe weldment	1	
7	304.58A.101	纸垫	Paper gasket	1	
8	JB/T8870-99	钢箍2A (25-38)	Hoop 2A (25-38)	2	
9	HG4-761-74	输油胶管 19×30×270	Hose 19×30×270	1	
10	GB97.1-85	垫圈 8	Plain washer 8-110HV	2	
11	GB5783-86	螺栓 M8×25	Hex. head bolt M8×25	2	
12	404B.58.102	滤清器支架	Filter plank	1	
13	GB97.1-85	垫圈 10	Plain washer 10-110HV	2	
14	GB93-87	垫圈 10	Spring lock washer 10	2	
15	GB5783-86	螺栓 M10×20	Hex. head bolt M10×20	2	
16	304.58.102	返回螺栓	Hollow bolt	1	
17	CBN-E310B	齿轮泵	Gear pump	1	左旋 Left circle
18	GB3452.1-82	O型圈 18×2.65	O-ring seal 18×2.65	2	
19	350.58.018	接头焊合件	Joint weldment	1	
20	GB5783-86	螺栓 M8×40	Hex. head bolt M8×40	3	
21	GB5783-86	螺栓 M8×35	Hex. head bolt M8×35	3	
22	GB93-87	垫圈 8	Spring lock washer 8	13	
23	JB982-1977	组合密封垫圈18	Washer 18	4	
24	250D.58.118	铰接螺栓 M18×1.5	Hollow bolt M18×1.5	2	
25	320.58.108	铰接螺栓 M22×1.5	Hollow bolt M22×1.5	2	

39.3 油泵、滤油器、油管总成(配490发动机) Oil Pump, Filter, Pipe and Fittings(For 490 engine)

续表

序号 Ser. No.	代号 Part No.	名称及规格	Name & Specifications	数量 Quantity	备注 Remarks
26	JB982-1977	组合密封垫圈22	Washer 22	4	
27	404-1.58.011	油泵进油管零件	Oil pipe	1	
28	YX0311A-0000	液阻过滤器总成	Filter	1	
29	300.58.131	尼龙垫圈	Nylon washer	1	
30	300.58.120-1	固定接头	Fixed join	1	
31	10Q/JBMH4-1991	快换接头21/2	Quick connector	1	
32	300.58.017-1	联接软管总成	Hose assy	1	
33	404-1.58.013	三通接头零件	three-way pipe weldment	1	
34	254G2.58.013	安全阀总成	Safety valve	1	
35	JB982-1977	组合密封垫圈14	Washer 14	2	
36	200.55.134	空心螺栓 M14×1.5	Hollow bolt M14×1.5	1	
37	404-1.58.014	安全阀回油管零件	Safety valve return pipe weldment	1	
38	JB/T8870-99	喉箍 (13-19)	Hoop (13-19)	1	
39	GB5783-86	螺栓 M8×45	Hex head bolt M8×45	2	

40.1 空滤器总成(配390发动机) Air Filter(For 390 engine)

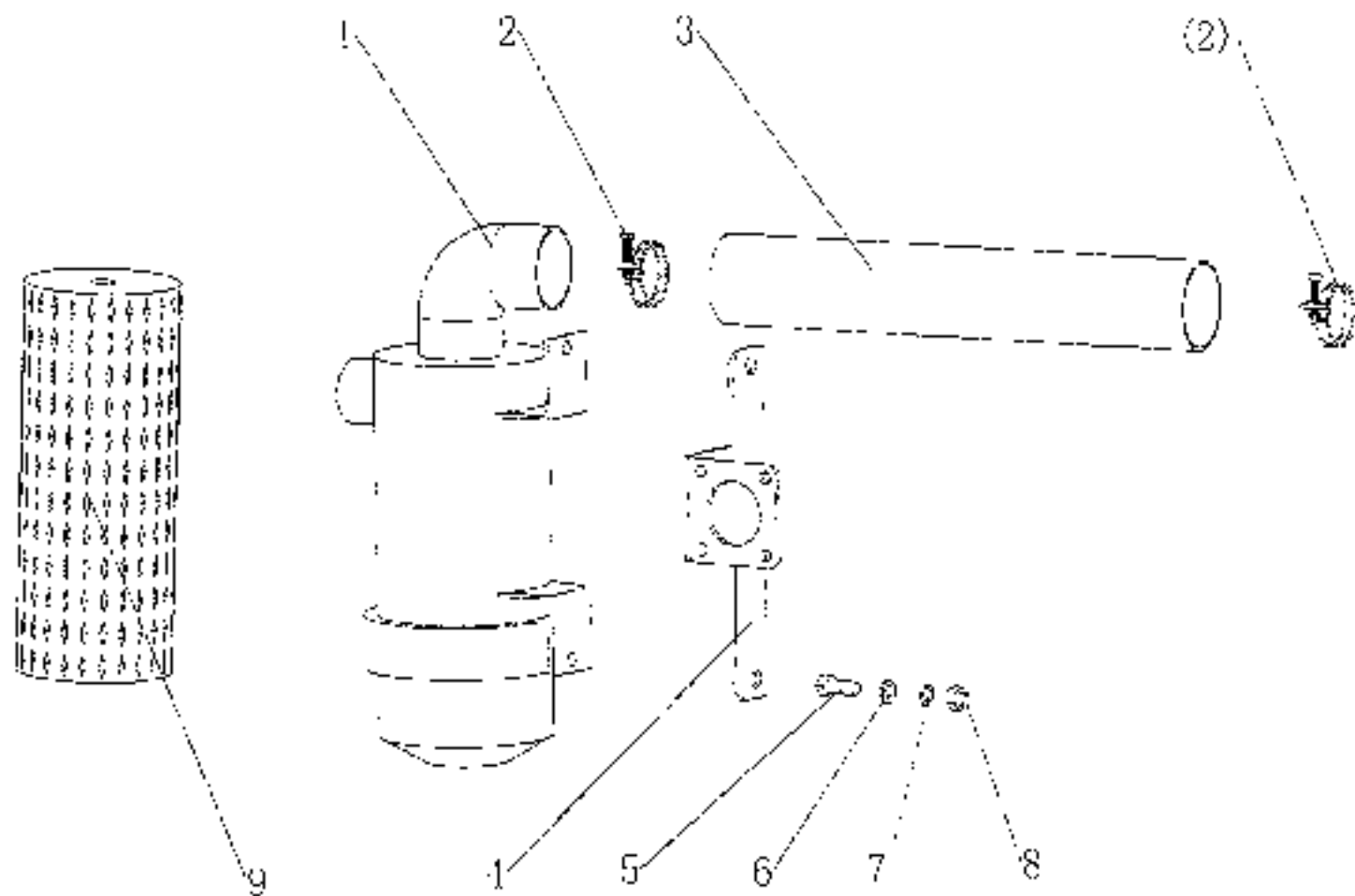

40.1 空滤器总成(配390发动机) Air Filter(For 390 engine)

序号 Ser.No	代号 Part No.	名称及规格	Name & Specifications	数量 Quantity	备注 Remarks
1	300.195.101	空气滤清器	Air filter	1	
2	ZBJ50001-87	卡簧 d70	Clip d70	2	
3	GB1186-81	空气胶管 64x550	Air rubber pipe 64x550	1	
4	300.1GB.111-1	空滤器支架	Air filter bracket	1	
5	GB5783-86	螺栓 10x20	Hex. head bolt M10x20	2	
6	GB97.1-85	垫圈 10	Plain washer 10	2	
7	GB93-87	垫圈 10	Spring lock washer 10	2	
8	GB6170-86	螺母 M10	Hex. nut M10	2	
9	KW1025	滤芯	filter screen	1	

40.2 空滤器总成(配395发动机) Air Filter (For 395 engine)

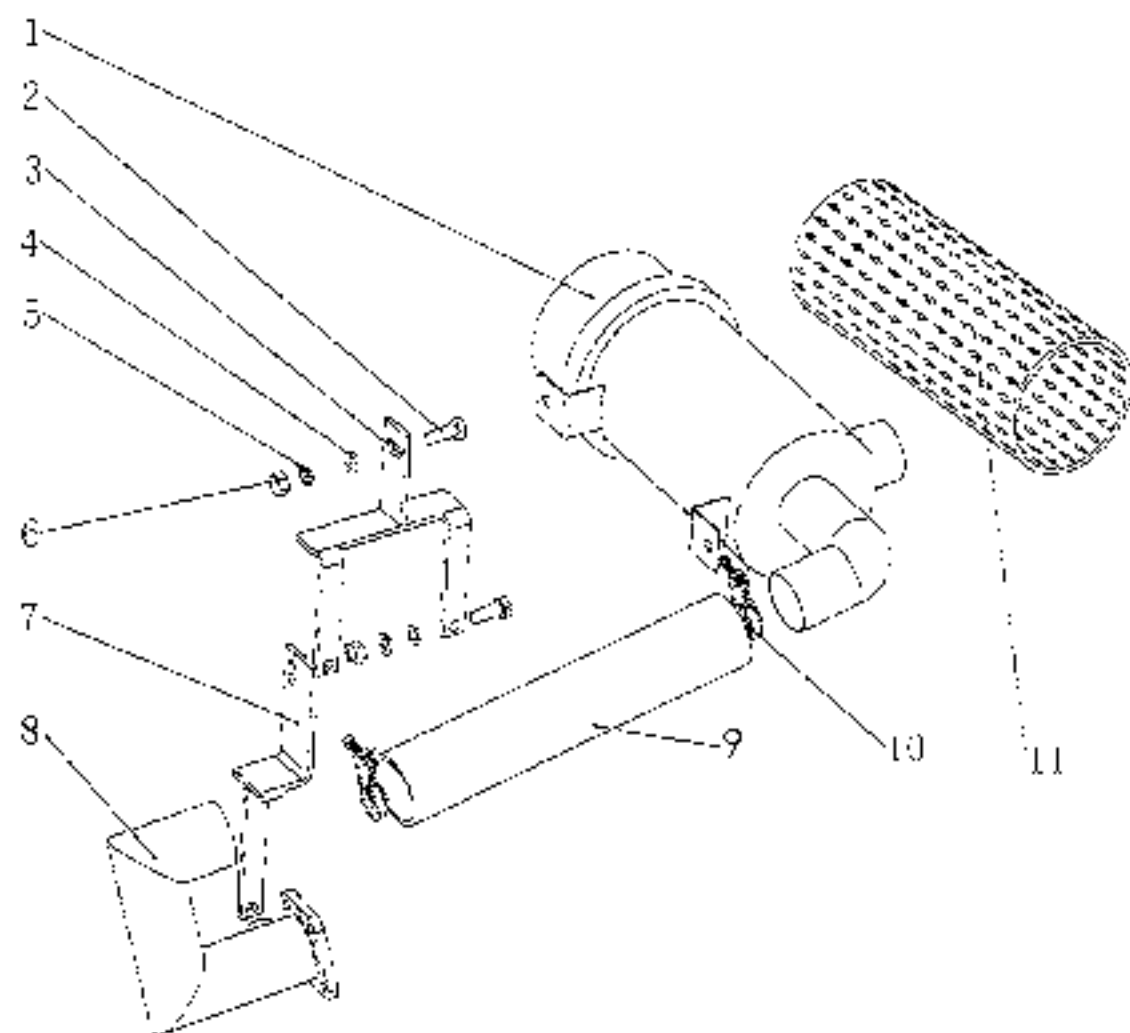

40.2 空滤器总成 (配395发动机) Air Filter (For 395 engine)

序号 Ser.No.	代号 Part No.	名称及规格	Name & Specifications	数量 Quantity	备注 Remarks
1	350-10H 101	空气滤清器	Air filter	1	
2	GB5783 86	螺栓 10×20	Hex head bolt M10×20	2	
3	350.10B.011	空滤器支架零件	Air filter bracket (1)	1	
4	GB97.1-85	垫圈 10	Plain washer 10	2	
5	GB93-87	垫圈 10	Spring lock washer 10	2	
6	GB6170 86	螺母 M10	Hex nut M10	2	
7	350.10B.012	空滤器支架 II	Air filter bracket (2)	1	
8	350.10B.013	进气管接头	Angle pipe	1	
9	350.10B.111	进气管	Air pipe	1	
10	ZB/Z50001-87	管箍 d62	Clp d62	2	
11	KW1025	滤芯	filter screen	1	

40.3 空滤器总成(配490发动机) Air Filter(For 490 engine)

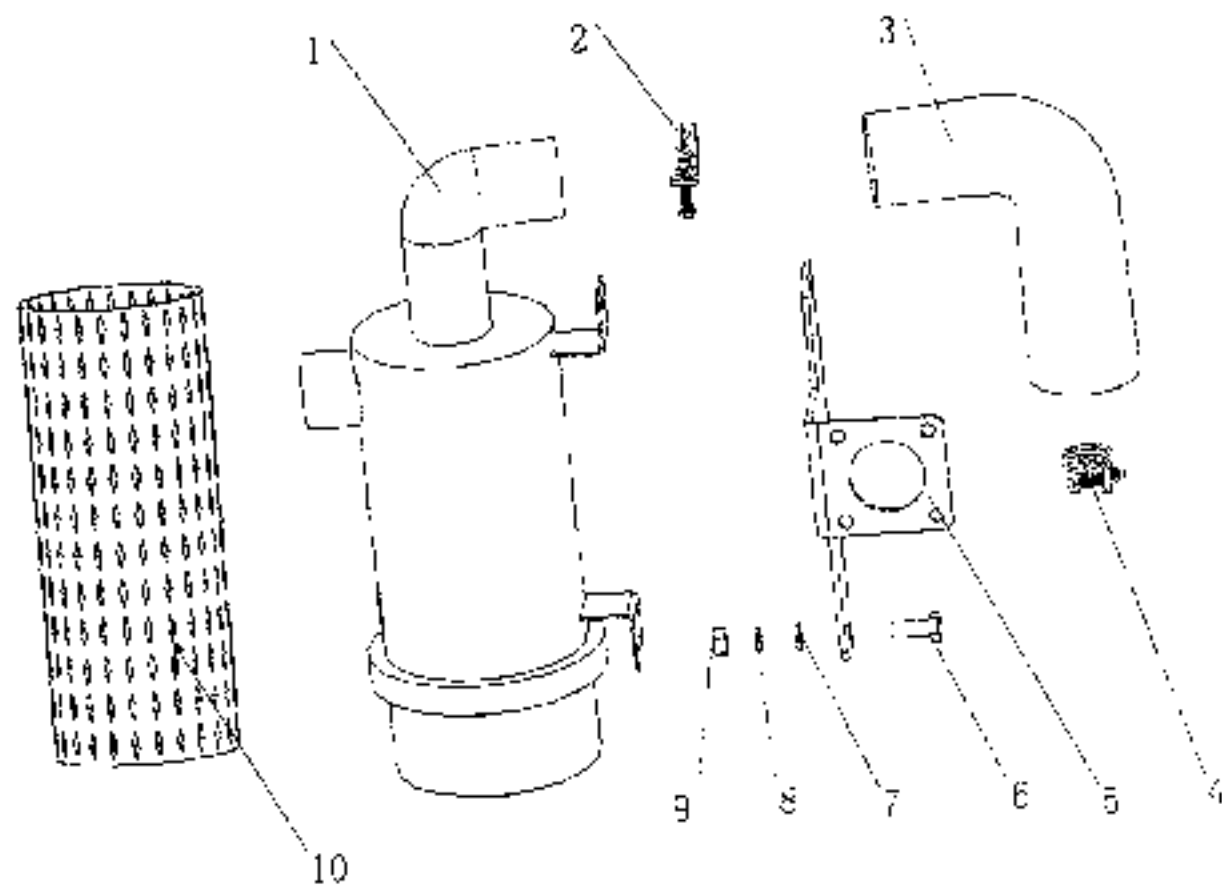

40.3 空滤器总成 (配490发动机) Air Filter (For 490 engine)

序号 Ser No	代号 Part No	名称及规格	Name & Specifications	数量 QUANTITY	备注 REMARKS
1	350.10B.101-2	空气滤清器	Air filter	1	
2	JB8870-1999	管箍 (51-70)	Clip (51-70)	1	
3	400-1.10.111	进气管	Air pipe	1	
4	JB8870-1999	管箍 (64-76)	Clip (64-76)	1	
5	300.10B.111-1	空滤器支架	Air filter bracket	1	
6	GB5783-86	螺母 10x20	Hex. head bolt M10x20	2	
7	GB97.1-85	垫圈 10	Plain washer 10	2	
8	GB97.87	垫圈 10	Spring lock washer 10	2	
9	GB6170-86	螺母 M10	Hex. nut M10	2	
10	KW1025	滤芯	filter screen	1	

41.1 散热器总成(配390发动机) Radiator (for 390 engine)

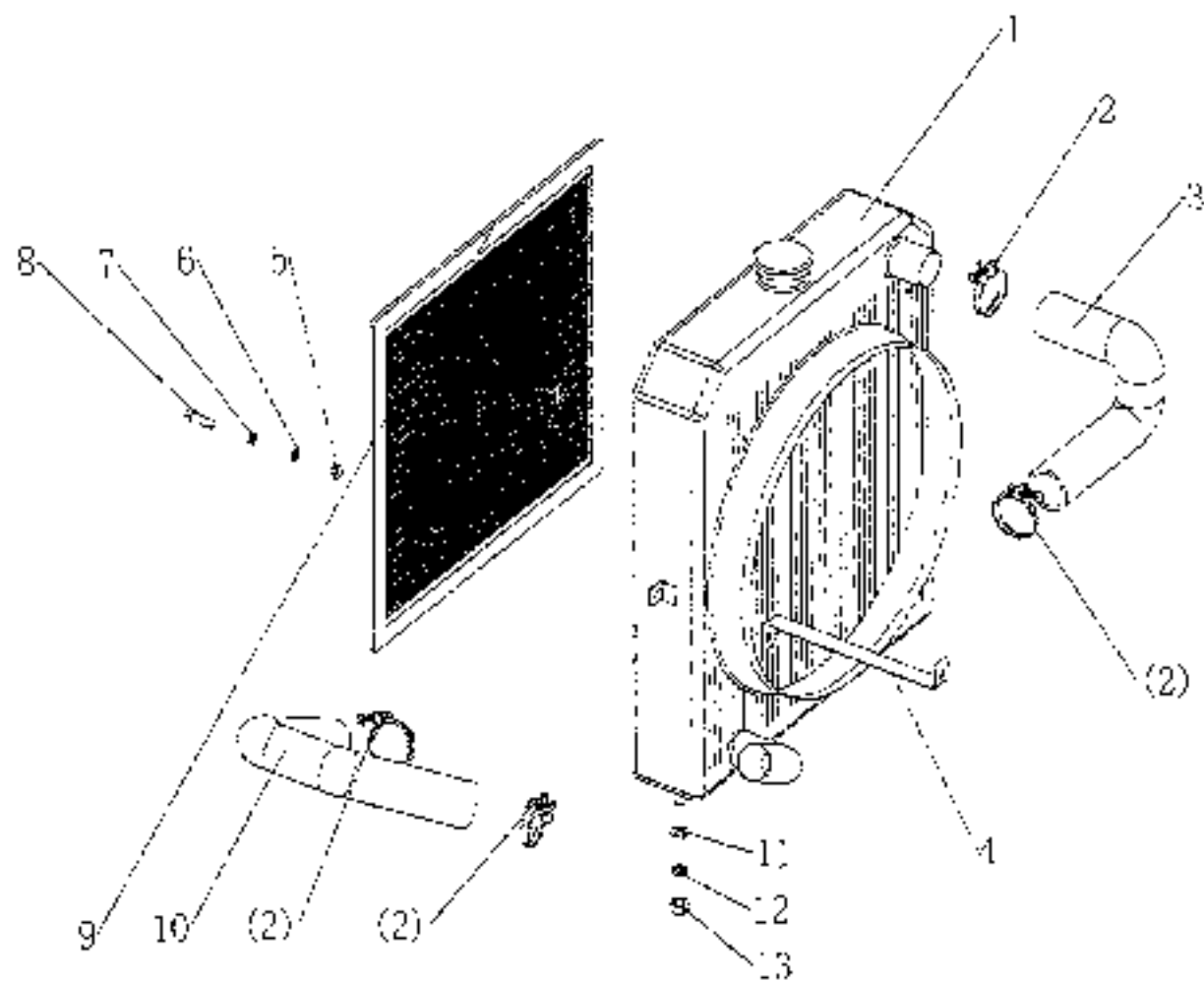

41.1 散热器总成(配390发动机) Radiator(For 390 engine)

序号 Ser.No.	代号 Part No.	名称及规格 Name & Specifications	数量 Quantity	备注 Remarks
1	300.13.011	散热器总成 Radiator	1	
2	ZBJ50001-87	夹箍2A(35-51) Clip 2A(35-51)	4	
3	300.13.101	上水管 Upper water hose	1	
4	300.13.104-1	左水箱拉片 Left securing rod, radiator	1	
5	GB6170-86	螺母 M8 Hex. Nut M8	1	
6	GB93-87	垫圈 8 Spring lock washer 8	1	
7	GB97.1-85	垫圈 8 Plain washer 8	1	
8	GB5781-86	螺栓 M8x20 Hex. head bolt M8	1	
9		网罩 Net	1	
10	300.13.102	下水管 Lower water hose	1	
11	GB97.1-85	垫圈 10 Plain washer 10	2	
12	GB93-87	垫圈 10 Spring lock washer 10	2	
13	GB6170-86	螺母 M10 Hex. nut M10	2	

41.2 散热器总成(配395发动机) Radiator (For 395 engine)

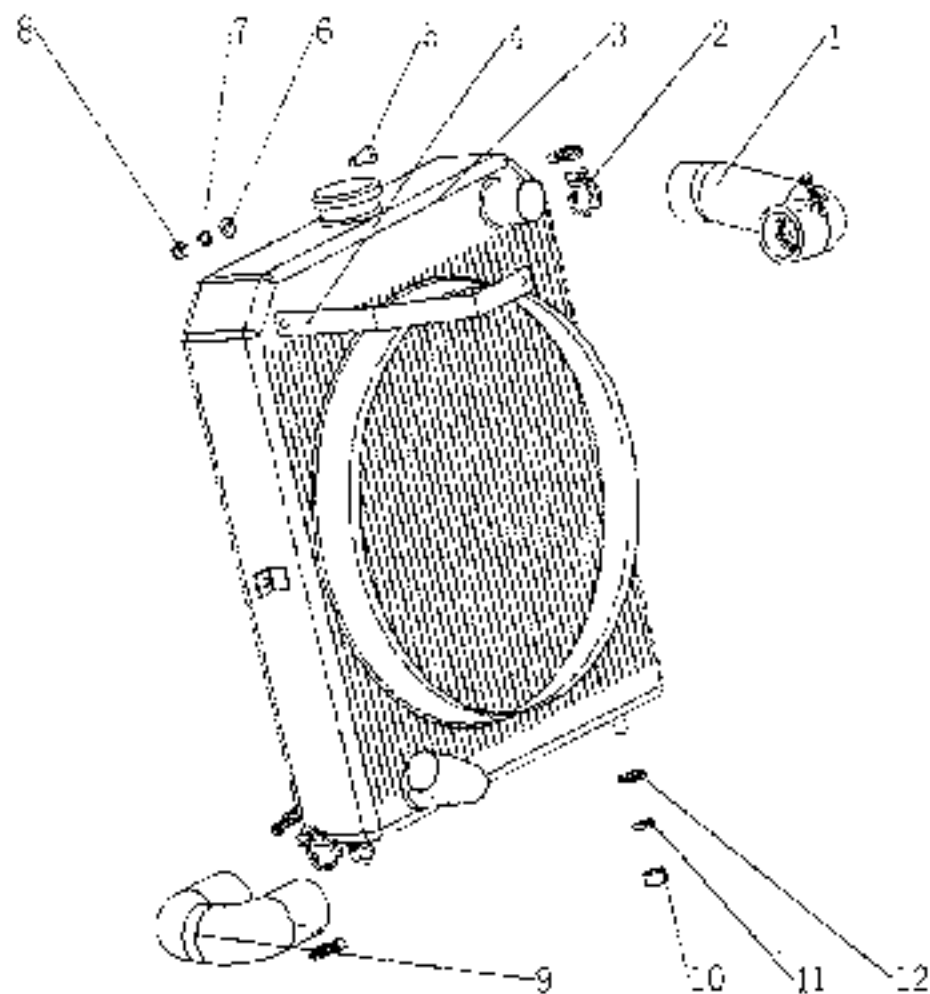

41.2 散热器总成(配395发动机) Radiator(For 395 engine)

序号 Ser.No	代号 Part No	名称及规格	Name & Specifications	数量 Quantity	备注 Remarks
1	354.13.101	上水管	Upper water hose	1	
2	ZDJ15001-87	带箍24(35-51)	Hose clamp 24 (35-51)	4	
3	354.13.013	散热器	Radiator	1	
4	354.13.103	水箱支架	Supporting rod, radiator	1	
5	GB5783-36	螺母 M8×20	Hex. nut bolt M8	1	
6	GB97.1-85	垫圈 8	Plain washer 8	1	
7	GB93.87	垫圈 8	Spring lock washer 8	1	
8	GB6170-86	螺母 M8	Hex. nut M8	1	
9	250C 00 302	下水管	Lower water pipe hose	1	
10	GB6170-86	螺母 M12	Hex. nut M12	2	
11	GB93.87	垫圈 12	Spring lock washer 12	2	
12	GB97.1-85	垫圈 12	Plain washer 12	2	

41.3 散热器总成(配490发动机) Radiator (For 490 engine)

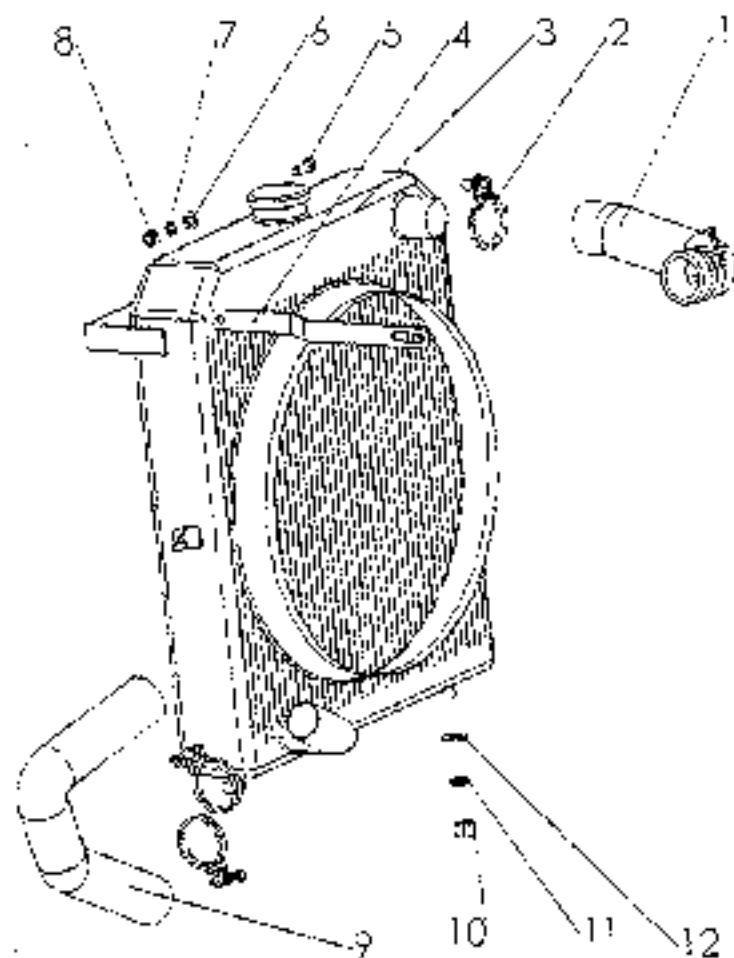

41.3 散热器总成(配490发动机) Radiator(For 490 engine)

* 序 Ser.No.	代号 Part No	名称及规格	Name & Specifications	数量 Quantity	备注 Remarks
	404B.13.001-2	上轮水管	Upper water hose	1	
2	JB8870-1999	软管ZA(35-51)	Hose clamp ZA (35-51)	4	
3	404B.13.013-2	散热器部件	Radiator	1	
4	404B.13.101	水箱支撑杆	Supporting rod, radiator	1	
5	GB5783-86	螺母 M8×20	Hex. nut bolt M8	2	
6	GB97.1-85	垫圈 8	Plain washer 8	2	
7	GB93-87	弹簧 8	Spring lock washer 8	2	
8	GB6170-86	螺母 M8	Hex. nut M8	2	
9	300.13.102	下轮水管	Lower water pipe hose	1	
10	GB6170-86	螺母 M12	Hex. nut M12	2	
11	GB93-87	垫圈 12	Spring lock washer 12	2	
12	GB97.1-85	垫圈 12	Plain washer 12	2	

42.1 排气管总成(配390/395发动机)

Exhaust pipe (For 390/395 engine)

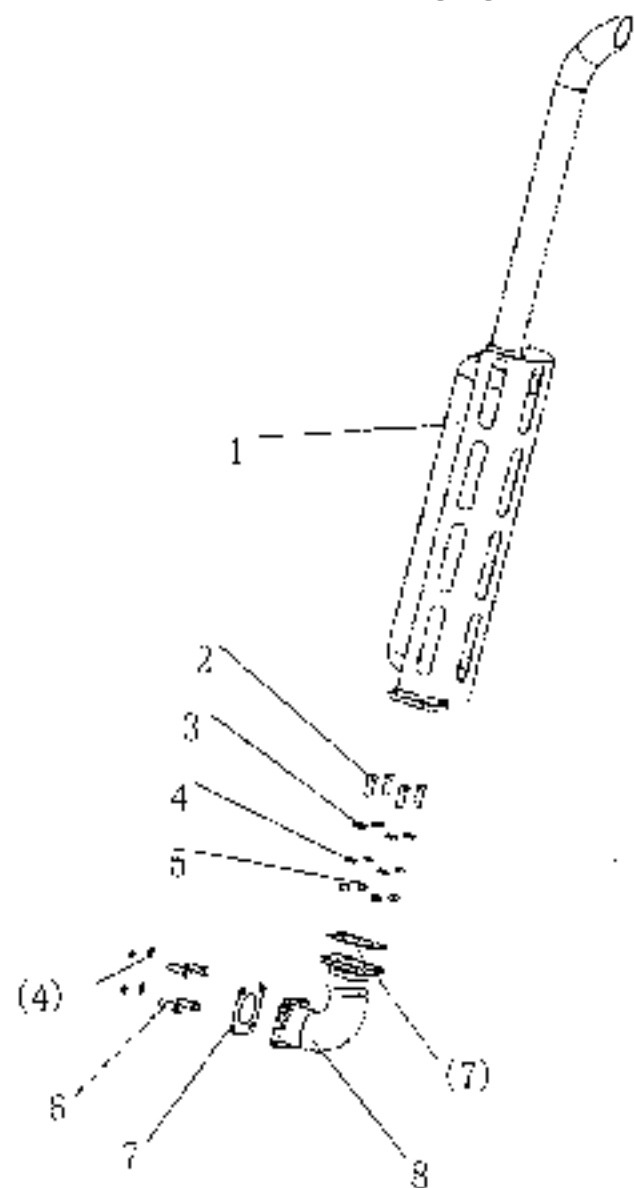

42.1 排气管总成(配390/395发动机) Exhaust pipe (For 390/395 engine)

序号 Ser.No.	代号 Part No.	名称及规格	Name & Specifications	数量 Quantity	备注 Remarks
1	200.00.021A-1	排气管组合件	Exhaust pipe (Silencer)	1	
2	GB5783-86	螺栓 M8X20	Hex. head bolt M8x20	4	
3	GB97.1-85	垫圈 8	Plain washer 8	4	
4	GB93-87	垫圈 8	Spring lock washer 8	8	
5	GB6170-86	螺母 M8	Hex. Nut M8	4	
6	GB5783-86	螺栓 M8X25	Hex. head bolt M8x25	4	
7	300.22.101	排气管纸垫	Paper gasket	2	
8	200.00.201-B	排气支管	Exhaust bent pipe	1	

42.2 排气管总成(配490发动机)
Exhaust pipe (For 490 engine)

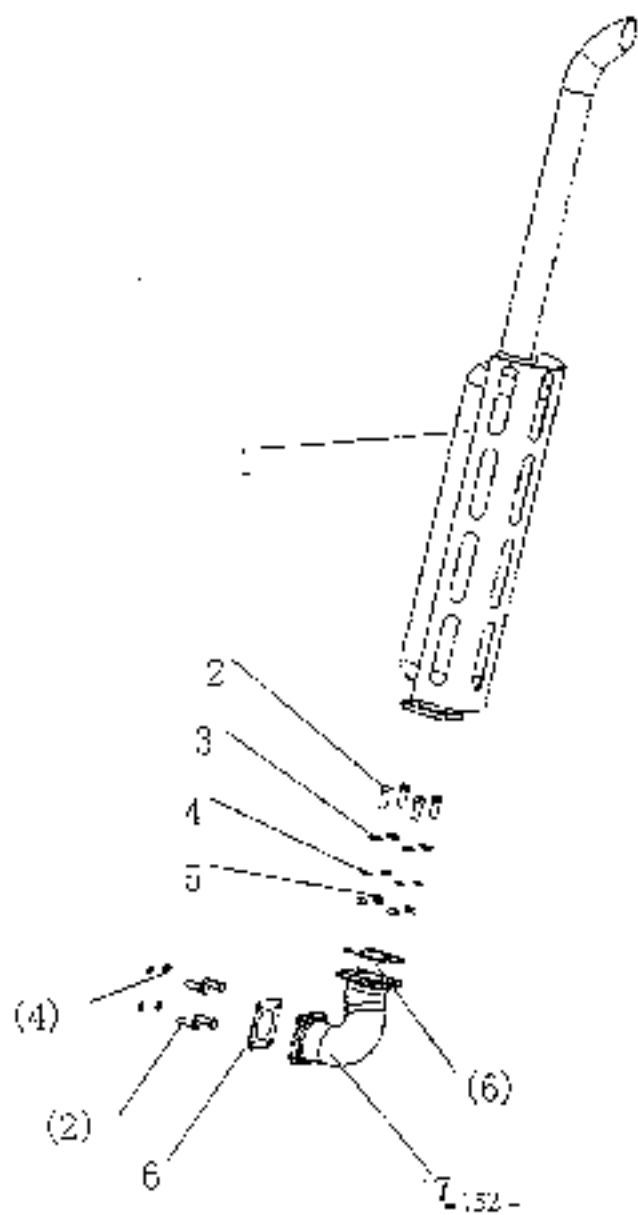

42.2 排气管总成(配490发动机) Exhaust pipe(For 490 engine)

序号 Ser.No.	代号 Part No.	名称及规格	Name & Specifications	数量 Quantity	备注 Remarks
1	450.22.011-1	排气管组合件	Exhaust pipe	1	
2	GB5783-86	螺栓 M10X30	Hex. head bolt M10×30	8	
3	GB97.1-85	垫圈 10	Plain washer 10	4	
4	GB93-87	垫圈 10	Spring lock washer 10	8	
5	GB6170-86	螺母 M10	Hex. Nut M10	4	
6	450.22.101	排气管纸垫	Paper gasket	2	
7	450.22.102	排气支管	Exhaust bent pipe	1	

42.3 排气管总成(防火星 配390/395发动机)

Exhaust pipe (With spark arrester For 390/395 engine)

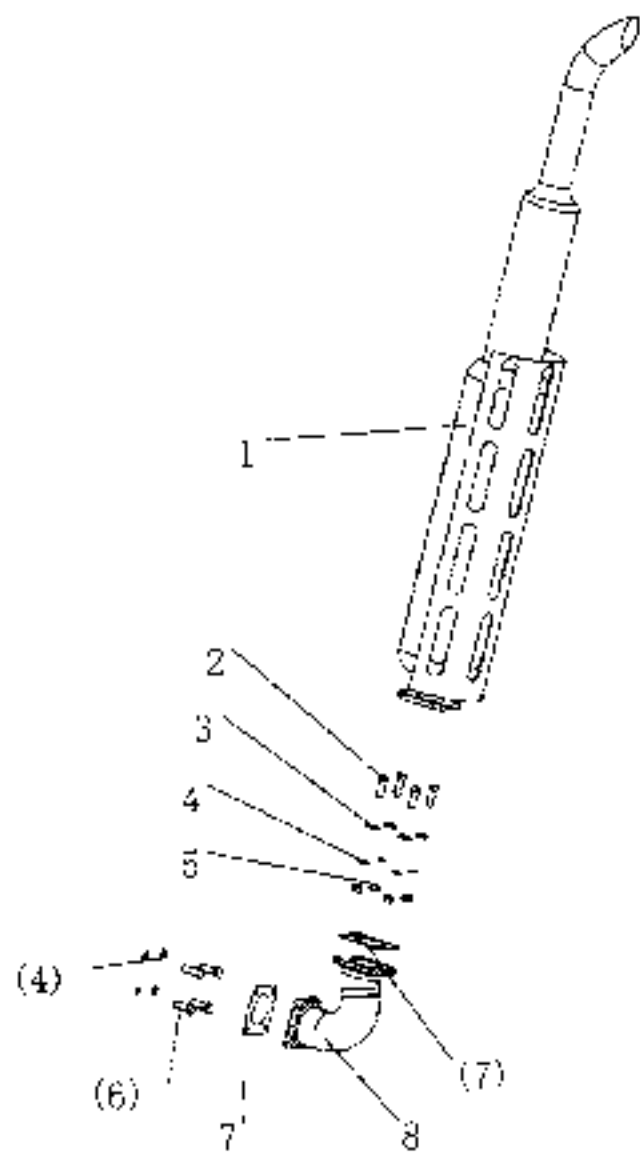

42.3 排气管总成(防火星、配390/395发动机)

Exhaust pipe (With spark arrester, For 390/395 engine)

序号 Ser.No.	代号 Part No.	名称及规格	Name & Specifications	数量 Quantity	备注 Remarks
1	200.00.021D	排气管组合件	Exhaust pipe	1	
2	GB5783-86	螺栓 M8X30	Hex. head bolt M8x30	4	
3	GB97.1-85	垫圈 8	Plat. washer 8	4	
4	GB93-87	垫圈 8	Spring lock washer 8	6	
5	GB6170-86	螺母 M8	Hex. Nut M8	4	
6	GB5783-85	螺栓 M8x25	Hex. head bolt M8x25	4	
7	300.22.101	排气管纸垫	Paper gasket	2	
8	200.00.201-B	排气支管	Exhaust bent pipe	1	

42.4 排气管总成(防火罩 配490发动机)

Exhaust pipe (With spark arrester For 490 engine)

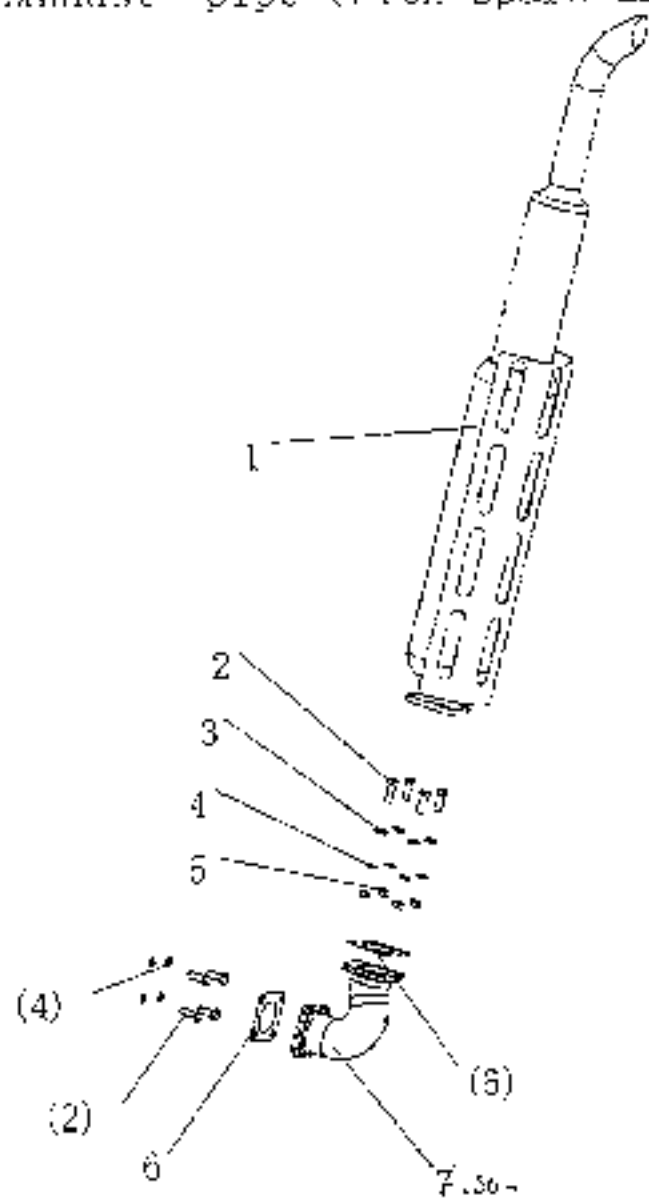

42.4 排气管总成(防火星、配490发动机)

Exhaust pipe(With spark arrester, For 490 engine)

序号 Ser.No	代号 Part No.	名称及规格	Name & Specifications	数量 Quantity	备注 Remarks
1	400B.22A.011	排气管总成	Exhaust pipe	1	
2	GB5783-86	螺栓 M10X30	Hex. head bolt M10X30	8	
3	GB97.1-85	垫圈 10	Plain washer 10	4	
4	GB93-87	弹簧 10	Spring lock washer 10	8	
5	GB6170-86	螺母 M10	Hex. Nut M10	4	
6	450.22.101	排气管纸垫	Paper gasket	2	
7	450.22.102	排气支管	Exhaust bent pipe	1	

43 电机防护罩 Protective shield

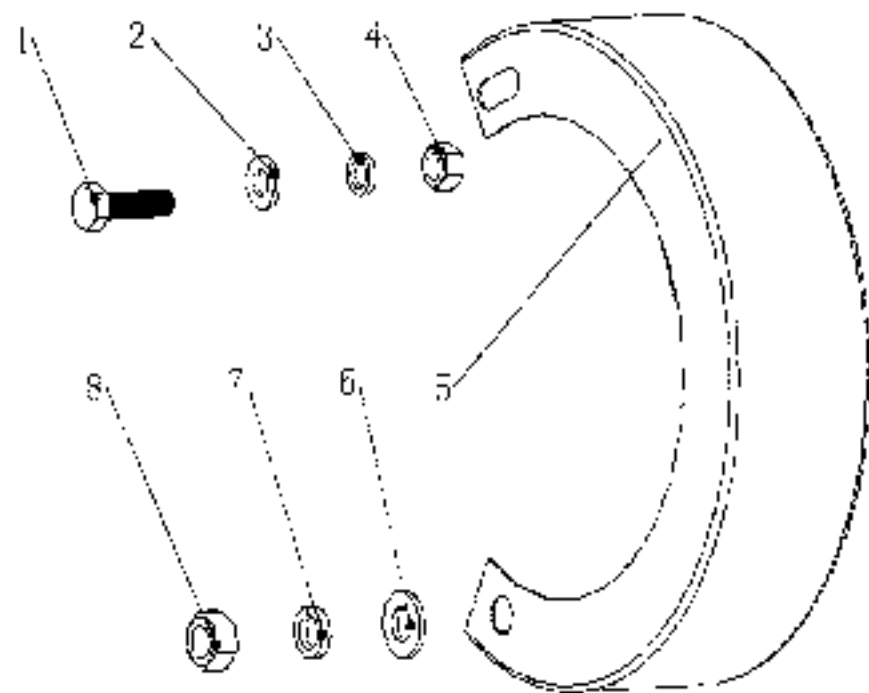

43 电机防护罩 Protective shield

序号	Sec.No.	代号 Part No.	名称及规格	Name & Specifications	数量 Quantity	备注 Remarks
1		GB9783-86	螺栓 M8×25	Hex. head bolt M8×25	1	
2		GB97.1-85	垫圈 8-140HV	Plain washer 8	1	
3		GB93-87	垫圈 8	Spring lock washer 8	1	
4		GB6170-86	螺母 M8	Hex. nut M8	1	
5		300.00.011	电机防护罩	Protective shield	1	
		300.00.103A	电机防护罩	Protective shield	1	配TM机罩 For TM hood
6		GB97.1-85	垫圈 10-140HV	Plain washer 10-140HV	1	
7		GB93-87	垫圈 10	Spring lock washer 10	1	
8		GB6170-86	螺母 M10	Hex. nut M10	1	

44 盘式制动器总成 Disc Brake

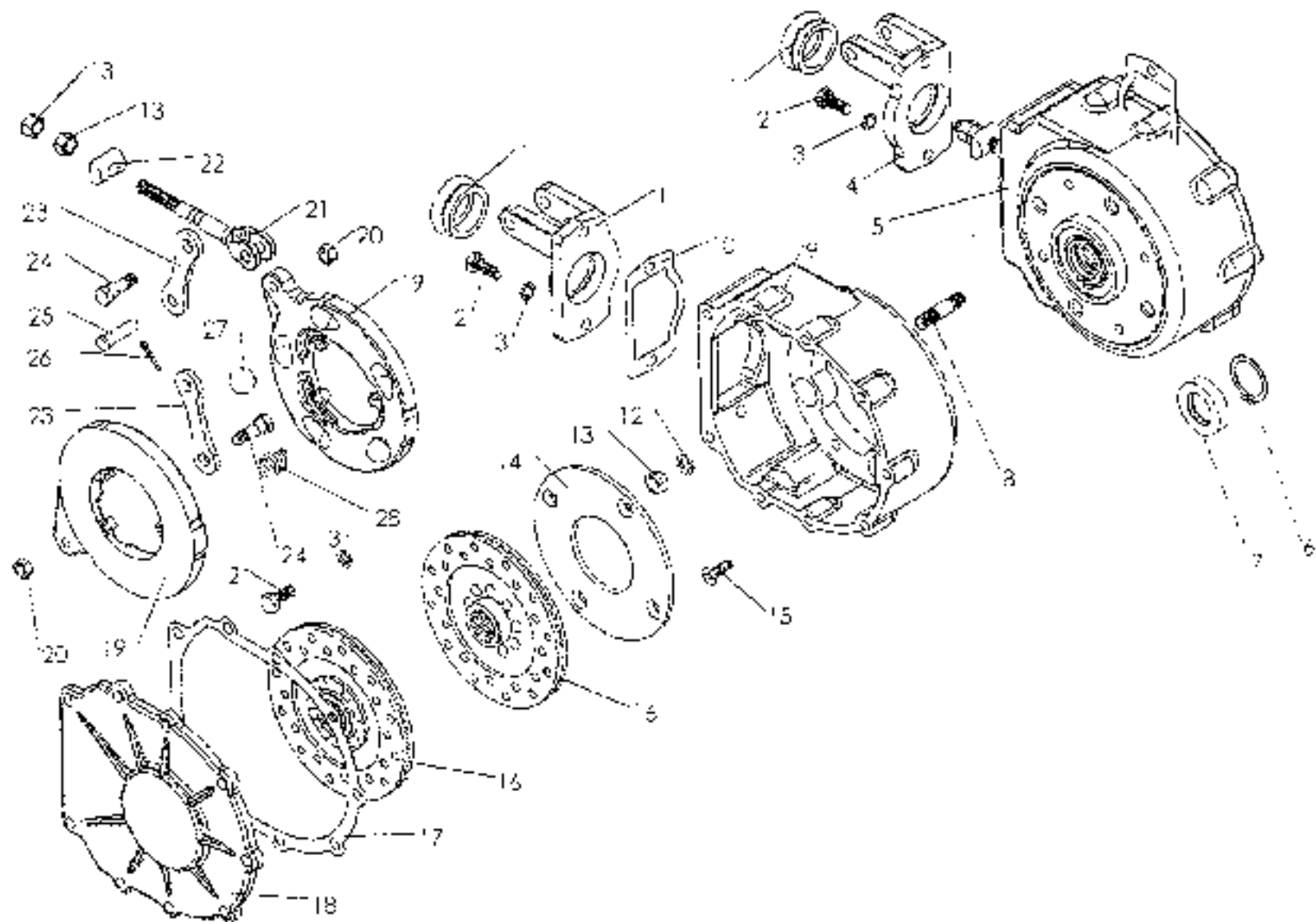

44 盘式制动器总成 · Disc Brake

序号 Ser.No.	代号 Part.No.	名称及规格	Name & Specifications	数量 Quantity	备注 Remarks
1	280.43.118	密封架	Seal carriage	2	
2	GB5783-86	螺栓 M10×25	Hex. head bolt M10×25	22	
3	GB93-87	垫圈 10	Spring lock washer 10	22	
4	280.43.110	右摇臂支座	Right rocker arm pedestal	1	
5	300.43.163-1	右制动器壳体	Right brake housing	1	
6	GB894.1-86	挡圈 35	Circlip for shaft 35	2	
7	HG4 692 67	油封 SD32×52×12	Oil seal SD 32×52×12	2	
8	GB898-88	双柱 AGM12-M12×35	Double end stud AGM12-M12×35	8	
9	300.43.152-1	左制动器壳体	Left brake housing	2	
10	280.43.103	纸垫	Paper gasket	2	
11	280.43.104	左摇臂支座	Left rocker arm pedestal	1	
12	GB93 87	垫圈 12	Spring lock washer 12	8	
13	GB6170-86	螺母 M12	Hex. nut M12	12	
14	300.43.154-1	制动片	Brake disc	2	
15	GB819-85	螺钉 M8×25	Screw M8×25	8	
16	300.43.024	从动盘总成	Brake driven disk	4	
17	300.43.153	纸垫	Brake cap gasket	2	
18	300.43.151	制动器盖	Brake cap	2	
19	300.43.160	升簧	Brake pressure plate	4	
20	GB6171-86	螺母 M10×1	Hex. nut M10×1	4	
21	300.43.161	调节杆	Adjusting rod	2	
22	280.43.105	自位垫块	Self-aligning block	2	
23	450.43.114	拉板	Draw plate	4	

44 盘式制动器总成 Disc Brake

续表:

序号 Ser.No.	代号 Part.No.	名称及规格	Name & Specifications	数量 Quantity	备注 Remarks
24	450.43.113	螺栓	Bolt	4	
25	GB882-86	销轴 B10×32	Clevis pin with head B10×32	2	
26	GB91-86	销 3.2×20	Split pin 3.2×20	2	
27	GB308 89	钢球 7/8"	Steel ball 7/8"	10	
28	450.43.112	内回位弹簧	Inner return spring	6	

45 盘式制动器操纵机构总成 Disc Brake Operation Mechanism

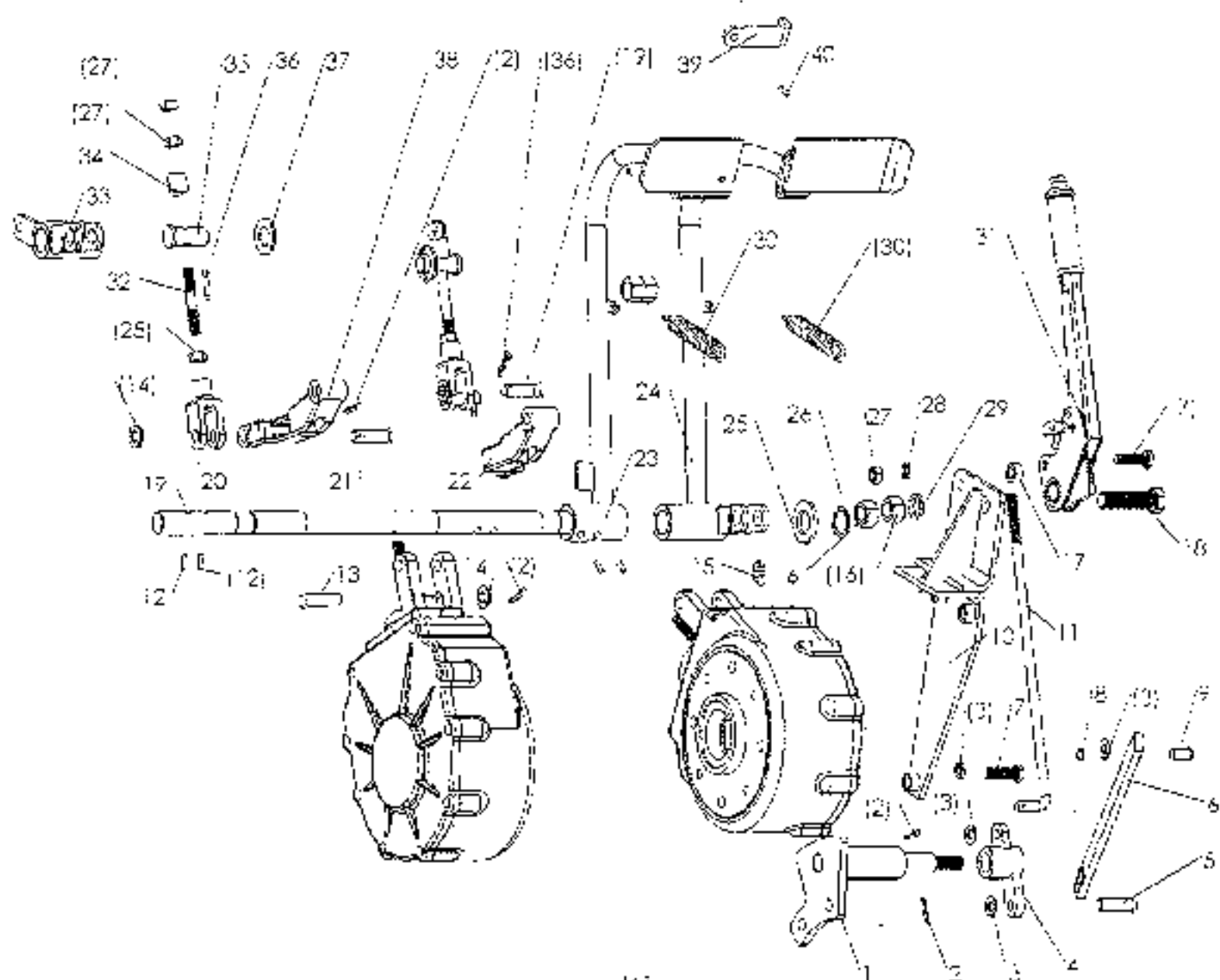

45 盘式制动器操纵总成 Disc Brake Operation Mechanism

序号	Ser.No	代号 Part No.	名称及规格	Name & Specifications	数量	Quantity	备注	Remarks
1		ITA300.43.016	转向叉球板焊合件	Rotate shafte support board weldment	1			
2		GB91-86	销3.2X20	Split pin 3.2x20	6			
3		GB97.1-85	垫圈10	Plain washer 10	8			
4		ITA300.43.017	转向叉焊合件	Rotate shafte weldment	1			
5		GB882-86	销轴10X22	Clevis pin with head 10x22	1			
6		ITA300.43.103	竖拉杆	Erect brake bar	1			
7		GB5785-86	螺帽M10X40	Hex. head bolt M10x40	4			
8		GB894.1-86	挡圈10	Circlip for shaft 10	1			
9		450.43.137	拉杆销轴	Brake bar clevis pin	1			
10		ITA300.43.015	手制动核板焊合件	Hand brake support board weldment	1			
11		ITA300.43.105	拉杆	Brake bar	1			
12		GB879-86	销8X40	Slotted spring pin 8x40	4			
13		GB882-86	销轴B12X70	Clevis pin with head B12x70	2			
14		GB97.1-85	垫圈12	Plain washer 12	4			
15		GB1153-89	油杯45°M10X1	Angle grease nipple 45°M10x1	1			
16		GB6170-86	螺母M16	Hex. nut M16	2			
17		450.43.106	垫套	Gasket sleeve	1			
18		GB5783-85	螺帽M16X60	Hex. head bolt M16x60	1			
19		ITA300.43.102	制动轴	Brake pedal shaft	1			
20		280.43.107	联接叉	Rad clevis	2			
21		GB882-86	销轴B12X40	Clevis pin with head B12x40	2			
22		300.43.150	右摇臂	Right rocker arm	1			

45 盘式制动器操纵总成 Disc Brake Operation Mechanism

续表:

序号 Ser.No	代号 Part No	名称及规格	Name & Specifications	数量 Quantity	备注 Remarks
23	300.43.011-1	左制动踏片组合件	Left brake pedal	1	
24	DA300.43.018	右制动踏片组合件	Right brake pedal	1	
25	GB97.1-85	垫圈24	Plain washer 24	1	
26	GB894.1-86	挡圈24	Circlip for shaft 24	1	
27	GB6170-86	螺母M10	Hex. nut M10	7	
28	GB93-87	垫圈10	Spring lock washer 10	2	
29	GB93-87	垫圈16	Spring lock washer 16	1	
30	200.43.125	外回位弹簧	Outer return spring	2	
31	450.43.019	手制动总成	Hand brake mechanism	1	
32	300.43.107-2	拉杆	Brake bar	2	
33	300.43.013A	左接头焊合件	Left brake arm	1	
34	200.43.128	调整套	Adjusting sleeve	2	
35	200.43.127	拉杆销	Brake bar pin	2	
36	GB91-86	销3.2X28	Split pin 3.2x28	2	
37	GB97.1-85	垫圈20	Plain washer 20	2	
38	300.43.155	左摇臂	Left rocker arm	1	
39	200.43.106	联锁片	Interlock piece	1	
40	GB879-86	销8X18	Slotted spring pin 8 x 18	1	

46 304.40.033 转向油缸总成 Steering Cylinder Assy

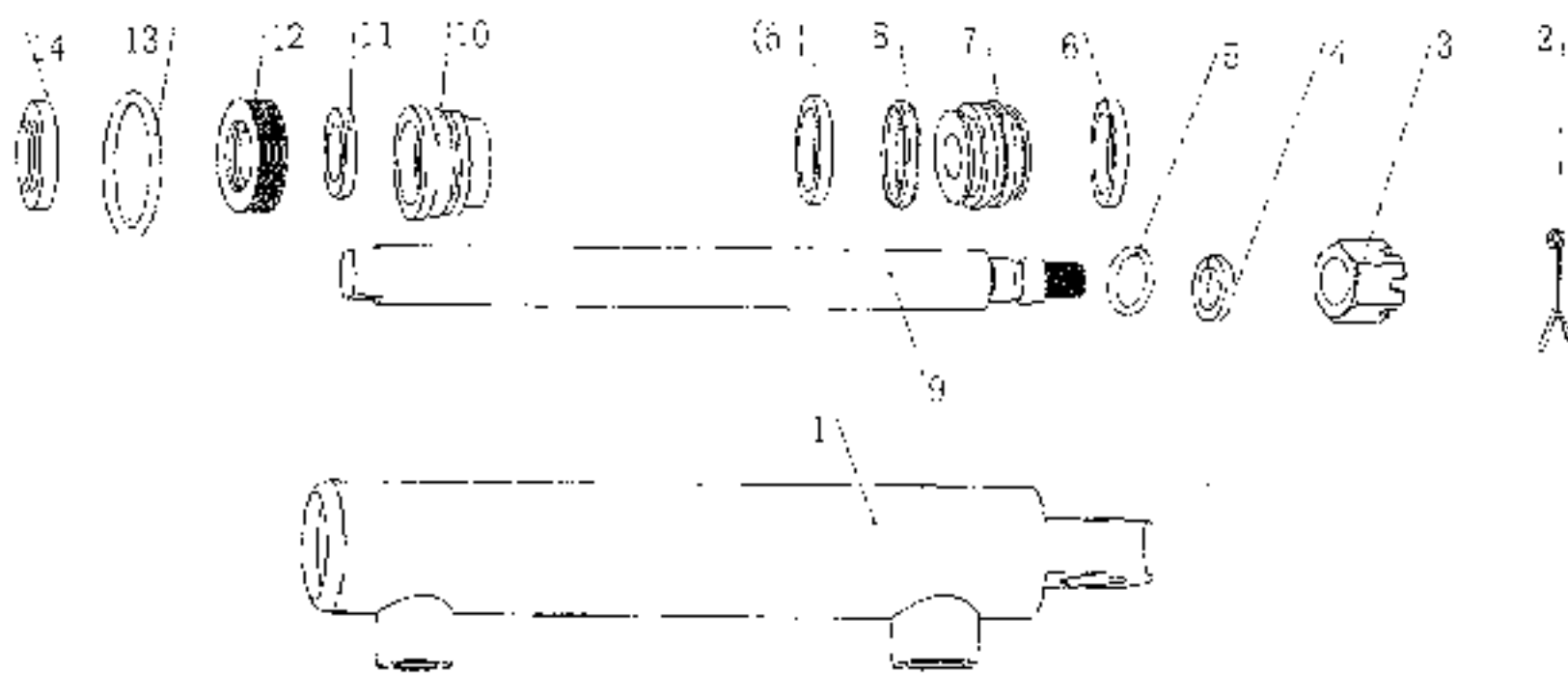

46 304.40.033 转向油缸总成 Steering cylinder assy

序号 Ser.No.	代号 Part No.	名称及规格	Name & Specifications	数量 Quantity	备注 Remarks
1	HSG40/22X160.01-00	缸筒总成	cylinder	1	
2	GB91-86	销 3.2x8	Split pin 3.2x8	1	
3	GB9459-88	螺母 M14x1.5	Hex. nut M14x1.5	1	
4	GB93-87	弹簧垫圈 14	Spring lock washer 14	1	
5	GB1235-76	O型密封圈 16X2.4	O-ring seal 16X2.4	1	
6	SWD	支承环	Supporting ring	1	
7	HSG40/22x160.01	活塞	Piston	1	
8	UN32	UN型密封圈 22x40x5.5	UN-seal 22x40x5.5	2	
9	HSG40/22x160.02	活塞杆	Piston rod	1	
10	HSG40/22x160.03	缸套	cylinder bush	1	
11	CKS	防尘封 CKS-0220	CKS-seal 0220	1	
12	UN22	UN型密封圈 22x30x6	UN-seal 22x30x6	1	
13	GB3452.1-92	O型密封圈 42.5X2.65	O-ring seal 42.5X2.65	1	
14	DH22.4	DH防尘圈 22.4x30.4x4.5	Dust-proof ring DH22.4x30.4x4.5	1	

47 CBN-E306B 齿轮泵总成 CBN-E306B Gear Pump

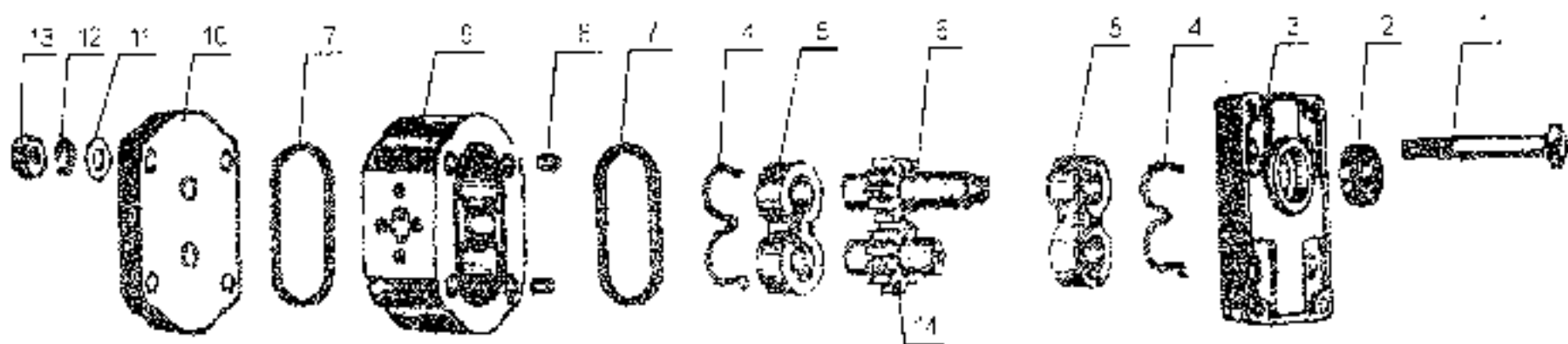

47 CBN-E306B 齿轮泵总成 Gear Pump

序号 Ser.No.	代号 Part No.	名称及规格	Name & Specifications	数量 Quantity	备注 Remarks
1	300-114	方头螺栓	square coes bolt	1	
2	JB7600-89	合泵油封	Ring seal	1	
3	E300-102A	前盖	Front cover	1	
4	E300-115	W型密封圈	W-ring seal	1	
5	E300-106	衬套	Bushing	1	
6	300-104A	主动齿轮	Drive gear	1	
7	E300-107	O型密封圈	O-ring seal	1	
8	GB119-86	定位销	Straight pin	2	
9	E300-101A	泵体	Gear pump housing	1	
10	E300-103A	后盖	Rear cover	1	
11	GB97.1-85	垫圈10	Flair washer 10	1	
12	GB93-87	弹簧圈10	Spring lock washer 10	1	
13	GB6170-86	螺母10	Hex. nut M10	1	
14	300-105	被动齿轮	Driven gear	1	

48 CBN-E314B 齿轮泵总成 CBN-E314B Gear Pump

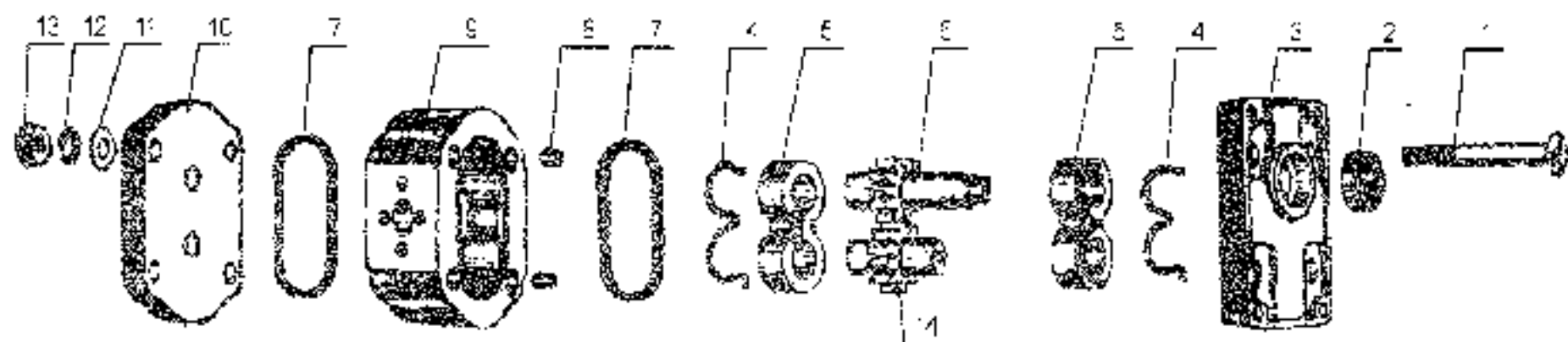

48 CBN-E314A 齿轮泵总成 Gear Pump

序号 Ser.No.	代号 Part No.	名称及规格	Name & Specifications	数量 Quantity	备注 Remarks
1	300-114	方头螺栓	Square toes bolt	1	
2	JB2600-30	骨架油封	Ring sea.	1	
3	E300-102A	前盖	Front cover	1	
4	E300-115	W型密封圈	W-ring seal	1	
5	E300-106	衬套	Bushing	1	
6	300-104A	主动齿轮	Drive gear	1	
7	E300-107	O型密封圈	O-ring seal	1	
8	GB119-86	定位销	Straight pin	2	
9	E300-101A	壳体	Gear pump housing	1	
10	E300-103A	后盖	Rear cover	1	
11	GB97.1-85	垫圈 10	Plain washer 10	1	
12	GB93-87	弹簧垫圈 10	Spring lock washer 10	1	
13	GB6170-86	螺母 10	Hex. nut M10	1	
14	300-105	被动齿轮	Driven gear	1	

49 B771-E80 转向器总成 Hydraulic Steering Gear

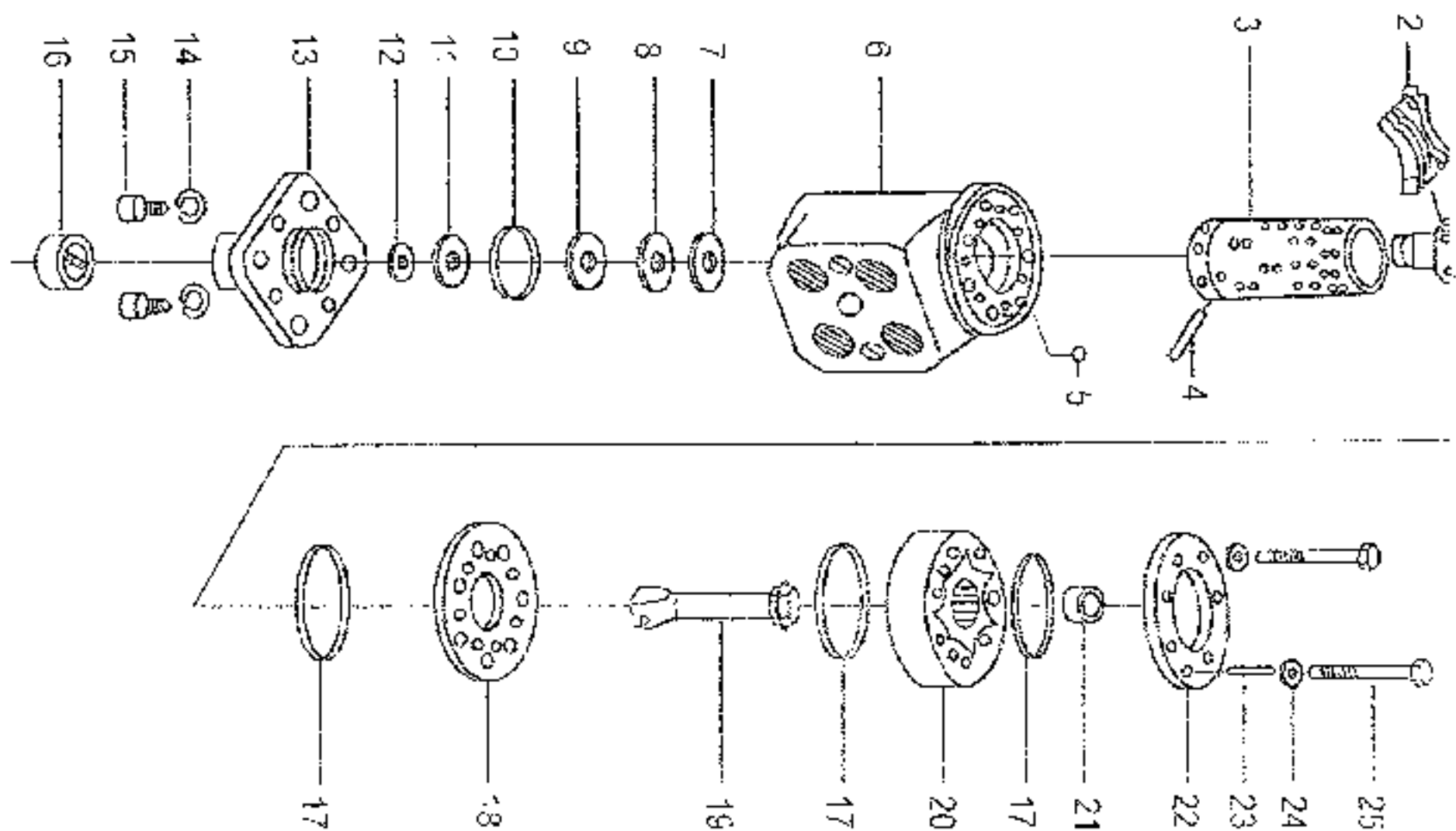

49 BZZ1-E80转向器总成 Hydraulic Steering Gear

序号 Ser No.	代号 Part No.	名称及规格	Name & Specifications	数量 Quanty	备注 Remarks
1	BZZ1.A301.01	阀芯	Valve core	1	
2	BZZ1.A303.01	弹簧片	Spring	1	
3	BZZ1.A302.01	阀套	Valve bush	1	
4	BZZ1.A304.01	拨销	Dial peg	1	
5	GB308-89	钢球	Steel ball	1	
6	BZZ1.A101.01	阀体	Valve housing	1	
7	BZZ1.A312.01	大挡环	Big snap ring	1	
8	BZZ1.A315.01	堆方滚针轴承	Bearing	1	
9	BZZ1.A311.01	小挡环	Small snap ring	1	
10	GB1235-76	O型密封圈 50x3.1	O-ring seal 50x3.1	1	
11	BZZ1.A401.01	X型密封圈	X-ring seal	1	
12	GB3452.1-82	O型密封圈 25.8x2.65	O-ring seal 25.8x2.65	1	
13	BZZ1.A101.02	前盖	Front cover	1	
14	GB93-87	弹簧垫圈	Spring lock washer 8	1	
15	GB70-85	螺钉M8x25	Hex. head screw M8x25	4	
16	BZZ1.A313.01/BZZ1.A314.01	连接块	Joined block	1	
17	GB3452.1-82	O型密封圈 77.5x2.65	O-ring seal 77.5x2.65	3	
18	BZZ1.A306.01	隔盘	Spacer disc	1	
19	BZZ1.A305.01	运动轴	Linked shaft	1	
20	BZZ1.A307.03/BZZ1-A308.03	转子、定子	Rotor, stator	1	
21	BZZ1.A309.01	限位柱	Limited pole	1	
22	BZZ1.A310.01	后盖	Behind cover	1	
23	GB879-86	销2x30	Parallel pin 3x30	2	
24	BZZ1.A405.01	组合密封垫圈	Combined seal washer	1	
25	GB5786-86	螺栓M10x1.25x20	Hex. head bolt M10x1.25x20	8	

50 FLD F6-H 分流阀总成 Distributory Valve Assy

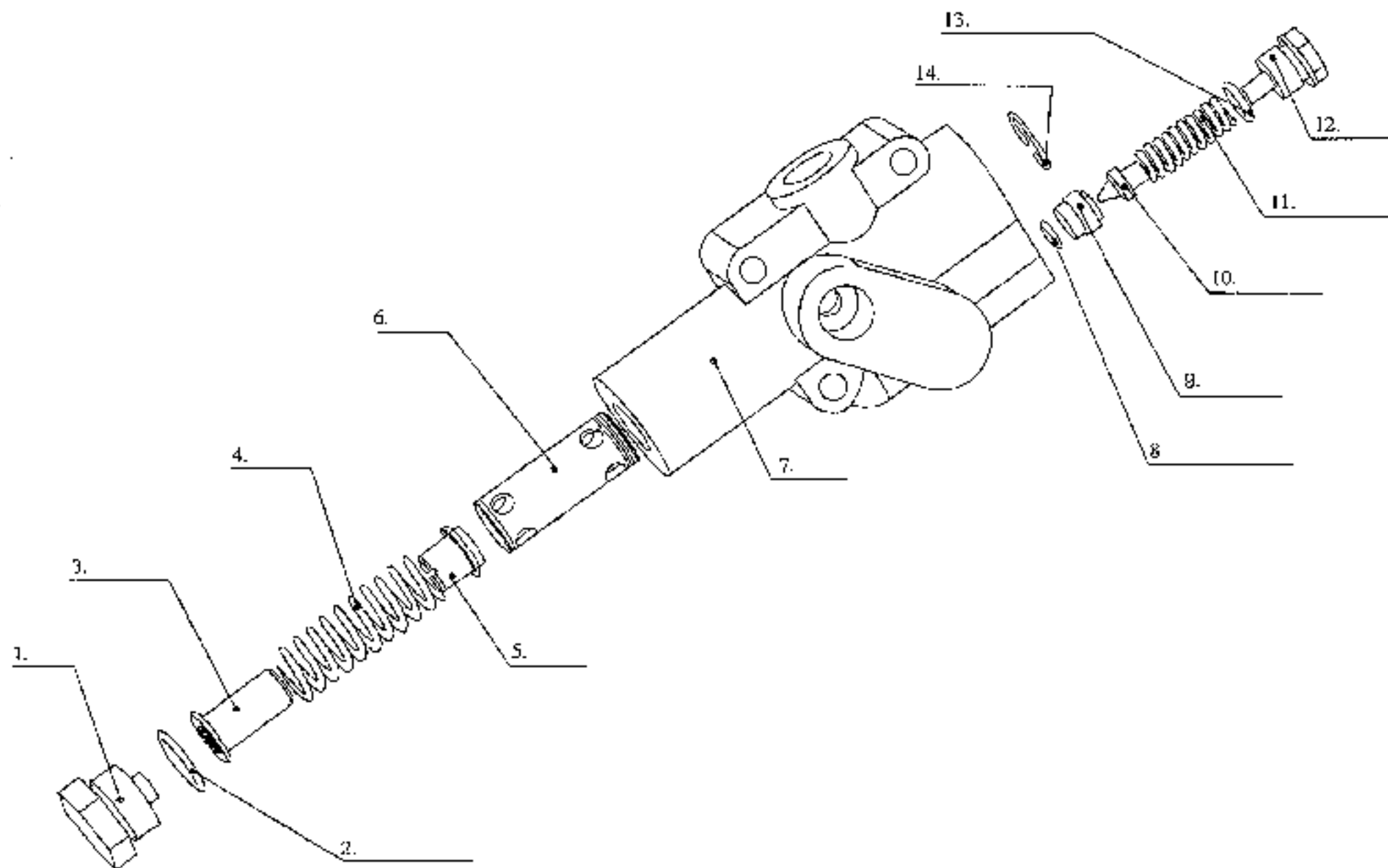

50 FLD-F6-II分流阀总成 Distributary valve assy

序号 Ser.No.	代号 Part No.	名称及规格	Name & Specifications	数量 Quantity	备注 Remarks
1	FLD-F15-305	堵头	Plug	1	
2	GB1235-76	O型密封圈 24x2.4	O-ring seal 24x2.4	1	
3	FLD-F15-304	限位导套	guide bush	1	
4	FLD-F15-303	主弹簧	Main spring	1	
5	FLD-F15-306	阻尼塞	damping stem	1	
6	FLD-F4-301	主簧芯	Main spring core	1	
7	FLD-F15-101	阀体	valve housing	1	
8	GB1235-76	O型密封圈 10x1.9	O-ring seal 10x1.9	1	
9	FLD-F15-311	安全阀座	Relief valve seat	1	
10	FLD-F15-310	安全阀芯	Relief valve core	1	
11	FLD-F15-301	安全阀弹簧	Relief valve spring	1	
12	FLD-F15-302	安全堵	Relief valve plug	1	
13	GB1235-76	O型密封圈 16x2.4	O-ring seal 16x2.4	1	
14	GB893.1-86	孔用挡圈 20	Circlip for hole 20	1	

51 HLCB-D06/06 恒流泵总成 Constant Flow Pump

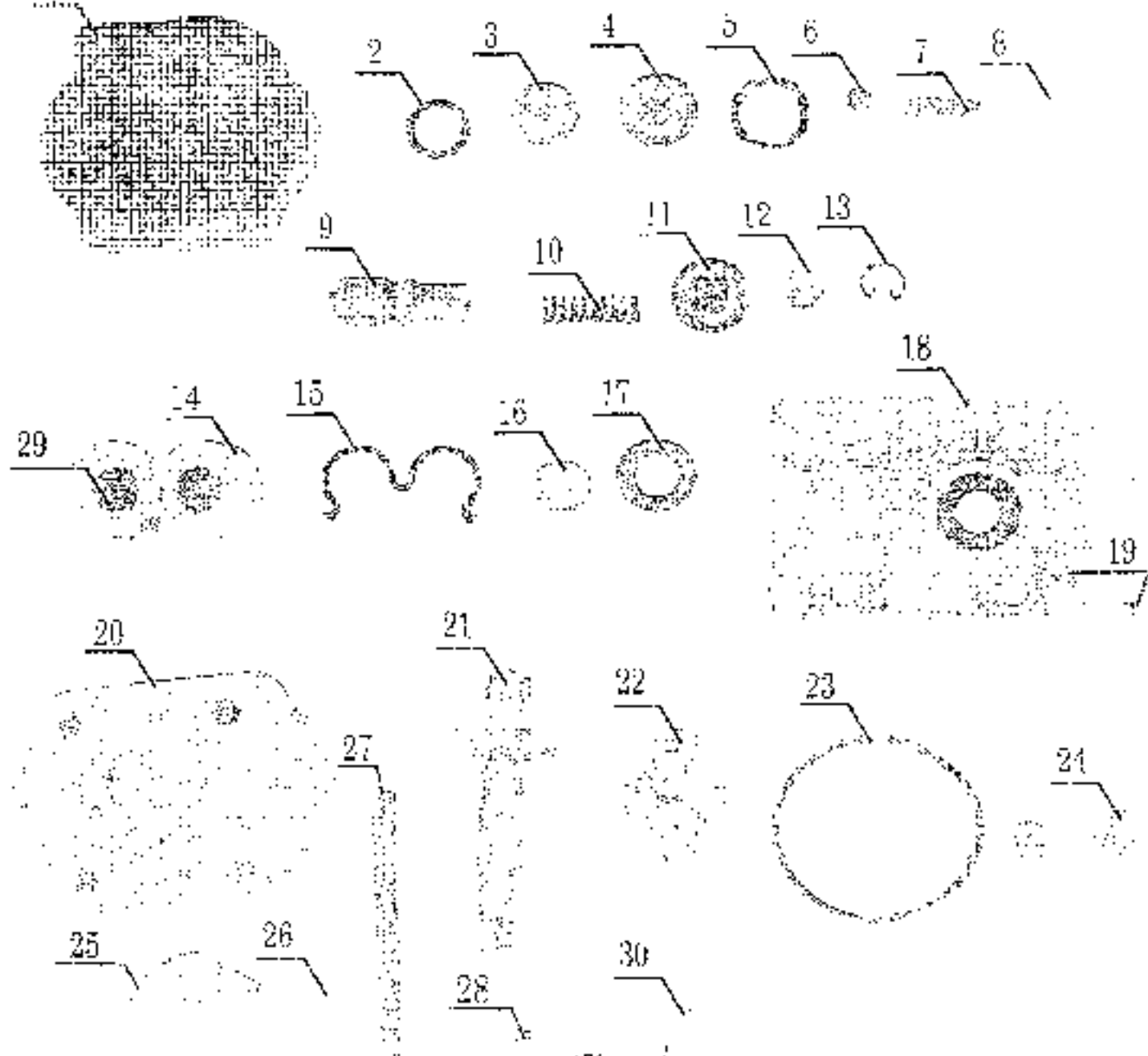

51 HLCB-D06/06恒流泵总成 Constant Flow Pump

序号 Ser.No	代号 Part No.	名称及规格	Name & Specifications	数量 Quantity	备注 Remarks
	HLCB-D00/00-101	恒流泵体	Constant flow pump housing	1	
2	JB892-77	组合密封垫圈18	Combined seal washer 18	1	
3	HLCB-D00/00-102	堵塞	Plug	1	
4	HLCB-D00/00-103	限位塞	Limited plug	1	
5	JB892-77	组合密封垫圈22	Combined seal washer 22	2	
6	GB73-85	半圆紧定螺钉M10x1x12	Set bolt M10x1x12	1	
7	HLCB-D00/00-104	回油节流阀	Return valve	1	
8	GB308-84	钢球φ	Steel ball φ	1	
9	HLCB-D00/00-105	回油阀芯	Return valve core	1	
10	HLCB-D00/00-106	回油弹簧	Return valve spring	1	
11	HLCB-D00/00-107	带孔孔用紧螺塞	Plug with a hole	1	
12	HLCB-D00/00-108	节流片	Throttled shim	1	
13	HLCB-D00/00-109	弹簧卡圈	Clip ring	1	
14	CBN-E300A-001-002	轴套	Bushing	2	
15	CBN-E300-104	密封圈	Ring seal	2	
16	CBN-E300A-113	龙须轴防护套	Protective cover	1	
17	HG4-692-67	密封	Seal	1	
18	HLCB-D00/00-110	前盖	Front cover	1	
19	HLCB-D00/00-111	销	Pin	4	
20	HLCB-D00/00-112	壳体	Housing	1	
21	CBN-E300A-101	主动齿轮	Driving gear	1	
22	CBN-E300-111	从动齿轮	Driven gear	1	
23	GB1755-76	O型密封圈75x3.1	O-ring seal 75x3.1	2	
24	CBN-E300-109	堵盖	Stopper	1	
25	HLCB-D00/00-113	胶圈	Scratcheeon	1	

5i HLCB-D06/06恒流泵总成 Constant Flow Pump

序号 Ser.No.	代号 Part No	名称及规格	Name & Specifications	数量 Quantity	备注 Remarks
1	HLCB-D00/00-101	恒流泵体	Constant flow pump housing	1	
2	JB892-77	组合密封垫圈18	Combined seal washer 18	1	
3	HLCB-D00/00-102	螺塞	Plug	1	
4	HLCB-D00/00-103	限位螺塞	Limited plug	1	
5	JB892-77	组合密封垫圈22	Combined seal washer: 22	2	
6	GB73-85	平头紧定螺钉M10x1x12	Set bolt M10x1x12	1	
7	HLCB-D00/00-104	回注阀带弹簧	Return valve	1	
8	GB303-84	钢球6	Steel bal. 6	1	
9	HLCB-D00/00-105	回注阀芯	Return valve core	1	
10	HLCB-D00/00-106	回注弹簧	Return valve spring	1	
11	HLCB-D00/00-107	带通孔的压紧螺塞	Plug with a hole	1	
12	HLCB-D00/00-108	节流片	Throttled shim	1	
13	HLCB-D00/00-109	弹簧卡圈	Clip ring	1	
14	CBN-E300A-001-002	衬套	Bushing	2	
15	CBN-E300-104	密封圈	Ring seal	2	
16	CBN-E300A-113	衬键轴防尘套	Protective cover	1	
17	HG4-692-67	油封	Seal	1	
18	HLCB-D00/00-110	前盖	Front cover	1	
19	HLCB-D00/00-111	销	Pin	4	
20	HLCB-D00/00-112	壳体	Housing	1	
21	CBN-E300A-101	主动齿轮	Driving gear	1	
22	CBN-E300-111	从动齿轮	Driven gear	1	
23	GB1235-76	O型密封圈75x3.1	O-ring seal 75x3.1	2	
24	CBN-E300-109	堵盖	Stopper	1	
25	HLCB-D00/00-113	刮片	Scutcheon	1	

51 HLCB-D06/06恒流泵总成 Constant Flow Pump

序号 Ser.No	代号 Part No	名称及规格	Name & Specifications	数量 Quantity	备注 Remarks
26	GB627-86	铆钉2x4	Rivet2x4	2	
27	HLCB-D00/00-114	六角头螺栓M10	Hex. head bolt M10	4	
28	HLCB-D00/00-115	弹簧座	Spring seat	1	
29	CBN-F300A-001-101	衬套	Bushing	4	
30	ZS-L10-132	塞堵	Stoper	1	