

Foreword

The parts atlas of series 50 wheeled tractors is compiled according to the existing production drawings and process routes. And the name, drawing No. and use quantity of parts atlas of series 50 wheeled tractors are systematically introduced through intuitive and understandable illustrations and detailed catalogue. It not only can help drivers and repairers know about the tractor structure and assembly relation among parts & components and improve the repair level, but also can provide convenience for selection and purchase of parts & components. The parts and components of the supporting engine and front drive axle are not compiled in the book in detail, and please see the illustrated book for parts and components of engine and the illustrated book for front drive axle provided together with the machine for the relevant detailed contents.

With the continual improvement and perfection of the product, some parts and components of tractor produced in the future may be inconsistent with that in the illustrated book, and it shall be based on the material object of existing tractor products, and please consult local distributors for any doubt. Users shall not put forward any unjustifiable requirements based on the detailed list of parts and components and illustration of parts and components in the book. After product improvement, the contents herein are subject to change without further notice, and the contents will be amended and supplemented when reprint of the illustrated book for parts and components. Sorry for the inconvenience.

If there is any mistake in the book, please point it out for our correction.

Contents

Grade	Parts code and specifications	Parts names	Page	Remark
1	B1.600.21	Air cleaner system assembly	P1-P2	
2	B1.500.13	Cooling system assembly	P3-P4	
3	3A.500.20	Engine control mechanism assembly	P5-P6	
4	3A.500.21	Clutch assembly	P7-P8	
5	B1.500.22	Exhaust System Assembly	P9-P9	
6	B554.31B	Front drive axle assembly	P10-P10	
7	B504.32Z.001	Front drive wheel assembly	P11-P11	
8	B504.34.001	Rear drive wheel assembly	P12-P13	
9	BL500.37	Gearbox assembly-1	P14-P15	
10	RT.500.37	Gearbox assembly-2	P16-P17	
11	BL500.37	Gearbox assembly-3	P18-P19	
12	BL500.37	Gearbox assembly-4	P20-P21	
13	RT.500.37	Gearbox assembly-4(Continued)	P22-P23	
14	RT.500.37	Gearbox assembly-5	P24-P25	
15	B500.38A	Rear axle assembly-1	P26-P27	
16	B500.38A	Rear axle assembly-2	P28-P29	
17	U500.38A	Rear axle assembly-3	P30-P31	
18	D500.38A	Rear axle assembly-4	P32-P33	
19	B500.38A	Rear axle assembly-5	P34-P35	
20	B300.39.001	Left final drive assembly	P36-P37	
21	B300.39.002	Right final drive assembly	P38-P39	
22	BL600J.40.001	Hydraulic steering assembly-1	P40-P41	
23	BL600J.40.001	Hydraulic steering assembly-2	P42-P43	
24	RT.554.42	Transfer case assembly-1	P44-P45	
25	BL554.42	Transfer case assembly-2	P46-P47	
26	HT.554.42	Transfer case assembly-3	P48-P49	
27	B500.43A	Braking system assembly-1	P50-P51	
28	B500.43A	Braking system assembly-2	P52-P53	
29	PS00.43A	Braking system assembly-3	P54-P55	
30	BL500L.44.001	Operator's seat assembly	P56-P56	
31	BA500.45?	Floor assembly	P57-P58	

BL600.11 Air Cleaner System Assembly

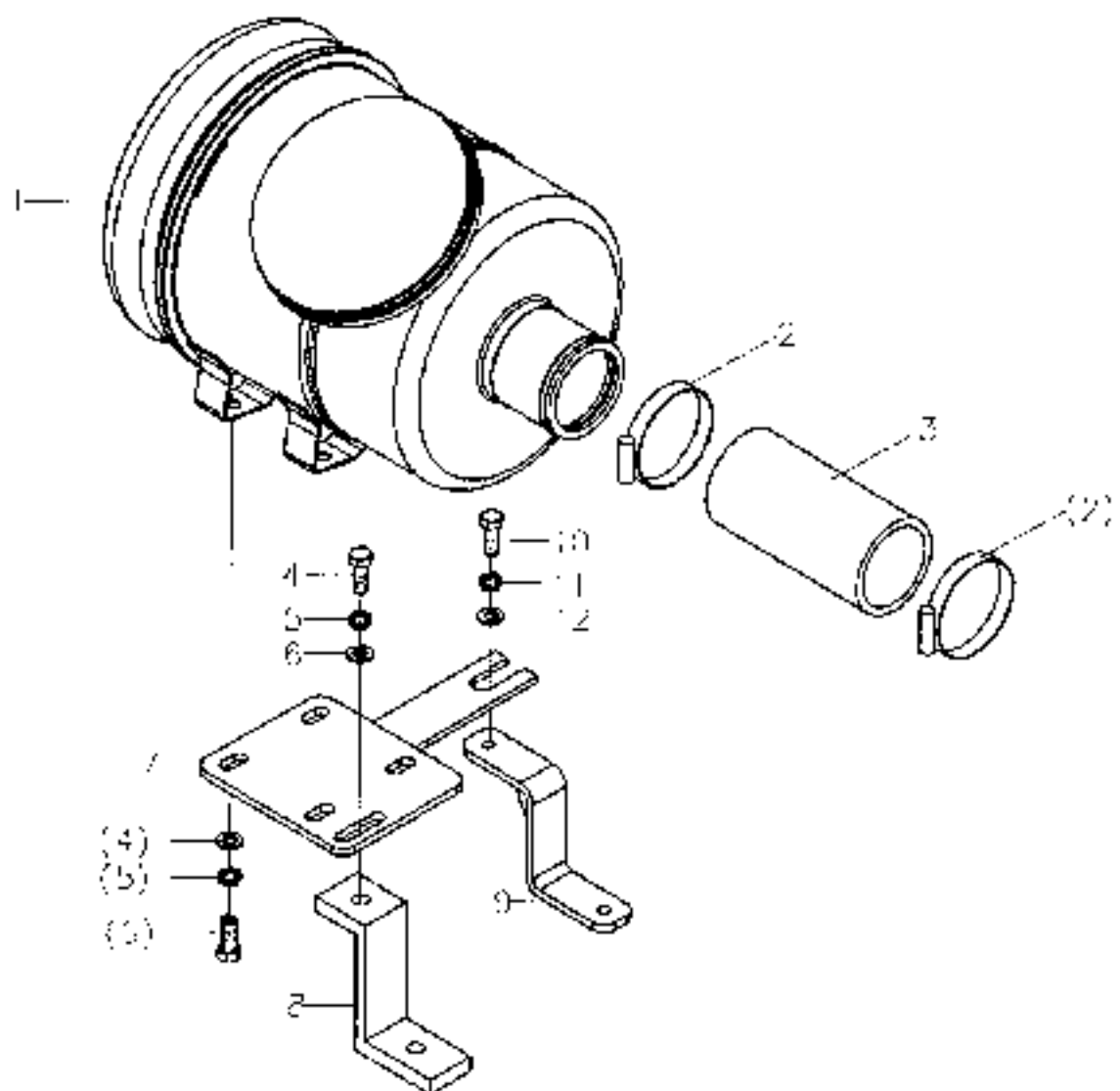

BL500.13 Cooling System Assembly

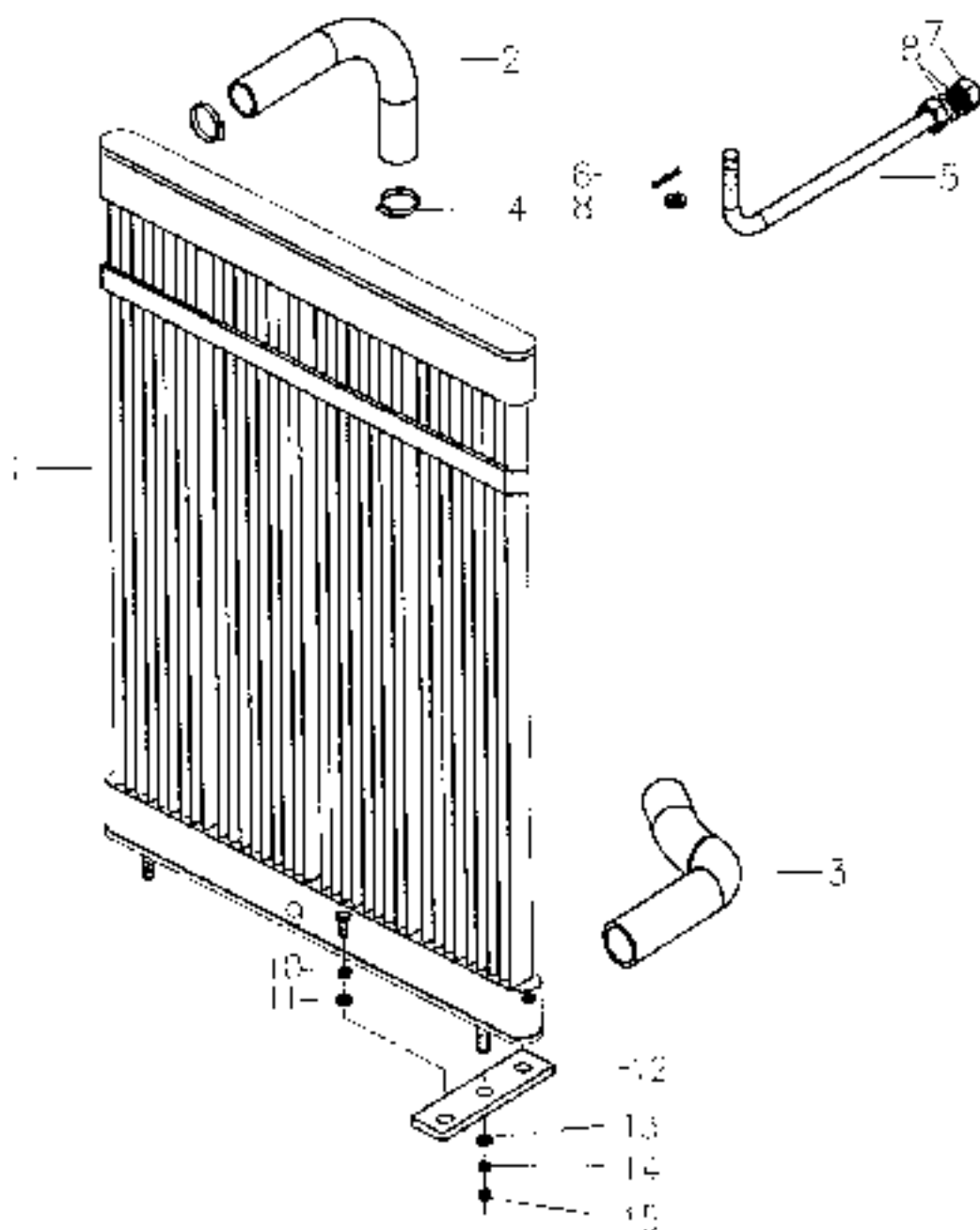

BA500.20 Engine Control Mechanism Assembly

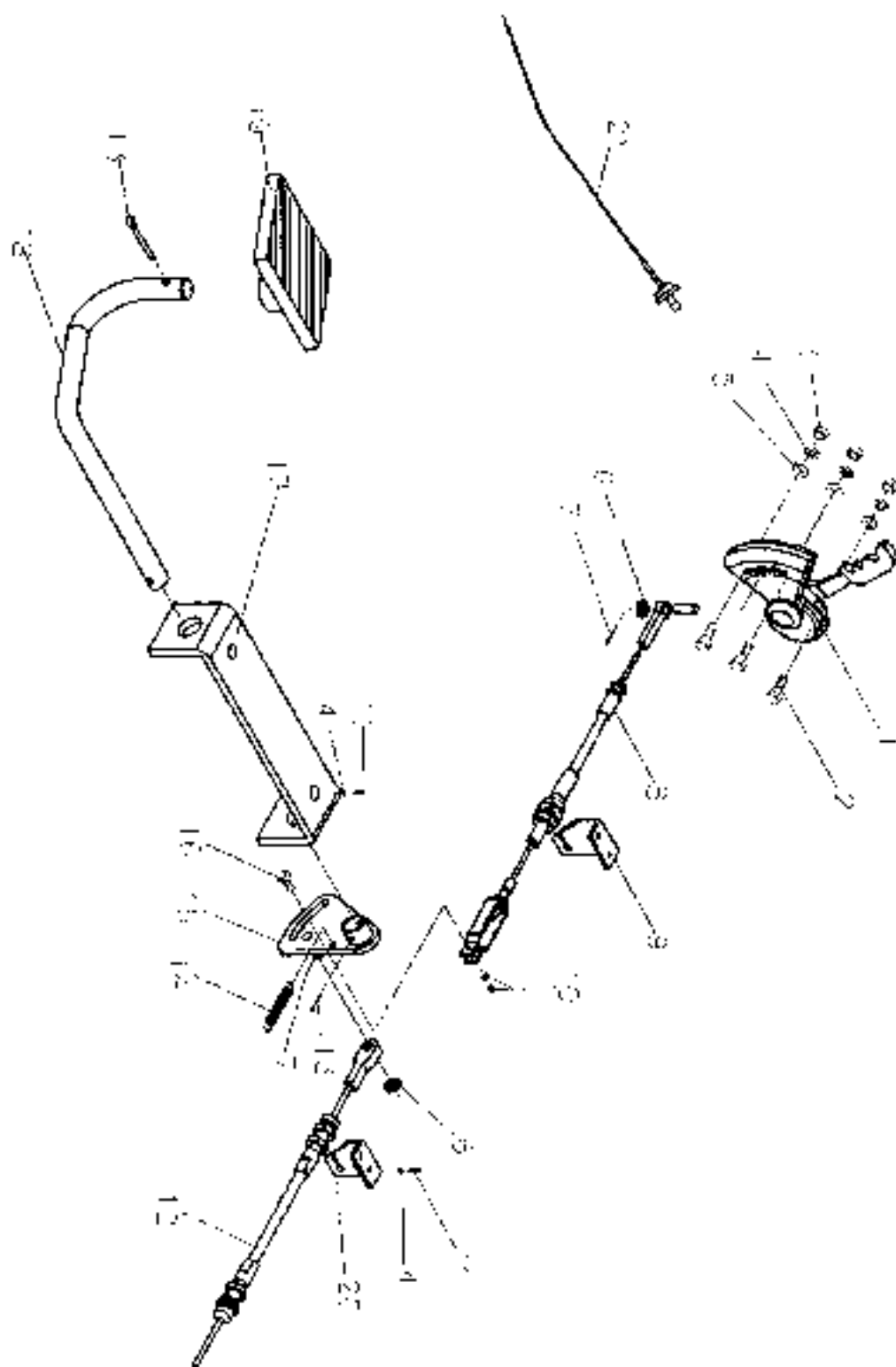

BA500.21 Clutch Assembly

Grade	Parts code and specifications	Parts names	Quantity	Remark
	BA500.21	Clutch assembly	1	
1	B500.21.010	Clutch assembly	1	
2	GB/T 93-10-Zn · D	Single coil spring lock washers	6	
3	GB/T 5782-M10×45-10.9 Zn · D	Hexagon head bolts	6	
4		Release bearing 6688213	1	
5	B500.21.102	Release bearing seat	1	
6	B500.21.103-1	Return spring	2	
7	B500.21.104	Release fork	1	
8	B500.21.105	Set screw of release fork	1	
9	B500.21B.011	Release fork shaft	1	
10	GB/T 5786-M10×1×45-Zn · D	Hexagon head bolts	1	
11	GB/T 6173-M10×1-Zn · D	Hexagon head nuts	1	
12	GB/T 582-88×30	Clevis pin with head	2	
13	GB/T 97.1-8-Zn · D	Plain washers	2	
14	GB/T 91-3.2×20	Single coil spring lock washers	2	
15	B500.21.107	Left connecting fork of pull rod	1	
16	GB/T 6170-M10 left-Zn · D	Hexagon head nuts	1	
17	B500.434.103	Pull rod	1	
18	GB/T 6170 M10-Zn · D	Hexagon head nuts	1	
19	B500.21.109	Right connecting fork of pull rod	1	
20	B500.21B.012	Clutch pedal assembly	1	
21	BV304.21.110	Pedal return spring	1	
22	GB/T 5783-M6×16-Zn · D	Hexagon head bolts	1	
23	GB/T 93-6-Zn · D	Single coil spring lock washers	1	
24	B1.500.21.012	Rotating shaft of clutch pedal	1	
25	JIT 7946.1-M10×1	Oil cup	1	
26	GB/T 5783 M8×45-Zn · D	Hexagon head bolts	1	
27	GB/T 6170-M8-Zn · D	Hexagon head nuts	1	
28	B1.500.21.110	Bushing of clutch rotating shaft	2	

BL500.22 Exhaust System Assembly

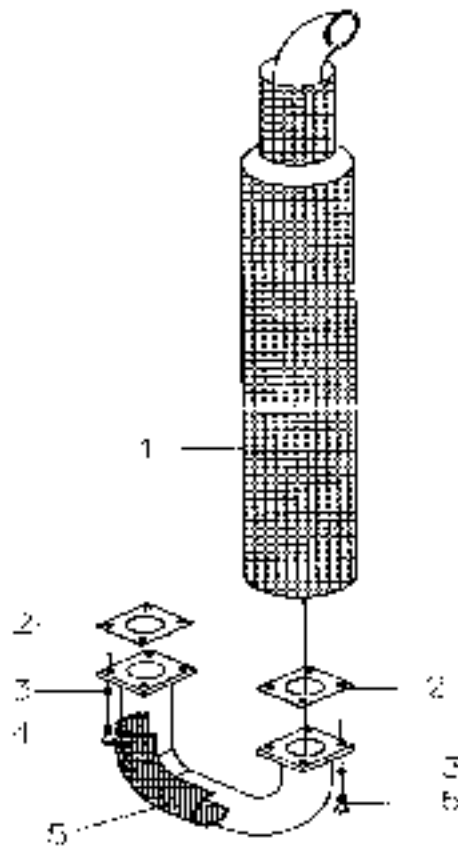

BL500.22 Exhaust System Assembly

Grade	Parts code and specifications	Parts names	Quantity	Remark
	BL500.22	Exhaust System Assembly	1	
1	SZ495T.08.001	Muffler assembly	1	
2		Exhaust pipe gasket	2	
3	GB/L 93 10-Zn · D	Single coil spring lock washers	4	
4	GB/T 5783-M10 x 30-Zn · D	Hexagon head bolts	4	
5	BL500.22.011	Exhaust elbow	1	
6	GB/T 5783-M10 x 40 Zn · D	Hexagon head bolts	4	

B554.31B Front Driving Axle Assembly

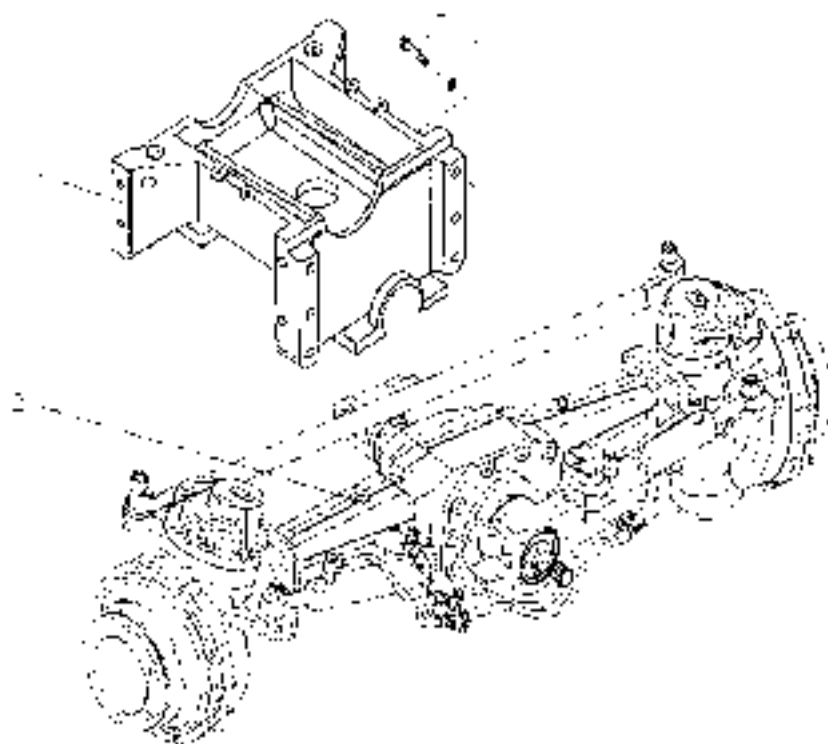

B554.31B Front Driving Axle Assembly

Grade	Parts code and specifications	Parts names	Quantity	Remark
1	B554.31B.PT	Front drive axle assembly	1	
1.1		Bracket	1	
1.2		Front drive axle assembly	1	
2	GB/T 5782 M16 x 60-Zn-D	Hexagon head bolts	6	
3	GB/T 93-16-Zn-D	Single coil spring lock washers	6	

B504.32Z.001 Front Driving Wheel Assembly

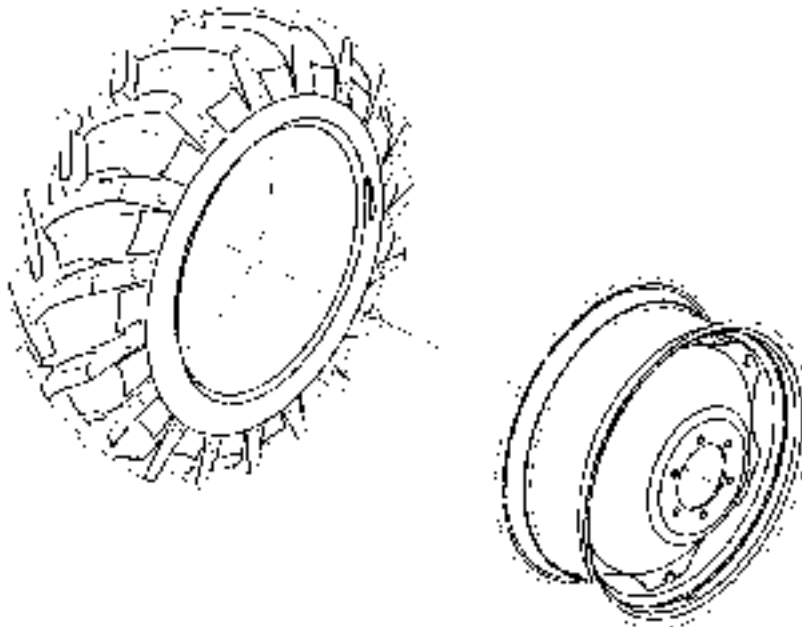

B504.32Z.001 Front Drive Wheel Assembly

Grade	Parts code and specifications	Parts name/s	Quantity	Remark
	B504.32Z.001	Front drive wheel assembly	1	
1	8.3-20-10R1	Tyre	2	
1.3	GB/T 2979-8.3-20-10PR R1	Cover	2	
1.2	GB/T 2979-8.3-20	Inner tube	2	
2	LM70QA(W? 20)	Rim assembly	2	

B504.34.001 Rear Drive Wheel Assembly

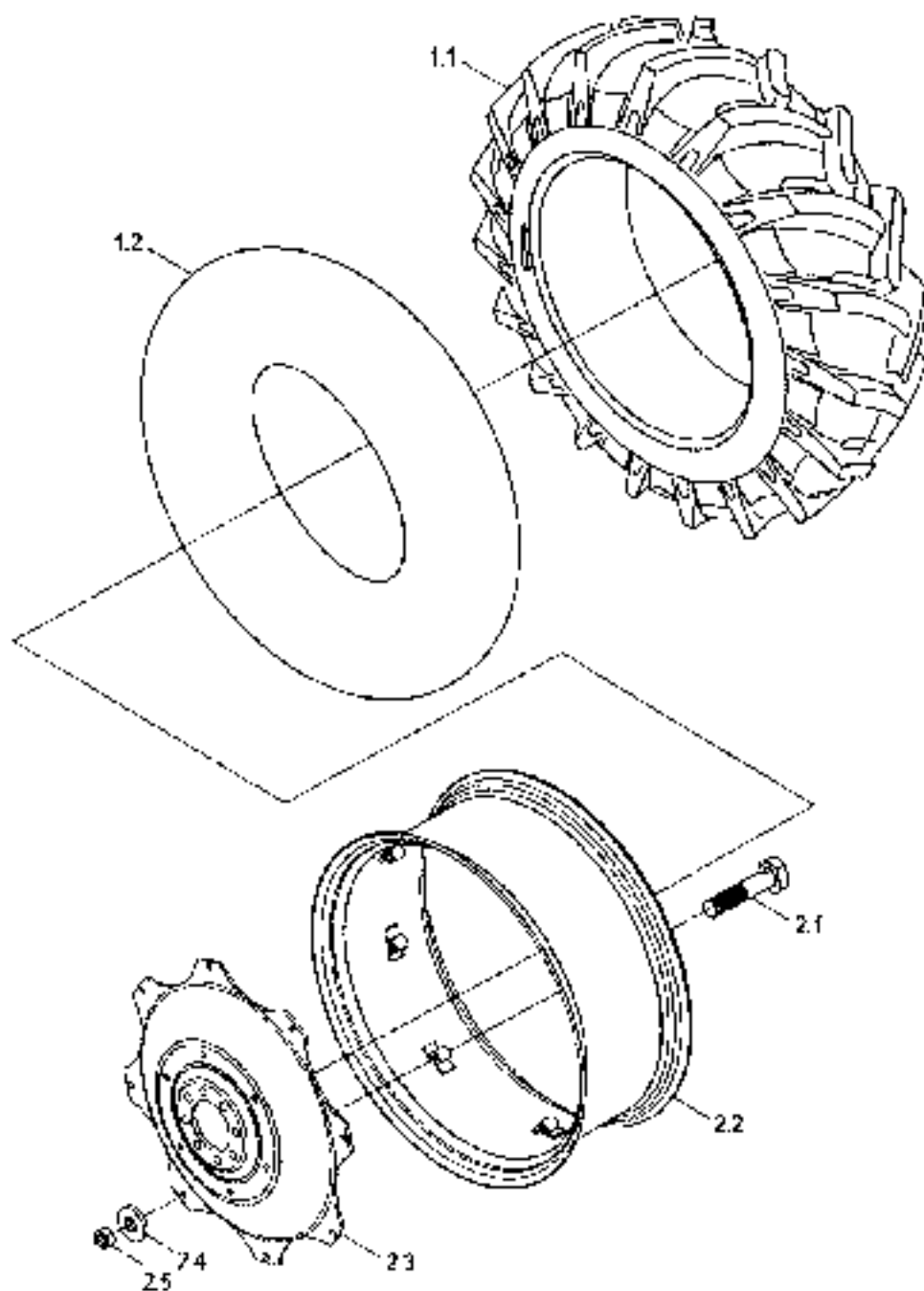

BL500.37 Gearbox Assembly-1

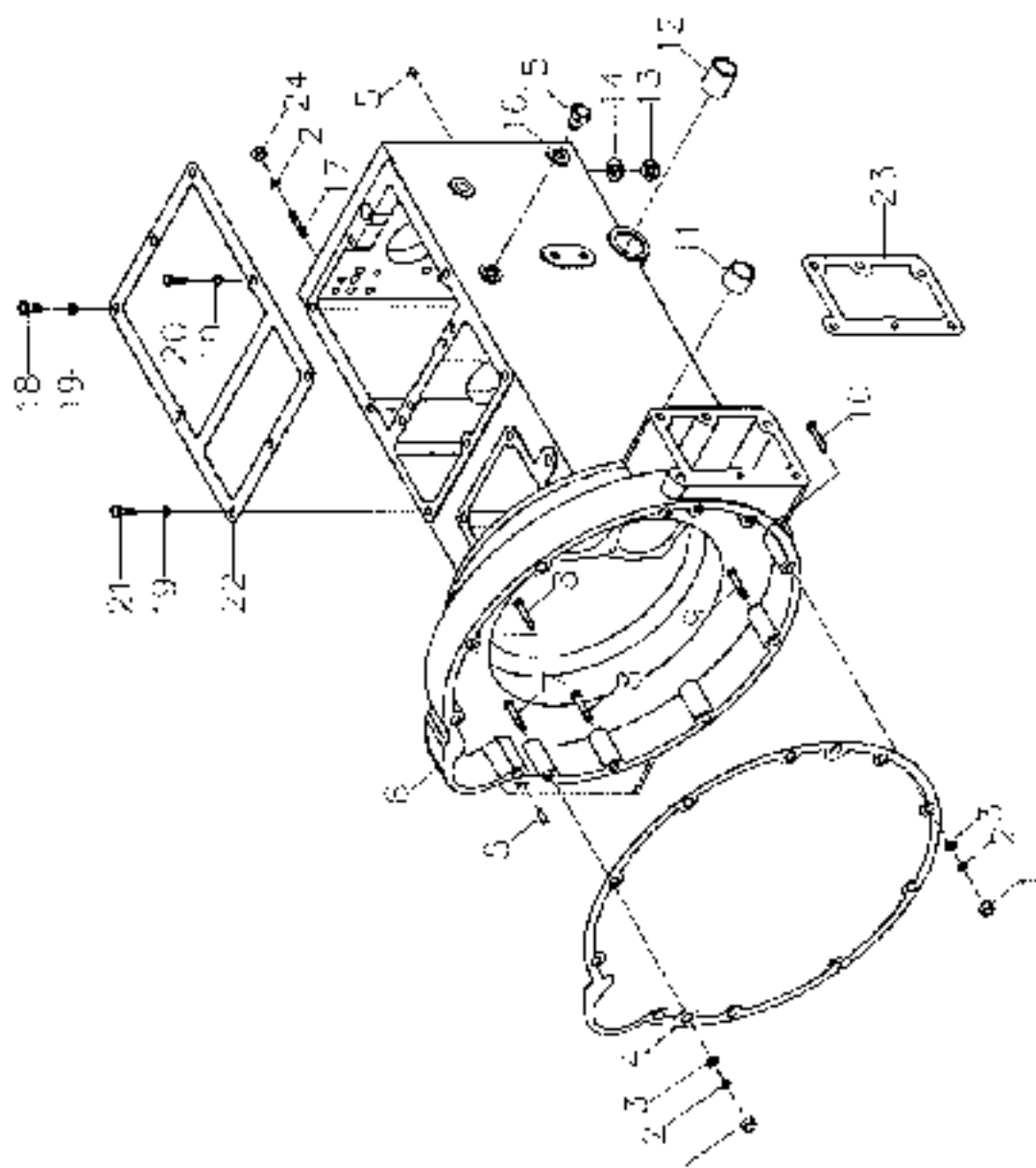

BL500.37 Gearbox Assembly-1

Grade	Parts code and specifications	Parts names	Quantity	Remark
	BL500.37	Gearbox assembly	1	
1	GB/T 6170-M12-Zn-D	Hexagon nuts	5	
2	GB/T 93-12-Zn-D	Single coil spring lock washers	22	
3	GB/T 97.1-12-Zn-D	Plain washers	5	
4	B300.37.121	Front paper gasket	1	
5	GB/T 119.2-12 x 30	Parallel pins	4	
6	B500.37.101	Housing of gear case	1	
7	GB/T 5782-M12 x 55-Zn-D	Hexagon head bolts	2	
8	GB/T 5782-M12 x 75-Zn-D	Hexagon head bolts	2	
9	GB/T 5782-M12 x 80-Zn-D	Hexagon head bolts	3	
10	GB/T 5782-M12 x 100-Zn-D	Hexagon head bolts	3	
11	B300.37.159	Release fork shaft bushing	2	
12	B300.37.158	Pedal shaft bushing	2	
13	B300.38.114	Oil drain plug	1	
14	JBT 982-20	Combination gasket	1	
15	B500.37.140	Sealing bolt	2	
16	JBT 982-14	Combination gasket	2	
17	GB/T 899-3012-Y12 x 1.5 x 35-8.8-Zn-D	Double end studs	12	
18	GB/T 5783-M10 x 80-Zn-D	Hexagon head bolts	3	
19	GB/T 93-10 Zn-D	Single coil spring lock washers	8	
20	GB/T 5783-M10 x 40-Zn-D	Hexagon head bolts	1	
21	GB/T 5783-M10 x 30-Zn-D	Hexagon head bolts	4	
22	B500.37.110	Paper gasket	1	
23	B500.37.150	Paper gasket	1	
24	GB/T 6176-M12 x 1.5-Zn-D	Hexagon nuts	12	

BL500.37 Gearbox Assembly-2

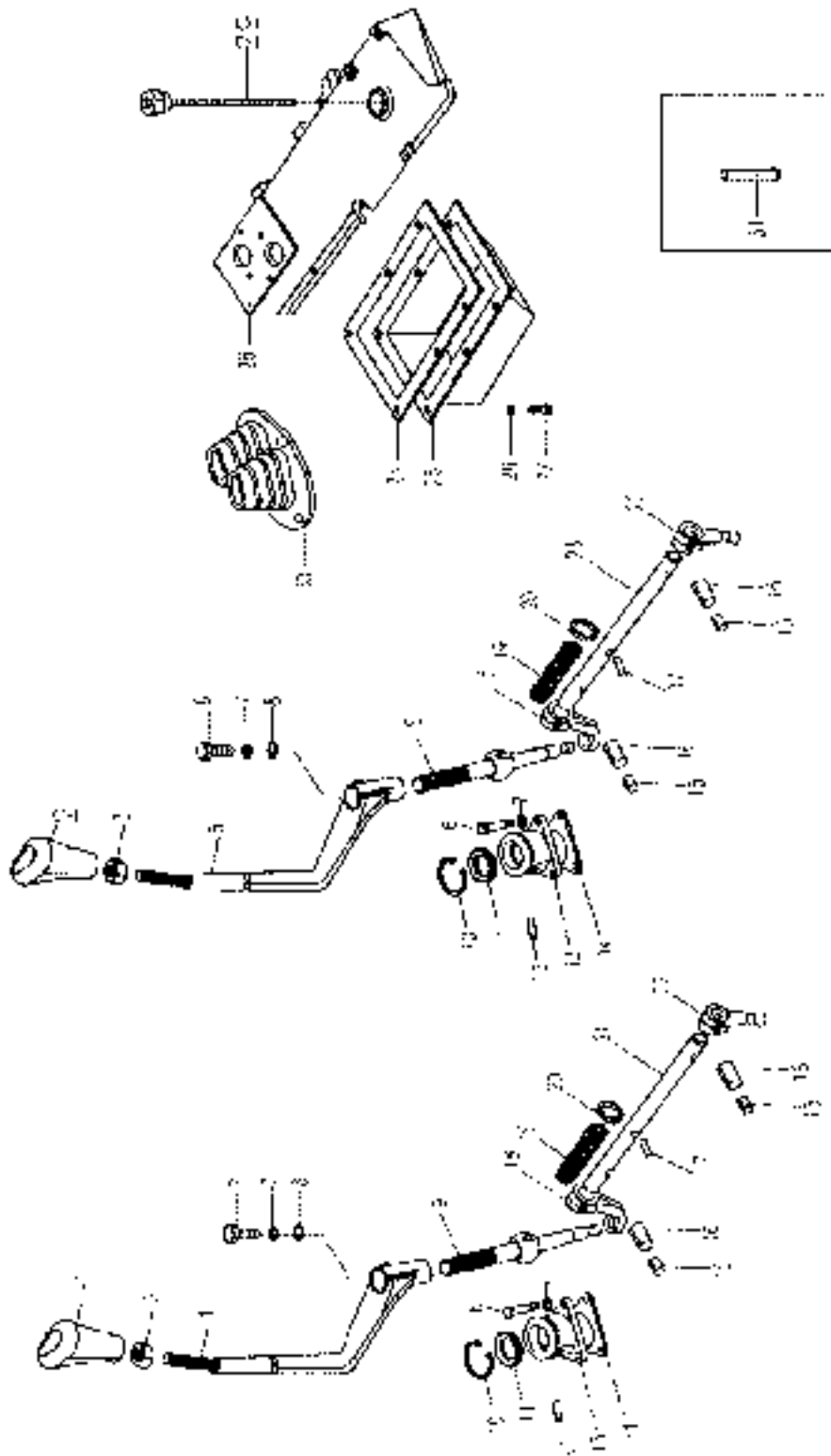

BL500.37 Gearbox Assembly-2

Grade	Parts code and specifications	Parts names	Quantity	Remark
	BL500.37	Gearbox assembly	1	
1	B300.37.015	Main gear control handle assembly	1	
2	B500.37.017A	Auxiliary gear control handle assembly	1	
3	GB/T 6172.1-M10-Zn·D	Hexagon nuts	2	
4	B600.37.020	Side control gear lever	1	
5	B600.37.021-1	Side control gear lever	1	
6	GB/T 5783-M8×20-Zn·D	Hexagon head bolts	8	
7	GB/T 93-8-Zn·D	Single coil spring lock washers	8	
8	GB/T 97.1-8-Zn·D	Hexagon head bolts	2	
9	B600.37.609	Lower control lever	2	
10	GB/T 893.1-40	Circlips for holes	2	
11	88498422 V1.29.195	Seal of main control lever	2	
12	5125555/1.21.067	Spacer pin	4	
13	5127967/1.32.217	Control lever support	2	
14	B600.37.607	Paper gasket of side control support	2	
15	GB/T 879.1-5×40	Spring-type straight pins	1	
16	GB/T 879.1-8×40	Spring-type straight pins	2	
17	GB/T 879.1-5×35	Spring-type straight pins	2	
18	B600.37.603	External gear transmission shifting block	2	
19	5127962/1.29.106	Return spring of control lever	2	
20	5132334/1.32.293	Spring swayer ring of transmission bar	2	
21	B600.37.606	Main gear transmission bar	1	
22	B600.37.602	Gear lever head	2	
23	B600.37.605	Auxiliary gear transmission bar	1	
24	B600.37.608	Lower cover paper gasket	1	
25	B600.37.604	Lower cover of side control	1	
26	GB/T 93-6-Zn·D	Single coil spring lock washers	6	
27	GB/T 5783-M6×20-Zn·D	Hexagon head bolts	6	
28	B600.37.601	Gear case cover	1	
29	B200.38.016-A	Oil filler plug assembly	1	
30	BL500.47.106	Direction of main and auxiliary gear lever	1	
31	B600.37A.021	Weld assembly of oil filler pipe	1	

BL500.37 Gearbox Assembly-3

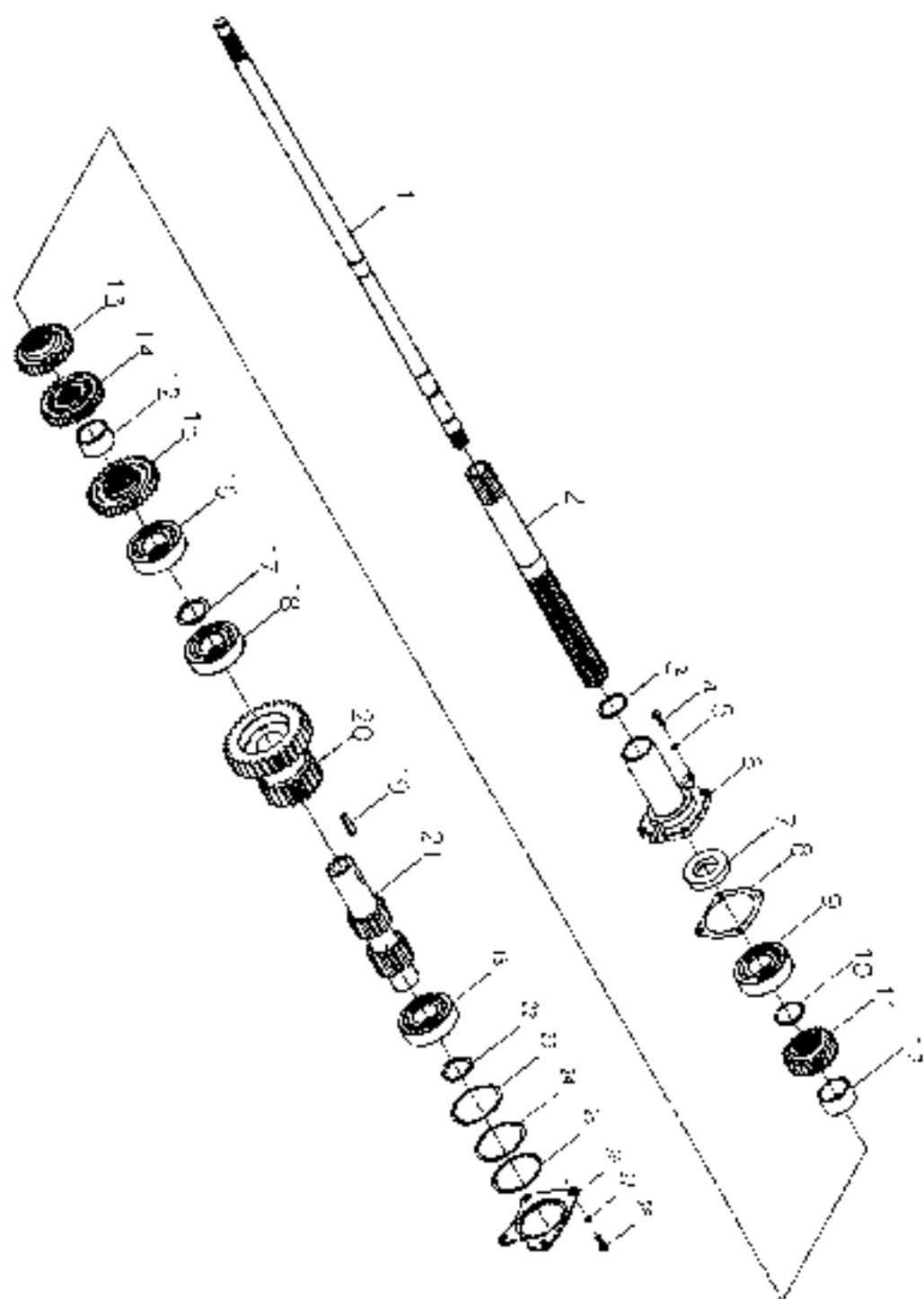

BL500.37 Gearbox Assembly-3

Grade	Parts code and specifications	Parts names	Quantity	Remark
	BL500.37	Gearbox assembly	1	
1	B500.37.102	Auxiliary control shaft	1	
2	B500.37.011	I' shaft assembly	1	
3	GB/T 3452.1-23.6 × 1.8	O-ring	1	
4	GB/T 5783 M8 × 25-Zn · D	Hexagon head bolts	4	
5	GB/T 93-B-Zn · D	Single coil spring lock washers	4	
6	B500.37.145	I' shaft bearing cover	1	
7	JB/T 2600 PG40 × 62 × 10	Oil seal	1	
8	B300.37.125	Paper gasket	1	
9	GB/T 276-6208	Rolling bearing	1	
10	CB/T 894.1-40	Retainer ring	-	
11	B500.37.103	Gear I driving gear	1	
12	B500.37.104	Spacer bush of driving gear	2	
13	B500.37.105	Gear II driving gear	1	
14	B500.37.106	Gear III driving gear	1	
15	B500.37.107	Gear IV driving gear	1	
16	GB/T 281-NJ208E	Rolling bearing	1	
17	B500.37.108	Spacer ring of I' shaft bearing	1	
18	GB/T 283-NJ208E	Rolling bearing	2	
19	CB/T 1096-12 × 80	Key	1	
20	B500.37.109	Constant mesh duplex gear	1	
21	B500.37.012	Driving gear shaft assembly of auxiliary gear	1	
22	GB/T 895.2-24	Retainer ring	1	
23	B500.37.111	Spacer	As required	
24	B500.37.112	Spacer	As required	
25	B500.37.113	Spacer	As required	
26	B500.37.114	Auxiliary gear bearing cover	1	
27	GB/T 93-B-Zn · D	Single coil spring lock washers	4	
28	GB/T 5783-M10 × 25-Zn · D	Hexagon head bolts	4	

BL500.37 Gearbox Assembly-4

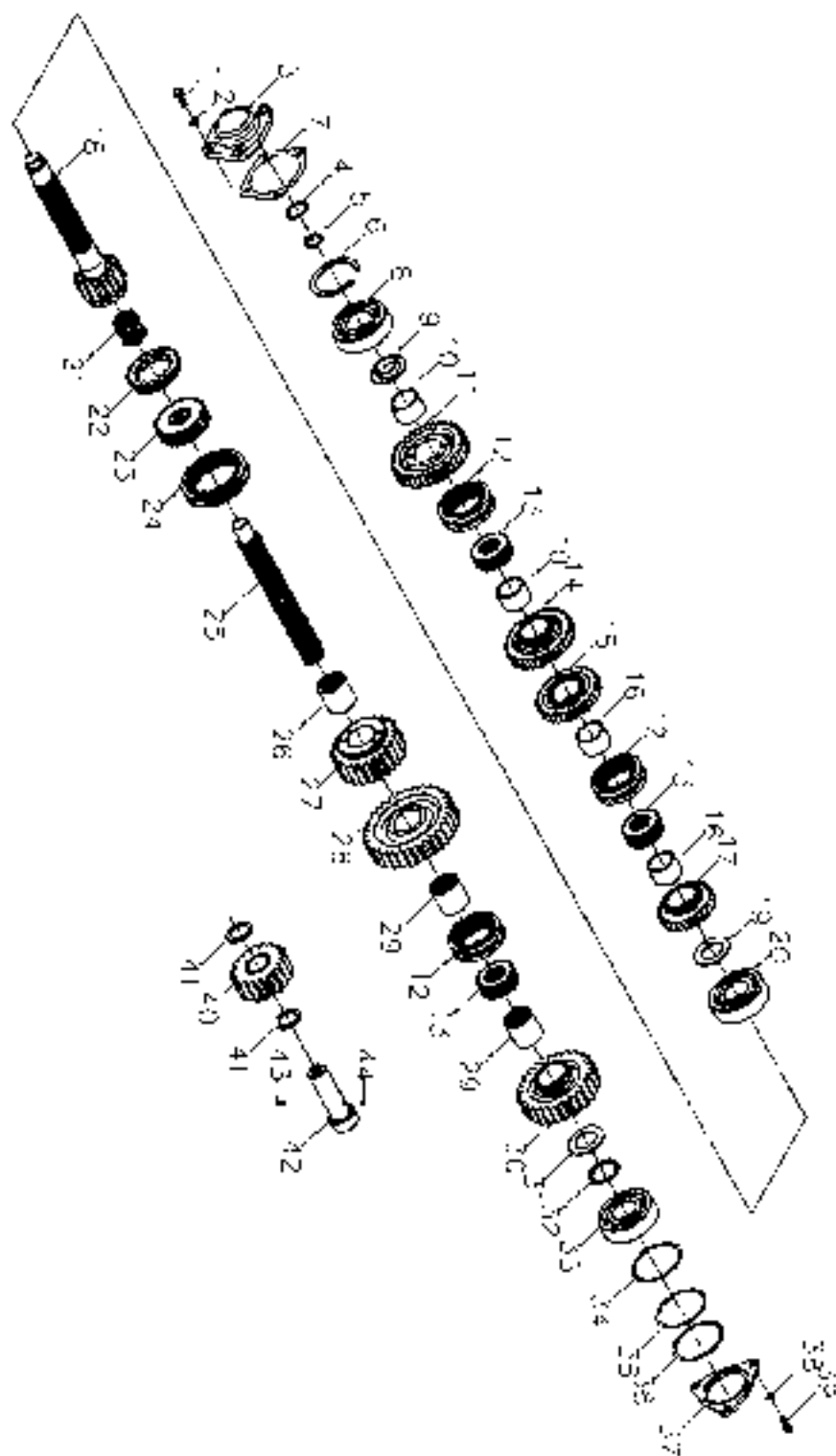

BL500.37 Gearbox Assembly-4

Grade	Parts code and specifications	Parts name	Quantity	Remark
	BL500.37	Gearbox assembly	1	
1	GB/T 5783-M8 × 25-Zn · D	Hexagon head bolts	4	
2	GB/T 93 8 Zn · D	Single coil spring lock washers	4	
3	B500.37.120	2 nd shaft bearing cover	1	
4	GB/T 812-M24 × 1.5	Round nuts	1	
5	GB/T 858-24	Tab washers for round nuts	1	
6	GB/T 305-72/78.6	Stop ring	1	
7	B300.37.119	Paper gasket of 2 nd shaft bearing cover	1	
8	GB/T 276-6306N	Rolling bearing	1	
9	B500.37.135	2 nd shaft end retainer ring	1	
10	B500.37.133	Bushing of driven gear, Gears I-II	2	
11	B500.37.134	Driven gear, Gear I	1	
12	B300.37.115	Mesh sleeve, Gears I-II	3	
13	B300.37.116	Seat of mesh gear, Gears I-II	3	
14	B500.37.132	Driven gear, Gear II	1	
15	B500.37.131	Driven gear, Gear III	1	
16	B500.37.130	Bushing of driven gear, Gears III-IV	2	
17	B500.37.129	Driven gear, Gear IV	1	
18	B500.37.136	2 nd shaft	1	
19	B500.37.128	2 nd shaft rear retainer ring	1	
20	GB/T 283-YU1207E	Rolling bearing	1	
21	GB/T 309-5 × 27.8 (12-2-4)	Needle roller	18	
22	B500.37.127	Hagl. gear seat, auxiliary gear	1	
23	B500.38.189-1	PTO mesh gear seat	1	
24	B500.38.416	PTO mesh sleeve	1	
25	B500.37.126	Output shaft	1	
26	B500.37.125	Driven gear bushing	1	
27	B500.37.124	Driven gear, mesh gear, auxiliary gear	1	
28	B500.37.123	Driven gear, low gear, auxiliary gear	1	
29	B500.37.122	Driven gear bushing, reverse gear	2	

BL500.37 Gearbox Assembly-4(Continued)

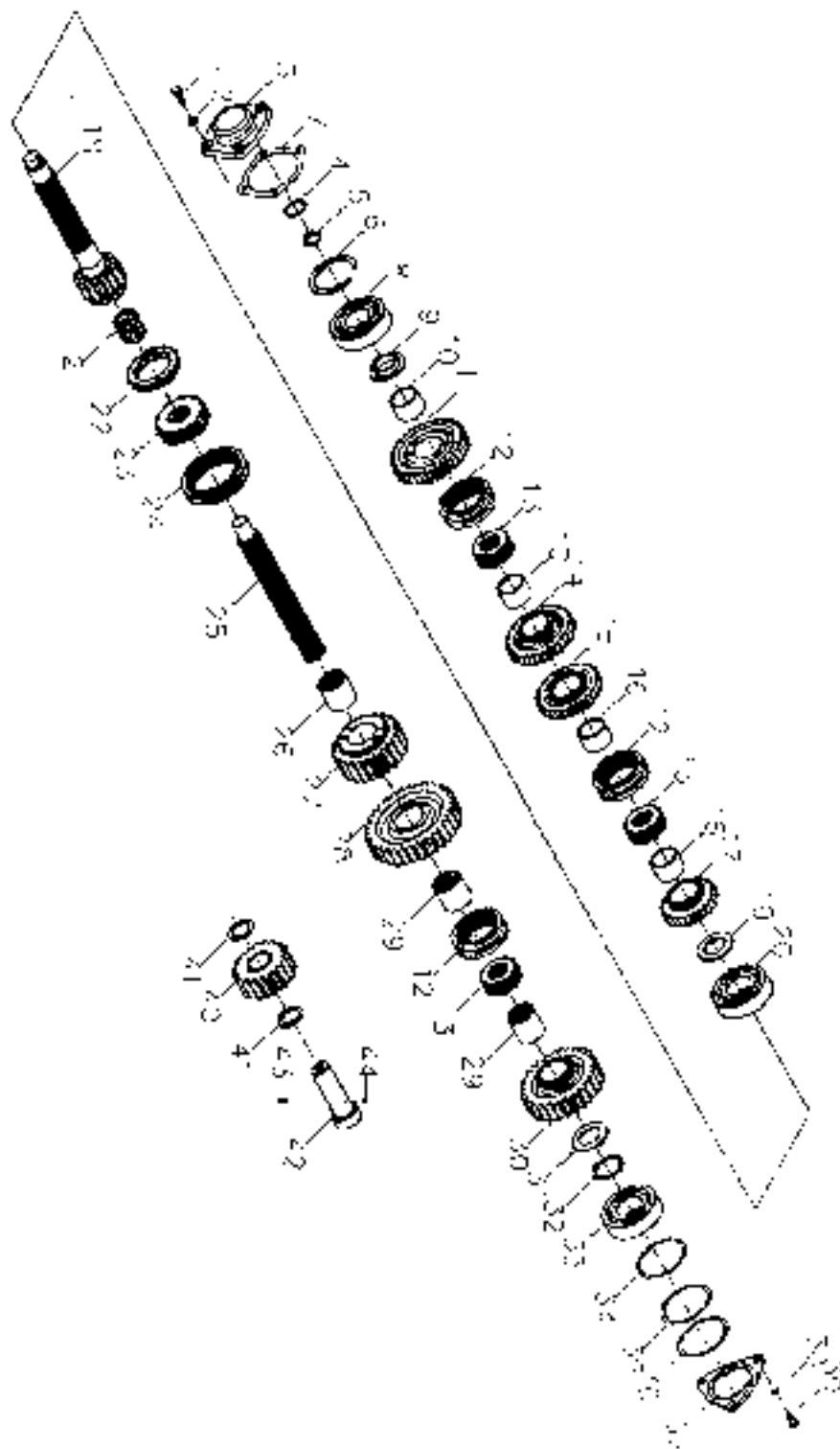

B500.38A Rear Axle Assembly-1

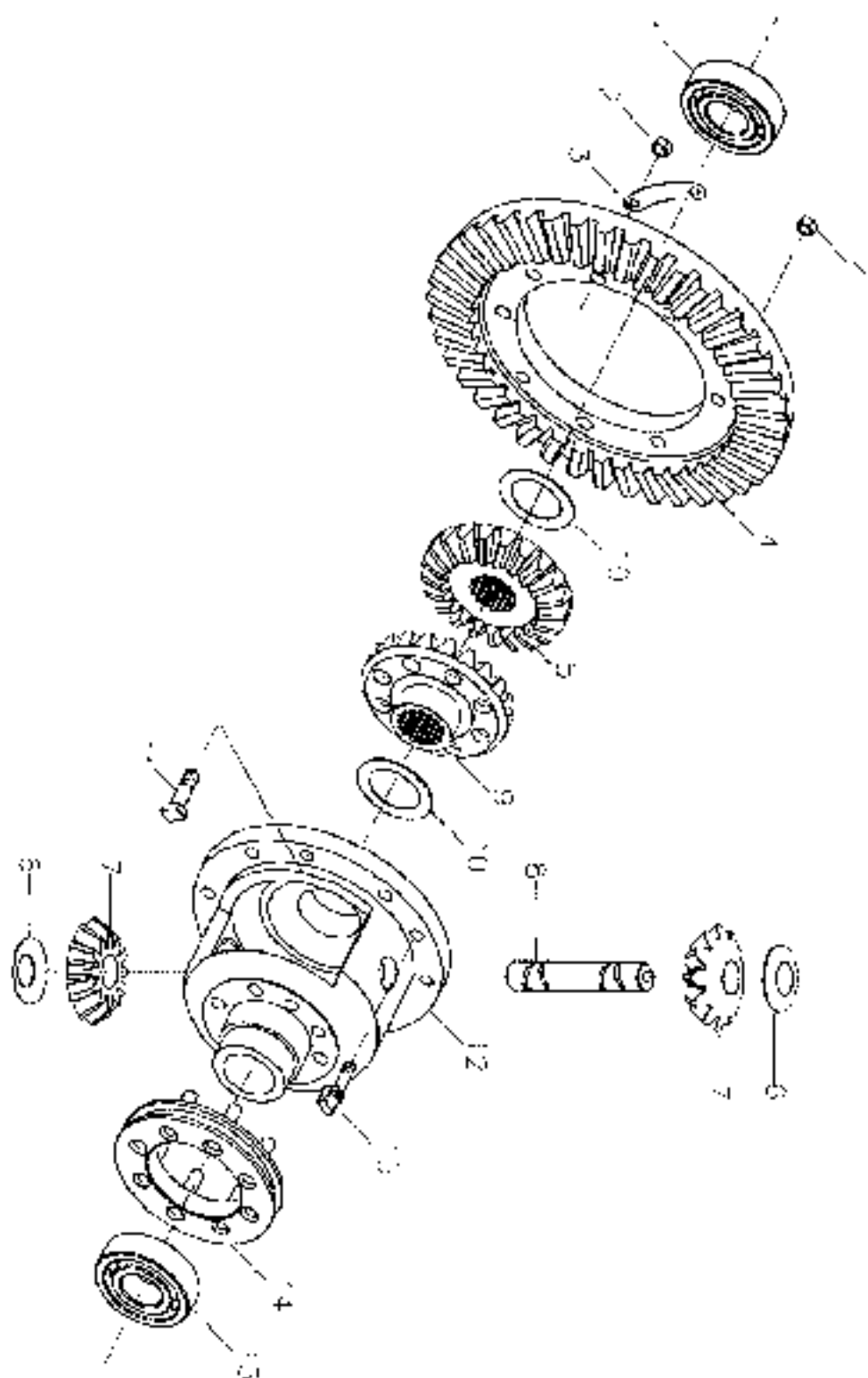

B500.38A Rear Axle Assembly-2

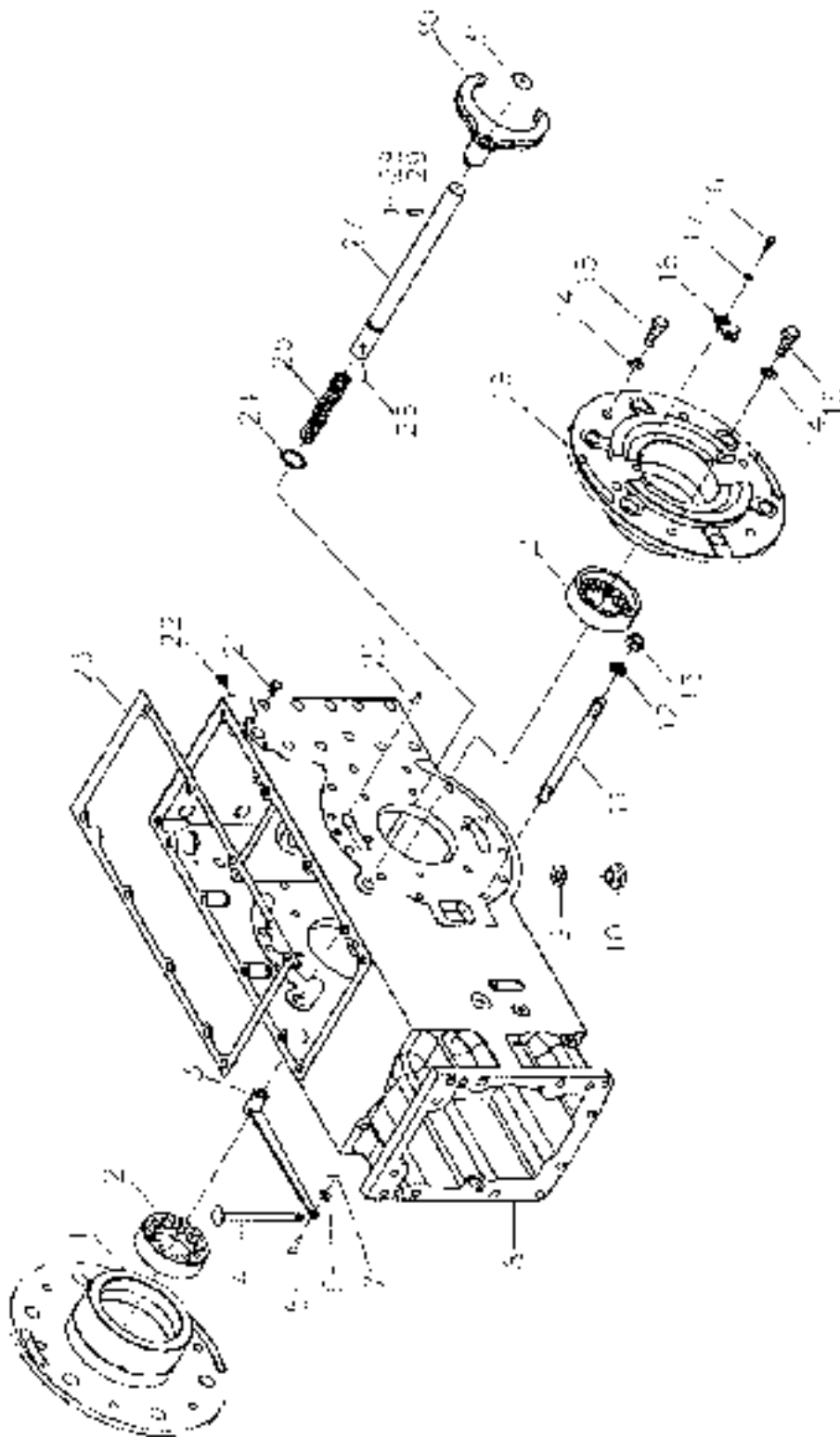

B500.38A Rear Axle Assembly-2

Grade	Parts code and specifications	Parts names	Quantity	Remark
	B500.38A	Rear axle assembly	1	
1	B300.38.177	Right differential bearing seat	1	
2	B300.38.151	Adjusting nut	2	
3	B500.38A.011	Weld assembly of rocker arm	1	
4	B500.38A.013	Weld assembly of pivot	1	
5	GB/T 882 B8 × 30	Clevis pin with head	1	
6	GB/T 97.1-8 Zn · D	Plain washers	1	
7	GB/T 91-3.2 × 20	Split pins	1	
8	B504.38.101	Rear axle housing	1	
9	JB/T 982-20	Combination gasket	1	
10	B300.38.114	Oil drain plug	1	
11	GB/T 899-AMI2-M12 × 1.5 × 150-8.8-Zn · D	Double end studs	24	
12	GB/T 93-12-Zn · D	Single coil spring lock washers	24	
13	GB/T 6171-M12 × 1.5-Zn · D	Hexagon nuts	24	
14	GB/T 93-10-Zn · D	Single coil spring lock washers	12	
15	GB/T 5783-M10 × 25-Zn · D	Hexagon head bolts	12	
16	GB/T 5783-M8 × 16-Zn · D	Hexagon head bolts	4	
17	GB/T 93-8 Zn · D	Single coil spring lock washers	4	
18	B300.38.161	Locking plate	2	
19	B300.38.142	Left differential bearing seat	1	
20	GB/T 119.2-12 × 30	Parallel pins	2	
21	B500.31.301	φ 16 Blanking cap	4	
22	B500.31.303	φ 12 Blanking cap	4	
23	B500.38.417	Paper gasket of rear axle case	1	
24	GB/T 3452.1-15 × 2.65G	O-ring	1	
25	B300.38.160	Return spring of differential lock	1	
26	GB/T 879.1-6 × 30	Spring-type straight pins	1	
27	B300.38.158	Fork shaft of differential lock	1	
28	GB/T 879.1-5 × 40	Spring-type straight pins	1	
29	GB/T 879.1-6 × 40	Spring-type straight pins	1	
30	B300.38.159	Differential lock fork	1	
31	QC/T 388-20	Bowl-shaped tubular plug	1	

B500.38A Rear Axle Assembly-3

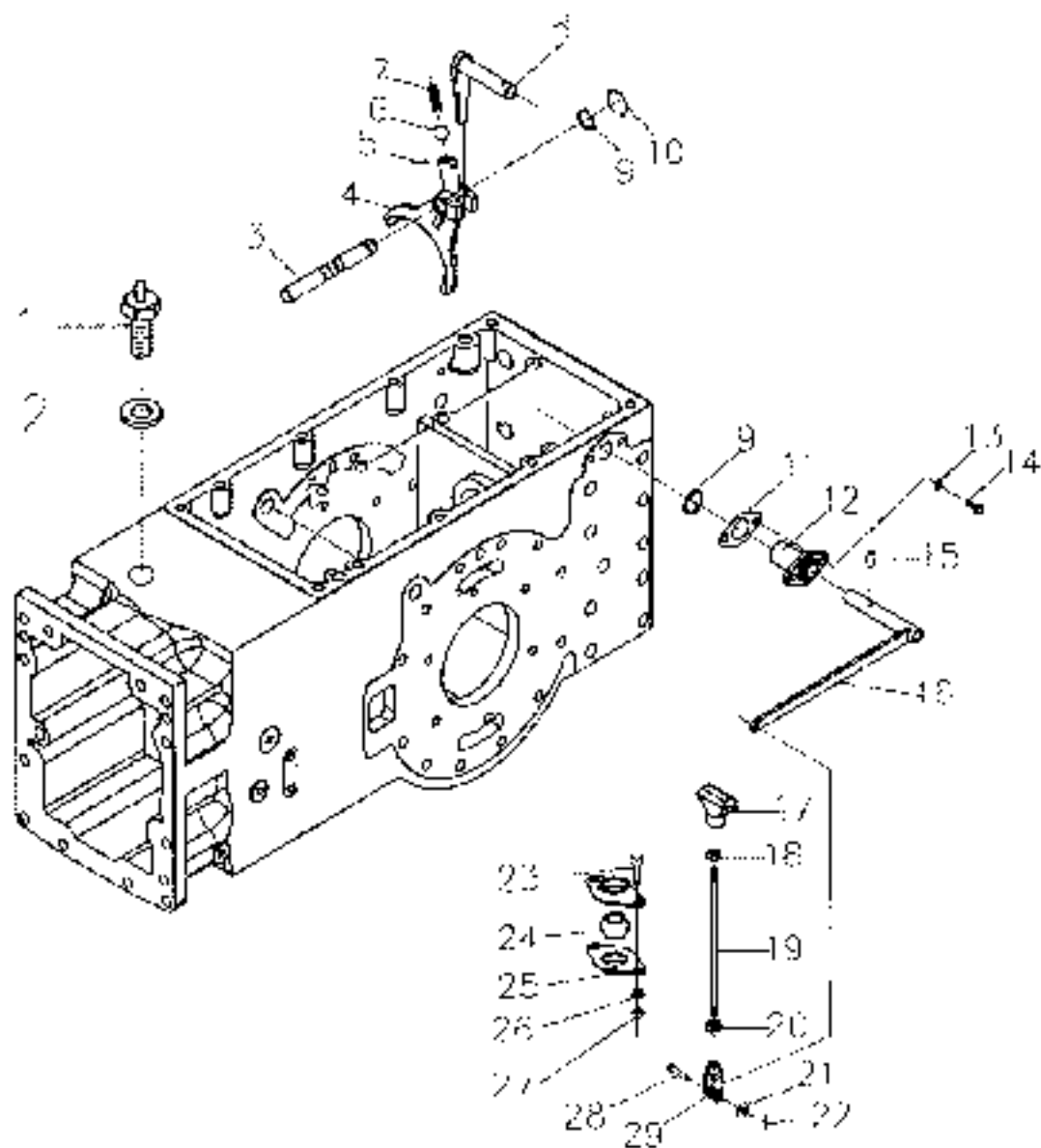

B500.38A Rear Axle Assembly-3

Grade	Parts code and specifications	Part's names	Quantity	Remark
	B500.38A	Rear axle assembly	1	
1	HXQ 500	Breather	1	
2	JM71 082-12	Combination gasket	1	
3	B500.38C.181	PTO fork shaft	1	
4	B500.19C.183	PTO gear shaft fork	1	
5	GB/T 91-4 × 32	Splits pins	1	
6	GB/T 308-9.5100 G10GB	Steel balls	1	
7	3300.37B.125	Inverter spring	1	
8	D300.38.013	Finger-shaped shifting lever	1	
9	GB/T 3652.1-1 2 × 2.65G	O-ring	2	
10	GB/T 894.1-16	Condiscs for shaft	1	
11	B300.38.133	Shifting lever bushing gasket	1	
12	B300.38.134	Shifting lever bushing	1	
13	GB/T 93-8-Zn · D	Single coil spring lock washers	2	
14	GB/T 5783-M8 × 20-Zn · D	Hexagon head bolts	2	
15	GB/T 879.1-8 × 40	Spring-type straight pins	1	
16	B500.38A.019	Weld assembly of rocker arm	1	
17	804.42.017	Pull-pree handle	1	
18	GB/T 6170-M10-Zn · D	Hexagon nuts	1	
19	3504.42A.101-1	Pull rod	1	
20	GB/T 6170-M10-Lef-Zn · D	Hexagon nuts	1	
21	GB/T 97.1-8-Zn · D	Plan washers	1	
22	GB/T 91-3.2 × 20	Splits pins	1	
23	GB/T 5783 M6 × 20-Zn · D	Hexagon head bolts	2	
24	5109058/1 80.254	Ball sleeve	1	
25	4908911/L/80.255	Ball sleeve seat	2	
26	GB/T 93-6-Zn · D	Single coil spring lock washers	2	
27	GB/T 6170 M6-Zn · D	Hexagon nuts	2	
28	GB/T 882-T4 × 30	Clevis pin with head	1	
29	B500.21.107	Left connecting fork of pull rod	1	

B500.38A Rear Axle Assembly-4

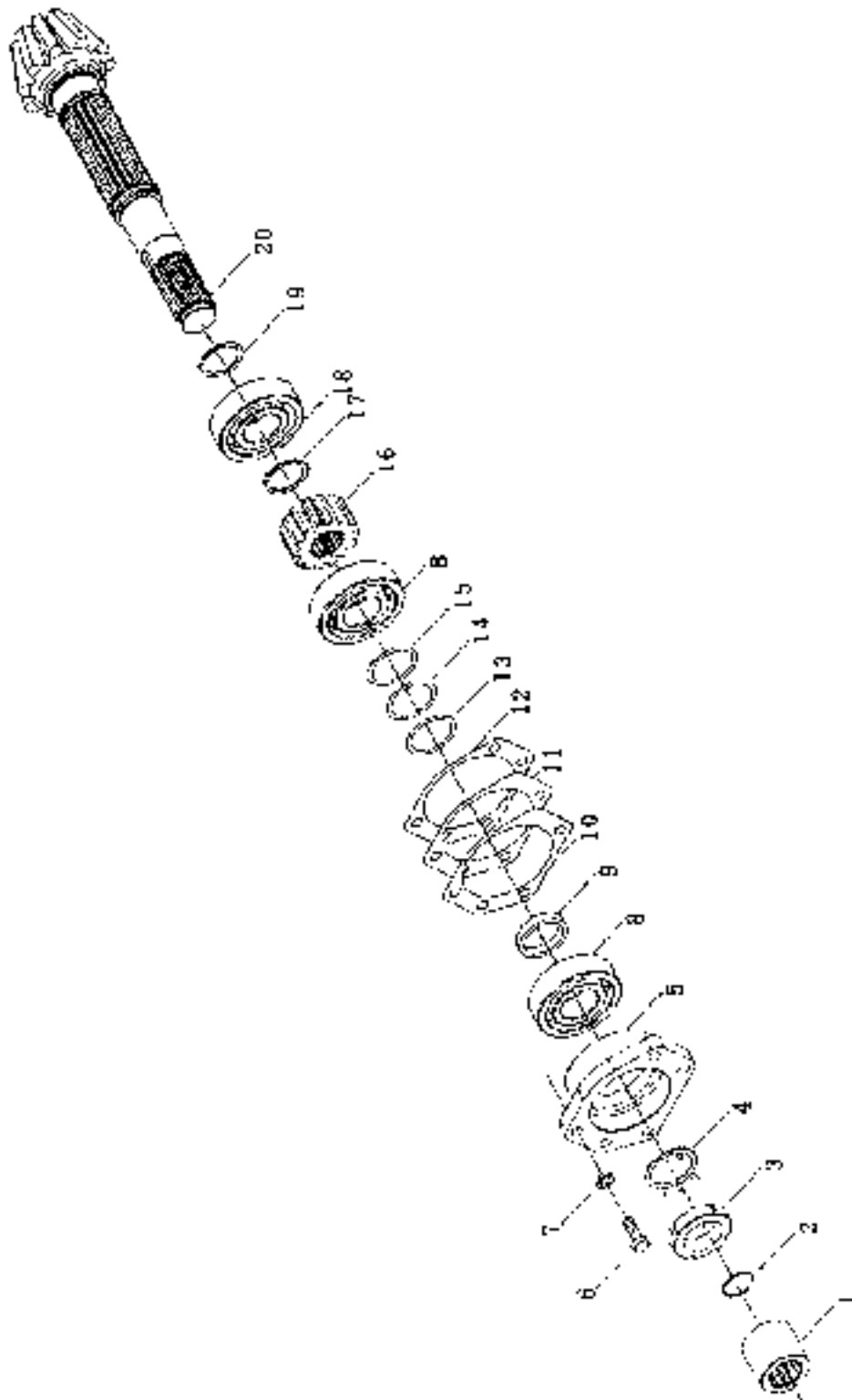

B500.38A Rear Axle Assembly-5

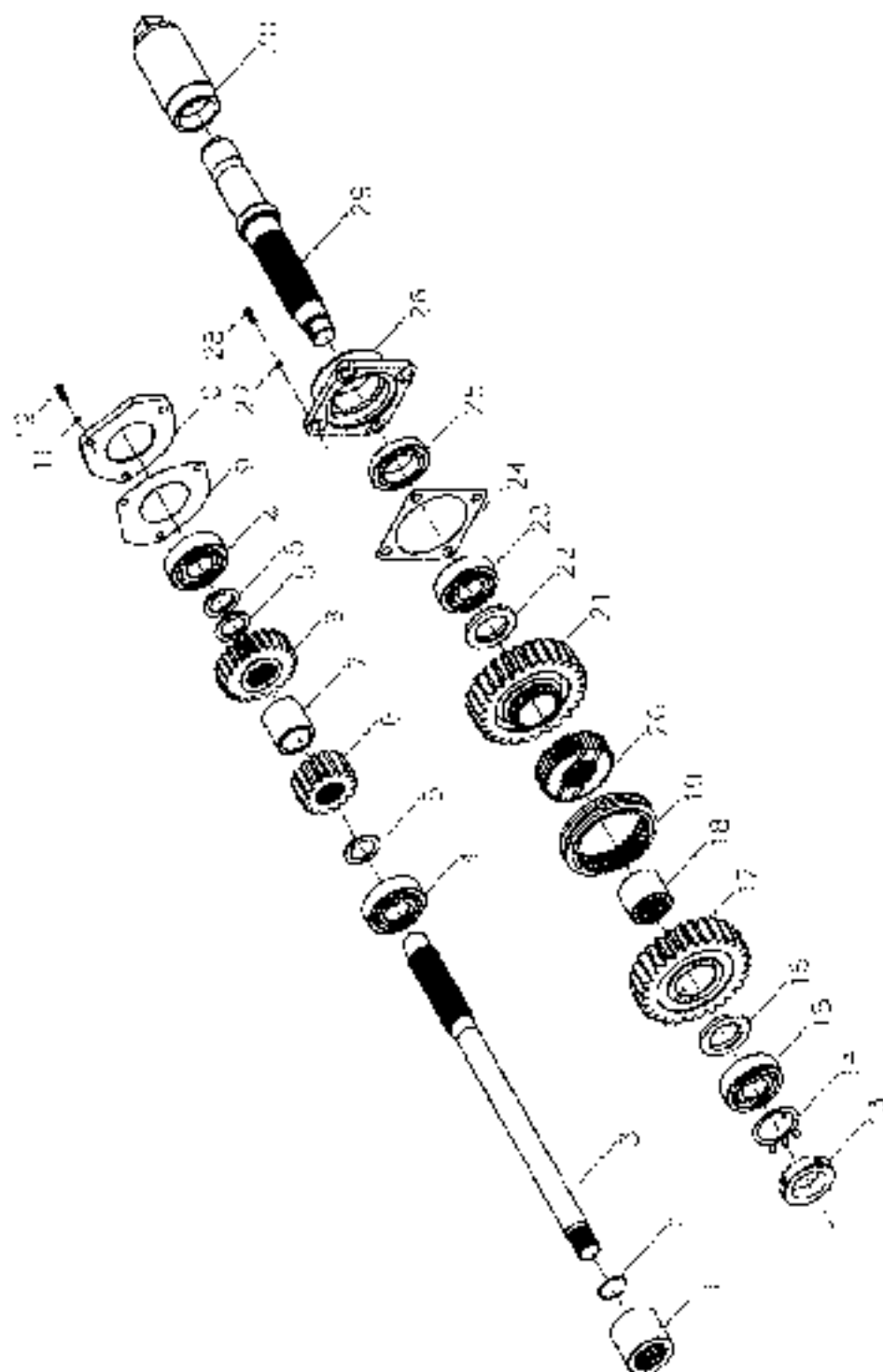

B500.38A Rear Axle Assembly-5

Grade	Parts code and specifications	Parts names	Quantity	Remark
	B500.38A	Rear axle assembly	1	
1	B300.37.196	Connecting sleeve	1	
2	GB/T 893.1-21	Retainer ring	1	
3	B500.38.103	PTO drive shaft	1	
4	GT/T 283-NJ305E	Rolling bearing	2	
5	B500.38.401	Gear washer	3	
6	B500.38C.183	PTO driving gear (540r/min)	1	
7	B500.38C.184	Spacer bush I	1	
8	B500.38C.185	PTO driving gear (1000r/min)	1	
9	B300.38.104	Gasket of rear end cover II	1	
10	B300.38.102	Rear end cover II	1	
11	GB/T 5783-M8 × 20-Zn · D	Hexagon head bolts	3	
12	GB/T 93-R-Zn · D	Single coil spring lock washers	3	
13	GB/T 812-M25 × 1.5	Round nut	1	
14	GB/T 858-25	Tab washers for round nuts	1	
15	GT/T 283-NJ306	Rolling bearing	1	
16	B500.38C.190-1	Retainer ring I	1	
17	B500.38C.187	PTO driven gear (540r/min)	1	
18	B500.38C.191	PTO Gear bushing	2	
19	B500.38.418	PTO Mesh sleeve	1	
20	B500.38C.189-1	PTO Mesh gear seat	1	
21	B500.38C.186	PTO driven gear (1000r/min)	1	
22	B500.38C.193-1	Retainer ring II	1	
23	GB/T 276-G307	Rolling bearing	1	
24	B300.38.105	Gasket of rear end cover I	1	
25	JB/T 2600-SG45 × 65 × 11	Oil seal	1	
26	B300.38.106	Rear end cover I	1	
27	GB/T 93-10 Zn · D	Single coil spring lock washers	4	
28	GB/T 5783-M10 × 25-Zn · D	Hexagon head bolts	4	
29	B300.38.109	PTO shaft	1	
30	B400.37.171	PTO shaft guard	1	

B300.39.001 Left Final Drive Assembly

Grade	Parts code and specifications	Parts names	Quantity	Remark
	B300.39.001	Left final drive assembly	1	
1	B300.39.108	Sealing gasket	2	
2	B300.39.107	Sun gear	1	
3	B300.39.101	Left half shaft	1	
4	B300.39.110	Thrust washer	1	
5	B300.39.112	Roll	1	
6	B300.39.111	Stopper	1	
7	B300.39.010	Planet carrier assembly	1	
7.1	B300.39.104-1	Planet carrier	1	
7.2	GB/T 879.1-8 × 25	Spring-type straight pins	3	
7.3	B300.39.106	Planet pin or shaft	3	
7.4	B300.39.109	External spacer ring of needle roller	6	
7.5	GB/T 309-5 × 23.8 G2, -2, -4	Needle roller	132	
7.6	B300.39.105	Internal spacer ring of needle roller	3	
7.7	B300.39.103	Planet gear	3	
8	B300.39.121	Adjusting shim	As required	
	B300.39.122	Adjusting shim	As required	
	B300.39.123	Adjusting shim	As required	
9	B300.39.113	Spacer bush	1	
10	GB/T 276-6211	Rolling bearing	1	
11	B300.39.115	Left final drive housing	1	
12	GB/T 276-6212	Rolling bearing	1	
13	GB/T 3452.1-115 × 3.55G1	O-ring	1	
14	JB/T 2600-5070 × 95 × 12	Oil seal	1	
15	B300.39.116	Oil seal seat	1	
16	GB/T 93-12-Zn + D	Single coil spring lock washers	4	
17	GB/T 5783-M12 × 25-Zn + D	Hexagon head bolts	4	
18	B300.39.118-1	Drive shaft	1	
19	B300.39.120-1	Rear hub bolt	8	
20	140.440.4986961	Planer washer	8	
21	GB/T 6171-M16 × 1.5-Zn + D	Hexagon nuts	8	

B300.39.002 Right Final Drive Assembly

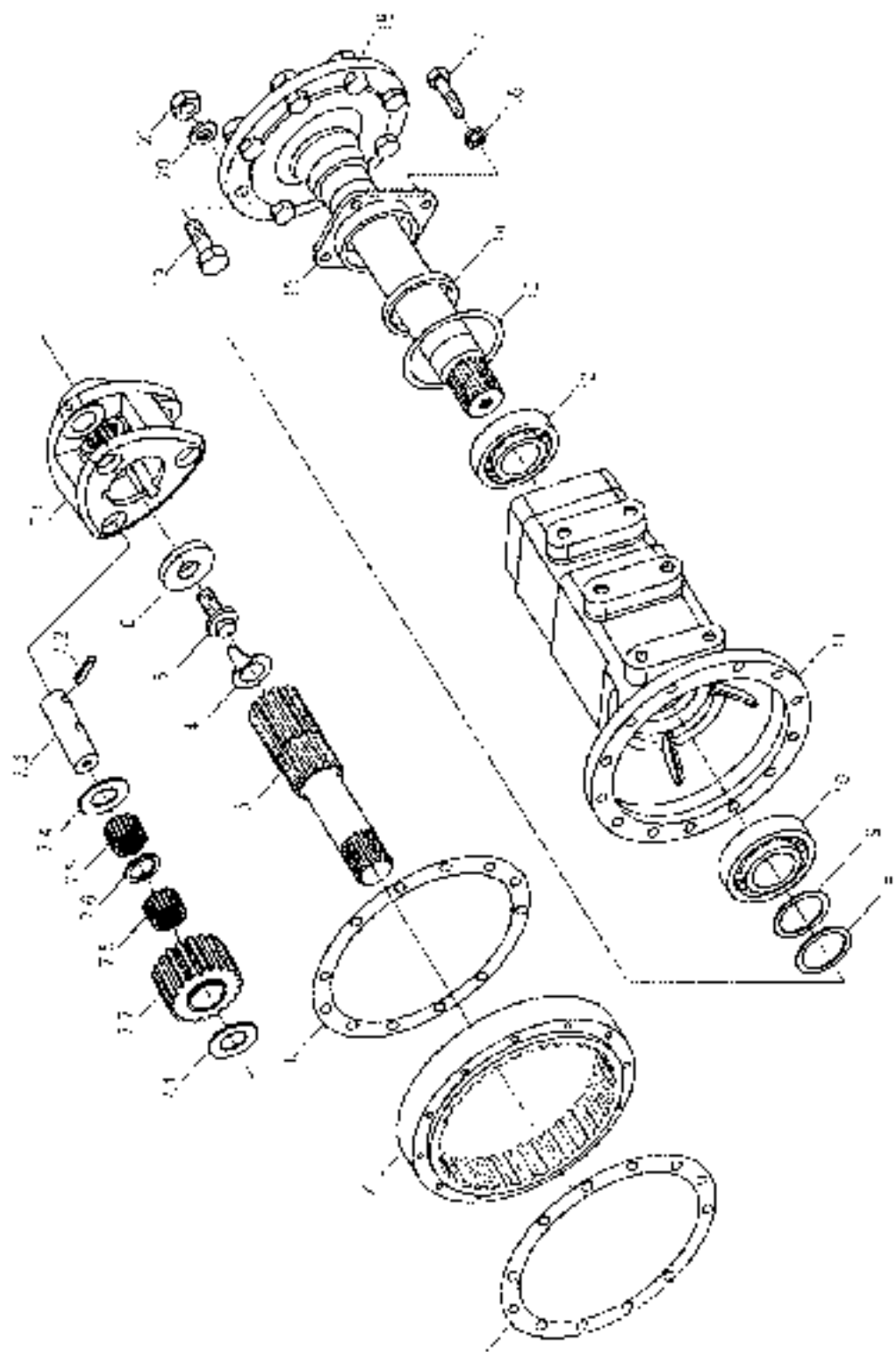

B300.39.002 Right Final Drive Assembly

Grade	Part no. and specifications	Part names	Quantity	Remark
	B300.39.002	Right final drive assembly	1	
1	B300.39.108	Sealing gasket	2	
2	B300.39.107	Sun gear	1	
3	B300.39.102	Right half shaft	1	
4	B300.39.110	Thrust washer	1	
5	B300.39.112	Bolt	1	
6	B300.39.111	Stopper	1	
7	B300.39.010	Planet carrier assembly	1	
7.1	B300.39.104-1	Planet carrier	1	
7.2	GB/T 879.1-8 × 25	Spring type straight pins	3	
7.3	B300.39.106	Planet gear shaft	3	
7.4	B300.39.109	External spacer ring of needle roller	6	
7.5	GB/T 309-5 × 23.8 G2, -2, -4	Needle roller	132	
7.6	B300.39.105	Internal spacer ring of needle roller	3	
7.7	B300.39.103	Planet gear	3	
8	B300.39.121	Adjusting shim	As required	
	B300.39.122	Adjusting shim	As required	
	B300.39.123	Adjusting shim	As required	
9	B300.39.113	Spacer bush	1	
10	GB/T 276-6211	Rolling bearing	1	
11	B300.39.114	Right final drive housing	1	
12	GB/T 276-6212	Rolling bearing	1	
13	GB/T 3452.1-115 × 3.55G	O-ring	1	
14	JB/T 2600-SC70 × 95 × 12	Oil seal	1	
15	B300.39.116	Oil seal set	1	
16	GB/T 93-12-Zn + D	Single coil spring lock washers	4	
17	GB/T 5783-M12 × 25-Zn + D	Hexagon head bolts	4	
18	B300.39.118-1	Drive shaft	1	
19	B300.39.120-1	Rear hub hub	8	
20	L 20.140.4986961	Plain washer	8	
21	GB/T 6171-M16 × 1.5-Zn + D	Hexagon nuts	8	

BL600J.40.001 Hydraulic Steering Assembly-1

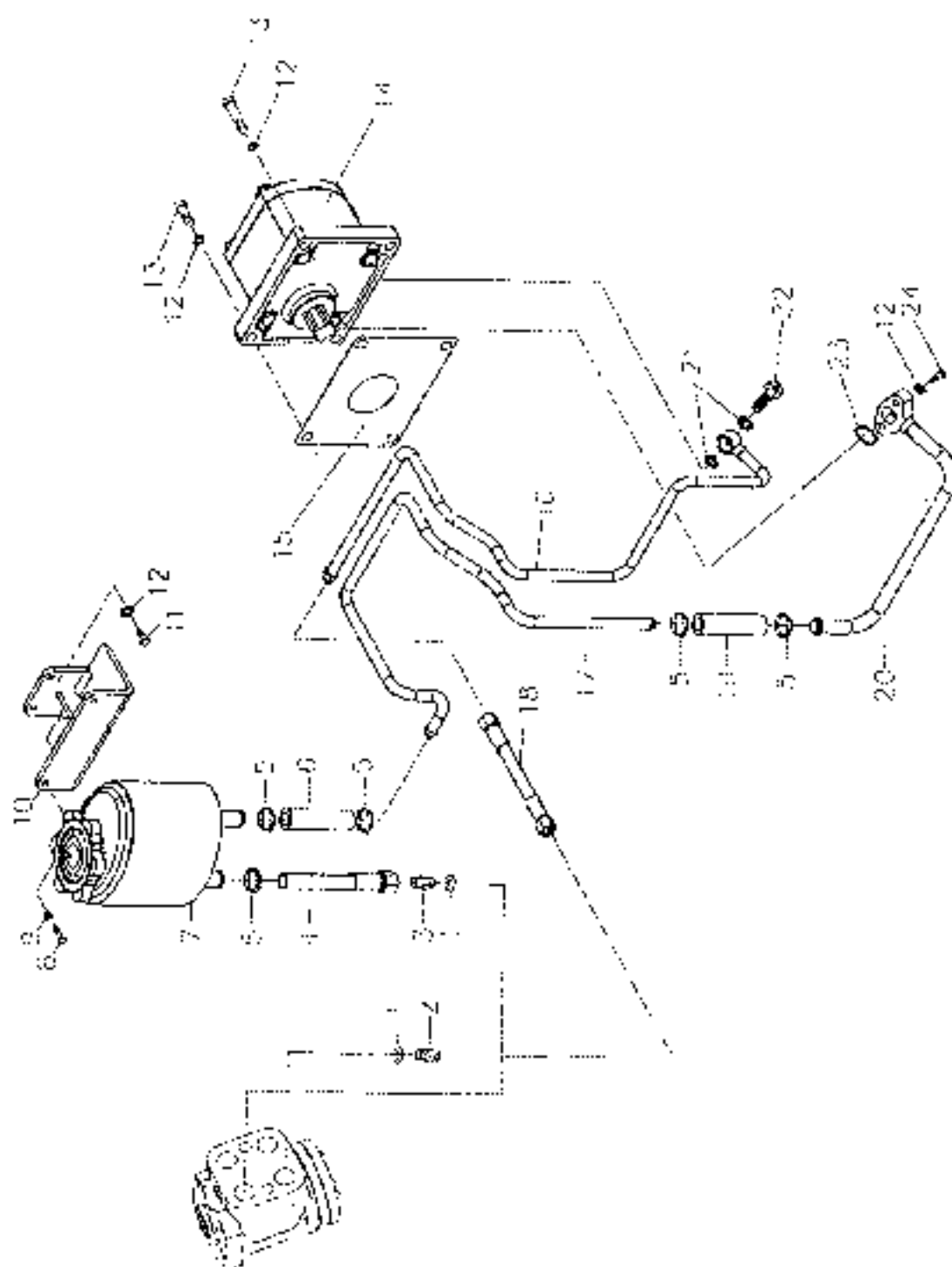

BL600J.40.001 Hydraulic Steering Assembly-1

Grade	Parts code and specifications	Parts names	Quantity	Remark
	BL600J.40.001	Hydraulic steering assembly	1	
1	JH/T 982-20	Combination gasket	2	
2	BL600.40.103	Straight tube adapter M20-M16	1	
3	BL600.40.102	Straight tube adapter M20-M27	1	
4	BL600.40.013	Oil return hose assembly	1	
5	ZBJ15011	Hose clamp 22-32	5	
6	ZC.16.270	Steering base	1	
7	1.6368808063111	Steering oil tank	1	
8	GB/T 5783 M10×20-Zn-D	Hexagon head bolts	2	
9	GB/T 93-10-Zn-D	Single coil spring lock washers	2	
10	BL600.40.015	Steering oil tank bracket	1	
11	GB/T 5782-M8×20-Zn-D	Hexagon head bolts	2	
12	GB/T 93-8-Zn-D	Single coil spring lock washers	8	
13	GB/T 70.1-M8×35-Zn-D	Hexagon socket head cap screws	4	
14	BS00.40.011	Steering pump HLCB-D06/06	1	
15		Paper gasket	1	
16	BL600J.40.012	Oil outlet pipe assembly of steering pump	1	
17	BL600J.40.105	Steering oil return pipe	1	
18	BL600.40.014	Steering hose assembly	1	
19	BL600J.40.106	Steering hose	1	
20	BL600J.40.016	Oil suction pipe assembly of steering pump	1	
21	JH/T 982-18	Combination gasket	2	
22	BS00.40.304	Hollow bolt	1	
23	GB/T 3452.1-18×2.65C	O-ring	1	
24	GB/T 5783-M8×35-Zn-D	Hexagon head bolts	2	

BL554.42 Transfer Case Assembly-1

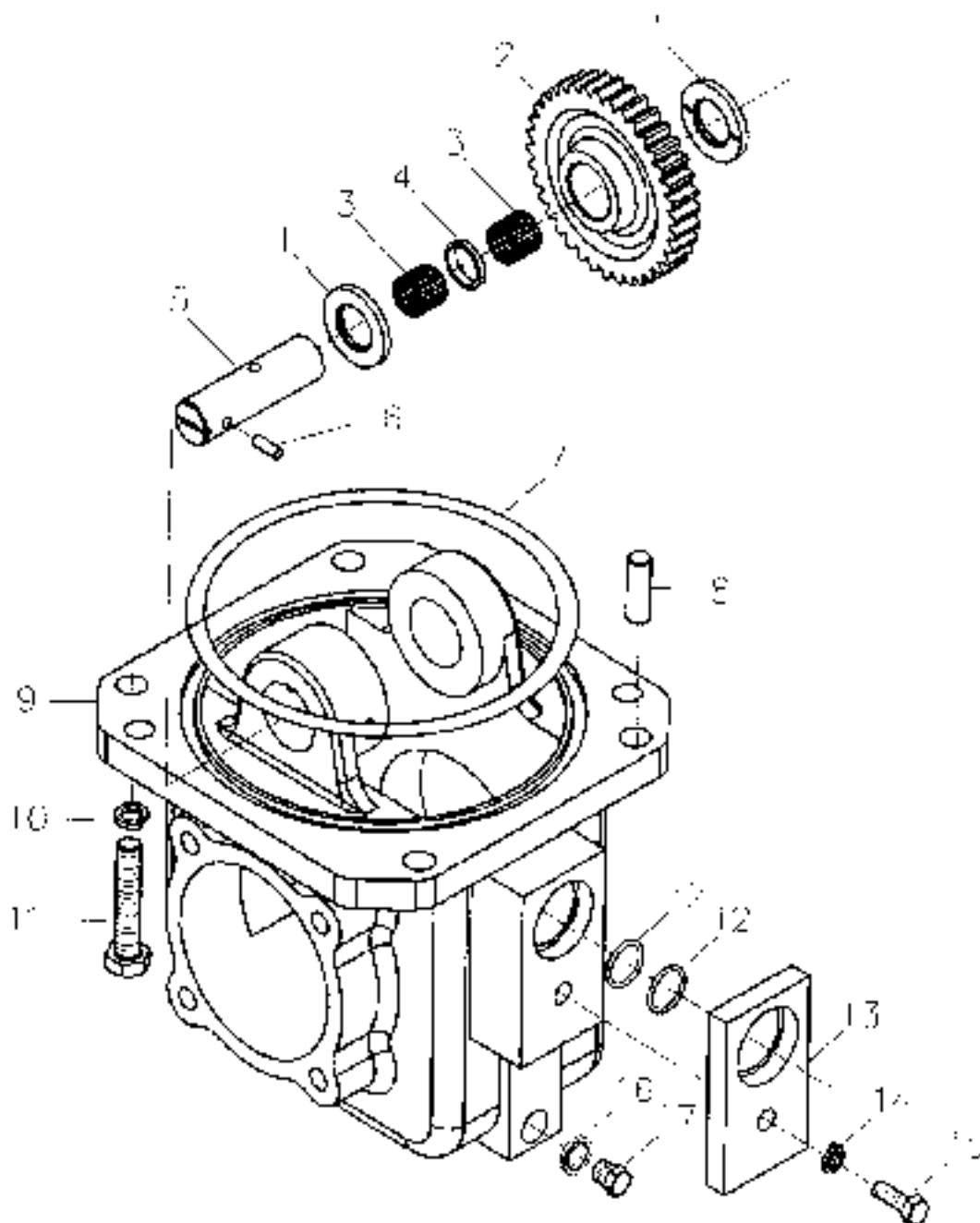

BL554.42 Transfer Case Assembly-2

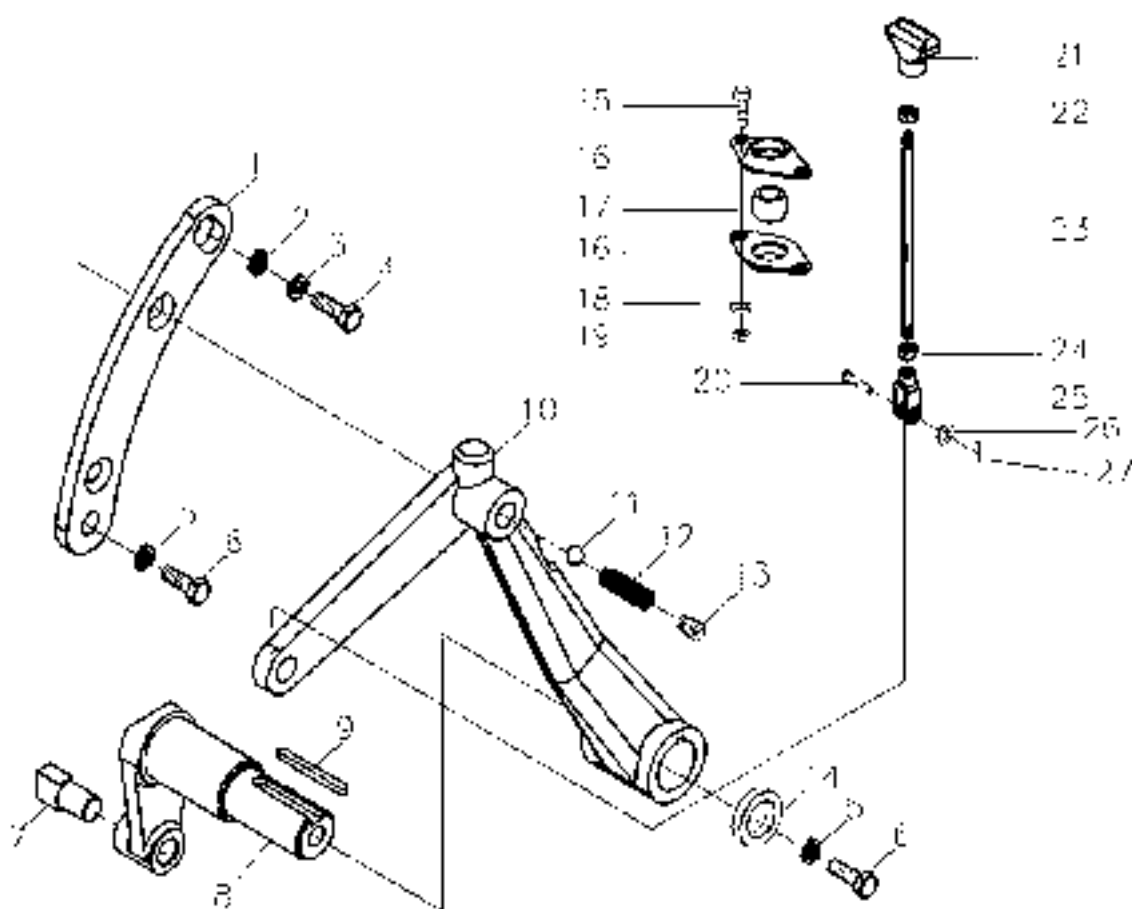

BL554.42 Transfer Case Assembly-2

Grade	Parts code and specifications	Parts names	Quantity	Remark
	BL554.42	Transfer case assembly	1	
1	B501.42.101	Locating plate	1	
2	GB/T 97.1-10-Zn · D	Plain washers	1	
3	GB/T 93-10-Zn · D	Single coil spring lock washers	1	
4	GB/T 5783-M10 × 20-Zn · D	Hexagon head bolts	1	
5	GB/T 93 8-Zn · D	Single coil spring lock washers	2	
6	GB/T 5783-M8 × 20-Zn · D	Hexagon head bolts	2	
7	B404.42.120	Fork head of transfer case	1	
8	B404.42.119	Fork shaft of transfer case	1	
9	GB/T 1096-C6 × 28	Square and rectangular keys	1	
10	B504.42A.011 · 1	Control lever	1	
11	GB/T 308-8.7312 (3400)	Steel ball	1	
12	RM304.37.251	Spring	1	
13	RM304.37.250	Screw	1	
14	B304.42.116	Plug	1	
15	GB/T 5783-M6 × 20-Zn · D	Hexagon head bolts	2	
16	4998311/1.80.255	Ball sleeve seat	2	
17	5109058/1.80.254	Ball sleeve	1	
18	GB/T 93-6-Zn · D	Single coil spring lock washers	2	
19	GB/T 6170-M6-Zn · D	Hexagon nuts	2	
20	GB/T 882-B8 × 30	Clevis pin with head	1	
21	B04.42.017	Pull-press handle	1	
22	GB/T 6170-M10-Zn · D	Hexagon nuts	1	
23	B500.43A.102	Pull rod	1	
24	GB/T 6170 M10-Left-Zn · D	Hexagon nuts	1	
25	B500.21.107	Left connecting fork of pull rod	1	
26	GB/T 97.1-8-Zn · D	Plain washers	1	
27	GB/T 91-3.2 × 20	Splits pins	1	

BL554.42 Transfer Case Assembly-3

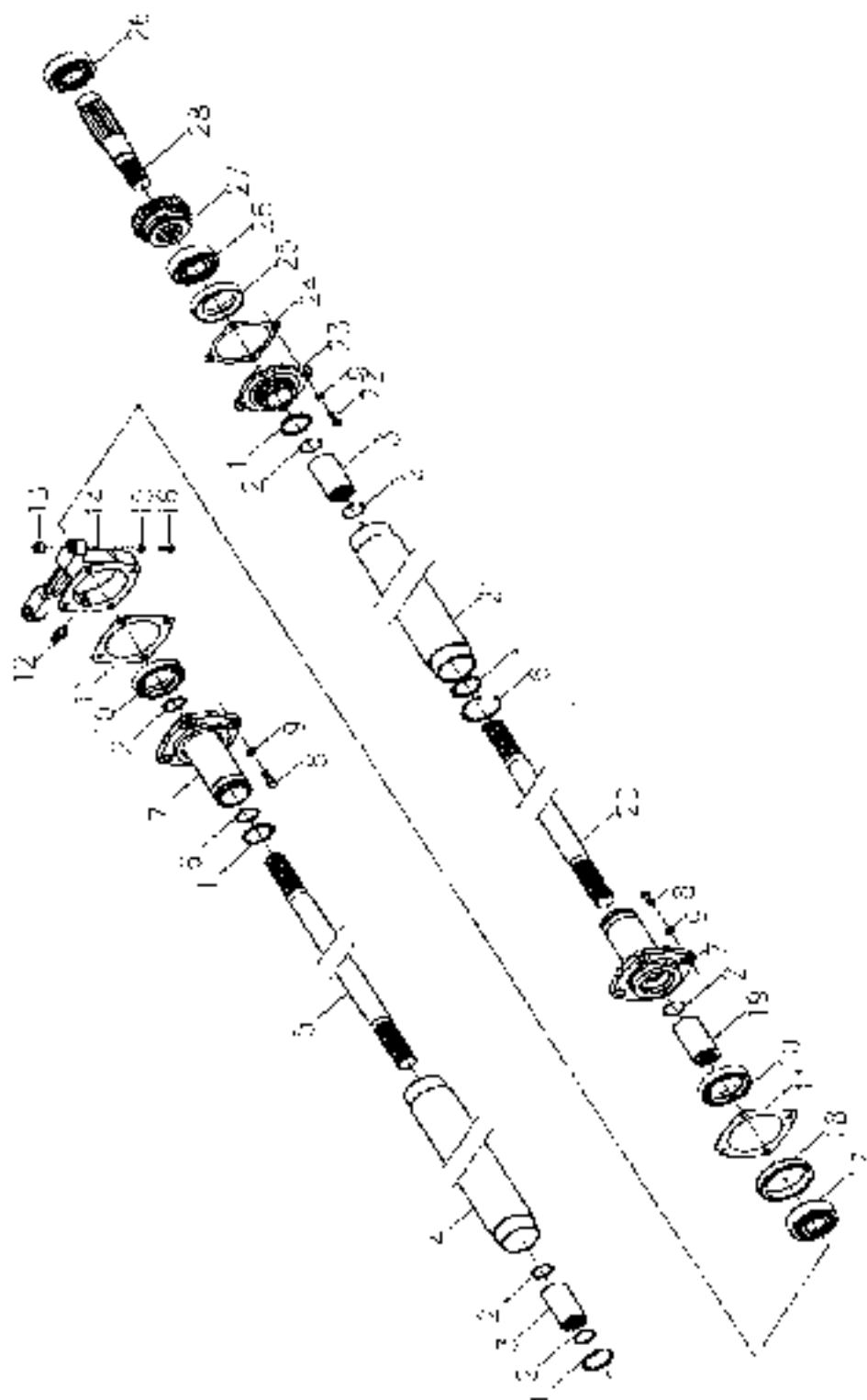

BL554.42 Transfer Case Assembly-3

Grade	Parts code and specifications	Parts names	Quantity	Remark
	BL554.42	Transfer case assembly	1	
1	GB/T 3452.1-43.7 × 2.65G	O-ring	4	
2	GB/T 894.1-25	Circclips for shaft	6	
3	B404.42.107	Spline housing	2	
4	B504.42.014-4	Sheath weld assembly	1	
5	B504.42.107-2	Transmission shaft	1	
6	GB/T 894.1-48	Circclips for shaft	2	
7	B504.42.013	Supporting tube	2	
8	GB/T 5783-M8 × 25-Zn · D	Hexagon head bolts	8	
9	GB/T 93-8-Zn · D	Single coil spring lock washers	12	
10	GB/T 9877.1-F1135 × 55 × 8	Oil seal	2	
11	B504.42.105	Paper pad	2	
12	JB/T 7940.1-M10 × 1	Oil cup	1	
13	B504.42.101	Locating sleeve	2	
14	B504.42.102	Supporting seat	1	
15	GB/T 93-10-Zn · D	Single coil spring lock washers	2	
16	GB/T 5783-M10 × 45-Zn · D	Hexagon head bolts	2	
17	GB/T 276-6007	Rolling bearing	1	
18	B504.42.106	Rubber ring	1	
19	B504.42.130	Middle spline housing	1	
20	B504.42.104	Transmission shaft	1	
21	B504.42.012	Sheath weld assembly	1	
22	GB/T 5783-M8 × 20-Zn · D	Hexagon head bolts	4	
23	B304.42.106	Bearing cover	1	
24	B304.42.112	Paper pad	1	
25	GB/T 9877.1-F1130 × 52 × 8	Oil seal	1	
26	GB/T 276-6306	Rolling bearing	2	
27	B404.42.104	Driven gear	1	
28	B404.42.105	Output shaft	1	

B500.43A Braking System Assembly-1

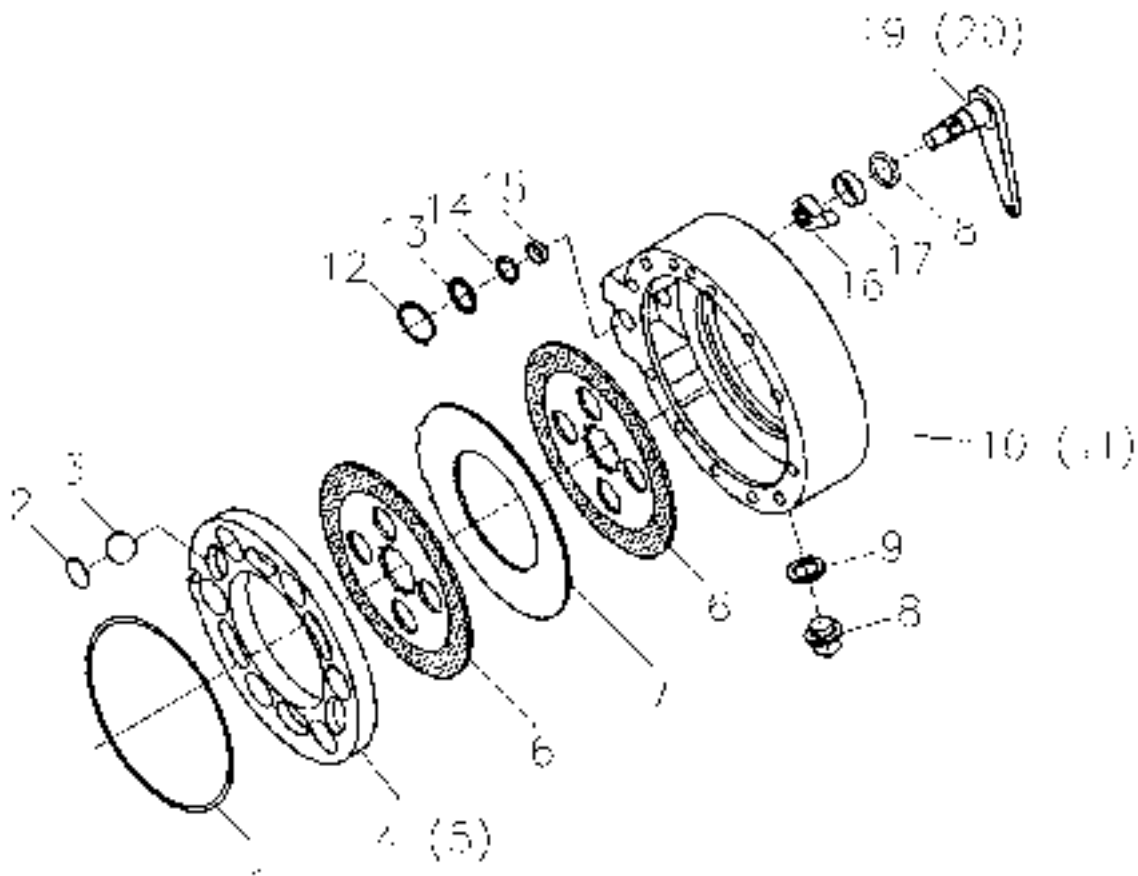

This drawing only plots the right brake assembly. They are special parts of left brake assembly in brackets and the rest are general parts of left and right brake assemblies.

B500.43A Braking System Assembly-2

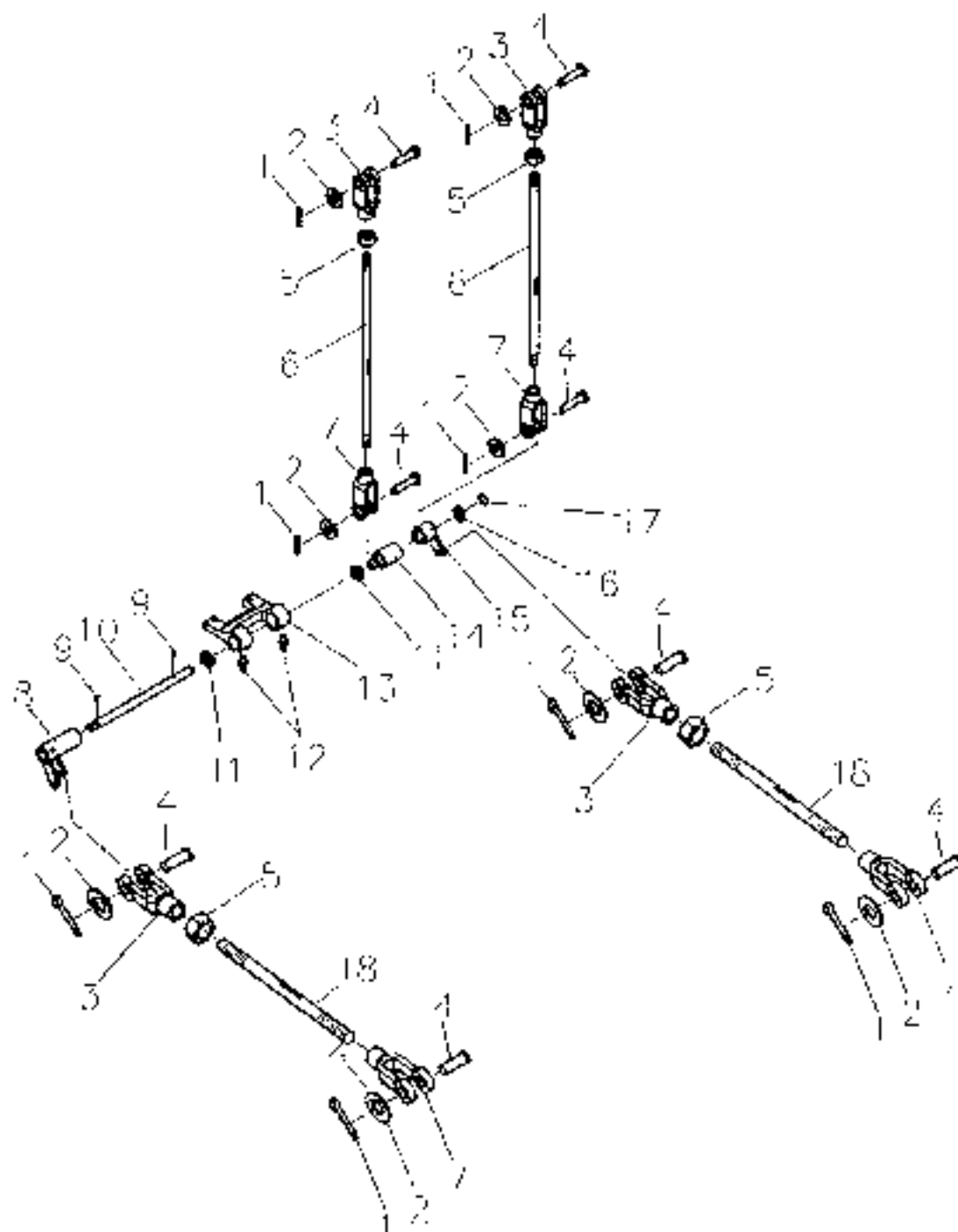

B500.43A Braking System Assembly-3

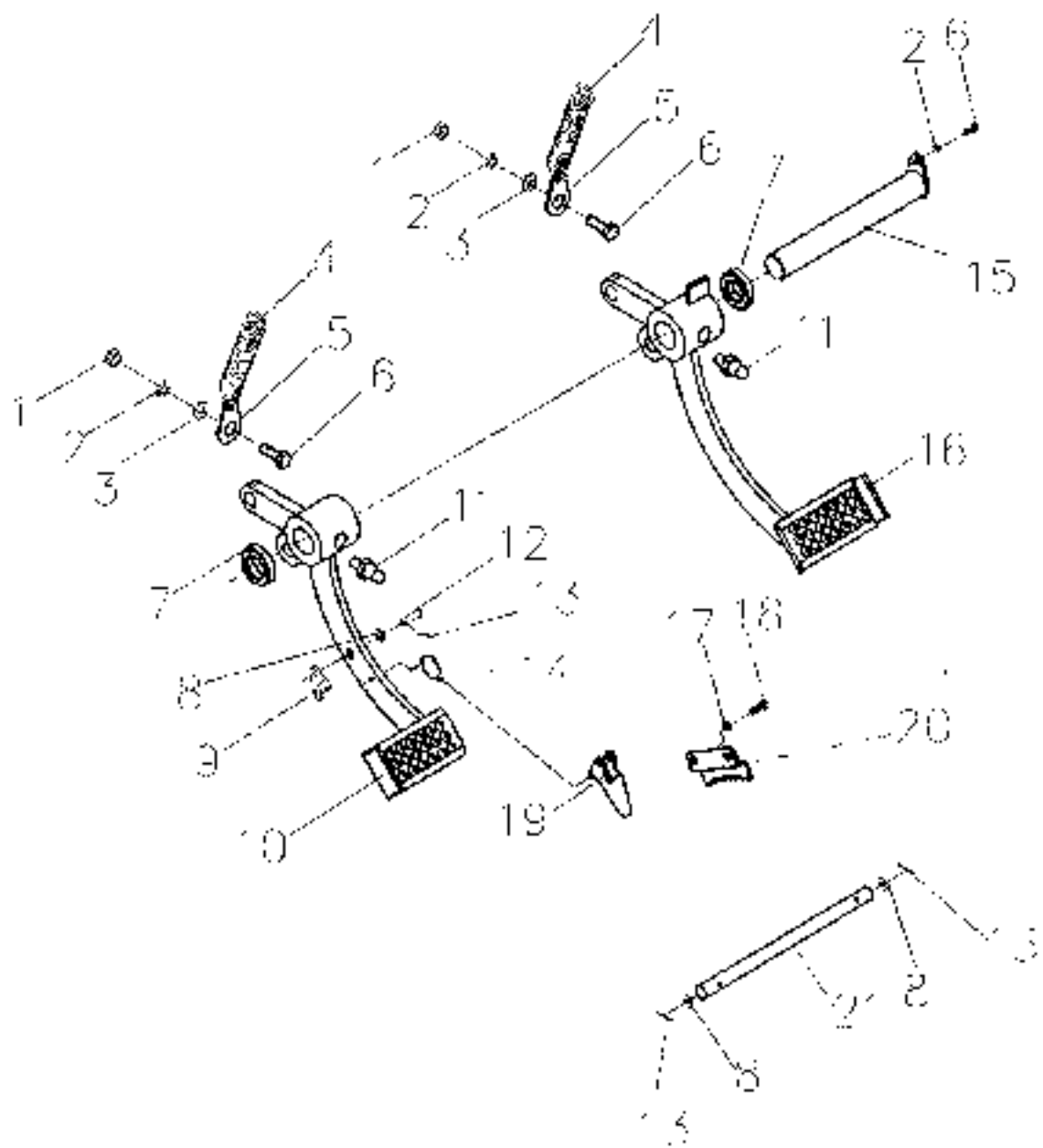

BL554.44.001 Operator's Seat Assembly

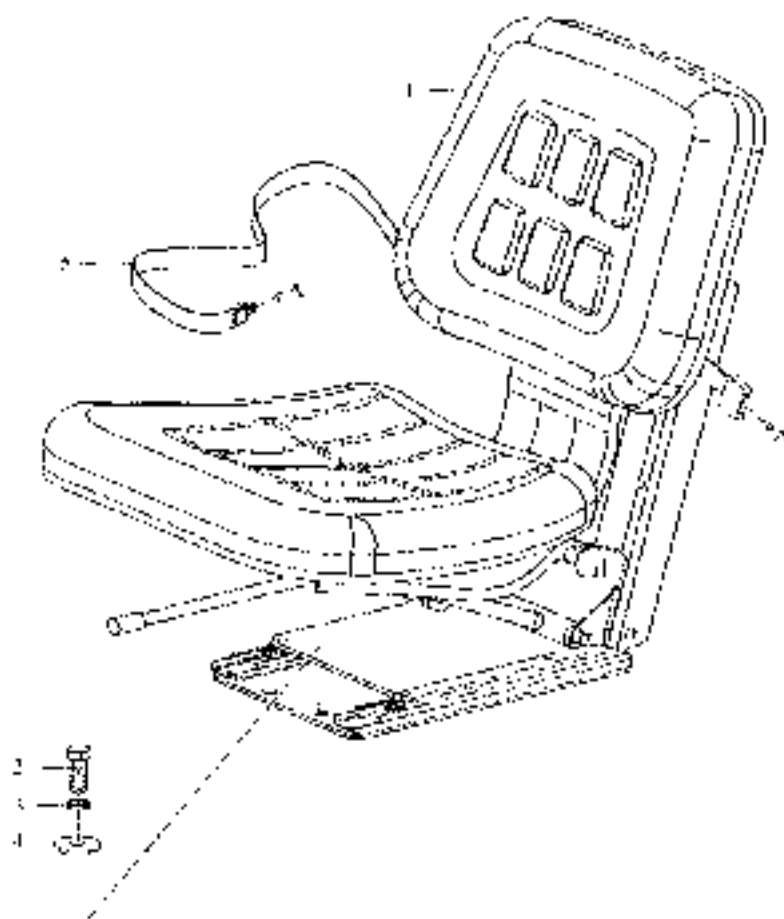

BL500.44.001 Operator's Seat Assembly

Grade	Parts code and specifications	Parts names	Quantity	Remark
	BL500.44.001	Operator's seat assembly	1	
1	BL500.44.010	Seat assembly	1	
2	GB/T 5783-M12 x 35-Zn-D	Hexagon head bolts	4	
3	GB/T 93-12-Zn-D	Single coil spring lock washers	4	
4	GB/T 97.1-12-Zn-D	Plain washers	4	

BA500.452 Floor Assembly

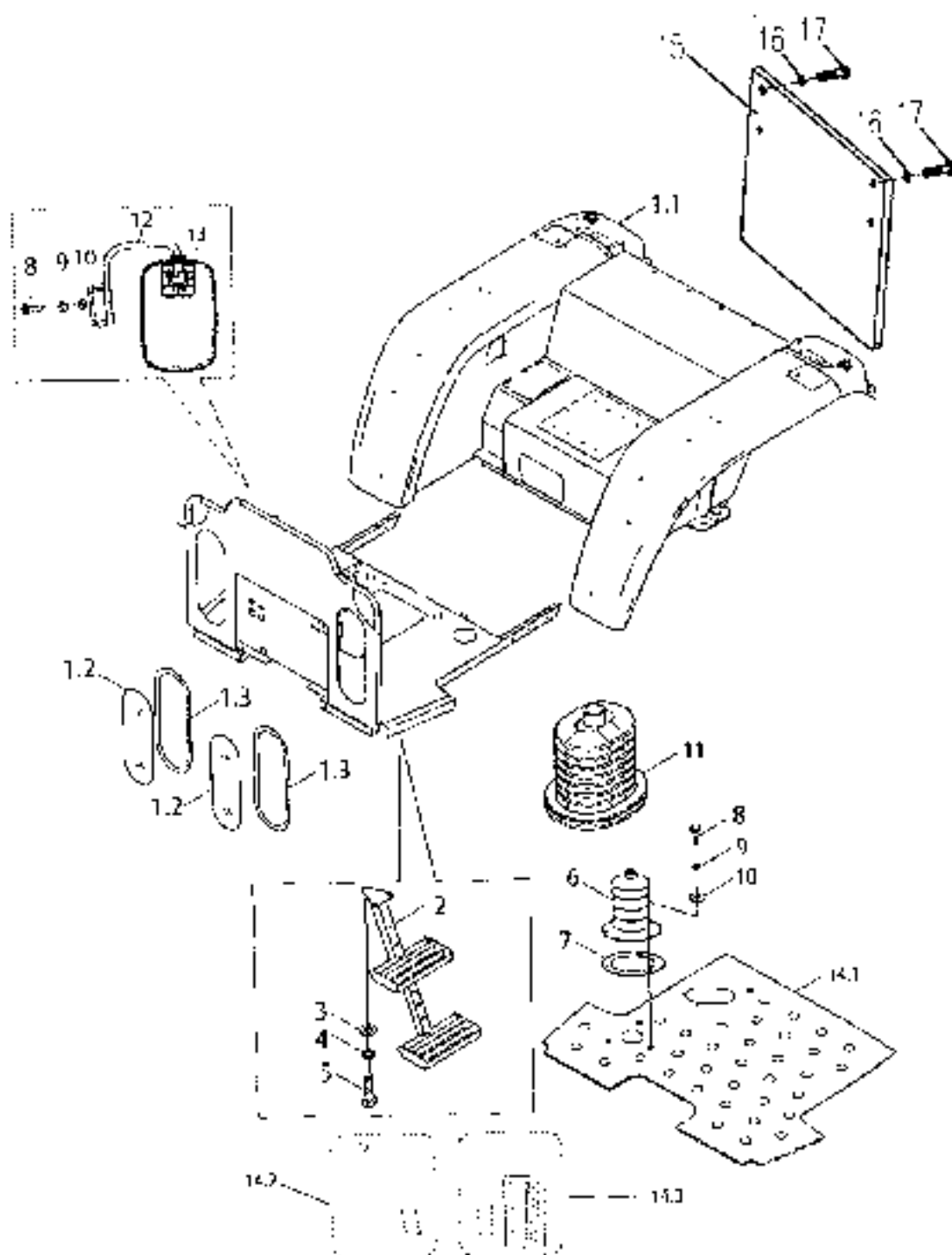

BA500.452 Floor Assembly

Grade	Parts code and specifications	Parts names	Quantity	Remark
	BA500.452	Floor assembly	1	
1	BA500.45.011	Fender apron assembly	1	
1.1	BA500.45.011.1	Fender apron	1	
1.2	BA500.45.011.2	Sealing strips for front windshield	2	
1.3	BA500.45.011.3	Front windshield	2	
2	BA500.452.3	Left pedal pad assembly	1	
	BA500.452.4	Right pedal pad assembly	1	
3	GB/T 97.1-10-Zn-D	Plain washers	6	
4	GB/T 93-10-Zn-D	Single coil spring lock washers	6	
5	GB/T 5783-M10×30-Zn-D	Hexagon head bolts	6	
6	B1500.47.108	Dust boot for foot accelerator	1	
7	B1500.47.115	Press plate	1	
8	GB/T 5783-M6×20-Zn-D	Hexagon head bolts	5	
9	GB/T 93-6-Zn-D	Single coil spring lock washers	5	
10	GB/T 97.1-6-Zn-D	Plain washers	5	
11	B1500.47.106	Dust boot for gear lever	1	
12	BA500.45.015	Gillet for rearview mirror	2	
13	B500.47.040	Rearview mirror	2	
14	BA500.45.019	Rubber floor mat assembly	1	
14.1	BA500.45.019.1	Middle floor mat	1	
14.2	BA500.45.019.2	Left floor mat	1	
14.3	BA500.45.019.3	Right floor mat	1	
15	BA500.45.108	Hear registration plates	1	
16	GB/T 93-8-Zn-D	Single coil spring lock washers	2	
17	GB/T 5783-M8×16-Zn-D	Hexagon head bolts	2	

BA500.453Z Front Connecting Devices Assembly

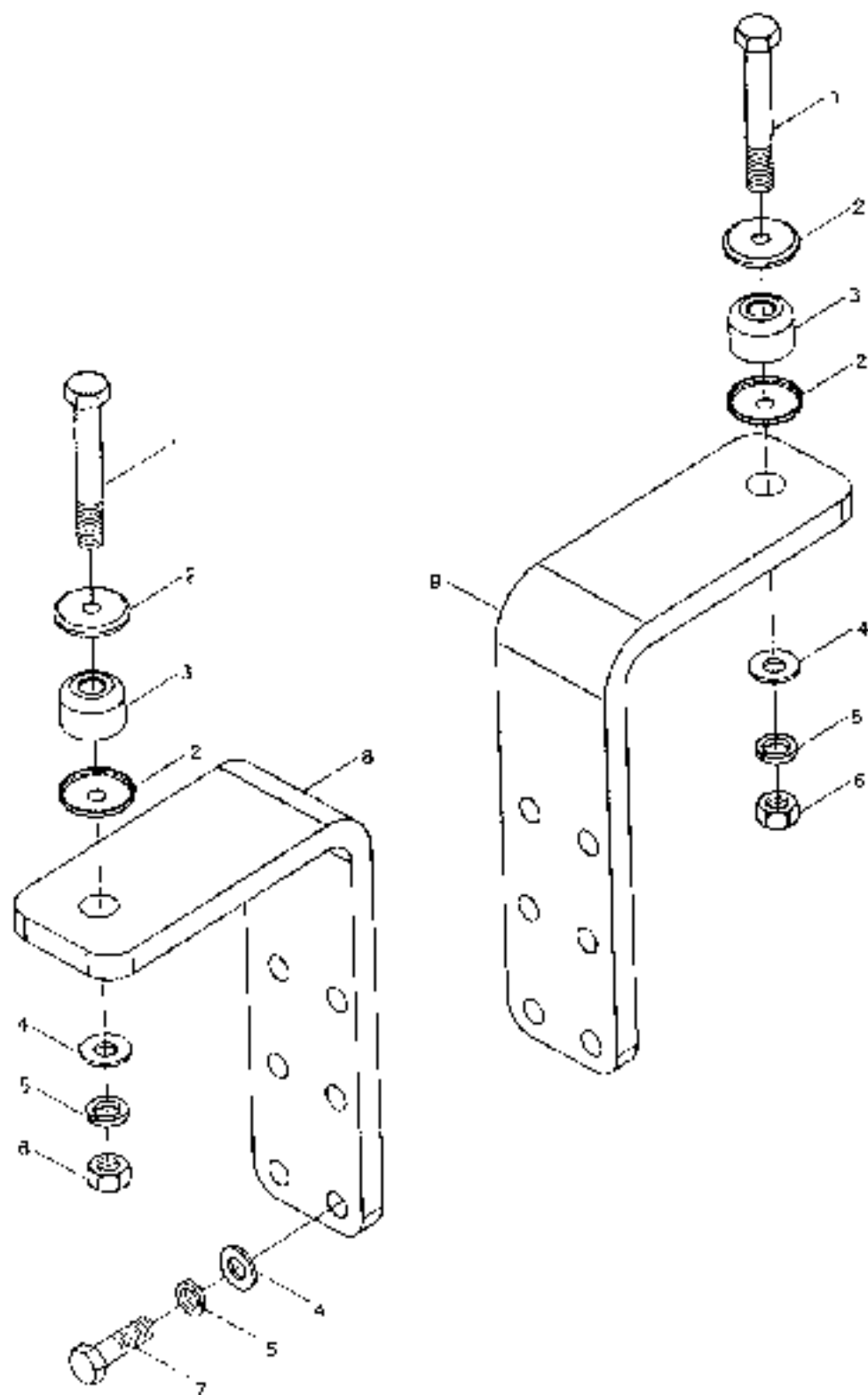

BA500.454 Rear Connecting Devices Assembly

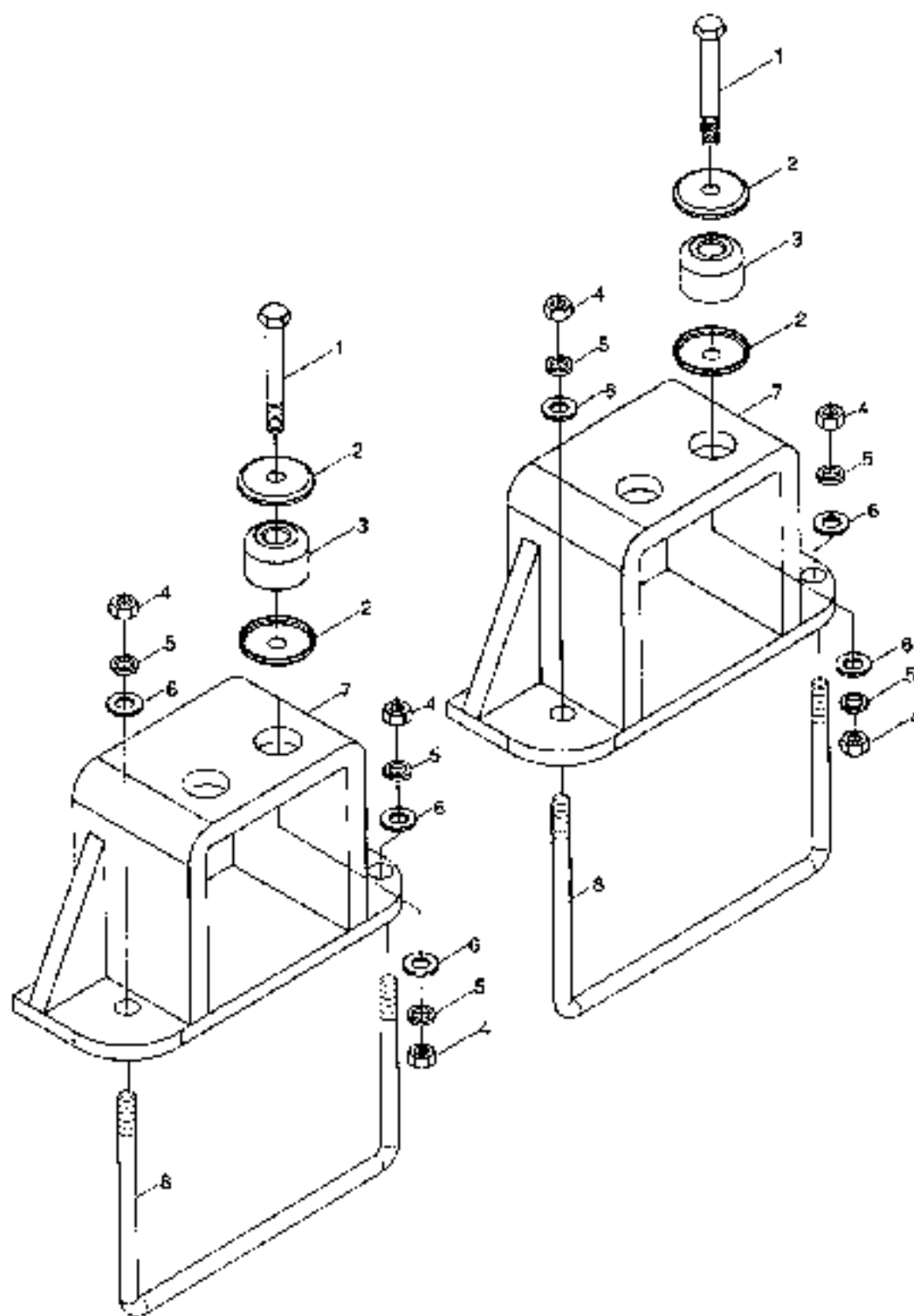

BA500.454 Rear Connecting Devices Assembly

Grade	Parts code and specifications	Parts names	Quantity	Remarks
	BA500.454	Rear connecting devices assembly	1	
1	GB/T 5782-M16×110-Zn·D	Hexagon head bolts	4	
2	800.45.149-1	Shield	8	
3	B1.500.45.101	Bumper block	4	
4	GB/T 6170-M16-Zn·D	Hexagon nuts	12	
5	GB/T 93 16-Zn·D	Single coil spring lock washers	12	
6	GB/T 97.1-16-Zn·D	Plain washers	12	
7	BA500.45.014	Rear connecting plate	2	
8	B300.47.201-1	35-belts	4	

BA500.461 Safety Shelf Assembly

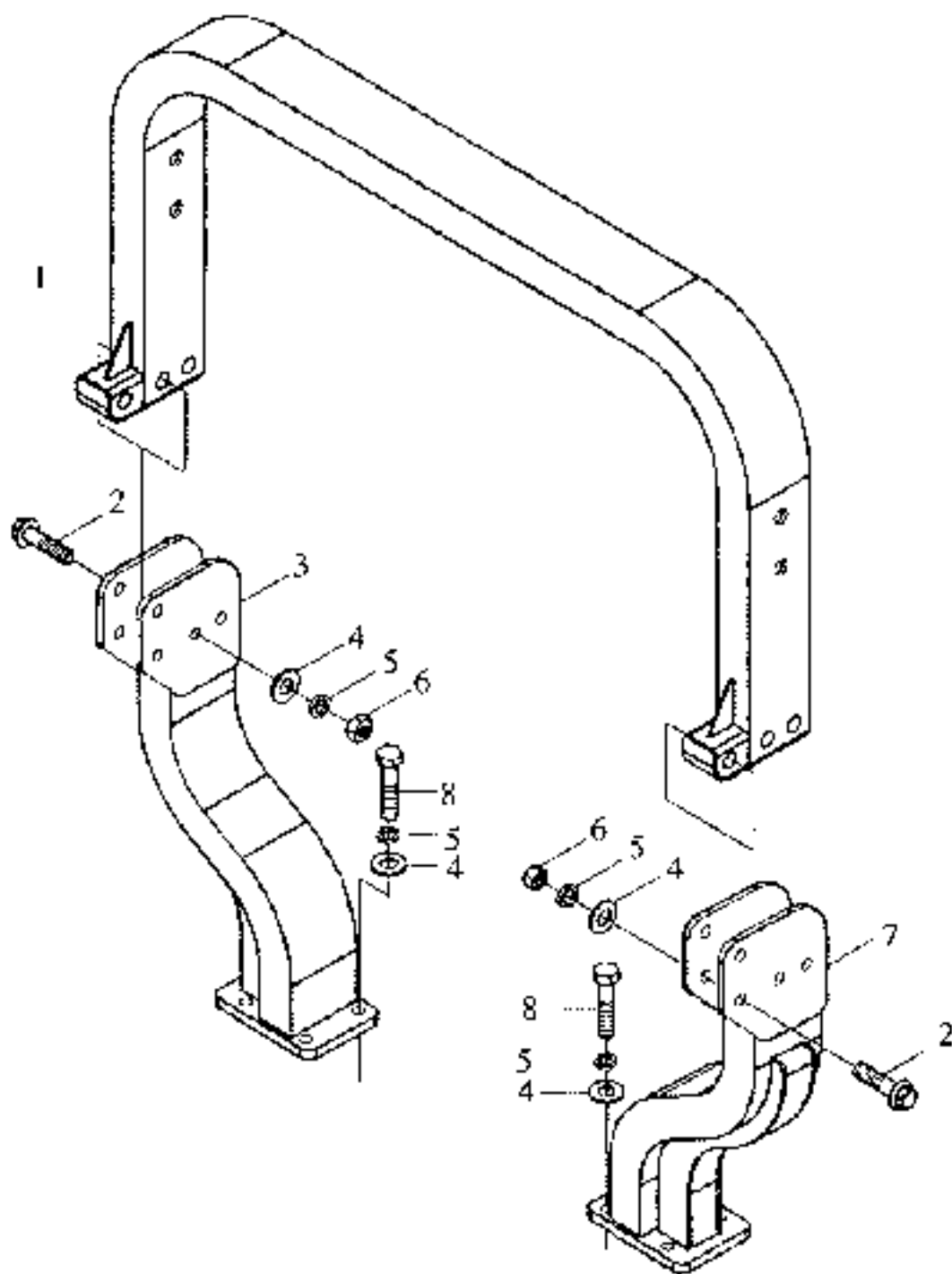

BA500.461 Safety Shelf Assembly

Grade	Parts code and specifications	Parts names	Quantity	Remark
	BA500.461	Safety shelf assembly	1	
1	BA500.46.010	Upper frame assembly	1	
2	GB/T 5782-M16×90-Zn-D	Hexagon head bolts	6	
3	BA500.46.011	Left pillar assembly	1	
4	GB/T 97.1-16-Zn-D	Plain washers	20	
5	GB/T 93-16-Zn-D	Single coil spring lock washers	14	
6	GB/T 6170-M16-Zn-D	Hexagon nuts	6	
7	BA500.46.012	Right pillar assembly	1	
8	GB/T 5783-M16×40-Zn-D	Hexagon head bolts	8	

BA500.462 Awning Assembly

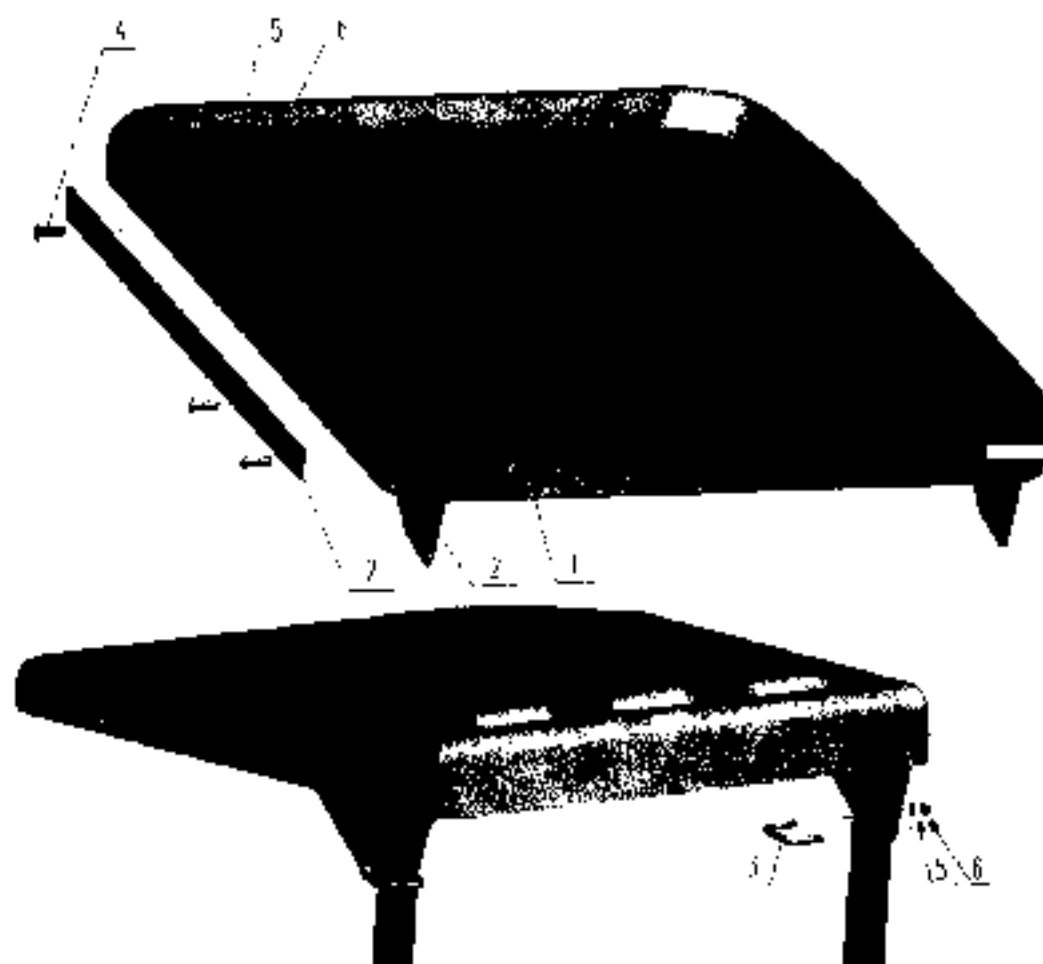

BA500.462 Awning Assembly

Grade	Parts code and specifications	Parts names	Quantity	Remark
	BA500.462	Awning assembly	1	
1	B500.46.201	Awning	1	
2	BA500.46.101	Junction plate	2	
3	BA500.46.102	U-bolts	4	
4	GWG 5783-M12×30-Zn-D	Hexagon head bolts	5	
5	GB/T 93-12-Zn-D	single coil spring lock washers	14	
6	GB/T 6170-M12-Zn-D	Hexagon nuts	14	

BA500.471 Engine Hood Assembly

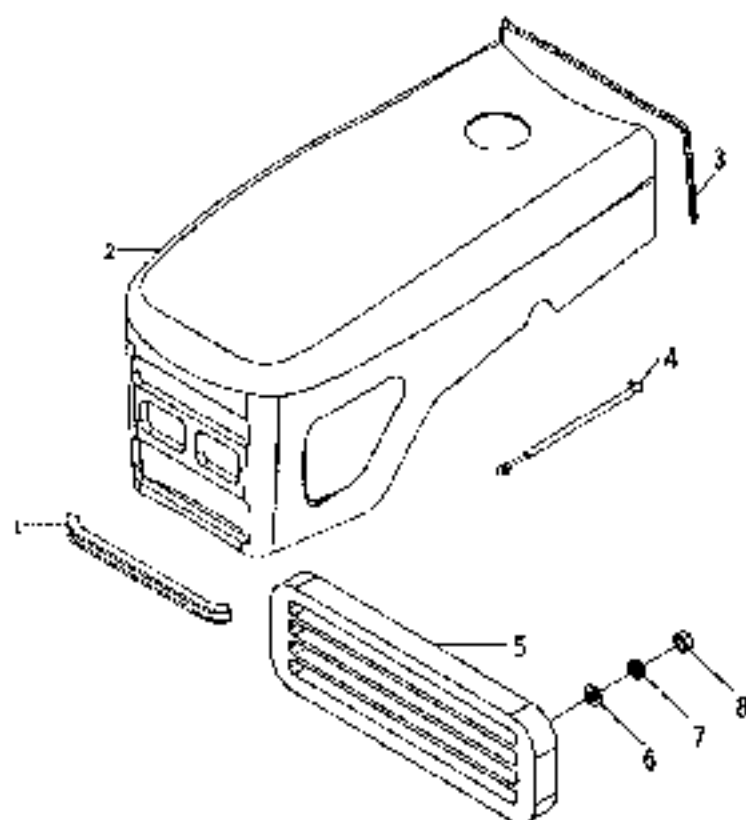

BA500.471 Engine Hood Assembly

Grade	Parts code and specifications	Parts names	Quantity	Remark
	BA500.471	Engine hood assembly	1	
1	BA500.471.1	Engine hood sealing strips	1	
2		Engine hood weldment	-	
3	BA500.471.3	Engine hood sealing strips	1	
4		Air spring	2	
5	BA500.471.108	Front screen	1	
6	GB/T 97.1-5-Zn-D	Plain washers	6	
7	GB/T 93-5-Zn-D	Single coil spring lock washers	6	
8	GB/T 6170-M5-Zn-D	Hexagon head nuts	6	

BA500.481 Engine Wiring Harness Assembly

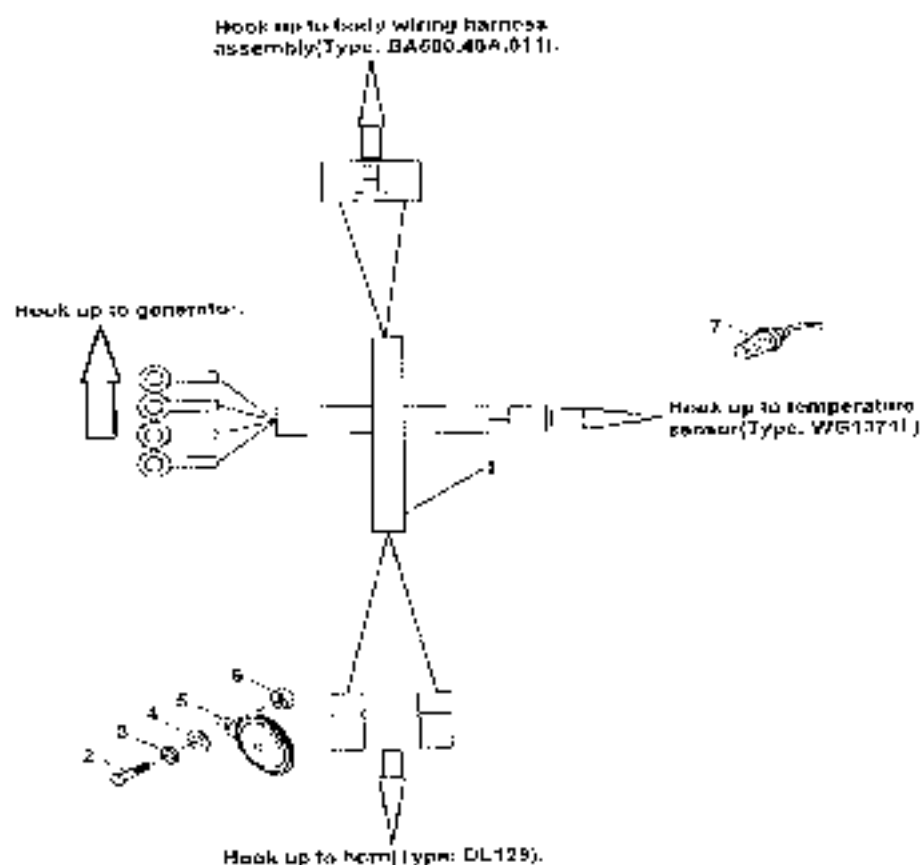

BA500.481 Engine Wiring Harness Assembly

Grade	Parts code and specifications	Parts name	Quantity	Remark
	BA500.481	Engine wiring harness assembly	1	
1	BA500.48.012	Engine wiring harness assembly	1	
2	GB/T 5783-M6 × 25-Zn · D	Hexagon head bolts	1	
3	GB/T 93 6-Zn · D	Single coil spring lock washers	1	
4	GB/T 97.1-6-Zn · D	Plain washers	1	
5	DL129	Horn	1	
6	GB/T 6170-M6-Zn · D	Hexagon nuts	1	
7	W461371	Temperature sensor	1	

BA500.482 Body Wiring Harness Assembly

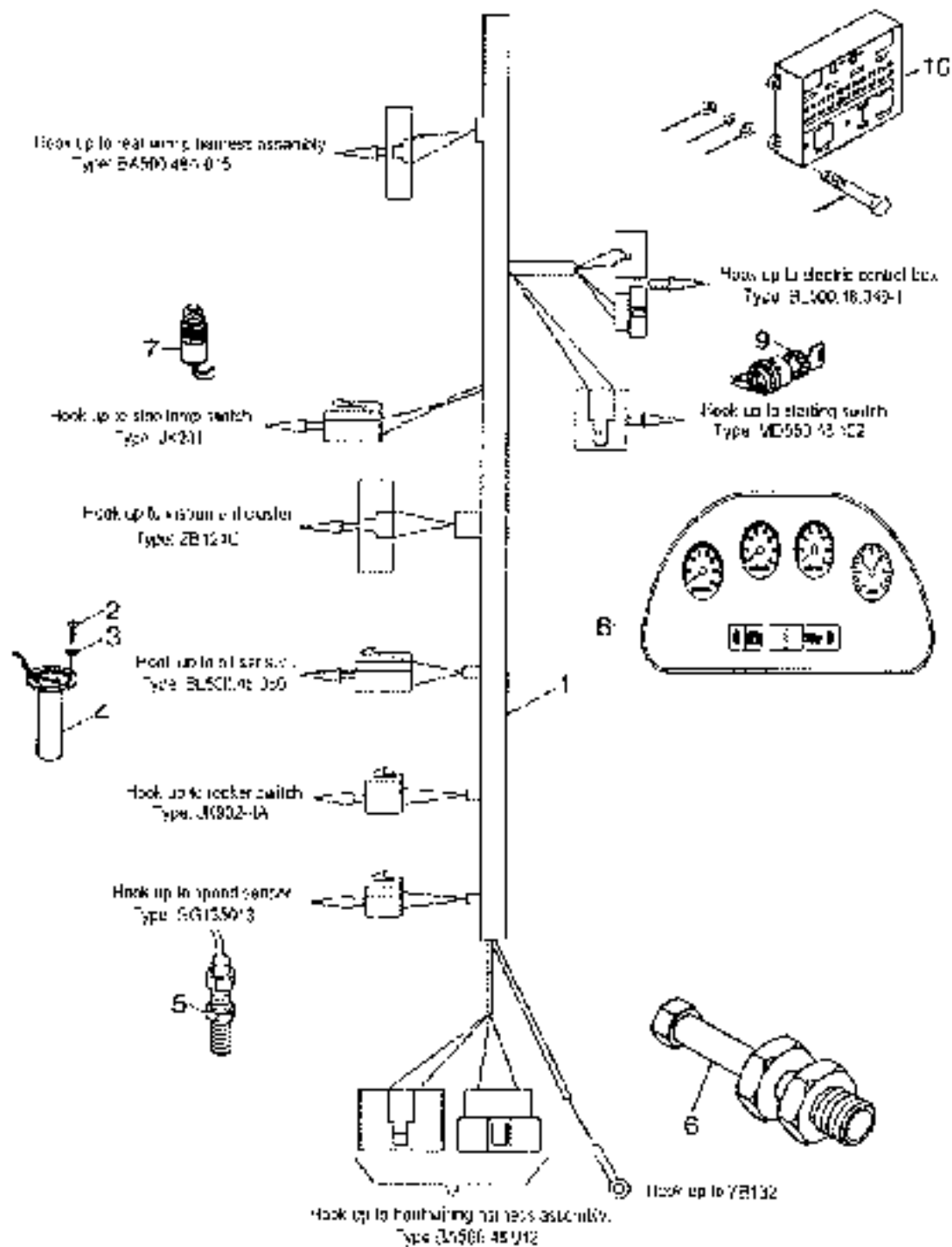

BA500.482 Body Wiring Harness Assembly

Grade	Parts code and specifications	Parts names	Quantity	Remark
	BA500.482	Body wiring harness assembly	1	
1	BA500.48A.011	Body wiring harness assembly	1	
2	GB/T 818-M5 × 12-Zn + D	Screws	5	
3	GB/T 93-S-7n + D	Single end spring lock washers	5	
4	BI.500.48.050	Oil sensors	1	
5	CG135013	Speed sensor	1	
6	JK271	Stop lamp switch	2	
7	JK972-4A	Backer switch	1	
8	ZBL210	Instrument cluster	1	
9	MD550.48.102	Starting switch	1	
10	BI.500.48.049-1	Electric control box	1	

BA500.483 Head Lamp Wiring Harness Assembly

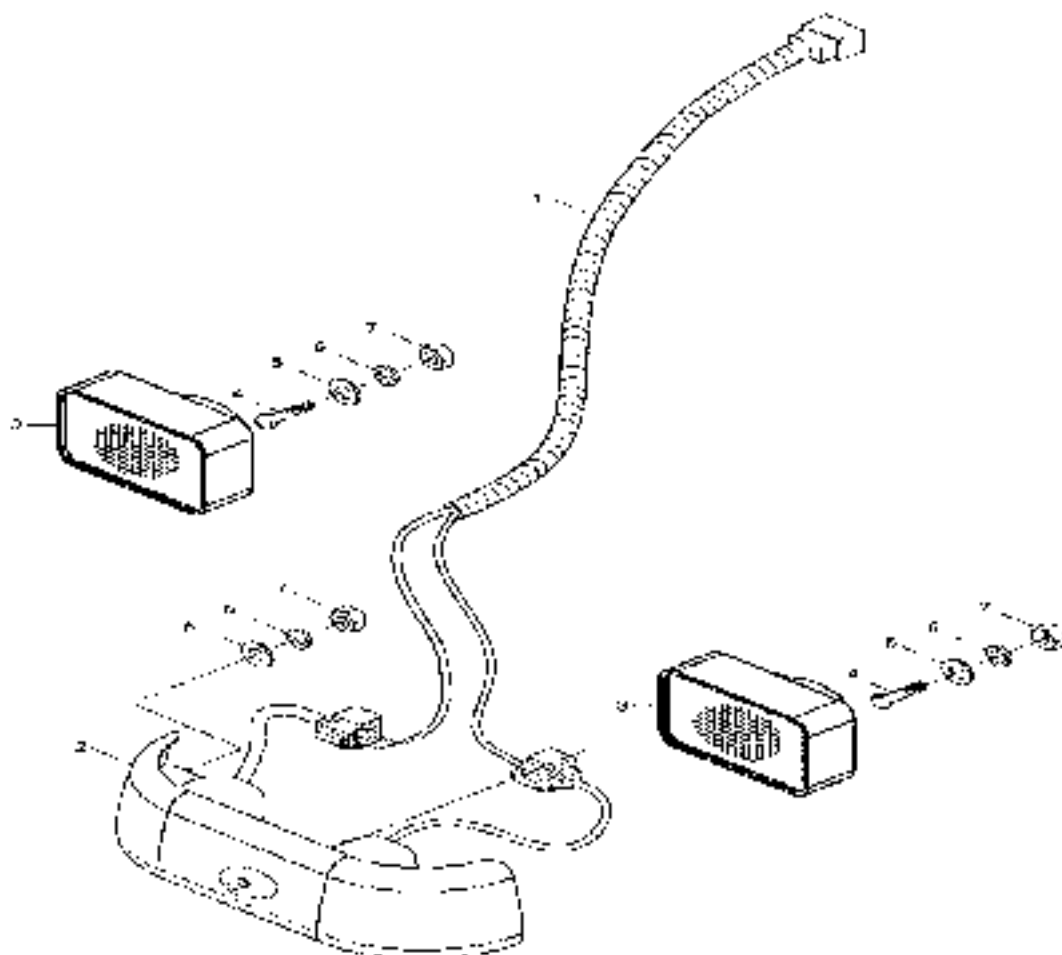

BA500.483 Head Lamp Wiring Harness Assembly

Grade	Parts code and specifications	Parts names	Quantity	Remark
	BA500.483	Head lamp wiring harness assembly	1	
1	BA500.48.012	Front wiring harness assembly	1	
2	B500.48.104	Front combined lamps	1	
3	B500.48.103	Head lamps	2	
4	GB/T 5782-M5×16-Zn-D	Hexagon nut bolts	8	
5	GB/T 97.1-5-Zn-D	Single overlapping lock washers	8	
6	GB/T 94-5-Zn-D	Plain washers	8	
7	GB/T 6170-M5-Zn-D	Hexagon bolts	8	

BA500.484 Rear Lamp Wiring Harness Assembly

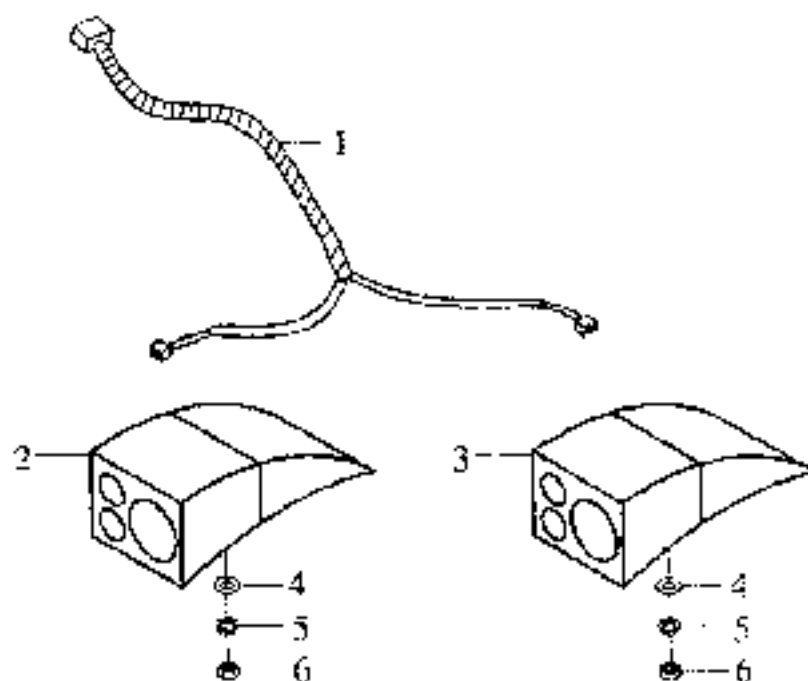

BA500.484 Rear Lamp Wiring Harness Assembly

Grade	Parts code and specifications	Parts names	Quantity	Remark
	BA500.484	Rear lamp wiring harness assembly	1	
1	BA500.48A.015	Rear wiring harness assembly	2	
2	B500.48.106	Rear combined lamps, left	5	
3	B500.48.105	Rear combined lamps, right	5	
4	GB/T 97.1-6-Zn-D	Plain washers	12	
5	GB/T 93.6-Zn-D	Plain washers	12	
6	GB/T 6170 M6-Zn-D	Hexagon nuts	12	

BA500.485 Battery Installation Assembly

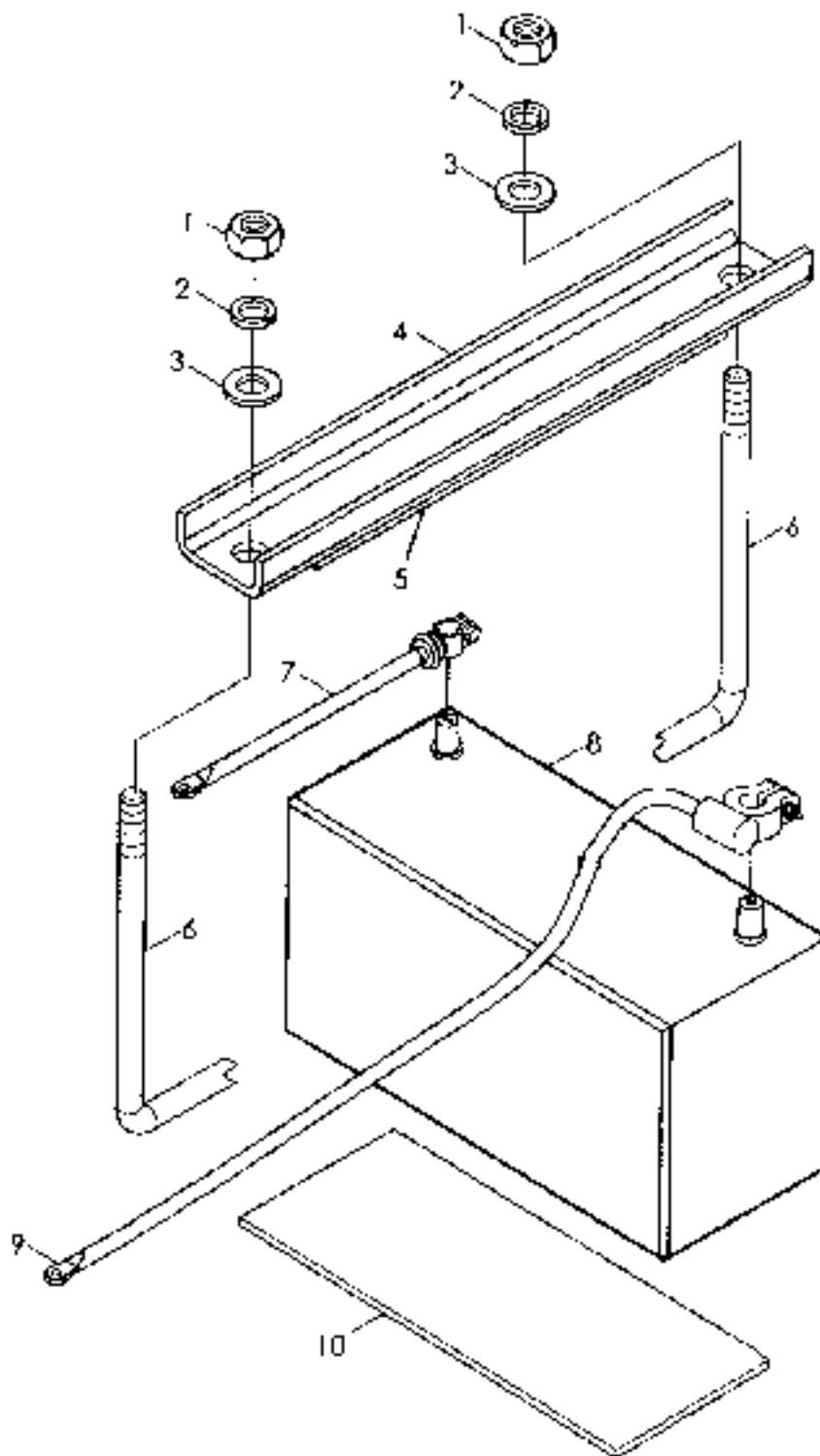

BA500.486 Instrument Desk Assembly

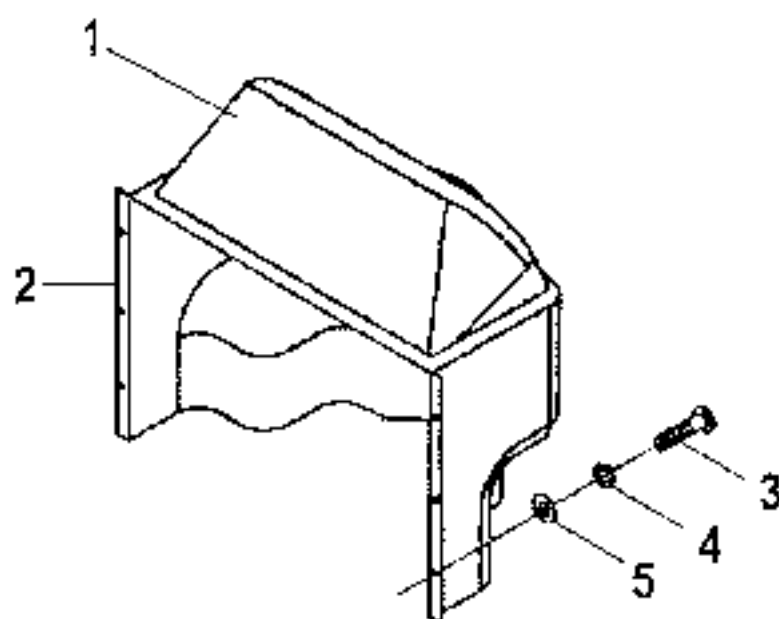

BA500.486 Instrument Desk Assembly

Grade	Parts code and specifications	Parts names	Quantity	Remark
	BA500.486	Instrument desk Assembly	1	
1	BA500.48.107	Instrument desk	1	
2	DL500.48.024	Instrument desk	1	
3	GB/T 5783-M6 x 16-Zn · D	Hexagon head bolts	6	
4	GB/T 93-6-Zn · D	Single coil spring lock washers	6	
5	GB/T 97.1-6-Zn · D	Plain washers	6	

BA500.50 Main and Auxiliary Fuel Tank Assembly-1

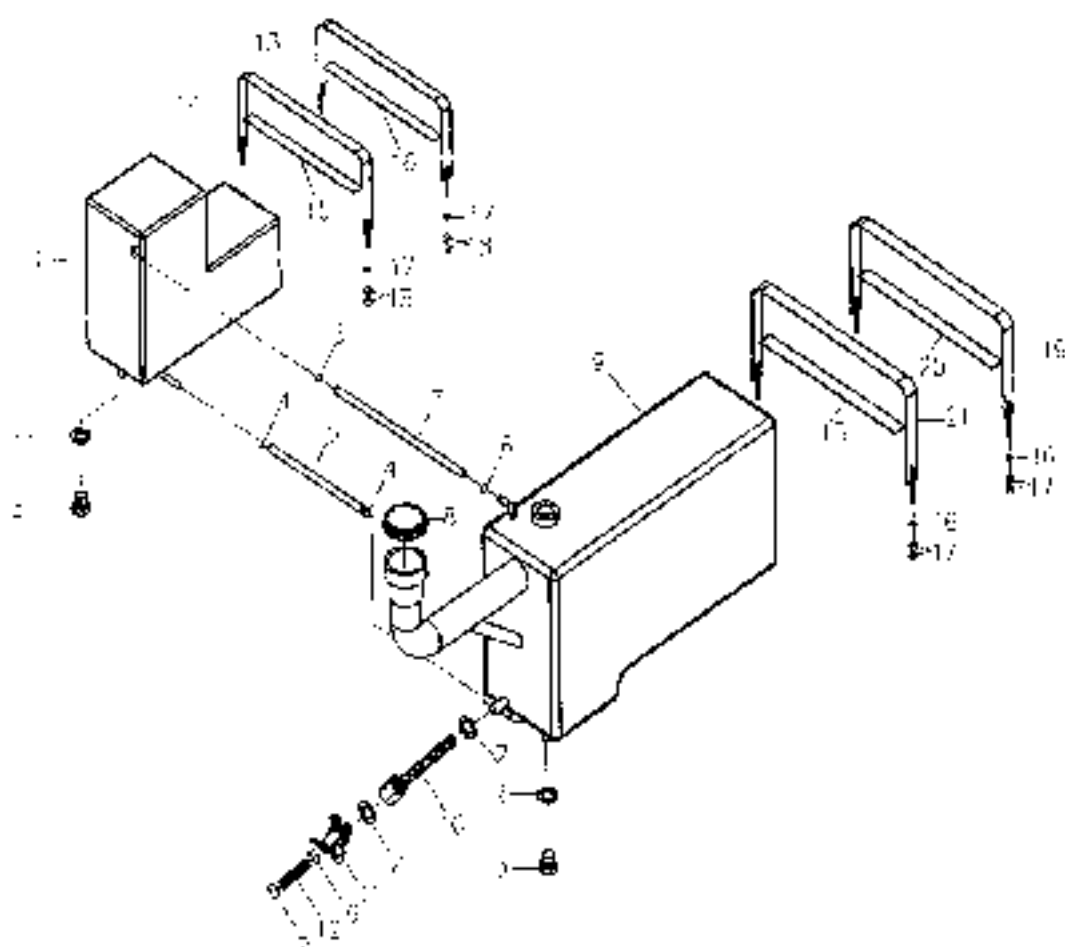

BA500.50 Main and Auxiliary Fuel Tank Assembly-1

Grade	Parts code and specifications	Parts names	Quantity	Remark
	BA500.50	Main and auxiliary fuel tank assembly	1	
1	BL600.50.011	Auxiliary diesel tank assembly	1	
2	GB/T 3452.1-95 5 × 1.8G	O-ring	4	
3	18.50.127	Oil drain plug	2	
4	ZBJ15001	Hose clamp 25 - 38	2	
5	3T.600.50.108	Lower connecting hose of diesel tank	1	
6	ZBJ15001	Hose clamp 10 - 16	4	
7	BL600.50.106	Upper connecting hose of diesel tank	1	
8	1.04.903/885105346	Fuel filler cap assembly	1	
9	BL600.50.010	Main diesel tank assembly	1	
10	18.50.016	Flange adapter assembly	1	
11	SL95-07700	Diesel tank switch assembly	1	
12	SLG.07.706	Fuel pipe	1	
13	BL600.50.019	Fuel tank holding strap	1	
14	BL600.50.017	Fuel tank holding strap	1	
15	BL600.50.113	Pad of fuel tank holding strap	2	
16	BL600.50.115	Pad of fuel tank holding strap	1	
17	GB/T 97.1-8-Zn-D	Plain washers	8	
18	GB/T 6170-M8-Zn-D	Hexagonal nuts	16	
19	BL600.50.018	Fuel tank holding strap	1	
20	BL600.50.104	Pad of fuel tank holding strap	1	
21	3T.600.50.016	Fuel tank holding strap	1	

BA500.50 Main and Auxiliary Fuel Tank Assembly-2

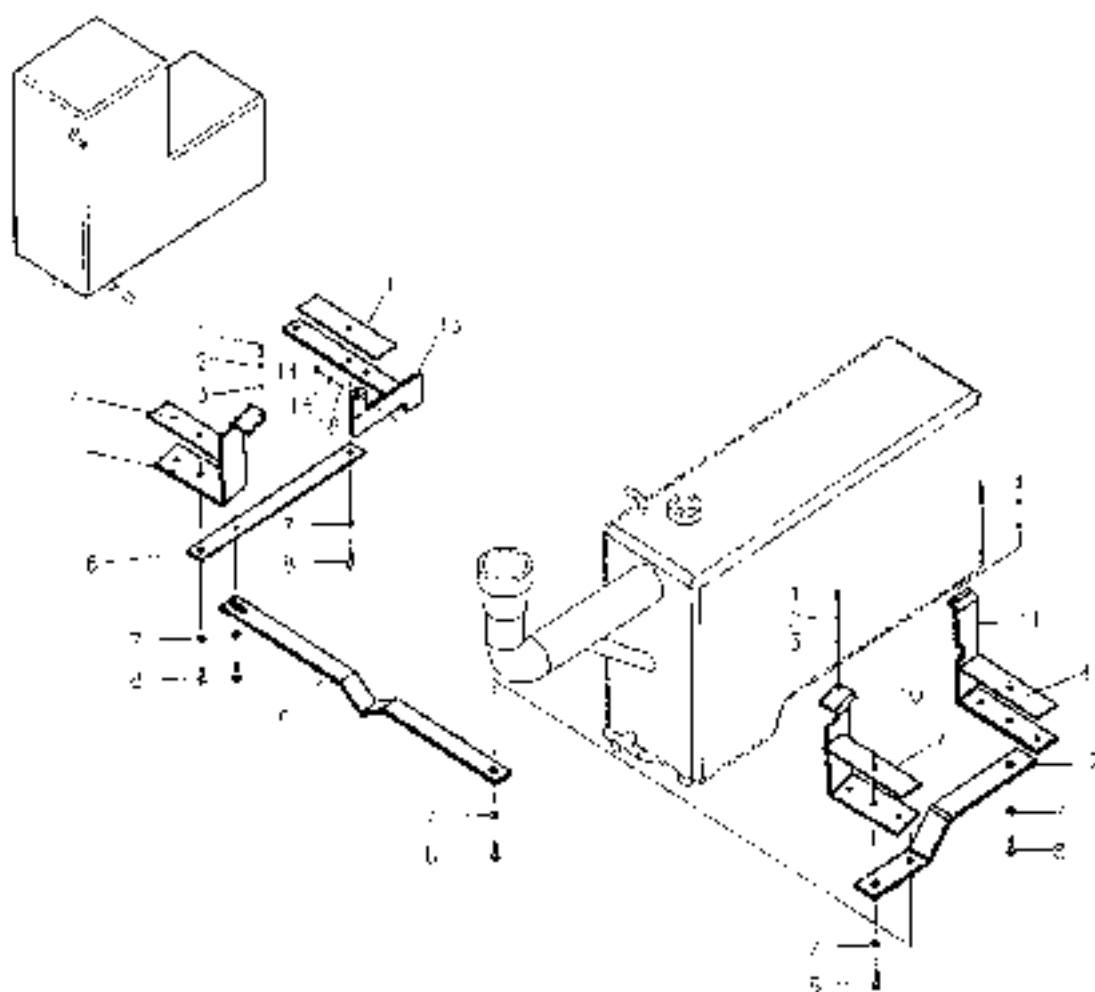

B500.35 Draught Device Assembly

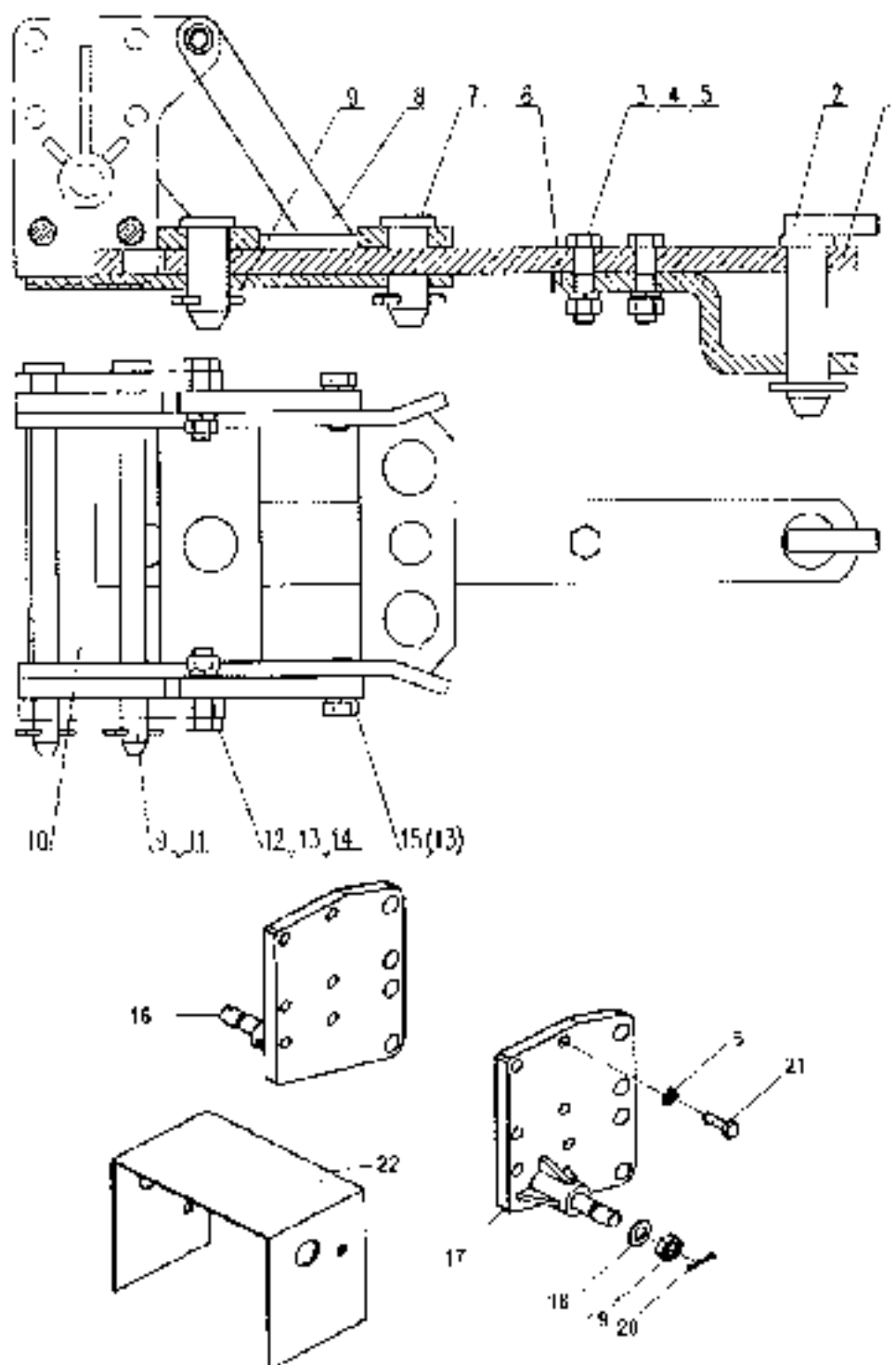

B500.35 Draught Device Assembly

Grade	Parts code and specifications	Parts names	Quantity	Remark
	B500.35	Draught device assembly	1	
1	MD400.35.101	Linkage drawbar	1	
2	MD400.35.012	Clevis pin with head weldment	1	
3	GB/T 5782-M16×65-Zn·D	Hexagon head bolts	2	
4	GB/T 6170-M16-Zn·D	Hexagon nuts	2	
5	GB/T 93-16-Zn·D	Single coil spring lock washers	10	
6	MD400.35.102	Linkage drawbar	3	
7	MD400.35.103	Clevis pin with head	1	
8	MD400.35.104	Pull rod	1	
9	B500.53.111	Lock pin assembly	6	
10	MD400.35.011	Traction frame weldment	1	
11	MD400.35.105	Clevis pin with head	1	
12	GB/T 5782-M14×70-Zn·D	Hexagon head bolts	2	
13	GB/T 93-14-Zn·D	Single coil spring lock washers	4	
14	GB/T 6170-M14-Zn·D	Hexagon nuts	2	
15	GB/T 5782-M14×40-Zn·D	Hexagon head bolts	2	
16	FS400.56.019	Support, left	1	
17	FS400.56.020	Support, right	1	
18	GB/T 97.1-20-Zn·D	Plain washers	2	
19	GB/T 6178-M20-Zn·D	Hexagon nuts	2	
20	GB/T 91-4×36	Spits pins	2	
21	GB/T 5783-M16×35-Zn·D	Hexagon head bolts	8	
22	B500.35.101	PTO shield	1	

B500.55 Lifter Assembly

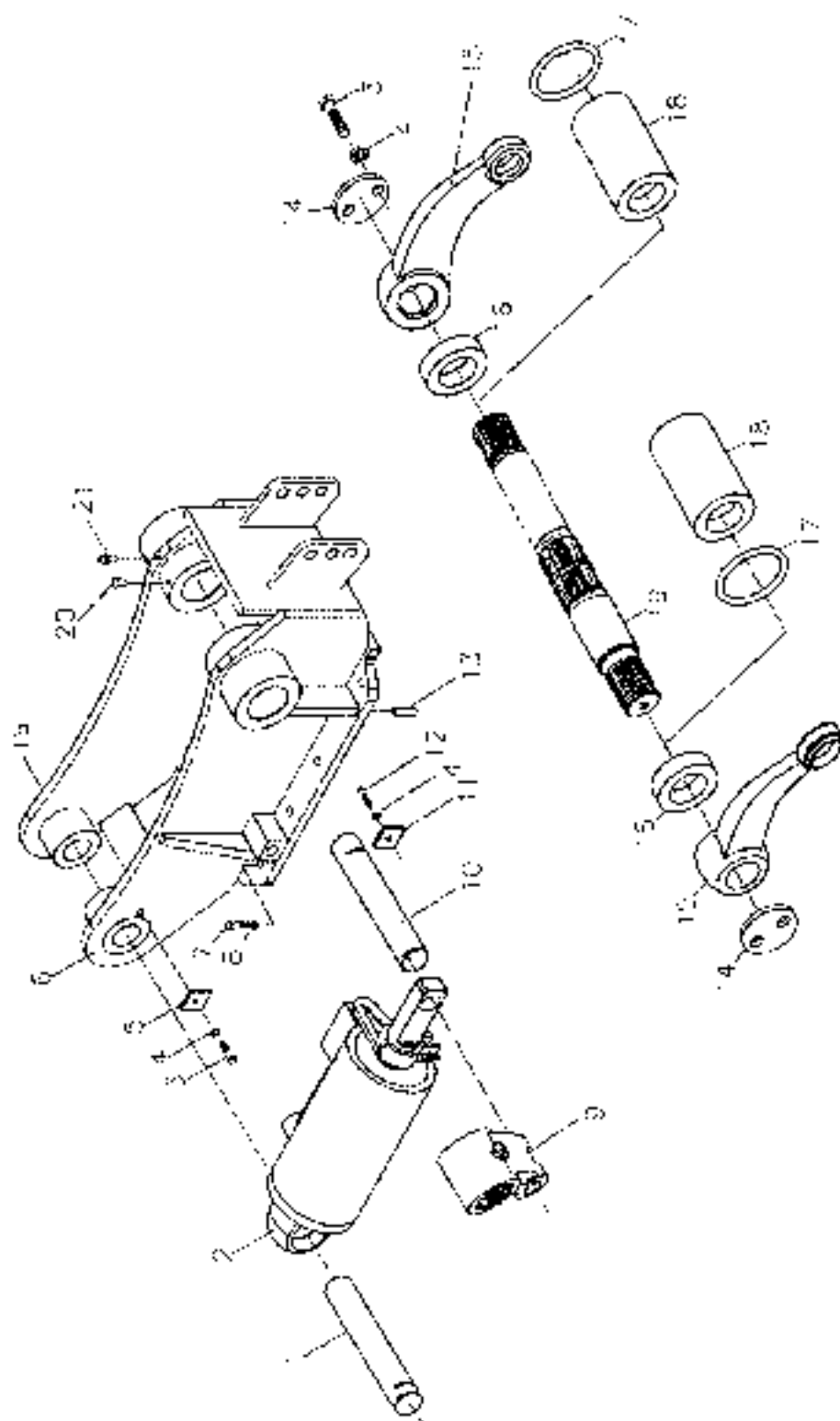

B500.56 Suspension Mechanism Assembly

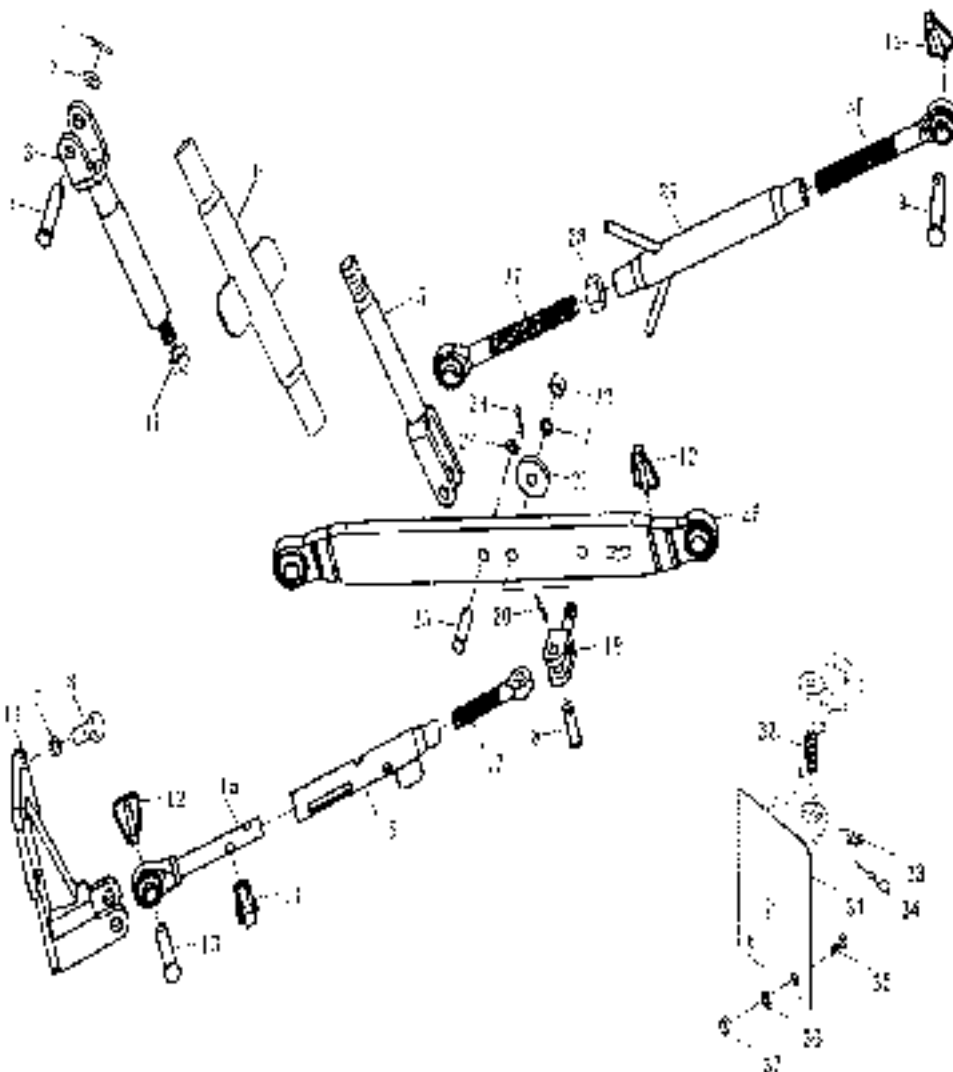

B500.56 Suspension Mechanism Assembly

Grade	Parts code and specifications	Parts names	Quantity	Remark
	B500.56	Suspension mechanism assembly	1	
1	GB/T 91-5 × 40	Splits pins	2	
2	GB/T 97.1-20-Zn.D	Plain washers	2	
3	B500.56.040	Upper connecting fork of lift rod	1	
4	B500.56.101	Connecting pin of lift rod	2	
5	B500.56.042	Lower connecting fork of lift rod	1	
6	B500.56.041	Adjusting spiral pipe of lift rod	2	
7	GB/T 93-20-Zn.D	Single end spring lock washers	10	
8	GB/T 5783-M16 × 35-Zn.D	Hexagon head bolts	8	
9	B500.55.121	Connecting pin of upper pull rod	2	
10	GB/T 6171-M20 × 2-Zn.D	Hexagon nuts	2	
11	B300.56.017	Left stop lever support assembly	1	
	B300.56.018	Right stop lever support assembly	1	
12	B500.53.015	Locking pin assembly	5	
13	B300.56.114	Connecting pin	2	
14	B300.56.036	Locking pin assembly of stop lever	2	
15	B300.56.034	Ball head assembly of expansion link	2	
16	B300.56.035	Conduit weld assembly	2	
17	B300.56.113	Adjusting screw	2	
18	GB/T 882 B16 × 50	Clevis pin with head	2	
19	B300.56.117	Connecting U-bolt of stop lever	2	
20	GB/T 91-4 × 45	Splits pins	2	
21	B300.56.116	Disc plate	2	
22	GB/T 6170-M20-Zn.D	Hexagon nuts	2	
23	GB/T 91-4 × 26	Splits pins	2	
24	GB/T 97.1-16-Zn.D	Plain washers	2	
25	GB/T 882 B16 × 55	Clevis pin with head	2	
26	B500.56.012	Lower left pull rod assembly	1	
	B500.56.012	Lower right pull rod assembly	1	

B500.56 Suspension Mechanism Assembly (Continued)

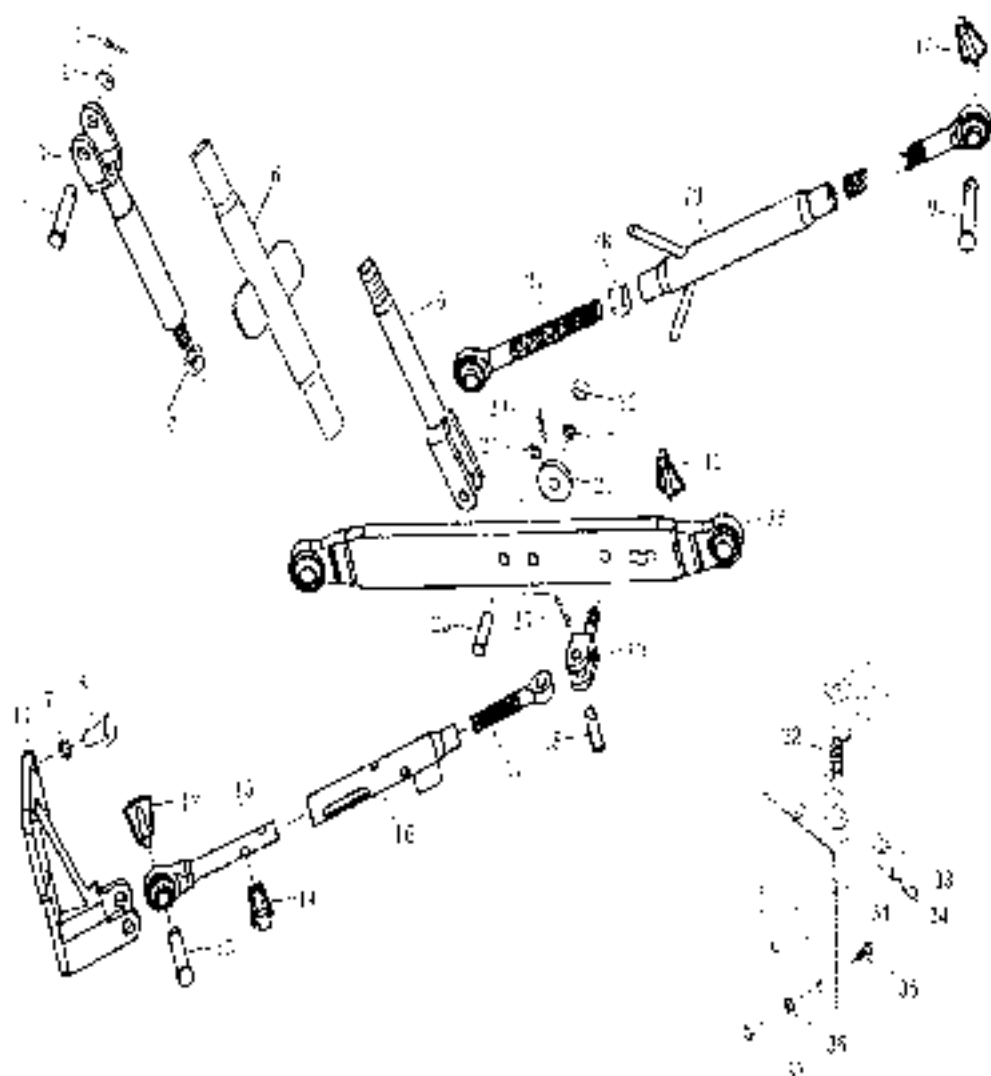

BL500.58Z Fuel Pump Pipe Filter Assembly-1

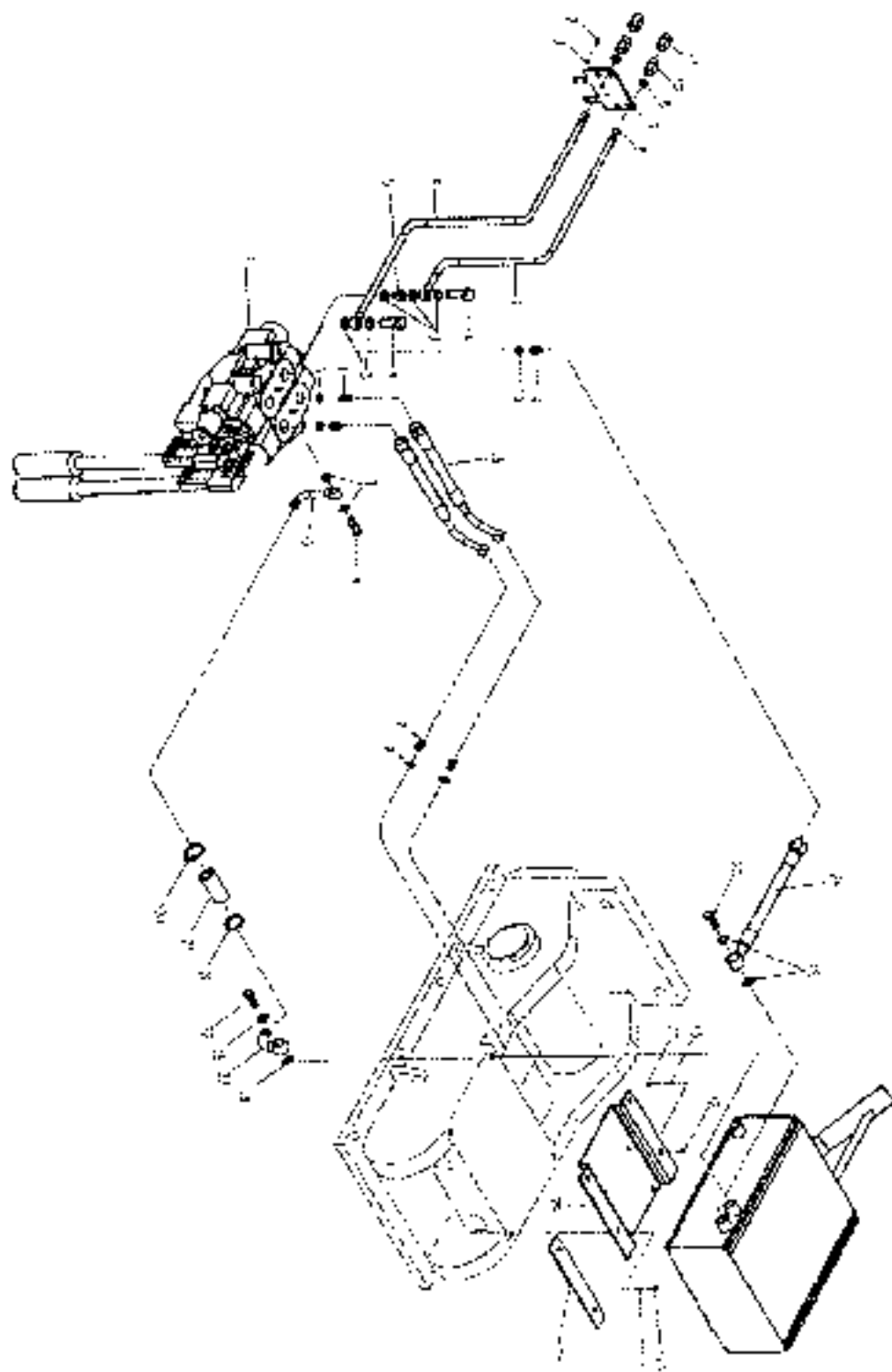

BL500.58Z Fuel Pump Pipe Filter Assembly-1

Grade	Parts code and specifications	Parts names	Quantity	Remark
	BL500.58Z	Fuel pump pipe filter assembly	1	
1	HL6007.58.025	Single-clip low-position floating valve	1	
2	D500.58.202	Straight tube adapter M18-M22	2	
3	JB/T 982-13	Combination gasket	9	
4	B500.40.304	Hollow bolt M18	3	
5	B500.58.200	Transition screw head M18-M18	1	
6	BL600.58.020	Upper right oil pipe assembly	1	
7	BL600.58.021	Upper left oil pipe assembly	1	
8	S1291687L82.785	Nut M24 x 1.5-Zn · D	4	
9	BJ600.58.106	Quick change coupler support	1	
10	S71204.58.033A	Quick change coupler (positive)	2	
11	S71204.58.033B	Quick change coupler (negative)	2	
12	GB/T 5783-M10 x 25-Zn · D	Hexagon head bolts	4	
13	GB/T 91-10-Zn · D	Single coil spring lock washers	4	
14	B500.58.204	Direct pipe head M22-M27	1	
15	JB/T 982-27	Combination gasket	5	
16	BL600.58.022	Multi-way valve-filter hose assembly	2	
17	HS001.58.201	Direct pipe head M20-M22	2	
18	JB/T 982-20	Combination gasket	2	
19	BL600.58.011	Side outlet pipe assembly	1	
20	ZHJ15001	Hose clamp 25 - 38	2	
21	BL600J.40.106	Connecting hose	1	
22	B500.40.300	Hollow bolt M22	2	
23	DL600.58.012	Inlet pipe assembly of auxiliary tank	1	
24	BL600.58.013	Oil return hose assembly	1	
25	GB/T 5783-M8 x 25-Zn · D	Hexagon head bolts	4	
26	GB/T 91-8-Zn · D	Single coil spring lock washers	4	
27	GB/T 6170 M10-Zn · D	Hexagon nuts	4	
28	BL600.58.102	Water pipe	2	
29	DL600.58.101	Auxiliary tank seat	1	

BL500.58Z Fuel Pump Pipe Filter Assembly-2

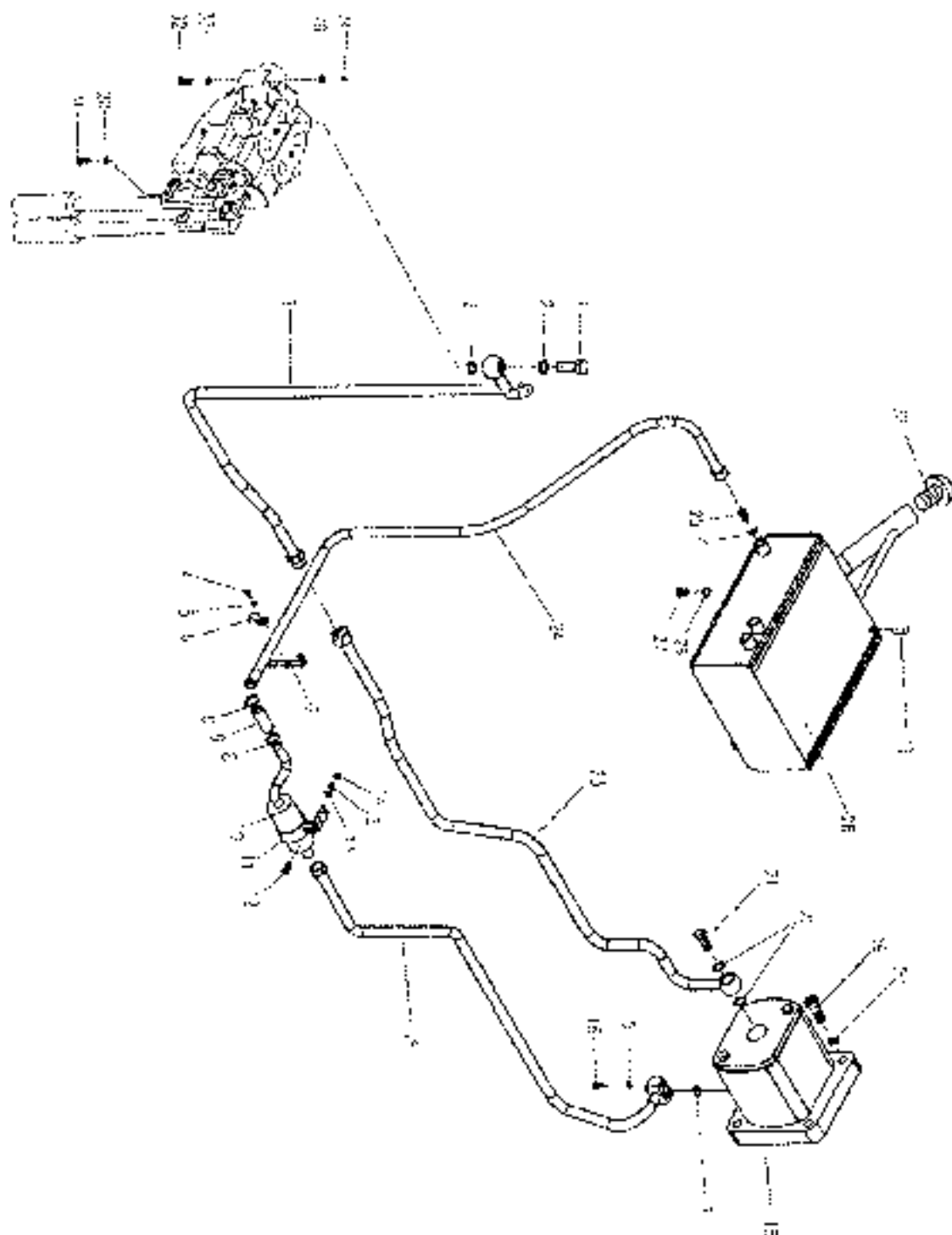

BL500.58Z Fuel Pump Pipe Filter Assembly-2

Grade	Parts code and specifications	Parts names	Quantity	Remark
	BL500.58Z	Fuel pump pipe filter assembly	1	
1	B500.40.300	Hollow bolt M22	1	
2	JB/T 982-23	Combination gasket	3	
3	BL600.58.016	Inlet pipe assembly	1	
4	GB/T 5783-M8×25-Zn·D	Hexagon head bolts	1	
5	GB/T 93-8-Zn·D	Single coil spring lock washers	4	
6	BL600.58.107	Outlet pipe clamp	1	
7	BL600.58.106	Auxiliary tank outlet pipe bracket	1	
8	ZRJ15001	Hose clamp 25×38	2	
9	RT600.58.105	Connecting hose of oil filter	1	
10	B300.58.021-1	Oil filter assembly	1	
11	BL600.58.104	Oil filter bracket	1	
12	GB/T 5783-M8×35-Zn·D	Hexagon head bolts	1	
13	GB/T 97.1-8-Zn·D	Plain washers	1	
14	GB/T 6170-M8-Zn·D	Hexagon nuts	1	
15	BL600.58.015	Suction pipe assembly of gear pump	1	
16	GB/T 5783-M8×45-Zn·D	Hexagon head bolts	2	
17	GB/T 3452.1-18×2.65G	O-ring	1	
18	B500.58A.011	Gear pump CHN-F3141-X	1	
19	GB/T 5782-M10×120-Zn·D	Hexagon head bolts	2	
20	GB/T 93-10-Zn·D	Single coil spring lock washers	6	
21	B500.40.304	Hollow bolt M18	1	
22	JB/T 982-18	Combination gasket	2	
23	BL600Z.58.017	Outlet pipe assembly of gear pump	1	
24	BL600.58.014	Outlet pipe assembly of auxiliary tank	1	
25	B500.58.204	Direct pipe head M22-M27	1	
26	GB/T 3452.1-9.5×1.8G	O-ring	1	
27	18.50.127	Oil drain plug	1	
28	BL600.58.010	Hydraulic tank assembly	1	
29	BL600.58.109	Breather	1	
30	B300.38.016-1	Filler plug assembly	1	
31	GB/T 5783-M10×20-Zn·D	Hexagon head bolts	1	
32	GB/T 5782-M10×70-Zn·D	Hexagon head bolts	3	
33	GB/T 97.1-10-Zn·D	Plain washers	3	
34	GB/T 6170-M10-Zn·D	Hexagon nuts	3	

BL500.74 Front Balance Weight Frame Assembly

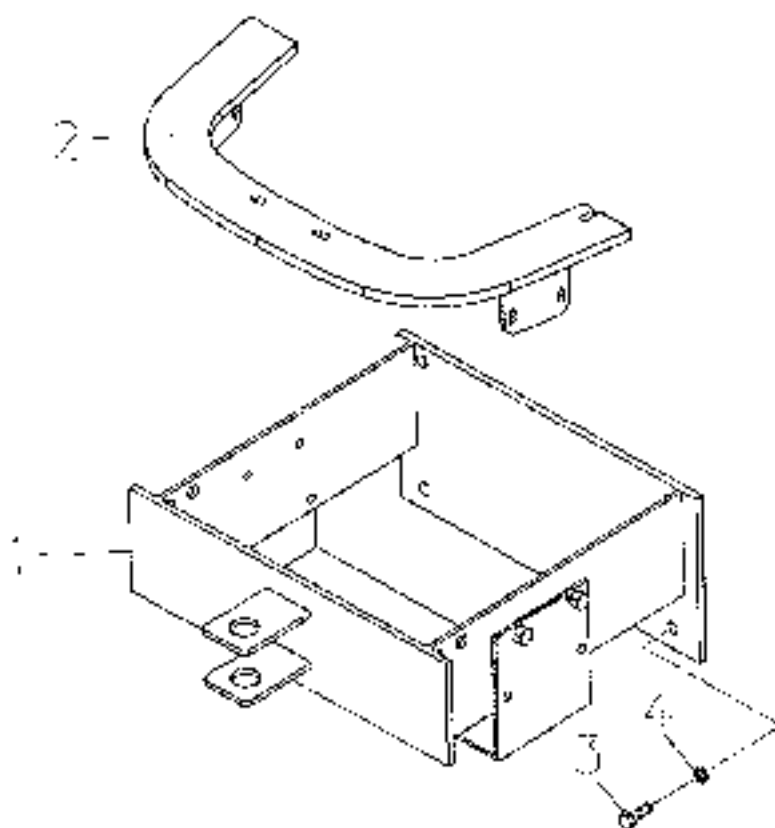

BL500.74 Front Balance Weight Frame Assembly

Grade	Parts code and specifications	Parts names	Quantity	Remark
	BL500.74	Front balance weight frame assembly	1	
1	BL500.74.0204	Battery box weldment assembly	1	
2	BA500.74.012	Supporting plate weldment	1	
3	GB/T 5783-M16 x 45-Zn-D	Hexagon head bolts	4	
4	GB/T 93-16-Zn-D	Single coil spring lock washers	2	

BL500.91 Rear Balance Weight Assembly

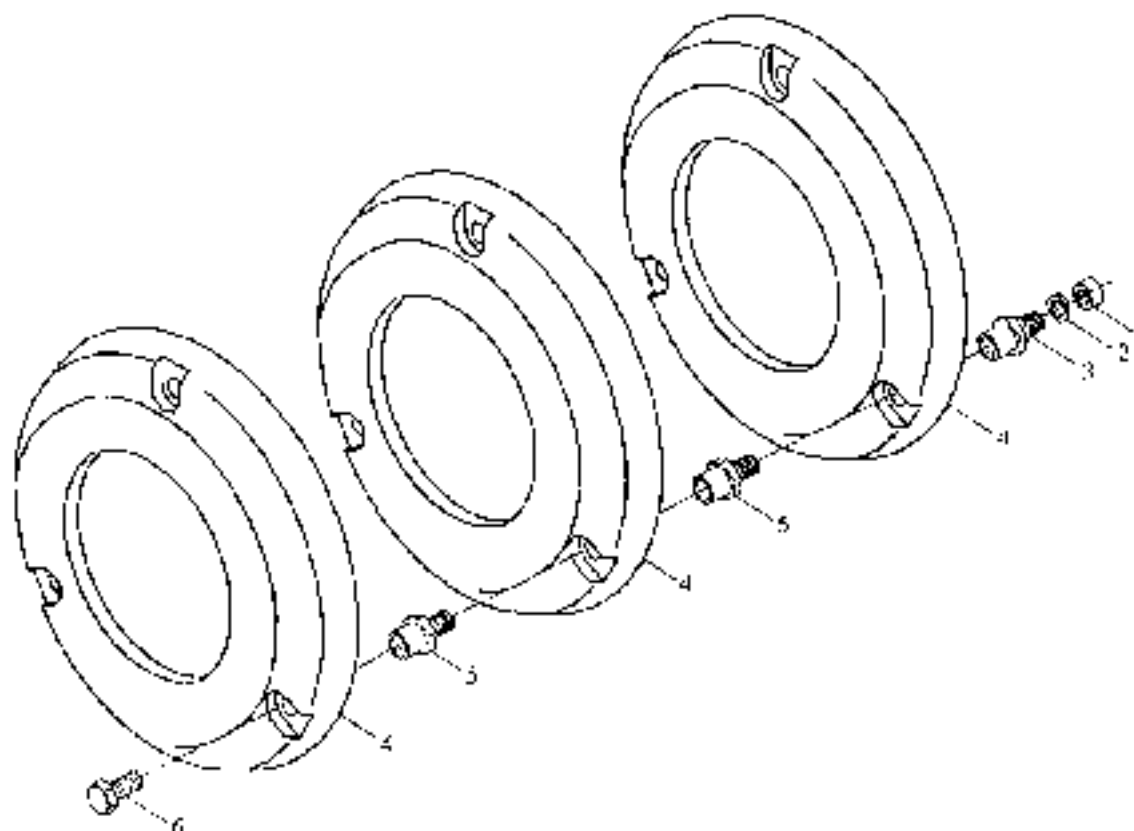

BL500.91 Rear Balance Weight Assembly

Grade	Parts code and specifications	Parts names	Quantity	Remarks
	BL500.91	Rear balance weight assembly	1	
1	GB/T 6171-M16×1.5-Zn-D	Hexagon nuts	6	
2	1.49.44/1.49.696	Plain washers	6	
3	44018046/1.49.723	Clamp weight screws	6	
4	PL500.34.101	Rear balance weight	6	
5	44018037/1.49.126	Chump weight screws	12	
6	GB/T 5785-M16×1.5×30-Zn-D	Hexagon head bolts	6	