

# POWER UNITS & Gardening Attachments

# OWNERS USE & CARE MANUAL

CODE NUMBER 90103079 EDITION 11.17

MODELS *NEW HANDLEBARS*

**710** GARDENER

**718** HARVESTER

**722** HARVESTER

**732** PROFESSIONAL

**948** PROFESSIONAL

**852** PROFESSIONAL

**853** PROFESSIONAL

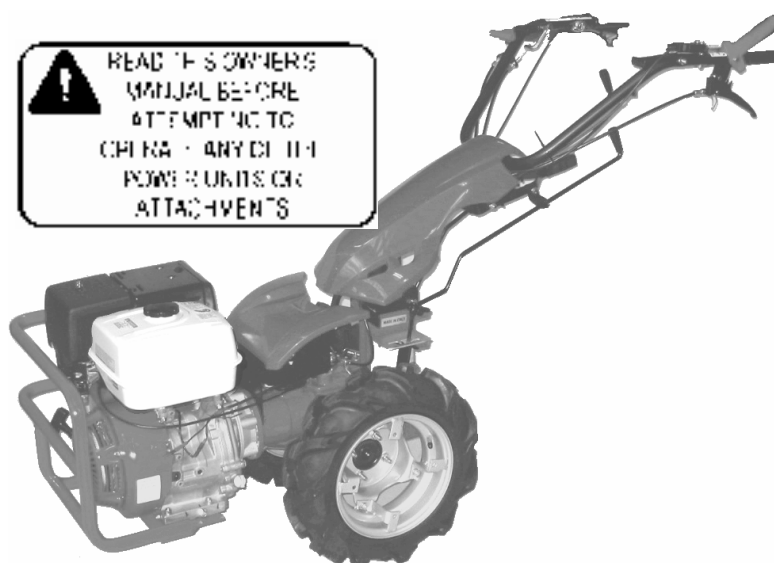
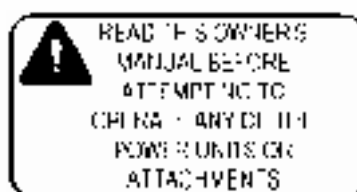

Dear Customer,  
Thank you for your purchase. Get set to enjoy the benefits your wise selection of a BCS unit has earned for you. We believe that no other make machine that can handle so many lawn and garden tasks with such fine results – and with so little effort on your part.

Your BCS unit has precision gearing for lasting, trouble-free service. There are no drive belts to stretch and break.

Our network of BCS distributors and servicing dealers stands ready to supply your needs for attachments, accessories, parts and service. With a yearly check-up, your dealer can help you keep your BCS equipment to shape. Meanwhile, be sure to follow the operating and maintenance tips in this owner's manual for satisfied performance of your machine.

**BCS America**

## **MODELS IN THIS EDITION**

BCS America maintains a dynamic updating policy. It notifies the field of the serial number of the first unit off the line after a change. This edition covers the models and model options listed in the specifications on page 16.

Accordingly, be sure to record the BCS unit serial number printed between two stars on the transmission, and the engine model and serial numbers from the engine name plate.

## **GRAPHIC SYMBOL**



**THIS SYMBOL IS LIKE A FLAG.  
IT FLAGS YOUR ATTENTION TO DANGER WARNINGS IN THE MANUAL.**



**WHEN PLACED OVER A PICTURE OR AN ITEM IN THE PICTURE, THIS SYMBOL SAYS  
“NO !” DO NOT DO, OR USE OR PERMIT WHATEVER IS SHOWN.**

 **WARNING**

**READ ALL SAFETY RULES AND OPERATING AND MAINTENANCE  
INSTRUCTIONS IN THIS MANUAL BEFORE USING ANY POWER UNIT,  
ATTACHMENT, OR ACCESSORY.**

# CONTENTS

## SECTION ONE

### RULES FOR SAFE OPERATION OF UNIT AND ATTACHMENTS

#### GENERAL PRECAUTIONS AND INSTRUCTIONS

REAR-TINE TILLER PRECAUTIONS	“ 8
ROTARY MOWER PRECAUTIONS	“ 9
CUTTER BAR MOWER PRECAUTIONS	“ 10
SNOW THROWER PRECAUTIONS	“ 10
POWER SPRAYER PRECAUTIONS	“ 11
CHIPPER/SHREDDER PRECAUTIONS	“ 12
POWER SWEPPER PRECAUTIONS	“ 13

## SECTION TWO

### SCHEME CONFIGURATIONS

#### MODELS DESIGNED FOR FRONT-MOUNTED ATTACHMENTS

#### MODELS DESIGNED FOR REAR-MOUNTED ATTACHMENTS

#### SPECIFICATIONS

MODEL 852, 853	“ 15
MODELS 710	“ 15
MODELS 718, 722, 732	“ 16
MODEL 948	“ 17

#### UNPACKING

#### ASSEMBLING THE UNIT

#### LUBRICATION FILTER AND FUEL

ENGINE CRANKCASE LUBRICATION	“ 21
GEARBOX LUBRICATION	“ 21
ENGINE AIR CLEANER	“ 25
GASOLINE ENGINE FUEL	“ 25

#### STARTING AND STOPPING

SETTING CONTROLS FOR COLD STARTING	“ 26
CRANKING TO START	“ 27
STOPPING	“ 28
DIFFERENTIAL AND TWO-WHEEL DRIVE	“ 29
WHEEL BRAKES	“ 30
SHUT-DOWN (STORAGE)	“ 30
TAKING CONTROL OF THE MACHINE	“ 31

#### GEAR AND P.T.O. ENGAGEMENT

MAKING A CONVERSION FRONT-TO-REAR, OR REAR-TO-FRONT	“ 31
---	------

#### OPERATING IN CONVERTED MODE

MAINTENANCE PROGRAM	“ 32
---------------------	------

## SECTION THREE

### USE AND CARE OF ATTACHMENTS

#### LUBRICATION OF ATTACHMENTS

#### COUPLING ATTACHMENT TO P.T.O.

#### USE AND CARE OF REAR-TINE TILLER

PREPARING NEW TILLER	“ 36
WIDTH OF TILTH	“ 36
TILLING DEPTH ADJUSTMENT	“ 37
GARDENING SUGGESTIONS	“ 37
TRANSPORT SULKY FOR REAR-TINE TILLER	“ 38

#### USE AND CARE OF CUTTER BAR MOWER ATTACHMENT

GENERAL CUTTER BAR MOWER INFORMATION	“ 39
RECOMMENDED OPERATION	“ 39
MOWER BAR MAINTENANCE	“ 39

#### USE AND CARE OF 2-BLADE ROTARY MOWER

THE UNITS CONVERTED FOR MOWER USE	“ 41
ASSEMBLY, CONNECTION AND LEVELING OF THE 2-BLADE MOWER	“ 41
LUBRICATION	“ 42
ROTARY MOWER OPERATION	“ 42
INSPECTION AND MAINTENANCE	“ 43

#### USE AND CARE OF SNOW THROWERS

GENERAL INFORMATION	“ 44
SNOW THROWER OPERATION	“ 44

#### USE AND CARE OF CHIPPER / SHREDDER

CHIPPER / SHREDDER MAINTENANCE	“ 45
--------------------------------	------

#### USE AND CARE OF POWER SWEEPER

OPERATION	“ 46
MAINTENANCE AND STORAGE	“ 46

#### USE AND CARE OF DOZER BLADE

	“ 47
--	------

# RECORD OF SERIAL NUMBERS

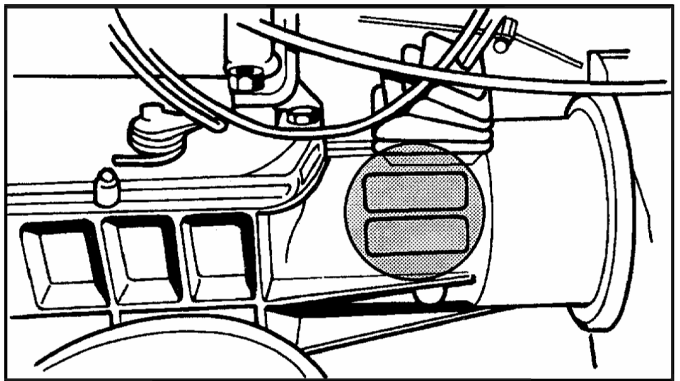

**BCS UNIT SERIAL NUMBER** \* \_\_\_\_\_ \*

(Located between stars on transmission)

**BRIGGS & STRATTON  
ENGINE SERIAL NUMBER** \_\_\_\_\_

(Stamped on crankcase about two inches from  
name plate on side of engine)

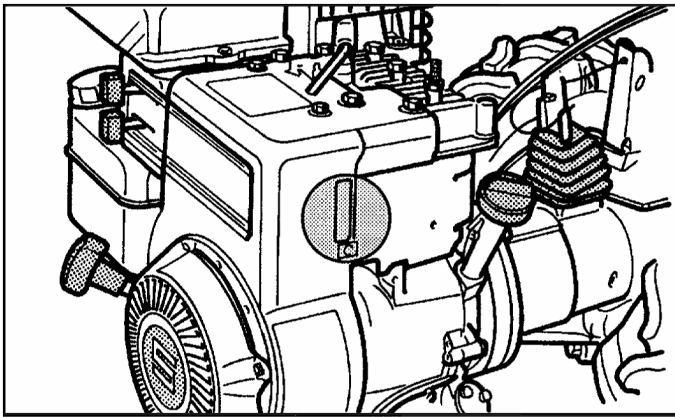

**HONDA ENGINE SERIAL NUMBER:**

TYPE \_\_\_\_\_

SERIAL No. \_\_\_\_\_

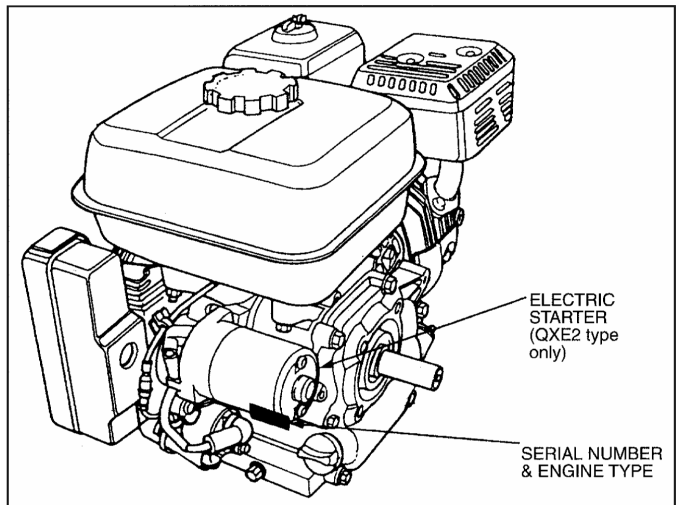

**KOHLER ENGINE SERIAL NUMBER** \_\_\_\_\_ (Located on engine crankcase)

## **WARNING**

**READ ALL SAFETY RULES AND OPERATING AND MAINTENANCE  
INSTRUCTIONS IN THIS MANUAL BEFORE USING ANY POWER UNIT,  
ATTACHMENT, OR ACCESSORY.**

# SECTION

# 1

## **INSTRUCTIONS FOR SAFE OPERATION OF BCS POWER UNITS AND ATTACHMENTS**

General precautions and instructions are followed by specific precautions for each combination of attachment and power unit in the owner's manual.

### **GENERAL PRECAUTIONS AND INSTRUCTIONS**

#### **TRAINING**

READ THIS OWNER'S MANUAL PRIOR TO OPERATING THE POWER UNITS AND ATTACHMENTS.

BCS power units and attachments are designed for operation by properly instructed adults only. Make certain that any person operating this equipment has read this manual.

DO NOT LET CHILDREN OPERATE THE POWER UNIT.

KEEP THE OPERATING AREA CLEAR OF PEOPLE AND ANIMALS. BE CAREFUL THAT CHILDREN DO NOT COME NEAR.

During storage, and whenever the power unit is unattended, disengage the PTO (power take-off) and render the engine unstartable by disconnecting the spark plug wire from spark plug.

#### **PREPARATION**

Wear appropriately protective clothing and safety protection articles for the climate and type of attachment you are to operate.

1. For all walk-behind applications, wear sturdy non-slip boots or safety toe shoes. See recommendations listed for use of a particular attachment. Do not wear open-toed sandals or go barefoot when operating these machines.
2. Wear snug-fitting protective clothing which allows freedom of movement without being loose-fitting. Ties, scarf and jewels which could be caught in the machinery should not be worn.
3. Wear hearing protection.
4. Wear eye protection when operating a snow-thrower, power sprayer, chipper / shredder or mower attachment.
5. Overexposure to sunlight can be damaging to your eyes and skin. When working in strong sunlight, protect your eyes with sun glasses and either keep your body covered or apply a sun screen lotion.

Do not operate on terrain where you cannot maintain good footing or where the machine could overturn or slide into you. When walking behind the unit, walk slowly. DO NOT RUN!



**ONLY PROPERLY INSTRUCTED PERSONS  
SHOULD USE THIS EQUIPMENT**

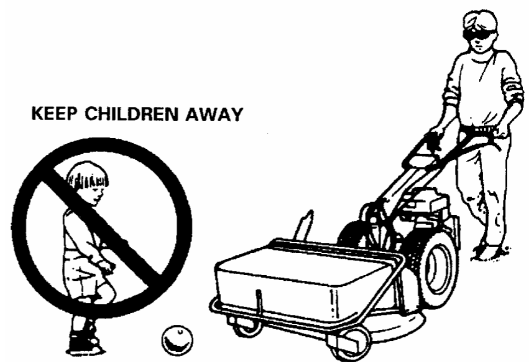

**KEEP CHILDREN AWAY**



**EYE AND HEARING  
PROTECTION**

**STURDY FOOTWEAR**



Thoroughly inspect the area where you are going to mow or thatch the lawn, sweep walks or drives or throw snow. Remove toys, stones, bones, wires, glass, newspapers and other objects which could be caught up and thrown by the machine. Take the following precautions for the safe handling and storage of fuel:

1. Keep fuel supplies in approved type, properly labelled fuel containers.
2. Do not store fuels or fuelled units in closed (unventilated) areas or in garages or shops connected to human living quarters. Do not store units or fuel where there are flames or sources of sparks such as electrical appliances and switches.
3. Obey all local regulations for the storage and handling of fuel.
4. Do not smoke when fuelling, or fuel where the fumes could be ignited by fire or sparks.
5. Do all fuelling outdoors over non-flammable surfaces. If fuel is spilled on the unit, wipe the unit dry and properly dispose of the wiping rag. ALWAYS MOVE THE UNIT AT LEAST 10 FEET (3 m.) AWAY from the fuelling spot and fuel supplies before starting the engine.
6. Always remove the engine fuel cap very slowly to equalize tank pressure and avoid spurting of fuel. Keep your face and eyes away from the tank while loosening the fuel cap.
7. Do not fuel a running or hot engine. Do not loosen the fuel cap until the engine has stopped.

Then wait several minutes for the engine to cool before pouring fuel. Before starting the engine, put all control levers in neutral (N) position. All "N" positions on the gear selector are neutral. Also be sure to disengage the PTO (power take-off) to the attachment. Never make blade height or any other adjustment to the power unit or any attachment while the engine is running.

## OPERATION

Operate only when there is good visibility. Do not operate at dusk or at night. Do not operate when it is foggy or hazy.

Never change the engine governor setting or overspeed the engine. Use the throttle and gear settings recommended for particular attachments and applications in this owner's manual.

Do not put hands and feet under the mower deck or into the discharge openings of a rotary mower.

Do not put fingers or any other part of the body into the intake or discharge openings of any mower, snow-thrower or chipper/shredder unless you have disconnected the spark plug wire so engine cannot be started accidentally.

Keep the machine clean-out holes closed. Stay out of the discharge stream of a mower, chipper/shredder, power sweeper or power sprayer.

Always stop operation of a rotary mower, a cutter bar mower, snow thrower or a tiller before crossing paved or gravel roadways.



DON'T KEEP FUEL OR FUELED ENGINES WHERE SPARKS COULD CAUSE FIRE OR EXPLOSIONS



DO NOT SMOKE OR BRING ANY FLAME OR SPARKS NEAR FUEL!

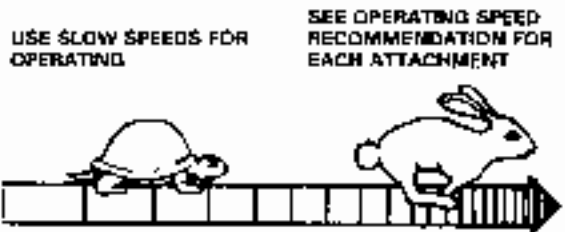

USE SLOW SPEEDS FOR OPERATING

SEE OPERATING SPEED RECOMMENDATION FOR EACH ATTACHMENT



NEVER PUT HANDS OR FEET UNDER MOWER DECK OR INTO OPENING

Never ride the tractor or an attachment. Ride only on riding accessories designed for the purpose. Do not take children on a sulky with you.

- 1. Use transport sulkies only for transport to and from the operating area and never for operation.
- 2. Use utility wagons only for hauling and limit the payload to the rated capacity of the wagon.
- 3. A mowing sulky is exclusively for operation of a rotary mower and must not be used with any other attachment.
- 4. Never use ride-on attachments on the highway or any city street.

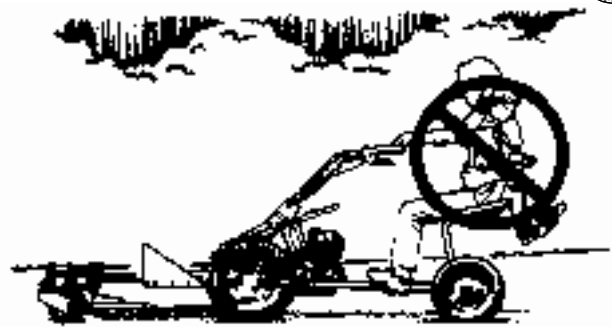

DO NOT LET CHILDREN RIDE WITH YOU ON A SULKY

Do not disconnect or otherwise defeat the purpose of the lockout devices.

The high-speed lockout prevents using too fast a gear for backing up a front-mounted attachment.

The PTO/REVERSE lockout permits backing up a rear-mounted attachment only when the PTO is disengaged. Read Section Two for explanation of the lockout devices.

Do not use the highest numbered gear on the gear selector when walking behind the machine.

On all units in this manual, the highest gear produces much faster than walking speed and is only to be used for transport in conjunction with a transport sulky.

Don't make adjustments or repairs to the machine when the engine is running.



DO NOT OPERATE IF MACHINE STARTS TO VIBRATE

Put all controls in neutral, wait until reciprocating or rotating parts of the attachment have stopped and disconnect the spark plug wire:

- 1. Before leaving the unit where unauthorized persons may start it accidentally.
- 2. When a foreign object has been struck or taken into the attachment. Proper operation should be restored before further use.
- 3. Before cleaning out a clogged attachment such as a rotary mower, cutter bar mower, snow-thrower, chipper/shredder or power sweeper.
- 4. If the machine suddenly starts to vibrate or run erratically. The entire machine should be inspected by an authorized BCS servicing dealer before further use.



UNIT SERVICING SHOULD BE DONE BY AUTHORIZED BCS DEALERS

All safety guards, plates, lockouts, deflectors and shields must be in proper position.

Do not operate if any safety devices or fastening parts are missing from the unit.

Do not run the engine indoors where deadly poisonous carbon monoxide fumes can collect.

If the engine is to be started inside a garage or barn, open the doors and windows wide so the fumes can escape.



BUILD-UP OF FUMES CAN BE VERY DANGEROUS



## MAINTENANCE AND STORAGE

Keep engine, tractor and all attachments in safe working condition. Clean the unit and accessories at regular intervals, also check for damaged or missing parts.

Check the tightness of all fasteners. Perform the items of maintenance recommended in this owner's manual. Do not attempt any disassembly and repairs for which instructions have not been furnished.

Certain engine adjustments, and interval servicing of the engine, tractor, clutch and transmission, and gearboxes of attachments should be done only by a BCS-trained service-man at an authorized BCS servicing dealer or distributor.

Do not store the machine with fuel in the system. Disconnect the fuel line at the carburettor inlet, and drain the fuel into a fuel container. Then reconnect the fuel line. Start and run the engine until it stops from lack of fuel.

When storing the machine, use the spring latch (illustrated on page 29) to latch the clutch lever in the depressed (disengaged) position. This prevents the clutch cone from sticking to the lining during storage.

Store the machine in a well-ventilated place, protected from dampness and the weather.

## REAR-TINE TILLER

### PRECAUTIONS

All the models have **PTO / reverse lockout** devices to prevent tine rotation while the Tiller is being backed up. These devices are shown and their operation described on page 28. Before operating the Tiller, always check that the lockout device is properly assembled on the machine. **Do not remove the high speed lockout or render it inoperable.**

Don't put hands or feet near or under the tiller housing. Keep away from the rotating tines. The tines of the BCS tiller rotate at high speeds independent of the tractor gear speed settings.

Inspect the area to be tilled. Pick up rocks and other objects of a size which may jam or otherwise interfere with tiller operation. Till only when there is good light.

Use caution to avoid slipping and falling. Wear footwear which will improve footing on slippery surfaces. Do not over-load the machine by attempting to till too deeply or in fast forward. See tiller operation instructions in Section 3.

On new (previously untilled) or hard, rocky ground, use lowest gear and throttle settings, and set the tiller tines for minimum soil penetration. Be alert for the possibility the machine may leap forward if the tines contact an underground obstruction. If this occurs, let go of the tiller handles to stop the engine.

Do not use makeshift accessories in conjunction with the tractor and the tiller. Use only wheels, counterweights, shaft extensions, connectors, and tine combinations recommended for each tractor and tiller attachment by BCS.

**The highest number gear selection is only for transport of the unit and tiller attachment in conjunction with a transport sulky.**

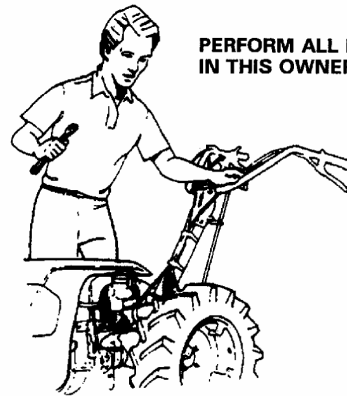

PERFORM ALL MAINTENANCE  
IN THIS OWNER'S MANUAL

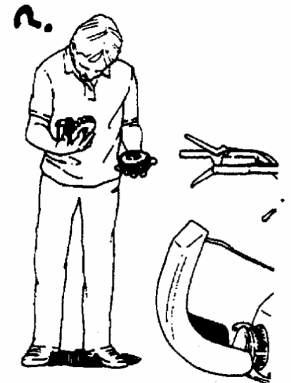

DON'T ATTEMPT REPAIRS  
NOT COVERED IN THIS  
OWNER'S MANUAL

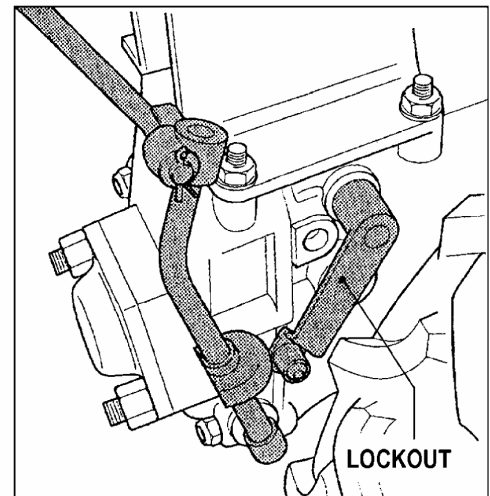

TILLER HITS HARD  
GROUND OBSTRUCTION  
AND TINE WALKS OR  
LEAPS FORWARD

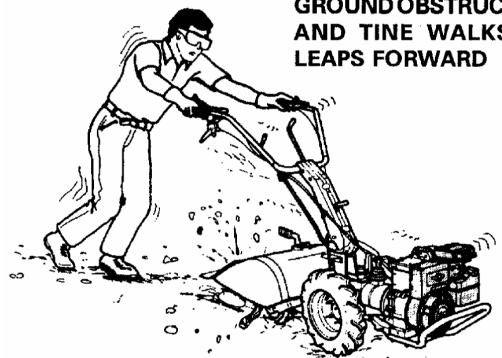



Don't operate the tiller in high gear. Don't use high transport speeds on slippery surfaces. When using a transport sulky, look behind and use care when backing.

**DO NOT MOW WITH GRASS DEFLECTORS OPEN**

## **ROTARY MOWER PRECAUTIONS**

### **IMPORTANT NOTICE**

**Do not deactivate the PTO Reverse Lockout on any of the convertible models. The new design lock-outs on these models automatically disengage during a conversion for front-mount attachments.**

Clear the area to be mowed of all objects (wires, rocks, toys, etc.) which might be picked up and thrown by the mower.

Disengage the PTO and put the transmission into neutral (gear selector position "N") before cranking to start the engine and also whenever leaving the operator zone behind the handlebar or dismounting from a sulky. Stay alert for holes, rocks, roots in the terrain and other hidden hazards. Keep away from drop-offs. Use wheel extensions for added stability of a walk-behind mower. When walking behind, be especially cautious when changing direction on slopes.

When operating from a riding sulky, reduce speed and use extreme caution on slopes and in sharp turns to prevent tipping and loss of control.

### **MOW SLOPES AS FOLLOWS:**

- 1.** When riding, mow up and down, never across the slopes.
- 2.** When walking behind, mow across the slopes, never up and down.
- 3.** Do not mow excessively steep slopes.

Be careful not to discharge grass in direction of roadways, houses, vehicles and people. Inspect grass bags frequently for wear and deterioration. Replace grass bags which are not in good condition.

When the **2-blade mower** is used without the grass bag, the grass deflector **must** be in the down position covering one discharge chute, and the door on the other chute **must** be closed to prevent open discharge from the chutes.

When mounting the grass bag on the deck to collect the cuttings, open the door and raise the deflector for discharge from the volutes into the bag.

Before removing the grass bag for emptying, disengage the PTO, shut off the engine and wait until the mower blades have stopped.

Never put hands in any openings of the mower or grass bag when the engine is running. If necessary to clear out the discharge chute with your hands, always first disconnect the spark plug wire.

Keep the mower blades in good condition. Inspect, sharpen and maintain blades as recommended for mower attachments in Section 3. Replace bent, badly worn blades, because pieces breaking off can become projectiles. After sharpening, blades should be balanced.

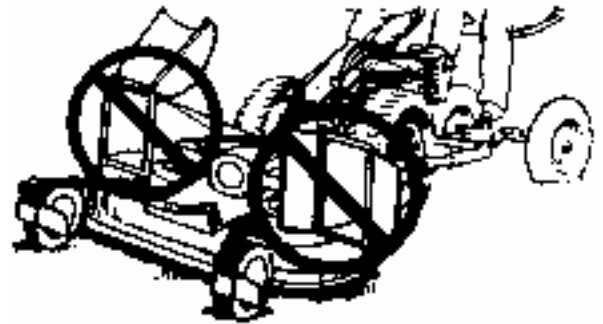

**WHEN RIDING, MOW UP AND DOWN SLOPES**



**WHEN WALKING BEHIND, MOW ACROSS THE SLOPES**



**CRACKS**



### **IMPORTANT NOTICE**

Do not deactivate the PTO Reverse Lockout on any of the convertible models. The new design lockouts on these models automatically disengage during a conversion for front-mount attachments.

## **CUTTER BAR MOWER**

### **PRECAUTIONS**

Cutter Bar Mower attachments are intended for walk behind operation only. Do not use a riding sulky.

Mow only at a slow rate of speed. See page 39 for recommended throttle and gear combinations for cutter bar mowing. Do not use (transport) gear # 4 on 852 for any purpose other than using a transport sulky for transport. Transport speed of these models far exceeds the walking speed of an operator.

The models 718, 722, 732 and 948 converted for cutter bar operation have high gear position blocked by a high speed lockout.

**Do not remove or otherwise defeat the purpose of the high speed lockout device.**

Disengage the PTO when backing the machine.

Cutter bar mowers are designed for mowing over terrain which is too rugged or steep for use of rotary mowers. Use care when mowing hilly terrain. Always mow across the face of a slope, never up and down. Use wheel extenders for added stability. Do not mow excessively steep slopes. Go slowly and carefully on all turns.

## **SNOW THROWER**

### **PRECAUTIONS**

Wear protective trim fitting winter clothing with no scarf or draw strings which could be caught in the machinery. Wear boots or shoes designed to improve your footing on slippery surfaces. Wear proper eye protection. When necessary to start the engine indoors and drive the machine out of the building, keep the doors and windows wide open. Exhaust fumes can be dangerous.

Never put your hands into the discharge opening or impeller/collector when the engine is running. Always disengage the PTO, shut off the engine and wait until all moving parts have stopped before doing the following:

1. Cleaning or deicing the impeller/collector and discharge chute (if possible, detach snow-thrower and thaw in a warm, dry place).
2. After striking a foreign object, thoroughly inspect for damage. Make repairs before further operation.

Never use the snow-thrower near glass enclosures, automobiles, window wells, drop-offs, etc., without adjusting the discharge angle away from them.

Keep children, pets and observers away.



**MOW ACROSS THE FACE OF A SLOPE**



**OPEN DOORS WIDE IF STARTING THE ENGINE INDOORS**

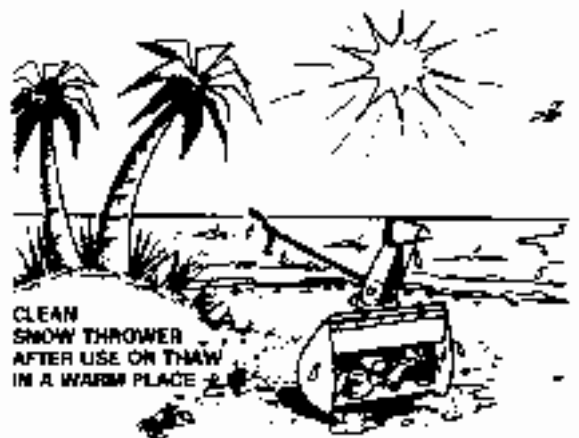

**CLEAN SNOW THROWER AFTER USE ON THAW IN A WARM PLACE**

# **POWER SPRAYER**

## **PRECAUTIONS**

Always read and follow the information and instructions for the application of herbicides, fungicides, insecticides and fertilizer obtained from the labels of such products or from the manufacturer.

In addition, advice on chemicals approved for use in your area can be obtained from your local county agent. Be sure you know the proper application rate for any chemical you wish to spray.

Inspect the sprayer before each use. The sprayer develops high pressure so be sure all pressure lines and connections are in good condition.

Choose windless days for the spraying of any chemical considered hazardous. Do not spray where drift could contaminate people, animals or property.

When applying any substance dangerous if breathed in or absorbed through skin, wear adequate protection. This should include rubber gloves and boots, goggles, respirator masks, caps and clothing to cover as much as possible of the body. Cotton articles are suggested for their washable as well as high absorbency. After the spraying of any hazardous substance, remove clothing articles for laundering and immediately take a thorough soap-and-water shower before residues have time to enter your body.

Before spraying, always prepare for proper wash-down of equipment.

Never allow passengers to ride the sprayer.

The pressure at the discharge nozzle is as high as 300 psi. The spray can penetrate the skin and cause severe blood poisoning. Do not put hands into the discharge stream. Do not direct spray at people or animals.

Unless the manufacturer of the chemicals claims that certain products can be combined for application, spray only one chemical at a time. Flush the sprayer tank before changing sprays.

Always hose down the equipment and flush the sprayer tank after each use. Select an area where the run-off will not contaminate ground water. Do not dump into ditches and storm sewers.



**DONT SPRAY ON WINDY DAYS**

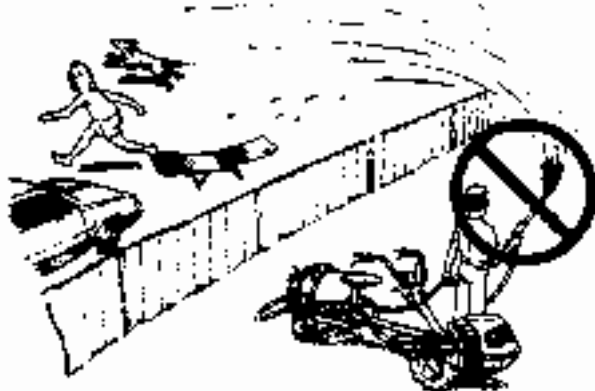

**TAKE A SOAP AND WATER SHOWER IMMEDIATELY AFTER SPRAYING**





# **CHIPPER/SHREDDER**

## **PRECAUTIONS**

Read all instructions in this owner's manual, plus detailed instructions in the Chipper/Shredder owner's manual.

Material may be thrown out of the intake or discharge openings at high velocity. Wear safety eye protection goggles stamped "Z87" (for ANSI Standard Z87). Also wear a hat.

Wear trim-fitting articles of clothing with no dangling ties laces, chains, etc. Remove rings, bracelets and wrist watches before operating the Chipper/Shredder. Gloves may be worn when feeding the Chipper but remove gloves before feeding material into the Shredder hopper.

Set up the machine on soft, firm ground which provides support and acts as a shock absorber. But, do not set up on hard paved or gravel surfaces which provide no cushion.

Before starting the engine, always look to be sure the Chipper/Shredder is empty.

Do not go on the discharge side when the Chipper/Shredder is running. Do not look into the Shredder hopper or place your head over it when feeding material. Do not feed the chipper chute from directly in front but always stand to the side.

Do not reach into the chipper chute to push through short pieces. Push short ends through with another long branch.

Put only materials which can be shredded into the hopper. Be careful not to include cloth, string plastics, grass, rubber, rocks or paving, bricks, large wood chunks, metal or long branches or vines. These things cannot be shredded and can cause violent ejection of materials from the Chipper/Shredder.

Do not allow processed material to pile up in the discharge area. A blockage of the discharge can result in kickback of material through the feed opening.

Always disengage the PTO before transporting the unit and attachment. Never leave the machine unattended without putting the controls in neutral and disconnecting the spark plug wire to prevent unauthorized operations.



**WEAR EYE PROTECTION GOGGLES**

**DO NOT WEAR THINGS WHICH COULD BE CAUGHT AND PULLED INTO THE HOPPER**



**DO NOT GO ON DISCHARGE SIDE WHEN THE CHIPPER/SHREDDER IS RUNNING**

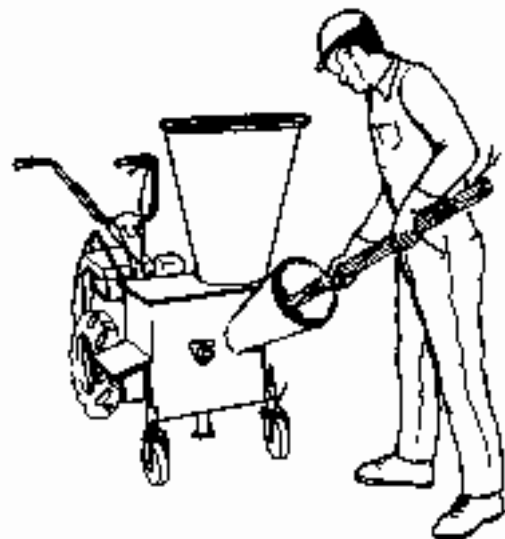

# **POWER SWEEPER**

## **PRECAUTIONS**

Follow "General Precautions and Instructions" in Section One of this manual, and all instructions in the Power Sweeper Attachment owner's manual (part number 101.00915) for the safe use of the Power Sweeper.

### **IMPORTANT NOTICE**

Deactivation of the PTO Reverse Lockout (see WARNING in Sweeper owner's manual) is not to be done on the tractor models in this updated owner's manual. New design lockouts automatically disengage during the conversion of these models for the Sweeper or any other front-mounted attachment.

Do not put hands, feet or any other part of your body near the sweeper brush or any other rotating part.

Keep the work area clear of people and pets. Do not let children come near. Be extremely careful on gravel or paved surfaces to direct the discharge away from people and passing vehicles.

Wear a dust mask or respirator for protection when sweeping dusty surfaces.

Wear eye protection goggles stamped "Z87" (for ANSI Standard Z87).

Before transport or storage of the unit adjust the casters of the sweeper so the bristles do not touch the ground.

Thoroughly inspect the surface to be swept and remove objects which could be thrown by the sweeper or cause it to run off course. Remove wires, glass objects, door-mats, boards, toys and other obstructions.

Always put the unit in gear before engaging the PTO to power the sweeper. If the sweeper bristles engage the ground when the unit is in neutral, the sweeper will drive back the unit.

On irregular terrain with hillocks, prepare to let go of the controls to stop all motion if the brush suddenly drives the unit backward.

Do not use the sweeper on any surface where you cannot keep your footing or the unit could overturn. Walk behind the unit. Disengage the PTO when going up or down a slope. Work across the slope when sweeping or thatching.

If using the sweeper on rooftops, set up barricades so you will not come too close to the edges. Be sure the surface is dry and does not pitch more than 5 degrees (1/2" per foot).

Do not drive the sweeper onto frozen lakes or ponds unless the ice is thick and strong enough to support the combined weight of you, the sweeper and the unit.

**WEAR GOOGLES AND DUST MASK**

**KEEP CHILDREN AWAY**



**PUT UNIT IN GEAR TO OPPOSE SWEEPER PUSH-BACK**

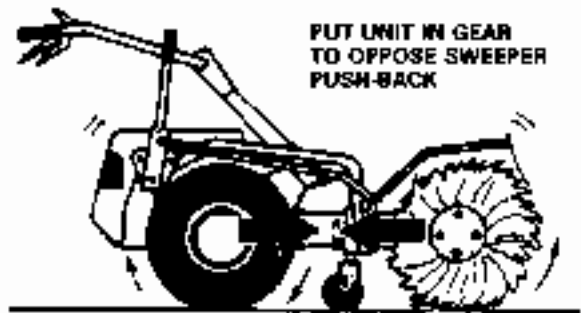

**DO NOT SWEEP ON ROOFTOPS WITH MORE THAN A 5° PITCH**

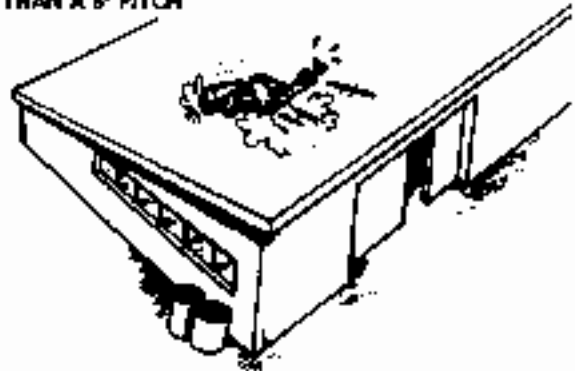

**WATCH OUT FOR THIN ICE**

# SECTION

# 2

## SCHEME CONFIGURATIONS

### NATURAL CONFIGURATION

**MODEL 852 / 853**  
FRONT-MOUNT MODE

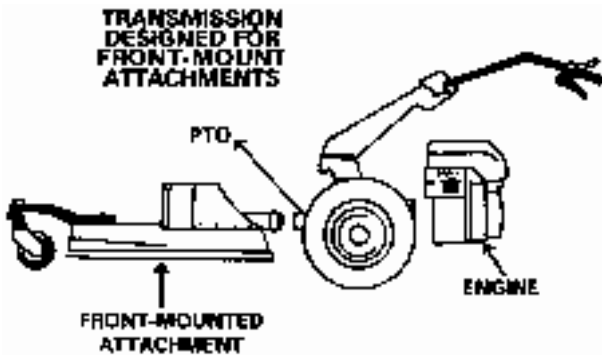

### CONVERSE-MODE CONFIGURATION

**MODEL 852 / 853**  
CONVERSION FOR REAR-MOUNT ATTACHMENT

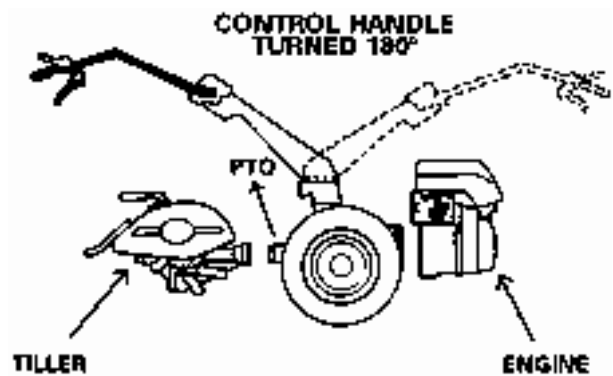

**MODELS 710/718/722/732**  
REAR-MOUNT MODE

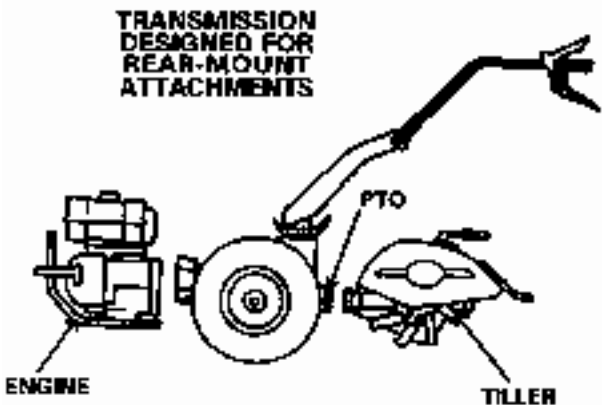

**MODELS 710/718/722/732**  
CONVERSION FOR FRONT-MOUNT ATTACHMENT

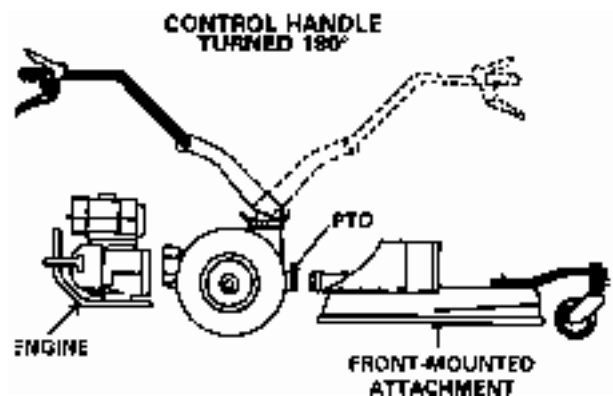

**MODEL 948**  
REAR-MOUNT MODE

**TRANSMISSION DESIGNED FOR REAR-MOUNT ATTACHMENTS**

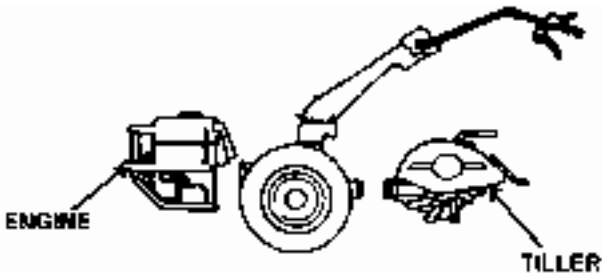

**MODEL 948**  
CONVERSION FOR FRONT-MOUNT ATTACHMENT

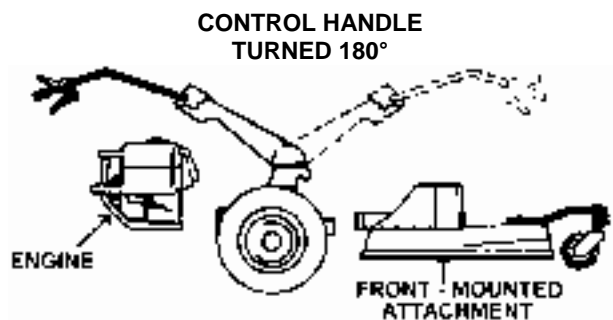

## MODELS DESIGNED FOR FRONT-MOUNTED ATTACHMENTS

Models of the 800 series are convertible model designed primarily as pusher for front-mount attachments, they have the PTO (power take-off) coupling up front, and the engine and control column at the rear.

852 has 4 speeds **forward** and 3 speeds **reverse** as pusher, 3 speeds forward and 3 speeds reverse as tractor. 853 has 3 speeds forward and 3 speeds reverse as pusher, but in rear-mount attachments (tractor) has 4 speeds forward and 3 speeds reverse.

Swinging the handlebars around to place them over the PTO coupling at the rear of the unit converts them for rear-mount attachments (tractor).

The transmission changes drive wheel rotation to drive the unit forward in either front-mount or rear-mount mode.

Selecting one of three available gear positions on the gear selector, and engaging the **red reverser lever** on the right handlebar backs up the unit in either front-mount or rear-mount mode.

The **high speed lockout blocks** selection of gear position #4 for backing up the units.

## MODELS DESIGNED FOR REAR-MOUNTED ATTACHMENTS

All models of the 700 series and 948 are designed for rear-mount tillers, and all models are convertible for front-mount attachments.

In the rear-mount mode, the PTO (power take-off) flange and the control column are at the rear and the engine is up front.

Models 710, 718, 722 and 732 have three speeds **forward**, two **reverse**.

Model 948 has four speeds **forward**, three **reverse**.

Swinging the control column around from the PTO end of the unit to the engine end converts it for front-mount attachments.

A safety high speed/reverse lockout device on the control column blocks the high **forward** speeds on 710, 718, 722, 732 and 948 which are too fast for use in backing the unit.

All models have a new type transmission that drives the unit forward when placed in gear-even when converted for front-mount attachments. In either front-drive or rear-drive mode, selecting any gear except the high speed (that the **lockout blocks**) and moving the **red reverser lever** on the right handlebar backs up the unit. Gear #3 (#4 for 948) is too fast for backing up the unit.

# SPECIFICATIONS

## ENGINE AND POWER UNIT

MODEL	852		853		710		718		722		732		948	
Design Type Convertible	Pusher To Tractor		Pusher To Tractor		Tractor To pusher		Tractor To pusher		Tractor To pusher		Tractor To pusher		Tractor To pusher	
Engine Make Type	HONDA GX390 carb. or KOHLER KD440		HONDA GX390 carb. or KOHLER KD440		Subaru SP170 Subaru EX27 Kohler CH270		HONDA GX200 carb.		HONDA GX240 carb.		HONDA GX340 carb. Subaru EX27 Kohler CH395		HONDA GX390 carb.	
Type of air filter	HONDA dry cartridge KOHLER oil bath				Dry cartridge									
Prefilter	Standard				Standard									
Transmission	Precision steel gears				Precision steel gears									
Differential	Yes				No		No		No		Yes		Yes	
Gears: Forward Reverse	Push. 4 3*	Tract. 3 3*	Push. 3 3*	Tract. 4 3*	Push. 2 2*	Tract. 3 2*	Push. 2 2*	Tract. 3 2*	Push. 2 2*	Tract. 3 2*	Push. 2 2*	Tract. 3 2*	Push. 3 3*	Tract. 4 3*
Speed $\neq$ (mph)														
1 <sup>st</sup>	0.8		0.8		0.7		0.7		0.7		0.7		0.6	
2 <sup>nd</sup>	1.6		1.6		1.6		1.6		1.6		1.6		1.4	
3 <sup>rd</sup>	2.7		2.7		7.0		7.0		7.0		7.5		2.1	
4 <sup>th</sup>	8.3		8.3		-		-		-		-		6.5	
1 <sup>st</sup> Reverse	0.8		0.8		0.7		0.7		0.7		0.7		0.6	
2 <sup>nd</sup> Reverse	1.7		1.7		1.6		1.6		1.6		1.7		1.5	
3 <sup>rd</sup> Reverse	2.8		2.8		-		-		-		-		2.2	
Power take-off	(independent – PTO rpm controlled by throttle setting on all models)													
PTO rpm/ Engine rpm Attaching Method	990 / 3600 2 threaded studs w / nuts		990 / 3600 2 threaded studs w / nuts		990 / 3600 2 threaded studs w / nuts		990 / 3600 2 threaded studs w / nuts		990 / 3600 2 threaded studs w / nuts		990 / 3600 2 threaded studs w / nuts		990 / 3600 3 threaded studs w / nuts	
Wheels & Tires Size	5.0 x 10"		5.0 x 10"		4.00 x 8"		4.00 x 8"		4.00 x 8"		4.0 x 10"		6.5 / 80 x 12"	
Tread Track width $\neq$	Tractor 20"		Tractor 20"		Tractor 17"		Tractor 17"		Tractor 17"		Tractor 19"		Tractor 26"	
Weight (lbs.) $\neq$	230		230		130		130		140		160		330	
Dimensions (in.)														
Height	47"		47"		40"		40"		40"		40"		34" - 43"	
Width	27"		27"		25"		25"		25"		25"		27"	
Lenght	47"		47"		63"		63"		63"		63"		78"	
Extra tires	5.00-12		5.00-12		-		-		-		-		-	
Capacities (L)														
Transmission	2.00		2.00		1.90		1.90		1.90		1.90		2.20	
Crankcase	1.10		1.10		0.60		0.60		1.10		1.10		1.10	
Running time @3000 rpm**	2 Hrs.		2 Hrs.		2 1/2 Hrs.		2 1/2 Hrs.		2 1/2 Hrs.		2 1/2 Hrs.		2 Hrs.	

**NOTE:** \* Has "Reverser" control to change direction of travel.

$\neq$  May be adapted by mode of mounting wheels, or with optional accessories.

$\neq$  Power unit with standard wheels and tires.

\*\* at  $\frac{3}{4}$  load.



# MODELS 852 / 853

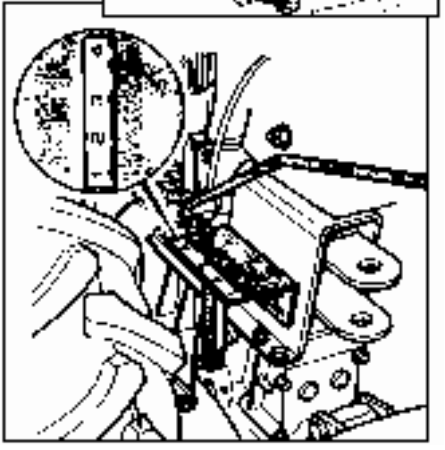
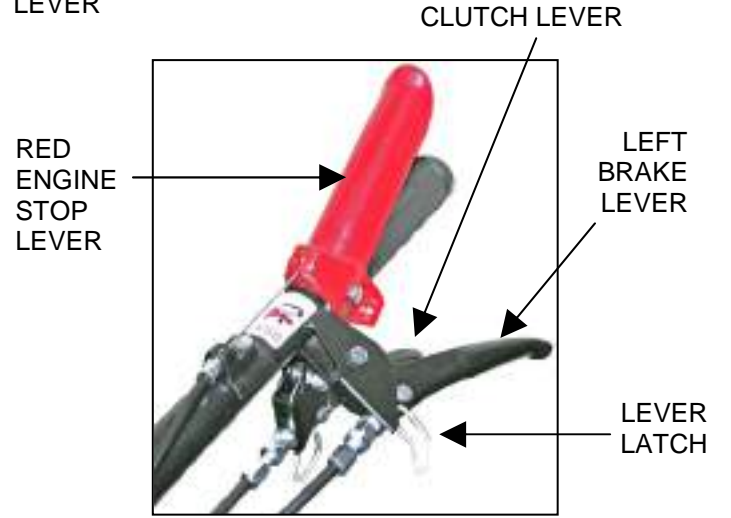
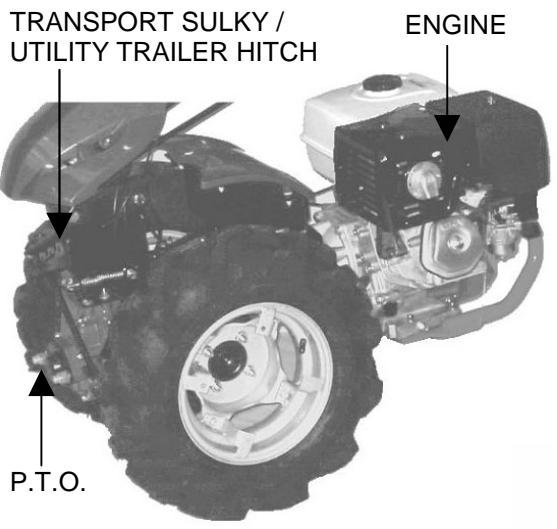
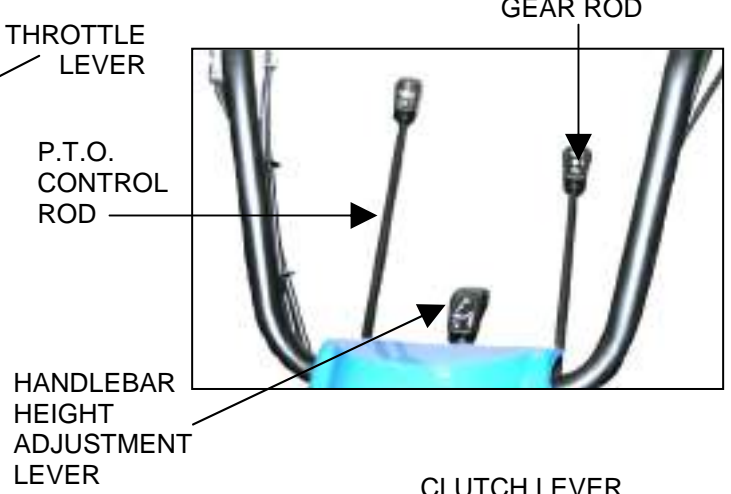
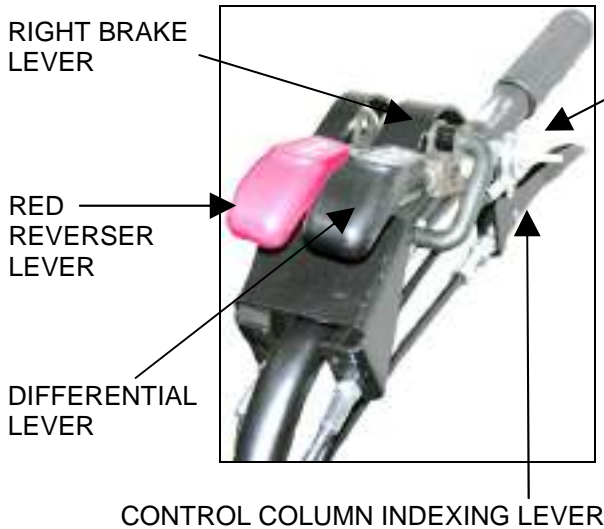

These "pusher" models, designed and geared to drive mowers and other front-mounted attachments, may be converted into a tractor by swinging the control handles around as illustrated on page 32.

Of the very latest design, they have both high speed and PTO / reverse safety lockout devices that function when needed, and require no disassembly or deactivation.

A differential lever on the right handlebar has two-wheel drive and differential drive settings.

In differential drive, applying just one wheel brake aids in turning to that side.

Whether in the front-drive or rear-drive mode, the unit will drive forward when placed in any gear on the gear selector.

With the reverser lever pulled and left against the handlebar, and gear position #1, #2 or #3 selected, the unit will back up.

Too fast to use when backing the unit, gear position #4 is blocked by the **high speed lockout**. 852 model has the fourth speed in pusher mode; 853 has the fourth speed in tractor mode.

2

# MODEL 710

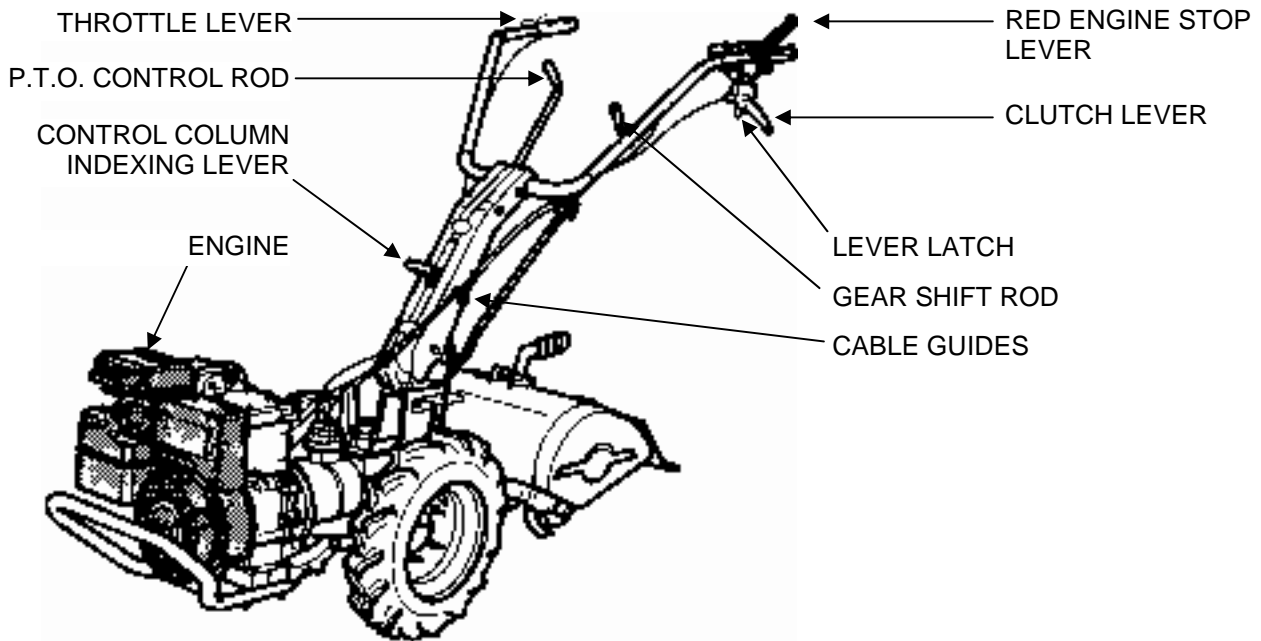

The model 710 is the smallest tractor of the BCS product line. It has 3 forward speeds and 2 reverse, without differential.

The drive is controlled using only one control rod located on the left side of the handlebar.

On these models there is also a PTO / reverse lockout device that prevents shifting into reverse with the tiller engaged.

The lockout disengages automatically when a front attachment is installed on the unit.

When a front attachment is installed on the unit, what was the reverse gear in the tilling mode is now the forward gear.

When a front mount attachment is on the unit, the third gear (transport gear) is blocked out.

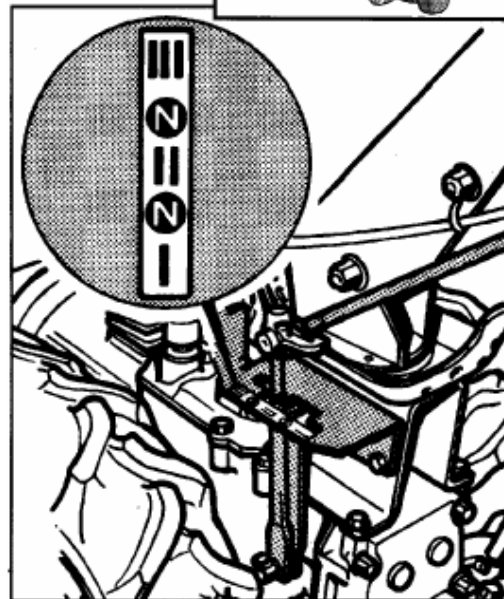
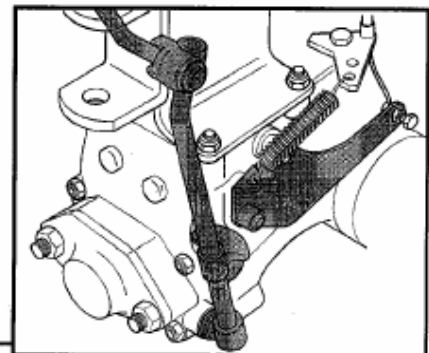

# MODELS 718 722 732

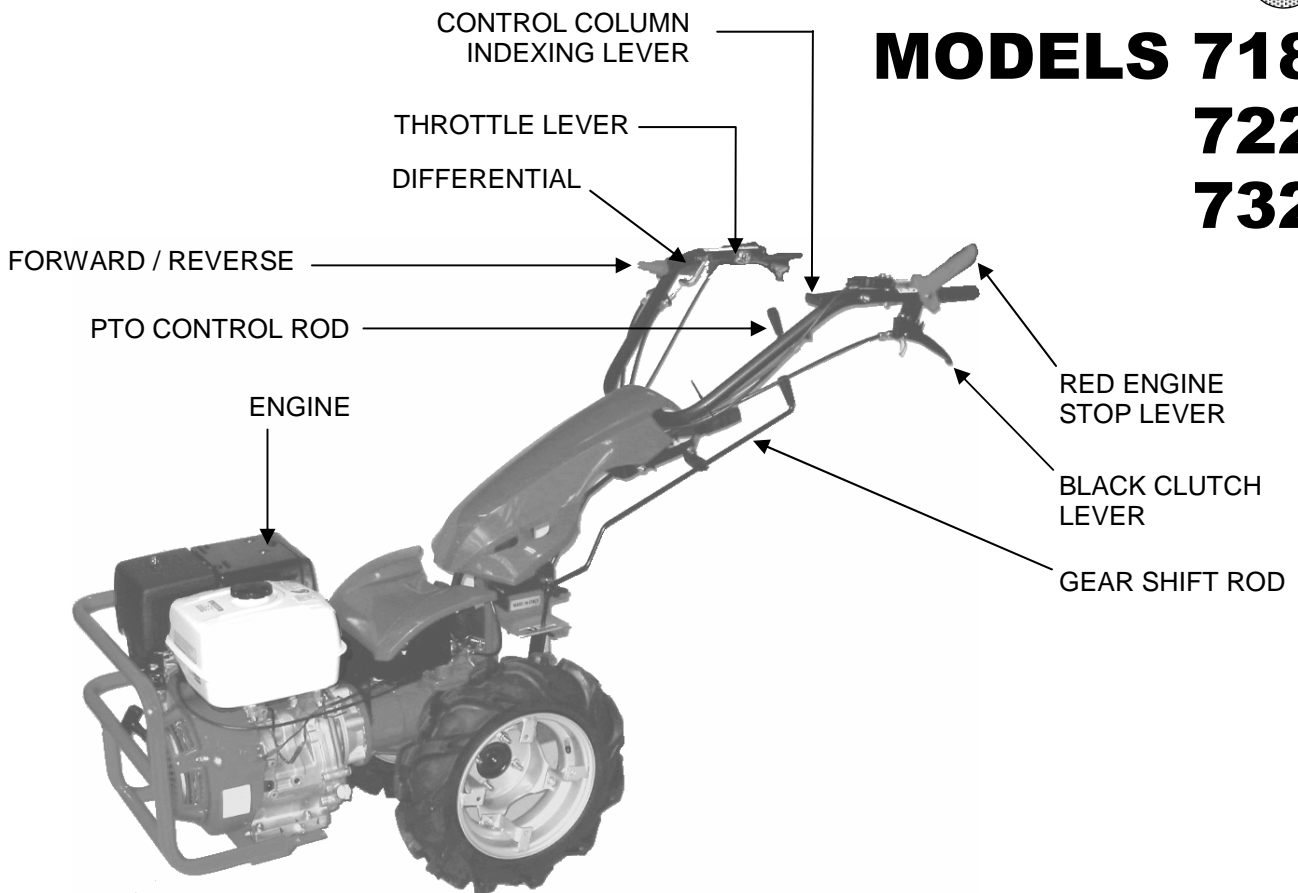

The models 718 / 722 / 732 have three forward speeds and two reverse.

The drive gears are available through a rod on the left side of the handlebar.

Forward and reverse are controlled with the **red** lever on the right top of the handlebar.

On each of these models, a PTO/ reverse lockout device prevents shifting into reverse with the tiller engaged. But the lockout disengages automatically during operation with a front mount attachment on the unit.

When a front mount attachment is on the unit, the third gear (transport gear) is blocked out.

**NOTE:**  
The differential is only on model 732.

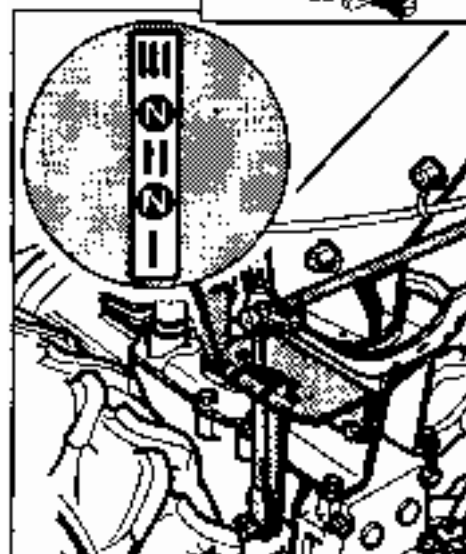

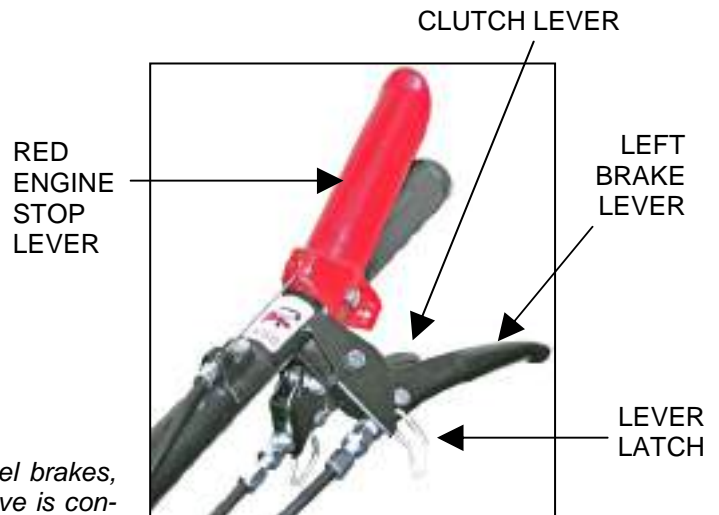
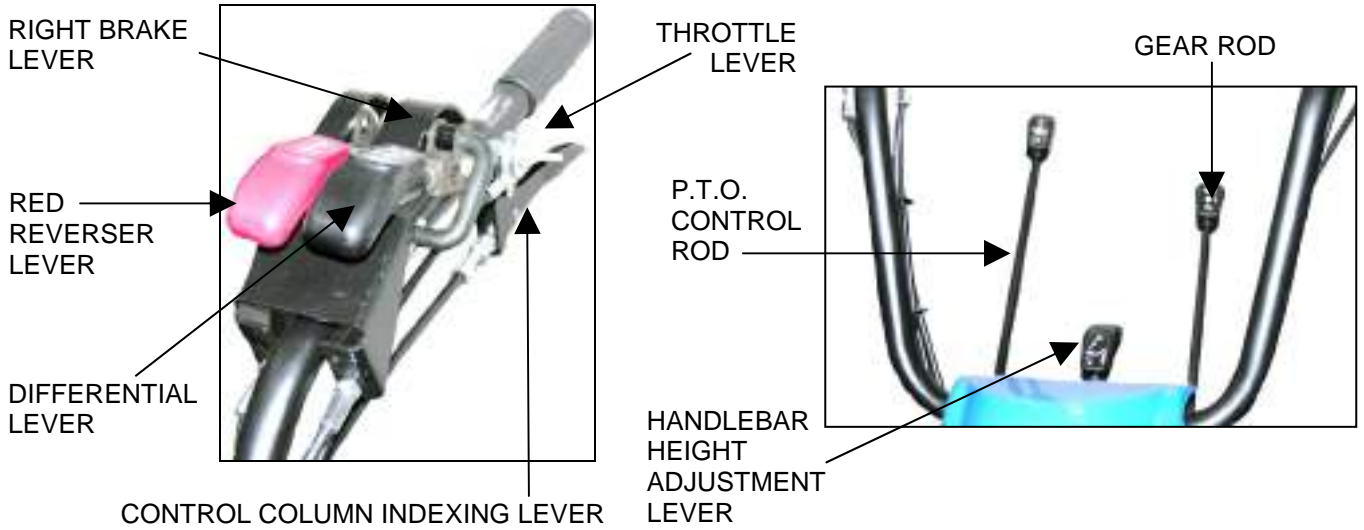

*This is the largest tractor in the BCS product line.*

*It has a differential drive transmission and two wheel brakes, four forward gears and three reverse gears. The drive is controlled using only one control rod located on the left side of the handlebar.*

*The PTO is controlled using one control rod located on the right side of the handlebar.*

*With the tiller attachment on this model there is also a PTO/reverse lockout device that prevent shifting into reverse with the tiller tines engaged. This lockout automatically disengages when a front-mount attachment is in-stalled.*

*This allows you to drive in forward or reverse with the PTO engaged.*

*When a front mount attachments installed, what was the reverse gears in the tilling mode are now the forward gears in the front attachment mode.*

*In the front attachment mode there is a high speed lock-out that blocks out the high speed gears that were used in the tilling mode.*

# UNPACKING

## **IMPORTANT**

Use extreme care to avoid crimping or severely bending the control cables while unpacking and assembling the unit.

## **⚠ WARNING**

Take care to avoid being cut by the staples or nails when opening the carton.

Open the top and lay out the sides of the carton. Remove the parts and tools to be used in assembling the unit. The fasteners required for assembly have been placed at locations where they are to be used.

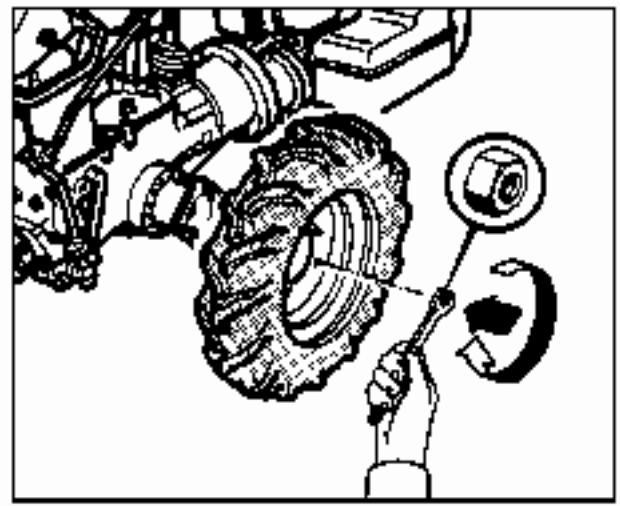

# ASSEMBLING THE UNIT

## **1. INSTALL THE WHEELS:**

- a) Except for one or two special sizes, most wheel and tire combinations can be mounted for either a wide or narrow track.  
For all applications except tilling and plowing, the recommended mounting is wide track for stability.  
The "Vees" of tractor tread tires should point in the direction of forwards rotation.  
On convertible models, which can be used with both front-mount and rear-mount attachments, mount the wheels for the attachment that will be used the most. It is not necessary to remount the wheels when changing attachments.
- b) For wide track, mount the wheels with the tire valves towards the outside.  
For a narrower track, mount the wheels with the valves toward the inside.

## **2. ADJUST THE PRESSURE TO 15 POUNDS.**

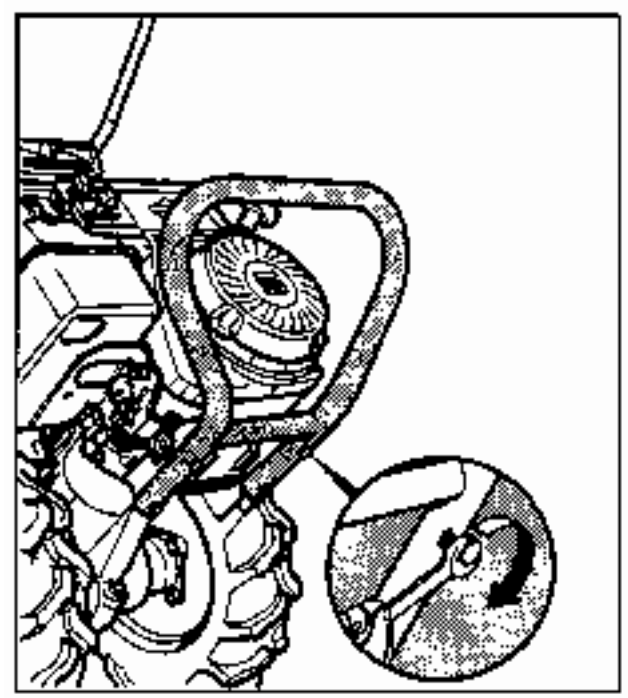

2

### 3. MODELS 852, 853 AND 948

*These models come with the control column and handlebar preassembled, but mounted in a compact position on the unit.*

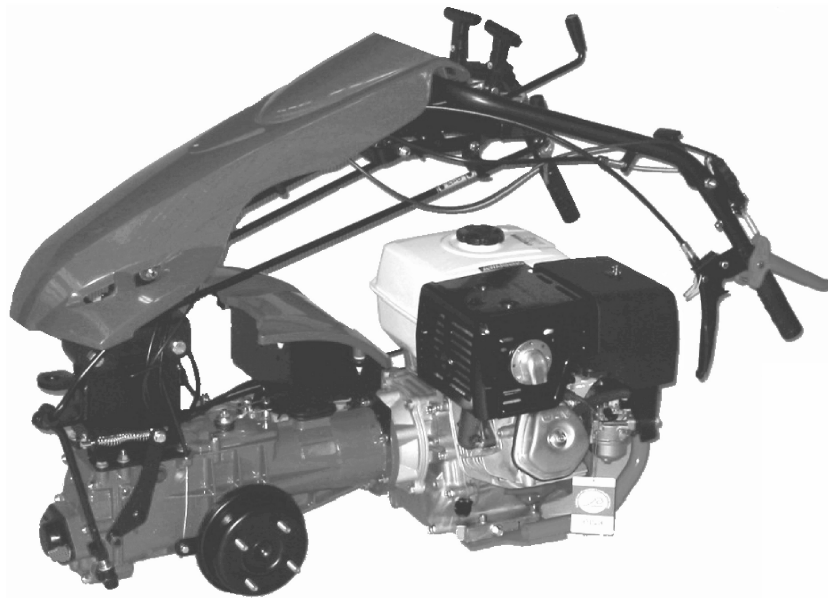

**NOTE**

Lined area for notes, consisting of multiple horizontal dotted lines.

2

#### 4. TRANSMISSION

For shipping purposes, the transmission (gear case) filler hole is sealed with a plastic plug and the dipstick is in the owner's kit.

Remove the plug. Before installing the dipstick, it is important to oil the O-ring with a light engine oil.

Then install the dipstick on the hole (see drawing).

Check the level of gear oil at this time (see "Gearbox Lubrication" on page 25).

#### 5. ENGINE PRE-SERVICE

##### BRIGGS AND STRATTON ENGINES

Remove and discard the thimble-shaped, clear plastic cover from the oil breather tube located to the left of the carburettor.

Remove the crankcase oil filler plug (or dipstick) and check that the oil is at proper level (see "Engine crankcase lubrication" on page 25 and its specific use and care manual).

##### HONDA AND KOHLER ENGINES

Check the oil fill cap/dipstick at the left of engine. If oil level is below full mark, see "Engine crankcase lubrication" on page 25.

No other pre-service is required. For Honda engine operating and service instructions see "Honda engine owner's manual 31ZH7622".

##### ELECTRIC SYSTEM BATTERY

The battery is a 12 Volt 14 : 16 AH  
(dimensions: mm 160x90x161 - ref. YB16;  
or mm 190x127x160 ref. UR1).

Push the unit to an open ventilated spot.

Wear safety goggles and gloves when filling the cells with the electrolyte solution.

Follow instructions supplied with the battery for filling with electrolyte, maintaining fluid level in the cells and charging and recharging.

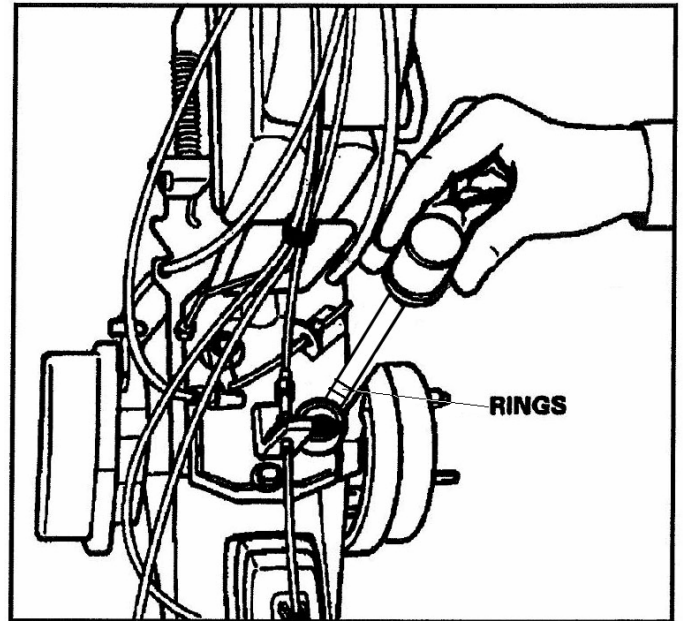

### **DANGER**

The battery electrolyte is a strong acid.  
The acid or the fumes from it can cause severe burns.  
The battery constantly emits hydrogen gas which can be exploded by flame or sparks. Avoid contact with the battery acid.

Always fill the battery in a well ventilated place and do not bring flame or sparks of any kind near the battery.  
If acid contacts your body, flood the area immediately with soap and water.



## **LUBRICATION,** **FILTERS AND FUEL**

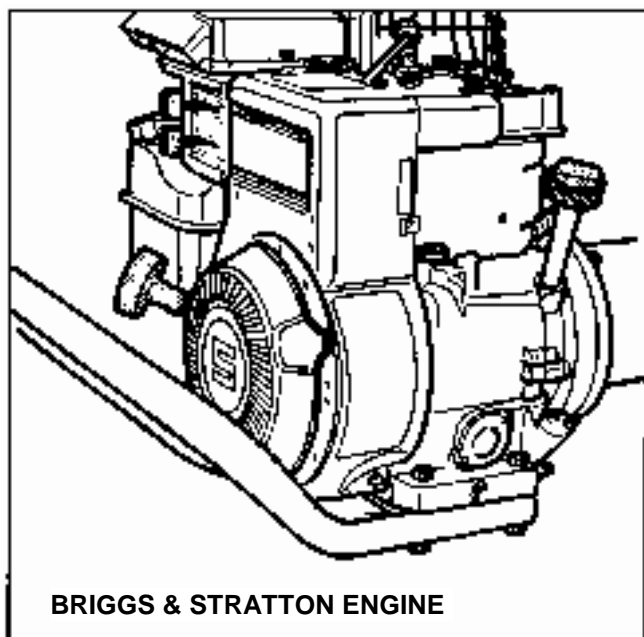

### **ENGINE CRANKCASE** **LUBRICATION**

The oils selected for use should be high quality, high detergent products of API service classification "SF".

The oil usually recommended for warm weather use a straight SAE 30 weight.

A multi-viscosity type oil such as SAE 10W-40 can also be used in warm weather.

When the air temperature falls below 32 degrees F (0° C) switch to 10W-40 or 10W-30 weight oil. For extremely cold (sub-zero Celsius) temperatures, it may be necessary to use SAE 5W-30 or 5W-20 weight oils.

**Always check the oil level every day of use.**

Change the oil after the first five hours of engine operation and at least once a season thereafter.

Put the unit on a level surface when checking oil level. If the engine has a dipstick, maintain the oil level between the high and low marks on the stick. If no dipstick, keep the oil level no lower than half an inch (12.7 mm) below the top thread of the filler hole.

**For all the engines check the oil level such as indicated on the owner's manual. Add oil if the oil level is at the half of the dipstick.**

#### **NOTE**

Engine manufacturers recommend the types and weights of oil for seasonal use in their engine. Always consult the engine instruction manual for their recommendations.

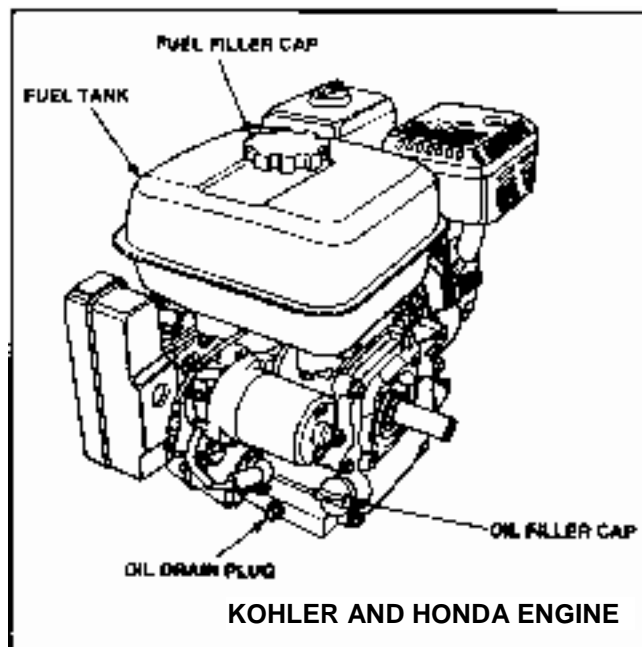

When changing oil, always run the engine to get the oil warm. Then shut down, remove the drain plug and drain the dirty oil into a container for proper disposal. Do not pollute the environment with waste oil.

### **GEARBOX LUBRICATION**

The gearbox requires maintenance of the oil level with SAE 80/90 or SAE 90 EP (extreme pressure) gear oil. The gearbox filler cap (see drawing on page 24) has a dipstick with marker rings denoting full and low levels.

#### **NOTE**

**When checked on a brand new machine, the oil level will be at the full mark on the dipstick. When it drops near the low mark add oil, but do not fill above the full mark. Do not operate if level is not up to the low mark.**

1. Twist and pull up the filler cap to check the dipstick. Checking every 50 operating hours is recommended.
2. Put the dipstick back into the filler hole and twist the stick around so the flat side is toward the centre of the transmission gearbox.

## ENGINE AIR CLEANER

The dry element filters used on B&S, Honda and Kohler engines are shown in different drawings. Optional commercial type pre-cleaner elements are available to fit these air cleaners.

Pre-cleaners are recommended particularly when using a Power Sweeper, Dozer Blade or Tiller, in dry and dusty conditions.

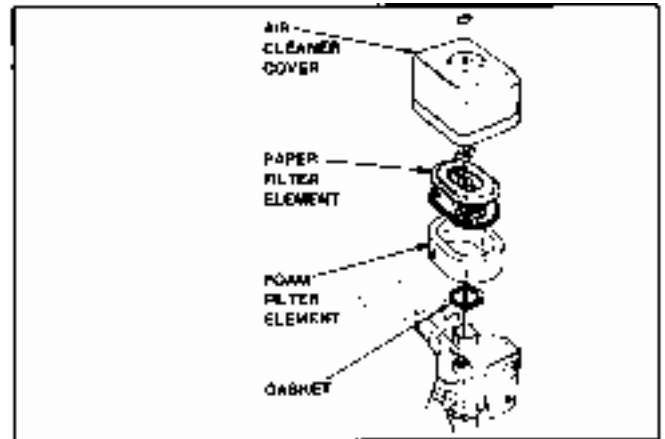
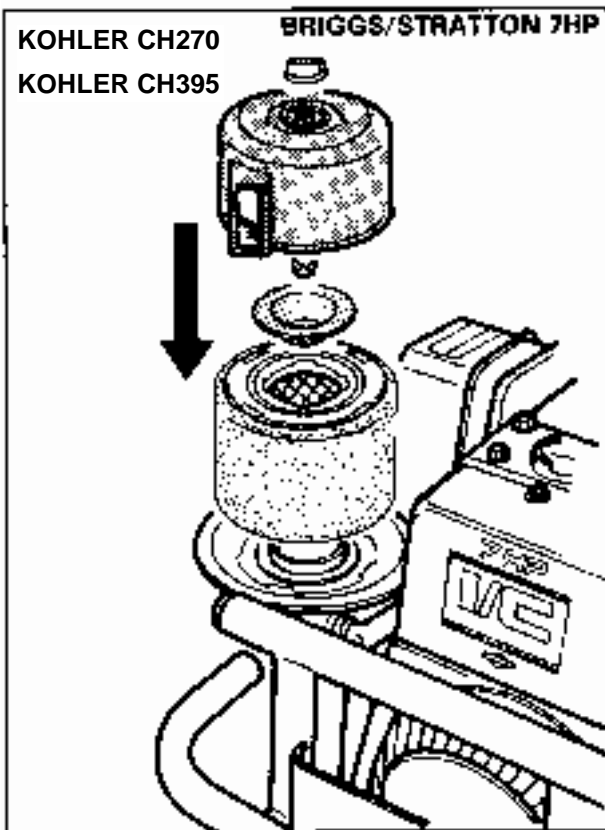
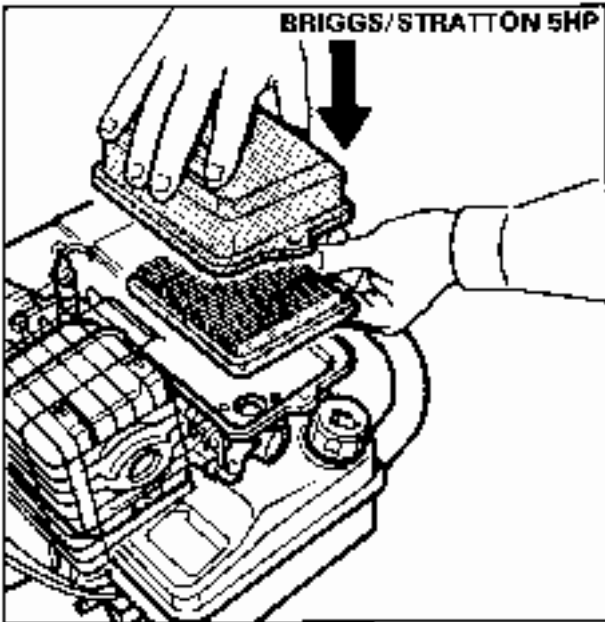

Open the air cleaner and check the air filter at regular intervals. Under very dusty conditions, check often and change filters when necessary. A clogged filter raises the engine temperature.

Dry element filters can be cleaned by tapping gently against a flat surface but it is far better to replace a dirty filter than try to clean it. The pre-cleaners, however, can be cleaned with soap and water or mineral spirits, but must be dried thoroughly, then oiled before use.

Soak the cleaned and dried pre-cleaner in clean engine oil. Then squeeze out the oil before installing the pre-cleaner.

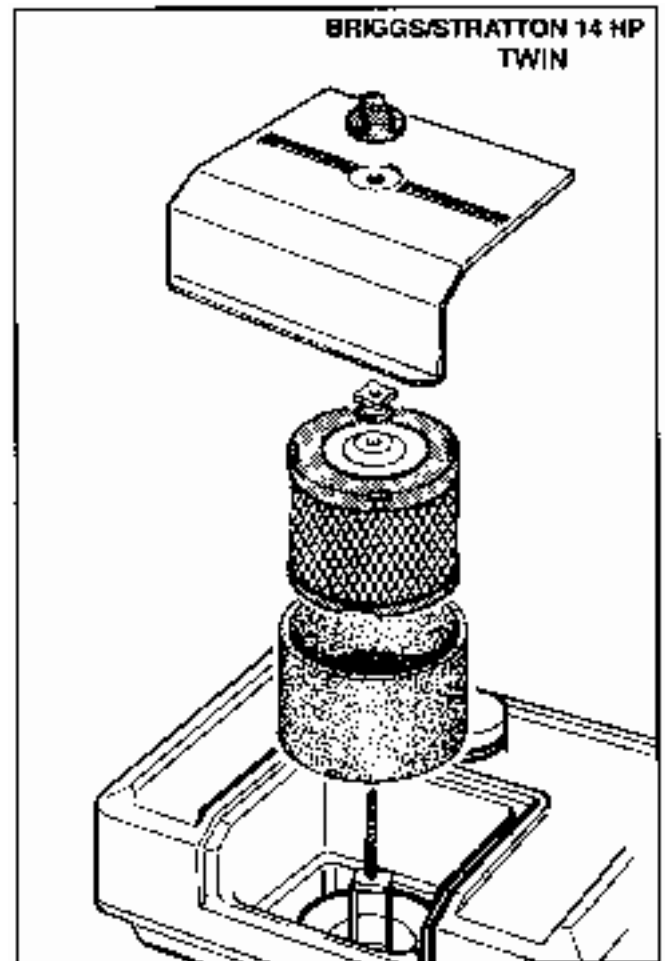

## GASOLINE ENGINE FUEL

The 4-cycle will run on either leaded or unleaded gasoline.

Gasoline of 87 to 93 octane is recommended.

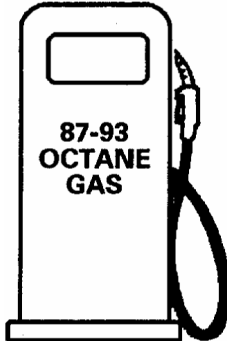

1. Remove the fuel cap, fill fuel tank, and re-install the cap securely.
2. Push the tractor at least 10 feet from fuelling area and wipe off any spillage before starting the engine.
3. Open the fuel line valve at the tank outlet, so fuel can flow by gravity to the carburettor.

## **⚠ DANGER**

Gasoline is explosive ! Read page 5 of safety "Rules", before filling the fuel tank and starting the engine.

Use approved type, properly labelled fuel containers. Do not smoke or bring fuel near any sparks or open flame.

Do all fuelling outdoors, never in a garage or shop connected to living quarters. Do not refuel when the engine is running or still hot.



**NO FLAME !  
NO SMOKING !**



**NO ELECTRICAL  
SPARKS !**

# STARTING AND STOPPING

## Including PTO Engagement and Control Unit

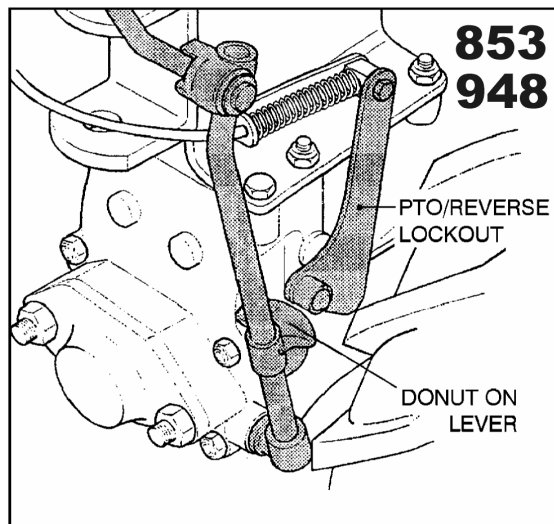
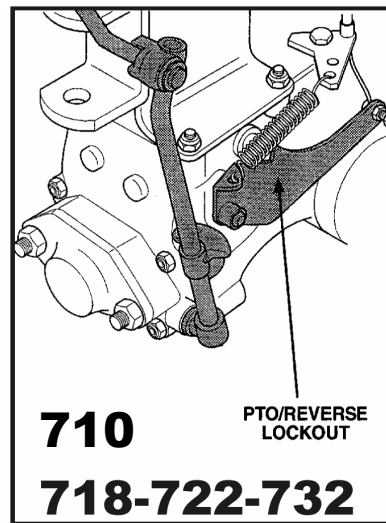
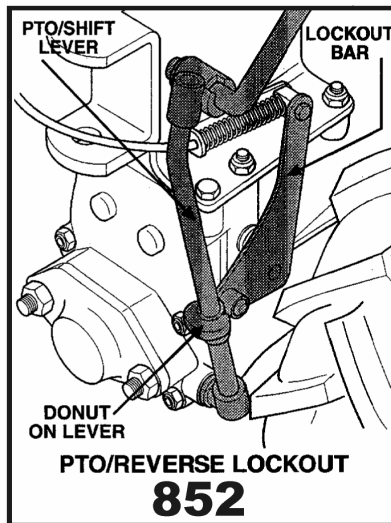

### **⚠ WARNING**

Backing with the PTO engaged is dangerous. So all convertible units have a PTO / REVERSE LOCK-OUT to prevent simultaneous engagement of PTO and REVERSE.

You must be sure that the PTO lockout bar is aligned with the donut-shaped stop on the PTO lever when the unit is in the rear-mount mode (see drawing).

**DO NOT REMOVE OR MOVE THIS LOCK-OUT BAR ASIDE FOR PTO ENGAGEMENT DURING BACKING OF THE TILLER.**

### **⚠ WARNING**

Be sure to shift into NEUTRAL (N) position on the gear selector, and disengage the PTO before starting the engine.

If started in gear, the unit will move along.

If started with the PTO engaged, a Tiller, or a Power Sweeper may run out of control.

Inadvertent operation of any attachment can be dangerous.

## **SETTING CONTROLS FOR COLD STARTING**

### **1. DISENGAGE THE PTO**

#### **IMPORTANT**

#### **MODELS IN REAR-MOUNT MODE:**

*Pull back on the PTO shift rod to disengage the PTO.*

#### **MODELS IN FRONT-MOUNT MODE:**

*Push down the PTO shift rod to disengage the PTO.*

### **2. SHIFT INTO NEUTRAL**

*On the gear speed selector, all positions marked "N" are neutral.*

### **3. OPEN THE THROTTLE**

*Advance the throttle lever on the right handlebar to between half and full throttle position.*

### **4. OPEN THE FUEL VALVE**

*If valve has a handle, open position is handle in line with the fuel line. If valve has a round control knob, turn the knob counter-clockwise (to the left).*

### **5. CLOSE THE CHOKE**

*Closed choke position on the carburettor is the upward or lateral position of the choke lever. Downward is "open choke", the position used after engine is running and warm.*

### **6. LATCH BOTH CLUTCH AND STOP SWITCH LEVERS FOR ENGINE STARTING**

*The clutch is the black lever and the stop switch is the red lever on the left handlebar. The red lever has to be held depressed during operation or it will shut off the engine. For starting, squeeze both levers against the handlebar with one hand and prop them in this position by setting the wire spring latch (see drawing).*

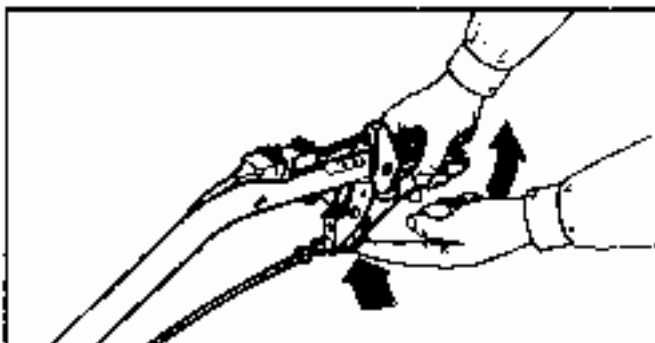

### **⚠ WARNING**

*The RED engine stop switch lever is designed to stop the engine in the event the operator loses control of the moving machine. It is necessary to latch the stop lever during starting, and to lock it in the run position when it is necessary for the operator to attend a stationary attachment such as the Chipper/Shredder. Pin holes are provided in the lever and handlebar for this purpose.*

*For use of a moving attachment, DO NOT LOCK, TAPE DOWN, or otherwise defeat the purpose of the stop switch lever.*

#### **NOTE**

*Squeezing the clutch lever dislodges the wire spring latch, letting you take over control of the clutch. If you let go of the handlebar, the engine will be switched to a stop.*

## **CRANKING TO START**

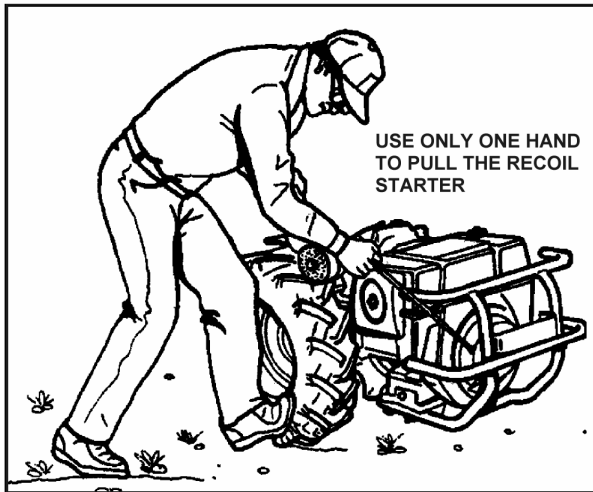

**RECOIL START ONLY:** Read warning about starter rope. Grasp the starter grip with one hand only. Place your foot against the side of the tire tread to steady the machine. Pull the grip gently until the starter engages THEN PULL RAPIDLY to crank engine. Open the choke when the engine starts.

### **⚠ WARNING**

**NEVER WRAP THE STARTER ROPE AROUND YOUR HAND OR WRIST, OR USE TWO HANDS TO PULL THE STARTER GRIP. You want the grip to slip from your grasp if the engine kicks during cranking.**

**ELECTRIC START ONLY:** Turn the ignition key to START to crank the engine. Key will return to the RUN position when you let go. When engine starts, open the choke.

**ENGINE WARM-UP PERIOD:** let the engine warm up for a few moments without any load (in neutral **N** and PTO disengaged) to give the oil time to reach the parts of the engine in need of lubrication.

**RESTARTING WARM ENGINE:** When the engine has run and is still warm, it requires no choking to start. In fact, cranking a warm engine at closed choke may flood it.

## **STOPPING**

Any time you let go of the left handlebar, the red stop lever on top will activate the ignition stop switch to stop the engine. On an electric start, turn off the switch to prevent current drain when the unit is not in use. In case the stop switch becomes open (disconnected) you can make an emergency stop on the engine either by closing the carburetor choke or by doing the instructions obtained from the engine owner's manual.

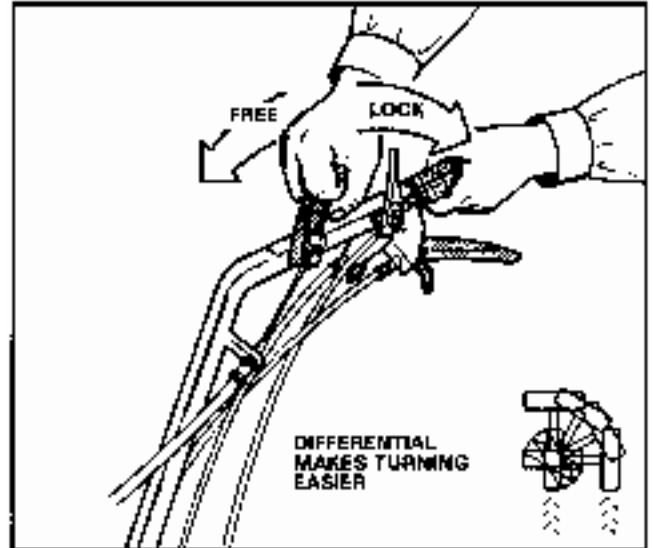

### **DIFFERENTIAL AND TWO-WHEEL DRIVE**

A feature of models 948, 852, 853, 732 the differential drive directs the driving to one wheel, allowing the other to free-wheel. Differential drive facilitates making tight turns with the unit.

When two-wheel drive is needed for traction, lock in the differential lever on the right handlebar.

When placed in differential drive, models 948, 852 and 853 can be turned by squeezing the left or right brake lever.

### **WHEEL BRAKES**

Models 852, 853 and 948 have two-wheel brakes, with brake levers on handlebar.

For parking pull completely both levers. However, the machine may also be placed in gear to keep it from rolling when the engine is shut off.

A brake kit is available for other models.

## IMPORTANT

*Directions such as right and left are always called out as you would see them when operating with the unit in the mode for which it was designed.*

*However when the handlebars of a convertible unit are swung 180 degrees from designated position, the right lever on the right handlebar will still brake the right wheel.*

*But the right wheel will be on the left side.*

## **SHUT-DOWN (STORAGE)**

(See instructions on page 8)

## **TAKING CONTROL OF THE MACHINE**

1. When the engine is running, grasp the left handlebar. Hold the **stop switch** depressed and squeeze the clutch lever to dislodge the spring latch. Now both clutch and stop levers will be under your control.
2. Do not let up the **stop switch** lever or it will stop the engine. When ready for action, shift into the desired gear and release the clutch lever. Instructions for operation of unconverted units are given immediately below, and those for converted units are on page 33.

## NOTE

**Transmission to the axle and wheels is independent of transmission through the PTO to an attachment. The advantage of this BCS design is that the most efficient operating rpm of the attachment can be selected by the throttle setting, and the desired machine movement chosen independently through a combination of throttle setting and gear selection.**

## **GEAR AND PTO**

## **ENGAGEMENT**

(For converted units, skip to page 33)

1. Start the engine and take over control of the unit. Keep the throttle at moderate speed setting.
2. Hold the clutch lever (left handlebar) depressed while shifting, and engaging the PTO lever, and until you are ready to drive.
3. Shift into the lowest forward speed position on the gear speed selector. If the gears will not engage, release (slip) the clutch just a bit until the gears mesh.
4. Smoothly release the clutch lever and the machine will move forward. If you wish to stop momentarily without killing the engine or shifting into neutral, depress the clutch lever fully.
5. USING RED REVERSER FOR BACKING.

### **Disengage the clutch**

Position 1, 2 and 3 (852 / 853 / 948) on the gear selector will be available for backing and 4 will be locked out. On the models 710, 718, 722 and 732 are available position 1 and 2; position 3 is locked out.

**Select speed, and depress the red reverser lever on right handlebar before engaging the clutch when going back to forward drive disengage the clutch.**

2

## **MAKING A CONVERSION** **FRONT-TO-REAR,** **OR REAR-TO-FRONT**

Mod. 852 – 853  
PUSHER TO TRACTOR

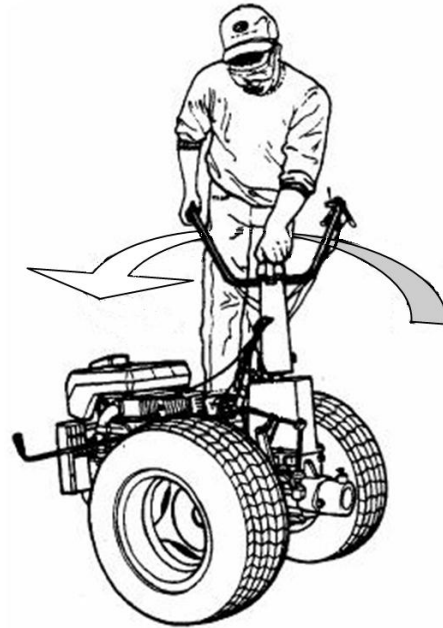

Mod. 718 – 722 – 732 – 948  
TRACTOR TO PUSHER

### **NOTE**

*Put on the new attachment (or leave the other in place) to keep unit from rotating during positioning of the control column.*

1. Shift into the lowest forward gear position. This will provide clearance for turning the handlebars to the other end of the unit.
2. Detach the PTO and gear selector shift rods from their supports and let them hang down.
3. Locate the control column indexing rod or lever (according to model; see drawings.) Use it to free the column from the support in preparation to swing it around.

Mod. 710  
TRACTOR TO PUSHER

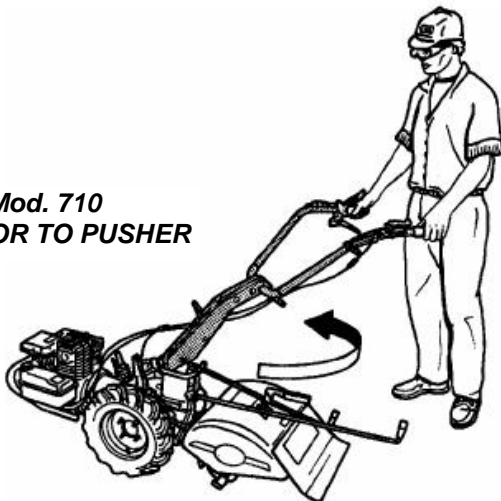

### **LOCATING OF CONTROL COLUMN INDEXING LEVERS**

Mod. 710

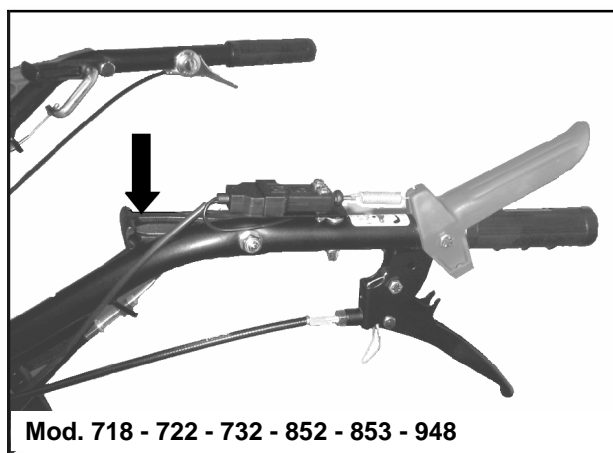
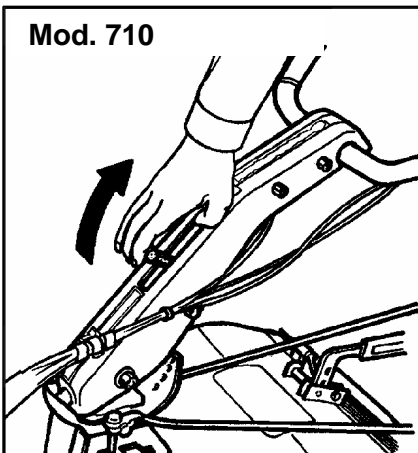

Mod. 718 - 722 - 732 - 852 - 853 - 948



- 4.** *Be careful not to stress or sharply bend the control cables while indexing the control column.  
Turn column 180 degrees as follows:*
- a) models 710,718,722,732 and 948:** *convert from tractor to pusher by pulling rod or lever and turning the control column 180 degrees counter-clockwise (to go back to tractor mode, turn clockwise).*
- b) models 852 and 853:** *convert from pusher to tractor by pulling the lever on right handlebar and turning column 180 degrees clockwise (to go back to pusher mode, turn counterclockwise).*
- 5.** *Put the shift rods back in their brackets on the control column. Check the position of the control cables and see that they are neither bunched up nor pulled taut.*

## **OPERATING IN CONVERTED MODE, ALL MODELS**

- 1. TRACTOR MODE:**  
*Push the PTO shift rod forward to engage the PTO, pull it back for the disengagement.*
- 2. PUSHER MODE:**  
*Pull the PTO shift rod back to engage the PTO, push it forward for the disengagement.*
- 3. SHIFTING THE GEARS:**  
*Shift into desired gear according to model.*

2

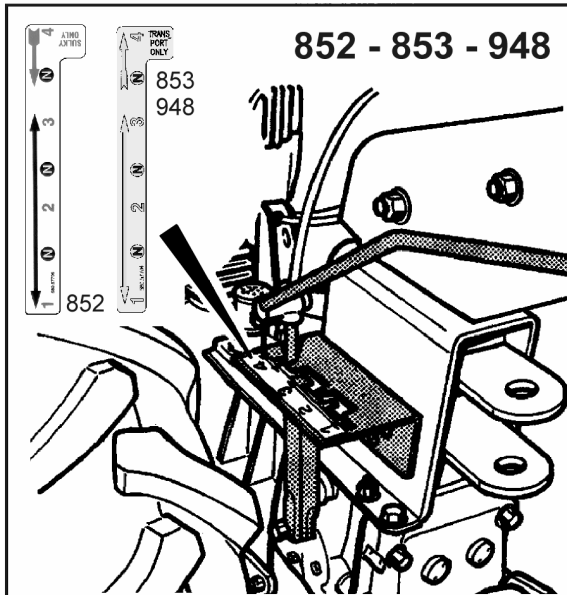

a) Models 852 and 948: in the converted mode, three of the four gear positions on the gear selector can be used for travel in either forward or reverse direction. The fourth gear is blocked because it is too fast to use for backing the unit: select desired gear and engage clutch to move forward. To back up, disengage clutch, engage the red reverser lever on the right handlebar and engage clutch. Models 853 and 948 have the fourth gear in tractor mode.

b) Models 710, 718, 722 and 732: two of the three gear positions can be used, in the converted mode, in either direction. The third is blocked because it is too fast to use in backing the unit.

3. Engage the PTO and the clutch to put the unit to work.

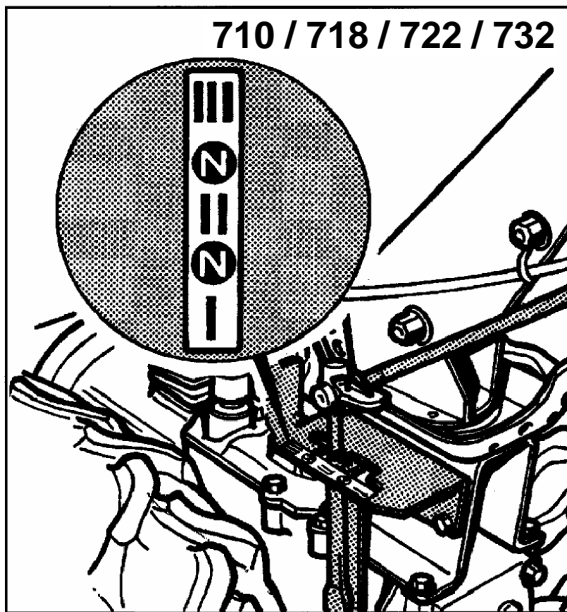

**MODEL 852-853**

**CONTROL HANDLE TURNED 180°**

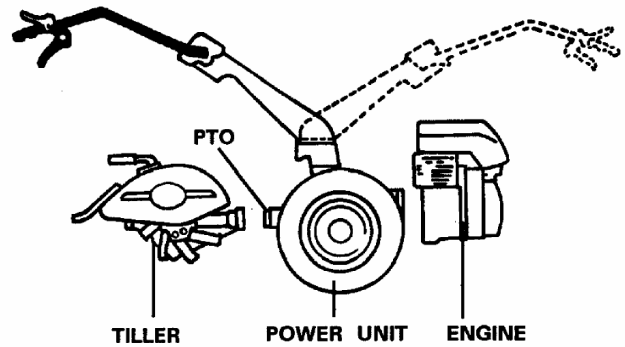

**MODELS 710 - 718 - 722 - 732 - 948**

**CONTROL HANDLE TURNED 180°**

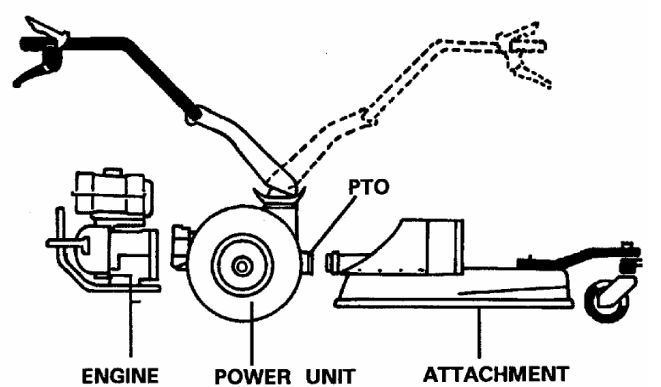

## **MAINTENANCE PROGRAM**

1. Refer to the maintenance instructions and illustrations in the "Use and Maintenance" manual furnished for your model engine.

Change oil, filters, etc., and clean the cylinder fins and crankcase breather as instructed in the engine manual.

### **2. DAILY CLEAN-UP:**

When the machine is very dirty you may hose down everything except the engine immediately after use.

But to avoid cracking the engine, you must let it cool before hosing it down. You may, however, idle the engine until it is warm enough to evaporate the wash water from around the spark plug.

### **3. AFTER FIRST 10 OPERATING HOURS**

(and afterwards as recommended):

- a) tighten nuts and bolts;
- b) check tire pressure;
- c) originally, the position of **A** lever is normal. As clutch wears out the same lever could have a wider opening being so uneasy to use, this means that it is necessary to adjust the cable, setting lever **A** on its original position acting on adjustment device **B** and on counter-nut **C**;
- d) check the gear oil level of each attachment. Re-check rotary mowers every 50 hours and the other attachments every 100 hours.

### **4. OCCASIONALLY AS NEEDED**

Clean any dirt and old grease from the PTO connections of all equipment and pack with clean bearing grease.

### **5. SEASONALLY:**

- a) lubricate the control cables with a light oil;
- b) models with engine hood: lubricate the hinge with a light oil. Do not use mineral oil.
- c) clean parts thoroughly and apply grease to the control column indexing rod or lever, column fork, column support or pivot post (according to model).

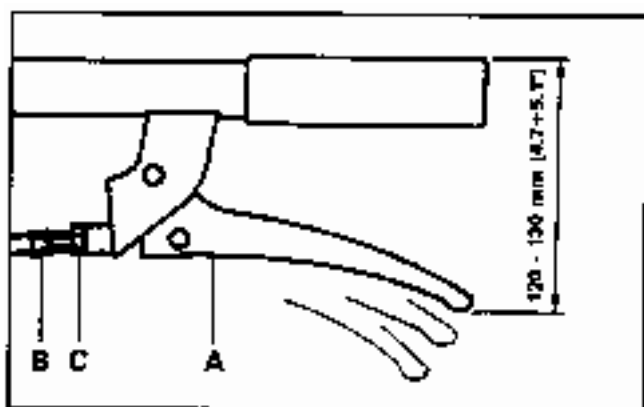
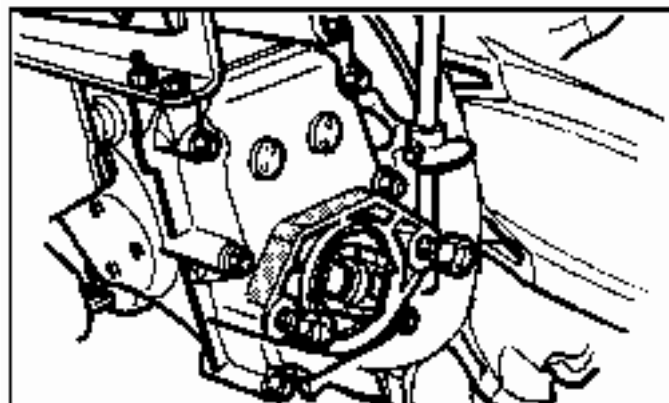
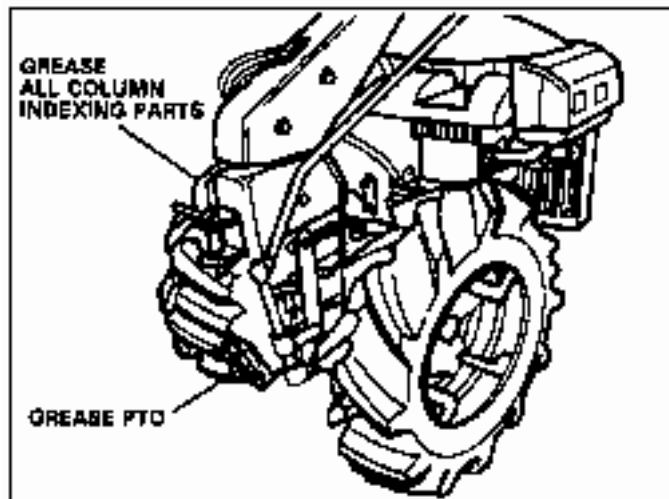

# SECTION

# 3

## USE AND CARE OF ATTACHMENTS

### LUBRICATION OF ATTACHMENTS

#### 1. TILLERS, ROTARY MOWERS, SNOW THROWERS AND POWER SWEEPERS:

Remove the pipe plug on top of the attachment gear housing. If the oil level is more than 2 inches (50 mm) below the filler hole, fill to the top with SAE 80/90 or SAE 90EP (extreme pressure) gear oil. Maintain at the nearly full level.

#### 2. MOWER BARS:

These require no gear oil but need frequent greasing with a lithium based (general purpose) grease pumped through two "zerk" type fittings on the housing.

#### 3. ALL ATTACHMENTS:

Remove dirty grease and lubricate the PTO coupling of the attachment with bearing grease whenever greasing the unit PTO. For other points of lubrication, see the particular attachment.

### COUPLING ATTACHMENT TO PTO

When the PTO flange of the attachment is coupled to the unit PTO flange and the PTO is engaged, the splined shaft slides out to engage the splined (grooved) shaft of the attachment.

Then the shafts rotate as a single member until the PTO shift lever is used to retract the drive shaft.

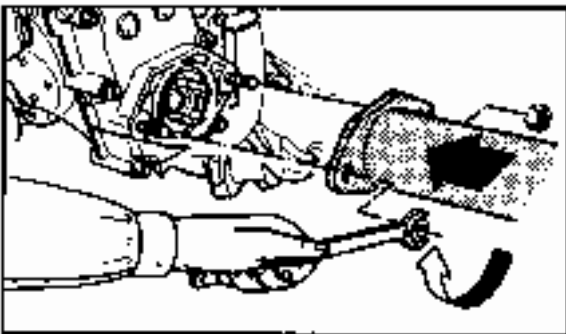

Although the attachment may be coupled directly to the unit PTO, there is a quick hitch that can shorten the time for coupling and uncoupling attachments. There are also PTO extensions in lengths of 3" and 6" which can be coupled between the PTO and attachment for better balance with certain attachment and engine combinations.

#### A. DIRECT COUPLING:

1. Remove the lock nuts and washers from the tractor PTO studs.
2. Align the tractor PTO with the connecting flange of the attachment. Always bring the tractor to the attachment. If necessary use props to level the attachment.
3. Slide the PTO studs into the attachment flange and secure with the washers and lock nuts.

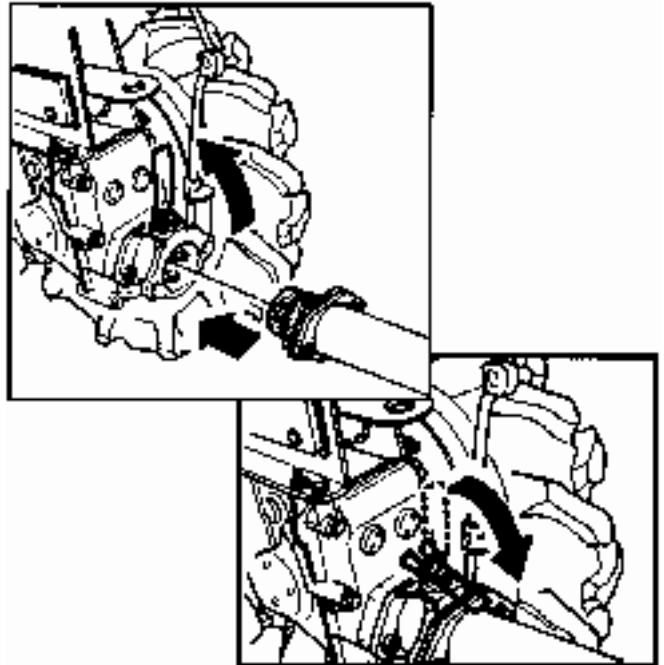

#### B. QUICK HITCH:

1. The hitch consists of two parts held together by a captive T-handled pin. Pull and turn pin side-ways to separate the parts.
2. Remove the two nuts from the tractor PTO studs and the two bolts and nuts from the quick hitch.
3. Attach the female part, pin-side-up, to the tractor PTO. Attach the male part, hole-side-up, to the attachment connecting flange. Install and tighten the four nuts.
4. Fit the attachment part into the PTO part. Twist the pin so it drops down into locking position, securing the two parts together.
5. To uncouple, pull the pin.

# USE AND CARE OF REAR-TINE TILLER ATTACHMENT

## PREPARING NEW TILLER

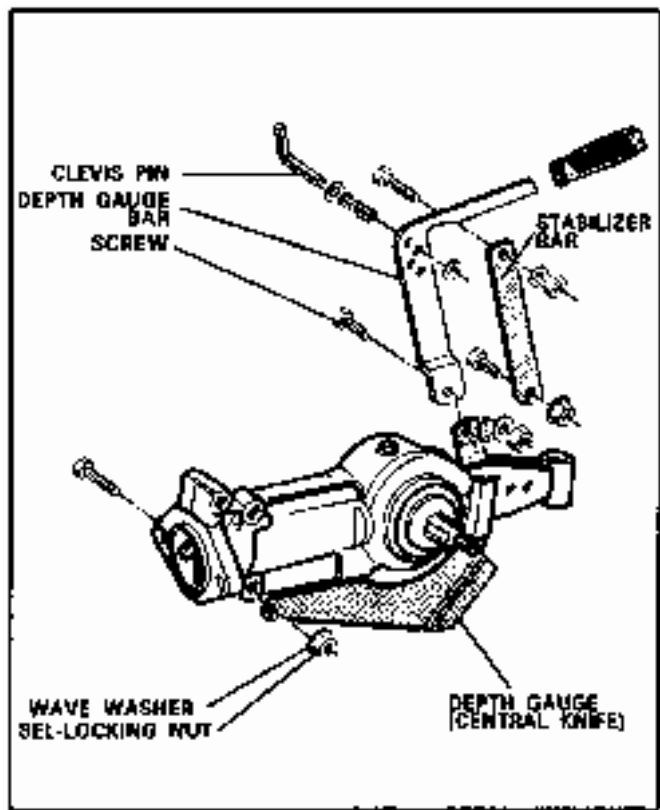

1. Open the carton and stand the tiller on end so you can see the underside. Fasteners required for assembly are included. The bolts in the assembly drawing are labeled (M8 or M10) for the metric diameters and length is given in millimetres.  
If a sulky or utility cart is to be hitched to the tractor, assemble the depth gauge bar in a position 180 degrees from that in the drawing.
2. Use the self-locking nut to fasten the depth gauge to the gear housing. Install the flange nut at the stabilizer bar bottom connection.
3. The depth gauge and stabilizer bar protrude through the top of the tiller housing. The bar is bolted to the brackets. The gauge is pinned with the clevis pin and "hair-pin". Tighten all nuts.

## WIDTH OF TILTH

### IMPORTANT

When changing sets of tines, it is important to keep the tines in place on one side for use as a model while changing tines on the other.  
Do not mount the tines backwards on the flange.

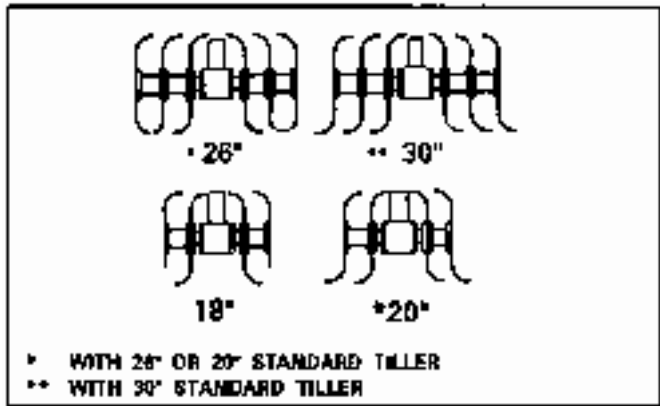

SINGLE ROW ATTACHMENT FOR 710, 718, 722, 732 (or converted 852):  
Available sizes are 18", 20", 26" and 30".

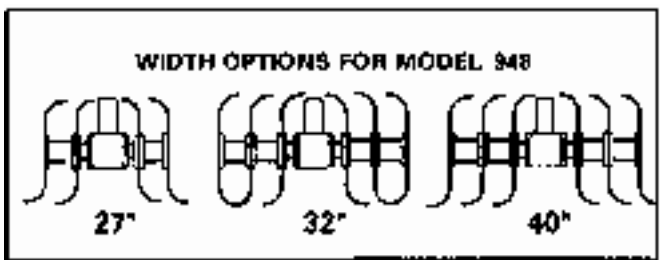
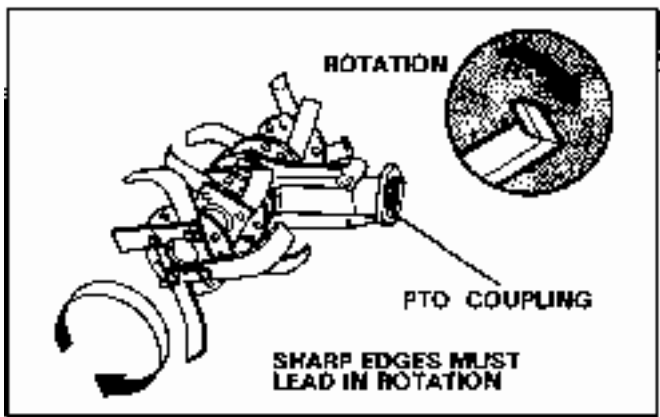

SINGLE ROW ATTACHMENT FOR MODEL 948:  
This comes preassembled for a 32" tilling width. The width can be increased to 40" or decreased to 27" by adding or removing flanges of tines, and by changing the tines to bend inward or outward (see drawing).

## TILLING DEPTH ADJUSTMENT

The procedure is the opposite of what many people first would believe. For the deepest soil penetration, you raise the depth controlling "knife" by pinning the bar in the bottom hole (see drawing).

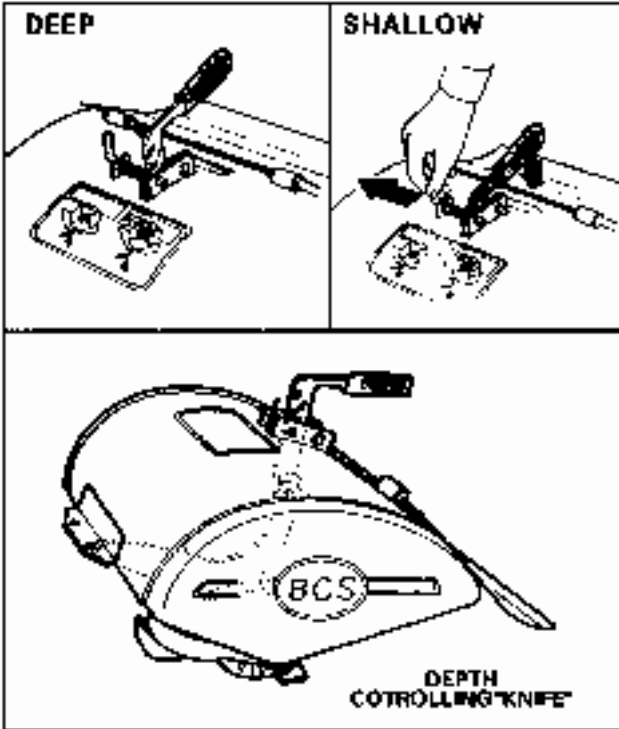

1. Remove the hairpin and the clevis pin from the bracket and bar.
2. Raise or lower the bar handle to align the holes in the bar and brackets. Pin the bar at desired setting, or as recommended in step 3.
3. In hard ground, as when tilling a patch of ground for the first time, pin the depth adjustment rod through the top hole for a shallow cut.  
After a pass or two to break up the hard top crust, stop the engine and pin the depth adjustment bar through the lower position hole.  
Pinning the bar through the bottom holes raises the depth-gauging "knife" for maximum tilling depth.

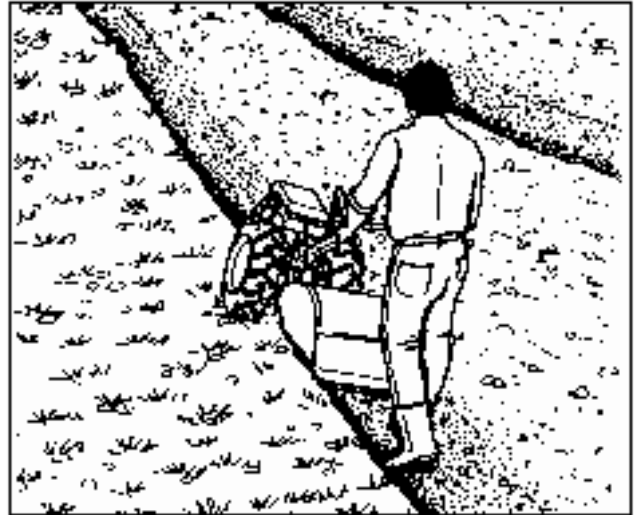

### GARDENING SUGGESTIONS

1. When breaking new ground or preparing hard, rocky soil, till at a maximum depth at the lowest gear setting and at a fast throttle setting.  
In soft soil you can probably start right off tilling at maximum depth and finest tilth are achieved in the lowest gear speeds.
2. You can avoid trampling over and tamping the fresh-tilled rows by walking to one side of the tiller.

Swing the handlebar to the side and adjust it to a comfortable height. After a bit of practice with the tiller, you can work out a pattern where your footprints will be erased with each new pass.

### TRANSPORT SULKY FOR REAR-TINE TILLER

The Transport Sulky is exclusively for riding the machine to and from the working site. As warned in Section One, you must never operate the Tiller from a sulky or wagon of any type. A curved coupling is needed to attach the Transport Sulky to most models.

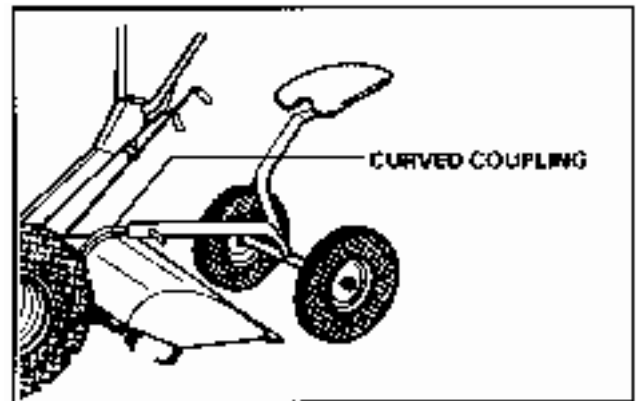
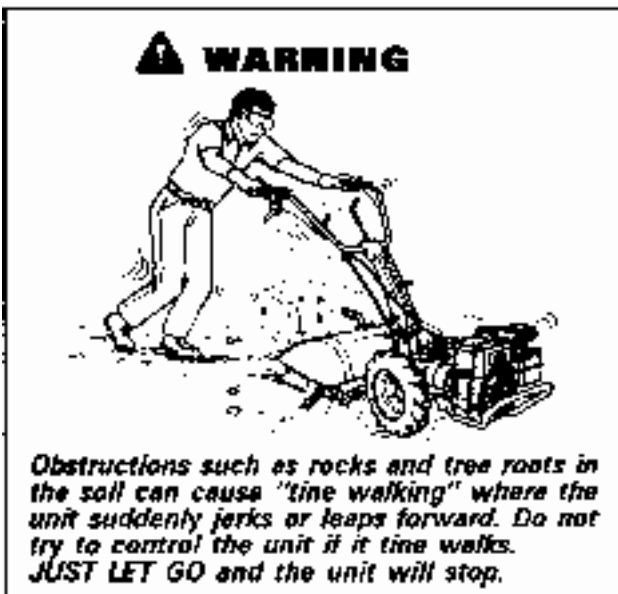

# USE AND CARE OF CUTTER BAR MOWER ATTACHMENTS

3

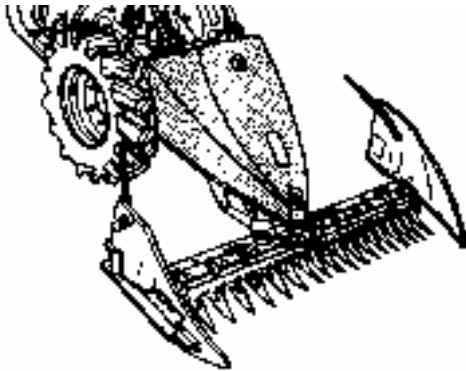

*SICKLE BAR DESIGNED FOR CUTTING FIELD AND CEREAL GRASSES-HAS LONG, POINTED TOOTH COMB. DOES NOT RECUT (MULCH).*

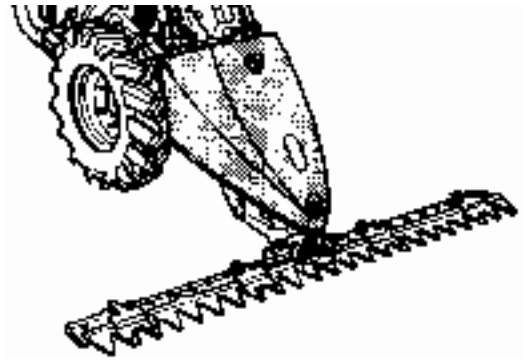

*COMBINATION BAR COMBINES SOME OF THE ABILITIES OF THE SICKLE BAR AND MULCHING BAR IN ONE ATTACHMENT.*

## **GENERAL CUTTER BAR MOWER INFORMATION**

- 1.** ALL THE TRACTORS must be converted to the front-mount mode.
- 2.** The SICKLE BAR and MULCHER BAR are the two original types of BCS mower bars.  
*The COMBINATION BAR combines features and abilities of both. Although construction of the bars is very similar, there are differences to be encountered in adjustment and maintenance.*

*Both the Mulching and Combination Bars are designed for re-cutting (mulching) mown grass. For brush cutting and also when operating in extremely rugged terrain, go slowly and deliberately with either type attachment.*

- 3.** The Sickle Bar is designed specifically for cutting grass. It cannot re-cut mown grass and is not suitable for cutting brush.

## **RECOMMENDED OPERATION**

### **WARNING**

**Never operate the mower bar from a mowing sulky.**

- 1.** It is unnecessary to run the engine at wide open throttle for satisfactory performance.  
*Cutter bar mowers give excellent results when operated at medium throttle settings and there is less wear and tear on the reciprocating parts.  
If necessary to increase ground speed, select a higher gear rather than advance the throttle.*
- 2.** The short teeth of the Mulching Bar can cut wet grass without clogging.

## **MOWER BAR MAINTENANCE**

- 1.** Wash down and re-oil the sliding parts after each use.
- 2.** Every four operating hours pump a lithium base grease into the blade control mechanism through the two grease fittings on the central housing (no gear oil is required for this attachment).
- 3.** The cutting teeth should be removed and sharpened with a grinder. For blade removal, remove the two bolts and the blade coupling. Then slide out the blade.

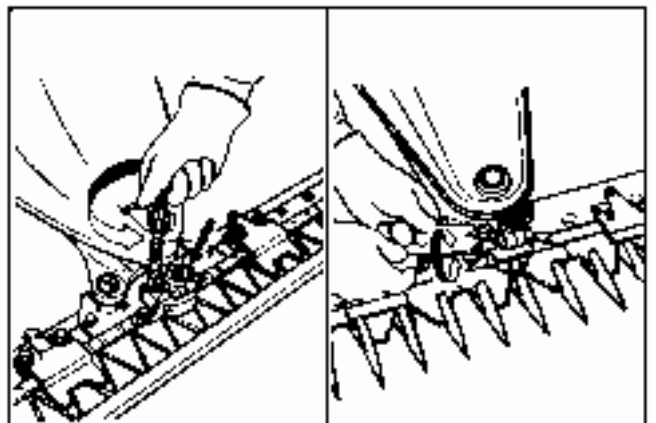

4. The tension between the blade and the tooth is set by adjusting the blade holders (described below).

**NOTE**

The tension must be snug enough for clean cutting action, but should not freeze or bind the blade against the tooth comb.

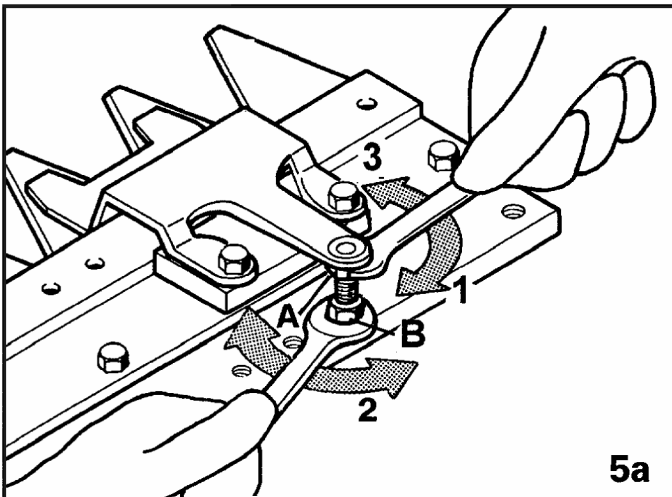

Two types of blade holders are available:

COMBO CUTTER BAR (fig.5a)

SICKLE CUTTER BAR (fig.5c)

**a) Blade holder adjustment for COMBO cutter bar**

Loosen the upper lock nut **A** (5a). Adjust the tension screw **B** until the blade slides freely between the tooth and blade holder without excessive slack. When the adjustment produces the best motion without binding, tighten the upper lock nut **A**.

**b) Blade holder adjustment for all sickle cutter bars**

Loosen the lock nut **A** (5c). Adjust the tension screw **B** until the blade slides freely between the tooth and blade holder without excessive slack. When the adjustment produces the best motion without binding, tighten the lock nut **A**.

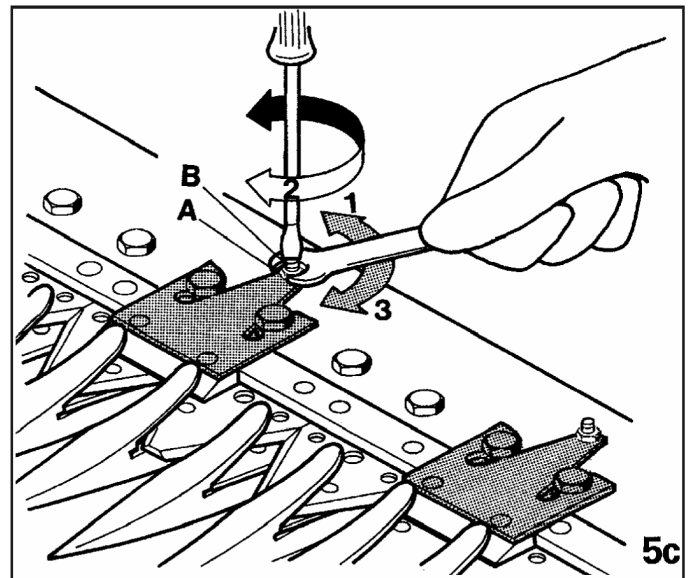

**6. REPLACEMENT PARTS:**

See your dealer for parts. Replacement teeth, and also complete, riveted mower blade assemblies are available.



# USE AND CARE OF 2-BLADE ROTARY MOWER

## THE UNITS CONVERTED FOR MOWER USE

For conversion and operation of your unit the front-drive mode see pages 33 and 34.

## ASSEMBLY, CONNECTION AND LEVELING OF THE 2-BLADE MOWER

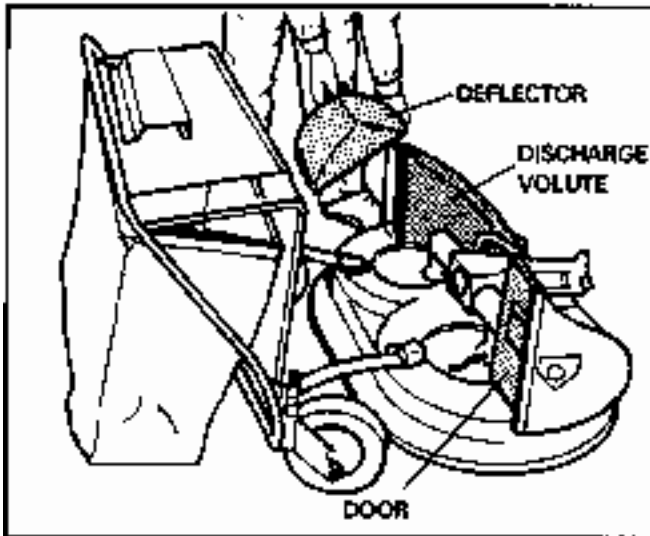

The attachment is packaged with the grass catcher in place on the deck but the following must be done in preparation for use:

1. Lift the catcher at the rear and tilt it forward.  
Note that the catcher assembly is pinned at the front on both sides and may be removed if not needed to catch the grass.
2. Remove bolts, washers and nuts from the discharge volute bracket. Use them to attach the curved discharge deflector to the bracket (see drawing).
3. The discharge volute on the opposite side from the one in step 2 has a flat door hinged down the side. No assembly is needed.

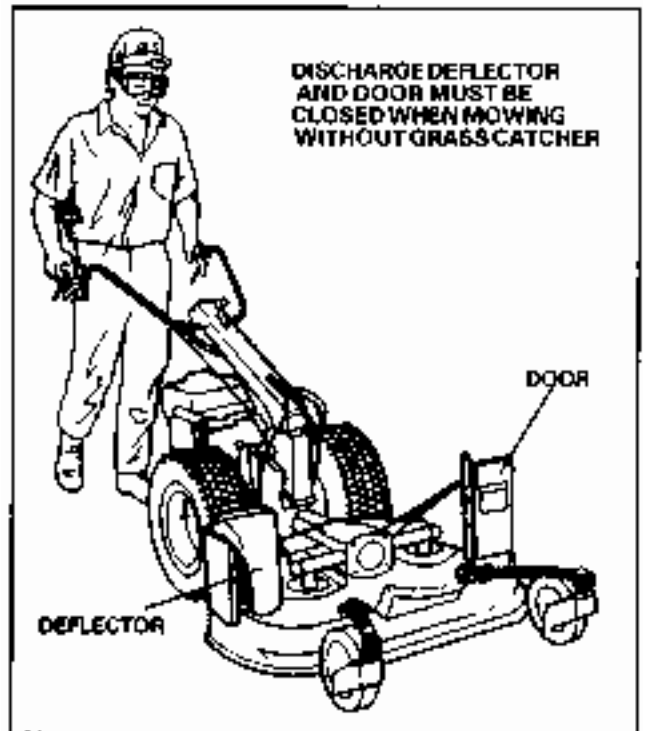
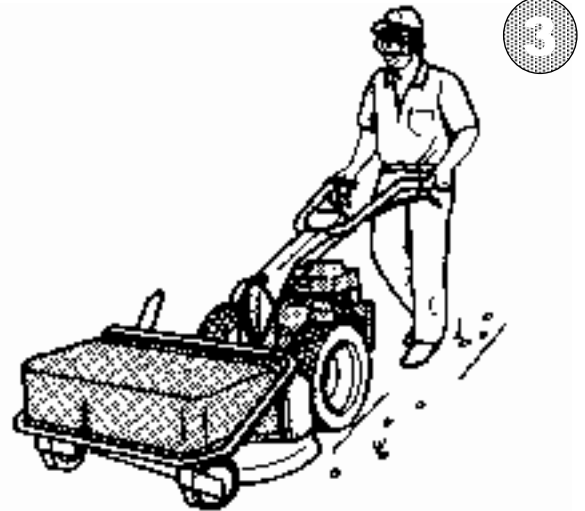

### **DANGER**

Open discharge from the volutes without the catcher in place can be very dangerous. Make sure door is closed and deflector is in the down position when moving without the grass catcher.

#### 4. POSITIONING OF THE DISCHARGE DEFLECTOR AND DOOR:

- a) For mowing without the grass catcher the discharge deflector **MUST** be in the down position, covering the opening so the clippings will not be thrown out. The door **MUST** be in closed position across the other opening for the same reason.

3

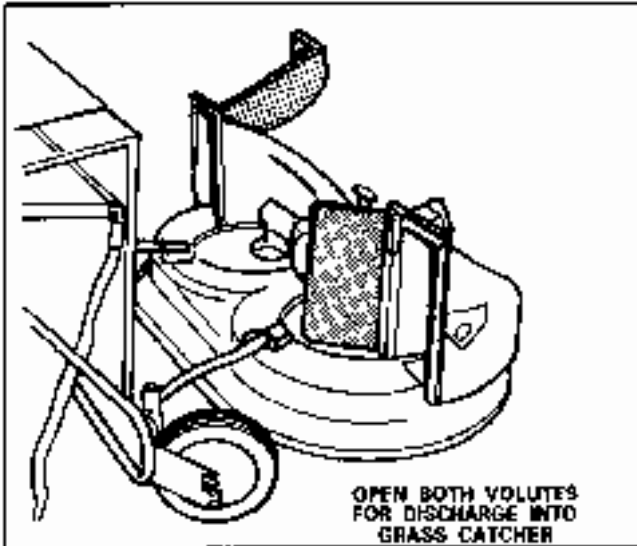

b) When putting the grass catcher into position on the deck, open up both volutes to discharge into the catcher compartment; swing open the door and lift the curved deflector upward out of the way.

**5. Put the unit on a level surface.**

Remove the nuts from the PTO studs and mount the mower to the PTO.

**6. The mower deck should be level for even mowing height. The wheel mounting brackets have three holes. If levelling is required, remove the wheel retaining hairpins and remount the wheels in a higher or lower hole as required.**

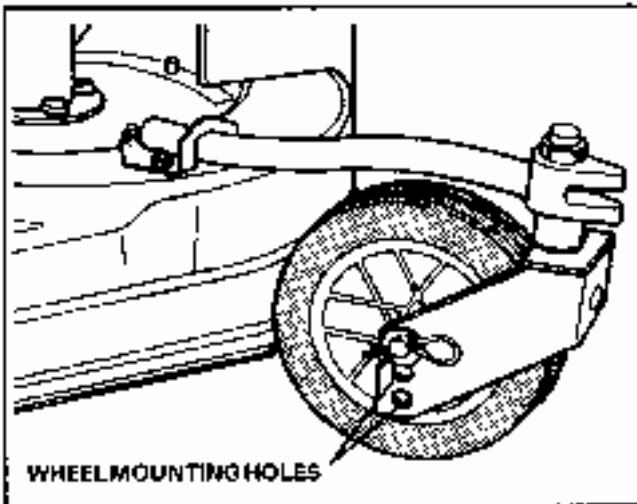

**LUBRICATION**

Before operating, remove the pipe plug at the top of the transmission housing. Check that the gear oil is within 2" of the top of the housing. If low, fill with SAE 80/90 or SAE 90EP gear oil to the top of the filler hole.

The oil level should be checked each 50 operating hours thereafter.

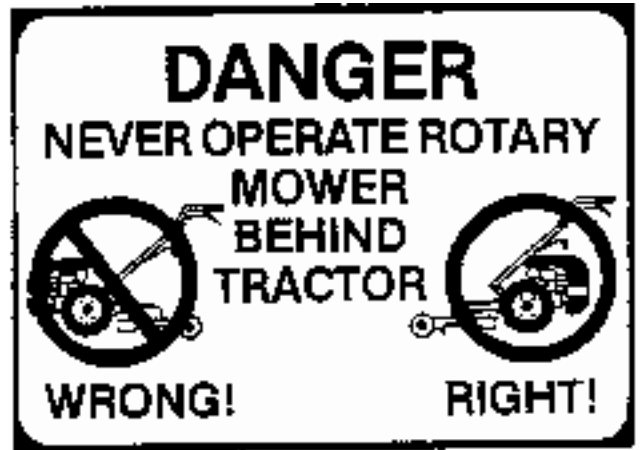

**ROTARY MOWER OPERATION**

**WARNING**

Read and obey all safety rules applicable to the unit and the rotary mower in Section One. Do not remove or defeat the purpose of the discharge deflector on the mower, or leave the discharge door open when not using the grass catcher.

Do not remove or destroy the operation of the high speed lockout device on the unit, or operate or leave the machine running with the RED STOP LEVER latched in the down position. Do not operate with the mower at the rear of the unit.

When operating from a sulky, always MOW UP AND DOWN (never across) a slope and make wide turns to guard against tipping.

When walking behind the mower, GO ACROSS (never up and down) the slopes while mowing.

**1. OPERATION FROM A RIDING SULKY:**

Only models with wheel brakes should be operated from a riding sulky.

An optional wheel brake kit may be installed if your unit does not have factory-installed brakes.

**WARNING**

Remember that a converted unit will pull to the left when the right brake lever is depressed and to the right when the left brake lever is depressed.

Forgetting this could result in loss of control especially on a unit in differential drive, or the model where the right and left brake levers are used in making turns.

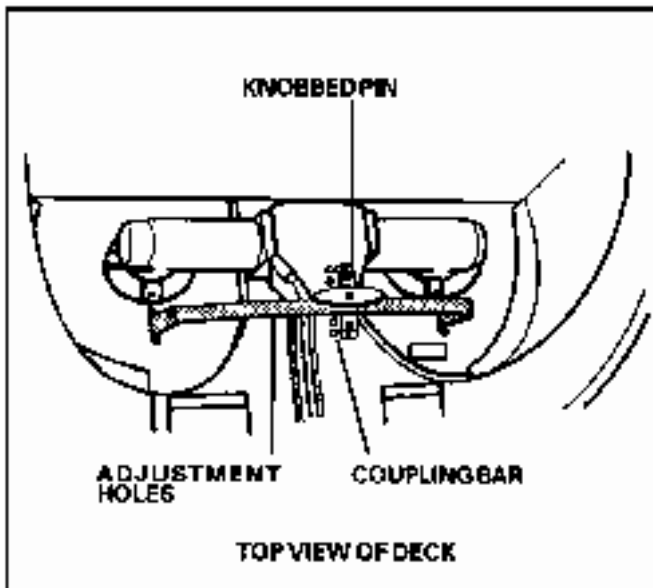

## 2. CUTTING HEIGHT ADJUSTMENT:

The cutting height is set by raising or lowering the mower blades under the deck. The deck stays at the same height above ground level. To adjust the cutting height pull up the knobbed, spring-loaded pin in the height adjustment bracket on the deck and pin it into the desired hole of the five holes in the top of the transmission housing (see drawing).

The hole nearest the PTO connection gives the shortest cutting height.

### 3. The cutting height range is 2" to 4".

To avoid shock to the grass it is recommended that only about 1/3 of the grass height, or a maximum of 2 inches, be removed at each cutting. For example, reduce a 6 inches growth to 4 inches on the first mowing, then reduce it to desired height later on with a second cutting.

### 4. Mowing wet lawns is not recommended because of poor results and also because it increases the potential for mildew and other grass diseases.

### 5. It is a good idea to vary the mowing pattern with each mowing. This will help to eliminate matting and give a more even overall appearance than when the mowing pattern is unvaried.

## INSPECTION AND MAINTENANCE

### WARNING:

If a hard object is stuck, shut down the engine immediately (see page 7) and inspect for a damaged blade. Do not try to straighten and remount a bent cutter because any impact, severe enough to bend it, may have put tiny cracks in the hardened steel. These could enlarge until the cutter shatters during operation.

Like all cutting tools, the mower must be kept in good condition to perform well.

1. Clean the underside of the deck often enough to prevent heavy caking of dirt and grass on the surfaces. Inspect the condition of the mower blade assemblies each time.
2. The left and right mower blade assemblies consist of fluked cutter blades mounted on both ends of blade holders by M10x30 mm lock nuts, special "super" lock washer and self-locking nuts. The mounting imparts a flail-like action to the cutters. The left side blade assembly rotates counter clockwise (ccw) and the right side assembly clockwise (cw).

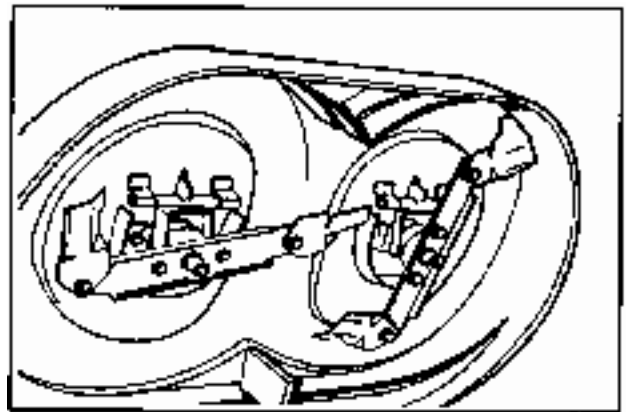

### WARNING

Do not substitute ordinary fasteners for those called out in step 2.

3. An extra set of cutter blades was packaged with the mower. Put these on the blade holders when the other set has been removed for grinding (cutting edges cannot be field). Grind the bottom edges of the cutters.
4. After grinding and remounting the cutters, check the balance of each blade assembly. If one end is heavy, remove the cutter from that end and grind it to improve blade balance. An out-of-balance condition causes excessive vibration.
5. The cutters gradually will wear thin at the bend of the flukes. Keep a watch for this. If you see cracks in this area, discard cutters before further wear occurs. Cracked pieces can break off, becoming high velocity missiles.

## **USE AND CARE OF SNOW THROWERS**



### **GENERAL INFORMATION**

All sizes of the Snow Throwers are similar in construction and operation.

Optional accessories include snow grips and wheel weights for added traction.

### **SNOW THROWER OPERATION**

1. Read all precautions in Section One pertaining to the safe operation of the machine and snow thrower attachment.
2. Only the lowest speed should be used for backing when the footing is slippery.
3. If necessary to start the engine in a barn or shed keep the doors wide open.
4. If necessary to back up be sure of your footing and be sure the way behind you is unobstructed.
5. Always shut off the engine, wait until all movement stops and disconnect the spark plug wire before deicing the discharge chute or the impeller. The wooden stick on the side of the Snow Thrower is for deicing. You also can let the machine thaw if a warm place is available.
6. Always be sure to direct the discharge chute away from living quarters, vehicles and people. Work in a pattern which will pile the snow where desired and which requires the fewest passes with the machine. With the wrong procedure you could be throwing snow over and over without clearing the area. Don't forget that the wind has an influence on how you should proceed.



### **⚠ WARNING**

Do not try to clear slopes so steep that you could lose control, or the machine could slide into you or an obstruction.

The snow-thrower has an impeller retard system designed to brake the impeller to a stop within three seconds after PTO disengagement or engine shutdown. Even so, never put hands and fingers inside the discharge chute or the impeller (collector) area unless the engine has been rendered unstartable, as explained in Section One at page 8.

## **USE AND CARE OF CHIPPER / SHREDDER**

Be sure to read the Manufacturer Chipper/Shredder Owner's Manual which comes with the attachment and also obey the safety messages printed on the unit and the Chipper / Shredder attachment. This unit reduces thick branches to chips and pulverizes lawn and garden waste for mulching or adding to your compost pile.

Careless or improper use can be very dangerous.

Wear safety goggles of the type specified by ANSI Safety Standard Z87. Also wear a hat.

Work gloves may be worn when feeding the Chipper but not when feeding the Shredder because they can pull your hands into the hopper if snagged by the material.

Remove jewels or clothing articles which could be drawn into the machine.

Set up on firm ground but not on gravel, concrete, brick or other surfaces which provide no cushion.

### **⚠ DANGER**

Do not start engine when there is material in the Shredder. Shut off engine and disconnect the spark plug wire before cleaning a jammed hopper, changing screens or performing any maintenance or service.

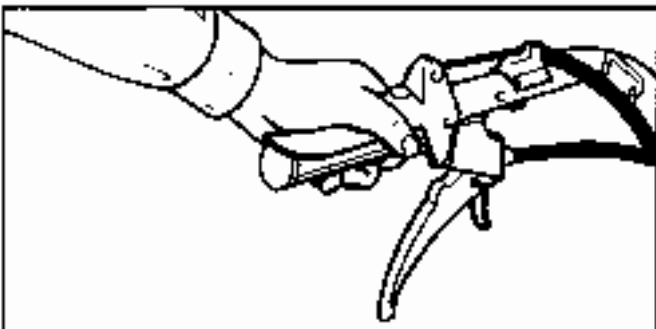

After latching the clutch and stop switch and starting the engine, leave the unit in neutral.

Disengage the clutch lever while pinning down the stop switch lever (see drawing).

Engage the PTO when ready to operate.

Be careful what you put into the Shredder hopper. The machine can shred most organic materials. However, objects of certain shape, size or texture may cause trouble even if organic.

The Shredder cannot handle thick branches or large chunks of wood.

Neither Shredder nor Chipper can handle cloth, string, glass, rubber, metal, rocks or paving or long vines.

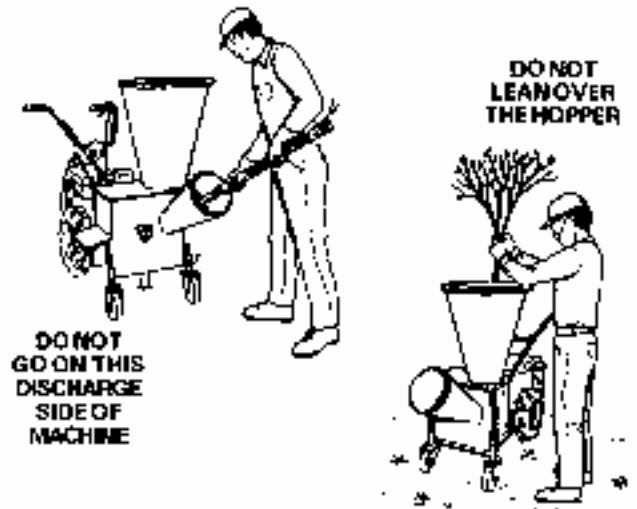

Soggy soil, green garden wastes and wet grass clippings can be processed through the Shredder by mixing dry leaves and wood chips with the wet stuff.

For wet processing, the standard curved screen with the "Swiss cheese" holes should be replaced with the set of five rods and tubes supplied with the attachment.

### **⚠ DANGER**

Do not use the Chipper/Shredder with an unscreened discharge. The discharge must be covered either with the rods and tubes or the standard screen.

### **IMPORTANT**

Always disengage the PTO lever before stopping the engine. If the PTO remains in engagement during engine shutdown, the rotating Chipper/Shredder shaft may motorize and restart the engine.

After shutdown, always check the paint splash across the drive shaft (near Chipper chute) to be sure all movement has stopped.

## **CHIPPER/SHREDDER MAINTENANCE**

1. Clean out the hopper before each use.
2. Clean the exterior at regular intervals and apply a light oil or wax to prevent rust.
3. Shaft bearings are the sealed, self-lubricating type requiring no further lubrication.
4. Check all fasteners frequently and tighten loose parts. Replace missing or worn parts. See the illustrated parts list in your Chipper/Shredder owner's manual for parts information.

## **USE AND CARE OF POWER SWEEPER 80 – 100 cm**

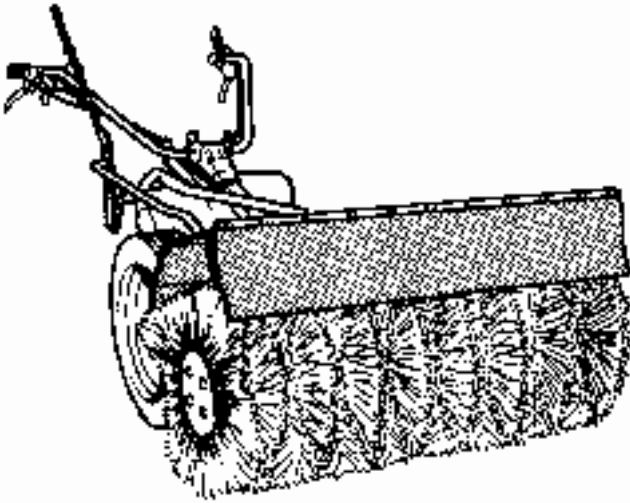

Be sure to read and follow the detailed instructions in Power Sweeper Operator's Manual that came with the attachment. Also follow the instructions for safe use of power units and the Power Sweeper attachment in Section One of this manual.

Your unit should have an 7 horsepower or larger engine to power the Sweeper. Installation of a pre-cleaner element in the engine air cleaner is recommended.

Safety equipment must include eye protection goggles of the type stamped "Z87" (for ANSI Safety Standard Z87).

A dust mask or respirator should be worn when sweeping surface where dust is raised.

Keep children, pets and bystanders away from the machine and keep well clear of the rotating parts.

### **NOTICE**

**In your Power Sweeper owner's manual, the instructions to deactivate the PTO lockout device for front operating attachment applies to earlier units than those of your model year.**

**On your unit, PTO lockout deactivation is not only unnecessary, but also must not be done. On your unit, the lockout is effective only when needed. In the front-drive mode, the lockout is inactive.**

### **OPERATION**

Move to the work site and adjust the casters for proper brush height; brush should touch flat, paved, surfaces; should barely clear the turf when re-moving lawn thatch. If adjusted too low, or when it runs into a hillock, the brush will drive the unit back towards the operator.

Always put the unit into gear before engaging the PTO. If the Sweeper is engaged first and the brush is in contact with the ground, it will drive back the unit.

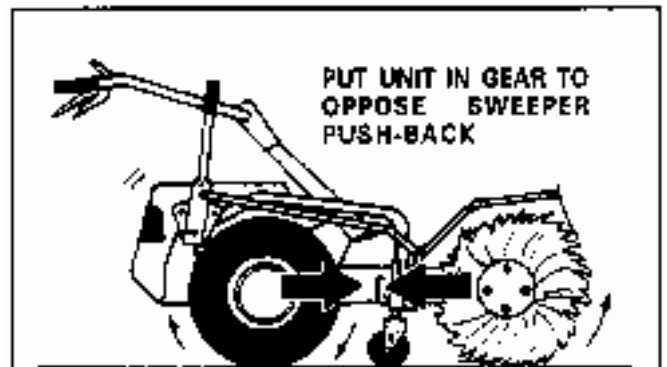

Be prepared to let go of the controls to stop all motion if the unit is driven backwards or you lose control.

Disengage the PTO and walk behind the unit when going up or down slopes. Work across the slope when sweeping. Do not work on terrain where you cannot keep your footing or control of the unit. It could overturn or slide into you. For rooftop sweeping, be sure the surface is dry and does not pitch more than 5 degrees (1/2" per foot). Set up warning barriers so you will know when you come near the edges of the roof.

### **MAINTENANCE AND STORAGE**

Grease the PTO shaft coupling, the U-joint and the quick hitch at the same time as you repack the unit PTO coupling with grease.

Also maintain the level of gear oil in the Sweeper transmission per instructions on page 36.

Clean the Power Sweeper prior to storage and apply auto wax of other rust preventative to the exterior surfaces. Store in a dry, well-ventilated place.

All parts of the Power Sweeper are available from your BCS dealer or distributor.

See the illustrated parts list in the power Sweeper owner's manual for parts identification.

## USE AND CARE OF DOZER BLADE

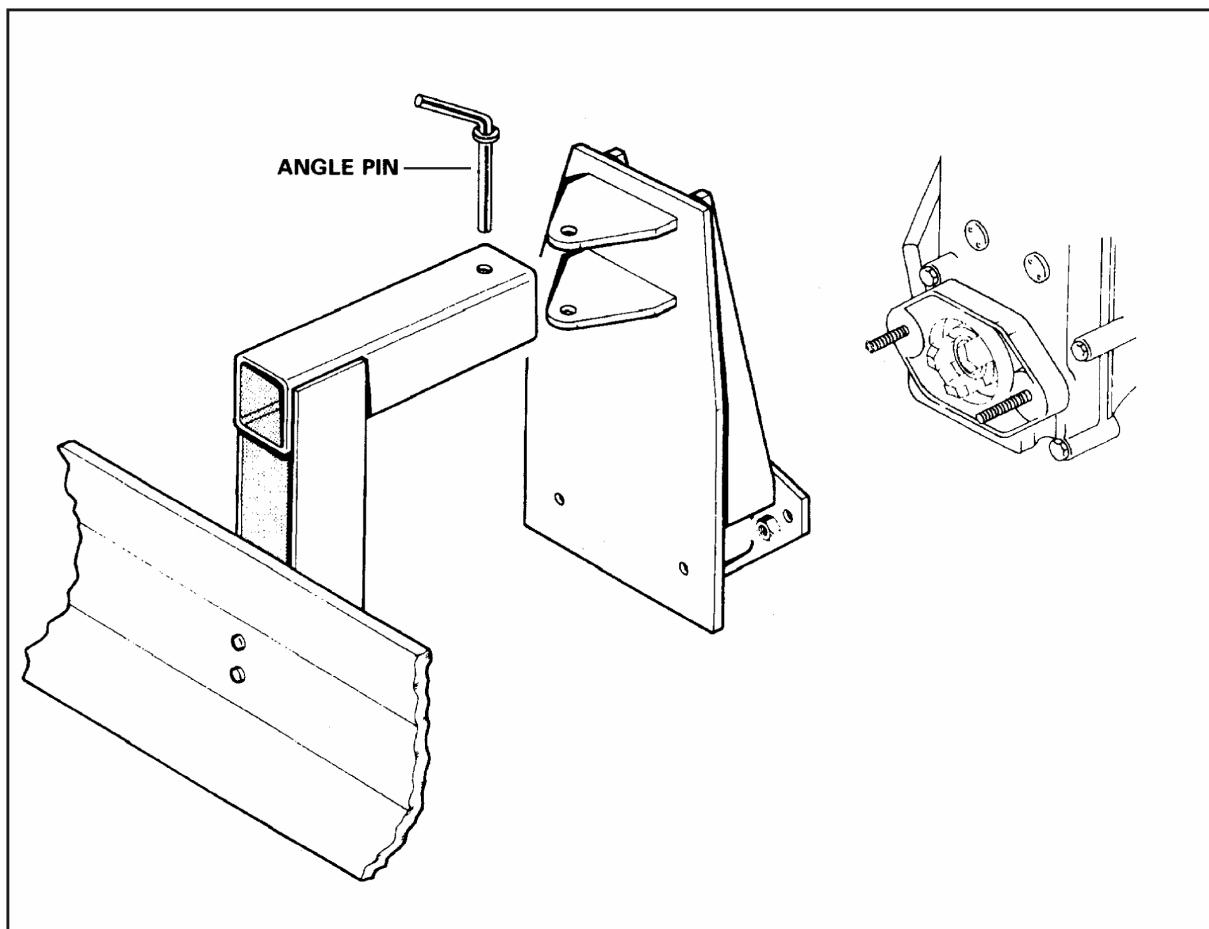

The Dozer Blade can be used either in front or behind the unit. It also can be set to doze material straight ahead or to either side.

The choice of best mounting position and best angle can be made after experimentation with the dozer blade and will vary with the condition of the soil, snow or whatever material is to be moved or spread.

Consider installation of wheel weights when maximum traction is needed. Instruction for assembly and use come with the Dozer Blade.

The models have an integral mounting bracket.

Fit the dozer blade tongue over the hitch (or special bracket) on the unit, and drop the hitch pin through the holes.

Drop the angle pin through the tongue hole into one of the slots in the angle bracket.

Now tighten the PTO stud nuts.

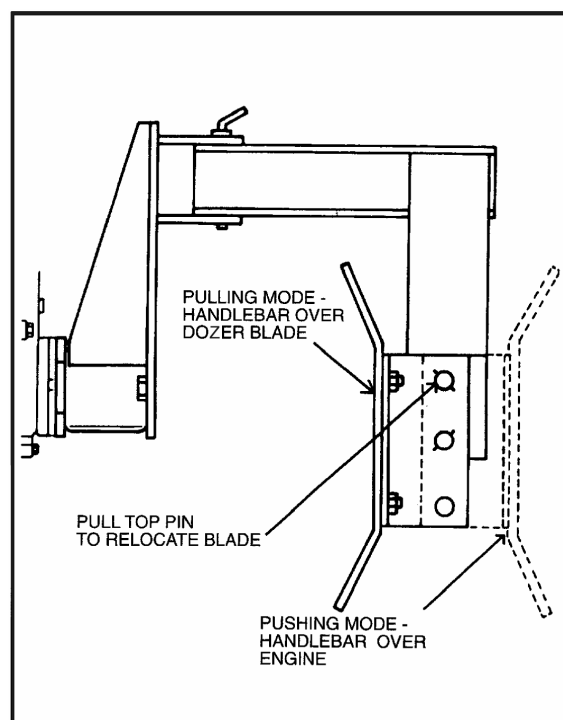

**SAVE THIS MANUAL  
FOR REFERENCE**



# Accessories for Power Units & Attachments

## MAIN ATTACHMENTS

For more information on the large variety of BCS attachments such as the different size Tillers, Sickle Bars, Snow Throwers, Heavy Duty Mowers and other attachments, please contact your nearest BCS dealer.

## QUICK HITCH FOR ATTACHMENTS

When two or more attachments are purchased, BCS offers a Quick Hitch accessory. The Quick Hitch will allow the attachments to be installed and removed from the tractor quickly and easily without the need for any tools. The Quick Hitch includes one bushing, to be installed on the tractor, and two tangs, to be installed on two attachments.

Part.# 922.90825

## TANG FOR QUICK HITCH

Each Quick Hitch accessory comes with two tangs to be installed on two attachments. If more than two attachments are purchased individual tangs can be purchased for each additional attachment.

Part.# 922.90826

## PTO EXTENSIONS

Available in 3" and 6" lengths needed for certain applications with a Rotary Mower or Cutter Bar Mower Attachment on diesel engine power units.

Part.# 922.90829 (three inch)

## PTO ADAPTOR

Converts the standard BCS PTO shaft to the American standard 1-3/8", 6-spline size

Part.# 922.90828

## WHEELS AND TIRES

Many sizes and types are available to suit your needs. Ask your BCS servicing dealer for complete information.

## STEEL CAGE WHEELS

For additional traction in loose or wet soils.

17" size - # 922.57779

(for 710,718,722,732)

23 1/2" size - # 922.49993 (for 948)

## BRAKE

Available in kit form.

Part.# 922.90833 (for 710,718,722)

Part.# 922.59505 (for 732)

## WHEEL SPACERS

Placed on wheel axles, these 2.5" spacers increase track width by 5".

Part.# 922.43685

## WHEEL WEIGHTS

Available in various weights for different wheel sizes, weights mount into the wheels for increased traction and / or deeper plowing or tilling.

Part.# 922.43686 for 4.00-8/3.50-8 (kg.11)

Part.# 922.48715 for 4.00-10 & 5.00-10 (kg.15)

Part.# 922.48720 for 6.50/80-12" (kg.34)

## UTILITY TRAILER

Use with 948 and 853 power units. Hauls up to 875 pounds of firewood, trash, shrubs, etc. has a separate footbrake for operating safety. Not for road use. A curved coupling is used for attachment to the unit hitch.

Trailer # 921.48701

Curved coupling # 922.59512

## MOWING SULKY

Converts your walking BCS Rotary Mower

Attachment to a riding mower.

For 852, 853 and 948 power units.

Part.# 921.49300

## TRANSPORT SULKY

For 852, 853 and 948 power units for transport of machine and operator to the work site. Not for work applications or road use. A curved coupling is used for attachment to the unit hitch.

Sulky # 921.48675

Curved coupling # 922.47720 (852, 853)

Curved coupling # 922.59512 (948)

## TILLER TINES

The standard tines supplied with the attachment have been proved over many years to be ideally suited for most soil types.

## TRANSPORT WHEEL

Providing fast, easy maneuvering, this rubber-tired wheel is mounted on the tiller by an easy-to-remove or install "presto" pin.

Part.# 922.42465

## HILLER / FURROWER

Two tools in one, Furrower has removable hiller wings so it can be used separately. Easily attaches to the Tiller hood by a "presto" pin.

Part.# 921.47860

## SINGLE BOTTOM PLOW

Will plow a furrow from 6" to 10". Size 5.00-12 or 6.5/80-12 tires and wheel weights are recommended for plowing.

Part.# 921.90799 (for 718, 722, 732, 852, 853)

Part.# 921.49992 (for 948)

## SWIVEL PLOW

Reversible plow allows gardener to return down next plow row. 6.5/80-12 tires and wheel weights are recommended.

Part.# 921.90797

## CUTTER BAR BLADE GUARD

To be installed on Cutter Bar Mower when not in use Protects operator. See servicing dealer for part number.

## DOZER/SCRAPER BLADE (40")

Can be pushed or pulled. Easily converts by "presto" pin. Angles are adjustable.

Part.# 921.90735





**WARNING:** the Engine Exhaust from this product contains chemicals known to the state of California to cause cancer, birth defects or other reproductive harm.

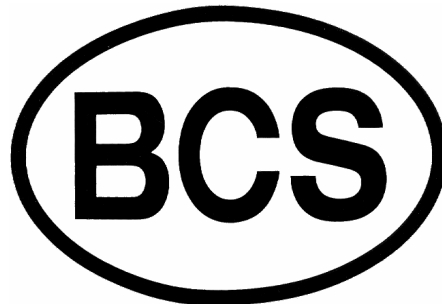

**BCS America LLC**

8111 N.E. Columbia Blvd

PORTLAND, OREGON 97218

Tel.: 503-2521249 / 800-5431040

Fax: 503-2528360

<http://www.bcs-america.com>